

About this Manual

We've added this manual to the Agilent website in an effort to help you support your product. This manual is the best copy we could find; it may be incomplete or contain dated information. If we find a more recent copy in the future, we will add it to the Agilent website.

Support for Your Product

Agilent no longer sells this product. Our service centers may be able to perform calibration and repair if necessary, but no other support from Agilent is available. You will find any other available product information on the Agilent Test & Measurement website, www.tm.agilent.com.

HP References in this Manual

This manual may contain references to HP or Hewlett-Packard. Please note that Hewlett-Packard's former test and measurement, semiconductor products and chemical analysis businesses are now part of Agilent Technologies. We have made no changes to this manual copy. In other documentation, to reduce potential confusion, the only change to product numbers and names has been in the company name prefix: where a product number/name was HP XXXX the current name/number is now Agilent XXXX. For example, model number HP8648A is now model number Agilent 8648A.

www.valuetronics.com

OPERATING AND SERVICE MANUAL



86242D 86245A 86250D RF PLUG-IN

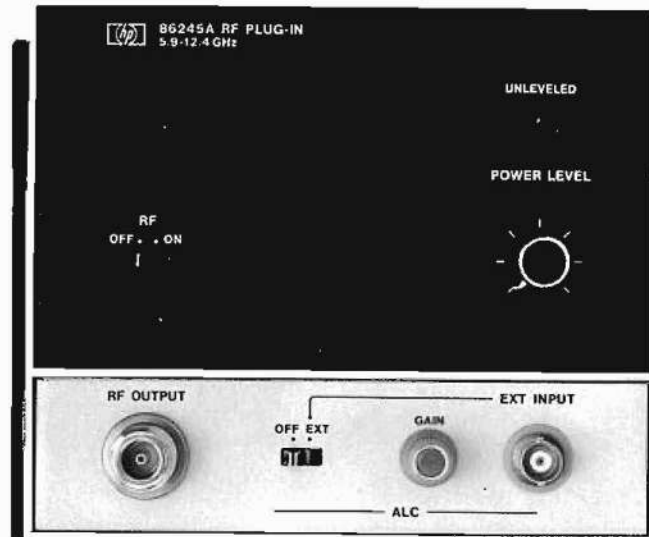

D-3-4-F



www.valuetronics.com

1596

SAFETY

This instrument has been designed and tested according to International Safety Requirements. To ensure safe operation and to keep the instrument safe, the information, cautions, and warnings in this manual must be heeded. Refer to Section I for general safety considerations applicable to this instrument.

CERTIFICATION

Hewlett-Packard Company certifies that this instrument met its published specifications at the time of shipment from the factory. Hewlett-Packard Company further certifies that its calibration measurements are traceable to the United States National Bureau of Standards, to the extent allowed by the Bureau's calibration facility, and to the calibration facilities of other International Standards Organization members.

WARRANTY AND ASSISTANCE

This Hewlett-Packard product is warranted against defects in materials and workmanship for a period of one year from the date of shipment. Hewlett-Packard will, at its option, repair or replace products which prove to be defective during the warranty period provided they are returned to Hewlett-Packard. Repairs necessitated by misuse of the product are not covered by this warranty. NO OTHER WARRANTIES ARE EXPRESSED OR IMPLIED, INCLUDING BUT NOT LIMITED TO THE IMPLIED WARRANTIES OF MERCHANTABILITY AND FITNESS FOR A PARTICULAR PURPOSE. HEWLETT-PACKARD IS NOT LIABLE FOR CONSEQUENTIAL DAMAGES.

Service contracts or customer assistance agreements are available for Hewlett-Packard products that require maintenance and repair on-site.

For any assistance, contact your nearest Hewlett-Packard Sales and Service Office. Addresses are provided at the back of this manual.



OPERATING AND SERVICE MANUAL

86242D
86245A
86250D
RF PLUG-IN

Includes Options 001, 004, and 008

SERIAL NUMBERS

This manual applies directly to HP Model 86242D and 86250D RF Plug-ins with serial numbers prefixed 1803A or 1818A and to HP Model 86245A RF Plug-ins with serial numbers prefixed 1740A or 1818A.

For additional important information about serial numbers see INSTRUMENT COVERED BY MANUAL in Section I.

©Copyright HEWLETT-PACKARD COMPANY 1978
1400 FOUNTAIN GROVE PARKWAY, SANTA ROSA, CA. 95404 U.S.A.

MANUAL PART NO. 86245-90001
Microfiche Part No. 86245-90002

Printed: APRIL 1978

CONTENTS

Section	Page	Section	Page
I GENERAL INFORMATION	1-1	3-3. Panel Features	3-1
1-1. Introduction	1-1	3-5. Operating Instructions	3-1
1-6. Specifications	1-1	3-6. Safety	3-1
1-8. Safety Considerations	1-1	3-9. Internal Leveling (Option 001)	3-1
1-9. General	1-1	3-12. External Crystal Detector Leveling	3-1
1-11. Safety Symbols	1-2	3-14. External Power Meter Leveling	3-2
1-12. Operation	1-2	3-16. External AM	3-2
1-14. Service	1-2	3-18. External FM	3-2
1-18. Instruments Covered by Manual	1-3	3-20. Phase Lock Operation	3-2
1-23. Description	1-3	3-23. FM-NORM-PL Switch	3-3
1-26. Options	1-3	3-25. Operator's Maintenance — Fuses	3-3
1-27. Option 001	1-3	IV PERFORMANCE TESTS	4-1
1-29. Option 004	1-8	4-1. Introduction	4-1
1-31. Option 008	1-8	4-4. Equipment Required	4-1
1-33. Equipment Required but Not Supplied	1-8	4-6. Abbreviated Performance Verification	4-1
1-35. Equipment Available	1-8	4-8. Frequency Range and Accuracy Test	4-1
1-36. Model 8755B/182T Swept Amplitude Analyzer	1-8	4-9. Frequency Stability Test	4-6
1-38. Power Meters and Crystal Detectors	1-8	4-10. Residual FM in 10 kHz Bandwidth Test	4-9
1-40. Model 8410B/8411A Network Analyzer	1-8	4-11. Power Level and Variation Test	4-10
1-42. Model 3700-Series Microwave Link Analyzer	1-8	4-12. Harmonic Spurious Signals Test	4-15
1-44. Accessories Supplied	1-8	4-13. Nonharmonic Spurious Signals Test	4-18
1-46. Accessories Available	1-8	4-14. Residual AM Test	4-20
1-47. Service Accessories	1-8	4-15. Equivalent Source SWR Test (Option 001 Only)	4-21
1-49. Service Aids	1-8	4-16. External Frequency Modulation Test	4-25
1-51. RF Section 36-Pin Extender	1-9	4-17. Amplitude Modulation Test	4-29
1-53. Recommended Test Equipment	1-9	4-18. FM Frequency Response Test	4-33
II INSTALLATION/ OPERATION VERIFICATION	2-1	4-19. Upconverter Simulation Test (Option 008 Only)	4-36
2-1. Introduction	2-1	V ADJUSTMENTS	5-1
2-3. Initial Inspection	2-1	5-1. Introduction	5-1
2-5. Preparation for Use	2-1	5-3. Equipment Required	5-1
2-6. Power Requirements	2-1	5-5. Factory Selected Components	5-1
2-8. Interconnections	2-1	5-7. Safety Considerations	5-1
2-10. Mating Connectors	2-1	5-13. Location of Test Points and Adjustments	5-1
2-12. Operating Environment	2-1	5-15. YIG Driver Frequency Adjustments	5-4
2-16. Frequency Scale Installation	2-1	5-16. ALC Adjustments	5-5
2-18. RF Plug-in Installation and Removal	2-3	5-17. FM Driver Adjustment	5-20
2-21. Storage and Shipment	2-4	5-18. FM Frequency Response Adjustment	5-23
2-22. Environment	2-4	VI REPLACEABLE PARTS	6-1
2-24. Packaging	2-5	6-1. Introduction	6-1
2-27. Operation Verification	2-5	6-3. Abbreviations	6-1
III OPERATION	3-1	6-5. Replaceable Parts List	6-1
3-1. Introduction	3-1	6-7. Ordering Instructions	6-1

CONTENTS (Cont'd)

Section	Page	Section	Page
VII MANUAL BACKDATING CHANGES	7-1	8-8. YIG-Tuned Oscillator	8-1
7-1. Introduction	7-1	8-15. Module Exchange Program	8-2
7-6. Manual Backdating Instructions	7-1	8-17. Service	8-2
VIII SERVICE	8-1	8-18. Safety	8-2
8-1. Introduction	8-1	8-22. Troubleshooting	8-4
8-3. Assembly Service Sheets	8-1	8-26. Recommended Test Equipment	8-4
8-5. Principles of Operation	8-1	8-28. Cleaning Switches	8-4
8-6. Circuit Description	8-1	8-30. Unleveled Lamp Removal and Replacement	8-4

ILLUSTRATIONS

Figure	Page	Figure	Page
1-1. RF Plug-in and Accessories Supplied	1-0	3-17. Increased Dynamic Range Using HP Model 8755B Swept Amplitude Analyzer	3-21
1-2. Typical Serial Number Plate	1-3	4-1. CW and Manual Sweep Accuracy Test Setup	4-2
1-3. Service Accessories, HP Part Number 08620-60124	1-10	4-2. Swept Frequency Endpoint and Marker Accuracy Test Setup	4-4
1-4. Service Aids for 86242D/86245A/86250D	1-11	4-3. Frequency Stability Test Setup	4-6
1-5. Delay Line Discriminator	1-12	4-4. 3:1 Load SWR Test Setup	4-8
1-6. RF Section 36-Pin Extender, HP Part Number 08621-60056	1-13	4-5. Residual FM Test Setup	4-9
2-1. Location of Mainframe Parts Pertinent to Frequency Scale and RF Plug-in Installation	2-2	4-6. Residual FM Display on Spectrum Analyzer	4-10
2-2. Mainframe Front Panel in Open Position	2-3	4-7. Crystal Detector Leveling Test Setup	4-11
2-3. RF Section Latch in Release Position	2-4	4-8. Power Meter Leveling Test Setup	4-13
2-4. Operation Verification Test Setup	2-5	4-9. Internal Leveling Test Setup	4-14
3-1. Amplitude Modulation Selector Switch A3S1 and External Leveling Selector Switch A3S2	3-2	4-10. Harmonic Spurious Signals Test Setup	4-16
3-2. Front Panel Indicator, Controls and Connectors	3-4	4-11. Nonharmonic Spurious Signals Test Setup	4-18
3-3. Rear Panel Connectors and Switch	3-5	4-12. Residual AM Test Setup	4-20
3-4. External Crystal Detector Leveling	3-6	4-13. Equivalent Source SWR Test Setup	4-22
3-5. Leveled RF Power Output	3-7	4-14. Typical Pattern of a Swept SWR Measurement	4-23
3-6. Unleveled RF Power Output	3-7	4-15. Conversion of Oscilloscope Trace to Source Match SWR	4-24
3-7. Oscillations Due to Excessive ALC Loop Gain	3-7	4-16. External Frequency Modulation Test Setup	4-25
3-8. Power Meter Leveling Operation	3-8	4-17. Typical Spectrum Analyzer Display of 100 Hz Frequency Deviation	4-26
3-9. External AM Operation	3-10	4-18. Spectrum Analyzer Display of Frequency Deviation	4-28
3-10. Internal Leveling	3-12	4-19. Amplitude Modulation Test Setup	4-30
3-11. Simultaneous Transmission, Reflection Measurement Using HP Model 8755B Swept Amplitude Analyzer	3-14	4-20. FM Frequency Response Test Setup	4-33
3-12. External FM Operation	3-17	4-21. FM Frequency Response Waveform	4-35
3-13. Spectrum Analyzer Display of Typical Frequency Modulated Waveform	3-18	4-22. Upconverter Simulation Test Setup	4-37
3-14. Phase Lock Operation	3-19	5-1. Test Point and Adjustment Locations	5-2
3-15. Spectrum Analyzer Display of Unstabilized CW Signal	3-20	5-2. YIG Driver Frequency Adjustments Test Setup	5-4
3-16. Spectrum Analyzer Display of Phase-Locked CW Signal	3-20	5-3. Preliminary ALC Adjustments Test Setup	5-6
		5-4. Offset Adjustment Test Setup	5-8
		5-5. Delay Adjustment Test Setup, Option 001	5-8
		5-6. Delay and Symmetry Adjustment Waveforms	5-9
		5-7. 8755B Symmetry Adjustment Test Setup (Option 001)	5-10

ILLUSTRATIONS (Cont'd)

Figure	Page	Figure	Page
5-8. Leveling OFF Adjustment Test Setup	5-11	8-8. UNLEVELED Lamp Removal and Replacement Procedure	8-5
5-9. External Leveling Adjustment Test Setup.	5-12	8-9. Schematic Diagram Notes	8-6
5-10. Delay Adjustment Test Setup, Standard.	5-14	8-10. Test Setup and Control Settings for Waveforms and Voltages on Schematic Diagrams.	8-8
5-11. Harmonics and Amplifier Bias Adjustment Test Setup	5-14	8-11. GaAs FET Amplifier	8-9
5-12. Swept Amplitude Display of Leveled Power and Harmonics	5-16	8-12. Troubleshooting Block Diagram	8-9
5-13. ALC Flatness Adjustment Test Setup	5-17	8-13. A2 YIG Driver Assembly, Component Locations	8-11
5-14. Slope/Breakpoint Adjustment Waveforms	5-19	8-14. A2 YIG Driver Assembly, Schematic.	8-11
5-15. FM Offset Adjustment Test Setup	5-20	8-15. A3 ALC Assembly, Component Locations	8-12
5-16. FM Sensitivity Adjustment Test Setup.	5-22	8-16. A3 ALC Assembly, Schematic	8-13
5-17. FM Frequency Response Adjustment Test Setup.	5-23	8-17. A1 FM Driver Assembly, Component Locations	8-15
7-1. A2 YIG Driver Assembly, Component Locations (Change A)	7-11	8-18. A1 FM Driver Assembly, Schematic	8-15
7-2. A2 YIG Driver Assembly, Schematic (Change A)	7-11	8-19. A6 ALC/YIG Interconnect Assembly, Component Locations	8-17
7-3. A3 ALC Assembly, Component Locations (Change A)	7-12	8-20. Overall Wiring Diagram.	8-17
7-4. A3 ALC Assembly, Schematic (Change A)	7-13	8-21. Major Assembly and Component Locations, Top View (Option 001/004)	8-19
7-5. A1 FM Driver Assembly, Component Locations (Change A)	7-15	8-22. Major Assembly and Component Locations, Bottom View (Option 001/004).	8-19
7-6. A1 FM Driver Assembly, Schematic (Change A)	7-15	8-23. Major Assembly and Component Locations	8-19
8-1. YIG Sphere in Non-Magnetic Field	8-1	8-24. Location of Test Points and Adjustments.	8-19
8-2. YIG Sphere in Magnetic Field	8-1	8-25. Major Assembly and Component Locations, Top View, 86242D/86250D (Option 008)	8-21
8-3. Net Magnetization Vector	8-1	8-26. Major Assembly and Component Locations, Bottom View, 86242D/86250D (Option 008)	8-21
8-4. Magnetization Vector With RF Field Applied	8-1	8-27. Major Assembly and Component Locations, 86242D/86250D.	8-21
8-5. Increase DC Magnetic Field	8-2	8-28. Location of Test Points and Adjustments, 86242D/86250D.	8-21
8-6. Coupling RF and DC Magnetic Fields to YTO YIG.	8-2		
8-7. Module-Exchange Procedure	8-3		

TABLES

Table	Page	Table	Page
1-1. Specifications for 86242D, 86245A, and 86250D Installed in 8620C	1-4	4-3. Frequency Stability Specifications	4-6
1-2. Supplemental Characteristics	1-6	4-4. Power Level and Variation Specifications.	4-11
1-3. Frequency Scale Supplied	1-8	5-1. Controls Listed in Adjustment Sequence	5-3
1-4. Recommended Test Equipment	1-14	6-1. Reference Designations and Abbreviations	6-2
2-1. Models 86242D/86245A/86250D Mating Connectors.	2-2	6-2. Replaceable Parts	6-4
3-1. FM Modulation Characteristics for FM-NORM-PL Switch Positions	3-3	6-3. Manufacturers Code List.	6-12
4-1. Frequency Range and Accuracy Specifications	4-2	7-1. Manual Backdating Changes by Serial Number Prefix	7-1
4-2. Frequency Meter Error.	4-5	7-2. Replaceable Parts (86242D/86250D Change A).	7-3

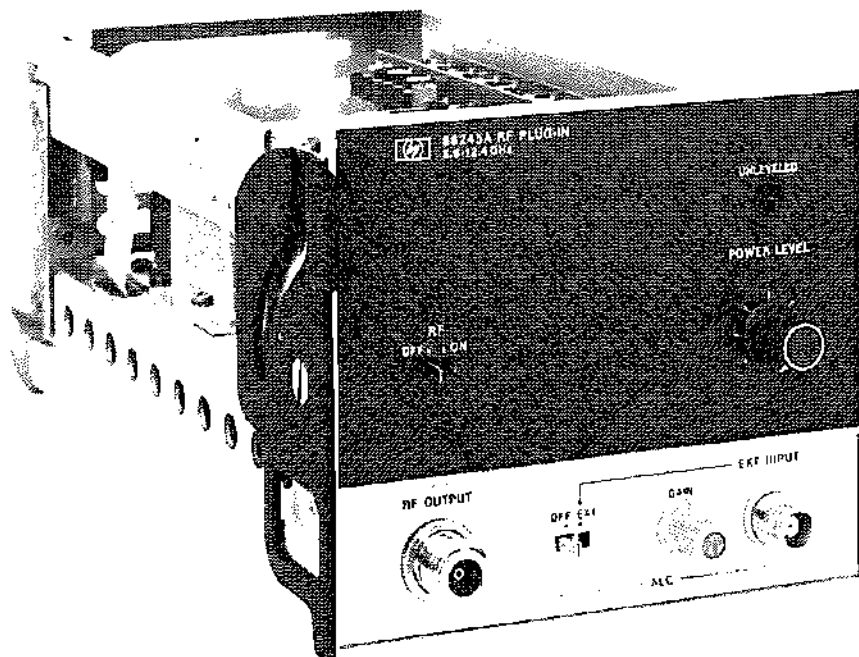

HP 86245A RF PLUG-IN

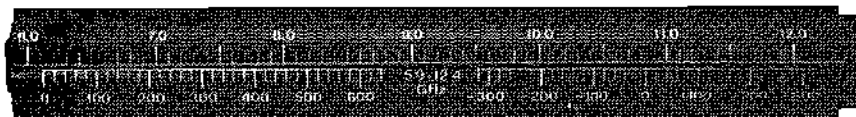

SCALE FOR 8620A and 8620C

NOTE

The 86245A and scale are shown, however, the 86242D, 86250D, and scales are similar in appearance. See ACCESSORIES SUPPLIED in Section I for part number

www.valuetronics.com

Figure 1-1, RF Plug-in and Accessories Supplied

SECTION I GENERAL INFORMATION

1-1. INTRODUCTION

1-2. This Operating and Service manual contains information required to install, operate, test, adjust, and service the Hewlett-Packard Model 86242D, 86245A, and 86250D RF Plug-Ins. Figure 1-1 shows the instrument and accessories supplied. This section covers instrument identification, description, options, accessories, specifications, and other basic information.

1-3. This manual is divided into eight sections which provide information as follows:

- a. SECTION I, GENERAL INFORMATION, contains the instrument description and specifications as well as the accessory and recommended test equipment list.
- b. SECTION II, INSTALLATION/OPERATION VERIFICATION, contains information relative to receiving inspection, preparation for use, mounting, packing, shipping, and operation verification.
- c. SECTION III, OPERATION, contains operating instructions for the instrument.
- d. SECTION IV, PERFORMANCE TESTS, contains information required to verify that instrument performance is in accordance with published specifications.
- e. SECTION V, ADJUSTMENTS, contains information required to properly adjust and align the instrument after repair.
- f. SECTION VI, REPLACEABLE PARTS, contains information required to order all parts and assemblies.
- g. SECTION VII, MANUAL BACKDATING CHANGES, contains information to make this manual compatible with earlier equipment configurations.

h. SECTION VIII, SERVICE, contains descriptions of the circuits, schematic diagrams, parts location diagrams, and troubleshooting procedures to aid the user in maintaining the instrument.

1-4. Supplied with this manual is an Operating Information Supplement. The Supplement is a copy of the first three sections of this manual, and should be kept with the instrument for use by the operator.

1-5. Listed on the title page of this manual is a Microfiche part number. This number can be used to order 4 x 6-inch microfilm transparencies of the manual. Each microfiche contains up to 60 photoduplicates of the manual pages. The microfiche package also includes the latest Manual Changes supplement as well as all pertinent Service Notes.

1-6. SPECIFICATIONS

1-7. Instrument specifications are listed in Table 1-1. These specifications are the performance standards or limits against which the instrument is tested. Table 1-2 lists supplemental characteristics. Supplemental characteristics are not specifications but are typical characteristics included as additional information for the user.

NOTE

To insure that the RF Plug-in meets specifications listed in Table 1-1, Performance Tests (Section IV) should be performed at least every six months.

1-8. SAFETY CONSIDERATIONS

1-9. General

1-10. This product and related documentation must be reviewed for familiarization with safety markings and instructions before operation. This product has been manufactured and tested in accordance with international safety standards.

1-11. SAFETY SYMBOLS



Instruction manual symbol: the apparatus will be marked with this symbol when it is necessary for the user to refer to the instruction manual in order to protect the apparatus against damage.



Indicates dangerous voltages.



Earth terminal.



The WARNING sign denotes a hazard. It calls attention to a procedure, practice, or the like, which, if not correctly performed or adhered to, could result in injury or loss of life. Do not proceed beyond a WARNING sign until the indicated conditions are fully understood and met.

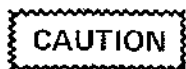

The CAUTION sign denotes a hazard. It calls attention to an operating procedure, practice, or the like, which, if not correctly performed or adhered to, could result in damage to or destruction of part or all of the equipment. Do not proceed beyond a CAUTION sign until the indicated conditions are fully understood and met.

1-12. Operation

1-13. BEFORE APPLYING POWER, refer to SAFETY CONSIDERATIONS in Section I of the Operating and Service manual for the mainframe.

The information, cautions, and warnings in this manual must be followed to ensure safe operation and to keep the instrument safe.



BEFORE SWITCHING ON THE INSTRUMENT, the protective earth terminal of the mainframe must be connected to the protective conductor of the (mains) power cord. The mains plug should only be inserted in a socket outlet provided with protective earth contact. This protec-

tion should not be negated by using an extension cord (power cable) without a protective grounding conductor. Grounding one conductor of a two-conductor outlet is not sufficient protection.

Any interruption of the protective (grounding) conductor, inside or outside the instrument, or disconnection of the protective earth terminal could make this instrument dangerous. Whenever it is likely that this protection has been impaired, the instrument should be made inoperative and secured against any unintended operation.



BEFORE SWITCHING THE INSTRUMENT ON, ensure that all ac line powered devices connected to the instrument are connected to the protective earth ground,



BEFORE APPLYING POWER, make sure the mainframe ac input is set for the available ac line voltage, that the correct fuse is installed, and that all normal safety precautions have been taken.

1-14. Service

1-15. The information, cautions, and warnings in this manual must be followed to ensure safe operation and to keep the instrument safe. SERVICE AND ADJUSTMENTS SHOULD BE PERFORMED ONLY BY QUALIFIED SERVICE PERSONNEL.

1-16. Adjustment or repair of the opened instrument with the ac power connected should be avoided as much as possible but, when unavoidable, should be performed only by qualified service personnel who are aware of the hazard involved.

1-17. Capacitors inside the instrument may still be charged even though the instrument has been disconnected from its source of supply.

WARNING

Servicing this instrument often requires working with the instrument's protective covers removed and ac power connected. Extreme caution should be exercised since energy available at many points in the instrument may, if contacted, result in personal injury.

BEFORE SWITCHING THE INSTRUMENT ON, ensure that all ac line powered devices connected to the instrument are connected to the protective earth ground.

1-18. INSTRUMENTS COVERED BY MANUAL

1-19. Attached to the instrument is a serial number plate. (A typical serial number plate is shown in Figure 1-2.) The serial number is in two parts. The first four digits and letter are the serial number prefix; the last five digits are the suffix. The prefix is the same for all identical instruments; it changes only when a change is made to the instrument. The suffix, however, is assigned sequentially and is different for each instrument. The contents of the manual apply to instruments with the serial number prefix(es) listed under SERIAL NUMBERS on the title pages.

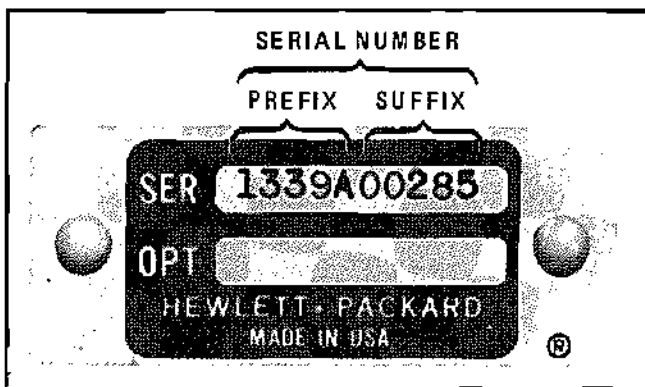

Figure 1-2. Typical Serial Number Plate

1-20. An instrument manufactured after the printing of this manual may have a serial number prefix that is not listed on the title page. This unlisted serial number prefix indicates the instrument is different from those described in this manual. The manual for this newer instrument is accompanied by a yellow Manual Changes supplement.

This supplement contains "change information" that explains how to adapt the manual to the newer instrument.

1-21. In addition to change information, the supplement may contain information for correcting errors in the manual. To keep this manual as current and accurate as possible, Hewlett-Packard recommends that you periodically request the latest Manual Changes supplement. The supplement for this manual is identified with this manual's print date and part number, both of which appear on the manual's title page. Complimentary copies of the supplement are available from Hewlett-Packard.

1-22. For information concerning a serial number prefix that is not listed on the title page or in the Manual Changes supplement, contact your nearest Hewlett-Packard office.

1-23. DESCRIPTION

1-24. The 86242D, 86245A, and 86250D are plug-ins for the HP Model 8620-Series Sweep Oscillator mainframes. The plug-ins consists of a fundamental oscillator and associated drive circuitry for tuning. Refer to Tables 1-1 and 1-2 for complete plug-in specifications and characteristics.

1-25. The RF output of the instrument is controlled by the front-panel POWER LEVEL control. Power can be leveled, externally or internally, across the band using a conventional power sampling and feedback technique. The automatic leveling control (ALC) switch selects the mode of leveling; either external (EXT), internal (INT), or (OFF). A front panel ALC input connector and gain control are provided to use with an external leveling loop. When the UNLEVELED light is on, it indicates that the RF power is not level across the band. BNC connectors on the rear panel allow for external FM signal inputs and frequency reference voltage output.

1-26. OPTIONS**1-27. Option 001**

1-28. Option 001 provides the capability of operating in the internal power leveling mode by adding a directional coupler and detector in the RF signal path.

Table 1-1. Specifications for 86242D, 86245A, and 86250D Installed in 8620C (1 of 2)

Specifications with RF Plug-in installed in 8620C Sweep Oscillator Mainframe	SPECIFICATIONS		
	86242D	86245A	86250D
FREQUENCY¹			
FREQUENCY RANGE, Calibrated:	5.9 – 9.0 GHz	5.9 – 12.4 GHz	8.0 – 12.4 GHz
FREQUENCY ACCURACY² (at 25°C and with FM-NORM-PL switch in NORM position: CW Mode: ³ All Sweep Modes (Sweep Time >0.1 sec):	±35 MHz ±40 MHz	±40 MHz ±50 MHz	±40 MHz ±50 MHz
FREQUENCY STABILITY:			
With Temperature:	<±750 kHz/°C	<±1.2 MHz/°C	<±1.2 MHz/°C
With 10% Line Voltage Change:	<±40 kHz	<±40 kHz	<±40 kHz
With 10 dB Power Level Change from Specified Maximum Power:	<±1.5 MHz	<±1.5 MHz	<±1.5 MHz
With 3:1 SWR Load Variation, All Phases:	<±250 kHz	<±250 kHz	<±250 kHz
RESIDUAL FM in 10 kHz BANDWIDTH:²			
CW Mode: FM-NORM-PL switch in NORM position:	<15 kHz peak	<15 kHz peak	<15 kHz peak
POWER OUTPUT¹			
POWER LEVEL:^{2,10} (For calibrated frequency range at 25°C):			
Maximum Leveled Power:	>+10 dBm (10 mW)	>+17 dBm (50 mW)	>+10 dBm (10 mW)
Internally Leveled (Option 001):	>+10 dBm (10 mW)	>+17 dBm (50 mW)	>+10 dBm (10 mW)
POWER VARIATION (at specified maximum power):			
Crystal Detector Leveled (External): ^{4,8}	<±0.1 dB	<±0.1 dB	<±0.1 dB
Power Meter Leveled (External): ^{4,5}	<±0.1 dB	<±0.1 dB	<±0.1 dB
Internally Leveled (Option 001):	<±0.5 dB	<±0.6 dB	<±0.5 dB
Power Control Range:	10 dB	10 dB	10 dB
EQUIVALENT SOURCE SWR:²			
Internally Leveled (Option 001):	<1.6	<1.6	<1.6
SPURIOUS SIGNALS (in dB below fundamental signal at specified maximum power):			
Harmonics:	>30 dB	>17 dB (5.9 – 7.0 GHz) >30 dB (7.0 – 12.4 GHz)	>30 dB
Nonharmonics:	>60 dB	>60 dB	>60 dB
RESIDUAL AM:			
(AM noise in 100 kHz bandwidth):			
Residual AM:	≥50 dB below carrier at specified maximum power	≥50 dB below carrier at specified maximum power	≥50 dB below carrier at specified maximum power

Table 1-1. Specifications for 86242D, 86245A, and 86250D Installed in 8620C (2 of 2)

Specifications with RF Plug-in Installed in 8620C Sweep Oscillator Mainframe	SPECIFICATIONS					
	86242D		86245A		86250D	
MODULATION¹						
EXTERNAL FM² (FM-NORM-PL switch in FM position):						
FM Frequency Response:						
DC to 2 MHz:	±1.5 dB		±1.5 dB		±1.5 dB	
DC to 10 MHz ⁹ :	±1.5 dB		±1.5 dB		±1.5 dB	
Maximum Deviation for Modulation Frequencies:						
DC to 100 Hz (all instruments):	±150 MHz		±150 MHz		±150 MHz	
DC to 1 kHz (Option 008 excluded):	±15 MHz		±15 MHz		±15 MHz	
DC to 2 MHz (Option 008 excluded):	±5 MHz		±5 MHz		±5 MHz	
90 kHz to 1 MHz ⁹ :	±7 MHz		±7 MHz		±7 MHz	
90 kHz to 5 MHz ⁹ :	±5 MHz		±5 MHz		±5 MHz	
90 kHz to 10 MHz ⁹ :	±1.5 MHz		±1.5 MHz		±1.5 MHz	
INTERNAL AM (Below maximum leveled power):						
1 kHz square wave. RF Blanking, and Marker ON/OFF Ratio:						
	>40 dB		>40 dB		>40 dB	
EXTERNAL AM (LINEAR-SQ WAVE switch in SQ WAVE position): ^{2,7}						
Symmetry: ⁶						
	40/60		40/60		40/60	
ON/OFF Ratio (>+1 volt input) (down from specified maximum power):						
	>40 dB		>40 dB		>40 dB	
UPCONVERTER SIMULATION⁹:						
*Across 30 MHz Sweep Width;						
**Across 50 MHz sweep width:						
Linearity at 277 kHz:	≤0.5%	≤0.83%	≤0.5%	≤0.83%	≤0.5%	≤0.83%
Group Delay at 277 kHz:	≤1 ns	≤1.7 ns	≤1 ns	≤1.7 ns	≤1 ns	≤1.7 ns
Differential Gain at 5.6 MHz:	≤0.5%	≤0.83%	≤0.5%	≤0.83%	≤0.5%	≤0.83%
Differential Phase at 5.6 MHz:	≤1°	≤1.7°	≤1°	≤1.7°	≤1°	≤0.83%

¹ Unless otherwise noted, all specifications are at RF OUTPUT and at 0 to 55 degrees C.

² Supplemental characteristics are listed in Table 1-2.

³ Approach desired frequency from low-frequency end of band.

⁴ Excluding coupler and detector variation.

⁵ Use HP Model 432A/B/C power meter. Sweep Duration >10 seconds.

⁶ Specific requirements for compatibility with HP 8755A/B: ±6V, 27.8 kHz squarewave MODULATOR DRIVE output connected to EXT AM input.

⁷ LINEAR-SQ WAVE switch A3S1 is located on A3 ALC Assembly.

⁸ Crystal Detector input to ALC EXT INPUT should be from -55 to -525 mV for specified leveling at specified power output. For use with negative polarity detectors such as HP Model 780 series Directional Detectors, and HP Models 423A/B and 424 Series Crystal Detectors.

⁹ Specification applies to upconverter versions only (Option 008).

¹⁰ For Option 008, less 1 dB (power loss due to insertion loss of additional isolator).

Table 1-2. Supplemental Characteristics (1 of 2)

SUPPLEMENTAL CHARACTERISTICS			
NOTE: Values in this table are not specifications but are typical characteristics included for user information.			
FREQUENCY	86242D	86245A	86250D
FREQUENCY ACCURACY: (FM-NORM-PL switch in NORM position): START-STOP end points and ΔF center frequency: Sweep Time 0.01 to 0.1 sec:	±35 MHz	±60 MHz	±60 MHz
MARKER: Sweep Time 0.01 to 0.1 sec:	±40 MHz	±65 MHz	±65 MHz
ΔF SWEEP WIDTH: MANUAL Sweep: AUTO Sweep (Sweep time 0.01 to 0.1 sec):	±1% of range ±5% of range	±1% of range ±5% of range	±1% of range ±5% of range
CW REMOTE PROGRAMMING: CW Frequency:	<±5 MHz	<±20 MHz	<±20 MHz
RESIDUAL FM IN 10 kHz BANDWIDTH: (FM-NORM-PL switch in NORM position): MANUAL Sweep Mode: AUTO Sweep Mode: All MANUAL, CW, or AUTO sweep modes with FM-NORM-PL switch in FM or PL position:	<15 kHz peak <30 kHz peak <30 kHz peak	<15 kHz peak <30 kHz peak <30 kHz peak	<15 kHz peak <30 kHz peak <30 kHz peak
FREQUENCY STABILITY: DRIFT (per 10 minute interval after 30-minute warm-up):	±600 kHz	±600 kHz	±600 kHz
POWER			
POWER LEVEL: Stability with Temperature Change:	<±0.1 dB/°C	<±0.1 dB/°C	<±0.1 dB/°C
Dynamic Range of POWER LEVEL Control (while maintaining 60/40 symmetry of internal 1 kHz square wave): Leveled:	>+10 dBm to <-3 dBm	>+17 dBm to <+4 dBm	>+10 dBm to <-3 dBm
Unleveled:	>20 dB	>20 dB	>20 dB
POWER VARIATION: (over dynamic range of POWER LEVEL control): Internally Leveled (Option 001): Unleveled:	<±0.4 dB <±3 dB	<±0.4 dB <±3 dB	<±0.4 dB <±3 dB
SOURCE SWR: Unleveled:	<2.5	<2.5	<2.5

Table 1-2. Supplemental Characteristics (2 of 2)

SUPPLEMENTAL CHARACTERISTICS			
NOTE: Values in this table are not specifications but are typical characteristics included for user information.			
MODULATION	86242D	86245A	86250D
EXTERNAL FM:³			
Sensitivity:			
FM-NORM-PL Switch in FM or NORM:	-20 MHz/V	-20 MHz/V	-20 MHz/V
FM-NORM-PL Switch in PL:	-6 MHz/V	-6 MHz/V	-6 MHz/V
Upconverter Mode (Option 008):	+20 MHz/V	+20 MHz/V	+20 MHz/V
Maximum Deviation:			
FM-NORM-PL Switch in NORM (DC-100 Hz):	±18 MHz	±18 MHz	±18 MHz
FM-NORM-PL Switch in PL (DC-100 Hz):	±50 MHz	±50 MHz	±50 MHz
EXTERNAL AM (LINEAR-SQ WAVE switch A3S1 in LINEAR position):			
Frequency Response (with RF signal 6 dB down from specified maximum power):			
Leveled or Unleveled:	DC to >30 kHz	DC to >30 kHz	DC to >30 kHz
Sensitivity: ¹			
ON/OFF Ratio (Down from specified maximum power with >+6V input):	>20 dB	>20 dB	>20 dB
EXTERNAL AM (LINEAR-SQ WAVE switch A3S1 in SQ WAVE position):			
Symmetry ² (between specified maximum power and -3 dBm):			
	45/55	45/55	45/55
OSCILLATOR TYPE: Fundamental.			
NET WEIGHT: Approximately 2.2 kg (5 lb)			
DIMENSIONS: Approximately 15 mm x 13 mm x 30 mm (6 in. x 5 in. x 12 in.)			
OUTPUT IMPEDANCE of RF OUTPUT connector: 50 ohms nominal			
¹ 20% reduction in power with +1 volt input.			
² Specific requirements for compatibility with HP 8755A/B ±6V, 27.8 kHz squarewave MODULATOR DRIVE output connected to EXT AM.			
³ Positive or negative frequency except for Option 008.			

www.valuetronics.com

1-29. Option 004

1-30. The Option 004 RF Section has the Type N RF output connector on the rear panel instead of the front panel.

1-31. Option 008

1-32. The Model 86242D/86245A/86250D Option 008 RF Plug-in provides compatibility with the 3700-Series Microwave Link Analyzer (MLA). The 86242D Option 008 provides MLA upconversion in the range of 5.9 GHz to 9 GHz. The 86250D Option 008 provides MLA upconversion in the range of 8.0 GHz to 12.4 GHz. The 86245A Option 008 provides MLA upconversion within the entire range of 5.9 GHz to 12.4 GHz.

1-33. EQUIPMENT REQUIRED BUT NOT SUPPLIED

1-34. To have a complete operating sweep oscillator unit, the 86242D, 86245A, or 86250D RF Plug-in must be installed in an 8620-Series Sweep Oscillator mainframe.

1-35. EQUIPMENT AVAILABLE

1-36. Model 8755B/182T Swept Amplitude Analyzer

1-37. The 86242D, 86245A, or 86250D RF Plug-in with an 8620C Sweep Oscillator mainframe is compatible with the Hewlett-Packard Model 8755A/B Swept Amplitude Analyzer. For all swept amplitude measurements, the 27.8 kHz squarewave modulation is applied directly to the 8620C rear-panel EXT AM connector. This eliminates the need for an external modulator, thus providing maximum available power to a test setup.

1-38. Power Meters and Crystal Detectors

1-39. The Hewlett-Packard Model 432A/B/C Power Meter may be used for external leveling of the RF plug-ins. External leveled power is also available using an HP 423A/B or 424-Series Crystal Detector. Section III contains detailed instructions for using the external power leveling systems.

1-40. Model 8410B/8411A Network Analyzer

1-41. The Model 8620C with 86242D, 86245A, or 86250D provides phase/gain measurement

capability with the Hewlett-Packard Model 8410B Network Analyzer System. The combination of the Model 8410B Network Analyzer, the Model 8411A Frequency Converter, and an appropriate display plug-in forms a phase meter and a ratio meter for direct phase and amplitude ratio measurement on RF voltages. These measurements can be made on single frequencies and on swept frequencies over full frequency range. The interfacing between the 8410B and the sweeper permits the 8410B to phase lock over the frequency range of the RF Plug-in.

1-42. Model 3700-Series Microwave Link Analyzer

1-43. The Model 8620C with 86242D, 86245A, or 86250D Option 008 provides measurement capability with the Hewlett-Packard Model 3700-Series Microwave Link Analyzer (MLA).

1-44. ACCESSORIES SUPPLIED

1-45. One frequency scale is supplied with the RF Plug-in as shown in Figure 1-1. This scale is for the Model 8620A and 8620C Sweep Oscillator mainframes. Table 1-3 relates plug-in, scale frequency range, and scale part number.

Table 1-3. Frequency Scale Supplied

Plug-in	Frequency Scale	HP Part Number
86242D	5.9 – 9.0 GHz	86342-00001
86245A	5.9 – 12.4 GHz	86245-00004
86250D	8.0 – 12.4 GHz	86350-00001

1-46. ACCESSORIES AVAILABLE

1-47. Service Accessories

1-48. A Service Accessories package is available for convenience in aligning and troubleshooting the mainframe and RF Plug-in. The Service Accessories package as shown in Figure 1-3, contains a plug-in extender cable, adjustment tool, and service boards. The package may be obtained from Hewlett-Packard by ordering HP Part Number 08620-60124.

1-49. Service Aids

1-50. Other service aids helpful in servicing the RF Plug-in are available and may be ordered through your nearest Hewlett-Packard office. The

service aids needed specifically for servicing the 86242D, 86245A, and 86250D RF Plug-ins are shown in Figure 1-4.

1-51. RF Section 36-Pin Extender

1-52. A 36-pin extender is available for extending the RF Section approximately 1 inch. This allows easy access to components located near the front of the instrument. This extender, shown in Figure

1-6, may be obtained from Hewlett-Packard by ordering Part No. 08621-60056.

1-53. RECOMMENDED TEST EQUIPMENT

1-54. Table 1-4 lists all of the equipment required for operation verification (V), performance tests (P), adjustments (A), troubleshooting (T), and repair of the 86242D, 86245A, and 862540D RF Plug-ins. Other equipment may be substituted if it meets or exceeds the critical specifications listed in the table.

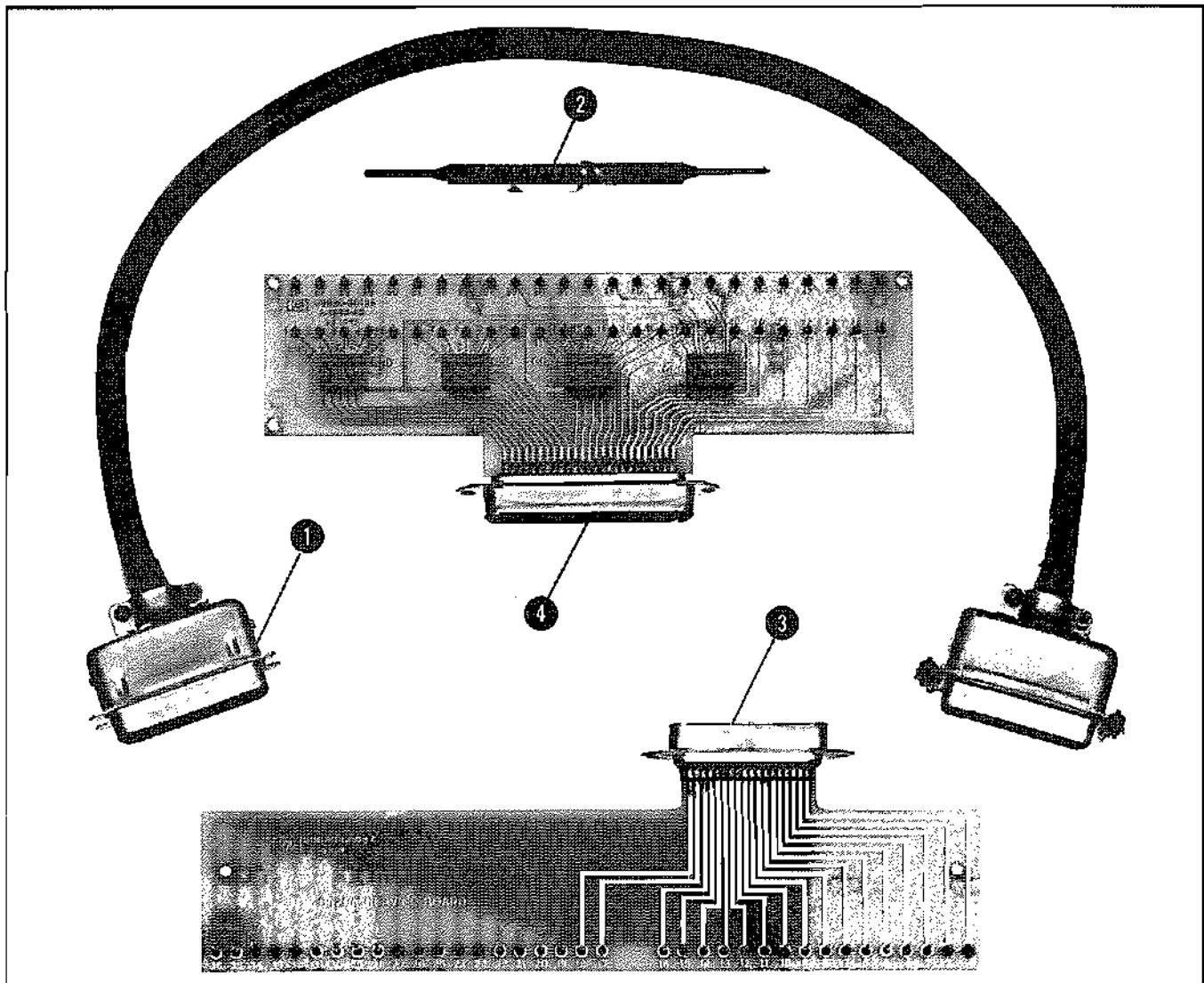

Item	Name	Part No.	Use
1	Extender Cable	08620-60032	Moves RF Plug-in outside mainframe for alignment or service.
2	Adjustment Tool	8830-0024	Fits miniature adjustment slot on potentiometers.
3	36-Pin Service Board	08620-60037	Allows probing RF Section interface connector, or rear-panel programming connector on all mainframes except 8620C, during performance testing or troubleshooting of 8620 Series mainframes.
4	50-Pin Service Board	08620-60125	Allows probing rear-panel programming connector during performance testing or troubleshooting of HP Model 8620C Sweep Oscillator mainframe.

www.valuetronics.com

Figure 1-3. Service Accessories, HP Part Number 08620-60124

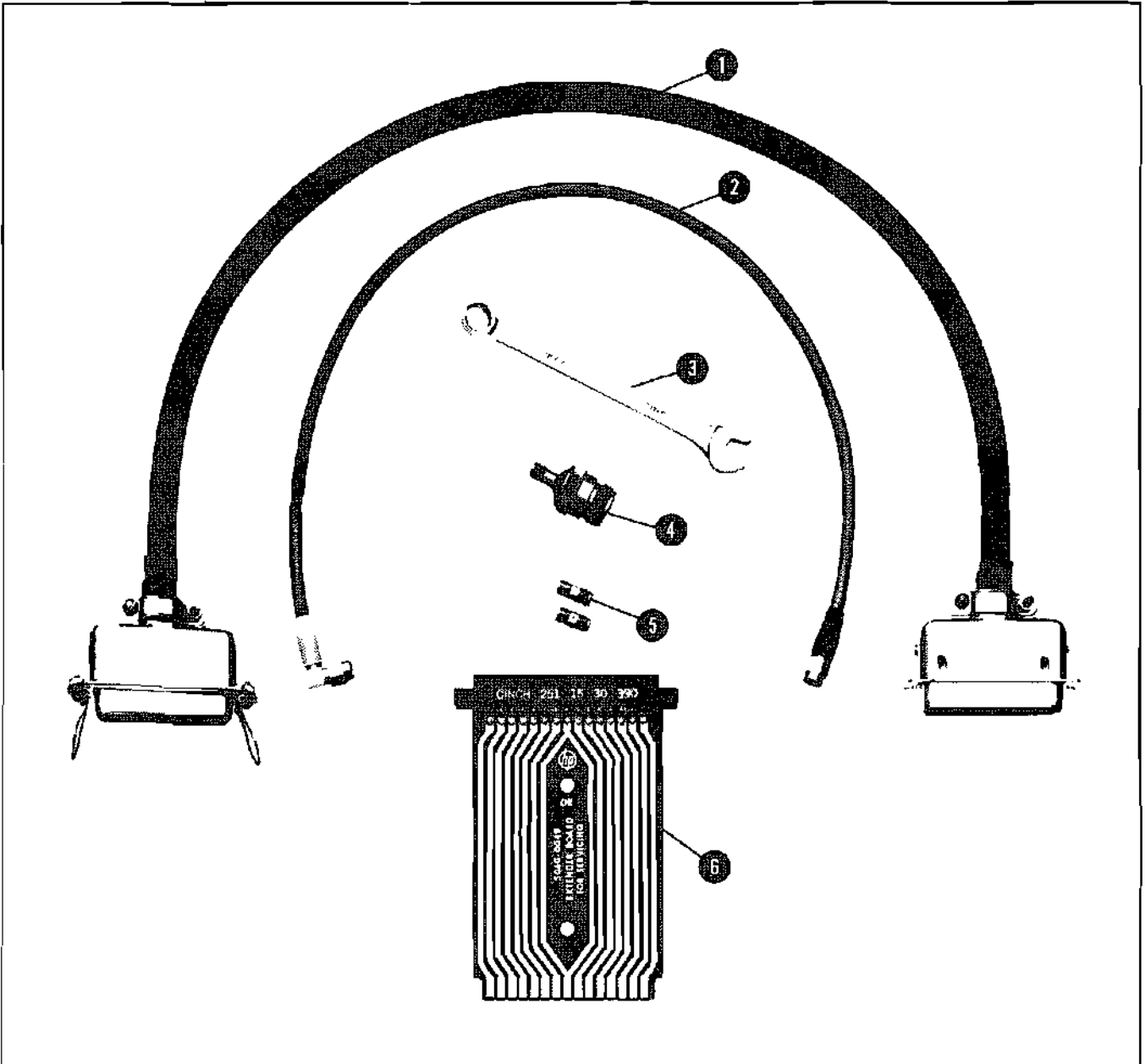

Item	Description	HP Part Number
1	Extender cable	08620-60032
2	RF service cable	8120-1578
3	Wrench, 5/16" slotted box end open end	08555-20097
4	Adapter, Type N to SMA	1250-1404
5	RF connector adapter (2), SMA jack to SMA jack	1250-1158
6	30-contact extender board (2 rows of 15 contacts)	5060-0049

www.valuetronics.com

Figure 1-4. Service Aids for 86242D/86245A/86250D

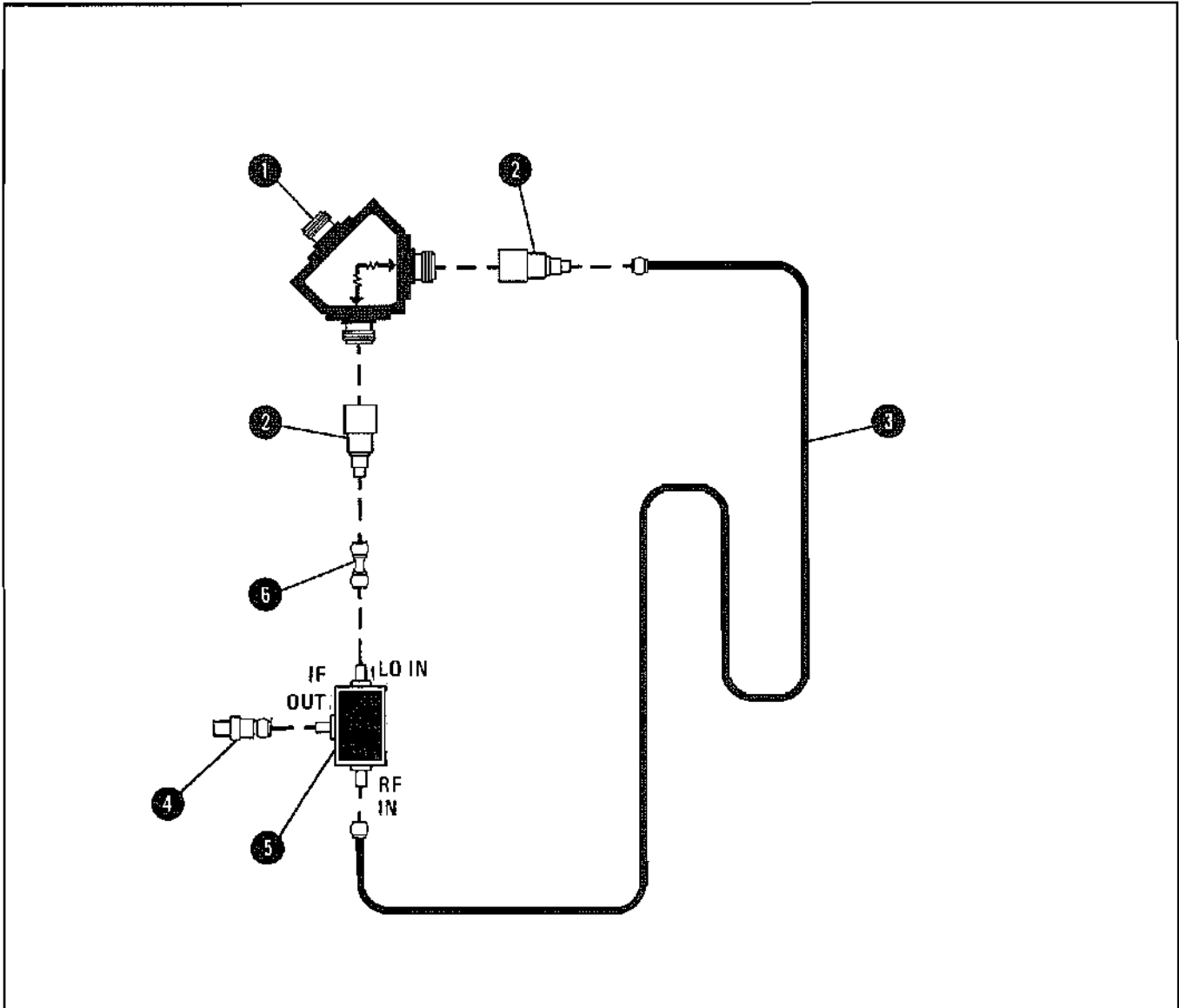

Item	Description	HP Part Number
1	Power Splitter	HP 11667A
2	Adapter: Type N Male to SMA Female (2 required)	1250-1250
3	Delay Line: > 3 feet in length, SMA male connectors	08503-20038
4	Adapter: BNC Female to Male SMA	1250-1200
5	Mixer: Double Balanced, 1 – 12 GHz RHG Electronics Part No. DM 1-12 (Refer to Table 6-4 for Address)	None
6	Adapter: SMA Male to SMA Male	1250-1159

www.valuetronics.com

Figure 1-5. Delay Line Discriminator

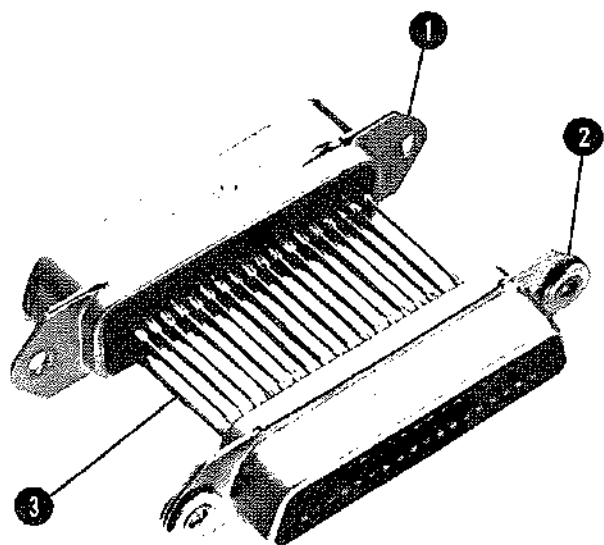

- ① 36-Pin Male Connector (2 x 18) HP Part No. 1251-0483
- ② 36-Pin Female Connector (2 x 18) HP Part No. 1251-0484
- ③ 1-inch 20-Gage Wire HP Part No. 8151-0011.

Figure 1-6. RF Section 36-Pin Extender, HP Part Number 08621-60056

Table 1-4. Recommended Test Equipment (1 of 3)

Instrument	Critical Specifications	Recommended Model	Use*
Sweep Oscillator	No substitute mainframe	HP 8620A or 8620C	P,A,T,V
Spectrum Analyzer	Frequency Range: 5.9 GHz to 22 GHz	HP 8565A	P
Oscilloscope	Vertical Amplifier: Dual trace with 10:1 probes Bandwidth: 20 MHz minimum Vertical Sensitivity: 5 mV/Div Horizontal Sweep Rate: 1 μ s/Div minimum	HP 180C/1801A/1820C	P,A,T,V
Digital Voltmeter	Range: -50V to +50V Accuracy: $\pm 0.01\%$ Input Impedance: 10 megohms minimum	HP 3480D/3484A	A,T
Swept Amplitude Analyzer and Oscilloscope Mainframe	Frequency Range: 5.9 - 12.4 GHz	HP 8755B/182T	P,A,T
Detectors (2 required)	Frequency Response: 5.9 - 12.4 GHz Error <1.3 dB Impedance: 50 ohms	HP 11664A	P,A,T
Frequency Counter	Range: 5.9 - 12.4 GHz	HP 5340A	P,A,T,V
Function Generator	Frequency: 100 Hz - 10 MHz Output: 6V p-p into 50 ohms	HP 3312A	P,A
Power Meter and Thermistor Mount	Frequency: 5.9 - 12.4 GHz Range: +10 dBm to -20 dBm	HP 432A/8478B	P,A,V
DC Power Supply	Range: 0 to 6 Vdc Current: 0.1 Amp	HP 6214A	P,A,T
Adjustable AC Line Transformer	Output: 100 to 150 Vac Power: 150 watts	General Radio MT3A	P
Frequency Meter	Range: 5.9 to 12.4 GHz	HP 537A	P
Adapter (2 required)	N to P	HP NP292A	P,A
Adapter (2 required)	Type N coax to P-band	HP P281B	P,A
Power Splitter	Frequency: 5.9 - 12.4 GHz Attenuation in each arm: 6 dB	HP 11667A	P
RMS Voltmeter	Scale: RMS volts Range: 0 to -70 dB Accuracy: $\pm 5\%$ Frequency Range: 10 Hz to 100 Hz	HP 3400A	P

Table 1-4. Recommended Test Equipment (2 of 3)

Instrument	Critical Specifications	Recommended Model	Use*
Directional Coupler (2 required)	Frequency: 5.9 – 12.4 GHz Coupling: 20 dB Directivity: >25 dB SWR all ports: <1.3 Type-N Male Connector at Input port	HP 779D	P,A
Crystal Detector (2 required)	Frequency: 5.9 – 12.4 GHz SWR: <1.7 Polarity: Negative	HP 423B	P,A,T
Crystal Detector (2 required)	Frequency: 5.9 – 12.4 GHz SWR: 1.7 (with matching load resistor) Polarity: Negative	HP 423B, Option 002	A
3 dB Attenuator	Attenuation: 3 dB±0.5 dB Frequency: 5.9 – 12.4 GHz	HP 8491B, Option 003	P
10 dB Attenuator	Attenuation: 10 dB±0.5 dB Frequency: 5.9 – 12.4 GHz	HP 8491B, Option 010	P,A,T
20 dB Attenuator	Attenuation: 20 dB±0.5 dB Frequency: 5.9 – 12.4 GHz	HP 8491B, Option 020	P,A,T,V
Adapter	Type-N male to APC-7	HP 11525A	P
Adjustable Short	Frequency Range: 5.9 – 12.4 GHz	Microlab/FXR SO-6MN	P
30 Pin Extender Board	(See Figure 1-4)	HP 5060-0049	A,T
RF Service Cable	Impedance: 50 ohms Connectors: SMA to SMA (Figure 1-4)	HP 8120-1578	T
Cable	2-ft. long, BNC connectors	HP 11086A	P
Extender Cable	(See Figure 1-4)	HP 08620-60032	T
BNC Tee (2 required)	Connectors: BNC jack and plug	HP 1250-0781	P,A
Adjustment Tool	(See Figure 1-4)	HP 8830-0024	A
RF Connector Adapter	SMA jack to SMA jack (Figure 1-4)	HP 1250-1158	T
Delay Line Discriminator	(Refer to Figure 1-5)		P,A
Air Line (2 required)	20 cm long, APC-7 connectors	HP 11567A	P
50 ohm Termination (2 required)	50 ohms nominal	HP 11593A	P

Table 1-4. Recommended Test Equipment (3 of 3)

Instrument	Critical Specifications	Recommended Model	*Use
For Instruments with Option 008 Installed:			
Sweep Oscillator	No substitute mainframe	HP 8620A or 8620C	P
RF Plug-in	5.9 – 12.4 GHz	HP 86245A	P
IF/BB Transmitter	No substitute	HP 3710A	P
BB/Transmitter (Plug-in)	No substitute	HP 3716A, Option 010	P
IF/BB Receiver	No substitute	HP 3702B	P
Differential Phase Detector (Plug-in)	No substitute	HP 3705A, Option 010	P
Down Converter	No substitute	HP 3730A	P
External LO Plug-in	No substitute	HP 37301A	P
Directional Detector	5.9 – 12.4 GHz	HP 784B	P

*P = Performance Test; A = Adjustments, T = Troubleshooting; V = Operation Verification

www.valuetronics.com

SECTION II INSTALLATION OPERATION VERIFICATION

2-1. INTRODUCTION

2-2. This section provides installation instructions for the Model 86242D/86245A/86250D RF Plug-in and its accessories. This section also includes information about initial inspection and damage claims, preparation for using the RF Plug-in and packaging, storage and shipment.

2-3. INITIAL INSPECTION

2-4. Inspect the shipping container for damage. If the shipping container or cushioning material is damaged it should be kept until the contents of the shipment have been checked for completeness and the instrument has been checked mechanically and electrically. The contents of the shipment should be as shown in Figure 1-1. Procedures for checking electrical performance are given in Section IV. If the instrument combination does not pass the electrical performance tests, refer to the Adjustments (Section V) in this manual. If, after the Adjustments have been made, the instrument combination still fails to meet specifications, refer to mainframe Adjustment in the applicable mainframe manual. If a circuit malfunction is suspected, refer to troubleshooting procedures section of this manual or applicable mainframe manual. If the instrument does not pass the electrical tests, or if the shipment contents are incomplete, or if there is mechanical damage or defect, notify the nearest Hewlett-Packard office. If the shipping container is damaged, or the cushioning material shows signs of stress, notify the carrier as well as the Hewlett-Packard office. Keep the shipping materials for carrier's inspection. The HP office will arrange for repair or replacement without waiting for claim settlement.

2-5. PREPARATION FOR USE

2-6. Power Requirements

2-7. When the RF Plug-in is properly installed, it obtains all power through the rear interface connector from the 8620-Series Sweep Oscillator

2-9. For the RF Plug-in to operate, it must be plugged into an 8620-Series mainframe. Connection is made by pushing the RF Plug-in into the mainframe so that the plug-in interface connector P1 mates with the mainframe connector.

2-10. Mating Connectors

2-11. All of the externally mounted connectors on the RF Plug-in are listed in Table 2-1. Opposite each RF Plug-in connector is an industry identification, the part number of a mating connector, and the part number of an alternate source for the mating connector.

2-12. Operating Environment

2-13. Temperature. The instrument may be operated in temperatures from 0°C to +55°C.

2-14. Humidity. The instrument may be operated in environments with humidity from 5% to 95% at 0° to 40°C. However, the instrument should also be protected from temperature extremes which cause condensation within the instrument.

2-15. Altitude. The instrument may be operated at altitudes up to 4572 metres (15000 feet).

2-16. Frequency Scale Installation

2-17. To install frequency scale, proceed as follows:

NOTE

If RF Plug-in is installed in mainframe, it must be removed to install frequency scale. See RF Plug-in removal instructions in Paragraph 2-20.

- a. Disengage mainframe front-panel latch handle, shown in Figure 2-1, by pushing downward on handle while pushing inward lightly on top of front panel.
- b. Swing front panel forward and down to position shown in Figure 2-2.

Table 2-1. Models 86242D/86245A/86250D Mating Connectors

86242D/86245A/86250D Connector		Mating Connector	
Connector Name	Industry Identification	Part Number	Alternate Source
J1 RF OUTPUT	TYPE-N	1250-0882	Specialty Connector 25 P117-2
J2 ALC EXT INPUT	BNC	1250-0256	Specialty Connector 28 P118-1
J3 FM	BNC	1250-0256	Specialty Connector 28 P118-1
J4 FREQ REF	BNC	1250-0256	Specialty Connector 28 P118-1
P4 INTERFACE	Micro-Ribbon 36-Contact Rack and Panel Plug	1251-0484	TRW Cinch Div. 57-20360-375

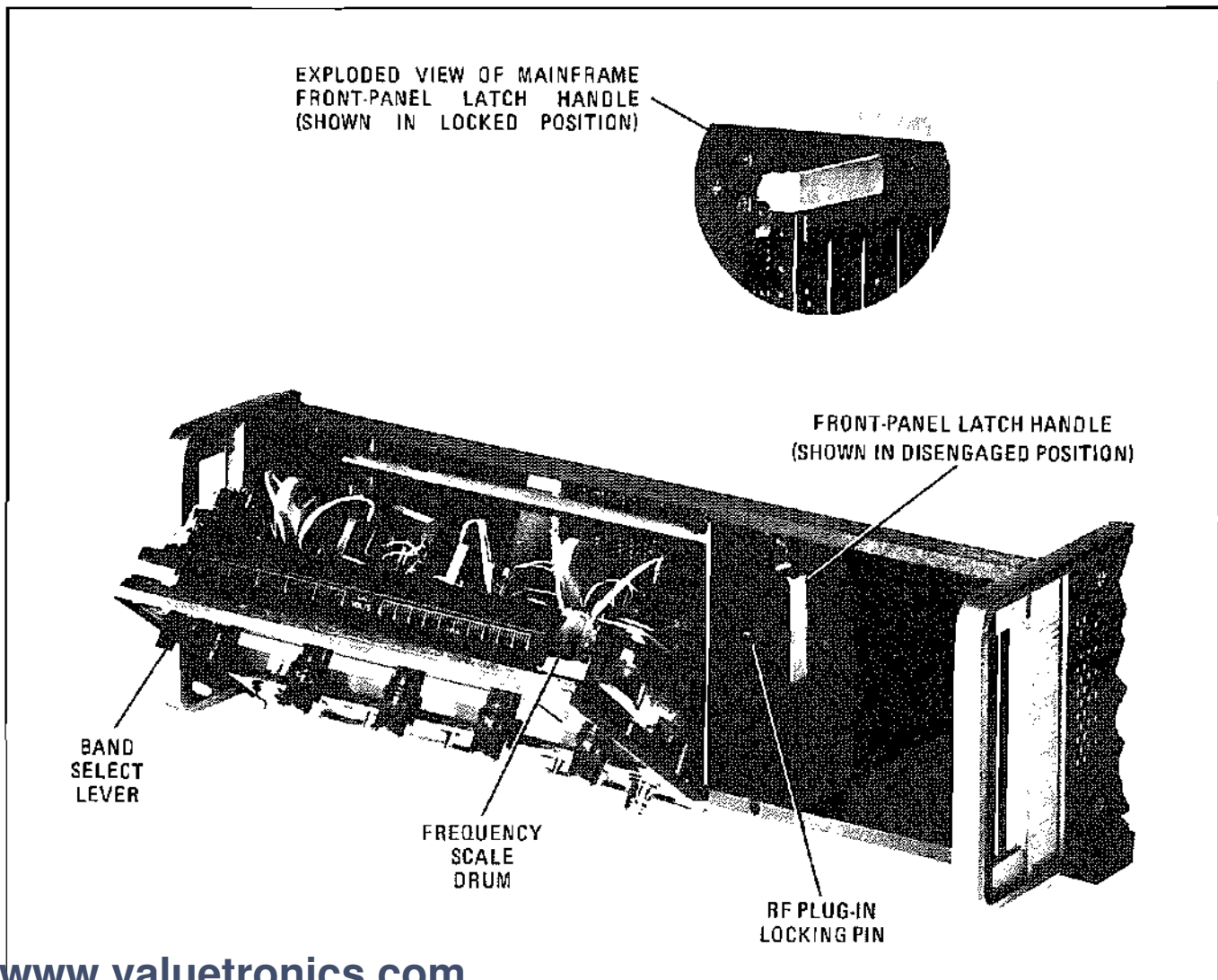

www.valuetronics.com

Figure 2-1. Location of Mainframe Parts Pertinent to Frequency Scale and RF Plug-in Installation

- c. Depress mainframe front-panel BAND select lever, shown in Figure 2-1, to rotate frequency scale drum until desired scale position is accessible.

NOTE

The frequency scale for the 86242D, 86245A, or 86250D RF Plug-in may be installed in any frequency scale drum position. If necessary to remove a frequency scale, exert a pressure **OUTWARD**, away from drum, on right-hand edge of scale.

- d. Insert frequency scale so key (a 1/16-inch long, 1/2 inch wide protrusion) on left end of scale fits into notch, shown in Figure 2-2, in roller on left-hand edge of drum.
- e. Push inward on right-hand edge of frequency scale to snap it in place in frequency scale drum.

CAUTION

To prevent damage to frequency pointers when frequency scale drum is rotated, make certain that fre-

quency scale is firmly in place and flush with drum edges.

- f. Return front panel to upright (closed) position, and, while pushing inward lightly on top of front panel, re-engage front-panel latch handle by pushing it upward to lock positions as shown in Figure 2-1, exploded view.

2-18. RF Plug-in Installation and Removal

2-19. Installation. To install RF Plug-in, proceed as follows:

- a. If mainframe power is ON, press mainframe LINE switch to OFF position.
- b. Position latch handle located on left side of RF Plug-in so it is perpendicular to front panel. Portion of handle with rectangular cut-out should be facing forward and portion with notch should be facing rear of RF Plug-in as shown in Figure 2-3.
- c. Slide RF Plug-in into mainframe towards rear of compartment. RF Plug-in latch handle will engage a locking pin, shown in Figure

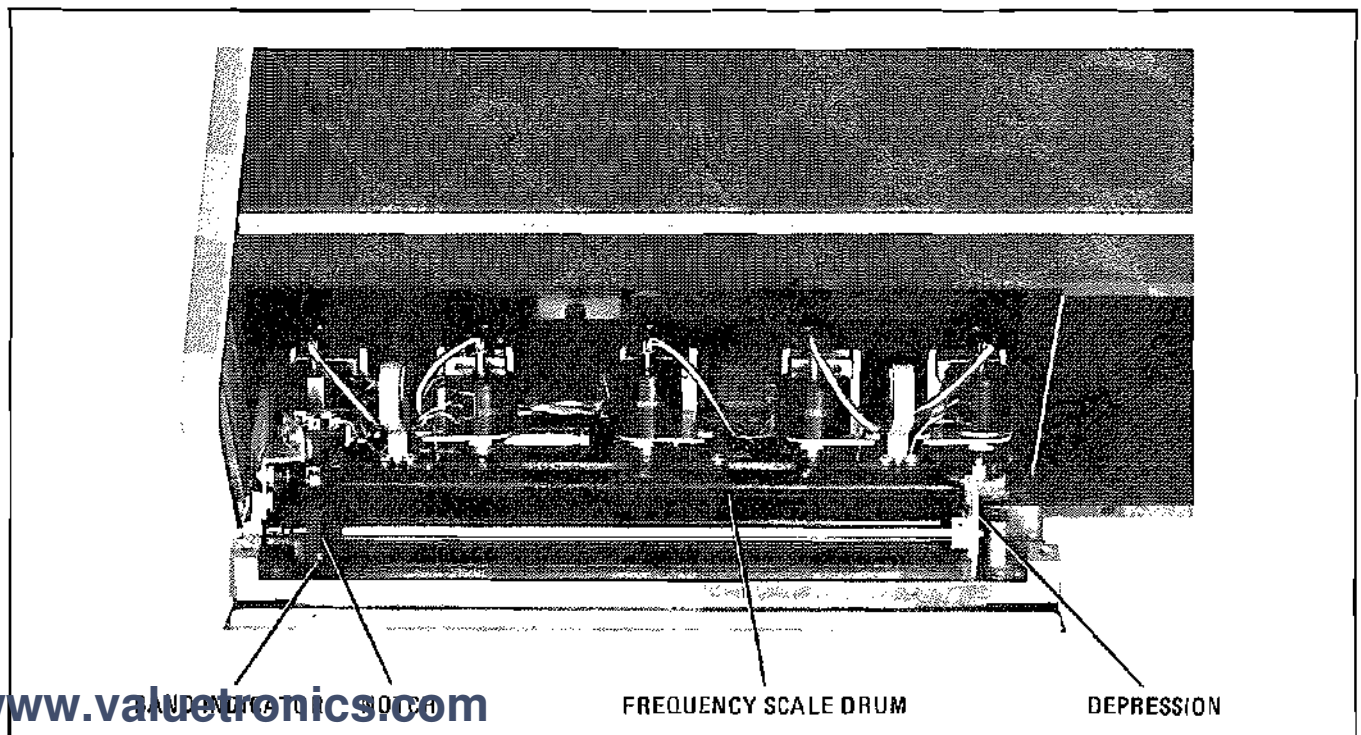

Figure 2-2. Mainframe Front Panel in Open Position

2-1, inside mainframe and exposed portion of latch handle will start to move downward.

- d. Push latch handle downward, while still pushing inward on RF Plug-in, until latch handle is flush with front panel.

2-20. Removal. To remove RF Plug-in, proceed as follows:

- a. Push inward on top of latch handle, shown in Figure 2-3, and pull forward and up on bottom of latch handle.
- b. When exposed portion of latch handle is in a position perpendicular to RF Plug-in front panel, it is disengaged from locking pin (Figure 2-1) and RF Plug-in may be removed by pulling forward on latch handle.

2-21. STORAGE AND SHIPMENT

2-22. Environment

2-23. The instrument may be stored or shipped in environments within the following limits:

Temperature -40°C to $+75^{\circ}\text{C}$
Humidity 5% to 95% at 0° to 40°C
Altitude Up to 15240 metres (50000 feet)

The instrument should also be protected from temperature extremes which cause condensation within the instrument.

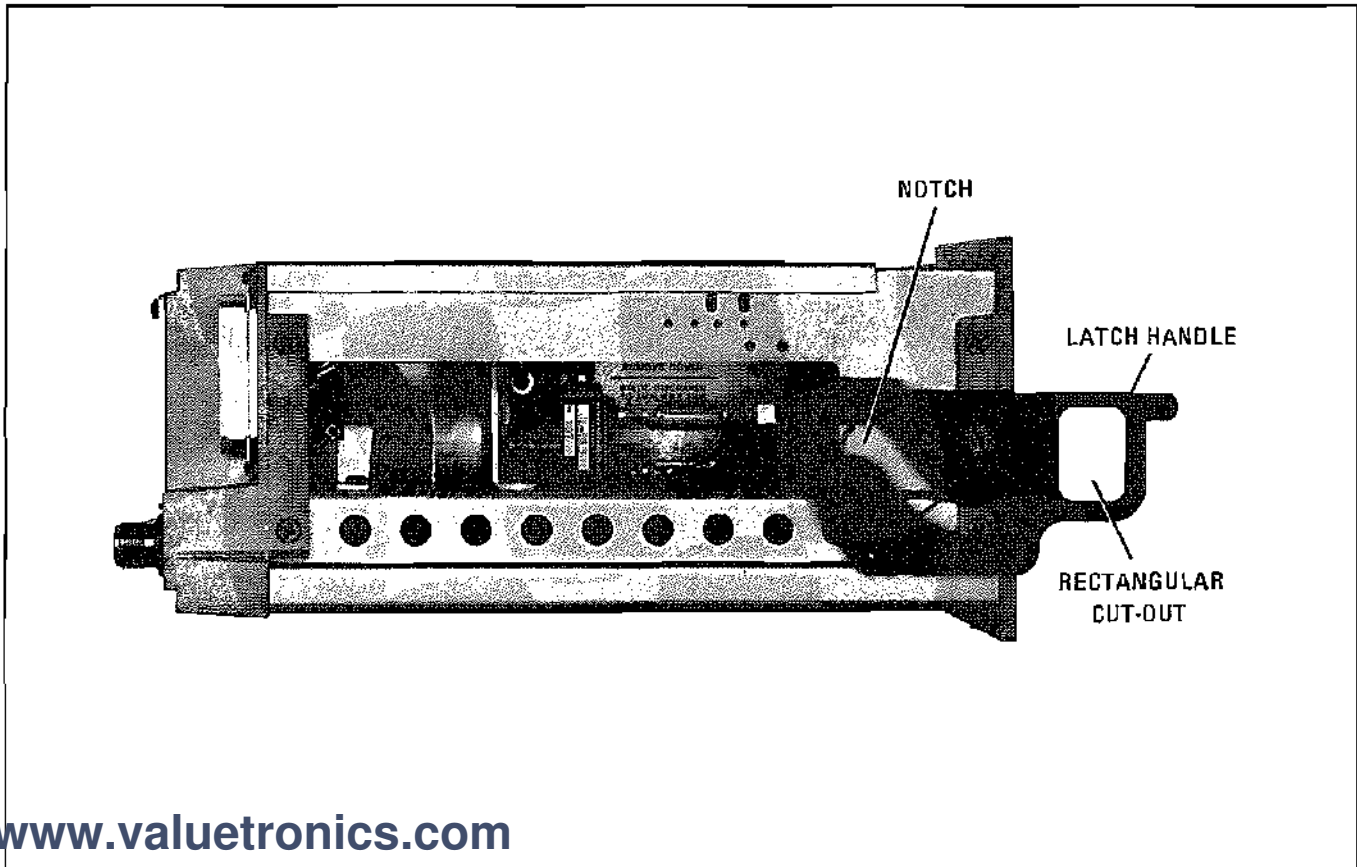

Figure 2-3. RF Section Latch in Release Position

2-24. Packaging

2-25. Original Packaging. Containers and materials identical to those used in factory packaging are available through Hewlett-Packard offices. If the instrument is being returned to Hewlett-Packard for servicing, attach a tag indicating the type of service required, return address, model number, and full serial number. Also, mark the container FRAGILE to assure careful handling. In any correspondence, refer to the instrument by model number and full serial number.

2-26. Other Packaging. The following general instructions should be used for re-packaging with commercially available materials:

- a. Wrap instrument in heavy paper or plastic. (If shipping to Hewlett-Packard Office or Service Center, attach tag indicating type of service required, return address, model number and full serial number.)
- b. Use a strong shipping container.
- c. Use enough shock-absorbing material around all sides of instrument to provide firm

cushion and prevent movement inside container. Protect control panel with cardboard.

- d. Seal shipping container securely.
- e. Mark shipping container FRAGILE to assure careful handling.
- f. In any correspondence, refer to instrument by model number and full serial number.

2-27. OPERATION VERIFICATION

2-28. The Operation Verification Tests are designed to meet the needs of an incoming inspection. The procedures test operation of controls and indicators and some of the critical specifications. Equipment required to perform the operation verification is listed in Table 1-4. If substitution is necessary for any of the equipment, the alternate models must meet or exceed the critical specifications listed in Table 1-4.

2-29. The Operation Verification Tests require much less time and equipment than the complete Performance Tests in Section IV. The Operation Verification Tests may also be used for verification of overall instrument operation after repair.

OPERATION VERIFICATION TESTS

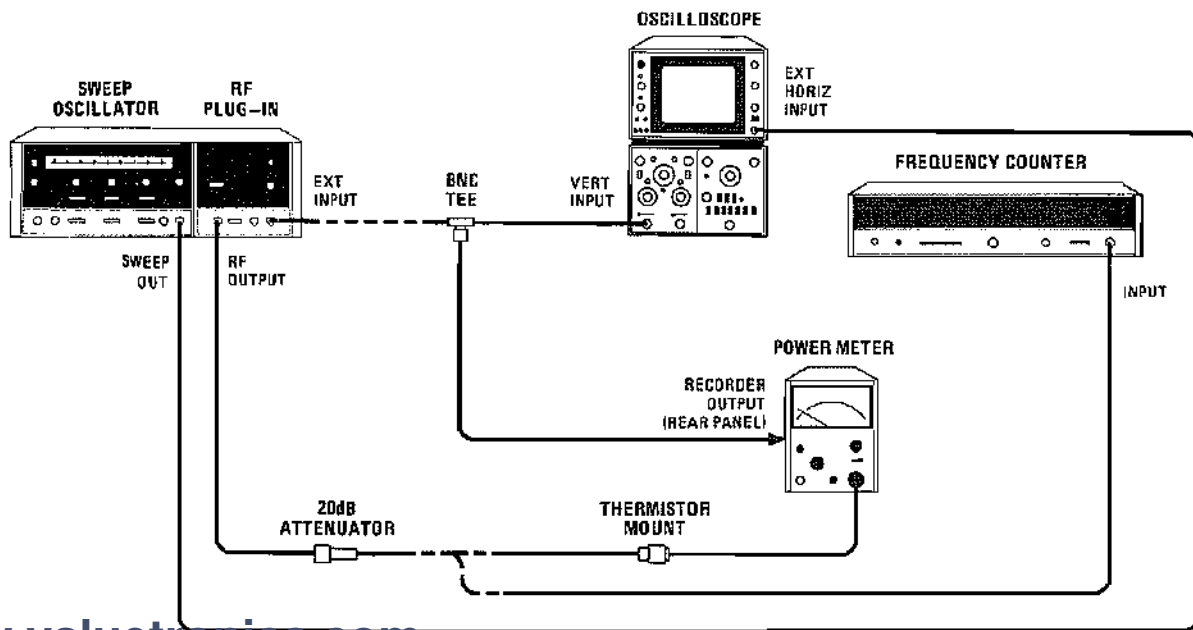

www.valuetronics.com

Figure 2-4. Operation Verification Test Setup

OPERATION VERIFICATION TESTS

EQUIPMENT:

Sweep Oscillator	HP 8620C
Oscilloscope	HP 180C/1801A/1820C
Frequency Counter	HP 5340A
Power Meter	HP 432A
Thermistor Mount	HP 8478B
20 dB Attenuator	HP 8491B, Option 020

PROCEDURE:

1. Frequency Range and Accuracy Test:

NOTE

Before installing RF Plug-in in mainframe, set External Leveling selector switch A3S2 to PM (down) position. Selector switch A3S2 is located at top of A3 ALC Assembly (see Figure 5-1)

- a. Connect equipment as shown in Figure 2-4 with frequency counter connected to 20 dB attenuator and no connection to RF Plug-in EXT INPUT.
- b. Set controls as follows:

8620C:

BAND	Frequency of Plug-in installed
CW MARKER pointer	5.9 GHz (86242D/86245A) or 8.0 GHz (86250D)
MODE	AUTO
TIME-SECONDS1 — .01
TIME-SECONDS Vernier	Fully clockwise
TRIGGER	INT
1 kHz SQ WV/OFF (rear panel)	OFF
RF BLANKING/OFF (rear panel)	OFF
DISPLAY BLANKING/OFF (rear panel)	OFF

RF Plug-in:

RF OFF-ON	ON
ALC switch	INT or OFF
POWER LEVEL	Fully clockwise
FM-NORM-PL	NORM

- c. Press 8620C LINE pushbutton to ON. Set frequency counter to measure frequency range of RF Plug-in. Press CW pushbutton and allow 30 minutes warm-up time.

NOTE

www.valuetronics.com

Always approach frequency settings from low-frequency end of band.

OPERATION VERIFICATION TESTS

- d. Frequency counter indication should be 5.9 GHz \pm 35 MHz for 86242D, 5.9 GHz \pm 40 MHz for 86245A, or 8.0 GHz \pm 40 MHz for 86250D.
- e. Set CW MARKER pointer to 7.5 GHz (86242D), 9.0 GHz (86245A), or 10.2 GHz (86250D). Frequency counter indication should be 7.5 GHz \pm 35 MHz for 86242D, 9.0 GHz \pm 40 MHz for 86245A, or 10.2 GHz \pm 40 MHz for 86250D.
- f. Set CW MARKER pointer to 9.0 GHz (86242D) or 12.4 Hz (86245A/86250D). Frequency counter indication should be 9.0 GHz \pm 35 MHz for 86242D or 12.4 GHz \pm 40 MHz for 86245A/86250D.

2. Power Level and Variation Test:

- a. Connect equipment as shown in Figure 2-4 with BNC tee connected to EXT INPUT and thermistor mount connected to 20 dB attenuator. Set RF Plug-in ALC switch to EXT.

NOTE

For power meter leveling, sweep rates slower than 10 seconds per sweep should be used. The rate of leveling is dependent on the comparatively slow response of the thermistor mount to power level changes.

- b. Set 8620C TIME-SECONDS to 100 — 10. Press FULL SWEEP pushbutton and set power meter range to obtain meter indication in upper half of scale.
- c. Adjust RF Plug-in POWER LEVEL and ALC GAIN controls to obtain flat RF power level across the entire band as indicated on oscilloscope. (If loop oscillations occur on oscilloscope trace, turn ALC GAIN control in counterclockwise direction.)
- d. Set RF Plug-in POWER LEVEL control fully clockwise, then counterclockwise until UNLEVELED light goes out.
- e. Set mainframe MODE switch to MANUAL. Power meter indication should be > -10 dBm ($> +10$ dBm OUTPUT power) for 86242D/86250D, or > -3 dBm ($> +17$ dBm OUTPUT Power) for 86245A.
- f. Set RF Plug-in POWER LEVEL control for power meter indication of -10 dBm ($+10$ dBm OUTPUT power) for 86242D/86250D, or -3 dBm ($+17$ dBm OUTPUT power) for 86245A. Turn 8620C MANUAL sweep control slowly through full range and note maximum and minimum power meter indications. Difference between maximum and minimum power meter indications should be < 0.2 dB.

3. Amplitude Modulation Test:

- a. Adjust RF Plug-in POWER LEVEL control for convenient reference on power meter.
- b. Switch 1 kHz SQ WV/OFF switch (rear panel of mainframe) to SQ WV position. Power meter indication should be approximately 3 dB less than reference set in step a.

4. Press 8620C LINE pushbutton to OFF and remove RF Plug-in. Set External Leveling selector switch to XTAL (up) position (see Figure 5-1).

SECTION III OPERATION

3-1. INTRODUCTION

3-2. This section explains the function of the controls and indicators of the HP Models 86242D, 86245A, and 86250D RF Plug-ins. It also describes typical operating modes.

3-3. PANEL FEATURES

3-4. Front and rear panel features are described in Figures 3-2 and 3-3. Description numbers match the numbers on the illustration.

3-5. OPERATING INSTRUCTIONS

3-6. Safety

3-7. BEFORE APPLYING POWER, refer to SAFETY CONSIDERATIONS in Section I of the Operating and Service manual for the mainframe.

3-8. The information cautions, and warnings in this manual must be followed to ensure safe operation and to keep the instrument safe.

WARNING

BEFORE SWITCHING ON THE INSTRUMENT, the protective earth terminal of the mainframe must be connected to the protective conductor of the (mains) power cord. The mains plug should only be inserted in a socket outlet provided with protective earth contact. This protection should not be negated by using an extension cord (power cable) without a protective grounding conductor. Grounding one conductor of a two-conductor outlet is not sufficient protection.

Any interruption of the protective (grounding) conductor, inside or outside the instrument, or disconnection of the protective earth terminal could make this instrument dangerous. Whenever it is suspected that this protection has

been impaired, the instrument should be made inoperative and secured against any unintended operation.

WARNING

BEFORE SWITCHING THE INSTRUMENT ON, ensure that all ac line powered devices connected to the instrument are connected to the protective earth ground.

CAUTION

BEFORE APPLYING POWER, make sure the mainframe ac input is set for the available ac line voltage, that the correct fuse is installed, and that all normal safety precautions have been taken.

3-9. Internal Leveling (Option 001)

3-10. The most convenient method of RF output leveling is internal leveling. When Option 001 is installed, the RF Plug-in has internal leveling capability, providing leveled power at the output port.

3-11. In the internal leveling mode, a directional detector senses the RF level at the output of the oscillator and applies the detected dc voltage to the automatic leveling control (ALC) circuit.

3-12. External Crystal Detector Leveling

CAUTION

Do not exceed maximum input level of ± 1 Vdc.

3-13. External leveling using a directional detector or directional coupler and crystal detector, provides leveled RF power near the point of measurement. In this leveling system, the coupler samples the RF Output signal and the detector produces a dc voltage proportional to the RF Output signal.

The dc voltage from the detector is applied, through the RF Plug-in front-panel ALC EXT INPUT connector, to the ALC circuitry where it is used to provide a correction signal to the PIN Modulator to control the RF Output level. For best operation the dc voltage supplied by the crystal detector should be between -55 and -525 mV. The ALC circuitry is designed for use with negative polarity crystal detectors.

3-14. External Power Meter Leveling



Do not exceed maximum input level of ± 4 Vdc.

3-15. External leveling can also be accomplished using a directional coupler and a power meter. In this leveling system, the coupler samples the RF Output signal and applies it to the power meter. The power meter produces a dc voltage (RECORDER OUTPUT) which is applied, through the RF Plug-in front-panel ALC EXT INPUT connector, to the ALC circuitry. External leveling selector switch A3S2 must be in the PM (Down) position when using external power meter leveling. (See Figure 3-1.) Location of selector switch A3S2 is shown in Figure 5-1.

3-16. External AM

3-17. The RF Output signal can be amplitude modulated using either a linear or square wave modulating signal applied through mainframe rear-panel EXT AM connector. External amplitude modulation is possible in all operating modes. See Tables 1-1 and 1-2 for specifications and supplemental characteristics for External AM

operation. Square wave modulation capability provides the specific requirements for compatibility with the HP Model 8755A/B Swept Amplitude Analyzer. External AM selector switch A3S1 selects either linear or square wave modulation. (See Figure 3-1.) Location of selector switch A3S1 is shown in Figure 5-1.

3-18. External FM



Do not exceed maximum input level of ± 12 Vdc.

3-19. The RF output signal can be frequency modulated using an external modulating signal applied through the FM connector. The external FM function provides a means of obtaining an output frequency that varies under the control of an external modulation signal. A positive-going voltage causes output frequency to decrease. For Option 008 (MLA Upconverter) a positive-going voltage causes output frequency to increase. Rear-panel selector switch S3 selects mode of FM operation. Refer to Paragraph 3-23.

3-20. Phase Lock Operation

3-21. The RF output (CW) signal may be phase-locked using an external phase-lock signal applied through the FM connector. The phase-lock function provides a means of obtaining a very stable CW frequency by transferring the frequency stability of a reference oscillator to the RF Plug-in. If the CW frequency starts to drift, the phase difference between the CW frequency and the reference frequency (reference oscillator) is

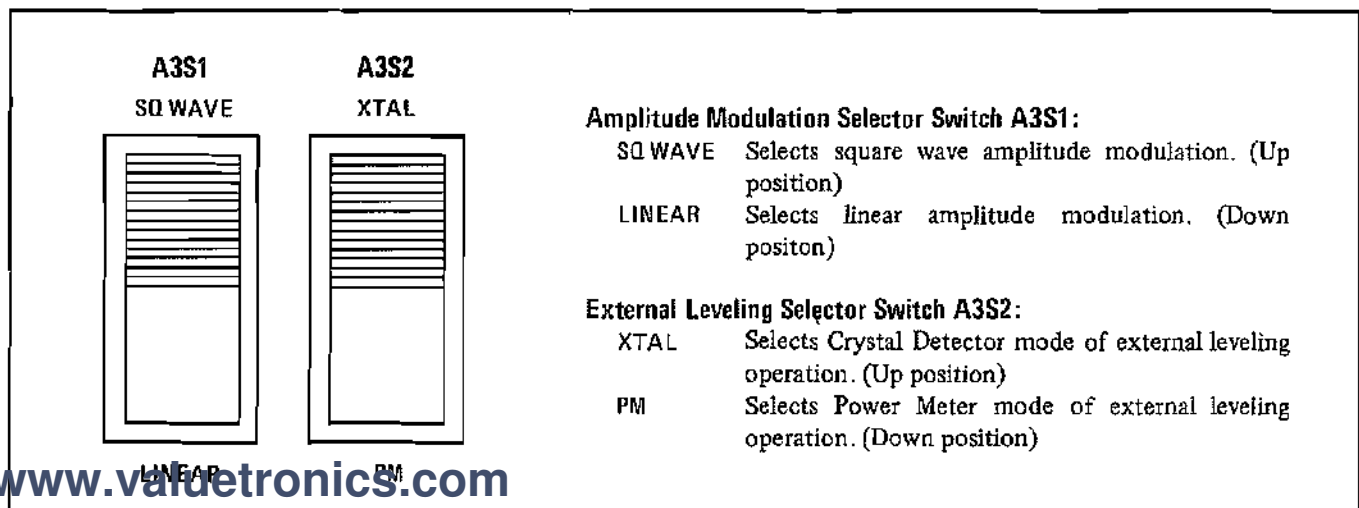

Figure 3-1. Amplitude Modulation Selector Switch A3S1 and External Leveling Selector Switch A3S2

detected, and a dc correction voltage is applied to restore the CW frequency to its previous point. Stability of this CW frequency is determined by the stability of the reference oscillator. Rear-panel selector switch S3 selects either FM or PL (phase lock) mode of operation. Refer to Paragraph 3-23.

3-22. A sweep signal output is available at the rear-panel **FREQ REF** connector J4. This signal may be used for phase-locking external equipment. The sweep signal is approximately 1V/GHz.

3-23. FM-NORM-PL Switch

3-24. Rear-panel selector switch S3, Figure 3-3, selects the mode of operation for input signal to rear-panel FM connector. In FM position, the input signal is applied to both the main and FM coils of the YIG Tuned Oscillator. Modulating frequencies up to 2 MHz may be used to provide frequency deviations up to ±150 MHz. In NORM posi-

tion, the input signal is applied to only the FM coil of the YIG Tuned Oscillator. This provides for less residual FM than in the FM position. In PL position, the input signal is applied to both coils of the YIG Tuned Oscillator to provide phase-locking. Table 3-1 relates the switch positions and external FM characteristics.

3-25. Operator's Maintenance — Fuses

3-26. Power circuits in the 86242D, 86245A, and 86250D are fused in the mainframe. Supplies in the 8620-Series mainframe that are used to power the plug-in are +5V, +20V, -10V and -40V. See the mainframe Operating and Service Manual for fuse replacement.

NOTE

The +20V supply is also fused in the RF Plug-in on the A2 YIG DRIVER Assembly. A2F1 is a one-ampere fuse, HP Part Number 2110-0047, manufactured by Bussman (part number GMW-1).

Table 3-1. FM Modulation Characteristics for FM-NORM-PL Switch Positions

External FM Characteristic	Switch Positions		
	FM	NORM	PL
Sensitivity (Standard)	-20 MHz/V	-20 MHz/V	-6 MHz/V
Sensitivity (Option 008)	+20 MHz/V	+20 MHz/V	
Maximum Deviation	±150 MHz	±18 MHz (typical)	±50 MHz (typical)
Residual FM	30 kHz peak	15 kHz peak	30 kHz peak

FRONT PANEL FEATURES

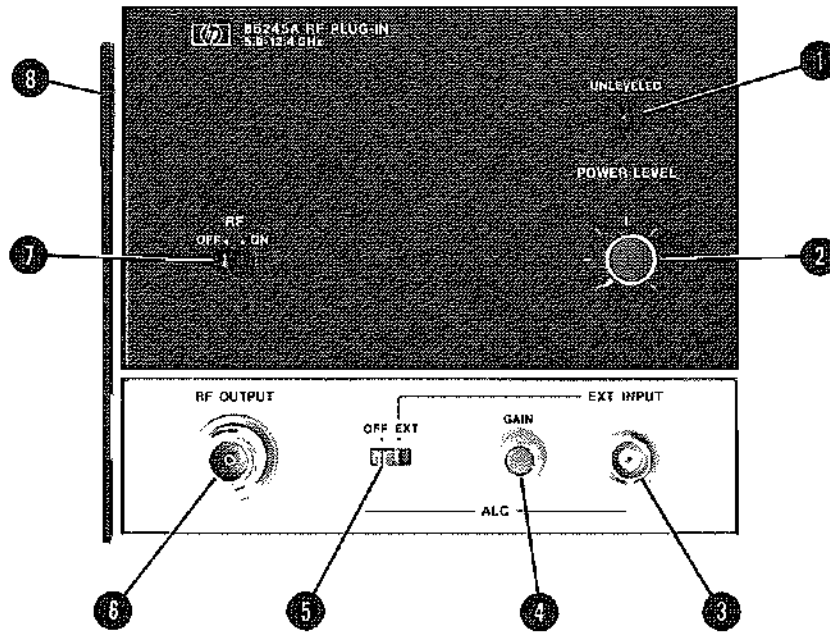

- ① **UNLEVELED lamp.** Lights when plug-in is not in an automatic leveling mode or when in a leveling mode and RF output is not level across band.
- ② **POWER LEVEL control.** Adjusts RF power output. Clockwise rotation increases power output.
- ③ **ALC EXT INPUT BNC connector J2.** Input, for external leveling, from crystal detector.
- ④ **ALC GAIN control.** Adjusts external leveling preamplifier gain when using external leveling. Clockwise rotation increases gain.
- ⑤ **ALC switch.** Selects EXT (external) power leveling or OFF (no leveling).

NOTE

The 86245A is shown, however the 86242D and 86250D are similar in appearance.

NOTE

When Option 001 is installed, ALC switch selects either INT (internal) or EXT (external) power leveling.

- ⑥ **RF OUTPUT connector J1.** Type-N 50-ohm RF output connector.

NOTE

When Option 004 is installed, RF OUTPUT connector is on rear panel.

- ⑦ **RF ON-OFF switch S1.** Turns RF power on and off. This is useful when zeroing a power meter.
- ⑧ **Drawer Latching Handle.** Aids in installing and removing RF Plug-in. After installing, handle locks to hold RF Plug-in in place.

Figure 3-2. Front Panel Indicator, Controls and Connectors

REAR PANEL FEATURES

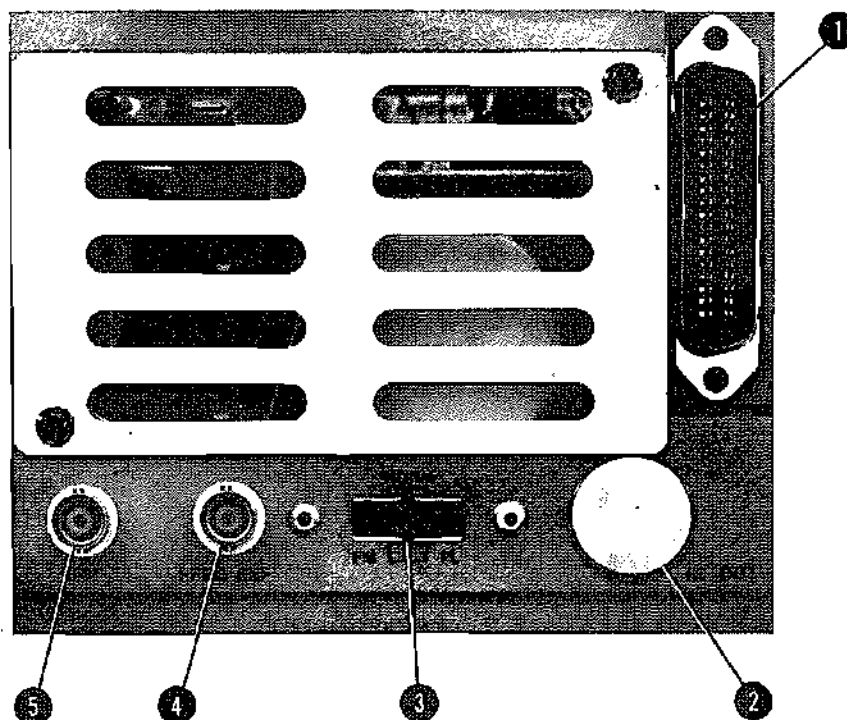

NOTE

- ① **Interface Connector P4.** Provides interconnections between mainframe and RF Plug-in.
- ② When Option 004 is installed, RF output connector is mounted on rear panel and lower front panel is different.
- ③ **FM-NORM-PL switch S3.** Operates in conjunction with FM input connector to provide optimum performance for either normal sweep (NORM), frequency modulation (FM), or phase lock (PL) operation. If FM or PL modes of operation are not being used, switch should be in NORM.
- ④ **FREQ REF BNC connector J4.** Provides approximately 1V/GHz sweep signal output, (5.9V — 9.0V for 86242D, 8.0V — 12.4V for 86250D, and 5.9V — 12.4V for 86245A).
- ⑤ **FM BNC connector J3.** Input connector for frequency modulation signal or phase-locking error signal.

NOTE

The 86245A is shown, however, the 86242D and 86250D are similar in appearance. RF Plug-ins with Option 008 installed have a two-position switch labeled MLA-NORM (no PL position).

www.valuetronics.com

Figure 3-3. Rear Panel Connectors and Switch

EXTERNAL CRYSTAL DETECTOR LEVELING

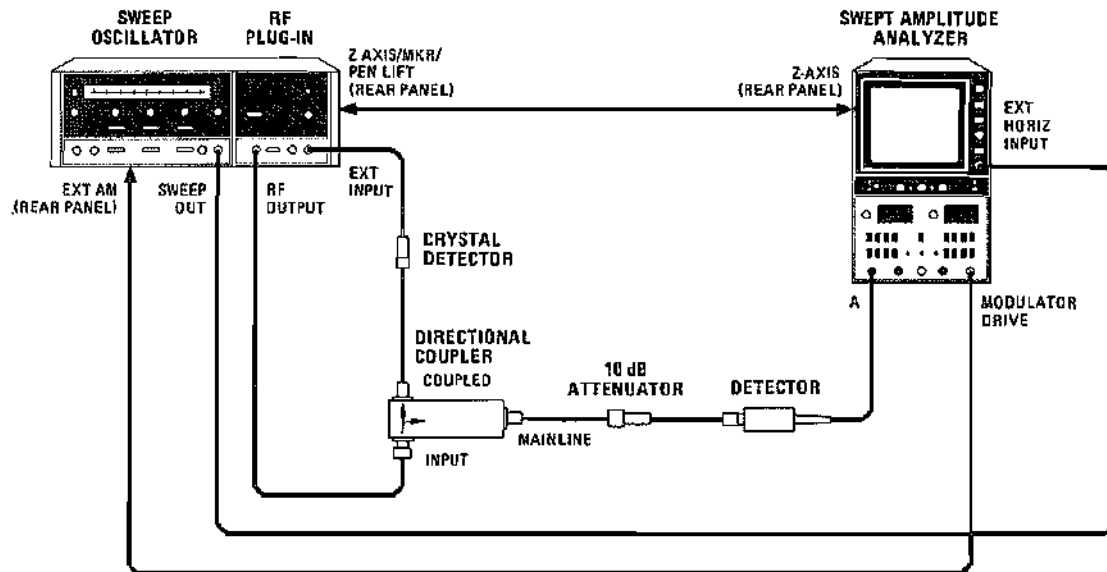

EQUIPMENT:

- Sweep Oscillator HP 8620C
- RF Plug-in HP 86242D, 86245A, or 86250D
- Swept Amplitude Analyzer HP 8755B/182T
- Detector HP 11664A
- Crystal Detector (Negative polarity) HP 423B
- 10 dB Attenuator HP 8491B, Option 010
- Directional Coupler HP 779D

PROCEDURE:

1. Connect equipment as shown in test setup above.

NOTE

The 86242D, 86245A, and 86250D RF Plug-ins are designed for use with negative (-) output crystals. These instruments will not function properly using positive (+) output crystals.

2. Set controls as follows:

8620C:

- BAND Frequency of Plug-in installed
- MARKERS OFF
- MODE AUTO
- TRIGGER INT
- TIME-SECONDS1 - .01
- TIME-SECONDS Vernier Fully clockwise
- 1 kHz SQ WV/OFF (rear panel) OFF
- RF BLANKING/OFF (rear panel) RF BLANKING
- DISPLAY BLANKING/OFF (rear panel) DISPLAY BLANKING

Figure 3-4. External Crystal Detector Leveling (1 of 2)

EXTERNAL CRYSTAL DETECTOR LEVELING

RF Plug-in:

RF OFF-ON ON
 POWER LEVEL Fully clockwise
 ALC switch. EXT
 ALC GAIN Fully clockwise
 PM-XTAL switch (located near top of ALC Board) XTAL

3. Press 8620C LINE switch to ON; LINE and FULL SWEEP pushbuttons should light. Allow 30 minutes warmup time.
4. Adjust RF Plug-in ALC GAIN and POWER LEVEL controls fully clockwise for maximum RF power and maximum external preamplifier gain. One of the conditions shown in Figures 3-5, 3-6, or 3-7 should be displayed on 8755B. If trace is unlevelled, as shown in Figure 3-6, or just partially leveled and UNLEVELED light is on, turn POWER LEVEL control counterclockwise to reduce power output until trace is level across band as shown in Figure 3-5. If external preamplifier gain is too high, oscillations may occur as shown in Figure 3-7. To remove oscillations, reduce external preamplifier gain by turning RF Plug-in ALC GAIN control counterclockwise.

Figure 3-4. External Crystal Detector Leveling (2 of 2)

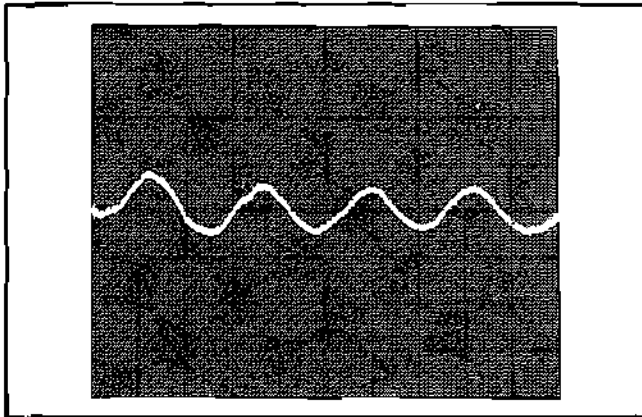

Figure 3-5. Leveled RF Power Output

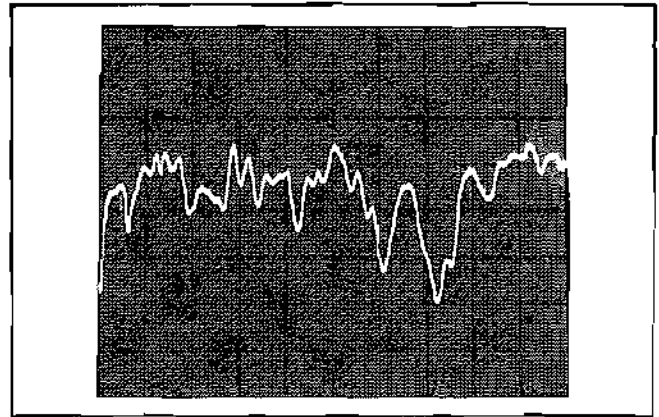

Figure 3-6. Unlevelled RF Power Output

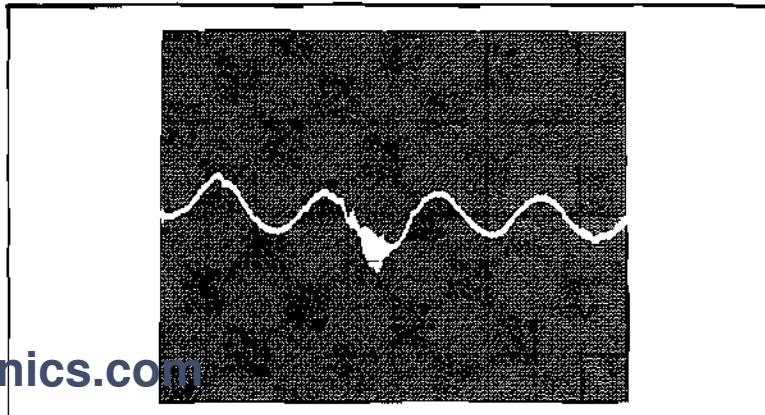
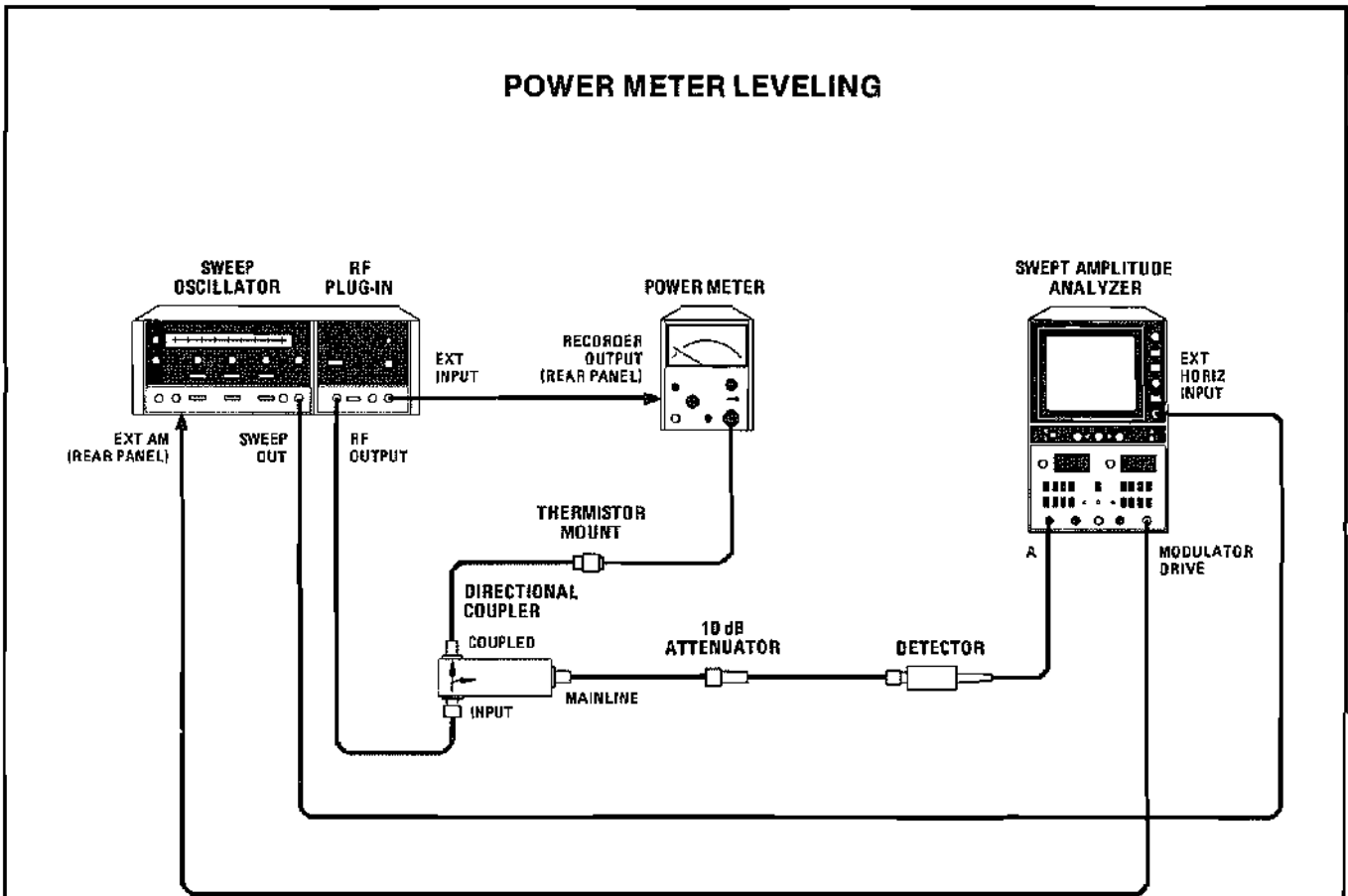

Figure 3-7. Oscillations Due to Excessive ALC Loop Gain



EQUIPMENT:

Sweep Oscillator	HP 8620C
RF Plug-in	HP 86242D, 86245A, or 86250D
Swept Amplitude Analyzer	HP 8755B/182T
Power Meter	HP 432A
Thermistor Mount	HP 8478B
Detector	HP 11664A
10 dB Attenuator	HP 8491B, Option 010
Directional Coupler	HP 779D

NOTE

Power meter leveling should use the slowest sweep rate because of the slow response time of the thermistor mount.

PROCEDURE:

1. Connect equipment as shown in test setup above.

Figure 3-8. Power Meter Leveling Operation (1 of 2)

POWER METER LEVELING

2. Set controls as follows:

8620C:

BAND Frequency of Plug-in installed
 MARKERS OFF
 MODE AUTO
 TRIGGER INT
 TIME-SECONDS 100 – 10
 TIME-SECONDS Vernier Fully clockwise
 1 kHz SQ WV/OFF (rear panel) OFF
 RF BLANKING/OFF (rear panel) OFF
 DISPLAY BLANKING/OFF
 (rear panel) DISPLAY BLANKING

RF Plug-in:

RF OFF-ON ON
 POWER LEVEL Fully clockwise
 ALC switch EXT
 ALC GAIN Fully clockwise
 PM-XLAL switch (located near top of ALC Board) PM

3. Press 8620C LINE pushbutton switch to ON; LINE and FULL SWEEP pushbuttons should light. Allow 30 minutes warm-up time.
4. Adjust power meter range to obtain an indication near top 1/3 of meter deflection range.
5. One of the conditions shown in Figures 3-5 through 3-7 should be displayed on 8755B. These displays will vary depending on directional coupler frequency response. If trace is unlevelled as shown in Figure 3-6, turn POWER LEVEL control counterclockwise to reduce power output until trace is level across band as shown in Figure 3-5. If loop gain is too high, oscillations may occur as shown in Figure 3-7. To remove oscillations, reduce gain by turning ALC GAIN control counterclockwise.

Figure 3-8. Power Meter Leveling Operation (2 of 2)

EXTERNAL AMPLITUDE MODULATION

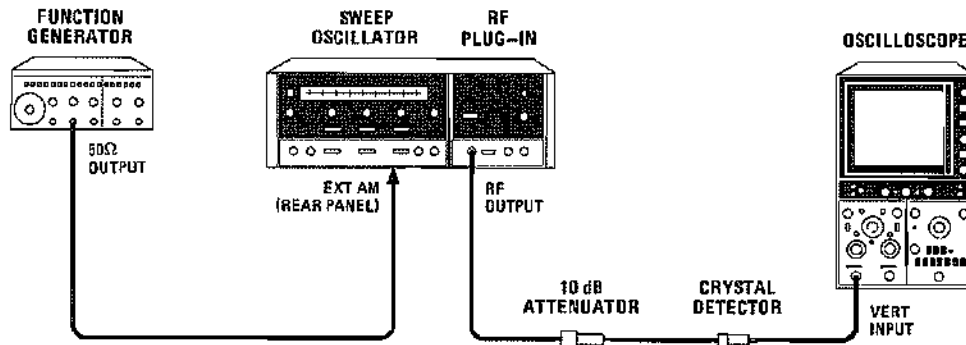

EQUIPMENT:

- Sweep Oscillator HP 8620C
- RF Plug-in HP 86242D, 86245A, or 86250D
- Oscilloscope HP 180C/1801A/1820C
- Function Generator HP 3312A
- Crystal Detector (Negative polarity) HP 423B
- 10 dB Attenuator HP 8491B, Option 010

PROCEDURE:

1. Connect equipment as shown in test setup above.
2. Set controls as follows:

8620C:

- CW MARKER pointer (white) Frequency desired
- MARKERS OFF
- 1 kHz SQ WV/OFF (rear panel) OFF
- RF BLANKING/OFF (rear panel) OFF
- DISPLAY BLANKING/OFF (rear panel) OFF

RF Plug-in:

- RF OFF-ON ON
- POWER LEVEL Fully clockwise
- ALC switch OFF (Standard)
INT (Option 001)
- ALC GAIN Fully counterclockwise
- LINEAR-SQ WAVE switch
(located near top of ALC Board) LINEAR

Figure 3-9. External AM Operation (1 of 2)

EXTERNAL AMPLITUDE MODULATION

3. Press 8620C LINE switch to ON. Press CW pushbutton. Allow 30 minutes warmup time.
4. Set oscilloscope for internal sweep and vertical sensitivity of 20 mV/div. Establish zero volt baseline near top graticule line of oscilloscope.
5. Set amplitude modulation source for modulating-frequency of 1 kHz (sine wave) and voltage output of 0V.
6. Set RF Plug-in POWER LEVEL control fully clockwise and note dc output of crystal detector on oscilloscope.
7. Using RF Plug-in POWER LEVEL control, decrease crystal detector output to one-third dc value noted in step 6. Adjust oscilloscope vertical controls for convenient display of this dc level.

NOTE

Amplitude modulation will appear on oscilloscope as a periodic waveform with same repetition rate as external modulation frequency.

8. Increase output voltage from amplitude modulation source until amplitude modulation is displayed on oscilloscope.

INTERNAL LEVELING (OPTION 001)

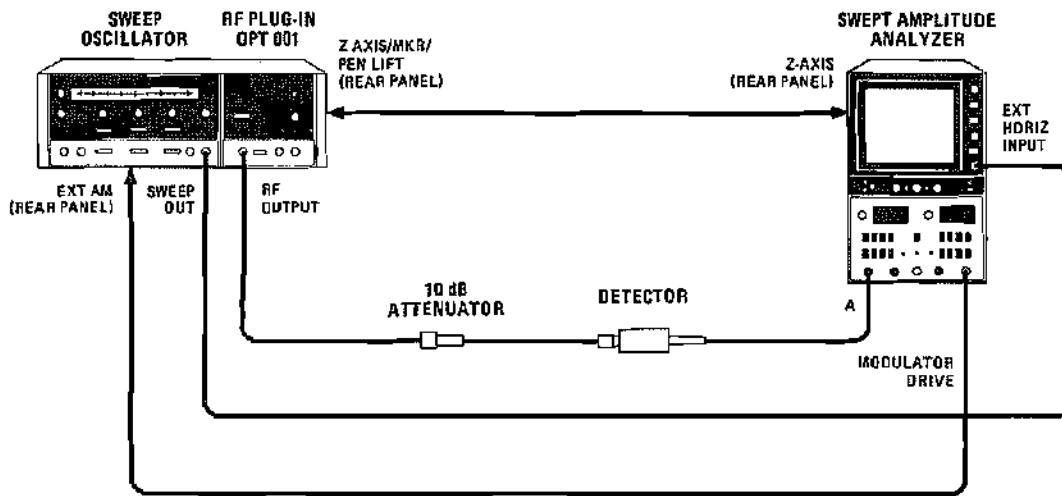

EQUIPMENT:

- Sweep OscillatorHP 8620C
- RF Plug-in.....HP 86242D Opt. 001, 86245A Opt. 001,
or 86250D Opt. 001
- Swept Amplitude Analyzer.....HP 8755B/182T
- Detector HP 11664A
- 10 dB AttenuatorHP 8491B, Option 010

PROCEDURE:

1. Connect equipment as shown above.

NOTE

The RF Plug-in must have an internal directional detector (Option 001) to operate in an internal leveling mode.

2. Set controls as follows:

8620C:

- BAND..... Frequency of Plug-in installed
- MARKERS..... OFF
- MODE..... AUTO
- TRIGGER..... INT
- TIME-SECONDS..... .1 — .01
- TIME SECONDS Vernier..... Fully clockwise
- 1 kHz S WV/OFF (rear panel)..... OFF
- RF BLANKING/OFF (rear panel)..... RF BLANKING
- DISPLAY BLANKING/OFF (rear panel)..... DISPLAY BLANKING

Figure 3-10. Internal Leveling (1 of 2)

INTERNAL LEVELING (OPTION 001)

RF Plug-in:

RF OFF-ON ON
POWER LEVEL Fully clockwise
ALC switch INT
ALC GAIN Fully clockwise

3. Press 8620C LINE pushbutton switch to ON; LINE and FULL SWEEP pushbuttons should light. Allow 30 minutes warm-up time.
4. From fully clockwise position, slowly adjust POWER LEVEL control counterclockwise until UNLEVELED lamp goes out. This is adjustment point for maximum leveled power. 8755B trace should be leveled as shown in Figure 3-5.

SIMULTANEOUS TRANSMISSION, REFLECTION MEASUREMENT

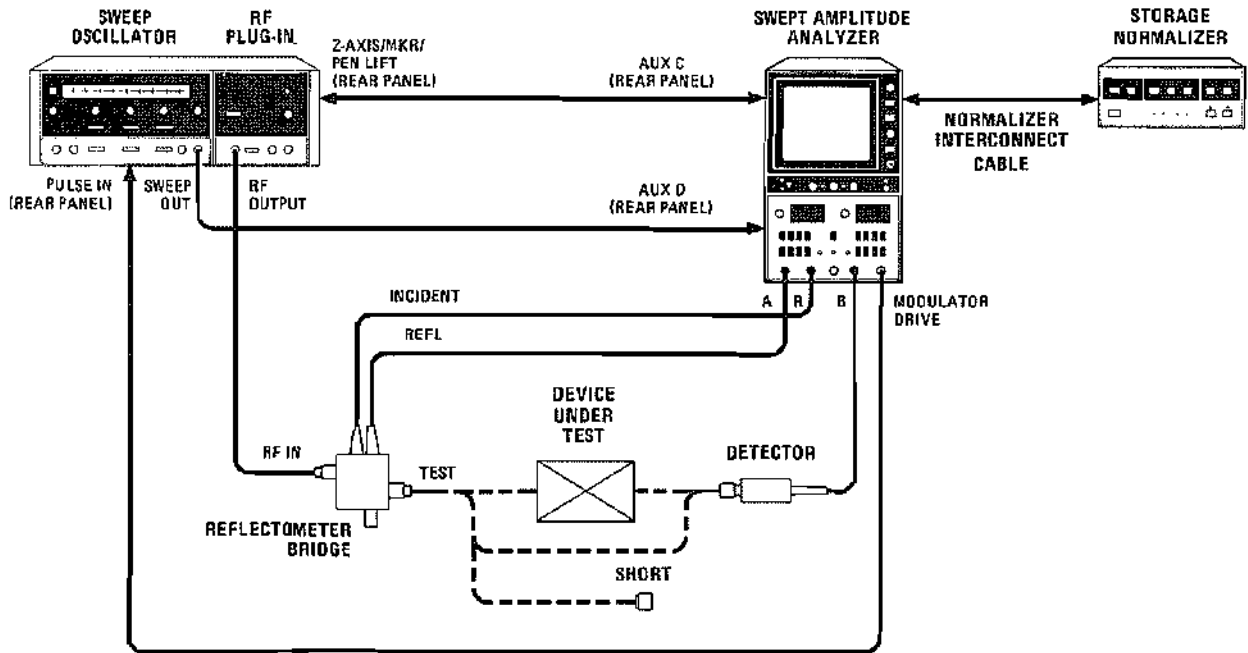

EQUIPMENT:

Sweep Oscillator	HP 8620C
RF Plug-in	HP 86242D, 86245A, or 86250D
Swept Amplitude Analyzer	HP 8755B/182T
Storage-Normalizer	HP 8750A
Detector	HP 11664A
Reflectometer Bridge	HP 11666A
Type N Male Short	HP 11512A
Normalizer Interconnect Cable	HP 08750-60014

PROCEDURE:

1. Connect equipment as shown in test setup above. Connect Type N short to 11666A Reflectometer Bridge TEST port.

www.valuetronics.com

Figure 3-11. Simultaneous Transmission, Reflection Measurement Using HP Model 8755B Swept Amplitude Analyzer (1 of 3)

SIMULTANEOUS TRANSMISSION, REFLECTION MEASUREMENT

2. Set controls as follows:

8620C:

CW MARKER pointer	Center-scale
MARKERS	OFF
1 kHz SQ WV/OFF (rear panel)	OFF
RF BLANKING/OFF (rear panel)	OFF
DISPLAY BLANKING/OFF (rear panel)	DISPLAY BLANKING

RF Plug-in:

RF OFF-ON	ON
ALC switch	OFF (Standard) INT (Option 001)
ALC GAIN	Fully counterclockwise
POWER LEVEL	Fully counterclockwise

3. Press 8620C LINE pushbutton switch ON. Allow 30 minutes warm-up time.
4. Press ΔF pushbutton and set ΔF control fully counterclockwise.

NOTE

The 8750A Storage-Normalizer and 8755B/182T Swept Amplitude Analyzer must be matched according to the procedure in Section III of the 8750A Operating and Service Manual.

5. Turn off 8755B CHANNEL 2 display by pressing one of the CHANNEL 2 DISPLAY Pushbuttons part way in to "pop" out all of the CHANNEL 2 DISPLAY pushbuttons.
6. Press 8750A BYPASS Pushbutton. Set 8755B CHANNEL 1 VERNIER ON/OFF switch to OFF and set CHANNEL 1 REFERENCE LEVEL thumbwheels to -00 dB.
7. Press 8755B CHANNEL 1 DISPLAY REFERENCE POSITION Pushbutton and adjust REFERENCE POSITION screwdriver adjustment to place CRT trace on center graticule line.
8. Press 8755B CHANNEL 1 DISPLAY A pushbutton and adjust RF plug-in POWER LEVEL to place the CRT trace on center graticule line.

www.valuetronics.com

Figure 3-11. Simultaneous Transmission, Reflection Measurement Using HP Model 8755B Swept Amplitude Analyzer (2 of 3)

SIMULTANEOUS TRANSMISSION, REFLECTION MEASUREMENT

9. Press 8755B CHANNEL 1 DISPLAY A/R pushbutton and set VERNIER ON/OFF switch to ON. Select dB/DIV resolution desired for reflection measurement and adjust CHANNEL 1 VERNIER control to place CRT trace on center graticule line.
10. Press 8750A CH 1 and INPUT pushbuttons to select CHANNEL 1 display. Normalize CRT display by pressing 8750A STORE INPUT, then INPUT – MEM pushbuttons. Center graticule line now represents 0 dB return loss.
11. Remove Type N short and connect 11664A Detector to 11666A TEST port.
12. Press 8750A BYPASS pushbutton. Turn off 8755B CHANNEL 1 display by pressing one of the CHANNEL 1 DISPLAY Pushbuttons part way in to “pop” out all of the CHANNEL 1 DISPLAY pushbuttons.
13. Set 8755B CHANNEL 2 VERNIER ON/OFF switch to OFF and set CHANNEL 2 REFERENCE LEVEL thumbwheels to –00 dB.
14. Press 8755B CHANNEL 2 DISPLAY REFERENCE POSITION pushbutton and adjust REFERENCE POSITION screwdriver adjustment to place CRT trace on center graticule line.
15. Press CHANNEL 2 DISPLAY B/R pushbutton and set VERNIER ON/OFF switch to ON. Select dB/DIV resolution desired for transmission measurement and adjust CHANNEL 2 VERNIER control to place CRT trace on center graticule line.
16. Press 8750A CH 2 and INPUT pushbuttons to select CHANNEL 2 display. Normalize CRT display by pressing 8750A STORE INPUT, then INPUT – MEM pushbuttons. Center graticule now represents 0 dB insertion loss.
17. Press 8755B CHANNEL 1 A/R DISPLAY pushbutton and connect device under test between 11666A TEST port and 11664A Detector.
18. The equipment is now calibrated for either a reflection (return loss) or transmission (insertion loss) measurement. Return loss is read directly by adding the 8755B CHANNEL 1 REFERENCE LEVEL setting to the CHANNEL 1 trace position below the center graticule line. Insertion loss is read directly by adding the 8755B CHANNEL 2 REFERENCE LEVEL setting to the CHANNEL 2 trace position below the center graticule line. If the trace is above the center graticule line, subtract that amount from the REFERENCE LEVEL setting.

EXTERNAL FREQUENCY MODULATION

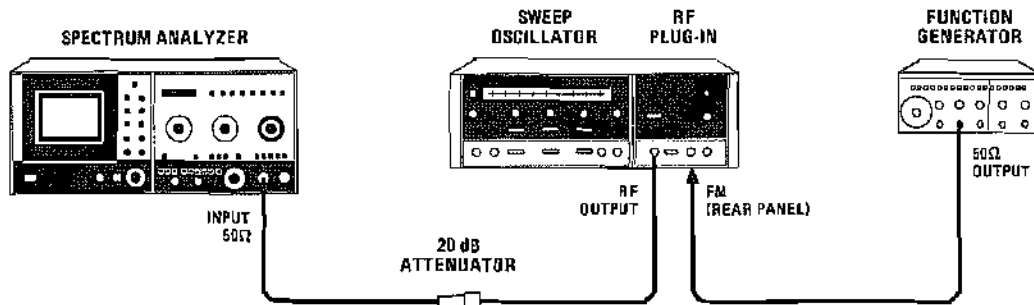

EQUIPMENT:

Sweep Oscillator	HP 8620C
RF Plug-in	HP 86242D, 86245A, or 86250D
Spectrum Analyzer	HP 8565A
Function Generator	HP 3312A
20 dB Attenuator	HP 8491B, Option 020

PROCEDURE:

1. Connect equipment as shown in test setup.
2. Set controls as follows:

8620C:

CW MARKER pointer (white)	Frequency Desired
MARKERS	OFF
1 kHz SQ WV/OFF (rear panel)	OFF
RF BLANKING/OFF (rear panel)	OFF
DISPLAY BLANKING/OFF (rear panel)	OFF

RF Plug-in:

RF OFF-ON	ON
POWER LEVEL	Fully clockwise
ALC switch	OFF (Standard)
	INT (Option 001)
ALC GAIN	Fully counterclockwise

3. Press 8620C LINE switch to ON. Press CW pushbutton. Allow 30 minutes warm-up time.

Figure 3-12. External FM Operation (1 of 2)

EXTERNAL FREQUENCY MODULATION

4. Set spectrum analyzer frequency SPAN/DIV to 5 MHz and center fundamental CW frequency on analyzer display.
5. Set Function generator for a 1 kHz sine wave modulating frequency and voltage output of 0V.
6. Increase modulation source output voltage until desired frequency deviation is obtained on spectrum analyzer display. Refer to example waveform shown in Figure 3-13.

Figure 3-12. External FM Operation (2 of 2)

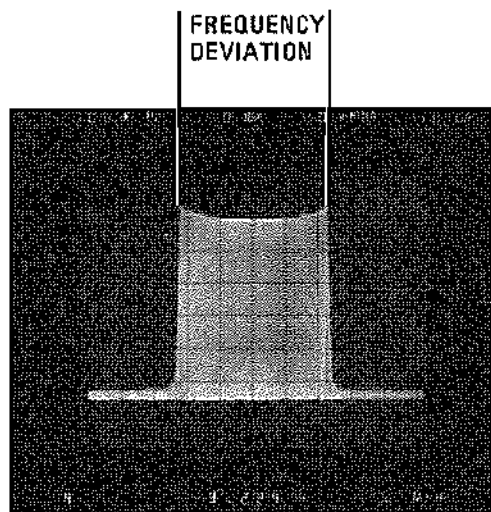
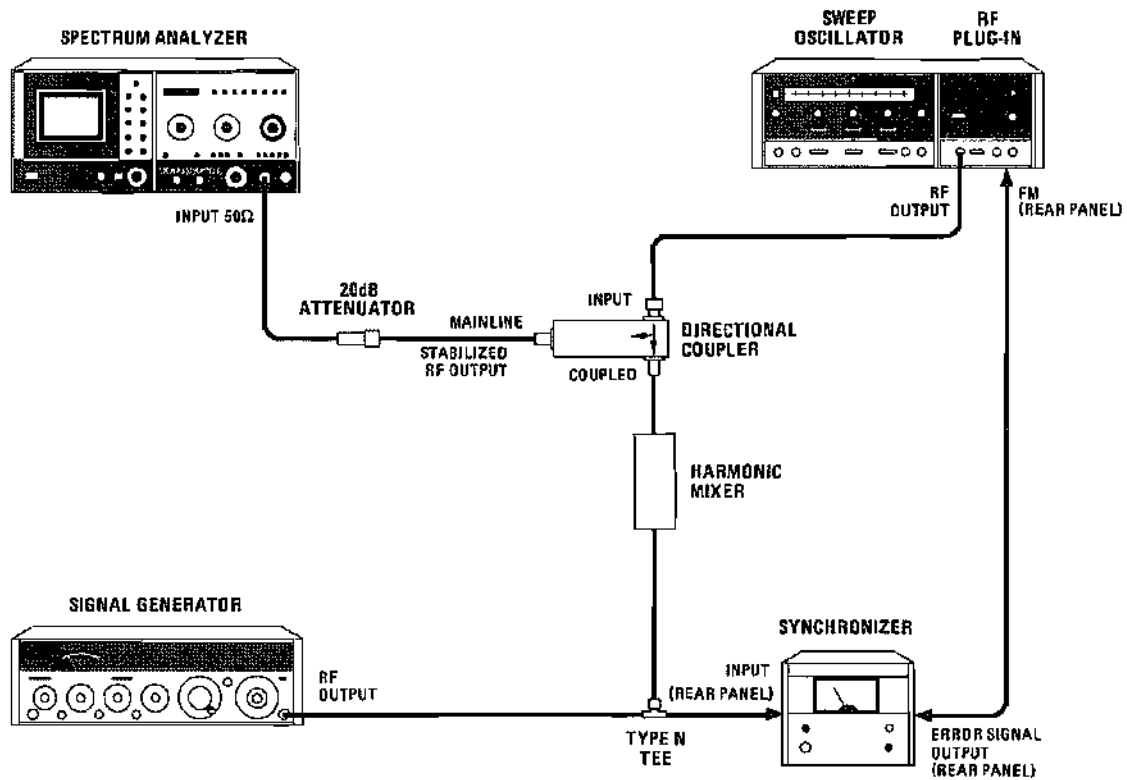

Figure 3-13. Spectrum Analyzer Display of Typical Frequency Modulated Waveform

PHASE LOCK OPERATION



EQUIPMENT:

Sweep Oscillator	HP 8620C
RF Plug-in	HP 86242D, 86245A, or 86250D
Spectrum Analyzer	HP 8565A
Signal Generator	HP 8640B
Synchronizer	HP 8709A
20 dB Attenuator	HP 8491B, Option 020
Directional Coupler	HP 779D
Harmonic Mixer	HP 8709A-K18
Type N TEE	HP 1250-0846

PROCEDURE:

1. Connect equipment as shown in test setup, except disconnect cable from RF plug-in FM connector.

Figure 3-14. Phase Lock Operation (1 of 2)

PHASE LOCK OPERATION

2. Set controls as follows:

8620C:

- CW MARKER pointer (white)..... Frequency Desired
- MARKERS OFF
- 1 kHz SQ WV/OFF (rear panel) OFF
- RF BLANKING/OFF (rear panel) OFF
- DISPLAY BLANKING/OFF (rear panel)..... OFF

RF Plug-in:

- RF OFF-ON ON
- POWER LEVEL Fully Clockwise
- ALC switch OFF (Standard)
INT (Option 001)
- ALC GAIN Fully Clockwise
- FM-NORM-PL (rear panel)..... PL

3. Press 8620C LINE switch to ON. Press CW pushbutton. Allow 30 minutes warm-up time.
4. Center fundamental CW frequency on spectrum analyzer display, unstabilized waveform should be similar to display in Figure 3-15.
5. Set 8709A SYNCHRONIZER rear-panel MOD. SENS. switch to 6.00 MHz/VOLT position. (The 8709A rear-panel switch sets 8709A modulation sensitivity to match sensitivity of RF plug-in to be stabilized.)
6. Connect 8709A ERROR OUT connector to RF Plug-in FM connector. Tune reference oscillator frequency until 8709A SYNCHRONIZER UNLOCKED light goes off.
7. Retune sweep oscillator until 8709A PHASE ERROR Meter indication is centered. STABILIZED (phase-locked) waveform should be similar to display of Figure 3-16.

Figure 3-14. Phase Lock Operation (2 of 2)

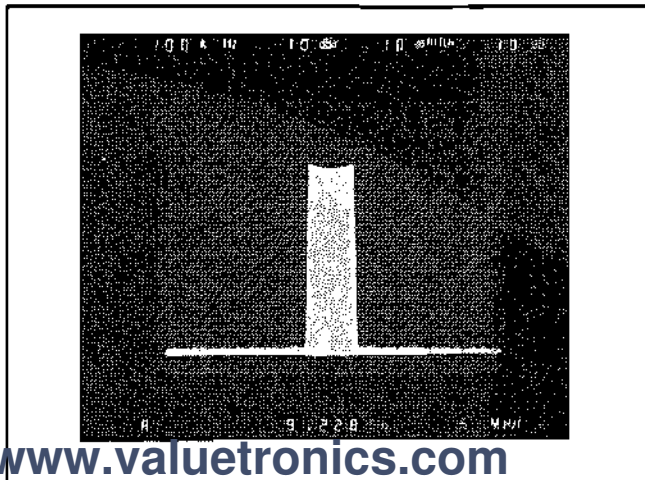

Figure 3-15. Spectrum Analyzer Display of Unstabilized CW Signal

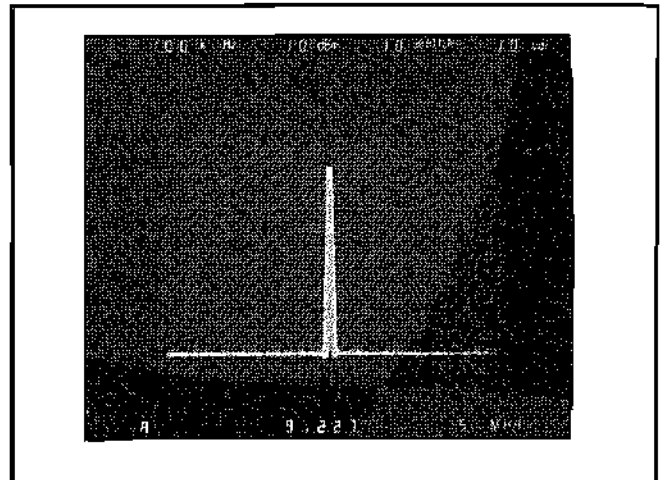
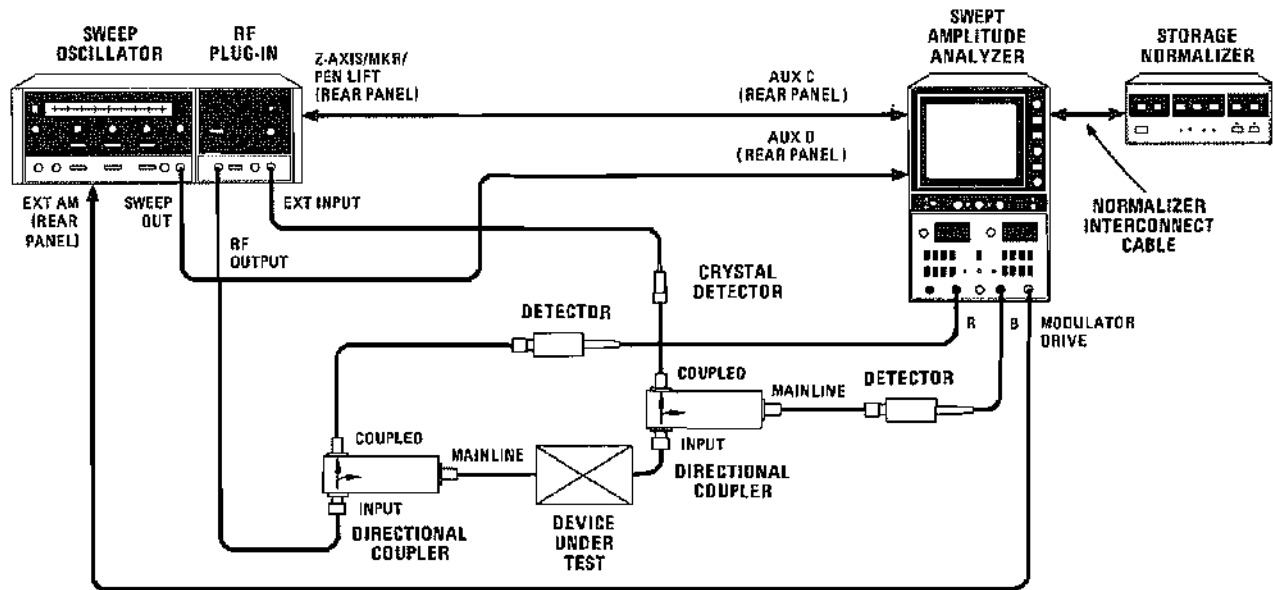

Figure 3-16. Spectrum Analyzer Display of Phase-Locked CW Signal

**INCREASED DYNAMIC RANGE
(86245A Only)**



EQUIPMENT:

Sweep Oscillator	HP 8620C
RF Plug-in	HP 86245A
Swept Amplitude Analyzer	HP 8755B/182T
Directional Coupler (2 required)	HP 779D
Detector (2 required)	HP 11664A
Crystal Detector (Negative polarity)	HP 423B
Storage-Normalizer	HP 8750A
Normalizer Interconnect Cable	HP 08750-60014

PROCEDURE:

1. Connect equipment as shown in test setup above with a direct connection between directional couplers (do not connect device under test).

2. Set controls as follows:

8620C:

START MARKER pointer (green) ..	Low frequency end of scale
STOP MARKER pointer (red)	High frequency end of scale
MARKERS	OFF
1 kHz SQ WV/OFF (rear panel)	OFF
RF BLANKING/OFF (rear panel)	OFF
DISPLAY BLANKING/OFF (rear panel)	DISPLAY BLANKING

Figure 3-17. Increased Dynamic Range Using HP Model 8755B Swept Amplitude Analyzer (1 of 3)

INCREASED DYNAMIC RANGE (86245A Only)

RF Plug-in:

RF OFF-ON ON
 ALC switch EXT
 ALC GAIN Fully counterclockwise
 POWER LEVEL Fully counterclockwise
 SQ WAVE-LINEAR switch (located on ALC Board) . . . SQ WAVE
 PM-XTAL switch (located near top of ALC Board) XTAL

3. Press 8620C LINE pushbutton switch ON. Allow 30 minutes warm-up time.
4. Press MARKER SWEEP pushbutton and set the START MARKER and STOP MARKER pointers to cover swept frequency required.

NOTE

The 8750A Storage-Normalizer and 8755B/182T Swept Amplitude Analyzer must be matched according to the procedure in Section III of the 8750A Operating and Service Manual.

5. Turn off 8755B CHANNEL 1 display by pressing one of the CHANNEL 1 DISPLAY pushbuttons part way in to "pop" out all of the CHANNEL 1 DISPLAY pushbuttons.
6. Press 8750A BYPASS pushbutton. Set 8755B CHANNEL 2 VERNIER ON/OFF switch to OFF, set CHANNEL 2 REFERENCE LEVEL thumbwheels to -00 dB, and select 10 dB/DIV resolution.
7. Press 8755B CHANNEL 2 DISPLAY REFERENCE POSITION pushbutton and adjust REFERENCE POSITION screwdriver adjustment to place CRT trace on center graticule line.
8. Press 8755B CHANNEL 2 DISPLAY B Pushbutton and adjust RF plug-in POWER LEVEL to place CRT trace one division above center graticule line (+ 10 dBm).
9. Press 8755B CHANNEL 2 DISPLAY B/R pushbutton and set VERNIER ON/OFF switch to ON. Adjust CHANNEL 2 VERNIER control to place CRT trace on center graticule line.
10. Press 8750A CH 2 and INPUT pushbuttons to select CHANNEL 2 display. Normalize CRT display by pressing 8750A STORE INPUT, then INPUT - MEM pushbuttons. Center graticule line now represents 0 dB insertion loss.

**INCREASED DYNAMIC RANGE
(86245A Only)**

11. Connect device under test between the two directional couplers as shown in the test setup.
12. Adjust CHANNEL 2 REFERENCE LEVEL thumbwheels to place CRT trace close to center graticule line. Insertion loss is read directly by adding the 8755B CHANNEL 2 REFERENCE LEVEL setting to the CRT trace position below the center graticule line. If the trace is above the center graticule line, subtract that amount from the REFERENCE LEVEL setting.

SECTION IV PERFORMANCE TESTS

4-1. INTRODUCTION

4-2. The procedures in this section test the electrical performance of the instrument using the specifications of Table 1-1 as the performance standards. All tests can be performed without access to the interior of the instrument.

4-3. The performance test procedures must be performed in the sequence given, since some procedures rely on satisfactory test results in foregoing steps. If a test measurement is slightly out of tolerance, go to Section V and perform adjustment procedures. If a function fails to operate, go to Section VIII and perform troubleshooting.

NOTE

In the following procedure, an 8620C mainframe is specified. However, an 8620A may be used, but the control names will be different than those called out in the procedures. These procedures assume that the mainframe is fully calibrated to its specifications.

NOTE

To ensure that the RF Plug-in meets specifications listed in Table 1-1, Performance Tests should be performed at least every six months.

4-4. EQUIPMENT REQUIRED

4-5. Equipment required for the performance tests is listed in the Recommended Test Equipment Table in Section I. Any equipment that satisfies the critical specifications given in the table may be substituted for the recommended models.

4-6. ABBREVIATED PERFORMANCE VERIFICATION

4-7. The Operation Verification Tests of Section II are designed to test only the most critical specifications and operating features of the instrument. The Operation Verification Tests require much less time and equipment than the complete Performance Tests in this section and are recommended for verification of overall instrument operation after repair.

PERFORMANCE TESTS

4-8. FREQUENCY RANGE AND ACCURACY TEST

SPECIFICATION:

See Table 4-1 for frequency range and accuracy specifications.

NOTE

Allow 30 minutes warm-up time.

PERFORMANCE TESTS

4-8. FREQUENCY RANGE AND ACCURACY TEST (Cont'd)

Table 4-1. Frequency Range and Accuracy Specifications

Plug-In	Frequency Range	Frequency Accuracy (at 25°C Ambient)
86242D	5.9 to 9.0 GHz	±35 MHz CW Mode* ±40 MHz All Sweep Modes**
86250D	5.9 to 12.4 GHz	±40 MHz CW Mode* ±50 MHz All Sweep Modes**
86250D	8.0 to 12.4 GHz	±40 MHz CW Mode* ±50 MHz All Sweep Modes**

*Approach desired CW frequency from low frequency end of band.
**Sweep time >0.1 sec.

DESCRIPTION:

CW frequency is checked at three points across the band to determine if the RF signal is within frequency tolerance. FULL SWEEP is then selected and frequency is checked at each end point. Marker accuracy is also checked in the FULL SWEEP mode.

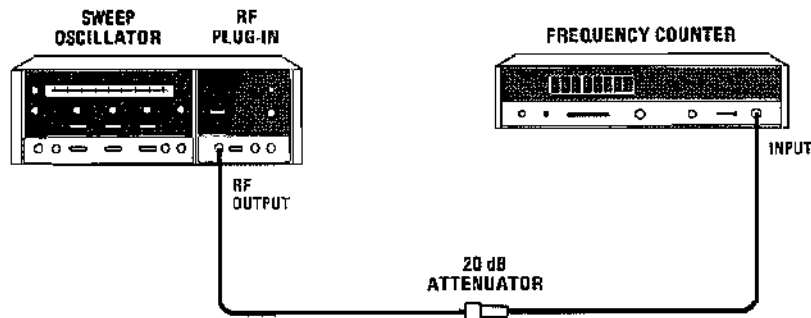

Figure 4-1. CW and Manual Sweep Accuracy Test Setup.

Equipment listed is for two test setups (Figures 4-1 and 4-2).

www.valuetronics.com

PERFORMANCE TESTS

4-8. FREQUENCY RANGE AND ACCURACY TEST (Cont'd)

EQUIPMENT:

Sweep Oscillator	HP 8620C
Frequency Counter	HP 5340A
Oscilloscope	HP 180C/1801A/1820C
Directional Coupler	HP 779D
Frequency Meter	HP 537A
Crystal Detector	HP 423B
20 dB Attenuator	HP 8491B, Option 020

PROCEDURE:

- a. Connect equipment as shown in Figure 4-1.
- b. Set controls as follows:

8620C:

BAND	Frequency of Plug-in installed
CW MARKER pointer	Center-scale
MODE	AUTO
TRIGGER	INT
TIME-SECONDS	1 - .1
TIME-SECONDS vernier	Fully clockwise
1 kHz SQ WV/OFF (rear panel)	OFF
RF BLANKING/OFF (rear panel)	RF BLANKING
DISPLAY BLANKING/OFF (rear panel)	OFF

RF Plug-in:

RF OFF-ON	ON
ALC switch	INT or OFF
POWER LEVEL	Fully clockwise
FM-NORM-PL switch (rear panel)	NORM

- c. Press 8620C LINE pushbutton to ON; press CW pushbutton. Set frequency counter to measure frequency range of RF Plug-in. Allow 30 minutes warm-up time.

NOTE

Always approach frequency settings from low-frequency end.

- d. Adjust CW MARKER pointer to high-frequency end, then to low-frequency end; repeat several times. Set CW pointer to low end of scale. Frequency counter indication should be 5.9 GHz \pm 35 MHz for 86242D, 5.9 GHz \pm 40 MHz for 86245A, or 8.0 GHz \pm 40 MHz for 86250D.
- e. Set 8620C CW MARKER pointer to 7.5 GHz (86242D), 9.0 GHz (86245A) or 10.2 GHz (86250D). Frequency counter indication should be 7.5 GHz \pm 35 Mz for 86242D, 9.0 GHz \pm 40 MHz for 86245A, or 10.2 GHz \pm 40 MHz for 86250D.

www.valuetronics.com

- f. Set CW MARKER pointer to high-end of scale. Frequency counter indication should be 9.0 GHz \pm 35 MHz for 86242D or 12.4 GHz \pm 40 MHz for 86245A/86250D.

PERFORMANCE TESTS

4-8. FREQUENCY RANGE AND ACCURACY TEST (Cont'd)

Swept Frequency Endpoint Accuracy:

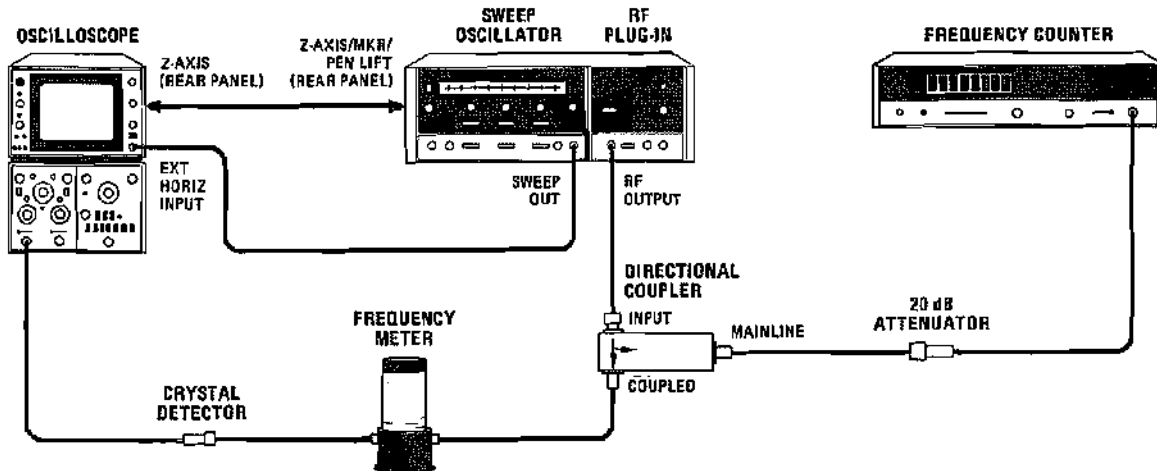

Figure 4-2. Swept Frequency Endpoint and Marker Accuracy Test Setup

- g. Connect equipment as shown in Figure 4-2.
- h. Press 8620C CW pushbutton. Adjust CW MARKER control for frequency counter indication of 5.900 GHz \pm 2 MHz for 86242D/86245A or 8.000 GHz \pm 2 MHz for 86250D.
- i. Adjust frequency meter for maximum change in amplitude on oscilloscope. Note dial setting of frequency meter. _____ GHz
- j. Press 8620C FULL SWEEP pushbutton. Adjust frequency meter to frequency start point (left edge of trace) on oscilloscope and read frequency meter setting. The difference between this frequency meter setting and that noted in step i must be less than 40 MHz for 86242D, less than 50 MHz for 86245A/86250D.
- k. Press 8620C CW pushbutton. Adjust CW MARKER control for frequency counter indication of 9.000 GHz \pm 2 MHz for 86242D or 12.400 GHz \pm 2 MHz for 86245A/86250D.
- l. Adjust frequency meter for maximum change in amplitude on oscilloscope. Note dial setting of frequency meter. _____ GHz
- m. Press 8620C FULL SWEEP pushbutton. Adjust frequency meter to frequency stop point (right edge of trace) on oscilloscope and read frequency meter setting. Subtract this frequency meter setting from that noted in step i. The difference must be less than 40 MHz for 86242D, less than 50 MHz for 86245A/86250D.

PERFORMANCE TESTS

4-8. FREQUENCY RANGE AND ACCURACY TEST (Cont'd)

Swept Frequency Marker Accuracy:

- n. Press 8620C CW and CW VERNIER pushbuttons. Set CW MARKER pointer to START MARKER pointer scale setting shown in Table 4-2. Adjust CW MARKER and CW VERNIER controls for a frequency counter indication of 6.000 GHz \pm 2 MHz for 86242D/86245A, or 8.100 GHz \pm 2 MHz for 86250D.
- o. Set frequency meter to frequency set in step n. Adjust frequency meter for maximum change in amplitude on oscilloscope. Record frequency meter error for START MARKER pointer scale setting in Table 4-2.

NOTE

Frequency meter error is the difference between frequency meter setting and "scale setting frequency" accurately set using frequency counter. Assign a minus sign (–) to error if frequency meter indication is lower than "scale setting frequency."

- p. Set CW MARKER pointer to CW MARKER pointer scale setting shown in Table 4-2. Adjust CW MARKER and CW VERNIER controls for a frequency counter indication of 7.500 GHz \pm 2 MHz for 86242D, 9.000 GHz \pm 2 MHz for 86245A, or 10.200 GHz \pm 2 MHz for 86250D.
- q. Set frequency meter to frequency set in step p. Adjust frequency meter for maximum change in amplitude on oscilloscope. Record frequency meter error for CW MARKER pointer scale setting in Table 4-2. (Refer to note in step o.)
- r. Set CW MARKER pointer to STOP MARKER pointer scale setting shown in Table 4-2. Adjust CW MARKER and CW VERNIER control for a frequency counter indication of 8.900 GHz \pm 2 MHz for 86242D, 12.00 GHz \pm 2 MHz for 86245A, or 12.200 GHz \pm 2 MHz for 86250D.
- s. Set frequency meter to frequency set in step r. Adjust frequency meter for maximum change in amplitude on oscilloscope. Record frequency meter error for STOP MARKER pointer scale setting in Table 4-2. (Refer to note in step o.)

Table 4-2. Frequency Meter Error

	Scale Settings (GHz)			Frequency Meter Error (MHz)
	86242D	86245A	86250D	
START MARKER Pointer	6.0	6.0	8.1	
CW MARKER Pointer	7.5	9.0	10.2	
STOP MARKER Pointer	8.9	12.0	12.2	

4-8. FREQUENCY RANGE AND ACCURACY TEST (Cont'd)

- t. Set 8620C START MARKER, CW MARKER, and STOP MARKER pointers to scale settings indicated in Table 4-2. Press FULL SWEEP pushbutton and set MARKERS switch to INTEN.
- u. Set frequency meter "pip" on STOP MARKER and record frequency (algebraically subtract frequency meter error recorded in Table 4-2, from frequency meter indication). Result should be 8.9 GHz \pm 40 MHz for 86242D, 12.0 GHz \pm 50 MHz for 86245A, or 12.2 GHz \pm 50 MHz for 86250D.
- v. Set frequency meter "pip" on CW MARKER and record frequency (algebraically subtract frequency meter error, recorded in Table 4-2, from frequency meter indication). Result should be 7.5 GHz \pm 40 MHz for 86242D, 9.0 GHz \pm 50 MHz for 86245A, or 10.2 GHz \pm 50 MHz for 86250D.
- w. Set frequency meter "pip" on START MARKER and record frequency (algebraically subtract frequency meter error, recorded in Table 4-2, from frequency meter indication). Result should be 6.0 GHz \pm 40 MHz for 86242D, 6.0 GHz \pm 50 MHz for 86245A, or 8.1 GHz \pm 50 MHz for 86250D.

4-9. FREQUENCY STABILITY TEST

SPECIFICATIONS:

Table 4-3. Frequency Stability Specifications

Plug-In	10% Line Voltage Change	10 dB Power Level Change	3:1 Load SWR	Temperature
86242D	< \pm 40 kHz	< \pm 1.5 MHz	< \pm 250 kHz	< \pm 750 kHz/ $^{\circ}$ C
86245A/86250D	< \pm 40 kHz	< \pm 1.5 MHz	< \pm 250 kHz	< \pm 1.2 MHz/ $^{\circ}$ C

DESCRIPTION:

Frequency is measured for changes in line voltage, power level, source match, or temperature.

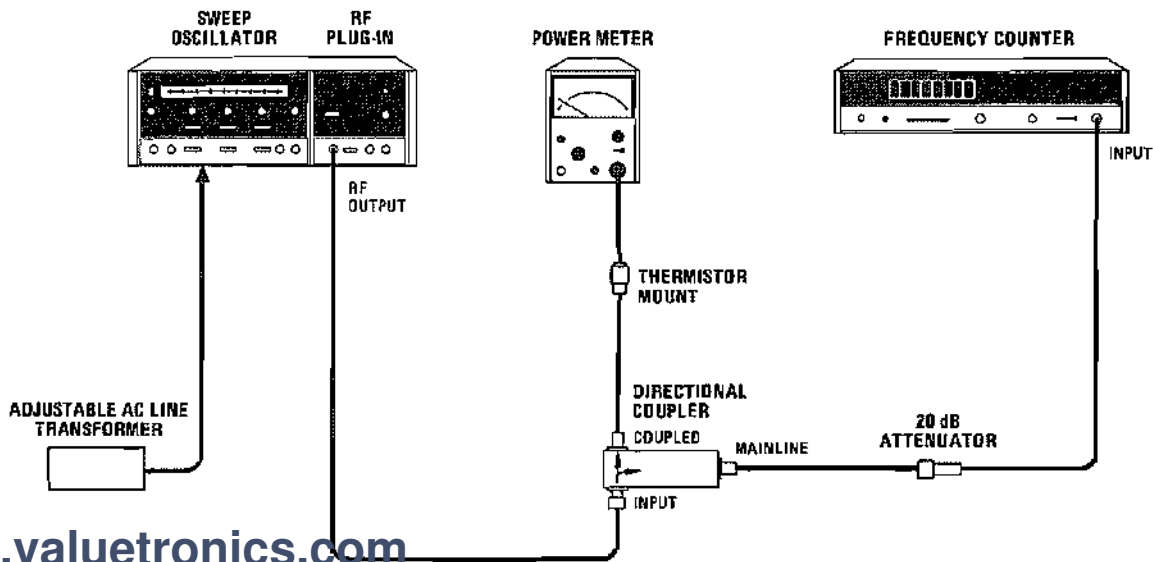

www.valuetronics.com

Figure 4-3. Frequency Stability Test Setup

PERFORMANCE TESTS

4-9. FREQUENCY STABILITY TEST (Cont'd)

NOTE

Equipment listed is for two test setups (Figure 4-3 and 4-4).

EQUIPMENT:

Sweep Oscillator	HP 8620C
Spectrum Analyzer	HP 8565A
Frequency Counter	HP 5340A
Power Meter	HP 432A
Thermistor Mount	HP 8478B
Adjustable AC Line Transformer	General Radio MT3A
Directional Coupler	HP 779D
Adjustable Short	Microlab/FXR S0-6MN
20 dB Attenuator	HP 8491B, Option 020
3 dB Attenuator	HP 8491B, Option 003

PROCEDURE:

- a. Connect equipment as shown in Figure 4-3.
- b. Set controls as follows:

8620C:	
BAND	Frequency of Plug-in installed
CW MARKER pointer	Center-scale
1 kHz SQ WV/OFF (rear panel)	OFF
RF BLANKING/OFF (rear panel)	RF BLANKING
DISPLAY BLANKING/OFF (rear panel)	OFF
RF Plug-in:	
RF OFF-ON	ON
ALC switch	INT or OFF
FM-NORM-PL	NORM

- c. Adjust RF Plug-in for maximum specified power.
- d. Set adjustable line voltage transformer to 115 Vac. Press 8620C LINE pushbutton to ON. Press CW pushbutton. Allow 30 minutes warm-up time.

Frequency change with line voltage change:

- e. Record frequency counter indication at 115 Vac.
- f. Set line voltage to 103 Vac with adjustable line transformer. Frequency change from that noted in step e should be less than 40 kHz.

g. Set line voltage to 127 Vac with adjustable line transformer. Frequency change from that noted in step e should be less than 40 kHz. Return line voltage to 115 Vac.

PERFORMANCE TESTS

4-9. FREQUENCY STABILITY TEST (Cont'd)

Frequency Change with power level change:

- h. Note frequency counter indication. Using RF Plug-in POWER LEVEL control, decrease power by 10 dB as indicated on power meter. Frequency change should be less than 1.5 MHz. Readjust RF Plug-in for maximum leveled power.

Frequency Change with 3:1 Load SWR:

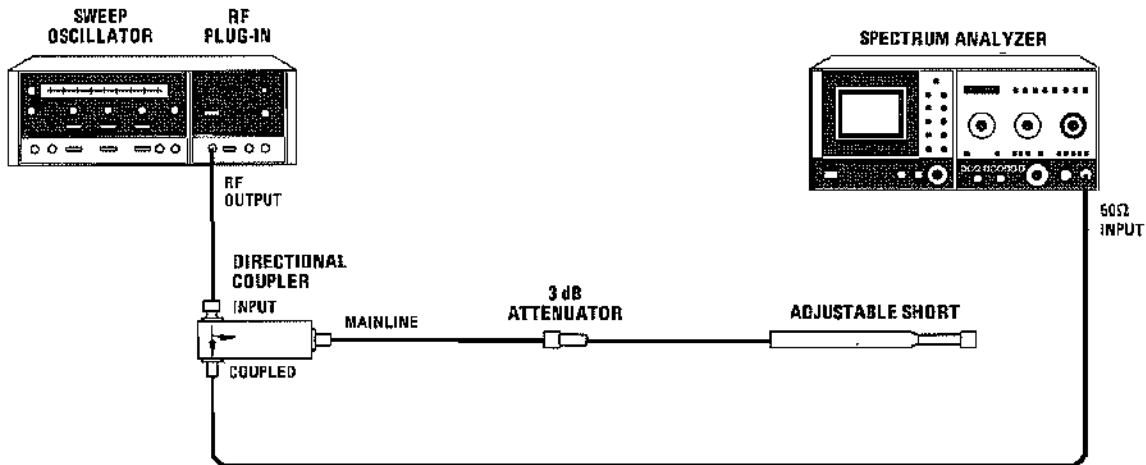

Figure 4-4. 3:1 Load SWR Test Setup

- i. Connect equipment as shown in Figure 4-4. Allow 30 minutes warm-up time.
- j. Center output signal on spectrum analyzer display.
- k. Set spectrum analyzer resolution bandwidth to 3 kHz and frequency span per division to 50 kHz while keeping signal centered on display.
- l. Set spectrum analyzer amplitude scale to 10 dB per division and adjust for full vertical display.
- m. Set sweep time per division to 20 msec, internal sweep source and free run sweep trigger.
- n. Tune adjustable short through full range while observing frequency change on analyzer. Frequency change must be less than ± 250 kHz.
- o. Repeat steps j through n for low end and high end of frequency band.

Frequency Change with Temperature Change:

NOTE

Verification of the frequency stability specification for temperature changes requires the RF Plug-in to be placed in a controlled environment (i.e., a heat chamber).

www.valuetronics.com

- p. Connect frequency counter (through 20 dB attenuator) to RF OUTPUT of RF Plug-in.

PERFORMANCE TESTS

4-9. FREQUENCY STABILITY TEST (Cont'd)

- q. Adjust RF Plug-in for maximum leveled power. Note frequency counter indication.
- r. Change ambient temperature 10°C within the range of 0°C to 55°. Allow 30 minutes settling time.
- s. Note frequency counter indication. Frequency change from that noted in step q should be less than 7.5 MHz for 86242D or less than 12 MHz for 86245A/86250D.

4-10. RESIDUAL FM IN 10 kHz BANDWIDTH TEST

SPECIFICATION:

CW Mode:

FM-NORM-PL switch in NORM Position: < 15 kHz peak.

DESCRIPTION:

RF output signal is displayed on a spectrum analyzer. Residual FM is observed on a storage display by displaying five superimposed traces.

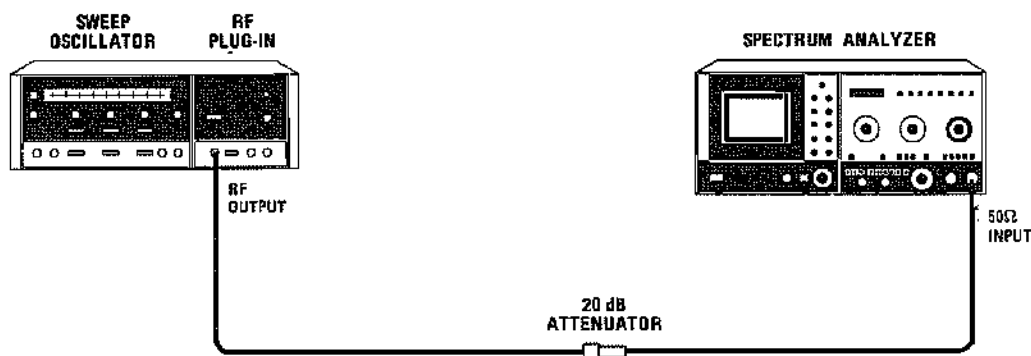

Figure 4-5. Residual FM Test Setup

EQUIPMENT:

Sweep Oscillator.....	HP 8620C
Spectrum Analyzer.....	HP 8565A
20 dB Attenuator.....	HP 8491B, Option 020

PROCEDURE:

- a. Connect equipment as shown in Figure 4-5.
- b. Set controls as follows:

8620C:

BAND.....	Frequency of Plug-in installed
CW MARKER pointer.....	Center-scale
1 kHz SQ WV/OFF (rear panel).....	OFF
1 kHz SQ ON/OFF (rear panel).....	OFF
DISPLAY BLANKING/OFF (rear panel).....	OFF

PERFORMANCE TESTS

4-10. RESIDUAL FM IN 10 kHz BANDWIDTH TEST (Cont'd)

RF Plug-in:

RF OFF-ON ON
 ALC switch..... INT or OFF
 POWER LEVEL Fully clockwise
 FM-NORM-PL switch (rear panel)..... NORM

- c. Press 8620C LINE Pushbutton to ON. Press CW pushbutton. Allow 30 minutes warm-up time.
- d. Center RF output signal on spectrum analyzer.
- e. Set spectrum analyzer resolution bandwidth to 10 kHz and frequency span per division to 10 kHz while keeping signal centered on CRT display. Automatic stabilizer should be on.
- f. On spectrum analyzer, select linear amplitude scale and adjust reference level controls for a full eight division display.
- g. Set sweep time per division to 20 msec and set sweep trigger to single sweep. Set persistence control fully clockwise and erase the trace.
- h. Push start/reset pushbutton five times at approximately one second intervals and store resultant traces on CRT screen. Display should be similar to that shown in Figure 4-6.

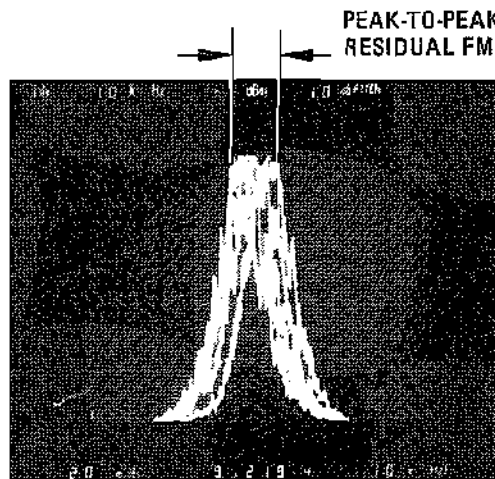

Figure 4-6. Residual FM Display on Spectrum Analyzer

- i. Peak-to-peak residual FM measured across top of trace should be less than 30 kHz (three divisions).

4-11. POWER LEVEL AND VARIATION TEST

SPECIFICATIONS:

www.valuetronics.com

See Table 4-4 for power level and variation specifications.

PERFORMANCE TESTS

4-11. POWER LEVEL AND VARIATION TEST (Cont'd)

Table 4-4. Power Level and Variation Specifications

Plug-In	Maximum Leveled Power (25°C) ⁴	Internally Leveled ¹ (Option 001)	Externally Leveled ¹ Crystal ² or Power Meter ³
86242D	>+10.0 dBm (10 mW)	<±0.5 dB	<±0.1 dB
86245A	>+17.0 dBm (50 mW)	<±0.6 dB	<±0.1 dB
86250D	>+10.0 dBm (10 mW)	<±0.5 dB	<±0.1 dB

¹ Example: ±3 dB variation means 6 dB peak-to-peak total variation.
² Specification excludes variations due to crystal detector and directional coupler.
³ Specification excludes variations due to thermistor mount and directional coupler. Sweep time must be at least 10 seconds. Use HP 432A/B/C Power Meter.
⁴ For Option 008, less 1dB (power loss due to insertion loss of additional isolator).

DESCRIPTION:

Maximum leveled power is checked with internal leveling, crystal detector leveling, and power meter leveling. In each mode, the power variations are measured on the oscilloscope trace. The trace is calibrated by changing the RF output power by the amount of the specification as noted on the power meter and the corresponding change in trace on the oscilloscope. In external leveling modes, the leveling variations are monitored in the feedback loop, therefore no error exists in the measurement. However, the usable RF output power from the directional coupler does contain variations in power level due to the frequency response of the directional coupler and the crystal detector or the thermistor mount.

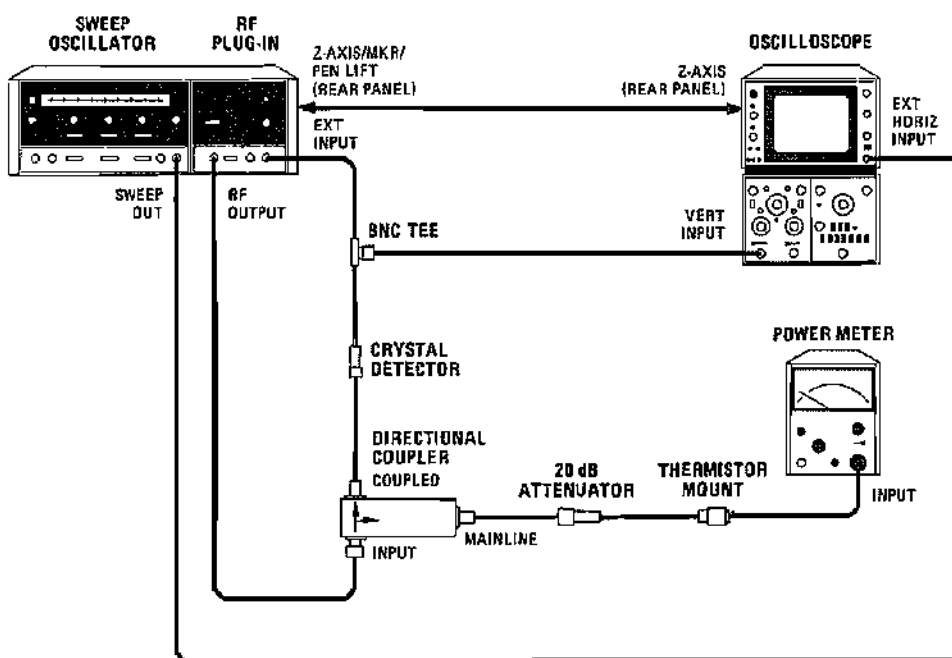

Figure 4-7. Crystal Detector Leveling Test Setup

PERFORMANCE TESTS

4-11. POWER LEVEL AND VARIATION TEST (Cont'd)**NOTE**

Equipment listed is for three test setups (Figure 4-7, 4-8 and 4-9).

EQUIPMENT:

Sweep Oscillator.....	HP 8620C
Power Meter	HP 432A
Thermistor Mount	HP 8478B
Oscilloscope	HP 180C/1801A/1820C
Crystal Detector.....	HP 423B
Directional Coupler	HP 779D
20 dB Attenuator.....	HP 8491B, Option 020

PROCEDURE:

External leveling with crystal detector:

- a. Connect equipment as shown in Figure 4-7. Set External Leveling Selector switch A3S2 to XTAL (Up) position. Selector switch A3S2 is located at top of A3 ALC Assembly. (Refer to Figure 5-1.)
- b. Set controls as follows:

8620C:

BAND	Frequency of Plug-in installed
CW MARKER pointer	Center-scale
ΔF Control	Fully counterclockwise
MODE	AUTO
TRIGGER.....	INT
TIME-SECONDS1 – .01
1 kHz SQ WV/OFF (rear panel)	OFF
RF BLANKING/OFF (rear panel)	OFF
DISPLAY BLANKING/OFF (rear panel)	DISPLAY BLANKING

RF Plug-in:

RF OFF-ON	ON
ALC switch.....	EXT
POWER LEVEL	Fully clockwise
ALC GAIN	Fully clockwise

- c. Press 8620C LINE pushbutton to ON; FULL SWEEP pushbutton should light. Allow 30 minutes warm-up time.
- d. Adjust RF Plug-in ALC GAIN and POWER LEVEL controls to obtain highest power meter indication with UNLEVELED light not lit. (If oscillations appear on trace, adjust ALC GAIN and POWER LEVEL controls counterclockwise as necessary to get a leveled trace. See Figures 3-5 through 3-7) Power meter indication plus loss of directional coupler should be $> +10.0$ dBm for 86242D/86250D or $> +17.0$ dBm for 86245A.

PERFORMANCE TESTS

4-11. POWER LEVEL AND VARIATION TEST (Cont'd)

- e. Press mainframe ΔF pushbutton. Adjust oscilloscope trace to bottom of display and note trace position. Decrease output power indication at power meter by 0.2 dB using RF Plug-in POWER LEVEL control. Note position of oscilloscope trace. (Area between two positions noted represents leveling tolerance of ± 0.1 dB.)
- f. Press mainframe FULL SWEEP pushbutton. Adjust RF Plug-in POWER LEVEL control fully clockwise, then counterclockwise until UNLEVELED Lamp goes out at maximum leveled power.
- g. Adjust position of oscilloscope trace vertically so it is displayed between upper and lower specification limits noted in step e. Highest and lowest portion of sweep trace must be within 0.2 dB peak-to-peak limit noted.

External leveling with power meter:

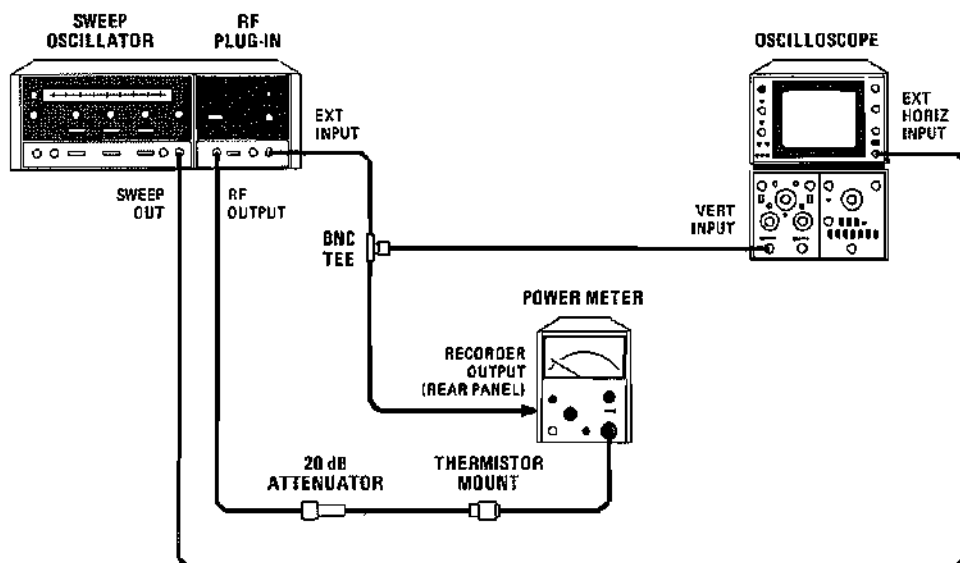

Figure 4-8. Power Meter Leveling Test Setup

- h. Connect equipment as shown in Figure 4-8. Set External Leveling Selector switch A3S2 to PM (Down) position. Selector switch A3S2 is located at top of A3 ALC Assembly. (Refer to Figure 5-1.)
- i. Set controls as follows:

8620C:

BAND	Frequency of Plug-in installed
CW MARKER pointer	Center-scale
MODE	AUTO
TRIGGER	INT

PERFORMANCE TESTS

4-11. POWER LEVEL AND VARIATION TEST (Cont'd)

TIME-SECONDS 100 — 10
 1 kHz SQ WV/OFF (rear panel) OFF
 RF BLANKING/OFF (rear panel) OFF
 DISPLAY BLANKING/OFF (rear panel) OFF

RF Plug-in:

RF OFF-ON ON
 ALC switch EXT
 POWER LEVEL Fully clockwise

NOTE

For power meter leveling, sweep rates slower than 10 sec per sweep should be used. The rate of leveling is dependent on the comparatively slow response of the thermistor mount to power level changes.

- j. Press mainframe FULL SWEEP pushbutton. Set power meter range to obtain meter indication in upper half of scale. Adjust RF Plug-in POWER LEVEL and ACL GAIN controls to obtain flat RF power level across the band as indicated on oscilloscope. (If loop oscillations occur on oscilloscope trace, turn ALC GAIN control in counterclockwise direction.)
- k. Adjust RF Plug-in POWER LEVEL control fully clockwise, then counterclockwise until UNLEVELED light goes out.
- l. Set mainframe MODE switch to MANUAL. Adjust MANUAL sweep control slowly through full range and note maximum and minimum power meter indications. Difference between maximum and minimum power meter indications should be >0.2 dB.

Internal Leveling (Option 001 only):

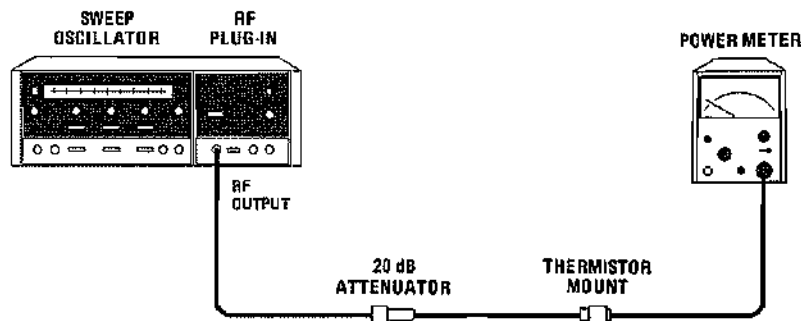

Figure 4-9. Internal Leveling Test Setup

PERFORMANCE TESTS

4-11. POWER LEVEL AND VARIATION TEST (Cont'd)

- m. Connect equipment as shown in Figure 4-9.
- n. Set controls as follows:

8620C:

BAND	Frequency of Plug-in installed
CW MARKER pointer	Center-scale
MARKERS	OFF
MODE	MANUAL
TRIGGER	INT
TIME-SECONDS1 - .01
1 kHz SQ WV/OFF (rear panel)	OFF
RF BLANKING/OFF (rear panel)	OFF
DISPLAY BLANKING/OFF (rear panel)	OFF
LINE	ON

RF Plug-in:

RF OFF-ON	ON
ALC switch	INT (Option 001)

- o. Adjust RF Plug-in POWER LEVEL and ALC controls for maximum leveled power. Adjust MANUAL sweep control slowly through full range and note maximum and minimum power meter indications. Difference between maximum and minimum power should be <1.0 dB for 86242D/86250D or <1.2 dB for 86245A.

4-12. HARMONIC SPURIOUS SIGNALS TEST

SPECIFICATION:

Spurious Signals (in dB below fundamental signal at specified maximum power):

Harmonics: 86242D/86250D: > 30 dB
 86245A: > 17 dB (5.9 — 7 GHz), > 30 dB (7 — 12.4 GHz)

DESCRIPTION:

The cutoff frequency of waveguide is utilized to provide a high pass filter. The high pass filter is placed in the B channel path of an HP 8755B Swept Amplitude Analyzer. The high pass filter passes harmonics but will not pass the fundamental signal. The A channel of the Swept Amplitude Analyzer is used to display the fundamental signal. The Swept Amplitude Analyzer displays the fundamental signal level and the harmonic signal level in a swept mode. The difference between the two levels displayed should be greater than 30 dB for the 86242D/86250D or greater than 17 dB from 5.9 to 7.0 GHz and greater than 30 dB for the 86245A. The harmonics for signals above 11.5 GHz cannot be measured unless a different high pass filter is employed.

PERFORMANCE TESTS

4-12. HARMONIC SPURIOUS SIGNALS TEST (Cont'd)

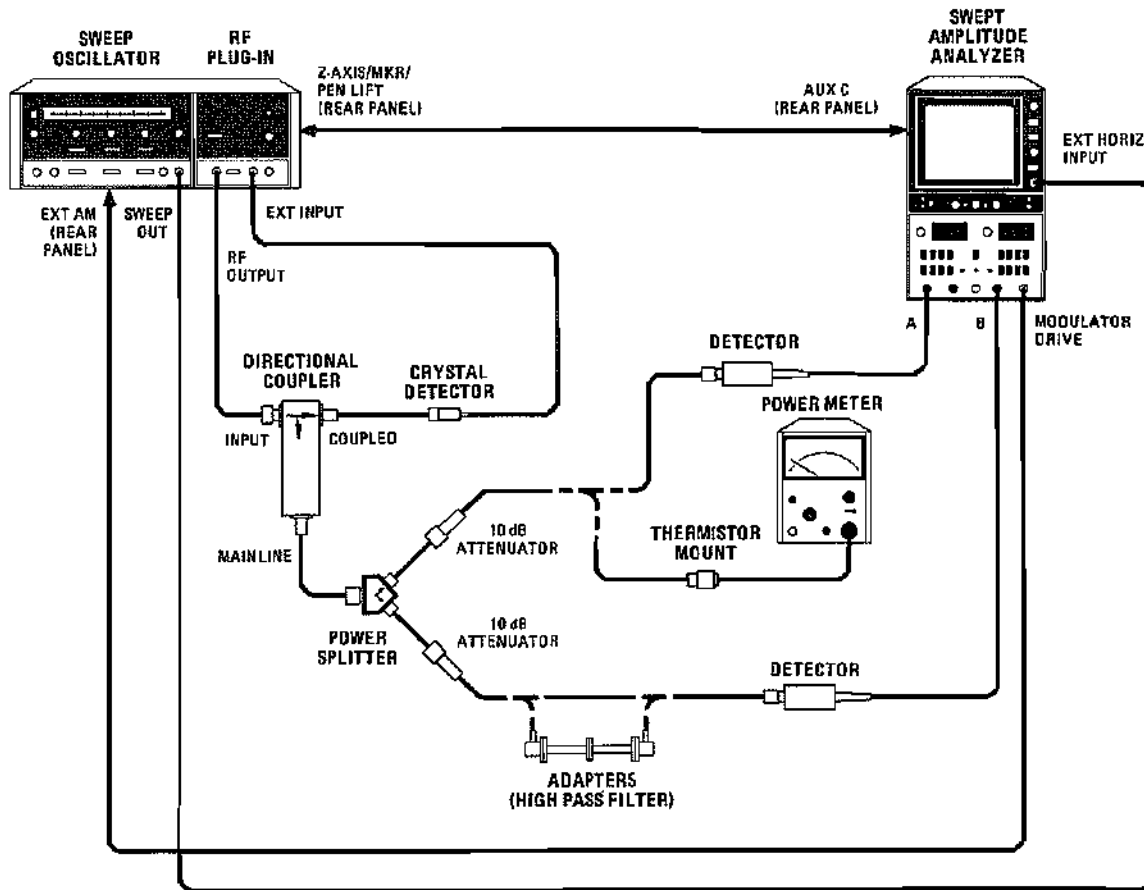

Figure 4-10. Harmonic Spurious Signals Test Setup

EQUIPMENT:

Sweep Oscillator	HP 8620C
Power Meter	HP 432A
Thermistor Mount	HP 8478B
Swept Amplitude Analyzer	HP 8755B/182T
Directional Coupler	HP 779D
Detector (2 required)	HP 11664A
Crystal Detector	HP 423B
10 dB Attenuator (2 required)	HP 8491B, Option 010
Adapter, N to P (2 required)	HP NP292A
Adapter, P to N to Coax (2 required)	HP P281B, Option 013
Power Splitter	HP 11667A

PERFORMANCE TESTS

4-12. HARMONIC SPURIOUS SIGNALS TEST (Cont'd)

- h. Connect adapters (high pass filter) between 10 dB attenuator and detector as shown in Figure 4-10.
- i. Harmonics should be greater than 30 dB down (from display A reference line) for 86242D/86250D or greater than 17 dB down from 5.9 GHz to 7 GHz and greater than 30 dB down from 7 GHz to 11.5 GHz for 86245A.
- j. If harmonics do not appear to be within specification, check at frequencies in question with 8620C in CW mode. Calibrate 8755B at each frequency point measured.

4-13. NONHARMONIC SPURIOUS SIGNALS TEST

SPECIFICATION:

Spurious Signals (in dB below fundamental signal at specified maximum power):

Nonharmonics: > 60 dB

DESCRIPTION:

RF output signal from sweep oscillator is displayed on a spectrum analyzer to verify that nonharmonic spurious signals are greater than 60 dB down from fundamental signal.

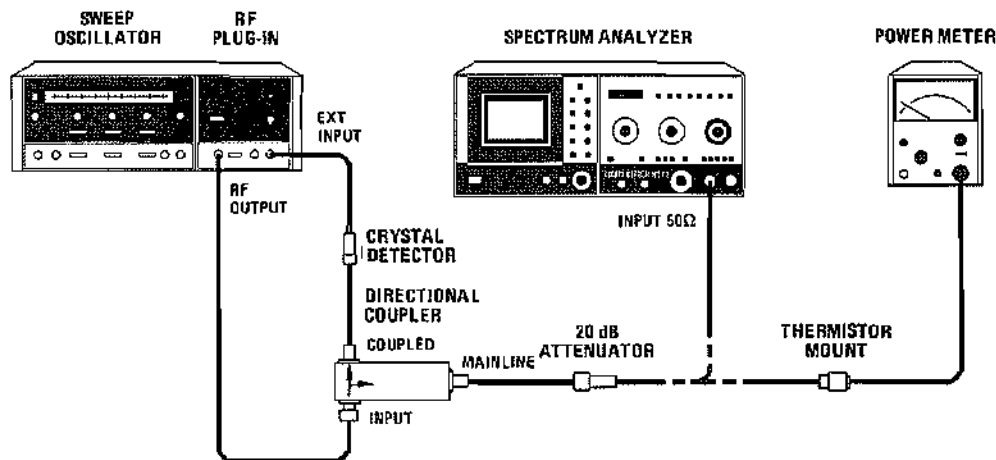

Figure 4-11. Nonharmonic Spurious Signals Test Setup

EQUIPMENT:

Sweep Oscillator	HP 8620C
Spectrum Analyzer	HP 8565A
Power Meter	HP 432A
Thermistor Mount	HP 8478B
20 dB Attenuator	HP 8491B, Option 020
Crystal Detector	HP 779D
	HP 423B

PERFORMANCE TESTS

4-14. RESIDUAL AM TEST

SPECIFICATION:

Residual AM (AM noise in 100 kHz Bandwidth below carrier at specified maximum power): ≥ 50 dB

DESCRIPTION:

RF Output signal from RF Plug-in is amplitude modulated with square wave from 8620C. This modulated signal is used to establish a reference on HP Model 3400A RMS Voltmeter that is 9 dB below actual carrier signal. The 9 dB reduction occurs because of voltmeter response to square wave and square-law response of crystal detector. Modulation is then removed and magnitude of Residual AM component is measured with respect to established reference.

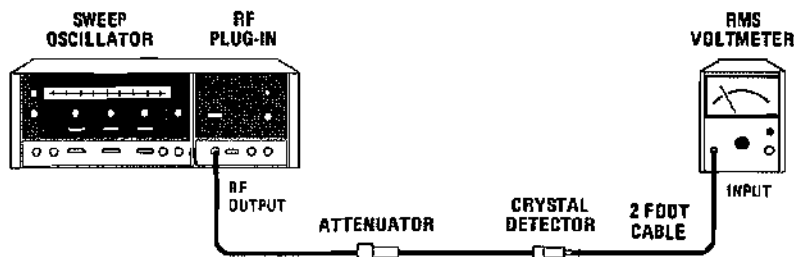

Figure 4-12. Residual AM Test Setup

EQUIPMENT:

- Sweep Oscillator HP 8620C
- RMS Voltmeter HP 3400A
- Attenuator Refer to PROCEDURE
- Crystal Detector HP 423B
- Two-foot cable (Limits bandwidth to approximately 100 kHz) HP 11086A

PROCEDURE:

a. Set controls as follows:

8620C:

- BAND Frequency of Plug-in installed
- CW MARKER pointer Center-scale
- 1 kHz SQ WV/OFF (rear panel) OFF
- RF BLANKING/OFF (rear panel) RF BLANKING
- DISPLAY BLANKING/OFF (rear panel) OFF

PERFORMANCE TESTS

4-14. RESIDUAL AM TEST (Cont'd)

RF Plug-in:

RF OFF-ON ON
 ALC switch INT or OFF
 POWER LEVEL Fully clockwise

- b. Press 8620C LINE Pushbutton to ON. Press CW pushbutton. Allow 30 minutes warm-up time.

NOTE

A 41 dB decrease in the RMS voltmeter indication corresponds to a 50-dB reduction in signal level. A correction factor of 9 dB is added because of the RMS voltmeter response to a square wave and the square-law response of the crystal detector.

- c. Using a power meter, thermistor mount, and 20 dB attenuator, set the POWER LEVEL control at specified maximum power for RF Plug-in. Disconnect power meter/thermistor mount from 20 dB attenuator. Set 8620C rear-panel 1 kHz SQ WV/OFF switch to 1 kHz SQ WV.
- d. Connect equipment as shown in Figure 4-12 using 20 dB attenuator. Note reading on RMS voltmeter.
- e. Select less or greater attenuation using 3 dB, 6 dB, and 10 dB attenuators until reading on RMS voltmeter is $-28 \text{ dB} \pm 3 \text{ dB}$. Note voltmeter reading.
- f. Set 8620C rear-panel 1 kHz SQ WV/OFF switch to OFF. Change RMS voltmeter range switch to obtain on-scale indication. Difference between this indication and indication noted in step e should be a minimum of 41 dB.

4-15. EQUIVALENT SOURCE SWR TEST (Option 001 ONLY)

SPECIFICATION:

Source SWR:

Leveled: (Option 001 only): < 1.6

DESCRIPTION:

The RF Output signal is measured using a directional coupler, crystal detector, and oscilloscope. The signal at the oscilloscope contains (1) the initial signal from the oscillator, and (2) the reflected signal. The reflected signal is developed as follows: The original oscillator signal travels down the 20-cm air lines, encounters the open end, and is reflected back to the source. If the reflected signal at the RF OUTPUT connector encounters a perfect 50-ohm source match, no signal is reflected back. However, the greater the mismatch, the greater the reflected signal. This reflected signal either adds to or subtracts from the incident oscillator signal. This variation of the oscillator signal is displayed on the oscilloscope.

PERFORMANCE TESTS

4-15. EQUIVALENT SOURCE SWR TEST (Option 001 ONLY) (Cont'd)

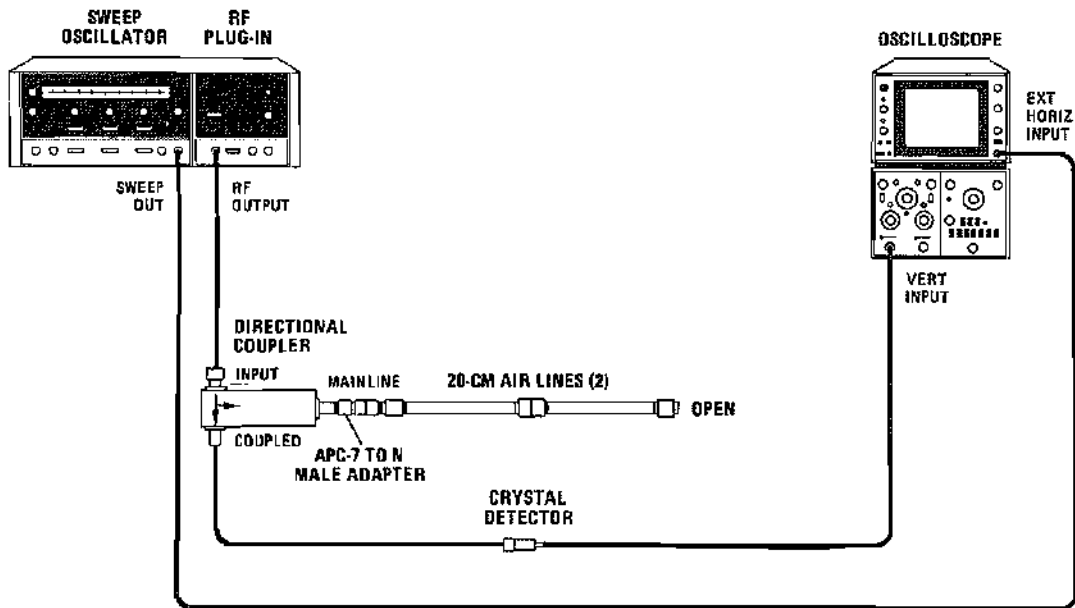

Figure 4-13. Equivalent Source SWR Test Setup

EQUIPMENT:

Sweep Oscillator	HP 8620C
Oscilloscope	HP 180C/1801A/1820C
Crystal Detector	HP 423B
20-cm Air Lines (2 required)	HP11567A
APC-7 to N Male Adapter	HP 11525A
Directional Coupler	HP 779D

PROCEDURE:

- a. Connect equipment as shown in Figure 4-13.
- b. Set controls as follows:

8620C:

BAND	Frequency of Plug-in installed
MARKERS	OFF
MODE	AUTO
TRIGGER	INT
TIME-SECONDS1 — .01
TIME—SECONDS Vernier	Fully clockwise
1 kHz SQ WV/OFF (rear panel)	OFF
APC-7 TO N MALE ADAPTER (rear panel)	RF BLANKING
DISPLAY BLANKING/OFF (rear panel)	OFF

PERFORMANCE TESTS

4-15. EQUIVALENT SOURCE SWR TEST (Option 001 ONLY) (Cont'd)

RF Plug-in:

RF OFF-ON ON
 ALC switch INT (Option 001)
 POWER LEVEL Fully clockwise

- c. Press 8620C LINE pushbutton to ON; FULL SWEEP pushbutton should light. Allow 30 minutes warm-up time.
- d. Note maximum amplitude on oscilloscope. If greater than -25 mV, adjust POWER LEVEL control counterclockwise for -25 mV maximum peak trace to place crystal detector in square-law output range. (Display should be similar to that shown in Figure 4-14.)
- e. Select points on trace where V_{max} and V_{min} appear to have greatest separation and calculate V_{max}/V_{min} for each point.
- f. Convert greatest V_{max}/V_{min} ratio noted in step e into source match SWR using Figure 4-15.
- g. In internal leveling mode, source match SWR should be < 1.6 .

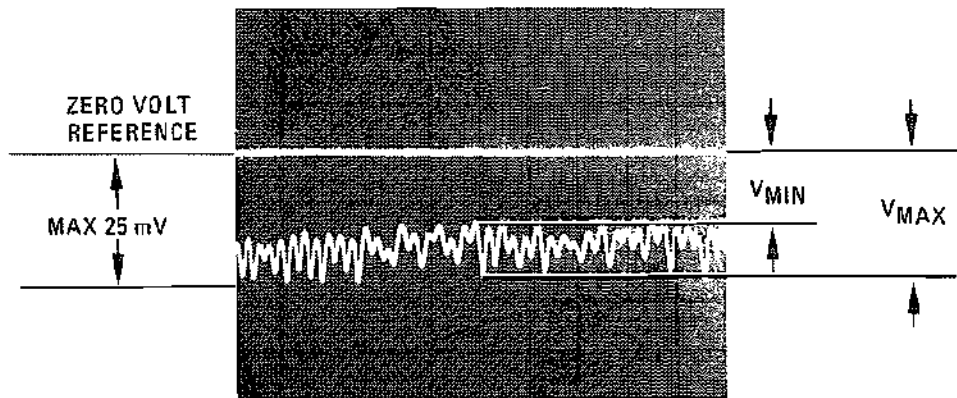
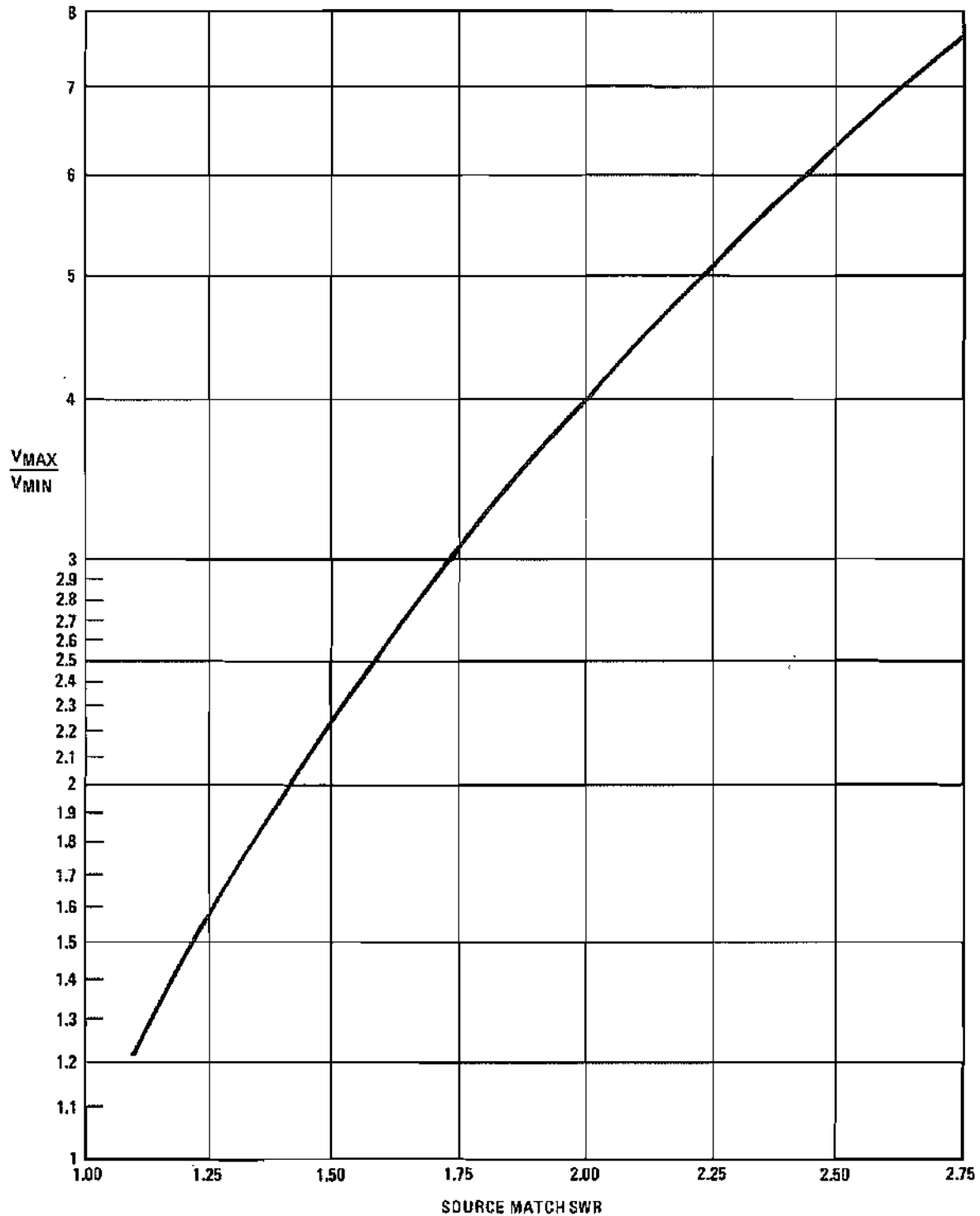

Figure 4-14. Typical Pattern of a Swept SWR Measurement.

PERFORMANCE TESTS

4-15. EQUIVALENT SOURCE SWR TEST (Option 001 ONLY) (Cont'd)



www.valuetronics.com

Figure 4-15. Conversion of Oscilloscope Trace to Source Match SWR

PERFORMANCE TESTS

4-16. EXTERNAL FREQUENCY MODULATION TEST

SPECIFICATION:

External FM: (FM-NORM-PL switch in FM position):

Maximum Deviation for Modulation Frequencies:

- DC to 100 Hz (all instruments): ± 150 MHz
- DC to 1 kHz (Option 008 excluded): ± 15 MHz
- DC to 2 MHz (Option 008 excluded): ± 5 MHz
- 90 kHz to 1 MHz (Option 008 only): ± 7 MHz
- 90 kHz to 5 MHz (Option 008 only): ± 5 MHz
- 90 kHz to 10 MHz (Option 008 only): ± 1.5 MHz

DESCRIPTION:

RF Output is modulated with an external signal source. The resulting FM deviation is displayed on a spectrum analyzer. Deviations up to 1 kHz are measured directly on spectrum analyzer. Deviations from 1 MHz to 10 MHz are calculated using the Bessel null method.

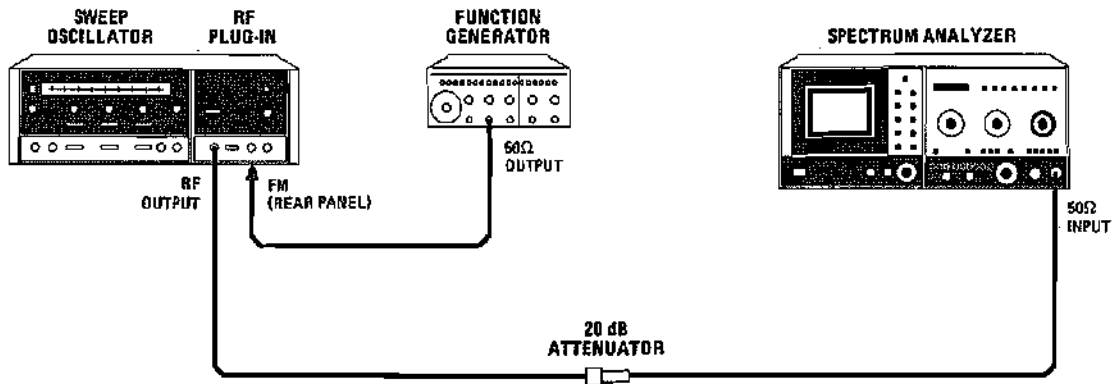

Figure 4-16. External Frequency Modulation Test Setup

EQUIPMENT:

Sweep Oscillator	HP 8620C
Spectrum Analyzer	HP 8565A
20 dB Attenuator	HP 3312A
	HP 8491B, Opt. 020

PERFORMANCE TESTS

4-16. EXTERNAL FREQUENCY MODULATION TEST (Cont'd)**NOTE**

If Option 008 (MLA upconverter) is installed, proceed to step o.

- f. Set function generator amplitude fully counterclockwise and frequency to 1 kHz.
- g. Adjust function generator amplitude control slowly clockwise while monitoring display on spectrum analyzer.
- h. Note point at which deviation becomes non-linear (+deviation does not equal -deviation). Deviation at this point should be at least ± 15 MHz.
- i. Set function generator amplitude fully counterclockwise and frequency to 2 MHz.
- j. Remove BNC cable from function generator 50 Ω output.
- k. Set spectrum analyzer amplitude scale to 10 dB per division and adjust reference level controls so signal displayed touches top graticule line.
- l. Reconnect FM input to function generator 50 Ω output.
- m. Increase function generator amplitude control while monitoring spectrum analyzer display. Sidebands will appear and carrier amplitude will start to decrease. Increase function generator amplitude until carrier reaches its first null.
- n. Point noted in step m is point of 5 MHz deviation. There should be no great frequency shift or frequency pulling at this point. (Refer to Figure 4-18a.)

Option 008 only

- o. Set function generator amplitude fully counterclockwise and frequency to 1 MHz.
- p. Remove BNC cable from function generator 50 Ω output.
- q. Set spectrum analyzer amplitude scale to 2 dB per division and adjust reference level controls so signal displayed touches top graticule line.
- r. Reconnect FM input to function generator 50 Ω output.
- s. Increase function generator amplitude control while monitoring spectrum analyzer display. Sidebands will appear and carrier amplitude will start to decrease. Increase function generator amplitude through two carrier nulls and up to next peak.
- t. Point noted in step s is point of 7 MHz deviation. There should be no great frequency shift or frequency pulling at this point. (Refer to Figure 4-18b.)
- u. Set function generator amplitude fully counterclockwise and frequency to 5 MHz.
- v. Remove BNC cable from function generator 50 Ω output.

PERFORMANCE TESTS

4-16. EXTERNAL FREQUENCY MODULATION TEST (Cont'd)

- w. Set spectrum analyzer amplitude scale to 2 dB per division and adjust reference level controls so signal displayed touches top graticule line.
- x. Reconnect FM input to function generator 50 Ω output.
- y. Increase function generator amplitude control until a frequency pulling of the carrier signal is observed on spectrum analyzer.
- z. Amplitude of carrier must have changed by more than 3 dB from established reference of step w at this point. (Refer to Figure 4-18c.)
- aa. Repeat steps u through z for function generator frequency of 10 MHz and spectrum analyzer in 10 dB per division.
- ab. At point of frequency pulling of carrier signal, closest sidebands must be less than 22 dB down from carrier signal. (Refer to Figure 4-18d.)

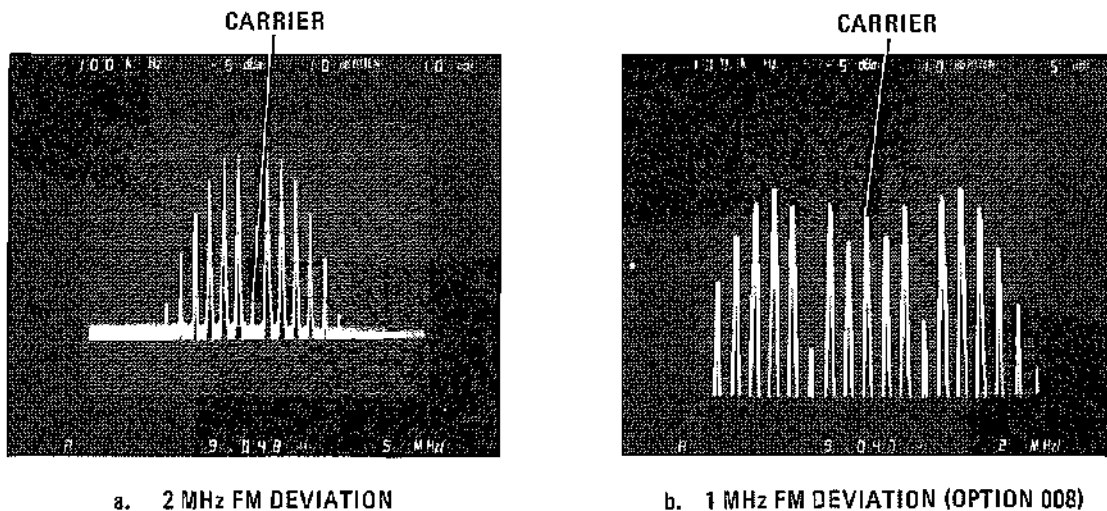

Figure 4-18. Spectrum Analyzer Display of Frequency Deviation (1 of 2)

PERFORMANCE TESTS

4-16. EXTERNAL FREQUENCY MODULATION TEST (Cont'd)

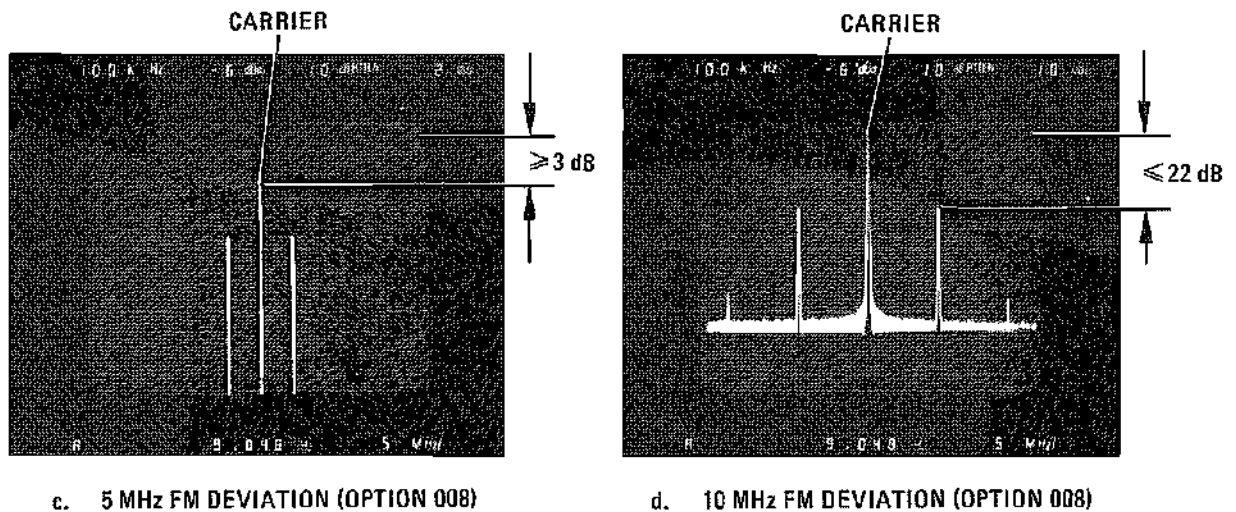

Figure 4-18. Spectrum Analyzer Display of Frequency Deviation (2 of 2)

4-17. AMPLITUDE MODULATION TEST

SPECIFICATION:

INTERNAL AM: (Below maximum leveled power):

1 kHz square wave, RF Blanking, and Marker ON/OFF ratio: < 40 dB

EXTERNAL AM (LINEAR-SQ WAVE switch in SQ WAVE position):

Symmetry: 40/60

ON/OFF Ratio: (> +5 Volt input): > 40 dB down from specified maximum power.

DESCRIPTION:

Attenuation is checked by applying +5.0 Vdc and observing corresponding decrease in RF Output power (40 dB below maximum leveled power). ON/OFF ratio is checked for both internal AM and external AM. Symmetry is checked for external AM to verify compatibility with HP 8755A/B Swept Amplitude Analyzer.

PERFORMANCE TESTS

4-17. AMPLITUDE MODUATION TEST (Cont'd)

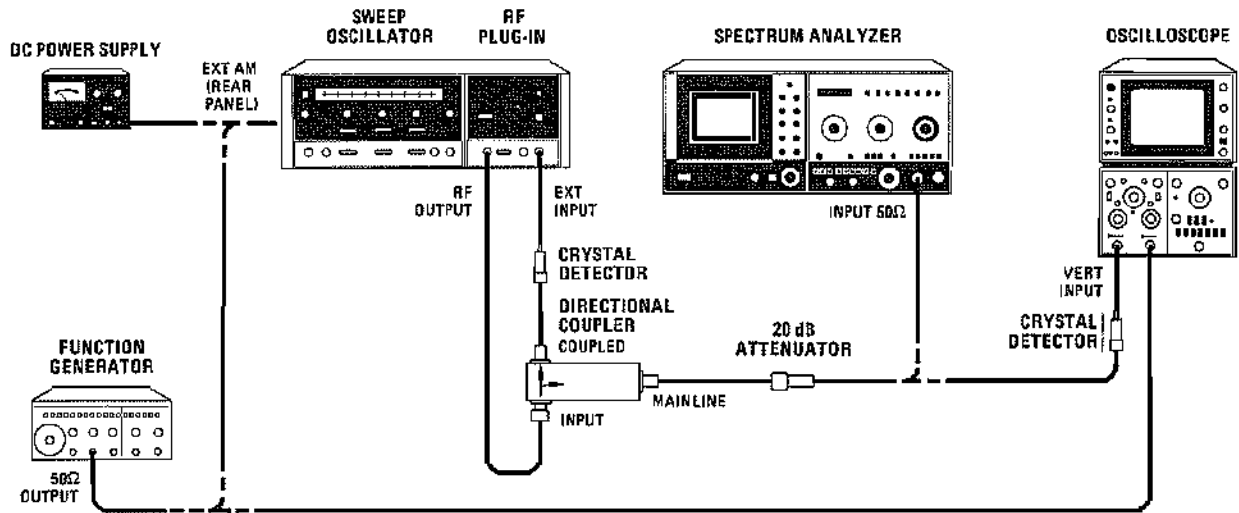

Figure 4-19. Amplitude Modulation Test Setup

EQUIPMENT:

Sweep Oscillator	HP 8620C
Function Generator	HP 3312A
Spectrum Analyzer	HP 8565A
Oscilloscope	HP 180C/1801A/1820C
DC Power Supply	HP 6214A
Crystal Detector (2 required)	HP 423B
Directional Coupler	HP 779D
20 dB Attenuator	HP 8491B, Option 020

PROCEDURE:

- a. Connect equipment as shown in Figure 4-19 with spectrum analyzer connected to 20 dB attenuator and power supply connected to rear panel EXT AM connector.

- b. Set controls as follows:

8620C:

BAND	Frequency of Plug-in installed
CW MARKER pointer	Center-scale
MARKERS	OFF
RF BLANKING/OFF (rear panel)	RF BLANKING
RF BLANKING/OFF (rear panel)	OFF
DISPLAY BLANKING/OFF (rear panel)	OFF

PERFORMANCE TESTS

4-17. AMPLITUDE MODULATION TEST (Cont'd)

RF Plug-in:
 RF-OFF-ON..... ON
 ALC switch..... INT or OFF
 POWER LEVEL..... Fully clockwise (Standard)
 Maximum leveled power (Option 001)

- c. Set power supply for zero volt output. Press 8620C LINE pushbutton to ON. Press CW pushbutton. Allow 30 minutes warm-up time.
- d. Set spectrum analyzer controls as follows:

FREQUENCY BAND GHz..... 5.8 — 12.9
 RESOLUTION BW..... 10 kHz
 FREQUENCY SPAN/DIV..... 20 MHz
 INPUT ATTENUATION..... 10 dB
 SWEEP TIME/DIV..... 5mSEC
 REF LEVEL..... 0 dBm
 AMPLITUDE SCALE..... 10 dB LOG/DIV
 VIDEO FILTER..... OFF
 SWEEP SOURCE..... INT

External AM Sensitivity Checks:

- e. Note signal level of fundamental frequency displayed on spectrum analyzer. This is reference level for test.
- f. Adjust external power supply for +5.0 Vdc output. Output power, as observed on spectrum analyzer, should be >40 dB below reference.
- g. Disconnect external power supply from 8620C rear-panel EXT AM connector.

27.8 kHz Square Wave External AM:

- h. Set controls as follows:

8620C:
 START MARKER pointer..... Low frequency end of scale
 STOP MARKER pointer..... High frequency end of scale
 MODE..... AUTO
 TIME-SECONDS..... .1 — .01
 TIME-SECONDS Vernier..... Fully clockwise
 1 kHz SQ WV/OFF (rear panel)..... OFF

RF Plug-in:
 RF OFF-ON..... ON
 ALC switch..... EXT
 POWER LEVEL..... Maximum Leveled Power

PERFORMANCE TESTS

4-17. AMPLITUDE MODULATION TEST (Cont'd)**8565A:**

FREQUENCY BAND GHz..... 5.8 — 12.9
 RESOLUTION BW..... 3 MHz
 INPUT ATTENUATION..... 10 dB
 SWEEP TIME/DIV..... 5 mSEC
 REF LEVEL..... 0 dBm
 AMPLITUDE SCALE..... 10 dB LOG/DIV
 FREQUENCY SPAN MODE..... ZERO SPAN
 AUTO STABILIZER..... OFF

- i. Connect function generator to 8620C EXT AM input and CH B input of oscilloscope as shown in Figure 4-19. Set function generator for 27.8 kHz and adjust for 6V peak-to-peak output as shown on CH B of oscilloscope. Connect VERTICAL OUTPUT from spectrum analyzer (rear panel) to CH A input of oscilloscope.
 - j. Set the oscilloscope (CH A) to 0.1 volt per division with an internal horizontal sweep time of 10 μ s per division. Calibrate oscilloscope for 10 dB per division vertical sensitivity as follows:
 1. Adjust 8565A TUNING control for maximum signal amplitude on spectrum analyzer display. Set REF LEVEL controls to place signal at top graticule line.
 2. Set oscilloscope to position top of square wave one division down from top graticule line on oscilloscope display.
 3. Adjust 8565A TUNING control to position signal one division down from top graticule line on spectrum analyzer display. Top of square wave should be at two divisions down from top graticule line on oscilloscope display. If not, adjust oscilloscope vertical sensitivity vernier and repeat steps j-1 through j-3.
 4. Adjust 8565A TUNING control to return signal to top graticule line of spectrum analyzer display.
 - k. Note difference in power levels of ON and OFF periods as shown on oscilloscope (CH A). ON/OFF ratio should be >40 dB (four divisions).
 - l. Disconnect spectrum analyzer from RF Plug-in. Connect oscilloscope and crystal detector to 20 dB attenuator as shown in Figure 4-19.
 - m. Observe ON period to OFF period ratio on CH A of oscilloscope. ON/OFF symmetry should be >40/60.
- 1 kHz Square Wave Internal AM:*
- n. Disconnect function generator from 8620C EXT AM input. Set 8620C rear panel 1 kHz SQ WV/OFF switch to 1 kHz SQ WV.
 - o. Connect spectrum analyzer as shown in Figure 4-19 and set controls same as in step h except set REF LEVEL controls to place signal at top graticule line. Adjust 8565A TUNING control for maximum signal amplitude on spectrum analyzer display. Set REF LEVEL controls to place signal at top graticule line.

PERFORMANCE TESTS

4-17. AMPLITUDE MODULATION TEST (Cont'd)

- p. Press 8565A SWEEP TRIGGER VIDEO pushbutton and adjust TRIGGER LEVEL as necessary. Note Maximum and Minimum power levels displayed on spectrum analyzer (ON and OFF periods). ON/OFF ratio should be >40 dB.

4-18. FM FREQUENCY RESPONSE TEST

SPECIFICATION:

External FM: (FM-NORM-PL switch in FM or MLA position):

- FM Frequency Response:
 - DC to 2 MHz: ± 1.5 dB
 - DC to 100 Hz (Option 008): ± 1.5 dB
 - 90 kHz to 10 MHz (Option 008): ± 1.5 dB

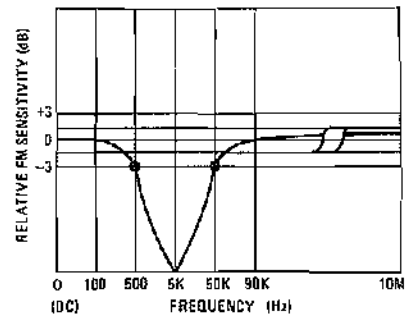

FM FREQUENCY RESPONSE, OPTION 008

DESCRIPTION:

FM deviation of the RF Plug-in is compared to a known voltage reference using an FM discriminator and the difference is measured with an oscilloscope. Since the oscilloscope is calibrated so four divisions equals 100 percent, each minor division equals five percent. Approximately ± 17 percent equals ± 1.5 dB.

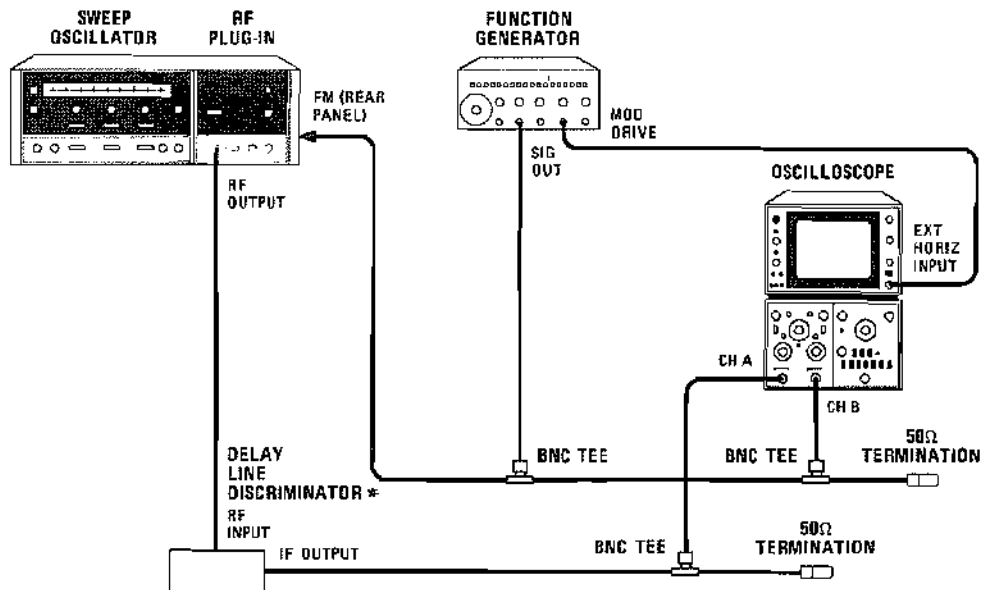

* REFER TO FIGURE 1-5 FOR DETAILS

Figure 4-20. FM Frequency Response Test Setup

PERFORMANCE TESTS

4-18. FM FREQUENCY RESPONSE TEST (Cont'd)**EQUIPMENT:**

Sweep Oscillator	HP 8620C
Oscilloscope	HP 180C/1801A/1820C
Function Generator	HP 3312A
10 dB Attenuator	HP 8491B, Option 010
Delay Line Discriminator	(Refer to Figure 1-5)

PROCEDURE:

- a. Connect equipment as shown in Figure 4-20.
- b. Set controls as follows:

8620C:

CW MARKER pointer	Center-scale
RF BLANKING/OFF (rear panel)	OFF
DISPLAY BLANKING/OFF (rear panel)	OFF
1 kHz SQ WV/OFF (rear panel)	OFF

RF Plug-in:

RF OFF-ON	ON
ALC switch	INT (Option 001) OFF (Standard)
POWER LEVEL	Fully clockwise
FM-NORM-PL switch (rear panel)	NORM

Oscilloscope:

Horizontal Display	EXT
Volts/per Division	
CH A	0.005 (CAL)
CH B	0.02 (CAL)
Vertical Display	CH B
Input	DC

Function Generator:

Range	100 Hz (Option 008 excluded) 100 kHz (Option 008)
Function	~
Frequency	10
Modulation	SWP
SYM	CAL
Offset	CAL
SWP START	Fully counterclockwise

- c. Press 8620C LINE pushbutton to ON. Allow 30 minutes warm-up time.

www.valuetronics.com

- d. Press 8620C CW and CW VERNIER pushbuttons.
-

PERFORMANCE TESTS

4-18. FM FREQUENCY RESPONSE TEST (Cont'd)

- e. Adjust function generator amplitude control for 8 divisions display on oscilloscope.
- f. Select CH A display on oscilloscope.
- g. Center signal on oscilloscope using CW MARKER and CW VERNIER controls.
- h. Using POWER LEVEL, CW MARKER and CW VERNIER controls, adjust oscilloscope display for 4 divisions centered about 0 volts.
- i. Select CH B display on oscilloscope.
- j. Using vertical position and VOLTS/DIV CAL knob, adjust oscilloscope display for 4 divisions centered about 0 volts.
- k. Select CHOP display on oscilloscope. Set function generator SWP START control to 2 o'clock position.

RF Plug-ins without Option 008 (Proceed to step o for Option 008):

- l. In sequence, press the 1 kHz through 100 kHz Range pushbuttons on function generator. In each position, adjust the two superimposed waveforms (using vertical position controls) so that they are aligned at the bottom edge at point where measuring. (See Figure 4-21a and 4-21b.)
- m. CH A waveform should not be more than 3 1/2 minor divisions higher or lower than CH B waveform. This indicates ± 17 percent since 4 major divisions equals 100 percent (5 percent per minor division).

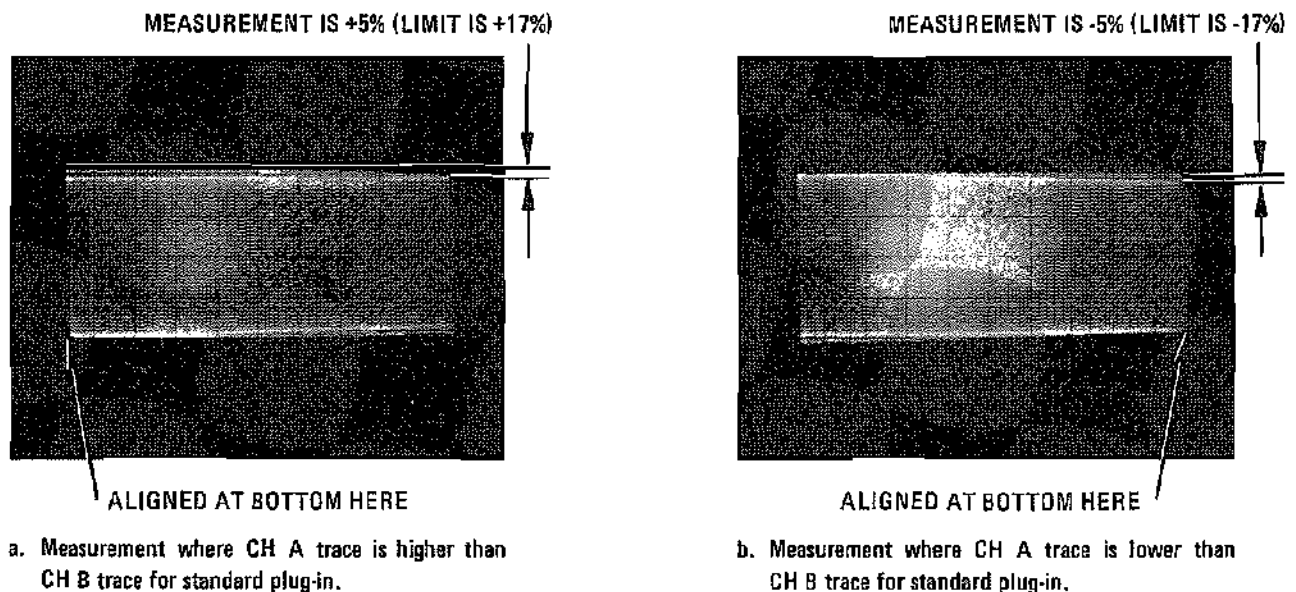

PERFORMANCE TESTS

4-18. FM FREQUENCY RESPONSE TEST (Cont'd)

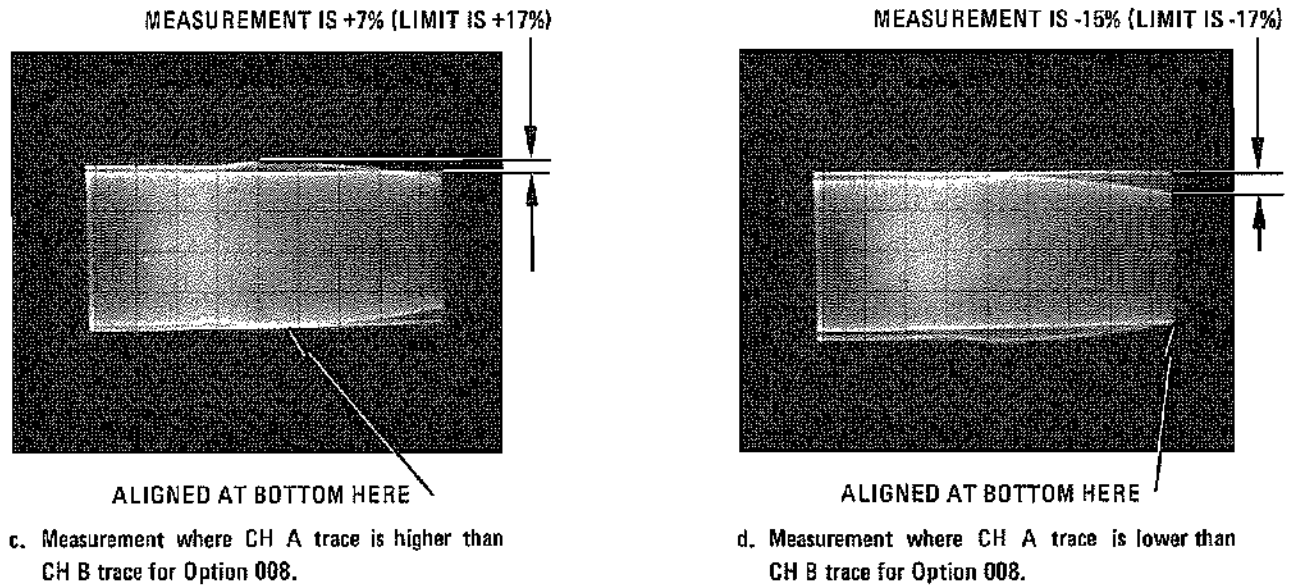

Figure 4-21. FM Frequency Response Waveform (2 of 2)

- n. Set function generator frequency control to 2 and press 1 MHz range pushbutton. Adjust two superimposed waveforms (using vertical position controls) so that they are aligned at bottom edge at point where measuring. (See Figure 4-21a and 4-21b.) Results should be same as in step m.

RF Plug-ins with Option 008:

- o. Adjust two superimposed waveforms (using vertical position controls) so that they are aligned at bottom edge at point where measuring. (See Figure 4-21c and 4-21d.) Results should be the same as in step m.
- p. Press function generator 1 MHz range pushbutton and repeat step o.

4-19. UPCONVERTER SIMULATION TEST (OPTION 008 ONLY)

SPECIFICATION:

Across 30 MHz sweep width:

- Linearity at 277 kHz: $\leq 0.5\%$
- Group Delay at 277 kHz: $\leq 1\text{ns}$
- Differential Gain at 5.6 MHz: $\leq 0.5\%$
- Differential Phase at 5.6 MHz: ≤ 1 degree

Across 50 Mhz sweep width

- Linearity at 277 kHz: $\leq 0.83\%$
- Group delay at 277 kHz: ≤ 1.7 ns
- Differential Gain at 5.6 MHz: $\leq 0.83\%$
- Differential Phase at 5.6 MHz: ≤ 1.7 degrees

PERFORMANCE TESTS

4-19. UPCONVERTER SIMULATION TEST (OPTION 008 ONLY) (Cont'd)

DESCRIPTION:

The RF Plug-in is connected as part of a Microwave Link Analyzer (MLA) system and the MLA is used to check upconverter simulation.

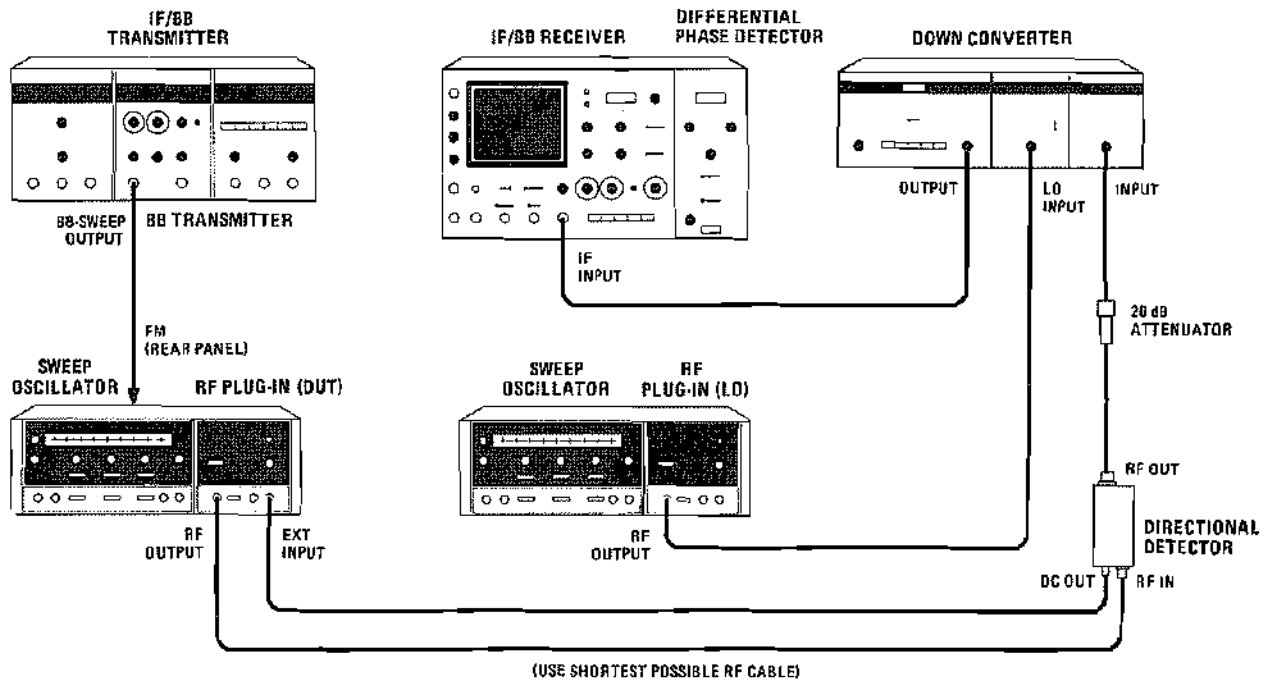

Figure 4-22. Upconverter Simulation Test Setup

EQUIPMENT:

Sweep Oscillator (2 required)	HP 8620C
RF Plug-in	HP 86245A
IF/BB Transmitter	HP 3710A
BB/Transmitter (Plug-in)	HP 3716A, Option 010
IF/BB Receiver	HP 3702B
Differential Phase Detector (Plug-in)	HP 3705A, Option 010
Down Converter	HP 3730A
External LO Plug-in	HP 37301A
Directional Detector	HP 784B
20 dB Attenuator	HP 8491B, Option 020

a. Connect equipment as shown in Figure 4-22.

b. Set controls as follows:

8620C: (DUT):

www.valuetronics.com	Frequency of Plug-in installed
CW MARKER pointer	Center-scale

PERFORMANCE TESTS

4-19. UPCONVERTER SIMULATION TEST (OPTION 008 ONLY) (Cont'd)

RF BLANKING/OFF (rear panel)	OFF
DISPLAY BLANKING/OFF (rear panel)	OFF
1 kHz SQ WV/OFF (rear panel)	OFF
RF Plug-in: (DUT):	
RF OFF-ON	ON
ALC switch	INT or OFF
POWER LEVEL	Midrange
MLA-NORM switch (rear panel)	MLA
8620C (LO)	
BAND	5.9 — 12.4 GHz
CW MARKER pointer	Center-scale
RF BLANKING/OFF (rear panel)	OFF
DISPLAY BLANKING/OFF (rear panel)	OFF
1 kHz SQ WV/OFF (rear panel)	OFF
86245A (LO)	
RF OFF-ON	ON
ALC switch	INT (Option 001) OFF (Standard)
POWER LEVEL	Fully clockwise
3702B/3705A Option 010:	
INTENSITY	Midrange
BLANKING	ON
CALIBRATION	OFF
SWEEP SOURCE	INT IF
X POSITION	Mid-position
Y1 GAIN/POSITION	Mid-position
Y2 GAIN/POSITION	Mid-position
BB POWER (- dBm)	20
Y1 DISPLAY	IF
Y2 DISPLAY	IF
Y1 Y2 CALIBRATION	OFF
MARKERS	SLIDING (no COMB)
MARKER OFFSET	Fully counterclockwise
IF ATTENUATOR	16 dB
SET LEVEL	Mid-position
BB FREQUENCY	277Δ kHz
DIFF PHASE CALIBRATION	OFF
BANDWIDTH (kHz)	1
3710A/3716A Option 010:	
SWEEPER	INT
OUTPUT LEVEL	1
BB POWER - dBm	18
SWEEP CAL	Fully counterclockwise
BB FREQUENCY	CAL
BB FREQUENCY	277Δ kHz

PERFORMANCE TESTS

4-19. UPCONVERTER SIMULATION TEST (OPTION 008 ONLY) (Cont'd)

- c. Press LINE Pushbutton to ON and press CW pushbutton on both 8620C mainframes. Allow 30 minutes warm-up time.

MLA Calibration:

- d. Set 3730A Down Converter AFC switch to OFF and press IF ATTENUATOR 10 dB pushbutton. Tune the 8620C (LO) for an indication of 70 on the 3730A IF CENTRE MHz meter.

NOTE

If the 3730A EXCESS LEVEL light is lit, reduce RF plug-in POWER LEVEL until light goes out.

- e. Set 3730A Down Converter AFC switch to ON then OFF; IF CENTRE MHz meter indication should stay at 70. If the IF CENTRE MHz meter indication changes, the 8620C (LO) is tuned to an image frequency (twice the IF frequency from the RF input frequency); tune the 8620C (LO) to a different frequency and repeat steps d and e.
- f. Adjust RF Plug-in POWER LEVEL for a 0 dB indication on the 3702B IF/BB Receiver IF/BB LEVEL meter. The 3702B IF UNCAL light should not be lit. If necessary, change IF ATTENUATION setting for correct indication.
- g. Set 3702B Y1 DISPLAY switch to BB and adjust the 3716A BB + SWEEP OUTPUT VERNIER for a 0 dB indication on the 3702B IF/BB LEVEL meter. If necessary, change 3716A B-B POWER attenuator setting to obtain correct meter indication.
- h. Adjust 3705A PHASE LOCK control for a full right deflection of the PHASE LOCK/LEVEL meter pointer.
- i. Adjust 3705A SET LEVEL control to center the PHASE LOCK/LEVEL meter indication in the green region.
- j. Repeat steps h and i until no further adjustment is necessary.
- k. Adjust 3702B X GAIN and X POSITION controls for a 10-division wide CRT trace horizontally centered on the graticule display.

NOTE

The following procedures measure linearity, group delay, differential gain, and differential phase of the RF Plug-in output at only one CW frequency ± 15 MHz and ± 25 MHz. These procedures should be repeated for each narrow band of interest.

Linearity:

www.valuetronics.com

1. Set 3702B MARKER OFFSET switch to ± 15 MHz (30 MHz sweep width).

PERFORMANCE TESTS

4-19. UP CONVERTER SIMULATION TEST (OPTION 008 ONLY) (Cont'd)

- m. Adjust 3716A SWEEP CAL control to place the plus and minus 15 MHz markers at each edge of the CRT graticule display.
- n. Set the 3702B BLANKING switch to OFF and adjust X PHASE SHIFT control so the normal trace and retrace marker pulses coincide. Reset BLANKING switch to the ON position.
- o. Set 3702B Y1 Y2 CALIBRATION switch to 1% position and adjust Y1 GAIN control for a one division envelope on CRT display. Reset Y1 Y2 CALIBRATION switch to the OFF position.
- p. Note worst point of linearity and slope of trace. (Downward slope from left to right is negative (–) linearity and upward slope is positive (+) linearity.) Tune 8620C (LO) to opposite side of RF signal. (If LO was tuned to 70 MHz below RF signal, tune LO 70 MHz above RF signal (and conversely.)
- q. Note worst point of linearity and slope of trace (positive or negative). Algebraically subtract the measurement noted in step p from the measurement noted in step q and divide by two (2).

Examples:

- 1. Linearity worst points of +0.5% and –0.3% measured in steps p and q: $\frac{+0.5\% - (-0.3\%)}{2} = 0.4\%$
- 2. Linearity worst points of +0.5% and +0.7% measured in steps p and q: $\frac{+0.5\% - (+0.7\%)}{2} = -0.1\%$
- r. Corrected linearity should be less than or equal to 0.5%.
- s. Set 3702B MARKER OFFSET switch to ± 25 MHz (50 MHz sweep width).
- t. Adjust 3716A SWEEP CAL control to place the plus and minus 25 MHz markers at each edge of the CRT graticule display.
- u. Repeat steps n through q. Corrected linearity should be less than or equal to 0.83%.

Group Delay:

- v. Set 3702B MARKER OFFSET switch to ± 15 MHz (30 MHz sweep width).
- w. Adjust 3716A SWEEP CAL control to place plus and minus 15 MHz markers at each edge of the CRT graticule display.
- x. Set the 3702B BLANKING switch to OFF and adjust X PHASE SHIFT control so the normal trace and retrace marker pulses coincide. Reset BLANKING switch to the ON position.
- y. Set the 3702B Y2 DISPLAY switch to DELAY and set the 3705A DIFF PHASE CALIBRATION switch to 1 ns. Adjust Y2 GAIN control for a one division envelope on CRT display. Reset DIFF PHASE CALIBRATION switch to the OFF position.
- z. Note maximum group delay and slope of trace. (Downward slope from left to right is negative (–) group delay and upward slope is positive (+) group delay.) Tune 8620C (LO) to opposite side of RF signal. (If LO was tuned 70 MHz below RF signal, tune LO 70 MHz above RF signal and conversely.)

PERFORMANCE TESTS

4-19. UPCONVERTER SIMULATION TEST (OPTION 008 ONLY) (Cont'd)

- aa. Note maximum group delay and slope of trace (positive or negative). Algebraically subtract the group delay noted in step z from the group delay noted in step aa and divide by two (2). Refer to previous examples following step q.
- ab. Corrected group delay should be less than or equal to 1 ns.
- ac. Set 3702B MARKER OFFSET switch to ± 25 MHz (50 MHz sweep width).
- ad. Adjust 3716A SWEEP CAL control to place the plus and minus 25 MHz markers at each edge of the CRT graticule display.
- ae. Repeat steps x through aa. Corrected group delay should be less than or equal to 1.7 ns.

Differential Gain:

- af. Set controls as follows:

3702B/3705A Option 010:
 BB POWER (- dBm) 12
 MARKER OFFSET Fully counterclockwise
 BB FREQUENCY 5.6 MHz

3710A/3716A Option 010:
 BB POWER (- dBm) 14
 BB FREQUENCY 5.6 MHz

- ag. Repeat MLA Calibration (steps d through k).
- ah. Set 3702B MARKER OFFSET switch to ± 15 MHz (30 MHz sweep width).
- ai. Adjust 3716A SWEEP CAL control to place the plus and minus 15 MHz markers at each edge of the CRT graticule display.
- aj. Set the 3702B BLANKING switch to OFF and adjust X PHASE SHIFT control so the normal trace and retrace marker pulses coincide. Reset BLANKING switch to the ON position.
- ak. Set the 3702B Y1 Y2 CALIBRATION switch to 1% and set Y1 GAIN control for a one division envelope on CRT display. Reset Y1 Y2 CALIBRATION switch to the OFF position.
- al. Note maximum differential gain and slope of trace. (Downward slope from left to right is negative (-) differential gain and upward slope is positive (+) differential gain.) Tune 8620C (LO) to opposite side of RF signal.
- am. Note maximum differential gain and slope of trace (positive or negative). Algebraically subtract the differential gain noted in step a from the differential gain noted in step am and divide by two (2). Refer to previous examples following step q.

PERFORMANCE TESTS

4-19. UP CONVERTER SIMULATION TEST (OPTION 008 ONLY) (Cont'd)

- an. Corrected differential gain should be less than or equal to 0.5%.
- ao. Set 3702B MARKER OFFSET switch to ± 25 MHz (50 MHz sweep width).
- ap. Adjust 3716A SWEEP CAL control to place the plus and minus 25 MHz markers at each edge of the CRT graticule display.
- aq. Repeat steps aj through am. Corrected differential gain should be less than or equal to 0.83%.

Differential Phase:

- ar. Set 3702B MARKER OFFSET switch to ± 15 MHz (30 MHz sweep width).
- as. Adjust 3716A SWEEP CAL control to place the plus and minus 15 MHz markers at each edge of the CRT graticule display.
- at. Set the 3702B BLANKING switch to OFF and adjust X PHASE SHIFT control so the normal trace and retrace marker pulses coincide. Reset BLANKING switch to the ON Position.
- au. Set the 3702B Y2 DISPLAY to DELAY and set the 3705A DIFF PHASE CALIBRATION switch to 1°. Adjust Y2 GAIN control for a one division envelope on CRT display. Reset DIFF PHASE CALIBRATION switch to OFF position.
- av. Note maximum differential phase and slope of trace. (Downward slope from left to right is negative (-) differential phase and upward slope is positive (+) differential phase.) Tune 8620C (LO) to opposite side of RF signal.
- aw. Note maximum differential phase and slope of trace (positive or negative). Algebraically subtract the differential phase noted in step av from the differential phase noted in step aw and divide by two (2). Refer to previous examples following step q.
- ax. Corrected differential phase should be less than or equal to 1 degree.
- ay. Set 3702B MARKER OFFSET switch to ± 25 MHz (50 MHz sweep width). Adjust 3716A SWEEP CAL control to place the plus and minus 25 MHz markers at each edge of the CRT graticule display.
- az. Repeat steps at through aw. Corrected differential phase should be less than or equal to 1.7 degrees.

SECTION V ADJUSTMENTS

5-1. INTRODUCTION

5-2. This section provides adjustment procedures for the Model 86242D/86245A/86250D RF Plug-ins. These procedures should not be performed as a routine maintenance procedure, but should be used after replacement of a part or component or when performance tests show that the specifications of Table 1-1 cannot be met. Before attempting any adjustment, allow 30 minutes warm-up time for the instrument. Table 5-1 lists the adjustment controls and the function of each control.

5-3. EQUIPMENT REQUIRED

5-4. Table 1-4 lists the equipment required for the adjustment procedures. If the test equipment recommended is not available, other equipment may be used if its performance meets the "Critical Specifications" listed in the table. The test setup used for an adjustment procedure is referenced in each procedure.

5-5. FACTORY SELECTED COMPONENTS

5-6. Factory selected components can be recognized by an asterisk on the schematic diagram. Selection of these component values is covered in the adjustment procedures.

5-7. SAFETY CONSIDERATIONS

5-8. Although this instrument has been designed in accordance with international safety standards, this manual contains information, cautions, and warnings which must be followed to ensure safe operation and to retain the instrument in safe condition. Service and adjustments should be performed only by qualified service personnel.

WARNING

Any interruption of the protective (grounding) conductor (inside or outside the instrument) or disconnecting the protective earth terminal could make this instrument dangerous.

5-9. Any adjustment, maintenance, and repair of the opened instrument under voltage should be avoided as much as possible, but when required, should be performed only by skilled persons who are aware of the hazard involved.

5-10. Capacitors inside the instrument may still be charged even if the instrument has been disconnected from its source of supply.

5-11. Make sure that only fuses with the required rated current and of the specified type (normal blow, time delay, etc.) are used for replacement. The use of repaired fuses and the shortcircuiting of fuseholders should be avoided.

5-12. Whenever it is likely that the protection offered by fuses has been impaired, the instrument should be made inoperative and secured against any unintended operation.

WARNING

Adjustments described herein are performed with power supplied to the instrument while protective covers are removed. Energy available at many points may, if contacted, result in personal injury.

5-13 LOCATION OF TEST POINTS AND ADJUSTMENTS

5-14. For location of adjustments and test points, refer to Figure 5-1.

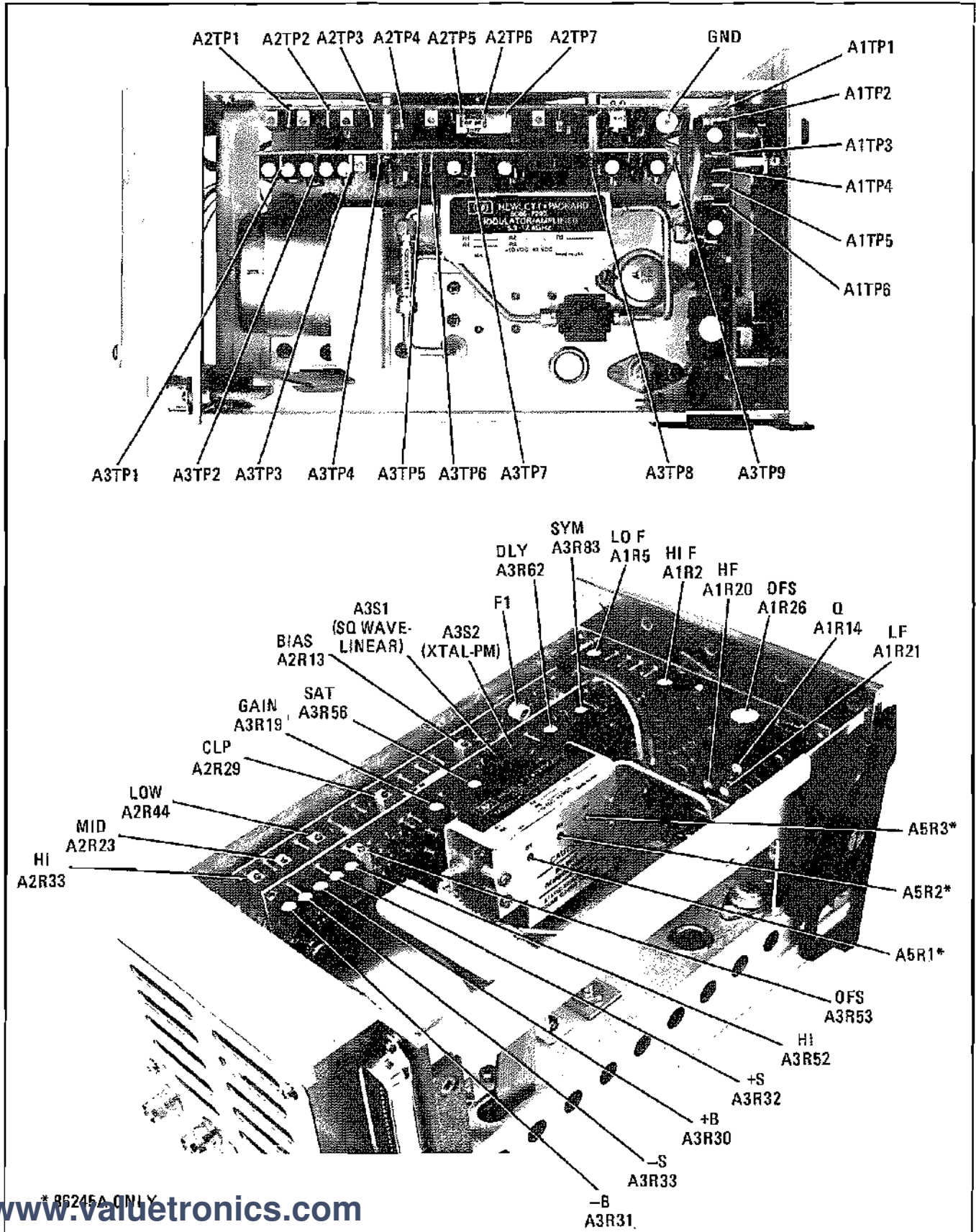

Figure 5-1. Test Point and Adjustment Locations

Table 5-1. Controls Listed in Adjustment Sequence

Adjustment Paragraph	Schematic Name	Reference Designation	Function Adjusted
5-15	CLP	A2R29	Adjusts maximum high-end frequency
5-15	LO	A2R44	Adjusts low-end frequency accuracy
5-15	MID	A2R23	Adjusts mid-range frequency accuracy
5-15	HI	A2R33	Adjusts high-end frequency accuracy
5-16	SAT	A3R56	Compensates Modulator/Amplifier
5-16	GAIN	A3R19	Adjusts ALC gain
5-16	OFS	A3R53	Adjusts ALC offset
5-16	DLY	A3R62	Adjusts ALC response (27.8 kHz MOD.)
5-16	SYM	A3R83	Adjusts ALC symmetry (27.8 kHz MOD.)
5-16	R1*	A5R1	} Amplifier bias
5-16	R2*	A5R2	
5-16	R3*	A5R3	
5-16	-S	A3R33	Adjusts ALC flatness (-slope)
5-16	+S	A3R32	Adjusts ALC flatness (+ slope)
5-16	-B	A3R31	Adjusts ALC flatness (- breakpoint)
5-16	+B	A3R30	Adjusts ALC flatness (+ breakpoint)
5-16	HI	A3R52	Adjusts range of POWER LEVEL control
5-17	OFS	A1R26	Adjusts FM offset
5-17	HIF	A1R2	Adjusts high-frequency FM sensitivity
5-17	LOF	A1R5	Adjusts low-frequency FM sensitivity
5-18	LF	A1R21	Adjusts FM frequency response
5-18	HF	A1R20	Adjusts FM frequency response
5-18	Q	A1R14	Adjusts FM frequency response

ADJUSTMENTS

5-15. YIG DRIVER FREQUENCY ADJUSTMENTS

REFERENCE:

SERVICE SHEET 2, A2 YIG Driver Assembly

DESCRIPTION:

Maximum high-end frequency is adjusted by setting CW and CW VERNIER controls for maximum and adjusting high frequency CLP control. Frequency accuracy is adjusted across the band by adjusting LO, MID, and HI controls to corresponding tuning voltages at low, mid and high end of frequency band.

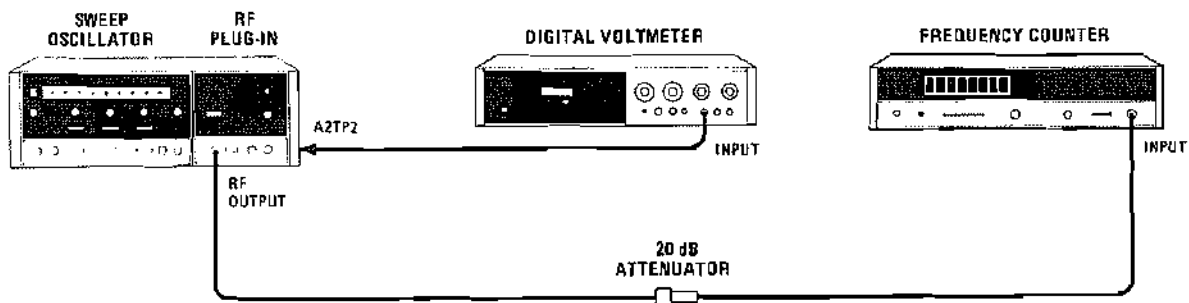

Figure 5-2. YIG Driver Frequency Adjustments Test Setup

EQUIPMENT:

Sweep Oscillator	HP 8620C
Frequency Counter	HP 5340A
Digital Voltmeter (DVM)	HP 3480D/3484A
20 dB Attenuator	HP 8491B, Option 020

PROCEDURE:

1. Connect equipment as shown in Figure 5-2.
2. Set controls as follows

8620C:

CW MARKER pointer	
86242D	9.0 GHz
86245A/86250D	12.4 GHz
ΔF control	Fully clockwise
ΔF multiplier	X1
CW VERNIER control	Fully clockwise
CW VERNIER multiplier	X1
MODE	MANUAL
MANUAL	Fully clockwise
TRIGGER	INT
TRIGGER switch1 — .01
TIME-SECONDS Vernier	Fully clockwise

 ADJUSTMENTS

5-15. YIG DRIVER FREQUENCY ADJUSTMENTS (Cont'd)

RF Plug-in:

 RF OFF-ON ON
 POWER LEVEL Fully clockwise

3. Press 8620C LINE pushbutton to ON; press ΔF pushbutton. Allow 30 minutes warm-up time.
 4. CLP Adjustment
 - a. Adjust CLP (A2R29) for frequency counter indication between 9.00 and 9.10 GHz for 86242D or between 12.40 and 12.50 GHz for 86245A/86250D.
 5. LO, MID, HI Adjustments
 - a. Press 8620C CW pushbutton to turn ΔF off.
 - b. Connect DVM to A2TP2. (Connect ground lead to 8620C A4 GND.)
 - c. Adjust CW MARKER and CW VERNIER controls for DVM indication of $0.000V \pm 0.005V$.
 - d. Adjust LO (A2R44) for frequency counter indication of 5.900 GHz ± 0.001 GHz for 86242D/86245A or 8.000 GHz ± 0.001 GHz for 86250D.
 - e. Adjust CW MARKER and CW VERNIER controls for DVM indication of $6.000V \pm 0.005V$ for 86242D/86250D or $6.500V \pm 0.005V$ for 86245A.
 - f. Adjust MID (A2R23) for frequency counter indication of 7.760 GHz ± 0.001 GHz for 86242D, 10.640 GHz ± 0.001 GHz for 86250D, or 10.125 GHz ± 0.001 GHz for 86245A.
 - g. Adjust CW MARKER and CW VERNIER controls for DVM indication of $10.000V \pm 0.005V$.
 - h. Adjust HI (A2R33) for frequency counter indication of 9.000 GHz ± 0.001 GHz for 86242D or 12.400 GHz ± 0.001 GHz for 86245A/86250D.
-

5-16. ALC ADJUSTMENTS

REFERENCE:

SERVICE SHEET 3, A3 ALC Assembly

DESCRIPTION:

Offset, gain, symmetry, flatness, and POWER LEVEL range are adjusted for Automatic Leveling Control (ALC) circuitry.

ADJUSTMENTS

5-16. ALC ADJUSTMENTS (Cont'd)

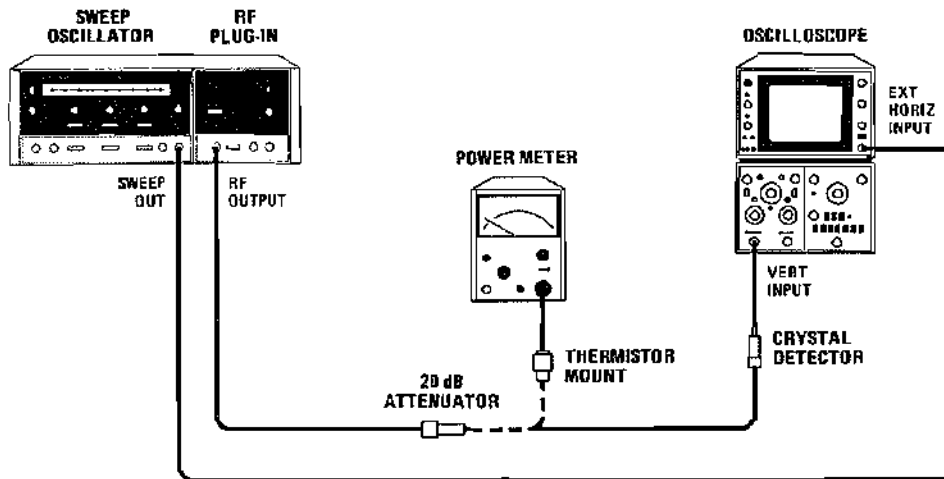

Figure 5-3. Preliminary ALC Adjustments Test Setup

NOTE

Equipment listed is for eight (8) test setups (Figures 5-3, 5-4, 5-5, 5-7, 5-8, 5-9, 5-10, and 5-13).

EQUIPMENT:

Sweep Oscillator	HP 8620C
Oscilloscope	HP 180C/1801A/1820C
Swept Amplitude Analyzer	HP 8755B/182T
Power Meter	HP 432A
Thermistor Mount	HP 8478A
Crystal Detector (2 required)	HP 423B, Option 002
10 dB Attenuator	HP 8491B, Option 010
20 dB Attenuator	HP 8491B, Option 020
Digital Voltmeter	HP 3480D/3484A
Detector	HP 11664A

PROCEDURE:

1. Connect equipment as shown in Figure 5-3 with oscilloscope connected to RF Plug-in RF OUTPUT.
2. Set controls as follows:

8620C:

MODE	AUTO
TRIGGER	INT
TIME-SECONDS	.1 — .01
TIME-SECONDS Vernier	Fully clockwise
RF BLANKING/OFF (rear panel)	RF BLANKING
1 kHz SQ WV/OFF (rear panel)	OFF
1 kHz SQ WV/OFF (rear panel)	OFF

ADJUSTMENTS

5-16. ALC ADJUSTMENTS (Cont'd)

RF Plug-in:

RF OFF-ON	ON
ALC Switch	EXT
ALC GAIN	Fully clockwise
POWER LEVEL	Fully clockwise

3. Set Amplitude Modulation Selector switch A3S1 to SQ WAVE (Up) position and External Leveling Selector switch A3S2 to XTAL (Up) position as shown in Figure 3-1. (Locations of A3S1 and A3S2 are shown in Figure 5-1.)
4. Press 8620C LINE Pushbutton ON (FULL SWEEP selected). Allow 30 minutes warmup time.
5. If adjustments are being performed on an HP 86242D or 86250D RF Plug-in, proceed to step 7.
6. SAT Adjustment
 - a. Adjust SAT (A3R56) to fully counterclockwise position.
 - b. Note detected RF signal display on oscilloscope. Adjust SAT (A3R56) clockwise for maximum power level indication at low end of band (left one-third of oscilloscope display).
 - c. Turn SAT adjust (A3R56) counterclockwise until power level at low end of band drops approximately 5% as indicated on oscilloscope.
7. If adjustments are being performed on an instrument without Option 001 installed, proceed to step 12.
8. GAIN Adjustment (Option 001 only)
 - a. Set RF Plug-in ALC switch to INT.
 - b. Turn HI (A3R52) fully counterclockwise and GAIN (A3R19) fully clockwise. Rotate POWER LEVEL control counterclockwise until oscillations appear. Adjust GAIN (A3R19) counterclockwise until oscillations disappear. Repeat this process until POWER LEVEL is in fully counterclockwise position.
 - c. Rotate GAIN (A3R19) an additional 1/16 turn counterclockwise.
9. OFFSET Adjustment (Option 001 only)
 - a. Connect equipment as shown in Figure 5-4.
 - b. Set controls as indicated in step 2.
 - c. Press ΔF pushbutton; adjust CW MARKER pointer to center-scale, and ΔF pointer fully counterclockwise.
 - d. Connect DVM to A3TP4 (ground lead to chassis).
 - e. Adjust POWER LEVEL control for DVM indication of +0.042 Vdc ±0.001 Vdc.

ADJUSTMENTS

5-16. ALC ADJUSTMENTS (Cont'd)

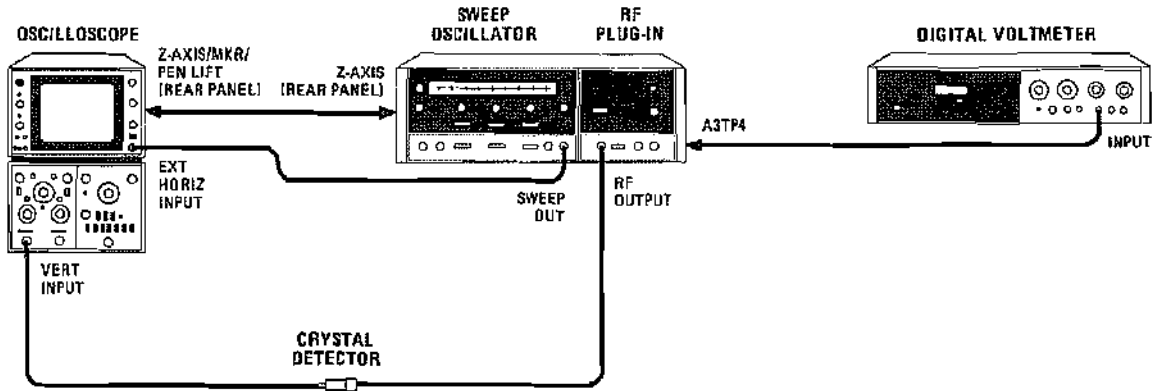
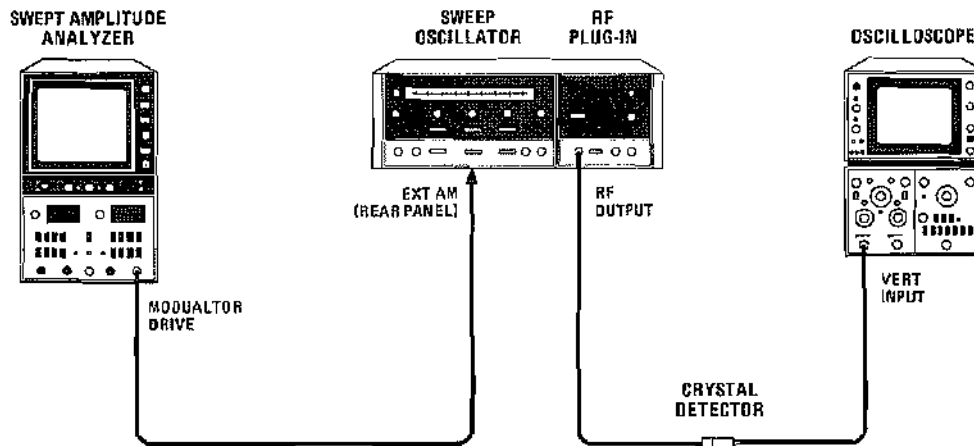

Figure 5-4. Offset Adjustment Test Setup

- f. Turn OFS (A3R53) fully counterclockwise. Note detected RF signal display on oscilloscope. Adjust OFS (A3R53) clockwise until RF signal level just goes to zero power level (blanking line) as indicated on oscilloscope display.

10. DELAY Adjustment (Option 001 only)



www.valuetronics.com

Figure 5-5. Delay Adjustment Test Setup, Option 001

ADJUSTMENTS

5-16. ALC ADJUSTMENTS (Cont'd)

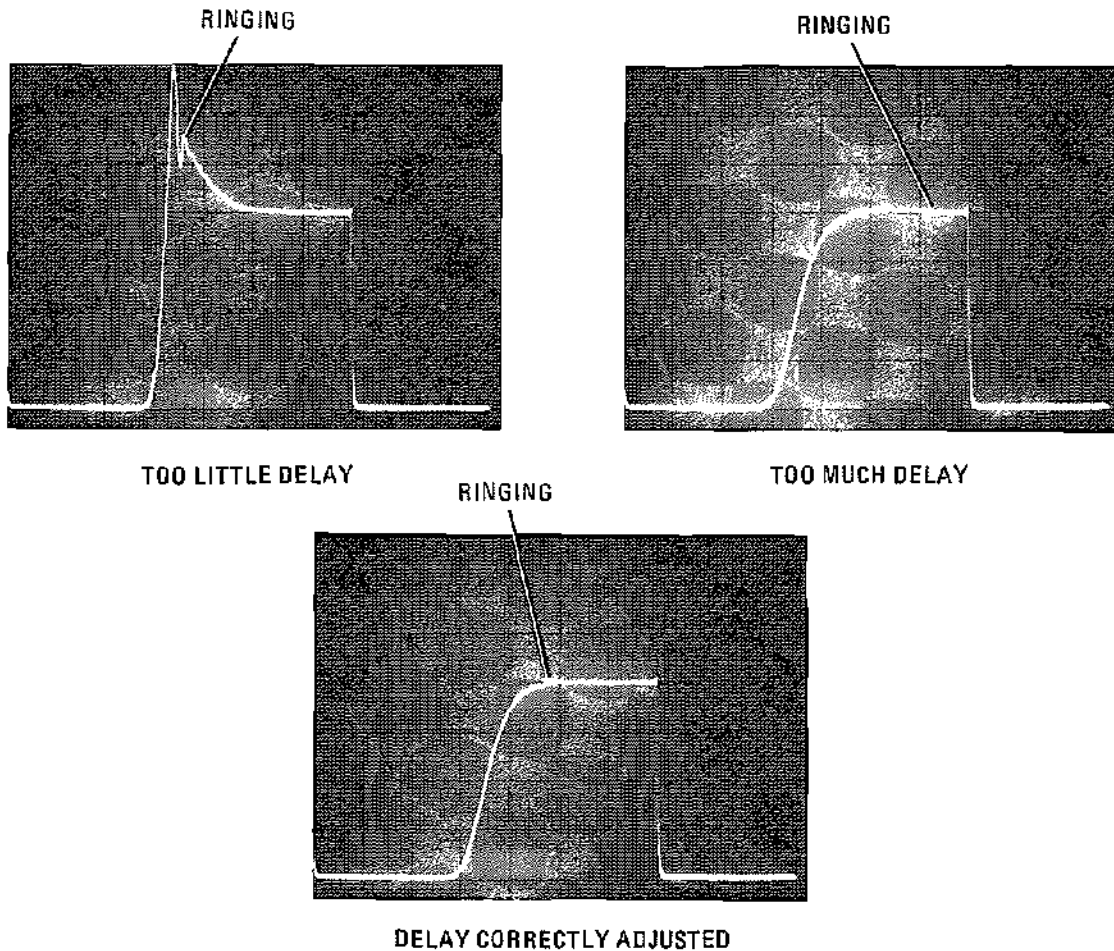

Figure 5-6. Delay and Symmetry Adjustment Waveforms

- a. Connect equipment as shown in Figure 5-5.
- b. Adjust DLY (A3R62) and SYM (A3R83) for oscilloscope display similar to the correctly adjusted delay waveform of Figure 5-6.
- c. Adjust POWER LEVEL control for approximately 2 divisions display on oscilloscope. Set oscilloscope TIME/DIV to $5\mu\text{SEC}$.
- d. Adjust SYM (A3R83) for approximately equal ON and OFF times (Figure 5-6) of RF signal as indicated on oscilloscope.
- e. Adjust DLY (A3R62) for best response. See Figure 5-6 for typical waveforms.
- f. Adjust POWER LEVEL control over full range while monitoring oscilloscope display. Adjust DLY (A3R62) for best response over full range of POWER LEVEL control.

ADJUSTMENTS

5-16. ALC ADJUSTMENTS (Cont'd)

11. 8755B Symmetry Adjustment (Option 001 only)

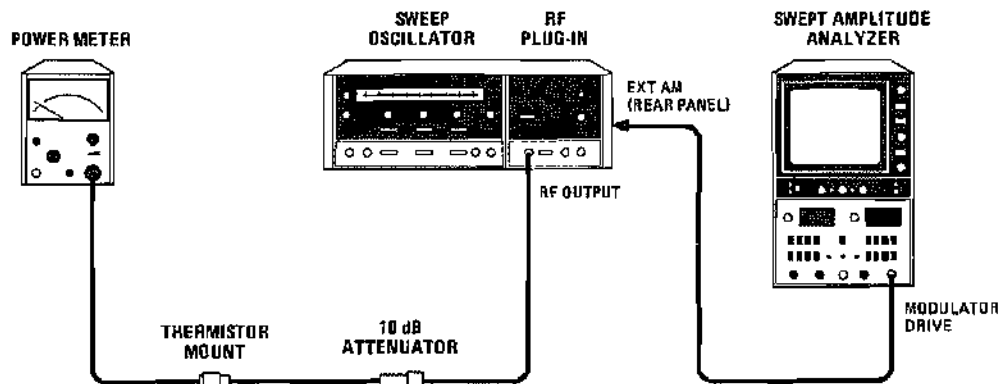

Figure 5-7. 8755B Symmetry Adjustment Test Setup (Option 001)

- a. Connect equipment as shown in Figure 5-7 except do not connect 8755B MODULATOR DRIVE to 8620C EXT AM input.
- b. Adjust POWER LEVEL control for -3 dBm indication on power meter for 86245A or -7 dBm for 86242D/86250D.
- c. Connect 8755B MODULATOR DRIVE to 8620C EXT AM input.
- d. Adjust SYM (A3R83) for -6 dBm indication on power meter for 86245A or -10 dBm for 86242D/86250D (3 dB drop).
- e. Disconnect 8755B MODULATOR DRIVE from 8620C EXT AM input.
- f. Set RF Plug-in POWER LEVEL control for maximum leveled power and note power meter indication.
- g. Reconnect 8755B MODULATOR DRIVE to 8620C EXT AM input. Power meter indication should be 3 dB down (maximum of -3.98 dB and minimum of -2.22 dB down) from power meter indication of previous step. If not, compromise SYM adjustment (A3R83) to bring symmetry within limits. Repeat steps a through c and insure that power level drops 3 dB (maximum of -3.98 dB and minimum of -2.22 dB).
- h. Repeat step e and set RF Plug-in POWER LEVEL control for a power meter indication of -13 dBm (-3 dBm output at RF Plug-in) for 86245A or -10 dBm (0 dBm output at RF Plug-in) for 86242D/86250D.

www.valuetronics.com

- i. Repeat step g.

ADJUSTMENTS

5-16. ALC ADJUSTMENTS (Cont'd)

12. Symmetry Adjustment (Standard only)

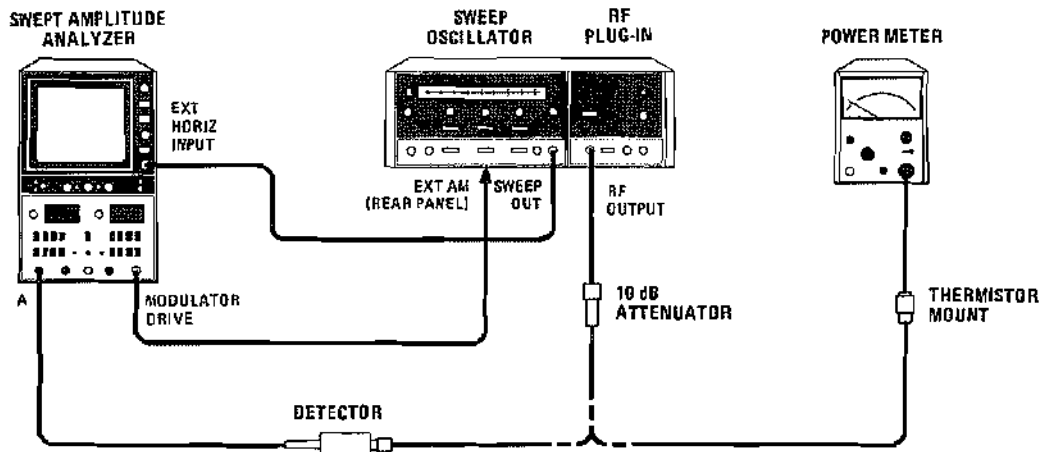

Figure 5-8. Leveling OFF Adjustment Test Setup

- a. Connect equipment as shown in Figure 5-8 with power meter connected to RF OUTPUT. Do not connect 8755B MODULATOR DRIVE.
- b. Press 8620C CW pushbutton; set CW MARKER pointer to center-scale. Set ALC switch to OFF. Adjust POWER LEVEL control to mid-range (12 o'clock).
- c. Turn GAIN (A3R19) fully counterclockwise.
- d. Adjust POWER LEVEL control for -3 dBm indication on power meter for 86245A or -7 dBm for 86242D/86250D. Connect 8755B MODULATOR DRIVE to 8620C EXT AM input.
- e. Adjust SYM (A3R83) for -6 dBm indication on power meter for 86245A or -10.0 dBm for 86242D/86250D (3 dB drop).
- f. Disconnect 8755B MODULATOR DRIVE from 8620C EXT AM input.
- g. Set RF Plug-in POWER LEVEL control for maximum specified power (power meter indication of $+7$ dBm for 86245A or 0 dBm for 86242D/86250D).
- h. Reconnect 8755B MODULATOR DRIVE to 8620C EXT AM input. Power meter indication should be 3 dB down (maximum of -3.98 dB and minimum of -2.22 dB down) from power meter indication of previous step. If not, compromise SYM adjustment (A3R83) to bring symmetry within limits. Repeat steps a through d and insure that power level drops 3 dB (maximum of -3.98 dB and minimum of -2.22 dB).
- i. Repeat step f and set RF Plug-in POWER LEVEL control for a power meter indication of -13 dBm (-3 dBm output at RF Plug-in) for 86245A or -10 dBm (0 dBm output at RF Plug-in) for 86242D/86250D.
- j. Repeat step h.

ADJUSTMENTS

5-16. ALC ADJUSTMENTS (Cont'd)

13. GAIN Adjustment (Standard only)

- a. Connect equipment as shown in Figure 5-8 with 8755B connected to RF OUTPUT through 11664A Detector.
- b. Press 8620C FULL SWEEP pushbutton. Rotate POWER LEVEL control fully clockwise. Set ALC switch to OFF.
- c. Set 8755B CHANNEL 1 dB/DIV to 10 and REFERENCE LEVEL for on-screen display. Adjust 8755B for full horizontal display.
- d. Note 8755B display. Set CHANNEL 1 VERNIER to ON and adjust VERNIER control to align lowest point of trace with graticule line two divisions above center line.
- e. Set RF Plug-in POWER LEVEL control fully counterclockwise.
- f. Adjust GAIN (A3R19) for power level at least 40 dB down from max power over full band.

14. HI Level Adjustment (Standard only)

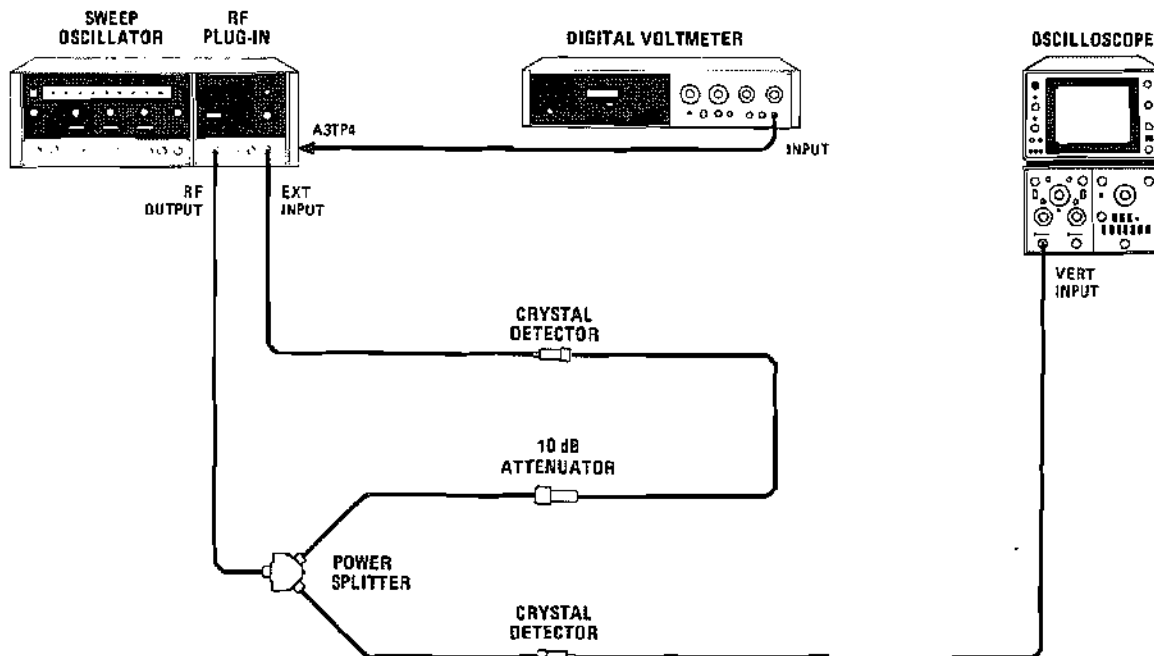

www.valuetronics.com

Figure 5-9. External Leveling Adjustment Test Setup

ADJUSTMENTS

5-16. ALC ADJUSTMENTS (Cont'd)

- a. Connect equipment as shown in Figure 5-9.
- b. Set controls as follows:
 - 8620C:
 - MODE AUTO
 - TRIGGER..... INT
 - TIME-SECONDS1 — .01
 - TIME-SECONDS Vernier Fully clockwise
 - RF Plug-in:
 - RF OFF-ON ON
 - ALC switch..... EXT
 - ALC GAIN Fully clockwise
- c. Press 8620C LINE pushbutton ON (FULL SWEEP selected). Allow 30 minutes warm-up time.
- d. Adjust POWER LEVEL control to one-half scale mark counterclockwise from full clockwise position for 86245A or three marks counterclockwise from full clockwise position for 86242D/86250D.
- e. Adjust HI (A3R52) fully counterclockwise then adjust clockwise until leveling begins to occur at any point on band as indicated on oscilloscope display.

15. Offset Adjustment (Standard only)

- a. Connect DVM to A3TP4 (ground lead to A2 GND).
- b. Press 8620C ΔF pushbutton and adjust CW MARKER pointer to center-scale and ΔF pointer fully counterclockwise.
- c. Adjust POWER LEVEL control for DVM indication of +0.042 Vdc ±0.001 Vdc.
- d. Adjust OFS (A3R53) fully counterclockwise, then adjust slowly clockwise until RF signal display on oscilloscope just goes to zero power level (blanking line).

16. Delay Adjustment (Standard only)

- a. Connect equipment as shown in Figure 5-10.
- b. Set POWER LEVEL control fully clockwise. Set oscilloscope TIME/DIV to 5μSEC.
- c. Adjust DLY (A3R62) for a display similar to the correctly adjusted delay waveform of Figure 5-6.
- d. Adjust POWER LEVEL control for approximately 2 divisions display on oscilloscope.
- e. Adjust DLY (A3R62) for best response. (See Figure 5-6.)
- f. Adjust POWER LEVEL control over full range while monitoring oscilloscope display. Adjust DLY (A3R62) for best response over full range of POWER LEVEL control.

ADJUSTMENTS

5-16. ALC ADJUSTMENTS (Cont'd)

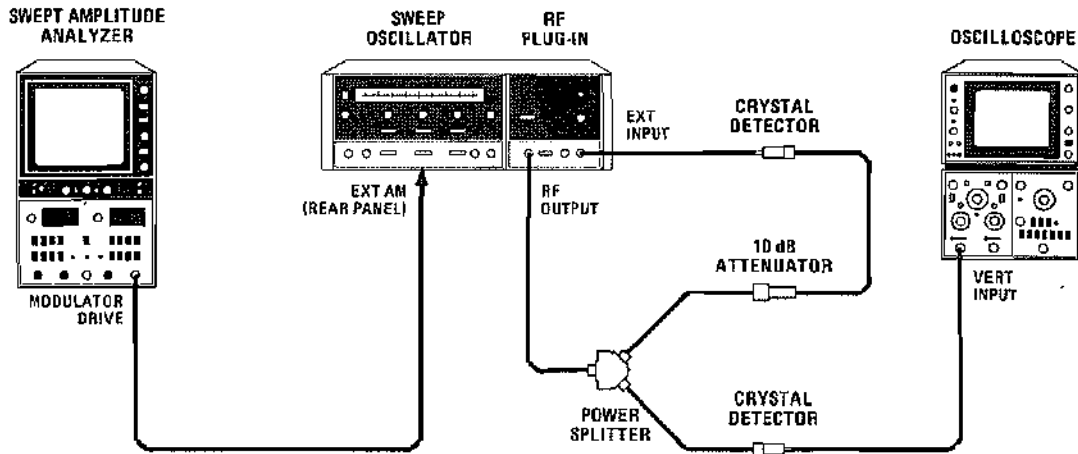

Figure 5-10. Delay Adjustment Test Setup, Standard

17. Harmonics and Amplifier Bias Adjustment (86245A only).

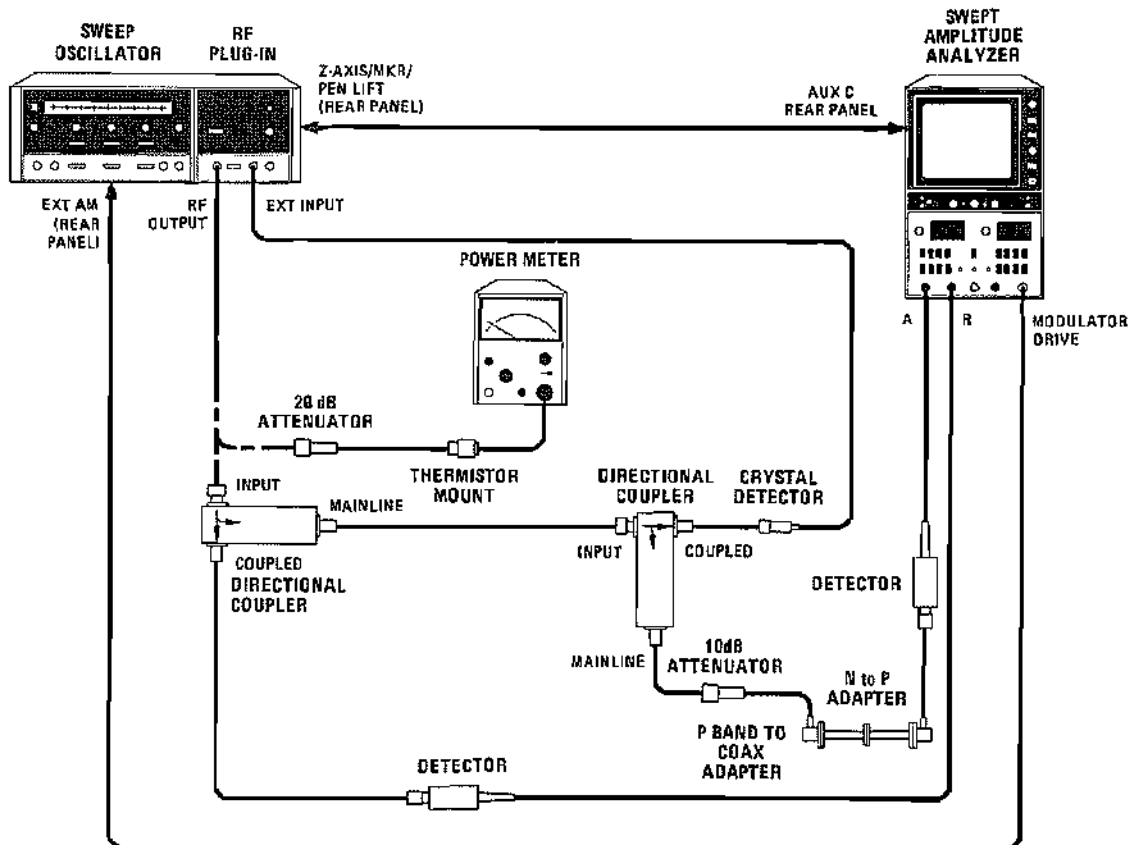

Figure 5-11. Harmonics and Amplifier Bias Adjustment Test Setup

ADJUSTMENTS

5-16. ALC ADJUSTMENTS (Cont'd)

EQUIPMENT:

Sweep Oscillator	HP 8620C
Power Meter	HP 432A
Thermistor Mount	HP 8478B
Swept Amplitude Analyzer	HP 8755B/182T
Directional Coupler (2 required)	HP 779D
Detector (2 required)	HP 11664A
Crystal Detector	HP 423B
10 dB Attenuator	HP 8491B, Option 010
20 dB Attenuator	HP 8491B, Option 020
Adapter, N to P (2 required)	HP NP292A
Adapter, P Band to Coax (2 required)	HP P281B, Option 013

- a. Connect equipment as shown in Figure 5-11 with power meter connected to RF OUTPUT (through 20 dB attenuator).
- b. Set controls as follows:

8620C:

START MARKER pointer	7.0 GHz
STOP MARKER pointer	12.4 GHz
MODE	AUTO
TRIGGER	INT
TIME-SECONDS1 — .01
TIME-SECONDS Vernier	Fully counterclockwise
MARKERS	INTEN
1 kHz SQ WV/OFF (rear panel)	OFF
RF BLANKING/OFF (rear panel)	OFF
DSIPALY BLANKING/OFF (rear panel)	OFF

RF Plug-in (86245A):

RF OFF-ON	ON
ALC switch	EXT
POWER LEVEL	Fully clockwise
FM-NORM-PL (rear panel)	NORM

8755B:

CHANNEL 1:

DISPLAY	A/R
dB/DIV	5
REFERENCE LEVEL	00 dB
VERNIER	ON

CHANNEL 2:

DISPLAY	R
dB/DIV	1
REFERENCE LEVEL	+17 dBm
VERNIER	ON

ADJUSTMENTS

5-16. ALC ADJUSTMENTS (Cont'd)

- c. Press 8620C CW pushbutton. Using CW MARKER control, locate the minimum power point. Set RF Plug-in POWER LEVEL control for +17 dBm at RF OUTPUT (-3 dBm power meter indication).
- d. Disconnect 20 dB attenuator/thermistor mount from RF OUTPUT port and connect directional couplers as shown in Figure 5-11.
- e. Press 8620C FULL SWEEP pushbutton and set TIME-SECONDS vernier for a flickering full-band display.
- f. Press 8755B CHANNEL 2 REFERENCE POSITION pushbutton and adjust reference line to center horizontal graticule line. Press 8755B CHANNEL 2 DISPLAY R pushbutton.
- g. Adjust 8755B CHANNEL 2 VERNIER to position lowest point of trace at center horizontal graticule line (see Figure 5-12). Set CW MARKER pointer to 11.5 GHz.
- h. Press 8755B CHANNEL 1 REFERENCE POSITION pushbutton and adjust reference line to top horizontal graticule line. Press 8755B CHANNEL 1 DISPLAY A/R.
- i. Adjust 8755B CHANNEL 1 VERNIER to position 12.4 GHz marker at top horizontal graticule line.
- j. The 8755B is now calibrated so that CHANNEL 1 displays relative level of harmonics for fundamental signals from 5.9 GHz to 11.5 GHz (cutoff of high pass filter) referenced to top horizontal graticule with a scale of 5 dB per division; CHANNEL 2 displays the fundamental signal level referenced to +17 dBm at center horizontal graticule line with a scale of 1 dB per division. (See Figure 5-12.)

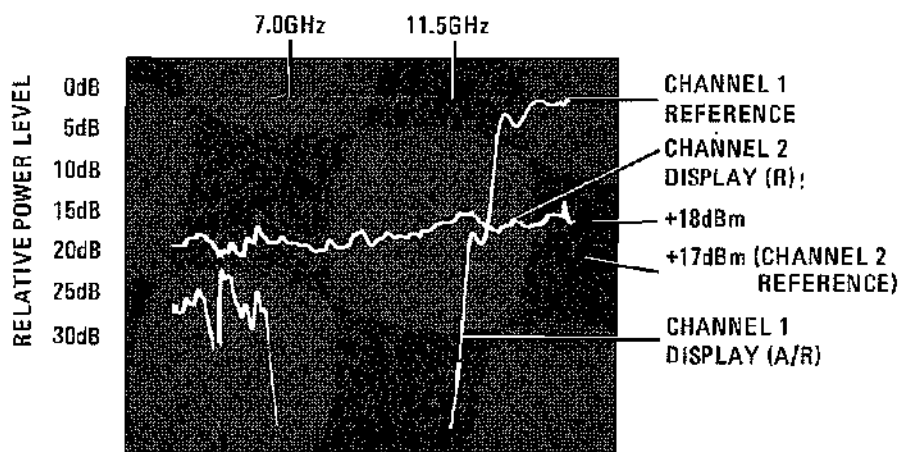

ADJUSTMENTS

5-16. ALC ADJUSTMENTS (Cont'd)

- k. Check to insure that harmonics are greater than 17 dB down (three major divisions plus two minor divisions down from top graticule line) from 5.9 GHz to 7 GHz (START MARKER) and 30 dB down (six major divisions down from top graticule line) from 7 GHz to 11.5 GHz.
- l. If harmonics do not appear to be within specification, check at frequencies in question with 8620C in CW mode. Calibrate 8755B at each frequency point measured.
- m. If harmonics still do not appear to be within specification, alternately adjust A5R1, A5R2, and A5R3 Amplifier bias adjustments for best harmonic rejection while maintaining leveled output power of +17 dBm or greater.
- n. Set 8755B CHANNEL 2 REFERENCE LEVEL to +7 dBm (10 dB down). Adjust RF Plug-in POWER LEVEL control to position lowest point of CHANNEL 2 trace at center horizontal graticule line.
- o. Repeat steps k and l.
- p. If harmonics still do not appear to be within specification, alternately adjust A5R1, A5R2, and A5R3 for best harmonic rejection.
- q. Set 8755B CHANNEL 2 REFERENCE LEVEL to +17 dBm. Adjust RF Plug-in POWER LEVEL control to position lowest point of CHANNEL 2 trace at center horizontal graticule line.
- r. Repeat steps k through m.

NOTE

Adjusting A5 Amplifier bias adjustments can introduce spurious signals. Whenever A5 Amplifier bias has been adjusted, the Nonharmonic Spurious Signals Test in Section IV, Paragraph 4-13, should be performed.

18. ALC Flatness Adjustment (Option 001 only)

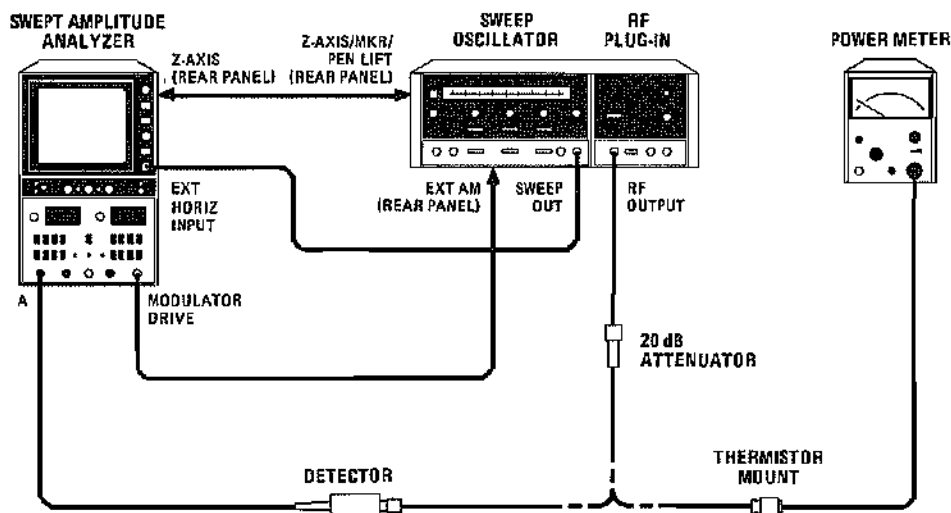

 ADJUSTMENTS

5-16. ALC ADJUSTMENTS (Cont'd)

- a. Connect equipment as shown in Figure 5-13 with 11664A Detector connected to RF OUTPUT.
- b. Adjust POWER LEVEL control to midrange (12 o'clock).
- c. Set 8755B controls as follows:

CHANNEL 1:

DISPLAY	A
dB/DIV25
REFERENCE LEVEL	-13 dB (86245A) -17 dB (86242D/86250D)
VERNIER	OFF

- d. Press 8755B CHANNEL 1 REFERENCE POSITION Pushbutton and adjust reference line to center horizontal graticule line. Press 8755B CHANNEL 1 DISPLAY A pushbutton.
- e. Adjust POWER LEVEL control to position trace at center graticule line of CRT display (approximately +7 dBm for 86245A or +3 dBm for 86242D/86250D).
- f. Set +B (A3R30) and -B (A3R31) fully counterclockwise. Set +S (A3R32) and -S (A3R33) fully clockwise.
- g. Note RF signal on CRT display. Determine polarity of trace slopes and location of breaks at low-end and high-end of band. (Refer to Figure 5-14a.)

NOTE

If trace has negative slope, then positive slope (+S) and positive breakpoint (+B) compensation is required. If trace has positive slope, then negative slope (-S) and negative breakpoint (-B) compensation is required.

- h. Adjust breakpoint control (-B or +B) required to compensate low end of band to location of break. (Refer to Figure 5-14a and 5-14b.)
 - i. Adjust corresponding slope control (+S for +B or -S for -B) for best flatness at low end of band. (Refer to Figure 5-14.)
 - j. Repeat steps h and i for high-end of band. (Figure 5-14d shows a typical response with adjustments completed.)
19. Power Level Range Adjustment (Option 001 only)
- a. Adjust POWER LEVEL to one-half scale mark counterclockwise from full clockwise position for 86245A or 3 marks counterclockwise from full clockwise position for 86242D/86250D.
 - b. Turn HI (A3R52) clockwise until leveling just occurs at any point of trace as indicated by 8755B display.
 - c. ALC adjustments are completed.

ADJUSTMENTS

5-16. ALC ADJUSTMENTS (Cont'd)

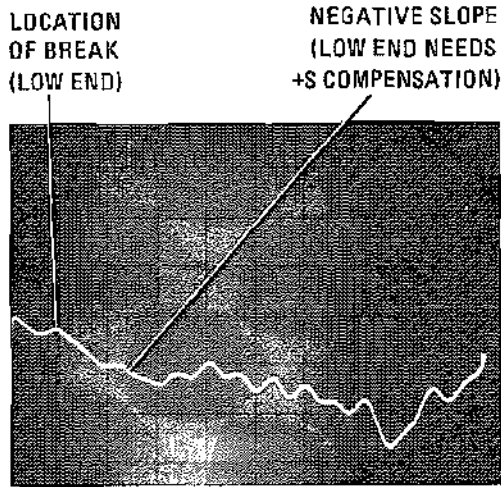

a. LOCATION OF BREAK AND SLOPE OF LOW-END OF BAND.

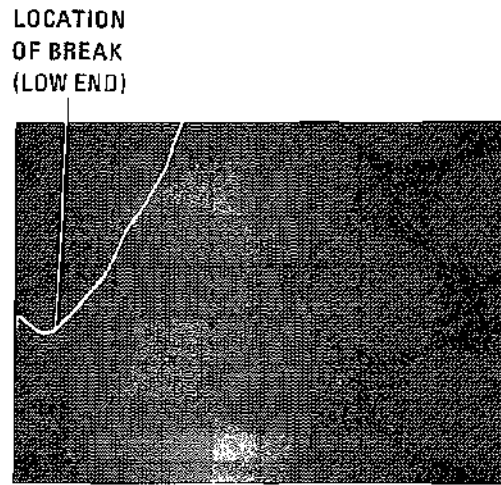

b. BREAKPOINT (+B ADJUSTED TO LOCATION OF BREAK FOR LOW-END OF BAND.

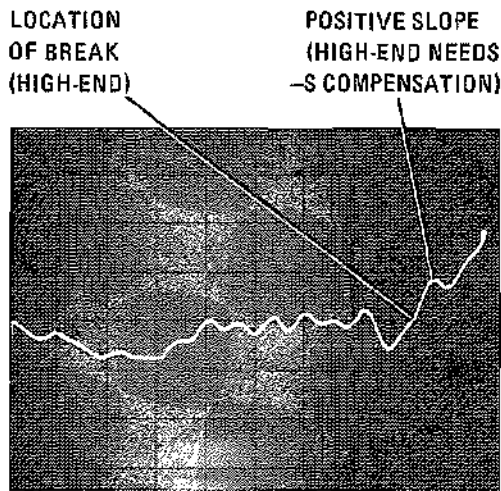

c. SLOPE ADJUSTED FOR BEST FLATNESS AT LOW-END OF BAND AND LOCATION OF BREAK POINT AND SLOPE OF HIGH END OF BAND.

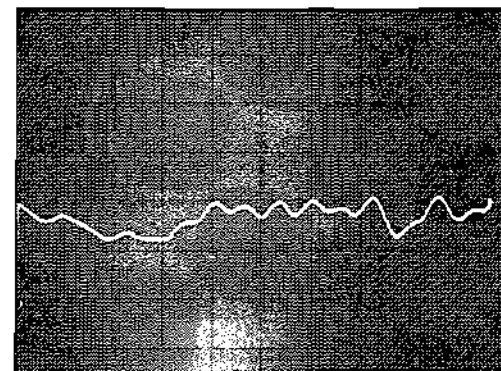

d. SLOPE/BREAKPOINT ADJUSTMENTS COMPLETE.

ADJUSTMENTS

5-17. FM DRIVER ADJUSTMENT

REFERENCE:

SERVICE SHEET 4, A1 FM Driver Assembly

DESCRIPTION:

FM Offset and Sensitivity are adjusted for optimum Frequency Modulation performance.

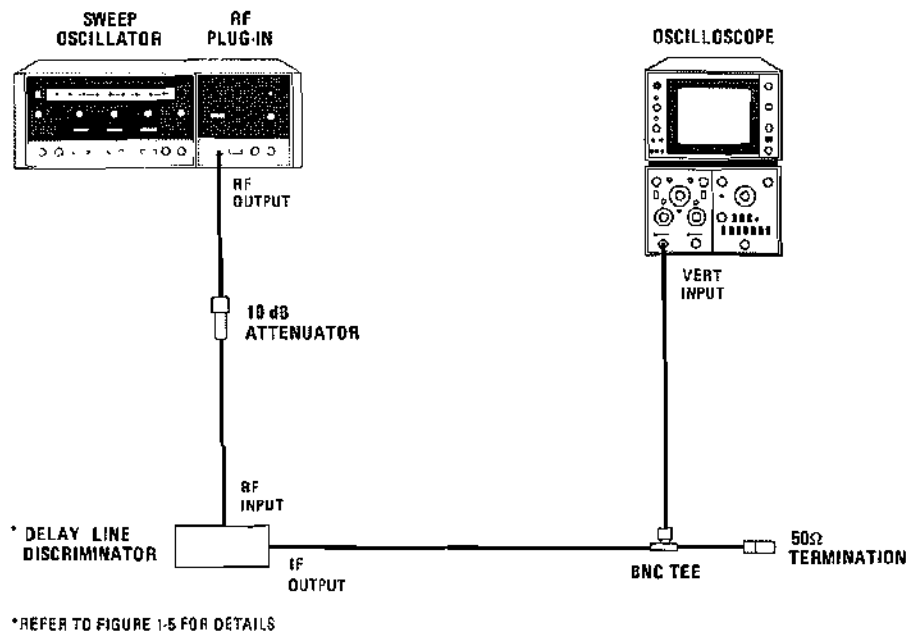

Figure 5-15. FM Offset Adjustment Test Setup

EQUIPMENT:

Sweep Oscillator	HP 8620C
Oscilloscope	HP 180C/1801A/1820C
Frequency Counter	HP 5340A
Digital Voltmeter	HP 3480D/3484A
Power Supply	HP 6214A
50 Ohm Termination	HP 11593A
10 dB Attenuator	HP 8491B, Option 010
20 dB Attenuator	HP 8491B, Option 020
Delay Line Discriminator	(See Figure 1-5)
Extender Board	HP 5060-0049

PROCEDURE:

www.valuetronics.com

1. Connect equipment as shown in Figure 5-15.

ADJUSTMENTS

5-17. FM DRIVER ADJUSTMENT (Cont'd)

2. Set controls as follows:

8620C:

CW MARKER pointer	Center-scale
CW VERNIER pointer	Center-scale
CW VERNIER multiplier	X.1
MODE	AUTO
TRIGGER	INT
TIME-SECONDS1 — .01
TIME-SECONDS Vernier	Fully clockwise
1 kHz SQ WV/OFF (rear panel)	OFF
RF BLANKING/OFF (rear panel)	OFF
DISPLAY BLANKING/OFF (rear panel)	OFF

RF Plug-in:

RF OFF-ON	ON
ALC switch	INT or OFF
POWER LEVEL	Fully clockwise
FM-NORM-PL (rear panel)	NORM

3. FM Offset Adjustment

- a. Remove RF Plug-in from mainframe and remove A1 FM Driver Assembly. Install RF Section 36-Pin Extender (Figure 1-6) on RF Plug-in rear interconnect P4. Place A1 FM Driver Assembly on extender board and install in RF Plug-in.
- b. Connect FM Input cable (green) to A1J1. Do not connect FM Output cable (yellow).
- c. Press 8620C LINE pushbutton ON.
- d. Press 8620C CW and CW VERNIER Pushbuttons. Allow 30 minutes warm-up time.
- e. Note signal trace on oscilloscope display. Adjust CW MARKER and CW VERNIER controls for $.000V \pm .001V$ level as indicated on oscilloscope.
- f. Connect FM Output cable (yellow) to A1J2.
- g. Note signal trace on oscilloscope display. Adjust OFS (A1R26) for $0.000V \pm 0.001V$ level as indicated on oscilloscope.
- h. Disconnect FM Output cable (yellow) from A2J2 and, if necessary, repeat steps e through h until no further adjustment is required.

ADJUSTMENTS

5-17. FM DRIVER ADJUSTMENT (Cont'd)

4. FM Sensitivity Adjustment

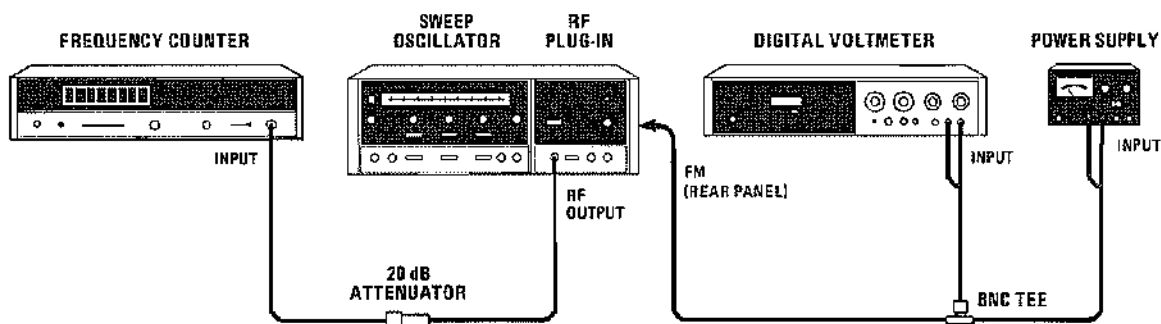

Figure 5-16. FM Sensitivity Adjustment Test Setup

- a. Connect equipment as shown in Figure 5-16. Do not connect power supply to rear panel FM input.
- b. Adjust power supply for $-0.50 \text{ Vdc} \pm 0.01 \text{ Vdc}$ indication on DVM. If Option 008 is installed, adjust power supply for $+0.50 \text{ Vdc} \pm 0.01 \text{ Vdc}$.
- c. Adjust CW MARKER and CW VERNIER controls for frequency counter indication of 8.000 GHz for 86242D/86245A or 10.000 GHz for 86250D.
- d. Connect power supply output to FM input.
- e. Adjust HI F (A1R2) for frequency counter indication of 8.010 GHz ± 0.001 GHz for 86242D/86245A or 10.010 ± 0.001 GHz for 86250D.
- f. Disconnect power supply from FM input. Note frequency counter indication. If necessary repeat steps b through f.
- g. Set RF Plug-in rear-panel FM-NORM-PL switch to FM (MLA for Option 008). Note frequency counter indication; frequency should be 8.000 GHz for 86242D/86245A or 10.000 GHz for 86250D as noted in step c.
- h. Reconnect power supply to FM input.

www.valuetronics.com (continued) 10 GHz ± 0.001 GHz for 86242D/86245A or 10.010 GHz ± 0.001 GHz for 86250D.

ADJUSTMENTS

5-18. FM FREQUENCY RESPONSE ADJUSTMENT

REFERENCE:

SERVICE SHEET 4, A1 FM Driver Assembly

DESCRIPTION:

FM Deviation of the RF Plug-in is compared to a known voltage reference using an FM Discriminator. The two signals being compared are displayed on an oscilloscope and frequency response of RF Plug-in is adjusted.

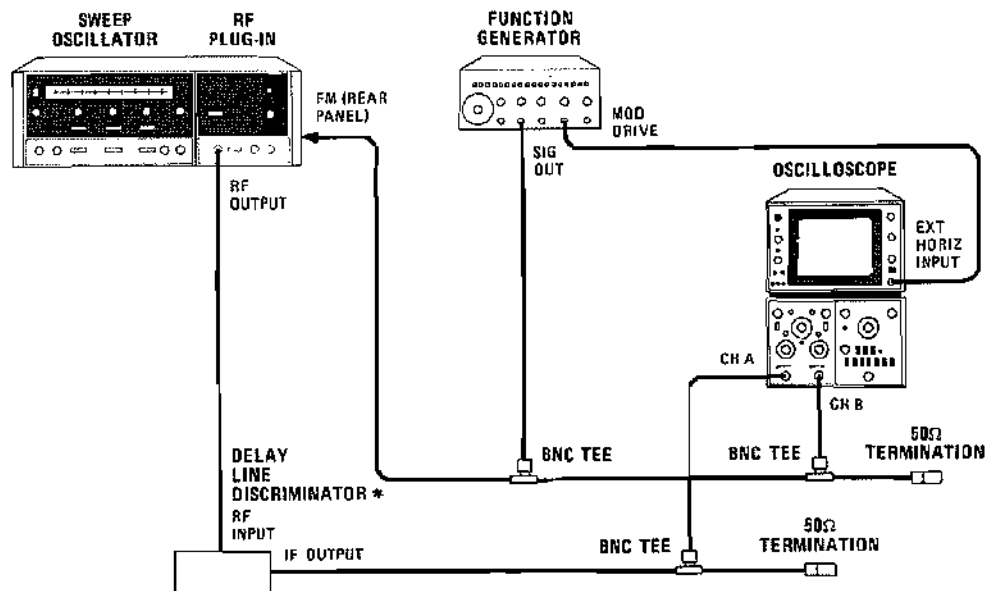

* REFER TO FIGURE 1-5 FOR DETAILS

Figure 5-17. FM Frequency Response Adjustment Test Setup

EQUIPMENT:

- Sweep Oscillator..... HP 8620C
- Oscilloscope..... HP 180C/1801A/1820C
- Function Generator..... HP 3312A
- 50-ohm Termination (2 required)..... HP 11593A
- Delay Line Discriminator..... HP 5060-0049
- Delay Line Discriminator..... (See Figure 1-5)

ADJUSTMENTS

5-18. FM FREQUENCY RESPONSE ADJUSTMENT (Cont'd)

PROCEDURE:

1. Connect equipment as shown in Figure 5-17.
2. Set controls as follows:

8620C:

CW MARKER pointer	Center-scale
RF BLANKING/OFF (rear panel)	OFF
1 kHz SQ WV/OFF (rear panel)	OFF
DISPLAY BLANKING/OFF (rear panel)	OFF

RF Plug-in:

RF OFF-ON	ON
ALC switch	OFF (Standard) INT (Option 001)
POWER LEVEL	Mid-range
FM-NORM-PL (rear panel)	NORM

Function Generator:

MODULATION	SWP
MODULATION RANGE	100
MODULATION RANGE Vernier	Fully clockwise
Amplitude	.1 — 1
SYM.	CAL
Modulation Start Frequency	30° from full clockwise
Frequency Dial (SWP STOP)	10
Function	~
Range	1 kHz

Oscilloscope:

Horizontal Display	EXT
Vertical Display	CH B
Volts/DIV	
CH A	0.005
CH B	0.02
INPUT	DC

3. Frequency Response Adjustments
 - a. Press 8620C LINE pushbutton to ON. Press CW and CW VERNIER pushbuttons.
 - b. Adjust GROUND REF of CH A and CH B of oscilloscope to center graticule line; select CH B.
 - c. Adjust function generator amplitude vernier control for 8 divisions peak-to-peak display as indicated on oscilloscope.

www.valuetronics.com and adjust CW VERNIER and POWER LEVEL controls for signal display of 4 divisions peak-to-peak centered about 0V.

ADJUSTMENTS

5-18. FM FREQUENCY RESPONSE ADJUSTMENT (Cont'd)

- e. Select CH B. Adjust oscilloscope VOLTS/DIV CAL knob for 4 divisions of display.
- f. Set oscilloscope display to CHOP mode. CH A and CH B signal traces should coincide. If not, adjust CW VERNIER control to align both signal traces.
- g. Adjust function generator frequency range slowly between 1 kHz and 1 MHz and note variation of CH A display with respect to CH B display.
- h. Using oscilloscope vertical position controls, align both signal traces at bottom edge.
- i. Adjust LF (A1R21) to align CH A and CH B signal traces as closely as possible over function generator range of 1 kHz to 1 MHz.
- j. Adjust function generator frequency range slowly between 1 MHz and 5 MHz and note variation of CH A display with respect to CH B display.
- k. Adjust HF (A1R20) to align CH A and CH B signal traces as closely as possible over function generator range of 1 MHz to 5 MHz.
- l. Adjust function generator frequency range slowly between 5 MHz and 10 MHz and note variation of CH A display with respect to CH B display.
- m. Adjust Q (A1R14) to align CH A and CH B signal traces as closely as possible over function generator range of 5 MHz to 10 MHz.
- n. Repeat steps g through m as required to achieve best alignment of CH A and CH B traces over full frequency range of 1 kHz to 10 MHz.

SECTION VI REPLACEABLE PARTS

6-1. INTRODUCTION

6-2. This section contains information for ordering parts. Table 6-1 lists abbreviations used in the parts list and throughout the manual. Table 6-2 lists all replaceable parts in reference designator order. Table 6-3 contains names and addresses that correspond to the manufacturer's code numbers.

6-3. ABBREVIATIONS

6-4. Table 6-1 lists abbreviations used in the parts list, schematics and throughout the manual. In some cases, two forms of the abbreviation are given, one uses all capital letters, and one partial or no capitals. This occurs because the abbreviations in the parts list are always all capitals. However, in the schematics and other parts of the manual, other abbreviation forms are used with both lower case and upper case letters.

6-5. REPLACEABLE PARTS LIST

6-6. Table 6-2 is the list of replaceable parts and is organized as follows:

- a. Electrical assemblies and their components in alpha-numerical order by reference designation.
- b. Chassis-mounted parts in alpha-numeric order by reference designation.
- c. Miscellaneous parts.

- a. The Hewlett-Packard part number.
- b. The total quantity (Qty) in the instrument.
- c. The description of the part.
- d. The typical manufacturer of the part in a five-digit code.

NOTE

The total quantity for each part is given only once — at the first appearance of the part number in the list.

6-7. ORDERING INSTRUCTIONS

6-8. To order a part listed in the replaceable parts table, quote the Hewlett-Packard part number, indicate quantity required, and address the order to the nearest Hewlett-Packard office.

6-9. To order a part that is not listed in the replaceable parts table, include the instrument model number, instrument serial number, the description and function of the part, and the number of parts required. Address the order to the nearest Hewlett-Packard office.

Table 6-1. Reference Designations and Abbreviations (1 of 2)

REFERENCE DESIGNATIONS

A assembly	E miscellaneous electrical part	P electrical connector (movable portion); plug	U integrated circuit; microcircuit
AT attenuator; isolator; termination	F fuse	Q transistor; SCR; triode thyristor	V electron tube
B fan; motor	FL filter	R resistor	VR voltage regulator; breakdown diode
BT battery	H hardware	RT thermistor	W cable; transmission path; wire
C capacitor	HY circulator	S switch	X socket
CP coupler	J electrical connector (stationary portion); jack	T transformer	Y crystal unit (piezo-electric or quartz)
CR diode; diode thyristor; varactor	K relay	TB terminal board	Z tuned cavity; tuned circuit
DC directional coupler	L coil; inductor	TC thermocouple	
DL delay line	M meter	TP test point	
DS annunciator; signaling device (audible or visual); lamp; LED	MP miscellaneous mechanical part		

ABBREVIATIONS

A ampere	COEF coefficient	EDP electronic data processing	INT internal
ac alternating current	COM common	ELECT electrolytic	kg kilogram
ACCESS accessory	COMP composition	ENCAP encapsulated	kHz kilohertz
ADJ adjustment	COMPL complete	EXT external	$k\Omega$ kilohm
A/D analog-to-digital	CONN connector	F farad	kV kilovolt
AF audio frequency	CP cadmium plate	FET field-effect transistor	lb pound
AFC automatic frequency control	CRT cathode-ray tube	F/F flip-flop	LC inductance-capacitance
AGC automatic gain control	CTL complementary transistor logic	FH flat head	LED light-emitting diode
AL aluminum	CW continuous wave	FIL H filister head	LF low frequency
ALC automatic level control	cw clockwise	FM frequency modulation	LG long
AM amplitude modulation	cm centimeter	FP front panel	LH left hand
AMPL amplifier	D/A digital-to-analog	FREQ frequency	LIM limit
APC automatic phase control	dB decibel	FXD fixed	LIN linear taper (used in parts list)
ASSY assembly	dBm decibel referred to 1 mW	g gram	lin linear
AUX auxiliary	dc direct current	GE germanium	LK WASH lock washer
avg average	deg degree (temperature interval or difference)	GHz gigahertz	LO low; local oscillator
AWG American wire gauge	° degree (plane angle)	GL glass	LOG logarithmic taper (used in parts list)
BAL balance	°C degree Celsius (centigrade)	GND ground(ed)	log logarithm(ic)
BCD binary coded decimal	°F degree Fahrenheit	H henry	LPF low pass filter
BD board	°K degree Kelvin	h hour	LV low voltage
BE CU beryllium copper	DEPC deposited carbon	HET heterodyne	m meter (distance)
BFO beat frequency oscillator	DET detector	HEX hexagonal	mA milliamper
BH binder head	diam diameter	HD head	MAX maximum
BKDN breakdown	DIA diameter (used in parts list)	HDW hardware	M Ω megohm
BP bandpass	DIFF AMPL differential amplifier	HF high frequency	MEG meg (10 ⁶) (used in parts list)
BPF bandpass filter	div division	HG mercury	MET FLM metal film
BRS brass	DPDT double-pole, double-throw	HI high	MET OX metallic oxide
BWO backward-wave oscillator	DR drive	HP Hewlett-Packard	MF medium frequency; microfarad (used in parts list)
CAL calibrate	DSB double sideband	HPF high pass filter	MFR manufacturer
ccw counter-clockwise	DTL diode transistor logic	HR hour (used in parts list)	mg milligram
CER ceramic	DVM digital voltmeter	HV high voltage	MHz megahertz
CHAN channel	ECL emitter coupled logic	Hz Hertz	mH millihenry
cm centimeter	EMF electromotive force	IC integrated circuit	mho mho
CMO cabinet mount only		ID inside diameter	MIN minimum
COAX coaxial		IF intermediate frequency	min minute (time)
		IMPG impregnated	... ' minute (plane angle)
		IN inch	MINAT miniature
		INCD incandescent	mm millimeter
		INCL include(s)	
		INP input	
		INS insulation	

NOTE

All abbreviations in the parts list will be in upper-case.

Table 6-1. Reference Designations and Abbreviations (2 of 2)

MOD modulator	OD outside diameter	PWV peak working voltage	TD time delay
MOM momentary	OH oval head	RC resistance-capacitance	TERM terminal
MOS metal-oxide semiconductor	OP AMPL operational amplifier	RECT rectifier	TFT thin-film transistor
ms millisecond	OPT option	REF reference	TGL toggle
MTG mounting	OSC oscillator	REG regulated	THD thread
MTR meter (indicating device)	OX oxide	REPL replaceable	THRU through
mV millivolt	oz ounce	RF radio frequency	TI titanium
mVac millivolt, ac	Ω ohm	RFI radio frequency interference	TOL tolerance
mVdc millivolt, dc	P peak (used in parts list)	RH round head; right hand	TRIM trimmer
mVpk millivolt, peak	PAM pulse-amplitude modulation	RLC resistance-inductance-capacitance	TSTR transistor
mVp-p millivolt, peak-to-peak	PC printed circuit	RMO rack mount only	TTL transistor-transistor logic
mVrms millivolt, rms	PCM pulse-code modulation; pulse-count modulation	rms root-mean-square	TV television
mW milliwatt	PDM pulse-duration modulation	RND round	TVI television interference
MUX multiplex	PF picofarad	ROM read-only memory	TWT traveling wave tube
MY mylar	PH BRZ phosphor bronze	R&P rack and panel	U micro (10 ⁻⁶) (used in parts list)
μA microampere	PHL Phillips	RWV reverse working voltage	UF microfarad (used in parts list)
μF microfarad	PIN positive-intrinsic-negative	S scattering parameter	UHF ultrahigh frequency
μH microhenry	PIV peak inverse voltage	s second (time)	UNREG unregulated
μho micromho	pk peak second (plane angle)	V volt
μs microsecond	PL phase lock	S-B slow-blow (fuse) (used in parts list)	VA voltampere
μV microvolt	PLO phase lock oscillator	SCR silicon controlled rectifier; screw	Vac volts, ac
μVac microvolt, ac	PM phase modulation	SE selenium	VAR variable
μVdc microvolt, dc	PNP positive-negative-positive	SECT sections	VCO voltage-controlled oscillator
μVpk microvolt, peak	P/O part of	SEMICON semiconductor	Vdc volts, dc
μVp-p microvolt, peak-to-peak	POLY polystyrene	SHF superhigh frequency	VDCW volts, dc, working (used in parts list)
μVrms microvolt, rms	PORC porcelain	SI silicon	V(F) volts, filtered
μW microwatt	POS positive; position(s) (used in parts list)	SIL silver	VFO variable-frequency oscillator
nA nanoampere	POSN position	SL slide	VHF very-high frequency
NC no connection	POT potentiometer	SNR signal-to-noise ratio	Vpk volts, peak
N/C normally closed	p-p peak-to-peak	SPDT single-pole, double-throw	Vp-p volts, peak-to-peak
NE neon	PP peak-to-peak (used in parts list)	SPG spring	Vrms volts, rms
NEG negative	PPM pulse-position modulation	SR split ring	VTO voltage-tuned oscillator
nF nanofarad	PREAMPL preamplifier	SPST single-pole, single-throw	VTVM vacuum-tube voltmeter
NI PL nickel plate	PRF pulse-repetition frequency	SSB single sideband	V(X) volts, switched
N/O normally open	PRR pulse repetition rate	SST stainless steel	W watt
NOM nominal	ps picosecond	STL steel	W/ with
NORM normal	P/T point	SQ square	WIV working inverse voltage
NPN negative-positive-negative	PTM pulse-time modulation	SWR standing-wave ratio	WW wirewound
NPO negative-positive zero (zero temperature coefficient)	PWM pulse-width modulation	SYNC synchronize	W/O without
NRFR not recommended for field replacement		T timed (slow-blow fuse)	YIG yttrium-iron-garnet
NSR not separately replaceable		TA tantalum	Z ₀ characteristic impedance
ns nanosecond		TC temperature compensating	
nW nanowatt			
OBD order by description			

NOTE

All abbreviations in the parts list will be in upper-case.

MULTIPLIERS

Abbreviation	Prefix	Multiple
T	tera	10 ¹²
G	giga	10 ⁹
M	mega	10 ⁶
k	kilo	10 ³
da	deka	10
d	deci	10 ⁻¹
c	centi	10 ⁻²
m	milli	10 ⁻³
μ	micro	10 ⁻⁶
n	nano	10 ⁻⁹
p	pico	10 ⁻¹²
f	femto	10 ⁻¹⁵
a	atto	10 ⁻¹⁸

Table 6-2. Replaceable Parts

Reference Designation	HP Part Number	Qty	Description	Mfr Code	Mfr Part Number
A1	86245-60013	1	ASSEMBLY, FM DRIVER	28480	86245-60013
A1 (OPTION 008)	86245-60014	1	ASSEMBLY, FM DRIVER (OPTION 008)	28480	86245-60014
A1C1			NOT ASSIGNED		
A1C2			NOT ASSIGNED		
A1C3	0160-4084	23	CAPACITOR-FXD .1UF +/-20% 50VDC CER	28480	0160-4084
A1C3 (OPTION 008)	0160-3536	1	CAPACITOR-FXD 620PF +/-5% 100VDC MICA (OPTION 008)	28480	0160-3536
A1C	0160-4084	1	CAPACITOR-FXD .1UF +/-20% 50VDC CER (A1C1 NOT ASSIGNED FOR OPTION 008)	28480	0160-4084
A1C5	0160-2199	4	CAPACITOR-FXD 30PF +/-5% 300VDC MICA	28480	0160-2199
A1C6	0160-4084		CAPACITOR-FXD .1UF +/-20% 50VDC CER	28480	0160-4084
A1C7	0160-4084		CAPACITOR-FXD .1UF +/-20% 50VDC CER	28480	0160-4084
A1C8	0160-4084		CAPACITOR-FXD .1UF +/-20% 50VDC CER	28480	0160-4084
A1C9	0140-0197	1	CAPACITOR-FXD 180PF +/-5% 300VDC MICA	72136	DM15F181J0300MV1CR
A1C10	0160-4084		CAPACITOR-FXD .1UF +/-20% 50VDC CER	28480	0160-4084
A1C11	0160-4084		CAPACITOR-FXD .1UF +/-20% 50VDC CER	28480	0160-4084
A1C12	0160-0116	4	CAPACITOR-FXD 6.8UF +/-10% 35VDC TA	56289	150D685X903582
A1C13			NOT ASSIGNED		
A1C14			NOT ASSIGNED		
A1C15#	0160-3879		CAPACITOR-FXD .01UF +/-20% 100VDC CER FACTORY SELECTED PART	28480	0160-3879
A1C16#	0160-0575		CAPACITOR-FXD .047UF +/-20% 50 VDC CER FACTORY SELECTED PART	28480	0160-0575
A1C17#			FACTORY SELECTED PART (NOT NORMALLY LOADED)		
A1C18#			FACTORY SELECTED PART (NOT NORMALLY LOADED)		
A1C19	0160-4084		CAPACITOR-FXD .1UF +/-20% 50VDC CER	28480	0160-4084
A1C20	0160-0116		CAPACITOR-FXD 6.8UF +/-10% 35VDC TA	56289	150D685X903582
A1C21	0160-0116		CAPACITOR-FXD 6.8UF +/-10% 35VDC TA	56289	150D685X903582
A1C22	0160-0116		CAPACITOR-FXD 6.8UF +/-10% 35VDC TA	56289	150D685X903582
A1C23	0160-1746	1	CAPACITOR-FXD 15UF +/-10% 20VDC TA	56289	150D156X902058
A1CR1	1901-0033	8	DIODE-GEN PRP 180V 200MA DO-7	28480	1901-0033
A1CR2	1901-0033		DIODE-GEN PRP 180V 200MA DO-7 (A1CR2 NOT ASSIGNED FOR OPTION 008)	28480	1901-0033
A1CR3	1901-0033		DIODE-GEN PRP 180V 200MA DO-7	28480	1901-0033
A1CR4	1901-0033		DIODE-GEN PRP 180V 200MA DO-7	28480	1901-0033
A1J1	1250-0257	2	CONNECTOR-RF 8MB M PC 50-OHM	28480	1250-0257
A1J2	1250-0257		CONNECTOR-RF 8MB M PC 50-OHM	28480	1250-0257
A1L1	9100-1619	3	COIL-MLD 6.8UH 10% Q#50 .155DX,375LG-NOM	28480	9100-1619
A1L2	9100-1619		COIL-MLD 6.8UH 10% Q#50 .155DX,375LG-NOM	28480	9100-1619
A1MP1	5040-6853	1	EXTRACTOR, PC BOARD	28480	5040-6853
A1MP2	5000-9043	1	PINIP.C. BOARD EXTRACTOR	28480	5000-9043
A1MP3	1200-0173	2	INSULATOR-X8TR DAP=GL (FOR Q4)	28480	1200-0173
A1MP4	1200-0173		INSULATOR-X8TR DAP=GL (FOR Q5)	28480	1200-0173
A1MP5	1205-0033	2	HEAT SINK TO-S/TC=39=PKG (FOR Q4)	28480	1205-0033
A1MP6	1205-0033		HEAT SINK TO-S/TC=39=PKG (FOR Q5)	28480	1205-0033
A1Q1	1855-0093	18	TRANSISTOR J-FET N=CHAN D=MODE TO-18 SI	28480	1855-0093
A1Q2	1855-0020		TRANSISTOR J-FET N=CHAN D=MODE TO-18 SI	28480	1855-0020
A1Q3	1855-0093		TRANSISTOR J-FET N=CHAN D=MODE TO-18 SI (A1Q3 NOT ASSIGNED FOR OPTION 008)	28480	1855-0093
A1Q4	1854-0395	2	TRANSISTOR NPN SI TO-39 PD=10W FT=50MHZ	28480	1854-0395
A1Q5	1854-0395		TRANSISTOR NPN SI TO-39 PD=10W FT=50MHZ	28480	1854-0395
A1Q6	1854-0332	2	TRANSISTOR NPN SI TO-39 PD=1W FT=800MHZ	28480	1854-0332
A1Q7	1854-0332		TRANSISTOR NPN SI TO-39 PD=1W FT=800MHZ	28480	1854-0332
A1Q8	1853-0314	3	TRANSISTOR PNP 2N2905A SI TO-39 PD=600MH	04713	2N2905A
A1Q9	1854-0404	8	TRANSISTOR NPN SI TO-18 PD=360MH	28480	1854-0404
A1Q10	1854-0404		TRANSISTOR NPN SI TO-18 PD=360MH	28480	1854-0404
A1R1	0698-3150	3	RESISTOR 2.37K 1% .125W F TC#0+=100 (A1R1 NOT ASSIGNED FOR OPTION 008)	24546	C4=1/8-T0=2371-F
A1R2	2100-2574	1	RESISTOR-TRMR 500 10% C SIDE=ADJ 1=TRN	30983	ET50X501
A1R3	0757-0442	12	RESISTOR 10K 1% .125W F TC#0+=100	24546	C4=1/8-T0=1002-F
A1R4	0757-0442		RESISTOR 10K 1% .125W F TC#0+=100	24546	C4=1/8-T0=1002-F
A1R5	2100-2514	3	RESISTOR-TRMR 20K 10% C SIDE=ADJ 1=TRN	30983	ET50M203
A1R6	0757-0442		RESISTOR 10K 1% .125W F TC#0+=100	24546	C4=1/8-T0=1002-F
A1R7	0757-0442		RESISTOR 10K 1% .125W F TC#0+=100	24546	C4=1/8-T0=1002-F
A1R8	0757-0442		RESISTOR 10K 1% .125W F TC#0+=100	24546	C4=1/8-T0=1002-F
A1R9	0757-0436	3	RESISTOR 5.11K 1% .125W F TC#0+=100	24546	C4=1/8-T0=5111-F
A1R10					
A1R11	0698-3150		RESISTOR 2.37K 1% .125W F TC#0+=100	24546	C4=1/8-T0=2371-F
A1R12	0757-0274	1	RESISTOR 1.21K 1% .125W F TC#0+=100	24546	C4=1/8-T0=1213-F
A1R13	0757-0346	3	RESISTOR 10 1% .125W F TC#0+=100	24546	C4=1/8-T0=10R0-F
A1R14	0698-3622	2	RESISTOR 120 5% 2H HO TC#0+=200	28480	0698-3622
A1R15	2100-2514	1	RESISTOR-TRMR 500 10% C TOP=ADJ 1=TRN	73138	82PR500

www.valuetronics.com

Table 6-2. Replaceable Parts

Reference Designation	HP Part Number	Qty	Description	Mfr Code	Mfr Part Number	
A1R15	0698-3622	3	RESISTOR 120 5X 2W MO TC0+200	28480	0698-3622	
A1R16	0698-0084		RESISTOR 2.15K 1X .125W F TC0+100	24546	C4=1/8-T0=2151-F	
A1R17	0698-3446		RESISTOR 383 1X .125W F TC0+100	24546	C4=1/8-T0=383R-F	
A1R18	0757-0346		RESISTOR 10 1X .125W F TC0+100	24546	C4=1/8-T0=10R0-F	
A1R19	0757-0346		RESISTOR 10 1X .125W F TC0+100	24546	C4=1/8-T0=10R0-F	
A1R20	2100-1985	1	RESISTOR-TRMR 20 20X C TOP-ADJ 1-TRN	32997	3329H=1-20R	
A1R21	2100-2060		RESISTOR-TRMR 50 20X C TOP-ADJ 1-TRN	73138	82PR50	
A1R22	0698-3620		RESISTOR 100 5X 2W MO TC0+200	28480	0698-3620	
A1R23	0698-3620		RESISTOR 100 5X 2W MO TC0+200	28480	0698-3620	
A1R24	0698-0084		RESISTOR 2.15K 1X .125W F TC0+100	24546	C4=1/8-T0=2151-F	
A1R25	0757-0416	3	RESISTOR 511 1X .125W F TC0+100	24546	C4=1/8-T0=511R-F	
A1R26	2100-1758		RESISTOR-TRMR 1K 5X WW SIDE-ADJ 1-TRN	28480	2100-1758	
A1R27	0698-3445		RESISTOR 348 1X .125W F TC0+100	24546	C4=1/8-T0=348R-F	
A1R28			NOT ASSIGNED			
A1R29	0757-0280		RESISTOR 1K 1X .125W F TC0+100	24546	C4=1/8-T0=1001-F	
A1R30	0698-0084	3	RESISTOR 2.15K 1X .125W F TC0+100	24546	C4=1/8-T0=2151-F	
A1R31	0698-3446		RESISTOR 383 1X .125W F TC0+100	24546	C4=1/8-T0=383R-F	
A1R32	0757-0442		RESISTOR 10K 1X .125W F TC0+100 (A1R32 NOT ASSIGNED FOR OPTION 008)	24546	C4=1/8-T0=1002-F	
A1R33	0757-0442		RESISTOR 10K 1X .125W F TC0+100	24546	C4=1/8-T0=1002-F	
A1R34	0757-0416		RESISTOR 511 1X .125W F TC0+100	24546	C4=1/8-T0=511R-F	
A1R35	0757-0401	4	RESISTOR 100 1X .125W F TC0+100	24546	C4=1/8-T0=101-F	
A1R36	0757-0394		RESISTOR 51.1 1X .125W F TC0+100	24546	C4=1/8-T0=51R1-F	
A1R37	0683-1055		RESISTOR 1M 5X .25W FC TC=800/+900 (A1R37 NOT ASSIGNED FOR OPTION 008)	01121	CB1055	
A1R38	0757-0442		RESISTOR 10K 1X .125W F TC0+100	24546	C4=1/8-T0=1002-F	
A1R39	0683-1055		RESISTOR 1M 5X .25W FC TC=800/+900	01121	CB1055	
A1R40	0757-0440	3	RESISTOR 7.5K 1X .125W F TC0+100	24546	C4=1/8-T0=7501-F	
A1U1	1820-0223		IC 301 OP AMP T0-99	18324	LM301A	
A1W1	8159-0005		8	WIRE 22AWG W PVC 1X22 80C (OPTION 008 ONLY)	28480	8159-0005
A1W2	8159-0005			WIRE 22AWG W PVC 1X22 80C (REMOVED FOR OPTION 008)	28480	8159-0005
A1W3	8159-0005			WIRE 22AWG W PVC 1X22 80C (OPTION 008 ONLY)	28480	8159-0005
A1W4	8159-0005	WIRE 22AWG W PVC 1X22 80C (REMOVED FOR OPTION 008)		28480	8159-0005	
A1W5	8159-0005	WIRE 22AWG W PVC 1X22 80C (OPTION 008 ONLY)		28480	8159-0005	
A1W6	8159-0005	WIRE 22AWG W PVC 1X22 80C (OPTION 008 ONLY)		28480	8159-0005	
A1W7	8159-0005	WIRE 22AWG W PVC 1X22 80C (REMOVED FOR OPTION 008)		28480	8159-0005	
A2 (86242D)	86242-60052	1	ASSEMBLY, YIG DRIVER (86242D ONLY)	28480	86242-60052	
A2 (86250D)	86250-60059		ASSEMBLY, YIG DRIVER (86250D ONLY)	28480	86250-60059	
A2 (86245A)	86245-60011		ASSEMBLY, YIG DRIVER (86245A ONLY)	28480	86245-60011	
A2C1	0180-0094	1	CAPACITOR-FXD 100UF+75-10X 25VDC AL	56289	30D107Q025002	
A2C2	0180-0291		CAPACITOR-FXD 1UF+10X 35VDC TA	56289	150D105X9035A2	
A2C3	0160-0153		CAPACITOR-FXD 1000PF +-10X 200VDC POLYE	28480	0160-0153	
A2C4	0180-0228		CAPACITOR-FXD 22UF+10X 15VDC TA	56289	150D226X9015B2	
A2C5	0180-0197		CAPACITOR-FXD 2.2UF+10X 20VDC TA	56289	150D225X9020A2	
A2C6	0160-2257	1	CAPACITOR-FXD 10PF +-5X 500VDC CER 0+-60	28480	0160-2257	
A2C7	0160-0302		CAPACITOR-FXD .018UF +-10X 200VDC POLYE	28480	0160-0302	
A2C8	0180-0356		CAPACITOR-FXD 70UF+20-15X 15VDC TA	06001	69F23507	
A2C9	0160-2199		CAPACITOR-FXD 30PF +-5X 300VDC MICA	28480	0160-2199	
A2C10	0160-2199		CAPACITOR-FXD 30PF +-5X 300VDC MICA	28480	0160-2199	
A2C11	0160-2199	2	CAPACITOR-FXD 30PF +-5X 300VDC MICA	28480	0160-2199	
A2C12	0180-2186		CAPACITOR-FXD 300UF+20X 30VDC TA	06001	69F45507	
A2C13	0180-2186		CAPACITOR-FXD 300UF+20X 30VDC TA	06001	69F45507	
A2C14	0160-2406		CAPACITOR-FXD .27UF +-10X 80VDC POLYE	28480	0160-2406	
A2CR1	1901-0159	2	DIODE-PWR RECT 400V 750MA DO=41	28480	1901-0159	
A2CR2	1901-0025		DIODE-GEN PRP 100V 200MA DO=7	28480	1901-0025	
A2CR3	1901-0025		DIODE-GEN PRP 100V 200MA DO=7	28480	1901-0025	
A2CR4	1901-0025		DIODE-GEN PRP 100V 200MA DO=7	28480	1901-0025	
A2CR5	1901-0025		DIODE-GEN PRP 100V 200MA DO=7	28480	1901-0025	
A2CR6	1901-0159		DIODE-PWR RECT 400V 750MA DO=41	28480	1901-0159	
A2CR7	1910-0016		DIODE-GE 60V 60MA 1US DO=7	28480	1910-0016	
A2CR8	1901-0025	1	DIODE-GEN PRP 100V 200MA DO=7	28480	1901-0025	
A2CR9	1901-0025		DIODE-GEN PRP 100V 200MA DO=7	28480	1901-0025	
A2CR10	1901-0025		DIODE-GEN PRP 100V 200MA DO=7	28480	1901-0025	
A2CR11	1901-0025		DIODE-GEN PRP 100V 200MA DO=7	28480	1901-0025	
A2CR12	1901-0539	4	NOT ASSIGNED			
A2F1	2110-0047		DIODE-SCHOTTKY	28480	1901-0539	
A2F1	2110-0047	1	FUSE 1A 125V NORM-BLO .25X.27	71400	GMW=1	

Table 6-2. Replaceable Parts

Reference Designation	HP Part Number	Qty	Description	Mfr Code	Mfr Part Number	
A2K1	0490-0875	1	RELAY 2C 12VDC-COIL 2A 30VDC	28480	0490-0875	
A2Q1	1854-0404	5	TRANSISTOR NPN SI TO-18 PD=360MH	28480	1854-0404	
A2Q2	1853-0451		TRANSISTOR PNP SI TO-18 PD=360MH	28480	1853-0451	
A2Q3	1853-0451		TRANSISTOR PNP SI TO-18 PD=360MH	28480	1853-0451	
A2Q4	1854-0404		TRANSISTOR NPN SI TO-18 PD=360MH	28480	1854-0404	
A2Q5	1884-0073		THYRISTOR-SCR TO-5 VRRM=100	28480	1884-0073	
A2Q6	1854-0404	1	TRANSISTOR NPN SI TO-18 PD=360MH	28480	1854-0404	
A2Q7	1853-0038		TRANSISTOR PNP SI TO-39 PDR1W FT=100MHZ	28480	1853-0038	
A2Q8	1854-0404		TRANSISTOR NPN SI TO-18 PD=360MH	28480	1854-0404	
A2R1	0757-0397	1	RESISTOR 68.1 1% .125W F TC0+100	24546	C4=1/8-T0=68R1-F	
A2R2	0698-3447	1	RESISTOR 422 1% .125W F TC0+100	24546	C4=1/8-T0=422R-F	
A2R3	0811-1668	1	RESISTOR 1.5 5% 2W PW TC0+100	75042	BHM2=1R5=J	
A2R4	0757-0199	2	RESISTOR 21.5K 1% .125W F TC0+100	24546	C4=1/8-T0=2152-F	
A2R5	0757-0441	2	RESISTOR 8.25K 1% .125W F TC0+100	24546	C4=1/8-T0=8251-F	
A2R6	0757-0199	3	RESISTOR 21.5K 1% .125W F TC0+100	24546	C4=1/8-T0=2152-F	
A2R7	0757-0401		RESISTOR 100 1% .125W F TC0+100	24546	C4=1/8-T0=101-F	
A2R8	0757-0444		RESISTOR 12.1K 1% .125W F TC0+100	24546	C4=1/8-T0=1212-F	
A2R9	0757-0442		RESISTOR 10K 1% .125W F TC0+100	24546	C4=1/8-T0=1002-F	
A2R10	0757-0274		RESISTOR 3.16K 1% .125W F TC0+100	24546	C4=1/8-T0=3161-F	
A2R11	0698-0083		2	RESISTOR 1.96K 1% .125W F TC0+100	24546	C4=1/8-T0=1961-F
A2R12	0757-0444		RESISTOR 12.1K 1% .125W F TC0+100	24546	C4=1/8-T0=1212-F	
A2R13	2100-3103		3	RESISTOR-TRMR 10K 10% C SIDE-ADJ 17-TRN	02111	43P103
A2R14	0757-0440		RESISTOR 7.5K 1% .125W F TC0+100	24546	C4=1/8-T0=7501-F	
A2R15	0757-0439		1	RESISTOR 6.81K 1% .125W F TC0+100	24546	C4=1/8-T0=6811-F
A2R16	0757-0458	1	RESISTOR 51.1K 1% .125W F TC0+100	24546	C4=1/8-T0=5112-F	
A2R17	0698-3401	1	RESISTOR 215 1% .5W F TC0+100	28480	0698-3401	
A2R18	0757-0280	1	RESISTOR 1K 1% .125W F TC0+100	24546	C4=1/8-T0=1001-F	
A2R19	0757-0440	2	RESISTOR 61.9K 1% .125W F TC0+100	24546	C4=1/8-T0=6192-F	
A2R20	0757-0278	2	RESISTOR 1.78K 1% .125W F TC0+100	24546	C4=1/8-T0=1781-F	
A2R21	0757-0401	4	RESISTOR 100 1% .125W F TC0+100	24546	C4=1/8-T0=101-F	
A2R22	0811-1178		RESISTOR 6.19K 1% .125W PWH TC0+10	07088	KP61=6191=1	
A2R23	2100-3154		1	RESISTOR-TRMR 1K 10% C SIDE-ADJ 17-TRN	02111	43P102
A2R24 (86242D)	0757-0438		RESISTOR 5.11K 1% .125W F TC0+100	24546	C4=1/8-T0=5111-F	
A2R24 (86250D)	0811-3052		4	RESISTOR 2.61K 1% .125W PWH TC0+10	20940	114=1/8-D=2611=+19=1
A2R24 (86245A)	0811-1195		1	RESISTOR 2.15K 1% .125W PWH TC0+10	20940	114=1/8=2151-F
A2R25 (86245A)	0811-3052		RESISTOR 2.61K 1% .125W PWH TC0+10	20940	114=1/8-D=2611=+19=1	
A2R25 (86242/50)	0811-1175		1	RESISTOR 4.22K 1% .125W PWH TC0+10	07088	KP61=4221=1
A2R26	0757-0416		RESISTOR 511 1% .125W F TC0+100	24546	C4=1/8-T0=511R-F	
A2R27	0757-0441		RESISTOR 8.25K 1% .125W F TC0+100	24546	C4=1/8-T0=8251-F	
A2R28	0698-0085	1	RESISTOR 2.61K 1% .125W F TC0+100	24546	C4=1/8-T0=2611-F	
A2R29 (86242D)	2100-3103	RESISTOR-TRMR 10K 10% C SIDE-ADJ 17-TRN	02111	43P103		
A2R29 (86245/50)	2100-3161	2	RESISTOR-TRMR 20K 10% C SIDE-ADJ 17-TRN	02111	43P203	
A2R30	0757-0464	1	RESISTOR 90.9K 1% .125W F TC0+100	24546	C4=1/8-T0=9092-F	
A2R31	0698-3155	2	RESISTOR 4.64K 1% .125W F TC0+100	24546	C4=1/8-T0=4641-F	
A2R32	0698-0082	1	RESISTOR 464 1% .125W F TC0+100	24546	C4=1/8-T0=4640-F	
A2R33	2100-3103	RESISTOR-TRMR 10K 10% C SIDE-ADJ 17-TRN	02111	43P103		
A2R34 (86242D)	0757-0279	RESISTOR 3.16K 1% .125W F TC0+100	24546	C4=1/8-T0=3161-F		
A2R34 (86245/50)	0757-0440	RESISTOR 7.5K 1% .125W F TC0+100	24546	C4=1/8-T0=7501-F		
A2R35	0757-0278	RESISTOR 1.78K 1% .125W F TC0+100	24546	C4=1/8-T0=1781-F		
A2R36 (86242/50)	0698-3155	RESISTOR 4.64K 1% .125W F TC0+100	24546	C4=1/8-T0=4641-F		
A2R36 (86245A)	0698-3279	1	RESISTOR 4.99K 1% .125W F TC0+100	24546	C4=1/8-T0=4991-F	
A2R37	0757-0442	1	RESISTOR 10K 1% .125W F TC0+100	24546	C4=1/8-T0=1002-F	
A2R38	0698-3453		RESISTOR 196K 1% .125W F TC0+100	24546	C4=1/8-T0=1963-F	
A2R39	0811-3052		RESISTOR 2.61K 1% .125W PWH TC0+10	20940	114=1/8-D=2611=+19=1	
A2R40	0757-0442		RESISTOR 10K 1% .125W F TC0+100	24546	C4=1/8-T0=1002-F	
A2R41 (86242D)	0698-3154		RESISTOR 4.22K 1% .125W F TC0+100	24546	C4=1/8-T0=4221-F	
A2R41 (86250D)	0698-4444	1	RESISTOR 4.87K 1% .125W F TC0+100	24546	C4=1/8-T0=4871-F	
A2R41 (86245A)	0757-0438	RESISTOR 5.11K 1% .125W F TC0+100	24546	C4=1/8-T0=5111-F		
A2R42 (86242D)	0698-3558	1	RESISTOR 4.02K 1% .125W F TC0+100	24546	C4=1/8-T0=4021-F	
A2R42 (86250D)	0698-4442	1	RESISTOR 4.42K 1% .125W F TC0+100	24546	C4=1/8-T0=4421-F	
A2R42 (86245A)	0698-3150	RESISTOR 2.37K 1% .125W F TC0+100	24546	C4=1/8-T0=2371-F		

Table 6-2. Replaceable Parts

Reference Designation	HP Part Number	Qty	Description	Mfr Code	Mfr Part Number
A2R43 (86242D)	0757-0279		RESISTOR 3.16K 1% .125W F TC0+/-100 (86242D ONLY)	24546	C4=1/8-T0=3161-F
A2R43 (86250D)	0757-0444		RESISTOR 12.1K 1% .125W F TC0+/-100 (86250D ONLY)	24546	C4=1/8-T0=1212-F
A2R43 (86245A)	0698-8810	1	RESISTOR 27.4K 1% .125W F TC0+/-15 (86245A ONLY)	28480	0698-8810
A2R44	2100-3123	1	RESISTOR-TRMR 500 10X C SIDE-ADJ 17-TRN NOT ASSIGNED	02111	43P501
A2R45					
A2R46	0811-1178		RESISTOR 6.19K 1% .125W PWH TC0+/-10	07088	KP61=6191-1
A2R47	0811-1178		RESISTOR 6.19K 1% .125W PWH TC0+/-10	07088	KP61=6191-1
A2R48	0698-0083		RESISTOR 1.96K 1% .125W F TC0+/-100	24546	C4=1/8-T0=1961-F
A2R49	0811-1178		RESISTOR 6.19K 1% .125W PWH TC0+/-10	07088	KP61=6191-1
A2R50	0698-0024	1	RESISTOR 2.61K 1% .5W F TC0+/-100	28480	0698-0024
A2R51	0698-3437	1	RESISTOR 133 1% .125W F TC0+/-100	24546	C4=1/8-T0=133R-F
A2R52	0811-3052		RESISTOR 2.61K 1% .125W PWH TC0+/-10	20940	114=1/8-D=2611-+19=1
A2R53	0698-3157	1	RESISTOR 19.6K 1% .125W F TC0+/-100	24546	C4=1/8-T0=1962-F
A2R54	0757-0280		RESISTOR 1K 1% .125W F TC0+/-100	24546	C4=1/8-T0=1001-F
A2U1	1820-0223		IC 301 OP AMP T0=99	18324	LM301A
A2U2	1820-0223		IC 301 OP AMP T0=99	18324	LM301A
A2U3	1820-0223		IC 301 OP AMP T0=99	18324	LM301A
A2U4	1820-0223		IC 301 OP AMP T0=99	18324	LM301A
A2U5	1820-0196	1	IC 723 V RGLTR T0=100	04713	MC1723CG
A2VR1	1902-0048	1	DIODE-ZNR 6.81V 5% DO-7 PD=.4W TC=+.043%	28480	1902-0048
A2VR2	1902-0064	1	DIODE-ZNR 7.5V 5% DO-7 PD=.4W TC=+.05%	28480	1902-0064
A2VR3	1902-0244	1	DIODE-ZNR 30.1V 5% DO-15 PD=1W TC=+.075%	28480	1902-0244
A2VR4	1902-0692	3	DIODE-ZNR 6.3 1% DO-7 PD=.4W TC=+.001%	28480	1902-0692
A2VR5	1902-0692		DIODE-ZNR 6.3 1% DO-7 PD=.4W TC=+.001%	28480	1902-0692
A2VR6	1902-0692		DIODE-ZNR 6.3 1% DO-7 PD=.4W TC=+.001%	28480	1902-0692
A3	86245-60012	1	ASSEMBLY, ALC	28480	86245-60012
A3C1	0160-4084		CAPACITOR-FXD .1UF +/-20% 50VDC CER	28480	0160-4084
A3C2	0160-4084		CAPACITOR-FXD .1UF +/-20% 50VDC CER	28480	0160-4084
A3C3	0180-0291		CAPACITOR-FXD .1UF +/-10% 35VDC TA	56289	150D105X9035A2
A3C4	0160-4084		CAPACITOR-FXD .1UF +/-20% 50VDC CER	28480	0160-4084
A3C5	0160-4084		CAPACITOR-FXD .1UF +/-20% 50VDC CER	28480	0160-4084
A3C6	0180-0291		CAPACITOR-FXD .1UF +/-10% 35VDC TA	56289	150D105X9035A2
A3C7	0160-0945	1	CAPACITOR-FXD 910PF +/-5% 100VDC MICA	28480	0160-0945
A3C8	0160-4084		CAPACITOR-FXD .1UF +/-20% 50VDC CER	28480	0160-4084
A3C9	0160-4084		CAPACITOR-FXD .1UF +/-20% 50VDC CER	28480	0160-4084
A3C10	0160-4084		CAPACITOR-FXD .1UF +/-20% 50VDC CER	28480	0160-4084
A3C11	0160-4084		CAPACITOR-FXD .1UF +/-20% 50VDC CER	28480	0160-4084
A3C12	0180-0291		CAPACITOR-FXD .1UF +/-10% 35VDC TA	56289	150D105X9035A2
A3C13	0160-2207	1	CAPACITOR-FXD 300PF +/-5% 300VDC MICA	28480	0160-2207
A3C14	0160-2208	1	CAPACITOR-FXD 330PF +/-5% 300VDC MICA	28480	0160-2208
A3C15	0160-4084		CAPACITOR-FXD .1UF +/-20% 50VDC CER	28480	0160-4084
A3C16	0180-0197		CAPACITOR-FXD 2.2UF +/-10% 20VDC TA	56289	150D225X9020A2
A3C17	0160-4084		CAPACITOR-FXD .1UF +/-20% 50VDC CER	28480	0160-4084
A3C18	0180-0230		CAPACITOR-FXD .1UF +/-20% 50VDC TA	28480	0180-0230
A3C19	0180-0291		CAPACITOR-FXD .1UF +/-10% 35VDC TA	56289	150D105X9035A2
A3C20	0180-0228		CAPACITOR-FXD 22UF +/-10% 15VDC TA	56289	150D226X9015B2
A3C21	0160-4084		CAPACITOR-FXD .1UF +/-20% 50VDC CER	28480	0160-4084
A3C22	0180-0291		CAPACITOR-FXD .1UF +/-10% 35VDC TA	56289	150D105X9035A2
A3CR1	1901-0040	14	DIODE-SWITCHING 30V 50MA 2NS DO-35	28480	1901-0040
A3CR2	1901-0040		DIODE-SWITCHING 30V 50MA 2NS DO-35	28480	1901-0040
A3CR3	1901-0040		DIODE-SWITCHING 30V 50MA 2NS DO-35	28480	1901-0040
A3CR4	1901-0040		DIODE-SWITCHING 30V 50MA 2NS DO-35	28480	1901-0040
A3CR5	1901-0518	5	DIODE-SCHOTTKY	28480	1901-0518
A3CR6	1901-0040		DIODE-SWITCHING 30V 50MA 2NS DO-35	28480	1901-0040
A3CR7	1901-0040		DIODE-SWITCHING 30V 50MA 2NS DO-35	28480	1901-0040
A3CR8	1901-0040		DIODE-SWITCHING 30V 50MA 2NS DO-35	28480	1901-0040
A3CR9	1901-0040		DIODE-SWITCHING 30V 50MA 2NS DO-35	28480	1901-0040
A3CR10	1901-0040		DIODE-SWITCHING 30V 50MA 2NS DO-35	28480	1901-0040
A3CR11	1901-0518		DIODE-SCHOTTKY	28480	1901-0518
A3CR12	1901-0518		DIODE-SCHOTTKY	28480	1901-0518
A3CR13	1901-0518		DIODE-SCHOTTKY	28480	1901-0518
A3CR14	1901-0518		DIODE-SCHOTTKY	28480	1901-0518
A3CR15	1901-0040		DIODE-SWITCHING 30V 50MA 2NS DO-35	28480	1901-0040
A3CR16	1901-0040		DIODE-SWITCHING 30V 50MA 2NS DO-35	28480	1901-0040
A3CR17	1901-0040		DIODE-SWITCHING 30V 50MA 2NS DO-35	28480	1901-0040
A3CR18	1901-0040		DIODE-SWITCHING 30V 50MA 2NS DO-35	28480	1901-0040
A3CR19	1901-0539		DIODE-SCHOTTKY	28480	1901-0539
A3CR20	1901-0539		DIODE-SCHOTTKY	28480	1901-0539

Table 6-2. Replaceable Parts

Reference Designation	HP Part Number	Qty	Description	Mfr Code	Mfr Part Number
A3CR21	1901-0539		DIODE-SCHOTTKY	28480	1901-0539
A3CR22	1901-0040		DIODE-SWITCHING 30V 50MA 2NS DO-35	28480	1901-0040
A3CR23	1901-0033		DIODE-GEN PRP 180V 200MA DO-7	28480	1901-0033
A3CR24	1901-0033		DIODE-GEN PRP 180V 200MA DO-7	28480	1901-0033
A3L1	9100-1619		COIL-MLD 6,8UH 10% QW50 .155DX,375LG-NOM	28480	9100-1619
A3MP1	1200-0172	2	INSULATOR=XSTR DAP=GL (FOR Q2, Q4)	28480	1200-0172
A3MP2	1200-0172		INSULATOR=XSTR DAP=GL	28480	1200-0172
A3MP3	1205-0011	2	HEAT SINK TO-5/TO-39-PKG (FOR U2, U5)	28480	1205-0011
A3MP4	1205-0011		HEAT SINK TO-5/TO-39-PKG	28480	1205-0011
A3Q1	1855-0241	1	TRANSISTOR MOSFET N-CHAN E-MODE TO-72 SI	18324	80215
A3Q2	1855-0020		TRANSISTOR J-FET N-CHAN D-MODE TO-18 SI	28480	1855-0020
A3Q3	1855-0020		TRANSISTOR J-FET N-CHAN D-MODE TO-18 SI	28480	1855-0020
A3Q4	1855-0020		TRANSISTOR J-FET N-CHAN D-MODE TO-18 SI	28480	1855-0020
A3Q5	1855-0020		TRANSISTOR J-FET N-CHAN D-MODE TO-18 SI	28480	1855-0020
A3Q6	1855-0020		TRANSISTOR J-FET N-CHAN D-MODE TO-18 SI	28480	1855-0020
A3Q7	1855-0314		TRANSISTOR PNP 2N2905A SI TO-39 PD=600MW	04713	2N2905A
A3Q8	1855-0020		TRANSISTOR J-FET N-CHAN D-MODE TO-18 SI	28480	1855-0020
A3Q9	1855-0404		TRANSISTOR NPN SI TO-18 PD=360MW	28480	1855-0404
A3Q10	1855-0451		TRANSISTOR PNP SI TO-18 PD=360MW	28480	1855-0451
A3Q11	1855-0020		TRANSISTOR J-FET N-CHAN D-MODE TO-18 SI	28480	1855-0020
A3Q12	1855-0020		TRANSISTOR J-FET N-CHAN D-MODE TO-18 SI	28480	1855-0020
A3Q13	1855-0020		TRANSISTOR J-FET N-CHAN D-MODE TO-18 SI	28480	1855-0020
A3Q14	1855-0020		TRANSISTOR J-FET N-CHAN D-MODE TO-18 SI	28480	1855-0020
A3Q15	1855-0020		TRANSISTOR J-FET N-CHAN D-MODE TO-18 SI	28480	1855-0020
A3Q16	1855-0020		TRANSISTOR J-FET N-CHAN D-MODE TO-18 SI	28480	1855-0020
A3Q17	1855-0020		TRANSISTOR J-FET N-CHAN D-MODE TO-18 SI	28480	1855-0020
A3Q18	1855-0404		TRANSISTOR NPN SI TO-18 PD=360MW	28480	1855-0404
A3Q19	1855-0451		TRANSISTOR PNP SI TO-18 PD=360MW	28480	1855-0451
A3Q20	1855-0451		TRANSISTOR PNP SI TO-18 PD=360MW	28480	1855-0451
A3Q21	1855-0314		TRANSISTOR PNP 2N2905A SI TO-39 PD=600MW	04713	2N2905A
A3Q22	1855-0020		TRANSISTOR J-FET N-CHAN D-MODE TO-18 SI	28480	1855-0020
A3Q23	1855-0020		TRANSISTOR J-FET N-CHAN D-MODE TO-18 SI	28480	1855-0020
A3R1	0698-7253	10	RESISTOR 5.11K 1% .05W F TC0+100	24546	C3-1/8-T0-5111-0
A3R2	0698-7253		RESISTOR 5.11K 1% .05W F TC0+100	24546	C3-1/8-T0-5111-0
A3R3	0698-7253		RESISTOR 5.11K 1% .05W F TC0+100	24546	C3-1/8-T0-5111-0
A3R4	0698-7236	7	RESISTOR 1K 1% .05W F TC0+100	24546	C3-1/8-T0-1001-0
A3R5	0698-7272	2	RESISTOR 31.6K 1% .05W F TC0+100	24546	C3-1/8-T0-3162-0
A3R6	0698-7279	2	RESISTOR 61.9K 1% .05W F TC0+100	24546	C3-1/8-T0-6192-0
A3R7	0698-7272		RESISTOR 31.6K 1% .05W F TC0+100	24546	C3-1/8-T0-3162-0
A3R8	0698-7229	1	RESISTOR 511 1% .05W F TC0+100	24546	C3-1/8-T0-511R-0
A3R9	0698-7252	1	RESISTOR 4.64K 1% .05W F TC0+100	24546	C3-1/8-T0-4641-0
A3R10	0698-7268	8	RESISTOR 21.5K 1% .05W F TC0+100	24546	C3-1/8-T0-2152-0
A3R11	0698-7236		RESISTOR 1K 1% .05W F TC0+100	24546	C3-1/8-T0-1001-0
A3R12	0698-7274	2	RESISTOR 38.3K 1% .05W F TC0+100	24546	C3-1/8-T0-3832-0
A3R13	0698-7274		RESISTOR 38.3K 1% .05W F TC0+100	24546	C3-1/8-T0-3832-0
A3R14	0698-7271	1	RESISTOR 28.7K 1% .05W F TC0+100	24546	C3-1/8-T0-2872-0
A3R15	0698-7279		RESISTOR 61.9K 1% .05W F TC0+100	24546	C3-1/8-T0-6192-0
A3R16	0698-7284		RESISTOR 100K 1% .05W F TC0+100	24546	C3-1/8-T0-1003-0
A3R17	0698-7268		RESISTOR 21.5K 1% .05W F TC0+100	24546	C3-1/8-T0-2152-0
A3R18	0698-7236		RESISTOR 1K 1% .05W F TC0+100	24546	C3-1/8-T0-1001-0
A3R19	2100-2521	1	RESISTOR=TRMR 2K 10% C SIDE=ADJ 1-TRN	30983	ET50X202
A3R20	0698-7264		RESISTOR 100K 1% .05W F TC0+100	24546	C3-1/8-T0-1003-0
A3R21	0698-7258	3	RESISTOR 8.25K 1% .05W F TC0+100	24546	C3-1/8-T0-8251-0
A3R22	0698-7236		RESISTOR 1K 1% .05W F TC0+100	24546	C3-1/8-T0-1001-0
A3R23	0698-7260	11	RESISTOR 10K 1% .05W F TC0+100	24546	C3-1/8-T0-1002-0
A3R24	0698-7260		RESISTOR 10K 1% .05W F TC0+100	24546	C3-1/8-T0-1002-0
A3R25	0698-7212	2	RESISTOR 100 1% .05W F TC0+100	24546	C3-1/8-T0-100R-0
A3R26	0698-7227	1	RESISTOR 422 1% .05W F TC0+100	24546	C3-1/8-T0-422R-0
A3R27	0698-7260		RESISTOR 10K 1% .05W F TC0+100	24546	C3-1/8-T0-1002-0
A3R28	0698-7270	2	RESISTOR 26.1K 1% .05W F TC0+100	24546	C3-1/8-T0-2612-0
A3R29	0757-0460		RESISTOR 61.9K 1% .125W F TC0+100	24546	C3-1/8-T0-6192-F
A3R30	2100-2522	1	RESISTOR=TRMR 10K 10% C SIDE=ADJ 1-TRN	30983	ET50X103
A3R31	2100-2489	2	RESISTOR=TRMR 5K 10% C SIDE=ADJ 1-TRN	30983	ET50X502
A3R32	2100-2514		RESISTOR=TRMR 20K 10% C SIDE=ADJ 1-TRN	30983	ET50X203
A3R33	2100-2514		RESISTOR=TRMR 20K 10% C SIDE=ADJ 1-TRN	30983	ET50X203
A3R34	0698-7258		RESISTOR 8.25K 1% .05W F TC0+100	24546	C3-1/8-T0-8251-0
A3R35	0698-7253		RESISTOR 5.11K 1% .05W F TC0+100	24546	C3-1/8-T0-5111-0
A3R36	0698-7260		RESISTOR 10K 1% .05W F TC0+100	24546	C3-1/8-T0-1002-0
A3R37	0698-7253		RESISTOR 5.11K 1% .05W F TC0+100	24546	C3-1/8-T0-5111-0
A3R38	0698-7258		RESISTOR 8.25K 1% .05W F TC0+100	24546	C3-1/8-T0-8251-0
A3R39	0698-7253		RESISTOR 5.11K 1% .05W F TC0+100	24546	C3-1/8-T0-5111-0
A3R40	0698-7253		RESISTOR 5.11K 1% .05W F TC0+100	24546	C3-1/8-T0-5111-0

Table 6-2. Replaceable Parts

Reference Designation	HP Part Number	Qty	Description	Mfr Code	Mfr Part Number
A3R01	0698-7264	1	RESISTOR 14.7K 1% .05W F TC=0+100	24546	C3-1/8-T0-1472-G
A3R02	0698-7253	1	RESISTOR 5.11K 1% .05W F TC=0+100	24546	C3-1/8-T0-5111-G
A3R03	0698-7253	1	RESISTOR 5.11K 1% .05W F TC=0+100	24546	C3-1/8-T0-5111-G
A3R04	0698-7260	1	RESISTOR 10K 1% .05W F TC=0+100	24546	C3-1/8-T0-1002-G
A3R05	0698-7283	2	RESISTOR 90.9K 1% .05W F TC=0+100	24546	C3-1/8-T0-9092-G
A3R06	0698-7283	1	RESISTOR 90.9K 1% .05W F TC=0+100	24546	C3-1/8-T0-9092-G
A3R07	0698-7284	1	RESISTOR 100K 1% .05W F TC=0+100	24546	C3-1/8-T0-1003-G
A3R08	0698-7288	1	RESISTOR 147K 1% .05W F TC=0+100	24546	C3-1/8-T0-1473-G
A3R09	0698-7287	1	RESISTOR 133K 1% .05W F TC=0+100	24546	C3-1/8-T0-1333-G
A3R50	0698-7280	2	RESISTOR 68.1K 1% .05W F TC=0+100	24546	C3-1/8-T0-6812-G
A3R51	0698-7269	1	RESISTOR 23.7K 1% .05W F TC=0+100	24546	C3-1/8-T0-2372-G
A3R52	2100-2433	1	RESISTOR-TRMR 1K 10% C SIDE-ADJ 1-TRN	30983	ET50X102
A3R53	2100-3161	1	RESISTOR-TRMR 20K 10% C SIDE-ADJ 17-TRN	02111	43P203
A3R54	0698-7260	1	RESISTOR 10K 1% .05W F TC=0+100	24546	C3-1/8-T0-1002-G
A3R55	0698-7260	1	RESISTOR 10K 1% .05W F TC=0+100	24546	C3-1/8-T0-1002-G
A3R56	2100-2489	1	RESISTOR-TRMR 5K 10% C SIDE-ADJ 1-TRN	30983	ET50X502
A3R57	0698-7212	2	RESISTOR 100 1% .05W F TC=0+100	24546	C3-1/8-T0-100R-G
A3R58	0698-7248	1	RESISTOR 3.16K 1% .05W F TC=0+100	24546	C3-1/8-T0-3161-G
A3R59	0698-7263	1	RESISTOR 13.3K 1% .05W F TC=0+100	24546	C3-1/8-T0-1332-G
A3R60	0698-7260	1	RESISTOR 10K 1% .05W F TC=0+100	24546	C3-1/8-T0-1002-G
A3R61	0698-7236	1	RESISTOR 1K 1% .05W F TC=0+100	24546	C3-1/8-T0-1001-G
A3R62	2100-2516	1	RESISTOR-TRMR 100K 10% C SIDE-ADJ 1-TRN	73138	82PAR100K
A3R63	0698-7251	1	RESISTOR 4.22K 1% .05W F TC=0+100	24546	C3-1/8-T0-4221-G
A3R64	0698-7277	1	RESISTOR 51.1K 1% .05W F TC=0+100	24546	C3-1/8-T0-5112-G
A3R65	0698-7260	1	RESISTOR 10K 1% .05W F TC=0+100	24546	C3-1/8-T0-1002-G
A3R66	0698-7260	1	RESISTOR 10K 1% .05W F TC=0+100	24546	C3-1/8-T0-1002-G
A3R67	0698-7268	1	RESISTOR 21.5K 1% .05W F TC=0+100	24546	C3-1/8-T0-2152-G
A3R68	0698-7248	1	RESISTOR 3.16K 1% .05W F TC=0+100	24546	C3-1/8-T0-3161-G
A3R69	0757-0401	1	RESISTOR 100 1% .125W F TC=0+100	24546	C4-1/8-T0-101-F
A3R70	0698-3444	1	RESISTOR 316 1% .125W F TC=0+100	24546	C4-1/8-T0-316R-F
A3R71	0757-0280	1	RESISTOR 1K 1% .125W F TC=0+100	24546	C4-1/8-T0-1001-F
A3R72	0698-7246	1	RESISTOR 2.61K 1% .05W F TC=0+100	24546	C3-1/8-T0-2611-G
A3R73	0698-7284	1	RESISTOR 100K 1% .05W F TC=0+100	24546	C3-1/8-T0-1003-G
A3R74	0698-7270	1	RESISTOR 26.1K 1% .05W F TC=0+100	24546	C3-1/8-T0-2612-G
A3R75	0698-7253	1	RESISTOR 5.11K 1% .05W F TC=0+100	24546	C3-1/8-T0-5111-G
A3R76	0698-7238	1	RESISTOR 1.21K 1% .05W F TC=0+100	24546	C3-1/8-T0-1211-G
A3R77	0698-3439	1	RESISTOR 178 1% .125W F TC=0+100	24546	C4-1/8-T0-178R-F
A3R78	0698-7236	1	RESISTOR 1K 1% .05W F TC=0+100	24546	C3-1/8-T0-1001-G
A3R79	0698-7267	1	RESISTOR 19.6K 1% .05W F TC=0+100	24546	C3-1/8-T0-1962-G
A3R80	0698-7264	1	RESISTOR 100K 1% .05W F TC=0+100	24546	C3-1/8-T0-1003-G
A3R81	0698-7280	1	RESISTOR 68.1K 1% .05W F TC=0+100	24546	C3-1/8-T0-6812-G
A3R82	0698-7284	1	RESISTOR 100K 1% .05W F TC=0+100	24546	C3-1/8-T0-1003-G
A3R83	2100-2517	1	RESISTOR-TRMR 50K 10% C SIDE-ADJ 1-TRN	30983	ET50X503
A3R84	0698-7260	1	RESISTOR 10K 1% .05W F TC=0+100	24546	C3-1/8-T0-1002-G
A3R85	0698-7260	1	RESISTOR 10K 1% .05W F TC=0+100	24546	C3-1/8-T0-1002-G
A3R86	0683-1055	1	RESISTOR 1M 5% .25W FC TC=800/+900	01121	CB1055
A3R87	0683-1055	1	RESISTOR 1M 5% .25W FC TC=800/+900	01121	CB1055
A3S1	3101-1273	2	SWITCH-8L DPDT-N8 SUBMIN 2A 120VAC PC	28480	3101-1273
A3S2	3101-1273	2	SWITCH-8L DPDT-N8 SUBMIN 2A 120VAC PC	28480	3101-1273
A3U1	1826-0092	2	IC OP AMP T0-99	28480	1826-0092
A3U2	1826-0319	1	IC OP AMP T0-99	27014	LF356H
A3U3	1820-1543	1	IC 8FR CMOS NON-INV HEX 1-INP	01928	CD4050AF
A3U4	1820-1538	1	IC GATE CMOS NAND QUAD 2-INP	01928	CD4011AF
A3U5	1826-0357	1	IC OP AMP T0-99	27014	LF357H
A3U6	1826-0092	1	IC OP AMP T0-99	28480	1826-0092
A3VR1	1902-0554	2	DIODE-ZNR 10V 5% DO-15 PD=1W TC=+.06%	28480	1902-0554
A3VR2	1902-0554	2	DIODE-ZNR 10V 5% DO-15 PD=1W TC=+.06%	28480	1902-0554
A3VR3	1902-0041	4	DIODE-ZNR 5.11V 5% DO-7 PD=.4W TC=+.009%	28480	1902-0041
A3VR4	1902-3234	1	DIODE-ZNR 19.6V 5% DO-7 PD=.4W TC=+.073%	28480	1902-3234
A3VR5	1902-3070	1	DIODE-ZNR 4.22V 5% DO-7 PD=.4W TC=+.038%	28480	1902-3070
A3VR6	1902-0041	1	DIODE-ZNR 5.11V 5% DO-7 PD=.4W TC=+.009%	28480	1902-0041
A4 (86242D)	5086-7274	1	Oscillator, 5.9-9 GHz, J-BAND (FOR 86242D ONLY)	28480	5086-7274
A4 (86242D)	5086-6274	1	RESTORED 5086-7274; EXCHANGE REQUIRED	28480	5086-6274
A4 (86250D)	5086-7277	1	Oscillator, 8.0-12.4 GHz, X-BAND (FOR 86250D ONLY)	28480	5086-7277
A4 (86250D)	5086-6277	1	RESTORED 5086-7277; EXCHANGE REQUIRED	28480	5086-6277
A4 (86245A)	5086-7290	1	Oscillator, 5.9-12.4 GHz (86245A ONLY)	28480	5086-7290
A4 (86245A)	5086-6290	1	RESTORED 5086-7290; EXCHANGE REQUIRED	28480	5086-6290
A5 (86242/50)	5086-7215	1	MODULATOR (86242D/86250D ONLY)	28480	5086-7215
A5 (86242/50)	5086-6215	1	RESTORED 5086-7215; EXCHANGE REQUIRED	28480	5086-6215
A5 (86245A OPT 001)	5086-7293	1	MODULATOR/AMPLIFIER (86245A OPTION 001 ONLY) CAN BE USED AS ALTERNATE FOR 5086-7298	28480	5086-7293
A5 (86245A OPT 001)	5086-6293	1	RESTORED 5086-7293; EXCHANGE REQUIRED	28480	5086-6293
A5 (86245A STD)	5086-7298	1	MODULATOR/AMPLIFIER (86245A STANDARD)	28480	5086-7298
A5 (86245A STD)	5086-6298	1	RESTORED 5086-7298; EXCHANGE REQUIRED	28480	5086-6298
A6	86245-60010	1	ASSEMBLY, ALC/YIG INTERCONNECT	28480	86245-60010

Table 6-2. Replaceable Parts

Reference Designation	HP Part Number	Qty	Description	Mfr Code	Mfr Part Number
A6CR1 A6CR2	1901-0033 1901-0033		DIODE=GEN PRP 180V 200MA DO=7 DIODE=GEN PRP 180V 200MA DO=7	28480 28480	1901-0033 1901-0033
A6S	8159-0005		WIRE 22AWG W PVC 1X22 80C (REMOVED FOR OPTION 001)	28480	8159-0005
A6VR1 A6VR2	1902-0041 1902-0041		DIODE=ZNR 5.11V 5% DO=7 PDM=.4W TCM=,009% DIODE=ZNR 5.11V 5% DO=7 PDM=.4W TCM=,009%	28480 28480	1902-0041 1902-0041
A6X42 A6X43	1251-1886 1251-1886	3	CONNECTOR=PC EDGE 15=CONT/ROW 2=ROWS CONNECTOR=PC EDGE 15=CONT/ROW 2=ROWS	28480 28480	1251-1886 1251-1886
A7	86242-60029	1	ASSEMBLY, FM INTERCONNECT	28480	86242-60029
A7J1	1200-0507	2	SOCKET=IC 16=CONT DIP=8LDR	28480	1200-0507
A7MP1 A7MP2 A7MP3 A7MP4	1251-2313 1251-2313 1251-2613 1251-2613	2	CONNECTOR=8GL CONT 8KT .04=IN=88C=8Z RND CONNECTOR=8GL CONT 8KT .04=IN=88C=8Z RND CONNECTOR=8GL CONT 8KT .033=IN=88C=8Z CONNECTOR=8GL CONT 8KT .033=IN=88C=8Z	28480 28480 28480 28480	1251-2313 1251-2313 1251-2613 1251-2613
A7XA1 A7XA5 (86245A)	1251-1886 1251-0478	1	CONNECTOR=PC EDGE 15=CONT/ROW 2=ROWS CONNECTOR=PC EDGE 8=CONT/ROW 2=ROWS (86245A ONLY)	28480 28480	1251-1886 1251-0478
A8	86242-60027	1	ASSEMBLY, REAR INTERCONNECT	28480	86242-60027
A8J1	1200-0507		SOCKET=IC 16=CONT DIP=8LDR	28480	1200-0507
A8R1	0698-7236		RESISTOR 1K 1% .05W F TC=0+-100	24546	C3-1/8-10-1001-0
A9	0960-0499	3	ISOLATOR	28480	0960-0499
A10	0960-0499		ISOLATOR (NOT ASSIGNED FOR 86245A)	28480	0960-0499
A11 (OPT 008)	0960-0499		ISOLATOR (OPTION 008 ONLY)	28480	0960-0499

Table 6-2. Replaceable Parts

Reference Designation	HP Part Number	Qty	Description	Mfr Code	Mfr Part Number
CHASSIS MOUNTED PARTS					
CR1	86290-60045	1	DETECTOR ASSEMBLY, (OPTION 001)	28480	86290-60045
DC1	0955-0111	1	DIRECTIONAL COUPLER (OPTION 001)	28480	0955-0111
DB1	1990-0325	1	LED-VISIBLE LUM=INT#800UCD IF#50MA=MAX	28480	5062-4403
FL1 (86242D)	86342-20009	1	FILTER ASSEMBLY (86242D ONLY)	28480	86342-20009
FL1 (86245/50)	86245-20005	1	FILTER ASSEMBLY (86245A/86250D ONLY)	28480	86245-20005
J1			CONNECTOR, RF OUTPUT		
J2	1250-0118	1	CONNECTOR=RF BNC FEM 8GL=HOLE=FR 50=OHM (EXT INPUT)	28480	1250-0118
J3	1250-0083	2	CONNECTOR=RF BNC FEM 8GL=HOLE=FR 50=OHM (FM)	28480	1250-0083
J4	1250-0083		CONNECTOR=RF BNC FEM 8GL=HOLE=FR 50=OHM (FREQ. REFERENCE)	28480	1250-0083
MP1	1250-1397	2	ADAPTER=COAX RTANG M=8MA M=8MA	28480	1250-1397
MP2 (86242/50)	1250-1397		ADAPTER=COAX RTANG M=8MA M=8MA (MOD=180L, 86242D/86250D ONLY)	28480	1250-1397
P4	1251-0483	1	CONNECTOR 36=PIN M MICRO RIBBON	28480	1251-0483
Q1	1853-0252	1	TRANSISTOR PNP 81 TO=3 PD=150H FT=4MHZ	28480	1853-0252
Q2	1854-0072	1	TRANSISTOR NPN 2N3054 81 TO=66 PD=25W	01928	2N3054
		2			
R1	0811-2650	2	RESISTOR 50 3% 12W PH TC=0+-30	28480	0811-2650
		1			
R2	0811-1227		RESISTOR 100 1% 12W PH TC=0+-20	91637	RK10-12-19-101-F
R3	2100-2930	1	RESISTOR-VAR CONTROL CCP 1K 10% DBC (POWER LEVEL)	28480	2100-2930
R4	2100-2492	1	RESISTOR-VAR CONTROL CCP 5K 20% LIN (GAIN)	28480	2100-2492
R5 (OPTION 008)	0757-0398	1	RESISTOR 75 1% .125W F TC=0+-100 (OPTION 008)	24546	CA=1/8-YO-75R0-F
S1	3101-0070	2	SWITCH=8L DPDT=N8 MINTR .5A 125VAC/DC LRF OFF=ON	28480	3101-0070
S2	3101-0070		SWITCH=8L DPDT=N8 MINTR .5A 125VAC/DC (ALC)	28480	3101-0070
S3	3101-0106	1	SWITCH=8L DP3T=N8 STD .5A 125VAC/DC (FM=NORM=PL)	28480	3101-0106
W1	86242-60031	1	INTERCONNECT CABLE, REAR	28480	86242-60031
W1P5	1251-2615	2	CONNECTOR 16=PIN M RECTANGULAR	28480	1251-2615
W2	86242-60030	1	INTERCONNECT CABLE, FRONT	28480	86242-60030
W2P6	1251-2615	1	CONNECTOR 16=PIN M RECTANGULAR	28480	1251-2615
W3 (86245A)	86242-20030	1	CABLE, RF 180=MOD, (86245A ONLY)	28480	86242-20030
W3 (86242/50)	86242-20041	1	CABLE, RF 180=MOD, (86242D/86250D ONLY)	28480	86242-20041
W4	86250-60026	1	CABLE ASSEMBLY, FM DRIVER, YELLOW	28480	86250-60026
W5	86250-60025	1	CABLE ASSEMBLY, FM INPUT, GREEN	28480	86250-60025
W6 (86242/50 OPT 001)	86242-20044	1	CABLE, FILTER-COUPLER (86242D/86250D, OPTION 001)	28480	86242-20044
W6 (86245A OPT 001)	86245-20001	1	CABLE, FILTER-COUPLER (86245A, OPT 001)	28480	86245-20001
W7	86250-60028	1	CABLE ASSEMBLY, ALC-DET, BROWN (OPT 001)	28480	86250-60028
W8 (86245A)	86242-20033	1	CABLE, RF FILTER-BULKHEAD (86245A ONLY)	28480	86250-60033
W8 (86242/50)	86242-20042	1	CABLE, RF FILTER-BULKHEAD (86242D/250D ONLY)	28480	86242-20042
W9	86250-20012	1	CABLE, RF OUTPUT	28480	86250-20012
W10	86250-20013	1	CABLE, RF REAR OUTPUT (OPT. 004 ONLY)	28480	86250-20013
W11	5020-9155	1	CABLE, RF OSC=180	28480	5020-9155
W12 (86242/50)	86250-60034	1	CABLE, MODULATOR DRIVE (86242D/86250D) NOT ASSIGNED (86245A ONLY)	28480	86250-60034
W12 (86245A)					
W13 (OPTION 008)	86245-20002	1	CABLE, RF BULKHEAD=180 (OPT 008 ONLY)	28480	86245-20002
W14 (OPTION 008)	86245-20003	1	CABLE, RF 180=OUT (OPT. 008 ONLY)	28480	86245-20003
FRONT PANEL					
	86245-00001	1	PANEL, UPPER FRONT (86245A)	28480	86245-00001
	86242-00017	1	PANEL, UPPER FRONT (86242D)	28480	86242-00017
	86250-00024	1	PANEL, UPPER FRONT (86250D)	28480	86250-00024
	86250-00017	1	PANEL, LOWER FRONT	28480	86250-00017
	86250-00018	1	PANEL, LOWER FRONT (OPTION 001)	28480	86250-00018

Table 6-2. Replaceable Parts

Reference Designation	HP Part Number	Qty	Description	Mfr Code	Mfr Part Number
	86250-00019	1	PANEL, LOWER FRONT (OPTION 004 ONLY)	28480	86250-00019
	86250-00021	1	PANEL, LOWER FRONT (OPT. 001/004 ONLY)	28480	86250-00021
	86250-20022	1	SUB-PANEL	28480	86250-20022
	0370-1001	1	KNDS=BASE 3/8 JGK ,125-IN-ID (GAIN)	28480	0370-1001
	0370-1101	1	KNDS=BASE=PTR 1/2 OBP ,125-IN-ID (POWER LEVEL)	28480	0370-1101
	5040-6936	1	LEVER SLIDE SWITCH, (RF OFF-ON)	28480	5040-6936
	08640-40052	1	LEVER, SLIDE SWITCH (ALC)	28480	08640-40052
	1400-0560	1	CLAMP/HOLDER=COMPNT/CA (MISC) (FOR UNLEVELED LAMP)	28480	1400-0560
	08731-210	1	NUT, LOCK (RF OUTPUT)	28480	08731-210
	00692-210	1	PIN KEY (RF OUTPUT)	28480	00692-210
	08621-20051	1	HANDLE, DRAWER LATCH	28480	08621-20051
	08621-20052	1	SCREW, DRAWER LATCH	28480	08621-20052
	1460-1186	1	SPRING, DRAWER LATCH	28480	1460-1186
CHASSIS PARTS					
	86245-00003	1	PLATE, SWITCH (OPTION 008)	28480	86245-00003
	86242-00005	1	DECK, MAIN	28480	86242-00005
	86230-00007	1	BRACE, FRAME, LEFT	28480	86230-00007
	86230-00006	1	BRACE, FRAME, RIGHT	28480	86230-00006
	6960-0016	2	PLUG-HOLE TR=HD FOR ,125=D-HOLE NYL	28480	6960-0016
	86242-00018	1	BRACKET, MODULATOR MOUNT (86242D/86250D)	28480	86242-00018
	86242-00007	1	BRACKET, RF CONNECTOR	28480	86242-00007
	86245-00005	1	BRACKET, ISOLATOR (OPTION 008)	28480	86245-00005
	86245-00002	1	BRACKET, DETECTOR (OPTION 001)	28480	86245-00002
	86250-00003	1	HEAT SINK, OSCILLATOR	28480	86250-00003
	86242-00008	1	CLAMP, OSCILLATOR	28480	86242-00008
	0340-0162	1	INSULATOR-XSTR. ALUMINUM (FOR Q2)	28480	0340-0162
	1200-0043	1	INSULATOR-XSTR. ALUMINUM (FOR Q3)	28480	1200-0043
REAR PANEL					
	08621-20002	1	FRAME, DRAWER REAR	28480	08621-20002
	08621-00005	1	COVER, REAR	28480	08621-00005
	6960-0046	1	PLUG-HOLE DOME=HD FOR ,688=D-HOLE BRG (FOR REAR PANEL RF OUT WHEN OPT. 004 NOT INSTALLED)	28480	6960-0046
	5040-0345	2	INSULATOR/CONNECTOR (FOR FM CONNECTOR)	28480	5040-0345
ACCESSORIES					
	86342-00001	1	SCALE, 5.9-9.0 GHZ (86242D ONLY)	28480	86342-00001
	86245-00004	1	SCALE, 5.9-12.4 GHZ (86245A ONLY)	28480	86245-00004
	86250-00001	1	SCALE, 6.0-12.4 GHZ (86250D ONLY)	28480	86250-00001

Table 6-3. Manufacturers Code List

MFR NO.	MANUFACTURER NAME	ADDRESS	ZIP CODE
01928	RCA CORP SOLID STATE DIV	BOMERVILLE NJ	08876
02111	SPECTROL ELECTRONICS CORP	CITY OF IND CA	91745
04713	MOTOROLA SEMICONDUCTOR PRODUCTS	PHOENIX AZ	85062
06001	GE CO ELEK CAP & BAT PROD DEPT	IRMO SC	29063
07088	KELVIN ELECTRIC CO	VAN NUYS CA	91411
18324	SIGNETICS CORP	SUNNYVALE CA	94086
19701	MEPCO/ELECTRA CORP	MINERAL WELLS TX	76067
20940	MICRO-OHM CORP	EL MONTE CA	91731
24546	CORNING GLASS WORKS (BRADFORD)	BRADFORD PA	16701
27014	NATIONAL SEMICONDUCTOR CORP	SANTA CLARA CA	95051
28480	HEWLETT-PACKARD CO CORPORATE HQ	PALO ALTO CA	94304
30983	MEPCO/ELECTRA CORP	SAN DIEGO CA	92121
32997	BOURNB INC TRIMPT PROD DIV	RIVERSIDE CA	92507
56269	SPRAGUE ELECTRIC CO	NORTH ADAMS MA	01247
71400	SUSSMAN MFG DIV OF MCGRAW-EDISON CO	ST LOUIS MO	63107
75136	BECKMAN INSTRUMENTS INC MEAS PT DIV	HILLIMANTIC CT	06226
75042	TRW INC PHILADELPHIA DIV	FULLERTON CA	92634
91637	DALE ELECTRONICS INC	PHILADELPHIA PA	19108
NONE	RHG ELECTRONICS LABORATORIES, INC.	COLUMBUS NE	68601
		DEER PARK NY	11729

SECTION VII MANUAL BACKDATING CHANGES

7-1. INTRODUCTION

7-2. This manual has been written for and applies directly to instruments with serial numbers prefixed as indicated on the title page. Earlier versions of the instrument (serial number prefixes lower than the ones indicated on the title page) may be slightly different in design or appearance. The purpose of this section of the manual is to document these differences.

7-3. With the information provided in this section, this manual can be corrected so that it applies to any earlier version or configuration of the instrument. Later versions of the instrument (serial

number prefixes higher than the ones indicated on the title page) are documented in a yellow Manual Changes supplement.

7-4. To adapt this manual to an earlier instrument, refer to Table 7-1 and make all of the manual backdating changes listed opposite your instrument serial number or serial number prefix. Perform these changes in the alphabetical sequence listed.

7-5. For additional important information about serial number coverage, refer to INSTRUMENTS COVERED BY MANUAL in Section I.

Table 7-1. Manual Backdating Changes by Serial Number Prefix

Serial Prefix	Make Manual Changes
1746A, 1706A	A
1709A	A, B

7-6. MANUAL CHANGE INSTRUCTIONS

CHANGE A

Page 6-4, Table 6-2:
Replace with Table 7-2.

Page 8-11, Figures 8-13 and 8-14, Service Sheet 2:
Replace with Figure 7-1 A2 YIG Driver Assembly, Component Locations (Change A) and Figure 7-2 A2 YIG Driver Assembly, Schematic (Change A).

Page 8-12, Figure 8-15, Service Sheet 3:
Replace with Figure 7-5 A2 Assembly, Component Locations (Change A).

Page 8-13, Figure 8-16, Service Sheet 3:

Replace with Figure 7-4 A3 ALC Assembly, Schematic (Change A).

Page 8-15, Figures 8-17 and 8-18, Service Sheet 4:

Replace with Figure 7-5 A1 FM Driver Assembly, Component Locations (Change A) and Figure 7-6 A1 FM Driver Assembly, Schematic (Change A).

CHANGE B

Page 7-8, Table 7-2:

Change A4 second entry to 5086-7127; OSCILLATOR, 8.0 — 12.4 GHz, X-BAND (86250D ONLY) (INCLUDES W11 AND A9).

NOTE

HP Part Number 5086-7127 is no longer available. If A4 Oscillator fails, order YTO Replacement Kit, HP Part Number 86250-60043. Changing to the newer A4 Oscillator also requires changing W11 to HP Part Number 5020-9155. (New W11 is included in YTO Replacement Kit.)

Page 7-9, Table 7-2:

Add "(86242D)" after W3.

Add W3 (86250D); 86250-20031; CALBE, RF ISO-MOD.

Add "(86242D)"; PART OF A4 NOT SEPARATELY REPLACEABLE.

NOTE

If A4 Oscillator has been replaced with HP Part Number 5086-7277 (part of YIG Replacement Kit), W11 is the same part number (5020-9155) for both the 86242D and 86250D and is separately replaceable.

Table 7-2. Replaceable Parts (86242D/86250D Change A)

Reference Designation	HP Part Number	Qty	Description	Mfr Code	Mfr Part Number
A1	86242-60025	1	BOARD ASSEMBLY, FM DRIVER	26480	86242-60025
A1C1			NOT ASSIGNED		
A1C2			NOT ASSIGNED		
A1C3	0160-4084	23	CAPACITOR-FXD .1UF +-20% 50VDC CER	26480	0160-4084
A1C4	0160-4084		CAPACITOR-FXD .1UF +-20% 50VDC CER	26480	0160-4084
A1C5	0160-2199	4	CAPACITOR-FXD 30PF +-5% 300VDC MICA	26480	0160-2199
A1C6	0160-4084		CAPACITOR-FXD .1UF +-20% 50VDC CER	26480	0160-4084
A1C7	0160-4084		CAPACITOR-FXD .1UF +-20% 50VDC CER	26480	0160-4084
A1C8	0160-4084		CAPACITOR-FXD .1UF +-20% 50VDC CER	26480	0160-4084
A1C9	0140-0197	1	CAPACITOR-FXD 160PF +-5% 300VDC MICA	72136	0M15F181J0300HV1CR
A1C10	0160-4084		CAPACITOR-FXD .1UF +-20% 50VDC CER	26480	0160-4084
A1C11	0160-4084		CAPACITOR-FXD .1UF +-20% 50VDC CER	26480	0160-4084
A1C12	0180-0116	4	CAPACITOR-FXD 6.8UF+-10% 35VDC TA	56289	150D685X903582
A1C13			NOT ASSIGNED		
A1C14			NOT ASSIGNED		
A1C15	0160-4084		CAPACITOR-FXD .1UF +-20% 50VDC CER	26480	0160-4084
A1C16	0160-4084		CAPACITOR-FXD .1UF +-20% 50VDC CER	26480	0160-4084
A1C17	0160-4084		CAPACITOR-FXD .1UF +-20% 50VDC CER	26480	0160-4084
A1C18	0160-4084		CAPACITOR-FXD .1UF +-20% 50VDC CER	26480	0160-4084
A1C19	0160-4084		CAPACITOR-FXD .1UF +-20% 50VDC CER	26480	0160-4084
A1C20	0180-0116		CAPACITOR-FXD 6.8UF+-10% 35VDC TA	56289	150D685X903582
A1C21	0180-0116		CAPACITOR-FXD 6.8UF+-10% 35VDC TA	56289	150D685X903582
A1C22	0180-0116		CAPACITOR-FXD 6.8UF+-10% 35VDC TA	56289	150D685X903582
A1C23	0180-1746	1	CAPACITOR-FXD 15UF+-10% 20VDC TA	56289	150D156X902082
A1C24	0160-3879	1	CAPACITOR-FXD .01UF +-20% 100VDC CER	26480	0160-3879
A1CR1	1901-0033	1	DIODE-GEN PRP 180V 200MA DO-7	26480	1901-0033
A1J1	1250-0257	2	CONNECTOR-RF 8MB M PC 50-OHM	26480	1250-0257
A1J2	1250-0257		CONNECTOR-RF 8MB M PC 50-OHM	26480	1250-0257
A1L1	9100-1619	3	COIL-MLD 6.8UH 10% Q=50 ,1550X,375LG-NOM	26480	9100-1619
A1L2	9100-1619		COIL-MLD 6.8UH 10% Q=50 ,1550X,375LG-NOM	26480	9100-1619
A1Q1	1855-0241	6	TRANSISTOR MOSFET N=CHAN E=MODE TO-72 8I	18324	8D215
A1Q2	1855-0241		TRANSISTOR MOSFET N=CHAN E=MODE TO-72 8I	18324	8D215
A1Q3	1855-0241		TRANSISTOR MOSFET N=CHAN E=MODE TO-72 8I	18324	8D215
A1Q4	1854-0404	8	TRANSISTOR NPN 8I TO-18 PD=360MW	26480	1854-0404
A1Q5	1854-0404		TRANSISTOR NPN 8I TO-18 PD=360MW	26480	1854-0404
A1Q6	1853-0314	3	TRANSISTOR PNP 2N2905A 8I TO-39 PD=600MW	04713	2N2905A
A1Q7	1854-0395	2	TRANSISTOR NPN 8I TO-39 PD=10W FT=50MHZ	26480	1854-0395
A1Q8	1854-0332	2	TRANSISTOR NPN 8I TO-39 PD=1W FT=800MHZ	26480	1854-0332
A1Q9	1854-0332		TRANSISTOR NPN 8I TO-39 PD=1W FT=800MHZ	26480	1854-0332
A1Q10	1854-0395		TRANSISTOR NPN 8I TO-39 PD=10W FT=50MHZ	26480	1854-0395
A1R1	0698-3150	2	RESISTOR 2.37K 1% .125W F TC=0+-100	24546	C4=1/8-T0=2371-F
A1R2	2100-2574	1	RESISTOR-TRMR 500 10X C 810E-ADJ 1-TRN	24546	E750X201
A1R3	0757-0442	11	RESISTOR 10K 1% .125W F TC=0+-100	24546	C4=1/8-T0=1002-F
A1R4	0757-0442		RESISTOR 10K 1% .125W F TC=0+-100	24546	C4=1/8-T0=1002-F
A1R5	2100-2514	3	RESISTOR-TRMR 20K 10X C 810E-ADJ 1-TRN	30983	E750X203
A1R6	0757-0442		RESISTOR 10K 1% .125W F TC=0+-100	24546	C4=1/8-T0=1002-F
A1R7	0757-0442		RESISTOR 10K 1% .125W F TC=0+-100	24546	C4=1/8-T0=1002-F
A1R8	0757-0442		RESISTOR 10K 1% .125W F TC=0+-100	24546	C4=1/8-T0=1002-F
A1R9	0757-0438	1	RESISTOR 5.11K 1% .125W F TC=0+-100	24546	C4=1/8-T0=5111-F
A1R10	0698-3150		RESISTOR 2.37K 1% .125W F TC=0+-100	24546	C4=1/8-T0=2371-F
A1R11	0757-0274	1	RESISTOR 1.21K 1% .125W F TC=0+-100	24546	C4=1/8-T0=1213-F
A1R12	0757-0346	3	RESISTOR 10 1% .125W F TC=0+-100	24546	C4=1/8-T0=10R0-F
A1R13	0698-3622	2	RESISTOR 120 5X 2H MO TC=0+-200	26480	0698-3622
A1R14	2100-1788	1	RESISTOR-TRMR 500 10X C TOP-ADJ 1-TRN	73138	82PR500
A1R15	0698-3622		RESISTOR 120 5X 2H MO TC=0+-200	26480	0698-3622
A1R16	0698-0084	3	RESISTOR 2.15K 1% .125W F TC=0+-100	24546	C4=1/8-T0=2151-F
A1R17	0698-3446	2	RESISTOR 383 1% .125W F TC=0+-100	24546	C4=1/8-T0=383R-F
A1R18	0757-0346		RESISTOR 10 1% .125W F TC=0+-100	24546	C4=1/8-T0=10R0-F
A1R19	0757-0346		RESISTOR 10 1% .125W F TC=0+-100	24546	C4=1/8-T0=10R0-F
A1R20	2100-1985	1	RESISTOR-TRMR 20 20X C TOP-ADJ 1-TRN	32997	3329H=1=20R
A1R21	2100-2060	1	RESISTOR-TRMR 50 20X C TOP-ADJ 1-TRN	73138	82PR50
A1R22	0698-3620	2	RESISTOR 100 5X 2H MO TC=0+-200	26480	0698-3620
A1R23	0698-3620		RESISTOR 100 5X 2H MO TC=0+-200	26480	0698-3620
A1R24	0698-0084		RESISTOR 2.15K 1% .125W F TC=0+-100	24546	C4=1/8-T0=2151-F
A1R25	0757-0416	2	RESISTOR 511 1% .125W F TC=0+-100	24546	C4=1/8-T0=511R-F
A1R26	2100-1758	1	RESISTOR-TRMR 1K 5X HW 810E-ADJ 1-TRN	26480	2100-1758
A1R27	0698-3446	1	RESISTOR 348 1% .125W F TC=0+-100	24546	C4=1/8-T0=348R-F
A1R28	0757-0442		RESISTOR 10K 1% .125W F TC=0+-100	24546	C4=1/8-T0=1002-F
A1R29	0757-0280	3	RESISTOR 1K 1% .125W F TC=0+-100	24546	C4=1/8-T0=1001-F
A1R30	0698-0084		RESISTOR 2.15K 1% .125W F TC=0+-100	24546	C4=1/8-T0=2151-F

Table 7-2. Replaceable Parts (86242D/86250D Change A)

Reference Designation	HP Part Number	Qty	Description	Mfr Code	Mfr Part Number
A1R31	0698-3446		RESISTOR 383 1X .125W F TC=0+-100	24546	C4=1/8-T0=383R-F
A1R32	0757-0442		RESISTOR 10K 1X .125W F TC=0+-100	24546	C4=1/8-T0=1002-F
A1R33	0757-0442		RESISTOR 10K 1X .125W F TC=0+-100	24546	C4=1/8-T0=1002-F
A1R34	0757-0416	1	RESISTOR 511 1X .125W F TC=0+-100	24546	C4=1/8-T0=511R-F
A1R35	0757-0401	4	RESISTOR 100 1X .125W F TC=0+-100	24546	C4=1/8-T0=101-F
A1R36	0757-0394	1	RESISTOR 51.1 1X .125W F TC=0+-100	24546	C4=1/8-T0=51R1-F
A1U1	1820-0223	5	IC 301 OP AMP T0=99	18324	LM301A
A1W1			NOT ASSIGNED		
A1W2	8159-0005	5	WIRE 22AWG W PVC 1X22 80C	28480	8159-0005
A1W3			NOT ASSIGNED		
A1W4	8159-0005		WIRE 22AWG W PVC 1X22 80C	28480	8159-0005
A1W5			NOT ASSIGNED		
A1W6			NOT ASSIGNED		
A1W7	8159-0005		WIRE 22AWG W PVC 1X22 80C	28480	8159-0005
		1	A1 MISCELLANEOUS		
	1200-0173	2	INSULATOR=XSTR DAP=GL	28480	1200-0173
	1205-0061	2	HEAT SINK T0=5/T0=39-PKG	28480	1205-0061
A2 (86242D)	86242-60026	1	BOARD ASSEMBLY, YIG DRIVER (86242D ONLY)	28480	86242-60026
A2 (86250D)	86250-60024		BOARD ASSEMBLY, YIG DRIVER (86250D ONLY)	28480	86250-60024
A2C1	0180-0094	1	CAPACITOR=FXD 100UF+75-10X 25VDC AL	56289	30010700250D2
A2C2	0180-0291	7	CAPACITOR=FXD 1UF+-10X 35VDC TA	56289	1500105X9033A2
A2C3	0160-0153	1	CAPACITOR=FXD 1000PF +-10X 200VDC POLYE	28480	0160-0153
A2C4	0180-0228	2	CAPACITOR=FXD 22UF+-10X 15VDC TA	56289	1500226X9015B2
A2C5	0180-0197	2	CAPACITOR=FXD 2.2UF+-10X 20VDC TA	56289	1500223X9020A2
A2C6	0160-2257	1	CAPACITOR=FXD 10PF +-5X 500VDC CER 0+-60	28480	0160-2257
A2C7	0160-0302	1	CAPACITOR=FXD .018UF +-10X 200VDC POLYE	28480	0160-0302
A2C8	0180-0356	1	CAPACITOR=FXD 70UF+20-15X 15VDC TA	06001	69F23507
A2C9	0160-2199		CAPACITOR=FXD 30PF +-5X 300VDC MICA	28480	0160-2199
A2C10	0160-2199		CAPACITOR=FXD 30PF +-5X 300VDC MICA	28480	0160-2199
A2C11	0160-2199		CAPACITOR=FXD 30PF +-5X 300VDC MICA	28480	0160-2199
A2C12	0180-2186	2	CAPACITOR=FXD 300UF+-20X 30VDC TA	06001	69F45507
A2C13	0180-2186		CAPACITOR=FXD 300UF+-20X 30VDC TA	06001	69F45507
A2CR1	1901-0159	2	DIODE=PHR RECT 400V 750MA D0=41	28480	1901-0159
A2CR2	1901-0025	7	DIODE=GEN PRP 100V 200MA D0=7	28480	1901-0025
A2CR3	1901-0025		DIODE=GEN PRP 100V 200MA D0=7	28480	1901-0025
A2CR4	1901-0025		DIODE=GEN PRP 100V 200MA D0=7	28480	1901-0025
A2CR5	1901-0025		DIODE=GEN PRP 100V 200MA D0=7	28480	1901-0025
A2CR6	1901-0159		DIODE=PHR RECT 400V 750MA D0=41	28480	1901-0159
A2CR7	1910-0016	1	DIODE=GE 60V 60MA 1U8 D0=7	28480	1910-0016
A2CR8	1901-0025		DIODE=GEN PRP 100V 200MA D0=7	28480	1901-0025
A2CR9	1901-0025		DIODE=GEN PRP 100V 200MA D0=7	28480	1901-0025
A2CR10	1901-0025		DIODE=GEN PRP 100V 200MA D0=7	28480	1901-0025
A2CR11			NOT ASSIGNED		
A2CR12	1901-0539	4	DIODE=8CH0TTKY	28480	1901-0539
A2F1	2110-0047	1	FUSE 1A 125V NORM-BLD .25X.27	71400	GMW=1
A2K1	0490-0875	1	RELAY 2C 12VDC-COIL 2A 30VDC	28480	0490-0875
A2Q1	1854-0404		TRANSISTOR NPN 8I T0=18 PD=360MW	28480	1854-0404
A2Q2	1853-0050	5	TRANSISTOR PNP 8I T0=18 PD=360MW	28480	1853-0050
A2Q3	1853-0050		TRANSISTOR PNP 8I T0=18 PD=360MW	28480	1853-0050
A2Q4	1854-0404		TRANSISTOR NPN 8I T0=18 PD=360MW	28480	1854-0404
A2Q5	1884-0073	1	THYRISTOR=8CR T0=5 VRRM=100	28480	1884-0073
A2Q6	1854-0404		TRANSISTOR NPN 8I T0=18 PD=360MW	28480	1854-0404
A2Q7	1853-0038	1	TRANSISTOR PNP 8I T0=39 PD=1W FT=100MHZ	28480	1853-0038
A2Q8	1854-0404		TRANSISTOR NPN 8I T0=18 PD=360MW	28480	1854-0404
A2R1	0757-0397	1	RESISTOR 68.1 1% .125W F TC=0+-100	24546	C4=1/8-T0=68R1-F
A2R2	0698-3447	1	RESISTOR 422 1% .125W F TC=0+-100	24546	C4=1/8-T0=422R-F
A2R3 (86242D)	0811-1665	1	RESISTOR .82 5% 2W PW (86242D ONLY)	75042	BWH2-82/100-U
A2R3 (86250D)	0811-1668		RESISTOR 1.5 5% 2WF (86250D ONLY)	28480	0811-1668
A2R4	0698-3162	1	RESISTOR 46.4K 1% .125W F TC=0+-100	24546	C4=1/8-T0=4642-F
A2R5	0757-0441	2	RESISTOR 8.25K 1% .125W F TC=0+-100	24546	C4=1/8-T0=8251-F
A2R6	0757-0199	1	RESISTOR 21.5K 1X .125W F TC=0+-100	24546	C4=1/8-T0=2152-F
A2R7	0757-0401		RESISTOR 100 1X .125W F TC=0+-100	24546	C4=1/8-T0=101-F
A2R8	0757-0444	3	RESISTOR 12.1K 1X .125W F TC=0+-100	24546	C4=1/8-T0=1212-F
A2R9	0757-0442		RESISTOR 10K 1X .125W F TC=0+-100	24546	C4=1/8-T0=1002-F
A2R10 (86242D)	0757-0290	1	RESISTOR 6.19K 1% .125W F (86242D ONLY)	19701	MF4C1/8-T0=6191-F
A2R10 (86250D)	0757-0279		RESISTOR 3.16K 1% .125W F (86250D ONLY)	28480	0757-0279
A2R11	0698-0053	2	RESISTOR 1.96K 1X .125W F TC=0+-100	24546	C4=1/8-T0=1961-F
A2R12	0757-0444		RESISTOR 12.1K 1X .125W F TC=0+-100	24546	C4=1/8-T0=1212-F
A2R13	2100-3103	2	RESISTOR=TRMR 10K 10X C 810E=ADJ 17=TRN	02111	43P103
A2R14	0757-0440	2	RESISTOR 7.5K 1X .125W F TC=0+-100	24546	C4=1/8-T0=7501-F
A2R15	0757-0439	2	RESISTOR 6.81K 1X .125W F TC=0+-100	24546	C4=1/8-T0=6811-F

Table 7-2. Replaceable Parts (86242D/86250D Change A)

Reference Designation	HP Part Number	Qty	Description	Mfr Code	Mfr Part Number
A2R16	0757-0458	1	RESISTOR 51.1K 1% .125W F TC=0+-100	24546	C4-1/8-T0=5112=F
A2R17	0698-3401	1	RESISTOR 215 1% .5W F TC=0+-100	28480	0698-3401
A2R18	0757-0280	1	RESISTOR 1K 1% .125W F TC=0+-100	24546	C4-1/8-T0=1001=F
A2R19	0757-0460	2	RESISTOR 61.9K 1% .125W F TC=0+-100	24546	C4-1/8-T0=6192=F
A2R20	0757-0278	2	RESISTOR 1.78K 1% .125W F TC=0+-100	24546	C4-1/8-T0=1781=F
A2R21	0757-0401	1	RESISTOR 100 1% .125W F TC=0+-100	24546	C4-1/8-T0=101=F
A2R22	0811-1178	4	RESISTOR 8.19K 1% .125W PWH TC=0+-10	07088	KP61-6191=1
A2R23	2100-3109	1	RESISTOR-TRMR 2K 10% C SIDE=ADJ 17-TRN	02111	43P202
A2R24 (86242D)	0811-1195	2	RESISTOR 2.15K 1% .125W PWH TC=0+-10 (86242D ONLY)	20940	114-1/8=2151=F
A2R24 (86250D)	0811-3052	3	RESISTOR 2.61K 1% .125W PWH TC=0+-10 (86250D ONLY)	20940	114-1/8-D=2611=+19=1
A2R25	0811-1175	1	RESISTOR 4.22K 1% .125W PWH TC=0+-10	07088	KP61-4221=1
A2R26	0757-0416	1	RESISTOR 511 1% .125W F TC=0+-100	24546	C4-1/8-T0=511R=F
A2R27	0757-0441	1	RESISTOR 8.25K 1% .125W F TC=0+-100	24546	C4-1/8-T0=8251=F
A2R28 (86242D)	0698-0085	1	RESISTOR 2.61K 1% .125W F TC=0+-100	24546	C4-1/8-T0=2611=F
A2R29 (86250D)	2100-3103	3	RESISTOR-TRMR 10K 10% C SIDE=ADJ 17-TRN (86242D ONLY)	02111	43P103
A2R29 (86250D)	2100-3161	3	RESISTOR-TRMR 20K 10% C SIDE=ADJ 17-TRN (86250D ONLY)	02111	43P203
A2R30	0757-0464	1	RESISTOR 90.9K 1% .125W F TC=0+-100	24546	C4-1/8-T0=9092=F
A2R31	0698-3155	3	RESISTOR 4.64K 1% .125W F TC=0+-100	24546	C4-1/8-T0=4641=F
A2R32 (86242D)	0698-0082	1	RESISTOR 464 1% .125W F TC=0+-100 (86242D ONLY)	24546	C4-1/8-T0=464R=F
A2R32 (86250D)	0698-3155	1	RESISTOR 4.64K 1% .125W F TC=0+-100 (86250D ONLY)	24546	C4-1/8-T0=4641=F
A2R33 (86250D)	2100-3161	1	RESISTOR-TRMR 20K 10% C SIDE=ADJ 17-TRN (86250D ONLY)	02111	43P203
A2R33 (86242D)	2100-3103	1	RESISTOR-TRMR 10K (86242D ONLY)	32997	3006P-1-103
A2R34	0757-0279	2	RESISTOR 3.16K 1% .125W F TC=0+-100 (86242D ONLY)	24546	C4-1/8-T0=3161=F
A2R34	0757-0440	1	RESISTOR 7.5K 1% .125W F TC=0+-100 (86250D ONLY)	24546	C4-1/8-T0=7501=F
A2R35	0757-0278	1	RESISTOR 1.78K 1% .125W F TC=0+-100	24546	C4-1/8-T0=1781=F
A2R36 (86242D)	0698-3558	1	RESISTOR 4.02K 1% .125W F TC=0+-100 (86242D ONLY)	24546	C4-1/8-T0=4021=F
A2R36 (86250D)	0698-3155	1	RESISTOR 4.64K 1% .125W F TC=0+-100 (86250D ONLY)	24546	C4-1/8-T0=4641=F
A2R37	0757-0442	1	RESISTOR 10K 1% .125W F TC=0+-100	24546	C4-1/8-T0=1002=F
A2R38	0698-3453	1	RESISTOR 196K 1% .125W F TC=0+-100	24546	C4-1/8-T0=1963=F
A2R39	0811-3052	1	RESISTOR 2.61K 1% .125W PWH TC=0+-10	20940	114-1/8-D=2611=+19=1
A2R40	0757-0442	1	RESISTOR 10K 1% .125W F TC=0+-100	24546	C4-1/8-T0=1002=F
A2R41 (86242D)	0698-3154	1	RESISTOR 4.22K 1% .125W F TC=0+-100	24546	C4-1/8-T0=4221=F
A2R41 (86250D)	0698-4444	1	RESISTOR 4.67K 1% .125W F TC=0+-100 (86250D ONLY)	24546	C4-1/8-T0=4671=F
A2R42 (86242D)	0698-3558	1	RESISTOR 4.02K 1% .125W F TC=0+-100 (86242D ONLY)	24546	C4-1/8-T0=4021=F
A2R42	0698-4442	1	RESISTOR 4.42K 1% .125W F TC=0+-100 (86250D ONLY)	24546	C4-1/8-T0=4421=F
A2R43 (86242D)	0757-0279	1	RESISTOR 3.16K 1% .125W F TC=0+-100 (86242D ONLY)	24546	C4-1/8-T0=3161=F
A2R43 (86250D)	0757-0444	1	RESISTOR 12.1K 1% .125W F TC=0+-100 (86250D ONLY)	24546	C4-1/8-T0=1212=F
A2R44	2100-3123	1	RESISTOR-TRMR 500 10% C SIDE=ADJ 17-TRN	02111	43P501
A2R45	0757-0465	1	RESISTOR 100K 1% .125W F TC=0+-100	24546	C4-1/8-T0=1003=F
A2R46	0811-1178	1	RESISTOR 6.19K 1% .125W PWH TC=0+-10	07088	KP61-6191=1
A2R47	0811-1178	1	RESISTOR 6.19K 1% .125W PWH TC=0+-10	07088	KP61-6191=1
A2R48	0698-0083	1	RESISTOR 1.96K 1% .125W F TC=0+-100	24546	C4-1/8-T0=1961=F
A2R49	0811-1178	1	RESISTOR 6.19K 1% .125W PWH TC=0+-10	07088	KP61-6191=1
A2R50	0698-0024	1	RESISTOR 2.61K 1% .5W F TC=0+-100	28480	0698-0024
A2R51 (86242D)	0698-3437	1	RESISTOR 133 1% .125W F TC=0+-100 (86242D ONLY)	24546	C4-1/8-T0=133R=F
A2R51 (86250D)	0698-3439	2	RESISTOR 178 1% .125W F TC=0+-100 (86250D ONLY)	24546	C4-1/8-T0=178R=F
A2R52 (86242D)	0811-1195	1	RESISTOR 2.15K 1% .125W PWH TC=0+-10 (86242D ONLY)	20940	114-1/8=2151=F
A2R52 (86250D)	0811-3052	1	RESISTOR 2.61K 1% .125W PWH TC=0+-10 (86250D ONLY)	20940	114-1/8-D=2611=+19=1
A2U1	1820-0223	1	IC 301 OP AMP T0=99	18324	LM301A
A2U2	1820-0223	1	IC 301 OP AMP T0=99	18324	LM301A
A2U3	1820-0223	1	IC 301 OP AMP T0=99	18324	LM301A
A2U4	1820-0223	1	IC 301 OP AMP T0=99	18324	LM301A
A2U5	1820-0196	1	IC 723 V RGLTR T0=100	04713	MC1723CG
A2VR1 (86250D)	1902-0048	1	DIODE-ZNR 6.81V 5% (86250D ONLY)		
A2VR1 (86242D)	1902-3193	1	DIODE-ZNR 13.3V 5% DO-7 PD=.4W TC=+.059% (86242D ONLY)	04713	SZ 10939-218
A2VR2 (86242D)	1902-3203	1	DIODE-ZNR 14.7V 5% DO-7 PD=.4W TC=+.057% (86242D ONLY)	28480	1902-3203
A2VR2 (86250D)	1902-0064	1	DIODE-ZNR 7.50V 5% (86250D ONLY)	28480	1902-0064
A2VR3	1902-0244	1	DIODE-ZNR 30.1V 5% DO-15 PD=1W TC=+.075%	28480	1902-0244
A2VR4	1902-0692	1	DIODE-ZNR 6.3V 1% DO-7 PD=.4W TC=+.001%	28480	1902-0692
A2VR5	1902-0692	1	DIODE-ZNR 6.3V 1% DO-7 PD=.4W TC=+.001%	28480	1902-0692

www.valueelectronics.com

Table 7-2. Replaceable Parts (86242D/86250D Change A)

Reference Designation	HP Part Number	Qty	Description	Mfr Code	Mfr Part Number
A2VR6	1902-0692		DIODE-ZNR 6.3V 1X DO-7 PD=4W TC=+.001X	28480	1902-0692
A2W1			NOT ASSIGNED		
A2W2	8159-0005		WIRE 22AWG W PVC 1X22 80C	28480	8159-0005
A3 (86242D)	86242-60024	1	BOARD ASSEMBLY, ALC (86242D ONLY)	28480	86242-60024
A3 (86250D)	86250-60022	1	BOARD ASSEMBLY, ALC (86250D ONLY)	28480	86250-60022
A3C1	0160-4084		CAPACITOR-FXD .1UF +-20% 50VDC CER	28480	0160-4084
A3C2	0160-4084		CAPACITOR-FXD .1UF +-20% 50VDC CER	28480	0160-4084
A3C3	0180-0291		CAPACITOR-FXD .1UF +-10% 35VDC TA	56289	150D105X9035A2
A3C4	0160-4084		CAPACITOR-FXD .1UF +-20% 50VDC CER	28480	0160-4084
A3C5	0160-4084		CAPACITOR-FXD .1UF +-20% 50VDC CER	28480	0160-4084
A3C6	0180-0291		CAPACITOR-FXD .1UF +-10% 35VDC TA	56289	150D105X9035A2
A3C7	0160-3536	1	CAPACITOR-FXD 620PF +-5% 100VDC MICA	28480	0160-3536
A3C8	0160-4084		CAPACITOR-FXD .1UF +-20% 50VDC CER	28480	0160-4084
A3C9	0160-4084		CAPACITOR-FXD .1UF +-20% 50VDC CER	28480	0160-4084
A3C10	0160-4084		CAPACITOR-FXD .1UF +-20% 50VDC CER	28480	0160-4084
A3C11	0160-4084		CAPACITOR-FXD .1UF +-20% 50VDC CER	28480	0160-4084
A3C12	0180-0291		CAPACITOR-FXD .1UF +-10% 35VDC TA	56289	150D105X9035A2
A3C13	0160-2207	1	CAPACITOR-FXD 300PF +-5% 300VDC MICA	28480	0160-2207
A3C14	0160-2208	1	CAPACITOR-FXD 330PF +-5% 300VDC MICA	28480	0160-2208
A3C15	0160-4084		CAPACITOR-FXD .1UF +-20% 50VDC CER	28480	0160-4084
A3C16	0180-0197		CAPACITOR-FXD 2.2UF+-10% 20VDC TA	56289	150D225X020A2
A3C17	0160-4084		CAPACITOR-FXD .1UF +-20% 50VDC CER	28480	0160-4084
A3C18	0180-0291		CAPACITOR-FXD .1UF +-10% 35VDC TA	56289	150D105X9035A2
A3C19	0180-0291		CAPACITOR-FXD .1UF +-10% 35VDC TA	56289	150D105X9035A2
A3C20	0180-0228		CAPACITOR-FXD 22UF+-10% 15VDC TA	56289	150D22X9015B2
A3C21	0160-4084		CAPACITOR-FXD .1UF +-20% 50VDC CER	28480	0160-4084
A3C22	0180-0291		CAPACITOR-FXD .1UF +-10% 35VDC TA	56289	150D105X9035A2
A3CR1	1901-0040	14	DIODE-SWITCHING 30V 50MA 2N8 DO-35	28480	1901-0040
A3CR2	1901-0040		DIODE-SWITCHING 30V 50MA 2N8 DO-35	28480	1901-0040
A3CR3	1901-0040		DIODE-SWITCHING 30V 50MA 2N8 DO-35	28480	1901-0040
A3CR4	1901-0040		DIODE-SWITCHING 30V 50MA 2N8 DO-35	28480	1901-0040
A3CR5	1901-0518	5	DIODE-SCHOTTKY	28480	1901-0518
A3CR6	1901-0040		DIODE-SWITCHING 30V 50MA 2N8 DO-35	28480	1901-0040
A3CR7	1901-0040		DIODE-SWITCHING 30V 50MA 2N8 DO-35	28480	1901-0040
A3CR8	1901-0040		DIODE-SWITCHING 30V 50MA 2N8 DO-35	28480	1901-0040
A3CR9	1901-0040		DIODE-SWITCHING 30V 50MA 2N8 DO-35	28480	1901-0040
A3CR10	1901-0040		DIODE-SWITCHING 30V 50MA 2N8 DO-35	28480	1901-0040
A3CR11	1901-0518		DIODE-SCHOTTKY	28480	1901-0518
A3CR12	1901-0518		DIODE-SCHOTTKY	28480	1901-0518
A3CR13	1901-0518		DIODE-SCHOTTKY	28480	1901-0518
A3CR14	1901-0518		DIODE-SCHOTTKY	28480	1901-0518
A3CR15	1901-0040		DIODE-SWITCHING 30V 50MA 2N8 DO-35	28480	1901-0040
A3CR16	1901-0040		DIODE-SWITCHING 30V 50MA 2N8 DO-35	28480	1901-0040
A3CR17	1901-0040		DIODE-SWITCHING 30V 50MA 2N8 DO-35	28480	1901-0040
A3CR18	1901-0040		DIODE-SWITCHING 30V 50MA 2N8 DO-35	28480	1901-0040
A3CR19	1901-0539		DIODE-SCHOTTKY	28480	1901-0539
A3CR20	1901-0539		DIODE-SCHOTTKY	28480	1901-0539
A3CR21	1901-0539		DIODE-SCHOTTKY	28480	1901-0539
A3CR22	1901-0040		DIODE-SWITCHING 30V 50MA 2N8 DO-35	28480	1901-0040
A3L1	9100-1619		COIL=MLD 6.8UH 10% Q=50 ,155DX,375LQ=NOM	28480	9100-1619
A3MP1	1200-0172	1	INSULATOR=XSTR D4P=GL	28480	1200-0172
A3MP2	1205-0011	2	HEAT SINK TO=5/TO=39=PKG	28480	1205-0011
A3Q1	1855-0241		TRANSISTOR MOSFET N=CHAN E=MODE TO=72 8I	18324	80215
A3Q2	1855-0020	13	TRANSISTOR J-FET N=CHAN D=MODE TO=18 8I	28480	1855-0020
A3Q3	1855-0020		TRANSISTOR J-FET N=CHAN D=MODE TO=18 8I	28480	1855-0020
A3Q4	1855-0020		TRANSISTOR J-FET N=CHAN D=MODE TO=18 8I	28480	1855-0020
A3Q5	1855-0020		TRANSISTOR J-FET N=CHAN D=MODE TO=18 8I	28480	1855-0020
A3Q6	1855-0020		TRANSISTOR J-FET N=CHAN D=MODE TO=18 8I	28480	1855-0020
A3Q7 (86242D)	1853-0314		TRANSISTOR PNP 2N2905A 8I TO=39 PDR600HW (86242D ONLY)	04713	2N2905A
A3Q8	1855-0020		TRANSISTOR J-FET N=CHAN D=MODE TO=18 8I	28480	1855-0020
A3Q9	1854-0404		TRANSISTOR NPN 8I TO=18 PDR360HW	28480	1854-0404
A3Q10	1853-0050		TRANSISTOR PNP 8I TO=18 PDR360HW	28480	1853-0050
A3Q11	1855-0020		TRANSISTOR J-FET N=CHAN D=MODE TO=18 8I	28480	1855-0020
A3Q12	1855-0020		TRANSISTOR J-FET N=CHAN D=MODE TO=18 8I	28480	1855-0020
A3Q13	1855-0020		TRANSISTOR J-FET N=CHAN D=MODE TO=18 8I	28480	1855-0020
A3Q14	1855-0020		TRANSISTOR J-FET N=CHAN D=MODE TO=18 8I	28480	1855-0020
A3Q15	1855-0020		TRANSISTOR J-FET N=CHAN D=MODE TO=18 8I	28480	1855-0020
A3Q16	1855-0020		TRANSISTOR J-FET N=CHAN D=MODE TO=18 8I	28480	1855-0020
A3Q17	1855-0020		TRANSISTOR J-FET N=CHAN D=MODE TO=18 8I	28480	1855-0020
A3Q18	1854-0404		TRANSISTOR NPN 8I TO=18 PDR360HW	28480	1854-0404
A3Q19	1853-0050		TRANSISTOR PNP 8I TO=18 PDR360HW	28480	1853-0050

Table 7-2. Replaceable Parts (86242D/86250D Change A)

Reference Designation	HP Part Number	Qty	Description	Mfr Code	Mfr Part Number
A3Q20	1853-0050		TRANSISTOR PNP 8I TO-18 PD=360MW	28480	1853-0050
A3Q21	1853-0314		TRANSISTOR PNP 2N2905A 8I TO-39 PD=600MW	04713	2N2905A
A3Q22	1855-0241		TRANSISTOR MOSFET N-CHAN E-MODE TO-72 8I	18324	80215
A3Q23	1855-0241		TRANSISTOR MOSFET N-CHAN E-MODE TO-72 8I	18324	80215
A3R1	0698-7253	10	RESISTOR 5.11K 1% .05W F TC=0+-100	24546	C3-1/8-T0=5111-G
A3R2	0698-7253		RESISTOR 5.11K 1% .05W F TC=0+-100	24546	C3-1/8-T0=5111-G
A3R3	0698-7253		RESISTOR 5.11K 1% .05W F TC=0+-100	24546	C3-1/8-T0=5111-G
A3R4	0698-7236	7	RESISTOR 1K 1% .05W F TC=0+-100	24546	C3-1/8-T0=1001-G
A3R5	0698-7272	2	RESISTOR 31.6K 1% .05W F TC=0+-100	24546	C3-1/8-T0=3162-G
A3R6	0698-7279	4	RESISTOR 61.9K 1% .05W F TC=0+-100	24546	C3-1/8-T0=6192-G
A3R7	0698-7272		RESISTOR 31.6K 1% .05W F TC=0+-100	24546	C3-1/8-T0=3162-G
A3R8	0698-7229	1	RESISTOR 511 1% .05W F TC=0+-100	24546	C3-1/8-T0=511R-G
A3R9	0698-7252	1	RESISTOR 4.64K 1% .05W F TC=0+-100	24546	C3-1/8-T0=4641-G
A3R10	0698-7284	8	RESISTOR 100K 1% .05W F TC=0+-100	24546	C3-1/8-T0=1003-G
A3R11	0698-7236		RESISTOR 1K 1% .05W F TC=0+-100	24546	C3-1/8-T0=1001-G
A3R12	0698-7274	2	RESISTOR 38.3K 1% .05W F TC=0+-100	24546	C3-1/8-T0=3832-G
A3R13	0698-7274		RESISTOR 38.3K 1% .05W F TC=0+-100	24546	C3-1/8-T0=3832-G
A3R14	0698-7271	1	RESISTOR 28.7K 1% .05W F TC=0+-100	24546	C3-1/8-T0=2872-G
A3R15	0698-7279		RESISTOR 61.9K 1% .05W F TC=0+-100	24546	C3-1/8-T0=6192-G
A3R16	0698-7284		RESISTOR 100K 1% .05W F TC=0+-100	24546	C3-1/8-T0=1003-G
A3R17	0698-7284		RESISTOR 100K 1% .05W F TC=0+-100	24546	C3-1/8-T0=1003-G
A3R18	0698-7236		RESISTOR 1K 1% .05W F TC=0+-100	24546	C3-1/8-T0=1001-G
A3R19	2100-2521	1	RESISTOR=TRMR 2K 10% C 8IDE=ADJ 1-TRN	30983	ET50X202
A3R20	0698-7284		RESISTOR 100K 1% .05W F TC=0+-100	24546	C3-1/8-T0=1003-G
A3R21	0698-7258	3	RESISTOR 8.25K 1% .05W F TC=0+-100	24546	C3-1/8-T0=8251-G
A3R22	0698-7236		RESISTOR 1K 1% .05W F TC=0+-100	24546	C3-1/8-T0=1001-G
A3R23	0698-7260	11	RESISTOR 10K 1% .05W F TC=0+-100	24546	C3-1/8-T0=1002-G
A3R24	0698-7260		RESISTOR 10K 1% .05W F TC=0+-100	24546	C3-1/8-T0=1002-G
A3R25	0698-7212	2	RESISTOR 100 1% .05W F TC=0+-100	24546	C3-1/8-T0=100R-G
A3R26	0698-7227	1	RESISTOR 422 1% .05W F TC=0+-100	24546	C3-1/8-T0=422R-G
A3R27	0698-7260		RESISTOR 10K 1% .05W F TC=0+-100	24546	C3-1/8-T0=1002-G
A3R28	0698-7270	2	RESISTOR 26.1K 1% .05W F TC=0+-100	24546	C3-1/8-T0=2612-G
A3R29	0757-0460		RESISTOR 61.9K 1% .125W F TC=0+-100	24546	C4-1/8-T0=6192-F
A3R30	2100-2522	1	RESISTOR=TRMR 10K 10% C 8IDE=ADJ 1-TRN	30983	ET50X103
A3R31	2100-2489	2	RESISTOR=TRMR 5K 10% C 8IDE=ADJ 1-TRN	30983	ET50X902
A3R32	2100-2514		RESISTOR=TRMR 20K 10% C 8IDE=ADJ 1-TRN	30983	ET50W203
A3R33	2100-2514		RESISTOR=TRMR 20K 10% C 8IDE=ADJ 1-TRN	30983	ET50W203
A3R34	0698-7258		RESISTOR 8.25K 1% .05W F TC=0+-100	24546	C3-1/8-T0=8251-G
A3R35	0698-7253		RESISTOR 5.11K 1% .05W F TC=0+-100	24546	C3-1/8-T0=5111-G
A3R36	0698-7260		RESISTOR 10K 1% .05W F TC=0+-100	24546	C3-1/8-T0=1002-G
A3R37	0698-7253		RESISTOR 5.11K 1% .05W F TC=0+-100	24546	C3-1/8-T0=5111-G
A3R38	0698-7258		RESISTOR 8.25K 1% .05W F TC=0+-100	24546	C3-1/8-T0=8251-G
A3R39	0698-7253		RESISTOR 5.11K 1% .05W F TC=0+-100	24546	C3-1/8-T0=5111-G
A3R40	0698-7253		RESISTOR 5.11K 1% .05W F TC=0+-100	24546	C3-1/8-T0=5111-G
A3R41	0698-7264	1	RESISTOR 14.7K 1% .05W F TC=0+-100	24546	C3-1/8-T0=1472-G
A3R42	0698-7253		RESISTOR 5.11K 1% .05W F TC=0+-100	24546	C3-1/8-T0=5111-G
A3R43	0698-7253		RESISTOR 5.11K 1% .05W F TC=0+-100	24546	C3-1/8-T0=5111-G
A3R44	0698-7260		RESISTOR 10K 1% .05W F TC=0+-100	24546	C3-1/8-T0=1002-G
A3R45 (86242D)	0698-7283	2	RESISTOR 90.9K 1% .05W F TC=0+-100	24546	C3-1/8-T0=9092-G
A3R45 (86250D)	0698-7279		(86242D ONLY) RESISTOR 61.9K 1% .05W F TC=0+-100	24546	C3-1/8-T0=6192-G
A3R46 (86242D)	0698-7283		(86242D ONLY) RESISTOR 90.9K 1% .05W F TC=0+-100	24546	C3-1/8-T0=9092-G
A3R46 (86250D)	0698-7279		(86250D ONLY) RESISTOR 61.9K 1% .05W F TC=0+-100	24546	C3-1/8-T0=6192-G
A3R47	0698-7284		RESISTOR 100K 1% .05W F TC=0+-100	24546	C3-1/8-T0=1003-G
A3R48	0698-7288	1	RESISTOR 147K 1% .05W F TC=0+-100	24546	C3-1/8-T0=1473-G
A3R49	0698-7287	1	RESISTOR 133K 1% .05W F TC=0+-100	24546	C3-1/8-T0=1333-G
A3R50	0698-7280	2	RESISTOR 68.1K 1% .05W F TC=0+-100	24546	C3-1/8-T0=6812-G
A3R51	0698-7269	1	RESISTOR 23.7K 1% .05W F TC=0+-100	24546	C3-1/8-T0=2372-G
A3R52	2100-2633	1	RESISTOR=TRMR 1K 10% C 8IDE=ADJ 1-TRN	30983	ET50X102
A3R53	2100-3161		RESISTOR=TRMR 20K 10% C 8IDE=ADJ 17-TRN	02111	43P203
A3R54	0698-7260		RESISTOR 10K 1% .05W F TC=0+-100	24546	C3-1/8-T0=1002-G
A3R55	0698-7273	1	RESISTOR 34.8K 1% .05W F TC=0+-100	24546	C3-1/8-T0=3482-G
A3R56	2100-2489		RESISTOR=TRMR 5K 10% C 8IDE=ADJ 1-TRN	30983	ET50X502
A3R57	0698-7212		(86242D ONLY) RESISTOR 100 1% .05W F TC=0+-100	24546	C3-1/8-T0=100R-G
A3R58	0698-7248	2	(86242D ONLY) RESISTOR 3.16K 1% .05W F TC=0+-100	24546	C3-1/8-T0=3161-G
A3R59	0698-7263	1	RESISTOR 13.3K 1% .05W F TC=0+-100	24546	C3-1/8-T0=1332-G
A3R60	0698-7260		RESISTOR 10K 1% .05W F TC=0+-100	24546	C3-1/8-T0=1002-G
A3R61	0698-7236		RESISTOR 1K 1% .05W F TC=0+-100	24546	C3-1/8-T0=1001-G
A3R62	2100-2516	1	RESISTOR=TRMR 100K 10% C 8IDE=ADJ 1-TRN	73138	82PAR100K
A3R63	0698-7251		RESISTOR 4.22K 1% .05W F TC=0+-100	24546	C3-1/8-T0=4221-G

Table 7-2. Replaceable Parts (86242D/86250D Change A)

Reference Designation	HP Part Number	Qty	Description	Mfr Code	Mfr Part Number
A3R64	0698-7277	1	RESISTOR 51.1K 1% .05W F TC=0+-100	24546	C3=1/8-T0=5112-G
A3R65	0698-7260		RESISTOR 10K 1% .05W F TC=0+-100	24546	C3=1/8-T0=1002-G
A3R66	0698-7260		RESISTOR 10K 1% .05W F TC=0+-100	24546	C3=1/8-T0=1002-G
A3R67	0698-7268	1	RESISTOR 21.5K 1% .05W F TC=0+-100	24546	C3=1/8-T0=2152-G
A3R68 (86242D)	0698-7248		RESISTOR 3.16K 1% .05W F TC=0+-100	24546	C3=1/8-T0=3161-G
A3R68 (86250D)	0698-7245	1	RESISTOR 2.37K 1% .05W F TC=0+-100 (86250D ONLY)	24546	C3=1/8-T0=2371-G
A3R69	0757-0401		RESISTOR 100 1% .125W F TC=0+-100	24546	C4=1/8-T0=101-F
A3R70	0698-3444	1	RESISTOR 316 1% .125W F TC=0+-100	24546	C4=1/8-T0=316R-F
A3R71	0757-0280		RESISTOR 1K 1% .125W F TC=0+-100	24546	C4=1/8-T0=1001-F
A3R72	0698-7246	1	RESISTOR 2.61K 1% .05W F TC=0+-100	24546	C3=1/8-T0=2611-G
A3R73	0698-7284		RESISTOR 100K 1% .05W F TC=0+-100	24546	C3=1/8-T0=1003-G
A3R74	0698-7270		RESISTOR 26.1K 1% .05W F TC=0+-100	24546	C3=1/8-T0=2612-G
A3R75	0698-7253		RESISTOR 5.11K 1% .05W F TC=0+-100	24546	C3=1/8-T0=5111-G
A3R76	0698-7238	1	RESISTOR 1.21K 1% .05W F TC=0+-100	24546	C3=1/8-T0=1211-G
A3R77	0698-3439		RESISTOR 178 1% .125W F TC=0+-100	24546	C4=1/8-T0=178R-F
A3R78	0698-7236		RESISTOR 1K 1% .05W F TC=0+-100	24546	C3=1/8-T0=1001-G
A3R79	0698-7267	1	RESISTOR 19.6K 1% .05W F TC=0+-100	24546	C3=1/8-T0=1962-G
A3R80	0698-7284		RESISTOR 100K 1% .05W F TC=0+-100	24546	C3=1/8-T0=1003-G
A3R81	0698-7280		RESISTOR 68.1K 1% .05W F TC=0+-100	24546	C3=1/8-T0=6812-G
A3R82	0698-7284		RESISTOR 100K 1% .05W F TC=0+-100	24546	C3=1/8-T0=1003-G
A3R83	2100-2517	1	RESISTOR=TRMR 50K 10X C 8IDE=ADJ 1=TRN	30983	ET50X503
A3R84	0698-7260		RESISTOR 10K 1% .05W F TC=0+-100	24546	C3=1/8-T0=1002-G
A3R85	0698-7260		RESISTOR 10K 1% .05W F TC=0+-100	24546	C3=1/8-T0=1002-G
A381	3101-1273	2	SWITCH=8L DPDT=N8 SUBMIN 2A 120VAC PC	28480	3101-1273
A382	3101-1273		SWITCH=8L DPDT=N8 SUBMIN 2A 120VAC PC	28480	3101-1273
A3U1	1826-0092	2	IC OP AMP T0=99	28480	1826-0092
A3U2	1826-0319	1	IC OP AMP T0=99	27014	LF356H
A3U3	1820-1543	1	IC BFR CMOS NON-INV HEX 1=INP	01928	C04050AF
A3U4	1820-1538	1	IC GATE CMOS NAND QUAD 2=INP	01928	C04011AF
A3U5	1826-0357	1	IC OP AMP T0=99	27014	LF357H
A3U6	1826-0092		IC OP AMP T0=99	28480	1826-0092
A3VR1	1902-0554	2	DIODE=ZNR 10V 5X DO=15 PD=1W TC=+.06X	28480	1902-0554
A3VR2	1902-0554		DIODE=ZNR 10V 5X DO=15 PD=1W TC=+.06X	28480	1902-0554
A3VR3	1902-0041	2	DIODE=ZNR 5.11V 5X DO=7 PD=.4W TC=-.009X	28480	1902-0041
A3VR4	1902-3234	1	DIODE=ZNR 19.6V 5X DO=7 PD=.4W TC=+.073X	28480	1902-3234
A3VR5	1902-3070	1	DIODE=ZNR 4.22V 5X DO=7 PD=.4W TC=-.038X	28480	1902-3070
A3VR6	1902-0041		DIODE=ZNR 5.11V 5X DO=7 PD=.4W TC=-.009X	28480	1902-0041
A4 (86250D)	5086-7277	1	OSCILLATOR, 8.0-12.46MHZ, X-BAND(86250D ONLY)	28480	5086-7277
A4	5086-6277		RESTORED 5086-7277; EXCHANGE REQUIRED	28480	5086-6277
A4 (86242D)	5086-7274	1	OSCILLATOR, 5.9-9.0MHZ, J-BAND(86242D ONLY)	28480	5086-7274
A4	5086-6274		RESTORED 5086-7274; EXCHANGE REQUIRED	28480	5086-6274
A5	5086-7215	1	MODULATOR	28480	5086-7215
A5	5086-6215		RESTORED 5086-7215; EXCHANGE REQUIRED	28480	5086-6215
A6	86242-60028	1	BOARD ASSEMBLY, ALC INTERCONNECT	28480	86242-60028
A6XA2	1251-1886	3	CONNECTOR=PC EDGE 15=CONT/ROW 2=ROWS	28480	1251-1886
A6XA3	1251-1886		CONNECTOR=PC EDGE 15=CONT/ROW 2=ROWS	28480	1251-1886
A7	86242-60040	1	BOARD ASSEMBLY, FM INTERCONNECT	28480	86242-60040
A7J1	1200-0507	2	SOCKET=IC 16=CONT DIP=8LDR	28480	1200-0507
A7MP1	1251-2313	2	CONNECTOR=8GL CONT SKT .04-IN=88C=8Z RND	28480	1251-2313
A7MP2	1251-2313		CONNECTOR=8GL CONT SKT .04-IN=88C=8Z RND	28480	1251-2313
A7MP3	1251-2613	2	CONNECTOR=8GL CONT SKT .033-IN=88C=8Z	28480	1251-2613
A7MP4	1251-2613		CONNECTOR=8GL CONT SKT .033-IN=88C=8Z	28480	1251-2613
A7XA1	1251-1886		CONNECTOR=PC EDGE 15=CONT/ROW 2=ROWS	28480	1251-1886
A8	86242-60027	1	BOARD ASSEMBLY, REAR INTERCONNECT	28480	86242-60027
A8J1	1200-0507		SOCKET=IC 16=CONT DIP=8LDR	28480	1200-0507
A8R1	0698-7236		RESISTOR 1K 1% .05W F TC=0+-100	24546	C3=1/8-T0=1001-G
A9 (86242D)	0960-0319	2	ISOLATOR (86242D ONLY)	28480	0960-0319
A9 (86250D)	0960-0142	2	ISOLATOR (86250D ONLY)	28480	0960-0142
A10 (86242D)	0960-0319		ISOLATOR (86242D ONLY)	28480	0960-0319
A10 (86250D)	0960-0142		ISOLATOR (86250D ONLY)	28480	0960-0142

Table 7-2. Replaceable Parts (86242D/86250D Change A)

Reference Designation	HP Part Number	Qty	Description	Mfr Code	Mfr Part Number
CHASSIS MOUNTED PARTS					
CR1	86290-60045	1	DETECTOR ASSEMBLY, (OPTION 001)	28480	86290-60045
DC1 (86242D)	0955-0091	1	DIRECTIONAL COUPLER(86242D, OPT 001)	28480	0955-0091
DC1 (86250D)	0950-1579	1	DIRECTIONAL COUPLER(86242D, OPT 001)	28480	0950-1579
D81	1990-0325	1	LED=VISIBLE LUM=INT=800UCD IF=50MA=MAX	28480	9082-4403
FL1 (86242D)	86342-20009	1	FILTER ASSEMBLY, (86242D ONLY)	28480	86342-20009
FL1 (86250D)	86250-20029	1	FILTER ASSEMBLY, (86250D ONLY)	28480	86250-20029
J1			CONNECTOR, RF OUTPUT		
J2	1250-0118	1	CONNECTOR=RF BNC FEM 3GL=HOLE=FR 50-OHM (EXT INPUT)	28480	1250-0118
J3	1250-0083	2	CONNECTOR=RF BNC FEM 3GL=HOLE=FR 50-OHM (FM)	28480	1250-0083
J4	1250-0083		CONNECTOR=RF BNC FEM 3GL=HOLE=FR 50-OHM (FREQ REFERENCE)	28480	1250-0083
MP1	1250-1397	1	ADAPTER=COAX RTANG M=8MA M=8MA (ISOL=FLTR)	28480	1250-1397
MP2	1250-1397		ADAPTER=COAX RTANG M=8MA M=8MA (MOD=ISOL)	28480	1250-1397
P4	1251-0483	1	CONNECTOR 36-PIN M MICRO RIBBON	28480	1251-0483
Q1	1853-0252	1	TRANSISTOR PNP 8I TD=3 PD=150W FT=4MHZ	28480	1853-0252
Q2	1854-0072	1	TRANSISTOR NPN 2N3054 8I TD=66 PD=25W	01928	2N3054
R1 (86242D)	0811-1227	2	RESISTOR 100 1X 12W PW TC=0+=20 (86242D ONLY)	91637	RH10-12-T9-101-F
R1 (86250D)	0811-2650	1	RESISTOR 50 3X 12W PW TC=0+=30 (86250D ONLY)	28480	0811-2650
R2 (86242D)	0811-2880	1	RESISTOR 150 1X 12W PW TC=0+=20 (86242D ONLY)	28480	0811-2880
R2 (86250D)	0811-1227		RESISTOR 100 1X 12W PW TC=0+=20 (86250D ONLY)	91637	RH10-12-T9-101-F
R3	2100-2930	1	RESISTOR=VAR CONTROL CCP 1K 10% DBC (POWER LEVEL)	28480	2100-2930
R4	2100-2492	1	RESISTOR=VAR CONTROL CCP 5K 20% LIN (GAIN)	28480	2100-2492
S1	3101-0070	2	SWITCH=8L DPDT=N8 MINTR .5A 125VAC/DC (RF OFF-ON)	28480	3101-0070
S2	3101-0070		SWITCH=8L DPDT=N8 MINTR .5A 125VAC/DC (ALC)	28480	3101-0070
S3	3101-0106	1	SWITCH=8L DP3T=N8 8TD .5A 125VAC/DC (FM=NORM=PL)	28480	3101-0106
W1	86242-60031	1	INTERCONNECT CABLE, REAR	28480	86242-60031
	8120-1711	2	CABLE=FL=RBN 28ANG 16=CNDCT UL=2651	28480	8120-1711
P5	1251-2615	5	CONNECTOR 16-PIN M RECTANGULAR	28480	1251-2615
W2	86242-60030	1	INTERCONNECT CABLE, FRONT	28480	86242-60030
	8120-1711		CABLE=FL=RBN 28ANG 16=CNDCT UL=2651	28480	8120-1711
P6	1251-2615		CONNECTOR 16-PIN M RECTANGULAR	28480	1251-2615
W3	86242-20041	1	CABLE, RF ISO=MOD.	28480	86242-20041
W4	86250-60026	1	CABLE ASSY, FM DRIVER, YELLOW	28480	86250-60026
W5	86250-60025	1	CABLE ASSY, FM INPUT, GRN	28480	86250-60025
W6	86242-20043	1	CABLE, FILTER=DET (OPTION 001 ONLY)	28480	86242-20043
W7	86250-60028	1	CABLE ASSY, ALC=DET BRN, (OPTION 001)	28480	86250-60028
W8	86242-20042	1	CABLE, RF FILTER=BULKHEAD	28480	86242-20042
W9	86250-20012	1	CABLE, RF OUTPUT	28480	86250-20012
W10	86250-20013	1	CABLE, RF REAR OUTPUT (OPTION 004 ONLY)	28480	86250-20013
W11	5020-9155	1	CABLE, RF OBC=180	28480	5020-9155
W12	86250-60034	1	CABLE MODULATOR DRIVE	28480	86250-60034
	86242-0017	1	PANEL, UPPER FRONT (86242D)	28480	86242-0017
	86250-00024	1	PANEL, UPPER FRONT (86250)	28480	86250-00024
	86250-00017	1	PANEL, LOWER FRONT	28480	86250-00017
	86250-00018	1	PANEL, LOWER FRONT (OPT. 001)	28480	86250-00018
	86250-00019	1	PANEL, LOWER FRONT (OPT. 004 ONLY)	28480	86250-00019
	86250-00021	1	PANEL, LOWER FRONT (OPT. 001/004 ONLY)	28480	86250-00021
	0370-1001	1	KNOB=BASE 3/8 JGK .125-IN-ID (GAIN)	28480	0370-1001
	0370-1101	1	KNOB=BASE=PTR 1/2 OBP .125-IN-ID (POWER LEVEL)	28480	0370-1101
	5040-6936	1	LEVER, SLIDE SWITCH (RF OFF-ON)	28480	5040-6936
	08640-40052	1	LEVER, SLIDE SWITCH (ALC)	28480	08640-40052
	1400-0560	1	CLAMP/HOLDER=CMPNT/CA (MISC) (FOR UNLEVELLED LAMP)	28480	1400-0560
	08731-210	1	NUT, LOCK (RF OUTPUT)	28480	08731-210
	00692-210	1	KEY (RF OUTPUT)	28480	00692-210
	08621-20051	1	HANDLE, DRAWER LATCH	28480	08621-20051

www.valuetronics.com

Table 7-2. Replaceable Parts (86242D/86250D Change A)

Reference Designation	HP Part Number	Qty	Description	Mfr Code	Mfr Part Number
	8621-20052 1460-1186	1 1	SCREW, DRAWER LATCH WIREFORM MUX BLK OXD	28480 28480	8621-20052 1460-1186
			CHASSIS PARTS		
	86242-00005 86230-00007 86230-00006 6960-0016 86242-00018	1 1 1 2 1	DECK, MAIN BRACE, FRAME, LEFT BRACE, FRAME, RIGHT PLUG-HOLE TR-HD FOR .125-D-HOLE NYL BRACKET, MODULATOR MOUNT	28480 28480 28480 28480 28480	86242-00005 86230-00007 86230-00006 6960-0016 86242-00018
	86242-00007 86250-00020 86250-00003 86242-00008	1 1 1 1	BRACKET, RF CONNECTOR BRACKET, DETECTOR (OPTION 001 ONLY) HEAT SINK, OSCILLATOR CLAMP, OSCILLATOR REAR PANEL	28480 28480 28480 28480	86242-00007 86250-00020 86250-00003 86242-00008
	8621-20002 8621-00005 6960-0046	1 1 1	FRAME, DRAWER REAR COVER, REAR PLUG-HOLE DOME-HD FOR .688-D-HOLE BR8 (FOR REAR PANEL RF DUT WHEN OPT, 004 NOT INSTALLED)	28480 28480 28480	8621-20002 8621-00005 6960-0046
	5040-0345	2	INSULATOR:CONNECTOR (FOR FM CONNECTOR) ACCESSORIES	28480	5040-0345
	86342-00001 86350-00001	1 1	SCALE, 5.9-9.0 GHZ (86242D ONLY) SCALE, 8.0-12.4 GHZ (86250D ONLY)	28480 28480	86342-00001 86350-00001

A2

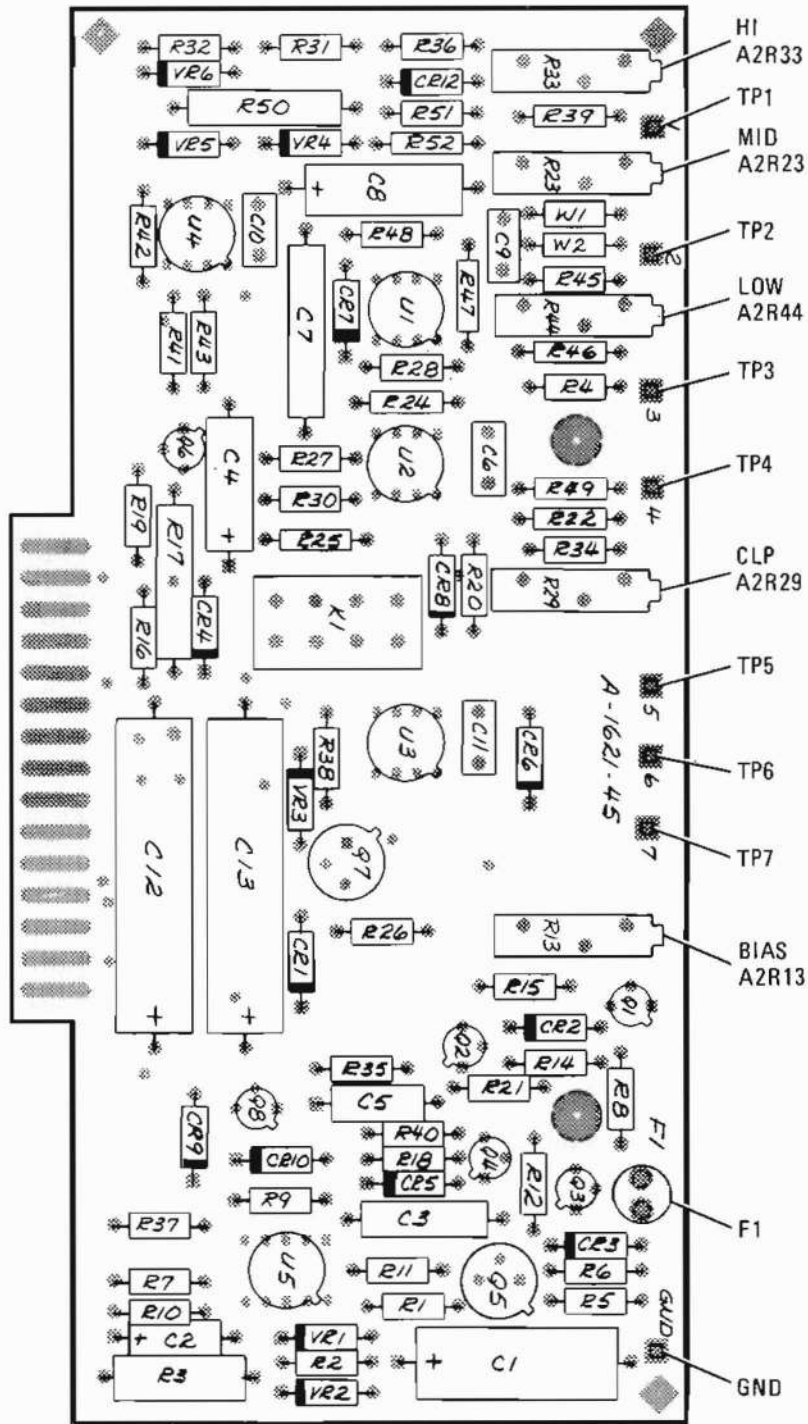

www.valuetronics.com

Figure 7-1. A2 YIG Driver Assembly, Component Locations (Change A)

A2
A2 YIG DRIVER ASSY
86242-60026 /
86250-60024

PIN	SIGNAL
1 16	BIAS -40
2 17	TUNING COIL -10V FREQ REF
3 18	NC
4 19	CW, MAN / NORM GND FREQ REF
5 20	-10V
6 21	+20V
7 22	Q2-B +5V
8 23	GND HIGH CURRENT
9 24	GND HIGH CURRENT FREQ REF
10 25	+20V FREQ REF
11 26	NC
12 27	NC
13 28	Q1-B
14 29	Q1-C
15 30	Q1-E
	Q2-E

KEY FOR BOARD PINS

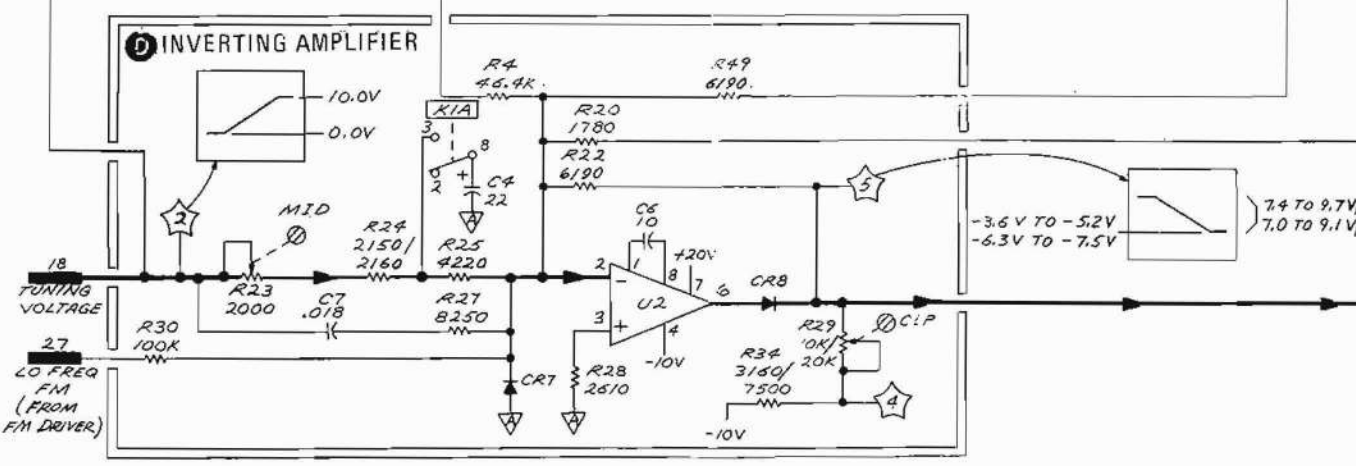
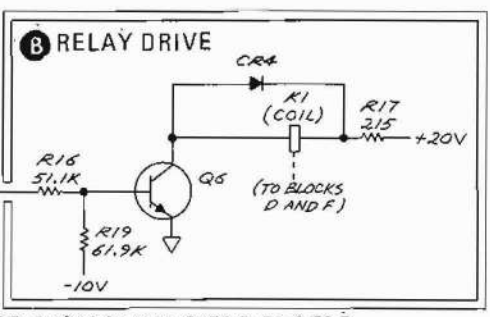
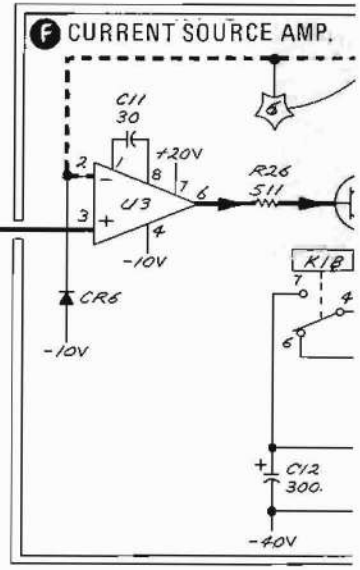
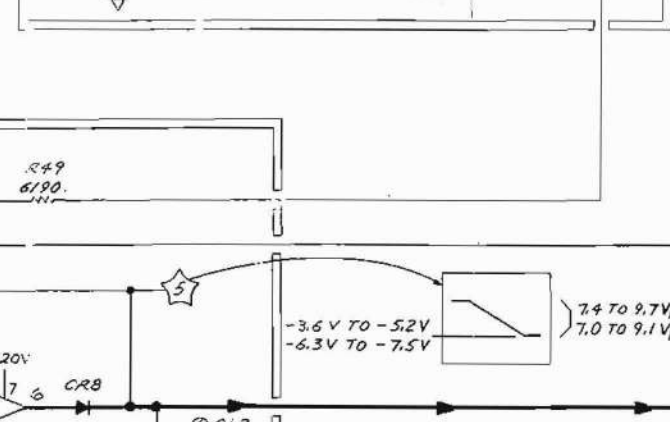
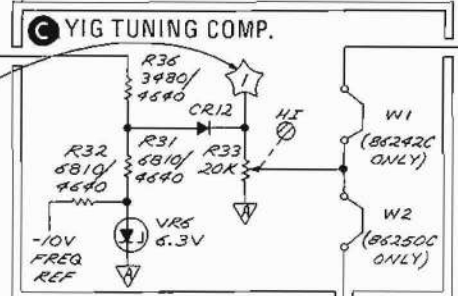
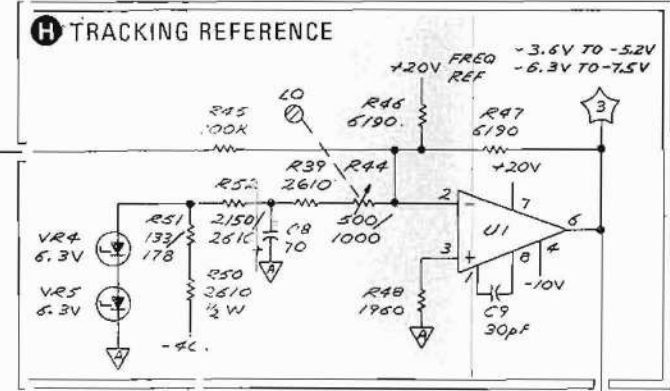
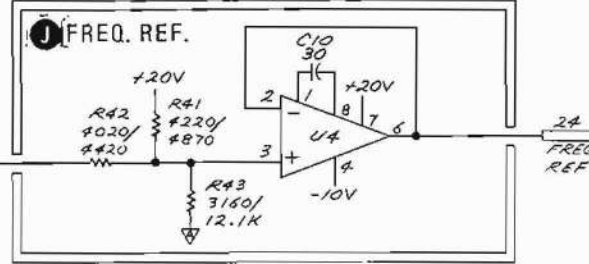
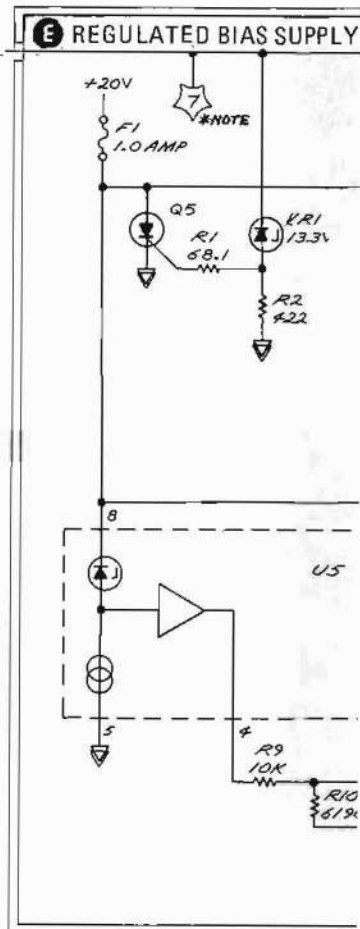
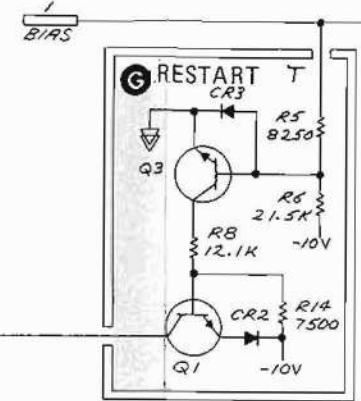
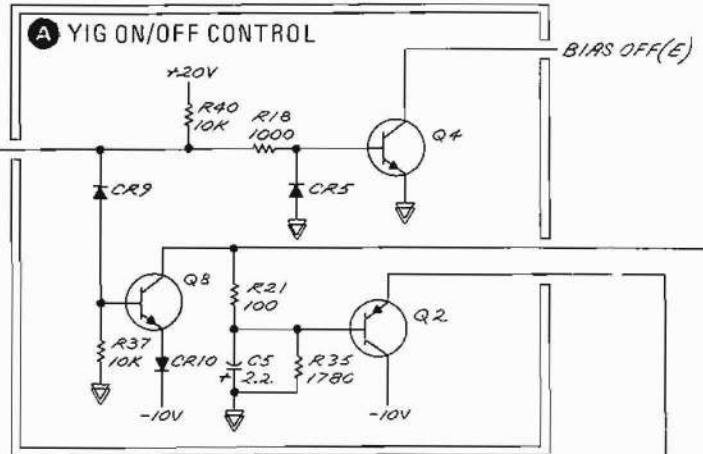
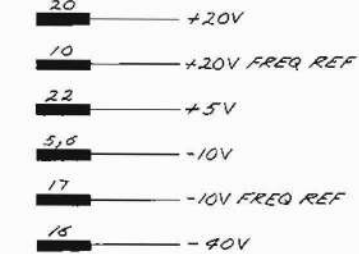

- NOTES:
- KEY FOR BOARD PINS
 INPUTS
 OUTPUTS
 I/O'S
 NOT USED
 GROUNDS
 - REFERENCE DESIGNATORS WITHIN THIS ASSEMBLY ARE ABBREVIATED. FOR COMPLETE REFERENCE DESIGNATOR, PREFIX REFERENCE DESIGNATOR SHOWN WITH THE ASSEMBLY REFERENCE DESIGNATOR.
 - UNLESS OTHERWISE INDICATED:
 RESISTANCE IN OHMS
 CAPACITANCE IN MICROFARADS
 INDUCTANCE IN MICROHENRIES
 - SEE INTERCONNECT DIAGRAM SERVICE SHEET 1.
 - TOP RESISTOR VALUES 86242-60026;
 BOTTOM RESISTOR VALUES 86250-60024.
 - TEST POINT VOLTAGES: TOP VOLTAGES FOR 86242C
 BOTTOM VOLTAGES FOR 86250C.

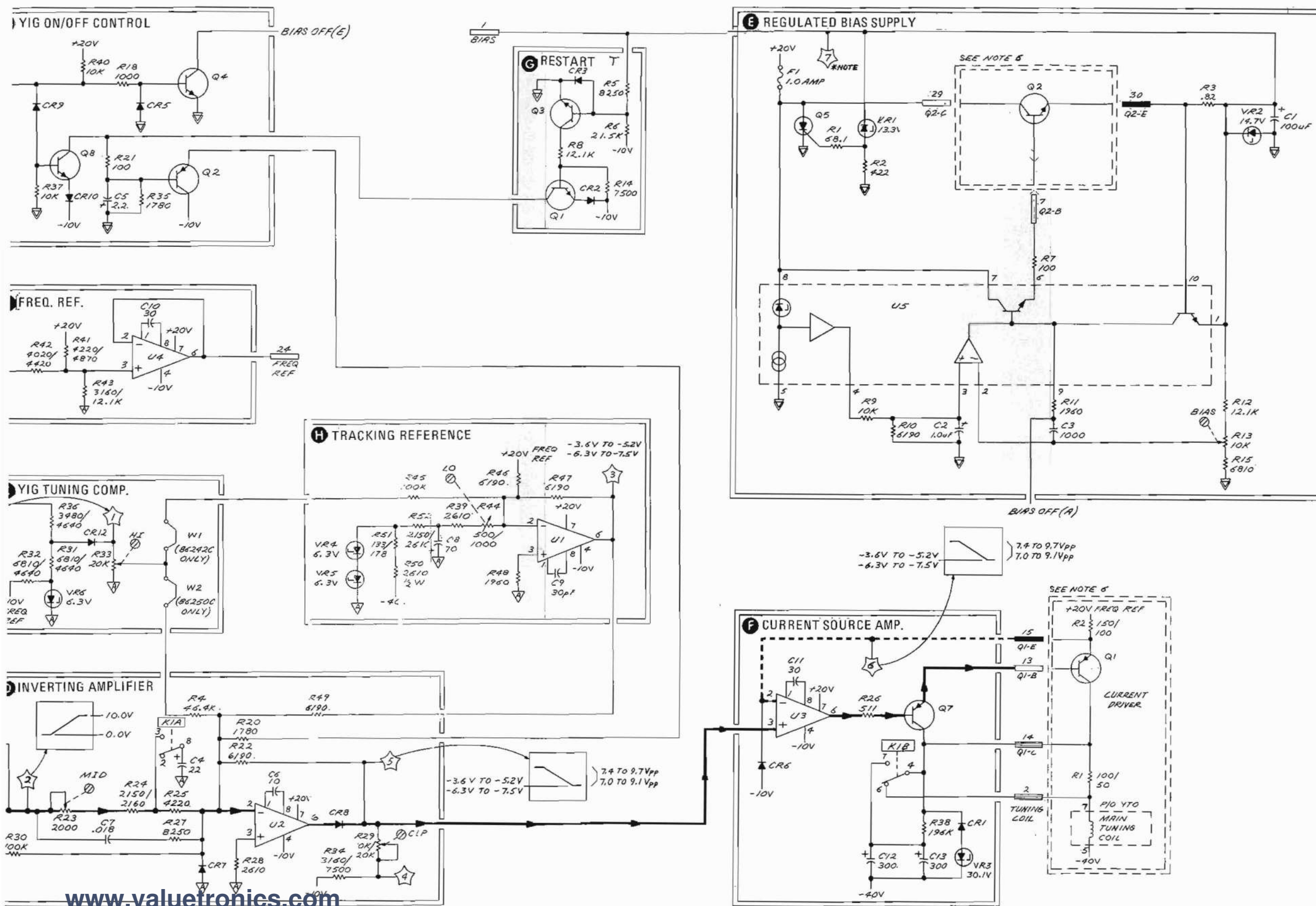

www.valuetronics.com

2
A2

Figure 7-2. A2 YIG Driver Assembly, Schematic (Change A)

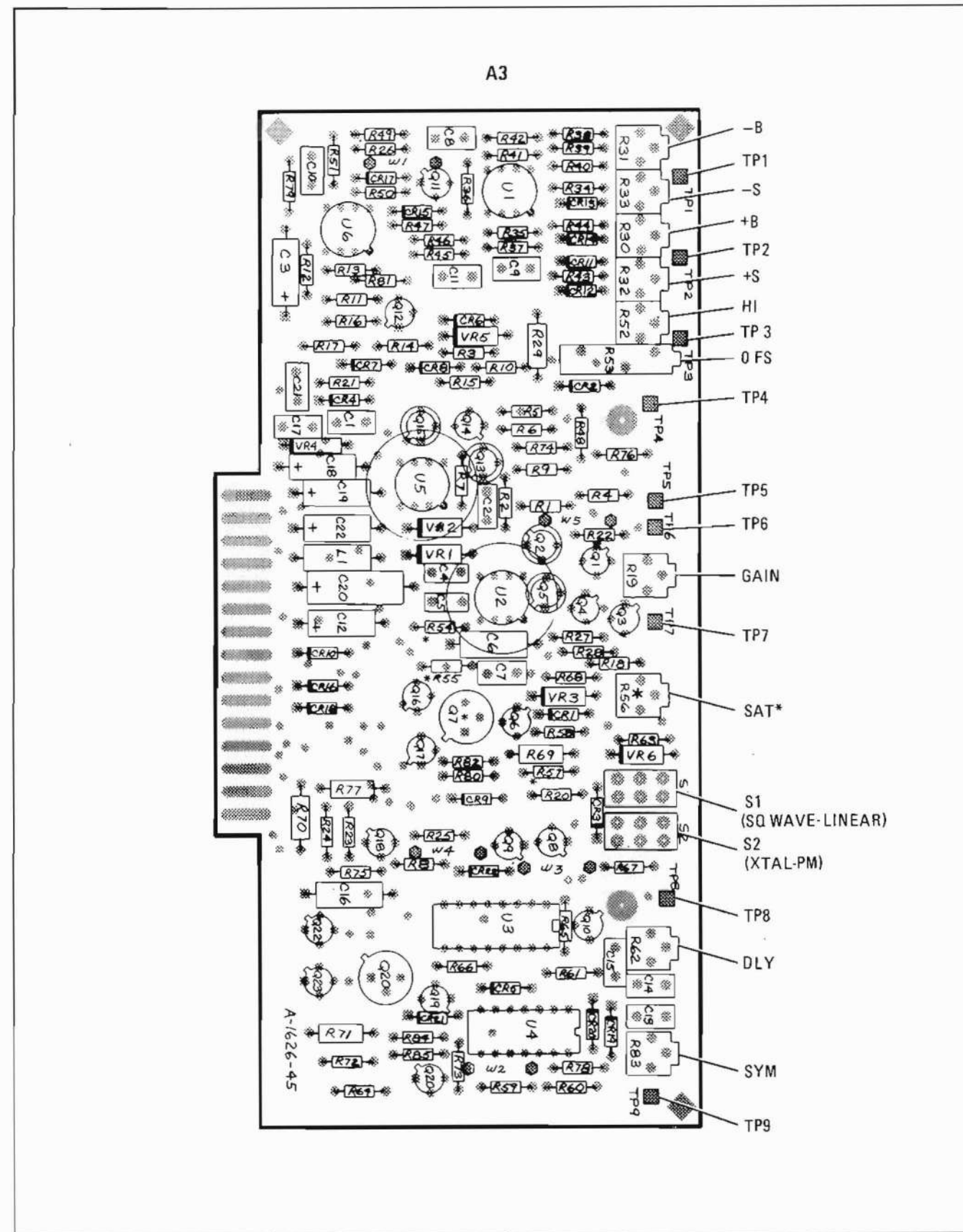

Figure 7-3. A3 ALC Assembly, Component Locations (Change A)

A3
 ALC ASSY
 86242-60024 /
 86250-60022

Pin	Signal
1 16	1 GAIN-1 -90V
2 17	2 GAIN-2 NC
3 18	3 GAIN-3 TUNING VOLTAGE
4 19	4 1 KHz SQWV (SWITCHED) NC
5 20	5 -10V
6 21	6 INT DET GND EXT INPUT GND
7 22	7 INT DET +0V
8 23	8 GND HI CURRENT NC
9 24	9 GND HI CURRENT RF BLANKING (SWITCHED)
10 25	10 EXT ALC MARKERS
11 26	11 ALC -20V EXT INPUT
12 27	12 OFF/INT NC
13 28	13 EXT AM (L) POWER LEVEL GND
14 29	14 POWER LEVEL REF MOD DRIVE
15 30	15 POWER LEVEL UNLEVELLED LAMP

KEY FOR BOARD PINS

- INPUTS
- OUTPUTS
- I/O'S
- NOT USED
- GNDS

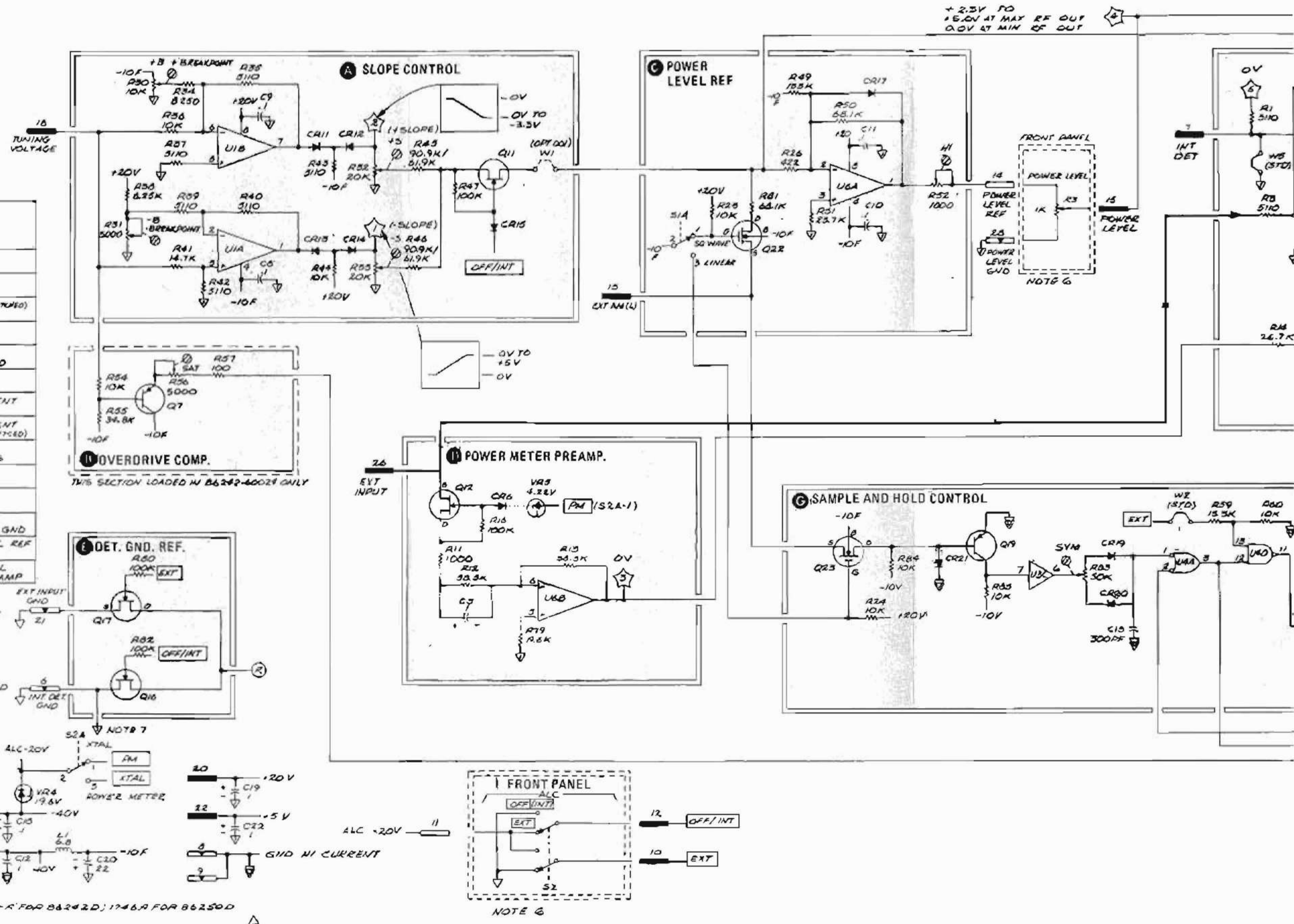

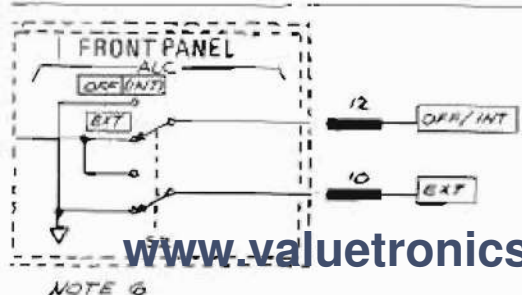
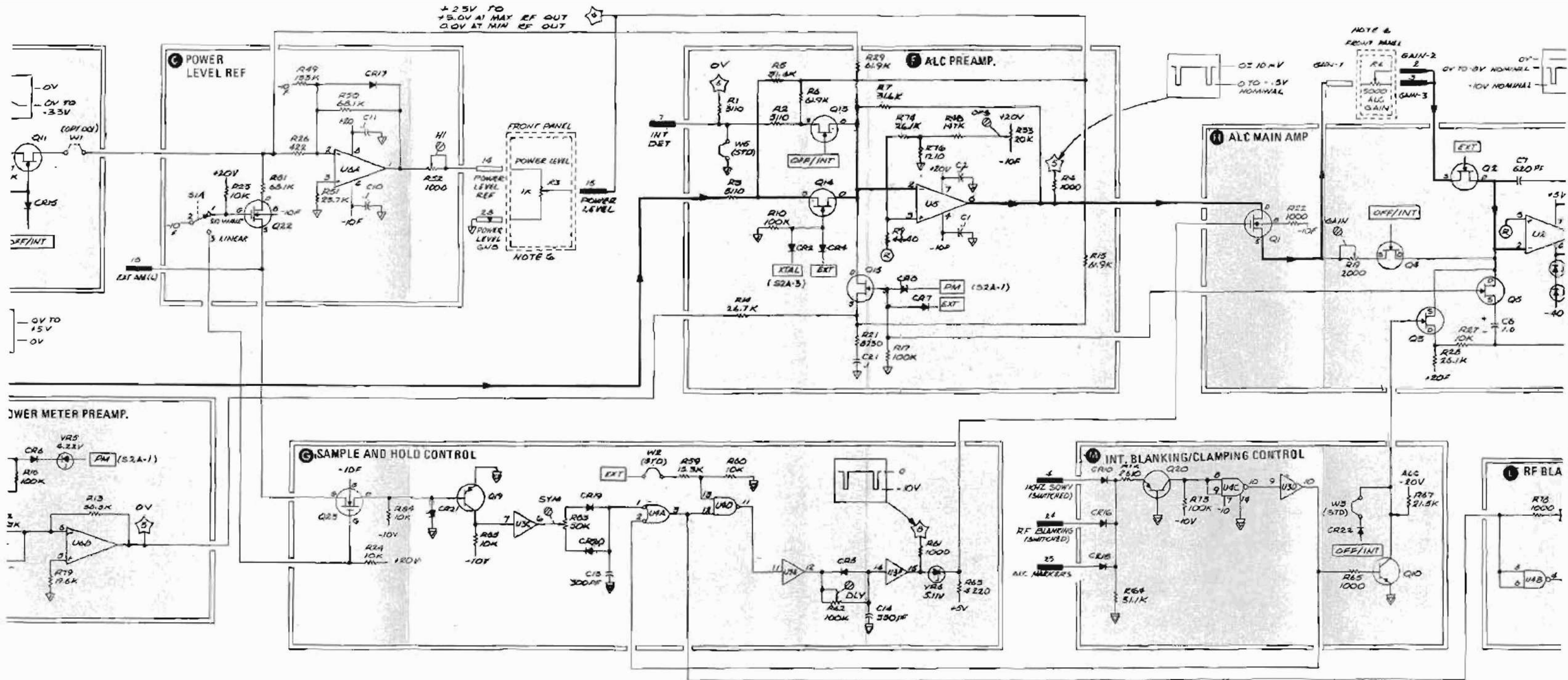

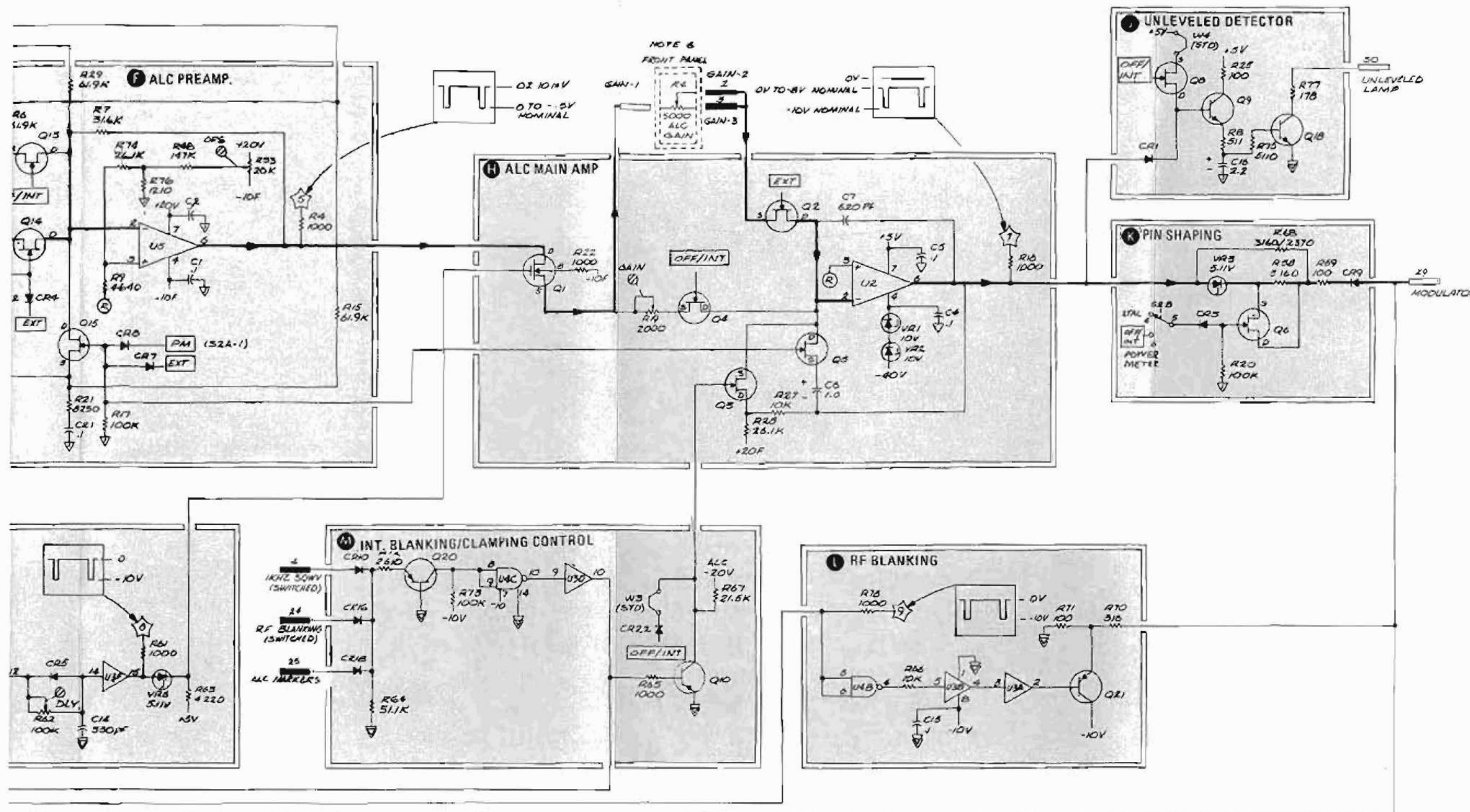

- NOTES
- KEY FOR BOARD PINS:
 — INPUTS
 — OUTPUTS
 — I/O S
 — NOT USED
 — GND
 - REFERENCE DESIGNATORS WITHIN THIS ASSEMBLY ARE ABBREVIATED. FOR COMPLETE REFERENCES DESIGNATOR, PREFIX REFERENCE DESIGNATOR SHOWN WITH THE ASSEMBLY REFERENCE DESIGNATOR.
 - UNLESS OTHERWISE INDICATED: R RESISTANCE IN OHMS CAPACITANCE IN MICROFARADS INDUCTANCE IN MICROHENS
 - SEE INTERCONNECT DIAGRAM SERVICE SHEET 1
 - THE INT. DET. GND () IS PROVIDED BY A JUMPER TO THE CHASSIS ON AN ALCOIG INTERCONNECT BOARD STANDARD, OR BY THE BODY OF INT. DETECTOR THROUGH THE SHIELDING OF CABLE W/ 10FT 8011.
 - TOP RESISTOR VALUE FOR 80242-00024; BOTTOM RES. VALUE FOR 80250-00022.

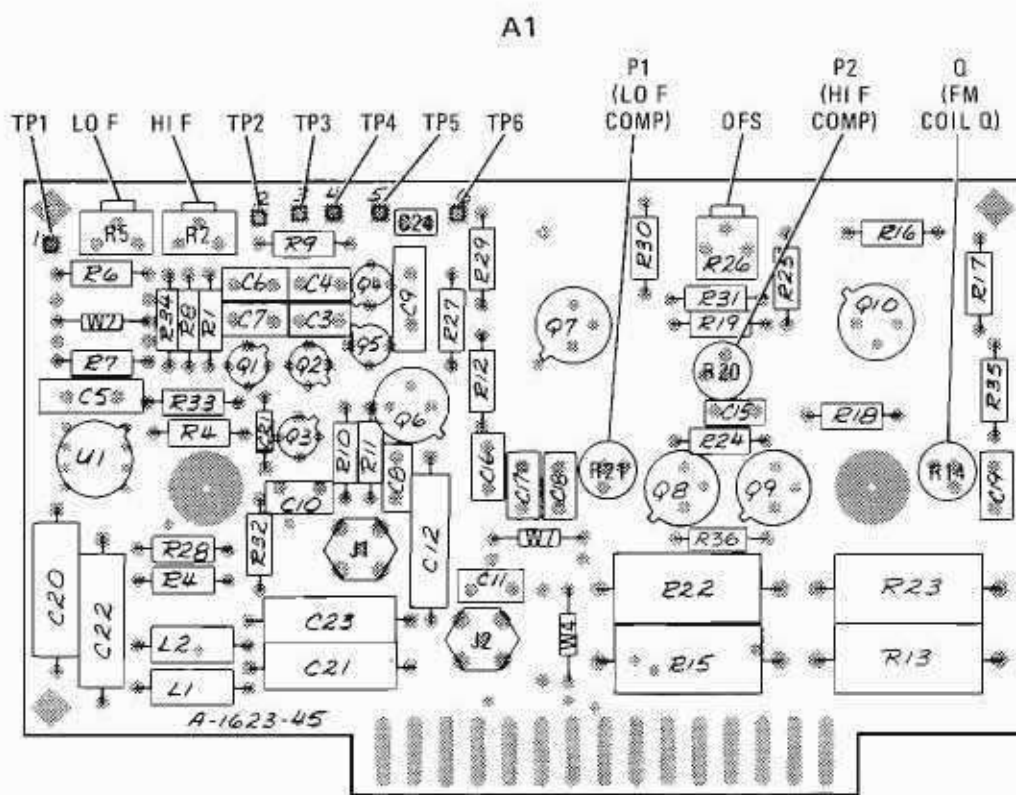

www.valuetronics.com

Figure 7-5. A1 FM Driver Assembly, Component Locations (Change A)

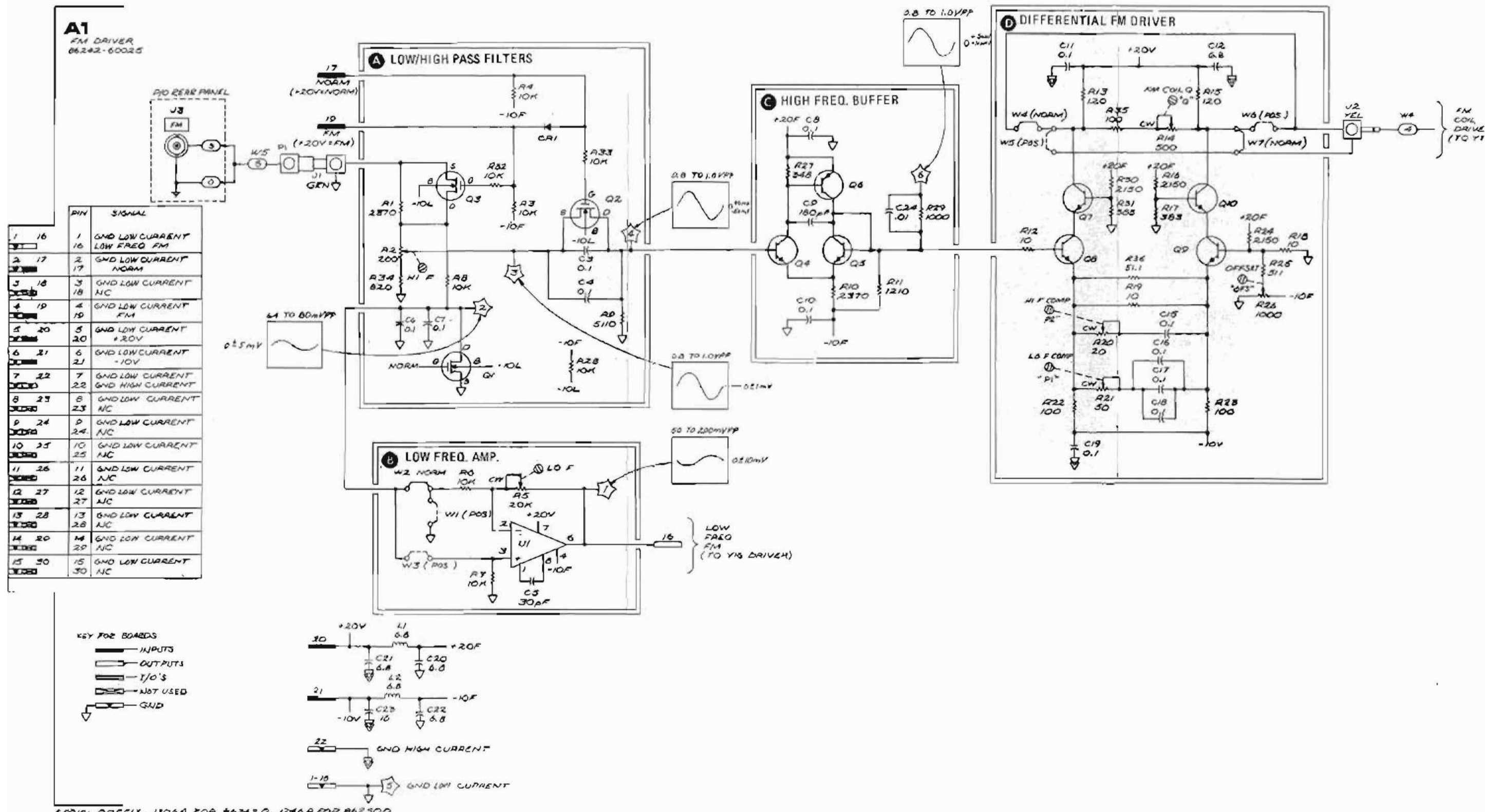

A1
FM DRIVER
86242-60025

PIN	SIGNAL
1	GND LOW CURRENT
16	LOW FREQ FM
2	GND LOW CURRENT
17	NORM
3	GND LOW CURRENT
18	NC
4	GND LOW CURRENT
19	FM
5	GND LOW CURRENT
20	+20V
6	GND LOW CURRENT
21	-10V
7	GND LOW CURRENT
22	GND HIGH CURRENT
8	GND LOW CURRENT
23	NC
9	GND LOW CURRENT
24	NC
10	GND LOW CURRENT
25	NC
11	GND LOW CURRENT
26	NC
12	GND LOW CURRENT
27	NC
13	GND LOW CURRENT
28	NC
14	GND LOW CURRENT
29	NC
15	GND LOW CURRENT
30	NC

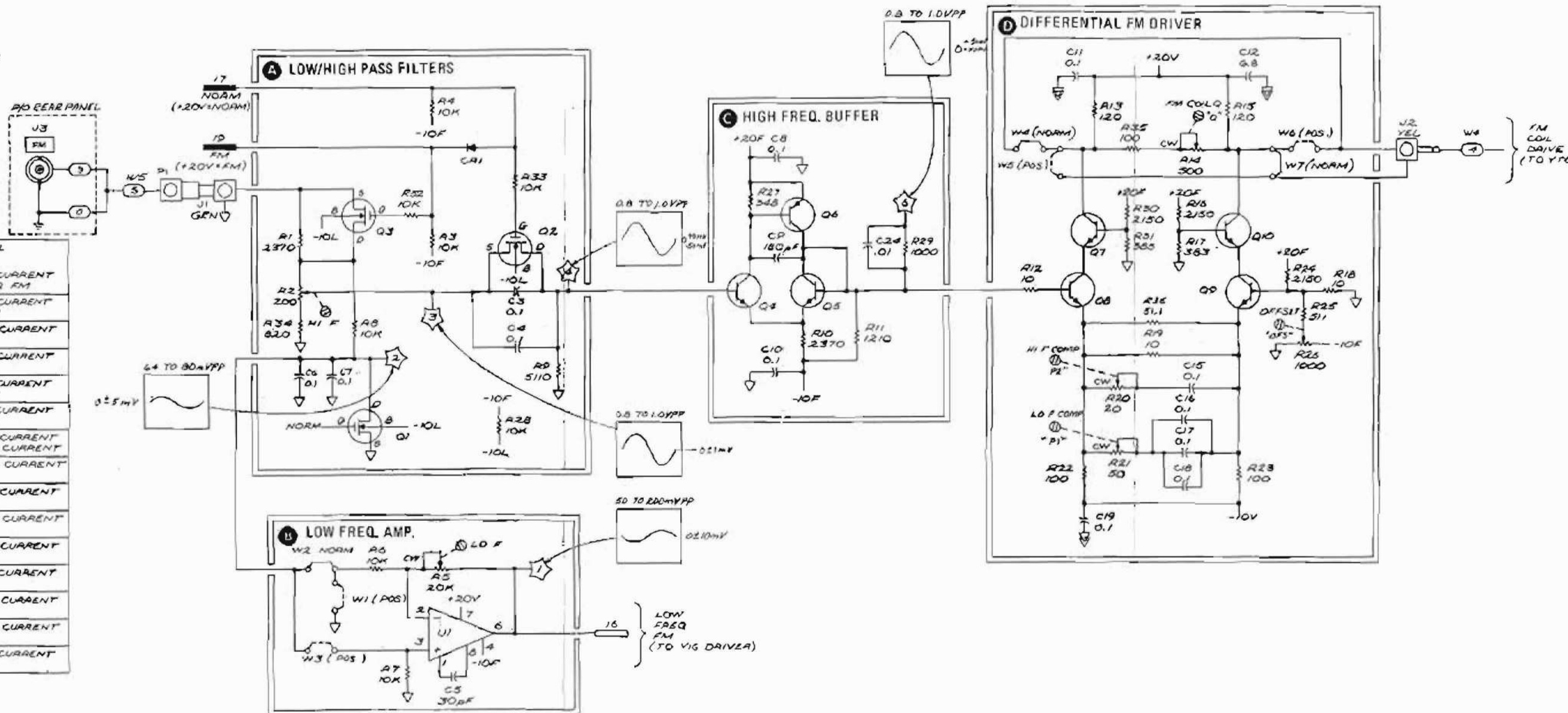

- NOTES
- KEY FOR BOARD PINS:
 - INPUTS
 - OUTPUTS
 - I/O'S
 - NOT USED
 - GND
 - REFERENCE DESIGNATORS WITHIN THIS ASSEMBLY ARE ABBREVIATED FOR COMPLETE REFERENCE DESIGNATOR. PREFIX REFERENCE DESIGNATOR SHOWN WITH THE ASSEMBLY REFERENCE DESIGNATOR.
 - UNLESS OTHERWISE INDICATED: RESISTANCE IN OHMS CAPACITANCE IN MICROFARADS INDUCTANCE IN MICROHENRIES

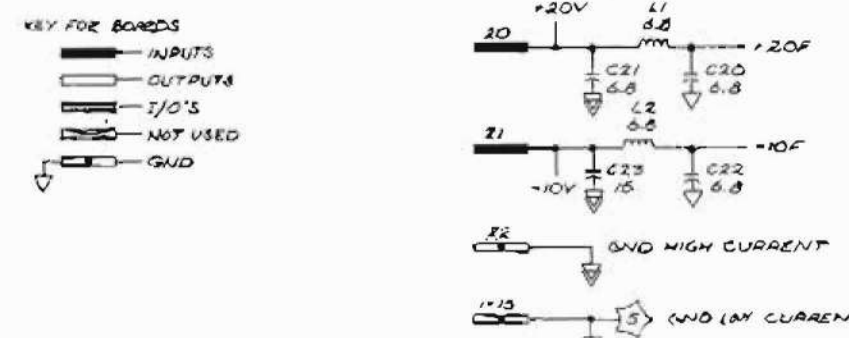

VAL PREFIX: 1104A FOR 86242.D, 1148A FOR 86250

www.valuetronics.com

4
A1

Figure 7-6. A1 FM Driver Assembly, Schematic (Change A)

www.valuetronics.com

A1 FM Driver Assembly, Component Locations (Change A)



A1 FM Driver Assembly, Schematic (Change A)

SECTION VIII SERVICE

8-1. INTRODUCTION

8-2. This section provides information for troubleshooting and repairing the Model 86242D/86245A/86250D RF Plug-ins. This information includes troubleshooting block diagrams and schematic diagrams. Circuit descriptions are included with the schematic diagrams of the assemblies. Component location illustrations are contained in this section to add visual information for servicing and repairing. Service Sheet 1 provides a block diagram and functional description of the RF Plug-in. Schematic presentations in this manual show electrical circuit operation and are not intended to serve as wiring diagrams.

8-3. ASSEMBLY SERVICE SHEETS

8-4. The schematics are arranged by service sheets. The service sheet numbers appear in the lower right-hand corner of the schematics (large number above assembly number). Included in the service sheet is the schematic as well as the accompanying circuit theory, component-parts location diagram and simplified block diagrams.

8-5. PRINCIPLES OF OPERATION

8-6. Circuit Description

8-7. Detailed circuit description for each individual schematic diagram is placed on the facing left-hand foldout page. This places material needed for printed-circuit-level diagnosis in one location and allows easy correlation between function and specific circuitry.

8-8. YIG-Tuned Oscillator

8-9. The YIG (yttrium-iron-garnet) is an electrically tunable resonant structure, made up from a single yttrium-iron-garnet crystal and formed into a highly polished sphere. Because yttrium-iron-garnet is a ferrimagnetic material, it consists of a high density of randomly oriented magnetic dipoles. Each dipole consists of a minute current

loop formed by a spinning electron. Because of the random orientations, there is no net magnetic effect external to the YIG sphere (Figure 8-1).

8-10. When a dc magnetic field, H_0 is applied, the dipoles align themselves parallel to it (Figure 8-2). This produces a net magnetization vector, M_0 , in the direction of H_0 (Figure 8-3).

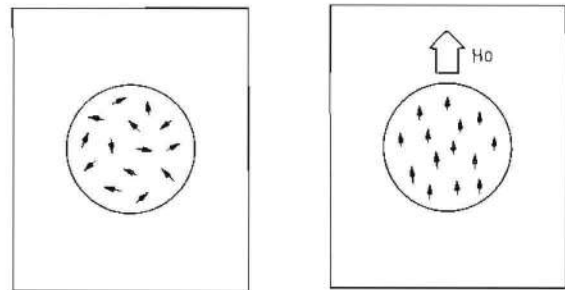

Figure 8-1. YIG Sphere in Non-Magnetic Field Figure 8-2. YIG Sphere in Magnetic Field

8-11. To support oscillations, a second magnetic field produced by an RF signal is applied perpendicular to the net magnetization vector. This causes the net magnetization vector to precess, or rotate, about the axis that is parallel to H_0 . See Figure 8-4.

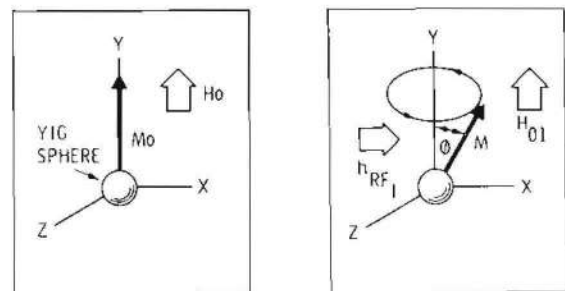

Figure 8-3. Net Magnetization Vector

Figure 8-4. Magnetization Vector With RF Field Applied

8-12. The rate of precession, or rotation, is at the frequency of the RF field. The unique characteristic of the YIG sphere is that it has a natural, or inherent, ferrimagnetic resonant frequency. At all other excitation frequencies of resonance, this angle will be very small. That is, it will not support oscillations at other than its ferrimagnetic resonant frequency.

8-13. A second unique characteristic of the YIG is that this natural resonant frequency is a linear function of the strength of the dc magnetic field, H_0 . Thus, the resonant frequency of the YIG sphere is tunable by varying the dc current through the electromagnet that produces H_0 . See Figure 8-5.

8-14. The small YIG sphere is positioned directly between the poles of an electromagnet. The current through the electromagnet is varied by the tuning voltage (or sweep ramp). The high frequency transistor oscillator is coupled to the YTO YIG by a single loop of flat wire. See Figure 8-6.

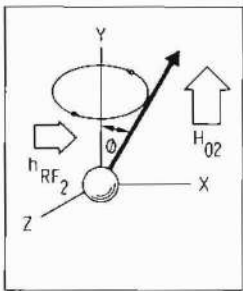

Figure 8-5. Increase DC Magnetic Field

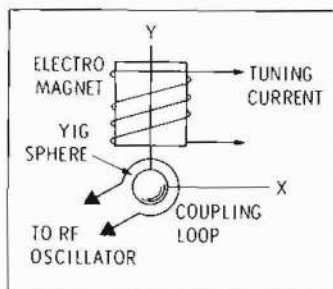

Figure 8-6. Coupling RF and DC Magnetic Fields to YTO YIG

8-15. MODULE EXCHANGE PROGRAM

8-16. THE A4 OSCILLATOR and the A5 MODULATOR/AMPLIFIER Assemblies may be ordered through the module exchange program. Table 6-2 lists the HP Part Numbers for restored A4 and A5 assemblies as well as for new assemblies. The restored assemblies may be purchased through the module exchange program at a reduced price. The lower price is dependent on the return of the defective module to Hewlett-Packard. For more information, see the procedure for ordering an assembly through the module exchange program.

8-17. SERVICE

8-18. Safety

8-19. The information, cautions, and warnings in this manual must be followed to ensure safe operation and to keep the instrument safe. **SERVICE AND ADJUSTMENTS SHOULD BE PERFORMED ONLY BY QUALIFIED SERVICE PERSONNEL.**

8-20. Adjustment or repair of the opened instrument with the ac power connected should be avoided as much as possible but, when unavoidable, should be performed only by qualified service personnel who are aware of the hazard involved.

8-21. Capacitors inside the instrument may still be charged even though the instrument has been disconnected from its source of supply.

WARNING

Servicing this instrument often requires working with the instrument's protective covers removed and ac power connected. Extreme caution should be exercised since energy available at many points in the instrument may, if contacted, result in personal injury.

BEFORE SWITCHING THE INSTRUMENT ON, ensure that all ac line powered devices connected to the instrument are connected to the protective earth ground.

With the ac power cable connected, the ac line voltage (115 or 230 Vac) is present at the terminals of mainframe power line assembly FL1 (mounted on rear panel) and at the mainframe **POWER** switch, whether the **POWER** switch is on or off. With the top cover removed, these terminals are exposed and carry ac voltages capable of causing death.

The module exchange program described here is a fast, efficient, economical method of keeping your Hewlett-Packard instrument in service.

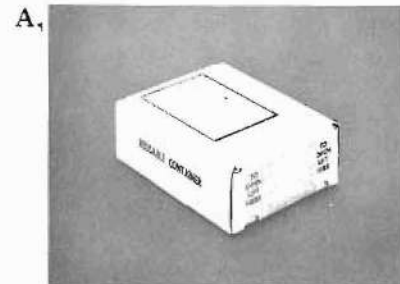
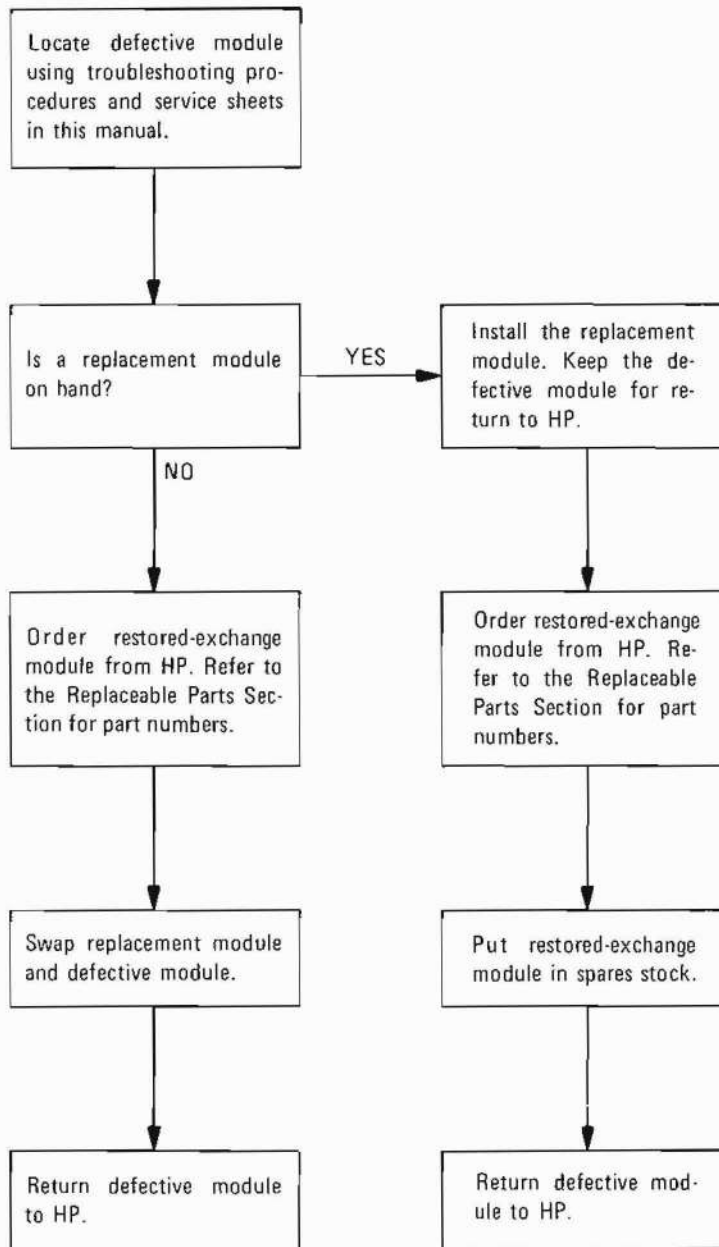

Rebuilt-exchange modules are shipped individually in boxes like this. In addition to the circuit module, the box contains:
 Module repair report
 Return address label
 Tape for resealing box



Open box carefully - it will be used to return defective module to HP. Complete repair report. Place it and defective module in box. Be sure to remove enclosed return address label.



Seal box with tape provided. Inside U.S.A.* stick preprinted return address label over label already on box, and return box to HP. Outside U.S.A., do not use address label; instead, address box to the nearest HP office.

Figure 8-7. Module-Exchange Procedure

8-22. Troubleshooting

8-23. Troubleshooting is divided into two maintenance levels in this manual. The first level isolates a trouble to a circuit or assembly. This is done using a troubleshooting block diagram with typical voltages and waveforms along with general circuit descriptions.

8-24. The second maintenance level isolates the trouble to the component. Schematic diagrams and circuit descriptions for each assembly aid in troubleshooting to the component level. The schematic also contains waveforms and voltages for use during troubleshooting. Test equipment setup and instrument control settings for waveforms and dc voltages are shown in Figure 8-10.

8-25. When troubleshooting a transistor stage, check for a forward bias condition of the base-emitter junction. If this condition exists, the next step is to remove this forward bias by shorting the base to the emitter and checking to see if the collector voltage rises to the approximate level of the supply. The next check that can be made, if it is known that the transistor is not operating in a saturated condition, is to check for a voltage drop between emitter and collector. Obviously these serve only as quick checks and will help in getting started with the problem. When an operational amplifier failure is suspected, a test can be made by inserting some resistance in series with the input and checking for a voltage drop across the resistor. If there is a voltage drop, the operational amplifier should be replaced, since the inputs should not draw current.

8-26. Recommended Test Equipment

8-27. Test equipment and accessories required to maintain the RF Plug-ins are listed in Table 1-4. If the equipment listed is not available, equipment that meets the minimum specifications shown may be substituted.

8-28. Cleaning Switches

8-29. The cleaning agent to be used on the switches is isopropyl alcohol, HP Part No. 8600-0755. Spray the alcohol into the switch and slide or rotate the switch back and forth. Repeat this procedure several times, continue to slide or rotate the switch back and forth until the alcohol is evaporated.

8-30. Unleveled Lamp Removal and Replacement

8-31. The procedure for replacing the UN-LEVELED lamp DS1 is described in Figure 8-8. Use the following procedure to test the UN-LEVELED lamp:

- a. Connect DS1 cathode (short lead) to ground.
- b. Connect a 178-ohm resistor between DS1 anode and +5V. If the lamp is good, it should light.

NOTE

The diode current must be limited to 30 ma to prevent damaging a good LED.

UNLEVELED LAMP DS1 REPLACEMENT PROCEDURE

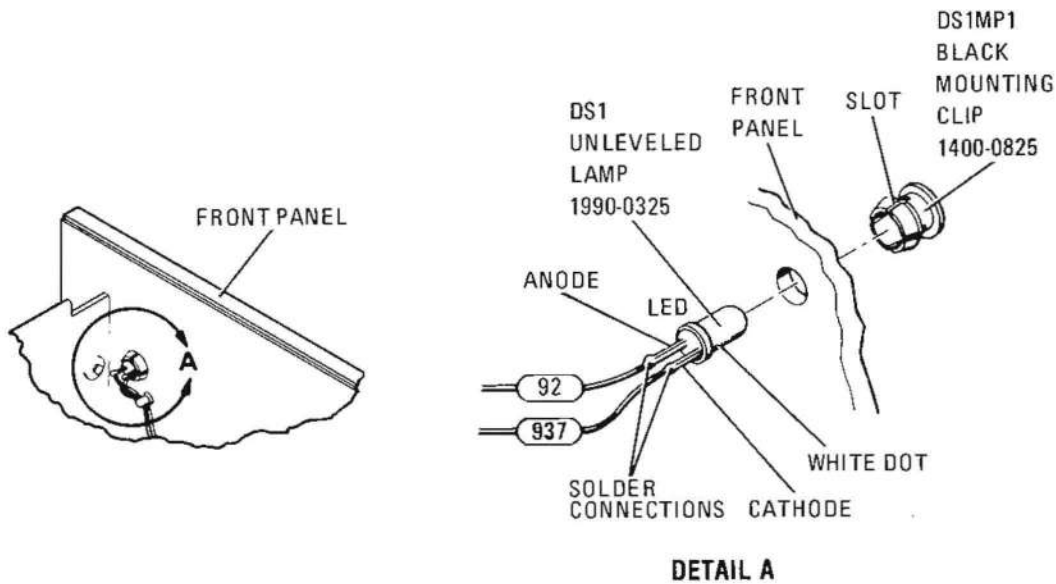

1. REMOVAL PROCEDURE:

- a. Remove RF Plug-in from mainframe, and remove A2 board from RF Plug-in.
- b. Push DS1 out back of front panel with thumb, or eraser-end of a pencil. Unsolder anode and cathode leads.

WARNING

If DS1 is not easily pushed out, protect the thumb with cardboard or cloth.

2. INSTALLATION PROCEDURE:

- a. Connect (solder) white-red wire to anode (long lead) of DS1, and white-orange-purple wire to cathode (short lead) of DS1.

NOTE

On some Light-Emitting Diodes (LED) the leads are the same length and the cathode is distinguished by a white dot.

- b. Slide DS1 into Mounting Clip as far as possible. Put a thin-bladed screwdriver through slot in Mounting Clip and push on metal rim at base of DS1 until lamp clicks into clip.

CAUTION

Do not push on the glass portion at the base of DS1 or the lamp may be broken.















Figure 8-8. UNLEVELED Lamp Removal and Replacement Procedure

SCHEMATIC DIAGRAM NOTES

For symbols not shown, refer to USA Standard Y32.2 – 1975 “Graphic Symbols for Electrical and Electronic Diagrams.”

Logic Symbols used conform to ANSI Y32.14 – 1973 “Graphic Symbols for Logic Diagrams (Two State Devices).”

Resistance is in ohms, capacitance is in microfarads, and inductance is in microhenries unless otherwise noted.

- * Asterisk denotes a factory-selected value. Value shown is typical. Capacitors may be omitted or resistors jumpered.
-  Screwdriver adjustment
  Panel control
-  Encloses front panel designations
-  Encloses rear panel designation
-  Circuit assembly borderline
-  Other assembly borderline
-  Heavy line with arrows indicates path and direction of main signal.
-  Heavy dashed line with arrows indicates path and direction of main feedback.
-  Wiper moves toward CW with clockwise rotation of control as viewed from shaft or knob.
-  Numbers in stars on circuit assemblies show locations of test points.
-  Encloses wire color code. Code used (MIL-STD-681) is the same as the resistor color code. First number identifies the base color, second number identifies the lowest color stripe, and third number identifies the highest color strip, e.g.,  denotes white base, yellow stripe, violet stripe.
-  Light-emitting diode.
-  Voltage regulator (breakdown diode).
-  Denotes Junction Field Effect transistor (FET) with N-type base.

www.valuetronics.com

Figure 8-9. Schematic Diagram Notes (1 of 2)

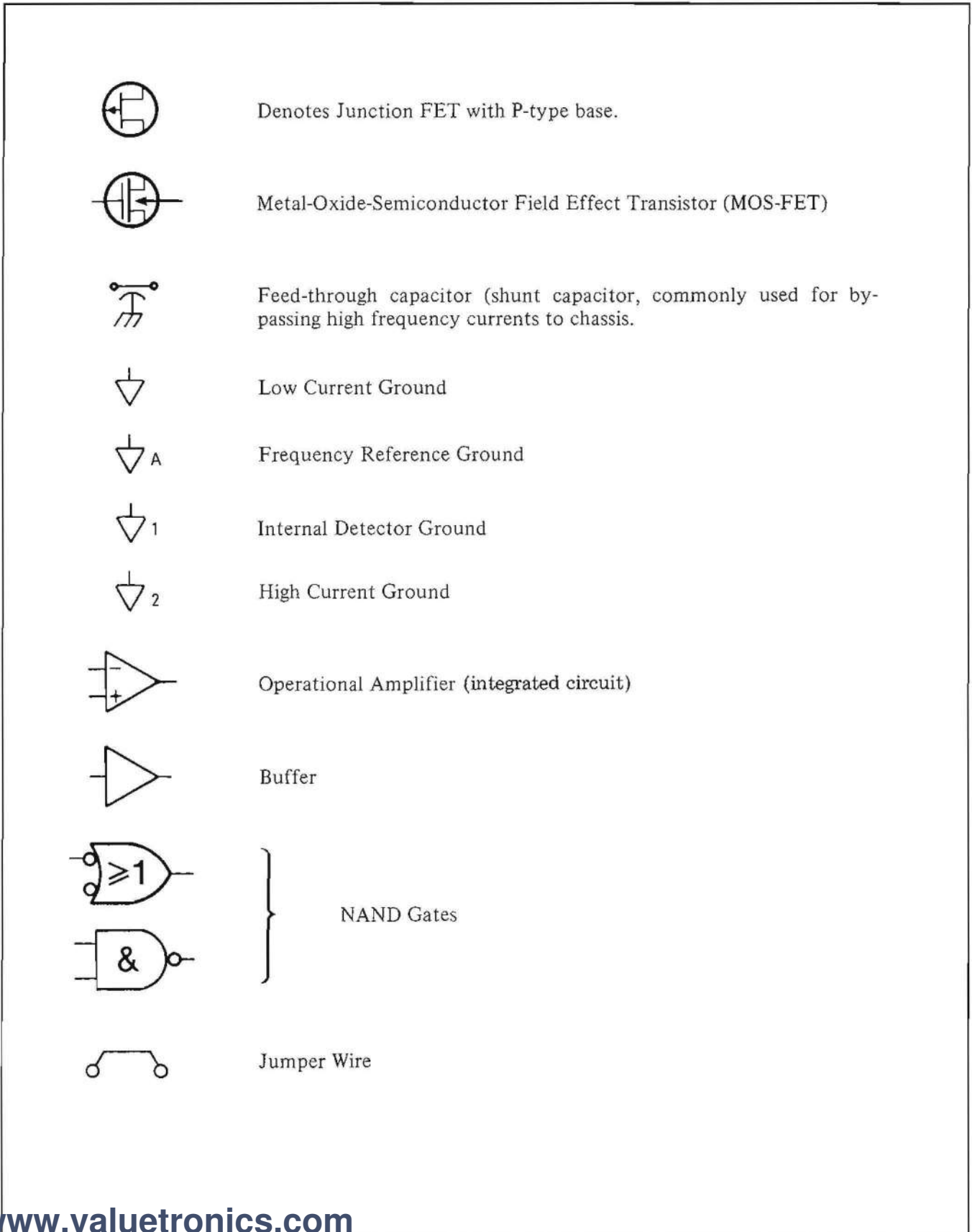

Figure 8-9. Schematic Diagram Notes (2 of 2)

SERVICE SHEET 1

TROUBLESHOOTING BLOCK DIAGRAM

General

The Troubleshooting Block Diagram, Figure 8-12, shows the overall RF signal path of the RF plug-in. Tuning current is supplied to the A4 YTO Assembly by the A2 YIG Driver Assembly. The A1 FM Driver Assembly provides up to 150 MHz deviation at low frequency rates and a maximum of 10 MHz deviation at high frequency rates. Leveling control of the RF output power is provided by the A3 ALC Assembly. The A3 ALC Assembly may be externally modulated using the HP 8755A/B Swept Amplitude Analyzer.

A2 YIG Driver Assembly

The A2 YIG Driver Assembly processes the tuning voltage from the HP 8620C mainframe to provide proportional tuning current and applies this current to the YTO main tuning coil.

Bias for the YTO, YIG ON/OFF control, and frequency reference voltage are also supplied by the A2 YIG Driver Assembly.

A3 ALC Assembly

The A3 ALC Assembly provides leveling control of the RF output power. This is accomplished by controlling the amount of current to the PIN modulator. Leveling control may be external with a crystal detector, external with a power meter, or internal (Option 001).

In external crystal detector leveling mode, leveling is accomplished by an input from an external crystal detector of between -55 and -525 mV to front-panel EXT INPUT connector.

In external power meter leveling mode, leveling is accomplished by an input to front-panel EXT INPUT connector from power meter recorder output.

Internal leveling (Option 001) is accomplished in the same manner as external crystal detector leveling except a coupler and detector are installed in the RF Plug-in.

A1 FM Driver Assembly

The A1 FM Driver Assembly provides for frequency modulating the RF output signal with frequency modulation rates of up to 2 MHz with frequency response of ± 1.5 dB.

Rear-panel FM-NORM-PL switch selects narrow deviation (NORM), Wide deviation (FM) or phase-locking (PL) FM modes of operation.

A5 Modulator/Amplifier Assembly

The 86245A RF Plug-in provide greater than 50 mW leveled output power. This high-power output is accomplished by use of a GaAs FET amplifier shown in Figure 8-11. This amplifier is highly susceptible to static discharge, therefore, no attempt should be made to disassemble or repair the A5 Modulator/Amplifier Assembly. **Any attempt to do so will result in voiding of the warranty.**

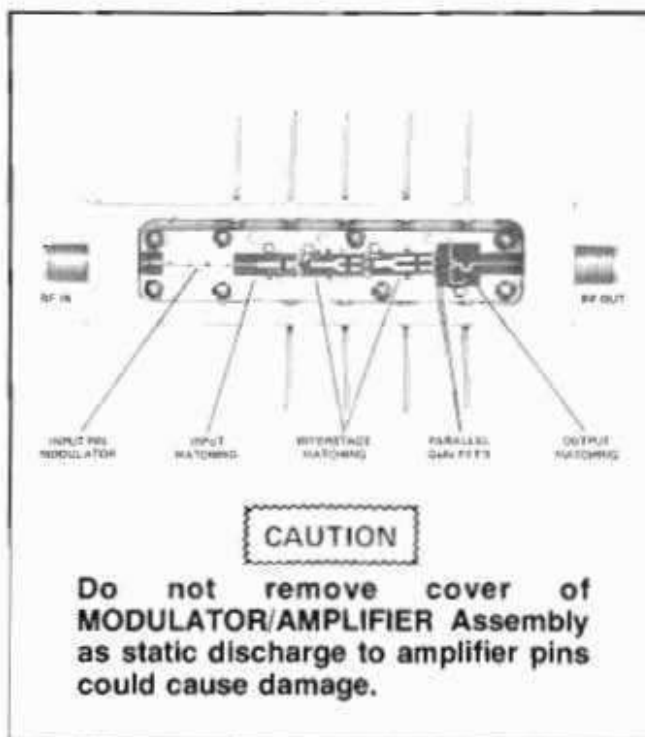
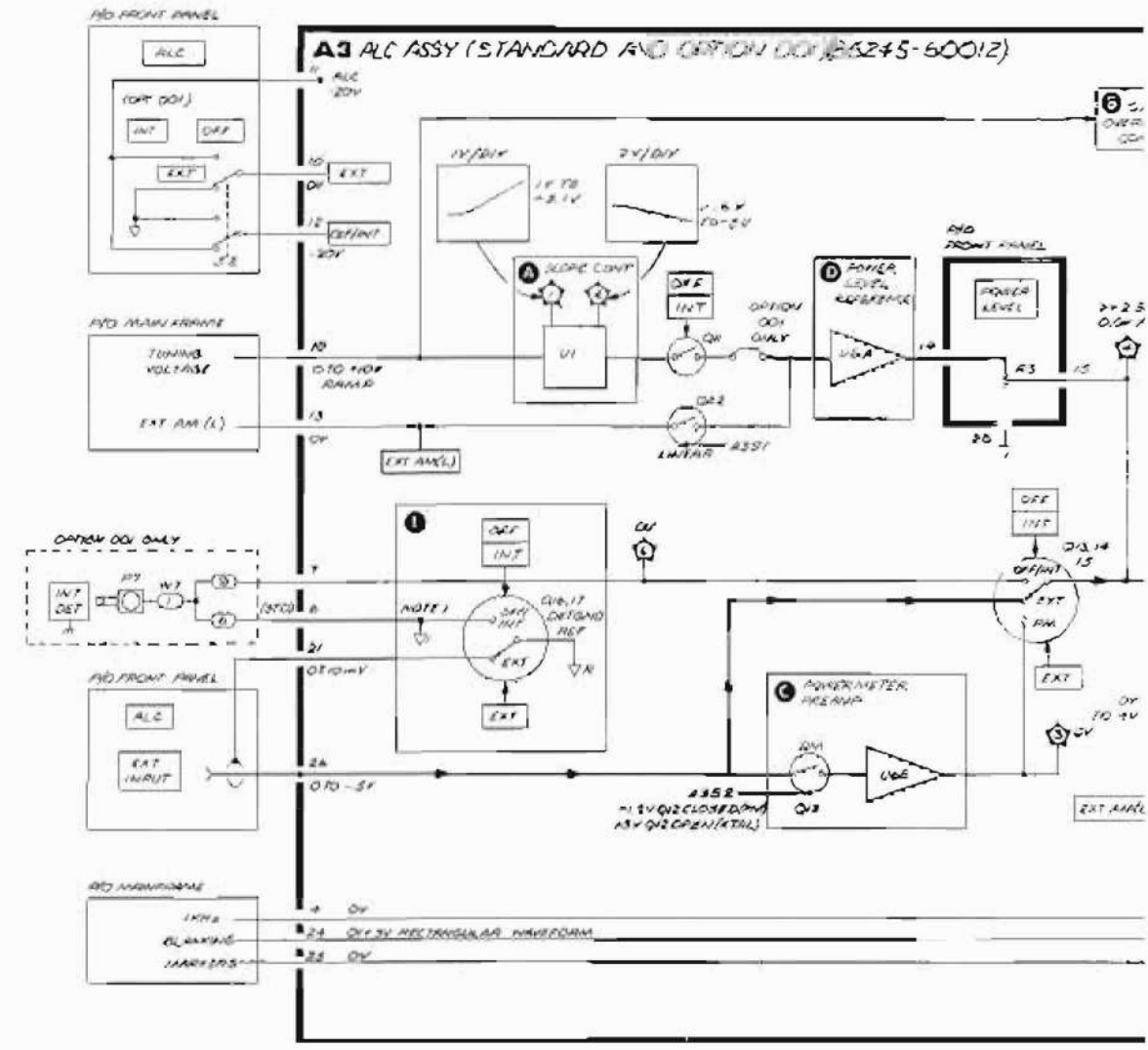
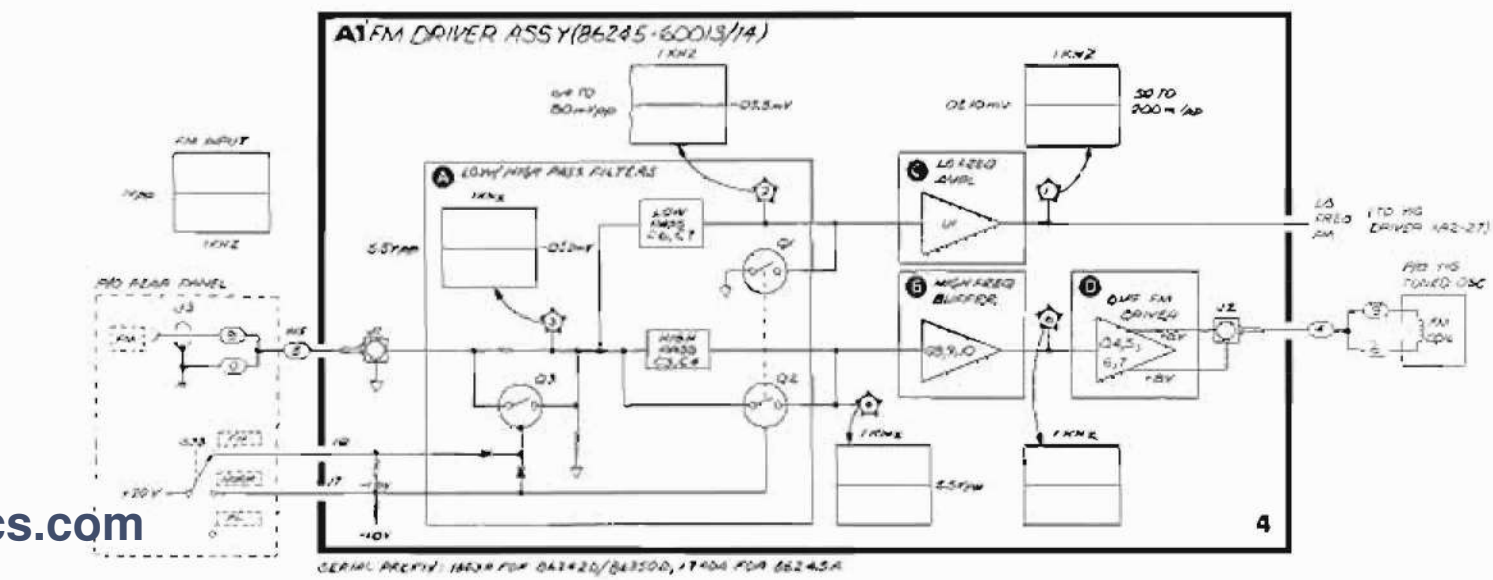
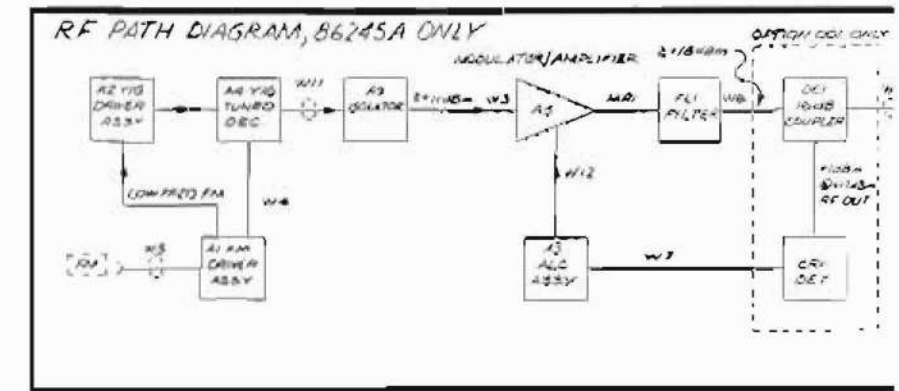
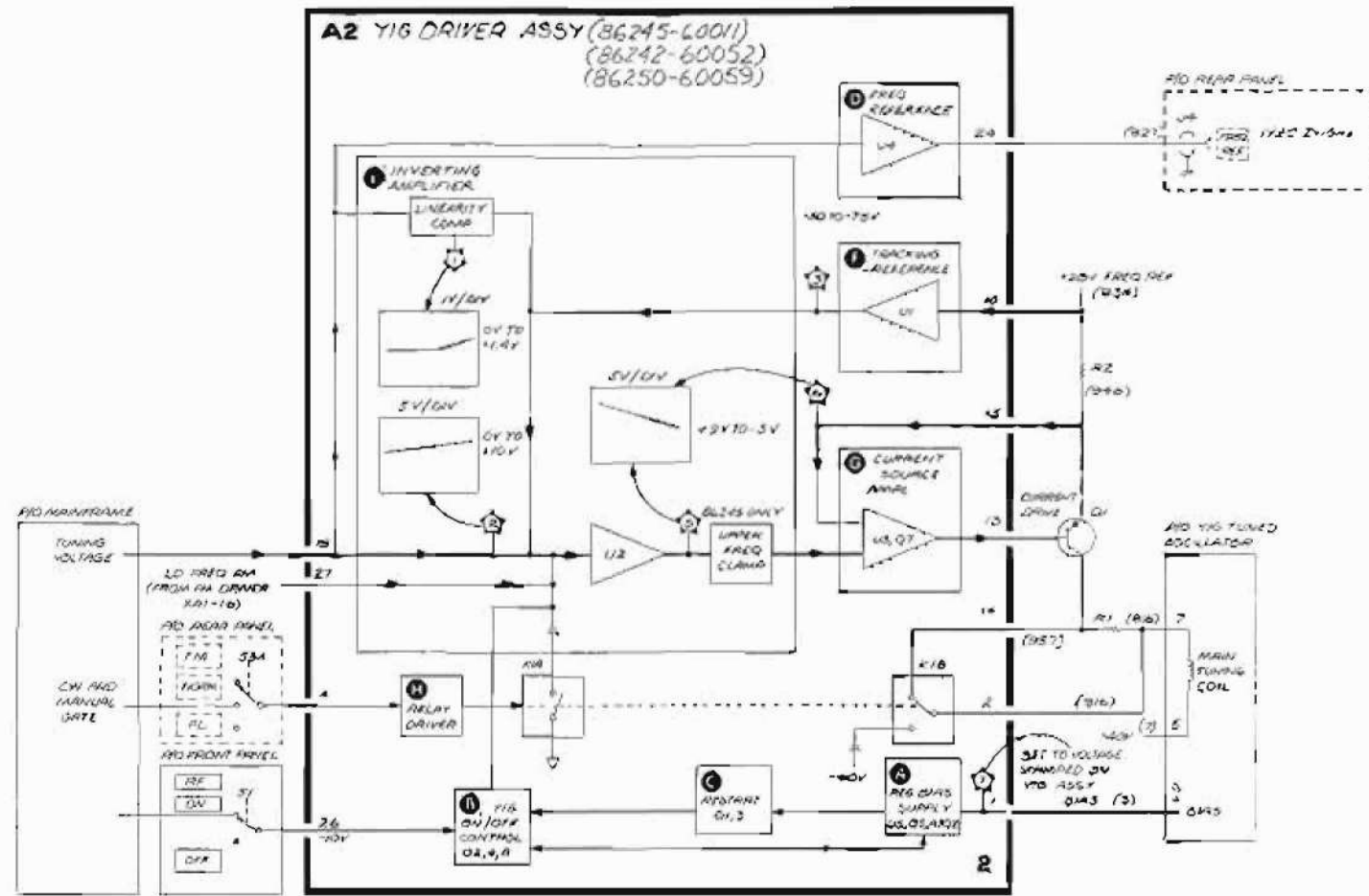

Figure 8-11. GaAs FET Amplifier



NOTES:
 1. THE ALC ASSEMBLY IS SHOWN SHOWN AS PROVIDED IN A NUMBER TO THE CORRESPONDING ALL/1/16 INTER-LINK TO ALC (STANDARD) OR B/THE P-2 (OPTION 001) DETECTOR IN THE SIGNAL OF Q23 (OPTION 001).

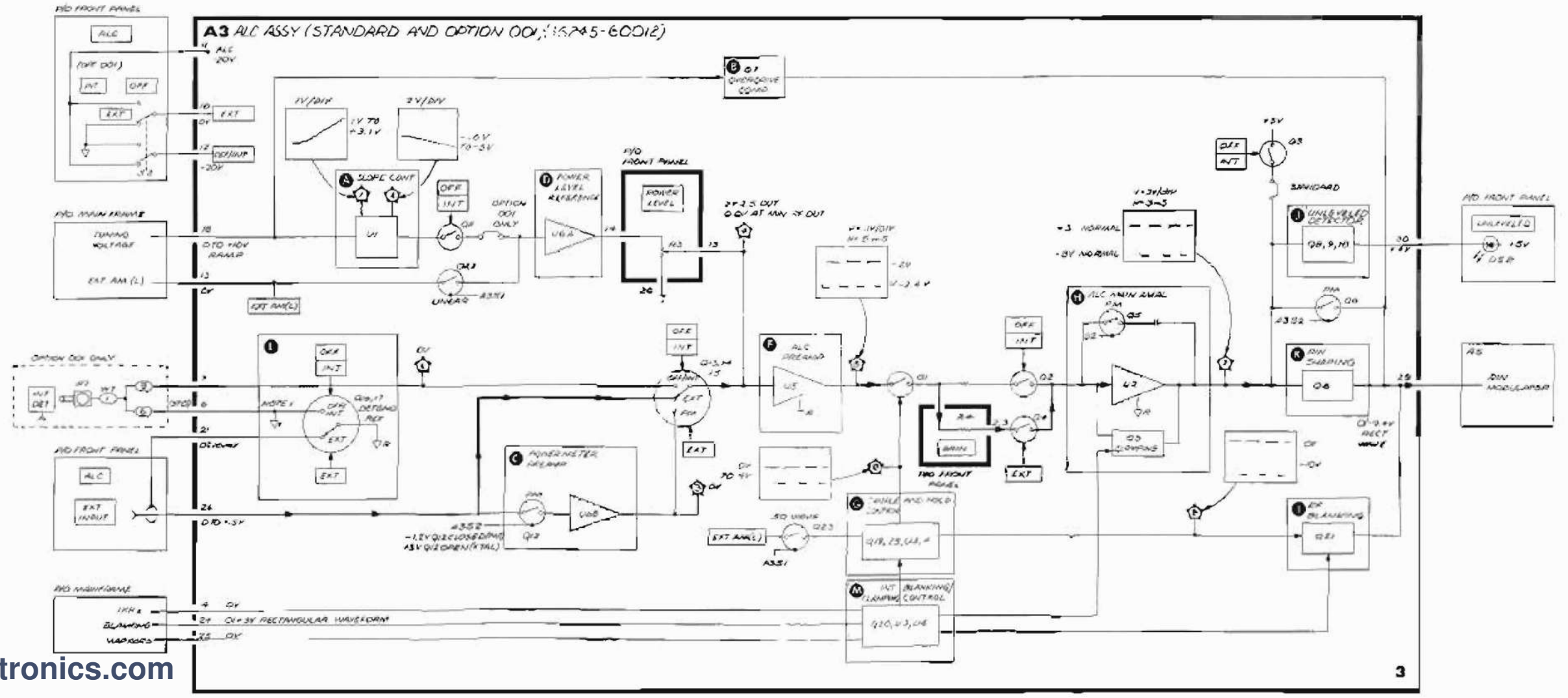
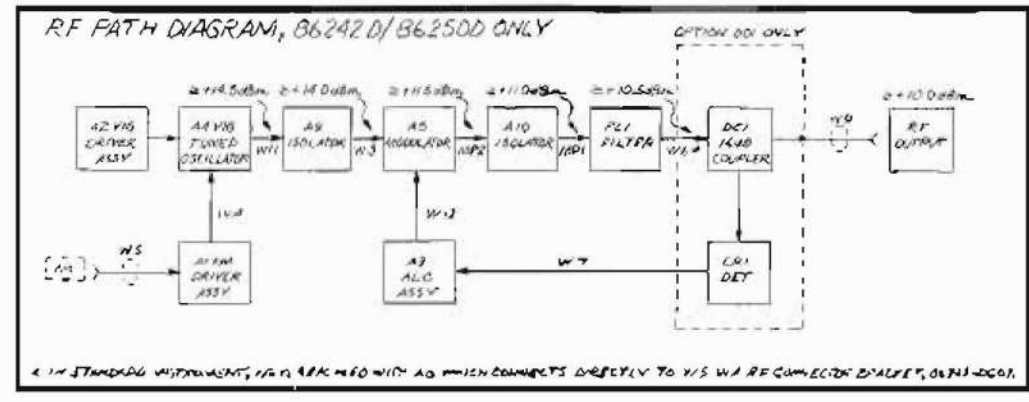
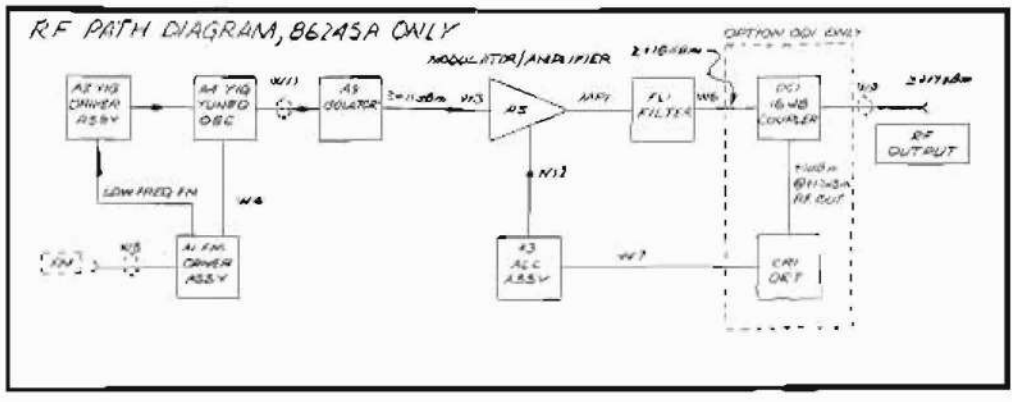

Figure 8-12. Overall Block Diagram

SERVICE SHEET 2**A2 YIG DRIVER ASSEMBLY, CIRCUIT DESCRIPTION****General**

The A2 YIG Driver Assembly controls the frequency of the RF output power, supplies bias to the YIG Tuned Oscillator, and produces a 1V/GHz reference output.

The Current Source supplies current to the YTO Main Tuning Coil. The Inverting Amplifier inverts and controls the amplitude of the mainframe tuning voltage. A fixed reference voltage, combined with the +20 frequency reference voltage, is fed from the Tracking Reference into the Inverting Amplifier. YIG tuning Comp compensates for YTO tuning non-linearity. Relay Driver switches in filter capacitors to reduce residual FM. YIG/Coil On-Off controls Current Source and Bias Reference.

YIG ON/OFF CONTROL **B**

When the RF ON/OFF switch is in OFF, Q4 is on, forcing the output of the Regulated Bias Supply to ground. Also, Q8 and Q2 conduct, forcing the YTO Main Summing Coil current to zero. When the RF ON/OFF switch is in ON, Q4 and Q8 are OFF, and Q2 turns off after a delay (determined by R35 and C5).

Relay Drive **H**

When the mainframe is in CW or MANUAL, and the FM-NORM-PL switch is in NORM, Q6 activates K1.

Inverting Amplifier **E**

R23 (MID) adjusts tuning range. The output of Tracking Reference is summed through R49. R29 (CLP), R34, and R22 set maximum negative voltage to limit maximum current in main tuning coil. R27, C7 are delay compensation. R20 saturates U2 to +20 supply for RF OFF and restart. YIG Slope Comp is summed through R4. C4 is switched in to reduce residual FM.

YIG tuning compensation is also provided in the Inverting Amplifier circuitry. R36, R31, and VR6 set the level at which CR12 conducts. R33 (HI) adjusts amount of compensation.

Regulated Bias Supply **A**

U5 supplies a reference voltage from pin 4 to (+) input pin 3 of internal op-amp. R9, R10, C2 filter this voltage. The internal op-amp adjusts the voltage at its (-) input to match the voltage at its (+) input. Since R12, R13, R15 make a voltage divider, the output will be a higher voltage than the reference. R13 (BIAS) adjusts this voltage. R11 and C3 compensate the internal op-amp as a function of frequency.

A buffer transistor in U5 drives Q2 (on chassis) through R7. Over-current is sensed by another transistor in U5 which monitors the voltage across R3.

VR2 protects against overvoltage surges. If overvoltage persists, VR1 triggers Q5 and blows F1.

Current Source Ampl **G**

U3 senses the voltage at the bottom end of R1 (on chassis) and makes it the same as the voltage supplied to its (+) input (from the Inverting Amplifier). Q7 and Q1 (on chassis) buffer the output of U3. Relay K1B switches R2 in series with the main tuning coil and also capacitors C12 and C13 across the coil to reduce residual FM.

R38 damps ringing of the tuning coil. CR1 and VR3 protect the driver transistors against back EMF.

Restart **C**

If the Regulated Bias Supply is not on, Q3 conducts, turning Q1 ON. This activates Q2, stopping current flow through the main tuning coil. When the Regulated Bias Supply rises to +5 volts, Q1 turns off.

Tracking Reference **F**

The Tracking Reference output is inversely proportional to the +20V FREQUENCY REFERENCE voltage. This is used as a correction voltage to maintain frequency accuracy independent of this supply. A change in the level of the +20V FREQUENCY REFERENCE voltage at the top of reference resistor R1 (on chassis) would normally cause a change of current through the YIG coil, however, the Tracking Reference corrects for any change in the supply voltage to maintain a constant current through the YIG coil.

Also, an adjustable reference voltage is summed in to determine the fixed value of the current through the main tuning coil. VR4 and VR5 form a voltage source, which is filtered by R52 and C8. R44 (LO) sets the level of this reference voltage at the (-) input pin 2 of U1.

Freq Reference **D**

The tuning voltage ramp is attenuated and level shifted by R41, R42, and R43 to produce a 1V/GHz frequency reference voltage. U4 buffers this voltage.

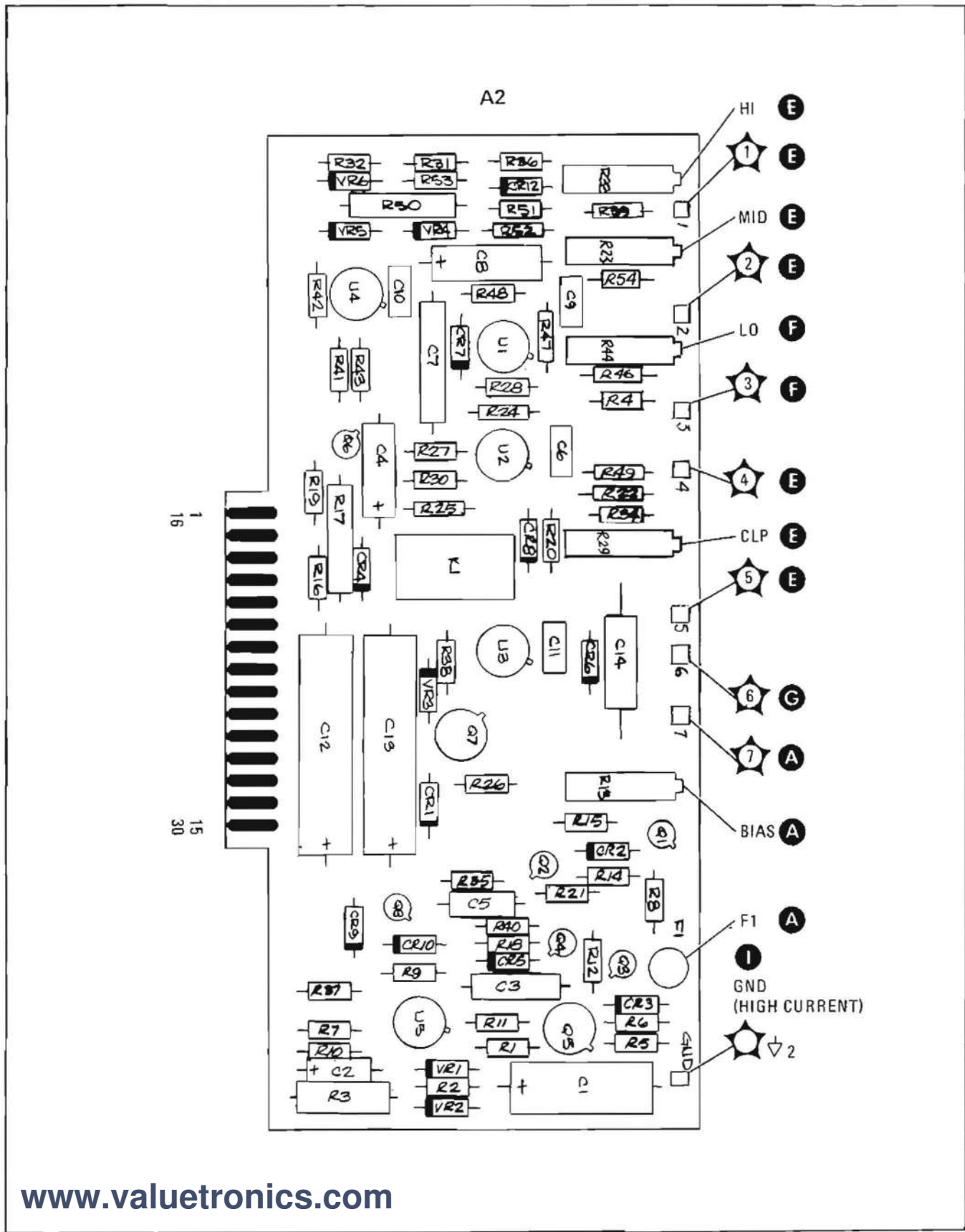

www.valuetronics.com

Figure 8-13. A2 YIG Driver Assembly, Component Locations

A2 YIG DRIVER ASSEMBLY

86242-60052
86245-60011
86250-60059

PIN	SIGNAL	TO/FROM	FUNCTION BLOCK
1	BIAS	P3-3 (3)	A
16	+10V		I
2	TUNING COIL -10V FREQ REF	P3-7 (316)	C
17			I
3	NC		
18	TUNING VOLTAGE	P4-1	D, E
4	CW MAN/NORM GND FREQ REF	S4 (935)	H
19			I
5	-10V		I
20	+20V		I
6	-10V		I
21	NC		
7	Q2-B	W2-14	A
22	+5V		I
8	GND HIGH CURRENT NC	P4-32	I
23			
9	GND HIGH CURRENT FREQ REF	P4-32	I
24			
10	+20V FREQ REF NC	U4 (927)	D
25			
11	NC		
26	RF ON/OFF	B1 (917)	B
12	NC		
27	LD FREQ FM	XA1-16	E
13	Q1-B	W2-9	C
28	NC		
14	Q1-C	W2-10	C
29	Q2-C	W2-0	A
15	Q1-E	W2-11	C
30	Q2-E	W2-5	A

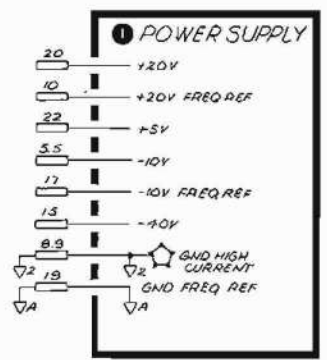
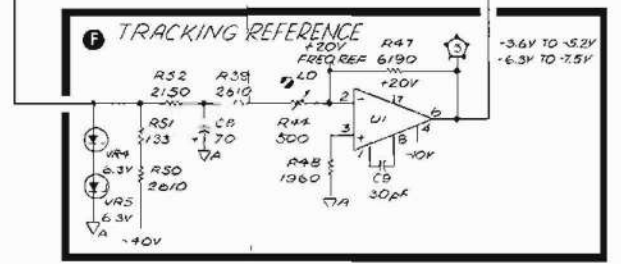
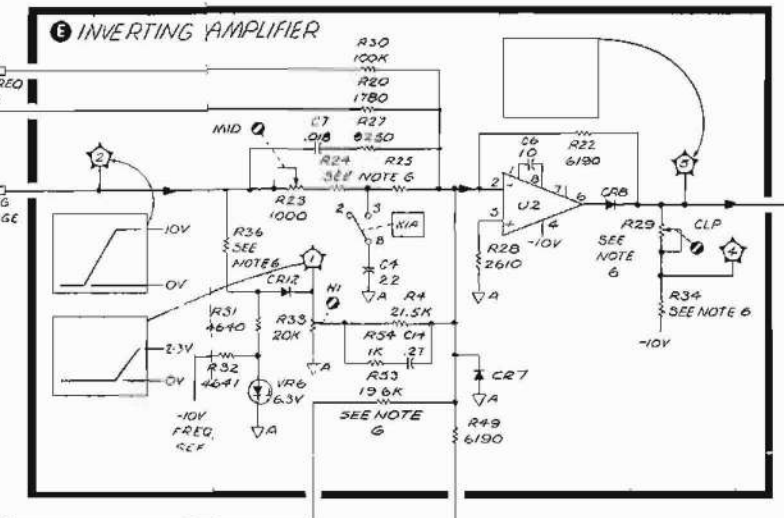
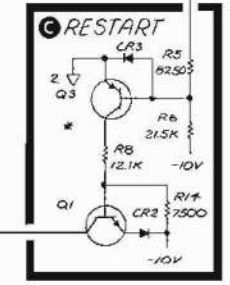
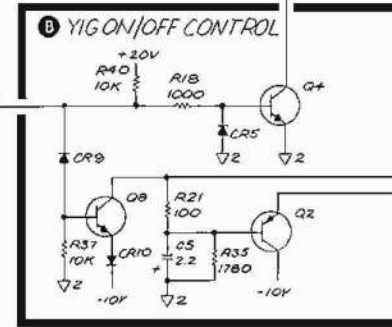
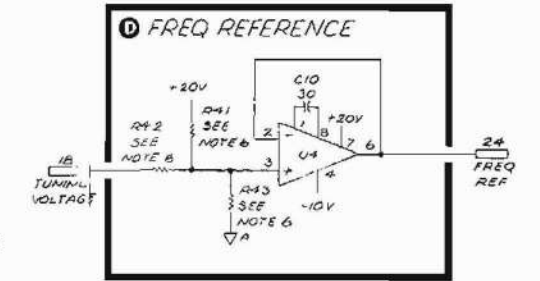
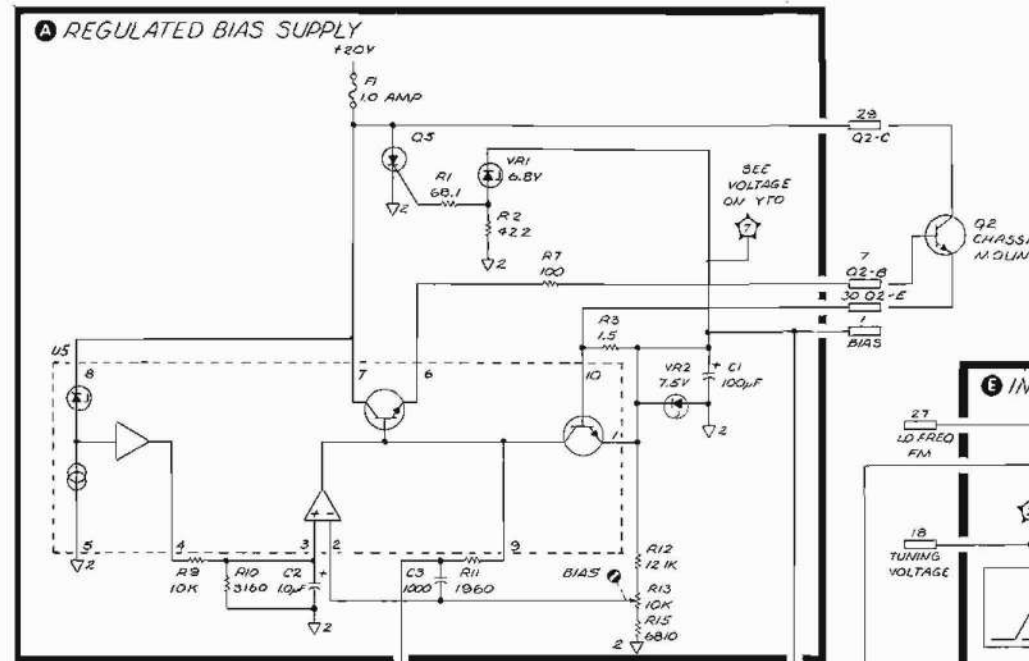

SERIAL PREFIX: 1803A FOR 86242,D,86250,D,1740A FOR 86245A

IVER ASSEMBLY

-60052
-60011
-60059

DM	FUNCTION BLOCK
3)	A
	I
1/6)	G
	I
1	D E
	I
3.5)	H
	I
	I
	I
4	A
	I
2	I
	I
2	I
	D
	I
7)	B
	I
6	E
3	G
	I
5	G
	A

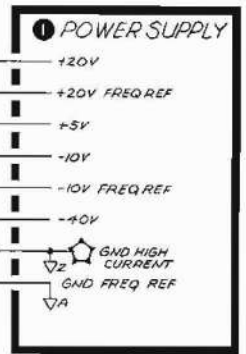
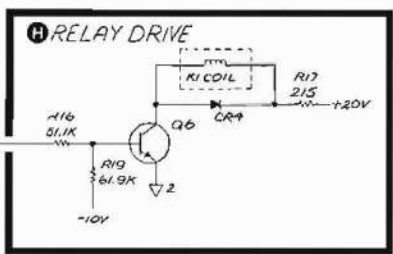
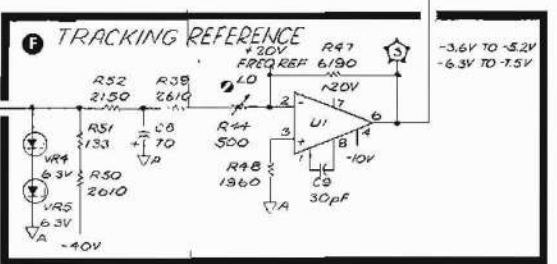
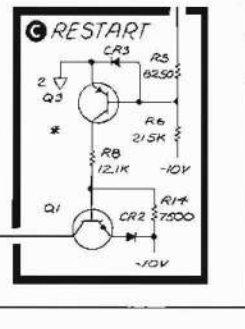
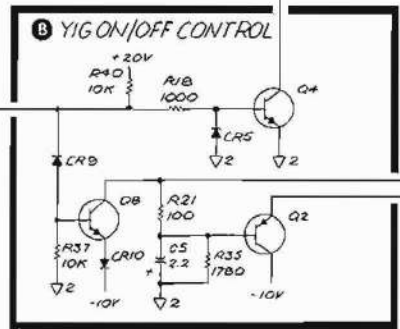
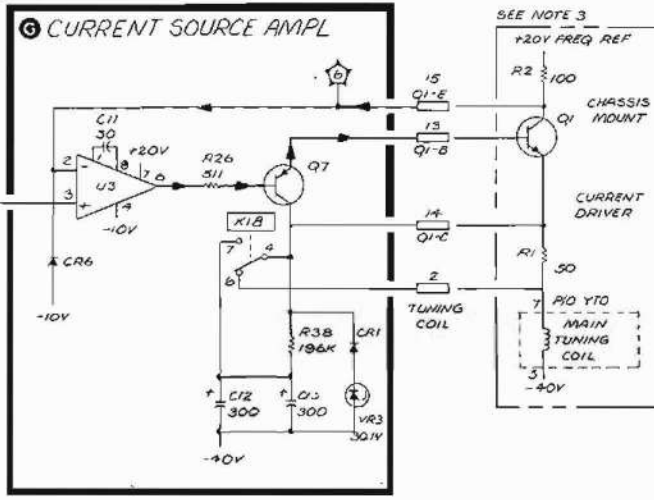
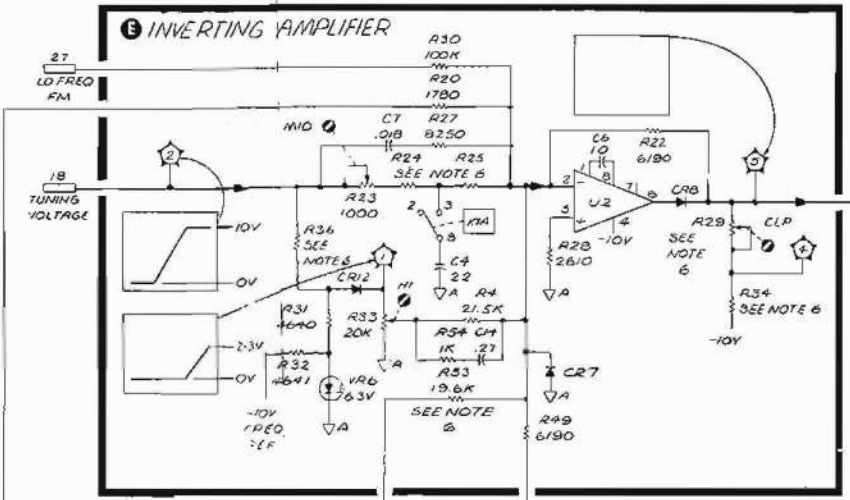
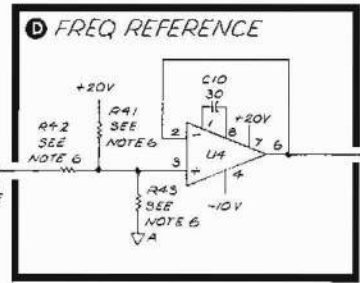
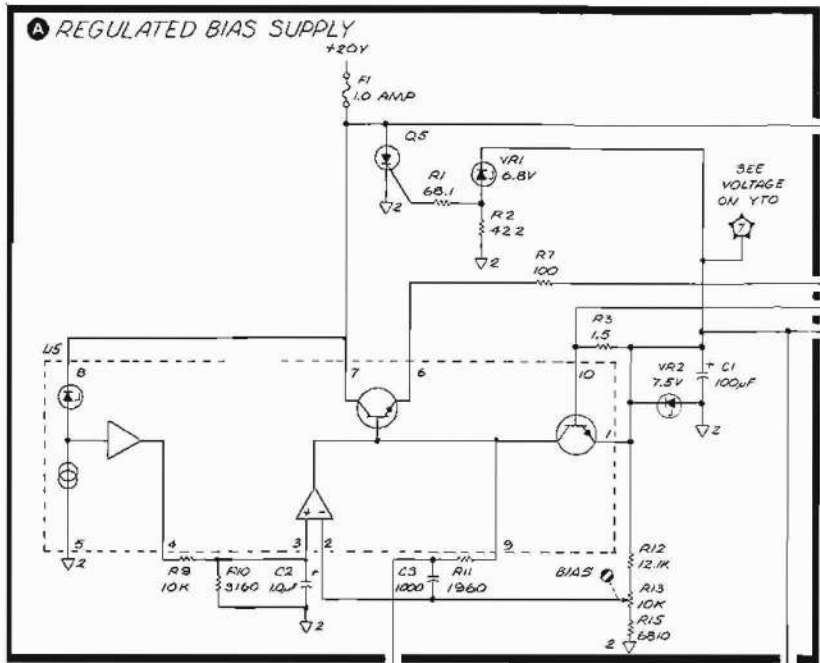

- NOTES:**
1. REFERENCE DESIGNATORS WITHIN THIS ASSEMBLY ARE ABBREVIATED. PREFIX ABBREVIATION WITH ASSEMBLY NUMBERS FOR COMPLETE REFERENCE DESIGNATOR.
 2. UNLESS OTHERWISE INDICATED: RESISTANCE IN OHMS (R), CAPACITANCE IN MICROFARADS (μF), INDUCTANCE IN MICROHENRIES (μH).
 3. SEE INTERCONNECT DIAGRAM SERVICE SHEET 1.
 4. TOP RESISTOR VALUES 862420, BOTTOM RESISTOR VALUES 862500.
 5. TEST POINT VOLTAGES: TOP VOLTAGES FOR 862420, BOTTOM VOLTAGES FOR 862500.
 6. TABLE SHOWS CORRECT RESISTOR VALUE FOR INSTRUMENT MODEL.

INSTRUMENT MODEL			
R2	862420	86245A	862500
R24	5110	2150	2610
R25	4220	2610	4220
R28	10K	20K	20K
R34	3160	7500	7000
R36	9660	4980	4640
R41	4220	5110	4670
R42	4020	2310	4420
R43	3160	227K	121K
R53	19.6K	19.6K	

2
A2

Figure 8-14. A2 YIG Driver Assembly. Schematic

SERVICE SHEET 3

A3 ALC ASSEMBLY, CIRCUIT DESCRIPTION

General

The A3 ALC Assembly contains circuitry to automatically level the RF OUTPUT signal.

In ALC EXTERNAL (XTAL) leveling mode of operation, a power-related voltage from an external detector is connected to the front-panel ALC EXT INPUT connector. This voltage is compared to a reference signal. The difference between the two signals is amplified and applied to the PIN Modulator as a control voltage.

In ALC EXTERNAL (PM) leveling mode, this voltage is provided by a power meter. The power meter Recorder Output is connected to the front-panel EXT INPUT connector. The operating characteristics of the main ALC Amplifier U2 are modified to compensate for the slower response of the power meter.

In the ALC Assembly, a reference amplifier supplies a dc reference voltage across the POWER LEVEL control R1, which directly controls the RF output signal in the ALC OFF mode of operation. Modulation signals are also applied to the PIN Modulator for modulating the RF OUTPUT. EXT AM signals are available from the mainframe as well as the internal 1 kHz square wave and RF markers.

In the INTERNAL mode of operation (Option 001 only) a portion of the output signal is coupled from the Directional Coupler DC1 to the Detector CR1. This signal is amplified by the ALC circuitry and routed to the PIN Modulator as in the EXTERNAL (XTAL) mode of operation. Compensation is added to the reference signal by Slope Control U1 to correct for coupler-detector frequency-dependent variations.

Overdrive Comp **B**

Overdrive Comp provides a small amount of current into the PIN Modulator to prevent saturation of the Modulator/Amplifier at the low-end of the frequency band (used in 86245A only).

The Tuning Voltage ramp is applied to the base of Q7. Q7 conducts until the Tuning Voltage ramp reaches approximately 2.7 volts. R56 (SAT) controls the amount of current applied to the PIN Modulator.

Slope Control **A**

General. In INTERNAL mode (Option 001 only), a correction is added to the ALC loop to compensate for the Coupler/Detector errors. The compensation amplifier consists of an inverting amplifier U1B, a noninverting amplifier U1A, clamping diodes, slope and offset controls, and associated circuitry. The tuning ramp voltage is applied to the inputs of a dual operational amplifier U1. The ramp sweeps between 0 and 10 volts and,

depending upon the value of the ramp voltage at a given frequency, an output voltage is produced by both amplifiers. The outputs are routed through FET Q11 to the reference amplifier U6A. Q11 is OFF in the EXT mode.

Amplifiers U1A and U1B. The tuning voltage is applied to the inverting input of U1B. At the output, a clamp CR12 passes only that portion of the waveform that is below ground. Depending upon the setting of the offset potentiometer R30, the ramp sweeps from zero in a negative direction and emerges from zero at whatever frequency is set by offset adjust R30 (+B). The tuning ramp is also applied to the noninverting input of U1A. At the output, clamp CR14 passes only that portion of the waveform that is above ground. The point at which this positive-going ramp emerges from zero and begins to go positive is set by offset adjust R31 (-B). The resulting compensation applied to U6A is a negative going ramp starting anywhere between the low and high ends of the band and also a positive-going ramp starting anywhere between the low and high ends of the band. The combination of these two ramps provide the shapes necessary to compensate for the Detector and Coupler.

The slope of the ramp is controlled by gain adjustments R32 (+S) and R33 (-S). These two adjustments form voltage dividers that determine what percent of the negative and positive amplifier outputs will be applied to the input of U6A. If R32 is adjusted toward CR12, the maximum percentage of the slope is applied to U6 and hence the largest slope. When R32 is adjusted toward ground there is no ramp and hence no slope. The same operation, but with different polarity, applies to voltage-divider R33. Diodes CR11 and CR13 are temperature-compensating diodes.

Power Level Reference **D**

The Power Level Reference amplifier U6A provides a dc reference voltage at the top end of the power level control. Without modulation, the output of U6A is a constant +5V at the output of U6A, set by the ratio of R50 to R49. HI level adjust (R52) sets the position of the POWER LEVEL pot at maximum leveled power.

When in LINEAR modulation mode, a positive input signal will decrease this reference voltage by one volt per one volt of input, set by the ratio of R50 to R81.

The output of the Slope Control circuitry is summed into U6A through R26 and Q11 when in the INT leveling mode (Option 001 only).

Power Meter Preamp **C**

When the internal XTAL/PM switch is in the PM position, Q12 is ON. This connects the ALC EXT INPUT to the Power Meter Preamp U6B. The dc gain of U6B is -1 to allow for the 0 to +1V output of the power meter. The gain, set by R11, R12, R13, and C3, increases to -38 at frequencies above 100 Hz to compensate for the slow response of the power meter.

ALC Preamp **F**

In the ALC OFF mode, Q13 is ON to connect ALC Preamp U5 to ground through resistor R2. The voltage from the front-panel POWER LEVEL control is amplified by -1/2 as set by the ratio of R7 to R6.

In the EXT (XTAL) mode, Q13 is OFF and Q14 is ON connecting U5 to the EXT INPUT through R3. The voltage at the EXT INPUT is amplified by -6, set by the ratio of R7 to R3, and summed with -1 times the reference voltage from the front-panel POWER LEVEL control as set by the ratio of R7 to R5. This sum, at TP5, will be zero when the ALC is leveled.

When leveled, the ALC can handle detector voltages from -55 to -525 mV. The external input ground is connected to U5 through R9 and Q17 (**L**). The ALC OFS (offset) R53 compensates for the voltage offset of ALC Preamp U5 and ALC Main Amplifier U2.

When the internal ALC XTAL/PM switch A3S2 is in the PM position, Q15 is ON and Q13 and Q14 are OFF. Q15 connects the output of the Power Meter Preamp U6B to U5 through R14. The output of U6B is amplified by -1.1, set by the ratio of R7 to R14, and summed with -1/2 the reference voltage from the front-panel POWER LEVEL control, set by the ratio of R7 to R15. This sum, at TP5, will be zero when the ALC is leveled. R21 and C21 prevent U5 from oscillating.

Sample and Hold Control **E**

Q23 is turned ON and Q22 (**D**) is OFF in the SQ WAVE modulation mode. This connects the source of Q23 to the EXT AM (L) input. R84 keeps Q19 saturated in the absence of an input. The EXT AM square wave is limited by a 1K resistor on the Rear Interconnect Board, so the signal appearing at the base of Q19 is -6V to +3V. The positive swing is limited by CR21, a schottky diode.

When the positive portion of the square wave is applied to EXT AM, the collector of Q19 goes to -10V. U3 buffers this output and symmetry adjust R83 (SYM) controls the charge and discharge of C13 through CR19 and CR20. U4A acts as a high gain comparator which switches between -3 and -7 volts. This produces a square wave with adjustable symmetry.

The output of U4A is connected to U4D. In OFF the output of U4D is forced to 0 volts. This forces Q1 (**H**) to be ON at all times. U3E buffers the output of U4D. C14 is charged through CR5 and discharged through R61. U3F acts as a high gain comparator which switches between -3 and -7 volts. This delays the turn on of sample and hold FET Q1, allowing the current in the PIN Modulator to return to the value it had before the RF was blanked out. VR6 and R63 level shift the output of U3F by +5 volts.

ALC Main Ampl **H**

When in ALC OFF mode, Q4 connects the ALC Main Amplifier U2 to the internal Gain control R19. Q1 normally connects R19 to the output of ALC Preamp U5. Q3 is on, and connects R27 and R28 to output of U2 for a minimum gain of -5 and an offset of $-7.7V$ on the output (TP7). The output of U2 (TP7) will range from $0V$ (maximum power) to about $-7.7V$ (minimum power).

In EXT (XTAL) mode, Q4 is off and Q2 connects ALC GAIN control R4 to U2 input. U2, ALC GAIN, and C7 form an integrating amplifier with very high dc gain. The output of U2 (TP7) will range from about $+3V$ (unleveled) to about $-8V$ (minimum power).

In EXT (PM) mode, Q5 switches C6 across U2 to compensate for the slow response of the power meter.

When the RF signal is blanked during square wave modulation, Q1 switches OFF and the output of U2 stays constant within 50 mV. The voltage on C7 is held due to the large input resistance of U2.

When in INT (Option 001 only) Q4 connects U2 to internal Gain control R19. Q16 (**L**) connects INT DET GROUND to U5 and U2. U2 and associated circuitry operate in the same manner as in EXT leveling.

Unleveled Detector **J**

When in ALC OFF, Q8 is ON, forward biasing Q9. Q9 supplies current to the base of Q18, causing the front-panel UNLEVELED lamp to light.

When in EXT, Q8 is OFF. If the output of U2 is greater than $+1.8V$, the unleveled lamp will be on. This will occur only if the ALC loop is unleveled. C16 acts as a peak detector so that the unleveled lamp will light if the ALC goes unleveled for even a short period of time. Operation in INT (Option 001 only) is the same as in EXT.

PIN Shaping **K**

The resistance between U2 and the PIN Diode Modulator is $3.26K$ until the current rises to about 1.6 mA. Then VR3 starts to conduct through Q6 dropping the resistance to 100 ohms at high current. CR9 prevents any positive voltage from going to the modulator.

Q6 is turned OFF when the XTAL/PM switch is in the PM position and the ALC switch is in the EXT position. In this mode the resistance drops to about $1K$ when CR3 conducts.

when the output of U4A (**E**) goes to $0V$. U4B inverts the output of U4A, and U3B and U3A buffer the input to Q21. U4B, R66, U3B, and U3A provide an equalizing delay for U4D, U3E, CR5, CR14 and U3F during 27.8 kHz square wave modulation. This enables sample and hold FET Q1 to turn OFF before the RF is blanked.

INT Blanking/Clamping Control **G**

The 1 kHz squarewave, RF blanking, and Marker signals are summed into the emitter of Q20 by CR10, CR16 and CR18. Q20 is a common-base amplifier, which amplifies the inputs and shifts the level by -10 volts. The 0 to -10 volt output of Q20 is connected to the input of U4C, where it is inverted. U3D buffers the signal from U4C and feeds it through R65 to the base of Q10 and to U4A in the Sample and Hold Control section.

The collector of Q10 is normally $-20V$, holding Q3 OFF. When the output of U3D is $+10V$ (when 1 kHz SQ WV, RF Blanking, or markers are HIGH), the collector of Q10 goes to $0V$, turning Q3 ON. This clamps the output of the ALC Main Amplifier U2 to $-7.7V$.

Q3 is held ON in the OFF mode.

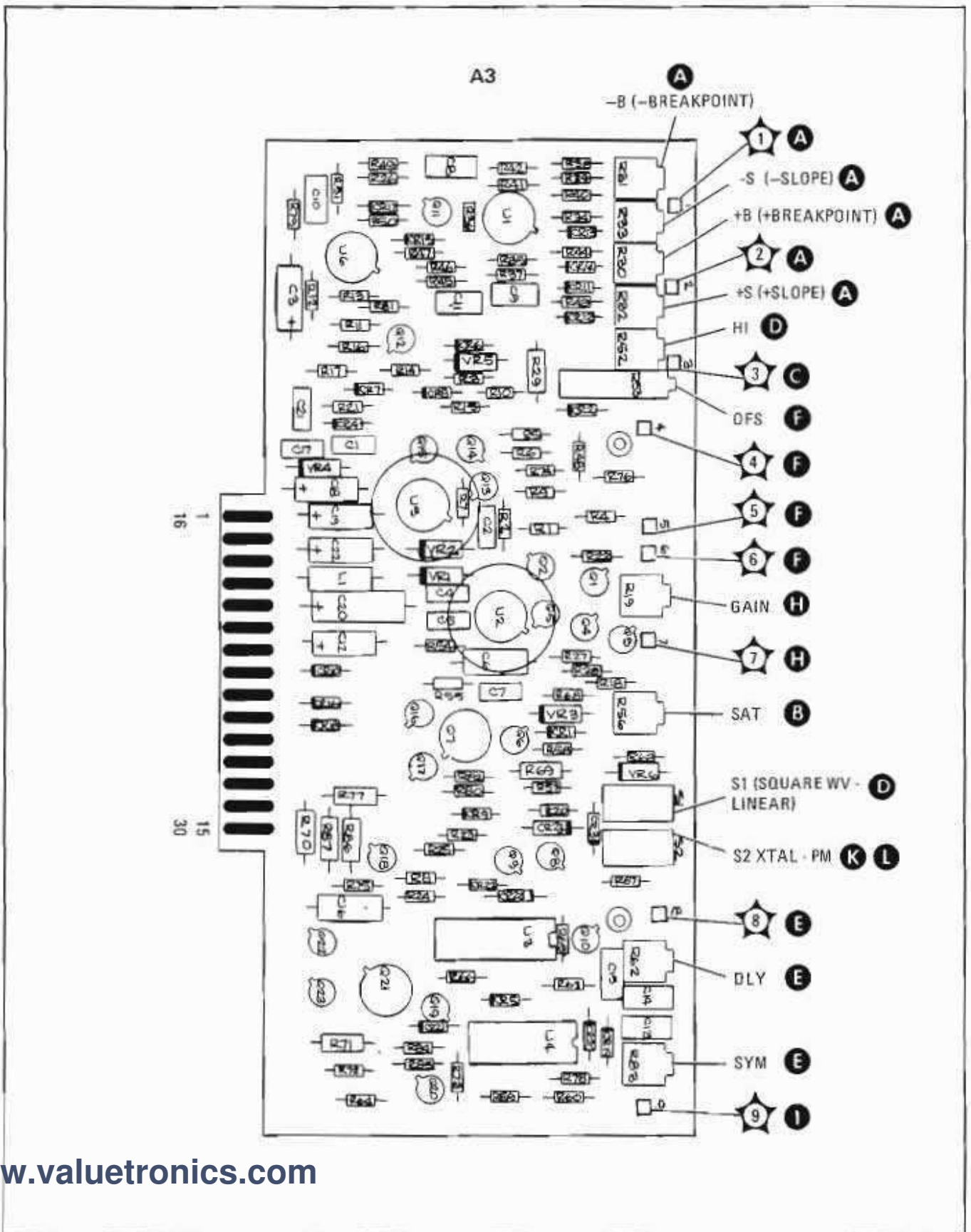

www.valuetronics.com

Figure 8-15. A3 ALC Assembly, Component Locations

A3 ALC ASSEMBLY
86245-60012

PIN	SIGNAL	TO/FROM	FUNCTION BLOCK
1	GAIN-1	R4 (93)	H
16	-40V		L
2	GAIN-2	R4 (92)	H
17	NC		
3	GAIN-3	R4 (94)	H
18	TUNING VOLTAGE	P4-1	A
4	1 KM 350V (SWITCHED)	P4-6	G
19	NC		
5	-10V		L
20	+20V		L
6	INT DET GND	W7 (5)	L
21	EXT INDET GND	J2 (30)	L
7	INT DET	W7 (2)	F
22	+5V		L
8	GND HI CURRENT		L
23	NC		
9	GND HI CURRENT		L
24	RF BLANKING (SWITCHED)	P4-3	G
10	EXT	S2 (95)	L
25	ALC MARKERS	P4-36	G
11	ALC -20V	S2 (94)	L
26	EXT INPUT	J2 (5)	C
12	OFF INT	S2 (93)	L
27	NC		
13	EXT AM (L)	ABR1	D
28	POWER LEVEL EL GND	R3 (96)	D
14	POWER LEVEL EL REF	R3 (94)	D
29	MOD DRIVE	YAS-6	K
15	POWER LEVEL UNLEVELLED LAMP	R3 (4)	F
30		DS2 (95)	J

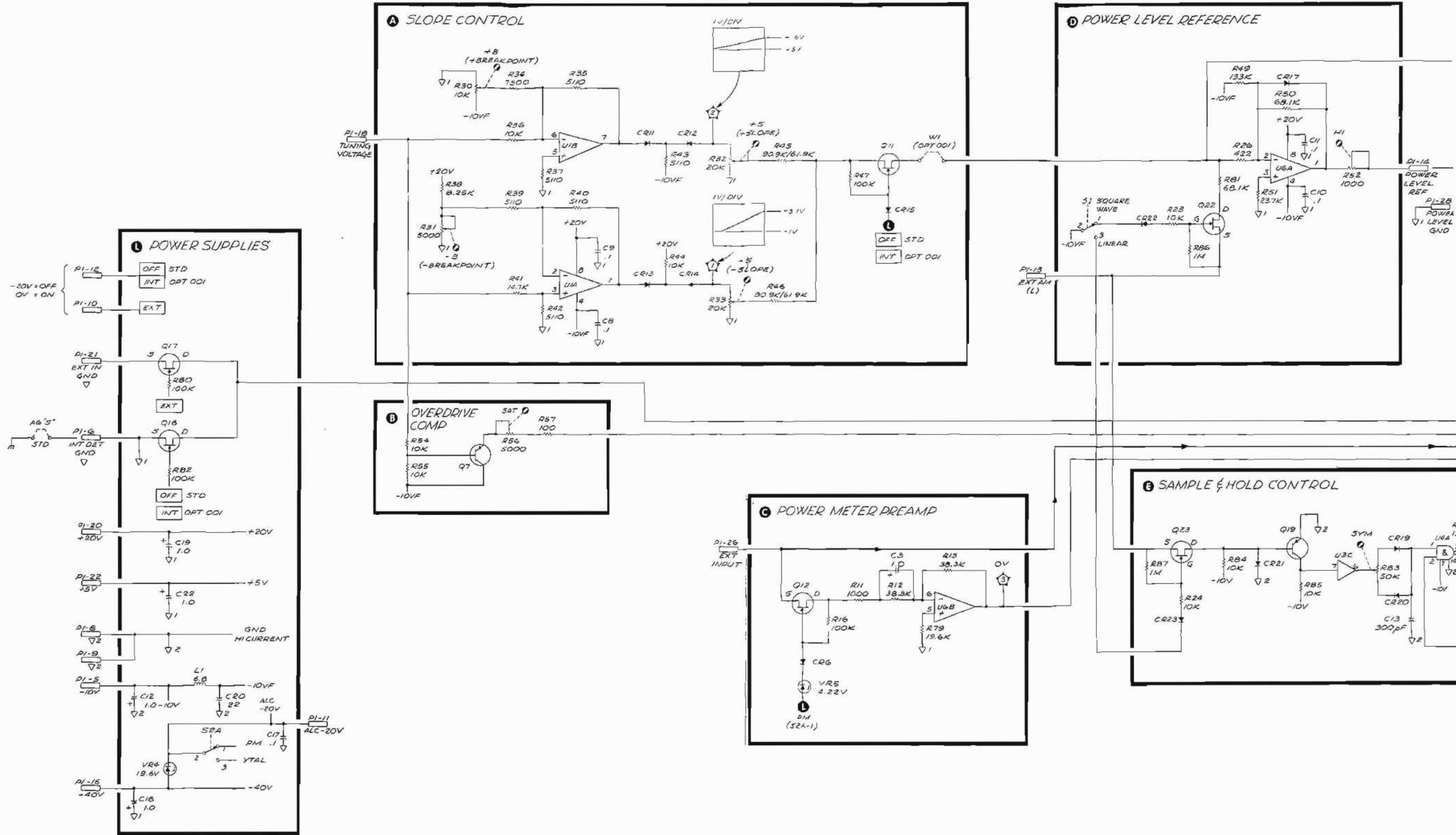

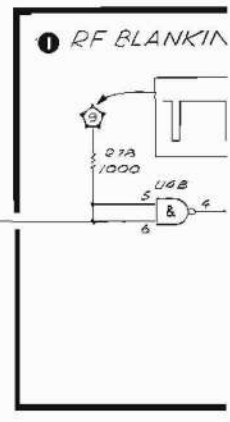
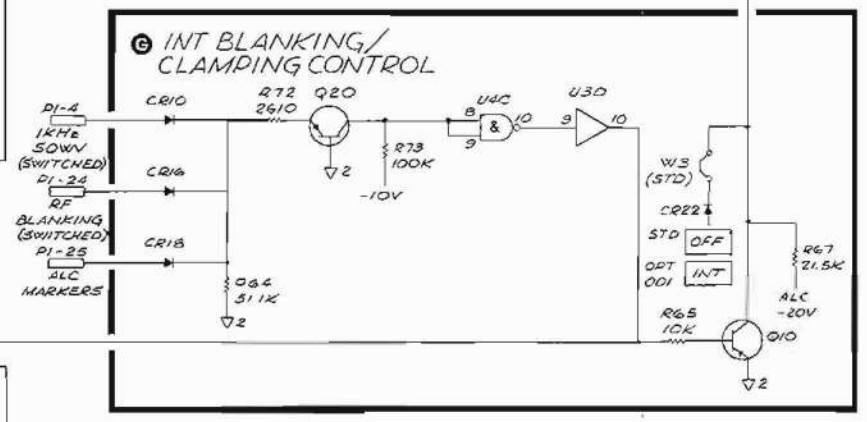
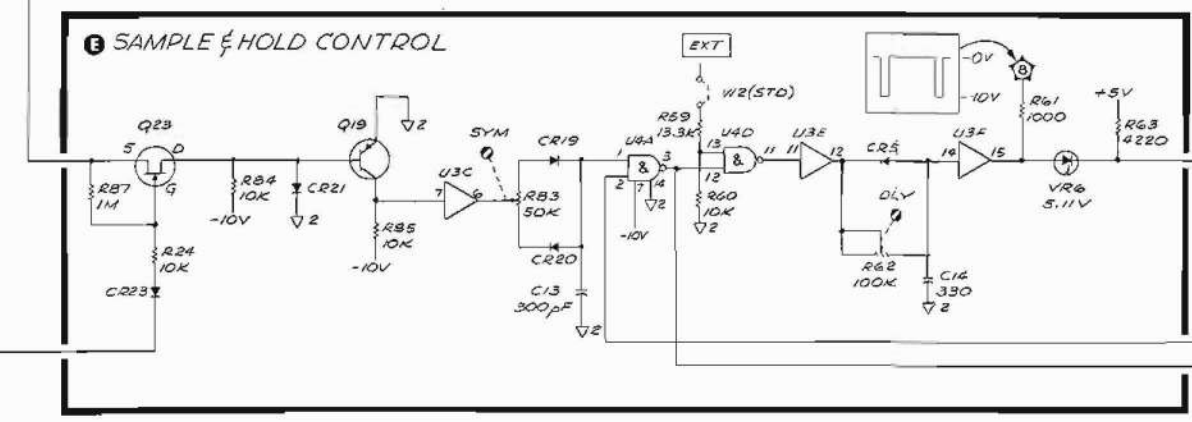
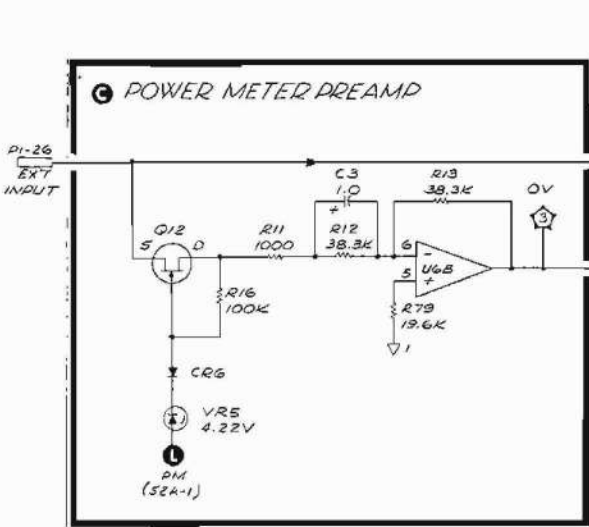
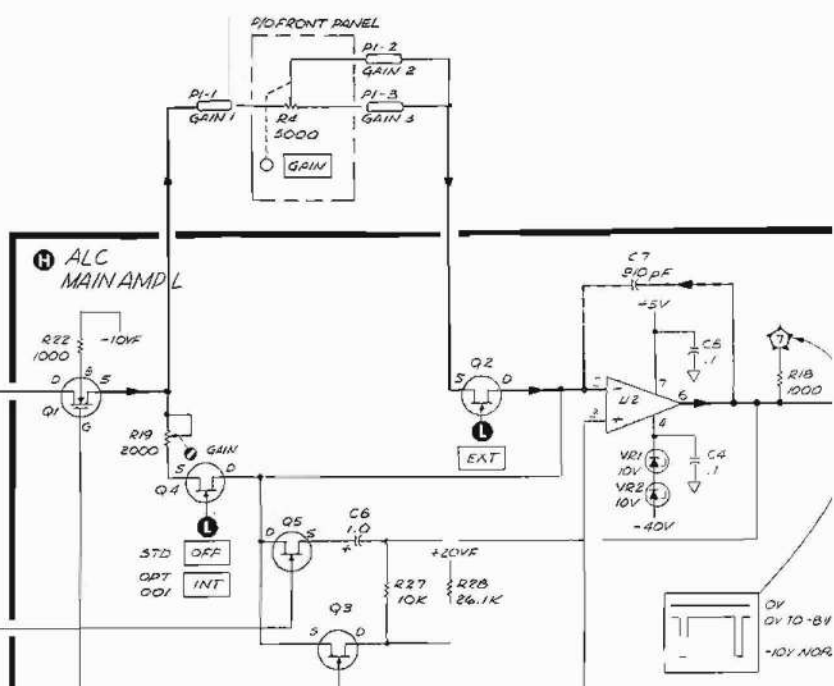
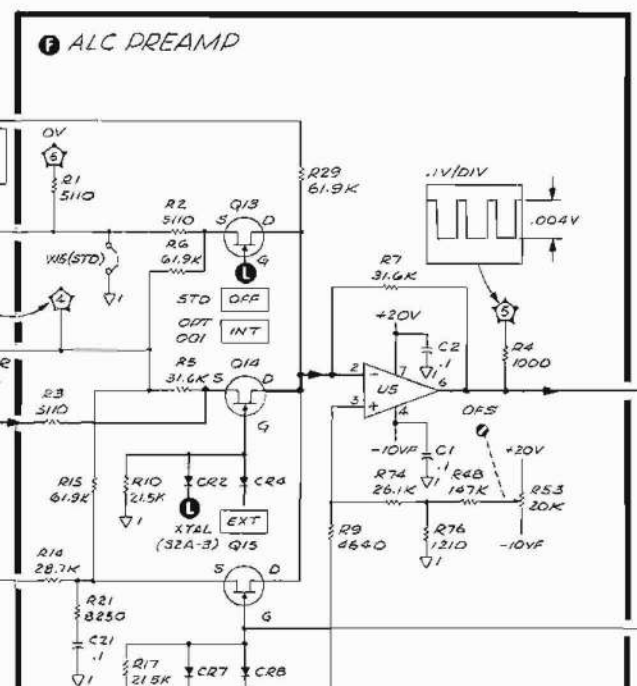
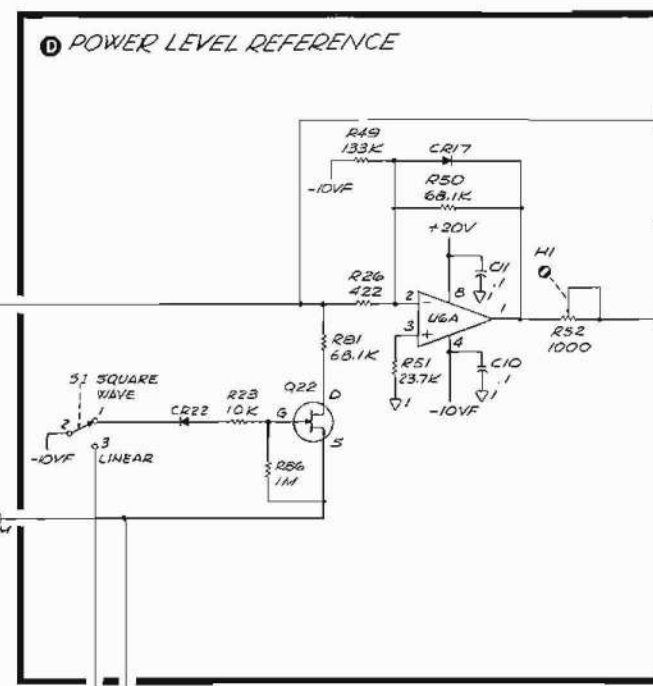
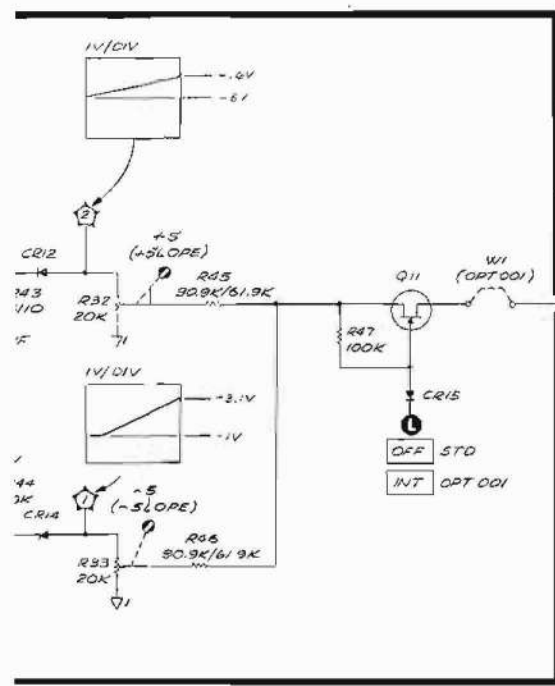

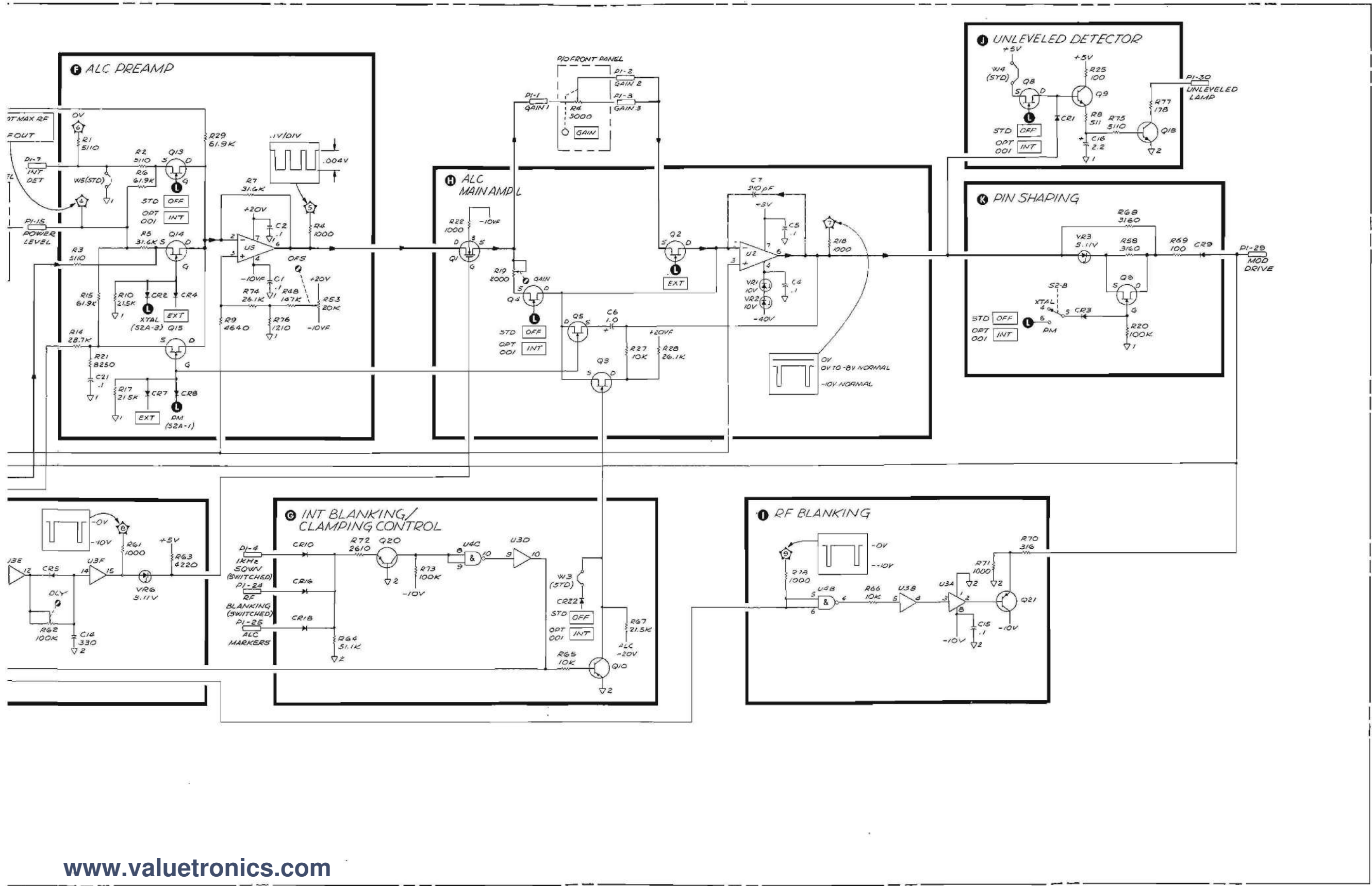

NOTES

1. REFERENCE DESIGNATORS WITHIN THIS ASSEMBLY ARE ABBREVIATED. PREFIX ABBREVIATION WITH ASSEMBLY NUMBERS FOR COMPLETE DESIGNATOR.

2. UNLESS OTHERWISE INDICATED:
 RESISTANCE IN OHMS (Ω)
 CAPACITANCE IN MICROFARADS (μF)
 INDUCTANCE IN MICROHENRIES (μH)

Figure 8-16. A3 ALC Assembly, Schematic

SERVICE SHEET 4**A1 FM DRIVER ASSEMBLY, CIRCUIT DESCRIPTION****General**

The FM Driver allows modulation of the RF frequency from an external input. Rear-panel FM-NORM-PL switch selects the mode of operation.

In the NORM mode, the FM input is sent through the High Freq Buffer and the Differential FM Driver to drive the FM coil. The input sensitivity is -20 MHz/volt for standard RF Plug-ins and $+20$ MHz/volt for RF Plug-ins with Option 008 installed. Filter capacitors are switched into the YIG Driver circuit to lower residual FM.

In the FM or MLA (Option 008) mode, the FM signal is split by high and low pass filters. High frequency FM is routed to the High Freq Buffer and low frequency FM routed to the Low Freq Amp. The output of the Low Freq Amp is routed to the YIG Driver to allow for greater deviations than the FM coil can handle. Sensitivity is -20 MHz/volt for standard RF Plug-ins and $+20$ MHz/volt for RF Plug-ins with Option 008 installed.

Operation in PL mode is the same as in FM except the sensitivity is -6 MHz/volt to provide interfacing with the HP 8709A Synchronizer. RF Plug-ins with Option 008 installed do not provide PL mode.

Low/High Pass Filters **A**

In NORM and FM, Q3 bypasses R1. High frequency FM signal level is adjusted by R2 (HI F). In PL the ratio of R1 to R2 and R34 changes sensitivity to 6 MHz/V.

In NORM, Q2 bypasses C3 and C4, and Q1 connects input of Low Freq Amp to ground. In FM and PL, Q2 is OFF and C3, C4 and R9 form an RC high pass filter (approximately 150 Hz at 3 dB point). Also, Q1 is OFF, and C6, C7, R8 and R6 form an RC low pass filter (approximately 150 Hz at 3 dB point). In RF Plug-ins with Option 008 installed, the low pass filter 3 dB point is at approximately 500 Hz and the high pass filter 3 dB point is at approximately 50 kHz.

High Freq Buffer **B**

A feedback amplifier is composed of Q9 and Q8. Transistor Q9 acts as a current source (approximately 2mA) while Q8 and C9 act as an integrator. Tracking diode level shift is provided by Q10. Current through Q8 (approximately 8 mA) is set by R11. The output (TP4) is held to within 100 mV of the input.

Differential FM Driver **D**

Transistors Q4, Q5, Q6 and Q7 form a differential cascode amplifier; Q6/Q7 form the differential amp while Q4/Q5 are common base stages. Resistors R16, R17, R30 and R31 set bias voltages (approximately 2.5V). R22 and R23 set quiescent dc collector current (approximately 100 mA). R13 and R15 return the collector current to the $+20$ V supply. R25 (OFS) nulls quiescent current through FM coil.

C16, C17, C18, and R21 ("LF"), and C15 and R20 ("HF") compensate for FM coil frequency response; R14 ("Q") adjusts the Q of the FM coil. For Option 008 (MLA Upconverter), W4 and W7 are removed; W5 and W6 are added. This provides positive FM sensitivity.

Low Freq Amp **C**

The signal developed across C6 and C7 is inverted and amplified by U1. Gain is adjustable from 0 to $+2$ by R5 (LO F). For Option 008, W2 is removed and W1 and W3 are added. This provides positive FM sensitivity (U1 does not invert signal).

A1

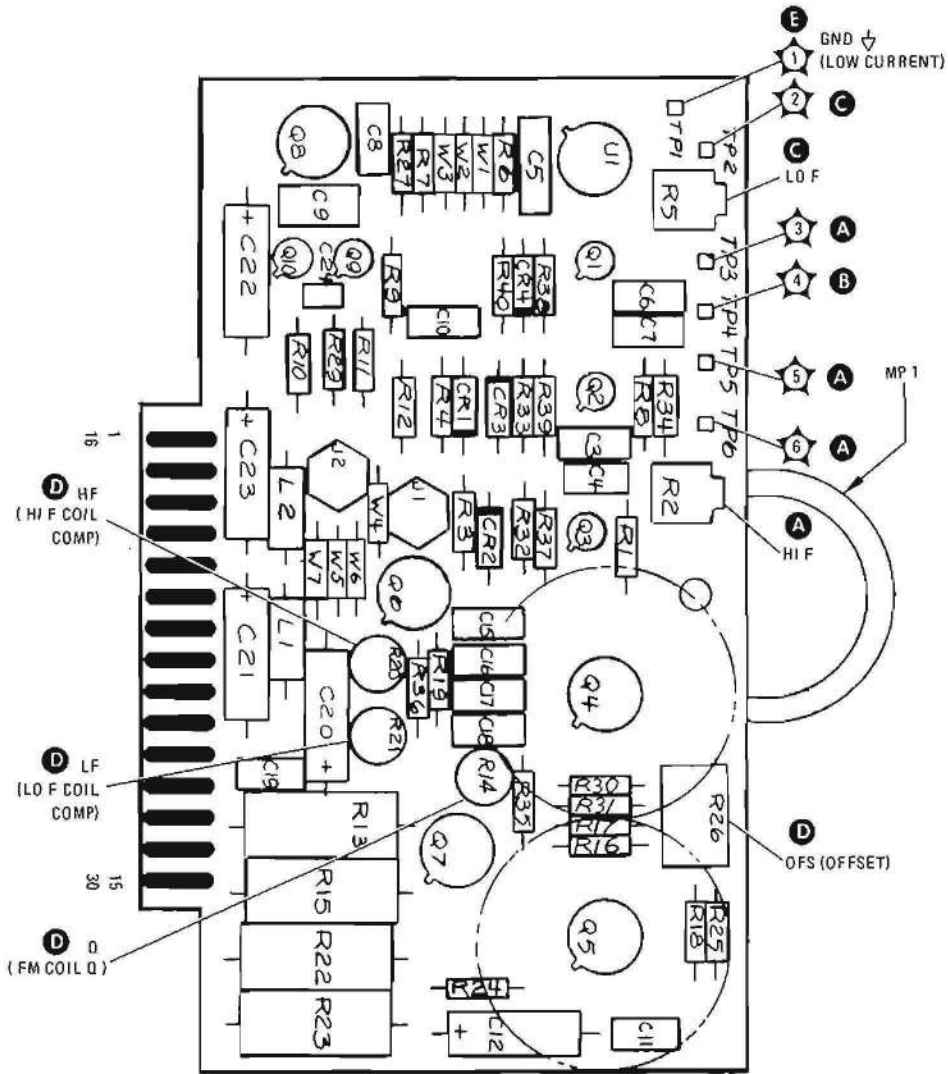

- NOTES: 1. W1, W3, W5, AND W6 ARE LOADED FOR OPTION 008 (86245-60014) BUT NOT FOR STANDARD (86245-60013).
2. W2, W4, AND W7 ARE LOADED FOR STANDARD (86245-60013) BUT NOT FOR OPTION 008 (86245-60014).
3. THE FOLLOWING COMPONENTS ARE NOT LOADED FOR OPTION 008 (86245-60014): C4, R1, Q3, R37, R32, AND CR2. (R1 IS REPLACED WITH A JUMPER.)

www.valuetronics.com

Figure 8-17. A1 FM Driver Assembly, Component Locations

A1 FM DRIVER ASSEMBLY
 (86245-60013)
 (86245-60014) SEE NOTE 3

Pin	WAVE	TO/FROM	FUNCTION BLOCK
1	SHD LOW CURRENT		1
14	SHD LOW CURRENT	142-27	2
2	SHD LOW CURRENT		3
17	SHD LOW CURRENT	33	4
3	SHD LOW CURRENT		5
18	SHD LOW CURRENT		6
4	SHD LOW CURRENT		7
19	SHD LOW CURRENT	32	8
5	SHD LOW CURRENT		9
20	SHD LOW CURRENT		10
6	SHD LOW CURRENT		11
21	SHD LOW CURRENT		12
7	SHD LOW CURRENT		13
22	SHD LOW CURRENT		14
8	SHD LOW CURRENT		15
23	SHD LOW CURRENT		16
9	SHD LOW CURRENT		17
24	SHD LOW CURRENT		18
10	SHD LOW CURRENT		19
25	SHD LOW CURRENT		20
11	SHD LOW CURRENT		21
26	SHD LOW CURRENT		22
12	SHD LOW CURRENT		23
27	SHD LOW CURRENT		24
13	SHD LOW CURRENT		25
28	SHD LOW CURRENT		26
14	SHD LOW CURRENT		27
29	SHD LOW CURRENT		28
15	SHD LOW CURRENT		29
30	SHD LOW CURRENT		30

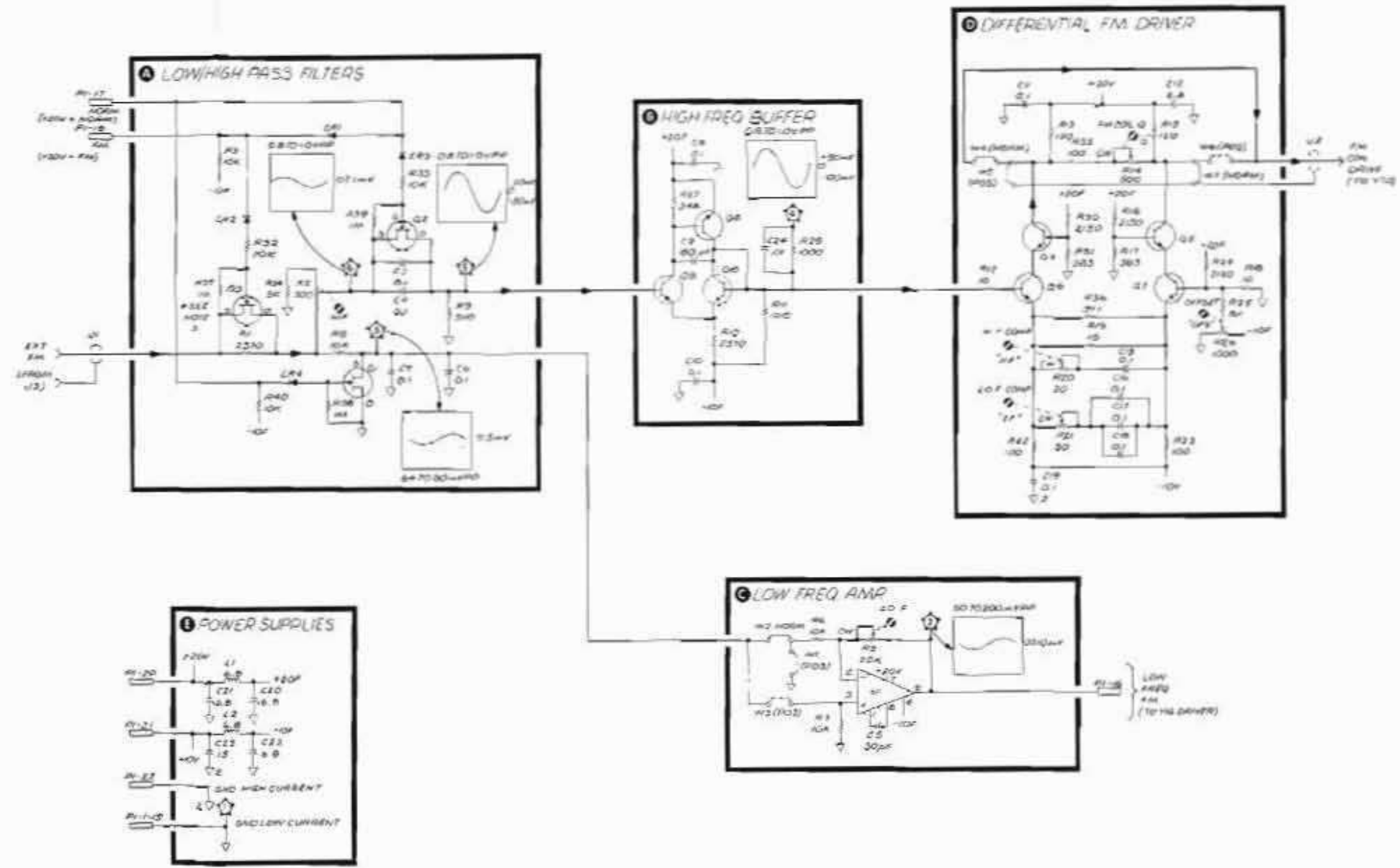

- NOTES:**
1. REFERENCE DESIGNATORS WITHIN THIS ASSEMBLY ARE INDICATED. ALL OTHER ASSEMBLY PARTS WITH ASSSEMBLY NUMBERS FOR COMPLETE REFERENCE DESIGNATION.
 2. UNLESS OTHERWISE INDICATED, RESISTANCE IN OHMS (Ω), CAPACITANCE IN MICROFARADS (μF), INDUCTANCE IN MILLIHENRIES (mH).
 3. 86245-60014 DERIVED FROM THE 86245-60013 AS FOLLOWS:
 2) REPLACED BY JUMPER
 23 DEL 4F
 24 DEL 4F
 14E, 14F, 14T REMOVED
 W1, W2, W3, W4 INSTALLED DEL 2E, 4E, 23T, 24E

Figure 8-18. A1 FM Driver Assembly Schematic

www.valuetronics.com

A1 FM Driver Assembly, Component Locations

A1 FM Driver Assembly, Schematic

◀ SERVICE SHEET 4

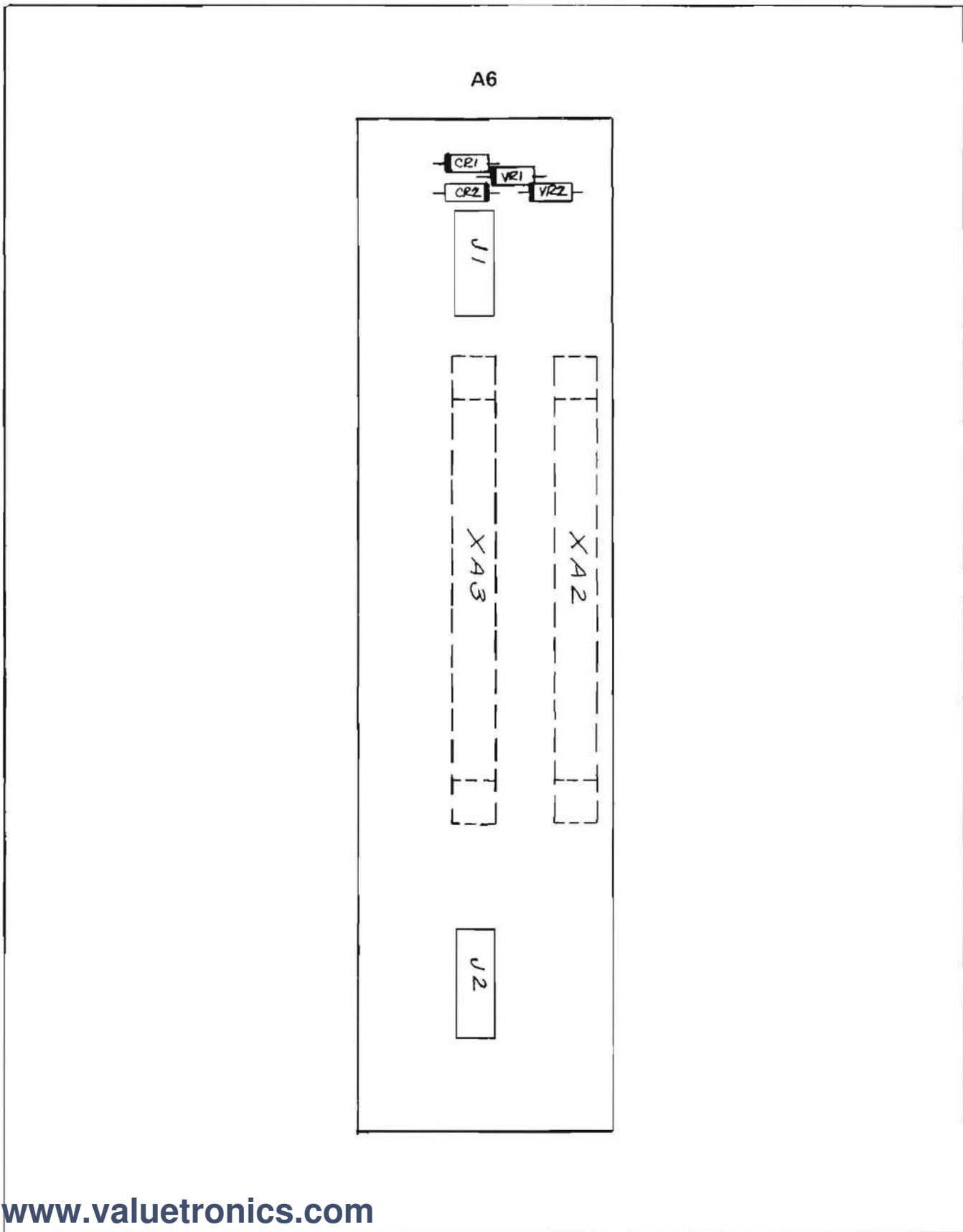

www.valuetronics.com

Figure 8-19. A6 ALC/YIG Interconnect Assembly, Component Locations

A7 FM INTERCONNECT ASSEMBLY (86242-60029)

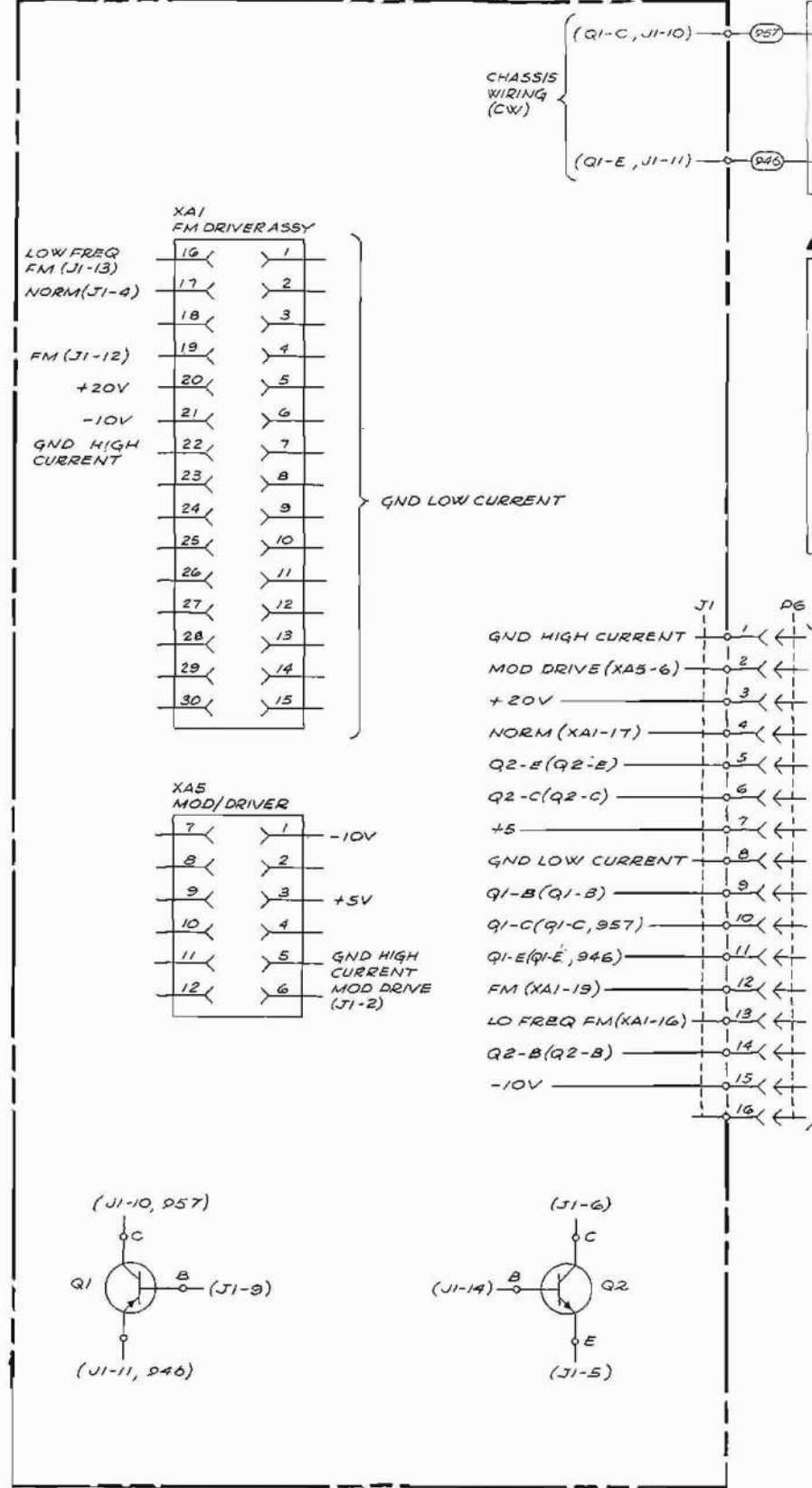

SERIAL PREFIX: 1B30A FOR 86242D/86250D, 1740A FOR 86245A

A4 YIG OSC

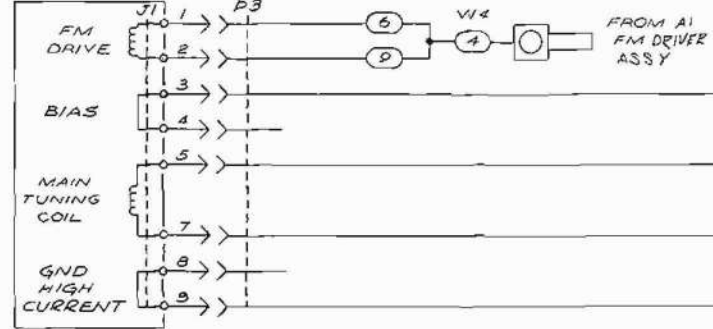

A6 ALC/YIG INTERCONNECT ASSEMBLY (86245-60)

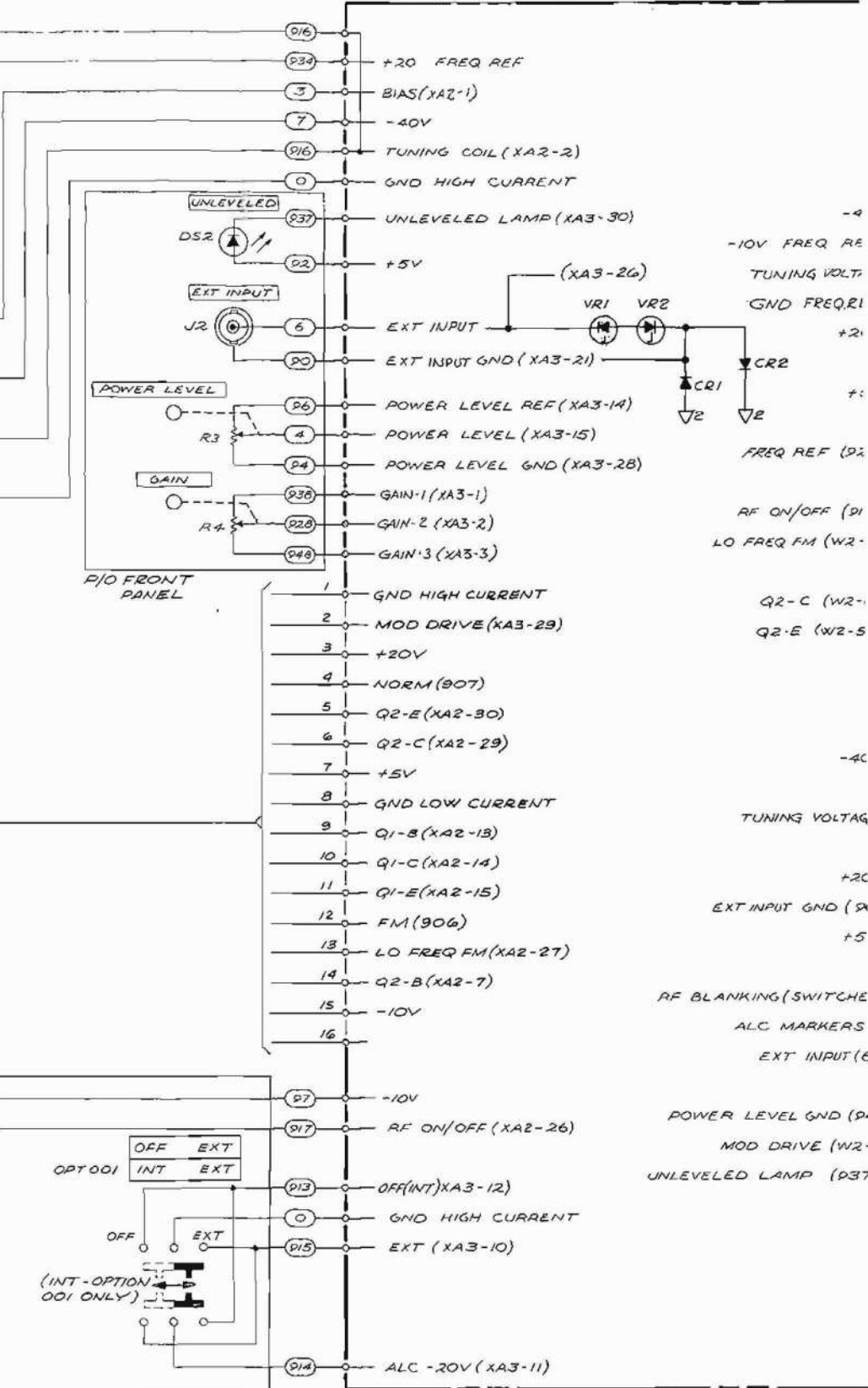

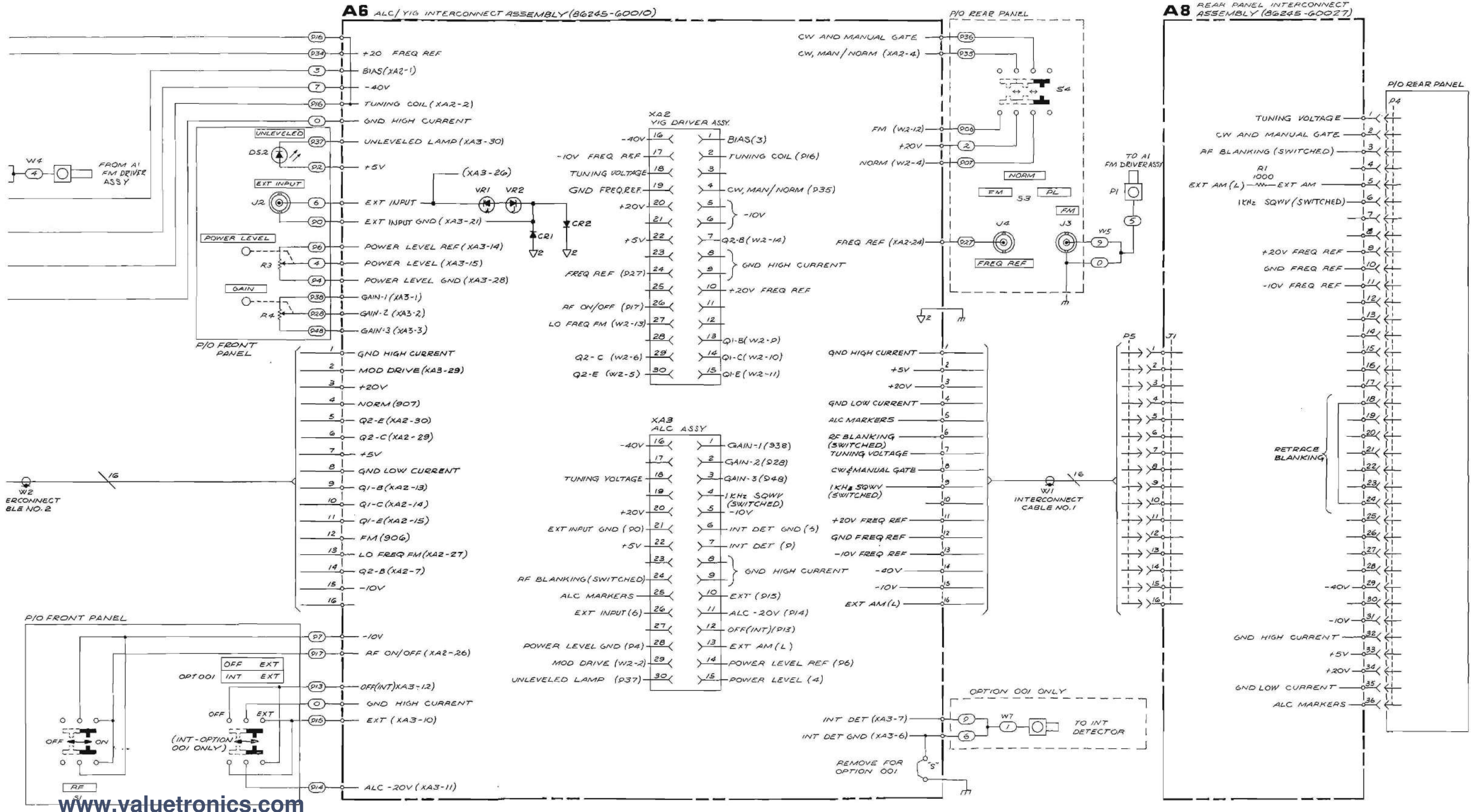

Figure 8-20. Overall Wiring Diagram

www.valuetronics.com

◀ A6 ALC/YIG Interconnect Assembly, Component Locations
Overall Wiring Diagram

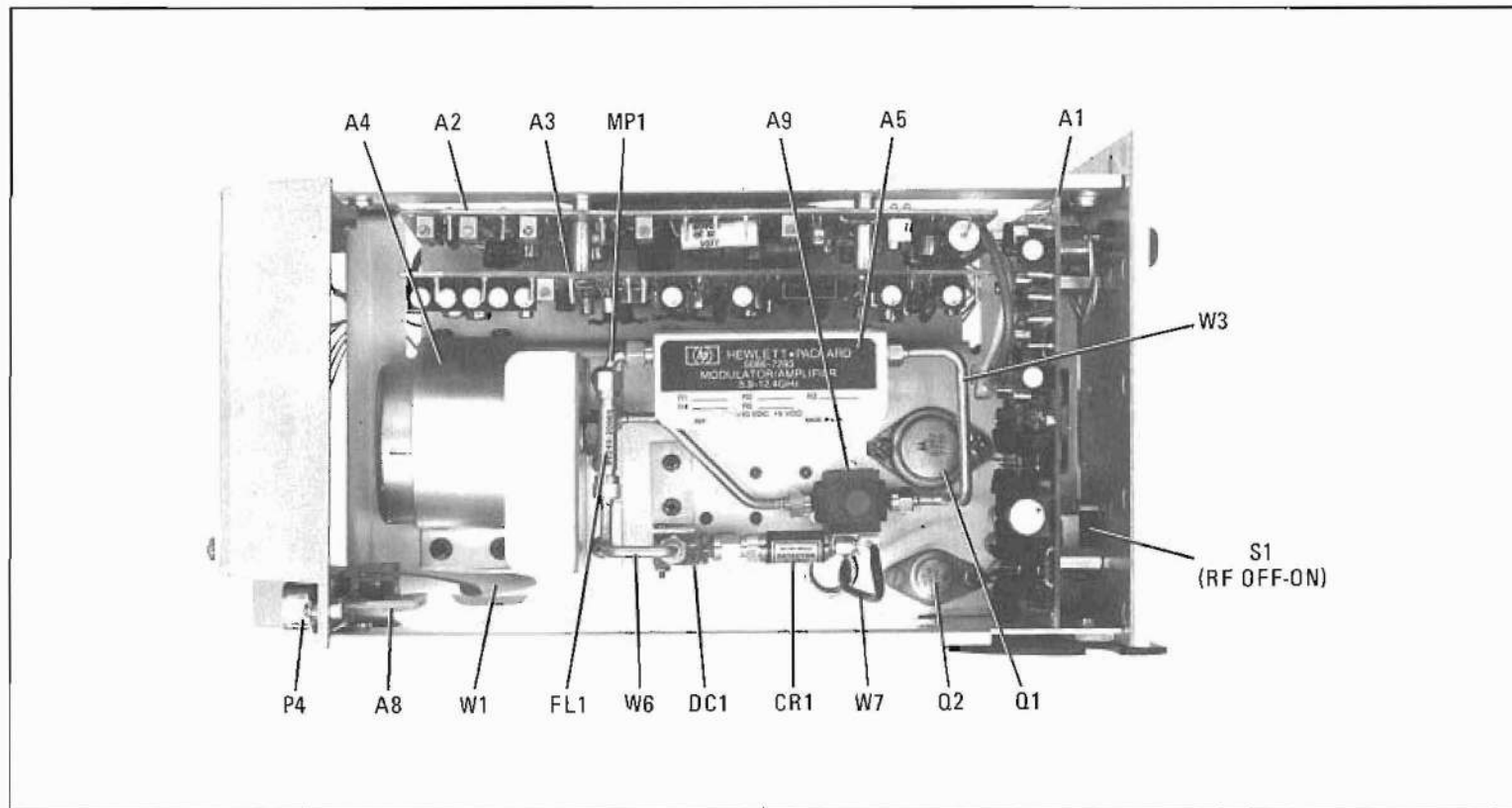

Figure 8-21. Major Assembly and Component Locations, Top View, 86245A (Option 001)

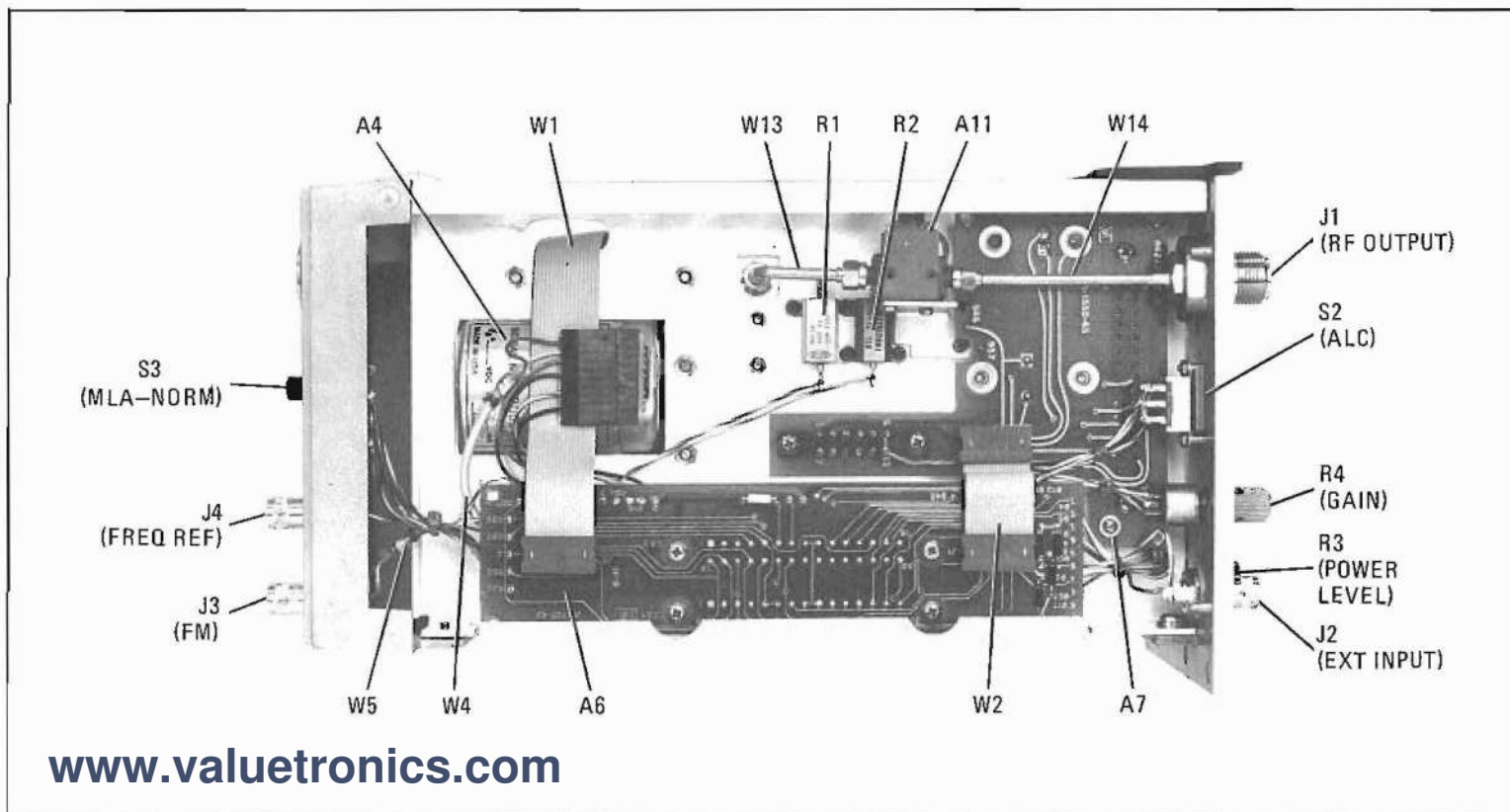

Figure 8-22. Major Assembly and Component Location, Bottom View, 86245A (Option 008)

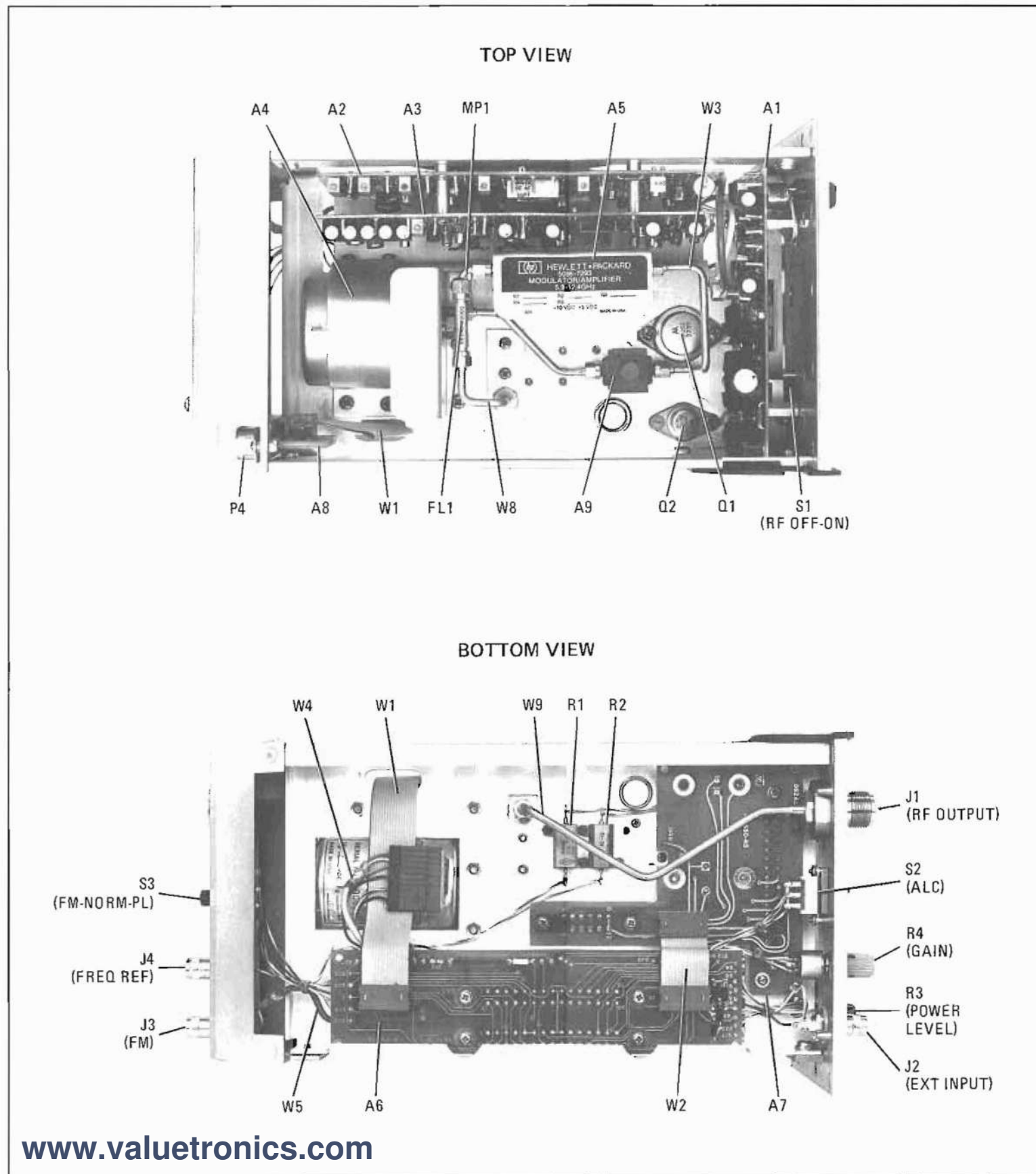

Figure 8-23. Major Assembly and Component Location, 86245A

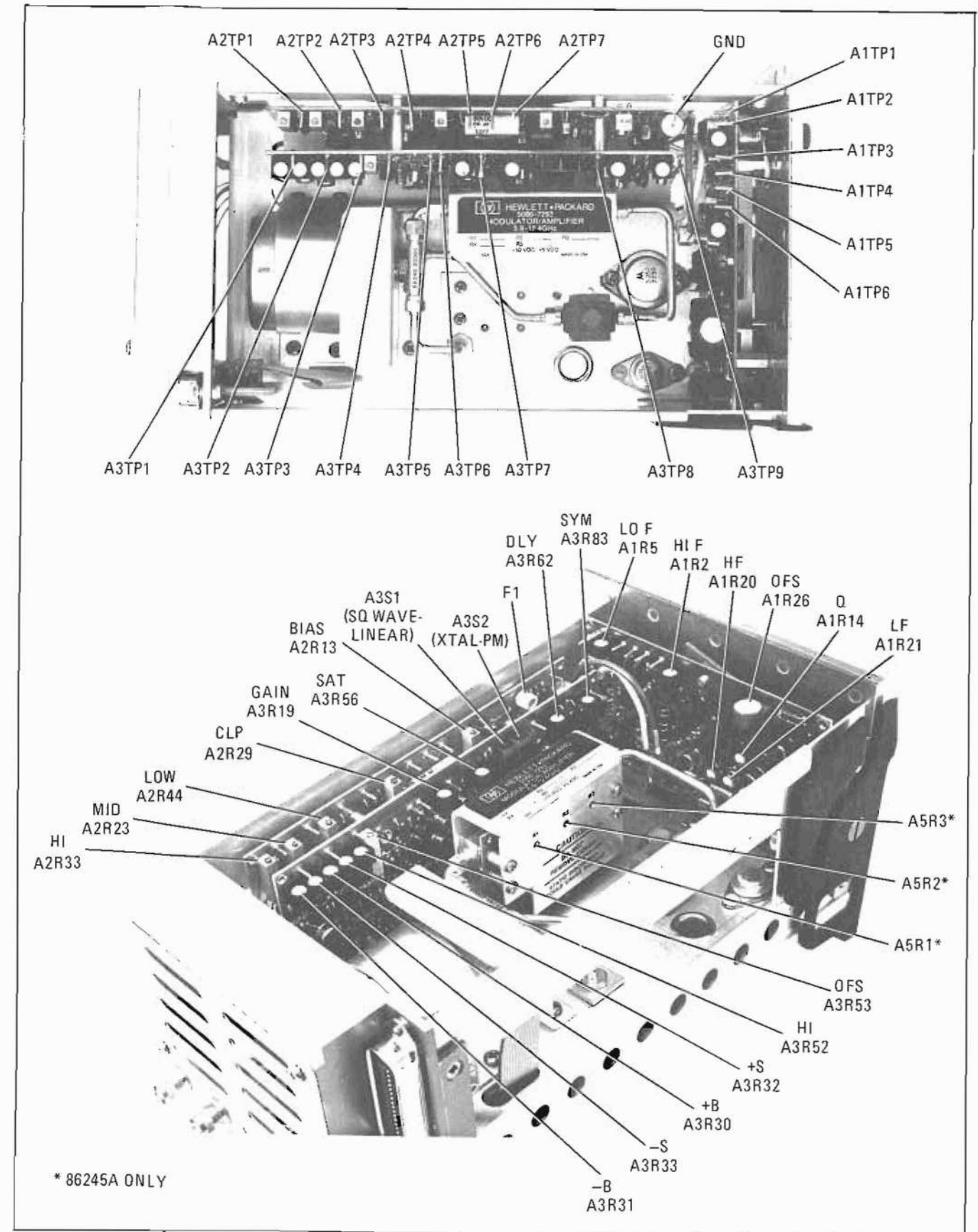

Figure 8-24. Location of Test Points and Adjustments, 86245A

www.valuetronics.com

Major Assembly and Component Locations, 86245A
◀ Location of Test Points and Adjustments, 86245A

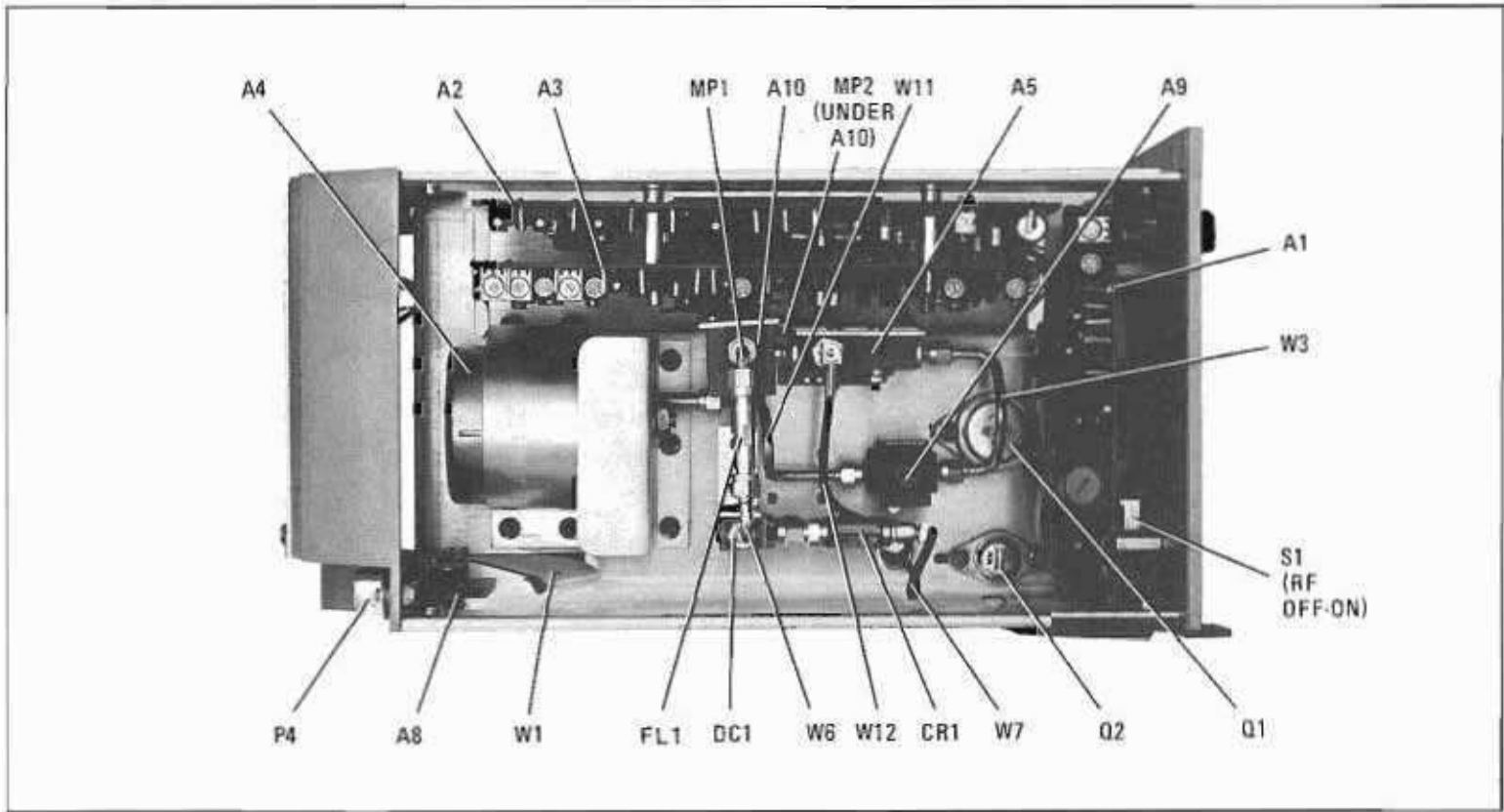

Figure 8-25. Major Assembly and Component Locations, Top View, 86242D/86250D (Option 001)

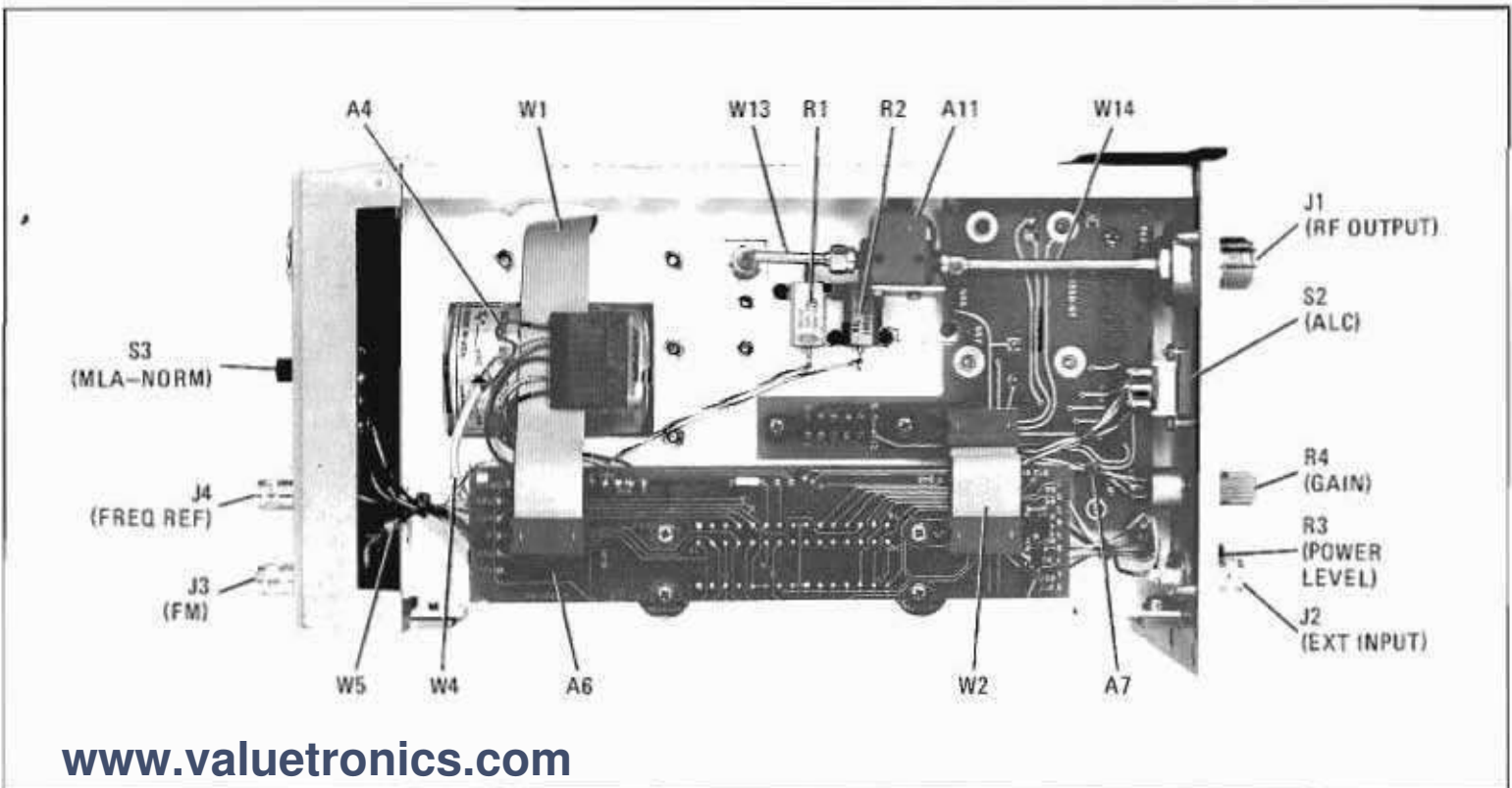

Figure 8-26. Major Assembly and Component Locations, Bottom View, 86242D/86250D (Option 008)

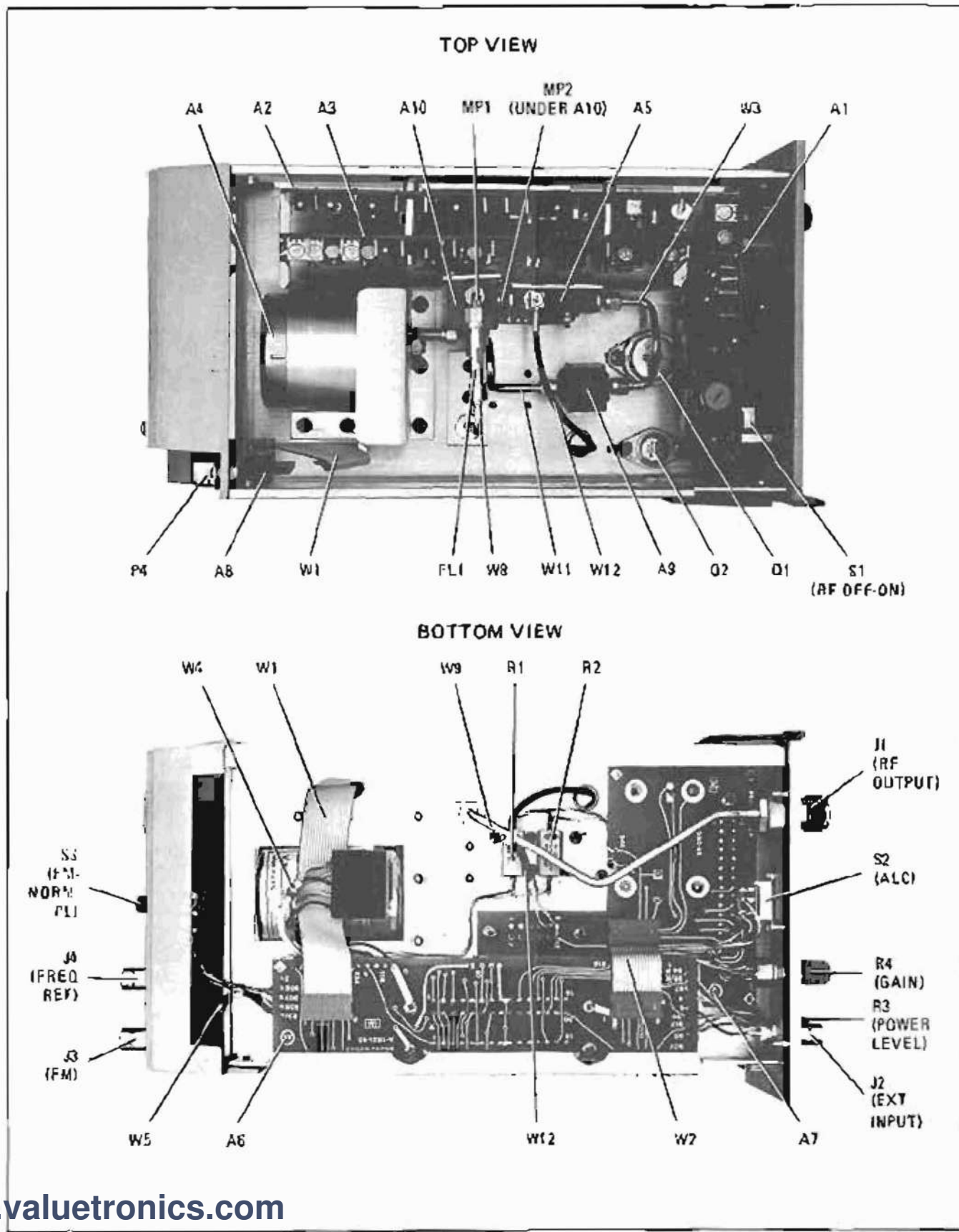

Figure 8-27. Major Assembly and Component Location, 8624D/86250D

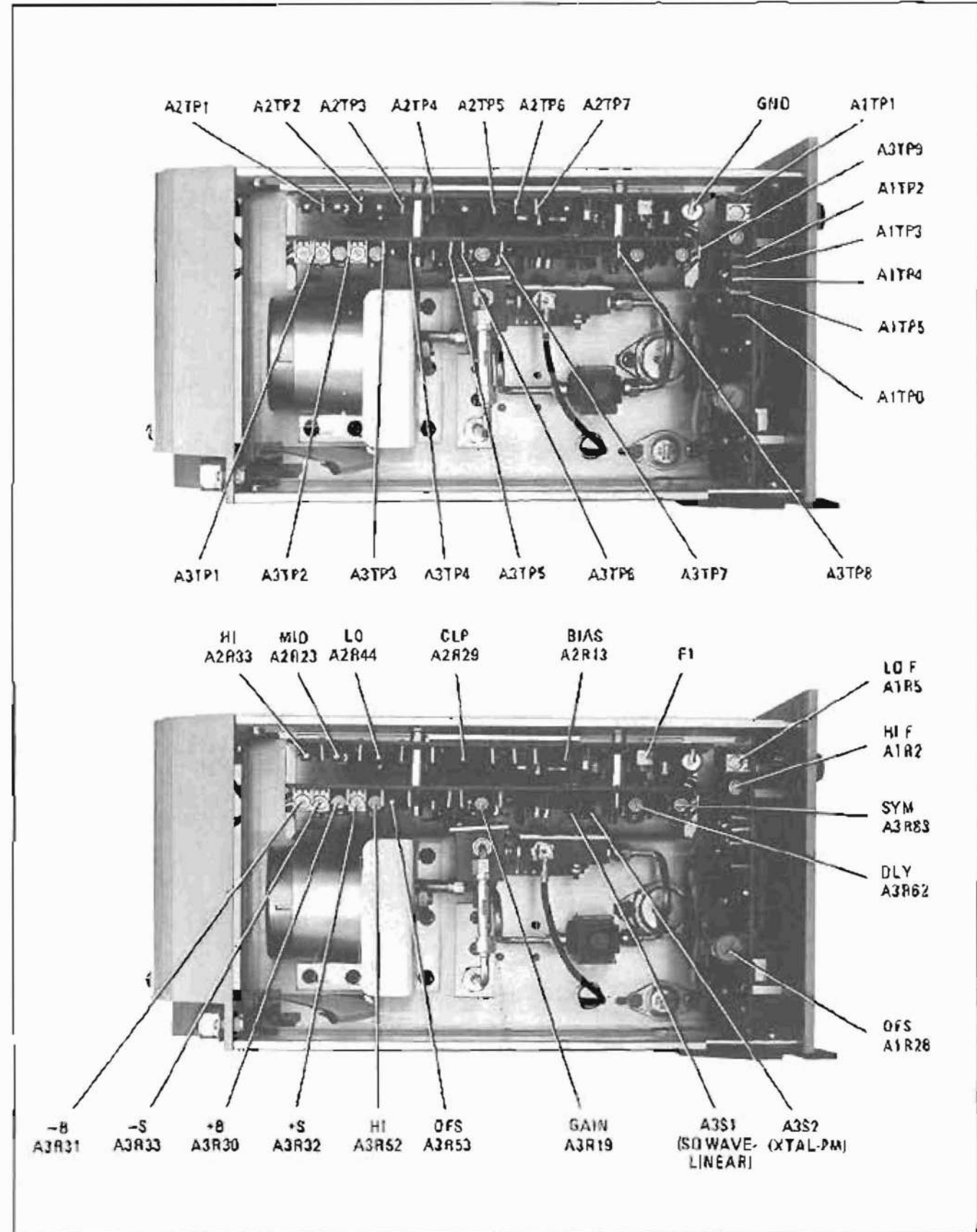

Figure 8-28. Location of Test Points and Adjustments, 86242D/86250D

www.valuetronics.com

Major Assembly and Component Locations,
86242D/86250D



Location of Test Points and Adjustments, 86242D/86250D

SALES & SERVICE OFFICES

AFRICA, ASIA, AUSTRALIA

ANGOLA

Electra
Empress Fabricade
Esplanade
Lufuense 3 & R.L.
R. Barboza Rodrigues 474 Q1
Cava Paper, 5417

LAOS

131-132
Cable TELECOM Luang
Prabang

AUSTRALIA

Hewlett-Packard Australia
Pty Ltd
11-17 Joseph Street
Blackburn Victoria 3130
P.O. Box 99
Newcastle East Victoria 2109
Tel: 39-6351
Telex: 31-024
Cable: HEWPAUD Melbourne
Pty Ltd

HAWAII

Hewlett-Packard Australia
Pty Ltd

FIJI

103 Universal Road
P.O. Box 506
Suva

FRANCE

Hewlett-Packard Australia
Pty Ltd

GERMANY

Hewlett-Packard Australia
Pty Ltd

HONG KONG

Hewlett-Packard Australia
Pty Ltd

INDIA

Hewlett-Packard Australia
Pty Ltd

INDONESIA

Hewlett-Packard Australia
Pty Ltd

JAPAN

Hewlett-Packard Australia
Pty Ltd

KENYA

Hewlett-Packard Australia
Pty Ltd

KOREA

Hewlett-Packard Australia
Pty Ltd

LAOS

Hewlett-Packard Australia
Pty Ltd

LIBERIA

Hewlett-Packard Australia
Pty Ltd

MACAU

Hewlett-Packard Australia
Pty Ltd

NETHERLANDS

Hewlett-Packard Australia
Pty Ltd

NEW ZEALAND

Hewlett-Packard Australia
Pty Ltd

PHILIPPINES

Hewlett-Packard Australia
Pty Ltd

RUSSIA

Hewlett-Packard Australia
Pty Ltd

SINGAPORE

Hewlett-Packard Australia
Pty Ltd

SOUTH AFRICA

Hewlett-Packard Australia
Pty Ltd

THAILAND

Hewlett-Packard Australia
Pty Ltd

TAIWAN

Hewlett-Packard Australia
Pty Ltd

TANZANIA

Hewlett-Packard Australia
Pty Ltd

UGANDA

Hewlett-Packard Australia
Pty Ltd

ZAMBIA

Hewlett-Packard Australia
Pty Ltd

ZIMBABWE

Hewlett-Packard Australia
Pty Ltd

HONG KONG

Somach & Co (Hong Kong) Ltd
P.O. Box 287
Cantonment Centre
Jiffy Floor
Cantonment Road Central
Hong Kong
Tel: 8525212-5
Telex: 74796 SHWMC HK
Cable: SHWOTCO Hong Kong

INDIA

Blue Star Ltd
2-34 Kothakavalam High Road
Madurai 625034
Tel: 4525212-5
Telex: 74796 SHWMC HK
Cable: SHWOTCO Hong Kong

INDONESIA

BERCA Indonesia P.T.
P.O. Box 956 Jkt
Jl. Wajidi Muli 62
Jakarta
Tel: 42359-49895-49235-331038
JKT 42359
Cable: BERCAOEW
BERCA Indonesia P.T.
63 J.L. Raya Gudang
Surabaya
Tel: 44359

ISRAEL

Electronics & Engineering Div.
107 Wolfsona 10441 Ltd
17 Kikarotokai Street
P.O. Box 25016
Tel-Aviv
Tel: 32972
Telex: 33689
Cable: BASTEL Tel-Aviv

JAPAN

Yokogawa-Hewlett-Packard Ltd
Shomi Building
26-1 Miyagi 1-Chome
Shibuya-Ku, Tokyo 151
Tel: 03-370 2291-92
Telex: 232-2024 HRP MARKET
Tokyo 23-124
Cable: YHPHARECT
Yokogawa-Hewlett-Packard Ltd
Chuo Bldg, 4th Floor
4-20, Nishi-Kojima 3-Chome
Shinjuku-Ku, Osaka 54
Osaka 532
Tel: 06-266-6021

KOREA

Yokogawa-Hewlett-Packard Ltd
Namsan Building
24 Nam-Gyeongcho
Kokkoku-Ku, Nagoya 456
Tel: 052-571-2177
Yokogawa-Hewlett-Packard Ltd
Tongmyong Building
2-24-1 Tongmyong
Kwangju-Ku
Kwangju 701
Tel: 642-512-1252
Telex: 983-3004 HRP YOK
Yokogawa-Hewlett-Packard Ltd
Mitsui Bldg Building
105, Daejeon 1 San-cho-mun
Mito, Daejeon 210
Tel: 042-251-1470
Yokogawa-Hewlett-Packard Ltd
Inseok Building
1348-5, Ansu-cho 1-chome
Anseong, Kangwon-do 242
Tel: 940-24-0452

NETHERLANDS

Blue Star Ltd
2-34 Kothakavalam High Road
Madurai 625034
Tel: 4525212-5
Telex: 74796 SHWMC HK
Cable: SHWOTCO Hong Kong

NEW ZEALAND

Blue Star Ltd
2-34 Kothakavalam High Road
Madurai 625034
Tel: 4525212-5
Telex: 74796 SHWMC HK
Cable: SHWOTCO Hong Kong

PHILIPPINES

Blue Star Ltd
2-34 Kothakavalam High Road
Madurai 625034
Tel: 4525212-5
Telex: 74796 SHWMC HK
Cable: SHWOTCO Hong Kong

RUSSIA

Blue Star Ltd
2-34 Kothakavalam High Road
Madurai 625034
Tel: 4525212-5
Telex: 74796 SHWMC HK
Cable: SHWOTCO Hong Kong

SINGAPORE

Blue Star Ltd
2-34 Kothakavalam High Road
Madurai 625034
Tel: 4525212-5
Telex: 74796 SHWMC HK
Cable: SHWOTCO Hong Kong

SOUTH AFRICA

Blue Star Ltd
2-34 Kothakavalam High Road
Madurai 625034
Tel: 4525212-5
Telex: 74796 SHWMC HK
Cable: SHWOTCO Hong Kong

THAILAND

Blue Star Ltd
2-34 Kothakavalam High Road
Madurai 625034
Tel: 4525212-5
Telex: 74796 SHWMC HK
Cable: SHWOTCO Hong Kong

TAIWAN

Blue Star Ltd
2-34 Kothakavalam High Road
Madurai 625034
Tel: 4525212-5
Telex: 74796 SHWMC HK
Cable: SHWOTCO Hong Kong

TANZANIA

Blue Star Ltd
2-34 Kothakavalam High Road
Madurai 625034
Tel: 4525212-5
Telex: 74796 SHWMC HK
Cable: SHWOTCO Hong Kong

TANZANIA

Blue Star Ltd
2-34 Kothakavalam High Road
Madurai 625034
Tel: 4525212-5
Telex: 74796 SHWMC HK
Cable: SHWOTCO Hong Kong

TANZANIA

Blue Star Ltd
2-34 Kothakavalam High Road
Madurai 625034
Tel: 4525212-5
Telex: 74796 SHWMC HK
Cable: SHWOTCO Hong Kong

TANZANIA

Blue Star Ltd
2-34 Kothakavalam High Road
Madurai 625034
Tel: 4525212-5
Telex: 74796 SHWMC HK
Cable: SHWOTCO Hong Kong

TANZANIA

Blue Star Ltd
2-34 Kothakavalam High Road
Madurai 625034
Tel: 4525212-5
Telex: 74796 SHWMC HK
Cable: SHWOTCO Hong Kong

TANZANIA

Blue Star Ltd
2-34 Kothakavalam High Road
Madurai 625034
Tel: 4525212-5
Telex: 74796 SHWMC HK
Cable: SHWOTCO Hong Kong

TANZANIA

Blue Star Ltd
2-34 Kothakavalam High Road
Madurai 625034
Tel: 4525212-5
Telex: 74796 SHWMC HK
Cable: SHWOTCO Hong Kong

TANZANIA

Blue Star Ltd
2-34 Kothakavalam High Road
Madurai 625034
Tel: 4525212-5
Telex: 74796 SHWMC HK
Cable: SHWOTCO Hong Kong

TANZANIA

Blue Star Ltd
2-34 Kothakavalam High Road
Madurai 625034
Tel: 4525212-5
Telex: 74796 SHWMC HK
Cable: SHWOTCO Hong Kong

TANZANIA

Blue Star Ltd
2-34 Kothakavalam High Road
Madurai 625034
Tel: 4525212-5
Telex: 74796 SHWMC HK
Cable: SHWOTCO Hong Kong

TANZANIA

Blue Star Ltd
2-34 Kothakavalam High Road
Madurai 625034
Tel: 4525212-5
Telex: 74796 SHWMC HK
Cable: SHWOTCO Hong Kong

TANZANIA

Blue Star Ltd
2-34 Kothakavalam High Road
Madurai 625034
Tel: 4525212-5
Telex: 74796 SHWMC HK
Cable: SHWOTCO Hong Kong

TANZANIA

Blue Star Ltd
2-34 Kothakavalam High Road
Madurai 625034
Tel: 4525212-5
Telex: 74796 SHWMC HK
Cable: SHWOTCO Hong Kong

TANZANIA

Blue Star Ltd
2-34 Kothakavalam High Road
Madurai 625034
Tel: 4525212-5
Telex: 74796 SHWMC HK
Cable: SHWOTCO Hong Kong

TANZANIA

Blue Star Ltd
2-34 Kothakavalam High Road
Madurai 625034
Tel: 4525212-5
Telex: 74796 SHWMC HK
Cable: SHWOTCO Hong Kong

TANZANIA

Blue Star Ltd
2-34 Kothakavalam High Road
Madurai 625034
Tel: 4525212-5
Telex: 74796 SHWMC HK
Cable: SHWOTCO Hong Kong

TANZANIA

TANZANIA

Blue Star Ltd
2-34 Kothakavalam High Road
Madurai 625034
Tel: 4525212-5
Telex: 74796 SHWMC HK
Cable: SHWOTCO Hong Kong

TANZANIA

Blue Star Ltd
2-34 Kothakavalam High Road
Madurai 625034
Tel: 4525212-5
Telex: 74796 SHWMC HK
Cable: SHWOTCO Hong Kong

TANZANIA

Blue Star Ltd
2-34 Kothakavalam High Road
Madurai 625034
Tel: 4525212-5
Telex: 74796 SHWMC HK
Cable: SHWOTCO Hong Kong

TANZANIA

Blue Star Ltd
2-34 Kothakavalam High Road
Madurai 625034
Tel: 4525212-5
Telex: 74796 SHWMC HK
Cable: SHWOTCO Hong Kong

TANZANIA

Blue Star Ltd
2-34 Kothakavalam High Road
Madurai 625034
Tel: 4525212-5
Telex: 74796 SHWMC HK
Cable: SHWOTCO Hong Kong

TANZANIA

Blue Star Ltd
2-34 Kothakavalam High Road
Madurai 625034
Tel: 4525212-5
Telex: 74796 SHWMC HK
Cable: SHWOTCO Hong Kong

TANZANIA

Blue Star Ltd
2-34 Kothakavalam High Road
Madurai 625034
Tel: 4525212-5
Telex: 74796 SHWMC HK
Cable: SHWOTCO Hong Kong

TANZANIA

Blue Star Ltd
2-34 Kothakavalam High Road
Madurai 625034
Tel: 4525212-5
Telex: 74796 SHWMC HK
Cable: SHWOTCO Hong Kong

TANZANIA

Blue Star Ltd
2-34 Kothakavalam High Road
Madurai 625034
Tel: 4525212-5
Telex: 74796 SHWMC HK
Cable: SHWOTCO Hong Kong

TANZANIA

Blue Star Ltd
2-34 Kothakavalam High Road
Madurai 625034
Tel: 4525212-5
Telex: 74796 SHWMC HK
Cable: SHWOTCO Hong Kong

TANZANIA

Blue Star Ltd
2-34 Kothakavalam High Road
Madurai 625034
Tel: 4525212-5
Telex: 74796 SHWMC HK
Cable: SHWOTCO Hong Kong

TANZANIA

Blue Star Ltd
2-34 Kothakavalam High Road
Madurai 625034
Tel: 4525212-5
Telex: 74796 SHWMC HK
Cable: SHWOTCO Hong Kong

TANZANIA

Blue Star Ltd
2-34 Kothakavalam High Road
Madurai 625034
Tel: 4525212-5
Telex: 74796 SHWMC HK
Cable: SHWOTCO Hong Kong

TANZANIA

Blue Star Ltd
2-34 Kothakavalam High Road
Madurai 625034
Tel: 4525212-5
Telex: 74796 SHWMC HK
Cable: SHWOTCO Hong Kong

TANZANIA

Blue Star Ltd
2-34 Kothakavalam High Road
Madurai 625034
Tel: 4525212-5
Telex: 74796 SHWMC HK
Cable: SHWOTCO Hong Kong

TANZANIA

TANZANIA

Blue Star Ltd
2-34 Kothakavalam High Road
Madurai 625034
Tel: 4525212-5
Telex: 74796 SHWMC HK
Cable: SHWOTCO Hong Kong

TANZANIA

Blue Star Ltd
2-34 Kothakavalam High Road
Madurai 625034
Tel: 4525212-5
Telex: 74796 SHWMC HK
Cable: SHWOTCO Hong Kong

TANZANIA

Blue Star Ltd
2-34 Kothakavalam High Road
Madurai 625034
Tel: 4525212-5
Telex: 74796 SHWMC HK
Cable: SHWOTCO Hong Kong

TANZANIA

Blue Star Ltd
2-34 Kothakavalam High Road
Madurai 625034
Tel: 4525212-5
Telex: 74796 SHWMC HK
Cable: SHWOTCO Hong Kong

TANZANIA

Blue Star Ltd
2-34 Kothakavalam High Road
Madurai 625034
Tel: 4525212-5
Telex: 74796 SHWMC HK
Cable: SHWOTCO Hong Kong

TANZANIA

Blue Star Ltd
2-34 Kothakavalam High Road
Madurai 625034
Tel: 4525212-5
Telex: 74796 SHWMC HK
Cable: SHWOTCO Hong Kong

TANZANIA

Blue Star Ltd
2-34 Kothakavalam High Road
Madurai 625034
Tel: 4525212-5
Telex: 74796 SHWMC HK
Cable: SHWOTCO Hong Kong

TANZANIA

Blue Star Ltd
2-34 Kothakavalam High Road
Madurai 625034
Tel: 4525212-5
Telex: 74796 SHWMC HK
Cable: SHWOTCO Hong Kong

TANZANIA

Blue Star Ltd
2-34 Kothakavalam High Road
Madurai 625034
Tel: 4525212-5
Telex: 74796 SHWMC HK
Cable: SHWOTCO Hong Kong

TANZANIA

Blue Star Ltd
2-34 Kothakavalam High Road
Madurai 625034
Tel: 4525212-5
Telex: 74796 SHWMC HK
Cable: SHWOTCO Hong Kong

TANZANIA

Blue Star Ltd
2-34 Kothakavalam High Road
Madurai 625034
Tel: 4525212-5
Telex: 74796 SHWMC HK
Cable: SHWOTCO Hong Kong

TANZANIA

Blue Star Ltd
2-34 Kothakavalam High Road
Madurai 625034
Tel: 4525212-5
Telex: 74796 SHWMC HK
Cable: SHWOTCO Hong Kong

TANZANIA

Blue Star Ltd
2-34 Kothakavalam High Road
Madurai 625034
Tel: 4525212-5
Telex: 74796 SHWMC HK
Cable: SHWOTCO Hong Kong

TANZANIA

Blue Star Ltd
2-34 Kothakavalam High Road
Madurai 625034
Tel: 4525212-5
Telex: 74796 SHWMC HK
Cable: SHWOTCO Hong Kong

TANZANIA

Blue Star Ltd
2-34 Kothakavalam High Road
Madurai 625034
Tel: 4525212-5
Telex: 74796 SHWMC HK
Cable: SHWOTCO Hong Kong

TANZANIA

TANZANIA

Blue Star Ltd
2-34 Kothakavalam High Road
Madurai 625034
Tel: 4525212-5
Telex: 74796 SHWMC HK
Cable: SHWOTCO Hong Kong

TANZANIA

EUROPE, NORTH AFRICA AND MIDDLE EAST

AUSTRIA

Hewlett-Packard Ges m B H
Handelskai 52
P.O. Box 7
A-1205 Vienna
Tel: (0222) 351621 to 27
Cable: HEWPAK Vienna
Telex: 75923 hewpak a

BELGIUM

Hewlett-Packard Benelux
S.A./N.V.
Avenue de Col-Vert 1
Groenenkraigden
B-1170 Brussels
Tel: (02) 672 22 40
Cable: PALDBEN Brussels
Telex: 23 434 paloben brv

CYPRUS

KYRONICS
19, Grigoriou & Xenopoulos Rd.
P.O. Box 1152
CY-Nicosia
Tel: 45628/29
Cable: KYRONICS PANDEHIS
Telex: 3019

CZECHOSLOVAKIA

Vývojová a Provozní Zakladna
Výzkumných Ústavů v Bechovicích
ČSSR-25097 Bechovice u Prahy
Tel: 89 93 41
Telex: 121333

Institute of Medical Biosciences

Výskumný Ústav Lekárskej Biologie
Jedlova 6
CS-88345 Bratislava-Kramere
Tel: 44-55145-541

DDR

Entwicklungslabor der TU Dresden
Forschungsinstitut Meinsberg
DDR-7305
Waldheim/Meinsberg
Tel: 37 567
Telex: 112145

Export Contact AG Zuerich

Gueschler Forbörger
Schlegelstrasse 15
1040 Berlin
Tel: 42-74-12
Telex: 111889

DENMARK

Hewlett-Packard A/S
Datavej 52
DK-3450 Birkerød
Tel: (02) 81 66 40
Cable: HEWPAK AS
Telex: 37409 hpas dk

Hewlett-Packard A/S

Nævestre 1
DK-8600 Silkeborg
Tel: (06) 82 71 66
Telex: 37409 hpas dk
Cable: HEWPAK AS

FINLAND

Hewlett-Packard Oy
Mankahousentie 5
P.O. Box 6
SF-00211 Helsinki 21
Tel: (90) 6923031
Cable: HEWPAK Oy Helsinki
Telex: 12-1563 HEWPA SF

FRANCE

Hewlett-Packard France
Quartier de Gouverneuf
Boite Postale No. 6
F-91400 Orsay Cédex
Tel: (1) 907 78 25
Cable: HEWPAK Orsay
Telex: 600048

Hewlett-Packard France

Agence Régionale
"Le Saquin"
Chemin des Mouilles
B.P. 182
F-69130 Ecullay
Tel: (78) 331 25
Cable: HEWPAK Ecullay
Telex: 31 06 17

Hewlett-Packard France

Agence Régionale
Boite Postale No. 6
F-91400 Orsay Cédex
Tel: (1) 907 78 25
Cable: HEWPAK Orsay
Telex: 600048

ARIZONA

2336 E. Magnolia St.
Phoenix 85034
Tel: (602) 244-1361
2424 East Aragon Rd
Tucson 85706
Tel: (602) 294-3148

*ARKANSAS

Medical Service Only
P.O. Box 5645
Brady Station
Little Rock 72215
Tel: (501) 376-1844

CALIFORNIA

1430 East Orangewood Ave
Fullerton 92631
Tel: (714) 870-1090
3939 Lankershim Boulevard
North Hollywood 91604
Tel: (213) 877-1282
TWX: 910-499-2621

*Los Angeles

World Wide Postal Center
Los Angeles 90009
Tel: (213) 970-7500
3003 Scott Boulevard
Santa Clara 95059
Tel: (408) 249-7000
TWX: 910-338-0516

*Los Angeles

3003 Scott Boulevard
Santa Clara 95059
Tel: (408) 249-7000
TWX: 910-338-0516

Hewlett-Packard France

Agence Régionale
Pôle Centre de la Capitale
Chemin de la Capitale, 20
F-31300 Toulouse-Le Mirail
Tel: (61) 40 11 12
Cable: HEWPAK 51957
Telex: 519857

Hewlett-Packard France

Agence Régionale
Aéroport principal de
Marseille-Marseille
F-13721 Marignane
Tel: (91) 39 12 38
Cable: HEWPAK MARGN
Telex: 410770

Hewlett-Packard France

Agence Régionale
63, Avenue de Rochester
B.P. 1124
F-35014 Rennes Cédex
Tel: (99) 35 33 21
Cable: HEWPAK 74912
Telex: 740912

Hewlett-Packard France

Agence Régionale
74, Allée de la Robertsau
F-67000 Strasbourg
Tel: (88) 33 20 20 21
Cable: HAWAR Athens
Telex: 21 59 62 rkar gr

Hewlett-Packard France

Agence Régionale
Centre Vauban
201, rue Colbert
Erlange A2
F-59000 Lille
Tel: (20) 51 44 14
Telex: 820744

Hewlett-Packard France

Centre d'Affaires Paris-Nord
Bâtiment Ampère
Rue de la Communauté de Paris
B.P. 300
F-93153 Le Blanc Mesnil Cédex
Tel: (01) 931 88 30

GERMAN FEDERAL

REPUBLIC
Hewlett-Packard GmbH
Vertriebszentrale Frankfurt
Bernerstrasse 117
Postfach 560 149
D-6000 Frankfurt 56
Tel: (061) 50 04-1
Cable: HEWPAKSA Frankfurt
Tel: (061) 50 04-1
Cable: HEWPAKSA Frankfurt
Tel: 04 13249 hpfdnd
Hewlett-Packard GmbH
Technisches Büro Böblingen
Herrenbergerstrasse 110
D-7030 Böblingen, Württemberg
Tel: (07031) 66-71

Hewlett-Packard GmbH

Technisches Büro Hamburg
Wendlandstrasse 23
D-2003 Hamburg 1
Tel: (040) 24 13 93
Cable: HEWPAKSA Hamburg
Telex: 21 63 032 hpnd d

Hewlett-Packard GmbH

Technisches Büro Hannover
Am Grossmarkt 6
D-3000 Hannover 91
Tel: (0511) 46 60 01
Telex: 092 3259

Hewlett-Packard GmbH

Technisches Büro Nürnberg
Herrenbergerstrasse 110
D-7030 Böblingen, Württemberg
Tel: (07031) 66-71

Hewlett-Packard GmbH

Technisches Büro Nürnberg
Herrenbergerstrasse 110
D-7030 Böblingen, Württemberg
Tel: (07031) 66-71

Hewlett-Packard GmbH

Technisches Büro Nürnberg
Herrenbergerstrasse 110
D-7030 Böblingen, Württemberg
Tel: (07031) 66-71

Hewlett-Packard GmbH

Technisches Büro Nürnberg
Herrenbergerstrasse 110
D-7030 Böblingen, Württemberg
Tel: (07031) 66-71

Hewlett-Packard GmbH

Technisches Büro Nürnberg
Herrenbergerstrasse 110
D-7030 Böblingen, Württemberg
Tel: (07031) 66-71

Hewlett-Packard GmbH

Technisches Büro Nürnberg
Herrenbergerstrasse 110
D-7030 Böblingen, Württemberg
Tel: (07031) 66-71

Hewlett-Packard GmbH

Technisches Büro Nürnberg
Herrenbergerstrasse 110
D-7030 Böblingen, Württemberg
Tel: (07031) 66-71

Hewlett-Packard GmbH

Technisches Büro Nürnberg
Herrenbergerstrasse 110
D-7030 Böblingen, Württemberg
Tel: (07031) 66-71

Hewlett-Packard GmbH

Technisches Büro Nürnberg
Herrenbergerstrasse 110
D-7030 Böblingen, Württemberg
Tel: (07031) 66-71

Hewlett-Packard GmbH

Werk Grotzingen
Dmstrasse 6
D-7500 Karlsruhe 41
Tel: (0721) 69 40 06
Telex: 07-825707

Hewlett-Packard GmbH

Technisches Büro Nürnberg
Reuther Str. 90
D-8500 Nuremberg
Tel: (0911) 56 35 83/85
Telex: 0623 860

Hewlett-Packard GmbH

Technisches Büro München
Unterhachinger Strasse 28
ISRA Center
D-8012 Ottobrunn
Tel: (089) 601 30 61/7
Cable: HEWPAKSA München
Telex: 0524985

Hewlett-Packard GmbH

Technisches Büro Berlin
Kath Strasse 2-4
D-1000 Berlin 30
Tel: (030) 24 90 86
Telex: 18 3405 hpnd d

Hewlett-Packard GmbH

Technisches Büro Berlin
Kath Strasse 2-4
D-1000 Berlin 30
Tel: (030) 24 90 86
Telex: 18 3405 hpnd d

Hewlett-Packard GmbH

Technisches Büro Berlin
Kath Strasse 2-4
D-1000 Berlin 30
Tel: (030) 24 90 86
Telex: 18 3405 hpnd d

Hewlett-Packard GmbH

Technisches Büro Berlin
Kath Strasse 2-4
D-1000 Berlin 30
Tel: (030) 24 90 86
Telex: 18 3405 hpnd d

Hewlett-Packard GmbH

Technisches Büro Berlin
Kath Strasse 2-4
D-1000 Berlin 30
Tel: (030) 24 90 86
Telex: 18 3405 hpnd d

Hewlett-Packard GmbH

Technisches Büro Berlin
Kath Strasse 2-4
D-1000 Berlin 30
Tel: (030) 24 90 86
Telex: 18 3405 hpnd d

Hewlett-Packard GmbH

Technisches Büro Berlin
Kath Strasse 2-4
D-1000 Berlin 30
Tel: (030) 24 90 86
Telex: 18 3405 hpnd d

Hewlett-Packard GmbH

Technisches Büro Berlin
Kath Strasse 2-4
D-1000 Berlin 30
Tel: (030) 24 90 86
Telex: 18 3405 hpnd d

Hewlett-Packard GmbH

Technisches Büro Berlin
Kath Strasse 2-4
D-1000 Berlin 30
Tel: (030) 24 90 86
Telex: 18 3405 hpnd d

Hewlett-Packard GmbH

Technisches Büro Berlin
Kath Strasse 2-4
D-1000 Berlin 30
Tel: (030) 24 90 86
Telex: 18 3405 hpnd d

Hewlett-Packard GmbH

Technisches Büro Berlin
Kath Strasse 2-4
D-1000 Berlin 30
Tel: (030) 24 90 86
Telex: 18 3405 hpnd d

Hewlett-Packard GmbH

Technisches Büro Berlin
Kath Strasse 2-4
D-1000 Berlin 30
Tel: (030) 24 90 86
Telex: 18 3405 hpnd d

Hewlett-Packard GmbH

Technisches Büro Berlin
Kath Strasse 2-4
D-1000 Berlin 30
Tel: (030) 24 90 86
Telex: 18 3405 hpnd d

Hewlett-Packard GmbH

Technisches Büro Berlin
Kath Strasse 2-4
D-1000 Berlin 30
Tel: (030) 24 90 86
Telex: 18 3405 hpnd d

Hewlett-Packard GmbH

Technisches Büro Berlin
Kath Strasse 2-4
D-1000 Berlin 30
Tel: (030) 24 90 86
Telex: 18 3405 hpnd d

ITALY

Hewlett-Packard Italiana S.p.A.
D-7500 Karlsruhe 41
Tel: (0721) 69 40 06
Telex: 07-825707

Hewlett-Packard Italiana S.p.A.

Casele postale 3645
I-20100 Milano
Tel: (2) 8251 110 lines
Cable: HEWPAKITA Milano
Tel: 32046

Hewlett-Packard Italiana S.p.A.

Via Pietro Maroncelli 40
(lang. Via Visentini)
I-59100 Pistoia
Tel: (49) 66 48 88
Telex: 41612 Hewpack
Medical only

Hewlett-Packard Italiana S.p.A.

Via G. Agnardi, 7
I-59100 Pistoia
Tel: (050) 2 32 04
Telex: 32046 via Milano
Hewlett-Packard Italiana S.p.A.
Via G. Agnardi 10
I-00143 Roma
Tel: (06) 54 69 61
Telex: 61514

Hewlett-Packard Italiana S.p.A.

Cable: HEWPAKITA Roma
Hewlett-Packard Italiana S.p.A.
Corso Giovanni Lanza
I-10031 Torino
Tel: (011) 682245/659308
Medical/Calculators only
Hewlett-Packard Italiana S.p.A.
Via Principe Nicola 43 G/C
I-95126 Catania
Tel: (095) 37 05 04

Hewlett-Packard Italiana S.p.A.

Via Amerigo Vesputcio, 9
I-80142 Napoli
Tel: (081) 35 77 11
Hewlett-Packard Italiana S.p.A.
Via E. Masi, 9/B
I-40137 Bologna
Tel: (051) 30 78 87

KUWAIT

Al-Khaleej Trading &
Consulting Co.
P.O. Box 830-Salt
Kuwait
Tel: 424910-411726
Telex: 2481 ateqy kt
Cable: VISCOUNT
Tel: 11716

SAUDI ARABIA

Modern Electronic Establishment
King Abdul Aziz Str. (Head Office)
P.O. Box 1228
Jeddah
Tel: 31173-32201
Cable: ELECTRA
P.O. Box 2728 (Service center)
Riyadh
Tel: 52596-68232
Cable: RAOUFCD

SPAIN

Hewlett-Packard Española, S.A.
Jerez, Calle 3
E-Madrid 16
Tel: (1) 458 26 00 (10 lines)
Telex: 23515 npe
Casablanca
Hewlett-Packard Española, S.A.
P.O. Box 665
E-Seville 5
Tel: 64 44 54/58
Hewlett-Packard Española, S.A.
Edificio Albia II 7° B
E-Bilbao
Tel: 23 83 06/23 82 06

Hewlett-Packard Española, S.A.

Calculators Only
Hewlett-Packard Española, S.A.
Via Fernando El Católico, 67
E-Valencia-8
Tel: 326 67 28/326 65 55

NORWAY

Hewlett-Packard Norge A/S
Knyevten 13
Box 149
N-1344 Haslum
Tel: (02) 53 83 60
Telex: 16621 hpnas n

MICHIGAN

23855 Research Drive
Farmington Hills 48024
Tel: (313) 478-6400
724 West Centre Ave.
Kalamazoo 49002
Tel: (606) 323-8362

MINNESOTA

2400 N. Prior Ave.
St. Paul 55113
Tel: (612) 636-0700

MISSISSIPPI

*Jackson
Medical Service only
Tel: (601) 982-9363

MISSOURI

11131 Colorado Ave.
Kansas City 64137
Tel: (816) 763-8000
TWX: 910-771-2087

NEBRASKA

Medical Only
7171 Mercy Road
Suite 10
Omaha 68106
Tel: (402) 392-0948

NEW JERSEY

W. 120 Century Rd
Paramus 07652
Tel: (201) 265-5000
TWX: 910-590-4951
Crystal Brook Professional
Building
Eatontown 07724
Tel: (201) 542-1364

NEW MEXICO

P.O. Box 11634
Station E
11300 Lomas Blvd., N.E.
Albuquerque 87123
Tel: (505) 282-1330
TWX: 910-989-1185

POLAND

Biuro Informacji Technicznej
Hewlett-Packard
Ul. Szlaku 2, 6P
00-950 Warszawa
Tel: 389562/385187
Telex: 81 74 53 nepa pl

UNIPAN

Zaklad Doswiadczalny
Budowy Aparatury Naukowej
Ul. Krzywki, Rady Narodowej 51/55
00-700 Warszawa
Tel: 36190
Telex: 81 46 48

Zaklady Naprawcze Sprzetu

Medycznego
Plac Komuny Panskiej 6
90-007 Lodz
Tel: 334-41, 337-83

PORTUGAL

Telectra-Empresa Técnica de
Equipamentos Electricos S.A./I
Rua Rodrigo da Fonseca 103
P.O. Box 2531
P-Lisbon
Tel: (1) 58 60 72
Cable: TELECTRA Lisbon
Telex: 12598

Medical only

Mundinter
Intercomércio Mundial de Comércio
S.A./I
Av. A de Aguiar 138
P.O. Box 2761
P-Lisbon
Tel: (1) 53 21 31/7
Cable: INTERCAMBIO Lisbon

RUMANIA

Hewlett-Packard Reprezentanta
Bd N. Balcescu 16
Bucharest
Tel: 58023/318885
Telex: 10440
I.I.R.U.C.
Introducere Pentru
Intretinere
Si Reparatia Utilajelor de Calcul
B-dul prof. Dm. Petre Pomper 6
Bucharest-Sectorul 2
Tel: 12 84 30
Telex: 11716

SAUDI ARABIA

Modern Electronic Establishment
King Abdul Aziz Str. (Head Office)
P.O. Box 1228
Jeddah
Tel: 31173-32201
Cable: ELECTRA
P.O. Box 2728 (Service center)
Riyadh
Tel: 52596-68232
Cable: RAOUFCD

SPAIN

Hewlett-Packard Española, S.A.
Jerez, Calle 3
E-Madrid 16
Tel: (1) 458 26 00 (10 lines)
Telex: 23515 npe
Casablanca
Hewlett-Packard Española, S.A.
P.O. Box 665
E-Seville 5
Tel: 64 44 54/58
Hewlett-Packard Española, S.A.
Edificio Albia II 7° B
E-Bilbao
Tel: 23 83 06/23 82 06

Hewlett-Packard Española, S.A.

Calculators Only
Hewlett-Packard Española, S.A.
Via Fernando El Católico, 67
E-Valencia-8
Tel: 326 67 28/326 65 55

NORWAY



www.valuetronics.com