

Errata

Title & Document Type: 8590A RF Spectrum Analyzer Installation and Verification Manual

Manual Part Number: 08590-90131

Revision Date: March 1990

HP References in this Manual

This manual may contain references to HP or Hewlett-Packard. Please note that Hewlett-Packard's former test and measurement, semiconductor products and chemical analysis businesses are now part of Agilent Technologies. We have made no changes to this manual copy. The HP XXXX referred to in this document is now the Agilent XXXX. For example, model number HP8648A is now model number Agilent 8648A.

About this Manual

We've added this manual to the Agilent website in an effort to help you support your product. This manual provides the best information we could find. It may be incomplete or contain dated information, and the scan quality may not be ideal. If we find a better copy in the future, we will add it to the Agilent website.

Support for Your Product

Agilent no longer sells or supports this product. You will find any other available product information on the Agilent Test & Measurement website:

www.tm.agilent.com

Search for the model number of this product, and the resulting product page will guide you to any available information. Our service centers may be able to perform calibration if no repair parts are needed, but no other support from Agilent is available.



Installation and Verification Manual

**HP 8590A Portable RF Spectrum Analyzer
Includes Options 001 and H18**



**HEWLETT
PACKARD**

**HP Part No. 08590-90130 Microfiche Part No. 08590-90131
Printed in USA March 1990**

Assistance

Product maintenance agreements and other customer assistance agreements are available for Hewlett-Packard products.

For any assistance, contact your nearest Hewlett-Packard Sales and Service Office.

Safety Symbols

The following safety symbols are used throughout this manual. Familiarize yourself with each of the symbols and its meaning before operating this instrument.

Caution



The *caution* sign denotes a hazard. It calls attention to a procedure which, if not correctly performed or adhered to, could result in damage to or destruction of the instrument. Do not proceed beyond a *caution* sign until the indicated conditions are fully understood and met.

Warning



The *warning* sign denotes a hazard. It calls attention to a procedure which, if not correctly performed or adhered to, could result in injury or loss of life. Do not proceed beyond a *warning* sign until the indicated conditions are fully understood and met.

General Safety Considerations

Warning



Before this instrument is switched on, make sure it has been properly grounded through the protective conductor of the ac power cable to a socket outlet provided with protective earth contact.

Any interruption of the protective (grounding) conductor, inside or outside the instrument, or disconnection of the protective earth terminal can result in personal injury.

Warning



There are many points in the instrument which can, if contacted, cause personal injury. Be extremely careful.

Any adjustments or service procedures that require operation of the instrument with protective covers removed should be performed only by trained service personnel.

Caution



Before this instrument is switched on, make sure its primary power circuitry has been adapted to the voltage of the ac power source.

Failure to set the ac power input to the correct voltage could cause damage to the instrument when the ac power cable is plugged in.

HP 8590A Spectrum Analyzer Documentation Description

Manuals Shipped with Your HP 8590A

- The Installation and Verification Manual (HP part number 08590-90130) and the Operating Manual (HP part number 08590-90005) are packaged in the **Documentation Package** (HP part number 08590-90001).

HP 8590A Installation and Verification Manual (HP part number 08590-90130)

- Describes how to install the HP 8590A Spectrum Analyzer.
- Tells how to make measurements with your HP 8590A Spectrum Analyzer.
- Describes analyzer features.
- Details what to do in case of a failure.

HP 8590A Operating Manual (HP part number 08590-90005)

- Describes how to make a simple measurement with the HP 8590A.
- Briefly describes the analyzer functions.
- Lists all programming commands.

Options

Option 910: Installation and Verification Manual and Operating Manual

- Provides an additional copy of the Installation and Verification Manual.
- Provides an additional copy of the Operating Manual.
- The Option 910 is also available by ordering HP part number 08590-90001.

Option 915: Installation and Verification Manual, Operating Manual, and Support Manual

- Describes troubleshooting and repair of the analyzer.
- Provides an additional copy of the Documentation Package.
- The Documentation Package is also available by ordering HP part number 08590-90001.
- The Support Manual is also available by ordering HP part number 08590-90096.

Programming Manuals

- Describes analyzer operation via remote controller (computer).
- HP part number 08590-90011 (Option 021, HP-IB)
- HP part number 08590-90013 (Option 022, HP-IL)
- HP part number 08590-90015 (Option 023, RS-232)

How to Order Manuals

Each of the manuals listed above can be ordered individually. To order, contact your local Hewlett-Packard Sales and Service Office.

How to Use This Manual

Where to Start

If you have just received the HP 8590A and want to get it ready to use for the first time:

- Skim Chapter 1, “Introducing the HP 8590A,” for a brief introduction to the unit and its capabilities.
- Thoroughly read Chapter 2, “Preparation for Use,” and follow its instructions for:
 - Unpacking the unit.
 - Preparing it for use.
 - Performing initial self-calibration routines (these are automatic self-checks and require no test equipment).
- If you need to verify the unit is operating within its specifications, perform the performance tests in Chapter 3, “Performance Tests.”
- Chapter 4, “If Something Goes Wrong . . . ,” details additional information for dealing with problems or questions pertaining to your analyzer.

If the Analyzer Has Been in Use

To verify that it is operating correctly or to solve an apparent problem:

- Perform the calibration routines at the end of Chapter 2, “Preparation for Use,” for a quick indication of proper operation.
- If you have the necessary test equipment, perform the performance tests in Chapter 3, “Performance Tests,” to verify that the unit is operating within its specifications.
- If there is an apparent problem, read Chapter 4, “If Something Goes Wrong . . . ,” for hints on what may be wrong and how to solve the problem, and instructions for calling Hewlett-Packard for additional help.

Manual Terms and Conventions

Front-panel keys appear within a box, for example **FRONT-PANEL KEY**. Softkeys appear within a shaded box, for example **SOFTKEY**.

Electrostatic Discharge

Electrostatic discharge (ESD) can damage or destroy electronic components. All work on electronic assemblies should be performed at a static-safe workstation. Figure 1 shows an example of a static-safe workstation using two types of ESD protection:

- Conductive table-mat and wrist-strap combination.
- Conductive floor-mat and heel-strap combination.

Both types, when used together, provide a significant level of ESD protection. Of the two, only the table-mat and wrist-strap combination provides adequate ESD protection when used alone.

To ensure user safety, the static-safe accessories must provide at least 1 M Ω of isolation from ground. Refer to Figure 1 for information on ordering static-safe accessories.

Warning



These techniques for a static-safe workstation should not be used when working on circuitry with a voltage potential greater than 500 volts.

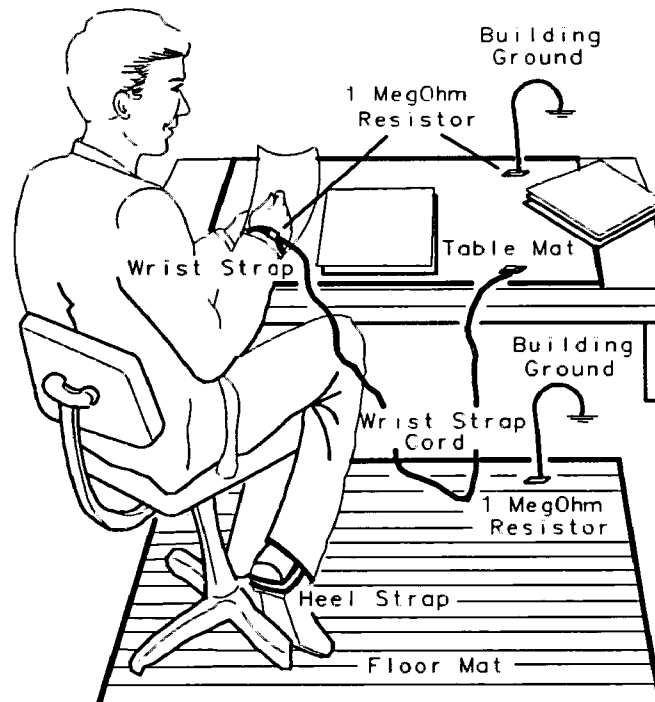

Figure 1. Example of a Static-Safe Workstation

Reducing Damage Caused by ESD

The following suggestions may help reduce ESD damage that occurs during testing and servicing operations.

- Before connecting any coaxial cable to an analyzer connector for the first time each day, momentarily ground the center and outer conductors of the cable.
- Personnel should be grounded with a resistor-isolated wrist strap before touching the center pin of any connector and before removing any assembly from the unit.
- Be sure that all instruments are properly earth-grounded to prevent a buildup of static charge.

Table 1 lists static-safe accessories that can be obtained from Hewlett-Packard by using the HP part numbers shown.

Table 1. Static-Safe Accessories

Accessory	Description	HP Part Number
Static-control mat and ground wire	Set includes: 3M static-control mat, 0.6 m × 1.2 m (2 ft × 4 ft) ground wire, 4.6 m (15 ft) (The wrist strap and wrist-strap cord are <i>not</i> included. They must be ordered separately.)	9300-0797
Wrist-strap cord	1.5 m (5 ft)	9300-0980
Wrist strap	Black, stainless steel with four adjustable links and 7-mm post-type connector (The wrist-strap cord is <i>not</i> included.)	9300-1383
ESD heel strap	Reusable 6 to 12 months	9300-1169
Hard-surface static-control mat*	Large, black, 1.2 m × 1.5 m (4 ft × 5 ft)	92175A
	Small, black, 0.9 m × 1.2 m (3 ft × 4 ft)	92175C
Soft-surface static-control mat*	Brown, 1.2 m × 2.4 m (4 ft × 8 ft)	92175B
Tabletop static-control mat*	58 cm × 76 cm (23 in × 30 in)	92175T
Antistatic carpet*	Small, 1.2 m × 1.8 m (4 ft × 6 ft)	
	natural color	92176A
	russet color	92176C
	Large, 1.2 m × 2.4 m (4 ft × 8 ft)	
	natural color	92176B
	russet color	92176D
* These accessories can be ordered either through a Hewlett-Packard Sales Office or through HP DIRECT Phone Order Service. In the USA, the HP DIRECT phone number is (800) 538-8787. Contact your nearest Hewlett-Packard Sales Office for more information about HP DIRECT availability in other countries.		

Contents

1. Introducing the HP 8590A	
What You'll Find in This Chapter	1-1
Introducing the HP 8590A Spectrum Analyzer	1-1
Options and Accessories Available	1-2
Options	1-2
75 Ω Input Impedance (Option 001)	1-2
HP-IB (Option 021)	1-2
HP-IL (Option 022)	1-2
RS-232 (Option 023)	1-2
Front Panel Cover (Option 040)	1-3
Rack Mount Flange Kit (Option 908)	1-3
1.79 GHz Extended Frequency (Option H18)	1-3
Rack Mount Flange Kit with Handles (Option 909)	1-3
Operating and Installation Manuals (Option 910)	1-3
Service Documentation (Option 915)	1-3
Accessories	1-3
AC Probe	1-3
Broadband Preamplifier	1-4
Close Field Probe	1-4
Computer	1-4
Monitor	1-4
Plotter	1-4
Printer	1-4
Rack Slide Kit	1-4
RF Limiter	1-4
Tracking Generator	1-5
Transit Case	1-5
50 Ω /75 Ω Minimum Loss Pad	1-5
75 Ω Matching Transformer	1-5
Analyzers Covered by This Manual	1-6
Serial Numbers	1-6
Specifications and Characteristics	1-7
Specifications	1-7
Characteristics	1-12

2. Preparation for Use	
What You'll Find in This Chapter	2-1
Getting Ready	2-1
Initial Inspection	2-1
Preparing the HP 8590A for Use	2-2
Power Requirements	2-3
Setting the Line Voltage Selector Switch	2-3
Checking the Fuse	2-4
Power Cable	2-5
Turning the HP 8590A On for the First Time	2-7
3. Performance Tests	
What You'll Find in This Chapter	3-1
What is Performance Verification?	3-1
What is Operation Verification?	3-2
Before You Start Verification Tests	3-3
Test Equipment You'll Need	3-3
Accessories You Should Have	3-3
Recording the Test Results	3-3
If the Analyzer Doesn't Meet Specifications	3-3
Periodically Verifying Operation	3-3
1. Frequency Readout Accuracy	3-10
Specification	3-10
Equipment	3-10
Test Procedure	3-11
Test Results	3-11
2. Displayed Average Noise	3-12
Specification	3-12
Equipment	3-12
Test Procedure (Standard Only)	3-12
Test Results	3-13
3. Frequency Response Flatness	3-14
Specification (with 10 dB of input attenuation)	3-14
Equipment	3-14
Additional Equipment for Option 001	3-15
Test Procedure: 10 kHz to 10 MHz (Option 001: 1 MHz to 10 MHz)	3-15
Test Procedure: 10 MHz to 1500 MHz (Option H18: 1500 MHz to 1790 MHz)	3-16
Procedure for System Characterization, Option 001 Only	3-18
Test Procedure Option 001: 10 MHz to 1500 MHz (Option 001/H18: 1500 MHz to 1790 MHz)	3-19
4. Calibrator Amplitude and Frequency Accuracy	3-23
Specification	3-23
Equipment	3-23
Test Procedure	3-23
Test Results	3-25
5. Frequency Span Readout Accuracy	3-26
Specifications	3-26
Equipment	3-26
Test Procedure (20 to 1500 MHz spans)	3-26
Test Procedure (50 kHz to 1 MHz spans)	3-29
Test Results	3-30

6. Sweep Time Accuracy Test	3-32
Specification	3-32
Equipment	3-32
Additional Equipment for Option 001	3-32
Test Procedure	3-32
7. Noise Sideband Test	3-35
Specifications	3-35
Equipment	3-35
Additional Equipment for Option 001	3-35
Test Procedure	3-35
8. Spurious Response Test	3-37
Specification	3-37
Equipment	3-37
Additional Equipment for Option 001	3-38
Test Procedure	3-38
Second Harmonic Distortion, 40 MHz	3-38
Third Order Intermodulation Distortion, 50 MHz	3-40
9. Residual Response Test	3-43
Specification	3-43
Equipment	3-43
Equipment for Option 001	3-43
Test Procedure	3-43
10. Reference Level Accuracy Test	3-45
Specification	3-45
Equipment	3-45
Additional Equipment for Option 001	3-45
Test Procedure	3-45
11. Scale Fidelity Test	3-48
Specification	3-48
Equipment	3-48
Additional Equipment for Option 001	3-48
Test Procedure: Log Scale Fidelity	3-48
Test Procedure: Linear Scale Fidelity	3-50
12. Frequency Drift Test	3-52
Specification	3-52
Equipment	3-52
Additional Equipment for Option 001	3-52
Test Procedure	3-52
13. Resolution Bandwidth Switching Test	3-54
Specification	3-54
Equipment	3-54
Equipment for Option 001	3-54
Test Procedure	3-54
14. Gain Compression Test	3-56
Specification	3-56
Equipment	3-56
Additional Equipment for Option 001	3-56
Test Procedure	3-56
15. Input Attenuator Accuracy Test	3-59
Specification	3-59
Equipment	3-59

Test Procedure	3-59
4. If Something Goes Wrong ...	
What You'll Find in This Chapter	4-1
Before You Call Hewlett-Packard	4-2
Check the Basics	4-2
Read the Warranty	4-3
Service Options	4-3
How to Call Hewlett-Packard	4-3
How to Return Your Analyzer for Service	4-5
Service Tag	4-5
Original Packaging	4-5
Other Packaging	4-6
A. HP 8590A Messages	
B. Service Requests	
Status Byte Definition	B-2
Service Request Activating Commands	B-3
Index	

Figures

1-1. The HP 8590A Spectrum Analyzer	1-1
1-2. Typical Serial Number Label	1-6
2-1. HP 8590A Shipping Container and Contents	2-2
2-2. Setting the Voltage Selector Switch	2-3
2-3. Checking the Line Fuse	2-4
3-1. Frequency Response Flatness Test Setup	3-16
3-2. System Characterization Test Setup (Option 001)	3-18
3-3. Frequency Response Test Setup Option 001: 10 MHz to 1500 MHz (Option 001/H18: 1500 MHz to 1790 MHz)	3-19
3-4. Calibrator Amplitude Accuracy Test Setup	3-24
3-5. Calibrator Frequency Accuracy Test Setup	3-24
3-6. Frequency Span Readout Accuracy	3-28
3-7. Sweep Time Accuracy Test Setup	3-33
3-8. Noise Sideband Test Setup	3-36
3-9. Second Harmonic Distortion Test Setup, 30 MHz	3-38
3-10. Third Order Intermodulation Distortion Test Setup	3-40
3-11. Spurious Response-Intermodulation Distortion Products	3-42
3-12. Reference Level Accuracy Test Setup	3-46
3-13. Scale Fidelity Test Setup	3-49
3-14. Frequency Drift Test Setup	3-53
3-15. Gain Compression Test Setup	3-58
3-16. Input Attenuator Accuracy Test Setup	3-60

Tables

1-1. HP 8590A Specifications	1-7
1-2. HP 8590A Characteristics	1-12
2-1. Power Requirements	2-3
2-2. AC Power Cables Available	2-6
3-1. HP 8590A Spectrum Analyzer Performance Tests	3-1
3-2. Recommended Test Equipment (Operation Verification)	3-4
3-3. Recommended Test Equipment (Performance Verification)	3-6
3-4. Recommended Accessories	3-9
3-5. Frequency Readout Accuracy	3-11
3-6. Displayed Average Noise	3-13
3-7. Frequency Response Flatness	3-17
3-8. Frequency Response Errors	3-21
3-9. Calibrator Amplitude and Frequency Accuracy	3-25
3-10. Frequency Span Readout Accuracy	3-30
3-11. Operation Verification Test Record	3-31
3-12. Sweep Time Accuracy Settings	3-34
3-13. Reference Level Accuracy Settings	3-47
3-14. Log Scale Fidelity Test Settings	3-51
3-15. Linear Scale Fidelity Test Settings	3-51
3-16. Resolution Bandwidth Switching Test Record	3-55
3-17. Input Attenuator Accuracy Settings/Readings	3-61
3-18. Performance Verification Test Record	3-62
4-1. Hewlett-Packard Sales and Service Offices	4-4
B-1. Status Byte Definition	B-2

Introducing the HP 8590A

What You'll Find in This Chapter

This chapter introduces you to the HP 8590A Spectrum Analyzer and its options and accessories that tailor the unit to your specific needs. To acquaint you with the analyzer's full capabilities, the HP 8590A specifications and characteristics are also provided.

Introducing the HP 8590A Spectrum Analyzer

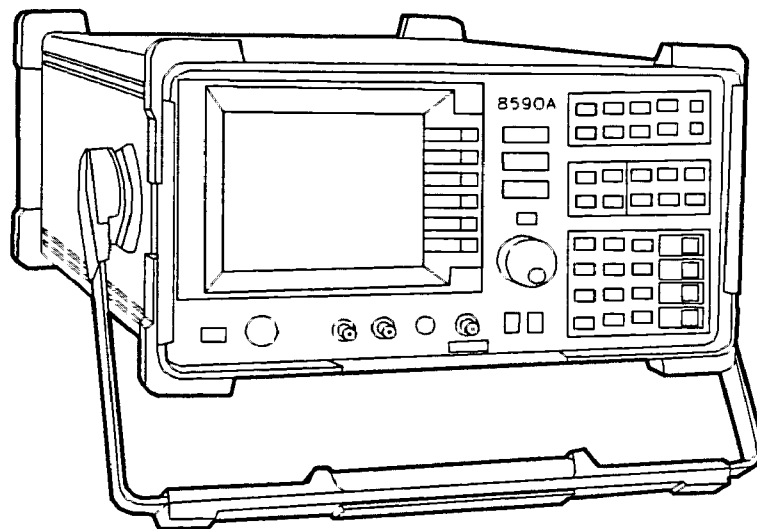

Figure 1-1. The HP 8590A Spectrum Analyzer

The HP 8590A Spectrum Analyzer is a small, lightweight test instrument that combines a wide frequency range (10 kHz to 1.5 GHz) and amplitude range (-115 dBm to $+30$ dBm) with over 100 easy-to-use functions to handle just about any RF signal measurement. Its portability and easy, highly automatic operation make it ideal for service and troubleshooting use in R&D labs and in manufacturing and service environments in the CATV, mobile radio, and related communications businesses.

The HP 8590A is a complete, self-contained instrument that needs only an external ac power source for operation. An ac power cable, suitable for use in the country to which the analyzer is originally shipped, is included with the unit.

Options and Accessories Available

Options

Many options are available to tailor the HP 8590A to your needs. Options can be ordered by option number when you order the analyzer. Some of the options are also available as kits that can be ordered and installed after you have received your HP 8590A.

75 Ω Input Impedance (Option 001)

This option provides a 75 Ω input impedance instead of the standard 50 Ω impedance. Analyzers with this option use different IF and RF circuit boards and a different front panel from the standard units.

Warning



Do not connect 50 Ω cables or adapters to the Option 001, 75 Ω RF INPUT or CAL OUTPUT connectors. Damage to the 75 Ω connectors will occur.

HP-IB (Option 021)

Option 021 enables you to control your HP 8590A from a computer that uses an HP-IB interface bus. Such computers include the HP 9000 series 200 and 300 and the HP Vectra. The option also enables the HP 8590A to control a printer or plotter. Option 021 includes an HP-IB connector on the rear panel and an HP-IB Programming Manual.

Option 021 is also available as a kit (HP part number 08590-60052). The kit includes a printed circuit board, connector, manual, and installation instructions.

HP-IL (Option 022)

Option 022 enables you to control your HP 8590A from a computer that uses an HP-IL interface bus. Such computers include the HP-71 and the HP-75. The option also enables the HP 8590A to control a printer or plotter. Option 022 includes an HP-IL connector on the rear panel and an HP-IL Programming Manual.

Option 022 is also available as a kit (HP part number 08590-60053). The kit includes a printed circuit board, connector, manual, and installation instructions.

RS-232 (Option 023)

Option 023 enables you to control your HP 8590A from a computer that uses an RS-232 interface bus. Such computers include the HP Vectra, the IBM PC, XT, and AT, and compatibles. The option also enables the HP 8590A to control a printer or plotter. Option 023 includes an RS-232 connector on the rear panel and an RS-232 Programming Manual.

Option 023 is also available as a kit (HP part number 08590-60054). The kit includes a printed circuit board, connector, manual, and installation instructions.

Front Panel Cover (Option 040)

The front-panel cover snaps onto the front of your HP 8590A to protect the front panel during travel and when the unit is not in use. The cover has a recessed area in which you can store the *HP 8590A Operating Manual*, a programming manual, or an HP-71 Handheld Computer.

Option 040 is also available as a kit (Impact Cover Assembly, Deep; HP part number 5062-4805).

Rack Mount Flange Kit (Option 908)

This option provides the parts necessary to mount the HP 8590A in an HP System II cabinet or in a standard 19 inch (482.6 mm) equipment rack.

Option 908 is also available as a kit (HP part number 5062-0800).

1.79 GHz Extended Frequency (Option H18)

Option H18 extends the upper limit of the frequency range over which the HP 8590A is specified from 1.5 GHz to 1.79 GHz.

Rack Mount Flange Kit with Handles (Option 909)

Option 909 is the same as Option 908 but includes front handles for added convenience.

Option 909 is also available as a kit (HP part number 5062-1900).

Operating and Installation Manuals (Option 910)

An additional copy of the *HP 8590A Operating Manual* and the Installation Verification Manual are available as a set under Option 910. This set is called the Documentation Package, and has HP part number 08590-90001.

Service Documentation (Option 915)

Option 915 includes one copy of the *HP 8590A Operating Manual*, the Installation Verification Manual, and the Support Manual. This set is called the Support Package and has HP part number 08590-90007.

The Support Manual is available separately as HP part number 08590-90096.

Accessories

A number of accessories are available from Hewlett-Packard to help you configure your HP 8590A for your specific needs.

AC Probe

The HP 8590A has a front-panel PROBE POWER connector for the use of high-impedance active probes such as the HP 85024A. High-impedance probes permit you to test high-frequency circuits without significant loading effects.

Caution

Do not use dc-coupled probes; they may cause damage to the spectrum analyzer input circuit.



Broadband Preamplifier

The HP 10855A Preamp provides a minimum of 22 dB gain from 2 MHz to 1300 MHz to enhance measurements of very low-level signals. It operates conveniently from the PROBE POWER output of the HP 8590A.

Close Field Probe

The HP 11940A Close Field Probe is a small, hand-held, electromagnetic-field sensor. The probe provides repeatable, absolute, magnetic-field measurements from 30 MHz to 1 GHz. When attached to a source, the probe generates a localized magnetic field for electromagnetic interference (EMI) susceptibility testing.

Computer

The HP-71 Handheld Computer is a powerful, readily portable computational tool well suited to test instrument control. It uses a powerful BASIC language that allows structured programming techniques. It can be used to control the HP 8590A through the HP-IL interface (Option 022 for the HP 8590A).

Monitor

The HP 82913A is a 12-inch monitor that provides a larger display for the HP 8590A in fixed installations.

Plotter

The HP ColorPro 7440A Graphics Plotter adds a color printout capability to the HP 8590A for permanent records of important measurements. The eight-pen HP ColorPro produces color plots with 0.025 mm (0.001 in) resolution either on 8.5 by 11 inch paper or transparency film. The plotter can be ordered with HP-IB or RS-232 interfaces to correspond to the interface option installed on the HP 8590A.

Printer

The HP 2225A ThinkJet Personal Printer provides fast, quiet, portable printing with graphics capability for another form of permanent records of your test results. The printer can be ordered with HP-IB, HP-IL, or RS-232 interfaces to correspond to the interface option installed on the HP 8590A.

Rack Slide Kit

This kit (HP part number 1494-0060) provides the hardware to adapt Rack Mount Kits (Options 908 and 909) for mounting the analyzer on slides in an HP System II cabinet.

RF Limiter

The HP 11867A Limiter protects the analyzer input circuits from damage due to high power levels. It operates over a frequency range of dc to 1800 MHz and begins reflecting signal levels over 1 mW up to 10 watts average power and 100 watts peak power.

Tracking Generator

The HP 8444A Option 59 Tracking Generator provides a leveled, calibrated signal output with a frequency equal to the tuned frequency of the HP 8590A. This lets you make swept frequency tests such as insertion loss and return loss at frequencies up to 1500 MHz.

Transit Case

The transit case (HP part number 9211-5604) provides extra protection for your HP 8590A for frequent travel situations. The HP transit case protects your instrument from hostile environments, shock, vibration, moisture, and impact while providing a secure enclosure for shipping.

50 Ω /75 Ω Minimum Loss Pad

The HP 11852A is a low VSWR minimum loss pad that is required for measurements on 75 Ω devices. Use with a 75 Ω Type N (f) to BNC (m) adapter (HP part number 1250-1534).

75 Ω Matching Transformer

The HP 11694A allows you to make measurements in 75 Ω systems while retaining amplitude calibration. It is effective over a frequency range of 3 to 500 MHz.

Analyzers Covered by This Manual

This manual applies to analyzers with the serial number prefixes listed under “Serial Numbers” on the title page.

Serial Numbers

Hewlett-Packard makes frequent improvements to its products to enhance their performance, usability, or reliability, and to control costs. Hewlett-Packard service personnel have access to complete records of design changes to each type of equipment, based on the equipment’s serial number. Whenever you contact Hewlett-Packard about your analyzer, have the complete serial number available to ensure obtaining the most complete and accurate information possible.

A Mylar serial number label is attached to the rear of the analyzer. The serial number has two parts: the prefix (the first four numbers and a letter), and the suffix (the last five numbers). See Figure 1-2.

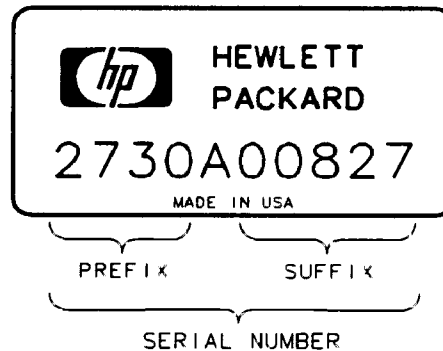

Figure 1-2. Typical Serial Number Label

The first four numbers of the prefix are a code that identifies the date of the last major design change that is incorporated in your analyzer. The letter identifies the country in which the unit was manufactured. The five-digit suffix is a sequential number and is different for each unit. Whenever you list the serial number or refer to it in obtaining information about your analyzer, be sure to use the complete number, including the full prefix and the suffix.

Specifications and Characteristics

Specifications describe the warranted analyzer performance over the temperature range of 0° to +55°C, unless stated otherwise. All specifications apply after the unit has reached a stable operating temperature as defined by the Temperature Stability Specification, and when functions are coupled (**Auto Couple** key), and after calibration routines have been run, if required.

Characteristics provide useful information in the form of typical, nominal, or approximate values for analyzer performance.

Specifications

The HP 8590A specifications are listed in Table 1-1.

Table 1-1. HP 8590A Specifications

GENERAL SPECIFICATIONS	
Temperature Range Operating Storage	0°C to +55°C -40°C to +75°C
Temperature Stability	The analyzer will meet its specifications 2 hours after storage at a constant temperature within the operating temperature range, and 30 minutes after the analyzer is turned on
EMI Compatibility	Conducted and radiated interference is in compliance with CISPR Publication 11 (1985) and Messemphaenger Postverfuegung 526/527/79 (Kennzeichnung Mit F-Nummer/Funkschutzzeichen)
Humidity Range	Type-tested from 50% to 95% relative humidity ($\leq +4^{\circ}\text{C}$) per requirements of MIL-STD-810C, Method 507.1, Procedure IV
Audible Noise	<37.5 dBA pressure and <5.0 Bels power (ISO DP7779)
Power Requirements	86 to 127, or 195 to 253 V rms; 47 to 66 Hz. Power consumption is less than 160 VA

Table 1-1. HP 8590A Specifications (continued)

FREQUENCY SPECIFICATIONS	
Frequency Range	10 kHz to 1.5 GHz 1 MHz to 1.5 GHz (<i>Option 001</i>) 10 kHz to 1.79 GHz (<i>Option H18</i>)
Frequency Accuracy Readout Accuracy (Tuning Accuracy)	$\pm (5 \text{ MHz} + 1\% \text{ of frequency span})$, from 10 kHz to 1.5 GHz (<i>Option 001</i> : 1 MHz to 1.5 GHz) $\pm (5 \text{ MHz} + 1\% \text{ of frequency span})$, from 10 kHz to 1.79 GHz (<i>Option H18</i>)
Resolution	4 digits
Frequency Spans Full Span Zero Span Frequency Span Readout Accuracy	50 kHz to 1.5 GHz with 4-digit resolution Analyzer functions as a manually tuned receiver, at the frequency indicated by the CENTER FREQUENCY readout, for time domain display of signal modulation < $\pm 3\%$ of indicated frequency span
Frequency Sweep Automatic (AUTO) Readout Accuracy	Sweep times from 20 milliseconds to 100 seconds, adjusted automatically to maintain absolute amplitude calibration for any combination of frequency span, resolution bandwidth, and video filter bandwidth < $\pm 10\%$ of indicated sweep time setting
Resolution and Stability Drift Noise Sidebands	<50 kHz/5 minutes after 2 hour warm-up and 5 minutes after setting center frequency <-65 dB down and >30 kHz offset from CW signal with 1 kHz resolution bandwidth and 30 Hz video bandwidth

Table 1-1. HP 8590A Specifications (continued)

AMPLITUDE SPECIFICATIONS	
Amplitude Range 1 MHz to 1.3 GHz 400 kHz to 1.5 GHz 1 MHz to 1.5 GHz (<i>Option 001</i>) 1.5 GHz to 1.79 GHz (<i>Option H18</i>)	-114 dBm to +30 dBm for 50Ω calibration -59.5 dBmV to +72 dBmV for 75Ω calibration (<i>Option 001</i>) -112 dBm to +30 dBm for 50Ω calibration -57.5 dBmV to +72 dBmV for 75Ω calibration (<i>Option 001</i>) -94 dBm to +30 dBm for 50Ω calibration (<i>Option H18</i>) -39.5 dBmV to +72 dBmV for 75Ω calibration (<i>Option 001/H18</i>)
Maximum Safe Input Levels	+30 dBm (1 W, 7.1 V rms), 0 V dc +72 dBmV (0.21 W, 4.0 V rms), 100 V dc + ac (≤ 100 Hz)(<i>Option 001</i>)
Gain Compression RF Input Internal IF	<1 dB for -10 dBm total power at input mixer <1 dB when signals are higher than reference level and total power at input mixer is -20 dBm
Displayed Average Noise Level	<-114 dBm for frequencies >1 MHz to 1.3 GHz <-112 dBm for frequencies >400 kHz to 1.5 GHz <-59.5 dBmV for frequencies >1 MHz to 1.3 GHz (<i>Option 001</i>) <-57.5 dBmV for frequencies >1 MHz to 1.5 GHz (<i>Option 001</i>) <-94 dBm for frequencies >1.5 GHz to 1.79 GHz (<i>Option H18</i>) <-39.5 dBmV for frequencies >1.5 GHz to 1.79 GHz (<i>Option 001/H18</i>) The displayed average noise level determines sensitivity (minimum discernible signal). Signals at this input level peak approximately 3 dB above the displayed noise level. Maximum average noise level with 0 dB input attenuation, 1 kHz resolution bandwidth, and 30 Hz video bandwidth.

Table 1-1. HP 8590A Specifications (continued)

AMPLITUDE SPECIFICATIONS (continued)	
Spurious Response Second Harmonic Distortion (for -45 dBm total power at mixer) Third Order Intermodulation Distortion	<-70 dBc for frequencies >5 MHz <-60 dBc for frequencies ≤5 MHz <-70 dBc for input signals greater than 5 MHz (input signals must be -30 dBm at the input mixer and greater than 50 kHz apart)
Residual Responses Calibrated Display Range Log; from reference level Linear	<-95 dBm with 0 dB input attenuation and no signal present at input <-88 dBm with 0 dB input attenuation and no signal present at input (<i>Option H18</i>) <-33.5 dBmV with 0 dB input attenuation and no signal present at input (<i>Option 001/H18</i>) 70 dB with 10 dB/div amplitude scale 1 to 20 dB/div amplitude scales in 1 dB steps Eight divisions with LINEAR amplitude scale
Maximum Dynamic Range	70 dB for on-screen viewing 70 dB for signal-to-distortion 95 dB for IF-compression-to-noise
Readout Resolution (with markers)	<0.05 dB for log scales <0.05% of reference level for linear scales Units in dBm, dBmV, dBμV, volts, and watts
Amplitude Accuracy Calibrator Output (CAL OUTPUT) 299.9 MHz ±300 kHz 50Ω calibration 75Ω calibration (<i>Option 001</i>)	With AUTO selected, amplitude accuracy is determined by one or more of the following factors and the signal-to-noise ratio. -20 dBm ±1 dB level (20—35°C) -20 dBm ±(1 dB + 0.05 dB/°C change >35°C, <20°C) +28.75 dBmV ±1 dB level (20—35°C) +28.75 dBmV ±(1 dB + 0.05 dB/°C change >35°C, <20°C)
Reference Level	10 dB steps for calibrated reference level adjustment from -139 dBm to +50 dBm

Table 1-1. HP 8590A Specifications (continued)

AMPLITUDE SPECIFICATIONS (continued)	
Reference Level Step Accuracy at Calibration Frequency (in corrected mode)	<p>NOTE: Before trying to verify these reference level step accuracies, you must run the Amplitude Calibration ((AMPTD CAL)) routine.</p> <p><±1.75 dB for +30 to -120 dBm range (0 to 60 dB attenuation)</p> <p><±1.25 dB for 0 to -120 dBm range (10 dB attenuation) at any fixed frequency</p> <p><±0.5 dB for 0 to -59 dBm range (10 dB attenuation) at any fixed frequency</p>
Frequency Response 10 kHz to 1.5 GHz <i>(Option 001: 1 MHz to 1.5 GHz)</i> Absolute Variation Peak Variation (Flatness) 1.5 to 1.79 GHz <i>(Option H18)</i> Absolute Variation Peak Variation (Flatness)	<p><±1.5 dB with 10 dB input attenuation referenced to the CAL OUTPUT signal</p> <p><±1.0 dB referenced to midpoint between highest and lowest peak excursions</p> <p>< ±3 dB with 10 dB input attenuation referenced to the CAL OUTPUT signal</p> <p>< ±2.0 dB referenced to midpoint between highest and lowest peak excursions</p> <p>NOTE: Frequency response may include input attenuator and mixer flatness.</p>
Input Attenuator	0 dB to 60 dB of input attenuation, selectable in 10 dB steps
Input Attenuator Step Accuracy at Calibration Frequency	<±0.5 dB over 60 dB range
Resolution Bandwidth Switching (Amplitude Variation)	<±0.25 dB for 3 kHz to 3 MHz range
Display Scale Fidelity Log Incremental Accuracy Log Maximum Cumulative Error Linear Accuracy	<p>CRT linearity and log fidelity affect amplitude accuracy at levels other than reference level.</p> <p><±0.1 dB/dB change over 70 dB range</p> <p>±0.75 dB maximum over -60 dB range from reference level</p> <p>±1.0 dB maximum over -70 dB range from reference level</p> <p><±3% of reference level setting</p>

Characteristics

The HP 8590A characteristics are listed in Table 1-2.

Table 1-2. HP 8590A Characteristics

SPECTRAL RESOLUTION AND STABILITY	
Resolution Bandwidths	1 kHz to 3 MHz, eight selectable resolution bandwidths in 1, 3, 10 sequence. Bandwidth shape is approximately Gaussian (synchronously tuned, 4-pole filter). Bandwidth may be selected independently or coupled for optimum ratio of frequency span to resolution bandwidth.
Video Bandwidths	30 Hz to 3 MHz in 1,3,10 sequence. Post-detection low-pass filter averages displayed noise for a smooth trace. Video bandwidth may be selected independently or coupled for optimum ratio of frequency span to resolution and video bandwidth.
Signal Track	Signal is held at display center, compensates for drift.
SWEEP TRIGGER	
Free Run	End of each sweep triggers new sweep.
Line	Sweep triggered at ac line (main) frequency.
Video	Sweep triggered on post-detection video waveform. Trigger level can be set by display line when video trigger is selected.
Single	Single sweep started or reset by pressing TRIG , SINGLE SWEEP .
External	BNC input (rear panel), TTL levels, positive edge triggers sweep.
AMPLITUDE ACCURACY	
Log Scale Switching	No significant error for 1 to 20 dB/div scale range. Scale switching is a built-in function of the product design.

Table 1-2. HP 8590A Characteristics (continued)

FRONT-PANEL INPUTS/OUTPUTS	
RF INPUT 50Ω	Input Impedance 50Ω nominal; 50Ω BNC female connector. 75Ω nominal; 75Ω BNC female connector (<i>Option 001</i>).
1ST LO OUTPUT	2.05 to 3.55 GHz, +10 dBm nominal, 50Ω BNC connector. Terminate with a 50Ω load when not in use.
CAL OUTPUT	-20 dBm at 299.9 MHz, with second through fourth harmonics greater than -60 dBm into 50Ω. +28.75 dBmV at 299.9 MHz into 75Ω (<i>Option 001</i>).
PROBE POWER	+15 V, -12.6 V, and GND (150 mA maximum) for use with high-impedance probes.
REAR-PANEL INPUTS/OUTPUTS	
AUX VIDEO OUTPUT	50Ω BNC connector, 0 to 1 V.
MONITOR OUTPUT	50Ω BNC connector, NTSC format, 19.2 kHz horizontal sync (The HP 82913A 12-inch monitor is recommended.)
HIGH SWEEP IN/OUT	BNC connector, TTL high = sweep, TTL low = retrace.
SWEEP OUTPUT	BNC connector, 5 kΩ, 0 to +10 V ramp.
AUX IF OUTPUT	50Ω BNC connector, -10 to -60 dBm signal level, 21.4 MHz.
EXTERNAL TRIGGER INPUT	BNC connector, TTL levels, positive edge triggers sweep.
Interface Connector	HP-IB (<i>Option 021</i>), HP-IL (<i>Option 022</i>), or RS-232 (<i>Option 023</i>).
HP-IB Codes	SH1, AH1, T6, L4, SR1, RL1, PP0, DC1, DT1, C1, C2, C3, and C28.

Table 1-2. HP 8590A Characteristics (continued)

WEIGHT	
Net	13.5 kg (29.8 lb)
Shipping	15.7 kg (34.8 lb)
DIMENSIONS	
<p>Legend: inches (millimeters)</p> <p>The technical drawings show the following dimensions:</p> <ul style="list-style-type: none"> TOP View: Overall height is 14-11/16 inches (373 mm). The height of the main body is 13-1/4 inches (337 mm). REAR View: The height of the rear panel is 8 inches (200 mm). SIDE View: The height of the side panel is 7-1/4 inches (184 mm). The length of the device is 18-1/8 inches (460.5 mm). 	

Preparation for Use

What You'll Find in This Chapter

This chapter describes the process of getting the HP 8590A ready to use. The process includes initial inspection procedures, setting up the unit for the selected ac power source, and performing automatic calibration routines and a confidence test to indicate that the unit is operating correctly.

Getting Ready

Initial Inspection

Inspect the shipping container for damage. If the shipping container or cushioning material is damaged, keep it until you have verified that the contents are complete and you have tested the analyzer mechanically and electrically.

The contents of the shipment should be as shown in Figure 2-1 and its accompanying legend. If the contents are incomplete or if the analyzer does not pass the operation verification tests (procedures are provided in Chapter 3), notify the nearest Hewlett-Packard office. If the shipping container is damaged or the cushioning material shows signs of stress, also notify the carrier. Keep the shipping materials for the carrier's inspection. The Hewlett-Packard office will arrange for repair or replacement without waiting for a claim settlement.

If the shipping container and cushioning material are in good condition, retain them for possible future use. You may wish to ship the analyzer to another location or return it to Hewlett-Packard for service. Chapter 4, "If Something Goes Wrong ...," provides instructions for repackaging and shipping the analyzer.

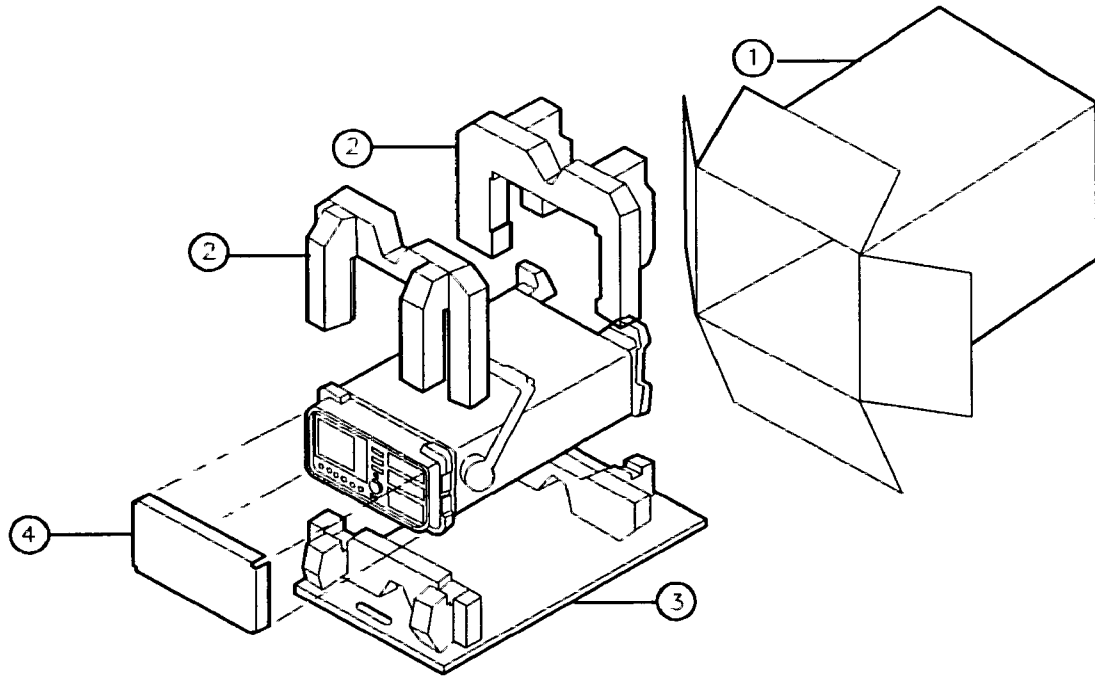

ITEM	DESCRIPTION	HP PART NUMBER
①	OUTER CARTON	9211-5636
②	PADS (2)	08590-80013
③	BOTTOM TRAY	08590-80014
④	FRONT PAD	9220-4488

Figure 2-1. HP 8590A Shipping Container and Contents

Preparing the HP 8590A for Use

The HP 8590A is a portable instrument and requires no physical installation other than connection to a source of ac power.

Caution



Do not connect ac power until you have verified that the line voltage is correct, the proper fuse is installed, and the line voltage selector switch is properly positioned, as described in the following paragraphs. Damage to the equipment could result.

Note



If you want to install your HP 8590A in an HP System II cabinet or a standard 19 inch (486.2 mm) equipment rack, complete instructions are provided in a Service Note that is included with Options 908 and 909 Rack Mounting Kits.

Power Requirements

The power requirements for the HP 8590A are listed in Table 2-1.

Table 2-1. Power Requirements

Characteristic	Requirement
Input Voltage	86 to 127, or 195 to 253 V rms
Frequency	47 to 66 Hz
Power	160 VA max

Setting the Line Voltage Selector Switch

Caution



Before connecting the HP 8590A to the power source, you must set the rear-panel voltage selector switch correctly to adapt the HP 8590A to the power source. An improper selector switch setting can damage the analyzer when it is turned on.

Set the instrument's rear panel voltage selector switch to the line voltage range (115 V or 230 V) corresponding to the available ac voltage. See Figure 2-2. Insert a small screwdriver or similar tool in the slot and slide the switch up or down so that the proper voltage label is visible.

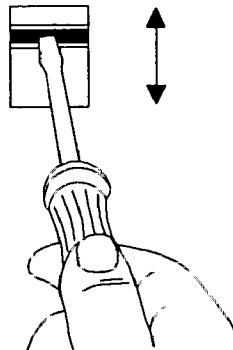

Figure 2-2. Setting the Voltage Selector Switch

Checking the Fuse

Note



The ac line input fuse is the same value regardless of the input line voltage. It is a fast-blow fuse, rated at 6.3 A, 250 V; its HP part number is 2110-0703.

The line fuse is housed in a small container immediately above the rear-panel power connector (see Figure 2-3). The container provides space for storing a spare fuse, as shown in the figure.

To check the fuse, insert the tip of a screwdriver in the slot at the bottom of the container and pry gently to remove the container. If the fuse is defective or missing, install a new fuse in the proper position and reinsert the fuse container.

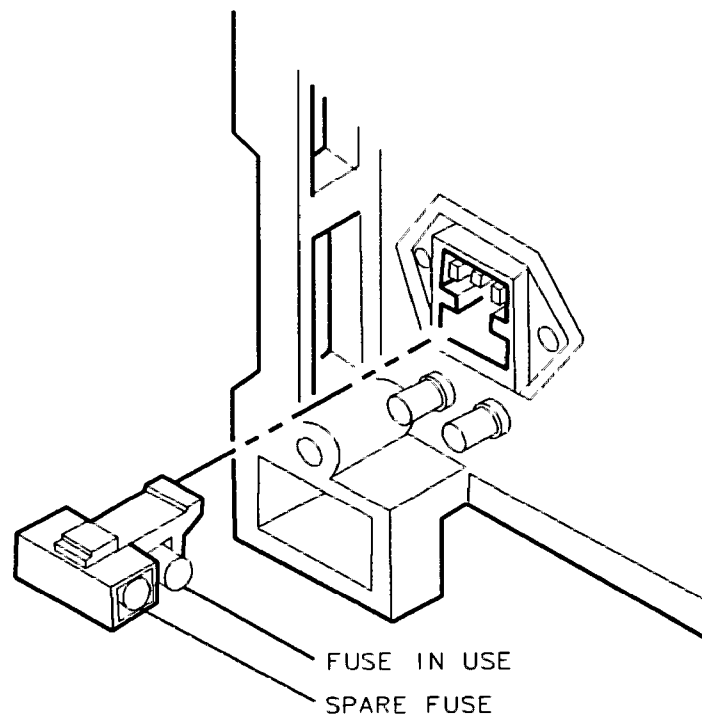

Figure 2-3. Checking the Line Fuse

Power Cable

The HP 8590A is equipped with a three-wire power cable, in accordance with international safety standards. When connected to an appropriate power line outlet, this cable grounds the instrument cabinet.







Warning

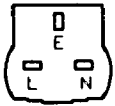

Failure to ground the analyzer properly can result in personal injury. Before turning on the HP 8590A, you must connect its protective earth terminals to the protective conductor of the main power cable. Insert the main power cable plug only into a socket outlet that has a protective earth contact. DO NOT defeat the earth-grounding protection by using an extension cable, power cable, or autotransformer without a protective ground conductor. If you are using an autotransformer, make sure its common terminal is connected to the protective earth contact of the power source outlet socket.

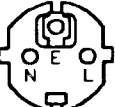
Various power cables are available to connect the HP 8590A to the types of ac power outlets unique to specific geographic areas. The cable appropriate for the area to which the analyzer is originally shipped is included with the unit. You can order additional ac power cables for use in different areas. Table 2-2 lists the available ac power cables, illustrates the plug configurations, and identifies the geographic area in which each cable is appropriate.

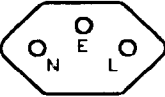
Table 2-2. AC Power Cables Available

PLUG TYPE *	CABLE HP PART NUMBER	PLUG DESCRIPTION	CABLE LENGTH CM (INCHES)	CABLE COLOR	FOR USE IN COUNTRY
250V 	8120-1351 8120-1703	Straight**BS1363A 90°	229 (90) 229 (90)	Mint Gray Mint Gray	Great Britain, Cyprus, Nigeria, Rhodesia, Singapore, So. Africa, India
250V 	8120-1369 8120-0696	Straight**NZSS198/ASC112 90°	201 (79) 221 (87)	Gray Gray	Australia, New Zealand
250V 	8120-1689 8120-1692	Straight**CEE7-Y11 90°	201 (79) 201 (79)	Mint Gray Mint Gray	East and West Europe, Saudi Arabia, United Arab Republic (unpolarized in many nations)
125V 	8120-1348 8120-1398 8120-1754	Straight**NEMA5-15P 90° Straight**NEMA5-15P	203 (80) 203 (80) 91 (36)	Black Black Black	United States Canada, Japan (100 V or 200 V), Mexico, Phillipines, Taiwan
	8120-1378 8120-1521 8120-1676	Straight**NEMA5-15P 90° Straight**NEMA5-15P	203 (80) 203 (80) 91 (36)	Jade Gray Jade Gray Jade Gray	
250V 	8120-2104	Straight**SEV1011 1959-24507 Type 12	201 (79)	Gray	Switzerland
220V 	8120-0698	Straight**NEMA6-15P			
250V 	8120-1860	Straight**CEE22-VI			

* E = Earth Ground, L = Line, N = Neutral
 ** Part number for plug is industry identifier for plug only. Number shown for cable is HP Part Number for complete cable, including plug

Turning the HP 8590A On for the First Time

When you turn the analyzer on for the first time, you should perform frequency and amplitude calibration routines to calibrate the unit and a confidence test that indicates that the unit generally is functioning correctly. These are automatic self-tests that are completed in less than 15 minutes and require no external test equipment.

Perform the following steps:

1. Press **LINE**.

After a few seconds, the screen displays the analyzer's model number (HP 8590A), and the firmware date (for example, 10.9.86 indicates September 10, 1986).

Note



Record the firmware date and keep it for reference. If you should ever need to call Hewlett-Packard for service or with any questions regarding your analyzer, it will be helpful to have the firmware date readily available.

If your analyzer is equipped with Option 021 (HP-IB interface) or Option 022 (HP-IL interface), the appropriate interface address (HP-IB ADRS: XX or HP-IL ADRS: XX) also appears on the screen. If your analyzer is equipped with Option 023 (RS-232 interface), the baud rate (RS232: XXXX) is displayed.

2. Allow the analyzer to warm up in accordance with the Temperature Stability specification in Table 1-1.
3. Connect a 50 Ω coaxial cable (such as HP 10502A) between the front-panel CAL OUTPUT and RF INPUT connectors. (*Option 001*: use HP part number 5062-6452, 75 Ω ; coaxial cable.)

Warning



Do not connect 50 Ω cables or adapters to the Option 001, 75 Ω RF INPUT or CAL OUTPUT connectors. Damage to the 75 Ω connectors will occur.

-
4. Perform the frequency calibration routine by pressing **CAL** and CAL FREQ. During the routine, CAL: SWEEP, CAL: FREQ, CAL: SPAN, and CAL: SWEEP DELAY are displayed as the sequence progresses. CAL: DONE appears when the routine is completed. Any failures or discrepancies produce a message on the screen; see Appendix A, "HP 8590A Messages."

5. Perform the amplitude calibration routine by pressing **CAL AMPTD**.

During the routine, **CAL; AMPTD**, **CAL: 3 dB BW**, **CAL: ATTEN**, and **CAL: LOGAMP** are displayed as the sequence progresses. **CAL: DONE** appears when the routine is completed. Any failures or discrepancies produce a message on the screen; see Appendix A, "HP 8590A Messages."

6. When the frequency and amplitude calibration routines have been completed successfully, store the data by pressing **CAL STORE**.

The calibration routines calibrate the analyzer by generating correction factors. **CAL STORE** stores the calibration correction factors in nonvolatile memory; the analyzer will automatically apply these factors in future measurements.

7. Perform a confidence test by pressing **CAL**, **MORE**, **CONF TEST**.

The analyzer performs a self-test by cycling through its major functions. The test is performed within 1 to 2 minutes. If the unit does not function properly, a message appears on the screen; see Appendix A, "HP 8590A Messages."

When the calibration routines and the confidence test have been completed successfully, the analyzer is ready for normal operation.

Performance Tests

What You'll Find in This Chapter

This chapter contains test procedures which test the electrical performance of the HP 8590A Spectrum Analyzer.

None of the performance tests require access to the interior of the analyzer.

What is Performance Verification?

The entire collection of procedures in this chapter test the analyzer's electrical performance using the specifications of Table 1-1.

You must complete 14 tests to verify that analyzer performance meets all the specifications. The Installation Manual contains all tests that constitute Performance Verification. The first five tests in this chapter cover Operation Verification; the entire chapter covers Performance Verification, of which Operation Verification is a subset. Table 3-1 lists all the tests and indicates test type and number. You must do the tests in the order shown in the table.

Table 3-1. HP 8590A Spectrum Analyzer Performance Tests

Test Number	Test Name	Test Type
1.	Frequency Readout Accuracy	Operation Verification
2.	Displayed Average Noise	Operation Verification
3.	Frequency Response Flatness	Operation Verification
4.	Calibrator Amplitude and Frequency Accuracy	Operation Verification
5.	Frequency Span Readout Accuracy	Operation Verification
6.	Sweep Time Accuracy	Performance Verification
7.	Noise Sideband	Performance Verification
8.	Spurious Response	Performance Verification
9.	Residual Response	Performance Verification
10.	Reference Level Accuracy	Performance Verification
11.	Scale Fidelity	Performance Verification
12.	Frequency Drift	Performance Verification
13.	Resolution Bandwidth Switching	Performance Verification
14.	Gain Compression	Performance Verification
15.	Input Attenuator Accuracy	Performance Verification

What is Operation Verification?

Operation Verification verifies that performance is within the most critical specifications of Table 1-1. The following tests are included in Operation Verification:

- Frequency Readout Accuracy
- Displayed Average Noise
- Frequency Response Flatness
- Calibrator Amplitude and Frequency Accuracy
- Frequency Span Readout Accuracy

Operation Verification takes less than 1 hour. You can use Operation Verification as a quick incoming inspection test or as a partial calibration test. If the analyzer passes Operation Verification, there is an 80% confidence level that it meets all its specifications.

An even quicker test of the spectrum analyzer's basic ability to function is called the Confidence Test. This test is described in the "Turning the HP 8590A On for the First Time" section in Chapter 2, "Preparation for Use."

The highest-level test, called a Performance Verification test, is an in-depth test that verifies that performance is within all specifications of Table 1-1. This test is time-consuming and requires extensive test equipment.

None of the Operation Verification test procedures involve removing the cover of the spectrum analyzer.

Before You Start Verification Tests

There are four things you must do *before* starting:

1. Switch the analyzer on and let it warm up in accordance with the Temperature Stability specification in Table 1-1.
2. Read Chapter 1 of the Operating Manual, “Making Your First Measurement.”
3. After the analyzer has warmed up as specified, perform the Calibration Procedure documented in “Making Your First Measurement.” The performance of the analyzer is only specified after the analyzer calibration routines have been run and if the analyzer is auto-coupled.
4. Read the rest of this section before you start any of the tests, and make a copy of the Operation or Performance Verification Test Record described below.

Test Equipment You’ll Need

Table 3-2 lists the recommended test equipment for Operation Verification. Table 3-3 lists the recommended test equipment for Performance Verification. Any equipment that meets the critical specifications given in the tables can be substituted for the recommended model(s).

Accessories You Should Have

Table 3-4 lists accessories used during Operation and Performance Verification.

Recording the Test Results

A small test results table is provided at the end of each test procedure for your convenience in recording test results as you perform the procedure.

In addition, a complete Operation Verification Test Record form is provided as Table 3-11, and a complete Performance Verification Test Record is provided as Table 3-18. We recommend that you make a copy of these tables, record the complete test results on the copies, and keep the copies for your calibration test record. This record could prove valuable in tracking gradual changes in test results over long periods of time.

If the Analyzer Doesn’t Meet Specifications

If the analyzer doesn’t meet one or more of the specifications, complete any remaining Operation Verification tests and record all test results on a copy of the test record. Then refer to Chapter 4, “If Something Goes Wrong . . . ,” for instructions on how to solve the problem.

Periodically Verifying Operation

The analyzer requires periodic verification of operation. Under most conditions of use, you should test the analyzer at least once a year with either Operation Verification or the Performance Verification Tests.

Table 3-2. Recommended Test Equipment (Operation Verification)

Instrument	Critical Specification	Recommended Model or HP Part Number
Synthesizer/ Level Generator	Frequency accuracy: 1×10^{-9} /day Output flatness: ± 0.5 dB Frequency range: 200 Hz to 10 MHz	HP 3335A
Synthesized Sweeper	Frequency accuracy: 1×10^{-9} /day Output flatness: $< \pm 0.6$ dB Frequency range: 10 MHz to 26.5 GHz	HP 8340A*
Measuring Receiver	Compatible with Power Sensors dB Relative Mode Resolution: 0.01 dB Reference Accuracy: $\pm 1.2\%$	HP 8902A
Power Meter	Measure levels 0 to -20 dBm Accuracy $\pm 0.5\%$	HP 436A
Power Sensor, 50 Ω	Frequency range: 100 kHz to 2 GHz Power range: 10 μ W to 1 mW	HP 8482A
Power Sensor, 75 Ω	Frequency Range: 100 kHz to 2 GHz Power Range: 1.0 μ W to 100 mW	HP 8483A w/Mechanical Adapter HP part number 1250-0597
Power Splitter	Equivalent output SWR: ≤ 1.10 (leveling) Frequency range: 10 MHz to 2 GHz Maximum input power: > -10 dBm	HP 11667A
Frequency Comb Generator	1, 10, 100 MHz combs Accuracy: $\pm 0.01\%$	HP 8406A

* The following alternate models can be used in place of the HP 8340A, as indicated, however, range limitations in their critical specifications may prevent complete testing:

1. For Frequency Readout Accuracy Test: HP 8640B AM/FM Signal Generator with Option 002 Doubler; frequency range: 500 kHz to 1024 MHz.
2. For Frequency Response Flatness Test: HP 8350A/83522A Sweep Oscillator; output flatness: $< \pm 0.6$ dB.
3. For both tests 1 and 2: HP 8642B Signal Generator; frequency range: 100 kHz to 2115 MHz

3-4 Performance Tests

Table 3-2. Recommended Test Equipment (Operation Verification) (continued)

Instrument	Critical Specification	Recommended Model or HP Part Number
AM/FM Signal Generator	Frequency range: 500 kHz to >500 MHz AM modulation: >20 Hz with external signal Pulse modulation: 500 Hz PRF, >2 μ s pulse width Output flatness: ± 0.5 dB Spurious: <-100 dBc	HP 8640B
Low-Pass Filter	Cutoff frequency: 300 MHz Rejection: >35 dBc	0955-0455
50 Ω Load (BNC)	Not critical	HP 11593A

Table 3-3. Recommended Test Equipment (Performance Verification)

Equipment	Critical Specifications	Recommended Model or HP Part Number	Use*
50Ω Termination	Not critical	HP 11593A	P
Power Splitter	Equivalent output SWR: <1.2/1 Frequency range: 10 MHz to 2 GHz Maximum input power: >-10 dBm	HP 11667A	P
1-dB Step Attenuator	Frequency range: dc to 1 GHz Accuracy: ±0.25 dB Calibrated at 30 MHz	HP 355C-H80	P,A
10-dB Step Attenuator	Frequency range: dc to 1 GHz Accuracy: ±1.5 dB Calibrated at 30 MHz	HP 355D-H82	P,A
Synthesizer	Frequency accuracy: 1×10^{-9} /day Output flatness: ±0.5 dB Frequency range: 50 to 100 MHz	HP 3335A	P
Synthesizer/ Function Generator	Harmonics: <-25 dB Sine wave amplitude Accuracy: ±0.2 dB Frequency resolution: 0.001 Hz	HP 3325A	P
Digital Voltmeter	Input resistance: > 1×10^{10} Ω Accuracy: ±0.0011% plus three counts (100 V scale)	HP 3456A	A,T
Digital Multimeter	Input resistance: > 1×10^{10} Ω Accuracy ±0.004% plus One count (100 V scale)	HP 3455A (alternative to HP 3456A)	A,T
Power Meter	Measure levels 0 to -90 dBm Accuracy: ±0.5%	HP 436A	P,A,T
Crystal Detector	Frequency range: 0.1 to 1.5 GHz	HP 423A	P
Frequency Counter	Frequency range: 500 to 1,500 MHz Accuracy: ±1 count	HP 5342A	A,T
Sweep Oscillator	Frequency accuracy: 1×10^{-9} /day Output flatness: within ±0.6 dB	HP 8340A	P

*P = Performance Test; A = Adjustment/Calibration; T = Troubleshooting

3-6 Performance Tests

**Table 3-3.
Recommended Test Equipment (Performance Verification) (continued)**

Equipment	Critical Specifications	Recommended Model or HP Part Number	Use*
Sweep Oscillator	Output flatness: within ± 0.6 dB	HP 8350A/83522A	P
Comb Generator	1, 10, 100 MHz combs Accuracy: $\pm 0.01\%$	HP 8406A	P,A,T
Power Sensor	Frequency range: 100 kHz to 2 GHz Power range: 0.01 to 100 mW	HP 8482A	P,A,T
Power Sensor	Frequency range: 100 kHz to 2 GHz Power range: 0.001 to 100 mW	HP 8483A	P,A,T
10-dB Attenuator (2 required)	Frequency range: 10 to 1500 MHz Accuracy: $\pm 5\%$	HP 8491A	P
Signal Generator (2 required)	Frequency range: 500 kHz to >500 MHz AM modulation: >20 Hz with external signal Pulse modulation: 500 Hz PRF, >0.002 ms pulse Output flatness: ± 0.5 dB Spurious: < -100 dBc	HP 8640B	P,A,T
Signal Generator	Frequency range: 100 kHz to 2115 MHz	HP 8642B	P
Directional Bridge	Frequency range: 0.1 to 110 MHz Directivity: >40 dB VSWR maximum: 1.1/1 Arm loss <6 dB	HP 8721A	P
Low-Pass Filter	Cutoff frequency: 50 MHz Rejection at 80 MHz: >50 dB	0955-0306	P,A,T
Low-Pass Filter	Cutoff frequency: 300 MHz Rejection: >35 dB	0955-0455	P,A,T
*P = Performance Test; A = Adjustment/Calibration; T = Troubleshooting			

**Table 3-3.
Recommended Test Equipment (Performance Verification) (continued)**

Equipment	Critical Specifications	Recommended Model or HP Part Number	Use*
Adapter (2 required)	BNC (f) to BNC (m)	1250-1288	P
Adapter (3 required)	Type N (m) to BNC (f)	1250-0780	P
Adapter	Type N (m) to BNC (m)	1250-0082	P
Adapter	Type N (f) to BNC (m)	1250-0077	P,A,T
Adapter	BNC (m) to BNC (m)	1250-0216	P,A,T
BNC Cable (4 required)	120 cm (48 inch)	HP 10503A	P,A,T
BNC Cable	20 cm (9 inch)	HP 10502A	P,A,T
Additional Equipment for Option 001:			
NOTE: Use a 75Ω to 50Ω adapter, and change display units to dBm before attempting the following tests.			
75Ω Termination	Not critical	11652-60010	P,A,T
Minimum Loss Adapter (75Ω to 50Ω)	Frequency range: 0.1 to 1500 MHz Maximum loss: <3 dB	HP 11852B	P,A,T
Adapter	75Ω N (f) to 75Ω BNC (m)	HP 1250-1534	P,A,T
BNC Cable	30 cm (12 inch), 75Ω	5062-6452	P,A,T
BNC Cable	94 cm (37 inch), 75Ω	15525-80010	P,A,T
Adapter	SMA (f) to SMA (f)	1250-1158	P,A,T
Adapter	BNC (f) to SMA (m)	1250-1200	P,A,T
Adapter	Type N (f), 75Ω to Type N (m), 50 Ω	1250-0597	P,A,T
* P = Performance Test; A = Adjustment/Calibration; T = Troubleshooting			

Table 3-4. Recommended Accessories

Accessory	Recommended Model or HP part number
Output Adapters for HP 8340:	
SMA (f) to SMA (f)	1250-1158
SMA (m) to BNC (f)	1250-1200
Adapter for HP 11667A	
Type N (m) to BNC (f) (<i>2 required</i>)	1250-0780
Type N (m) to BNC (m)	1250-0082
Cable, BNC, (<i>2 required</i>)	HP 10503A
Cable, BNC 50Ω 23 cm (9 in)	HP 10502A
Adapters for Power Mount 8482A:	
Type N (f) to BNC (m)	1250-0077
Type N (m) to BNC (f)	1250-0780
<i>Option 001:</i>	
75Ω Termination	11652-60010
Minimum Loss Adapter,	HP 11852B
75Ω BNC (f) to 50Ω BNC (m)	
Cable, 75Ω 94 cm (37 in)	15525-80010
Cable, 75Ω 30 cm (12 in)	5062-6452
Adapters	
75Ω Type N (m) to 75Ω BNC (m)	1250-1533
75Ω Type N (f) to 75Ω BNC (m)	1250-1534
75Ω BNC (m) to BNC (m)	1250-1288

1. Frequency Readout Accuracy

This test verifies the analyzer's ability to measure the frequency of a single CW signal. The test requires a synthesized frequency source that has better frequency accuracy than the HP 8590A. Note that two different Hewlett-Packard synthesized sources are recommended to cover the specified frequency range of the analyzer. The following steps summarize the Frequency Readout Accuracy test:

- Inject a 50 MHz CW signal from a synthesized source into the RF INPUT of the analyzer.
- Position the marker on the signal peak.
- Compare the analyzer's marker frequency to the specification.
- Repeat the preceding steps for source frequencies of 100, 500, 1000, and 1500 MHz.

Specification

$\pm(5 \text{ MHz} + 1\% \text{ of frequency span})$

Equipment

Synthesized Sweeper HP 8340A
BNC cable HP 10503A
Output adapters for HP 8340:
SMA (f) to SMA (f)..... HP part number 1250-1158
SMA (m) to BNC (f)..... HP part number 1250-1200
Option 001:
Minimum Loss Adapter (MLA) HP 11852B
Adapter, Type N (m) to BNC (f) HP part number 1250-0780
Adapter, 75 Ω ; Type N (f) to 75 Ω ; BNC (m) HP part number 1250-1534

1. Frequency Readout Accuracy

Test Procedure

1. Connect the RF OUTPUT of the HP 8340A Synthesized Sweeper to the RF INPUT of the HP 8590A Spectrum Analyzer with a BNC cable. (*Option 001*: Use MLA with adapters.)
2. Set the HP 8340A output to 50 MHz and -10 dBm with no modulation (*Option 001*: -4 dBm).
3. Press the following spectrum analyzer keys:
 PRESET (wait until the preset is complete)
 FREQUENCY 50 MHz
 PEAK SEARCH SIGNAL TRACK
 SPAN 10 MHz
4. Record the analyzer's frequency reading in Table 3-5, Frequency Readout Accuracy Test Results, and in Table 3-11, Operation Verification Test Record.
5. Repeat steps 2, 3, and 4 for the frequencies shown in the test record. Press PEAK SEARCH to center the signal.

Test Results

Table 3-5. Frequency Readout Accuracy

Test Description	Minimum Results	Actual Results	Maximum Results
Frequency Readout Accuracy			
50 MHz	44.90 MHz	_____	55.10 MHz
100 MHz	94.90 MHz	_____	105.10 MHz
500 MHz	494.90 MHz	_____	505.10 MHz
1000 MHz	994.90 MHz	_____	1005.10 MHz
1500 MHz	1494.90 MHz	_____	1505.10 MHz
1700 MHz (<i>Option H18</i>)	1694.90 MHz	_____	1705.10 MHz

2. Displayed Average Noise

This test measures the noise generated by the circuits of the HP 8590A Spectrum Analyzer. This noise, called average noise, affects the analyzer's ability to measure small signals. The lower the average noise level, the greater the sensitivity and dynamic range.

This test uses the marker to measure the displayed noise with no input signal present. Since the noise measured by this test is internal to the analyzer, it is not affected by the input attenuator. However, the input attenuator setting is coupled to the displayed amplitude level. Therefore, the input attenuator must be set to 0 dB to get an accurate amplitude reading of the noise.

The following steps summarize this test:

- Connect a 50 Ω load to the RF INPUT of the analyzer. (*Option 001*: Use a 75 Ω load.)
- Set the analyzer to the specified settings and use the marker to measure the noise.

Specification

Maximum average noise level with 0 dB input attenuation, 1 kHz resolution bandwidth, and 30 Hz video bandwidth:

- < -114 dBm for frequencies >1 MHz to 1.3 GHz
- < -112 dBm for frequencies >400 kHz to 1.5 GHz
- < -59.5 dBmV for frequencies >1 MHz to 1.3 GHz (*Option 001*)
- < -57.5 dBmV for frequencies >1 MHz to 1.5 GHz (*Option 001*)
- < -94 dBm for frequencies >1.5 GHz to 1.79 GHz (*Option H18*)
- < -39.5 dBmV for frequencies >1.5 GHz to 1.79 GHz (*Option 001/H18*)

Equipment

- 50 Ω Termination, BNC HP 11593A
- 75 Ω Termination, BNC HP part number 11652-60010

Test Procedure (Standard Only)

1. Connect the 50 Ω termination to the RF INPUT of the HP 8590A Spectrum Analyzer.
2. Press the following analyzer keys:

PRESET (wait until the preset is complete)

SPAN 0 **Hz**

SWEEP BW **RES BW** 1 **kHz**

VID BW 30 **Hz**

SWEEP TIME 5 **sec**

AMPLITUDE 80 **-dBm**

ATTEN 0 **+dBm**

FREQUENCY 400 **kHz** (standard only)

2. Displayed Average Noise

3. Press the following analyzer keys:

SGL SWP
TRACE CLEAR WRITE A
VID AVERAGE 10 Hz

Wait until **AVG 10** is displayed to the left of the graticule (the analyzer will take 10 sweeps, then stop).

4. Press **PEAK SEARCH** and record the MKR frequency as the Measurement Frequency for 400 kHz.
5. Repeat steps 3 and 4 for the analyzer frequencies (1 MHz, 750 MHz, and 1500 MHz) shown in Table 3-6.
6. Record the test results in Table 3-6, Displayed Average Noise, and in Table 3-11, Operation Verification Test Record.

Test Results

Table 3-6. Displayed Average Noise

Test Description	Maximum Results <i>Option 001</i>	Actual Results	Maximum Results
Displayed Average Noise 400 kHz (Standard and <i>Option H18</i>)		_____	-112 dBm
1 MHz	-59.5 dBmV	_____	-114 dBm
750 MHz	-59.5 dBmV	_____	-114 dBm
1500 MHz	-57.5 dBmV	_____	-112 dBm
1700 MHz (<i>Option H18</i>)	-39.5 dBmV	_____	-94 dBm

3. Frequency Response Flatness

This test measures the analyzer's ability to accurately compare the amplitudes of two signals of different frequencies (for example, a two-tone intermodulation measurement) or to compare the amplitudes of two related signals of unequal amplitude (for example, carriers and sidebands).

A synthesized sweeper is used for this test because its flatness is relatively better than the analyzer's. The sweeper sweeps a signal through the band of the analyzer while the analyzer is in **MAX HOLD A**. This procedure traces the flatness of the analyzer on the analyzer's screen. Two different synthesized sweepers are used to cover the entire frequency range of the analyzer.

Specification (with 10 dB of input attenuation)

Absolute Reference

10 kHz to 1500 MHz (*Option 001: 1 MHz to 1500 MHz*)
<±1.5 dB referenced to a 300 MHz, -10 dBm signal
<±3.0 dB referenced to a 300 MHz, -10 dBm signal (*Option H18: 1500 MHz to 1790 MHz*)

Peak Variation (Flatness)

<±1.0 dB referenced to a midpoint between the highest and lowest amplitude excursions
<±2.0 dB referenced to a midpoint between the highest and lowest amplitude excursions (*Option H18: 1500 MHz to 1790 MHz*)

Equipment

Frequency Synthesizer HP 3335A
Synthesized Sweeper HP 8340A
Power Meter HP 436A
Power Sensor HP 8482A
Power Splitter HP 11667A
BNC cable (*3 required*) HP 10503A
Output adapters for HP 8340:
SMA (f) to SMA (f) HP part number 1250-1158
SMA (m) to BNC (f) HP part number 1250-1200
Adapters for HP 11667A:
Type N (m) to BNC (f) (*2 required*) HP part number 1250-0780
Type N (m) to BNC (m) HP part number 1250-0082

Additional Equipment for Option 001

Power Meter	HP 436A
Power Sensor	HP 8483A
Cable, BNC, 120 cm (48 in), 75Ω	HP part number 15525-80010
Mechanical Adapter, Type N (f) 75Ω to Type N (m) 50Ω	HP part number 1250-0597
Adapter Type N (m) to BNC (m) 75Ω	HP part number 1250-1533

Test Procedure: 10 kHz to 10 MHz (Option 001: 1 MHz to 10 MHz)

1. Press the following keys on the analyzer:

PRESET (wait until the preset is complete)
FREQUENCY 5.01 **MHz** (*Option 001: 5.5 MHz*)
DISPLAY **DISPLAY UNITS** **dBm** (*Option 001 only*)
AMPLITUDE 6 **-dBm**
SPAN 2 **MHz**

2. Set the HP 3335A Frequency Synthesizer to a CW output of 5.01 MHz at -10 dBm. Connect the equipment as shown in Figure 3-1.

(*Option 001 only: Set CW to 5.5 MHz and power to -10 dBm and output switch to 75Ω. Connect the HP 3335A 75Ω output to the RF input using the 75Ω BNC cable.*)

3. Tune the HP 8590A to place the signal at the center of the analyzer's screen. Set the sweep width of the frequency synthesizer and the SPAN of the HP 8590A to 10 MHz.

(*Option 001 only: Set sweep width of the HP 3335A and the HP 8590A to 9 MHz.*)

4. Press **LOG dB/DIV** 1 **+dBm** on the analyzer. Adjust the output power of the frequency synthesizer to place the signal at approximately midscreen.

5. Press **GO TO START FREQ** on the frequency synthesizer and press **TRACE A** **MAX HOLD A** on the analyzer.

6. Start a 50 second single sweep in the frequency synthesizer. At the end of the sweep, press **VIEW A** on the analyzer.

7. Press **PEAK SEARCH** **MARKER DELTA** and rotate the knob to locate the minimum power point in the response curve. Note the marker delta reading in dB. To calculate the midpoint of the trace variation divide the marker delta reading by 2.

8. The frequency response flatness is the maximum peak-to-peak trace variation on the spectrum analyzer's screen. This variation should be less than ±1.0 dB referenced to the midpoint between the highest and lowest amplitude excursions.

9. Record the test results on copies of Table 3-7, Frequency Response Flatness, and Table 3-11, Operation Verification Test Record.

3. Frequency Response Flatness

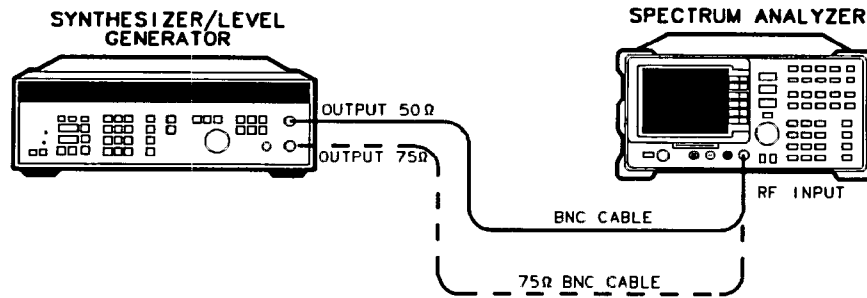

10 kHz to 10 MHz
OPT 001 & 001/H18: 1 MHz to 10 MHz

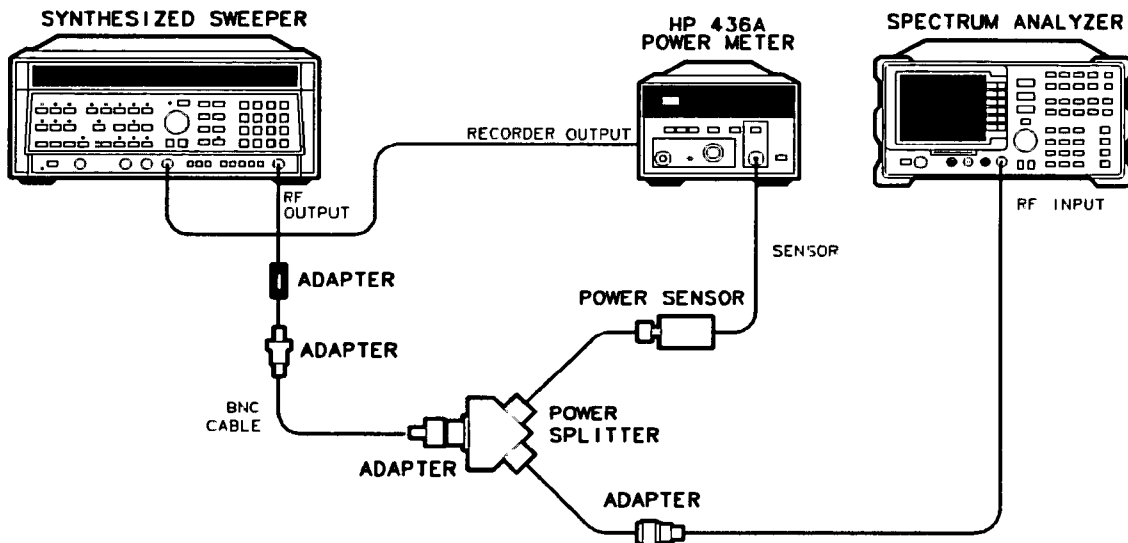

10 MHz to 1500 MHz
OPT H18: 1500 MHz to 1790 MHz

Figure 3-1. Frequency Response Flatness Test Setup

Test Procedure: 10 MHz to 1500 MHz (Option H18: 1500 MHz to 1790 MHz)

1. Press the following keys on the analyzer:

PRESET (wait until the preset is complete)

FREQUENCY

START FREQ 10 **MHz**

STOP FREQ 1500 **MHz**

AMPLITUDE 6 **-dBm**

LOG dB/DIV 1 **+dBm**

3. Frequency Response Flatness

2. Set the HP 8340A Synthesized Sweeper to CW 300 MHz, then set the power level to -4 dBm.
3. Calibrate the power meter.
4. Connect the equipment as shown in Figure 3-1.
5. Switch the HP 436A range to hold. On the HP 8340A, switch leveling to meter and, if necessary, adjust the output power of the synthesized sweeper to position the 300 MHz signal four divisions down from the analyzer's reference level. NOTE: Ignore meter flutter; it is normal.
6. Set the synthesized sweeper's start frequency to 10 MHz and the stop frequency to 1500 MHz. Set the sweep time to 100 seconds and set sweep to single (sweep LED out).
7. On the analyzer, press **TRACE A** and **MAX HOLD A**.
8. On the synthesized sweeper, press **SINGLE SWEEP** to start and complete one sweep.
9. On the analyzer, press **VIEW A** to store the display.
10. Press **PEAK SEARCH** **MARKER DELTA** and adjust the tuning knob to place the delta marker at the lowest point on the trace.
11. Read the amplitude difference (direct readout displayed in both the active function block and marker readout areas of the screen). Press **MKR**, **MARKERS OFF**.
12. The frequency response flatness is the maximum peak-to-peak trace variation on the spectrum analyzer's screen. This variation should be less than ± 1.0 dB, referenced to the midpoint between the highest and lowest amplitude excursions.
13. Record the test results on copies of Table 3-7, Frequency Response Flatness, and Table 3-11, Operation Verification Test Record.
14. *Option H18 only:* Press **TRACE A** **CLEAR WRITE A** **MKR** **MARKERS OFF** and repeat steps 6 through 13 for frequency start/stop settings of 1500 to 1790 MHz.

Table 3-7. Frequency Response Flatness

Test Description	Minimum Results	Actual Results	Maximum Results
Frequency Response Flatness			
10 kHz to 10 MHz (Option 001)		_____	<2.0 dB
1 MHz to 10 MHz		_____	<2.0 dB
10 MHz to 1500 MHz (Option H18)		_____	<2.0 dB
1500 MHz to 1790 MHz		_____	<4.0 dB

3. Frequency Response Flatness

Procedure for System Characterization, Option 001 Only

1. Zero and calibrate the HP 8902A and HP 8482A as described in the HP 8902A Operation Manual.
2. Zero and calibrate the HP 436A and the HP 8483A as described in the HP 436A Operation Manual.
3. Press **INSTR PRESET** on the HP 8340A/B. Set the HP 8340A/B controls as follows:
CW 10 MHz
FREQ STEP 50 MHz
POWER LEVEL 5 dBm
4. Connect the equipment as shown in Figure 3-2.

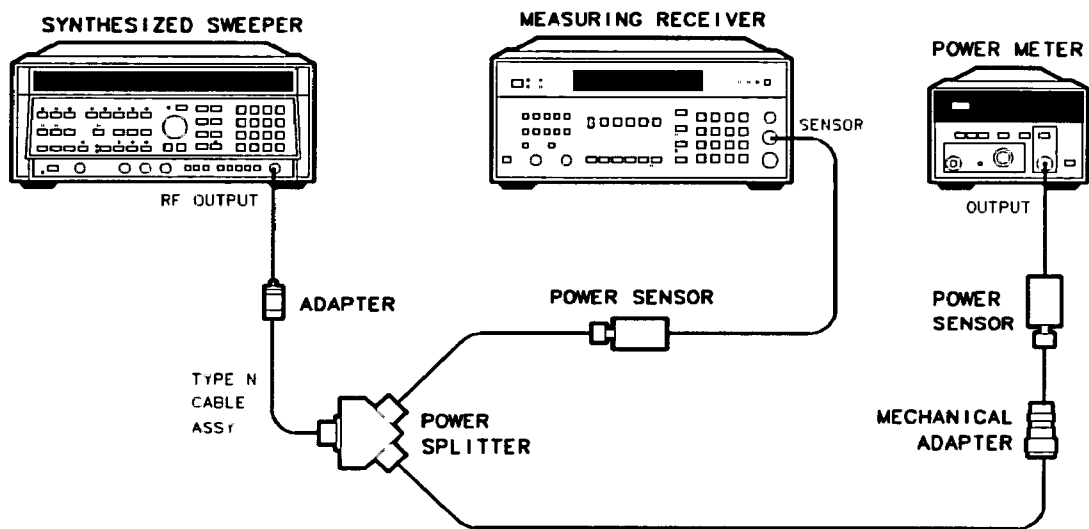

Figure 3-2. System Characterization Test Setup (Option 001)

3. Frequency Response Flatness

5. Adjust the HP 8340A/B power level for a 0 dBm reading on the HP 8902A.
6. Record the HP 436A reading in column 3 of Table 3-8, taking into account the Cal Factors of both the HP 8482A and the HP 8483A.
7. On the HP 8340A/B, press **CW** 50 **MHz**, and then **▲** (step up), to step through the remaining frequencies listed in Table 3-8.

At each new frequency repeat steps 5 and 6, entering each power sensor's Cal Factor into the respective power meter.

Test Procedure

Option 001: 10 MHz to 1500 MHz (Option 001/H18: 1500 MHz to 1790 MHz)

1. Zero and calibrate the HP 8902A and HP 8482A in log mode as described in the HP 8902A Operation Manual.
2. Connect the equipment as shown in Figure 3-3.

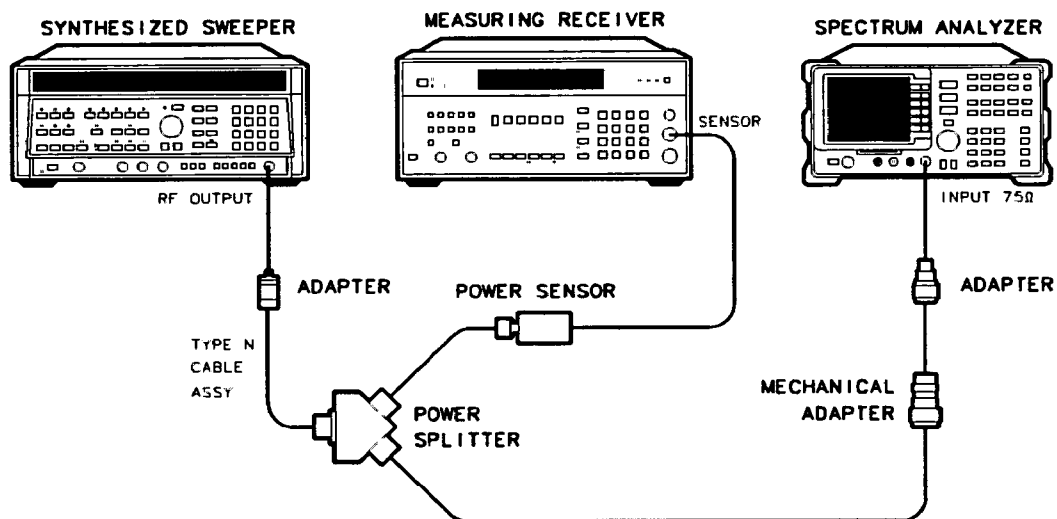

Figure 3-3.

Frequency Response Test Setup

Option 001: 10 MHz to 1500 MHz (Option 001/H18: 1500 MHz to 1790 MHz)

3. Frequency Response Flatness

3. Press **INSTR PRESET** on the HP 8340A/B. Set the HP 8340A/B controls as follows:

CW 300 MHz
FREQ STEP 50 MHz
POWER LEVEL -4 dBm

4. On the analyzer, press **PRESET** and wait for the preset to finish. Press **FREQUENCY**. Set the analyzer's controls as follows:

CENTER FREQUENCY 300 MHz
CF STEP 50 MHz
SPAN 10 MHz

Press **DISPLAY** **DISPLAY UNITS** **dBm**.

REF LEVEL -6 dBm
LOG dB/DIV 1 dB
RES BW 1 MHz
VIDEO BW 3 kHz

5. On the analyzer, press **PEAK SEARCH**, **SIGNAL TRACK** (ON).
6. Adjust the HP 8340A/B power level for a MKR-TRK amplitude reading of -10 dBm ± 0.05 dB.
7. Set the sensor Cal Factor on the HP 8902A and then press **RATIO** on the HP 8902A.
8. Set the HP 8340A/B CW to 10 MHz.
9. Set the analyzer center frequency to 10 MHz.
10. Adjust the HP 8340A power level for an analyzer MKR-TRK amplitude reading of -10 dBm ± 0.05 dB.
11. Set the sensor Cal Factor on the HP 8902A and record the negative of the power ratio in Table 3-8.
12. Set the HP 8340A/B CW to 50 MHz.
13. Set the analyzer center frequency to 50 MHz.
14. Adjust the HP 8340A/B power level for an analyzer MKR-TRK amplitude reading of -10 dBm ± 0.05 dB.
15. Set the sensor Cal Factor on the HP 8902A and record the negative of the power ratio displayed on the HP 8902A in Table 3-8 as the Error Relative to 300 MHz.
16. On the HP 8340A/B, press **CW** and **▲**, and on the analyzer, press **FREQUENCY** and **▲**, to step through the remaining frequencies listed in Table 3-8. At each new frequency, repeat steps 14 through 16, entering the power sensor's Cal Factor into the HP 8902A as indicated in Table 3-8.
17. Starting with the error at 10 MHz, subtract column 4 (System Error) to column 2 (Error Relative to 300 MHz) and record the result in column 5 (Corrected Error Relative to 300 MHz). Transfer the results in column 5 to Table 3-11.

Table 3-8. Frequency Response Errors

Frequency (MHz)	Error Relative to 300 MHz (dB)	Sensor CAL FACTOR Frequency (GHz)	(Option 001) System Error (dB)	(Option 001) Corrected Error Relative to 300 MHz (dB)
10	_____	0.05	_____	_____
50	_____	0.05	_____	_____
100	_____	0.1	_____	_____
150	_____	0.1	_____	_____
200	_____	0.3	_____	_____
250	_____	0.3	_____	_____
300 (Ref)	_____	0.3	_____	_____
350	_____	0.3	_____	_____
400	_____	0.3	_____	_____
450	_____	0.3	_____	_____
500	_____	0.3	_____	_____
550	_____	1.0	_____	_____
600	_____	1.0	_____	_____
650	_____	1.0	_____	_____
700	_____	1.0	_____	_____
750	_____	1.0	_____	_____
800	_____	1.0	_____	_____
850	_____	1.0	_____	_____
900	_____	1.0	_____	_____
950	_____	1.0	_____	_____
1000	_____	1.0	_____	_____
1050	_____	1.0	_____	_____
1100	_____	1.0	_____	_____
1150	_____	1.0	_____	_____
1200	_____	1.0	_____	_____
1250	_____	1.0	_____	_____
1300	_____	1.0	_____	_____
1350	_____	1.0	_____	_____
1400	_____	1.0	_____	_____
1450	_____	1.0	_____	_____
1500	_____	1.0	_____	_____

Table 3-8. Frequency Response Errors (continued)

Frequency (MHz)	Error Relative to 300 MHz (dB)	Sensor CAL FACTOR Frequency (GHz)	(Option 001) System Error (dB)	(Option 001) Corrected Error Relative to 300 MHz (dB)
<i>Option H18</i>				
1550	_____	2.0	_____	_____
1600	_____	2.0	_____	_____
1650	_____	2.0	_____	_____
1700	_____	2.0	_____	_____
1750	_____	2.0	_____	_____
1800	_____	2.0	_____	_____

4. Calibrator Amplitude and Frequency Accuracy

This test measures the accuracy of the analyzer's calibrator signal. The analyzer uses this signal in its calibration routines; therefore, the calibration of the analyzer depends on the accuracy of this signal.

The calibrator signal is measured directly using a power meter for amplitude accuracy, a low-pass filter to suppress harmonics above 300 MHz, and a frequency counter for frequency accuracy. (*Option 001 only*: Omit the low-pass filter).

Specification

Amplitude: $-20 \text{ dB} \pm 1.0 \text{ dB}$ (50 Ω calibration)
 $+28.75 \text{ dBmV} \pm 1.0 \text{ dB}$ (*Option 001*: 75 Ω calibration)
Frequency: 299.9 MHz ± 300 kHz

Equipment

Frequency Counter HP 5342A
Power Meter HP 436A
Power Sensor HP 8482A
BNC cable HP 10503A
300 MHz Low-Pass Filter HP part number 0955-0455
Adapter, Type N (f) to BNC (m) HP part number 1250-0077
Option 001
Power Sensor HP 8483A
BNC Cable, 75 Ω HP part number 15525-80010
Mechanical Adapter, 75 Ω to 50 Ω HP part number 1250-0597
Adapter, Type N (f) 75 Ω to BNC (m) 75 Ω HP part number 1250-1534

Test Procedure

1. Press **PRESET** on the HP 8590A Spectrum Analyzer.
2. Zero and calibrate the power meter and power sensor with the low-pass filter. Enter the power sensor's 300 MHz Cal Factor into the power meter. See Figure 3-4.

(*Option 001 only*: The HP 8483A power sensor is supplied with an adapter (HP part number 1250-0597) for joining the power sensor's 75 Ω Type N connector to the 50 Ω power reference connector on the power meter. This accessory is a mechanical adapter only, not an impedance transformer. Therefore, an impedance mismatch exists and the meter should be calibrated to REF CF of the power mount. The specification of CAL OUTPUT is $+28.75 \text{ dBmV}$ ($\text{dBmV} = \text{dBm} + 30 + 10 \log 75$). However, the power meter will read out the same power at standard products (that is, -20 dBm). Add 48.75 (conversion factor dBm to dBmV) to the power reading.)

4. Calibrator Amplitude and Frequency Accuracy

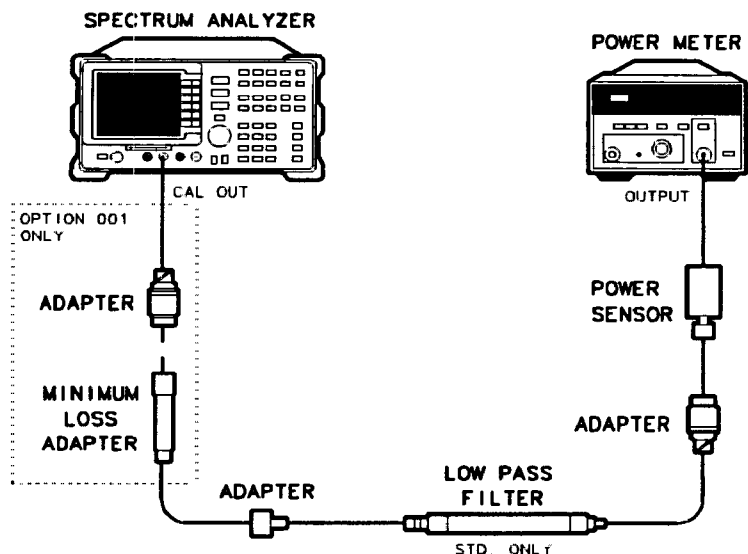

Figure 3-4. Calibrator Amplitude Accuracy Test Setup

3. Connect the power sensor with the low-pass filter to the **CAL OUTPUT** of the analyzer. (*Option 001 only: Connect the HP 8483A to the CAL OUTPUT using the adapter with HP part number 1250-1534.*)
4. Record the power reading on a copy of the test record. The power reading should be between the values shown on the test record.
5. Set the frequency counter input impedance to 50Ω and the gate time to MHz.
6. Connect the analyzer's **CAL OUTPUT** to the input of the frequency counter. (*Option 001 only: Use the 75Ω BNC cable. See Figure 3-5.*)
7. Record the frequency reading on the counter on copies of Table 3-9 and Table 3-11. The frequency reading should be between the values shown on the tables.

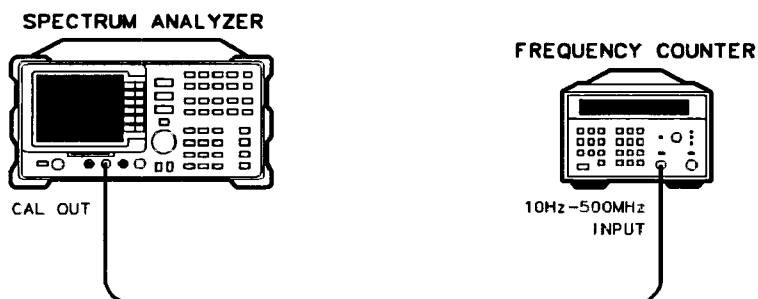

Figure 3-5. Calibrator Frequency Accuracy Test Setup

4. Calibrator Amplitude and Frequency Accuracy

Test Results

Table 3-9. Calibrator Amplitude and Frequency Accuracy

Test Description	Minimum Results	Actual Results	Maximum Results
Calibrator Amplitude			
50Ω: -20 dBm	-21 dBm	_____	-19 dBm
<i>(Option 001)</i>			
75Ω: +28.75 dBmV	+27.75 dBmV	_____	+29.75 dBmV
Frequency Accuracy			
299.9 MHz	299.6 MHz	_____	300.2 MHz

5. Frequency Span Readout Accuracy

This test measures the analyzer's ability to read the frequency of two signals at the same time accurately. The test uses a frequency comb generator. A comb generator gets its name from the signals it generates. The signals are evenly spaced in the frequency spectrum so that they resemble the teeth of a comb.

The comb generator is used to test the wide spans (20 MHz to 1500 MHz). A signal generator is modulated with a synthesizer to generate comb signals for testing the narrow spans (50 kHz to 1 MHz).

The span readout accuracy test is summarized as follows:

- Set the comb generator frequency so that a comb tooth signal falls on each graticule (or every other graticule) of the analyzer span under test.
- Place one of the analyzer's markers on the first comb signal from the left edge of the screen. Place the other marker on the first comb signal from the right edge of the screen.
- Read the span as the marker delta frequency and compare it to the specification.

Specifications

<±3% of indicated frequency span, 50 kHz to 1500 MHz

Equipment

Frequency Comb Generator	HP 8406A
AM/FM Signal Generator.....	HP 8640B
Frequency Synthesizer	HP 3335A
BNC cable (<i>2 required</i>)	HP 10503A
Adapter, Type N (m) to BNC (f) (<i>2 required</i>)	HP part number 1250-0780
<i>Option 001:</i>	
Minimum Loss Adapter	HP 11852B
Adapter, 75Ω Type N (f) to 75Ω BNC (m)	HP part number 1250-1534

Test Procedure (20 to 1500 MHz spans)

1. Set the HP 8406A Comb Generator to 100 MC, with the INTERPOLATION AMPLITUDE 1 MHz to off, and the OUTPUT AMPLITUDE control completely clockwise.
2. Connect the equipment as shown in Figure 3-6.

5. Frequency Span Readout Accuracy

3. Press the following spectrum analyzer keys:

PRESET (wait until the preset is complete)

FREQUENCY

Use the knob to place the 300 MHz comb signal on the second graticule, then press:

TRIG SINGLE SWEEP

PEAK SEARCH NEXT PK RIGHT MARKER DELTA

Press **NEXT PK RIGHT** until the delta marker is on the 1400 MHz comb signal (the 1400 MHz comb should be just right of the ninth graticule).

4. Read the marker delta frequency as the frequency span. Record the span on copies of Table 3-10, Frequency Span Readout Accuracy, and Table 3-11, Operation Verification Test Record. The span should fall between the values shown on the table.

Press **MKR MARKERS OFF TRIG CONT SWEEP**.

5. Repeat step 4 for frequency spans of 1000, 500, 100 and 20 MHz. Press **FREQUENCY**, use the knob to align a comb signal on the first graticule line. For spans of 100 MHz and 20 MHz, see note, below.

Press **TRIG SINGLE SWEEP PEAK SEARCH**. Press **NEXT PK RIGHT OR LEFT** to place the marker on the comb signal aligned with the first graticule.

Press **MARKER DELTA**. Press **NEXT PK RIGHT** to place the delta marker on the comb signal nearest the ninth graticule line.

Record the marker delta frequency as the frequency span in Table 3-10.

Press **MKR MARKERS OFF TRIG CONT SWEEP**.

Note



In the 20 MHz span, set the analyzer attenuator to 0 dBm. In the 20 and 100 MHz spans, set the comb frequency to 1 MHz and 10 MHz, respectively. It may be necessary to change **ATTEN** to 0 dB in 20 MHz span.

5. Frequency Span Readout Accuracy

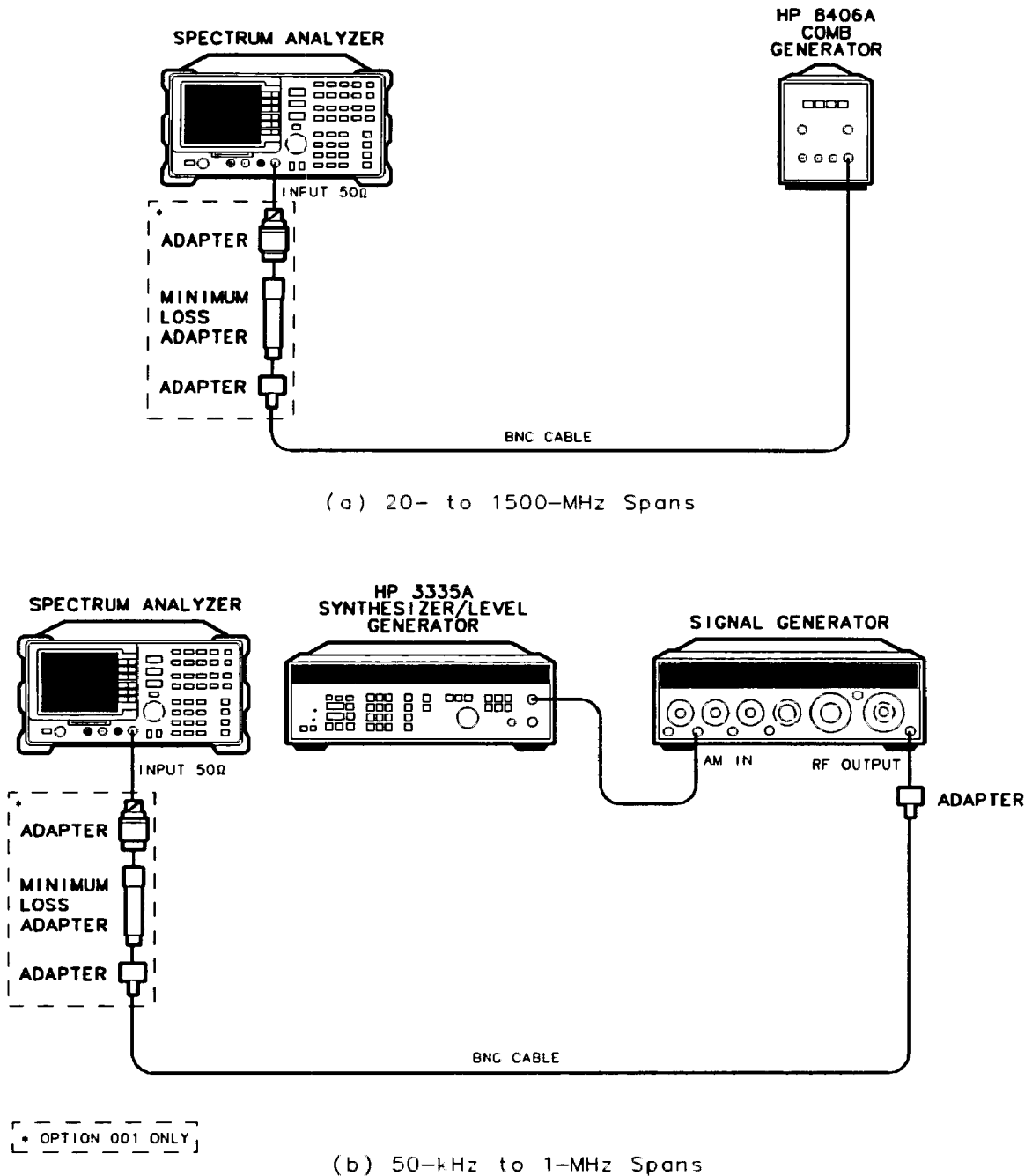

Figure 3-6. Frequency Span Readout Accuracy

Test Procedure (50 kHz to 1 MHz spans)

1. Connect the equipment as shown in Figure 3-6.
2. Set the HP 8640B Signal Generator for -10 dBm, 10 MHz, and its amplitude modulation input for ac coupling.
3. Set the HP 3335A Frequency Synthesizer to +10 dBm at 100 kHz and adjust the signal generator for 90% amplitude modulation.
4. Press the following analyzer keys:
 (PRESET) (wait until the preset is complete)
 (FREQUENCY) 10 (MHz)
 (SPAN) 1 (MHz) (PEAK SEARCH) (SIGNAL TRACK)
 (TRIG) SINGLE SWEEP (PEAK SEARCH) (NEXT PK LEFT(RIGHT)) to set the marker on the peak of the comb signal on the first graticule line.
 (MARKER DELTA) (NEXT PK RIGHT) to set the delta marker on the peak of the comb signal at the ninth graticule. (Note: Adjust the output level vernier on the HP 8640B to achieve optimum display of the modulation signal.)
5. Read the frequency separation as the marker delta frequency. Record the frequency separation on the copies of Table 3-10 and Table 3-11. The frequency separation should fall between the values shown on the tables (800 kHz ±30 kHz). (MARKERS) (MARKERS OFF) (TRIGGER) CONT SWP.
6. Repeat step 4, skipping the (PRESET) and (FREQUENCY) steps, for a span of 500 kHz with the frequency synthesizer set to 50 kHz. Record the frequency separation (marker reading) (400 kHz ±15 kHz) on the copies of Table 3-10 and Table 3-11. (MARKERS OFF) (CONT SWP)
7. Use the following settings to test the analyzer's 50 and 100 kHz spans. Record the results. Continue as in step 4 and step 5.

Analyzer Span	HP 3335A Frequency
50 kHz	5 kHz
100 kHz	10 kHz

5. Frequency Span Readout Accuracy

Test Results

Table 3-10. Frequency Span Readout Accuracy

Test Description	Minimum Results	Actual Results	Maximum Results
Frequency Span Readout Accuracy			
50 kHz	38.50 kHz	_____	41.50 kHz
100 kHz	77.00 kHz	_____	83.00 kHz
500 kHz	385.00 kHz	_____	415.00 kHz
1 MHz	770.00 kHz	_____	830.00 kHz
20 MHz	15.40 MHz	_____	16.60 MHz
100 MHz	77.00 MHz	_____	83.00 MHz
500 MHz	385.00 MHz	_____	415.00 MHz
1000 MHz	770.00 MHz	_____	830.00 MHz
1500 MHz	1255.00 MHz	_____	1345.00 MHz

Table 3-11. Operation Verification Test Record

Hewlett-Packard Company

Tested by _____

HP Model 8590A

Spectrum Analyzer 10 kHz to 1.5 GHz

Date _____

Option 001: 1 MHz to 1.5 GHz

Option H18: 10 kHz to 1.79 GHz

Serial No. _____

Test Description	Minimum Results	Actual Results	Maximum Results
Frequency Readout Accuracy			
50 MHz	44.90 MHz	_____	55.10 MHz
100 MHz	94.90 MHz	_____	105.10 MHz
500 MHz	494.90 MHz	_____	505.10 MHz
1000 MHz	994.90 MHz	_____	1005.10 MHz
1500 MHz	1494.90 MHz	_____	1505.10 MHz
1700 MHz (<i>Option H18</i>)	1694.90 MHz	_____	1705.10 MHz
Displayed Average Noise			
400 kHz (Standard & <i>Option H18</i> only)		_____	-112 dBm
1 MHz		_____	-114 dBm
750 MHz		_____	-114 dBm
1500 MHz		_____	-112 dBm
1700 MHz (<i>Option H18</i>)		_____	-94 dBm
Frequency Response Flatness			
10 kHz to 10 MHz		_____	<2.0 dB
10 MHz to 1500 MHz (<i>Option H18</i>)		_____	<2.0 dB
1500 MHz to 1790 MHz		_____	<4.0 dB
Calibrator Amplitude			
50Ω: -20 dBm (<i>Option 001</i>)	-21 dBm	_____	-19 dBm
75Ω +28.75 dBmV	+27.75 dBmV	_____	+29.75 dBmV
Frequency Accuracy			
299.9 MHz	299.6 MHz	_____	300.2 MHz
Frequency Span			
Readout Accuracy			
50 kHz	38.50 kHz	_____	41.50 kHz
100 kHz	77.00 kHz	_____	83.00 kHz
500 kHz	385.00 kHz	_____	415.00 kHz
1 MHz	770.00 kHz	_____	830.00 kHz
20 MHz	15.40 MHz	_____	16.60 MHz
100 MHz	77.00 MHz	_____	83.00 MHz
500 MHz	385.00 MHz	_____	415.00 MHz
1000 MHz	770.00 MHz	_____	830.00 MHz
1500 MHz	1255.00 MHz	_____	1345.00 MHz

6. Sweep Time Accuracy Test

This test uses a synthesizer function generator to amplitude modulate a 500 MHz, CW signal from another signal generator. The analyzer demodulates this signal in zero span to display the response in the time domain. The marker delta frequency function of the analyzer is used to read out the sweep time accuracy.

Specification

Frequency Sweep Readout Accuracy: $<\pm 10\%$ of indicated sweep time setting.

Equipment

Synthesizer Function Generator HP 3325A
Signal Generator HP 8640B
BNC Cable 120 cm (48 in) (*2 required*) HP 10503A
Adapter Type N (m) to BNC (f) HP part number 1250-0780

Additional Equipment for Option 001

Minimum Loss Adapter (MLA), 75 Ω to 50 Ω HP 11852B
Adapter, Type N (m) to BNC (f) HP part number 1250-0780
Adapter, 75 Ω Type N (f) to 75 Ω BNC (m) HP part number 1250-1534

Test Procedure

1. Set the signal generator to output a 500 MHz, -10 dBm, CW signal. Set the AM and FM controls OFF. (*Option 001*: Set the output to -4 dBm.)
2. Set the synthesizer function generator to output a 500 Hz, +5 dBm, triangle waveform signal.
3. Connect the equipment as shown in Figure 3-7.

Note



The lower the function generator output level, the narrower the displayed pulse on the analyzer CRT. If the function generator frequency setting is decreased to 1 Hz or lower, it may be necessary to increase the function generator output to +10 dBm to display an adequate signal on the analyzer CRT. The signal generator output and the percentage of AM modulation may also need to be increased.

6. Sweep Time Accuracy Test

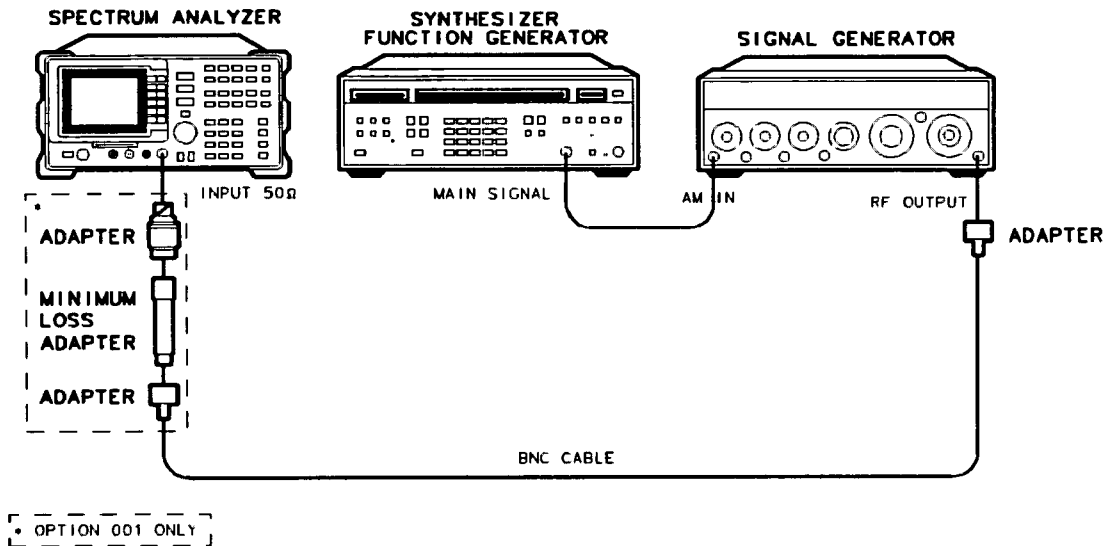

Figure 3-7. Sweep Time Accuracy Test Setup

4. Press **PRESET** on the analyzer and wait for the preset to finish. Set the controls as follows:

FREQUENCY	500 MHz
SPAN	10 MHz

 Press **PEAK SEARCH**. Set the controls as follows:

SIGNAL TRACK	ON
SPAN	50 kHz

 Wait for the AUTO ZOOM routine to finish. Press **SIGNAL TRACK OFF** **SPAN ZERO SPAN**.
 Set the controls as follows:

BW	3 MHz
AMPLITUDE SCALE	LINEAR
SWEEP TIME	20 ms
5. Set the signal generator AM switch to the AC position.
6. On the analyzer, press **TRIG VIDEO**.
 Adjust the video trigger so that the analyzer is sweeping.

6. Sweep Time Accuracy Test

7. Press **SGL SWP**. After the completion of the sweep, press **PEAK SEARCH**. If necessary, press **NEXT PEAK** until the marker is on the leftmost signal. This is the "marked signal."
8. Press **MARKER DELTA**, **MARKER DELTA** and press **NEXT PK RIGHT** until the marker delta is on the eighth signal peak. Record the marker delta reading in Table 3-12 and Table 3-18. Press **MKR** **MARKERS OFF** **TRIG** **CONT SWEEP**.
9. Repeat steps 6 through 9 for the remaining sweep time settings listed in Table 3-12 and Table 3-18.

Table 3-12. Sweep Time Accuracy Settings

HP 8590A Sweep Time	HP 3325A Frequency	Minimum Reading	MKR Δ	Maximum Reading
20 ms	500 Hz	14.0 ms	_____	18.0 ms
50 ms	200 Hz	35.0 ms	_____	45.0 ms
100 ms	100 Hz	70.0 ms	_____	90.0 ms
500 ms	20 Hz	350.0 ms	_____	450.0 ms
1 s	10 Hz	700.0 ms	_____	900.0 ms
10 s	1 Hz	7.0 s	_____	9.0 s
50 s	0.2 Hz	35.0 s	_____	45.0 s
100 s	0.1 Hz	70.0 s	_____	90.0 s

7. Noise Sideband Test

A 500 MHz, CW signal is applied to the analyzer RF input. The signal sidebands are examined for noise amplitude and unwanted responses.

Specifications

Noise sideband levels: <-65 dB down and >30 kHz offset from CW signal with 1 kHz resolution and 30 Hz video bandwidth.

Equipment

Signal Generator HP 8640B
BNC Cable, 120 cm (48 in) HP 10503A

Additional Equipment for Option 001

Minimum Loss Adapter, 75Ω to 50Ω HP 11852B
BNC Cable, 30 cm (37 in), 75Ω HP part number 15525-80010
Adapter, Type N (m) to BNC (f) HP part number 1250-0780
Adapter, 75Ω Type N (f) to 75Ω BNC (m) HP part number 1250-1534

Test Procedure

1. Set the signal generator to output the 500 MHz, -0 dBm, CW signal. Set the AM and FM controls OFF, and the RF control ON.
2. Connect the equipment as shown in Figure 3-8. If your analyzer has Option 001 (75Ω RF input), connect the 75Ω side of the minimum loss adapter to the RF input of the analyzer, and connect the 50Ω cable from the signal generator to the 50Ω side of the minimum loss adapter.
3. Press the following analyzer keys:

```
PRESET (wait until preset is complete)
PEAK SEARCH
SIGNAL TRACK
SPAN 100 kHz
DISPLAY DISPLAY UNITS dBm
MRK→ MARKER→RL
SIGNAL TRACK OFF
SWEEP BW RES BW 1 kHz
VID BW 30 Hz
PEAK SEARCH MARKER→CF
TRIG
SINGLE SWEEP
PEAK SEARCH MARKER DELTA
```

Move the marker delta using the knob and measure the frequency and amplitude of every sideband. The marker delta reading should be <-65 dBc for signals >30 kHz offset from the CW signal.

7. Noise Sideband Test

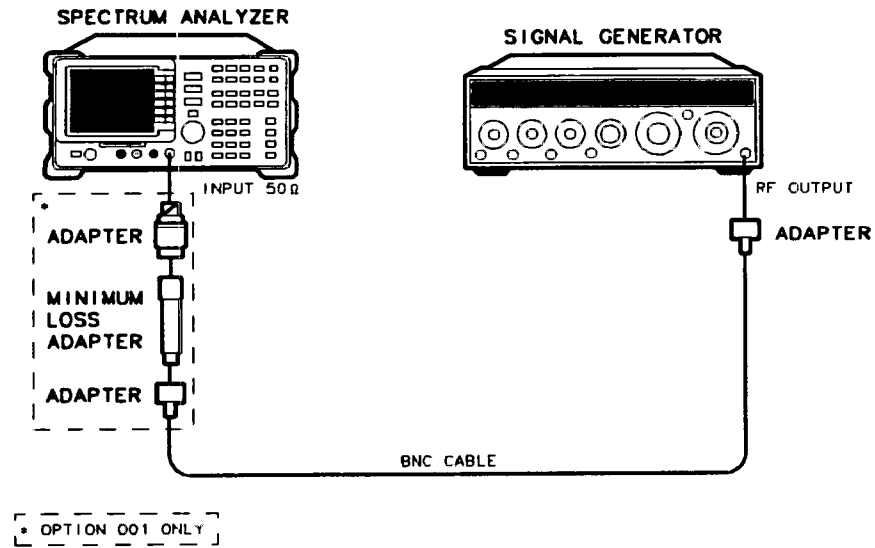

Figure 3-8. Noise Sideband Test Setup

4. Record the Noise Sideband highest levels below and in Table 3-18.

_____ < -65 dBc

8. Spurious Response Test

This test is performed in two parts. The first part measures second harmonic distortion; the second part measures third order intermodulation distortion.

To test second harmonic distortion, a 50 MHz low-pass filter is used to filter the source output, ensuring that harmonics read by the analyzer are internally generated and not coming from the source. To measure the distortion products, the power at the mixer is set 25 dB higher than specified. New test limits have been developed based on this higher power.

With -45 dBm at the input mixer and the distortion products suppressed by 70 dBc, the equivalent second-order intercept (SOI) is $+25$ dBm (-45 dBm plus 70 dBc). Therefore, with -20 dBm at the mixer, and the distortion products suppressed by 45 dBc, the equivalent SOI is also $+25$ dBm (-20 dBm plus 45 dBc).

For third order intermodulation distortion, two signals are combined in a directional bridge (for isolation) and are applied to the analyzer input. The power level of the two signals is 8 dB higher than specified, so the distortion products should be suppressed by 16 dB less than specified. In this manner, the equivalent third-order intercept (TOI) is measured.

With two -30 dBm signals at the input mixer and the distortion products suppressed by 70 dBc, the equivalent TOI is $+5$ dBm (-30 dBm plus 70 dBc/2). However, if two -22 dBm signals are present at the input mixer and the distortion products are suppressed by 54 dBc, the equivalent TOI is also $+5$ dBm (-22 dBm plus 54 dBc/2).

Performing the test with a higher power level maintains the measurement integrity while reducing both test time and the dependency on the source's noise sideband performance.

Specification

Second Harmonic Distortion:

- < -70 dBc, Frequencies > 5 MHz (-45 dBm at input mixer)
- < -60 dBc, Frequencies ≤ 5 MHz

Third Order Intermodulation Distortion:

- < -70 dBc, 5 MHz to 1.5 GHz, for two -30 dBm tones at input mixer and > 50 kHz signal separation.
- < -60 dBc for 100 kHz to 5 MHz signals

Equipment

Synthesizer/Level Generator.....	HP 3335A
Synthesized Sweeper	HP 8340A
Measuring Receiver (or Power Meter).....	HP 8902A (HP 436A)
Power Sensor, 100 kHz to 4.2 GHz	HP 8482A
50 MHz Low-Pass Filter	HP part number 0955-0306
Directional Bridge	HP 8721A
BNC Cable, 120 cm (48 in) (<i>2 required</i>).....	HP 10503A

8. Spurious Response Test

Adapter, SMA (f) to SMA (f)	HP part number 1250-1158
Adapter, SMA (m) to BNC (f)	HP part number 1250-1200
Adapter, Type N (f) to BNC (m)	HP part number 1250-0077
Adapter, Type N (m) to BNC (f)	HP part number 1250-0780
Adapter, BNC (m) to BNC (m)	HP part number 1250-0216

Additional Equipment for Option 001

Power Sensor	HP 8483A
Minimum Loss Adapter	HP 11852B
Mechanical Adapter, 75Ω to 50Ω	HP part number 1250-0597
Adapter, Type N(f) to BNC(m), 75Ω	HP part number 1250-1534
Adapter, BNC(m) to BNC(m), 75Ω	HP part number 1250-1288
Adapter, N(m) to BNC(f)	HP part number 1250-0780

Test Procedure

Second Harmonic Distortion, 40 MHz

1. Set the HP 3335A controls as follows:

FREQUENCY	40 MHz
AMPLITUDE	-10 dBm
AMPLITUDE (<i>Option 001</i>)	-4.3 dBm

2. Connect the equipment as shown in Figure 3-9.

(*Option 001:* Connect the HP 11852B between the low-pass filter and INPUT 75Ω.)

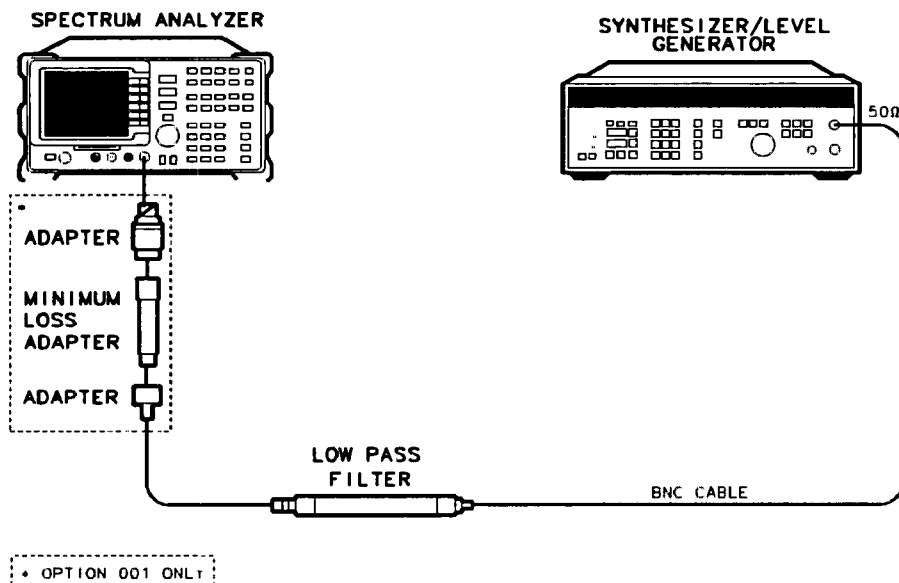

Figure 3-9. Second Harmonic Distortion Test Setup, 30 MHz

8. Spurious Response Test

3. Press **PRESET** on the analyzer and wait for the preset to finish. Set the controls as follows:

CENTER FREQUENCY..... 40 MHz

SPAN..... 10 MHz

Option 001: Press **DISPLAY** DISPLAY UNITS **dBm**

Ref Level..... -10 dBm

Press **PEAK SEARCH** **SIGNAL TRACK** (ON) **SPAN** 1 **MHz** **BW** 30 **kHz**.

4. Adjust the HP 3335A amplitude to place the peak of the signal at the reference level (-10 dBm, ± 0.2 dB). Press **SIGNAL TRACK** OFF.

5. Set the analyzer control as follows:

RES BW..... 10 kHz

VIDEO BW..... 300 Hz

6. Wait for two sweeps to finish. On the analyzer, press **PEAK SEARCH** **MARKER DELTA**

SIGNAL TRACK **FREQUENCY** CF STEP SIZE 40 **MHz** **FREQUENCY**.

7. Press the **▲** (step up) key on the analyzer to step to the second harmonic (at 80 MHz).

Press **PEAK SEARCH**. Record the marker delta amplitude reading here and on Table 3-18.

Note



If necessary, increase **SPAN** to 5 MHz to acquire the signal, press

PEAK SEARCH and **SPAN** 1 **MHz**.

8. Repeat steps 3 through 7 setting the Level Generator to 2 MHz and checking the second harmonic at 4 MHz. (Set marker CF step size to 2 MHz.)

_____ < -45 dBc

8. Spurious Response Test

Third Order Intermodulation Distortion, 50 MHz

1. Zero and calibrate the HP 8902A and HP 8482A combination in log mode (RF power readout in dBm). Enter the power sensor's 50 MHz Cal Factor into the HP 8902A.
(*Option 001:* Calibrate the HP 8483A 75 Ω power sensor.)
2. Connect the equipment as shown in Figure 3-10 with the output of the directional bridge connected to the power sensor.
(*Option 001:* Use the HP 8483A power sensor with a Type N (f) to BNC (m) 75 Ω adapter (HP part number 1250-1534) and use a BNC (m) to BNC (m) 75 Ω adapter (HP part number 1250-1288) in place of the 50 Ω adapter.)

Note



Option 001: The power measured at the output of the 50 Ω directional bridge by the 75 Ω power sensor is the equivalent power "seen" by the 75 Ω analyzer.

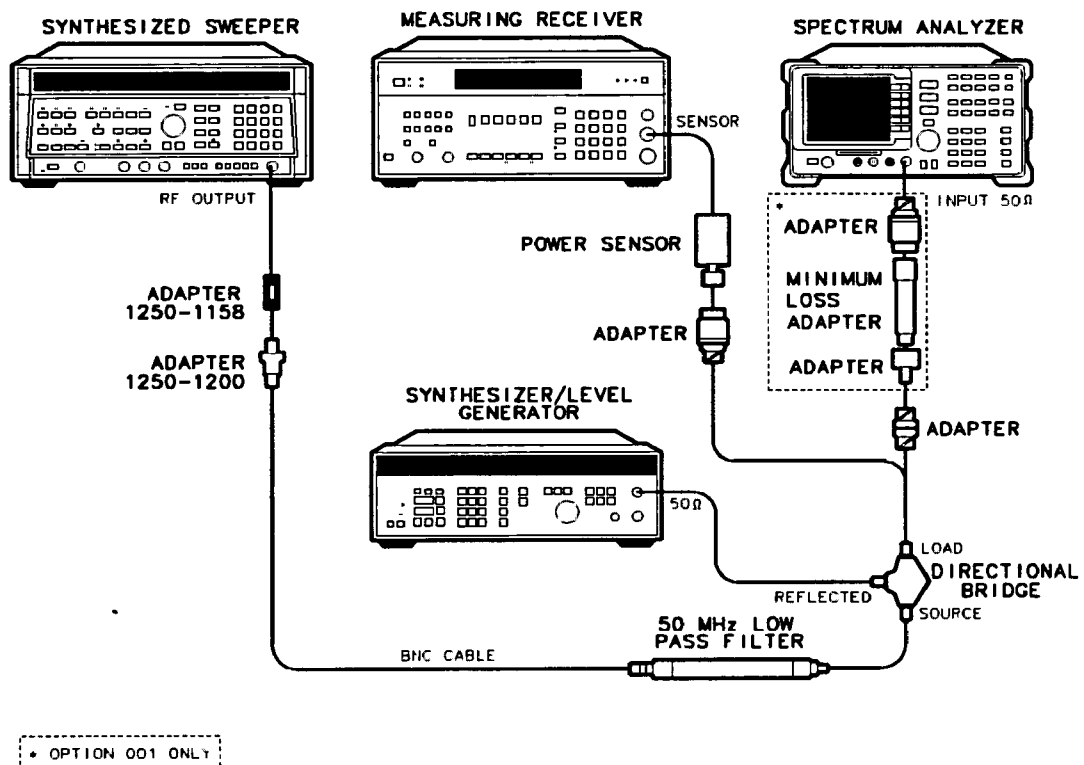

Figure 3-10. Third Order Intermodulation Distortion Test Setup

8. Spurious Response Test

3. Press **INSTR PRESET** the HP 8340A. Set the HP 8340A controls as follows:

POWER LEVEL -6 dBm
CW 50 MHz
RF OFF

4. Set the HP 3335A controls as follows:

FREQUENCY 50.050 MHz
AMPLITUDE -6 dBm
50Ω/75Ω switch 75Ω (no RF output)

5. On the analyzer, press **PRESET** and wait until the preset is finished. Set the controls as follows:

CENTER FREQUENCY 50 MHz
SPAN 10 MHz

(Option 001: Press **DISPLAY** DISPLAY UNITS **dBm**.)

AMPLITUDE -10 dBm

Press the following analyzer keys:

PEAK SEARCH PEAK EXCURSN 3 **dB**

DISPLAY THRESHLD 90 **-dBm**

6. On HP 8340A, set RF ON. Adjust the power level until the HP 8902A reads -12 dBm ±0.05 dB.

7. Disconnect the power sensor from the directional bridge. Connect the directional bridge directly to the analyzer's RF INPUT using an adapter (do not use a cable).

(Option 001: Use a 75Ω adapter, BNC (m) to BNC (m).)

8. On the analyzer, press **PEAK SEARCH** **SIGNAL TRACK** (ON) **SPAN** 200 **kHz**. Wait for the AUTO ZOOM message to disappear. Press **SIGNAL TRACK** (OFF) **PEAK SEARCH** **MKR →** **MARKER → RL**.

9. On the HP 3335A, set the 50Ω/75Ω switch to the 50Ω position (RF on). Adjust the amplitude until the two signals are displayed at the same amplitude.

10. If necessary, adjust the analyzer center frequency until the two signals are centered on the display. Set the controls as follows:

11. RES BW 1 kHz
VIDEO BW 100 Hz

12. Press **PEAK SEARCH** **DISPLAY** DSP LINE. Set the display line to a value of 54 dB below the current reference level setting.

13. The third order intermodulation distortion products should appear 50 kHz below the lower frequency signal and 50 kHz above the higher frequency signal. Their amplitude should be less than the display line.

8. Spurious Response Test

14. If the distortion products can be seen, proceed as follows:

- On the analyzer, press **SGL SWEEP**, wait for completion of the sweep, then press **PEAK SEARCH**, **MARKER DELTA**.
- Repeatedly press **NEXT PEAK** until the active marker is on the highest distortion product.
- Record the marker delta amplitude reading below and in Table 3-18. The marker delta reading should be less than -54 dBc.

Third Order Intermodulation Distortion, 50 MHz:

_____ < -54 dBc

15. If the distortion products cannot be seen, proceed as follows:

- On both the HP 8642A and the HP 3335A, increase the power level by 5 dB. Distortion products should now be visible at this higher power level.
- On the analyzer, press **SGL SWEEP** **PEAK SEARCH** **MARKER DELTA**.
- Repeatedly press **NEXT PEAK** until the active marker is on the highest distortion products.
- On both the HP 8642A and the HP 3335A, reduce the power level by 5 dB and wait for the completion of a new sweep.
- Record the marker delta amplitude reading below and in Table 3-18. The marker delta reading should be less than -54 dBc.

Third Order Intermodulation Distortion, 50 MHz:

_____ < -54 dBc

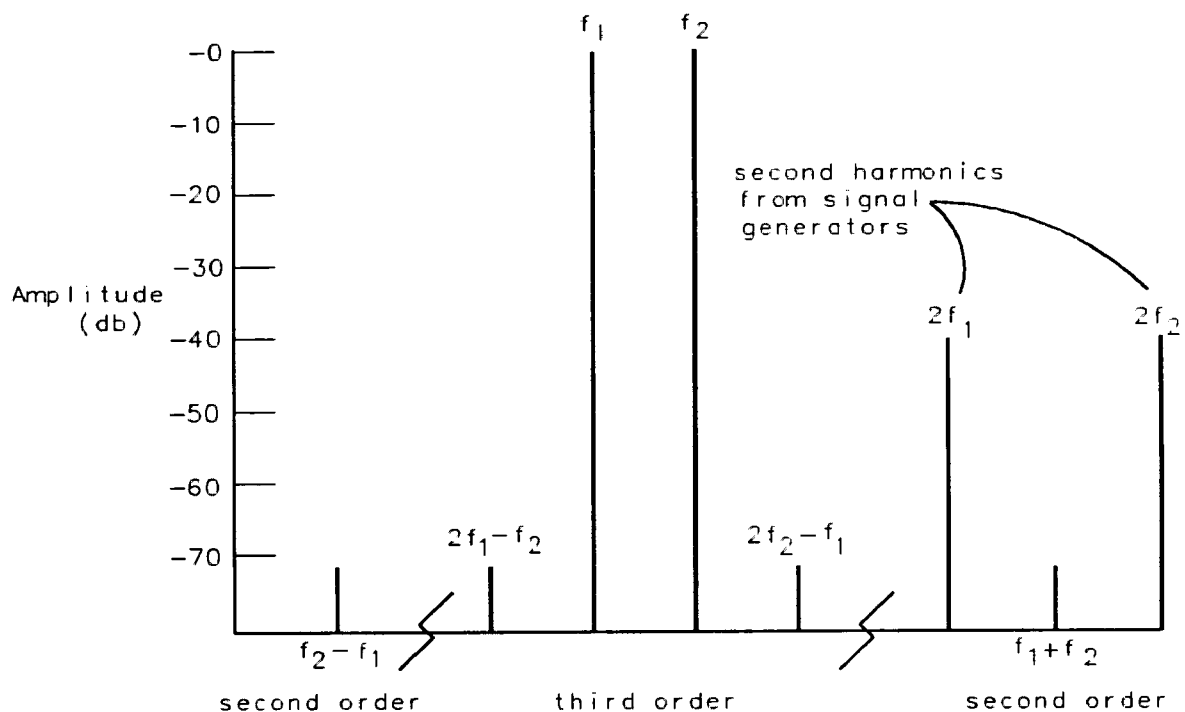

Figure 3-11. Spurious Response-Intermodulation Distortion Products

9. Residual Response Test

Residual response is checked by terminating the RF input of the analyzer, setting input attenuation to 0 dB, and measuring any residuals across the instrument's input frequency range. The analyzer CRT is used to make the measurements.

Specification

Residual Responses:

- < -95 dBm with 0 dB input attenuation and no signal present at input (standard and *Option 001*.)
- < -88 dBm with 0 dB input attenuation and no signal present at input (*Option H18* and *Option 001/H18* at 1728 MHz.)

Equipment

50 Ω Termination HP 11593A

Equipment for Option 001

75 Ω Termination HP part number 11652-60010

Test Procedure

Note



The following procedure can be completed in approximately 30 minutes with the frequency step size and span given.

1. Connect the 50 Ω termination to the analyzer RF input.
(*Option 001*: Connect the 75 Ω termination to the RF input instead.)
2. Press the following analyzer keys:

PRESET (wait until preset is complete)
FREQUENCY 25 **MHz**
SPAN 50 **MHz**
(*Option 001*: **DISPLAY** **DISPLAY UNITS** **dBm**)
AMPLITUDE 60 **-dBm**
ATTEN 0 **dB**
SWEEP BW **RES BW** 3 **kHz**
VID BW 1 **kHz**
DISPLAY **DISPLAY LINE** 95 **-dBm**
FREQUENCY **CF STEP SIZE** 45 **MHz** **FREQUENCY**

9. Residual Response Test

3. Press analyzer **TRIG** and **SINGLE SWEEP** keys, and wait for the sweep to be completed. Look for any residual responses at or above the display line on the analyzer CRT. If a residual is suspected, press the **SINGLE SWEEP** key again to determine if the response persists. A residual will persist on repeated sweeps, but a noise peak will not. Any residual responses must be at or below the display line. Press **PEAK SEARCH** after each sweep and note the marker reading in dBm.
4. Press the analyzer **FREQUENCY** and **▲** (step up) keys to step to the next higher center frequency, which is 45 MHz above the last setting. Repeat step 3.
5. Repeat steps 3 and 4 until the complete analyzer frequency range has been evaluated (that is, until you reach the maximum frequency of 1.510 GHz). This requires 33 additional frequency steps. There should be no residual responses at or above the display line at frequencies below 1500 MHz.
6. Record the maximum residual response here and in Table 3-18.

Standard and Option 001	_____	<-95 dBm
Option H18 and Option 001/H18 at 1728 MHz	_____	<-88 dBm

10. Reference Level Accuracy Test

A 50 MHz CW signal is applied to the INPUT 50Ω of the analyzer through two step attenuators. The attenuators increase the effective amplitude range of the source. The amplitude of the source is decreased in 10 dB steps and the analyzer marker functions are used to measure the amplitude difference between steps. The source's internal attenuator is used as the reference standard. The test is performed in both log and linear amplitude scales.

It is only necessary to test reference levels as low as -90 dBm (with 10 dB ATTEN) since lower reference levels are a function of the analyzer microprocessor's manipulating the trace data. There is no error associated with the trace data manipulation.

Specification

- <±1.75 dB for +30 to -120 dBm range (0 to 60 dB attenuation)
- <±1.25 dB for 0 to -120 dBm range (10 dB attenuation) at any fixed frequency
- <±0.5 dB for) to -59 dBm range (10 dB attenuation) at any fixed frequency

Equipment

Synthesizer/Level Generator.....	HP 3335A
Step Attenuator, 1 dB steps	HP 355C
Step Attenuator, 10 dB steps	HP 355D
BNC Cable, 122 cm (48 in) (2 required).....	HP 10503A
Adapter, BNC (m) to BNC (m)	HP part number 1250-0216

Additional Equipment for Option 001

Minimum Loss Adapter	HP 11852B
Adapter, Type N (f) to BNC (m), 75Ω	HP part number 1250-1534
Adapter, Type N (M) to BNC (f)	HP part number 1250-0780

Test Procedure

1. Set the HP 3335A controls as follows:

FREQUENCY	50 MHz
AMPLITUDE	-10 dBm
AMPTD INCR	10 dB
OUTPUT	50Ω

2. Connect the equipment as shown in Figure 3-12. Set the HP 355D to 10 dB attenuation and the 355C to 0 dB attenuation.

(*Option 001:* Connect the minimum loss adapter to the INPUT 75Ω (using adapters), and set the HP 355D to 0 dB attenuation.)

10. Reference Level Accuracy Test

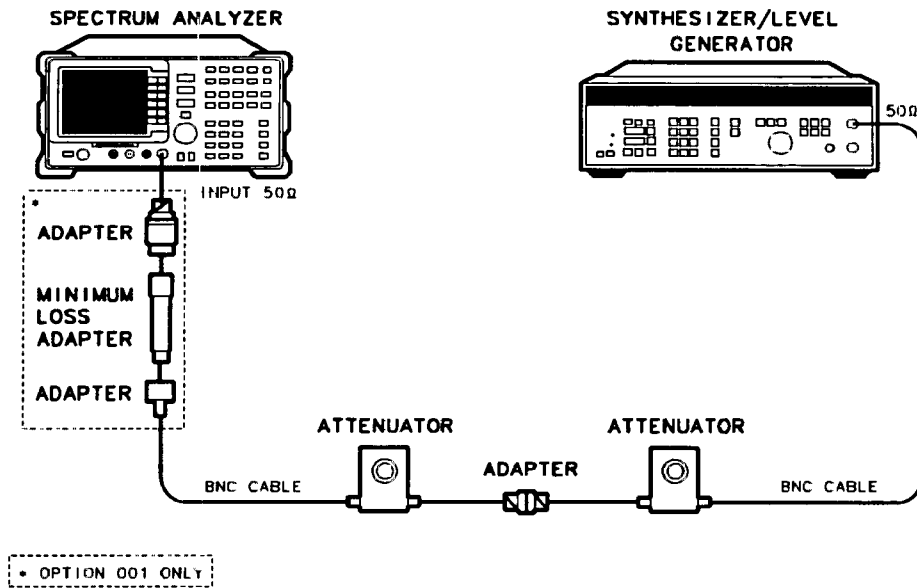

Figure 3-12. Reference Level Accuracy Test Setup

3. Press **PRESET** on the analyzer and wait for the preset to finish. Set the controls as follows:

CENTER FREQUENCY 50 MHz
 SPAN 10 MHz
 PEAK SEARCH SIGNAL TRACK ON
 SPAN 50 kHz

(Option 001: Press **DISPLAY** DISPLAY UNITS **dBm**.)

Set the controls as follows:

REF LEVEL -20 dBm
 LOG dB/DIV 1 dB
 RES BW 3 kHz
 VIDEO BW 30 Hz

4. Set the HP 355C attenuation to place the signal peak 1 to 2 dB (one to two divisions) below the reference level.

5. On the analyzer, press the following keys:

SGL SWP
PEAK SEARCH MARKER DELTA

6. Set the HP 3335A Amplitude and HP 8590A Ref Level according the Table 3-13. At each setting, press **SGL SWP** **PEAK SEARCH** on the analyzer. Record the marker delta amplitude reading in Table 3-13 and Table 3-18. The marker delta reading should be within the limits shown.

Table 3-13. Reference Level Accuracy Settings

HP3335A Amplitude (dBm)	HP 8590A REF LEVEL (dBm)	Minimum MKR Δ Reading (dBm)	Actual MKR Δ Reading (dBm)	Maximum MKR Δ Reading (dBm)
-10	-20	0(Ref)	0(Ref)	0(Ref)
0	-10	-0.5	_____	+0.5
+10	0	-0.5	_____	+0.5
-20	-30	-0.5	_____	+0.5
-30	-40	-0.5	_____	+0.5
-40	-50	-0.5	_____	+0.5
-50	-60	-1.25	_____	+1.25
-60	-70	-1.25	_____	+1.25
-70	-80	-1.25	_____	+1.25
-80	-90	-1.25	_____	+1.25

11. Scale Fidelity Test

This test is performed in two parts. The first part measures log scale fidelity; the second part checks linear scale fidelity. Both procedures use the same test method.

A 50 MHz, CW signal is connected to the analyzer RF input. The generator output level is adjusted to place the signal peak at the selected analyzer reference level. The signal amplitude is then reduced using the generator. The scale fidelity figure is determined by calculating the error between the actual displayed and theoretical amplitude levels.

Specification

Log Incremental Accuracy

< ± 0.1 dB/dB change over 70 dB range

Log Maximum Cumulative Error

± 0.75 dB maximum over -60 dB range from reference level

± 1.0 dB maximum over -70 dB range from reference level

Linear Accuracy

< $\pm 3\%$ of reference level setting

Equipment

Synthesizer/Level Generator..... HP 3335A

BNC Cable 120 cm (48 in) HP 10503A

Additional Equipment for Option 001

BNC Cable, 94 cm (37 in), 75Ω HP part number 15525-80010

Test Procedure: Log Scale Fidelity

1. Set the synthesizer/level generator to output a 50 MHz, 0 dBm, CW signal. Set the output switch to 50Ω .

(*Option 001*: Set the switch to 75Ω .)

2. Connect the equipment as shown in Figure 3-13.

(*Option 001*: Use the 75Ω cables as specified.)

3. Press the following analyzer keys:

PRESET
 PEAK SEARCH
 SIGNAL TRACK
 SPAN 100 kHz
 SWEEP BW RES BW 10 kHz
 VID BW 300 Hz
 (Option 001: DISPLAY DISPLAY UNITS dBm)

4. Press the following analyzer keys:

PEAK SEARCH MARKER DELTA
 SIGNAL TRACK

Note

The marker delta should read 0.0 ± 0.02 dB. If it doesn't, decrease level generator power and repeat step 5.



5. Set the generator AMPTD INCR for 10 dBm and press **INCR** ∇ . Record the marker delta readout in Table 3-14 and in Table 3-18.
6. Repeat step 5 until -70 dBm is obtained. Log scale fidelity error should not exceed ± 0.75 dB over the 0 to 60 dB attenuator range, nor ± 1.0 dB over the 0 to 70 attenuator range. Additionally, the difference measured between each 10 dB setting should not exceed ± 1.0 dB per 10 dB attenuator step.

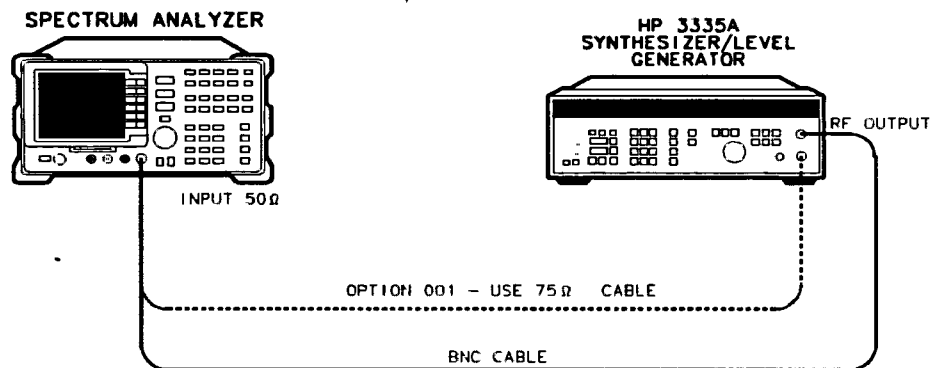

Figure 3-13. Scale Fidelity Test Setup

11. Scale Fidelity Test

Test Procedure: Linear Scale Fidelity

1. As necessary, reset the signal generator to output to 50 MHz, 0 dBm, CW signal. Set generator AMPTD INCR for 6 dBm.
2. Press the following analyzer keys:

PRESET
FREQUENCY 50 MHz
SPAN 10 MHz
PEAK SEARCH
SIGNAL TRACK
SWEEP BW RES BW 1 MHz
AMPLITUDE LINEAR

3. Set the generator output level as needed to place the display trace for the signal peak at the top graticule line. Note the marker amplitude reading on the display at the reference level. A theoretical level of 0 dBm should correspond to a displayed level of 223.6 mV.

(Option 001: 0 dB should correspond to displayed level of 273.9 mV.)

Note



When changing generator settings in the following steps, allow the analyzer to sweep the signal several times before recording the marker amplitude. This delay allows the video bandwidth filter in the analyzer to charge fully and thus improve overall test accuracy.

4. Press the generator INCR ∇ . The displayed signal peak trace should be at the fourth graticule division above the baseline. The marker amplitude should read half as much as in step 4, $\pm 3\%$ of the reference level amplitude (that is, 111.8 mV ± 6.71 mV). Record the test result in Table 3-15 and Table 3-18.

(Option 001: 136.95 mV ± 8.22 mV)

5. Set the step attenuator for 12 dB of attenuation. The displayed signal peak trace should be at the sixth graticule division above the baseline. The marker amplitude should read half as much as in step 5, $\pm 3\%$ of the reference level amplitude (that is, 55.9 mV ± 6.71 mV). Record the test result in Table 3-15 and Table 3-18.

(Option 001: 68.48 mV ± 8.22 mV)

Table 3-14. Log Scale Fidelity Test Settings

HP 3335A (dB)	Maximum Amplitude (dB)	Actual Amplitude (dB)	Minimum Amplitude (dB)
0	0	0 (Ref)	0
-10	-9.25	_____	-10.75
-20	-19.25	_____	-20.75
-30	-29.25	_____	-30.75
-40	-39.25	_____	-40.75
-50	-49.25	_____	-50.75
-60	-59.25	_____	-60.75
-70	-69.00	_____	-71.00

Table 3-15. Linear Scale Fidelity Test Settings

Attenuator Settings (dB)	Maximum Amplitude (mV)	Actual Amplitude (mV)	Minimum Amplitude (mV)
0	≈223.6	≈223.6 (Ref)	≈223.6
6	105.11	_____	118.49
12	49.21	_____	62.59
<i>Option 001</i>			
0	≈273.9	≈273.9	≈273.9
6	128.73	_____	145.17
12	60.26	_____	76.70
Option 001			
0	≈273.9	≈273.9	≈273.9
6	128.73	_____	145.17
12	60.26	_____	76.70

12. Frequency Drift Test

A 300 MHz, CW signal is applied to the analyzer RF input. After centering the signal on the analyzer display (CRT) for 5 minutes, the marker delta function of the analyzer is used to determine frequency drift over a 5 minute period. The spectrum analyzer must be warmed up for a minimum of 2 hours prior to running this test.

Specification

Frequency drift:

<50 kHz/5 minutes after 2 hour warm-up and 5 minutes after setting center frequency.

Equipment

Signal Generator HP 8340A
BNC Cable 120 cm (48 in) HP 10503A
Adapter, Type SMA (m) to BNC (f) HP part number 1250-1200
Adapter, Type SMA (f) to SMA (f) HP part number 1250-1158

Additional Equipment for Option 001

Minimum Loss Adapter HP 11852B
Adapter, Type N (m) to BNC (f) HP part number 1250-0780
Adapter, 75 Ω Type N (m) to 75 Ω BNC (m) HP part number 1250-1534
BNC Cable, 94 cm (37 in), 75 Ω HP part number 15525-80010

Test Procedure

Note



Be sure the unit is warmed up as described in specifications before performing the frequency drift test. This is needed to ensure an accurate evaluation of instrument operation and calibration.

1. Set the sweeper to output a 300 MHz, -10 dBm, CW signal.
2. Connect equipment as shown in Figure 3-14.
(*Option 001:* Connect the signal generator to the HP 8590A with the minimum loss adapter.)
3. Press the following analyzer keys:

PRESET (wait until preset is complete)
FREQUENCY 300 **MHz**
PEAK SEARCH
SIGNAL TRACK
SPAN 100 **kHz**

4. Wait 5 minutes, then press the following analyzer keys:

MARKER **MARKERS OFF** **TRACE A** **MAX HOLD A**

Wait 5 minutes, accurately timing the period using a timepiece.

Press **MKR** **MARKER NORMAL** . Using the knob, place the marker on the peak of the lowest frequency.

Press **MARKER DELTA** . Using the knob, place the delta marker on the peak of the highest frequency.

Read the marker delta frequency. Drift should not exceed 50 kHz plus a span accuracy of 0.3 kHz per graticule division. Record the frequency drift below and in Table 3-18.



Drift contributed by the signal generator is negligible, provided the critical specifications in test equipment (Table 3-3) are satisfied.

Frequency Drift _____ <50 kHz (+0.3 kHz/div)

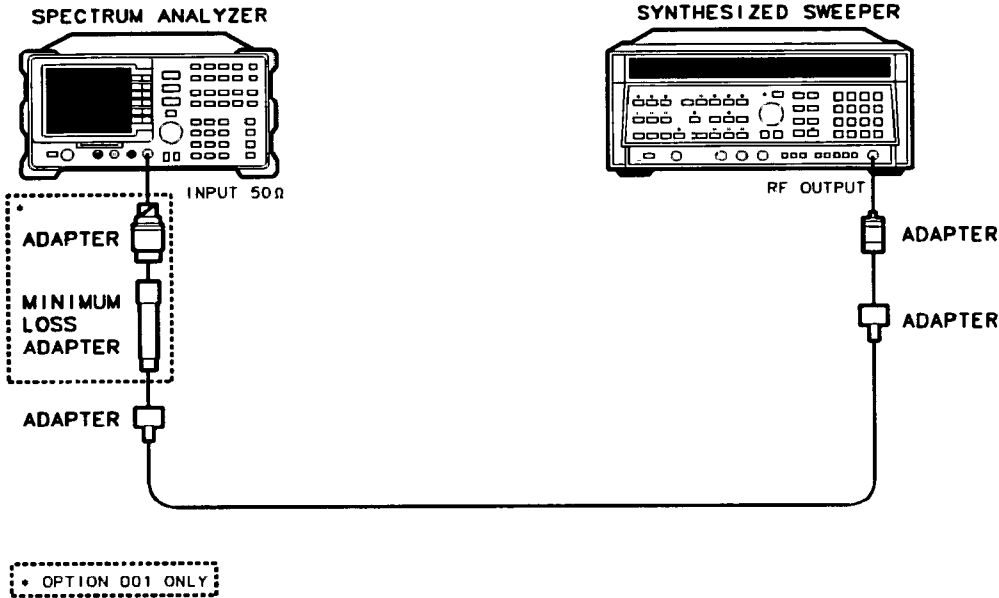

Figure 3-14. Frequency Drift Test Setup

13. Resolution Bandwidth Switching Test

In this test, the analyzer calibration (CAL Output) signal is applied to the RF input. The deviation in displayed peak signal amplitude for each IF resolution bandwidth filter is measured using the peak search function.

Specification

Resolution Bandwidth Switching (Amplitude Variation)

< ± 0.25 dB for 3 kHz to 3 MHz range

Equipment

BNC Cable, 23 cm (9 in) HP 10502A

Equipment for Option 001

BNC Cable, 30 cm (12 in), 75 Ω HP part number 5062-6452

Test Procedure

1. Connect the BNC cable from the CAL output to the RF input of the analyzer.
2. Press the following analyzer keys:

PRESET (wait until preset is complete)

PEAK SEARCH (be sure you are on the Cal signal or use **NEXT PEAK RIGHT**)

SIGNAL TRACK

SPAN 50 **kHz**

SWEEP BW **RES BW** 3 **kHz**

VID BW 1 **kHz**

(Option 001: **DISPLAY** **DISPLAY UNITS** **dBm**)

AMPLITUDE 20 **-dBm**

LOG dB/DIV 1 **dB**

3. Press **AMPLITUDE** and use the knob to place the signal peak one division below the reference level. Press **PEAK SEARCH** **MARKER DELTA** **SIGNAL TRACK**.
4. Set the **RES BW** and **SPAN** according to Table 3-16.
The amplitude reading should be within the limits in Table 3-16.
5. Repeat step 4 for each of the remaining resolution bandwidths and spans indicated in Table 3-16.

13. Resolution Bandwidth Switching Test

Table 3-16. Resolution Bandwidth Switching Test Record

Resolution Bandwidth	Span	MKR Δ TRK Amplitude Reading	MKR Δ TRK Measurement Limit (dB)
3 kHz	50 kHz	0(Ref)	0(Ref)
10 kHz	50 kHz	_____	±0.25 dB
30 kHz	500 kHz	_____	±0.25 dB
100 kHz	500 kHz	_____	±0.25 dB
300 kHz	5 MHz	_____	±0.25 dB
3 MHz	10 MHz	_____	±0.25 dB
1 MHz	5 MHz	_____	±0.25 dB

14. Gain Compression Test

A signal generator and a synthesizer are used to input two signals to the analyzer input mixer via a directional bridge. The synthesizer is set to output an 80 MHz, -24 dBm, CW signal through the directional bridge, which has a 6 dB loss. This signal must be at least 20 dB below the analyzer's compression-level threshold, which is -10 dBm. The signal generator is set to output a 100 MHz, 0 dBm, CW signal at the directional bridge's load connector.

First, the signal generator and synthesizer output levels are calibrated using a power meter. The synthesizer output is then connected to the bridge and measured by the analyzer to establish a reference level for the test. Next, the signal generator is connected, and the synthesizer is disconnected, for the compression-level evaluation. The analyzer's marker delta function is used to determine the resulting compression level.

Specification

Gain Compression

RF Input <1 dB for -10 dBm total power at input mixer
Internal IF <1 dB when signals are higher than reference level and total power at input mixer is -20 dBm.

Equipment

Level Generator	HP 3335A
Synthesized Sweeper	HP 8340A/B
Directional Bridge	HP 8721A
Power Meter	HP 436A
Power Sensor	HP 8482A
BNC Cable, 120 cm (48 in) (<i>2 required</i>)	HP 10503A
Adapter, Type N (f) to BNC (m)	HP part number 1250-0077
Adapter, BNC (m) to BNC (m)	HP part number 1250-0216
Adapter, Type SMA (m) to BNC (f)	HP part number 1250-1200
Adapter, Type SMA (f) to SMA (f)	HP part number 1250-1158

Additional Equipment for Option 001

Power Sensor, 75 Ω	HP 8483A
Adapter, Type N (f) to BNC (m), 75 Ω	HP part number 1250-1534
Adapter, BNC (m) to BNC (m), 75 Ω	HP part number 1250-1288

Test Procedure

1. Zero and calibrate the HP 436A and HP 8482A combination in log mode (power reads out in dBm). Enter the power sensor's 50 MHz Cal Factor into the HP 8902A.
(*Option 001: Calibrate the HP 8483A 75 Ω power sensor.*)

14. Gain Compression Test

2. Set the signal generator to output a 100 MHz, CW signal. Connect the level generator to the REFLECTED power connector of the directional bridge, as shown in Figure 3-15. Use the power meter and power sensor to set the signal generator output level to 0 dBm, measured at the LOAD connector of the directional bridge. Temporarily disconnect the signal generator from the directional bridge. Terminate the REFLECTED port with a 50 Ω load.
3. Set the synthesizer to output an 80 MHz, CW signal. Connect the BNC cable to the synthesizer RF output. Use a power meter and power sensor to set the synthesizer output level to -24 dBm at the free end of the BNC cable. Connect the synthesizer to the SOURCE connector of the directional bridge, as shown in Figure 3-15.
4. Connect the LOAD connector of the directional bridge with the adapter, to the HP 8590A RF input, as shown in Figure 3-15.

(Option 001: Use the HP 8483A power sensor with a Type N (f) to BNC (m) 75 Ω adapter (HP part number 1250-1534) and use a BNC (m) to BNC (m) 75 Ω adapter (HP part number 1250-1288) in place of the 50 Ω adapter.)

5. Press the following analyzer keys:

PRESET (wait until preset is complete)
FREQUENCY 80 **MHz**
SPAN 10 **MHz**
PEAK SEARCH
SIGNAL TRACK
SWEEP BW RES BW 3 **MHz**
VID BW 300 **Hz**
(Option 001: **DISPLAY** DISPLAY UNITS dBm)
AMPLITUDE LOG dB/DIV 5 **-dB**
MKR MARKER DELTA

6. Reconnect the level generator to the REFLECTED connector of the directional bridge. Note the marker delta readout on the analyzer display. The marker delta amplitude change should not exceed 1 dB.

14. Gain Compression Test

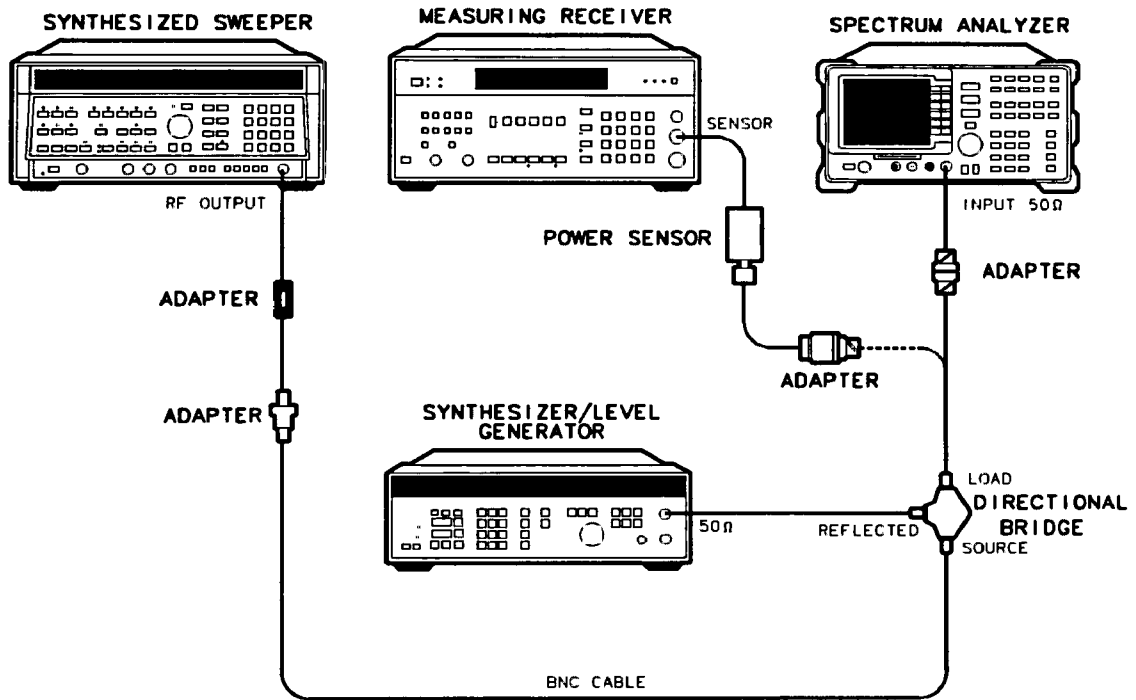

Figure 3-15. Gain Compression Test Setup

15. Input Attenuator Accuracy Test

The input attenuator's switching accuracy is tested over the full 0 dB to 70 dB range. Switching accuracy is referenced to the 10 dB attenuator setting. The attenuator in the synthesizer/level generator is the measurement standard.

Specification

- <±0.5 dB over 0 to 60 dB range
- <±0.75 dB over 0 to 70 dB range

Equipment

- Synthesizer/Level Generator HP 3335A
- Step Attenuator, 1 dB steps HP 355C
- Step Attenuator, 10 dB steps HP 355D

Cable Assembly

- BNC Cable (120 cm, 48 in) HP 10503A
- BNC Cable (120 cm, 48 in) HP 10502A

Adapters

- Type BNC (m) to BNC (m) HP part number 1250-0216

Test Procedure

1. Connect the equipment as shown in Figure 3-16. Set the HP 355D to 20 dB attenuation and the HP 355C to 0 dB attenuation.

2. Set the HP 3335A controls as follows:

FREQUENCY 50 **MHz**
AMPLITUDE -50 **dBm**
AMPTD INCR 10 **dB**
OUTPUT 50 **ohms**

3. On the HP 8590A, press **PRESET** and wait for the preset to finish. Set the controls as follows:

CENTER FREQUENCY 50 **MHz**
SPAN 10 **MHz**
REF LEVEL -70 **dBm**
LOG dB/DIV 1 **dB**
RES BW 10 **kHz**

4. On the HP 8590A, press:

PEAK SEARCH
SIGNAL TRACK (ON)
SPAN 100 **kHz**

Set the **VID BW** to 100 Hz.

15. Input Attenuator Accuracy Test

5. Set the HP 355C attenuation to place the signal peak 2 to 3 dB (two to three divisions) below the reference level.
6. On the HP 8590A, press:
TRIG
SINGLE SWEEP
PEAK SEARCH
MARKER DELTA
SIGNAL TRACK
7. Set the HP 3335A **AMPLITUDE** to -60 dBm as indicated in row 2 of Table 3-17.
8. Set the HP 8590A, **REF LEVEL** to -80 dBm and **ATTEN** to 0 dB as indicated in row 2 of Table 3-17.
9. On the HP 8590A, press **TRIG** and **SINGLE SWEEP**, and wait for a new sweep to finish. Press **PEAK SEARCH** and record the marker delta amplitude in Table 3-17 as the Actual reading. The marker delta amplitude reading should be within the limits shown.
10. Repeat steps 7 through 10 using the HP 3335A **AMPLITUDE** and HP 8590A **REF LEVEL** and **ATTEN** settings listed in Table 3-17.

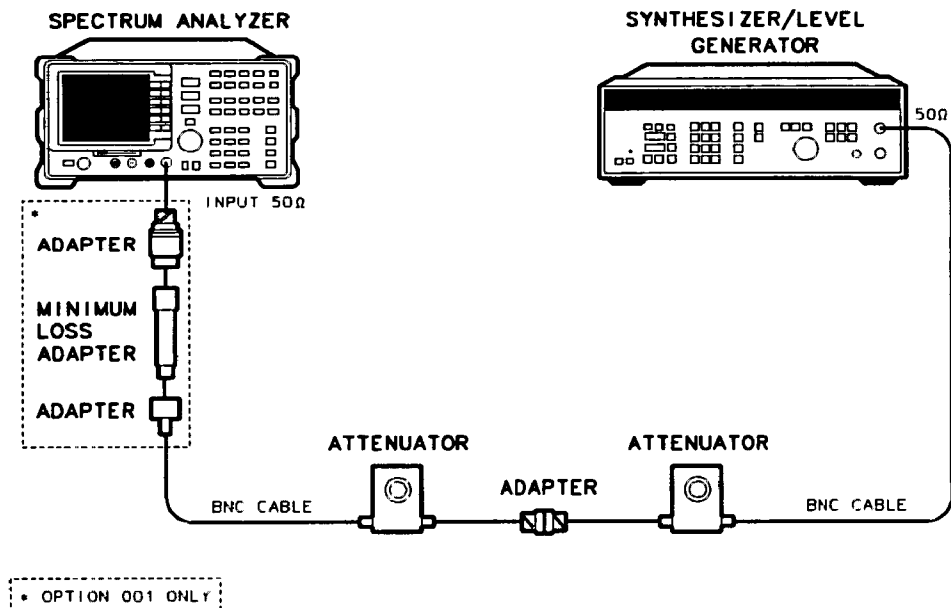

Figure 3-16. Input Attenuator Accuracy Test Setup

Table 3-17. Input Attenuator Accuracy Settings/Readings

HP 3335A Amplitude (dBm)	HP 8590A REF LEVEL (dBm)	HP 8590A ATTEN (dB)	Minimum MKR Δ Reading (dBm)	Actual MKR Δ Reading (dBm)	Maximum MKR Δ Reading (dBm)
-50	-70	10	0(Ref)	0(Ref)	0(Ref)
-60	-80	0	-0.5	_____	+0.5
-40	-60	20	-0.5	_____	+0.5
-30	-50	30	-0.5	_____	+0.5
-20	-40	40	-0.5	_____	+0.5
-10	-30	50	-0.5	_____	+0.5
0	-20	60	-0.5	_____	+0.5
10	-10	70	-0.75	_____	+0.75

Table 3-18. Performance Verification Test Record (1 of 4)

Hewlett-Packard Company

Tested by _____

HP Model 8590A

Spectrum Analyzer 10 kHz to 1.5 GHz

Date _____

Option 001: 1 MHz to 1.5 GHz

Option H18: 10 kHz to 1.79 GHz

Serial No. _____

Test Description	Minimum Results	Actual Results	Maximum Results
Frequency Readout Accuracy			
50 MHz	44.90 MHz	_____	55.10 MHz
100 MHz	94.90 MHz	_____	105.10 MHz
500 MHz	494.90 MHz	_____	505.10 MHz
1000 MHz	994.90 MHz	_____	1005.10 MHz
1500 MHz	1494.90 MHz	_____	1505.10 MHz
1700 MHz (<i>Option H18</i>)	1694.90 MHz	_____	1705.10 MHz
Displayed Average Noise			
400 kHz (Standard & <i>Option H18</i> only)		_____	-112 dBm
1 MHz		_____	-114 dBm
750 MHz		_____	-114 dBm
1500 MHz		_____	-112 dBm
1700 MHz (<i>Option H18</i>)		_____	-94 dBm
Frequency Response Flatness			
10 kHz to 10 MHz		_____	<2.0 dB
10 MHz to 1500 MHz (<i>Option H18</i>)		_____	<2.0 dB
1500 MHz to 1790 MHz		_____	<4.0 dB
Calibrator Amplitude			
50Ω: -20 dBm (<i>Option 001</i>)	-21 dBm	_____	-19 dBm
75Ω: +28.75 dBmV	+27.75 dBmV	_____	+29.75 dBmV
Frequency Accuracy			
299.9 MHz	299.6 MHz	_____	300.2 MHz
Frequency Span			
Readout Accuracy			
50 kHz	38.50 kHz	_____	41.50 kHz
100 kHz	77.00 kHz	_____	83.00 kHz
500 kHz	385.00 kHz	_____	415.00 kHz
1 MHz	770.00 kHz	_____	830.00 kHz
20 MHz	15.40 MHz	_____	16.60 MHz
100 MHz	77.00 MHz	_____	83.00 MHz
500 MHz	385.00 MHz	_____	415.00 MHz
1000 MHz	770.00 MHz	_____	830.00 MHz
1500 MHz	1255.00 MHz	_____	1345.00 MHz

Table 3-18. Performance Verification Test Record (2 of 4) (continued)

Hewlett-Packard Company

Tested by _____

HP Model 8590A

Spectrum Analyzer 10 kHz to 1.5 GHz

Date _____

Option 001: 1 MHz to 1.5 GHz

Option H18: 10 kHz to 1.79 GHz

Serial No. _____

Test Description	Minimum Results	Actual Results	Maximum Results
Sweep Time Accuracy			
20 ms	14.0 ms	_____	18.0 ms
50 ms	35.0 ms	_____	45.0 ms
100 ms	70.0 ms	_____	90.0 ms
500 ms	350.0 ms	_____	450.0 ms
1 s	700.0 ms	_____	900.0 ms
10 s	7.0 s	_____	9.0 s
50 s	35.0 s	_____	45.0 s
100 s	70.0 s	_____	90.0 s
Noise Sidebands			
> -65 dBc down	> -65 dBc	_____	
Spurious Response			
2nd harmonic*:			
> -70 dBc, Frequency > 5 MHz		_____	
> -60 dBc, Frequency ≤ 5 MHz		_____	
3rd order distortion:			
> -70 dBc, Frequency > 5 MHz		_____	
Residual Response			
Standard and <i>Option 001</i>		_____	< -95 dBm
<i>Option 001/H18</i> at 1728 MHz		_____	< -88 dBm
Reference Level Accuracy (< ±0.5 dB)	(limits)		(limits)
-10 dBm		Reference Level	
-20 dBm	-0.5	_____dB	+0.5
-30 dBm	"	_____dB	"
-40 dBm	"	_____dB	"
-50 dBm	"	_____dB	"
-60 dBm	-1.25	_____	+1.25
-70 dBm	"	_____dB	"
-80 dBm	"	_____dB	"
-90 dBm	"	_____dB	"
* For information only. This measurement not covered by HP 8590A specifications.			

Table 3-18. Performance Verification Test Record (3 of 4) (continued)

Hewlett-Packard Company

Tested by _____

HP Model 8590A

Spectrum Analyzer 10 kHz to 1.5 GHz

Date _____

Option 001: 1 MHz to 1.5 GHz

Option H18: 10 kHz to 1.79 GHz

Serial No. _____

Test Description	Minimum Results	Actual Results	Maximum Results
Log Scale Fidelity			
0 dB	0 dB	Reference Level	0 dB
10 dB	9.5 dB	_____dB	10.5 dB
20 dB	19.5 dB	_____dB	20.5 dB
30 dB	29.5 dB	_____dB	30.5 dB
40 dB	39.5 dB	_____dB	
50 dB	50.5 dB		
60 dB	59.5 dB	_____dB	60.5 dB
70 dB	69.2 dB	_____dB	
Linear Scale Fidelity			
0 dB	≈223.6 mV	Reference Level	≈223.6 mV
6 dB	105.09 mV	_____	111.51 mV
12 dB	49.19 mV	_____	62.61 mV
<i>Option 001</i>			
0 dB	≈273.9 mV	Reference Level	≈273.9 mV
6 dB	128.73 mV	_____	76.70 mV
Frequency Drift**			
<50 kHz per 5 minutes (+0.3 kHz/div)		_____	
Resolution Bandwidth Switching			
3 kHz	-0.25	_____Ref	+0.25
10 kHz	"	_____dB	"
30 kHz	"	_____dB	"
100 kHz	"	_____dB	"
300kHz	"	_____dB	"
1 MHz	"	_____dB	"
Gain Compression			
<1.0 dB		_____dB	
** 2-hour minimum warmup required before running test.			

Table 3-18. Performance Verification Test Record (4 of 4) (continued)

Hewlett-Packard Company

Tested by _____

HP Model 8590A

Spectrum Analyzer 10 kHz to 1.5 GHz

Date _____

Option 001: 1 MHz to 1.5 GHz

Option H18: 10 kHz to 1.79 GHz

Serial No. _____

Test Description	Minimum Results	Actual Results	Maximum Results
Input Attenuator Accuracy (Referenced to 10 dB INPUT ATTEN setting)			
0 dB ATTEN	-0.5 dB	_____	+0.5 dB
20 dB ATTEN	-0.5 dB	_____	+0.5 dB
30 dB ATTEN	-0.5 dB	_____	+0.5 dB
40 dB ATTEN	-0.5 dB	_____	+0.5 dB
50 dB ATTEN	-0.5 dB	_____	+0.5 dB
60 dB ATTEN	-0.5 dB	_____	+0.5 dB
70 dB ATTEN	-0.75 dB	_____	+0.75 dB

**If Something
Goes Wrong**

If Something Goes Wrong ...

What You'll Find in This Chapter

Your HP 8590A Spectrum Analyzer is built to provide dependable service. It is unlikely that you will experience a problem with the HP 8590A. However, if you do, or if you desire additional information or wish to order parts, options, or accessories, Hewlett-Packard's worldwide sales and service organization is ready to provide the support you need.

In general, a problem can be caused by a hardware failure, a software error, or a user error. Follow these general steps to determine the cause and to resolve the problem:

- Perform the quick checks listed in the "Check the Basics" section; these checks may eliminate the problem altogether, or may give a clearer idea of its cause.
- If the problem is a hardware problem, you have several options:
 - Repair it yourself; see the "Service Options" section.
 - Return the analyzer to Hewlett-Packard for repair;
 - If the analyzer is still under warranty or is covered by a Hewlett-Packard maintenance contract, it will be repaired under the terms of the warranty or maintenance contract (the warranty is printed on the inside front cover of this manual).
 - If the analyzer is no longer under warranty or covered by a Hewlett-Packard maintenance contract, Hewlett-Packard will notify you of the cost of the repair after examining the unit.

See the "How to Call Hewlett-Packard" and "How to Return Your Analyzer for Service" sections for more information.

Before You Call Hewlett-Packard

Check the Basics

A problem often can be solved by rechecking what was being done when the problem occurred. A few minutes spent in performing some simple checks may save waiting for your instrument to be repaired. Before calling Hewlett-Packard or returning the analyzer for service, please make the following checks:

- Is the analyzer plugged in to the proper ac power source? Does the line socket have power?
- Is the rear-panel voltage selector switch set correctly? Is the line fuse good?
- Is the analyzer turned on?
- If other equipment, cables, and connectors are being used with the HP 8590A, are they connected properly and operating correctly?
- Review the procedure for the test being performed when the problem appeared. Are all the switch settings correct?
- Is the test being performed, and the results that are expected, within the specifications and capabilities of the HP 8590A? (See Chapter 1, "Introducing the HP 8590A," Table 1-1, for analyzer specifications.)
- Is the HP 8590A displaying an error message? If so, refer to Appendix A, "HP 8590 Messages."
- Are the analyzer's measurements obviously inaccurate? If so, the analyzer's calibration data may have been destroyed. Refer to the *HP 8590A Support Manual* or contact the nearest Hewlett-Packard Sales and Service Office listed in Table 4-1.
- Perform the frequency and amplitude calibration routines given in the "Turning the HP 8590A On for the First Time" section in Chapter 2, "Preparation for Use." After running these routines, perform the Confidence Test that is described in the same section. Record all error messages that appear.
- If the necessary test equipment is available, perform the Operation Verification tests given in Chapter 3, "Performance Tests." Record all results on an Operation Verification Test Record form (Figure 2-1).

Read the Warranty

The warranty for your HP 8590A is printed on the inside front cover of this manual. Please read it and become familiar with its terms.

If your analyzer is covered by a separate maintenance contract, please be familiar with its terms.

Service Options

Hewlett-Packard offers several maintenance services for your analyzer after the warranty has expired. Call your Hewlett-Packard Sales and Service office for full details.

If you want to service the analyzer yourself after the warranty expires, you can purchase a Service Documentation Package that provides all necessary test and maintenance information. You can order the Service Documentation Package, HP part number 08590-90007, through your HP Sales and Service office. The package is described under "Service Documentation (Option 915)" in Chapter 1, "Introducing the HP 8590A," of this manual.

How to Call Hewlett-Packard

Hewlett-Packard has Sales and Service offices around the world to provide you with complete support for your HP 8590A. To obtain servicing information or to order replacement parts, contact the nearest Hewlett-Packard Sales and Service Office listed in Table 4-1. In any correspondence or telephone conversations, refer to the instrument by its model number and full serial number. With this information, the Hewlett-Packard representative can quickly determine whether your unit is still within its warranty period.

Table 4-1. Hewlett-Packard Sales and Service Offices

<p>IN THE UNITED STATES</p> <p>California Hewlett-Packard Co. 1421 South Manhattan Ave. P.O. Box 4230 Fullerton, CA 92631 (714) 999-6700</p> <p>Hewlett-Packard Co. 301 E. Evelyn Mountain View, CA 94039 (415) 694-2000</p> <p>Colorado Hewlett-Packard Co. 24 Inverness Place, East Englewood, CO 80112 (303) 649-5000</p> <p>Georgia Hewlett-Packard Co. 2000 South Park Place P.O. Box 105005 Atlanta, GA 30339 (404) 955-1500</p> <p>Illinois Hewlett-Packard Co. 5201 Tollview Drive Rolling Meadows, IL 60008 (312) 255-9800</p> <p>New Jersey Hewlett-Packard Co. 120 W. Century Road Paramus, NJ 07653 (201) 265-5000</p> <p>Texas Hewlett-Packard Co. 930 E. Campbell Rd. Richardson, TX 75081 (214) 231-6101</p>	<p>IN AUSTRALIA Hewlett-Packard Australia Ltd. 31-41 Joseph Street Blackburn, Victoria 3130 895-2895</p> <p>IN CANADA Hewlett-Packard (Canada) Ltd. 17500 South Service Road Trans-Canada Highway Kirkland, Quebec H9J 2X8 (514) 697-4232</p> <p>IN FRANCE Hewlett-Packard France F-91947 Les Ulis Cedex Orsay (6) 907-78-25</p> <p>IN GERMAN FEDERAL REPUBLIC Hewlett-Packard GmbH Vertriebszentrale Frankfurt Berner Strasse 117 Postfach 560 140 D-6000 Frankfurt 56 (0611) 50-04-1</p> <p>IN GREAT BRITAIN Hewlett-Packard Ltd. King Street Lane Winnersh, Wokingham Berkshire RG11 5AR 0734 784774</p> <p>IN OTHER EUROPEAN COUNTRIES Hewlett-Packard (Schweiz) AG Allmend 2 CH-8967 Widn (Zurich) (0041) 57 31 21 11</p>	<p>IN JAPAN Yokogawa-Hewlett-Packard Ltd. 29-21 Takaido-Higashi, 3 Chome Sugunami-ku Tokyo 168 (03) 331-6111</p> <p>IN PEOPLE'S REPUBLIC OF CHINA China Hewlett-Packard, Ltd. P.O. Box 9610, Beijing 4th Floor, 2nd Watch Factory Main Bldg. Shuang Yu Shu, Bei San Huan Rd. Beijing, PRC 256-6888</p> <p>IN SINGAPORE Hewlett-Packard Singapore Pte. Ltd. 1150 Depot Road Singapore 0410 273 7388 Telex HPSGSO RS34209 Fax (65) 2788990</p> <p>IN TAIWAN Hewlett-Packard Taiwan 8th Floor, Hewlett-Packard Building 337 Fu Hsing North Road Taipei (02) 712-0404</p> <p>IN ALL OTHER LOCATIONS Hewlett-Packard Inter-Americas 3495 Deer Creek Rd. Palo Alto, California 94304</p>
---	--	---

How to Return Your Analyzer for Service

Service Tag

If you are returning the analyzer to Hewlett-Packard for servicing, fill in and attach a blue service tag. Several service tags are supplied at the rear of this manual.

Please be as specific as possible about the nature of the problem. If you have recorded any error messages that appeared on the screen, or have completed a Performance Test Record, or have any other specific data on the performance of the analyzer, please send a copy of this information with the unit.

Original Packaging

Before shipping, pack the unit in the original factory packaging materials if they are available. If the original materials were not retained, identical packaging materials are available through any Hewlett-Packard office. Descriptions of the packaging materials are listed in the legend for Figure 2-1.

Other Packaging

Caution



Analyzer damage can result from using packaging materials other than those specified. Never use styrene pellets in any shape as packaging materials. They do not adequately cushion the equipment or prevent it from shifting in the carton. They cause equipment damage by generating static electricity and by lodging in the analyzer fan.

You can repackage the instrument with commercially available materials, as follows:

1. Attach a completed service tag to the instrument.
2. If you have a front-panel cover, install it on the instrument; if not, protect the control panel with cardboard.
3. Wrap the instrument in antistatic plastic to reduce the possibility of damage caused by electrostatic discharge.
4. Use a strong shipping container. A double-walled, corrugated cardboard carton with 159 kg (350 lb) bursting strength is adequate. The carton must be both large enough and strong enough to accommodate the analyzer. Allow at least 3 to 4 inches on all sides of the analyzer for packing material.
5. Surround the equipment with 3 to 4 inches of packing material and prevent the equipment from moving in the carton. If packing foam is not available, the best alternative is S.D.-240 Air Cap™ from Sealed Air Corporation (Commerce, California, 90001). Air Cap looks like a plastic sheet filled with 1-1/4 inch air bubbles. Use the pink-colored Air Cap to reduce static electricity. Wrapping the equipment several times in this material should both protect the equipment and prevent it from moving in the carton.
6. Seal the shipping container securely with strong nylon adhesive tape.
7. Mark the shipping container "FRAGILE, HANDLE WITH CARE" to assure careful handling.
8. Retain copies of all shipping papers.

HP 8590A Messages

The HP 8590A can generate various messages that appear on its screen during operation to provide an indication of progress through a procedure or to indicate a problem.

There are three types of messages: hardware error messages (H), user-created error messages (U), and informational messages (M).

- Hardware error messages indicate the HP 8590A hardware is probably broken.
- User-created error messages appear when the analyzer is used incorrectly. They are usually generated during remote operation.
- Informational messages indicate analyzer progress within a specific procedure.

The messages are listed in alphabetical order on the following pages; each message is defined, and its type is indicated by an (H), (U), or (M). In several instances, you are referred to the command description (for example, “See AUNITS.”) These command descriptions are contained in the HP-IB, HP-IL, and RS-232 Programming Manuals.

ADC-GND FAIL

Indicates a failure in the analog-to-digital converter. (H)

ADC-TIME FAIL

Indicates a failure in the analog-to-digital converter. (H)

ADC-2v FAIL

Indicates a failure in the analog-to-digital converter. (H)

CAL: FM SPAN SENS FAIL

The analyzer could not set up span sensitivity of the FM coil. (H)

CAL: LINEAR DET FAIL

The linear calibration routine failed. (H)

CAL: RES BW AMPL FAIL

The relative insertion loss of the resolution bandwidth is incorrect. (H)

CAL: SPAN SENS FAIL

The calibration span sensitivity routine failed. (H)

CAL: ---

During the calibration routine, messages may appear on the display indicating the routine is progressing: MC DELAY, FM DELAY, DONE, SWEEP, SWP DELAY, FREQ, SPAN, AMPTD, 3dB BW, ATTEN, LOG AMP. (M)

COMMAND ERROR: ---

The specified command is not recognized by the analyzer. (U)

CONFLICT TABLE OVERFLOW

A command has been used that is not compatible with the HP 8590A. (U)

FAIL: ---

An error was discovered during the power-up check. The 4-digit by 8-digit code indicates the type of error. (H)

INVALID AUNITS: ---

The amplitude units are not valid. See AUNITS. (U)

INVALID BLOCK FORMAT: IF STATEMENT

An invalid block format appeared within the IF statement. (U)

INVALID CHECKSUM: USTATE

The user-defined state does not follow the expected format. (U)

INVALID COMPARE OPERATOR

An IF/THEN or DO/UNTIL routine is improperly constructed. (U)

INVALID DETECTOR: ---

The specified detector is not valid. See DET. (U)

INVALID ENTER FORMAT

The enter format is not valid. See the appropriate command description to determine the correct format. (U)

INVALID HP-IB ADDRESS OR OPERATION

An HP-IB operation was aborted due to an incorrect address or invalid operation. (U)

INVALID HP-IB OPERATION REN TRUE

The HP-IB operation is not allowed. (Usually caused by print/plot when a calculator is on the interface bus.) (U)

INVALID HP-IL ADDRESS OR OPERATION

An HP-IL operation was aborted due to an incorrect address or invalid operation. (U)

INVALID HP-IL OPERATION REN TRUE

The HP-IL operation is not allowed. (Usually caused by print/plot when a calculator is on the interface bus.) (U)

INVALID KEYNAME: ___

The specified keyname is not allowed. (The keyname may conflict with an analyzer command.) (U)

INVALID OUTPUT FORMAT

The output format is not valid. See the appropriate command description to determine the correct format. (U)

INVALID REPEAT MEM OVFL

Memory overflow occurred due to REPEAT routine. (U)

INVALID REPEAT NEST LEVEL

The nesting level in the REPEAT routine is improperly constructed. (U)

INVALID RS-232 ADDRESS OR OPERATION

An RS-232 operation was aborted due to an incorrect address or invalid operation. (U)

INVALID SAVE REG

Data has not been saved in the specified state register. (U)

INVALID SYMTAB: EEROM OVERFLOW

The operator has cataloged too much data. (U)

INVALID SYMTAB: SYMTAB OVERFLOW

There is a symbol table overflow. (U)

INVALID TRACE: ___

The specified trace is invalid. See trace commands (VIEW, MXMH, CLRW, or BLANK). (U)

INVALID TRACE NAME: ___

The specified trace name is not allowed. (U)

INVALID TRIGGER MODE: ___

The specified trigger mode is invalid. See TM. (U)

INVALID VARDEF: ___

The specified variable name is not allowed. (U)

INVALID WINDOW TYPE: ___

The specified window is invalid. See TWNDOW. (U)

MEAS UNCAL

The measurement is uncalibrated. Check the sweep time, span, and bandwidth settings. (U)

PARAMETER ERROR: ___

The specified parameter is not recognized by the analyzer. See the appropriate command description to determine the correct parameters. (U)

SRQ ---

The specified service request is active. Service requests are a form of informational message and are explained in Appendix B. (M)

SOFTKEY OVFL

Softkey nesting exceeds the maximum number of levels. (U)

UNDEF KEY

A referenced softkey is not recognized by the analyzer. (U)

Service Requests

This appendix describes the analyzer service request (SRQ) capability. A service request is an analyzer output that tells the operator or computer that a specific event has taken place in the analyzer.

When writing programs, service requests can be used to interrupt the computer program sequence, causing the program to branch to a subroutine. For example, by using service requests, the computer can perform other operations while the analyzer is sweeping. When the sweep is completed, the computer can service the analyzer by changing the analyzer state or reading data from the display memory.

Note

Service requests do not work with computers that have only an RS-232 interface. HP-IB and HP-IL computers do not all have the same service request capabilities. Refer to the manuals supplied by your computer's manufacturer.

When making a service request, the analyzer places the I/O interface SRQ line true and the analyzer CRT display reads out SRQ with a number. Setting the SRQ line true announces to the computer that the analyzer requires attention. The computer can then command the analyzer to send its "status byte." The status byte indicates the type of service request.

Note

If the CRT display annotation has been blanked, the service request notation will not appear.

Note

A serial polling technique must be used by the computer to test for service requests. The analyzer does not respond to parallel polling.

Status Byte Definition

The status byte sent by the analyzer determines the nature of the service request. The meaning of each bit of the status byte is explained in Table B-1.

Table B-1. Status Byte Definition

Bit	Message	CRT Display Message
0 (LSB)	Unused	—
1	Unit Key	SRQ 102
2	End of sweep	SRQ 104
3	Hardware broken	SRQ 110
4	Command complete	SRQ 120
5	Illegal analyzer command	SRQ 140
6	Universal HP-IB service request. HP-IB RQS bit	—
7	Unused	—

The CRT display message is an octal number based on the binary value of the status byte. This octal number always begins with a "1" since this is translated from bit 6, the universal service request bit. The status byte for an illegal analyzer command (SRQ 140) is as follows:

bit number	7	6	5	4	3	2	1	0
status byte	0	1	1	0	0	0	0	0

The CRT displays the octal equivalent of the status byte binary number:

SRQ 140

The octal equivalent is based on the whole binary number:

01100000 (binary) = 140 (octal)

One simple way to determine the octal equivalent of the binary number is to partition the binary number three bits at a time from the least significant bit, and treat each part as a single binary number:

binary	0	1	1	0	0	0	0
octal	1	4	0				

The decimal equivalent of the octal number is determined as follows:

$$140 \text{ (octal)} = 1 \times (8) + 4 \times (8) + 0 \times (8) = 96 \text{ (decimal)}$$

More than one service request can be sent at the same time. For example, if an illegal analyzer command (SRQ 140) and the end of a sweep (SRQ 104) occurred at the same time, SRQ 144 appears on the CRT display, because both bit 5 and bit 2 are set as shown below:

bit number	7 6	5 4 3	2 1 0
status byte	0 1	1 0 0	1 0 0
octal value	1	4	4

Service Request Activating Commands

With the exceptions of SRQ 140 and SRQ 102, service requests can only be activated from a computer. (SRQ 140 and SRQ 102 are always activated.) Your *HP 8590A Programming Manual* describes service request activating commands in Chapter 4, "If Something Goes Wrong ...," under RQS and SRQ.

Index

7

75 Ω Input Impedance (Option 001), 1-2

A

Accessories, 1-3, 3-3

50 Ω /75 Ω Minimum Loss Pad, 1-5

75 Ω Matching Transformer, 1-5

AC Probe, 1-3

Broadband Preamplifier, 1-4

Close Field Probe, 1-4

Computer, 1-4

Monitor, 1-4

Plotter, 1-4

Printer, 1-4

Rack Slide Kit, 1-4

RF Limiter, 1-4

Tracking Generator, 1-5

Transit Case, 1-5

AC Power

Cables, 2-6

Fuse, 2-5

Requirements, 2-3

Voltage Selector Switch, 2-4

AC Probe, 1-3

Amplitude Calibration Routine, 2-9

Analyzers Covered by This Manual, 1-6

B

Before You Call Hewlett-Packard, 4-2

Before You Start Verification Tests, 3-3

C

Cable, AC Power, 2-6

Calibration Routines

Amplitude, 2-9

Frequency, 2-8

Calibrator Amplitude and Frequency Accuracy,
3-23

Case, Transit, 1-5

Characteristics, 1-12

Checking the Fuse, 2-5

Check the Basics, 4-2

Confidence Test, 2-9

D

Displayed Average Noise, 3-12

E

Equipment Rack, 2-3

Error Messages, A-1

Extended Frequency (Option H18), 1-3

F

Frequency Calibration Routine, 2-8

Frequency Drift Test, 3-53

Frequency Readout Accuracy, 3-10

Frequency Response Flatness, 3-14

Frequency Span Readout Accuracy, 3-26

Front Panel Cover (Option 040), 1-3

Fuse, 2-5

G

Gain Compression Test, 3-57

Getting Ready, 2-1

H

H18 Option, 1-3

How to Call Hewlett-Packard, 4-3

How to Return Your Analyzer for Service, 4-5

HP-IB (Option 021), 1-2

HP-IL (Option 022), 1-2

I

If the Analyzer Doesn't Meet Specifications, 3-3

Initial Inspection, 2-1

Input Attenuator Accuracy Test, 3-60

Inspection, Initial, 2-1

Introducing the HP 8590A, 1-1

K

Kit, Rack Slide, 1-4

L

Limiter, RF, 1-4

Line Voltage Selector Switch, 2-4

M

Message, A-1

N

Noise Sideband Test, 3-35

O

Operating and Installation Manuals (Option 910), 1-3

Operation Verification, 3-2

Operation Verification Test Record, 3-31, 3-63

Options, 1-2

179 GHz Extended Frequency (Option H18), 1-3

75Ω Input Impedance (Option 001), 1-2

Front Panel Cover (Option 040), 1-3

HP-IB (Option 021), 1-2

HP-IL (Option 022), 1-2

Operating and Installation Manuals (Option 910), 1-3

Rack Mount Flange Kit (Option 908), 1-3

Rack Mount Flange Kit with Handles (Option 909), 1-3

RS-232 (Option 023), 1-2

Service, 4-3

Service Documentation (Option 915), 1-3

Options and Accessories Available, 1-2

Original Packaging, 2-1, 4-5

Other Packaging, 4-6

P

Packaging

Original, 2-1, 4-5

Other, 4-6

Performance Tests, 3-1

Before Starting, 3-3

Calibrator Amplitude and Frequency Accuracy,

3-23

Displayed Average Noise, 3-12

Frequency Drift, 3-53

Frequency Readout Accuracy, 3-10

Frequency Response Flatness, 3-14

Frequency Span Readout Accuracy, 3-26

Gain Compression, 3-57

Input Attenuator Accuracy, 3-60

Noise Sideband, 3-35

Reference Level Accuracy, 3-46

Residual Response, 3-44

Resolution Bandwidth Switching, 3-55

Scale Fidelity, 3-49

Spurious Response, 3-37

Sweep Time Accuracy, 3-32

Performance Verification, 3-1

Performance Verification Test Record, 3-64

Periodically Verifying Operation, 3-3

Power Cable, 2-6

Power Requirements, 2-3

Preamplifier, Broadband, 1-4

Preparing the HP 8590A for Use, 2-3

Probe

AC, 1-3

Close Field, 1-4

Procedures

Amplitude Calibration Routine, 2-9

Checking the Fuse, 2-5

Confidence Test, 2-9

Frequency Calibration Routine, 2-8

Returning the Analyzer for Service, 4-5

Setting the Line Voltage Selector Switch, 2-4

Turning the HP 8590A On for the First Time, 2-8

R

Rack, Equipment, 2-3

Rack Mount Flange Kit (Option 908), 1-3

Rack Mount Flange Kit with Handles (Option 909), 1-3

Recording the Test Results, 3-3

Reference Level Accuracy Test, 3-46

Residual Reponse Test, 3-44

Resolution Bandwidth Switching Test, 3-55

Routine

Amplitude Calibration, 2-9

Frequency Calibration, 2-8

RS-232 (Option 023), 1-2

S

Scale Fidelity Test, 3-49

Serial Numbers, 1-6

Service

Documentation (Option 915), 1-3

How to Return Your Analyzer, 4-5

Offices, 4-3

Options, 4-3

Service Request Activating Commands, B-3

Service Requests (SRQ), B-1

Service Tag, 4-5

Setting the Line Voltage Selector Switch, 2-4

Specifications, 1-7

Spurious Response Test, 3-37

SRQ (service requests), B-1

Status Byte Definition, B-2

Sweep Time Accuracy Test, 3-32

Switch, Line Voltage Selector, 2-4

System II Cabinet, 2-3

T

Test

Calibrator Amplitude and Frequency Accuracy, 3-23

Confidence, 2-9
Displayed Average Noise, 3-12
Frequency Drift, 3-53
Frequency Readout Accuracy, 3-10
Frequency Response Flatness, 3-14
Frequency Span Readout Accuracy, 3-26
Gain Compression, 3-57
Input Attenuator Accuracy, 3-60
Noise Sideband, 3-35
Reference Level Accuracy, 3-46
Residual Response, 3-44
Resolution Bandwidth Switching, 3-55

Scale Fidelity, 3-49
Spurious Response, 3-37
Sweep Time Accuracy, 3-32
Test Equipment You'll Need, 3-3
Test Record, Operation Verification, 3-31, 3-63
Test Record, Performance Verification, 3-64
Test Results, Recording, 3-3
Turning the HP 8590A On for the First Time, 2-8

V

Voltage Selector Switch, 2-4