

The HP 8566B Spectrum Analyzer

Designed for bench and system use, the HP 8566B offers superior measurement speed, microwave frequency accuracy, and sensitivity. Measure low-level signals up to 22 GHz with narrow resolution bandwidths. Synthesizer stability virtually eliminates long-term drift and residual FM.

Frequency range is 100 Hz to 22 GHz with a dc-coupled input. Preselected external mixers extend this coverage from 26.5 to 75 GHz. Other external mixers allow measurement to 325 GHz.

An internal bus and microcomputer control make possible many powerful operating and data processing features, as well as flexibility under computer control. Sixteen Kbytes of user RAM are available for storing trace data, instrument states, and custom downloadable programs (DLPs). All displayed information can be sent directly to an HP-IB plotter when sweep time is greater than or equal to 20 ms.

Accurate Measurements

Amplitude measurement range extends from +30 to -135 dBm with a 90 dB calibrated display.

Less than 1×10^{-9} /day frequency reference error and the spectrum analyzer selectivity allow high frequency accuracy even when you are measuring small signals in the presence of large ones.

The Spectrum Analyzer That Keeps Getting Better

Turbo Speed Option

Already a world leader in measurement speed, the HP 8566B can be made even faster with Option 002, which nearly doubles the internal processing speed of the analyzer. Some measurements can be made up to 50% faster, and overall throughput is typically improved by 5 to 25%. (Sweep speed is not affected by Option 002.)

The Turbo option is compatible with all HP 8566B accessories, and it can be added to any HP 8566B without affecting specifications. (An HP 8566A must first be upgraded to an HP 8566B.)

Accessories and Options

By adding measurement accessories and options, the HP 8566B spectrum analyzer fits into many applications, including electromagnetic compatibility (EMC) testing, broadband signal surveillance, and component stimulus-response testing.

• EMI measurement accessories and software create systems for testing to commercial and military standards.

• Microwave tracking sources add scalar measurement capability.

• Preselected external mixers simplify millimeter-wave measurements from 26.5 to 75 GHz.

• Interactive test generator (ITG) soft-front-panel-based drivers speed software development.

• MIL-STD 45662A calibrations are available.

Custom Softkey Programming

You can create complex measurement routines on an external controller, store the programs in user RAM, and execute them using a single custom softkey.

Simple measurement routines can be entered from the instrument front panel, stored in user RAM, and executed using a single custom softkey.

Turbo Speed Improvements

Operation	Standard HP 8566B	Turbo HP 8566B	Speed Improvement
Trace Dump	1083 ms	532 ms	51%
MKR AMPL	8.4 ms	3.7 ms	56%
Harmonics Test	1007 ms	782 ms	22%
FFT	473 ms	243 ms	49%

**The HP 8566B Microwave Spectrum Analyzer—
Smart Enough to Make
Its Own Decisions with
Precision and Speed**

One keystroke sends all CRT information directly to a plotter*

Easy-to-read, annotated display shows instrument settings and multiple traces

Coupled functions

SAVE and RECALL store instrument settings



* Instrument sweep times greater than or equal to 20 ms

Measurement aids include four tunable markers for direct and relative signal measurements

Powerful signal and trace-processing functions perform complex data analysis

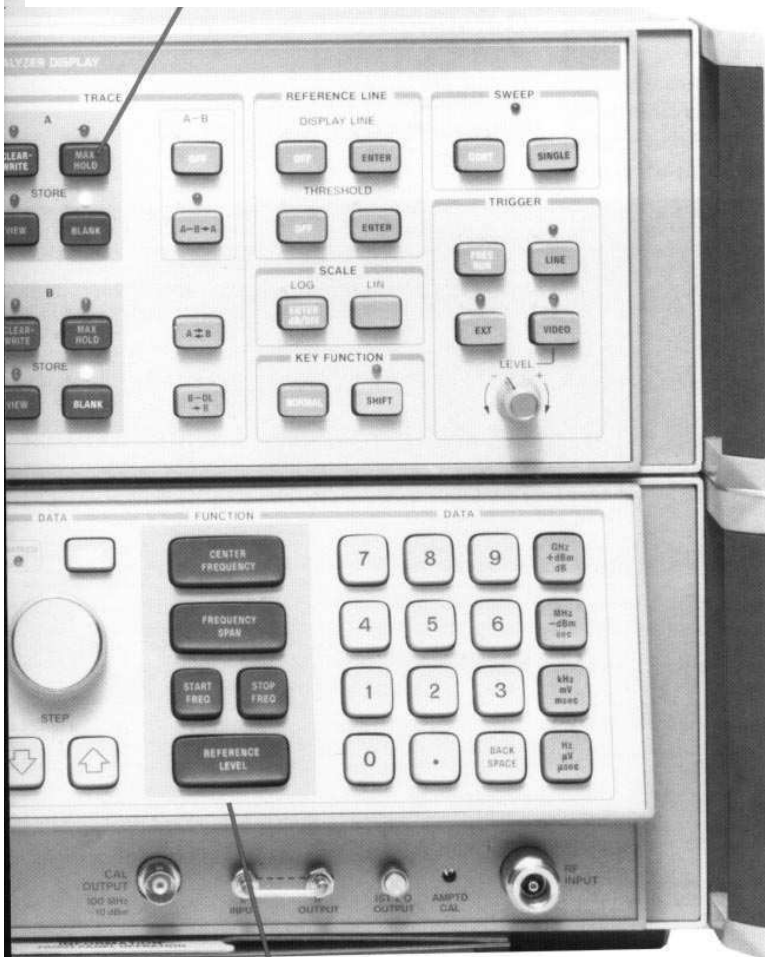

Interactive function and data controls simplify operation

Today's HP 8566B Offers

- *Exceptional microwave performance*
- *Decision-making capability*
- *Enhanced processing speed*
- *Preselected millimeter coverage*

- *Advanced functions*
- *Downloadable programming capability*
- *Distributed processing with a computer*

- *Proven reliability, performance, and support*

Dedicated keys make basic operation easy

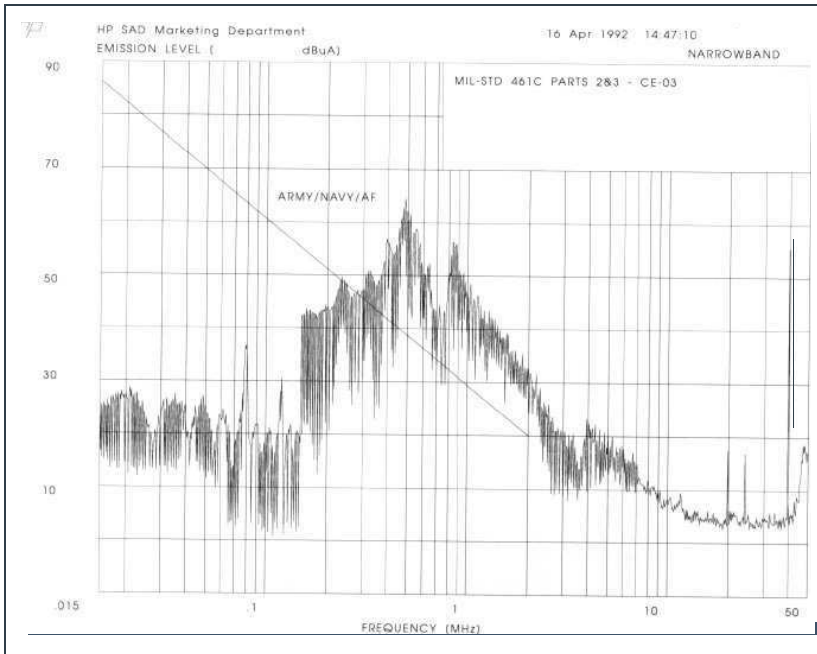

Test Systems Tailored to Your Needs

For EM1 troubleshooting and pre-qualification testing, use your HP 8566B spectrum analyzer with components and accessories from HP's complete line of EM1 products. The many offerings include current probes, line impedance stabilization networks (LISNs), antennas, positioning equipment, EM1 measurement software, an RF preselector, and a quasi-peak adapter.

EMC Measurement Solutions

Commercial and MIL EM1 Receivers

The HP 8566B spectrum analyzer forms the heart of two powerful and flexible EM1 receivers. These receivers are ideal for commercial and military EM1 compliance testing from 20 Hz to 40 GHz.

The HP 8571A receiver is optimized for military EM1 testing, making both peak and average detection measurements using impulse bandwidths. The HP 85728 includes all the features and capabilities of the HP 85718, but adds quasi-peak detection and specialized IF bandwidths for commercial compliance measurements.

Both receivers offer ± 2 dB absolute amplitude accuracy over their full 20 Hz to 22 GHz frequency range, as required by MIL-STD 461 and CISPR Publication 16. For higher frequency measurements, a 22 to 40 GHz block downconverter can be added. The receivers include a built-in, 1 to 26.5 GHz amplifier and a 20 Hz to 50 MHz input port with a built-in limiter and rugged attenuator. They are also compatible with HP's EM1 measurement software and complete line of test accessories.



Accessories That Enhance Performance

Millimeter Mixers

Preselected Mixers

The HP 11974 series preselected mixers eliminate the need for time-consuming signal identification routines at millimeter frequencies. With preselection, no images or multiples are generated to confuse measurements. These external mixers allow you to quickly locate true signals, and they simplify software development for automated measurements. The HP 11974 series mixers are available in four bands covering 26.5 to 75 GHz!

Harmonic Mixers

The HP 11970 series waveguide mixers are general-purpose external harmonic mixers. They offer flat frequency response and low conversion loss without requiring external dc bias or tuning adjustment. The HP 11970 series mixers are offered in six bands covering 18 to 110 GHz!

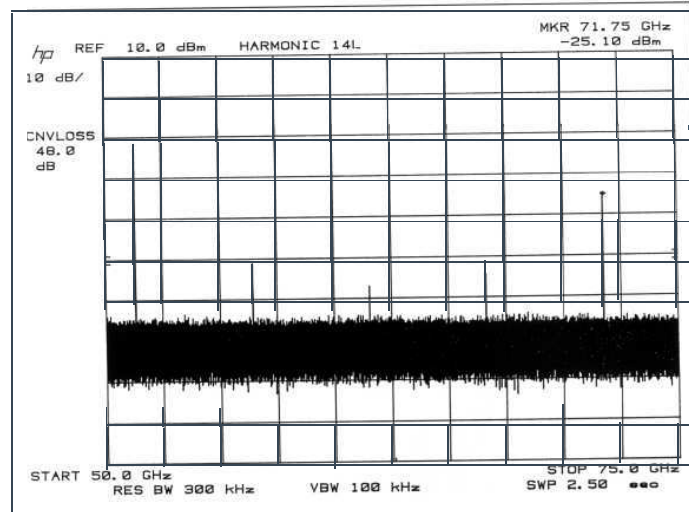

Preselected mixers eliminate images and multiples.

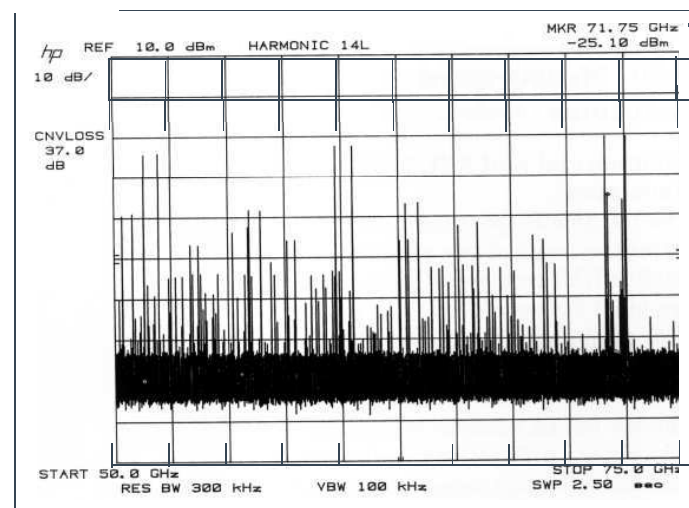

Harmonic mixing extends frequency range.

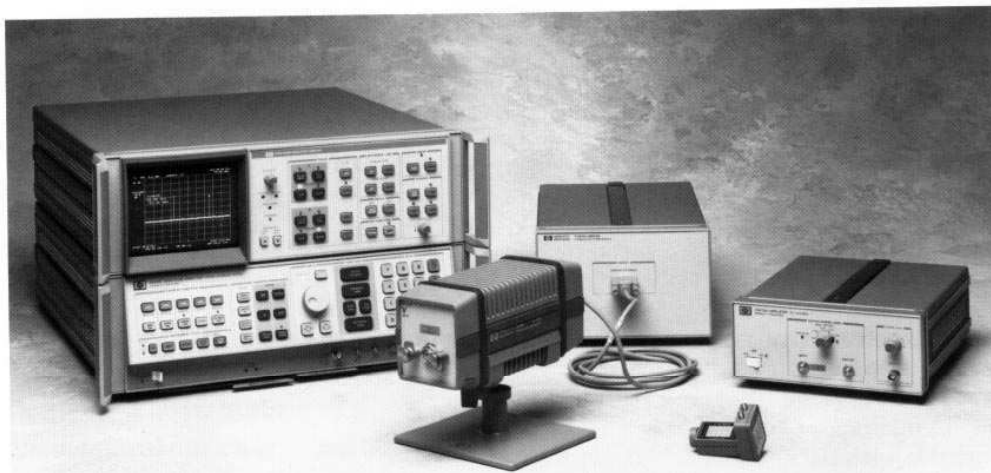

Tracking Sources

Add high dynamic range scalar measurement capability to the HP 8566B. The HP 856448 and 856458 portable tracking sources allow you to use your spectrum analyzer for measuring transmission and reflection characteristics of devices. You can also characterize harmonic distortion, intermodulation distortion, spurious products, and more.

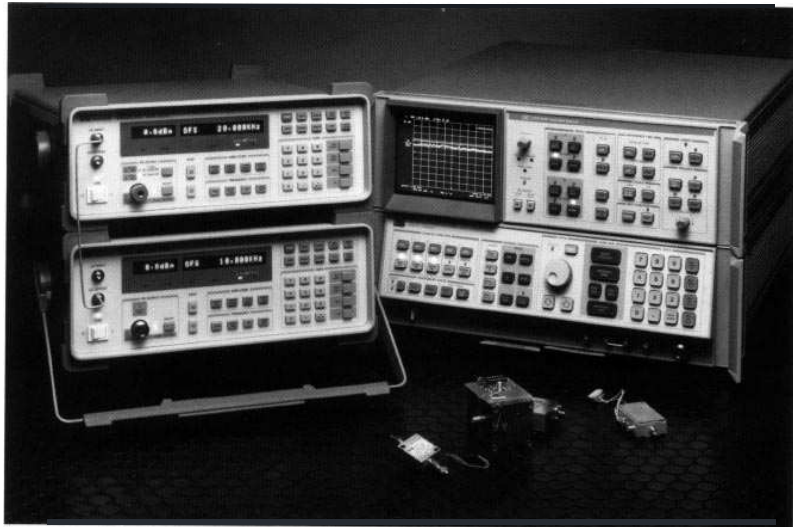

The tracking sources give the HP 8566B dynamic range greater than 125 dB up to 12.5 GHz and greater than 105 dB through 22 GHz.

Other features include:

- *swept offset tracking for mixer testing and swept TOI measurements*
- *up to +10 dBm leveled output power*
- *standalone CW source capability*

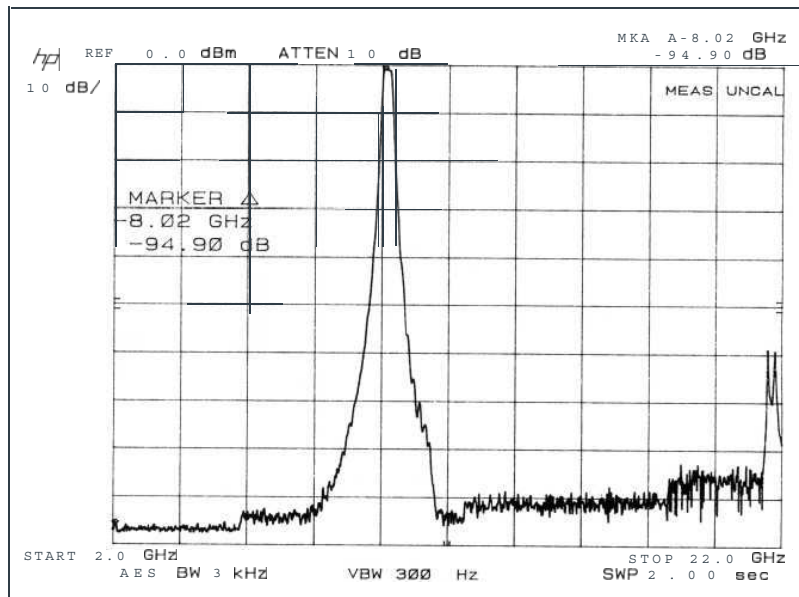

High dynamic range scalar measurement

Microwave Preamplifier

Boost the sensitivity of the HP 8566B spectrum analyzer with the HP 8449B microwave preamplifier. This low noise, high gain preamplifier has a frequency range of 1 to 26.5 GHz. Sensitivity improvements of up to 25 dB allow you to detect and analyze very low level signals in dramatically reduced time, using wider bandwidths. Low return loss on the input and output ports of the preamplifier minimizes mismatch uncertainty.

Displayed Average Noise Level

0 dB Attenuation, 10 Hz RBW

(characteristic)

1.0 to 2.5 GHz	-155 dBm
2.0 to 5.8 GHz	-154 dBm
5.8 to 12.5 GHz	-150 dBm
12.5 to 18.6 GHz	-144 dBm
18.6 to 22 GHz	-140 dBm



Computers and Plotters

The HP 8566B spectrum analyzer works with computers that support HP BASIC, including HP 9000 Series 200 and 300 computers and IBM PC/AT-compatible models.

The HP 7440 and 7550 plotters are recommended for use with the HP 8566B. Data can be sent directly from the analyzer to the plotter, without the need for a computer.

Specifications

Specifications describe the instrument's warranted performance over the 0° to 55° C temperature range (unless otherwise noted), with autocoupled function operation and preselector tracking optimized. **Characteristics** provide information about non-warranted instrument performance.

Frequency

Measurement Range 100 Hz to 22 GHz, dc-coupled input; up to 325 GHz with external mixers

Frequency Reference Error

Aging Rate $< 1 \times 10^{-9}$ /day and $< 2.5 \times 10^{-7}$ /year
Temperature Stability $< 7 \times 10^{-9}$ over 0° to 55° C range
Center Frequency 0 Hz to 22 GHz

Center Frequency Readout Accuracy

Spans $\leq n \times 5 \text{ MHz} \pm (2\% \text{ of frequency span} + \text{frequency reference error} \times \text{center frequency} + 10 \text{ Hz})$
Spans $> n \times 5 \text{ MHz} \pm (2\% \text{ of frequency span} + n \times 100 \text{ kHz} + \text{frequency reference error} \times \text{center frequency})$
 where n is the harmonic mixing number, depending on center frequency:

n	Center Frequency
1	100 Hz to 5.8 GHz
2	5.8 to 12.5 GHz
3	12.5 to 18.6 GHz
4	> 18.6 GHz

(After adjusting freq zero, add 30% of RES BW setting if error correction is not used.)

Zero Span \pm (frequency reference error x center frequency)

Frequency Span

0 Hz, 100 Hz to 22 GHz over 10 division CRT horizontal axis; variable in approximately 1% increments. Two FULL SPAN keys select spans from 0 to 2.5 GHz and from 2 to 22 GHz.

Frequency Span Readout Accuracy

Spans $\leq n \times 5 \text{ MHz} \pm 1\%$ of indicated frequency separation
Spans $> n \times 5 \text{ MHz} \pm 3\%$ of indicated frequency separation

Start or Stop Frequency Same as center frequency

Resolution

Resolution Bandwidth 3 dB bandwidths of 10 Hz to 3 MHz in a 1, 3, 10 sequence. Bandwidth may be selected manually or coupled to frequency span (AUTO mode).

3 dB Bandwidth Accuracy

3 MHz $\pm 20\%$
 3 kHz to 1 MHz $\pm 10\%$
 10 Hz to 1 kHz $\pm 20\%$
 (30 kHz and 100 kHz bandwidth accuracy figures apply only with $\leq 90\%$ relative humidity, $\leq 40^\circ \text{C}$.)

60 dB/3 dB Bandwidth Selectivity Ratio

100 kHz to 3 MHz $< 15:1$
 3 kHz to 30 kHz $< 13:1$
 30 Hz to 1 kHz $< 12:1$
 (60 dB points on 100 Hz bandwidth are separated by $< 100 \text{ Hz}$.)

Bandwidth Shape

Synchronously tuned, approximately Gaussian

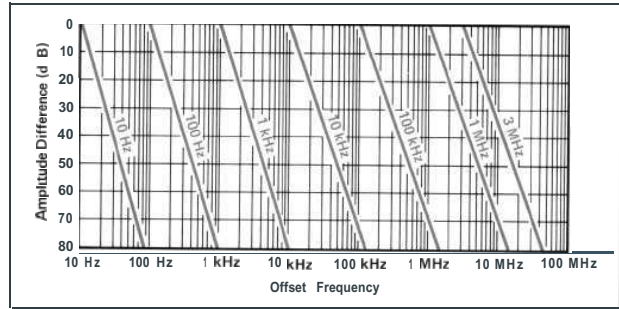

Fig. 1. Typical spectrum analyzer resolution

Stability

Residual FM (typical) For fundamental mixing ($n=1$) $< 50 \text{ kHz}$ peak-to-peak, freq. span $> 5 \text{ MHz}$.

Drift Because analyzer is phase-locked at beginning of each sweep, drift occurs only during time of one sweep.

Frequency Span	Center Frequency Drift*
$\leq 100 \text{ kHz}$	$< 10 \text{ Hz/min}$ of sweep time
100 kHz-5 MHz	$< 500 \text{ Hz/min}$ of sweep time
$\geq 5 \text{ MHz}$	$< 5 \text{ KHz/min}$ of sweep time

* Typical, after 1 hr warmup at stabilized temp
 COUPLED FUNCTION not required.

Spectral Purity

Noise Sidebands (for frequency span $\leq 25 \text{ kHz}$ —except 100 kHz offset—and center frequency from 100 Hz to 5.8 GHz)

Offset from Carrier Sideband Level

320 Hz	-80 dBc/Hz
1 kHz	-85 dBc/Hz
10 kHz	-90 dBc/Hz
100 kHz	-105 dBc/Hz

Typical Noise Sideband Performance

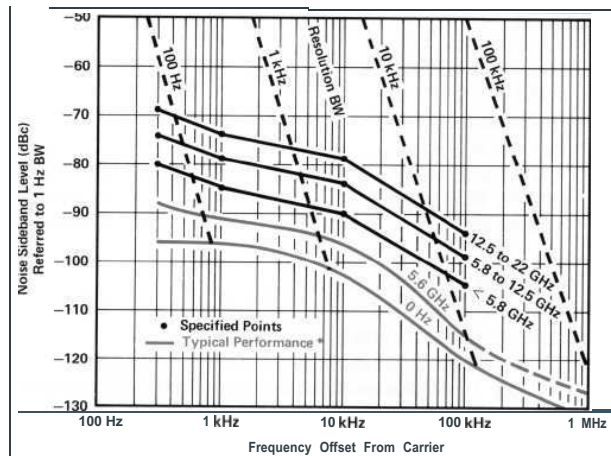

Fig. 2. Single sideband noise normalized to 1 Hz BW vs offset from carrier

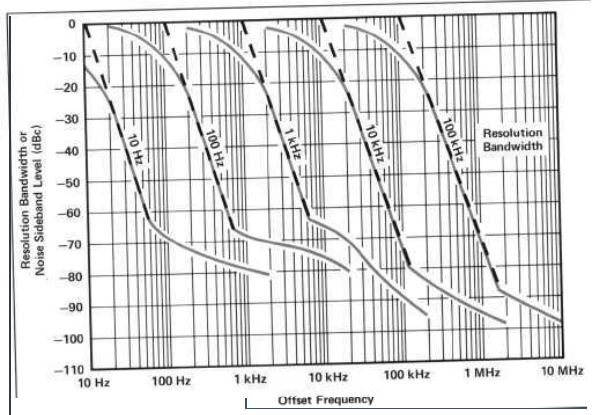

Fig. 3. Typical analyzer and SSB noise at 5.0 GHz center frequency. May be limited by average noise level.

Power-Line-Related Sidebands

(for line conditions specified in Power Requirements section)

Offset from Carrier	SIDE BANDS				
	≤ 100 MHz	> 100 MHz to 5.8 GHz	6.8 to 12.6 GHz	12.6 to 18.6 GHz	18.6 to 22 GHz
< 360 Hz	-70 dBc	-60 dBc	-64dBc*	-60 dBc*	-58dBc*
360 kHz to 2 kHz	-75 dBc	-75dBc*	-69dBc*	-65dBc*	-63dBc*
> 2 kHz	-80dBC	-80dBc*	-74dBc*	-70dBc*	-63dBc*

Typical*

Amplitude

Measurement Range

Measurement range is the total amplitude range over which the analyzer can measure signal responses. The low value is determined by sensitivity (10 Hz RBW and 0 dB RF input attenuation) and the high value by damage level.

Tuned Frequency	Range
Non-preselected	
100 Hz to 50 kHz	- 95 to + 30 dBm
50 kHz to 1 MHz	- 112 to + 30 dBm
1 MHz to 2.5 GHz	- 134 to + 30 dBm
Preselected	
2.0 to 5.8 GHz	- 132 to + 30 dBm
5.8 to 12.5 GHz	- 125 to + 30 dBm
12.5 to 18.6 GHz	- 119 to + 30 dBm
18.6 to 22 GHz	- 114 to + 30 dBm

Displayed Values

Scale (over a 10 division CRT vertical axis with 0 dB reference level at top graticule line)

Calibration

- Log 10 dB/div for 90 dB display from reference level.
- Expanded from reference level:
 - 5 dB/div for 50 dB display
 - 2 dB/div for 20 dB display
 - 1 dB/div for 10 dB display
- Linear 10% of ref level/div when calibrated voltage

Reference Level

Range

Log +30.0 to -99.9 dBm or equivalent in dBmV, dBμV, volts. Readout expandable to +60.0 dBm to -119.9 dBm (-139.9 dBm for ≤ 1 kHz RBW)*

Linear 7.07 V to 2.2 μV full scale. Readout expandable to 223.6 V to 2.2 μV (0.22 μV for < 1 kHz RBW)*

* Maximum total input power not to exceed +30 dBm damage level

Accuracy

The sum of the following factors determines the accuracy of the reference level readout. Measurement technique used after calibration with CAL signal determines applicability of uncertainty sources. Specifications given with preselector tracking optimized using MARKER PRESELECTOR PEAK.

With corrected readout (SHIFT W and SHIFT X executed just prior to measurement), 20° to 30° C temperature range, and minimum one hour warmup time.

Calibrator Uncertainty ±0.3 dB

Frequency Response (Flatness) Uncertainty

(10 dB attenuation)	
100 Hz to 2.5 GHz	±0.6 dB
2.0 to 12.5 GHz	±1.7 dB
12.5 to 20 GHz	±2.2 dB
20 to 22.0 GHz	±3.0 dB
Cumulative, 100 Hz to 20 GHz	±2.2 dB

Absolute Amplitude Calibration Uncertainty

The uncertainty of setting the frequency response curve absolutely when using the internal CAL signal or other calibration signal in the 100 Hz to 2.5 GHz band (10 dB input attenuation). ±0.6 dB

Resolution Bandwidth Switching Uncertainty

Referenced to 1 MHz RES BW	
10 Hz	±1.1 dB
30 Hz	±0.4 dB
100 Hz to 1 MHz	±0.2 dB
3 MHz	±0.2 dB

Log Scale Switching Uncertainty ±0.1 dB

Log Fidelity	
Incremental	±0.1 dB/dB over 0 to 80 dB display
Cumulative	
10 Hz RBW	≤ ±2.1 dB over 0 to 90 dB
≥ 30 Hz RBW	≤ ±1.5 dB over 0 to 90 dB
	≤ ±1.0 dB over 0 to 80 dB

Linear Fidelity < ±3% of reference level over top 9-1/2 divisions of the display

IF Gain Uncertainty Reference to -10 dBm; reference level with 10 dB input attenuation.

RBW	Reference Level
RBW ≥ 3 kHz	0 to -59.9 dBm ≤ ±0.3 dB
	-60 to -100 dBm ≤ ±1.0 dB
RBW 100 Hz-1 kHz	0 to -79.9 dBm ≤ ±0.3 dB
	-80 to -100 dBm ≤ ±1.0 dB
RBW 30 Hz	0 to -79.9 dBm ≤ ±0.3 dB
	-80 to -100 dBm ≤ ±2.0 dB
RBW 10 Hz	0 to -79.9 dBm ≤ ±1.0 dB
	-80 to -100 dBm ≤ ±2.0 dB

Log Digitization Uncertainty

10 dB/div	± 0.2 dB
5 dB/div	± 0.1 dB
2 dB/div	± 0.04 dB
1 dB/div	± 0.02 dB

Linear Digitization Uncertainty ± 0.2% of ref level

Error Correction Accuracy (applicable when SHIFT W and SHIFT X are executed) ± 0.4 dB

Reference Line Accuracy Equals the sum of reference level accuracy plus the scale fidelity between the reference level and the reference line level.

Dynamic Range

Spurious Responses (signals generated by the analyzer due to input signals) for signals ≤ -40 dBm at the input mixer, all harmonic and intermodulation distortion > 70 dB below input signal.

Second Harmonic Distortion (for mixer levels ≤ -40 dBm)

100 Hz to 50 MHz	< -70 dBc
50 to 700 MHz	< -80 dBc
700 MHz to 2.5 GHz	< -70 dBc

For mixer levels ≤ -10 dBm

2 to 22 GHz	< -100 dBc
-------------	------------

Image, Multiple, and Out-of-Band Responses

Image responses are due to input signals that are two times the IF frequency above or below the tuned frequency. Multiple responses are due to input signals mixing with more than one LO harmonic. Out-of-band responses are due to input signals outside of the selected frequency band.

Applied Tuned Frequency Frequency

(GHz)	0-2.5	2.0-5.8	5.8-12.5	12.5-18.6	18.6-22.0
0-2.5	NA	-60 dBc	-60 dBc	-60 dBc	-60 dBc
2.0-5.8	-60 dBc	-70 dBc	-60 dBc	-60 dBc	-60 dBc
5.8-12.5	-50 dBc	-60 dBc	-70 dBc	-60 dBc	-60 dBc
12.5-18.6	-45 dBc	-60 dBc	-60 dBc	-70 dBc	-60 dBc
18.6-22.0	-40 dBc	-60 dBc	-60 dBc	-60 dBc	-70 dBc*

*Image Responses: -60 dBc, 18.6-20.0 GHz; -50 dBc, 20.0-22 GHz

Residual Responses (signals displayed by the analyzer independent of input signals), 0 dB input attenuation, no input signal.

100 Hz to 5.8 GHz	< -100 dBm*
5.8 to 12.5 GHz	< -95 dBm
12.5 to 18.6 GHz	< -85 dBm
18.6 to 22 GHz	< -80 dBm

*Limited by the appropriate DANL or -100 dBm, whichever is greater.

Gain Compression

< 1.0 dB, 100 Hz to 22 GHz, with ≤ -5 dBm at input mixer

Displayed Average Noise Level (Sensitivity)

0 dB input attenuation, 10 Hz RBW

100 Hz to 50 kHz	< -95 dBm
50 kHz to 1.0 MHz	< -112 dBm
1.0 MHz to 2.5 GHz	< -134 dBm
2.0 to 5.8 GHz	< -132 dBm
5.8 to 12.5 GHz	< -125 dBm
12.5 to 18.6 GHz	< -119 dBm
18.6 to 22 GHz	< -114 dBm

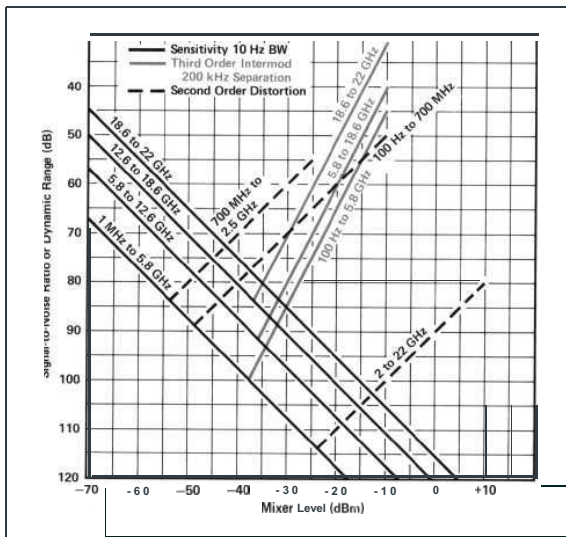

Fig. 4. Typical optimum dynamic range

Third Order Intermodulation Distortion

Third Order Intercept (TOI)

100 Hz to 5 MHz	> + 5 dBm
5 MHz to 5.8 GHz	> + 7 dBm
5.8 GHz to 18.6 GHz	> + 5 dBm
18.6 to 22 GHz	> + 5 dBm (typical)
2 to 22 GHz, for > 100 MHz signal separation	> + 50 dBm (typical)

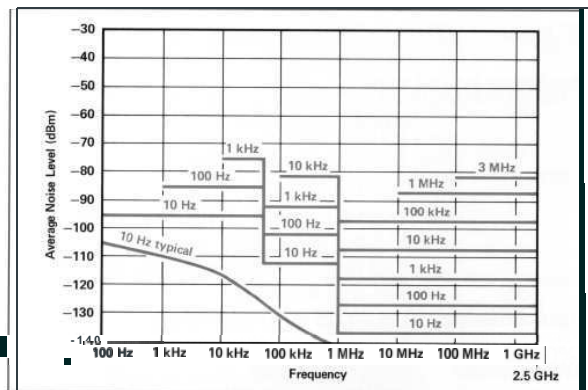

Fig. 5. Specified average displayed noise level, 100 Hz to 2.5 GHz, non-preselected tuning range

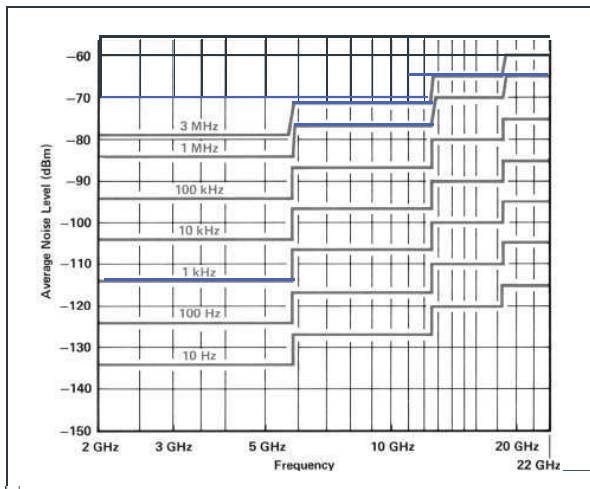

Fig. 6. Specified average displayed noise level, 2.0 to 22 GHz, preselected tuning range

Marker

(frequency and amplitude are read out continuously)

Marker Type	Frequency Accuracy	Amplitude Accuracy
Normal	same as center frequency accuracy	same as reference level accuracy + scale fidelity between the reference level and marker position
Delta	same as frequency span accuracy	
Normal	same as reference level accuracy + scale fidelity between the reference level and marker position	same as frequency response uncertainty and scale fidelity between two markers
Delta	same as frequency response uncertainty and scale fidelity between two markers	

Sweep Time Accuracy (1 μ s to 1500s full sweep)

- ≤ 200 second sweep time, $\pm 10\%$
- > 200 second sweep time, $\pm 30\%$

Inputs

RF Input 100 Hz to 22 GHz, precision type-N female connector, dc-coupled

Maximum Input Level

- ac** Continuous power: +30 dBm from 50 ohm source
Mixer protected by diode limiter, 100 Hz-2.5 GHz
Pulse power: ≤ 100 W, 1 μ s pulse width with ≥ 50 dB input attenuation (≤ 0 dBm peak power to input mixer)
- dc** < 100 mA damage level

Input Attenuator 0 to 70 dB in 10 dB steps

SWR (typical)	Tune Frequency		
Input Attenuation	100Hz to 2.5 GHz	2 GHz to 5.8 GHz	5.8 GHz to 22 GHz
10 dB	1.2	1.5	1.9
0 dB*	2.3	3.0	3.0

*when tuned to within ± 3 MHz of signal

IF Input

Maximum Input Level

- ac** +10 dBm continuous power from 50 ohm source
- dc** 20 V with rise time of < 1 V/ μ s

External Sweep Trigger Input (rear panel) Must be ≥ 2.4 V (5 V max), 1 kohm nominal input impedance.

External Frequency Reference Input Must equal 5 MHz ± 25 Hz or 10 MHz ± 50 Hz, 0 to +10 dBm, 50 ohm nominal input impedance. Analyzer performance will be degraded unless frequency reference phase noise and spurious signals are < -140 dBd single sideband (1 Hz) referred to 10 MHz at a 100 Hz to 10 kHz offset.

Quasi-Peak (rear panel; nominal values)

Video Input 0 to 2 V, 139 ohm input impedance

21.4 MHz IF Input Nominally -11 dBm with 10 dB input attenuation, 50 ohm input impedance

Outputs

Calibrator

100 MHz \pm (frequency reference error x 100 MHz)
-10 dBm ± 0.3 dB; 50 ohm impedance, nominal

1st LO

2.3 to 6.1 GHz; $\geq +5$ dBm;
50 ohm impedance, nominal

Sweep and Tune Output

(rear panel)
-1 V/GHz of tuned frequency $\pm (2\% + 10$ mV)
10 kohm impedance, nominal

Display Outputs

(typical parameters)
X, Y, and Z outputs for auxiliary CRT displays.
X, Y 1 V for full deflection
Z 0 to 1 V intensity modulation, -1 V blank
BLANK TTL level ≥ 2.4 V for blanking
Compatible with most oscilloscopes.

Recorder Outputs

(typical parameters)
Outputs to drive all current HP X-Y recorders using positive pencoils or TTL pen uplift.

Horizontal Sweep Output

(X-axis)
A voltage proportional to the horizontal sweep of the frequency sweep generator. 0 V for left edge, +10 V for right edge; 1.7 kohm impedance, nominal.

Video Output

(Y-axis)
Detected video output (before A-D conversion) proportional to vertical deflection of the CRT trace
100 mV/div from 0 to 1 V; ≤ 475 ohm impedance, nominal.

Penlift Output

(Z-axis)
During sweep, pen down 0 V from 10 ohm source
During retrace, pen up +15 V from 10 kohm source

21.4 MHz Output

(rear panel, typical)
21.4 MHz; 50 ohm impedance, nominal: -20 dBm for a signal at reference level. In log scales, the IF output logarithmically related to RF input signal; in linear, the output is linearly related.

Frequency Reference

(rear panel, typical)
10.000 MHz, 0 dBm; 50 ohm output impedance

10 MHz Output

(rear panel, typical)
 ≥ 5 dBm to ohm output impedance

Video Output 0 to 2 V, ≥ 10 ohm output impedance

Display

Cathode Ray Tube Post deflection accelerator, aluminumized P31 phosphor, electrostatic focus and deflection.

Viewing Area Approximately 9.6 cm vertically by 11.9 cm horizontally (3.8 in x 4.7 in)

General Specifications

Environmental

Temperature

Operation 0° to 55° C

Storage -40° to 75° c

Increased internal temperatures may result if the rear panel air filters are not cleaned regularly.

Altitude

Operation $\leq 4,572$ m (15,000 ft)

Storage $\leq 15,240$ m (50,000 ft)

Power Requirements 50 to 60 Hz; 100,200, 120,220, or 240 V (+5%|-10%); approximately 650 VA (40 VA in standby). 400 Hz operation with Option 400.

Humidity

Operation Type tested to 95% relative humidity, 25° to 40° C, except as noted in electrical specifications.

Storage 5% to 90% relative humidity, 0° to 40° C

EMI Conducted and radiated interference is within the requirements of MIL-STD-461C, Part 7 RE02 and CE03 (Air Force), and CISPR Publication 11; VDE 0871 and FTZ 526/527/79.

Warm-Up Time

Operation Requires 30 minute warm-up from cold start, 0° to 55° C. Internal temperature equilibrium is reached after 2-hour warm-up at stable outside temperature.

Frequency Reference (typical)

Frequency reference aging rate attained after 24 hour warm-up from cold start at 25° C. Frequency is within 1×10^{-8} of final stabilized frequency within 30 minutes.

Weight

Total, net	50 kg (112 lb)
RF section, net	29 kg (65 lb)
IF display section, net	21 kg (47 lb)
RF section, shipping	35 kg (78 lb)
IF display section, shipping	27 kg (60 lb)

Dimensions

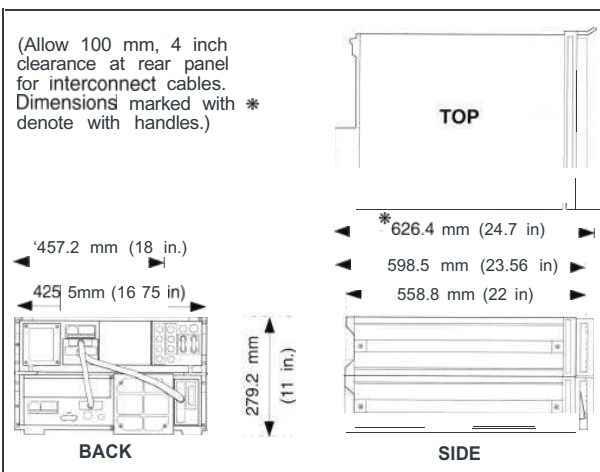
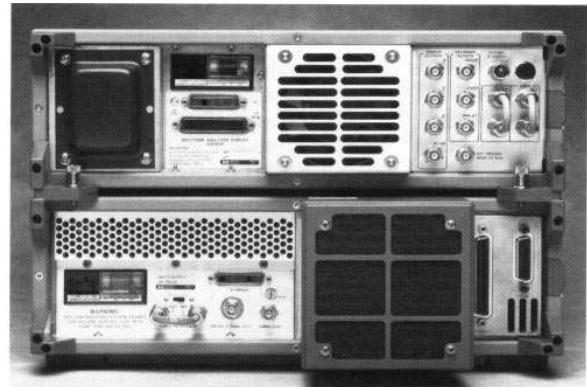

Fig.7. Instrument dimensions with and without handles



Remote Operation

The standard HP 8566B operates on the Hewlett-Packard Interface Bus (HP-IB). All analyzer control settings (with the exception of VIDEO TRIGGER LEVEL, FOCUS, ALIGN, INTENSITY, FREQ ZERO, AMPTD CAL, and LINE power) are remotely programmable. Function values, marker frequency/amplitude, and A/B traces may be output; CRT labels and graphics may be input.

LCL Returns analyzer to local control, if not locked out by controller.

Service Request

SHIFT r calls an HP-IB request for service.

HP-IB Interface Functions

SH1, AH1, T6, L4, SRI, RL1, PPO, DC1, CI, C2, C3, C28, E2

Options

All specifications for options are identical to standard HP 85668 except as noted.

400 Hz Power Line Frequency Operation (Option 400)

Power Line Related Sidebands

(center frequency from 100 Hz to 5.8 GHz)

Offset from Carrier	Sideband Level
≤ 2 kHz	-55 dBc
2 kHz to 5.5 kHz	-65 dBc

Power Requirements

Line frequency 400 Hz $\pm 10\%$ line frequency (50 to 60 Hz operation for servicing only)

Line voltage 100 to 120 v (+5%|-10%)

Operating Temperature Range

400 Hz 0° to 55° c

50 Hz to 60 Hz (service only, not for extended periods) 0° to 40° C

Ordering Information

- HP 8566B Spectrum Analyzer** 100 Hz to 22 GHz
- Option R02** Turbo retrofit kit for any HP 8566B
- Option 002** Turbo option for faster measurements
- Option 010** Rack mount slide kit
- Option 016** Installed EM1 receiver functions
- Option 031** German operating manual
- Option 080** Information card in Japanese
- Option 081** Information card in French
- Option 1BN** MIL-STD 45662A calibration certification
- Option 1BP** MIL-STD 45662A calibration certification with test data
- Option 400** 400 Hz operation
- Option 462** 100 Hz, 1 kHz, and 1 MHz Impulse bandwidth filters for EM1 measurements
- Option 908** Rack flange kit without handles
- Option 910** Extra operating and test and adjustment manuals
- Option 913** Rack flange kit with handles
- Option 915** Troubleshooting and repair manual set
- Option W30** 3-year customer return repair
- Option W32** 3-year customer return calibration
- Option W50** 5-year customer return repair
- Option W52** 5-year customer return calibration

HP 8566AB Retrofit kit to convert HP 8566A to HP 8566B

Recommended Accessories

- HP 85644A** Tracking source 300 kHz to 6.5 GHz
- HP 85645A** Tracking source 300 kHz to 26.5 GHz
- HP 8449B** Preamplifier 1 to 26.5 GHz
- HP 11975A** Amplifier 2 to 8 GHz

Preselected Mixers

- HP 11974A** 26.5 to 40 GHz preselected mixer
- HP 11974Q** 33 to 50 GHz preselected mixer
- HP 11974U** 40 to 60 GHz preselected mixer
- HP 11974V** 50 to 75 GHz preselected mixer
- HP 11974**
- Option 003** Delete power supply

Harmonic Mixers*

- HP 11970K** 18 to 26.5 GHz mixer
- HP 11970A** 26.5 to 40 GHz mixer
- HP 11970Q** 33 to 50 GHz mixer
- HP 11970T** 18 to 40 GHz mixers, hardwood case, cables, tools
- Option 001** Add 40 to 60 GHz mixer
- Option 002** Add 33 to 50 GHz mixers
- HP 11970U** 40 to 60 GHz mixer
- HP 11970V** 50 to 75 GHz mixer
- HP 11970W** 75 to 110 GHz mixer
- Option 009** Mixer connection set adds three 1-meter low-loss SMA cables, wrench, Allen screw driver for any HP 11970 series mixer.

* For more information about other mixers, contact your local HP sales office.

United States:
Hewlett-Packard Company
4 Choke Cherry Road
Rockville, MD 20850
(301) 670 4300

Hewlett-Packard Company
5201 Tollview Drive
Rolling Meadows, IL 60008
(708) 255 9800

Hewlett-Packard Company
5651 W. Manchester
Los Angeles, CA 90045
(213) 337 8035

Hewlett-Packard Company
2000 South Park Place
Atlanta, GA 30339
(404) 980 7351

Canada:
Hewlett-Packard Ltd.
6877 Goreway Drive
Mississauga, Ontario L4V 1M8
(416) 678 9430

Europe:
Hewlett-Packard
European Marketing Centre
P.O. Box 999
1180 AZ Amstelveen
The Netherlands
(31) 20 547 9999

Japan:
Yokogawa-Hewlett-Packard Ltd.
15-7, Nishi Shinjuku 4 Chome
Shinjuku-ku
Tokyo 160, Japan
(03) 53711315

Latin America
Latin American Region Headquarters
Monte Pelvoux No. 111
Lomas de Chapultepec
11000 Mexico, D.F.
(525) 202 0155

Australia/New Zealand:
Hewlett-Packard Australia Ltd
31-41 Joseph Street
Blackburn, Victoria 3130
Australia (A.C.N. 004 394 763)
(03) 895 2895

Far East: Asia Pacific
Hewlett-Packard Asia Pacific Ltd
22/F Bond Centre, West Tower
89 Queensway, Central, Hong Kong
(852) 848 7777

For more information, call your local HP sales office listed in your telephone directory or an HP regional office listed below for the location of your nearest sales office.

Data subject to change
Printed in U.S.A. 4/92
5091-3385E