

Notice

Hewlett-Packard to Agilent Technologies Transition

This documentation supports a product that previously shipped under the Hewlett-Packard company brand name. The brand name has now been changed to Agilent Technologies. The two products are functionally identical, only our name has changed. The document still includes references to Hewlett-Packard products, some of which have been transitioned to Agilent Technologies.



Agilent Technologies

Printed in USA March 2000

By internet, phone, or fax, get assistance with all your test and measurement needs.

Table 1-1 Contacting Agilent

Online assistance: www.agilent.com/find/assist

United States
(tel) 1 800 452 4844

Latin America
(tel) (305) 269 7500
(fax) (305) 269 7599

Canada
(tel) 1 877 894 4414
(fax) (905) 282-6495

Europe
(tel) (+31) 20 547 2323
(fax) (+31) 20 547 2390

New Zealand
(tel) 0 800 738 378
(fax) (+64) 4 495 8950

Japan
(tel) (+81) 426 56 7832
(fax) (+81) 426 56 7840

Australia
(tel) 1 800 629 485
(fax) (+61) 3 9210 5947

Asia Call Center Numbers

Country	Phone Number	Fax Number
Singapore	1-800-375-8100	(65) 836-0252
Malaysia	1-800-828-848	1-800-801664
Philippines	(632) 8426802 1-800-16510170 (PLDT Subscriber Only)	(632) 8426809 1-800-16510288 (PLDT Subscriber Only)
Thailand	(088) 226-008 (outside Bangkok) (662) 661-3999 (within Bangkok)	(66) 1-661-3714
Hong Kong	800-930-871	(852) 2506 9233
Taiwan	0800-047-866	(886) 2 25456723
People's Republic of China	800-810-0189 (preferred) 10800-650-0021	10800-650-0121
India	1-600-11-2929	000-800-650-1101

Service Guide

Agilent Technologies 85422E and 85462A EMI Receiver RF Section



Part Number: 5962-5084

Printed in USA

April 1999

© Copyright 1999 Agilent Technologies, Inc.

Notice

The information contained in this document is subject to change without notice.

Hewlett-Packard makes no warranty of any kind with regard to this material, including but not limited to, the implied warranties of merchantability and fitness for a particular purpose. Hewlett-Packard shall not be liable for errors contained herein or for incidental or consequential damages in connection with the furnishing, performance, or use of this material.

© Copyright Hewlett-Packard Company 1994, 1999
All Rights Reserved. Reproduction, adaptation, or translation without prior written permission is prohibited, except as allowed under the copyright laws.
1400 Fountaingrove Parkway, Santa Rosa CA, 95403-1799, USA

Certification

Hewlett-Packard Company certifies that this product met its published specifications at the time of shipment from the factory. Hewlett-Packard further certifies that its calibration measurements are traceable to the United States National Institute of Standards and Technology, to the extent allowed by the Institute's calibration facility, and to the calibration facilities of other International Standards Organization members.

Regulatory Information

Regulatory information is located in the *EMI Receiver Series Reference* at the end of Chapter 1, "Specifications and Characteristics."

Warranty

This Hewlett-Packard instrument product is warranted against defects in material and workmanship for a period of one year from date of shipment. During the warranty period, Hewlett-Packard Company will, at its option, either repair or replace products which prove to be defective.

For warranty service or repair, this product must be returned to a service facility designated by Hewlett-Packard. Buyer shall prepay shipping charges to Hewlett-Packard and Hewlett-Packard shall pay shipping charges to return the product to Buyer. However, Buyer shall pay all shipping charges, duties, and taxes for products returned to Hewlett-Packard from another country.

Hewlett-Packard warrants that its software and firmware designated by Hewlett-Packard for use with an instrument will execute its programming instructions when properly installed on that instrument. Hewlett-Packard does not warrant that the operation of the instrument, or software, or firmware will be uninterrupted or error-free.

LIMITATION OF WARRANTY

The foregoing warranty shall not apply to defects resulting from improper or inadequate maintenance by Buyer, Buyer-supplied software or interfacing, unauthorized modification or misuse, operation outside of the environmental specifications for the product, or improper site preparation or maintenance.

NO OTHER WARRANTY IS EXPRESSED OR IMPLIED. HEWLETT-PACKARD SPECIFICALLY DISCLAIMS THE IMPLIED WARRANTIES OF MERCHANTABILITY AND FITNESS FOR A PARTICULAR PURPOSE.

EXCLUSIVE REMEDIES

THE REMEDIES PROVIDED HEREIN ARE BUYER'S SOLE AND EXCLUSIVE REMEDIES. HEWLETT-PACKARD SHALL NOT BE LIABLE FOR ANY DIRECT, INDIRECT, SPECIAL, INCIDENTAL, OR CONSEQUENTIAL DAMAGES, WHETHER BASED ON CONTRACT, TORT, OR ANY OTHER LEGAL THEORY.

Assistance

Product maintenance agreements and other customer assistance agreements are available for Hewlett-Packard products. For any assistance, contact your nearest Hewlett-Packard Sales and Service Office.

Compliance

This instrument has been designed and tested in accordance with IEC Publication 348, Safety Requirements for Electronic Measuring Apparatus, and has been supplied in a safe condition. The instruction documentation contains information and warnings which must be followed by the user to ensure safe operation and to maintain the instrument in a safe condition.

Safety Notes

The following safety notes are used throughout this manual. Familiarize yourself with each of the notes and its meaning before operating this instrument.

WARNING **Warning denotes a hazard. It calls attention to a procedure which, if not correctly performed or adhered to, could result in injury or loss of life. Do *not* proceed beyond a warning note until the indicated conditions are fully understood and met.**

CAUTION Caution denotes a hazard. It calls attention to a procedure that, if not correctly performed or adhered to, would result in damage to or destruction of the instrument. Do *not* proceed beyond a caution sign until the indicated conditions are fully understood and met.

General Safety Considerations

- WARNING**
- These servicing instructions are for use by qualified personnel only. To avoid electrical shock, do not perform any servicing unless you are qualified to do so.
 - The opening of covers or removal of parts is likely to expose dangerous voltages. Disconnect the instrument from all voltage sources while it is being opened.
 - Protective earth ground on this equipment must be maintained to provide protection from electric shock.
 - This is a Safety Class I product (provided with a protective earthing ground incorporated in the power cord). The mains plug shall only be inserted in a socket outlet provided with a protective earth contact. Any interruption of the protective conductor, inside or outside the instrument, is likely to make the instrument dangerous. Intentional interruption is prohibited.
 - The power cord is connected to internal capacitors that may remain live for 5 seconds after disconnecting the plug from its power supply.
 - For continued protection against fire hazard, replace line fuse only with same type and rating ([F 5A/250V]). The use of other fuses or material is prohibited.
 - No user serviceable parts are inside this instrument. The cathode-ray tube is dangerous to handle. Refer servicing to qualified personnel.
 - X-rays generated by this instrument are sufficiently screened.
Die in dieswem gerat entstehende rontgenstrahlung ist ausreichend abgeschirmt.
Acell. Voltage/Besehl. SPG<20kV
-

- CAUTION**
- Before switching on this instrument, make sure that the line voltage selector switch is set to the voltage of the power supply and the correct fuse is installed.
 - For continued protection against fire hazard, replace the fuse only with a fuse of the same type and rating.
 - Always use the three-prong ac power cord supplied with this instrument. Failure to ensure adequate earth grounding by not using this cord may cause instrument damage.
 - Equipment damage may result from incorrect usage.
 - Both metric and inch hardware are used in this instrument.
 - Only clean the instrument cabinet using a damp cloth.
-



The instruction documentation symbol. The product is marked with this symbol when it is necessary for the user to refer to the instructions in the documentation.

CE The CE mark is a registered trademark of the European Community. (If accompanied by a year, it is when the design was proven.)

ISM1-A This is a symbol of an Industrial Scientific and Medical Group 1 Class A product.

CSA The CSA mark is a registered trademark of the Canadian Standards Association.

Manual Conventions

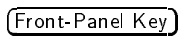
 This represents a key physically located on the instrument.

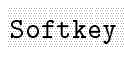
 This indicates a “softkey,” a key whose label is determined by the firmware of the instrument.

Screen Text This indicates text displayed on the instrument’s screen.

EMI Receiver Series Documentation Description

The following documents are provided with either the EMI receiver or the receiver RF section.

- *Installation and Verification* provides information for installing your instrument, verifying instrument operation, and customer support.
- *User's Guide* describes instrument features and how to make measurements with your EMI receiver or receiver RF section.
- *Reference* provides specifications and characteristics, menu maps, error messages, and key descriptions.
- *Programmer's Guide* provides information on remote control instrument configuration, creating programs, and parameters for each of the programming commands available.

Contents

1. Introduction

Service Guide Organization	1-2
Description	1-3
Firmware Revision Date	1-4
Firmware Upgrade Kit Ordering Information	1-4
Safety Considerations	1-5
Reliability Considerations	1-6
Instrument Input Protection	1-6
Protection from Electrostatic Discharge	1-8
Handling of Electronic Components and ESD	1-8
Test Equipment Usage and ESD	1-9
For Additional Information about ESD	1-9

2. Making Adjustments

Safety	2-2
Before You Start	2-2
Test equipment you will need	2-2
If there are abnormal indications during adjustment	2-2
Periodically verifying calibration	2-2
Standard-value replacement components	2-3
If you replace or repair an assembly	2-3
When running software tests	2-3
Preparing the instrument for adjustments	2-8
Disconnecting the HP 85420E / HP 85460A preselector	2-8
Display	2-9
Sampler Match	2-12
10 MHz Reference	2-14
Crystal and LC Bandwidth Filter	2-17
Cal Attenuator Error	2-23
Log and Linear Amplifier	2-24
CAL FREQ Adjustment Routine	2-28
CAL AMP Adjustment Routine	2-29
CAL YTF Adjustment Routine	2-30
CAL MXR Adjustment Routine	2-32
Third Converter and Second IF Bandpass	2-33
Absolute Amplitude Calibration	2-37
Low Frequency Flatness Calibration	2-38
Flatness Calibration	2-39
PREAMP Flatness Calibration	2-40
Time and Date	2-41
First LO Distribution Amplifier	2-42
Tracking Generator Power Level	2-44
Tracking Oscillator	2-48

3. Troubleshooting the Instrument	
Before You Start	3-1
Service equipment you will need	3-1
Replacement Assemblies	3-2
After a repair	3-2
Problems at Instrument Power-Up	3-3
Troubleshooting an Inoperative Instrument	3-5
Step 1. Check the Instrument Setup	3-5
Step 2. Check the Power Supply	3-5
If the line fuse has blown	3-7
If the fan is not operating	3-7
If all the A16 power-supply LEDs are off	3-8
If individual A16 power-supply LEDs are off	3-9
If all the A16 power-supply LEDs are on	3-9
If Using Defaults <N> is displayed	3-9
Troubleshooting the A2 Display Assembly	3-10
If the display has an intensity problem	3-11
If the display is blank	3-11
Isolating an RF, LO, IF, or Video Problem	3-13
Procedure for Isolating an RF, LO, IF, or Video Failure	3-13
If there is only a horizontal trace with no signal or noise floor present	3-14
If the instrument displays a low signal level	3-15
If the instrument displays a high noise floor	3-15
If the displayed signal amplitude appears too high	3-16
If the displayed signal is distorted	3-16
If the signal is off frequency	3-17
If the signal is off frequency in spans <10 MHz only	3-17
If the signal displays in low band only	3-17
Using the Internal Service-Diagnostic Routines	3-18
If a flat line appears at mid screen	3-18
If a service-diagnostic routine fails	3-18
Verify the displayed calibration data	3-19
Verify the 2 V reference detector	3-20
Verify the ground reference detector	3-21
Verify the main coil driver	3-22
Verify the FM coil driver	3-23
Verify the FM coil driver for spans >10 MHz	3-25
Verify the sweep ramp	3-26
Verify the 10 V reference detector	3-27
Verify the -10 V reference detector	3-28
Verify the YTF driver	3-29
Troubleshooting the A24 Processor Board Assembly	3-30
If the LED power-on sequence is not operational	3-30
If a signal cannot be displayed	3-30
If the instrument does not respond (locked up)	3-31
Performing a Free-Run Check	3-31

4. Troubleshooting the IF Section	
Before You Start	4-1
Service equipment you will need	4-1
After an instrument repair	4-2
IF Section Information	4-3
IF Power-Level Measurement	4-3
To set up the instrument for an IF power-level measurement	4-4
To check the gains for the IF assemblies	4-5
To measure the IF signal from the A9 third converter board	4-5
To inject a signal at the output of the A11 bandwidth filter board	4-6
To inject a signal at the output of the A13 bandwidth filter board	4-7
To check bandwidth control lines for the A11 and A13 bandwidth filter board	4-8
To check IF section gain control	4-9
Control lines for the A12 amplitude control board	4-11
To check linear gain control lines for the A14 log amplifier board	4-12
Troubleshooting IF Overload Failures	4-13
Troubleshooting the A15 Motherboard Assembly	4-14
5. Troubleshooting the RF Section	
Before You Start	5-1
Service equipment you will need	5-1
After an instrument repair	5-2
Troubleshooting the RF Section	5-3
Making RF Power-Level Measurements	5-3
Connector Pin-Out Information	5-5
Preamplifier Section Switch Pin-Out Information	5-6
Preamplifier Switches	5-6
VIEW CAL ON OFF Switches	5-6
To check control of the A3A4 input attenuator	5-7
To check the A4A10 tracking generator operation	5-8
If the output goes unlevelled (TG UNLVL message displayed)	5-8
To check excessive residual FM	5-10
If flatness is out of tolerance	5-11
If vernier accuracy is out of tolerance	5-12
If harmonic/spurious outputs are too high	5-13
If power sweep is not functioning properly	5-14
If there is no output power	5-15
To check the A4A7 local oscillator distribution amplifier (LODA) operation	5-16
6. Replacing Major Assemblies	
Introduction	6-1
Before You Start	6-1
Service equipment you will need	6-1
After a repair	6-2
Removal and Replacement Procedures in this Chapter	6-2
1. Instrument Cover	6-3
2. RF Cover	6-5
3. A1 Front Panel Assembly	6-7
4. A1A1 Keyboard	6-10
5. A26 Rear Panel	6-12
6. A16 Power Supply Assembly	6-14
7. B1 Fan	6-16
8. A24 Processor Board Assembly	6-18
9. A24 Processor Board Assembly ROMs	6-20
10. A25 Graphics Processor Board	6-21

11. BT1 Battery	6-23
12. A22 HP-IB/RS-232 Board	6-25
13. A2 Display	6-27
14. A17 Graphic Signal Processor Assembly	6-30
15. A15 Motherboard/IF Section Assembly	6-32
16. A21 Disk Drive Controller Board	6-34
17. A19 Disk Drive	6-36
18. A20 10 MHz Precision Reference	6-37
19. A23 Counter Lock Assembly	6-38
20. A5 Analog Interface Board	6-40
21. A3 Preamplifier Section/A4 RF Section Assembly	6-42
7. Customer Support	
If You Have a Problem	7-1
Calling HP Sales and Service Offices	7-1
Check the Basics	7-2
If Your EMI Receiver Does Not Turn On	7-2
If the RF Filter Section Does Not Seem to be Working	7-2
If the EMI Receiver Cannot Communicate Via HP-IB	7-2
Verification of Proper Operation	7-2
If the RF filter section Does Not Power Off	7-2
Error Messages	7-2
Additional Support Services	7-3
CompuServe	7-3
FAX Support Line	7-3
Returning the EMI Receiver for Service	7-5
Package the EMI receiver for shipment	7-5
8. Assembly Descriptions	
RF and LO Section	8-1
RF Section Assemblies	8-2
A3A2 Preamplifier	8-2
A4A10 Tracking Generator	8-3
Tracking Oscillator	8-3
Upconverter	8-3
Pentupler	8-3
Modulator	8-3
Coupler	8-3
Output Mixer	8-3
Output Amplifier	8-3
Bias Board	8-3
A8 Tracking Generator Control Board	8-4
A4A7 First LO Distribution Amplifier (LODA)	8-4
LO Section Assemblies	8-5
A9 Third Converter Assembly	8-6
A23 Counterlock Assembly	8-7
IF Section	8-8
IF Section Assemblies	8-8
A11 Bandwidth Filter	8-8
A12 Amplitude Control	8-8
A13 Bandwidth Filter	8-9
A14 Log Amplifier	8-9
A24 Processor	8-9
A25 Graphics Processor Board	8-10
A5 Analog Interface	8-10

A16 Power Supply Assembly	8-11
A6 Narrow Bandwidth	8-11
A7 Demodulator/Quasi-Peak/Average Detector Board	8-12
A2 Color Display and A17 Graphic Signal Processor	8-12
A21 Disk Drive Controller Board	8-12
A19 Disk Drive	8-13

9. Major Assembly and Cable Locations

10. Replaceable Parts

Ordering Information	10-2
Direct Mail-Order System	10-2
Direct Phone-Order System	10-2
Regular Orders	10-2
Hotline Orders	10-2
Standard-Value Replacement Components	10-7
Assembly-Level Replaceable Parts and Cables	10-12

11. Service Softkey Descriptions

Calibration, Service, and Diagnostic Softkey Functions	11-1
CALIBRATE Softkey Organization	11-1
Understanding Instrument Passcodes	11-3
-37 Hz passcode	11-3
-2001 Hz passcode	11-3
Entering A Passcode	11-3
Understanding Correction Data	11-4
Self-Calibration Correction Factors	11-4
Service-Calibration Correction Constants	11-4
φLock ON OFF Phase Lock On/Off	11-5
+10 V REF DETECTOR +10 V Reference Detector	11-5
-10 V REF DETECTOR -10 V Reference Detector	11-5
2v REF DETECTOR 2 V Reference Detector	11-6
CAL 85422 Calibrate HP 85422	11-6
CAL 85462 Calibrate HP 85462	11-6
CAL ALL Calibrate All	11-7
CAL AMP Calibrate Amplitude	11-7
CAL FETCH Calibration Fetch	11-9
CAL FREQ Calibrate Frequency	11-9
CALIBRATE Calibration Key	11-11
CAL INPUT 1 Calibrate Input 1	11-11
CAL INPUT 2 Calibrate Input 2	11-12
CAL MXR Calibrate Mixer	11-12
CAL STORE Calibration Store	11-13
CAL TIMEBASE Calibrate Timebase	11-13
CAL TRK GEN Calibrate Tracking Generator	11-14
CAL YTF Calibrate YTF	11-14
COARSE TUNE DAC Coarse Tune DAC	11-15
CORRECT ON OFF Correction On/Off	11-15

DACS DACs	11-16
DEFAULT CAL DATA Default Calibration Data	11-18
DISPLAY CAL DATA Display Calibration Data	11-19
Display Sys Data Display System Data	11-22
DROOP Droop	11-23
EDIT FLATNESS Edit Flatness	11-23
EDIT PA FLTNESS Edit Preamplifier Flatness	11-24
EXECUTE TITLE Execute Title	11-24
EXIT Exit	11-24
FINE TUNE DAC Fine Tune DAC	11-24
FLATNESS DATA Flatness Data	11-25
FM COIL DRIVE FM Coil Drive	11-25
FM GAIN FM Gain	11-26
FM OFFSET FM Offset	11-27
FM SPAN FM Span	11-29
FREQ DIAG Frequency Diagnostics	11-30
FRQ DISC NORM OFF Frequency Discriminator Normal/Off	11-31
GND REF DETECTOR Ground-Reference Detector	11-32
IDNUM Identification Number	11-32
IF GAINS Intermediate Frequency Gain Settings	11-32
INIT FLT Initialize Flatness	11-33
INPUT 1 Input 1	11-33
INPUT 1 PREAMP Input 1 Preamplifier	11-33
INPUT 2 Input 2	11-33
INPUT 2 PREAMP Input 2 Preamplifier	11-34
MAIN COIL DR Main-Coil Drive	11-34
MAIN SPAN Main Span	11-35
MIXER BIAS DAC Mixer-Bias DAC	11-35
PRESEL DAC Preselector DAC	11-36
QP DET ON OFF Quasi-Peak Detector On/Off	11-36
QP GAIN ON OFF Quasi-Peak GAIN On/Off	11-36
QPD OFFSET Quasi-Peak Detector Offset	11-37
QPD RST ON OFF Quasi-Peak Detector Reset On/Off	11-37
Service Cal Service Calibration	11-37
Service Diag Service Diagnostics	11-37
SET ATTN ERROR Set Attenuator Error	11-38
STORE FLATNESS Store Flatness	11-39
STOR PWR ON UNITS Store Power-On Units	11-40
STP GAIN ZERO Step-Gain Zero	11-40
SWEEP RAMP Sweep Ramp	11-40

SWEEP TIME DAC Sweep-Time DAC	11-41
X FINE TUNE DAC Extra-Fine Tune DAC	11-41
YTF DRIVER YTF Driver	11-42
YTF SPAN YTF Span	11-43
YTF TUNE COARSE YTF Tune Coarse	11-43
YTF TUNE FINE YTF Tune Fine	11-44

12. Instrument Messages

Interpreting Instrument Messages	12-1
Chapter Organization	12-1
ϕ LOCK OFF (U) (H)	12-2
Related Assemblies	12-2
Troubleshooting Hints	12-2
ADC-GND FAIL (H)	12-2
Related Assemblies	12-2
Troubleshooting Hints	12-2
ADC-TIME FAIL (H)	12-4
Related Assemblies	12-4
Troubleshooting Hints	12-4
ADC-2V FAIL (H)	12-4
Related Assemblies	12-4
Troubleshooting Hints	12-4
bad FDC status -> mass storage hardware failure (H)	12-5
Related Assemblies	12-5
bad io command -> internal error (H)	12-5
Related Assemblies	12-5
bad io parameter -> internal error (H)	12-5
Related Assemblies	12-5
Bus grant failed (H)	12-5
Related Assemblies	12-5
CAL:_ _ _ (M)	12-5
Troubleshooting Hints	12-5
CAL:_ _ _ : done Press CAL STORE to save (M)	12-6
CAL: cannot execute CALAMP enter: 0 dB PREAMP GAIN (U)(H)	12-6
Troubleshooting Hints	12-6
CAL: DATA NOT STORED CAL AMP NEEDED (U)(H)	12-6
Related Assemblies	12-6
Troubleshooting Hints	12-6
CAL: FM SPAN SENS FAIL (H)	12-7
Related Assemblies	12-7
Troubleshooting Hints	12-7
CAL Freq Fail (H)	12-7
Related assemblies	12-7
CAL: GAIN FAIL (H)	12-7
Related Assemblies	12-7
Troubleshooting Hints	12-7
Cal harmonic >= 5.7 GHz NOT found (U)(H)	12-8
Related Assemblies	12-8
Troubleshooting Hints	12-8
CAL: MAIN COIL SENSE FAIL (H)	12-8
Related Assemblies	12-8
Troubleshooting Hints	12-8
CAL: NBW 200 Hz notch amp failed (H)	12-8

Related Assemblies	12-8
Troubleshooting Hints	12-8
CAL: NBW 200 Hz notch failed (H)	12-8
Related Assemblies	12-8
Troubleshooting Hints	12-8
CAL: NBW 200 Hz width failed (H)	12-9
Related Assemblies	12-9
Troubleshooting Hints	12-9
CAL: NBW gain failed (H)	12-9
Related Assemblies	12-9
Troubleshooting Hints	12-9
CAL: NBW width failed (H)	12-9
Related Assemblies	12-9
Troubleshooting Hints	12-9
CAL: PASSCODE NEEDED (M)	12-9
Troubleshooting Hints	12-9
CAL: RES BW AMPL FAIL (H)	12-10
Related Assemblies	12-10
Troubleshooting Hints	12-10
CAL SIGNAL NOT FOUND (U)(H)	12-11
Related Assemblies	12-11
Troubleshooting Hints	12-11
CAL: SPAN SENS FAIL (H)	12-12
Related Assemblies	12-12
Troubleshooting Hints	12-12
CAL: USING DEFAULT DATA (M)	12-12
Troubleshooting Hints	12-12
CAL YTF FAILED (U)(H)	12-12
Related Assemblies	12-12
Troubleshooting Hints	12-12
CAL: ZERO FAIL (H)	12-12
Related Assemblies	12-12
Troubleshooting Hints	12-12
Cannot engage phase lock with current CAL FREQ data (U)	12-13
Related Assemblies	12-13
Troubleshooting Hints	12-13
Cannot reach N dB points (U)	12-13
Related Assemblies	12-13
Troubleshooting Hints	12-13
check disk error -> medium uninitialized (H)	12-13
Related Assemblies	12-13
Check trigger input (U)	12-13
Related Assemblies	12-13
Troubleshooting Hints	12-13
CONF TEST FAIL (U)(H)	12-14
Troubleshooting Hints	12-14
COMMAND ERROR:_ _ _ (U)	12-14
Related Assemblies	12-14
Troubleshooting Hints	12-14
COMPARE_CMD timeout (H)	12-14
Related Assemblies	12-14
Compare ERROR (H)	12-14
Related Assemblies	12-14
EMI BW FAIL (H)	12-14
Related Assemblies	12-14

Troubleshooting Hints	12-14
error number not recognized -> internal error (H)	12-14
Related Assemblies	12-14
Factory dlp, not adaptable (U)	12-15
FAIL: XXXX XXXXXXXXXXXX (H)	12-15
The Four-Digit Failure Code	12-15
The 10-Digit Failure Code	12-16
Related Assemblies	12-17
Troubleshooting Hints	12-17
fatal error -> mass storage system error (H)	12-18
Related Assemblies	12-18
FDC did not ID during instrument setup (H)	12-18
Related Assemblies	12-18
FDC Ready Timeout (H)	12-18
Related Assemblies	12-18
File type incompatible (U)	12-18
FMERRP error (H)	12-18
Related assemblies	12-18
FMT_INIT_CMD failed (H)	12-18
Related Assemblies	12-18
FREQ UNCAL (U) (H)	12-19
Related Assemblies	12-19
Troubleshooting Hints	12-19
Function not available in current Mode (U)	12-19
Function not available with analog display (U)	12-19
Gate card not calibrated (U)(H)	12-19
Troubleshooting Hints	12-19
general error -> mass storage system error (H)	12-20
Related Assemblies	12-20
Hi RAM Bus Grant FAIL (H)	12-20
Related Assemblies	12-20
INIT_CMD timeout (H)	12-20
Related Assemblies	12-20
INPUT CAL FAILED: 300 MHz out of range (H)	12-20
Related Assemblies	12-20
INPUT CAL FAILED: TG EXT ALC out of range (H)	12-20
Related Assemblies	12-20
INPUT CAL FAILED: TG INT ALC out of range (H)	12-20
Related Assemblies	12-20
Insufficient Memory (H)	12-20
Related Assemblies	12-20
INTERNAL LOCKED (U)	12-20
INVALID ACTDEF: _ _ _ (U)	12-21
INVALID AMPCOR: FREQ (U)	12-21
INVALID BLOCK FORMAT: IF STATEMENT (U)	12-21
INVALID CHECKSUM: USTATE (U)	12-21
INVALID COMPARE OPERATOR (U)	12-21
INVALID DET: FM or TV option only (U)	12-21
INVALID ENTER FORMAT (U)	12-21
INVALID <file name> NOT FOUND (U)	12-21
INVALID FILENAME _ _ _ (U)	12-21
INVALID HP-IB ADRS/OPERATION (U)	12-21
Related Assemblies	12-21
Troubleshooting Hints	12-21
INVALID HP-IB OPERATION REN TRUE (U)	12-22

Related Assemblies	12-22
Troubleshooting Hints	12-22
INVALID ITEM:_ _ _ (U)	12-22
INVALID KEYLBL: _ _ _ (U)	12-22
INVALID KEYNAME:_ _ _ (U)	12-22
Related Assemblies	12-22
Troubleshooting Hints	12-22
INVALID OUTPUT FORMAT (U)	12-22
INVALID RANGE: Stop < Start (U)	12-22
INVALID REGISTER NUMBER (U)	12-22
INVALID REPEAT MEM OVFL (U)	12-23
INVALID REPEAT NEST LEVEL (U)	12-23
INVALID RS-232 ADRS/OPERATION (U)	12-23
Related Assemblies	12-23
Troubleshooting Hints	12-23
INVALID SAVE REG (U)	12-23
INVALID SCRMOVE (H)	12-23
Related Assemblies	12-23
Troubleshooting Hints	12-23
INVALID START INDEX (U)	12-23
INVALID STOP INDEX (U)	12-23
INVALID STORE DEST: _ _ _ (U)	12-23
INVALID SYMTAB ENTRY: SYMTAB OVERFLOW (U)	12-24
Related Assemblies	12-24
Troubleshooting Hints	12-24
INVALID TRACE: _ _ _ (U)	12-24
INVALID TRACE NAME: _ _ _ (U)	12-24
INVALID TRACENAME: _ _ _ (U)	12-24
INVALID VALUE PARAMETER: _ _ _ (U)	12-24
INVALID VARDEF: _ _ _ (U)	12-25
INVALID WINDOW TYPE: _ _ _ (U)	12-25
io buffer overflow -> internal error (H)	12-25
Related Assemblies	12-25
io data error -> read data error (H)	12-25
Related Assemblies	12-25
LOST SIGNAL (U)	12-25
Related Assemblies	12-25
Troubleshooting Hints	12-25
Lo RAM Bus Grant FAIL (H)	12-25
Related Assemblies	12-25
LO UNLVL (U)(H)	12-25
Related Assemblies	12-25
Troubleshooting Hints	12-25
Marker Count Reduce SPAN (U)	12-26
Marker Count Widen RES BW (U)	12-26
MEAS UNCAL (U)	12-26
No card found (U)	12-26
MIXER BIAS CAL FAILED (H)	12-26
Related assemblies	12-26
Troubleshooting Hints	12-26
no disk found -> medium changed or not present (H)	12-26
Related Assemblies	12-26
No ID response (H)	12-26
Related Assemblies	12-26
No points defined (U)	12-27

OVEN COLD (M)	12-27
Related Assemblies	12-27
Troubleshooting Hints	12-27
PARAMETER ERROR: _ _ _ (U)	12-27
PARAMETER ERROR: FDCTESTS (H)	12-27
Related Assemblies	12-27
PASSCODE NEEDED (U)	12-27
POS-PK FAIL (H)	12-27
Related Assemblies	12-27
Troubleshooting Hints	12-27
READ_CMD timeout (H)	12-28
Related Assemblies	12-28
RECAL_CMD timeout (H)	12-28
Related Assemblies	12-28
REF UNLOCK (M)(H)	12-28
Related Assemblies	12-28
Troubleshooting Hints	12-28
Require 1 signal > PEAK EXCURSION above THRESHOLD (U)	12-28
Require 3 signals > PEAK EXCURSION above THRESHOLD (U)	12-29
Require 4 signals > PEAK EXCURSION above THRESHOLD (U)	12-29
Required option not installed (U)	12-29
RES-BW NOISE FAIL (H)	12-29
Related Assemblies	12-29
Troubleshooting Hints	12-29
RES-BW SHAPE FAIL (H)	12-30
Related Assemblies	12-30
Troubleshooting Hints	12-30
RF PRESEL ERROR (H)	12-30
Related Assemblies	12-30
Troubleshooting Hints	12-30
RF PRESEL TIMEOUT (H)	12-31
Related Assemblies	12-31
Troubleshooting Hints	12-31
RFFS Error: HARDWARE (H)	12-31
Related Assemblies	12-31
RFFS Error: TIMEOUT (H)	12-31
Related Assemblies	12-31
SAMPLE FAIL (H)	12-31
Related Assemblies	12-31
Troubleshooting Hints	12-31
SETUP ERROR (U)	12-31
SIGNAL CLIPPED (U)	12-31
Signals do not fit expected % AM pattern (U)	12-32
Signals do not fit expected TOI pattern (U)	12-32
SMPLR UNLCK (U)(H)	12-32
Related Assemblies	12-32
Troubleshooting Hints	12-32
SOFTKEY OVFL (U)	12-32
SRQ _ _ _ (M)	12-32
STEP GAIN/ATTEN FAIL (H)	12-33
Related Assemblies	12-33
Troubleshooting Hints	12-33
Stop at marker not available with negative detection (U)	12-33
SYMTAB EMPTY (U)	12-33
Related Assemblies	12-33

Troubleshooting Hints	12-33
TABLE FULL (U)	12-33
TG SIGNAL NOT FOUND (U)	12-34
Description	12-34
Related Assemblies	12-34
Troubleshooting Hints	12-34
TG UNLVL (U)(H)	12-34
Related Assemblies	12-34
Troubleshooting Hints	12-34
Too many signals with valid N dB points (U)	12-34
There is another I/O card at that address. (H)	12-35
Related Assemblies	12-35
Trace A is not available (U)	12-35
UNDF KEY (U)	12-35
uP load fail	12-35
Related Assemblies	12-35
USING DEFAULTS: _ _ _	12-35
Related Assemblies	12-35
Troubleshooting Hints	12-35
USING DEFAULTS self cal needed (U)	12-35
Verify gate trigger input is disconnected before CAL AMP (U)	12-35
VID-BW FAIL (H)	12-36
Related Assemblies	12-36
Troubleshooting Hints	12-36
Waiting for gate input ... (U)	12-36
Related Assemblies	12-36
Troubleshooting Hints	12-36
WDISCP error (H)	12-36
Related assemblies	12-36
write protected -> write protected (H)	12-36
Related Assemblies	12-36
WRITE_CMD status timeout (H)	12-36
Related Assemblies	12-36
WRITE_CMD timeout (H)	12-36
Related Assemblies	12-36

13. Service Equipment and Tools

Static-Safe Accessories	13-1
Recommended Test Equipment	13-3
Recommended Service Tools	13-6

Index

Figures

1-1. Example of a Static-Safe Work Station	1-8
2-1. Display Adjustment Location	2-9
2-2. A23 Counter Lock Assembly Test Points (On the Bottom of the Instrument)	2-13
2-3. Precision Frequency Reference Setup	2-14
2-4. Oven Reference Adjustment Location	2-16
2-5. R8 of the A11/A13 Bandwidth Filter Board	2-22
2-6. Cal Attenuator Error Correction Setup 1	2-23
2-7. Cal Attenuator Error Correction Setup 2	2-23
2-8. Log and Linear Amplifier Adjustment Setup	2-24
2-9. Log and Linear Amplifier Adjustment Location	2-26
2-10. CAL FREQ Adjustment Routine Setup	2-28
2-11. CAL AMP Adjustment Routine Setup	2-29
2-12. CAL YTF Adjustment Routine Setup	2-30
2-13. CAL MXR Adjustment Routine Setup	2-32
2-14. Second IF Bandpass Filter Adjustment Setup	2-33
2-15. LPF Characterization	2-35
2-16. 300 MHz Calibrator Amplitude Accuracy Test Setup	2-36
2-17. Absolute Amplitude Calibration Setup	2-37
2-18. Low Frequency Flatness Calibration Setup	2-38
2-19. Flatness Calibration Setup	2-39
2-20. PREAMP Flatness Calibration Setup	2-40
2-21. First LO Distribution Amplifier Adjustment Setup	2-42
2-22. Tracking Generator Power Level Adjustment Setup	2-45
2-23. Tracking Generator Power Level Adjustment Locations	2-46
2-24. Frequency Tracking Range Setup	2-48
2-25. Tracking Oscillator Adjustment Setup	2-50
3-1. A24 Power Supply Test Point Location	3-5
3-2. A15J13 Connector-Pin Designation	3-8
3-3. Detail of Power Supply Connector, A16J6	3-10
3-4. A24J1 Connector-Pin Orientation	3-12
3-5. Card-Cage Connector-Pin Orientation	3-12
3-6. 2 V Reference Detector	3-20
3-7. Ground Reference Detector	3-21
3-8. Main Coil Driver Typical Display	3-22
3-9. FM Coil Driver with ≤ 10 MHz Span	3-24
3-10. FM Coil Driver with >10 MHz Span	3-25
3-11. Typical Sweep Ramp Display	3-26
3-12. 10 V Reference Detector	3-27
3-13. -10 V Reference Detector	3-28
3-14. YTF Driver	3-29
3-15. A24U12 Pin Location	3-32
4-1. A15 Motherboard Connector Designation	4-15
4-2. A15 Connectors with Additional Associated Circuitry (1 of 2)	4-16
4-2. A15 Connectors with Additional Associated Circuitry (2 of 2)	4-17
4-3. A15J13 Connector-Pin Designation	4-17
4-4. Card-Cage Connector Pin Designation	4-18

6-1. Instrument Cover Replacement	6-3
6-2. RF Cover Replacement	6-5
6-3. A1 Front Panel Assembly Replacement	6-8
6-4. A1A1 Keyboard Replacement	6-10
6-5. A26 Rear Panel Replacement	6-12
6-6. A16 Power Supply Assembly Replacement	6-14
6-7. B1 Fan Replacement	6-16
6-8. A24 Processor Board Assembly Replacement	6-18
6-9. A24 Processor Board Assembly ROMs Replacement	6-20
6-10. A25 Graphics Processor Board Replacement	6-21
6-11. BT1 Battery Replacement	6-23
6-12. A22 HP-IB/RS-232 Board Replacement	6-25
6-13. A2 Display Replacement	6-28
6-14. A17 Graphic Signal Processor Assembly Replacement	6-30
6-15. A15 Motherboard/IF Section Assembly Replacement	6-32
6-16. A21 Disk Drive Controller Board Replacement	6-34
6-17. A19 Disk Drive Replacement	6-36
6-18. A20 10 MHz Precision Reference Replacement	6-37
6-19. A23 Counter Lock Assembly Replacement	6-38
6-20. A5 Analog Interface Board Replacement	6-40
6-21. A3 Preamplifier Section/A4 RF Section Assembly Replacement	6-42
8-1. A3A2 Preamplifier Block Diagram	8-2
8-2. HP 85422E/HP 85462A RF Section, Block Diagram	8-15
8-3. HP 85422E/HP 85462A LO Section, Block Diagram	8-17
8-4. HP 85422E/HP 85462A Third Converter, Block Diagram	8-19
8-5. HP 85422E/HP 85462A IF/Control Section, Block Diagram	8-21
8-6. HP 85422E/HP 85462A Wiring Diagram	8-23
9-1. A1 Front Panel Assembly, Rear View	9-1
9-2. HP 85422E/HP 85462A Receiver RF Section, Top View	9-2
9-3. HP 85422E/HP 85462A Receiver RF Section IF Section, Top View	9-3
9-4. HP 85422E/HP 85462A Receiver RF Section, Bottom View	9-4
9-5. HP 85422E/HP 85462A Receiver RF Section, Bottom View (with A23 Counter Lock Assembly Removed)	9-5
9-6. A4 RF Section Assemblies, Front Right-Side View	9-6
9-7. A4 RF Section Cable and Wire Connections, Front Right-Side View	9-7
9-8. A4 RF Section Assemblies, Rear Left-Side View	9-8
9-9. A4 RF Section Cable and Wire Connections, Rear Left-Side View	9-9
9-10. A3 Preamplifier Section, Top View	9-10
11-1. Calibration, Service, and Diagnostic Softkey Tree	11-2
11-2. Typical Calibration Data: Page 1	11-19
11-3. Typical Calibration Data: Page 2	11-19
11-4. Typical Calibration Data: Page 3	11-20
11-5. Typical Calibration Data: Page 4	11-20
11-6. LO Frequency Diagnostic Data Display	11-30
12-1. A24J1 Connector-Pin Orientation	12-3
13-1. Special Service Tools	13-7

Tables

1-1. HP 8542E/HP 8546A EMI receiver and HP 85422E/HP 85462A receiver RF section Frequency Ranges	1-3
1-2. Maximum Safe Input Levels for HP 85422E/HP 85462A receiver RF section	1-7
2-1. Automated and Manual Adjustment Procedures	2-1
2-2. Adjustments and Tests for Replaced or Repaired Assemblies	2-4
2-3. Bandwidth Amplitude-Correction Map	2-22
2-4. Log Fidelity Check	2-27
2-5. Linear Gain Check	2-27
2-6. Mixer Bias DAC Correction Value	2-31
2-7. Tracking Oscillator Range Centering	2-51
3-1. Instrument Failure Symptoms at Power-On	3-4
3-2. Power Supply Tolerances	3-6
3-3. A24 Processor Board Assembly LED Diagnostics	3-30
3-4. Free-Run Conditions for A24 Processor Board Assembly U12	3-32
4-1. Nominal Resolution Bandwidth Control Line Voltages	4-8
4-2. IF Section Gain Table in dB	4-10
4-3. 10 dB Step-Gain Control Lines	4-11
4-4. Calibration-Attenuator Control Lines	4-11
4-5. Linear Gain Control Lines on the A14 Log Amplifier Board	4-12
4-6. A15 Motherboard Mnemonic Descriptions	4-19
4-7. A15 Motherboard Pin Designations	4-23
5-1. RF Section Block Diagram Measurement Point Power Levels	5-4
5-2. A5J4 2nd Converter Drive Pin Designation	5-5
5-3. A5J301 YTF Driver Pin Designation	5-5
5-4. A8J1 Tracking Generator Control Pin Designation	5-5
5-5. Preamplifier Switch Control Lines	5-6
5-6. VIEW CAL ON OFF Switch Control Lines	5-6
5-7. Input Attenuator Control Output at A5J5	5-7
6-1. Rear-Panel BNC Connectors	6-13
6-2. A15 Motherboard Cable Connections	6-33
7-1. Hewlett-Packard Sales and Service Offices	7-6
8-1. HP 85422E/HP 85462A receiver RF section Frequency Ranges	8-1
10-1. Reference Designations, Abbreviations and Multipliers (1 of 4)	10-3
10-1. Reference Designations, Abbreviations, and Multipliers (2 of 4)	10-4
10-1. Reference Designations, Abbreviations, and Multipliers (3 of 4)	10-5
10-1. Reference Designations, Abbreviations, and Multipliers (4 of 4)	10-6
10-2. Standard Value Replacement Capacitors	10-7
10-3. Standard Value Replacement Resistors, 0.125 W	10-8
10-4. Standard Value Replacement Resistors, 0.5 W	10-10
10-5. Assembly-Level Replaceable Parts	10-12
10-6. Replaceable Cables	10-14
12-1. Possible Cause of the Error Message “ADC-GND FAIL”	12-2
12-2. Possible Cause of the Error Message “ADC-2V FAIL”	12-4
12-3. Four-Digit Failure Code Interpretation	12-15
12-4. I/O Bus Address Failure-Code Interpretation	12-16
12-5. I/O Data Bus Failure Code Interpretation	12-16

12-6. A24 Video Ram Address Failure Code Interpretation	12-17
13-1. Static-Safe Accessories	13-2
13-2. Recommended Test Equipment	13-3
13-3. Recommended Accessories	13-4
13-4. Recommended Cables	13-5
13-5. Special Service Tools	13-6
13-6. Required Common Hand Tools	13-8

Introduction

The HP 85422E/HP 85462A Receiver RF Section Service Guide provides the information needed to adjust and repair the HP 8542E/HP 8546A EMI receiver and HP 85422E/HP 85462A receiver RF section to the assembly level.

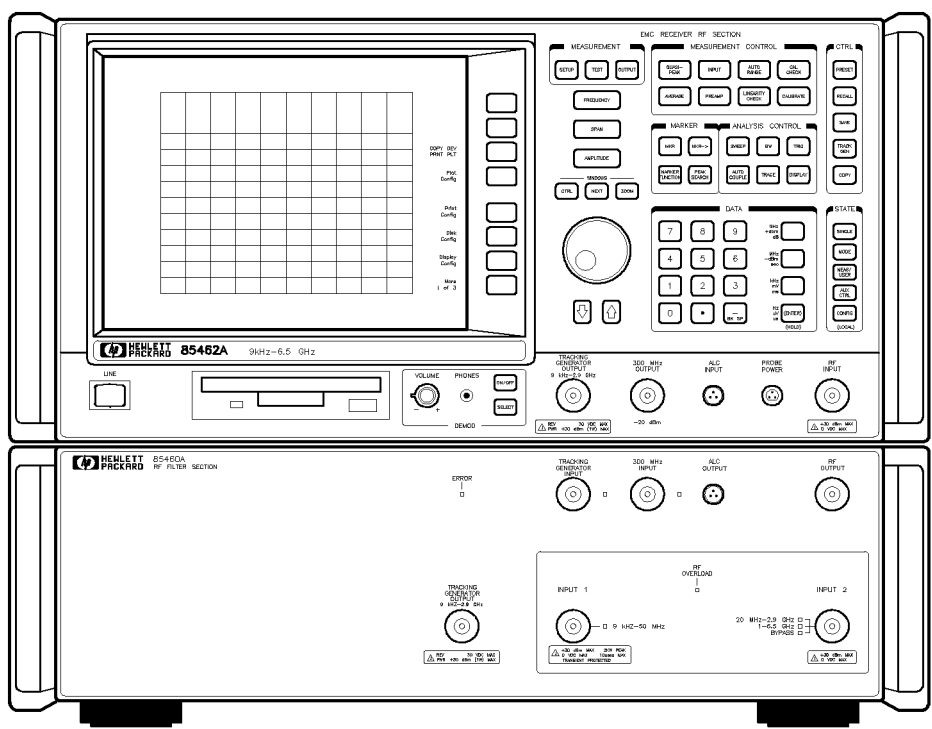

Receiver RF Section
(HP 85422E and HP 85462A)

RF Filter Section
(HP 85420E and HP 85460A)

receiver

**HP 8542E/HP 8546A EMI receiver
HP 85422E/HP 85462A receiver RF section**

Service Guide Organization

The guide is divided into the following chapters:

- Chapter 1, “Introduction,” contains information on the receiver identification, firmware revisions and upgrades, and safety and reliability considerations.
- Chapter 2, “Making Adjustments,” contains the adjustment procedures needed to adjust the receiver to meet its specifications.
- Chapter 3, “Troubleshooting the Instrument,” contains information for starting to troubleshoot a instrument failure.
- Chapter 4, “Troubleshooting the IF Section,” contains specific troubleshooting information for selected assemblies in the IF section and the A15 Motherboard assembly.
- Chapter 5, “Troubleshooting the RF Section,” contains troubleshooting information for the RF section of the receiver.
- Chapter 6, “Replacing Major Assemblies,” contains instructions for the removal and replacement of most major assemblies.
- Chapter 7, “Customer Support,” contains information on how to contact Hewlett-Packard, return the instrument for repair, and services offered by the Hewlett-Packard support team.
- Chapter 8, “Assembly Descriptions,” contains information and block diagrams describing instrument operation and individual assemblies.
- Chapter 9, “Major Assembly and Cable Locations,” contains figures identifying all major assemblies and most cables.
- Chapter 10, “Replaceable Parts,” contains information needed to order assemblies for the instrument.
- Chapter 11, “Service Softkey Descriptions,” contains a description of the calibration, service, and diagnostic softkeys.
- Chapter 12, “Error Messages,” contains a description of the error messages that are displayed when there is a problem with the instrument.
- Chapter 13, “Service Equipment and Tools,” contains information about test equipment and tools used to service the instrument.

Description

The HP 8542E/HP 8546A EMI receiver and HP 85422E/HP 85462A receiver RF section provide measurement capabilities over the RF and Microwave frequency ranges.

The frequency ranges of the instruments are described below.

Table 1-1.
HP 8542E/HP 8546A EMI receiver and
HP 85422E/HP 85462A receiver RF section Frequency Ranges

Instrument Model	Frequency Range
HP 8542E/85422E	9 kHz to 2.9 GHz
HP 8546A/85462A	9 kHz to 6.5 GHz

Further information about the HP 8542E/HP 8546A EMI receiver and HP 85422E/HP 85462A receiver RF section, and additional features, is provided in the HP 8546A/HP 8542E EMI Receiver and HP 85462A/HP 85422E Receiver RF Section User's Guide.

Firmware Revision Date

When the instrument is first turned on, a display appears that contains the copyright date and firmware revision date. The first line of the display indicates if the instrument I/O is HP-IB or RS-232. Refer to the example below.

The version of firmware installed in the instrument is identified by the day, month, and year in the following format:

HP-IB ADRS: nn		<i>or RS232: nnnn</i>
© Copyright HP 1986, 1989, 1994		
Rev 85462: yy.mm.dd	85460: yy.mm.dd	<i>(if HP 8546A receiver)</i>
		<i>or</i>
Rev 85422: yy.mm.dd	85420: yy.mm.dd	<i>(if HP 8542E receiver)</i>

Whenever you contact Hewlett-Packard about your instrument, be sure to provide the firmware date along with the complete serial number and option designation. This will ensure that you obtain accurate service information.

Firmware Upgrade Kit Ordering Information

There are occasions when the factory revises the instrument firmware to correct defects or make performance improvements. When a firmware revision is needed a service note is distributed by the factory to all Hewlett-Packard service centers. The service note identifies, by serial-number prefix, the instruments that require the latest firmware upgrade kit.

If your instrument requires a firmware upgrade kit, it can be obtained by contacting the nearest Hewlett-Packard Sales and Service office. Refer to Table 7-1 for a list of Hewlett-Packard Sales and Service offices.

Instructions for the replacement of the firmware ROMs is located under "A24 Processor Board Firmware ROM" in Chapter 6 of this guide.

Safety Considerations

Before servicing the instrument, familiarize yourself with the safety markings on the instrument and the safety instructions in this manual. This instrument has been manufactured and tested according to international safety standards. To ensure safe operation of the instrument and the personal safety of the user and service personnel, the cautions and warnings in this manual must be heeded.

Refer to the summary of safety considerations at the front of this guide. Individual chapters also contain detailed safety notation.

WARNING Failure to ground the instrument properly can result in personal injury, as well as instrument damage.

Before turning on the instrument, connect a three-wire power cable with a standard IEC 320-C13 (CEE 22-V) inlet plug to the instrument power receptacle. The power cable outlet plug must be inserted into a power-line outlet socket that has a protective earth-contact. DO NOT defeat the earth-grounding protection by using an extension cable, power cable, or autotransformer without a protective ground conductor.

If you are using an autotransformer, make sure its common terminal is connected to the protective ground conductor of its power-source outlet socket.

Reliability Considerations

Instrument Input Protection

The input circuitry can be damaged by power levels that exceed the maximum safe input-level specifications. Table 1-2 provides the input specifications. To prevent input damage, these specified levels for your instrument must not be exceeded.

The input can also be damaged by large transients. If it is likely that your instrument will be exposed to potentially damaging transients, take whatever precautions are necessary to protect its input circuitry.

The HP 85422E/HP 85462A receiver RF section input can easily be protected by disconnecting it from the signal source whenever it is likely that large transients will be present. When it is impractical to disconnect the instrument, a transient-limiting device should be used.

The HP 11947A Transient Limiter is an accessory that protects the input circuitry from transients and accidental overloads. Contact your local Hewlett-Packard Sales or Service office for more information about the HP 11947A.

CAUTION Transients are often produced during electromagnetic interference (EMI) conducted emissions testing. One type of device, the line impedance stabilization network (LISN), can produce large transients when its switch position or voltage input is changed.

**Table 1-2.
Maximum Safe Input Levels for
HP 85422E/HP 85462A receiver RF section**

Average Continuous Power 9 kHz to 2.9 GHz 2.9 kHz to 6.5 GHz ¹	+ 30 dBm + 30 dBm (with ≥ 10 dB input attenuation)
Peak Pulse Power Preamplifier Off	+ 50 dBm (100 W) for 10 μ s pulse width and, 1% duty cycle, input atten >30 dB.
DC	0 V (DC coupled)

¹ HP 85462A only

Protection from Electrostatic Discharge

Electrostatic discharge (ESD) can damage or destroy electronic components. All work on electronic assemblies should be performed at a static-safe work station. Figure 1-1 shows an example of a static-safe work station using two types of ESD protection:

- Conductive table-mat and wrist-strap combination.
- Conductive floor-mat and heel-strap combination.

Both types, when used together, provide a significant level of ESD protection. Of the two, only the table-mat and wrist-strap combination provides adequate ESD protection when used alone. To ensure user safety, the static-safe accessories must provide at least 1 M Ω of isolation from ground. Refer to Chapter 13 for information on ordering static-safe accessories.

WARNING These techniques for a static-safe work station should not be used when working on circuitry with a voltage potential greater than 500 volts.

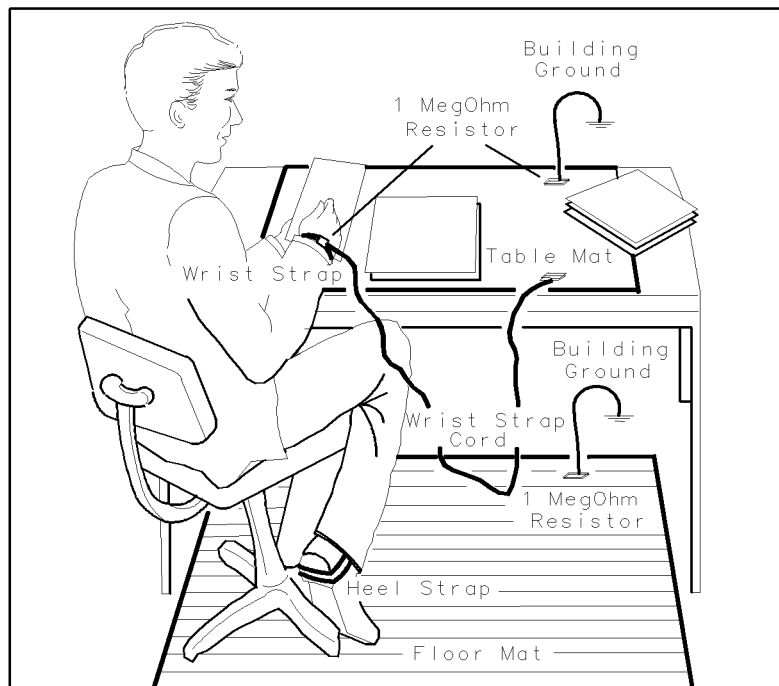

FORMAT46

Figure 1-1. Example of a Static-Safe Work Station

Handling of Electronic Components and ESD

The possibility of unseen damage caused by ESD, is present whenever components are transported, stored, or used. The risk of ESD damage can be greatly reduced by close attention to how all components are handled.

- Perform work on all components at a static-safe work station.
- Keep static-generating materials at least one meter away from all components.
- Store or transport components in static-shielding containers.

CAUTION Always handle printed circuit board assemblies by the edges. This will reduce the possibility of ESD damage to components and prevent contamination of exposed plating.

Test Equipment Usage and ESD

- Before connecting any coaxial cable to an instrument connector for the first time each day, momentarily short the center and outer conductors of the cable together.
- Personnel should be grounded with a 1 M Ω resistor-isolated wrist-strap before touching any instrument connector and before removing any assembly from the instrument.
- Be sure that all instruments are properly earth-grounded to prevent build-up of static charge.

For Additional Information about ESD

For more information about preventing ESD damage, contact the Electrical Overstress/Electrostatic Discharge (EOS/ESD) Association, Inc. The ESD standards developed by this agency are sanctioned by the American National Standards Institute (ANSI).

Making Adjustments

Most adjustments require access to the interior of the instrument.

Commands within parenthesis after a softkey, for example (ON), are used throughout this chapter to indicate the part of a softkey that should be underlined when the key is pressed.

There are both automated and manual adjustments. Table 2-1 lists the adjustments and indicates if the adjustment procedure is automated or manual. In some cases, both automated and manual procedures are provided. These manual procedures are provided as a convenience for those customers that do not need to perform any other automated adjustments.

Table 2-1. Automated and Manual Adjustment Procedures

Adjustment Name	Automated Adjustment	Manual Adjustment
Display		✓
Sampler Match		✓
10 MHz Reference		✓
Crystal and LC Bandwidth Filter		✓
Cal Attenuator Error	✓	
Log and Linear Amplifier		✓
CAL FREQ Adjustment Routine	✓	✓
CAL AMP Adjustment Routine	✓	✓
CAL YTF Adjustment Routine	✓	✓
CAL MXR Adjustment Routine	✓	
Third Converter and Second IF Bandpass		✓
Absolute Amplitude Calibration	✓	
Low Frequency Flatness Calibration	✓	
Flatness Calibration	✓	
PREAMP Flatness Calibration	✓	
Time and Date		✓
First LO Distribution Amplifier		✓
Tracking Generator Power Level		✓
Tracking Oscillator		✓

Safety

Familiarize yourself with the safety symbols marked on the instrument and read the symbol definitions given in the front of this guide *before* you begin the procedures in this chapter. Refer to “General Safety Considerations” at the front of this manual for general *WARNINGS* and *CAUTIONS* related to safety considerations. *WARNINGS* and *CAUTIONS* related to specific procedures are included with the procedure.

Before You Start

There are three things you should do before starting an adjustment procedure:

- Check that you are familiar with the safety symbols marked on the instrument, and read the general safety instructions and the symbol definitions given in the front of this manual.
- Check that the instrument has been turned on and allowed to warm up for at least 30 minutes at room temperature before making any adjustments. The instrument *must* be allowed to stand at room temperature at least 2 hours prior to the 30 minute warm-up.
- Read the rest of this section.

Test equipment you will need

Refer to Chapter 13 for a list of recommended equipment for the instrument adjustments. Any equipment that meets the critical specifications given in the table can be substituted for the recommended model.

If there are abnormal indications during adjustment

If the indications received during an adjustment do not agree with the normal conditions given in the adjustment procedures, a fault exists in your instrument. The fault should be repaired *before* proceeding with any further adjustments. Refer to the troubleshooting and repair information in Chapter 3 of this guide.

Periodically verifying calibration

The instrument requires periodic verification of operation. Under most conditions of use, you should test the instrument at least once a year with the complete set of performance verification tests.

When test results show proper operation and calibration, no adjustments are necessary. However, if test results indicate that the instrument does not meet specifications, the cause should be determined and rectified. Refer to the troubleshooting information in Chapter 3 before attempting recalibration.

Standard-value replacement components

Part numbers for standard-value replacement components used in the adjustment procedures are located in Chapter 10 of this service guide.

If you replace or repair an assembly

If one or more assemblies has been replaced or repaired, related adjustment procedures should be done prior to verifying operation. Refer to Table 2-2 to determine which adjustment to perform after replacing or repairing an assembly. Find the assembly that has been repaired or replaced in the left-hand column. Then perform the adjustments marked across the adjustment column for that assembly. It is important that adjustments are performed in the order indicated to ensure that the instrument meets all of its specifications.

When running software tests

If you are running a software test, always run the “Instrument Setup” test before beginning to run other tests on the menu.

Table 2-2. Adjustments and Tests for Replaced or Repaired Assemblies

Replaced or Repaired Assembly	Related Adjustments and Adjustment Routines	Related Performance Verification Tests
A1 Front Panel *	CAL FREQ CAL AMP Flatness Calibration	Flatness Residual Responses
A1A1 Keyboard	CAL FREQ CAL AMP Flatness Calibration	Flatness Residual Responses
A1A2 Rotary Pulse Generator	CAL FREQ CAL AMP Flatness Calibration	Flatness Residual Responses
A2 Monitor *	Display CAL AMP	Residual Responses
A3A1 Switch *	CAL FREQ CAL AMP Absolute Amplitude Calibration 300 MHz Calibrator Amplitude Adjustment portion of the Third Converter and Second IF Bandpass adjustment	Absolute Amplitude Uncertainty
A3A2 Switched Preamplifier	CAL FREQ CAL AMP Flatness Calibration PREAMP Flatness Calibration	Flatness Residual Responses
A3A3 Switch	CAL FREQ CAL AMP Flatness Calibration	Flatness Residual Responses
A3A4 Input Attenuator	CAL FREQ CAL AMP CAL YTF (HP 85462A only) Absolute Amplitude Calibration Low Frequency Flatness Calibration Flatness Calibration PREAMP Flatness Calibration	Flatness Residual Responses
A3A5 Switch	CAL FREQ CAL AMP Flatness Calibration PREAMP Flatness Calibration	Flatness Residual Responses
A3A6 Switch	CAL FREQ CAL AMP Flatness Calibration PREAMP Flatness Calibration	Flatness Residual Responses
A3AT1 3dB Attenuator	CAL FREQ CAL AMP Flatness Calibration PREAMP Flatness Calibration	Flatness Residual Responses
<p>* These assemblies require a combination of the CAL FREQ, CAL AMP, and CAL YTF adjustment procedures. Performing the combination of the CAL FREQ, CAL AMP, and CAL YTF adjustment procedures using the manual procedures is quicker than performing these adjustments using the automated procedures because these assemblies require no other automated adjustments. Note that the CAL YTF adjustment is not required for the HP 85422E.</p>		

**Table 2-2.
Adjustments and Tests for Replaced or Repaired Assemblies (continued)**

Replaced or Repaired Assembly	Related Adjustments and Adjustment Routines	Related Performance Verification Tests
A4A1 LPF, 2.9 GHz *	CAL FREQ CAL AMP CAL YTF (HP 85462A only)	Flatness Residual Responses
A4A2 BPF, 321.4 MHz *	CAL FREQ CAL AMP	None
A4A3 Second Converter *	CAL FREQ CAL AMP CAL YTF (HP 85462A only)	Noise Sidebands Power-Line Related Sidebands Flatness Gain Compression Displayed Average Noise Residual Responses
A4A4 SYTF	CAL FREQ CAL AMP CAL YTF (HP 85462A only) CAL MXR (HP 85462A only) Absolute Amplitude Calibration Low Frequency Flatness Calibration Flatness Calibration PREAMP Flatness Calibration	Noise Sidebands Power-Line Related Sidebands Flatness Displayed Average Noise Residual Responses
A4A6 Dual Band Mixer	CAL FREQ CAL AMP CAL YTF (HP 85462A only) CAL MXR (HP 85462A only) Absolute Amplitude Calibration Low Frequency Flatness Calibration Flatness Calibration PREAMP Flatness Calibration	Noise Sidebands Power-Line Related Sidebands Flatness Gain Compression Displayed Average Noise Residual Responses
A4A7 Local Oscillator Distribution Amplifier (LODA)	CAL FREQ CAL AMP CAL YTF (HP 85462A only) CAL MXR (HP 85462A only) Absolute Amplitude Calibration Low Frequency Flatness Calibration Flatness Calibration PREAMP Flatness Calibration	Frequency Readout Accuracy Marker Count Accuracy Noise Sidebands Power-Line Related Sidebands Residual FM Frequency Span Accuracy Flatness Residual Responses
A4A8 LPF, 4.4 GHz *	CAL FREQ CAL AMP	Residual Responses
A4A9 YTO *	CAL FREQ CAL AMP CAL YTF (HP 85462A only)	Frequency Readout Accuracy Marker Count Accuracy Noise Sidebands Power-Line Related Sidebands Residual FM Frequency Span Accuracy Flatness Residual Responses

* These assemblies require a combination of the CAL FREQ, CAL AMP, and CAL YTF adjustment procedures. Performing the combination of the CAL FREQ, CAL AMP, and CAL YTF adjustment procedures using the manual procedures is quicker than performing these adjustments using the automated procedures because these assemblies require no other automated adjustments. Note that the CAL YTF adjustment is not required for the HP 85422E.

**Table 2-2.
Adjustments and Tests for Replaced or Repaired Assemblies (continued)**

Replaced or Repaired Assembly	Related Adjustments and Adjustment Routines	Related Performance Verification Tests
A4A10 Tracking Generator *	CAL FREQ CAL AMP CAL YTF (HP 85462A only) Tracking Generator Power Level CAL TRK GEN Refer to Chapter 11	Frequency Readout Accuracy Marker Count Accuracy Noise Sidebands Power-Line Related Sidebands Residual FM Frequency Span Accuracy Flatness Residual Responses Tracking Generator Feedthrough Absolute Amplitude, Vernier, and Power Tracking Generator Level Flatness Tracking Generator Power Sweep Range Tracking Generator LO Feedthrough TG Harmonic Spurious Outputs TG Non-Harmonic Spurious Outputs
A5 Analog Interface Board	CAL FREQ CAL AMP CAL YTF (HP 85462A only.) CAL MXR (HP 85462A only.)	Frequency Readout Accuracy Marker Count Accuracy Noise Sidebands Residual FM Power-Line Related Sidebands Frequency Span Accuracy Sweep Time Accuracy Log Fidelity Reference Level Switching Uncertainty Absolute Amplitude Calibration Resolution Bandwidth Switching Flatness
A6 Narrow Bandwidth Board *	CAL FREQ CAL AMP	IF Bandwidth Shape Check Resolution Bandwidth Switching
A7 Demodulator/Quasi-Peak/Average Detector Board *	CAL FREQ CAL AMP	Pulse Response IF Overload Check
A8 Tracking Generator Control Board *	CAL FREQ CAL AMP CAL YTF (HP 85462A only)	Flatness Absolute Amplitude, Vernier and Power Tracking Generator Level Flatness Tracking Generator Power Sweep Range
A9 Third Converter Board*	CAL FREQ CAL AMP Third Converter & Second IF Bandpass Tracking Generator Power Level	Noise Sidebands Power-Line Related Sidebands Absolute Amplitude Calibration Resolution Bandwidth Switching Displayed Average Noise Residual Responses Tracking Generator Feedthrough Absolute Amplitude, Vernier, and Power Tracking Generator Level Flatness Tracking Generator Power Sweep Range Tracking Generator LO Feedthrough TG Harmonic Spurious Outputs TG Non-Harmonic Spurious Outputs
A11 Bandwidth Board *	Crystal and LC Bandwidth Filter CAL FREQ CAL AMP	IF Bandwidth Shape Check Absolute Amplitude Calibration Resolution Bandwidth Switching
* These assemblies require a combination of the CAL FREQ, CAL AMP, and CAL YTF adjustment procedures. Performing the combination of the CAL FREQ, CAL AMP, and CAL YTF adjustment procedures using the manual procedures is quicker than performing these adjustments using the automated procedures because these assemblies require no other automated adjustments. Note that the CAL YTF adjustment is not required for the HP 85422E.		

**Table 2-2.
Adjustments and Tests for Replaced or Repaired Assemblies (continued)**

Replaced or Repaired Assembly	Related Adjustments and Adjustment Routines	Related Performance Verification Tests
A12 Amplifier Control Board *	CAL FREQ CAL AMP	Log Fidelity Displayed Average Noise IF Overload Check
A13 Bandwidth Board *	Crystal and LC Bandwidth Filter CAL FREQ CAL AMP	IF Bandwidth Shape Check Absolute Amplitude Calibration Resolution Bandwidth Switching
A14 Log Amplifier Board *	Log and Linear Amplifier CAL FREQ CAL AMP	Log Fidelity Reference Level Switching Uncertainty
A15 Motherboard *	CAL FREQ CAL AMP	All Performance Tests
A16 Power Supply Assembly *	CAL FREQ CAL AMP	Power-Line Related Sidebands Residual Responses
A17 Graphic Signal Processor Assembly	Display	None
A18 Speaker	None	AM and FM Demodulation Check
A19 Disk Drive	None	Insert the Limit Line and Antenna Factor Library Disk into the disk drive and make sure that you can load a limit line into the receiver RF section.
A20 10 MHz Reference	10 MHz Reference	10 MHz Reference Output Check
A21 Disk Drive Controller Board	None	Insert the Limit Line and Antenna Factor Library Disk into the disk drive and make sure that you can load a limit line into the receiver RF section.
A22 HP-IB/RS-232 Board	None	Initial Setup
A23 Counter Lock Assembly *	CAL FREQ CAL AMP	Frequency Readout Accuracy Marker Count
A23AT2 10dB Attenuator *	CAL FREQ CAL AMP	Frequency Readout Accuracy Marker Count
A24 Processor Board Assembly	10 MHz Reference CAL FREQ CAL AMP CAL YTF (HP 85462A only) CAL MXR (HP 85462A only) † Cal Attenuator Error † Absolute Amplitude Calibration Low Frequency Flatness Calibration † Flatness Calibration † PREAMP Flatness Calibration † Time and Date	Reference Level Switching Uncertainty Flatness
A25 Graphics Processor Board	None	Display
A26 Rear Panel	None	10 MHz Reference Output Check
B1 Fan	None	Power-Line Related Sidebands Residual Responses
<p>* These assemblies require a combination of the CAL FREQ, CAL AMP, and CAL YTF adjustment procedures. Performing the combination of the CAL FREQ, CAL AMP, and CAL YTF adjustment procedures using the manual procedures is quicker than performing these adjustments using the automated procedures because these assemblies require no other automated adjustments. Note that the CAL YTF adjustment is not required for the HP 85422E.</p> <p>† These adjustments are not necessary if valid correction constants are recovered from the defective A24 processor assembly. See the A24 processor assembly replacement procedure in this service guide.</p>		

Preparing the instrument for adjustments

If the HP 85422E / HP 85462A is connected to a preselector, perform the following steps to disconnect the preselector prior to performing adjustments. If a preselector is not present, then this section may be omitted.

Disconnecting the HP 85420E / HP 85460A preselector

CAUTION To prevent instrument damage, the power cords must be disconnected from both instruments prior to disconnecting the 9-pin bus cable.

1. Switch off the power switch on the instruments front panel.
2. Detach the power cords from both instruments.
3. Disconnect the 9-pin bus cable that is connected to the AUX INTERFACE ports on both instruments.
4. Disconnect the rest of the cables between the two instruments, then separate the receiver from the preselector.
5. Attach the power cord to the HP 85422E / HP 85462A.
6. Turn the POWER switch ON. Let the instrument warm-up for 30 minutes before performing any adjustments.

Display

The display adjustments allow the vertical position and the background intensity of the display to be set. Instructions are also included for degaussing the display. These are the only display adjustments that can be performed outside the factory.

Before beginning the display adjustments allow the instrument to warm up for at least 30 minutes.

Equipment Required

CRT Demagnetizer or Bulk Tape Eraser

Procedure

Vertical Position Adjustment

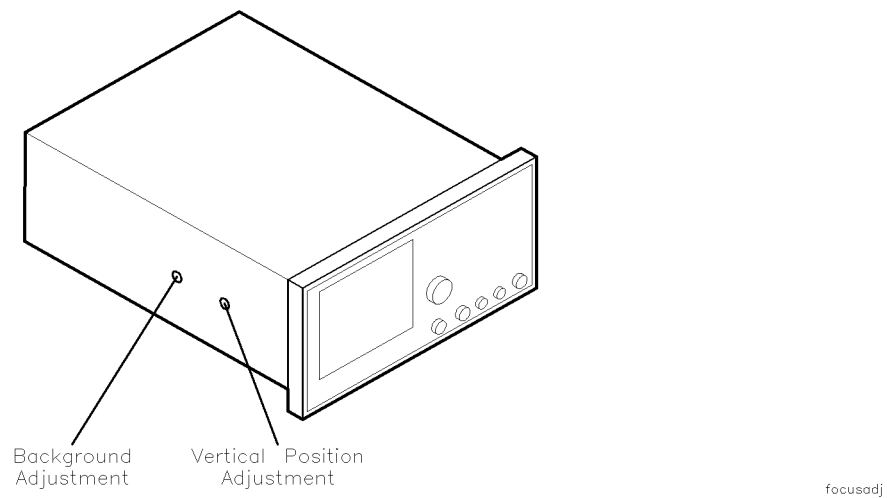

Figure 2-1. Display Adjustment Location

1. Insert a non-conductive adjustment tool into the vertical position access hole in the left side of the instrument.
2. Adjust the control until the softkey labels are aligned with the softkeys.

Degaussing (Demagnetizing)

Note Color purity problems may be caused by a magnetized display or by a magnetic field generated external to the instrument. Before attempting to degauss the display, try moving the instrument to a new location to determine if its location was creating the color purity problem.

1. If the display is magnetized or if it has a color purity problem, cycle the instrument power several times, leaving the instrument turned off for at least 15 seconds before turning it back on.

This will activate a degaussing circuit in the display.

Display

2. If the problem still exists, degauss the display using a CRT demagnetizer or bulk tape eraser.

CAUTION Applying an excessively strong magnetic field to the display face can permanently damage the display. Follow the manufacturer's instructions, keeping following in mind:

- The degaussing device should be placed not closer than 4 inches (10 cm) from the face of the display.
-

Like most displays, this display can be sensitive to large magnetic fields generated by unshielded motors. In countries that use 50 Hz, some 50 Hz jitter may be observed. The device creating the magnetic field must be moved to correct the problem.

Background Adjustment

The background adjustment should be performed in a dimly-lit room (or with the display shaded from bright lights).

1. Press the following keys:

```
PRESET
DISPLAY Display Config
INTENSTY 1 ENTER
BRIGHT 6 ENTER
Adjust Color Edit Colors
```

2. Set the background color by pressing the following keys:

```
BACKGRND
HSL RGB until RGB is underlined.
RED 0 ENTER
GREEN 0 ENTER
BLUE 0 ENTER
PREVIOUS MENU
```

3. Set the graticule color by pressing the following keys:

```
GRATICUL
HSL RGB until RGB is underlined.
RED 1 ENTER
GREEN 1 ENTER
BLUE 1 ENTER
```

4. Insert a non-conductive adjustment tool into the background adjustment access hole in the left side of the instrument.
5. Adjust the background adjustment until the graticule *barely* visible. The background should be black.

6. Set the monitor to its default colors by pressing the following keys:

Previous Menu More 1 of 3 More 2 of 3

Previous Menu

DEFAULT COLORS

Sampler Match

The match between the sampling oscillator and the sampler is optimized by first setting the sampling-oscillator frequency for midrange, then adjusting the sampler-match adjustment for maximum dc volts as read on a digital multimeter.

Equipment Required

Digital multimeter
DMM test leads

Procedure

1. Turn the **(LINE)** switch to OFF. Remove the instrument cover.
2. Turn the **(LINE)** switch to ON.
3. Set the center frequency of the instrument to 194 MHz.
4. Press the following keys:

```
(CONFIG) (local)
(MODE)
Signal Analysis
(Frequency)
Center Freq
194 (MHz)
SPAN
10 (MHz)
(SWEEP)
(AUTO)
```

5. Connect the digital multimeter (DMM) from chassis ground to A23TP1. Refer to Figure 2-2.
6. Adjust A23C107 for maximum voltage as read on the DMM. This voltage must be +1.5 V \pm 1.0 V.
7. Measure the voltage at A23TP2. It should be -1.5 V \pm 1.0 V. If it is not, readjust A23C107 until a compromise is established between the two test points, such that the voltage specifications of steps 6 and 7 are met.

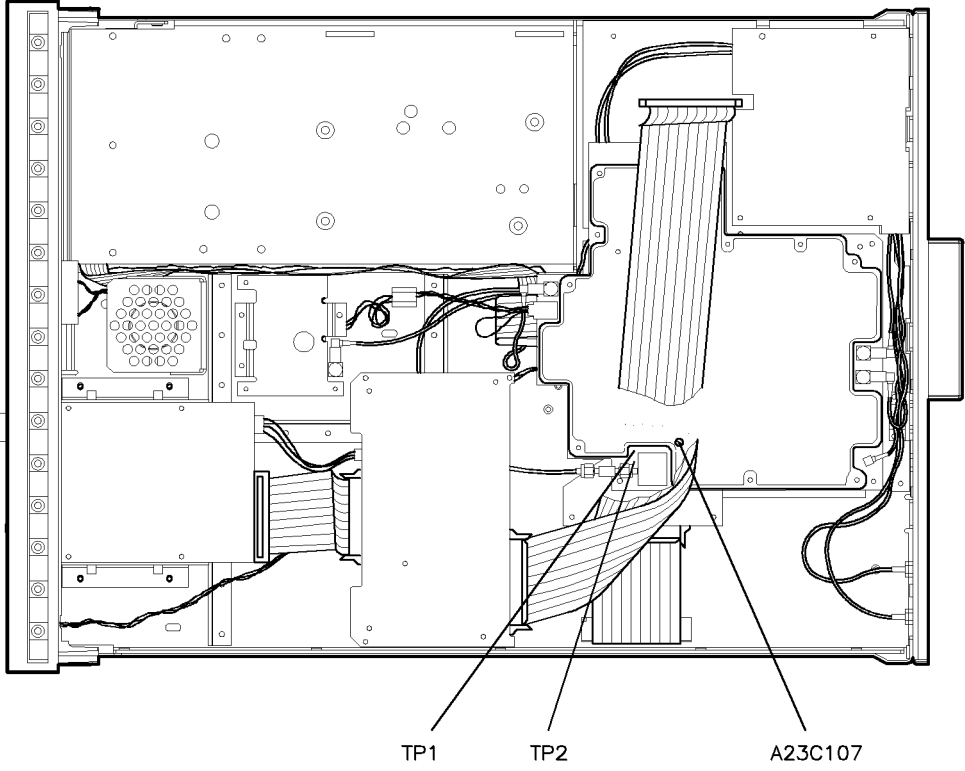

a23top

Figure 2-2.
A23 Counter Lock Assembly Test Points
(On the Bottom of the Instrument)

10 MHz Reference

Readjustment Not Recommended.

Replacement oscillators are factory adjusted after a complete warmup and after the specified aging rate has been achieved. Readjustment should not be necessary after oscillator replacement, and is not recommended.

Note that the instrument must be ON continuously for at least 24 hours immediately prior to adjusting the oscillator to allow both the temperature and frequency of the oscillator to stabilize. Failure to allow sufficient stabilization time could result in the misadjustment of the oscillator.

The frequency of the internal 10 MHz frequency reference is compared to a known frequency standard and adjusted for minimum frequency error. This procedure does not adjust the short-term stability or long-term stability of the 10 MHz Ovenized Crystal Oscillator (OCXO), which are determined by characteristics of the particular oscillator and the environmental and warmup conditions to which it has been recently exposed. The instrument must be ON continuously for at least 24 hours immediately prior to oscillator adjustment to allow both the temperature and frequency of the oscillator to stabilize.

Equipment Required

- Frequency standard
- Frequency counter
- Cable, BNC, 122 cm (48 in) (*two required*)

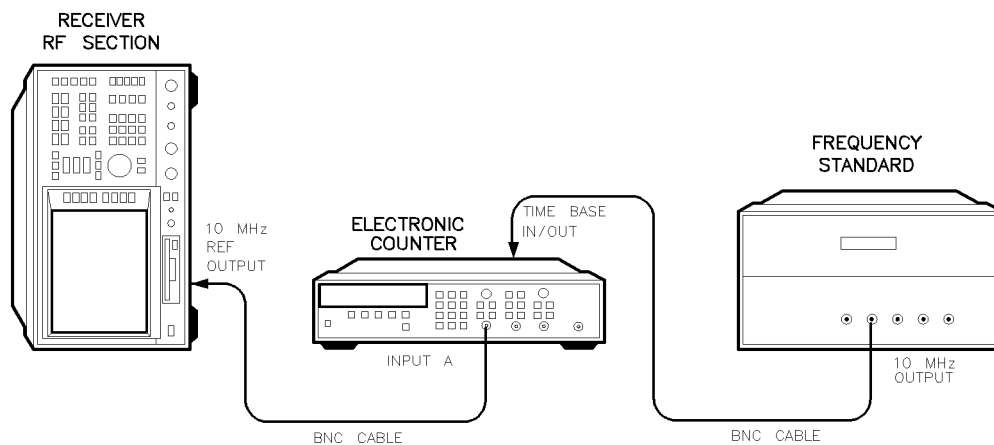

sh25e

Figure 2-3. Precision Frequency Reference Setup

Procedure

1. Place the instrument on its side as shown in Figure 2-3 and set the LINE switch of the instrument to ON.
2. Allow the instrument to remain powered ON and undisturbed for at least 24 hours, so that both the temperature and frequency of the OCXO can stabilize.
3. Connect the frequency standard to the frequency counter rear-panel TIMEBASE IN/OUT connector. Refer to Figure 2-3.
4. Disconnect the jumper between the 10MHz REF OUTPUT and EXT REF IN jacks on the rear panel. Connect a BNC cable between the 10MHz REF OUTPUT jack and INPUT A of the frequency counter.
5. Set the frequency counter controls as follows:

FUNCTION/DATA	FREQ A
INPUT A:	
x10 ATTN	OFF
AC	OFF (DC coupled)
50 Ω Z	OFF (1 M Ω input impedance)
AUTO TRIG	ON
100 kHz FILTER A	OFF
INT/EXT switch (rear panel)	EXT

6. On the frequency counter, select a 1 second gate time and a 10 MHz offset of the displayed frequency by pressing the following frequency counter keys:

(GATE TIME) 1 (GATE TIME)
 MATH (SELECT/ENTER)
 (CHS/EEX) 10 (CHS/EEX) 6 (SELECT/ENTER)
 (SELECT/ENTER)

The frequency counter should now display the difference between the frequency of the INPUT A signal and 10.0 MHz with a displayed resolution of 0.001 Hz.

7. Locate the FREQ ADJ control on the OCXO. See Figure 2-4. Remove the dust cap screw.
8. Use a nonconductive adjustment tool to adjust the FREQ ADJ control on the OCXO for a frequency counter indication of 0.00 Hz.
9. Select a 10 second gate time by pressing the following frequency counter keys:

(GATE TIME) 10 (GATE TIME)

The frequency counter should now display the difference between the frequency of the INPUT A signal and 10.0 MHz with a resolution of 0.001 Hz.

10. Wait at least 2 gate periods for the frequency counter to settle, and then adjust the FREQ ADJ control on the OCXO for a stable frequency counter indication of 0.000 ± 0.010 Hz.
11. Replace the dust cap screw on the OCXO.

10 MHz Reference

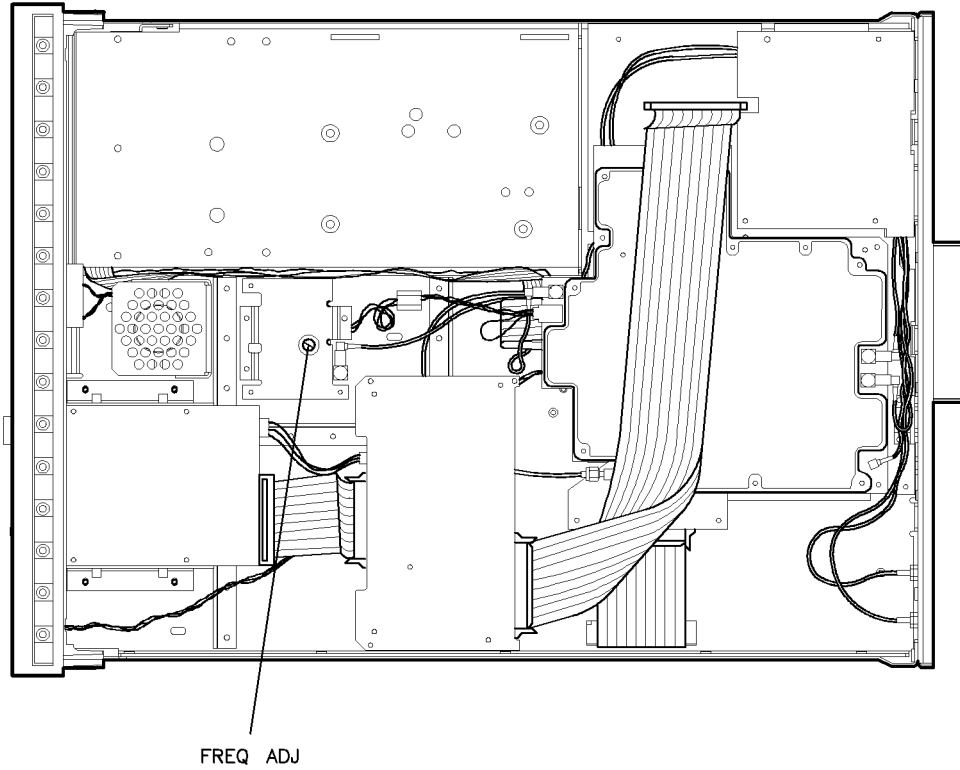

Figure 2-4. Oven Reference Adjustment Location

Crystal and LC Bandwidth Filter

The crystal and LC bandwidth filter circuits are adjusted for symmetry, center frequency, and peak amplitude.

First, correction constants are turned off. This allows for uncorrected 3 dB resolution bandwidth centering and amplitude adjustments.

New corrections are then generated by performing the CAL FREQ and CAL AMP adjustment routines.

Equipment Required

Crystal shorts (*set of three, P/N 5062-4855*)

Note This part is very small and can easily fall into the card cage. Use extreme care when inserting them. It might be useful to create a handle for the jumper with wood and epoxy.

Procedure

1. Turn the **LINE** switch to OFF. Remove the instrument cover assembly.
2. Turn the **LINE** switch to ON, then press the following keys:

```

PRESET
MODE SIGNAL ANALYSIS
CALIBRATE More 1 of 4
CORRECT ON OFF (OFF)
  
```

Crystal Alignment

3. Connect a short cable from the 300 MHz port to the RF INPUT of the instrument under test.
4. Press the following keys:

```

FREQUENCY 300 MHz
SPAN 10 MHz
PEAK SEARCH
MARKER FUNCTION MK TRACK ON OFF (ON)
SPAN 200 kHz
AMPLITUDE 20 -dBm
SCALE LOG LIN (LIN)
More 1 of 3 Amptd Units dBm
BW 3 kHz
  
```

5. Press **AMPLITUDE**, then use the knob to place the signal at the sixth graticule line from the bottom.
6. Press **BW** 30 **kHz** on the instrument.

Crystal and LC Bandwidth Filter

CAUTION Shorting the crystal test points to ground may permanently damage the bandwidth board assembly. If you make your own shorts, it is advisable to insulate the bare wires and connectors.

7. Connect the crystal shorts (through the access holes on the assembly cover) across the following pairs of test points:

A13TP1 and A13TP2
A11TP1 and A11TP2
A11TP4 and A11TP5

8. Adjust A13C54 CTR for minimum signal amplitude. Then adjust A13C38 SYM and A13C54 CTR for a centered and symmetrical bandpass response.

There is a notch near the peak of the signal. This notch can be ignored when adjusting for centering and symmetry.

9. Remove the crystal short from A13TP1 and A13TP2 and connect it across A13TP4 and A13TP5.
10. Adjust A13C25 CTR for minimum signal amplitude. Then adjust A13C15 SYM and A13C25 CTR for a centered and symmetrical bandpass response.
11. Remove the crystal short from A11TP4 and A11TP5. Connect the short across A13TP1 and A13TP2.
12. Adjust A11C54 CTR for minimum signal amplitude. Then adjust A11C38 SYM and A11C54 CTR for a centered and symmetrical bandpass response.
13. Remove the crystal short from A11TP1 and A11TP2. Connect the short across A11TP4 and A11TP5.
14. Adjust A11C25 CTR for minimum signal amplitude. Then adjust A11C15 SYM and A11C25 CTR for a centered and symmetrical bandpass response.
15. Remove the crystal shorts and press the following keys:

PEAK SEARCH
MARKER FUNCTION MK TRACK ON OFF (ON)
SPAN 50 (kHz)
MARKER FUNCTION MK TRACK ON OFF (OFF)
BW 3 (kHz)
PEAK SEARCH MARKER Δ
BW 30 (kHz)
PEAK SEARCH

16. Verify that the MARKER Δ frequency does not exceed 3 kHz.

If the signal shift is out of tolerance, repeat steps 3 through 16.

17. Press the following keys:

MKR
MARKER 1 ON OFF (OFF)

LC Alignment

18. Press the following keys:

BW 100 **(kHz)**
SPAN 5 **(MHz)**

19. Widen all but one of the LC filter poles by shorting A11TP10 and A11TP11, A11TP12 and A11TP13, and A13TP10 and A13TP11 using the crystal shorts.

CAUTION Use a tool with a nonmetallic body to make the LC dip adjustment.

Shorting components to ground may result in permanent damage to the bandwidth board assembly.

20. Center the signal on the display by pressing the following keys:

PEAK SEARCH
MARKER FUNCTION MK TRACK ON OFF (ON)

21. Adjust A13C47 LC dip for a minimum signal amplitude.

22. Move the short from A13TP10 and A13TP11 to A13TP12 and A13TP13, then adjust A13C17 LC dip for a minimum signal amplitude.

23. Move the short from A11TP10 and A11TP11 to A13TP10 and A13TP11, then adjust A11C17 LC dip for a minimum signal amplitude.

24. Move the short from A11TP12 and A11TP13 to A11TP10 and A11TP11, then adjust A11C47 LC dip for a minimum signal amplitude.

LC Centering

Note that the center frequency of the 100 kHz bandwidth is referenced to the 30 kHz bandwidth. During this procedure it is advisable to switch to the 30 kHz bandwidth occasionally and recenter it using **PEAK SEARCH** **MARKER** → **CF**.

25. Short A11TP10 and A11TP11, A11TP12 and A11TP13, and A13TP10 and A13TP11 using the crystal shorts used in the crystal alignment section. Press the following keys:

BW 30 **(kHz)**
SPAN 200 **(kHz)**
MARKER FUNCTION MK TRACK ON OFF (OFF)
BW 100 **(kHz)**

26. Adjust A11C45 LC CTR for maximum signal at center-screen.

27. Move the short from A11TP10 and A11TP11 to A11TP12 and A11TP13, then adjust A11C23 LC CTR for maximum signal at center-screen.

28. Move the short from A13TP12 and A13TP13 to A11TP10 and A11TP11, then adjust A13C45 LC CTR for maximum signal at center-screen.

29. Move the short from A13TP10 and A13TP11 to A13TP12 and A13TP13, then adjust A13C23 LC CTR for maximum signal at center-screen.

30. Disconnect all the shorts from A11 and A13 bandwidth board assemblies.

Crystal and LC Bandwidth Filter

LC Amplitude

31. Press the following keys:

BW 3 **MHz**
SPAN 2 **MHz**

32. Press **AMPLITUDE** and adjust the signal level one division below the top graticule using the knob.

33. Press the following keys:

PEAK SEARCH **MARKER** Δ
MARKER FUNCTION **MK TRACK ON OFF** (ON)
BW 100 **kHz**

It may be necessary to occasionally recenter the 30 kHz bandwidth.

34. Adjust A11R26 LC and A13R26 LC equally for a **MARKER** Δ amplitude of 0 dB. Each potentiometer should be adjusted to accomplish one-half of the necessary increase in signal amplitude. If A11R26 or A13R26 reaches its limit, recenter both potentiometers and repeat steps 31 through 35.

35. Press **MARKER FUNCTION**, **MK TRACK ON OFF** (OFF) on the instrument.

Final LC Centering

36. Press the following keys:

BW 30 **kHz**
SPAN 100 **kHz**
PEAK SEARCH **MARKER** \rightarrow **CF**
BW 100 **kHz**

37. Make final adjustments by adjusting A11C23, A11C45, A13C23, and A13C45 in succession to peak the amplitude of the marker at center-screen.

38. Repeat steps 36 and 37 until the 30 kHz and 100 kHz bandwidths are centered in relation to each other.

39. Press the following keys:

BW 30 **kHz**
PEAK SEARCH
MARKER Δ
BW 100 **kHz**
PEAK SEARCH

40. Verify that the **MARKER** Δ frequency does not exceed 10 kHz.

If the signal shift is out of tolerance, repeat steps 26 through 39.

Crystal Amplitude

41. Press the following keys:

BW 30 **(kHz)**

SPAN 10 **(kHz)**

PEAK SEARCH

MARKER Δ

MARKER FUNCTION MK TRACK ON OFF (ON)

BW 1 **(kHz)**

42. Adjust A11R31 XTL and A13R31 XTL equally for a MARKER Δ amplitude reading of 0 dB. Each potentiometer should be adjusted to accomplish one-half of the necessary increase in signal amplitude. If A11R31 or A13R31 reaches its limit, recenter both potentiometers and repeat steps 41 and 42.

Final BW Amplitude Check

43. Run the “CAL FREQ Adjustment Routine” and the “CAL AMP Adjustment Routine”.

44. Remember to press **CAL STORE** after the completion of the routines to store data in nonvolatile memory.

45. Press the following keys to verify that the bandwidth amplitude corrections are within specifications:

CALIBRATE More 1 of 3 More 2 of 3

Service Diag

DISPLAY CAL DATA

46. Refer to the BW-AMP column of the display to locate the LC and XTL bandwidth amplitude-correction numbers of the instrument. All LC and XTL bandwidth readings should be between -0.8 dB to $+0.5$ dB. Table 2-3 describes and shows an example of the LC and XTL bandwidth amplitude-correction numbers that will be displayed on the instrument. Perform the following steps that apply to your instrument.

- If the difference between the bandwidth amplitude-correction numbers of the 30 kHz XTL and 3 MHz LC is greater than 0.8 dB, pad A11R8 or A13R8 and repeat the Final BW Amplitude Check. Refer to Figure 2-5 for the location of A11R8 and A13R8.
- If the 30 kHz XTL bandwidth amplitude correction is greater than the 3 MHz LC bandwidth correction, increase the value of A11R8 or A13R8.
- If the 3 MHz LC bandwidth amplitude correction is greater than the 30 kHz XTL bandwidth correction, decrease the value of A11R8 or A13R8.
- If just the 100 kHz LC amplitude is out of range, repeat steps 23 through 38 and steps 43 through 46.
- If the 1 kHz XTL amplitude is out of the above range, repeat steps 41 through 46.

Crystal and LC Bandwidth Filter

Table 2-3. Bandwidth Amplitude-Correction Map

Resolution Bandwidths	BW-AMP Correction Numbers
not used	0.00
not used	0.00
not used	0.00
not used	0.00
XTL: 9 kHz	0.00
300 Hz	0.46
1 kHz	0.06
3 kHz	-0.02
10 kHz	0.00
30 kHz	0.00
LC: 100 kHz	-0.27
300 kHz	-0.40
1 MHz	-0.43
3 MHz	-0.47
5 MHz	-0.54
120 kHz	-0.17

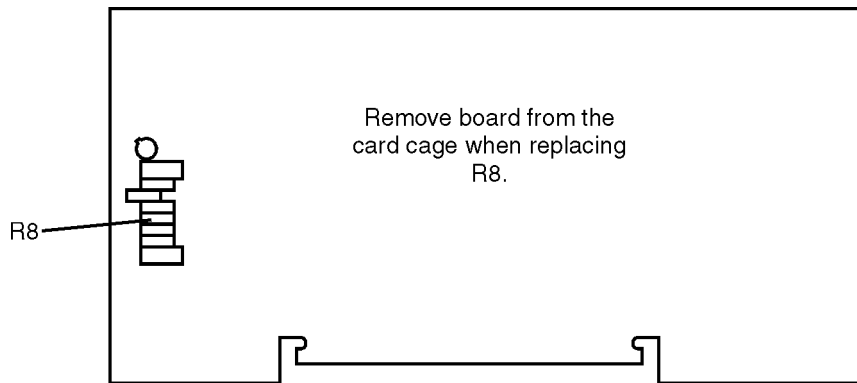

a13comp

Figure 2-5. R8 of the A11/A13 Bandwidth Filter Board

Cal Attenuator Error

This is an automated adjustment.

The A12 amplitude control assembly has one 10 dB and two 20 dB nonadjustable amplifiers. It also has 1 dB, 2 dB, 4 dB, and 16 dB attenuators which are correctable. The 16 dB step is not used at this time.

The attenuator error correction procedure involves disabling the attenuator correction constants, determining the attenuator step errors, and entering the new correction constants into the instrument memory.

Equipment Required

- Computer
- HP-IB Cable (*two required*)
- Level generator
- Cable, BNC, 120 cm (48 in)
- Adapter Type N (m) to BNC (f)

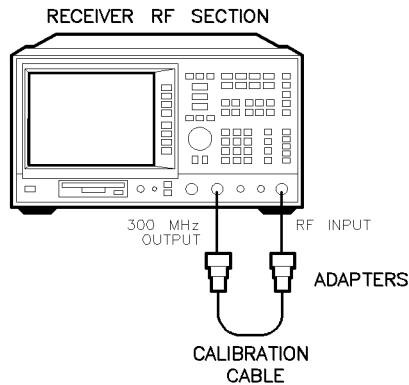

aacal

Figure 2-6. Cal Attenuator Error Correction Setup 1

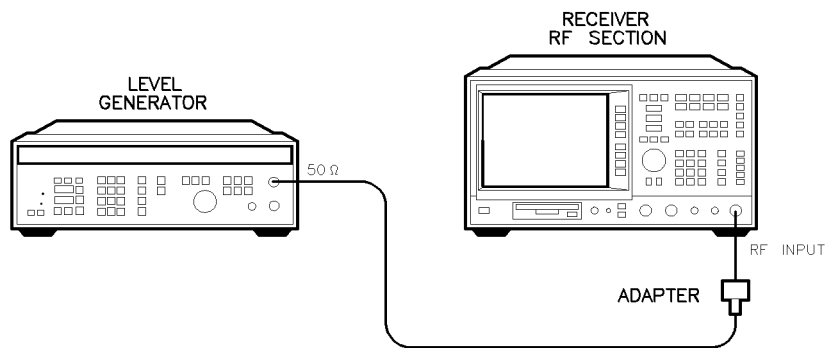

sh26e

Figure 2-7. Cal Attenuator Error Correction Setup 2

Log and Linear Amplifier

A 21.4 MHz signal is injected into an IF test board that has been inserted in place of the first resolution bandwidth assembly, A11. The gain of the A14 log amplifier assembly is adjusted by observing the voltage at the AUX VIDEO output on the rear panel with a digital multimeter.

Equipment Required

Level generator
Digital multimeter (DMM)
IF test board (P/N 5062-6421)
Cable, BNC, 120 cm (48 in)
Cable, BNC (f) to dual banana plug
Test cable

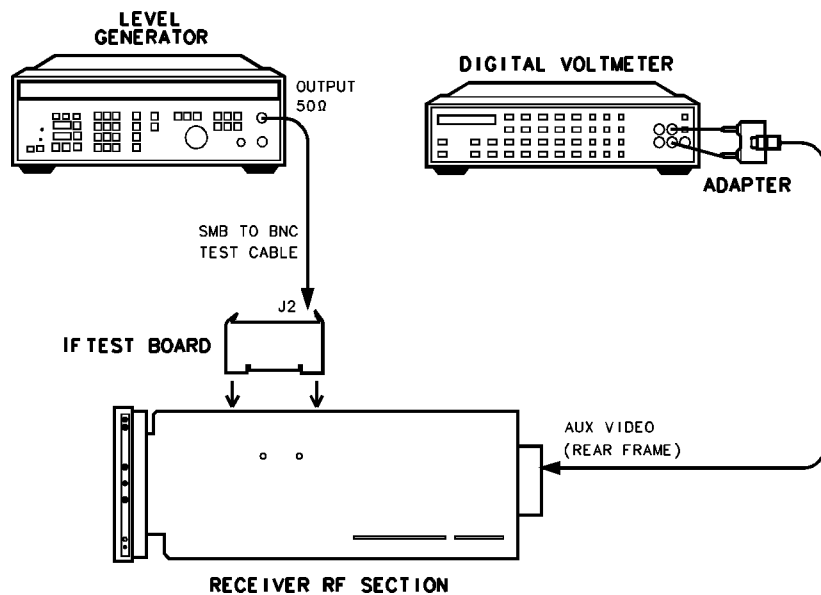

sh27e

Figure 2-8. Log and Linear Amplifier Adjustment Setup

Procedure

1. Turn the **LINE** switch to OFF. Remove the instrument cover assembly.
2. Remove the first IF bandwidth filter assembly, A11. Install the IF test board into the A11 slot. Turn the **LINE** switch to ON.
3. Set the DMM to read dc volts.

4. Press the following keys:

```

(PRESET)
(MODE) SIGNAL ANALYSIS
(CALIBRATE) More 1 of 3
CORRECT ON OFF (OFF) More 2 of 3
Service Diag
STP GAIN ZERO
(SPAN) 0 (Hz)
(BW) 10 (kHz)
AVG BW AUTO MAN 300 (Hz)
(AMPLITUDE) 10 (-dBm)
SCALE LOG LIN (LIN)
    
```

5. Set the level generator as follows:

FREQUENCY	21.4 MHz
MANUAL TUNE	ON
AMPTD INCR	0.01 dBm
AMPLITUDE	-6 dBm

6. Connect equipment as shown in Figure 2-8. Connect the output of the level generator to J2 of the IF test board. Connect the DMM to the AUX VIDEO output located on the rear panel.

Log Fidelity Adjustment

- Adjust the level generator knob for maximum signal amplitude on the display. Adjust the level generator amplitude as necessary to keep the signal on the display.
- Adjust the level generator output level for a DMM reading of 1000 mV \pm 1.0 mV. Record the level generator amplitude readout for later reference: _____ **dBm**
- Press AMPTD INCR 10 dB on the level generator.
- Press **SCALE LOG LIN** (LOG) on the instrument.
- Set the level generator to the level recorded in step 8 and adjust A14R23 SLOPE (refer to Figure 2-9) for a DMM reading of 1000 mV \pm 1 mV.

Log and Linear Amplifier

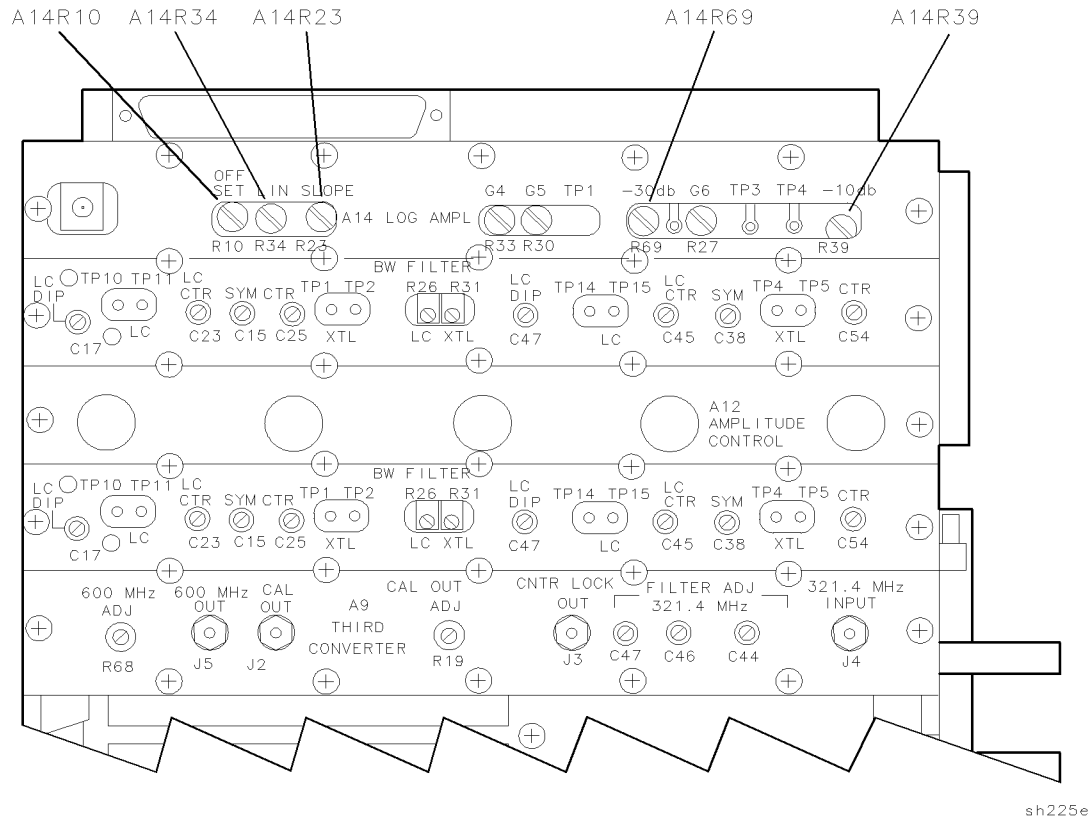

Figure 2-9. Log and Linear Amplifier Adjustment Location

12. Set the level generator amplitude 60 dB below that recorded in step 8 by pressing AMPLITUDE and then pressing STEP DOWN six times. Adjust A14R10 OFFSET for the DMM reading of $250 \text{ mV} \pm 1 \text{ mV}$.
13. Repeat steps 11 and 12 until no further adjustment is necessary.
14. Set the level generator amplitude 30 dB below that recorded in step 8 and adjust the A14R23 SLOPE for a DMM reading of $625 \text{ mV} \pm 1 \text{ mV}$.
15. Set the level generator amplitude to the level recorded in step 8 and adjust the A14R69 -30 dB for a DMM reading of $1000 \text{ mV} \pm 1 \text{ mV}$.
16. Repeat steps 14 and 15 until no further adjustment is necessary.
17. Set the level generator amplitude 10 dB below that recorded in step 8 and adjust the A14R23 SLOPE for a DMM reading of $875 \text{ mV} \pm 1 \text{ mV}$.
18. Set the level generator amplitude to the level recorded in step 8 and adjust the A14R39 -10 dB for a DMM reading of $1000 \text{ mV} \pm 1 \text{ mV}$.
19. Repeat steps 17 and 18 until no further adjustment is necessary.
20. Repeat steps 11 through 19 until the limits in Table 2-4 are met.

Table 2-4. Log Fidelity Check

Level Generator Output Level	DMM Reading
Reference (from step 8)	1000 mV \pm 1 mV
Reference - 10 dB	875 mV \pm 3 mV
Reference - 20 dB	750 mV \pm 4 mV
Reference - 30 dB	625 mV \pm 4 mV
Reference - 40 dB	500 mV \pm 5 mV
Reference - 50 dB	375 mV \pm 6 mV
Reference - 60 dB	250 mV \pm 7 mV
Reference - 70 dB	125 mV \pm 8 mV

Linear Output and Step Gain Adjustments

21. Press the following keys:

AMPLITUDE 50 -dBm
 SCALE LOG LIN (LIN) More 1 of 3
 Amptd Units dBm

22. Set the level generator amplitude to the level recorded in step 8 and adjust A14R34 LIN for a DMM reading of 1000 mV \pm 1 mV.
23. Use Table 2-5 to set the level generator amplitude and receiver level, then complete the adjustments indicated.

Table 2-5. Linear Gain Check

Adjust	Level Generator Output Level	Reference Level (dBm)	DMM Reading
A14R34	Reference (from step 8)	-50	1000 mV \pm 1 mV
A14R33	Reference - 10 dB	-60	1000 mV \pm 5 mV
A14R30	Reference - 20 dB	-70	1000 mV \pm 5 mV
A14R27	Reference - 30 dB	-80	1000 mV \pm 5 mV
N/A	Reference - 40 dB	-90	1000 mV \pm 30 mV

CAL FREQ Adjustment Routine

This is an automated adjustment.

The CAL FREQ adjustment routine accesses an internal self-adjustment routine. This routine adjusts the instrument to obtain frequency accuracy using the CAL OUT signal. The following adjustments are performed by the CAL FREQ routine:

- Sweep time calibration.
- YTO offset and slope.
- FM coil timing constants.
- Span attenuator.
- FM detector sensitivity.

Equipment Required

Computer
HP-IB cable

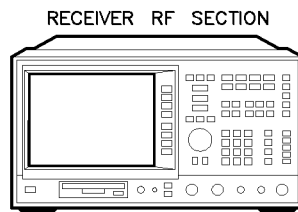

sh29e

Figure 2-10. CAL FREQ Adjustment Routine Setup

Alternate Manual Procedure

These manual procedures are provided so that you do not have to perform this procedure using the automated version. This is only for your convenience

Interrupting this routine may result in corrupt data being stored in RAM. If this occurs, rerun the CAL FREQ adjustment routine.

1. Press the following keys:

(MODE) **SIGNAL ANALYSIS**

(CALIBRATE) **More 1 of 3 CAL FREQ**

The CAL FREQ adjustment routine will take a few minutes to run.

The internal adjustment data will be stored in working RAM. To store this data in nonvolatile memory, press **CAL STORE**.

CAL AMP Adjustment Routine

This is an automated adjustment.

The CAL AMP adjustment routine accesses an internal self-adjustment routine. The following adjustments are automatically performed by this adjustment routine:

- The reference level is calibrated by adjusting the gain of the IF section.
- The 3 dB resolution bandwidths are adjusted.
- Bandwidth amplitude errors are determined. Errors are corrected with video offsets.
- Step-gain and input-attenuator errors are determined. Errors are corrected with video offsets.
- Log fidelity is checked in 1 dB steps. Errors are corrected with video offsets.
- Frequency accuracy is tested and adjusted by using frequency offsets.

Equipment

Computer
HP-IB cable

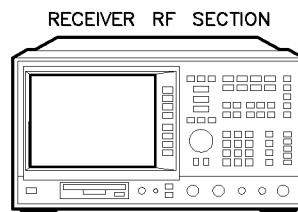

sh29e

Figure 2-11. CAL AMP Adjustment Routine Setup

Alternate Manual Procedure

These manual procedures are provided so that you do not have to perform this procedure using the automated version. This is only for your convenience

Perform the "CAL FREQ Adjustment Routine" before to performing this adjustment routine.

1. Press the following keys:

MODE **SIGNAL ANALYSIS**

CALIBRATE More 1 of 3 **CAL AMP**

The **CAL AMP** routine takes approximately 5 to 7 minutes to run. The internal adjustment data will be stored in working RAM. To store this data in nonvolatile memory, press **CAL STORE**.

CAL YTF Adjustment Routine

This is an automated adjustment.

For the HP 85462A only.

The CAL YTF adjustment routine accesses an internal adjustment routine. This routine adjusts the slope and offset of the A4A4 YTF tune voltage for each harmonic mixing band. Perform the “CAL FREQ Adjustment Routine” before performing this adjustment.

Equipment Required

Computer
HP-IB cable

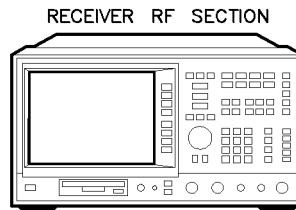

sh29e

Figure 2-12. CAL YTF Adjustment Routine Setup

Alternate Manual Procedure

These manual procedures are provided so that you do not have to perform this procedure using the automated version. This is only for your convenience

1. Perform the “CAL FREQ Adjustment Routine”. This adjustment is located in this chapter.
2. Press the following keys:

MODE **SIGNAL ANALYSIS**

CALIBRATE **More 1 of 3** **More 2 of 3** **CAL YTF**

The **CAL YTF** routine will take a few minutes to run. The internal adjustment data is displayed when the routine has finishes.

If the message “NO CAL SIGNAL FOUND” is displayed, perform the Mixer Bias DAC Initialization procedure located on the next page.

3. Press **CAL STORE** to store the YTF correction data in nonvolatile memory.

Mixer Bias DAC Initialization

Perform this procedure *only* if the “NO CAL SIGNAL FOUND” message is displayed during the “CAL YTF Adjustment Routine”.

The “NO CAL SIGNAL FOUND” message indicates the current mixer bias DAC settings may not be adequate to ensure that a signal is displayed. Initialization of the mixer bias DAC may be required.

- 1. Press the following keys:

```
(MODE) SIGNAL ANALYSIS
(CALIBRATE) More 1 of 3 More 2 of 3
Service Diag
DISPLAY CAL DATA
```

- 2. Record the displayed “Optimum Bias” DAC value.

The optimum bias DAC value is the numbers located at the right of “MXRB” on the display.

Table 2-6. Mixer Bias DAC Correction Value

Displayed Optimum Bias Value	Acceptable Bias Range
_____	800 to 1900

- 3. If the recorded “Optimum Bias” value is within the acceptable range indicated in Table 2-6, RF section troubleshooting is necessary.

If the recorded “Optimum Bias” value is not within the acceptable range indicated in Table 2-6, complete the rest of this procedure to initialize the mixer bias DAC values.

- 4. Press the following keys to allow entry of the default mixer bias DAC value:

```
(MODE) SIGNAL ANALYSIS
(FREQUENCY) -2001 (Hz)
(DISPLAY)
CHANGE TITLE
```

- 5. Enter CALMXRDATA 1600,1; as a title entry to set the mixer bias value to 1600 for band 1.

- 6. Press the following keys to store the mixer bias value for band 1 in nonvolatile memory:

```
(CALIBRATE) More 1 of 3 More 2 of 3
Service Cal
EXECUTE TITLE
```

- 7. Repeat the “CAL YTF Adjustment Routine”.
8. Perform the “CAL MXR Adjustment Routine”.

CAL MXR Adjustment Routine

This is an automated adjustment.

For the HP 85462A only.

The CAL MXR adjustment routine optimizes the dc bias for the A4A6 Dual Band Mixer when in high band. Perform the “CAL YTF Adjustment Routine” before performing this adjustment. New frequency response correction constants must be developed following this adjustment routine.

Equipment Required

Computer
HP-IB cable

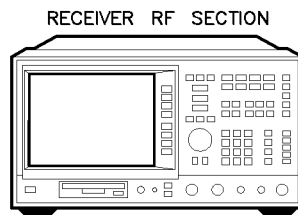

sh29e

Figure 2-13. CAL MXR Adjustment Routine Setup

Third Converter and Second IF Bandpass

The 321.4 MHz, second IF bandpass filter is adjusted for maximum signal amplitude.

The CAL OUT amplitude is measured and adjusted for $-20 \text{ dBm} \pm 0.4 \text{ dB}$. The insertion loss of a low pass filter (LPF) and 10 dB attenuator are characterized. The harmonics of the CAL OUT signal are suppressed with the LPF before the amplitude accuracy is measured using a power meter.

Equipment Required

- Synthesized sweeper
- Microwave spectrum analyzer
- Measuring receiver (*used as a power meter*)
- Power meter
- Low power sensor with a 50 MHz reference attenuator
- Power sensor, 1 MHz to 350 MHz
- Power splitter
- Attenuator, 10 dB, Type N (m to f)
- Low pass filter, 300 MHz
- IF test board
- Cable, Type N, 152 cm (60 in)
- Cable, BNC, 120 cm (48 in)
- Test cable, (*two required*)
- Adapter, APC 3.5 (f) to Type N (f)
- Adapter, Type N (f) to BNC (m) (*two required*)
- Adapter, Type N (m) to BNC (f)

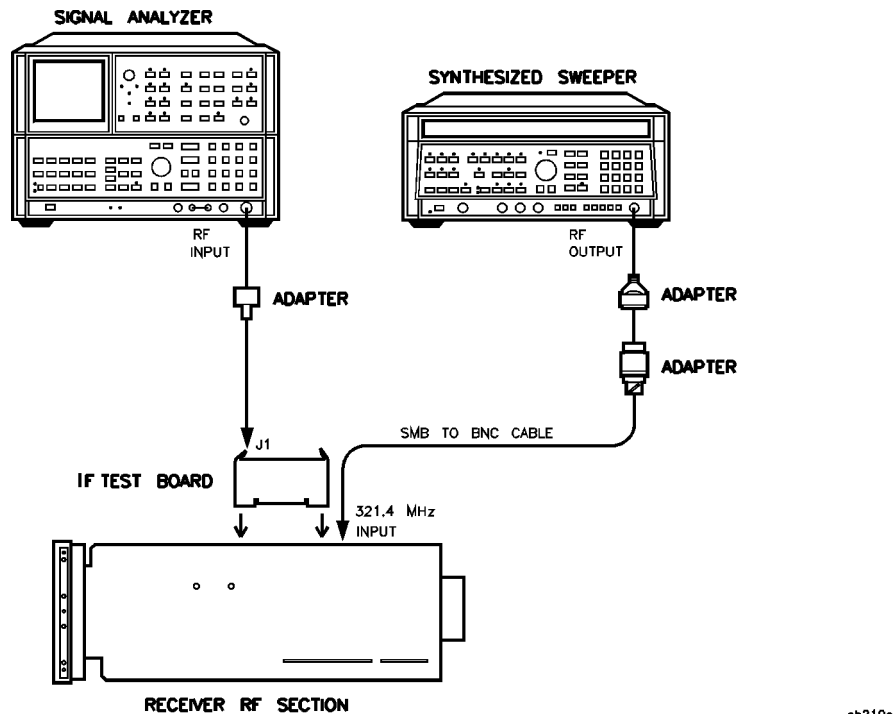

Figure 2-14. Second IF Bandpass Filter Adjustment Setup

Third Converter and Second IF Bandpass

Procedure

Second IF Bandpass Filter

1. Press INSTRUMENT PRESET on the microwave spectrum analyzer, then set the controls as follows:

CENTER FREQUENCY	21.4 MHz
FREQUENCY SPAN	50 MHz
REFERENCE LEVEL	-30 dBm
dB/DIV	1 dB/DIV

2. Set the synthesized sweeper controls as follows:

CW	321.4 MHz
POWER LEVEL	-26 dBm

3. Turn the Receiver RF section **LINE** switch to OFF. Remove the instrument cover and the RF cover.
4. Remove the A11 IF bandwidth filter assembly from the instrument.
5. Install the IF test board into the A11 slot.
6. Remove the W9 cable from A9J4, 321.4 MHz IF INPUT.
7. Connect the synthesized sweeper output to A9J4. Refer to Figure 2-14.
8. Press the Receiver RF section **LINE** switch to ON.
9. Press the following keys:

PRESET
SPAN 0 **Hz**

10. Connect the microwave spectrum analyzer RF INPUT to J1 of the IF test board. Refer to Figure 2-14.
11. Adjust A9C44, A9C46, and A9C47 for maximum signal amplitude as observed on the microwave spectrum analyzer. Adjust the reference level of the microwave spectrum analyzer, as necessary, to display the signal below the top graticule.
12. Remove the test board from the A11 slot and reinstall the A11 IF bandwidth filter assembly.
13. Reconnect W9 to A9J4, 321.4 MHz INPUT.

LPF, Attenuator and Adapter Insertion Loss Characterization

14. Zero and calibrate the measuring receiver and power sensor combination in LOG mode as described in the measuring receiver operation manual.

CAUTION Do not attempt to calibrate the power sensor without the reference attenuator or damage to the power sensor will occur.

15. Zero and calibrate the power meter and 300 MHz power sensor, as described in the power meter operation manual.
16. Connect the equipment as shown in Figure 2-15. Connect the 300 MHz power sensor directly to the power splitter (bypass the LPF, attenuator, and adapters).

Third Converter and Second IF Bandpass

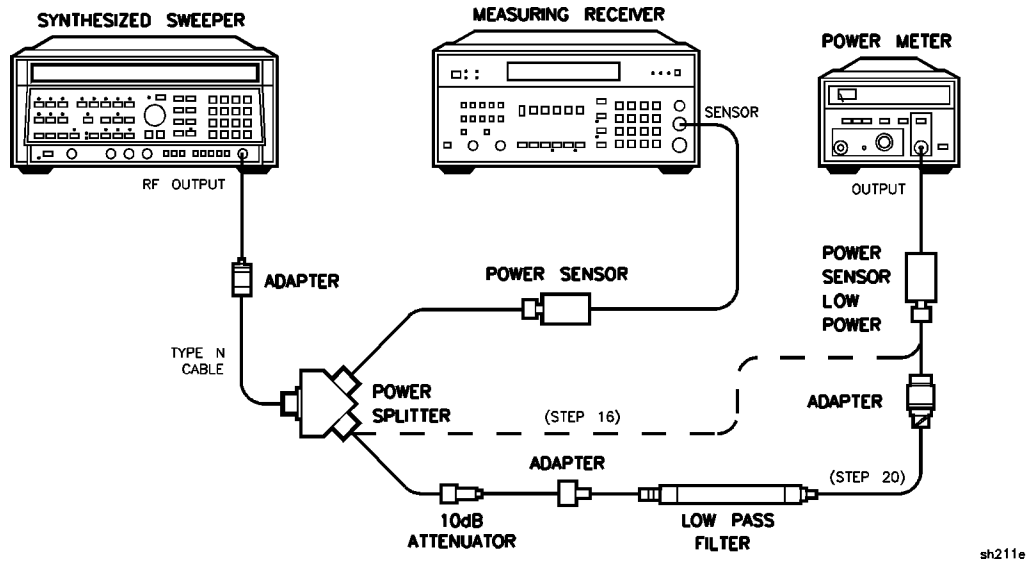

Figure 2-15. LPF Characterization

17. Press INSTRUMENT PRESET on the synthesized sweeper. Set the controls as follows:

CW	300 MHz
POWER LEVEL	-15 dBm

18. Allow the power sensors to settle, then on the measuring receiver, press RATIO mode. Power indication should be 0 dB.
19. On the power meter, press the dB REF mode key. Power indication should be 0 dB.
20. Connect the LPF, attenuator, and adapters as shown in Figure 2-15.
21. Record the measuring receiver reading in dB. This is the relative error due to mismatch.

Mismatch Error _____ dB

22. Record the power meter reading in dB. This is the relative uncorrected insertion loss of the LPF, attenuator, and adapters.

Uncorrected Insertion Loss _____ dB

23. Subtract the Mismatch Error (step 21) from the Uncorrected Insertion Loss (step 22). This is the corrected insertion loss.

Corrected Insertion Loss _____ dB

For example, if the mismatch error is +0.3 dB and the uncorrected insertion loss is -10.2 dB, subtract the mismatch error to the insertion loss gives a corrected reading of -10.5 dB.

Third Converter and Second IF Bandpass

300 MHz Calibrator Amplitude Adjustment

24. Connect the equipment as shown in Figure 2-16. The instrument should be positioned so that the setup of the adapters, LPF, and attenuator do not bind. It may be necessary to support the center of gravity of the devices.

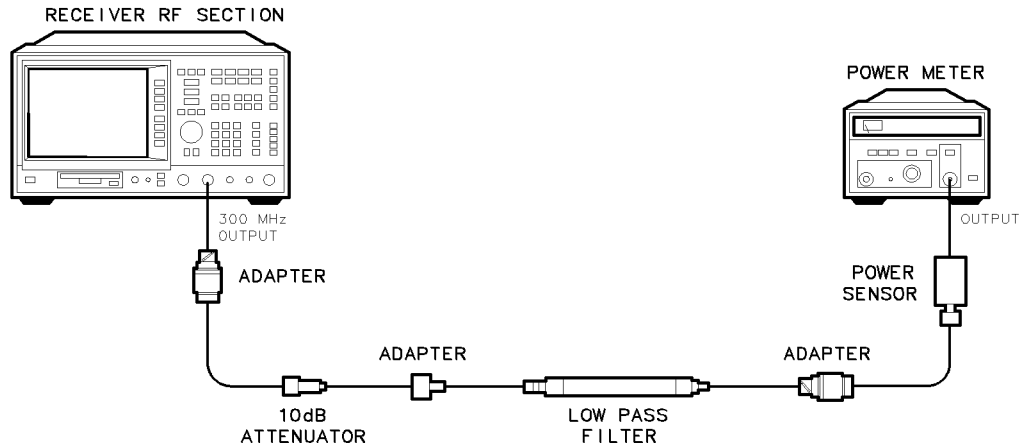

sh212e

Figure 2-16. 300 MHz Calibrator Amplitude Accuracy Test Setup

25. On the power meter, press the dBm mode key. Record the power meter reading in dBm.

Power Meter Reading _____ dBm

26. Subtract the Corrected Insertion Loss (step 23) from the power meter reading (step 25) and record as the CAL OUT power. The CAL OUT should be $-20 \text{ dBm} \pm 0.4 \text{ dB}$.

$$\text{CAL OUT Power} = \text{Power Meter Reading} - \text{Corrected Insertion Loss}$$

For example, if the Corrected Insertion Loss is -10.0 dB , and the measuring receiver reading is -30 dB , then $-30 \text{ dB} - (-10.0) \text{ dB} = -20 \text{ dB}$

CAL OUT Power _____ dBm

27. Adjust A9R19 CAL OUT ADJ accordingly if the CAL OUT amplitude is not $-20 \text{ dBm} \pm 0.4 \text{ dB}$ as calculated in step 26.

Absolute Amplitude Calibration

This is an automated adjustment.

The absolute amplitude calibration calibrates and checks HP 85422E/HP 85462A receiver RF section for absolute amplitude using the HP 85422E/HP 85462A receiver RF section firmware's absolute amplitude calibration feature. This feature provides the correct value for the calibration path error.

Equipment Required

- Computer
- HP-IB cable
- Calibration cable, 9 in, BNC
- Adapter, BNC (f) to Type N (m) *(two required)*

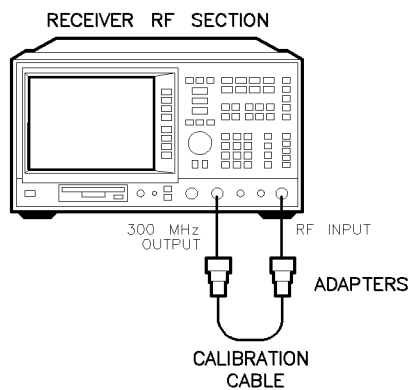

aacal

Figure 2-17. Absolute Amplitude Calibration Setup

Low Frequency Flatness Calibration

This is an automated adjustment.

Using the absolute accuracy of the level generator, this adjustment finds the correct frequency response of the instrument at certain frequency points. Once the measurement is taken, the correct number is entered into the instrument's RAM. The instrument then uses this number to correct the frequency response of the instrument.

Equipment Required

- Computer
- HP-IB cable
- Level generator
- Cable, BNC 122 cm (48 in)
- Adapter, BNC (f) to Type N (m)

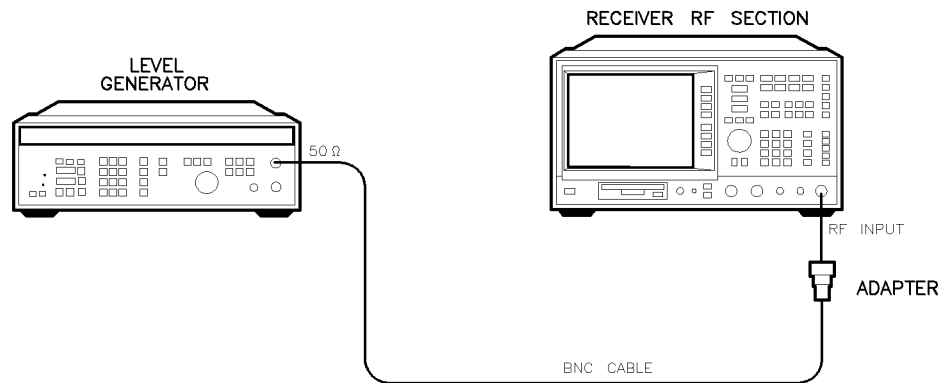

1fflcal

Figure 2-18. Low Frequency Flatness Calibration Setup

Flatness Calibration

This is an automated adjustment.

Using power meter leveling, this adjustment finds the correct frequency response of the power meter level to determine the correct frequency response of the instrument at certain frequency points. Once the measurement is taken, the correct number is entered into the instrument's RAM. The instrument then uses this number to correct the frequency response of the instrument.

Equipment Required

- Computer
- HP-IB cable (*three required*)
- Synthesized sweeper
- Power meter
- Power splitter
- Power sensor
- Cable, APC 3.5
- Adapter, APC 3.5 (f) to APC 3.5 (f) (*two required*)
- Adapter, APC 3.5 (f) to Type N (m)

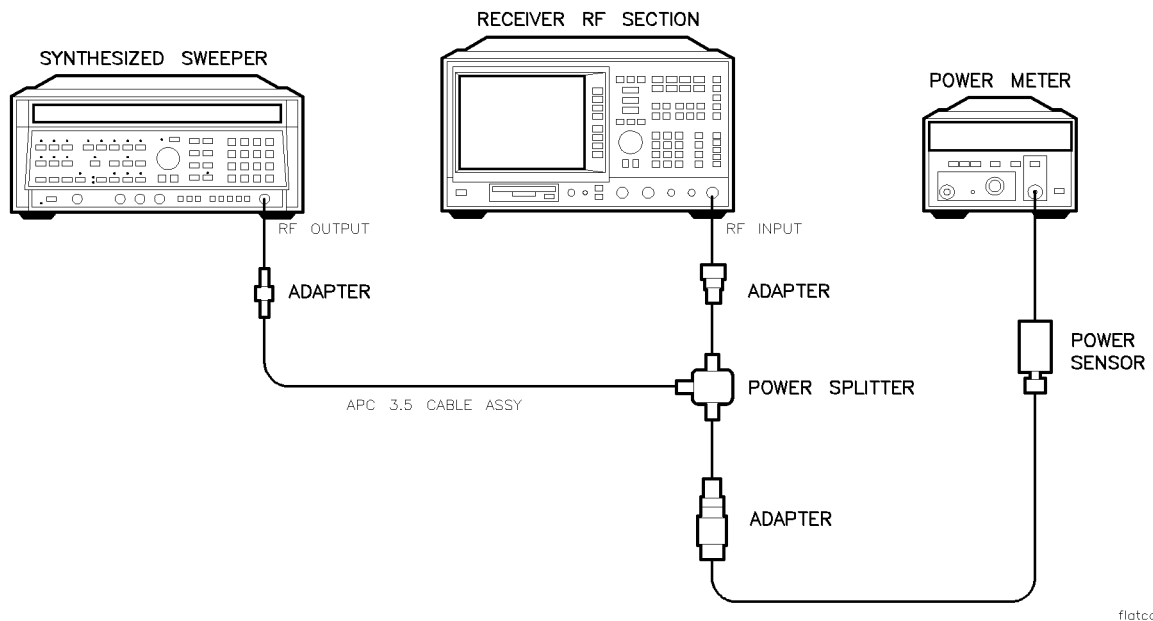

Figure 2-19. Flatness Calibration Setup

PREAMP Flatness Calibration

This is an automated adjustment.

This test uses power meter leveling to level the source power so that the frequency response of the instrument can be measured. Once the measurement is taken, the correction data is entered into the instrument's RAM. The instrument then uses this data to correct for its frequency response.

Equipment Required

- Computer
- HP-IB cable (*three required*)
- Synthesized sweeper
- Power meter
- Power splitter
- Power sensor, low power
- Cable, APC 3.5
- Adapter, APC 3.5 (f) to APC 3.5 (f) (*two required*)
- Adapter, APC 3.5 (f) to Type N (m)

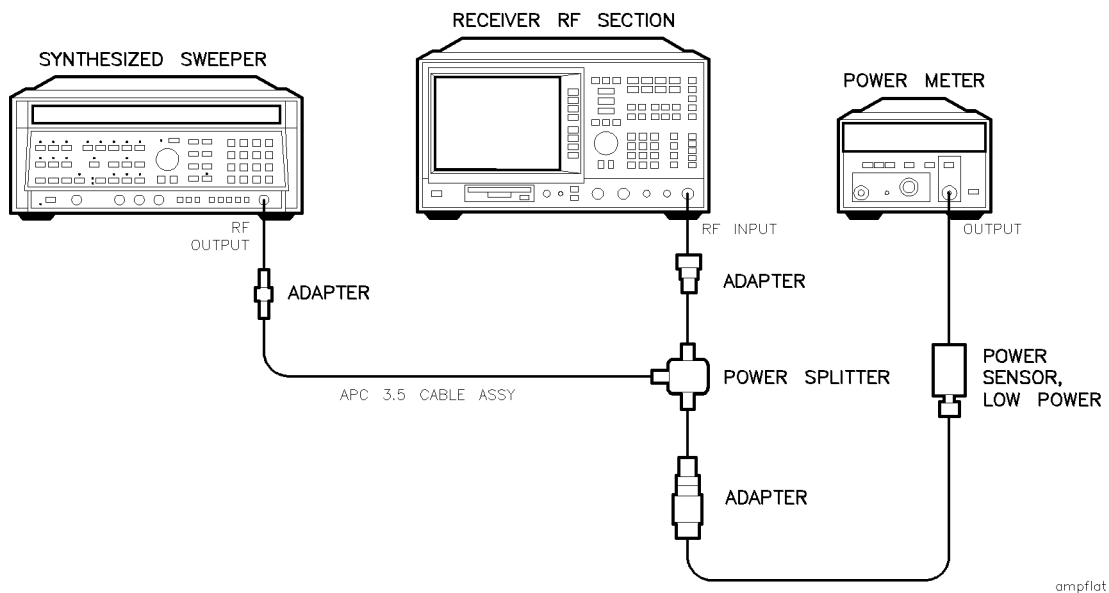

Figure 2-20. PREAMP Flatness Calibration Setup

Time and Date

The time and date are displayed in the top left corner of the display when the time-date mode is activated. The time and date are changed using the front-panel keys.

Procedure

1. To turn the time and date ON or OFF, press the following keys:

```

CONFIG
More 1 of 3
Time Date
TIMEDATE ON OFF (ON) or (OFF) as desired

```

The time and date will be displayed in the top-left corner with ON underlined.

2. The time and date may be displayed as month, day, and year (MDY) or as day, month, and year (DMY). To change the display, press the following keys:

```

CONFIG
More 1 of 3
Time Date
DATEMODE MDY DMY (MDY) or (DMY) as desired

```

3. To change the date, press the following keys:

```

CONFIG
More 1 of 3
Time Date
SET DATE

```

The active function block of the instrument will display YYYYMMDD (year, month, and day). Use the data keys on the instrument to enter the correct date as YYYYMMDD. Terminate the entry with one of the **ENTER** data keys.

4. To change the time, press the following keys:

```

CONFIG
More 1 of 3
Time Date
SET TIME

```

The active function block of the instrument will display HHMMSS (hours, minutes, and seconds). Use the data keys on the instrument to enter the correct time as HHMMSS. Terminate the entry with one of the **ENTER** data keys.

First LO Distribution Amplifier

The gate bias for the A4A7 LO distribution amplifier assembly is adjusted to the value specified on a label on the RF section. The LO power is adjusted so that the LO SENSE voltage is equal to the value specified on the label. The adjustments are made on the A8 tracking generator control assembly, which is located in the card cage.

Equipment Required

Measuring receiver
Digital multimeter
Power sensor
DMM test leads
Adapter, dual banana plug

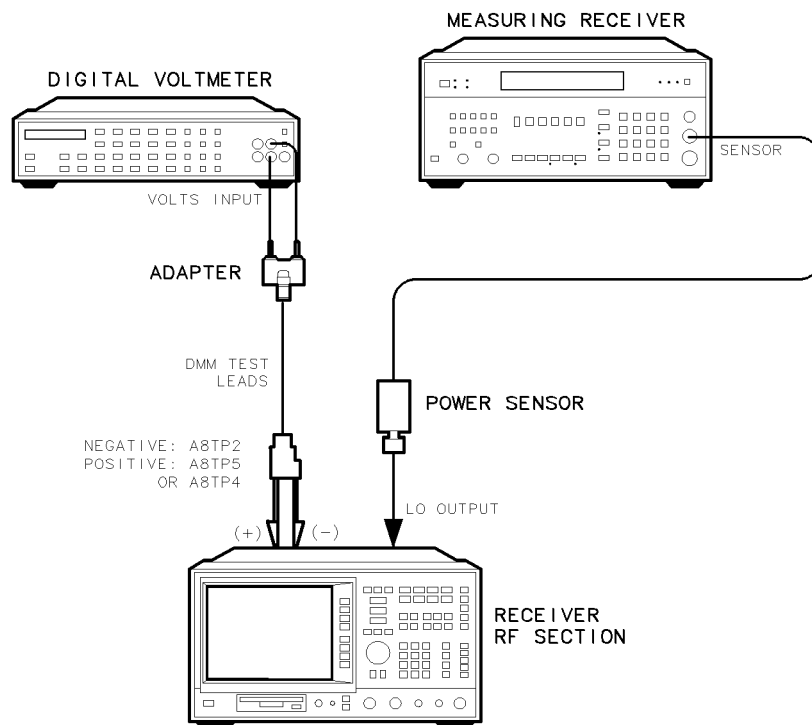

sh216e

Figure 2-21. First LO Distribution Amplifier Adjustment Setup

Procedure

1. Set the **LINE** switch to off, then disconnect the line cord. Remove the cover assembly and the RF cover, then reconnect the line cord.
2. Remove the 50 Ω termination from the rear-panel LO OUTPUT connector.
3. Connect the positive DMM test lead to A8TP5, GB (gate bias). Connect the negative DMM test lead to A8TP2, AGND (analog ground). See Figure 2-21.
4. Set the digital voltmeter controls as follows:

FUNCTION	DC VOLTS
RANGE	10 V
RESOLUTION	1 mV

First LO Distribution Amplifier

5. Set the **LINE** switch to on.
6. Adjust A8R29 (GATE) for a digital voltmeter reading within 5 mV of the GATE (gate bias) voltage printed on the RF section label. This label is attached to the top of the A4 RF section below the filters located on top.
7. Zero and calibrate the measuring receiver and power sensor in LOG mode. (Power levels read in dBm.) Enter the power sensor's 5 GHz cal factor into the measuring receiver.
8. Connect the power sensor to the LO OUTPUT.
9. On the instrument, press:
PRESET, **SPAN**, **ZERO SPAN**, **FREQUENCY**, 4.6786, **GHz**.
10. Connect the positive DMM test lead to A8TP4, LOS (LO sense).
11. Note the SENS (LO sense) voltage printed on the RF section label. Adjust A8R25, LO AMP (LO power) until the DMM reads equal to the SENS voltage printed on the RF section label.
12. Check that the measuring receiver power level reads greater than +12 dBm.
13. Disconnect the power sensor from LO OUTPUT, then reconnect the 50 Ω termination to LO OUTPUT.
14. Disconnect the DMM leads from A8TP4 and A8TP2.

Tracking Generator Power Level

Not recommended for field repair.

This is *not* a routine adjustment. This adjustment should only be performed if the tracking generator fails the tracking generator level flatness test or the tracking generator absolute amplitude, vernier, and power test.

The tracking generator has two adjustments for setting the output power. The -10 dB ADJ (A4A10R13) sets the power level when the source power level is set to -10 dBm, and the 0 dB ADJ (A4A10R18) sets the power level when the source power level is set to 0 dBm. The -10 dB ADJ acts as an offset adjustment, while 0 dB ADJ acts as a gain adjustment.

These adjustments are set in the factory for a 10 dB difference in output power between the -10 dBm and 0 dBm source power level settings. When installing a replacement tracking generator, it should only be necessary to adjust -10 dB ADJ (the offset adjustment) to account for variations in cable loss from the tracking generator to the TRACKING GENERATOR OUTPUT connector. This adjustment is done at a 0 dBm source power level setting. This ensures that the absolute power level with a 0 dBm source power level setting is 0 dBm, with little or no affect on the vernier accuracy.

In some cases, the power level at the -10 dBm source power level setting might be out of tolerance. In such cases, the -10 dB ADJ is set at a source power level setting of -10 dBm and the 0 dB ADJ is set at a source power level setting of 0 dBm. These two adjustments must be repeated until the power level at the two settings are within the given tolerances.

Equipment Required

Measuring receiver
Power sensor, 1 MHz to 350 MHz
Cable, Type N, 62 cm (24 in.)

Procedure

1. Set the **(LINE)** switch to off. Disconnect the line cord. Remove the instrument cover and the RF cover, then reconnect the line cord.
2. Set the AOFST by pressing the following keys:

(PRESET)

(DISPLAY) Change Title

Enter the following :

MWR 16753252,0:CAL STORE;

(CALIBRATE) More 1 of 3 More 2 of 3

Service Diag **DISPLAY CAL DATA** **NEXT PAGE** **NEXT PAGE**

Verify that AOFST=0 under the tracking generator readouts.

3. Connect the cable between the TRACKING GENERATOR OUTPUT and RF INPUT connectors on the instrument.
4. Press **(PRESET)** on the instrument and set the controls as follows:

CENTER FREQ
SPAN

300 MHz
0 Hz

Tracking Generator Power Level

5. On the instrument, press the following keys:

BW 10 **kHz**

TRACK GEN SRC PWR ON OFF (ON) 10 **-dBm**

6. On the instrument, press **TRACKING PEAK**. Wait for the PEAKING message to disappear.

7. Zero and calibrate the measuring-receiver/power-sensor combination in log mode (power levels readout in dBm). Enter the power sensor 300 MHz cal factor into the measuring receiver.

8. Disconnect the cable from the TRACKING GENERATOR OUTPUT connector, then connect the power sensor to the TRACKING GENERATOR OUTPUT connector. See Figure 2-22.

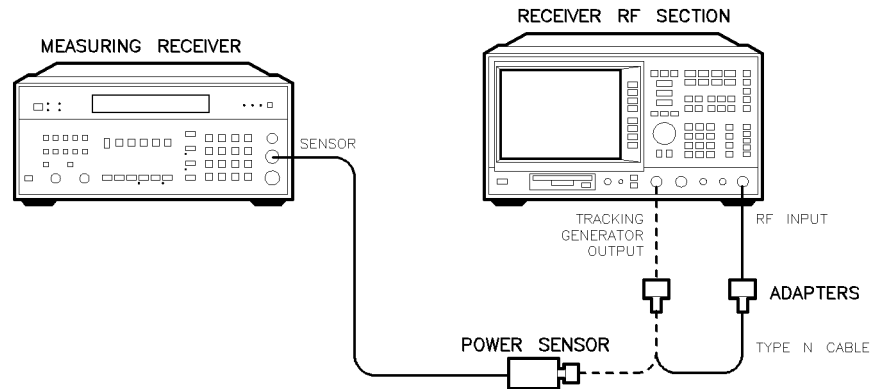
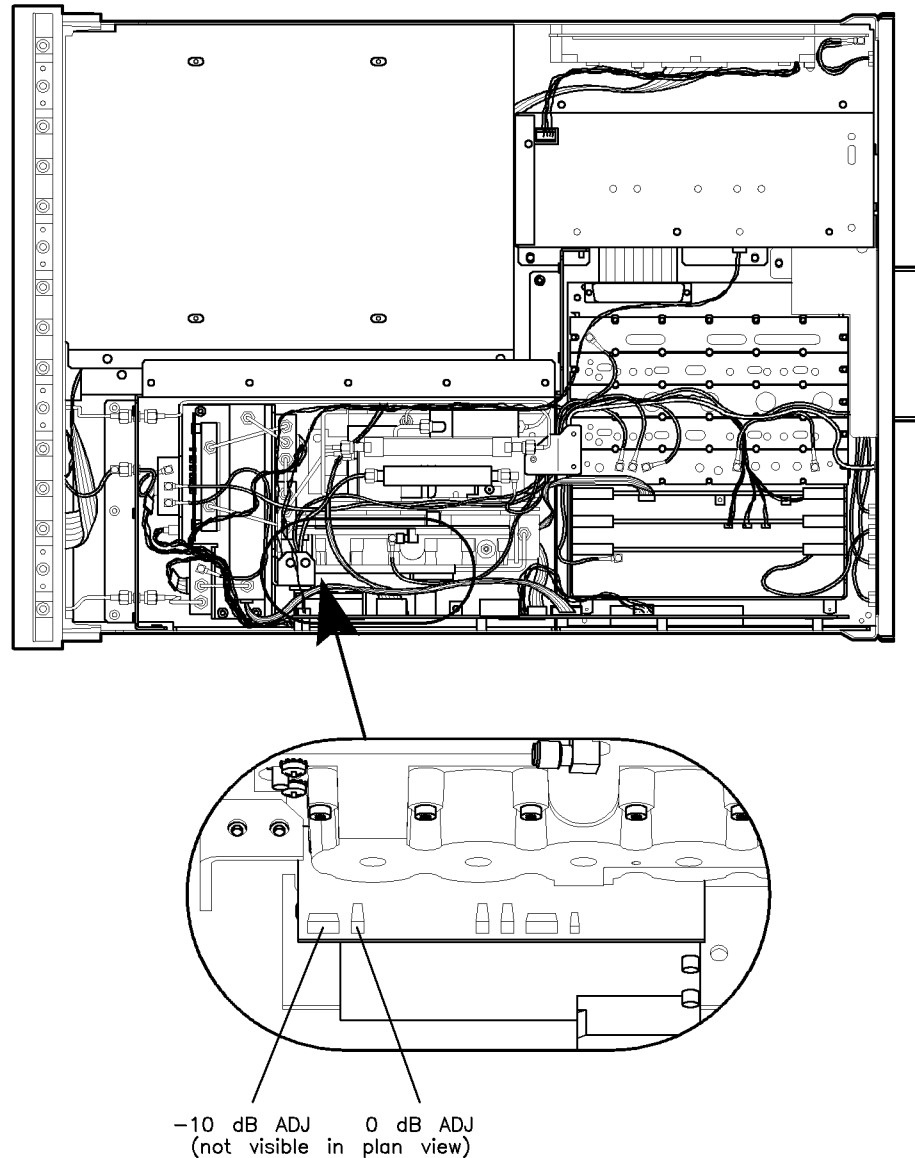

Figure 2-22. Tracking Generator Power Level Adjustment Setup

Tracking Generator Power Level



sh218e

Figure 2-23. Tracking Generator Power Level Adjustment Locations

9. On the instrument, press **SRC PWR ON OFF** (ON), 0, **[dBm]**, **[SWEEP]**.

Note that some instruments may have sealing compound over A4A10R13 (–10 dB ADJ) and A4A10R18 (0 dB ADJ) adjustments. Remove this compound before making these adjustments.

10. Adjust –10 dB ADJ (A4A10R13) for a 0 dBm ± 0.05 dB reading on the measuring receiver. Refer to Figure 2-23 for adjustment location.
11. Set the SRC PWR level to –10 dBm. Note the power displayed on the measuring receiver.

If the power level is –9.77 dBm to –10.23 dBm, then the adjustment is complete. If the power level is not within the range, then continue with step 12.

Power at –10 dBm Setting _____ dBm

Tracking Generator Power Level

12. If the power level noted in step 11 was outside the range of $-10 \text{ dBm} \pm 0.23 \text{ dB}$ perform the following:
 1. With the SRC PWR level set to -10 dBm , adjust -10 dB ADJ (A4A10R13) for a $-10 \text{ dBm} \pm 0.1 \text{ dB}$ reading on the measuring receiver. Refer to Figure 2-23 for adjustment location.
 2. Set the SRC PWR level to 0 dBm . Adjust 0 dB ADJ (A4A10R18) for a $0 \text{ dBm} \pm 0.2 \text{ dB}$ reading on the measuring receiver. Refer to Figure 2-23 for adjustment location.
 3. Repeat this step until the output power level is within the tolerances indicated at both the -10 dBm and 0 dBm SRC PWR level settings. Adjust -10 dB ADJ only with the SRC POWER level set to -10 dBm , and adjust 0 dB ADJ only with the SRC PWR level set to 0 dBm .

Tracking Oscillator

Not recommended for field repair.

This is *not* a routine adjustment. This adjustment should only be performed if the range of either the automatic tracking peak adjustment (**TRACKING PEAK**) or the manual tracking peak adjustment (**MAN TRK ADJUST**) is insufficient to peak a signal.

The centering of the tracking oscillator range is adjusted in the factory to ensure that the tracking adjustment will work properly. Over a period of 5 years, however, the center frequency of the tracking oscillator range may drift outside of acceptable limits.

The tracking oscillator range is checked first. A tracking peak test is performed and the output frequency is recorded. Then the manual tracking adjustment is set to its minimum and maximum values and the output frequency is recorded. The minimum and maximum frequencies are compared to the peaked frequency. If the difference is less than 5 kHz, adjustment is necessary.

The adjustment recenters the tracking oscillator range. The A4 RF assembly is placed in its service position to perform this adjustment. A frequency counter is used to measure the output frequency.

Equipment Required

- Microwave frequency counter
- Termination, 50 Ω
- Alignment tool, non-metallic
- Cable, BNC, 122 cm (48 in.) (*two required*)
- Adapter, Type N (f) to APC-3.5 (f)
- Adapter, Type N (m) to BNC (f)

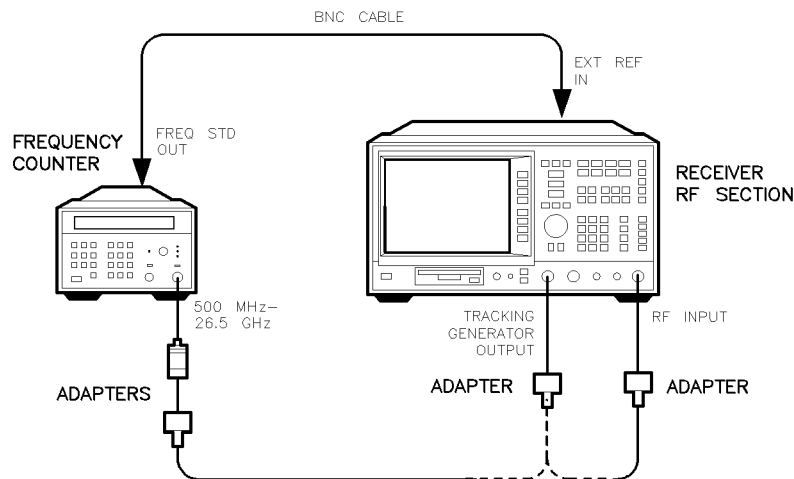

sh219e

Figure 2-24. Frequency Tracking Range Setup

Procedure

Frequency Tracking Range Check

1. Connect a cable between the TRACKING GENERATOR OUTPUT and RF INPUT connectors on the instrument.
2. Remove the rear-panel jumper that is between the 10MHz REF OUTPUT and EXT REF IN jacks. Connect the frequency counter FREQ STD OUT connector to the instrument EXT REF IN connector as shown in Figure 2-24.
3. Press **PRESET** on the instrument, then set the controls as follows:

CENTER FREQ	500 MHz
SPAN	0 Hz

4. On the instrument, press the following key:

BW 10 **kHz**
TRACK GEN SRC PWR ON OFF (ON) 5 **-dBm**

5. On the instrument press **TRACKING PEAK**. Wait for the PEAKING message to disappear.
6. Set the microwave frequency counter controls as follows:

SAMPLE RATE	Midrange
10 Hz-500 MHz/500 MHz-26.5 GHz Switch	500 MHz - 26.5 GHz
RESOLUTION	1 Hz

7. Connect the TRACKING GENERATOR OUTPUT connector to the microwave frequency counter input as shown in Figure 2-24.
8. Wait for the microwave frequency counter to gate two or three times, then record the microwave frequency counter reading below as the peaked frequency:

Peaked Frequency: _____ MHz

9. On the instrument, press **MAN TRK ADJUST**, 4095, **ENTER**. Wait for the microwave frequency counter to gate two or three times, then record the microwave frequency counter reading below as the minimum frequency:

Minimum Frequency: _____ MHz

10. On the instrument, press **MAN TRK ADJUST**, 0, **ENTER**. Wait for the microwave frequency counter to gate two or three times, then record the microwave frequency counter reading below as the maximum frequency:

Maximum Frequency: _____ MHz

11. If the absolute value of the difference between either the minimum or maximum frequency and the peaked frequency is less than 5 kHz, proceed with the adjustment procedure below. If the differences are greater than 5 kHz, no adjustment is necessary.
12. Disconnect the cable from the EXT REF IN connector, then replace the rear-panel jumper.

Tracking Oscillator

Adjust the Tracking Oscillator

- Remove the A4 RF section assembly as described in Chapter 6. With A4 sitting on top of the instrument, reconnect all cables from A4 to their respective jacks on the A5 analog interface board, the A9 3rd converter board, the A23 counter lock assembly, and the A8 tracking generator control board. Reconnect W40 to A4A10J8. Connect the 50 Ω termination to the end of W42.
- Connect the equipment as shown in Figure 2-25. The microwave frequency counter provides the frequency reference for the instrument.

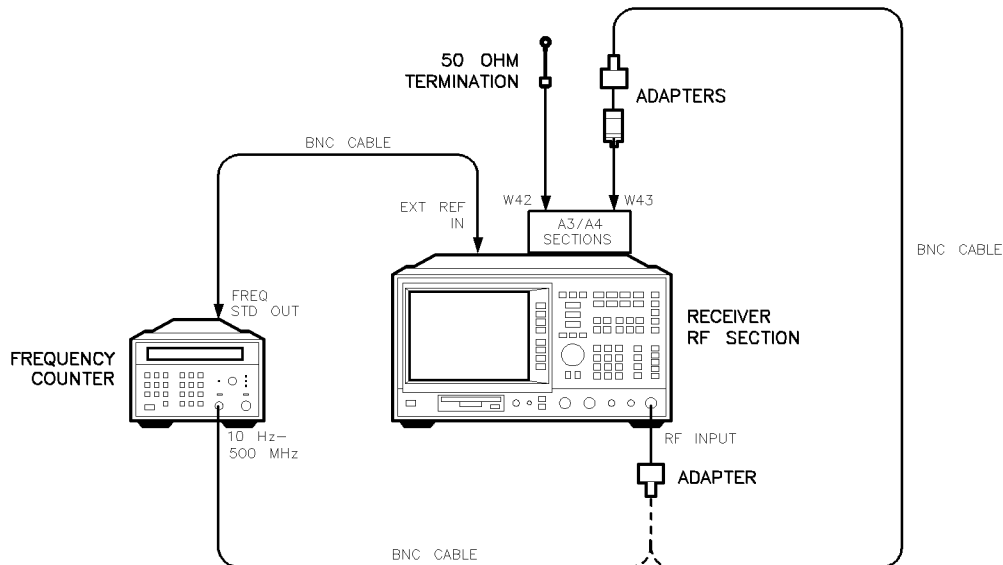

sh220e

Figure 2-25. Tracking Oscillator Adjustment Setup

- Set the **LINE** switch to on. Press **TRACK GEN**, **SRC PWR ON OFF** (ON). Allow the instrument to warm up for at least 5 minutes. Set the controls as follows:

CENTER FREQ	300 MHz
SPAN	0 Hz
- Set the microwave frequency counter controls as follows:

SAMPLE RATE	Fully CCW
10 Hz-500 MHz/500 MHz-26.5 GHz Switch	10 Hz-500 MHz
50 Ω - 1 MΩ Switch	50 Ω
- Remove the screw, located on the front of the tracking generator, used to seal the tracking oscillator adjustment.
- On the instrument, press **TRACK GEN**, **MAN TRK ADJUST**, 0, **Hz**.
- Record the microwave frequency counter reading in Table 2-7 as F1.
- On the instrument, press **MAN TRK ADJUST**, 4095, **Hz**.
- Record the microwave frequency counter reading in Table 2-7 as F2.
- Calculate Fcenter as shown below, and record it in Table 2-7.

$$F_{\text{center}} = (F1 + F2)/2$$

Tracking Oscillator

23. Set SRC TRACK ADJ to 350. This sets the tracking oscillator near the center of its frequency range. (The relationship between the SRC TRACK ADJ DAC number and the output frequency is nonlinear.) Adjust SRC TRACK ADJ until the microwave frequency counter reads $F_{center} \pm 100$ Hz.
24. Record the value of SRC TRACK ADJ in Table 2-7.

CAUTION A4A10C3 (TRK OSC CTR) is rated for a maximum of 10 adjustment cycles. Due to this limitation, adjust TRK OSC CTR only when absolutely necessary.

25. Adjust A4A10C3 (TRK OSC CTR) until the microwave frequency counter reads 300 MHz ± 500 Hz.
26. Repeat steps 18 through 24 at least once more until no further adjustment of A4A10C3 is necessary.
27. Set the **(LINE)** switch to off, then replace the screw removed in step 17.
28. Reinstall the A4 RF section assembly into the instrument.
29. Replace the rear-panel jumper between the 10MHz REF OUTPUT and EXT REF IN connectors.

Table 2-7. Tracking Oscillator Range Centering

N	F1 (MHz)	F2 (MHz)	F _{center} (MHz)	SRC TRACK ADJ Setting
1				
2				
3				
4				
5				
6				

Troubleshooting the Instrument

This chapter provides information that is useful when starting to troubleshoot an instrument failure. It provides procedures for troubleshooting common failures and isolating problems in the instrument.

Additional troubleshooting details for specific assemblies are available in Chapter 4 and Chapter 5 of this service guide. Assembly descriptions are located in Chapter 8.

Before You Start

There are four things you should do before starting to troubleshoot a failure:

- Check that you are familiar with the safety symbols marked on the instrument, and read the general safety instructions and the symbol definitions given in the front of the service guide.
- The instrument contains static sensitive components. Read the section entitled “Protection From Electrostatic Discharge” in Chapter 1.
- Become familiar with the organization of the troubleshooting information in this chapter and the chapters that follow.
- Read the rest of this section.

WARNING This instrument contains potentially hazardous voltages.

Familiarize yourself with the safety symbols marked on the instrument and read the symbol definitions given in the front of this guide *before* you begin the procedures in this chapter. Refer to “General Safety Considerations” at the front of this manual for general *WARNINGS* and *CAUTIONS* related to safety considerations. *WARNINGS* and *CAUTIONS* related to specific procedures are included with the procedure.

Failure to heed the safety precautions can result in severe or fatal injury.

Service equipment you will need

Refer to Chapter 13 of this guide for a list of the recommended test equipment needed to troubleshoot and repair the instrument. Although Hewlett-Packard equipment is recommended, any equipment that meets the critical specifications given in the table can be substituted for the recommended model.

Refer to Chapter 13 of this guide for a list of required service and hand tools needed to troubleshoot and repair the instrument.

Replacement Assemblies

None of the HP 8542E/HP 8546A EMI receiver or HP 85422E/HP 85462A receiver RF section assemblies are repairable to the component level. The following lists the replaceable assemblies.

- A2 display
- A4A1 2.9 GHz low-pass filter
- A4A3 second converter
- A3A4 input attenuator
- A4A6 dual band mixer
- A4A9 EYO
- A4A4 switched YIG-tuned filter (SYTF)
- A4A2 321.4 MHz band-pass filter
- A4A7 local oscillator distribution amplifier (LODA)
- A4A10 tracking generator
- A16 power supply assembly
- A20 10 MHz precision reference
- A23A1 counter lock sampler
- A6 narrow bandwidth board

Refer to Chapter 10 when ordering replacement assemblies.

After a repair

If one or more assemblies have been repaired or replaced, perform the related adjustments and performance verification tests. Refer to Chapter 2 for a table of the related adjustments and performance verification tests required for each assembly.

Problems at Instrument Power-Up

This section describes symptoms that can occur when the instrument is first powered on.

CAUTION Immediately unplug the instrument from the ac power line if the unit shows any of the following symptoms:

- Smoke, arcing, or unusual noise from inside the unit.
- No response of any kind when unit is plugged into ac power mains and turned on.
- The instrument's ac power fuse blows.
- A circuit breaker or fuse on the main ac power line opens.

These potentially serious faults must be corrected before proceeding. Refer to "Troubleshooting an Inoperative Instrument."

The AM/FM speaker normally emits noise from the speaker at power-up. This is not a problem, adjust the volume control as desired.

Table 3-1 lists symptoms that can occur when the instrument is first powered on. Refer to this table for an overview of symptoms at power-up and their possible cause.

Table 3-1. Instrument Failure Symptoms at Power-On

Line LED	A16 LED -24 V	A16 LED -15 V	A16 LED +15 V	A16 LED +5 V	A16 LED +12 V	A24 LEDs DS1-DS16	B1 Fan	A2 Display	Possible Cause
ON	ON	ON	ON	ON	ON	M	ON	ON	Normal Operation ¹
OFF	ON	ON	ON	ON	ON	M	ON	ON	W1 wiring to Line LED, or Line LED
OFF	OFF	OFF	OFF	OFF	OFF	OFF	OFF	OFF	Line fuse, A16 primary circuit failure
ON	M	M	M	M	M	X	M	X	A16 primary overload
ON	ON	OFF	ON	ON	ON	X	ON	X	-15 V supply failure
ON	ON	OFF	M	M	M	X	M	X	-15 V supply overload
ON	ON	ON	OFF	ON	ON	X	ON	X	+15 V supply failure
ON	ON	M	OFF	M	M	X	M	X	+15 V supply overload
OFF	M	M	M	OFF	M	X	M	X	+5 V supply failure or supply overload
ON	ON	ON	ON	ON	OFF	X	OFF	OFF	+12 V supply failure
ON	M	M	M	M	OFF	X	OFF	OFF	+12 V supply overload
ON	ON	ON	ON	ON	ON	M	OFF	ON	Fan failure or open along +12 V supply line to fan
ON	ON	ON	ON	ON	ON	OFF	ON	OFF	No HPWRUP signal
ON	ON	ON	ON	ON	ON	ON	ON	X	A24 assembly failure
ON	ON	ON	ON	ON	ON	M	ON	OFF	Display failure, intensity-control failure, or A24 memory failure
ON	ON	ON	ON	ON	ON	M	ON	M	Intensity control failure, or A24 memory failure
ON	OFF	ON	ON	ON	ON	X	X	X	-24 V supply failure
ON	OFF	ON	ON	ON	ON	X	X	X	-24 V supply overload

M = LED or assembly may be momentarily on, then go off.
X = Status of LED or assembly does not matter.

¹ DS13 remains on after **PRESET** is pressed

Troubleshooting an Inoperative Instrument

When an instrument appears to be dead there is often little evidence that points directly to the cause. This section provides steps and solutions to typical failure modes relating to an inoperative instrument.

Before troubleshooting a instrument, ensure that it has been set up correctly and the power supply is functioning properly by performing Step 1 and Step 2 below.

Step 1. Check the Instrument Setup

- Check that the voltage-selector switch on the rear of the A16 power supply is correct for the ac power line in use.
- Check that the ac line-power voltage is present and that the instrument line cord is in good condition.
- Check the line fuse. If it has blown, perhaps a nonstandard fuse with too low a current rating was installed. If the line fuse still blows, continue with the section entitled “If the line fuse has blown.”

CAUTION If the fuse must be replaced, make sure that the replacement fuse is specified for the line voltage in use. Failure to use the proper fuse specified for the instrument can cause substantial instrument damage, and is a serious fire hazard.

Step 2. Check the Power Supply

The power supply voltages are checked using a digital voltmeter.

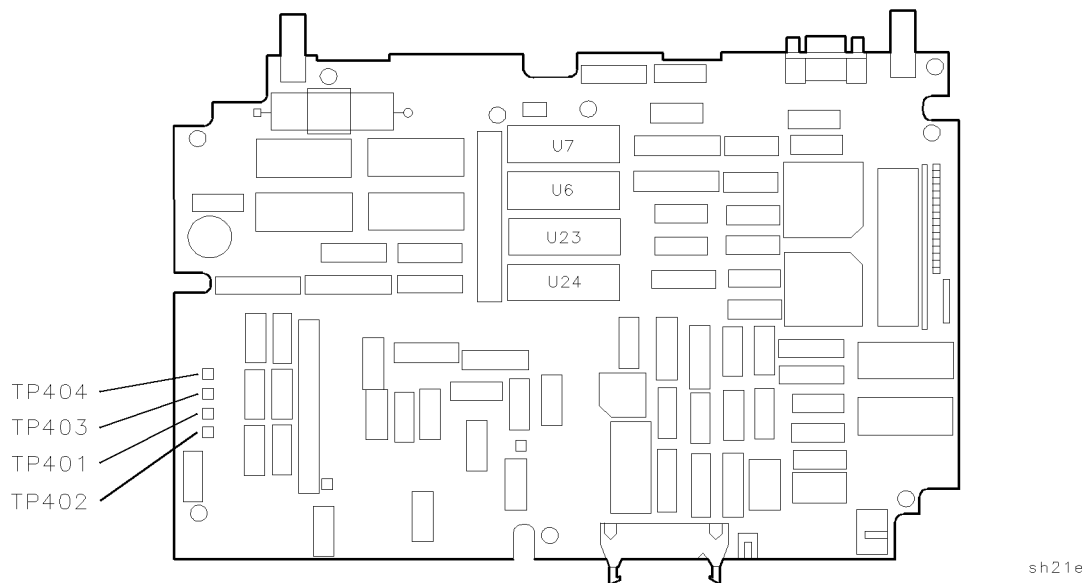

Figure 3-1. A24 Power Supply Test Point Location

1. Turn the **(LINE)** switch to OFF. Remove the instrument cover assembly.
2. Connect the DMM test leads from the chassis (ground) to A24TP403. See Figure 3-1.

WARNING The instrument contains potentially hazardous voltages. Refer to the safety symbols provided on the instrument, and in the general safety instructions in this guide, before operating the unit with the cover removed. Ensure that safety instructions are strictly followed. Failure to do so can result in severe or fatal injury.

3. Turn the **(LINE)** switch to ON.
4. Locate the power supply test point using Figure 3-1. Check the supply voltages as indicated in Table 3-2. Be sure the voltage readings are within the limits shown in Table 3-2.
5. Repeat step 4 for each power supply listed in Table 3-2.

Table 3-2. Power Supply Tolerances

Power Supply	Test Point	Specification
+5.1 V	A24TP403	+5.0 to +5.25 Vdc
+12.0 V	A24TP404	+11.1 to +12.8 Vdc
+15.0 V	A24TP401	+14.7 to +15.25 Vdc
-15.0 V	A24TP402	-14.7 to -15.25 Vdc

If the line fuse has blown

If the instrument was set up correctly, and the line fuse still blows, suspect that the power supply is defective.

CAUTION The A16 power supply assembly is a switching power-supply and does not operate normally without a load on the dc power-supply outputs. Do not attempt to operate the power supply out of the instrument. Damage to the power supply may occur.

If the fan is not operating

CAUTION The A16 power supply may be hot if the instrument has been operating without the fan running. Allow the instrument to cool down before troubleshooting.

The B1 fan receives +12 V dc from the A16 power supply after the power supply receives the start-up signal, low-power-on (LPWRON) from the front-panel LINE switch. First check the +12 V dc supply to the fan at the Rear Frame.

1. Disconnect the line-power cord from the instrument.
2. Look through the fan grill. If the cables routed near the fan are jammed in the fan, remove the fan from the rear frame, reroute the cables, and remount the fan.
3. Remove the fan from the rear frame and disconnect its wiring connector from A15J19.
4. Reconnect line power to the instrument and turn it on.
5. Refer to “Troubleshooting the A15 Motherboard Assembly” in Chapter 4 for the pin identification of the fan-supply connector, A15J19, and the A16 power-supply connector, A16J1.
6. Check that pin 2 on A15J19 is connected to digital common-ground (DCOM). If the ground connection is open, suspect the A15 Motherboard.
7. Check pin 1 on A15J19 for +12 V dc.

If the +12 V dc is present, check for a defective B1 fan assembly by connecting the fan to an external DC supply.

If the +12 V dc is absent, do the following:

- Disconnect the instrument from the line power.
- Remove the A16 power supply.
- Check the continuity of the A15 motherboard from pin 1 on A15J19 to pin 8 on A15J13.
- If the continuity of the motherboard is correct, suspect a bad connection on the D sub-connector (between pin 8 on A15J13 and pin 8 on A16J1), a defective power supply, or a damaged ribbon cable between the motherboard and the power supply.

If all the A16 power-supply LEDs are off

If all the power-supply LEDs remain off, the low-power-on (LPWRON) control line must be checked from the front-panel line switch, through the A24 processor assembly and A15 motherboard, to the A16 power supply.

1. Disconnect the instrument line-power cord, remove the instrument cover, and turn the instrument so its bottom side faces up.
2. Check that the line switch provides the correct LPWRON signal at pin 2 on A24J9.
 - LPWRON becomes TTL low when the line switch is on. The closed switch connects A24J9 pin 2 to the digital common-ground (DCOM) through the W1 wiring harness.
 - LPWRON is pulled TTL high by the power supply when the line switch is in STANDBY.
3. Check the continuity of the LPWRON signal trace from pin 2 on A24J9 to pin 19 on A15J13. Refer to Figure 3-2 for the pin designations of the A15J13 connector.
4. Refer to “Troubleshooting the A15 Motherboard Assembly” in Chapter 4 for the connector-pin designations of the A24 and A15 assemblies.
5. If the LPWRON signal path from the previous step is correct, suspect a bad connection on the D sub-connector (between pin 19 on A15J13 and pin 19 on A16J1), a defective power supply, or a damaged ribbon cable between the motherboard and the power supply. Isolate the failure to the power supply by substituting another power supply assembly into the instrument.

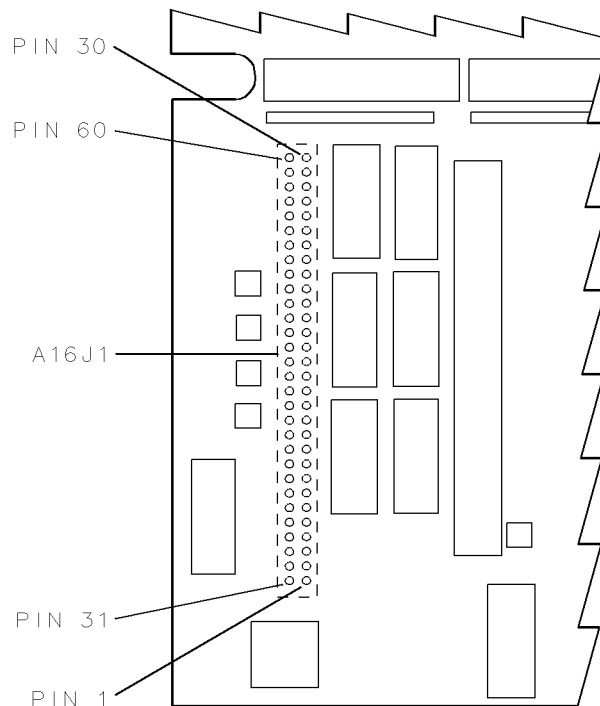

sh235e

Figure 3-2. A15J13 Connector-Pin Designation

If individual A16 power-supply LEDs are off

If one or more of the A16 power-supply LEDs remain off, determine whether the power supply is defective or circuitry on the dc power-supply distribution network is loading the power supply down by substituting another power supply assembly.

If all the A16 power-supply LEDs are on

If all the A16 power-supply LEDs are on, check the dc power-supply voltages on the A24 processor assembly. Check each voltage at the A24 assembly test points, TP401 through TP404. Refer to Figure 8-5, for the dc-voltage assignment of each test point.

If a dc voltage is missing, suspect an open connection in the dc power-supply distribution network. Refer to “Troubleshooting the A15 Motherboard Assembly” in Chapter 4 for the connector-pin designation of each assembly connected to the missing dc voltage supply.

If Using Defaults <N> is displayed

A dead BT1 battery will cause the loss of all correction-factor and correction-constant data. When the data stored in memory is lost, the instrument substitutes the default-correction data stored in ROM and performs the instrument-preset routine. The message *Using Defaults <N>* will appear on the display. Where *N* is an integer that represents a code that was used during the development of the firmware.

If the battery is dead, replace the battery as described in Chapter 6.

Troubleshooting the A2 Display Assembly

Use this section when the A16 power supply is functioning but there appears to be a defective A2 display assembly. Check the following conditions before proceeding with the A2 display troubleshooting procedures.

- Check that the B1 fan is running and the green LED above the **LINE** switch is on when the instrument is on. If they are not operating, refer to the appropriate section of “Troubleshooting an Inoperative Instrument.”
- Check the five LEDs on the A16 power supply assembly. If they are not on, refer to the appropriate section of “Troubleshooting an Inoperative Instrument.”

Note that the A16 power supply draws current whenever ac line power is applied, even when the LINE switch is in the STANDBY position. However, no voltages are distributed outside the A16 power supply assembly when the LINE switch is in the STANDBY position, except for a TTL high on LPWRON.

WARNING The following procedures are likely to expose dangerous voltages. These servicing instructions are for use by qualified personnel only. To avoid electrical shock, do not perform any servicing unless you are qualified to do so. Refer to “General Safety Considerations” in the front of this manual.

- Check the dc power supplied to the A17 graphic signal processor assembly. There is +65 Vdc and +5 Vdc supplied to A17 via W73. These supplies can be checked at the output connector on top of the power supply. Refer to Figure 3-3.

These supplies can also be checked on the A17 graphic signal processor assembly to make sure the continuity of the cable assembly supplying the A17 graphic signal processor assembly is good.

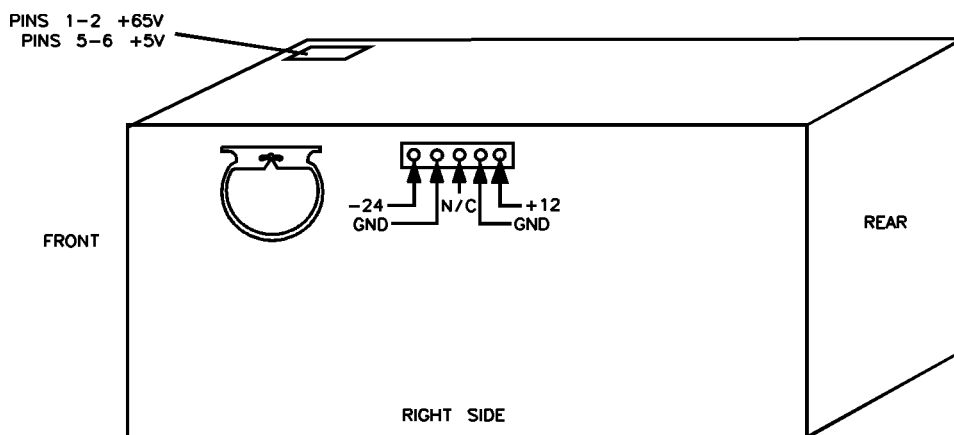

sh281e

Figure 3-3. Detail of Power Supply Connector, A16J6

- Check the dc power supplied to W84 for the A2 display. There should be +65 Vdc on pins 1 through 2 of J5 on the A17 graphic signal processor assembly.

WARNING High voltage is present within the A2 display and remains for some time after it has been disconnected. Be careful while troubleshooting the display outside of its enclosure.

If an A2 display assembly failure is suspected, the display must be removed from its enclosure for further troubleshooting. Refer to the A2 display assembly removal procedure in Chapter 6 before checking the continuity of the W2 wire harness. If W2 is good, suspect the A2 display or W84. W84 is part of the A2 display.

The A2 display is not field-repairable, and must be replaced as an assembly. Refer to Chapter 10 for HP part number information.

After replacement, adjust the new display, refer to Chapter 2.

If the display has an intensity problem

CAUTION The A1R1 potentiometer leads are easily broken. Do not twist the W102 wire harness where it attaches to A1R1.

1. Disconnect W102 from the A1R1 intensity control potentiometer on the front frame.
2. Check the continuity and resistance range (0 to 100 k Ω) of the inner potentiometer on A1R1.
3. Reconnect W102 to A1R1.

If the display is blank

1. Verify the RGB monitor outputs, located on the rear frame, by performing the following:
 - Attach an external color monitor to the RGB monitor output connectors. The MONITOR OUTPUT drives an RGB monitor with horizontal at 3.14 μ s and a vertical rate of 111.0 μ s. The “G” line from the A17 Graphic Signal Processor Assembly is also used as the “Sync” line. If a normal instrument display is present, the display failure is limited to the A2 display and its related circuitry.
2. Verify that there is a good connection between the A25 graphics processor board and the A24 processor board assembly by pressing on the connection.
3. Verify the High-Power-Up signal from the A16 power supply by Checking for the +5 V TTL HPWRUP signal at pin 54 on the A24J1. The A24J1 connector is on the trace side of the A24 processor assembly. Refer to Figure 3-4 for the numbering order of A24J1 connector-pins accessible from the component side of the A24 processor assembly.

Note that the A16 power supply assembly sends the high-power-up (HPWRUP) signal to the A24 processor assembly after it receives the low-power-on (LPWRON) signal and the +5 V supply has stabilized. If HPWRUP is low, the display remains blank and the A24 failure LEDs (DS1 through DS16) will not come on during power-up.

- If the HPWRUP signal is missing, trace the signal back through the A15 motherboard to the A16 power supply assembly, pin 37 on A16J1. Refer to “Troubleshooting the A15 Motherboard Assembly” in Chapter 4 for the connector-pin designation of the HPWRUP signal path.

The HPWRUP signal can be measured on pin 55 of each card-cage slot on the A15 motherboard. Refer to Figure 3-5 for the numbering order of the connector pins on A15J3 through A15J6.

- If the HPWRUP signal is present, yet one or more of the A24 processor assembly outputs is incorrect, suspect a defective A24 processor assembly.
- If all the A24 display outputs are correct, suspect a defective A2 display.

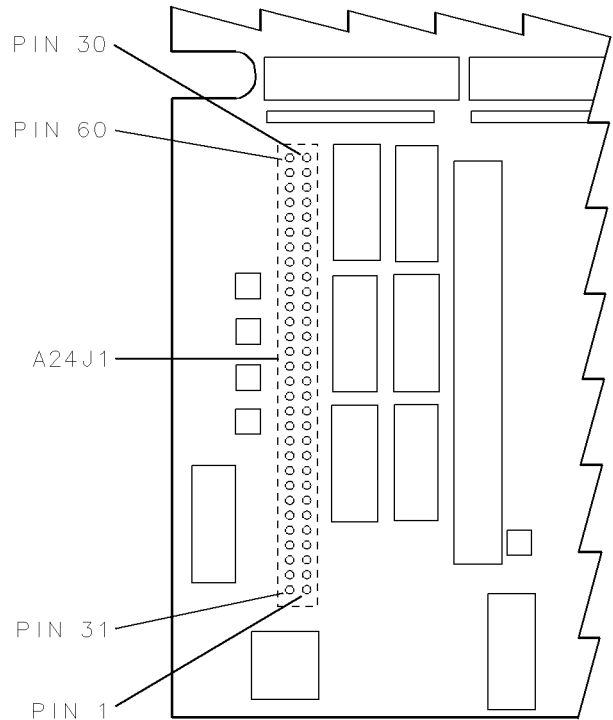

sh238e

Figure 3-4. A24J1 Connector-Pin Orientation

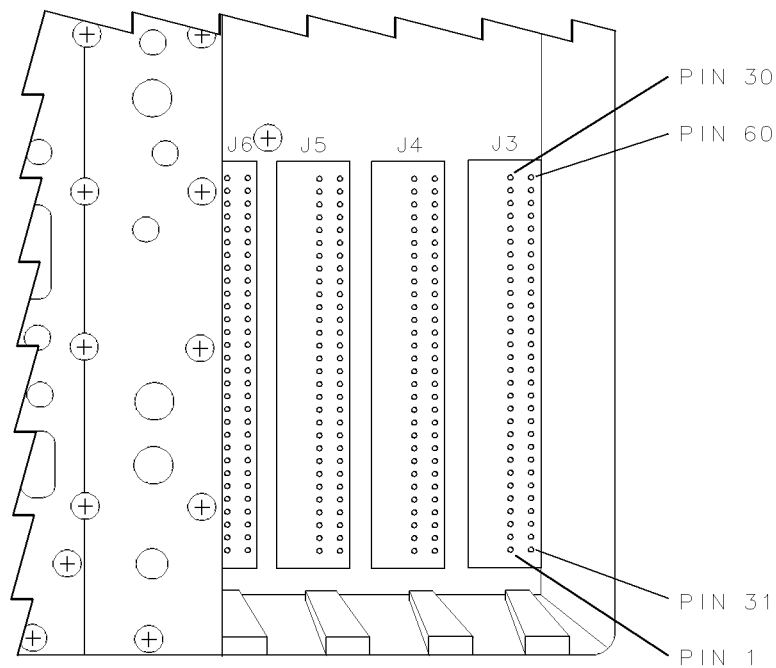

sh239e

Figure 3-5. Card-Cage Connector-Pin Orientation

Isolating an RF, LO, IF, or Video Problem

This section provides techniques for isolating amplitude failures along the signal path from the instrument input to the A24 processor assembly. These troubleshooting methods isolate the failure to one of four functional sections in the instrument:

- The RF section. This section includes the assemblies from the instrument input to the input of the A9 third converter assembly.
- The LO section. This section involves the assemblies that provide a local oscillator output to the RF section. The A23 counter lock assembly is one of the assemblies involved.
- The IF section. This section includes the assemblies from the input of the A9 Third Converter to the output of the A14 log amplifier assembly.
- The video section. This includes the circuitry from the output of the A14 log amplifier assembly to the ADC section on the A24 processor. This section of the instrument processes the detected 21.4 MHz IF signal from the IF section.

Procedure for Isolating an RF, LO, IF, or Video Failure

Perform the following procedure to isolate an RF, LO, IF, or Video problem:

1. With the failure symptoms present, switch the instrument from positive-peak detector to sample-detector mode.
 - If the instrument returns to normal operation, the positive-peak detector is defective.
 - If the failure symptoms remain, continue with the next step.
2. Verify the 2 V reference detector and the ground reference detector are operating properly by performing the internal service-diagnostic routines in this chapter.
 - If either the 2 V or ground reference detectors are not operating properly, suspect the ADC circuitry on the A24 processor board assembly.
 - If the 2 V or ground reference detectors are functioning properly, continue with the next step.
3. Use the display calibration data to find the DAC value used to adjust the gain at the output of the A9 third converter assembly. The DAC value is in the REF LVL CAL DAC block. Refer to the internal service-diagnostic routines in this chapter.

The DAC value is unique for each instrument. The **CAL AMP** self-calibration routine adjusts this value based on the amplitude of the digitized video signal on the processor board assembly. The calibration routine makes this adjustment while calibrating the reference level at top screen.

After running the **CAL AMP** calibration routine, the REF LVL CAL DAC has a typical value of 165 with a range of 130 to 185. The higher the DAC value, the greater the output from the A9 third converter assembly.

4. Check the signal path from the instrument input to the output of the A14 log amplifier assembly. Refer to “IF Power-Level Measurement” located in Chapter 4 of this guide.
5. Measure the 321.4 MHz input to the A9 third converter assembly by connecting the CAL OUT to the INPUT 50 Ω with a BNC cable.

Then, disconnect the W9 cable assembly from the third converter and measure at the cable output.

The 321.4 MHz input typically measures between -36 and -39 dBm with zero input attenuation.

- If the REF LVL CAL DAC value is 255 and the input to the A9 third converter assembly is above the test limit, suspect a low gain problem in the IF section. Continue with the troubleshooting procedures in “IF Power-Level Measurement.”
 - If the REF LVL CAL DAC value is 0 and the input to the A9 third converter assembly is nominal, suspect a high gain problem in the IF section. Continue with the troubleshooting procedures in “IF Power-Level Measurement.”
 - If the REF LVL CAL DAC value is 255 and the input to the A9 third converter is below the test limit, suspect a low gain problem in the RF/LO sections. Continue with the next step.
 - If the REF LVL CAL DAC value is 0 and the input to the A9 third converter is above the test limit, suspect a high gain problem in the RF section. Continue with the next step.
6. Set up the instrument as shown in “Instrument Settings for RF Power-Level Measurement” in this chapter.
 7. Isolate the failure to an RF or LO assembly by performing the “Making the RF Power-Level Measurements” procedure in Chapter 5 of this guide.

Once the problem has been isolated to one of the four sections, use standard troubleshooting methods to locate the source of the failure.

The following failure symptoms are examples to help isolate a failure to either the RF, LO, IF, or Video sections.

If there is only a horizontal trace with no signal or noise floor present

1. Check for a peak-detector failure by switching between the positive-peak detector and sample detector modes.
2. Perform the 2 V reference detector and ground reference detector diagnostic routines. Refer to “Using the Internal Service-Diagnostic Routines” in this chapter.
3. Check the signal path from the instrument input to the output of the A14 log amplifier assembly. Refer to “IF Power-Level Measurement” located in Chapter 4 of this service guide.

If the instrument displays a low signal level

A low signal level can cause the **CAL AMP** self-calibration routine to stop if the REF LVL CAL DAC reaches 255. The routine does not store the correction factors from an incomplete calibration; however, the corrections from the incomplete calibration are temporarily retained and can be viewed by displaying the calibration data (**DISPLAY CAL DATA**) as described in “Using the Internal Service-Diagnostic Routines.” Refer to Chapter 12 for a description of the displayed error message.

Perform the following steps to help isolate the problem.

1. Check the amplitude of the CAL OUT signal and ensure that the CAL OUT signal is properly connected to the instrument input. (The self-calibration routines perform an initial set-up check. If the signal level is below -40 dBm, the routine fails.)
2. Use **DEFAULT CAL DATA** to set the REF LVL CAL DAC to a default value of 200 by pressing the following keys:

```
FREQUENCY – 2001 Hz
CALIBRATE More 1 of 3 More 2 of 3
DEFAULT CAL DATA
```

3. Check the signal path from the instrument input to the output of the A14 log amplifier assembly. Refer to “IF Power-Level Measurement” located in Chapter 4 of this service guide.

If the instrument displays a high noise floor

This problem can be due to low gain somewhere along the RF or IF signal path.

The **CAL AMP** self-calibration routine compensates for the low gain by increasing the gain of the A9 Third Converter assembly using the REF LVL CAL DAC. The excessive gain may cause the high noise floor by amplifying the noise level from the RF section or over-driving a stage in the IF section.

The instrument may also fail the displayed average noise performance verification test.

1. Check the REF LVL CAL DAC value using **DISPLAY CAL DATA** as described in “Using the Internal Service-Diagnostic Routines.” This type of problem causes the DAC value to be close to the 255 maximum.
2. Measure the 321.4 MHz input to the A9 third converter assembly by connecting the CAL OUT to the INPUT $50\ \Omega$ with a BNC cable. Make sure the preamplifier is off.

Then, disconnect the W9 cable assembly from the third converter and measure at the cable output.

The 321.4 MHz input typically measures between -36 and -39 dBm with zero input attenuation.

3. Check the signal path from the instrument input to the output of the A14 log amplifier assembly. Refer to “IF Power-Level Measurement” located in Chapter 4 of this service guide.

If the displayed signal amplitude appears too high

This problem is caused by high gain somewhere along the RF or IF signal path. The displayed CAL OUT signal appears to have an amplitude greater than -20 dBm. The excessive gain causes a calibration error that makes the CAL OUT signal appear higher than normal.

The CAL AMP self-calibration routine may not fail.

- Check for a REF LVL CAL DAC value of 0 using DISPLAY CAL DATA as described in “Using the Internal Service-Diagnostic Routines.” The values in the ERR column are 0.00 or have a negative value.
- Measure the 321.4 MHz input to the A9 third converter assembly by pressing:

INPUT

VIEW CAL ON OFF until ON is underlined

Then, disconnect the W9 cable assembly from the third converter and measure at the cable output.

The 321.4 MHz input typically measures between -36 and -39 dBm with zero input attenuation.

- Check the signal path from the instrument input to the output of the A14 log amplifier assembly. Refer to “IF Power-Level Measurement” located in Chapter 4 of this service guide.

If the displayed signal is distorted

This failure may result in the displayed signal having distinct lobes on each side. A high noise floor may also be present.

Note that an intermittent hardware failure during the CAL AMP self-calibration routine can cause this type of amplitude failure. The erroneous calibration data causes the failure symptoms even while the hardware is operating normally.

1. If the signal looks normal when CORRECT ON OFF is off, check the values in the RFATN and SGAIN columns using DISPLAY CAL DATA as described in “Using the Internal Service-Diagnostic Routines.”

If a correction factor in either column is greater than two, there may be a failure on the input attenuator or the A12 amplitude control assembly.

Refer to Chapter 11 for the description of the corrections that are disabled when CORRECT ON OFF is off.

2. Troubleshoot the input attenuator or step gain symptoms with CORRECT ON OFF turned off.
3. Measure the 321.4 MHz input to the A9 third converter assembly by connecting the CAL OUT to the INPUT 50Ω with a BNC cable.

Then, disconnect the W9 cable assembly from the third converter and measure at the cable output.

The 321.4 MHz input typically measures between -36 and -39 dBm with zero input attenuation.

4. Check the signal path from the instrument input to the output of the A14 log amplifier assembly. Refer to “IF Power-Level Measurement” located in Chapter 4 of this service guide.

Recalibration of the instrument is necessary after the adjustment or replacement of each suspect assembly. A functioning instrument may still appear to be defective if calibration data from before the repair is used.

If the signal is off frequency

This failure may result in the **CAL FREQ** self-calibration routine failing.

Perform all of the internal service-diagnostic routines. Refer to “Using the Internal Service-Diagnostic Routines” in this chapter.

If the signal is off frequency in spans <10 MHz only

1. Perform all of the internal service-diagnostic routines. Refer to “Using the Internal Service-Diagnostic Routines” in this chapter.
2. Disconnect the A23 counter lock assembly, perform the frequency calibration routine by pressing:

CALIBRATE

More 1 of 3

FREQ CAL

Then operate the instrument as an unlock instrument.

If the problem is corrected, suspect the A23 counter lock assembly.

If the signal displays in low band only

(HP 8546A/HP 85462A only)

Perform all of the internal service-diagnostic routines. Refer to “Using the Internal Service-Diagnostic Routines” in this chapter.

If the A5 Analog Interface board assembly appears to be functioning properly, see Chapter 5.

Note that the HP 8542E only has low band.

Using the Internal Service-Diagnostic Routines

The HP 8542E/HP 8546A EMI receiver and HP 85422E/HP 85462A receiver RF section have an internal service-diagnostics routine menu available within the calibration menus.

Reference voltages and ramps are routed through a mux located on the A5 analog interface board assembly. These voltages and ramps can be displayed on the instrument or on an oscilloscope by connecting a probe to A5TP2 when a service-diagnostic routine is performed. The only exception is the 2VREF and GNDREF, these reference voltages originate on the A24 processor board assembly.

The service-diagnostic routines included in this section are the most useful routines used to help isolate problems with the A5 analog interface and A24 processor board assemblies. Illustrations are included with each procedure to show the expected displayed results.

Access the service-diagnostic routine softkeys by pressing the following keys:

```
CALIBRATE
More 1 of 3
More 2 of 3
Service Diag
```

Note that whenever an instrument setting has been changed while in a service-diagnostic routine, you must return to the service-diagnostic routine softkey menu by pressing the key sequence listed above.

If a flat line appears at mid screen

When a service-diagnostic routine is selected and only a flat line appears at mid screen, connect an oscilloscope to A5TP2. If the expected signal is there, then the ANA_TEST line is either shorted or open. This can be caused by bent pins or solder bridges on either the A5, A24, or A15 board assemblies. This condition will cause the frequency calibration routine to fail, as it uses this line to set up the sweep ramp at the beginning of the calibration routine.

If a service-diagnostic routine fails

When a service-diagnostic routine fails it is recommended to continue verifying the rest of the service-diagnostic routines to isolate a failure for further troubleshooting. For example, the main coil driver is dependant on the sweep ramp and the -10 V reference to function properly.

Verify the displayed calibration data

1. Press the following keys:

CALIBRATE

More 1 of 3

More 2 of 3

Service Diag

DISPLAY CAL DATA

2. Verify that the digital correction values are within their limits. Refer to Chapter 12 for typical examples of the calibration data displays.
 - If default values are being used, all digital corrections should be zero.
 - If corrections are being used, make sure that all digital corrections are present. Typical values should be below 1.00.
3. Return to the diagnostics menu by pressing the following keys:

PRESET

CALIBRATE

More 1 of 3

More 2 of 3

Service Diag

Verify the 2 V reference detector

This service-diagnostic routine verifies the 2 V reference circuitry on the A24 processor board.

1. Access the diagnostics menu by pressing the following keys:

```
PRESET
CALIBRATE
More 1 of 3
More 2 of 3
Service Diag
```

2. Press **More 1**.
3. Verify the 2 V reference by pressing **2V REF DETECTOR**.
 - If the signal trace is at the top of the display the 2 V reference is functioning properly. See Figure 3-6.
 - If the signal is not at the top of the display the problem is isolated to the A24 processor board assembly. Refer to “Troubleshooting the A24 Processor Board Assembly,” located in this chapter for further troubleshooting.

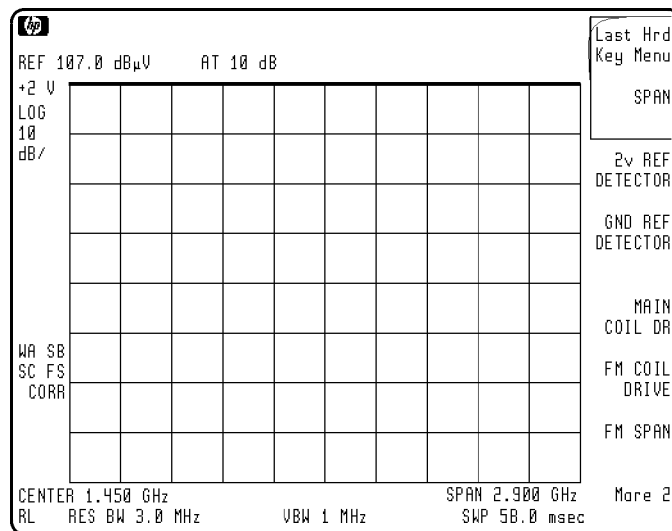

Figure 3-6. 2 V Reference Detector

Verify the ground reference detector

This service-diagnostic routine verifies the ground reference circuitry on the A24 processor board.

1. Access the diagnostics menu by pressing the following keys:

PRESET

CALIBRATE

More 1 of 3

More 2 of 3

Service Diag

2. Press More 1.

3. Verify the ground reference by pressing GND REF.

- If the signal trace is at the bottom of the display the ground reference is functioning properly. See Figure 3-7.
- If the signal is not at the bottom of the display the problem is isolated to the A24 processor board assembly. Refer to "Troubleshooting the A24 Processor Board Assembly," located in this chapter for further troubleshooting.

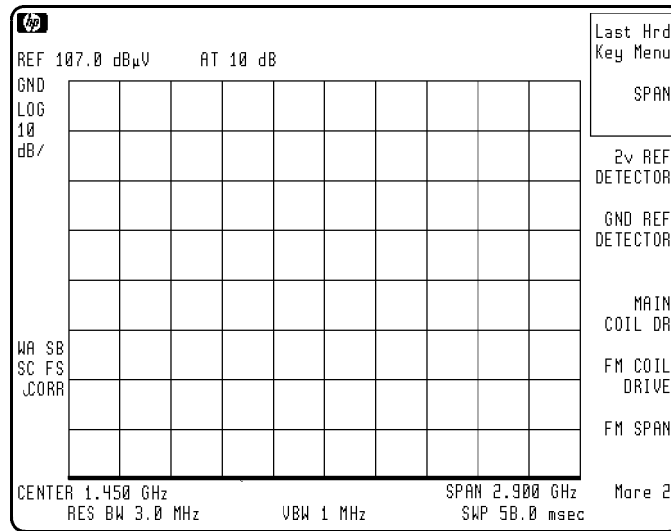

Figure 3-7. Ground Reference Detector

Verify the main coil driver

This service-diagnostic routine verifies that the ramp is driving the EYO.

1. Select a single band (if more than one band is available on your instrument).

Note that any band is acceptable unless the problem is isolated to a specific band. In that case, choose the appropriate band.

2. Access the diagnostics menu by pressing the following keys:

```
CALIBRATE
More 1 of 3
More 2 of 3
Service Diag
```

3. Press **More 1**.

4. Verify the main coil driver by pressing **MAIN COIL DR.**

- If the signal trace is similar to Figure 3-8 the main coil driver is functioning properly.
- If the signal is not similar suspect the A5 analog interface assembly.

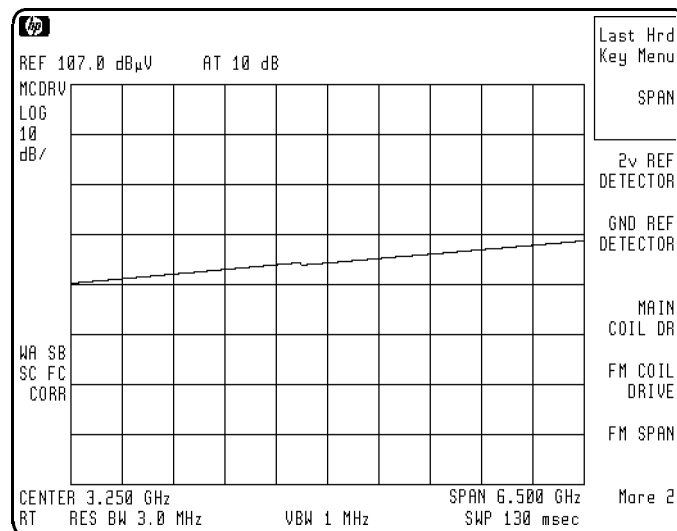

Figure 3-8. Main Coil Driver Typical Display

Note

Figure 3-8 shows the trace on the HP 85462A receiver RF section. The trace starts mid-screen at the left side of the display and rises almost 1 graticule when reaching the right side of the display. The same trace on the HP 85422E receiver RF section starts at the same position (mid-screen at the left side of the display), however, it only rises about one-half of a graticule when reaching the right side of the display. Of course, the settings between the two models are also different.

Verify the FM coil driver

It is only necessary to perform this service-diagnostic routine if the failure appears in narrow spans (10 MHz and below).

1. Band lock the instrument in band 0 and set the span to 10 MHz by pressing the following keys:

```
PRESET
MODE SIGNAL ANALYSIS
FREQUENCY More 1 of 2
Band Lock 0-2.9 Gz BAND 0
SPAN 10 MHz
```

Be sure to set the span before performing the service-diagnostic routine.

2. Return to the diagnostics menu by pressing the following keys:

```
CALIBRATE
More 1 of 3
More 2 of 3
Service Diag
```

Note The instrument shows intermittent FREQ UNCAL messages in this state. However, observing the trace indicates how the FM coil driver is working in this state.

3. More 1

4. Verify the FM coil driver by pressing FM COIL DRIVE .

- If the signal trace is similar to Figure 3-9 the FM coil driver is functioning properly.
- If the signal is not similar suspect the A5 analog interface board assembly.
- If all other service-diagnostic routines operate properly, disconnect the A23 counter lock assembly, perform the FREQ CAL calibration routine, then operate the instrument as an unlocked instrument.

If the problem is corrected, suspect the A23 counter lock assembly.

Verify the FM coil driver for spans > 10 MHz

It is only necessary to perform this service-diagnostic routine if the failure appears in spans wider than 10 MHz.

1. Set the instrument span to 11 MHz.
2. Return to the diagnostics menu by pressing the following keys:

CALIBRATE
 More 1 of 3
 More 2 of 3
 Service Diag

3. Press More 1.
4. Verify the FM coil driver by pressing FM COIL DRIVE .
 - If the signal trace is similar to Figure 3-10 the FM coil driver is functioning properly.
 - If the signal is not similar continue with the next service-diagnostic routine.

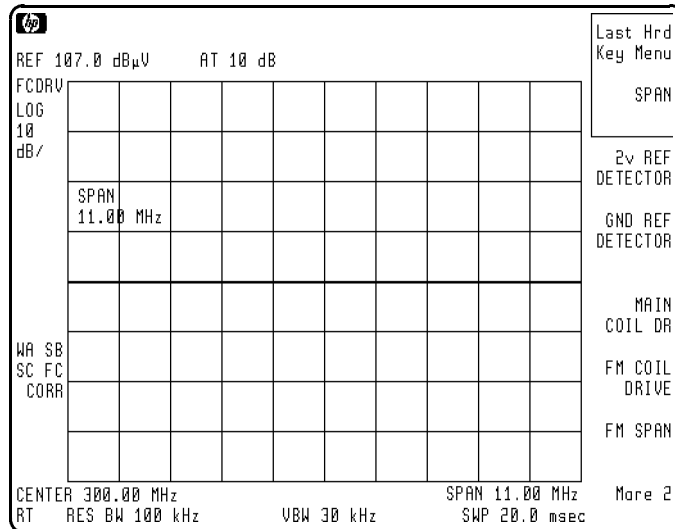

Figure 3-10. FM Coil Driver with >10 MHz Span

Verify the sweep ramp

1. Access the diagnostics menu by pressing the following keys:

```
CALIBRATE
More 1 of 3
More 2 of 3
Service Diag
```

2. Press **More 1** **More 2**.
3. Verify the sweep ramp by pressing **SWEEP RAMP**.

- If the signal trace is similar to Figure 3-11 the sweep ramp is functioning properly.

Note that before a successful frequency calibration is performed the ramp will not be corner to corner, but will have some overshoot or undershoot.

- If the signal is not similar suspect the A5 analog interface board assembly. Refer to Chapter 5 for further information about troubleshooting the A5 board assembly.

4. Change the instrument sweep time.

Note that it is recommended to check all sweep times due to the A5 analog interface board assembly operating differently for the different RC combinations. This can result in the instrument appearing to operate properly in one sweep time and not in another.

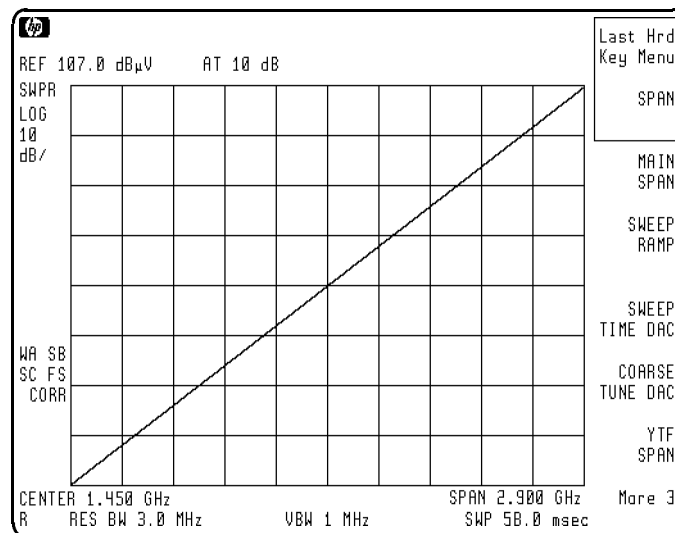

Figure 3-11. Typical Sweep Ramp Display

Verify the 10 V reference detector

This service-diagnostic routine verifies the 10 V reference. +10 V is used as a reference for the DACs and originates on the A5 analog interface board assembly. Frequency and amplitude errors will occur if this voltage is incorrect.

1. Access the diagnostics menu by pressing the following keys:

CALIBRATE
More 1 of 3
More 2 of 3
Service Diag

2. Press More 1 More 2 More 3.

3. Verify the 10 V reference detector by pressing +10V REF DETECTOR.

- If the signal trace is at the top of the display the 10 V reference detector is functioning properly. See Figure 3-12.
- If the signal is not at the top of the display the problem is isolated to the A5 analog interface board assembly. Refer to Chapter 5 for further troubleshooting.

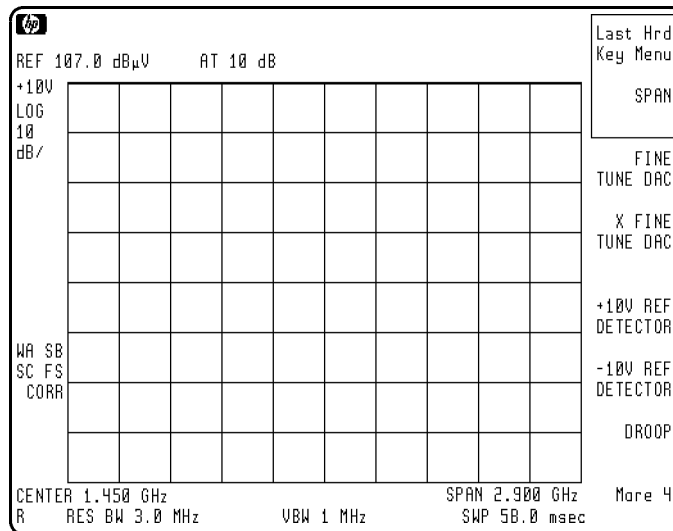

Figure 3-12. 10 V Reference Detector

Verify the -10 V reference detector

This service-diagnostic routine verifies the -10 V reference. -10 V is summed with the tuning voltages and used in the main coil driver and originates on the A5 analog interface board assembly. Frequency and amplitude errors will occur if this voltage is incorrect.

1. Access the diagnostics menu by pressing the following keys:

CALIBRATE

More 1 of 3

More 2 of 3

Service Diag

2. Press More 1 More 2 More 3.

3. Verify the -10 V reference detector by pressing -10V REF DETECTOR.

- If the signal trace is at the bottom of the display the -10 V reference detector is functioning properly. See Figure 3-13.
- If the signal is not at the bottom of the display the problem is isolated to the A5 analog interface board assembly. Refer to Chapter 5 for further troubleshooting.

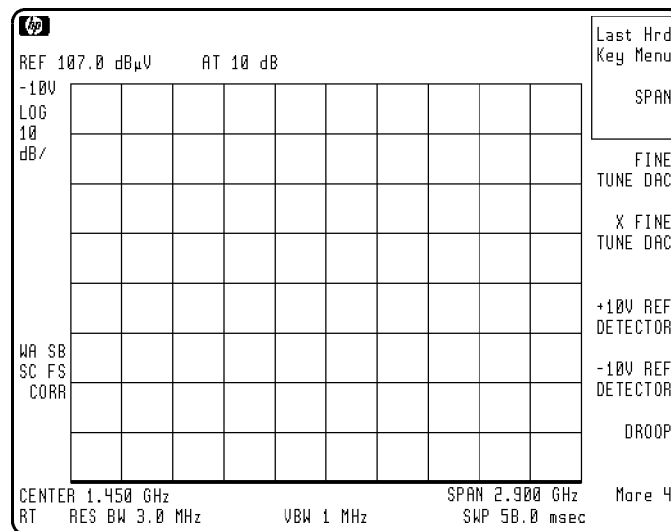

Figure 3-13. -10 V Reference Detector

Verify the YTF driver

HP 85462A only.

This routine verifies the YTF driver. The YTF is a sensitive device and the minimum of ramp voltage error can result in the YTF being out of specification.

1. Enter band 1 by pressing the following keys:

```
PRESET
MODE SIGNAL ANALYSIS
FREQUENCY More 1 of 2
Band Lock 2.75 - 6.5 BAND 1
```

2. Access the diagnostics menu by pressing the following keys:

```
CALIBRATE
More 1 of 3
More 2 of 3
Service Diag
```

3. Press More 1 More 2 More 3 More 4 More 5.

4. Verify the YTF driver by pressing YTF DRIVER.

- If the signal trace is similar to Figure 3-14 the YTF driver is functioning properly.
- If the signal is not similar suspect the A5 analog interface board assembly. Refer to Chapter 5 for further information about troubleshooting the A5 board assembly.

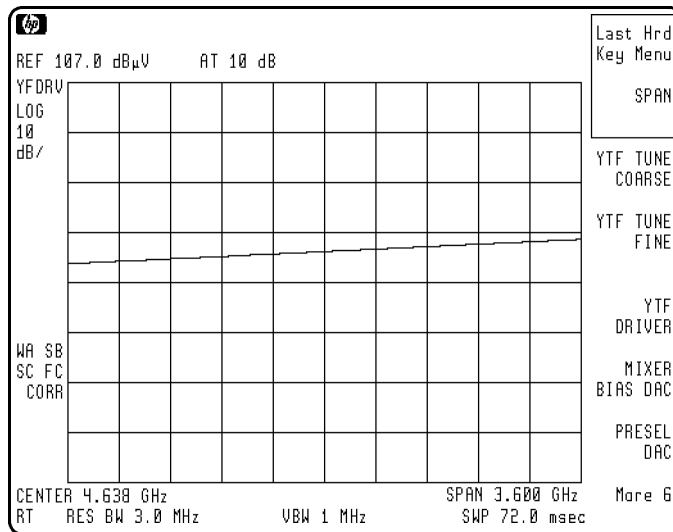

Figure 3-14. YTF Driver

Troubleshooting the A24 Processor Board Assembly

If the LED power-on sequence is not operational

When the instrument is powered-on or **PRESET** is pressed, LED's DS1 through DS16 should turn on. These LED's indicate the status of the instrument self tests. As different sections of the test are completed, the corresponding LED will turn off. The exception is DS13 which will remain on after **PRESET** is pressed.

Refer to "FAIL XXXX XXXXXXXXXXXX" in Chapter 12 for more information on diagnostics.

If an LED does not light, refer to Table 3-3 for information on possible failures and where they may have occurred.

Table 3-3. A24 Processor Board Assembly LED Diagnostics

LED	Failure Description	Failure Location
DS1	ROM even A	U24
DS2	ROM odd A	U7
DS3	ROM even B	U23
DS4	ROM odd B	U6
DS5	not used	
DS6	not used	
DS7	User RAM	U22
DS8	User RAM	U5
DS9	User RAM	U22
DS10	User RAM	U5
DS11	I/O bus even	U3
DS12	I/O bus odd	U2
DS13	68230	U57 *
DS14	CPU	U12
DS15	I/O Address	U18
DS16	Video Circuit	U305, U306
* Failure may also occur in peripheral IC's that enable communication		

If a signal cannot be displayed

If a signal cannot be displayed, and it has been determined that a top-screen signal of two volts is present at VIDEO_IF, the problem may be on the A24 processor board assembly.

1. Put 0 V into the video circuit, simulating a bottom-screen signal level condition by setting the diagnostic to the ground reference detector. Refer to "Verify the ground reference detector" located in this chapter.

Use an oscilloscope to check for the following conditions.

- Check for 0 V throughout the signal path through U201, U61, U45, and U46.

- Check the offset by measuring the inverting and noninverting pins on U201, U61, U45, and U46. The difference between both measured values should not exceed 5 mV.
2. Replace any components with excess offset voltage.
 3. Put 2 V into the video circuit, simulating a top-screen signal level condition by setting the diagnostic to the 2 V reference detector. Refer to “Verify the 2 V reference detector” located in this chapter.

Use an oscilloscope to check for the following conditions.

- Check for 2 V throughout the signal path through U201, U61, U45, and U46.
 - Check the offset by measuring the inverting and noninverting pins on U201, U61, U45, and U46. The difference between both measured values should not exceed 5 mV.
4. Replace any components with excess offset voltage.
 5. Switch between POS PEAK and SAMPLE detector modes. If the signal appears when in the SAMPLE detector, suspect something in the positive-peak detector circuit.

If the instrument does not respond (locked up)

If the instrument is not responding or is continuously doing instrument presets, and cycling power does not correct the problem perform the following steps:

1. Check for a defective Down Loadable Program (DLP) that has been installed into the instrument.
2. Clear the user memory by performing the step, for your instrument, listed below.

If the instrument is equipped with Option 023 (RS-232 remote interface), connect it to a computer. Execute the Break command, and pres the following keys:

```
(CONFIG) More 1 of 3
Dispose User Mem
Dispose User Mem
```

Connect the instrument to a controller. Execute the following remote program line to erase user memory and clear the problem.

```
SEND 7;UNL MTA LISTEN 18 CMD 12
```

Performing a Free-Run Check

This procedure allows you to set the microprocessor to a known state so that certain basic functions can be checked. A MOVEQ instruction is read from the system data bus. The MOVEQ instruction may be thought of as a no operation (NOP) for this procedure. The microprocessor will increment the address lines A1 through A23, then continue to read data on the system data bus.

1. Turn the power off.
2. Remove A24U25 (16 pin dip jumper pack)
3. Connect a clip lead from A24TP1 pin 7 to ground.
4. Turn the power on.

CAUTION While measuring pins on the microprocessor chip, exerting too much pressure on a pin may cause one of the data lines to open. This may result in factory correction constants to be erased.

5. Check A24U12 for the conditions described in Table 3-4 while in the free-run mode.

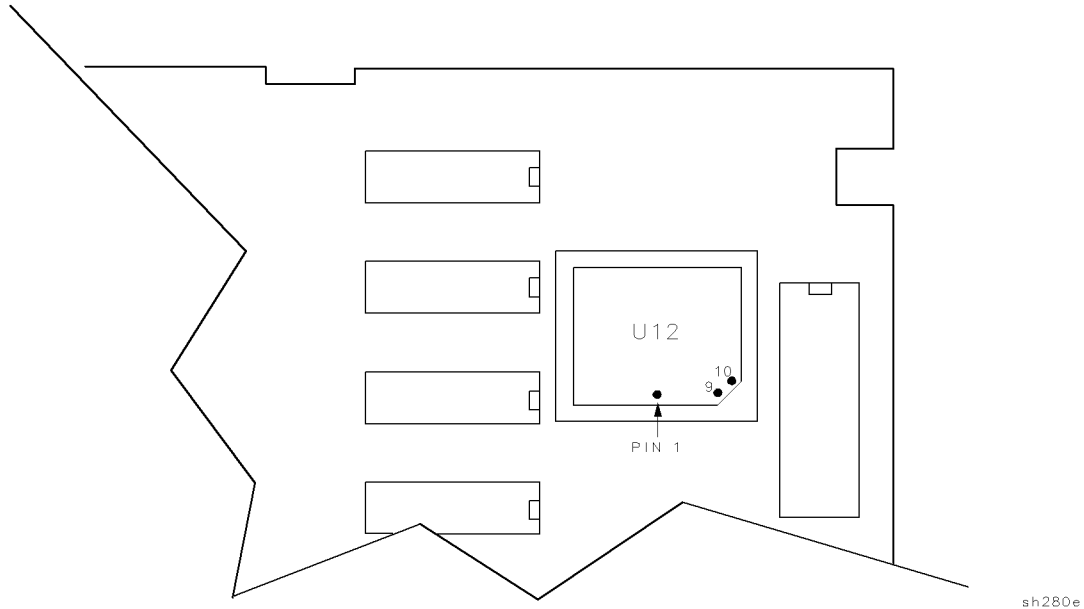

Figure 3-15. A24U12 Pin Location

Table 3-4.
Free-Run Conditions for A24 Processor Board Assembly U12

A24U12 Pin Location	A24U12 Free-Run Mode Condition
6	AS is toggling
7	UDS is toggling
8	LDS is toggling
9	R/W is logical one
32-55	Address lines A1 through A23 are counting in binary <i>where:</i> <i>A1 (pin 32) = LSB</i>

6. Check for +5 V at pin 1 of ROM's U6, U7, U23, and U24.

The Free-Run Check is now complete.

7. Turn the power off.

8. Remove the clip lead from A24TP1 pin 7 and ground.

9. Replace A24U25 (16 pin dip jumper pack)

10. Turn the power on.

Troubleshooting the IF Section

This chapter provides troubleshooting information for the IF section of the HP 85422E/HP 85462A receiver RF section. Troubleshooting information for tracing signals on the A15 motherboard is also provided.

Refer to Chapter 3 for procedures that are useful when first starting to troubleshoot a failure.

Before You Start

There are four things you should do before starting to troubleshoot a failure:

- Check that you are familiar with the safety symbols marked on the instrument, and read the general safety instructions and the symbol definitions given in the front of the Service Guide.
- The instrument contains static sensitive components. Read the section entitled “Protection From Electrostatic Discharge” in Chapter 1.
- Become familiar with the organization of the troubleshooting information in this service guide.
- Read the rest of this section.

WARNING This instrument contains potentially hazardous voltages.

Familiarize yourself with the safety symbols marked on the instrument and read the symbol definitions given in the front of this guide *before* you begin the procedures in this chapter. Refer to “General Safety Considerations” at the front of this manual for general *WARNINGS* and *CAUTIONS* related to safety considerations. *WARNINGS* and *CAUTIONS* related to specific procedures are included with the procedure.

Failure to heed the safety precautions can result in severe or fatal injury.

Service equipment you will need

Refer to Chapter 13 of this guide for a table listing the recommended test equipment needed to troubleshoot and repair the instrument. Although Hewlett-Packard equipment is recommended, any equipment that meets the critical specifications given in the table can be substituted for the recommended model.

Refer to Chapter 13 of this guide for a list of required service and hand tools needed to troubleshoot and repair the instrument.

After an instrument repair

If one or more assemblies have been repaired or replaced, perform the related adjustments and performance verification tests. Refer to Chapter 2 for a table of Adjustments and Tests for Replaced or Repaired Assemblies, for the related adjustments and performance verification tests required for each assembly.

IF Section Information

This section provides the control details for the assemblies in the IF section. The control-line outputs are valid when the instrument settings provided with each table are used.

For many IF functions, the A5 analog interface board converts the digital control signals from the A24 processor board assembly to analog control signals. Some instrument functions are performed directly by the A24 processor board assembly. The A24 processor board assembly also makes amplitude error corrections to improve instrument performance. The instrument-setting changes and error-correction functions performed on the A24 assembly are a combined mathematical offset of the digitized video signal.

For more information about the A15 motherboard and the tracing of specific signals in the IF section, refer to “Troubleshooting the A15 Motherboard Assembly”.

Note Before starting to troubleshoot the instrument, set it to the signal analysis mode by pressing:

PRESET
MODE
SIGNAL ANALYSIS

IF Power-Level Measurement

The following measurement procedures are used for troubleshooting along the 21.4 MHz IF signal path from the A9 third converter board, through the IF section, to output of the A14 log amplifier board.

To calibrate the reference level of the instrument, the CAL AMP self-calibration routine adjusts the gain of the 21.4 MHz IF variable amplifier on the A9 third converter board and mathematically offsets the digitized video signal on the A24 processor board assembly. Due to component variations it is unlikely that any two instruments will have the same 21.4 MHz IF signal level for the same instrument settings. Furthermore, a defective instrument may produce misleading IF signal levels if the CAL AMP routine has been run.

An IF test board is used in the following procedures to simplify troubleshooting. The test board is used to isolate the RF section from the IF section and allows the testing of individual IF assemblies. Refer to Chapter 13 for the part number of the IF test board.

To set up the instrument for an IF power-level measurement

The power levels provided with the measurement procedures in this section are accurate when the following steps are followed.

1. Ensure that the CAL OUT amplitude is within specification. Refer to the calibrator amplitude performance test in the *HP 8542E/HP 8546A EMI receiver and HP 85422E/HP 85462A receiver RF section User's Guide*.

2. Set up the CAL OUT signal to be checked internally by pressing:

INPUT

VIEW CAL ON OFF (ON)

3. Press **PRESET** on the instrument, then wait for the preset routine to finish. Set the instrument by pressing the following keys:

FREQUENCY **CENTER FREQ** 300 **MHz**

SPAN 0 **Hz**

To check the gains for the IF assemblies

The overall gain of individual assemblies in the IF section are listed below. The gain level provided for the A12 amplitude control board is correct only when the instrument is set as provided in step three, above.

- The A11 bandwidth filter board produces 10 dB of gain.
- The A12 amplitude control board produces +5 dB of gain.
- The A13 bandwidth filter board produces 10 dB of gain.
- A +10 dBm signal at the input of the A14 log amplifier board produces a 2 volt signal (VIDEO_IF) that is equivalent to a top-screen display.

To measure the IF signal from the A9 third converter board

Measure the 21.4 MHz IF output from the A9 third converter board with the following procedure. Refer to the IF/control section block diagram (Figure 8-5) while performing this procedure.

1. Remove the A11 bandwidth filter board.
2. Insert the IF test board in the A11 bandwidth filter board slot.
3. Measure the 21.4 MHz IF output at J1 on the IF test board using an active probe, with a instrument attached. (Use of a 50Ω instrument will cause erroneous power-level measurements.)
4. The test limit for the 21.4 MHz IF signal is $-25 \text{ dBm} \pm 2 \text{ dB}$. The test board receives the signal at measurement point A (near the input of the A11 bandwidth filter board) on the block diagram.

Note that the variable IF amplifier at the output of the A9 third converter board has a gain range of -15 to $+2$ dB. This level is dependent on the output from the reference level DAC, located on the A5 analog interface board, that is adjusted during the CAL AMP self-calibration routine.

To inject a signal at the output of the A11 bandwidth filter board

Inject a 21.4 MHz signal at the output of the A11 bandwidth filter board using the following procedure. Refer to the IF/control section block diagram (Figure 8-5).

1. Remove the A11 bandwidth filter board.
2. Insert the IF test board in the A11 bandwidth filter board slot.
3. Connect a level generator to the J2 input connector on the IF test board. The test board injects the signal at A15J8 pin 22.
4. Set the signal source for 21.4 MHz at +4 dBm. This signal level provides +10 dBm at the input to the A14 log amplifier board and simulates a top-screen signal.
5. Check for the following nominal signal outputs.
 - A -10 dBm at the AUX IF OUTPUT connector on the rear panel. Refer to Figure 8-5.
Use an active probe to make the measurement. If a 50 Ω instrument is used, an additional 6 dB drop in signal level results. (The AUX IF OUTPUT has a 50 Ω output impedance.)
 - One volt at the AUX VIDEO OUTPUT connector on the rear panel. A voltage divider on the A15 motherboard reduces the uncorrected 2 volt video signal (AUX_VIDEO) to a 1 volt output.
 - A signal at the top graticule line and a marker reading of approximately 0 dBm.

Use **CORRECT ON OFF** to observe the magnitude of video offsets that the A24 processor board assembly is currently using to correct the signal position at top-screen. Refer to Chapter 11 for more information about **CORRECT ON OFF**.

To inject a signal at the output of the A13 bandwidth filter board

Inject a 21.4 MHz signal at the output of the A13 bandwidth filter board with the following procedure. Refer to the “IF/Control Section Block Diagram” (Figure 8-5).

1. Remove the A13 bandwidth filter board.
2. Insert the IF test board in the A13 bandwidth filter board slot.
3. Connect a level generator to the J2 input connector on the IF test board. The test board injects the signal at A15J11 pin 22.
4. Set the signal source for 21.4 MHz at +13 dBm. This signal level provides +10 dBm at the input to the A14 log amplifier board and simulates a signal at top-screen. The output impedance of the IF test board interacts with circuitry on the A15 motherboard to cause a 3 dB signal loss.
5. Check for the following nominal signal outputs.
 - A -10 dBm at the AUX IF OUTPUT connector on the rear panel. Refer to Figure 8-5.
Use an active probe to make the measurement. If a 50Ω instrument is used, an additional 6 dB drop in signal level results. (The AUX IF OUTPUT has a 50Ω output impedance.)
 - One Volt at the AUX VIDEO OUTPUT connector on the rear panel. A voltage divider on the A15 motherboard reduces the uncorrected 2 V video signal (AUX_VIDEO) to a 1 V output.
 - A signal at the top graticule line and a marker reading of approximately 0 dBm.

Use `CORRECT ON OFF` to observe the magnitude of video offsets that the A24 processor board assembly is currently using to correct the signal position at top-screen. Refer to Chapter 11 for more information about `CORRECT ON OFF`.

To check bandwidth control lines for the A11 and A13 bandwidth filter board

Table 4-1 provides nominal bandwidth control voltages sent to the A11 and A13 bandwidth filter board from the A5 analog interface board. A calibrated instrument produces control voltages similar to the values in Table 4-1. (The values in Table 4-1 were measured while default calibration data was in use.)

- Use the difference in control voltage between bandwidths from the table as a guide for normal bandwidth operation.
- Use an extender board to measure the bandwidth control voltages at the motherboard connector for the A5 assembly or the A11/A13 filter assemblies.
- Refer to “Troubleshooting the A15 Motherboard Assembly” for the location of the control lines for each assembly.

Table 4-1. Nominal Resolution Bandwidth Control Line Voltages

Resolution Bandwidth	BW5	BW6	BW7
3 dB			
5 MHz	+ 14.0	-9.9	+ 4.4
3 MHz	+ 14.0	-9.9	+ 6.4
1 MHz *	+ 14.0	-9.9	+ 8.5
.3 MHz	+ 14.0	-9.9	+ 9.4
.1 MHz	+ 14.0	-9.9	+ 9.7
30 kHz	- 1.0	+ 9.25	+ 9.7
10 kHz	- 1.0	+ 8.96	+ 9.7
3 kHz	- 1.0	+ 8.51	+ 9.7
1 kHz	- 1.0	+ 7.5	+ 9.7
.3 kHz	- 1.0	+ 7.5	+ 9.7
6 dB EMI			
200 Hz	- 1.0	+ 7.5	+ 9.7
9 kHz	- 1.0	+ 8.81	+ 9.7
120 kHz	+ 14.0	-9.9	+ 9.6
1 MHz †	+ 14.0	-9.9	+ 8.5
* Firmware dates before 940811.			
† Firmware date 940811 and later.			

To check IF section gain control

Table 4-2 lists the changes in IF Section gain that alter the displayed signal position when the reference level is changed in increments as small as 1 dB. The control voltages from the A5 analog interface board that change the gain of specific IF assemblies are provided in Table 4-3, Table 4-4, and Table 4-5.

When the reference level is changed, the A24 processor board assembly performs two step-gain functions that change the position of the displayed signal. Refer to Table 4-2 for the reference levels where the A24 processor board assembly changes the signal position in increments of 10 dB. When a reference-level change of less than 1 dB is required, the A24 assembly makes a corresponding change in the signal position. These changes in signal position are made by mathematically offsetting the digitized video signal on the A24 assembly.

The A24 processor board assembly also makes amplitude error corrections to improve instrument performance. The reference-level changes and error-correction functions are a combined mathematical offset of the digitized video signal. This makes it difficult to distinguish which offset is contributing to a change in displayed signal level when the reference level is changed. Disable the error corrections by setting `CORRECT ON OFF` to OFF.

Refer to “Troubleshooting the A15 Motherboard Assembly” when tracing control lines in the IF section.

The entries in Table 4-2 are valid after pressing the following keys:

`PRESET`

`MODE`

`SIGNAL ANALYSIS`

`CALIBRATE`

`CORRECT ON OFF` (OFF)

Be sure that the input attenuator setting remains at 10 dB.

Table 4-2. IF Section Gain Table in dB

Reference Level (dBm)	A12 Calibration Attenuator (Log/Linear Mode)	A12 Step Gain * (Log/Linear Mode)	A14 Gain (Linear Mode)	A24 Video Offset (Log Mode) †	A24 Video Offset (Linear Mode) †
0	10	0	0	0	0
-1	9	0	0	0	0
-2	8	0	0	0	0
-3	7	0	0	0	0
-4	6	0	0	0	0
-5	5	0	0	0	0
-6	4	0	0	0	0
-7	3	0	0	0	0
-8	2	0	0	0	0
-9	1	0	0	0	0
-10	10	10	0	0	0
-20	10	20	0	0	0
-30	10	30	0	0	0
-40	10	40	0	0	0
-50	10	50	0	0	0
-60	10	50	10	10	0
-70	10	50	20	20	0
-80	10	50	30	30	0
-90	10	50	40	40	0
-100	10	50	40	50	10
-110	10	50	40	60	20
-120	10	50	40	70	30
-130	10	50	40	80	40
-131	9	50	40	80	40
-132	8	50	40	80	40
-133	7	50	40	80	40
-134	6	50	40	80	40
-135	5	50	40	80	40
-136	4	50	40	80	40
-137	3	50	40	80	40
-138	2	50	40	80	40
-139	1	50	40	80	40

* The gain of the 10 dB step-gain stage is 15 dB when enabled and 5 dB when disabled.
† Turn **CORRECT ON OFF** off to remove the amplitude error corrections generated by **CAL AMP**.

Control lines for the A12 amplitude control board

Table 4-3 and Table 4-4 provide the control line output from the A5 analog interface board that change the gain of the A12 amplitude control board when the reference level is changed. The calibration attenuator settings in Table 4-4 provide reference-level changes in 1 dB increments for the full reference-level range of the instrument.

Refer to “Troubleshooting the A15 Motherboard Assembly” when tracing control lines in the IF section. The entries in Table 4-3 and Table 4-4 are valid after pressing the following keys:

PRESET

MODE

SIGNAL ANALYSIS

CALIBRATE

CORRECT ON OFF (OFF)

Be sure that the input attenuator setting remains at 10 dB.

Table 4-3. 10 dB Step-Gain Control Lines

Reference Level (dBm)	10 dB Step Gains	IFG1 (10 dB Step) A12J2-14	IFG2 (20-1 dB Step) A12J2-13	IFG3 (20-2 dB Step) A12J2-12
0	0	L	L	L
-10	10	H	L	L
-20	20	L	H	L
-30	30	H	H	L
-40	40	L	H	H
-50	50	H	H	H

H = >2.5 V (TTL High)
L = <0.8 V (TTL Low)

For each reference level in Table 4-3, the Calibration Attenuator control lines are set to 10 dB of attenuation as shown in the first entry of Table 4-4. The control line settings from Table 4-4 repeat, starting with each reference level in Table 4-3 to produce reference-level changes in 1 dB increments.

Table 4-4. Calibration-Attenuator Control Lines

Reference Level (dBm)	Calibration Attenuator	IFA1 (1 dB) A12J2-4	IFA2 (2 dB) A12J2-3	IFA3 (4 dB) A12J2-2	IFA4 (8 dB) A12J2-1	IFA5 (16 dB) A12J2-11
0	10	L	H	L	H	L
-1	9	H	L	L	H	L
-2	8	L	L	L	H	L
-3	7	H	H	H	L	L
-4	6	L	H	H	L	L
-5	5	H	L	H	L	L
-6	4	L	L	H	L	L
-7	3	H	H	L	L	L
-8	2	L	H	L	L	L
-9	1	H	L	L	L	L

H = >2.5 V (TTL High)
L = <0.8 V (TTL Low)

To check linear gain control lines for the A14 log amplifier board

Table 4-5 provides the control line voltages from the A5 analog interface board to the A14 log amplifier board. When the instrument is in linear mode, the seven A14 log amplifier board stages are biased to operate as linear amplifiers. Four of the seven stages are also used to provide 40 dB of gain in 10 dB increments. The linear gains are enabled for the reference levels indicated in Table 4-2 and Table 4-5. Two of the four stages operate as one 20 dB amplifier and are controlled by the same control line, IFG6.

Refer to “Troubleshooting the A15 Motherboard Assembly” when tracing control lines in the IF section.

When enabled, each control line has a -7.6 V dc output. This voltage is supplied by the -8 VT temperature-compensated power supply located on the A14 log amplifier board.

The entries in Table 4-5 are valid when the instrument is set up as follows:

PRESET
MODE
SIGNAL ANALYSIS
AMPLITUDE
SCALE LOG LIN (LIN)
Amptd Units dBm
CALIBRATE
CORRECT ON OFF (OFF)

Table 4-5.
Linear Gain Control Lines on the
A14 Log Amplifier Board

Reference Level (dBm)	A14 Gain in Linear Mode (dB)	IFG4 (10-1 dB Step)	IFG5 (10-2 dB Step)	IFG6 (20 dB Step)
-50	0	H	H	H
-60	10	L	H	H
-70	20	L	L	H
-80	30	L	H	L
-90	40	L	L	L

H = +14.3 V dc (disabled)
L = -7.6 V dc (enabled)

Troubleshooting IF Overload Failures

This section helps identify which assembly is most likely causing the IF Overload Check of the performance test to fail.

If the failure message from the IF Overload Check indicates that the IF video overload failed, the primary assembly to suspect is the A7 demodulator/quasi-peak/average detector board. This is almost certainly the case if the remaining IF overload checks function properly.

If the failure message from the IF Overload Check indicates that the main IF overload failed, the primary assembly to suspect is the A12 amplitude control board. The secondary assembly to suspect in this case is the A7 demodulator/quasi-peak/average detector board. Also, check W96, the wire pair between A12 amplitude control board and A7 demodulator/quasi-peak/average detector board, to make sure that there is continuity between the board assemblies.

Troubleshooting the A15 Motherboard Assembly

Use this section to identify and locate all the signals and voltages that pass through the A15 motherboard. The location of active components on the motherboard are also provided.

The following information is provided in this section:

- Figure 4-1, A15 Motherboard Connector Designation. Shows the location and reference designator for each connector on the motherboard.
- Figure 4-2, A15 Connectors with Additional Associated Circuitry. Provides a simplified circuit diagram for the components on the motherboard. To help locate the components, the motherboard connector-pin that is connected to each component is shown.
- Figure 4-3, A15J13 Connector-Pin Designation. Provides the pin numbering sequence for the connector that connects the A16 power supply assembly to the motherboard.
- Figure 4-4, Card-Cage Connector Pin Designation. Provides the pin-numbering sequence for the four motherboard connectors in the card cage. The motherboard connector for the A5 analog interface board (not shown) has the same pin-numbering sequence, but is installed in a position that is reversed when compared to the card-cage connectors.
- Table 4-6, A15 Motherboard Mnemonic Descriptions. Provides the mnemonic, full name, and functional description for each signal and voltage on the motherboard.
- Table 4-7, A15 Motherboard Pin Designations. Identifies the signal or voltage distribution for each signal and voltage on the motherboard.

Each column identifies the instrument assembly that is connected to the A15 motherboard. The associated motherboard reference designator for each assembly is also supplied.

The mnemonics from Table 4-6 are arranged alphabetically by row on the left-hand side of the table.

For a given mnemonic, read across the row to find all the assemblies that the signal or voltage is connected to. The A15 connector pin numbers in each box indicate the A15 connector pins where the signal or voltage appear.

Be sure to read the footnotes at the bottom of Figure 4-1.

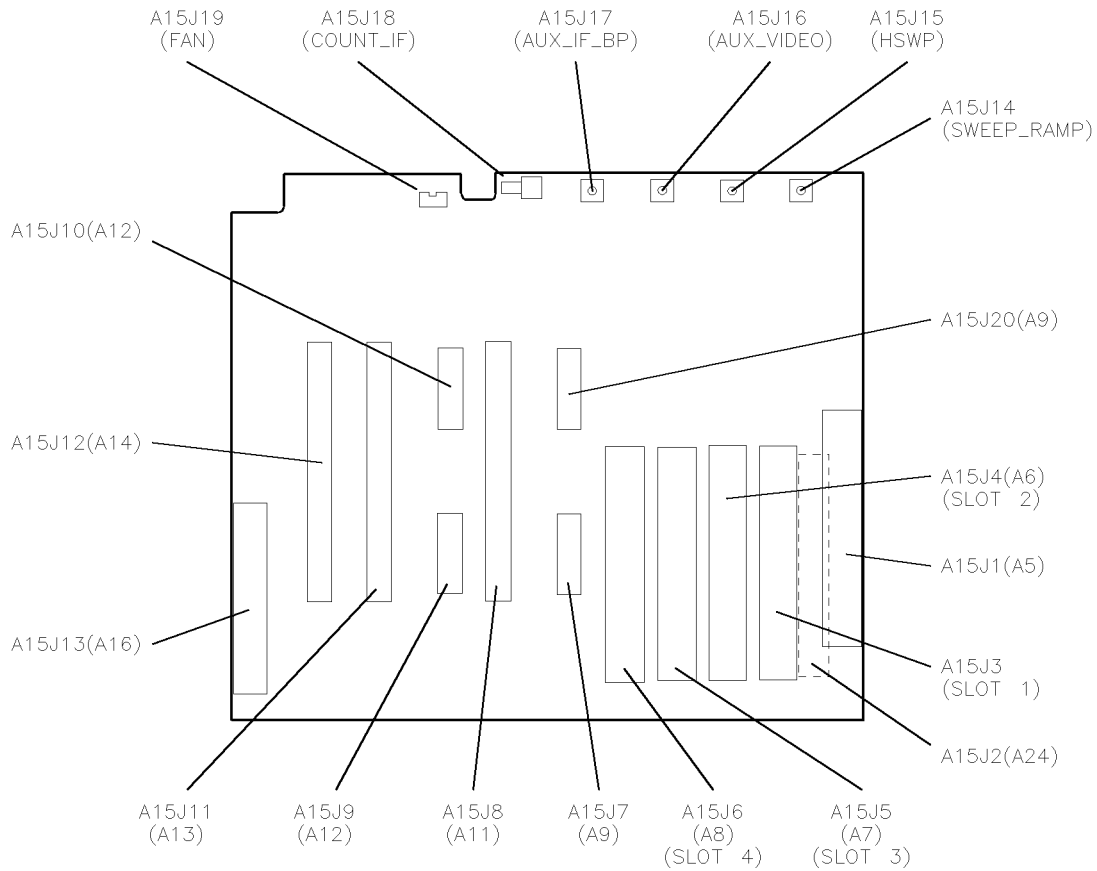

sh247e

Figure 4-1. A15 Motherboard Connector Designation

- All connector pins on A9J20 are tied to ground (ACOM).
- The A15J1 connector for the A5 analog interface board is installed in a position that is reversed when compared to card-cage connectors A15J3, A15J4, A15J5, and A15J6; therefore, the pin-numbering order is also reversed for A15J1 when compared to the card-cage connectors.

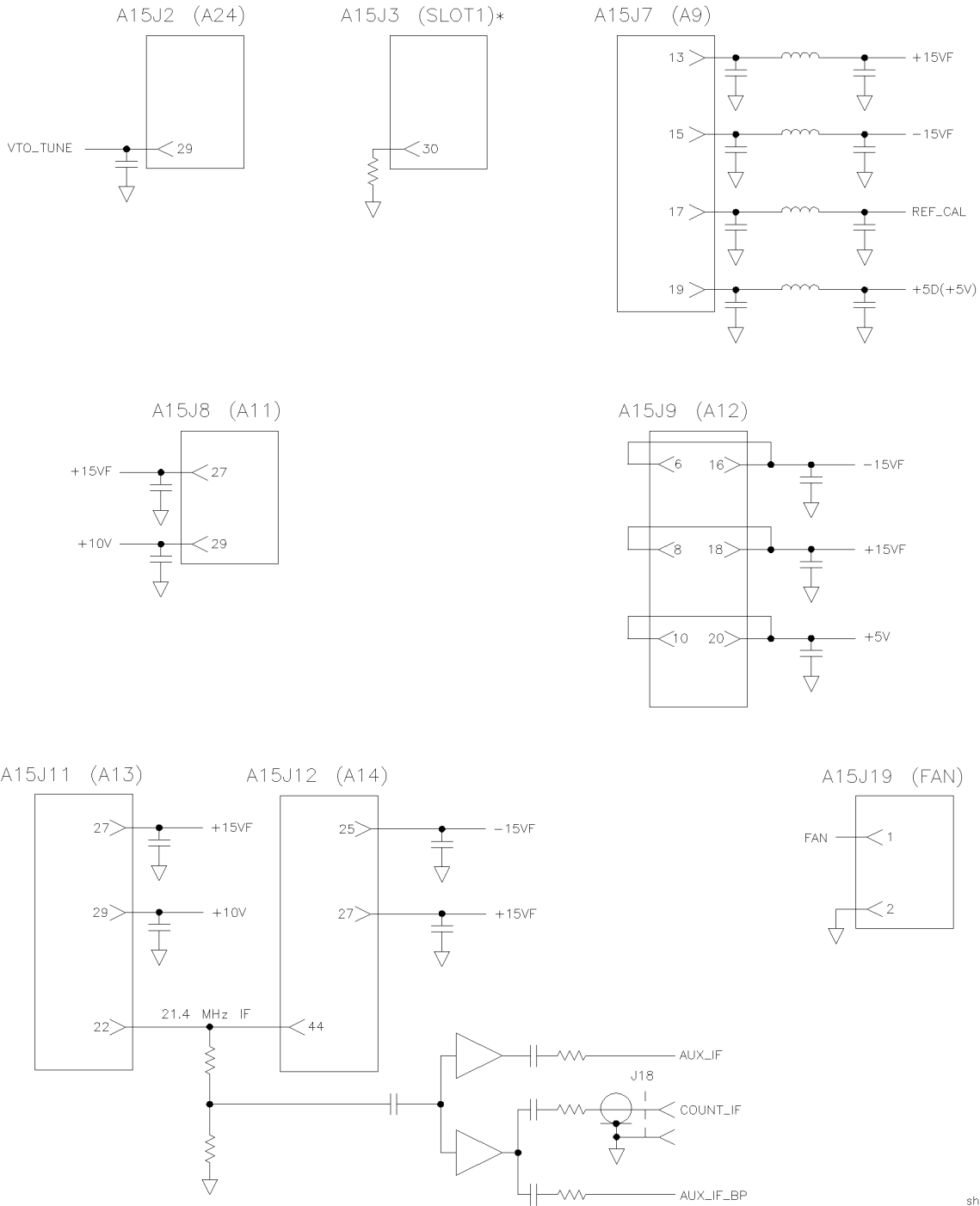

sh248e

Figure 4-2. A15 Connectors with Additional Associated Circuitry (1 of 2)

REAR FRAME CONNECTORS



sh249e

Figure 4-2. A15 Connectors with Additional Associated Circuitry (2 of 2)

- The A15 motherboard pin designation for the 21.4 MHz IF signal path is provided in Table 4-7.
- All the connector pins with the same number are connected in parallel for the card-cage connectors A15J3, A15J4, A15J5, and A15J6.

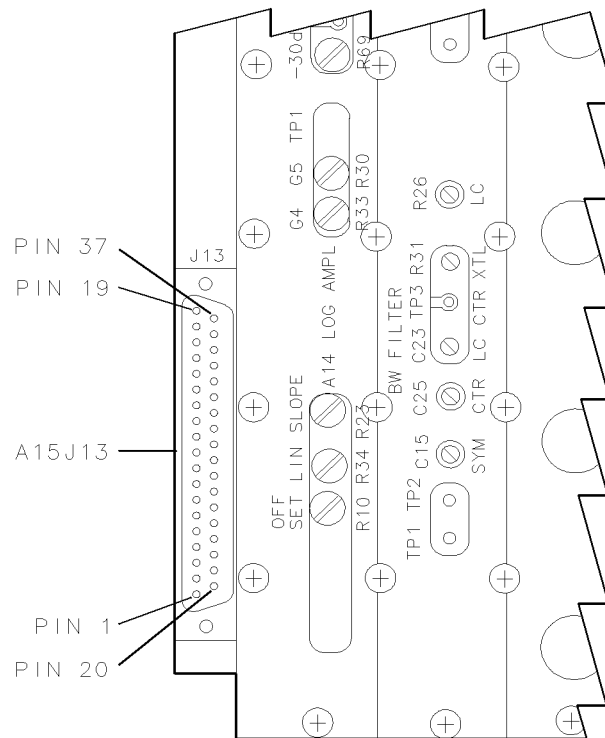

sh250e

Figure 4-3. A15J13 Connector-Pin Designation

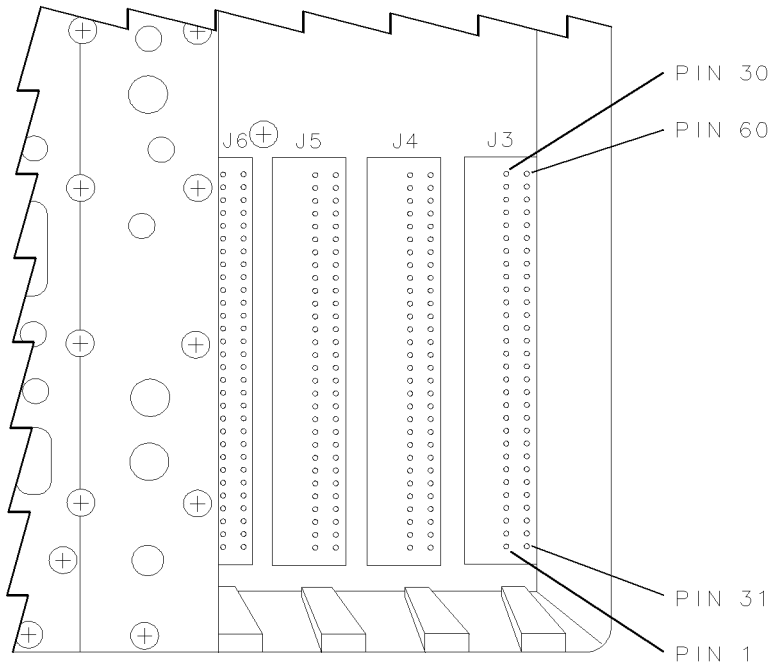

sh268e

Figure 4-4. Card-Cage Connector Pin Designation

Table 4-6. A15 Motherboard Mnemonic Descriptions

Mnemonic	Full Name	Description
21.4 MHz IF	21.4 MHz IF	The 21.4 MHz IF signal between the A9 third converter assembly and the detector on the A14 log amplifier board.
+ 10V	+ 10 V Supply	The A5 analog assembly provides a + 10 V bias supply for the LC bandwidth filters on the A11/A13 bandwidth filter assemblies.
+ 12V	+ 12 V Supply	+ 12 V supply for the A2 Display and the RS-232 option, referenced to DCOM.
+ 15VF	+ 15 V Supply	+ 15 V power supply, referenced to ACOM.
+ 5V	+ 5 V Supply	+ 5 V power supply, referenced to DCOM.
- 15V	- 15 V Supply	- 15 V power supply, referenced to ACOM.
-8VT	-8 V Temperature Compensated Supply	Provides -8 V from the temperature-compensated (TC) power supply on the A14 log amplifier board to the A5 analog interface board. The A5 provides temperature-compensation for the IFG4-IFG6 and the Log/Lin control lines using the -8 VT as a TC reference.
ACOM	Analog Common	A common ground for all analog circuitry.
ADC_SYNC	A/D Conversion Synchronization	A positive-going signal that indicates when the main ADC on the A24 processor board assembly has started a A/D conversion. ADC_SYNC resets the peak detectors located on assemblies installed in the card cage.
ADR0-ADR4	Address 0-4	Input/Output (IO) address lines.
ANA_TEST	Analog Test	Provides a series of test signals from A5 analog interface assembly to A24 processor board assembly during instrument calibration and troubleshooting. (Refer to the A5 overview section)
AUX_IF	Auxiliary IF	An uncorrected, buffered 21.4 MHz IF signal from the output of the A13 bandwidth filter board to the four card-cage slots.
AUX_IF_BP	Auxiliary IF Back Panel	A uncorrected, buffered 21.4 MHz IF signal from the output of the A13 bandwidth filter board to J17, AUX IF OUTPUT.
AUX_VIDEO	Auxiliary Video	A detected video signal (0–2 V) that has passed through the video filters. No amplitude corrections have been applied to this signal. A voltage divider at J16, AUX VIDEO OUTPUT, reduces the signal amplitude to 0–1 V.

Table 4-6. A15 Motherboard Mnemonic Descriptions (continued)

Mnemonic	Full Name	Description
BW5	Bandwidth 5	A bias voltage that activates either the LC or crystal bandwidth-filter mode.
BW6	Bandwidth 6	Controls the crystal-filter bandwidth.
BW7	Bandwidth 7	Controls the LC filter bandwidth.
COUNT_IF	Counterlock IF	A buffered 21.4 MHz IF signal from the output of the A13 bandwidth filter board to A23 counter lock assembly.
CRD_ANLG_1	Card Cage Analog 1	An analog signal from assemblies installed in the card cage to the A24 input multiplexer. When it is selected, the signal passes through the A24 video-filter and peak-detector sections. It is available on AUX_VIDEO after it passes through the video filter.
CRD_ANLG_2	Card Cage Analog 2	An analog signal from assemblies installed in the card cage. The signal goes directly to A24 A/D conversion section, bypassing both the video-filter and peak-detector sections.
DCOM	Digital Common	A common ground for all digital circuitry.
DISCRIM or DISCRIMINATOR	Discriminator	For Spans ≤ 10 MHz, the A23 counter lock assembly sends a dc tuning voltage through the A24 processor board assembly to the A5 analog interface board. The A5 assembly then adjusts the YTO to reduce residual FM.
EXT_HSWP	External High Sweep	EXT_HSWP performs two functions: 1) It provides external control of high sweep on the A24 processor when an external signal is connected to J15, HIGH SWEEP INPUT/OUTPUT. 2) It provides the HSWP signal as a rear-panel output at J15, HIGH SWEEP INPUT/OUTPUT. <i>This is an open-collector signal. It should never be driven high.</i>
FAN	FAN	+ 12 V power supply for the B1 fan.
HPWRUP	High Power Up	Enables the initial start-up sequence for the CPU on the A24 processor board assembly when the instrument is first turned on. This occurs prior to the start-up of other related assemblies.
HSWP	High Sweep	Provides control for the instrument display sweep and retrace. A TTL high starts a sweep and a TTL low initiates a retrace. <i>This is an open-collector signal. It should never be driven high.</i>

Table 4-6. A15 Motherboard Mnemonic Descriptions (continued)

Mnemonic	Full Name	Description
IFA1	IF Attenuation 1	Control line for 1dB step attenuator on the A12 amplitude control board.
IFA2	IF Attenuation 2	Control line for the 2 dB step attenuator on the A12 amplitude control board.
IFA3	IF Attenuation 3	Control line for the 4 dB step attenuator on the A12 amplitude control board.
IFA4	IF Attenuation 4	Control line for the 8 dB step attenuator on the A12 amplitude control board.
IFA5	IF Attenuation 5	Control line for the 16 dB step attenuator on the A12 amplitude control board.
IFG1	IF Gain 1	Control line for the 10 dB step gain on the A12 amplitude control board.
IFG2	IF Gain 2	Control line for the first 20 dB step gain on the A12 amplitude control board.
IFG3	IF Gain 3	Control line for the second 20 dB step gain on the A12 amplitude control board.
IFG4	IF Gain 4	Temperature-compensated control line for the 10 dB linear gain on the A14 log amplifier board.
IFG5	IF Gain 5	Temperature-compensated control line for the 10 dB linear gain on the A14 log amplifier board.
IFG6	IF Gain 6	Temperature-compensated control line for the 20 dB linear gain on the A14 log amplifier board.
INTERBUS	Interbus	A communication line between the four slots in the card cage. It coordinates functions between options when more than one option is installed in the card cage.
IOB0-IOB15	Input/Output Bus 0 – Input/Output Bus 15	Input/Output (IO) data lines used between the A24 processor assembly and related assemblies.
LBIO	Low Bottom-box Input/Output	Strobe line for Input/Output (IO) data transfers.
LINE_TRIG	Line Trigger	Provides a TTL signal at the power-line frequency rate. It enables the line-trigger mode on the A24 processor assembly.
LOG_LIN	Log Linear	Controls switching between log and linear modes on the A14 log amplifier board.

Table 4-6. A15 Motherboard Mnemonic Descriptions (continued)

Mnemonic	Full Name	Description
LPWRON	Low Power On	The front-panel line switch provides a TTL low when the switch is depressed. This initiates start-up of the A16 power supply and A24 processor board assembly.
LTIO	Low Top-box Input/Output	Strobe line for Input/Output (I/O) data transfers.
REF_CAL	Reference Cal	A DAC on the A5 analog interface board adjusts the gain of the A9 third converter board through REF_CAL. (Refer to the A5 overview section)
SWEEP_RAMP	Sweep Ramp	A 0 to +10 V ramp signal that corresponds to signal sweep across the display. The signal is sent to J14, SWEEP OUTPUT, on the rear frame.
VIDEO_IF	Video IF	The detected 21.4 MHz IF signal from the detector on the A14 log amplifier board to the input multiplexer on the A24 processor board assembly.
VTO_TUNE	Voltage-Tuned Oscillator Tune	A tuning voltage from the A23 counter lock assembly to A9 third converter board. It locks the 600 MHz oscillator on the A9 assembly to the frequency reference.

Table 4-7. A15 Motherboard Pin Designations

Mnemonic	Instrument Assemblies									Card Cage
	A5 A15J1	A16 A15J13	A9 A15J7	A11 A15J8	A12 A15J9 A15J10		A13 A15J11	A14 A15J12	A24 A15J2	Slots 1, 2, 3, 4 A15J3, 4, 5, 6
21.4 MHz IF			9	22, 23	1	20	22, 23 †	44 †		
+ 10 V	22 †			29			29 †			
+ 12 V		13, 32							27, 57	
+ 15 V	3, 33	1, 2, 3, 20, 21, 22 †	‡	27 †	8, 18		27 †	27 †	8, 38	9, 39
+ 5 V	19, 49	9, 10, 11, 12, 28, 29, 30, 31 †	‡		10, 20				25, 26, 55, 56	26, 56
- 15 V	4, 34	4, 5, 6, 23, 24, 25 †	‡		6, 16 †			25 †	9, 39	10, 40
- 8 VT	23							8 †		
ACOM	2, 32	7, 26, 27	1-8, 10, 12, 14, 16, 18, 20	1-21, 24-26, 28, 33-44	2-5, 7, 9, 11-15, 17, 19	5-10, 15-19	1-21, 24-26, 28, 33-44	1, 3-7, 9-24, 26, 28-30, 32-37, 41-43	2, 4, 6, 32-37	2, 4, 6, 8, 29, 31-38, 59, 60
ADC_SYNC									30 †	27
ADR0	6								11 †	12
ADR1	36								41 †	42
ADR2	7								12 †	13
ADR3	37								42 †	43
ADR4	8								13 †	14
ANA_TEST	31								31 †	
AUX_IF							22 † ‡			30
AUX_IF_BP							22 † ‡			
AUX_VIDEO †									7 †	7
BW5	24 †			30			30			
BW6	54 †			31			31			
BW7	25 †			32			32			
COUNT_IF †										
CRD_ANLG_1									3 †	3
CRD_ANLG_2									5 †	5
DCOM	11, 16, 35, 38, 43, 48	14-17, 33-36							16, 21, 40, 43, 48, 53	17, 22, 41, 44, 49, 54

† Pin numbers indicate assembly where signal or voltage originates.
‡ Refer to Figure 4-2.

Table 4-7. A15 Motherboard Pin Designations (continued)

Mnemonic	Instrument Assemblies									Card Cage
	A5	A16	A9	A11	A12		A13	A14	A24	Slots 1, 2, 3, 4
	A15J1	A15J13	A15J7	A15J8	A15J9	A15J10	A15J11	A15J12	A15J2	A15J3, 4, 5, 6
DISCRIMINATOR	21								28 †	
EXT_HSWP ‡										
FAN ‡		8 †								
HPWRUP	50	37 †							54	55
HSWP ‡									58 †	57
IFA1	58 †					4				
IFA2	29 †					3				
IFA3	59 †					2				
IFA4	30 †					1				
IFA5	60 †					11				
IFG1	55 †					14				
IFG2	26 †					13				
IFG3	56 †					12				
IFG4	27 †							38		
IFG5	57 †							39		
IFG6	28 †							40		
INTERBUS										58 ‡
IOB0	9								14	15
IOB1	39								44	45
IOB2	10								5	16
IOB3	40								45	46
IOB4	41								46	47
IOB5	12								17	18
IOB6	42								47	48
IOB7	13								18	19
IOB8	14								19	20
IOB9	44								49	50
IOB10	15								20	21
IOB11	45								50	51
IOB12	46								51	52
IOB13	17								22	23
IOB14	47								52	53
IOB15	18								23	24

† Pin numbers indicate assembly where signal or voltage originates.
‡ Refer to Figure 4-2.

Table 4-7. A15 Motherboard Pin Designations (continued)

Mnemonic	Instrument Assemblies									Card Cage
	A5 A15J1	A16 A15J13	A9 A15J7	A11 A15J8	A12 A15J9 A15J10		A13 A15J11	A14 A15J12	A24 A15J2	Slots 1, 2, 3, 4 A15J3, 4, 5, 6
LBIO	5								10 †	11
LINE_TRIG		18 †							60	
LOG_LIN	52 †							31		
LPWRON		19							59 †	
LTIO									24 †	25
REF_CAL	53 †		‡							
SWEEP_RAMP ‡	51 †									28
VIDEO_IF								2 †	1	1
VTO_TUNE			11						29 † ‡	

† Pin numbers indicate assembly where signal or voltage originates.
‡ Refer to Figure 4-2.

Troubleshooting the RF Section

This chapter provides troubleshooting information for the RF section of the HP 85422E/HP 85462A receiver RF section.

Refer to Chapter 3 for troubleshooting procedures that are useful when first starting to troubleshoot a failure.

Before You Start

There are four things you should do before starting to troubleshoot an instrument failure:

- Check that you are familiar with the safety symbols marked on the instrument, and read the general safety instructions and the symbol definitions given in the front of the service guide.
- The instrument contains static sensitive components. Read the section entitled “Protection From Electrostatic Discharge” in Chapter 1.
- Become familiar with the organization of the troubleshooting information in this service guide.
- Read the rest of this section.

WARNING This instrument contains potentially hazardous voltages.

Familiarize yourself with the safety symbols marked on the instrument and read the symbol definitions given in the front of this guide *before* you begin the procedures in this chapter. Refer to “General Safety Considerations” at the front of this manual for general *WARNINGS* and *CAUTIONS* related to safety considerations. *WARNINGS* and *CAUTIONS* related to specific procedures are included with the procedure.

Failure to heed the safety precautions can result in severe or fatal injury.

Service equipment you will need

Refer to the calibration guide for your instrument for a table listing the recommended test equipment needed to troubleshoot and repair the instrument. Although Hewlett-Packard equipment is recommended, any equipment that meets the critical specifications given in the table can be substituted for the recommended model.

Refer to Chapter 13 of this guide for a list of required service and hand tools needed to troubleshoot and repair the instrument.

After an instrument repair

If one or more instrument assemblies have been repaired or replaced, perform the related adjustments and performance verification tests. Refer to Chapter 2 for a table of Adjustments and Tests for Replaced or Repaired Assemblies, for the related adjustments and performance verification tests required for each assembly.

Troubleshooting the RF Section

Note Before starting to troubleshoot the instrument, set it to the signal analysis mode by pressing:

PRESET
MODE
SIGNAL ANALYSIS

Making RF Power-Level Measurements

The RF section block diagram (Figure 8-2), located in Chapter 8 includes measurement points A through E. Table 5-1 lists power level readings for these measurement points. The power level ranges listed in Table 5-1 apply after performing the following steps:

1. Ensure that the CAL OUT amplitude is within specification.
2. Select the appropriate input signal for the desired frequency band:
Band 0 300 MHz at -20 dBm (CAL OUT signal)
Band 1 5 GHz at 0 dBm (*HP 85462A only*)
3. Press **PRESET**, then wait for the instrument to complete the preset routine.
4. Press the following instrument keys:

MODE
SPECTRUM ANALYSIS
FREQUENCY (same as input signal)
SPAN 0 (Hz)
AMPLITUDE 0 (dBm)
ATTEN AUTO MAN (MAN) 10 (dB)
BW
IF BW AUTO MAN (MAN) 3 (MHz)
SWEEP
SWEPTIME AUTO MAN 20 (ms)

Table 5-1. RF Section Block Diagram Measurement Point Power Levels

Measurement Point	Measurement Frequency	Power Level Range *	
		Band 0	Band 1 <i>(HP 85462A only)</i>
A	Same as input frequency	-30 to -33 dBm	—
B	Same as input frequency	—	-14 to -19 dBm
C	321.4 MHz	—	10 to 16 dB below B †
D	3.9214 GHz	8 to 12 dB below A †	—
E	321.4 MHz	5 to 11 dB below D †	1 to 6 dB below C †
<p>* A frequency-selective measuring device, such as a spectrum analyzer, is recommended for making these measurements. Broadband measuring devices, such as power meters, will give erroneous results due to the presence of other, higher-amplitude signals.</p> <p>† The power-level range is relative to the actual measurement taken at the measurement point indicated.</p>			

Connector Pin-Out Information

The RF section receives control voltages from the A5 analog interface board. It also receives power-supply voltages for the attenuator and second converter assemblies from the A5 analog interface board. Table 5-2 and Table 5-3 identify the signals that are supplied to the two RF assemblies from the A5 analog interface board. Table 5-4 identify the signals from the A8 tracking generator control board and the A4A10 tracking generator.

Table 5-2. A5J4 2nd Converter Drive Pin Designation

A5J4 Pin Number	Signal Description
1	2nd Mixer Bias
2	+ 5 A
3	ACOM
4	+ 10 VF
5	PIN_SW
6	KEY
7	N/C
8	N/C
9	N/C
10	N/C

Table 5-3. A5J301 YTF Driver Pin Designation

A5J301 Pin Number	W34 Wire Color	Signal Description
1	Brown	YIG_FLT+
2	Orange	YIG_FLT-
3	Green	- 15 VF
4	Violet	+ 15 VF

Table 5-4. A8J1 Tracking Generator Control Pin Designation

A8J1 Pin Number	Signal Description
1	+ 15 VF
2	ACOM
3	- 15 VF
4	OSC_PWR
5	TUNE
6	ALC_MON
7	KEY
8	PWR_LVL
9	+ 5 VF1
10	ALC_EXT

Preamplifier Section Switch Pin-Out Information

The four switches in the A3 preamplifier section (two switches controlling the preamplifier and two switches controlling the VIEW CAL ON OFF) are controlled from J501 of the A5 analog interface board via W70. Normally, the switch has +12 V_{dc} maintained on its two control lines. To change the switch state, A5 analog interface board sends a pulse of 0 V_{dc} to the switch control line. The presence of the pulse can be determined using an oscilloscope.

Preamplifier Switches

Switches A3A5 (labeled 1 on top of the switch) and A3A6 (labeled 2) are changed by pressing **PREAMP**. This toggles between including the preamplifier in the signal path and bypassing the preamplifier. The following table provides the conditions for toggling A3A5 and A3A6. Refer to the wiring diagram in Chapter 8 for additional information.

Table 5-5. Preamplifier Switch Control Lines

Preamplifier State	A5 J501 Pin 1 and 2	A5 J501 Pin 5 and 6
Preamp ON	+12 V _{dc} —0 V _{dc} Pulse	+12 V _{dc}
Preamp OFF	+12 V _{dc}	+12 V _{dc} —0 V _{dc} Pulse

VIEW CAL ON OFF Switches

Switches A3A3 (labeled 3 on top of the switch) and A3A1 (labeled 4) are changed by pressing **INPUT VIEW CAL ON OFF**. This toggles between sending the 300 MHz calibration signal from the A9 third converter board out the front panel 300 MHz output (the VIEW CAL OFF state) and sending the 300 MHz calibration signal to the A3A4 input attenuator (the VIEW CAL ON state). The following table provides the conditions for toggling A3A3 and A3A1. Refer to the wiring diagram in Chapter 8 for additional information.

Table 5-6. VIEW CAL ON OFF Switch Control Lines

VIEW CAL ON OFF State	A5 J501 Pin 13 and 14	A5 J501 Pin 15 and 16
View Cal On	+12 V _{dc}	+12 V _{dc} —0 V _{dc} Pulse
View Cal Off	+12 V _{dc} —0 V _{dc} Pulse	+12 V _{dc}

To check control of the A3A4 input attenuator

The A5 analog interface board controls the three attenuator steps and blocking capacitor in the A3A4 input attenuator using eight control lines. Refer to the RF section block diagram for your instrument at the end of Chapter 8. Each attenuator step requires two control lines, as shown in Table 5-7. The attenuator is connected to A5J5 on the A5 analog interface board with the ribbon cable, W36.

Use a digital multimeter (DMM) and the values from Table 5-7 to check the control voltages. Measure the voltages at the A5J5 pins on the trace side of the A5 analog interface board.

Table 5-7. Input Attenuator Control Output at A5J5

Attenuator Setting (dB)	10 dB Step		40 dB Step		20 dB Step		Blocking Capacitor	
	Pin 2	Pin 1	Pin 9	Pin 4	Pin 8	Pin 5	Pin 7	Pin 6
0	H	L	H	L	H	L	—	—
10	L	H	H	L	H	L	—	—
20	H	L	H	L	L	H	—	—
30	L	H	H	L	L	H	—	—
40	H	L	L	H	H	L	—	—
50	L	H	L	H	H	L	—	—
60	H	L	L	H	L	H	—	—
70	L	H	L	H	L	H	—	—
Blocking Capacitor In	—	—	—	—	—	—	L	H
Blocking Capacitor Out	—	—	—	—	—	—	H	L

H = -10 V (with the attenuator connected at A5J5)
H = 0 V (A floating output if the attenuator is disconnected.)
L = -15 V (A low at pin 2, 9, or 8 indicates that the attenuator step is in the signal path. A low at pin 7 indicates the blocking capacitor is in the signal path.)

To check the A4A10 tracking generator operation

The following troubleshooting information is aimed at isolating tracking-generator-related faults to either the A4A10 tracking generator or one of the other supporting assemblies, such as A9, A8, or A4A7.

If the output goes unlevelled (TG UNLVL message displayed)

A window comparator on the A8 tracking generator control board is used to monitor the control line ALC_MON (ALC Monitor) from the A4A10 tracking generator. If ALC_MON is greater than +1.0 Vdc or less than -0.10 Vdc TG UNLVL will be displayed, indicating that the output of the tracking generator (TG) is unlevelled. The tracking generator can typically be set for +2.75 dBm output power and remain levelled. In any case, the output should remain levelled for output power settings of +1 dBm or less. It is normal for the tracking generator to be unlevelled at frequencies below 300 kHz.

The ALC_MON line is continuously monitored during a sweep, but the TG UNLVL message will only be displayed at the end of the sweep. For this reason, it is possible that the output could be unlevelled during a portion of a sweep, and although the output returns to a levelled condition by the end of the sweep, TG UNLVL will be displayed at the end of the sweep.

If TG UNLVL is displayed, proceed as follows:

1. Check at which frequencies the output is unlevelled. Set the instrument to zero span and step the center frequency in 50 MHz increments. Note at which frequencies the output is unlevelled.
2. Check at which power levels the output is unlevelled. Connect the RF OUT 50Ω connector to the INPUT 50Ω connector. With the instrument in zero span, set CENTER FREQ to 300 MHz or one of the frequencies noted in step 1, with the instrument in zero span. Press the following keys:

```
PRESET
MODE
SIGNAL ANALYSIS
TRACK GEN
SRC PWR ON OFF (ON)
TRACKING PEAK
```

Wait for the PEAKING message to disappear. Step the SRC POWER setting in 1 dB increments and note at which power levels the output is unlevelled. The output should be unlevelled only when the power level is greater than +1 dBm or if the frequency is outside of the specified range.

3. Check maximum power available from the tracking generator. Connect the RF OUT 50Ω connector to the INPUT 50Ω connector. Press the following keys:

```
PRESET
MODE
SIGNAL ANALYSIS
AMPLITUDE 20 (+dBm)
SCALE LOG LIN (LOG) 5 (dB)
TRACK GEN
SRC PWR ON OFF (ON)
MORE 1 OF 2
ALC INT EXT (EXT)
```

The available power should always be greater than +1 dBm. If the output is unlevelled only at specific frequencies, a power hole will usually be visible at those frequencies.

4. Check the LO OUTPUT power level as follows:
 - a. Set the instrument to zero span at a 0 Hz center frequency.
 - b. Zero and calibrate a power-meter/power-sensor combination. Set the power meter to readout power in dBm. Enter the power sensor's 4 GHz cal factor into the power meter.
 - c. Connect the power sensor to the LO OUTPUT connector on the instrument's rear panel.
 - d. Record the power meter reading. The power level should be greater than +12.5 dBm.
 - e. Increase the instrument's center frequency setting by 100 MHz. The LO OUTPUT frequency will be 3.9214 GHz greater than the center frequency setting.
 - f. Enter the appropriate power sensor cal factor into the power meter.
 - g. Repeat steps d through f until the center frequency setting is 2.9 GHz.
5. If the LO OUTPUT power-level check fails, note the center frequency setting at which the power level was out of tolerance. If the LO OUTPUT power level check passes, proceed to step 7.
6. Place the A3/A4 front end assembly in its service position. Place the A4A10 tracking generator in its service position. Disconnect W41 from A4A10J4 (LO IN). Connect the power sensor to the free end of W41. Repeat the LO OUTPUT power level check above, noting the center frequency settings at which the power level is out of tolerance. The power level for this check should be +16.5 dBm \pm 2 dB.
 - If the power level is within tolerance at W41, but out of tolerance at the LO OUTPUT (rear panel), and the center frequency setting of the out-of-tolerance power levels is close to the frequencies at which the output is unlevelled, suspect A4A10.
 - If the power level at W41 is also out of tolerance, suspect either the A4A7 local oscillator distribution amplifier (LODA), A4A9 EYO, or W41. Refer to the "LO Section Assemblies" in Chapter 8.
7. If the output is unlevelled only at certain power level settings or certain frequencies, monitor A8J1 pin 8 with a DMM. Connect the negative DMM lead to A5TP1. Vary the SRC POWER setting or center frequency setting, as appropriate, and plot the voltage variation versus power level or frequency. A discontinuity in the plot near the frequency or power level at which the output is unlevelled indicates a problem on the A8 tracking generator control board .

To check excessive residual FM

Either the tracking oscillator or the ALC circuitry could be responsible for excessive residual FM. The residual FM should be measured on a spectrum analyzer, such as an HP 8566A/B or HP 8568A/B, using slope detection with the instrument set to zero span. Proceed as follows to troubleshoot residual FM problems:

1. Perform the Residual FM performance test for the instrument (see the HP 8546A/HP 8542E EMI Receiver and HP 85462A/HP 85422E Receiver RF Section User's Guide). If this test passes, the 1st LO input and 600 MHz drive signals should be within tolerance. If the test fails, troubleshoot the LO section.
2. Monitor A8J1 pin 5 (TUNE) with an oscilloscope. Connect the oscilloscope probe ground lead to A5TP1. The voltage at this point should be greater than 500 mV.
 - If the voltage is less than 500 mV, perform the "Frequency Tracking Range Check" in the Tracking Oscillator adjustment procedure, in Chapter 2. If this check fails, perform the tracking oscillator adjustment procedure following the "Frequency Tracking Range Check".
 - If the noise on this tune line is greater than 10 mV, troubleshoot the A8 tracking generator control board .
3. With the instrument set in zero span, monitor the output of the tracking generator with a spectrum analyzer. Check for high-amplitude spurious responses from 100 kHz to at least 3 GHz. If the spurious responses are too high in amplitude, the (broadband) ALC detector may cause the ALC loop to oscillate, generating FM sidebands. If any spurious responses are excessively high, refer to "If harmonic/spurious outputs are too high" in this section.
4. If no spurious responses are present, or if the spurious responses are sufficiently low enough in amplitude to not cause a problem, suspect the tracking oscillator in the A4A10 tracking generator.

If flatness is out of tolerance

The output level flatness of the tracking generator is specified at a 0 dBm output power setting. In general, most flatness problems will be a result of a failure in the A4A10 tracking generator microcircuit. However, the PWR_LVL signal from the A8 tracking generator control board and the 1ST LO IN signal from the A4A7 local oscillator distribution amplifier (LODA) can also contribute to flatness problems.

1. Check the function of the PWR_LVL signal from the A8 tracking generator control board . Set the SRC POWER setting to a level at which the flatness is out of tolerance. Monitor A8J1 pin 8 with a DMM, step the center frequency setting in 100 MHz increments from 100 MHz to 2.9 GHz, and plot the voltage variation versus frequency. A discontinuity in the plot near the frequency at which the flatness is out of tolerance indicates a problem on the A8 tracking generator control board .
2. Check the flatness of the 1ST LO IN signal. Perform the LO OUTPUT amplitude check as described in “If the output goes unlevelled (TG UNLVL message displayed),” in this section.
 - If the check passes, the fault is most likely in the A4A10 tracking generator.
 - If the test fails, note the center frequency setting at which the power level was out of tolerance and compare against the frequencies at which the flatness was out of tolerance. Repeat the check with the power sensor connected to the end of W41 that is nearest the A4A10 tracking generator, noting the center frequency of any out of tolerance power levels. The power level should be $+16.5 \text{ dBm} \pm 2 \text{ dB}$.
 - If the power level is within tolerance at W41, but out of tolerance at the LO OUTPUT connector (rear panel), and the center frequency settings of the out-of-tolerance power levels are close to the frequencies at which the flatness is out of tolerance, suspect the A4A10 tracking generator.
 - If the power level at W41 is also out of tolerance, suspect either the A4A7 local oscillator distribution amplifier (LODA) or the A4A9 EYO. Refer “LO Section Assemblies” in Chapter 8.
3. Check all coax cables, especially semi-rigid cables. A fault in one of these cables can cause a very-high-Q power hole.

If vernier accuracy is out of tolerance

Vernier accuracy is a function of the PWR_LVL drive signal from the A8 tracking generator control board and the ALC circuitry on A4A10. The vernier accuracy is specified at 300 MHz. Since vernier accuracy is tested using a broadband power sensor, abnormally high spurious responses could cause the measured vernier accuracy to fail when in fact the accuracy of the 300 MHz signal alone is within specification.

1. Check the PWR_LVL drive signal from A8 tracking generator control board . Monitor A8J1 pin 8 with a DMM. Change the SRC POWER setting in 1 dB steps and note the voltage at each power level setting. The voltage should change by the same amount for each 1 dB step. If the voltage does not change by the same amount for each 1 dB step, the fault lies on the A8 tracking generator control board .
2. Check for abnormally high spurious outputs. Connect the RF OUT 50Ω connector to the input of a spectrum analyzer. Set the spectrum analyzer to sweep from 9 kHz to 2.9 GHz, with a sweeptime of 100 msec or less. Set the instrument to sweep from 9 kHz to 2.9 GHz with a 50 second sweeptime. Press **(SINGLE)** on the instrument and observe any responses on the spectrum analyzer, ignoring the desired output signal. If any spurious responses are greater than -20 dBc, the vernier accuracy measurement may fail. Refer to “If harmonic/spurious outputs are too high” in this section.
3. Check for excessive LO feedthrough. Use the LO Feedthrough performance test in the HP 8546A/HP 8542E EMI Receiver and HP 85462A/HP 85422E Receiver RF Section User’s Guide, but check over a center frequency range of 9 kHz to 100 MHz. The LO feedthrough will be 3.9214 GHz greater than the center frequency setting.

If harmonic/spurious outputs are too high

Harmonic and spurious outputs may be generated by A4A10 itself or may be present on either the 600 MHz drive or 1st LO drive signal. There is a direct relationship between spurious signals on the 1st LO and spurious signals on the tracking generator output. There is a five-to-one relationship between spurious signals on the 600 MHz drive and the spurious signals on the tracking generator output. For example, if the 600 MHz signal moves 1 MHz, the tracking generator output signal will move 5 MHz. This is due to the multiplication in the pentupler.

1. If the Harmonic Spurious Responses performance test failed, connect another spectrum analyzer, such as an HP 8566A/B, to the instrument's LO OUTPUT connector on the rear panel. Set the instrument to each frequency as indicated in the performance test, with the SPAN set to 0 Hz. The 1st LO frequency will be 3.9214 GHz greater than the center frequency setting. Use the HP 8566A/B to measure the level of the second and third harmonics of the 1st LO signal.

Note The 1st LO typically has a higher harmonic content than the tracking generator output. For the purposes of this check, it is the variation in harmonic content versus frequency which is important.

If the variation of the harmonic level of the 1st LO versus frequency tracks the harmonic level variation of the tracking generator output, repeat step 1 while measuring the 1st LO signal at the end of W41 nearest A4A10. If there is little variation in the 1st LO harmonic level between the LO OUTPUT connector and W41, and the relative variation in harmonic level tracks with the tracking generator output harmonic level, suspect either the A4A7 local oscillator distribution amplifier (LODA) or the A4A9 EYO.

If the harmonic level variation of the 1st LO versus frequency does not track the harmonic level variation of the tracking generator output, suspect A4A10.

2. If sidebands are present at the same frequency offset at every output frequency, use another spectrum analyzer to check the spectral purity of the 1st LO and the 600 MHz drive signals. When checking the 1st LO, the instrument must be set to zero span. The 1st LO frequency will be 3.9214 GHz greater than the center frequency setting. A 1 MHz sideband on the 1st LO will appear as a 1 MHz sideband on the output signal.

To verify that the 600 MHz drive or 1st LO signal is responsible for the sidebands, substitute a clean signal for the 600 MHz drive or 1st LO signal. If the sidebands on the output disappear when using the clean signal, the substituted signal was responsible for the sidebands.

Note The 600 MHz drive signal should be $-8 \text{ dBm} \pm 3.5 \text{ dB}$. The 1st LO signal should be $+16 \text{ dBm} \pm 2 \text{ dB}$.

If power sweep is not functioning properly

Power sweep is accomplished by summing an attenuated SWEEP RAMP signal with the PWR_LVL signal. The SWEEP_RAMP is attenuated using the 12-bit power sweep DAC. The power sweep DAC output is then fed to a summing amplifier where it is summed with the power level DAC output to yield the PWR_LVL signal.

1. If some power sweep ranges do not appear to work properly, the fault is probably the power sweep DAC on the A8 tracking generator control board . Check the operation of the power sweep DAC as follows:

- a. Monitor A8U9 pin 7 with an oscilloscope. Connect the ground lead of the oscilloscope to A8TP1. Trigger the oscilloscope using the spectrum analyzer's HIGH SWEEP IN/OUT signal on the rear panel.

- b. Set the instrument by pressing the following keys:

```
FREQUENCY
CENTER FREQ 300 (MHz)
SPAN 0 (Hz)
BW 300 (kHz)
TRACK GEN
SRC POWER ON OFF (ON) -10 (dBm)
PWR SWP ON OFF (ON) 10 (dB)
```

- c. The amplitude of the positive-going ramp displayed on the oscilloscope should be approximately 7.8V.
- d. Change the power sweep setting to any value between 1 and 11 dB. The ramp amplitude displayed on the oscilloscope should be 780 mV per dB of the power sweep setting.

Note Although the source power sweep may be set to a 12.75 dB sweep width, the power sweep function is only warranted to have a 11 dB sweep width.

2. Perform the Vernier Accuracy performance test. See the Installation, Verification, and Operation Manual. If this test fails, refer to “If vernier accuracy is out of tolerance” located earlier in this section.

If there is no output power

The A4A10 tracking generator requires power supplies, a 1st LO signal, and a 600 MHz drive signal in order to provide power output.

1. Check the power supplies on A8J1 and A4A10J1.
2. Verify that the voltage at A8J1 pin 4 is greater than +14 Vdc when the tracking generator is on. If the voltage is not greater than +14 Vdc, troubleshoot A8.
3. Check that ALC_EXT, measured at A8J1 pin 10, is at a TTL low when the tracking generator is set to ALC INT and at a TTL high when the tracking generator is set to ALC EXT.
4. Check that the 600 MHz drive signal is $-8 \text{ dBm} \pm 3.5 \text{ dB}$. If the signal is outside of this range, troubleshoot the A9 third converter board.
5. Check that the 1st LO input signal is $+16 \text{ dBm} \pm 2 \text{ dB}$. Perform the LO OUTPUT amplitude check described in “If the output goes unlevelled (TG UNLVLD message displayed)” earlier in this section, measuring instead at the end of W41 nearest A4A10.
6. Check the tracking adjustment controls. Monitor A8J1 pin 5 with a DMM. On the instrument, use the step keys and knob to change the MAN TRACK ADJUST value from 0 to 4095. The voltage measured should increase from 0 V to +12 V.

CAUTION The following step requires adjustment of A4A10C3. The lifetime of A4A10C3 is rated for less than 10 cycles. Do not adjust A4A10C3 unless it is absolutely necessary.

7. If all of the checks above are acceptable, the tracking oscillator might not be functioning. Setup the instrument as indicated in the Tracking Oscillator adjustment procedure in Chapter 2, using a spectrum analyzer, such as an HP 8566A/B, in place of the frequency counter. Try to adjust A4A10C3 until a signal is displayed on the HP 8566A/B. If adjusting A4A10C3 does not result in the tracking generator beginning to function, the A4A10 tracking generator is suspect.

To check the A4A7 local oscillator distribution amplifier (LODA) operation

The following troubleshooting information is aimed at isolating 1st LO amplitude-related faults to either the A4A7 local oscillator distribution amplifier (LODA), A8 tracking generator control board , or the A4A9 EYO.

1. Place the A3/A4 Front End assembly in its service position. Place the A8 tracking generator control board on an extender board. Remove W33, the semi-rigid coax cable between A4A7 and A4A6. Do not reconnect W20 to A23AT2.
2. Connect a DMM's negative lead to A8TP2, AGND. Connect the positive lead to A8TP6 (PIN).
3. Set the instrument by pressing the following keys:

```
FREQUENCY
CENTER FREQ 300 (MHz)
SPAN 20 (MHz)
TRIG SWEEP CONT SGL (SGL)
```

4. Measure the LO power at A4A7J2 and the free end of W20. Refer to the LO section block diagram (Figure 8-3) for acceptable power level ranges.
5. If both LO power levels are lower than acceptable, the voltage on A8TP6 (PIN) should be above 0 V. If both LO power levels are higher than acceptable, this voltage should be more negative than -10 V.
6. If the voltage measured in step 5 is as described, the LODA drive circuitry is acceptable. Check the A4A9 EYO output power level. Refer to the RF section block diagram (Figure 8-2) for acceptable power level range.
7. If the voltage measured in step 5 is not as described, either the LODA drive circuitry or the LODA itself is malfunctioning. Check that the operational amplifier's output is consistent with its inputs.
8. Set the instrument (LINE) switch to off, disconnect W38 from A8J2, then set the instrument (LINE) switch to on.
9. Connect a jumper between A8J2 and A8TP2. This connects ground A2, a floating ground, to AGND. Connect another jumper between A8TP4, LOS (LO sense) and +10VR.
10. The voltage measured on the DMM should be greater than +14 Vdc.
11. Move the jumper from +10VR to -10VR. The voltage measured should be more negative than -13 Vdc.
12. If the voltages do not meet the limits described in steps 10 and 11, troubleshoot the A8 tracking generator control board .
13. Connect the positive DMM lead to A8J2 pin 1.
14. The measured voltage should be approximately +5 Vdc. If the voltage is not +5 Vdc, troubleshoot the A8 tracking generator control board .
15. Connect the positive DMM lead to A8TP5, GB (gate bias). The voltage should measure within 5% of the GATE voltage listed on the RF section label.
16. If the voltage is not within this range, rotate A8R29 (GATE) through its range while monitoring the DMM.
17. If the voltage varies between 0 Vdc and -2 Vdc, adjust A8R29 (GATE) for a DMM reading within 5% of the GATE voltage listed on the RF section label. If the voltage does not vary outside the range of 0 Vdc and -2 Vdc, troubleshoot the A8 assembly.

18. Set the instrument **LINE** switch to off, reconnect W38 to A8J2, then set the instrument **LINE** switch to on.
19. If the DMM reading changes more than 50 mV, the A4A7 LODA is probably defective.

Replacing Major Assemblies

Introduction

The procedures in this chapter describe the removal and replacement of major assemblies.

The words “right” and “left” are used throughout these procedures to indicate the sides of the instrument as normally viewed from the front of the instrument. Numbers in parentheses, for example (1), indicate numerical callouts on the figures.

Before You Start

There are four things you should do before starting to troubleshoot an instrument failure:

- Check that you are familiar with the safety symbols marked on the instrument, and read the general safety instructions and the symbol definitions given in the front of the Service Guide.
- The instrument contains static sensitive components. Read the section entitled “Protection From Electrostatic Discharge” in Chapter 1.
- Become familiar with the organization of the troubleshooting information in this service guide.
- Read the rest of this section.

WARNING This instrument contains potentially hazardous voltages.

Familiarize yourself with the safety symbols marked on the instrument and read the symbol definitions given in the front of this guide *before* you begin the procedures in this chapter. Refer to “General Safety Considerations” at the front of this manual for general *WARNINGS* and *CAUTIONS* related to safety considerations. *WARNINGS* and *CAUTIONS* related to specific procedures are included with the procedure.

Failure to heed the safety precautions can result in severe or fatal injury.

Service equipment you will need

Refer to the Chapter 13 for a list of the recommended test equipment needed to troubleshoot and repair the instrument. Although Hewlett-Packard equipment is recommended, any equipment that meets the critical specifications given in the table can be substituted for the recommended model.

Chapter 13 also includes a list of required service and hand tools needed to troubleshoot and repair the instrument.

After a repair

If one or more assemblies have been repaired or replaced, perform the related adjustments and performance verification tests. Refer to Chapter 2 for a table of Adjustments and Tests for Replaced or Repaired Assemblies, for the related adjustments and performance verification tests required for each assembly.

Removal and Replacement Procedures in this Chapter

1. Instrument Cover
2. RF Cover
3. A1 Front Panel Assembly
4. A1A1 Keyboard
5. A26 Rear Panel
6. A16 Power Supply Assembly
7. B1 Fan
8. A24 Processor Board Assembly
9. A24 Processor Board Assembly ROMs
10. A25 Graphics Processor Board
11. BT1 Battery
12. A22 HP-IB/RS-232 Board
13. A2 Display
14. A17 Graphic Signal Processor Assembly
15. A15 Motherboard/IF Section Assembly
16. A21 Disk Drive Controller Board
17. A19 Disk Drive
18. A20 10 MHz Precision Reference
19. A23 Counter Lock Assembly
20. A5 Analog Interface Board
21. A3 Preamplifier Section/A4 RF Section Assembly

1. Instrument Cover

Removal

1. Disconnect the instrument from ac power.

CAUTION To prevent damage to the front-frame, use a soft cloth or towel between the work surface and the front-frame.

2. Place the instrument on the work surface with its front panel down.
3. Remove the four rear-foot screws using a Torx screwdriver.
4. Pull the cover off towards the rear.

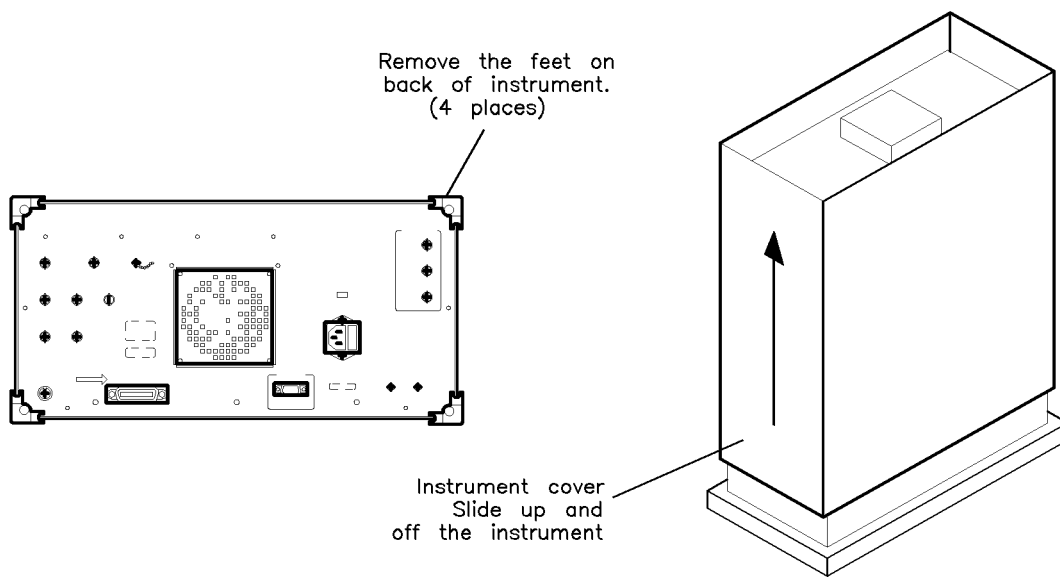

Figure 6-1. Instrument Cover Replacement

1. Instrument Cover

Replacement

1. Disconnect the instrument from ac power.

CAUTION To prevent damage when replacing the instrument cover, remember the following:

- Place a soft cloth or towel between the work surface and the front-frame.
- Ensure that cables do not bind between the instrument cover and its internal assemblies.

-
2. Place the instrument on the work surface with its front panel down.
 3. Replace the instrument cover assembly by matching the seam on the cover with the bottom of the instrument.
 4. Fit the leading edge of the cover completely into the slot on the back of the front-frame assembly. The cover should fit snugly against the EMI gasket in the slot.
 5. Replace and tighten the four rear-feet screws using a Torx screwdriver.

2. RF Cover

Removal

1. Remove the instrument cover. Refer to the removal procedures for “1. Instrument Cover”.
2. Remove the 4 screws that attach the rear panel to the RF cover (1).
3. Remove the 7 screws that attach the RF cover to the right side frame (2).
4. Remove the 3 screws that attach the RF cover to the front of the RF section frame (3).
5. Remove the 5 screws that attach the RF cover to the left side of the RF section frame (4).
6. Remove the 2 screws that attach the RF cover to the bracket at the right side of the power supply (5).
7. Remove the 4 screws that attach the RF cover to the top of the power supply (6).
8. Remove the RF cover from the instrument.

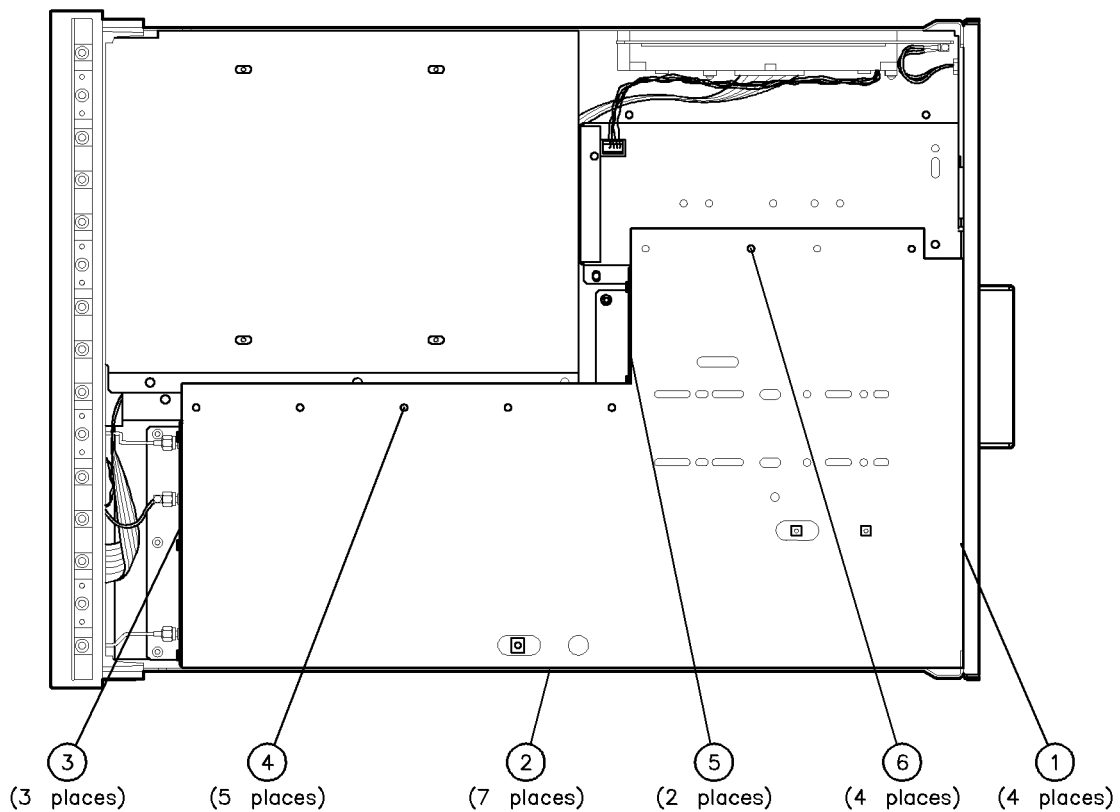

rfcvr

Figure 6-2. RF Cover Replacement

2. RF Cover

Replacement

CAUTION When placing the RF cover in the instrument, make sure that the grounding gasket is not bent by the edges of the instrument. The front edges of the RF cover are areas to watch closely.

1. Place the RF cover into its location in the instrument.
2. Replace the 4 screws that attach the RF cover to the top of the power supply **(6)**.
3. Replace the 2 screws that attach the RF cover to the bracket at the right side of the power supply **(5)**.
4. Replace the 5 screws that attach the RF cover to the left side of the RF section frame **(4)**.
5. Replace the 3 screws that attach the RF cover to the front of the RF section frame **(3)**.
6. Replace the 7 screws that attach the RF cover to the right side frame **(2)**.
7. Replace the 4 screws that attach the rear panel to the RF cover **(1)**.
8. Replace the instrument cover. Refer to the replacement procedures for “1. Instrument Cover”.

3. A1 Front Panel Assembly

Removal

1. Remove the instrument cover. Refer to the removal procedures for “1. Instrument Cover”.
2. Remove the counter lock assembly. Refer to the removal procedures for “19. A23 Counter Lock Assembly”.
3. Remove the OCXO assembly. Refer to the removal procedures for “18. A20 10 MHz Precision Reference”.
4. Remove the speaker bracket **(1)**.
5. Remove the RF cover. Refer to the removal procedures for “2. RF Cover”.
6. Remove the cable ties from the cable bundle above the IF section.
7. Remove the RF/IF bracket **(2)**.
8. Disconnect the Volume knob wires (Blue/Purple/Gray) from the Demodulator/QPD board **(3)**.
9. Disconnect the Earphone jack wires (Black/Red/Yellow) from the Demodulator/QPD board **(4)**.
10. Disconnect the ALC connector wires (Red/White) from the front side of the tracking generator **(5)**. Note how the excess wire is routed toward the rear on the left side of the A4 RF section.
11. Route the Volume knob wires, Earphone jack wires, and the ALC connector wires from the top of the instrument through to the bottom of the instrument and back to the front panel.
12. Disconnect the front-panel line switch wire harness (blue/red/orange) **(6)** from the processor board.
13. Disconnect the ribbon cable **(7)** between the front panel and the processor board from the processor board.
14. Disconnect the 300 MHz Output cable between the front panel and the internal bulkhead from the internal bulkhead **(8)**.
15. Disconnect the Tracking Generator Output cable between the front panel and the internal bulkhead from the internal bulkhead **(9)**.
16. Disconnect the RF Input cable between the front panel and the internal bulkhead from the internal bulkhead **(10)**.
17. Remove the 4 torx screws on each side of the front-panel that attach the front panel to the side frame of the instrument **(11)**.
18. Remove the 4 torx screws on the bottom of the instrument that secure the front panel to the instrument **(12)**.
19. Remove the 5 torx screws on the bottom of the instrument that secure the front panel to the instrument **(13)**.
20. Pull the front panel from the front of the instrument.

3. A1 Front Panel Assembly

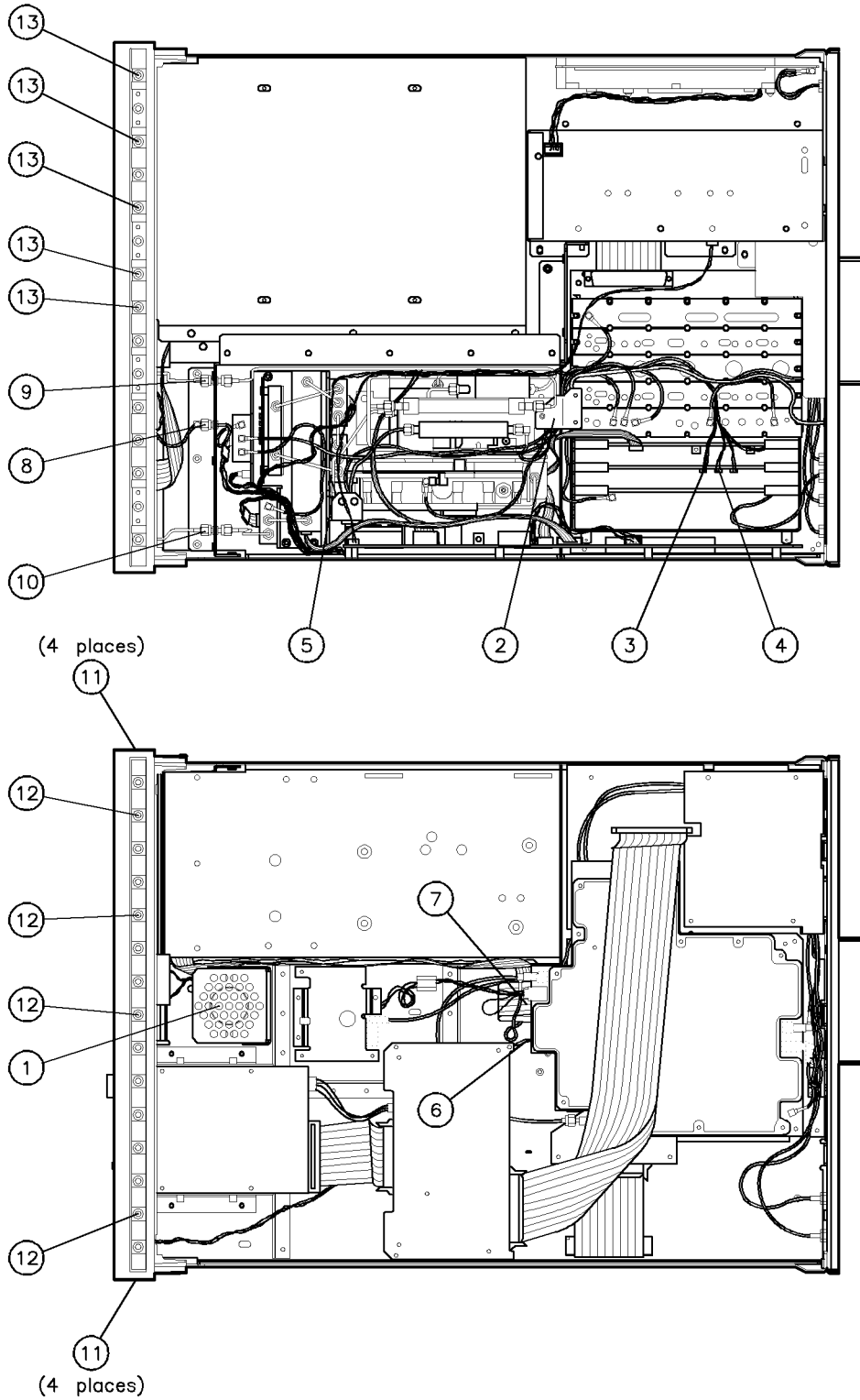

Figure 6-3. A1 Front Panel Assembly Replacement

o1front

Replacement

1. Replace the front panel into the front of the instrument.
2. Replace the 5 torx screws on the bottom of the instrument that secure the front panel to the instrument **(13)**.
3. Replace the 4 torx screws on the bottom of the instrument that secure the front panel to the instrument **(12)**.
4. Replace the 4 torx screws on each side of the front-panel that attach the front panel to the side frame of the instrument **(11)**.
5. Connect the 300 MHz Output cable between the front panel and the internal bulkhead to the internal bulkhead **(10)**.
6. Connect the Tracking Generator Output cable between the front panel and the internal bulkhead to the internal bulkhead **(9)**.
7. Connect the RF Input cable between the front panel and the internal bulkhead to the internal bulkhead **(8)**.
8. Connect the ribbon cable **(7)** between the front panel and the processor board to the processor board.
9. Connect the front-panel line switch wire harness **(6)** (blue/red/orange) to the processor board.
10. Route the Volume knob wires, Earphone jack wires, and the ALC connector wires from the bottom of the instrument through to the top of the instrument.
11. Connect the ALC connector wires **(5)** (Red/White) to the front side of the tracking generator. Route the wires so that the excess wire is pulled toward the rear at the left side of the A4 RF section.
12. Connect the Earphone jack wire harness **(4)** (Black/Red/Yellow) to the Demodulator/QPD board.
13. Connect the Volume knob wire harness **(3)** (Blue/Purple/Gray) to the Demodulator/QPD board.
14. Replace the RF/IF bracket **(2)**.
15. Replace the cable ties to bundle the wires and cables above the IF section.
16. Replace the RF cover. Refer to the replacement procedures for “2. RF Cover”.
17. Replace the speaker bracket **(1)**.
18. Replace the OCXO assembly. Refer to the replacement procedures for “18. A20 10 MHz Precision Reference”.
19. Replace the counter lock assembly. Refer to the replacement procedures for “19. A23 Counter Lock Assembly”.
20. Replace the instrument cover. Refer to the replacement procedures for “1. Instrument Cover”.

4. A1A1 Keyboard

Removal

1. Remove the instrument cover. Refer to the removal procedures for “1. Instrument Cover”.
2. Remove the counter lock assembly. Refer to the removal procedures for “19. A23 Counter Lock Assembly”.
3. Remove the OCXO assembly. Refer to the removal procedures for “18. A20 10 MHz Precision Reference”.
4. Remove the RF cover. Refer to the removal procedures for “2. RF Cover”.
5. Remove the front-panel assembly. Refer to the removal procedures for “3. A1 Front Panel Assembly”.
6. Disconnect the RPG wire harness from the keyboard (1).
7. Disconnect the probe power wire harness from the keyboard (2).
8. Remove the 12 screws that attach the keyboard to the front panel (3).
9. Remove the keyboard from the front panel.
10. Remove the keypad from the front panel.

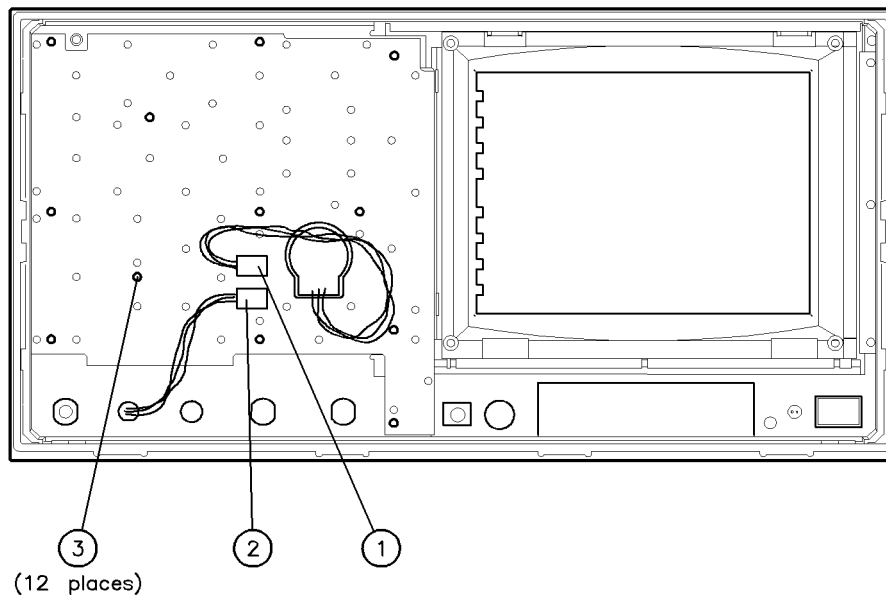

Figure 6-4. A1A1 Keyboard Replacement

a1a1key

Replacement

1. Lay the keypad into the front panel.
2. Place the keyboard over the top of the keypad.
3. Gently shake the front panel back and forth a few times to make sure that the keys fall into their openings on the front of the front panel. Check to make sure all of the keys are in place in the front panel.
4. Replace the 12 screws that attach the keyboard to the front panel **(3)**.
5. Connect the probe power wire harness to the keyboard **(2)**.
6. Connect the RPG wire harness from the keyboard **(1)**.
7. Replace the front-panel assembly. Refer to the replacement procedures for “3. A1 Front Panel Assembly”.
8. Replace the RF cover. Refer to the replacement procedures for “2. RF Cover”.
9. Replace the OCXO assembly. Refer to the replacement procedures for “18. A20 10 MHz Precision Reference”.
10. Replace the counter lock assembly. Refer to the replacement procedures for “19. A23 Counter Lock Assembly”.
11. Replace the instrument cover. Refer to the replacement procedures for “1. Instrument Cover”.

5. A26 Rear Panel

Removal

1. Remove the instrument cover. Refer to the removal procedures for “1. Instrument Cover”.
2. Remove the RF cover. Refer to the removal procedures for “2. RF Cover”.
3. Remove the LO OUTPUT cable from the rear panel by removing its nut (1).

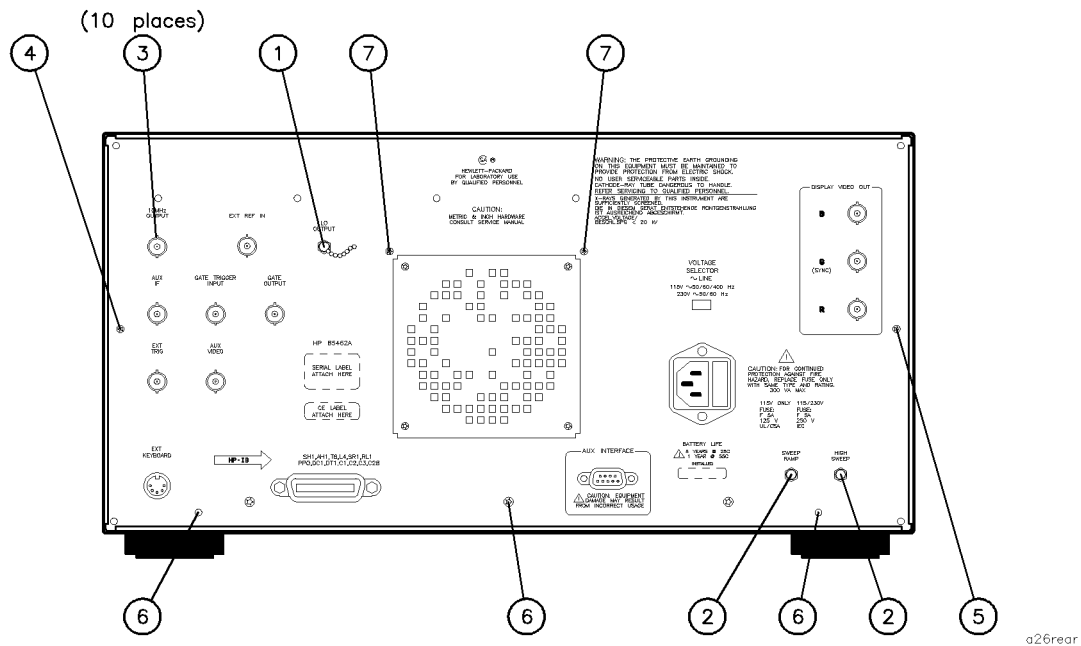

Figure 6-5. A26 Rear Panel Replacement

4. Remove nuts (2) that attach the SWEEP RAMP and the HIGH SWEEP cables to the rear panel.
5. Remove the 10 nuts (3) that attach the 10 BNC cables to the rear panel.
6. Remove the 7 screws that connect rear panel to instrument.
 - 1 screw attached to the right-side frame (4)
 - 1 screw attached to the left-side frame (5)
 - 3 screws attached to the instrument deck (6)
 - 2 screws attached to the power supply baffle (7)
7. Pull the rear panel away from the instrument and remove the BNC cables from the rear panel.
8. Disconnect fan wire harness from the motherboard.
9. Disconnect the line module cable harness from the power supply.

Replacement

1. Connect the line module cable harness to the power supply.
2. Connect the fan wire harness to the motherboard.
3. Replace the 10 BNC cables into the rear panel and secure each cable in place with a nuts **(3)**. The following table lists the rear-panel label where each cable must be returned.

Table 6-1. Rear-Panel BNC Connectors

Rear-Panel Label	Tape Color	Tape Number
10MHz REF OUTPUT	purple	7
EXT REF IN	red	2
AUX IF	black	0
GATE TRIGGER INPUT	orange	3
GATE OUTPUT	yellow	4
EXT TRIGGER	gray	8
AUX VIDEO	blue	6
B	See the Graphic Signal Processor board for labeling	
G	See the Graphic Signal Processor board for labeling	
R	See the Graphic Signal Processor board for labeling	

4. Replace the SWEEP RAMP and the HIGH SWEEP cables to the rear panel and secure them in place with a nut **(2)**.
5. Replace the LO OUTPUT cable to the rear panel and secure it in place with its nut **(1)**.
6. Position the rear panel to the back of the instrument and replace the 7 screws that connect rear panel to instrument.
 - 1 screw attached to the right-side frame **(4)**
 - 1 screw attached to the left-side frame **(5)**
 - 3 screws attached to the instrument deck **(6)**
 - 2 screws attached to the power supply baffle **(7)**
7. Replace the RF cover. Refer to the replacement procedures for “2. RF Cover”.
8. Replace the instrument cover. Refer to the replacement procedures for “1. Instrument Cover”.

6. A16 Power Supply Assembly

Removal

1. Remove the instrument cover. Refer to the removal procedures for “1. Instrument Cover”.
2. Remove the RF cover. Refer to the removal procedures for “2. RF Cover”.
3. Remove the rear panel. Refer to the removal procedures for “5. A26 Rear Panel”.
4. Remove the power supply baffle by removing the remaining screw attaching it to the instrument **(1)**.

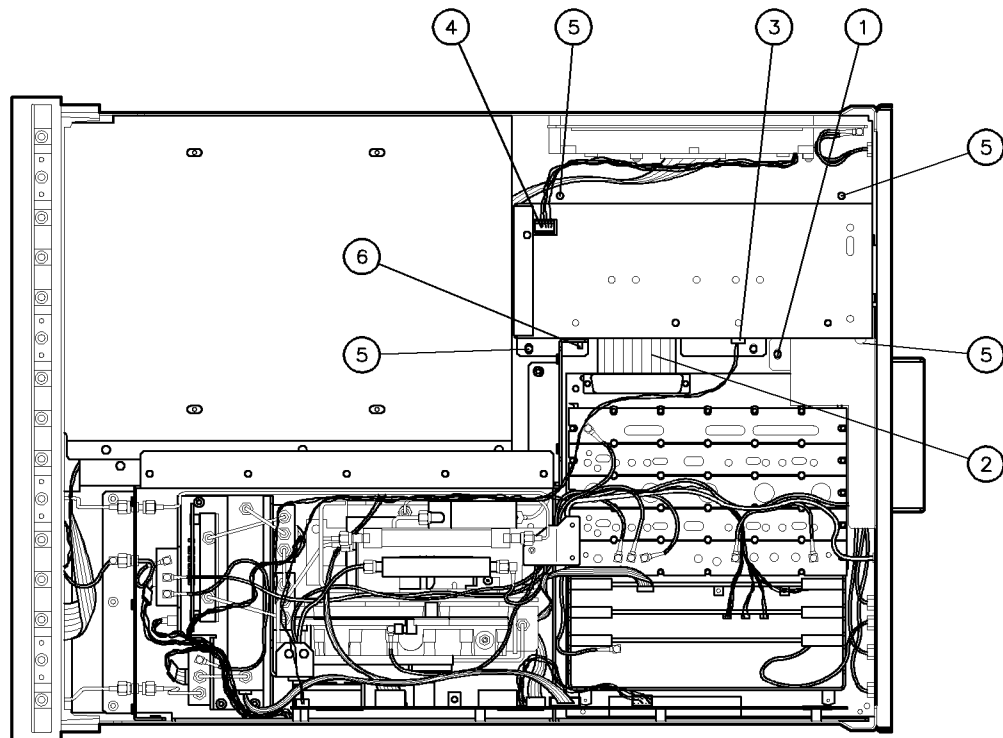

016pwr

Figure 6-6. A16 Power Supply Assembly Replacement

5. Disconnect the ribbon cable from the right side of the power supply **(2)**.
6. Disconnect the 2-wire cable harness (brown/yellow) from the right side of power supply **(3)**.
7. Disconnect the 8-wire cable harness from the top of the power supply **(4)**.
8. Remove the 4 screws that secure the power supply to the instrument **(5)**.
9. Use a 3-mm wrench to loosen the 3 nuts near the front right side of power supply **(6)**.
10. Slide the power supply back and out of the instrument.

Replacement

1. Put the power supply back in the instrument and slide it forward to its position.
2. Make sure the 3 power supply studs at the front right side of power supply **(6)** are in the slots in the aluminum frame. Make sure the nuts and washers are on right side aluminum frame.
3. Replace the 4 screws that secure power supply to the instrument **(5)**.
4. Use a 3-mm wrench to tighten the 3 nuts near the front right side of power supply **(6)**.
5. Connect the 8-wire cable harness to the top of the power supply **(4)**.
6. Connect the 2-wire cable harness (brown/yellow) to the right side of the power supply **(3)**.
7. Connect the ribbon cable to the right side of the power supply **(2)**.
8. Replace the power supply baffle by replacing the screw that attaches to the instrument **(1)**.
9. Replace the rear panel. Refer to the replacement procedures for “5. A26 Rear Panel”.
10. Replace the RF cover. Refer to the replacement procedures for “2. RF Cover”.
11. Replace the instrument cover. Refer to the replacement procedures for “1. Instrument Cover”.

7. B1 Fan

Removal

1. Remove the instrument cover. Refer to the removal procedures for “1. Instrument Cover”.
2. Remove the RF cover. Refer to the removal procedures for “2. RF Cover”.
3. Remove the 3 screws that attach the power supply baffle to the instrument (1).

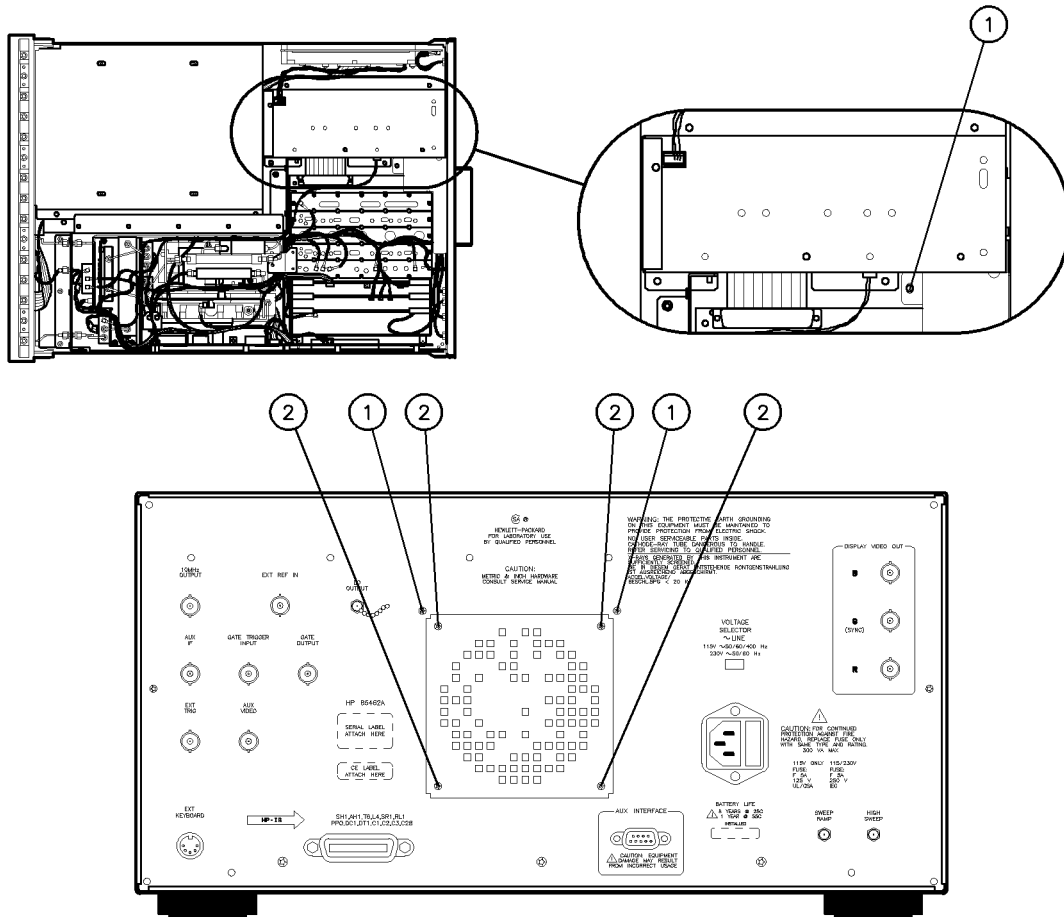

b1fan

Figure 6-7. B1 Fan Replacement

4. Remove the 4 screws that attach the fan housing to the rear panel (2).
5. Disconnect fan wire harness from the motherboard.

Replacement

1. Connect fan wire harness to the motherboard.
2. Replace the 4 screws that attach the fan housing to the rear panel **(2)**.
3. Replace the 3 screws that attach the power supply baffle to the instrument **(1)**.
4. Replace the RF cover. Refer to the replacement procedures for “2. RF Cover”.
5. Replace the instrument cover. Refer to the replacement procedures for “1. Instrument Cover”.

8. A24 Processor Board Assembly

Removal

1. Remove the instrument cover. Refer to the removal procedures for “1. Instrument Cover”.
2. Remove the counter lock assembly. Refer to the removal procedures for “19. A23 Counter Lock Assembly”.
3. Remove the HP-IB/RS-232 board. Refer to the removal procedures for “12. A22 HP-IB/RS-232 Board”.
4. Remove the graphics processor board. Refer to the removal procedures for “10. A25 Graphics Processor Board”.
5. Disconnect the ribbon cable from the front edge of the processor board (1).

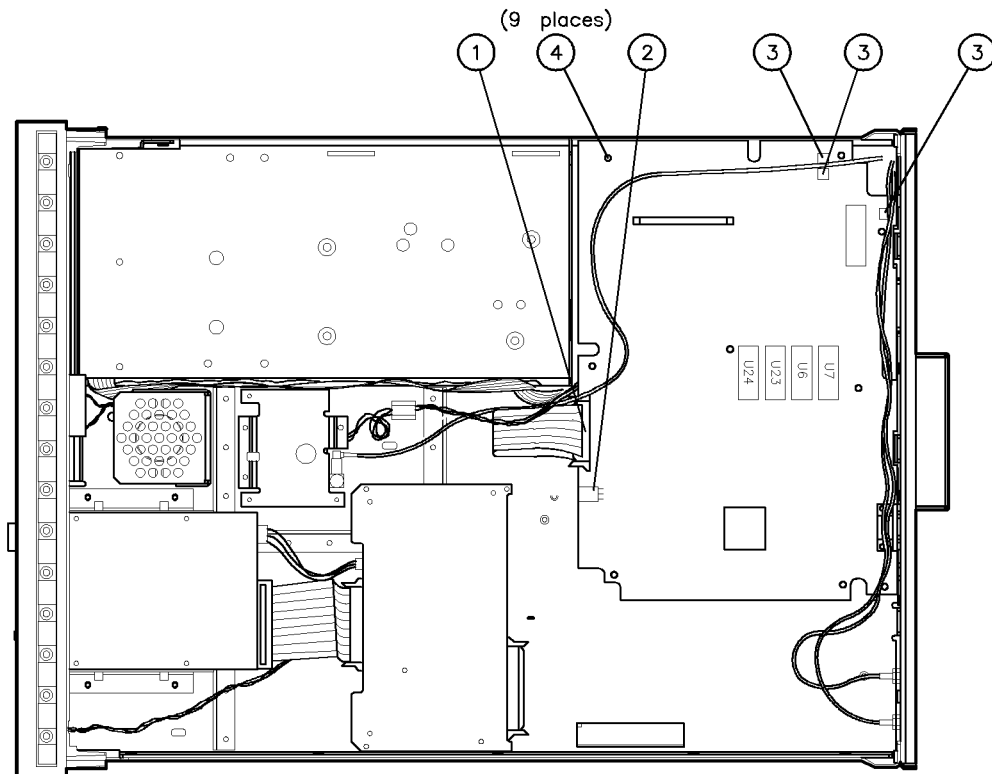

a24proc

Figure 6-8. A24 Processor Board Assembly Replacement

6. Disconnect the switch cable (blue/red/orange) from front edge of the processor board (2).
7. Disconnect the 3 cables from below HP-IB/RS-232 board (3).
8. Remove the 9 screws that attach the processor board to the instrument (4).

Replacement

1. Replace the 9 screws that attach the processor board to the instrument (4).
2. Connect the 3 cables to the processor board connectors located below HP- IB/RS-232 board (3).
3. Connect the switch cable to front edge of the processor board (2).
4. Connect the ribbon cable to the front edge of the processor board (1).
5. Replace the graphics processor board. Refer to the replacement procedures for “10. A25 Graphics Processor Board”.
6. Replace the HP-IB/RS-232 board. Refer to the replacement procedures for “12. A22 HP-IB/RS-232 Board”.
7. Replace the counter lock assembly. Refer to the replacement procedures for “19. A23 Counter Lock Assembly”.
8. Replace the instrument cover. Refer to the replacement procedures for “1. Instrument Cover”.

9. A24 Processor Board Assembly ROMs

Removal

1. Remove the instrument cover. Refer to the removal procedures for “1. Instrument Cover”.
2. Remove the counter lock assembly. Refer to the removal procedures for “19. A23 Counter Lock Assembly”.
3. Remove the HP-IB/RS-232 board. Refer to the removal procedures for “12. A22 HP-IB/RS-232 Board”.
4. Remove the graphics processor board. Refer to the removal procedures for “10. A25 Graphics Processor Board”.

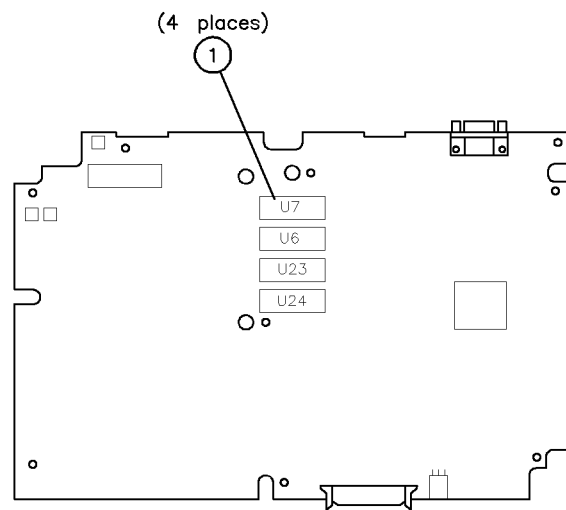

procroms

Figure 6-9. A24 Processor Board Assembly ROMs Replacement

5. Remove the 4 ROM chips from the processor board (1).

Replacement

1. Install the 4 ROM chips in their processor board sockets (1).
2. Replace the graphics processor board. Refer to the replacement procedures for “10. A25 Graphics Processor Board”.
3. Replace the HP-IB/RS-232 board. Refer to the replacement procedures for “12. A22 HP-IB/RS-232 Board”.
4. Replace the instrument cover. Refer to the replacement procedures for “1. Instrument Cover”.

10. A25 Graphics Processor Board

Removal

1. Remove the instrument cover. Refer to the removal procedures for “1. Instrument Cover”.
2. Remove the counter lock assembly. Refer to the removal procedures for “19. A23 Counter Lock Assembly”.

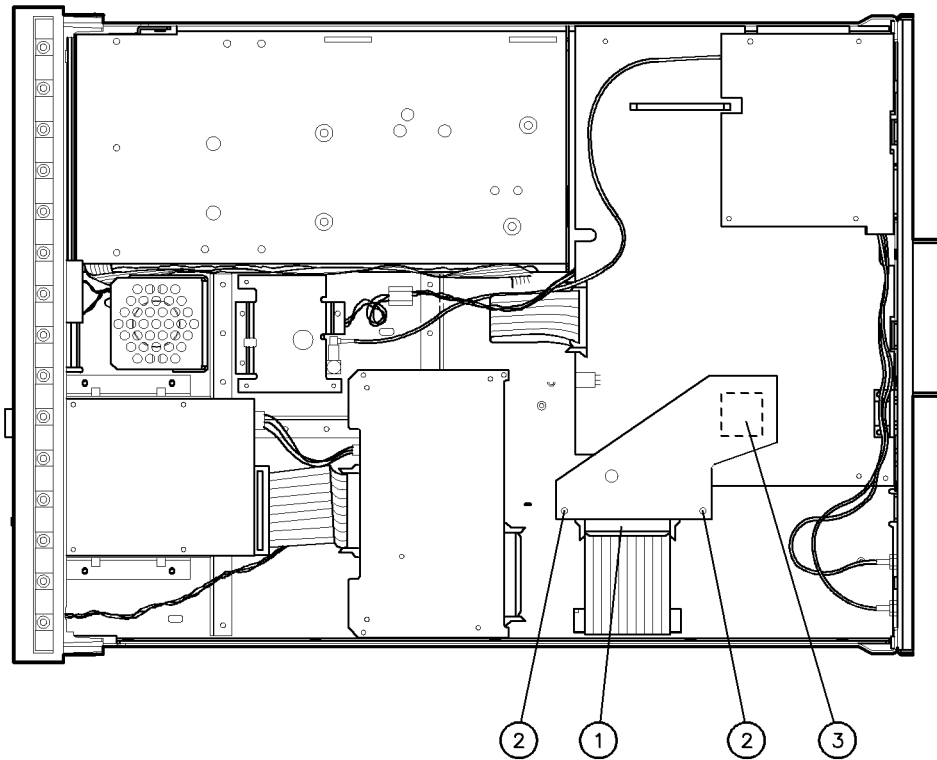

a25graph

Figure 6-10. A25 Graphics Processor Board Replacement

3. Disconnect the ribbon cable from the graphics processor board (1).
4. Remove the 2 screws that attach the graphics processor board to the instrument (2).
5. Pull the graphics processor board straight up, disconnecting it from its processor board socket (3).

10. A25 Graphics Processor Board

Replacement

CAUTION When installing the graphics processor board on the processor board, be careful so that the connector pins are not bent when inserting into the processor board socket.

1. Carefully press the graphics processor board into its processor board socket **(3)**.
2. Replace the 2 screws that attach the graphics processor board to the instrument **(2)**.
3. Connect the ribbon cable to the graphics processor board **(1)**.
4. Replace the counter lock assembly. Refer to the replacement procedures for “19. A23 Counter Lock Assembly”.
5. Replace the instrument cover. Refer to the replacement procedures for “1. Instrument Cover”.

11. BT1 Battery

Removal

1. Remove the instrument cover. Refer to the removal procedures for “1. Instrument Cover”.
2. Remove the counter lock assembly. Refer to the removal procedures for “19. A23 Counter Lock Assembly”.
3. Remove the HP-IB/RS-232 board. Refer to the removal procedures for “12. A22 HP-IB/RS-232 Board”.
4. Remove the graphics processor board. Refer to the removal procedures for “10. A25 Graphics Processor Board”.
5. Remove the processor board. Refer to the removal procedures for “8. A24 Processor Board Assembly”.
6. Unsolder the battery to remove it from the processor board (1).

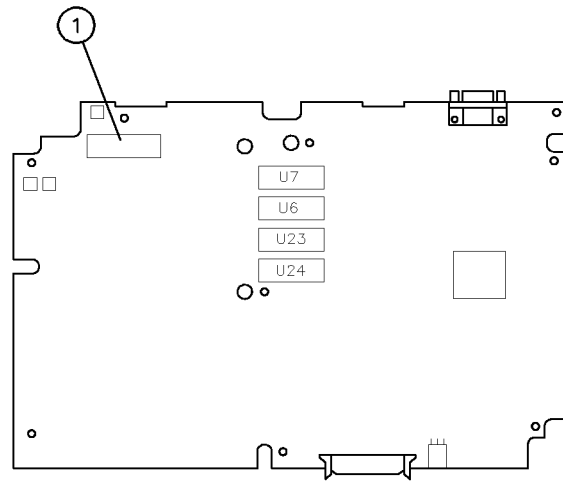

battery

Figure 6-11. BT1 Battery Replacement

WARNING Battery BT1 contains lithium iodide. Do not incinerate or puncture this battery. Dispose of the discharged battery in a safe manner. Only use the same type of battery to replace BT1. Do not replace BT1 with a rechargeable battery. Refer to Chapter 10 for the HP part number of the replacement battery.

11. BT1 Battery

Replacement

1. Insert the new battery into the processor board, noting the polarity **(1)**.
The positive polarity is marked with a + on the processor board.
2. Solder the battery to the processor board.
3. Replace the processor board. Refer to the replacement procedures for “8. A24 Processor Board Assembly”.
4. Replace the graphics processor board. Refer to the replacement procedures for “10. A25 Graphics Processor Board”.
5. Replace the HP-IB/RS-232 board. Refer to the replacement procedures for “12. A22 HP-IB/RS-232 Board”.
6. Replace the counter lock assembly. Refer to the replacement procedures for “19. A23 Counter Lock Assembly”.
7. Replace the instrument cover. Refer to the replacement procedures for “1. Instrument Cover”.

12. A22 HP-IB/RS-232 Board

Removal

1. Remove the instrument cover. Refer to the removal procedures for “1. Instrument Cover”.
2. Remove the 11 remaining screws on the rear panel.
 - 1 screw attached to the right-side frame (1)
 - 1 screw attached to the left-side frame (2)
 - 3 screws attached to the instrument deck (3)
 - 4 screws attached to the RF cover (4)
 - 2 screws attached to the power supply baffle (5)
3. Remove the 4 screws that secure the HP-IB/RS-232 board in the instrument (6).

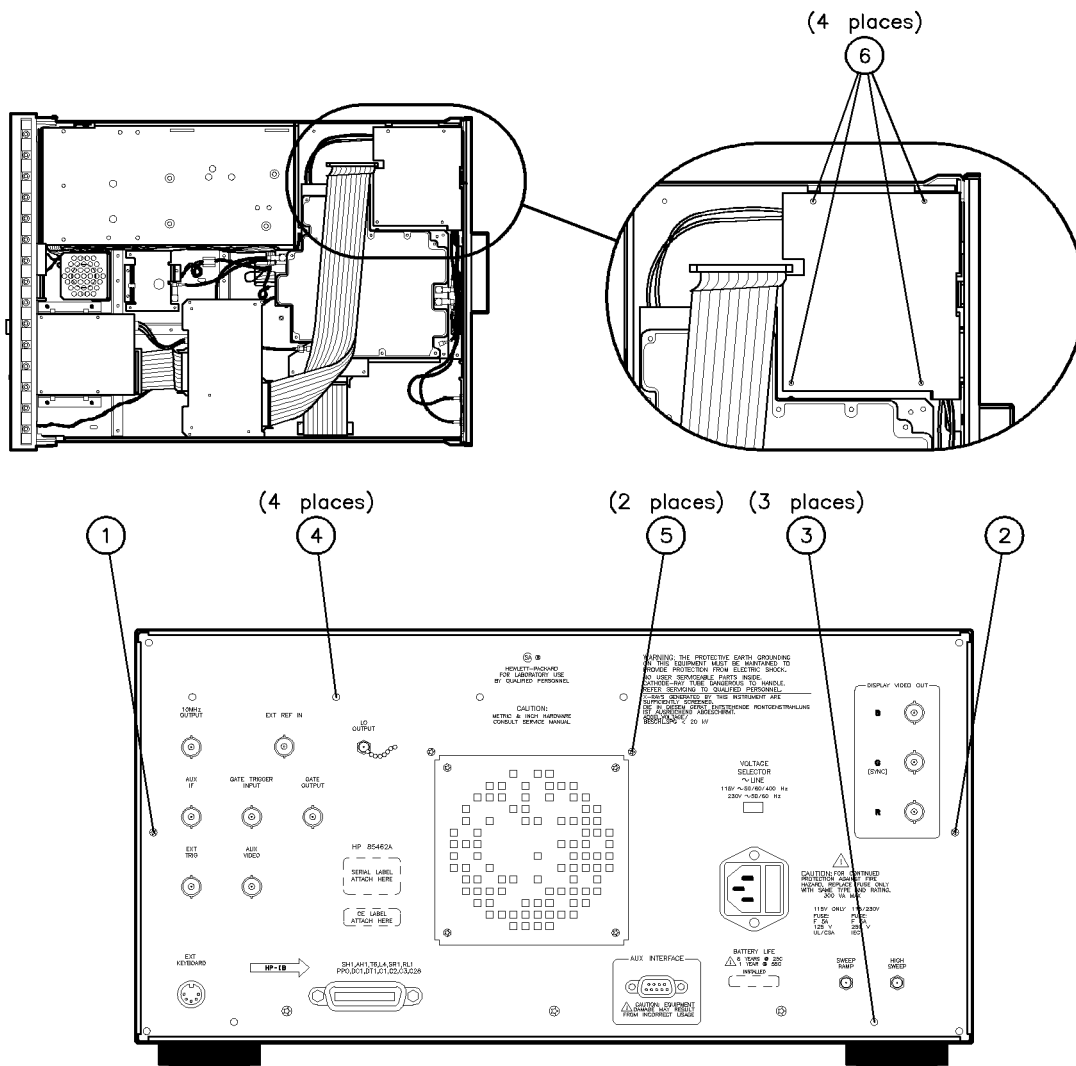

a22rs232

Figure 6-12. A22 HP-IB/RS-232 Board Replacement

12. A22 HP-IB/RS-232 Board

Replacement

1. If the board is an RS-232, install the ground clip over the RS-232 connector.
2. Place the HP-IB/RS-232 board into the instrument.
3. Replace the 4 screws that attach the HP-IB/RS-232 board to the instrument **(6)**.
4. Replace the 11 screws on the rear panel **(1 through 5)**.
5. Replace the instrument cover. Refer to the replacement procedures for “1. Instrument Cover”.

13. A2 Display

WARNING The monitor is extremely heavy! Use both hands when handling.

Removal

1. Remove the instrument cover. Refer to the removal procedures for “1. Instrument Cover”.
2. Remove the RF cover. Refer to the removal procedures for “2. RF Cover”.
3. Remove the rear panel. Refer to the removal procedures for “5. A26 Rear Panel”.
4. Remove the power supply. Refer to the removal procedures for “6. A16 Power Supply Assembly”.
5. Remove the graphic signal processor assembly. Refer to the removal procedures for “14. A17 Graphic Signal Processor Assembly”.
6. Remove the OCXO assembly. Refer to the removal procedures for “18. A20 10 MHz Precision Reference”.
7. Remove the disk drive controller board. Refer to the removal procedures for “16. A21 Disk Drive Controller Board”.
8. Remove the disk drive assembly. *Do not remove* the brackets from the disk drive assembly. Refer to the removal procedures for “17. A19 Disk Drive”.
9. Remove speaker and its bracket **(1)**.
10. Remove the 3 screws near the top edge of the left side frame that attach the left side frame to the monitor **(2)**.
11. Remove the 5 screws from the top of the front panel that attach to the monitor **(3)**.
12. Remove the 7 screws that attach the instrument deck to the bottom of the monitor **(4)**.
13. Loosen the 4 top monitor screws slightly **(5)**. Do not remove.
14. Slide the monitor back in the instrument.
15. Lift the monitor out of the instrument. Use 2 people to lift the monitor, if possible.

13. A2 Display

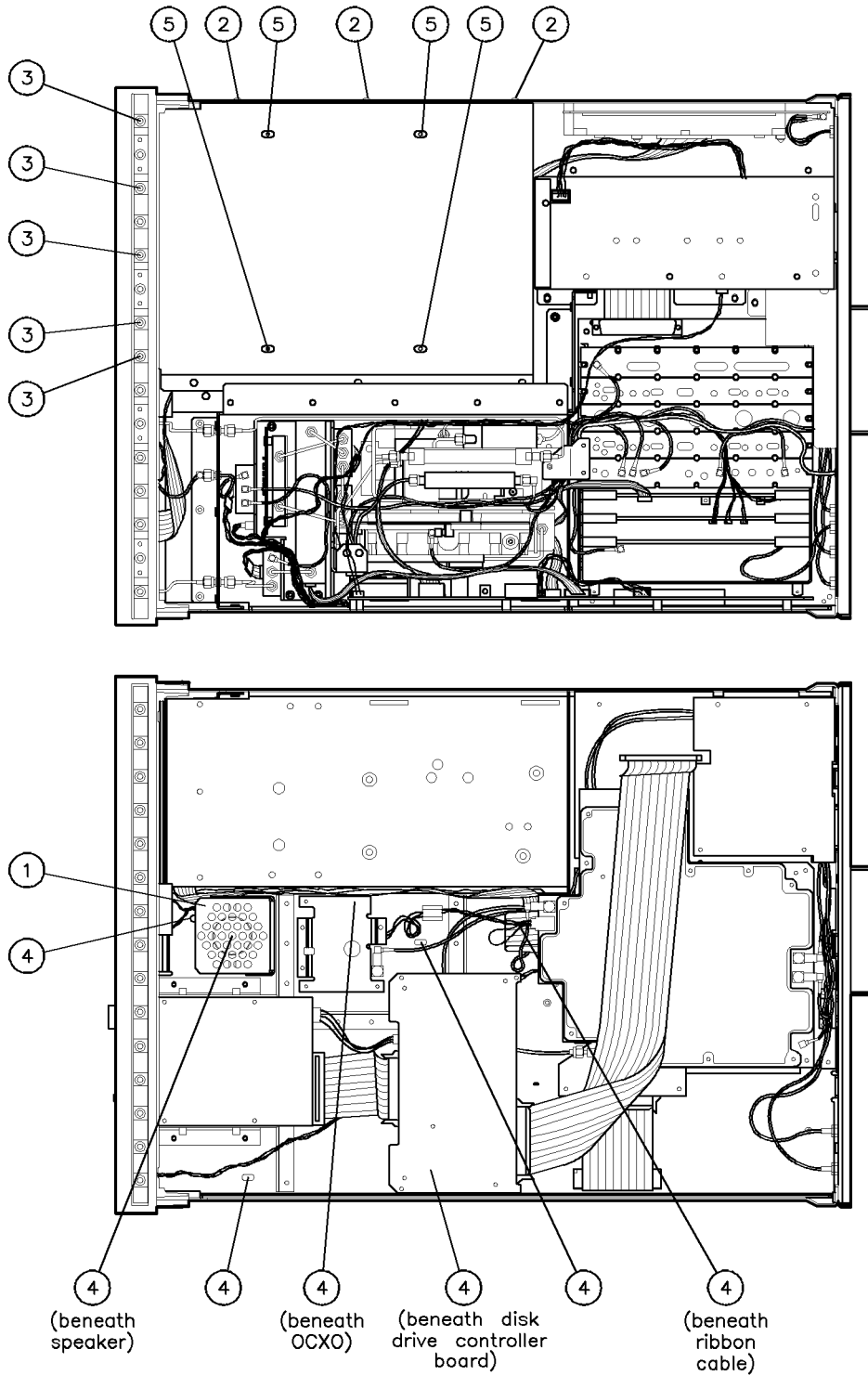

Figure 6-13. A2 Display Replacement

a2monitr

Replacement

1. Set the monitor into the instrument. Use 2 people to lift the monitor, if possible.
2. Slide the monitor forward into the instrument.
3. Tighten the 4 top monitor screws **(5)**.
4. Replace the 7 screws that attach the instrument deck to the bottom of the monitor **(4)**.
5. Replace the 5 screws that attach the top of the front panel to the monitor **(3)**.
6. Replace the 3 screws near the top edge of the left side frame that attach the left side frame to the monitor **(2)**.
7. Replace speaker and its bracket **(1)**.
8. Replace the disk drive assembly. Refer to the replacement procedures for “17. A19 Disk Drive”.
9. Replace the disk drive controller board. Refer to the replacement procedures for “16. A21 Disk Drive Controller Board”.
10. Replace the OCXO assembly. Refer to the replacement procedures for “18. A20 10 MHz Precision Reference”.
11. Replace the graphic signal processor assembly. Refer to the replacement procedures for “14. A17 Graphic Signal Processor Assembly”.
12. Replace the power supply. Refer to the replacement procedures for “6. A16 Power Supply Assembly”.
13. Replace the rear panel. Refer to the replacement procedures for “5. A26 Rear Panel”.
14. Replace the RF cover. Refer to the replacement procedures for “2. RF Cover”.
15. Replace the instrument cover. Refer to the replacement procedures for “1. Instrument Cover”.

14. A17 Graphic Signal Processor Assembly

Removal

1. Remove the instrument cover. Refer to the removal procedures for “1. Instrument Cover”.
2. Remove the 4 screws that attach the left side frame to the graphic signal processor assembly.
3. Lift the graphic signal processor assembly out of the instrument.
4. Disconnect the 3 SMB cables from J1, J2, and J3 (1) that connect to the rear panel EXT VID connectors.

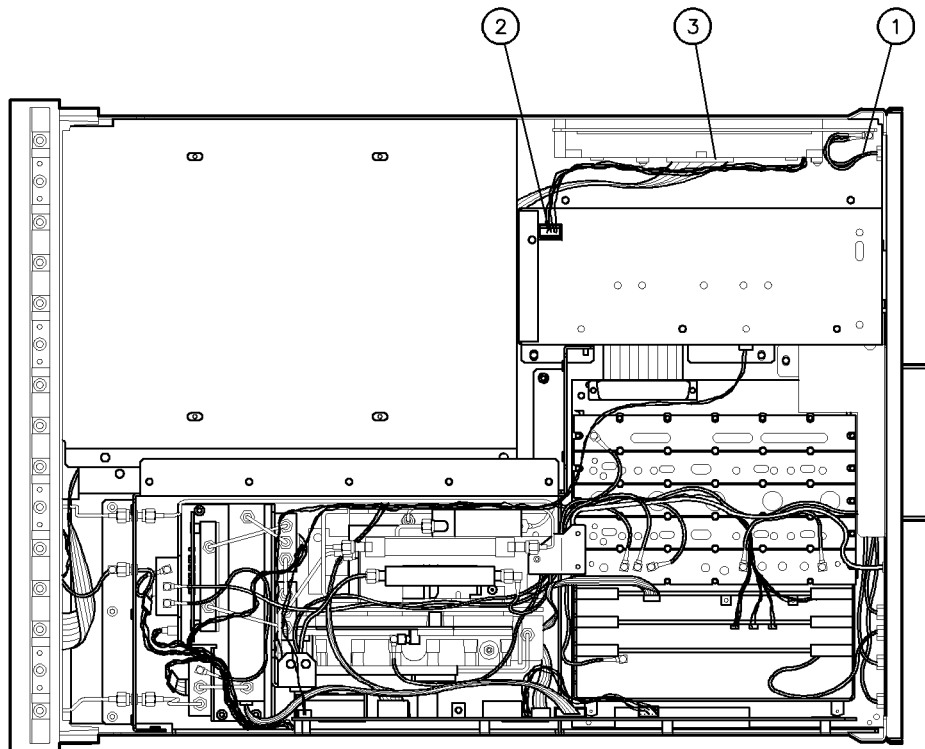

a17grsig

Figure 6-14. A17 Graphic Signal Processor Assembly Replacement

5. Disconnect the 8-wire cable harness from J4 (2) that connects to the top of the power supply.
6. Disconnect the ribbon cable from J5 (3) that connects to the monitor.

14. A17 Graphic Signal Processor Assembly

Replacement

1. Connect the ribbon cable from the monitor to connector J5 **(3)**.
2. Connect the 8-wire cable harness from the top of the power supply to connector J4 **(2)**.
3. Connect the 3 SMB cables from the rear panel EXT VID connectors to connectors J1, J2, and J3 **(1)**.
4. Place the graphic signal processor assembly into the instrument.
5. Replace the 4 screws that attach the left side frame to the graphic signal processor assembly.
6. Replace the instrument cover. Refer to the replacement procedures for “1. Instrument Cover”.

15. A15 Motherboard/IF Section Assembly

Removal

1. Remove the instrument cover. Refer to the removal procedures for “1. Instrument Cover”.
2. Remove the RF cover. Refer to the removal procedures for “2. RF Cover”.
3. Remove the analog interface board. Refer to the removal procedures for “20. A5 Analog Interface Board”.

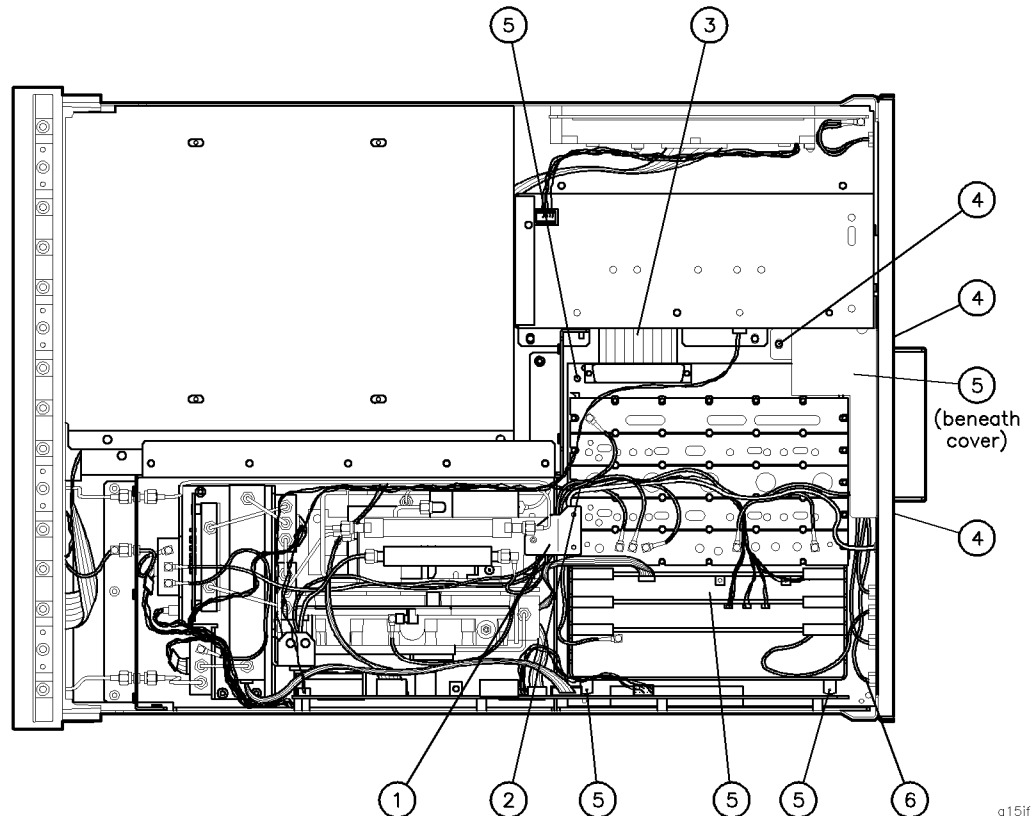

Figure 6-15. A15 Motherboard/IF Section Assembly Replacement

4. Remove the RF/IF bracket (1).
5. Disconnect all cables attached to the IF section boards (2) and pull the cables forward in the instrument.
6. Remove all 7 boards from IF section.
7. Remove the ribbon cable attached to the right side of the power supply (3).
8. Remove the power supply baffle by removing the 3 screws (4).
9. Remove the 5 screws that attach the motherboard to the instrument (5).
10. Remove the rear panel screws and lower the rear panel.
11. Disconnect the 6 cables attached to the rear edge of the motherboard (6).

15. A15 Motherboard/IF Section Assembly

12. Rock the motherboard/IF section assembly back and forth while pulling it up to remove it from the instrument.
13. Remove the motherboard from the IF section casting/card cage frame by removing the 42 screws from the bottom of the motherboard.

Replacement

1. Reattach the motherboard to the IF section casting/card cage frame by replacing the 42 screws on the bottom of the motherboard.
2. Place the motherboard/IF section assembly back into the instrument.
3. Connect the 6 cables to the SMB connectors on the rear edge of the motherboard **(6)**.

Table 6-2. A15 Motherboard Cable Connections

Motherboard Connector	Tape Color	Tape Number	Description
J14	Orange	3	SWP RMP
J15	Yellow	4	HSWP
J16	Blue	6	AUX VID from the rear panel
J17	Black	0	AUX IF from the rear panel
J18	Green	5	COUNT IF from the counter lock assembly
J200	No Color	N/A	From the narrow bandwidth board

4. Reattach the rear panel by replacing the rear panel screws.
5. Replace the 5 screws that attach the motherboard to the instrument **(5)**.
6. Replace the power supply baffle and attach it to the instrument by replacing the 3 screws **(4)**.
7. Reconnect the ribbon cable to the right side of the power supply **(3)**.
8. Reinstall all 7 boards in the IF section.
9. Reconnect all cables to the IF section boards **(2)**.
10. Replace the RF/IF bracket **(1)**.
11. Replace the analog interface board. Refer to the replacement procedures for “20. A5 Analog Interface Board”.
12. Replace the RF cover. Refer to the replacement procedures for “2. RF Cover”.
13. Replace the instrument cover. Refer to the replacement procedures for “1. Instrument Cover”.

16. A21 Disk Drive Controller Board

Removal

1. Remove the instrument cover. Refer to the removal procedures for “1. Instrument Cover”.
2. Remove the ribbon cable **(1)** between the disk drive and the disk drive controller board from the front edge of the disk drive controller board.

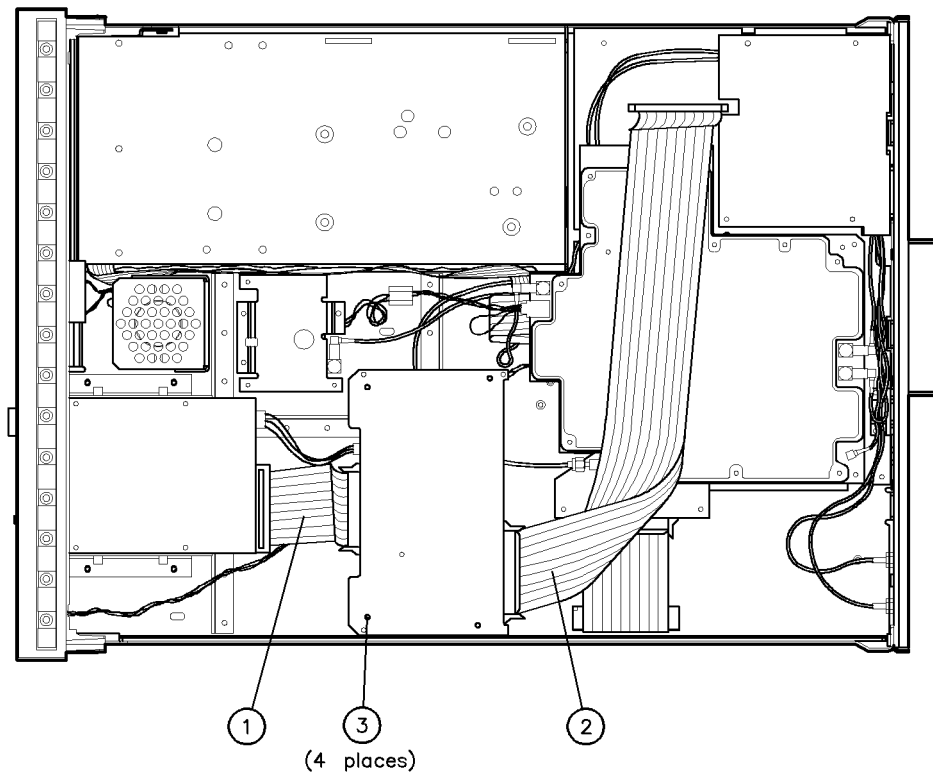

Figure 6-16. A21 Disk Drive Controller Board Replacement

3. Remove the ribbon cable **(2)** between the processor board and the disk drive controller board from the rear edge of the disk drive controller board.
4. Remove the four screws **(3)** from the disk drive controller board.
5. Remove the disk drive controller board from the instrument.

Replacement

1. Replace the disk drive controller board into the instrument.
2. Replace the four screws **(3)** in the disk drive controller board.
3. Replace the ribbon cable **(2)** from the processor board to the rear edge of the disk drive controller board.
4. Replace the ribbon cable **(1)** from the disk drive to the front edge of the disk drive controller board.
5. Replace the instrument cover. Refer to the replacement procedures for “1. Instrument Cover”.

17. A19 Disk Drive

Removal

1. Remove the instrument cover. Refer to the removal procedures for “1. Instrument Cover”.
2. Remove the ribbon cable (1) from the front edge of the disk drive controller board.

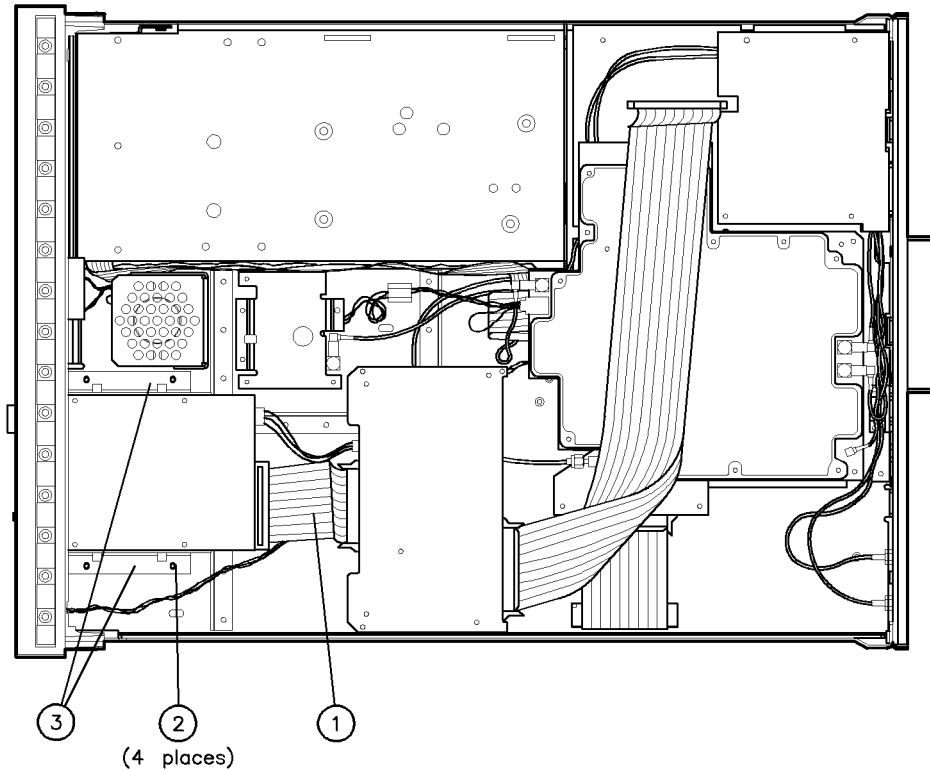

diskrepl

Figure 6-17. A19 Disk Drive Replacement

3. Remove the four screws (2) holding the two disk drive brackets in the instrument.
4. Remove the disk drive with its brackets attached.
5. Remove the disk drive brackets (3) from the disk drive.

Replacement

1. Install the disk drive brackets (3) to the new disk drive.
2. Replace the disk drive with its attached brackets and install into the instrument using the four screws (2).
3. Connect the disk drive ribbon cable (1) to the front edge of the disk drive controller board.
4. Replace the instrument cover. Refer to the replacement procedures for “1. Instrument Cover”.

18. A20 10 MHz Precision Reference

Removal

1. Remove the instrument cover. Refer to the removal procedures for “1. Instrument Cover”.

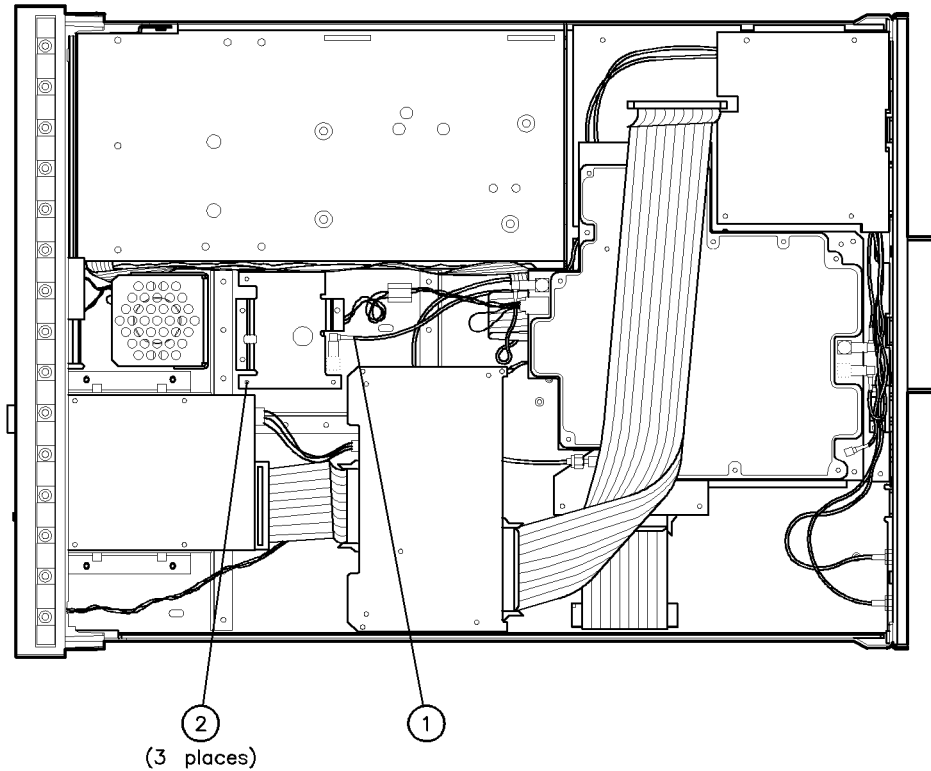

Figure 6-18. A20 10 MHz Precision Reference Replacement

2. Disconnect the OCXO cable (1).
3. Remove the three screws that attach the OCXO bracket to the instrument (2).
4. Remove the three screws that attach the OCXO to its bracket.

Replacement

1. Replace the three screws that attach the OCXO to its bracket.
2. Replace the three screws that attach the OCXO bracket to the instrument (2).
3. Reconnect the OCXO cable (1).
4. Replace the instrument cover. Refer to the replacement procedures for “1. Instrument Cover”.

19. A23 Counter Lock Assembly

Removal

1. Remove the instrument cover. Refer to the removal procedures for “1. Instrument Cover”.

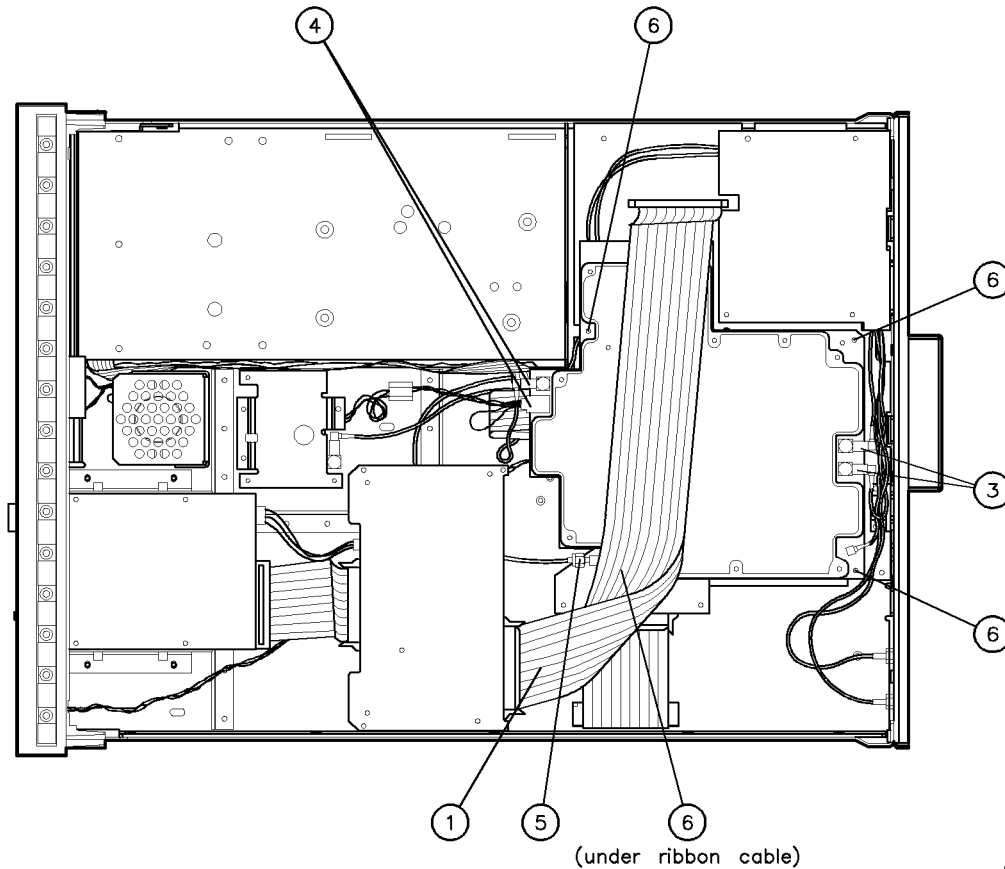

Figure 6-19. A23 Counter Lock Assembly Replacement

2. Disconnect the ribbon cable from the rear edge of the disk drive controller board (1).
3. Disconnect the large ribbon cable from the processor board (2).
4. Disconnect the 2 cables attached to the rear edge of the counter lock assembly (3).
5. Disconnect the 2 cables from the front edge of the counter lock assembly (4).
6. Disconnect the cable from the left edge of the counter lock assembly (5).
7. Remove the 4 screws that attach the counter lock assembly to the instrument (6).
8. Remove the counter lock assembly from the instrument.

Replacement

1. Replace the counter lock assembly in the instrument.
2. Replace the 4 screws that attach the counter lock assembly to the instrument **(6)**.
3. Connect the cable to the left edge of the counter lock assembly **(5)**.
4. Connect the 2 cables to the front edge of the counter lock assembly **(4)**.
5. Connect the 2 cables to the rear edge of the counter lock assembly **(3)**.
6. Connect the large ribbon cable to the processor board **(2)**.
7. Connect the ribbon cable to the rear edge of the disk drive controller board **(1)**.
8. Replace the instrument cover. Refer to the replacement procedures for “1. Instrument Cover”.

20. A5 Analog Interface Board

Removal

1. Remove the instrument cover. Refer to the removal procedures for “1. Instrument Cover”.
2. Remove the RF cover. Refer to the removal procedures for “2. RF Cover”.
3. Remove the red/brown/blue/green cable harness (1) from the analog interface board.
4. Remove the multi-colored ribbon cable (2) from the analog interface board.
5. Remove the gray ribbon cable (3) from the analog interface board.
6. Remove the yellow/brown cable harness (4) from the analog interface board.

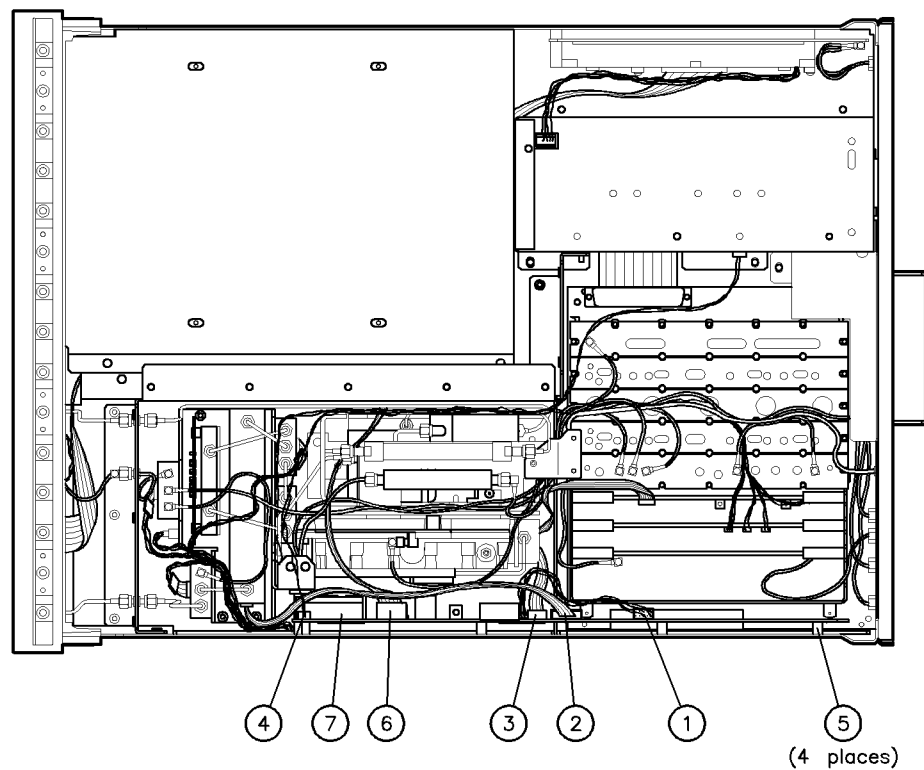

Figure 6-20. A5 Analog Interface Board Replacement

7. Remove the 4 screws from the right side frame that attaches the frame to the analog interface board (5).
8. Remove the analog interface board about half way out of the instrument by lift it up. A pair of needle-nose pliers may be used to grab the back corner of the board to help remove the board.
9. Remove the remaining ribbon cable (6) from the analog interface board.
10. Remove the green/orange/purple/red wire harness (7) from the analog interface board.
11. Remove the analog interface board from the instrument completely.

Replacement

1. Insert the analog interface board about half way into the instrument.
2. Reconnect the green/orange/purple/red wire harness **(7)** to the analog interface board.
3. Reconnect the ribbon cable **(6)** to the analog interface board.
4. Place the analog interface board into the instrument completely.

CAUTION Be careful not to bend the connector pins when installing the board.

5. Replace the 4 screws on the right side frame that attach the frame to the analog interface board **(5)**.
6. Reconnect the yellow/brown cable harness **(4)** to the analog interface board.
7. Reconnect the gray ribbon cable **(3)** to the analog interface board.
8. Reconnect the multi-colored ribbon cable **(2)** to the analog interface board.
9. Reconnect the red/brown/blue/green cable harness **(1)** to the analog interface board.
10. Replace the RF cover. Refer to the replacement procedures for “2. RF Cover”.
11. Replace the instrument cover. Refer to the replacement procedures for “1. Instrument Cover”.

21. A3 Preamplifier Section/A4 RF Section Assembly

The A3 preamplifier section assembly and the A4 RF section assembly are removed together. Once they are out of the instrument, they may be separated and worked on separately.

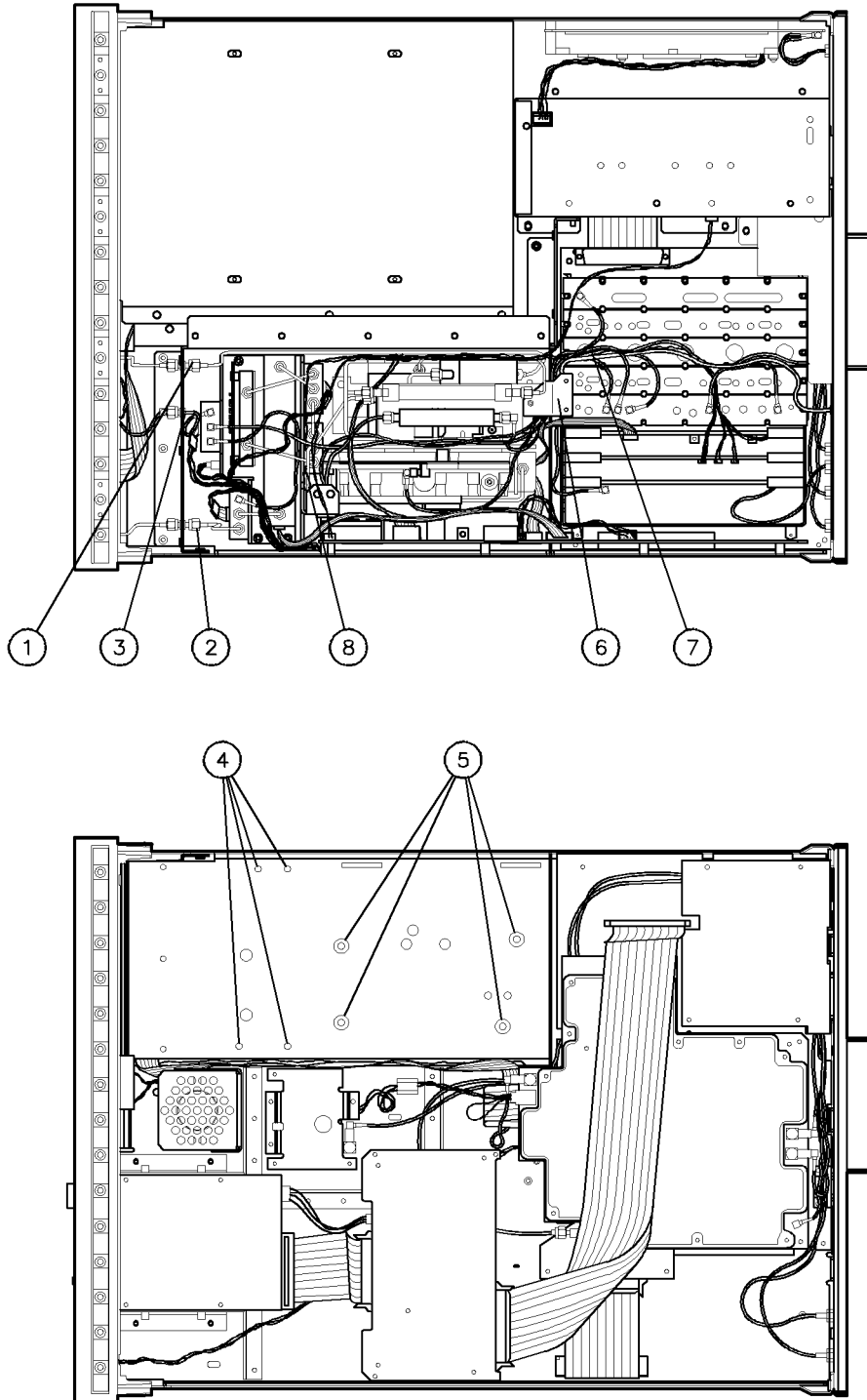

a3a4

Figure 6-21. A3 Preamplifier Section/A4 RF Section Assembly Replacement

21. A3 Preamplifier Section/A4 RF Section Assembly

Removal

1. Remove the instrument cover. Refer to the removal procedures for “1. Instrument Cover”.
2. Remove the RF cover. Refer to the removal procedures for “2. RF Cover”.
3. Remove the analog interface board. Refer to the removal procedures for “20. A5 Analog Interface Board”.
4. Disconnect the tracking generator output cable from the connector on the bulkhead **(1)**.
5. Disconnect the 300 MHz output cable from the A3A3 switch **(2)**.
6. Disconnect the RF input cable from the A3A1 switch **(3)**.
7. Remove the 4 screws from the bottom of the A3 preamplifier section **(4)**.
8. Remove the 4 screws from the bottom of the A4 RF section **(5)**.
9. Remove the RF/IF bracket from the instrument **(6)**.
10. Remove the wires and cables from the boards in the IF section **(7)**.
11. Disconnect the ALC connector wires (Red/White) from the front side of the tracking generator **(8)**. Note how the excess wire is routed toward the rear on the left side of the A4 RF section.
12. Remove the A3 preamplifier section/A4 RF section from the instrument.

Replacement

1. Place the A3 preamplifier section/A4 RF section assembly in the instrument.
2. Connect the ALC connector wires **(8)** (Red/White) to the connector at the front of the tracking generator. Route the wires so that the excess wire is pulled toward the rear at the left side of the A4 RF section.
3. Reconnect the wires and cables to the boards in the IF section **(7)**.
4. Replace the RF/IF bracket in the instrument **(6)**.
5. Replace the 4 screws at the bottom of the A4 RF section **(5)**.
6. Replace the 4 screws at the bottom of the A3 preamplifier section **(4)**.
7. Connect the RF input cable to the A3A1 switch **(3)**.
8. Connect the 300 MHz output cable to the A3A3 switch **(2)**.
9. Connect the tracking generator output cable to the connector on the bulkhead **(1)**.
10. Replace the analog interface board. Refer to the replacement procedures for “20. A5 Analog Interface Board”.
11. Replace the RF cover. Refer to the replacement procedures for “2. RF Cover”.
12. Replace the instrument cover. Refer to the replacement procedures for “1. Instrument Cover”.

Customer Support

Your EMI receiver is built to provide dependable service. It is unlikely that you will experience a problem. However, Hewlett-Packard's worldwide sales and service organization is ready to provide the support you need.

If You Have a Problem

Before calling Hewlett-Packard or returning the EMI receiver for service, please make the checks listed in "Check the Basics." If you still have a problem, please read the warranty printed at the front of this manual. If your EMI receiver is covered by a separate maintenance agreement, please be familiar with its terms.

Hewlett-Packard offers several maintenance plans to service your EMI receiver after warranty expiration. Call your HP Sales and Service Office for full details.

If you want to service the EMI receiver yourself after warranty expiration, contact your HP Sales and Service Office to obtain the most current test and maintenance information.

Calling HP Sales and Service Offices

Sales and service offices are located around the world to provide complete support for your EMI receiver. To obtain servicing information or to order replacement parts, contact the nearest Hewlett-Packard Sales and Service office listed in Table 7-1. In any correspondence or telephone conversations, refer to the EMI receiver by its model number and full serial number. With this information, the HP representative can quickly determine whether your unit is still within its warranty period.

Check the Basics

In general, a problem can be caused by a hardware failure, a software error, or a user error. Often problems may be solved by repeating what was being done when the problem occurred. A few minutes spent in performing these simple checks may eliminate time spent waiting for instrument repair.

If Your EMI Receiver Does Not Turn On

- Check that the EMI receiver is plugged into the proper ac power source.
- Check that the line socket has power.
- Check that the rear-panel voltage selector switches are set correctly.
- Check that the line fuses are good.
- Check that the EMI receiver is turned on.

If the RF Filter Section Does Not Seem to be Working

- Check the ac power to the EMI receiver as described above.
- Verify that the rear-panel auxiliary interface cable is properly connected.
- Verify that the rear-panel sweep ramp and high sweep cables are properly connected.

If the EMI Receiver Cannot Communicate Via HP-IB

- Verify that the proper HP-IB address has been set.
- Verify that there are no equipment address conflicts.
- Check that the other equipment and cables are connected properly and operating correctly.
- Verify that the HP-IB cable is connected to the receiver RF section and not the RF filter section.

Verification of Proper Operation

- Check that the test being performed and the expected results are within the specifications and capabilities of the EMI receiver.
- Check operation by performing the operation verification procedures in Chapter 2 of the EMI Receiver Series Installation and Verification. Record all results in the operation verification test record.

If the RF filter section Does Not Power Off

- Verify that the service power switch on the RF filter section is set to normal mode.

Error Messages

- Check the EMI receiver display for error messages. Refer to Chapter 4 of the EMI Receiver Series Installation and Verification.

Additional Support Services

CompuServe

CompuServe, the worldwide electronic information utility, provides technical information and support for EMC instrumentation and communication with other EMI users.

With a CompuServe account and a modem-equipped computer, simply type GO HPSYS and select the EMC system section to get information on documentation, application notes, product notes, service notes, software, firmware revision listings, data sheets, and more.

If you are not a member of CompuServe and would like to join, call CompuServe and take advantage of the Free Introductory Membership. The membership includes the following:

- An introductory usage credit to CompuServe
- A private User ID and Password
- A complimentary subscription to CompuServe's monthly computing publication, *CompuServe Magazine*

To take advantage of the CompuServe Free Introductory Membership offer, call one of the telephone numbers below and ask for Representative Number 999.

Country	Toll-Free	Direct
Argentina	—	(+54) 01-372-7883
Australia	008-023-158	(+61) 2-410-4555
Canada	—	(+1) 614-457-8650
Chile	—	(+56) 2-696-8807
Germany	0130 86 4643	(+49) (+89) 66 55 0-222
Hong Kong	—	(+852) 867-0102
Israel	—	(+972) 3-290466
Japan	0120-22-1200	(+81) 3-5471-5806
Korea	080-022-7400	(+82) 2-569-5400
New Zealand	0800-441-082	—
South Africa	—	(+27) 12-841-2530
Switzerland	155 31 79	—
Taiwan	—	(+886) 2-515-7035
United Kingdom	0800 289458	(+44) (+272) 255111
United States	800-848-8990	(+1) 614-457-8650
Venezuela	—	(+58) 2-793-2984
Elsewhere	—	(+1) 614-457-8650

FAX Support Line

A fax sheet is provided at the end of this chapter as a method in which to directly contact the HP EMC support team in the event of a problem. The fax cover sheet provides EMC support team with information about your company, the product, and a detailed description about the problem.

Note All items on the fax cover sheet *must* be completed in order to expedite your response. Any incomplete item may delay your response.

Simply copy the fax cover sheet, fill out the requested information, include any additional information sheets, and fax the sheet(s) to HP EMC Support at (707) 577-4200. Depending on the complexity of the problem, you should receive a response back within a few days.

Returning the EMI Receiver for Service

Use the information in this section if it is necessary to return the EMI receiver to Hewlett-Packard.

Note If you are returning an EMI receiver, you must return both the receiver RF section and RF filter section to the service center for repair and calibration. Also, you must package the units individually to avoid damage.

Package the EMI receiver for shipment

Use the following steps to package the EMI receiver for shipment to Hewlett-Packard for service:

1. Fill in a service tag (available at the end of this chapter) and attach it to the instrument. Please be as specific as possible about the nature of the problem. Send a copy of any or all of the following information:
 - Any error messages that appeared on the EMI receiver display.
 - A completed operation verification test record located at the end of Chapter 2 in the EMI Receiver Series Installation and Verification.
 - Any other specific data on the performance of the EMI receiver.

CAUTION Damage to the EMI receiver can result from using packaging materials other than those specified. Never use styrene pellets in any shape as packaging materials. They do not adequately cushion the instrument or prevent it from shifting in the carton. Styrene pellets cause equipment damage by generating static electricity and by lodging in the fan.

2. Use the original packaging materials, if possible. You may also use strong shipping containers that are made of double-walled, corrugated cardboard with 159 kg (350 lb) bursting strength. The cartons must be both large enough and strong enough and allow at least 3 to 4 inches on all sides of the instrument for packing material. Containers and materials for factory shipments are also available through any Hewlett-Packard sales or service office.
3. Protect the front panel with cardboard.
4. Surround the instrument with at least 3 to 4 inches of packing material, or enough to prevent the instrument from moving in the carton. If packing foam is not available, the best alternative is SD-240 Air Cap™ from Sealed Air Corporation (Hayward, CA 94545). Air Cap looks like a plastic sheet covered with 1-1/4 inch air-filled bubbles. Use the pink Air Cap to reduce static electricity. Wrap the instrument several times in the material to both protect the instrument and prevent it from moving in the carton.
5. Seal the shipping container securely with strong nylon adhesive tape.
6. Mark the shipping container “FRAGILE, HANDLE WITH CARE” to ensure careful handling.
7. Retain copies of all shipping papers.

Table 7-1. Hewlett-Packard Sales and Service Offices

US FIELD OPERATIONS		
<p>Customer Information Hewlett-Packard Company 19320 Pruneridge Avenue Cupertino, CA 95014, USA (800) 752-0900</p>	<p>California, Northern Hewlett-Packard Co. 301 E. Evelyn gw421 South Manhattan Ave. Mountain View, CA 94041 (415) 694-2000</p>	<p>California, Southern Hewlett-Packard Co. Fullerton, CA 92631 (714) 999-6700</p>
<p>Colorado Hewlett-Packard Co. 24 Inverness Place, East Englewood, CO 80112 (303) 649-5000</p>	<p>Georgia Hewlett-Packard Co. 2000 South Park Place Atlanta, GA 30339 (404) 955-1500</p>	<p>Illinois Hewlett-Packard Co. 5201 Tollyview Drive Rolling Meadows, IL 60008 (708) 255-9800</p>
<p>New Jersey 120 W. Century Road Paramus, NJ 07653 (201)599-5000</p>	<p>Texas 930 E. Campbell Rd. Richardson, TX 75081 (214) 231-6101</p>	
EUROPEAN FIELD OPERATIONS		
<p>Headquarters Hewlett-Packard S.A. 150, Route du Nant-d'Avril 1217 Meyrin 2/Geneva Switzerland (41 22) 780.8111</p>	<p>France Hewlett-Packard France 1 Avenue Du Canada Zone D'Activite De Courtaboeuf F-91947 Les Ulis Cedex France (33 1) 69 82 60 60</p>	<p>Germany Hewlett-Packard GmbH Berner Strasse 117 6000 Frankfurt 56 West Germany (49 69) 500006-0</p>
<p>Great Britain Hewlett-Packard Ltd Eskdale Road, Winnersh Triangle Wokingham, Berkshire RF11 5DZ England (44 734) 696622</p>		
INTERCON FIELD OPERATIONS		
<p>Headquarters Hewlett-Packard Company 3495 Deer Creek Rd. Palo Alto, California 94304-1316 (415) 857-5027</p>	<p>Australia Hewlett-Packard Australia Ltd. 31-41 Joseph Street Blackburn, Victoria 3130 (61 3) 895-2895</p>	<p>Canada Hewlett-Packard (Canada) Ltd. 17500 South Service Road Trans-Canada Highway Kirkland, Quebec H9J 2X8 Canada (514) 697-4232</p>
<p>China China Hewlett-Packard Co. 38 Bei San Huan X1 Road Shuang Yu Shu Hai Dian District Beijing, China (86 1) 256-6888</p>	<p>Japan Yokogawa-Hewlett-Packard Ltd. 1-27-15 Yabe, Sagamihara Kanagawa 229, Japan (81 427) 59-1311</p>	<p>Singapore Hewlett-Packard Singapore (Pte.) Ltd 1150 Depot Road Singapore 0410 (65) 273-7388</p>
<p>Taiwan Hewlett-Packard Taiwan 8th Floor, H-P Building 337 Fu Hsing North Road Taipei, Taiwan (886 2) 712-0404</p>		



HEWLETT PACKARD

Fax Cover Sheet

To: **HP EMC Support** **FAX Number: (707) 577-4200** Page ____ of ____

Date Transmitted: _____ Time Transmitted: _____

From:

Company: _____

Last Name: _____ First Name: _____

Address: _____

City: _____ State: _____

Country: _____ Postal Code: _____ Mail Stop: _____

Telephone Number (include Country Code): _____

Fax Number (required): _____

Product:

HP 8542E HP 85422E Option(s): _____

HP 8546A HP 85462A Option(s): _____

Serial Number(s):

Receiver RF Section

RF Filter Section

HP 8542E EMI Receiver: HP 85422E _____ HP 85420E _____

HP 8546A EMI Receiver: HP 85462A _____ HP 85460A _____

Firmware Revision:

HP 85422E _____ HP 85420E _____

HP 85462A _____ HP 85460A _____

Is the problem reproducible?

Yes

No

Detailed Problem Description: (include all setup information and any additional pages)

Assembly Descriptions

This chapter describes the operation of the HP 85422E/HP 85462A receiver RF section that is useful when first troubleshooting a failure.

The HP 85422E/HP 85462A receiver RF section are microprocessor-controlled swept receivers covering the following frequency ranges. The overall description briefly describes each of the major instrument assemblies.

Table 8-1.
HP 85422E/HP 85462A receiver RF section Frequency Ranges

Instrument Model	Frequency Range
HP 85422E	9 kHz to 2.9 GHz
HP 85462A	9 kHz to 6.5 GHz

RF and LO Section

The HP 85422E/HP 85462A receiver RF section includes the following assemblies in the RF and LO sections:

- A4A1 2.9 GHz LPF
- A4A3 second converter
- A3A4 input attenuator
- A4A6 dual-band mixer
- A4A4 YTF (YIG-Tuned Filter)
- A4A2 321.4 MHz band pass filter
- A4A5 3 dB pad
- A4A10 tracking generator
- A5 analog interface
- A9 third converter
- A4A8 4.4 GHz low pass filter

For details about the operation of the HP 85422E/HP 85462A RF section, refer to Figure 8-2, located in the back of this chapter.

RF Section Assemblies

The RF section converts all input signals to a fixed 21.4 MHz IF. The microcircuits in the RF section are controlled by signals from the A5 analog interface assembly. The A5 analog interface assembly also includes circuitry for controlling the LO and IF sections.

The HP 8546A/HP 85462A consists of two frequency bands and the HP 8542E/HP 85422E consists of one frequency band.

Band 0 (low band) uses triple conversion to produce the final 21.4 MHz IF. The A4A6 dual band mixer up-converts the RF input to a 3.9214 GHz first IF. The A4A3 second converter down-converts the 3.9214 GHz first IF to a 321.4 MHz second IF. The A9 third converter down-converts the second IF to the final 21.4 MHz IF.

Band 1 (high band) use double conversion. The A4A6 dual-band mixer down-converts the RF input to a 321.4 MHz first IF. Although this first IF passes through the A4A3 second converter, it bypasses the second mixer. The second and final conversion occurs in the A9 third converter where the first IF is down-converted to produce the final 21.4 MHz IF.

A3A2 Preamplifier

The A3A2 preamplifier is a wideband preamplifier with a frequency range from 9 kHz to 6.5 GHz. A bipolar amplifier is used from 9 kHz to 1 GHz and a FET amplifier is used from 500 MHz to 6.5 GHz. These amplifiers are connected to identical Diplexers at their inputs and outputs. These diplexers have a cross-over frequency of approximately 900 MHz. The lowband path is switched into a 50Ω load in front of the lowband amplifier giving the preamplifier preselection capabilities using the highpass filter portion of the input diplexer.

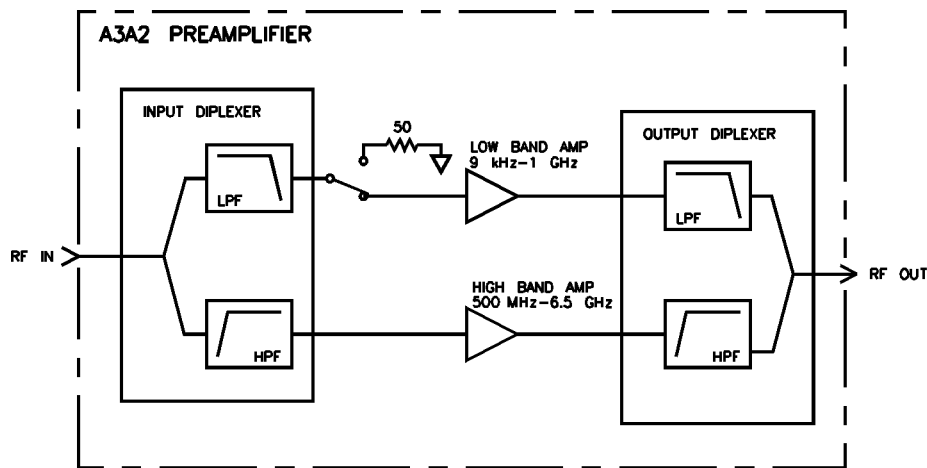

a3a2blk

Figure 8-1. A3A2 Preamplifier Block Diagram

The amplifier is mated to a bias board which actively biases the various FET stages. The I_{ds} current for the middle stages of the highband amplifier can be adjusted. This I_{ds} adjustment is used to equalize the gain of the highband amplifier with the lowband amplifier. The switch driver for switching the lowband path into 50Ω is also on the bias board.

A4A10 Tracking Generator

The A4A10 tracking generator assembly consists of several smaller circuits. The A4A10 tracking generator assembly is not component-level repairable; a rebuilt exchange assembly is available.

The tracking generator recreates only one of the intermediate frequencies. This minimizes isolation problems associated with a built-in tracking generator. Each of the blocks of the A4A10 tracking generator assembly is described below.

Tracking Oscillator. The tracking oscillator enables the fine adjustment of the tracking generator output frequency to compensate for the frequency inaccuracies of the 21.4 MHz IF. The tracking oscillator determines the residual FM and frequency drift of the tracking generator. The 184.28 MHz output frequency is obtained by doubling the output of a crystal oscillator operating at 92.14 MHz.

Upconverter. The upconverter mixes the tracking oscillator output with the buffered 600 MHz reference from the A9 third converter assembly. The upconverter also contains a filter to pass only the 784.28 MHz upper sideband.

Pentupler. The pentupler multiplies the 784.28 MHz signal by five to generate 3.9214 GHz, the instrument first IF in low band. A dual cavity bandpass filter centered at 3.9214 GHz eliminates all unwanted multiples of 784.28 MHz.

Modulator. The output of the pentupler is passed through a modulator to adjust the power level into the output mixer. The modulator is controlled by an ALC circuit on the bias board, which is fed by a detector in the output amplifier. If the detected output power is too high, the ALC will drive the modulator to decrease the input level into the output mixer, resulting in a decrease in output power.

Coupler. The first LO signal from the A4A7 first LO distribution amplifier assembly is coupled off, then buffered to drive the output mixer. The main line of the coupler is fed to the LO OUTPUT connector on the rear panel. The loss through the coupler main line is less than 2.5 dB.

Output Mixer. The 3.9214 GHz signal from the modulator is fed into the RF port of the output mixer. The LO port of the output mixer is driven by the buffered first LO signal from the coupler. The output of the mixer is then amplified.

Output Amplifier. The output amplifier filters the signal emerging from the output mixer and then amplifies it into a usable range. The amplifier also contains a detector for leveling the output.

Bias Board. The bias board contains the ALC circuitry for the tracking generator and distributes dc power from the A8 tracking generator control assembly to the rest of the tracking generator. The ALC inputs come from the A8 tracking generator control assembly (for controlling the power level), the EXT ALC INPUT line, and the detector in the output amplifier. The ALC loop drives the modulator.

A8 Tracking Generator Control Board

The A8 tracking generator control board has two major functions. The first function is to control the A4A10 tracking generator RF output power and output attenuator. The other main function is to provide bias and a summing junction for the leveling loop used by the A4A7 Local Oscillator Distribution Amplifier (LODA) microcircuit.

The tracking generator output power is controlled by the voltage at J1-pin 8 (PWR_LVL). This voltage is normally 0 to $-12 V_{dc}$ for tracking generator output power levels of -10 to $+2.75$ dBm at 300 MHz tuned frequency. The voltage is determined from two major components:

1. The Level Reference DAC (U16A) which takes the information from the IOB bus and converts it to a dc voltage.
2. The Power Sweep section attenuates the sweep ramp based on the amount of slope correction calculated by the internal self cal routine and the amount of power sweep requested by the user.

The output attenuator is controlled by a simple latch plus buffer/invertor scheme.

The Tune Control section provides a dc voltage to control the tracking oscillator VCO in the A4A10 tracking generator. This VCO is tuned to correct for errors in the host analyzer IF centering.

The LODA Drive section consists of an opamp acting as a summing node for the ALC error voltage and the adjustable target voltage. The voltages are compared and a control level is sent to the PIN attenuator in the LODA microcircuit.

ALC/LODA Status block consists of two window comparitors which monitor the PIN_ATTEN and ALC_MON lines from the LODA and tracking generator microcircuits.

Board identification is handled by the Address Decode and Sub Address Latch section.

A4A7 First LO Distribution Amplifier (LODA)

The A4A7 first LO distribution amplifier, (LODA), amplifies and levels the first LO signal from the A4A9 EYO and distributes it to the A23A1 sampler (through attenuator AT1), A4A6 dual band mixer, and A4A10 tracking generator. The leveling control circuitry is on the A8 tracking generator control assembly.

The LODA consists of a PIN diode attenuator, an amplifier, three directional couplers, a buffer amplifier, and a detector. Refer to Figure 8-2 and Figure 8-3. All three directional couplers are connected in series. The main line of the directional couplers is the output to the A4A10 tracking generator assembly. The directional coupler outputs feed the A4A6 dual-band mixer, the detector, and the buffer amplifier for driving the A23A1 sampler.

The detector output is fed to the A8 tracking generator control assembly. Here it is fed into a loop integrator. The reference voltage for the loop integrator is adjustable and determines the output power of the LODA. The gate bias adjustment is also on A8. Note that the LODA drive circuit common is connected only to the A4A7 LODA itself and not to any other grounds on A8.

LO Section Assemblies

The LO Section includes the following assemblies:

- A4A9 EYO (Electronic YIG-tuned Oscillator)
- A5 analog interface
- A9 third converter
- A20 precision frequency reference
- A23 counterlock
- AT1 10 dB Pad

Refer to Figure 8-3, located at the back of this chapter for details about the operation of the LO section.

The LO section provides a 3.0 to 6.8214 GHz first LO, a 600 MHz second LO, a 300 MHz third LO, a 300 MHz CAL OUT signal, and an IF frequency counter. The counter and the local oscillators use a 10 MHz precision frequency reference, A20 oven-controlled crystal oscillator (OCXO).

The 10 MHz reference phase-locks the 600 MHz oscillator on the A9 third converter. The 600 MHz signal drives the second converter and is divided to produce the 300 MHz third LO and CAL OUT signals. A 300 MHz signal that is sent to the A23 counterlock assembly is divided down further to produce a 7.5 MHz reference signal. This 7.5 MHz reference is used by the stabilizer, the sampling oscillator, and frequency counter. The phase-frequency detector is located on the A23 counterlock assembly.

The first LO output of the A4A9 EYO is fed to the A4A6 dual-band mixer. The coupled output is fed through the AT1 10 dB pad to the A23A1 sampler. The sampler mixes the first LO with a harmonic of the sampling oscillator to generate a 60 to 100 MHz sampler IF. This value is then divided by 10, producing a 6 to 10 MHz output.

During retrace, the EYO is locked to the selected first LO frequency. The divided sampler IF is then counted in the frequency counter. The EYO tune DACs on the A5 analog interface assembly are adjusted until the counted frequency is equal to the desired frequency. In LO spans less than or equal to 10 MHz, the divided sampler IF is also fed to a stabilizer, which generates the DISCRIM (discriminator) signal. DISCRIM tunes the EYO precisely to the desired first LO frequency.

When a trigger signal occurs, a sweep ramp is applied to the main coil drivers while in LO spans greater than 10 MHz, or to the FM coil drivers while in LO spans less than or equal to 10 MHz. During a main coil sweep, the sampling oscillator is disconnected from the A23A1 sampler.

In frequency count mode, the first LO sweeps up to the marked signal and pauses. The divided sampler IF is counted to calculate the actual first LO frequency. Then the prescaled 21.4 MHz IF, nominally 5.35 MHz, is counted and the actual input frequency calculated.

A9 Third Converter Assembly

The A9 Third Converter performs the following functions:

- Down-converts the 321.4 MHz IF to the final 21.4 MHz IF.
- Generates the 300 MHz third LO.
- Provides variable gain from the calibrator amplifier that adjusts the amplitude of the 21.4 MHz IF during the `CAL AMP` self-calibration routine.
- Generates the 600 MHz second LO drive signal for the A4A3 second converter assembly and for the tracking generator.
- Generates the 300 MHz CAL OUT signal at -20 dBm.
- Provides a buffered 300 MHz to drive the external reference PLL circuitry on the A23 counterlock assembly.

Refer to Figure 8-4, located at the back of this chapter for details about the operation of the A9 third converter assembly.

Refer to “Troubleshooting the A15 Motherboard Assembly” in Chapter 4 when tracing control signals for the A9 third converter assembly.

The output of the 600 MHz surface acoustical wave (SAW) oscillator is buffered, providing the second LO signal to the A4A3 second converter. This signal is further buffered, divided by two, and buffered again to produce three 300 MHz outputs. A second 600 MHz output drive signal is available for the tracking generator.

The amplitude of the 300 MHz signal from the calibrator amplifier is adjusted to provide the -20 dBm output for the 300 MHz CAL OUT signal. This amplifier produces rich harmonics that are used in the instrument self-calibration routines.

The 300 MHz signal sent to the 300 MHz Buffer produces the other two 300 MHz outputs:

- The 300 MHz third LO sent to the mixer/filter.
- The 300 MHz feedback signal sent to the A23 counterlock assembly by the counterlock buffer. This signal is divided down and compared to the 10 MHz reference in a phase/frequency detector on the A23 counterlock assembly. The output of the phase/frequency detector, VTO_TUNE, is fed back to the 600 MHz SAW Oscillator to increase its frequency stability.

The 321.4 MHz second IF signal from the A4A3 second converter is amplified and bandpass-filtered on the A9 third converter assembly. This signal is mixed with the 300 MHz third LO to produce the 21.4 MHz difference signal that is then bandpass-filtered and buffered.

The buffered 21.4 MHz IF signal is amplified in the IF calibration amplifier (IF Cal Amp). The gain of the calibration amplifier is controlled by a DAC on the A5 analog interface assembly via the REF_LVL_CAL control line. During the `CAL AMP` routine, the gain of the calibration amplifier is adjusted so that the reference level at top-screen is calibrated. The amplitude reference for the routine is provided by the -20 dBm CAL OUT signal with 10 dB of A3A5 input attenuation in band 0. Refer to “IF Power-Level Measurement” in Chapter 4 for more information about the 21.4 MHz output from the A9 third converter assembly.

A23 Counterlock Assembly

The A23 counterlock assembly performs four main functions:

- Phase-locks the 600 MHz SAW oscillator on the A9 third converter to the 10 MHz reference.
- Counts the first LO frequency.
- Provides discriminator output, DISCRIM, to the A5 analog interface assembly.
- Counts the 21.4 MHz IF.

Refer to Figure 8-2 and Figure 8-3, located at the back of this chapter for details about the operation of the A23 counterlock assembly.

On the A9 third converter, the output of the 600 MHz oscillator is divided by two and the resulting 300 MHz signal is routed to the A23 counterlock assembly. The A23 counterlock assembly divides the 300 MHz signal by 40 to generate a 7.5 MHz reference for the sampling oscillator, stabilizer, and frequency counter. The 7.5 MHz reference and the 10 MHz reference are divided further and compared in a phase-frequency detector. The output of the phase-frequency detector, VTO_TUNE, is fed back to A9 to tune the 600 MHz oscillator.

The sampling oscillator provides a 279 to 298 MHz driving signal to the A23A1 sampler. The first LO signal is also applied to A23A1 sampler. The first LO signal is mixed with a harmonic of the sampling oscillator signal to generate the sampler IF. This IF is divided by 10 and fed to one input of the frequency counter. The equation used to produce the first LO frequency is:

$$\text{1st LO Frequency} = N \times F_{SO} + \text{Sampler IF}$$

N represents the harmonic of the sampling oscillator.

F_{SO} represents the sampling oscillator frequency.

Sampler IF represents the counted sampler IF (may be negative).

The stabilizer mixes the divided sampler IF (nominally 8.25 MHz) with the 7.5 MHz, and feeds the difference signal into the discriminator. The discriminator output, DISCRIM, is fed back to the A5 analog interface assembly to tune the A4A9 EYO precisely to the center frequency.

When the frequency count marker is active, the instrument pauses at the marked frequency and counts the first LO as described previously. The 21.4 MHz IF is then divided by four, to a nominal value of 5.35 MHz, fed to another frequency counter input, and counted. With the second LO, the third LO, the counted first LO, and the counted final IF all referenced to the 10 MHz reference, the actual input signal frequency is calculated.

IF Section

This section describes the operation of the IF section assemblies and the A24 processor assembly. The related operation of the A5 analog interface assembly and the A16 Power Supply are also described. Figure 8-5 illustrates the assembly descriptions in this section.

The A15 motherboard pin designation of related assemblies along the IF signal path are detailed on Figure 8-5.

IF Section Assemblies

A11 Bandwidth Filter

The A11 bandwidth filter assembly contains two synchronously tuned LC filter poles and two synchronously tuned crystal filter poles. Buffer amplifiers provide isolation for each filter pole.

Eight IF bandwidths, from 1 kHz to 3 MHz, can be selected in a 1,3,10 sequence. The desired IF passband, or resolution bandwidth, is produced by either a four-pole LC bandpass filter or a four-pole crystal bandpass filter. The A13 bandwidth filter assembly is identical to the A11 assembly and provides two of the four filter poles. The LC bandpass filters provide the 100 kHz to 3 MHz bandwidths, and the crystal bandpass filters provide the 1 kHz to 30 kHz bandwidths.

When a bandwidth is selected, the A5 analog interface assembly interprets the A24 processor assembly commands and produces the corresponding bandwidth control currents. The A5 assembly produces a bias voltage (BW5) to select LC or crystal mode, and a bandwidth control current for either the LC filters (BW7) or the crystal filters (BW6).

Bandwidth errors are corrected by the `CAL AMP` self-calibration routine. Refer to Chapter 11 for a description of `CAL AMP`.

The resolution bandwidths are normally coupled to the frequency span of the instrument for an optimum ratio of span to resolution bandwidth. Sweep time is also coupled to both resolution bandwidth and span for optimum amplitude response. The resolution bandwidth, sweep time, and span can be set independently.

A12 Amplitude Control

The A12 amplitude control assembly provides gain or attenuation in eight stages: three step-gain amplifiers and five step attenuators. All stages, except the 10 dB step gain, provide full gain or attenuation when turned on and unity gain when turned off. The 10 dB step gain has a gain of 15 dB when on and a gain of 5 dB when off.

When the reference level is changed, the A5 analog interface assembly interprets the A24 processor assembly commands and produces the appropriate combination of gain and attenuation control voltages in 1 dB increments. Reference-level resolution of less than 1 dB is produced by mathematically offsetting the digitized video signal on the A24 processor assembly.

A12 step-gain errors are corrected by correction factors produced by the `CAL AMP` self-calibration routine. Each correction factor is an offset of the digitized video signal and is stored in nonvolatile memory on the A24 assembly.

A12 step-attenuator errors are corrected by correction constants that are characterized values initially installed at the factory. The corrected calibration attenuators provide the amplitude reference used by `CAL AMP` self-calibration routine.

A13 Bandwidth Filter

The A13 bandwidth filter assembly is identical to the A11 assembly. Refer to the A11 assembly description in this section.

After leaving the A13 assembly, the 21.4 MHz IF signal branches on the A15 motherboard:

- One branch passes directly to the A14 log amplifier assembly.
- A buffer amplifier on the A15 motherboard attenuates the IF signal by 20 dB and distributes it to the card-cage assemblies (AUX_IF), the rear panel AUX IF OUTPUT connector (AUX_IF_BP), and the A23 counterlock assembly (COUNT_IF). The COUNT_IF signal is used by the A23 assembly to count the actual IF frequency when **MKR CNT ON** is selected.
- Another buffer amplifier on the A15 assembly sends the IF signal (AUX_IF) to assemblies installed in the card cage.

A14 Log Amplifier

The A14 log amplifier assembly provides the following functions:

- Log Mode. The input signal is logarithmically displayed due to the sequential response of seven log amplifier stages.
 - The log amplifier stages have an overall range of 70 dB. This allows a greater range of signal amplitudes to be simultaneously displayed.
 - All seven amplifier stages are at maximum gain for low input signal levels.
 - As the signal level increases, the gain of the each 10 dB amplifier is reduced in sequence, with the last stage dropping to unity gain first.
 - The vertical display axis is calibrated in dBm (relative to a milliwatt) rather than volts.
- Linear Mode. The seven log amplifier stages are biased to operate as linear amplifiers. Linear gains from 0 dB to 40 dB can be selected.
- The Video Detector. The detector is a half-wave rectifier and filter. The video signal (VIDEO_IF) has a 0 to 2 volt output that is proportional to the signal level.
- T/C Supply. A temperature-compensated -8 V reference supply (-8 VT).
 - Maintains amplitude stability of the log stages over temperature.
 - Maintains linear step-gain accuracy by providing a stable voltage source for the linear step-gain control lines that originate on the A5 assembly.

A24 Processor

The A24 assembly coordinates the operation of all assemblies to perform all instrument functions. This section briefly describes the major functions provided directly by the A24 processor assembly.

- Selection of the input signal for the ADC. The input MUX selects one of the following:
 - An analog signal from assemblies installed in the card cage.
 - The detected 21.4 MHz IF signal (VIDEO_IF).
 - A $+2$ V reference used for ADC calibration of the graticule at top screen.
 - An analog ground (ACOM) reference used for ADC calibration of graticule at bottom screen.
- Final processing of the detected 21.4 MHz IF signal before the video signal is converted by the ADC for further digital processing by the central processing unit (CPU).

- Video bandwidths from 30 Hz to 3 MHz are available in a 1, 3, 10 sequence.
- The ADC input MUX selects the positive-peak detector, or bypasses the positive-peak detector, and selects the sample detector. In sample mode, the video signal passes directly to the ADC from the video bandwidth circuitry.
- The MUX can also select the processed video signal from an assembly in the card cage.
- Mathematical offset of the digitized video signal for greater reference-level resolution and calibration accuracy.
- Digital control of instrument assemblies directly over the IO bus.
- Analog control of instrument assemblies via the A5 analog interface assembly.
- Nonvolatile RAM memory-storage of DLP software, calibration data, and error correction data. Refer to Chapter 11 for more information about calibration and error correction.
- Processing and integration of trace and text information for output to the A2 display assembly. The digitized video signal is merged by the CPU with other trace information. The trace information is then combined with text information for input to the display drive circuitry.
- Generation of the A2 display drive signals. The digital display input is converted back into analog voltages by the A24 display drive-circuitry and sent to the A2 assembly. The display signal is also sent to MONITOR OUTPUT on the rear panel.

A25 Graphics Processor Board

The A5 analog interface board provides address, data, and control bus buffering for the interconnection between the A24 processor board assembly and the A17 graphic signal processor assembly.

A5 Analog Interface

The A5 analog interface assembly converts the digital commands from the A24 assembly to analog control signals for the following assemblies shown on Figure 8-5:

- DAC control of the A11/A13 bandwidth filter assemblies.
 - LC to crystal mode switching. BW5 controls switching between crystal and LC bandwidth filter modes.
 - Bandwidth control. The A5 bandwidth control DACs supply two control lines to drive the PIN diodes on the A11 and A13 assemblies. Companding DACs are used because their nonlinear output compensates for the nonlinear resistance-versus-current of the PIN diodes they control.
 - BW6 control line. Controls the crystal bandwidths from 30 kHz to 1 kHz. More DAC current produces a narrower bandwidth in crystal mode.
 - BW7 control line. Controls the LC bandwidths from 5 MHz to 100 kHz. In LC mode, more DAC current produces a wider bandwidth.

Bandwidth error is corrected by the **CAL AMP** self-calibration routine. Refer to Chapter 11 for a description of **CAL AMP**.

- A12 amplitude control assembly. When the reference level is changed, the A5 assembly switches the calibration attenuators and the step gains on the A12 assembly to change the displayed signal position.

- Calibration attenuators. A TTL high on selected A5 control lines activates a combination of attenuator steps. The 1, 2, 4, and 8 dB step attenuators are combined to provide attenuation in 1 dB increments. Currently, the 16 dB attenuator is not used.
- 10 dB step gains. Temperature-compensated control voltages activate a combination of the three A12 step-gain stages. Step gains are produced in 10 dB increments over a 50 dB range. Step gain errors are corrected by the CAL AMP self-calibration routine. Refer to Chapter 11 for a description of CAL AMP.
- A14 log amplifier assembly. The A5 assembly controls two functions on the A14 assembly:
 - Log/linear mode switching. A temperature-compensated control bias voltage switches the seven A14 amplifier stages to function as either linear amplifiers or logging amplifiers.
 - 10 dB linear step gains. In linear mode, three temperature-compensated control lines bias four of the seven linear amplifiers to provide step gains in 10 dB increments over a 40 dB range. Two amplifiers are switched by one control line to provide the 20 dB step-gain stage.

Linear step gain errors are corrected by the CAL AMP self-calibration routine. Refer to Chapter 11 for a description of CAL AMP.
- A3 preamplifier section. The A5 analog interface board performs these functions on the A3 preamplifier section:
 - Switch control. A5 controls the switching of switches A3A1, A3A3, A3A5, and A3A6. These switches are controlled via W70.
 - Preamplifier control. A5 provides the control signals for the A3A2 switched preamplifier via W70.
 - Input attenuator control. A5 controls the attenuation of the A3A4 input attenuator. This control is provided via W36.

A16 Power Supply Assembly

The A16 power supply assembly is a switching power supply that plugs into a connector on the A15 motherboard. It is not repairable to the component level.

When the line switch is on, it produces the low-power-on (LPWRON) signal that activates the power supply. The power supply then provides the following:

- +12 V for the B1 fan.
- The +5 V, +15 V, -15 V, and +12 V supply voltages.
- A line-trigger signal (LINE_TRIG) at the power-line frequency.
- The high-power-on (HPWRUP) signal used to coordinate the start-up of the A24 processor board assembly.
- +65 V for the A2 display

A6 Narrow Bandwidth

The narrow bandwidth assembly provides four synchronously-tuned bandwidths of 10 Hz, 30 Hz, 100 Hz, and 300 Hz. In addition, it also has a 200 Hz CISPR bandwidth. There are no adjustments necessary on this assembly. All adjustments and corrections are done automatically during the self-cal routine.

When the narrow bandwidths are selected, the instrument re-routes the IF signal through the narrow bandwidth assembly. The narrow bandwidth assembly has a built-in step gain,

log amplifier, and detector which performs all the normal IF section duties. Therefore, the IF specifications must be tested first in the wide bandwidth mode, then repeated for the narrow bandwidth mode.

Refer to the “A6 Narrow Bandwidth Assembly” section of Figure 8-5. The narrow bandwidth assembly is inserted into one of the four card-cage slots. The narrow bandwidth assembly receives the 21.4 MHz AUX_IF from the A15 motherboard. The AUX_IF signal is available to all the card-cage assemblies. The 21.4 MHz signal is downconverted to a 8.56 kHz IF. This low IF frequency was chosen to facilitate the necessary Q for the bandwidth filters and to eliminate the need for bulky crystal circuits.

The 8.56 kHz IF is buffered, put through two poles of active filtering, then the signal goes through 0 to 40 dB of step gain. After the step gain, there are two more active filter poles before the signal is put through a detector. If the instrument is in log mode the signal is amplified logarithmically. Otherwise, the signal is amplified with linear circuits. The detected video signal is then routed back to the A15 motherboard as VIDEO_IF. This signal then goes to the A24 processor assembly and converted to digital.

Refer to the “A14 Log Amplifier/Detector” section of the IF/Control block diagram. The video signal takes a different path when Option 130 is installed and bandwidths greater than 300 Hz (wide bandwidths) are selected. After the signal is detected on the A14 log amplifier assembly, the video is routed to A14J2, DAISY CHAIN VIDEO OUTPUT, then W130 sends the video signal to the A6 narrow bandwidth assembly at A6J3. This video signal goes to the output multiplexer located on the A6 narrow bandwidth assembly. In the wide bandwidths, this signal is selected and is then routed to back to the A15 motherboard as VIDEO_IF.

The A6 narrow bandwidth assembly also has a DAISY CHAIN VIDEO OUTPUT (A6J2). However, this output is not currently in use.

A7 Demodulator/Quasi-Peak/Average Detector Board

The A7 demodulator/quasi-peak/average detector board provides both AM and FM demodulation of the 21.4 MHz IF input. The A7 demodulator/quasi-peak/average detector board also has CISPR specified quasi-peak and average detectors which detect the Video IF input. The A7 demodulator/quasi-peak/average detector board contains an IF overload detector and provisions for an external “click” detector.

A2 Color Display and A17 Graphic Signal Processor

The color display consists of two assemblies: the A17 graphic signal processor (GSP) and the A2 display. The gsp is an interface between the A24 processor board and the A2 display. The gsp reads formatted data from the processor board and converts that data to video signals (digital TTL horizontal and vertical synch signals) and RGB signals. It sends the video and RGB signals to the A2 display and to the A26 rear panel. The gsp also passes the +65 V power supply to the A2 display. The gsp itself uses the +5 V processor board power supply.

The A2 color display is a 7.5 inch scan CRT with associated drive circuitry. It receives its power and input signals from the GSP as described above. Each time the instrument is turned on, the color display automatically degausses itself to minimize color impurity.

A21 Disk Drive Controller Board

The Disk Drive Controller System (DDCS) consists of the A21 disk drive controller board, the host analyzer system, and the A19 disk drive. The A21 disk drive controller board’s major blocks are: control logic, IO interface, SRAMS and pseudo addressing, floppy disk interface, and microprocessor.

When the instrument powers up, the firmware used to run the DDCS is downloaded to the SRAM on the A21 disk drive controller board. The HPWRUP line is a hardware generated hold

off for the A21 disk drive controller board's microprocessor. LRESET_CNTRL is used by the host processor to hold the A21 disk drive controller board's processor in reset until the program has been written to the SRAMs and verified. The program is loaded to SRAM, then read by the host as a test of the IO and RAM subsystems. If errors are detected the user is alerted to the failure on the instrument display. Once the program has been loaded and read back, the A21 disk drive controller board's processor idles until a request is sent from the host processor.

The processor on the A21 disk drive controller board is used primarily to control data flow between the Floppy Disk Interface (FDI) and the host processor. Data is transferred via the IOB bus interface to the SRAMS then to the FDI controller chip.

The Control Logic circuitry contains the PAL which identifies the A21 disk drive controller board to the host processor upon power up.

A19 Disk Drive

The disk drive is compatible with 3.5 inch, double-sided, high density, 135 TPI floppy disks. It complies with the American National Standards Institute (ANSI) X3B8 standard. This disk drive requires a single 5 volt power supply. Its typical power consumption is 1.45 W in the "read" mode.

Insert RF Block Diagram here.

Figure 8-2. HP 85422E/HP 85462A RF Section, Block Diagram

Insert LO Block Diagram here.

Insert 3rd Converter Block Diagram here.

Insert IF/Control Section Block Diagram here.

Insert Wiring Diagram here.

Figure 8-6. HP 85422E/HP 85462A Wiring Diagram

Major Assembly and Cable Locations

The various assemblies and cables of the HP 85422E/HP 85462A receiver RF section are illustrated in this chapter. Refer to Chapter 10 for part numbers, assembly descriptions, and ordering information.

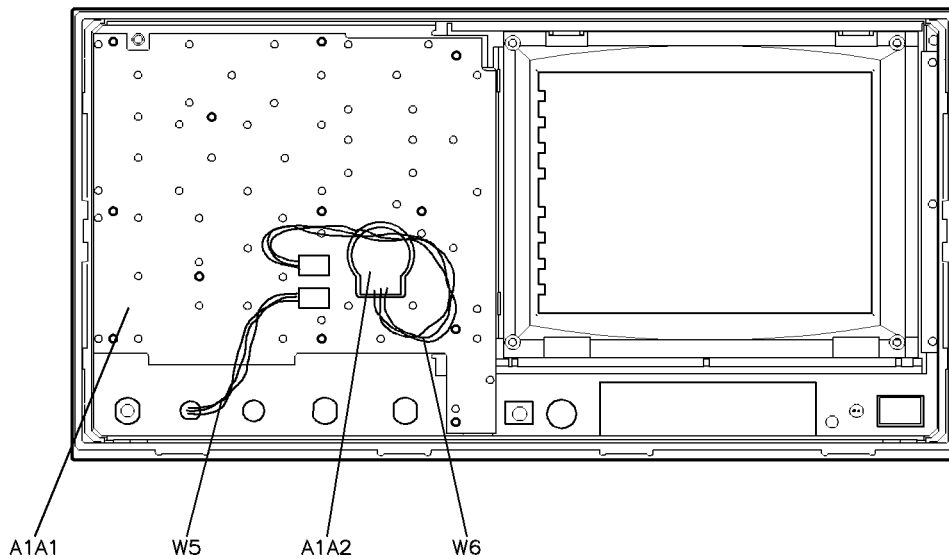

a1assy

Figure 9-1. A1 Front Panel Assembly, Rear View

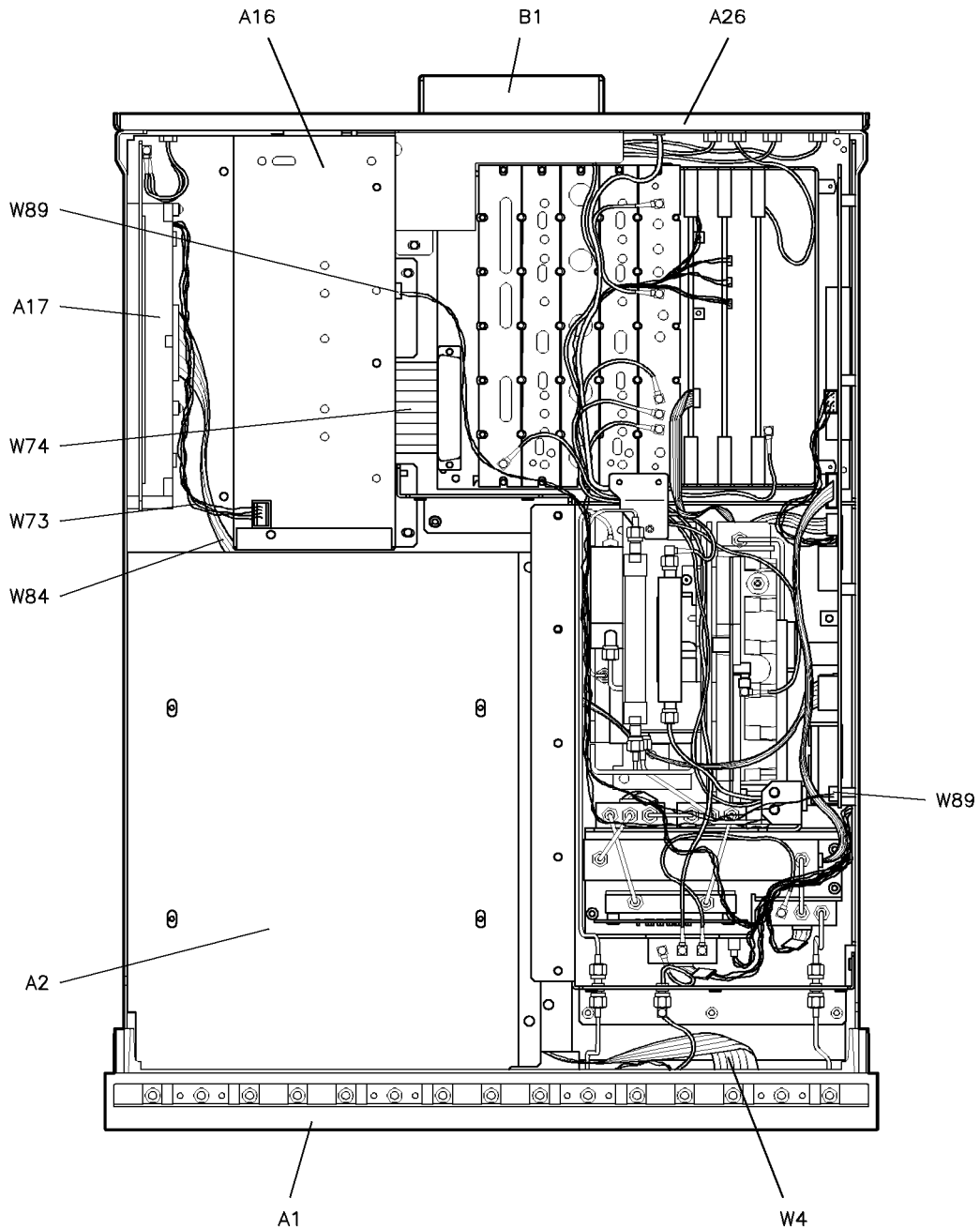
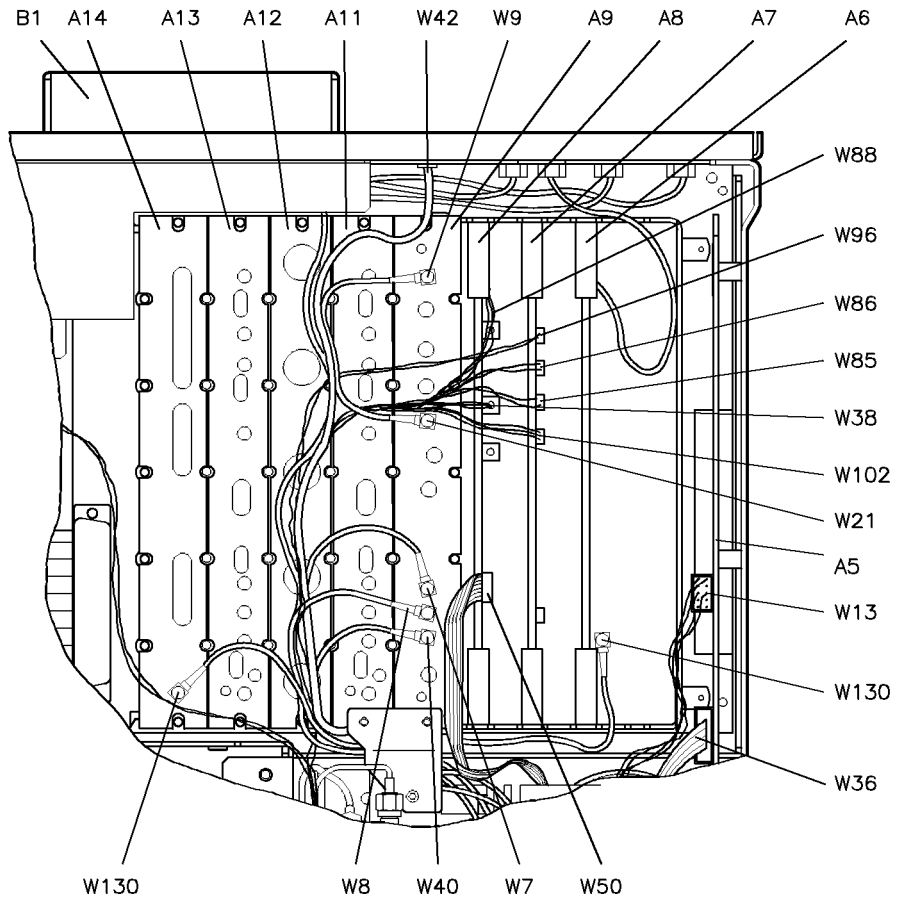

Figure 9-2. HP 85422E/HP 85462A Receiver RF Section, Top View

insttop



iftop

Figure 9-3. HP 85422E/HP 85462A Receiver RF Section IF Section, Top View

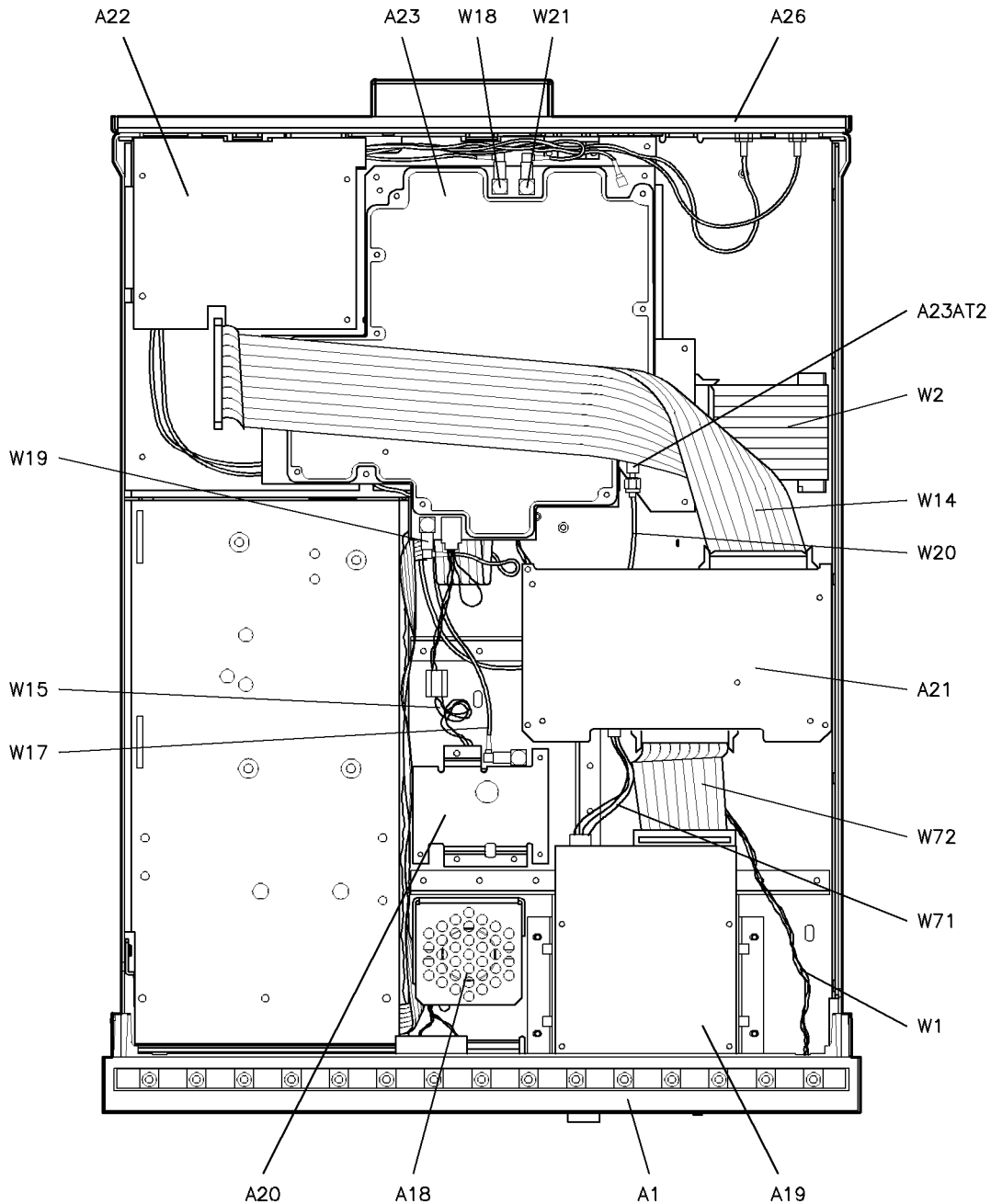

instbtm

Figure 9-4. HP 85422E/HP 85462A Receiver RF Section, Bottom View

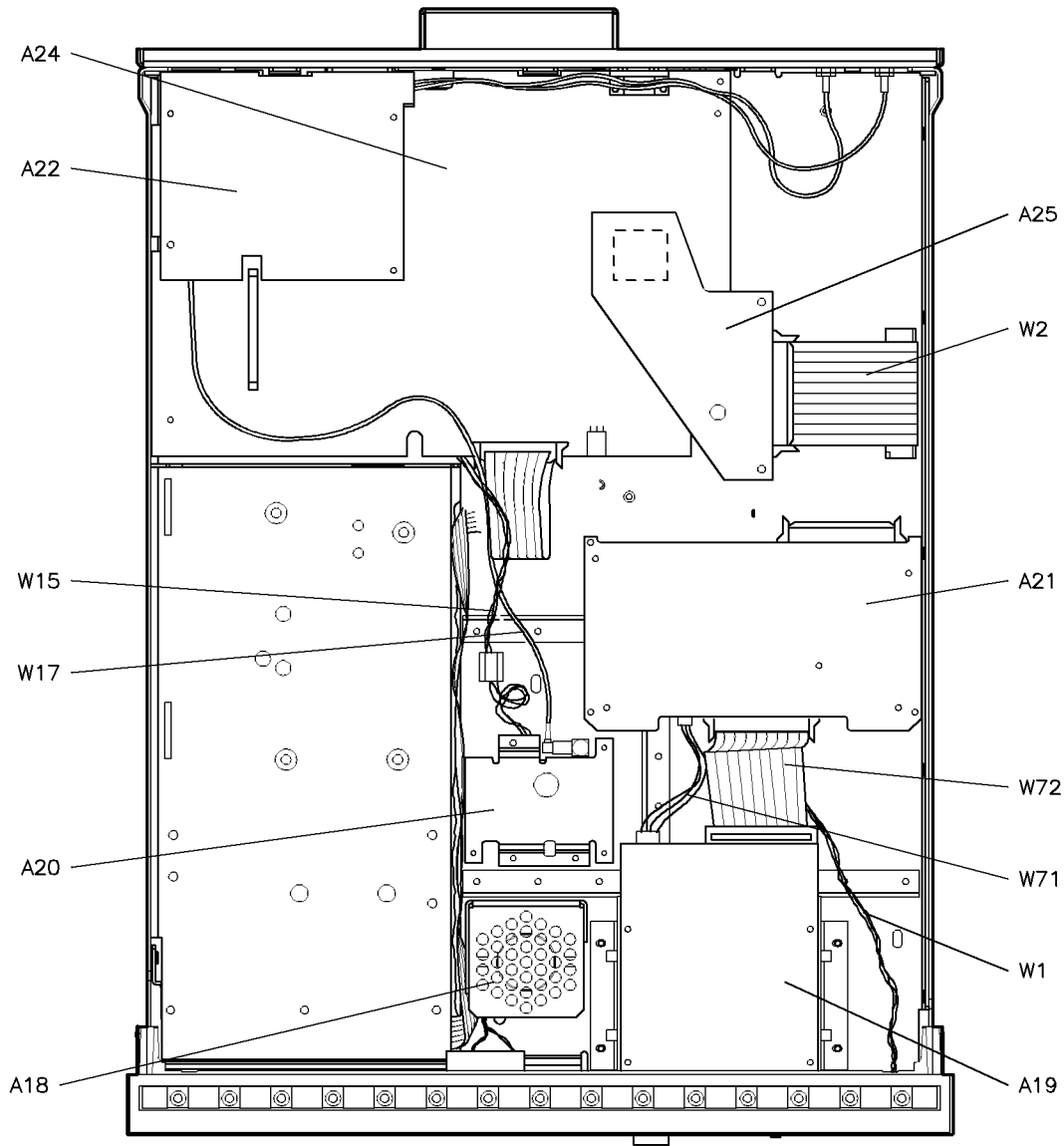

a23remov

Figure 9-5.
HP 85422E/HP 85462A Receiver RF Section, Bottom View (with A23 Counter Lock Assembly Removed)

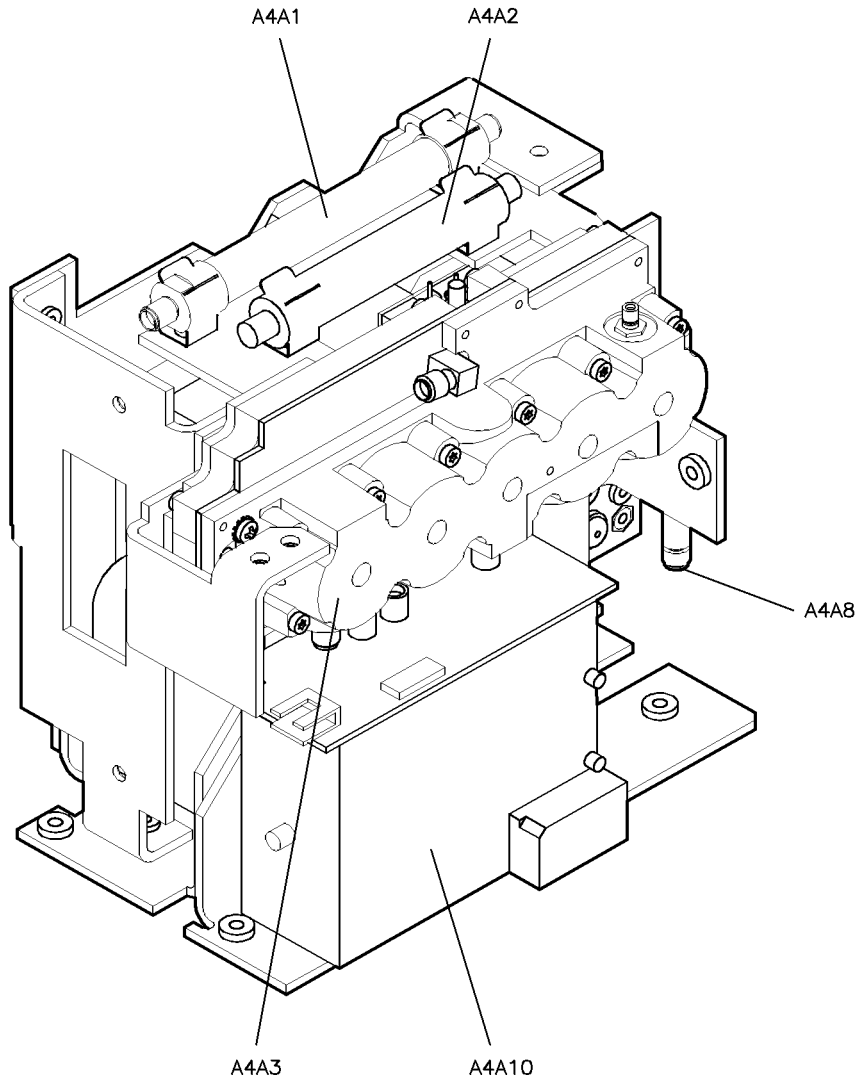

rftoplft

Figure 9-6. A4 RF Section Assemblies, Front Right-Side View

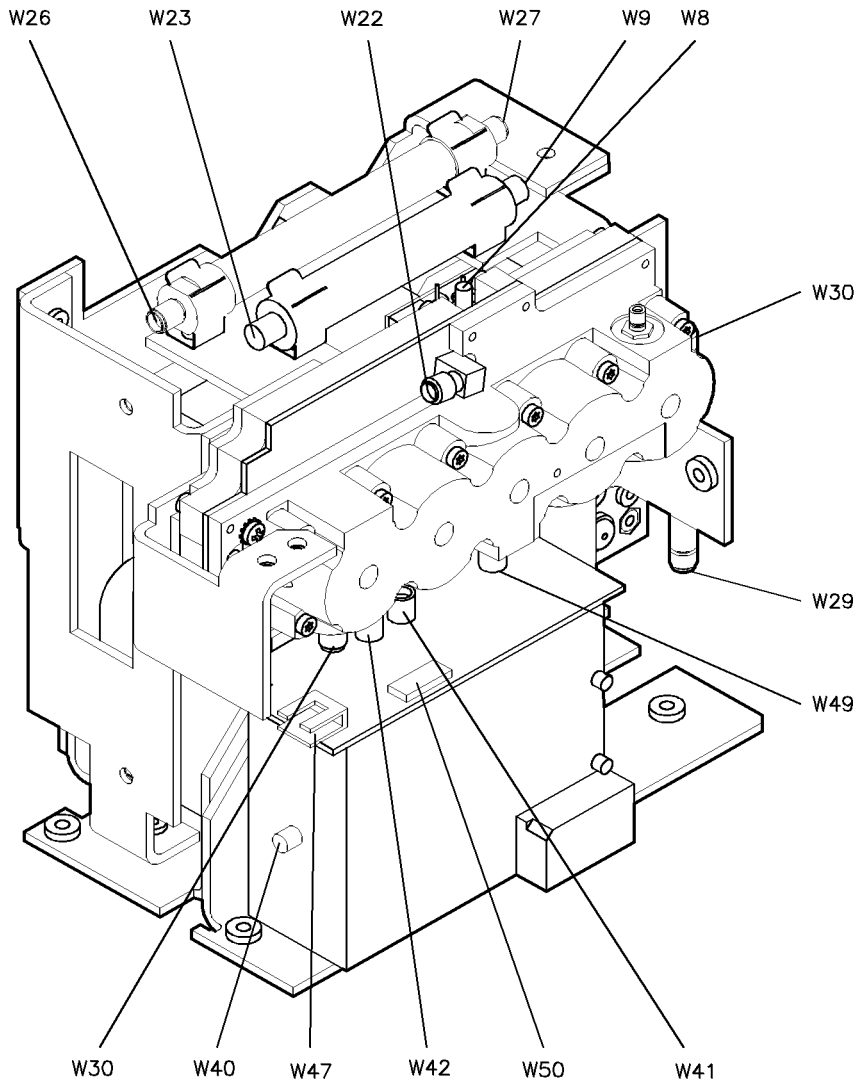

Note: This illustration shows the cable or wire numbers that connect to the A4 RF section assembly connectors displayed.

rfcable1

Figure 9-7. A4 RF Section Cable and Wire Connections, Front Right-Side View

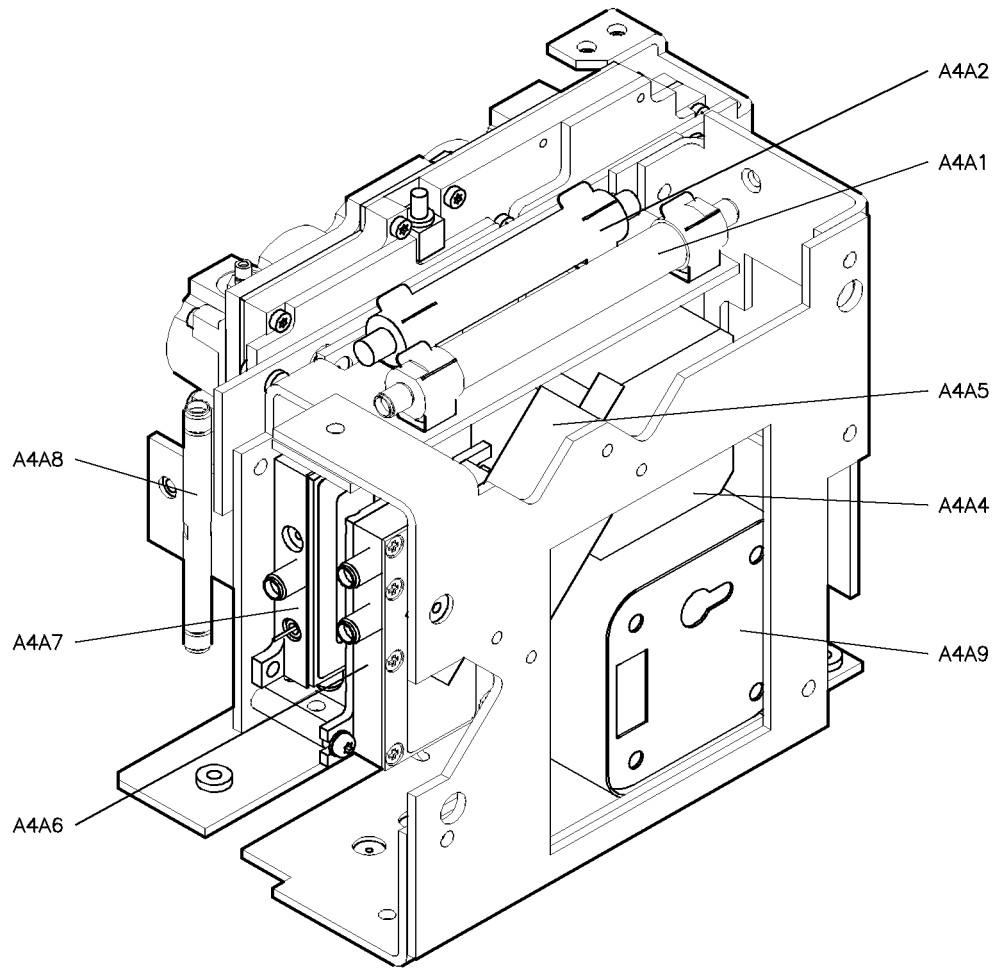

rrear.

Figure 9-8. A4 RF Section Assemblies, Rear Left-Side View

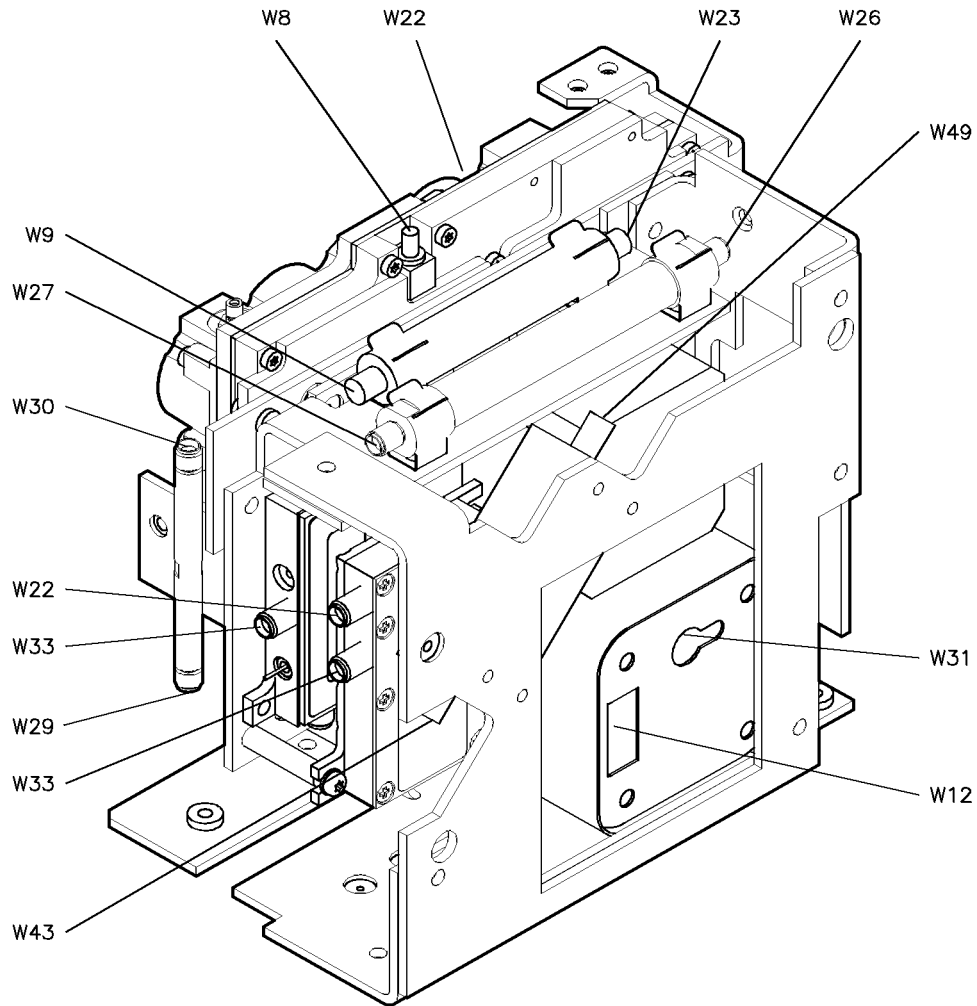

Note: This illustration shows the cable or wire numbers that connect to the A4 RF section assembly connectors displayed.

rfcable2

Figure 9-9. A4 RF Section Cable and Wire Connections, Rear Left-Side View

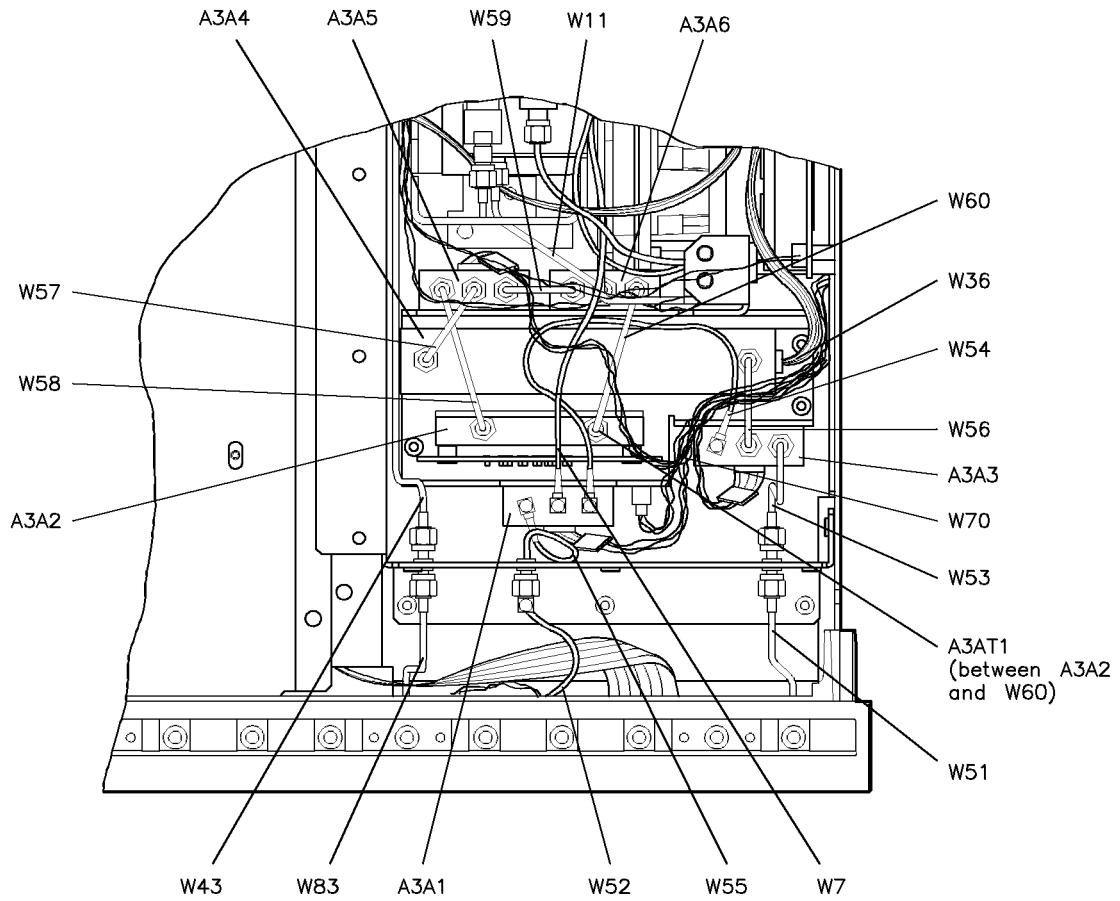

a3top

Figure 9-10. A3 Preamplifier Section, Top View

Replaceable Parts

This chapter contains information for identifying and ordering replacement assemblies for the HP 85422E/HP 85462A receiver RF section.

Major assembly and cable location information is given in Chapter 9.

The following tables and figures are also included in this chapter:

- Table 10-1 lists reference designations, abbreviations, and value multipliers used in the parts lists.
- Table 10-2 lists standard value replacement capacitors.
- Table 10-3 lists standard value replacement resistors, 0.125 W.
- Table 10-4 lists standard value replacement resistors, 0.5 W.
- Table 10-5 lists all major assemblies.
- Table 10-6 lists the cable assemblies.

Ordering Information

To order an assembly or part listed in this chapter, quote the Hewlett-Packard part number and the check digit, and indicate the quantity required.

To order a part that is *not* listed, include the following information with the order:

- Instrument model number.
- Instrument serial number.
- Description of where the part is located, what it looks like, and its function (if known).
- Quantity needed.

Parts can be ordered by addressing the order to the nearest Hewlett-Packard office. Customers within the USA can also use either the direct mail-order system, or the direct phone-order system described below. The direct phone-order system has a toll-free phone number available.

Direct Mail-Order System

Within the USA, Hewlett-Packard can supply parts through a direct mail-order system. Advantages of using the system are as follows:

- Direct ordering and shipment from Hewlett-Packard.
- No maximum or minimum on any mail order. (There is a minimum order amount for parts ordered through a local HP office when the orders require billing and invoicing.)
- Prepaid transportation. (There is a small handling charge for each order.)
- No invoices.

To provide these advantages, a check or money order must accompany each order. Mail-order forms and specific ordering information are available through your local HP office.

Direct Phone-Order System

Within the USA, a phone order system is available for regular and hotline replacement parts service. A toll-free phone number is available, and Mastercard and Visa are accepted.

Regular Orders

The toll-free phone number, (800) 227-8164, is available Monday through Friday, 6 AM to 5 PM (Pacific time). Regular orders have a four-day delivery time.

Hotline Orders

Hotline service is available 24 hours a day, 365 days a year, for emergency parts ordering. The toll-free phone number, (800) 227-8164, is available Monday through Friday, 6 AM to 5 PM (Pacific time). After-hours and on holidays, call (415) 968-2347.

To cover the cost of freight and special handling, there is an additional hotline charge on each order (three line items maximum per order). Hotline orders are normally delivered the next business day after they are ordered.

Table 10-1.
Reference Designations, Abbreviations and Multipliers (1 of 4)

REFERENCE DESIGNATIONS		
A Assembly	F Fuse	RT Thermistor
AT Attenuator, Isolator, Limiter, Termination	FL Filter	S Switch
B Fan, Motor	HY Circulator	T Transformer
BT Battery	J Electrical Connector (Stationary Portion), Jack	TB Terminal Board
C Capacitor	K Relay	TC Thermocouple
CP Coupler	L Coil, Inductor	TP Test Point
CR Diode, Diode Thyristor, Step Recovery Diode, Varactor	M Meter	U Integrated Circuit, Microcircuit
DC Directional Coupler	MP Miscellaneous Mechanical Part	V Electron Tube
DL Delay Line	P Electrical Connector (Movable Portion), Plug	VR Breakdown Diode (Zener), Voltage Regulator
DS Annunciator, Lamp, Light Emitting Diode (LED), Signaling Device (Visible)	Q Silicon Controlled Rectifier (SCR), Transistor, Triode Thyristor	W Cable, Wire, Jumper
E Miscellaneous Electrical Part	R Resistor	X Socket
		Y Crystal Unit (Piezoelectric, Quartz)
		Z Tuned Cavity, Tuned Circuit

ABBREVIATIONS		
A	BSC Basic	CNDCT Conducting, Conductive, Conductivity, Conductor
A Across Flats, Acrylic, Air (Dry Method), Ampere	BTN Button	
ADJ Adjust, Adjustment	C	CONT Contact, Continuous, Control, Controller
ANSI American National Standards Institute (formerly USASI-ASA)	C Capacitance, Capacitor, Center Tapped, Cermet, Cold, Compression	CONV Converter
ASSY Assembly	CCP Carbon Composition Plastic	CPRSN Compression
AWG American Wire Gage	CD Cadmium, Card, Cord	CUP-PT Cup Point
B	CER Ceramic	CW Clockwise, Continuous Wave
BCD Binary Coded Decimal	CHAM Chamfer	D
BD Board, Bundle	CHAR Character, Characteristic, Charcoal	D Deep, Depletion, Depth, Diameter, Direct Current
BE-CU Beryllium Copper	CMOS Complementary Metal Oxide Semiconductor	DA Darlington
BNC Type of Connector		
BRG Bearing, Boring		
BRS Brass		

Table 10-1.
Reference Designations, Abbreviations, and Multipliers (2 of 4)

ABBREVIATIONS					
DAP-GL	Diallyl Phthalate Glass	FT	Current Gain Bandwidth Product (Transition Frequency), Feet, Foot	JFET	Junction Field Effect Transistor
DBL	Double			K	
DCCR	Decoder				
DEG	Degree				
D-HOLE	D-Shaped Hole	FXD	Fixed	K	Kelvin, Key, Kilo, Potassium
DIA	Diameter				
DIP	Dual In-Line Package		G	KNRLD	Knurled
DIP-SLDR	Dip Solder			KVDC	Kilovolts Direct Current
D-MODE	Depletion Mode	GEN	General, Generator		
DO	Package Type Designation	GND	Ground		
DP	Deep, Depth, Diametric Pitch, Dip	GP	General Purpose, Group		L
DP3T	Double Pole Three Throw		H	LED	Light Emitting Diode
DPDT	Double Pole Double Throw	H	Henry, High	LG	Length, Long
DWL	Dowell	HDW	Hardware	LIN	Linear, Linearity
	E	HEX	Hexadecimal, Hexagon, Hexagonal	LK	Link, Lock
E-R	E-Ring	HLCL	Helical	LKG	Leakage, Locking
EXT	Extended, Extension, External, Extinguish	HP	Hewlett-Packard Company, High Pass	LUM	Luminous
	F		I		M
F	Fahrenheit, Farad, Female, Film (Resistor), Fixed, Flange, Frequency	IC	Collector Current, Integrated Circuit	M	Male, Maximum, Mega, Mil, Milli, Mode
FC	Carbon Film/Composition, Edge of Cutoff Frequency, Face	ID	Identification, Inside Diameter	MA	Milliampere
FDTHRU	Feedthrough	IF	Forward Current, Intermediate Frequency	MACH	Machined
FEM	Female	IN	Inch	MAX	Maximum
FIL-HD	Fillister Head	INCL	Including	MC	Molded Carbon Composition
FL	Flash, Flat, Fluid	INT	Integral, Intensity, Internal	MET	Metal, Metallized
FLAT-PT	Flat Point		J	MHZ	Megahertz
FR	Front			MINTR	Miniature
FREQ	Frequency	J-FET	Junction Field Effect Transistor	MIT	Miter
				MLD	Mold, Molded
				MM	Magnetized Material, Millimeter
				MOM	Momentary
				MTG	Mounting
				MTLC	Metallic
				MW	Milliwatt

**Table 10-1.
Reference Designations, Abbreviations, and Multipliers (4 of 4)**

ABBREVIATIONS					
U		VAR	Variable	Y	
UCD	Microcandela	VDC	Volts—Direct Current	YIG	Yttrium-Iron-Garnet
UF	Microfarad	W			
UH	Microhenry	W	Watt, Wattage, White, Wide, Width	Z	
UL	Microliter, Underwriters' Laboratories, Inc.	W/SW	With Switch	ZNR	Zener
UNHDND	Unhardened	WW	Wire Wound		
V		X			
V	Variable, Violet, Volt, Voltage	X	By (Used with Dimensions), Reactance		
VAC	Vacuum, Volts— Alternating Current				

MULTIPLIERS					
Abbreviation	Prefix	Multiple	Abbreviation	Prefix	Multiple
T	tera	10 ¹²	m	milli	10 ⁻³
G	giga	10 ⁹	μ	micro	10 ⁻⁶
M	mega	10 ⁶	n	nano	10 ⁻⁹
k	kilo	10 ³	p	pico	10 ⁻¹²
da	deka	10	f	femto	10 ⁻¹⁵
d	deci	10 ⁻¹	a	atto	10 ⁻¹⁸
c	centi	10 ⁻²			

Standard-Value Replacement Components

Table 10-2. Standard Value Replacement Capacitors

Capacitors					
Type: Tubular Range: 1 to 24 pF Tolerance: 1 to 9.1 pF = ± 0.25 pF 10 to 24 pF = $\pm 5\%$			Type: Dipped Mica Range: 27 to 470 pF Tolerance: $\pm 5\%$		
Value (pF)	HP Part Number	CD	Value (pF)	HP Part Number	CD
1.0	0160-2236	8	27	0160-2306	3
1.2	0160-2237	9	30	0160-2199	2
1.5	0150-0091	8	33	0160-2150	5
1.8	0160-2239	1	36	0160-2308	5
2.0	0160-2240	4	39	0140-0190	7
2.2	0160-2241	5	43	0160-2200	6
2.4	0160-2242	6	47	0160-2307	4
2.7	0160-2243	7	51	0160-2201	7
3.0	0160-2244	8	56	0140-0191	8
3.3	0150-0059	8	62	0140-0205	5
3.6	0160-2246	0	68	0140-0192	9
3.9	0160-2247	1	75	0160-2202	8
4.3	0160-2248	2	82	0140-0193	0
4.7	0160-2249	3	91	0160-2203	9
5.1	0160-2250	6	100	0160-2204	0
5.6	0160-2251	7	110	0140-0194	1
6.2	0160-2252	8	120	0160-2205	1
6.8	0160-2253	9	130	0140-0195	2
7.5	0160-2254	0	150	0140-0196	3
8.2	0160-2255	1	160	0160-2206	2
9.1	0160-2256	2	180	0140-0197	4
10.0	0160-2257	3	200	0140-0198	5
11.0	0160-2258	4	220	0160-0134	1
12.0	0160-2259	5	240	0140-0199	6
13.0	0160-2260	8	270	0140-0210	2
15.0	0160-2261	9	300	0160-2207	3
16.0	0160-2262	0	330	0160-2208	4
18.0	0160-2263	1	360	0160-2209	5
20.0	0160-2264	2	390	0140-0200	0
22.0	0160-2265	3	430	0160-0939	4
24.0	0160-2266	4	470	0160-3533	0

Table 10-3. Standard Value Replacement Resistors, 0.125 W

Resistors					
Type: Fixed-Film					
Range: 10Ω to 464 KΩ					
Wattage: 0.125 at 125°C					
Tolerance: ±1.0%					
Value (Ω)	HP Part Number	CD	Value (Ω)	HP Part Number	CD
10.0	0757-0346	2	422	0698-3447	4
11.0	0757-0378	0	464	0698-0082	7
12.1	0757-0379	1	511	0757-0416	7
13.3	0698-3427	0	562	0757-0417	8
14.7	0698-3428	1	619	0757-0418	9
16.2	0757-0382	6	681	0757-0419	0
17.8	0757-0294	9	750	0757-0420	3
19.6	0698-3429	2	825	0757-0421	4
21.5	0698-3430	5	909	0757-0422	5
23.7	0698-3431	6	1.0K	0757-0280	3
26.1	0698-3432	7	1.1K	0757-0424	7
28.7	0698-3433	8	1.21K	0757-0274	5
31.6	0757-0180	2	1.33K	0757-0317	7
34.8	0698-3434	9	1.47K	0757-1094	9
38.3	0698-3435	0	1.62K	0757-0428	1
42.2	0757-0316	6	1.78K	0757-0278	9
46.4	0698-4037	0	1.96K	0698-0083	8
51.1	0757-0394	0	2.15K	0698-0084	9
56.2	0757-0395	1	2.37K	0698-3150	6
61.9	0757-0276	7	2.61K	0698-0085	0
68.1	0757-0397	3	2.87K	0698-3151	7
75.0	0757-0398	4	3.16K	0757-0279	0
82.5	0757-0399	5	3.48K	0698-3152	8
90.9	0757-0400	9	3.83K	0698-3153	9
100	0757-0401	0	4.22K	0698-3154	0
110	0757-0402	1	4.64K	0698-3155	1
121	0757-0403	2	5.11K	0757-0438	3
133	0698-3437	2	5.62K	0757-0200	7
147	0698-3438	3	6.19K	0757-0290	5
162	0757-0405	4	6.81K	0757-0439	4
178	0698-3439	4	7.50K	0757-0440	7
196	0698-3440	7	8.25K	0757-0441	8
215	0698-3441	8	9.09K	0757-0288	1
237	0698-3442	9	10.0K	0757-0442	9
261	0698-3132	4	11.0K	0757-0443	0
287	0698-3443	0	12.1K	0757-0444	1
316	0698-3444	1	13.3K	0757-0289	2
348	0698-3445	2	14.7K	0698-3156	2
383	0698-3446	3	16.2K	0757-0447	4

Table 10-3. Standard Value Replacement Resistors, 0.125 W (continued)

Resistors					
Type: Fixed-Film Range: 10 Ω to 464 K Ω Wattage: 0.125 at 125°C Tolerance: $\pm 1.0\%$					
Value (Ω)	HP Part Number	CD	Value (Ω)	HP Part Number	CD
17.8K	0698-3136	8	100K	0757-0465	6
19.6K	0698-3157	3	110K	0757-0466	7
21.5K	0757-0199	3	121K	0757-0467	8
23.7K	0698-3158	4	133K	0698-3451	0
26.1K	0698-3159	5	147K	0698-3452	1
28.7K	0698-3449	6	162K	0757-0470	3
31.6K	0698-3160	8	178K	0698-3243	8
34.8K	0757-0123	3	196K	0698-3453	2
38.3K	0698-3161	9	215K	0698-3454	3
42.2K	0698-3450	9	237K	0698-3266	5
46.4K	0698-3162	0	261K	0698-3455	4
51.1K	0757-0458	7	287K	0698-3456	5
56.2K	0757-0459	8	316K	0698-3457	6
61.9K	0757-0460	1	348K	0698-3458	7
68.1K	0757-0461	2	383K	0698-3459	8
75.0K	0757-0462	3	422K	0698-3460	1
82.5K	0757-0463	4	464K	0698-3260	9
90.9K	0757-0464	5			

Table 10-4. Standard Value Replacement Resistors, 0.5 W

Resistors					
Type: Fixed-Film Range: 10Ω to 1.47 MΩ Wattage: 0.5 at 125°C Tolerance: ±1.0%					
Value (Ω)	HP Part Number	CD	Value (Ω)	HP Part Number	CD
10.0	0757-0984	4	383	0698-3404	3
11.0	0575-0985	5	422	0698-3405	4
12.1	0757-0986	6	464	0698-0090	7
13.3	0757-0001	6	511	0757-0814	9
14.7	0698-3388	2	562	0757-0815	0
16.2	0757-0989	9	619	0757-0158	4
17.8	0698-3389	3	681	0757-0816	1
19.6	0698-3390	6	750	0757-0817	2
21.5	0698-3391	7	825	0757-0818	3
23.7	0698-3392	8	909	0757-0819	4
26.1	0757-0003	8	1.00K	0757-0159	5
28.7	0698-3393	9	1.10K	0757-0820	7
31.6	0698-3394	0	1.21K	0757-0821	8
34.8	0698-3395	1	1.33K	0698-3406	5
38.3	0698-3396	2	1.47K	0757-1078	9
42.2	0698-3397	3	1.62K	0757-0873	0
46.4	0698-3398	4	1.78K	0698-0089	4
51.1	0757-1000	7	1.96K	0698-3407	6
56.2	0757-1001	8	2.15K	0698-3408	7
61.9	0757-1002	9	2.37K	0698-3409	8
68.1	0757-0794	4	2.61K	0698-0024	7
75.0	0757-0795	5	2.87K	0698-3101	7
82.5	0757-0796	6	3.16K	0698-3410	1
90.0	0757-0797	7	3.48K	0698-3411	2
100	0757-0198	2	3.83K	0698-3412	3
110	0757-0798	8	4.22K	0698-3346	2
121	0757-0799	9	4.64K	0698-3348	4
133	0698-3399	5	5.11K	0757-0833	2
147	0698-3400	9	5.62K	0757-0834	3
162	0757-0802	5	6.19K	0757-0196	0
178	0698-3334	8	6.81K	0757-0835	4
196	0757-1060	9	7.50K	0757-0836	5
215	0698-3401	0	8.25K	0757-0837	6
237	0698-3102	8	9.09K	0757-0838	7
261	0757-1090	5	10.0K	0757-0839	8
287	0757-1092	7	12.1K	0757-0841	2
316	0698-3402	1	13.3K	0698-3413	4
348	0698-3403	2	14.7K	0698-3414	5

Table 10-4. Standard Value Replacement Resistors, 0.5 W (continued)

Resistors					
Type: Fixed-Film					
Range: 10 Ω to 1.47 M Ω					
Wattage: 0.5 at 125 $^{\circ}$ C					
Tolerance: \pm 1.0%					
Value (Ω)	HP Part Number	CD	Value (Ω)	HP Part Number	CD
16.2K	0757-0844	5	162K	0757-0130	2
17.8K	0698-0025	8	178K	0757-0129	9
19.6K	0698-3415	6	196K	0757-0063	0
21.5K	0698-3416	7	215K	0757-0127	7
23.7K	0698-3417	8	237K	0698-3424	7
26.1K	0698-3418	9	261K	0757-0064	1
28.7K	0698-3103	9	287K	0757-0154	0
31.6K	0698-3419	0	316K	0698-3425	8
34.8K	0698-3420	3	348K	0757-0195	9
38.3K	0698-3421	4	383K	0757-0133	5
42.2K	0698-3422	5	422K	0757-0134	6
46.4K	0698-3423	6	464K	0698-3426	9
51.1K	0757-0853	6	511K	0757-0135	7
56.2K	0757-0854	7	562K	0757-0868	3
61.9K	0757-0309	7	619K	0757-0136	8
68.1K	0757-0855	8	681K	0757-0869	4
75.0K	0757-0856	9	750K	0757-0137	9
82.5K	0757-0857	0	825K	0757-0870	7
90.9K	0757-0858	1	909K	0757-0138	0
100K	0757-0367	7	1M	0757-0059	4
110K	0757-0859	2	1.1M	0757-0139	1
121K	0757-0860	5	1.21M	0757-0871	8
133K	0757-0310	0	1.33M	0757-0194	8
147K	0698-3175	5	1.47M	0698-3464	5

Assembly-Level Replaceable Parts and Cables

Table 10-5. Assembly-Level Replaceable Parts

Reference Designator	Description	HP Part Number
A1	Front Frame Assembly	85462-60008
A1A1	Keyboard	85462-60048
A1A2	Rotary Pulse Generator (RPG)	1990-1525
A2	Monitor	85462-60029
	Rebuilt CRT	5180-8484
A3A1	Switch	33314-60014
A3A2	Switched Preamplifier	5086-7902
	Exchange Switched Preamplifier (Rebuilt)	5086-6902
A3A3	Switch	33314-60014
A3A4	Input Attenuator	33321-60036
A3A5	Switch	33314-60014
A3A6	Switch	33314-60014
A3AT1	3 dB Attenuator	0955-0114
A4A1	Low Pass Filter (LPF), 2.9 GHz	0955-0420
A4A2	Band Pass Filter (BPF), 321.4 MHz	9135-0252
A4A3	Second Converter	5086-7858
A4A4	Switched YIG-Tuned Filter (SYTF) (<i>For an HP 8546A/HP 85462A only.</i>)	5086-7803
A4A5	Output Attenuator	0955-0679
A4A6	Dual Band Mixer	5086-7977
A4A7	Local Oscillator Distribution Amplifier (LODA)	5086-7744
A4A8	Low Pass Filter (LPF), 4.4 GHz	0955-0519
A4A9	Electronic YIG Oscillator (EYO)	5086-7903
A4A10	Tracking Generator	5086-7917
A5	Analog Interface Board (<i>HP 8546A/HP 85462A only</i>)	85462-60015
	Analog Interface Board (<i>HP 8542E/HP 85422E only</i>)	85422-60001
A6	Narrow Bandwidth Board	08590-60352
A7	Demodulator/Quasi-Peak/Average Detector Board	85462-60042
A8	Tracking Generator Control Board	5063-0635
A9	Third Converter Board	08593-60062
A11	Bandwidth Board	85462-60034
A12	Amplitude Control Board	85462-60037
A13	Bandwidth Board	85462-60034

Table 10-5. Assembly-Level Replaceable Parts (continued)

Reference Designator	Description	HP Part Number
A14	Log Amplifier Board	08590-60386
A15	Motherboard	85462-60014
A16	Power Supply Assembly	85462-60010
A17	Graphic Signal Processor Assembly	08753-60170
A18	Speaker	8120-6336
A19	Disk Drive	0950-2075
A20	10 MHz Reference	1813-0644
A21	Disk Drive Controller Board	85462-60046
A22	HP-IB	08590-60345
A22	RS-232 Board (<i>For Option 023 only</i>)	08590-60346
A23	Counter Lock Assembly	08591-60098
A23AT2	10 dB Attenuator	5086-7806
A24	Processor Board Assembly	85462-60032
A25	Graphics Processor Board	85462-60005
A26	Rear Frame Assembly	85462-60009
B1	Fan	3160-0828
BT1	Battery (located on the A24 Processor Board - not shown in Chapter 9)	1420-0331
FL1	Line Filter (located on the A26 Rear Panel - not shown in Chapter 9)	0950-2341

Table 10-6. Replaceable Cables

Reference Designator	Description	HP Part Number
W1	A1 Front Panel Assembly to A24 Processor Board Assembly, LINE SWITCH	8120-6168
W2	A25 Graphics Processor Board to A17 Graphic Signal Processor Assembly, Ribbon Cable	8120-6130
W4	A24 Processor Board Assembly to A1A1 Keyboard, Ribbon Cable	08592-60037
W5	A1A1 Keyboard to A1 Front Panel Assembly, PROBE POWER	5062-4826
W6	A1A1 Keyboard to A1A2 Rotary Pulse Generator	0960-0745
W7	A9 Third Converter Board to A3A1 Switch, 300 MHZ CAL OUT	8120-5106
W8	A9 Third Converter Board to A4A3 Second Converter, 600 MHZ	8120-5020
W9	A4A2 321.4 MHz Band-Pass Filter to A9 Third Converter Board, 321.4 MHZ	8120-5106
W11	A3A6 Switch to A4A4 Switched YIG-Tuned Filter (SYTF), Semi-Rigid Cable	85462-20012
W12	A5 Analog Interface Board to A4A9 Electronic YIG Oscillator (EYO), Ribbon Cable, EYO CONTROL	8120-6135
W13	A5 Analog Interface Board to A4A4 Switched YIG-Tuned Filter (SYTF) and A4A6 Dual Band Mixer, SYTF/DUAL BAND MIXER CONTROL	5063-0206
W14	A24 Processor Board Assembly to A21 Disk Drive Controller Board and A23 Counter Lock Assembly, RIBBON CABLE	8120-6134
W15	A23 Counter Lock Assembly to A20 10 MHz Precision Reference, OCXO POWER	5063-0205
W17	A20 10 MHz Precision Reference to A26 Rear Panel, 10MHZ REF OUTPUT	8120-5057
W18	A23 Counter Lock Assembly to A26 Rear Panel, EXT REF IN	8120-5055
W19	A15 Motherboard to A23 Counter Lock Assembly	08591-60012
W20	A4A7 Local Oscillator Distribution Amplifier (LODA) to A23 Counter Lock Assembly	8120-5148
W21	A9 Third Converter Board to A23 Counter Lock Assembly, COUNTER LOCK OUTPUT	8120-5023
W22	A4A6 Dual Band Mixer to A4A3 Second Converter, Semi-Rigid Cable, HIGH BAND	8120-5067
W23	A4A3 Second Converter to A4A2 321.4 MHz Band-Pass Filter, Semi-Rigid Cable, 321.4 MHZ	8120-5058
W26	A4A4 Switched YIG-Tuned Filter (SYTF) to A4A1 2.9 GHz Low-Pass Filter, Semi-Rigid Cable, SYTF LOW BAND	08595-20003
W27	A4A1 2.9 GHz Low-Pass Filter to A4A6 Dual Band Mixer, Semi-Rigid Cable	08593-20010
W28	A4A4 Switched YIG-Tuned Filter (SYTF) to A4A6 Dual Band Mixer, Adapter, 3-6 GHZ	1250-1788
W29	A4A6 Dual Band Mixer to A4A8 4.4 GHz Low-Pass Filter, Semi-Rigid Cable	08593-20011
W30	A4A8 4.4 GHz Low-Pass Filter to A4A3 Second Converter, Semi-Rigid Cable, LOW BAND	08593-20012
W31	A4A9 Electronic YIG Oscillator (EYO) to A4A7 Local Oscillator Distribution Amplifier (LODA), Semi-Rigid Cable	08593-20004

Table 10-6. Replaceable Cables (continued)

Reference Designator	Description	HP Part Number
W33	A4A6 Dual Band Mixer to A4A7 Local Oscillator Distribution Amplifier (LODA), Semi-Rigid Cable	08593-20003
W34	A5 Analog Interface Board to A4A4 Switched YIG-Tuned Filter (SYTF), SYTF POWER	08590-60018
W35	A5 Analog Interface Board to A4A3 Second Converter, Ribbon Cable, 2ND CONVERTER CONTROL	5062-6434
W36	A5 Analog Interface Board to A3A4 Input Attenuator, Ribbon Cable, INPUT ATTENUATOR CONTROL CABLE	8120-6127
W38	A8 Tracking Generator Control Board to A4A7 Local Oscillator Distribution Amplifier (LODA), Ribbon Cable, LODA CONTROL	08593-60009
W40	A9 Third Converter Board to A4A10 Tracking Generator, 600 MHZ TG	8120-5023
W41	A4A7 Local Oscillator Distribution Amplifier (LODA) to A4A10 Tracking Generator, Semi-Rigid Cable, LO IN	08593-20002
W42	A4A10 Tracking Generator to A26 Rear Panel, LO OUTPUT	5062-7710
W43	A4A5 Output Attenuator to Bulkhead Connector, Semi-Rigid Cable, TG OUT	85462-20021
W47	A1 Front Panel Assembly to A4A10 Tracking Generator, ALC IN	8120-6138
W49	A4A10 Tracking Generator to A4A5 Output Attenuator, Semi-Rigid Cable, TG OUT	08593-20008
W50	A8 Tracking Generator Control Board to A4A10 Tracking Generator, Ribbon Cable, TG CONTROL	8120-6131
W51	A1 Front Panel Assembly to Bulkhead Connector, Semi-Rigid Cable, RF INPUT	85462-20006
W52	Bulkhead Connector to A1 Front Panel Assembly, 300 MHZ OUTPUT	08592-60024
W53	Bulkhead Connector to A3A3 Switch, Semi-Rigid Cable, RF INPUT	85462-20020
W54	A3A1 Switch to A3A3 Switch	8120-5067
W55	A3A1 Switch to Bulkhead Connector, CAL OUT	8120-5066
W56	A3A3 Switch to A3A4 Input Attenuator, Semi-Rigid Cable	85462-20009
W57	A3A4 Input Attenuator to A3A5 Switch, Semi-Rigid Cable, INPUT ATTENUATOR OUTPUT	85462-20009
W58	A3A5 Switch to A3A2 Switched Preamplifier, Semi-Rigid Cable	85462-20007
W59	A3A5 Switch to A3A6 Switch, Semi-Rigid Cable	85462-20008
W60	A3A2 Switched Preamplifier to A3A6 Switch, Semi-Rigid Cable, PREAMPLIFIER OUTPUT	85462-20022
W70	A5 Analog Interface Board to A3A1 Switch, A3A2 Switched Preamplifier, A3A3 Switch, A3A5 Switch, and A3A6 Switch, SWITCH CONTROL	8120-6128
W71	A19 Disk Drive to A21 Disk Drive Controller Board, DISK DRIVE POWER	8120-6130

Table 10-6. Replaceable Cables (continued)

Reference Designator	Description	HP Part Number
W72	A19 Disk Drive to A21 Disk Drive Controller Board, RIBBON CABLE, DISK DRIVE CONTROL	8120-6129
W73	A16 Power Supply Assembly to A17 Graphic Signal Processor Assembly	8120-6133
W74	A16 Power Supply Assembly to A15 Motherboard, Ribbon Cable	8120-6132
W75	A15 Motherboard to A26 Rear Panel, AUX VIDEO	8120-5053
W76	A15 Motherboard to A26 Rear Panel, AUX IF	8120-5053
W77	A24 Processor Board Assembly to A26 Rear Panel, EXT TRIGGER	8120-5055
W78	A15 Motherboard to A26 Rear Panel, HIGH SWEEP	8120-6169
W79	A15 Motherboard to A26 Rear Panel, SWEEP RAMP	8120-6169
W80	A17 Graphic Signal Processor Assembly to A26 Rear Panel, EXT VIDEO B	8120-5053
W81	A17 Graphic Signal Processor Assembly to A26 Rear Panel, EXT VIDEO G/SYNC	8120-5053
W82	A17 Graphic Signal Processor Assembly to A26 Rear Panel, EXT VIDEO R	8120-5053
W83	Bulkhead Connector to A1 Front Panel Assembly, Semi-Rigid Cable, TG OUT	85462-20014
W84	A17 Graphic Signal Processor Assembly to A2 Display, Ribbon Cable, DISPLAY CONTROL	8120-6385
W85	A7 Demodulator/Quasi-Peak/Average Detector Board to A1 Front Panel Assembly, EARPHONE	8120-6140
W86	A7 Demodulator/Quasi-Peak/Average Detector Board to A18 Speaker Assembly, SPEAKER	8120-6336
W87	B1 Fan to A15 Motherboard	3160-0828
W88	A8 Tracking Generator Control Board to A4A5 Output Attenuator, ATTENUATOR CONTROL	8120-8141
W89	A16 Power Supply Assembly to A5 Analog Interface Board, +12V	8120-6139
W90	FL1 Line Filter to A16 Power Supply Assembly	8120-6138
W91	A6 Narrow Bandwidth Board to A15 Motherboard	8120-5030
W93	A24 Processor Board Assembly to A26 Rear Panel, GATE TRIGGER IN	8120-5055
W94	A24 Processor Board Assembly to A26 Rear Panel, GATE OUT	8120-5055
W95	FL1 Line Filter to FL1 Line Filter	0950-2341
W96	A12 Amplitude Control Board to A7 Demodulator/Quasi-Peak/Average Detector Board, OVERLOAD DETECTOR	8120-6447
W102	A7 Demodulator/Quasi-Peak/Average Detector Board to A1 Front Panel Assembly, VOLUME	8120-6137
W130	A6 Narrow Bandwidth Board to A14 Log Amplifier Board	8120-5020

Service Softkey Descriptions

Refer to this chapter for an explanation of the instrument passcodes, the two types of instrument correction data, and the service-related softkeys that are available after pressing **CALIBRATE**.

The calibration, service, and diagnostic softkey functions are listed alphabetically. A list of service-related softkeys follows each softkey description, when appropriate. Refer to the description of each related softkey to understand how the softkey functions interrelate.

Calibration, Service, and Diagnostic Softkey Functions

The front-panel **CALIBRATE** key provides the softkey menus for the self-calibration routines, the service-calibration and service-diagnostic routines. Refer to Figure 11-1 for the organization of the softkeys related to **CALIBRATE**.

CAUTION Correction-constant data can be lost if the **Service Cal** softkeys are used improperly. Refer to the appropriate softkey description for instructions on softkey usage.

CALIBRATE Softkey Organization

Figure 11-1 provides the organization of all softkeys available after pressing **CALIBRATE**. Each block of softkeys represents the softkeys that are displayed at one time. The diagram flow indicates the actual key sequence used for each softkey. The footnotes identify softkeys that appear only when a passcode has been entered or a specific instrument option is installed in the instrument.

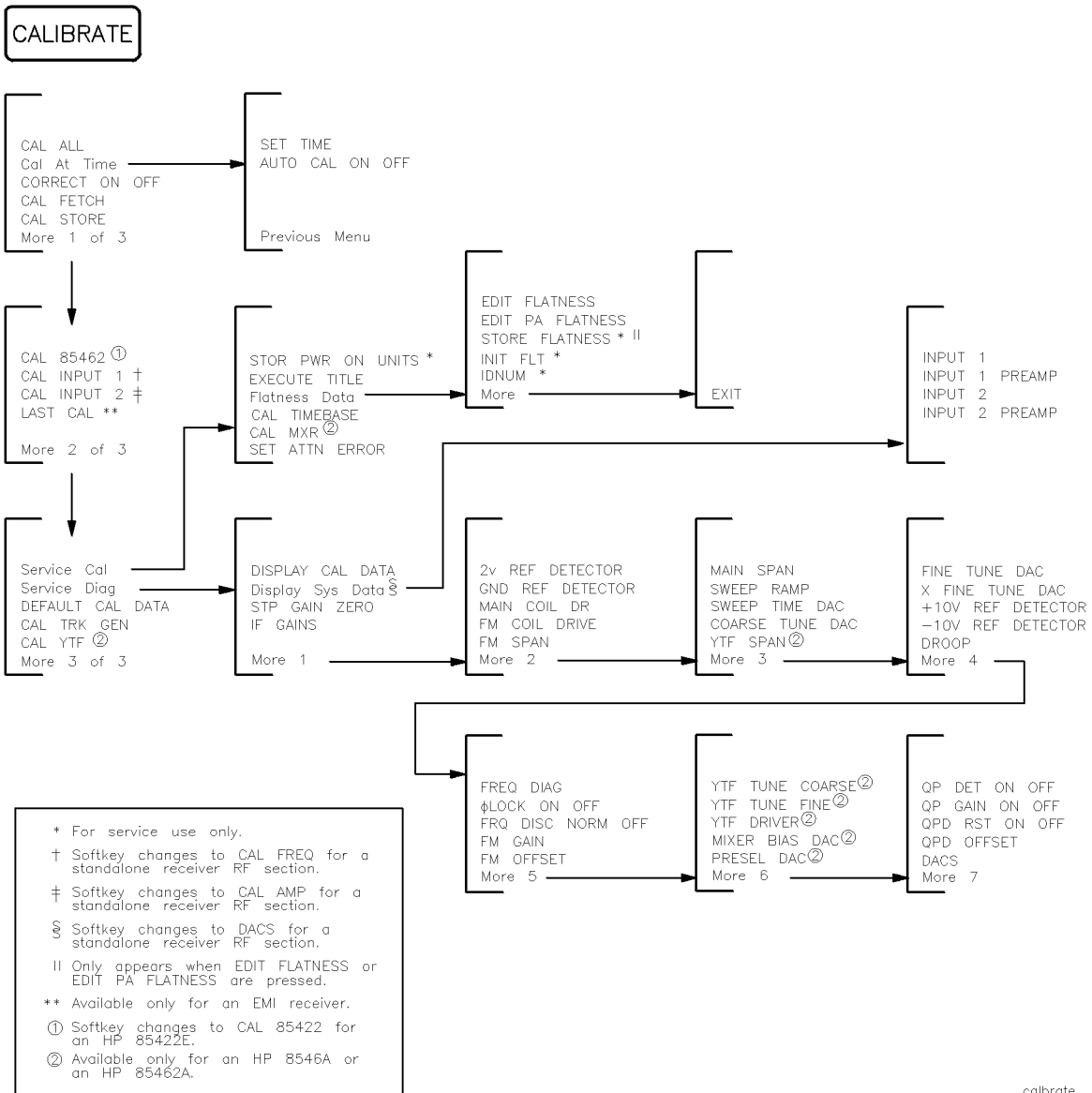

Figure 11-1. Calibration, Service, and Diagnostic Softkey Tree

Understanding Instrument Passcodes

Passcodes activate specific softkey functions and protect the correction data from accidental erasure or modification. The two passcodes, –37 Hz and –2001 Hz, are explained below.

–37 Hz passcode

Use the –37 Hz passcode to perform the following functions:

- Replace the current calibration-factors with the default calibration data provided by `DEFAULT CAL DATA`.
- Bypass the CAL OUT set-up check within individual self-calibration routines.

–2001 Hz passcode

Use the –2001 Hz service passcode to perform the following functions:

- Set the start frequency, stop frequency, and step size of the flatness correction points using `INIT FLT`.
- Edit the flatness-correction constants using `EDIT FLATNESS`.
- Edit the A12 amplitude control step-attenuator correction constants using `SET ATTN ERROR`.
- Set the correction factor for the 10 MHz frequency reference (standard timebase).
- Modify the displayed power units that appear when the instrument is first turned on using `STOR PWR ON UNITS`.
- Bypass the CAL OUT signal check within individual self-calibration routines.

Entering A Passcode

The passcode must be entered before pressing `CALIBRATE`. Press the following keys to enter a passcode.

`FREQUENCY`

`CENTER FREQ`

–37 `HZ` *or* –2001 `HZ`

`CALIBRATE`

When SV appears in the lower-left corner of the display, the passcode has been accepted.

Understanding Correction Data

The firmware uses correction data to improve instrument performance by minimizing the effect of variations in hardware. There are two categories of correction data:

- Self-calibration correction factors.
- Service-calibration correction constants.

Most correction data can be displayed and modified with the softkey functions provided by **CALIBRATE**.

Self-Calibration Correction Factors

Self-calibration correction factors enhance instrument accuracy by adjusting DACs on the A5 analog interface assembly and by adding offsets to trace information. The correction factor data is stored in nonvolatile memory on the A24 processor assembly after pressing **CAL STORE**.

The correction-factor data is produced by the **CAL AMP** and **CAL FREQ** self-calibration routines. Refer to the softkey descriptions in this section for further information.

Service-Calibration Correction Constants

The service-calibration correction constants enhance instrument performance by compensating for frequency-response variation and A12 amplitude control step-attenuation errors. The correction constants are unique for each instrument.

The correction constants for flatness can be viewed, or modified, using **FLATNESS DATA**. Refer to any of the flatness calibration procedures in Chapter 2 for instructions on generating new correction constants.

The correction constants for step-attenuation errors on the A12 amplitude control assembly can be modified using **SET ATTN ERROR**. Refer to the cal attenuator adjustment error procedure in Chapter 2 for instructions on generating new correction constants.

Instruments equipped with an A4A10 Tracking Generator use two correction constants to improve the performance of the external automatic level control (ALC).

The initial service-calibration correction constants are stored by the factory in nonvolatile memory on the A24 assembly. After shipment, new correction constants must be manually generated whenever an adjustment or repair affects flatness or A12 amplitude control step attenuation.

Refer to “After a Repair” in Chapter 3 for the specific assemblies that affect flatness. Whenever the A24 processor assembly is replaced, new correction constants must also be generated, unless valid correction constants were saved prior to the instrument failure.

Note that the manual generation of the new service-calibration correction constants is a lengthy procedure. Avoid having to generate new correction constants manually by periodically recording the current correction constants.

Refer to the softkey descriptions in this section for specific information about the use and modification of the correction-constant data.

ϕLock ON OFF Phase Lock On/Off

DESCRIPTION	<p>Disables locking of the first LO to allow faster response of the keypad and the sweep when the instrument has a poor frequency calibration.</p> <p>Before a normal sweep, the instrument uses the frequency calibration to set the first LO close to the desired value. It then counts the frequency of the first LO and adjusts it until the correct frequency is achieved within the count resolution. Next it closes the discriminator if the span is less than 10 MHz, then begins the sweep.</p> <p>Note that if the frequency calibration is poor, this procedure of locking the LO requires a long time, often many seconds or even minutes. During this time the instrument does not respond quickly to the keypad. This key disables locking until a frequency calibration can be successfully completed.</p> <p>When the instrument determines that the frequency calibration is poor, it automatically disables the first LO lock and the message VLock OFF will appear on screen.</p>
-------------	--

+10 V REF DETECTOR + 10 V Reference Detector

DESCRIPTION	<p>Displays the output of the +10 V reference from the A5 analog interface assembly as a horizontal line along the top graticule.</p> <p>Refer to Chapter 3 for additional troubleshooting information.</p>
RELATED SOFTKEYS	-10 V REF DETECTOR

-10 V REF DETECTOR -10 V Reference Detector

DESCRIPTION	<p>Displays the output of the -10 V reference from the A5 analog interface assembly as horizontal line at the bottom graticule.</p> <p>Refer to Chapter 3 for additional troubleshooting information.</p>
RELATED SOFTKEYS	+10 V REF DETECTOR

2v REF DETECTOR 2 V Reference Detector

DESCRIPTION	<p>Displays the output of the 2 V reference produced on the A24 processor assembly as a horizontal line at the top graticule. If the line is at the top graticule, the main ADC is adjusted correctly.</p> <p>This routine uses the 2 V reference at the input MUX on the A24 assembly. Refer to Figure 8-5, IF/Control Overall Block Diagram, for the location of the input MUX.</p> <p>Note that during the preset routine, the analog-ground and 2 V reference are used to calibrate the main ADC. The analog ground and 2 V reference at the input MUX are used during calibration. If either signal is out of range, the ADC-GND FAIL or ADC-2V FAIL error message is displayed.</p>
RELATED SOFTKEYS	CAL AMP

CAL 85422 Calibrate HP 85422

For an HP 8542E only.

DESCRIPTION	The CAL 85422 softkey performs a calibration only on the HP 85422E receiver RF section when configured as an HP 8542E EMI receiver.
RELATED SOFTKEYS	CAL 85462

CAL 85462 Calibrate HP 85462

For an HP 8546A only.

DESCRIPTION	The CAL 85462 softkey performs a calibration only on the HP 85462A receiver RF section when configured as an HP 8546A EMI receiver.
RELATED SOFTKEYS	CAL 85422

CAL ALL Calibrate All

For an HP 8542E/HP 8546A only.

DESCRIPTION CAL ALL initiates frequency and amplitude correction routines. The calibration procedures take approximately 20 minutes to complete. When the calibration is successfully completed, the internal adjustment data is stored in volatile RAM and the following message is displayed:

```
CAL ALL : done
INPUT 1 : Passed
INPUT 2 : Passed
Press CAL STORE to save
```

If the calibration procedure encounters a detectable error that prevents part of the receiver from meeting all of the specifications at all frequencies, the calibration *will be completed* and a message will be displayed identifying the input that failed. If the receiver encounters an error that will *not allow* the calibration to be completed, messages such as the following will be displayed:

```
CAL INPUT 1 : Data Not valid
CAL INPUT 1 required

INPUT CAL FAILED:
300 MHz out of range

INPUT CAL FAILED:
TG INT ALC out of range

INPUT CAL FAILED:
TG EXT ALC out of range
```

These messages tell you which sections of the receiver have encountered problems during the calibration procedure.

RELATED SOFTKEYS CAL STORE

 LAST CAL

 CAL 85422

 CAL 85462

CAL AMP Calibrate Amplitude

For an HP 85422E/HP 85462A only.

DESCRIPTION Note that if both CAL FREQ and CAL AMP self-calibration routines are required, perform the CAL FREQ routine first.

The CAL AMP softkey initiates an amplitude self-calibration routine. During the CAL AMP self-calibration routine, messages are sequentially displayed, indicating a specific calibration activity. Each calibration performed by CAL AMP is described below.

- While CAL : AMP is displayed, the following calibrations are performed:
 - The amplitude error of each IF bandwidth is corrected using the 3 kHz IF bandwidth as the amplitude reference. Each amplitude error is then stored as a calibration factor.
 - The center frequency error of each bandwidth is corrected.
 - The top-screen reference level is calibrated using the amplitude of the CAL OUT signal as a reference.
 1. The amplitude of the detected 21.4 MHz IF signal is measured on the A24 processor assembly.
 2. The Reference-Level-Calibration DAC on the A5 analog interface assembly adjusts the gain of the IF calibration amplifier on the A9 third converter assembly to correct the amplitude measured on the A24 assembly.
 3. After the A5 DAC adjusts the A9 output, fine amplitude corrections are made with a digital offset of the video signal on the A24 assembly.
 4. The A5 DAC value and video offset are stored as correction factors on the A24 assembly.
- While CAL : 3dB BW is displayed, the following calibrations are performed:
 - The 3 dB and 6 dB EMI IF bandwidths are measured.
 - DACs on the A5 analog interface assembly adjust the bandwidth of the LC and crystal filters on the A11 and A13 bandwidth filter assemblies.
 - The DAC bandwidth correction factors are stored on the A24 processor assembly.
- While CAL : ATTEN is displayed, the following calibrations are performed:
 - The amplitude error of the 10 dB step gains on the A12 amplitude control assembly and the 10 dB linear gains on the A14 log amplifier/detector assembly are corrected.
 - The 10 dB step gain on the A12 assembly is the amplitude reference.
 - Step-gain and linear-gain errors are corrected with digital offsets of the video signal on the A24 assembly.
 - The video offsets are stored as correction factors.
 - Amplitude errors for the A3A4 input attenuator are corrected.
 - The 10 dB step attenuator is the amplitude reference.
 - Input attenuator errors are corrected with digital offsets of the video signal on the A24 assembly.
 - The attenuator offsets are stored as correction factors.

- While CAL : LOG AMP is displayed, the following calibrations are performed:
 - The log fidelity is measured in 1 dB steps.
 - Errors are corrected with digital offsets of the video signal on the A24 assembly.
 - The video offsets are stored as correction factors.

If a failure occurs during this calibration routine, an error message is displayed. Refer to Chapter 12 for the description of displayed error messages.

Be sure to press **CAL STORE** after running the **CAL AMP** routine.

CAL FETCH Calibration Fetch

DESCRIPTION **CAL FETCH** retrieves the self-calibration correction factors from the area of memory that retains data when the instrument is turned off and places it in working (volatile) RAM memory.

CAUTION Pressing **CAL FETCH** clears the correction-data-error flag and can permit erroneous data to be stored. Use **CAL FETCH** only for troubleshooting.

RELATED SOFTKEYS **CAL AMP**
 CAL FREQ
 CAL STORE

CAL FREQ Calibrate Frequency

For an HP 85422E/HP 85462A only.

DESCRIPTION **CAL FREQ** initiates the frequency self-calibration routine.

Note that it is normal for the **FREQ UNCAL** error message to appear briefly during **CAL FREQ**.

During the **CAL FREQ** self-calibration routine, messages are sequentially displayed, indicating a specific calibration activity. Each function performed by **CAL FREQ** is described below.

- Before the calibration routine starts, an instrument setup check is performed.

The CAL OUT signal must be within 300 MHz \pm 50 MHz and greater than or equal to -45 dBm to pass the setup check. If the CAL OUT signal is not present, the routine stops.

If the DEFAULT CAL DATA correction factors are in use, a frequency offset may occur that prevents the CAL OUT signal from being found. If desired, the instrument setup check can be bypassed. Enter the -37 Hz passcode before pressing **CALIBRATE** and **CAL FREQ**.

Refer to the CAL SIGNAL NOT FOUND error message description in Chapter 12 for more information.

- While CAL : SWEEP is displayed:
 - The sweep ramp is calibrated.
 - The values are stored as correction factors.
- While CAL : FREQ is displayed:
 - Harmonics of the CAL OUT signal are used to adjust the start and stop end-points for the A4A9 YTO.
 - The end-point values are stored as correction factors.
- While CAL : SPAN is displayed:
 - The main-coil sweep sensitivity and span attenuator are adjusted for LO spans greater than 10 MHz.
 - The adjustment routine checks for three displayed signals: 0 Hz, 300 MHz, and 600 MHz. The test passes if all three signals are found within a 750 MHz span.
- FM DAC Error Check:
 - The instrument changes the center frequency setting to move the displayed signal four divisions.
 - If the signal moves within ± 1.25 divisions of the expected display position, the FM coil drive is within tolerance.
- While CAL : FM GAIN + OFFSET is displayed:
 - The FM offset DAC is adjusted to position the signal at center-screen. This calibrates the center screen-position so that it represents an unmodulated signal.
 - The top to bottom screen deviation of a demodulated FM signal, referenced to center screen, is calibrated for a specific frequency deviation.
 - A demodulated signal with a 100 kHz frequency deviation is simulated using the CAL OUT signal and a center frequency step of 100 kHz.
 - The center frequency is stepped up and the FM gain is adjusted to position the signal at top screen.
 - The center frequency is stepped down and the FM gain is adjusted to position the signal at bottom-screen.

If a failure occurs during this calibration routine, an error message is displayed. Refer to Chapter 12 for descriptions of displayed error messages.

Be sure to press **CAL STORE** after running the **CAL FREQ** routine.

RELATED SOFTKEYS **CAL AMP**
CAL FETCH
CAL STORE
DISPLAY CAL DATA
FM GAIN
FM OFFSET

CALIBRATE Calibration Key

DESCRIPTION **CALIBRATE** provides access to the softkeys for the self-calibration, service-diagnostics, and service-calibration functions. A passcode is required for access to specific softkeys.

RELATED SOFTKEYS Refer to Figure 11-1 at the beginning of this chapter for the softkeys that are available after pressing **CALIBRATE**.

CAL INPUT 1 Calibrate Input 1

For an HP 8542E/HP 8546A only.

DESCRIPTION **CAL INPUT 1** calibrates the conducted measurement band of the instrument, 9 kHz to 50 MHz, for amplitude flatness through each filter.

RELATED SOFTKEYS **CAL STORE**
LAST CAL
CAL 85422
CAL 85462

CAL INPUT 2 Calibrate Input 2

For an HP 8542E/HP 8546A only.

DESCRIPTION CAL INPUT 2 calibrates the radiated measurement band of the instrument, 20 MHz to 2.9 GHz, for amplitude flatness through each filter.

RELATED SOFTKEYS

- CAL STORE
- LAST CAL
- CAL 85422
- CAL 85462

CAL MXR Calibrate Mixer

CAUTION Do not use this softkey. Use the CAL MXR adjustment routine in Chapter 2 to perform this calibration.

For an HP 8546A/HP 85462A only.

DESCRIPTION The high-band mixer in the A4A6 Dual-Band Mixer receives a mixer-bias current from a DAC on the A5 analog interface assembly. The mixer-bias current must be adjusted for each frequency band to minimize conversion loss in the A4A6 dual-band mixer.

Be sure to use the YTF CAL cable when performing the CAL MXR routine. Refer to Chapter 2.

The CAL MXR routine adjusts the bias-current DAC setting for the optimum displayed-signal amplitude, using the CAL OUT signal. The routine adjusts the bias current at several frequencies in each band; an optimum bias setting for that band is then determined. During the routine, TRACE A displays the frequency spectrum, while TRACE B displays the signal amplitude versus mixer-bias DAC setting.

The -2001 passcode must be entered to activate the CAL MXR calibration routine. Enter the passcode before pressing the CALIBRATE key.

Note that the CAL YTF routine must be performed before running the CAL MXR routine. New flatness correction constants must also be generated whenever the CAL MXR routine is used. Refer to Chapter 2 for instructions on the use of the CAL YTF and CAL MXR routines.

Once the **CAL MXR** routine is finished, the optimum bias-current value for each frequency band is displayed. The displayed values are the mixer bias DAC setting multiplied by 16. The DAC values are automatically stored as correction constants in nonvolatile memory on the A24 processor assembly.

RELATED SOFTKEYS

CAL YTF

EDIT FLATNESS

CAL STORE Calibration Store

DESCRIPTION

CAL STORE copies the correction factors from working RAM to the area of memory on the A24 processor assembly that retains data after the instrument is turned off.

CAUTION

If the correction factors are not stored, they will be lost when the instrument is turned off.

RELATED SOFTKEYS

CAL AMP

CAL FREQ

CAL FETCH

CAL TIMEBASE

CAL TRK GEN

CAL TIMEBASE Calibrate Timebase

DESCRIPTION

This softkey has been reserved for a future enhancement.

CAL TRK GEN Calibrate Tracking Generator

DESCRIPTION CAL TRK GEN initiates the tracking generator self-calibration routine.

Be sure to perform the CAL ALL self-calibration routines before using CAL TRK GEN.

For HP 85422E/HP 85462A receiver RF section:
Connect the Receiver RF section's TRACKING GENERATOR OUTPUT to its RF INPUT.

For HP 8542E/HP 8546A EMI receiver:
Connect the RF filter section's TG OUT to its INPUT 2.

When the CAL TRK GEN routine is complete, press CAL STORE to store the tracking generator correction factors in nonvolatile memory. The correction factors cannot be viewed.

CAUTION If the correction factors are not stored, they will be lost when the instrument is turned off.

RELATED SOFTKEYS CAL AMP
CAL FREQ
CAL STORE

CAL YTF Calibrate YTF

For an HP 8546A/HP 85462A only.

DESCRIPTION Note that the user should perform the CAL YTF routine if there has been a large change in ambient temperature. Since YTF tracking varies with temperature, the CAL YTF routine is required to meet the unpeaked flatness specification.

In band 1, amplitude accuracy is a function of how well the A4A4 SYTF bandpass filter tracks the tuned frequency of the instrument. YTF tuning is controlled by DACs located on the A5 analog interface assembly. CAL YTF minimizes amplitude uncertainty due to YTF tracking by determining the optimum YTF DAC settings for each band.

Refer to Chapter 2 to perform the CAL YTF routine.

The CAL YTF routine, using the CAL OUT signal, tunes the instrument to two frequencies in band 1. The routine minimizes tracking error by adjusting the YTF coarse-tune and fine-tune DAC settings for an optimum displayed-signal amplitude in each band. TRACE A displays the typical frequency spectrum and TRACE B displays the amplitude versus YTF DAC setting.

The routine then sets the instrument to sweep over the frequency range of each band. The YTF Span DAC is adjusted for the maximum swept-amplitude response in each band. During this part of the routine, **TRACE A** displays the frequency spectrum, and **TRACE B** displays the amplitude versus YTF span DAC setting.

Be sure to press **CAL STORE** after running the **CAL YTF** routine.

RELATED SOFTKEYS

CAL STORE

CAL MXR

COARSE TUNE DAC Coarse Tune DAC

DESCRIPTION

Displays the analog output of the YTO coarse-tune DAC located on the A5 analog interface assembly. The mnemonic for the control voltage is C_TUNE.

When **COARSE TUNE DAC** is selected, a horizontal line is displayed in the lower four divisions of the screen. The line represents the 0 V to –10 V DAC output voltage. When the YTO DAC voltage becomes more negative, the YTO frequency is increased, and the displayed line moves lower on screen.

Refer to Chapter 5 for additional LO troubleshooting information.

RELATED SOFTKEYS

FINE TUNE DAC

CORRECT ON OFF Correction On/Off

DESCRIPTION

The instrument corrects for variations in hardware performance in two ways:

- Digital offsets of the video signal on the A24 processor assembly.
- Adjustment of the DAC control voltages provided by the A5 analog interface assembly.

The **CORRECT ON OFF** function affects only the digital offsets of the video signal.

The uncorrected performance of individual assemblies can be checked by disabling the correction data. The following corrections are disabled when **CORRECT OFF** is selected:

- Step-gain-error correction factors. New correction factors are produced by the **CAL AMP** self-calibration routine.
- Bandwidth-amplitude correction factors. New correction factors are produced by the **CAL AMP** self-calibration routine.
- Log-scale-fidelity correction factors. New correction factors are produced by the **CAL AMP** self-calibration routine.
- Input-attenuator correction factors. New correction factors are produced by the **CAL AMP** self-calibration routine.
- Bandwidth-centering correction factors. New correction factors are produced by the **CAL AMP** self-calibration routine.
- Flatness-correction constants. The original constants are placed in the instrument memory at the factory. New constants must be generated using the automated flatness calibration procedures in Chapter 2.
- A12 amplitude control step-attenuator-correction constants. The original constants are placed in the instrument memory at the factory. New constants must be generated manually using the cal attenuator error correction procedure in Chapter 2.

The **CORRECT ON OFF** function does not affect the following DAC adjustments:

- IF bandwidth corrections.
- Reference level amplitude correction.
- YTO frequency and span corrections.
- 10 MHz reference (standard timebase) DAC correction.

Refer to the **CAL AMP** description in this chapter when the displayed signal exhibits symptoms of either low or high gain.

RELATED SOFTKEYS

CAL AMP

CAL FREQ

CAL STORE

DEFAULT CAL DATA

DACS DACs

DESCRIPTION

Use **DACS** to change the DAC numbers of the span, YTO coarse-tune, YTO fine-tune, and YTO FM tune DACs located on the A5 analog interface assembly. The following terminator keys are used to select the desired DAC.

YTO Adjustment DAC Selection	Terminator Key
Span DAC	GHz
YTO coarse-tune DAC	MHz
YTO fine-tune DAC	kHz
YTO FM tune DAC	Hz

Press the following keys to select a YTO adjustment DAC:

CALIBRATE
 More 1 of 3
 More 2 of 3
 Service Diag
 More 1
 More 2
 More 3
 More 4
 More 5
 More 6
 DACS

Press the terminator key for the desired DAC.

Each DAC may be set to any integer between 0 and 4095 using the A1A2 RPG knob on the front panel. Use the **↑** and **↓** keys to make large changes in the DAC settings:

- The **↑** key increments the DAC setting in an even binary progression of 0, 2, 4, 8, 16, . . . , 4096.
- The **↓** key decrements the DAC setting in an odd binary progression of 4095, 2047, 1023, 511, . . . , 1.

Refer to Chapter 5 for additional LO troubleshooting information.

RELATED SOFTKEYS

COARSE TUNE DAC
FINE TUNE DAC
X FINE TUNE DAC
FM SPAN
MAIN SPAN

DEFAULT CAL DATA Default Calibration Data

DESCRIPTION

The current correction-factor data is replaced in nonvolatile memory by the factory-loaded default calibration data when **DEFAULT CAL DATA** is used. The default data can be used only if a passcode, either -37 Hz or -2001 Hz, has been entered.

There are two types of correction factors that are changed when the default data is used:

Video offsets are used on the A24 processor assembly.

DAC settings are used on the A5 analog interface assembly.

After entering the passcode and pressing **DEFAULT CAL DATA**, the default data can be viewed using **DISPLAY CAL DATA**.

Refer to the **DISPLAY CAL DATA** illustrations (Figure 11-2 through Figure 11-5) for the format that the default calibration data is displayed.

RELATED SOFTKEYS

DISPLAY CAL DATA

CAL FREQ

CAL AMP

CAL TIMEBASE

CORRECT ON OFF

DISPLAY CAL DATA Display Calibration Data

DESCRIPTION

Displays the current correction-factor data generated by the **CAL FREQ** and **CAL AMP** self-calibration routines. Refer to Figure 11-2 through Figure 11-3 for an example of typical calibration data displayed when using **DISPLAY CAL DATA**. Press **(PRESET)** to exit the data display.

BANDWIDTH				AMPLITUDE					
6dB	BWAMP	LC	XTL	RFATN	SGAIN	LOG	LIN	NBW	
9K	0.04	0	135	0.10	0dB	-0.05			
200H	0.69	120	123	0.00	10dB	0.00	0.57	0.00	
120K	-0.30	49	255	-0.13	20dB	0.32	0.44	0.00	
				-0.20	30dB	0.37	0.63	0.00	
3dB	BWAMP	LC	XTL	-0.05	40dB	0.71	0.60	0.00	
10H	1.52	120	120	-0.05	50dB	0.73			
30H	0.85	100	100	-0.24	60dB				
100H	0.71	120	120	-0.01	70dB	MCDLY		150	
300H	0.71	120	120						
1K	-0.35	0	225	CA	ATT	ERR	BND	GAIN	ERR
3K	-0.07	0	169	1	0.00		0	227	0.00
10K	0.03	0	106	2	0.00		1	227	0.00
30K	-0.16	0	39	4	0.00		2	227	0.00
100K	-0.27	63	255	8	0.00		3	227	0.00
300K	-0.09	111	255	16	0.00		4	227	0.00
1M	-0.04	150	255						
3M	-0.02	227	255	HAM		1			
~5M	-0.10	242	255	MXRB		1600			

Figure 11-2. Typical Calibration Data: Page 1

TUNING					
CAL	300000000	Sweepsens	<10M	0.000101549	
ZERO	116992102	Sweepsens	Wide	0.00001001	
FAST	54072611	Main Coil	Sens	0.059059702	
MED	1002023102	FM Coilsens	Er	1.572002091	
SLOW	21710006	Wide Disc	Err	4.307295799	
Pkofst	-7	Wdsc	sweepsens	0.000490605	
TCXO	-4	EYO		3.003E7	
Last Cal Freq	00:00:00	---	00,	2000	
Last Cal Amp	14:12:26	AUG	00,	1994	
CISPR BW	+1.5dB	-1.5dB	-6dB	-20dB	
200 Hz	N/A	106	104	414	
9 kHz	N/A	4500	0730	19530	
120 kHz	N/A	50000	120000	274000	
Internal Cal Route		0			

Figure 11-3. Typical Calibration Data: Page 2

TRACKING GEN			FM DEMODULATION		DETECTOR OFFSETS		Last Hrd Key Menu
ROFST	0	ZERO	0	PEAK	-7		SPAN
XOFST	3095	SLOPE	17159	QPD	-12 -12		NEXT
DCORR	-32640	Narrow BW	1934		-12 -12		PAGE
ASLOP	1.075999975	Wide BW	1935	AVG	-12 -23		Display Sys Data
FSLOP	0.000000120				0 0		
XSLOP	0.307900012						STP GAIN ZERO
							IF GAINS
							More 1

Figure 11-4. Typical Calibration Data: Page 3

Narrow Bandwidth						Last Hrd Key Menu
VCXO tune	127	Gain Corr		Width Corr		SPAN
Det offset	129	200 Hz	69	Q1	Q2	DISPLAY
Log offset	133	10 Hz	152	200 Hz	120 123	CAL DATA
Pole CF tune		30 Hz	85	10 Hz	120 120	Display
P0	100	100 Hz	71	30 Hz	100 100	Sys Data
P1	191	300 Hz	71	100 Hz	120 120	
P2	102			300 Hz	120 120	
P3	172	SG error				STP GAIN ZERO
		0 dB	16			
		10 dB	16			
		20 dB	0			
		30 dB	-19			IF GAINS
		40 dB	7			
						More 1

Figure 11-5. Typical Calibration Data: Page 4

The following text describes each column of correction data illustrated in Figure 11-2 through Figure 11-5. The sections of Figure 11-2 through Figure 11-5 that contain numbers retain data that is the same for all instruments; the data is stored in memory at the factory and cannot be changed.

TUNING These miscellaneous frequency correction values correct for variations in instrument hardware performance.

BW-AMP The bandwidth amplitude corrections are mathematical offsets of the digitized video signal on the A24 processor assembly. Refer to the **CAL AMP** softkey description for more information.

LC-XTAL	<p>The A5 analog interface assembly uses these DAC values to adjust the bandwidths of the 21.4 MHz crystal and LC bandwidth filters on the A11 and A13 Bandwidth Filter assemblies. The CAL AMP self-calibration routine produces DAC values that adjust each bandwidth to within specifications.</p> <p>The 9 kHz and 120 kHz entries are for the 6 dB EMI IF bandwidths. All other entries are for the 3 dB IF bandwidths.</p> <p>Refer to the CAL AMP softkey description for more information.</p>
RFATN	<p>The input attenuator corrections are mathematical offsets of the digitized video signal on the A24 processor assembly.</p> <p>The 10 dB attenuator step is the amplitude reference used by the CAL AMP self-calibration routine while calibrating the input attenuator. Refer to the CAL AMP softkey description for more information about the calibration of the input attenuators.</p> <p>Refer to Chapter 5 to identify the attenuators that are in use for a given input attenuation setting.</p>
SGAIN	<p>The step-gain and linear-gain corrections are mathematical offsets of the digitized video signal on the A24 processor assembly. The first six entries in the “SGAIN” column are for the 10 dB step gains on the A12 amplitude control assembly. The CAL AMP self-calibration routine uses the 10 dB step gain as an amplitude reference while calibrating the step gains.</p> <p>The last four entries in the “SGAIN” column are for the 10 dB linear gains on the A14 log amplifier assembly.</p> <p>Refer to the CAL AMP softkey description for more information about the calibration of the step-gain and linear-gain stages. Refer to Chapter 4 to identify the gain stages that are in use for a given reference-level setting.</p>
GAIN	<p>The reference-level-vernier error corrections are DAC values that calibrate the reference level at top-screen during the CAL AMP self-calibration routine.</p> <p>The first five entries are fixed constants. The second five entries provide a coarse gain-adjustment of the A9 third converter assembly. Only one DAC value is produced by the calibration routine and is duplicated for all five entries. The A5 analog interface assembly uses the DAC value to adjust the gain of the A9 assembly. The DAC adjustment range is from 0 to 255. The higher the DAC value, the greater the gain on the A9 assembly. Refer to the CAL AMP softkey description for more information.</p>

ERR The ERR column, next to GAIN, is the video offset “fine tuning” of the reference level calibration.

CAL ATT ERR These error corrections are mathematical offsets of the digitized video signal on the A24 processor assembly.

The first five entries in the “ERR” column are correction constants that correct amplitude errors for the calibration attenuators on the A12 amplitude control assembly. Currently, the entry for the 16 dB attenuator is not used.

The calibration attenuators on the A12 amplitude control assembly are the amplitude reference for the **CAL AMP** self-calibration routine. The five constants are stored in nonvolatile memory initially at the factory. When required, new constants are produced using the Cal Attenuator Error adjustment procedures in Chapter 2.

Refer to the **SET ATTN** softkey description for more information about the calibration attenuators on the A12 assembly.

The second five entries in the “ERR” column are one correction factor that provides a fine adjustment of the reference-level during the **CAL AMP** self-calibration routine. The calibration routine produces one video offset and stores it for all five entries.

The video offset is used to make a fine reference-level adjustment after a coarse reference-level adjustment is done using the DAC correction values from “RL-VENR”.

RELATED SOFTKEYS

- CAL FREQ**
- CAL AMP**
- DEFAULT CAL DATA**
- CAL STORE**
- CAL FETCH**
- SET ATTN ERROR**
- CAL TIMEBASE**

Display Sys Data Display System Data

DESCRIPTION The **Display Sys Data** softkey accesses a menu to display system calibration data for input 1.

- RELATED SOFTKEYS**
- INPUT 1**
 - INPUT 1 PREAMP**

DROOP Droop

DESCRIPTION Droop disables the reset of the peak detector on the A24 processor assembly after each analog-to-digital conversion. When an impulse signal is applied, the decrease, or droop, in the peak-detector output is visible. The peak detector will charge up to the peak value of the input signal and then its amplitude will decrease over time.

Refer to Chapter 3 for additional troubleshooting information about the peak detector.

RELATED SOFTKEYS none

EDIT FLATNESS Edit Flatness

DESCRIPTION The flatness-correction constants can be viewed or modified using **EDIT FLATNESS**.

- To view the flatness-correction constants, do not enter the passcode before proceeding to **EDIT FLATNESS**.
- To edit the flatness data, enter the –2001 Hz passcode, press **CALIBRATE** and proceed to **EDIT FLATNESS**.
 1. After pressing **EDIT FLATNESS**, the **STORE FLATNESS** softkey appears, and the flatness data is ready for editing. *Use the A1A2 RPG knob, the **↑** key, or the **↓** key to move along the frequency range of the instrument.
 2. Enter the amplitude offset for the desired frequency point and terminate the entry with **–dBm** or **+dBm**.

CAUTION Avoid pressing the **INIT FLT** softkey when pressing the **STORE FLATNESS** softkey. All the flatness-correction constants will be lost if **INIT FLT** is pressed accidentally.

3. Store the flatness constants by pressing **STORE FLATNESS**; the new correction constants are stored and an instrument preset is performed.

- Exit the routine at any time by pressing **EXIT**: no changes are made to the existing correction constants and an instrument preset is performed.

Refer to any of the flatness calibration procedures in Chapter 2 for complete instructions related to the flatness-correction constants.

RELATED SOFTKEYS **INIT FLT**
STORE FLATNESS
FLATNESS DATA
EXIT

EDIT PA FLTNESS Edit Preamplifier Flatness

DESCRIPTION The **EDIT PA FLTNESS** softkey allows the service center or factory to view the preamplifier on flatness data of the instrument.

Note that the service password must be entered to execute this command.

RELATED SOFTKEYS none

EXECUTE TITLE Execute Title

DESCRIPTION Use **EXECUTE TITLE** to execute remote programming commands that have been entered from the front-panel using **CHANGE TITLE**. Refer to the user's guide for more information about **CHANGE TITLE**.

RELATED SOFTKEYS **CHANGE TITLE**

EXIT Exit

DESCRIPTION Use **EXIT** to withdraw from a softkey function. No changes are made within the function and an instrument preset is performed.

RELATED SOFTKEYS **EDIT FLATNESS**

FINE TUNE DAC Fine Tune DAC

DESCRIPTION Displays the output of the YTO fine-tune DAC produced on the A5 analog interface assembly.

When **FINE TUNE DAC** is selected, a horizontal line is displayed in the lower four divisions of the screen. The line represents the 0 V to -10 V DAC output voltage. When the YTO DAC voltage becomes more negative, the YTO frequency is increased, and the displayed line moves lower on-screen.

Refer to Chapter 5 for additional LO troubleshooting information.

RELATED SOFTKEYS **COARSE TUNE DAC**

FLATNESS DATA Flatness Data

DESCRIPTION Provides access to the softkeys used for viewing or editing the flatness correction constants. The -2001 Hz passcode is required when editing the correction data.

CAUTION Avoid pressing the **INIT FLT** softkey when pressing the **STORE FLATNESS** softkey. All the flatness-correction constants will be lost if **INIT FLT** is pressed accidentally.

RELATED SOFTKEYS **EDIT FLATNESS**
STORE FLATNESS
INIT FLT

FM COIL DRIVE FM Coil Drive

DESCRIPTION Displays the output of the FM Coil Driver produced on the A5 analog interface assembly. Perform the following steps to observe the output of the FM coil driver For the FM spans (LO spans less than or equal to 10 MHz):

1. Activate **SPAN** before pressing **CALIBRATE** to select the **FM COIL DRIVE** function.
2. Press **FM COIL DRIVE** to display a positive-going ramp.
3. Adjust the span setting while observing the displayed ramp. The slope of the ramp increases as the span is increased.

Due to quantization errors, the display appears flat for LO spans less than 500 kHz. For the main-coil spans (LO spans greater than 10 MHz) the display is a flat line.

Refer to Chapter 5 for additional LO troubleshooting information.

RELATED SOFTKEYS **FM SPAN**
FINE TUNE DAC
X FINE TUNE DAC

FM GAIN FM Gain

DESCRIPTION

This softkey duplicates the functions of the **FM GAIN** key that is accessed using either **CALIBRATE** or **SELECT**. **FM GAIN** adjusts the top-to-bottom screen deviation range of a demodulated FM signal, referenced to center-screen. The **CAL FREQ** self-calibration routine calibrates the FM screen deviation and modulation offset.

Use **FM GAIN** to do a functional check of the demodulation circuitry. The **CAL OUT** signal can be used in place of a FM modulated signal source.

1. Connect the **CAL OUT** signal to the instrument input and make the following instrument settings:

PRESET

MODE

SIGNAL ANALYSIS

FREQUENCY

300 MHz

CF STEP AUTO MAN (MAN)

500 kHz

SPAN

0 Hz

BW

5 **MHz**

AMPLITUDE

-20 dBm

2. Press the following keys:

SELECT

DEMOD ON OFF (ON)

DEMOD AM FM (FM)

FM GAIN

When **FM GAIN** is first enabled, it has a 100 kHz deviation from center-screen.

3. Set the maximum deviation from center screen by entering 500 kHz using the data keys, the A1A2 RPG knob, or the **↑** and **↓** keys.
4. Simulate a 500 kHz modulated signal by pressing the following keys:

FREQUENCY

↑

If **FM GAIN** is functioning correctly, the displayed signal is deflected from center screen to bottom screen as the center frequency is stepped up 500 kHz from the original center frequency setting.

5. Press the **⇧** key twice. The displayed signal moves from bottom-screen to top-screen as the center frequency is stepped down 500 kHz from the original center frequency.

RELATED SOFTKEYS

DEMOD

DEMOD AM FM

FM OFFSET

FM OFFSET **FM Offset**

DESCRIPTION

Use **FM OFFSET** to adjust the horizontal trace for center-screen with no modulation on the carrier. This function is useful for adjusting the carrier offset when **FM GAIN** is set for a modulated signal with a small frequency deviation. The **CAL FREQ** self-calibration routine calibrates an initial center-screen offset.

Use **FM OFFSET** to do a functional check of the demodulation circuitry. The **CAL OUT** signal can be used in place of an unmodulated carrier signal.

1. Connect the **CAL OUT** signal to the instrument input and make the following instrument settings:

PRESET

MODE

SIGNAL ANALYSIS

FREQUENCY

300 MHz

SPAN

0 Hz

BW

5 **MHz**

AMPLITUDE

-20 dBm

2. Press the following keys:

SELECT

DEMOD ON OFF (ON)

DEMOD AM FM (FM)

CALIBRATE

More 1 of 3

More 2 of 3

Service Diag

More 1

More 2

More 3

More 4

FM OFFSET

3. Adjust the position of the horizontal trace to center-screen using the A1A2 RPG knob.
4. To calculate the actual frequency offset in kHz, multiply the displayed value by 300.

RELATED SOFTKEYS

DEMOD

DEMOD AM FM

FM GAIN

FM SPAN FM Span

DESCRIPTION

Displays the FM_SPAN signal from the Span Dividers on the A5 analog interface assembly.

Perform the following steps to observe the FM_SPAN signal for FM spans (LO spans less than or equal to 10 MHz):

1. Activate **SPAN** before pressing **CALIBRATE** to select the **FM SPAN** function.
2. Press **FM SPAN** to display a negative-going ramp.
3. Adjust the span setting while observing the displayed ramp. The slope of the ramp increases as the span is increased.

Due to quantization errors, the display appears flat for LO spans less than 500 kHz.

For the main-coil spans (LO spans greater than 10 MHz) the display is a flat line.

Refer to Chapter 5 for additional LO troubleshooting information.

RELATED SOFTKEYS

MAIN SPAN

FREQ DIAG Frequency Diagnostics

DESCRIPTION Displays, in real-time, frequency diagnostic information for the LO section. Refer to Figure 11-6 for the location of each block of frequency data.

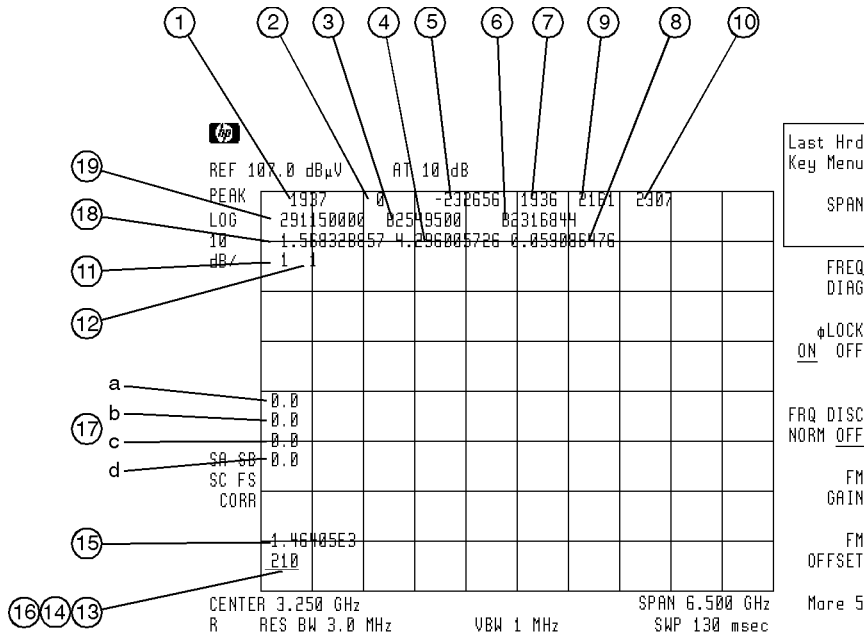

nwfreqdi

Figure 11-6. LO Frequency Diagnostic Data Display

1	Calculated coarse-tune DAC (0-4095)
2	Sampler harmonic number
3	Calculated sampler IF in Hz
4	Wide-band discriminator sensitivity factor
5	Actual frequency error in Hz on last count
6	Actual measured sampler IF in Hz
7	Actual coarse tune DAC number (0-4095)
8	Main coil sensitivity in number of bits per Hz
9	Actual fine tune DAC number (0-4095) Spans >10 MHz, changes from sweep to sweep Spans ≤10 MHz, relatively stable from sweep to sweep
10	Actual extra-fine tune DAC number (0-4095)
11	Current sweep segment
12	Current sweep band
13	Extra-fine tune DAC iterations to get to correct frequency (not present for spans ≤10 MHz)
14	Fine-tune DAC iterations to get to correct frequency
15	Counter timebase
16	Coarse-tune DAC iterations to get to correct frequency
17a	Initial LO count
17b	Initial IF count
17c	Final LO count
17d	Narrow bandwidth IF count
18	Discriminator sensitivity factor
19	Sampling oscillator frequency in Hz

Refer to Chapter 5 for additional LO troubleshooting information.

RELATED SOFTKEYS DISPLAY CAL DATA

FRQ DISC NORM OFF Frequency Discriminator Normal/Off

DESCRIPTION	<p>Indicates the status of the frequency discriminator as a function of LO span.</p> <ul style="list-style-type: none"> ■ In LO spans less than or equal to 10 MHz, <u>NORM</u> should be underlined, indicating the discriminator is in use. ■ In LO spans greater than 10 MHz, <u>OFF</u> should be underlined, indicating the discriminator is not in use.
-------------	---

GND REF DETECTOR Ground-Reference Detector

DESCRIPTION Displays the output of the analog-ground reference produced on the A24 processor assembly. A horizontal line at the bottom graticule line indicates that the ADC is adjusted correctly. The ground reference is produced on the A24 processor assembly.

The **CAL AMP** self-calibration routine uses the analog-ground reference to calibrate the bottom-screen level of the main ADC on the A24 processor assembly.

Note that during **PRESET** the analog-ground and +2 V signal are used to calibrate the main ADC. The analog ground and 2 V reference at the input MUX are used during calibration. If the signals are out of range, the ADC-GND FAIL or ADC-2V FAIL error messages are displayed.

RELATED SOFTKEYS **CAL AMP**

IDNUM Identification Number

DESCRIPTION All other instruments are identified through hardware during instrument initialization.

Selects the identity of the instrument. By selecting the appropriate identification number (IDNUM), the firmware configures the instrument to the proper frequency range and instrument functions.

RELATED SOFTKEYS none

IF GAINS Intermediate Frequency Gain Settings

DESCRIPTION The **IF GAINS** softkey displays the gain setting of the following: RF Atten, 3rd Conv DAC, 21.4 Gain, Cal Atten, Lin Gain, and NBW Sgain.

RELATED SOFTKEYS none

INIT FLT Initialize Flatness

DESCRIPTION Prepares the instrument memory for the entry of new flatness correction constants. The -2001 Hz passcode is required and must be entered before pressing **CALIBRATE**.

INIT FLT performs the following functions:

- Sets up the start frequency, stop frequency, and step size of the frequency-response-correction points.
- Initializes A24 memory by entering a default value of 0 dB into memory for all frequency points.

CAUTION The current flatness-correction constants are lost when **INIT FLT** is pressed.

RELATED SOFTKEYS **EDIT FLATNESS**

STORE FLATNESS

INPUT 1 Input 1

For an HP 8542E/HP 8546A only.

DESCRIPTION **INPUT 1** displays the system calibration data for input 1. This is a service calibration function and is for service use only.

RELATED SOFTKEYS **Display Sys Data** None

INPUT 1 PREAMP Input 1 Preamplifier

For an HP 8542E/HP 8546A only.

DESCRIPTION **INPUT 1 PREAMP** displays the system calibration data for input 1, with the preamplifier on. This is a service calibration function and is for service use only.

RELATED SOFTKEYS None

INPUT 2 Input 2

For an HP 8542E/HP 8546A only.

DESCRIPTION This softkey has been reserved for a future enhancement.

INPUT 2 PREAMP **Input 2 Preamplifier**

For an HP 8542E/HP 8546A only.

DESCRIPTION This softkey has been reserved for a future enhancement.

MAIN COIL DR **Main-Coil Drive**

DESCRIPTION Displays the output of the main-coil driver produced on the A5 analog interface assembly. Perform the following steps to observe the output of the main-coil driver:

1. Activate either **SPAN** or **CENTER FREQ**, as needed.
2. Press **CALIBRATE** to select the MAIN COIL DR function.
3. Change either the span or center-frequency setting and observe the displayed signal.

- When the span setting is increased (For LO spans greater than 10 MHz), the positive slope of the displayed ramp increases.

Due to quantization errors, the display appears flat for LO spans less than 500 MHz.

- When the center frequency setting is increased within a band, the vertical position of the ramp moves up the screen. The vertical position of the ramp is a function of the YTO tune frequency.

The combination of the ramp slope and vertical position represents a voltage that is proportional to the current in the A4A9 YTO main coil.

Refer to Chapter 5 for additional LO troubleshooting information.

RELATED SOFTKEYS **FM COIL DRIVE**

MAIN SPAN Main Span

DESCRIPTION	<p>Displays the main-coil-span signal, MC_SPAN, from the span dividers on the A5 analog interface assembly.</p> <p>Perform the following steps to observe MC_SPAN for the main-coil spans (LO spans greater than 10 MHz):</p> <ol style="list-style-type: none">1. Press SPAN before pressing CALIBRATE.2. Press MAIN SPAN to display a negative-going ramp.3. Adjust the span setting while observing the displayed ramp. The slope of the ramp increases as the span increases. <p>Due to quantization errors, the display appears flat for LO spans less than 100 MHz.</p> <p>For FM coil spans (LO spans less than or equal to 10 MHz), the display is a flat line.</p> <p>Refer to Chapter 5 for additional LO troubleshooting information.</p>
RELATED SOFTKEYS	FM SPAN

MIXER BIAS DAC Mixer-Bias DAC

For an HP 8546A/HP 85462A only.

DESCRIPTION	<p>Displays the output of the mixer-bias DAC from the first-converter driver on the A5 analog interface assembly. This DAC provides a bias current for the high-band mixer in the A4A6 dual-band mixer. The instrument must be in a single-band sweep for the display to be valid.</p> <p>The top four display divisions represent the DAC range of 0 V to +10 V. A horizontal line, representing the DAC output voltage, is displayed within the top four divisions. The DAC voltage should not change within a frequency band.</p> <p>Refer to Chapter 5 for additional troubleshooting information.</p>
RELATED SOFTKEYS	CAL MXR

PRESEL DAC Preselector DAC

For an HP 8546A/HP 85462A only.

DESCRIPTION Peaks the YTF preselector by manually adjusting the YTF fine-tune DAC. The front-panel entry range for the DAC is from 1 to 3840.

The instrument firmware adds the entered value to an 8-bit value (0 to 255), yielding a result between 1 and 4095. This result then drives the 12-bit YTF fine-tune DAC.

Be sure to use either **PRESET** or **PRESEL DEFAULT** to set the **PRESEL DAC** to an initial value of 2048.

RELATED SOFTKEYS **CAL YTF**

PRESEL DEFAULT

QP DET ON OFF Quasi-Peak Detector On/Off

DESCRIPTION **QP DET ON OFF** turns the quasi-peak detector on or off.

RELATED SOFTKEYS **QP GAIN ON OFF**

QP RST ON OFF

QPD OFFSET

QP GAIN ON OFF Quasi-Peak GAIN On/Off

DESCRIPTION **QP GAIN ON OFF** amplifies the video signal ten times (20 dB).

Note that the reference level offset is not changed. The marker readout and reference level readout must be divided by 10 to obtain the correct amplitude readout.

RELATED SOFTKEYS **QP DET ON OFF**

QP RST ON OFF

QPD OFFSET

QPD OFFSET **Quasi-Peak Detector Offset**

DESCRIPTION Sets the offset of the quasi-peak detector.

For accurate quasi-peak measurements, **QPD OFFSET** should be set to a value of 29. The quasi-peak detector offset is set to a value of 29 by pressing **(PRESET)**.

RELATED SOFTKEYS **QP DET ON OFF**
QP GAIN ON OFF
QPD RST ON OFF

QPD RST ON OFF **Quasi-Peak Detector Reset On/Off**

DESCRIPTION **QPD RST ON OFF** discharges and resets the quasi-peak detector.

RELATED SOFTKEYS **QP DET ON OFF**
QP GAIN ON OFF
QPD OFFSET

Service Cal **Service Calibration**

DESCRIPTION Provides access to the service-softkey functions.

RELATED SOFTKEYS Refer to Figure 11-1.

Service Diag **Service Diagnostics**

DESCRIPTION Provides access to the service-diagnostic softkey functions. For selected service softkeys, an abbreviation for the active service function appears in the detector display block. The display block is located in the upper left-hand corner of the display.

RELATED SOFTKEYS Refer to Figure 11-1.

SET ATTN ERROR Set Attenuator Error

DESCRIPTION Note that to avoid losing correction-constant data, make a backup copy of all correction data before servicing the instrument.

Refer to **DISPLAY CAL DATA** and **EDIT FLATNESS** for the location of the correction data.

The step attenuators on the A12 amplitude control assembly are the relative amplitude reference for the **CAL AMP** routine. Four of the five step attenuators (the 1 dB, 2 dB, 4 dB, and 8 dB steps) are used. Currently, the 16 dB attenuator step is not used.

If the factory-loaded attenuator-correction constants are no longer valid, new attenuator-correction constants must be developed for the following circumstances:

- A new A12 amplitude control assembly is installed.
- A new A24 processor assembly is installed.
- The battery-backed nonvolatile memory contains errors caused by any one of the following:
 - A dead BT1 battery.
 - Correction data accidentally altered by the user after he has entered the passcode and gained access to the **Service Cal** softkeys.
 - Defective hardware on the A24 assembly.

Use the Cal Attenuator Error adjustment procedure in Chapter 2 to characterize the four attenuator steps and produce new attenuator correction constants.

Enter the new correction constants into A24 RAM with the following procedure:

1. Press the following keys:

PRESET

FREQUENCY -2001 **Hz**

CALIBRATE

More 1 of 3

More 2 of 3

Service Cal

SET ATTN ERROR

2. The data-entry instruction for the 1 dB step, **ENTER CAL ATTN ERROR 1**, is displayed in the active-function block, just below the active entry for the reference-level-offset value, **REF LVL OFFSET**.
3. Enter the characterization data for the 1 dB, 2 dB, 4 dB, and 8 dB steps, with a 0.01 dB resolution for each entry.

4. Terminate each entry with either the **(+dBm)** or **(-dBm)** key.
5. Enter the original factory value, or a default value of 0 dBm, for the 16 dB step.

After each entry the characterized value is displayed, with 0.1 dB resolution, to the left of the graticule, followed by the offset-reference-level indicator, **OFFSET**.

If desired, use **DISPLAY CAL DATA** to review the new attenuator-characterization data with 0.01 dB resolution. Refer to **DISPLAY CAL DATA** for an explanation of the displayed calibration data.

RELATED SOFTKEYS

CAL AMP

DISPLAY CAL DATA

STORE FLATNESS **Store Flatness**

DESCRIPTION

Note that the **STORE FLATNESS** softkey is accessible only after entering the -2001 Hz passcode prior to pressing the **(CALIBRATE)** and **EDIT FLATNESS** softkeys.

After entering new flatness-correction constants, use **STORE FLATNESS** to store them in nonvolatile memory.

CAUTION Avoid pressing the **INIT FLT** softkey when pressing the **STORE FLATNESS** softkey. All the flatness-correction constants will be lost if **INIT FLT** is pressed accidentally.

RELATED SOFTKEYS **EDIT FLATNESS**

STOR PWR ON UNITS Store Power-On Units

DESCRIPTION Allows the user to change the amplitude display units that appear at instrument power-on or when **PRESET** is pressed. The following amplitude display units can be selected: dBm, dBmV, dB μ V, Volts, and Watts. For example, pressing the following keys sets the instrument power-on units to read out in dBmV in log mode, volts in linear mode, and input impedance to 50 or 75 ohms.

PRESET

FREQUENCY -2001 **Hz**

AMPLITUDE More 1 of 3 **INPUT Z 50 Ω 75 Ω**

AMPLITUDE **SCALE LOG LIN (LOG)** More 1 of 3 **Amptd Units dBmV**

AMPLITUDE **SCALE LOG LIN (LIN)** More 1 of 3 **Amptd Units Volts**

CALIBRATE More 1 of 3 **More 2 of 3 Service Cal**

STOR PWR ON UNITS

Note that selecting **INPUT Z 50 Ω 75 Ω** (50) ensures that the instrument will make amplitude calculations based on a 50 Ω system. Changing **INPUT Z 50 Ω 75 Ω** does not affect the input impedance of the instrument.

STP GAIN ZERO Step-Gain Zero

DESCRIPTION Disables the two 20-dB step-gain amplifiers on the A12 amplitude control assembly. While disabled, the A12 assembly provides the same gain for all reference-level settings of -10 dBm and below.

The two amplifiers are disabled as part of the A14 log amplifier adjustment procedure in Chapter 2. Use **PRESET** to reset the step-gain amplifiers.

SWEEP RAMP Sweep Ramp

DESCRIPTION Displays the RAMP signal from the sweep-ramp generator on the A5 analog interface assembly. The RAMP signal has a range of -10 V to +10 V. A positive-going ramp extending from the lower-left corner of the screen to the upper-right corner represents a normal RAMP signal.

Refer to Chapter 5 for additional LO troubleshooting information.

SWEEP TIME DAC Sweep-Time DAC

DESCRIPTION Displays the output of the sweep-time DAC, SWP_DAC, from the sweep-ramp generator on the A5 analog interface assembly. The top graticule represents +10 V and the bottom represents -10 V.

The sweep times are grouped into three ranges:

- 20 milliseconds to less than 300 milliseconds.
- 300 milliseconds to less than 6 seconds.
- 6 seconds to 100 seconds.

Within each range, a negative voltage is displayed and becomes more negative as the sweep time is decreased.

Refer to Chapter 3 for additional troubleshooting information.

RELATED SOFTKEYS **SWEEP RAMP**

X FINE TUNE DAC Extra-Fine Tune DAC

DESCRIPTION Displays the output of the YTO extra-fine-tune DAC, FM_TUNE, on the A5 analog interface assembly.

The lower four divisions of the screen represent a 0 to -10 V output range. Midscreen represents 0 V and bottom-screen represents -10 V. The DAC voltage level is displayed as a horizontal line within the four divisions.

Refer to Chapter 5 for additional LO troubleshooting information.

RELATED SOFTKEYS **COARSE TUNE DAC**

FINE TUNE DAC

DACS

YTF DRIVER YTF Driver

For an HP 8546A/HP 85462A only.

DESCRIPTION Displays the output of the sample-and-hold circuit in the YTF span divider and driver on the A5 analog interface assembly. This signal is then converted to a current to drive the YTF.

The instrument must be in a single-band sweep for the display to be valid.

The lower four divisions of the screen represent a 0 to -10 V output range. Midscreen represents 0 V and bottom-screen represents -10 V.

A ramp is displayed for all spans except zero span. In zero span, a horizontal line is displayed.

The displayed voltage is the sum of the YTF fine-tune DAC, YTF coarse-tune DAC, and YTF span voltages. The voltage becomes more negative as the tuned frequency increases.

Refer to Chapter 5 for further troubleshooting information.

RELATED SOFTKEYS

YTF TUNE COARSE

YTF TUNE FINE

YTF SPAN

YTF SPAN YTF Span

For an HP 8546A/HP 85462A only.

DESCRIPTION Displays the output of the YTF span divider, YTF_SPAN, on the A5 analog interface assembly.

The instrument must be in a single-band sweep for the display to be valid. The swept range of the A4A4 SYTF cannot exceed 7 GHz.

Perform the following steps to observe YTF_SPAN:

1. Press **SPAN** before pressing **CALIBRATE**.
2. Press **YTF SPAN** to display a negative-going ramp, centered about the center horizontal graticule.
3. Adjust the span setting while observing the displayed ramp. The slope of the ramp increases as the span is increased.
4. Press **YTF SPAN** after each change in span setting.

For spans of less than 200 MHz, the display appears flat, due to quantization errors.

Refer to Chapter 5 for further troubleshooting information.

RELATED SOFTKEYS **YTF TUNE COARSE**

YTF TUNE FINE

YTF DRIVER

YTF TUNE COARSE YTF Tune Coarse

For an HP 8546A/HP 85462A only.

DESCRIPTION Displays the output of the YTF coarse-tune DAC produced on the A5 analog interface assembly.

The instrument must be in a single-band sweep for the display to be valid.

The lower four divisions of the screen represent a 0 to -10 V output range. Midscreen represents 0 V and bottom-screen represents -10 V.

The DAC voltage level is displayed as a horizontal line within the four lower divisions. The voltage becomes more negative as the center frequency is increased. Refer to Chapter 5 for further troubleshooting information.

RELATED SOFTKEYS **YTF TUNE FINE**

YTF DRIVER

YTF SPAN

YTF TUNE FINE YTF Tune Fine

For an HP 8546A/HP 85462A only.

DESCRIPTION

Displays the output of the YTF fine-tune DAC on the analog interface assembly. This DAC voltage provides only fine adjustment of the YTF tuning; there is no direct correlation between the DAC voltage and the center-frequency setting.

The instrument must be in a single-band sweep for the display to be valid.

The lower four divisions of the screen represent a 0 to -10 V output range. Midscreen represents 0 V and bottom-screen represents -10 V.

The DAC voltage level is displayed as a horizontal line within the four lower divisions.

Refer to Chapter 5 for further troubleshooting information.

RELATED SOFTKEYS

YTF TUNE COARSE

PRESEL DAC

PRESEL DEFAULT

Instrument Messages

Refer to this chapter for information about hardware-error, user-error, and informational messages that are displayed when a problem with the operation of the instrument occurs.

Interpreting Instrument Messages

The instrument firmware displays error messages and informational prompts to warn the user of instrument failure or improper use.

There are three types of messages: hardware-error messages (H), informational messages (M), and user-created error messages (U).

- Hardware-error messages indicate that the firmware has detected a fault in the instrument hardware.
- Informational messages provide prompts or messages to inform the user of the instrument status during a specific routine.
- User-created error messages indicate the instrument is being used incorrectly. They are usually generated during remote operation.

Chapter Organization

Each instrument message is listed in alphabetical order. The following information is provided, where applicable:

- The message type, identified by an H, M, or U.
- An operational definition for each instrument message.
- The related instrument assembly, or assemblies, that is the likely cause of the problem defined by the hardware-error message.
- Relevant troubleshooting hints.

ϕ LOCK OFF (U) (H)

Indicates slow EYO tuning. This message may appear if the instrument is using default correction factors. ϕ LOCK OFF appears briefly during the CAL FREQ routine, during instrument preset, or when the frequency value is changed; this is normal and does not indicate a problem.

Related Assemblies

A4A9 EYO, A9 third converter, A23 counter lock

Troubleshooting Hints

If this message appears constantly, perform the CAL FREQ routine to try to eliminate this message.

ADC-GND FAIL (H)

During an instrument preset, the analog-to-digital converter reading for ground on the A24 processor assembly is outside the test limit. An instrument preset routine is also performed during the self-calibration routines.

Related Assemblies

A5 analog interface, A16 power supply, A15 motherboard, A24 processor assembly, assemblies installed in the card cage

Troubleshooting Hints

The +15 V and –15 V supplies from the A16 power supply can cause this error message. If the power-supply LEDs for both power supplies are on, check that the supplies are within tolerance using the test points on the A24 processor assembly.

A voltage greater than +10 V dc on pins 1, 3, 5, 7, or 31 of A24J1 can cause this error message. Refer to Figure 12-1 for the numbering order of the A24J1 connector pins that are accessible from the component side of the A24 assembly. If a voltage greater than +10 V is present on any one of the A24J1 pins indicated, use Table 12-1 to locate the source of the error message.

Table 12-1. Possible Cause of the Error Message “ADC-GND FAIL”

A24J1 Pin Number	Possible Error-Message Source
1	A14 log amplifier assembly An assembly installed in the card cage
3	An assembly installed in the card cage
5	An assembly installed in the card cage
7	A24 processor assembly An assembly installed in the card cage Signal incorrectly applied to the AUX VIDEO output
31	A5 analog interface

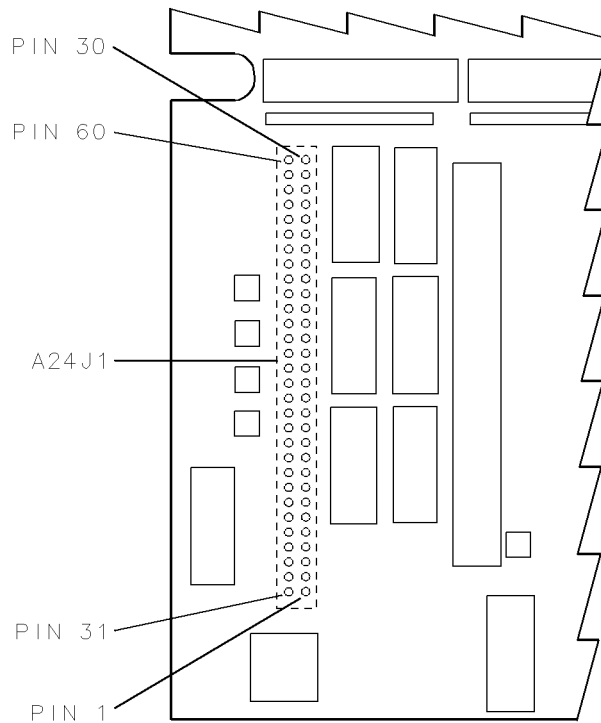

sh238e

Figure 12-1. A24J1 Connector-Pin Orientation

Before removing the A24 processor assembly, check all assemblies that are identified in Table 12-1.

1. Turn the instrument power off and remove each assembly, one at a time.
2. Turn the instrument on.
 - If the ADC ground fault remains, the instrument preset at power-up displays the error message.
 - If the error message goes away, the last assembly removed is the cause of the problem.
 - If the error message remains after the removal of all related assemblies, suspect the A24 processor assembly.

An ADC ground failure can also be checked manually, using the service diagnostic. Press **CALIBRATE**, **More 1 of 3**, **More 2 of 3**, **Service Diag**, **More 1**, **GND REF DETECTOR**.

ADC-TIME FAIL (H)

During an instrument preset, the time between analog-to-digital conversion readings is greater than the test limit. An instrument preset routine is also performed during the self-calibration routines.

Related Assemblies

A24 processor assembly

Troubleshooting Hints

If the instrument does not sweep, and all other instrument functions are normal, the probable cause of the error message is a defective A24 processor assembly.

ADC-2V FAIL (H)

During an instrument preset, the analog-to-digital converter reading for the +2 V reference on the A24 processor assembly is outside the test limit. An instrument preset routine is also performed during the self-calibration routines.

Related Assemblies

A16 power supply, A15 motherboard, A24 processor assembly, assemblies installed in the card cage

Troubleshooting Hints

The +15 V and –15 V supplies from the A16 power supply can cause this problem. If the power-supply LEDs for both supplies are on, check that the supplies are within tolerance using the test points on the A24 processor assembly.

A voltage greater than +10 V dc on pins 1, 3, 5, 7, or 31 of A24J1 can cause this error message. Refer to Figure 12-1 for the numbering order of the A24J1 connector pins that are accessible from the component side of the A24 assembly. If a voltage greater than +10 V is present on any one of the A24J1 pins indicated, use Table 12-2 to locate the source of the error message.

Table 12-2. Possible Cause of the Error Message “ADC-2V FAIL”

A24J1 Pin Number	Possible Error-Message Source
1	A14 log amplifier assembly An assembly installed in the card cage
3	An assembly installed in the card cage
5	An assembly installed in the card cage
7	A24 processor assembly An assembly installed in the card cage Signal incorrectly applied to the AUX VIDEO output
31	A5 analog interface assembly

Before removing the A24 processor assembly, check all assemblies that are identified in Table 12-2.

1. Turn the instrument power off and remove each assembly, one at a time.
2. Turn the instrument on.
 - If the ADC 2 V fault remains, the instrument preset at power-up displays the error message.
 - If the error message goes away, the last assembly removed is the cause of the problem.
 - If the error message remains after the removal of all related assemblies, suspect the A24 processor assembly.

Check the ADC 2 V reference voltage on the A24 processor assembly. A 2 V reference failure can also be checked manually, using the service diagnostics. Press **CALIBRATE**, **More 1 of 3**, **More 2 of 3**, **Service Diag**, **More 1**, **2v REF DETECTOR**.

bad FDC status -> mass storage hardware failure (H)

Related Assemblies

A21 disk drive controller board, A19 disk drive

bad io command -> internal error (H)

Related Assemblies

A21 disk drive controller board, A19 disk drive

bad io parameter -> internal error (H)

Related Assemblies

A21 disk drive controller board, A19 disk drive

Bus grant failed (H)

Related Assemblies

A21 disk drive controller board

CAL: _ _ _ (M)

During the self-calibration routine, messages may appear on the display to indicate how the calibration routines are progressing. For example, **sweep**, **freq**, **span**, **MC delay**, **FM coil**, and **atten** can appear on the instrument display.

Please note that it is normal for the ϕ **LOCK OFF** and **REF UNLOCK** error messages to appear briefly during **CAL FREQ**.

Troubleshooting Hints

If the firmware detects a problem during the self-calibration routine, the routine will stop and display an error message (H). Refer to the appropriate error-message description in this section.

CAL: _ _ _ : done Press CAL STORE to save (M)

Indicates that the self-calibration routine is finished and that you should press **CAL STORE**.

CAL: cannot execute CALAMP enter: 0 dB PREAMP GAIN (U)(H)

The preamplifier gain is not set to 0 dB. The preamplifier gain must be set to 0 dB for the **CAL AMP** routine to be performed.

Troubleshooting Hints

Reset the preamplifier gain to 0 dB using the following routines:

1. Press **AMPLITUDE**, **More 1 of 3**, **EXTERNAL PREAMPG** and set the preamplifier gain to 0 dB.
2. Perform the **CAL AMP** routine.
3. Press **CAL STORE** to store the new calibration factors and the preamplifier setting of 0 dB.

Please note that pressing **PRESET** does not initialize the preamp-gain setting to 0 dB.

If this message is still displayed after resetting the preamp gain, it is likely there is a failure in RAM on the A24 processor assembly.

CAL: DATA NOT STORED CAL AMP NEEDED (U)(H)

The current correction-factor data is the default calibration data. The instrument firmware prevents the default data from being stored. While the default data is in use, a flag is set. If **CAL STORE** is pressed, the error message is displayed and **CAL STORE** is disabled. Successful completion of the **CAL AMP** routine clears the flag.

Related Assemblies

A24 processor assembly

Troubleshooting Hints

Perform the **CAL FREQ** and **CAL AMP**. Perform the **CAL YTF** routine. If the error message reappears after pressing **CAL STORE**, the **CAL AMP** routine was not successfully completed.

Pressing **CAL FETCH** also clears the correction-data error flag and can permit erroneous data to be stored. Use **CAL FETCH** only for troubleshooting.

CAL: FM SPAN SENS FAIL (H)

During the **CAL FREQ** self-calibration routine the instrument cannot set the span sensitivity of the FM coil. The output of the fine-tune DAC, located on the A5 analog interface assembly, is changed to move the displayed signal four divisions. If the signal does not move to within ± 1.25 divisions of the expected display position, the error message is displayed.

Related Assemblies

A4A9 EYO, A5 analog interface

Troubleshooting Hints

Perform the **CAL FREQ** routine again

CAL Freq Fail (H)

During calibration of the YIG tuned oscillator FM coil, the center frequency of the YIG tuned oscillator could not be set properly. The test is determining the sensitivity of the FM coil in the YIG tuned oscillator.

Related assemblies

A4A9 EYO, A5 analog control board

CAL: GAIN FAIL (H)

During the **CAL AMP** routine, the amplitude of the video signal at the ADC on the A24 processor assembly is too low. The error message appears when the reference-level-calibration DAC, located on the A5 analog interface assembly, has been adjusted to its maximum of 255, and the amplitude of the video signal remains below tolerance.

Related Assemblies

A4 front end, A5 analog interface, A9 third converter, A11 bandwidth filter, A12 amplitude control, A13 bandwidth filter, A14 log amplifier

Troubleshooting Hints

The **CAL AMP** routine checks the amplitude of the video signal as it adjusts the reference-level-calibration DAC. Normally, the video-signal amplitude should move within tolerance as the DAC changes the gain of the IF calibration amplifier on the A9 third converter assembly. Refer to the block diagrams in Chapter 8 for more information.

Check the signal amplitude along the signal path from the RF input, through the IF section, to the output of the A14 log amplifier. Refer to “Isolating an RF, LO, IF, or Video Problem” in Chapter 3 for further troubleshooting information.

Cal harmonic > = 5.7 GHz NOT found (U)(H)

Indicates that the CAL YTF routine cannot find a harmonic of the 300 MHz calibration signal.

Related Assemblies

A9 third converter

Troubleshooting Hints

Ensure that the CAL OUT connector is connected to the instrument input, perform the CAL FREQ and AMP routine, and then perform the CAL YTF routine again.

CAL: MAIN COIL SENSE FAIL (H)

The instrument could not set up span sensitivity of the main coil.

Related Assemblies

A4A9 EYO, A5 analog interface

Troubleshooting Hints

If this message appears, press **FREQUENCY**, **-37**, **Hz**, **CALIBRATE**, **More 1 of 3**, **More 2 of 3**, **DEFAULT CAL DATA**, and perform the CAL FREQ routine again.

CAL: NBW 200 Hz notch amp failed (H)

Indicates that the 200 Hz resolution bandwidth is not the correct shape for the calibration routine.

Related Assemblies

A6 narrow resolution bandwidth card

Troubleshooting Hints

Perform the **CAL AMP**.

CAL: NBW 200 Hz notch failed (H)

Indicates that the 200 Hz resolution bandwidth is not the correct shape for the calibration routine.

Related Assemblies

A6 narrow resolution bandwidth card

Troubleshooting Hints

Perform the **CAL AMP**.

CAL: NBW 200 Hz width failed (H)

Indicates that the 200 Hz resolution bandwidth is not the correct bandwidth for the calibration routine.

Related Assemblies

A6 narrow resolution bandwidth card

Troubleshooting Hints

Perform the `CAL AMP`.

CAL: NBW gain failed (H)

Indicates that one of the resolution bandwidths is not the correct amplitude for the calibration routine.

Related Assemblies

A6 narrow resolution bandwidth card

Troubleshooting Hints

Perform the `CAL AMP`.

CAL: NBW width failed (H)

Indicates that one of the resolution bandwidths is not the correct width for the calibration routine.

Related Assemblies

A6 narrow resolution bandwidth card

Troubleshooting Hints

Perform the `CAL AMP`.

CAL: PASSCODE NEEDED (M)

The service function executed cannot be performed without the service passcode.

Troubleshooting Hints

Before performing any function that requires a service passcode, be sure you understand the consequences of the function. Improper use of functions that require a passcode can delete factory correction constants that are difficult to replace.

Refer to “Understanding Instrument Passcodes” in Chapter 11 for information about the proper use of the passcodes.

CAL: RES BW AMPL FAIL (H)

During the CAL AMP routine, the insertion loss of a resolution bandwidth filter, relative to the amplitude of the 3 kHz resolution bandwidth filter, was greater than 2.2 dB.

Related Assemblies

A5 analog interface, A11 bandwidth filter, A13 bandwidth filter, A14 log amplifier/detector

Troubleshooting Hints

The CAL AMP routine will stop at the resolution bandwidth that failed. If the A11/A13 bandwidth filter assemblies require realignment, use the crystal and LC bandwidth filter adjustment procedures in Chapter 2.

If a defective bandwidth filter board is suspected, refer to the “IF Power-Level Measurement” section in Chapter 4.

CAL SIGNAL NOT FOUND (U)(H)

During a self-calibration routine, the CAL OUT signal cannot be found. The primary purpose of the CAL OUT check is to confirm that CAL OUT is connected to the input. A CAL OUT signal that is not within 300 MHz \pm 50 MHz, or is not greater than or equal to -45 dBm, causes this error message to be displayed.

This error message indicates the calibration software could not detect the 300 MHz calibration signal. This error is usually seen in conjunction with another error message such as “Cal: YTF Failed”. The occurrence of this message may indicate a failure of either the 300 MHz calibration signal itself, or a component in the signal path in question.

Related Assemblies

A5 analog interface, A9 third converter

Troubleshooting Hints

If one of the following conditions are present, the error message is displayed:

- The CAL OUT signal is missing. Ensure that the CAL OUT is connected to the input connector using the CAL OUT cable supplied with the instrument.

Refer to Table 1-4 for the part number of the CAL OUT cable.

If the calibration cable is connected properly, manually check the CAL OUT signal.

- The CAL OUT signal is not within ± 50 MHz of 300 MHz, or it has an amplitude less than or equal to -45 dBm. The test limits are large enough to indicate an obvious failure for either the CAL OUT signal or the instrument.
- The **DEFAULT CAL DATA** is in use and the frequency of the CAL OUT signal appears out of tolerance.

The default data introduces frequency offsets that can make an accurate CAL OUT signal appear to be outside the test limits for the CAL OUT check. If desired, the instrument CAL OUT check can be bypassed. Enter the -37 Hz passcode before pressing **CALIBRATE** and the desired self-calibration softkey.

Refer to the description of **DEFAULT CAL DATA** in Chapter 11 for additional information.

- The instrument has extremely low gain. Refer to “Isolating an RF, LO, IF, or Video Problem” in Chapter 3.

Be sure to perform all internal self-calibration routines after resolving the calibration signal problem.

CAL: SPAN SENS FAIL (H)

During the **CAL FREQ** self-calibration routine the main-coil span-sensitivity adjustment routine has failed, indicating that the spans controlled by the main coil (LO spans greater than 10 MHz) are not working correctly. The span-sensitivity adjustment routine checks for three displayed signals: 0 Hz, 300 MHz, and 600 MHz. If three signals are not found in a 750 MHz span, the error message is displayed.

Related Assemblies

A4A9 EYO, A5 analog interface, A9 third converter, A24 processor assembly

Troubleshooting Hints

Spurious signals can cause this routine to fail.

Refer to the **MAIN SPAN** softkey description for further information in Chapter 11.

CAL: USING DEFAULT DATA (M)

The **CAL AMP** routine was not completed and default correction factors are being used.

Troubleshooting Hints

Interruption of the **CAL AMP** routine can cause the routine to terminate and produce this message.

Refer to Chapter 11 for more information about **DEFAULT CAL DATA**.

CAL YTF FAILED (U)(H)

Indicates that the CAL YTF routine could not be successfully completed.

Related Assemblies

A4A4 switched yig-tuned filter, A5 analog interface assembly

Troubleshooting Hints

If this message appears, ensure that the CAL OUT connector is connected to the instrument input, perform the CAL FREQ and AMP routine, and then perform the CAL YTF routine again.

CAL: ZERO FAIL (H)

The instrument could not set up the tuning sensitivity of the main coil.

Related Assemblies

A4A9 EYO, A5 analog interface assembly

Troubleshooting Hints

If this message appears, press **FREQUENCY**, **-37**, **Hz**, **CALIBRATE**, **More 1 of 3**, **More 2 of 3**, **DEFAULT CAL DATA**, and perform the CAL FREQ routine again.

Cannot engage phase lock with current CAL FREQ data (U)

Indicates that the CAL FREQ routine needs to be performed before phase locking can be turned on.

Related Assemblies

A9 third converter assembly

Troubleshooting Hints

If this message appears, press **FREQUENCY**, **-37**, **Hz**, **CALIBRATE**, **More 1 of 3**, **More 2 of 3**, **DEFAULT CAL DATA**, and perform the CAL FREQ routine again.

Cannot reach N dB points (U)

Indicates that the number of dB specified for the N dB PTS function is greater than the distance of the signal peak from the instrument noise floor or peak threshold.

Related Assemblies

A9 third converter, A24 processor assembly

Troubleshooting Hints

Access the detector by pressing **TRACE**, **More 1 of 3**, **DETECTOR SMP PK**. Toggle between SAMPLE and PEAK detector while looking for a difference in trace amplitude. If there appears to be a drastic difference in amplitude, the problem lies in the PEAK detector section of the A24 processor assembly.

check disk error -> medium uninitialized (H)

Related Assemblies

A21 disk drive controller board, A19 disk drive

Check trigger input (U)

Indicates that the instrument needs an external trigger signal to use the time-gating functions.

Related Assemblies

A24 processor assembly

Troubleshooting Hints

Ensure there is a trigger pulse connected to the GATE TRIGGER INPUT connector on the rear panel of instrument and that the GATE OUTPUT is connected the EXT TRIG INPUT connector.

CONF TEST FAIL (U)(H)

Indicates that the confidence test failed. If this happens, ensure that the CAL OUT connector is connected to the instrument input, perform the CAL FREQ and AMP routine, and then perform the confidence test again. This message also sets SRQ 110.

Troubleshooting Hints

The confidence test routine identifies the instrument function that failed the test.

COMMAND ERROR: _ _ _ (U)

The specified programming command is not recognized by the instrument.

Related Assemblies

A24 processor assembly

Troubleshooting Hints

Refer to the HP 8546A/HP 8542E EMI Receiver and HP 85462A/HP 85422E Receiver RF Section Programmer's Guide for a description of legal commands.

COMPARE_CMD timeout (H)

Related Assemblies

A21 disk drive controller board

Compare ERROR (H)

Related Assemblies

A21 disk drive controller board

EMI BW FAIL (H)

The calibration of the filter shapes for the 9 kHz and 120 kHz CISPR bandwidths failed.

Related Assemblies

A11 bandwidth, A12 amplitude control, A13 bandwidth

Troubleshooting Hints

The EMI CISPR filters use the same hardware as the regular RBW filters, and are tuned to either 9 kHz or 120 kHz.

error number not recognized -> internal error (H)

Related Assemblies

A21 disk drive controller board, A19 disk drive

Factory dlp, not adaptable (U)

Indicates that the downloadable program or variable that you have selected is used by a “personality” and cannot be edited. A personality is a program that is manufactured by Hewlett Packard and is available for use with the instrument.

FAIL: XXXX XXXXXXXXXXXX (H)

A circuit-test failure was detected by the central processing unit (CPU) during power-up or instrument preset. A failure code has two major parts: a 4-digit code followed by a 10-digit code. The 10-digit code contains three separate failure codes. Each failure code must be converted from hexadecimal to binary before it can be interpreted, using Table 12-3 through Table 12-6.

The Four-Digit Failure Code

The four-digit failure code identifies the circuit location of the failure on the A24 processor assembly. Component-level failure information is also provided. Each digit of the four-digit hexadecimal segment must be translated to its binary equivalent before using Table 12-3 to locate the probable failure.

The 16 LEDs along the right-hand side of the A24 assembly provide the same error information that is contained in the 4-digit failure code. Use Table 12-3 to interpret the illuminated LEDs for an instrument failure.

Here is an example of a failure code. It is unlikely that an instrument would have so severe a failure involving all the components indicated. The example is for demonstration only.

FAIL: DF40 0625C1F72D

The four-digit failure code (DF40) is interpreted in Table 12-3. The three fail codes within the 10-digit section (0625C1F72D) are interpreted in the “The 10-Digit Failure Code” description.

Table 12-3. Four-Digit Failure Code Interpretation

Digits From Example	Equivalent Binary Value	A24 LEDs	A24 Circuit Tested	A24 Reference Designator
D →	8	16	Video RAM *	U305, U306
↵	4	15	I/O Bus Address *	U18
↵	2	14	CPU	U12
↵	1	13	68230	U57
F →	8	12 [†]	I/O Bus (Odd byte)	U2
↵	4	11	I/O Bus (Even byte)	U3
↵	2	10	User RAM	U5
↵	1	9	User RAM	U22
4 →	8	8	User RAM	U5
	4	7	User RAM	U22
		6	NOT USED	
		5	NOT USED	
0	8	4	ROM (Odd B LSB)	U6
	4	3	ROM (Even B LSB)	U23
	2	2	ROM (Odd A LSB)	U7
	1	1	ROM (Even A LSB)	U24

* Refer to the 10-digit failure code description for more information.

[†] LED DS12 remains on after pressing (PRESET).

The 10-Digit Failure Code

The 10-digit segment provides further failure information for the I/O address bus, the I/O data bus, and the A24 video RAM circuitry. Each digit of the 10-digit hexadecimal segment must be translated to its binary equivalent to obtain the failure information.

The 10-digit failure code section is divided into three separate codes. The 10-digit failure code example (0625C1F72D) is separated into three codes as shown below:

FAIL: DF40 (06) (25C1) (F72D)

Each failure code from the example is converted from hexadecimal to binary and interpreted in Table 12-4, Table 12-5, and Table 12-6.

The I/O Address Bus Failure Code. The first two digits of the 10-digit code identify the failed address lines on the I/O address bus. Convert the two digits to binary and interpret them with Table 12-4.

Table 12-4. I/O Bus Address Failure-Code Interpretation

Digits From Example	Equivalent Binary Value	A24 Circuit Tested	A24 Reference Designator
0	8	Not Used	U18
	4	Not Used	
	2	Not Used	
	1	Error at ADR 4	
6 →	8	Error at ADR 3	U18
	4	Error at ADR 2	U18
	2	Error at ADR 1	U18
	1	Error at ADR 0	U18

The I/O Data-Bus Failure Code. The next four digits identify failed data lines on the I/O data bus. Convert the four digits to binary and interpret them with Table 12-5.

Table 12-5. I/O Data Bus Failure Code Interpretation

Digits From Example	Equivalent Binary Value	A24 Circuit Tested	A24 Reference Designator
2 →	8	Error at IOB 15	U3
	4	Error at IOB 14	U3
	2	Error at IOB 13	U3
	1	Error at IOB 12	U3
5 →	8	Error at IOB 11	U3
	4	Error at IOB 10	U3
	2	Error at IOB 9	U3
	1	Error at IOB 8	U3
C →	8	Error at IOB 7	U2
	4	Error at IOB 6	U2
	2	Error at IOB 5	U2
	1	Error at IOB 4	U2
1 →	8	Error at IOB 3	U2
	4	Error at IOB 2	U2
	2	Error at IOB 1	U2
	1	Error at IOB 0	U2

The Video RAM Failure Code. The last four digits identify the failure address for the video RAM on the A24 assembly. A video RAM failure code indicates an internal failure on the A24 assembly; the section of the video RAM circuitry that is tested is not connected to other instrument assemblies. Convert the four digits to binary and interpret them with Table 12-6.

Table 12-6. A24 Video Ram Address Failure Code Interpretation

Digits From Example	Equivalent Binary Value	A24 Circuit Tested	A24 Reference Designator
F →	8	Error at MAD 15 *	U306
↵	4	Error at MAD 14	U305
↵	2	Error at MAD 13	U306
↵	1	Error at MAD 12	U305
7 →	8	Error at MAD 11	U306
↵	4	Error at MAD 10	U305
↵	2	Error at MAD 9	U306
↵	1	Error at MAD 8	U305
2 →	8	Error at MAD 7	U306
	4	Error at MAD 6	U305
	2	Error at MAD 5	U306
	1	Error at MAD 4	U305
D →	8	Error at MAD 3	U306
↵	4	Error at MAD 2	U305
	2	Error at MAD 1	U306
↵	1	Error at MAD 0	U305
<p>* The acronym <i>MAD</i> stands for “Multiplexed Address and Data.” There are no separate address and data lines within the A24 video RAM circuitry.</p>			

Related Assemblies

A5 analog interface, A24 processor assembly, A23 counter lock, assemblies installed in the card cage

Troubleshooting Hints

Refer to the block diagrams in Chapter 8 for an overview of the assemblies attached to the I/O bus. Refer also to “Troubleshooting the A15 Motherboard Assembly” in Chapter 4 for the location of specific I/O signal traces on related assemblies.

- If a failure code for an I/O bus address or data line occurs, remove the related assemblies one at a time until the failure message disappears. Be sure to turn the instrument power off while removing and installing each assembly.
 - If the failure message disappears, suspect the assembly that was removed last.
 - If the failure message remains after all related assemblies have been removed, suspect the A24 assembly.
- If a A24 video RAM fail code occurs, the A24 assembly is defective.

fatal error -> mass storage system error (H)

Related Assemblies

A21 disk drive controller board, A19 disk drive

FDC did not ID during instrument setup (H)

Press the front-panel numeric key which corresponds to the FDC PCA address switch setting (0 through 7)

Related Assemblies

A21 disk drive controller board

FDC Ready Timeout (H)

Related Assemblies

A21 disk drive controller board

File type incompatible (U)

Indicates that the selected file is not a display image file. The file name for a display image file is always preceded by an "i."

FMERRP error (H)

During calibration of the YIG tuned oscillator FM coil, the span for $100 \text{ kHz} < F_c < 10 \text{ MHz}$ could not be calibrated. The test is determining the sensitivity of the FM coil in the YIG tuned oscillator.

Related assemblies

A4A9 EYO, A5 analog control board

FMT_INIT_CMD failed (H)

Related Assemblies

A21 disk drive controller board

FREQ UNCAL (U) (H)

The EYO (Electronic YIG-tuned oscillator) frequency is more than 20 MHz from the desired frequency. If the FREQ UNCAL message appears constantly, it indicates an EYO-tuning error. If this message appears constantly, perform the CAL FREQ routine. FREQ UNCAL appears briefly during the CAL FREQ routine; this is normal and does not indicate a problem. (U) and (H)

Related Assemblies

A4A9 EYO, A5 analog interface, A23 counter lock

Troubleshooting Hints

- This error message may occur when using correction data from **DEFAULT CAL DATA**. Refer to the **DEFAULT CAL DATA** description in Chapter 11 for more information.

If **DEFAULT CAL DATA** is in use, the instrument self-calibration routines must be run.

- The error message may occur if incomplete frequency calibration factors are used. Interrupting the **CAL FREQ** self-calibration routine produces incomplete frequency calibration data.

Performing the **CAL FREQ** routine may eliminate the problem. Be sure to press **CAL STORE** to store the correction factors produced by **CAL FREQ**.

- The error message may occur if either the reference oscillator or the sampling oscillator on the A23 assembly is unlocked.

Refer to “Isolating an RF, LO, IF or Video Problem” in Chapter 3 for further information.

Function not available in current Mode (U)

Indicates that the function that you have selected can only be used with the spectrum analysis mode. You can use the **(MODE)** key to select the spectrum analysis mode.

Function not available with analog display (U)

Indicates that the function that you have selected is not compatible with the Analog+ display mode. To use the function, you must first turn off the Analog+ display mode with **ANALOG+ ON OFF**.

Gate card not calibrated (U)(H)

This message can indicate that either the CAL AMP routine need to be performed before the time-gating functions can be used, or that something was connected to the GATE TRIGGER INPUT connector during the CAL AMP or CAL FREQ and AMP routines.

Troubleshooting Hints

Ensure that nothing is connected to the GATE TRIGGER INPUT connector when the CAL AMP or CAL FREQ and AMP routines are performed.

general error -> mass storage system error (H)

Related Assemblies

A21 disk drive controller board, A19 disk drive

Hi RAM Bus Grant FAIL (H)

Related Assemblies

A21 disk drive controller board

INIT_CMD timeout (H)

Related Assemblies

A21 disk drive controller board

INPUT CAL FAILED: 300 MHz out of range (H)

During the system calibration, the RF filter section preamplifier could not be adjusted for the proper amplitude level at 300 MHz.

Related Assemblies

RF filter section A14 AMPVAR, RF filter section A9 high frequency filters

INPUT CAL FAILED: TG EXT ALC out of range (H)

During the system calibration, the tracking generator external ALC could not adjust the tracking generator output power to within tolerance.

Related Assemblies

A4A5 Attenuator, A4A10 tracking generator, A8 tracking generator control board

INPUT CAL FAILED: TG INT ALC out of range (H)

During the system calibration, the tracking generator internal ALC could not adjust the tracking generator output power to within tolerance.

Related Assemblies

A4A5 Attenuator, A4A10 tracking generator, A8 tracking generator control board

Insufficient Memory (H)

Related Assemblies

A21 disk drive controller board

INTERNAL LOCKED (U)

The instrument's internal trace and state registers have been locked. To unlock the trace or state registers, press **SAV LOCK ON OFF** so that OFF is underlined. For remote operation, use PSTATE OFF.

INVALID ACTDEF: _ _ _ (U)

The specified ACTDEF name is not valid. See the ACTDEF programming command.

INVALID AMPCOR: FREQ (U)

For the AMPCOR command, the frequency data must be entered in increasing order. See the description for the AMPCOR programming command for more information.

INVALID BLOCK FORMAT: IF STATEMENT (U)

An invalid block format appeared within the IF statement. See the description for the IF THEN ELSE ENDIF programming command for more information.

INVALID CHECKSUM: USTATE (U)

The user-defined state does not follow the expected format.

INVALID COMPARE OPERATOR (U)

An IF/THEN or REPEAT/UNTIL routine is improperly constructed. Specifically, the IF or UNTIL operands are incorrect.

INVALID DET: FM or TV option only (U)

Indicates that the selected detector cannot be used until the appropriate option is installed in the instrument.

INVALID ENTER FORMAT (U)

The enter format is not valid. See the appropriate programming command description to determine the correct format.

INVALID <file name> NOT FOUND (U)

Indicates that the specified file could not be loaded into instrument memory or purged from memory because the file name cannot be found.

INVALID FILENAME _ _ _ (U)

Indicates the specified file name is invalid. A file name is invalid if there is no file name specified, if the first letter of the file name is not alphabetic, or if the specified file type does not match the type of file. See the description SAVRCLW or STOR programming command for more information.

INVALID HP-IB ADRS/OPERATION (U)

An HP-IB operation was aborted due to an incorrect address or invalid operation.

Related Assemblies

A24 processor assembly, A22 HP-IB interface board assembly

Troubleshooting Hints

Check that there is only one controller (the instrument) connected to the printer or plotter.

INVALID HP-IB OPERATION REN TRUE (U)

The HP-IB operation is not allowed.

Related Assemblies

A24 processor assembly, A22 HP-IB interface board assembly

Troubleshooting Hints

This is usually caused by trying to print or plot when a controller is on the interface bus with the instrument. To use the instrument print or plot functions, you must disconnect any other controllers on the HP-IB. If you are using programming commands to print or plot, you can use an HP BASIC command instead of disconnecting the controller. Ensure the instrument is configured properly for PRINT or PLOT, B/W or Paintjet, and the printer or plotter address is set correctly. See the HP 8546A/HP 8542E EMI Receiver and HP 85462A/HP 85422E Receiver RF Section Programmer's Guide for more information.

INVALID ITEM: _ _ _ (U)

Indicates an invalid parameter has been used in a programming command.

INVALID KEYLBL: _ _ _ (U)

Indicates that the specified key label contains too many characters. A key label is limited to 8 printable characters per label line.

INVALID KEYNAME: _ _ _ (U)

The specified key name is not allowed.

Related Assemblies

A24 processor assembly

Troubleshooting Hints

The key name may have conflicted with a instrument programming command. To avoid this problem, use an underscore as the second character in the key name, or avoid beginning the key name with the following pairs of letters: LB, OA, OL, TA, TB, TR, MA, MF, TS, OT, and DR.

INVALID OUTPUT FORMAT (U)

The output format is not valid. See the appropriate programming command description to determine the correct format.

INVALID RANGE: Stop < Start (U)

Indicates that the first trace element specified for a range of trace elements is larger than ending trace element. When specifying a trace range the starting element must be less than the ending element. For example, TRA[2,300] is legal but TRA[300,2] is not.

INVALID REGISTER NUMBER (U)

The specified trace register number is invalid.

INVALID REPEAT MEM OVFL (U)

Memory overflow occurred due to a REPEAT routine. This can occur if there is not enough instrument memory for the REPEAT UNTIL declaration, or if the REPEAT UNTIL declaration exceeds 2047 characters.

INVALID REPEAT NEST LEVEL (U)

The nesting level in the REPEAT routine is improperly constructed. This can occur if too many REPEAT routines are nested. When used within a downloadable program (DLP), the maximum number of REPEAT UNTIL statements that can be nested is 20.

INVALID RS-232 ADRS/OPERATION (U)

An RS-232 operation was aborted due to an invalid operation.

Related Assemblies

A24 processor assembly

Troubleshooting Hints

Reset all instruments attached to the bus.

INVALID SAVE REG (U)

Data has not been saved in the specified state or trace register, or the data is corrupt.

INVALID SCRMOVE (H)

Indicates the instrument may have a hardware failure.

Related Assemblies

All internal assemblies

Troubleshooting Hints

Remove instrument from bus. Perform an instrument preset.

INVALID START INDEX (U)

Indicates that the first trace element specified for a range of trace elements is not within the trace range of the specified trace.

INVALID STOP INDEX (U)

Indicates that the ending trace element specified for a range of trace elements is not within the trace range of the specified trace.

INVALID STORE DEST: _ _ _ (U)

The specified destination field is invalid.

INVALID SYMTAB ENTRY: SYMTAB OVERFLOW (U)

This message indicates that too many user-defined items (functions, variables, key definitions), or downloadable programs have been loaded into instrument memory.

Related Assemblies

A24 processor assembly

Troubleshooting Hints

Use **DISPOSE USER MEM** and then load the user-defined item or downloadable program into instrument memory.

Press the following instrument keys:

CONFIG More 1 of 3
Dispose User Mem

If the above keys are not accessible perform the following steps.

1. Press the following instrument keys:

DISPLAY
Change Title

Use the knob to select the letters **DISPOSE ALL;**, be sure to include the semicolon (;).

2. Press the following instrument keys:

CALIBRATE More 1 of 3 More 2 of 3
Service Cal
EXECUTE TITLE

If the instrument still appears to be locked up, refer to “Troubleshooting the A24 Processor Board Assembly,” in Chapter 3.

INVALID TRACE: _ _ _ (U)

The specified trace is invalid.

INVALID TRACE NAME: _ _ _ (U)

The specified trace name is not allowed. Use an underscore as the second character in the trace name, or avoid beginning the trace name with the following pairs of letters: LB, OA, OL, TA, TB, TR, MA, MF, TS, OT, and DR.

INVALID TRACENAME: _ _ _ (U)

Indicates the specified trace could not be saved because the trace name is not allowed. To avoid this problem, use an underscore as the second character in the trace name, or avoid beginning the trace name with the following pairs of letters: LB, OA, OL, TA, TB, TR, MA, MF, TS, OT, and DR.

INVALID VALUE PARAMETER: _ _ _ (U)

The specified value parameter is invalid.

INVALID VARDEF: _ _ _ (U)

The specified variable name is not allowed. To avoid this problem, use an underscore as the second character in the variable label, or avoid beginning the variable label with the following pairs of letters: LB, OA, OL, TA, TB, TR, MA, MF, TS, OT, and DR.

INVALID WINDOW TYPE: _ _ _ (U)

The specified window is invalid. See the description for the TWINDOW programming command.

io buffer overflow -> internal error (H)**Related Assemblies**

A21 disk drive controller board, A19 disk drive

io data error -> read data error (H)**Related Assemblies**

A21 disk drive controller board, A19 disk drive

LOST SIGNAL (U)

This message indicates that the cable from the CAL OUT connector is defective or has been disconnected during the CAL YTF routine. Be sure to use a short, low-loss cable to connect the signal to the instrument input when performing the CAL YTF routine.

Related Assemblies

A5 analog interface board

Troubleshooting Hints

Concentrate on the RF control sections of the A5 analog interface board.

Lo RAM Bus Grant FAIL (H)**Related Assemblies**

A21 disk drive controller board

LO UNLVL (U)(H)

Indicates that the instrument's local oscillator distribution amplifier is not functioning properly.

Related Assemblies

A8 tracking generator control

Troubleshooting Hints

Check the LO_{sense} and gate bias adjustments on A8. Bias voltages are marked on a label on the top of the high frequency RF.

Marker Count Reduce SPAN (U)

Indicates the resolution bandwidth to span ratio is too small to use the marker count function. Check the span and resolution bandwidth settings.

Marker Count Widen RES BW (U)

Indicates that the current resolution bandwidth setting is too narrow to use with the marker counter function. The marker counter function can be in narrow resolution bandwidths (bandwidths that are less than 1 kHz) with the following procedure:

1. Place the marker on the desired signal.
2. Increase the resolution bandwidth to 1 kHz and verify the marker is on the signal peak.
3. If the marker is on the signal peak, the marker count function can be used in either the 1 kHz resolution bandwidth or the original narrow resolution bandwidth setting. If the marker is not on the signal peak, it should be moved to the signal peak and the marker counter function should not be used with a resolution bandwidth setting of less than 1 kHz.

MEAS UNCAL (U)

The measurement is uncalibrated. Check the sweep time, span, and bandwidth settings, or press **AUTO COUPLE**, **AUTO ALL**.

No card found (U)

Indicates that the memory card is not inserted.

MIXER BIAS CAL FAILED (H)

The first mixer bias could not be set properly. The calibration routine sets the mixer bias by applying a calibration signal internally to the mixer and adjusting the bias while looking at the peaks of the calibration signal.

Related assemblies

A4A6 dual band mixer, A5 analog control board

Troubleshooting Hints

This test uses the 300 MHz calibration signal as the source. Perform a **CAL ALL** to insure proper operation of the 300 MHz calibration signal.

no disk found -> medium changed or not present (H)

Related Assemblies

A21 disk drive controller board, A19 disk drive

No ID response (H)

Related Assemblies

A21 disk drive controller board

No points defined (U)

Indicates the specified limit line or amplitude correction function cannot be performed because no limit line segments or amplitude correction factors have been defined.

OVEN COLD (M)

The message is displayed for 5 minutes after the instrument is turned on. The message alerts the user that the oven in the A20 precision frequency reference has not been on long enough to warm the reference to its operating temperature.

Related Assemblies

A20 precision frequency reference

Troubleshooting Hints

This is a timed message that comes on whenever the instrument is turned on; the temperature of the A20 precision frequency reference oven-controlled crystal oscillator (OCXO) is not measured.

The instrument firmware displays the message only when it senses that the A20 assembly is connected to its power supply through W15, the OCXO power cable. If the message does not appear, check the W15 cable.

PARAMETER ERROR: _ _ _ (U)

The specified parameter is not recognized by the instrument. See the appropriate programming command description to determine the correct parameters.

PARAMETER ERROR: FDCTESTS (H)

Related Assemblies

A21 disk drive controller board

PASSCODE NEEDED (U)

Indicates that the function cannot be accessed without the pass code.

POS-PK FAIL (H)

The positive-peak-detector check has failed during the confidence test routine, `CONF TEST`. The level of the noise floor for the positive-peak detector is statistically compared to that of the sample detector. The mean of the data from the positive-peak detector should be greater than the mean of the data from the sample detector.

Related Assemblies

A24 processor assembly

Troubleshooting Hints

This test performs a functional check of switching for the positive-peak detector on the A24 processor assembly.

READ_CMD timeout (H)

Related Assemblies

A21 disk drive controller board

RECAL_CMD timeout (H)

Related Assemblies

A21 disk drive controller board

REF UNLOCK (M)(H)

The oscillator on the A9 third converter is not locked to a 10 MHz frequency reference. The instrument must be connected to one of the following frequency references:

- Precision frequency reference. The reference is a oven-controlled crystal oscillator (OCXO).
- External 10 MHz frequency reference.

Related Assemblies

A20 precision frequency reference, A23 counter lock

Troubleshooting Hints

Refer to the block diagrams in Chapter 8 for more information.

1. Check the rear-panel cable connections for the 10 MHz reference.

When using the precision frequency reference, make sure that the 10 MHz REF OUT on the rear panel is connected to the EXT REF IN. The W6 jumper is supplied with the instrument for this purpose.

When using an external 10 MHz reference, make sure it is connected to the EXT REF IN on the rear panel.

2. If the rear panel connection is correct, check the power output of the 10 MHz frequency reference.
 - A20 precision frequency reference (OCXO), has a typical output of $0 \text{ dBm} \pm 3 \text{ dB}$.
 - An external 10 MHz reference should have an output between -2 dBm and $+10 \text{ dBm}$.
3. If the output of the 10 MHz reference is correct, check the continuity of W18, the EXT REF IN cable, and W17, the 10 MHz OUT cable.
4. Check the continuity of the VTO_TUNE control line.
5. Check the continuity of the W14 ribbon cable and the W21 coaxial cable.
6. Check the continuity of the A23 assembly connections to the A9 assembly that pass through the A15 motherboard.
7. If the error message is still present, suspect the A23 counter lock assembly.

Require 1 signal > PEAK EXCURSION above THRESHOLD (U)

Indicates that the N dB PTS routine cannot locate a signal that is high enough to measure. The signal must be greater than the peak excursion above the threshold level to measure.

Require 3 signals > PEAK EXCURSION above THRESHOLD (U)

Indicates that the % AM routine cannot locate three signals that are high enough to measure. The signals must be greater than the peak excursion above the threshold level to measure.

Require 4 signals > PEAK EXCURSION above THRESHOLD (U)

Indicates that the TOI routine cannot locate four signals that are high enough to measure. The signals must be greater than the peak excursion above the threshold level to measure.

Required option not installed (U)

Some instrument functions require that an option be installed in the instrument. See the description for the function in the HP 8546A/HP 8542E EMI Receiver and HP 85462A/HP 85422E Receiver RF Section User's Guide for more information about which option is required.

RES-BW NOISE FAIL (H)

During the confidence test routine, `CONF TEST`, the noise floor level was too high for the indicated resolution bandwidth.

Starting with the widest resolution bandwidth, the test compares the noise floor amplitude of each bandwidth to the noise floor amplitude of the next, narrower resolution bandwidth. If a decrease in noise-floor amplitude does not occur, the test displays the narrower bandwidth as a test failure.

Related Assemblies

A11 bandwidth filter, A13 bandwidth filter

Troubleshooting Hints

- A high noise floor can be caused by a defective bandwidth control line.
Look for a change in noise floor level and bandwidth when manually switching between bandwidths. If no change occurs, check the bandwidth control lines from the A5 analog interface assembly.
Refer to the block diagrams in Chapter 8 for further information.
- A high noise floor can also be caused by loose screws in the IF assembly section. Make sure the IF assembly cover screws are properly tightened.

RES-BW SHAPE FAIL (H)

During the confidence test routine, **CONF TEST**, the 3 dB bandwidth of a resolution bandwidth was not within 20% of its nominal value. The 10 kHz, 30 kHz, 100 kHz, 300 kHz, 1 MHz, and 3 MHz bandwidths are checked and the bandwidths that fail are displayed.

Related Assemblies

A5 analog interface, A11 bandwidth filter, A13 bandwidth filter

Troubleshooting Hints

- The bandwidth of the failed resolution bandwidths may have drifted since the last time the self-calibration routines were run. The **CAL AMP** self-calibration routine corrects for bandwidth error.

If a bandwidth drifts out of tolerance soon after performing **CAL AMP**, a bandwidth-filter assembly or bandwidth control line may be unstable.

1. Check the 3 dB bandwidth of the failed resolution bandwidths using the **3 dB POINTS** softkey.
2. Use **DISPLAY CAL DATA** to view the current bandwidth control factors.
3. Perform the **CAL AMP** self-calibration routine. Use **DISPLAY CAL DATA** to monitor changes in the bandwidth control factors each time the **CAL AMP** routine is performed.
4. Repeat the **CONF TEST** routine. If the error message is still present, look for an unstable bandwidth-filter assembly or bandwidth control line.

Refer to bandwidth control line information in Chapter 4 when troubleshooting the bandwidth control lines.

- The bandpass shape of the failed resolution bandwidths may have drifted since the last time the self-calibration routines were run.
 1. Look at the bandpass shape of each failed bandwidth. If realignment is needed, refer to the crystal and LC bandwidth filter adjustment procedure in Chapter 2.
 2. Run the **CAL AMP** self-calibration routine and store the data using **CAL STORE**.
 3. Repeat the **CONF TEST** routine. If the error message is still present, one of the bandwidth-filter assemblies may be defective.

RF PRESEL ERROR (H)

Indicates that the preselector peak routine cannot be performed.

Related Assemblies

A5 analog interface assembly, A4A4 (switched) yig-tuned filter

Troubleshooting Hints

Ensure that the signal source is connected to the RF input.

RF PRESEL TIMEOUT (H)

Indicates that the preselector peak routine cannot be performed.

Related Assemblies

A5 analog interface assembly, A4A4 (switched) yig-tuned filter

Troubleshooting Hints

Ensure that the signal source is connected to the RF input.

RFFS Error: HARDWARE (H)

The RF filter section is reporting its hardware has a fault.

Related Assemblies

A24 processor, RF filter section processor

RFFS Error: TIMEOUT (H)

While communicating with the RF filter section via the aux bus, a response was not received within the maximum time.

Related Assemblies

A24 processor, RF filter section processor

SAMPLE FAIL (H)

During the confidence test routine, `CONF TEST`, the sample-detector test has failed. The test makes a statistical comparison between the peak-to-peak amplitude of the noise floor for the positive-peak detector and the noise floor for the sample detector.

The error message is displayed if the standard deviation of the data for the sample detector is less than the standard deviation of data for the positive-peak detector.

Related Assemblies

A24 processor assembly

Troubleshooting Hints

This test performs a functional check of switching for the sample detector on the A24 processor assembly.

SETUP ERROR (U)

Indicates that the span, channel bandwidth, or channel spacing are not set correctly for the adjacent channel power or channel power measurement.

SIGNAL CLIPPED (U)

Indicates that the current FFT measurement sweep resulted in a trace that is above the top graticule line on the instrument display. If this happens, the input trace (trace A) has been “clipped,” and the FFT data is not valid.

Signals do not fit expected % AM pattern (U)

Indicates that the % AM routine cannot perform the percent AM measurement because the on-screen signals do not have the characteristics of a carrier with two sidebands.

Signals do not fit expected TOI pattern (U)

Indicates that the TOI routine cannot perform the third-order intermodulation measurement because the on-screen signals do not have the characteristics of two signals and two distortion products.

SMPLR UNLCK (U)(H)

Indicates that the sampling oscillator circuitry is not functioning properly.

Related Assemblies

A4A9 EYO, A23 counter lock board assembly

Troubleshooting Hints

Check that the external frequency reference is correctly connected to the EXT REF INPUT. Observe the frequency diagnostics. Look for numbers that are out of tolerance.

SOFTKEY OVFL (U)

Softkey nesting exceeds the maximum number of levels.

SRQ _ _ _ (M)

The specified service request is active. Service requests are a form of informational message and are explained in Appendix A of the *HP 8546A/HP 8542E EMI Receiver and HP 85462A/HP 85422E Receiver RF Section Reference Guide*.

STEP GAIN/ATTEN FAIL (H)

During the confidence test routine, `CONF TEST`, the step-gain switching check has failed. Looking at displayed noise, the test steps the reference level from -60 dBm to $+30$ dBm, in 10 dB increments, with the input attenuator set to 60 dB. The error message is displayed if the noise level does not increase for each 10 dB step in reference level.

Related Assemblies

A12 amplitude control

Troubleshooting Hints

The confidence test performs a functional check of the A12 assembly step gains; it does not check the function of the A12 step attenuators. The test passes if it detects any increase in noise floor level for each 10 dB change in reference level.

There is no manual adjustment for the 10 dB step gains. The `CAL AMP` self-calibration routine corrects for the 10 dB step gains and input attenuator errors. Refer to the `CAL AMP` description in Chapter 11 for more information.

If one of the 10 dB step gains appears to be faulty, check the step-gain control lines from the A5 analog interface assembly.

Refer to “Troubleshooting the A15 Motherboard Assembly” in Chapter 4 for the location of the step gain control lines.

If the control lines function correctly, suspect a A12 amplitude control assembly failure.

Refer to the IF section gain control information in Chapter 4 for further information about the operation of the 10 dB step gains.

Stop at marker not available with negative detection (U)

Indicates that the marker counter cannot be used when negative peak detection is selected. To use the marker counter, turn off negative peak detection with `DETECTOR PK SP NG`.

SYMTAB EMPTY (U)

Indicates that the user-defined items (user-defined functions, user-defined variables, user-defined traces, user-defined softkeys) and any personalities in the instrument's memory have been deleted.

Related Assemblies

A24 processor assembly

Troubleshooting Hints

Use `Dispose User Mem` to clear instrument memory. Perform instrument calibrations. If the message is still displayed, it may indicate a hardware failure.

TABLE FULL (U)

Indicates the upper or lower table of limit lines contains the maximum number of entries allowed. Additional entries to the table are ignored.

TG SIGNAL NOT FOUND (U)

Description

During the CAL TRK GEN self-calibration routine, a signal response above the first division from bottom screen is not present. The primary purpose of the error message is to indicate that the CAL cable is not connected from the tracking generator RF OUT to the RF INPUT.

This error message indicates the calibration software could not detect the tracking generator signal. This error is usually seen in conjunction with another error message such as “Cal: YTF Failed”. The occurrence of this message may indicate a failure of either the tracking generator signal itself, or a component in the signal path in question.

Related Assemblies

A8 tracking generator control

Troubleshooting Hints

- If a low signal response is present within the first division from bottom screen, check the cable connection from the RF OUT to the RF INPUT.

A cable with excessive loss can cause a low-level signal. Use the CAL cable that is supplied with the instrument. Be sure to use the same CAL cable when performing all the self-calibration routines.

Refer to Table 1-4 for the part number of the CAL cable.

- If no signal response is present, check the output of the tracking generator at the RF OUT connector. Refer to the block diagrams in Chapter 8 for more information.

TG UNLVL (U)(H)

This message can indicate the following: that the source power is set higher or lower than the instrument can provide, that the frequency span extends beyond the specified frequency range of the tracking generator, or that the calibration data for the tracking generator is incorrect. See the HP 8546A/HP 8542E EMI Receiver and HP 85462A/HP 85422E Receiver RF Section User's Guide for more information.

Related Assemblies

A8 tracking generator control assembly

Troubleshooting Hints

Perform the tracking generator control routine.

Too many signals with valid N dB points (U)

Indicates the N dB PTS function has located two or more signals that have amplitudes within the specified dB from the signal peak. If this happens, you should decrease the span of the instrument so that only the signal that you want to measure is displayed.

There is another I/O card at that address. (H)

Check the FDC address switch and try again.

Related Assemblies

A21 disk drive controller board

Trace A is not available (U)

Indicates that trace A is in the store-blank mode and cannot be used for limit-line testing. Use **CLEAR WRITE A** or **VIEW A** to change trace A from the store-blank mode to the clear write mode, and then turn on limit-line testing.

UNDF KEY (U)

The softkey number is not recognized by the instrument.

uP load fail

Related Assemblies

A21 disk drive controller board

USING DEFAULTS: _ _ _

The analyzer has determined that the contents of certain RAM locations are not within the expected values. The number following the colon corresponds to the location that caused the default condition. This number was used during the initial design and is not applicable to troubleshooting.

Related Assemblies

A24 processor assembly

Troubleshooting Hints

This message may indicate that the battery used to power the RAM is is dead. Refer to restoring analyzer memory.

USING DEFAULTS self cal needed (U)

Indicates that the current correction factors are the default correction factors and that the CAL FREQ and AMP routine needs to be performed. The CAL YTF routine is also required.

Verify gate trigger input is disconnected before CAL AMP (U)

This message is meant to remind you that nothing should be connected to the GATE TRIGGER INPUT connector on the instrument's rear panel during the CAL AMP routine.

VID-BW FAIL (H)

During the **CONF TEST** routine the video bandwidth check has failed. The test checks for a decrease in the peak-to-peak excursion of the noise trace as the video bandwidth is decreased.

Related Assemblies

A14 log amplifier/detector, A24 processor assembly

Troubleshooting Hints

Problems with the low-pass filter on the A14 log amplifier/detector assembly can cause the video bandwidths to appear to be incorrect.

Waiting for gate input ... (U)

Indicates that the instrument needs an external trigger signal to use the time-gating functions.

Related Assemblies

A24 processor assembly

Troubleshooting Hints

Before using the time-gating functions, ensure there is a trigger pulse connected to the GATE TRIGGER INPUT connector on the rear panel of instrument and that the GATE OUTPUT is connected the EXT TRIG INPUT connector. If the connections are correct and, after an instrument preset, the error message is still displayed, the internal triggering circuitry on the A24 processor assembly may not be functioning correctly. If you do not want to use the time-gating functions, press **PRESET**.

WDISCP error (H)

During calibration of the YIG tuned oscillator FM coil, the span for $F_c < 100$ kHz could not be calibrated. The test is determining the sensitivity of the FM coil in the YIG tuned oscillator.

Related assemblies

A4A9 EYO, A5 analog control board

write protected -> write protected (H)

Related Assemblies

A21 disk drive controller board, A19 disk drive

WRITE_CMD status timeout (H)

Related Assemblies

A21 disk drive controller board

WRITE_CMD timeout (H)

Related Assemblies

A21 disk drive controller board

Service Equipment and Tools

This chapter contains information about service equipment and tools needed to perform spectrum analyzer calibration, adjustments, and troubleshooting.

Static-Safe Accessories

Electrostatic discharge (ESD) can damage or destroy electronic components. All work performed on assemblies containing electronic components should be done *only* at a static-safe work station.

Table 13-1 provides information on ordering static-safe accessories and shows an example of a static-safe work station using two types of ESD protection:

- Conductive table-mat and wrist-strap combination.
- Conductive floor-mat and heel-strap combination.

The two types must be used together to ensure adequate ESD protection.

WARNING These techniques for a static-safe work station should not be used when working on circuitry that has a voltage potential greater than 500 volts.

For more information about preventing ESD damage, contact the Electrical Overstress/Electrostatic Discharge (EOS/ESD) Association, Inc. The ESD standards developed by this agency are sanctioned by the American National Standards Institute (ANSI).

Table 13-1. Static-Safe Accessories

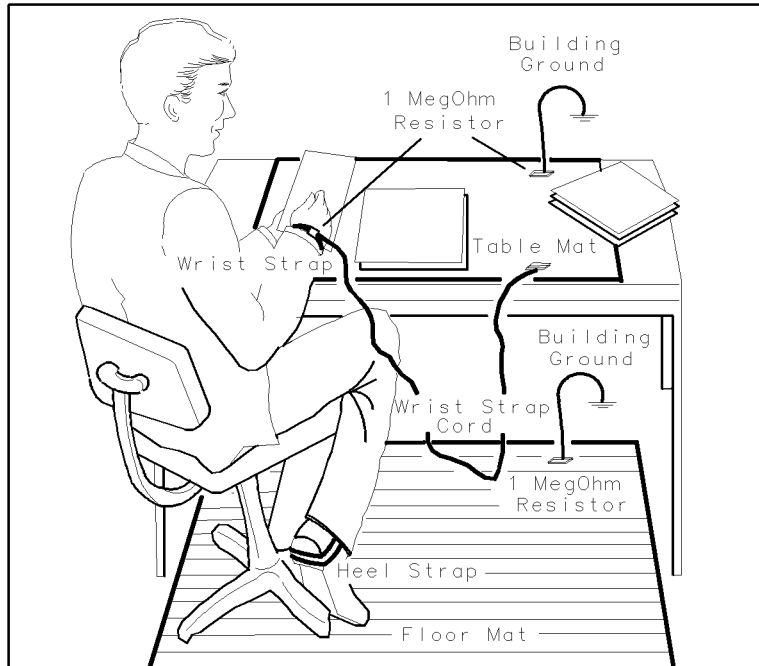

FORMAT46

HP Part Number	Description
9300-0797	Set includes: 3M static control mat 0.6 m x 1.2 m (2 ft x 4 ft) and 4.6 cm (15 ft) ground wire. (The wrist-strap and wrist-strap cord are not included. They must be ordered separately.)
9300-0980	Wrist-strap cord 1.5 m (5 ft)
9300-1383	Wrist-strap, color black, stainless steel, without cord, has four adjustable links and a 7 mm post-type connection.
9300-1169	ESD heel-strap (reusable 6 to 12 months).

Recommended Test Equipment

The tables in this section list the recommended test equipment required to perform the performance test, adjustments, and troubleshooting.

Table 13-2. Recommended Test Equipment

Equipment	Critical Specifications for Equipment Substitution	Recommended Model
CRT Demagnetizer or Bulk Tape Eraser	None	Any commercially available model
Digital multimeter	Input Resistance: $\geq 10 \text{ M}\Omega$ Accuracy: $\pm 10 \text{ mV}$ on 100 V range	HP 3458A
Frequency standard	Frequency: 10 MHz Timebase Accuracy (Aging): $< 1 \times 10^{-9}/\text{day}$	HP 5061B
Frequency counter	Frequency: 10 MHz Resolution: $\pm 0.002 \text{ Hz}$ External Timebase	HP 5334A/B
Microwave frequency counter	Frequency Range: 9 MHz to 7 GHz Timebase Accuracy (Aging): $< 5 \times 10^{-10}/\text{day}$	HP 5343A
Level generator	Frequency Range: 500 Hz to 80 MHz Amplitude Range: +12 to -85 dBm Flatness: $\pm 0.15 \text{ dB}$ Attenuator Accuracy: $\pm 0.09 \text{ dB}$	HP 3335A
Measuring receiver	Compatible with Power Sensors dB Relative Mode Resolution: 0.01 dB Reference Accuracy: $\pm 1.2\%$	HP 8902A
Microwave spectrum analyzer	Frequency Range: 10 MHz to 7 GHz	HP 8566A/B
Power meter	Power Range: Calibrated in dBm and dB relative to reference power -70 dBm to +44 dBm, sensor dependent	HP 438A
Power sensor	Frequency Range: 1 MHz to 350 MHz Maximum SWR: 1.1 (1 MHz to 2.0 GHz) 1.30 (2.0 to 2.9 GHz)	HP 8482A
Power Sensor, Low Power (with a 50 MHz reference attenuator)	Frequency Range: 300 MHz Amplitude Range: -20 to -70 dBm Maximum SWR: 1.1 (300 MHz)	HP 8481D

Table 13-2. Recommended Test Equipment (continued)

Equipment	Critical Specifications for Equipment Substitution	Recommended Model
Synthesized sweeper	Frequency Range: 10 MHz to 6.5 GHz Frequency Accuracy (CW): $\pm 0.02\%$ Leveling Modes: Internal and External Modulation Modes: AM Power Level Range: -35 to $+16$ dBm	HP 8340A/B <i>or</i> HP 83630A

Table 13-3. Recommended Accessories

Equipment	Critical Specifications for Accessory Substitution	Recommended Model
Adapter	APC 3.5 (f) to Type N (f)	1250-1745
Adapter	APC 3.5 (f) to Type N (m)	1250-1744
Adapter	Type N (f) to BNC (m) (<i>two required</i>)	1250-1477
Adapter	Type N (m) to BNC (f) (<i>two required</i>)	1250-1476
Adapter	BNC (f) to Dual banana plug	1251-2277
Adapter	APC 3.5 (f) to APC 3.5 (f) <i>two required</i>	1250- 1749
Crystal shorts (<i>set of three</i>)	Refer to Table 13-5 in the following section.	
IF test board	Refer to Table 13-5 in the following section.	5062-6421
Power splitter	Frequency Range: 50 kHz to 6.5 GHz Insertion Loss: 6 dB (nominal) Output Tracking: < 0.25 dB Equivalent Output SWR: $< 1.22:1$	HP 11667B
Attenuator, 10 dB	Type N (m to f) Frequency: 300 MHz	HP 8491A Option 010
Low pass filter, 300 MHz	Cutoff Frequency: 300 MHz Bandpass Insertion Loss: < 0.9 dB at 300 MHz Stopband Insertion Loss: > 40 dB at 435 MHz	0955-0455
Termination, 50 Ω Termination	Impedance: 50 Ω (nominal)	HP 908A <i>or</i> HP 909D

Table 13-4. Recommended Cables

Equipment	Critical Specifications for Cable Substitution	Recommended Model
Cable	APC 3.5 (m) both ends	HP 11500E
Cable	Frequency Range: dc to 1 GHz Length: ≥ 91 cm (36 in) Connectors: BNC (m) both ends <i>(two required)</i>	HP 10503A
Cable	Frequency Range: dc to 1 GHz Length: ≥ 91 cm (36 in) Connectors: BNC (m) both ends	HP 10502A
Cable	Length: 112 cm (44 in) Connectors: BNC (m) to dual banana plug	11001-60001
Cable	Type N, 152 cm (60 in)	HP 11500D
Cable, Test	Length: ≥ 91 cm (36 in) Connectors: SMB (f) to BNC (m) <i>(two required)</i>	85680-60093
Cable	Type N, 60 cm (24 in.)	HP 11500B/C
DMM test leads	Dual Banana Plug to Alligator Clips	HP 11002A

Recommended Service Tools

Table 13-5 and Figure 13-1 provide descriptions and HP part numbers for special service tools that are used throughout this manual.

Table 13-6 provides an additional list of common hand tools that are also recommended for repairing the HP 85422E/HP 85462A receiver RF section.

Refer to “Ordering Information” in Chapter 10 when ordering equipment, tools, and accessories.

Table 13-5. Special Service Tools

Item	Description	HP Part Number	Use*
1	Board puller, two prongs to lift PC boards	03950-4001	A,T
2	Extender board, pin and socket, 20 contacts (two required)	5062-1999	T
3	Extender board, pin and socket, 60 contacts	5062-2000	T
4	Extender board, 22 pin edge connector, 44 contacts	08565-60107	T
5	Injector board	5062-6421	A,T
6	Crystal bandwidth shorts (set of three)	5062-4855	A,T
	<i>Components Needed to Build One Crystal Short</i>		
6a	0.01 μ F capacitor	0160-4832	
6b	90.0 Ω resistor	0757-0400	
6c	Square, single-connector terminal (two required)	1251-4182	
6d	Two-terminal connector body	1251-0689	
6e	3/16 inch dia. heat shrink tubing, 1 1/8 inches long	0890-0029	
7	Combination wrench, 5/16 inch, with slotted box end (two required)	08555-20097	A,R
8	Combination wrench, 1/4 inch	8720-0014	R
9	Open end wrench, 15/64 inch, open end	8710-0946	R
10	Torque wrench, break-away, 10 inch-pounds, 5/16 inch, open end	40-60271 †	R
11	Cable puller, pry-bar style	5021-6773	A,T,R
12	Alignment tool, metal tip, plastic body	8710-0630	A,T
13	Alignment tool, nonmetallic tip, fiber body	8710-0033	A,T
14	TORX hand driver with required T8 and T10 bits, included in TORX driver kit with multiple bits (See tool-tip illustration)	8710-1426	A,R

*A = Adjustment, T = Troubleshooting, R = Replacement Procedure

† The part number provided is a non-HP part number. This tool can be ordered from:

Assembly Systems Inc.
16595 Englewood Avenue
Los Gatos, California 95032
(408) 395-5313

If you order a similar tool from your local supplier, it is important that the outside dimension of the wrench be no wider than 0.518 inches. This allows the wrench to be used on semirigid cable connectors in confined areas.

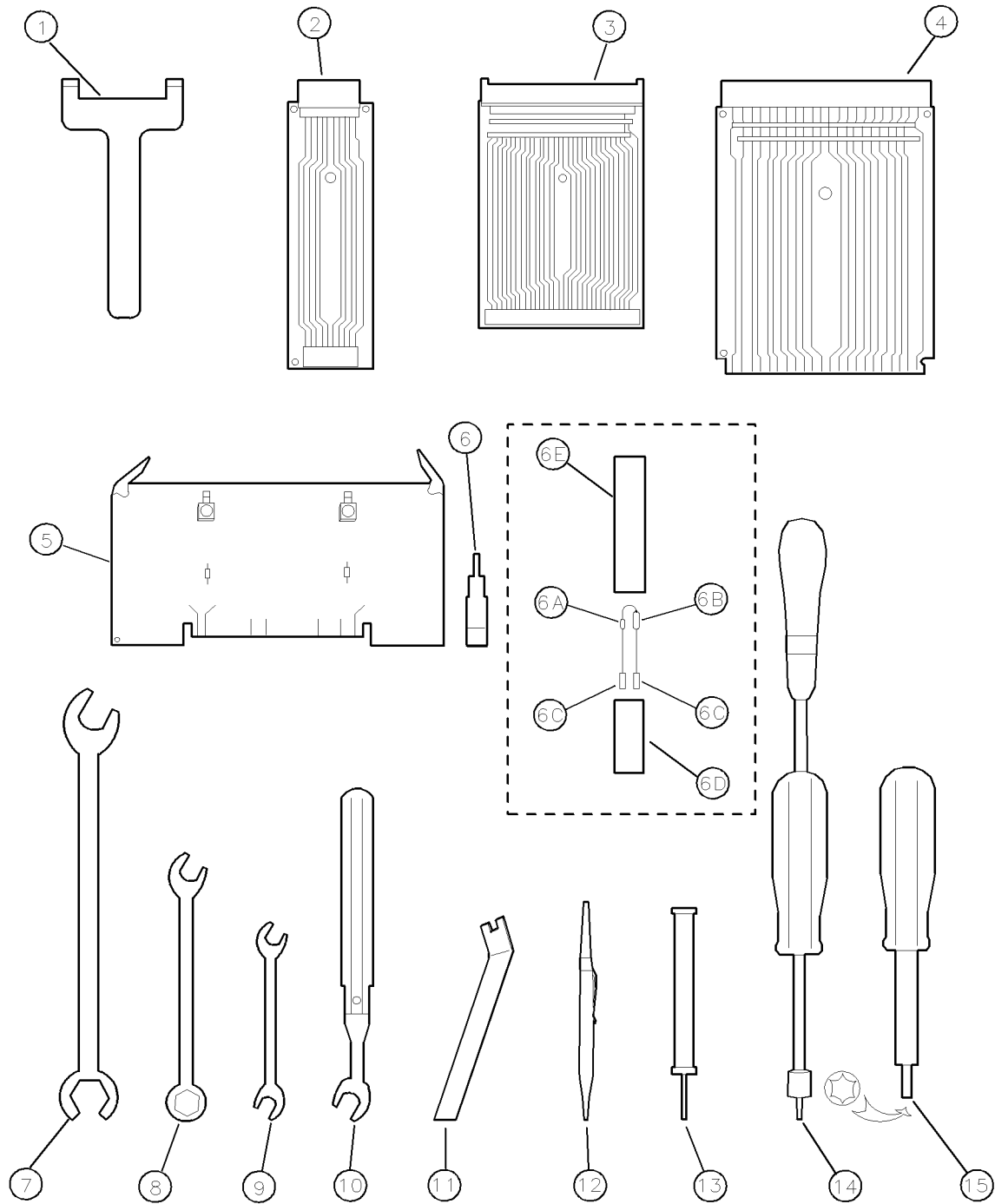

FORMAT94

Figure 13-1. Special Service Tools

Table 13-6. Required Common Hand Tools

Description	HP Part Number	Use*
Hex (Allen) wrench, 3mm	8710-1392	R
Hex (Allen) wrench, 4mm	8710-1755	A,R
Hex (Allen) wrench, no. 4	5020-0288	R
Hex (Allen) wrench, no. 6	5020-0289	R
Nut driver, 7mm	8710-1217	R
Nut driver, 3/8 inch	8720-0005	R
Nut driver, 5/16 inch	8720-0003	R
Nut driver, 7/16 inch	8720-0006	R
Nut driver, 9/16 inch, drilled out, end covered with heatshrink tubing to protect front/rear-panel surface	8720-0008	R
Phillips Screwdriver, small no. 0	8710-0978	R
Posidriv screwdriver, small no. 1	8710-0899	A,R
Posidriv screwdriver, large no. 2	8710-0900	A,R
Long-nose pliers	8710-0003	R
Wire cutters	8710-0012	R
Wire strippers	8710-0058	R
* A = Adjustment, T = Troubleshooting, R = Replacement Procedure		

