

Errata

Title & Document Type: 84812A 400E / 400EL AC Voltmeter Operating and Service Manual

Manual Part Number: 00400-90021

Revision Date: March 1986

About this Manual

We've added this manual to the Agilent website in an effort to help you support your product. This manual provides the best information we could find. It may be incomplete or contain dated information, and the scan quality may not be ideal. If we find a better copy in the future, we will add it to the Agilent website.

HP References in this Manual

This manual may contain references to HP or Hewlett-Packard. Please note that Hewlett-Packard's former test and measurement, life sciences, and chemical analysis businesses are now part of Agilent Technologies. The HP XXXX referred to in this document is now the Agilent XXXX. For example, model number HP8648A is now model number Agilent 8648A. We have made no changes to this manual copy.

Support for Your Product

Agilent no longer sells or supports this product. You will find any other available product information on the Agilent Test & Measurement website:

www.agilent.com

Search for the model number of this product, and the resulting product page will guide you to any available information. Our service centers may be able to perform calibration if no repair parts are needed, but no other support from Agilent is available.



Agilent Technologies



OPERATING AND SERVICE MANUAL

HP MODELS 400E/400EL AC VOLTMETER

SERIAL NUMBERS

This manual applies to 400Es with Serial Number Prefix 1208 and 400ELs with Serial Prefix 1211.

IMPORTANT NOTICE

If your instrument's prefix/serial number is lower than shown above, refer to Section VIII for backdating information. If the prefix number is higher, updating information may be on a yellow *MANUAL CHANGES* supplement.

WARNING

To help minimize the possibility of electrical fire or shock hazards, do not expose the instrument to rain or excessive moisture.

Manual Part No. 00400-90021

Microfiche Part No. 00400-90071

© Copyright Hewlett-Packard Company 1966
P.O. Box 301, Loveland, Colorado 80539

Printed: March 1986



CERTIFICATION

Hewlett-Packard Company certifies that this product met its published specifications at the time of shipment from the factory. Hewlett-Packard further certifies that its calibration measurements are traceable to the United States National Bureau of Standards, to the extent allowed by the Bureau's calibration facility, and to the calibration facilities of other International Standards Organization members.

WARRANTY

This Hewlett-Packard instrument product is warranted against defects in materials and workmanship for a period of one year from date of shipment [except that in the case of certain components listed in Section I of this manual, the warranty shall be for the specified period]. During the warranty period, Hewlett-Packard Company will, at its option, either repair or replace products which prove to be defective.

For warranty service or repair, this product must be returned to a service facility designated by -hp-. Buyer shall prepay shipping charges to -hp- and -hp- shall pay shipping charges to return the product to Buyer. However, Buyer shall pay all shipping charges, duties, and taxes for products returned to -hp- from another country.

Duration and conditions of warranty for this instrument may be superseded when the instrument is integrated into (becomes a part of) other -hp- instrument products.

Hewlett-Packard warrants that its software and firmware designated by -hp- for use with an instrument will execute its programming instructions when properly installed on that instrument. Hewlett-Packard does not warrant that the operation of the instrument, or software, or firmware will be uninterrupted or error free.

LIMITATION OF WARRANTY

The foregoing warranty shall not apply to defects resulting from improper or inadequate maintenance by Buyer, Buyer-supplied software or interfacing, unauthorized modification or misuse, operation outside of the environmental specifications for the product, or improper site preparation or maintenance.

NO OTHER WARRANTY IS EXPRESSED OR IMPLIED. HEWLETT-PACKARD SPECIFICALLY DISCLAIMS THE IMPLIED WARRANTIES OF MERCHANTABILITY AND FITNESS FOR A PARTICULAR PURPOSE.

EXCLUSIVE REMEDIES

THE REMEDIES PROVIDED HEREIN ARE BUYER'S SOLE AND EXCLUSIVE REMEDIES. HEWLETT-PACKARD SHALL NOT BE LIABLE FOR ANY DIRECT, INDIRECT, SPECIAL, INCIDENTAL, OR CONSEQUENTIAL DAMAGES, WHETHER BASED ON CONTRACT, TORT, OR ANY OTHER LEGAL THEORY.

ASSISTANCE

Product maintenance agreements and other customer assistance agreements are available for Hewlett-Packard products.

For any assistance, contact your nearest Hewlett-Packard Sales and Service Office. Addresses are provided at the back of this manual.



**HEWLETT
PACKARD**

SAFETY SUMMARY

The following general safety precautions must be observed during all phases of operation, service, and repair of this instrument. Failure to comply with these precautions or with specific warnings elsewhere in this manual violates safety standards of design, manufacture, and intended use of the instrument. Hewlett-Packard Company assumes no liability for the customer's failure to comply with these requirements. This is a Safety Class 1 instrument.

GROUND THE INSTRUMENT

To minimize shock hazard, the instrument chassis and cabinet must be connected to an electrical ground. The instrument is equipped with a three-conductor ac power cable. The power cable must either be plugged into an approved three-contact electrical outlet or used with a three-contact to two-contact adapter with the grounding wire (green) firmly connected to an electrical ground (safety ground) at the power outlet. The power jack and mating plug of the power cable meet International Electrotechnical Commission (IEC) safety standards.

DO NOT OPERATE IN AN EXPLOSIVE ATMOSPHERE

Do not operate the instrument in the presence of flammable gases or fumes. Operation of any electrical instrument in such an environment constitutes a definite safety hazard.

KEEP AWAY FROM LIVE CIRCUITS

Operating personnel must not remove instrument covers. Component replacement and internal adjustments must be made by qualified maintenance personnel. Do not replace components with power cable connected. Under certain conditions, dangerous voltages may exist even with the power cable removed. To avoid injuries, always disconnect power and discharge circuits before touching them.

DO NOT SERVICE OR ADJUST ALONE

Do not attempt internal service or adjustment unless another person, capable of rendering first aid and resuscitation, is present.

DO NOT SUBSTITUTE PARTS OR MODIFY INSTRUMENT

Because of the danger of introducing additional hazards, do not install substitute parts or perform any unauthorized modification to the instrument. Return the instrument to a Hewlett-Packard Sales and Service Office for service and repair to ensure that safety features are maintained.

DANGEROUS PROCEDURE WARNINGS

Warnings, such as the example below, precede potentially dangerous procedures throughout this manual. Instructions contained in the warnings must be followed.

WARNING

Dangerous voltages, capable of causing death, are present in this instrument. Use extreme caution when handling, testing, and adjusting.

A

Operating and Safety Symbols

Symbols Used On Products And In Manuals

~ LINE

AC line voltage input receptacle.



Instruction manual symbol affixed to product. Cautions the user to refer to respective instruction manual procedures to avoid possible damage to the product.



Indicates dangerous voltage – terminals connected to interior voltage exceeding 1000 volts.

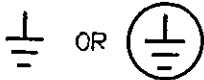

Protective conductor terminal. Indicates the field wiring terminal that must be connected to earth ground before operating equipment – protects against electrical shock in case of fault.



Clean ground (low-noise). Indicates terminal that must be connected to earth ground before operating equipment – for single common connections and protection against electrical shock in case of fault.

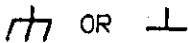

Frame or chassis ground. Indicates equipment chassis ground terminal – normally connects to equipment frame and all metal parts.



Affixed to product containing static sensitive devices – use anti-static handling procedures to prevent electrostatic discharge damage to components.

NOTE

NOTE

Calls attention to a procedure, practice, or condition that requires special attention by the reader.

CAUTION

CAUTION

Calls attention to a procedure, practice, or condition that could possibly cause damage to equipment or permanent loss of data.

WARNING

WARNING

Calls attention to a procedure, practice, or condition that could possibly cause bodily injury or death.

TABLE OF CONTENTS

<p>Section</p> <p>I. GENERAL INFORMATION..... 1-1</p> <p>1-1. Description..... 1-1</p> <p>1-4. Options Available..... 1-1</p> <p>1-5. Option 01 (400E Only)..... 1-1</p> <p>1-6. Option 02..... 1-1</p> <p>1-7. Instrument and Manual Identification..... 1-1</p> <p>Section</p> <p>II. INSTALLATION..... 2-1</p> <p>2-1. Introduction..... 2-1</p> <p>2-3. Initial Inspection..... 2-1</p> <p>2-5. Power Requirements..... 2-1</p> <p>2-7. Power Cords..... 2-1</p> <p>2-9. Grounding Requirements..... 2-1</p> <p>2-11. Installation..... 2-1</p> <p>2-13. Bench Mounting..... 2-1</p> <p>2-15. Instrument Case..... 2-1</p> <p>2-17. Rack Mounting..... 2-1</p> <p>2-19. Combination Mounting..... 2-2</p> <p>2-21. Repackaging For Shipment..... 2-2</p> <p>Section</p> <p>III. OPERATING INSTRUCTION..... 3-1</p> <p>3-1. Introduction..... 3-1</p> <p>3-4. Location of Controls and Indicators..... 3-1</p> <p>3-6. Operating Instructions..... 3-1</p> <p>3-7. Standard 400E/EL..... 3-1</p> <p>3-12. 400E With Option 01..... 3-4</p> <p>3-14. 400E/EL With Option 02..... 3-4</p> <p>Section</p> <p>IV. THEORY OF OPERATION..... 4-1</p> <p>4-1. General..... 4-1</p> <p>4-8. Schematic Description..... 4-1</p> <p>4-9. Impedance Converter..... 4-1</p> <p>4-12. Meter Amplifier..... 4-2</p> <p>4-15. Meter Bridge..... 4-3</p> <p>4-21. AC Output Circuit..... 4-3</p> <p>4-23. Power Supply..... 4-3</p> <p>Section</p> <p>V. MAINTENANCE..... 5-1</p> <p>5-1. Introduction..... 5-1</p> <p>5-3. Required Test Equipment..... 5-1</p> <p>5-5. Test Card..... 5-1</p> <p>5-7. Warm-Up Time..... 5-1</p> <p>5-9. Mechanical Zero Adjust (400E Only)..... 5-2</p> <p>5-11. Performance Tests..... 5-2</p> <p>5-13. Accuracy and Frequency Response Tests..... 5-2</p>	<p>Section</p> <p>V. MAINTENANCE (Cont'd)</p> <p>5-16. Accuracy Checks from 10Hz to 110kHz..... 5-2</p> <p>5-18. Frequency Response Checks from 110kHz to 10MHz..... 5-6</p> <p>5-20. Optional Frequency Response Checks from 110kHz to 10MHz..... 5-7</p> <p>5-22. Optional Accuracy Checks from 10Hz to 10MHz..... 5-7</p> <p>5-24. Input Impedance Check..... 5-7</p> <p>5-26. Input Resistance Check..... 5-7</p> <p>5-27. Input Capacitance Check..... 5-8</p> <p>5-28. AC to DC Converter Output Impedance Check..... 5-8</p> <p>5-29. AC Output Voltage Check..... 5-9</p> <p>5-30. Alignment and Calibration Procedures..... 5-9</p> <p>5-32. Cover Removal..... 5-9</p> <p>5-34. Checking Power Supplies..... 5-9</p> <p>5-36. Bias Adjust..... 5-10</p> <p>5-38. AC Output Adjust..... 5-10</p> <p>5-40. Calibration..... 5-10</p> <p>5-42. Accuracy Calibration Using Thermal Converters..... 5-10</p> <p>5-44. Calibration Procedure Using an AC Calibrator..... 5-12</p> <p>5-47. 10MHz Calibration Using Thermal Converters..... 5-13</p> <p>5-49. 10MHz Calibration Using an Oscillator..... 5-13</p> <p>5-51. Troubleshooting..... 5-14</p> <p>5-53. Power Supply..... 5-15</p> <p>5-55. Amplifiers..... 5-16</p> <p>5-61. AC Output Circuit..... 5-16</p> <p>5-63. Adjustment of Factory Selected Components..... 5-17</p> <p>Section</p> <p>VI. REPLACEABLE PARTS..... 6-1</p> <p>6-1. Introduction..... 6-1</p> <p>6-4. Ordering Information..... 6-1</p> <p>6-6. Non-Listed Parts..... 6-1</p> <p>Section</p> <p>VII. CIRCUIT DIAGRAMS..... 7-1</p> <p>7-1. Introduction..... 7-1</p> <p>Section</p> <p>VIII. BACKDATING..... 8-1</p> <p>8-1. Introduction..... 8-1</p>
--------------------------------------------------------------------------------------------------------------------------------------------------------------------------------------------------------------------------------------------------------------------------------------------------------------------------------------------------------------------------------------------------------------------------------------------------------------------------------------------------------------------------------------------------------------------------------------------------------------------------------------------------------------------------------------------------------------------------------------------------------------------------------------------------------------------------------------------------------------------------------------------------------------------------------------------------------------------------------------------------------------------------------------------------------------------------------------------------------------------------------------------------------------------------------------------------------------------------------------------------------------------------------------------------------------------------------------------------------------------------------------------------------------------------------------------------------------------------------------------------------------------------------------------------------------------------------------------------------------------------------------------------------------------------------------------------------------------------------------------------------------------------------------------------------------------------------------------------------	-----------------------------------------------------------------------------------------------------------------------------------------------------------------------------------------------------------------------------------------------------------------------------------------------------------------------------------------------------------------------------------------------------------------------------------------------------------------------------------------------------------------------------------------------------------------------------------------------------------------------------------------------------------------------------------------------------------------------------------------------------------------------------------------------------------------------------------------------------------------------------------------------------------------------------------------------------------------------------------------------------------------------------------------------------------------------------------------------------------------------------------------------------------------------------------------------------------------------------------------------------------------------------------------------------------------------------------------------------------------------------------------------------------------------------------------------------------------------------------------------------------------------------------------------------------------------------------------------------------------------------------------------------------------------------------------------------------------------------------------------------

LIST OF TABLES

Table	Page	Figure	Page
1-1. Specifications.....	1-0	5-9. Meter Amplifier Voltages.....	5-16
1-2. Performance Characteristics.....	1-2	5-10. AC Voltage Output Circuit.....	5-16
3-1. Effect of Distortion on Average Responding Meter.....	3-1	5-11. Factory Selected Components.....	5-17
3-2. AC Amplifier Gain.....	3-4	6-1. Standard Abbreviations.....	6-1
5-1. Required Test Equipment.....	5-1	6-2. Code of Manufacturers.....	6-2
5-2. Accuracy Tolerances.....	5-4	6-3. Replaceable Parts.....	6-3
5-3. Performance Test Limits.....	5-4	8-1. Manual Changes.....	8-1
5-4. Calibration Accuracy Graphs.....	5-5	8-2. Make Changes to Table 6-3 (Change 2).....	8-3
5-5. Alternate Calibration Procedure.....	5-10	8-3. Make Changes to Table 6-3 (Change 11).....	8-6
5-6. Troubleshooting Tips.....	5-15	8-4. Make Changes to Table 6-3 (Change 12).....	8-7
5-7. Power Supply Voltages.....	5-15	8-5. Make Changes to Table 6-3 (Change 15).....	8-9
5-8. Impedance Converter Voltages.....	5-16	8-6. Make Changes to Table 6-3 (Change 18).....	8-11
		8-7. Make Changes to Table 6-3 (Change 22).....	8-13

LIST OF ILLUSTRATIONS

Figure	Page	Figure	Page
1-1. Models 400E and 400 EL AC Voltmeters.....	1-1	6-1. Chassis and Mechanical Parts.....	6-7
2-1. Power Cords.....	2-2	6-2. Cabinet Parts.....	6-8
3-1. External Battery Connection.....	3-3	6-3. Chassis and Switch Components (Bottom View).....	6-9
3-2. Location of Controls and Indicators.....	3-2	7-1. 400E/EL Schematic Diagram and Locations of Components.....	7-3
3-3. Isolation Transformer.....	3-3	8-1. AIK1 and K2 Part Number (Change 4).....	8-4
3-4. Impedance Correction Graph.....	3-4	8-2. Component Locator for Change 11.....	8-6
4-1. Simplified Block Diagram.....	4-1	8-3. Component Locator for Change 13.....	8-8
4-2. Meter Bridge.....	4-2	8-4. Component Locators for Change 15.....	8-9
5-1. Accuracy Test Setup.....	5-3	8-5. Make Changes to Figure 6-3 (Change 18).....	8-11
5-2. Frequency Response (and Optional Accuracy) Checks.....	5-6	8-6. Make Changes to Figure 7-1 (Change 23).....	8-13
5-3. Input Impedance Checks.....	5-8	8-7. Component Locator for Change 23.....	8-14
5-4. Location of Internal Adjustments.....	5-9		

SECTION I

GENERAL INFORMATION

1-1. DESCRIPTION.

1-2. The -hp- Models 400E and 400EL are versatile ac voltmeters and dB meters. Both models can be used as ac to dc converters or wideband amplifiers. The Model 400E is primarily intended for voltage measurements, whereas the Model 400EL is primarily a dB meter. However, both meters indicate both volts and dB. The 400E has a linear ac scale with a logarithmic dB scale underneath, and the 400EL has a linear dB scale with a logarithmic ac scale underneath. Since the difference in scales is the only difference between the two instruments, this manual will use the term 400E/EL in reference to both instruments.

1-3. Figure 1-1 shows both the Model 400E and the Model 400EL. Table 1-1 is a list of specifications.

1-4. OPTIONS AVAILABLE.

1-5. OPTIONS 01 (400E ONLY).

1-6. Option 01 places the dB scale uppermost for greater resolution when making dB measurements.

1-7. OPTION 02.

1-8. Option 02 adds a relative reference adjustment to the 400E/EL. The REL. REF. control allows a continuous reduction in sensitivity by a maximum of 3 dB in order to make relative voltage or dB measurements.

1-9. Option 910. An additional Operating and Service Manual, Part Number 00400-90021.

1-10. INSTRUMENT AND MANUAL IDENTIFICATION.

1-11. Hewlett-Packard uses a two-section serial number. If the first section (serial prefix) of the serial number on your instrument does not agree with those on the title page of this manual, change sheets supplied with the manual will define the differences between your instrument and the Model 400E/EL described in this manual. Some serial numbers may have a letter separating the two sections of the number. This letter indicates the country in which the instrument was manufactured.

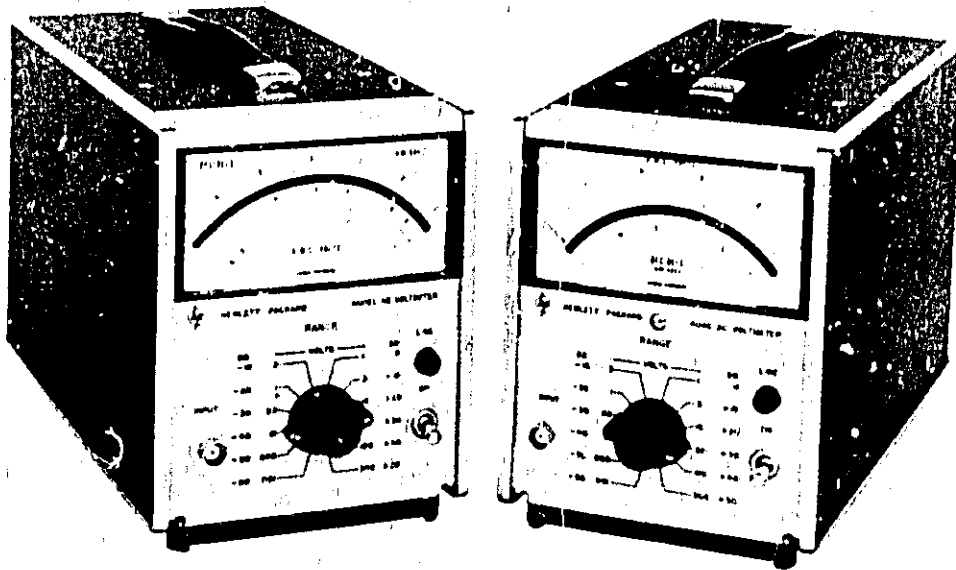
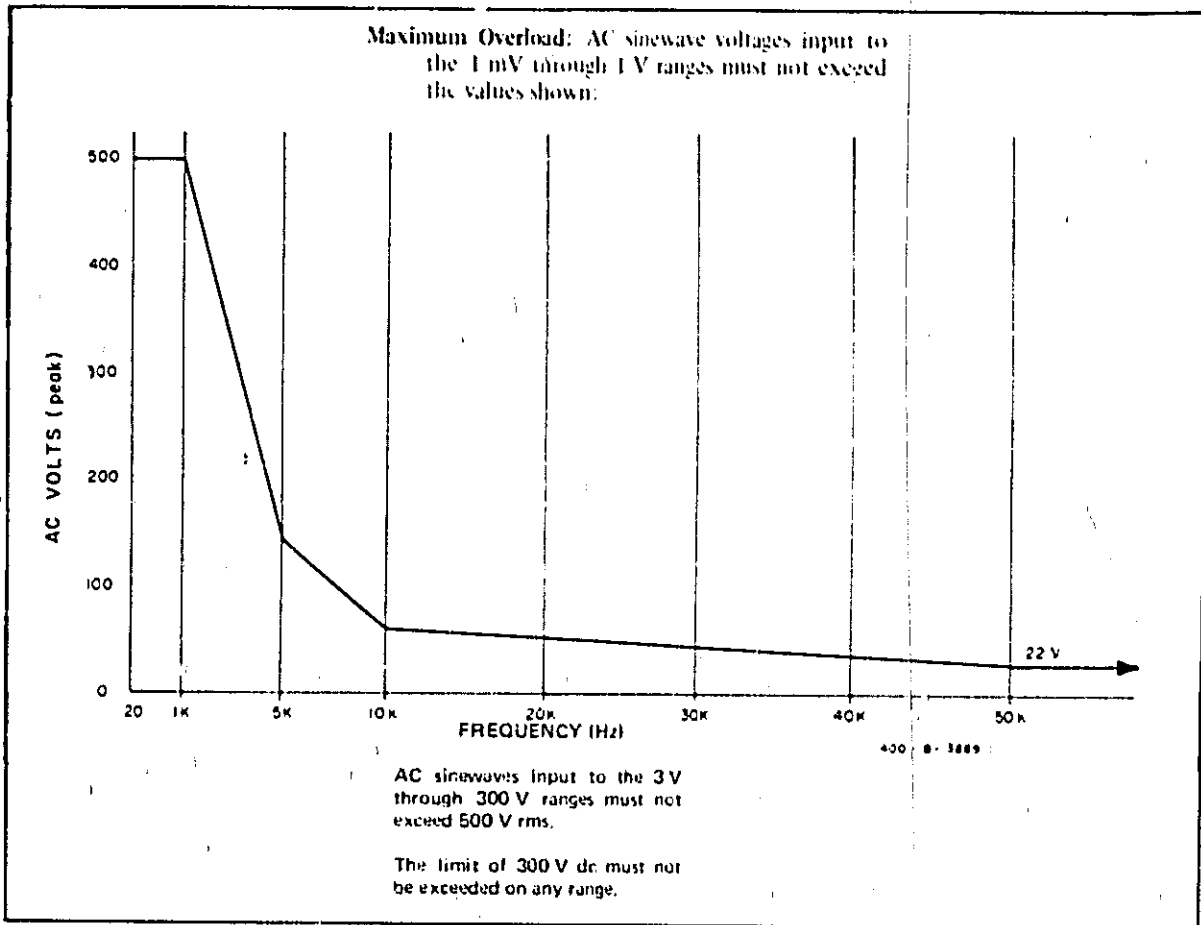

Figure 1-1. Models 400E and 400EL AC Voltmeters

Table 1-2. Performance Characteristics



SECTION II INSTALLATION

2-1. INTRODUCTION.

2-2. This section contains information and instructions necessary for the installation and shipping of the Model 400E and 400EL Voltmeters. Included are initial inspection procedures, power and grounding requirements, installation information, and instructions for repackaging for shipment.

2-3. INITIAL INSPECTION.

2-4. This instrument was carefully inspected both mechanically and electrically before shipment. It should be physically free of marks or scratches and in perfect electrical order upon receipt. To confirm this, the instrument should be inspected for physical damage in transit. Also check for supplied accessories, and test the electrical performance of the instrument using the procedure outlined in Paragraph 5-7. If there is damage or deficiency, see the warranty on the inside front cover of this manual.

2-5. POWER REQUIREMENTS.

2-6. The Model 400E/EL can be operated from any source of 115 or 230 volts at 48 to 440 Hz or from two 35 to 55 volt batteries connected to the rear panel BATTERY terminals. The 115/230 V slide switch on the rear panel selects the desired line voltage. Power dissipation is 10 watts maximum.

CAUTION

Before applying ac power to the 400E or 400EL, be sure it is set for the proper line voltage.

2-7. POWER CORDS.

2-8. Figure 2-1 illustrates the standard power plug configurations that are used throughout the United States and in other countries. The -hp- part number directly below each drawing is the part number for a 400E/EL power cord equipped with a power plug of that configuration. If the appropriate power cord is not included with the instrument, notify the nearest -hp- Sales and Service Office and a replacement cord will be provided.

2-9. GROUNDING REQUIREMENTS.

2-10. To protect operating personnel, the National Electrical Manufacturers' Association (NEMA) recommends that the instrument panel and cabinet be grounded. All Hewlett-Packard instruments are equipped with a three-conductor power cable which, when plugged into an appropriate receptacle, grounds the instrument. The offset pin on the power cable three-prong connector is the ground wire.

WARNING

For operator protection during battery operation, connect chassis terminal (MP26) to earth ground.

2-11. INSTALLATION.

2-12. The Model 400E/EL is fully transistorized; therefore, no special cooling is required. However, the instrument should not be operated where the ambient temperature exceeds 55° C (131° F) or the relative humidity exceeds 95%.

2-13. BENCH MOUNTING.

2-14. The Model 400E/EL is shipped with plastic feet and tilt stand in place, ready for use as a bench instrument.

2-15. INSTRUMENT CASE.

2-16. The 400E/EL can be placed in a rugged, high impact plastic case (-hp- 11076A). The instrument can be operated, stored or carried in this splash-proof case. A dual purpose tilt stand also serves as a carrying handle. Storage space is located at the rear of the case and in the front lid.

2-17. RACK MOUNTING.

2-18. The Model 400E/EL may be rack mounted by using an adapter frame (-hp- Part No. 5060-0797). The adapter frame is a rack frame that accepts any combination of submodular units. It can be rack

mounted only. For additional information, address inquiries to your -hp- Sales and Service Office. (See Appendix B for office locations.)

2-19. COMBINATION MOUNTING.

2-20. The Model 400E/EL may be mounted in combination with other submodular units by using a Combining Case (-hp- Model 1051A or 1052A). The Combining Case is a full-module unit which accepts various combinations of submodular units. Being a full-module unit, the combining case can be bench or rack mounted and is analogous to any full-module instrument.

2-21. REPACKAGING FOR SHIPMENT.

2-22. The following paragraphs contain a general guide for repackaging of the instrument for shipment. Refer to Paragraph 2-23 if the original container is to be used; 2-24 if it is not. If you have any questions, contact your local -hp- Sales and Service Office. (See Appendix B for office locations.)

ber of the instrument. In any correspondence, identify the instrument by model number, serial number, and serial number prefix.

2-23. If original container is to be used, proceed as follows:

- a. Place instrument in original container if available. If original container is not available, a suitable container can be purchased from your nearest -hp- Sales and Service Office.
- b. Ensure that container is well sealed with strong tape or metal bands.

2-24. If original container is not to be used, proceed as follows:

- a. Wrap instrument in heavy paper or plastic before placing in an inner container.
- b. Place packing material around all sides of instrument and protect panel face with cardboard strips.
- c. Place instrument and inner container in a heavy carton or wooden box and seal with strong tape or metal bands.
- d. Mark shipping container with "DELICATE INSTRUMENT," "FRAGILE," etc.

NOTE

If the instrument is to be shipped to Hewlett-Packard for service or repair, attach a tag to the instrument identifying the owner and indicating the service or repair to be accomplished; include the model number and full serial number of the instrument.

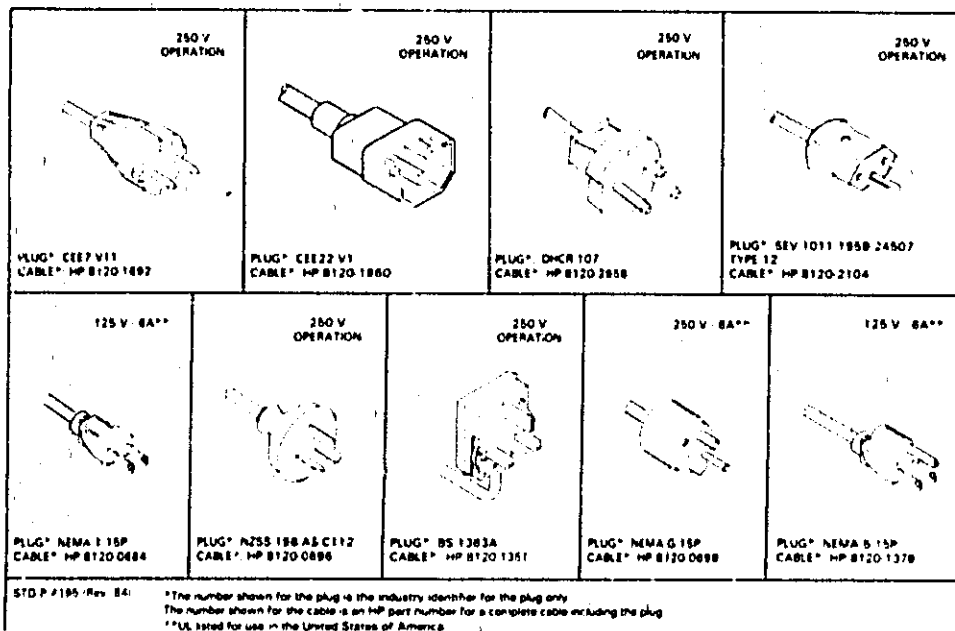

Figure 2-1. Power Cords.

SECTION III OPERATING INSTRUCTIONS

3-1. INTRODUCTION.

3-2. The Model 400E/EL is primarily an ac voltmeter and dB meter, but it can be used as an ac to dc converter or as a wide band amplifier.

3-3. This section explains the controls of the 400E/EL and outlines the operating procedures for each mode of operation.

3-4. LOCATION OF CONTROLS AND INDICATORS.

3-5. Figure 3-2 shows the location of each of the 400E/EL controls and explains the function of each.

3-6. OPERATING INSTRUCTIONS.

3-7. STANDARD 400E/EL.

3-8. AC Voltmeter.

NOTE

Since the 400E/EL is average responding and rms calibrated, any distortion will affect the accuracy of the measurement. Table 3-1 shows the errors caused by distortion.

- a. Ensure that 115/230 V ac slide switch on the rear panel matches line voltage used, and connect power to the instrument. Mechanically zero the instrument using the procedure outlined in Paragraph 5-5.
- b. To operate the Model 400E/EL with battery power, connect two 35 to 55 volt batteries as shown in Figure 3-1. Since the front panel LINE switch has no effect during battery operation, the switch in Figure 3-1 can be used as a convenient method of disconnecting the batteries when the instrument is not in use. Two 35 volt batteries will deliver approximately 75 mA and two 55 volt batteries will deliver approximately 50 mA.

Table 3-1. Effect of Distortion on Average Responding Meter

Harmonic	% Distortion	% ERROR (* Fundamental)	
		Max. Positive	Max. Negative
Any even	0.1	0.000	
	0.5	0.001	
	1.0	0.005	
	2.0	0.020	
Third	0.1	0.033	0.003
	0.5	0.168	0.167
	1.0	0.338	0.328
	2.0	0.687	0.667
Fifth	0.1	0.020	0.020
	0.5	0.101	0.099
	1.0	0.205	0.195
	2.0	0.420	1.380

* Depends on phase relationship between harmonic and fundamental.

WARNING

For operator protection during battery operation, connect chassis terminal (MP26) to earth ground.

- c. Turn line ON toggle switch to up position. LINE lamp will glow.
- d. Select approximate range of signal to be measured.

CAUTION

Do not apply more than 500 volts ac to input. Do not overload the .001 through 1 volt ranges. Consult Table 1-2 for overload limits. If any of these overloads are exceeded, the instrument may be damaged.

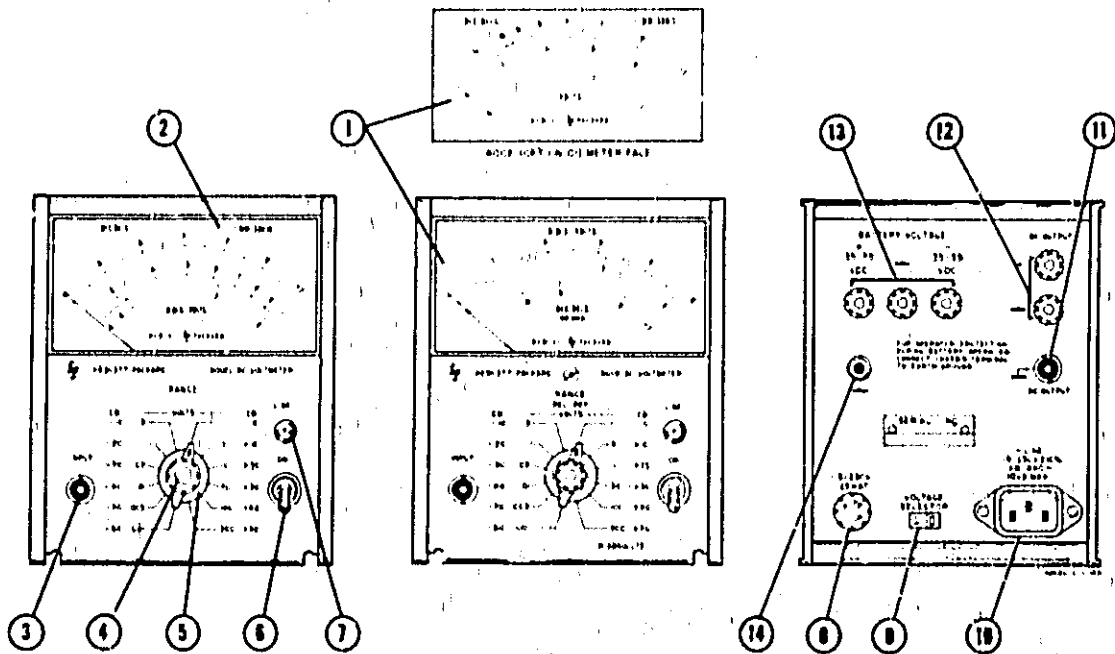

- ① 400E Scale: Indicates magnitude of applied signal in volts and dB. Option 01 places the dB scale uppermost for greater resolution. $0\text{dBm} = 1\text{mW}$ in 600 ohms.
- ② 400EL Scale: Indicates magnitude of applied signal in volts and dB. DB scale is linear, and voltage scales are logarithmic. This arrangement allows better resolution for dB reading. $0\text{dBm} = 1\text{mW}$ in 600 ohms.
- ③ AC INPUT: BNC input jack connects signal to be measured.
- ④ REL. REF Adjust (Option 02): Varies indication on meter by 3dB. Fully clockwise, ABSOLUTE position retains full meter indication. This control is used to vary meter indication with a given input in order to make relative readings easier.
- ⑤ RANGE Selector: Selects full scale reading of meter. DB reading on scale adds, algebraically to dB setting of RANGE selector.
- ⑥ Line ON Toggle Switch: Applies primary power.
- ⑦ LINE Indicator Lamp: Indicates application of primary power.
- ⑧ FUSE: 1/8A. Protects instrument against current overload.
- ⑨ 115/230 Volt Slide Switch: Selects 115 or 230 volts ac for line operation.
- ⑩ PRIMARY POWER CONNECTOR: Line voltage is applied through this connector.
- ⑪ AC OUTPUT: Ac amplifier output. Output impedance is 50 ohms.
- ⑫ DC OUTPUT: Ac to dc converter output. Dc voltage is proportional to percentage of meter deflection. Output impedance is 1000 ohms.
- ⑬ BATTERY VOLTAGE Terminals: 400E/EL may be powered by connecting two 35 to 55 volt batteries to these terminals.
- ⑭ CHASSIS TERMINAL: Chassis ground connection for battery operation.

Figure 3-2. Location of Controls and Indicators

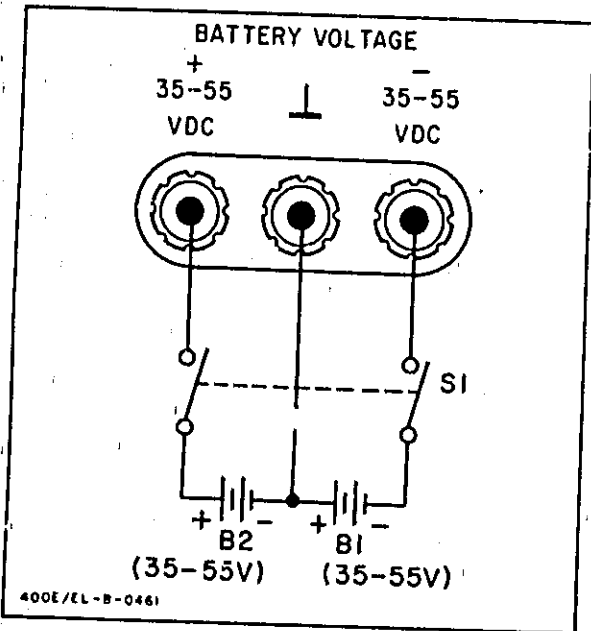

Figure 3-1. External Battery Connection

- c. Connect signal to be measured to INPUT terminals, and read the rms voltage on the scale.

3-9. DB Meter.

- To make a dB or dBm measurement, follow steps a through e in Paragraph 3-8, and add the scale reading to the RANGE setting. For example: If the scale reading is +1.5 and the RANGE is -30dB, the final measurement is -28.5dB.
- The 400E/EL dB scale is calibrated in dBm. 0dBm is equivalent to 1 milliwatt dissipated by a 600 ohm load. Consequently, any dBm measurements must be made across a total impedance of 600 ohms. Measurements across other impedances will be in dB, but not dBm.
- To convert a dB reading to dBm, use the Impedance Correction Graph (Figure 3-3). For example: To convert a +30dB reading made across 50 ohms to dBm, locate the load impedance on the bottom of the graph. Follow the impedance line to the heavy black line and read the meter correction at that point. The correction for 50 ohms is +10.5dBm, and the corrected reading is +40.5dBm.

3-10. Ac to Dc Converter.

- Follow steps a through e in Paragraph 3-8.
- Connect the rear panel DC OUTPUT terminals to a dc measuring device with a high input impedance. The dc output resistance is 1000 ohms; and if it is loaded, the dc output signal will be inaccurate.
- The dc output is a 0 to 1 volt signal proportional to the percentage of 400E/EL meter deflection.

3-11. Wide Band Ac Amplifier.

- Follow turn-on steps a through e in Paragraph 3-8.
- Select approximate range of input on RANGE switch.
- Connect SIGNAL to be amplified to INPUT terminals.
- When using an ac power source, ground loops can be eliminated by connecting the 400E/EL to an adequate isolation transformer. This will open the power line ground circuit as shown in Figure 3-3.

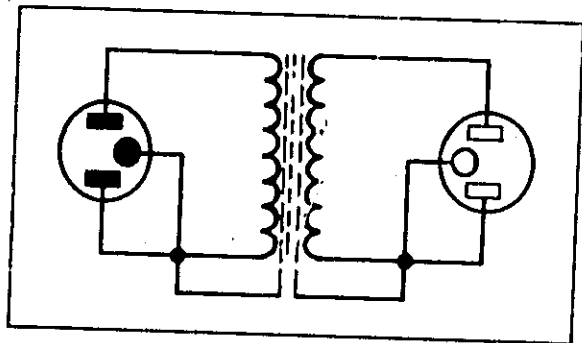

Figure 3-3. Isolation Transformer.

NOTE

Place a 1 kilohm shielded load across the DC OUTPUT, if it is not being used, when using the AC OUTPUT. This is especially necessary on low ranges.

- The gain of the amplifier depends on the RANGE selection. On the 0.1 volt range and below, the 400E/EL amplifies the input; and

on the 0.3 volt range and above, it attenuates the input. On the 0.001 volt ranges, the maximum output is 105mV. On all other ranges, the maximum output is 150mV. Table 3-2 shows the ac amplifier gain for each range setting.

Table 3-2. AC Amplifier Gain

RANGE	GAIN	RANGE	GAIN
0.001	+40dB	1	-16dB
0.003	+34dB	3	-26dB
0.01	+24dB	10	-36dB
0.03	+14dB	30	-46dB
0.1	+4dB	100	-56dB
0.3	-6dB	300	-66dB

3-12. 400E WITH OPTION 01.

3-13. Operation of the 400E with Option 01 is essentially the same as operation of the standard 400E: The dB scale reads from -15 to +2 instead of from -12 to +2, and is placed at the top of the scale for better resolution.

3-14. 400E/EL WITH OPTION 02.

3-15. Option 02 adds a relative reference adjustment to the 400E/EL. This adjustment allows a meter indication to be varied by 3dB. Use the REL. REF adjustment to set the meter at any convenient reference (0dB for example) in order to make relative readings easier. When the REL REF adjustment is in the fully clockwise ABSOLUTE position, it has no effect on the meter accuracy.

3-16. In all other respects, operation of a Option 02 instrument is the same as operation of a standard Model 400E/EL.

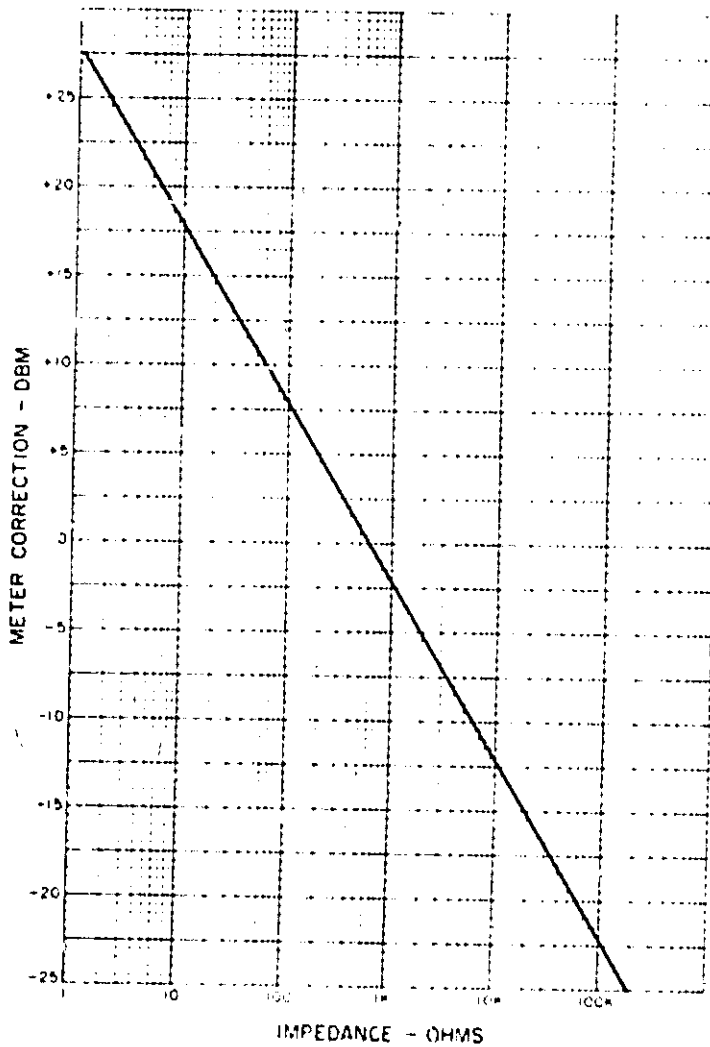

Figure 3-4. Impedance Correction Graph.

SECTION IV

THEORY OF OPERATION

4-1. GENERAL.

4-2. The 400E/EL is a solid state, average responding, rms calibrated voltmeter. It also has applications as an ac to dc converter and a wide band amplifier. Figure 4-1 shows a simplified block diagram of the instrument.

4-3. When relay K1 is closed, the input is not attenuated; when K1 is open and K2 is closed, the input is attenuated by 50 dB. On the 0.001 through 1 volt ranges, K1 is closed and K2 is open. K2 is closed and K1 is open on the 3 through 300 volt ranges. The entire Input Attenuator assembly is shielded, and the relays are operated remotely by voltages applied through the RANGE switch. Variable capacitor A1C2 is adjusted on the 3 volt range with a 3 volt 100 kHz input in order to shape the frequency response of the Input Attenuator.

4-4. The signal from the input attenuator is applied to the impedance converter. The impedance converter is a unity gain, feedback stabilized amplifier that matches the high Impedance of the Input Attenuator to the much lower impedance of the Post Attenuator.

4-5. The Post Attenuator attenuates the output of the Impedance Converter by 10dB for each step of the RANGE switch. On the 3 volt range, the Post

Attenuator is switched back to the 30dB position, and then it attenuates 10dB per step on the higher ranges. Variable capacitor S2C2 is adjusted on the .003 volt range with a 3mV, 8MHz input to adjust the 8MHz response of the .003 volt range. With a full scale input on any range except the .001 volt range, the output of the Post Attenuator should be 3mV. On the .001 volt range, the output should be 1mV.

4-6. The Meter Amplifier is a four-stage, high-gain amplifier utilizing both ac and dc feedback for gain stabilization. The Meter Bridge, connected in the ac feedback path of the meter amplifier, converts the ac output of the amplifier to a dc voltage proportional to its average value. This dc voltage drives the meter. A2C28 and A2R38 adjust the gain of the amplifier so that the meter will read rms volts. A2R38 is adjusted at 400Hz, and A2C28 is adjusted at 10MHz.

4-7. The DC Output is a 0-1 volt level that is proportional to meter deflection. R2 is adjusted to calibrate the dc output. The AC Amplifier samples the ac feedback and generates 9 to 150mV ac output that is directly proportional to meter deflection.

4-8. SCHEMATIC DESCRIPTION.

(See Figure 7-1).

4-9. IMPEDANCE CONVERTER.

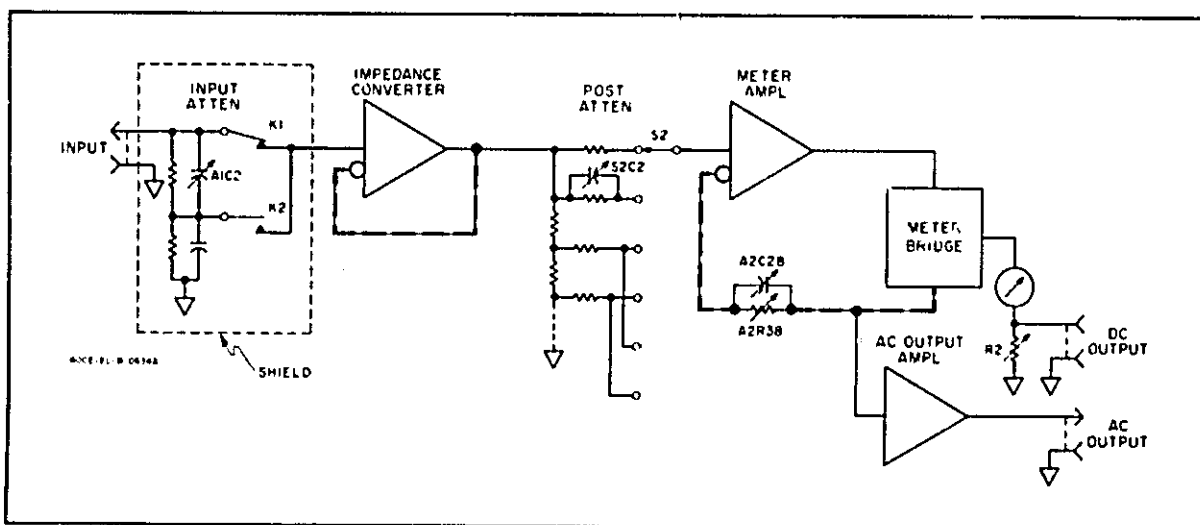

Figure 4-1. Simplified Block Diagram

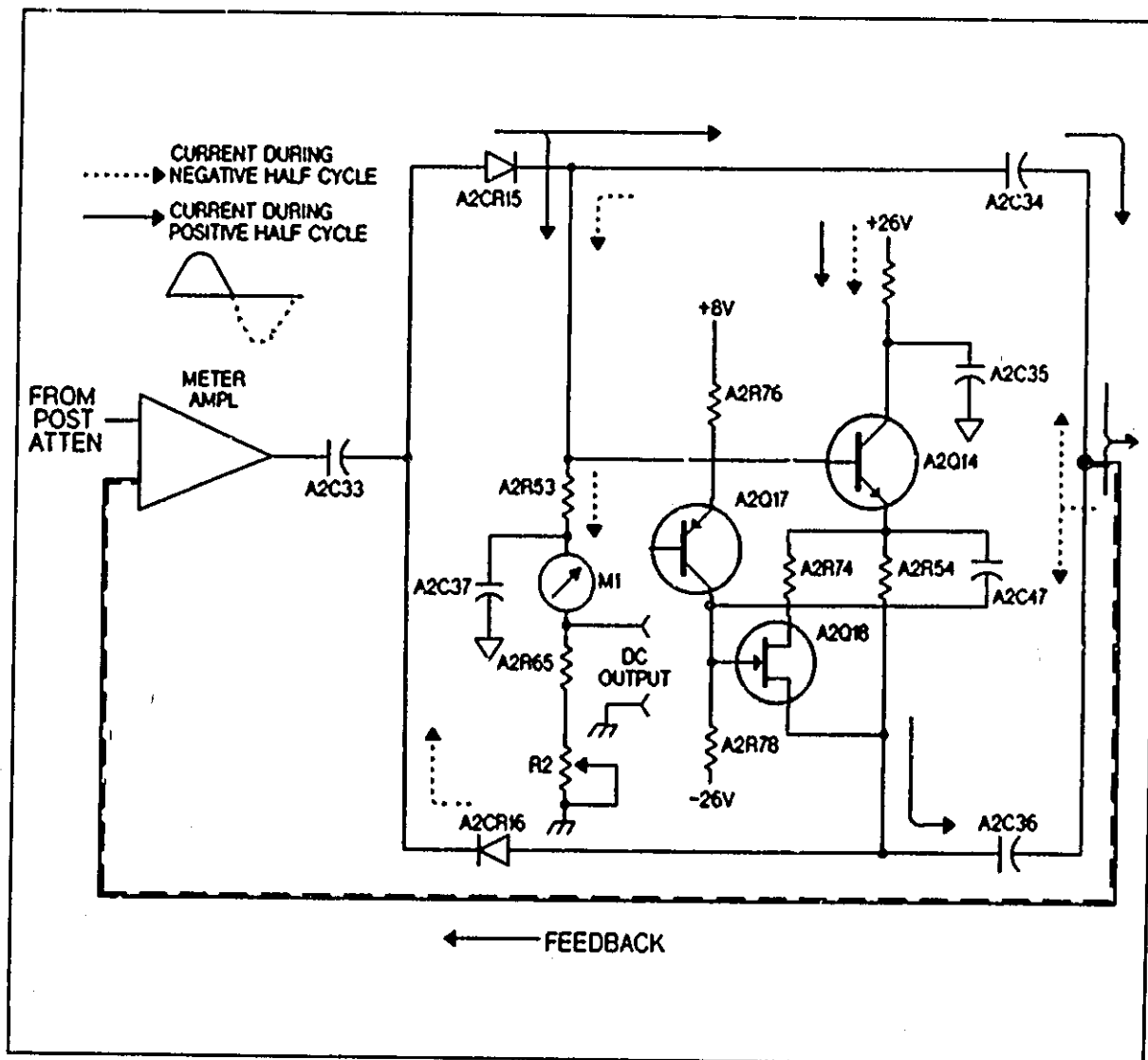

Figure 4-2. Meter Bridge

4-10. The impedance converter, located on the main voltmeter board (A2), matches the high impedance of the input attenuator to the relatively low impedance of the Post Attenuator. Breakdown diodes A2CR17 and A2CR18 bias diodes A2CR9 and A2CR10 at +5 and -5 volts respectively. A2CR9 and A2CR10 limit the input to 10 volts peak-to-peak, providing overload protection. Breakdown diodes A2CR20 and A2CR21 stabilize the bias voltages on A2Q5. Fuse A2F1 protects the instrument against destructive overloads.

4-11. A field-effect transistor (A2Q5) is used in the input stage of the impedance converter because of its characteristically high input impedance and good frequency response. A2R17 adjusts the dc bias of the

impedance converter. The output is taken from the emitter circuit of A2Q7 and applied to the post attenuator and then applied to the meter amplifier. The solid black lines on the schematic show the signal path, and the broken lines show the feedback paths.

4-12. METER AMPLIFIER.

4-13. The meter amplifier amplifies its input signal by a fixed gain on all ranges except the .001 volt range. The amplifier itself is a four-stage, dc coupled amplifier with a cascade-coupled final stage (A2Q12 and A2Q13). DC feedback is coupled from the emitter of A2Q12 back to the base of A2Q9. Breakdown diodes A2CR12, A2CR13 and A2CR14 establish fixed dc bias levels in the amplifier.

4-14. The output from the collector of A2Q13 is coupled through the Meter Bridge and fed back to the emitter of A2Q9. A2C28 in the feedback circuit adjusts the amount of feedback at the high end of the frequency range, and A2R38 adjusts the feedback at the low end. This calibrates the amplifier gain at both ends of the frequency range. A2R44, 45 and 72 are switched into the feedback circuit on the 0.001 volt range, boosting the gain on that range. A2R44 adjusts the gain on the 1mV range with a 400Hz input. A2R31 adjusts the dc bias level of the amplifier.

4-15. METER BRIDGE.

4-16. Figure 4-2 shows a partial schematic of the Meter Bridge. The meter bridge rectifies the ac amplifier output and supplies the dc current to drive the meter. In order to use part of the meter bridge output as the rear terminal dc output, the meter has to be referenced to ground. Transistor A2Q14 references the meter to ground.

4-17. During the positive half cycle, A2CR15 conducts. Part of the current (solid line) goes through A2C34 into the feedback path, and part of the current goes through A2R53 and the meter to ground. The current through A2R53 turns on A2Q14, and A2Q14 draws current from the positive supply. The current from A2Q14 goes through A2C36 into the feedback path. The current through A2Q14 and A2C36 is equal to the current drawn through the meter, so the current out of the bridge is equal to the current into the bridge.

4-18. During the negative half cycle, A2CR16 conducts and draws current from the feedback path (dotted line). Part of the current goes through A2C36 and A2CR16 into the amplifier, and part goes through A2R53 and the meter to ground. The current through A2R53 turns on A2Q14, and the current from A2Q14 goes through A2R54 and A2CR16 to the amplifier. Again the current through the meter equals the current through A2R54, and the current into the bridge equals the current out.

4-19. Transistor A2Q14 replaces current drawn by the meter, so the meter bridge is kept floating while the meter is referenced to ground. The dc output, taken across A2R65 and R2, is also referenced to ground.

4-20. FET A2Q18 provides a small resistance at $\frac{1}{2}$ scale inputs and a large resistance at full scale inputs. This in turn causes the bridge to partially turn off at full scale inputs. Any full scale readings at 10 MHz are then lowered and the $\frac{1}{2}$ scale readings are increased. Any excess peaking at full scale and excess rolloff at $\frac{1}{2}$ scale at 10 MHz is prevented. At frequencies below 6 MHz, the amplifier's gain is enough to override the bridge being partially turned off.

4-21. AC OUTPUT CIRCUIT.

4-22. The ac output circuit isolates the meter bridge and amplifier from the ac output load. It consists of two emitter followers (A2Q15 and Q16) connected in cascade. A2R59 in the base circuit of A2Q15 zeroes the output dc level at the ac output.

4-23. POWER SUPPLY.

4-24. The power supply produces regulated +26 volts and -26 volts. Breakdown diode A2CR7 established a reference voltage of 6.98 volts. Part of the power supply output is applied to the base of A2Q2, and A2Q2 senses the difference between the supply output and the reference. If the output voltage changes, the emitter to base voltage of A2Q2 will change; and the output of A2Q2 will change the current through A2Q1, the regulator.

4-25. The negative regulator, A2Q3 and A2Q4, uses the +26 volt output as a reference. Consequently, the negative supply is dependent upon the positive supply.

SECTION V

MAINTENANCE

5-1. INTRODUCTION.

5-2. This section has the maintenance information for the HP 400E/EL. Included are the Performance Tests, Calibration Procedures, and Troubleshooting Procedures.

5-3. REQUIRED TEST EQUIPMENT.

5-4. The required test equipment to maintain the Model 400E/EL is listed in Table 5-1. Other equipment may be used as long as the critical specifications are met.

5-5. TEST CARD.

5-6. The performance test card is at the end of this section to record the performance test results. The card may be used as a permanent record and may be reproduced without written permission from Hewlett-Packard.

5-7. WARM-UP TIME.

5-8. The HP 400E/EL and the required test equipment should be warmed up for at least a half hour before doing any testing or calibration.

Table 5-1. Required Test Equipment.

Instrument	Critical Specifications	Recommended Model
Ac Calibrator	Accuracy: 0.022% to 0.205% Voltage Range: .1mV to 300V Frequency Range: 10Hz to 110kHz	Fluke Model 5200A and Model 5215A
Function Generator (Test Oscillator)	Frequency Range: 10Hz to 10MHz Output: 3V rms max. Distortion: < 1% max.	HP Model 3312A
Digital Multimeter (2 Required)	Range: 0V to 100V Sensitivity: 100 microvolts Accuracy: >0.01%	HP Model 3468A or HP Model 3478A
Thermal Converters	a. Input: 3V rms Output: 7mV dc b. Input: 1V rms Output: 7mV dc c. Input 0.45V rms Output: 7mV dc	a. HP Model 11049A b. HP Model 11050A c. HP Model 11051A
Resistors	100k, $\pm 1\%$ tolerance 1k, $\pm 1\%$ tolerance	HP P/N 0757-0465 HP P/N 0757-0280
Termination	Feed-through, 50 ohm impedance	HP Model 11048C
Coaxial Attenuators	a. 50dB attenuation, $\pm .01$ dB tolerance dc to 10MHz b. 40dB attenuation, $\pm .01$ dB tolerance dc to 10MHz	a. Weinschel Engineering Model 50-40S b. Weinschel Engineering Model 50-50S
Wideband AC Voltmeter	Frequency Range: 10Hz to 4MHz Accuracy: $> \pm 1\%$	HP Model 3403C

5-9. MECHANICAL ZERO ADJUST (400E Only).

5-10. Adjust the front panel meter to the zero position before doing any performance tests and calibrations. Do the following:

- a. Make sure the instrument has been off at least a minute, or momentarily short the meter terminals.
- b. Rotate the mechanical meter adjustment screw *CLOCKWISE* until the meter pointer is to the left of zero and moving upscale toward zero.
- c. Continue rotating the screw *CLOCKWISE* until the pointer is exactly on zero. If needle overshoots, repeat step b.
- d. With the pointer exactly on zero, turn the adjustment screw slightly *COUNTERCLOCKWISE* to relieve any tension on the suspension. If the pointer moves to the left, repeat the adjustment procedure but make sure the counterclockwise rotation is less.

5-11. PERFORMANCE TESTS.

5-12. The performance tests verify the HP 400E/EL's accuracy specifications listed in Table 1-1. Perform these tests for incoming and periodic inspections, and before instrument calibration. The performance tests are separated as follows:

- Accuracy Checks from 10Hz to 110kHz - paragraph 5-16
- Frequency Response Checks from 110kHz to 10MHz - paragraph 5-18
- Optional Frequency Response Checks from 110kHz to 10MHz - paragraph 5-20
- Optional Accuracy Checks from 10Hz to 10MHz - paragraph 5-22
- Input Impedance Check - paragraph 5-24
- AC to DC Converter Output Impedance Check - paragraph 5-28
- AC Output Voltage Check - paragraph 5-29

5-13. ACCURACY AND FREQUENCY RESPONSE TESTS.

5-14. Two tests are given to check the HP 400E/EL's performance. The first test checks

the accuracy on all ranges at frequencies from 10Hz to 110kHz. The second test checks the frequency response on the 1V and 3V ranges only from 110kHz to 10MHz. You may also use the second test to check the accuracy at 10Hz to 10MHz by using an additional thermal converter (.45V converter, HP 11051A). The additional converter checks the HP 400E/EL's lower 1mV and 3mV ranges. Since this test is slower to perform than the first, use it only for the frequency response test or for all tests if the first test's equipment is unavailable.

5-15. The first test uses an ac calibrator to check the HP 400E/EL's accuracy. The second test uses thermal converters to check the response. Instead of thermal converters, you can also use an oscillator that is flat in the 1kHz to 10MHz frequency range. The absolute output accuracy of the oscillator is unimportant, but it has to be flat within $\pm .25\%$ from 1kHz to 10MHz.

NOTE

For HP 400E/EL Option 02 instruments, set the "REL. REF" adjustment to the clockwise ABSOLUTE position before making any accuracy checks.

5-16. Accuracy Checks from 10Hz to 110kHz.

5-17. Refer to Figure 5-1. Use the recommended ac calibrator and digital multimeter to check the Model 400E/EL accuracy on the .001V through 100V ranges. To check the 300V range, use the recommended power amplifier (Fluke Model 5215A) with the ac calibrator. Do the following:

NOTE

Before performing any accuracy checks, warmup both the Model 400E/EL and the test equipment for at least one half hour.

Always uprange the HP 400E/EL before upranging the ac calibrator and always downrange the ac calibrator before downranging the HP 400E/EL.

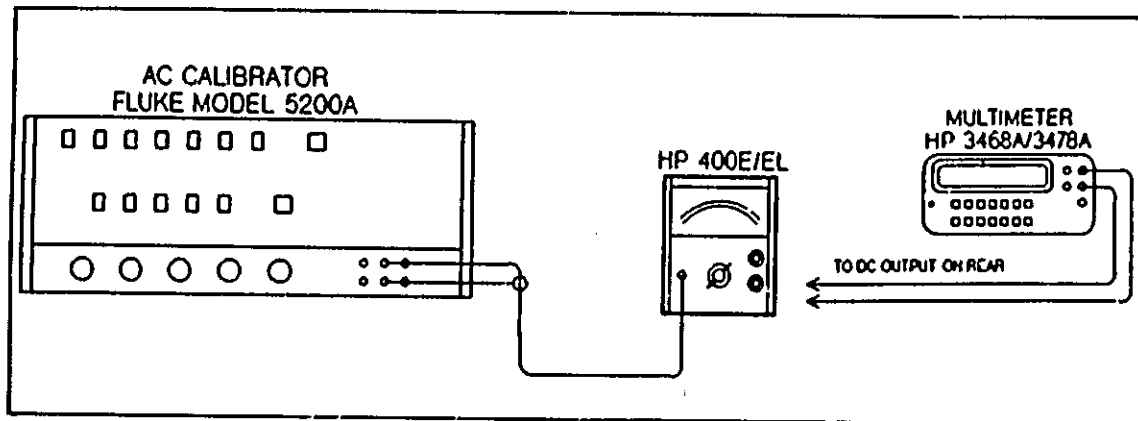

Figure 5-1. Accuracy Test Setup.

- a. Set the HP 400E/EL to the 3V range and setup the ac calibrator for a 3V at 400Hz output. Setup the digital multimeter to measure dc volts on autorange.
- b. Connect the ac calibrator and digital multimeter to the Model 400E/EL as shown in Figure 5-1.
- c. Set the ac calibrator error range to 3% and turn the error marker to 0%.
- d. Read the dc output on the multimeter. Make sure the reading is within the specified limits under the "DC Output" heading in Tables 5-2 and 5-3.
- e. Use the error control on the ac calibrator to determine the meter error on the HP 400E/EL. Do this by adjusting the error control until the reading on the HP 400E/EL agrees with the calibrator output. Then read the error directly from the error control scale. For errors above 3%, use the ac calibrator's output voltage setting to determine the error. Adjust the output voltage until the HP 400E/EL displays the correct voltage. Then calculate the error from the voltage setting. Make sure the errors are within the specified limits under the "Meter" heading in Tables 5-2 and 5-3.
- f. Repeat steps c, d, and e for each voltage setting and range at frequencies from 10Hz to 110kHz, as listed in Tables 5-2 and 5-3. To check the 1mV and 3mV ranges, connect a precision 40dB attenuator between the ac calibrator and HP 400E/EL. Set the appropriate output on the ac calibrator to supply 1mV and 3mV to the HP 400E/EL. If any readings and measurements are out the specified limits, go to paragraph 5-30 for calibration.

NOTE

For accuracy and frequency response checks not listed in Tables 5-2 and 5-3, use the "Accuracy Graphs" in Table 5-4. Obtain the accuracy percentage from Table 1-1 and select the appropriate graph from the percentage. Find the point on the curve for any point from full scale to $\frac{1}{3}$ scale. Horizontally select the percent of reading.

Table 5-2. Accuracy Tolerances

Frequency (Hz)	3 Volt Range			1 Volt Range E		
	Voltage Input	Meter (% of reading)	DC OUTPUT (Volts)	Voltage Input	Meter (% of reading)	DC OUTPUT (Volts)
10	3	3.00 ± 5%	0.949 ± 0.047	1.0	1.00 ± 5%	1.00 ± 0.05
	2	2.00 ± 6.3%	0.633 ± 0.040	0.5	0.50 ± 7.5%	0.50 ± 0.038
	1	1.00 ± 10%	0.316 ± 0.032	0.3	0.30 ± 10.8%	0.30 ± 0.033
40	3	3.00 ± 1%	0.949 ± 0.010	1.0	1.00 ± 1%	1.00 ± 0.010
	2	2.00 ± 1.5%	0.633 ± 0.010	0.5	0.50 ± 2%	0.50 ± 0.010
	1	1.00 ± 3%	0.316 ± 0.01	0.3	0.30 ± 3.3%	0.30 ± 0.010
100 or 400	3	3.00 ± 1%	0.949 ± 0.010	1.0	1.00 ± 1%	1.00 ± 0.01
	2	2.00 ± 1.5%	0.633 ± 0.010	0.5	0.50 ± 2%	0.50 ± 0.01
	1	1.00 ± 3%	0.316 ± 0.010	0.3	0.30 ± 3.3%	0.30 ± 0.01
500k	3	3.00 ± 1%	0.949 ± 0.010	1.0	1.00 ± 1%	1.00 ± 0.01
	2	2.00 ± 1.5%	0.633 ± 0.010	0.5	0.50 ± 2%	0.50 ± 0.01
	1	1.00 ± 3%	0.316 ± 0.010	0.3	0.30 ± 3.3%	0.30 ± 0.01
1 M	3	3.00 ± 1%	0.949 ± 0.010	1.0	1.00 ± 1%	1.00 ± 0.01
	2	2.00 ± 1.5%	0.633 ± 0.010	0.5	0.50 ± 2%	0.50 ± 0.01
	1	1.00 ± 3%	0.316 ± 0.010	0.3	0.30 ± 3.3%	0.30 ± 0.01
4 M	3	3.00 ± 3%	0.949 ± 0.029	1.0	1.00 ± 3%	1.00 ± 0.03
	2	2.00 ± 3.8%	0.633 ± 0.024	0.5	0.50 ± 4.5%	0.50 ± 0.023
	1	1.00 ± 6%	0.316 ± 0.019	0.3	0.30 ± 6.5%	0.30 ± 0.020
10 M	3	3.00 ± 5%	0.949 ± 0.0475	1.0	1.00 ± 5%	1.00 ± 0.05
	2	2.00 ± 6.5%	0.633 ± 0.0411	0.5	0.50 ± 8%	0.50 ± 0.04
	1	1.00 ± 15%	0.316 ± 0.0348	0.3	0.30 ± 12%	0.30 ± 0.036

ΔThese tolerances can also be used on the following ranges: 10 mV, 100 mV.

Table 5-3. Performance Test Limits

Frequency (Hz)	1 Millivolt Range Only			Frequency (Hz)	1 Millivolt Range Only		
	Voltage Input	Meter (mV) (% of reading)	DC Output (Volts)		Voltage Input	Meter (mV) (% of reading)	DC Output (Volts)
10	1.00 mV	1.00 ± 5%	1.00 ± 0.05	100 k	1.00 mV	1.00 ± 1%	1.00 ± 0.005
	0.5 mV	0.50 ± 7.6%	0.50 ± 0.036		0.5 mV	0.50 ± 2%	0.50 ± 0.0045
	0.3 mV	0.30 ± 10.8%	0.30 ± 0.033		0.3 mV	0.30 ± 3.3%	0.30 ± 0.0043
40	1.00 mV	1.00 ± 1%	1.00 ± 0.02	500 k	1.00 mV	1.00 ± 1%	1.00 ± 0.02
	0.5 mV	0.50 ± 2%	0.50 ± 0.015		0.3 mV	0.30 ± 3.3%	0.30 ± 0.013
	0.3 mV	0.30 ± 3.3%	0.30 ± 0.013				
100 or 400	1.00 mV	1.00 ± 1%	1.00 ± 0.005	4 M	1.00 mV	1.00 ± 5%	1.00 ± 0.05
	0.5 mV	0.50 ± 2%	0.50 ± 0.0045		0.3 mV	0.30 ± 10.8%	0.30 ± 0.033
	0.3 mV	0.30 ± 3.3%	0.30 ± 0.0043				

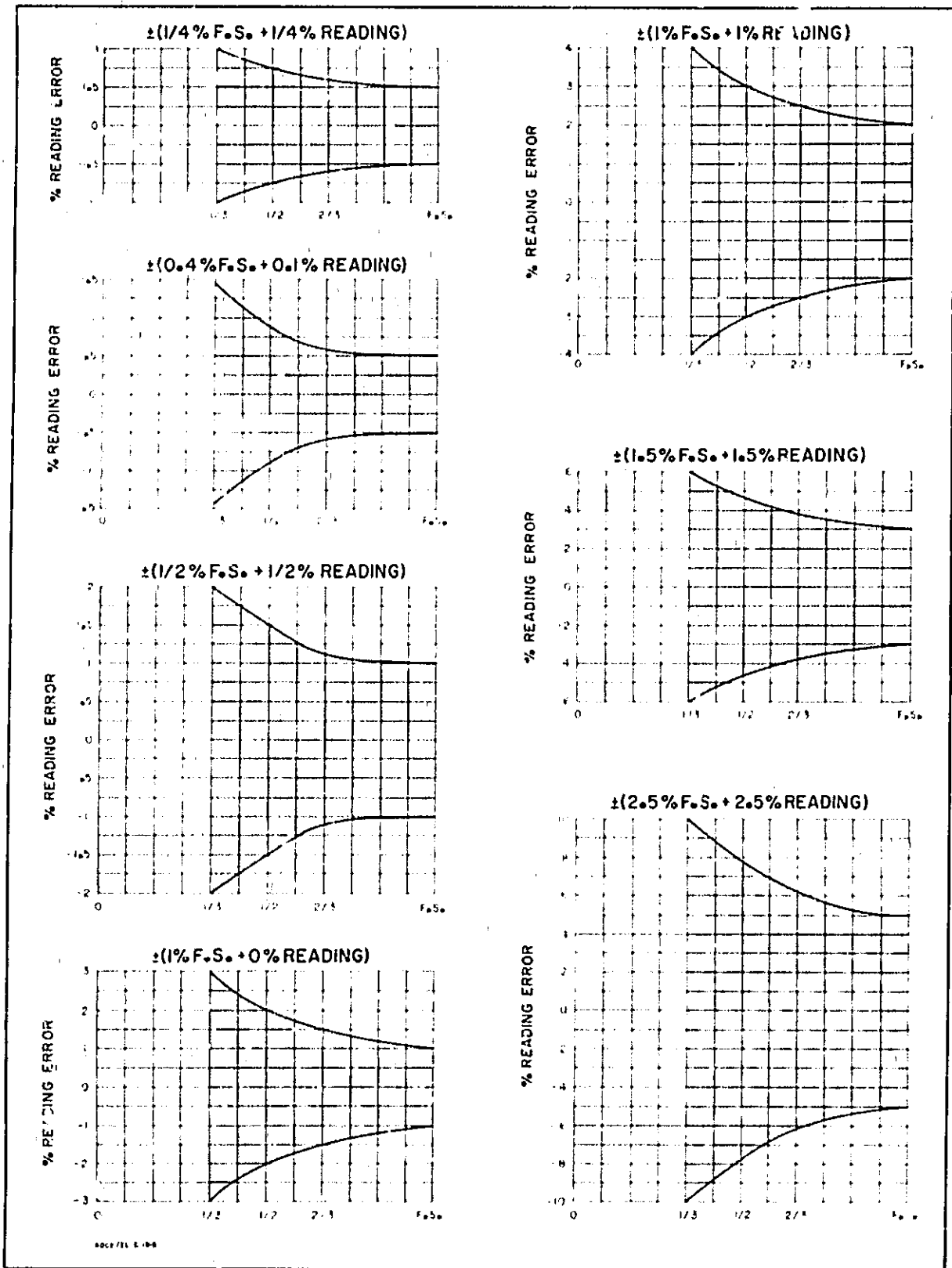

Table 5-4. Calibration Accuracy Graphs

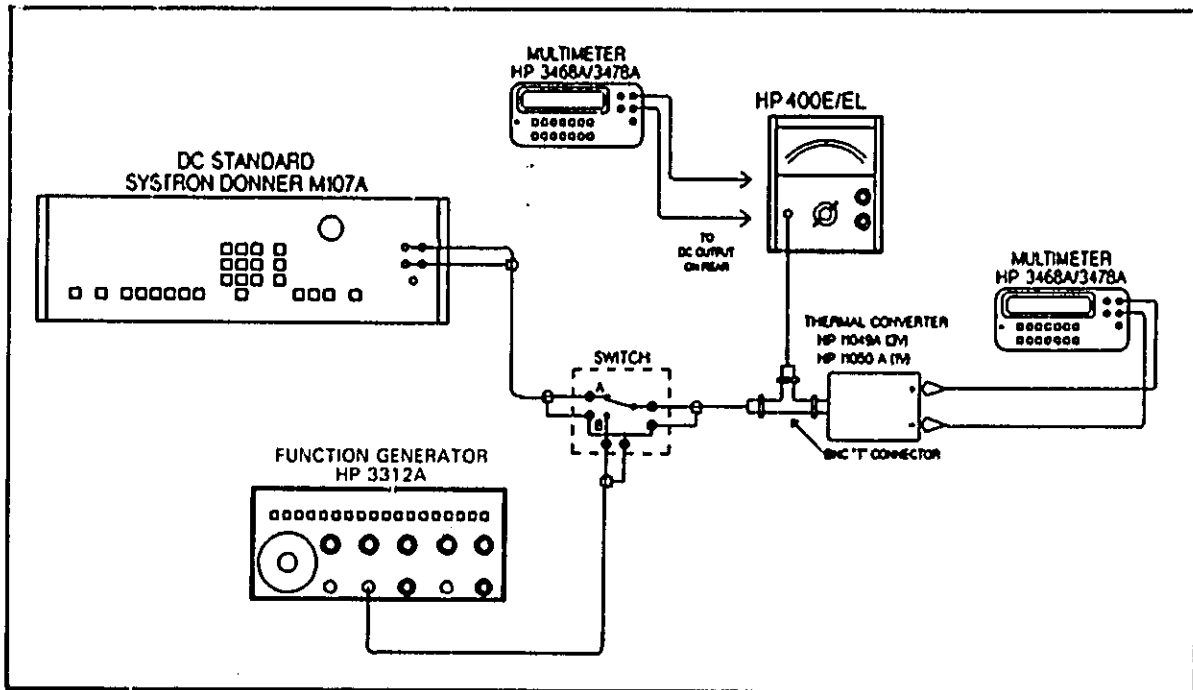

Figure 5-2. Frequency Response (and Optional Accuracy) Checks.

5-18. Frequency Response Checks from: 110kHz to 10Mz.

5-19. Refer to Figure 5-2. Use the recommended dc standard, function generator (ie., oscillator), digital multimeters, and thermal converters to check the HP 400E/EL accuracy on the 1V and 3V ranges. Do the following:

NOTE

The function generator/oscillator should have distortion levels below 1%. This is because the thermal converter and an average responding circuit, like the HP 400E/EL, react differently to distortion that could cause a reading/calibration error. However, the distortion level is less critical at high frequencies (4MHz and above) allowing the use of a function generator/oscillator with higher distortion levels.

- a. Setup the test equipment as follows:

DC Standard - 3V Output with Output Off

Function Generator - 3V at 500kHz Sine Wave Output
Digital Multimeters - DC Volts Function and Autorange
Switch - Position A

- b. Except for the HP 400E/EL (it will be connected later), connect the equipment as shown in Figure 5-2. Use the 3V Thermal Converter (HP 11049A) in the test setup.
- c. Turn the dc standard output on. Measure the thermal converter's output voltage as read on the digital multimeter connected to the converter. Note this voltage.

CAUTION

Turn the dc standard output off and set the function generator output to minimum before connecting to the thermal converter. Also, reduce the function generator output to minimum before changing the frequency. Any voltage above the rated input voltage of the thermal converter can destroy the converter.

- d. Set the switch to position B. Adjust the output on the function generator until the thermal converter's output voltage is the same as read in step c.
- e. Set the HP 400E/EL to the 3V range. Connect it to the "T" connector as shown in Figure 5-2.
- f. Read the dc output on the digital multimeter connected to the HP 400E/EL. Make sure the reading is within the specified limits under the "DC Output" heading in Tables 5-2 and 5-3.
- g. Note the reading on the HP 400E/EL. Make sure the reading is within the specified limits under the "Meter" heading in Tables 5-2 and 5-3.
- h. Repeat steps a through g to check the HP 400E/EL 1V range at frequencies from 110kHz to 10MHz (as listed in Tables 5-2 and 5-3). Use the 1V Thermal Converter (HP 11050A) for this test and set the dc standard and function generator for 1V outputs. If any readings and measurements are out of the specified limits for both the 1V and 3V tests, go to paragraph 5-30 for calibration.

5-20. Optional Frequency Response Checks from 110kHz to 10MHz.

5-21. This test can be used if an oscillator is used that is flat within $\pm .25\%$ from 1kHz to 10MHz. The ac calibrator and digital multimeter are also required to perform this test. Do the following:

- a. Set the HP 400E/EL to the 3V range and setup the ac calibrator for a 3V at 1kHz output (error range to zero). Set the digital multimeter to dc volts and autorange.
- b. Setup the oscillator for a 3V at 1kHz output. Do not connect it to the HP 400E/EL at this time.
- c. Connect the ac calibrator and digital multimeter to the Model 400E/EL as shown in Figure 5-1.

- d. Read the dc output on the multimeter and note the reading. Also note the reading on the Model 400E/EL.
- e. Disconnect the ac calibrator from the HP 400E/EL and connect the oscillator to the Model 400E/EL.
- f. Adjust the oscillator output to the reading on the multimeter noted in step d.
- g. Change the oscillator frequency to one you want to check. Note the reading on the multimeter and the HP 400E/EL. Determine the percent error of the HP 400E/EL by calculating the differences between these readings and the ones taken in step d. Make sure these readings are within the specified limits under the "DC Output" and "Meter" headings in Tables 5-2 and 5-3.
- h. Repeat steps a through g for the HP 400E/EL 1V range.

5-22. Optional Accuracy Checks from 10Hz to 10MHz.

5-23. Use the procedure in paragraph 5-18 to check the accuracy on the HP 400E/EL 1V and 3V ranges only. Check the 1mV and 3mV ranges by using a .45V Thermal Converter (HP 11051A). The only difference between this procedure and the one in paragraph 5-18 is that the Model 400E/EL is checked at additional frequencies and ranges.

5-24. INPUT IMPEDANCE CHECK.

5-25. There are two tests to check the HP 400E/EL input impedance. One checks the input resistance and the other checks the input capacitance. The tests are as follows:

5-26. Input Resistance Check.

- a. Setup the function generator for a 3V at 40Hz output. Set the HP 400E/EL to the 3V range.
- b. Connect the function generator to the HP 400E/EL. Adjust the function generator output for a full scale reading on the Model 400E/EL.

- c. Connect a 100k Ω resistor between the function generator output and the HP 400E/EL input, as shown in Figure 5-3.
- d. The HP 400E/EL reading should not drop more than 1 minor division from full scale. This indicates a 10M Ω or greater input resistance.
- e. Setup the function generator for a 1V at 40Hz output. Set the HP 400E/EL to the 1V range.
- f. Adjust the function generator output for a full scale reading on the Model 400E/EL.
- g. Increase the function generator frequency until the HP 400E/EL reading drops to 0.707V. This should occur at approximately 63.5kHz indicating an input capacitance of 25pF or less on the 1V range.

5-27. Input Capacitance Check.

- a. Setup the function generator for a 3V at 40Hz output. Set the HP 400E/EL to the 3V range.
- b. Connect a 100k Ω resistor between the function generator output and the HP 400E/EL input, as shown in Figure 5-3. Insert the resistor directly into the connector on the HP 400E/EL. Connect the ground lead to the outer shield of the HP 400E/EL connector. Do not use an adapter to connect the resistor to the HP 400E/EL. An adapter adds extra capacitance to the instrument's input.
- c. Adjust the function generator output for a full scale reading on the Model 400E/EL.
- d. Increase the function generator frequency until the HP 400E/EL reading drops to 2.12V. This should occur at approximately 132kHz indicating an input capacitance of 12pF or less on the 3V range.

5-28. AC TO DC CONVERTER OUTPUT IMPEDANCE CHECK.

- a. Setup the function generator for a 1V at 100kHz output. Set the HP 400E/EL to the 3V range.
- b. Connect a digital multimeter to the dc output of the Model 400E/EL. Set the multimeter to dc volts and autorange.
- c. Connect the function generator through a 50 ohm feed-through resistor to the HP 400E/EL. Adjust the function generator output for a 1.00000V reading on the digital multimeter.
- d. Place a 1000 ohm resistor across the dc output of the HP 400E/EL. Make sure the dc output voltage is between .475V and .525V as read on the digital multimeter. This shows an output impedance of 1000 ohms \pm 5%.

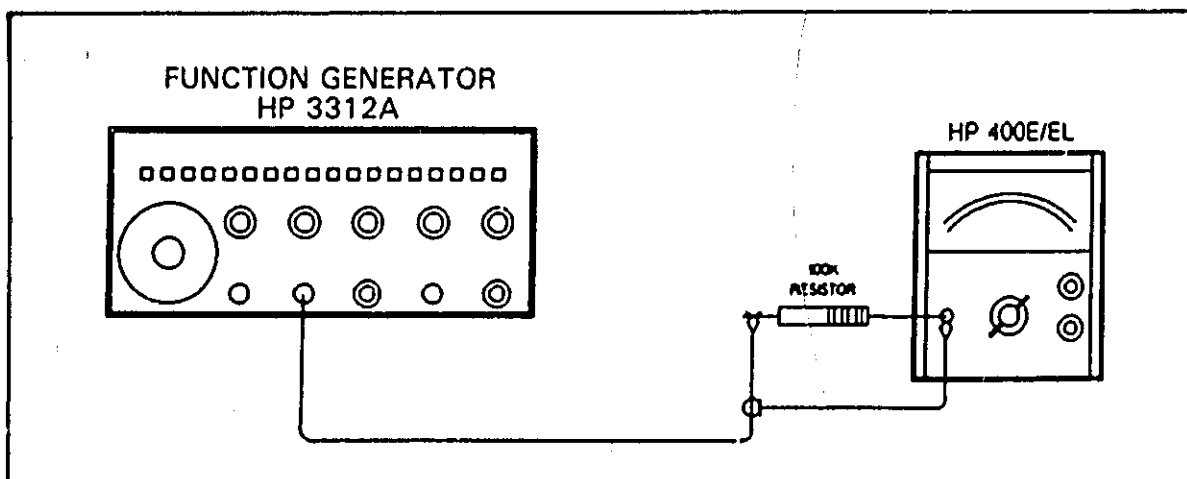

Figure 5-3. Input Impedance Checks.

5-29. AC OUTPUT VOLTAGE CHECK.

- Setup the function generator for a 1V at 10Hz output. Set the HP 400E/EL to the 3V range.
- Connect a digital ac voltmeter to the ac output of the Model 400E/EL.
- Connect the function generator through a 50 ohm feed-through resistor to the HP 400E/EL. Adjust the function generator output for a full scale reading on the Model 400E/EL.
- The ac voltmeter should read 150mV $\pm 10\%$. Change the frequency on the function generator from 10Hz to 4MHz and make sure the output voltage remains within the specified limits.
- Repeat steps a through d for the 100mV, 10mV, and 1mV ranges. For the 1mV range only, the ac voltmeter should read 105mV $\pm 10\%$.

5-30. ALIGNMENT AND CALIBRATION PROCEDURES.

5-31. Refer to Figure 5-4 for the alignment and calibration adjustment locations. The adjustments

are made with the instrument's covers removed. If unable to correctly perform any adjustment, go to paragraph 5-51 for troubleshooting.

NOTE

For HP 400E/EL Option 02 instruments, set the "REL. REF" adjustment to the clockwise ABSOLUTE position before calibration. Also, always set the bias level first (see paragraph 5-36) before calibration.

5-32. COVER REMOVAL.

5-33. Remove the top and bottom covers by removing the screws at the rear of the covers. Then slide the cover off about one inch to the rear and lift it off. To replace the cover, use the removal procedure in reverse. The side covers are removed by removing the four screws securing the covers in place. Then lift the cover off.

5-34. CHECKING POWER SUPPLIES.

5-35. Before doing any calibration, check the HP 400E/EL's power supplies. Using a digital multimeter, check for +26V $\pm 2V$ at TP1 and -26V $\pm 2V$ at TP2. If any voltage is wrong, go to paragraph 5-51 for troubleshooting.

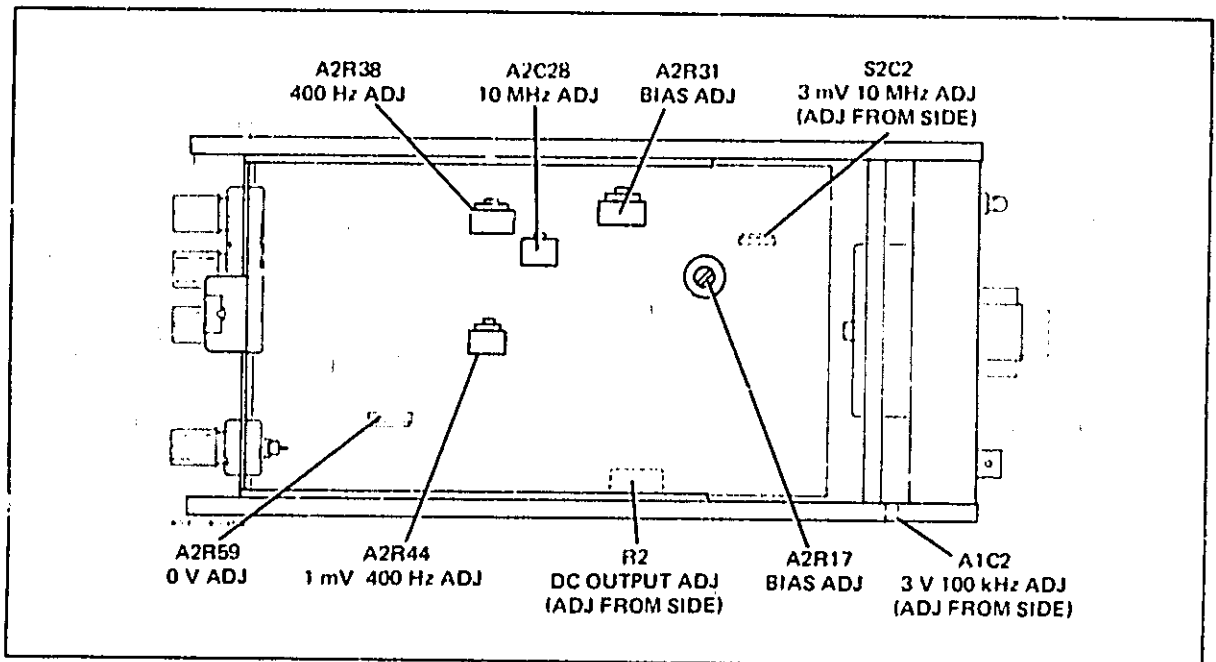

Figure 5-4. Location of Internal Adjustments

5-36. BIAS ADJUST.

5-37. Connect a digital multimeter to TP3 and adjust A2R17 for $-6.0V \pm 0.25V$ dc. Connect a digital multimeter to TP4 and adjust A2R31 for $+10.0V \pm 1V$ dc.

5-38. AC OUTPUT ADJUST.

5-39. Connect a digital multimeter to TP5 and adjust A2R59 for $0V \pm 0.05V$ dc.

5-40. CALIBRATION.

5-41. Two main procedures are given to calibrate the HP 400E/EL. The first procedure uses thermal converters and associated equipment. The second procedure uses an ac calibrator. If the second procedure is used, some sections of the first procedure must also be used for high frequency (above 110kHz) calibration. You can, however, use an oscillator that is flat in the 1kHz to 10MHz frequency range instead of the first procedure. The absolute output accuracy of the oscillator is unimportant, but it has to be flat within $\pm .25\%$ from 1kHz to 10MHz. The adjustment order for both procedures are given in Table 5-5.

5-42. Accuracy Calibration using Thermal Converters.

5-43. Refer to Figure 5-2. Use the recommended dc standard, function generator (ie., oscillator), digital multimeters, and thermal converters to calibrate the HP 400E/EL. A 0.45V thermal converter (HP 11051A) is also needed for calibration. Do the following:

NOTE

The function generator/oscillator should have distortion levels below 1%. This is important because the thermal converter and an average responding circuit, like the HP 400E/EL, react differently to distortion. This could cause a reading/calibration error. However, the distortion level is less critical at high frequencies (4MHz and above) allowing the use of a function generator/oscillator with higher distortion levels.

- a. Setup the test equipment as follows:

DC Standard - 1V Output with Output Off
 Function Generator - 1V at 400Hz Sine Wave Output
 Digital Multimeters - DC Volts Function and Autorange
 Switch - Position A

- b. Except for the HP 400E/EL (it will be connected later), connect the equipment as shown in Figure 5-2. Use the 1V Thermal Converter (HP 11050A) in the test setup.
- c. Turn the dc standard output on. Measure the thermal converter's output voltage as read on the digital multimeter connected to the converter. Note this voltage.

Table 5-5. Alternate Calibration Procedure

Step	400E/EL Range	Calibration Signal	Adjustment	400 E/EL Indication	
				Meter	DC Output
1	0.01V	10mV 400 Hz	A2R38	10mV \pm 0.1mV	
			R2		1.000 \pm 0.005Vdc
2	0.01V	10mV 10MHz	A2C28	10mV \pm 0.5mV	1.000 \pm 0.05Vdc
3	0.003V	3mV 10MHz	S2C2	3mV \pm 0.15mV	0.949 \pm 0.047Vdc
4	0.001V	1mV 400Hz	A2R44	1mV \pm 0.01mV	1.000 \pm 0.005Vdc
5	3V	3V 100kHz	A1C2	3V \pm 0.03V	0.949 \pm 0.004Vdc

CAUTION

Turn the dc standard output off and set the function generator output to minimum before connecting to the thermal converter. Also, reduce the function generator output to minimum before changing the frequency. Any voltage above the rated input voltage of the thermal converter can destroy the converter.

- d. Set the switch to position B. Adjust the output on the function generator until the thermal converter's output voltage is the same as read in step c.
- e. Set the HP 400E/EL to the .01V range. Connect a precision 40dB coaxial attenuator between the HP 400E/EL input and the "T" connector.
- f. Adjust A2R38 for a $0.01V \pm 0.1mV$ reading on the HP 400E/EL.
- g. Adjust R2 for a $1.000V \pm 0.005V$ dc reading on the digital multimeter connected to the HP 400E/EL output.
- h. Set the output voltage of the function generator as low as possible. Then set the output frequency to 10MHz.
- i. Adjust the output on the function generator until the thermal converter's output voltage is the same as read in step c.
- j. Adjust A2C28 for a $1.000V \pm 0.04V$ reading on the digital multimeter connected to the HP 400E/EL output.
- k. Remove the 40dB precision attenuator from the HP 400E/EL and replace it with a 50dB precision coaxial attenuator. Set the HP 400E/EL to the .003V range. The input voltage to the Model 400E/EL should now be 3.162mV.
- l. Adjust S2C2 for a $1.000V \pm 0.04V$ reading on the digital multimeter connected to the HP 400E/EL output.

NOTE

Check and make sure the HP 400E/EL accuracy is good at 4MHz and 6MHz. The amplitude can be lowered at 4MHz by moving A2C11 and C13 closer together.

- m. Set the switch to position A and set the dc standard output to 0.3162V. Set the function generator to 400Hz and set its output as low as possible.
- n. Replace the 1V thermal converter with a .45V (HP 11051A) converter.
- o. Measure the thermal converter's output voltage as read on the digital multimeter connected to the converter. Note this voltage.
- p. Set the switch to position B. Adjust the output on the function generator until the thermal converter's output voltage is the same as read in step o.
- q. Adjust A2R44 for a $1.000V \pm 0.005V$ dc reading on the digital multimeter connected to the HP 400E/EL output. Then remove both the 50dB precision attenuator and the HP 400E/EL from test equipment.
- r. Set the switch to position A. Set the function generator to 100kHz and set its output as low as possible.
- s. Replace the .45V thermal converter with a 3V (HP 11049A) converter. Then set the dc standard output to 3V.
- t. Measure the thermal converter's output voltage as read on the digital multimeter connected to the converter. Note this voltage.
- u. Set the switch to position B. Adjust the output on the function generator until the thermal converter's output voltage is the same as read in step t.
- v. Set the HP 400E/EL to the 3V range and connect it to the "T" connector.

- w. Adjust A1C2 for a $0.949V \pm 0.004V$ dc reading on the digital multimeter connected to the HP 400E/EL output.
- x. Remove all equipment from the thermal converter. This completes the HP 400E/EL calibration procedure. If unable to perform any calibration, go to Table 5-11 and determine if some factory selected components may need changing.
- d. Adjust R2 for a $1.000V \pm 0.005V$ dc reading on the digital multimeter connected to the HP 400E/EL output.
- e. Disconnect the ac calibrator from the HP 400E/EL and calibrate at 10MHz next. If you plan to use thermal converters, use the procedure in paragraph 5-47. If you plan to use an oscillator, use the procedure in paragraph 5-49. Once the HP 400E/EL has been calibrated at 10MHz, continue with the following steps.

NOTE

The bias voltage at TP4 can affect the frequency response at low frequencies (ie., 10Hz and 20Hz, etc.). The readings at 10Hz and/or 20Hz are low, decrease the voltage at TP4 but remain in the 8V to 12V dc limits. Make sure the high and low frequency response is good after readjusting the bias level.

5-44. Calibration Procedure Using an AC Calibrator.

5-45. This procedure uses an ac calibrator for calibration. However, since the calibrator frequency response goes only to 110kHz, use thermal converters to check and adjust in the 4MHz to 10MHz frequency range. If the thermal converters are unavailable, an oscillator that is flat in the 1kHz to 10MHz frequency range can be used. The absolute output accuracy of the oscillator is unimportant, but it has to be flat within $\pm .25\%$ from 1kHz to 10MHz.

5-46. Calibrate the HP 400E/EL using the calibration points and adjustments listed in Table 5-5. Do the following:

- a. Set the HP 400E/EL to the .010V range and setup the ac calibrator for a 10mV at 400Hz output. Setup the digital multimeter to measure dc volts on autorange.
- b. Refer to Figure 5-1. Connect the ac calibrator and digital multimeter to the HP400E/EL as shown in the figure.
- c. Adjust A2R38 for a $0.01V \pm 0.1mV$ reading on the HP 400E/EL.
- f. After the 10MHz calibration in either paragraph 5-47 or 5-49 has been performed, set the HP 400E/EL to the .001V range. Set the ac calibrator for a 1V at 400Hz output.
- g. Connect a precision 40 dB attenuator between the ac calibrator and HP 400E/EL.
- h. Adjust A2R44 for a $1.000V \pm 0.005V$ dc reading on the digital multimeter.
- i. Remove the 40dB attenuator from the HP 400E/EL. Set the HP 400E/EL to the 3V range and setup the ac calibrator for a 3V at 100kHz output. Reconnect the ac calibrator to the Model 400E/EL.
- j. Adjust A1C2 for a $0.949V \pm 0.004V$ dc reading on the digital multimeter connected to the HP 400E/EL output.
- k. Disconnect the ac calibrator and digital multimeter from the HP 400E/EL. This completes the HP 400E/EL calibration procedure. If unable to perform any calibration, go to Table 5-11 and determine if some factory selected components may need changing.

NOTE

The bias voltage at TP4 can affect the frequency response at low frequencies (ie., 10Hz and 20Hz, etc.). If the readings at 10Hz and/or 20Hz are low, decrease the voltage at TP4 but remain in the 8V to 12V dc limits. Make sure the high and low frequency response is good after readjusting the bias level.

5-47. 10MHz Calibration Using Thermal Converters.

5-48. This procedure can be used to calibrate the HP 400E/EL at 10MHz while using the procedure in paragraph 5-45 to calibrate at 400Hz and 100kHz. The 1V (HP 11050A) thermal converter is required for this procedure. Do the following:

NOTE

The function generator/oscillator should have distortion levels below 1%. This is important because the thermal converter and an average responding circuit, like the HP 400E/EL, react differently to distortion. This could cause a reading/calibration error. However, the distortion level is less critical at high frequencies (4MHz and above) allowing the use of a function generator/oscillator with higher distortion levels.

- a. Refer to Figure 5-2 and setup the test equipment to the following:

DC Standard - 1V Output with Output Off
Function Generator - 1V at 10MHz Sine Wave Output
Digital Multimeters - DC Volts Function and Autorange
Switch - Position A

- b. Except for the HP 400E/EL (it will be connected later), connect the equipment as shown in Figure 5-2.
- c. Turn the dc standard output on. Measure the thermal converter's output voltage as read on the digital multimeter connected to the converter. Note this voltage.



Turn the dc standard output off and set the function generator output to minimum before connecting to the thermal converter. Also, reduce the function generator output to minimum before changing the frequency. Any voltage above the rated input voltage of the thermal converter can destroy the converter.

- d. Set the switch to position B. Adjust the output on the function generator until the thermal converter's output voltage is the same as read in step c.
- e. Set the HP 400E/EL to the .01V range. Connect a precision 40dB coaxial attenuator between the HP 400E/EL input and the "T" connector.
- f. Adjust A2C28 for a 1.000V \pm 0.04V reading on the digital multimeter connected to the HP 400E/EL output.
- g. Remove the 40dB precision attenuator from the HP 400E/EL and replace it with a 50dB precision coaxial attenuator. Set the HP 400E/EL to the .003V range. The input voltage to the Model 400E/EL should now be 3.162mV.
- h. Adjust S2C2 for a 1.000V \pm 0.04V reading on the digital multimeter connected to the HP 400E/EL output.

NOTE

Check and make sure the HP 400E/EL accuracy is good at 4MHz and 6MHz. The amplitude can be lowered at 4MHz by moving A2C11 and C13 closer together.

The 1mV range at 4MHz can also be adjusted by dressing the white/orange/yellow wire connected between the second attenuator and meter amplifier input. Moving the wire towards the deck lowers the response. To adjust, dress the wire until the reading on the HP 400E/EL is 1.5% high with the bottom cover removed. The reading should be good with the cover installed. See Figure 6-3 for the location of the wire.

- i. Remove the test equipment from the HP 400E/EL. Continue with step e in the procedure in paragraph 5-46.

5-49. 10MHz Calibration Using an Oscillator.

5-50. This procedure can be used to calibrate the HP 400E/EL at 10MHz while using the procedure

in paragraph 5-45 to calibrate at 400Hz and 100kHz. Do the following:

- a. Set the HP 400E/EL to the 1V range and setup the ac calibrator for a 1V at 1kHz output (error range to zero). Set the digital multimeter to dc volts and autorange.
- b. Setup the oscillator for a 1V at 1kHz output. Do not connect it to the HP 400E/EL at this time.
- c. Connect the ac calibrator and digital multimeter to the Model 400E/EL as shown in Figure 5-1.
- d. Read the dc output on the multimeter and note the reading.
- e. Connect the oscillator to the HP 400E/EL.
- f. Adjust the oscillator output to the reading on the multimeter noted in step d.
- g. Set the output to 10MHz.
- h. Connect a 40dB coaxial attenuator between the oscillator and the Model 400E/EL. Then set the Model 400E/EL to the .01V range.
- i. Adjust A2C28 for a $1.000V \pm 0.04V$ reading on the digital multimeter.
- j. Remove the 40dB precision attenuator from the HP 400E/EL and replace it with a 50dB precision coaxial attenuator. Set the HP 400E/EL to the .003V range. The input voltage to the Model 400E/EL should now be 3.162mV.

- k. Adjust S2C2 for a $1.000V \pm 0.04V$ reading on the digital multimeter connected to the HP 400E/EL output.
- l. Remove the test equipment from the HP 400E/EL. Continue with step e in the procedure in paragraph 5-46.

5-51. TROUBLESHOOTING.

5-52. Use the following procedures if unable to test or calibrate the HP 400E/EL according to the performance test and calibration procedures. If the Model 400E/EL is only slightly out of the specification limits that cannot be corrected by calibration, refer to Table 5-11 to select new component values. If the HP 400E/EL is inoperative or completely out of the specification limits, try the following:

- a. Check the instrument for any evidence of failed components, like burned components. Check for cracked printed circuit boards or broken traces on the boards. Check for loose or broken wires.
- b. Isolate the failure to an area by using the instrument's block diagram in Figure 4-1 and schematic in Figure 7-1. Then go to the appropriate troubleshooting procedure for that area. Use Table 5-6 for some probable causes of specific symptoms.

NOTE

Unless otherwise noted, allow a 10% tolerance for the test voltages noted on the schematic and troubleshooting procedures.

Table 5-6. Troubleshooting Tips

SYMPTOM	PROBABLE TROUBLE
1. No response to input signal	1. Fuse A2F1 open. Check power supply voltages. Check AC signal according to Paragraphs 5-53 through 5-55 to isolate the area of trouble.
2. Low B+ voltage at TP1 or Low B- voltage at TP2	2. Disconnect jumper wire. Measure resistance to ground at both jumper terminals. If 10 ohms on the meter side, C16 or C19 is shorted, if 100 ohms, C35 or C29 is shorted, if zero, C8 or C9 is shorted. Disconnect R20 and R28 to isolate the Impedance Converter. If low resistance is on power supply side refer to Paragraph 5-51 and Table 5-7.
3. Low gain at high frequencies	3. Check A2C22 for open if 10% low. Lift A2C39 and check for oscillations, if no oscillations check A2Q15 and 16.
4. High gain at high frequencies	4. Check A2C30 for an open.
5. Low full scale readings	5. Check A2CR15 and A2CR16.
6. Instrument will not range above 1 volt but works OK at 1 volt and below	6. Relay A1K1 stuck in closed position.
7. Instrument will not range below 3 volts but works OK on 3 volt range and above	7. Relay K2 stuck in closed position.
8. TP3 voltage can not be adjusted properly	8. Extreme condition: check A2Q5, Q6 and Q7. Small variation: change value of A2R18*. (Refer to Table 5-11).
9. TP5 voltage can not be adjusted properly	9. AC output circuit. Check A2Q15 and Q16. Refer to Paragraph 5-58 and Table 5-11.
10. TP4 voltage can not be adjusted properly	10. Meter Amplifier Circuit. Check A2Q8 thru Q13.
11. TP4 voltage varies and meter needle wobbles	11. Isolate by shorting A2C17 to ground. If voltage at TP4 still varies the trouble is in the Meter Amplifier. Refer to Paragraph 5-54 and Table 5-9. If voltage is constant the trouble is in the Impedance Converter. Refer to Paragraph 5-55 and Table 5-8.
12. Low line transients	12. Check A2Q3 and Q4. (If an old instrument change A2Q4, A2R73 and R74 to current part number). Check A2CR20 and CR21.
13. Transients on range change (1V to 3V)	13. Match reverse resistance of A2CR9 and CR10. Check S2CR1 and S2CR2. Check relays.
14. Peaking at 5MHz (10%)	14. Isolate by disconnecting orange wire to switch. Voltage at pin 21 should be same as input. Refer to Paragraph 5-55 or 5-56.
15. Voltage slightly low on 1mV range	15. Change value of A2R72* (refer to Table 5-11).
16. Low voltage (10 and 20Hz) near full scale	16. Check A2Q13. Change value of A2C31* (Table 5-11). Check A2C10 and C20.

5-53. POWER SUPPLY.

5-54. Check with a digital multimeter at TP1 and TP2 for +26 volts and -26 volts respectively. If the TP voltages are improper, check the voltages listed in Table 5-7. If the voltage for a given component is wrong, the trouble is probably in that component or its associated circuit.

Table 5-7. Power Supply Voltages

COMPONENT	VOLTAGE
Collector Q1	+ 39V
Collector Q2	+ 26.5V
Emitter Q2	+ 6.98V
Base Q3	- 0.6V
Collector Q3	- 23.5V
Collector Q4	- 39V

5-55. AMPLIFIERS.

5-56. Set the 400E/EL to the 1 volt range, and connect a full scale input. With a sensitive ac voltmeter, monitor the ac amplifier output at the negative side of A2C34 or A2C36. The output should be 150mV. If it not 150mV, measure the ac voltage at A2 pin 22. The voltage at pin 22 should be 3mV. If these two voltage readings are correct, the meter amplifier and meter bridge are operating properly.

5-57. If the voltage at pin 22 is low, pull the wht/orn/yel wire from pin 22, and measure the ac signal at the wire. It should be 3mV. If the voltage on the wire is proper, the trouble is in the meter amplifier. If it isn't correct, the trouble is either in the Post Attenuator or the Impedance Converter.

5-58. To check the Impedance Converter, measure the ac voltage at its output (A2 pin 21). The output voltage should be very close to the input voltage since the Impedance Converter is a unity gain amplifier. With a 1 volt input, the output should be 0.98 volts \pm 0.02 volts.

5-59. Both the Impedance Converter and the meter amplifier are internally dc coupled. If the dc voltages anywhere in the amplifier are incorrect, the amplifier won't operate properly. Consequently a check of the dc voltages is a good check of the amplifiers.

5-60. Tables 5-8 and 5-9 contain the dc voltages on all of the transistors in the meter amplifier and the Impedance Converter. If the measured voltage on a given transistor is wrong, the trouble is probably in that transistor or its associated circuit.

NOTE

Measure these dc voltages with the input shorted. A dc voltmeter with low input capacitance and very high input resistance must be used. The HP Model 3450B is recommended. All dc voltages are \pm 10% except where otherwise stated.

Table 5-8. Impedance Converter Voltages

TRANSISTOR	E	B	C
Q5	(S) - 6V	(G)*	(D) - 14.6V
Q6	- 15.3V	- 14.6V	- 7.4V
Q7	- 6.7V	- 7.4V	- 21.5V
*Cannot be measured.			

Table 5-9. Meter Amplifier Voltages

TRANSISTOR	E	B	C
Q8	+ 19V \pm 20%	19.5V \pm 20%	+ 2 ⁺ .5V
Q9	+ 0.02V	+ 0.57V	+ 8.5V
Q10	+ 8.2V	+ 8.5V	+ 1.8V
Q11	+ 0.9V	+ 1.9V	+ 8.5V
Q12	+ 9V	+ 8.5V	+ 0.7V
Q13	+ 0.7V	0	- 4.6V
Q14*	+ 3V	+ 3.5V	+ 26V
*In bridge circuit.			

5-61. AC OUTPUT CIRCUIT.

5-62. To check the ac output circuit, measure the dc voltages at the points shown in Table 5-10. If a given measured voltage is incorrect, the trouble is probably in that component or its associated circuit.

Table 5-10. AC Voltage Output Circuit.

TRANSISTOR	E	B	C
Q15	+ 0.62V	+ 1.3V	+ 5V
Q16	0	+ 0.62V	+ 5V

Table 5-1 describes the function of the factory selected components and gives instructions for their selection. Normally, these components do not need to be changed unless another associated component is changed. Replacement of a transistor, for example, may require the changing of a factory selected component.

Table 5-11. Factory Selected Components.

COMPONENT	FUNCTION AND SELECTION
A1R4*	29 ohms to 45.3 ohms. Adjusts high frequency response on the 3 volt range. If readings are low, increase resistance.
A1C24*	None to 24pf. Adjusts the 8MHz and 10MHz frequency response. Normally not loaded but add to increase the readings at 8MHz and 10MHz. 5pf 0160-0763 12pf 0140-0201 24pf 0160-0196
A2C31*	1.8 μ F to 2.7 μ F. Adjusts the 10Hz and 20Hz frequency response on all ranges. A 15 μ F capacitor is normally installed. If the readings are low, install a capacitor in parallel with the 15 μ F capacitor. 1.8 μ F 0180-0101 2.2 μ F 0180-0155 2.7 μ F 0180-0117 15 μ F 0180-1746
A2C32*	39pf to none. Changes the 10MHz frequency response.
A2R18*	36 kilohms to 68 kilohms. Adjusts the bias level at A2Q5 due to variables in the FET. If unable to adjust the bias at TP3 to -6 volts (i.e., voltage too negative), increase value of resistor R18*.
A2R22*	549 ohms. Adjusts frequency response at 4MHz. If readings are low, decrease value of R22*. 453 ohms 0698-3510 402 ohms 0698-4453 340 ohms 0698-4451 294 ohms 0698-4448
A2R50*	2320 ohms to 3320 ohms. Adjusts low frequency response on the 1mV and 3mV ranges at 10Hz and 20Hz. If readings are high, decrease value of R50*. May affect high frequency response.
A2R51*	133 ohms to 187 ohms. Adjusts frequency response at 10MHz.
A2R72*	110 ohms to 182 ohms. Adjusts the range of the 1mV at 400Hz adjustment (A2R44). If reading is low and A2R44 is unable to bring within specifications, decrease resistance of R72*.
A2R77*	1.21 kilohms. Adjusts frequency response at 10 scale at 10MHz. If 10 scale reading is too low at 10MHz, decrease value of R77*. 715 ohms 0698-3700 301 ohms 0757-0410
S2C1*	1.2pF to 24pF. Adjusts high frequency response on the .01V and 3V ranges.
S2C2*	8-50pF or 5-25pF. Adjust the frequency response on the .003V range at 10MHz.
S2C4*	1.8 μ F to 6.8 μ F, 35Vdc. Adjusts 10Hz frequency response on the 1mV and 3mV ranges. If reading is low, increase capacitance.

5-63. ADJUSTMENT OF FACTORY SELECTED COMPONENTS.

5-64. Certain components within the Model 400E/EL are individually selected in order to com-

pensate for slightly varying circuit parameters. These components are denoted by an asterisk (*) on the schematic, and the typical value is shown.

PERFORMANCE CHECK TEST CARD

hp-Model 400E/EL

Test performed by: _____

AC Voltmeter

Date: _____

Serial No. _____

1 Accuracy Check

Range	INPUT SIGNAL		SPECIFICATION		INDICATION	
	Voltage	Frequency	Meter (V)	DC Output (V)	Meter	DC Output
3 V ↓	3.00 V ↓	10 Hz 400 Hz 100 kHz 1 MHz 4 MHz 10 MHz	3.00 ± 0.15 ± 0.03 ± 0.03 ± 0.03 ± 0.09 3.00 ± 0.15	0.949 ± 0.047 ± 0.0047 ± 0.0047 ± 0.0095 ± 0.047 0.949 ± 0.047		
3 V ↓	1.00 V ↓	10 Hz 400 Hz 100 kHz 1 MHz 4 MHz 10 MHz	1.00 ± 0.10 ± 0.03 ± 0.03 ± 0.03 ± 0.06 1.00 ± 0.15	0.316 ± 0.032 ± 0.0032 ± 0.0032 ± 0.0063 ± 0.032 0.316 ± 0.032		
1 V ↓	1.00 V ↓	10 Hz 400 Hz 100 kHz 1 MHz 4 MHz 10 MHz	1.00 ± 0.05 ± 0.01 ± 0.01 ± 0.01 ± 0.03 1.00 ± 0.05	1.00 ± 0.05 ± 0.005 ± 0.005 ± 0.010 ± 0.05 1.00 ± 0.05		
1 V ↓	0.30 V ↓	10 Hz 400 Hz 100 kHz 1 MHz 4 MHz 10 MHz	0.30 ± 0.032 ± 0.01 ± 0.01 ± 0.01 ± 0.02 0.30 ± 0.032	0.30 ± 0.033 ± 0.0033 ± 0.0033 ± 0.0065 ± 0.033 0.30 ± 0.033		
.3 V ↓	0.30 V ↓	10 Hz 400 Hz 100 kHz 1 MHz 4 MHz 10 MHz	0.30 ± .015 ± .003 ± .003 ± .003 ± .009 0.30 ± .015	0.949 ± 0.047 ± 0.0047 ± 0.0047 ± 0.0095 ± 0.047 0.949 ± 0.047		
.3 V ↓	0.10 V ↓	10 Hz 400 Hz 100 kHz 1 MHz 4 MHz 10 MHz	.100 ± .01 ± .003 ± .003 ± .003 ± .006 .100 ± .01	0.316 ± 0.032 ± 0.0032 ± 0.0032 ± 0.0063 ± 0.032 0.316 ± 0.032		

Range	INPUT SIGNAL		SPECIFICATION		INDICATION	
	Voltage	Frequency	Meter Reading (V)	DC Output (V)	Meter	DC Output
.1 V ↓	0.10 V ↓	10 Hz 400 Hz 100 kHz 1 MHz 4 MHz 10 MHz	.100 ± .005 ± .001 ± .001 ± .001 ± .003 .100 ± .005	1.00 ± 0.05 ± 0.005 ± 0.005 ± 0.010 ± 0.05 1.00 ± 0.05		
.001 V ↓	0.001 V ↓	10 Hz 400 Hz 100 kHz 1 MHz 4 MHz	.001 ± .00005 ± .00001 ± .00001 ± .00005 ± .00005	1.00 ± 0.05 ± 0.005 ± 0.005 ± 0.02 ± 0.05		
.001 V ↓	0.0003 V ↓	10 Hz 400 Hz 100 kHz 1 MHz 4 MHz	.0003 ± .000032 ± .00001 ± .00001 ± .000032 ± .000032	0.30 ± 0.033 ± 0.0043 ± 0.0043 ± 0.013 ± 0.033		

Table 6-2. Code of Manufacturers.

Mfr. No.	Manufacturer Name	Address
00853	Sangamo Elec Co	Pickens, SC 29671
01121	Allen-Bradley Co	Milwaukee, WI 53204
01281	TRW Semiconductors, Inc.	Lawndale, CA 90260
03292	Corning Glass Work	Bradford, PA 16701
03877	Transitron Electric Corp	Wakefield, MA 01880
03888	Pyrofilm Resistor Co, Inc	Whippany, NJ 07981
04062	Arco Electronic Inc	Great Neck, NY 11022
04200	Sprague Electric Co	North Adams MA 01247
04713	Motorola Semiconductor Prod Div	Phoenix AZ 85062
05820	Wakefield Engineering Inc	Wakefield, MA 01880
06486	Kaurz-Kasch Inc	Daton, OH 45401
07263	Fairchild Semiconductor Div	Mountain View, CA 94042
07910	Continental Device Corp	Hawthorne, CA 90250
11236	Cts of Berne, Inc	Berne, IN 46711
14433	ITT Semiconductor Div	West Palm Beach FL 33480
16299	Elec Component Div	Raleigh, NC 27604
19701	Mepco/Electra Corp	Mineral Wells, TX 76067
24446	General Electric Co	Schenectady, NY 12305
26365	Gries Reproducer Corp	New Rochelle, NY 10804
28480	Hewlett-Packard Co	Palo Alto, CA 94304
56789	Sprague Electric Co	North Adams MA 01247
70563	Amperite Co, Inc	Union City, NJ 07083
70903	Belden Mfg Co	Chicago, IL 60622
71400	Bussmann Mfg Div	St. Louis, MO 63121
72136	Electro-Motive Mfg Co Inc	Willimantic CT 06226
72982	Erie Technological Products, Inc	Erie, PA 16512
73138	Beckman Instruments Helipot Div	Fullerton, CA 92634
75042	TRW Inc Philadelphia Div	Philadelphia, PA 19108
75915	Littlefuse, Inc	Des Plaines, IL 60016
78189	Illinois Tool Works Shakeproof Div	Elgin, IL 60120
78553	Tinnerman Products, Inc	Cleveland, OH 44141
81856	Kemlite Laboratories	Chicago, IL 60622
82142	Jeffers Electronics Division	Du Bois, PA 15801
82389	Switchcraft, Inc	Chicago, IL 60630
83385	Central Screw Co	Chicago, IL 60622
86684	RCA Electronic Corp & Devices Div	Harrison, NJ 07029
90201	Mallory Capacitor Div	Indianapolis, IN 46206
91418	Radio Materials Co	Chicago, IL 60622
93332	Semiconductor Div Sylvania Elec	Waburn MA 02158
95712	Dage Electric Co., Inc	Franklin, IN 46131

Table 6-3. Replaceable Parts

Reference Designation	HP Part Number	C D	Qty	Description	Mfr Code	Mfr Part Number
C81	1961-0001	1	1	TRK 11 1000 1000	0000	
C82	1961-0002	1	1	TRK 11 1000 1000	0000	
C83	1961-0003	1	1	TRK 11 1000 1000	0000	
C84	1961-0004	1	1	TRK 11 1000 1000	0000	
C85	1961-0005	1	1	TRK 11 1000 1000	0000	
C86	1961-0006	1	1	TRK 11 1000 1000	0000	
C87	1961-0007	1	1	TRK 11 1000 1000	0000	
C88	1961-0008	1	1	TRK 11 1000 1000	0000	
C89	1961-0009	1	1	TRK 11 1000 1000	0000	
C90	1961-0010	1	1	TRK 11 1000 1000	0000	
C91	1961-0011	1	1	TRK 11 1000 1000	0000	
C92	1961-0012	1	1	TRK 11 1000 1000	0000	
C93	1961-0013	1	1	TRK 11 1000 1000	0000	
C94	1961-0014	1	1	TRK 11 1000 1000	0000	
C95	1961-0015	1	1	TRK 11 1000 1000	0000	
C96	1961-0016	1	1	TRK 11 1000 1000	0000	
C97	1961-0017	1	1	TRK 11 1000 1000	0000	
C98	1961-0018	1	1	TRK 11 1000 1000	0000	
C99	1961-0019	1	1	TRK 11 1000 1000	0000	
C100	1961-0020	1	1	TRK 11 1000 1000	0000	
C101	1961-0021	1	1	TRK 11 1000 1000	0000	
C102	1961-0022	1	1	TRK 11 1000 1000	0000	
C103	1961-0023	1	1	TRK 11 1000 1000	0000	
C104	1961-0024	1	1	TRK 11 1000 1000	0000	
C105	1961-0025	1	1	TRK 11 1000 1000	0000	
C106	1961-0026	1	1	TRK 11 1000 1000	0000	
C107	1961-0027	1	1	TRK 11 1000 1000	0000	
C108	1961-0028	1	1	TRK 11 1000 1000	0000	
C109	1961-0029	1	1	TRK 11 1000 1000	0000	
C110	1961-0030	1	1	TRK 11 1000 1000	0000	
C111	1961-0031	1	1	TRK 11 1000 1000	0000	
C112	1961-0032	1	1	TRK 11 1000 1000	0000	
C113	1961-0033	1	1	TRK 11 1000 1000	0000	
C114	1961-0034	1	1	TRK 11 1000 1000	0000	
C115	1961-0035	1	1	TRK 11 1000 1000	0000	
C116	1961-0036	1	1	TRK 11 1000 1000	0000	
C117	1961-0037	1	1	TRK 11 1000 1000	0000	
C118	1961-0038	1	1	TRK 11 1000 1000	0000	
C119	1961-0039	1	1	TRK 11 1000 1000	0000	
C120	1961-0040	1	1	TRK 11 1000 1000	0000	
C121	1961-0041	1	1	TRK 11 1000 1000	0000	
C122	1961-0042	1	1	TRK 11 1000 1000	0000	
C123	1961-0043	1	1	TRK 11 1000 1000	0000	
C124	1961-0044	1	1	TRK 11 1000 1000	0000	
C125	1961-0045	1	1	TRK 11 1000 1000	0000	
C126	1961-0046	1	1	TRK 11 1000 1000	0000	
C127	1961-0047	1	1	TRK 11 1000 1000	0000	
C128	1961-0048	1	1	TRK 11 1000 1000	0000	
C129	1961-0049	1	1	TRK 11 1000 1000	0000	
C130	1961-0050	1	1	TRK 11 1000 1000	0000	
C131	1961-0051	1	1	TRK 11 1000 1000	0000	
C132	1961-0052	1	1	TRK 11 1000 1000	0000	
C133	1961-0053	1	1	TRK 11 1000 1000	0000	
C134	1961-0054	1	1	TRK 11 1000 1000	0000	
C135	1961-0055	1	1	TRK 11 1000 1000	0000	
C136	1961-0056	1	1	TRK 11 1000 1000	0000	
C137	1961-0057	1	1	TRK 11 1000 1000	0000	
C138	1961-0058	1	1	TRK 11 1000 1000	0000	
C139	1961-0059	1	1	TRK 11 1000 1000	0000	
C140	1961-0060	1	1	TRK 11 1000 1000	0000	
C141	1961-0061	1	1	TRK 11 1000 1000	0000	
C142	1961-0062	1	1	TRK 11 1000 1000	0000	
C143	1961-0063	1	1	TRK 11 1000 1000	0000	
C144	1961-0064	1	1	TRK 11 1000 1000	0000	
C145	1961-0065	1	1	TRK 11 1000 1000	0000	
C146	1961-0066	1	1	TRK 11 1000 1000	0000	
C147	1961-0067	1	1	TRK 11 1000 1000	0000	
C148	1961-0068	1	1	TRK 11 1000 1000	0000	
C149	1961-0069	1	1	TRK 11 1000 1000	0000	
C150	1961-0070	1	1	TRK 11 1000 1000	0000	
C151	1961-0071	1	1	TRK 11 1000 1000	0000	
C152	1961-0072	1	1	TRK 11 1000 1000	0000	
C153	1961-0073	1	1	TRK 11 1000 1000	0000	
C154	1961-0074	1	1	TRK 11 1000 1000	0000	
C155	1961-0075	1	1	TRK 11 1000 1000	0000	
C156	1961-0076	1	1	TRK 11 1000 1000	0000	
C157	1961-0077	1	1	TRK 11 1000 1000	0000	
C158	1961-0078	1	1	TRK 11 1000 1000	0000	
C159	1961-0079	1	1	TRK 11 1000 1000	0000	
C160	1961-0080	1	1	TRK 11 1000 1000	0000	
C161	1961-0081	1	1	TRK 11 1000 1000	0000	
C162	1961-0082	1	1	TRK 11 1000 1000	0000	
C163	1961-0083	1	1	TRK 11 1000 1000	0000	
C164	1961-0084	1	1	TRK 11 1000 1000	0000	
C165	1961-0085	1	1	TRK 11 1000 1000	0000	
C166	1961-0086	1	1	TRK 11 1000 1000	0000	
C167	1961-0087	1	1	TRK 11 1000 1000	0000	
C168	1961-0088	1	1	TRK 11 1000 1000	0000	
C169	1961-0089	1	1	TRK 11 1000 1000	0000	
C170	1961-0090	1	1	TRK 11 1000 1000	0000	
C171	1961-0091	1	1	TRK 11 1000 1000	0000	
C172	1961-0092	1	1	TRK 11 1000 1000	0000	
C173	1961-0093	1	1	TRK 11 1000 1000	0000	
C174	1961-0094	1	1	TRK 11 1000 1000	0000	
C175	1961-0095	1	1	TRK 11 1000 1000	0000	
C176	1961-0096	1	1	TRK 11 1000 1000	0000	
C177	1961-0097	1	1	TRK 11 1000 1000	0000	
C178	1961-0098	1	1	TRK 11 1000 1000	0000	
C179	1961-0099	1	1	TRK 11 1000 1000	0000	
C180	1961-0100	1	1	TRK 11 1000 1000	0000	

See introduction to this section for ordering information
 *Indicates factory selected value

Table 6-3. Replaceable Parts

Reference Designation	HP Part Number	CD	Qty	Description	Mfr Code	Mfr Part Number
*1	0257-0210	1	1
*2	0257-0210	1	1
*3	0257-0210	1	1
*4	0257-0210	1	1
*5	0257-0210	1	1
*6	0257-0210	1	1
*7	0257-0210	1	1
*8	0257-0210	1	1
*9	0257-0210	1	1
*10	0257-0210	1	1
*11	0257-0210	1	1
*12	0257-0210	1	1
*13	0257-0210	1	1
*14	0257-0210	1	1
*15	0257-0210	1	1
*16	0257-0210	1	1
*17	0257-0210	1	1
*18	0257-0210	1	1
*19	0257-0210	1	1
*20	0257-0210	1	1
*21	0257-0210	1	1
*22	0257-0210	1	1
*23	0257-0210	1	1
*24	0257-0210	1	1
*25	0257-0210	1	1
*26	0257-0210	1	1
*27	0257-0210	1	1
*28	0257-0210	1	1
*29	0257-0210	1	1
*30	0257-0210	1	1
*31	0257-0210	1	1
*32	0257-0210	1	1
*33	0257-0210	1	1
*34	0257-0210	1	1
*35	0257-0210	1	1
*36	0257-0210	1	1
*37	0257-0210	1	1
*38	0257-0210	1	1
*39	0257-0210	1	1
*40	0257-0210	1	1
*41	0257-0210	1	1
*42	0257-0210	1	1
*43	0257-0210	1	1
*44	0257-0210	1	1
*45	0257-0210	1	1
*46	0257-0210	1	1
*47	0257-0210	1	1
*48	0257-0210	1	1
*49	0257-0210	1	1
*50	0257-0210	1	1
*51	0257-0210	1	1
*52	0257-0210	1	1
*53	0257-0210	1	1
*54	0257-0210	1	1
*55	0257-0210	1	1
*56	0257-0210	1	1
*57	0257-0210	1	1
*58	0257-0210	1	1
*59	0257-0210	1	1
*60	0257-0210	1	1
*61	0257-0210	1	1
*62	0257-0210	1	1
*63	0257-0210	1	1
*64	0257-0210	1	1
*65	0257-0210	1	1
*66	0257-0210	1	1
*67	0257-0210	1	1
*68	0257-0210	1	1
*69	0257-0210	1	1
*70	0257-0210	1	1
*71	0257-0210	1	1
*72	0257-0210	1	1
*73	0257-0210	1	1
*74	0257-0210	1	1
*75	0257-0210	1	1
*76	0257-0210	1	1
*77	0257-0210	1	1
*78	0257-0210	1	1
*79	0257-0210	1	1
*80	0257-0210	1	1
*81	0257-0210	1	1
*82	0257-0210	1	1
*83	0257-0210	1	1
*84	0257-0210	1	1
*85	0257-0210	1	1
*86	0257-0210	1	1
*87	0257-0210	1	1
*88	0257-0210	1	1
*89	0257-0210	1	1
*90	0257-0210	1	1
*91	0257-0210	1	1
*92	0257-0210	1	1
*93	0257-0210	1	1
*94	0257-0210	1	1
*95	0257-0210	1	1
*96	0257-0210	1	1
*97	0257-0210	1	1
*98	0257-0210	1	1
*99	0257-0210	1	1
*100	0257-0210	1	1

See introduction to this section for ordering information
 *Indicates factory selected value

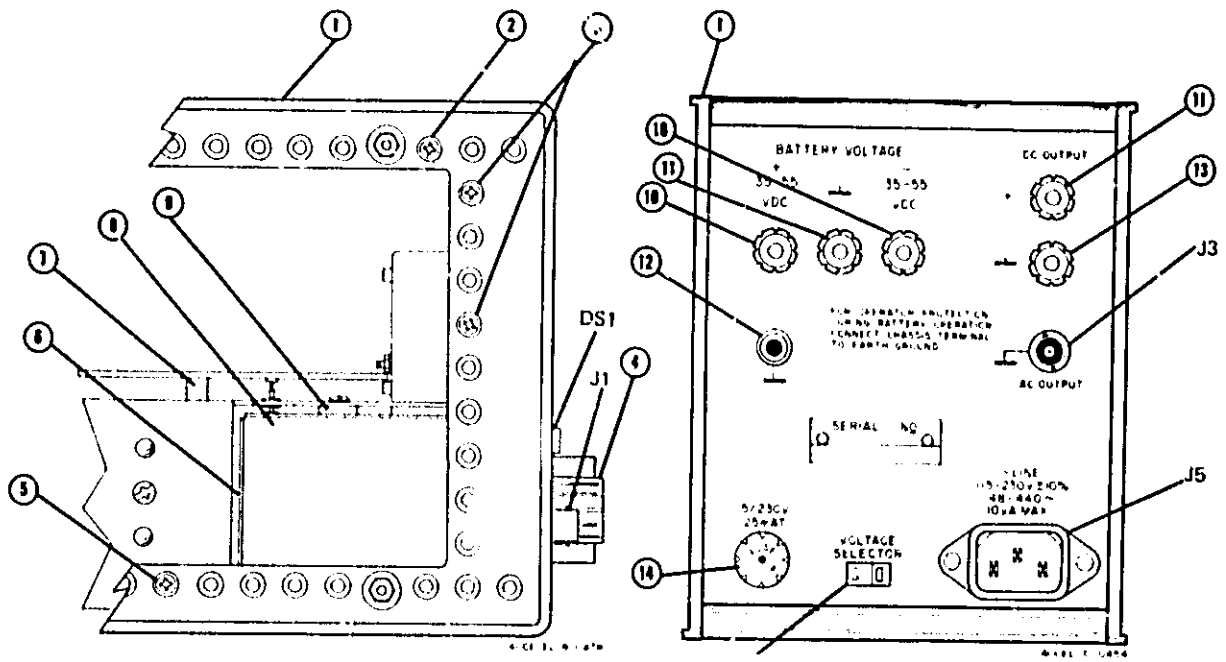

LEFT SIDE VIEW

BACK VIEW

Index/Ref Number	C D	Qty	HP Part Number	Description
1	3	2	5060-0703	Frame: Side
2	9	1	2360-0194	Screw 6-32 .312 100 Deg. Pozi
3	5	4	2360-0322	Screw 6-32 .375 100 Deg. Pozi
4	0	1	0370-0112	Knob: Bar w/one arrow Black
4	1	1	0370-0113	Knob: Bar (for Option 02 only)
4	2	1	0370-0114	Knob: Round Red (for Option 02 only)
5	7	11	2360-0316	Screw 6-32 .25 100 Deg. Pozi
6	6	1	00400-05501	Shield Box: Attenuator
7	4	5	2360-0123	Screw 6-32 .625 Pan Head Pozi
8	0	1	00400-04101	Cover: Shield Box (Attenuator)
9	7	1	5040-4503	Grommet: Insulator Plastic
10	3	2	1510-0091	Bdg Post-Assy (Grey/Red)
11	2	2	1510-0107	Bdg Post-Assy (Grey/Black)
12	8	1	1510-0038	Bdg Post-Single
13	2	1	1510-0090	Bdg Post-Assy (Grey)
14	8	1	2110-0564	Fuseholder Body
14	9	1	2110-0565	Fuseholder Cap
14	3	1	2110-0569	Fuseholder Nut
DS1	9	1	1450-0574	Pilot Indicator
J1/J3	3	2	1250-0118	Connector BNC
J5	8	1	1251-2357	Connector: Power Cord
S3	2	1	2101-1234	Switch: Power Selector

Figure 6-1. Chassis and Mechanical Parts.

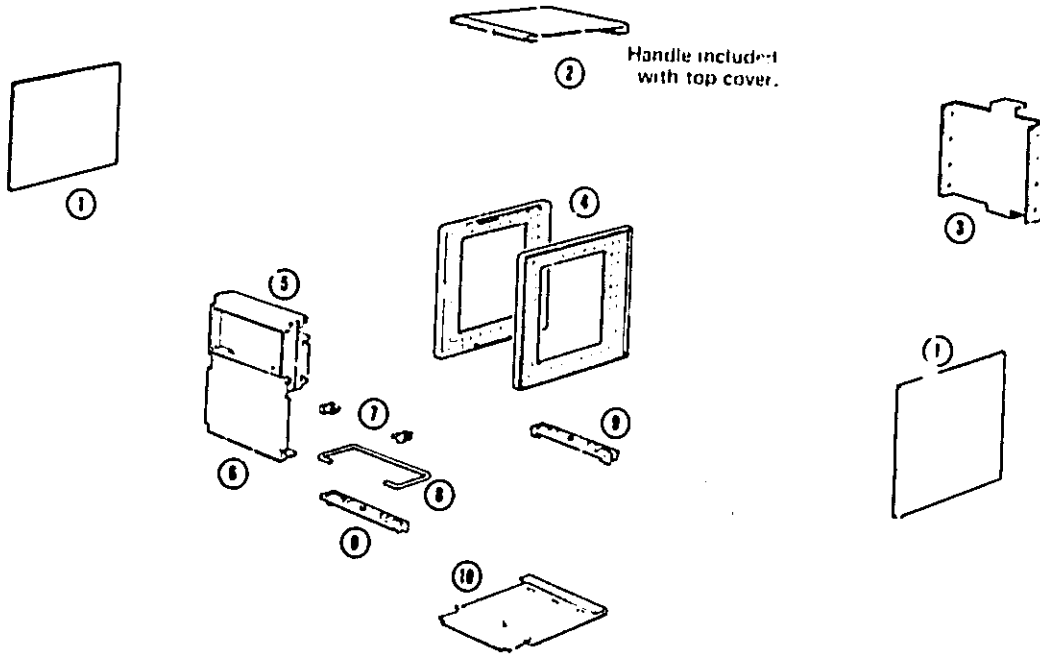

Index/Rc Number	C D	Qty	HP Part Number	Description
1	5	2	5000-8565	Cover: Side
	8	8	2360-0193	Side Cover Screws: 6-32 .25 100 Deg. Pozi
2	8	1	00400-64103	Cover: Top with Handle
	9	3	2360-0194	Top Cover Screws: 6-32 .312 100 Deg. Pozi
	3	3	0590-0052	Nut under Top Cover: 6-32 .5 Sheetmetal J
	1	1	1440-0048	Strap on Handle Assembly
	2	2	1440-0049	Cap on Handle Assembly
	5	2	1440-0050	Handle Retainer
	3	1	00400-60203	Panel: Rear
4	3	5060-0703	Frame: Side	
5	1	5020-6852	Meter Trim	
6	1	00400-00217	Panel: Front (400E, and 400E Option 01)	
6	6	1	00400-00220	Panel: Front (400EL, and 400EL Option 01)
6	3	1	00400-00219	Panel: Front (400E Option 02)
6	7	1	00400-00221	Panel: Front (400EL Option 02)
7	1	1	5040-0700	Hinge: Tilt Stand
8	7	1	1490-0031	Stand: Tilt
9	1	2	5060-0727	Foot Assembly
10	3	1	5000-8571	Cover: Bottom
	9	1	2360-0194	Pot. Cover Screw: 6-32 .312 100 Deg. Pozi
	3	1	0590-0052	Nut under Bottom Cover: 6-32 .5 Sheetmetal J

Figure 6-2. Cabinet Parts.

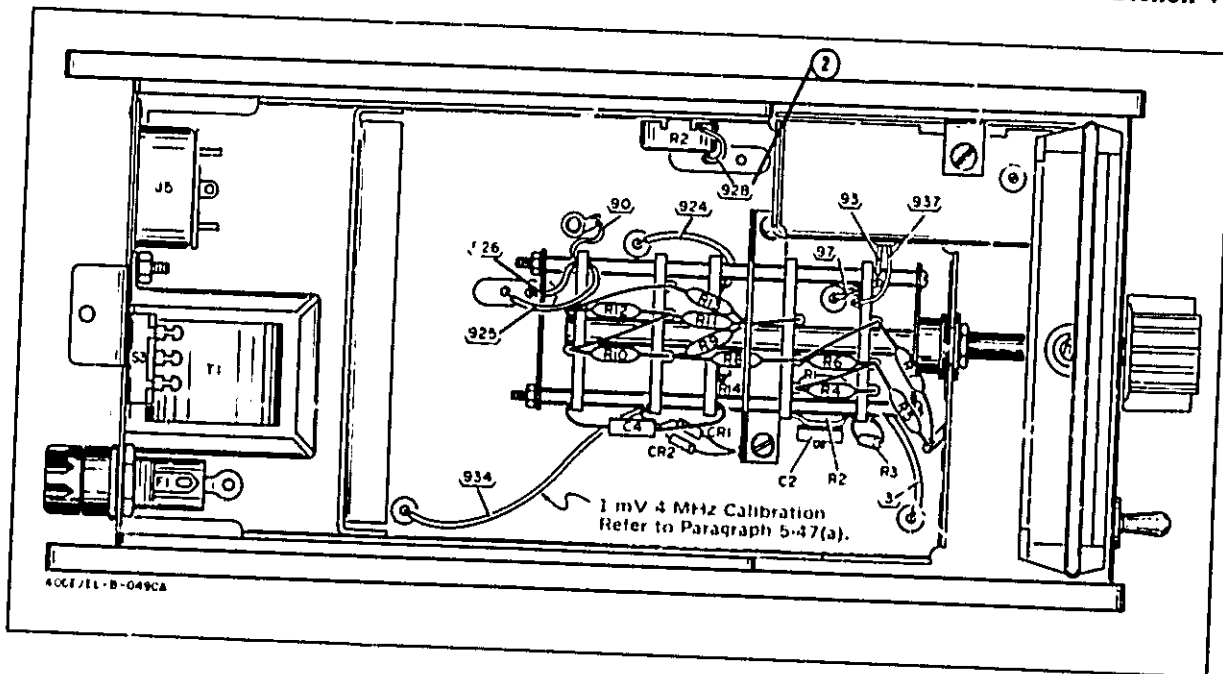

Figure 6-3. Chassis and Switch Components (Bottom View).

SECTION VII

CIRCUIT DIAGRAMS

7-1. INTRODUCTION.

layout to be used for maintenance and operation of the 400 E.E.L.

7-2. This section contains a schematic diagram, component locator, and a PC board component







7-3 An explanation of terms and symbols used as reference designators is given in the Schematic Notes.

SCHEMATIC NOTES

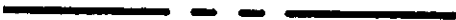
1. PARTIAL REFERENCE DESIGNATIONS ARE SHOWN: PREFIX WITH ASSEMBLY OR SUBASSEMBLY DESIGNATION(S) OR BOTH FOR COMPLETE DESIGNATION.
2. COMPONENT VALUES ARE SHOWN AS FOLLOWS UNLESS OTHERWISE NOTED:

RESISTANCE IN OHMS

CAPACITANCE IN MICROFARADS

3.  DENOTES ASSEMBLY.
-  DENOTES MAIN SIGNAL PATH.
-  DENOTES MAIN FEEDBACK PATH.
4. ALL DC VOLTAGES ARE $\pm 10\%$ EXCEPT THE BASE AND EMITTER OF Q8 WHICH IS $\pm 20\%$.
5. * AVERAGE VALUE SHOWN. OPTIMUM VALUE SELECTED AT FACTORY.
6. † REFER TO BACKDATING CHANGES IN APPENDIX C.
7. 918 DENOTES WIRE COLOR USING STANDARD COLOR CODE.
(e.g. 918 = WHITE, BROWN, GRAY)
8.  DENOTES POWER LINE GROUND.
9.  DENOTES CHASSIS GROUND.
10.  DENOTES CIRCUIT GROUND (ASSEMBLY).

A2 Board
Component Locations

	C	CR	D	R	D		C	R		R
1	B1	C1	A1	A1	D6	26	C5	C7	51	C6
2	B1	A1	A2	A1		27		C7		
3	A2	C1	D2	A2					52	D6
						28	A4	C7	53	A6
4	A2	B1	C1	A1		29	D5	B8	54	A7
5	C1	A1	D8	B3		30	C4	B5		
6	B3	C1	C8	A3					55	E6
						31	D5	A6	56	D3
7	C2	A3	D8	C2		32	C4	B6	57	D3
8	B3	C3	B6	C1		33	D4	B5		
9	C3	D8	A5	D1					58	E3
						34	E5	B5	59	D3
10	D8	D8	B5	D3		35	D6	B5	60	D2
11	C7	B8	C5	C3		36	E5	C5		
12	B8	B6	C5	A7					61	D3
						37	D7	D4	62	D2
13	C7	C4	D4			38	E1	A3	63	D2
14	B7	C6	D5			39	D3	B5		
15	B8	E4	D3	E8					64	D2
						40	E3	B4	65	E6
16	C7	E4	E2	B7		41	D1	B4	66	C4
17	A7	D7	D6	B7		42	D7	C4		
18	A7	D7	E6	B7					67	C2
						43	D7	D4	68	D7
19	B8	B6		D8		44		C3	69	D7
20	A5	C7		C7		45	E1	C4		
21	B6	B7		C7					70	B5
						46	C7	C6	71	B5
22	C6	D2		B7		47	E5	C5	72	C4
23	B5			C8		48		C5		
24	B6		C8						73	B7
						49		D4	74	B7
25	B5			B8		50		C6	75	B4
									76	C7
									77	D6
									78	D5

1	2	3	4	5	6	7	8
---	---	---	---	---	---	---	---

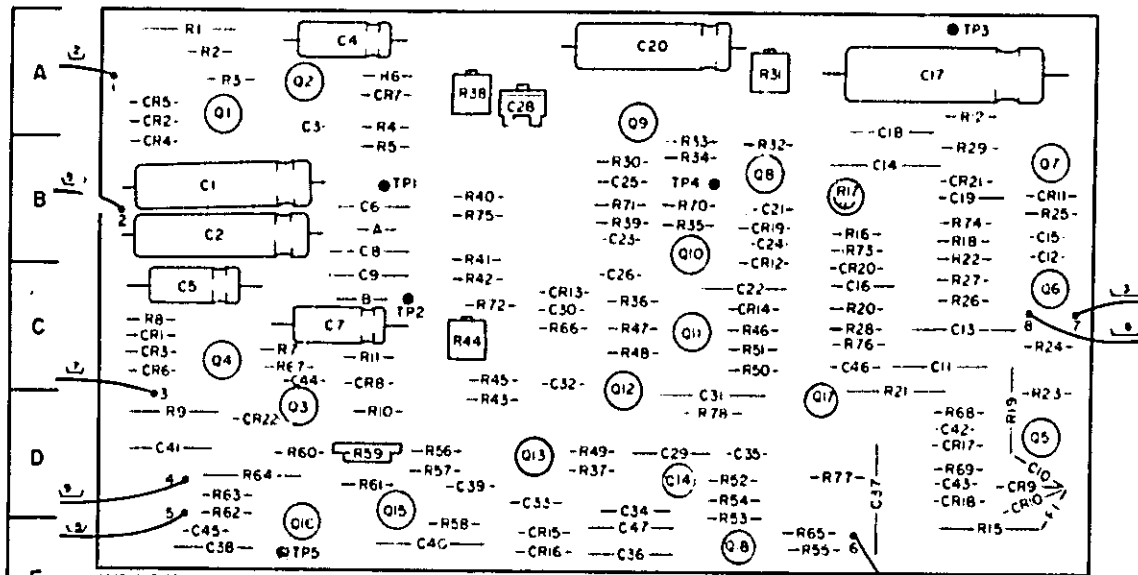

A2
hp Part No. 00400-66521

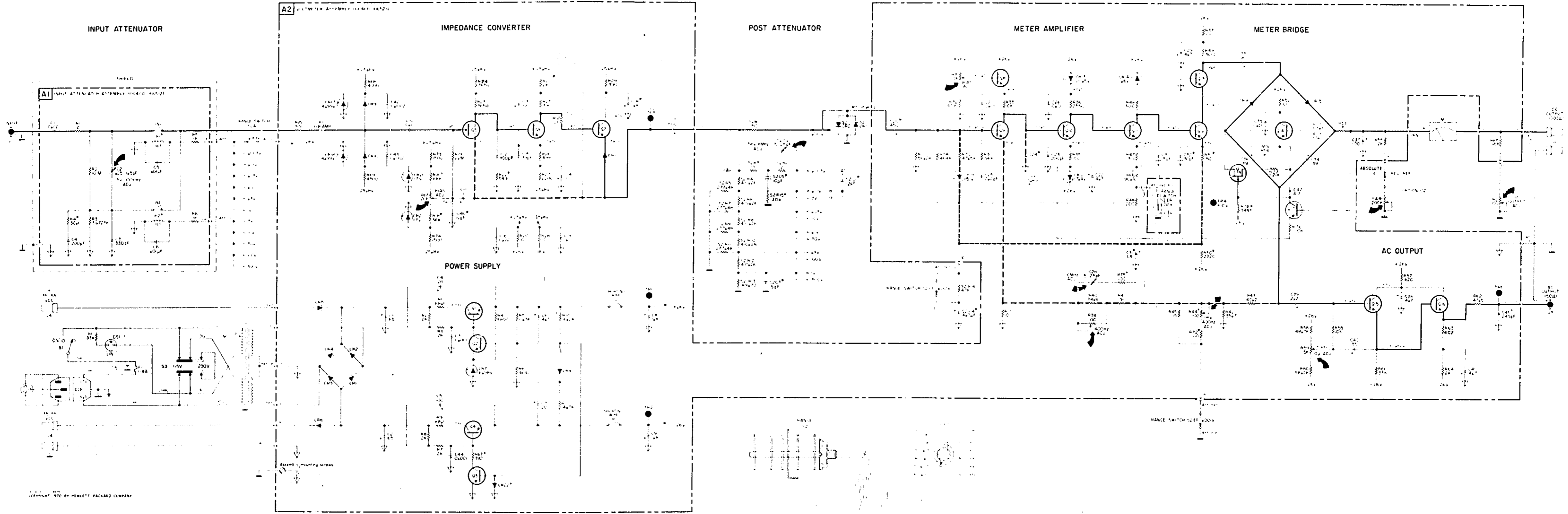
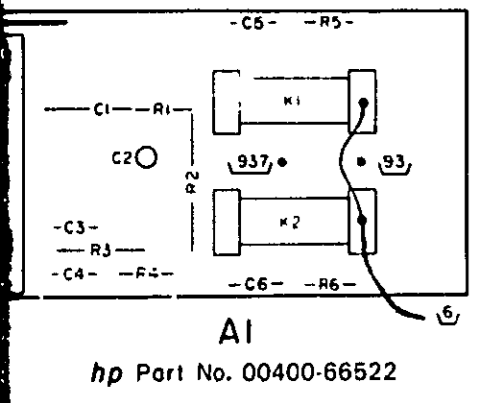

Figure 7-1. 400E/EL Schematic Diagram and Location of Components.

SECTION VIII

BACKDATING

8-1. INTRODUCTION.

8-2. This section has information to adapt this manual to HP 400E/ELs with serial number prefixes and/or serial numbers below the ones shown on the title page. If the component values or part numbers in your instrument are different than shown on the schematics or parts list (Table 6-3), and are NOT listed in this section, use the values and part numbers presently shown on the schematics and parts list.

8-3. Use Table 8-1 to locate the change number(s) for those instruments with serial number prefix or serial number(s) different than shown on the title page. Select and make the appropriate manual changes from the change number(s). Make the highest number change first. For example, for changes 2 and 3, make change 3 first before making change 2.

Table 8-1. Manual Changes.

Instrument Prefix/Serial Number	Make Manual Changes
400E/EL: 536-00101 thru 536-01000	26,24,21,22,18,16,15,12 thru 1
400E/EL: 536-01101 thru 536-01350	26,24,22,21,18,16,15,12 thru 2
400E/EL: 536-01351 thru 536-02403	26,24,22,21,18,16,15,12 thru 3
400E/EL: 536-02404 thru 536-04253	26,24,22,21,18,16,15,12 thru 4
400E/EL: 536-04154 thru 536-04854	26,24,22 thru 20,18,16,15,12 thru 5
400E/EL: 536-04855 thru 536-05503	26,24,22 thru 20,18,16,15,12 thru 6
400E/EL: 536-05504 thru 536-08383	26,24,22 thru 20,18,16,15,12 thru 7
400E/EL: 536-08384 thru 536-09153	26,24,22 thru 20,18,16,15,12 thru 8
400E/EL: 536-09154 thru 536-09553	26,24,22 thru 20,18,16,15,12 thru 9
400E/EL: 949-09554 thru 949-09753	26,24,22 thru 20,18,16,15,12 thru 10
400E/EL: 0949A11853 and Below	26,24,22 thru 20,18,16,15,12,11
400E/EL: All	12
400E: 0949A11854 thru 1131A12353 400EL: 0949A11853 thru 1131A12603	26,24,22 thru 20,18,16,15,13
400E: 1150A12354 thru 1208A12853 400EL: 1150A12754 thru 1208A13003	26,24,22 thru 20,18,16,15,14
400E: 1131A12603 and Below 400EL: 1131A12753 and Below	26,24,22 thru 20,18,16,15
400E: 1208A07332 and Below 400EL: 1208A16379 and Below	26,24,22 thru 20,18,16

Table 8-1. Manual Changes (Cont'd).

Instrument Prefix/Serial Number	Make Manual Changes
400E: 1131A1266.1 thru 1208A18153	26,24,22 thru 20,18, 7
400E: 1208A18968 and Below 400EL: 1208A18868 and Below	26,24,22 thru 20,18
400E: 1131A12604 thru 1208A20368 400EL: 1131A12754 thru 1208A20319	26,24,22,21,19
400E: 1131A12604 thru 1208A23848 400EL: 1131A12754 thru 1208A23898	26,24,22 thru 20
400E: 1208A24128 and Below 400EL: 1208A24168 and Below	26,24,22,21
400E: 1208A28933 and Below 400EL: 2214A29003 and Below	26,22
400E: 1131A12354 thru 1208A28943 400EL: 1131A12604 thru 2214A29013	26,23
400E: 1208A29188 and Below 400EL: 2214A29268 and Below	26,24
400E: 1208A28944 thru 1208A29290 400EL: 2214A29014 thru 2214A29428	26,25
400E: 1208A29333 and Below 400EL: 2214A29493 and Below	26

CHANGE 1

The transformer mounting and pin receptacles are different for this change, and S2C2 is a fixed value capacitor. If replacement of these components is required, use parts currently in parts list.

Section VI, Table 6-3 Changes.

Use the following part number only to update this manual for instruments requiring Change 1. If replacement of this part is required, use the part number presently in Table 6-3.

Ref. Des.	HP Part Number	C D	Description
S2C2	0160-0181	8	30pF ± 5% Fixed Capacitor

Section VII, Figure 7-1 (Schematic Diagram) Changes.

Change the value of S2C2 to a 30pF fixed capacitor.

CHANGE 2

If ANY Change 2 part in the applicable instruments is changed to one presently listed in Table 6-3 and Figure 7-1, change/add ALL of the appropriate parts to the ones presently listed in Table 6-3 and Figure 7-1.

Section VI, Table 6-3 Changes.

Do the changes in Table 6-3 as shown in Table 8-2.

Table 8-2. Make Changes to Table 6-3 (Change 2).

Reference Designation	HP Part Number	C D	Description
Delete:			
A2C44	0150-0050	9	CAPACITOR FND 1000PF 600VDCW CER
A2CR20	1902-3222	9	DIODE-ZNR 17.4C \pm 5%
A2CR21	1902-3222	9	DIODE-ZNR 17.4C \pm 5%
A2CR22	1901-0025	2	DIODE-GEN PRP 100 V 200MA DO-7
A2R72	0757-0402	1	RESISTOR 110 1% .125W
A2R73	0683-1525	4	RESISTOR 1500 5% .25W
A2R74	0683-1525	4	RESISTOR 1500 5% .25W
Change:			
A2Q3	1853-0016	8	TRANSISTOR PNP 2N3638 SJ
A2Q4	1850-0064	8	TRANSISTOR PNP 2N1183 GE
A2R16	0683-8235	7	RESISTOR 82K 5% .25W
A2R44*	0757-0284	7	RESISTOR 150 1% .125W
A2R67	0683-3915	0	RESISTOR 390 5% .25W

Section VII, Figure 7-1 (Schematic Diagram) Changes.

Delete: A2C44, A2CR20, A2CR21, A2CR22, A2R72, A2R73, A2R74,

Change:

- A2R16 to 82k ohms
- A2R44 to 150 ohms factory selected component
- A2R67 to 390 ohms

CHANGE 3**Section VI, Table 6-3 Changes.**

Ref. Des.	HP Part Number	C D	Description
Change:			
A2C12	0140-0194	1	110pF \pm 5% Capacitor
Delete:			
A2CR22	1901-0025	2	Diode
A2R67	0757-0413	4	392 ohm Resistor

Section VII, Figure 7-1 (Schematic Diagram) Changes.

Change the value of A2C12 to a 110pF capacitor.

Delete A2R67 and A2CR22

CHANGE 4

The A1 assembly with HP Part Number 00400-66502 had different locations for A1K1 and K2 relay connections. Check your relay connections and order the appropriate relay part number according to location of relay terminals, as shown in Figure 8-1. However, the A1K1 and K2 relays with HP Part Numbers 0490-0195 and 0490-0196, respectively, are no longer available. If your A1 assembly needs any of these relays, replace the complete A1 assembly (HP Part Number 00400-66522).

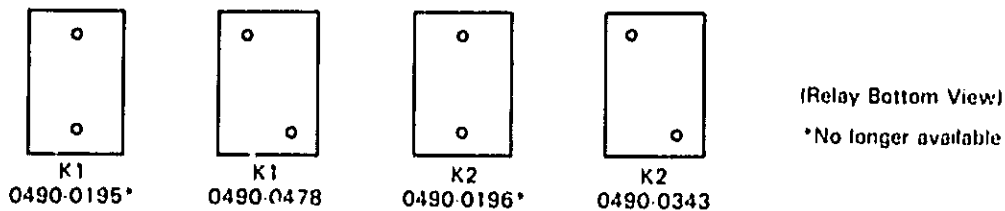

Figure 8-1. A1K1 and K2 Part Number (Change 4).

CHANGE 5

This changes the part numbers of A2Q5 and A2R16. If Q5 needs replacing, replace both Q5 and R16 using part numbers presently in Table 6-3.

Section VI, Table 6-3 Changes.

Use the following part numbers only to update this manual for instruments requiring Change 5. If replacement of Q5 is required, use the part numbers presently in Table 6-3.

Ref. Des.	HP Part Number	C D	Description
A2Q5	1B55-0068	4	FET
A2R16	0683-8325	6	82k ohm \pm 5% Resistor

Section VII, Figure 7-1 (Schematic Diagram) Changes.

Change the value of A2R16 to 82k ohms.

CHANGE 6

This changes the values and part number of A2R73 and R74. If noise is noted on the instrument, replace the resistor values with the one presently in Table 6-3.

Section VI, Table 6-3 Changes.

Use the following part numbers only to update this manual for instruments requiring Change 6. If replacement of any component is required, use the part number presently in Table 6-3.

Ref. Des.	HP Part Number	C D	Description
A2R73	0683-4725	2	4.7k ohm \pm 5% Resistor
A2R74	0683-4725	2	4.7k ohm \pm 5% Resistor

Section VII, Figure 7-1 (Schematic Diagram) Changes.

Change the values of A2R73 and R74 to 4.7k ohms.

CHANGE 7**Section VI, Table 6-3 and Section VII, Figure 7-1 Changes.**

Delete A2R75

CHANGE 8**Section VI, Table 6-3 and Section VII, Figure 7-1 Changes.**

Delete A2C45

CHANGE 9

This changes the rear panel part number, power cord, and power cord connector.

Section VI, Table 6-3 Changes.

Ref. Des.	HP Part Number	C D	Description
J5	1251-0148	1	Power Cord Connector
W1	8120-0078	6	Power Cord
MP10	00400-00202	4	Rear Panel

CHANGE 10

This changes the rear panel DPDT 115V/230V voltage selector switch.

Section VI, Table 6-3 Changes.

Ref. Des.	HP Part Number	C D	Description
S3	3101-0033	8	Slide Switch

CHANGE 11

This changes the A2 assembly part number to 00400-66501. If the board is to be replaced, use the replacement board presently listed in Table 6-3.

Section VI, Table 6-3 Changes.

Do the changes in Table 6-3 as shown in Table 8-3.

Table 8-3. Make Changes to Table 6-3 (Change 11).

Reference Designation	HP Part Number	C D	Description
Change:			
A2	00400-66501	4	MAIN PC BOARD ASSEMBLY
A2C28	0130-0016	8	CAPACITOR-V 5-25 PF CERE
A2R17	2100-0093	7	RESISTOR-TRMR 20K \pm 20% COMP
A2R31	2100-0092	6	RESISTOR-TRMR 10K \pm 20% COMP
A2R38	2100-0277	9	RESISTOR-TRMR 100 \pm 20% COMP
A2R44	2100-1836	8	RESISTOR-TRMR 100 \pm 20% COMP
Add:			
MP27	00400-00603	9	PC BOARD SHIELD

Section VII, Figure 7-1 (Schematic Diagram) Changes.

Change:

- A2 to HP Part Number 00400-66501
- A2C28 to 5-25 pF
- A2R17 to 20k ohms var. resistor
- A2R31 to 10k ohms var. resistor
- A2R44 to 100 ohms var. resistor

Section VII, Figure 7-1 (Component Locator) Changes.

Use the component locator shown in Figure 8-2.

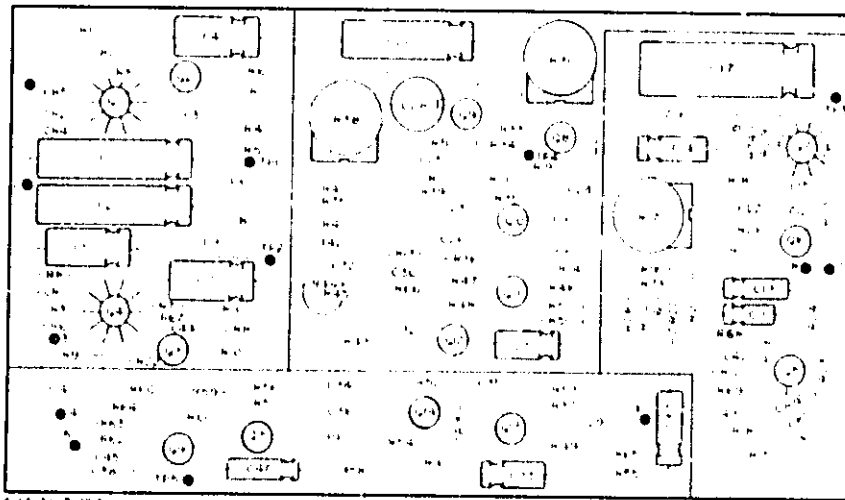

A2
hp Part No. 00400-66501
Rev. E.

Figure 8-2. Component Locator for Change 11.

CHANGE 12

This changes the color of the instrument covers, panels, and trims. The older 400 series had blue covers and light grey panels.

Section VI, Table 6-3 Changes.

Do the changes in Table 6-3 as shown in Table 8-4. Table 8-4 lists the covers and panels part numbers for the older instruments with blue and light grey colors.

Table 8-4. Make Changes to Table 6-3 (Change 12).

Reference Designation	HP Part Number	C D	Description
Change:			
MP11	00400-062-01	3	PANEL: FRONT (400E AND 400E OPTION 01)
MP11	00400-00203	5	PANEL: FRONT (400EL AND 400EL OPTION 01)
MP11	00400-00204	6	PANEL: FRONT (400E OPTION 02)
MP11	00400-00205	7	PANEL: FRONT (400EL OPTION 02)
MP12	5020-5388	6	METER TRIM: 1/2 MODULE
MP18	00400-64102	7	COVER: TOP WITH HANDLE
MP19	5000-0703	7	COVER: SIDE
MP20	5000-0711	7	COVER: BOTTOM

CHANGE 13

This changes the A2 assembly part number to 00400-66511. If the board is to be replaced, use the replacement board presently listed in Table 6-3.

Section VI, Table 6-3 Changes.

Ref. Des.	HP Part Number	C D	Description
A2	00400-66511	6	A2 Assembly

Section VII, Figure 7-1 (Component Locator) Changes.

Use the component locator in Figure 8-3.

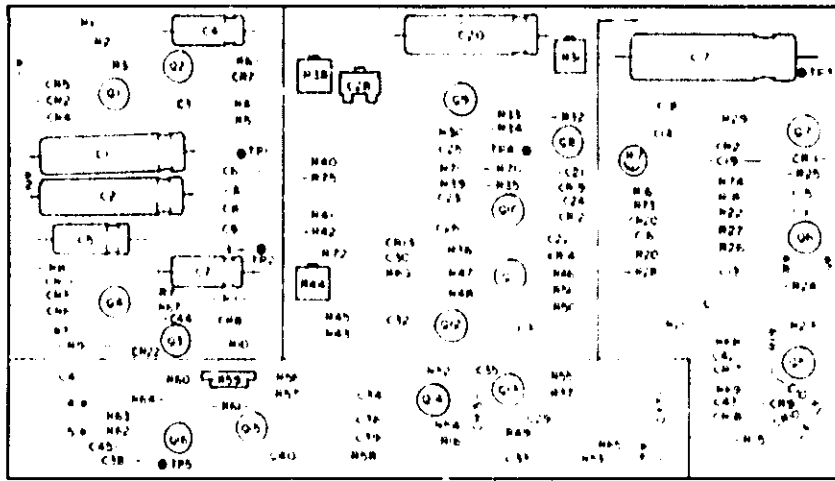

A2
hp Part No. 00-C0-6650

Figure 8-3. Component Locator for Change 13.

CHANGE 14

The instruments for Change 14 had a 500 MF capacitor (C1) across the output terminals with some instruments having an 470 MF capacitor for A2C37. Capacitor C1 is not necessary and can be removed (it caused a slow meter response). If this is done, make sure C37 is at the value and part number presently listed in Table 6-3.

CHANGE 15

This changes the A1 assembly part number to 00400-66502 and the A2 assembly to part number 00400-66511. If the boards are to be replaced, use the board part numbers presently listed in Table 6-3.

Section VI, Table 6-3 Changes.

Do the changes in Table 6-3 as shown in Table 8-5.

Table 8-5. Make Changes to Table 6-3 (Change 15).

Reference Designation	HP Part Number	C D	Description
Change:			
A1	00400-66502	5	INPUT ATTENUATOR PC BOARD ASSEMBLY
A2	00400-66511	6	MAIN PC BOARD ASSEMBLY
A1C2	0121-0407	9	CAPACITOR-V 0.7-3PF 5%
A1C3	0140-0149	6	CAPACITOR-FXD 470PF 5% MICA
A1K1	0490-0194	2	RELAY-REED
A1K2	0490-0366	0	RELAY-REED
A2R22	0698-3510	2	RESISTOR 453 1% .125W
Delete:			
S2C1	0160-0205	7	CAPACITOR-FXD 10PF 500V
S2C3	0160-0205	7	CAPACITOR-FXD 10PF 500V
Add:			
A1C5	0150-0093	0	CAPACITOR-FXD .01UF CER
A1C6	0150-0093	0	CAPACITOR-FXD .01UF CER

Section VII, Figure 7-1 (Schematic Diagram) Changes.

Change:

- A1C2 to 0.7-3 pF variable capacitor
- A1C3 to 470 pF capacitor
- A1CR1 and CR2 to A1CR5 and CR6 .01 MF capacitors, respectively
- A1R22 to 453 ohms

Section VII, Figure 7-1 (Component Locator) Changes.

Use the component locators in Figure 8-4.

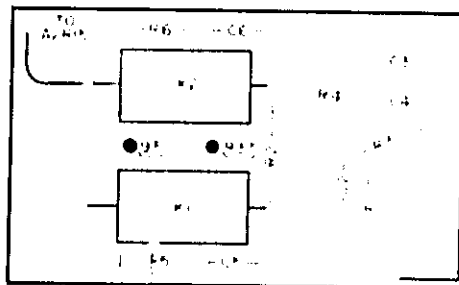

A1
hp Part No. 00400-66502

Figure 8-4. Component Locators for Change 15.

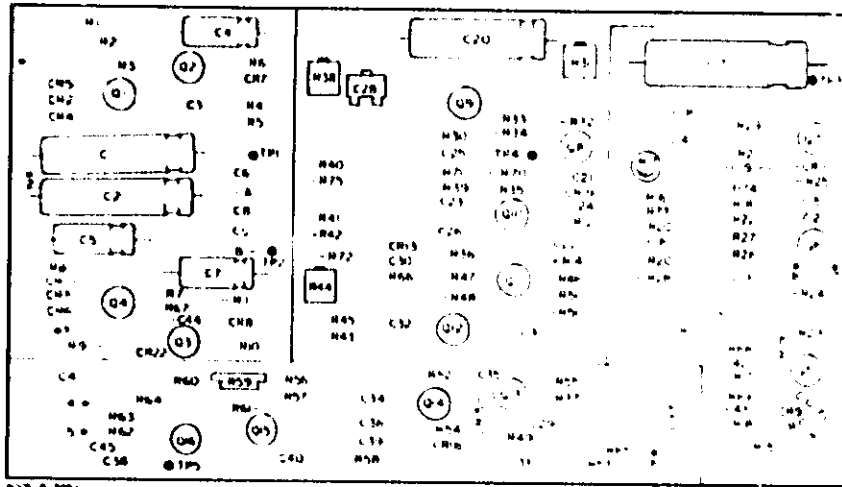

A2

hp Part No. 00400-855

Figure 8-4. Component Locators for Change 15 (Cont'd).

CHANGE 16

Section VI, Table 6-3 Changes.

Delete the following component from Table 6-3.

Ref. Des.	HP Part Number	C D	Description
A2R12	0683 1215	9	120 ohm Resistor

Section VII, Figure 7-1 (Schematic Diagram) Changes.

Delete A2R12 and connect the collector of A2Q6 directly to the base of A2Q7.

CHANGE 17

Section VII, Figure 7-1 (Component Locator).

Delete the blue (16) jumper from the A1 component locator.

CHANGE 18

This changes the binding post assembly hardware.

Section VI, Table 6-3 Changes.

Do the changes in Table 6-3 as shown in Table 8-6

Table 8-6. Make Changes to Table 6-3 (Change 18).

Reference Designation	HP Part Number	C D	Description
Change:			
MP4	5060-0634	9	BINDING POST ASSEMBLY: RED WITH HARDWARE
MP5	5060-0635	0	BINDING POST ASSEMBLY: BLACK WITH HARDWARE
MP21	0340-0090	0	INSULATOR: FRONT DOUBLE
MP22	0340-0086	4	INSULATOR: REAR DOUBLE
MP23	0340-0091	1	INSULATOR: FRONT TRIPLE
MP24	0340-0087	5	INSULATOR: REAR TRIPLE

Section VI, Figure 6-3 Changes.

Use Figure 8-5 in place of Figure 6-3.

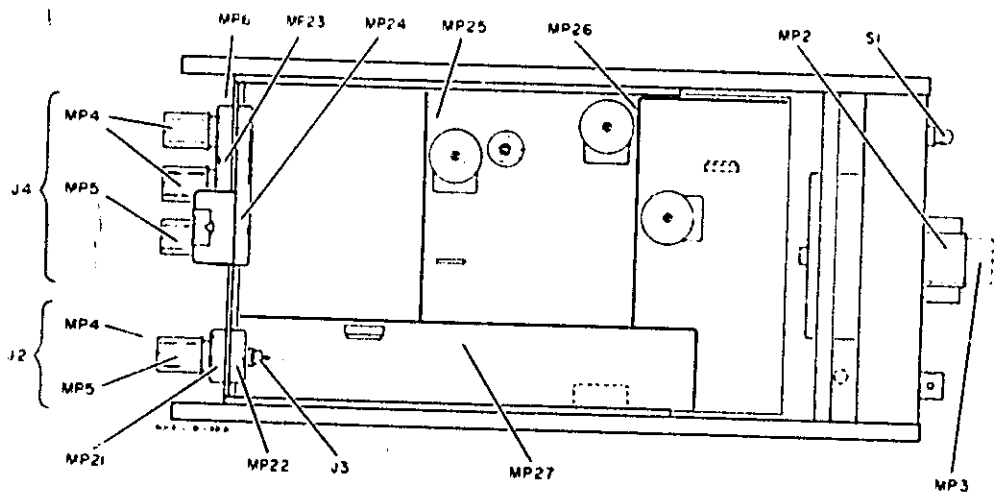

Figure 8-5. Make Changes to Figure 6-3 (Change 18).

CHANGE 19

This changes the part number of the A1 assembly to 00400-66512. Since the board presently listed in Table 6-3 is interchangeable with the 66512 board, use the part number for the board presently listed in Table 6-3 for replacement.

CHANGE 20

This changes the part numbers of the A1K1 and K2 relays. If K2 needs replacing, use part number presently in Table 6-3. The older K1 with relay part number 0490-0194 and coil part number 0490-1028 is no longer available. If your A1 Assembly needs K1 with these part numbers, replace the complete A1 Assembly (with HP Part Number 00400-66522).

Section VI, Table 6-3 Changes.

Use the following part number only to update this manual for instruments requiring Change 20. If replacement of K2 is required, use the part number presently in Table 6-3. If replacement of K1 is required, replace the complete A1 Assembly (with HP Part Number 00400-66522).

Ref. Des.	HP Part Number	C D	Description
Change:			
A1K1	0490-0194	2	Relay
A1K2	0490-0356	0	Relay
Add:			
	0490-1028	3	Relay Coil

CHANGE 21

Section VI, Table 6-3 Changes.

Change the following components in the table.

Ref. Des.	HP Part Number	C D	Description
A2C18	0180-0101	2	1.8 MF Capacitor
A2R29	0683-3915	0	390 ohms Resistor

Section VII, Figure 7-1 (Schematic Diagram) Changes.

Change:

A2C18 to 1.8 MF

A2R29 to 390 ohms.

CHANGE 22

Section VI, Table 6-3 Changes.

Change the following component in the table.

Ref. Des.	HP Part Number	C D	Description
	00400-61602	8	Power Cable

CHANGE 23

This deletes a FFT, a PNP transistor, and three resistors from the meter bridge circuitry of the A2 assembly. This change applies to 00400-66521 boards, Revision E and below.

Section IV, Paragraph 4-20 Changes.

Delete paragraph 4-20 from the manual.

Section IV, Figure 4-2 (Meter Bridge) Changes.

Delete A2Q17 and Q18, and A2R76 through R78 from the figure.

Section VI, Table 6-3 Changes.

Do the changes in Table 6-3 as shown in Table 8-7.

Table 8-7. Make Changes to Table 6-3 (Change 22).

Reference Designation	HP Part Number	C D	Description
Delete:			
A2Q17	1853-0010	2	TRANSISTOR PNP
A2Q18	1855-0093	5	TRANSISTOR JFET N CHANNEL
A2R76	0698-3458	3	RESISTOR 100K 5% .25W
A2R77	0698-3458	7	RESISTOR 348K 1% .125W
A2R78	0698-4411	4	RESISTOR 140 1% .125W

Section VII, Figure 7-1 (Schematic Diagram) Changes.

Figure 8-6. Make Changes to Figure 7-1 (Change 23).

CHANGE 24

This changes the value of resistor A2R63. If any one of transistor A2Q14, Q15, or Q16 is replaced, check the instrument's frequency response at 8 MHz. If the instrument is out of tolerance, try replacing A2R63 to the value presently listed in Table 6-3.

Section VI, Table 6-3 Changes.

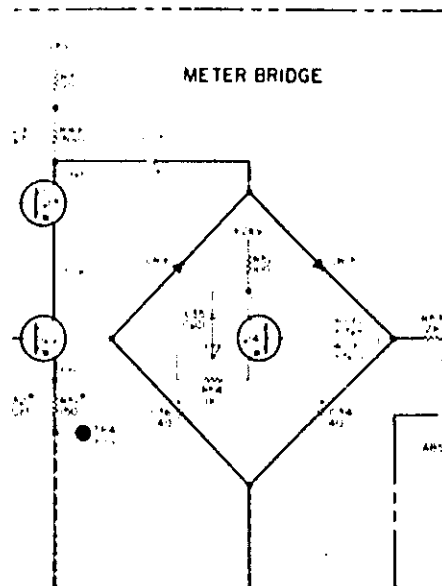
Use the following part number to update this manual for instruments requiring Change 24.

Ref. Des.	HP Part Number	C D	Description
A2R63	0757-0401	1	Change to: 100 ohms Resistor

Section VII, Figure 7-1 (Schematic Diagram) Changes.

Change A2R63 to 100 ohms.

CHANGE 25

This change deletes capacitor A2C47 from the A2 assembly. This change applies to Revisor F boards only.

Section VI, Table 6-3 Changes.

Delete the following component from the table.

Ref. Des.	HP Part Number	C D	Description
A2C47	0180-0100	3	4.7MF 35V Capacitor

Section VII, Figure 7-1 (Schematic Diagram) Changes.

Delete A2C47 from the figure.

CHANGE 26

This change deletes C5 and R15 from the S2 switch assembly. If non-linearity above 1 MHz is noted on the .003 V range, add C5 and R15 to S2 as shown in Figure 7-1. Use part numbers presently in Table 6-3.

Section VI, Table 6-3 Changes.

Delete the following part numbers to update this manual for instruments requiring Change 26.

Ref. Des.	HP Part Number	C D	Description
S2C5	0150-2257	3	10 pF 500V Capacitor
S2R15	0683-3035	5	30K ohm 5% .25W Resistor

Section VII, Figure 7-1 (Schematic Diagram) Changes.

Delete S2C5 and S2R15 from the figure only to update this manual for instruments requiring Change 26.

hp MANUAL CHANGES

-hp- MODEL 400E/EL

AC VOLTMETER

Manual Part Number 00400-90021

ADDENDUM

Add the specifications table (Table 1-1) to the manual.
Use table shown in Table CS-1.

Table CS-1. Specifications

Models 400E/400EL							
<p>Voltage Range: 1mV full scale to 300V full scale in 12 ranges; dB scale -10 to +2dB, 10dB between ranges.</p> <p>Frequency Range: 10Hz to 10MHz.</p> <p>Calibration: Responds to absolute average value of applied signal, calibrated in rms volts.</p> <p>Input Impedance: 10 megohms shunted by less than 25pF on the 1mV-1V ranges and 10 megohms shunted by less than 12pF on the 3V-300V ranges.</p> <p>Amplifier AC Output: 150mV rms for full scale meter indication; output impedance 50 ohms, 10Hz to 10MHz (105mV on the 1mV range). Accuracy: $\pm 10\%$, 10Hz to 4MHz.</p> <p>AC-DC Converter Output: 1Vdc output for full scale meter deflection (linear output for Model 400E/EL).</p>	<p>Output Resistance: 1000 ohms $\pm 5\%$</p> <p>Response Time: 1 second to within 1% of final value for a step change.</p> <p>AC Power: 115 or 230 volts $\pm 10\%$, 48 to 440 Hz, 10 watts.</p> <p>Temperature Range: 0 to +55° C (except where noted on accuracy charts).</p> <p>External Battery Operation: Terminals are provided on rear panel; positive and negative voltages between 35V and 55V are required; current drain from 50 to 75mA.</p> <p>Weight: Net: 6 lbs. (2.7 kg). Shipping: 8 lbs. (4 kg).</p> <p>Dimensions: 6-1/2 in. high, 5-1/8 in wide, 11 in deep (165.1 X 130.2 X 279.4 mm).</p>						
Models 400E/400EL							
Accuracy: \pm (% of full scale + % of Reading)							
Range	10 Hz	40 Hz	500 kHz	2 MHz	4 MHz	10 MHz	
.001 V†	$\pm (2.5 + 2.5)$	$\pm (1 + 0)$	$\pm (2.5 + 2.5)$				
.003 V	$\pm (2.5 + 2.5)$		$\pm (1 + 0)$		$\pm (1.5 + 1.5)$	$\pm (2.5 + 2.5)$	
.01 V - 3 V	$\pm (2.5 + 2.5)$		$\pm (1 + 0)$		$\pm (1.5 + 1.5)$	$\pm (3.0 + 2.0)**$	
10 V - 30 V	$\pm (2.5 + 2.5)$		$\pm (1 + 0)$		$\pm (1.5 + 1.5)$	$\pm (3.5 + 3.5)$	
100 V - 300 V	$\pm (2.5 + 2.5)$		$\pm (1 + 0)$		$\pm (1.5 + 1.5)$		
** Accuracy for the 3 V range at 1/3 full scale and below, 6 MHz to 10 MHz is: $\pm (3.75 + 3.75)$. † Accuracy applies to 1/3 full scale to full scale only.							
AC to DC Converter Output							
Range	10 Hz	20 Hz	100 Hz	500 kHz	1 MHz	4 MHz	10 MHz
.001 V†	$\pm (2.5 + 2.5)$	$\pm (1 + 1)$	$\pm (0.4 + 0.1)*$	$\pm (1 + 1)$	$\pm (2.5 + 2.5)$		
.003 V	$\pm (2.5 + 2.5)$	$\pm (1 + 1)$	$\pm (0.25 + 0.25)*$	$\pm (0.5 + 0.5)$	$\pm (2.5 + 2.5)$		
.01 V - 3 V	$\pm (2.5 + 2.5)$	$\pm (1 + 1)$	$\pm (0.25 + 0.25)*$	$\pm (0.5 + 0.5)$	$\pm (2.5 + 2.5)$	$\pm (3.0 + 2.0)$	
10 V - 30 V	$\pm (2.5 + 2.5)$	$\pm (1 + 1)$	$\pm (0.25 + 0.25)$	$\pm (0.5 + 0.5)$	$\pm (2.5 + 2.5)$	$\pm (3.5 + 3.5)$	
100 V - 300 V	$\pm (2.5 + 2.5)$	$\pm (1 + 1)$	$\pm (0.25 + 0.25)$	$\pm (0.5 + 0.5)$	$\pm (2.5 + 2.5)$		
* Accuracy applies for a temperature of 15°C to 40°C on the 1 mV to 1 V ranges only.							

**GENERAL
INFORMATION
AND
INSTALLATION**

OPERATING AND SERVICE MANUAL

HP 400E/400EL

AC VOLTMETER 400E/400EL

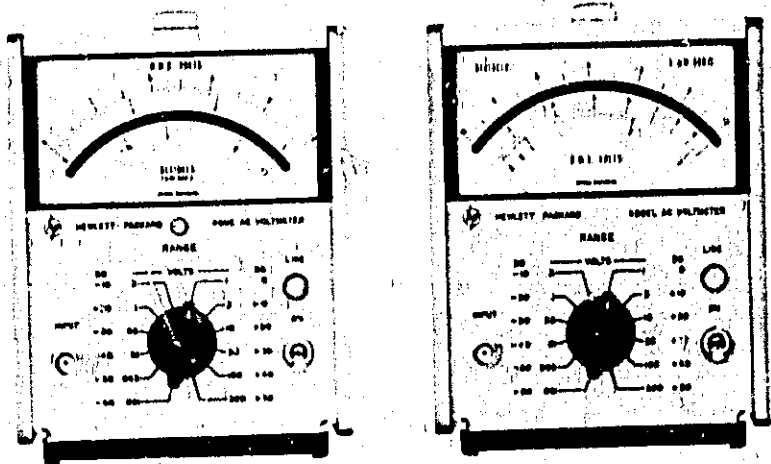

 **HEWLETT
PACKARD**

HP 400E/400EL



HEWLETT
PACKARD

OPERATING AND SERVICE MANUAL

**MODELS 400E/400EL
AC VOLTMETER**

Serial Prefixed: 1208A

See Section VIII
Manual Backdating Changes

WARNING

To help minimize the possibility of electrical fire or shock hazards, do not expose this instrument to rain or excess moisture.

-hp- Manual Part No. 00400-90020

Microfiche Part No. 00400-90067

© Copyright Hewlett-Packard Company 1966
P.O. Box 301, Loveland, Colorado 80537 U.S.A.

Printed: January 1980



CERTIFICATION

Hewlett-Packard Company certifies that this product met its published specifications at the time of shipment from the factory. Hewlett-Packard further certifies that its calibration measurements are traceable to the United States National Bureau of Standards, to the extent allowed by the Bureau's calibration facility, and to the calibration facilities of other International Standards Organization members.

WARRANTY

This Hewlett-Packard product is warranted against defects in material and workmanship for a period of one year from date of shipment [except that in the case of certain components listed in Section I of this manual, the warranty shall be for the specified period]. During the warranty period, Hewlett-Packard Company will, at its option, either repair or replace products which prove to be defective.

For warranty service or repair, this product must be returned to a service facility designated by -hp-. Buyer shall prepay shipping charges to -hp- and -hp- shall pay shipping charges to return the product to Buyer. However, Buyer shall pay all shipping charges, duties, and taxes for products returned to -hp- from another country.

Hewlett-Packard warrants that its software and firmware designated by -hp- for use with an instrument will execute its programming instructions when properly installed on that instrument. Hewlett-Packard does not warrant that the operation of the instrument, or software, or firmware will be uninterrupted or error free.

LIMITATION OF WARRANTY

The foregoing warranty shall not apply to defects resulting from improper or inadequate maintenance by Buyer, Buyer-supplied software or interfacing, unauthorized modification or misuse, operation outside of the environmental specifications for the product, or improper site preparation or maintenance.

NO OTHER WARRANTY IS EXPRESSED OR IMPLIED. HEWLETT-PACKARD SPECIFICALLY DISCLAIMS THE IMPLIED WARRANTIES OF MERCHANTABILITY AND FITNESS FOR A PARTICULAR PURPOSE.

EXCLUSIVE REMEDIES

THE REMEDIES PROVIDED HEREIN ARE BUYER'S SOLE AND EXCLUSIVE REMEDIES. HEWLETT-PACKARD SHALL NOT BE LIABLE FOR ANY DIRECT, INDIRECT, SPECIAL, INCIDENTAL, OR CONSEQUENTIAL DAMAGES, WHETHER BASED ON CONTRACT, TORT, OR ANY OTHER LEGAL THEORY.

ASSISTANCE

Product maintenance agreements and other customer assistance agreements are available for Hewlett-Packard products.

For any assistance, contact your nearest Hewlett-Packard Sales and Service Office. Addresses are provided at the back of this manual.

TABLE OF CONTENTS

Section	Page
I. GENERAL INFORMATION	1-1
1-1. Description	1-1
1-4. Options Available.....	1-1
1-5. Option 01 (400E/Only).....	1-1
1-7. Option 02.....	1-1
1-16. Instrument and Manual Identification.....	1-1

Section	Page
II. INSTALLATION	2-1
2-1. Introduction.....	2-1
2-3. Initial Inspection.....	2-1
2-5. Power Requirements.....	2-1
2-7. Power Cords.....	2-1
2-9. Grounding Requirements.....	2-1
2-11. Installation.....	2-1
2-13. Bench Mounting.....	2-1
2-15. Instrument Case.....	2-2
2-17. Rack Mounting.....	2-2
2-19. Combination Mounting.....	2-2
2-21. Repackaging For Shipping.....	2-2

Section	Page
III. OPERATING INSTRUCTIONS	3-1
3-1. Introduction.....	3-1
3-4. Location of Controls and Indicators.....	3-1
3-6. Operating Instructions.....	3-1
3-7. Standard 4001/11.....	3-1
3-12. 400E With Option 01.....	3-4
3-14. 400V/11 With Option 02.....	3-4

Section	Page
IV. THEORY OF OPERATION	4-1
4-1. General.....	4-1
4-8. Schematic Description.....	4-1
4-9. Impedance Converter.....	4-1
4-12. Meter Amplifier.....	4-2
4-15. Meter Bridge.....	4-3
4-20. AC Output Circuit.....	4-3
4-22. Power Supply.....	4-3

Section	Page
V. MAINTENANCE	5-1
5-1. Introduction.....	5-1
5-3. Required Equipment.....	5-1
5-5. Mechanical Zero Adjust (400E Only).....	5-1
5-7. Performance Checks.....	5-1
5-9. Accuracy and Frequency Response Tests.....	5-1
5-24. Input Impedance Check.....	5-8
5-27. AC to DC Converter Output Impedance Check.....	5-8
5-29. AC Output Voltage Check.....	5-8
5-31. Conclusion of Performance Checks.....	5-9
5-33. Alignment and Calibration Procedure.....	5-9
5-34. Cover Removal.....	5-9
5-36. Bias Adjust.....	5-9
5-38. AC Output Zero.....	5-9
5-40. Calibration.....	5-9
5-45. Troubleshooting.....	5-13
5-50. Power Supply.....	5-14
5-52. Amplifiers.....	5-14
5-58. AC Output Circuit.....	5-15
5-60. Adjustment of Factory Selected Components.....	5-15

Section	Page
VI. REPLACEABLE PARTS	6-1
6-1. Introduction.....	6-1
6-4. Ordering Information.....	6-1
6-6. Non-Listed Parts.....	6-1

Section	Page
VII. CIRCUIT DIAGRAMS	7-1
7-1. Introduction.....	7-1

Section	Page
VIII. MANUAL BACKDATING CHANGES	8-1

LIST OF TABLES

Table	Page
1-1. Specifications	1-0
1-2. Performance Characteristics	1-2
3-1. Effect of Distortion on Average Responding Meter	3-1
5-1. Required Test Equipment	5-0
5-2. Accuracy Tolerances	5-3
5-3. Calibration Tolerances	5-4
5-4. Calibration Accuracy Graphs	5-5
5-5. Alternate Calibration Procedure	5-11
5-6. Troubleshooting Tips	5-13
5-7. Power Supply Voltages	5-14
5-8. Impedance Converter Voltages	5-14
5-9. Meter Amplifier Voltages	5-14
5-11. Factory Selected Components	5-15
6-1. Standard Abbreviations	6-1
6-2. Code of Manufacturers	6-2
6-3. Replaceable Parts	6-3

LIST OF ILLUSTRATIONS

Figure	Page
1-1. Models 400E and 400E-1 AC Voltmeters	1-1
2-1. Power Cords	2-1
3-2. Location of Controls and Indicators	3-2
3-1. External Battery Connection	3-3
3-3. Isolation Transformer	3-3
3-4. Impedance Correction Graph	3-4
4-1. Simplified Block Diagram	4-1
4-2. Meter Bridge	4-2
5-1. Accuracy Test Setup	5-2
5-2. Accuracy and Frequency Response Test Setup	5-4
5-3. Input Impedance Check	5-7
5-4. Location of Internal Adjustments	5-9
5-5. Alternate Calibration and Frequency Test Setup	5-12
6-1. Mechanical Parts	6-7
6-2. Chassis and Switch Components	6-8

SAFETY SUMMARY

The following general safety precautions must be observed during all phases of operation, service, and repair of this instrument. Failure to comply with these precautions or with specific warnings elsewhere in this manual violates safety standards of design, manufacture, and intended use of the instrument. Hewlett-Packard Company assumes no liability for the customer's failure to comply with these requirements.

GROUND THE INSTRUMENT.

To minimize shock hazard, the instrument chassis and cabinet must be connected to an electrical ground. The instrument is equipped with a three-conductor ac power cable. The power cable must either be plugged into an approved three-contact electrical outlet or used with a three-contact to two-contact adapter with the grounding wire (green) firmly connected to an electrical ground (safety ground) at the power outlet. The power jack and mating plug of the power cable meet International Electrotechnical Commission (IEC) safety standards.

DO NOT OPERATE IN AN EXPLOSIVE ATMOSPHERE.

Do not operate the instrument in the presence of flammable gases or fumes. Operation of any electrical instrument in such an environment constitutes a definite safety hazard.

KEEP AWAY FROM LIVE CIRCUITS.

Operating personnel must not remove instrument covers. Component replacement and internal adjustments must be made by qualified maintenance personnel. Do not replace components with power cable connected. Under certain conditions, dangerous voltages may exist even with the power cable removed. To avoid injuries, always disconnect power and discharge circuits before touching them.

DO NOT SERVICE OR ADJUST ALONE.

Do not attempt internal service or adjustment unless another person, capable of rendering first aid and resuscitation, is present.

DO NOT SUBSTITUTE PARTS OR MODIFY INSTRUMENT.

Because of the danger of introducing additional hazards, do not install substitute parts or perform any unauthorized modification to the instrument. Return the instrument to a Hewlett-Packard Sales and Service Office for service and repair to ensure that safety features are maintained.

DANGEROUS PROCEDURE WARNINGS.

Warnings, such as the example below, precede potentially dangerous procedures throughout this manual. Instructions contained in the warnings must be followed.

WARNING

Dangerous voltages, capable of causing death, are present in this instrument. Use extreme caution when handling, testing, and adjusting.

Table I-1. Specifications

Models 400E/400EL	
Voltage Range: 1mV full scale to 300V full scale in 12 ranges; dB scale -10 to +2dB, 10dB between ranges.	Output Resistance: 1000 ohms $\pm 5\%$ Response Time: 1 second to within 1% of final value for a step change.
Frequency Range: 10Hz to 10MHz.	AC Power: 115 or 230 volts $\pm 10\%$, 48 to 440 Hz, 10 watts.
Calibration: Responds to absolute average value of applied signal, calibrated in rms volts.	Temperature Range: 0° to +55° C (except where noted on accuracy charts).
Input Impedance: 10 megohms shunted by less than 25pF on the 1mV-1V ranges and 10 megohms shunted by less than 12pF on the 3V-300V ranges.	External Battery Operation: Terminals are provided on rear panel; positive and negative voltages between 35V and 55V are required; current drain from 50 to 75mA.
Amplifier AC Output: 150mV rms for full scale meter deflection; output impedance 50 ohms, 10Hz to 10MHz (105mV on the 1mV range). Accuracy: $\pm 10\%$, 10Hz to 4MHz.	Weight: Net: 6 lbs. (2.7 kg) Shipping: 8 lbs. (4 kg).
AC-DC Converter Output: 1Vdc output for full scale meter deflection (linear output for Model 400E/EL).	Dimensions: 6 1/2 in. high, 5 1/8 in. wide, 11 in. deep (165, 1 X 130, 2 X 279, 4 mm).

Models 400E/400EL

Accuracy: \pm (% of full scale + % of Reading)

Range	Frequency					
	10 Hz	40 Hz	500 Hz	2 MHz	4 MHz	10 MHz
001 V [†]	$\pm (2.5 + 2.5)$	$\pm (1 + 0)$	$\pm (2.5 + 2.5)$			
003 V	$\pm (2.5 + 2.5)$		$\pm (1 + 0)$	$\pm (1.5 + 1.5)$	$\pm (2.5 + 2.5)$	
01 V - 3 V	$\pm (2.5 + 2.5)$		$\pm (1 + 0)$	$\pm (1.5 + 1.5)$	$\pm (3.0 + 2.0)^{**}$	
10 V - 30 V	$\pm (2.5 + 2.5)$		$\pm (1 + 0)$	$\pm (1.5 + 1.5)$	$\pm (3.5 + 3.5)$	
100 V - 300 V	$\pm (2.5 + 2.5)$		$\pm (1 + 0)$	$\pm (1.5 + 1.5)$		

** Accuracy for the 3 V range at 1/3 full scale and below, 6 MHz to 10 MHz is $\pm (3.75 + 3.75)$.

† Accuracy applies to 1/3 full scale to full scale only.

AC to DC Converter Output

Range	Frequency						
	10 Hz	20 Hz	100 Hz	500 Hz	1 MHz	1 MHz	10 MHz
001 V [†]	$\pm (2.5 + 2.5)$	$\pm (1 + 1)$	$\pm (0.4 + 0.1)^*$	$\pm (1 + 1)$	$\pm (2.5 + 2.5)$		
003 V	$\pm (2.5 + 2.5)$	$\pm (1 + 1)$	$\pm (0.25 + 0.25)^*$	$\pm (0.5 + 0.5)$	$\pm (2.5 + 2.5)$		
01 V - 3 V	$\pm (2.5 + 2.5)$	$\pm (1 + 1)$	$\pm (0.25 + 0.25)^*$	$\pm (0.5 + 0.5)$	$\pm (2.5 + 2.5)$	$\pm (3.0 + 2.0)$	
10 V - 30 V	$\pm (2.5 + 2.5)$	$\pm (1 + 1)$	$\pm (0.25 + 0.25)$	$\pm (0.5 + 0.5)$	$\pm (2.5 + 2.5)$	$\pm (3.5 + 3.5)$	
100 V - 300 V	$\pm (2.5 + 2.5)$	$\pm (1 + 1)$	$\pm (0.25 + 0.25)$	$\pm (0.5 + 0.5)$	$\pm (2.5 + 2.5)$		

* Accuracy applies for a temperature of 15° C to 40° C on the 1 mV to 1 V ranges only.

SECTION I

GENERAL INFORMATION

1-1. DESCRIPTION.

1-2. The -hp- Models 400E and 400EL are versatile ac voltmeters and dB meters. Both models can be used as ac to dc converters or wideband amplifiers. The Model 400E is primarily intended for voltage measurements, whereas the Model 400EL is primarily a dB meter. However, both meters indicate both volts and dB. The 400E has a linear ac scale with a logarithmic dB scale underneath, and the 400EL has a linear dB scale with a logarithmic ac scale underneath. Since the difference in scales is the only difference between the two instruments, this manual will use the term 400E/EL in reference to both instruments.

1-3. Figure I-1 shows both the Model 400E and the Model 400EL. Table I-1 is a list of specifications.

1-4. OPTIONS AVAILABLE.

1-5. OPTIONS 01 (400E ONLY).

1-6. Option 01 places the dB scale uppermost for greater resolution when making dB measurements.

1-7. OPTION 02.

1-8. Option 02 adds a relative reference adjustment to the 400E/EL. The REL. REF. control allows a continuous reduction in sensitivity by a maximum of 3 dB in order to make relative voltage or dB measurements.

1-9. Option 910. An additional Operating and Service Manual, Part Number 00400-90020.

1-10. INSTRUMENT AND MANUAL IDENTIFICATION.

1-11. Hewlett-Packard uses a two-section serial number. If the first section (serial prefix) of the serial number on your instrument does not agree with those on the title page of this manual, change sheets supplied with the manual will define the differences between your instrument and the Model 400E/EL described in this manual. Some serial numbers may have a letter separating the two sections of the number. This letter indicates the country in which the instrument was manufactured.

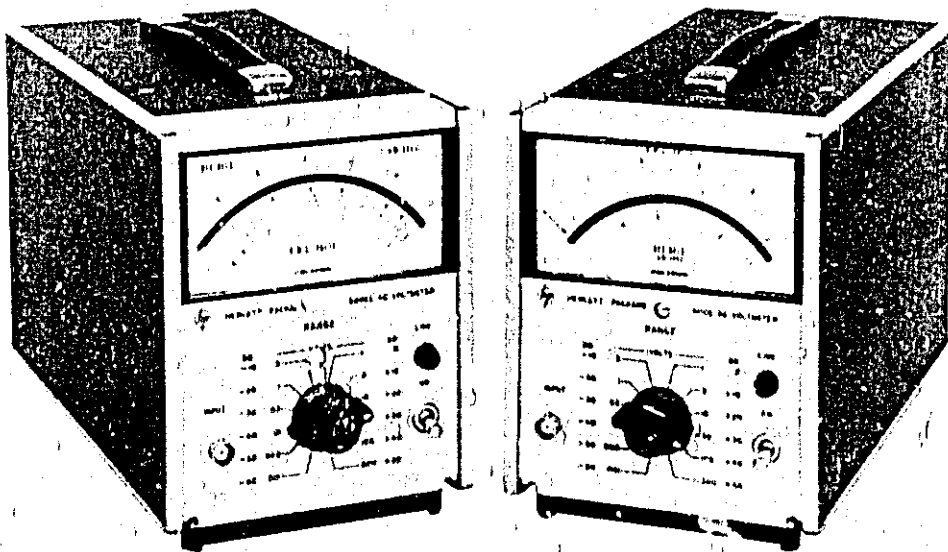
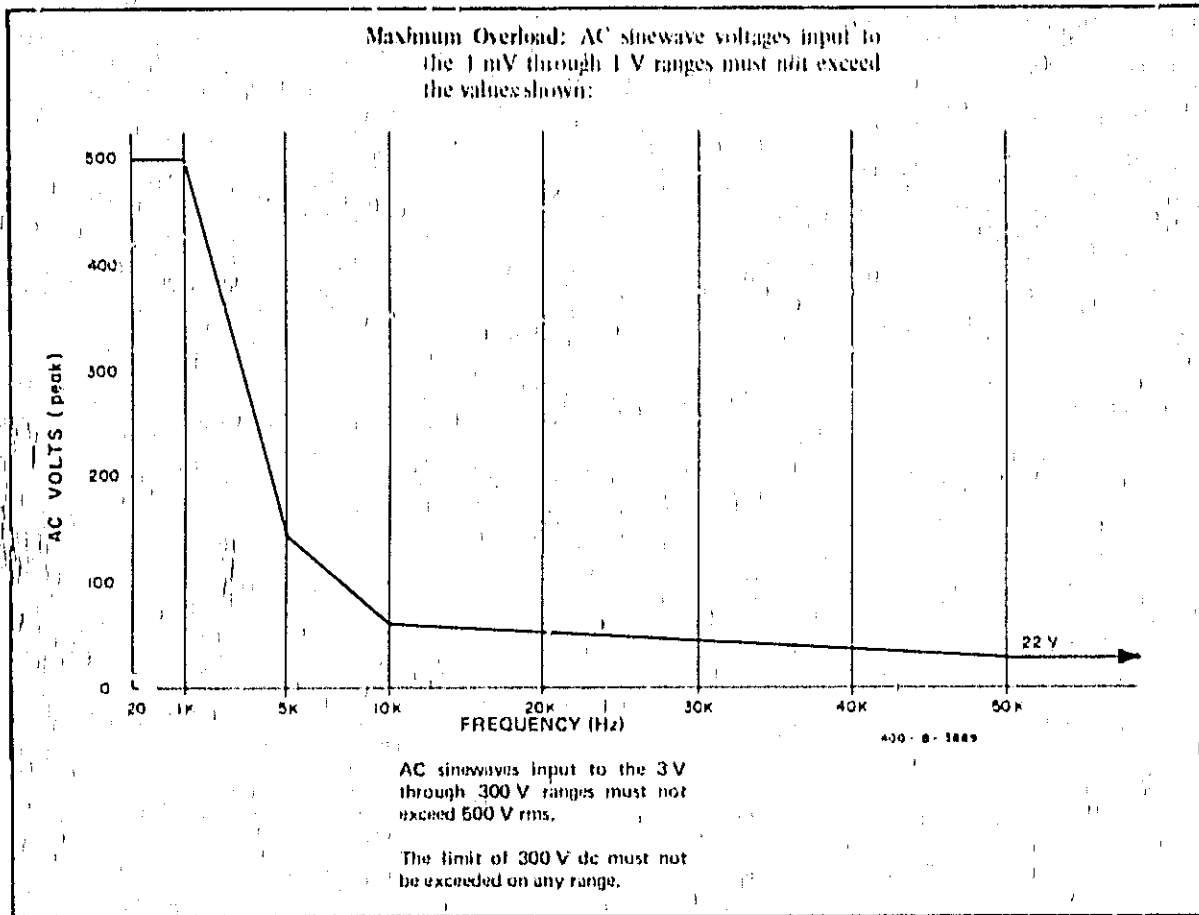

Figure I-1. Models 400E and 400EL AC Voltmeters

Table 1-2. Performance Characteristics



SECTION II INSTALLATION

2-1. INTRODUCTION.

2-2. This section contains information and instructions necessary for the installation and shipping of the Model 400E and 400EL Voltmeters. Included are initial inspection procedures, power and grounding requirements, installation information, and instructions for repackaging for shipment.

2-3. INITIAL INSPECTION.

2-4. This instrument was carefully inspected both mechanically and electrically before shipment! It should be physically free of marks or scratches and in perfect electrical order upon receipt. To confirm this, the instrument should be inspected for physical damage in transit. Also check for supplied accessories, and test the electrical performance of the instrument using the procedure outlined in Paragraph 5-7. If there is damage or deficiency, see the warranty on the inside front cover of this manual.

2-5. POWER REQUIREMENTS.

2-6. The Model 400E/EL can be operated from any source of 115 or 230 volts at 48 to 440 Hz or from two 35 to 55 volt batteries connected to the rear panel BATTERY terminals. The 115/230 V slide switch on the rear panel selects the desired line voltage. Power dissipation is 10 watts maximum.



Before applying ac power to the 400E or 400EL, be sure it is set for the proper line voltage.

2-7. POWER CORDS.

2-8. Figure 2-1 illustrates the standard power plug configurations that are used throughout the United States and in other countries. The hp- part number directly below each drawing is the part number for a 400E/EL power cord equipped with a power plug of that configuration. If the appropriate power cord is not included with the instrument, notify the nearest hp- Sales and Service Office and a replacement cord will be provided.

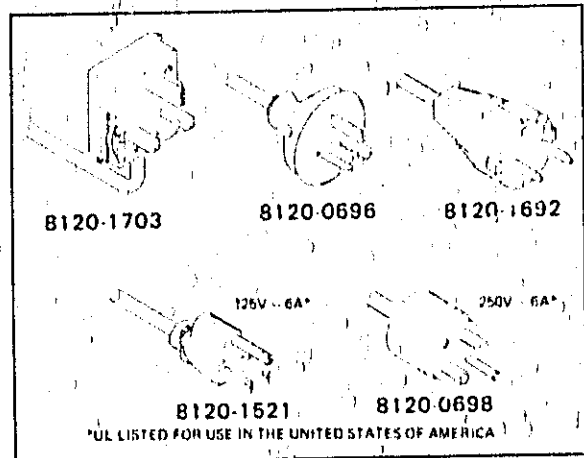

Figure 2-1. Power Cords.

2-9. GROUNDING REQUIREMENTS.

2-10. To protect operating personnel, the National Electrical Manufacturers' Association (NEMA) recommends that the instrument panel and cabinet be grounded. All Hewlett-Packard instruments are equipped with a three-conductor power cable which, when plugged into an appropriate receptacle, grounds the instrument. The offset pin on the power cable three-prong connector is the ground wire.

WARNING

For operator protection during battery operation, connect chassis terminal (MP26) to earth ground.

2-11. INSTALLATION.

2-12. The Model 400E/EL is fully transistorized; therefore, no special cooling is required. However, the instrument should not be operated where the ambient temperature exceeds 55° C (131° F) or the relative humidity exceeds 95%.

2-13. BENCH MOUNTING.

2-14. The Model 400E/EL is shipped with plastic feet and tilt stand in place, ready for use as a bench instrument.

2-15. INSTRUMENT CASE.

2-16. The 400E/EL can be placed in a rugged, high impact plastic case (-hp- 11076A). The instrument can be operated, stored or carried in this splash-proof case. A dual purpose tilt stand also serves as a carrying handle. Storage space is located at the rear of the case and in the front lid.

2-17. RACK MOUNTING.

2-18. The Model 400E/EL may be rack mounted by using an adapter frame (-hp- Part No. 5060-0797). The adapter frame is a rack frame that accepts any combination of submodular units. It can be rack mounted only. For additional information, address inquiries to your -hp- Sales and Service Office. (See Appendix B for office locations.)

2-19. COMBINATION MOUNTING.

2-20. The Model 400E/EL may be mounted in combination with other submodular units by using a Combining Case (-hp- Model 1051A or 1052A). The Combining Case is a full-module unit which accepts various combinations of submodular units. Being a full-module unit, the combining case can be bench or rack mounted and is analogous to any full-module instrument.

2-21. REPACKAGING FOR SHIPMENT.

2-22. The following paragraphs contain a general guide for repackaging of the instrument for shipment. Refer to Paragraph 2-23 if the original container is to be used; 2-24 if it is not. If you have any questions, contact your local -hp- Sales and Service Office. (See Appendix B for office locations.)

NOTE

If the instrument is to be shipped to Hewlett-Packard for service or repair, attach a tag to the instrument identifying the owner and indicating the service or repair to be accomplished; include the model number and full serial number of the instrument. In any correspondence, identify the instrument by model number, serial number, and serial number prefix.

2-23. If original container is to be used, proceed as follows:

- a. Place instrument in original container, if available. If original container is not available, a suitable container can be purchased from your nearest -hp- Sales and Service Office.
- b. Ensure that container is well sealed with strong tape or metal bands.

2-24. If original container is not to be used, proceed as follows:

- a. Wrap instrument in heavy paper or plastic before placing in an inner container.
- b. Place packing material around all sides of instrument and protect panel face with cardboard strips.
- c. Place instrument and inner container in a heavy carton or wooden box and seal with strong tape or metal bands.
- d. Mark shipping container with "DELICATE INSTRUMENT," "FRAGILE," etc.

OPERATION

SECTION III OPERATING INSTRUCTIONS

3-1. INTRODUCTION.

3-2. The Model 400E/EL is primarily an ac voltmeter and dB meter, but it can be used as an ac to dc converter or as a wide band amplifier.

3-3. This section explains the controls of the 400E/EL and outlines the operating procedures for each mode of operation.

3-4. LOCATION OF CONTROLS AND INDICATORS.

3-5. Figure 3-2 shows the location of each of the 400E/EL controls and explains the function of each.

3-6. OPERATING INSTRUCTIONS.

3-7. STANDARD 400E/EL.

3-8. AC Voltmeter.

Table 3-1. Effect of Distortion on Average Responding Meter

Harmonic	% Distortion	% ERROR (* Fundamental)	
		Max. Positive	Max. Negative
Any even	0.1	0.000	
	0.5	0.001	
	1.0	0.005	
	2.0	0.020	
Third	0.1	0.033	0.003
	0.5	0.168	0.167
	1.0	0.338	0.328
	2.0	0.687	0.667
Fifth	0.1	0.020	0.020
	0.5	0.101	0.099
	1.0	0.205	0.195
	2.0	0.420	1.380

* Depends on phase relationship between harmonic and fundamental.

NOTE

Since the 400E/EL is average responding and rms calibrated, any distortion will affect the accuracy of the measurement. Table 3-1 shows the errors caused by distortion.

- a. Ensure that 115/230 V ac slide switch on the rear panel matches line voltage used, and connect power to the instrument. Mechanically zero the instrument using the procedure outlined in Paragraph 5-5.
- b. To operate the Model 400E/EL with battery power, connect two 35 to 55 volt batteries as shown in Figure 3-1. Since the front panel LINE switch has no effect during battery operation, the switch in Figure 3-1 can be used as a convenient method of disconnecting the batteries when the instrument is not in use. Two 35 volt batteries will deliver approximately 75 mA and two 55 volt batteries will deliver approximately 50 mA.

WARNING

For operator protection during battery operation, connect chassis terminal (MP26) to earth ground.

- c. Turn line ON toggle switch to up position. LINE lamp will glow.
- d. Select approximate range of signal to be measured.

CAUTION

Do not apply more than 500 volts ac to input. Do not overload the .001 through 1 volt ranges. Consult Table 1-2 for overload limits. If any of these overloads are exceeded, the instrument may be damaged.

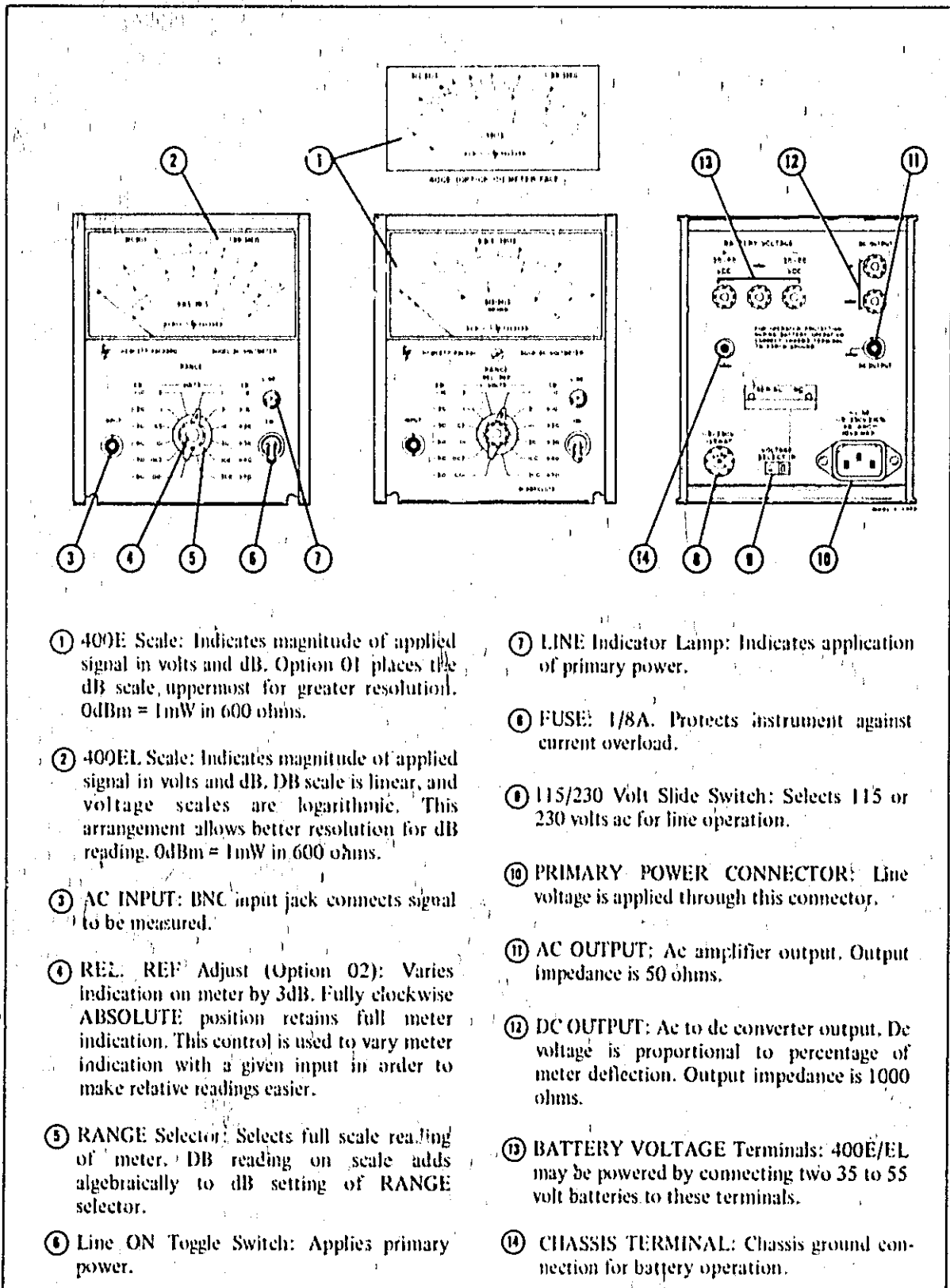

- ① 400E Scale: Indicates magnitude of applied signal in volts and dB. Option 01 places the dB scale, uppermost for greater resolution. $0\text{dBm} = 1\text{mW}$ in 600 ohms.
- ② 400EL Scale: Indicates magnitude of applied signal in volts and dB. DB scale is linear, and voltage scales are logarithmic. This arrangement allows better resolution for dB reading. $0\text{dBm} = 1\text{mW}$ in 600 ohms.
- ③ AC INPUT: BNC input jack connects signal to be measured.
- ④ REL. REF Adjust (Option 02): Varies indication on meter by 3dB. Fully clockwise ABSOLUTE position retains full meter indication. This control is used to vary meter indication with a given input in order to make relative readings easier.
- ⑤ RANGE Selector: Selects full scale reading of meter. DB reading on scale adds algebraically to dB setting of RANGE selector.
- ⑥ Line ON Toggle Switch: Applies primary power.
- ⑦ LINE Indicator Lamp: Indicates application of primary power.
- ⑧ FUSE: 1/8A. Protects instrument against current overload.
- ⑨ 115/230 Volt Slide Switch: Selects 115 or 230 volts ac for line operation.
- ⑩ PRIMARY POWER CONNECTOR: Line voltage is applied through this connector.
- ⑪ AC OUTPUT: Ac amplifier output. Output impedance is 50 ohms.
- ⑫ DC OUTPUT: Ac to dc converter output. Dc voltage is proportional to percentage of meter deflection. Output impedance is 1000 ohms.
- ⑬ BATTERY VOLTAGE Terminals: 400E/EL may be powered by connecting two 35 to 55 volt batteries to these terminals.
- ⑭ CHASSIS TERMINAL: Chassis ground connection for battery operation.

Figure 3-2. Location of Controls and Indicators

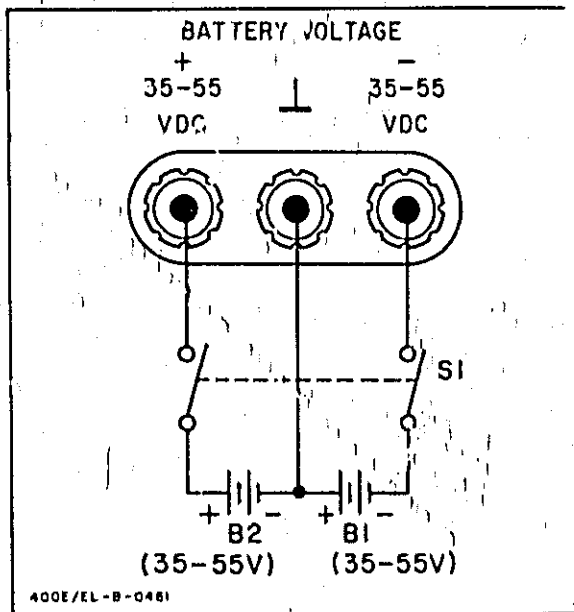

Figure 3-1. External Battery Connection

- e. Connect signal to be measured to INPUT terminals, and read the rms voltage on the scale.

3-9. DB Meter.

- a. To make a dB or dBm measurement, follow steps a through e in Paragraph 3-8, and add the scale reading to the RANGE setting. For example: If the scale reading is +1.5 and the RANGE is -30dB, the final measurement is -28.5dB.
- b. The 400E/EL dB scale is calibrated in dBm. 0dBm is equivalent to 1 milliwatt dissipated by a 600 ohm load. Consequently, any dBm measurements must be made across a total impedance of 600 ohms. Measurements across other impedances will be in dB, but not dBm.
- c. To convert a dB reading to dBm, use the Impedance Correction Graph (Figure 3-3). For example: To convert a +30dB reading made across 50 ohms to dBm, locate the load impedance on the bottom of the graph. Follow the impedance line to the heavy black line and read the meter correction at that point. The correction for 50 ohms is +10.5dBm, and the corrected reading is +40.5dBm.

3-10. Ac to Dc Converter.

- a. Follow steps a through e in Paragraph 3-8.
- b. Connect the rear panel DC OUTPUT terminals to a dc measuring device with a high input impedance. The dc output resistance is 1000 ohms; and if it is loaded, the dc output signal will be inaccurate.
- c. The dc output is a 0 to 1 volt signal proportional to the percentage of 400E/EL meter deflection.

3-11. Wide Band Ac Amplifier.

- a. Follow turn-on steps a through e in Paragraph 3-8.
- b. Select approximate range of input on RANGE switch.
- c. Connect SIGNAL to be amplified to INPUT terminals.
- d. When using an ac power source, ground loops can be eliminated by connecting the 400E/EL to an adequate isolation transformer. This will open the power line ground circuit as shown in Figure 3-3.

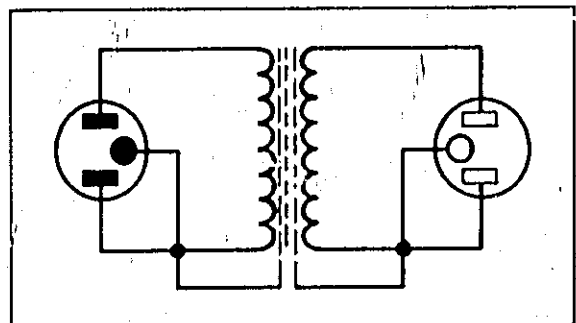

Figure 3-3. Isolation Transformer.

NOTE

Place a 1 kilohm shielded load across the DC OUTPUT, if it is not being used, when using the AC OUTPUT. This is especially necessary on low ranges.

- e. The gain of the amplifier depends on the RANGE selection. On the 0.1 volt range and below, the 400E/EL amplifies the input; and

on the 0.3 volt range and above, it attenuates the input. On the 0.001 volt ranges, the maximum output is 105mV. On all other ranges, the maximum output is 150mV. Table 3-2 shows the ac amplifier gain for each range setting.

Table 3-2. AC Amplifier Gain

RANGE	GAIN	RANGE	GAIN
0.001	+40dB	1	-16dB
0.003	+34dB	3	-26dB
0.01	+24dB	10	-36dB
0.03	+14dB	30	-46dB
0.1	+4dB	100	-56dB
0.3	-6dB	300	-66dB

3-12. 400E WITH OPTION 01.

3-13. Operation of the 400E with Option 01 is essentially the same as operation of the standard 400E. The dB scale reads from -15 to +2 instead of from -12 to +2, and is placed at the top of the scale for better resolution.

3-14. 400E/EL WITH OPTION 02.

3-15. Option 02 adds a relative reference adjustment to the 400E/EL. This adjustment allows a meter indication to be varied by 3dB. Use the REL. REF adjustment to set the meter, at any convenient reference (0dB for example) in order to make relative readings easier. When the REL. REF adjustment is in the fully clockwise ABSOLUTE position, it has no effect on the meter accuracy.

3-16. In all other respects, operation of a Option 02 instrument is the same as operation of a standard Model 400E/EL.

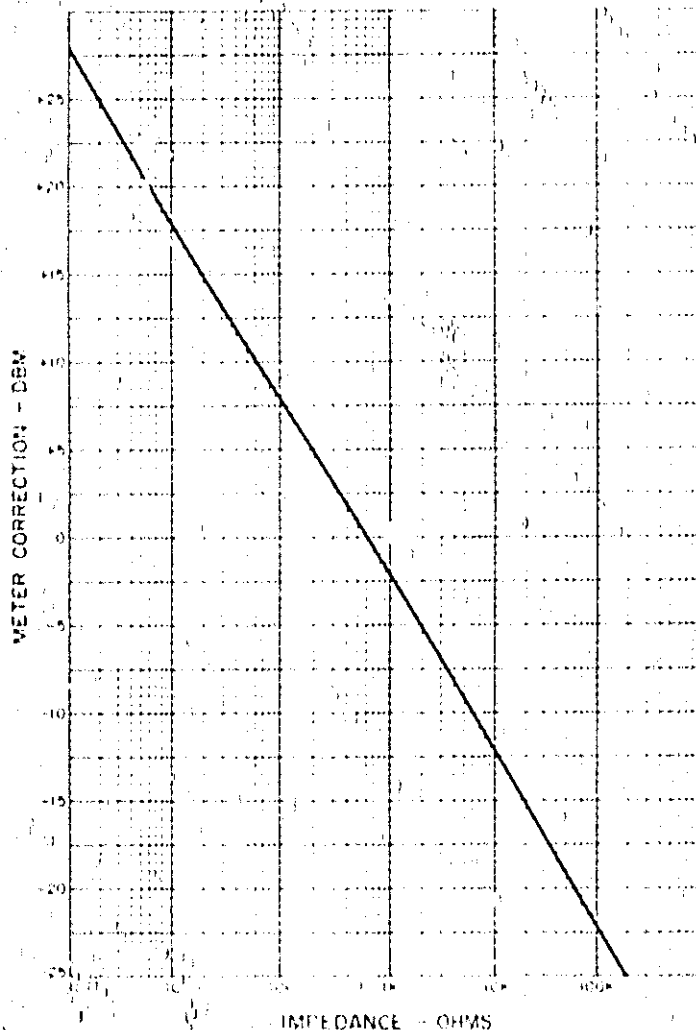

Figure 3-4. Impedance Correction Graph.

THEORY

SECTION IV THEORY OF OPERATION

4-1. GENERAL.

4-2. The 400E/EL is a solid state, average responding, rms calibrated voltmeter. It also has applications as an ac to dc converter and a wide band amplifier. Figure 4-1 shows a simplified block diagram of the instrument.

4-3. When relay K1 is closed, the input is not attenuated; when K1 is open and K2 is closed, the input is attenuated by 50 dB. On the 0.001 through 1 volt ranges, K1 is closed and K2 is open. K2 is closed and K1 is open on the 3 through 300 volt ranges. The entire Input Attenuator assembly is shielded, and the relays are operated remotely by voltages applied through the RANGE switch. Variable capacitor A1C2 is adjusted on the 3 volt range with a 3 volt 100 kHz input in order to shape the frequency response of the Input Attenuator.

4-4. The signal from the input attenuator is applied to the impedance converter. The impedance converter is a unity gain, feedback stabilized amplifier that matches the high impedance of the Input Attenuator to the much lower impedance of the Post Attenuator.

4-5. The Post Attenuator attenuates the output of the Impedance Converter by 10dB for each step of the RANGE switch. On the 3 volt range, the Post

Attenuator is switched back to the 30dB position, and then it attenuates 10dB per step on the higher ranges. Variable capacitor S2C2 is adjusted on the .003 volt range with a 3mV, 8MHz input to adjust the 8MHz response of the .003 volt range. With a full scale input on any range except the .001 volt range, the output of the Post Attenuator should be 3mV. On the .001 volt range, the output should be 1mV.

4-6. The Meter Amplifier is a four-stage, high-gain amplifier utilizing both ac and dc feedback for gain stabilization. The Meter Bridge, connected in the ac feedback path of the meter amplifier, converts the ac output of the amplifier to a dc voltage proportional to its average value. This dc voltage drives the meter. A2C28 and A2R38 adjust the gain of the amplifier so that the meter will read rms volts. A2R38 is adjusted at 400Hz, and A2C28 is adjusted at 10MHz.

4-7. The DC Output is a 0-1 volt level that is proportional to meter deflection. R2 is adjusted to calibrate the dc output. The AC Amplifier samples the ac feedback and generates 0 to 150mV ac output that is directly proportional to meter deflection.

4-8. **SCHEMATIC DESCRIPTION.**
(See Figure 7-1).

4-9. **IMPEDANCE CONVERTER.**

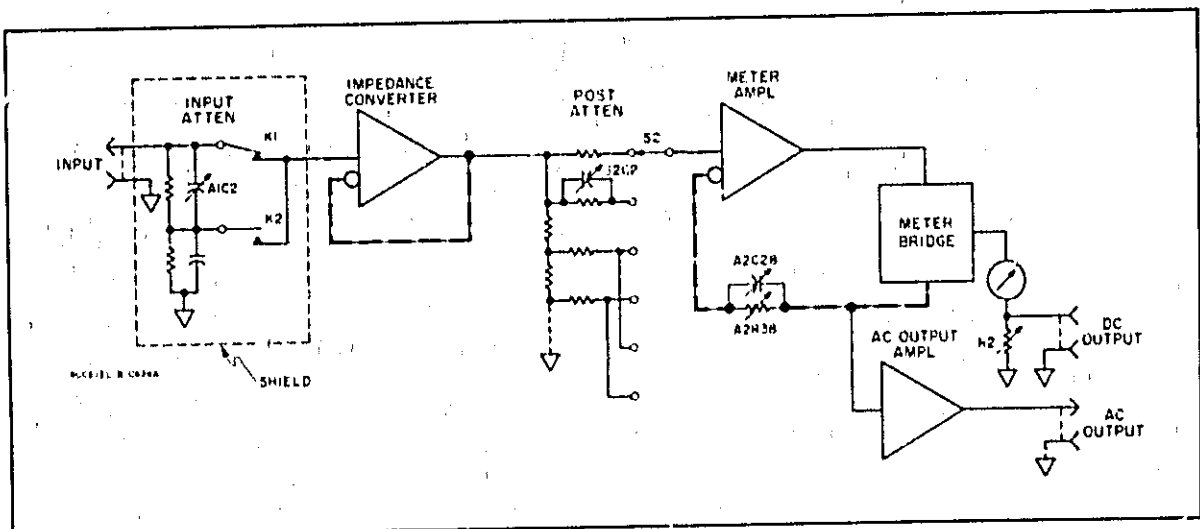

Figure 4-1. Simplified Block Diagram

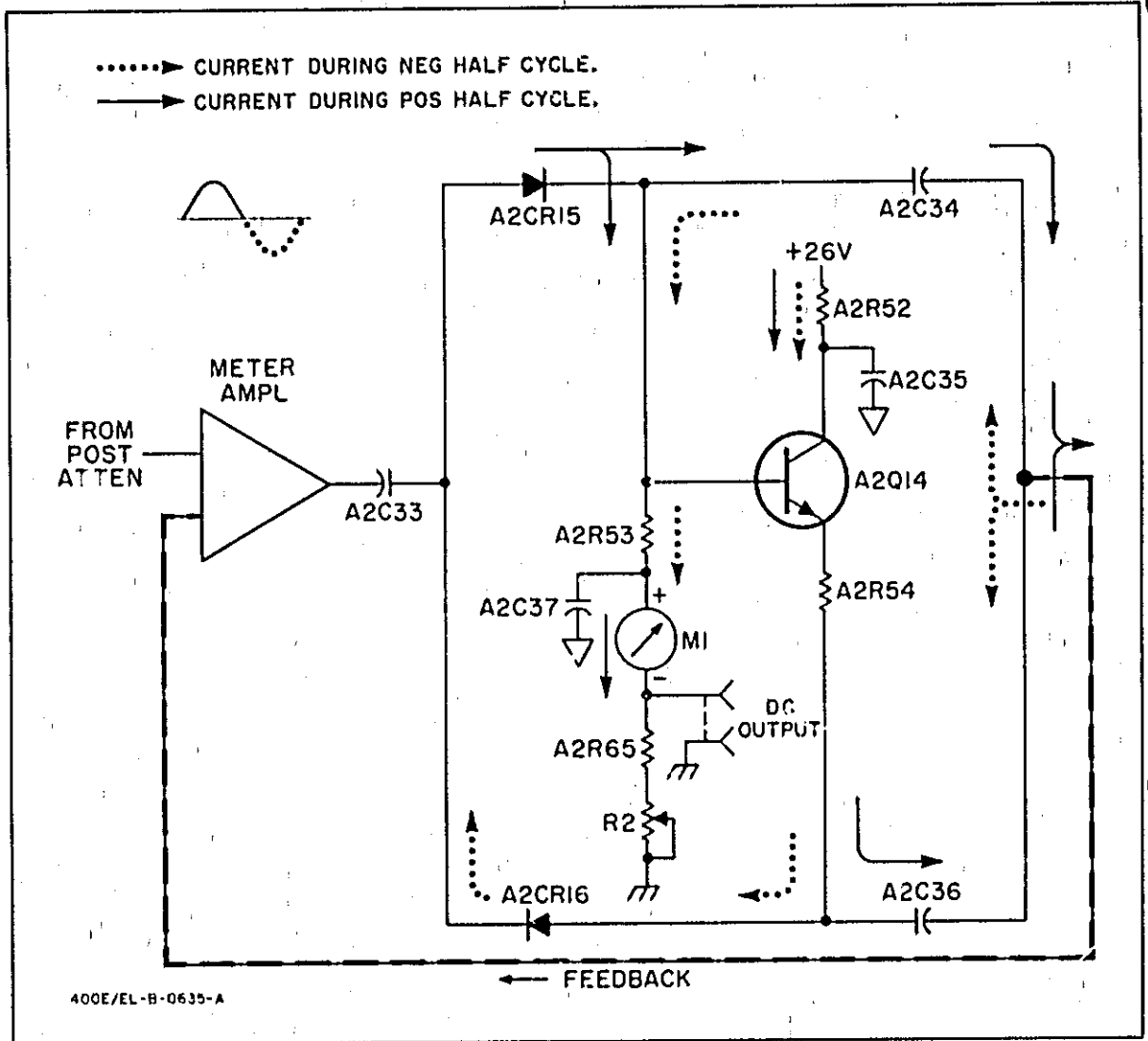

Figure 4-2. Meter Bridge

4-10. The impedance converter, located on the main voltmeter board (A2), matches the high impedance of the input attenuator to the relatively low impedance of the Post Attenuator. Breakdown diodes A2CR17 and A2CR18 bias diodes A2CR9 and A2CR10 at +5 and -5 volts respectively. A2CR9 and A2CR10 limit the input to 10 volts peak-to-peak, providing overload protection. Breakdown diodes A2CR20 and A2CR21 stabilize the bias voltages on A2Q5. Fuse A2F1 protects the instrument against destructive overloads.

4-11. A field-effect transistor (A2Q5) is used in the input stage of the impedance converter because of its characteristically high input impedance and good frequency response. A2R17 adjusts the dc bias of the

impedance converter. The output is taken from the emitter circuit of A2Q7 and applied to the post attenuator and then applied to the meter amplifier. The solid black lines on the schematic show the signal path, and the broken lines show the feedback paths.

4-12. METER AMPLIFIER.

4-13. The meter amplifier amplifies its input signal by a fixed gain in all ranges except the .001 volt range. The amplifier itself is a four-stage, dc coupled amplifier with a cascade-coupled final stage (A2Q12 and A2Q13). DC feedback is coupled from the emitter of A2Q12 back to the base of A2Q9. Breakdown diodes A2CR12, A2CR13 and A2CR14 establish fixed dc bias levels in the amplifier.

4-14. The output from the collector of A2Q13 is coupled through the Meter Bridge and fed back to the emitter of A2Q9. A2C28 in the feedback circuit adjusts the amount of feedback at the high end of the frequency range, and A2R38 adjusts the feedback at the low end. This calibrates the amplifier gain at both ends of the frequency range. A2R44, 45 and 72 are switched into the feedback circuit on the 0.001 volt range, boosting the gain on that range. A2R44 adjusts the gain on the 1mV range with a 400Hz input. A2R31 adjusts the dc bias level of the amplifier.

4-15. METER BRIDGE.

4-16. Figure 4-2 shows a partial schematic of the Meter Bridge. The meter bridge rectifies the ac amplifier output and supplies the dc current to drive the meter. In order to use part of the meter bridge output as the rear terminal dc output, the meter has to be referenced to ground. Transistor A2Q14 references the meter to ground.

4-17. During the positive half cycle, A2CR15 conducts. Part of the current (solid line) goes through A2C34 into the feedback path, and part of the current goes through A2R53 and the meter to ground. The current through A2R53 turns on A2Q14, and A2Q14 draws current from the positive supply. The current from A2Q14 goes through A2C36 into the feedback path. The current through A2Q14 and A2C36 is equal to the current drawn through the meter, so the current out of the bridge is equal to the current into the bridge.

4-18. During the negative half cycle, A2CR16 conducts and draws current from the feedback path (dotted line). Part of the current goes through A2C36

and A2CR16 into the amplifier, and part goes through A2R53 and the meter to ground. The current through A2R53 turns on A2Q14, and the current from A2Q14 goes through A2R54 and A2CR16 to the amplifier. Again the current through the meter equals the current through A2R54, and the current into the bridge equals the current out.

4-19. Transistor A2Q14 replaces current drawn by the meter, so the meter bridge is kept floating while the meter is referenced to ground. The dc output, taken across A2R65 and R2, is also referenced to ground.

4-20. AC OUTPUT CIRCUIT.

4-21. The ac output circuit isolates the meter bridge and amplifier from the ac output load. It consists of two emitter followers (A2Q15 and Q16) connected in cascade. A2R59 in the base circuit of A2Q15 zeroes the output dc level at the ac output.

4-22. POWER SUPPLY.

4-23. The power supply produces regulated +26 volts and -26 volts. Breakdown diode A2CR7 establishes a reference voltage of 6.98 volts. Part of the power supply output is applied to the base of A2Q2, and A2Q2 senses the difference between the supply output and the reference. If the output voltage changes, the emitter to base voltage of A2Q2 will change, and the output of A2Q2 will change the current through A2Q1, the regulator.

4-24. The negative regulator, A2Q3 and A2Q4, uses the +26 volt output as a reference. Consequently, the negative supply is dependent upon the positive supply.

MAINTENANCE

WARNING

Maintenance described herein is performed with power supplied to the instrument, and protective covers removed. Such maintenance should be performed only by service-trained personnel who are aware of the hazards involved (for example, fire and electrical shock). Where maintenance can be performed without power applied, the power should be removed.

Table 5-1. Required Test Equipment

INSTRUMENT TYPE	REQUIRED SPECIFICATIONS	RECOMMENDED MODEL
AC Calibrator	Accuracy: 0.022% to 0.205% Voltage Ranges: 0.1mV to 300V Frequency Range: 10Hz to 110kHz	-hp- Model 745A/746A AC Calibrator
Test Oscillator	Frequency Range: 10Hz to 10MHz Output: 3.0 volts rms max. Distortion: less than 1% Frequency Response: adjustable to 0.25% (652A)	-hp- Model 651B or 652A Test Oscillator
AC/DC Voltmeter	Range: 0 to 100 volts Sensitivity: 100 microvolts Accuracy: greater than 0.1%	-hp- Model 3450B Multi-Function Meter with Option 001
DC Null Meter	Range: ± 3 microvolts full scale to 10mV full scale Accuracy: 2% of full scale	-hp- Model 419A DC Null Voltmeter
Thermal Converters	a. Input: 3 volts rms, R = 200 ohms/volt Output: 7mV/dc b. Input: 1 volt ac/1.045 volt rms Output: 7mV/dc Accuracy: 0.2% or better Frequency Range: dc to 10MHz	a. -hp- Model 1102-11049A (600 ohms input) b. -hp- Model 11050A and 11051A Thermal Converters (50 ohms input)
DC Standard	Output: Adjustable to 0.45V, 1V and 3V Accuracy: 0.1% or better	-hp- Model 740B DC Standard Differential Voltmeter
0-10 MV Reference Supply	See Figure 5-2 for schematic. a. Resistor: fxd. 6500 ohms $\pm 1\%$ b. Resistor: var. 500 ohms $\pm 5\%$, 10-turn c. Resistor: var. 50 ohms $\pm 5\%$, 10-turn d. Battery: 1.34 volts	a. -hp- Part No. 0811-0392 b. -hp- Part No. 2100-0324 c. -hp- Part No. 2100-1481 d. Mallory RM-42R
AC/DC Voltmeter Ohmmeter	Accuracy: $\pm 3\%$ Input Capacity: ≤ 1.5 pF Input Impedance: ≥ 10 M Ω	-hp- Model 410C Electronic Voltmeter
Resistors	Fxd. 100 kilohms $\pm 1\%$ Fxd. 1 kilohm $\pm 1\%$ Var. 15 kilohms, ww $\pm 5\%$, 10-turn	-hp- Part No. 0757-0465 -hp- Part No. 0757-0280 -hp- Part No. 2100-0896
Voltmeter Calibrator	Voltage Accuracy: $\pm 0.25\%$ at 400Hz Output: 0 to 3 volts	-hp- Model 738BR Voltmeter Calibrator
Termination	Feed-through, 50 ohm impedance	-hp- Model 11048C 50 ohm Feed-through Termination
Coaxial Attenuators	50 dB attenuation ± 0.01 dB dc to 10 MHz 40 dB attenuation ± 0.01 dB dc to 10 MHz	Wenschel Engineering Models 50-40S and 50-50S Coaxial Attenuators
Wideband AC Voltmeter	Frequency Range: 10 Hz to 1 MHz Accuracy: Greater than $\pm 1\%$	-hp- Model 3403C True RMS Voltmeter

SECTION V MAINTENANCE

5-1. INTRODUCTION.

5-2. This section contains information necessary to maintain the Model 400E/EL. The following paragraphs describe the Performance Checks, the Calibration Procedures, and the Troubleshooting Procedures.

5-3. REQUIRED EQUIPMENT.

5-4. Table 5-1 is a list of the equipment required to properly maintain the Model 400E/EL. If the model recommended in Table 5-1 is not available, a substitute may be used as long as it meets the required specifications.

5-5. MECHANICAL ZERO ADJUST (400E Only).

5-6. Before any performance checks or calibration is begun, complete the mechanical zero adjustment in the following steps:

- a. Be sure the meter has been off for at least one minute, or momentarily short the meter terminals.
- b. Rotate mechanical adjustment screw **CLOCKWISE** until meter pointer is to the left of zero and moving upscale toward zero.
- c. Continue to rotate adjustment screw clockwise. **STOP** when needle is exactly on zero. If needle overshoots, repeat step b.
- d. When pointer is exactly over zero, rotate adjustment screw slightly **COUNTERCLOCKWISE** to relieve tension on suspension. If the pointer moves to the left, repeat whole procedure, but make counterclockwise rotation less.

5-7. PERFORMANCE CHECKS.

5-8. The performance checks are "in cabinet" tests that compare the 400E/EL with its specifications. These procedures can be used both for incoming inspection and periodic inspection. The performance checks should be conducted before any attempt is made to calibrate the instrument. A Performance Check Test Card is provided at the end of this section for recording the performance of the instrument during the performance checks. The card can be removed from the manual and used as a permanent record of the incoming inspection or of a routine performance check.

5-9. ACCURACY AND FREQUENCY RESPONSE TESTS.

5-10. The accuracy and frequency response tests compare the Model 400E/EL with its accuracy specifications. Three methods are given in the following paragraphs. Any one of the three procedures can be used dependent upon the test equipment available and the desired accuracy to which the 400E/EL is to be checked. The procedure using the hp-745A AC Calibrator and the 746A Amplifier is the simplest and most accurate for all voltages at frequencies from 10Hz to 110kHz. From 110kHz to 10MHz, the 652A Test Oscillator can be used for the 3 and 1 volt ranges with an accuracy of 0.25% (0.75% for lower ranges). The Thermal Converter Method is more time consuming and subject to burn-out! but it has an accuracy uncertainty of 0.04% to 0.18%. The E02-738BR can be used to check all ranges at 400Hz to a minimum of .3 millivolts. The accuracy at 400Hz is 0.2% at 300 volts and 0.3% using the attenuator. The frequency response can be checked with a maximum of 3 volts with the 652A Test Oscillator. The 654A Test Oscillator can be used below 1 volt output from 10Hz to 10MHz with a flatness of 0.5%. This flatness is without adjusting the amplitude at each change of frequency.

5-11. Accuracy Check from 10Hz to 110kHz.

5-12. The test setup in Figure 5-1 uses the 745A AC Calibrator System. This calibrator can produce any voltage level from 0.1mV to 100 volts in a seven digit readout for frequencies from 10Hz to 110kHz. The accuracy is from 0.022% to 0.205%. The 746A Amplifier can be used for voltages above 100 volts with the same accuracy.

NOTE

For optimum performance, let the 400E/EL and the 745A/746A warmup for at least one-half hour.

- a. Place the 400E/EL on the 3 volt range and position the 745A to read 3.00000 volts at 400Hz.
- b. Connect the test setup as shown in Figure 5-1. Set the 745A SENSE switch to LOCAL, or if more accuracy is desired place the SENSE switch to REMOTE and connect the sense terminals to the input of the 400E/EL.

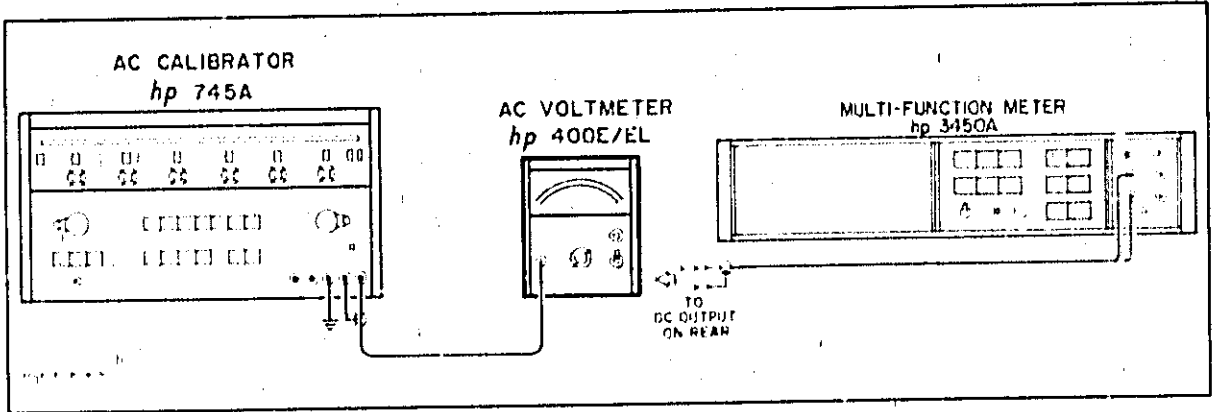

Figure 5-1. Accuracy Test Setup

- c. Set the error range to X1 and turn the marker to zero position. Read the dc output on the digital voltmeter. The dc output should read within the tolerances listed in Table 5-2. With some test setups, it may be necessary to connect a 500 microfarad capacitor across the 400E/EL output to obtain the required resolution at 10 Hz.
 - d. Adjust the 745A error control until the 400E/EL reads exactly the applied voltage. Read the 400E/EL error directly in % from the 745A. Where the meter error exceeds $\pm 3\%$, return the 745A error control to zero, bring the 400E/EL to the required reading with the 745A voltage controls and calculate the error. Any error should be within the tolerance listed in Table 5-2 under Meter.
 - e. Repeat steps c and d for each 745A frequency and voltage listed in Table 5-2 and 5-3. Connect the precision 40 dB attenuator between the 745A and the 400E/EL to calibrate the 1 mV and 3 mV ranges. If the 400E/EL is not within the tolerances listed in Table 5-2 and 5-3 refer to Paragraph 5-32 Alignment and Calibration Procedure.
- c. Change the frequency to those in Table 5-2 and 5-3. Adjust the 652A AMPLITUDE control until 0 is read on the expanded scale of the meter. The dc output of the 400E/EL should be within tolerances listed in Table 5-2 or 5-3 for range, voltage and frequency settings. Change the fine adjust on the 652A until the 400E/EL meter reads exactly the voltage applied. Read error on the 652A Meter. Where the meter error exceeds $\pm 2.5\%$, readjust the 652A AMPLITUDE control for 0 on the expanded scale of the meter and read the error on the 400E/EL. The error should be within the tolerances listed in Table 5-2 and 5-3 for range, voltage and frequency settings. If out of tolerance refer to Paragraph 5-32 Alignment and Calibration Procedure.

NOTE

For accuracy of voltage tracking not listed in Table 5-2 and 5-3 refer to the Accuracy Graphs Table 5-4. Obtain the percentage of accuracy from the specifications Table 1-1. Select the proper graph for the percentage of accuracy. Find the point on the curve for any tracking point from full scale to less than 1/3 full scale. Horizontally locate the error in percent of reading.

5-13. Frequency Response Check from 110kHz to 10MHz.

- a. For frequencies from 110kHz to 10MHz adjust the 652A (using the 50 ohm output and a 50 ohm load) to the same reading on the 400E/EL at 1kHz as read with the 745A. 3 and 1 volt only can be used on the expanded scale. (3 and 1 volt can be attenuated by the 652A range switch at less accuracy.)
- b. Turn the 652A to the expanded scale and adjust the REF SET control for 0% or 0dB.

5-14. Accuracy Check Using Thermal Converters.

5-15. The test setup in Figure 5-2 uses a thermal converter with a null circuit to adjust the frequency response of the test oscillator to within 0.2% over its entire band. Construct the 0 to 10mV Reference Supply shown in Figure 5-2 and allow it at least 24 hours to stabilize.

Table 5-2. Accuracy Tolerances

Frequency (Hz)	3 Volt Range			1 Volt Range Δ		
	Voltage Input	Meter (% of reading)	DC OUTPUT (Volts)	Voltage Input	Meter (% of reading)	DC OUTPUT (Volts)
10	3	3.00 \pm 5%	0.949 \pm 0.047	1.0	1.00 \pm 5%	1.00 \pm 0.05
	2	2.00 \pm 6.3%	0.633 \pm 0.040	0.5	0.50 \pm 7.5%	0.50 \pm 0.038
	1	1.00 \pm 19%	0.316 \pm 0.032	0.3	0.30 \pm 10.8%	0.30 \pm 0.033
40	3	3.00 \pm 1%	0.949 \pm 0.010	1.0	1.00 \pm 1%	1.00 \pm 0.010
	2	2.00 \pm 1.5%	0.633 \pm 0.010	0.5	0.50 \pm 2%	0.50 \pm 0.010
	1	1.00 \pm 3%	0.316 \pm 0.01	0.3	0.30 \pm 3.3%	0.30 \pm 0.010
100 or 400	3	3.00 \pm 1%	0.949 \pm 0.010	1.0	1.00 \pm 1%	1.00 \pm 0.01
	2	2.00 \pm 1.5%	0.633 \pm 0.010	0.5	0.50 \pm 2%	0.50 \pm 0.01
	1	1.00 \pm 3%	0.316 \pm 0.010	0.3	0.30 \pm 3.3%	0.30 \pm 0.01
500k	3	3.00 \pm 1%	0.949 \pm 0.010	1.0	1.00 \pm 1%	1.00 \pm 0.01
	2	2.00 \pm 1.5%	0.633 \pm 0.010	0.5	0.50 \pm 2%	0.50 \pm 0.01
	1	1.00 \pm 3%	0.316 \pm 0.010	0.3	0.30 \pm 3.3%	0.30 \pm 0.01
1 M	3	3.00 \pm 1%	0.949 \pm 0.010	1.0	1.00 \pm 1%	1.00 \pm 0.01
	2	2.00 \pm 1.5%	0.633 \pm 0.010	0.5	0.50 \pm 2%	0.50 \pm 0.01
	1	1.00 \pm 3%	0.316 \pm 0.010	0.3	0.30 \pm 3.3%	0.30 \pm 0.01
4 M	3	3.00 \pm 3%	0.949 \pm 0.029	1.0	1.00 \pm 3%	1.00 \pm 0.03
	2	2.00 \pm 3.8%	0.633 \pm 0.024	0.5	0.50 \pm 4.5%	0.50 \pm 0.023
	1	1.00 \pm 6%	0.316 \pm 0.019	0.3	0.30 \pm 6.5%	0.30 \pm 0.020
10 M	3	3.00 \pm 5%	0.949 \pm 0.0475	1.0	1.00 \pm 5%	1.00 \pm 0.05
	2	2.00 \pm 6.5%	0.633 \pm 0.0411	0.5	0.50 \pm 8%	0.50 \pm 0.04
	1	1.00 \pm 15%	0.316 \pm 0.0348	0.3	0.30 \pm 12%	0.30 \pm 0.036

Δ These tolerances can also be used on the following ranges: 10 mV, 100 mV.

NOTE

The test oscillator used must have very low distortion (less than 1%). A thermal converter and an average responding circuit react differently to distortion, and any distortion present would create a calibration error.

5-16. Reference Supply Calibration.

5-17. Use the following procedure to calibrate the thermal converter and reference supply.

- Connect the dc standard, the 400E/EL, the null voltmeter, the reference supply, and a 3 volt thermal converter (H02-110-49A with 600 ohm input impedance) as shown in

Figure 5-2. Set switch S1 to position A connecting the dc standard output to the thermal converter input. The reference supply and the thermal converter are sensitive to variations in ambient temperature. Ensure that the ambient temperature variations are less than $\pm 2.0^\circ$ C.

NOTE

If a 400E/EL Option 02 instrument is used, set the REL. REF adjustment to the fully clockwise ABSOLUTE position before making accuracy check.

- Set the dc standard output to +3.000 volts dc.

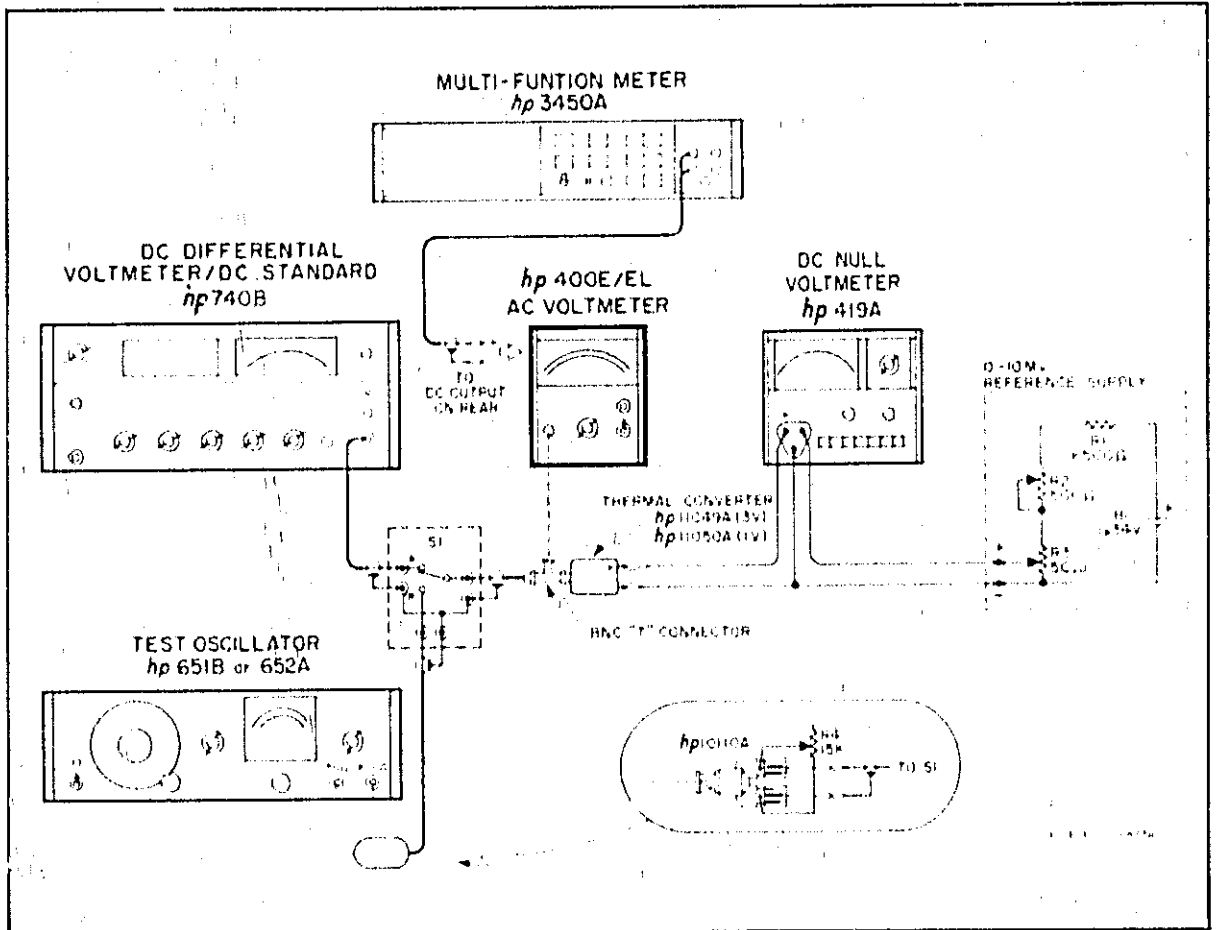

Figure 5-2. Accuracy and Frequency Response Test Setup

Table 5-3. Calibration Tolerances

Frequency (Hz)	1 Millivolt Range Only.			Frequency (Hz)	1 Millivolt Range Only.		
	Voltage Input	Meter (mV) (% of reading)	DC Output (Volts)		Voltage Input	Meter (mV) (% of reading)	DC Output (Volts)
10	1.00mV	1.00 ± 5%	1.00 ± 0.05	100k	1.00mV	1.00 ± 1%	1.00 ± 0.005
	0.5mV	0.50 ± 7.6%	0.50 ± 0.038		0.5mV	0.50 ± 2%	0.50 ± 0.0045
	0.3mV	0.30 ± 10.8%	0.30 ± 0.033		0.3mV	0.30 ± 3.3%	0.30 ± 0.0043
40	1.00mV	1.00 ± 1%	1.00 ± 0.02	500k	1.00mV	1.00 ± 1%	1.00 ± 0.02
	0.5mV	0.50 ± 2%	0.50 ± 0.015		0.5mV	0.50 ± 2%	0.50 ± 0.015
	0.3mV	0.30 ± 3.3%	0.30 ± 0.013		0.3mV	0.30 ± 3.3%	0.30 ± 0.013
100 or 400	1.00mV	1.00 ± 1%	1.00 ± 0.005	4M	1.00mV	1.00 ± 5%	1.00 ± 0.05
	0.5mV	0.50 ± 2%	0.50 ± 0.0045		0.5mV	0.50 ± 7.6%	0.50 ± 0.038
	0.3mV	0.30 ± 3.3%	0.30 ± 0.0043		0.3mV	0.30 ± 10.8%	0.30 ± 0.033

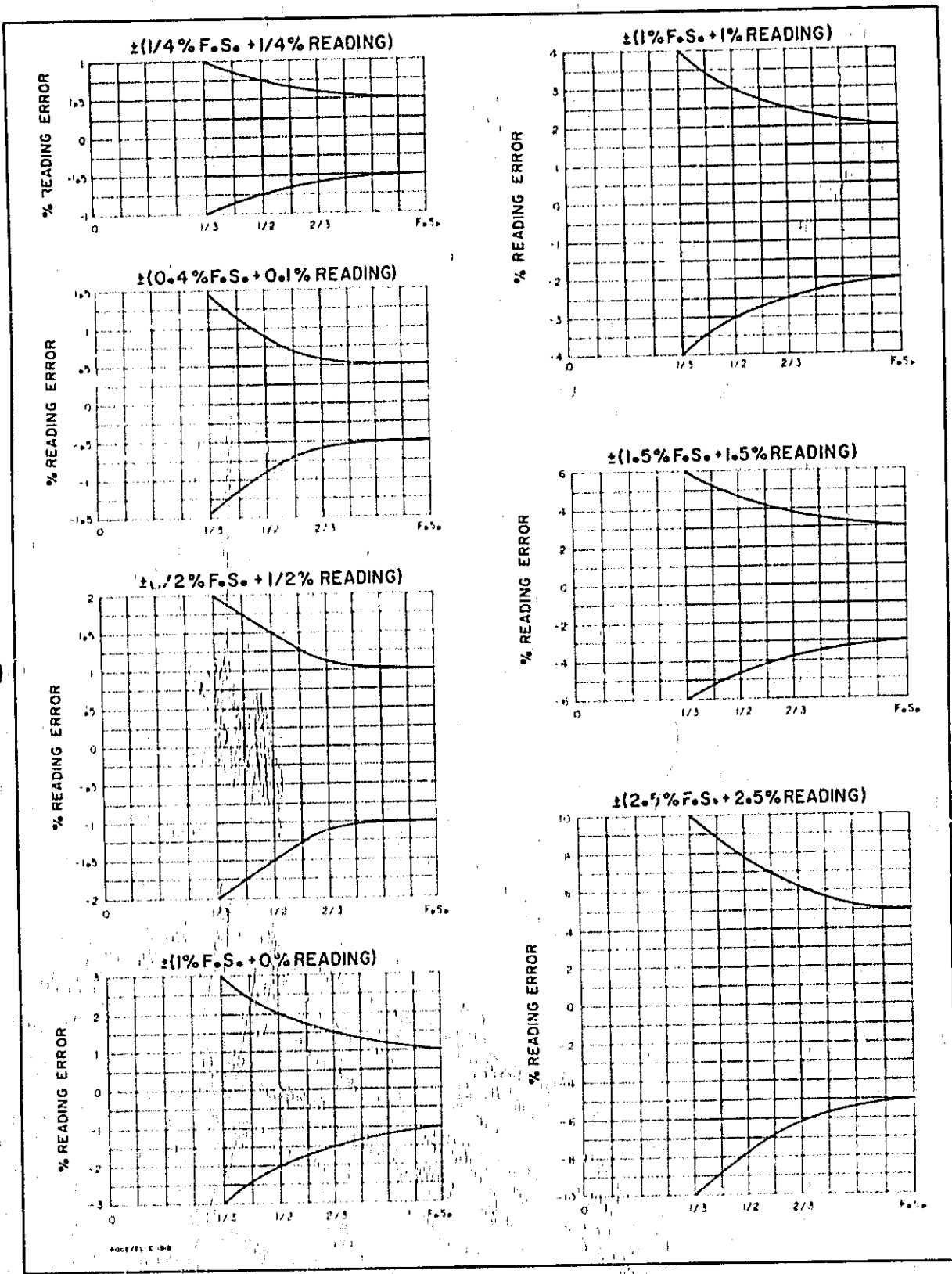

Table 5-4. Calibration Accuracy Graphs

- c. Using the null voltmeter, adjust the reference supply until its output is within ± 1.5 microvolts of the thermal converter output.

5-18. 3 Volt and 1 Volt Accuracy Test.

5-19. Check the 400E/EL accuracy and frequency response on the 3 volt and 1 volt ranges according to the following steps.

CAUTION

SET TEST OSCILLATOR OUTPUT TO MINIMUM BEFORE CONNECTING. REDUCE OSCILLATOR OUTPUT BEFORE CHANGING FREQUENCY RANGE. DO NOT ALLOW OSCILLATOR OUTPUT TO EXCEED RATED INPUT OF THERMAL CONVERTER. ANY OVERLOAD MAY DESTROY THERMAL CONVERTER.

- Set switch S1 in Figure 5-2 to position B, connecting the test oscillator's 600 ohm output to the thermal converter input. Connect the digital voltmeter to the 400E/EL DC OUTPUT terminals.
- Set the 400E/EL Range Switch to 3 volts and set the oscillator frequency to 10Hz. Connect the BNC "T" connector directly to the 400E/EL INPUT.
- Using the oscillator amplitude control as coarse adjustment and resistor R4 (Figure 5-2) as fine adjustment, increase the oscillator amplitude until the thermal converter output nulls the reference supply. Observe the 400E/EL meter indication and dc output.
- Repeat step c for each frequency listed in Table 5-2. If the 400E/EL is within specifications, the meter indication and the dc output will be within the tolerances listed in Table 5-2.
- Recalibrate the 10mV reference supply according to the procedure in Paragraph 5-17 using a 1 volt thermal converter and a 1 volt output from the dc standard.

- Repeat steps a through d in this paragraph using the one volt thermal converter and the 50 ohm output of the test oscillator. Set the 400E/EL to the 1 volt range.

5-20. Range Tracking Test.

5-21. The range tracking test checks the accuracy of the 400E/EL with a $1/3$ scale input over its entire frequency range.

5-22. After verifying the full scale calibration with the accuracy test in Paragraph 5-19, check the range tracking with the following procedures.

- Recalibrate the 10mV reference supply according to the procedure in Paragraph 5-17. Use a 600 ohm input, 3 volt thermal converter and 3 volt output from the dc standard.

CAUTION

SET TEST OSCILLATOR OUTPUT TO MINIMUM BEFORE CONNECTING. REDUCE OSCILLATOR OUTPUT BEFORE CHANGING FREQUENCY RANGE. DO NOT ALLOW OSCILLATOR OUTPUT TO EXCEED RATED INPUT OF THERMAL CONVERTER. ANY OVERLOAD MAY DESTROY THERMAL CONVERTER.

- Set S1 in Figure 5-2 to position B, connecting the test oscillator 600 ohm output to the thermal converter input. Connect the digital voltmeter to the 400E/EL DC OUTPUT terminals.
- Set the 400E/EL switch to 10 volts and the oscillator to 10Hz. Connect the BNC "T" connector directly to the 400E/EL INPUT.
- Using the oscillator amplitude control as coarse adjustment and resistor R4 as a fine adjustment, set the oscillator output so that the thermal converter output nulls the reference supply output.
- Repeat step d for each frequency listed in Table 5-2. If the 400E/EL is within specifications, the meter indication and the dc output will be within the tolerances listed in the table.

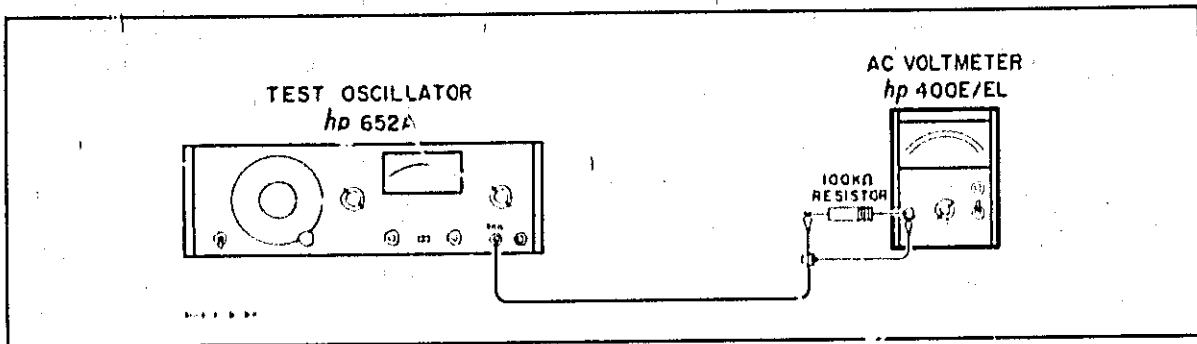

Figure 5-3. Input Impedance Check

- f. Repeat steps a through e in this paragraph using a 50 ohm input, 1 volt thermal converter and a +1.000 volt dc output from the dc standard. Set the 400E/EL to the 3 volt range and use the 50 ohm output of the test oscillator.

5-23. 3mV and 1mV Range Accuracy Test.

- a. Recalibrate the 10mV reference supply according to the procedures in Paragraph 5-17 using a 0.45 volt thermal converter and a 0.3000 volt output from the dc standard.
- b. Set S1 in Figure 5-2 to position B, connecting the test oscillator output to the thermal converter input. Connect the digital voltmeter to the 400E/EL DC OUTPUT terminals.

CAUTION

SET TEST OSCILLATOR OUTPUT TO MINIMUM BEFORE CONNECTING. REDUCE OSCILLATOR OUTPUT BEFORE CHANGING FREQUENCY RANGE. DO NOT ALLOW OSCILLATOR OUTPUT TO EXCEED RATED INPUT OF THERMAL CONVERTER. ANY OVERLOAD MAY DESTROY THERMAL CONVERTER.

- c. Set the 400E/EL RANGE switch to 3 millivolts (.003 volts) and the oscillator to 10Hz. Connect a precision 40dB coaxial attenuator between the BNC "T" connector and the 400E/EL INPUT.
- d. Using the oscillator amplitude control as coarse adjustment and resistor R4 as a fine

adjustment, set the oscillator output so that the thermal converter output nulls the reference supply output.

- e. Repeat step d for each frequency listed in Table 5-2. If the 400E/EL is within specifications, the meter indication and the dc output will be within the tolerances listed in the table.
- f. Recalibrate the 10mV reference supply according to the procedures in Paragraph 5-17 using a 0.45 volt thermal converter and a 0.3162 volt output from the dc standard.

CAUTION

SET TEST OSCILLATOR OUTPUT TO MINIMUM BEFORE CONNECTING. REDUCE OSCILLATOR OUTPUT BEFORE CHANGING FREQUENCY RANGE. DO NOT ALLOW OSCILLATOR OUTPUT TO EXCEED RATED INPUT OF THERMAL CONVERTER. ANY OVERLOAD MAY DESTROY THERMAL CONVERTER.

- g. Set the 400E/EL RANGE switch to .001 volts and set the test oscillator to 10Hz. Connect a precision coaxial 50dB attenuator between the BNC "T" and the 400E/EL INPUT.
- h. Using the oscillator amplitude control as coarse adjustment and resistor R4 (Figure 5-2) as fine adjustment, increase the oscillator amplitude until the thermal converter output nulls the reference supply. Observe the 400E/EL meter indication and dc output.

- i. Repeat step h for each frequency listed in Table 5-3. If the 400E/EL is within specifications, the meter indication and the dc output will be within the tolerances listed in Table 5-3.
- j. Place the 400E/EL RANGE switch to .003V and repeat step h at 1/3 scale using the frequencies listed in Table 5-2.

—————NOTE—————

Refer to paragraph 5-46 for an alternate calibration accuracy check.

5-24. INPUT IMPEDANCE CHECK.

5-25. Input Resistance Check.

- a. Connect the 50 ohm output of the test oscillator to the input of the 400E/EL.
- b. Set the test oscillator and the 400E/EL to the 3 volt range. Set the oscillator output to 40Hz, and adjust the output for a full scale indication.
- c. Connect a 100 kilohm resistor between the test oscillator output and the 400E/EL input as shown in Figure 5-3.
- d. The 400E/EL indication should not drop more than one small scale division from full scale. This verifies an input resistance of 10 megohms.

5-26. Input Capacity Check.

- a. Connect a test oscillator, a 100 kilohm resistor, and the 400E/EL as shown in Figure 5-3. Insert the resistor lead directly into the BNC connector on the 400E/EL, and connect the ground lead to the outer shield of the 400E/EL input connector. Do not use an adapter, as any adapter will add input capacity.
- b. With the 400E/EL on the 3 volt range, adjust the test oscillator for 3 volt reading on the 400E/EL at 40Hz.
- c. Increase the test oscillator frequency until the 400E/EL indication drops to 2.12 volts. This should occur at a frequency of 132kHz or greater, verifying an input capacity of 12pF or less on the 3 volt range.

- d. Repeat steps a and b with the 400E/EL on the 1 volt range.
- e. Increase the test oscillator frequency until the 400E/EL indication drops to 0.707 volts. This should occur at a frequency of 63.5kHz or greater, verifying an input capacity of 25pF or less on the 1 volt range.

5-27. AC TO DC CONVERTER OUTPUT IMPEDANCE CHECK.

5-28. Proceed as follows:

- a. Connect an -hp- 651B or 652A Test Oscillator through a 50 ohm load to the input of the 400E/EL.
- b. Connect a dc digital voltmeter to the dc output of the 400E/EL located on the rear panel. Set the 400E/EL to the 3 volt RANGE.
- c. Set the oscillator frequency to 100kHz and the OUTPUT ATTENUATOR to 3 volts.
- d. Adjust the oscillator amplitude to read 1.000 vol on the digital voltmeter at the dc output.
- e. Place a 1000 ohm $\pm 1\%$ metal film resistor (-hp- part number 0757-0280) across the dc output of the 400E/EL. The voltage should read between 0.475 and 0.525 volts. This verifies that the dc output impedance is 1000 ohms $\pm 5\%$.

5-29. AC OUTPUT VOLTAGE CHECK.

5-30. Proceed as follows:

- a. Connect an oscillator (651B or 652A) to the input of the 400E/EL through a 50 ohm load. Connect an ac digital voltmeter (-hp- 3403C) to the ac output of the 400E/EL.
- b. Place the 400E/EL and the oscillator on the one volt range.
- c. Adjust the oscillator's amplitude for full scale deflection on the 400E/EL meter. The ac digital voltmeter should read 150 mV $\pm 10\%$ from 10 Hz to 4 MHz.
- d. Decrease the range of the oscillator and 400E/EL to 100 mV and 10 mV, repeating Step c for each voltage.

- e. Place the oscillator and the 400E/EL on the 1 mV range. Increase the oscillator's amplitude for full scale deflection on the 400E/EL meter. The ac digital voltmeter should read $105\text{mV} \pm 10\%$.

5-31. CONCLUSION OF PERFORMANCE CHECKS.

NOTE

When the 400E/EL has passed these checks it has met its specifications listed in Table 1-1.

5-32. ALIGNMENT AND CALIBRATION PROCEDURE.

NOTE

The location of adjustments on A2 depends on the applicable board revision (see Pages 7-2 and 7-3).

5-33. The calibration adjustments are "cover off" procedures to adjust the 400E/EL to its performance specifications. If the instrument cannot be properly adjusted, refer to the Troubleshooting Procedures (Paragraph 5-18). Figure 5-4 shows the location of all the internal adjustments.

5-34. COVER REMOVAL.

5-35. To remove the top or bottom covers, remove the Phillips screws holding the cover, slide the cover about 1 inch to the rear, and lift it off. To replace the cover, reverse the removal procedure. If it is necessary to remove a side cover, remove the four Phillips screws and lift it off.

NOTE

Connect a dc voltmeter to TP1. The voltage should be $+26 \pm 2\text{V}$. Connect a dc voltmeter to TP2. The voltage should read $-26 \pm 2\text{V}$. If these voltages are not correct refer to Troubleshooting Paragraph 5-18.

5-36. BIAS ADJUST.

5-37. Connect a dc voltmeter to TP3 and adjust A2R17 for $-6.0 \pm 0.25\text{Vdc}$. Connect a dc voltmeter to TP4 and adjust A2R31 for $+10.0 \pm 1\text{Vdc}$.

5-38. AC OUTPUT ZERO.

5-39. Connect a dc voltmeter to TP5 and adjust A2R59 for $0.0 \pm 0.050\text{Vdc}$.

5-40. CALIBRATION.

NOTE

If a 400E/EL Option 02 is to be

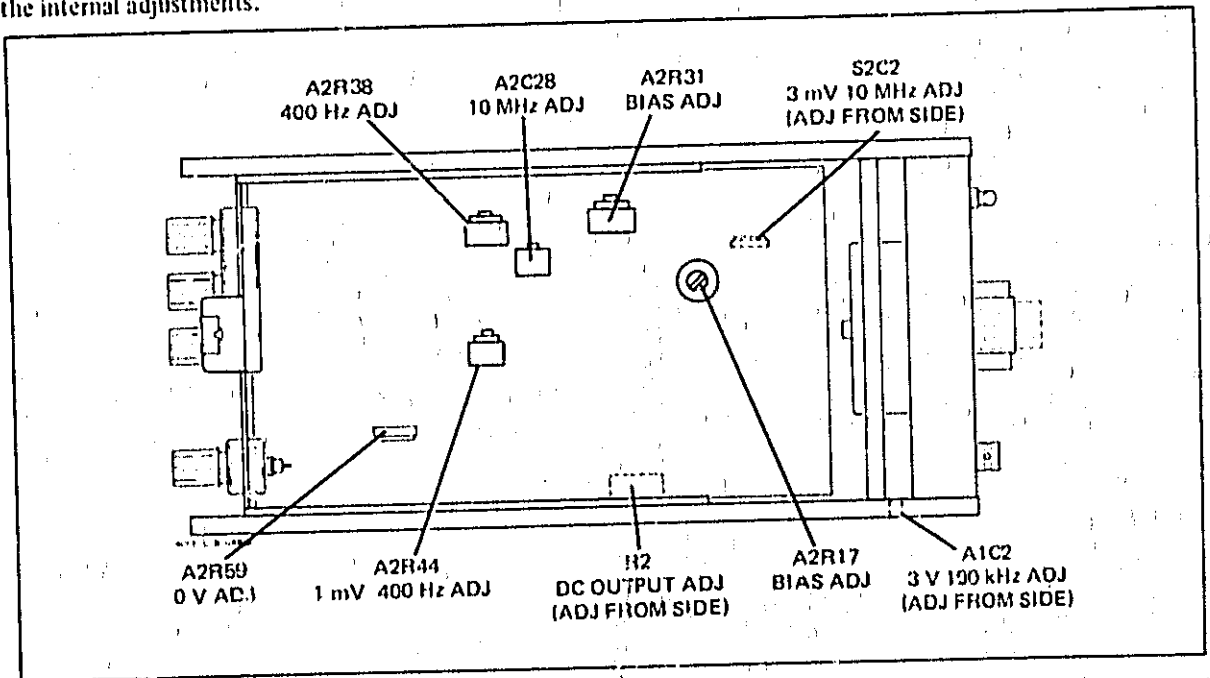

Figure 5-4. Location of Internal Adjustments

calibrated, set the REL. REF adjustment to the fully clockwise ABSOLUTE position before beginning the calibration. Always check and set the bias levels first before calibration.

5-41. Accuracy and Frequency Response Calibration.

a. Calibrate the reference supply in Figure 5-2 with a 1 volt thermal converter according to the steps in Paragraph 5-17.

b. Disconnect the standard and connect the test oscillator, the 400E/EL, and the digital voltmeter as shown in Figure 5-2. Connect a precision 40dB coaxial attenuator between the BNC "T" connector and the 400E/EL INPUT. When the thermal converter and reference supply outputs are nulled, the input to the 400E/EL will be 10mV. Set the oscillator frequency to 400Hz and the 400E/EL to the 0.01 volt range. Using the amplitude control as coarse adjustment and R4 as fine adjustment, increase the oscillator output until the thermal converter output nulls the reference supply.

Adjust A2R38 for a 400E/EL meter reading of 10mV \pm 0.1mV or less.

d. Adjust R2 for a digital voltmeter display of 1.000 \pm 0.005Vdc or less.

e. Lower test oscillator output and set frequency to 10MHz. Readjust oscillator amplitude until thermal converter output nulls reference supply.

f. Adjust A2C28 for digital voltmeter display of 1.000 \pm 0.04 or less.

g. Lower test oscillator output and set the frequency to 10 MHz. Disconnect the precision 40 dB attenuator and connect a precision 50 dB attenuator in its place. When the thermal converter and the reference supply are nulled, the input to the 400E/EL will be 3.162mV. Set the 400E/EL RANGE to 0.003 volts.

h. Using the amplitude control as a coarse adjustment and R4 (Figure 5-2) as a fine adjustment, increase the oscillator output until the thermal converter exactly nulls the reference supply output.

i. Adjust S2C2 for a digital voltmeter indication of 1.000 \pm 0.04Vdc. The 400E/EL should read 3.16 \pm 0.158mV.

NOTE

Check at 6 and 4MHz. Amplitude can be lowered at 4MHz by moving A2C11 and C13 closer together.

j. Lower the test oscillator output and set the frequency to 400Hz. Replace the 1 volt thermal converter with a 0.45 volt thermal converter, and calibrate it according to the procedure in Paragraph 5-17 using a 0.3162 volt output from the dc standard.

k. Disconnect the dc standard and connect the test oscillator to the thermal converter as shown in Figure 5-2. Set the 400E/EL range switch to 0.001 volts. Using the amplitude control as a coarse adjustment and R4 as a fine adjustment, increase the oscillator output until the thermal converter output exactly nulls the reference supply output. At null, the input to the 400E/EL will be 1mV at 400Hz.

m. Adjust A2R44 for a digital voltmeter display of 1.000 \pm 0.005Vdc.

NOTE

The voltage at TP 4 affects frequency response. If the frequency response is low at 10 and 20Hz decrease voltage at TP4 (extreme limits 8 to 12 volts). After changing voltage at TP4, check high and low frequency response.

n. If the accuracy and frequency response can not be brought into specifications with the preceding adjustments, refer to Table 5-11 Factory Selected Components.

5-42. Calibration Procedure Using hp- 745A/746A Calibrator.

5-43. Calibrate the 400E/EL for frequencies from 10Hz to 110kHz with the test setup shown in Figure 5-1.

a. Set the 745A to the voltage levels and frequencies listed in Table 5-5. Alternate Calibration Procedure (omit steps 2 and 3). Select the proper 400E/EL range.

Table 5-5. Alternate Calibration Procedure

STEP	400E/EL RANGE	CALIBRATION SIGNAL	ADJUSTMENT	400E/EL INDICATION	
				METER	DC OUTPUT
1	0.01V	10mV 400Hz	A2R38	10mV ± 0.1 mV	
			R2		1.000 ± 0.005 Vdc
2	0.01V	10mV 10MHz	A2C28	10mV ± 0.5 mV	1.000 ± 0.05 Vdc
3	0.003V	3mV 10 MHz	S2C2	3mV ± 0.15 mV	0.949 ± 0.047 Vdc
4	0.001V	1mV 450Hz	A2R44	1mV ± 0.01 mV	1.000 ± 0.005 Vdc
5	3V	3V 100kHz	A1C2	3V ± 0.03 V	0.949 ± 0.004 Vdc

b. With the adjustment components listed in Table 5-5 adjust within the specified error. For steps 2 and 3 the adjustment procedure in Paragraph 5-41 or 5-47 must be used because of frequency.

c. If the accuracy can not be brought into specifications refer to Table 5-11 Factory Selected Components.

5-44. Attenuator Alignment.

a. Use the setup shown in Figure 5-2 to align the attenuator. Calibrate the reference supply according to the procedures in Paragraph 5-17 using a 3 volt thermal converter.

b. Disconnect the dc standard and connect the test oscillator and 400E/EL as shown in Figure 5-2. Set the oscillator frequency to 100kHz and the 400E/EL to the 3 volt range. Using the amplitude control as coarse adjustment and R4 as fine adjustment, increase the oscillator output until the thermal converter output nulls the reference supply.

c. Adjust A' 2 in the 400E/EL for a meter reading of 3.00 ± 0.03 volts or less.

5-45. Alternate Calibration and Performance Check.

5-46. The following alternate procedure can be used for both a Performance Check and for calibration. The alternate procedure uses an Hip-Model 738BR voltmeter calibrator to generate a 400 Hz signal from 300 volts to 3 millivolts. The accuracy of this calibrator is 0.2% at 300 volts and 0.3% using the attenuator. For greater accuracy the calibrator output can be monitored by the ac differential voltmeter and the

AC INTERNAL CALIBRATION adjustment can be used to adjust the calibrator output to the accuracy of the ac differential voltmeter. Each time the calibrator voltage range is changed the output must be monitored and adjusted. Do not readjust the calibrator below the 50 millivolt range.

5-47. This 400 Hz voltage is used as a reference to set up the 652A for a frequency response test from 10 Hz to 10 MHz at voltages up to 3 volts.

a. Connect the circuit as in Figure 5-5 position A. Place the ac differential voltmeter to 300 volts (maximum sensitivity) and place the calibrator to 400Hz rms, 300 volts.

b. Adjust the AC INTERNAL CALIBRATION for an exact reading on the differential voltmeter.

c. Connect the circuit as in Figure 5-5 position B. The 400E/EL should read 300 volts $\pm 1\%$ or ± 3 volts. The dc output should be .949 ± 0.0047 .

d. Change the calibrator and ac differential voltmeter to 100 volts. Connect as in Figure 5-5 position A. Adjust the AC INTERNAL CALIBRATION for an exact reading on the differential voltmeter.

e. Connect the circuit as in position B with the 400E/EL on the 300V range. The 400E/EL meter and dc output should read within the tolerances in Table 5-2 for 1 volt input on the 3 volt range.

f. Change the 400E/EL to the 100 volt range. Use the tolerances in Table 5-2 for 1 volt input on the 1 volt range.

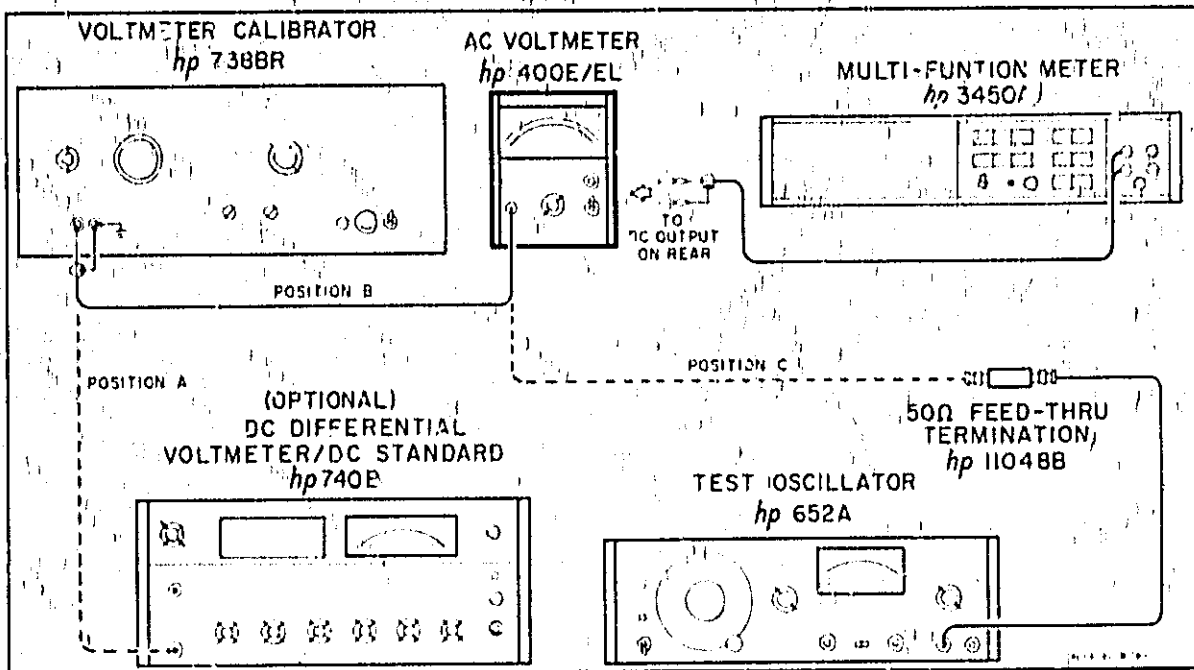

Figure 5-5. Alternate Calibration and Frequency Test Setup

- g. Repeat steps d and e for each range of the 400E/EL checking full scale and 1/3 full scale for each descending range.
- h. On the 3 volt range record the reading on the 400E/EL meter and dc output.
- i. Connect the circuit as in Figure 5-5 position C.
- j. Adjust the amplitude of the test oscillator at 400Hz to the value recorded in step h.
- k. Set the test oscillator to the EXPAND scale position and adjust the REF. SET for a 0% or 0dB reading on the meter.
- m. Change the frequency to those in Table 5-2 and readjust the oscillator AMPLITUDE to 0% or 0dB. The 400E/EL dc output should read within the tolerance for that frequency, range and voltage input. Adjust the oscillator's fine control for an exact meter reading of the 400E/EL. The % reading on the oscillator's meter should be within tolerance.
- n. Repeat steps h thru m for descending ranges at full scale and 1/3 full scale using the appropriate tables for tolerances. Below 50mV do not use Figure 5-5 position A as the calibrator is more accurate than the differential voltmeter at these low voltages.
- p. For checking the accuracy of the 1mV range of the 400E/EL use tolerances listed in Table 5-3.
- q. 1 mV 4 MHz is calibrated by dressing the white/orange/yellow jumper wire between the second attenuator and input to the meter amp. Moving the jumper wire towards the deck lowers the response. Set RESPONSE 1.5% high with the bottom cover off. The installation of the cover will lower the response by 1.5%. See Figure 6-2 for location of the white/orange/yellow jumper wire.
- r. If the 400E/EL is out of specifications at a frequency, adjust the component listed in Table 5-5 for a 400E/EL meter and dc output reading within the proper tolerance. Use the range specified for adjustment.

NOTE

The 654A Test Oscillator can be used in place of the 652A Test Oscillator for an output of 1 volt or less. The accuracy is 0.5% without readjusting the amplitude at each change of frequency.

Table 5-6. Troubleshooting Tips

SYMPTOM	PROBABLE TROUBLE
1. No response to input signal	1. Fuse A2F1 open. Check power supply voltages. Check AC signal according to Paragraphs 5-53 through 5-55 to isolate the area of trouble.
2. Low B+ voltage at TP1 or Low B- voltage at TP2	2. Disconnect jumper wire. Measure resistance to ground at both jumper terminals. If 10 ohms on the meter side, C16 or C19 is shorted, if 100 ohms, C35 or C29 is shorted; if zero, C8 or C9 is shorted. Disconnect R20 and R28 to isolate the Impedance Converter. If low resistance is on power supply side refer to Paragraph 5-51 and Table 5-7.
3. Low gain at high frequencies	3. Check A2C22 for open if 10% low. Lift A2C39 and check for oscillations; if no oscillations check A2Q15 and 16.
4. High gain at high frequencies	4. Check A2C30 for an open.
5. Low full scale readings	5. Check A2CR15 and A2CR16.
6. Instrument will not range above 1 volt but works OK at 1 volt and below	6. Relay A1K1 stuck in closed position.
7. Instrument will not range below 3 volts but works OK on 3 volt range and above	7. Relay K2 stuck in closed position.
8. TP3 voltage can not be adjusted properly	8. Extreme condition: check A2Q5, Q6 and Q7. Small variation: change value of A2R18*. (Refer to Table 5-11).
9. TP5 voltage can not be adjusted properly	9. AC output circuit. Check A2Q15 and Q16. Refer to Paragraph 5-58 and Table 5-11.
10. TP4 voltage can not be adjusted properly	10. Meter Amplifier Circuit. Check A2Q8 thru Q13.
11. TP4 voltage varies and meter needle wobbles	11. Isolate by shorting A2C17 to ground. If voltage at TP4 still varies the trouble is in the Meter Amplifier. Refer to Paragraph 5-54 and Table 5-9. If voltage is constant the trouble is in the Impedance Converter. Refer to Paragraph 5-55 and Table 5-8.
12. Low line transients	12. Check A2Q3 and Q4. (If an old instrument change A2Q4, A2R73 and R74 to current part number). Check A2CR20 and CR21.
13. Transients on range change (1V to 3V)	13. Match reverse resistance of A2CR9 and CR10. Check S ² CR1 and S2CR2. Check relays.
14. Peaking at 5MHz (10%)	14. Isolate by disconnecting orange wire to switch. Voltage at pin 21 should be same as input. Refer to Paragraph 5-55 or 5-56.
15. Voltage slightly low on 1mV range	15. Change value of A2R72* (refer to Table 5-11).
16. Low voltage (10 and 20Hz) near full scale	16. Check A2Q13. Change value of A2C31* (Table 5-11). Check A2C10 and C20.

5-48. TROUBLESHOOTING.

5-49. These procedures should only be performed when the 400E/EL can not be calibrated according to procedures in Paragraphs 5-32 through 5-47. If the

400E/EL is slightly out of specifications and can not be corrected by the proper adjustment, refer to Table 5-11 Factory Selected Values. If the 400E/EL is inoperative or completely out of specifications proceed as follows:

- a. Check the instrument for any obvious evidence of trouble, such as loose or broken wires or broken connectors. Check for burnt or loose components or separations or cracks in the printed circuit boards. Ensure that all pins are clean.
- b. Isolate the trouble to a particular circuit using the block diagram Figure 4-1 and the schematic Figure 7-1. Then refer to the troubleshooting steps for that circuit. Table 5-6 gives some probable troubles for specific symptoms.

NOTE

Test voltages in this section and on the schematic are nominal. A tolerance of $\pm 10\%$ is allowable and more when stated.

5-50. POWER SUPPLY.

5-51. Check with a dc voltmeter (3450B) at TP1 and TP2 for +26 volts and -26 volts respectively. If the TP voltages are improper, check the voltages listed in Table 5-7. If the voltage for a given component is wrong, the trouble is probably in that component or its associated circuit.

Table 5-7. Power Supply Voltages

COMPONENT	VOLTAGE
Collector Q1	+39V
Collector Q2	+26.5V
Emitter Q2	+6.98V
Base Q3	-0.6V
Collector Q3	-23.5V
Collector Q4	-39V

5-52. AMPLIFIERS.

5-53. Set the 400E/EL to the 1 volt range, and connect a full scale input. With a sensitive ac voltmeter, monitor the ac amplifier output at the negative side of A2C34 or A2C36. The output should be 150mV. If it is not 150mV, measure the ac voltage at A2 pin 22. The voltage at pin 22 should be 3mV. If these two voltage readings are correct, the meter amplifier and meter bridge are operating properly.

5-54. If the voltage at pin 22 is low, pull the wht/orn/yel wire from pin 22, and measure the ac signal at the wire. It should be 3mV. If the voltage on the wire is proper, the trouble is in the meter

amplifier. If it isn't correct, the trouble is either in the Post Attenuator or the Impedance Converter.

5-55. To check the Impedance Converter, measure the ac voltage at its output (A2 pin 21). The output voltage should be very close to the input voltage since the Impedance Converter is a unity gain amplifier. With a 1 volt input, the output should be 0.98 volts ± 0.02 volts.

5-56. Both the Impedance Converter and the meter amplifier are internally dc coupled. If the dc voltages anywhere in the amplifier are incorrect, the amplifier won't operate properly. Consequently a check of the dc voltages is a good check of the amplifiers.

5-57. Tables 5-8 and 5-9 contain the dc voltages on all of the transistors in the meter amplifier and the Impedance Converter. If the measured voltage on a given transistor is wrong, the trouble is probably in that transistor or its associated circuit.

NOTE

Measure these dc voltages with the input shorted. A dc voltmeter with low input capacitance and very high input resistance must be used. The μ p- Model 3450B is recommended. All dc voltages are $\pm 10\%$ except where otherwise stated.

Table 5-8. Impedance Converter Voltages

TRANSISTOR	E	B	C
Q5	(S) -6V	(G)*	(D) -14.6V
Q6	-15.3V	-14.6V	-7.4V
Q7	-6.7V	-7.4V	-21.5V

*Cannot be measured.

Table 5-9. Meter Amplifier Voltages

TRANSISTOR	E	B	C
Q8	+19V $\pm 20\%$	19.5V $\pm 20\%$	+25.5V
Q9	+0.02V	+0.57V	+8.5V
Q10	+8.2V	+8.5V	+1.8V
Q11	+0.9V	+1.9V	+8.5V
Q12	+9V	+8.5V	+0.7V
Q13	+0.7V	0	-4.6V
Q14*	+3V	+3.5V	+26V

*In bridge circuit.

5-58. AC OUTPUT CIRCUIT.

5-59. To check the ac output circuit, measure the dc voltages at the points shown in Table 5-10. If a given measured voltage is incorrect, the trouble is probably in that component or its associated circuit.

Table 5-10. AC Voltage Output Circuit.

TRANSISTOR	E	B	C
Q15	+ 0.62 V	+ 1.3 V	+ 5 V
Q16	0	+ 0.62 V	+ 5 V

5-60. ADJUSTMENT OF FACTORY SELECTED COMPONENTS.

5-61. Certain components within the Model 400E/EL are individually selected in order to compensate for slightly varying circuit parameters. These components are denoted by an asterisk (*) on the schematic, and the typical value is shown. Table 5-11 describes the function of the factory selected components and gives instructions for their selection. Normally, these components do not need to be changed unless another associated component is changed. Replacement of a transistor, for example, may require the changing of a factory selected component.

Table 5-11. Factory Selected Components.

COMPONENT	FUNCTION AND SELECTION
A1R4*	29 to 45.3 ohms. Adjusts high frequency response on the 3 volt range. For low readings on the 3 volt range at high frequencies, increase resistance.
A2C24*	0 to 24 pF. Adjust 8 and 10 MHz frequency response. Normally not loaded. Used to raise response. <div style="text-align: right; margin-right: 20px;"> 6 pF 0160-0763 12 pF 0140-0201 24 pF 0160-0196 </div>
A2C31*	18 to 22 μ F. Adjusts 10 and 20 Hz frequency response on all ranges. Increasing the capacitance increases the response.
A2C32*	39pF to zero. Affects 10 MHz response.
A2R18*	36 kilohms to 68 kilohms. Adjusts the bias level at A2Q5 due to FET variables. When A2R17 will not adjust voltage at TP3 to -6 volts. If the voltage at TP3 is too negative, increase the resistance of R18*.
A2R22*	294 ohms. Adjust high frequency response at 4 MHz. For high readings at 4 MHz increase the resistance of R22.
A2R50*	2320 to 3320 ohms. Adjusts low frequency response on the 1 and 3 mV ranges. For high readings at 10 and 20 Hz on the 1 and 3 mV ranges decrease the resistance of R50. Also affects high frequency response.
A2R51*	133 to 187 ohms. Adjusts frequency response at 10 MHz.
S2C1*	10 pF to 24 pF 500 V. Adjusts the high frequency response on the .01 V and 3 V ranges.
S2C3*	5 pF or 10 pF 500 V. Adjust the high frequency response on the 1 V and 300 V ranges.
A2R72*	110 - 182 ohms. Adjusts to range of the 1 mV, 400 Hz adjustment, A2R44. If readings are low and A2R44 will not bring the amplitude within specifications, decrease the resistance of R72.
S2C4*	1.8 to 6.8 μ F, 35 vdw. Adjusts 10 Hz frequency response on the 1 mV and 3 mV ranges. Increasing capacitance increases response.

PERFORMANCE CHECK TEST CARD

hp Model 400E/EL

Test performed by: _____

AC Voltmeter

Date: _____

Serial No. _____

1. Accuracy Check

Range	INPUT SIGNAL		SPECIFICATION		INDICATION	
	Voltage	Frequency	Meter (V)	DC Output (V)	Meter	DC Output
3 V ↓ ↓ ↓	3.00 V ↓ ↓ ↓	10 Hz	3.00 ± 0.15	0.949 ± 0.047		
		400 Hz	± 0.03	± 0.0047		
		100 kHz	± 0.03	± 0.0047		
		1 MHz	± 0.03	± 0.0095		
		4 MHz	± 0.09	± 0.047		
		10 MHz	3.00 ± 0.15	0.949 ± 0.047		
3 V ↓ ↓ ↓	1.00 V ↓ ↓ ↓	10 Hz	1.00 ± 0.10	0.316 ± 0.032		
		400 Hz	± 0.03	± 0.0032		
		100 kHz	± 0.03	± 0.0032		
		1 MHz	± 0.03	± 0.0063		
		4 MHz	± 0.06	± 0.032		
		10 MHz	1.00 ± 0.15	0.316 ± 0.032		
1 V ↓ ↓ ↓	1.00 V ↓ ↓ ↓	10 Hz	1.00 ± 0.05	1.00 ± 0.05		
		400 Hz	± 0.01	± 0.005		
		100 kHz	± 0.01	± 0.005		
		1 MHz	± 0.01	± 0.010		
		4 MHz	± 0.03	± 0.05		
		10 MHz	1.00 ± 0.05	1.00 ± 0.05		
1 V ↓ ↓ ↓	0.30 V ↓ ↓ ↓	10 Hz	0.30 ± 0.032	0.30 ± 0.033		
		400 Hz	± 0.01	± 0.0033		
		100 kHz	± 0.01	± 0.0033		
		1 MHz	± 0.01	± 0.0065		
		4 MHz	± 0.02	± 0.033		
		10 MHz	0.30 ± 0.032	0.30 ± 0.033		
3 V ↓ ↓ ↓	0.30 V ↓ ↓ ↓	10 Hz	0.30 ± 0.015	0.949 ± 0.047		
		400 Hz	± 0.003	± 0.0047		
		100 kHz	± 0.003	± 0.0047		
		1 MHz	± 0.003	± 0.0095		
		4 MHz	± 0.009	± 0.047		
		10 MHz	0.30 ± 0.015	0.949 ± 0.047		
3 V ↓ ↓ ↓	0.10 V ↓ ↓ ↓	10 Hz	0.100 ± 0.01	0.316 ± 0.032		
		400 Hz	± 0.003	± 0.0032		
		100 kHz	± 0.003	± 0.0032		
		1 MHz	± 0.003	± 0.0063		
		4 MHz	± 0.006	± 0.032		
		10 MHz	0.100 ± 0.01	0.316 ± 0.032		

Range	INPUT SIGNAL		SPECIFICATION		INDICATION	
	Voltage	Frequency	Meter Reading (V)	DC Output (V)	Meter	DC Output
.1 V ↓ ↓ ↓	0.10 V ↓ ↓ ↓	10 Hz	0.100 ± 0.005	1.00 ± 0.05		
		400 Hz	± 0.001	± 0.005		
		100 kHz	± 0.001	± 0.005		
		1 MHz	± 0.001	± 0.010		
		4 MHz	± 0.003	± 0.05		
		10 MHz	0.100 ± 0.005	1.00 ± 0.05		
.001 V ↓ ↓ ↓	0.001 V ↓ ↓ ↓	10 Hz	0.001 ± 0.00005	1.00 ± 0.05		
		400 Hz	± 0.00001	± 0.005		
		100 kHz	± 0.00001	± 0.005		
		1 MHz	± 0.00005	± 0.02		
		4 MHz	0.001 ± 0.00005	± 0.05		
		10 MHz	0.001 ± 0.00005	± 0.05		
.001 V ↓ ↓ ↓	0.0003 V ↓ ↓ ↓	10 Hz	0.003 ± 0.00032	0.30 ± 0.033		
		400 Hz	± 0.00001	± 0.0043		
		100 kHz	± 0.00001	± 0.0043		
		1 MHz	± 0.00032	± 0.013		
		4 MHz	0.003 ± 0.00032	± 0.033		
		10 MHz	0.003 ± 0.00032	± 0.033		

PARTS LIST

SECTION VI REPLACEABLE PARTS

6-1. INTRODUCTION.

6-2. This section contains information for ordering replacement parts. Table 6-3 lists parts in alphabetic order of their reference designators and indicates the description, -hp- part number of each part, together with any applicable notes, and provides the following:

- a. Total quantity used in the instrument (TQ column). The total quantity of a part is given the first time the part number appears.
- b. Description of the part. (See list of abbreviations below.)
- c. Typical manufacturer of the part in a five-digit code. (See Appendix A for list of manufacturers.)
- d. Manufacturer's part number.

6-3. Miscellaneous parts are listed at the end of Table 6-3.

6-4. ORDERING INFORMATION

6-5. To obtain replacement parts, address order or inquiry to your local Hewlett-Packard Field Office. (See Sales and Service for list of office locations.) Identify parts by their Hewlett-Packard part numbers.

6-6. NON-LISTED PARTS.

6-7. To obtain a part that is not listed, include:

- a. instrument model number.
- b. Instrument serial number.
- c. Description of the part.
- d. Function and location of the part.

Table 6-1. Standard Abbreviations.

		ABBREVIATIONS				ABBREVIATIONS	
Pa	power	Hr	hour	ADJ	adjustment	U	unit
At	attenuation	Q	quality factor	AK	anode	U1	unit 1
A	ampere	Q1	quality factor 1	AK1	anode 1	U2	unit 2
Av	attenuation	Q2	quality factor 2	AK2	anode 2	U3	unit 3
C	capacitor	Q3	quality factor 3	AK3	anode 3	U4	unit 4
cat	cathode	Q4	quality factor 4	AK4	anode 4	U5	unit 5
conf	configuration	Q5	quality factor 5	AK5	anode 5	U6	unit 6
com	common	Q6	quality factor 6	AK6	anode 6	U7	unit 7
comp	compensation	Q7	quality factor 7	AK7	anode 7	U8	unit 8
con	connection	Q8	quality factor 8	AK8	anode 8	U9	unit 9
CP	double pole double throw	Q9	quality factor 9	AK9	anode 9	U10	unit 10
DPDT	double pole double throw	Q10	quality factor 10	AK10	anode 10	U11	unit 11
DPST	double pole single throw	Q11	quality factor 11	AK11	anode 11	U12	unit 12
dist	distortion	Q12	quality factor 12	AK12	anode 12	U13	unit 13
encl	enclosure	Q13	quality factor 13	AK13	anode 13	U14	unit 14
F	farad	Q14	quality factor 14	AK14	anode 14	U15	unit 15
FLT	fault	Q15	quality factor 15	AK15	anode 15	U16	unit 16
GAAs	gallium arsenide	Q16	quality factor 16	AK16	anode 16	U17	unit 17
GHz	gigahertz	Q17	quality factor 17	AK17	anode 17	U18	unit 18
Hz	hertz	Q18	quality factor 18	AK18	anode 18	U19	unit 19
Ca	calcium	Q19	quality factor 19	AK19	anode 19	U20	unit 20
cond	condenser	Q20	quality factor 20	AK20	anode 20	U21	unit 21
H	henry	Q21	quality factor 21	AK21	anode 21	U22	unit 22
Hg	mercury	Q22	quality factor 22	AK22	anode 22	U23	unit 23
		Q23	quality factor 23	AK23	anode 23	U24	unit 24
		Q24	quality factor 24	AK24	anode 24	U25	unit 25
		Q25	quality factor 25	AK25	anode 25	U26	unit 26
		Q26	quality factor 26	AK26	anode 26	U27	unit 27
		Q27	quality factor 27	AK27	anode 27	U28	unit 28
		Q28	quality factor 28	AK28	anode 28	U29	unit 29
		Q29	quality factor 29	AK29	anode 29	U30	unit 30
		Q30	quality factor 30	AK30	anode 30	U31	unit 31
		Q31	quality factor 31	AK31	anode 31	U32	unit 32
		Q32	quality factor 32	AK32	anode 32	U33	unit 33
		Q33	quality factor 33	AK33	anode 33	U34	unit 34
		Q34	quality factor 34	AK34	anode 34	U35	unit 35
		Q35	quality factor 35	AK35	anode 35	U36	unit 36
		Q36	quality factor 36	AK36	anode 36	U37	unit 37
		Q37	quality factor 37	AK37	anode 37	U38	unit 38
		Q38	quality factor 38	AK38	anode 38	U39	unit 39
		Q39	quality factor 39	AK39	anode 39	U40	unit 40
		Q40	quality factor 40	AK40	anode 40	U41	unit 41
		Q41	quality factor 41	AK41	anode 41	U42	unit 42
		Q42	quality factor 42	AK42	anode 42	U43	unit 43
		Q43	quality factor 43	AK43	anode 43	U44	unit 44
		Q44	quality factor 44	AK44	anode 44	U45	unit 45
		Q45	quality factor 45	AK45	anode 45	U46	unit 46
		Q46	quality factor 46	AK46	anode 46	U47	unit 47
		Q47	quality factor 47	AK47	anode 47	U48	unit 48
		Q48	quality factor 48	AK48	anode 48	U49	unit 49
		Q49	quality factor 49	AK49	anode 49	U50	unit 50
		Q50	quality factor 50	AK50	anode 50	U51	unit 51
		Q51	quality factor 51	AK51	anode 51	U52	unit 52
		Q52	quality factor 52	AK52	anode 52	U53	unit 53
		Q53	quality factor 53	AK53	anode 53	U54	unit 54
		Q54	quality factor 54	AK54	anode 54	U55	unit 55
		Q55	quality factor 55	AK55	anode 55	U56	unit 56
		Q56	quality factor 56	AK56	anode 56	U57	unit 57
		Q57	quality factor 57	AK57	anode 57	U58	unit 58
		Q58	quality factor 58	AK58	anode 58	U59	unit 59
		Q59	quality factor 59	AK59	anode 59	U60	unit 60
		Q60	quality factor 60	AK60	anode 60	U61	unit 61
		Q61	quality factor 61	AK61	anode 61	U62	unit 62
		Q62	quality factor 62	AK62	anode 62	U63	unit 63
		Q63	quality factor 63	AK63	anode 63	U64	unit 64
		Q64	quality factor 64	AK64	anode 64	U65	unit 65
		Q65	quality factor 65	AK65	anode 65	U66	unit 66
		Q66	quality factor 66	AK66	anode 66	U67	unit 67
		Q67	quality factor 67	AK67	anode 67	U68	unit 68
		Q68	quality factor 68	AK68	anode 68	U69	unit 69
		Q69	quality factor 69	AK69	anode 69	U70	unit 70
		Q70	quality factor 70	AK70	anode 70	U71	unit 71
		Q71	quality factor 71	AK71	anode 71	U72	unit 72
		Q72	quality factor 72	AK72	anode 72	U73	unit 73
		Q73	quality factor 73	AK73	anode 73	U74	unit 74
		Q74	quality factor 74	AK74	anode 74	U75	unit 75
		Q75	quality factor 75	AK75	anode 75	U76	unit 76
		Q76	quality factor 76	AK76	anode 76	U77	unit 77
		Q77	quality factor 77	AK77	anode 77	U78	unit 78
		Q78	quality factor 78	AK78	anode 78	U79	unit 79
		Q79	quality factor 79	AK79	anode 79	U80	unit 80
		Q80	quality factor 80	AK80	anode 80	U81	unit 81
		Q81	quality factor 81	AK81	anode 81	U82	unit 82
		Q82	quality factor 82	AK82	anode 82	U83	unit 83
		Q83	quality factor 83	AK83	anode 83	U84	unit 84
		Q84	quality factor 84	AK84	anode 84	U85	unit 85
		Q85	quality factor 85	AK85	anode 85	U86	unit 86
		Q86	quality factor 86	AK86	anode 86	U87	unit 87
		Q87	quality factor 87	AK87	anode 87	U88	unit 88
		Q88	quality factor 88	AK88	anode 88	U89	unit 89
		Q89	quality factor 89	AK89	anode 89	U90	unit 90
		Q90	quality factor 90	AK90	anode 90	U91	unit 91
		Q91	quality factor 91	AK91	anode 91	U92	unit 92
		Q92	quality factor 92	AK92	anode 92	U93	unit 93
		Q93	quality factor 93	AK93	anode 93	U94	unit 94
		Q94	quality factor 94	AK94	anode 94	U95	unit 95
		Q95	quality factor 95	AK95	anode 95	U96	unit 96
		Q96	quality factor 96	AK96	anode 96	U97	unit 97
		Q97	quality factor 97	AK97	anode 97	U98	unit 98
		Q98	quality factor 98	AK98	anode 98	U99	unit 99
		Q99	quality factor 99	AK99	anode 99	U100	unit 100

Table 6-2. Code of Manufacturers.

Mfr. No.	Manufacturer Name	Address
00853	Sangam Elec Co	Pickens, SC 29671
01121	Allen-Bradley Co	Milwaukee, WI 53204
01281	TRW Semiconductors, Inc.	Lawndale, CA 90260
03292	Corning Glass Work	Bradford, PA 16701
03877	Transitron Electric Corp	Wakefield, MA 01880
03888	Pyrofilm Resistor Co, Inc	Whippany, NJ 07981
04062	Arco Electric Inc	Great Neck, NY 11022
04200	Sprague Electric Co	North Adams MA 01247
04713	Motorola Semiconductor Prod Div	Phoenix AZ 85067
05820	Wakefield Engineering Inc	Wakefield, MA 01880
06486	Kaurz-Kasch Inc	Daton, OH 45401
07263	Fairchild Semiconductor Div	Mountain View, CA 94042
07910	Continental Device Corp	Hawthorne, CA 90202
11236	Cts of Berra, Inc	Berne, IN 46711
14433	ITT Semiconductor Div	West Palm Beach FL 33480
16299	Elec Component Div	Raleigh, NC 27604
19701	Mepco/Electra Corp	Mineral Wells, TX 76067
24446	General Electric Co	Schenectady, NY 12306
26365	Gries Reproducer Corp	New Rochelle, NY 10804
28480	Hewlett-Packard Co	Palo Alto, CA 94304
56289	Sprague Electric Co	North Adams MA 01247
70563	Amperite Co, Inc	Union City, NJ 07083
70903	Belden Mfg Co	Chicago, IL 60622
71400	Bussmann Mfg Div	St. Louis, MO 63121
72136	Electro-Motive Mfg Co Inc	Willimantic, CT 06226
72982	Erie Technological Products, Inc	Erie, PA 16512
73138	Beckman Instruments Helipot Div	Fullerton, CA 92634
75042	TRW Inc Philadelphia Div	Philadelphia, PA 19106
75915	Littlefuse, Inc	Des Plaines, IL 60016
78189	Illinois Tool Works Shakeproof Div	Elgin, IL 60120
78553	Tinnerman Products, Inc	Cleveland, OH 44141
81856	Kemlite Laboratories	Chicago, IL 60622
82142	Jeffers Electronics Division	Du Bois, PA 15801
82389	Switchcraft, Inc	Chicago, IL 60630
83305	Central Screw Co	Chicago, IL 60622
86684	RCA Electronic Corp & Devices Div	Harrison, NJ 07029
90201	Mallory Capacitor Div	Indianapolis, IN 46206
91418	Radio Materials Co	Chicago, IL 60622
93332	Semiconductor Div Sylvania Elec	Waburn MA 02158
95712	Oape Electric Co., Inc	Franklin, IN 46131

Table 6-3. Replaceable Parts.

REFERENCE DESIGNATOR	hp-PART NO.	TO	DESCRIPTION	MFR.	MFR. PART NO.
A1	00400-66521	1	PC Board Ass'y; input attenuator	-hp-	
C1	0150 0024	1	C: fxd cer 20,000pF ±80% -20% 600vdcw	72987	841-000 05 203Z
C2	0121-0168	1	C: var 0.25 - 1.5 pF 600 Vdcw	72987	630 007
C3	0160-2208	1	C: fxd mica 330 pF 5%	72136	obd
C4	0140 0198	2	C: fxd mica 200pF ±5%	00853	RDM15F201J3C
C5,C6	0160-3847	2	C: fxd cer 0.01 pF ±100 0% 25 vdcw	-hp-	0160 3847
R1	0683 1005	1	R: fxd comp 10 chms 15% 1/4W	01121	CR1005
R2	0698 4128	1	R: fxd prec met film 10 0 megohm ±1/4% 1/2W	03888	PME 70
R3	0698 4129	1	R: fxd prec met film 31723 ohms ±0.1% 1/2W	19701	MF5C T-3
R4*	0757-0388	1	R: fxd film 30.1 ohms ±1% 1/8W 2W	-hp-	0757 0388
R5,R6	0684-1021	1	R: fxd comp 1000 ohms ±10% 1/4W	01121	CB1021
K1	0490 1205	1	Switch Assy: Reed and Coil	28480	0490 1205
K2	0490-1203	1	Switch Assy: Reed and Coil	28480	0490-1203
A2	00400-66521	1	PC Board Ass'y	-hp-	
C1,C2	0180 0149	2	C: fxd Al elect 66uF ±100% -10% 60 vdcw	56289	Type 30D D3697B
C3	0150 0050	2	C: fxd cer 1000pF 600 vdcw	01281	Type E
C4	0180 0142	2	C: fxd Al elect 20uF ±100% -10% 25 vdcw	56289	Type 40D D36039
C5	0180 0061	1	C: fxd elect 100uF ±100% -10% 15 vdcw	56289	30D10/G0150104
C6	0180 0100	6	C: fxd Ta elect 4.7uF ±20% 35 vdcw	14433	SM4 7NF
C7	0180 0142	3	C: fxd Al elect 20uF ±100% -10% 25 vdcw	56289	Type 40D D36039
C8,C9	0180 0101	3	C: fxd Ta elect 1.8uF ±20% 35 vdcw	14433	SM1 BNF
C10	0150 0084	1	C: fxd cer 0.1uF ±80% -20% 50 vdcw	72987	845 222Y5V0104Z
C11	0180 0119	1	C: fxd elect 1uF ±75% -10% 25 vdcw	56289	30D105G026BA2 DSM
C12	0140 0193	1	C: fxd mica 82pF ±5%	04062	RDM15E820J3C
C13	0180 0137	2	C: fxd Ta elect 100uF ±20% 10 vdcw	31856	K100J10B
C14	0150 0059	1	C: fxd elect 10uF ±100% -10% 25 vdcw	56289	30D106G025BB4
C15	0140 0190	2	C: fxd mica 39pF ±5%	00853	RDM15E390J3C
C16	0180 1735	2	C: fxd Ta elect 0.22uF ±10% 35 vdcw	56289	150D224X9035A2
C17	0180 1780	1	C: fxd Al elect 500uF ±75% -10% 10 vdcw	56289	2JD507G010EJ4
C18*	0180-0373	1	C: fxd Ta elect .68 pF ±10% 35vdcw	04200	150D68X9035A2
C19	0150-0121	1	C: fxd cer. 0.1 pF ±80 -20% 50 vdcw	56289	6C50BIS CML
C20*	0150 1793	1	C: fxd Al elect 450uF ±50% -10% 3 vdcw	56289	30D595 DSM
C21	0150 0093	2	C: fxd cer dorez coated disc 0.01uF ±80% -20% 10 vdcw	91418	TA
C22	0180 0100	1	C: fxd Ta elect 4.7uF ±10% 35 vdcw	14433	SM4 7NF
C23	0140 0198	1	C: fxd mica 200pF ±5%	00853	RDM15F201J3C
C24*		1	See Table 5-11		
C25	0150 0015	1	C: fxd TiO 2.2pF ±10% 500 vdcw	82142	Type JM
C26	0150 0093	1	C: fxd cer dorez coated disc 0.01uF ±80% -20% 100 vdcw	91418	TA
C27		1	Not assigned		
C28	0121 0036	1	C: var cer 5 - 18 pF	72987	538 006 5.5 - 18
C29	0180 0100	1	C: fxd Ta elect 4.7uF ±10% 35 vdcw	14433	SM4 7NF
C30	0140 0202	1	C: fxd mica 15pF ±5%	00853	RDM15C150J5C
C31*	0180-1779	2	C: fxd Ta elect 18 pF 35 vdcw	56289	150D186X9035R2
C32*	0140 0203	2	C: fxd mica 30pF ±5% 500 vdcw	72136	DM15E300J0500VV1CR
C33	0180 1779	2	C: fxd Ta elect 18uF 35 vdcw	56289	150D186X9035R2
C34	0180 0354	2	C: fxd Ta elect 40uF 15% 10 vdcw	56289	150D406X5010B2
C35	0150 0093	1	C: fxd cer dorez coated disc 0.01uF ±80% -20% 100 vdcw	04062	RDM15E820J3C
C36	0180 0354	1	C: fxd Ta elect 40uF 15% 10 vdcw	56289	150D406X5010B2
C37	0180 0137	1	C: fxd Ta elect 100uF ±20% 10 vdcw	51556	K100J10B

Table 6-3. Replaceable Parts (Cont'd).

REFERENCE DESIGNATOR	-hp- PART NO.	TO	DESCRIPTION	MFR.	MFR. PART NO.
C38	0180 0100		C: fxd Ta elect 4.7uF ±10% 35 vdcw	14433	SM4. 7NF
C39	0180 0155	1	C: fxd Ta elect 2.2uF ±20% 20 vdcw	56289	1500225X0020A2
C40	0180 0064	1	C: fxd elect 35uF ±100% -10% 6 vdcw	56289	300346G0068B4
C41	0180 0100		C: fxd Ta elect 4.7uF ±10% 35 vdcw	14433	SM4. 7NF
C42,C43	0150 0122	2	C: fxd cer 2000pF ±20% 500 vdcw	72982	801-000-Y6S-202M
C44	0150 0050		C: fxd cer 1000pF 600 vdcw	01281	Type E
C45*	0140 0109		C: fxd mica 240 pF 5%	00853	obd
C46*	0140 020*		C: fxd 12 pF 500 V	72136	obd
CH1 thru CH6	1901 0033	6	Diode: Si 100mA at 1V 180 wiv 13pF	93332	D6238
CH7	1902 3125	1	Diode: Si breakdown 6.98V ±2% 400mW	06486	obd
CH8	1901 0025	3	Diode: Si 100mA at +1V 100 piv 12pF	93332	D3072
CH9,CH10	1901 0044	2	Diode: Si 20mA at 1V 10mA at -10V 50 wiv 2pF	07910	SF42
CH11	1901 0025		Diode: Si 100mA at 1V 100 piv 12pF	93332	D3072
CH12	1902 3222	3	Diode: Si breakdown 17.4V ±5% 400mW	06486	SZ10939 251
CH13	1902 0182	1	Diode: breakdown 20.5V ±5% 400mW	06486	obd
CH14	1902 79	1	Diode: Si breakdown 11.8V ±5% 400mW	06486	obd
CH15,CH16	1901 0347		Diode: Si 20mA at +1V 1.5pF	-hp-	
CH17,CH18	1902 3090	2	Diode: breakdown 4.99V	04713	SZ10939 94
CH19	1902 0677		Diode: breakdown 15V ±5% 100pF 400mW	07263	FZ1641
CH20,CH21	1902 3222		Diode: breakdown 17.4V ±5%	068486	SZ10939 251
CH22	1901 0025		Diode: Si 100mA at 1V 100 piv 12pF	93332	D3072
F1	2110 0301		Fuse: .125A 125V	28480	2110-0301
Q1	1854 0039	1	TSTR: Si NPN 2N3053	04713	2N3053
	1205 0033	2	Heat dissipator semiconductor for A201	05820	NF-207
Q2	1854 0033	2	TSTR: Si NPN 2N3391	24446	2N3391
Q3	1853 0062	1	TSTR: Si PNP 2N3645	07263	2N3645
Q4	1853 0006	1	TSTR: Si PNP 2N3134	04713	2N3134
	1205 0033		Heat dissipator semiconductor for A204	05820	NF-207
Q5	1855 0082	1	TSTR: Si FET P-Channel	-hp-	
Q6	1854 0073	2	TSTR: Si NPN 2N3478	86684	2N3478
Q7	1853 0009	2	TSTR: Si PNP**	-hp-	
	1205 0018	1	Heat dissipator semiconductor for A207	05820	NF-203
Q8	1854 0033		TSTR: Si NPN 2N3391	24446	2N3391
Q9	1854 0272	1	TSTR: Si NPN**	-hp-	
Q10	1853 0009		TSTR: Si PNP**	-hp-	
Q11	1854 0073		TSTR: Si NPN 2N3478	86684	N3478
Q12,Q13	1853 0010	2	TSTR: Si PNP**	-hp-	
Q14 thru Q16	1854 0057	3	TSTR: Si NPN**	-hp-	
R1	0757 0734	2	R: fxd prec met film 68 1 ohms ±1% 1/2W	75042	CEA T-O
R2,R3	0683 2025	5	R: fxd comp 2000 ohms ±5% 1/4W	01121	CB2025
R4	0683 6825	1	R: fxd comp 6800 ohms ±5% 1/4W	01121	CB6825
R5	0698 4121	1	R: fxd prec met film 11.3 kilohms ±1% 1/8W	19701	ME6C T-O
R6	0698 3155	1	R: fxd prec met film 4640 ohms ±1% 1/8W	75042	CEA T-O
R7,R8	0683 2025	5	R: fxd comp 2000 ohms ±5% 1/4W	01121	CB2025
R9	0757 0794		R: fxd prec met film 68.1 ohms ±1% 1/2W	75042	CEA T-O
R10	0757 0447	1	R: fxd prec met film 10.2 kilohms ±1% 1/8W	75042	CEA T-O
R11	0698 3156	1	R: fxd prec met film 14.7 kilohms ±1% 1/8W	75042	CEA T-O
R12	0683 1215		R: fxd 120 ohms ±5% 1/4W	01121	CB1215
R13, R14			Not assigned		
R15	0698 5344	1	R: fxd prec met film 301 ohms ±1% 1/2 W	-hp-	
R16	0683 6835	1	R: fxd comp 68 kilohms ±5% 1/4 W	01121	CB6835
R17	2100 2030	1	R: var comp pot lin 20 kilohms ±10% 1/2 W	73138	62-210-1
R18*	0683 4735	1	R: fxd comp 47 kilohms ±5% 1/4 W	01121	CB4735
R19	0686 2265	1	R: fxd comp 22 megohms ±5% 1/2 W	01121	EB2265
R20	0684-1001	2	R: fxd comp 10 ohm ±10% 1/4 W	01121	CB1001
R21	0757 0824	2	R: fxd prec met film 2000 ohms ±1% 1/2 W	75042	CEC T-O
R22*	0698-4448	1	R: fxd 294 ohms ±1% 1/8 W	16219	CA-178 TO 294H-F

Table 6-3. Replaceable Parts (Cont'd).

REFERENCE DESIGNATOR	-hp- PART NO.	TO	DESCRIPTION	MFR.	MFR. PART NO.	
R23,R24	0757 0434	2	R: fxd prec met flm 3650 ohms ±1% 1/8W	75042	CEA T-O	obd
R25	0683 3916	2	R: fxd comp 390 ohms ±5% 1/4W	01121	CB3915	
R26	0698 4123	1	R: fxd prec met flm 499 ohms ±1% 1/8W	19701	MF5C T-O	obd
R27	0683 2225	1	R: fxd comp 2200 ohms ±5% 1/4W	01121	CB2225	
R28	0684 1001	1	R: fxd comp 10 ohms ±10% 1/4W	01121	CB1001	
R29	0698 4422		R: fxd comp 1270 ohms ±5% 1/4W	03292	C4-1/3-TO-1271-F	
R30	0698 2353	1	R: fxd met flm 196 kilohm ±1% 1/8W	75042	CEA	obd
R31	2100 2522	1	R: var pot lin 10 kilohms ±20% 1/2 W	73138	62-227-1	obd
R32	0634 4721	1	R: fxd comp 4700 ohms ±1-10% 1/4W	01121	CB4721	
R33	0757 0442	1	R: fxd met flm 10 kilohms ±1% 1/8W	75042	CEA T-O	obd
R34	0698 3260	1	R: fxd met flm 464 kilohms ±1% 1/8W	75042	CEA T-O	obd
R35	0757 0401	2	R: fxd met flm 100 ohms ±1% 1/8W	75042	CEA T-O	obd
R36	0698 3179	1	R: fxd met flm 2550 ohms ±1% 1/8W	75042	CEA T-O	obd
R37	0684 1011	3	R: fxd comp 100 ohms ±10% 1/4W	01121	CB1011	
R38	2190 2632	1	R: var pot lin 100 ohms ±10% 1/2 W	73138	62-221-1	obd
R39	0757 0346	1	R: fxd met flm 10 ohms ±1% 1/8W	19701	MF5C T-O	obd
R40	0698 3434	1	R: fxd met flm 34 ohms ±1% 1/8W	75042	CEA T-O	obd
R41	0698 3147	1	R: fxd met flm 191 ohms ±1% 1/8W	75042	CEA	obd
R42	0698 4126	1	R: fxd met flm 35.7 ohms ±1% 1/8W	19701	MF7C T-O	obd
R43	0698 3262	1	R: fxd met flm 40.2 ohms ±1% 1/8W	75042	CEA T-O	obd
R44	2100 2632	1	R: var lin 100 ohms ±10% 1/2 W	73138	62-221-1	
R45	0757 0381	1	R: fxd met flm 15 ohms ±1% 1/8W	75042	CEA T-O	obd
R46	0757 0273	2	R: fxd met flm 3010 ohms ±1% 1/8W	75042	CEA	obd
R47	0757 0410	1	R: fxd met flm 301 ohms ±1% 1/8W	75042	CEA T-C	obd
R48	0757 0407	1	R: fxd met flm 200 ohms ±1% 1/8W	75042	CEA T-O	obd
R49	0757 0273		R: fxd met flm 3010 ohms ±1% 1/8W	75042	CEA T-O	obd
R50*	0698 4434	1	R: fxd met flm 2320 ohms ±1% 1/8W	75042	CEA	obd
R51*	0757 0284	1	R: fxd met flm 150 ohms ±1% 1/8W	75042	CEA	obd
R52	0684 1011		R: fxd comp 100 ohms ±10% 1/4W	01121	CB1011	
R53	0757 0283	1	R: fxd met flm 2000 ohms ±1% 1/8W	75042	CEA	obd
R54	0698 3368	1	R: fxd met flm 1000 ohms ±1% 1/8W	75042	CEA T-O	obd
R55	0683 2025		R: fxd comp 2000 ohms ±5% 1/4W	01121	CB2025	
R56	0698 4497	1	R: fxd met flm 48.7 kilohms ±1% 1/8W	19701	MF5C T-O	obd
R57	0757 0428	1	R: fxd met flm 1620 ohms ±1% 1/2W	75042	CEA T-O	obd
R58	0683 1035	1	R: fxd comp 10 kilohms ±5% 1/4W	01121	CB1035	
R59	2100 0962	1	R: var comp pot lin 3000 ohms ±30% 1/4W	90201	MTC-1	obd
R60	0757 0459	2	R: fxd met flm 56.2 kilohms ±1% 1/8W	19701	MF4C	obd
R61	0683 3335	1	R: fxd comp 33 kilohms ±5% 1/4W	01121	CB3335	
R62	0757 0393	1	R: fxd met flm 47.5 ohm ±1% 1/8W	75042	CEA T-O	obd
R63	0757 0401	1	R: fxd met flm 190 ohms ±1% 1/8W	75042	CEA T-O	obd
R64	0757 0824		R: fxd met flm 2000 ohms ±1% 1/2W	75042	CEC T-O	obd
R65	0698 4125	1	R: fxd met flm 953 ohms ±1% 1/8W	19701	MF5C T-O	obd
R66	0757 0400	1	R: fxd met flm 90.9 ohms ±1% 1/8W	75042	CEA T-O	obd
R67	0757 0413	1	R: fxd met flm 392 ohms ±1% 1/8W	19701	MF4C	obd
R68,R69	0683 4325	2	R: fxd comp 4.3 kilohms ±5% 1/4W	01121	CB4325	
R70	0757 0457	1	R: fxd met flm 47.5 kilohms ±1% 1/8W	75042	CEA T-O	obd
R71	0757 0459		R: fxd met flm 56.2 kilohms ±1% 1/8W	75042	CEA T-O	obd
R72*	0757 0402	1	R: fxd met flm 110 ohms ±1% 1/8W	19701	MF4C	obd
R73,R74	0683 1525	2	R: fxd comp 1500 ohms ±5% 1/4W	01121	CB1525	
R75	0684 1011		R: fxd comp 100 ohms ±10% 1/4 W	01121	CB1011	
	B150 3375	2	Shorting Wire: 22AWG, FORMED	75042	ZEROHM	
CHASSIS MOUNTED COMPONENTS						
C1	0180 2151	1	C: fxd 500 μF ±75% -10%	66289	3001610	
DS1	1450 0574	1	DS: pilot indicator NE-2E neon in white plastic body	28480	1450 0574	
F1	2110 0318	1	Fuse: 0.125 A 250 V slow blow	75400	MDL 1/B	

Table 6-3. Replaceable Parts (Cont'd).

REFERENCE DESIGNATOR	-hp- PART NO.	TO	DESCRIPTION	MFR.	MFR. PART NO.
J1 J2 J3 J4 J5	1250 011B 1250 011B 1251-2357	2 1	Connector: BNC input front panel Connector: DC output (See Figure 6-1 for parts) Connector: BNC AC output rear panel Connector: battery (See Figure 6-1 for parts) Connector: power cor)	95712 95712 92389	30384-1 30384-1 EAC-301
M1 M1 M1	1120 0919 1120 0902 1120 0908	1 1 1	Meter: Log (400EL and 400EL Option 02) Meter: Linear (400E and 400E Option 02) Met., Linear (400E Option 01 only)	-hp- -hp- -hp-	
R1 R2	0687 3331 2100 0021		R: fxd comp 33 kilohms $\pm 10\%$ 1/2W R: var ww 100 ohms $\pm 20\%$ 1-1/2W	01121 11236	EB3331 112 otd
S1	3101-2-47	1	S: tog SPST 3A 250 V ac-dc	28480	3101-2147
S2	00400-61901		Switch Ass'y: RANGE	-hp-	
C1* C2 C3* C4*	0160 0205 0130 0014 0160-0205 0180-0100		C: fxd 10 pF 200 V C: var cor 5 25pF C: fxd 10pF 500V C: fxd Ta elect 4.7 μ F $\pm 10\%$ 35 vdcw	72136 72982 72136 14433	otd 567 062 COPO 39H otd SMA.7NF
CR1,CR2	1901 0040		Diode: 30mA at $\pm 1V$ 30 piv 2pF 2ns	03877	SC5050
R1 R2 R3 R4 R5	0757 0715 0757 0069 0757 0178 0698 4119 0698 4118		R: fxd met flm 150 ohms $\pm 1\%$ 1/4W R: fxd met flm 121 ohms $\pm 1\%$ 1/4W R: fxd met flm 100 ohms $\pm 1\%$ 1/4W R: fxd met flm 410.26 ohms $\pm 0.1\%$ 1/4W R: fxd met flm 277.48 ohms $\pm 0.1\%$ 1/4W	75042 75042 75042 19701 75042	CEA T-O CEB T-O CEB T-O MF6C T-3 CEA T-O otd otd otd otd otd
R6 R7 R8 R9 R10	0698 4119 0698 4118 0698 4119 0698 4118 0698 4119		R: fxd met flm 410.26 ohms $\pm 0.1\%$ 1/4W R: fxd met flm 277.48 ohms $\pm 0.1\%$ 1/4W R: fxd met flm 410.26 ohms $\pm 0.1\%$ 1/4W R: fxd met flm 277.48 ohms $\pm 0.1\%$ 1/4W R: fxd met flm 410.26 ohms $\pm 0.1\%$ 1/4W	19701 75042 19701 75042 19701	MF6C T-3 CEA T-O CEA T-O CEA T-O MF6C T-3 otd otd otd otd otd
R11 R12 R13 R14	0698 4118 0698 4119 0698 4117 0683-4735		R: fxd met flm 277.48 ohms $\pm 0.1\%$ 1/4W R: fxd met flm 410.26 ohms $\pm 0.1\%$ 1/4W R: fxd met flm 189.72 ohms $\pm 0.1\%$ 1/4W R: fxd comp 47 kilohms $\pm 5\%$ 1/4W	75042 19701 75042 01121	CEA T-O MF6C T-3 CEA T-O CB4735 otd otd otd otd
S2	00400-61902	1	Switch Ass'y: RANGE (for Option 02 only) (Same as 00400 61901 with S4 added)	-hp-	
S3	3101-1234	1	Switch: slide DPOT 115/230 V rated 6A 259 VAC	82389	11A-1242A
S4 R1	2100 1723		P/O 00400 61902 ass'y R: var 200 kilohms $\pm 20\%$ log dB taper (Option 02 only)	-hp- 01121	Type V otd

Table 6-3. Replaceable Parts (Cont'd).

REFERENCE DESIGNATOR	hp PART NO.	QTY	DESCRIPTION	MFR.	MFR. PART NO.
T1	9100-1321		Transformer: line	hp	
W1	8120 1348		Assy: cable AC power cord set	70903	KHS-7041
MECHANICAL PARTS (See Figure 6-1)					
MP1	0370 0112	1	Knob: bar w/one arrow black	hp	
MP2	0370 0113	1	Knob: bar (Option 02 only) 3/4 inch diam black	hp	
MP3	0370 0114	1	Knob: round red (Option 02 only) 5/8 inch diam	hp	
MP4			Not assigned		
MP5			Not assigned		
MP6	1400 0084	1	Holder: fuse extractor post type black	75915	342014
MP7	00400 05501	1	Shield box: attenuator	hp	
MP8	5040 4503	1	Grommet: insulator plastic	hp	
MP9	1490 0031	1	Screw: 1/3 module tilt	hp	
MP10	00400 00211	1	Panel: rear	hp	
MP11	00400 00217	1	Panel: front (400E and 400E Option 01)	hp	
MP11	00400 00220	1	Panel: front (400EL and 400EL Opt 01)	hp	
MP11	00400 00219	1	Panel: front (400E Opt 02)	hp	
MP11	00400 00221	1	Panel: front (400EL Opt 02)	hp	
MP12	5020 6852	1	Meter Trim: 1/3 module	hp	
MP13	00400 04101	1	Cover: shield box (attenuator)	hp	
MP14	5060 0703	2	Frame: 6 X 11 sub module	hp	
MP15	5060 0727	2	Foot Ass'y: 1/3 module	hp	
MP16	0580 0052	2	Nut: Tinnerman	78563	C-8020 632 24B
MP17	5000 5838	2	Bracket: cover retainer	hp	
MP18	00400 64103	1	Cover: top with handle	hp	
MP19	5000 8565	2	Cover: side 6 X 11 SM	hp	
MP20	5000 8571	1	Cover: bottom 5 X 11 SM	hp	
MP21, MP22	1510 0091		Big Post-Assy (grey/red)	hp	
MP23, MP24	1510 0107		Big Post-Assy (grey/black)	hp	
MP25	1510 0090		Big Post-Assy (grey)	hp	
MP26	1510 0038		Big Post-Simple	hp	
MP27			Not Assigned		
MP28	5040 0700	1	Hinge: tilt stand 1/3 module	hp	
MP29	2190 0047	2	Lock washer: top cover	78189	1506 00
MP30	2370 0013	4	Screw: top and bottom cover phillips head 6 32	87385	obd
MISCELLANEOUS					
	0340-1512	4	Insulator: feed thru	28480	0340-1512
	0380-0059	5	Spacer: captive (for PC board)	28480	0380-0059
	0360-0480		Terminal: pin matches with 1200-0162	70563	61038-1
	4330-0496	10	Beads: seed component standoff	000LP	2158
	1200-0162		Connector: pin receptical	70563	60804-1
	00400 01201	1	Ground strap	hp	
	00400 61602	1	Cable: power	hp	
	00400 64101	0	Kit: for cover with handle (includes hardware)	hp	
	7120 4600	1	Label Warning "Warning for Operator Protection"	hp	
	2950 0144	5	Nut Hex-Dbl Cham	26365	913 891

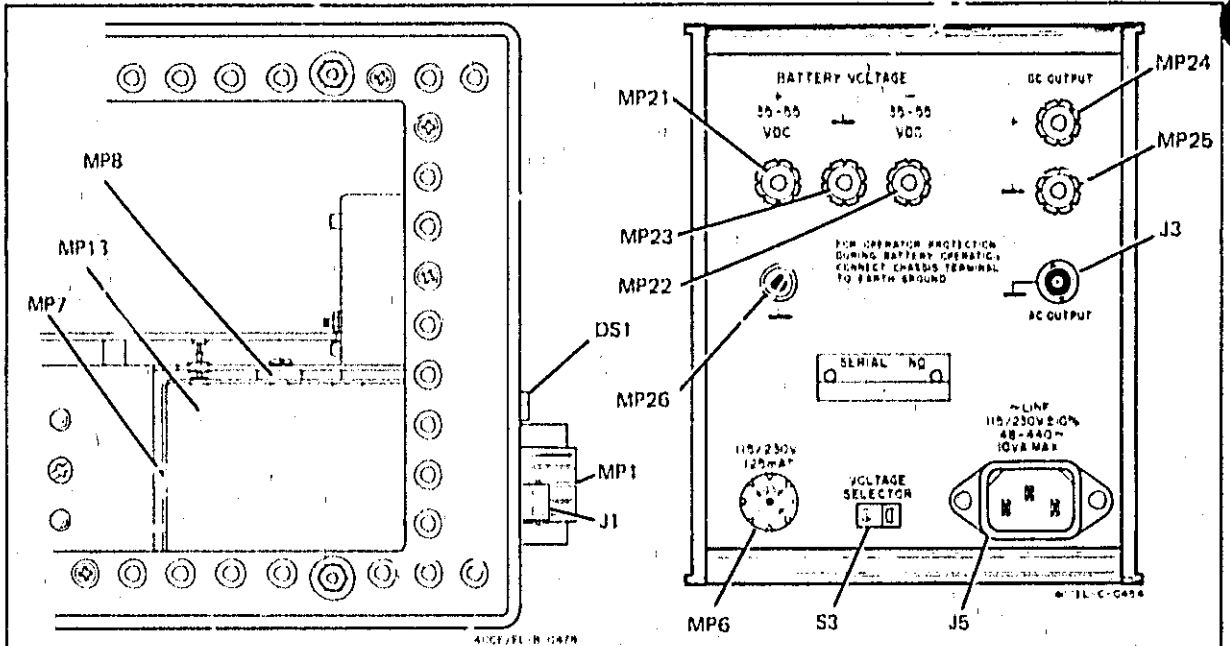

LEFT SIDE VIEW

BACK VIEW

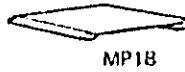
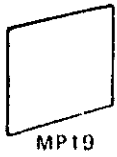

Handle included with top cover. Refer to Misc. Page 6-6 for handle kit.

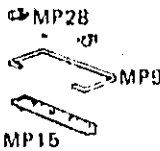
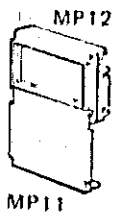
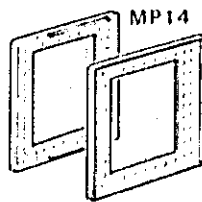
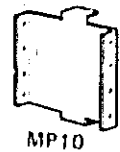

NOTE

The following hardware not shown:

- MP16 Nut: innerman
- MP17 Bracket: cover retainer
- MP29 Lock washer: external
- MP30 Screw: top and bottom cover
- MP31 Screw: side cover

Figure 6-1. Mechanical Parts

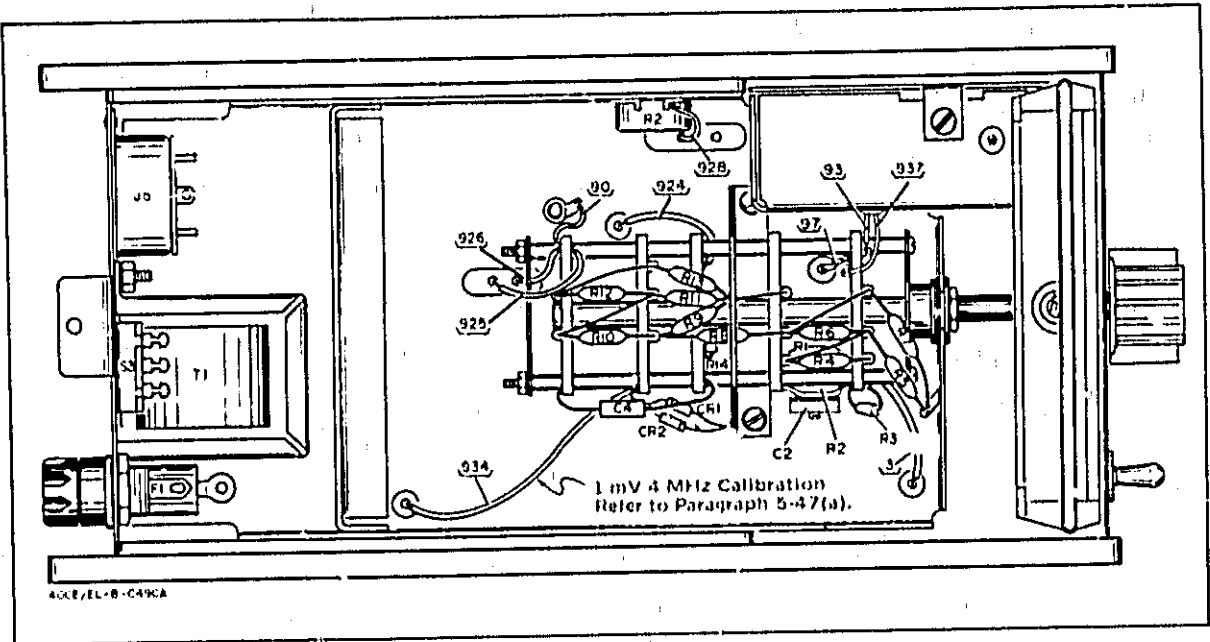

Figure 6-2. Chassis and Switch Components.

SCHEMATIC DIAGRAMS

SECTION VII CIRCUIT DIAGRAMS

7-1. INTRODUCTION.

layout to be used for maintenance and operation of the 400 E/EL.

7-2. This section contains a schematic diagram, component locator, and a PC board component

7-3. An explanation of terms and symbols used as reference designators is given in the Schematic Notes.







SCHEMATIC NOTES

1. PARTIAL REFERENCE DESIGNATIONS ARE SHOWN. PREFIX WITH ASSEMBLY OR SUBASSEMBLY DESIGNATION(S) OR BOTH FOR COMPLETE DESIGNATION.

2. COMPONENT VALUES ARE SHOWN AS FOLLOWS UNLESS OTHERWISE NOTED:

RESISTANCE IN OHMS

CAPACITANCE IN MICROFARADS

3.  DENOTES ASSEMBLY.
 DENOTES MAIN SIGNAL PATH.
 DENOTES MAIN FEEDBACK PATH.
4. ALL DC VOLTAGES ARE $\pm 10\%$ EXCEPT THE BASE AND EMITTER OF Q8 WHICH IS $\pm 20\%$.
5. * AVERAGE VALUE SHOWN, OPTIMUM VALUE SELECTED AT FACTORY.
6. † REFER TO BACKDATING CHANGES IN APPENDIX C.
7. 918 DENOTES WIRE COLOR USING STANDARD COLOR CODE.
(e.g. 918 = WHITE, BROWN, GRAY)
8.  DENOTES POWER LINE GROUND.
9.  DENOTES CHASSIS GROUND.
10.  DENOTES CIRCUIT GROUND (ASSEMBLY).

A2 Board
Component Locations

	C	CR	Q	R	F	C	R		R	
1	B1	C1	A1	A1	38	26	C5	C7	51	C6
2	B1	A1	A2	A1		27	--	F7		
3	A2	C1	D2	A2					52	D6
4	A2	B1	C1	A3		28	A1	C7	53	F6
5	C1	A1	D8	B1		29	D5	D8	54	A7
6	B1	C1	C8	A3		30	C4	B5		
7	C2	A3	B8	C2		31	D5	A6	55	F6
8	B1	C3	D6	C1		32	C4	D6	56	D4
9	C3	D8	A5	D1		33	D4	B5	57	D4
10	D8	D8	B5	D3		34	F5	B5	58	F3
11	C7	D8	C5	C1		35	D6	B5	59	D4
12	D8	D6	C5	A7		36	F5	C5	60	D2
13	C7	C4	D4	--		37	D7	D4	61	D4
14	B7	C6	D5	--		38	F1	A3	62	D7
15	B8	F4	D3	E8		39	D3	B5	63	D2
16	C7	F4	F2	B7		40	F3	D4	64	F6
17	A7	D7	--	B7		41	D1	D4	65	C4
18	A7	D7	--	B7		42	D7	C4		
19	D8	D6	--	D8		43	D7	D4	67	C2
20	A5	C7	--	C7		44	--	C4	68	D7
21	D6	B7	--	C7		45	F1	C4	69	D7
22	C6	D2	--	B7		46	--	C6	70	B5
23	B5	--	--	C8		47	--	C5	71	B5
24	D6	--	--	C8		48	--	C5	72	C4
25	B5	--	--	B8		49	--	D4	73	B7
						50	--	C6	74	B7
									75	B4

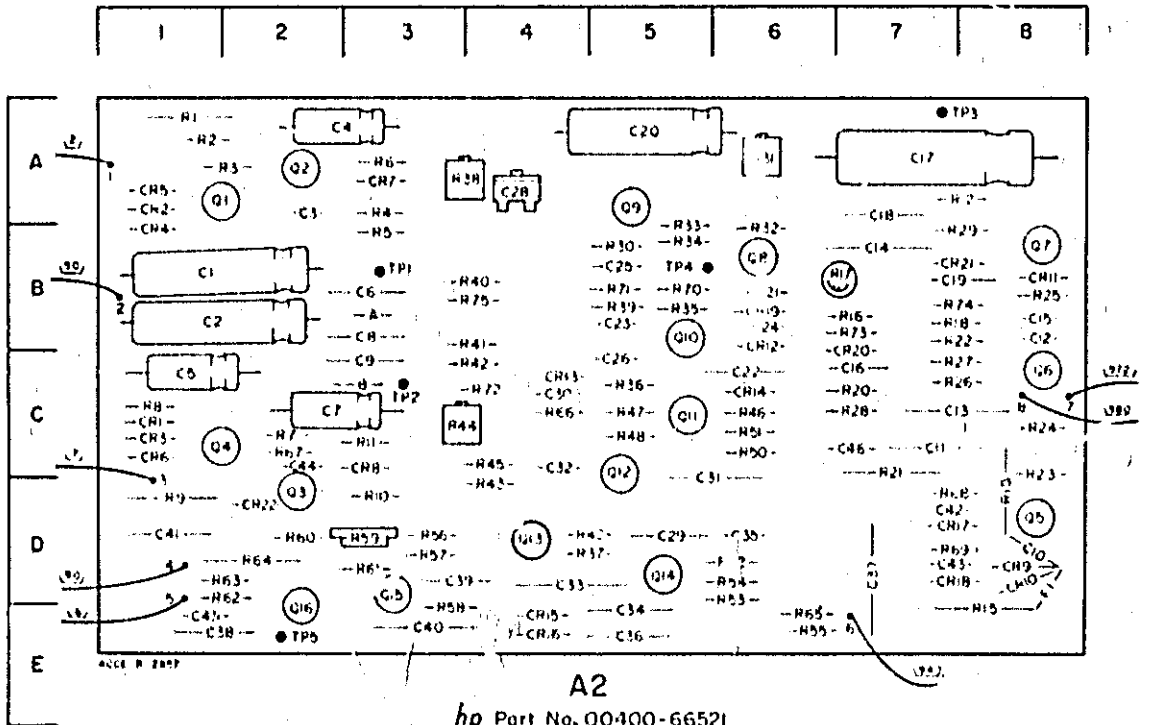

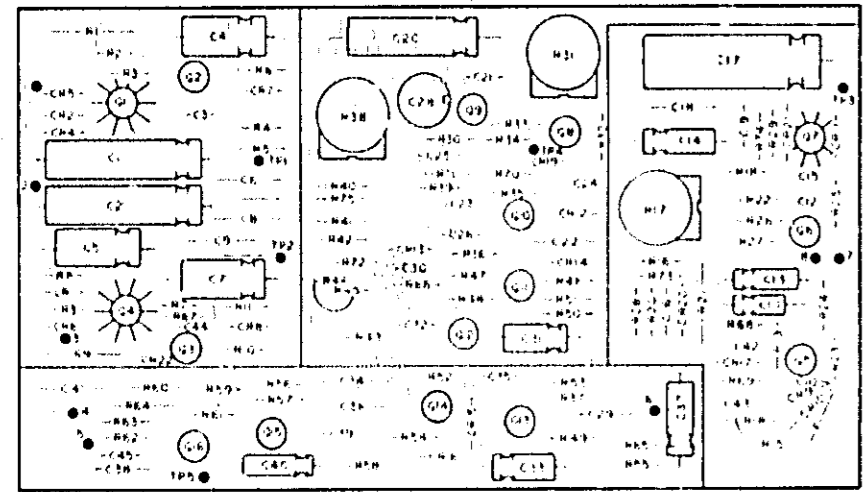

A2
hp Part No. 00400-66501
Rev E

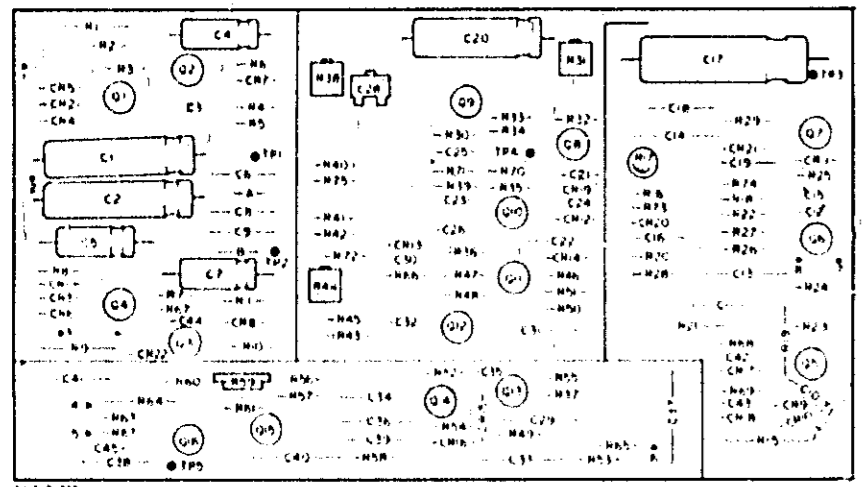

A2
hp Part No. 00400-66511

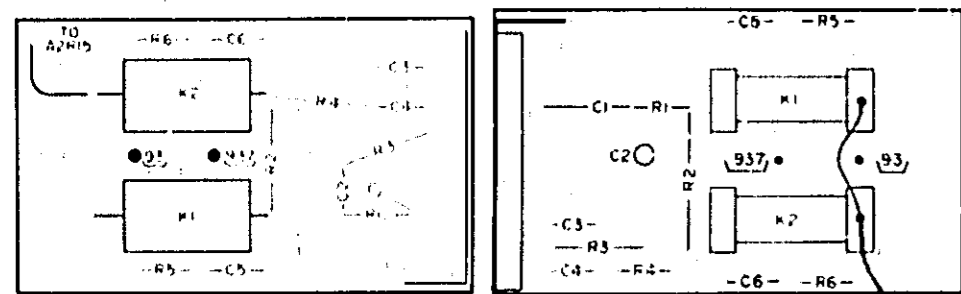

A1
hp Part No. 00400-66502

A1
hp Part No. 00400-66512

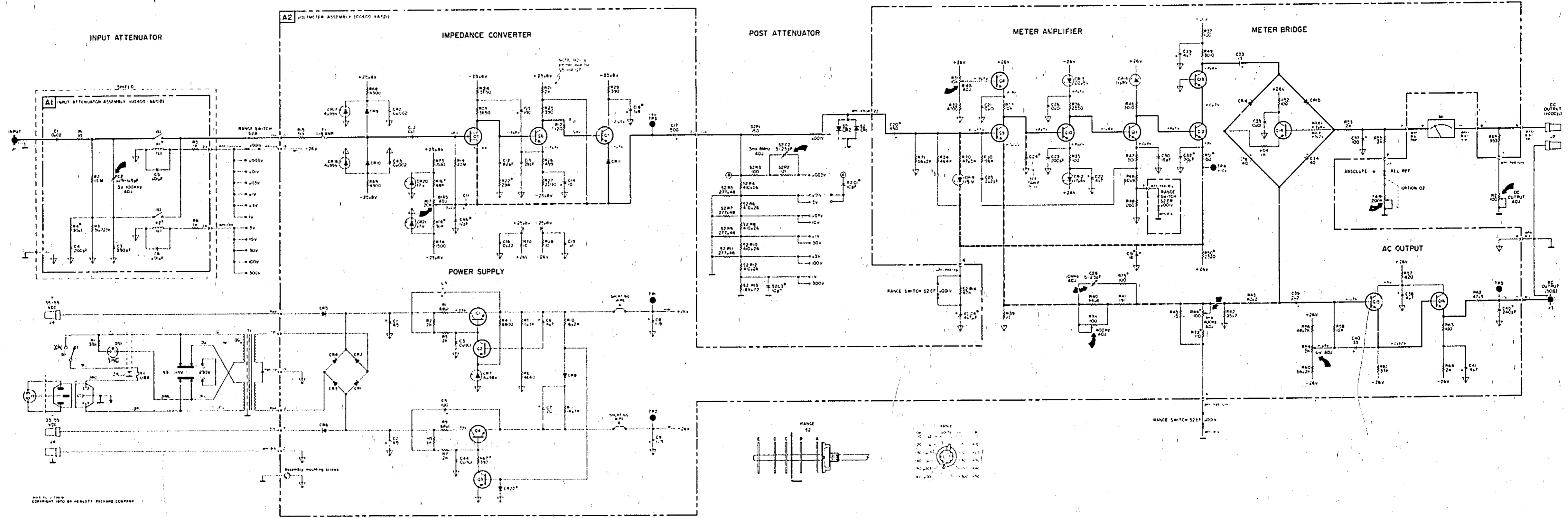

Figure 7-1. 400E/EL Schematic Diagram and Location of Components

**BACK DATING
MANUAL
CHANGES**

SECTION VIII

MANUAL BACKDATING CHANGES

This manual backdating sheet makes this manual applicable to earlier instruments. Instrument-component values that differ from those in the manual, yet are not listed in the backdating sheet, should be replaced using the part number given in the manual.

Instrument Serial Prefix	Make Manual Changes	Instrument Serial Prefix	Make Manual Changes
536-00101 to -01100	1 thru 12, 14	All	12
536-01101 to -01350	2 thru 12, 14	1150A12354 to 1208A12853	13
536-01351 to -02403	3 thru 12, 14	1131A12603 and Earlier	14
536-02404 to -04253	4 thru 12, 14	400E 1208A07332 & Earlier 400EL 1208A16379 & Earlier	15
536-04254 to -04854	5 thru 12, 14	1208A18153 to 1131A12604	16
536-04855 to -05503	6 thru 12, 14	1208A18968 & Earlier	17
536-05504 to -08353	7 thru 12, 14	400E 1208A21368 & Earlier 400EL 1208A21319 & Earlier	18
536-08354 to -09153	8 thru 12, 14	400E 1208A21489 thru 23849 400EL 1208A21549 thru 23898	19
536-09154 to -09553	9 thru 12, 14	400E 1208A23848 & Earlier 400EL 1208A23898 & Earlier	20
949-09554 to -09753	10 thru 12, 14	400E 1208A24068 & Earlier 400EL 1208A24118 & Earlier	21
0949A11853 & Earlier	11, 12, 14	400E 1208A24128 & Earlier 400EL 1208A24168 & Earlier	22

CHANGE NO. 1 Transformer mounting and pin receptacles are different but current parts should be used.

Section VI Replaceable Parts and Figure 7-1 Schematic Diagram:

Change S2C2 to C: fxd 30 pF \pm 5%; -hp- Part Number 0160-0181.

CHANGE NO. 2 Section VI Replaceable Parts and Figure 7-1 Schematic Diagram:

NOTE

If any of the parts listed in Change 2 are changed to values shown in Table 6-1 and Schematic Figure 7-1, app parts should be changed.

Change A2R44 to R*: fxd met flm 150 ohms \pm 1%; -hp- Part Number 0757-0284.

Change A2R16 to R: fxd comp 82 kilohms \pm 5%; -hp- Part Number 0683-8235.

Delete A2R72, A2R73, A2R74, A2CR20, A2CR21, A2C44.

Change A2Q3 to TSTR: Si PNP 2N3638; -hp- Part Number 1853-0016.

Change A2Q4 to TSTR: Ge PNP 2N1183; -hp- Part Number 1850-0064.

Change A2R67 to R: fxd comp 390 ohms \pm 5%; -hp- Part Number 0683-3915 and delete A2CR22.

CHANGE NO. 3 Section VI Replaceable Parts and Figure 7-1 Schematic Diagram

Delete: A2R67 and A2CR22.

Change A2C12 to C: fxd 110 pF \pm 5%; -hp- Part Number 0140-0194.

CHANGE NO. 4 Section VI Replaceable Parts

00400-66502 printed circuit board has different location for relay connections: A1K1 and A1K2. Check configuration of relay connections and order part numbers shown according to location of relay terminals.

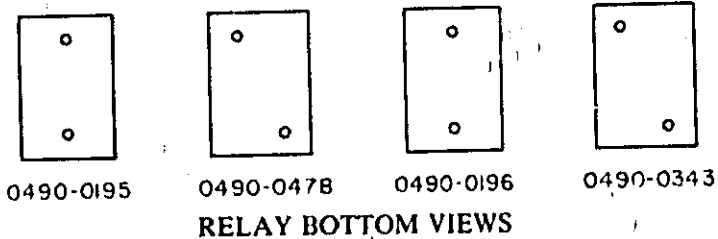

CHANGE NO. 5 Table 6-1 Replaceable Parts and Figure 7-1 Schematic:

Change A2Q5 to -hp- Part Number 1855-0068 and A2R16 to 82 kilohms \pm 5%, -hp- Part Number 0683-8325. If A2Q5 should be defective, replace both A2Q5 and A2R16 with latest part numbers to reduce noise.

CHANGE NO. 6 Table 6-1 Replaceable Parts and Figure 7-1 Schematic

Change A2R73, R74 to 4.7 kilohms, -hp- Part Number 0683-4725. Replace with latest part numbers to reduce noise produced by A2CR20 and CR21.

CHANGE NO. 7 Table 6-1 Replaceable Parts and Figure 7-1 Schematic.

Delete: A2R75.

CHANGE NO. 8 Table 6-1 Replaceable Parts and Figure 7-1 Schematic.

Delete: A2C45.

CHANGE NO. 9 Table 6-1 Replaceable Parts.

Change J5 connector power cord to -hp- Part Number 1251-0148.

Change Panel rear to 00400-00202.

Change Cord Assy power to 8120-0078.

CHANGE NO. 10 Table 6-1 Replaceable Parts.

Change S3 rear panel switch DPDT 115 V/230 V 1/2 -hp Part Number 3101-0033.

CHANGE NO. 11 Table 6-1:

Change A2 Part Number to 00400-66501.
 Change A2C28 to 0130-0016 C: var cer 5-25 pF.
 Change A2R17 to 2100-0093 R: var comp 20 K \pm 20% 0.1 W.
 Change A2R31 to 2100-0092 R: var comp 10 K \pm 20% 0.15 W.
 Change A2R38 to 2100-0277 R: var comp 100 Ω \pm 20% 0.15 W.
 Change A2R44 to 2100-1836 R: var comp 100 Ω \pm 20% 0.1 W.
 Change MP27 to 00400-00603

Page 7-3:

Change the affected to reflect the above values.

CHANGE NO. 12 The covers, panel and trim listed on Page 6-6 are for newer brown instruments. Parts for older blue instruments are listed below.

MP11 00400-00201 Panel: front (400E and 400E Option 01)
 MP11 00400-00203 Panel: front (400EL and 400EL Option 01)
 MP11 00400-00204 Panel: front (400E Option 02)
 MP11 00400-00205 Panel: front (400EL Option 02)
 MP12 5020-5388 Meter trim: 1/3 module
 MP18 00400-64102 Cover: top with handle
 MP19 5000-0703 Cover: side 6 x 11 SM
 MP20 5000-0711 Cover: bottom 5 x 11 SM

CHANGE NO. 13 Instruments that fall within this band of serial numbers have a 500 μ F capacitor across the output terminals. This capacitor made the meter response too slow and is no longer being used.**CHANGE NO. 14** Table 6-1

Change A1 to -hp- Part Number 00400-66502.
 Change A1C2 to 0121-0407; C: var 0.7 -3 pF.
 Change A1C3 to 0140-0149; C: fxd mica 470 pF \pm 5%.
 Change A1CR1, CR2 to A1CJ, C6; 0150-0093; C: fxd cer 0.01 μ F.
 Change relays to: A1K1 0490-0194 Relay, Reed and A1K2 0490-0366 Relay, Reed.
 Delete coils for K1, K2.
 Change A2 to 00400-66511 PC Board Assembly (see drawings on Page: 7-3).
 Change A2R22* to 0698-3510 R: fxd 453 ohms 1%.
 Delete S2C1, C3.

CHANGE NO. 15 Page 6-3, Table 6-1. Delete A2R12.
Page 7-2. Delete A2R12.
Page 7-3, Figure 7-1. Delete A2R12. A2Q6 collector is directly connected to A2Q7 base.**CHANGE NO. 16** Page 7-3, Figure 7-1. Delete the blue (6) jumper from A1 00400-66512 component: locator drawing.

- CHANGE NO. 17** Page 6-6, Table 6-1. Change MP4 to 5060-0634, Binding post Ass'y: red with hardware.
 Change MP5 to 5060-0635, Binding Post Assy'y: black with hardware.
 Change MP21 to 0340-0090, Insulator: front double with locating key p/o J2.
 Change MF22 to 0340-0086, Insulator: rear double without locating key p/o J2.
 Change MP23 to 0340-0091, Insulator: front triple in line with locating key p/o J4.
 Change MP24 to 0340-0087, Insulator: rear triple in line without locating key p/o J4.
- Page 6-7, Figure 6-1. Replace Back View drawing with Figure C-1.
- CHANGE NO. 18** The A1 PC board, Part Number 00400-66522, is a direct replacement for the older A1 PC board, Part Number 00400-66512.
- CHANGE NO. 19** The Part Number for the A1K1 relay was changed from 00400-61905 to Part Numbers 0490-0194 for the reed relay switch and 0490-1028 for the reed relay coil.
- CHANGE NO. 20** Change A1K1 Part Number from 0490-1205 to Part Numbers 1490-0194 for the reed relay switch and 0490-1028 for the reed relay coil. Also change A1K2 from Part Number 0490-1205 to 0490-1028 for the reed relay switch and 0490-0366 for the reed relay coil.
- CHANGE NO. 21** The S1 power switch Part Number 3101-0036 is replaced by Part Number 3101-2147.
- CHANGE NO. 22** Table 6-1, page 6-2. Change C18 to 1.8 μ F -hp- Part Number 0180-0101.
 Table 6-1, Page 6-4. Change R29 to 390 ohm, -hp- part Number 0683-3915.

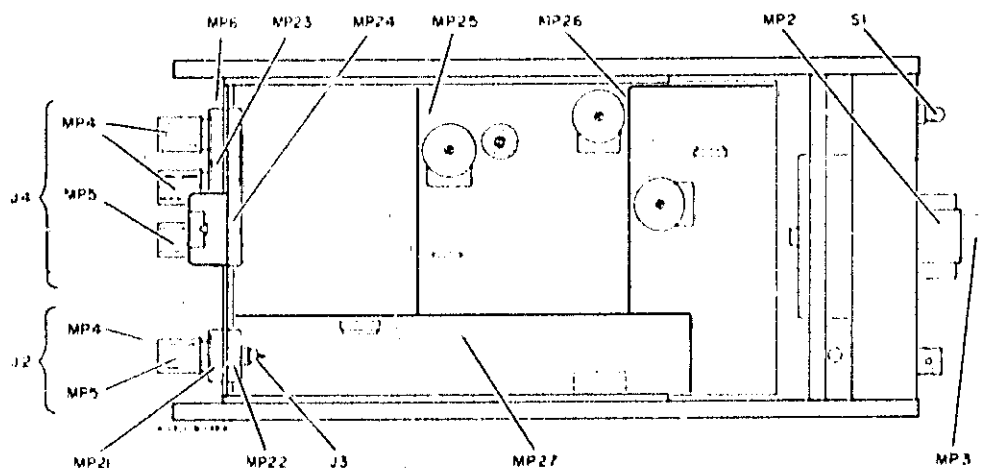

SAFETY SYMBOLS

General Definitions of Safety Symbols Used On Equipment or In Manuals.



Instruction manual symbol: the product will be marked with this symbol when it is necessary for the user to refer to the instruction manual in order to protect against damage to the instrument.



Indicates dangerous voltage (terminals fed from the interior by voltage exceeding 1000 volts must be so marked).

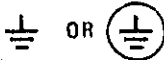

Protective conductor terminal. For protection against electrical shock in case of a fault. Used with field wiring terminals to indicate the terminal which must be connected to ground before operating equipment.



Low-noise or noiseless, clean ground (earth) terminal. Used for a signal common, as well as providing protection against electrical shock in case of a fault. A terminal marked with this symbol must be connected to ground in the manner described in the installation (operating) manual, and before operating the equipment.

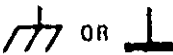

Frame or chassis terminal. A connection to the frame (chassis) of the equipment which normally includes all exposed metal structures.



Alternating current (power line).



Direct current (power line).



Alternating or direct current (power line).

WARNING

The WARNING sign denotes a hazard. It calls attention to a procedure, practice, condition or the like, which, if not correctly performed or adhered to, could result in injury or death to personnel.

CAUTION

The CAUTION sign denotes a hazard. It calls attention to an operating procedure, practice, condition or the like, which, if not correctly performed or adhered to, could result in damage to or destruction of part or all of the product.

NOTE:

The NOTE sign denotes important information. It calls attention to procedure, practice, condition or the like, which is essential to highlight.

MANUAL CHANGES

hp MANUAL CHANGES

-hp MODEL 400E/EL

AC VOLTMETER

Manual Part Number 00400-90020

Page 5-4, Table 5-3. Replace Table 5-3, Calibration Tolerances, with Table MC1 of this Change Sheet.

Table MC 1.

Frequency (Hz)	1 Millivolt Range Only			Frequency (Hz)	1 Millivolt Range Only		
	Voltage Input	Meter (mV) (% of reading)	DC Output (Volts)		Voltage Input	Meter (mV) (% of reading)	DC Output (Volts)
10	1.00 mV	1.00 ± 5%	1.00 ± 0.05	100 k	1.00 mV	1.00 ± 1%	1.00 ± 0.005
	0.5 mV	0.50 ± 7.6%	0.50 ± 0.038		0.5 mV	0.50 ± 2%	0.50 ± 0.0045
	0.3 mV	0.30 ± 10.8%	0.30 ± 0.033		0.3 mV	0.30 ± 3.3%	0.30 ± 0.0043
40	1.00 mV	1.00 ± 1%	1.00 ± 0.02	500 k	1.00 mV	1.00 ± 1%	1.00 ± 0.02
	0.5 mV	0.50 ± 2%	0.50 ± 0.015		0.3 mV	0.30 ± 3.3%	0.30 ± 0.013
	0.3 mV	0.30 ± 3.3%	0.30 ± 0.013				
100 or 400	1.00 mV	1.00 ± 1%	1.00 ± 0.005	4 M	1.00 mV	1.00 ± 5%	1.00 ± 0.05
	0.5 mV	0.50 ± 2%	0.50 ± 0.0045		0.3 mV	0.30 ± 10.8%	0.30 ± 0.033
	0.3 mV	0.30 ± 3.3%	0.30 ± 0.0043				

CHANGE NO. 5 applies to all serial numbers.

Table 5-1. Required Test Equipment should have the following changes made:

- The AC Calibrator recommended model should be a Fluke 5200A and 5215A.
- The AC/DC Voltmeter recommended model should be an -hp- Model 3466.
- The DC Standard recommended model should be a Systron Donner Model M107A.
- The Voltmeter Calibrator should be deleted from the table.

Page 5-2. Figure 5-1. Accuracy Test Setup, should be altered to show the use of the Fluke 5200A AC Calibrator rather than the -hp- Model 745A.

Page 5-4. Figure 5-2. Accuracy and Frequency Response Test Setup, should be altered to show the use of the Systron Donner Model M107 DC Standard rather than the -hp- Model 740A.

Page 5-11. Figure 5-2. Delete paragraphs 5-45, 5-46, and 5-47.

Page 5-12. Delete Figure 5-5, Alternate Calibration and Frequency Test Setup.

ERRATA

Page 5-3, Table 5-3 (Replaceable Parts). Change the -hp- Part Number of the A1 Assembly from "00400-66521" to "00400-66522".

CHANGE NO. 6. 400E: Applies to Serial Numbers 1208A2894 and Above.
400EL: Applies to Serial Numbers 1208A29014 and Above.

Section VI, Table 5-3 (Replaceable Parts). Do the following changes in the table:

Ref. Des.	-hp- Part Number	Description
A2C47	0180-0100	Add 4.7µF 35V Capacitor
A2Q17	1853-0010	Add SM4713 PNP Transistor
A2Q18	1855-0093	Add F1748 N Channel JFET
A2R75	0693-1045	Add 100K ohms 5% 1/4W Resistor
A2R77*	0757-0274	Add 1.12K ohms 1% 1/8W Resistor
A2R77*	0698-3700	Add 715 ohms 1% 1/8W Resistor
A2R77*	0698-0410	Add 301 ohms 1% 1/8W Resistor
A2R78	0698-3458	Add 349K ohms 1% 1/8W Resistor

Section VII, Figure 7-1 (400 E/EL Schematic Diagram and Location of Components). Do the following changes in the figure.

Change the Meter Bridge to the bridge shown in Figure C-1.

Change the component locator of the A2 Assembly (-hp- Part Number 00400-66521) to the one shown in Figure C-2.

25 June 1984

Supplement A for 00400-90020

CHANGE NO. 7 400E: Applies to All Serial Numbers
400EL: Applies to All Serial Numbers

Section VI, Table 6-3 (Replaceable Parts). Change the value and -hp- Part Number of A2R59 from 3K ohms (Part Number 2100-0962) to 5K ohms (Part Number 2100-3252).

CHANGE NO. 8 400E: Applies to Serial Numbers 1208A28334 and Above
400EL: Applies to Serial Numbers 1208A28494 and Above

Section VI, Table 6-3 (Replaceable Parts). Do the following changes in the table:

Ref. Des.	-hp- Part Number	Description
S2C6	0160-2257	Add 10pF 500V Capacitor
S2R15	0683-3035	Add 30K ohms 5% 1/4W Resistor

Section VII, Figure 7-1 (400E/EL Schematic Diagram and Location of Components). Change the S2C2, S2P2, and S2R3 circuitry to the one shown in Figure C-3.

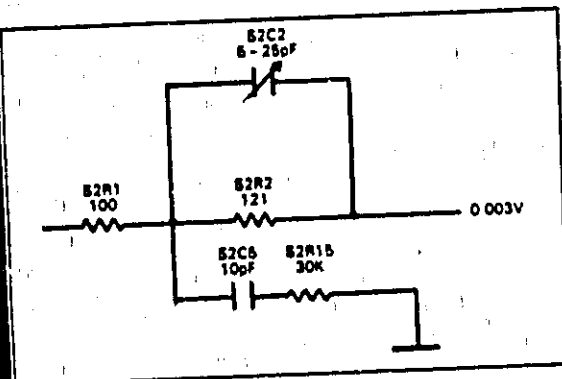

Figure C-3.

Schematic Diagram Changes (Change #8)

CHANGE NO. 8 400E: Applies to Serial Numbers 1208A28378 and Above
400EL: Applies to Serial Numbers 1208A28515 and Above

Section VI, Table 6-3 (Replaceable Parts). Do the following changes to the table:

Ref. Des.	-hp- Part Number	Description
A2R30*	0698-4505	Change to 71.5K ohms 1% 1/8W Resistor
A2R30*	0698-3453	Change to 126K ohms 1% 1/8W Resistor
A2R30*	0757-0468	Change to 130K ohms 1% 1/8W Resistor

CHANGE NO. 10. 400E: Applies to Serial Numbers 1208A28378 and Above
400EL: Applies to Serial Numbers 1208A28515 and Above

Section VI, Table 6-3 (Replaceable Parts). Do the following changes in the table:

Ref. Des.	-hp- Part Number	Description
A2R30	0698-3453	Change to 196K ohms 1% 1/8W Resistor
S2C1*	0160-2237	Change to 1.2pF Capacitor

SALES & SUPPORT OFFICES

Arranged alphabetically by country



Product Line Sales/Support Key

Key Product Line

- A Analytical
 - CM Components
 - C Computer Systems Sales only
 - CH Computer System, Hardware Sales and Services
 - CS Computer Systems Software Sales and Services
 - E Electronic Instruments & Measurement Systems
 - M Medical Products
 - MP Medical Products Primary SRO
 - MS Medical Products Secondary SRO
 - P Personal Computation Products
- Sales only for specific product line
Support only for specific product line

IMPORTANT: These symbols designate general product line capability. They do not insure sales or support availability for all products within a line, at all locations. Contact your local sales office for information regarding locations where HP support is available for specific products.

HP distributors are printed in italics.

HEADQUARTERS OFFICES

If there is no sales office listed for your area, contact one of these headquarters offices.

NORTH/CENTRAL AFRICA

Hewlett-Packard S.A.
7, Rue du Bois-du-Lan
CH-1217 MEYRIN 2, Switzerland
Tel: (022) 83 12 12
Telex: 27835 hpse
Cable: HEWPACKSA Geneva

ASIA

Hewlett-Packard Asia Ltd.
6th Floor, Sun Hung Kai Centre
30 Harbour Rd.
G.P.O. Box 785
HONG KONG
Tel: 5-832 3211
After Jan. 1, 1984
47th Floor, China Resources Bldg.
26 Harbour Rd., Wanchai
HONG KONG
Tel: 66678 HEWPA HX
Cable: HEWPACK HONG KONG

CANADA

Hewlett-Packard (Canada) Ltd.
6877 Goreway Drive
MISSISSAUGA, Ontario L4V 1M8
Tel: (416) 678-9430
Telex: 610-492-4246

EASTERN EUROPE

Hewlett-Packard Ges.m.b.H.
Liebigasse 1
P.O. Box 72
A-1222 VIENNA, Austria
Tel: (222) 2365110
Telex: 1 3 4425 HEPA A

NORTHERN EUROPE

Hewlett-Packard S.A.
Uienstede 475
P.O. Box 899
NL-1100 AZ AMSTELVEER
The Netherlands
Tel: 20 437771

SOUTH EAST EUROPE

Hewlett-Packard S.A.
7, Rue du Bois-du-Lan
CH-1217 MEYRIN 2, Switzerland
Tel: (022) 83 12 12
Telex: 27835 hpse
Cable: HEWPACKSA Geneva

OTHER EUROPE

Hewlett-Packard S.A.
P.O. Box
150, Rte du Nant-D'Avril
CH-1217 MEYRIN 2, Switzerland
Tel: (022) 83 8111
Telex: 22488 hpse
Cable: HEWPACKSA Geneva

MEDITERRANEAN AND MIDDLE EAST

Hewlett-Packard S.A.
Mediterranean and Middle East
Operations
Atrina Centre
32 Kilissias Ave.
Paralissos-Amarousion, ATHENS
Greece
Tel: 682 88 11
Telex: 21-6588 HPAT GR
Cable: HEWPACKSA Athens

EASTERN USA

Hewlett-Packard Co.
4 Choke Cherry Road
ROCKVILLE, MD 20850
Tel: (301) 258-2000

MIDWESTERN USA

Hewlett-Packard Co.
5201 Tollview Drive
ROLLING MEADOWS, IL 60008
Tel: (312) 255-9000

SOUTHERN USA

Hewlett-Packard Co.
2000 South Park Place
P.O. Box 105075
ATLANTA, GA 30348
Tel: (404) 955-1500

WESTERN USA

Hewlett-Packard Co.
3939 Lankershim Blvd.
P.O. Box 3919
LOS ANGELES, CA 91604
Tel: (213) 506-3700

OTHER INTERNATIONAL AREAS

Hewlett-Packard Co.
Intercontinental Headquarters
3495 Deer Creek Road
PALO ALTO, CA 94304
Tel: (415) 857-1501
Telex: 034-8300
Cable: HEWPACK

ANGOLA

Telectra
Empresa Técnica de Equipamentos
R. Barbosa Rodrigues, 41-I DT.
Caixa Postal 6487
LUANDA
Tel: 355 15,355 16
E.P.

ARGENTINA

Hewlett-Packard Argentina S.A.
Avenida Santa Fe 2035
Martinez 1640 BUENOS AIRES
Tel: 798-5735, 792-1293
Telex: 17595 BIONAR
Cable: HEWPACKARG
A,E,CH,CS,P
Biotron S.A.C.I.M. e I.
Av Paseo Colon 221, Piso 9
1399 BUENOS AIRES
Tel: 30-4846, 30-1851
Telex: 17595 BIONAR
M

AUSTRALIA

Adelaide, South Australia Office

Hewlett-Packard Australia Ltd.
153 Greenhill Road
PARKSIDE, S.A. 5063
Tel: 272-5911
Telex: 82536
Cable: HEWPAKD Adelaide
A*,CH,CM,E,MS,P

Brisbane, Queensland Office

Hewlett-Packard Australia Ltd.
10 Payne Road
THE GAP, Queensland 4061
Tel: 30-4133
Telex: 42133
Cable: HEWPAKD Brisbane
A,CH,CM,E,M,P

Canberra, Australia Capital Territory Office

Hewlett-Packard Australia Ltd.
121 Wokongong Street
FYSHWICK, A.C.T. 2609
Tel: 80 4244
Telex: 62650
Cable: HEWPAKD Canberra
CH,CM,E,P

Melbourne, Victoria Office

Hewlett-Packard Australia Ltd.
31-41 Joseph Street
BLACKBURN, Victoria 3130
Tel: 895-2895
Telex: 31-024
Cable: HEWPAKD Melbourne
A,CH,CM,CS,E,MS,P

Perth, Western Australia Office

Hewlett-Packard Australia Ltd.
261 Stirling Highway
CLAREMONT, W.A. 6010
Tel: 383-2188
Telex: 93859
Cable: HEWPAKD Perth
A,CH,CM,E,MS,P

Sydney, New South Wales Office

Hewlett-Packard Australia Ltd.
17-23 Talavera Road
P.O. Box 308
NORTH RYDE, N.S.W. 2113
Tel: 887-1611
Telex: 21581
Cable: HEWPAKD Sydney
A,CH,CM,CS,E,MS,P

AUSTRIA

Hewlett-Packard Ges.m.b.H.
Grottenhofstrasse 84
A-8052 GRAZ
Tel: (0316) 291 5 66
Telex: 32375
CH,E

Hewlett-Packard Ges.m.b.H.

Liebigasse 1
P.O. Box 72
A-1222 VIENNA
Tel: (0222) 23 65 11-0
Telex: 134425 HEPA A
A,CH,CM,CS,E,MS,P

BAHRAIN

Green Salon
P.O. Box 557
Manama
BAHRAIN
Tel: 255503-253950
Telex: 84419
P

Wael Pharmacy

P.O. Box 648
BAHRAIN
Tel: 256123
Telex: 8550 Wael BN
E,C,M

BELGIUM

Hewlett-Packard Belgium S.A./N.V.
Blvd de la Woluwe, 100
Woluwe
B-1200 BRUSSELS
Tel: (02) 762-32-00
Telex: 23-494 palobei
A,CH,CM,CS,E,MP,P

BRAZIL

Hewlett-Packard do Brasil I.e.C. Ltda.
Alameda Rio Negro, 750
Alphaville
06400 BARUERI SP
Tel: (011) 421.1311
Telex: (011) 33872 HPBR-BR
Cable: HEWPACK Sao Paulo
A,CH,CM,CS,E,M,P

Hewlett-Packard do Brasil I.e.C. Ltda.

Avenida Epitacio Pessoa, 4664
22471 RIO DE JANEIRO-RJ
Tel: (021) 286.0237
Telex: 021-21905 HPBR-BR
Cable: HEWPACK Rio de Janeiro
A,CH,CM,E,MS,P*

ANAMED I.C.E.I. Ltda.

Rua Bage, 103
04012 SAO PAULO
Tel: (011) 570-5726
Telex: 021-21905 HPBR-BR
M

SALES & SUPPORT OFFICES

Arranged alphabetically by country

CANADA

Alberta
Hewlett-Packard (Canada) Ltd.
3030 3rd Avenue N.E.
CALGARY, Alberta T2A 6T7
Tel: (403) 235-3100
A,CH,CM,E*,MS,P*

Hewlett-Packard (Canada) Ltd.
11120A-178th Street
EDMONTON, Alberta T5S 1P2
Tel: (403) 486-8686
A,CH,CM,CS,E,MS,P

British Columbia
Hewlett-Packard (Canada) Ltd.
10691 Shelbridge Way
RICHMOND,
British Columbia V6X 2W7
Tel: (604) 270-2277
Tel: 610-922-5059
A,CH,CM,CS,E*,MS,P*

Manitoba
Hewlett-Packard (Canada) Ltd.
380-550 Century Street
WINNIPEG, Manitoba R3H 0Y1
Tel: (204) 786-8701
A,CH,CM,E,MS,P*

Nova Scotia
Hewlett-Packard (Canada) Ltd.
P.O. Box 931
900 Windmill Road
DARTMOUTH, Nova Scotia B2Y 3Z6
Tel: (902) 469-7820
CH,CM,CS,E*,MS,P*

Ontario
Hewlett-Packard (Canada) Ltd.
3325 N. Service Rd., Unit 6
BURLINGTON, Ontario P3A 2A3
Tel: (416) 335-8644
CS,M*

Hewlett-Packard (Canada) Ltd.
552 Newbold Street
LONDON, Ontario N6E 2S5
Tel: (519) 686-9181
A,CH,CM,E*,MS,P*

Hewlett-Packard (Canada) Ltd.
6877 Goreway Drive
MISSISSAUGA, Ontario L4V 1M8
Tel: (416) 678-9430
A,CH,CM,CS,E,MP,P

Hewlett-Packard (Canada) Ltd.
2670 Queensview Dr.
OTTAWA, Ontario K2B 8K1
Tel: (613) 820-6483
A,CH,CM,CS,E*,MS,P*

Hewlett-Packard (Canada) Ltd.
220 Yorkland Blvd., Unit #11
WILLOWDALE, Ontario M2J 1R5
Tel: (416) 499-9333
CH

Quebec
Hewlett-Packard (Canada) Ltd.
17500 South Service Road
Trans-Canada Highway
KIRKLAND, Quebec H9J 2M5
Tel: (514) 697-4232
A,CH,CM,CS,E,MP,P*

Hewlett-Packard (Canada) Ltd.
Les Galeries du Vallon
2323 Du Versant Nord
STE. FOY, Quebec G1N 4C2
Tel: (418) 687-4570
CH

CHILE

Jorge Calcagni y Cia. Ltda.
Av. Italia 634 Santiago
Casilla 16475
SANTIAGO 9
Tel: 222-0222
Telex: Public Booth 440001
A,CM,E,M

Olympia (Chile) Ltda.
Av. Rodrigo de Araya 1045
Casilla 256-V
SANTIAGO 21
Tel: (02) 22 55 044
Telex: 240-565 OLYMP CL
Cable: Olympiachile Santiagochile
CH,CS,P

CHINA, People's Republic of
China Hewlett-Packard Rep. Office
P.O. Box 418
1A Lane 2, Luchang St.
Beiwei Rd., Xuanwu District
BEIJING
Tel: 33-1947, 33-7426
Telex: 22601 GTSHP CN
Cable: 1920
A,CH,CM,CS,E,P

COLOMBIA

Instrumentación
H. A. Langeback & Kier S.A.
Carrera 4A No. 52A-26
Apartado Aereo 6287
BOGOTA 1, D.E.
Tel: 212-1466
Telex: 44400 INST CO
Cable: AARIS Bogota
CM,E,M

Casa Humboldt Ltda.
Carrera 14, No. 98-60
Apartado Aereo 51283
BOGOTA 1, D.E.
Tel: 256-1686
Telex: 45403 CCAL CO.

COSTA RICA

Cientifica Costarricense S.A.
Avenida 2, Calle 5
San Pedro de Montes de Oca
Apartado 10159
SAN JOSE
Tel: 24-38-20, 24-08-19
Telex: 2367 GALGUR CR
CM,E,M

CYPRUS

Telerex Ltd.
P.O. Box 4869
14C Stasinou Avenue
NICOSIA
Tel: 62698
Telex: 2894 LEVDO CY
E,M,P

DENMARK

Hewlett-Packard A/S
Datavej 52
DK-3460 BIRKEROD
Tel: (02) 81-86-40
Telex: 37409 hpas dk
A,CH,CM,CS,E,MS,P

Hewlett-Packard A/S
Rølgårdsvej 32
DK-8240 RISSKOV, Aarhus
Tel: (06) 17-80-00
Telex: 37409 hpas dk
CH,E

DOMINICAN REPUBLIC

Microprog S.A.
Juan Tomás Mejía y Coles No. 60.
Arroyo Hondo
SANTO DOMINGO
Tel: 565-6268
Telex: 4510 ARENTA DR (RCA) P

ECUADOR

CYEDE Cia. Ltda.
Avenida Eloy Alfaro 1749
Casilla 6423 CCI
QUITO
Tel: 450-975, 243-052
Telex: 2548 CYEDE ED
CM,E,P

Hospitalar S.A.
Robles 625
Casilla 3590
QUITO
Tel: 545-250, 545-122
Telex: 2485 HOSPTL ED
Cable: HOSPITALAR-Quito
M

EGYPT

International Engineering Associates
24 Hussein Hegazi Street
Kasr-el-Aini
CAIRO
Tel: 23829, 21641
Telex: IEA UN 93830
CH,CS,E,M

EGYPTOR
P.O. Box 2558
42 El Zahraa Street
CAIRO, Egypt
Tel: 65 00 21
Telex: 93 337
P

EL SALVADOR

IPESA de El Salvador S.A.
29 Avenida Norte 1216
SAN SALVADOR
Tel: 26-6858, 26-6868
Telex: 20539 IPESASAL
A,CH,CM,CS,E,P

FINLAND

Hewlett-Packard Oy
Revontuntie 7
PL 24
SF-02101 ESPOO 10
Tel: (90) 4550211
Telex: 121563 hewpa sf
CH,CM,CS,P

Hewlett-Packard Oy
(Ouarinkuoma 7)
PL 24
02101 ESPOO 10
Tel: (90) 4521022
A,E,MS

Hewlett-Packard Oy
Aaloksenkatu 10-C
SF-40720-72 JYVASKYLA
Tel: (941) 216318
CH

Hewlett-Packard Oy
Kainuntie 1-C
SF-90140-14 OULU
Tel: (981) 338785
CH

FRANCE

Hewlett-Packard France
Z.I. Mercure B
Rue Berthelot
F-13763 Les Milles Cedex
AUX-EN-PROVENCE
Tel: 16 (42) 59-41-02
Telex: 410770F
A,CH,E,MS,P*

Hewlett-Packard France
64, rue Marchand Saillant
F-81000 ALENCON
Tel: 16 (33) 29 04 42

Hewlett-Packard France
Boite Postale 503
F-25026 BESANCON
28 rue de la Republique
F-25000 BESANCON
Tel: 16 (81) 83-16-22
CH,M

Hewlett-Packard France
13, Place Napoleon III
F-29000 BREST
Tel: 16 (98) 03-38-35

Hewlett-Packard France
Chemin des Mouilles
Boite Postale 162
F-69130 ECULLY Cedex (Lyon)
Tel: 16 (78) 833-81-25
Telex: 310617F
A,CH,CS,E,MP

Hewlett-Packard France
Tour Lorraine
Boulevard de France
F-91035 EVRY Cedex
Tel: 16 6 077-96-80
Telex: 692315F
E

Hewlett-Packard France
Parc d'Activite du Bois Briard
Ave. du Lac
F-91040 EVRY Cedex
Tel: 16 6 077-8383
Telex: 692315F
E

Hewlett-Packard France
5, avenue Raymond Chanas
F-38320 EYBENS (Grenoble)
Tel: 16 (76) 25-81-41
Telex: 990124 HP GREN08 EYBE
CH

Hewlett-Packard France
Centre d'Affaire Paris-Nord
Bâtiment Ampère 5 étage
Rue de la Commune de Paris
Boite Postale 300
F-93153 LE BLANC MESSIL
Tel: 16 (1) 865-44-52
Telex: 211032F
CH,CS,E,MS

Hewlett-Packard France
Parc d'Activités Cadere
Quartier Jean Mermoz
Avenue du Président JF Kennedy
F-33700 MÉRIGNAC (Bordeaux)
Tel: 16 (56) 34-00-84
Telex: 550105F
CH,E,MS

Hewlett-Packard France
Immeuble "Les 3 B"
Nouveau Chemin de la Garde
ZAC de Bois Briard
F-44085 NANTES Cedex
Tel: 16 (40) 50-32-22
CH**

SALES & SUPPORT OFFICES

Arranged alphabetically by country

3



FRANCE (Cont'd)

Hewlett-Packard France
125, rue du Faubourg Banner
F-45000 ORLEANS
Tel: 16 (38) 68 01 63

Hewlett-Packard France
Zone Industrielle de Courtabouf
Avenue des Tropiques
F-91947 Les Ulis Cedex ORSAY
Tel: (6) 907-78-25
Telex: 600048F
A,CH,CM,CS,E,MP,P

Hewlett-Packard France
Paris Porte-Maillot
15, Avenue de L'Amiral Brix
F-75782 PARIS CEDEX 16
Tel: 16 (1) 502-12-20
Telex: 613033F
CH,MS,P

Hewlett-Packard France
124, Boulevard Tourasse
F-64000 PAU
Tel: 16 (59) 80 38 02

Hewlett-Packard France
2 Allée de la Bourgonnette
F-35100 RENNES
Tel: 16 (99) 51-42-44
Telex: 740912F
CH,CM,E,MS,P*

Hewlett-Packard France
88 Avenue de Bretagne
F-76100 ROUEN
Tel: 16 (35) 63-57-66
CH*,CS

Hewlett-Packard France
4 Rue Thomas Mann
Boite Postale 56
F-67033 STRASBOURG Cedex
Tel: 16 (88) 28-56-46
Telex: 890141F
CH,E,MS,P*

Hewlett-Packard France
Le Péripole
20, Chemin du Pigeonnier de la
Cépière
F-31083 TOULOUSE Cedex
Tel: 16 (61) 40-11-12
Telex: 531639F
A,CH,CS,E,P*

Hewlett-Packard France
9, rue Baudin
F-26000 VALENCE
Tel: 16 (75) 42 76 16

Hewlett-Packard France
Carolor
ZAC de Bois Briand
F-57640 VIGY (Metz)
Tel: 16 (8) 771 20 22
CH

Hewlett-Packard France
Immeuble Péricentre
F-59658 VILLENEUVE D'ASCO Cedex
Tel: 16 (20) 91-41-25
Telex: 160124F
CH,E,MS,P*

GERMAN FEDERAL REPUBLIC

Hewlett-Packard GmbH
Geschäftsstelle
Keithstrasse 2-4
D-1000 BERLIN 30
Tel: (030) 24-90-86
Telex: 018 3405 hpbn d
A,CH,E,MP

Hewlett-Packard GmbH
Geschäftsstelle
Herrenberger Strasse 130
D-7030 BOESLINGEN
Tel: (7031) 14-0
Telex:

A,CH,CM,CS,E,MP,P
Hewlett-Packard GmbH
Geschäftsstelle
Emanuel-Leutze-Strasse 1
D-4000 DUSSELDORF
Tel: (0211) 5971-1
Telex: 085/86 533 hpdd d
A,CH,CS,E,MS,P

Hewlett-Packard GmbH
Geschäftsstelle
Schleefstr. 28a
D-4600 DORTMUND-Aplerbeck
Tel: (0231) 45001

Hewlett-Packard GmbH
Vertriebszentrale Frankfurt
Demer Strasse 117
Postfach 560 140
D-6000 FRANKFURT 56
Tel: (0611) 50-04-1
Telex: 04 13249 hpffm d
A,CH,CM,CS,E,MP,P

Hewlett-Packard GmbH
Geschäftsstelle
Aussenstelle Bad Homburg
Louisenstrasse 115
D-6380 BAD HOMBURG
Tel: (06172) 109-0

Hewlett-Packard GmbH
Geschäftsstelle
Kapstadttring 5
D-2000 HAMBURG 60
Tel: (040) 63804-1
Telex: 021 63 032 hpoh d
A,CH,CS,E,MS,P

Hewlett-Packard GmbH
Geschäftsstelle
Heidering 37-39
D-3000 HANNOVER 61
Tel: (0511) 5706-0
Telex: 092 3259
A,CH,CM,E,MS,P

Hewlett-Packard GmbH
Geschäftsstelle
Rosslauer Weg 2-4
D-6800 MANNHEIM
Tel: (0621) 70050
Telex: 0462 105
A,C,E

Hewlett-Packard GmbH
Geschäftsstelle
Messerschmittstrasse 7
D-7910 NEU ULM
Tel: 0731-70241
Telex: 0712816 HP ULM-D
A,C,E*

Hewlett-Packard GmbH
Geschäftsstelle
Ehlicherstr. 13
D-8500 NÜRNBERG 10
Tel: (0911) 5205-0
Telex: 0623 860
CH,CM,E,MS,P

Hewlett-Packard GmbH
Geschäftsstelle
Eschenstrasse 5
D-8028 TAUFKIRCHEN
Tel: (089) 6117-1
Telex: 0524985
A,CH,CM,E,MS,P

GREAT BRITAIN

See United Kingdom

GREECE

Kostas Karayannis S.A.
8 Omirou Street
ATHENS 133
Tel: 32 30 303, 32 37 371
Telex: 215962 RKAR GR
A,CH,CM,CS,E,MP

PLAISIO S.A.
G. Gerardos
24 Stourara Street
ATHENS
Tel: 36-11-160
Telex: 221871
P

GUATEMALA

IPESA
Avenida Reforma 3-48, Zona 9
GUATEMALA CITY
Tel: 316627, 314786
Telex: 4192 TELTRO GU
A,CH,CM,CS,E,MP

HONG KONG

Hewlett-Packard Hong Kong, Ltd.
G.P.O. Box 795
5th Floor, S-n Hung Kai Centre
30 Harbour Road
HONG KONG
Tel: 5-8323211
Telex: 66678 HEWPA HX
Cable: HEWPACK HONG KONG
E,CH,CS,P

CET Ltd.
1402 Tung Wah Mansions,
199-203 Hennessy Rd.
Wanchia, HONG KONG
Tel: 5-729376
Telex: 85148 CET HX
CM
Schmidt & Co. (Hong Kong) Ltd.
Wing On Centre, 28th Floor
Connaught Road, C.
HONG KONG
Tel: 5-455644
Telex: 74766 SCHMX HX
AM

ICELAND

Elding Trading Company Inc.
Hafnarvolf-Tryggvagotu
P.O. Box 815
IS-REYKJAVIK
Tel: 1-58-20, 1-63-03
M

INDIA

Computer products are sold through
Blue Star Ltd. All computer repairs and
maintenance service is done through
Computer Maintenance Corp.

Blue Star Ltd.
Sabri Complex - II Floor
24 Residency Rd.
BANGALORE 560 025
Tel: 55660
Telex: 0845-430
Cable: BLUESTAR
A,CH*,CM,CS*,E

Blue Star Ltd.
Band Box House
Prabhadevi
BOM BAY 400 025
Tel: 422-3101
Telex: 011-3751
Cable: BLUESTAR
AM

Blue Star Ltd.
Sahas
414/2 Vir Savarkar Marg
Prabhadevi
BOMBAY 400 025
Tel: 422-6155
Telex: 011-4093
Cable: FROSTBLUE
A,CH*,CM,CS*,E,M

Blue Star Ltd.
Kalyan, 19 Vishwas Colony
Akrapuri, BORODA, 390 005
Tel: 65235
Cable: BLUE STAR
A

Blue Star Ltd.
7 Hare Street
CALCUTTA 700 001
Tel: 12-01-31
Telex: 021-7655
Cable: BLUESTAR
AM

Blue Star Ltd.
133 Kodambakkam High Road
MADRAS 600 034
Tel: 82057
Telex: 041-379
Cable: BLUESTAR
AM

Blue Star Ltd.
Bhandari House, 7th/8th Floors
91 Newry Place
NEW DELHI 110 024
Tel: 682547
Telex: 031-2463
Cable: BLUESTAR
A,CH*,CM,CS*,E,M

Blue Star Ltd.
15/16-C Wellesley Rd.
PUNE 411 011
Tel: 22775
Cable: BLUE STAR
A

Blue Star Ltd.
2-2-47/1108 Bolaram Rd.
SECUNDERABAD 500 003
Tel: 7,2057
Telex: 0155-459
Cable: BLUEFROST
A,E

Blue Star Ltd.
T.C. 7/603 Poomma
Maruthankuzhi
TRIVANDRUM 695 013
Tel: 65799
Telex: 0884-259
Cable: BLUESTAR
E
Computer Maintenance Corporation
Ltd.
115, Sarojini Devi Road
SECUNDERABAD 500 003
Tel: 310-184, 345-774
Telex: 031-2960
CH**



SALES & SUPPORT OFFICES

Arranged alphabetically by country

INDONESIA

BERCA Indonesia P.T.
P.O.Box 496/Jkt.
J. Abdul Muis 62
JAKARTA
Tel: 21-373009
Telex: 46748 BERSAL IA
Cable: BERSAL JAKARTA
P

BERCA Indonesia P.T.
P.O.Box 2497/Jkt
Antara Bldg., 17th Floor
J. Medan Merdeka Selatan 17
JAKARTA-PUSAT
Tel: 21-344-181
Telex: BERSAL IA
A,C,S,E,M

BERCA Indonesia P.T.
P.O. Box 174/SBY.
J. Kutei No. 11
SURABAYA
Tel: 68172
Telex: 31146 BERSAL SB
Cable: BERSAL-SURABAYA
A*,E,M,P

IRAQ

Hewlett-Packard Trading S.A.
Service Operation
Al Mansoor City 98/3/7
BAHGDAD
Tel: 551-49-73
Telex: 212-455 HEPARAO IK
CH,CS

IRELAND

Hewlett-Packard Ireland Ltd.
82/83 Lower Leeson Street
DUBLIN 2
Tel: 0001 808800
Telex: 30439
A,CH,CM,CS,E,M,P
Cardiac Services Ltd.
Kilmore Road
Artane
DUBLIN 5
Tel: (01) 351820
Telex: 30439
M

ISRAEL

Eidan Electronic Instrument Ltd.
P.O.Box 1270
JERUSALEM 91000
16, Chalav St.
JERUSALEM 94467
Tel: 533 221, 553 242
Telex: 25231 AB/PAKRO IL
A

Electronics Engineering Division
Motorola Israel Ltd.
16 Kremenetski Street
P.O. Box 25016
TEL-AVIV 67009
Tel: 3 88 388

Telex: 33569 Motil IL
Cable: BASTEL Tel-Aviv
CH,CM,CS,E,M,P

ITALY

Hewlett-Packard Italiana S.p.A.
Traversa 99C
Via Giulio Petroni, 19
I-70124 BARI
Tel: (080) 41-07-44
M

Hewlett-Packard Italiana S.p.A.
Via Martin Luther King, 38/M
I-40132 BOLOGNA
Tel: (051) 402394
Telex: 511630
CH,E,MS

Hewlett-Packard Italiana S.p.A.
Via Principe Nicola 43G/C
I-95126 CATANIA
Tel: (095) 37-10-87
Telex: 970291
C,P

Hewlett-Packard Italiana S.p.A.
Via G. Di Vittorio 9
I-20063 CERNUSCO SUL NAVIGLIO
(Milano)
Tel: (02) 923691
Telex: 334632
A,CH,CM,CS,E,MP,P

Hewlett-Packard Italiana S.p.A.
Via C. Colombo 49
I-20090 TREZZANO SUL NAVIGLIO
(Milano)
Tel: (02) 4459041
Telex: 322116
C,M

Hewlett-Packard Italiana S.p.A.
Via Nuova San Rocco a
Capodimonte, 62/A
I-80131 NAPOLI
Tel: (081) 7413544
Telex: 710698
A,CH,E

Hewlett-Packard Italiana S.p.A.
Viale G. Mozzano 33
I-16156 GENOVA PEGLI
Tel: (010) 68-37-07
Telex: 215238
E,C

Hewlett-Packard Italiana S.p.A.
Via Peizzo 15
I-35128 PADOVA
Tel: (049) 664888
Telex: 430315
A,CH,E,MS

Hewlett-Packard Italiana S.p.A.
Viale C. Pavese 340
I-00144 ROMA EUR
Tel: (06) 54331
Telex: 610514
A,CH,CM,CS,E,MS,P*

Hewlett-Packard Italiana S.p.A.
Via di Casellina 57/C
I-50018 SCANDICCI-FIRENZE
Tel: (055) 753883

Hewlett-Packard Italiana S.p.A.
Corso Svizzera, 185
I-10144 TORINO
Tel: (011) 74 4044
Telex: 221079
CH,E

Hewlett-Packard Italiana S.p.A.
Viale C. Pavese 340
I-00144 ROMA EUR
Tel: (06) 54331
Telex: 610514
A,CH,CM,CS,E,MS,P*

Hewlett-Packard Italiana S.p.A.
Via di Casellina 57/C
I-50018 SCANDICCI-FIRENZE
Tel: (055) 753883

Hewlett-Packard Italiana S.p.A.
Corso Svizzera, 185
I-10144 TORINO
Tel: (011) 74 4044
Telex: 221079
CH,E

JAPAN

Yokogawa-Hewlett-Packard Ltd.
152-1, Onna
ATSUGI, Kanagawa, 243
Tel: (0462) 28-0451
CM,C*,E

Yokogawa-Hewlett-Packard Ltd.
Meiji-Seimei Bldg. 6F
3-1 Hon Chiba-Cho
CHIBA, 280
Tel: 472 25 7701
E,CH,CS

Yokogawa-Hewlett-Packard Ltd.
Yasuda-Seimei Hiroshima Bldg.
6-11, Hon-dori, Naka-ku
HIROSHIMA, 730
Tel: 82-241-0611

Yokogawa-Hewlett-Packard Ltd.
Towa Building
2-3, Kaigan-dori, 2 Chome Chuo-ku
KOBE, 650
Tel: (078) 392-4791
C,E

Yokogawa-Hewlett-Packard Ltd.
Kumagaya Asahi 82 Bldg
3-4 Tsukuba
KUMAGAYA, Saitama 360
Tel: (0485) 24-6563
CH,CM,E

Yokogawa-Hewlett-Packard Ltd.
Asahi Shinbun Daichi Seimei Bldg.
4-7, Hanabata-cho
KUMAMOTO, 860
Tel: (0963) 54-7311
CH,E

Yokogawa-Hewlett-Packard Ltd.
Shin-Kyoto Center Bldg.
614, Higashi-Shiojoi-cho
Karasuma-Nishiku
Shiojoi-dori, Shimogyo-ku
KYOTO, 600
Tel: 075-345-0921
CH,E

Yokogawa-Hewlett-Packard Ltd.
Mito Mitsui Bldg
4-73, Sanno-maru, 1 Chome
MITO, Ibaraki 310
Tel: (0292) 25-7470
CH,CM,E

Yokogawa-Hewlett-Packard Ltd.
Sumitomo Seimei 14-9 Bldg.
Meleki-Minami, 2 Chome
Nakamura-ku
NA GOYA, 450
Tel: (052) 671-5171
CH,CM,CS,E,MS

Yokogawa-Hewlett-Packard Ltd.
Chuo Bldg.,
4-20 Nishinakajima, 5 Chome
Yodogawa-ku
OSAKA, 532
Tel: (06) 304-6021
Telex: YHPOSA 523-3624
A,CH,CM,CS,E,MP,P*

Yokogawa-Hewlett-Packard Ltd.
27-15, Yabe, 1 Chome
SAGAMIHARA Kanagawa, 229
Tel: 0427 59-1311

Yokogawa-Hewlett-Packard Ltd.
Daichi Seimei Bldg.
7-1, Nishi Shinjuku, 2 Chome
Shinjuku-ku, TOKYO 160
Tel: 03-348-4611
CH,E

Yokogawa-Hewlett-Packard Ltd.
29-21 Takaido-Higashi, 3 Chome
Suginami-ku TOKYO 168
Tel: (03) 331-6111
Telex: 232-2024 YHPTOK
A,CH,CM,CS,E,MP,P*

Yokogawa-Hewlett-Packard Ltd.
Daichi Asano Building
2-8, Odori, 5 Chome
UTSUNOMIYA, Tochigi 320
Tel: (0286) 25-7155
CH,CS,E

Yokogawa-Hewlett-Packard Ltd.
Yasuda Seimei Nishiguchi Bldg.
30-4 Tsuruya-cho, 3 Chome
YOKOHAMA 221
Tel: (045) 312-1252
CH,CM,E

JORDAN

Mouasher Cousins Company
P.O. Box 1387
AMMAN
Tel: 24907, 39907
Telex: 21456 SABCO JO
CH,E,M,P

KENYA

ADCOM Ltd., Inc., Kenya
P.O.Box 30070
NAIROBI
Tel: 331955
Telex: 22639
E,M

KOREA

Samsung Electronics HP Division
12 Fl. Kinam Bldg.
San 75-31, Yeoksam-Dong
Kangnam-Ku
Yeongdong P.O. Box 72
SEOUL
Tel: 555-7555, 555-5447
Telex: K27364 SAMSAN
A,CH,CM,CS,E,M,P

Samsung Electronics HP Division
12 Fl. Kinam Bldg.
San 75-31, Yeoksam-Dong
Kangnam-Ku
Yeongdong P.O. Box 72
SEOUL
Tel: 555-7555, 555-5447
Telex: K27364 SAMSAN
A,CH,CM,CS,E,M,P

KUWAIT

Al-Khakiya Trading & Contracting
P.O. Box 830 Safat
KUWAIT
Tel: 42 4910, 41-1726
Telex: 22481 Areeg ki
CH,E,M

Photo & Cine Equipment
P.O. Box 270 Safat
KUWAIT
Tel: 42-2846, 42-3801
Telex: 22247 Main ki
P

LEBANON

G.M. Dornadjan
Achrafieh
P.O. Box 165.167
BEIRUT
Tel: 290293
MP**

Computer Information Systems
P.O. Box 11-6274
BEIRUT
Tel: 89 40 73
Telex: 22259
C

LUXEMBOURG

Hewlett-Packard Belgium S.A./N.V.
Bldg de la Woluwe, 100
Woluwedal
B-1200 BRUSSELS
Tel: (02) 762-32-00
Telex: 23-494 paloben bru
A,CH,CM,CS,E,MP,P

MALAYSIA

Hewlett-Packard Sales (Malaysia)
Sdn. Bhd.
1st Floor, Bangunan British
American
Jalan Semantan, Damansara Heights
KUALA LUMPUR 23-03
Tel: 943022
Telex: MA31011
A,CH,E,M,P*

SALES & SUPPORT OFFICES

Arranged alphabetically by country

5



MALAYSIA (Cont'd)

Protel Engineering
P.O. Box 1917
Lot 6624, Section 64
23/4 Pending Road
Ruching, SARAWAK
Tel: 36299
Telex: MA 7090 PROMAL
Cable: PROTELENG
A.E.M.

MALTA

Philip Toledo Ltd.
Notable Rd.
MIEHEL
Tel: 447 47, 455 66
Telex: Media MW 649
E.P.

MEXICO

Hewlett-Packard Mexicana, S.A.
de C.V.
Av. Periferico Sur No. 6501
Tepepan, Xochimilco
16020 MEXICO D.F.
Tel: 6-76-46-00
Telex: 17-74-507 HEWPACK MEX
A,CH,CS,E,MS,P
Hewlett-Packard Mexicana, S.A.
de C.V.
Ave. Colonia del Valle 409
Col. del Valle
Municipio de Garza Garcia
MONTERREY, Nuevo Leon
Tel: 78 42 41
Telex: 038 410
CH
ECISA
José Vasconcelos No. 218
Col. Condesa Deleg. Cuauhtémoc
MEXICO D.F. 06140
Tel: 553-1206
Telex: 17-72755 ECE ME
M

MOROCCO

Dobbeu
81 rue Karatchi
CASABLANCA
Tel: 3041-82, 3068-38
Telex: 23051, 22822
E

Gerep

2 rue d'Agadir
Boite Postale 156
CASABLANCA
Tel: 272093, 272095
Telex: 23 739
P

NETHERLANDS

Hewlett-Packard Nederland B.V.
Van Heuven Goedhartlaan 121
NL 1181KK AMSTELVEEN
P.O. Box 687
NL 1180 AR AMSTELVEEN
Tel: (020) 47-20-21
Tel: 13 216 HEFA NL
A,CH,CM,CS,E,MP,P
Hewlett-Packard Nederland B.V.
Bongerd 2
NL 2906VK CAPELLE A/D IJSEL
P.O. Box 41
NL 2900AA CAPELLE A/D IJSEL
Tel: (10) 51-64-44
Tel: 21261 HEPAC NL
A,CH,CS,E

Hewlett-Packard Nederland B.V.
Pastoor Petersstraat 134-136
NL 5612 LV EINDHOVEN
P.O. Box 2342
NL 5600 CH EINDHOVEN
Tel: (040) 326911
Telex: 51484 hepae nl
A,CH,E,M

NEW ZEALAND

Hewlett-Packard (N.Z.) Ltd.
5 Owens Road
Epsom, AUCKLAND
Tel: 687-159
Cable: HEWPACK Auckland
CH,CM,E,P
Hewlett-Packard (N.Z.) Ltd.
4-12 Cruickshank Street
Kilbirnie, WELLINGTON 3
P.O. Box 94/3
Courtenay Place, WELLINGTON 3
Tel: 877-199
Cable: HEWPACK Wellington
CH,CM,E,P
Northrop Instruments & Systems Ltd.
369 Khyber Pass Road
P.O. Box 8602
AUCKLAND
Tel: 794-091
Telex: 60605
A.M

Northrop Instruments & Systems Ltd.
110 Mandeville St.
P.O. Box 8388
CHRISTCHURCH
Tel: 485-328
Telex: 4203
A.M
Northrop Instruments & Systems Ltd.
Sturdee House
85-87 Ghuznee Street
P.O. Box 2406
WELLINGTON
Tel: 850-091
Telex: NZ 3380
A.M

NORTHERN IRELAND

See United Kingdom

NORWAY

Hewlett-Packard Norge A/S
Folke Bernadottes vei 50
P.O. Box 3558
N-5033 FYLLINGSDALEN (Bergen)
Tel: 0047/516 55 40
Telex: 16621 hpnas n
CH,CS,E,MS

Hewlett-Packard Norge A/S
Østerdalen 16-18
P.O. Box 34
N-1345 ØSTERÅS
Tel: 047/217 11 80
Telex: 16621 hpnas n
A,CH,CM,CS,E,MP

OMAN

Khiriil Rari das
P.O. Box 19
MUSCAT
Tel: 722225, 745601
Telex: 3289 BROKER MB MUSCAT
P
Suhail & Saud Bahwan
P.O. Box 169
MUSCAT
Tel: 734 201-3
Telex: 3274 BAHWAN MB

PAKISTAN

Mushko & Company Ltd.
1-B, Street 43
Sector F-8/1
ISLAMABAD
Tel: 51071
Cable: FEMUS Rawalpindi
A.E.M
Mushko & Company Ltd.
Oosman Chambers
Abdullah Haroon Road
KARACHI 0302
Tel: 524131, 524132
Telex: 2894 MUSKO PX
Cable: COOPERATOR Karachi
A.E.M.P

PANAMA

Eléctrico Balboa, S.A.
Calle Samuel Lewis, Ed. Alfa
Apartado 4929
PANAMA 5
Tel: 63-6613, 63-6748
Telex: 3483 ELECTRON PG
A,CM,E,MP

PERU

Cia Electro Médica S.A.
Los Flamencos 145, San Isidro
Casilla 1030
LIMA 1
Tel: 41-4325, 41-3703
Telex: Pub. Booth 25306
CM,E,MP

PHILIPPINES

The Online Advanced Systems
Corporation
Rico House, Amoroso Cor. Herrera
Street
Legaspi Village, Makati
P.O. Box 1510
Metro MANILA
Tel: 85-35-81, 85-34-91, 85-32-21
Telex: 3274 ONLINE
A,CH,CS,E,M
Electronic Specialists and Proponents
Inc.
690-B Epifanio de los Santos Avenue
Cubao, QUEZON CITY
P.O. Box 2649 Manila
Tel: 98-96-81, 98-96-82, 98-96-83
Telex: 40018, 42000 ITT GLOBE
MACKAY BOOTH
P

PORTUGAL

Mundinter
Intercambio Mundial de Comércio
S.A.R.L.
P.O. Box 2761
Av. Antonio Augusto de Aguiar 138
P-LISBON
Tel: (19) 53-21-31, 53-21-37
Telex: 16691 munter p
M
Soquímica
Av. da Liberdade, 220-2
1298 LISBOA Codex
Tel: 56 21 81/2/3
Telex: 13316 SABASA
P

Telectra-Empresa Técnica de
Equipamentos Eléctricos S.A.R.L.
Rua Rodrigo da Fonseca 103
P.O. Box 2531
P-LISBON 1
Tel: (19) 68-60-72
Telex: 12598
CH,CS,E,P

PUERTO RICO

Hewlett-Packard Puerto Rico
Ave. Muñoz Rivera #101
Esq. Calle Ocho
HATO REY, Puerto Rico 00918
Tel: (809) 754-7800
Hewlett-Packard Puerto Rico
Calle 272 Edificio 203
Urb. Country Club
RIO PIEDRAS, Puerto Rico
P.O. Box 4407
CAROLINA, Puerto Rico 00628
Tel: (809) 762-7255
A,CH,CS

QATAR

Computearbia
P.O. Box 2750
DOHA
Tel: 883555
Telex: 4806 CHPARB
P
Eastern Technical Services
P.O. Box 4747
DOHA
Tel: 329 893
Telex: 4156 EASTEC DH
Nasser Trading & Contracting
P.O. Box 1563
DOHA
Tel: 22170, 23539
Telex: 4439 NASSER DH
M

SAUDI ARABIA

Modern Electronic Establishment
Hewlett-Packard Division
P.O. Box 22015
Thuobah
AL-KHOBAR
Tel: 895-1760, 895-1764
Telex: 671 106 HPMEEK SJ
Cable: ELECTA AL-KHOBAR
CH,CS,E,M
Modern Electronic Establishment
Hewlett-Packard Division
P.O. Box 1228
Redec Plaza, 6th Floor
JEDDAH
Tel: 644 38 48
Telex: 4027 12 FARNAS SJ
Cable: ELECTA JEDDAH
CH,CS,E,M

Modern Electronic Establishment
Hewlett-Packard Division
P.O. Box 22015
RIYADH
Tel: 491-97 15, 491-63 87
Telex: 202049 MEERYD SJ
CH,CS,E,M
Abdul Ghani El Ajou
P.O. Box 78
RIYADH
Tel: 40 41 717
Telex: 200 932 EL AJOU
P

SCOTLAND

See United Kingdom

SINGAPORE

Hewlett-Packard Singapore (Sales)
Pte. Ltd.
#08-00 Inchcape House
450-2 Alexandra Road
P.O. Box 58 Alexandra Rd. Post Office
SINGAPORE, 9115
Tel: 631788
Telex: HPSGSU RS 34209
Cable: HEWPACK, Singapore
A,CH,CS,E,MS,P

SALES & SUPPORT OFFICES

Arranged alphabetically by country



SINGAPORE (Cont'd)

Dynamar International Ltd.
Unit 05-11 Block 6
Kohlan Ayer Industrial Estate
SINGAPORE 1334
Tel: 747-6158
Telex: RS 26283
CM

SOUTH AFRICA

Hewlett-Packard Go Africa (Pty.) Ltd.
P.O. Box 120
Howard Place CAPE PROVINCE 7450
Pine Park Center, Forest Drive,
Pinelands
CAPE PROVINCE 7405
Tel: 63-7954
Telex: 57-20006
A,CH,CM,E,MS,P
Hewlett-Packard So Africa (Pty.) Ltd.
P.O. Box 37099
92 Overport Drive
DURBAN 4067
Tel: 28-4178, 28-4179, 28-4110
Telex: 6-22954
CH,CM

Hewlett-Packard So Africa (Pty.) Ltd.
6 Linton Arcade
511 Cape Road
Linton Grange
PORT ELIZABETH 6000
Tel: 041-302148
CH

Hewlett-Packard So Africa (Pty.) Ltd.
P.O. Box 33345
Glenstantia 0010 TRANSVAAL
1st Floor East
Constantia Park Ridge Shopping
Centre
Constantia Park
PRETORIA
Tel: 982043
Telex: 32163
CH,E

Hewlett-Packard So Africa (Pty.) Ltd.
Private Bag Wendywood
SANDTON 2144
Tel: 802-5111, 802-5125
Telex: 4-20877
Cable: HEWPACK Johannesburg
A,CH,CM,CS,E,MS,P

SPAIN

Hewlett-Packard Española S.A.
Calle Entenza, 321
E-BARCELONA 29
Tel: 322.24.51, 321.73.54
Telex: 52603 hpbce
A,CH,CS,E,MS,P

Hewlett-Packard Española S.A.
Calle San Vicente S/No
Edificio Albia II
E-BILBAO 1
Tel: 423.83.06
A,CH,E,MS

Hewlett-Packard Española S.A.
Ctra. de la Corona, Km. 16, 400
Las Rozas
E-MADRID
Tel: (1) 637.00.11
CH,CS,M

Hewlett-Packard Española S.A.
Avda. S. Francisco Javier, S/No
Planta 10. Edificio Sevilla 2,
E-BEVILLA 5
Tel: 64.44.54
Telex: 72833
A,CS,MS,P

Hewlett-Packard Española S.A.
Calle Ramon Gordo, 1 (Entlo.3)
E-VALENCIA 10
Tel: 361-1354
CH,P

SWEDEN

Hewlett-Packard Sverige AB
Sunnanvagen 14K
S-2226 LUND
Tel: (046) 13-69-79
Telex: (854) 17886 (via Spånga
office)
CH

Hewlett-Packard Sverige AB
Östra Tullgatan 3
S-21128 MALMÖ
Tel: (040) 70270
Telex: (854) 17886 (via Spånga
office)
CH

Hewlett-Packard Sverige AB
Västra Vintergatan 9
S-70344 ÖREBRO
Tel: (19) 10-48-80
Telex: (854) 17886 (via Spånga
office)
CH

Hewlett-Packard Sverige AB
Skalhögsgatan 9, Kista
Box 19
S-16393 SPÅNGA
Tel: (08) 750-2000
Telex: (854) 17886
Telefax: (08) 7627781
A,CH,CM,CS,E,MS,P

Hewlett-Packard Sverige AB
Fröfällsgatan 30
S-42132 VÄSTRA-FRÖLUNDA
Tel: (031) 49-09-50
Telex: (854) 17886 (via Spånga
office)
CH,E,P

SWITZERLAND

Hewlett-Packard (Schweiz) AG
Clarastrasse 12
CH-4058 BASEL
Tel: (61) 33-59-20
A

Hewlett-Packard (Schweiz) AG
7, rue du Bois-du-Lan
Case Postale 365
CH-1217 MEYRIN 2
Tel: (0041) 22-83-11-11
Telex: 27333 HPAG CH
CH,CM,CS

Hewlett-Packard (Schweiz) AG
Allmend 2
CH-8967 WIEN
Tel: (0041) 57 31 21 11
Telex: 53933 hpag ch
Cable: HPAG CH
A,CH,CM,CS,E,MS,P

SYRIA

General Electronic Inc.
Nuri Basha Ahsal Ebn Kays Street
P.O. Box 5781
DAMASCUS
Tel: 33-24-87
Telex: 411 215
Cable: ELECTROBOR DAMASCUS
E

Middle East Electronics
P.O. Box 2308
Abu Rumaneh
DAMASCUS
Tel: 33 4 5 92
Telex: 411 304
M

TAIWAN

Hewlett-Packard Far East Ltd.
Kaohsiung Office
2/F 68-2, Chung Cheng 3rd Road
KAOHSIUNG
Tel: (07) 241-2318
CH,CS,E

Hewlett-Packard Far East Ltd.
Taiwan Branch
8th Floor
337 Fu Hsing North Road
TAIPEI

Tel: (02) 712-0404
Telex: 24439 HEWPACK
Cable: HEWPACK Taipei
A,CH,CM,CS,E,M,P
Ing Lih Trading Co.
3rd Floor, 7 Jen-Ai Road, Sec. 2
TAIPEI 100
Tel: (02) 3948191
Cable: INGLIH TAIPEI
A

THAILAND

Unimesa
30 Patpong Ave., Sunwong
BANGKOK 5
Tel: 235-5727
Telex: 84439 Simonco TH
Cable: UNIMESA Bangkok
A,CH,CS,E,M
Bangkok Business Equipment Ltd.
5/5-6 Dejo Road
BANGKOK
Tel: 234-8670, 234-8671
Telex: 87669-BEQUPT TH
Cable: BUSIQUPT Bangkok
P

TRINIDAD & TOBAGO

Caribbean Telecoms Ltd.
50/A Jerningham Avenue
P.O. Box 732
PORT-OF-SPAIN
Tel: 62-44213, 62-44214
Telex: 235,272 HUGCO WG
CM,E,M,P

TUNISIA

Tunisie Electronique
31 Avenue de la Liberte
TUNIS
Tel: 280-144
E,P

Corema
1 ter. Av. de Carthage
TUNIS
Tel: 253-821
Telex: 12319 CABAM TN
M

TURKEY

Tekrim Company Ltd.
Iran Caddesi No. 7
Kavakliere, ANKARA
Tel: 275800
Telex: 42155 TKM TR
E

E.M.A.

Medina Fikim Sokak No.4 1/6
Yuksekkaddesi
ANKARA
Tel: 175 622
Telex: 42 591
M

UNITED ARAB EMIRATES

Emilac Ltd.
P.O. Box 2711
ABU DHABI
Tel: 82 04 19-20
Cable: EMTAC ABUDHABI

Emilac Ltd.
P.O. Box 1641
SHARJAH
Tel: 591 181
Telex: 68136 Emilac Sh
CH,CS,E,M,P

UNITED KINGDOM

GREAT BRITAIN
Hewlett-Packard Ltd.
Trafalgar House
Navigation Road
ALTRINCHAM
Cheshire WA14 1NU
Tel: 061 928 6422
Telex: 668068
A,CH,CS,E,M,MS,P

Hewlett-Packard Ltd.
Elstree House, Elstree Way
BOREHAMWOOD, Herts WD6 1SG
Tel: 01 207 5000
Telex: 8952716
E,CH,CS,P

Hewlett-Packard Ltd.
Oakfield House, Oakfield Grove
Clifton BRISTOL, Avon BS8 2BN
Tel: 0272 736806
Telex: 444302
CH,CS,E,P

Hewlett-Packard Ltd.
Bridewell House
Bridewell Place
LONDON EC4V 6BS
Tel: 01 683 6565
Telex: 298163
CH,CS,P

Hewlett-Packard Ltd.
Fourier House
257-263 High Street
LONDON COLNEY
Herts. AL2 1HA, St. Albans
Tel: 0727 24400
Telex: 1-8952716
CH,CS

Hewlett-Packard Ltd.
Pontefract Road
NORMANTON, West Yorkshire WF6 1RN
Tel: 0924 895566
Telex: 557355
CH,CS,P

Hewlett-Packard Ltd.
The Quadrangle
106-118 Station Road
REDHILL, Surrey RH1 1PS
Tel: 0737 68655
Telex: 947234
CH,CS,E,P

SALES & SUPPORT OFFICES

Arranged alphabetically by country



GREAT BRITAIN (Cont'd)

Hewlett-Packard Ltd.
Avon House
435 Stratford Road
Shirley, SOLIHULL, West Midlands
B90 4BL

Tel: 021 745 890J
Telex: 339105
CH,CS,E,P

Hewlett-Packard Ltd.
West End House
41 High Street, West End
SOUTHAMPTON
Hampshire SO3 300
Tel: 04219 6767
Telex: 477138
CH,CS,P

Hewlett-Packard Ltd.
Eskdale Rd.
Winnersh, WOKINGHAM
Berkshire RG31 5DZ
Tel: 0734 696822
Telex: 848884
E

Hewlett-Packard Ltd.
King Street Lane
Winnersh, WOKINGHAM
Berkshire RG11 5AF
Tel: 0734 784774
Telex: 847178
A,CH,CS,E,M,MP,F

Hewlett-Packard Ltd.
Nine Mile Ride
Easthampstead, WOKINGHAM
Berkshire, RG11 3LL
Tel: 0344 773100
Telex: 848805
CH,CS,E,P

IRELAND

NORTHERN IRELAND

Hewlett-Packard Ltd.
Cardiac Services Building
95A Finaghy Road South
BELFAST BT10 0BY
Tel: 0232 625-566
Telex: 747626
CH,CS

SCOTLAND

Hewlett-Packard Ltd.
SOUTH QUEENSFERRY
West Lothian, EH30 9TG
Tel: 031 331 1183
Telex: 72602
CH,CM,CS,E,M,P

UNITED STATES

Alabama

Hewlett-Packard Co.
700 Century Park South, Suite 128
BIRMINGHAM, AL 35226
Tel: (205) 622-8802
A,CH,M

Hewlett-Packard Co.
420 Wynn Drive
HUNTSVILLE, AL 35805
P.O. Box 7700
HUNTSVILLE, AL 35807
Tel: (205) 830-2000
CH,CM,CS,E,M*

Arizona

Hewlett-Packard Co.
8080 Pointe Parkway West
PHOENIX, AZ 85044
Tel: (602) 273-8000
A,CH,CM,CS,E,MS

Hewlett-Packard Co.
2424 East Aragon Road
TUCSON, AZ 85706
Tel: (602) 899-4631
CH,E,MS**

California

Hewlett-Packard Co.
99 South Hill Dr.
BRISBANE, CA 94006
Tel: (415) 330-2500
CH,CS

Hewlett-Packard Co.
P.O. Box 7830 (93747)
5060 E. Clinton Avenue, Suite 102
FRESNO, CA 93727
Tel: (209) 252-9652
CH,CS,MS

Hewlett-Packard Co.
P.O. Box 4230
1430 East Orangethorpe
FULLERTON, CA 92631
Tel: (714) 870-1000
CH,CM,CS,E,MP

Hewlett-Packard Co.
320 S. Kellogg, Suite B
GOLETA, CA 93117
Tel: (805) 967-3405
CH

Hewlett-Packard Co.
5400 W. Alseccans Boulevard
LAWDALE, CA 90260
P.O. Box 92105
LOS ANGELES, CA 90009
Tel: (213) 970-7500
Telex: 910-325-6608
CH,CM,CS,MP

Hewlett-Packard Co.
3155 Porter Oaks Drive
PALO ALTO, CA 94304
Tel: (415) 857-8000
CH,CS,E

Hewlett-Packard Co.
4244 So. Market Court, Suite A
P.O. Box 15976
SACRAMENTO, CA 95852
Tel: (916) 929-7222
A*,CH,CS,E,MS

Hewlett-Packard Co.
9606 Aero Drive
P.O. Box 23333
SAN DIEGO, CA 92139
Tel: (619) 279-3200
CH,CM,CS,E,MP

Hewlett-Packard Co.
2305 Camino Ramon "C"
SAN RAMON, CA 94583
Tel: (415) 838-5900
CH,CS

Hewlett-Packard Co.
3005 Scott Boulevard
SAN JUAN CLARA, CA 95050
Tel: (408) 988-7000
Telex: 910-338-0586
A,CH,CM,CS,E,MP

Hewlett-Packard Co.
5703 Corsa Avenue
WESTLAKE VILLAGE, CA 91362
Tel: (213) 706-6800
E*,CH*,CS*

Colorado

Hewlett-Packard Co.
24 Inverness Place, East
ENGLEWOOD, CO 80112
Tel: (303) 649-5000
A,CH,CM,CS,E,MS

Connecticut

Hewlett-Packard Co.
47 Barnes Industrial Road South
P.O. Box 5007
WALLINGFORD, CT 06492
Tel: (203) 265-7801
A,CH,CM,CS,E,MS

Florida

Hewlett-Packard Co.
2901 N.W. 62nd Street
P.O. Box 24210
FORT LAUDERDALE, FL 33307
Tel: (305) 973-2600
CH,CS,E,MP

Hewlett-Packard Co.
6177 Lake Ellenor Drive
P.O. Box 10910
ORLANDO, FL 32859
Tel: (305) 859-2900
A,CH,CM,CS,E,MS

Hewlett-Packard Co.
5750B N. Hoover Blvd., Suite 123
P.O. Box 15200
TAMPA, FL 33614
Tel: (813) 884-3222
A*,CH,CM,CS,E*,M*

Georgia

Hewlett-Packard Co.
2000 South Park Place
P.O. Box 105005
ATLANTA, GA 30348
Tel: (404) 955-1500
Telex: 810-766-4890
A,CH,CM,CS,E,MP

Hawaii

Hewlett-Packard Co.
Kawahalo Plaza, Suite 180
567 South King Street
HONOLULU, HI 96813
Tel: (808) 526-1555
A,CH,E,MS

Illinois

Hewlett-Packard Co.
304 Eldorado Road
P.O. Box 1607
BLOOMINGTON, IL 61701
Tel: (309) 662-9411
CH,MS**

Hewlett-Packard Co.
1100 31st Street, Suite 100
DOWNS GROVE IL 60515
Tel: (312) 960-5160
CH,CS

Hewlett-Packard Co.
5201 Tollview Drive
ROLLING MEADOWS, IL 60008
Tel: (312) 255-8900
Telex: 910-887-1066
A,CH,CM,CS,E,MP

Indiana

Hewlett-Packard Co.
7301 No. Shadeland Avenue
P.O. Box 50807
INDIANAPOLIS, IN 46250
Tel: (317) 842-1000
A,CH,CM,CS,E,MS

Iowa

Hewlett-Packard Co.
1776 22nd Street, Suite 1
WEST DES MOINES, IA 50265
Tel: (515) 224-1435
CH,MS**

Kansas

Hewlett-Packard Co.
7804 East Funston Road, #203
WICHITA, KS 67207
Tel: (316) 684-8491
CH

Kentucky

Hewlett-Packard Co.
10300 Linn Station Road, #100
LOUISVILLE, KY 40223
Tel: (502) 426-0100
A,CH,CS,MS

Louisiana

Hewlett-Packard Co.
160 James Drive East
ST. ROSE, LA 70087
P.O. Box 1449
KENNER, LA 70063
Tel: (504) 467-4100
A,CH,CS,E,MS

Maryland

Hewlett-Packard Co.
3701 Koppers Street
BALTIMORE, MD 21227
Tel: (301) 644-5800
Telex: 710-862-1943
A,CH,CM,CS,E,MS

Hewlett-Packard Co.
2 Choke Cherry Road
ROCKVILLE, MD 20850
Tel: (301) 948-6370
A,CH,CM,CS,E,MP

Massachusetts

Hewlett-Packard Co.
1775 Waverman Road
ANDOVER, MA 01810
Tel: (617) 682-1500
A,CH,CS,CM,E,MP,P*

Hewlett-Packard Co.
32 Harwell Avenue
LEXINGTON, MA 02173
Tel: (617) 861-8960
CH,CS,E

Michigan

Hewlett-Packard Co.
4326 Cascade Road S.E.
GRAND RAPIDS, MI 49506
Tel: (616) 957-1970
CH,CS,MS

Hewlett-Packard Co.
1771 W. Big Beaver Road
TROY, MI 48064
Tel: (313) 643-6474
CH,CS

Minnesota

Hewlett-Packard Co.
2025 W. Larpenteur Ave.
ST. PAUL, MN 55113
Tel: (612) 644-1100
A,CH,CM,CS,E,MP

Missouri

Hewlett-Packard Co.
11131 Colorado Avenue
KANSAS CITY, MO 64137
Tel: (816) 763-8000
A,CH,CM,CS,E,MS

Hewlett-Packard Co.
13001 Hollenberg Drive
BRIDGETON, MO 33044
Tel: (314) 344-5100
A,CH,CS,E,MP



SALES & SUPPORT OFFICES

Arranged alphabetically by country

UNITED STATES (Cont'd)

Nebraska

Hewlett-Packard
10824 Old Mill Rd., Suite 3
OMAHA, NE 68154
Tel: (402) 334-1813
CM,MS

New Jersey

Hewlett-Packard Co.
120 W. Century Road
PARAMUS, NJ 07652
Tel: (201) 265-5000
A,CH,CM,CS,E,MP
Hewlett-Packard Co.
60 New England Av. West
PISCATAWAY, NJ 08854
Tel: (201) 981-1199
A,CH,CM,CS,E

New Mexico

Hewlett-Packard Co.
11300 Lomas Blvd., N.E.
P.O. Box 11834
ALBUQUERQUE, NM 87112
Tel: (505) 292-1330
CH,CS,E,MS

New York

Hewlett-Packard Co.
5 Computer Drive South
ALBANY, NY 12205
Tel: (518) 458-1550
A,CH,E,MS

Hewlett-Packard Co.

9600 Main Street
P.O. Box 3C
CLARENCE, NY 14031
Tel: (716) 759-8621
CH

Hewlett-Packard Co.
200 Cross Keys Office Park
FAIRPORT, NY 14450
Tel: (716) 223-9950
CH,CM,CS,E,MS

Hewlett-Packard Co.
7641 Henry Clay Blvd.
LIVERPOOL, NY 13088
Tel: (315) 451-1620
A,CH,CM,E,MS

Hewlett-Packard Co.
No. 1 Pennsylvania Plaza
55th Floor
347 Street & 8th Avenue
MANHATTAN NY 10119
Tel: (212) 971-0000
CH,CS,E*,M*

Hewlett-Packard Co.
250 Westchester Avenue
WHITE PLAINS, NY 10604
Tel: (914) 684-6100
CM,CH,CS,E

Hewlett-Packard Co.
3 Crossway Park West
ROCKSBURY, NY 11797
Tel: (516) 821-0300
A,CH,CM,CS,E,MS

North Carolina
Hewlett-Packard Co.
5605 Roanne Way
P.O. Box 26500
GREENSBORO, NC 27420
Tel: (919) 852-1800
A,CH,CM,CS,E,MS

Ohio

Hewlett-Packard Co.
9920 Carver Road
CINCINNATI, OH 45242
Tel: (513) 891-9870
CH,CS,MS

Hewlett-Packard Co.
16500 Sprague Road
CLEVELAND, OH 44130
Tel: (216) 243-7300
A,CH,CM,CS,E,MS

Hewlett-Packard Co.
962 Crupper Ave.
COLUMBUS, OH 43229
Tel: (614) 435-1041
Eff: Nov. 25, 1983
675 Brooksedge Blvd.
WESTERVILLE, OH 43081
CH,CM,CS,E*

Hewlett-Packard Co.
330 Progress Rd.
DAYTON, OH 45449
Tel: (513) 859-8202
A,CH,CM,E*,MS

Oklahoma

Hewlett-Packard Co.
304 N. Meridian, Suite A
P.O. Box 75809
OKLAHOMA CITY, OK 73147
Tel: (405) 946-9499
A*,CH,E*,MS

Hewlett-Packard Co.
3840 S. 103rd E. Avenue, #100
P.O. Box 15747
TULSA, OK 74153
Tel: (918) 665-3300
A*,CH,CS,M*

Oregon

Hewlett-Packard Co.
9255 S. W. Pioneer Court
P.O. Box 328
WILSONVILLE, OR 97070
Tel: (503) 682-8000
A,CH,CS,E*,MS

Pennsylvania

Hewlett-Packard Co.
111 Zeta Drive
PITTSBURGH, PA 15238
Tel: (412) 782-0400
A,CH,CS,E,MP

Hewlett-Packard Co.
2750 Monroe Boulevard
P.O. Box 713
VALLEY FORGE, PA 16482
Tel: (215) 666-9000
A,CH,CM,E,M

South Carolina

Hewlett-Packard Co.
Brookside Park, Suite 122
1 Harbison Way
P.O. Box 21708
COLUMBIA, SC 29221
Tel: (803) 732-0400
CH,E,MS

Hewlett-Packard Co.
Koger Executive Center
Chesterfield Bldg., Suite 124
GREENVILLE, SC 29615
Tel: (803) 297-4120

Tennessee

Hewlett-Packard Co.
224 Peters Road, Suite 102
P.O. Box 22490
KNOXVILLE, TN 37922
Tel: (615) 691-2371
A*,CH,MS

Hewlett-Packard Co.
3070 Directors Row
MEMPHIS, TN 38131
Tel: (901) 346-8370
A,CH,MS

Texas

Hewlett-Packard Co.
4171 North Mesa
Suite C-110
EL PASO, TX 79902
Tel: (915) 533-3555
CH,E*,MS**

Hewlett-Packard Co.
10535 Harwin Drive
P.O. Box 42816
HOUSTON, TX 77042
Tel: (713) 776-6400
A,CH,CM,CS,E,MP

Hewlett-Packard Co.
930 E. Campbell Rd.
P.O. Box 1270
RICHARDSON, TX 75080
Tel: (214) 231-6101
A,CH,CM,CS,E,MP

Hewlett-Packard Co.
1020 Central Parkway South
P.O. Box 32993
SAN ANTONIO, TX 78216
Tel: (512) 494-9336
CH,CS,E,MS

Utah

Hewlett-Packard Co.
3530 W. 2100 South
SALT LAKE CITY, UT 84119
Tel: (801) 974-1700
A,CH,CS,E,MS

Virginia

Hewlett-Packard Co.
4305 Cox Road
GLEN ALLEN, VA 23060
P.O. Box 9069
RICHMOND, VA 23228
Tel: (804) 747-7750
A,CH,CS,E,MS

Washington

Hewlett-Packard Co.
15815 S.E. 37th Street
BELLEVUE, WA 98006
Tel: (206) 843-4000
A,CH,CM,CS,E,MP

Hewlett-Packard Co.
Suite A
708 North Argonne Road
SPOKANE, WA 99212
Tel: (509) 922-7000
CH,CS

West Virginia

Hewlett-Packard Co.
4604 MacCorkle Ave.
P.O. Box 4297
CHARLESTON, WV 25304
Tel: (304) 925-0492
A,MS

Wisconsin

Hewlett-Packard Co.
150 S. Sunny Slope Road
BROOKFIELD, WI 53005
Tel: (414) 784-8800
A,CH,CS,E*,MP

URUGUAY

Pablo Ferrando S.A.C. e.l.
Avenida Italia 2877
Casilla de Correo 370
MONTEVIDEO
Tel: 80-2586
Telex: Public Booth 901
A,CM,E,M

VENEZUELA

Hewlett-Packard de Venezuela C.A.
3RA Transversal Los Ruices Norte
Edificio Segre 1, 2 & 3
Apartado 50933
CARACAS 1071
Tel: 239-4133
Telex: 251046 HEWPACK
A,CH,CS,E,MS,P

Hewlett-Packard de Venezuela C.A.
Calle 72-Entre 3H y 3Y, No. 3H-40
Edificio Ada-Evelyn, Local B
Apartado 2646
4001, MARACAIBO, Estado Zulia
Tel: (061) 80.304
C,E*

Hewlett-Packard de Venezuela C.A.
Calle Vargas Rondon
Edificio Seguros Carabobo, Piso 10
VALENCIA
Tel: (041) 51 385
CH,CS,P

Bioelectronica Medica C.A.
Calle Buen Pastor
Edif. Cota MI-Piso 2 y Semi Solano 1
Boleita Norte
Apartado 50710 CARACAS 1050A
Tel: 239 84 41
Telex: 26518

ZIMBABWE

Field Technical Sales
45 Kelvin Road, North
P.B. 3458
SALISBURY
Tel: 705 231
Telex: 4-122 FH
C,E,M,P

July 1983 5952-6900

Indicates main office

HP distributors are printed in italics.

END