

Errata

Title & Document Type: 8167B/8D/8E/8F Tunable Laser Source User's Guide

Manual Part Number: 08168-91031

Revision Date: February 1, 1998

HP References in this Manual

This manual may contain references to HP or Hewlett-Packard. Please note that Hewlett-Packard's former test and measurement, semiconductor products and chemical analysis businesses are now part of Agilent Technologies. We have made no changes to this manual copy. The HP XXXX referred to in this document is now the Agilent XXXX. For example, model number HP8648A is now model number Agilent 8648A.

About this Manual

We've added this manual to the Agilent website in an effort to help you support your product. This manual provides the best information we could find. It may be incomplete or contain dated information, and the scan quality may not be ideal. If we find a better copy in the future, we will add it to the Agilent website.

Support for Your Product

Agilent no longer sells or supports this product. You will find any other available product information on the Agilent Test & Measurement website:

www.tm.agilent.com

Search for the model number of this product, and the resulting product page will guide you to any available information. Our service centers may be able to perform calibration if no repair parts are needed, but no other support from Agilent is available.



User's Guide

HP 8167B/8D/8E/8F Tunable Laser Source

SERIAL NUMBERS

This guide applies to the 8167B, 8168D, 8168E and 8168F tunable laser sources. It does not always apply to the 8167A. Serial numbers of the 8167B begin with the letters DE.



HP Part No. 08168-91031
Printed in Germany

First Edition
E0298

Notices

This document contains proprietary information that is protected by copyright. All rights are reserved.

No part of this document may be photocopied, reproduced, or translated to another language without the prior written consent of Hewlett-Packard GmbH.

© Copyright 1997 by:
Hewlett-Packard GmbH
Herrenberger Str. 130
71034 Boeblingen
Germany

Subject Matter

The information in this document is subject to change without notice.

Hewlett-Packard makes no warranty of any kind with regard to this printed material, including, but not limited to, the implied warranties of merchantability and fitness for a particular purpose.

Hewlett-Packard shall not be liable for errors contained herein or for incidental or consequential damages in connection with the furnishing, performance, or use of this material.

Printing History

New editions are complete revisions of the guide reflecting alterations in the functionality of the instrument. Updates are occasionally made to the guide between editions. The date on the title page changes when an updated guide is published. To find out the current revision of the guide, or to purchase an updated guide, contact your Hewlett-Packard representative.

Warranty

This Hewlett-Packard instrument product is warranted against defects in material and workmanship for a period of one year (8167A and 8168D) or three years (8168E and 8168F) from date of shipment. During the warranty period, HP will, at its option, either repair or replace products that prove to be defective.

For warranty service or repair, this product must be returned to a service facility designated by HP. Buyer shall prepay shipping charges to HP and HP shall pay shipping charges to return the product to Buyer. However, Buyer shall pay all shipping charges, duties, and taxes for products returned to HP from another country.

HP warrants that its software and firmware designated by HP for use with an instrument will execute its programming instructions when properly installed on that instrument. HP does not warrant that the operation of the instrument, software, or firmware will be uninterrupted or error free.

Limitation of Warranty

The foregoing warranty shall not apply to defects resulting from improper or inadequate maintenance by Buyer, Buyer-supplied software or interfacing, unauthorized modification or misuse, operation outside of the environmental specifications for the product, or improper site preparation or maintenance.

No other warranty is expressed or implied. Hewlett-Packard specifically disclaims the implied warranties of Merchantability and Fitness for a Particular Purpose.

Exclusive Remedies

The remedies provided herein are Buyer's sole and exclusive remedies. Hewlett-Packard shall not be liable for any direct, indirect, special, incidental, or consequential damages whether based on contract, tort, or any other legal theory.

Assistance

Product maintenance agreements and other customer assistance agreements are available for Hewlett-Packard products. For any assistance contact your nearest Hewlett-Packard Sales and Service Office.

Certification

Hewlett-Packard Company certifies that this product met its published specifications at the time of shipment from the factory.

Hewlett-Packard further certifies that its calibration measurements are traceable to the United States National Institute of Standards and Technology, NIST (formerly the United States National Bureau of Standards, NBS) to the extent allowed by the Institutes's calibration facility, and to the calibration facilities of other International Standards Organization members.

ISO 9001 Certification

Produced to ISO 9001 international quality system standard as part of our objective of continually increasing customer satisfaction through improved process control.

08168-91031 : First Edition : 1st July 1997 : E0797 : 1st September 1997 : E0997 : 1st February 1998 : E0298

Safety Summary

The following general safety precautions must be observed during all phases of operation, service, and repair of this instrument. Failure to comply with these precautions or with specific warnings elsewhere in this manual violates safety standards of design, manufacture, and intended use of the instrument. Hewlett-Packard Company assumes no liability for the customer's failure to comply with these requirements.

General This is a Safety Class 1 instrument (provided with terminal for protective earthing) and has been manufactured and tested according to international safety standards.

Operation - Before applying power Comply with the installation section. Additionally, the following shall be observed:

- Do not remove instrument covers when operating.
- Before the instrument is switched on, all protective earth terminals, extension cords, auto-transformers and devices connected to it should be connected to a protective earth via a ground socket. Any interruption of the protective earth grounding will cause a potential shock hazard that could result in serious personal injury.
- Whenever it is likely that the protection has been impaired, the instrument must be made inoperative and be secured against any unintended operation.
- Make sure that only fuses with the required rated current and of the specified type (normal blow, time delay, etc.) are used for replacement. The use of repaired fuses and the short-circuiting of fuseholders must be avoided.
- Adjustments described in the manual are performed with power supplied to the instrument while protective covers are removed. Be aware that energy at many points may, if contacted, result in personal injury.
- Any adjustments, maintenance, and repair of the opened instrument under voltage should be avoided as much as possible, and when unavoidable, should be carried out only by a skilled person who is aware of the hazard involved. Do not attempt internal service or adjustment unless another person, capable of rendering first aid and resuscitation is present. Do not replace components with power cable connected.
- Do not operate the instrument in the presence of flammable gases or fumes. Operation of any electrical instrument in such an environment constitutes a definite safety hazard.
- Do not install substitute parts or perform any unauthorized modification to the instrument.
- Be aware that capacitors inside the instrument may still be charged even if the instrument has been disconnected from its source of supply.

Safety Symbols



The apparatus will be marked with this symbol when it is necessary for the user to refer to the instruction manual in order to protect the apparatus against damage.



Caution, risk of electric shock.



Frame or chassis terminal.



Protective conductor terminal.



Hazardous laser radiation.

Warning



The WARNING sign denotes a hazard. It calls attention to a procedure, practice or the like, which, if not correctly performed or adhered to, could result in injury or loss of life. Do not proceed beyond a WARNING sign until the indicated conditions are fully understood and met.

Caution



The CAUTION sign denotes a hazard. It calls attention to an operating procedure, practice or the like, which, if not correctly performed or adhered to, could result in damage to or destruction of part or all of the equipment. Do not proceed beyond a CAUTION sign until the indicated conditions are fully understood and met.

Initial Safety Information for the Tunable Laser Source

The Specifications for these instruments are as follows:

	HP 8167B	HP 8168D	HP 8168E	HP 8168F
Laser Type	Fabry Perot-Laser InGaAsP	Fabry Perot-Laser InGaAsP	Fabry Perot-Laser InGaAsP	Fabry Perot-Laser InGaAsP
Laser Class According to 21 CFR 1040.20 (USA, Canada, Japan)	IIIb	1	1	IIIb
According to IEC 825-1 (Other countries) EN 60825-1 Europe	3A	3A	3A	3A
Permissible Output Power (CW)	<9.9mW	<1.6mW	<1.6mW	<9.9mW
Beam Diameter	9 μ m	9 μ m	9 μ m	9 μ m
Numerical Aperture	0.1	0.1	0.1	0.1
Wavelength	1255-1365nm	1490-1565nm	1475-1575nm	1450-1590nm

Note



All Tunable Laser Source modules (8167B, 8168D/68E/68F) use two LED devices (HLMP-1503) as indicator lamps on the front panel. These LED devices are measured to be less than AEL Class 1 Laser Products per EN60825-1 Standard.

Note



USA

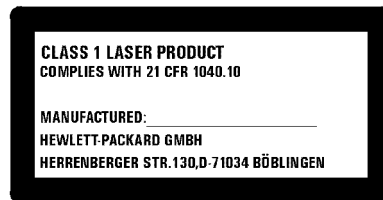

Class 1 laser safety warning labels, required for the 8168D and 8168E in the USA, Canada, or Japan.

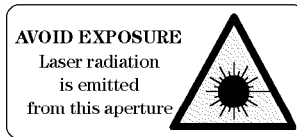
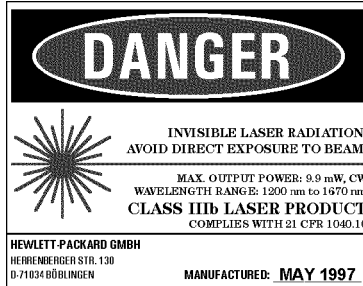

Class IIIb stickers, required for 8167B and 8168F in the USA, Canada, and Japan.

Caution



The use of optical instruments with this product will increase eye hazard.

Note



Other countries (not USA, Canada, or Japan)

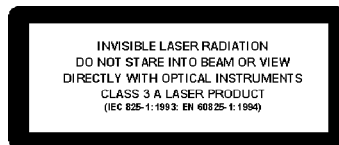

Class 3A stickers, required for all Tunable Laser Sources outside the USA, Canada, and Japan.

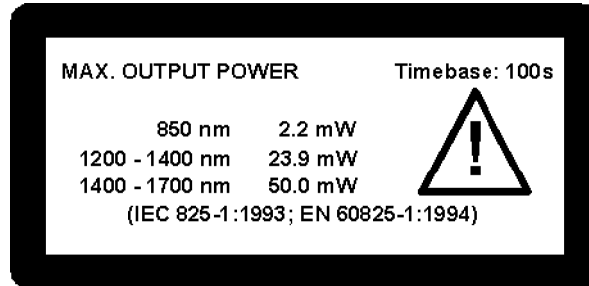

Class 3A Output Power stickers, required for all Tunable Laser Sources outside the USA, Canada, and Japan.

Note



A sheet of laser safety warning labels are included with the instrument. You *MUST* stick the labels in the local language onto the outside of the instrument, in a position where they are clearly visible to anyone using the instrument.

Note



You *MUST* return instruments with malfunctioning laser boxes to an HP Service Center for repair and calibration.

The instrument has built in safety circuitry that will disable the optical output in the case of a fault condition.

Warning



Use of controls or adjustments or performance of procedures other than those specified for the laser source may result in hazardous radiation exposure.

Warning



Refer Servicing only to qualified and authorized personnel.

Warning



Do not enable the laser when there is no fiber attached to the optical output connector.

The optical output connector is at the bottom right of the instrument front panel.

The laser is enabled by pressing the gray button beside the optical output connector on the front panel. The laser is enabled when the green LED on the front panel of the instrument is lit.

Warning



Under no circumstances look into the end of an optical cable attached to the optical output when the device is operational.

The laser radiation is not visible to the human eye, but it can seriously damage your eyesight.

Introduction

This guide is arranged into five categories:

- **Getting Started**
This section gives an introduction to the instrument, and aims to make the instrument familiar to you: Chapter 1.
- **Local Control**
This is the information on how to control the instrument from the front panel: Chapters 2 and 3.
- **Remote Control**
This is the information on how to control the instrument over the HP-IB. This is made of general information for using the HP-IB, a command reference, and some programming examples.: Chapters 4, 5, and 6.
- **Additional Information**
This is supporting information of a non-operational nature. This contains installation information, accessories, specifications, function tests, cleaning procedures, and error codes: Appendices A to F.
- **PACT software**
Appendix G gives you information about using the Passive Component Test Software.

Attenuator  Some information in this manual applies only to the tunable laser source with the built in optical attenuator (option 003). This paragraph is marked the way that all the passages which only apply to the attenuator option are marked in this manual.

Contents

1. Getting Started

What is a Tunable Laser Source?	1-1
A description of the Front Panel	1-2
Starting the 8167B or 8168F	1-3
Getting Help	1-5
Changing the Value of a Parameter	1-6
Making Big Changes to a Parameter	1-6
Making a Small Change to a Parameter	1-6
Setting a Parameter to its Default Value	1-7
If You Make a Mistake	1-8
If the Parameter Will Not Change	1-8
A Sample Session	1-8
Measuring the Power of a Modulated Signal	1-8
Setting the Wavelength	1-9
Setting the Modulated Power	1-10
Measuring a Wavelength Characteristic	1-11
Setting Up the Wavelength Sweep	1-11
Performing the Wavelength Characteristic Measurement	1-12

2. Setting Wavelength and Power

Setting the Wavelength	2-2
Setting the Wavelength Directly	2-2
Setting a Relative Wavelength	2-3
Changing the Base Wavelength	2-3
Performing a Wavelength Sweep	2-4
Setting the Wavelength Sweep	2-5
Setting the Maximum Power for the Sweep Range	2-5
Executing an Automatic Sweep	2-6
Performing a Manual Sweep	2-6
Setting the Power	2-8
Setting the Output Power of a CW Signal	2-8
Setting Power and Attenuation	2-9

What is Excessive Power?	2-9
The Analog Output	2-9
Setting a Modulated Signal	2-10
Using the Internal Modulation	2-11
Setting the Output Power of a Modulated Signal	2-11
Setting the Frequency of a Modulated Signal	2-11
The Modulation Output	2-12
Using External Modulation	2-12
Setting the Output Power of a Modulated Signal	2-13
The Modulation Input	2-13
Using Coherence Control	2-13
Setting the Output Power of a Coherence Control Signal	2-13
The Coherence Control Uncal Power	2-14
3. Other Functions	
Storing and Recalling Instrument Settings	3-1
Using the System Utilities	3-2
Switching the Instrument into Stand-By	3-3
Increasing the Lifetime of the Display	3-3
Setting the HP-IB Address	3-4
Setting the Modulation Output	3-4
Getting Information about the Instrument	3-4
Setting the Date and Time	3-4
Performing a Selftest	3-5
Auxiliary Functions	3-6
Viewing the Power as a Function of Wavelength	3-6
Setting the Peak Power	3-7
Passive Component Test (PACT)	3-7
Automatic Realignment	3-7
Secure	3-9
Lock the Instrument	3-9
Change the Password	3-11
4. Programming the Tunable Laser Source	
HP-IB Interface	4-1
Setting the HP-IB Address	4-3
Returning the Instrument to Local Control	4-3
How the Tunable Laser Source Receives and Transmits Messages	4-3
How the Input Queue Works	4-3
Clearing the Input Queue	4-4
The Output Queue	4-4

The Error Queue	4-4
Some Notes about Programming and Syntax Diagram Conventions	4-5
Short Form and Long Form	4-5
Command and Query Syntax	4-5

5. Remote Commands

Units	5-1
Command Summary	5-2
The Common Commands	5-5
Common Status Information	5-5
SRQ, The Service Request	5-6
*CLS	5-7
*ESE	5-7
*ESE?	5-8
*ESR?	5-8
*IDN?	5-9
*OPC	5-10
*OPC?	5-10
*OPT?	5-10
*RCL	5-11
*RST	5-11
*SAV	5-12
*SRE	5-12
*SRE?	5-13
*STB?	5-13
*TST?	5-14
*WAI	5-16
:DISPlay Commands	5-16
:DISPlay:ENABle	5-16
:DISPlay:ENABle?	5-16
:LOCK Commands	5-17
:LOCK	5-17
:LOCK?	5-17
:OUTPut Commands	5-17
:OUTPut[:STATe]	5-17
:OUTPut[:STATe]?	5-18
[:SOURce] Commands	5-18
[:SOURce]:AM:INTerNal:FREQuency	5-18
[:SOURce]:AM:INTerNal:FREQuency?	5-19
[:SOURce]:AM:SOURce	5-19
[:SOURce]:AM:SOURce?	5-19

[:SOURce]:AM:STATe	5-20
[:SOURce]:AM:STATe?	5-20
[:SOURce]:MODOUT	5-21
[:SOURce]:MODOUT?	5-21
[:SOURce]:POWER:ATTenuation	5-22
[:SOURce]:POWER:ATTenuation?	5-22
[:SOURce]:POWER:ATTenuation:AUTO	5-23
[:SOURce]:POWER:ATTenuation:AUTO?	5-23
[:SOURce]:POWER:ATTenuation:DARK	5-24
[:SOURce]:POWER:ATTenuation:DARK?	5-24
[:SOURce]:POWER[:LEVel][:IMMediate][:AMPlitude]	5-25
[:SOURce]:POWER[:LEVel][:IMMediate][:AMPlitude]?	5-25
[:SOURce]:POWER:UNIT	5-26
[:SOURce]:POWER:UNIT?	5-26
[:SOURce]:WAVElength[:CW]:FIXED]	5-27
[:SOURce]:WAVElength[:CW]:FIXED]?	5-27
[:SOURce]:WAVElength:REFerence?	5-28
[:SOURce]:WAVElength:REFerence:DISPlay	5-28
[:SOURce]:WAVElength:FREQuency	5-28
[:SOURce]:WAVElength:FREQuency?	5-28
:STATus Commands	5-29
:STATus:OPERation:CONDition?	5-30
:STATus:OPERation:ENABle	5-31
:STATus:OPERation:ENABle?	5-31
:STATus:OPERation[:EVENT]?	5-31
:STATus:OPERation:NTRansition	5-32
:STATus:OPERation:NTRansition?	5-32
:STATus:OPERation:PTRansition	5-32
:STATus:OPERation:PTRansition?	5-32
:STATus:QUESTionable:CONDition?	5-33
:STATus:QUESTionable:ENABle	5-33
:STATus:QUESTionable:ENABle?	5-33
:STATus:QUESTionable[:EVENT]?	5-34
:STATus:QUESTionable:NTRansition	5-34
:STATus:QUESTionable:NTRansition?	5-34
:STATus:QUESTionable:PTRansition	5-35
:STATus:QUESTionable:PTRansition?	5-35
:STATus:PRESet	5-35
:SYSTem Commands	5-36
:SYSTem:DATE	5-36
:SYSTem:DATE?	5-36

:SYSTem:ERRor?	5-36
:SYSTem:TIME	5-37
:SYSTem:TIME?	5-37
:TRACe Commands	5-37
:TRACe:CATalog?	5-37
:TRACe:POINts? <trace_name>	5-38
:TRACe[:DATa]? <trace_name>	5-38
Other Commands	5-38
WAVEACT	5-38
Passive Component Test software	5-40
BDATA? <i>nn</i>	5-40
DOSMODE	5-41
DOSMODE?	5-41

6. Programming Examples

Example 1 - Checking Communication	6-2
Example 2 - Status Registers and Queues	6-3
Example 3 - Measuring the Power of a Modulated Signal	6-7
Example 4 - Measuring a Wavelength Characteristic	6-10
Example 5 - Increased Tuning Linearity	6-12

A. Installation

Safety Considerations	A-1
Initial Inspection	A-1
AC Line Power Supply Requirements	A-2
Line Power Cable	A-2
Changing the Battery	A-4
Changing the Fuse	A-4
Operating and Storage Environment	A-6
Temperature	A-6
Humidity	A-6
Instrument Positioning and Cooling	A-6
Switching on the Tunable Laser Source	A-7
Self test	A-7
Initializing	A-7
Stabilizing	A-8
Stabilizing during Operation	A-8
Signal Outputs.	A-9
Optical Output	A-9
HP-IB Interface	A-10
Connector	A-10

HP-IB Logic Levels	A-11
Claims and Repackaging	A-12
Return Shipments to HP	A-12
B. Accessories	
Mainframe	B-1
Options	B-2
Option 003:	B-2
Option 007:	B-2
Connector Interfaces and Other Accessories	B-2
Option 021, Straight Contact Connector	B-3
Option 022, Angled Contact Connector	B-4
Option 023, Diamond HMS-10/HRL Angled, Non-Contact Connector	B-6
HP-IB Cables and Adapters	B-7
C. Specifications	
Definition of Terms	C-1
Performance Specifications	C-4
Supplementary Performance Characteristics	C-7
Characteristics	C-7
Operating Modes	C-7
Internal Modulation	C-7
External modulation	C-7
Coherence Control	C-7
General	C-7
Polarization maintaining fiber	C-7
HP-IB Interface	C-8
Passive Component Test Software	C-8
Laser Class	C-8
Environmental	C-8
Listed options	C-9
Other Specifications	C-9
Declaration of Conformity	C-10

D. Performance Tests	
Introduction	D-1
Equipment Required	D-1
Test Record	D-2
Test Failure	D-3
Instrument Specification	D-3
Wavelength Tests	D-3
Relative Wavelength Accuracy	D-4
Wavelength Repeatability	D-5
Power Tests	D-6
Maximum Output Power	D-7
Power Linearity	D-10
Power Flatness over Wavelength	D-14
Power Stability	D-15
Source Spontaneous Emission	D-16
E. Cleaning Procedures	
The Cleaning Kit	E-1
Other Cleaning Tools	E-3
Preserving Connectors	E-4
Cleaning Instrument Housings	E-4
Cleaning Procedures	E-5
Cleaning Cable Connectors	E-5
Cleaning Connector Adapters	E-6
Cleaning Connector Interfaces	E-7
Cleaning Bare Fiber Adapters	E-8
Cleaning Bare Fiber Ends	E-8
Cleaning Lenses	E-9
Cleaning Large Area Lenses and Mirrors	E-10
Cleaning Fixed Connector Interfaces	E-11
Cleaning Optical Glass Plates	E-11
Cleaning Physical Contact Interfaces	E-11
Cleaning Recessed Lens Interfaces	E-12
Cleaning Fragile Optical Devices	E-12
Cleaning Metal Filters or Attenuator Gratings	E-13

F. Error Messages	
Display Messages	F-1
HP-IB Messages	F-3
Instrument Specific Errors	F-3
Command Errors	F-3
Execution Errors	F-6
Device-Specific Errors	F-7
Query Errors	F-8
G. The Passive Component Test (PACT) software	
Getting Started	G-1
What is the Passive Component Test Software?	G-1
Starting the Passive Component Test Software	G-1
Getting Help while Using the System	G-2
Making Loss Measurements	G-3
Setting Up the Hardware	G-3
Making the Loss Measurement	G-4
Setting the Power Meter	G-5
Setting the Sweep	G-6
Measuring the Reference	G-7
Measuring the Device Under Test	G-8
Looking at the Results	G-8
Example, Measuring the Characteristic of a Fabry-Perot Resonator	G-8
Making Return Loss Measurements	G-12
Setting Up the Hardware	G-12
Making the Return Loss Measurement	G-13
Setting the Power Meter	G-15
Setting the Sweep	G-16
Measuring the Reference Reflection	G-17
Measuring the Termination Parameter	G-17
Including or Excluding the Termination Parameter	G-18
Measuring the Termination Parameter	G-18
Measuring the Device Under Test	G-18
Looking at the Results	G-19
Example, Measuring the Return Loss of a Fabry-Perot Resonator	G-20
Making Loss Ratio Measurements	G-25
Setting Up the Hardware	G-25
Making the Loss Ratio Measurement	G-26
Setting the Power Meter	G-28
Setting the Sweep	G-29
Measuring the Reference	G-30

Measuring the Device Under Test	G-30
Looking at the Results	G-31
Example, Measuring the Characteristic of a Wavelength Division Multiplexer	G-32
Printing Your Results	G-36
Setting Up the Printer	G-37
Setting Up the Hardware	G-37
Setting Up the Printer in Software	G-38
Selecting the Printer	G-39
Setting the Layout of the Printout	G-39
Setting the X- or Y-Axis Scaling	G-41
Editing Text for a Result	G-41
To Replace Text	G-42
To Change the Cursor Position in the Text	G-42
To Change between Overwriting and Inserting	G-42
To Put Characters into the Text	G-43
To End the Edit	G-43
Showing the Results	G-43
Selecting the Result to Show	G-43
Selecting Non-Standard Other Results	G-44
Previewing the Results on the Display	G-44
Making Readings from the Results	G-45
Printing the Results	G-46
Example, Printing Results of Loss against Wavelength	G-47
Saving Your Results	G-51
Formatting a Memory Card	G-52
Saving a Measurement or Result	G-53
Selecting the Measurement or Result to Save	G-53
Saving the Measurement or Result	G-54
Saving to Your Own Filename	G-54
To Replace a Filename	G-54
To Change the Cursor Position in the Filename	G-54
To Change between Overwriting and Inserting	G-55
To Put Characters into the Filename	G-55
To End the Edit and Save the Measurement or Result	G-55
Loading a Measurement or Result	G-56
Deleting a File	G-57
Example, Moving Termination Data to the DUT Data Area	G-58
Using Data on a PC	G-60
If the Data is Already On Your PC	G-61

If the Data is On the Memory Card in your Tunable Laser	
Source ...	G-61
Developing Your Own Converter	G-62
Reading .SLK Files into a Spreadsheet	G-62
Microsoft Excel	G-62
Borland Quattro Pro/Windows	G-62
Lotus 1-2-3W	G-62
Error Code Descriptions	G-62
The Result and Measurement Data Format	G-65
Backdating Information	G-71

Index

Figures

1-1. The Tunable Laser Source Front Panel	1-2
1-2. Starting Screen for the 8167B/8168F	1-3
1-3. “Secure: Unlock Instrument” Screen	1-4
1-4. “Secure” Screen	1-4
1-5. A Summary of the Help Hard- and Softkeys	1-5
1-6. The Help Topics Menu	1-5
1-7. Connecting the Instruments for the Sample Session	1-9
1-8. Tunable Laser Source Display after Setting Up Wavelength and Power	1-11
1-9. Tunable Laser Source Display during Setting Up for the Wavelength Sweep	1-12
2-1. A Summary of the additional Output Power Softkeys for the Attenuator Option	2-2
2-2. Setting the Wavelength Directly	2-2
2-3. Setting a Relative Wavelength	2-3
2-4. Setting Up for a Wavelength Sweep	2-4
2-5. The Parameters for a Wavelength Sweep	2-5
2-6. Performing a Manual Sweep	2-7
2-7. Setting the Output Power of a CW Signal	2-8
2-8. The Modulated Signal	2-11
2-9. Setting the Output Power of an Internally Modulated Signal	2-11
2-10. External Modulation and Output Power	2-12
2-11. Setting the Output Power of an Externally Modulated Signal	2-13
2-12. Setting the Output Power of a Coherence Controlled Signal	2-14
2-13. The Coherence Control Uncalibrated Power and the Maximum Power Level	2-14
3-1. User Setting Number 1	3-1
3-2. Summary of the Setting Hard- and Softkeys	3-2
3-3. The System Screen	3-3
3-4. Summary of the System Hard- and Softkeys	3-3
3-5. Auxiliary Functions (8168D/E)	3-6
3-6. Auxiliary Functions (8167B and 8168F)	3-6

3-7. Auto Realignment	3-8
3-8. "Secure" screen	3-9
3-9. "Secure: Lock Instrument" screen	3-10
3-10. "Secure" screen - instrument is locked	3-10
3-11. "Secure: Unlock Instrument" screen	3-10
3-12. "Secure: Change Password" screen	3-11
3-13. "Secure: Change Password": Enter new password	3-11
3-14. "Secure: Change Password": Enter new password again	3-11
5-1. Common Status Registers	5-6
5-2. The Status Registers	5-30
6-1. Connecting the Instruments for the Sample Session	6-8
6-2. Measurement setup for Increased Tuning Linearity	6-12
6-3. Flow chart describing Increased Tuning Linearity program.	6-13
A-1. Line Power Cables - Plug Identification	A-2
A-2. Rear Panel Markings	A-4
A-3. Releasing the Fuse Holder	A-5
A-4. The Fuse Holder	A-5
A-5. Correct Positioning of the Tunable Laser Source	A-7
A-6. PMF Output	A-10
A-7. HP-IB Connector	A-11
B-1. Tunable Laser Source Options Overview	B-2
B-2. Tunable Laser Source Option 021 Configuration	B-3
B-3. Tunable Laser Source Option 022 Configuration	B-5
B-4. Tunable Laser Source Option 023 Configuration	B-6
C-1. Maximum Specified Output Power for 8168D, E and F (without options)	C-1
D-1. Test Setup for the Wavelength Tests	D-4
D-2. Test Setup for the Maximum Output Power Test (HP 8168D,E)	D-8
D-3. Test Setup for the Maximum Output Power Test (HP 8167B and 8168F)	D-9
D-4. Test Setup for the Power Tests (except Maximum Output Power)	D-11
D-5. Test Setup for the Source Spontaneous Emission Test	D-17
G-1. The Main Screen	G-2
G-2. A Summary of the Help Hard- and Softkeys	G-2
G-3. The Help Topics Menu	G-2
G-4. Hardware Set-Up for a Loss Measurement	G-3
G-5. A Summary of the Loss Softkeys	G-4
G-6. The Loss Measurement Display	G-5
G-7. The Set Power Meter Display	G-6
G-8. The Parameters for a Wavelength Sweep	G-7
G-9. Measuring the Reference	G-7

G-10. Test Set-Up to Characterize a Fabry-Perot Resonator	G-9
G-11. Hardware Set-Up for a Return Loss Measurement	G-13
G-12. A Summary of the Return Loss Softkeys	G-14
G-13. The Return Loss Measurement Display	G-14
G-14. The Set Power Meter Display	G-15
G-15. The Parameters for a Wavelength Sweep	G-16
G-16. Measuring the Reference Reflection	G-17
G-17. Measuring the Termination Parameter	G-18
G-18. Test Set-Up to Measure the Reference Reflection	G-20
G-19. Test Setup for Measuring the Termination Parameter	G-23
G-20. Test Setup for Measuring the Fabry-Perot Resonator	G-23
G-21. Hardware Setup for a Loss Ratio Measurement	G-25
G-22. A Summary of the Loss Ratio Softkeys	G-27
G-23. The Loss Ratio Measurement Display	G-27
G-24. The Set Power Meter Display	G-28
G-25. The Parameters for a Wavelength Sweep	G-29
G-26. Measuring the Reference	G-30
G-27. Test Setup to Measure the Reference for Channel A	G-32
G-28. Test Setup to Characterize a Wavelength Division Multiplexer	G-35
G-29. The Show Display	G-36
G-30. A Summary of the Show Softkeys	G-37
G-31. Printer Hardware Setup	G-38
G-32. The Show Setting Display	G-38
G-33. The Layout of the Printout	G-40
G-34. The Edit Text Display	G-42
G-35. The Show Menu	G-43
G-36. Making an Absolute Reading	G-45
G-37. Making a Relative Reading	G-46
G-38. Set-Up to Print Out	G-47
G-39. The Memory Display	G-51
G-40. A Summary of the Memory Softkeys	G-52
G-41. The MemSave Display	G-54
G-42. The Show Text Display	G-54

Tables

4-1. HP-IB Capabilities	4-2
5-1. Units and Allowed Mnemonics	5-1
5-2. Common Command Summary	5-2
5-3. Command List	5-3
5-4. Reset State (Default Setting)	5-12
5-5. Specified Wavelength range	5-27
5-6. Command Summary	5-40
6-1. Program Description: Increased Tuning Linearity	6-16
A-1. Temperature	A-6

Getting Started

This chapter gives you basic information on how you can operate the tunable laser source from the front panel.

What is a Tunable Laser Source?

A tunable laser source is a laser source for which the wavelength is not fixed. The Hewlett-Packard tunable laser sources also allow you to set the output power, and to choose between continuous wave or modulated output power.

Note

The single greatest factor affecting the performance of the tunable laser source, as with all fiber optic measurements, is the cleanliness of the connectors. Ensure that your connectors are always clean. For cleaning instructions, see Appendix E.

A description of the Front Panel

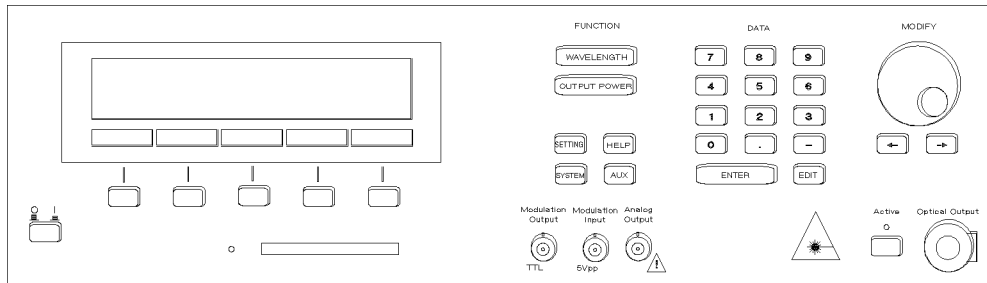

Figure 1-1. The Tunable Laser Source Front Panel

A softkey is a key whose function changes depending on the keys that you have pressed before. The function of a softkey is shown on the display above the softkey.

The memory card drive allows you to load replacement, or additional, software to increase the capabilities of your tunable laser source.

There are six function keys. These allow you

- to set the wavelength, or to perform a wavelength sweep.
- to set the output power,
- to save the wavelength and output power setting,
- to check or change the system configuration: to test the instrument, to switch off the laser and display, to change the HP-IB Address, to select whether the internal modulation signal is available at the Modulation Output constantly, or only when the power is being output, or to get information about the instrument and the software revision,
- to get help information (see “Getting Help” in the next section of this chapter), or
- to perform an auxiliary application such as examine the power characteristic, or to set the instrument for maximum power output.

The numeric keypad, the cursor keys, and the modify knob are used to edit parameters.

1-2 Getting Started

The modulation output gives a TTL level signal of the same frequency as the internal modulating signal.

The modulation input allows you to input a signal to modulate the power of the optical output.

The analog output gives a dc-signal proportional to the output power. The relationship between this voltage level and the output power is not calibrated, but is approximately 1mV for each $1\mu\text{W}$.

At the back of the 8167B and 8168F, you also have a Remote Interlock Connector. This is to protect the user from injury. If the short-circuit at this BNC connector is opened, the laser is switched off immediately and cannot be switched on until it is closed again.

Starting the 8167B or 8168F

When you turn on the 8167B or the 8168F, the instrument is locked. This is to prevent unauthorized persons from using this Laser Safety Class IIb instrument. The Starting screen for the 8167B/8168F is shown below:

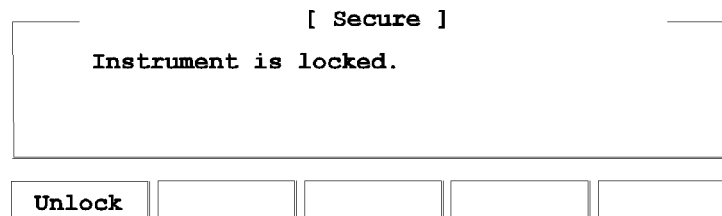

Figure 1-2. Starting Screen for the 8167B/8168F

If you have not set a new password, you also see the message:

default pwd: 8167, please change it! (8167B), or

default pwd: 8168, please change it! (8168F).

This message appears in the “Secure” screen until you set a new password (see “Secure” in Chapter 3).

To unlock the instrument, press **Unlock**. You see the following screen:



1

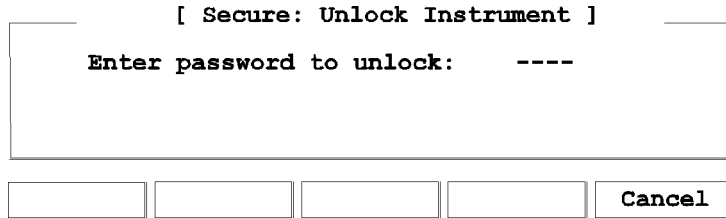

Figure 1-3. “Secure: Unlock Instrument” Screen

Enter the 4-figure password using the DATA keys. The default password is 8167 (8167B) or 8168 (8168F), although you can change this from the AUX menu (see “Secure” in Chapter 3).

When you enter the correct password, the instrument is unlocked, and you see the following screen:

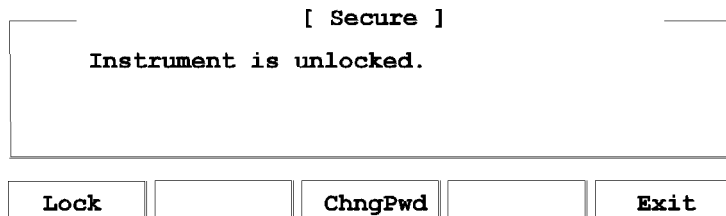

Figure 1-4. “Secure” Screen

Press **Exit**, or any of the function keys, to view the main screen.

Getting Help

Press **HELP** to get help.

When you press this key, the first help screen is displayed, this is either the last screen that was used, or the screen with the limit values for the parameters.

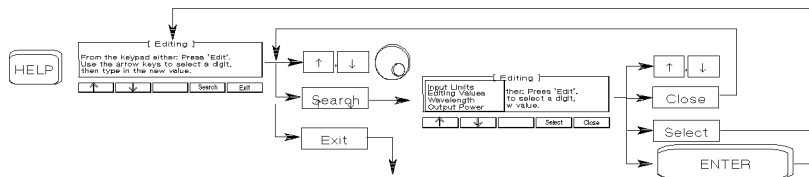

Figure 1-5. A Summary of the Help Hard- and Softkeys

Press **Search** to get the help topics menu.

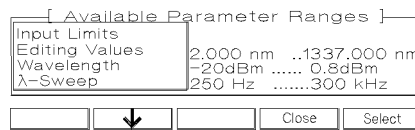

Figure 1-6. The Help Topics Menu

Choose a topic using **↑** and **↓**, or the Modify Knob. Press **Select**, or **ENTER** to get the information.

Press **Close** to close the help topics menu without selecting a topic.

Many of the help texts are longer than one screen. You move between screens of information using **↑** and **↓**.

Changing the Value of a Parameter

What follows is a description of the various methods of changing the value of parameters on the tunable laser source. Examples in which actual parameter values are changed are given with the parameter descriptions.

Making Big Changes to a Parameter

If you are changing the value of a parameter completely, you can directly type in the value on the keypad, and press **(ENTER)**.

Example To change the output power from 200 μ W to 1025 μ W.

1. Press **(OUTPUT POWER)**. The cursor moves to P on the right hand side of the display.

λ : 1540.000nm P: 200 μ W

2. Type the new value for the output power on the numeric keypad.

λ : 1540.000nm P: 1025 μ W

3. Press **(ENTER)** to end the editing.

Making a Small Change to a Parameter

For small changes to a parameter use **(EDIT)**, or the Modify Knob.

Select the parameter and then:

1. Press **(EDIT)**, **(←)**, **(→)**, or turn the Modify Knob slightly. If you start with Modify Knob the cursor moves to the digit that was most recently changed. If no digit was changed before, or if you started with another key, the cursor moves to the position of the most significant digit of the parameter.
2. If you want to move the cursor and select another digit to edit, use **(←)** and **(→)**.

3. Enter the new value for the digit at the cursor on the keypad, or by turning the Modify Knob. If you have entered the value from the keypad, the cursor moves to the next digit.
4. Repeat steps 2 and 3 to continue editing the value.
5. When you have finished editing the value, press **(ENTER)**. The edited value becomes the new value of the parameter.

Example To change the wavelength from 1540.000nm to 1542.500nm.

1. Press **(WAVELENGTH)**. The cursor moves to λ on the left hand side of the display.

```

      λ: 1540.000nm      P: 200μW
  
```

2. Press **(EDIT)**. The cursor moves to the most significant digit of the wavelength value.

```

      λ: 1540.000nm      P: 200μW
  
```

3. Press **(⇒)** three times to move the cursor to the units digit. Press **(2)** on the numeric keypad. The units digit changes, and the cursor moves to the next digit.

```

      λ: 1542.000nm      P: 200μW
  
```

4. Press **(5)** on the numeric keypad, to change the tenths digit. Press **(ENTER)** to end the editing.

```

      λ: 1542.500nm      P: 200μW
  
```

Setting a Parameter to its Default Value

There is a default softkey that you can use to set a parameter to its default value.

1. Press **(EDIT)**.
2. Press **Default**.

If You Make a Mistake

If you make a mistake while you are editing a parameter, you can cancel the editing, and get the previous value for the parameter back by pressing **Cancel**. Alternatively, you can press **Clear** and type in the parameter again.

If the Parameter Will Not Change

If, when you press **(ENTER)** after editing, the tunable laser source returns immediately to the previous value for the parameter, then the value you tried to enter is outside the calibrated range. Press **(HELP)**, and select the **Input Limits** help topic to see the calibrated range.

A Sample Session

There are two short tasks in this sample session. The first is to measure the power of a modulated signal at a single wavelength, and then a wavelength characteristic at a fixed power.

The sample session is written for an HP 8168E/F Tunable Laser Source, and an HP 8153A Lightwave Multimeter with an HP 81532A Power Sensor (It is assumed that the power sensor is inserted in channel A). To perform the sample session as described here, you also need a connector interface for the multimeter (for example, an HP 81000AI), and a patchcord (if you are using the HP 81000AI, then a Diamond HMS-10/HP/HRL to Diamond HMS-10/HP patchcord, HP 81109AC).

These same procedures are repeated in “Example 3 - Measuring the Power of a Modulated Signal” in Chapter 6 and “Example 4 - Measuring a Wavelength Characteristic” in Chapter 6, where they are performed using the HP-IB.

Measuring the Power of a Modulated Signal

We want to measure the power of a 1540nm signal, modulated by a 100kHz square wave, at 500 μ W.

1. Make sure that all your connectors and connector interfaces are clean.
2. Make sure that the Optical Output on the laser source is not Active.

3. Connect the output of the laser source to the input of the power sensor (as shown in the figure below). Make sure that the connector with the orange strain-relief sleeve is connected to the tunable laser source (the orange sleeve indicates an angled connector).

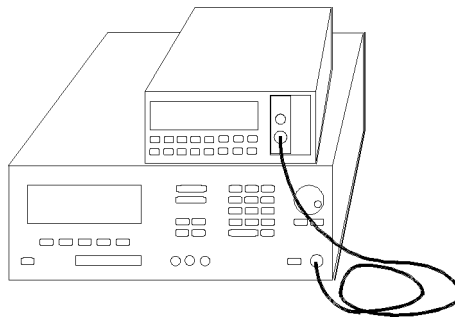

Figure 1-7. Connecting the Instruments for the Sample Session

Typically, you would connect a component to test between the tunable laser source and the power meter.

4. Make sure that both instruments are powered up.

Note

Normally you also need to be sure that the instruments are properly warmed up before using the source, or making any measurements. Here, because the measurements are not critical, it is okay to proceed immediately to the next step.

Setting the Wavelength

5. On the tunable laser source:
 - a. Press **WAVELENGTH**.
 - b. Make sure that you are setting the wavelength directly.
(Press **nm/GHz** if necessary until there is only one parameter (λ) shown on the left side of the display).
 - c. Press **EDIT** and then **Default** to set the wavelength to 1540.000nm.

1

6. On the multimeter set the wavelength for the power sensor to 1540.0nm, set the measurement averaging time to 1s
(**Chan**→A; **Mode**→MEAS; **Param**→λ→1540.0nm; **Param**→T→1s).

Setting the Modulated Power

7. On the tunable laser source:
 - a. Press **OUTPUT POWER**.
 - b. Make sure that you have a modulated signal selected
(Press **Mod/CW** if necessary until there are two parameters (POWER and FREQ) shown on the right side of the display).
 - c. Make sure that POWER is selected
(the label of the selected parameter is displayed in inverse, press **Power** if it is not selected).
 - d. Make sure that the power is being shown in μWatts
(if necessary, press **W/dBm** to change the units).
 - e. Type 500 on the keypad and press **ENTER**.
8. On the multimeter, make sure that Watts are selected and that the instrument is autoranging
(**dBm/W**→W; **Auto**→AUTO).
9. On the tunable laser source:
 - a. Press **Freq.**
 - b. Type in 100 on the keypad.
 - c. Make sure that the units are set to kHz
(If necessary, press **Hz/kHz** to change the units).
 - d. Press **ENTER**.



Figure 1-8.
Tunable Laser Source Display after Setting Up Wavelength and Power

10. Press the button beside the Optical Output, the green LED should be lit to indicate that the laser is now active.

You should notice that the power reading on the multimeter is approximately half the value set on the laser source. This is because the output is modulated by a square wave with a 50% duty cycle.

Measuring a Wavelength Characteristic

For the second part, we assume that the instruments are in the state given after the first task (see Figure 1-8).

We now want to measure the wavelength characteristic by measuring the power at 1nm steps between 1535nm and 1545nm, at the highest power level possible that is available over the full sweep range.

11. On the laser source, press **Mod/CW** to return the laser source to CW operation.

Setting Up the Wavelength Sweep

12. On the laser source:
 - a. Press **(WAVELENGTH)**, and then **λ-Sweep**.
 - b. Type in 1535 on the keypad and press **(ENTER)** to set the start wavelength for the sweep.
 - c. Type in 1545 on the keypad and press **(ENTER)** to set the stop wavelength for the sweep.
 - d. Type in 1 on the keypad and press **(ENTER)** to set the size of the wavelength step for the sweep.

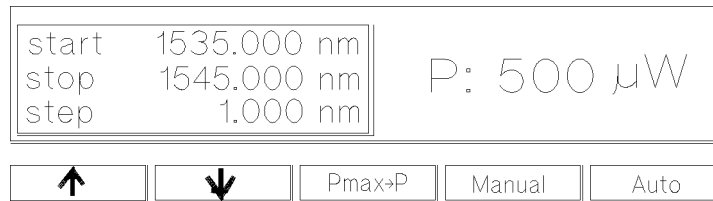

Figure 1-9.
Tunable Laser Source Display during Setting Up for the Wavelength Sweep

- e. Press **↓** to skip over the dwell parameter.
 - f. Type in 1 on the keypad and press **(ENTER)** to set the number of times that the sweep is to be performed.
13. On the laser source, press **Pmax→P** to set the output power to the highest value that can be maintained for the full sweep range.
 14. On the power meter:
 - a. Set λ to 1535nm
 ((Param)→ λ →1535.0nm).
 - b. Make sure that the parameter cursor is in the units position (that is, at the second "5").

Performing the Wavelength Characteristic Measurement

15. Make sure that the laser source is still active.
16. On the laser source, press **Manual**.
17. Read the value for the power at 1535nm on the multimeter.
18. Repeat the following steps at each wavelength in the sweep range
 - a. On the laser source, press **Next**.
 - b. On the multimeter, increment λ (press **(↑)**).
 - c. Read the value for the power at the wavelength on the multimeter.
19. On the laser source, press **Stop** to end the sweep.

1-12 Getting Started

This procedure can be used in practice to measure the wavelength characteristic of a component.

1



Setting Wavelength and Power

This chapter describes how to set the wavelength and the power of the output.

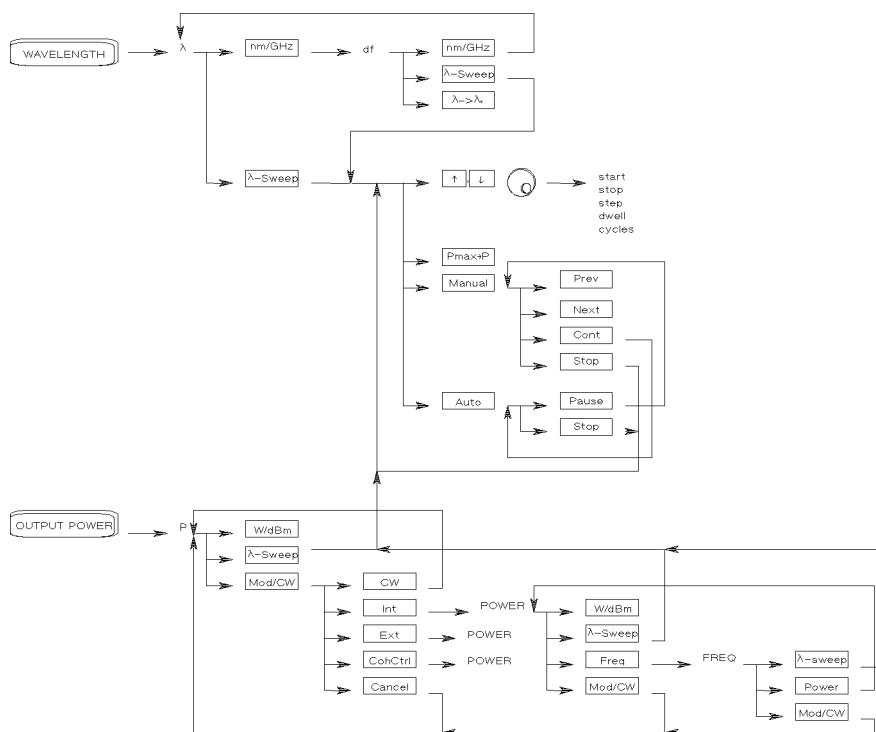

A Summary of the Wavelength and Output Power Hard- and Softkeys

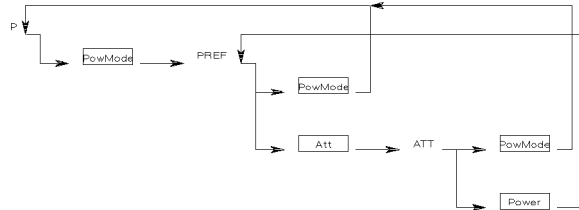

Figure 2-1.
A Summary of the additional Output Power Softkeys for the Attenuator Option

Setting the Wavelength

There are three ways to set the wavelength of the tunable laser source.

- You can set the wavelength (λ) directly,
- You can set the wavelength from a base wavelength and an offset in the frequency domain, or
- You can set a range of wavelengths for the instrument to “sweep”

Press **WAVELENGTH** to select the wavelength parameter.

Use **nm/GHz** to select how you set the wavelength.

Use **λ -Sweep** to perform a wavelength sweep.

Setting the Wavelength Directly

You can set the wavelength directly if the display looks like this:



Figure 2-2. Setting the Wavelength Directly

2-2 Setting Wavelength and Power

Press **WAVELENGTH** and **nm/GHz** as necessary to get this display.

See “Changing the Value of a Parameter” in Chapter 1 if you need details on how to edit parameters.

Example To set the wavelength to 1505.500nm (on an HP 8168E/F)

1. Press **WAVELENGTH**
2. Press **nm/GHz**, if necessary, until the display looks as shown in Figure 2-2
3. Type in 1505.5 on the numeric keypad, and press **ENTER**.

Setting a Relative Wavelength

You use a relative wavelength for heterodyning, for example, when you are measuring the linewidth of DFB (distributed feedback) lasers.

You can set a relative wavelength if the display looks like this:

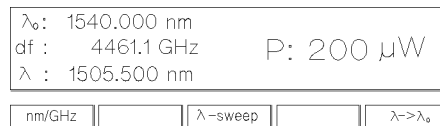

Figure 2-3. Setting a Relative Wavelength

Press **WAVELENGTH** and **nm/GHz** as necessary to get to this display.

The output wavelength (λ) is set from the base wavelength (λ_0) and the frequency offset (df). The formula for calculating the output wavelength is:

$$\lambda = \frac{c}{(\lambda_0)df + c} \lambda_0$$

where c is the speed of light in a vacuum ($2.998 \times 10^8 \text{ms}^{-1}$).

You can edit only the value of df directly. See “Changing the Value of a Parameter” in Chapter 1 if you need details on how to edit parameters.

Changing the Base Wavelength

If you want to change λ_0 ,

1. set λ to the value to which you want to set the base wavelength (by calculating df , or by setting the wavelength directly) and then

2

2. press $\lambda \rightarrow \lambda_0$.

Example

Set the base wavelength to 1540.000nm, and then set df, so that the output wavelength is 1507.5nm (on an HP 8168E/F)

1. Press **(WAVELENGTH)**.
2. Press **nm/GHz** until the screen looks as shown in Figure 2-2 (that is, to set the wavelength *directly*).
3. Press **(EDIT)** and then **Default**.
4. Press **nm/GHz**, to set a relative wavelength.
5. Press $\lambda \rightarrow \lambda_0$

The base wavelength is now set.

6. Calculate the value for df

$$df = \frac{c}{\lambda} - \frac{c}{\lambda_0} = \frac{2.998E8}{1507.500E-9} - \frac{2.998E8}{1540.000E-9} = 4196.980GHz$$

7. Type in the value for df (4197.0) on the numeric keypad, and press **(ENTER)**.
8. Because of inaccuracies in the value taken for the speed of light, this gives a λ value of 1507.499nm. Use the Modify Knob to edit the value for df to get $\lambda = 1507.5nm$

Performing a Wavelength Sweep

You can perform a wavelength sweep when the screen looks like this

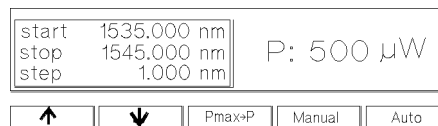

Figure 2-4. Setting Up for a Wavelength Sweep

Press **(WAVELENGTH)** and **λ -Sweep** as necessary to get this display.

2-4 Setting Wavelength and Power

Setting the Wavelength Sweep

There are five parameters for the wavelength sweep,

- **start**, the wavelength with which the sweep begins,
- **stop**, the wavelength at which the sweep ends,
- **step**, the size of the change in wavelength for each step,
- **dwell**, the amount of time spent at the wavelength during each step, and
- **cycles**, the number of times the sweep is repeated.

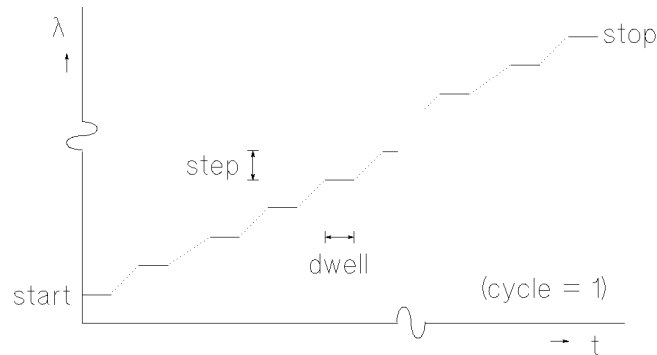

Figure 2-5. The Parameters for a Wavelength Sweep

You move from one parameter to the next, using \uparrow and \downarrow , the Modify Knob, or **(ENTER)**. Only three of the parameters can be displayed at a time, you scroll the other parameters onto the display.

See “Changing the Value of a Parameter” in Chapter 1 if you need details on how to edit parameters.

Setting the Maximum Power for the Sweep Range

Pmax→P sets the power to the maximum for the selected sweep range.

Alternatively, you can set a power level in the way described in “Setting the Power”.

Note

If coherence control is enabled, and the uncal power level cannot be exceeded for the full wavelength range chosen, the wavelength range is reduced as necessary.

Executing an Automatic Sweep

You can perform an automatic sweep if you press **Auto** after setting up the sweep parameters, or if you press **Cont** during a manual sweep.

Press **Pause** to interrupt the sweep. The instrument switches to a manual sweep (see “Performing a Manual Sweep”).

Press **Stop** to end the sweep.

Example Set the instrument to sweep the range 1495nm to 1555nm, three times, in 1nm steps, stopping for half a second at each wavelength, at the highest power level available at all wavelengths.

1. Press **WAVELENGTH** and then **λ -Sweep**.
2. Make sure you are at the **start** parameter.
3. Type in 1495 and then **ENTER**, to set the start wavelength.
4. Type in 1555 and then **ENTER**, to set the stop wavelength.
5. Type in 1 and then **ENTER**, to set the step size.
6. Type in 0.5 and then **ENTER**, to set the dwell time.
7. Type in 3 and then **ENTER**, to set the number of cycles.
8. Press **Pmax→P**, to set the power.
9. Enable the optical output, if necessary.
10. Press **Auto**, to run the application.

Performing a Manual Sweep

You can perform a manual sweep if you press **Manual** after setting up the sweep parameters, or if you press **Pause** during an automatic sweep. During a manual sweep the display looks as follows:



2

Figure 2-6. Performing a Manual Sweep

Press **Next** to move on to the next wavelength step.

Press **Prev** to move back to the previous wavelength step.

Press **Cont** to continue with an automatic sweep, from the current wavelength.

Press **Stop** to end the sweep.

Setting the Power

The laser output can be either

- a continuous wave (CW), fixed-amplitude signal,
- a modulated signal, or
- a signal with increased linewidth (coherence control).

Attenuator If you have the built in attenuator, there are two power modes for both the fixed-amplitude, the modulated, and the increased linewidth signals. You can either



- specify the output power (Power Mode), or
- specify the laser power and the attenuation (Attenuation Mode).

The two modes are separate, the values set in one mode do not affect the values set in the other.

Press **OUTPUT POWER** to select the output power parameter. Use **Mod/CW** to choose CW, modulated, or coherence control.

Attenuator If you have the optional attenuator installed, use **PowMode** to choose between Power Mode (specifying the output power) and Attenuation Mode (specifying the laser power and attenuation).



Setting the Output Power of a CW Signal

You can set the output power of a CW signal if the display looks like this:



Figure 2-7. Setting the Output Power of a CW Signal

Press **OUTPUT POWER**, **Mod/CW** and **CW** as necessary to get to this display.

2-8 Setting Wavelength and Power

See “Changing the Value of a Parameter” in Chapter 1 if you need details on how to edit parameters.

You can change the units by pressing **W/dBm**.

Attenuator If you have the optional attenuator installed, you may need to press **PowMode** to get the display shown above.



Setting Power and Attenuation

Attenuator If you have the optional attenuator installed, you can also set the output power by setting first the laser output power, and then setting the amount of attenuation.



Press **PowMode** from the screen shown in Figure 2-7 to change to the Attenuation Mode.

Press **Att** to select the attenuation parameter. Press **Pref** to select the laser output power.

What is Excessive Power?

An EXCESSIVE message indicates that the value you have set for the output power is larger than the laser diode is capable of producing at this wavelength. The instrument sets the output power as high as possible; it is this actual output power that is shown as part of the EXCESSIVE message.

Note If the chosen value is simultaneously too low for the coherence control, if you are also using this, the EXCESSIVE is shortened to EXC.



The Analog Output

The Analog Output, on the front panel of the instrument, outputs a dc level that is proportional to the laser output power. The relationship between this voltage level and the output power is not calibrated, but is approximately 1mV for each 1 μ W.

2

Attenuator If you have the optional attenuator installed, the Analog Output signal depends on the power mode you have chosen.



In Power Mode the laser output power, and therefore the Analog Output signal, is not linearly proportional to the output power. This is because the actual output optical power is derived by the optimum combination of the laser output power and the attenuation.

In Attenuation Mode the relationship between the Pref and the voltage level is approximately 1.35mV for each 1 μ W. (The difference between this value and that of the tunable laser source without the attenuator is due to the insertion loss of the attenuator). This value is only proportional to the output power if the attenuation remains constant. Here, the attenuator adds a constant offset to the voltage level.

Example

To set the power to -10dBm.

1. Press **OUTPUT POWER**.
2. Press **Mod/CW**, and **CW** if necessary, so that the display looks as shown in Figure 2-7.
3. Press **W/dBm**, if necessary, so that the power is displayed in dBm.
4. Type -10 on the numeric keypad, and press **ENTER**.

Setting a Modulated Signal

There are two ways of modulating the amplitude of the optical output.

- Using the internal modulation, and
- using external modulation.

Using the Internal Modulation

The internal modulating source is a square wave with a 50% duty-cycle. You can set both the amplitude and the frequency of this signal. The amplitude is set by the power parameter. This is the maximum output power of the output signal; at the minimum, nothing is output.

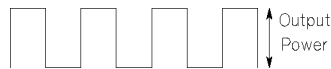

Figure 2-8. The Modulated Signal

Setting the Output Power of a Modulated Signal

You can set the output power of a modulated signal if the display looks like this:

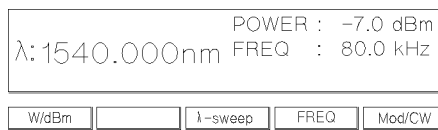

Figure 2-9. Setting the Output Power of an Internally Modulated Signal

Press **OUTPUT POWER**, **Mod/CW**, and **Int** as necessary to get to this display.

See “Changing the Value of a Parameter” in Chapter 1 if you need details on how to edit parameters.

You can change the units by pressing **W/dBm**.

The notes above about excessive power, and the analog output apply also to the power of a modulated signal.

Setting the Frequency of a Modulated Signal

You can also set the frequency of a modulated signal from the display shown above. Press **Freq** to select the parameter. See “Changing the Value of a Parameter” in Chapter 1 if you need details on how to edit parameters.

You can change the units by pressing **Hz/kHz** while you are editing the value. The new units come into effect when you press **ENTER**.

The Modulation Output

The Modulation Output on the front panel outputs a version of the modulating signal that has the same frequency and phase as the modulating signal, but has a fixed, TTL-level amplitude. You can use this to synchronize your external measuring equipment to the tunable laser source.

To allow for your possible synchronization requirements, there are two ways in which the signal can be output. Either the signal is combined with the laser-ready signal, so that the output is kept low when there is no optical signal being output (for example, while the laser is settling after a change of wavelength). Or the modulation signal is output all the time. This is set by the **(System) MODOUT** parameter (see “Setting the Modulation Output” in Chapter 3).

Example Set the frequency of the modulated output to 300Hz.

1. Press **(OUTPUT POWER)**.
2. Press **Mod/CW**, and **Int** if necessary, so that the display looks as shown in Figure 2-9.
3. Press **Freq**.
4. Type 300 on the numeric keypad.
5. Press **Hz/kHz**, if necessary, to set the units to Hz, and press **(ENTER)**.

Using External Modulation

The external modulating source can be any signal of up to $5V_{pp}$. A $5V_{pp}$ signal causes 15% modulation of the power of the optical output signal.

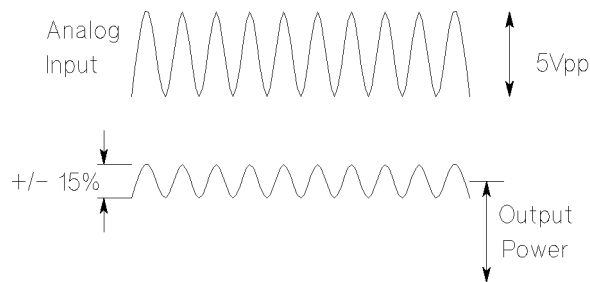

Figure 2-10. External Modulation and Output Power

Setting the Output Power of a Modulated Signal

You can set the output power of a modulated signal if the display looks like this:



Figure 2-11. Setting the Output Power of an Externally Modulated Signal

Press **OUTPUT POWER**, **Mod/CW**, and **Ext** as necessary to get to this display.

See “Changing the Value of a Parameter” in Chapter 1 if you need details on how to edit parameters.

You can change the units by pressing **W/dBm**.

The notes above about excessive power, and the analog output apply also to the power of a modulated signal.

The Modulation Input

The Modulation Input on the front panel is where you input your modulating signal.

Using Coherence Control

Enabling the coherence control increases the linewidth of the optical output signal to between 30 and 500MHz (typically). This drastically reduces interference effects and therefore improves the power stability in sensitive test setups.

Setting the Output Power of a Coherence Control Signal

You can set the output power of a coherence controlled signal if the display looks like this:

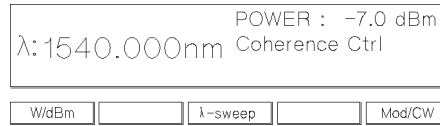

Figure 2-12. Setting the Output Power of a Coherence Controlled Signal

Press **OUTPUT POWER**, **Mod/CW**, and **CohCtrl** as necessary to get to this display.

See “Changing the Value of a Parameter” in Chapter 1 if you need details on how to edit parameters.

You can change the units by pressing **W/dBm**.

The notes above about excessive power, and the analog output apply also to the power of a coherence controlled signal.

The Coherence Control Uncal Power

At any particular wavelength, coherence control is only available with the specified linewidth, above a level known as the Coherence Control Uncalibrated Power, and below the Maximum Power level (that is, in the area between the two curves in the diagram). The message **CC UNCAL** indicates that the laser power is not high enough to provide the specified linewidth. The linewidth is still broadened.

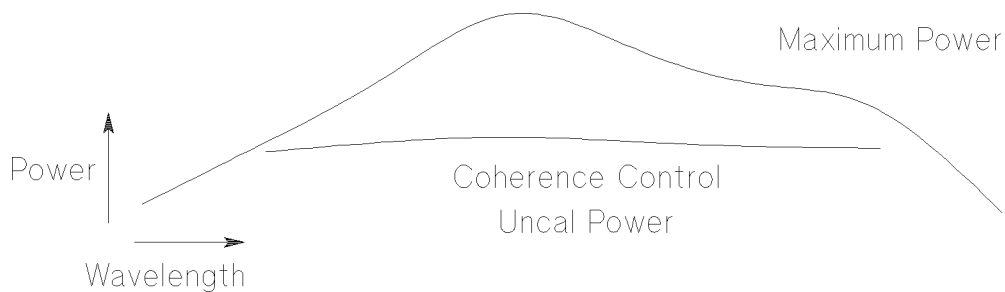

Figure 2-13.
The Coherence Control Uncalibrated Power and the Maximum Power Level

Other Functions

This chapter describes how to save and recall measurement settings for the tunable laser source, and how to use the system functions of the instrument.

Storing and Recalling Instrument Settings

The **(SETTING)** key gives you access to the instrument settings displays. These displays look as follows:

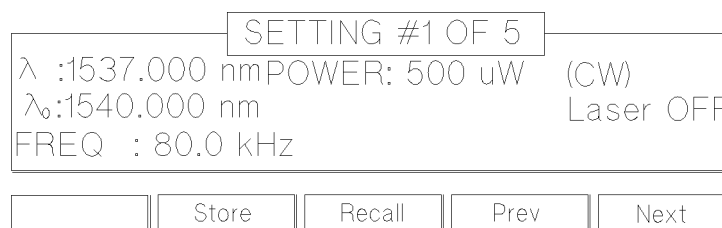



Figure 3-1. User Setting Number 1

There are seven settings:

Attenuator  When you have the optional attenuator installed, then the setting also includes the laser output power (Pref), the attenuation (Att), and the power mode (PowMode, or AttMode).

- the Actual Setting, which is the setting being used by the instrument,
- the Default Setting, and
- five user settings.

Note

The Default Setting does *not* contain λ -Sweep information. All other settings contain this information, although it is not shown on the display.

3

Figure 3-2. Summary of the Setting Hard- and Softkeys

Use **Prev** and **Next** to move between the different setting displays.

Press **Default** to reset the Actual Setting to default values.

Press **Recall** to recall the Default Setting, or the currently displayed user setting for use as the Actual Setting (overwriting the Actual Setting).

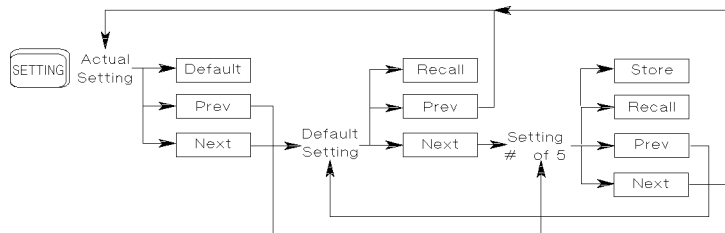
Press **Store** to store the Actual Setting to the currently displayed user setting (overwriting the user setting).

Using the System Utilities

Press **(SYSTEM)** to access configuration information for the tunable laser source. You get the following screen:

3-2 Other Functions



Figure 3-3. The System Screen

3 [REDACTED]

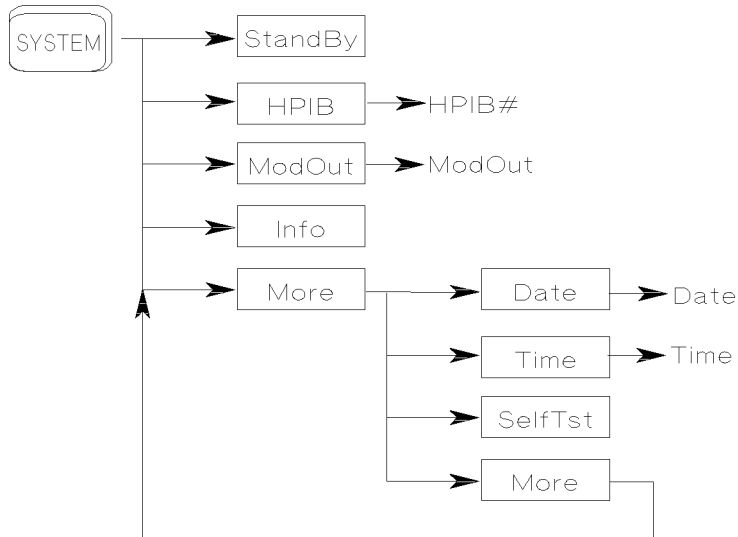

Figure 3-4. Summary of the System Hard- and Softkeys

There are not enough function keys under the display for all the system functions, therefore they have been divided into two sections. You change from one section to the other by pressing the **More** Softkey.

Switching the Instrument into Stand-By

Increasing the Lifetime of the Display

Normally the display is on at all times. If you want to switch off the display (and the laser), but keep the instrument running (for example, to prevent

display burn-in, but to keep the heat chamber up to temperature), press **StandBy** (you may have to press **More** to get to this softkey).

While the instrument is in standby mode the laser is switched off, and the word standby is flashed on the screen. Press any key to reactivate the instrument.

3

Setting the HP-IB Address

Press **HPIB** to select the parameter for setting the HPIB address (you may have to press **More** to get to this softkey).

See “Changing the Value of a Parameter” in Chapter 1 if you need details on how to edit parameters.

The default HP-IB address is 24.

Setting the Modulation Output

Press **MODOUT** to toggle the modulation output (you may have to press **More** to get to this softkey). The two possible values are

- **FRQ&RDY**, where the modulation signal is combined with the laser-ready signal, so that the output is kept low when there is no optical signal being output (for example, while the laser is settling after a change of wavelength), and
- **FRQ**, where the modulation signal is output all the time.

Getting Information about the Instrument

Press **Info** for information on the firmware revision, serial number and the date of the last calibration of your instrument (you may have to press **More** to get to this softkey).

Setting the Date and Time

Press **Date** to set the date (you may have to press **More** to get to this softkey). You can type in the six numbers for the date directly from the numeric keypad, or you can use the arrow keys and the numeric keypad to edit the date. The date is changed when you press the **(Enter)** key.

The date is in the format month/day/year.

3.4 Other Functions

You cannot use the Modify Knob for editing the date.

Press **Time** to set the time (you may have to press **More** to get to this softkey). You can type in the four numbers for the time directly from the numeric keypad, or you can use the arrow keys and the numeric keypad to edit the time. The time is changed when you press the **Enter** key.

The time is in the format hours:minutes.

You cannot use the Modify Knob for editing the time.

3

Performing a Selftest

Press **SelfTst** to start the internal instrument self-test. The instrument performs a full self-test, indicating after each test, the test that has just been performed, and the result (passed or failed):

μ P1 Board	indicates the test of the first microprocessor board.
μ P2 Board	indicates the test of the second microprocessor board.
Cal. Data	is the test of the calibration data, which is stored in the instrument.
HW-Interface	tests the hardware interface.
ADC	is the test of the analog to digital converter.
Laser Board	tests the laser driver board.
Motor 1	tests the first of the two motors used to control the tuning of the laser.
Motor 2	tests the second of the two motors used to control the tuning of the laser.

Attenuator	Motor 3	tests the motor used to control the attenuation.
-------------------	---------	--



When the test is completed, the message `Selftest.... .. passed` is shown on the display. If the instrument fails a selftest, the end of the test is signalled by three short beeps and the message `Selftest failed` is displayed. Even if the instrument fails the selftest, it will continue to operate as far as possible.

Auxiliary Functions

There are four or five auxiliary functions, accessed by **(AUX)**:

- **Pmax(λ)**, the power characteristic (maximum power as a function of the wavelength),
- **->Peak**, the setting for maximum output power,
- **PACT**, the Passive Component Test,
- **Realign**, Automatic Realignment, and
- **Secure**, the instrument lock (8167B and 8168F only).

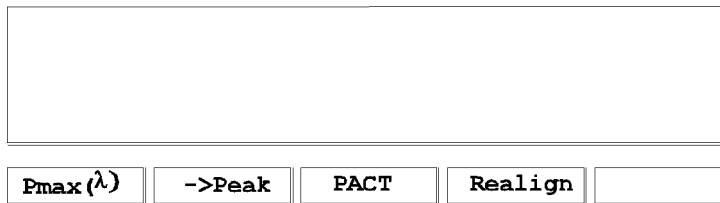

Figure 3-5. Auxiliary Functions (8168D/E)

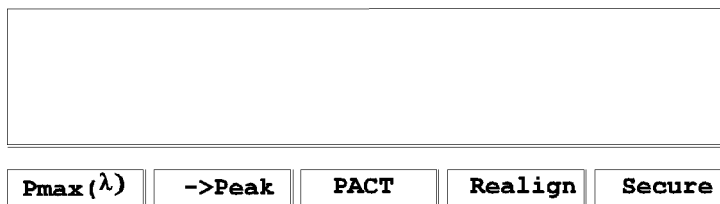

Figure 3-6. Auxiliary Functions (8167B and 8168F)

Viewing the Power as a Function of Wavelength

Press **Pmax(λ)** to get the graph of the maximum power as a function of the wavelength. This graph is drawn from the calibration data for the instrument. You can view the graph for the continuous wave power as a function of the wavelength if you make sure that the CW is selected for the output power. If coherence control is enabled, you will also be able to see the coherence control

3-6 Other Functions

uncal power level. Similarly, to view the maximum power for a modulated signal, you must make sure that Mod is selected.

There is a cursor on this graph, and the values for the wavelength position of this cursor, and the maximum power that can be output at this wavelength are given at the right of the display. If coherence control is enabled, the value for the minimum power that you should select is also given here.

You can move the cursor with the Modify Knob, or the \leftarrow , and the \rightarrow keys.

Setting the Peak Power

The peak power is the highest power that the instrument can deliver. To set the output for peak power, press \rightarrow Peak. This changes the wavelength to the lowest wavelength at which the peak power can be achieved, and sets the power to this peak value.

Passive Component Test (PACT)

See Appendix G.

Automatic Realignment

Press **Realign** to request automatic realignment. This realigns the laser cavity after Laser Protection. You should use Automatic Realignment if you have already tried reactivating the laser and reducing the power, and this has been unsuccessful.

You should not use Automatic Realignment when the laser is stabilizing.

After pressing **Realign**, you get the following message:

```
Laser will be active while realigning.  
Please disconnect any device from  
output to avoid damage.  
Realignment will take approx tt minutes
```

where **tt** is the approximate time that Realignment will take. This will be roughly 15 minutes, although actual time taken depends on the wavelength range of the instrument.

Press the **Start** softkey. The message **Running** is flashed in the Display window. The Display also shows the estimated time before realignment is

complete. The extreme right softkey offers you the chance to abort, and may be pressed at any time.

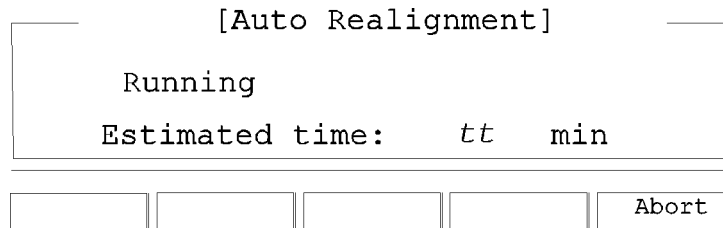

3

Figure 3-7. Auto Realignment

After realignment, one of the following messages appears in the Display window:

Abort by user - you have pressed the **Abort** softkey during realignment. The laser cavity has not been realigned.

A power down interrupted Auto Realignment at a critical moment - Automatic Realignment has been interrupted by a power down. The laser cavity has not been realigned. Continue by pressing the **Realign** or **Exit** softkey.

Realignment OK - the laser cavity has been realigned successfully with laser protection occurring for at most 1 wavelength point over the tuning range.

No improvement - the laser cavity has been realigned, but laser protection has occurred for more than 1 wavelength point over the tuning range. It is still safe to continue.

Realignment impossible, contact service - the laser cavity cannot be realigned because of a serious error. This error is unlikely to be directly concerned with realignment. Contact service and do not continue.

Not allowed during stabilizing - you tried to **Start** an operation while stabilizing when the working temperature is too low. Please wait until it has stabilized. See "Stabilizing" in Appendix A for more information.

Stabilizing occurred try again later - the instrument has resumed stabilizing. Realignment is not possible at present.

3-8 Other Functions

Secure

Press **Secure** to lock the instrument. This is to prevent unauthorized persons from using this Laser Safety Class IIIb instrument (8167B and 8168F only).

When you press **Secure**, you see the following screen:

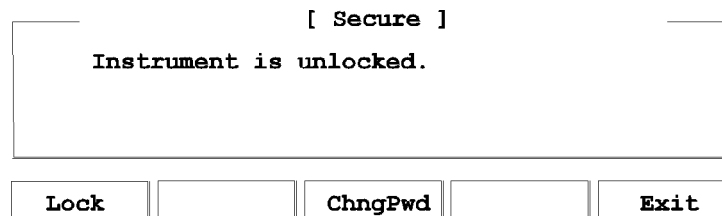

Figure 3-8. "Secure" screen

You may also see the message **default pwd: 8167, please change it!** or **default pwd: 8168, please change it!**. If you see this message, your password is still 8167 (8167B default) or 8168 (8168F default). To prevent unauthorized persons using the instrument, you should change the password (see below).

The "Secure" screen offers you the following facilities:

- **Lock**: lock the instrument,
- **ChngPwd**: change the password,
- **Exit**: return to the main screen.

Lock the Instrument

When you press **Lock**, you see the following screen:

```
[ Secure: Lock Instrument ]
Enter password to lock: ----
[ ] [ ] [ ] [ ] [ Cancel ]
```

Figure 3-9. "Secure: Lock Instrument" screen

To lock the screen, you enter the 4-figure password using the DATA keys. The default password is 8167 (8167B) or 8168 (8168F), but you can change this by pressing **ChngPwd** from the "Secure" screen (see below).

When you enter the correct password, you see the following screen:

```
[ Secure ]
Instrument is locked.
[ Unlock ] [ ] [ ] [ ] [ ]
```

Figure 3-10. "Secure" screen - instrument is locked

The laser is switched off as soon as the instrument is locked.

Press **Unlock** to unlock the instrument. You get the following screen:

```
[ Secure: Unlock Instrument ]
Enter password to unlock: ----
[ ] [ ] [ ] [ ] [ Cancel ]
```

Figure 3-11. "Secure: Unlock Instrument" screen

Enter the correct password to return to the "Secure" screen (Figure 3-8)

3-10 Other Functions

Change the Password

Press **ChngPwd** from the “Secure” screen. You see the following screen:

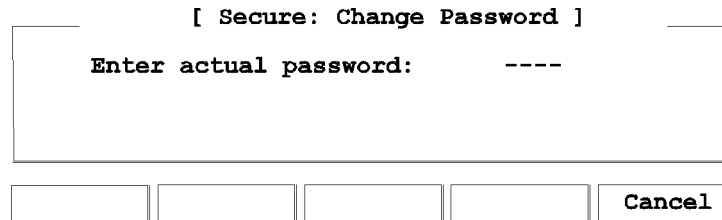

[Secure: Change Password]

Enter actual password: ----

Figure 3-12. “Secure: Change Password” screen

Enter the 4-figure password, using the DATA keys. If you have not changed the password before, the default is 8167 (8167B) or 8168 (8168F). When you enter the password correctly, you get the following screen:

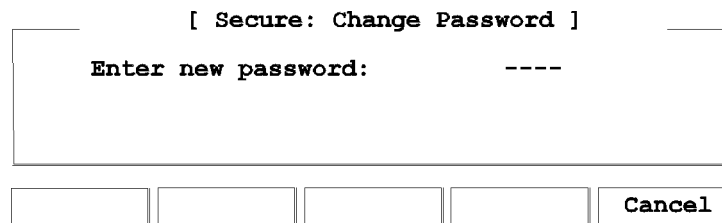

[Secure: Change Password]

Enter new password: ----

Figure 3-13.
“Secure: Change Password”: Enter new password

Enter a new 4-figure password. You will be asked to verify this number:

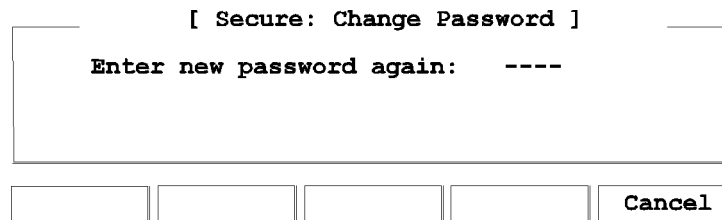

[Secure: Change Password]

Enter new password again: ----

Figure 3-14.
“Secure: Change Password”: Enter new password again



When you enter the same number again, the password is changed and you return to the “Secure” screen (Figure 3-8). This new password is used to lock the instrument (see above), and you must enter it when you turn on the machine (see “Starting the 8167B or 8168F” in Chapter 1).

If you forget your password, please contact Hewlett-Packard.

 **3**

3-12 Other Functions

Programming the Tunable Laser Source

This chapter gives general information on how to control the tunable laser source remotely. Descriptions for the actual commands for the tunable laser source are given in the following chapters. The information in these chapters is specific to the tunable laser source, and assumes that you are already familiar with programming the HP-IB.

4

HP-IB Interface

The interface used by the tunable laser source is the HP-IB (Hewlett-Packard Interface Bus).

This is the interface used for communication between a controller and an external device, such as the tunable laser source. The HP-IB conforms to IEEE standard 488-1978, ANSI standard MC 1.1 and IEC recommendation 625-1.

If you are not familiar with the HP-IB, then refer to the following books:

- Hewlett-Packard Company. *Tutorial Description of Hewlett-Packard Interface Bus*, 1987.
- The International Institute of Electrical and Electronics Engineers. *IEEE Standard 488.1-1987, IEEE Standard Digital Interface for Programmable Instrumentation*. New York, NY, 1987
- The International Institute of Electrical and Electronics Engineers. *IEEE Standard 488.2-1987, IEEE Standard Codes, Formats, Protocols and Common Commands For Use with ANSI/IEEE Std 488.1-1987*. New York, NY, 1987

To obtain a copy of either of these last two documents, write to:
The Institute of Electrical and Electronics Engineers, Inc.
345 East 47th Street
New York, NY 10017
USA.

In addition, the commands not from the IEEE-488.2 standard, are defined according to the Standard Commands for Programmable Instruments (SCPI). For an introduction to SCPI, and SCPI programming techniques, refer to the following documents:

- Hewlett-Packard Press (Addison-Wesley Publishing Company, Inc.). *A Beginners Guide to SCPI*. Barry Eppler. 1991.
- The SCPI Consortium. *Standard Commands for Programmable Instruments*. Published periodically by various publishers. To obtain a copy of this manual, contact your Hewlett-Packard representative.

The tunable laser source interfaces to the HP-IB as defined by the IEEE Standards 488.1 and 488.2. The table shows the interface functional subset that the tunable laser source implements.

Table 4-1. HP-IB Capabilities

Mnemonic	Function
SH1	Complete source handshake capability
AH1	Complete acceptor handshake capability
T6	Basic talker; serial poll; unaddressed to talk if addressed to listen
L4	Basic listener; unaddressed to listen if addressed to talk; no listen only
SR1	Complete service request capability
RL1	Complete remote/local capability
PP0	No parallel poll capability
DC1	Device clear capability
DT0	No device trigger capability
C0	No controller capability (Controller capability to be implemented)

4-2 Remote Operation

Setting the HP-IB Address

You can only set the HP-IB address from the front panel. See “Setting the HP-IB Address” in Chapter 3.

The default HP-IB address is 24.

Returning the Instrument to Local Control

If the instrument has been operated in remote the only key you can use is **Local**. This key returns the instrument to local control. **Local** does not operate if local lockout has been enabled.

How the Tunable Laser Source Receives and Transmits Messages

The tunable laser source exchanges messages using an input and an output queue. Error messages are kept in a separate error queue.

How the Input Queue Works

The input queue is a FIFO queue (first-in first-out). Incoming bytes are stored in the input queue as follows:

1. Receiving a byte:
 - a. Clears the output queue.
 - b. Clears Bit 7 (MSB).
2. No modification is made inside strings or binary blocks. Outside strings and binary blocks, the following modifications are made:
 - a. Lower-case characters are converted to upper-case.
 - b. The characters 00_{16} to 09_{16} and $0B_{16}$ to $1F_{16}$ are converted to spaces (20_{16}).
 - c. Two or more blanks are truncated to one.

3. An EOI (End Or Identify) sent with any character is put into the input queue as the character followed by a line feed (LF, $0A_{16}$). If EOI is sent with a LF, only one LF is put into the input queue.
4. The parser starts if the LF character is received or if the input queue is full.

Clearing the Input Queue

Switching the power off, or sending a Device Interface Clear signal, causes commands that are in the input queue, but have not been executed to be lost.

The Output Queue

The output queue contains responses to query messages. The tunable laser source transmits any data from the output queue when a controller addresses the instrument as a talker.

Each response message ends with a carriage return (CR, $0D_{16}$) and a LF ($0A_{16}$), with EOI=TRUE. If no query is received, or if the query has an error, the output queue remains empty.

The Message Available bit (MAV, bit 4) is set in the Status Byte register whenever there is data in the output queue.

The Error Queue

The error queue is 30 errors long. It is a FIFO queue (first-in first-out). That is, the first error read is the oldest error to have occurred. A new error is only put into the queue if it is not already in it.

If more than 29 errors are put into the queue, the message '-350 <Queue Overflow>' is placed as the last message in the queue.

4.4 Remote Operation

Some Notes about Programming and Syntax Diagram Conventions

A program message is a message containing commands or queries that you send to the tunable laser source. The following are a few points about program messages:

- You can use either upper-case or lower-case characters.
- You can send several commands in a single message. Each command must be separated from the next one by a semicolon (;).
- You end a program message with a line feed (LF) character, or any character sent with End-Or-Identify (EOI).
- You can use any valid number/unit combination.

Example 1500nm, 1.5 μ m and 1.5e-6m are all equivalent.

If you do not specify a unit, then the default unit is assumed. The default unit for the commands are given with command description in the next chapter.

Short Form and Long Form

The instrument accepts messages in short or long forms. For example, the message :STATUS:OPERATION:ENABLE 768 is in long form, the short form of this message is :STAT:OPER:ENAB 768.

In this manual the messages are written in a combination of upper and lower case. Upper case characters are used for the short form of the message. For example, the above command would be written :STATus:OPERation:ENABle.

The first colon can be left out for the first command or query in your message. That is, the example given above could also be sent as STAT:OPER:ENAB 768.

Command and Query Syntax

All characters not between angled brackets must be sent exactly as shown.

The characters between angled brackets (< . . . >) indicate the kind of data that you should send, or that you get in a response. You do not type the angled brackets in the actual message. Descriptions of these items follow the syntax description. The most common of these are:

string is ascii data. A string is contained between a " at the start and the end, or a ' at the start and the end.

value is numeric data in integer (12), decimal (34.5) or exponential format (67.8E-9).

wsp is a white space.

Other kinds of data are described as required.

The characters between square brackets ([...]) show optional information that you can include with the message.

The bar (|) shows an either-or choice of data, for example, *a|b* means either *a* or *b*, but not both simultaneously.

Extra spaces are ignored; they can be inserted to improve readability.

4

4-6 Remote Operation

Remote Commands

This chapter gives a list of the HP 8167B/8D/8E/8F Remote commands, for use with the HP-IB.

In the remote command descriptions the parts given in upper-case characters must be given. The parts in lower-case characters can also be given, but they are optional.

Units

The units and all the allowed mnemonics are given in the table below.

Table 5-1. Units and Allowed Mnemonics

Unit	Default	Allowed Mnemonics
decibel/1mW	DBM	DBM, DBMW
Hertz	HZ	HZ, KHZ, MAHZ, GHZ, THZ
meter	M	PM, NM, UM, MM, M
Watt	Watt	PW, NW, UW, MW, W

Where units are specified with a command, only the Default is shown, by the full range of mnemonics can be used.



Command Summary

Table 5-2. Common Command Summary

Command	Parameter/Response	Min	Max	Function
*CLS				Clear Status Command
*ESE	<value>	0	255	Standard Event Status Enable Command
*ESE?	<value>	0	255	Standard Event Status Enable Query
*ESR?	<value>	0	255	Standard Event Status Register Query
*IDN?	<string>			Identification Query
*OPC				Operation Complete Command
*OPC?	<value>			Operation Complete Query
*OPT?	<string>			Options Query
*RCL	<location>	0	5	Recall Instrument Setting
*RST				Reset Command
*SAV	<location>	1	5	Save Instrument Setting
*SRE	<value>	0	255	Service Request Enable Command
*SRE?	<value>	0	255	Service Request Enable Query
*STB?	<value>	0	255	Read Status Byte Query
*TST?	<value>	0	65535	Self Test Query
*WAI				Wait Command

5

Table 5-3. Command List

Command	Parameter Response	Unit	Min	Max	Default	Notes
:DISPlay						
:ENABle	OFF ON 0 1				1	
:ENABle?	0 1					
:LOCK	OFF ON 0 1, <value>					password
:LOCK?	0 1					
:OUTPut						
[:STATe]	OFF ON 0 1				0	
[:STATe]?	0 1					
[:SOURce]						
:AM						
:INTernal						
:FREQuency	<value> MIN DEF MAX	HZ	250	300000	80000	
:FREQuency?	<value>	HZ				
MIN DEF MAX	<value>	HZ				
:SOURce	INT INT1 INT2 EXT 0 1 2				0	
:SOURce?	0 1 2					
:STATe	OFF ON 0 1				0	
:STATe?	0 1					
[:SOURce]						
:MODout	FRQ FRQ&RDY 0 1					
[:SOURce]						
:MODout?	0 1					
[:SOURce]						
:POWer						
:ATTenuation	<value> MIN DEF MAX	[DB]	40.0dBm†	0.0dBm†	0.0dBm	
:ATTenuation?	<value>	DB				
MIN DEF MAX	<value>	DB				
:AUTO	OFF ON 0 1				0	
:AUTO?	0 1					
:DARK	OFF ON 0 1				0	
:DARK?	0 1					
[:LEVel]						
[:IMMediate]						
[:AMPLitude]	<value> MIN DEF MAX	DBM	-10dBm†	-4dBm†	-7.0dBm	
		W	100μW†	398μW†	200μW	
			Attenuator Option			
		DBM	-50dBm†	-5.5dBm†	-7.0dBm	
		W	10nW†	300μW†	200μW	
[:AMPLitude]?	<value>	DBM, W				
MIN DEF MAX	<value>	DBM, W				
:UNIT	DBM DBMW W				DBM	
:UNIT?	DBM W					

5



Table 5-3. Command List (continued)

Command	Parameter Response	Unit	Min	Max	Default	Notes
[:SOURce]						
:WAVElength						
[:CW]:FIXED]	<value> MIN DEF MAX	M				
			1255nm†	1365nm†	1310nm	HP 8167B
			1490nm†	1565nm†	1540nm	HP 8168D
			1475nm†	1575nm†	1540nm	HP 8168E
			1450nm†	1590nm†	1540nm	HP 8168F
[:CW]:FIXED)?	<value>	M				
MIN DEF MAX	<value>	M				
:REFERence?	<value>					
:DISPlay						
:FREQuency	<value>					
:FREQuency?	<value>					
:STATus						
:OPERation						
[:EVENT]?	<value>					
:CONDition?	<value>					
:ENABle	<value>					
:ENABle?	<value>					
:NTRansition	<value>					
:NTRansition?	<value>					
:PTRansition	<value>					
:PTRansition?	<value>					
:QUESTionable						
[:EVENT]?	<value>					
:CONDition?	<value>					
:ENABle	<value>					
:ENABle?	<value>					
:NTRansition	<value>					
:NTRansition?	<value>					
:PTRansition	<value>					
:PTRansition?	<value>					
:PRESet						

5

5-4 Remote Commands

Table 5-3. Command List (continued)

Command	Parameter Response	Unit	Min	Max	Default	Notes
:SYSTem						
:DATE	<value>, <value>, <value>					Year,Month,Day
:DATE?	<value>/<value>/<value>					Year/Month/Day
:ERRor?	<value>		-32768	32767		
:TIME	<value>, <value>, <value>					Hour,Minute,Second
:TIME?	<value>:<value>:<value>					Hour:Minute:Second
:TRACe						
:CATalog?	<string>					trace_names
:POINTs?						
	<trace_name> <value>					the number of points
[:DATA]?						
	<trace_name> <value>, <value>, ...					X- and Y-value for each point
WAVEACT	<value>					Wavelength in meters

5

† These are specified minimum and maximum values. Actual values depend on the calibration of the instrument.

The Common Commands

The IEEE 488.2 standard has a list of reserved commands, called common commands. These are the commands that start with an asterisk. Some of these commands must be implemented by any instrument using the standard, others are optional. The tunable laser source implements all the necessary commands, and some optional ones. This chapter describes the implemented commands.

Common Status Information

There are four registers for the common status information. Two of these are status-registers and two are enable-registers. These registers conform to the *IEEE Standard 488.2-1987*. You can find further descriptions of these registers under “*ESE”, “*ESR?”, “*SRE”, and “*STB?”.

The following figure shows how the registers are organized.

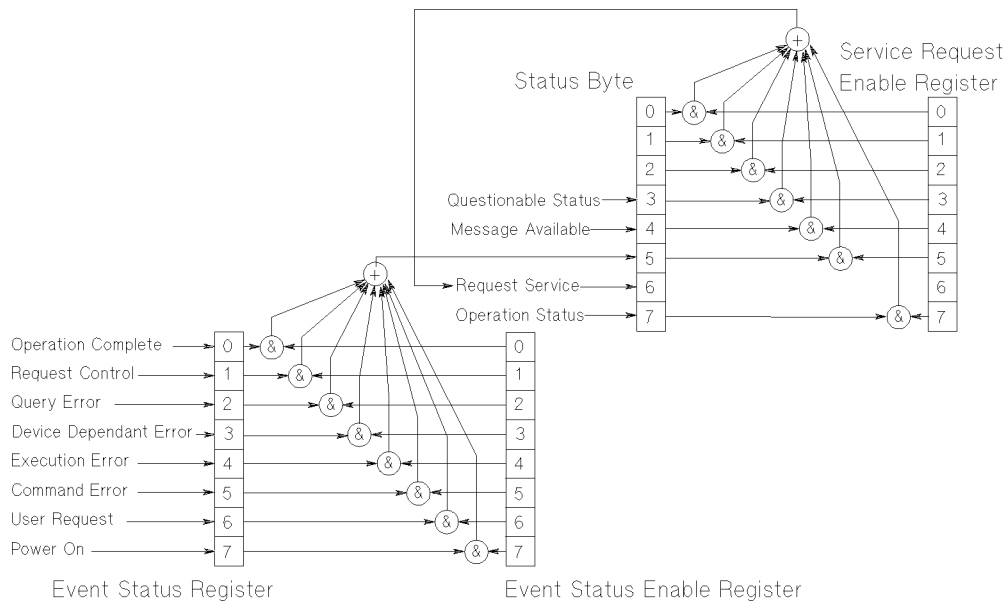

Figure 5-1. Common Status Registers

*The questionable and operation status trees are described in “:STATUS Commands”.

Note

Unused bits in any of the registers return 0 when you read them.



SRQ, The Service Request

A service request (SRQ) occurs when a bit in the Status Byte register goes from 0 → 1 AND the corresponding bit in the Service Request Enable Mask is set.

The Request Service (RQS) bit is set to 1 at the same time that the SRQ is caused. This bit can only be reset by reading it by a serial poll. The RQS bit is

5-6 Remote Commands

not affected by the condition that caused the SRQ. The serial poll command transfers the value of the Status Byte register to a variable.

***CLS**

Syntax *CLS

Definition The *CLS command clears the following:

- Error queue
- Standard event status register (ESR)
- Status byte register (STB)

After the *CLS command the instrument is left waiting for the next command. The instrument setting is unaltered by the command, though *0PC/*0PC? actions are canceled.

If the *CLS command occurs directly after a program message terminator, the output queue and MAV, bit 4, in the status byte register are cleared, and if condition bits 2-0 of the status byte register are zero, MSS, bit 6 of the status byte register is also zero.

Example OUTPUT 724; "*CLS"

***ESE**

Syntax *ESE <wsp><value>
 $0 \leq \text{value} \leq 255$

Definition The *ESE command sets bits in the standard event status enable register (ESE) that enable the corresponding bits in the standard event status register (ESR).

The register is cleared:

- At power-on
- By sending a value of zero

The register is not changed by the *RST and *CLS commands.

BIT	MNEMONIC	BIT VALUE
7	Power On	128
6	User Request	64
5	Command Error	32
4	Execution Error	16
3	Device Dependent Error	8
2	Query Error	4
1	Request Control	2
0	Operation Complete	1

The Event Status Enable Register

5

*ESE?

The standard event status enable query returns the contents of the standard event status enable register.

Example

```
OUTPUT 724;"*ESE 21"
OUTPUT 724;"*ESE?"
ENTER 724; A$
```

*ESR?

Syntax

*ESR?

Definition

The standard event status register query returns the contents of the standard event status register. The register is cleared after being read.

$0 \leq \text{contents} \leq 255$

BITS	MNEMONICS	BIT VALUE
7	Power On	128
6	User Request	64
5	Command Error	32
4	Execution Error	16
3	Device Dependent Error	8
2	Query Error	4
1	Request Control	2
0	Operation Control	1

The Standard Event Status Register

Example OUTPUT 724; "*ESR?"
ENTER 724; A\$

5

***IDN?**

Syntax *IDN?

Definition The identification query commands the instrument to identify itself over the interface.

Response: HEWLETT-PACKARD, HP8167B, *mmmmmmmmmm*, n.n.n

HEWLETT-PACKARD: manufacturer

HP8167B or HP8168D or HP8168E or HP8168F: instrument model number

mmmmmmmmmm: serial number (not supplied)

n.n.n: firmware revision level

Example DIM A\$ [100]
OUTPUT 724; "*IDN?"
ENTER 724; A\$

*OPC

Syntax *OPC

Definition The instrument parses and executes all program message units in the input queue and sets the operation complete bit in the standard event status register (ESR). This command can be used to avoid filling the input queue before the previous commands have finished executing.

*OPC?

This query causes all the program messages in the input queue to be parsed and executed. Once it has completed it places an ASCII '1' in the output queue. There is a short delay between interpreting the command and putting the '1' in the queue.

Example OUTPUT 724;"*CLS;*ESE 1;*SRE 32"
OUTPUT 724;"*OPC"

OUTPUT 724;"*CLS;*ESE 1;*SRE 32"
OUTPUT 724;"*OPC?"
ENTER 724;A\$

*OPT?

Syntax *OPT?

Definition This query returns a string with the options installed in the tunable laser source.

If the Passive Component Test software is available, the first position in the option string is *Passive Component Test*. If it is not available, the first position returns 0.

If the optional attenuator is installed, the third position in the option string is *ATTENUATOR*. If it is not installed, the third position returns 0.

If Coherence Control is available, the fourth position in the option string is *COHERENCE CONTROL*. If it is not available, the fourth position returns 0.

Example OUTPUT 724;"*OPT?"
ENTER 724;A\$

5-10 Remote Commands

***RCL**

Syntax *RCL <wsp> <location>
 $0 \leq \text{location} \leq 5$

Definition An instrument setting from the internal RAM is made the actual instrument setting.

You can recall user settings from locations 1-5. See “*SAV”. Location 0 contains the default setting, which is the same as that obtained by *RST.

Example OUTPUT 724; "*RCL 3"

***RST**

Syntax *RST

Definition The reset setting (default setting) stored in ROM is made the actual setting.

Instrument state: the instrument is placed in the idle state awaiting a command.

The following are not changed:

- HP-IB (interface) state
- Instrument interface address
- Output queue
- Service request enable register (SRE)
- Standard event status enable register (ESE)

The commands and parameters of the reset state are listed in the following table.

Table 5-4. Reset State (Default Setting)

Parameter	Reset Value			
	HP 8167B	HP 8168D	HP 8168E	HP8168F
Wavelength	1310nm	1540nm	1540nm	1540nm
df	0GHz			
Display Mode	nm			
Power	minimum*			
Power/Attenuation Mode	Power			
Unit (Power)	μ W			
Modulation Timing	External			
Modulation Status	Off			

*The minimum value is determined, individually for each instrument at calibration.

Example OUTPUT 724;"*RST"

***SAV**

Syntax *SAV <wsp> <location>

1 ≤ location ≤ 5

Definition The instrument setting is stored in RAM. You can store settings in locations 1-5. The scope of the saved setting is identical with the scope of the standard setting described in “*RST”.

Example OUTPUT 724;"*SAV 3"

***SRE**

Syntax *SRE <wsp> <value>

0 ≤ value ≤ 255

Definition The service request enable command sets bits in the service request enable register that enable the corresponding status byte register bits.

The register is cleared:

- At power-on
- By sending a value of zero.

The register is not changed by the *RST and *CLS commands.

5-12 Remote Commands

BITS	MNEMONICS	BIT VALUE
7	Operation Status	128
6	Request Status	64
5	Event Status Byte	32
4	Message Available	16
3	Questionable Status	8
2	Not used	0
1	Not used	0
0	Not used	0

The Service Request Enable Register

Note Bit 6 cannot be masked.



5

***SRE?**

The service request enable query returns the contents of the service request enable register.

Example OUTPUT 724; "*SRE 48"

OUTPUT 724; "*SRE?"
ENTER 724; A\$

***STB?**

Syntax *STB?

Definition The read status byte query returns the contents of the status byte register.

$0 \leq \text{contents} \leq 255$

BITS	MNEMONICS	BIT VALUE
7	Operation Status	128
6	Request Service	64
5	Event Status Byte	32
4	Message Available	16
3	Questionable Status	8
2	Not used	0
1	Not used	0
0	Not used	0

The Status Byte Register

5

Example OUTPUT 724; "*STB?"
ENTER 724; A\$

***TST?**

Syntax *TST?

Definition The self-test query commands the instrument to perform a self-test and place the results of the test in the output queue.
Returned value: $0 \leq \text{value} \leq 65535$. This value is the sum of the results for the individual tests

BITS	MNEMONICS	BIT VALUE
15	μ P1 Board	32768
14	μ P2 Board	16384
13	Battery Test	8192
6	Motor 3 (Opt. 003)	64
5	Motor 2	32
4	Motor 1	16
3	Laser Control Board	8
2	Analog to Digital Conv.	4
1	Hardware Interface	2
0	Calibration Data	1

The Self Test Results

5

So 16 would mean that Motor 1 had failed, 18 would mean that Motor 1 had failed, and so had the hardware interface. A value of zero indicates no errors.

If the self-test fails, the results are also put in the error queue. It is recommended that you read self-test results from the error queue. Explanations for the non-zero results of the self-test are given in Appendix F.

No further commands are allowed while the test is running.

The instrument is returned to the setting that was active at the time the self-test query was processed.

The self-test does not require operator interaction beyond sending the *TST? query.

Example

```
OUTPUT 724; "*TST?"
ENTER 724; A$
```

***WAI**

Syntax *WAI

Definition The wait-to-continue command prevents the instrument from executing any further commands, all pending operations are completed. There is a delay of approximately 0.1 seconds between the completion of the final operation and the parsing of the next command.

Example OUTPUT 724;"*WAI"

:DISPlay Commands

:DISPlay:ENABle

Syntax :DISPlay:ENABle <wsp> OFF|ON|0|1

Description This command enables or disables the front panel display.
Set the state to OFF or 0 to switch the display off, set the state to ON or 1 to switch the display on. The default is for the display to be on.

:DISPlay:ENABle?

Syntax :DISPlay:ENABle?

Description The query returns the current state of the display.
A returned value of 0 indicates that the display is off. A returned value of 1 indicates that the display is on.

Example OUTPUT 724;":DISP:ENAB ON"
OUTPUT 724;":DISP:ENAB?"
ENTER 724;A\$

:LOCK Commands

:LOCK

Syntax :LOCK <wsp> OFF|ON|0|1 , <value>

Description This command switches the lock off and on.

Set the state to OFF or 0 to switch the lock off. Set the state to ON or 1 to switch the lock on. The laser is switched off immediately when the instrument is locked.

<value> is the four-figure password.

:LOCK?

Syntax :LOCK?

Description The query returns the current state of the lock.

A returned value of 0 indicates that the lock is off. A returned value of 1 indicates that the lock is on.

Example OUTPUT 724; ":LOCK ON, 8168"

OUTPUT 724; ":LOCK?"
ENTER 724; A\$

5

:OUTPut Commands

:OUTPut[:STATe]

Syntax :OUTPut[:STATe] <wsp> OFF|ON|0|1

Description This command switches the laser current off and on.

Laser light emerges only when the current is on. Set the state to OFF or 0 to switch the laser current off, set the state to ON or 1 to switch the laser current on. The default is for the laser current to be off.

:OUTPut[:STATe]?

Syntax :OUTPut[:STATe]?

Description The query returns the current state of the laser current.
A returned value of 0 indicates that the laser current is off. A returned value of 1 indicates that the laser current is on.

Example OUTPUT 724;":OUTP ON"
OUTPUT 724;":OUTP?"
ENTER 724;A\$

[[:SOURce] Commands

5

[[:SOURce]:AM:INTernal:FREQuency

Syntax [:SOURce]:AM:INTernal:FREQuency <wsp>
<value>|MIN|DEF|MAX

Description This command sets the frequency of the amplitude modulation of the laser output.

The frequency can be set in the range 250Hz to 300kHz. You can set to the minimum, default or maximum programmable values by sending MIN, DEF, or MAX, respectively, instead of the value.

The default units are HZ, though KHZ, MAHZ, GHZ, THZ can alternatively be specified.

The resolution of the frequency is given in the table below:

Range (Hz)	Resolution (Hz)
250 ... 999	1
1 000 ... 9 990	10
10 000 ... 99 900	100
100 000 ... 300 000	1000

[[:SOURce]:AM:INTernal:FREQuency?

Syntax [[:SOURce]:AM:INTernal:FREQuency? [MIN|DEF|MAX]

Description This query returns the frequency of the amplitude modulation, as a floating point number in Hertz. If you specify MIN, DEF, or MAX with the query, it will return, respectively, the minimum, default, or maximum modulation frequency.

Example OUTPUT 724; ":AM:INT:FREQ 40.4KHZ"
OUTPUT 724; ":AM:STAT ON"

OUTPUT 724; ":AM:INT:FREQ?"
ENTER 724; A\$

[[:SOURce]:AM:SOURce

Syntax [[:SOURce]:AM:SOURce <wsp> INT|INT1|INT2|EXT|0|1|2

Description This command chooses the type or source of the modulation of the laser output.

Set the source to INT, INT1 or 0 to select internal modulation, set the source to INT2 or 1 to select coherence control, or set the source to EXT or 2 to select external modulation. The default is for internal modulation to be selected.

Modulation Input When external modulation is selected, the signal is modulated according to the signal applied to the modulation input on the front panel of the instrument. The maximum signal that can be applied is $5V_{pp}$, which results in 15% modulation of the optical output.

[[:SOURce]:AM:SOURce?

Syntax [[:SOURce]:AM:SOURce?

Description The query returns the current state of modulation.

A returned value of 0 indicates that internal modulation is selected. A returned value of 1 indicates that coherence control is selected, 2 indicates that external modulation is selected.

Example OUTPUT 724; ":AM:SOUR ON"

OUTPUT 724; ":AM:SOUR?"
ENTER 724; A\$

[[:SOURce]:AM:STATe

Syntax `[[:SOURce]:AM:STATe <wsp> OFF|ON|0|1`

Description This command enables and disables amplitude modulation of the laser output.

Set the state to OFF or 0 to disable modulation, set the state to ON or 1 to enable modulation. The default is for the modulation to be disabled.

Modulation Output When the internal modulation is selected, the Modulation Output on the front panel outputs a version of the modulating signal that has the same frequency and phase as the modulating signal, but has a fixed, TTL-level amplitude. You can use this to synchronize your external measuring equipment to the tunable laser source.

To allow for your possible synchronization requirements, there are two ways in which the signal can be output. Either the signal is combined with the laser-ready signal, so that the output is kept low when there is no optical signal being output (for example, while the laser is settling after a change of wavelength). Or the modulation signal is output all the time. This is set by the :SOURCE:MODOUT command (see “[[:SOURCE]:MODOUT”).

[[:SOURce]:AM:STATe?

Syntax `[[:SOURce]:AM:STATe?`

Description The query returns the current state of modulation.

A returned value of 0 indicates that modulation is disabled. A returned value of 1 indicates that modulation is enabled.

Example `OUTPUT 724;":AM:STAT ON"`

```
OUTPUT 724;":AM:STAT?"  
ENTER 724;A$
```

[:SOURCE]:MODOUT

Note This command does not confirm to the SCPI standard.



Syntax [:SOURCE]:MODOUT FRQ|FRQRDY|0|1

Description This command sets the modulation output. The two possible values are

- FRQ or 0, where the modulation signal is output all the time, and
- FRQRDY or 1, where the modulation signal is combined with the laser-ready signal, so that the output is kept low when there is no optical signal being output (for example, while the laser is settling after a change of wavelength).

[:SOURCE]:MODOUT?

Note This command does not confirm to the SCPI standard.



Syntax [:SOURCE]:MODOUT?

Description This queries the mode of the modulation output. The two possible values are

- 0, where the modulation signal is output all the time, and
- 1, where the modulation signal is combined with the laser-ready signal, so that the output is kept low when there is no optical signal being output (for example, while the laser is settling after a change of wavelength).

[[:SOURce]:POWer:ATTenuation

Attenuator Syntax

`[[:SOURce]:POWer:ATTenuation <wsp>
<value>|MIN|DEF|MAX`



Description

This command sets the level of attenuation of an inbuilt optional attenuator, if this is installed.

The range for the attenuation is specified in Appendix C. You can set to the minimum, default or maximum programmable values by sending MIN, DEF, or MAX, respectively, instead of the value.

The resolution of the attenuation is specified to be 0.1dB. The actual resolution of the attenuator is better than this (typically 0.04dB). To allow you access to this resolution, you can specify the attenuation to two decimal places with the HP-IB command.

You need to be in the Attenuation Mode (see “[[:SOURce]:POWer:ATTenuation:AUTO]”) for this value to have an affect. The output power is a combination of this value and the laser output power (see “[[:SOURce]:POWer[:LEVel][:IMMediate][:AMPLitude]”).

In this respect, this command does not confirm to the SCPI standard. The SCPI standard requires that entering an explicit value for the attenuation switches the attenuation mode OFF.

The default units are DB.

[[:SOURce]:POWer:ATTenuation?

Attenuator Syntax

`[[:SOURce]:POWer:ATTenuation? [MIN|DEF|MAX]`



Description

This query returns the attenuation level of the optional attenuator if this has been installed.

The value returned is applies only to the attenuation mode (see “[:SOURce]:POWer:ATTenuation:AUTO?”).

If you specify MIN, DEF, or MAX with the query, it will return, respectively, the minimum, default, or maximum amplitude level.

Example

```
OUTPUT 724; ":POW:ATT:AUTO OFF"
OUTPUT 724; ":POW 200UW OUTPUT
724; ":POW:ATT 22.32DB"
```

```
OUTPUT 724; ":POW:ATT?" ENTER 724; A$
```

[:SOURce]:POWer:ATTenuation:AUTO

Attenuator	Syntax	[:SOURce]:POWer:ATTenuation:AUTO <wsp> OFF ON 0 1
	Description	This command selects Power or Attenuation Mode. In Power Mode, you specify the output power. In Attenuation Mode, you must specify both the laser output power, and the attenuation level. Use ON or 1 to select Power Mode. Use OFF or 0 to select Attenuation Mode

5

[:SOURce]:POWer:ATTenuation:AUTO?

Attenuator	Syntax	[:SOURce]:POWer:ATTenuation:AUTO?
	Description	This query returns whether the instrument is in Power Mode, or Attenuation Mode. 1 indicates Power Mode. 0 indicates Attenuation Mode

[:SOURce]:POWer:ATTenuation:DARK

Note This command does not confirm to the SCPI standard.



Attenuator	Syntax	<code>[:SOURce]:POWer:ATTenuation:DARK OFF ON 0 1</code>
-------------------	---------------	--



Description	Use ON or 1 to set the attenuator to the “dark” position. This blocks all light from the laser. You can use this as an alternative to disabling the laser; the advantage of doing this is that you avoid the laser rise time.
--------------------	---

This command is available in Attenuation Mode Only.

5

[:SOURce]:POWer:ATTenuation:DARK?

Note This command does not confirm to the SCPI standard.



Attenuator	Syntax	<code>[:SOURce]:POWer:ATTenuation:DARK? 0 1</code>
-------------------	---------------	--



Description	This query returns whether the attenuator is in the “dark” position (where all light is blocked by the laser) or not. If the attenuator is in the dark position, 1 is returned.
--------------------	---

Example	<code>OUTPUT 724; ":POW:ATT:DARK ON"</code>
----------------	---

`OUTPUT 724; ":POW:ATT:DARK?" ENTER 724; A$`

[[:SOURce]:POWer[:LEVel][:IMMediate][:AMPlitude]

Syntax `[[:SOURce]:POWer[:LEVel][:IMMediate][:AMPlitude] <wsp>
<value>|MIN|DEF|MAX`

Description This command sets the power of the laser output.
The range for the amplitude is specified in Appendix C. You can set to the minimum, default or maximum programmable values by sending MIN, DEF, or MAX, respectively, instead of the value.

Attenuator If you have the optional attenuator installed, the range is specified in Appendix C under option #003.



If you are using the Attenuation Mode (see “[[:SOURce]:POWer:ATTenuation:AUTO]”), then this value sets the laser output power, which is not the same as the output power. The output power is a combination of this value and the attenuation (see “[[:SOURce]:POWer:ATTenuation]”).

The values for the output power that you set in the Power Mode, and the laser output power that you set in the Attenuation Mode, are stored and used independently.

Note The instrument may not be able to output a signal with the maximum programmable power, it will output a signal with the maximum power. Use the “[[:SOURce]:POWer[:LEVel][:IMMediate][:AMPlitude]?]” query to find out the power being output.



The default units are DBM, or W, depending on the unit selected by the “[[:SOURce]:POWer:UNIT]” command. Independently of the chosen default unit, you can also specify the unit to be used as DBM, DBMW, PW, NW, UW, MW or W.

[[:SOURce]:POWer[:LEVel][:IMMediate][:AMPlitude]?]

Syntax `[[:SOURce]:POWer[:LEVel][:IMMediate][:AMPlitude]?
[MIN|DEF|MAX]`

Description This query returns the amplitude level of the output power. The value returned is the actual amplitude that is output, which may be different from the value set for the output. If these two

figures are not the same, it is indicated in the STATUS:OPERation register.

Attenuator  If you have the optional attenuator installed, the value returned for the power is dependent on whether you are in power or attenuation mode (see “[:SOURCE]:POWER:ATTenuation:AUTO?”). If you are in power mode, the value returned is the output power. If you are in attenuation mode, the value returned is the laser output power, and you must also use the attenuation value to calculate the output power (see “[:SOURCE]:POWER:ATTenuation?”).

If you specify MIN, DEF, or MAX with the query, it will return, respectively, the minimum, default, or maximum amplitude level.

Example OUTPUT 724;":POW:UNIT DBM"
 OUTPUT 724;":POW? MAX"
 ENTER 724;A\$ OUTPUT 724;":POW ",A\$

[:SOURCE]:POWER:UNIT

Syntax [:SOURCE]:POWER:UNIT <wsp> DBM|DBMW|Watt

Description This command sets the power units. Set the units to dBm by sending DBM or DBMW. Set the units to watts by sending W. The default units are dBm.

[:SOURCE]:POWER:UNIT?

Syntax [:SOURCE]:POWER:UNIT?

Description The query returns the units currently being used. The response is either 0 for dBm or dBmW, or 2 for Watts.

Example OUTPUT 724;":POW:UNIT DBM"

 OUTPUT 724;":POW:UNIT?"
 ENTER 724;A\$

[[:SOURce]:WAVElength[:CW]:FIXED]

Syntax `[[:SOURce]:WAVElength[:CW]:FIXED] <wsp>
<value>|MIN|DEF|MAX`

Description This command sets the absolute wavelength of the output. The default units for the wavelength are meters.

The specified range for the wavelength is given in the table below.

Table 5-5. Specified Wavelength range

Min	Max	Default
HP 8167B		
1255nm	1365nm	1310nm
HP 8168D		
1490nm	1565nm	1540nm
HP 8168E		
1475nm	1575nm	1540nm
HP 8168F		
1450nm	1590nm	1540nm

5

The programmable range is larger than this. The programmable range is set individually for each instrument when it is calibrated during production. You can set the wavelength to the maximum, default or minimum wavelength by sending MIN, DEF, or MAX, respectively, instead of the value.

The default units are M, though PM, NM, UM, MM can alternatively be specified.

[[:SOURce]:WAVElength[:CW]:FIXED]?

Syntax `[[:SOURce]:WAVElength[:CW]:FIXED]? [MIN|DEF|MAX]`

Description The query returns the current wavelength in meters. If you specify MIN, DEF, or MAX with the query, it will return, respectively, the minimum, default, or maximum wavelength.

Example OUTPUT 724;":WAVE:REF:STAT OFF"
 OUTPUT 724;":WAVE 1542E-9"

 OUTPUT 724;":WAVE?"
 ENTER 724;A\$

[:SOURCE]:WAVElength:REFerence?

Syntax [:SOURCE]:WAVElength:REFerence?

Description The query returns the reference wavelength (λ_0) in meters.

Example OUTPUT 724;":WAVE:REF?"
 ENTER 724;A\$

[:SOURCE]:WAVElength:REFerence:DISPlay

Syntax [:SOURCE]:WAVElength:REFerence:DISPlay

Description This command sets the reference wavelength to the value of the output wavelength ($\lambda \rightarrow \lambda_0$).

Example OUTPUT 724;":WAVE:REF:DISP"

[:SOURCE]:WAVElength:FREQuency

Syntax [:SOURCE]:WAVElength:FREQuency <wsp> <value>

Description This command sets the frequency difference used to calculate a relative wavelength. The output wavelength is made up of the reference wavelength and this frequency difference. The default units for the frequency are Hertz. The output wavelength (λ) is set from the base wavelength (λ_0) and the frequency offset (df). The formula for calculating the output wavelength is:

$$\lambda = \frac{c}{(\lambda_0)df + c} \lambda_0$$

where c is the speed of light in a vacuum ($2.998 \times 10^8 \text{ms}^{-1}$).

[:SOURCE]:WAVElength:FREQuency?

Syntax [:SOURCE]:WAVElength:FREQuency?

Description The query returns the frequency difference in Hertz.

Example OUTPUT 724; ":WAVE:FREQ 11E9"
OUTPUT 724; ":WAVE:FREQ?"
ENTER 724; A\$

:STATus Commands

Each node of the status circuitry has five registers:

- A condition register (CONDition), which contains the current status. This register is updated continuously. It is not changed by having its contents read.
- A positive transition register (PTRansition), which, when enabled, puts a 1 into the event register, when the corresponding bit in the condition register goes from 0 to 1.

The power-up condition for this register is for all the bits to be disabled.

- A negative transition register (NTRansition), which, when enabled, puts a 1 into the event register, when the corresponding bit in the condition register goes from 1 to 0.

The power-up condition for this register is for all the bits to be disabled.

- The event register (EVENT), which contains the output from the transition registers. The contents of this register are cleared when it is read.
- The enable register (ENABLE), which enables changes in the event register to affect the Status Byte.

The status registers for the tunable laser source are organized as shown:

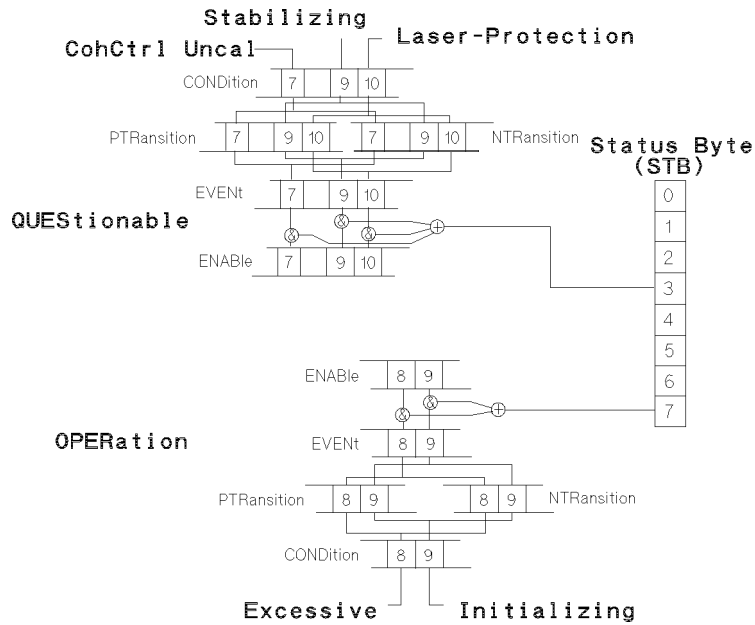

Figure 5-2. The Status Registers

The OPERation branch of the status registers indicates things that can happen during normal operation. The QUEStionable branch indicates error conditions.

:STATus:OPERation:CONDition?

Syntax :STATus:OPERation:CONDition?

Description This query reads the contents of the OPERation:CONDition register. Only two bits of the condition register are used:

- Bit 8, which is 1 when the output power that you set exceeds what the laser is capable of producing.
- Bit 9, which is 1 while the instrument is performing its power-up initialization.

Example OUTPUT 724;":STAT:OPER:COND?"
ENTER 724;A\$

:STATus:OPERation:ENABLE

Syntax :STATus:OPERation:ENABLE <wsp> <value>

Description This command sets the bits in the ENABLE register that enable the contents of the EVENT register to affect the Status Byte (STB). Setting a bit in this register to 1 enables the corresponding bit in the EVENT register to affect bit 7 of the Status Byte.

:STATus:OPERation:ENABLE?

Syntax :STATus:OPERation:ENABLE?

Description This query returns the current contents of the OPERATION:ENABLE register.

Example OUTPUT 724; ":STAT:OPER:ENAB 768"
OUTPUT 724; ":STAT:OPER:ENAB?"
ENTER 724; A\$

5

:STATus:OPERation[:EVENT]?

Syntax :STATus:OPERation[:EVENT]?

Description This query reads the contents of the OPERATION:EVENT register. Only two bits of the event register are used (whether these bits contain information depends on the transition register configuration):

- Bit 8, which can reflect the excessive state (when the output power that you set exceeds what the laser is capable of producing).
- Bit 9, which can reflect the initializing state (the instrument is performing its power-up initialization).

Example OUTPUT 724; ":STAT:OPER:PTR 768"
OUTPUT 724; ":STAT:OPER:COND?"
ENTER 724; A\$

:STATus:OPERation:NTRansition

Syntax :STATus:OPERation:NTRansition <wsp> <value>

Description This command sets the bits in the NTRansition register. Setting a bit in this register enables a negative transition (1→0) in the corresponding bit in the CONDition register to set the bit in the EVENT register.

:STATus:OPERation:NTRansition?

Syntax :STATus:OPERation:NTRansition?

Description This query returns the current contents of the OPERation:NTRansition register.

Example OUTPUT 724;":STAT:OPER:NTR 768"
OUTPUT 724;":STAT:OPER:NTR?"
ENTER 724;A\$

:STATus:OPERation:PTRansition

Syntax :STATus:OPERation:PTRansition <wsp> <value>

Description This command sets the bits in the PTRansition register. Setting a bit in this register enables a positive transition (0→1) in the corresponding bit in the CONDition register to set the bit in the EVENT register.

:STATus:OPERation:PTRansition?

Syntax :STATus:OPERation:PTRansition?

Description This query returns the current contents of the OPERation:PTRansition register.

Example OUTPUT 724;":STAT:OPER:PTR 768"
OUTPUT 724;":STAT:OPER:PTR?"
ENTER 724;A\$

:STATus:QUEStionable:CONDition?

Syntax :STATus:QUEStionable:CONDition?

Description This query reads the contents of the QUEStionable:CONDition register. Only three bits of the condition register are used:

- Bit 7, which is 1 when coherence control has been activated and the chosen power level is too low (that is, below the Coherence Control Uncalibrated Power for that wavelength).
- Bit 9, which is 1 when the temperature in the laser heat chamber is out of range (stabilizing).
- Bit 10, which is 1 when the output has been switched off to protect the laser diode.

Example OUTPUT 724; ":STAT:QUES:COND?"
ENTER 724; A\$

:STATus:QUEStionable:ENABle

Syntax :STATus:QUEStionable:ENABle <wsp> <value>

Description This command sets the bits in the ENABle register that enable the contents of the EVENt register to affect the Status Byte (STB). Setting a bit in this register to 1 enables the corresponding bit in the EVENt register to affect bit 3 of the Status Byte.

:STATus:QUEStionable:ENABle?

Syntax :STATus:QUEStionable:ENABle?

Description This query returns the current contents of the QUEStionable:ENABle register.

Example OUTPUT 724; ":STAT:QUES:ENAB 1536"
OUTPUT 724; ":STAT:QUES:ENAB?"
ENTER 724; A\$

:STATus:QUEStionable[:EVENT]?

Syntax :STATus:QUEStionable[:EVENT]?

Description This query reads the contents of the QUEStionable:EVENT register. Only three bits of the event register are used (whether these bits contain information depends on the transition register configuration):

- Bit 7, which is 1 when coherence control has been activated and the chosen power level is too low (that is, below the Coherence Control Uncalibrated Power for that wavelength).
- Bit 9, which can reflect that the temperature in the laser heat chamber is out of range (stabilizing).
- Bit 10, which can reflect that the output has been switched off to protect the laser diode.

Example OUTPUT 724;":STAT:QUES:PTR 1536"
OUTPUT 724;":STAT:QUES:COND?"
ENTER 724;A\$

:STATus:QUEStionable:NTRansition

Syntax :STATus:QUEStionable:NTRansition <wsp> <value>

Description This command sets the bits in the NTRansition register. Setting a bit in this register enables a negative transition (1→0) in the corresponding bit in the CONDition register to set the bit in the EVENT register.

:STATus:QUEStionable:NTRansition?

Syntax :STATus:QUEStionable:NTRansition?

Description This query returns the current contents of the QUEStionable:NTRansition register.

Example OUTPUT 724;":STAT:QUES:NTR 768"
OUTPUT 724;":STAT:QUES:NTR?"
ENTER 724;A\$

:STATus:QUEStionable:PTRansition

Syntax :STATus:QUEStionable:PTRansition <wsp> <value>

Description This command sets the bits in the PTRansition register. Setting a bit in this register enables a positive transition (0→1) in the corresponding bit in the CONDition register to set the bit in the EVENt register.

:STATus:QUEStionable:PTRansition?

Syntax :STATus:QUEStionable:PTRansition?

Description This query returns the current contents of the QUEStionable:PTRansition register.

Example OUTPUT 724; ":STAT:QUES:PTR 1536"
OUTPUT 724; ":STAT:QUES:PTR?"
ENTER 724; A\$

:STATus:PRESet

Syntax :STATus:PRESet

Description This command presets all the enable registers and transition filters for both the OPERation and QUEStionable nodes.

- All the bits in the ENABLE registers are set to 0
- All the bits in the PTRansition registers are set to 1
- All the bits in the NTRansition registers are set to 0

Example OUTPUT 724; ":STAT:PRES"

:SYSTem Commands

:SYSTem:DATE

Syntax :SYSTem:DATE <wsp> <value>,<value>,<value>

where

- the first value is the year (two or four digits),
- the second value is the month, and
- the third value is the day.

Description This command sets the date.

:SYSTem:DATE?

Syntax :SYSTem:DATE?

Description This query returns the current date in the format YY/MM/DD, where YY is the year, MM is the month, and DD is the day.

Example OUTPUT 724;":STAT:DAT 93,3,15"

:SYSTem:ERRor?

Syntax :SYSTem:ERRor?

Description This query returns the next error from the error queue (see "The Error Queue" in Chapter 4). Each error has the error code and a short description of the error, separated by a comma, for example 0, "No error". Error codes are numbers in the range -32768 and +32767. Negative error numbers are defined by the SCPI standard. Positive error numbers are device dependent. The errors are listed in Appendix F

Example OUTPUT 724;":SYST:ERR?"
ENTER 724;A\$

:SYSTem:TIME

Syntax :SYSTem:TIME <wsp> <value>, <value>, <value>

where

- the first value is the hour,
- the second value is the minute, and
- the third value is the seconds.

Description This command sets the time.

:SYSTem:TIME?

Syntax :SYSTem:TIME?

Description This query returns the current time in the format HH:MM:SS, where HH is the hour, MM is the minute, and SS is the seconds.

Example OUTPUT 724; ":SYST:TIM 16,15,00"

5

:TRACe Commands

:TRACe:CATalog?

Syntax :TRACe:CATalog?

Description This query returns a string with a list of the traces stored in the instrument. At the moment, this is only CC_UNCAL.

Note



The trace for the maximum power trace is not available using :TRACe commands because of the large number of data points. Use the :POWer? MAX query to get data points for particular wavelengths.

Example OUTPUT 724; ":TRAC:CAT?"
ENTER 724; A\$

:TRACe:POINts? <trace_name>

Syntax :TRACe:POINts?

Description This query returns the number of data points that are in the trace. Each data point is described by an x- and a y-value.

Example OUTPUT 724;":TRAC:POIN? CC_UNCAL"
ENTER 724;A\$

:TRACe[:DATa]? <trace_name>

Syntax :TRACe[:DATa]?

Description This query returns the trace data for the named trace. The information is returned as a string with the values separated by commas (,). The values are grouped into data points. Each data point has an x-value and a y-value. The x-values are given in meters, the y-values are given in Watts.

Example OUTPUT 724;":TRAC? CC_UNCAL"
ENTER 724;A\$

5

Other Commands

WAVEACT

Note WAVEACT cannot be used with the 8168D module



Syntax WAVEACT <wsp> <value>

where

- <value> is the wavelength. If no units are specified, <value> is taken to be in meters.

Description This command allows the Tunable Laser Source to adjust the wavelength at least ± 1 pm of the wavelength meter reading.

5-38 Remote Commands

Note

The accuracy of WAVEACT is dependent on the wavemeter specification.

It is only as exact as the Wavelength meter.

Set <value> to the actual wavelength measured with a wavelength meter. Repeat the call to WAVEACT until the new wavelength is accurate enough, or will not get any better.

When WAVEACT is active, you see the message EXT. λ REF. at the bottom left of the Tunable Laser Source Screen.

You cannot call WAVEACT with a value that would set the Tunable Laser Source to a wavelength that is not in its wavelength range.

For example, suppose the current wavelength is at the lower wavelength limit of, say, 1480.000 nm. Calling WAVEACT with a different value would cause the wavelength to be corrected to be outside the valid range.

So, after WAVEACT 1480.009, the Tunable Laser Source will attempt to set a new wavelength of 1479.991 nm, which is outside the wavelength limits.

Note

It is advisable not to call WAVEACT with modulation or coherence control on.

For an example of the use of WAVEACT, see “Example 5 - Increased Tuning Linearity” in Chapter 6.

Example

WAVEACT 1541nm

Passive Component Test software

This section gives the additional HP-IB commands that are implemented in the Passive Component Test (PACT) software for the tunable laser source. For more information about the PACT software, see Appendix G.

Note



You should not attempt to use the HP-IB while the tunable laser source is running a measurement.

Table 5-6. Command Summary

```
BDATA? <binary block>
DOSMODE 0|1|OFF|ON
DOSMODE? 0|1
```

BDATA? *nn*

Binary Data query.

Response

<binary block>

Description

The BDATA? *nn* query returns the binary data for the file on the memory card with the index number *nn*, where *nn* is a number in the range 1 to 80.

The full binary information is 5220 bytes long. It includes a Cyclic Redundancy Check for the data (this is a check to make sure there are no errors in the data). If the data is changed in any way, the CRC does not correspond to the data, and the system can no longer use the data: this means, that you cannot edit the data.

The format of the binary data is given in “The Result and Measurement Data Format” in Appendix G.

Example

```
OUTPUT 724;"BDATA? 1"
REM Input the header
REM Transfer the data
Wsize = 5220/2
FOR I = 1 TO Wsize
    ENTER 724 USING "#,W";TRACE(I)
NEXT I
```

5-40 Remote Commands

DOSMODE

Dump Device command.

Syntax DOSMODE 0|1|OFF|ON

Description This command selects the data format for transferring binary information.

- 0 or OFF selects non-DOS binary data format, that is high byte first.
- 1 or ON selects DOS binary data format, that is low byte first.

DOSMODE?

Response 0|1

Description This query returns the selected binary data format.

Example OUTPUT 724;"DOSMODE 0"
 OUTPUT 724;"DOSMODE?"
 ENTER 724;A\$

5



6

Programming Examples

This chapter gives some programming examples. The language used for the programming is BASIC 5.1 Language System used on HP 9000 Series 200/300 computers. Example 5 also gives an equivalent listing in C.

These programming examples do not cover the full command set for the instrument. They are intended only as an introduction to the method of programming the instrument. The programming examples use the HP-IB.

6



Example 1 - Checking Communication

Function

This program sends a queries, and displays the reply.

Listing

```
10  !-----
20  !
30  ! HP 8167B/8D/8E/8F Programming Example 1
40  !
50  ! A Simple Communications Check
60  !
70  !-----
80  !
90  ! Definitions and initializations
100 !
110 Tls=724
```

This statement sets the address of the tunable laser source. The first 7 is to access the HP-IB card in the controller; the 24 is the HP-IB address of the tunable laser source

```
120 DIM String$(50)
130 !
140 CLEAR SCREEN
150 PRINT TABXY(5,10);"Programming Example 1, Simple Communications"
160 !
170 ! Send an IDN query to the TLS and get the TLS Identification
180 !
190 OUTPUT Tls;"*IDN?"
200 ENTER Tls;String$
210 PRINT TABXY(10,12);"Identification : ";String$
The *IDN? query gets the identification of the tunable laser source.
220 !
230 END
```

6

Example 2 - Status Registers and Queues

```
300 PRINT TABXY(4,6);"          :"  
310 PRINT TABXY(4,7);" +-----+ "  
320 PRINT TABXY(4,8);" :          OR          : "  
330 PRINT TABXY(4,9);" +-----+ "  
340 PRINT TABXY(4,10);" ^ ^ ^ ^ ^ ^ ^ ^ ^ ^ "  
350 PRINT TABXY(4,11);" +---+---+---+---+---+---+---+---+---+ "  
360 PRINT TABXY(4,12);" : : : : : : : : : : "  
370 PRINT TABXY(4,13);" +---+---+---+---+---+---+---+---+---+ "  
380 PRINT TABXY(4,14);" PON URQ CME EXE DDE QYE RQC OPC "  
390 PRINT TABXY(40,12);"Standard Event Status Register"  
400 PRINT TABXY(4,16);"Last Command : "  
410 PRINT TABXY(4,17);"Last Error   : "  
420 PRINT TABXY(4,18);"Output Queue : "  
430 !  
440 ! Start the program loop and enable the interrupt for the errors  
450 !  
460 Ende=0  
470 GOSUB Pmm_srq  
480 ENABLE INTR 7;2  
490 !  
500 ! The Central Loop  
510 !  
520 REPEAT  
530   INPUT "Command ?  ",Inp$  
540   GOSUB Pmm_srq  
550   OUTPUT Tls;Inp$  
560   PRINT TABXY(21,16);"          "  
570   PRINT TABXY(21,16);Inp$          "  
580   WAIT 1.0  
590 UNTIL Ende=1  
600 GOTO 1380  
610 !  
620 !-----  
630 Pmm_srq: ! Interrupt Handling Subroutine to display the status, and the  
640 ! error and output queues  
650 !-----  
660 !  
670 ! Get the value for the Status Byte  
680 !  
690 Value=SPOLL(Tls)  
700 !  
710 ! Initialize and start the display of the registers  
720 !  
730 PRINT TABXY(21,17);"          "  
740 PRINT TABXY(21,18);"          "  
750 Ypos=3
```

6-4 Programming Examples

Example 2 - Status Registers and Queues

```
760 FOR Z=0 TO 1
770   Bit=128
780   Xpos=7
790   !
800   ! Do it for each bit
810   !
820   REPEAT
830     Quot=Value DIV Bit
840     !
850     ! If the bit is set then display 1
860     !
870     IF Quot>0 THEN
880       PRINT TABXY(Xpos,Ypos);"1"
890       Value=Value-Bit
900       !
910       ! If MAV is set, then get and display the output queue contents
920       !
930       IF Z=0 THEN
940         IF Bit=16 THEN
950           ENTER Tls;A$
960           PRINT TABXY(21,18);A$
970         END IF
980       END IF
990       !
1000      ! If the bit is not set, then display 0
1010      !
1020      ELSE
1030        PRINT TABXY(Xpos,Ypos);"0"
1040      END IF
1050      !
1060      ! Set up for the next iteration
1070      !
1080      Bit=Bit DIV 2
1090      Xpos=Xpos+4
1100    UNTIL Bit=0
1110    !
1120    ! Now that the status byte is displayed, get the Standard Events
1130    ! Status Register
1140    !
1150    OUTPUT Tls;"*ESR?"
1160    ENTER Tls;Value
1170    !
1180    ! Set up to display the ESR
1190    !
1200    Ypos=12
1210  NEXT Z
```

Example 2 - Status Registers and Queues

```
1220 !
1230 ! Read and display any messages in the error queue
1240 !
1250 REPEAT
1260     OUTPUT T1s;"SYSTEM:ERROR?"
1270     ENTER T1s;Value,A$
The SYSTEM:ERROR? query gets the number of the last error in the error queue.
1280     IF Value<>0 THEN PRINT TABXY(21,17);Value,A$
1290 UNTIL Value=0
1300 !
1310 ! Clear the Status structure and reenale the interrupt before returning
1320 !
1330 OUTPUT T1s;"*CLS"
1340 ENABLE INTR 7
1350 !
1360 RETURN
1370 !
1380 END
```

Example 3 - Measuring the Power of a Modulated Signal

Example 3 - Measuring the Power of a Modulated Signal

Function

This program performs the same sequence as the first part of the sample session given in chapter 1. That is, to measure the power of 1540nm signal, modulated by a 100kHz square wave, at 500 μ Watts.

Requirements

The sample session is written for an HP 8168E/F Tunable Laser Source, and an HP 8153A Lightwave Multimeter with an HP 81532A Power Sensor (It is assumed that the power sensor is inserted in channel A). To perform the sample session as described here, you also need a connector interface for the multimeter (for example, an HP 81000AI), and a patchcord (if you are using the HP 81000AI, then a Diamond HMS-10/HP/HRL to Diamond HMS-10/HP patchcord, HP 81109AC).

Setting Up the Equipment

1. Make sure that all your connectors, and connector interfaces are clean.
2. Make sure that the Optical Output on the laser source is not Active.
3. Connect the output of the laser source to the input of the power sensor (as shown in the figure below). Make sure that the connector with the orange strain-relief sleeve is connected to the tunable laser source (the orange sleeve indicates an angled connector).

6



Example 3 - Measuring the Power of a Modulated Signal

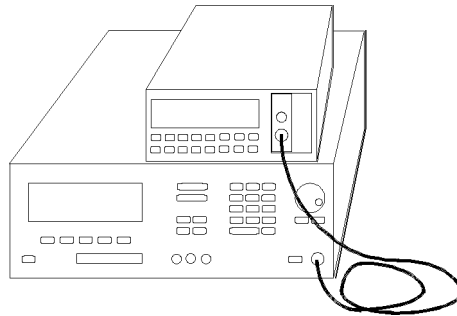

Figure 6-1. Connecting the Instruments for the Sample Session

Typically, you would connect a component to test between the tunable laser source and the power meter.

4. Make sure that both instruments are powered up.

Note



Normally you also need to be sure that the instruments are properly warmed up before using the source, or making any measurements. In this case, because the measurements are not critical, it is acceptable to proceed immediately to the next step.

6

Listing

```
10 !-----
20 !
30 ! Programming Example 3
40 !
50 ! Measuring the Power of a Modulated Signal
60 !
70 !-----
80 !
90 ! Definitions and Initializations
100 !
110 Tls=724
120 Mm=722
130 !
140 Wavel=1.540E-6
150 Oppwr=5.00E-4
160 Opfrq=1.00E+5
170 !
180 ! Set the multimeter to measure in Watts, with an averaging time of 1s,
```

6-8 Programming Examples

Example 3 - Measuring the Power of a Modulated Signal

```
190 ! and to autorange
200 !
210 OUTPUT Mm;"sense1:power:unit W;atime 1s;range:auto on"
220 !
230 CLEAR SCREEN
240 PRINT TABXY(2,2);"Programming example 3: Measuring the power of a Modulated Signal"
250 !
260 ! Set up the power on the tunable laser source, and on the meter
270 !
280 OUTPUT Tls;"wavelength ";Wavel
290 OUTPUT Mm;"sense1:power:wavelength ";Wavel
300 !
310 ! Set the modulated power on the TLS
320 !
330 OUTPUT Tls;"power:unit W;:power ";Oppwr
340 OUTPUT Tls;"am:state on;internal:frequency ";Opfrq
350 !
360 ! Switch on the optical output of the TLS
370 ! Read the value from the multimeter, and display it
380 !
390 OUTPUT Tls;"output on"
400 WAIT 3
Let everything settle before making a reading
410 OUTPUT Mm;"read1:power?"
420 ENTER Mm;A
430 PRINT TABXY(4,4);"The power read is";A*1E6;"uW"
440 !
450 END
```

Example 4 - Measuring a Wavelength Characteristic

Function

This program performs the same sequence as the second part of the sample session given in chapter 1. That is, to measure a wavelength characteristic.

The requirements and the setting up are as described in Example 3.

Listing

```
10  !-----
20  !
30  ! HP 8168E/F Programming Example 4
40  !
50  ! Measuring a Wavelength Characteristic
60  !
70  !-----
80  !
90  ! Definitions and Initializations
100 !
110 Tls=724
120 Mm=722
130 !
140 Startw=1.535E-6
150 Stopw=1.545E-6
160 Stepw=1.E-9
170 !
180 ! Initialize the two instruments
190 !
200 OUTPUT Tls;"power:unit W;:am:state off"
210 OUTPUT Mm;"sense1:power:unit W;:atime 1s;range:auto:on"
220 !
230 CLEAR SCREEN
240 PRINT TABXY(2,2);"Programming Example 4: Measuring a Wavelength Characteristic"
250 PRINT
260 PRINT
270 !
280 ! Find the maximum power for the full range
290 !
300 OUTPUT Tls;"power max"
We set the power to the absolute maximum for the instrument
310 OUTPUT Tls;"power? max"
320 ENTER Tls;Maxpower
330 Wavel=Startw
340 REPEAT
```

6-10 Programming Examples

Example 4 - Measuring a Wavelength Characteristic

```
350     OUTPUT Tls;"Wavelength ";Wavel
360     OUTPUT Tls;"power?"
370     Enter Tls;Power
This reads back the actual (maximum) power that is being output
380     IF Power<Maxpower THEN Maxpower=Power
We want to find the lowest maximum power
390     Wavel=Wavel+Stepw
400     UNTIL Wavel>Stopw+(Stepw/2)
We check for the end this way because these are floating point numbers, and they may not fulfill an
end condition exactly
410     OUTPUT Tls;"power ";Maxpower
420     !
430     ! Switch on the laser source
440     !
450     OUTPUT Tls;"output on"
460     WAIT 2
470     !
480     ! Measure the power over the range
490     !
500     Wavel=Startw
510     REPEAT
520         OUTPUT Tls;"Wavelength ";Wavel
530         OUTPUT Mm;"sense1:power:wavelength ";Wavel
540         WAIT 1
550         OUTPUT Mm;"read1:power?"
560         ENTER Mm;A
570         PRINT "The power read at";Wavel*1.E+9;"nm is";A*1.E+6;"uW"
580         Wavel=Wavel+Stepw
590     UNTIL Wavel>Stopw+(Stepw/2)
600     !
610     END
```

Example 5 - Increased Tuning Linearity

Function

This example shows how you can increase the Tuning Linearity, using the HP-IB command `WAVEACT`. Figure 6-2 shows the measurement setup.

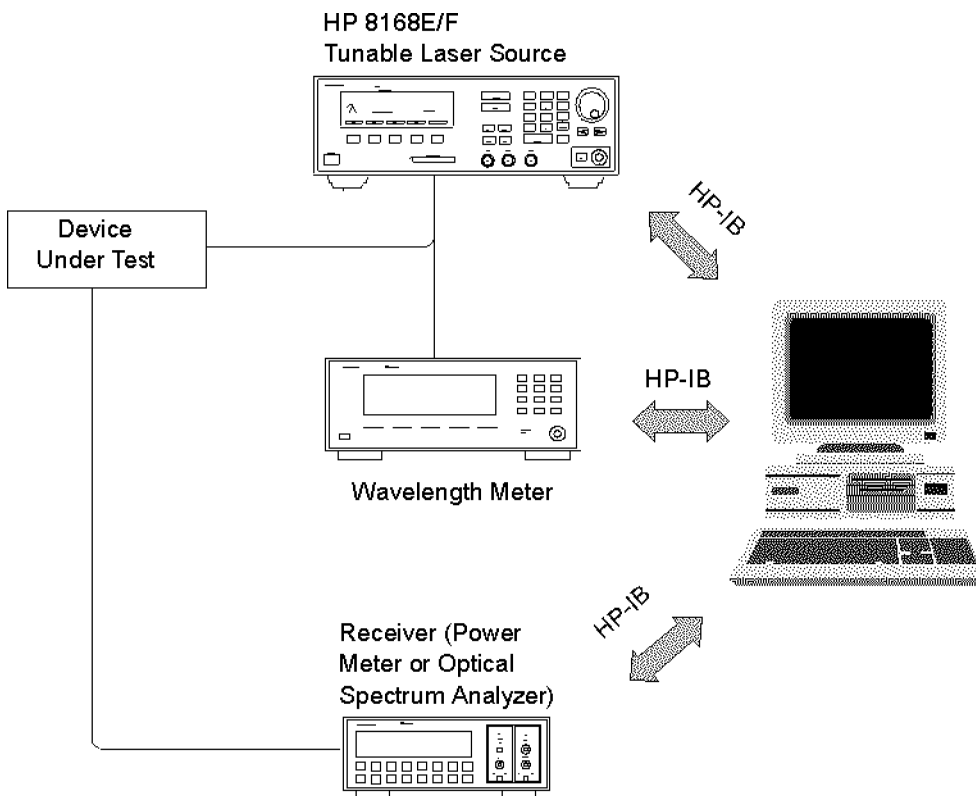

Figure 6-2. Measurement setup for Increased Tuning Linearity

The tunable laser source and wavelength meter are initialized. The TLS is then programmed to the first wavelength of the sweep: for example, 1550.000 nm.

The actual wavelength is read from the wavelength meter, which might be 1550.018 nm. The difference between the measured and programmed values is

Example 5 - Increased Tuning Linearity

18 pm, which is larger than the 1 pm tolerance allowed in this example. The measured wavelength reading is therefore sent to the TLS using the HP-IB command WAVEACT.

The TLS will now detune itself to reduce the difference. The new wavelength is read with the wavelength meter, and the correction loop repeated until the difference is reduced to the allowed tolerance. Once the correct wavelength is achieved, the receiver can be read.

This process is repeated for each wavelength in the sweep (Figure 6-3).

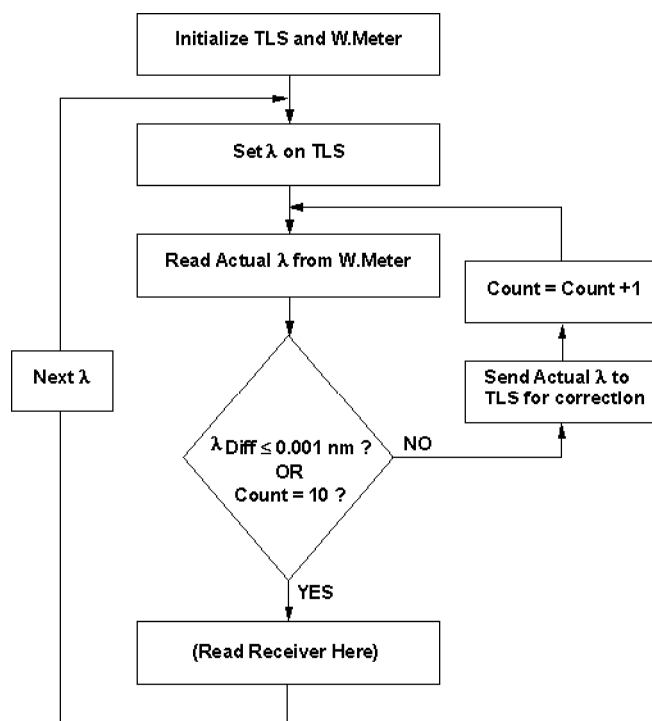

Figure 6-3.
Flow chart describing Increased Tuning Linearity program.

In this example, the allowed wavelength difference is 1 pm, that is the minimum achievable on the TLS. This will typically take several cycles through the correction loop. Allowing a larger tolerance will reduce the average number of correction cycles and overall test time.

Example 5 - Increased Tuning Linearity

The program also exits the loop after ten tries, regardless of the wavelength difference. If the TLS does not reach the desired tolerance within ten tries, there is a problem in the system. It is most likely that the tolerance has been set at a smaller value than that of the stability (noise) of the wavelength meter. This must be avoided, since the tunable laser will be chasing a moving number, which will waste time without improving performance.

Any wavelength meter of sufficient accuracy, linearity, and stability can be used.

Basic Listing

```
1  ! This program first sets the targeted wavelength
2  ! It then enters in a loop until the Targeted wavelength
3  ! is close enough to the targeted one.
4  ! This program uses the HP 86120A multi-wavelength meter
10 COM Elevat,Start_wl,Stop_wl,Step_wl,Allow_diff,Numb_tries
20 COM Target_wl,Current_wl,Diff_wl,Loop_count
30  !
40  !
50  Start_wl=1550
60  Stop_wl=1555
70  Step_wl=.001
80  Allow_diff=.001
90  Numb_tries=10
100 !
110 Target_wl=0
120 Current_wl=0
130 Diff_wl=0
140 !
150 ASSIGN @Tls TO 724
160 ASSIGN @Mwm TO 720
170 !
180 OUTPUT @Tls;"*CLS"
190 OUTPUT @Tls;"*RST"
200 !
210 OUTPUT @Mwm;"*CLS"
220 OUTPUT @Mwm;"*RST"
230 OUTPUT @Mwm;"SENSE:CORR:ELEV 2000"
240 !
250 OUTPUT @Tls;"OUTP ON"
260 !
270 !
280 FOR I=Start_wl TO Stop_wl STEP Step_wl
290 !
300     PRINT ""
```

6

6-14 Programming Examples

Example 5 - Increased Tuning Linearity

```
310 PRINT "Target = ";I;" NM"
320 !
330 Target_wl=I*1.0E-9
340 !
350 OUTPUT @Tls;":WAVE";Target_wl
360 OUTPUT @Tls;":*OPC?"
370 ENTER @Tls;Ready
380 !
390 Loop_count=0
400 !
410 LOOP
420 OUTPUT @Mwm;":MEAS:SCAL:POW:WAV?"
430 ENTER @Mwm;Current_wl
440 Diff_wl=Current_wl-Target_wl
450 PRINT "Current =";Current_wl*1.0E+9,"Diff
=";PROUND(Diff_wl*1.E+9,-4)
460 EXIT IF ABS(Diff_wl)<(Allow_diff+.0005)*1.0E-9 OR
Loop_count=Numb_tries
470 OUTPUT @Tls;":WAVEACT ";Current_wl
480 Loop_count=Loop_count+1
490 END LOOP
500 !
510 ! (Read the receiver at this point)
520 !
530 NEXT I
540 !
550 END
```

Example 5 - Increased Tuning Linearity

Table 6-1. Program Description: Increased Tuning Linearity

Line No.	Description
10 to 20	Dimension, and make common all variables.
50 to 90	Start, stop and step size are set here for the sweep range. Allow_diff is the tolerance for wavelength correction. All wavelength values entered in nm here. Numb_tries is the maximum number of times through the correction loop.
110 to 130	Set working variables to zero.
150 to 160	Tls (HP 8168E/F tunable laser source) is at HP-IB address 24, and the Mwm (HP 86120A multi-wavelength meter) is at HP-IB address 20.
180 to 220	*CLS (clear status byte) and *RST (reset to default settings) the Tls and Mwm. *RST is important for the Mwm because it must be in single trigger mode for line 420 to work (single trigger is the default mode).
230	For accuracy, the elevation must be sent to the Mwm in meters. The default is 0 m, so this line can be omitted if used at sea level.
250	Enable the output of the Tls.
280	Start of the FOR .. NEXT loop for the wavelength sweep. Start, stop and step values set in lines 50 to 70. End of this loop is line 530.
300 to 310	Optional. Prints a blank line and then the programmed or "target" wavelength.
330	Convert the target wavelength in nm to meters, which is the default unit on the Tls and Mwm.
350	Program the Tls with the "target" wavelength.
360 to 370	The Tls must be settled (have finished tuning) before being read by the Mwm. The Tls will not respond to *OPC? (operation complete) until it is settled.
390	Reset the correction loop counter.
410	The start of the wavelength correction loop. The loop ends at line 490.
420	This triggers a single wavelength measurement on the Mwm.
430	Enter the measured wavelength in the variable Current_wl.
440	Calculate the wavelength difference between Current_wl (measured by the Mwm) and Target_wl (to which the Tls is set). This is the wavelength error
450	Optional. Print the current (measured) wavelength (converted back to nm) and the difference wavelength (the error, converted to nm and rounded to four digits).
460	The correction loop is exited if either the Diff_wl (wavelength difference or error) is less than or equal to that set as Allow_diff (in line 80), or if this loop has been repeated Numb_tries (set in line 90) times. It is necessary to take the absolute value of Diff_wl for the comparison. One half pm is added to Allow_diff, and < is used as a way to accomplish < or = conditional. This avoids noise problems of less than 1 pm.
470	This is the special command to send the wavelength measured by the Mwm to the Tls for wavelength correction. The Tls internally compares this measured wavelength with the programmed wavelength (of line 350) and attempts to correct it's output wavelength.
480	Increments the loop counter by 1.
490	End of the correction loop.
510	The Tls is corrected at this point. Put commands to read the receiver (power meter, *OSA , and so on) here.
530	End of the wavelength sweep loop.

6

6-16 Programming Examples

Example 5 - Increased Tuning Linearity

C Listing

```
/*-----*
 *
 * File: set_wave.c
 *
 * Notes:
 *
 * o You have to include <math.h>, <your_hpib_interface.h> to use
 *   these functions.
 *
 * o There is no error handling shown here.
 *
 * o Instruments are not initialized here.
 *
 * o Maybe you should wait until your instruments have completed
 *   their operations. (e.g. Wait for OPC on HP 8167/68)
 *
 * o In this example we use the hpib library SICL
 *   (Standard Instrument Control Library);
 *   used commands:
 *   - iopen      open an instrument          (like fopen)
 *   - iclose     close an instrument        (like fclose)
 *   - iprintf    send a message to an instrument (like fprintf)
 *   - iscanf     get a message from an instrument (like fscanf)
 *   - ipromptf   a combination of iprintf and iscanf
 *   the type INST is an instrument handle (like FILE)
 *
 * o to compile we use the command
 *   cc -Aa -o set_wave set_wave.c -lsicl -lm
 *
 *
 *-----*/

#include <stdlib.h>
#include <stdio.h>
#include <math.h>
#include <sicl.h>                                /* for our hpib library */

int SetExactWvl (double theWvl);                /* function prototypes */
double GetWavelength (INST theInstrument);

/*-----*/
int main (int argc, char **argv)
/*-----*/
{
    double theWvl;
```

Example 5 - Increased Tuning Linearity

```
if (argc != 2)
    exit(-1);

sscanf(argv[1], "%lf", &theWvl);

return (SetExactWvl (theWvl));
}

/*-----*/
int SetExactWvl (double theWvl)
/*-----*/
{
    INST laserSource = iopen("hpib,24");    /* open the instruments:    */
    INST waveMeter   = iopen("hpib,06");    /* laser source at hpib address 24 */
                                           /* wave meter at hpib address 6    */

    int trialCnt;
    int trialMax = 10;

    double actWvl;
    double diffWvlMax = 1.5e-12;           /* 1.5 pm */

    iprintf (laserSource, "WAVE %lg\n", theWvl);    /* set the wavelength */
    iprintf (laserSource, "OUTP ON\n");             /* turn the laser on */

    for (trialCnt = 0; trialCnt < trialMax; trialCnt++)
    {
        actWvl = GetWavelength (waveMeter);         /* read the wavelength */

        if (fabs(actWvl - theWvl) < diffWvlMax)    /* break if near enough */
            break;

        iprintf (laserSource, "WAVEACT %lg\n", actWvl); /* tell the laser source */
                                                         /* the actual wavelength */
    }

    iclose (laserSource);                             /* close the instruments */
    iclose (waveMeter);

    return trialCnt;
}

/*-----*/
double GetWavelength (INST theInstrument)
/*-----*/
{
    double actualWvl;
```

6

Example 5 - Increased Tuning Linearity

```
/* With this cryptic command we get the wavelength */
/* from an ADVANTEST TQ8325 wavelength meter */

ipromptf (theInstrument, "HODOMO1E\n", "%lf", &actualWvl);

return (actualWvl);
}
```



Installation

This appendix provides installation instructions for the tunable laser source. It also includes information about initial inspection and damage claims, preparation for use, packaging, storage, and shipment.

Safety Considerations

The Model tunable laser source is a Safety Class 1 instrument (that is, an instrument with an exposed metal chassis directly connected to earth via the power supply cable). The symbol used to show a protective earth terminal in the instrument is .

Before operation, you should review the instrument and manual, including the red safety page, for safety markings and instructions. You must follow these to ensure safe operation and to maintain the instrument in safe condition.

Initial Inspection

Inspect the shipping container for damage. If there is damage to the container or cushioning, you should keep them until you have checked the contents of the shipment for completeness and verified the instrument both mechanically and electrically.

The Function Test gives a procedure for checking the operation of the instrument. If the contents are incomplete, mechanical damage or defect is apparent, or if an instrument does not pass the operator's checks, notify the nearest Hewlett-Packard office.

A

Warning

To avoid hazardous electrical shock, do not perform electrical tests when there are signs of shipping damage to any portion of the outer enclosure (covers, panels, etc.).

AC Line Power Supply Requirements

The tunable laser source can operate from any single-phase AC power source that supplies between 100V and 240V at a frequency in the range from 50 to 60Hz. The maximum power consumption is 360VA with all options installed.

Line Power Cable

According to international safety standards, this instrument has a three wire power cable. When connected to an appropriate AC power receptacle, this cable earths the instrument cabinet. The type of power cable shipped with each instrument depends on the country of destination. Refer to Figure A-1 for the part numbers of the power cables available.

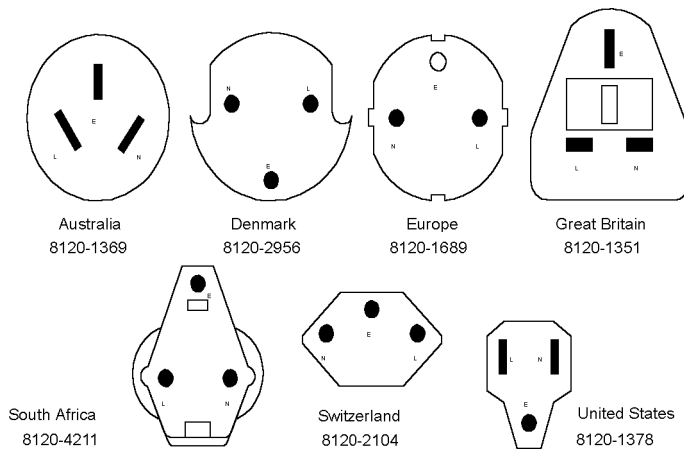

Figure A-1. Line Power Cables - Plug Identification

A-2 Installation

Warning

To avoid the possibility of injury or death, you must observe the following precautions before switching on the instrument.

- **If this instrument is to be energized via an autotransformer for voltage reduction, ensure that the Common terminal connects to the earthed pole of the power source.**
- **Insert the power cable plug only into a socket outlet provided with a protective earth contact. Do not negate this protective action by the using an extension cord without a protective conductor.**
- **Before switching on the instrument, the protective earth terminal of the instrument must be connected to a protective conductor. You can do this by using the power cord supplied with the instrument.**
- **Do not interrupt the protective earth connection.**

The following work should be carried out by a qualified electrician. All local electrical codes must be strictly observed. If the plug on the cable does not fit the power outlet, or if the cable is to be attached to a terminal block, cut the cable at the plug end and rewire it.

The color coding used in the cable depends on the cable supplied. If you are connecting a new plug, it should meet the local safety requirements and include the following features:

- Adequate load-carrying capacity (see table of specifications).
- Ground connection.
- Cable clamp.

The AC power requirements are summarized on the rear panel of the instrument.

A



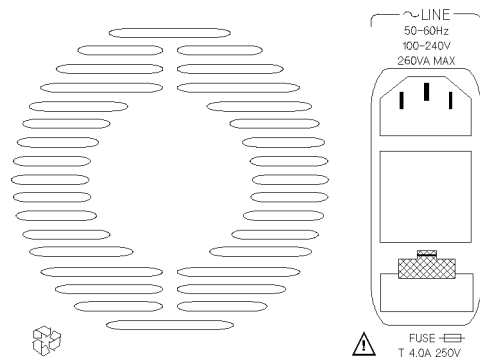

Figure A-2. Rear Panel Markings

Changing the Battery



This instrument contains a lithium battery. Changing the battery should be carried out only by a qualified electrician or by HP service personnel. There is a danger of explosion if the battery is incorrectly replaced. Replace only with the same or an equivalent type (HP part number 1420-0298). Discard used batteries according to local regulations.

Changing the Fuse



There are two fuses in this instrument. Both of the fuses are T4.0A/250V time-lag (HP Part No. 2110-0014). The fuse holder is at the rear of the instrument, below the line power connector. To change a fuse,

1. Release the fuse holder: use the blade of a flat-headed screwdriver to depress the catch at the top of the holder and then pull the holder out a little.

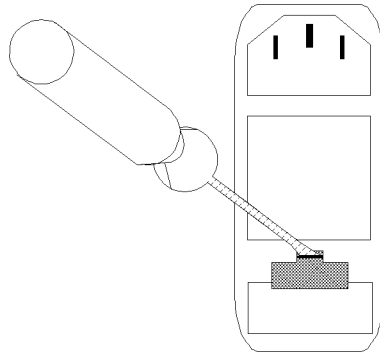

Figure A-3. Releasing the Fuse Holder

2. Pull the fuse holder out of the instrument.

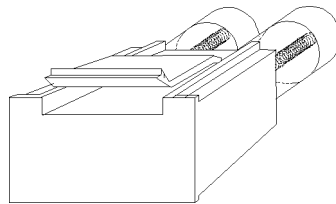

Figure A-4. The Fuse Holder

3. Check and change the fuses as necessary.
4. Place the fuse holder back in the instrument, and push it until the catch clicks back into place.

A



Operating and Storage Environment

The following summarizes the tunable laser source operating environment ranges. In order for the tunable laser source to meet specifications, the operating environment must be within these limits.

Warning



The tunable laser source is not designed for outdoor use. To prevent potential fire or shock hazard, do not expose the instrument to rain or other excessive moisture.

Temperature

The instrument should be protected from temperature extremes and changes in temperature that may cause condensation within it.

The storage and operating temperature for the tunable laser source are given in the table below.

Table A-1. Temperature

	Operating Range	Storage Range
Specified	10°C to 35°C	-40°C to 70°C

Humidity

The operating humidity for the tunable laser source is 15% to 95% from 10°C to 35°C.

A

Instrument Positioning and Cooling

The tunable laser source has a cooling fan mounted internally. Mount or position the instrument upright and horizontally so that air can circulate through it freely. When operating the tunable laser source, choose a location that provides at least 75mm (3inches) of clearance at the rear, and at least 25mm (1inch) of clearance at each side. Failure to provide adequate air clearance may result in excessive internal temperature, reducing instrument reliability.

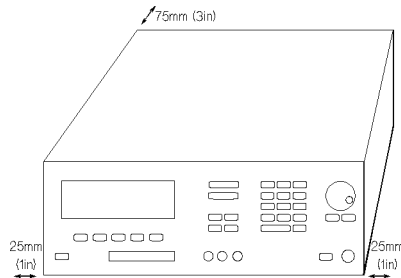

Figure A-5. Correct Positioning of the Tunable Laser Source

Switching on the Tunable Laser Source

When you switch on the tunable laser source it goes through three start-up phases

1. Self test,
2. Initializing, and
3. Stabilizing.

Self test

This is the same self test as described in “Performing a Selftest” in Chapter 3.

Initializing

Initializing takes a minute or two. During this time, the instrument performs a self test. The first test is of the memory; while this is being done, all the elements on the display are turned on. If the instrument fails the memory test, this display will start blinking. After this, the rest of the self test is performed. The test being performed is shown on the display.

A



Stabilizing

Stabilizing is the process of heating up the heat chamber to its operating temperature ($55\pm 1^\circ\text{C}$). The length of time taken depends on how warm the heat chamber is when the instrument is first switched on. Under normal (laboratory) conditions, this takes approximately one hour. The percentage of operating temperature that has been reached is displayed as part of the STABILIZING message that is shown at the top of the screen during the process. The instrument only meets specifications while the heat chamber is at the operating temperature.

If you try to set a power level which cannot be supplied during the stabilizing, then the AVAILABLE message is displayed with the maximum power that is available.

Note



If the value is simultaneously too low for the coherence control, if you are also using this, the AVAILABLE is shortened to AVA.

Stabilizing during Operation

The instrument will maintain the heat chamber within the operating limits ($54^\circ\text{C}\rightarrow 56^\circ\text{C}$) if you are using the instrument in a normal laboratory environment. If you are using the tunable laser source in either an extremely warm, or an extremely cold environment, the STABILIZING message may appear from time to time as the instrument tries to get back to the operating temperature. The stabilizing level should not decrease beyond 95%.

In an extreme case, the STABILIZING message will appear and the percentage value will decrease below 95%, and possibly keep decreasing. In this case you should switch off the instrument, and let it cool down completely before powering it up again.

A

Signal Outputs.

There are two signal outputs on the front panel of the tunable laser source.

- One of these is the Modulation Output, which outputs the internal signal used to modulate the optical output. This is a squarewave signal with 50% duty cycle, and is at TTL levels (see “Setting the Modulation Output” in Chapter 3 and “[:SOURCE]:MODOUT” in Chapter 5 for more information).
- The other is the analog output, which outputs a voltage level proportional to the power of the output laser signal. The relationship between this voltage level and the output power is not calibrated, but is approximately 1mV for each $1\mu\text{W}$.



Caution



The maximum external voltages that can be applied to the outputs of this instrument are $\pm 10\text{V}$.

Optical Output

Caution



If the optical termination on your instrument is angled, you can only use cables with angled connectors with the instrument.

See “Connector Interfaces and Other Accessories” in Appendix B for further details on connector interfaces and accessories.

Option 007



If you have an instrument with a polarization maintaining fiber (PMF), the PMF will be automatically aligned and maintain the state of polarization..

The fiber is of Panda type, with T_E mode in the slow axis in line with the connector key.

A



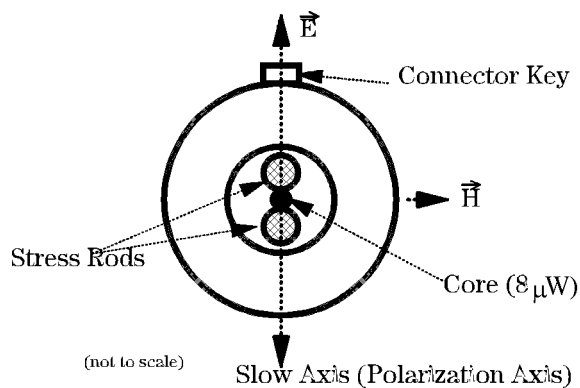

Figure A-6. PMF Output

HP-IB Interface

You can connect your HP-IB interface into a star network, a linear network, or a combination star and linear network. The limitations imposed on this network are as follows:

- The total cable length cannot exceed 20 meters
- The maximum cable length per device is 2 meters
- No more than 15 devices may be interconnected on one bus.

Connector

The following figure shows the connector and pin assignments.

Connector Part Number: 1251-0293

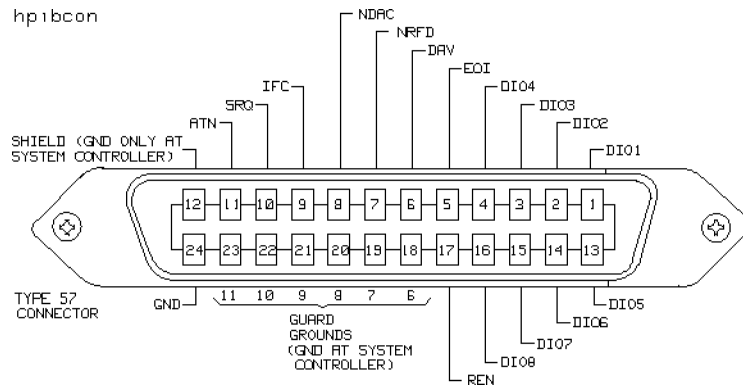

Figure A-7. HP-IB Connector

Caution



HP products delivered now are equipped with connectors having ISO metric- threaded lock screws and stud mounts (ISO M3.5×0.6) that are black in color. Earlier connectors may have lock screws and stud mounts with imperial-threaded lock screws and stud mounts (6-32 UNC) that have a shiny nickel finish.

Caution



- It is recommended that you do not stack more than three connectors, one on top of the other.
- Hand-tighten the connector lock screws. Do not use a screwdriver.

HP-IB Logic Levels

The tunable laser source HP-IB lines use standard TTL logic, as follows:

- True = Low = digital ground or 0Vdc to 0.4Vdc
- False = High = open or 2.5Vdc to 5Vdc

All HP-IB lines have LOW assertion states. High states are held at 3.0Vdc by pull-ups within the instrument. When a line functions as an input, it requires approximately 3.2mA to pull it low through a closure to digital ground. When a line functions as an output, it will sink up to 48mA in the low state and approximately 0.6mA in the high state.

A



Note

The HP-IB line screens are not isolated from ground.



Claims and Repackaging

If physical damage is evident or if the instrument does not meet specification when received, notify the carrier and the nearest Hewlett-Packard Service Office. The Sales/Service Office will arrange for repair or replacement of the unit without waiting for settlement of the claim against the carrier.

Return Shipments to HP

If the instrument is to be shipped to a Hewlett-Packard Sales/Service Office, attach a tag showing owner, return address, model number and full serial number and the type of service required.

The original shipping carton and packing material may be reusable, but the Hewlett-Packard Sales/Service Office will provide information and recommendation on materials to be used if the original packing is no longer available or reusable. General instructions for repackaging are as follows:

1. Wrap instrument in heavy paper or plastic.
2. Use strong shipping container. A double wall carton made of 350-pound test material is adequate.
3. Use enough shock absorbing material (3 to 4 inch layer) around all sides of the instrument to provide a firm cushion and prevent movement inside container. Protect control panel with cardboard.
4. Seal shipping container securely.
5. Mark shipping container FRAGILE to encourage careful handling.
6. In any correspondence, refer to instrument by model number and serial number.

B

Accessories

Mainframe

Mainframe Description	Model No.
Tunable Laser Source 1255nm to 1365nm	HP 8167B
Tunable Laser Source 1490nm to 1565nm	HP 8168D
Tunable Laser Source 1470nm to 1580nm	HP 8168E
Tunable Laser Source 1450nm to 1590nm	HP 8168F
Handle Kit	Option 1CN
Rack Kit	Option 1CM
(Additional) Operating and Programming Manual	Option 0B2

B



Options

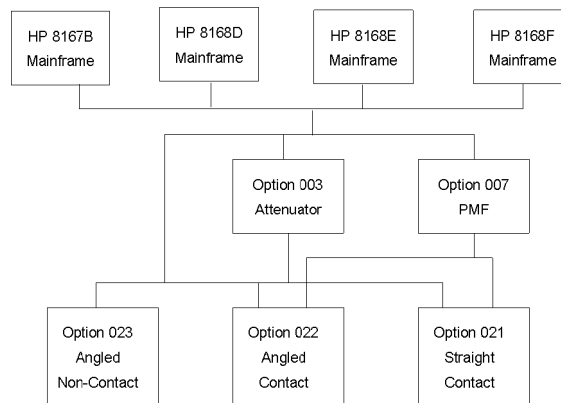

Figure B-1. Tunable Laser Source Options Overview

Option 003:

Built-in optical attenuator with 40dB attenuation range, cannot be combined with option 007.

Option 003 is not available for the 8168D.

Option 007:

Polarization maintaining fiber, Panda-type, for straight or angled connector types (depending on the connector option selected), cannot be combined with option 003 or 023.

Option 007 is available for all models.

Connector Interfaces and Other Accessories

The tunable laser source is supplied with one of three connector interface options.

- Option 021 with a straight contact connector
- Option 022 with an angled contact connector
- Option 023 with a Diamond HMS-10/HP/HRL angled, non-contact connector. Cannot be combined with option 007.

Option 023 is not available for the 8168D.

B-2 Accessories

Option 021, Straight Contact Connector. If you want to use straight connectors (such as FC/PC, Diamond HMS-10, DIN, Biconic, SC, ST, or D4) to connect to the instrument, you must

1. attach your connector interface (see the list of connector interfaces below) to the interface adapter,
2. then connect your cable.

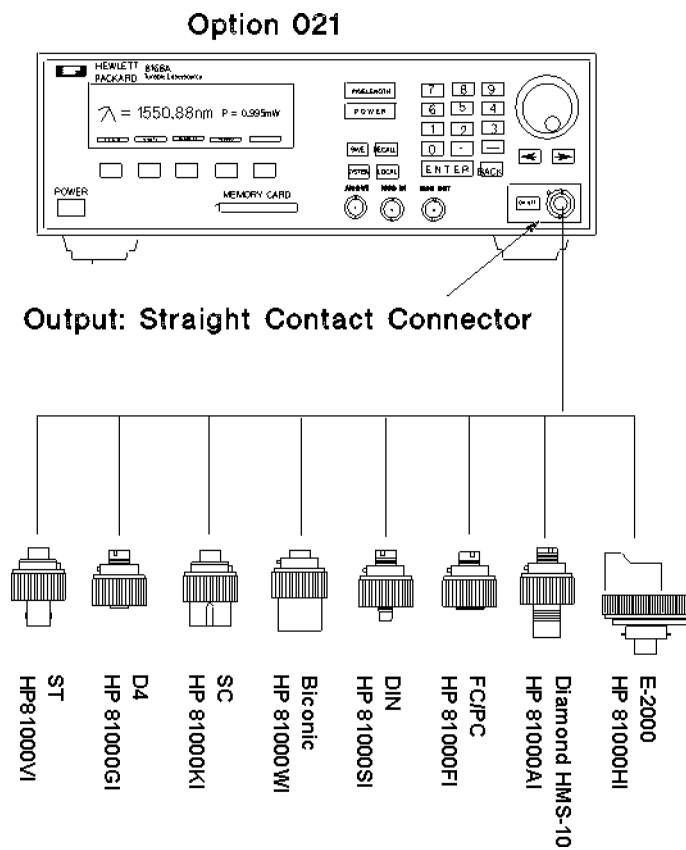

Figure B-2. Tunable Laser Source Option 021 Configuration

B

Connector Interface	
Description	Model No.
Biconic	HP 81000WI
D4	HP 81000GI
Diamond HMS-10	HP 81000AI
DIN 47256	HP 81000SI
FC/PC	HP 81000FI
SC	HP 81000KI
ST	HP 81000VI
E-2000	HP 81000HI

Option 022, Angled Contact Connector. If you want to use angled contact connectors (such as FC/APC, Diamond HRL-10, DIN, or SC/APC) to connect to the instrument, you must

1. attach your connector interface (see the list of connector interfaces below) to the interface adapter,
2. then connect your cable.



B-4 Accessories

Option 022

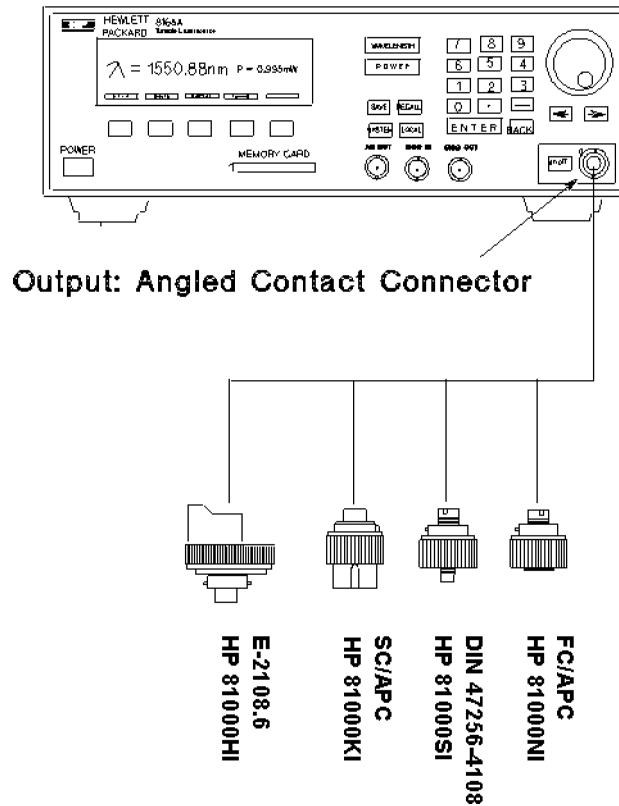

Figure B-3. Tunable Laser Source Option 022 Configuration

Connector Interface	
Description	Model No.
DIN 47256/4108.6	HP 81000SI
FC/APC	HP 81000NI
SC/APC	HP 81000KI
E-2108.6	HP 81000HI

B 

Option 023, Diamond HMS-10/HRL Angled, Non-Contact Connector. The instrument as it is delivered with this option can only be used with cables with Diamond HMS-10/HP/HRL angled connectors. To connect angled connectors (such as FC/APC, DIN 47256-4108, Radiall, and so on), use the appropriate patchcord.

If you want to use straight connectors (such as FC/PC, Diamond HMS-10, DIN, Biconic, SC, ST, or D4) to connect to the instrument, you must

1. replace the HMS-10 connector interface with an interface adapter (HP 81000UI),
2. attach your connector interface (see the list of connector interfaces below) to the interface adapter,
3. then connect your cable.

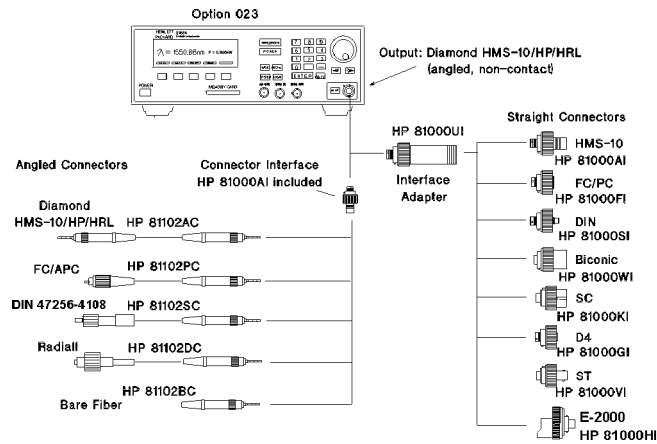

Figure B-4. Tunable Laser Source Option 023 Configuration

B

B-6 Accessories

Cables with Angled Connectors

<u>Description</u>	<u>Model No.</u>
Diamond HMS-10/HP/HRL - Bare Fiber	HP 81102BC
Diamond HMS-10/HP/HRL - Diamond HMS-10/HP/HRL	HP 81102AC
Diamond HMS-10/HP/HRL - Diamond HMS-10/HP	HP 81109AC
Diamond HMS-10/HP/HRL - DIN 47256-4108	HP 81102SC
Diamond HMS-10/HP/HRL - FC/APC	HP 81102PC
Diamond HMS-10/HP/HRL - Radiall	HP 81102DC

Interface Adapter

<u>Description</u>	<u>Model No.</u>
Interface Adapter	HP 81000UI

HP-IB Cables and Adapters

The HP-IB connector is compatible with the connectors on the following cables and adapters.

- HP-IB Cable, 10833A, 1 m (3.3 ft.)
- HP-IB Cable, 10833B, 2 m (6.6 ft.)
- HP-IB Cable, 10833C, 4 m (13.2 ft.)
- HP-IB Cable, 10833D, 0.5 m (1.6 ft.)
- HP-IB Adapter, 10834A, 2.3 cm extender.

B



Accessories B-7



Specifications

Definition of Terms

Absolute wavelength accuracy:	<p>The maximum difference between the actual wavelength and the displayed wavelength of the TLS. Wavelength is defined as wavelength in vacuum.</p> <p><i>Conditions:</i> constant power level, temperature within operating temperature range, coherence control off.</p> <p><i>Measurement</i> with wavelength meter.</p>
Linewidth:	<p>The 3 dB width of the optical spectrum, expressed in Hertz.</p> <p><i>Conditions:</i> temperature within operating temperature range, coherence control off.</p> <p><i>Measurement</i> with heterodyning technique: the output of the laser under test is mixed with another laser of the same type on a wide bandwidth photodetector. The electrical noise spectrum of the photodetector current is measured with HP lightwave signal analyzer.</p>
Maximum specified output power:	<p>The maximum output power specified at a specific wavelength.</p> <p><i>Measurement</i> at the end of a patchcord.</p>

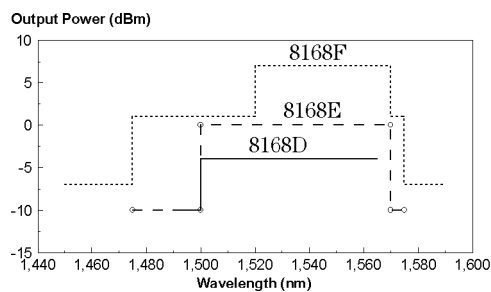

Figure C-1.
Maximum Specified Output Power for 8168D, E and F
(without options)

Minimum output power: The minimum output power for which the specifications apply.

Output power:	The maximum output power for the specified TLS tuning range. <i>Conditions:</i> temperature within operating temperature range. <i>Measurement</i> with power meter at the end of a single-mode fiber patchcord.
Peak power:	The highest optical power within specified wavelength range.
Polarization extinction ratio:	The ratio of optical power in the slow axis of the polarization-maintaining fiber to optical power in the fast axis within a specified wavelength range. <i>Conditions:</i> only for TLS with polarization maintaining fiber; TE mode in slow axis and oriented in line with connector key. <i>Measurement</i> with rotatable polarizer at the end of a polarization-maintaining patchcord, with polarizer orientations for the fast and slow axes kept fixed while changing the wavelength.
Power flatness:	When changing the wavelength and measuring the differences between actual and displayed power levels, the power flatness is \pm half the span between the maximum and the minimum value of all differences relative to the mean power. <i>Conditions:</i> uninterrupted line voltage, constant power setting, temperature within ± 1 K. <i>Measurement</i> with optical power meter.
Power linearity:	When changing the power level and measuring the differences between actual and displayed power levels, the power linearity is \pm half the span between the maximum and the minimum value of all differences. <i>Conditions:</i> uninterrupted TLS line voltage, constant wavelength- and power level settings, temperature within ± 1 K. <i>Measurement</i> with optical power meter.
Power repeatability:	The random uncertainty in reproducing the power level after changing and re-setting the power level or wavelength. The power repeatability is \pm half the span between the maximum and the minimum value of all differences relative to the mean power. <i>Conditions:</i> uninterrupted TLS line voltage, constant wavelength, temperature within ± 1 K. <i>Measurement</i> with optical power meter.
Power stability:	The change of the power level during a given time span, expressed as \pm half the span of power changes relative to the mean power. <i>Conditions:</i> uninterrupted TLS line voltage, constant wavelength- and power level settings, temperature within ± 1 K, time span as specified. <i>Measurement</i> with optical power meter.

C

C-2 Specifications

Relative intensity noise (RIN):	<p>The square of the RMS optical power amplitude divided by the measurement bandwidth and the square of the average optical power, expressed in dB/Hz.</p> <p><i>Conditions:</i> coherence control off, temperature within operating temperature range, frequency range 0.1 to 6 GHz.</p> <p><i>Measurement</i> with HP lightwave signal analyzer.</p>
Relative wavelength accuracy:	<p>When randomly changing the wavelength and measuring the differences between the actual and displayed wavelengths, the relative wavelength accuracy is \pm half the span between the maximum and the minimum value of all differences.</p> <p><i>Conditions:</i> uninterrupted TLS line voltage, constant power level, temperature within operating temperature range, coherence control off.</p> <p><i>Measurement</i> with wavelength meter.</p>
Sidemode suppression ratio:	<p>The ratio of average signal power to the optical power of the highest sidemode within a distance from 0.1 to 6 GHz to the signal's optical frequency, expressed in dB.</p> <p><i>Conditions:</i> at a specified output power and wavelength range, temperature within operating temperature range, coherence control off.</p> <p><i>Measurement</i> with HP lightwave signal analyzer using heterodyning method.</p>
Source spontaneous emission:	<p>The ratio of spontaneous emission power in 0.1 nm bandwidth to signal power within a ± 2 nm window around the signal wavelength, at \rightarrow maximum specified output power, expressed in dB per 0.1 nm.</p> <p><i>Conditions:</i> at maximum specified output power; temperature within operating temperature range, coherence control off.</p> <p><i>Measurement</i> with optical spectrum analyzer at 0.1 nm resolution bandwidth.</p>
Wavelength range:	The range of wavelengths for which the specifications apply.
Wavelength repeatability:	<p>The uncertainty in reproducing the wavelength after detuning and re-setting the wavelength. The wavelength repeatability is \pm half the span between the maximum and the minimum value of all changes.</p> <p><i>Conditions:</i> uninterrupted TLS line voltage, constant power level, temperature within operating temperature range, coherence control off.</p> <p><i>Measurement</i> with wavelength meter.</p>
Wavelength resolution:	The smallest possible displayed wavelength increment / decrement.
Wavelength stability:	<p>The change of wavelength during a given time span, expressed as \pm half the span between the maximum and the minimum wavelengths.</p> <p><i>Conditions:</i> uninterrupted TLS line voltage, constant wavelength- and power level settings, coherence control off, temperature within ± 1 K, time span as specified.</p> <p><i>Measurement</i> with wavelength meter</p>

C



Performance Specifications

Specifications describe the instrument's warranted performance. They are measured at the end of a 2m long patchcord and are valid for the output power and the wavelength ranges stated below.

Supplementary performance characteristics describe the instrument's non-warranted typical performance.



C

C-4 Specifications

	HP 8167B	HP 8168D	HP 8168E	HP 8168F
Wavelength Range	1255nm to 1365nm	1490nm to 1565nm	1475nm to 1575nm	1450nm to 1590nm
Absolute Wavelength Accuracy, typ¹	± 0.1nm	± 0.2nm	± 0.1nm	
Relative Wavelength Accuracy	± 0.035nm (1310-1350nm) ± 0.050nm (1255-1365nm) typ ± 0.001nm ²	± 0.1nm	± 0.035nm, typ ± 0.001nm ²	± 0.035nm (1475-1575nm) ± 0.050nm (1450-1590nm), typ ± 0.001nm ²
Wavelength Resolution	0.001nm, 170MHz at 1300nm	0.1nm	0.001nm, 125MHz at 1550nm	
Wavelength Stability (typ over 1 hour at constant temperature)	< ± 100MHz	± 1GHz	< ± 100MHz	
Wavelength Repeatability	± 0.035nm (1310-1350nm) ± 0.050nm (1255-1365nm) typ ± 0.001nm ²	± 0.1nm	± 0.035nm, typ ± 0.001nm ²	± 0.035nm (1475-1575nm) ± 0.050nm (1450-1590nm), typ ± 0.001nm ²
Sidemode Suppression Ratio, typ³	> 40dB (1260-1360nm at -3dBm)	<i>n/a</i>	> 40dB (1500-1570nm at 0dBm)	> 50dB (1475-1575nm at 1dBm)
Source Spontaneous Emission⁴	< -45dB/0.1nm (1310-1350nm) < -40dB/0.1nm (1260-1360nm) < -35dB/0.1nm (1255-1365nm)	< -40dB/0.1nm (1500-1565nm) < -35dB/0.1nm (1490-1565nm)	< -45dB/0.1nm (1500-1570nm) < -35dB/0.1nm (1475-1575nm)	< -55dB/0.1nm (1520-1570nm) < -45dB/0.1nm (1475-1575nm) < -35dB/0.1nm (1450-1590nm)
Relative Intensity Noise (RIN), typ	< -145dB/Hz			
Linewidth (typ), coherence control off	100kHz			
Effective Linewidth (typ), coherence control on⁵	10-500MHz (1260-1360nm)	30-500MHz (1500-1565nm)	50 to 500MHz (1500-1570nm)	50 to 500 MHz (1475-1575nm)
¹ Measured with a wavelength meter in a vacuum. ² Performance when controlled with appropriate wavelength meter. ³ Measured by heterodyning method. Reduce output power if options are attached. ⁴ Measured with optical spectrum analyzer at 0.1nm resolution bandwidth at maximum specified output power. ⁵ At power levels larger than CC uncal value.				

C



	HP 8167B	HP 8168D	HP 8168E	HP 8168F
Tuning Speed (typ for a 1/10/100nm step)^{6 7} <i>with #003⁸</i>	200ms/300ms/2s			
	250ms/300ms/2s	<i>n/a</i>	250ms/300ms/2s	
Output Power⁹	> +4dBm peak typ > +3dBm (1310-1350nm) > -3dBm (1260-1360nm) > -7dBm (1255-1365nm)	> -3dBm peak typ > -4dBm (1500-1565nm) > -10dBm (1490-1565nm)	> +1dBm peak typ > 0dBm (1500-1570nm) > -10dBm (1475-1575nm)	> +8dBm peak typ > +7dBm (1520-1570nm) > 1dBm (1475-1575nm) > -7dBm (1450-1590nm)
<i>for #023⁸</i>	reduce by 1dB	<i>n/a</i>	reduce by 1dB	
<i>for #003⁸</i>	reduce by 1.5dB	<i>n/a</i>	reduce by 1.5dB	
<i>for #007⁸</i>	reduce by 1dB	reduce by 1dB	reduce by 1dB	
<i>for #023 and #003⁸</i>	reduce by 2.5dB	<i>n/a</i>	reduce by 2.5dB	
Minimum Output Power <i>with #003⁸</i>	-7dBm -47dBm	-10dBm <i>n/a</i>	-50dBm	-7dBm -47dBm
Power Linearity <i>with #003⁸</i>	$\pm 0.3\text{dB}^{11}$	$\pm 0.1\text{dB}$ <i>n/a</i>	$\pm 0.3\text{dB}$	$\pm 0.1\text{dB}^{10}$ $\pm 0.3\text{dB}^{10}$
Power Stability (over 1 hour)	$\pm 0.03\text{dB}^{12}$ (typ $\pm 0.01\text{dB}$)	$\pm 0.03\text{dB}$ (typ $\pm 0.01\text{dB}$)		
Power Repeatability (typ)	$\pm 0.04\text{dB}^{11}$	$\pm 0.04\text{dB}$		$\pm 0.04\text{dB}^{10}$
Power Flatness versus Wavelength	$\pm 0.1\text{dB}$	$\pm 0.2\text{dB}$ typ $\pm 0.1\text{dB}$	$\pm 0.1\text{dB}$	$\pm 0.1\text{dB}^{10}$ (1475-1575nm) $\pm 0.2\text{dB}^{10}$ (1450-1590nm)
<i>with #003⁸</i>	$\pm 0.2\text{dB}^{12}$	<i>n/a</i>	$\pm 0.2\text{dB}$	$\pm 0.2\text{dB}^{10}$ (1475-1575nm) $\pm 0.3\text{dB}^{10}$ (1450-1590nm)
⁶ Applicable for CW operation. ⁷ The Tuning Speed increases when Modulation is on. ⁸ Listed options are described in the Supplementary Performance Characteristics ⁹ The Maximum power is lower when Modulation is on. ¹⁰ For power settings below -3dBm (with option 003:P _{REF} < -3dBm, independent of attenuator setting, or power setting below -43dBm), the values shown may increase by up to 5 times. ¹¹ with option #003: at constant Relative Humidity ($\pm 5\%$) ¹² with option #003: at 1355.0 nm and 1359.5 nm, power may vary by up to ± 0.25 typically, depending on ambient relative humidity and related water absorption.				

C

C-6 Specifications

Supplementary Performance Characteristics

Characteristics

- Output isolation (typ): 50dB
- Return loss (typ): 60dB (except option 021).

Operating Modes

Internal Modulation

Modulation frequency: 250Hz to 300kHz (squarewave)

Duty cycle: 50% fixed

Modulation depth: 100% (on/off)

Modulation output: TTL reference signal. Max power reduced by 1dB.

External modulation

Modulation frequency: 200kHz to 20MHz (at 3dB optical bandwidth, typ)

Modulation depth (max, typ): $\pm 15\%$

Coherence Control

Effective linewidth of 50 to 500MHz typ (30-500MHz typ for HP 8167B and HP 8168D).

For measurements on components with 2m long patchcords and connectors with 14dB return loss, the effective linewidth results in a typical power stability of $< \pm 0.025\text{dB}$ ($< \pm 0.1\text{dB}$ for HP 8167B and HP 8168D) over 1 minute by drastically reducing interference effects in the test setup.

General

Polarization maintaining fiber

Fiber type: Panda

Orientation T_E mode in slow axis, in line with connector key.

Polarization Extinction Ratio:

C



>15dB for HP8167B between 1310 and 1350nm, (>12dB over the full wavelength range).

>15dB for HP8168D over the full wavelength range;

>15dB for HP8168E/F between 1490 and 1575nm, (>12dB over the full wavelength range).

HP-IB Interface

HP-IB Interface function code: SH1, AH1, T6, L4, SR1, RL1, PP0, DC2, DT0, C0

Passive Component Test Software

Files and data can be stored on memory cards according to PCMCIA type 1, standard PCMCIA 1.0/JEIDA 4.0. Type 1 cards are 3.3mm thick. Recommended card capacity 512kByte.

Laser Class

HP8168D/E: Class 1 according to FDA 21 CFR 1040.10, Class 3A according to IEC 825-1 (1993).

HP 8167B and HP 8168F: Class IIIb according to FDA 21 CFR 1040.10, Class 3A according to IEC 825-1 (1993).

Analog output: provides output voltage proportional to optical output power (except #003).

Recalibration period: 2 years.

Warm-up time: typically <1 hour, can be used with reduced power in this phase.

Environmental

Altitude: up to 4,600m (15,000 feet).

Storage temperature: -40°C to +70°C

Operating temperature: 10°C to 35°C

Humidity: <95%R.H. (10°C to 35°C)

Installation Category (IEC 664): II

Pollution Degree (IEC 664): 2

C-8 Specifications

Specifications are valid at non-condensing conditions.

Power: 100 to 240V_{rms}, ±10%. 260VA maximum.

Dimensions: 145mm H, 426mm W, 545mm D (5.8"×16.9"×21.6")

Weight: net 18kg (40lbs), shipping 21kg (46lbs).

Listed options

Option 003: built-in attenuator

Option 007: polarization maintaining Panda fiber

Option 021: straight contact output connector

Option 023: angled non-contact output connector

Other Specifications

Acoustic Noise Emission:

For ambient temperature up to 30°C

L_p = 40.2dB(A)

L_w = 4.8 Bel

Typical operator position,
normal operation.

Data are results from type tests per ISO 7779
(EN 27779).

Geräuschemissionswerte:

Bei einer Umgebungstemperatur bis 30°C

L_p = 40.2dB(A)

L_w = 4.8 Bel

am Arbeitsplatz,
normaler Betrieb.

Die Angabe ist das Ergebnis einer Typprüfung
gemäß ISO 7779 (EN 27779).



Declaration of Conformity

Manufacturer: Hewlett-Packard GmbH
Böblingen Instruments Division
Herrenberger Straße 130
D-71034 Böblingen
Germany

We declare that the product

Product Name: Tunable Laser Source
Model Numbers: **HP8167B**
HP8168D, HP8168E, HP8168F
Options: All

conforms to the following standards

Safety: IEC 1010-1:1990 incl. Addendum 1:1992, EN 61010:1993
IEC 825-1:1993, EN 60825-1:1994

EMC: EN 55011:1991/CISPR 11, Group 1 Class B
EN 50082-1:1992
IEC 801-2:1991 ESD 4kV cd, 8kV ad
IEC 801-3:1992 Radiated Immunity 3 V/m
IEC 801-4:1988 Fast Transients 0.5 kV, 1 kV

Supplementary Information:

The product herewith complies with the requirements of the

* Low Voltage Directive (73/23/EEC) and the

* EMC Directive (89/336/EEC).

The system also conforms to other standards not listed here. If you need information on conformance to a particular standard, please contact your local Hewlett-Packard Sales and Service Office.

This system was tested in a typical configuration with HP systems.

Böblingen, 4 July 1997

Wolfgang Fenske
BID Regulations Consultant

C

C-10 Specifications

Performance Tests

Introduction

The procedures in this section test the optical performance of the instrument. The complete specifications to which the HP 8167B/8D/8E/8F is tested are given in Appendix C. All tests can be performed without access to the interior of the instrument. The performance tests refer specifically to tests using the Diamond HMS-10/HP connector.

Equipment Required

The equipment required for the performance test is listed in the table below. Any equipment which satisfies the critical specifications of the equipment given in the table, may be substituted for the recommended models.

Equipment Required

Instrument	Description	#021	#022	#023
HP 71452B #E14 ¹	Optical Spectrum Analyzer	1	1	1
HP 8153A	Lightwave Multimeter	1	1	1
HP 81532A	Power Sensor Module	1	1	1
HP 86120B ²	Multi-Wavelength Meter	1	1	1
HP 81000AI	Diamond HMS-10 Connector Interface	3	2	2
HP 81000SI	DIN 47256 Connector Interface		1	
HP 81000UM	Universal Through Adapter	1	1	
HP 81109AC	Diamond HMS-10/HP/HRL - Diamond HMS-10/HP Patchcord	2	1	1
HP 81102SC	Diamond HMS-10/HP/HRL - DIN 47250-4108		1	1
HP 81102AC	Diamond HMS-10/HP/HRL - Diamond HMS-10/HP/HRL			1
additional for 8167B and 8168F (max power test only):				
HP 81533B	Optical Head Interface Module	1	1	1
HP 81525A	Optical Head	1	1	1
or 81524A	Optical Head and 81001FF, 10dB filter	1	1	1
HP 81000AA	Diamond HMS-10 Connector	1	1	1

¹ replaces older model HP71450A #009.

² replaces older model HP86120A.

Test Record

Results of the performance test may be tabulated on the Test Record provided at the end of the test procedures. It is recommended that you fill out the Test Record and refer to it while doing the test. Since the test limits and setup information are printed on the Test Record for easy reference, the record can also be used as an abbreviated test procedure (if you are already familiar with the test procedures). The Test Record can also be used as a permanent record and may be reproduced without written permission from Hewlett-Packard.

D-2 Performance Tests

Test Failure

If the HP8167B/8D/8E/8F fails any performance test, return the instrument to the nearest Hewlett-Packard Sales/Service Office for repair.

Instrument Specification

Specifications are the performance characteristics of the instrument which are certified. These specifications, listed in Appendix C, are the performance standards or limits against which the HP 8167B/8D/8E/8F can be tested. The specifications also list some supplemental characteristics of the HP 8167B/8D/8E/8F. Supplemental characteristics should be considered as additional information.

Any changes in the specifications due to manufacturing changes, design, or traceability to the National Institute of Standards and Technology (NIST), will be covered in a manual change supplement, or revised manual. Such specifications supercede any that were previously published.

General



- Make sure that all fiber connectors are clean
- Turn the instruments on, enable the laser and allow the instruments to warm up until STABILIZING is no longer shown on the display.

Wavelength Tests

Connect the TLS (DUT) to the Wavelength Meter as shown in Figure D-1.

Note



The connector housings for the patchcord cannot be screwed fully onto the wavelength meter.

This does not affect the wavelength measurements.

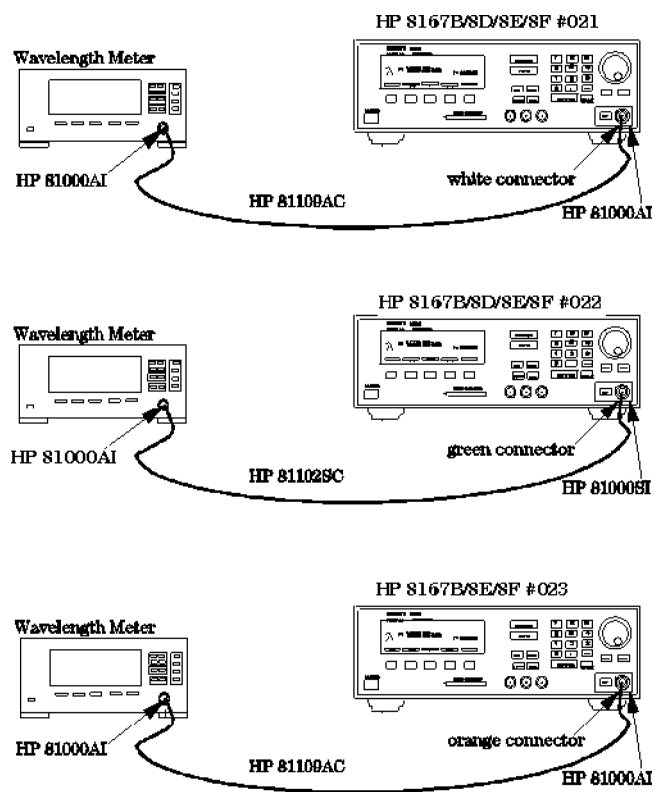

Figure D-1. Test Setup for the Wavelength Tests

Relative Wavelength Accuracy

1. Set the wavelength meter:
 - a. Press SYSTEM (Preset).
 - b. Press DISPLAY (Peak WL).
 - c. Press DELTA (OFF).
 - d. Press MEASUREMENT (Cont).
2. Set the TLS :

D-4 Performance Tests

- a. Switch off Coherence Control.
 - b. Set the output power to -10dBm (8167B and 8168F to -7dBm), activate laser output.
3. Set the wavelength on the TLS to:
- | | |
|----------|--------|
| HP 8167B | 1255nm |
| HP 8168D | 1490nm |
| HP 8168E | 1475nm |
| HP 8168F | 1450nm |
4. Note the displayed wavelength of the wavelength meter in the test report.
5. Increase wavelength setting on TLS by the steps shown in the test report.
6. Repeat list item 4 and list item 5 up to
- | | |
|----------|--------|
| HP 8167B | 1365nm |
| HP 8168D | 1565nm |
| HP 8168E | 1575nm |
| HP 8168F | 1590nm |
7. Repeat list item 3 to list item 6 another 4 times.
8. From each of the repetitions of the measurements, pick the maximum and minimum deviations, and note these values in the test report.
9. Pick the largest Maximum Deviation, and note it as the Largest Maximum Deviation in the test report.
10. Pick the smallest Minimum Deviation, and note it as the Smallest Minimum Deviation in the test report.
11. Calculate the Relative Wavelength Accuracy

Wavelength Repeatability

1. Set the wavelength meter:
 - a. Press SYSTEM (Preset).
 - b. Press DISPLAY (Peak WL).
 - c. Press DELTA (OFF).
 - d. Press MEASUREMENT (Cont).
2. Set the TLS (DUT)

D

- a. Switch off Coherence Control.
 - b. Set the output power to -10dBm (8167B and 8168F to -7dBm), activate laser output.
 - c. Set the wavelength to

HP 8167B	1350nm
HP 8168D	1565nm
HP 8168E	1575nm
HP 8168F	1575nm
3. Set the TLS to any wavelength in its range and note it in the test record.
 4. Set the TLS back to the wavelength setup in list item 3 and wait a few seconds.
 5. Measure the wavelength with the Wavelength Meter and note the result in test record.
 6. Repeat list item 3 to list item 5 with different wavelength settings on the TLS 4 times.
 7. Set the wavelength of the 8167B to 1365nm, the wavelength of the 8168F to 1595nm, and repeat steps list item 3 to list item 6.

Power Tests

General



- Make sure that a second module or a blank insert is installed in the second slot of the HP 8153A Mainframe.
 - Turn the instruments on, enable the laser and allow the instruments to warm up until STABILIZING is no longer on the display.
 - Make sure that you keep the relative humidity stable within $\pm 5\%$ during measurements.
-

Maximum Output Power

Note

Absolute Power Accuracy is not specified.
The result of the measurement below is greatly influenced by
the quality and the matching of the used interconnections.

1. Set up the equipment as shown

- HP 8168D,E as shown in Figure D-2
- HP 8167B,68F as shown in Figure D-3

D

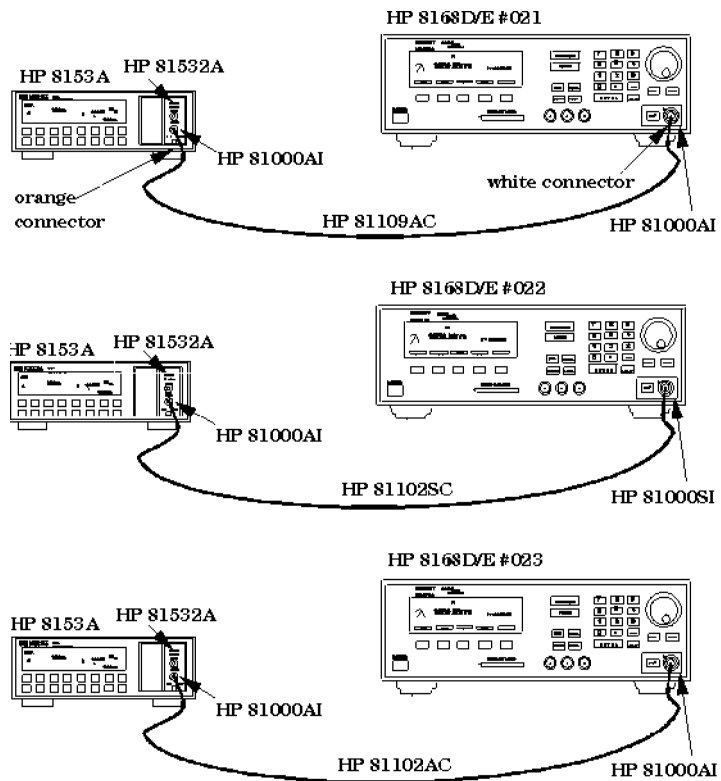

Figure D-2.
Test Setup for the Maximum Output Power Test (HP 8168D,E)

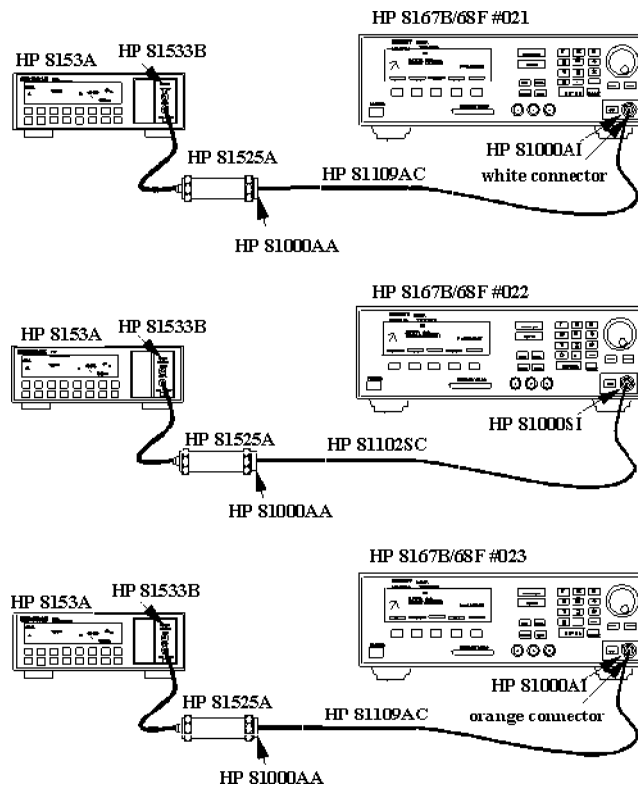

Figure D-3.
Test Setup for the Maximum Output Power Test (HP 8167B and 8168F)

Note



Instead of the HP81525A, an HP81524A can be used in conjunction with an HP81001FF 10dB filter. In this case, an HP81010BL lens is recommended.

2. Set the Power Meter
 - a. Select Auto Range.
 - b. Select averaging time 500ms.

D

- c. Select display in dBm.
3. Set the TLS
 - a. Set the power to maximum possible value:
 - i. Press **Output Power**.
 - ii. Use the Modify knob to increase the displayed value to the maximum.
 - b. Set the wavelength to

HP 8167B	1255nm
HP 8168D	1490nm
HP 8168E	1475nm
HP 8168F	1450nm
 - c. Activate the laser output.

Note



The laser output is limited to its maximum possible value at this wavelength, the display will probably show **excessive: P = x.yy μ W**

4. Measure the output power with the 8153A and note the result for this wavelength in the test report.
5. Increase the wavelength on the TLS as shown in the test report.
6. Increase the wavelength on the 8153A by the same amount that you have increased the wavelength the TLS.
7. Repeat list item 4 to list item 6 until the end of the wavelength range of the TLS is reached.

Power Linearity

1. Set up the equipment as shown in Figure D-4 (HP 8167B, 8168D,E,F).

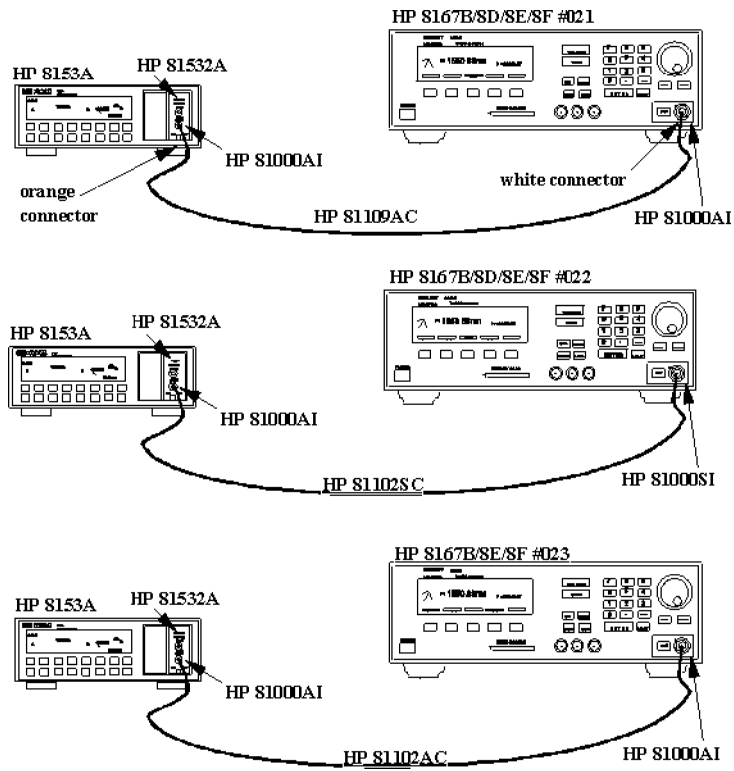

Figure D-4.
Test Setup for the Power Tests (except Maximum Output Power)

2. Set the TLS
 - a. Set the wavelength to

HP 8167B	1310nm
HP 8168D,E,F	1540nm
 - b. Set the power to

D

	<u>without attenuator</u>	<u>with attenuator</u>
8167B	+1dBm	0.0dBm
8168D	-5dBm	n/a
8168E	-1dBm	-2.5dBm
8168F	+1dBm	0.0dBm

- c. Make sure the optical output is inactive.
3. Set the Power Meter
 - a. Zero the 8153A
 - b. Select Auto Range
 - c. Select averaging time 500ms
 - d. Select display in dB
 - e. Set the wavelength to
 - HP 8167B 1310nm
 - HP 8168D,E,F 1540nm
4. Activate the optical output.
5. Measure the output power with the Power Meter
6. Press **DISP.>REF**
7. Change the power setting on the TLS to the next value listed in the test report and measure the power again.
Note the displayed value on the Power Meter as “Relative Power of actual setting”.
8. Calculate the “Power Linearity at current setting” as
“Relative Power of current setting” + “Power Reduction from start condition”
9. Repeat list item 7 to list item 8 for all power levels listed the test report.
10. Check the calculated values of the Power Linearity of the various settings for the maximum and minimum values and note these in the test report.
11. Calculate the difference for the maximum and minimum values of the Power Linearity of the various settings as Final Power Linearity

D-12 Performance Tests

*Example***Power Linearity**

(HP 8168D without attenuator)

	Power Setting at current setting	Relative Power from start	Power Reduction at current setting	Power Linearity
start:	-5.0dBm	REF	0.0dB	0.00dB
	-5.5dBm	-0.55dB	0.5dB	-0.05dB
	-6.0dBm	-1.01dB	1.0dB	-0.01dB
	-6.5dBm	-1.47dB	1.5dB	+0.03dB
	-7.0dBm	-2.03dB	2.0dB	-0.03dB
	-7.5dBm	-2.52dB	2.5dB	-0.02dB
	-8.0dBm	-2.94dB	3.0dB	+0.06dB
	-8.5dBm	-3.52dB	3.5dB	-0.02dB
	-9.0dBm	-4.03dB	4.0dB	-0.03dB
	-9.5dBm	-4.54dB	4.5dB	-0.04dB
	-10.0dBm	-4.98dB	5.0dB	+0.02dB

Maximum Power Linearity at current setting +0.06dB

Minimum Power Linearity at current setting -0.05dB

Final Power Linearity

(= Max Power Linearity - Min Power Linearity) 0.11dBpp
Specification 0.2dBpp

D

Power Flatness over Wavelength

1. Set up the equipment as shown in Figure D-4 (HP 8167B, 8168D,E,F).
2. Set the TLS
 - a. Set the power to:

	#023	#003	#023 + #003	#007
8167B	-3dBm	-4dBm	-4.5dBm	-5.5dBm -4dBm
8168D	-4dBm	n/a	n/a	n/a -5dBm
8168E	0dBm	-1dBm	-1.5dBm	-2.5dBm -1dBm
8168F	+1dBm	0dBm	-0.5dBm	-2.5dBm 0dBm

- b. Set the wavelength to
 - HP 8167B 1260nm
 - HP 8168D 1500nm
 - HP 8168E 1500nm
 - HP 8168F 1475nm
3. Set the Power Meter
 - a. Select Auto Range.
 - b. Select averaging time 500ms.
 - c. Select display in dB.
 - d. Set the wavelength to
 - HP 8167B 1260nm
 - HP 8168D 1500nm
 - HP 8168E 1500nm
 - HP 8168F 1475nm
 - e. Set **DISP->REF**
4. Increase the wavelength on the TLS and on the Power Meter by the steps listed in the test record. Measure the output power.
Note the result in the test record
5. repeat list item 4 for the wavelength settings given in the test record.
6. From the measurement results calculate the difference between the maximum and minimum deviation from REF and note the result as Flatness.

D-14 Performance Tests

Power Stability

1. Set up the equipment as shown in Figure D-4 (HP 8167B, 8168D,E,F).
2. Set the TLS
 - a. Set the wavelength to

HP 8167B	1310nm
HP 8168D,E,F	1540nm

- b. Set the power to high power

	#023	#003	#023 + #003	#007	
8167B	+1dBm	+1dBm	+1dBm	+0.5dBm	+0.5dBm
8168D	-4dBm	n/a	n/a	n/a	-5dBm
8168E	0dBm	-1dBm	-1.5dBm	-2.5dBm	-1dBm
8168F	+1dBm	+1dBm	+1dBm	+1dBm	0dBm

- c. Deactivate the laser output.

3. Set the Power Meter

- a. Zero the 8153A.
 - b. Select Auto Range.
 - c. Select averaging time 500ms.
 - d. Select display in dB.
 - e. Set the wavelength to

HP 8167B	1310nm
HP 8168D,E,F	1540nm

- f. Set 8153A to Logging, T_Total = 1 hour:

- i. Press **Menu**.

- ii. Press **Record** to get STABILITY.

- iii. Press **Edit** to get T_TOTAL and modify the display until it shows 01:00:00.

- iv. Press **Edit**.

4. Activate the optical output of the laser source, and wait 1 minute.

D

5. On the power meter, press **(Exec)**.
Display will show RUNNING (blinking) a few moments then show the remaining time. When logging time is over the display will show STABILITY.
6. Get the results
 - a. Press **(More)** to get SHOW.
 - b. Press **(Edit)** to get MAXIMUM.
Note the value in the test record.
 - c. Press **(Next)** to get MINIMUM.
Note the value in the test record.
 - d. Press **(Edit)**, and **(Mode)** to return to normal operation.
7. Calculate the Stability as the difference between the maximum and the minimum.
8. Set the TLS to low output power:

#003

8167B	-7dBm	-47dBm
8168D	-10 dBm	n/a
8168E	-10dBm	-50dBm
8168F	-7dBm	-47dBm

9. Repeat list item 5 to list item 7 and note the results in the test report.

Source Spontaneous Emission

1. Connect the TLS (DUT) to the wavelength meter as shown in Figure D-5.

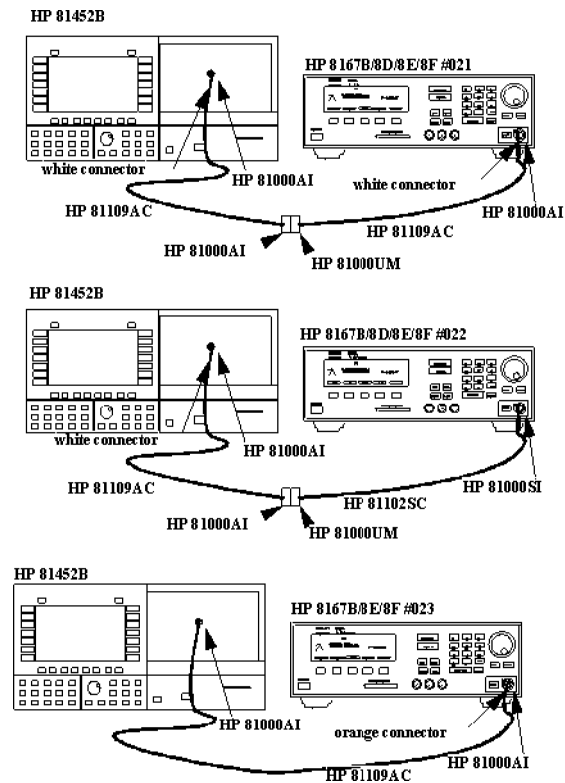

Figure D-5. Test Setup for the Source Spontaneous Emission Test

2. Set the Optical Spectrum Analyzer
 - a. Set the Span to 4nm, Resolution Bandwidth to 0.1nm and the Sensitivity to -60dBm.
(Waveln -> SPAN -> {4} -> nm -> BW.SWP -> {0.1} -> nm; Amptd -> SENS Man -> {-60} -> dBm)
 - b. Set the wavelength to the wavelength of the TLS.
(Waveln -> {xxxx.000} -> nm)

D

3. Set the TLS:
Set the power to high power as stated in the test report.
4. On the spectrum analyzer, set the Marker to the highest peak and select delta. (Marker -> HIGHEST PEAK -> DELTA)
5. Using the MODIFY knob move the second marker to the highest peak of the displayed side modes and note the delta between the 2 markers in the test report.
6. Repeat list item 4 to list item 5 within the wavelength range of the TLS in 10nm steps.

Performance Test for the HP 8167B

Test Facility:

_____	Report No. _____
_____	Date _____
_____	Customer _____
_____	Tested By _____

Model HP 8167B Tunable Laser Source

Serial No. _____	Ambient temperature _____ °C
Options _____	Relative humidity _____ %
Firmware Rev. _____	Line frequency _____ Hz

Special Notes:



D

Performance Test for the HP 8167B

Model HP 8167B Tunable Laser Source Report No. _____ Date _____

Test Equipment Used:

Description	Model No.	Trace No.	Cal. Due Date
1. Lightwave Multimeter with	HP 8153A		
2. Sensor Module	HP 81532A		
3a. Optical Spectrum Analyzer	HP 71452B		
3b. Optical Spectrum Analyzer	HP 70950A		
3c. OSA Display	HP 70004A		
4. Wavelength Meter	_____		
5a. Connector Interface (x2)	HP 81000AI		
5b. Connector Interface (#021)	HP 81000AI		
6. Connector Interface (#022)	HP 81000SI		
7. Universal Through Adapter (#021, #022)	HP 81000UM		
8a. High Return Loss Cable	HP 81109AC		
8b. High Return Loss Cable (#021)	HP 81109AC		
9. High Return Loss Cable	HP 81102SC		
10. _____	_____	_____	_____
11. _____	_____	_____	_____
12. _____	_____	_____	_____
13. _____	_____	_____	_____
14. _____	_____	_____	_____
15. _____	_____	_____	_____

D-20 Performance Tests

Performance Test for the HP 8167B

Model HP 8167B Tunable Laser Source Report No. _____ Date _____

Relative Wavelength Accuracy

Repetition	Wavelength Setting	Wavelength Measured	Deviation meas - set value	Maximum Deviation	Minimum Deviation
1	1255.000nm	_____nm	_____nm		
	1260.000nm	_____nm	_____nm		
	1270.000nm	_____nm	_____nm		
	1280.000nm	_____nm	_____nm		
	1290.000nm	_____nm	_____nm		
	1300.000nm	_____nm	_____nm		
	1310.000nm	_____nm	_____nm		
	1320.000nm	_____nm	_____nm		
	1330.000nm	_____nm	_____nm		
	1340.000nm	_____nm	_____nm		
	1350.000nm	_____nm	_____nm	1310 to 1350nm	_____nm
	1360.000nm	_____nm	_____nm		
	1365.000nm	_____nm	_____nm	1255 to 1365nm	_____nm

D

Performance Test for the HP 8167B

Page 4 of 14

Model HP 8167B Tunable Laser Source Report No. _____ Date _____

Relative Wavelength Accuracy

Repetition	Wavelength Setting	Wavelength Measured	Deviation meas - set value	Maximum Deviation	Minimum Deviation
2	1255.000nm	_____nm	_____nm		
	1260.000nm	_____nm	_____nm		
	1270.000nm	_____nm	_____nm		
	1280.000nm	_____nm	_____nm		
	1290.000nm	_____nm	_____nm		
	1300.000nm	_____nm	_____nm		
	1310.000nm	_____nm	_____nm		
	1320.000nm	_____nm	_____nm		
	1330.000nm	_____nm	_____nm		
	1340.000nm	_____nm	_____nm		
	1350.000nm	_____nm	_____nm	1310 to 1350nm	_____nm
	1360.000nm	_____nm	_____nm		
	1365.000nm	_____nm	_____nm	1255 to 1365nm	_____nm

D-22 Performance Tests

Performance Test for the HP 8167B

Model HP 8167B Tunable Laser Source Report No. _____ Date _____

Relative Wavelength Accuracy

Repetition	Wavelength Setting	Wavelength Measured	Deviation meas - set value	Maximum Deviation	Minimum Deviation	
3	1255.000nm	_____nm	_____nm			
	1260.000nm	_____nm	_____nm			
	1270.000nm	_____nm	_____nm			
	1280.000nm	_____nm	_____nm			
	1290.000nm	_____nm	_____nm			
	1300.000nm	_____nm	_____nm			
	1310.000nm	_____nm	_____nm			
	1320.000nm	_____nm	_____nm			
	1330.000nm	_____nm	_____nm			
	1340.000nm	_____nm	_____nm			
	1350.000nm	_____nm	_____nm	1310 to 1350nm	_____nm	_____nm
	1360.000nm	_____nm	_____nm			
	1365.000nm	_____nm	_____nm	1255 to 1365nm	_____nm	_____nm

D

Performance Test for the HP 8167B

Page 6 of 14

Model HP 8167B Tunable Laser Source Report No. _____ Date _____

Relative Wavelength Accuracy

Repetition	Wavelength Setting	Wavelength Measured	Deviation meas - set value	Maximum Deviation	Minimum Deviation
4	1255.000nm	_____nm	_____nm		
	1260.000nm	_____nm	_____nm		
	1270.000nm	_____nm	_____nm		
	1280.000nm	_____nm	_____nm		
	1290.000nm	_____nm	_____nm		
	1300.000nm	_____nm	_____nm		
	1310.000nm	_____nm	_____nm		
	1320.000nm	_____nm	_____nm		
	1330.000nm	_____nm	_____nm		
	1340.000nm	_____nm	_____nm		
	1350.000nm	_____nm	_____nm	1310 to 1350nm	_____nm
	1360.000nm	_____nm	_____nm		
	1365.000nm	_____nm	_____nm	1255 to 1365nm	_____nm

Performance Test for the HP 8167B

Model HP 8167B Tunable Laser Source Report No. _____ Date _____

Relative Wavelength Accuracy

Repetition	Wavelength Setting	Wavelength Measured	Deviation meas - set value	Maximum Deviation	Minimum Deviation
5	1255.000nm	_____nm	_____nm		
	1260.000nm	_____nm	_____nm		
	1270.000nm	_____nm	_____nm		
	1280.000nm	_____nm	_____nm		
	1290.000nm	_____nm	_____nm		
	1300.000nm	_____nm	_____nm		
	1310.000nm	_____nm	_____nm		
	1320.000nm	_____nm	_____nm		
	1330.000nm	_____nm	_____nm		
	1340.000nm	_____nm	_____nm		
	1350.000nm	_____nm	_____nm	1310 to 1350nm	_____nm
	1360.000nm	_____nm	_____nm		
	1365.000nm	_____nm	_____nm	1255 to 1365nm	_____nm

Range 1310 to 1350nm Largest Maximum Deviation _____nm
 Smallest Minimum Deviation _____nm

Relative Wavelength Accuracy
 (= Largest Maximum Deviation - Smallest Minimum Deviation) _____nm
 Specification 0.07nm

Range 1255 to 1365nm Largest Maximum Deviation _____nm
 Smallest Minimum Deviation _____nm

Relative Wavelength Accuracy
 (= Largest Maximum Deviation - Smallest Minimum Deviation) _____nm
 Specification 0.10nm

Measurement Uncertainty ±0.01nm

D

Performance Test for the HP 8167B

Model HP 8167B Tunable Laser Source Report No. _____ Date _____

Wavelength Repeatability

Description	Min Spec	Result	Max Spec	Measurement Uncertainty
1350.000nm		REF		±0.002nm
from _____nm to REF	1349.965nm	_____nm	1350.035nm	
from _____nm to REF	1349.965nm	_____nm	1350.035nm	
from _____nm to REF	1349.965nm	_____nm	1350.035nm	
from _____nm to REF	1349.965nm	_____nm	1350.035nm	
from _____nm to REF	1349.965nm	_____nm	1350.035nm	

Wavelength Repeatability

Description	Min Spec	Result	Max Spec	Measurement Uncertainty
1365.000nm		REF		±0.002nm
from _____nm to REF	1364.950nm	_____nm	1365.050nm	
from _____nm to REF	1364.950nm	_____nm	1365.050nm	
from _____nm to REF	1364.950nm	_____nm	1365.050nm	
from _____nm to REF	1364.950nm	_____nm	1365.050nm	
from _____nm to REF	1364.950nm	_____nm	1365.050nm	

Performance Test for the HP 8167B

Page 9 of 14

Model HP 8167B Tunable Laser Source Report No. _____ Date _____

Maximum Power Test

Wavelength	Minimum Spec				Result	Measurement Uncertainty
	option	std	#007 #023	#003 #023+ #003		
			(circle the appropriate)			±0.30dB
1255nm	-7.0dBm	-8.0dBm	-8.5dBm	-9.5dBm	_____dBm	
1260nm	-3.0dBm	-4.0dBm	-4.5dBm	-5.5dBm	_____dBm	
1270nm	-3.0dBm	-4.0dBm	-4.5dBm	-5.5dBm	_____dBm	
1280nm	-3.0dBm	-4.0dBm	-4.5dBm	-5.5dBm	_____dBm	
1290nm	-3.0dBm	-4.0dBm	-4.5dBm	-5.5dBm	_____dBm	
1300nm	-3.0dBm	-4.0dBm	-4.5dBm	-5.5dBm	_____dBm	
1310nm	+3.0dBm	+2.0dBm	+1.5dBm	+0.5dBm	_____dBm	
1320nm	+3.0dBm	+2.0dBm	+1.5dBm	+0.5dBm	_____dBm	
1330nm	+3.0dBm	+2.0dBm	+1.5dBm	+0.5dBm	_____dBm	
1340nm	+3.0dBm	+2.0dBm	+1.5dBm	+0.5dBm	_____dBm	
1350nm	+3.0dBm	+2.0dBm	+1.5dBm	+0.5dBm	_____dBm	
1360nm	-3.0dBm	-4.0dBm	-4.5dBm	-5.5dBm	_____dBm	
1365nm	-7.0dBm	-8.0dBm	-8.5dBm	-9.5dBm	_____dBm	



D

Performance Test for the HP 8167B

Page 10 of 14

Model HP 8167B Tunable Laser Source Report No. _____ Date _____

Power Linearity (HP 8167B without attenuator)

	Power Setting at current setting	Relative Power from start	Power Reduction at current setting	Power Linearity
start:	+1.0dBm	REF	0.0dB	0.00dB
	0.0dBm	_____dB	1.0dB	_____dB
	-1.0dBm	_____dB	2.0dB	_____dB
	-2.0dBm	_____dB	3.0dB	_____dB
	-3.0dBm	_____dB	4.0dB	_____dB
	-4.0dBm	_____dB	5.0dB	_____dB
	-5.0dBm	_____dB	6.0dB	_____dB
	-6.0dBm	_____dB	7.0dB	_____dB
	-7.0dBm	_____dB	8.0dB	_____dB
	Maximum Power Linearity at current setting			_____dB
	Minimum Power Linearity at current setting			_____dB
	Final Power Linearity (= Max Power Linearity - Min Power Linearity)			_____dBpp
	Specification			0.2dBpp
	Measurement Uncertainty			±0.05dB

Performance Test for the HP 8167B

Page 11 of 14

Model HP 8167B Tunable Laser Source Report No. _____ Date _____

**Power Linearity
(HP 8167B with attenuator)**

	Power Setting at current setting	Relative Power from start	Power Reduction at current setting	Power Linearity
start:	0.0dBm	REF dB	0.0dB	0.00 dB
	-5.0dBm	_____dB	5.0dB	_____dB
	-10.0dBm	_____dB	10.0dB	_____dB
	-15.0dBm	_____dB	15.0dB	_____dB
	-20.0dBm	_____dB	20.0dB	_____dB
	-25.0dBm	_____dB	25.0dB	_____dB
	-30.0dBm	_____dB	30.0dB	_____dB
	-35.0dBm	_____dB	35.0dB	_____dB
	-40.0dBm	_____dB	40.0dB	_____dB
	-47.0dBm	_____dB	47.0dB	_____dB

Maximum Power Linearity at current setting _____dB

Minimum Power Linearity at current setting _____dB

Final Power Linearity
(= Max Power Linearity - Min Power Linearity) _____dBpp
Specification 0.6dBpp

Measurement Uncertainty ±0.05dB



Performance Test for the HP 8167B

Model HP 8167B Tunable Laser Source Report No. _____ Date _____

Power Flatness versus Wavelength

Wavelength	Deviation
1260nm	0.00 (start value, REF)
1270nm	_____dB
1280nm	_____dB
1290nm	_____dB
1300nm	_____dB
1310nm	_____dB
1320nm	_____dB
1330nm	_____dB
1340nm	_____dB
1350nm	_____dB
1360nm	_____dB

Maximum deviation _____dB

Minimum deviation _____dB

Flatness

(= Maximum - Minimum deviation) _____dBpp
 Specification 0.2dBpp without #003
 0.4dBpp with #003

Measurement Uncertainty ±0.07dB

Performance Test for the HP 8167B

Page 13 of 14

Model HP 8167B Tunable Laser Source Report No. _____ Date _____

Power Stability**High power**

Maximum deviation _____dB

Minimum deviation _____dB

Power Stability(= Max - Min deviation) _____dBpp
Specification 0.06dBpp**Low power**

Maximum deviation _____dB

Minimum deviation _____dB

Power Stability(= Max - Min deviation) _____dBpp
Specification 0.06dBppMeasurement Uncertainty ± 0.02 dB

D

Performance Test for the HP 8167B

Model HP 8167B Tunable Laser Source Report No. _____ Date _____

Source Spontaneous Emission

Wavelength	Option	Output Power			Maximum Spec	Result	Measurement Uncertainty
		#007	#023	#003			
		(circle the appropriate)					±1.20dB
1255nm	-7.0dBm	-8.0dBm	-8.5dBm	-9.5dBm	-35dB	_____dB	
1260nm	-3.0dBm	-4.0dBm	-4.5dBm	-5.5dBm	-40dB	_____dB	
1270nm	-3.0dBm	-4.0dBm	-4.5dBm	-5.5dBm	-40dB	_____dB	
1280nm	-3.0dBm	-4.0dBm	-4.5dBm	-5.5dBm	-40dB	_____dB	
1290nm	-3.0dBm	-4.0dBm	-4.5dBm	-5.5dBm	-40dB	_____dB	
1300nm	-3.0dBm	-4.0dBm	-4.5dBm	-5.5dBm	-40dB	_____dB	
1310nm	+3.0dBm	+2.0dBm	+1.5dBm	+0.5dBm	-45dB	_____dB	
1320nm	+3.0dBm	+2.0dBm	+1.5dBm	+0.5dBm	-45dB	_____dB	
1330nm	+3.0dBm	+2.0dBm	+1.5dBm	+0.5dBm	-45dB	_____dB	
1340nm	+3.0dBm	+2.0dBm	+1.5dBm	+0.5dBm	-45dB	_____dB	
1350nm	+3.0dBm	+2.0dBm	+1.5dBm	+0.5dBm	-45dB	_____dB	
1360nm	-3.0dBm	-4.0dBm	-4.5dBm	-5.5dBm	-40dB	_____dB	
1365nm	-7.0dBm	-8.0dBm	-8.5dBm	-9.5dBm	-35dB	_____dB	

Performance Test for the HP 8168D

Test Facility:

_____	Report No. _____
_____	Date _____
_____	Customer _____
_____	Tested By _____

Model HP 8168D Tunable Laser Source

Serial No. _____	Ambient temperature _____ °C
Options _____	Relative humidity _____ %
Firmware Rev. _____	Line frequency _____ Hz

Special Notes:



D

Performance Test for the HP 8168D

Model HP 8168D Tunable Laser Source Report No. _____ Date _____

Test Equipment Used:

Description	Model No.	Trace No.	Cal. Due Date
1. Lightwave Multimeter with	HP 8153A		
2. Sensor Module	HP 81532A		
3a. Optical Spectrum Analyzer	HP 71452B		
3b. Optical Spectrum Analyzer	HP 70950A		
3c. OSA Display	HP 70004A		
4. Wavelength Meter	_____		
5a. Connector Interface (x2)	HP 81000AI		
5b. Connector Interface (#021)	HP 81000AI		
6. Connector Interface (#022)	HP 81000SI		
7. Universal Through Adapter (#021, #022)	HP 81000UM		
8a. High Return Loss Cable	HP 81109AC		
8b. High Return Loss Cable (#021)	HP 81109AC		
9. High Return Loss Cable	HP 81102SC		
10. _____	_____	_____	_____
11. _____	_____	_____	_____
12. _____	_____	_____	_____
13. _____	_____	_____	_____
14. _____	_____	_____	_____
15. _____	_____	_____	_____

D-34 Performance Tests

Performance Test for the HP 8168D

Model HP 8168D Tunable Laser Source Report No. _____ Date _____

Relative Wavelength Accuracy

Repetition	Wavelength Setting	Wavelength Measured	Deviation meas - set value	Maximum Deviation	Minimum Deviation
1	1490.000nm	_____nm	_____nm		
	1500.000nm	_____nm	_____nm		
	1510.000nm	_____nm	_____nm		
	1520.000nm	_____nm	_____nm		
	1530.000nm	_____nm	_____nm		
	1540.000nm	_____nm	_____nm		
	1550.000nm	_____nm	_____nm		
	1560.000nm	_____nm	_____nm		
	1565.000nm	_____nm	_____nm	_____nm	_____nm
2	1490.000nm	_____nm	_____nm		
	1500.000nm	_____nm	_____nm		
	1510.000nm	_____nm	_____nm		
	1520.000nm	_____nm	_____nm		
	1530.000nm	_____nm	_____nm		
	1540.000nm	_____nm	_____nm		
	1550.000nm	_____nm	_____nm		
	1560.000nm	_____nm	_____nm		
	1565.000nm	_____nm	_____nm	_____nm	_____nm



D

Performance Test for the HP 8168D

Page 4 of 11

Model HP 8168D Tunable Laser Source Report No. _____ Date _____

Relative Wavelength Accuracy

Repetition	Wavelength Setting	Wavelength Measured	Deviation meas - set value	Maximum Deviation	Minimum Deviation
3	1490.000nm	_____nm	_____nm		
	1500.000nm	_____nm	_____nm		
	1510.000nm	_____nm	_____nm		
	1520.000nm	_____nm	_____nm		
	1530.000nm	_____nm	_____nm		
	1540.000nm	_____nm	_____nm		
	1550.000nm	_____nm	_____nm		
	1560.000nm	_____nm	_____nm		
	1565.000nm	_____nm	_____nm	_____nm	_____nm
4	1490.000nm	_____nm	_____nm		
	1500.000nm	_____nm	_____nm		
	1510.000nm	_____nm	_____nm		
	1520.000nm	_____nm	_____nm		
	1530.000nm	_____nm	_____nm		
	1540.000nm	_____nm	_____nm		
	1550.000nm	_____nm	_____nm		
	1560.000nm	_____nm	_____nm		
	1565.000nm	_____nm	_____nm	_____nm	_____nm

Performance Test for the HP 8168D

Page 5 of 11

Model HP 8168D Tunable Laser Source Report No. _____ Date _____

Relative Wavelength Accuracy

Repetition	Wavelength Setting	Wavelength Measured	Deviation meas - set value	Maximum Deviation	Minimum Deviation
5	1490.000nm	_____nm	_____nm		
	1500.000nm	_____nm	_____nm		
	1510.000nm	_____nm	_____nm		
	1520.000nm	_____nm	_____nm		
	1530.000nm	_____nm	_____nm		
	1540.000nm	_____nm	_____nm		
	1550.000nm	_____nm	_____nm		
	1560.000nm	_____nm	_____nm		
	1565.000nm	_____nm	_____nm	_____nm	_____nm

Largest Maximum Deviation _____nm

Smallest Minimum Deviation _____nm

Relative Wavelength Accuracy

 (= Largest Maximum Deviation - Smallest Minimum Deviation) _____nm
 Specification 0.2nm
Measurement Uncertainty ± 0.01 nm

D

Performance Test for the HP 8168D

Page 6 of 11

Model HP 8168D Tunable Laser Source Report No. _____ Date _____

Wavelength Repeatability

Description	Min Spec	Result	Max Spec	Measurement Uncertainty
1565.000nm		REF		±0.002nm
from _____nm to REF	1564.965nm	_____nm	1565.035nm	
from _____nm to REF	1564.965nm	_____nm	1565.035nm	
from _____nm to REF	1564.965nm	_____nm	1565.035nm	
from _____nm to REF	1564.965nm	_____nm	1565.035nm	
from _____nm to REF	1564.965nm	_____nm	1565.035nm	

Performance Test for the HP 8168D

Page 7 of 11

Model HP 8168D Tunable Laser Source Report No. _____ Date _____

Maximum Power Test

Wavelength	Minimum Spec		Result	Measurement Uncertainty
	std	#007		
option: (circle the appropriate)				
1490nm	-10.0dBm	-11.0dBm	_____ dBm	±0.30dB
1500nm	-4.0dBm	-5.0dBm	_____ dBm	
1510nm	-4.0dBm	-5.0dBm	_____ dBm	
1520nm	-4.0dBm	-5.0dBm	_____ dBm	
1530nm	-4.0dBm	-5.0dBm	_____ dBm	
1540nm	-4.0dBm	-5.0dBm	_____ dBm	
1550nm	-4.0dBm	-5.0dBm	_____ dBm	
1560nm	-4.0dBm	-5.0dBm	_____ dBm	
1565nm	-4.0dBm	-5.0dBm	_____ dBm	

Performance Test for the HP 8168D

Model HP 8168D Tunable Laser Source Report No. _____ Date _____

Power Linearity

(HP 8168D)

	Power Setting at current setting	Relative Power from start	Power Reduction at current setting	Power Linearity
start:	-5.0dBm	REF	0.0dB	0.00dB
	-5.5dBm	_____dB	0.5dB	_____dB
	-6.0dBm	_____dB	1.0dB	_____dB
	-6.5dBm	_____dB	1.5dB	_____dB
	-7.0dBm	_____dB	2.0dB	_____dB
	-7.5dBm	_____dB	2.5dB	_____dB
	-8.0dBm	_____dB	3.0dB	_____dB
	-8.5dBm	_____dB	3.5dB	_____dB
	-9.0dBm	_____dB	4.0dB	_____dB
	-9.5dBm	_____dB	4.5dB	_____dB
	-10.0dBm	_____dB	5.0dB	_____dB
			Maximum Power Linearity at current setting	_____dB
			Minimum Power Linearity at current setting	_____dB
			Final Power Linearity	
			(= Max Power Linearity - Min Power Linearity)	_____dBpp
			Specification	0.2dBpp
			Measurement Uncertainty	±0.05dB

Performance Test for the HP 8168D

Page 9 of 11

Model HP 8168D Tunable Laser Source Report No. _____ Date _____

Power Flatness versus Wavelength

Wavelength	Deviation
1500nm	0.00 (start value, REF)
1510nm	_____dB
1520nm	_____dB
1530nm	_____dB
1540nm	_____dB
1550nm	_____dB
1560nm	_____dB
1565nm	_____dB
	Maximum deviation _____dB
	Minimum deviation _____dB
	Flatness
(= Maximum - Minimum deviation)	_____dBpp
Specification	0.4dBpp
	0.2dBpp typical
Measurement Uncertainty	±0.07dB



D

Performance Test for the HP 8168D

Page 10 of 11

Model HP 8168D Tunable Laser Source Report No. _____ Date _____

Power Stability

High power

Low power

Maximum deviation _____dB

Maximum deviation _____dB

Minimum deviation _____dB

Minimum deviation _____dB

Power Stability
(= Max - Min deviation) _____dBpp
Specification 0.06dBpp

Power Stability
(= Max - Min deviation) _____dBpp
Specification 0.06dBpp

Measurement Uncertainty ± 0.02 dB

Performance Test for the HP 8168D

Page 11 of 11

Model HP 8168D Tunable Laser Source Report No. _____ Date _____

Source Spontaneous Emission

Wavelength	Output Power	Maximum Spec	Result	Measurement Uncertainty
option:	#007 (circle the appropriate)			± 1.20 dB
1490nm	-10.0dBm	-11.0dBm	-35dB	_____dB
1500nm	-4.0dBm	-5.0dBm	-40dB	_____dB
1510nm	-4.0dBm	-5.0dBm	-40dB	_____dB
1520nm	-4.0dBm	-5.0dBm	-40dB	_____dB
1530nm	-4.0dBm	-5.0dBm	-40dB	_____dB
1540nm	-4.0dBm	-5.0dBm	-40dB	_____dB
1550nm	-4.0dBm	-5.0dBm	-40dB	_____dB
1560nm	-4.0dBm	-5.0dBm	-40dB	_____dB
1565nm	-4.0dBm	-5.0dBm	-40dB	_____dB



D

Performance Test for the HP 8168E

Page 1 of 12

Test Facility:

Report No. _____

Date _____

Customer _____

Tested By _____

Model HP 8168E Tunable Laser Source

Serial No. _____

Ambient temperature _____ °C

Options _____

Relative humidity _____ %

Firmware Rev. _____

Line frequency _____ Hz

Special Notes:

D-44 Performance Tests

Performance Test for the HP 8168E

Page 2 of 12

Model HP 8168E Tunable Laser Source Report No. _____ Date _____

Test Equipment Used:

Description	Model No.	Trace No.	Cal. Due Date
1. Lightwave Multimeter with	HP 8153A		
2. Sensor Module	HP 81532A		
3a. Optical Spectrum Analyzer	HP 71452B		
3b. Optical Spectrum Analyzer	HP 70950A		
3c. OSA Display	HP 70004A		
4. Wavelength Meter	_____		
5a. Connector Interface (×2)	HP 81000AI		
5b. Connector Interface (#021)	HP 81000AI		
6. Connector Interface (#022)	HP 81000SI		
7. Universal Through Adapter (#021, #022)	HP 81000UM		
8a. High Return Loss Cable	HP 81109AC		
8b. High Return Loss Cable (#021)	HP 81109AC		
9. High Return Loss Cable	HP 81102SC		
10a. Optical Head Interfacer Module	HP 81533B		
10b. Optical Head	HP 81525A		
10c. Diamond HMS-10 Connector	HP 81000AA		
11. _____	_____	_____	_____
12. _____	_____	_____	_____
13. _____	_____	_____	_____
14. _____	_____	_____	_____

Performance Tests D-45

D

Performance Test for the HP 8168E

Page 3 of 12

Model HP 8168E Tunable Laser Source Report No. _____ Date _____

Relative Wavelength Accuracy

Repetition	Wavelength Setting	Wavelength Measured	Deviation meas - set value	Maximum Deviation	Minimum Deviation
1	1475.000nm	_____nm	_____nm		
	1485.000nm	_____nm	_____nm		
	1495.000nm	_____nm	_____nm		
	1505.000nm	_____nm	_____nm		
	1515.000nm	_____nm	_____nm		
	1525.000nm	_____nm	_____nm		
	1535.000nm	_____nm	_____nm		
	1545.000nm	_____nm	_____nm		
	1555.000nm	_____nm	_____nm		
	1565.000nm	_____nm	_____nm		
	1575.000nm	_____nm	_____nm	_____nm	_____nm
2	1475.000nm	_____nm	_____nm		
	1485.000nm	_____nm	_____nm		
	1495.000nm	_____nm	_____nm		
	1505.000nm	_____nm	_____nm		
	1515.000nm	_____nm	_____nm		
	1525.000nm	_____nm	_____nm		
	1535.000nm	_____nm	_____nm		
	1545.000nm	_____nm	_____nm		
	1555.000nm	_____nm	_____nm		
	1565.000nm	_____nm	_____nm		
	1575.000nm	_____nm	_____nm	_____nm	_____nm

D-46 Performance Tests

Performance Test for the HP 8168E

Page 4 of 12

Model HP 8168E Tunable Laser Source Report No. _____ Date _____

Relative Wavelength Accuracy

Repetition	Wavelength Setting	Wavelength Measured	Deviation meas - set value	Maximum Deviation	Minimum Deviation
3	1475.000nm	_____nm	_____nm		
	1485.000nm	_____nm	_____nm		
	1495.000nm	_____nm	_____nm		
	1505.000nm	_____nm	_____nm		
	1515.000nm	_____nm	_____nm		
	1525.000nm	_____nm	_____nm		
	1535.000nm	_____nm	_____nm		
	1545.000nm	_____nm	_____nm		
	1555.000nm	_____nm	_____nm		
	1565.000nm	_____nm	_____nm		
	1575.000nm	_____nm	_____nm	_____nm	_____nm
4	1475.000nm	_____nm	_____nm		
	1485.000nm	_____nm	_____nm		
	1495.000nm	_____nm	_____nm		
	1505.000nm	_____nm	_____nm		
	1515.000nm	_____nm	_____nm		
	1525.000nm	_____nm	_____nm		
	1535.000nm	_____nm	_____nm		
	1545.000nm	_____nm	_____nm		
	1555.000nm	_____nm	_____nm		
	1565.000nm	_____nm	_____nm		
	1575.000nm	_____nm	_____nm	_____nm	_____nm

Performance Tests D-47



D

Performance Test for the HP 8168E

Page 5 of 12

Model HP 8168E Tunable Laser Source Report No. _____ Date _____

Relative Wavelength Accuracy

Repetition	Wavelength Setting	Wavelength Measured	Deviation meas - set value	Maximum Deviation	Minimum Deviation
5	1475.000nm	_____nm	_____nm		
	1485.000nm	_____nm	_____nm		
	1495.000nm	_____nm	_____nm		
	1505.000nm	_____nm	_____nm		
	1515.000nm	_____nm	_____nm		
	1525.000nm	_____nm	_____nm		
	1535.000nm	_____nm	_____nm		
	1545.000nm	_____nm	_____nm		
	1555.000nm	_____nm	_____nm		
	1565.000nm	_____nm	_____nm		
	1575.000nm	_____nm	_____nm	_____nm	_____nm

Range 1475 to 1575nm Largest Maximum Deviation _____nm

Smallest Minimum Deviation _____nm

Relative Wavelength Accuracy

(= Largest Maximum Deviation - Smallest Minimum Deviation) _____nm
Specification 0.07nm

Measurement Uncertainty ±0.01nm

Performance Test for the HP 8168E

Page 6 of 12

Model HP 8168E Tunable Laser Source Report No. _____ Date _____

Wavelength Repeatability

Description	Min Spec	Result	Max Spec	Measurement Uncertainty
1575.000nm		REF		±0.002nm
from _____nm to REF	1574.965nm	_____nm	1575.035nm	
from _____nm to REF	1574.965nm	_____nm	1575.035nm	
from _____nm to REF	1574.965nm	_____nm	1575.035nm	
from _____nm to REF	1574.965nm	_____nm	1575.035nm	
from _____nm to REF	1574.965nm	_____nm	1575.035nm	

D

Performance Test for the HP 8168E

Model HP 8168E Tunable Laser Source Report No. _____ Date _____

Maximum Power Test

Wavelength	Minimum Spec				Result	Measurement Uncertainty
		#007				±0.30dB
option:		#023	#003	#023 + #003		
	(circle the appropriate)					
1475nm	-10.0dBm	-11.0dBm	-11.5dBm	-12.5dBm	_____dBm	
1480nm	-10.0dBm	-11.0dBm	-11.5dBm	-12.5dBm	_____dBm	
1490nm	-10.0dBm	-11.0dBm	-11.5dBm	-12.5dBm	_____dBm	
1500nm	0dBm	-1.0dBm	-1.5dBm	-2.5dBm	_____dBm	
1510nm	0dBm	-1.0dBm	-1.5dBm	-2.5dBm	_____dBm	
1520nm	0dBm	-1.0dBm	-1.5dBm	-2.5dBm	_____dBm	
1530nm	0dBm	-1.0dBm	-1.5dBm	-2.5dBm	_____dBm	
1540nm	0dBm	-1.0dBm	-1.5dBm	-2.5dBm	_____dBm	
1550nm	0dBm	-1.0dBm	-1.5dBm	-2.5dBm	_____dBm	
1560nm	0dBm	-1.0dBm	-1.5dBm	-2.5dBm	_____dBm	
1570nm	0dBm	-1.0dBm	-1.5dBm	-2.5dBm	_____dBm	
1575nm	-10.0dBm	-11.0dBm	-11.5dBm	-12.5dBm	_____dBm	

Performance Test for the HP 8168E

Page 8 of 12

Model HP 8168E Tunable Laser Source Report No. _____ Date _____

**Power Linearity
(HP 8168E without attenuator)**

	Power Setting at current setting	Relative Power from start	Power Reduction at current setting	Power Linearity
start:	-1.0dBm	REF	0.0dB	0.00dB
	-1.5dBm	_____dB	0.5dB	_____dB
	-2.0dBm	_____dB	1.0dB	_____dB
	-2.5dBm	_____dB	1.5dB	_____dB
	-3.0dBm	_____dB	2.0dB	_____dB
	-3.5dBm	_____dB	2.5dB	_____dB
	-4.0dBm	_____dB	3.0dB	_____dB
	-4.5dBm	_____dB	3.5dB	_____dB
	-5.0dBm	_____dB	4.0dB	_____dB
	-5.5dBm	_____dB	4.5dB	_____dB
	-6.0dBm	_____dB	5.0dB	_____dB
	-6.5dBm	_____dB	5.5dB	_____dB
	-7.0dBm	_____dB	6.0dB	_____dB
	-7.5dBm	_____dB	6.5dB	_____dB
	-8.0dBm	_____dB	7.0dB	_____dB
	-8.5dBm	_____dB	7.5dB	_____dB
	-9.0dBm	_____dB	8.0dB	_____dB
	-9.5dBm	_____dB	8.5dB	_____dB
	-10.0dBm	_____dB	9.0dB	_____dB

Maximum Power Linearity at current setting _____dB

Minimum Power Linearity at current setting _____dB

Final Power Linearity

(= Max Power Linearity - Min Power Linearity) _____dBpp
Specification 0.2dBpp

Measurement Uncertainty ± 0.05 dB



Performance Test for the HP 8168E

Model HP 8168E Tunable Laser Source Report No. _____ Date _____

**Power Linearity
(HP 8168E with attenuator)**

	Power Setting at current setting	Relative Power from start	Power Reduction at current setting	Power Linearity
start:	-2.5dBm	REF +	0.0dB =	0.00dB
	-10.0dBm	_____dB	7.5dB	_____dB
	-15.0dBm	_____dB	12.5dB	_____dB
	-20.0dBm	_____dB	17.5dB	_____dB
	-25.0dBm	_____dB	22.5dB	_____dB
	-30.0dBm	_____dB	27.5dB	_____dB
	-35.0dBm	_____dB	32.5dB	_____dB
	-40.0dBm	_____dB	37.5dB	_____dB
	-45.0dBm	_____dB	42.5dB	_____dB
	-50.0dBm	_____dB	47.5dB	_____dB
	Maximum Power Linearity at current setting			_____dB
	Minimum Power Linearity at current setting			_____dB
	Final Power Linearity (= Max Power Linearity - Min Power Linearity)			_____dBpp
	Specification			0.6dBpp
	Measurement Uncertainty			±0.05dB

Performance Test for the HP 8168E

Page 10 of 12

Model HP 8168E Tunable Laser Source Report No. _____ Date _____

Power Flatness versus Wavelength

Wavelength	Deviation
1500nm	0.00 (start value, REF)
1510nm	_____dB
1520nm	_____dB
1530nm	_____dB
1540nm	_____dB
1550nm	_____dB
1560nm	_____dB
1570nm	_____dB

Maximum deviation _____dB

Minimum deviation _____dB

Flatness

(= Maximum - Minimum deviation) _____dBpp
 Specification 0.2dBpp without #003
 0.4dBpp with #003

Measurement Uncertainty ± 0.07 dB



D

Performance Test for the HP 8168E

Page 11 of 12

Model HP 8168E Tunable Laser Source Report No. _____ Date _____

Power Stability

High power

Maximum deviation _____dB

Minimum deviation _____dB

Power Stability
(= Max - Min deviation) _____dBpp
Specification 0.06dBpp

Low power

Maximum deviation _____dB

Minimum deviation _____dB

Power Stability
(= Max - Min deviation) _____dBpp
Specification 0.06dBpp

Measurement Uncertainty ± 0.02 dB

Performance Test for the HP 8168E

Page 12 of 12

Model HP 8168E Tunable Laser Source Report No. _____ Date _____

Source Spontaneous Emission

Wavelength		Output Power			Maximum Spec	Result	Measurement Uncertainty
		#007	#003	#023 + #003			
option:		(circle the appropriate)					±1.20dB
1475nm	-10.0dBm	-11.0dBm	-11.5dBm	-12.5dBm	-35dB	_____dB	
1480nm	-10.0dBm	-11.0dBm	-11.5dBm	-12.5dBm	-35dB	_____dB	
1490nm	-10.0dBm	-11.0dBm	-11.5dBm	-12.5dBm	-35dB	_____dB	
1500nm	0dBm	-1.0dBm	-1.5dBm	-2.5dBm	-45dB	_____dB	
1510nm	0dBm	-1.0dBm	-1.5dBm	-2.5dBm	-45dB	_____dB	
1520nm	0dBm	-1.0dBm	-1.5dBm	-2.5dBm	-45dB	_____dB	
1530nm	0dBm	-1.0dBm	-1.5dBm	-2.5dBm	-45dB	_____dB	
1540nm	0dBm	-1.0dBm	-1.5dBm	-2.5dBm	-45dB	_____dB	
1550nm	0dBm	-1.0dBm	-1.5dBm	-2.5dBm	-45dB	_____dB	
1560nm	0dBm	-1.0dBm	-1.5dBm	-2.5dBm	-45dB	_____dB	
1570nm	0dBm	-1.0dBm	-1.5dBm	-2.5dBm	-45dB	_____dB	
1575nm	-10.0dBm	-11.0dBm	-11.5dBm	-12.5dBm	-35dB	_____dB	



D

Performance Test for the HP 8168F

Page 1 of 14

Test Facility:

Report No. _____

Date _____

Customer _____

Tested By _____

Model HP 8168F Tunable Laser Source

Serial No. _____

Ambient temperature _____ °C

Options _____

Relative humidity _____ %

Firmware Rev. _____

Line frequency _____ Hz

Special Notes:

Performance Test for the HP 8168F

Page 2 of 14

Model HP 8168F Tunable Laser Source Report No. _____ Date _____

Test Equipment Used:

Description	Model No.	Trace No.	Cal. Due Date
1. Lightwave Multimeter with	HP 8153A		
2. Sensor Module	HP 81532A		
3a. Optical Spectrum Analyzer	HP 71452B		
3b. Optical Spectrum Analyzer	HP 70950A		
3c. OSA Display	HP 70004A		
4. Wavelength Meter	_____		
5a. Connector Interface (x2)	HP 81000AI		
5b. Connector Interface (#021)	HP 81000AI		
6. Connector Interface (#022)	HP 81000SI		
7. Universal Through Adapter (#021, #022)	HP 81000UM		
8a. High Return Loss Cable	HP 81109AC		
8b. High Return Loss Cable (#021)	HP 81109AC		
9. High Return Loss Cable	HP 81102SC		
10a. Optical Head Interfacer Module	HP 81533B		
10b. Optical Head	HP 81525A or HP81524A		
10c. Diamond HMS-10 Connector	HP 81000AA		
11. _____	_____	_____	_____
12. _____	_____	_____	_____
13. _____	_____	_____	_____
14. _____	_____	_____	_____

Performance Tests D-57

D

Performance Test for the HP 8168F

Page 3 of 14

Model HP 8168F Tunable Laser Source Report No. _____ Date _____

Relative Wavelength Accuracy

Repetition	Wavelength Setting	Wavelength Measured	Deviation meas - set value	Maximum Deviation	Minimum Deviation
1	1450.000nm	_____nm	_____nm		
	1460.000nm	_____nm	_____nm		
	1475.000nm	_____nm	_____nm		
	1490.000nm	_____nm	_____nm		
	1500.000nm	_____nm	_____nm		
	1510.000nm	_____nm	_____nm		
	1520.000nm	_____nm	_____nm		
	1530.000nm	_____nm	_____nm		
	1540.000nm	_____nm	_____nm		
	1550.000nm	_____nm	_____nm		
	1560.000nm	_____nm	_____nm		
	1575.000nm	_____nm	_____nm	1475 to 1575nm	_____nm
	1580.000nm	_____nm	_____nm		
	1590.000nm	_____nm	_____nm	1450 to 1590nm	_____nm

D-58 Performance Tests

Performance Test for the HP 8168F

Model HP 8168F Tunable Laser Source Report No. _____ Date _____

Relative Wavelength Accuracy

Repetition	Wavelength Setting	Wavelength Measured	Deviation meas - set value	Maximum Deviation	Minimum Deviation
2	1450.000nm	_____nm	_____nm		
	1460.000nm	_____nm	_____nm		
	1475.000nm	_____nm	_____nm		
	1490.000nm	_____nm	_____nm		
	1500.000nm	_____nm	_____nm		
	1510.000nm	_____nm	_____nm		
	1520.000nm	_____nm	_____nm		
	1530.000nm	_____nm	_____nm		
	1540.000nm	_____nm	_____nm		
	1550.000nm	_____nm	_____nm		
	1560.000nm	_____nm	_____nm		
	1575.000nm	_____nm	_____nm	1475 to 1575nm	_____nm
	1580.000nm	_____nm	_____nm		
	1590.000nm	_____nm	_____nm	1450 to 1590nm	_____nm

D

Performance Test for the HP 8168F

Model HP 8168F Tunable Laser Source Report No. _____ Date _____

Relative Wavelength Accuracy

Repetition	Wavelength Setting	Wavelength Measured	Deviation meas - set value	Maximum Deviation	Minimum Deviation
3	1450.000nm	_____nm	_____nm		
	1460.000nm	_____nm	_____nm		
	1475.000nm	_____nm	_____nm		
	1490.000nm	_____nm	_____nm		
	1500.000nm	_____nm	_____nm		
	1510.000nm	_____nm	_____nm		
	1520.000nm	_____nm	_____nm		
	1530.000nm	_____nm	_____nm		
	1540.000nm	_____nm	_____nm		
	1550.000nm	_____nm	_____nm		
	1560.000nm	_____nm	_____nm		
	1575.000nm	_____nm	_____nm	1475 to 1575nm	_____nm
	1580.000nm	_____nm	_____nm		
	1590.000nm	_____nm	_____nm	1450 to 1590nm	_____nm

Performance Test for the HP 8168F

Model HP 8168F Tunable Laser Source Report No. _____ Date _____

Relative Wavelength Accuracy

Repetition	Wavelength Setting	Wavelength Measured	Deviation meas - set value	Maximum Deviation	Minimum Deviation
4	1450.000nm	_____nm	_____nm		
	1460.000nm	_____nm	_____nm		
	1475.000nm	_____nm	_____nm		
	1490.000nm	_____nm	_____nm		
	1500.000nm	_____nm	_____nm		
	1510.000nm	_____nm	_____nm		
	1520.000nm	_____nm	_____nm		
	1530.000nm	_____nm	_____nm		
	1540.000nm	_____nm	_____nm		
	1550.000nm	_____nm	_____nm		
	1560.000nm	_____nm	_____nm		
	1575.000nm	_____nm	_____nm	1475 to 1575nm	_____nm
	1580.000nm	_____nm	_____nm		
	1590.000nm	_____nm	_____nm	1450 to 1590nm	_____nm

D

Performance Test for the HP 8168F

Model HP 8168F Tunable Laser Source Report No. _____ Date _____

Relative Wavelength Accuracy

Repetition	Wavelength Setting	Wavelength Measured	Deviation meas - set value	Maximum Deviation	Minimum Deviation
5	1450.000nm	_____nm	_____nm		
	1460.000nm	_____nm	_____nm		
	1475.000nm	_____nm	_____nm		
	1490.000nm	_____nm	_____nm		
	1500.000nm	_____nm	_____nm		
	1510.000nm	_____nm	_____nm		
	1520.000nm	_____nm	_____nm		
	1530.000nm	_____nm	_____nm		
	1540.000nm	_____nm	_____nm		
	1550.000nm	_____nm	_____nm		
	1560.000nm	_____nm	_____nm		
	1575.000nm	_____nm	_____nm	1475 to 1575nm	_____nm
	1580.000nm	_____nm	_____nm		
	1590.000nm	_____nm	_____nm	1450 to 1590nm	_____nm

Range 1475 to 1575nm Largest Maximum Deviation _____nm
 Smallest Minimum Deviation _____nm

Relative Wavelength Accuracy
 (= Largest Maximum Deviation - Smallest Minimum Deviation) _____nm
 Specification 0.07nm

Range 1450 to 1590nm Largest Maximum Deviation _____nm
 Smallest Minimum Deviation _____nm

Relative Wavelength Accuracy
 (= Largest Maximum Deviation - Smallest Minimum Deviation) _____nm
 Specification 0.10nm

Measurement Uncertainty ±0.01nm

D-62 Performance Tests

Performance Test for the HP 8168F

Page 8 of 14

Model HP 8168F Tunable Laser Source Report No. _____ Date _____

Wavelength Repeatability

Description	Min Spec	Result	Max Spec	Measurement Uncertainty
1575.000nm		REF		±0.002nm
from _____nm to REF	1574.965nm	_____nm	1575.035nm	
from _____nm to REF	1574.965nm	_____nm	1575.035nm	
from _____nm to REF	1574.965nm	_____nm	1575.035nm	
from _____nm to REF	1574.965nm	_____nm	1575.035nm	
from _____nm to REF	1574.965nm	_____nm	1575.035nm	

Wavelength Repeatability

Description	Min Spec	Result	Max Spec	Measurement Uncertainty
1590.000nm		REF		±0.002nm
from _____nm to REF	1594.950nm	_____nm	1595.050nm	
from _____nm to REF	1594.950nm	_____nm	1595.050nm	
from _____nm to REF	1594.950nm	_____nm	1595.050nm	
from _____nm to REF	1594.950nm	_____nm	1595.050nm	
from _____nm to REF	1594.950nm	_____nm	1595.050nm	

Performance Tests D-63

D

Performance Test for the HP 8168F

Model HP 8168F Tunable Laser Source Report No. _____ Date _____

Maximum Power Test

Wavelength	Minimum Spec				Result	Measurement Uncertainty ±0.30dB
	option: (circle the appropriate)	#007 #023	#003	#023 + #003		
1450nm	-7.0dBm	-8.0dBm	-8.5dBm	-9.5dBm	_____dBm	
1460nm	-7.0dBm	-8.0dBm	-8.5dBm	-9.5dBm	_____dBm	
1475nm	+1.0dBm	0.0dBm	-0.5dBm	-1.5dBm	_____dBm	
1480nm	+1.0dBm	0.0dBm	-0.5dBm	-1.5dBm	_____dBm	
1490nm	+1.0dBm	0.0dBm	-0.5dBm	-1.5dBm	_____dBm	
1500nm	+1.0dBm	0.0dBm	-0.5dBm	-1.5dBm	_____dBm	
1510nm	+1.0dBm	0.0dBm	-0.5dBm	-1.5dBm	_____dBm	
1520nm	+7.0dBm	+6.0dBm	+5.5dBm	+4.5dBm	_____dBm	
1530nm	+7.0dBm	+6.0dBm	+5.5dBm	+4.5dBm	_____dBm	
1540nm	+7.0dBm	+6.0dBm	+5.5dBm	+4.5dBm	_____dBm	
1550nm	+7.0dBm	+6.0dBm	+5.5dBm	+4.5dBm	_____dBm	
1560nm	+7.0dBm	+6.0dBm	+5.5dBm	+4.5dBm	_____dBm	
1570nm	+7.0dBm	+6.0dBm	+5.5dBm	+4.5dBm	_____dBm	
1575nm	+1.0dBm	0.0dBm	-0.5dBm	-1.5dBm	_____dBm	
1580nm	-7.0dBm	-8.0dBm	-8.5dBm	-9.5dBm	_____dBm	
1590nm	-7.0dBm	-8.0dBm	-8.5dBm	-9.5dBm	_____dBm	

D-64 Performance Tests

Performance Test for the HP 8168F

Page 10 of 14

Model HP 8168F Tunable Laser Source Report No. _____ Date _____

**Power Linearity
(HP 8168F without attenuator)**

	Power Setting at current setting	Relative Power from start	Power Reduction at current setting	Power Linearity
start:	+1.0dBm	REF	0.0dB	0.00dB
	0.0dBm	_____dB	1.0dB	_____dB
	-1.0dBm	_____dB	2.0dB	_____dB
	-2.0dBm	_____dB	3.0dB	_____dB
	-3.0dBm	_____dB	4.0dB	_____dB
	-4.0dBm	_____dB	5.0dB	_____dB
	-5.0dBm	_____dB	6.0dB	_____dB
	-6.0dBm	_____dB	7.0dB	_____dB
	-7.0dBm	_____dB	8.0dB	_____dB

Maximum Power Linearity at current setting _____dB

Minimum Power Linearity at current setting _____dB

Final Power Linearity
 (= Max Power Linearity - Min Power Linearity) _____dBpp
 Specification 0.2dBpp

Measurement Uncertainty ±0.05dB

Performance Test for the HP 8168F

Model HP 8168F Tunable Laser Source Report No. _____ Date _____

**Power Linearity
(HP 8168F with attenuator)**

	Power Setting at current setting	Relative Power from start	Power Reduction at current setting	Power Linearity
start:	0.0dBm	REF dB	0.0dB	0.00 dB
	-5.0dBm	_____dB	5.0dB	_____dB
	-10.0dBm	_____dB	10.0dB	_____dB
	-15.0dBm	_____dB	15.0dB	_____dB
	-20.0dBm	_____dB	20.0dB	_____dB
	-25.0dBm	_____dB	25.0dB	_____dB
	-30.0dBm	_____dB	30.0dB	_____dB
	-35.0dBm	_____dB	35.0dB	_____dB
	-40.0dBm	_____dB	40.0dB	_____dB
	-47.0dBm	_____dB	47.0dB	_____dB
	Maximum Power Linearity at current setting			_____dB
	Minimum Power Linearity at current setting			_____dB
	Final Power Linearity (= Max Power Linearity - Min Power Linearity)			_____dBpp
	Specification			0.6dBpp
	Measurement Uncertainty			±0.05dB

Performance Test for the HP 8168F

Page 12 of 14

Model HP 8168F Tunable Laser Source Report No. _____ Date _____

Power Flatness versus Wavelength

Wavelength	Deviation
------------	-----------

1475nm	0.00 (start value, REF)
--------	-------------------------

1480nm	_____dB
--------	---------

1490nm	_____dB
--------	---------

1500nm	_____dB
--------	---------

1510nm	_____dB
--------	---------

1520nm	_____dB
--------	---------

1530nm	_____dB
--------	---------

1540nm	_____dB
--------	---------

1550nm	_____dB
--------	---------

1560nm	_____dB
--------	---------

1570nm	_____dB
--------	---------

1575nm	_____dB
--------	---------

Maximum deviation	_____dB
-------------------	---------

Minimum deviation	_____dB
-------------------	---------

Flatness

(= Maximum - Minimum deviation)	_____dBpp
---------------------------------	-----------

Specification	0.2dBpp without #003
---------------	----------------------

	0.4dBpp with #003
--	-------------------

Measurement Uncertainty	±0.07dB
-------------------------	---------

Performance Tests D-67

D

Performance Test for the HP 8168F

Page 13 of 14

Model HP 8168F Tunable Laser Source Report No. _____ Date _____

Power Stability

High power

Maximum deviation _____dB

Minimum deviation _____dB

Power Stability

(= Max - Min deviation) _____dBpp
Specification 0.06dBpp

Low power

Maximum deviation _____dB

Minimum deviation _____dB

Power Stability

(= Max - Min deviation) _____dBpp
Specification 0.06dBpp

Measurement Uncertainty ± 0.02 dB

Performance Test for the HP 8168F

Model HP 8168F Tunable Laser Source Report No. _____ Date _____

Source Spontaneous Emission

Wavelength	Option	Output Power			Maximum Spec	Result	Measurement Uncertainty
		#007	#003	#023 + #003			
		(circle the appropriate)					±1.20dB
1450nm	-7.0dBm	-8.0dBm	-8.5dBm	-9.5dBm	-35dB	_____dB	
1460nm	-7.0dBm	-8.0dBm	-8.5dBm	-9.5dBm	-35dB	_____dB	
1475nm	+1.0dBm	0.0dBm	-0.5dBm	-1.5dBm	-45dB	_____dB	
1480nm	+1.0dBm	0.0dBm	-0.5dBm	-1.5dBm	-45dB	_____dB	
1490nm	+1.0dBm	0.0dBm	-0.5dBm	-1.5dBm	-45dB	_____dB	
1500nm	+1.0dBm	0.0dBm	-0.5dBm	-1.5dBm	-45dB	_____dB	
1510nm	+1.0dBm	0.0dBm	-0.5dBm	-1.5dBm	-45dB	_____dB	
1520nm	+7.0dBm	+6.0dBm	+5.5dBm	+4.5dBm	-55dB	_____dB	
1530nm	+7.0dBm	+6.0dBm	+5.5dBm	+4.5dBm	-55dB	_____dB	
1540nm	+7.0dBm	+6.0dBm	+5.5dBm	+4.5dBm	-55dB	_____dB	
1550nm	+7.0dBm	+6.0dBm	+5.5dBm	+4.5dBm	-55dB	_____dB	
1560nm	+7.0dBm	+6.0dBm	+5.5dBm	+4.5dBm	-55dB	_____dB	
1570nm	+7.0dBm	+6.0dBm	+5.5dBm	+4.5dBm	-55dB	_____dB	
1575nm	+1.0dBm	0.0dBm	-0.5dBm	-1.5dBm	-45dB	_____dB	
1580nm	-7.0dBm	-8.0dBm	-8.5dBm	-9.5dBm	-35dB	_____dB	
1590nm	-7.0dBm	-8.0dBm	-8.5dBm	-9.5dBm	-35dB	_____dB	



Cleaning Procedures

The Cleaning Kit

A full cleaning kit contains the following items:

- Isopropyl alcohol** This is usually available from pharmaceutical suppliers or chemists.
 - If possible, use alcohol supplied for medical purposes, rather than impure alcohol or alcohol with additives.
 - Caution**
Do not use other solvents as some can damage plastic materials and claddings. For example, Acetone dissolves the adhesives used in fiber optic devices.
 - Warning**
Never drink this alcohol as this can lead to blindness or other serious damage to your health.

- Cotton-swabs** Use swabs such as Q-tips or other cotton-swabs. These are typically available from local distributors of medical or hygiene products (such as supermarkets or pharmacies).
 - Note** If you are cleaning connector interfaces or adapters, the diameter of the cotton swab is important. Cotton swabs for babies normally have a smaller diameter.
 - Caution**
 - Do not use foam swabs, as these can leave filmy deposits on the surface you are cleaning.
 - Store your cotton-swabs carefully and never reuse them. Dust and dirt from the air or from previous cleaning, can scratch or dirty your optical device.

- Soft-tissues** These are available from most stores and distributors of medical and hygiene products (such as supermarkets or pharmacies).
 - Use multi-layer tissues made from non-recycled cellulose. These are more absorbent and softer than other types and they do not scratch the surface of your device.
 - Caution**
Store your soft-tissues carefully and never reuse them, as dust and dirt from the air or from previous cleaning can scratch and dirty your optical device.

**E****Pipe-cleaner**

This is available from tobacco shops.

Ensure that the bristles of the pipe-cleaner are soft, so that they do not scratch your device during cleaning.

Caution

Store your pipe-cleaners carefully and never reuse them as dust and dirt from the air or from previous cleaning can scratch and dirty your optical device.

Compressed Air

This is available from laboratory suppliers.

It is essential that your compressed air is free of dust, water and oil. Only use clean, dry air. If you do not, it can lead to filmy deposits or scratches.

When using compressed air from a can,

- Hold the can upright. A slant can cause propellant to escape with the compressed air and dirty your optical device.
- Spray the first couple of seconds into the air, as the first stream of compressed air can contain condensation or propellant. Any condensation produces a filmy deposit.

If you are using compressed air from a can, you should select one with a CFC-free propellant, for the sake of the environment.

Other Cleaning Tools

To examine devices you also require:

- Microscope** Select a microscope with a magnification range of between 50X and 300X. These should be available from photographic stores or laboratory suppliers.
- Ensure that the light source of the microscope is flexible. This helps you to examine your device closely and from different angles.
- A microscope allows you to determine the type of dirt on your device and its extent. Then you can choose the correct cleaning procedure and later to examine the results of cleaning. With a microscope you can also determine if your optical device is scratched.
- Ultrasonic bath** This is typically available from photographic stores or laboratory suppliers.
- An ultrasonic bath very gently removes greasy and other stubborn dirt from optical devices.
- Only use an ultrasonic bath with isopropyl alcohol, as other solvents can damage or dirty your optical device.
- Warm water and liquid soap** Use water only if you are sure that your optical device will not corrode or be damaged. Do not use hot water, as this can lead to mechanical stress that can damage your optical device. Ensure that your liquid soap has no abrasive properties or perfume in it, as these can scratch or damage your optical device. Do not use normal washing-up liquid, as it can leave behind an iridescent film.
- Premoistened cleaning wipes** These are available from HP. The part number is HP 92193N (80 Wipes per box). These are tissues that are moistened with isopropyl alcohol.
- Polymer film** This is typically available from professional photographic stores or laboratory suppliers.
- Polymer film is very gentle on optical surfaces and is particularly good for cleaning extremely sensitive devices such as mirrors.
- Infrared sensor card** This is typically available from laboratory suppliers.
- With this card you can qualitatively check the uniformity of your emitted laser light, because when the laser light is projected onto the sensor card it becomes visible.
- Lens Cleaning Paper** Some lens cleaning papers and cleaning kits available, for example, in photographic stores are not suitable for cleaning fiber optic devices. To be sure, please ask the salesperson or the manufacturer.

E

Preserving Connectors

Listed below are some hints on how to keep your connectors in the best possible condition.

Making Connections

Before you make any connection you must ensure that all cables and connectors are clean. If they are dirty, use the appropriate cleaning procedure.

When inserting the ferrule of a patchcord into a connector or an adapter, make sure that the fiber end does not touch the outside of the mating connector or adapter. Otherwise you will rub the fiber end against an unsuitable surface, producing scratches and dirt deposits on the surface of your fiber.

Dust Caps and Shutter Caps

Be careful when replacing dust caps after use. Do not press the bottom of the cap onto the fiber as any dust in the cap can scratch or dirty your fiber surface.

When you have finished cleaning, put the dust cap back on, or close the shutter cap if the equipment is not going to be used immediately.

Keep the caps on the equipment always when it is not in use.

All of Hewlett-Packard's lightwave instruments and accessories are shipped with either laser shutter caps or dust caps. If you need additional or replacement dust caps, contact your Hewlett-Packard sales office.

Immersion Oil and Other Index Matching Compounds

Where it is possible, do not use immersion oil or other index matching compounds with your device. They are liable to impair and dirty the surface of the device. In addition, the characteristics of your device can be changed and your measurement results affected.

Cleaning Instrument Housings

Use a dry and very soft cotton tissue to clean the instrument housing and the keypad. Do not open the instruments as there is a danger of electric shock, or electrostatic discharge. Opening the instrument can cause damage to sensitive components, and in addition your warranty will be voided.

Cleaning Procedures

If you are unsure about the correct cleaning procedure for your device or if you are unsure whether the procedure given here is suitable for your device, check with the manufacturer or sales distributor, or try the procedure on a dummy or test device first.

In general, *whenever possible use physically contacting connectors, and dry connections*. Fiber connectors may be used dry or wet. Dry means without index matching compound. If there is a need to use an index matching compound, use only HP index matching oil (part number 8500-4922). Clean the connectors, interfaces and bushings carefully each time after use.

Warning



Make sure to disable all sources when you are cleaning any optical interfaces.

Under no circumstances look into the end of an optical cable attached to the optical output when the device is operational.

The laser radiation is not visible to the human eye, but it can seriously damage your eyesight.

Cleaning Cable Connectors

Cleaning connectors is difficult as the core diameter of a singlemode fiber is only about $9\mu\text{m}$. This generally means you cannot see streaks or scratches on the surface. To be certain of the condition of the surface of your connector and to check it after cleaning, you need a microscope.

In the case of scratches, or of dust that has been burnt onto the surface of the connector, you may have no option but to polish the connector. This depends on the degree of dirtiness, or the depth of the scratches. This is a difficult procedure and should only be performed by skilled personnel, and as a last resort as it wears out your connector.

Warning



Never look into the end of an optical cable that is connected to an active source.

E

To assess the projection of the emitted light beam you can use an infrared sensor card. Hold the card approximately 5 cm from the output of the connector. The invisible emitted light is projected onto the card and becomes visible as a small circular spot.

Preferred Procedure

1. Clean the connector by rubbing a new, dry cotton-swab over the surface using a small circular movement.
2. Blow away any remaining lint with compressed air.

Procedure for Stubborn Dirt

Use this procedure particularly when there is greasy dirt on the connector:

1. Moisten a new cotton-swab with isopropyl alcohol.
2. Clean the connector by rubbing the cotton-swab over the surface using a small circular movement.
3. Take a new, dry soft-tissue and remove the alcohol, dissolved sediment and dust, by rubbing gently over the surface using a small circular movement.
4. Blow away any remaining lint with compressed air.

An Alternative Procedure

The better, more gentle, but more expensive cleaning procedure is to use an ultrasonic bath with isopropyl alcohol.

1. Hold the tip of the connector in the bath for at least three minutes.
2. Take a new, dry soft-tissue and remove the alcohol, dissolved sediment and dust, by rubbing gently over the surface using a small circular movement.
3. Blow away any remaining lint with compressed air.

Cleaning Connector Adapters

Caution

Some adapters have an anti-reflection coating on the back to reduce back reflection. This coating is extremely sensitive to solvents and mechanical abrasion. Extra care is needed when cleaning these adapters.

Preferred Procedure

1. Clean the adapter by rubbing a new, dry cotton-swab over the surface using a small circular movement.
2. Blow away any remaining lint with compressed air.

Procedure for Stubborn Dirt

Use this procedure particularly when there is greasy dirt on the adapter:

1. Moisten a new cotton-swab with isopropyl alcohol.
2. Clean the adapter by rubbing the cotton-swab over the surface using a small circular movement.
3. Take a new, dry soft-tissue and remove the alcohol, dissolved sediment and dust, by rubbing gently over the surface using a small circular movement.
4. Blow away any remaining lint with compressed air.

Cleaning Connector Interfaces

Caution

- Be careful when using pipe-cleaners, as the core and the bristles of the pipe-cleaner are hard and can damage the interface.
- Do not use pipe-cleaners on optical head adapters, as the hard core of normal pipe cleaners can damage the bottom of an adapter.

Preferred Procedure

1. Clean the interface by pushing and pulling a new, dry pipe-cleaner into the opening. Rotate the pipe-cleaner slowly as you do this.
2. Then clean the interface by rubbing a new, dry cotton-swab over the surface using a small circular movement.
3. Blow away any remaining lint with compressed air.

Procedure for Stubborn Dirt

Use this procedure particularly when there is greasy dirt on the interface:

1. Moisten a new pipe-cleaner with isopropyl alcohol.
2. Clean the interface by pushing and pulling the pipe-cleaner into the opening. Rotate the pipe-cleaner slowly as you do this.
3. Moisten a new cotton-swab with isopropyl alcohol.
4. Clean the interface by rubbing the cotton-swab over the surface using a small circular movement.
5. Using a new, dry pipe-cleaner, and a new, dry cotton-swab remove the alcohol, any dissolved sediment and dust.
6. Blow away any remaining lint with compressed air.

E

Cleaning Bare Fiber Adapters

Bare fiber adapters are difficult to clean. Protect from dust unless they are in use.

Caution

Never use any kind of solvent when cleaning a bare fiber adapter as

- Solvents can damage the foam inside some adapters.
- They can deposit dissolved dirt in the groove, which can then dirty the surface of an inserted fiber.

Preferred Procedure

Blow away any dust or dirt with compressed air.

Procedure for Stubborn Dirt

Use this procedure particularly when there is greasy dirt on the adapter:

Caution

Be careful when using pipe-cleaners, as the core and the bristles of the pipe-cleaner are hard and can damage the adapter.

1. Clean the adapter by pushing and pulling a new, dry pipe-cleaner into the opening. Rotate the pipe-cleaner slowly as you do this.
2. Clean the adapter by rubbing a new, dry cotton-swab over the surface using a small circular movement.
3. Blow away any remaining lint with compressed air.

Cleaning Bare Fiber Ends

Bare fiber ends are often used for splices or, together with other optical components, to create a parallel beam. The end of a fiber can often be scratched. You make a new cleave. To do this:

1. Strip off the cladding.
2. Take a new soft-tissue and moisten it with isopropyl alcohol.
3. Carefully clean the bare fiber with this tissue.
4. Make your cleave and immediately insert the fiber into your bare fiber adapter in order to protect the surface from dirt.

Cleaning Lenses

Some lenses have special coatings that are sensitive to solvents, grease, liquid and mechanical abrasion. Take extra care when cleaning lenses with these coatings.

Lens assemblies consisting of several lenses are not normally sealed. Therefore, use as little alcohol as possible, as it can get between the lenses and in doing so can change the properties of projection.

Preferred Procedure

1. Clean the lens by rubbing a new, dry cotton-swab over the surface using a small circular movement.
2. Blow away any remaining lint with compressed air.

Procedure for Stubborn Dirt

Use this procedure particularly when there is greasy dirt on the lens:

1. Moisten a new cotton-swab with isopropyl alcohol.
2. Clean the lens by rubbing the cotton-swab over the surface using a small circular movement.
3. Using a new, dry cotton-swab remove the alcohol, any dissolved sediment and dust.
4. Blow away any remaining lint with compressed air.

E

Cleaning Large Area Lenses and Mirrors

Caution

Some mirrors, such as those from a monochromator, are very soft and sensitive. Therefore, never touch them and do not use cleaning tools such as compressed air or polymer film.

Some lenses have special coatings that are sensitive to solvents, grease, liquid and mechanical abrasion. Take extra care when cleaning lenses with these coatings.

Lens assemblies consisting of several lenses are not normally sealed. Therefore, use as little liquid as possible, as it can get between the lenses and in doing so can change the properties of projection.

Preferred Procedure

1. Blow away any dust or dirt with compressed air.

Procedure for Stubborn Dirt

Use this procedure particularly when there is greasy dirt on the lens:

Caution

- Only use water if you are sure that your device does not corrode.
- Do not use hot water as this can lead to mechanical stress, which can damage your device.
- Make sure that your liquid soap has no abrasive properties or perfume in it, because they can scratch and damage your device.
- Do not use normal washing-up liquid as sometimes an iridescent film remains.

1. Moisten the lens or the mirror with water.
2. Put a little liquid soap on the surface and gently spread the liquid over the whole area.
3. Wash off the emulsion with water, being careful to remove it all, as any remaining streaks can impair measurement accuracy.
4. Take a new, dry soft-tissue and remove the water, by rubbing gently over the surface using a small circular movement.
5. Blow away remaining lint with compressed air.

Alternative Procedure A

To clean lenses that are extremely sensitive to mechanical stress or pressure you can also use an optical clean polymer film. This procedure is time-consuming, but you avoid scratching or destroying the surface.

1. Put the film on the surface and wait at least 30 minutes to make sure that the film has had enough time to dry.
2. Remove the film and any dirt with special adhesive tapes.

Alternative Procedure B

If your lens is sensitive to water then:

1. Moisten the lens or the mirror with isopropyl alcohol.
2. Take a new, dry soft-tissue and remove the alcohol, dissolved sediment and dust, by rubbing gently over the surface using a small circular movement.
3. Blow away remaining lint with compressed air.

E-10 Cleaning Procedures

Cleaning Fixed Connector Interfaces

A few instruments, such as the HP 8158B, have fixed connector interfaces. Generally, avoid cleaning this kind of interface, because it is difficult to remove any used alcohol or lint from the input of the optical block. Keep the dust caps on the interfaces unless it is in use.

If there is dust on the interface, try cleaning it using compressed air.

If there is fluid or greasy dirt on the interface then contact Hewlett-Packard, where trained personnel can open the instrument and do the cleaning. Never open the instrument to clean the optical block yourself, because the optical components can be easily scratched or misaligned.

Cleaning Optical Glass Plates

Some instruments, for example, the optical heads from Hewlett-Packard have an optical glass plate to protect the sensor. Clean this glass plate in the same way as optical lenses (see "Cleaning Lenses").

Cleaning Physical Contact Interfaces

Remove any connector interfaces from the optical output of the instrument before you start the cleaning procedure.

Cleaning interfaces is difficult as the core diameter of a singlemode fiber is only about $9\mu\text{m}$. This generally means you cannot see streaks or scratches on the surface. To be certain of the degree of pollution on the surface of your interface and to check whether it has been removed after cleaning, you need a microscope.

Warning

Never look into an optical output, because this can seriously damage your eye sight.

To assess the projection of the emitted light beam you can use an infrared sensor card. Hold the card approximately 5 cm from the interface. The invisible emitted light is projected onto the card and becomes visible as a small circular spot.

Preferred Procedure

1. Clean the interface by rubbing a new, dry cotton-swab over the surface using a small circular movement.
2. Blow away any remaining lint with compressed air.

Procedure for Stubborn Dirt

Use this procedure particularly when there is greasy dirt on the interface:

1. Moisten a new cotton-swab with isopropyl alcohol.
2. Clean the interface by rubbing the cotton-swab over the surface using a small circular movement.
3. Take a new, dry soft-tissue and remove the alcohol, dissolved sediment and dust, by rubbing gently over the surface using a small circular movement.
4. Blow away any remaining lint with compressed air.

E**Cleaning Recessed Lens Interfaces****Preferred Procedure**

1. Blow away any dust or dirt with compressed air.

If this is not sufficient, then

1. Clean the interface by rubbing a new, dry cotton-swab over the surface using a small circular movement.
2. Blow away any remaining lint with compressed air.

Procedure for Stubborn Dirt

Use this procedure particularly when there is greasy dirt on the interface, and using the procedure for light dirt is not sufficient. Using isopropyl alcohol should be your last choice for recessed lens interfaces because of the difficulty of cleaning out any dirt that is washed to the edge of the interface:

1. Moisten a new cotton-swab with isopropyl alcohol.
2. Clean the interface by rubbing the cotton-swab over the surface using a small circular movement.
3. Take a new, dry soft-tissue and remove the alcohol, dissolved sediment and dust, by rubbing gently over the surface using a small circular movement.
4. Blow away any remaining lint with compressed air.

Cleaning Fragile Optical Devices

Some optical devices, such as the HP 81000BR Reference Reflector, which has a gold plated surface, are very sensitive to mechanical stress or pressure. Do not use cotton-swabs, soft-tissues or other mechanical cleaning tools, as these can scratch or destroy the surface.

Preferred Procedure

1. Blow away any dust or dirt with compressed air.

Procedure for Stubborn Dirt

To clean devices that are extremely sensitive to mechanical stress or pressure you can also use an optical clean polymer film. This procedure is time-consuming, but you avoid scratching or destroying the surface.

1. Put the film on the surface and wait at least 30 minutes to make sure that the film has had enough time to dry.
2. Remove the film and any dirt with special adhesive tapes.

Alternative Procedure

For these types of optical devices you can often use an ultrasonic bath with isopropyl alcohol. Only use the ultrasonic bath if you are sure that it won't cause any damage to the device.

1. Put the device into the bath for at least three minutes.
2. Blow away any remaining liquid with compressed air.

If there are any streaks or drying stains on the surface, repeat the cleaning procedure.

Cleaning Metal Filters or Attenuator Gratings

This kind of device is extremely fragile. A misalignment of the grating leads to inaccurate measurements. Never touch the surface of the metal filter or attenuator grating. Be very careful when using or cleaning these devices. Do not use cotton-swabs or soft-tissues, as there is the danger that you cannot remove the lint and that the device will be destroyed by becoming mechanically distorted.

Preferred Procedure 1. Use compressed air at a distance and with low pressure to remove any dust or lint.

Procedure for Stubborn Dirt Do not use an ultrasonic bath as this can damage your device.

Use this procedure particularly when there is greasy dirt on the device:

1. Put the optical device into a bath of isopropyl alcohol, and wait at least 10 minutes.
2. Remove the fluid using compressed air at some distance and with low pressure.

If there are any streaks or drying stains on the surface, repeat the whole cleaning procedure.



Error Messages

Display Messages

AVA is the equivalent of **AVAILABLE** (see below), if Coherence Control is on or below Uncal level.

AVAILABLE indicates that the set value is too high for laser output while the instrument is warming up.

The value given in the message is the maximum power available.

CC UNCAL indicates that the set power value is too small to achieve full linewidth broadening.

EXC is the equivalent of **EXCESSIVE** (see below), if Coherence Control is on or below Uncal level.

EXCESSIVE indicates that the set value is greater than the laser can output at this wavelength.

The value given in the message (P =) is the actual power being output, the maximum power available at that wavelength.

INITIALIZING is displayed while the instrument is performing its internal initialization.

LASER PROTECTION indicates that the laser has been switched off to prevent damage to the laser diode.

Try, once or twice, to reenable the laser. If this does not work, try reducing the power, and then reenabling. If this does not work, press **(AUX) Realign** for Automatic Realignment. This will automatically realign the laser cavity. See “Automatic Realignment” in Chapter 3 for more information.

STABILIZING indicates that the laser heat chamber is not at operating temperature. It can take around 1 hour for the temperature to stabilize. The percentage value given as part of the message indicates how close the

instrument is to the operating temperature (100%). (See “Stabilizing” in Appendix A for more detailed information about stabilizing.)



HP-IB Messages

Instrument Specific Errors

These are error messages with positive error numbers. They indicate errors such as incompatible modes.

200 Not Attenuation Mode

This indicates that a command or query was received that cannot be executed or answered in Power Mode (see “[:SOURce]:POWER:ATTenuation:AUTO” in Chapter 5).

Command Errors

These are error messages in the range -100 to -199. They indicate that a syntax error has been detected by the parser in a command, such as incorrect data, incorrect commands, or misspelled or mistyped commands.

A command error is signaled by the command error bit (bit 5) in the event status register.

-100 Command error. This indicates that the parser has found a command error but cannot be more specific.

-101 Invalid character. The command contains an invalid or unrecognized character.

-102 Syntax error. The command or data could not be recognized.

-103 Invalid separator. The parser was expecting a separator (for example, a semicolon (;) between commands) but did not find one.

-104 Data type error. The parser was expecting one data type, but found another (for example, was expecting a string, but received numeric data).

-105 GET not allowed. A Group Execute Trigger was received within a program message (see IEEE 488.2, 7.7)

-108 Parameter not allowed. More parameters were received for a command than were expected.

F

-109 Missing parameter. Fewer parameters were received than the command requires.

-110 Command header error. A command header is the mnemonic part of the command (the part not containing parameter information. This error indicates that the parser has found an error in the command header but cannot be more specific.

F

-111 Header separator error. A character that is not a valid header separator was encountered.

-112 Program mnemonic too long. The program mnemonic must be 12 characters or shorter.

-113 Undefined header. This header is not defined for use with the instrument.

-114 Header suffix out of range. The header contained an invalid character. This message sometimes occurs because the parser is trying to interpret a non-header as a header.

-120 Numeric data error. This error indicates that the parser has found an error in numeric data (including nondecimal numeric data) but cannot be more specific.

-121 Invalid character in number. An invalid character was found in numeric data (note, this may include an alphabetic character in a decimal data, or a "9" in octal data).

-123 Exponent too large. The exponent must be less than 32 000.

-124 Too many digits. The mantissa of a decimal number can have a maximum of 255 digits (leading zeros are not counted).

-128 Numeric data not allowed. Another data type was expected for this command.

-130 Suffix error. The suffix is the unit, and the unit multiplier for the data. This error indicates that the parser has found an error in the suffix but cannot be more specific.

-131 Invalid suffix. The suffix is incorrect or inappropriate.

-134 Suffix too long. A suffix can have a maximum of 12 characters.

-138 Suffix not allowed. A suffix was found where none is allowed.

F-4 Error Messages

- 140 **Character data error.** This error indicates that the parser has found an error in character data but cannot be more specific.
- 141 **Invalid character data.** The character data is incorrect or inappropriate.
- 144 **Character data too long.** Character data can have a maximum of 12 characters.
- 148 **Character data not allowed.** Character data was found where none is allowed.
- 150 **String data error.** This error indicates that the parser has found an error in string data but cannot be more specific.
- 151 **Invalid string data.** The string data is incorrect, (for example, an END message was received before the terminal quote character).
- 158 **String data not allowed.** String data was found where none is allowed.
- 160 **Block data error.** This error indicates that the parser has found an error in block data but cannot be more specific.
- 161 **Invalid block data.** The block data is incorrect (for example, an END message was received before the length was satisfied).
- 168 **Block data not allowed.** Block data was found where none is allowed.

F



Execution Errors

These are error messages in the range -200 to -299. They indicate that an execution error has been detected by the execution control block.

An execution error is signaled by the execution error bit (bit 4) in the event status register.

F

-200 Execution error. This indicates that an execution error has occurred but the control block cannot be more specific.

-201 Invalid while in local. This command is invalid because it conflicts with the configuration under local control.

-202 Settings lost due to rtl. A local setting was lost when the instrument was changing from remote to local control, or from local to remote control.

-220 Parameter error. This indicates that a parameter error has occurred but the control block cannot be more specific.

-221 Settings conflict. A valid parameter was received, but could not be used during execution because of a conflict with the current state of the instrument.

-222 Data out of range. The data, though valid, was outside the range allowed by the instrument.

-223 Too much data. The block, expression, or string data was too long for the instrument to handle.

-224 Illegal parameter value. One value from a list of possible values was expected. The parameter received was not found in the list.

-240 Hardware error. Indicates that a command could not be executed due to a hardware error but the control block cannot be more specific.

-241 Hardware missing. Indicates that a command could not be executed because of missing instrument hardware.

Device-Specific Errors

These are error messages in the range -300 to -399, or between 1 and 32767. They indicate that an error has been detected that is specific to the operation of the tunable laser source.

A device-specific error is signaled by the device-specific error bit (bit 3) in the event status register.

-300 Device-specific error. This indicates that a device-specific error has occurred. No more specific information is available.

-310 System error. An instrument system error has occurred.

-311 Memory error. A memory error has been detected.

-314 Save/recall memory lost. The nonvolatile data saved by the *SAV command has been lost.

-315 Configuration memory lost. The nonvolatile configuration data saved by the instrument has been lost.

-330 Self-test failed. Further information about the self-test failure is available by using *TST?.

-350 Queue overflow. The error queue has overflowed. This error is written to the last position in the queue, no further errors are recorded.

F

Query Errors

These are error messages in the range -400 to -499. They indicate that an error has been detected by the output queue control.

A device-specific error is signaled by the query error bit (bit 2) in the event status register.

F

-300 Query error. This indicates that a query error has occurred. No more specific information is available.

-410 Query INTERRUPTED. A condition occurred that interrupted the transmission of the response to a query (for example, a query followed by a DAB or a GET before the response was completely sent).

-420 Query UNTERMINATED. A condition occurred that interrupted the reception of a query (for example, the instrument was addressed to talk and an incomplete program message was received).

-430 Query DEADLOCKED. A condition causing a deadlocked query has occurred (for example, both the input and the output buffer are full and the device cannot continue).

-440 Query UNTERMINATED after indefinite response. Two queries were received in the same message. The error occurs on the second query if the first requests an indefinite response, and was already executed.

The Passive Component Test (PACT) software

Getting Started

What is the Passive Component Test Software?

This software makes it possible for you to use your tunable laser source to control a system for testing pigtailed or connectorized passive devices (filters, couplers, and isolators) over wavelength. A typical system consists of a tunable laser source, a power meter and a printer. This manual describes how to use this software.

Depending on the configuration of the system you have, you can measure

- Insertion loss (single channel power measurement) over wavelength.
- Coupling ratio (dual channel power ratio measurement) over wavelength.
- Return loss over wavelength.

The system also has a memory card slot, and a printer driver so that you can make electronic and hardcopy records of your measurements.

The measurement applications, and the use of the memory card and of printers, are described individually in the following sections.

Starting the Passive Component Test Software

Press **(Aux)**, and then **PACT** to start the passive component test software.

The main display for the software shows the hardware configuration of the system, with the HP-IB connections between the instruments and the printer, and the optical connections to the Device Under Test (DUT).

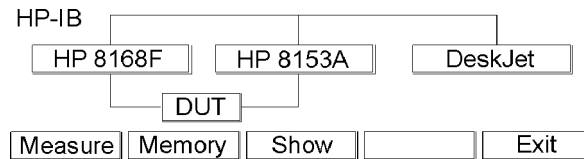

Figure G-1. The Main Screen

Getting Help while Using the System

Press **HELP** to get help.

When you press this key, the first help information is displayed.



G

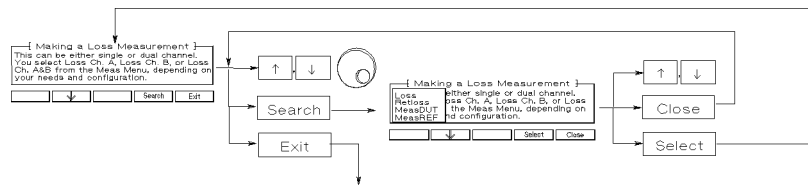

Figure G-2. A Summary of the Help Hard- and Softkeys

Press **Search** to get the help topics menu.

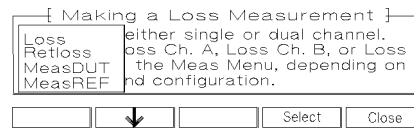

Figure G-3. The Help Topics Menu

Choose a topic using **↑** and **↓**, or the Modify Knob. Press **Select**, or **ENTER** to get the information.

Press **Close** to close the help topics menu without selecting a topic.

Many of the help texts are longer than one display. You move through the information using **↑** and **↓**.

G-2 The Passive Component Test (PACT) software

Making Loss Measurements

This section describes the steps used to make a loss measurement, and gives an example of a loss measurement you can make with a minimum of extra equipment.

Setting Up the Hardware

To make a loss (insertion loss) measurement you will need the following items.

- Your tunable laser source with
 - a connector interface on the optical output.
- a HP 8153A Lightwave Multimeter mainframe with
 - a lightwave multimeter power sensor module in either channel A or channel B with
 - a connector interface on the optical input.
- a HP-IB cable to connect the source to the multimeter.

Depending on the optical system you are measuring, you will also need

- A patchcord to connect the source to the device under test.
- A patchcord to connect the device under test to the sensor.

Set up the hardware as shown in the figure below, making sure that all the connectors are clean.

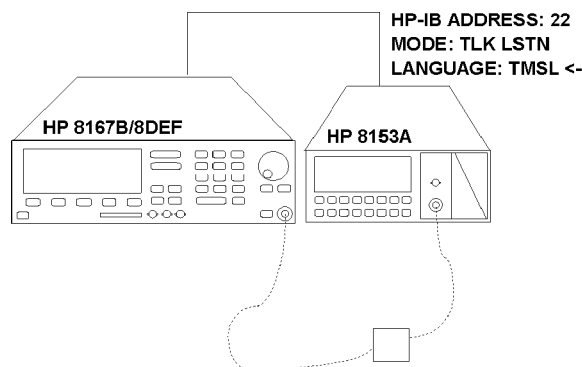

Figure G-4. Hardware Set-Up for a Loss Measurement

If you are connecting a printer, you may want to do this at the same time. See “Setting Up the Printer” for details on connecting printers.



Making the Loss Measurement

Note



You cannot set the output power from within the passive component test software. You should set this before starting the software. See Chapter 2.

If you want to set the power to the maximum level, you may find it useful to know that the sweep parameters inside and outside the passive component test software are the same. This means that you can set the sweep parameters in the standard software, and use $P_{max} \rightarrow P$ to set the power level, and then use these values in the passive component test software.

G

To start the loss measurement you should do the following.

1. If it is not already active, activate the passive component test software (Press **Aux**), and then **PACT**. You can also use this key sequence to return to the Main display from within the passive component test software).

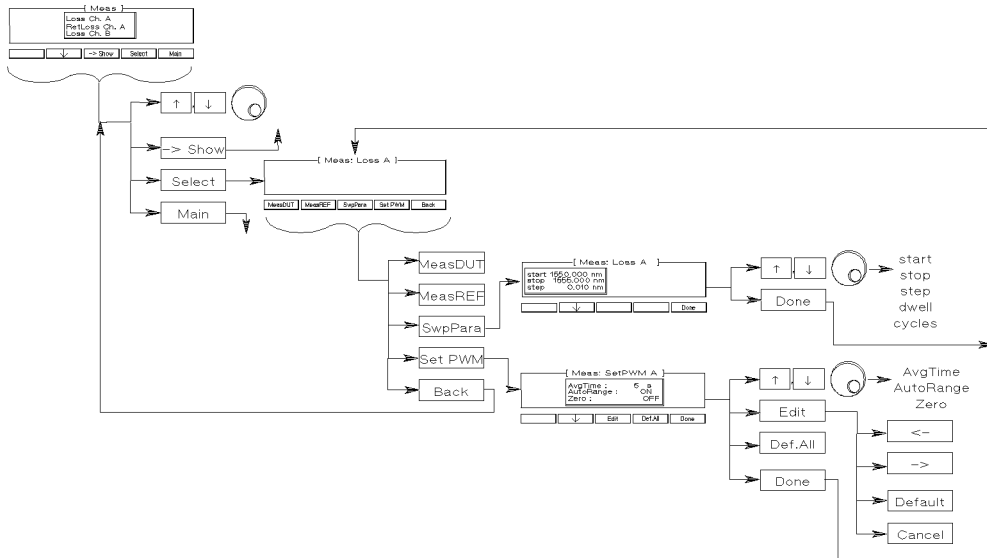

Figure G-5. A Summary of the Loss Softkeys

2. Press **Measure**.

G-4 The Passive Component Test (PACT) software

3. Scroll through the menu (use the up and down arrow softkeys, or the Modify Knob), until Loss Ch. A or Loss Ch. B is highlighted, whichever is applicable (that is, Loss Ch. A if your sensor is in channel A of the multimeter, Loss Ch. B if it is in channel B).
4. Press **Select**.



Figure G-6. The Loss Measurement Display

This is the loss measurement display. From here you set up for and run the loss measurement.

Setting the Power Meter

Note The values you set for the power meter apply to all of the measurements using this channel. They are not set specifically for each measurement.



If you need to set up the power meter for the measurement, press **SetPWM**.

There are three parameters for the power meter,

- AvgTime, this is the averaging time for the measurement,
- AutoRange, this sets whether the meter is autoranging or not,
- Zero, this sets whether the meter is zeroed before each set of measurements (that is, a measurement over the complete wavelength sweep, such as a reference measurement, or a DUT measurement) or not.

Note The laser active LED is left on even if the sensor is being zeroed. The laser itself, is switched off while the zeroing is being carried out.





Figure G-7. The Set Power Meter Display

You move from one parameter to the next, using \uparrow and \downarrow , the Modify Knob, or **ENTER**.

Press **Def.All** to set all of the parameters to their default values (200ms averaging time, autoranging on, without zeroing).

Edit a parameter by pressing **EDIT** or **Edit**.

All of these parameters have restricted possible values. You choose between these values using the **<-** and the **->** keys.

Press **ENTER** or **Enter** when you have finished editing the parameter.

Press **Back** to return to the loss measurement.

Setting the Sweep

Note



The values you set for the sweep apply to all of the measurements and to the λ -Sweep of the tunable laser source. They are not set specifically for each measurement.

There are five parameters for the wavelength sweep. You access these by pressing **SwpPara**.

- **start**, the wavelength with which the sweep begins.
- **stop**, the wavelength at which the sweep ends.
- **step**, the size of the change in wavelength for each step.
- **dwll**, the amount of time spent at the wavelength during each step. The power meter begins to measure after the dwell time is finished.
- **cycles**, the number of times the sweep is repeated. The results from the cycles are averaged.

G-6 The Passive Component Test (PACT) software

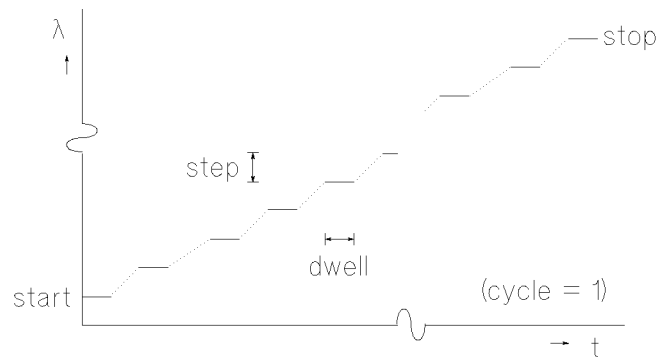

Figure G-8. The Parameters for a Wavelength Sweep

G

You move from one parameter to the next, using \uparrow and \downarrow , the Modify Knob, or **(ENTER)**. Only three of the parameters can be displayed at a time, you scroll the other parameters onto the display.

Edit a parameter by pressing **(EDIT)** or by starting to type the new value.

Press **(ENTER)** when you have finished editing the parameter.

Press **Done** to return to the loss measurement.

Measuring the Reference

Set up the hardware for measuring the reference, making sure that all the connectors are clean. That is, connect the source to the sensor, through all the system components, but excluding the Device Under Test.

In the simplest case you can use a universal through adapter with the appropriate connector interfaces to join the two patchcords.

Press **MeasREF** to start the reference measurement.



Figure G-9. Measuring the Reference

The percentage value at the bottom left of the display indicates the amount of the measurement that has been completed (this number is useful when you are averaging over a number of cycles).

Measuring the Device Under Test

Put the Device Under Test (DUT) into the test setup.

Press **MeasDUT** to measure the DUT.

The percentage value at the bottom left of the display indicates the amount of the measurement that has been completed (this number is useful when you are averaging over a number of cycles).

G

Looking at the Results

You can look at the results of the test, on the display, or print them on a printer. See “Printing Your Results” for more details on showing the results.

There is a short cut to the Show Display:

After making the measurement, from the Loss Measurement Display, press **Back**.

On the Measurement Display, press **→ Show**

Example, Measuring the Characteristic of a Fabry-Perot Resonator

This example uses the loss measurement to measure the characteristic of a simple Fabry-Perot resonator. The resonator is created by separating two connectors in a through-adaptor. The measurement is made in the range 1550nm to 1555nm, with a resolution of 0.025nm. The DUT connectors are Diamond HMS-10/HP. We will use a HP 81531A Power Sensor.

1. Set up the hardware as shown below, making sure that all the connectors are clean:

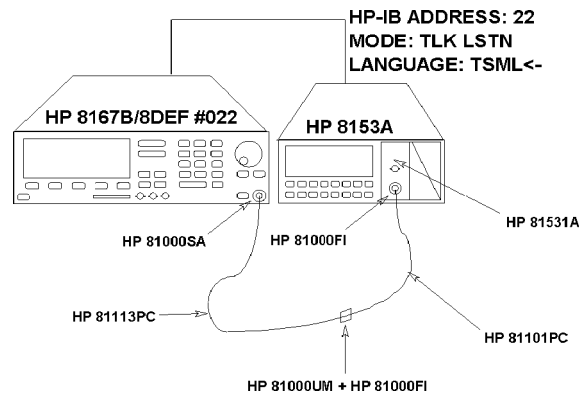

G 

Figure G-10. Test Set-Up to Characterize a Fabry-Perot Resonator

- a. Connect the tunable laser source to the multimeter with the HP-IB cable.
- b. Make sure that the power sensor is installed in the multimeter mainframe in channel A.
- c. Connect both instruments to the electric supply.
- d. Switch on both instruments.

Note



Under normal circumstances you should leave the instruments to warm-up. (The multimeter needs around 20 minutes to warm-up. The tunable laser displays *Stabilizing* at the top of its display until it is warmed-up). Warming up is necessary for accuracy of the sensor, and the output power of the source.

- e. Connect patchcords to the sensor module and to the tunable laser source. If your tunable laser source has a slanted connector, make sure that the orange-sleeved (slanted) connector on the fiber is connected to the tunable laser source. You can do this while the instruments are warming up.
- f. Connect the two patchcords together using the through-adapter.

2. Set the power to the default value:
 - a. Press **OUTPUT POWER**.
 - b. Press **EDIT**.
 - c. Press **Default**.
3. Start the passive component test software:
 - a. Press **Aux**.
 - b. Press **PACT**.
4. Select the loss application:
 - a. Press **Measure**.
 - b. Scroll through the applications until **Loss Ch. A** is highlighted. You can do this with the **↑** and **↓** keys, or with the Modify Knob.
 - c. Press **Select**.
5. Set the power meter to default conditions (that is, for a 200ms averaging time, with autoranging enabled, but no zeroing):
 - a. Press **SetPWM**.
 - b. Press **Def.All**.
 - c. Press **Done**.
6. Set the sweep parameters for a sweep from 1550nm to 1555nm, with a step size of 0.025nm:
 - a. Press **SwpPara**.
 - b. Type 1550, and press **ENTER**.
 - c. Type 1555, and press **ENTER**.
 - d. Type 0.025, and press **ENTER**.
 - e. Type 0, and press **ENTER**.
 - f. Type 1, and press **ENTER**.
 - g. Press **Done**.

G-10 The Passive Component Test (PACT) software

7. Measure the reference:

- a. Make sure that the two connectors are tightly in the through-adapter.
- b. Activate the laser.
- c. Press **MeasREF**.

8. Measure the Device Under Test (DUT):

- a. Unscrew the two connectors, and pull each of them slightly out of the through-adapter, so that they are separated by a millimeter or two.
- b. Press **MeasDUT**.

To look at a graph of the wavelength characteristic:

9. Change to the Show function:

- a. Press **Back**.
- b. Press **→Show**.

10. Look at the graph of the result from A in Watts:

- a. Scroll through the available graphs until **A / RefA [dB]** is highlighted.
- b. Press **Select**.
- c. Press **Preview**.

11. When you have finished with the preview, press any of the unmarked softkeys to return to the Show Display.

12. Press **Back** and then **→Meas** to return to the Measurement Display.

G

Making Return Loss Measurements

This section describes how to make a return loss measurement using the HP 81534A Return Loss Module, and gives an example of a return loss measurement you can make with a minimum of extra equipment.

Note



It is also possible to make this measurement with the software using an external splitter and a standard sensor module.

G

Setting Up the Hardware

To make a return loss measurement you will need the following items.

- Your tunable laser source with
 - a connector interface on the optical output.
- a HP 8153A Lightwave Multimeter mainframe with
 - the HP 81534A Return Loss Module in either channel A or channel B with
 - connector interfaces on the optical input and output.
- a HP-IB cable to connect the source to the multimeter.

Depending on the optical system you are measuring, you will also need

- a patchcord to connect the laser source to the input of the return loss module,
- a patchcord to connect the module to the device under test.

Note



Check the notes in the manual for your return loss module for extra things you should consider if you are using the pigtail option.

Set up the hardware as in the figure below, making sure that all the connectors are clean.

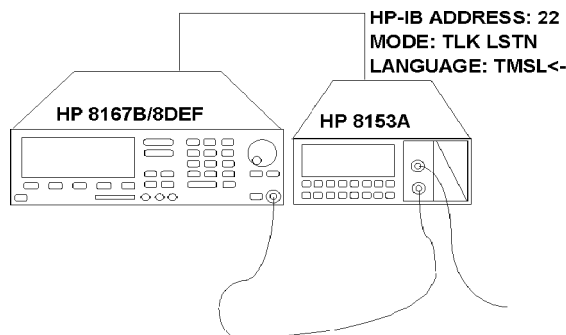

Figure G-11.
Hardware Set-Up for a Return Loss Measurement

G 

If you are connecting a printer you may want to do this at the same time. See “Setting Up the Printer” for details on connecting printers.

Making the Return Loss Measurement

For information on the theory behind this method of measuring the Return Loss, please refer to the manual with your HP 81534A Return Loss Module. This also explains the terms used by the Passive Component Test Software.

Note



You cannot set the output power from within the passive component test software. You should set this before starting the software. See Chapter 2.

If you want to set the power to the maximum level, you may find it useful to know that the sweep parameters inside and outside the passive component test software are the same. This means that you can set the sweep parameters in the standard software, and use **Pmax->P** to set the power level, and then use these values in the passive component test software.

To start the return loss measurement you should do the following.

1. If it is not already active, activate the passive component test software (Press **Aux**, and then **PACT**. You can also use this key sequence to return to the Main display from within the passive component test software).

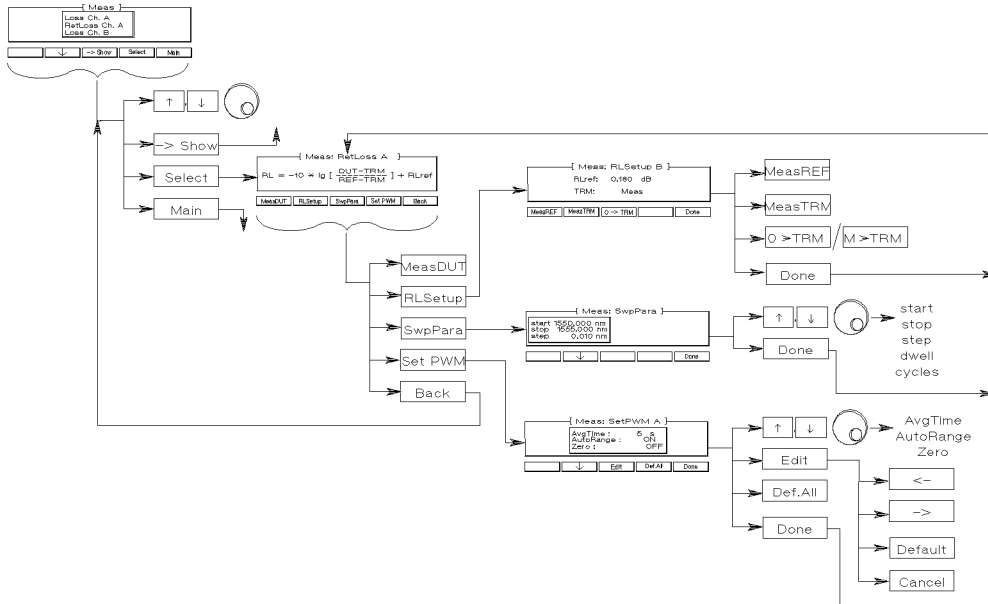

Figure G-12. A Summary of the Return Loss Softkeys

2. Press **Measure**.
3. Scroll through the menu (use the up and down arrow softkeys, or the Modify Knob), until **RetLoss Ch. A** or **RetLoss Ch. B** is highlighted, whichever is applicable (that is, **RetLoss Ch. A** if your sensor is in channel A of the multimeter, **RetLoss Ch. B** if it is in channel B).
4. Press **Select**.

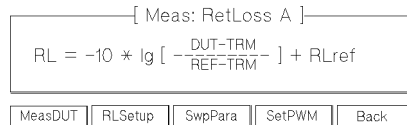



Figure G-13. The Return Loss Measurement Display

This is the return loss measurement display. From here you set up for and run the return loss measurement.

G-14 The Passive Component Test (PACT) software

The formula on the display is the one used to calculate the return loss. For a derivation of this formula, see the manual for the HP 81534A Return Loss Module.

Setting the Power Meter

Note  The values you set for the power meter apply to all of the measurements using this channel. They are not set specifically for each measurement.

If you need to set up the power meter for the measurement, press **SetPwM**.

There are three parameters for the power meter,

- **AvgTime**, this is the averaging time for the measurement,
- **AutoRange**, this sets whether the meter is autoranging or not,
- **Zero**, this sets whether the meter is zeroed before each set of measurements (that is, a measurement over the complete wavelength sweep, such as a reference measurement, or a DUT measurement) or not.



Note  The laser active LED is left on even if the sensor is being zeroed. The laser itself, is switched off while the zeroing is being carried out.



Figure G-14. The Set Power Meter Display

You move from one parameter to the next, using  and , the Modify Knob, or **ENTER**.

Press **Def.All** to set all of the parameters to their default values (200ms averaging time, autoranging on, without zeroing).

Edit a parameter by pressing **EDIT** or **Edit**.



All of these parameters have restricted possible values. You choose between these values using the <- and the -> keys.

Press **ENTER** or **Enter** when you have finished editing the parameter.

Press **Back** to return to the loss measurement.

Setting the Sweep

Note



The values you set for the sweep apply to all of the measurements and to the λ -Sweep of the tunable laser source. They are not set specifically for each measurement.

There are five parameters for the wavelength sweep. You access these by pressing **SwpPara**.

- **start**, the wavelength with which the sweep begins.
- **stop**, the wavelength at which the sweep ends.
- **step**, the size of the change in wavelength for each step.
- **dwll**, the amount of time spent at the wavelength during each step. The power meter begins to measure after the dwell time is finished.
- **cycles**, the number of times the sweep is repeated. The results from the cycles are averaged.

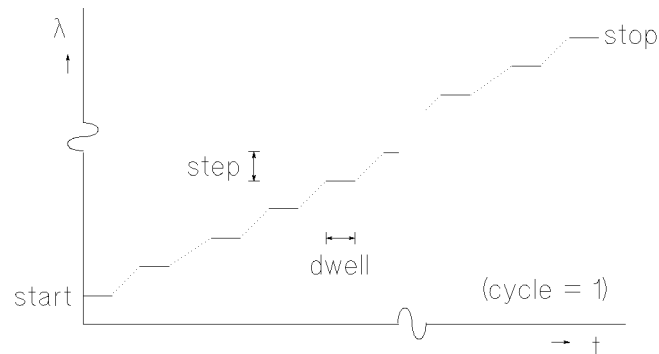

Figure G-15. The Parameters for a Wavelength Sweep

You move from one parameter to the next, using \uparrow and \downarrow , the Modify Knob, or **ENTER**. Only three of the parameters can be displayed at a time, you scroll the other parameters onto the display.

Edit a parameter by pressing **EDIT** or by starting to type the new value.

Press **ENTER** when you have finished editing the parameter.

Press **Done** to return to the loss measurement.

Measuring the Reference Reflection

The reference reflection (REF) and the reflection factor for the reference reflection (RLref) are on the RLSetup display (you may need to press **RLSetup** from the return loss measurement display to get to this display).

Set up the hardware for measuring the reference reflection, making sure that all the connectors are clean. That is, connect the setup, but instead of the DUT attach an element with a known reflection factor. In the simplest case, this will be an open connector (which has a reflection factor of 14.6dB), but more accurate is a HP 81000BR Reference Reflector (which has a reflection factor of 0.18 ± 0.1 dB).

Set the value of **RLref** to that for the reflection factor.

Press **MeasREF** to start the measurement of the reference reflection.

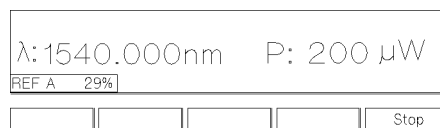

Figure G-16. Measuring the Reference Reflection

The percentage value at the bottom left of the display indicates the amount of the measurement that has been completed (this number is useful when you are averaging over several cycles).

Measuring the Termination Parameter

The termination parameter is measured with the test setup terminated, so that there are no reflections from the end where the DUT will be attached. This is a measurement of the optical and the electrical background noise in the setup.



Including or Excluding the Termination Parameter. The termination parameter (TRM) is on the RLSetup display (you may need to press **RLSetup** from the return loss measurement display to get to this display). It shows whether the termination parameter is being used in the calculation or not (because its value is small, you may want to ignore it, rather than measure it). If TRM is **Meas** then the measured value is necessary for the calculation, if it is **Ignore** then the value is being ignored.

Press **0** → **TRM** to exclude the termination parameter from the calculation.

Press **M** → **TRM** to include the measured termination parameter in the calculation.

G

Measuring the Termination Parameter. If you are measuring the termination parameter, set up the hardware, making sure that all the connectors are clean. That is, connect the full setup up to the DUT, but terminate the setup just before the DUT. You can do this by wrapping the fiber just before the final connector around a pencil or pen four or five times.

Press **MeasTRM** to measure the termination parameter.

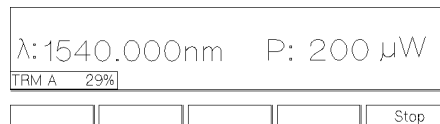

Figure G-17. Measuring the Termination Parameter

The percentage value at the bottom left of the display indicates the amount of the measurement that has been completed (this number is useful when you are averaging over several cycles).

Measuring the Device Under Test

Put the device under test into the setup.

Press **MeasDUT** to measure the DUT.

The percentage value at the bottom left of the display indicates the amount of the measurement that has been completed (this number is useful when you are averaging over several cycles).

Looking at the Results

You can look at the results of the test, on the display, or print them on a printer. See “Printing Your Results” for more details on showing the results.

There is a short cut to the Show Display:

After making the measurement, from the Return Loss Measurement Display, press **Back**.

On the Measurement Display, press **→ Show**

G



Example, Measuring the Return Loss of a Fabry-Perot Resonator

This example measures the return loss characteristic of a simple Fabry-Perot resonator. The resonator is created by separating two connectors in a through adapter.

The measurement is made in the range 1500nm to 1565nm, with a resolution of 0.25nm. The laser is given half a second to settle before the measurement is made, and the measurement is made twice to eliminate noise. The DUT connectors are Diamond HMS-10/HP.

1. Set up the hardware as shown below, making sure that all the connectors are clean:

Caution



Make sure that the slanted connector is connected to the output of the return loss module. Failure to do this can damage the connectors.

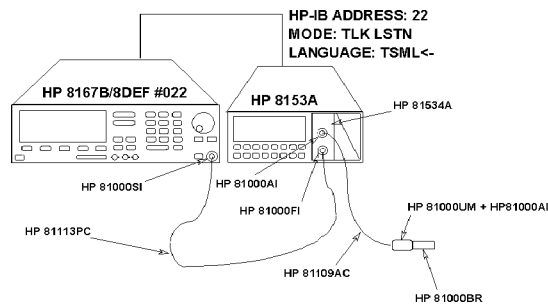

Figure G-18. Test Set-Up to Measure the Reference Reflection

- a. Connect the tunable laser source to the multimeter with the HP-IB cable.

G-20 The Passive Component Test (PACT) software

- b. Make sure that the return loss module is installed in the multimeter mainframe in channel A.
- c. Connect both instruments to the electric supply.
- d. Switch on both instruments.

Note



Under normal circumstances you should leave the instruments to warm-up. (The multimeter needs around 20 minutes to warm-up. The tunable laser displays *Stabilizing* at the top of its display until it is warmed-up). Warming up is necessary for accuracy of the sensor, and the output power of the source.

- e. Connect a patchcord from the tunable laser source to the input of the return loss module. If your tunable laser source has an angled connector, make sure that the orange-sleeved (slanted) connector on the fiber is connected to the tunable laser source.
 - f. Connect a patchcord from the output of the return loss module to the HP 81000AM Through Adapter
 - g. Attach the HP 81000BR Reference Reflector to the other side of the through adapter.
2. Set the sweep parameters for a sweep from 1500nm to 1565nm, with a step size of 0.25nm:
 - a. Press **WAVELENGTH**
 - b. Press **λ-Sweep**.
 - c. Type 1500, and press **ENTER**.
 - d. Type 1565, and press **ENTER**
 - e. Type 0.25, and press **ENTER**.
 - f. Type 0.5, and press **ENTER**.
 - g. Type 2, and press **ENTER**.
 3. Set the power to the maximum value:
 - a. Press **Pmax→P**.
 4. Start the passive component test software:
 - a. Press **Aux**.

G



b. Press **PACT**.

5. Select the return loss application:

a. Press **Measure**.

b. Scroll through the applications until **RetLoss Ch. A** is highlighted. You can do this with the **↑** and **↓** keys, or with the **Modify Knob**.

c. Press **Select**.

6. Set the power meter for default conditions, that is 200ms averaging time, with autoranging enabled, but no zeroing:

a. Press **SetPWM**.

b. Press **Def.All**.

c. Press **Done**.

7. Measure the reflection reference:

a. Type 0.18, press **ENTER**.

b. Make sure that the fiber and the reflector are tightly in the through adapter.

c. Activate the laser.

d. Press **RLSetup**.

e. Press **MeasREF**.

8. Measure the termination parameter:

a. Remove the reference reflector and store it away carefully.

b. Make sure that **TRM** is set to **Meas** (press **M→TRM** if it is not).

c. Wind the fiber just in front of the through adapter four or five times around the shaft of a pencil.

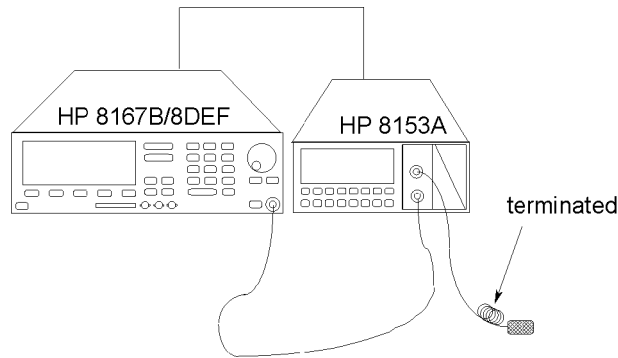

Figure G-19. Test Setup for Measuring the Termination Parameter

- d. Press **MeasTRM**.
9. Measure the Device Under Test (DUT):
- a. Unwind the fiber at the through adapter.
 - b. Attach a terminated fiber to the other side of the through adapter (this is an ordinary patchcord, with the fiber after the connector wrapped four or five times around the shaft of a pencil).
 - c. Unscrew the two connectors, and pull each of them slightly out of the through adapter, so that they are separated by a millimeter or two.

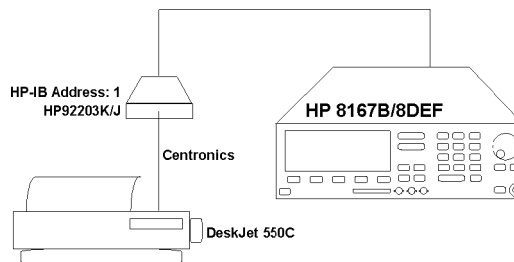

Figure G-20. Test Setup for Measuring the Fabry-Perot Resonator

G

d. Press **Done**.

e. Press **MeasDUT**.

To look at a graph of the wavelength characteristic:

10. Change to the Show function:

a. Press **Back**.

b. Press **—Show**.

11. Look at the results:

a. Scroll through the available graphs until **RetLossA [dB]** is highlighted.

b. Press **Select**.

c. Press **Preview**.

12. When you have finished with the preview, press any of the unmarked softkeys to return to the Show Display.

13. Press **Back** and then **->Meas** to return to the Measurement Display.

G

Making Loss Ratio Measurements

This section describes how to make a ratio measurement. The result could also be crosstalk, coupling ratio, or suppression, according to the the device being measured. At the end of the section there is a ratio measurement you can make with an additional wave-division multiplexer.

Setting Up the Hardware

To make a ratio measurement you will need the following items:

- Your tunable laser source with
 - a connector interface on the optical output.
- An HP 8153A Lightwave Multimeter mainframe with
 - a lightwave multimeter power sensor module in both channel A and channel B with
 - a connector interface on the optical input of each.
- An HP-IB cable to connect the source to the multimeter.

Depending on the optical system you are measuring, you will also need

- A patchcord to connect the source to the device under test.
- Patchcords to connect the device under test to the sensors.

Set up the hardware as shown in the figure below, making sure that all the connectors are clean.

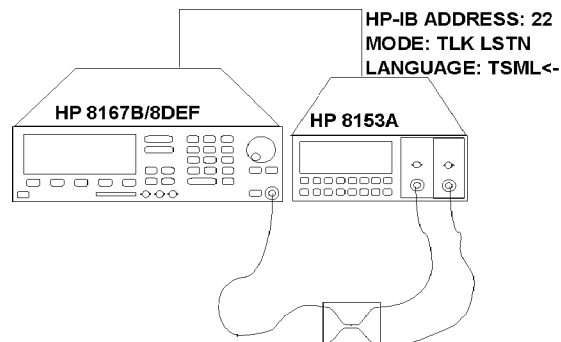

Figure G-21.
Hardware Setup for a Loss Ratio Measurement



If you are connecting a printer, you may want to do this at the same time. See “Setting Up the Printer” for details on connecting printers.

Making the Loss Ratio Measurement

Note



You cannot set the output power from within the passive component test software. You should set this before starting the software. See Chapter 2.

If you want to set the power to the maximum level, you may find it useful to know that the sweep parameters inside and outside the passive component test software are the same. This means that you can set the sweep parameters in the standard software, and use **Pmax->P** to set the power level, and then use these values in the passive component test software.

To start the ratio measurement you should do the following.

1. If it is not already active, activate the passive component test software (Press **Aux**, and then **PACT**. You can also use this key sequence to return to the Main display from within the passive component test software).

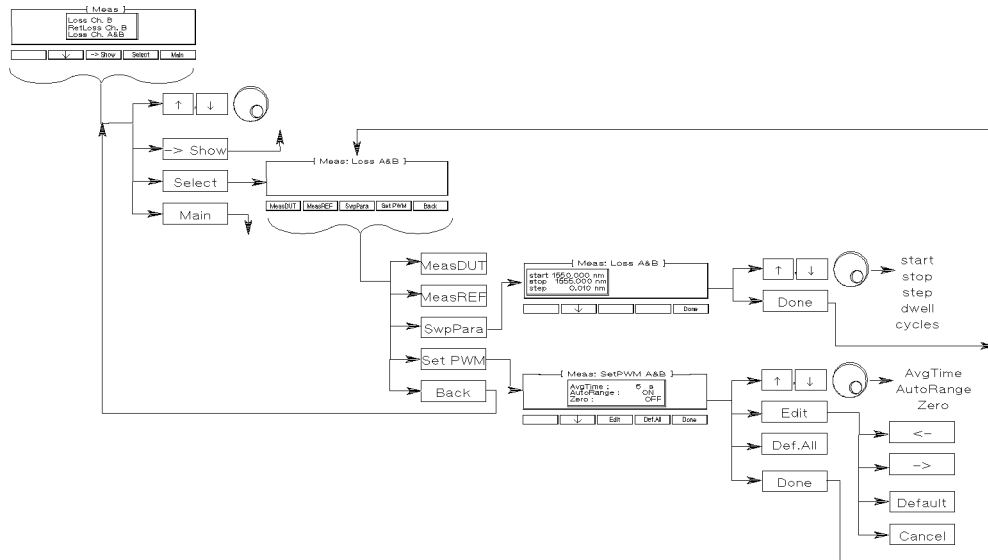

Figure G-22. A Summary of the Loss Ratio Softkeys

2. Press **Measure**.
3. Scroll through the menu (use the up and down arrow softkeys, or the Modify Knob), until **Loss Ch. A&B** is highlighted.
4. Press **Select**.

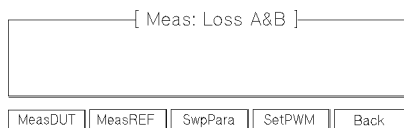

Figure G-23. The Loss Ratio Measurement Display

This is the ratio measurement display. From here you set up for and run the ratio measurement.

Setting the Power Meter

Note



The values you set for the power meter apply to all of the measurements using this channel. They are not set specifically for each measurement.

If you need to set up the power meter for the measurement, press **SetPWM**.

There are three parameters for the power meter,

- **AvgTime**, this is the averaging time for the measurement,
- **AutoRange**, this sets whether the meter is autoranging or not,
- **Zero**, this sets whether the meter is zeroed before each set of measurements (that is, a measurement over the complete wavelength sweep, such as a reference measurement, or a DUT measurement) or not.

Note



The laser active LED is left on even if the sensor is being zeroed. The laser itself, is switched off while the zeroing is being carried out.



Figure G-24. The Set Power Meter Display

You move from one parameter to the next, using **↑** and **↓**, the Modify Knob, or **ENTER**.

Press **Def.All** to set all of the parameters to their default values (200ms averaging time, autoranging on, without zeroing).

Edit a parameter by pressing **EDIT** or **Edit**.

All of these parameters have restricted possible values. You choose between these values using the **<-** and the **->** keys.

Press **ENTER** or **Enter** when you have finished editing the parameter.

Press **Back** to return to the loss measurement.

Setting the Sweep

Note



The values you set for the sweep apply to all of the measurements and to the λ -Sweep of the tunable laser source. They are not set specifically for each measurement.

There are five parameters for the wavelength sweep. You access these by pressing **SwpPara**.

- **start**, the wavelength with which the sweep begins.
- **stop**, the wavelength at which the sweep ends.
- **step**, the size of the change in wavelength for each step.
- **dwll**, the amount of time spent at the wavelength during each step. The power meter begins to measure after the dwell time is finished.
- **cycles**, the number of times the sweep is repeated. The results from the cycles are averaged.

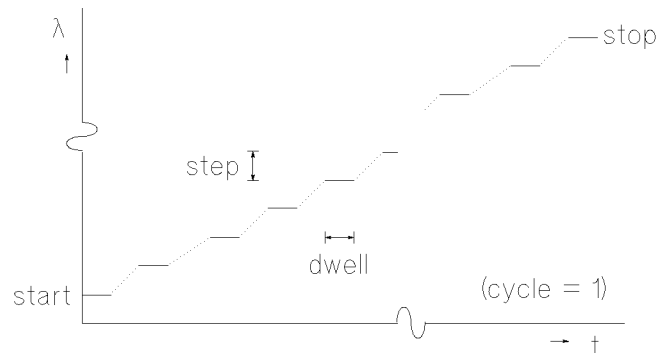

Figure G-25. The Parameters for a Wavelength Sweep

You move from one parameter to the next, using **↑** and **↓**, the Modify Knob, or **ENTER**. Only three of the parameters can be displayed at a time, you scroll the other parameters onto the display.



Edit a parameter by pressing **EDIT** or by starting to type the new value.

Press **ENTER** when you have finished editing the parameter.

Press **Done** to return to the loss measurement.

Measuring the Reference

Set up the hardware for measuring the reference, making sure that all the connectors are clean. That is, connect the source to the sensors, through all the system components, but excluding the the Device Under Test.

In the simplest case you can use a universal through adapter with the appropriate connector interfaces to join the two patchcords.

Press **MeasREF** to start the reference measurement.



G

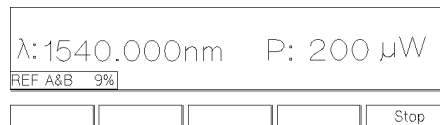

Figure G-26. Measuring the Reference

The percentage value at the bottom left of the display indicates the amount of the measurement that has been completed (this number is useful when you are averaging over several cycles).

If the device under test is a coupler, and you have problems measuring the reference for both channels simultaneously, you can measure the reference for each channel separately (using **MeasREF** under Loss Ch. A, and then under Loss Ch. B).

Measuring the Device Under Test

Put the Device Under Test (DUT) into the system under test.

Press **MeasDUT** to measure the DUT.

The percentage value at the bottom left of the display indicates the amount of the measurement that has been completed (this number is useful when you are averaging over several cycles).

G-30 The Passive Component Test (PACT) software

Looking at the Results

You can look at the results of the test, on the display, or print them on a printer. See “Printing Your Results” for more details on showing the results.

There is a short cut to the Show Display:

After making the measurement, from the Loss Ratio Measurement Display, press **Back**.

On the Measurement Display, press **→ Show**



Example, Measuring the Characteristic of a Wavelength Division Multiplexer

This example uses the ratio measurement to measure the characteristic of a wavelength division multiplexer. The measurement is made in the range 1500nm to 1565nm, with a resolution of 0.025nm. The DUT input connector is Diamond HMS-10/HP, the output connectors are PC. We will use two HP 81531A Power Sensors.

1. Set up the hardware as shown below, making sure that all the connectors are clean:

Caution



If you have a slanted connector on your tunable laser source, make sure that the slanted connector on the fiber is connected to the tunable laser source. Failure to do this can damage the laser source.

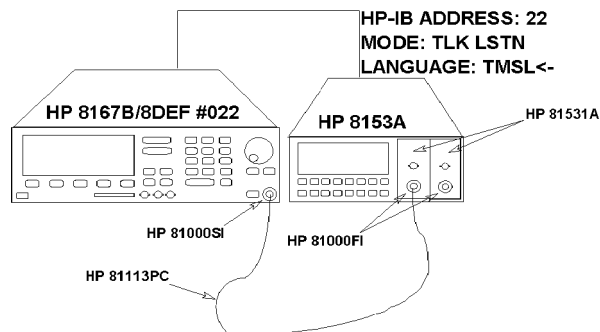

Figure G-27. Test Setup to Measure the Reference for Channel A

- a. Connect the tunable laser source to the multimeter with the HP-IB cable.
- b. Make sure that the power sensors are installed in the multimeter mainframe.

G-32 The Passive Component Test (PACT) software

- c. Connect both instruments to the electric supply.
- d. Switch on both instruments.

Note

Under normal circumstances you should leave the instruments to warm-up. (The multimeter needs around 20 minutes to warm-up. The tunable laser displays *Stabilizing* at the top of its display until it is warmed-up). Warming up is necessary for accuracy of the sensor, and the output power of the source.

- e. Connect a patchcord from the tunable laser source to the input of the sensor in channel A. If your tunable laser source has a slanted connector, make sure that the orange-sleeved (slanted) connector on the fiber is connected to the tunable laser source. You can do this while the instruments are warming up.
2. Set the power to the default value:
 - a. Press **OUTPUT POWER**.
 - b. Press **EDIT**.
 - c. Press **Default**.
 3. Start the passive component test software:
 - a. Press **Aux**.
 - b. Press **PACT**.
 4. Select the loss A&B application:
 - a. Press **Measure**.
 - b. Scroll through the applications until **Loss Ch. A&B** is highlighted. You can do this with the **↑** and **↓** keys, or with the Modify Knob.
 - c. Press **Select**.
 5. Set the power meter to default conditions (that is, for a 200ms averaging time, with autoranging enabled, but no zeroing):
 - a. Press **SetPWM**.
 - b. Press **Def.All**.

G

- c. Press **Done**.
6. Set the sweep parameters for a sweep from 1500nm to 1565nm, with a step size of 0.25nm:
- Press **SwpPara**.
 - Type 1550, and press **ENTER**.
 - Type 1555, and press **ENTER**.
 - Type 0.25, and press **ENTER**.
 - Type 0, and press **ENTER**.
 - Type 1, and press **ENTER**.
 - Press **Done**.
7. Measure the reference for channel A:
- Press **Back**
 - Scroll through the applications until **Loss Ch. A** is highlighted. You can do this with the **↑** and **↓** keys, or with the Modify Knob.
 - Press **Select**
 - Activate the laser.
 - Press **MeasREF**.
8. Measure the reference for channel B:
- Disconnect the patchcord from the input of channel A, and connect it to the input of channel B.
 - Press **Back**
 - Scroll through the applications until **Loss Ch. B** is highlighted. You can do this with the **↑** and **↓** keys, or with the Modify Knob.
 - Press **Select**
 - Press **MeasREF**.
9. Measure the Device Under Test (DUT):

G-34 The Passive Component Test (PACT) software

- a. Connect the DUT into the setup as shown in the figure below:

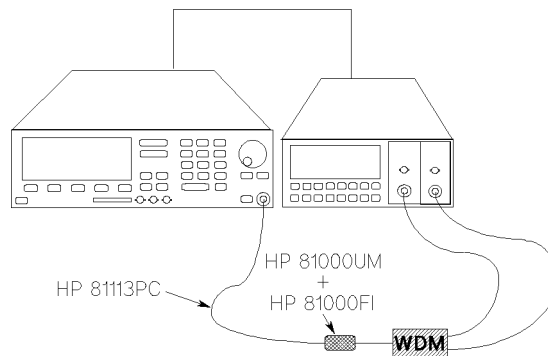

Figure G-28.
Test Setup to Characterize a Wavelength Division Multiplexer

- i. Disconnect the patchcord from the input of channel B and connect it to an HP 81000AM Through Adapter.
- ii. Connect one channel of the Wavelength Division Multiplexer (WDM) to the other side of the through adapter.
- iii. Connect one output of the WDM to the input of the sensor in channel A.
- iv. Connect one output of the WDM to the input of the sensor in channel B.
- b. Press **Back**
- c. Scroll through the applications until **Loss Ch. A&B** is highlighted. You can do this with the **↑** and **↓** keys, or with the Modify Knob.
- d. Press **Select**
- e. Press **MeasDUT**.



Printing Your Results

This section describes how to preview your results on the display, and how to print them on a printer.

You enter the show functions by pressing **Show** from the Main display, or by pressing **→Show** from the Measure display.

The menu shows the full range of results that can be displayed. If you do not intend to print a result now (if you just want to set up your printer) press **Select**. Otherwise, see “Selecting the Result to Show” for more details on choosing the correct result to print. This brings you to the Show display

G



Figure G-29. The Show Display

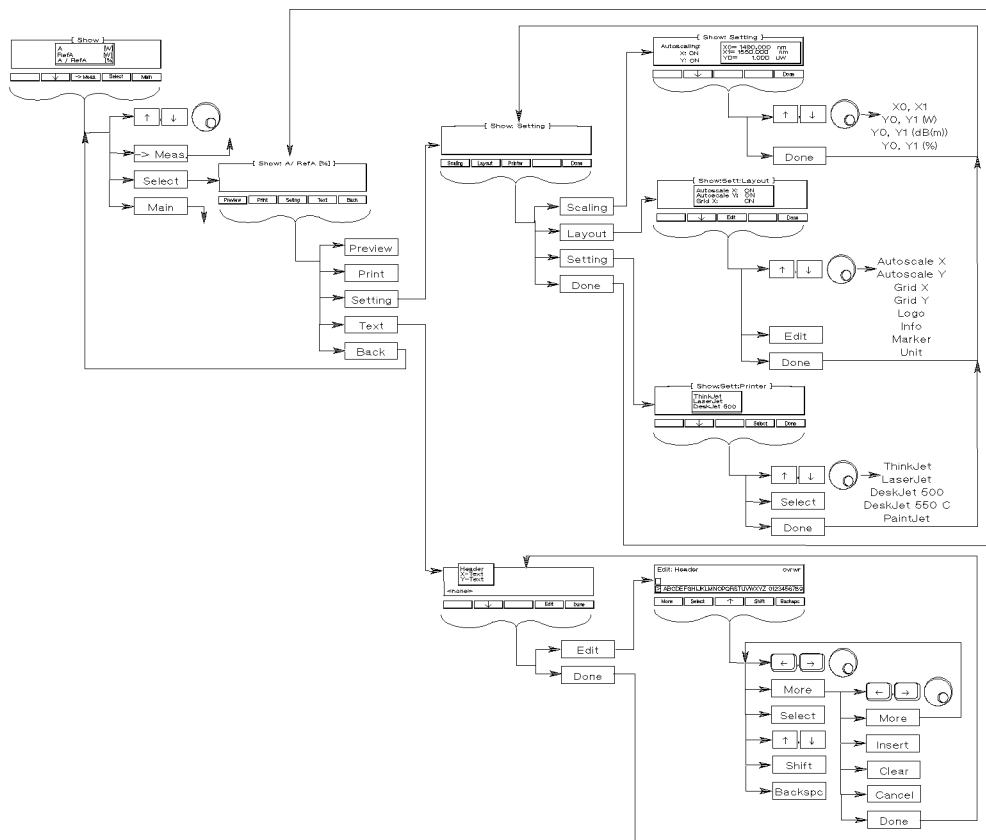

Figure G-30. A Summary of the Show Softkeys

Setting Up the Printer

Setting Up the Hardware

To print out results you will need the following items:

- Your tunable laser source.
- A ThinkJet, LaserJet, DeskJet, or PaintJet printer, with either
 - a HP-IB cable to connect the source to the printer, if your printer has a HP-IB Connector,
 - or
 - a HP-IB cable to connect the source to a interface converter,

- an interface converter (to convert to Centronics from HP-IB), and
- a Centronics printer cable to connect the interface converter to the printer.

Connect the source to the interface converter (if this is necessary), and connect this to the printer.



G

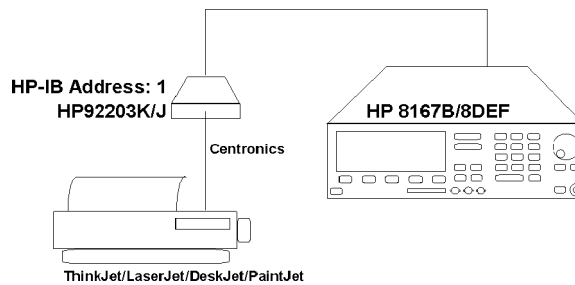

Figure G-31. Printer Hardware Setup

Make sure that the HP-IB address for the printer is set to 1.

Setting Up the Printer in Software

To setup your printer, you must start the show functions, and then use the Setting functions.

From the Show display, press **Setting**.

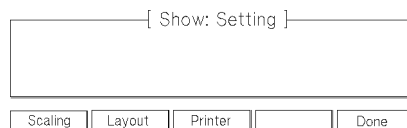

Figure G-32. The Show Setting Display

G-38 The Passive Component Test (PACT) software

This is the Show Setting display. From here you set up for printing.

Selecting the Printer. From the Show Setting display

1. Press **Printer**.
2. Scroll through the menu (use the up and down arrow softkeys, or the Modify Knob), until your printer is highlighted.
3. Press **Select**.

Setting the Layout of the Printout

There are eight elements in the printout.

G



G

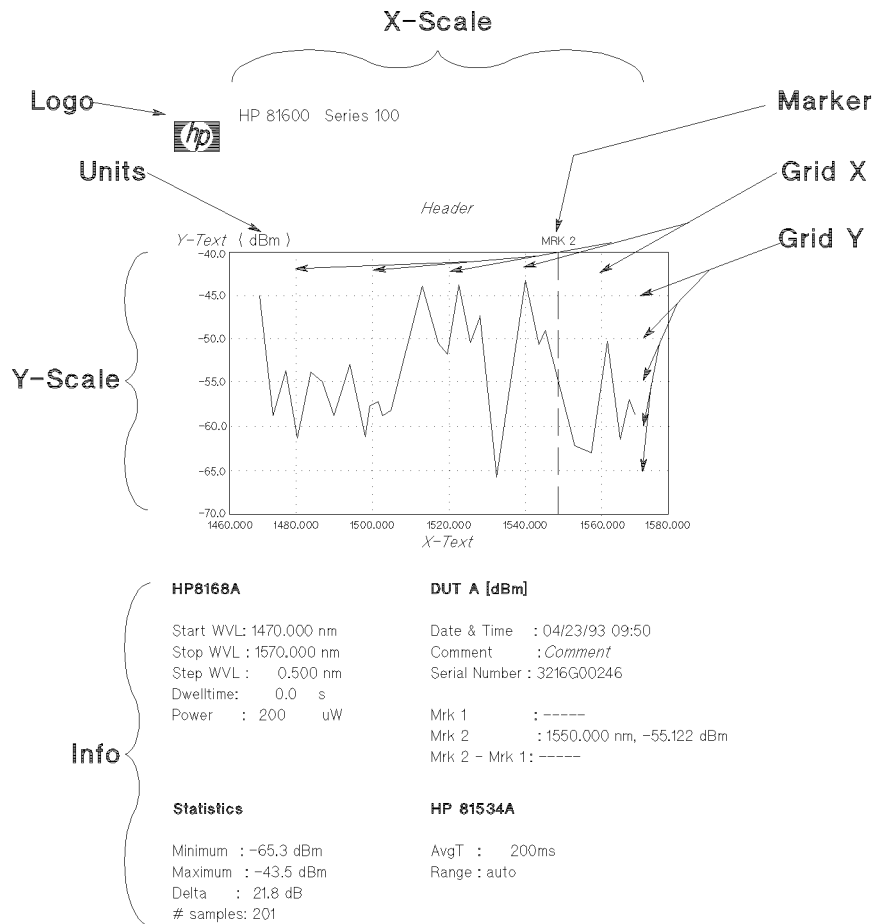

Figure G-33. The Layout of the Printout

You can set the x- and y-scale of the result yourself, or you can let the software set it automatically (Autoscale). You can select whether the y-scale is logarithmic (dBm and dB) or linear(W and %).

The result is always printed, but the other elements are optional.

There are also four user definable pieces of text on the printout.

To switch an element on or off, to enable or disable autoscaling, or to select linear or log scaling, from the Show Setting display

G-40 The Passive Component Test (PACT) software

1. Press **Layout**.
2. Scroll through the elements (use the up and down arrow softkeys, or the Modify Knob), until the element you want to switch is highlighted.
3. Press **Edit**.
4. Toggle the value with **<-** or **->**.
5. Press **Enter**.

Setting the X- or Y-Axis Scaling

If you want the x- or y-axis scaling to be done automatically, set Autoscale X or Autoscale Y to ON in the layout (see “Setting the Layout of the Printout”, above).

Otherwise, from the Show Setting display

1. Press **Scaling**.
2. Make sure that the corresponding Autoscale X or Autoscale Y is set to OFF. This is displayed at the left of the display. You change the values in the layout (see “Setting the Layout of the Printout”, above).

There is one set of x-axis scaling parameters, and three sets of y-axis scaling parameters, one for each type of unit (Watts, dB/dBm, and %).

Each set has a lower limit (X0, or Y0) and an upper limit (X1, or Y1).

To edit a limit,

3. Scroll through the limits (use the up and down arrow softkeys, or the Modify Knob), until the limit you want to edit is highlighted.
4. Press **Edit**.
5. Edit the value.
6. Press **Enter**.

Editing Text for a Result

To add or edit the text for a result

1. Press **Text** from the Show display.

G

2. Scroll through the menu (use the up and down arrow softkeys, or the Modify Knob), until the piece of text you want to edit is highlighted.
3. Press **Edit**.



Figure G-34. The Edit Text Display

G

The text is shown on the second line from the bottom of the display, and the available characters are shown on the bottom line of the display.

To Replace Text.

1. Press **More**, if necessary, to get to the second set of softkeys (with **Insert**, and so on), then
2. Press **Clear**.

Then begin entering the new text.

To Change the Cursor Position in the Text.

1. Press **More**, if necessary, to get to the first set of softkeys (with **Select**, and so on), then
2. Press **↑**, if necessary, so that the prompt > at the left of the text is highlighted.
3. Move the cursor within the text with the Modify knob, or with **←** or **→**.

To Change between Overwriting and Inserting.

1. Press **More**, if necessary, to get to the second set of softkeys (with **Insert**, and so on), then
2. Press **Insert**.

When inserting is active **insert** is shown at the top right of the display. Characters are inserted at the cursor position, and the existing text, and the cursor, is shifted to the right.

When overwrite is active `overwr` is shown at the top right of the display. The character at the cursor position is overwritten and the the cursor is shifted to the right.

To Put Characters into the Text.

1. Press `More`, if necessary, to get to the first set of softkeys (with `Select`, and so on), then
2. Press `↓`, if necessary, so that the prompt `>` at the left of the available characters is highlighted.
3. Highlight the character you want to put into the text with the Modify knob, or with `←` or `→`.
 - a. If you need to change to or from upper case characters, or if you need to change to or from the numerals, press `Shift`.
4. Press `Select` to put the highlighted character into the text at the cursor position.

To End the Edit.

1. Press `More`, if necessary, to get to the second set of softkeys (with `Insert`, and so on), then
2. Press `Done`.

Showing the Results

Enter the show function by pressing `Show` from the Main display, or by pressing `→Show` from the Measure display.

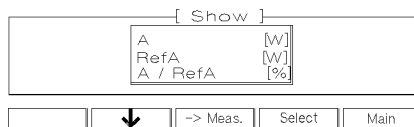

Figure G-35. The Show Menu

Selecting the Result to Show

Three types of measurement data is stored for each channel. These are the DUT measurement, the reference measurement, and the termination measurement.

G

The results that can be displayed are prepared from these sets of measurement data. Either

- individually: in which case A is the DUT measurement, $RefA$ is the reference measurement, and $TermA$ is the termination measurement for channel A, and similarly for B;
- combined from a single channel: for example $A / RefA$ is the ratio of the DUT measurement to the reference, $RetLossA$ is the return loss prepared from the DUT, reference and termination measurements, and so on; or
- combined from both channels: here A / B is the ratio of channel A to channel B, $A/B / RefA/B$ is the ratio of channel A to channel B with respect to references taken for those channels, and so on.

G

Note



Selecting the unit in which the result will be prepared is done in the Setting Layout.

A result is prepared when you select and preview, print, or save. This prepared result is stored in a separate location from the measurement data. You can print or preview this result (without preparing) by selecting `Last Result`

To select a result,

1. Scroll through the results (use the up and down arrow softkeys, or the `Modify Knob`), until the one you want to show is highlighted.
2. Press `Select`.

Selecting Non-Standard Other Results. If you want to prepare results other than those offered on this menu, you can save the sets of measurements to the memory card, and then load them into different positions in the tunable laser source.

See “Example, Moving Termination Data to the DUT Data Area”, for an example moving the termination data to the DUT data area using the memory card.

Previewing the Results on the Display

Press `Preview` to show the result on the display.

The result is shown with the scaling set by the `Layout and Scaling` displays.

Press any of the unmarked softkeys to return to the `Show` display.

G-44 The Passive Component Test (PACT) software

Making Readings from the Results. When you preview a result, it is shown with either one or two markers.

Making an Absolute Reading When the result is shown with one marker (which is also indicated by the label `absolute` at the left of the display), the absolute values for the wavelength at which the marker is positioned, and the power at this position are shown to the left of the result.

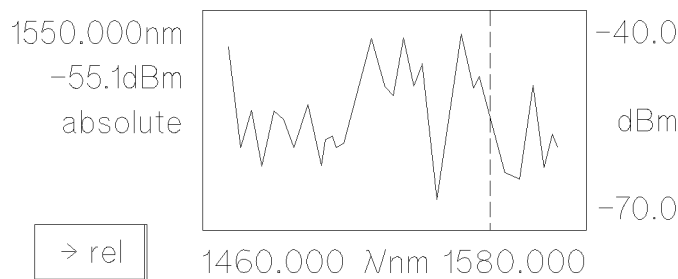

Figure G-36. Making an Absolute Reading

To make an absolute reading

1. Make sure that you have the absolute result on the display (Press `→abs` if you have the relative result).
2. Use the Modify knob, `←`, and `→` to position the marker on the result.

You can now read the wavelength and the power to the left of the result.

Making a Relative Reading When the result is shown with two markers (which is also indicated by the label `relative` at the left of the display), the values for the difference in wavelength and power between the markers, are shown to the left of the display.



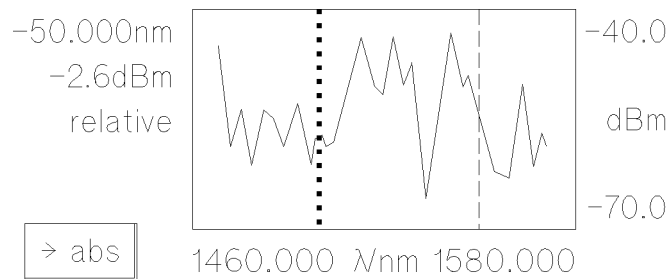

Figure G-37. Making a Relative Reading

G

To make a relative reading

1. Make sure that you have the absolute result on the display (Press **→abs** if you have the relative result).
2. Use the Modify knob, **←**, and **→** to position the marker at the reference position on the result.
3. Press **→rel**.
4. Use the Modify knob, **←**, and **→** to position the second marker at the relative position on the result.

You can now read the wavelength difference between the markers, together with the power difference between these wavelengths to the left of the result.

Printing the Results

From the Show display, press **Print**.

If you have problems with getting the printout, or with the printout form:

- Check that the correct printer is selected (Show: Setting, **Printer**).
- Check that the layout is what you want (Show: Setting, **Layout**, and **Scaling**).
- Edit the text if necessary (Show, **Text**).
- If the markers are not correctly positioned, position them on the Preview (Show, **Preview**).

Example, Printing Results of Loss against Wavelength

This example sets up the printer and result, and then prints a result with a measure of the power difference between 1500nm and 1520nm.

The results are for a loss measurement made in the range 1470 to 1570nm, measured at a resolution of 0.250nm.

The printer is a DeskJet 550C.

1. Set up the hardware as shown below:

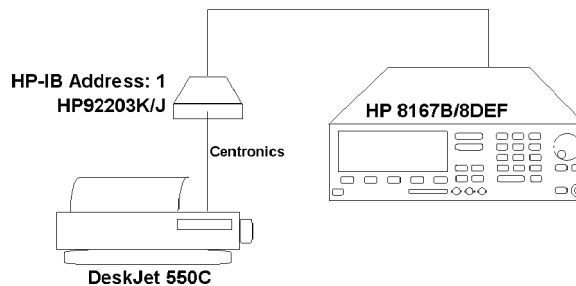

Figure G-38. Set-Up to Print Out

- a. Connect the tunable laser source to the interface converter with the HP-IB cable. The interface must have the address 1 (see the manual you got with the interface for information on checking and changing the address if this is necessary).
 - b. Connect the connector interface to the printer with the Centronics cable.
 - c. Connect the tunable laser source, the connector interface, and the printer to the electric supply. If you are a non-US user, the connector interface is powered from an AC-adaptor.
 - d. Switch on the source, interface and printer.
2. Start the passive component test software:
 - a. Press **Aux**.
 - b. Press **PACT**.
 3. Select the loss result for channel A:
 - a. Press **Show**.



b. Scroll through the results until `RefA` is highlighted. You can do this with the `↑` and `↓` keys, or with the Modify Knob.

c. Press `Select`.

4. Set the printer type:

a. Press `Setting`.

b. Press `Printer`.

c. Scroll through the printers until `DeskJet 550 C` is highlighted. You can do this with the `↑` and `↓` keys, or with the Modify Knob.

d. Press `Select`.

5. Set the Layout of the Results

a. Press `Layout`.

b. Scroll through the parameters with the `↑` and `↓` keys, or with the Modify Knob.

If any of the parameters are set to `OFF`

i. Scroll through the parameters until the parameter that is `OFF` is highlighted.

ii. Press `Edit`.

iii. Press `<-`, or `->` to turn the parameter `ON`.

iv. Press `Enter`.

If `Unit` is set to `LIN`

i. Scroll through the parameters until `Unit` is highlighted.

ii. Press `Edit`.

iii. Press `<-`, or `->` to turn it to `LOG`.

iv. Press `Enter`.

When all the parameters are `ON`, and `Unit` is set to `LOG`:

- c. Press **Done**.
 - d. Press **Done**.
6. Set the position of the markers on the preview:
- a. Press **Preview**
 - b. If the result is labelled `relative` (at the left of the display), press **→absolute**
 - c. Move the marker to 1500.000nm using the Modify knob, the **←** and the **→** keys.
 - d. Press **→rel**.
 - e. Move the marker to 20.000nm using the Modify knob, the **←** and the **→** keys.
 - f. Press any of the unmarked softkeys.
7. Add a header labelling this as the “Operating Example”.
- a. Press **Text**
 - b. Scroll through the pieces of text until `Header` is highlighted.
 - c. Press **Edit**.
 - d. Press **More**, then **Clear**, then **More** again.
 - e. Scroll through the available characters until `0` is highlighted.
 - f. Press **Select**.
 - g. Press **Shift**
 - h. Highlight and select the characters “p” “e” “r” “a” “t” “i” “n” “g” in turn. Then the space character [between `z` and `{`].
 - i. Press **Shift**
 - j. Highlight and select the character “H”.
 - k. Press **Shift**

G

- 
- G**
- l. Highlight and select the characters “x” “a” “m” “p” “l” “e” in turn.
 - m. Press **More** and then **Done**.
 8. Label the x-axis “Wavelength (nm)”
 - a. Press **|**.
 - b. Press **Edit**.
 - c. Press **More**, then **Clear**, then **More** again.
 - d. Highlight and select the characters “W” “a” “v” “e” “l” “e” “n” “g” “t” “h” “(” “n” “m” “)” in turn.
 - e. Press **More** and then **Done**.
 9. Label the y-axis “Power” (the units are automatically labelled).
 10. Leave text editing.
 - a. Press **Done**.
 11. Print the result.
 - a. Press **Print**

Saving Your Results

This section describes the saving and loading of measurements and results to and from memory cards.

You enter the memory functions by pressing **Memory** from the Main display.

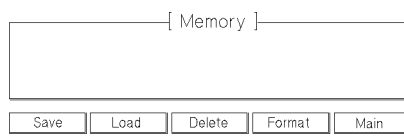

Figure G-39. The Memory Display

G

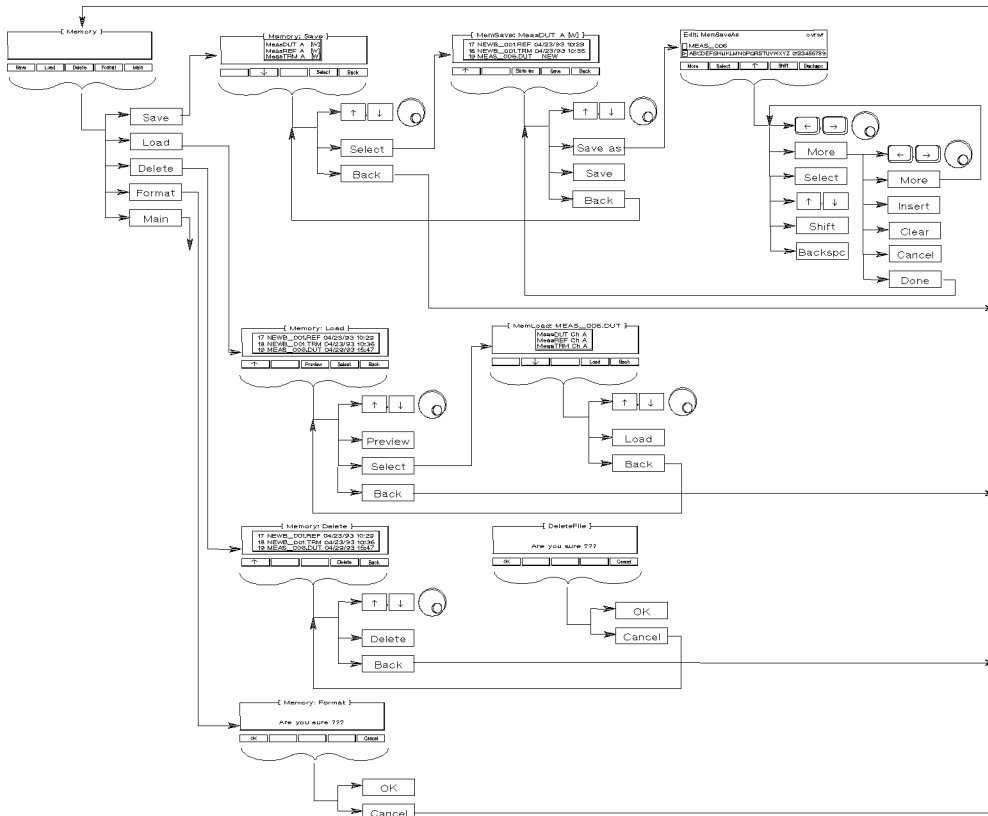

Figure G-40. A Summary of the Memory Softkeys

Formatting a Memory Card

The memory card drive formats cards for the DOS FAT-based file system, that is, the normal DOS format.

To format a card:

1. Make sure that there is no data on the card that you need to keep. Formatting a card destroys all the data that is on it.
2. From the Memory display, press **Format**.
3. You are asked **Are you sure ???**, and if you are sure, press **OK** to format the card.

G-52 The Passive Component Test (PACT) software

Saving a Measurement or Result

Selecting the Measurement or Result to Save

For each channel of the multimeter, three types of measurement data that can be saved. These are:

- $Meas_{DUT}$ is the DUT measurement,
- $Meas_{REF}$ is the reference measurement, and
- $Meas_{TRM}$ is the termination measurement.

The channel is given after the data type. That is, $Meas_{DUT A}$ is the DUT measurement for channel A.

You can also save result data, which is prepared from the measurement data. Either

- individually: here A is the DUT measurement, $Ref A$ is the reference measurement, $Term A$ is the termination measurement, and similarly for B;
- combined for a single channel: here $A / Ref A$ is the ratio of the DUT measurement to the reference, $RetLoss A$ is the return loss prepared from the DUT, reference and termination measurements, and so on;
- combined for both channels: here A / B is the ratio of channel A to channel B, $A / B / Ref A / Ref B$ is the ratio of channel A to channel B with respect to references taken for those channels, and so on.

The units for the result are set under Show Setting Layout.

The result is calculated when you preview, print, or save. This calculated result is stored in a separate location from the measurement data until the next result is calculated. You can save the most recently calculated result by selecting **Last Result**.

One reason to save such a result, is to use it for processing on another computer. See “Using Data on a PC” for information on how to convert the result file to .SLK format for use with spreadsheets and other programs.

To select measurement or result data to save, from the Memory display

1. Press **Save**.
2. Scroll through the measurements and results (use the up and down arrow softkeys, or the Modify Knob), until the one you want to save is highlighted.

3. Press **Select**.

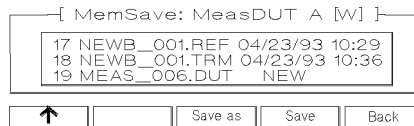

Figure G-41. The MemSave Display

Saving the Measurement or Result

Once you have selected the measurement or result data, press **Save** to save it to an automatically generated filename.

Saving to Your Own Filename

To change or edit the name of a file press **Save as** from the MemSave display.



Figure G-42. The Show Text Display

The filename is shown on the second line from the bottom of the display, and the available characters are shown on the bottom line of the display.

To Replace a Filename.



1. Press **More**, if necessary, to get to the second set of softkeys (with **Insert**, and so on), then
2. Press **Clear**.

Then begin entering the new filename.

To Change the Cursor Position in the Filename.

1. Press **More**, if necessary, to get to the first set of softkeys (with **Select**, and so on), then
2. Press **↑**, if necessary, so that the prompt > at the left of the filename is highlighted.

G-54 The Passive Component Test (PACT) software

3. Move the cursor within the filename with the Modify knob, or with  or .



To Change between Overwriting and Inserting.

1. Press **More**, if necessary, to get to the second set of softkeys (with **Insert**, and so on), then
2. Press **Insert**.

When inserting is active **insert** is shown at the top right of the display. Characters are inserted at the cursor position, and the existing filename text, and the cursor, is shifted to the right. A filename can have a maximum of eight characters. If you insert characters into a filename that already has eight characters, the last character is deleted.

When overwrite is active **overwr** is shown at the top right of the display. The character at the cursor position is overwritten and the the cursor is shifted to the right.

To Put Characters into the Filename.

1. Press **More**, if necessary, to get to the first set of softkeys (with **Select**, and so on), then
2. Press , if necessary, so that the prompt > at the left of the available characters is highlighted.
3. Highlight the character you want to put into the filename with the Modify knob, or with  or 
 - a. If you need to change to or from upper case characters, or if you need to change to or from the numerals, press **Shift**.

Note Lower case characters are converted to upper case in the filename on the card.



4. Press **Select** to put the highlighted character into the filename at the cursor position.

To End the Edit and Save the Measurement or Result.

1. Press **More**, if necessary, to get to the second set of softkeys (with **Insert**, and so on), then



2. Press **Done** .
3. Press **Save** .

Loading a Measurement or Result

There are two types of data that can be saved on the memory card, measurement data, and result data.

Measurement data files have the endings .DUT, .REF, and .TRM for device under test, reference, and termination measurements respectively.

Result data files have the ending .RES.

There are seven areas in the tunable laser source where data can be stored.

Any measurement data file can be stored in any of the measurement data areas. There are three of these for each channel. These are:

- MeasDUT for the DUT measurement,
- MeasREF for the reference measurement, and
- MeasTRM for the termination measurement.

The channel is given after the measurement data type.

Result data can only be stored in the area for results.

To load a Measurement or Result, from the Memory display

1. Press **Load** .
2. Scroll through the files (use the up and down arrow softkeys, or the Modify Knob), until the one you want to load is highlighted.
 - If you are not sure of the contents of a file, you can check it by pressing **Preview** .
3. Press **Select** .
4. Scroll through the areas where you can store data until the one you want to load to is highlighted. (Remember, result data can only be stored in Result, measurement data can be stored in MeasDUT, MeasREF, or MeasTRM).
5. Press **Load** .

Deleting a File

To delete a file, from the Memory display

1. Press **Delete**.
2. Scroll through the files (use the up and down arrow softkeys, or the Modify Knob), until the one you want to delete is highlighted
3. Press **Delete**
4. You are asked Are you sure ???, and if you are sure, press **OK** to delete the file.

G



Example, Moving Termination Data to the DUT Data Area

This example saves the data from the termination measurement for channel A to the card, loads it into the DUT data area, and then deletes the data on the card.

It is assumed that a full return loss measurement has been made on the system (that is, that there a termination has been measured), and that a memory card is in the card reader.

1. Start the passive component test software:
 - a. Press **Aux**.
 - b. Press **PACT**.
2. Press **Memory** to select the memory functions.
3. Select the termination data for channel A to save:
 - a. Press **Save**.
 - b. Scroll through the data types until **MeasTERM A** is highlighted. You can do this with the **↑** and **↓** keys, or with the Modify Knob.
 - c. Press **Select**.
4. Change the filename to "TEMP":
 - a. Press **Save as**.
 - b. Press **More**, then **Clear**, and then **More** again.
 - c. Move the cursor to **T** with the **←** and **→** keys, or with the Modify Knob. Press **Select**.
 - d. Select **E**, **M**, and **F** similarly.
 - e. Press **More**, and then **Done**.
5. Press **Save** to save the file, and **Back** to leave the save function.
6. Load the file into the DUT data area.
 - a. Press **Load**.

- b. Press **Select** .
 - c. Scroll through the data areas until MeasDUT A is highlighted. You can do this with the **↑** and **↓** keys, or with the Modify Knob.
 - d. Press **Load** .
 - e. Press **Back** to leave the load function.
7. Delete the file from the card.
- a. Press **Delete** .
 - b. Press **Delete** .
 - c. Press **OK** .
 - d. Press **Back** to leave the delete function.

G

Using Data on a PC

This section covers using result and measurement data on your PC, for example, in an application such as a spreadsheet.

The data produced by the passive component test software is in binary format (the format of this data is described in “The Result and Measurement Data Format”). You received a disk with your passive component test system that contains simple programs to convert these binary data files into .SLK format for use with spreadsheet applications such as Lotus[®]1-2-3[®], and Microsoft[®] Excel.

There are two directories

- \PACTCONV.HP, which includes the program, and source files for use with a Hewlett-Packard HP 82335x interface card.

The card must be installed with the Interface Select Code set to 7, and the information must appear in the corresponding line in your CONFIG.SYS file, DEVICE= ~EMM386 ... X=DC00-DFFF

- \PACTCONV.NTL that includes the program, and source files for use with a National Instruments[®] NI-488.2 card.

The NI-488.2 card must be installed with the following settings

GPIO-PC Mode: GPIO-PCIIA

Controller 7210 if you use the standard controller
Mode: 9914 if you use the TI controller TI9914A

I/O Address: 2E1: A6= on, A7= on

Interrupt IRQ7: A3= A4= A5= off

Settings: Jumper set

DMA Level: 1 DRQ1 + DACK1

Jumper set

The programs are intended only to be examples, and are only valid for the defined configurations mentioned above, and for use with the HP 8167B and HP 8168D/E/F Tunable Laser Sources.

The source code is provided so that you can write your own applications. The

G-60 The Passive Component Test (PACT) software

source code is protected by copyright, however Hewlett-Packard permits you to use and modify it without requiring a license fee, as long as it is only used with Hewlett-Packard test equipment.

There are two ways of converting with this program.

If the Data is Already On Your PC ...

Use

PACTCONV *source_file_name* [*destination_file_name*]

to convert the data file, where

source_file_name is the full name of the data file you want to convert, including the file extension (.DUT, .REF, .TRM, or .RES).

[*destination_file_name*] is an optional destination file name.

If you give no value for this, the converted data is saved as *source_file_name* with the file extension .SLK.

This file always has the extension .SLK

G

Note



You can specify pathnames as part of the source and destination filenames, but they must be on the same drive as the PACTCONV program.

For example, to convert the MEAS_001.DUT file into a .SLK file

1. Type PACTCONV MEAS_001.DUT at the cursor, and press **Enter**.

This produces the file MEAS_001.SLK.

If the Data is On the Memory Card in your Tunable Laser Source ...

Note



You should not attempt to use the PACTCONV program while the tunable laser source is running a measurement.

Use

PACTCONV -p *source_file_number* [*destination_file_name*] [-h *HP-IB_Address*]

to transfer and convert the data file, where

source_file_number is the index number of the data file on the memory card that you want to convert.

The index number is shown to the left of the file name when you list the files

on the memory card (Press **Aux**, **PACT**, **Memory**, **Load** to get this list; Press **Back** and **Main** when you have finished).

[*destination_file_name*] is an optional destination file name.

If you give no value for this, the converted data is saved as *source_file_name* with the file extension **.SLK**.

This file always has the extension **.SLK**

HP-IB_Address is the HP-IB address of your tunable laser source.

If you do not specify a HP-IB address, the default address (24) is assumed.

Note

You can specify pathnames as part of the destination filename, but it must be on the same disk as the PACTCONV program.



For example, to convert the 10th file on the memory card into a **.SLK** file called **MY_FILE**,

1. Type **PACTCONV -p 10 MY_FILE** at the cursor, and press **Enter**.

This produces the file **MY_FILE.SLK**.

Developing Your Own Converter

The PACTCONV program is a simple, single solution to converting your data. To help you develop your own custom converter, the source code for the PACTCONV program is included on the disk.

Reading .SLK Files into a Spreadsheet

This section gives some tips on reading your **.SLK** files into some of the more common spreadsheet packages

Microsoft Excel. During the File Open, set the File Type to ***.SLK**.

Borland Quattro Pro/Windows. **.SLK** files can be read directly with a normal File Open.

Lotus 1-2-3W. Use the TRANSLATE utility (**.SLK** files are Multiplan files), or at the DOS prompt, use the TRANSYLK program.

Error Code Descriptions

Error Code Trouble Detected

G-62 The Passive Component Test (PACT) software

- 2 No memory available for using function
- 3 You defined the output filename twice
- 4 Output filename was not defined
- 5 You defined the input filename twice
- 6 Input filename was not defined
- 8 Input filename does not exist
- 9 Input file cannot be closed due to wrong format
- 10 No valid input file
- 11 Output filename already exists
- 12 Output file was not opened
- 13 No correct usage of output file possible
- 14 Trouble while closing the output file
- 15 HP-IB write error
- 16 HP-IB read error
- 17 Insufficient data received from HP-IB, perhaps an invalid PACT data file was specified
- 18 File identification number (-p x) is wrong
- 19 HP-IB cannot be initialized
- 20 HP-IB address is not available
- 21 Incorrect HP-IB address was specified
- 22 Unknown options in command line
- 23 Too few arguments in command line
- 24 The filename extension is too long
- 25 Too few arguments in command line
- 26 The filename cannot be stored correctly due to DOS limitations
- 27 Extension in output filename detected
- 29 HP-IB timeout error - check connection
- 30 The received data file was empty

G

Lotus, and 1-2-3 are U.S. registered trademarks of Lotus Development Corporation.

Microsoft is a U.S. registered trademark of Microsoft Corp.

National Instruments is a U.S. registered trademark of National Instruments.

The program is copyrighted to the Hewlett-Packard Company 1993. All rights are reserved.



G

G-64 The Passive Component Test (PACT) software

The Result and Measurement Data Format

This section describes the format of the binary data, as a C-language data structure.

```
#ifndef CURVEDATA
#define CURVEDATA

typedef short boolean;

/* Definition der ECL-Datenstrukturen */

#define GRAPH_TEXT_MAX      40
#define PACT_ID_LENGTH     40
#define PM_DUMMIES         40
#define MAX_NOV            1001

struct scaledata {
    float      min;
    float      max;
    float      minmin;
    float      maxmax;
    signed char direction;
    char       dummy;
    float      delta;
    float      factor;
    unsigned short preComma;
    unsigned short postComma;
    char       autoScaleOnOff;
    char       gridOnOff;
    float      gridStep;
    float      gridStart;
};

typedef struct scaledata scaledata;

struct scaling {
    float x0, y0, y0dB, y0mW, y0Percent;
    float x1, y1, y1dB, y1mW, y1Percent;
};

typedef struct scaling scaling;

struct coorddata {
```

G



```
    unsigned short  x0, y0, x1, y1;
    unsigned short  axisX0, axisY0, axisX1, axisY1;
};
```

```
typedef struct coorddata coorddata;
```

```
struct head {
    char          cset;
    char          height, width;
    char          dummy;
    char          hText [GRAPH_TEXT_MAX + 10];
    char          xText [GRAPH_TEXT_MAX + 10];
    char          yText [GRAPH_TEXT_MAX + 10];
    char          comment [GRAPH_TEXT_MAX + 10];
};
```

```
typedef struct head head;
```

```
struct retlossdata {
    float         constTerm;
    float         reference;
    char          useConstTerm;
    char          dummy;
};
```

```
typedef struct retlossdata retlossdata;
```

```
struct powermeter {
    signed char   sense;
    signed char   valid;
    short        moduleType;
    char         moduleName [20];
    long         resultAddress;
    char         autoRange;
    char         range;
    char         unit;
    char         referenced;
    float        atime;
    float        wavelength;
    float        power;
    char         continuous;
    char         zeroOnOff;
    char         dummy [PM_DUMMIES];
};
```

```
typedef struct powermeter powermeter;
```

G-66 The Passive Component Test (PACT) software

```

struct instrumentInfo {
    boolean attiOption;
    boolean msibOption;
    boolean pactOption;
    boolean option4;
    boolean option5;
    boolean option6;
    boolean option7;
    boolean option8;
    boolean option9;
    boolean option10;
    boolean dosmode;
    char   serialNumber [22];
    char   productNumber [22];
    char   calibrationDate [22];
    char   blockNumber [22];
};

typedef struct instrumentInfo instrumentInfo;

struct marker {
    float   wavelength;
    float   power;
};

typedef struct marker marker;

struct powerDefMinMax {
    unsigned short   def, min, max;
};

typedef struct powerDefMinMax powerDefMinMax, attenDefMinMax;

struct waveDefMinMax {
    unsigned long   def, min, max;
};

typedef struct waveDefMinMax   waveDefMinMax, timeDefMinMax,
    power03DefMinMax, modulationDefMinMax;

struct indexDefMinMax {
    long           def, min, max;
};

```

G

```
typedef struct indexDefMinMax indexDefMinMax;
```

```
struct sweep {  
    waveDefMinMax    start;  
    waveDefMinMax    stop;  
    waveDefMinMax    step;  
    indexDefMinMax   index;  
    indexDefMinMax   rounds;  
    unsigned long    roundIndex;  
    waveDefMinMax    center;  
    waveDefMinMax    span;  
    unsigned long    points;  
    timeDefMinMax    dwell;  
    timeDefMinMax    stepTime;  
    timeDefMinMax    time;  
    long             direction;  
    unsigned short   power;  
    boolean          marker;  
    boolean          powerSearch;  
    boolean          manual;  
};
```

```
typedef struct sweep sweep;
```

```
struct date {  
    char    year;  
    char    month;  
    char    day;  
    char    dummy;  
};
```

```
typedef struct date date;
```

```
struct time {  
    char    hour;  
    char    minute;  
    char    second;  
    char    dummy;  
};
```

```
typedef struct time time;
```

```
struct power03 {  
    unsigned long    hwValue;          /* Normal Power Mode (only OPT003) */  
};
```

G-68 The Passive Component Test (PACT) software

```

    unsigned long      swValue;                /* Powervalue on Display */
    power03DefMinMax   dmm;
    char               unit;
    char               dummy;
}

typedef struct power03 power03;

struct power {                                /* Power in the Attenuation Mode (OPT003) */
    unsigned short    hwValue;
    unsigned short    swValue;                /* Powervalue on Display */
    powerDefMinMax    dmm;
    char              unit;
    char              dummy;
}

typedef struct power power;

struct atten {                                  /* Attenuation in mdBm (OPT003) */
    unsigned long     hwValue;
    unsigned long     swValue;
    attenDefMinMax    dmm;
    char              unit;
    char              state;
};

typedef struct atten atten;

struct modulation {                             /* when modulation ON */
    unsigned long     freq;                  /* here is the frequency in Hz */
    modulationDefMinMax dmm;
    char              state;
    char              unit;
};

typedef struct modulation modulation;

struct curve {
    char              chksum;
    char              dummy;
    char              serialNumber [40];     /* your HP8168 Serial number */
    instrumentInfo    instrumentInfo;
    float             measValue [MAX_NOV];  /* the real measurement values */
    unsigned long     count;                /* how many values */
    marker            marker1;
}

```



```

marker      marker2;
sweep       sweep;
powermeter  lpwm;
powermeter  lpwmAdd;
retlossdata retloss;
char        powerState;
power03     power03;
power       power;
atten       atten;
modulation  modulation;
date        date;
time        time;
};

```

G

```

typedef struct curve curve;

struct curvedataType {
char          checksum;
char          dummy1;
char          pactID [PACT_ID_LENGTH];
long         version;
char          filename [30];
scaledata    xScale;
scaledata    yScale;
char          yUnit [6];
float        yScaleFactor;
scaling      scaling;
coorddata    cdData;
head         head;
unsigned short whatToPrint;
char         whatToPrintString [30];
char         logoOnOff;
char         infoOnOff;
char         markerOnOff;
char         dummy2;
retlossdata  rlData;
powermeter   lpwmA;
powermeter   lpwmB;
curve        curve;
};

typedef struct curvedataType curvedataType, *curvedata;

#endif

```

G-70 The Passive Component Test (PACT) software

Backdating Information

The software described in this manual comes as standard with the tunable laser source. Previously this software was sold, either as option 001, or as part of a bundle under the name HP 81600 Scalar Device Analysis System Series 100 Passive Component Test System.

References to the bundled system have been removed from the manual. The table below shows the correspondence between the bundles and the possible measurements, with the relevant section.

Bundle, Test and Section Cross Reference

System 100 Bundle	Tests	Section
E4325A 1-channel loss test set 1280nm - 1330nm PC connector types	Loss Measurement	2
E4326A 1-channel loss test set 1500nm - 1550nm PC connector types	Loss Measurement	2
E4327A 1-channel loss test set 1280nm - 1330nm pigtailed	Loss Measurement	2
E4328A 1-channel loss test set 1500nm - 1550nm pigtailed	Loss Measurement	2
E4329A 2-channel loss test set 1280nm - 1330nm PC connector types	Loss Measurement Ratio Measurement	2 4

G

Bundle, Test and Section Cross Reference (continued)

System 100 Bundle	Tests	Section
E4330A 2-channel loss test set 1500nm - 1550nm PC connector types	Loss Measurement Ratio Measurement	2 4
E4331A 2-channel loss test set 1280nm - 1330nm pigtailed	Loss Measurement Ratio Measurement	2 4
E4332A 2-channel loss test set 1500nm - 1550nm pigtailed	Loss Measurement Ratio Measurement	2 4
E4333A 1-channel loss/return loss test set 1280nm - 1330nm PC connector types	Loss Measurement Return Loss Measurement	2 3
E4334A 1-channel loss/return loss test set 1500nm - 1550nm PC connector types	Loss Measurement Return Loss Measurement	2 3

G

Index

A

AC Power Supply, A-2
AC Power Supply Cable, A-2
Actual Setting, 3-1, 3-2, 5-11
ADC, 3-5
Analog Output, 2-9, A-9
ANSI MC 1.1, 4-1
Assistance, ii
Attenuation, 5-22
 Changing, 5-22
 Limits, 5-23
 Setting, 2-9
Attenuation Mode, 2-8, 2-9, 5-23,
 5-24, 5-25
Attenuator Mode, 2-10
Att Softkey, 2-9
Automatic λ -Sweep, 2-6. *See also*
 λ -Sweep, Automatic
Automatic Realignment, 3-7
Auto ranging (power meter), G-5,
 G-15, G-28
Auto Softkey, 2-6
Autotransformer, A-3
AVA, A-8
AVAILABLE, A-8
Averaging
 Sweep cycles, G-6, G-16, G-29
Averaging time (power meter), G-5,
 G-15, G-28

B

Banner. *See* Header
Base Wavelength, 2-3. *See also* λ_0
Battery
 Replacing, A-4
BDATA query, 5-40
Binary data
 Format, 5-41
 Transfer over HP-IB, 5-40

C

Cable
 HP-IB, B-7
 Optical, B-6
 Power, A-2
Cal. Data, 3-5
Calibration
 Date, 3-4
 Laser, viii
Cancel Softkey, 1-8
Capital Letters (when Programming),
 4-5
Case Sensitivity, 4-5
Centronics
 Interface converter. *See* Interface
 converter
Certification, ii
Clear Softkey, 1-8
Close softkey, 1-5
*CLS, 5-7, 5-12, 6-3
Coherence Control, 2-13, 5-33, 5-34,
 5-37, 5-38

Index

Uncalibrated Power, 5-33, 5-34
Coherence Controlled Output
 Setting Power, 2-13
Commands. *See* Messages
Comment
 Editing text. *See* Editing text
Common Commands, 5-5
CONDition Register, 5-29. *See also*
 Operation Status, Questionable
 Status
Connector Interface, A-9, B-3, B-5
 Replacing, A-9
Connectors, 1-1
Continuous Wave Output, 2-8. *See also*
 CW Output
Cont Softkey, 2-7
Cooling, A-6
Coupling Ratio. *See* Loss Ratio
Crosstalk. *See* Loss Ratio
c (Speed of Light), 2-3, 5-28
CW Output, 2-8, 5-19, 5-20, 6-10
cycles, G-6, G-16, G-29
cycles, λ -Sweep, 2-5

D

Data Keys, 1-6
Date, 5-36, 5-37
 Setting, 3-4
Date Softkey, 3-4
dBm, 2-9
Declaration of Conformity, C-10
Def.All softkey, G-6, G-15, G-28
Default Setting, 3-1, 3-2, 5-11
 λ -Sweep, 3-1
Default Softkey (Editing), 1-7
Default Softkey (Setting), 3-2
DeskJet. *See* Printer
Device Under Test. *See* DUT
df, 2-3, 2-4, 5-28
 Editing, 2-4
DFB Lasers, 2-3

Index-2

Display
 Burn-In, 3-3, 5-16
;DISPlay;ENABLE, 5-16
;DISPlay;ENABLE?, 5-16
DOSMODE command, 5-41
DOSMODE query, 5-41
dwell, λ -Sweep, 2-5
dwell time, G-6, G-16, G-29

E

Editing, 1-6
 Cancelling, 1-8
 Power meter parameters, G-6,
 G-15, G-28
 Problems, 1-8
EDIT Key, 1-6
ENABLE Register, 5-29, 5-35. *See also*
 Operation Status, Questionable
 Status
Error Queue, 4-4, 5-7, 5-36
Errors, 5-36, F-1
*ESE, 5-7, 6-3
*ESE?, 5-8
*ESR?, 5-8, 6-3
EVENT Register, 5-29. *See also*
 Operation Status, Questionable
 Status
Event Status Enable Register, 5-5,
 5-7, 5-8, 5-11
Event Status Register, 5-5, 5-7, 5-8,
 5-10, 5-12, 5-13
EXC, 2-9
EXCESSIVE, 2-9
Excessive Power, 2-9, 5-30, 5-31

F

Firmware Revision, 3-4, 5-9
Freq Softkey, 2-11
Frequency
 Modulation, 5-19
 Modulation, Changing, 5-18

- Modulation, Limits, 5-19. *See also* Parameters, Limits
- Modulation, Setting, 1-10, 2-11, 6-8
- Wavelength Offset, 2-3. *See also* df
- Front Panel, 1-2
- Function Test, A-1
- Fuse
 - Replacing, A-4
- G**
- GP-IB. *See* HP-IB
- Guide Organisation, x
- H**
- Header
 - Editing text. *See* Editing text
- Heat Chamber, A-8. *See also* Stabilizing
- Help Keys, 1-5
- Heterodyning, 2-3
- Hewlett-Packard Interface Bus, 4-1. *See also* HP-IB
- HP-IB, 4-1
 - Address, 3-4, 4-3, 5-11
 - Capabilities, 4-2
 - Command Summary, 5-2
 - Controller conflict, 5-40
 - Default Address, 3-4, 4-3
 - Interface Functional Subset, 4-2
 - Printer interface converter. *See* Interface converter
 - Reference Works, 4-1
- HP-IB Adapter, B-7
- HP-IB Cable, B-7
- HP-IB commands
 - PACT, 5-40
- HP-IB Connector, A-10
- HP-IB Interface, A-10
- HP-IB Logic Levels, A-11
- HPIB Softkey, 3-4
- Humidity
 - Operating, A-6
- HW-Interface, 3-5
- I**
- *IDN?, 5-9, 6-2
- IEC 625-1, 4-1
- IEEE
 - Address, 4-1
 - IEEE 488.1-1987, 4-1
 - IEEE 488-1978, 4-1
 - IEEE 488.2-1987, 4-1, 5-5
- Info Softkey, 3-4
- Initial Inspection, A-1
- Initializing, 5-30, 5-31, A-7
- Input Queue, 4-3, 5-10
 - Clearing, 4-4
- Insertion loss measurement. *See* Loss measurement
- Inspection
 - Initial, A-1
- Institute of Electrical and Electronics Engineers, Inc.
 - Address, 4-1
- Interface Adapter, B-3, B-4, B-6, B-7
- L**
- Labels
 - Laser Safety, vi
- λ , 2-2. *See also* Wavelength
- λ_0 , 2-3, 5-28
 - Changing, 5-28
 - Setting, 2-3
- λ -Sweep, 2-4, G-6, G-16, G-29. *See also* Sweep
 - Automatic, 2-6, 2-7
 - Continuing, 2-7
 - delay, 2-5
 - HP-IB, 6-10
 - Manual, 1-12, 2-6

Index

- Manual, Setting Wavelength, 2-7
- Pausing, 2-6
- Power, 2-5
- Power, Setting Maximum, 1-12, 2-5, 6-10
- Repeating, 2-5
- Setting Information, 3-1
- Setting Up, 1-11, 2-5
- Stopping, 2-6, 2-7
- λ -Sweep Softkey, 2-2
- Laser Board, 3-5
- Laser Current, 5-17, 5-18, 6-8, 6-10
- LaserJet. *See* Printer
- Laser output
 - During zeroing, G-5, G-15, G-28
- Laser Protection, 5-33, 5-34
- Laser Safety, vi
- Linewidth Measurements, 2-3
- Local Softkey, 4-3
- ;LOCK, 5-17
- Lock, 3-9
- ;LOCK?, 5-17
- Long Form, 4-5

M

- Maintenance
 - Agreements, ii
- Manual λ -Sweep, 2-6. *See also* λ -Sweep, Manual
- Manual Softkey, 2-6
- Manufacturer, 5-9
- MAV, 4-4, 5-7, 5-12, 5-13
- Memory Card Drive, 1-2
- Message Available, 4-4. *See also* MAV
- Message Exchange, 4-3
 - Reception, 4-3
- Messages
 - Long Form, 4-5
 - Short Form, 4-5
- Message Terminator
 - Input, 4-3, 4-5

- Output, 4-4
- Mod/CW Softkey, 2-8
- Model Number, 5-9
- Modify Knob, 1-6
- Modulated Output, 2-10, 5-19, 5-20, 6-8, 6-10
 - Setting Frequency, 2-11. *See also* Frequency, Modulation, Setting
 - Setting Power, 2-11, 2-13. *See also* Power, Modulation, Setting
- Modulation Input, 2-13
- Modulation Output, 2-12, 5-21, A-9
- More Softkey, 3-3
- Motor 1, 3-5
- Motor 2, 3-5
- Motor 3, 3-5
- MSS, 5-7
- Multimeter. *See* Power meter
- Multiple Commands (in One Message), 4-5

N

- Next Softkey (λ -Sweep), 2-7
- Next Softkey (Setting), 3-2
- nm/GHz Softkey, 2-2
- n/ μ /mW Softkey, 2-9
- Node (STATus), 5-29
- NTRansition Register, 5-29, 5-35.
 - See also* Operation Status, Questionable Status
- Numeric Keypad, 1-6

O

- Offset Frequency, 2-3. *See also* df
- On-Line Help, 1-5
- *OPC, 5-7, 5-10
- *OPC?, 5-7, 5-10
- Operation Complete, 5-10
- Operation Status, 5-12, 5-13, 5-29, 5-30, 5-35
 - Condition Register, 5-30

- Enable Register, 5-31
 - Event Register, 5-31
 - Negative Transition Register, 5-32
 - Positive Transition Register, 5-32
 - *OPT?, 5-10
 - Optical Cable, B-6
 - Optical Output, A-9
 - Optical Termination, A-9
 - Output
 - Enable, ix, 5-17, 6-8, 6-10
 - OUTPUT POWER Key, 2-8. *See also*
 - Power
 - Output Queue, 4-4, 5-10, 5-11, 5-14
 - ;OUTPut[;STATe], 5-17, 6-8, 6-10
 - ;OUTPut[;STATe]?, 5-18
- P**
- P1
 - μ P1 Board, 3-5
 - P2
 - μ P2 Board, 3-5
 - PACT, 3-7, G-1
 - absolute reading, G-45
 - Autoscale, G-41
 - Averaging Sweep cycles, G-20
 - Cursor position, G-42
 - Deleting a file, G-57
 - DUT, G-8, G-18, G-30
 - Editing Filename, G-54
 - Editing text, G-41
 - Format Memory card, G-52
 - Help, G-2
 - HP-IB commands, 5-40
 - Ignore Termination, G-18
 - Introduction, G-1
 - Last Result, G-44, G-53
 - Loading measurements, G-56
 - Loss measurement, G-3
 - Loss measurement Reference, G-7
 - Loss Ratio measurement, G-25,
G-26, G-30
 - MeasDUT softkey, G-18, G-30
 - MeasREF softkey, G-17
 - MeasTRM softkey, G-18
 - Memory softkey, G-51
 - Output Power Setting, G-4, G-13,
G-26
 - Overwriting and inserting, G-42
 - PACTCONV command, G-61
 - PACTCONV program, G-62
 - Preview, G-44
 - Print, G-36, G-46
 - Printer Interface Converter, G-37
 - Printout Layout, G-39
 - Reference Reflection, G-17
 - Relative preview, G-45
 - Replacing filename, G-54
 - Result Data format, G-65
 - Return Loss measurement, G-12,
G-13, G-20
 - Save softkey, G-54
 - Saving measurements, G-51, G-53
 - Saving Selecting Result, G-53
 - Selecting characters, G-43
 - Selecting results, G-43
 - Setting softkey, G-38
 - Show softkey, G-36, G-43
 - SLK format, G-60
 - Starting, G-1
 - Sweep, G-20
 - X-scale, G-41
 - Y-scale, G-41
 - PaintJet. *See* Printer
 - Parallel printer
 - Interface converter. *See* Interface
converter
 - Parameters
 - Cannot Change, 1-8
 - Default Value, 1-7
 - Editing, 1-6
 - Limits, 1-8
 - Parser, 5-10

Index

Starting, 4-4
Passive Component Test, 3-7, G-1
Password, 1-4, 3-9, 3-11
Pause Softkey, 2-6
Peak
 →Peak Softkey, 3-7
Performance
 Factors Affecting, 1-1
Pmax(λ) Softkey, 3-6
Pmax→P Softkey, 2-5
PMF, A-9
Pmin (coherence control), 3-7
Polarization Maintaining Fiber, A-9
Power, 5-25, 6-10
 Changing, 5-25
 Coherence Control, Setting, 2-13
 Limits, 5-26. *See also* Parameters, Limits
 Maximum as a function of Wavelength, 3-6
 Maximum, Setting, 3-7
 Modulation, 5-25, 6-10
 Modulation, Changing, 5-25
 Modulation, Limits, 5-26. *See also* Parameters, Limits
 Modulation, Setting, 1-10, 2-11, 2-13, 6-8
 Setting, 2-8, 6-8, 6-10
 Setting Maximum for λ -Sweep, 1-12, 2-5, 6-10
 Units, 2-9, 5-26, 6-8, 6-10
Power meter
 Default values, G-6, G-15, G-28
 Editing parameters, G-6, G-15, G-28
 parameters, G-5, G-15, G-28
 Setting, G-5, G-15, G-28
Power Mode, 2-8, 2-10, 5-23, 5-24, 5-25
Power Supply
 Requirements, AC, A-2

PowMode Softkey, 2-8
Pref Softkey, 2-9
Prev Softkey (λ -Sweep), 2-7
Prev Softkey (Setting), 3-2
Printer Interface
 Converter. *See* Interface converter
Printing History, ii
Programming
 General, 4-5
PTRansition Register, 5-29, 5-35.
 See also Operation Status, Questionable Status

Q

Queries. *See* Messages
Questionable Status, 5-12, 5-13, 5-29, 5-30, 5-35
 Condition Register, 5-33
 Enable Register, 5-33
 Event Register, 5-34
 Negative Transition Register, 5-34
 Positive Transition Register, 5-35

R

*RCL, 5-11
Realignment
 Automatic Realignment, 3-7
Recall Softkey, 3-2
Reference Wavelength. *See* λ_0
Relative Wavelength, 2-3
Remote Interlock Connector, 1-3
Repair
 Laser, viii
Request Service, 5-6. *See also* RQS
Restoring. *See* Loading
Roadmap
 Documentation, x
RQS, 5-6, 5-12, 5-13
*RST, 5-7, 5-11, 5-12

S

Safety

Laser, vi

*SAV, 5-12

SCPI, 4-1

Long Form, 4-5

Reference Works, 4-2

Short Form, 4-5

Search Softkey, 1-5

Secure, 3-9

Select Softkey, 1-5

Self test, A-7

Selftest, 3-5, 5-14

Selftest... .. failed, 3-5

Selftest... .. passed, 3-5

SelfTst Softkey, 3-5

Serial Number, 3-4, 5-9

Serial Poll, 5-6

Service Request, 5-6. *See also* SRQ

Service Request Enable, 5-6

Service Request Enable Register,

5-5, 5-11, 5-12, 5-13

Servicing, viii

SetPWM softkey, G-5, G-15, G-28

SETTING Key, 3-1

Setting # of 5, 3-1. *See also* User

Setting

Settling time, G-6, G-16, G-29

Short Form, 4-5

Softkey, 1-2

[;SOURce];AM;INTernal;FREQuency,

5-18, 6-8

[;SOURce];AM;INTernal;FREQuency?,

5-19

[;SOURce];AM;SOURce, 5-19

[;SOURce];AM;SOURce?, 5-19

[;SOURce];AM;STATe, 5-20, 6-8, 6-10

[;SOURce];AM;STATe?, 5-20

[;SOURCE];MODOUT, 5-21

[;SOURCE];MODOUT?, 5-21

[;SOURce];POWer;ATTenuation, 5-22

[;SOURce];POWer;ATTenuation?, 5-22

[;SOURce];POWer;ATTenuation;AUTO,

5-23

[;SOURce];POWer;ATTenuation;AUTO?,

5-23

[;SOURce];POWer;ATTenuation;DARK,

5-24

[;SOURce];POWer;ATTenuation;DARK?,

5-24

[;SOURce];POWer[;LEVel][;IMM][;AMP],

5-25, 6-8, 6-10

[;SOURce];POWer[;LEVel][;IMM][;AMP]?,

5-25, 6-10

[;SOURce];POWer;UNIT, 5-26, 6-8,

6-10

[;SOURce];WAVElength[;CW;FIXED],

5-27, 6-8, 6-10

[;SOURce];WAVElength[;CW;FIXED]?,

5-27

[;SOURce];WAVElength;FREQuency,

5-28

[;SOURce];WAVElength;FREQuency?,

5-28

[;SOURce];WAVElength;REF;DISPlay,

5-28

[;SOURce];WAVElength;REFerence?,

5-28

Specifications, ii, C-4

Speed of Light, 2-3, 5-28

*SRE, 5-12, 6-3

*SRE?, 5-13

SRQ, 5-6

Stabilizing, 5-33, 5-34, A-8

Standard Commands for

Programmable Instruments,

4-1. *See also* SCPI

Standard Event Status Enable

Register. *See* Event Status Enable

Register

Standard Event Status Register. *See*

Event Status Register

Index

- Standards
 - Traceability, ii
- Standby mode, 3-4
- StandBy Softkey, 3-3
- start, λ -Sweep, 2-5
- start wavelength, G-6, G-16, G-29
- Status
 - Common, 5-5
- Status Byte, 4-4, 5-5, 5-6, 5-7, 5-12, 5-13, 5-29, 5-31
- STATus Nodes, 5-29
- ;STATus;OPERation;CONDition?, 5-30
- ;STATus;OPERation;ENABle, 5-31
- ;STATus;OPERation;ENABle?, 5-31
- ;STATus;OPERation[;EVENT]?, 5-31
- ;STATus;OPERation;NTRansition, 5-32
- ;STATus;OPERation;NTRansition?, 5-32
- ;STATus;OPERation;PTRansition, 5-32
- ;STATus;OPERation;PTRansition?, 5-32
- ;STATus;PRESet, 5-35
- ;STATus;QUEStionable;CONDition?, 5-33
- ;STATus;QUEStionable;ENABle, 5-33
- ;STATus;QUEStionable;ENABle?, 5-33
- ;STATus;QUEStionable[;EVENT]?, 5-34
- ;STATus;QUEStionable;NTRansition, 5-34
- ;STATus;QUEStionable;NTRansition?, 5-34
- ;STATus;QUEStionable;PTRansition, 5-35
- ;STATus;QUEStionable;PTRansition?, 5-35
- *STB?, 5-13
- step, λ -Sweep, 2-5
- step size, G-6, G-16, G-29
- stop, λ -Sweep, 2-5
- Stop Softkey, 2-6, 2-7
- stop wavelength, G-6, G-16, G-29
- Store Softkey, 3-2
- Storing. *See* Saving
- String. *See* Editing text
- Subject Matter, ii
- Suppression. *See* Loss Ratio
- Sweep
 - Averaging, G-6, G-16, G-29
 - Parameters, G-6, G-16, G-29
 - repeating, G-6, G-16, G-29
 - Setting, G-6, G-16, G-29
- SwpPara softkey, G-6, G-16, G-29
- Syntax, 4-5
- ;SYSTem;DATE, 5-36
- ;SYSTem;DATE?, 5-36
- ;SYSTem;ERRor?, 5-36, 6-3
- SYSTEM Key, 3-2
- ;SYSTem;TIME, 5-37
- ;SYSTem;TIME?, 5-37

T

- Temperature
 - Cooling, A-6
 - Operating, A-6
 - Stabilizing, A-8. *See also* Stabilizing
 - Storing, A-6
- Terminator. *See* Message Terminator
- ThinkJet. *See* Printer
- Time, 5-37
 - Setting, 3-5
- Time Softkey, 3-5
- ;TRACe;CATalog?, 5-37
- ;TRACe[;DATA]?, 5-38
- ;TRACe;POINts?, 5-38
- *TST?, 5-14
- Tuning linearity, 5-38
- Tuning Linearity, 6-12

U

Uncalibrated Power
 Coherence Control, 5-33, 5-34
Uncal Power Level, 5-37, 5-38
Uncal Power Level (coherence control), 3-7
Units
 Mnemonics, 5-1
 Power, 2-9, 5-26, 6-8, 6-10
 Programming, 4-5, 5-1
Unlock, 1-3, 3-10
User Setting, 3-1
 Recalling, 3-2, 5-11
 Storing, 3-2, 5-12

W

*WAI, 5-16
Warming Up, 1-9
Warranty, ii
Watts, 2-9
WAVEACT, 5-38, 6-12
Wavelength, 5-27
 Changing, 5-27, 6-10

 Limits, 5-27. *See also* Parameters, Limits
 Relative, 2-3, 5-28
 Setting, 1-9, 2-2, 6-8
WAVELENGTH Key, 2-2
Wavelength step, G-6, G-16, G-29
Wavelength Sweep, 2-4. *See also* λ -Sweep
W/dBm Softkey, 2-9

X

X-text
 Editing text. *See* Editing text

Y

Y-text
 Editing text. *See* Editing text

Z

Zeroing
 Laser output, G-5, G-15, G-28
Zeroing (power meter), G-5, G-15, G-28