

Errata

**Title & Document Type: 8131A Programmable Pulse Generator
Operating and Programming Manual**

Manual Part Number: 08131-90011

Revision Date: 1989-02-01

HP References in this Manual

This manual may contain references to HP or Hewlett-Packard. Please note that Hewlett-Packard's former test and measurement, semiconductor products and chemical analysis businesses are now part of Agilent Technologies. We have made no changes to this manual copy. The HP XXXX referred to in this document is now the Agilent XXXX. For example, model number HP8648A is now model number Agilent 8648A.

About this Manual

We've added this manual to the Agilent website in an effort to help you support your product. This manual provides the best information we could find. It may be incomplete or contain dated information, and the scan quality may not be ideal. If we find a better copy in the future, we will add it to the Agilent website.

Support for Your Product

Agilent no longer sells or supports this product. You will find any other available product information on the Agilent Test & Measurement website:

www.tm.agilent.com

Search for the model number of this product, and the resulting product page will guide you to any available information. Our service centers may be able to perform calibration if no repair parts are needed, but no other support from Agilent is available.



**HP 8131A
PROGRAMMABLE
PULSE GENERATOR**

**INCLUDING OPTIONS:
001 and 020**

**OPERATING and
PROGRAMMING MANUAL**

Serial Numbers:

**This manual applies to instruments
with serial number 2839 G00148 and following**

Manual updating: contact an HP Sales Office.

Manual backdating: see Appendix D.



**Edition 1
Update 4 Incorporated I0689**

**Manual Part Number: 08131-90011
Microfiche Part Number: 08131-95011
Printed in FRG, 07/89**

NOTICES

SUBJECT MATTER

The information in this document is subject to change without notice.

Hewlett Packard shall not be liable for errors contained herein or for incidental or consequential damages in connection with the furnishing, performance, or use of this material.

COPYRIGHT

This document contains proprietary information which is protected by copyright. All rights are reserved.

No part of this document may be photocopied, reproduced, or translated to another language without the prior written consent of Hewlett Packard GmbH.

© Copyright 1988, 1989 by:

Hewlett Packard GmbH
Herrenberger Str. 130
7030 Boeblingen
Federal Republic of Germany

front cover photograph

The instrument photograph on the front cover shows the HP 8131A with OPTION 020 installed.

**PRODUCT
WARRANTY**

This Hewlett-Packard instrument product is warranted against defects in material and workmanship for a period of one year from date of shipment. During the warranty period, Hewlett Packard will, at its option, either repair or replace products which prove to be defective.

For warranty service or repair, this product must be returned to a service facility designated by Hewlett Packard.

Buyer shall prepay shipping charges to Hewlett Packard and Hewlett Packard shall pay shipping charges to return the product to Buyer. However, Buyer shall pay all shipping charges, duties, and taxes for products returned to Hewlett Packard from another country.

Hewlett Packard warrants that its software and firmware designated by Hewlett Packard for use with an instrument will execute its programming instructions when properly installed on that instrument. Hewlett Packard does not warrant that the operation of the instrument, or software, or firmware will be uninterrupted or error free.

**LIMITATION
OF
WARRANTY**

The foregoing warranty shall not apply to defects resulting from improper or inadequate maintenance by Buyer, Buyer-supplied software or interfacing, unauthorized modification or misuse, operation outside of the environmental specifications for the product, or improper site preparation or maintenance.

No other warranty is expressed or implied. Hewlett Packard specifically disclaims the implied warranties of Merchantability and Fitness for a Particular Purpose.

**EXCLUSIVE
REMEDIES**

The remedies provided herein are Buyer's sole and exclusive remedies. Hewlett Packard shall not be liable for any direct, indirect, special, incidental, or consequential damages whether based on contract, tort, or any other legal theory.

CERTIFICATION

Hewlett-Packard Company certifies that this product met its published specifications at the time of shipment from the factory.

Hewlett-Packard further certifies that its calibration measurements are traceable to the United States National Institute of Standards and Technology, NIST (formerly the United States National Bureau of Standards, NBS) to the extent allowed by the Bureau's calibration facility and to the calibration facilities of other International Standards Organization members.

PRINTING HISTORY

PRINTING HISTORY	<u>EDITION</u>	<u>DATE</u>	<u>PART NUMBER</u>	<u>CODE</u>
	Edition 1	12/01/88	08131-90011	E1288
	Update 1	02/15/89		U0289
	Update 2	03/15/89		U0389
	Update 3	03/20/89		U0389
	Update 4	06/29/89		U0689

Update 4, 06/29/89

HP 8131A-Printing History

v

LIST OF EFFECTIVE PAGES

This table lists only pages that are changes to Edition 1.

<u>PAGE</u>	<u>DATE</u>	<u>PAGE</u>	<u>DATE</u>
Title Page (i)	03/20/89	5-1	03/15/89
ii	02/89	5-6	03/15/89
iv	02/89	5-8	02/89
v	03/15/89	5-9	03/15/89
vi	03/15/89	5-10	03/15/89
		5-11	03/15/89
		5-13	03/15/89
		5-14	03/15/89
1-1	02/89	5-15	03/15/89
		5-16	03/15/89
2-1	03/15/89	5-28	03/15/89
2-3	03/15/89	5-29	03/15/89
2-4	03/15/89	5-30	03/15/89
		5-42	03/15/89
		5-46	03/15/89
		6-8	02/89
3-1	03/15/89	7-34	03/15/89
3-4	02/89	A-1 to A-8	03/15/89
3-7	03/15/89	B-2	02/89
		C-13	03/15/89
		D-1 to D-3	02/89
4-6	02/89	D-4	03/15/89
		E.0-1	02/89
		E.2-1	02/89
		E.3-1	02/89
		E.4-1	02/89
		E.9-4	03/15/89
		E.10-3	06/29/89
		G-8 to G-9	03/15/89
		G-10	02/89

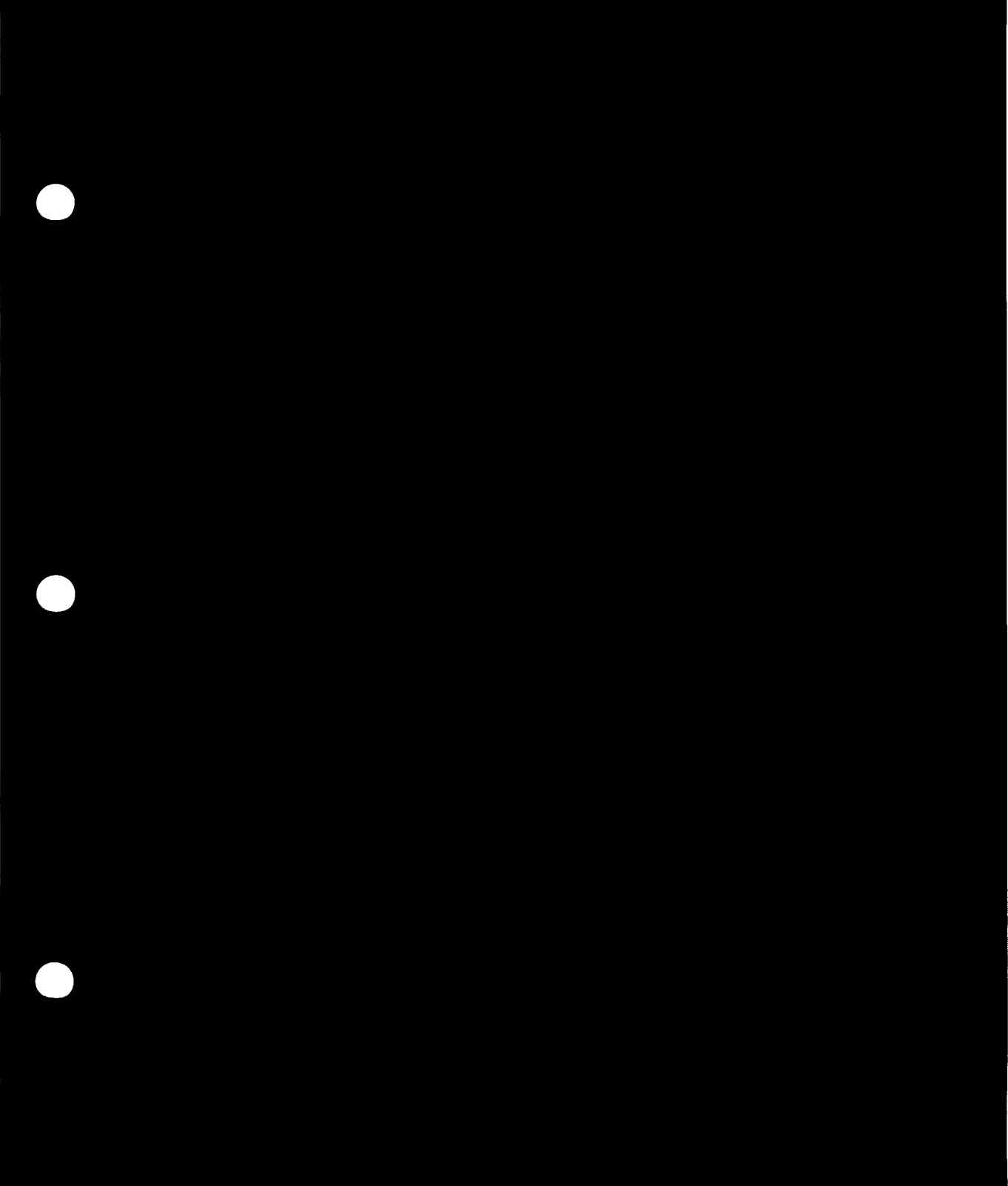

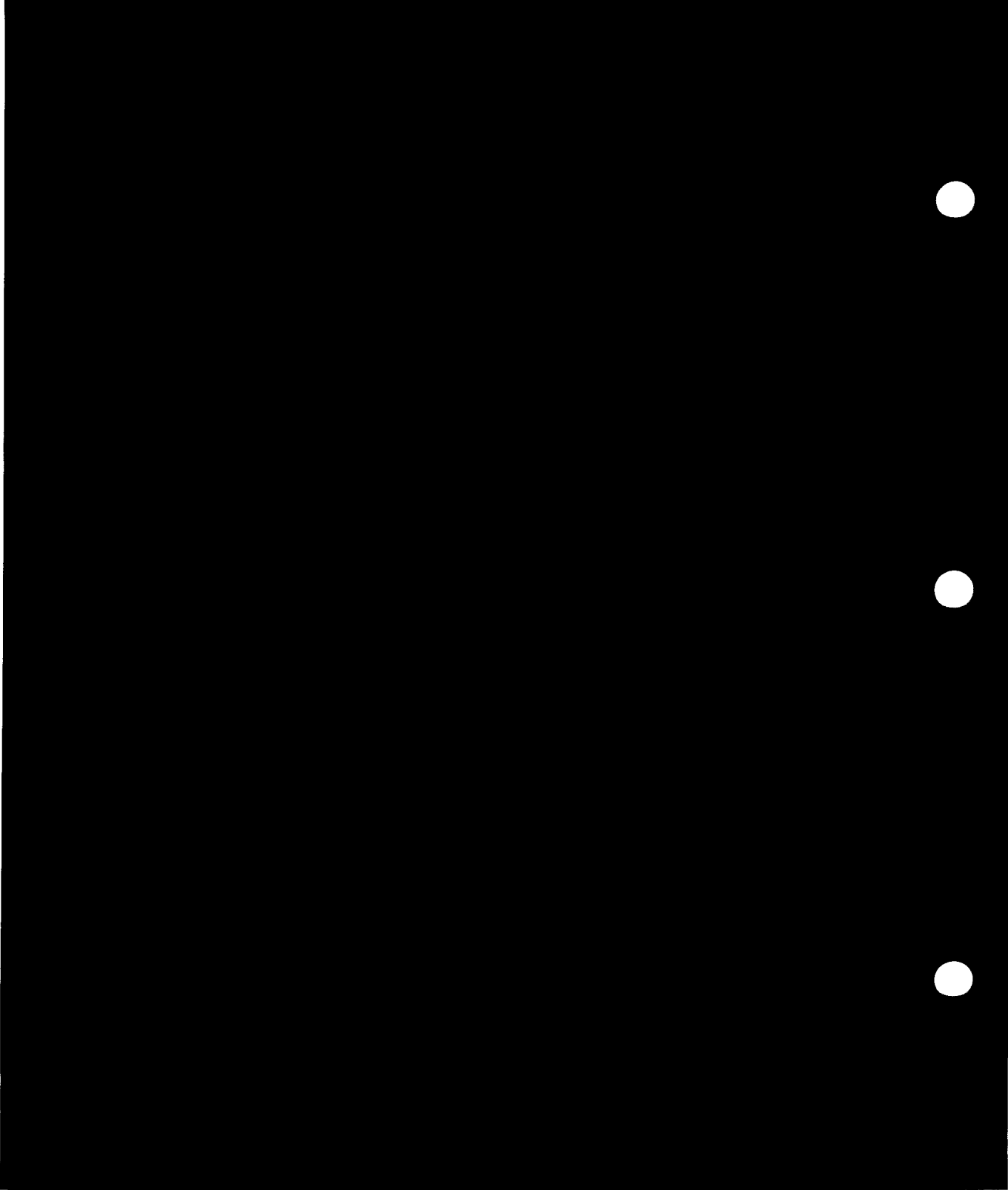

**RADIO FREQUENCY INTERFERENCE STATEMENT
DEUTSCHE BUNDESPOST
FEDERAL REPUBLIC OF GERMANY ONLY**

**HERSTELLER-
BESCHEINIGUNG**

Hiermit wird bescheinigt, dass das Geraet, Pulsgenerator-HP 8131A, in Uebereinstimmung mit den Bestimmungen von Postverfuegung 1046/1984 funkentstoert ist.

Der Deutschen Bundespost wurde das Inverkehrbringen dieses Geraetes angezeigt und die Berechtigung zur Ueberpruefung der Serie auf Einhaltung der Bestimmungen eingeraeumt.

Zusatzinformation fuer Mess- und Testgeraete: Werden Mess- und Testgeraete mit ungeschirmten Kabeln und/oder in offenen Messaufbauten verwendet, so ist vom Betreiber sicherzustellen, dass die Funk-Entstoerbestimmungen unter Betriebsbedingungen an seiner Grundstuecksgrenze eingehalten werden.

**MANUFACTURER'S
DECLARATION**

This is to certify that the HP 8131A pulse generator operates in accordance with the radio frequency interference requirements of Deutsche Bundespost (German Post Office) Directive FTZ 1046/1984.

The German Post Office was notified that this equipment was put into circulation. The German Post Office retains the right to check future Hewlett-Packard model HP 8131A instruments for compliance with directive FTZ 1046/1984.

Additional information for test and measurement equipment: If test and measurement equipment is operated with unshielded cables and/or used for measurements on open set-ups, the user must assure that, under operating conditions, the radio interference limits are still met at the border of his premises.

INTRODUCTION

The manual information is arranged into four categories:

INSTRUMENT DESCRIPTION

Descriptions of selected operating principles:
Chapters 1-4.

QUICK REFERENCE GUIDES

Local control and remote control programming information:
Chapters 5-7.

REFERENCE DATA

Supporting information of a non-operational nature:
Appendices A-G.

CUSTOMER ASSISTANCE

Sales and Service information:
Customer Assistance Information
Sales and Support Offices Directory.

Application programming level knowledge of IEEE Standards 488.1-1987 and 488.2-1987 is desirable for remote control programming of the HP 8131A.

Appendix G contains cross reference information for earlier instrument languages and the HP 8131A language which is based on IEEE Draft Standard 488.2-1987.

Viel Spass!
Hewlett-Packard GmbH

CONTENTS

INSTRUMENT DESCRIPTION

Features	1-1
Getting Started	2-1
Remote Messages	3-1
Operating State	4-1

QUICK REFERENCE GUIDES

Local Control Programming	
Local (Front Panel) Functions	5-1
Remote Control Programming	
Common Commands	6-1
Device Dependent Commands	7-1

REFERENCE DATA

Specifications	A-1
Options and Accessories	B-1
Installation and Maintenance	C-1
Backdating	D-1
Performance Tests	E-1
Language Cross References	F-1
Errors	G-1

INDEX	Index-1
--------------	---------

CUSTOMER ASSISTANCE

Customer Assistance Information	CA-1
Sales and Support Office Directory	SSO-1

CHAPTER 1

INSTRUMENT FEATURES

INTRODUCTION

The HP 8131A is a 500 MHz pulse generator providing differential output signals from 100 mV_{pp} to 5.00V_{pp} with fixed transition times of ≤ 200 ps.

The standard instrument contains one channel; a non-retrofitable second channel is available.

Specifications: Appendix A.
Options and Accessories: Appendix B.

INSTRUMENT FEATURES

INPUT

- External Input
- Manual
- Single PulsE
- Polarity
- Threshold

MODES

- Automatic
- Trigger
- Gate
- Burst
- External Width
- Transducer

PULSE

- Period, Width, Duty Cycle
- Delay, Double Pulse
- High Level, Low Level, Limit
- Amplitude, Offset

DIFFERENTIAL OUTPUT

- State
- Polarity

TRIGGER OUTPUT

MEMORY

- Save setting
- Recall settig

SET (calculated setting)

PULSE PARAMETERS

Time Reference Point: Median (50 % amplitude point on pulse edge).
Pulse Period: The time interval between the leading edge medians of consecutive trigger output pulses.
Trigger Delay: Interval between trigger point of input signal and the trigger output pulse's leading edge median. Applies in trigger, external width, gate and burst modes.

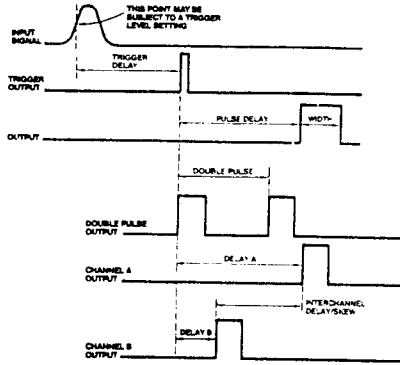

Pulse Delay: Interval between leading edge medians of trigger output pulse and output pulse.
Double Pulse: Interval between leading edge medians of the double pulse.
Interchannel Delay/Skew: Interval between corresponding leading edge medians.
Pulse Width: Interval between leading- and trailing-edge medians.

Duty Cycle: Percentage ratio of pulse width to period. In pulse/function generators, this term is also used to define sine and triangle symmetry.

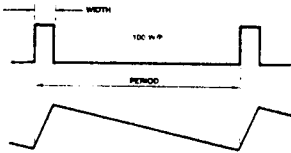

Transition Time: Interval between the 10 % and 90 % amplitude points on the leading/trailing edge.
Linearity: Peak deviation of an edge from a straight line through the 10 % and 90 % amplitude points, expressed as percentage of pulse amplitude.

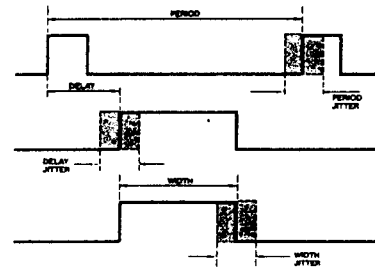

Stability: Long-term, average instability, expressed as percentage of main parameter over a specific time duration, e.g. hour, year. Excludes jitter.

Jitter: Short term timing instability; rms jitter is based on 1000 measurements and is identical to the standard deviation.

Pulse Width: The specified and displayed value is that obtained with fastest edges; essentially equal to the interval from the start of the leading edge to the start of the trailing edge.

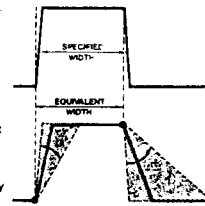

By designing so that the pulse edges turn about their start points, the interval from leading edge start to trailing edge start stays unchanged* when transition times are varied. This is more convenient for programming and the width display is easy to interpret.

*In practice, start points may shift with change in transition time.

Delay: The specified and displayed value is that obtained with the fastest leading edge. For a slower edge, the actual delay exceeds the displayed delay by the combined shift of start-point and median.

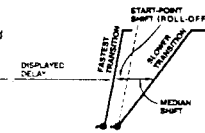

Pulse Level: High level and low level. Any limitation is expressed by an amplitude specification.



Pulse Amplitude (alternative to level definition): Pulse amplitude and offset* are specified. Any limitation is expressed by a window (max high level; min low level).

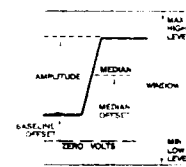

*Pulse generation use baseline offset. Function generator outputs are symmetrical and consequently use median offset.

Preshoot, Overshoot, Ringing: Preshoot and overshoot are peak distortions preceding/following an edge. Ringing is the positive peak and negative peak distortion excluding overshoot, on pulse top or base. A combined preshoot/overshoot/ringing specification of e.g. $\pm 5\%$ implies:

- Overshoot/undershoot $< 5\%$.
- Largest pulse-top oscillation $< \pm 5\%$ of pulse amplitude.

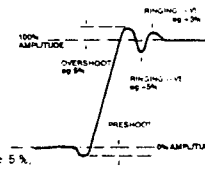

Settling Time: Time taken for pulse levels to settle within level specification, measured from 90 % point on leading edge.

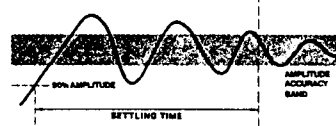

Output Impedance/Resistance: Effective pulse source impedance/dc resistance

Reflection Coefficient: Reflection at pulse generator output expressed in percent of incident pulse amplitude. (Test pulse edges correspond to generator's fastest transitions).

Repeatability: When an instrument operates under the same environmental conditions, and with the same settings, the value of a parameter will lie within a band inside the accuracy window. Repeatability defines the width of this band.

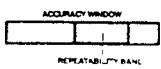

CHAPTER 2

GETTING STARTED

CONTENTS

Introduction	2-3
Power-on	2-3
Power-on Test	2-3
Normal State	2-3
Abnormal State	2-3
Power-off	2-3
Instrument Setting	2-4
Local Control Programming	2-4
Function Selection	2-4
Data Entry	2-4
Device Errors	2-4
Remote Control Programming	2-5
Program Messages	2-5
Response Messages	2-5
Under-programming	2-5
Interface	2-6
Status Indicators	2-6
Address	2-6
Displaying	2-6
Changing	2-6
EXT INPUT	2-6
Outputs	2-6
Channel 1 and 2	2-6
TRIG OUTPUT	2-6

POWER-ON

At power-on, the instrument:

1. Performs a power-on test and
2. Enters the normal or abnormal state.

Power-on Test

The instrument performs the following tests.

1. Processor board tests
2. Parametric board Tests

See Appendix G, Table G-1, for the scope of the power-on test.

Normal State

In the normal state (operating error free condition):

1. The instrument is initialized and enters the IDLE state.
2. The instrument's setting is restored:
 - a. To the setting stored at power-off, however, the outputs are disabled. The power-off address is restored.
 - b. To the standard setting if the internal memory data is invalid. The instrument's address is set to 11, the default address.

Abnormal State

In the abnormal state (operating error condition exists):

1. Processor board test failure: the instrument **can not be operated**. The error condition code is reported at the instrument's display in the format **Fnnn**. See Appendix G, Table G-1, for a list of the Fnnn type errors.
2. Parametric board test failure: the instrument is **operable**, however, **parametric capability is restricted**. The error condition code is reported at the instrument's display in the format **Ennn**. See Appendix G, Table G-1, for a list of the Ennn type errors.

POWER-OFF

At power-off, the instrument's setting and interface address are stored in battery supported internal memory.

INSTRUMENT SETTING

The instrument setting contains the complete operating state of the instrument.

The setting can also be stored in or recalled from internal memory (There are 19 user storage locations.) which is battery supported at power off.

LOCAL CONTROL PROGRAMMING

In the local mode, the instrument is programmed with the front panel controls.

The front panel controls and functions are described in Chapter 5.

Function Selection and Data Entry

To select a function, press the corresponding key and an LED lights to indicates the function is active. If data is to be changed, use the up or down vernier or range keys to make the changes.

Device Errors

Device errors are indicated at the front panel by blinking LEDs. For a description of the parametric relationships describing the conflicts, see Chapter 5.

REMOTE CONTROL PROGRAMMING

The instrument is programmed via program messages and returns test, operating state, setting data, and identification information in response messages.

Program Messages

The program messages are:

1. Defined in Chapter 3
2. Diagrammed in Chapters 6 and 7.
 - a. Common commands: Chapter 6
 - b. Device commands: Chapter 7

Response Messages

The response messages are:

1. Defined in Chapter 3
2. Listed in Chapters 6, 7, and Appendix G.
 - a. Common commands: Chapter 6.
 - b. Device commands: Chapter 7
 - c. Error responses: Appendix G.

UNDER-PROGRAMMING Period and width under-programming is allowed. See Chapters 5 and 7.

INTERFACE

The interface, HP-IB, is a byte-serial, bit-parallel, asynchronous, digital interface.

The interface port is located on the rear panel.

Status Indicators

The following three indicators on the front panel show interface status.

1. RMT (remote) indicates when the instrument is in the remote control programming mode.
2. ADS (address) indicates when the instrument is listen or talk addressed.
3. SRQ (service request) indicates when a service request is pending; the interface SRQ control line is asserted.

Address Displaying

The instrument address can be read on the front panel display by pressing the LCL (local) key while in the local operating mode only.

Address Changing

To change the address (local control programming mode only):

1. Depress the LCL key
2. Change the address in the display with a vernier key.
3. Release the LCL key.

The address cannot be changed if the instrument is talk or listen addressed, a service request is pending or in the remote control mode.

EXTERNAL INPUT

External input is the signal input for the trigger, gate, burst, external width, or transducer instrument trigger modes. Each mode is described in Chapter 5.

CHANNEL 1/2 OUTPUTS

Each channel has differential outputs. The standard instrument has one channel. Channel 2 is an optional second channel; note however, it is not a retrofitable option.

TRIGGER OUTPUT

Trigger output is the reference signal for the channel 1 and 2 output waveforms.

CHAPTER 3

REMOTE MESSAGES

CONTENTS

Introduction	3-3
Message Types	3-3
Language Cross Reference	3-3
Coupled Commands	3-3
Short Form/Long Form	3-3
Program Message Syntax	3-4
Response Message Syntax	3-5
Reading Response Messages	3-5
Conventions	3-6

FIGURE

Device Commands	3-7
-----------------	-----

INTRODUCTION

Messages, commands, and syntax are described in this chapter.

MESSAGE TYPES

Two types of messages are used.

1. Program messages which are sent from a remote controller to the HP 8131A.
2. Response messages which are sent from the HP 8131A to the controller.

HP 8112A HP 8160A/61A COMMAND CROSS REFERENCE

The language used by the HP 8131A is based on IEEE Standard 488.2-1987 and is different from the languages used in the HP 8112A, HP 8160A, and HP 8161A.

To assist in converting programs from one language to the other, Appendix F contains cross referenced examples of the HP 8112A/60A/61A and HP 8131A instrument commands.

COUPLED COMMANDS

The following commands are coupled.

:PULS:LEV:HIGH, :PULS:LEV:LOW,
:PULS:LEV:AMPL, and :PULS:LEV:OFFS

The relationships of the coupled commands are given in Chapter 5.

SHORT FORM LONG FORM

The instrument will accept the short and long forms of the commands in upper and lower case.

EXAMPLE:

Long form = :INPut:TRIGger:STATe ON

Short Form = :INP:TRIG:STAT ON

PROGRAM MESSAGE SYNTAX

Program messages = <ASCII-string><pmt>:

1. <ASCII-string> is one or more program message units.

Message units are separated by a program message unit separator (<pmus> = ;).

Each path in the syntax diagrams of Chapters 6 and 7 represent a complete program message unit

2. <pmt> = program message terminator

There are three possible <pmt>:

1. <lf>
2. <^END>
- 3' <lf><^END>

'^' indicates that the END message is asserted at the last byte of the program message on the general interface management bus, signal line end or identify (EOI).

NOTE: <lf> is equivalent to NL (New LINE).

PROGRAM MESSAGE EXAMPLE

```
OUTPUT 711;  "*"RST;  
              :PULSe:TIMing:DELay 20 ns;  
              WIDT 200us;  
              :pulse:level:high 3.5V;  
              low 1"
```

RESPONSE MESSAGE SYNTAX

Response messages = <ASCII-string><rmt>

1. <ASCII-string> is one or more response message units.

The message units are defined in Chapters 6 and 7.

2. <rmt> = response message terminator

<lf><^END> is the only <rmt> used by the instrument. '^' indicates that the 'END' message is asserted at the last byte of the response message on the general interface management bus, signal line end or identify (EOI).

NOTE: <lf> is equivalent to NL.

Responses return values only; the base units are implied.

See Chapters 6 and 7 for examples.

READING RESPONSE MESSAGES

A query response must be read before the next program message is parsed or the message is deleted from the output queue.

RESPONSE MESSAGE EXAMPLE

OUTPUT 711; "*"RST"

OUTPUT 711;":PULSe:LEVel:HIGH?"
ENTER 711; A\$

PRINT A\$ -----> 0.50

SYNTAX DIAGRAM CONVENTIONS

Non-terminals, substitute the required characters:
wsp, value, unit, data, code.

Terminals: all terms not defined as non-terminals are terminals and are input as given. Short and long forms of the commands are allowed.

The instrument accepts character strings in upper and/or lower case equally.

MIN = minimum.

1. MIN in a program message unit sets up the minimum setting allowed for that parameter.
2. MIN in a query message unit returns the minimum value allowed for that parameter.

MAX = maximum.

The action is the same as for MIN except that maximum values are used.

value = integer (12), decimal (85.5),
exponential format (99.9E-9)
(E-12, E-9, E-6, or E-3 are allowed.)

unit bypass and base units:

S (seconds)
V (volts)
PCT (percent)

units = ps/PS, ns/NS, us/US, ms/MS, s/S
uv/UV, mv/MV, v/V

NL = ASCII <lf>.

| = either/or (a|b = either a or b but not both
at the same time)

<...> = non-terminal

[...] = optional

white space, wsp = ASCII control characters and the space but excludes the newline.

FIGURE 3-1. DEVICE COMMANDS

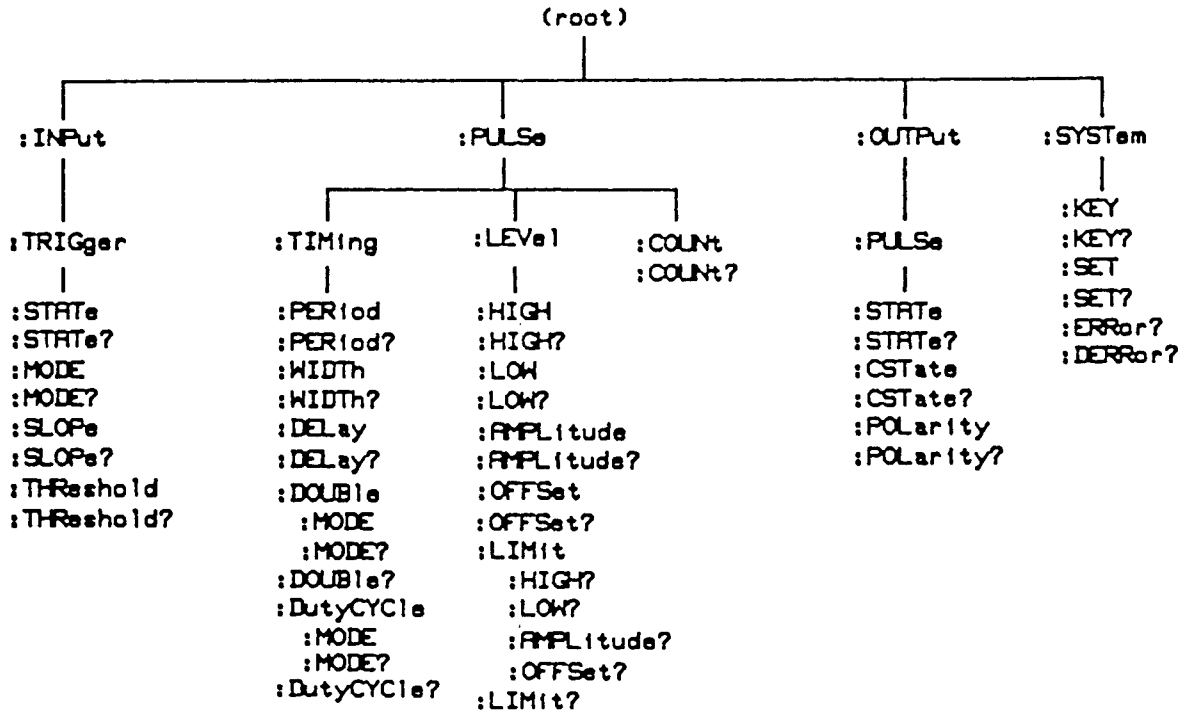

CHAPTER 4

OPERATING STATE

CONTENTS

Introduction	4-3
Power-on	4-3
Parser Operation	4-3
Error types	4-4
Local Messages	4-5
Remote Messages	4-5
Polling	4-6
STB Message	4-7
Status Byte Register (STB)	4-8
Service Request Enable Register (SRE)	4-9
Standard Event Status Register (ESR)	4-10
Standard Events Status Enable Register (ESE)	4-11
Input Buffer	4-12
Output Queue	4-12
Error Queue	4-12
Key Queue	4-12
Register bit assignment	4-13
Synchronization	4-13

FIGURE

Status Reporting	4-14
------------------	------

HP 8131A-State	4-1
----------------	-----

INTRODUCTION

Power-on, parser operation, and status data structures are described in this chapter.

POWER-ON

At power-on, the instrument:

1. Initializes itself:
 - a. The input buffer is cleared.
 - b. The output queue is cleared.
 - c. The key queue is cleared.
 - d. STB, SRE, ESR, ESE and the error queue are cleared.
 - e. The parser is reset.
 - f. The execution Control is reset.
 - g. The response formatter is reset.
2. Enters the IDLE state awaiting a command.
3. The setting at power-off is restored as the current setting; however, the outputs are disabled.
4. The power-off address is also restored.

NOTE, if the RAM data is invalid, the power-off setting cannot be restored. In this case, the standard setting and the default address, 11, are restored.

PARSER OPERATION

Normally, the instrument removes all DABs , END, and GET bytes from the interface. Then it parses the bytes in the input buffer.

The exception is when the input buffer is full, and additional bytes remain to be input. In this case, the parser removes one byte from the input buffer and parses it. Then a byte is removed from the interface. If additional bytes remain to be input, the process of parsing one byte and inputting one byte continues until all bytes are input. Then the entire input buffer is parsed.

ERROR TYPES

There are four categories of instrument errors. All errors are listed in Appendix G.

1. Power-on test errors identify microprocessor and output board failures occurring at power-on. See Appendix G, Table G-1 for the extent of the test.
2. Self-test (*TST?) errors identify output board failures. The test is identical to the output board test performed at power-on. See Appendix G, Table G-2.
3. Command, execution, device dependent, and query error events are reported in the standard event status register (ESR). These errors can be read in response to the :SYST:ERR? query. See Appendix G, Table G-3.
4. Device dependent error conditions are reported in bit 0 of the status byte register. These errors can be read in response to the :SYST:DERR? query. See Appendix G, Table G-4 or G-5.

The device dependent errors are reported on the front panel by blinking LEDs and are referred to as conflicts in the manual.

LOCAL MESSAGES

Power-on error messages are displayed immediately after the power-on tests are completed. See Appendix G, Table G-1 for a list of messages.

There are two types:

1. Processor board test failure:
the instrument **can not be operated**.

The error condition code is reported at the instrument's display in the format **Fnnn**.

2. Parametric board test failure:
the instrument is **operable**, however, **parametric capability is restricted**.

The error condition code is reported at the instrument's display in the format **Ennn**.

REMOTE MESSAGES

Remote error messages can be read in response to the following queries:

1. *TST? (See Appendix G, Table G-2).
2. :ERR? (See Appendix G, Table G-3)
3. :DERR? (See Appendix G, Table G-4)

POLLING

The instrument's interface talker subset is T6. Thus, the serial poll method of requesting service is used.

Polling: STB Bit 0 Behavior

Bit 0 of the status byte register always reflects the actual state of the device. If a conflict is present, Bit 0 will be set. If all conflicts are cleared, Bit 0 will also be cleared.

If Bit 0 is set (1), a service request is generated if a service request is not pending (bit 0 of the service request enable register must be set).

STB MESSAGE

The status message is transmitted in bits 7 and 5-0 of the status byte register.

Bit 7: not used

Bit 5: ESB (Event Status Bit)

Bit 4: MAV (Message Available)

Bit 3: not used

Bit 2: not used

Bit 1: not used

Bit 0: H (hardware error summary-condition-bit)

The errors related to bit 0 are reported in response to a :DERR? query:
See Appendix G, Table G-4 for a listing of the :SYST:DERR? query errors.

STB

STATUS BYTE REGISTER

The status byte register (STB) is described in the following figure.

The Master Summary Status (MSS) message is true when any enabled bit of the STB register is set excluding Bit 6.

[BIT 7] [BIT 6] [BIT 5] [BIT 4] [BIT 3] [BIT 2] [BIT 1] [BIT 0]

Bit 7:	Not used, value = 0
Bit 6:	RQS / MSS (Request Service / Master Summary Status)
Bit 5:	ESB (Event Status Bit)
Bit 4:	MAV (Message Available)
Bit 3:	Not used, value = 0
Bit 2:	Not used, value = 0
Bit 1:	Not used, value = 0
Bit 0:	H (Hardware error summary-condition-bit)

READING THE STB REGISTER

After reading the status byte register with:

1. **An *STB? query:**
 - a. The status byte, RQS message, and the master summary message, MSS, are not directly altered as a result of the query.
 - b. MSS is reported in bit six of the status byte register.

NOTE: MSS can be indirectly altered by the query when MAV is enabled.
2. **A serial poll:**
 - a. The request for service, RQS, message is cleared; the status byte and the MSS message are not altered as a result of the query.
 - b. RQS is reported in bit six of the status byte register.

SERVICE REQUEST ENABLE REGISTER

The service request enable register (SRE) allows enabling of status byte register (STB) bits. See Chapter 6, *SRE command.

Bit six of the status byte register cannot be disabled. Thus, the bit value of sixty-four, if transmitted in an *SRE message, will be ignored.

The register is masked with the *SRE command and cleared with an '*SRE 0' message.

[BIT 7] [BIT 6] [BIT 5] [BIT 4] [BIT 3] [BIT 2] [BIT 1] [BIT 0]

Bit 7: Not used, value = 0
Bit 6: Not used, value = 0
Bit 5: ESB (Event Status Byte)
Bit 4: MAV (Message Available)
Bit 3: Not used, value = 0
Bit 2: Not used, value = 0
Bit 1: Not used, value = 0
Bit 0: H (Hardware error summary-condition-bit)

READING THE SRE REGISTER

The service request enable register (SRE) is non-destructively read with the *SRE? query.

ESR

STANDARD EVENT STATUS REGISTER

The standard event status register (ESR) is described in the following figure.

[BIT 7] [BIT 6] [BIT 5] [BIT 4] [BIT 3] [BIT 2] [BIT 1] [BIT 0]

Bit 7: PON, Power-on
Bit 6: Not used, value = 0
Bit 5: CME, Command Error
Bit 4: EXE, Execution Error
Bit 3: DDE, Device Dependent Error
Bit 2: QYE, Query Error
Bit 1: Not used, value = 0
Bit 0: OPC, Operation Complete

READING THE STANDARD EVENTS STATUS REGISTER

The standard events status register is read with the *ESR? query.

The register is cleared after being read.

Additional CME, EXE, DDE, and QYE status is obtained with the :SYST:ERR? query. See Chapter 7 and Appendix G, Table G-3.

STANDARD EVENT STATUS ENABLE REGISTER

The standard events status enable register(ESE) described in the following figure, enables bits of the standard events status register, ESR.

The register is masked with the *ESE command and cleared with an **ESE 0' message.

[BIT 7] [BIT 6] [BIT 5] [BIT 4] [BIT 3] [BIT 2] [BIT 1] [BIT 0]

Bit 7: PON, Power-on
Bit 6: Not used, value = 0
Bit 5: CME, Command Error
Bit 4: EXE, Execution error
Bit 3: DDE, Device Dependent Error
Bit 2: QYE, Query Error
Bit 1: Not used, value = 0
Bit 0: OPC, Operation Complete

READING THE ESE REGISTER

The standard event status enable (ESE) register is non-destructively read with the *ESE? query.

INPUT BUFFER

The input buffer is:

1. FIFO buffer (first-in first-out)
2. 100 bytes long.

OUTPUT QUEUE

The output queue is:

1. FIFO queue (first-in first-out)
2. 40 response messages long

The message available, MAV, message is reported in bit four of the status byte when the output queue contains a message.

The output queue and the MAV message are cleared when a new program message is received directly after a program message terminator.

ERROR QUEUE

The error queue is a:

1. FIFO queue (first-in first-out)
2. 10 errors long

If the queue overflows, message '-350 <too many errors>' overlays the last message in the queue.

KEY QUEUE

The key queue records real key presses, not :SYST:KEY simulated key presses.

The key queue is a:

1. FIFO queue (first-in first-out)
2. 1 key long

If the queue is empty, message '0' is returned in response to the :SYST:KEY? query.

The key queue is cleared after pon or *RST.

REGISTER BIT ASSIGNMENT	BIT	WEIGHT	SIGNIFICANCE	INTERFACE ASSIGNMENT
	[BIT 7]	128	Most (MSB)	DIO8
	[BIT 6]	64		DIO7
	[BIT 5]	32		DIO6
	[BIT 4]	16		DIO5
	[BIT 3]	8		DIO4
	[BIT 2]	4		DIO3
	[BIT 1]	2		DIO2
	[BIT 0]	1	Least (LSB)	DIO1

NOTE: Unused register bits have a value of zero or are ignored.

SYNCHRONIZATION

All commands are sequential commands.

If *OPC or *OPC? is parsed, a delay of two seconds occurs before the OPC bit is set or an ASCII coded '1' is placed in the output queue.
See Chapter 6.

If *WAI is parsed, a delay of two seconds occurs before executing any other commands.
See Chapter 6.

At the end of two seconds, all operations are complete.

FIGURE 4-1. STATUS REPORTING

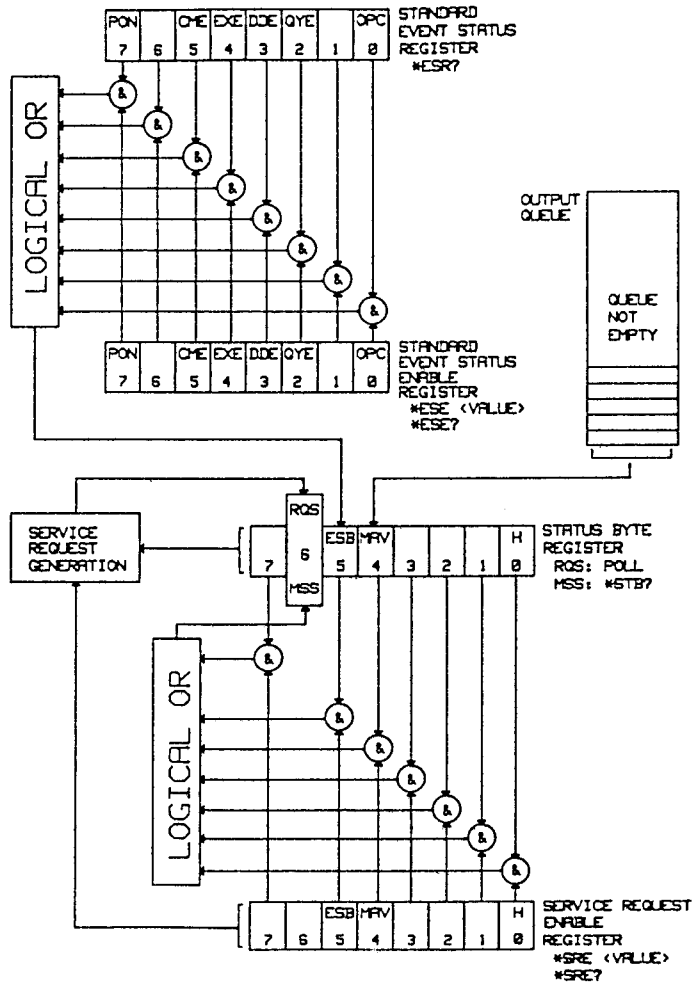

CHAPTER 5

LOCAL FUNCTIONS

CONTENTS

1 PULSE (single pulse)	MAN (manual)
ADDRESS (See LCL.)	MEM (memory)
ADS (addressed)	OFFS (offset)
AMPL (amplitude)	OUTPUT (differential)
AUTO (automatic)	PERIOD
BURST	POWER OFF/ON
COMP (complement)	RANGE
COUNT	RCL (recall setting)
DCYC (duty cycle)	RMT (remote)
DEL (delay)	SAVE (save setting)
DISABLE (output)	SET (calculated setting)
DOUB (double pulse)	SINGLE PULSE (See 1 PULSE.)
ERROR	SLOPE (external input)
E. WIDTH (external width)	SRQ (service request)
EXT INPUT (external input)	THRE (threshold)
GATE	TRANS (transducer)
HIGH	TRIG (trigger)
LCL (local)	TRIG OUTPUT (trigger)
LIMIT	UNITS
LOW	VERNIER
	WIDTH

FIGURE	5-1	Overvoltage Window	5-13
TABLE	5-1	Period, Delay, Double, and Width Ranges	5-47

1 PULSE

FUNCTION

1 PULSE
Single Pulse

DESCRIPTION

TRIG operating mode
One pulse or double pulse is generated per key press.

GATE operating mode
One pulse or double pulse is generated per key press.

BURST operating mode
One pulse or double pulse is generated per key press.

Device command: none

FUNCTION

DESCRIPTION

ADDRESSED

The ADS indicator (lighted LED) indicates when the instrument is listen or talk addressed.

The interface address cannot be changed when the instrument is talk or listen addressed.

Device command: none

Interface commands: MLA, MTA, UNL, UNT

AMPL

FUNCTION

AMPLITUDE

DESCRIPTION

0.10 V <= AMPLITUDE <= 5.00 V

Resolution: 0.01 V
Default: 1.00 V

Amplitude, offset, high level, and low level are coupled.

Amplitude = High - Low

OVERVOLTAGE DISABLING: See DISABLE.

Device command:
:PULSe:LEVel:AMPLitude <value>|MIN|MAX

FUNCTION

DESCRIPTION

AUTO

AUTOMATIC operating mode:

A continuous waveform (free run mode) is generated.

Select the AUTO mode by pressing the mode select key. The AUTO LED lights when the AUTO mode is active.

The mode is common to channels 1 and 2 in dual channel instruments.

The external input is disabled when the AUTO operating mode is active.

Device command:
:INPut:TRIGger:MODE AUTO

BURST

FUNCTION

BURST

PERIOD-BURST RELATIONSHIP

DESCRIPTION

BURST operating mode:

A specified number of pulses or double pulses (1-9999) are generated for each burst trigger signal.

IF PERIOD < 5.00 ns
THEN BURST mode is not allowed.

Burst trigger signals:

1. External Input (See EXT INPUT.)
2. Manual key press (SEE MAN.)
3. *TRG (See Chapter 6.)

The mode is common to channels 1 and 2 in dual channel instruments.

The number of pulses or double pulses per burst is set with the COUNT function.

Device command:

:INPut:TRIGger:MODE BURSt

Related command:

:PULSe:COUNT <value>|MIN|MAX

Common command: *TRG

FUNCTION

DESCRIPTION

COMPLEMENT

Disabled, default

The OUTPUT pulse or double pulse is output as specified by the setting.

Enabled, LED lighted

The OUTPUT pulse or double pulse is inverted with respect to the setting.

In both cases, disabled or enabled, the COMPLEMENT OUTPUT is the inverted form of OUTPUT.

Device command:

:OUTPut:PULSe:POLarity NORM|COMP

COUNT

FUNCTION

COUNT

DESCRIPTION

$1 \leq \text{COUNT} \leq 9999$

Resolution: 1
Default: 1

The COUNT function sets the number of pulses or double pulses contained in the burst.

The burst count is common to channels 1 and 2 in dual channel instruments.

Device command:
:PULSe:COUNT <value>|MIN|MAX

Related command:
:INPut:TRIGger:MODE BURSt

Common command: *TRG

FUNCTION

DUTY CYCLE

DESCRIPTION

1% <= DUTY CYCLE <= 99%

Resolution: 1

Default: mode = OFF
duty cycle = 50 percent

If DOUBLE PULSE is inactive:

WIDTH = PERIOD * DCYC / 100

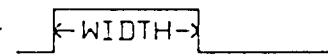
OUTPUT 

If DOUBLE PULSE is active:

WIDTH = PERIOD * DCYC / 200

OUTPUT 

Device command:

:PULSe:TIMing:DutyCYCle <value>|MIN|MAX
:PULSe:TIMing:DutyCYCle:MODE ON|OFF|1|0

Related command:

:PULSe:TIMing:PERiod <value>|MIN|MAX

DCYC

FUNCTION

DESCRIPTION

PERIOD-DCYC RELATIONSHIP

PERIOD < 5.00 ns
IF WIDTH \geq 1.00 ns
THEN WIDTH \leq 0.5*PERIOD
ELSE WIDTH \leq 0.5*PERIOD - 0.5 ns

5 ns \leq PERIOD < 20.0 ns
WIDTH \leq 0.7*PERIOD - 1.00 ns

PERIOD \geq 20.0 ns
WIDTH \leq 0.90*PERIOD - 5.00 ns

DOUB-DCYC RELATIONSHIP

IF WIDTH < 1.00 ns
THEN WIDTH \leq 0.8*DOUB - 1.10 ns

IF WIDTH \geq 1.00 ns
THEN WIDTH \leq 0.8*DOUB - 0.6 ns

DCYC-TRIG RELATIONSHIP

DCYC and TRIG are incompatible.

FUNCTION

DESCRIPTION

DELAY

0.00 ps <= PULSE DELAY <= 99.9 ms

Resolution: See Table 5-1, page 5-47.

Default: 0.00 ps

Delay = Programmed DELAY + fixed delay (20 ns)

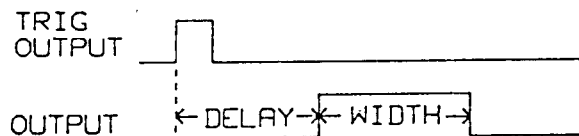

PERIOD-DELAY RELATIONSHIP

IF PERIOD < 2.00 ns

THEN DELAY = 0.00 NS

IF 2.00 ns <= PERIOD < 5.00 ns

THEN DELAY <= 0.5 PERIOD - 1.00 ns

IF 5.00 NS <= PERIOD < 20.0 NS

THEN DELAY <= 0.7*PERIOD - 2.00 NS

IF PERIOD >= 20.0 ns

THEN DELAY <= 0.9*PERIOD - 6.00 ns

Device command:

:PULSe:TIMing:DELay <value>|MIN|MAX

Related command:

:PULSe:TIMing:DOUBle:MODE ON|OFF|1|0

(OFF = DEL / ON = DOUB)

DISABLE

FUNCTION

DISABLE

DESCRIPTION

Disabled state, LED lighted, default
OUTPUT or COMPLEMENT OUTPUT is disabled.

Enabled state, led not lighted
OUTPUT or COMPLEMENT OUTPUT is enabled.

Each output has an independent disable function.

The output amplifier is switched off during the time an output is enabled or disabled.

OUTPUT and COMPLEMENT OUTPUT are disabled:

1. At power-on
2. After a reset (*RST)
3. When the standard setting is recalled (*RCL 0)
4. When an overvoltage occurs. See the following page for additional information.

Device commands:

OUTPUT

:OUTPut:PULSe:STAtE ON|OFF|1|0

COMPLEMENT OUTPUT

:OUTPut:PULSe:CStAtE ON|OFF|1|0

DISABLE

FUNCTION

DESCRIPTION

The window in the following diagram defines the output voltage conditions under which an enabled output will remain enabled. A voltage that exceeds a window limit causes an output to be automatically disabled.

If an output drives into an open circuit, the output voltage is doubled. The instrument disables the outputs if the voltage $> \pm 6.5V$

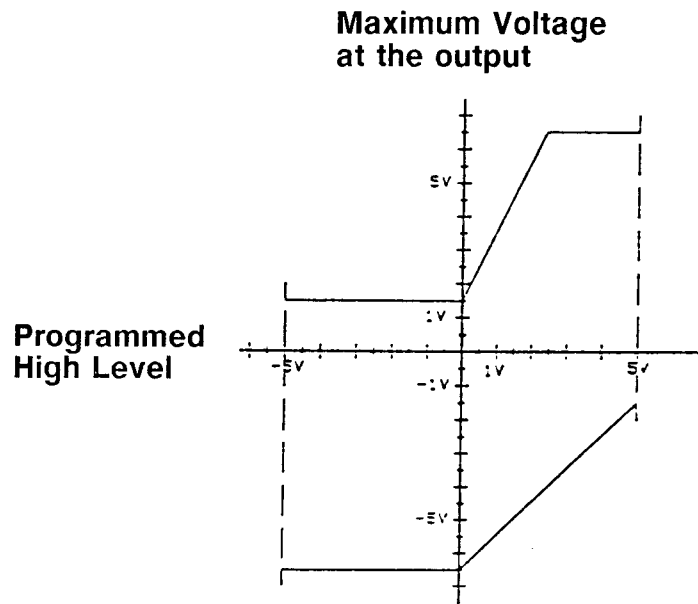

FIGURE 5-1. OUTPUT VOLTAGE WINDOW

DOUB

FUNCTION

DOUBLE PULSE (delay)

DESCRIPTION

$2.0 \text{ ns} \leq \text{DOUBLE PULSE DELAY} \leq 99.9 \text{ ms}$

Resolution: See Table 5-1, page 5-46.

Default: mode = OFF
double pulse delay = 200 us

Pulse delay (first pulse delay with respect to the trigger output) is not available. However, there is a fixed delay of 20 ns.

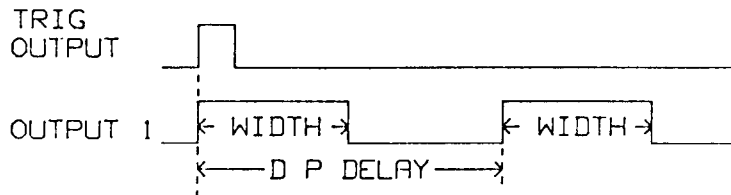

DOUBLE PULSE (width)

If duty cycle is inactive.

WIDTH = programmed value of WIDTH

If duty cycle is active.

WIDTH = PERIOD*DCYC/200

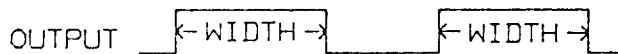

Device commands:

:PULSe:TIMing:DOUBle <value>|MIN|MAX

:PULSe:TIMing:DOUBle:MODE ON|OFF|!0

(OFF = DEL / ON = DOUB)

FUNCTION

DESCRIPTION

PERIOD-DOUB RELATIONSHIP

IF PERIOD < 5.00 ns
THEN DOUB is not possible.

IF 5.00 ns <= PERIOD < 10.0 ns
THEN DOUB <= 0.5*PERIOD

IF PERIOD >= 10.0ns
THEN DOUB <= 0.9*PERIOD - 4.00 ns

IF WIDTH < 1.00 ns
THEN WIDTH <= 0.7(PERIOD-DOUB) - 1.50 ns

IF 1.00 ns <= WIDTH < 10.0 ns
THEN WIDTH <= 0.7(PERIOD-DOUB) - 1.00 ns

IF WIDTH >= 10.0 ns
THEN WIDTH <= 0.85(PERIOD-DOUB) - 2.50 ns

WIDTH-DOUB RELATIONSHIP

IF WIDTH < 1.00 ns
THEN WIDTH <= 0.8*DOUB - 1.10 ns

IF WIDTH >= 1.00 ns
THEN WIDTH <= 0.8*DOUB - 0.6 ns

DOUB-DCYC RELATIONSHIP

IF WIDTH < 1.00 ns
THEN WIDTH <= 0.8*DOUB - 1.10 ns

IF WIDTH >= 1.00 ns
THEN WIDTH <= 0.8*DOUB - 0.6 ns

ERROR

FUNCTION

DESCRIPTION

POWER-ON ERRORS

F-TYPE

F-type errors indicate that the instrument cannot operate under the conditions represented by the error code.

See Appendix G, Table G-1 for a description of the error codes.

E-TYPE

E-type errors indicate that the capability of the instrument is restricted, but the instrument can still operate.

See Appendix G, Table G-1, for a description of the error codes and how the capability of the instrument is restricted.

DEVICE ERRORS

PARAMETRIC CONFLICTS

An attempt has been made to exceed the physical limits of the instrument. Blinking LEDs indicate when and which error is present in the instrument.

See Appendix G, Table G-5 or one of the function listings in this chapter for a description of the parametric relationships.

E. WIDTH

FUNCTION

DESCRIPTION

EXTERNAL WIDTH

EXTERNAL WIDTH operating mode

The pulse width and period are controlled by a signal applied at the EXT INPUT.

E. WIDTH external input signal:

Input bandwidth: DC to 500 MHz
Input transitions: < 50 ns
Minimum amplitude: ≥ 300 mVpp

Select the E. WIDTH mode by pressing the mode select key. The E. WIDTH led lights when the E. WIDTH is active.

The mode is common to channels 1 and 2 in the dual channel instrument.

Device command:
:INPut:TRIGger:MODE ExternalWIDth

EXT INPUT

FUNCTION

DESCRIPTION

EXTERNAL INPUT

EXT INPUT is the signal input for the TRIG, GATE, BURST, E. WIDTH, and TRANS operating modes.

The external input is disabled when the AUTO operating mode is active.

Slope

POS (positive), default

The TRIG, GATE, and BURST operating modes are triggered on a positive slope.

The gate closes on the negative slope of the trigger signal in the GATE operating mode.

NEG (negative)

The TRIG, GATE, and BURST operating modes are triggered on a negative slope.

The gate closes on the positive slope of the trigger signal in the GATE operating mode.

Threshold

-5.0 V <= THRESHOLD <= 5.0V

Resolution: 0.1V

Default: 0.0V

Device commands:

```
:INPut:TRIGger:MODE AUTO|TRIG|GATE  
                                          BURST|EWID|TRAN  
:INPut:TRIGger:SLOPe POS|NEG  
:INPut:TRIGger:THReshold <value>|MIN|MAX
```

FUNCTION

GATE

DESCRIPTION

GATE operating mode

A continuous waveform is generated for the duration of the gate signal.

GATE signal:

1. External Input (EXT INPUT)
2. Manual key (MAN)

The first pulse generated is synchronous with the leading edge of the gate signal.

The last pulse gated is always completed.

Select the GATE mode by pressing the mode select key. The GATE LED lights when the GATE mode is active.

The mode is common to Channels 1 and 2 in dual channel instruments.

Device command:

:INPut:TRIGger:MODE GATE

HIGH

FUNCTION

HIGH LEVEL

DESCRIPTION

-4.90V <= HIGH LEVEL <= 5.00V

Resolution: 0.01V
Default: 0.50V

High level, low level, amplitude, and offset are coupled.

High Level = Offset + Amplitude / 2

OVERVOLTAGE DISABLING: See DISABLE.

Device command:
:PULSe:LEVel:HIGH <value>|MIN|MAX

FUNCTION

DESCRIPTION

LOCAL

If the instrument is in the remote control programming mode,
the instrument is returned to local control operation unless local lockout is active.

Local lockout is cleared by the interface command GTL or at power-on.

If the instrument is in the local control programming mode,
the instrument's interface address is displayed, for example, A11.

Address range: 0 to 30

To change the interface address (local control mode only):

1. Depress the LCL key.
2. Change the address with the vernier keys.

The address cannot be changed:

1. If the instrument is talk or listen addressed
2. If a service request is pending.
3. If the instrument is in the remote control state

Device command: none

Interface commands: GTL, LLO, SPD< SPE

LIMIT

FUNCTION

LIMIT

DESCRIPTION

High and low level limits are set for OUTPUT and COMPLEMENT OUTPUT.

Enabling the limit function (The LIMIT key LED is lighted.) makes the current levels the limit levels.

To change the limits:

1. Disable the LIMIT function if it is enabled.
2. Set the levels required for the limit values.
3. Enable the LIMIT function.

If the LIMIT function is active, incrementing or decrementing stops when the limit is reached.

NOTE: The high level, low level, amplitude, and offset are coupled.

Device command:

```
:PULSe:LEVel:LIMit ON|OFF|1|0
```

Related command:

```
:PULSe:LEVel:HIGH|LOW|AMPL|OFFS
```

FUNCTION

DESCRIPTION

LOW LEVEL

-5.00V <= LOW LEVEL <= 4.90V

Resolution: 0.01V

Default: -0.50V

Low level, high level, amplitude and offset are coupled.

Low Level = Offset - Amplitude / 2

OVERVOLTAGE DISABLING: See DISABLE.

Device command:

:PULSe:LEVel:LOW <value>

MAN

FUNCTION

MANUAL

DESCRIPTION

The manual function simulates an external input signal in the TRIG, GATE, and BURST operating modes.

The external input (EXT INPUT) is disabled during manual (MAN) operations.

TRIG operating mode

One pulse or double pulse is generated per key press.

GATE operating mode

A continuous pulse stream is generated during the time the MAN key is depressed.

BURST operating mode

One pulse or double pulse burst is generated per key press.

E. WIDTH operating mode

A continuous pulse stream is generated during the time the MAN key is depressed.

Device command: none

FUNCTION

DESCRIPTION

MEMORY

SAVE or RCL (recall) memory operations

SAVE

The instrument's setting is stored in internal memory.

SAVE execution:

1. Press MEM (memory).
2. Enter the location (1-19).
3. Press SAV (save).

RCL (recall)

A setting is copied from internal memory and made the instrument's current setting.

RCL execution:

1. Press MEM (memory).
2. Enter the location (0-20).
3. Press RCL (recall).

Location 0 contains the standard setting. See *RST, Chapter 6 for a description of the standard setting.

Locations 1-19 are user stored settings.

Device command: none

Common commands:

*SAV <location>

*RCL <location>

OFFS

FUNCTION

DESCRIPTION

OFFSET

-4.95 V <= OFFSET <= 4.95 V

Resolution: 0.01 V

Default: 0.00 V

Offset, amplitude, high level, and low level are coupled.

Median offset, see page 1-2.

Offset = (High Level + Low Level) / 2

OVERVOLTAGE DISABLING: See DISABLE.

Device command:

:PULSe:LEVel:OFFSet <value>|MIN|MAX

OUTPUT

FUNCTION

DESCRIPTION

OUTPUT

OUTPUT is the normal format of the output signal defined by the setting.

OUTPUT has a separate DISABLE function.

The COMPLEMENT and LIMIT functions apply to OUTPUT and COMPLEMENT OUTPUT.

Device commands:

:OUTPut:PULSe:STATe ON|OFF|1|0

Related commands:

:OUTPut:PULSe:POLarity NORM|COMP

:PULSe:LEVel:LIMit ON|OFF|1|0

COMPLEMENT OUTPUT

COMPLEMENT OUTPUT is the inverted format of the OUTPUT signal defined by the setting.

COMPLEMENT OUTPUT has a separate DISABLE function.

The COMPLEMENT and LIMIT functions apply to OUTPUT and COMPLEMENT OUTPUT.

Device commands:

:OUTPut:PULSe:CSTate ON|OFF|1|0

Related commands:

:OUTPut:PULSe:POLarity NORM|COMP

:PULSe:LEVel:LIMit ON|OFF|1|0

PERIOD

FUNCTION

PERIOD

DESCRIPTION

1.50 ns <= PERIOD <= 99.9 ms

Range: 2.00 ns to 99.9 ms

Resolution: See Table 5-1, page 5-46.

Default: 1.00 ms

NOTE: The differential outputs are delayed approximately 20 ns (fixed delay) with respect to the trigger output signal.

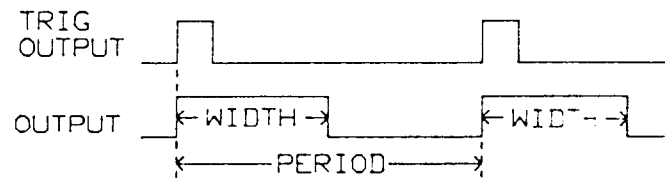

Device command:

:PULSe:TIMing:PERiod <value>|MIN|MAX

PERIOD

FUNCTION

DESCRIPTION

PERIOD-BURST RELATIONSHIP

IF PERIOD < 5.0 ns
THEN BURST mode is not allowed.

PERIOD-WIDTH RELATIONSHIP

PERIOD < 5.00 ns
IF WIDTH \geq 1.00 ns
THEN WIDTH \leq 0.5*PERIOD
ELSE WIDTH \leq 0.5*PERIOD - 0.50 ns

IF 5 ns \leq PERIOD < 20.0 ns
THEN WIDTH \leq 0.70*PERIOD - 1.00 ns

IF PERIOD \geq 20.0 ns
THEN WIDTH \leq 0.9*PERIOD - 5.00 ns

PERIOD-DELAY RELATIONSHIP

IF PERIOD < 2.00 ns
DELAY = 0.0 NS

IF 2.00 ns \leq PERIOD < 5.00 ns
THEN DELAY \leq 0.5*PERIOD - 1.00 ns

IF 5.00 NS \leq PERIOD < 20.0 ns
DELAY \leq 0.70*PERIOD - 2.00 ns

IF PERIOD \geq 20.0 NS
THEN DELAY \leq 0.9*PERIOD - 6.00 NS

PERIOD

FUNCTION

DESCRIPTION

PERIOD-DCYC RELATIONSHIP

PERIOD < 5.00 ns
IF WIDTH \geq 1.00 ns
THEN WIDTH \leq 0.5*PERIOD
ELSE WIDTH \leq 0.5*PERIOD - 0.50 ns

5.00 ns \leq PERIOD < 20.0 ns
WIDTH \leq 0.7*PERIOD - 1.00 ns

PERIOD \geq 20.0 ns
WIDTH \leq 0.9*PERIOD - 5.00 ns

PERIOD-DOUB RELATIONSHIP

IF PERIOD < 5.00 ns
THEN DOUB is not possible.

IF 5.00 ns \leq PERIOD < 10.0 ns
THEN DOUB \leq 0.5*PERIOD

IF PERIOD \geq 10.0 ns
THEN DOUB \leq 0.9*PERIOD - 4.00 ns

IF WIDTH < 1.00 ns
THEN WIDTH \leq 0.7(PERIOD-DOUB) - 1.50 ns

IF 1.00 ns \leq WIDTH < 10.0 ns
THEN WIDTH \leq 0.7(PERIOD-DOUB) - 1.00 ns

IF WIDTH \geq 10.0 ns
THEN WIDTH \leq 0.85(PERIOD-DOUB) - 2.50 ns

POWER-OFF/ON

FUNCTION

DESCRIPTION

POWER-OFF

The instrument's setting and interface address are stored in internal memory.

POWER-ON

The setting and interface address stored at power-off are restored; however, the outputs are disabled.

NOTE, if the internal memory data is invalid at power-on, the power-off setting cannot be restored. In this case, the standard setting and the default interface address, II are restored.

Power-on errors (F or E type): See ERROR.

Device command: none

RANGE

FUNCTION

RANGE

DESCRIPTION

The range function increments or decrements the displayed value by a factor of ten (10).

Device command: :SYSTem:KEY

FUNCTION

DESCRIPTION

RECALL

A setting is copied from internal memory and made the instrument's setting.

Execution:

1. Press MEM (memory).
2. Specify the location (0-20).
3. Press RCL (recall).

Location 0 contains the standard setting.
See *RST, Chapter 6 for a description
of the standard setting.

Locations 1-19 are user stored settings.

RCL is identical to *RCL; see Chapter 6.

Device command:

:SYSTEM:KEY 35 (:KEY 33 is also required>)

Common command:

*RCL <location>

Related command:

*SAV <location>

RMT

FUNCTION

REMOTE

DESCRIPTION

The RMT LED indicates when the instrument is remotely enabled.

The front panel controls are inactive except for LCL unless local lockout is active.

Device command:

Interface command: REN

Related commands: GTL, LLO

FUNCTION

SAVE

DESCRIPTION

The instrument's setting is stored in internal memory.

SAVE execution:

1. Press MEM (memory).
2. Enter the location (1-19).
3. Press SAV (save).

Saving to location 0 (standard setting) is not allowed.

The scope of the saved setting is identical to the scope of the standard setting; see Chapter 6, *RST.

SAVE is identical to *SAV; see Chapter 6.

Device command:

:SYSTem:KEY 34 (:KEY 33 is also required.)

Common command:

*SAV <location>

Related command:

*RCL <location>

SET

FUNCTION

SET

DESCRIPTION

The instrument setting is set as follows:

PERIOD:	no change*
WIDTH:	PERIOD / 2
DELAY:	0.00 ps
DOUB:	Mode = OFF Delay = no change*
DCYC:	Mode = no change* Duty cycle = 50 percent
Operating Mode:	AUTO
Levels:	no change*
Output Format:	no change*

* The values are the programmed values prior to the SET operation.

NOTE: Set is not related to the device command :SYSTEM:SET.

Device command: none

SLOPE

FUNCTION

DESCRIPTION

SLOPE

Slope sets the trigger slope of the external input signal.

POS (positive), default

The TRIG, GATE, E. WIDTH, and BURST operating modes are triggered on a positive slope.

The gate closes on the negative slope of the trigger signal in the GATE operating mode.

NEG (negative)

The TRIG, GATE, E.WIDTH, and BURST operating modes are triggered on a negative slope.

The gate closes on the positive slope of the trigger signal in the GATE operating mode.

Selecting both slopes is not allowed.

Device command:
:INPut:TRIGger:SLOPe POS|NEG

SRQ

FUNCTION

SERVICE REQUEST

DESCRIPTION

The SRQ LED indicates when a service request is pending.

The interface line SRQ is in the asserted state.

The interface address cannot be changed when a service request is pending.

Device command: none

Related commands: SPE, SPD, *STB?

FUNCTION

DESCRIPTION

THRESHOLD

-5.0 V <= THRESHOLD <= 5.0 V

Resolution: 0.1 V

Default: 0.0 V

Input impedance: 50 ohm

Threshold sets the trigger level
for the external input signal.

Device command:

:INPut:TRIGger:THREshold <value>[MIN|MAX]

TRANS

FUNCTION

TRANSDUCER

DESCRIPTION

TRANSDUCER operating mode:

A rectangular waveform is generated from a sine wave applied at the EXT INPUT.

TRANS sine wave external input signal:

Frequency: 10 MHz to 1GHz
Minimum amplitude: ≥ 600 mVpp
External Input = ac coupled

The function applies to both channels in dual channel instruments.

The transition times are fixed.

The output levels are programmable.

The period is controlled by the external input signal.

Device command:
:INPut:TRIGger:MODE TRAN

FUNCTION

DESCRIPTION

TRIGGER

TRIGGER operating mode:

One pulse or double pulse is generated for each trigger signal.

The mode is common to channels 1 and 2 in dual channel instruments.

Trigger signals:

1. External Input (See EXT INPUT.)
2. Manual key press (See MAN.)
3. *TRG (See Chapter 6.)
4. Single pulse (See 1 PULSE.)

The period is controlled by the external input signal.

Conflict: The DCYC function and the TRIG (trigger) operating mode are incompatible.

Device command:

:INPut:TRIGger:MODE TRIG

Common command: *TRG

TRIG OUTPUT

FUNCTION

TRIGGER OUTPUT

DESCRIPTION

TRIGGER OUTPUT is the reference signal for the differential output signals.

The trigger output signal is an EECL level signal.

The differential outputs are delayed approximately 20 ns (fixed delay) with respect to the trigger output signal.

The trigger output signal is delayed approximately 16 ns (fixed delay) with respect to the external input signal.

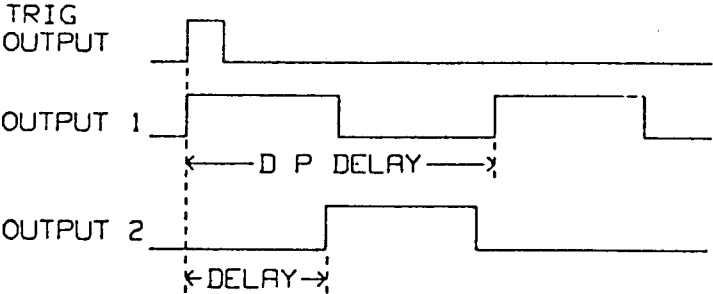

Device command: none

UNITS

FUNCTION

DESCRIPTION

UNITS

ps	=	pico seconds,	E-12
ns	=	nano seconds,	E-9
us	=	micro seconds,	E-6
ms	=	milli seconds,	E-3
V	=	Volts	
PCT	=	percent	

Device command: none

VERNIER

FUNCTION

VERNIER

DESCRIPTION

The vernier keys are used to set parameter values or change the interface address.

Each key corresponds to a display segment as shown in the figure.

Increment values with the up arrow keys.

Decrement values with the down arrow keys.

If the LIMIT function is active, incrementing or decrementing a level function stops when the limit is reached.

See LCL for changing the interface address.

Device command: :SYSTem:KEY

WIDTH

FUNCTION

WIDTH

DESCRIPTION

0.30 ns <= WIDTH <= 99.9 ms

Range: 0.50 ns to 99.9 ms

Resolution: See Table 5-1, page 5-46.

Default: 100 us

NOTE: The differential outputs are delayed approximately 20 ns (fixed delay) with respect to the trigger output signal.

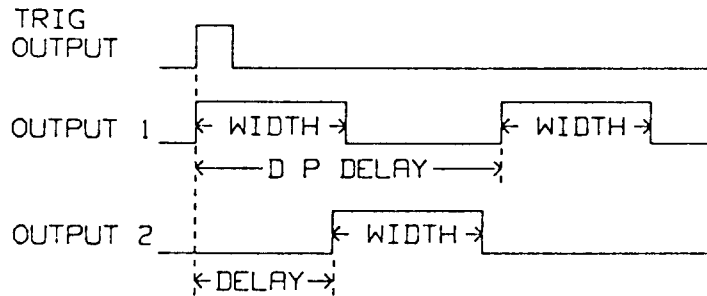

Device command:

`:PULSe:TIMing:WIDth <value>|MIN|MAX`

Related commands:

`:PULSe:TIMing:DutyCYCle <value>|MIN|MAX`

`:PULSe:TIMing:PERiod <value>|MIN|MAX`

WIDTH

FUNCTION

DESCRIPTION

PERIOD-WIDTH RELATIONSHIP

PERIOD < 5.0 ns
IF WIDTH \geq 1.00 ns
THEN WIDTH \leq 0.5*PERIOD
ELSE WIDTH \leq 0.5*PERIOD - 0.50 ns

5.00 ns \leq PERIOD < 20.0 ns
WIDTH \leq 0.70*PERIOD - 1.00 ns

PERIOD \geq 20.0 ns
WIDTH \leq 0.9*PERIOD - 5.00 ns

WIDTH-DOUB RELATIONSHIP

IF WIDTH < 1.00 ns
THEN WIDTH \leq 0.8*DOUB - 1.10 ns

IF WIDTH \geq 1.00 ns
THEN WIDTH \leq 0.8*DOUB - 0.60 ns

TABLE 5-1. PERIOD, DELAY, DOUBLE, AND WIDTH RANGES

<u>RANGE NUMBER</u>	<u>RANGE</u>	<u>RESOLUTION</u>
1	*** - 9.99 ns	0.01 ns
2	10.0 ns - 99.9 ns	0.1 ns
3	100 ns - 999 ns	1 ns
4	1.00 us - 9.99 us	0.01 us
5	10.0 us - 99.9 us	0.1 us
6	100 us - 999 us	1 us
7	1.00 ms - 9.99 ms	0.01 ms
8	10.0 ms - 99.9 ms	0.1 ms

*** PERIOD: 2.00 ns
 DELAY: 0.00 ns
 DOUBLE: 2.00 ns
 WIDTH: 0.50 ns

CHAPTER 6 COMMON COMMANDS

CONTENTS

*CLS	Clear Status
*ESE	Standard Event Status Enable
*ESE?	Standard Event Status Enable Query
*ESR?	Standard Event Status Register Query
*IDN?	Identification Query
*LRN?	Learn Device Setup Query
*OPC	Operation Complete
*OPC?	Operation Complete Query
*RCL	Recall
*RST	Reset
*SAV	Save
*SRE	Service Request Enable
*SRE?	Service Request Enable Query
*STB?	Read Status Byte Query
*TRG	Trigger
*TST?	Self Test Query
*WAI	Wait to Continue

*CLS

CLEAR STATUS COMMAND

-----*CLS-----

DEFINITION

The *CLS command clears the following:

1. Error queue
2. Standard event status register (ESR)
3. Status byte register bit 5 (STB)
4. A service request
5. OCAS and OQAS

No changes are made to the following:

1. Status byte register bits 6, 4, 2-0 (STB)
2. Output queue
3. Event status enable register (ESE)
4. Service request enable register (SRE)
5. Key Queue

State:

1. IDLE state
2. Setting prior to *CLS
3. *OPC/*OPC? actions are cancelled.

If the *CLS command occurs directly after a program message terminator, the output queue and MAV, bit 4, in the status byte register are cleared, and if condition bits 2-0 of the status byte register are zero, MSS, bit 6 of the status byte register is also zero.

Interface command: SDC

EXAMPLE

OUTPUT 711; "CLS"

STANDARD EVENT STATUS ENABLE COMMAND

-----*ESE--<wsp>--<value>-----

0 <= value <= 255

DEFINITION

The *ESE command sets bits in the standard event status enable register (ESE) which enable the corresponding bits in the standard event status register (ESR).

The register is cleared:

1. At power-on
2. By sending a value of zero

The register is not changed by the *RST and *CLS commands.

<u>BIT</u>	<u>MNEMONIC</u>	<u>BIT VALUE</u>
7	PON	128
6	Not used	0
5	CME	32
4	EXE	16
3	DDE	8
2	QYE	4
1	Not used	0
0	OPC	1

Related commands: *ESE?

EXAMPLE

OUTPUT 711;"*ESE 21"

*ESE?

STANDARD EVENT STATUS ENABLE QUERY

-----*ESE?-----

DEFINITION

The standard event status enable query returns the contents of the standard event status enable register.

0 <= contents <= 255

<u>BITS</u>	<u>MNEMONICS</u>	<u>BIT VALUE</u>
7	PON	128
6	Not used	0
5	CME	32
4	EXE	16
3	DDE	8
2	QYE	4
1	Not used	0
0	OPC	1

Related commands: *ESE

EXAMPLE

```
OUTPUT 711;"*ESE?"  
ENTER 711; A$
```

STANDARD EVENT STATUS REGISTER QUERY

-----*ESR?-----

DEFINITION

The standard event status register query returns the contents of the standard event status register. The register is cleared after being read.

0 <= contents <= 255

<u>BITS</u>	<u>MNEMONICS</u>	<u>BIT VALUE</u>
7	PON	128
6	Not used	0
5	CME	32
4	EXE	16
3	DDE	8
2	QYE	4
1	Not used	0
0	OPC	1

Related commands: *ESR

EXAMPLE

```
OUTPUT 711;"*ESR?"  
ENTER 711; A$
```

*IDN?

IDENTIFICATION QUERY

-----*IDN?-----

DEFINITION

The identification query commands the instrument to identify itself over the interface.

Response: HEWLETT-PACKARD, 8131A, 0, n.n

HEWLETT-PACKARD	=	manufacturer
8131A	=	instrument model number
0	=	indicates serial numbers are not provided.
n.n	=	firmware revision level

EXAMPLE

```
DIM A$ [100]
OUTPUT 711;"*IDN?"
ENTER 711; A$
```

LEARN DEVICE SETUP QUERY

-----*LRN?-----

DEFINITION

The learn query returns the status of the instrument's setting.

The response message can be retransmitted as a program message without requiring any alterations.

The returned commands are listed in Table 7-1.

The learn response message is a single ASCII string without image specifiers. The format of Table 6-1 is for legibility only.

EXAMPLE

```
DIM A$ [1000]  
OUTPUT 711;"*LRN?"  
ENTER 711; A$
```

*LRN?

TABLE 6-1. PULSE *LRN?

NOTES: Channel 2 command paths apply only to dual channel instruments.
For definitions of <value>, see Chapter 7.

:INPut:TRIGger	:STATe ON OFF; MODE AUTO TRIGGER GATE BURST EWIDTH TRANSDUCER; SLOPe POS NEG; THReshold <value>;
:PULSe:COUNT	<value>;
:PULSe:TIMing	:PERiod <value>;
:PULSe2:TIMing	:WIDTh <value>; DELay <value>; DOUBle <value>; DutyCYCle <value>; DutyCYCle:MODE ON OFF;
:PULSe2:TIMing	:DOUBle:MODE ON OFF;
:PULSe2:LEVel	:HIGH <value>; LOW <value>; LIMit ON OFF;
:OUTPut2:PULSe	:POLarity NORM COMP; STATe ON OFF; CState ON OFF;

:PULSe1:TIMing	:WIDTh <value>; DELay <value>; DOUBle <value>; DutyCYClE <value>; DutyCYClE:MODE ON OFF;
:PULSe1:TIMing	:DOUBle:MODE ON OFF;
PULSe1:LEVel	:HIGH <value>; LOW <value>; LIMit ON OFF;
:OUTPut1:PULSe	:POLarity NORM COMP STATe ON OFF; CState ON OFF;

***OPC**

OPERATION COMPLETE COMMAND

-----*OPC-----

DEFINITION

The instrument parses all program message units in the message and after a wait period of two seconds, sets the operation complete bit in the standard event status register (ESR).

The following actions cancel *OPC (device goes to OCIS):

1. pon
2. dcas
3. *CLS
4. *RST

Related commands: *OPC?, *WAI

EXAMPLE

OUTPUT 711;"*CLS;*ESE 1;*SRE 32"
OUTPUT 711;"*OPC"

OPERATION COMPLETE QUERY

-----*OPC?-----

DEFINITION

The instrument parses all program message units in the message and after a wait period of two seconds, places an ASCII '1' in the output queue.

The following actions cancel *OPC? (device goes to OCIS):

1. pon
2. dcas
3. *CLS
4. *RST

Related commands: *OPC, *WAI

EXAMPLE

```
OUTPUT 711;"*OPC?"  
ENTER 711;A$
```

*RCL

RECALL COMMAND

-----*RCL--<wsp>--<location>-----

0 <= location <= 19

DEFINITION

A setting stored in RAM is made the instrument setting.

The instrument can recall twenty settings, locations 0-19.

Location 0 = standard setting, see *RST.
Location 1-19 = user stored settings, see *SAV.

The *RCL command is identical to the local function RCL (recall); see Chapter 5.

Related commands: *SAV

EXAMPLE

OUTPUT 711; "RCL 3"

RESET COMMAND

-----*RST-----

DEFINITION

The reset setting (standard setting) stored in ROM is made the instrument setting.

Pending *OPC/*OPC? actions are cancelled.

Instrument state: the instrument is placed in the IDLE state awaiting a command.

The *RST command clears the key queue.

The following are not changed:

1. HP-IB (interface) state
2. Instrument interface address
3. Output queue
4. Service request enable register (SRE)
5. Standard event status enable register (ESE)

The commands and parameters of the reset state are listed in the following table.

Related commands: none

EXAMPLE

OUTPUT 711; "RST"

*RST

TABLE 6-2. RESET STATE (STANDARD SETTING)

COMMANDS	PARAMETERS (DEFAULTS)	CHANNEL (Channel 2: in dual channel instruments)
:INPut		
:TRIGger		
:STATe	OFF	
:MODE	AUTO	
:SLOPe	POS	
:THREshold	0.0V	
:PULSe		
:COUNt	1	
:TIMing		
:PERiod	1.00ms	
:WIDTh	100us	1/2
:DELay	0.00ps	1/2
:DOUBle	200us	1/2
:MODE	OFF	1/2
:DutyCYCle	50 PCT	1/2
:MODE	OFF	1/2
:LEVel		
:HIGH	+0.50V	1/2
:LOW	-0.50V	1/2
:AMPLitude	1.00V	1/2
:OFFSet	0.00V	1/2
:LIMit	OFF	1/2
:OUTPut		
:PULSe		
:POLarity	NORM	1/2
:STATe	OFF	1/2
:CState	OFF	1/2

SAVE COMMAND

-----*SAV--<wsp>--<location>-----

1 <= location <= 19

DEFINITION

The instrument setting is stored in RAM.

The instrument can store nineteen settings, locations 1-19.

The scope of the saved setting is identical to the scope of the standard setting.

The *SAV command is identical to the local function SAVE; see Chapter 5.

Related commands: *RCL

EXAMPLE

OUTPUT 711;"*SAV 3"

*SRE

SERVICE REQUEST ENABLE REGISTER

-----*SRE--<wsp>--<value>-----

0 <= value <= 255

DEFINITION

The service request enable command sets bits in the service request enable register which enable the corresponding status byte register bits

The register is cleared:

1. At power-on
2. By sending a value of zero.

The register is not changed by the *RST and *CLS commands.

<u>BITS</u>	<u>MNEMONICS</u>	<u>BIT VALUE</u>
7	Not used	0
6	RQS/MSS	64
5	ESB	32
4	MAV	16
3	Not used	0
2	Not used	0
1	Not used	0
0	H	1

Related commands: *SRE?, *STB?

EXAMPLE

OUTPUT 711;"*SRE 48"

*SRE?

SERVICE REQUEST ENABLE QUERY

-----*SRE?-----

DEFINITION

The service request enable query returns the contents of the service request enable register.

0 <= contents <= 255

<u>BITS</u>	<u>MNEMONIC</u>	<u>BIT VALUE</u>
7	Not used	0
6	MSS/RQS	64
5	ESB	32
4	MAV	16
3	Not used	0
2	Not used	0
1	Not used	0
0	H	1

Related commands: *SRE, *STB?

EXAMPLE

```
OUTPUT 711; "*SRE?"  
ENTER 711; A$
```

*STB?

READ STATUS BYTE QUERY

-----*STB?-----

DEFINITION

The read status byte query returns the contents of the status byte register.

0 <= contents <= 255

The MSS message is reported in bit six of the status byte register.

<u>BITS</u>	<u>MNEMONICS</u>	<u>BIT VALUE</u>
7	Not used	0
6	MSS	64
5	ESB	32
4	MAV	16
3	Not used	0
2	Not used	0
1	Not used	0
0	H	1

Related commands: *SRE, *SRE?

EXAMPLE

OUTPUT 711;"*STB?"
ENTER 711; A\$

TRIGGER COMMAND

-----*TRG-----

DEFINITION

The trigger command has the same effect as a GROUP EXECUTE TRIGGER (GET).

If operating mode trigger or burst is selected, a trigger event occurs, and one pulse, double pulse, burst is generated.

:INPut:TRIGger:STATe ON changes to :STATE OFF when *TRG processed.

Related commands: GET (interface command)

EXAMPLE

OUTPUT 711; "*TRG"

*TST?

SELF-TEST QUERY

-----*TST?-----

DEFINITION

The self-test query commands the instrument to perform a self-test and place the results of the test in the output queue.

Returned value: $0 \leq \text{value} \leq 657$.

A value of zero indicates no errors.

Explanations of the non-zero results of the self-test are given in Appendix G, Table G-1.

No entries are allowed while the test is running.

The instrument is returned to the setting that was active at the time the self-test query was processed.

The self-test does not require operator interaction beyond sending the *TST? query.

Related command: none

EXAMPLE

```
OUTPUT 711; "*TST?"  
ENTER 711; A$
```

WAIT-TO-CONTINUE-COMMAND

-----*WAI-----

DEFINITION

The wait-to-continue command prevents the instrument from executing any further commands for two seconds. All pending operations are completed during the wait period.

Related commands: *OPC, *OPC?

EXAMPLE

OUTPUT 711;"*WAI"

CHAPTER 7

DEVICE

COMMANDS

CONTENTS

Command List	7-3
Command Descriptions	
:INPut:TRIGger path	7-7
:OUTput:PULSe path	7-13
:PULSe:COUNt path	7-19
:PULSe:LEVel path	7-21
:PULSe:TIMing path	7-29
:SYSTem path	7-39

TABLE

Key Codes	7-43
-----------	------

FIGURES

SYNTAX DIAGRAMS

:INPut:TRIGger path	7-7
:OUTput:PULSe path	7-13
:PULSe:COUNt path	7-19
:PULSe:LEVel path	7-21
:PULSe:TIMing path	7-29
:SYSTem path	7-39

:INPut

COMMAND

PARAMETER

:INPut

:TRIGger

:MODE

:MODE?

:SLOPe

:SLOPe?

:STATe

:STATe?

:THReshold

:THReshold?

AUTO|TRIG|GATE|BURS|EWID|TRANS

POSitive|NEGative

ON|OFF|1|0

<value>|MIN|MAX

:OUTPut

COMMAND

PARAMETER

:OUTPut	
:PULSe	
:CStAtE	ON OFF 1 0
:CStAtE?	
:POLArity	NORMAl COMPLement
:POLArity?	
:StAtE	ON OFF 1 0
:StAtE?	

:PULSe

<u>COMMAND</u>	<u>PARAMETER</u>
:PULSe	
:COUNT	<value> MIN MAX
:COUNT?	
:LEVel	
:AMPLitude	<value> MIN MAX
:AMPLitude?	
:HIGH	<value> MIN MAX
:HIGH?	
:LIMit	ON OFF 1 0
:HIGH?	
:LOW?	
:AMPLitude?	
:OFFSet?	
:LIMit?	
:LOW	<value> MIN MAX
:LOW?	
:OFFSet	<value> MIN MAX
:OFFSet?	
:TIMing	
:DELay	<value> MIN MAX
:DELay?	
:DOUBle	<value> MIN MAX
:MODE	ON OFF 1 0
:MODE?	
:DOUBle?	
:DutyCYCle	<value> MIN MAX
:MODE	ON OFF 1 0
:MODE?	
:DutyCYCle?	
:PERiod	<value> MIN MAX
:PERiod?	
:WIDTh	<value> MIN MAX
:WIDTh?	

:SYSTem

COMMAND

PARAMETER

:SYSTem	
:DERRor?	[NUMeric STRing]
:ERRor?	[NUMeric STRing]
:KEY	<code>
:KEY?	
:SET	<data>
:SET?	

:INPut:TRIGger

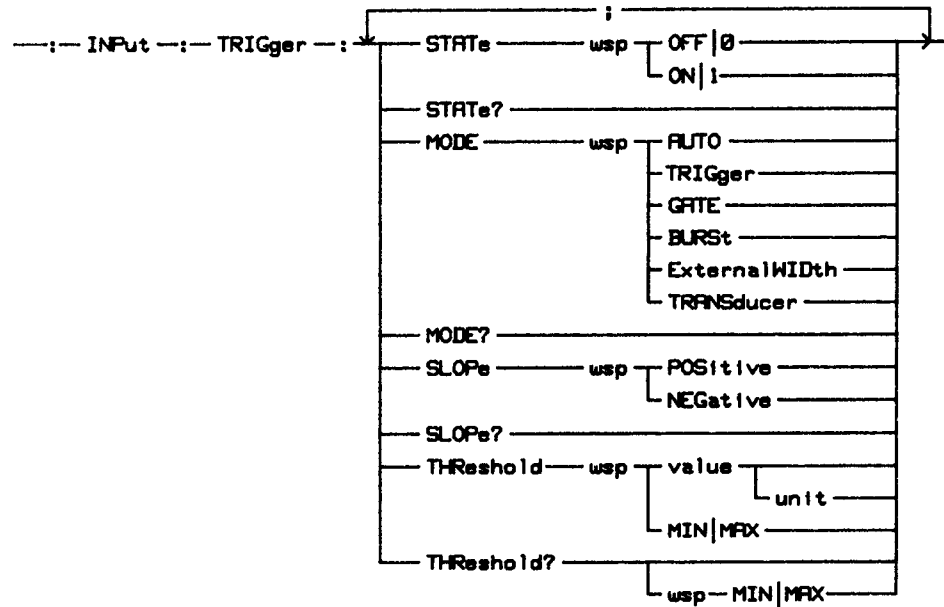

:INPut:TRIGger:MODE

:MODE

AUTO, default mode

A continuous waveform (free run mode) is generated. The external input is disabled.

TRIGger

One pulse or double pulse signal is generated per trigger signal: EXT INPUT or *TRG command.

Conflict: <Trigger-DCYC>
:INPut:TRIGger:MODE TRIGger and
:PULSe:TIMing:DutyCYCLe:MODE ON
are incompatible.

GATE

Pulses or double pulses are generated for the duration of the gate.

BURSt

A specified number of pulses or double pulses are generated for each burst trigger signal: EXT INPUT or *TRG command.

Conflict: <Period-Burst>
IF :PULSe:TIMing:PERiod < 5.00 ns
THEN :INPut:TRIGger:MODE BURSt
is not allowed.

Related command: :PULSe:COUNT <value>|MIN|MAX

:INPut:TRIGger:MODE

ExternalWIDth

The pulse width and period are controlled by a signal applied at the EXT INPUT.

TRANsducer

A rectangular waveform is generated from a sine wave applied at the EXT INPUT.

All modes are common to channels 1 and 2 in dual channel instruments.

Local Functions: AUTO, TRIG, GATE, BURST,
 E. WIDTH, TRANS, and EXT INPUT

:MODE?

**Response: AUTO|TRIGGER|GATE|BURST|EWIDTH|
 TRANSDUCER**

EXAMPLES

OUTPUT 711;":INP:TRIG:MODE AUTO"

OUTPUT 711;":INP:TRIG:MODE?"
ENTER 711;A\$

:INPut:TRIGger:SLOPe

:SLOPe

POSitive, default mode

Positive edge triggering

NEGative

Negative edge triggering

Selecting both POS and NEG is not allowed.

Local Functions: SLOPE, EXT INPUT

:SLOPe?

Response: POSITIVE or NEGATIVE

EXAMPLES

OUTPUT 711;":INP:TRIG:SLOP POS"

OUTPUT 711;":INP:TRIG:SLOP?"

ENTER 711; A\$

:INPut:TRIGger:STATe

:STATe

OFF | 0, default state

The external input is disabled.

ON | 1

The external input is enabled.

The state is common to channels 1 and 2
in dual channel instruments.

If a *TRG command is processed, :STATE ON
changes to :STATE OFF.

Local Function: EXT INPUT

:STATe?

Response: OFF | ON

EXAMPLES

OUTPUT 711;":INP:TRIG:STAT ON"

OUTPUT 711;":INP:TRIG:STAT?"
ENTER 711;A\$

:INPut:TRIGger:THReshold

:THReshold

-5.0 <= value <= 5.0|MIN|MAX

Range: -5.0V to 5.0V

Resolution: 0.1V

Default: 0.0V

Local Functions: THRE, EXT INPUT

:THReshold?

Response:threshold value in decimal form

Example: 3.5

EXAMPLES

OUTPUT 711;":INP:TRIG:THR 3.5V"

OUTPUT 711;":INP:TRIG:THR?"

ENTER 711;A\$

:OUTPut:PULSe

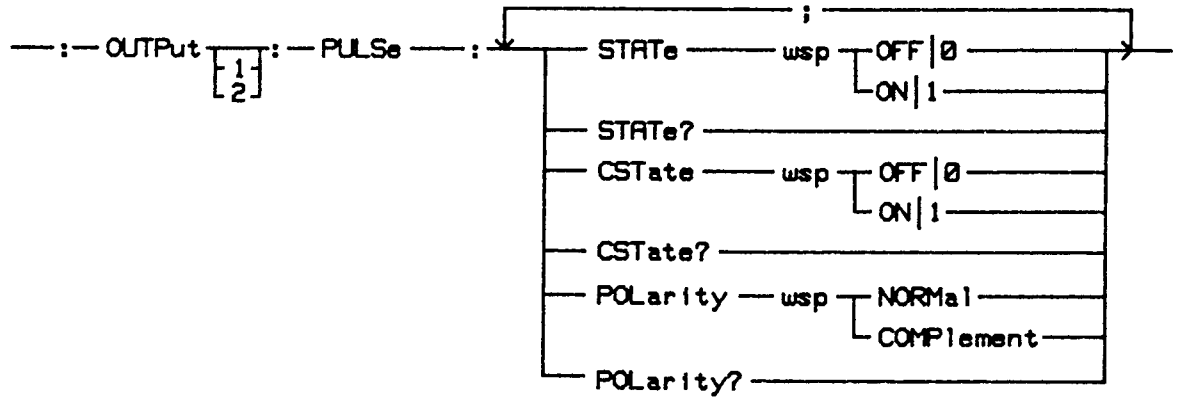

:OUTPut <channel>

:OUTPut

Bypass
Channel 1

1
Channel 1

2
Channel 2

:OUTPut:PULSe:CSTate

:CSTate

OFF | 0, default

CSTate = complement state

The specified channel's COMPLEMENT OUTPUT is disabled.

ON | 1

CSTate = complement state

The specified channel's COMPLEMENT OUTPUT is enabled.

COMPLEMENT OUTPUT is disabled at power-on and after a reset.

Local Function: DISABLE

:CSTate?

Response:OFF | ON

EXAMPLES

OUTPUT 711;":OUTPI:PULS:CSTate ON"

OUTPUT 711;":OUTPI:PULS:CSTate?
ENTER 711;A\$

:OUTPut:PULSe:POLarity

:POLarity

NORMAl, default

The OUTPUT signal is output as specified by the other setting parameters..

COMPLement

The OUTPUT signal is inverted with respect to the other setting parameters.

In both cases (NORM or COMP) COMPLEMENT OUTPUT is the inverted form of OUTPUT.

Local Function: COMP

:POLarity?

Response:NORMAL or COMPLEMENT

EXAMPLES

```
OUTPUT 711;":OUTP1:PULS:POL COMP"
```

```
OUTPUT 711;":OUTP1:PULS:POL?"  
ENTER 711;A$
```

:OUTPut:PULSe:STATe

:STATe

OFF | 0, default

The specified channel's OUTPUT is disabled.

ON | 1

The specified channel's OUTPUT is enabled.

Local Function: DISABLE

:STATe?

Response: OFF | ON

EXAMPLES

```
OUTPUT 711;":OUTP1:PULSSTAT ON"
```

```
OUTPUT 711;":OUTP1:PULSSTAT?"  
ENTER 711;A$
```

:PULSe:COUnT

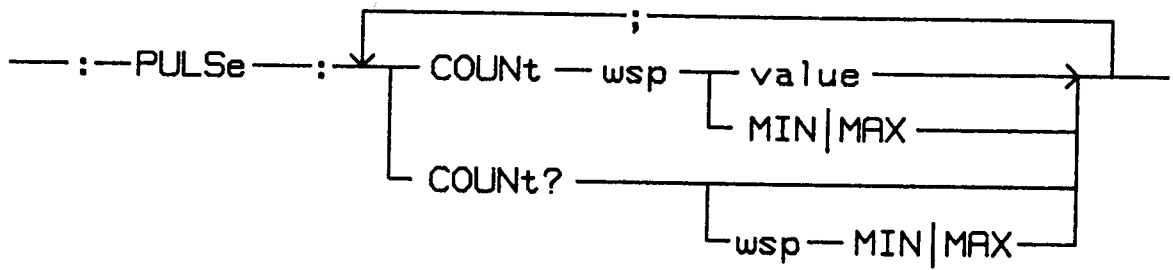

:PULSe:COUNT

:COUNT

1 <= COUNT <= 9999|MIN|MAX

Range: 1 to 9999

Resolution: 1

Default: 1

Count sets the number of pulses or double pulses contained in the burst.

Related command:

:INPut:TRIG:MODE BURSt

Local Function: COUNT

:COUNT?

Response:count value in integer form

Example: 999

EXAMPLES

OUTPUT 711;":PULS:COUN 999"

OUTPUT 711;":PULS:COUN?"

ENTER 711;A\$

:PULSe:LEVel

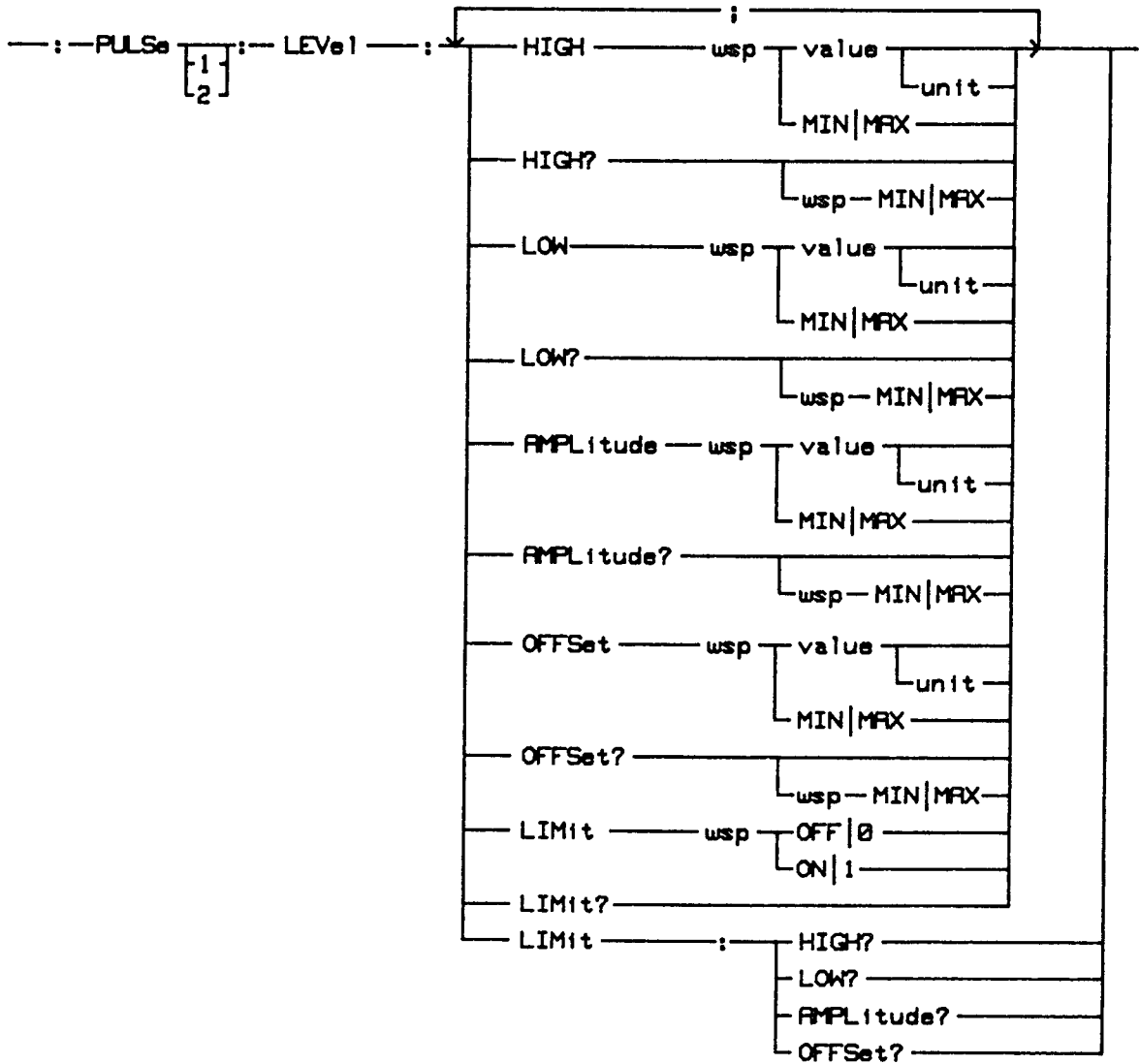

:PULSe:LEVel <channel>

:PULSe

Bypass
Channel 1

1
Channel 1

2
Channel 2

:PULSe:LEVel:AMPLitude

:AMPLitude

0.10 <= value <= 5.0|MIN|MAX

Range: 0.10V to 5.00 V

Resolution: 0.01V

Default: 1.00V

Amplitude, offset, high level, and low level are coupled.

Amplitude = High Level - Low Level

OVERVOLTAGE DISABLING: See DISABLE, Chapter 5.

Local Function: AMPL

:AMPLitude?

Response:amplitude value in decimal form

Example: 2.10

EXAMPLES

```
OUTPUT 711;":PULSI:LEV:AMPL 2.10V"
```

```
OUTPUT 711;":PULSI:LEV:AMPL?"
```

```
OUTPUT 711;A$
```

:PULSe:LEVel:HIGH

:HIGH

-4.90 <= value <= 5.00|MIN|MAX

Range: -4.90V to 5.00V

Resolution: 0.01V

Default: 0.50V

High level, low level, amplitude, and offset are coupled.

High Level = Offset + (Amplitude/2)

High Level = Low Level + Amplitude

OVERVOLTAGE DISABLING: See DISABLE, Chapter 5.

Local Function: HIGH

:HIGH?

Response:high level value in decimal form

Example: 1.55

EXAMPLES

OUTPUT 711;":PULSI:LEV:HIGH 1.55V"

OUTPUT 711;":PULSI:LEV:HIGH?"

ENTER 711:A\$

:PULSe:LEVel:LIMit

:LIMit

OFF | 0, default

The limit function is disabled.

ON | 1

The limit function is enabled.

High and low level limits are set for OUTPUT and COMPLEMENT OUTPUT.

The high level, low level, amplitude, and offset commands are coupled commands and are processed before a limit enabling command within the same program message.

The high and low level limits are set as follows:

1. Disable the limit function if it is enabled.
2. Set the levels to the required limit values.
3. Enable the limit function.

Local Function: LIMIT

:LIMit?

Response: OFF | ON

EXAMPLES

OUTPUT 711;":PULS:LEV:LIM ON"

OUTPUT 711;":PULS:LEV:LIM?"
ENTER 711;A\$

:PULSe:LEVel:LIMit

:LIMit:HIGH?
:LIMit:LOW?
:LIMit:AMPLitude?
:LIMit:OFFSet?

Response:limit value queried in decimal form
Example: 2.5

EXAMPLE

```
OUTPUT 711;":PULS:LEV:LIM:OFFS?"  
OUTPUT 711;A$
```

:PULSe:LEVel:LOW

:LOW

-5.00 <= value <= 4.90|MIN|MAX

Range: -5.00V to 4.90V

Resolution: 0.01V

Default: -0.50V

Low level, high level, amplitude, and offset are coupled.

Low Level = Offset - (Amplitude/2)

Low Level = High Level - Amplitude

OVERVOLTAGE DISABLING: See DISABLE, Chapter 5.

Local Function: LOW

:LOW?

Response:low level value in decimal form

Example: -.55

EXAMPLES

```
OUTPUT 711;";PULS1:LEV:LOW -0.55V"
```

```
OUTPUT 711;";PULS1:LEV:LOW?"
```

```
ENTER 711;A$
```

:PULSe:LEVel:OFFSet

:OFFSet

-4.95 <= value <= 4.95|MIN|MAX

Range: -4.95 V to 4.95 V

Resolution: 0.01V

Default: 0.00V

Offset, amplitude, and the levels are coupled.

Offset = (High Level + Low Level) / 2

OVERVOLTAGE DISABLING: See DISABLE, Chapter 5.

Local Function: OFFS

:OFFSet?

Response:offset value in decimal form

Example: .50

EXAMPLES

OUTPUT 711;":PULS:LEV:OFFS 0.50V"

OUTPUT 711;":PULS:LEV:OFFS?"

ENTER 711:A\$

:PULSe:TIMing

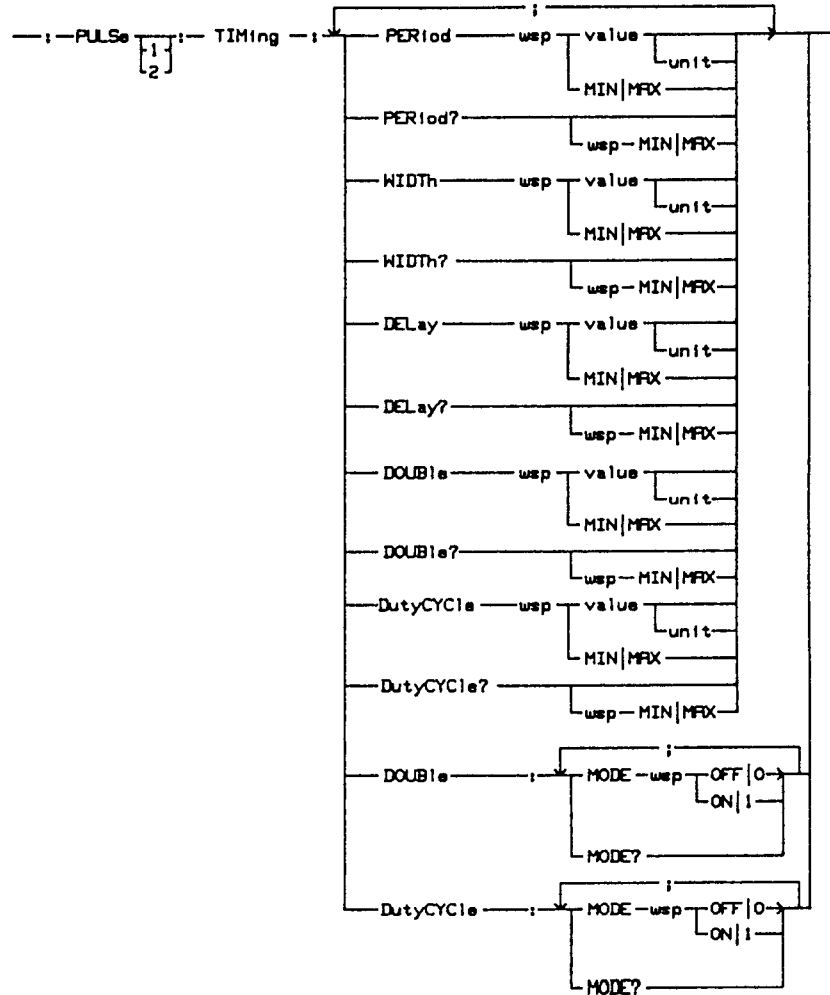

:PULSe <channel>

:PULSe

Bypass
Channel 1

1
Channel 1

2
Channel 2

:PULSe:TIMing:DELay

:DELay

0.00 <= value (delay) <= 99.9|MIN|MAX

Range: 0.00 ps to 99.9 ms

Resolution: See Table 5-1, page 5-46.

Default: 0.00 ps

Fixed delay (from the trigger output to the differential outputs): 20 ns

Conflict: <Period-Delay>
See Chapter 5 or Appendix G
for a description of the timing
relationships.

Related command: :PULS:TIM:DOUB:MODE OFF|ON
(OFF = delay/ON = double pulse)

Local Function: DEL

:DELay?

**Response:delay value in exponential form
Example; 11.1E-9**

EXAMPLES

OUTPUT 711;":PULS:TIM:DEL 11.1E-9"
or
OUTPUT 711;":PULS:TIM:DEL 11.1NS"

OUTPUT 711;":PULS:TIM:DEL?"
ENTER 711;A\$

:PULSe:TIMing:DOUBle

:DOUBle

2.00 <= value (double pulse delay) <= 99.9|MIN|MAX

Range(delay): 2.00 ns to 99.9 ms

Resolution(delay): See Table 5-1, page 5-46.

Default(delay): 200 us

If DCYC is inactive:

Double pulse width = WIDTH

IF DCYC is active:

Double pulse width = PERIOD*DCYC/200

Related commands:

:PULS:TIM:DOUB:MODE OFF|ON

:PULS:TIM:DCYC:MODE OFF|ON

Conflicts:

<Period-Double>

<Width-Double>

<Double-DCYC>

See Chapter 5 or Appendix G
for a description of the timing
relationships.

Local Functions: DOUB, DCYC

:DOUBle?

**Response:double pulse delay value
in exponential form**

Example: 211E-6

EXAMPLES

OUTPUT 711;":PULS:TIM:DOUB 211E-6" or
OUTPUT 711;":PULS:TIM:DOUB 211NS"

OUTPUT 711;":PULS:TIM:DOUB?"
ENTER 711;A\$

:PULSe:TIMing:DOUBle:MODE

:DOUBle:MODE

OFF | 0, default mode

Pulse delay is selected>

ON | 1

Double pulse is selected

Pulse delay (delay of the first pulse)
with respect to TRIG OUTPUT is
not available in the double pulse mode.

Local Functions: DOUB, DEL

:DOUBle:MODE?

Response:OFF | ON

EXAMPLES

OUTPUT 711;":PULSI:TIM:DOUB:MODE ON"

OUTPUT 711;":PULSI:TIM:DOUB:MODE?"
ENTER 711;A\$

:PULSe:TIMing:DutyCYcle

:DutyCYcle

1 <= value <= 99|MIN|MAX

Range: 1 PCT to 90 PCT

Resolution: 1

Default: 50 PCT

PCT = percent

Conflicts: <Period-DCYC>
<Double-DCYC>
See Chapter 5 or Appendix G
for a description of the timing
relationships.

Local Function: DCYC, DOUB

:DutyCYcle?

Response: duty cycle value in integer form
Example: 11

EXAMPLES

OUTPUT 711;":PULSI:TIM:DCYC 11PCT

OUTPUT 711;":PULSI:TIM:DCYC?
ENTER 711;A\$

:PULSe:TIMing:DutyCYCle:MODE

:DutyCYCle:MODE

OFF | 0, default mode

Duty Cycle is disabled.
The pulse width or double pulse width is specified by the WIDTH parameter.

ON | 1

Duty cycle is enabled>

If Double pulse is inactive:
Pulse width = PERIOD*DCYC/100

If Double pulse is inactive:
Double pulse width = PERIOD*DCYC/200

Conflict: <Trigger-DCYC>
:INP:TRIG:MODE TRIG and
:PULS:TIM:DCYC:MODE ON
are incompatible.

Related command:
:PULS:TIM:DOUB:MODE OFF|ON
(OFF = DEL / ON = DOUB)

Local Function: DCYC

:DutyCYCle:MODE?

Response: OFF | ON

EXAMPLES

OUTPUT 711;":PULS:TIM:DCYC:MODE ON"

OUTPUT 711;":PULS:TIM:DCYC:MODE?"
ENTER 711;A\$

:PULSe:TIMing:PERiod

:PERiod

1.50 <= value <= 99.9|MIN|MAX

Range: 2.00 ns to 99.9 ms

Resolution: See Table 5-1, page 5-46.

Default: 1.00 ms

In the TRIG, EWID, and TRAN operating modes the period is controlled by the EXT INPUT signal.

The period parameter is common to Channels 1 and 2 in dual channel instruments.

Conflicts: <Period-Burst>
 <Period-Width>
 <Period-Delay>
 <Period-DCYC>
 <Period-DOUB>
 See Chapter 5 or Appendix G
 for a description of the timing
 relationships.

Local Function: PERIOD

:PERiod?

**Response:the period value in exponential form
Example: 1.11E-3**

EXAMPLES

```
OUTPUT 711,":PULS2:TIM:PER 1.11E-3" or  
OUTPUT 711,":PULS2:TIM:PER 1.11MS"
```

```
OUTPUT 711,":PULS2:TIM:PER?"  
ENTER 711;A$
```

:PULSe:TIMing:WIDTh

:WIDTh

0.30 <= value <= 99.9|MIN|MAX

Range: 0.50 ns to 99.9 ms

Resolution: See Table 5-1, page 5-46.

Default: 100 us

Conflicts: <Period-Width>

<Width-Double>

See Chapter 5 or Appendix G
for a description of the timing
relationships.

Local Function: WIDTH

:WIDTh?

Response:width value in exponential form

Example: 111E-6

EXAMPLES

```
OUTPUT 711;":PULSI:TIM:WIDT 111E-6"
```

```
or
```

```
OUTPUT 711;":PULSI:TIM:WIDT 111US"
```

```
OUTPUT 711;":PULSI:TIM:WIDT?"
```

```
ENTER 711;A$
```

:SYSTem

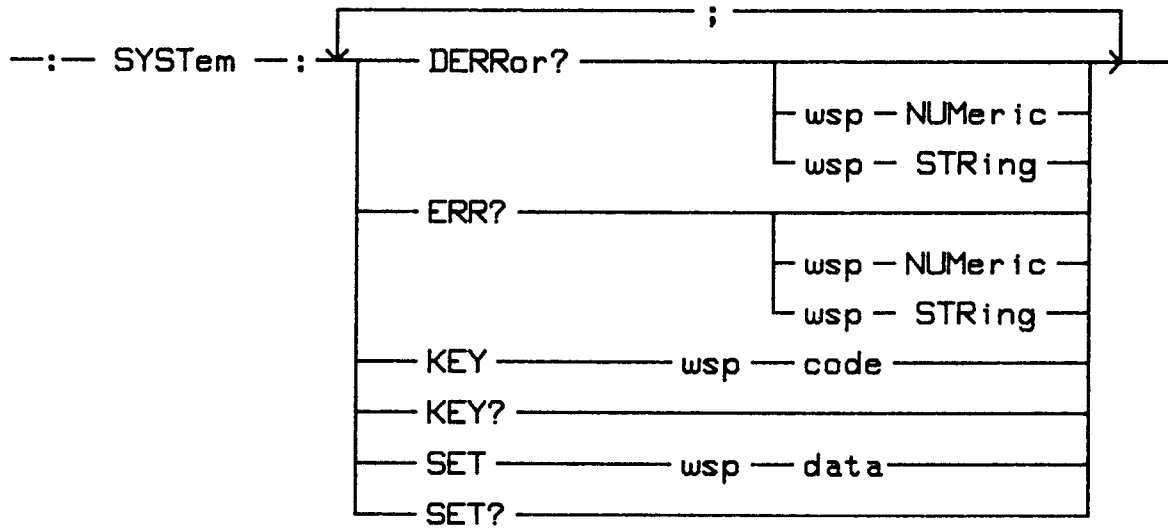

:SYSTem:DERRor?

:DERRor?

Bypass, default

Device dependent error codes are returned, for example, -100.

NUMeric

Device dependent error codes are returned, for example, -100.

STRing

Device dependent error codes are returned plus a brief description of the error, for example, -100,<Period - Width Ch. 1>.

See Chapter 4 for additional information.

Appendix G contains a list of errors reported by the :DERR? query.

Error code 0 = no errors

EXAMPLES

```
DIM A$ [5000]
```

```
OUTPUT 711;":SYST:DERR?"
```

```
or
```

```
OUTPUT 711;":SYST:DERR? NUM"
```

```
or
```

```
OUTPUT 711;":SYST:DERR? STR"
```

```
ENTER 711;A$
```

:SYSTem:ERRor?

:ERRor?

Bypass, default

The oldest error code is returned, for example, -350.

NUMeric

The oldest error code is returned, for example, -350.

STRing

The oldest error code plus a brief description of the error is returned, for example, -350,<Too Many Errors>.

Only one error is returned per query.

Appendix G contains a list of errors reported by the :ERR? query.

Error code 0 = no errors

EXAMPLES

```
DIM A$ [1000]
```

```
OUTPUT 711;":SYST:ERR?"
```

```
or
```

```
OUTPUT 711;":SYST:ERR? NUM"
```

```
or
```

```
OUTPUT 711;":SYST:ERR? STR"
```

```
ENTER 711;A$
```

:SYSTem:KEY

:KEY

<code>

The :KEY command simulates the pressing of a front panel key. The codes is a 16 bit integer value. The codes are listed in the following table.

:KEY?

**Response:a key code in integer format
EXAMPLE:13.**

Only real key presses are recorded in the key queue.

The queue length is one code.

If the queue is empty, an ASCII zero (0) is returned.

The codes are listed in the following table.

See Chapter 4 for additional information.

EXAMPLES

OUTPUT 711;":SYST:KEY 13"

OUTPUT 711;":SYST:KEY?"
ENTER 711;A\$

:SYSTem:KEY

<u>CODE</u>	<u>KEY</u>		<u>CODE</u>	<u>KEY</u>	
1	RANGE	down	2	RANGE	up
3	VERNIER 1	down	4	VERNIER 1	up
5	VERNIER 10	down	6	VERNIER 10	up
7	VERNIER 100	down	8	VERNIER 100	up
RIGHT CHANNEL(single or dual channel instruments)					
9	DELAY/DOUB		10	WIDTH/DCYC	
11	HIGH/AMPL		12	LOW/OFFS	
13	DISABLE (normal)		14	LIMIT	
15	COMP		16	DISABLE (complement)	
LEFT CHANNEL (dual channel instruments only)					
17	DELAY/DOUB		18	WIDTH/DCYC	
19	HIGH/AMPL		20	LOW/OFFS	
21	DISABLE (normal)		22	LIMIT	
23	COMP		24	DISABLE (complement)	
CHANNEL INDEPENDENT					
33	MEM		34	SAV	
35	RCL		36	positive slope	
37	negative slope		38	THRE	
39	MAN		40	1 PULSE	
41	SET		42	none	
43	none		44	MODE	
45	LCL (address)		46	PERIOD/COUNT	

:SYSTem:SET

:SET

<data>

The :SYST:SET command transfers binary data.

See the example for the application of :SYST:SET.

NOTE: :SYSTem:SET is not related to the local function SET.

:SET?

Response:binary data is returned which contains the instrument's current setting.

The block of data is identical to the block of data saved and recalled by the *SAV and *RCL commands.

The scope of the command is identical to the scope of the *LRN? command.

:SYSTem:SET

EXAMPLE:

```
10    DIM Query$[100],Setting$[200]BUFFER
20    !
30    ASSIGN @Hpib_device TO 711
40    ASSIGN @Path TO BUFFER Setting$
50    !
60    !Read current setting from the HP 8131A
70    Query$=":SYST:SET?"
80    GOSUB Fetch
90    !
100   !Write stored setting to the HP 8131A
110   Count_out=176
120   GOSUB Write
130   !
140   STOP
150   !
160  Fetch: !
170   Output @Hpib_device;Query$
180   TRANSFER @Hpib-device TO @Path;END,WAIT
190   RETURN
200   !
210  Write: !
220   TRANSFER @Path TO @Hpib_device;
      COUNT count_out, WAIT
230   RETURN
240   !
250  END
```

A

SPECIFICATIONS

CONTENTS

Specifications	A-2
Supplemental Specifications	A-2
Restrictions	A-2
Warranted Specifications:	
Differential Outputs	
Timing Parameters	
Period	A-3
Delay	A-3
Double Pulse	A-3
Width	A-3
Transition Times	A-3
Level Parameters	A-5
Performance Parameters	A-5
Supplemental Specifications	
Differential Outputs	
Duty Cycle	A-5
Amplitude	A-5
Offset	A-5
Impedance, source	A-5
Skew	A-5
Trigger Output	A-6
External Input	A-6
Interface	A-7
Battery	A-8
Environmental	A-8
Power	A-8
Weight	A-8
Dimensions	A-8
Calibration Period	A-8

TABLES

A-1	Width and Delay: Maximum Values	A-4
A-2	Double Pulse: Maximum Values	A-4
A-3	Programming Times	A-7

SPECIFICATIONS

The specifications describe the instrument's warranted performance characteristics unless indicated as being supplemental or typical in nature. The performance tests and recommended test equipment listed in Appendix E can be used to verify the performance characteristics.

Supplemental, Specifications

Supplemental specifications are typical, non-warranted, performance characteristics provided for customer convenience.

Restrictions

The specifications apply to 50 ohm loads unless stated otherwise.

Ambient temperature.

0 to 55 degrees Celcius: The first or only value specified is for this range.

20 to 30 degrees Celcius: The specified values for this range are given in brackets, [], following the 0 to 55 degree Celcius specification.

The instrument warm-up period is 30 minutes.

Period, width, delay, and double pulse are specified at the amplitude 50% points.

Period and width underprogramming is allowed. See Chapters 5 and 7.

Accuracy refers to the programmed values.

WARRANTED SPECIFICATION:

DIFFERENTIAL OUTPUTS

TIMING PARAMETERS

Resolution:	3 digits, best case = 10 ps
Repeatability:	factor of 4 better than accuracy
Jitter(rms)	
10 ns to 100 ns range:	0.05% of programmed value + 15 ps
All other ranges:	0.025% of programmed value + 15 ps

Period

Range:	2 ns to 99.9 ms
Accuracy:	+/- 5% of programmed value +/- 100 ps

Delay (between trigger output and differential outputs)

Range:	0 ns to 99.9 ms
Accuracy:	+/- 5% of programmed value +/- 1.5 ns
Fixed Delay:	20 ns (typical)

Double Pulse

Range:	2 ns to 99.9 ms
Accuracy:	+/- 5% of programmed value +/- 250 ps

Width

Range:	500 ps to 99.9 ms
Accuracy:	+/- 5% of programmed value +/- 250 ps

Transition Times

10%-90% of amplitude:	<200 ps, 300 mV to 3V range
20%-80% of amplitude:	<200 ps, 100 mV to 5V range

TABLE A-1. WIDTH AND DELAY: MAXIMUM VALUES

PERiod (ns)	Width	Delay
2.00	500ps or 1ns	0ns
2.01 ... 2.99	50% of PER *	50% of PER - 1ns
3.00 ... 4.99	50% of PER	
5.00 ... 19.99	70% of PER - 1ns	70% of PER - 2ns
≥20.0	90% of PER - 5ns	90% of PER - 6ns

*Width < 1 ns: maximum width is 50% of period - 0.5 ns

TABLE A-2. DOUBLE PULSE: MAXIMUM VALUES

PERiod (ns)	Double Pulse
2.00 ... 4.99	n/a
5.00 ... 9.99	50% of PER **
≥10.0	90% of PER - 4ns

**Period < 5.72 ns: double pulse < 50% of period

LEVEL PARAMETERS

Resolution:	3 digits, best case 10 mV
Accuracy:	+/- 1% of programmed value +/- 3% of amplitude +/- 40 mV
Repeatability:	factor of 4 better than accuracy
High Level:	-4.90 V to +5.00 V
Low Level:	-5.00 V to +4.90 V
Settling Time:	10 ns (typical)

PERFORMANCE PARAMETERS

Overshoot:	< 15% of amplitude +/- 20 mV
Ringing:	< 15% of amplitude +/- 20 mV
Reflections:	< 10% at 1 GHz

SUPPLEMENTAL SPECIFICATIONS

DIFFERENTIAL OUTPUTS

Duty Cycle

Range:	1% to 99%
Resolution:	1

Amplitude:

100 mV_{pp} to 5 V_{pp} into 50 ohm

The output levels double when the output drives into an open circuit.

The outputs are disabled if the output voltage > +/- 6.5 V

Offset:

-4.95 V to 4.95 V into 50 ohm

Impedance (source):

50 ohm +/- 1%

Skew:

< 100 ps between differential outputs
of same channel

TRIGGER OUTPUT

Levels:	High = 0.0 V; Low = -0.6 V
Impedance:	50 ohm +/- 10%
Fixed Delay:	16 ns (between external input and trigger output)
External Voltage:	+/- 5V maximum

EXTERNAL INPUT

Trigger, gate, burst, and external width operating modes

Input impedance:	50 ohm +/- 5%
Threshold:	-5 V to +5 V
Resolution:	100 mV
Input voltage:	+/- 10 V maximum
Input transitions:	< 50 ns
Input frequency:	dc to 500 MHz
Pulse width:	1 ns minimum
Input sensitivity:	>= 300 mV _{p-p}

Transducer operating mode

Input impedance:	50 ohm +/- 5%
Input transition:	< 50 ns
Input frequency:	10 Mhz to 1 GHz
Input sensitivity:	>= 600 mV _{p-p}

INTERFACE

HP-IB

HP-IB conforms to IEEE Standard 488.1-1987,
Digital Interface for Programmable Information.

Subsets

IEEE Std. 488 interface function subsets:
AH1, SH1, T6, L4, SR1, RL1, PP0, DC1, DT1, CO.

For information regarding interface codes,
formats, protocols, and common commands,
use IEEE **Draft** Standard 488.2-1987,
Codes, Formats, Protocols, and Common Commands,
as a guide. No claim of conformance is made.

TABLE A-3. PROGRAMMING TIMES

Code 8131A version	Binary				ASCII *		
	upload	download		total	download of parameters		
	of a complete parameter set	transfer	implemen- tation		one	two	three
transfer	transfer	implemen- tation	total	transfer + implementation			
1 channel	110	30	140	170	<60	<90	<110
2 channel	110	30	190	220	-	-	-

Milliseconds (ms) is the base unit for all times listed
in the table above.

*Add 25 ms for "enable output" statements.

BATTERY

Memory is supported for 7 years.

ENVIRONMENTAL

Storage Temperature: -40 to +65 degrees C
Operating Temperature: 0 to 55 degrees C
Humidity: 95% R.H.
(0 to 40 degrees C)

POWER

100/120/220/240 Vrms $\pm 10\%$
250 VA maximum
48-66 Hz
Single phase

WEIGHT

Net: 20 kg (44.4 lb)
Shipping: 28 kg (62.2 lb)

DIMENSIONS

height x width x depth
145 mm x 426 mm x 525 mm
5.7 in x 16.75 in x 20.65 in

**CALIBRATION
PERIOD**

1 year recommended

B

OPTIONS ACCESSORIES

OPTIONS

001	Rear panel inputs and outputs
020	Second Channel
908	Rack Mounting Flange Kit (P/N 5061-9678)
910	One Operating and Programming Manual and one Service Manual
915	One Service Manual (P/N 08131-90001)
916	One Operating and Programming Manual (P/N 08131-90011)
W30	Two additional years of Return-to-HP service

ACCESSORIES

<u>TYPE</u>	<u>PART NUMBER</u>
Adapter, APC 3.5(m) to APC 3.5(m)	1250-1748
Adapter, APC 3.5(f) to APC 3.5(f)	1250-1749
Adapter, APC 3.5(m) to APC 3.5(f)	1250-1866
Adapter, SMA(m) to SMA(m)	1250-1158
Adapter, SMA(f) to SMA(f)	1250-1159
Adapter, SMA(m) to BNC(f)	1250-1200
Attenuator, 10 dB, SMA	8493A #10
Attenuator, 20 dB, SMA	8493A #20
Cable, coaxial, SMA(m) to SMA(m)	8120-4948
End Cap, Precision 3.5 and SMA, female	1401-0202
End Cap, Precision 3.5 and SMA, male	1401-0208
Manual, <u>Microwave Connector Care</u>	08510-90064
Torque Wrench, Precision 3.5 connectors, 8 lb-in/90 N-cm,	1250-1863
Torque Wrench, SMA connectors, 5 lb-in/56 N-cm,	1250-1582
Transition Time Converter, 300ps	15432A
Transition Time Converter, 500ps	15433A
Transition Time Converter, 1 ns	15434A

TRANSITION TIME CONVERTER

MODEL 15432A / 15433A / 15434A

ACCESSORIES FOR

HP 8131A PROGRAMMABLE 500 MHZ PULSE GENERATOR

General Information

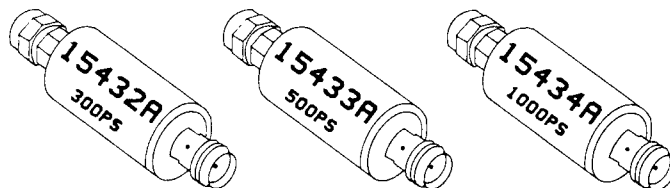

Figure 1: Transition Time Converters

The transition time converter converts the fixed transition time of the HP 8131A (<200 ps) to a fixed transition time of 300 ps (HP 15432A), 500 ps (HP 15433A), 1 ns (HP 15434A). Due to the design of the converter and the slower transitions a better pulse performance results, thus reflection and overshoot sensitive applications can be satisfied by the combination of HP 8131A plus transition time converter.

Connector Characteristics:

The transition time converter has SMA (m,f) connectors. Connect the converter carefully with its SMA (m) connector to the HP 8131A's SMA (f) connector. When the converter is not in use, use the delivered caps to protect the connectors from mechanical damage.

PRINTED:

© Copyright 1989 by: Hewlett-Packard GmbH, Herrenbergerstr. 130,
7030 Boeblingen, Federal Republic of Germany

Federal Republic of Germany, April 1989
B100, Part No: 15432-90020

Typical Performance Characteristics:

	15432A	15433A	15434A
Output Transition Times	300 ps	500 ps	1000 ps
Intrinsic Transition Times	260 ps	480 ps	990 ps
3 dB Corner Frequency	1120 MHz	660 MHz	330 MHz
Input Voltage	< 10.0 V peak-to-peak		
Insertion Loss	< 0.2 dB		
Overshoot and Ringing	< 5%		
VSWR	< 2.0		

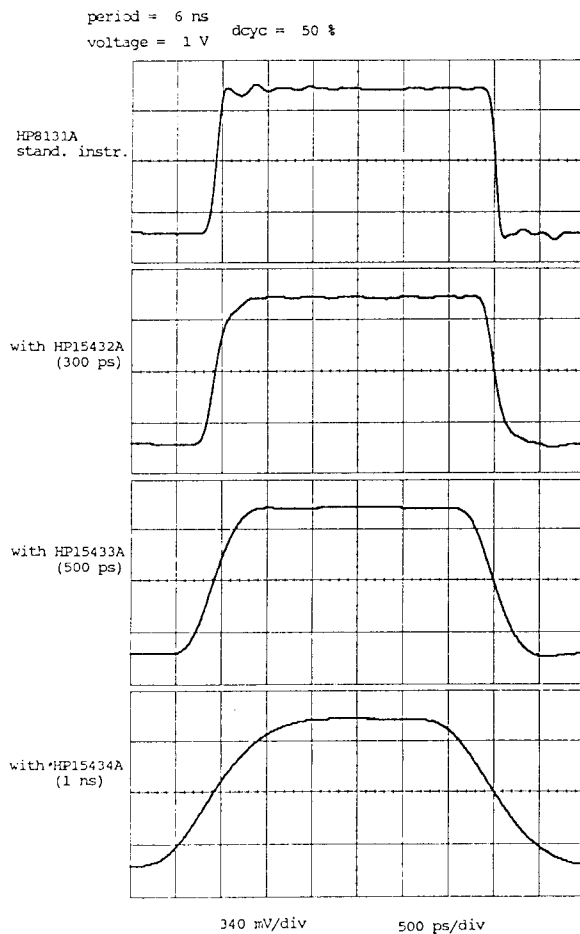

Figure 2:
Waveforms are plotted from
the HP 54121T Digitizing
Oscilloscope

C

INSTALLATION and MAINTENANCE

CONTENTS

Safety	C-3
AC Power	
Requirements	C-3
Line Voltage Selection	C-4
Line Fuse Selection	C-4
Cord C-6	
Cords, Types of	C-7
Cord Modification	C-8
Input and Output Port Connectors	C-9
HP-IB (Interface)	
Networks	C-12
Cable, Adapter	C-12
Connector	C-13
Operating Environment	C-14
Mounting Hardware	C-14
(OPTIONS AND ACCESSORIES)	
Preventive Maintenance	C-14
Customer Self-service	C-14
HP Service	C-14

FIGURES

C-1 Line Power Input Module	C-5
C-2 AC Power Cord	C-7
C-3 SMA and Precision Connectors	C-11
C-4 HP-IB Connector	C-13

SAFETY

The HP 8131A is a Safety Class I instrument.

It has an exposed metal chassis that is directly connected to earth potential through the line power cord.

Before installing the instrument, review:

1. The Safety Summary (red page)
2. The Instrument Reference Manuals
3. The instrument safety markings.

ALTERNATING CURRENT (AC) POWER

Requirements

Nominal line power:

1. 100/120/220/240Vac
2. 250VA maximum
3. 50-60 Hz
4. Single Phase

Fuses:

1. 100/120Vac operation
 - a. Time Delay Fuse (T)
 - b. 3 Ampere (A)
 - c. 250 Volt (V)
2. 220/240Vac operation
 - a. Time Delay Fuse (T)
 - b. 1.5 Ampere (A)
 - c. 250 Volt (V)

CAUTION

**Line Voltage
and
Line Fuse
Selection**

Before connecting the line power cord to the instrument, check the line voltage selector setting and the line fuse rating.

WARNING

Disconnect the line power cord from the instrument before opening the line power input module cover. See Figure C-1.

To change the voltage selector:

1. Pry open the cover at the position labeled slot in Figure C-1.
2. Position the selector drum so that the required voltage appears in the cover window.
3. Change the fuse, as described below, if the new voltage requires a fuse with a different rating.
3. Close the cover.

To check or change the line fuse:

1. Pry open the cover at the position labeled slot in Figure C-1.
2. Withdraw the fuse holder.
3. After checking or changing the fuse, insert the fuse holder in the module with the arrow pointing to the right as indicated by the arrows on the fuse holder and cover. See Figure C-1.
4. Close the cover.

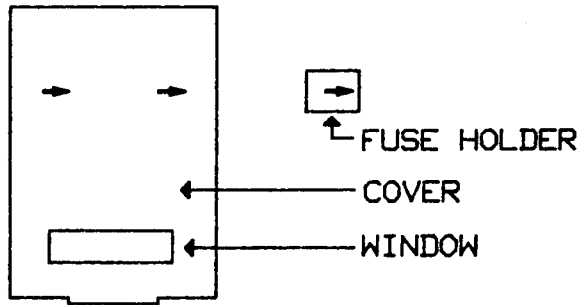
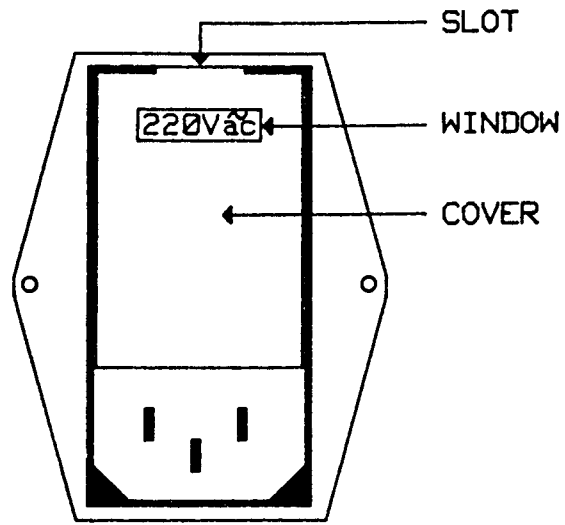

FIGURE C-1. LINE VOLTAGE INPUT MODULE

Line Power Cord

In accordance with international safety standards, this instrument is equipped with a three wire alternating current power cord.

WARNING

To prevent electrical shock injury, the following precautions must be followed:

1. If this instrument is to be energized via an auto transformer for voltage reduction, the common terminal must be connected to the earth terminal of the power source.
2. The line power cord plug must only be inserted into an outlet with a protective earth contact.

The protective earth action must not be interrupted.

3. Before switching on the instrument, the protective earth terminal of the instrument must be connected to the protective earth conductor of the power cord.









This is accomplished by using the power cord which is supplied with the instrument.

4. Intentional interruption of the protective earth connection is prohibited.

**Line Power Cords,
Types of**

See the following figure for the types of cords and part numbers of available line power cords.

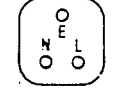
**FIGURE C-2.
POWER CORDS**

POWER CORD (MALE PLUG) OPTIONS					
OPTION NO.	PLUG CONFIGURATION*	SPEC. CONT. DWG. MJR. USING ENTRIES	OPTION NO.	PLUG CONFIGURATION*	SPEC. CONT. DWG. MJR. USING ENTRIES
900		A-8120-9051-1 U.K.	905		A-8120-9052-1 (SYSTEMS, CABINET, USE)
901		A-8120-9085-1 AUSTRALIA, NEW ZEALAND CHINA	906		A-8120-9100-1 SWITZERLAND
902		A-8120-9059-1 EUROPEAN CONTINENT	912		A-8120-9134-1 DENMARK
903		A-8120-9050-1 USA, CANADA (120 V)	917		A-8120-9239-1 SOUTH AFRICA, INDIA
904		A-8120-0638-1 USA, CANADA (240 V)	918		A-8120-9252-1 JAPAN**
<p>NOTE: OPTION NO. 904 <u>CANADA:</u> REQUIRES NEUTRAL CONDUCTOR IDENTIFIED RELATED TO 3 PHASE, 4 WIRE, 416 V CIRCUITS. <u>USA:</u> REQUIRES NO POLARITY BECAUSE BOTH "L" AND "N" TERMINALS ARE CONSIDERED TO BE LINE TERMINALS. **NOTE: OPTION 918 USE OPTION 918 FOR CORD SETS ONLY, FOR POWER CORDS USE OPTION 903</p>					

*VIEW OF PLUG FACE.

E = EARTH OR SAFETY GROUND
 N = NEUTRAL OR IDENTIFIED CONDUCTOR
 L = LINE OR ACTIVE CONDUCTOR

WARNING

Power Cord Modification

Modification must be performed only by a qualified electrician.

All local electrical codes must be observed.

If a new plug is to be connected, the plug must meet local safety requirements and include:

1. Adequate load carrying capacity (see the instrument Specifications).
2. Three terminals
 1. Line
 2. Neutral
 3. Earth
3. Cord Clamp.

CONNECTORS

INPUT AND OUTPUT PORT CONNECTORS

The HP 8131A uses SMA (Sub-Miniature, type A) connectors on the input and output ports. Thus, it is recommended that test cables be permanently connected to the instrument's SMA connectors to provide a connector saver function. If this is not practical and frequent connections are made, the use of connector savers (adapters) is recommended; see Appendix B, Accessories.

PRECISION 3.5 CONNECTORS

Precision 3.5 connectors are designed to allow mating with SMA connectors. However, remember; SMA connectors are semi-precision connectors and are constructed differently than precision 3.5 connectors.

CONNECTOR MATING

When mating connectors, two points are important:

1. The mating planes of the outer conductors must seat correctly.
2. The center conductors of the connectors must engage correctly.



SMA and precision 3.5 connectors require careful handling to prevent connector damage. HANDLING AND STORAGE, VISUAL INSPECTION, and MAKING CONNECTIONS and Figure C-3 provide information which will help preserve connectors.

Cleaning, gauging, etc., of connectors is beyond the scope of this document. However, Hewlett-Packard manual Microwave Connector Care is an excellent reference which describes connector usage. It is listed in Appendix B, Options and Accessories.

HANDLING AND STORAGE

Keep connectors clean.
Do not touch the mating plane surfaces.
Do not set connectors contact-end down.
Before storing, extend the sleeve or connector nut.
Use plastic end caps over the mating plane surfaces.
Never store connectors loose in a box or drawer.

VISUAL INSPECTION

Inspect all connectors carefully before every connection.
Look for metal particles, scratches, dents, worn plating, deformed threads, bent/broken/misaligned center conductors.
Never use a damaged connector.

MAKING CONNECTIONS

Align connectors carefully.
Make a preliminary connection lightly.
Turn the connector nut **ONLY** in making connections.
Do not rotate devices in making connections.
Use a torque wrench for the final connection; see Appendix B, Accessories.

SMA CONNECTORS

MALE

FEMALE

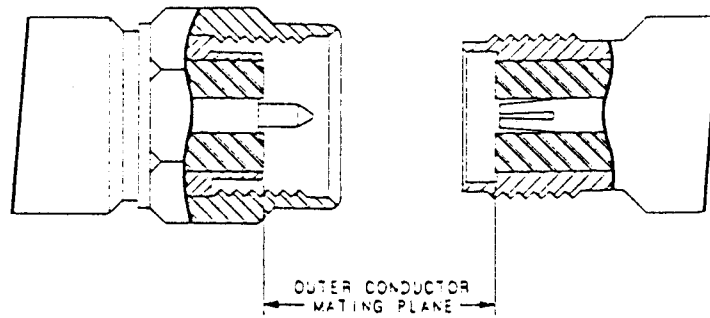

PRECISION 3.5mm CONNECTORS

MALE

FEMALE

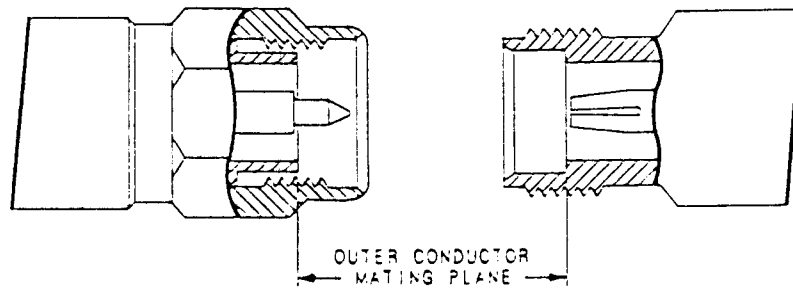

FIGURE C-3. SMA AND PRECISION CONNECTORS

HP-IB INTERFACE

Networks

The network may be:

1. A star network
2. A linear network
3. A combination star and linear network.

Limitations:

1. The total cable length cannot exceed 20 meters
2. The maximum cable length per device is 2 meters
3. No more than 15 devices may be interconnected on one bus.



1. It is recommended that no more than three connectors be stacked one on top of the other.
2. Hand tighten the connector lock screws. Do not use a screwdriver.

Cables and Adapter

The HP-IB connector is compatible with the connectors on the following cables and adapter.

1. HP-IB Cable, 10833A, 1 m (3.3 ft.)
2. HP-IB Cable, 10833B, 2 m (6.6 ft.)
3. HP-IB Cable, 10833C, 4 m (13.2 ft.)
4. HP-IB Cable, 10833D, 0.5 m (1.6 ft.)
5. HP-IB Adapter, 10834A, 2.3 cm. extender.

Connector

The following figure shows the connector and pin assignments.

Connector Part Number: 1251-0293

**FIGURE C-4
HP-IB CONNECTOR**

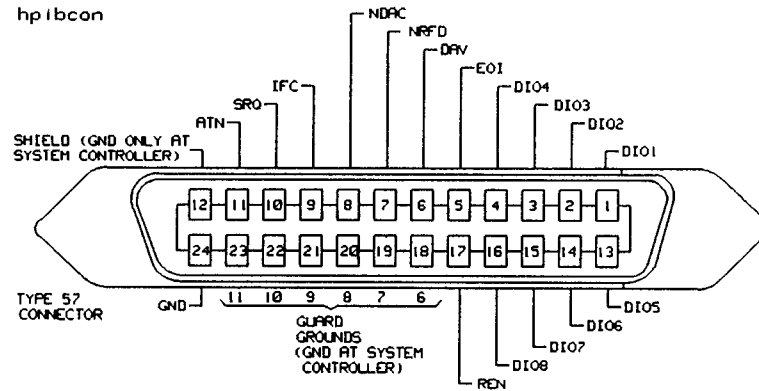

CAUTION

Connector Lock Screw Compatibility

HP products delivered now are equipped with connectors having ISO metric-threaded lock screws and stud mounts (ISO M3.5x0.6) which are black in color.

Earlier connectors may have lock screws and stud mounts with English-threaded lock screws and stud mounts (6-32 UNC) which have a shiny nickel finish.

OPERATING ENVIRONMENT

See appendix A.

MOUNTING HARDWARE

See appendix B.

PREVENTIVE MAINTENANCE

None required.

CUSTOMER SELF-SERVICE

The Service Manual contains the following service information:

1. Performance Tests
2. Adjustment Procedures
3. Theory and schematics
4. Replaceable Parts List.

HP SERVICE

HP offers the following services:

1. Performance Testing
2. Adjustment
3. Repair
4. Calibration

D

BACKDATING

CONTENTS

Introduction D-1

Backdating D-3

TABLE

BACKDATING: Serial Numbers D-4

Update 1, 02/89

Backdating

D-1

INTRODUCTION

If a manual applying to instruments with serial numbers less than the serial number listed on the Title Page (page ii) is required, consult Table 1, and make the changes listed in that table.

When backdating the manual, enter the control serial number on page ii for future reference.

TABLE D-1. BACKDATING: SERIAL NUMBERS

<u>FROM (CONTROL) SERIAL NUMBER</u>	<u>TO SERIAL NUMBER</u>	<u>DELETE PAGES</u>	<u>DATE</u>	<u>ADD PAGES</u>	<u>DATE</u>
2839 G00100	2839 G00147	5-10	03/15/89	5-10	03/20/89
		5-11	03/15/89	5-11	03/20/89
		5-29	03/15/89	5-29	03/20/89
		5-30	03/15/89	5-30	03/20/89
		5-46	03/15/89	5-46	03/20/89
		7-34	03/15/89	7-34	03/20/89
		A-1	03/15/89	A-1	none
		A-2	03/15/89	A-2	03/20/89
		A-3	03/15/89	A-3	none
		A-4	03/15/89	A-4	none
		A-5	03/15/89	A-5	none
		A-6	03/15/89		
		A-7	03/15/89		
		A-8	03/15/89		
		E.2-1	02/89	E.2-1	03/20/89
		E.4-1	02/89	E.4-1	03/20/89
		G-8	03/15/89	G-8	03/20/89
		G-9	03/15/89	G-9	03/20/89

FUNCTION

DUTY CYCLE

DESCRIPTION

1% <= DUTY CYCLE <= 99%

Resolution: 1

Default: mode = OFF
duty cycle = 50 percent

If DOUBLE PULSE is inactive:

WIDTH = PERIOD * DCYC / 100

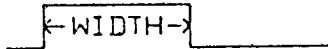
OUTPUT 

If DOUBLE PULSE is active:

WIDTH = PERIOD * DCYC / 200

OUTPUT 

Device command:

:PULSe:TIMing:DutyCYCLe <value>|MIN|MAX

:PULSe:TIMing:DutyCYCLe:MODE ON|OFF|1|0

Related comand:

:PULSe:TIMing:PERiod <value>|MIN|MAX

DCYC

FUNCTION

DESCRIPTION

PERIOD-DCYC RELATIONSHIP

PERIOD < 5.00 ns
IF WIDTH \geq 1.00 ns
THEN WIDTH \leq 0.5*PERIOD
ELSE WIDTH \leq 0.5*PERIOD - 0.5 ns

IF 5 ns \leq PERIOD < 10.0 ns
THEN WIDTH \leq 0.7*PERIOD - 1.00 ns

IF PERIOD \geq 10.0 ns
THEN WIDTH \leq 0.90*PERIOD - 3.00 ns

DOUB-DCYC RELATIONSHIP

IF WIDTH < 1.00 ns
THEN WIDTH \leq 0.8*DOUB - 1.10 ns

IF WIDTH \geq 1.00 ns
THEN WIDTH \leq 0.8*DOUB - 0.6 ns

DCYC-TRIG RELATIONSHIP

DCYC and TRIG are incompatible.

FUNCTION

DESCRIPTION

DELAY

0.00 ps <= PULSE DELAY <= 99.9 ms

Resolution: See Table 5-1, page 5-47.

Default: 0.00 ps

DELAY = Programmed delay + fixed delay.



PERIOD-DELAY RELATIONSHIP

IF PERIOD < 5.00 ns
THEN DELAY <= 0.5 PERIOD - 1.00 ns

IF 5.00 NS <= PERIOD < 10.0 NS
THEN DELAY <= 0.7*PERIOD - 2.00 NS

IF PERIOD >= 10.0 ns
THEN DELAY <= 0.9*PERIOD - 4.00 ns

Device command:

:PULSe:TIMing:DELay <value>|MIN|MAX

Related command:

:PULSe:TIMing:DOUBle:MODE ON|OFF|1|0

(OFF = DEL / ON = DOUB)

DISABLE

FUNCTION

DISABLE

DESCRIPTION

Disabled state, LED lighted, default

OUTPUT or COMPLEMENT OUTPUT is disabled.

Enabled state, led not lighted

OUTPUT or COMPLEMENT OUTPUT is enabled.

Each output has an independent disable function.

The output amplifier is switched off during the time an output is enabled or disabled.

OUTPUT and COMPLEMENT OUTPUT are disabled:

1. At power-on
2. After a reset (*RST)
3. When the standard setting is recalled (*RCL 0)
4. When an overvoltage occurs. See the following page for additional information.

Device commands:

OUTPUT

:OUTPut:PULSe:STATe ON|OFF|1|0

COMPLEMENT OUTPUT

:OUTPut:PULSe:CState ON|OFF|1|0

PERIOD

FUNCTION

DESCRIPTION

PERIOD-BURST RELATIONSHIP

IF PERIOD < 5.0 ns
THEN BURST mode is not allowed.

PERIOD-WIDTH RELATIONSHIP

PERIOD < 5.00 ns
IF WIDTH \geq 1.00 ns
THEN WIDTH \leq 0.5*PERIOD
ELSE WIDTH \leq 0.5*PERIOD - 0.50 ns

IF 5 ns \leq PERIOD < 10.0 ns
THEN WIDTH \leq 0.70*PERIOD - 1.00 ns

IF PERIOD \geq 10.0 ns
THEN WIDTH \leq 0.9*PERIOD - 3.00 ns

PERIOD-DELAY RELATIONSHIP

IF PERIOD < 5.00 ns
THEN DELAY \leq 0.5*PERIOD - 1.00 ns

IF 5.00 NS \leq PERIOD < 10.0 ns
DELAY \leq 0.70*PERIOD - 2.00 ns

IF PERIOD \geq 10.0 NS
THEN DELAY \leq 0.9*PERIOD - 4.00 NS

PERIOD

FUNCTION

DESCRIPTION

PERIOD-DCYC RELATIONSHIP

PERIOD < 5.00 ns
IF WIDTH \geq 1.00 ns
THEN WIDTH \leq 0.5*PERIOD
ELSE WIDTH \leq 0.5*PERIOD - 0.50 ns

5.00 ns \leq PERIOD < 10.0 ns
WIDTH \leq 0.7*PERIOD - 1.00 ns

PERIOD \geq 10.0 ns
WIDTH \leq 0.9*PERIOD - 3.00 ns

PERIOD-DOUB RELATIONSHIP

IF PERIOD < 5.00 ns
THEN DOUB is not possible.

IF 5.00 ns \leq PERIOD < 10.0 ns
THEN DOUB \leq 0.5*PERIOD

IF PERIOD \geq 10.0 ns
THEN DOUB \leq 0.9*PERIOD - 4.00 ns

IF WIDTH < 1.00 ns
THEN WIDTH \leq 0.7(PERIOD-DOUB) - 1.50 ns

IF 1.00 ns \leq WIDTH < 10.0 ns
THEN WIDTH \leq 0.7(PERIOD-DOUB) - 1.00 ns

IF WIDTH \geq 10.0 ns
THEN WIDTH \leq 0.85(PERIOD-DOUB) - 2.50 ns

WIDTH

FUNCTION

WIDTH

DESCRIPTION

0.30 ns <= WIDTH <= 99.9 ms

Range: 0.50 ns to 99.9 ms

Resolution: See Table 5-1, page 5-46.

Default: 100 us

NOTE: The differential outputs are delayed approximately 20 ns (fixed delay) with respect to the trigger output signal.

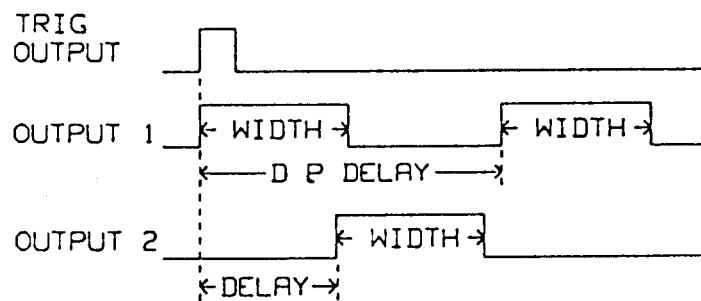

Device command:

`:PULSe:TIMing:WIDth <value>|MIN|MAX`

Related commands:

`:PULSe:TIMing:DutyCYCle <value>|MIN|MAX`

`:PULSe:TIMing:PERiod <value>|MIN|MAX`

WIDTH

FUNCTION

DESCRIPTION

PERIOD-WIDTH RELATIONSHIP

PERIOD < 5.0 ns
IF WIDTH \geq 1.00 ns
THEN WIDTH \leq 0.5*PERIOD
ELSE WIDTH \leq 0.5*PERIOD - 0.50 ns

5.00 ns \leq PERIOD < 10.0 ns
WIDTH \leq 0.70*PERIOD - 1.00 ns

PERIOD \geq 10.0 ns
WIDTH \leq 0.9*PERIOD - 3.00 ns

WIDTH-DOUB RELATIONSHIP

IF WIDTH < 1.00 ns
THEN WIDTH \leq 0.8*DOUB - 1.10 ns

IF WIDTH \geq 1.00 ns
THEN WIDTH \leq 0.8*DOUB - 0.60 ns

:PULSe:TIMing:DOUBle:MODE

:DOUBle:MODE

OFF | 0, default mode

Pulse delay is selected>

ON | 1

Double pulse is selected

Pulse delay (delay of the first pulse)
with respect to TRIG OUTPUT is
not available in the double pulse mode.

Local Functions: DOUB, DEL

:DOUBle:MODE?

Response:OFF | ON

EXAMPLES

OUTPUT 711;":PULSI:TIM:DOUB:MODE ON"

OUTPUT 711;":PULSI:TIM:DOUB:MODE?"

ENTER 711;A\$

:PULSe:TIMing:DutyCYCle

:DutyCYCle

1 <= value <= 99|MIN|MAX

Range: 1 PCT to 99 PCT

Resolution: 1

Default: 50 PCT

MIN = 1 PCT

MAX = 99 PCT

PCT = percent

Conflicts: <Period-DCYC>
<Double-DCYC>
See Chapter 5 or Appendix G
for a description of the timing
relationships.

Local Function: DCYC, DOUB

:DutyCYcle?

Reponse:duty cycle value in integer form

Example: 11

EXAMPLES

OUTPUT 711;":PULSI:TIM:DCYC 11PCT

OUTPUT 711;":PULSI:TIM:DCYC?
ENTER 711;A\$

A

SPECIFICATIONS

INTRODUCTION

The specifications describe the instrument's warranted performance characteristics unless indicated as being supplemental or typical in nature. The performance tests and recommended test equipment listed in Appendix E can be used to verify the performance characteristics.

Supplemental, Specifications

Supplemental specifications are typical, non-warranted, performance characteristics provided for customer convenience.

Restrictions

The specifications apply to 50 ohm loads unless stated otherwise.

Ambient temperature.

0 to 55 degrees Celcius: The first or only value specified is for this range.

20 to 30 degrees Celcius: The specified values for this range are given in brackets, [], following the 0 to 55 degree Celcius specification.

The instrument warm-up period is 30 minutes.

Period, width, delay, and double pulse are specified at the amplitude 50% points.

Period and width underprogramming is allowed. See Chapters 5 and 7.

Accuracy refers to the programmed values.

WARRANTED SPECIFICATIONS

TIMING PARAMETERS

Resolution: 3 digits, best case = 10 ps

Repeatability: factor of 4 better than accuracy

Jitter(RMS): 10 ns to 100 ns range: 0.05% of programmed value + 15 ps
All other ranges: 0.025% of programmed value + 15 ps

NOTE: See Chapter 5 for the relationships governing the timing parameters maximum values.

PERIOD

Range: 2 ns to 99.9 ms

Accuracy: +/- 5% of programmed value +/- 100 ps

DELAY

Range: 0 ns to 99.9 ms

Fixed internal circuit delay: 20 ns (typical)

Accuracy: +/- 5% of programmed value +/- 1.5 ns

DOUBLE PULSE

Range: 2 ns to 99.9 ms

Accuracy: +/- 5% of programmed value +/- 250 ps

WIDTH

Range: 500 ps to 99.9 ms

Accuracy: +/- 5% of programmed value +/- 250 ps

DUTY CYCLE

Range: 1% to 99%

Resolution: 1

TRANSITION TIMES

10%-90% of amplitude: <200 ps, 300 mV to 3V range

20%-80% of amplitude: <200 ps, 100 mV to 5V range

OUTPUT LEVELS

Resolution: 3 digits, best case 10 mV

Repeatability: factor of 4 better than accuracy

Accuracy: +/- 1% of programmed value +/- 3% of amplitude +/- 40 mV

HIGH LEVEL

Range: -4.90 V to +5.00 V

LOW LEVEL

Range: -5.00 V to +4.90 V

PULSE PERFORMANCE

Overshoot: < 15% of amplitude +/- 20 mV

Ringing: < 15% of amplitude +/- 20 mV

Reflections: < 10% at 1 GHz

SUPPLEMENTAL SPECIFICATIONS

OUTPUTS AND INPUTS

DIFFERENTIAL OUTPUTS (main outputs)

Amplitude: 100 mVpp to 5 Vpp into 50 ohm

Offset: -4.95 V to 4.95 V into 50 ohm

Source impedance: 50 ohm +/- 1%

Output levels double when driving into open circuits.

The instrument automatically disables an output if the output voltage exceeds 6 V. See Chapter 5, DISABLE.

TRIGGER OUTPUT

Levels: EECL (0 V and -0.6V)

Source impedance: 50 ohm +/- 5%

External input to trigger output delay: 16 ns

Maximum external voltage: +/- 5V

EXTERNAL INPUT

Trigger, gate, burst, and external width operating modes:

Input impedance: 50 ohm +/- 5%

Threshold: -5 V to +5 V

Resolution: 100 mV

Maximum input voltage: +/- 10 V

Input transitions: < 50 ns

Input frequency dc to 500 MHz

Minimum pulse width: 1 ns

Input sensitivity: >= 300 mVp-p

Transducer operating mode:

Input impedance: 50 ohm +/- 5%

Input transition: < 50 ns

Input frequency: 10 Mhz to 1 GHz

Input sensitivity: >= 600 mVp-p

External input is ac coupled in the transducer operating mode

INTERFACE

HP-IB HP-IB conforms to IEEE Standard 488.1-1987,
Digital Interface for Programmable Information.

Subsets IEEE Std. 488 interface function subsets:
AH1, SH1, T6, L4, SR1, RL1, PP0, DC1, DT1, CO.

For information regarding interface codes,
formats, protocols, and common commands,
use IEEE Draft Standard 488.2-1987,
Codes, Formats, Protocols, and Common Commands,
as a guide. No claim of conformance is made.

ADDITIONAL FEATURES

Battery Memory is supported for 7 years.

Environmental

Storage Temperature	-40 to +65 degrees C
Operating Temperature	0 to 55 degrees C
Humidity	95% R.H. (0 to 40 degrees C)

Power 100-120/220-240 V_{rms} ±10%
250 VA maximum
48-66 Hz
Single phase

Weight Net: 20 kg (44.4 lb)
Shipping: 28 kg (62.2 lb)

Dimensions height x width x depth
145 mm x 426 mm x 525 mm
5.7 in x 16.75 in x 20.65 in

**Recalibration
Period** 1 year recommended

2. DELAY TEST

This test consists of two parts:

1. Minimum Delay Test
2. Long Delay Test

NOTES: Repeat the entire delay test procedure for the second channel, if installed.

The specifications and tests are for the 50 % point of amplitude.

SPECIFICATIONS

Range:	0 ns to 99.9 ms
	Fixed Delay (Trigger Output to Main Output): 20 ns nominal.
Maximum Delay:	Period \geq 10.0 ns: $0.90 \times \text{Period} - 4.00$ ns
Resolution:	3 digits (best case: 10 ps)
Accuracy:	5 % of programmed value \pm 1.5 ns
rms Jitter:	10 ns to 100 ns range: 0.05 % of prog. value + 15 ps All other ranges: 0.025 % of programmed value + 15 ps
Repeatability:	Factor 4 better than accuracy

EQUIPMENT

1. HP 54120T Digitizing Oscilloscope with Accessory
2. Pulse Generator
3. Counter
4. Cable, 50 ohm, BNC to BNC, coaxial, 2 each.

PART 1 MINIMUM DELAY TEST

SET-UP

1. Set Pulse Generator:
 - a. PER = 500 ns
 - b. WID = 100 ns
 - c. HIL = 0.5 V LOL = -0.5 V
 - d. Fixed Transition Time

2. Set the HP 8131A:

MODE	=	TRIG		OPT 020
		Slope positive		
TIMING	=	DEL : 0 ns		0 ns
		WIDTH : 100 ns		10 ns
OUTPUT	=	HIGH : 1.5 V		1.5 V
		LOW : -1.5 V		-1.5 V
		ENABLE		DISABLE

4. Connect the Pulse Generator's Output via a 50 ohm feedthrough to the HP 8131A's EXT INPUT, use a BNC (f) to SMA (m) Adapter.

5. Connect the HP 8131A's TRIG OUTPUT via a Cable assy-coaxial SMA (m-m), and APC 3.5 mm 20dB Attenuator (f-m) to the Input 3 of the HP 54121A.

6. Connect the HP 8131A OUTPUT 1/2 via a same second accessory assembly to the Input 4 of the HP 54121A.

7. Connect the Pulse Generator's Trigger Output via a BNC (f) to SMA (m) Adapter and an APC 3.5 mm 20 dB Attenuator (f-m) to the TRIG input of the HP 54121A.

4. WIDTH TEST

This test consists of two parts.

1. Minimum Width Test
2. Long Width Test

NOTES: Repeat the entire width test procedure for the second channel, if installed.

The specifications and tests are for the 50 % point of amplitude.

SPECIFICATIONS

Range:	500 ps to 99.9 ns
Maximum Width:	Period \geq 10.0 ns: $0.9 \times \text{Period} - 3.00$ ns
Resolution:	3 digits (best case: 10 ps)
Accuracy:	5 % of programmed value \pm 250 ps
rms Jitter:	10 ns to 100 ns range: 0.05 % of prog. value + 15 ps All other ranges: 0.025 % of programmed value + 15 ps
Repeatability:	Factor 4 better than accuracy

EQUIPMENT

1. HP 54120T Digitizing Oscilloscope with Accessory
2. Counter
3. Cable, 50 ohm, BNC to BNC, coaxial, 2 each.

PART 1 MINIMUM WIDTH TEST

SET-UP

1. Set the HP 8131A:

MODE	=	AUTO		OPT 020	
TIMING	=	PERIOD	: 200 ns		
		DEL	: 0 ns		0 ns
		WIDTH	: 10 ns		1 ns
OUTPUT	=	HIGH	: + 1.5 V		+ 1.5 V
		LOW	: - 1.5 V 0 V		- 1.5 V
		ENABLE			DISABLE
3. Connect the HP 8131A's TRIG OUTPUT via a Cable assy-coaxial SMA (m-m), and APC 3.5 mm 20dB Attenuator (f-m) to the TRIG Input of the HP 54121A.
4. Connect the HP 8131A OUTPUT 1/2 via a same second accessory assebly to the Input 4 of the HP 54121A.

ERROR CODE

COMMAND ERRORS

The occurrence of command errors also sets bit five (CME) of the standard event status register (ESR).

-130

<Non-Numeric Argument Error>

The non-numeric argument is invalid.

-120

<Numeric Argument Error>

The numeric argument is invalid.

-100

<Command Error>

The command is invalid.

1. The required command is incorrectly transmitted.
2. The command is not allowed in the command path transmitted.

<mnemonic> = the command mnemonic.

ERROR FREE

0

<No error>

TABLE G-4. :SYSTem:DERRor?

ERROR CODE		ERROR MESSAGE
CHANNEL 1	CHANNEL 2	
50	50	<p><Period - Count></p> <p>IF PERIOD < 5.00 NS THEN BURST MODE IS NOT ALLOWED.</p>
100	200	<p><Period - Width Ch. 1 2></p> <p>PERIOD < 5.00 NS IF WIDTH >= 1.0NS THEN WIDTH <= 0.5*PERIOD ELSE WIDTH <= 0.5*PERIOD - 0.5NS</p> <p>5.00 NS <= PERIOD < 10.0 NS WIDTH <= 0.7*PERIOD - 1.00 NS</p> <p>PERIOD >= 10.0 NS WIDTH <= 0.9*PERIOD -3.00 NS</p>
101	201	<p><Period - Delay Ch. 1 2></p> <p>IF PERIOD < 5.00 NS THEN DELAY <= 0.5*PERIOD - 1.00 NS</p> <p>IF 5.00 NS <= PERIOD < 10.0 NS THEN DELAY <= 0.7*PERIOD - 2.00 NS</p> <p>IF PERIOD >= 10.0 NS THEN DELAY <= 0.9*PERIOD - 4.00 NS</p>

ERROR CODE
CHANNEL 1 CHANNEL 2 ERROR MESSAGE

102	202	<p><Period - Dcyc Ch. 1 2></p> <p>PERIOD < 5.00 NS IF WIDTH \geq 1.00NS THEN WIDTH \leq 0.5*PERIOD ELSE WIDTH \leq 0.5*PERIOD - 0.50 NS</p> <p>5.00 NS \leq PERIOD < 10.0 NS THEN WIDTH \leq 0.7*PERIOD - 1.00 NS</p> <p>PERIOD \geq 10.0 NS WIDTH \leq 0.9*PERIOD - 3.00 NS</p>
103	203	<p><Period - Double Ch. 1 2></p> <p>IF PERIOD < 5.00 NS THEN DOUBLE PULSE is not possible.</p> <p>IF 5.00 NS \leq PERIOD < 10.0 NS THEN DOUB \leq 0.5*PERIOD</p> <p>IF PERIOD \geq 10.0NS THEN DOUB \leq 0.9*PERIOD - 4.00 NS</p> <p>IF WIDTH < 1.00 NS THEN WIDTH \leq 0.7*(PERIOD-DOUB) - 1.50 NS</p> <p>IF 1.00 NS \leq WIDTH < 10.0 NS THEN WIDTH \leq 0.7*(PERIOD-DOUB) - 1.00 NS</p> <p>IF WIDTH \geq 10.0 NS THEN WIDTH \leq 0.85*(PERIOD-DOUB) - 2.50 NS</p>

ERROR CODE
CHANNEL 1 CHANNEL 2 ERROR MESSAGE

104	204	<Width - Double Ch. 1 2> IF WIDTH < 1.00 NS THEN WIDTH <= 0.8*DOUB - 1.10 NS IF WIDTH >= 1.00 NS THEN WIDTH <= 0.8*DOUB - 0.60 NS
105	205	<Double - Dcyc Ch. 1 2> IF WIDTH < 1.00 NS THEN WIDTH <= 0.8*DOUB - 1.10 NS IF WIDTH >= 1.00 NS THEN WIDTH <= 0.8*DOUB - 0.60 NS
106	206	<Trigger - Dcyc Ch. 1 2> :INPut:TRIG:MODE TRIGger and :PULSe:TIMing:DutyCYCle:MODE ON are incompatible.

E

PERFORMANCE TESTS

CONTENTS

Introduction	E.0-3
Safety	E.0-3
Test Record	E.0-3
Performance Tests	
1. Period	E.1-1
2. Delay	E.2-1
3. Double Pulse	E.3-1
4. Width	E.4-1
5. Jitter	E.5-1
6. High Level, Low Level	E.6-1
7. Transitions	E.7-1
8. Pulse Aberration	E.8-1
Test Record	E.9-1

TABLE

E-1	Recommended Test Equipment	E.10-1
-----	----------------------------	--------

FIGURE

E-1	50 Ohm Feed-through	E.10.4
-----	---------------------	--------

INTRODUCTION

The performance tests verify the instruments specified performance characteristics.

They are suitable for incoming inspection, preventative maintenance, troubleshooting, and final test.

Make the Performance Tests in the order of occurrence in the manual.

Recommended test equipment is listed in Table 1.

SAFETY

The HP 8131A is a Safety Class 1 instrument. It has an exposed metal chassis that is directly connected to earth potential through the line power cord.

Before testing the instrument review:

1. The Safety Summary (red page)
2. The Instrument Reference Manuals
3. The instrument safety markings.

TEST RECORD

A test record is located at the end of this chapter.

The test results are identified as TR ENTRIES in the performance tests and on the test record.

1. PERIOD TEST

SPECIFICATIONS

Range: 2 ns to 99.9 ms
Resolution: 3 digits (best case: 10 ps)
Accuracy: 5 % of programmed value \pm 100 ps
rms Jitter: 10 ns to 100 ns range: 0.05 % of progr. value
+ 15 ps
all other ranges: 0.025 % of programmed value
+ 15 ps
Repeatability: Factor 4 better than accuracy

EQUIPMENT

1. Counter.
2. Cable, 50 ohm, BNC to BNC, coaxial.

SET-UP

1. Connect the HP 8131A's OUTPUT 1/2 to the Counter's channel A input (HP5335A) /
FREQ input (HP5370B).
2. Set the HP 8131A:

MODE	=	AUTO		OPT 020
TIMING	=	PERIOD	: 2.00 ns	
		DEL	: 0 ns	0 ns
		WIDTH	: 1 ns	1 ns
OUTPUT	=	HIGH	: + 1.5 V	+ 1.5 V
		LOW	: - 1.5 V 0 V	- 1.5 V
		ENABLE		DISABLE
4. Set Counter:
 - a. FUNCTION = PERIOD
 - b. CHANNEL A = 50 ohm
 - c. TRIGGER LEVEL = PRESET

PROCEDURE

1. Check the HP 8131A period at the following settings:

<u>PERIOD</u>	<u>ACCEPTABLE RANGE</u>		<u>TR ENTRY</u>
2.00 ns	1.8 ns	2.2 ns	1-1
5.00 ns	4.65 ns	5.35 ns	1-2
10.0 ns	9.4 ns	10.6 ns	1-3
50.0 ns	47.4 ns	52.6 ns	1-4
100 ns	94.9 ns	105.1 ns	1-5
500 ns	474.9 ns	525.1 ns	1-6
1.00 us	949.9 ns	1.05 us	1-7
5.00 us	4.75 us	5.25 us	1-8
10.0 us	9.5 us	10.5 us	1-9
50.0 us	47.5 us	52.5 us	1-10
100 us	95 us	105 us	1-11
500 us	475 us	525 us	1-12
1.00 ms	950 us	1.05 ms	1-13
5.00 ms	4.75 ms	5.25 ms	1-14
10.0 ms	9.5 ms	10.5 ms	1-15
50.0 ms	47.5 ms	52.5 ms	1-16
99.9 ms	94.9 ms	104.9 ms	1-17

2. DELAY TEST

This test consists of two parts:

1. Minimum Delay Test
2. Long Delay Test

NOTES: Repeat the entire delay test procedure for the second channel, if installed.

The specifications and tests are for the 50 % point of amplitude.

SPECIFICATIONS

Range: 0 ns to 99.9 ms
Fixed Delay (Trigger Output to Main Output):
20 ns nominal.
Maximum Delay: Period \geq 20.0 ns: $0.90 \cdot \text{Period} - 6.00$ ns
Resolution: 3 digits (best case: 10 ps)
Accuracy: 5 % of programmed value \pm 1.5 ns
rms Jitter: 10 ns to 100 ns range: 0.05 % of prog. value +
15 ps
All other ranges: 0.025 % of programmed value
+ 15 ps
Repeatability: Factor 4 better than accuracy

EQUIPMENT

1. HP 54120T Digitizing Oscilloscope with Accessory
2. Pulse Generator
3. Counter
4. Cable, 50 ohm, BNC to BNC, coaxial, 2 each.

PART 1 MINIMUM DELAY TEST

SET-UP

1. Set Pulse Generator:
 - a. PER = 500 ns
 - b. WID = 100 ns
 - c. HIL = 0.5 V LOL = -0.5 V
 - d. Fixed Transition Time

2. Set the HP 8131A:

MODE	=	TRIG		OPT 020
			Slope positive	
TIMING	=	DEL	: 0 ns	0 ns
		WIDTH	: 100 ns	10 ns
OUTPUT	=	HIGH	: 1.5 V	1.5 V
		LOW	: - 1.5 V	- 1.5 V
		ENABLE		DISABLE

4. Connect the Pulse Generator's Output via a 50 ohm feedthrough to the HP 8131A's EXT INPUT, use a BNC (f) to SMA (m) Adapter.

5. Connect the HP 8131A's TRIG OUTPUT via a Cable assy-coaxial SMA (m-m), and APC 3.5 mm 20dB Attenuator (f-m) to the Input 3 of the HP 54121A.

6. Connect the HP 8131A OUTPUT 1/2 via a same second accessory assembly to the Input 4 of the HP 54121A.

7. Connect the Pulse Generator's Trigger Output via a BNC (f) to SMA (m) Adapter and an APC 3.5 mm 20 dB Attenuator (f-m) to the TRIG input of the HP 54121A.

PROCEDURE

1. Setup HP 54120T Oscilloscope:
 - press AUTOSCALE
 - set TIME/DIV = 20 ns/div
 - select the Display menu and set the Screen function to Single
set the Number of Averages to 64
 - select the Delta V menu and turn the voltage markers On and assign marker 1 to channel 3 and marker 2 to channel 4
 - set Preset Levels = 50-50% and press Auto Level Set
 - select the Delta t menu and turn the time markers On
 - set START ON EDGE = POS1 and STOP ON EDGE = POS1
 - Press Precise Edge Find
2. Press the Precise Edge Find key for each new Delay setting.
3. Check the HP 8131A delay at the following settings:

	<u>DELAY</u>	<u>ACCEPTABLE RANGE</u>		<u>TR ENTRY</u>
1.	0.00 ns	*fixed Delay		2-1
2.	10.0 ns	8.0 ns	12.0 ns	2-2
3.	20.0 ns	17.5 ns	22.5 ns	2-3
4.	50.0 ns	46.0 ns	54.0 ns	2-4
5.	80.0 ns	74.5 ns	85.5 ns	2-5
6.	99.9 ns	93.4 ns	106.4 ns	2-6

* Record the value of the fixed Delay, and subtract it from the other readings.

4. Step with the Vernier up keys from:

0 ps	to	100 ps	in	10 ps steps
100 ps	to	1 ns	in	100 ps steps
1 ns	to	10 ns	in	1 ns steps

Check the function/variation on scope.

PART 2 MAXIMUM DELAY TEST

SET-UP

1. Set the HP 8131A:

MODE	=	AUTO	OPT 020
TIMING	=	PERIOD	: 95 us
		DEL	: 100 ns
		WIDTH	: 100 ns
OUTPUT	=	HIGH	: + 1.5 V
		LOW	: - 1.5 V
		ENABLE	DISABLE

2. Set the Counter:
 - a. FUNCTION = TI A to B
 - b. START = 50 ohm, POS (+) slope, DC, X1
 - c. STOP = 50 ohm, POS (+) slope, DC, X1
 - d. Gate Time = as necessary
 - e. INPUT MODE = SEP (SEPARATE)
 - f. START/STOP trigger levels = preset

3. Connect the HP 8131A TRIG OUTPUT to the Counter's START input.

4. Connect the HP 8131A OUTPUT 1/2 to the Counter's STOP input.

PROCEDURE

1. Check the HP 8131A delay at the following Period and Delay settings:

<u>PERIOD</u>	<u>DELAY</u>	<u>ACCEPTABLE RANGE</u>		<u>TR ENTRY</u>
*95 us	100 ns	93.5 ns	106.5 ns	2-7
*95 us	500 ns	473.5 ns	526.5 ns	2-8
*95 us	999 ns	947.55 ns	1,051 us	2-9
99.9 ms	100 us	95 us	105 us	2-10
99.9 ms	1 ms	950 us	1.05 ms	2-11
99.9 ms	80 ms	76 ms	84 ms	2-12

* Take the fixed delay into account.

3. DOUBLE PULSE TEST

This test consists of two parts:

1. Minimum Double Pulse Test
2. Long Double Pulse Test

NOTES: Repeat the entire double pulse test procedure for the second channel, if installed.

The specifications and tests are for the 50 % point of amplitude.

SPECIFICATIONS

Range:	2 ns to 99.9 ms
Maximum	
Double Pulse:	Period \geq 10.0 ns: $0.9 \times \text{Period} - 4.00$ ns
Resolution:	3 digits (best case: 10 ps)
Accuracy:	5 % of programmed value \pm 250 ps
rms Jitter:	10 ns to 100 ns range: 0.05 % of prog. value + 15 ps ns All other ranges: 0.025 % of programmed value + 15 ps
Repeatability:	Factor 4 better than accuracy

EQUIPMENT

1. HP 54120T Digitizing Oscilloscope with Accessory
2. Counter
3. Cable, 50 ohm, BNC to BNC, coaxial, 2 each.

PART 1 MINIMUM DOUBLE PULSE TEST

SET-UP

1. Set the HP 8131A:

MODE	=	AUTO			OPT 020
TIMING	=	PERIOD	: 200 ns		
		DOUB	: 20 ns		2 ns
		WIDTH	: 10 ns		1 ns
OUTPUT	=	HIGH	: + 1.5 V		+ 1.5 V
		LOW	: - 1.5 V 0 V		- 1.5 V
		ENABLE			DISABLE
2. Connect the HP 8131A's TRIG OUTPUT via a Cable assy-coaxial SMA (m-m), and APC 3.5 mm 20dB Attenuator (f-m) to the TRIG Input of the HP 54121A.
3. Connect the HP 8131A OUTPUT 1/2 via a same second accessory asseby to the Input 4 of the HP 54121A.

PROCEDURE

1. Setup HP 54120T Oscilloscope:
 - press AUTOSCALE
 - select the Display menu and set the Number of Averages to 64
 - select the Delta V menu and turn the voltage markers On
 - set Preset Levels = 50-50% and press Auto Level Set
 - select the Delta t menu and turn the time markers On
 - set START ON EDGE = POS1 and STOP ON EDGE = POS2
2. Press the Precise Edge Find key for each new Double setting.
3. Check the HP 8131A double pulse delay at the following settings:

<u>DOUBLE</u>	<u>ACCEPTABLE RANGE</u>		<u>TR ENTRY</u>
20.0 ns	18.75 ns	21.25 ns	3-1
50.0 ns	47.25 ns	52.75 ns	3-2
80.0 ns	75.75 ns	84.25 ns	3-3
99.9 ns	94.65 ns	105.15 ns	3-4

4. Change the HP 8131A Width to 1 ns, and Double to 2 ns.
5. Check the HP 8131A double pulse delay at the following settings:

<u>DOUBLE</u>	<u>ACCEPTABLE RANGE</u>		<u>TR ENTRY</u>
2.00 ns	1.65 ns	2.35 ns	3-5
5.00 ns	4.5 ns	5.5 ns	3-6
10.0 ns	9.25 ns	10.75 ns	3-7

PART 2 MAXIMUM DOUBLE PULSE TEST

SET-UP

1. Set the HP 8131A:

MODE	=	AUTO		OPT 020
TIMING	=	PERIOD : 95 us		
		DOUB : 200 ns		2 ns
		WIDTH : 100 ns		1 ns
OUTPUT	=	HIGH : + 1.5 V		+ 1.5 V
		LOW : - 1.5 V		- 1.5 V
		ENABLE		DISABLE

2. Set the Counter:

- FUNCTION = TI A to B
- START = 50 ohm, POS (+) slope, DC, X1
- STOP = 50 ohm, POS (+) slope, DC, X1
- Gate Time = as necessary
- INPUT MODE = COM
- START/STOP trigger levels = Preset

3. Connect the HP 8131A OUTPUT 1/2 to the Counter's START input.

PROCEDURE

1. Check the HP 8131A double pulse delay at the following Period and Double settings:

<u>PERIOD</u>	<u>DOUBLE</u>	<u>ACCEPTABLE RANGE</u>		<u>TR ENTRY</u>
95 us	200 ns	189.75 ns	210.25 ns	3-8
95 us	1 us	950 ns	1.05 us	3-9
95 us	10 us	9.5 us	10.5 us	3-10
99.9 ms	100 us	95 us	105 us	3-11
99.9 ms	1 ms	950 us	1.05 ms	3-12
99.9 ms	10 ms	9.5 ms	10.5 ms	3-13
99.9 ms	80 ms	76 ms	84 ms	3-14

4. WIDTH TEST

This test consists of two parts.

1. Minimum Width Test
2. Long Width Test

NOTES: Repeat the entire width test procedure for the second channel, if installed.

The specifications and tests are for the 50 % point of amplitude.

SPECIFICATIONS

Range:	500 ps to 99.9 ms
Maximum Width:	Period \geq 20.0 ns: $0.9 \cdot \text{Period} - 5.00$ ns
Resolution:	3 digits (best case: 10 ps)
Accuracy:	5 % of programmed value \pm 250 ps
rms Jitter:	10 ns to 100 ns range: 0.05 % of prog. value + 15 ps All other ranges: 0.025 % of programmed value + 15 ps
Repeatability:	Factor 4 better than accuracy

EQUIPMENT

1. HP 54120T Digitizing Oscilloscope with Accessory
2. Counter
3. Cable, 50 ohm, BNC to BNC, coaxial, 2 each.

PART 1 MINIMUM WIDTH TEST

SET-UP

1. Set the HP 8131A:

MODE	=	AUTO		OPT 020	
TIMING	=	PERIOD	: 200 ns		
		DEL	: 0 ns		0 ns
		WIDTH	: 10 ns		1 ns
OUTPUT	=	HIGH	: + 1.5 V		+ 1.5 V
		LOW	: - 1.5 V 0 V		- 1.5 V
		ENABLE			DISABLE

3. Connect the HP 8131A's TRIG OUTPUT via a Cable assy-coaxial SMA (m-m), and APC 3.5 mm 20dB Attenuator (f-m) to the TRIG Input of the HP 54121A.
4. Connect the HP 8131A OUTPUT 1/2 via a same second accessory asseby to the Input 4 of the HP 54121A.

PROCEDURE

1. Setup HP 54120T Oscilloscope:
 - press AUTOSCALE
 - select the Display menu and set the Number of Averages to 64
 - select the Delta V menu and turn the voltage markers On
 - set Preset Levels = 50-50% and press Auto Level Set
 - select the Delta t menu and turn the time markers On
 - set START ON EDGE = POS1 and STOP ON EDGE = NEG1
2. Change the scope timebase to 500 ps/div.
Change the HP 8131A Width to 500 ps.
3. Press the Precise Edge Find key for each new Width setting.
4. Check the HP 8131A pulse width at the following settings:

<u>WIDTH</u>	<u>ACCEPTABLE RANGE</u>		<u>TR ENTRY</u>
500 ps	225 ps	775 ps	4-1
800 ps	510 ps	1.09 ns	4-2
2.00 ns	1.65 ns	2.35 ns	4-3
5.00 ns	4.5 ns	5.5 ns	4-4
10.0 ns	9.25 ns	10.75 ns	4-5
20.0 ns	18.75 ns	21.25 ns	4-6
50.0 ns	47.25 ns	52.75 ns	4-7
80.0 ns	75.75 ns	84.25 ns	4-8
99.9 ns	94.65 ns	105.15 ns	4-9

5. Step with the Vernier up keys from:

500 ps	to	600 ps	in	10 ps steps
600 ps	to	1 ns	in	100 ps steps
1 ns	to	10 ns	in	1 ns steps

Check the function/variation on scope.

PART 2 MAXIMUM WIDTH TESTS

SET-UP

1. Set the HP 8131A:

MODE	=	AUTO		OPT 020
TIMING	=	PERIOD	: 95 us	
		DEL	: 0 ns	0 ns
		WIDTH	: 500 ns	1 ns
OUTPUT	=	HIGH	: + 1.5 V	+ 1.5 V
		LOW	: - 1.5 V0 V	- 1.5 V
		ENABLE		DISABLE

2. Set the Counter:
 - a. FUNCTION = TI A to B
 - b. START = 50 ohm, POS (+) slope, DC, X1
 - c. STOP = 50 ohm, NEG (-) slope, DC, X1
 - d. Gate Time = as necessary
 - e. INPUT MODE = COM
 - f. START/STOP trigger levels = Preset

3. Connect the HP 8131A OUTPUT 1/2 to the Counter's START input.

PROCEDURE

1. Check the HP 8131A pulse width at the following Period and Width settings:

<u>PERIOD</u>	<u>WIDTH</u>	<u>ACCEPTABLE RANGE</u>		<u>TR ENTRY</u>
95 us	500 ns	474.75 ns	525.25 ns	4-10
95 us	999 ns	948.8 ns	1.049 us	4-11
95 us	10 us	9.5 us	10.5 us	4-12
99.9 ms	100 us	95 us	105 us	4-13
99.9 ms	1 ms	950 us	1.05 ms	4-14
99.9 ms	80 ms	76 ms	84 ms	4-15

5. JITTER TESTS

This test consists of three parts: Period Jitter, Delay Jitter, and Width Jitter.

Repeat the tests for the second channel, if installed.

SPECIFICATIONS

rms Jitter: 10 ns to 100 ns range: 0.05 % of programmed value
+ 15 ps
All other ranges: 0.025% of programmed value
+ 15 ps

EQUIPMENT

1. HP 54120T Digitizing Oscilloscope with Accessory

PART 1 PERIOD JITTER TEST

SET-UP

1. Set the HP 8131A:

MODE	=	AUTO		OPT 020	
TIMING	=	PERIOD	: 50 ns		
		DEL	: 0 ns		0 ns
		WIDTH	: 25 ns		500 ps
OUTPUT	=	HIGH	: + 1.0 V		+ 1.0 V
		LOW	: - 0.0 V0 V		- 0.0 V
		ENABLE			DISABLE
2. Connect an APC 3.5 mm 20dB Attenuator (f-m) to the TRIG Input of the HP 54121A.
3. Connect one output, APC 3.5 mm (f), of the Power Splitter HP 11667B via a SMA (m-m) Adapter to the 20dB Attenuator at the TRIG Input of the 54121A.
4. Connect to the other output of the Power Splitter a SMA (m) - BNC (f) Adapter and connect 4 BNC (m-m) cables (61 cm) together to this adapter (use BNC Adapters (f-f), 3 each).
5. Connect this cable assembly via a BNC (f) - SMA (m) Adapter to the Input 3 of the 54121A.
6. Connect the 8115A OUTPUT 1/2 via a Cable assy-coaxial SMA (m-m) to the Input of the Power Splitter.

PROCEDURE

1. Setup HP 54120T Oscilloscope:
 - press AUTOSCALE
 - select the Display menu and set the Number of Averages to 128
 - select the Timebase menu and set the TIME/DIV to 10 ps/div
 - center the first positive going edge of the signal (approx. Delay = 17.8 ns)
 - select the Channel menu and set the Atten factor to 1 (Channel 3)
 - set the VOLT/DIV to 10 mV/div
 - select the Delta V menu and turn the V Markers On
 - set the Marker 1 Position to 240 mV and the Marker 2 Position to 245 mV
 - select the Delta t menu and turn the T Markers On
 - set START ON EDGE = POS1 and STOP ON EDGE = POS1
 - press the Precise Edge Find key

2. **RECORD** the delta t! It is the risetime of the ref. signal within a 1% amplitude window of the signal connected to Input 3. This value is needed later to calculate the correct jitter.

3. Select the scopes Timebase menu and center the second positive going edge of the signal (actual Delay + 50.x ns = approx. Delay 66.x ns)
4. Press More and Histogram.
5. Select the Window submenu and set:
 Source is Channel 3
 choose the time Histogram
 press WINDOW MARKER 1 and set it to 240 mV
 press WINDOW MARKER 2 and set it to 245 mV
6. Select the Acquire submenu and set the Number of Samples to 1000.
 Press Start Acquiring.
7. After the data for the time histogram is acquired (#Samples = 100%), select the Result submenu.
8. Press Mean and Sigma. Notice the value of Sigma!
9. The rms jitter has to be calculated as follows:

$$\frac{(\text{Sigma} \times 6) - \text{delta t of ref. signal}}{6}$$

10. Maximum rms jitter (period = 50 ns) is 40 ps

TR ENTRY 5-1

11. Set the HP 8131A: PER 500 ns

12. Repeat steps 3 to 9.

NOTE: Time/Div 100 ps/div Delay approx. 51x.x ns

- Maximum rms jitter (period = 500 ns) is 140 ps

TR ENTRY 5-2

PART 2 WIDTH JITTER TEST

SET-UP

1. Same set-up as before.
2. Set the HP 8131A:
TIMING = PER : 1 us
WIDTH : 1 ns | 500 ps

PROCEDURE

1. Setup HP 54120T Oscilloscope:
 - press the More key
 - select the Display menu and set the #Aves = 256
 - select the Timebase menu and center the first negative going edge of the signal (Time/Div 10 ps/div, approx. Delay = 17.x ns)
 - select the Delta V menu and set the Marker 1 Position to 260 mV and the Marker 2 Position to 255 mV
 - select the Delta t menu and set START ON EDGE = NEG1 and STOP ON EDGE = NEG1
 - press the Precise Edge Find key
2. Notice the delta t! It is the falltime of the signal within a 1% amplitude window of the signal connected to Input 3. This value is needed later to calculate the correct jitter.
3. Set the HP 8131A: WID 50 ns
4. Select the scopes Timebase menu and center the first neg. going edge of the signal (Time/Div 20 ps/div, Delay approx. 66.x ns).
3. Press More = Histogram.
4. Select the Window submenu and
 - press WINDOW MARKER 1 and set it to 260 mV
 - press WINDOW MARKER 2 and set it to 255 mV
5. Select the Acquire submenu and press Start Acquiring.

6. After the data for the time histogram is acquired (#Samples = 100%), select the Result submenu.
7. Press Mean and Sigma. Notice the value of Sigma!
8. The rms jitter has to be calculated as follows:

$$\frac{(\text{Sigma} \times 6) - \text{delta t of signal}}{6}$$

9. Maximum rms jitter (width = 50 ns) is 40 ps

TR ENTRY 5-3

10. Set the HP 8131A: WID 500 ns

11. Repeat steps 4 to 8.

NOTE: Time/Div 100 ps/div, Delay 51x.x ns

Maximum rms jitter (width 500 ns) is 140 ps.

TR ENTRY 5-4

12. DISABLE THE HP 8131A OUTPUTS !

PART 3 DELAY JITTER TEST

SET-UP

1. Set the HP 8131A:

MODE	=	AUTO		OPT 020	
TIMING	=	PERIOD	: 500 ns		
		DEL	: 250 ns		0 ps
		WIDTH	: 50 ns		500 ps
OUTPUT	=	HIGH	: + 5 V		+ 5 V
		LOW	: 0.0 V		0.0 V
		DISABLE			DISABLE

2. Connect the HP 8131A's TRIG OUTPUT via a Cable assy-coaxial SMA (m-m), and APC 3.5 mm 20dB Attenuator (f-m) to the TRIG Input of the HP 54121A.
3. Connect the HP 8131A OUTPUT 1/2 via a Cable assy-coaxial SMA (m-m), and APC 3.5 mm 20 dB Attenuator (f-m) to the Input 3 of the HP 54121A.
4. ENABLE the output.

PROCEDURE

1. Setup HP 54120T Oscilloscope:
 - press AUTOSCALE
 - select the Display menu and set the #Avs = 128
 - select the Timebase menu and set the TIME/DIV = 50 ps/div
 - center the first positive going edge of the signal (approx. Delay = 26x.x ns)
 - select the Channel menu and set the VOLT/DIV = 10 mV/div
2. Press More = Histogram.
3. Select the Window submenu and
 - press WINDOW MARKER 1 and set it to 240 mV
 - press WINDOW MARKER 2 and set it to 245 mV
4. Select the Acquire submenu and press Start Acquiring.
5. After the data for the time histogram is acquired (#Samples = 100%), select the Result submenu.
6. Press Mean and Sigma. Notice the value of Sigma!
7. The rms jitter has to be calculated as follows:
$$\frac{(\text{Sigma} \times 6) - \text{delta t of ref. signal}}{6}$$
8. Max. rms jitter (delay = 250 ns) is 67.5 ps

TR ENTRY 5-5

6. HIGH LEVEL AND LOW LEVEL TESTS

Repeat the high level and low level tests for the second channel, if installed.

SPECIFICATIONS

NOTE: This specification applies to 50 ohm sources and 50 ohm loads.

High Level:	-4.90 V to 5.00 V.
Low Level:	-5.00 V to 4.90 V.
Resolution:	3 digits (best case: 10.0 mV).
Level Accuracy:	1% of programmed value \pm 3% of pulse amplitude, \pm 40 mV.
Repeatability:	Factor 4 better than accuracy
Settling time:	10 ns + transition time.

EQUIPMENT

1. Multimeter
2. 50 ohm feedthrough termination, **0.1%, 10 W**
3. Adapter, BNC to dual banana plug
4. Cables, BNC to BNC, two each.
5. Pulse Generator with a 50 ohm feedthrough termination

SET-UP

1. Set the HP 8131A:

MODE	=	AUTO			OPT 020
TIMING	=	PERIOD	: 99.9 ms		
		DEL	: 30 us		0 ps
		WIDTH	: 50 ms		500 ps
OUTPUT	=	HIGH	: + 5 V		+ 5 V
		LOW	: 0.0 V		0.0 V
		ENABLE			DISABLE
2. Set the Multimeter (HP 3478).
 - a. SGL TRIG = Single Trigger
 - b. Blue/AUTO ZERO = Auto Zero off
 - c. BLUE/4 = 4 digits
3. Set the Pulse Generator:
 - a. Mode: Trigger
 - b. Trigger slope positive
 - c. Width: 500 ns
 - d. HIL: 2.0 V
4. Connect the HP 8131A OUTPUT 1/2 via a SMA (m) to BNC (f)Adapter, a 50 ohm feedthrough (**0.1%, 10 W**), BNC (m-m) cable, and a BNC to dual banana plug adapter to the Multimeters Input.
5. Connect the HP 8131A TRIG OUTPUT via a SMA (m) to BNC (f) to the Pulse Generators External Input.
6. Connect the Pulse Generators Output via a 50 ohm feedthrough terminator to the Multimeters Trigger Input.

PROCEDURE

HIGH LEVEL TEST

1. Check the HP 8131A high level at the following HIGH settings with the low level set to 0.00 V.

<u>HIGH LEVEL</u>	<u>ACCEPTABLE RANGE</u>		<u>TR ENTRY</u>
5.0 V	4.76 V	5.24 V	6-1
3.0 V	2.84 V	3.16 V	6-2
1.0 V	920 mV	1.08 V	6-3
0.5 V	440 mV	560 mV	6-4
0.1 V	56 mV	144 mV	6-5

The low level 0.0 V may vary within $\pm 3\%$ of pulse amplitude, ± 40 mV.

LOW LEVEL TEST

SET-UP

1. Set the HP 8131A:

MODE	=	AUTO		OPT 020
TIMING	=	PERIOD	: 99.9 ms	
		DEL	: 30 ms	0 ps
		WIDTH	: 50 ms	500 ps
OUTPUT	=	HIGH	: 0.0 V	0.0 V
		LOW	: - 0.1 V	- 0.1 V
		ENABLE		DISABLE

2. Check the HP 8131A low level at the following LOW settings with the high level set to 0.00 V.

<u>LOW LEVEL</u>	<u>ACCEPTABLE RANGE</u>		<u>TR ENTRY</u>
- 0.1 V	56 mV	144 mV	6-6
- 0.5 V	440 mV	560 mV	6-7
- 1.0 V	920 mV	1.08 V	6-8
- 3.0 V	2.84 V	3.16 V	6-9
- 5.0 V	4.76 V	5.24 V	6-10

The high level 0.0 V may vary within $\pm 3\%$ of pulse amplitude, ± 40 mV.

7. TRANSITION TIME TEST

Repeat the entire transition time test procedure for the second channel.

SPECIFICATIONS

10% - 90% of amplitude: < 200 ps, 300 mv to 3 V range
20% - 80% of amplitude: < 200 ps, 100 mV to 5 V range

EQUIPMENT

1. HP 54120T Digitizing Oscilloscope with Accessory

SET-UP

1. Set the HP 8131A:

MODE	=	AUTO		OPT 020
TIMING	=	PERIOD		
		: 500 us		
		DEL		0 ps
		: 10 ns		
		DCYC		50 %
		: 50 %		
OUTPUT	=	HIGH		+ 5 V
		: + 5 V		
		LOW		0.0 V
		: 0.0 V		
		ENABLE		DISABLE

2. Connect the HP 8131A's TRIG OUTPUT via a Cable assy-coaxial SMA (m-m), and APC 3.5 mm 20dB Attenuator (f-m) to the TRIG Input of the HP 54121A.
3. Connect the HP 8131A OUTPUT 1/2 via a same second accessory asseby to the Input 4 of the HP 54121A.

PROCEDURE

1. Setup HP 54120T Oscilloscope:
 - press AUTOSCALE
 - center one pulse horizontal and vertical on screen
(for example, TIME/DIV = 50 us/div, DELAY = 375 us,
VOLT/DIV = 800 mV/div, Offset = 2.5 V).
 - select the Display menu and set the Number of Averages to 64
 - select the Channel menu and set the Atten factor to 10
 - select the Delta V menu and turn the voltage markers On
 - set Preset Levels = 20-80% and press Auto Level Set
 - select the Timebase menu and
set TIME/DIV = 20 ns, DELAY = 16 ns
 - select the Delta t menu and turn the time markers On
 - set START ON EDGE = POS1 and STOP ON EDGE = POS1

2. Set HP 8131A: Period: 250 ns

3. While the Oscilloscope is in the Delta t menu, press the Precise Edge Find Key.

4. Check for Risetime < 200 ps. **TR ENTRY 7-1**

5. Select the scopes Delta t menu and set START ON EDGE = NEG1 and STOP ON EDGE = NEG1.

6. Press the Precise Edge Find key.

7. Check for Falltime < 200 ps. **TR ENTRY 7-2**

8. Repeat steps 1 to 8.
Set HP 8131A: HIGH = 3.0 V **TR ENTRY 7-3**
TR ENTRY 7-4

NOTES: Set the Voltage Marker in the Delta V menu
to the 10-90% Levels.

Take the scopes trace flatness error (GaAs input circuit)
into account.

8. PULSE ABERRATION TEST

Repeat this test for the second channel, if installed.

SPECIFICATIONS

Overshoot and Ringing: $\leq 15\%$ of the pulse amplitude ± 20 mV.

EQUIPMENT

1. HP 54120T Digitizing Oscilloscope with Accessory

SET-UP

1. Set the HP 8131A:

MODE	=	AUTO		OPT 020	
TIMING	=	PERIOD	: 500 us		
		DEL	: 5 ns		0 ps
		DCYC	: 50 %		50 %
OUTPUT	=	HIGH	: + 5 V		+ 5 V
		LOW	: 0.0 V		0.0 V
		ENABLE			DISABLE

2. Connect the HP 8131A's TRIG OUTPUT via a Cable assy-coaxial SMA (m-m), and APC 3.5 mm 20dB Attenuator (f-m) to the TRIG Input of the HP 54121A.
3. Connect the HP 8131A OUTPUT 1/2 via a same second accessory assebly to the Input 4 of the HP 54121A.

PROCEDURE

1. Setup HP 54120T Oscilloscope:
 - press AUTOSCALE
 - center one pulse horizontal and vertical on screen (e.g. TIME/DIV = 50 us/div, DELAY = 350 us, VOLT/DIV = 800 mV/div)
 - select the Display menu and set the Number of Averages to 64
 - select the Channel menu and set the Atten factor to 10
 - select the Delta V menu and turn the voltage markers On
 - set the VARIABLE LEVELS = 85-115% and press Auto Level Set
 - select the Channel menu and center vertical the pulse top (Offset = 5 V)
 - set the VOLTS/DIV to 500 mV/div
 - select the Timebase menu and set TIME/DIV = 500 ps, DELAY = 17.x ns
2. Set HP 8131A: Period: 500 ns
3. Check the Overshoot and Ringing for $\leq 15\% \pm 20 \text{ mV}$ **TR ENTRY 8-1**

(Take the scopes trace flatness error (GaAs input circuit) into account.)
4. Repeat steps 1 to 3.
Set HP 8131A; HIGH = 500 mV **TR ENTRY 8-2**

PERFORMANCE TEST RECORD

MODEL: HP 8118A TESTED BY: _____
 SERIAL NUMBER: _____ DATE: _____
 CUSTOMER: _____ CSO#: _____
 COMMENTS: _____

<u>TEST</u>	<u>LIMIT MINIMUM</u>	<u>ACTUAL (TR ENTRY)</u>	<u>LIMIT MAXIMUM</u>	<u>PASS</u>	<u>FAIL</u>
PERIOD:					
2.00 ns	1.8 ns	(1-1) _____	2.2 ns	_____	_____
5.00 ns	4.65 ns	(1-2) _____	5.35 ns	_____	_____
10.0 ns	9.4 ns	(1-3) _____	10.6 ns	_____	_____
50.0 ns	47.4 ns	(1-4) _____	52.6 ns	_____	_____
100 ns	94.9 ns	(1-5) _____	105.1 ns	_____	_____
500 ns	474.9 ns	(1-6) _____	525.1 ns	_____	_____
1.00 us	949.9 ns	(1-7) _____	1.05 us	_____	_____
5.00 us	4.75 us	(1-8) _____	5.25 us	_____	_____
10.0 us	9.5 us	(1-9) _____	10.5 us	_____	_____
50.0 us	47.5 us	1-10) _____	52.5 us	_____	_____
100 us	95 us	(1-11) _____	105 us	_____	_____
500 us	475 ms	(1-12) _____	525 us	_____	_____
1.00 ms	950 ms	(1-13) _____	1.05 ms	_____	_____
5.00 ms	4.75 ms	(1-14) _____	5.25 ms	_____	_____
10.0 ms	9.5 ms	(1-15) _____	10.5 ms	_____	_____
50 ms	47.5 ms	(1-16) _____	52.5 ms	_____	_____
99.9 ms	94.9 ms	(1-17) _____	104.9 ms	_____	_____

<u>TEST</u>	<u>LIMIT MINIMUM</u>	<u>ACTUAL (TR ENTRY)</u>	<u>LIMIT MAXIMUM</u>	<u>PASS</u>	<u>FAIL</u>
MINIMUM DELAY:					
0.00 ns		(2-1) _____		_____	_____
10.0 ns	8.0 ns	(2-2) _____	12.0 ns	_____	_____
20.0 ns	17.5 ns	(2-3) _____	22.5 ns	_____	_____
50.0 ns	46.0 ns	(2-4) _____	54.0 ns	_____	_____
80.0 ns	74.5 ns	(2-5) _____	85.5 ns	_____	_____
99.9 ns	93.4 ns	(2-6) _____	106.4 ns	_____	_____
MAXIMUM DELAY					
100 ns	93.5 ns	(2-7) _____	106.5 ns	_____	_____
500 ns	473.5 ns	(2-8) _____	526.5 ns	_____	_____
999 ns	947.55 ns	(2-9) _____	1.051 us	_____	_____
100 us	95 us	(2-10) _____	105 us	_____	_____
1 ms	950 ms	(2-11) _____	1.05 ms	_____	_____
80 ms	76 ms	(2-12) _____	84 ms	_____	_____
MINIMUM DOUBLE PULSE:					
20.0 ns	18.75 ns	(3-1) _____	21.25 ns	_____	_____
50.0 ns	47.25 ns	(3-2) _____	52.75 ns	_____	_____
80.0 ns	75.75 ns	(3-3) _____	84.25 ns	_____	_____
99.9 ns	94.65 ns	(3-4) _____	105.15 ns	_____	_____
2.00 ns	1.65 ns	(3-5) _____	2.35 ns	_____	_____
5.00 ns	4.5 ns	(3-6) _____	5.5 ns	_____	_____
10.0 ns	9.25 ns	(3-7) _____	10.75 ns	_____	_____
MAXIMUM DOUBLE PULSE					
200 ns	189.75 ns	(3-8) _____	210.25 ns	_____	_____
1 us	950 ns	(3-9) _____	1.05 us	_____	_____
10 us	9.5 us	(3-10) _____	10.5 us	_____	_____
100 us	95 us	(3-11) _____	105 us	_____	_____
1 ms	950 us	(3-12) _____	1.05 ms	_____	_____
10 ms	9.5 ms	(3-13) _____	10.5 ms	_____	_____
80 ms	76 ms	(3-14) _____	84 ms	_____	_____

<u>TEST</u>	<u>LIMIT MINIMUM</u>	<u>ACTUAL (TR ENTRY)</u>	<u>LIMIT MAXIMUM</u>	<u>PASS</u>	<u>FAIL</u>
MINIMUM WIDTH:					
500 ps	225 ps	(4-1) _____	775 ps	_____	_____
800 ps	510 ps	(4-2) _____	1.09 ns	_____	_____
2.00 ns	1.65 ns	(4-3) _____	2.35 ns	_____	_____
5.00 ns	4.5 ns	(4-4) _____	5.5 ns	_____	_____
10.0 ns	9.25 ns	(4-5) _____	10.75 ns	_____	_____
20.0 ns	18.75 ns	(4-6) _____	21.25 ns	_____	_____
50.0 ns	47.25 ns	(4-7) _____	52.75 ns	_____	_____
80.0 ns	75.75 ns	(4-8) _____	84.25 ns	_____	_____
99.9 ns	94.65 ns	(4-9) _____	105.15 ns	_____	_____
MAXIMUM WIDTH:					
500 ns	474.75 ns	(4-10) _____	525.25 ns	_____	_____
999 ns	948.8 ns	(4-11) _____	1.049 us	_____	_____
10 us	9.5 us	(4-12) _____	10.5 us	_____	_____
100 us	95 us	(4-13) _____	105 us	_____	_____
1 ms	950 us	(4-14) _____	1.05 ms	_____	_____
80 ms	76 ms	(4-15) _____	84 ms	_____	_____
PERIOD JITTER					
<= 40 ps		(5-1) _____		_____	_____
<= 140 ps		(5-2) _____		_____	_____
WIDTH JITTER					
<= 40 ps		(5-3) _____		_____	_____
<= 140 ps		(5-4) _____		_____	_____
DELAY JITTER					
<= 67.5 ps		(5-5) _____		_____	_____

<u>TEST</u>	<u>LIMIT MINIMUM</u>	<u>ACTUAL (TR ENTRY)</u>	<u>LIMIT MAXIMUM</u>	<u>PASS</u>	<u>FAIL</u>
HIGH LEVEL:					
5.0 V	4.76 V	(6-1) _____	5.24 V	_____	_____
3.0 V	2.84 V	(6-2) _____	3.16 V	_____	_____
1.0 V	920 mV	(6-3) _____	1.08 V	_____	_____
0.5 V	440 mV	(6-4) _____	560 mV	_____	_____
0.1 V	56 mV	(6-5) _____	144 mV	_____	_____
LOW LEVEL:					
-0.1 V	-56 mV	(6-6) _____	-144 mV	_____	_____
-0.5 V	-440 mV	(6-7) _____	-560 mV	_____	_____
-1.0 V	-920 mV	(6-8) _____	-1.08 V	_____	_____
-3.0 V	-2.84 V	(6-9) _____	-3.16 V	_____	_____
-5.0 V	-4.76 V	(6-10) _____	-5.24 V	_____	_____
TRANSITIONS					
< 200 ps		(7-1) _____		_____	_____
< 200 ps		(7-2) _____		_____	_____
< 200 ps		(7-3) _____		_____	_____
< 200 ps		(7-4) _____		_____	_____
PULSE ABERRATION					
<= 15% +/- 20 mV		(8-1) _____		_____	_____
<= 15% +/- 20 mV		(8-2) _____		_____	_____

TABLE E-1. RECOMMENDED TEST EQUIPMENT

Other equipment can be used provided it meets the specifications of this equipment.

<u>TYPE (QUANTITY)</u>	<u>MODEL</u>	<u>SPECIFICATIONS</u>
1:1 Probe (1)	HP 10026A	100 V max., 1:1, 50 ohm,
10:1 Probe (1)	HP 10017A	300 V max., 10:1, 1 M ohm, 8 pF.
50 ohm feedthrough (1) termination	HP 10100C	50 ohm, 2W, 1%.
50 ohm feedthrough (1) termination	See Figure 11-1.	50 ohm, 10 W, 0.1 %.
Adapter, (1) BNC to Banana	HP 1251-2277	BNC(f) to dual banana plug, 50 ohm.
Cable Assembly (5)	HP 8120-1839	50 ohm, 24 inches, coax, 2 BNC (m).

<u>TYPE (QUANTITY)</u>	<u>MODEL</u>	<u>SPECIFICATIONS</u>
Counter (1)	HP 5335A/ HP 5370B	50 uHz to 50 MHz; 8 digit display; INPUT: 50 ohm/1M ohm, X1/X10, AC/DC, seperate/common; variable trigger level; TI/PERIOD/FREQUENCY.
Isolation Transformer (1)		Suitable for use with the variac.
Multimeter (1)	HP 3478A/ HP 3456A	4 1/2 digit display; VDC: 30 mV to 300 V; 30 to 35 readings/second; external trigger; input resistance: >10 M ohm.
Oscilloscope (1) (Realtime)	HP 1725A	275 MHz bandwidth; external trigger; 50 ohm/1 M ohm inputs; 0.1 to 5 V.
Oscilloscope (1) (Sampling)	HP 54120T	20 GHz
Smpling Scope Accessories		
Attenuator (3)	33340C	APC 3.5 mm (f-m), 20 dB
Adapter (2)	1250-1200	SMA (m) to BNC (f)
Cable (3)	8120-4948	SMA (m-m) coaxial
Adapter (1)	1250-1159	SMA (m-m)
Adapter (2)	1250-1700	SMA (f) to BNC (m)
Power Splitter (1)	11667B	APC 3.5 mm
Variac (1) (Variable AC Power Supply)		>= 5 A, 0-300 VAC

FIGURE 11-1.

**50 OHM, 0.1%,
10 W
FEEDTHROUGH
TERMINATION**

This feedthrough must be used only where specified for DC voltage measurements.

The following figure provides a schematic and a parts list except for the case. The case must provide shielding and maintain grounding integrity.

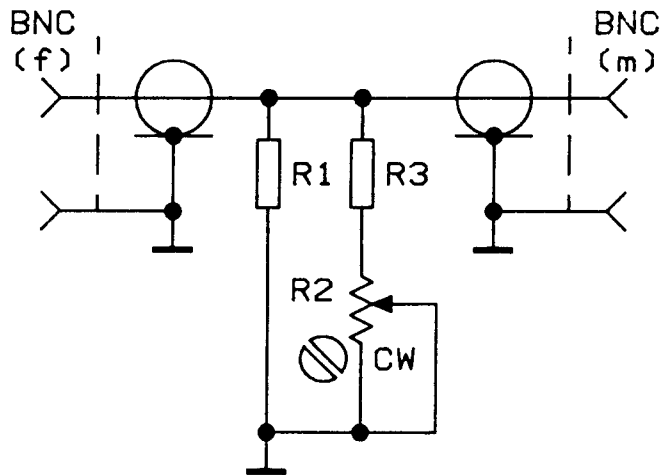

- R1 = 53.6 ohm, 1%, 10 W;
HP Part Number: 0699-0146.
- R2 = 200 ohm, 10%, 0.5 W, Variable trimmer;
HP Part Number: 2100-3350.
- R3 = 681 ohm, 1%, 0.5 W;
HP Part Number: 0757-0816.
- BNC (M): HP Part Number: 1250-0045.
- BNC (F): HP Part Number: 1250-0083.

F

COMMAND

CROSS-REFERENCES

CONTENTS

Introduction

F-3

TABLES

1 HP 8112A and HP 8131A

F-4

2 HP 8160A/61A and HP 8131A

F-7

HP 8131A-Cross Reference

F-1

INTRODUCTION

The cross reference tables in this appendix cross reference comparable but not identical commands. For example, the HP 8112A interrogate command IHIL returns a message that contains the mnemonic, value, and units. The comparable HP 8131A command, :PULSe:LEVel:HIGH?, returns only the value in decimal format. Therefore, it is important to consult Chapters 5, 6, and 7 for additional HP 8131A command information.

Chapter 5 describes the instrument functions as they are used in the local operating mode. Each cross reference table contains a column labeled LOCAL which identifies the alpha listing of that function in Chapter 5, for example, LOW.

Chapter 6 contains an alpha listing of the common commands, for example, *RST.

Chapter 7 contains

1. An alpha listing of the device commands listed by command header, for example, :PULSe:TIMing:DutyCYCLE
2. Syntax diagrams

TABLE F-1. HP 8112A and HP 8131A

<u>HP 8112A</u>	<u>HP 8131A</u>	<u>LOCAL</u>
BUR 1234#	:PULSe:COUNT 1234	COUNT
C0	:OUTPut:PULSe:POLarity NORMal	COMP
C1	:OUTPut:PULSe:POLarity COMPLEMENT	COMP
CST	*LRN?	----
CT0	not available	----
CT1	not available	----
CT2	not available	----
CT3	not available	----
CT4	not available	----
D0	:OUTPut:PULSe:STATe OFF	DISABLE
D1	:OUTPut:PULSe:STATe ON	DISABLE
DBL 200us	:PULSe:TIMing:DOUBle 200us	DOUB
DEL 75.0ns	:PULSe:TIMing:DELay 75.0ns	DEL
DTY 10%	:PULSe:TIMing:DutyCYCle 10PCT	DCYC
EST	*TST?	----
HIL 2.00V	:PULSe:LEVel:HIGH 2.00V	HIGH
IBUR	:PULSe:TIMing:BURSt?	BURST
IDBL	:PULSe:TIMing:DOUBle?	DOUB
IDEL	:PULSe:TIMing:DELay?	DEL
IDTY	:PULSe:TIMing:DutyCYCle?	DCYC
IERR	:SYSTem:DERRor?	----
IHIL	:PULSe:LEVel:HIGH?	HIGH
ILEE	not available (fixed transition)	----
ILOL	:PULSe:LEVel:LOW?	LOW
IPER	:PULSe:TIMing:PERiod?	PERIOD
IRLCn	not available	----
ITRE	not available (fixed transition)	----
IWID	:PULSe:TIMing:WIDTh?	WIDTH

HP 8112A**HP 8131A****LOCAL**

L0	:PULSe:LEVel:LIMit OFF	LIMIT
L1	:PULSe:LEVel:LIMit ON	LIMIT
LD	:SYSTem:KEY 3	----
LEE 20.0ns	not available (fixed transition)	----
LOL 1.00V	:PULSe:LEVel:LOW 1.00V	LOW
LU	:SYSTem:KEY 4	----
M1	:INPut:TRIGger:MODE AUTO	AUTO
M2	:INPut:TRIGger:MODE TRIGger	TRIG
M3	:INPut:TRIGger:MODE GATE	GATE
M4	:INPut:TRIGger:MODE ExternalWIDth	E. WIDTH
M5	:INPut:TRIGger:MODE BURSt	BURST
MD	:SYSTem:KEY 7	----
MU	:SYSTem:KEY 8	----
PER 1.00ms	:PULSe:TIMing:PERiod 1.00ms	PERIOD
RCL 1	*RCL 1	RCL
RD	:SYSTem:KEY 1	----
RU	:SYSTem:KEY 2	----
SD	:SYSTem:KEY 5	----
SR0	not available (fixed transitions)	----
SR1	not available (fixed transitions)	----
SM0	not available	----
SM1	:SYSTem:KEY 41 (See Chapter 5, SET.)	SET
STO 1	*SAV 1	SAVE
SU	:SYSTem:KEY 6	----
T0	not available	----
T1	:INPut:TRIGger:SLOPe POS	SLOPE
T2	:INPut:TRIGger:SLOPe NEG	SLOPE
T3	not available	----
TRE 20.0ns	not available (fixed transition)	----

HP 8112A**HP 8131A****LOCAL**

W1	not available (fixed linear transitions)	----
W2	not available (fixed linear transitions)	----
W3	not available (fixed linear transitions)	----
WID 100us	:PULSe:TIMing:WIDTh 100us	WIDTH

EXAMPLES:

HP 8112A: OUTPUT 712;"M2T1"

HP 8131A: OUTPUT 711;"INP:TRIG:MODE TRIG;SLOP POS"

TABLE F-2. HP 8160A/61A and HP 8131A

<u>HP 8160A/61A</u>	<u>HP 8131A</u>	<u>LOCAL</u>
A1 (60A only)	not available	----
A5 (60A only)	not available	----
AA	not available	----
AC	:OUTPut1:PULSe:POLarity COMPlement	COMP
AD (61 only)	:OUTPut1:PULSe:STATe OFF	DISABLE
AE (61 only)	:OUTPut1:PULSe:STATe ON	DISABLE
AN	:OUTPut1:PULSe:POLarity NORMal	COMP
AS	not available	----
B1 (60A only)	not available	----
B5 (60A only)	not available	----
BC	:OUTPut2:PULSe:POLarity COMPlement	COMP
BD (61A only)	:OUTPut2:PULSe:STATe OFF	DISABLE
BE (61A only)	:OUTPut2:PULSe:STATe ON	DISABLE
BN	:OUTPut2:PULSe:POLarity NORMal	COMP
BUR 1234BT	:PULSe:COUNT 1234	COUNT
DBL 200us	:PULSe:TIMing:DOUBle 200us	DOUB
DEL 75.0ns	:PULSe:TIMing:DELay 75.0ns	DEL
DI	not available	----
	Outputs are independently disabled:	
	:OUTPut1:PULSe:STATe OFF	DISABLE
	:OUTPut2:PULSe:STATe OFF	DISABLE
E1	:INPut:TRIGger:SLOPe POS	SLOPE
E2	:INPut:TRIGger:SLOPe NEG	SLOPE
EC (61A only)	not available	----
EN	not available	----
	Outputs are independently enabled:	
	:OUTPut1:PULSe:STATe ON	DISABLE
	:OUTPut2:PULSe:STATe ON	DISABLE

<u>HP 8160A/61A</u>	<u>HP 8131A</u>	<u>LOCAL</u>
HIL 2.00V (60A-50 ohm only)	:PULSe:LEVel:HIGH 2.00V	HIGH
I1	:INPut:TRIGger:MODE AUTO	AUTO
I2	:INPut:TRIGger:MODE TRIGger	TRIG
I3	:INPut:TRIGger:MODE GATE	GATE
I4	:INPut:TRIGger:MODE BURSt	BURST
LEE 20.0ns	not available (fixed transition)	---
LOL 1.00V (60A-50 ohm only)	:PULSe:LEVel:LOW 1.00V	LOW
PER 1.00ms	:PULSe:TIMing:PERiod 1.00ms	PERIOD
RCL 1	*RCL 1	RCL
SETn	not available	---
SET:	*LRN?	---
STO 1	*SAV 1	SAVE
TRE 20.0ns	not available (fixed transition)	---
TT (61A only)	not available	---
WID 100us	:PULSe:TIMing:WIDTh 100us	WIDTH

EXAMPLES:

HP 8160A: OUTPUT 717;"I2E1"

HP 8131A: OUTPUT 711;":INP:TRIG:MODE TRIG;SLOP POS"

G

ERRORS

Power-on

TABLE G-1

The instrument tests the microprocessor, timing, and output boards. Error conditions are reported at the display immediately after performing the tests.

*TST?

TABLE G-2

The self-test query causes the instrument to test the timing and output board tests.

:SYST:ERR?

TABLE G-3

Command, execution, device dependent, and query error events are reported in response to the :ERR? query.

:SYST:DERR?

TABLE G-4

Device dependent error conditions are reported in response to the :DERR? query.

CONFLICTS

TABLE G-5

The conflicts are identical to the device dependent error conditions listed in Table G-4.
The codes are listed in Table G-5.

TABLE G-1. POWER-ON SELF-TEST

<u>ERROR CODE</u>	<u>PROCESSOR BOARD ERROR MESSAGE</u>
F100	Static RAM (number 2) error
F101	Static RAM (number 1) error
F102	EPROM (number 2) error
F103	EPROM (number 1) error
F104	Timer cycle error
F105	Keyboard controller error
F106	Device bus error
F500	Configuration error An incorrect combination of timing and output boards has been installed in the instrument.

ERROR CODE

E200

TIMING BOARD ERROR MESSAGE

Same as E200 in TABLE G-2.

E300-307

OUTPUT BOARD 1 ERROR MESSAGE

Same as E300-307 in TABLE G-2.

E400-407

OUTPUT BOARD 2 ERROR MESSAGE

Same as E400-407 in TABLE G-2.

CONFIGURATION ERROR MESSAGES

E500

Dual Channel Instrument

Each output board contains a transducer.
The transducer is required in channel 1
and is not needed in channel 2.

E501

Dual Channel Instrument

Neither output board contains transducer
capability.

E502

Single Channel Instrument

The output board does not contain
transducer capability.

E503

Single or Dual Channel instruments

A timing board was not installed.
Only the transducer mode is possible.

E504

**The instrument contains a dual channel
timing board but only one output board.**

TABLE G-2. *TST?

<u>ERROR CODE</u>		<u>TIMING BOARD ERROR MESSAGE</u>
E200		The adjust values on the EEPROM have been destroyed. Correct parametric timing is not possible.
<u>CHANNEL 1</u>	<u>CHANNEL 2</u>	<u>OUTPUT BOARD ERROR MESSAGE</u>
E300	E400	OUTPUT channel: Polarity error (normal path) on the output board.
E301	E401	OUTPUT channel: Polarity error (complement path) on the output board.
E302	E402	$\overline{\text{OUTPUT}}$ channel: Polarity error (complement path) on the output board.
E303	E403	$\overline{\text{OUTPUT}}$ channel: Polarity error (normal path) on the output board.
E304	E404	OUTPUT $\overline{\text{OUTPUT}}$ channel: Polarity error (normal path) on the transducer board.
E305	E405	OUTPUT $\overline{\text{OUTPUT}}$ channel: Polarity error (complement path) on the transducer board.
E306	E406	Polarity error at the input to the transducer board.
E307	E407	Polarity error at the input to the transducer board.

TABLE G-3. :SYSTem:ERRor?

<u>ERROR CODE</u>	<u>QUERY ERRORS</u>
-400	<Generic Query Error> The occurrence of query errors also set bit two (QYE) of the standard event status register (ESR). An unspecified query error has occurred. Check for deadlock, unterminated, or interrupted actions.
	<u>DEVICE ERRORS</u>
	The occurrence of device dependent errors also sets bit three (DDE) of the standard event status register (ESR).
-350	<Too Many Errors> More than ten error conditions are present. Error code -350 was loaded into the error queue replacing the last error, error number 10.
-340	<Self Test Failed> Parametric board failure See Chapter 6, *TST? and Appendix G, Table G-2.
-330	<Power-on Test Failed> Error conditions are presented at the display. See Tables G-1.
-312	<RAM Data Loss> RAM memory failure, data is invalid.

ERROR CODE

EXECUTION ERRORS

The occurrence of execution errors also sets bit four (EXE) of the standard event status register (ESR).

-212

<Argument Out of Range>

The received value is out of its allowed range.

See the syntax diagrams for the ranges.

-200

<Generic Execution Error>

A :SYST:SET binary transfer has failed.

A remotely programmed level conflict occurred.

ERROR CODE**COMMAND ERRORS**

The occurrence of command errors also sets bit five (CME) of the standard event status register (ESR).

-130**<Non-Numeric Argument Error>**

The non-numeric argument is invalid.

-120**<Numeric Argument Error>**

The numeric argument is invalid.

-100**<Command Error>**

The command is invalid.

1. The required command is incorrectly transmitted.
2. The command is not allowed in the command path transmitted.

<mnemonic> = the command mnemonic.

ERROR FREE**0****<No error>**

TABLE G-4. :SYSTem:DERRor?

ERROR CODE		ERROR MESSAGE
CHANNEL 1	CHANNEL 2	
50	50	<p><Period - Count></p> <p>IF PERIOD < 5.00 NS THEN BURST MODE IS NOT ALLOWED.</p>
100	200	<p><Period - Width Ch. 1 2></p> <p>PERIOD < 5.00 NS IF WIDTH >= 1.0NS THEN WIDTH <= 0.5*PERIOD ELSE WIDTH <= 0.5*PERIOD - 0.5NS</p> <p>5.00 NS <= PERIOD < 20.0 NS WIDTH <= 0.7*PERIOD - 1.00 NS</p> <p>PERIOD >= 20.0 NS WIDTH <= 0.9*PERIOD - 5.00 NS</p>
101	201	<p><Period - Delay Ch. 1 2></p> <p>IF PERIOD < 2.00 NS THEN DELAY = 0.00 NS</p> <p>IF 2.00 NS <= PERIOD < 5.00 NS THEN DELAY <= 0.5*PERIOD - 1.00 NS</p> <p>IF 5.00 NS <= PERIOD < 20.0 NS THEN DELAY <= 0.7*PERIOD - 2.00 NS</p> <p>IF PERIOD >= 20.0 NS THEN DELAY <= 0.9*PERIOD - 6.00 NS</p>

ERROR CODE
CHANNEL 1 CHANNEL 2 ERROR MESSAGE

102	202	<p><Period - Dcyc Ch. 1 2></p> <p>PERIOD < 5.00 NS IF WIDTH \geq 1.00NS THEN WIDTH \leq 0.5*PERIOD ELSE WIDTH \leq 0.5*PERIOD - 0.50 NS</p> <p>5.00 NS \leq PERIOD < 20.0 NS THEN WIDTH \leq 0.7*PERIOD - 1.00 NS</p> <p>PERIOD \geq 20.0 NS WIDTH \leq 0.9*PERIOD - 5.00 NS</p>
103	203	<p><Period - Double Ch. 1 2></p> <p>IF PERIOD < 5.00 NS THEN DOUBLE PULSE is not possible.</p> <p>IF 5.00 NS \leq PERIOD < 10.0 NS THEN DOUB \leq 0.5*PERIOD</p> <p>IF PERIOD \geq 10.0NS THEN DOUB \leq 0.9*PERIOD - 4.00 NS</p> <p>IF WIDTH < 1.00 NS THEN WIDTH \leq 0.7(PERIOD-DOUB) - 1.50 NS</p> <p>IF 1.00 NS \leq WIDTH < 10.0 NS THEN WIDTH \leq 0.7(PERIOD-DOUB) - 1.00 NS</p> <p>IF WIDTH \geq 10.0 NS THEN WIDTH \leq 0.85(PERIOD-DOUB) - 2.50 NS</p>

ERROR CODE		ERROR MESSAGE
CHANNEL 1	CHANNEL 2	

104	204	<p><Width - Double Ch. 1 2></p> <p>IF WIDTH < 1.00 NS THEN WIDTH <= 0.8*DOUB - 1.10 NS</p> <p>IF WIDTH >= 1.00 NS THEN WIDTH <= 0.8*DOUB - 0.60 NS</p>
105	205	<p><Double - Dcyc Ch. 1 2></p> <p>IF WIDTH < 1.00 NS THEN WIDTH <= 0.8*DOUB - 1.10 NS</p> <p>IF WIDTH >= 1.00 NS THEN WIDTH <= 0.8*DOUB - 0.60 NS</p>
106	206	<p><Trigger - Dcyc Ch. 1 2></p> <p>:INPut:TRIG:MODE TRIGger and :PULSe:TIMing:DutyCYCle:MODE ON are incompatible.</p>

TABLE G-5. CONFLICTS

The conflicts are listed in Chapter 5 under one of the two corresponding functions which are in conflict. They are also identical to the :SYSTEM:DError? error codes which are defined in TABLE G-4.

<u>CONFLICT</u>	<u>:SYSTEM:DError?</u>	
	<u>CHANNEL 1</u>	<u>CHANNEL 2</u>
PERIOD-COUNT	50	50
PERIOD-WIDTH	100	200
PERIOD-DELAY	101	201
PERIOD-DCYC	102	202
PERIOD-DOUB	103	203
WIDTH-DOUB	104	204
DOUB-DCYC	105	205
TRIG-DCYC	106	206

CUSTOMER ASSISTANCE

CONTENTS

Introduction	CA-3
Sales and Support Offices	CA-3
Incoming Inspection	CA-3
Contents	CA-4
Discrepancies	CA-4
Performance Tests	CA-5
Warranty	CA-5
Claims	CA-5
Shipment Damage	CA-5
Returns	CA-6
Instrument Identification	CA-6
Shipment	CA-6
Storage	CA-6
Packaging	CA-7
Parts Ordering Information	CA-8
Serial Number	CA-8

INTRODUCTION

Product maintenance agreements and other customer assistance agreements are available for Hewlett-Packard products.

For any assistance, contact your nearest Hewlett-Packard Sales and Support Office.

SALES AND SUPPORT OFFICES

Sales and Support Offices are listed in the Sales and Support Office Directory at the back of all instrument reference manuals.

The Service Manual contains an expanded directory containing local offices.

INCOMING INSPECTION

Inspect the shipment for the following:

1. Packaging Material Condition
2. Invoice
3. Contents
4. Serial Number
5. Physical condition
6. Electrical condition.

NOTE: If the instrument is damaged during shipment, the packaging material must be saved for the carrier's inspection.

Contents

The contents of the shipment are:

1. Invoice
2. The standard instrument
3. Line power cord, 1 each
4. Line fuse, 1 each
5. Operating and Programming Manual, 1 each
6. Manual updates when required, 1 each

PLUS

8. Options as ordered
9. Accessories as ordered.

NOTE: Service Manuals are available as options.
See Appendix B, Options and Accessories.

Discrepancies

If there are any discrepancies, contact a Hewlett Packard Sales and Support Office before doing anything further with the contents of the shipment.

PERFORMANCE TESTS

Performance Tests for checking the instrument's electrical operation are in Appendix E, which also contains a list of recommended test equipment.

The tests verify the instruments specified performance characteristics as described in Appendix A.

WARRANTY

The WARRANTY is on page iii.

CLAIMS

See the WARRANTY on page iii

Shipment Damage

If damage is caused during shipment, a Hewlett Packard Sales and Support Office will arrange for repair or replacement of the damaged items without waiting for settlement of a claim against the carrier.

The shipping material must be retained for the carrier's inspection.

RETURNS

See the WARRANTY on page iii.

Instrument Identification

Attach a tag with the following information to the instrument when returning it:

1. Owner Identification
 - a. Contact's name
 - b. Contact's telephone number
 - c. Owner's return address
2. HP Identification
 - a. Representative's name
 - b. Telephone number
 - c. Office name
3. Model number of the instrument
4. Instrument's complete serial number
5. Description of the service required.

Shipment

Shipment or storage:

1. The instrument can be shipped or stored at temperatures between -40 degrees Celsius and 65 degrees Celsius.
2. The instrument must be protected from conditions which cause condensation within the instrument.

Storage

The conditions are the same as those given for SHIPMENT.

Packaging

Use the original shipping carton and packaging material if they are not damaged.

A Hewlett Packard Sales and Support Office will provide recommendations on packaging material to be used.

General instructions for packing:

1. Wrap the instrument in heavy paper or plastic.
2. Use a strong shipping container.

A double wall carton made of 350 pound/ 159 kg test material is adequate.
3. Protect the front panel with cardboard.
4. Use a 3 to 4 inch layer of shock absorbing material around the instrument to provide a firm cushion and to prevent instrument movement inside the container.
5. Seal the shipping container securely.
6. Mark the shipping container with "FRAGILE".

**PARTS ORDERING
INFORMATION**

Parts and parts ordering information is contained in the Service Manual.

SERIAL NUMBER

The instrument's serial number (identification number) is located on the rear panel of the instrument.

INDEX

A	Accessories	B-1
	Address, instrument(HP-IB)	2-6, 5-21
	ADS	2-6, 5-3
	AMPL,Amplitude	5-4
	AUTO	5-5
	Automatic output disable	5-12
B	Buffers	4-12
	BURST	5-6
	Bypass	3-6
C	CAUTION	red page
	Carriage return <cr>	3-4,5,6
	Certification	iv
	Claims	CA-5
	Commands	
	Common	6-1
	Coupled	3-3
	Cross Reference	3-3, F-1
	Device Dependent	7-1
	Hierarchy	3-7
	Long/Short form	3-3
	Command Errors	4-4, G-1
	Command Hierarchy (tree)	3-7
	Common Commands	6-1
	COMP, Complement	5-7
	Conflicts	2-4, 4-4, 5-16, G-1
	Contents	xv
	Conventions(syntax diagrams)	3-6
	Copyright Notice	ii
	COUNT	5-8
	Coupled commands	3-3
	<cr> carriage return	3-4,5,6

D

dcas	See IEEE 488.2
DCYC, duty cycle	5-9
<data>	3-6
DEL, Delay	
Pulse	5-11
Double Pulse	5-14
Description, Instrument	1-1
Device Dependent Commands	7-1
Device Dependent Errors	2-4, 4-4; Ch. 5,7; G-1
Differential Outputs	2-6, 5-27
Dimensions, Physical	A-7
DISABLE	5-12
DOUB, Double Pulse	
Double Pulse Delay	5-14
Double Pulse Width	5-14
Duty cycle, DCYC	5-9

E	E type error	2-3, 5-16
	Edition	v
	Effective pages	vi
	Environmental	A-5
	Error Queue	4-12
	Errors	
	:DERR?	4-4, 7-40, G-1
	:ERR?	4-4, 7-41, G-1
	E	2-3, 4-5, G-1
	F	2-3, 4-5, G-1
	Power-on	2-3, 4-4, 5-16, G-1
	Self-test (*TST)	4-4, 6-20, G-1
	ESB	4-8, 4-14
	ESE	4-11, 6-3, 6-4
	ESR	4-10, 6-5
	External Input	2-6, 5-18
	External Width	5-17
Exclusive remedies	iii	
Execution Errors	4-4, G-1	
External Input	5-18	
F	F type error	2-3, 5-16
	Fuse, Line	C-3, C-4
G	GATE	5-19
	GTL	See IEEE Std. 499.1.

H	Sales and Support Office	
	Directory	SSO-1
	HIGH Level	5-20
	HP-IB	
	Adapter	C-12
	Address Selection	5-21
	Cables	C-12
	Connectors	C-9
	Functions	A-5
	Lock Screw	C-13
Logic Levels	C-12	
Networks	C-12	
I	Input Buffer	4-12
	Inspection, Incoming	CA-3
	Installation	
	Safety	C-3
	AC Power	C-3
	Connectors, I/O	C-9 Interface C-12
	Instrument Setting	2-4
	Interface Address	5-21
	Interface (HP-IB)	2-6, A-5, C-12
Introduction	xi	
J/K	Key Queue	4-12
	Key Codes	7-43
	Known State	
	Standard Setting (*RST)	6-14

L	LCL	5-21
	Learn (*LRN?)	6-7
	Levels	
	HIGH	5-20
	LOW	5-23
	<lf> line feed	3-4,5,6
	LIMIT	5-22
	Limitation of Warranty	iii
	Line Feed <lf>	3-4,5,6
	Line Voltage Selector	C-4, C-5
	LLO	See IEEE Std. 488.1.
	Local Messages	4-5
	LOW Level	5-23
	M	MAN, manual
MAV		4-8, 4-14
MAX (maximum)		3-6
MEM, memory		5-25
MLA		See IEEE Std. 488.1.
MTA		See IEEE Std. 488.1.
Messages		
Program		3-3, 3-4
Response		3-3, 3-5
		Reading 3-5
MIN (minimum)	3-6	
N	New Line (NL)	3-4,5,6
	NL, <lf>/new line	3-4,5,6
	NORM = AUTO	5-5

O	OFFS (offset)	5-26
	Operating Environment	A-5
	Options	B-1
	OUTPUT	5-27
	Output Buffer	4-12
	Output state	5-12, 7-15, 7-17
	Output Queue (Buffer)	4-12
	Overvoltage (DISABLE)	5-12
P	Packaging	C-7
	Parser 4-3	
	Performance Tests	Appendix E
	PERIOD 5-28	
	<pmt> 3-4	
	<pmu> 3-4	
	<pmus> 3-4	
	Polarity	7-16
	Polling 4-5	
	pon See IEEE Std. 488.2.	
	Power	
	Cable C-6	
	Cable Modification	C-7
	Cable, types of	C-7
	Requirements	C-3
	Power-off	2-3, 5-31
	Power-on	2-3, 4-3, 5-31
	Power-on test	2-3, G-1
	Normal State	2-3
	Abnormal State	2-3
	E type error	2-3, 4-5, 5-16
	F type error	2-3, 4-5, 5-16
	Printing History	vi
	Product Warranty	iii
	Program Message	2-5, 3-4
	Program Message Unit	3-4
	Program Message Unit	
	Seperator	3-4
	Program Message Syntax	3-6
	Program Message	
	Terminaror	3-4
	Pulse Definitions	1-2

Q	Query Errors	4-4, G-1
	Queues	4-12
R	RANGE	5-32
	Ranges, timing	5-47
	RCL, recall	5-33
	*RCL	6-12
	Recall	5-33, 6-12
	Registers	4-8,9,10,11
	Register Bit Assignment	4-13
	Remote Messages	3-1
	REN	See IEEE Std. 488.1.
	Reset State (*RST)	6-13
	Resolution, timing	5-47
	Response Message	2-5, 3-5
	Reading	3-5
	*RST	6-13
	Response Message Unit	3-5
	Response Message Unit	
	Seperator	3-5
	Response Message Syntax	3-5
	Response Message Terminator	3-5
	Returns	CA-6
	RMT	2-6, 5-34
	<rmt>	3-5
	<rmu>	3-5
	<rmus>	3-5

S

Safety	red page, C-3
Safety Summary	red page
Sales and Support Offices	SSO-1
*SAV	6-15
Save	5-35, 6-15
Self-test	
Power-on	2-3, G-1
*TST	6-20, G-1
Seperators	3-4, 3-6
Sequential Commands	4-13
Serial Number	i v, CA-8
Serial Poll	4-6
Service request (SRQ)	4-6
Service Request Enable	
Register (SRE)	4-9
SET	5-36
Setting, Instrument	
reset (*RST)	6-14
standard	5-33, 6-14
Single pulse, 1 PULSE	5-2
Slope, external input	5-37
SPD	See IEEE Std. 488.1.
SPE	See IEEE Std. 488.1.
Specifications	A-1
Interface	A-5
Restrictions	A-1
Typical	A-1
Warranted	A-1

S (continued)

SRE	4-9, 6-16, 6-17
SRQ	See IEEE Std. 488.1.
SRQ indicator	2-6, 5-38
Standard Event Status	
Enable Register (ESE)	4-11
Standard Event Status	
Register (ESR)	4-10
Standard Setting (*RST)	6-14
State, Outputs 1 and 2	5-27, 7-15, 7-17
Status Byte	4-7
Status Byte Register (STB)	4-8, 6-17, 6-18
STB	4-8, 6-17, 6-18
Status Data Structures	
Diagram	4-14
Registers	4-8,9,10,11
Queues	4-12
Store	
SAVE	5-35
*SAV	6-15
Subject Matter Notice	ii
Synchronization	4-13
*OPC	6-10
*OPC?	6-11
*WAI	6-21
Syntax	
Conventions	3-6
Diagrams	
Common	6-1
Device Dependent	
:INPut:TRIGger	7-7
:OUTPut:PULSe	7-13
:PULSe:COUNt	7-19
:PULSe:LEVel	7-21
:PULSe:TIMing	7-29
:SYSTem	7-39

T	Terminators	3-4, 3-5
	THRE, Threshold	5-39
	Timing ranges	5-47
	Title Page	ii
	TRAN, transducer	5-40
	*TRG	6-19
	TRIG, Trigger	5-41, 6-19
	Trigger Output	2-6, 5-42
U	Under-programming units	2-5, A-1 3-6, 5-43
	<unit>	3-6
	UNL	See IEEE Std. 488.1.
	UNT	See IEEE Std. 488.1.
V	<value>	3-6
	VERNIER	5-44
	Viel Spass!!!!!!	ENJOY!!!!!!
	Voltage Selection	C-3, C-4, C-5
W/X/Y/Z	WARNING	red page
	Warranty	iii
	WIDTH	5-45
	<wsp>	3-6
1	1 PULSE	5-1