

Errata

Title & Document Type: 8010A Pulse Generator Operating and Service Manual

Manual Part Number: 08010-90000

Revision Date: August 1970

HP References in this Manual

This manual may contain references to HP or Hewlett-Packard. Please note that Hewlett-Packard's former test and measurement, semiconductor products and chemical analysis businesses are now part of Agilent Technologies. We have made no changes to this manual copy. The HP XXXX referred to in this document is now the Agilent XXXX. For example, model number HP8648A is now model number Agilent 8648A.

About this Manual

We've added this manual to the Agilent website in an effort to help you support your product. This manual provides the best information we could find. It may be incomplete or contain dated information, and the scan quality may not be ideal. If we find a better copy in the future, we will add it to the Agilent website.

Support for Your Product

Agilent no longer sells or supports this product. You will find any other available product information on the Agilent Test & Measurement website:

www.tm.agilent.com

Search for the model number of this product, and the resulting product page will guide you to any available information. Our service centers may be able to perform calibration if no repair parts are needed, but no other support from Agilent is available.





**PRELIMINARY
OPERATING AND SERVICE MANUAL**

**MODEL 8010A
PULSE GENERATOR**

This manual contains service information for instruments with the serial number prefix

G958

For supplementary information pertaining to instruments with higher prefix numbers, refer to the manual supplement for those instruments.

COPYRIGHT HEWLETT-PACKARD GMBH 1970
703 BÖBLINGEN, HERRENBERGER STR. 110, WEST GERMANY

TABLE OF CONTENTS

Section		Page
I	GENERAL INFORMATION	
	1-1 Introduction	1-1
	1-5 Available Accessories	1-1
	1-7 Identification	1-1
	1-9 Ordering Information	1-1
II	OPERATING INSTRUCTIONS	
	2-1 General	2-1
	2-3 Internal Triggering Mode	2-1
	2-5 External Trigger Mode	2-1
	2-7 Manual Trigger Mode	2-1
	2-9 Gating Modes	2-1
	2-11 Delay Mode	2-1
	2-13 Square Pulse Mode	2-1
	2-15 Ten Volt Output	2-1
	2-17 Pulse Output	2-1
	2-19 Preparation for use	2-5
	2-20 Power Source Requirements	2-5
	2-22 Fuse Replacement	2-5
	2-24 Power Cable	2-5
	2-26 Temperature Requirements	2-5
	2-28 Initial Turn-On Procedure	2-5
	2-30 Repacking	2-5
III	PRINCIPLES OF OPERATION	
	3-1 Introduction	3-1
	3-4 Rep. Rate Generator	3-1
	3-6 Free Running Mode	3-2
	3-10 External Triggering	3-2
	3-15 Manual Triggering	3-2
	3-17 Gating	3-2
	3-19 Asynchronous Gating	3-3
	3-21 Synchronous Gating	3-3
	3-28 Pulse/Square Wave Switching	3-4
	3-31 Pulse Delay	3-4
	3-36 Width Circuit	3-5
	3-41 Pulse Shaping	3-6
	3-44 Integrator	3-6
	3-48 Emitter Follower and Inverter	3-7
	3-51 Output Amplifiers	3-7
	3-53 Positive Amplifier	3-8
	3-57 Negative Amplifier	3-8
	3-60 DC Offset	3-8
	3-62 Output Switching and Attenuator	3-8
	3-65 Power Supply	3-8
IV	REPLACEABLE PARTS	
	4-1 Introduction	4-1
	4-3 Ordering Information	4-1
V	CIRCUIT DIAGRAMS	
	5-1 Introduction	5-1

LIST OF ILLUSTRATIONS

Number	Title	Page
2-1	Instrument Controls and Connectors	2-2
3-1	Repetition Rate and Trigger Input Block Diagram	3-1
3-2	Rep. Rate Generator Output Distribution Block Diagram	3-3
3-3	Square Wave of Pulse Selection Block Diagram	3-4
3-4	Delay Generator Block Diagram	3-5
3-5	Width Generator Block Diagram	3-6
3-6	Integrator Block Diagram	3-7
5-1	Block Diagram of 8010A	5-3
5-2	Top View	5-4
5-3	Bottom View	5-5
5-4	Assembly A1 Component Location	5-6
5-5	Assembly A2 and A3 Component Location	5-7
5-6	Assembly A4 and A5 Component Location	5-8
5-7	Assembly A6 Component Location	5-9
5-8	Assembly A7 Component Location	5-10
5-9	Assembly A8 Component Location	5-11
5-10	Assembly A9 Component Location	5-12
5-11	Assembly A11 Component Location	5-13
5-12	Trigger Input Circuit	5-15
5-13	Rep. Rate and Gate Input Circuit	5-17
5-14	Square Wave or Pulse Selection Circuit	5-19
5-15	Delay Channel A Circuit	5-21
5-16	Width Channel A Circuit	5-23
5-17	Pulse Shaping Channel A Circuit	5-25
5-18	Integration Channel A Circuit	5-27
5-19	Emitter Followers Channel A Circuit	5-29
5-20	Positive Output Amplifier Channel A Circuit	5-31
5-21	Negative Output Amplifier Channel A Circuit	5-33
5-22	Delay Channel B Circuit	5-35
5-23	Width Channel B Circuit	5-37
5-24	Pulse Shaping Channel B Circuit	5-39
5-25	Integration Channel B Circuit	5-41
5-26	Emitter Followers Channel B Circuit	5-43
5-27	Positive Output Amplifier Channel B Circuit	5-45
5-28	Negative Output Amplifier Channel B Circuit	5-47
5-29	DC Offset Circuit	5-49
5-30	Output and Attenuator Circuit	5-51
5-31	Power Supply Circuit	5-53

LIST OF TABLES

Number	Title	Page
1-1	Specifications	1-0
4-1	Reference Designation Index	4-1
5-1	Schematic Diagram Notes	5-1

Table 1-1. Specifications

PULSE CHARACTERISTICS (with 50 Ω load impedance)	vides continuous adjustment between ranges.
Rise and Fall Times Sep. Outputs: < 10 ns to 1 second in eight ranges; ranges are common for rise and fall times. Independent verniers provide separate control of rise and fall times within each range up to a maximum ratio of 1 : 10. Combined Outputs: < 12 ns to 1 second 10 V Output: < 20 ns to 1 second	Serial: Max. delay for channel B can be doubled.
Accuracy: $\pm 10\%$ of setting, $\pm 2\%$ of full scale ± 4 ns.	Accuracy: $\pm 10\%$ of setting, $\pm 2\%$ of full scale ± 4 ns.
Linearity: For transition time > 30 ns maximum amplitude deviation from a straight line between the 10% and 90% points is less than 4% of pulse amplitude.	Delay Jitter: < 0.1% on any delay setting.
Overshoot and Ringing: < 5% of pulse amplitude.	REPETITION RATE AND TRIGGER
Pulse Width: < 20 ns to 1 second in eight ranges. Vernier provides continuous adjustment between ranges.	Free Running: 1 Hz to 10 MHz in seven ranges. Vernier provides continuous adjustment between ranges.
Accuracy: $\pm 10\%$ of setting, $\pm 2\%$ of full scale ± 4 ns.	Accuracy: $\pm 10\%$ of setting, $\pm 2\%$ of full scale.
Maximum Duty Cycle: > 80% for repetition rates from 1 Hz to 1 MHz; > 50% from 1 MHz to 10 MHz.	Period Jitter: < 0.1%.
Width Jitter: < 0.1% on any width setting.	Square Wave: 1 Hz to 10 MHz output symmetrical to ground, rise and fall times variable, 50% duty cycle.
Maximum Output: 5 V separate or combined outputs, 10 V channel B (channel A no output).	Double Pulse: Minimum pulse distance of < 50 ns allows maximum rep. rate up to 20 MHz.
Attenuator: Seven-step attenuator reduces output to 0.05 V in 5, 2.5, 1 sequence. Vernier provides continuous adjustment between steps and reduces minimum output to < 0.02 V.	External Triggering
Accuracy: $\pm 10\%$ of setting $\pm 2\%$ of full scale.	Repetition Rate: 0 to 10 MHz. Can be triggered with sines waves or pulses of either polarity. (For Square Wave Output frequency divided by a factor of 2).
Pulse Outputs Sep. Outputs: Two outputs, each positive or negative selectable. Comb. Outputs: Outputs of channel A and B internally added (no loss of amplitude). Outputs short-circuit proof.	Trigger Input: Sine waves 1 V p-p. Pulses 0.5 V peak at least 20 ns wide, maximum 10 V. Delay: Approximately 30 ns between trigger input and trigger output. Input Impedance: 1.0 k Ω Manual: Push button for single pulse. < - Separate Triggering of channel A or B: Spikes + 2 V amplitude < 50 ns width. Input impedance 50 Ω (inputs on rear panel).
Source Impedance: 50 Ω $\pm 10\%$ shunted by typically 20 pF.	Trigger Output Amplitude < + 2 V across 50 Ω from 50 Ω . Width: 15 ns ± 10 ns.
DC Offset: ± 2 V across 50 Ω load. Independent of attenuator and vernier setting; can be switched off.	GATING
Pulse Delay (Parallel): < 80 ns to 1 second delay with respect to trigger output. Eight ranges. Vernier pro-	Synchronous Gating: Gating signal turns generator "on".
	Asynchronous Gating: Gating signal turns the output pulse "on". Trigger output always available.
	Gate Inputs: At least -2 V enabling to -10 V.
	Operating Temperature Range: 0 $^{\circ}$ C to + 55 $^{\circ}$ C.
	GENERAL
	Power Requirements: 115 V or 230 V + 10%, - 15%, 48 Hz to 440 Hz.
	Weight: Net 23.45 lb (10.7 kg).
	Dimensions: 16-3/4" wide, 7-1/4" high, 18-3/8" deep overall (425 x 184 x 466 mm).

SECTION I

GENERAL INFORMATION

1-1 INTRODUCTION

1-2 The Model 8010A is a dual channel pulse generator with a repetition rate of 1 Hz to 10 MHz, extendable in double pulse mode, to 20 MHz. Individual switching of channels A and B permits the application of an external trigger to one channel while the other remains internally triggered. Front panel controls facilitate complete regulation of the pulse delay, width, rise and fall times, amplitude and dc offset. With the exception of the dc offset all front panel controls are calibrated. Complete specifications are given in Table 1-1.

1-3 In the normal delay mode, parallel operation, both pulses are referenced to the trigger output, therefore, optional delay of either pulse can be obtained while the other remains fixed. Under these circumstances the output of A or B can be delayed from 50 ns to 1 s with respect to the trigger output. Combining A and B in the series mode makes channel A the reference for channel B.

1-4 Channel amplitudes are independently adjustable from 5 volts to 0.02 volts with consideration for the output impedance of 50 ohms, a seven-step attenuator reduces the output in a 5, 2.5, and 1 sequence. A maximum of 10 volts output amplitude is readily available from Channel B, by operation of a rear panel switch and the output combining switch. The pulse parameters are consequently controlled through channel B.

1-5 AVAILABLE ACCESSORIES

1-6 Electronic test equipment, cables, connectors, adapters, and other accessory items are available from Hewlett-Packard. For more information on specific items consult the Hewlett-Packard Catalog or Sales/Service Office.

1-7 IDENTIFICATION

1-8 The title page of this manual lists the serial prefix number of instruments to which the contents of this book apply directly. For newer instruments with different serial prefix, a manual change sheet will be included describing the changes necessary to update the manual. For instruments having special electrical modifications, the manual will include an insert sheet describing the particular modification. If a change sheet or special information sheet is missing, it can be supplied by Hewlett-Packard Sales and Service Offices listed at the back of this manual.

1-9 ORDERING INFORMATION

1-10 One manual is shipped with each pulse generator. Additional manuals may be purchased from your local Hewlett-Packard field office (see list at the rear of this manual for addresses). Specify the model number, complete serial number prefix, and HP stock number provided on the title page.

SECTION II

OPERATING INSTRUCTIONS

2-1 GENERAL

2-2 Figure 2-1 indicates the location of, and briefly explains the function of, the Model 8010A front panel controls, adjustments, switches, and connectors.

2-3 INTERNAL TRIGGERING MODE

2-4 The Model 8010A will generate internally any repetition rate from 1 Hz to 10 MHz. The repetition rate is established by setting the REP. RATE selector to any of the seven internal ranges and then adjusting the REP. RATE VERNIER to the specific rate desired.

2-5 EXTERNAL TRIGGER MODE

2-6 With the REP. RATE selector set to EXT. + or EXT. -, external signals may be used to generate pulses in the Model 8010A. Trigger signals, which will cause one pulse out for each trigger in, may be sine waves or pulses of either positive or negative polarity up to 10 MHz. Sine waves must be of at least 1 volt peak to peak amplitude, and pulses at least 0.5 volt peak and 20 nanoseconds wide. Maximum signal is ± 10 volts peak.

2-7 MANUAL TRIGGER MODE

2-8 With the REP. RATE selector set to the EXT.-/MAN. position, a single output pulse is generated by the Model 8010A for two actions of the manual push button. This is only true when both channels are in the PULSE mode.

2-9 GATING MODES

2-10 A front panel switch selects three modes of operation, SYNCH, NORM, or ASYNCH. In the NORM mode of operation the 8010A functions normally. In the SYNCH mode the rep. rate generator is turned off until a gate signal of at least -2 V is applied to the GATE INPUT. The gate signal turns the instrument on producing pulses determined by the front panel settings. The ASYNCH mode functions in a similar manner except that the 8010A is turned off before the delay circuit and, hence, the trigger output is available.

NOTE: In all modes of operation, it is important that the width, delay and rep. rate be compatible, i.e., the width

plus delay must be smaller than the period determined by the REP. RATE setting, taking into account the maximum available duty cycle. Illegal settings will not harm the instrument, but the output may be wrongly interpreted.

2-11 DELAY MODE

2-12 The Model 8010A is delivered with a fixed delay of approximately 80 ns between the trigger output and the signal from the internal repetition rate generator. With the DELAY MODE set to PAR the pulse is independently adjustable for both channels. Switching to the SEP position combines both generators making channel A delay the reference for channel B. In the SEP mode, double pulses are not available.

2-13 SQUARE-PULSE MODE

2-14 The SQUARE mode, selectable for either channel, produces an output with variable repetition rates, rise and fall times, and amplitude. When operated in the external trigger mode (maximum 10 MHz), the output frequency is half that of the input trigger. As the square-wave output is symmetrical to ground, neither channel PULSE POLARITY switches have any effect.

2-15 TEN VOLT OUTPUT

2-16 By parallel driving channel A with channel B (rear panel control) and adding them (front panel control), a maximum amplitude of 10 volts is available. The controls of channel B become the master for varying the pulse parameters and, consequently, there is no output from channel A. The 10 volt output is the absolute amplitude, i.e., either 10 volts of pulse with zero dc offset or a voltage combination of pulse and dc offset.

2-17 PULSE OUTPUT

2-18 The AMPLITUDE of each channel output is selectable by a seven-step attenuator in conjunction with the VERNIER control. A switch designated SEP - A + B permits a choice of separate or common outputs. In the A + B position both outputs are combined to appear at the OUTPUT B connector. With the rear panel OUTPUT AMPLIFIER switch set to PAR 10 V and the front panel output selector set to A + B, OUTPUT B provides a maximum output of ten volts. The controls of CHANNEL B vary the pulse parameters, and the AMPLITUDE control readings

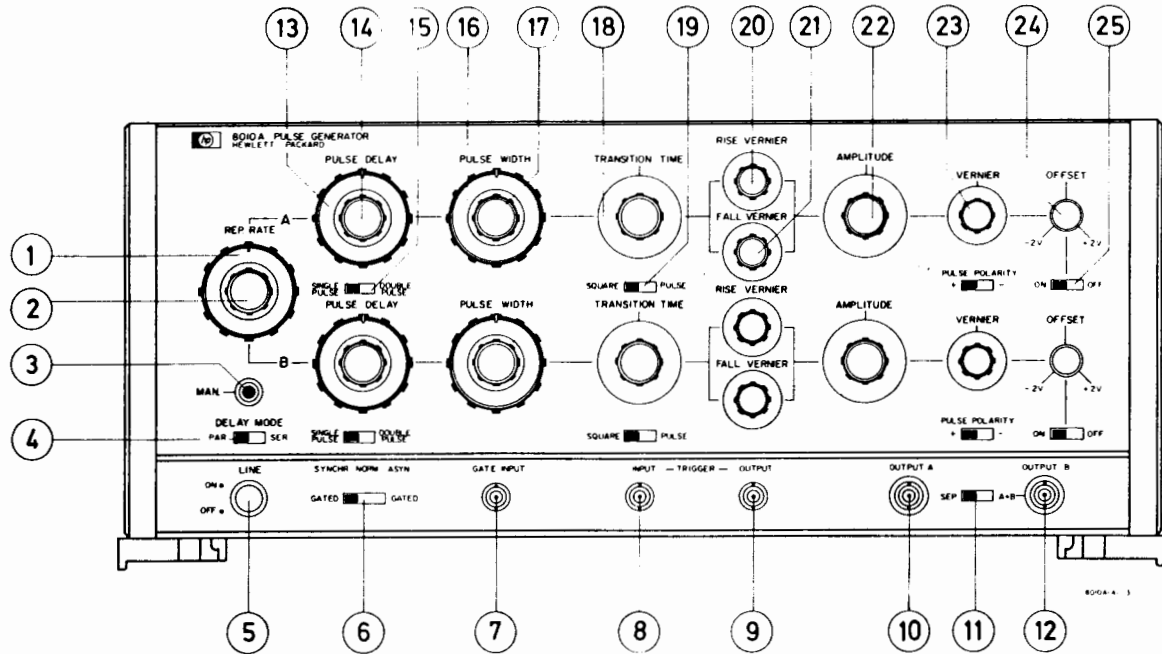

FRONT PANEL CONTROLS

Group I: Common to Both Channels

- | | |
|-------------------------|----------------------------------------------------------------------------------------------------------------------------------------------------------------------------------------------------------------------------------|
| 1. Rep. Rate | Selector switch selects internally triggered repetition rate, external positive or negative or manual triggering for both channels. Setting indicates lower limit of range. |
| 2. Rep. Rate Vernier | Adjusts internal repetition rate for both channels. Clockwise rotation adjusts the frequency from the value selected by the rep. rate switch to the next higher value on the rep. rate selector switch. |
| 3. MAN. | Push button provides a single pulse from both channels when rep. rate selector switch is set to the Ext. MAN. position. |
| 4. Delay mode PAR./SER. | In PAR. position of switch, pulse delay is independently adjustable for each channel. In SER. position, delay of channel A is added to delay of channel B, making channel A the reference for channel B; no change in channel A. |
| 5. LINE Push ON/OFF | ON/OFF switch. |

Figure 2-1. Instrument Controls and Connectors

- | | | |
|------------------------------------------------|------------------------------|-------------------------------------------------------------------------------------------------------------------------------------------------------------------------------------------------------------------------------|
| 6. | SYNCHR., NORM.,
ASYNCHR. | Three-position switch selects synchronous, asynchronous, or normal operating mode. |
| 7. | Gate Input | Female BNC connector accepts gating signal. - 2 V applied with 6 in either the synchr. or asynchr. position opens the gate permitting output pulses from channel A and channel B to pass. |
| 8. | Trigger Input | Female BNC connector accepts external triggering signals. |
| 9. | Trigger Output | Female BNC connector supplies positive trigger pulses. |
|
Group II: Separate for Each Channel | | |
| 10. | Output A | Female BNC connector supplies channel A output pulses. No output available in the A + B mode. |
| 11. | SEP./A + B | Switch selects separate or combined outputs. In A + B mode combined pulses are available at output B. |
| 12. | Output B | BNC connector supplies channel B output pulses. In A + B mode, combined pulses are available at this connector, attenuator B controls the amplitude of the combination, with vernier A still operational. |
| 13. | Pulse Delay | Selector switch selects a time delay of the output pulse with respect to the trigger pulse. |
| 14. | Pulse Delay
Vernier | Adjusts the pulse delay. Clockwise rotation of the vernier control adjusts the delay from the limit selected to the next larger value shown on the pulse delay selector switch. |
| 15. | Single Pulse
Double Pulse | Selects pulse mode when delay mode switch 2 is set to PAR., in SER. position only single pulses are supplied. In double pulse mode delay controls 13 and 14 determine spacing between the double pulses. |
| 16. | Pulse Width | Switch selects the width of each output pulse. Position selected is the smaller value of the width range. |
| 17. | Pulse Width
Vernier | Adjusts the width of the output pulse. Clockwise rotation of the vernier control adjusts the width from the limit selected to the next larger value shown on the pulse width selector switch. |
| 18. | Time Range | Selector switch selects the time range for both the rise and fall times of one channel. Position selected is the lower limit of time range. |

Figure 2-1. Instrument Controls and Connectors (cont'd)

19.	Square Pulse	Switch selects square-wave output (symmetrical to ground) or pulse output. The rise and fall time and frequency are variable in square-wave mode. Pulse output characteristics are determined by front-panel settings.
20.	Rise Vernier	Adjusts the rise time of the pulse. Clockwise rotation of the vernier control adjusts the rise time from the faster value to the slower value, shown on the time range selector switch.
21.	Fall Vernier	Adjusts the fall time of the pulses. Clockwise rotation of the vernier control adjusts the fall time from the faster value to the slower value shown on the time range selector switch.
22.	Amplitude	Selector switch selects the amplitude range. Position selected is the upper limit of the amplitude range. With 11 in position A + B, the selector switch of B controls the amplitude of the two added output pulses.
23.	Vernier	Adjusts the output pulse. Counterclockwise rotation of the vernier control adjusts the amplitude from the limit selected to 1/5 (0.2) of that value.
24.	Pulse Polarity	Switch selects polarity of output pulse.
25.	Offset	Clockwise rotation of the offset control adjusts the base line of the output pulse from - 2 V to + 2 V. With 11 in position A + B, the baseline is controlled from channel B.
26.	ON/OFF	Switch controls presence or absence of baseline shift in the output signal.
REAR PANEL CONTROLS		
27.	Output Amplitude PAR NORM (10 V) (50)	In the 10 V position a max. output amplitude of 10 V is available from output B with 11 in position A + B. Controls of channel B will vary the pulse parameters; no signal available from output A.
28.	Separate Triggering A	Slide switch to select channel A for external triggering, channel B remains connected to internal rep. rate generator.
29.	Separate Triggering B	Slide switch to select channel B for external triggering, channel A remains connected to internal rep. rate generator.
NOTE:		Both channel A and B may be selected for external triggering simultaneously.

Figure 2-1. Instrument Controls and Connectors (cont'd)

have to be doubled. No output is available from channel A. With the OFFSET switches set to ON, the base line of the output pulses can be adjusted from - 2 to + 2 volts.

2-19 PREPARATION FOR USE

2-20 Power Source Requirements

2-21 The Model 8010A may be operated from an ac source of 115 or 230 volt + 10%, - 15%, at 48 to 440 Hz. Power dissipation is approximately 203 V A max. When the instrument is shipped from the factory, it is ready for 230 volt operation. For 115 volt operation move the rear panel slide switch, with the instrument power cable disconnected, until the number 115 is visible. A narrow-blade screwdriver may be used to operate this switch.

CAUTION

Be sure that the number visible on the voltage slide switch and the fuse correspond to the line voltage used before operating the instrument; otherwise, the instrument may be damaged.

2-22 FUSE REPLACEMENT

2-23 The fuse is located on the rear panel. Fuse F1 should be 2 ampere Slow Blow for 115 volt operation or 1 ampere Slow Blow for 230 volt operation.

2-24 POWER CABLE

2-25 The HP Model 8010A is equipped with a 3-wire power cable, which, when connected to an appropriate receptacle, grounds the instrument, cabinet, and panel. To preserve the protection feature when operating the instrument from another type of outlet without ground, use an

appropriate adapter and connect the ground lead to an external ground.

2-26 TEMPERATURE REQUIREMENTS

2-27 The HP Model 8010A uses solid-state components and requires no special cooling. The instrument operates within specifications when the ambient temperature is between 0°C (32°F) and 55°C (131°F). The pulse generator may be stored between - 40°C (- 40°F) and 75°C (167°F).

2-28 INITIAL TURN-ON PROCEDURE

2-29 Turn the instrument on by pressing the LINE button. For nominal operation set the 8010A controls as given below and, where applicable, for both channels.

REP RATE	1 K - X1
PULSE DELAY	0.1 M - X1
PULSE WIDTH	0.1 M - X1
TRANSITION TIME	10 μ s
RISE AND FALL	X1
AMPLITUDE	5 volts
PULSE POLARITY	A +, B -
OFFSET	OFF
DELAY MODE	PAR.
SQUARE PULSE	PULSE
OUTPUT	SEP.
OPER. MODE	NORM
SEP. TRIGGERING A + B..	OFF
OUTPUT AMPLIFIER	5 V NORM

2-30 REPACKING

2-31 The original shipping carton and packing material can be used for reshipment. The Hewlett-Packard Sales/Service Office will also provide information and recommendations on material to be used if the original packing material is not available or damaged. If the instrument is to be shipped to a Hewlett-Packard Sales/Service Office for repair, attach a tag showing owner, model, serial number, and repairs required.

SECTION III

PRINCIPLES OF OPERATION

3-1 INTRODUCTION

3-2 This section describes the basic principles of operation of the Model 8010A Pulse Generator. The major blocks and switching functions are given by Figure 3-1. The repetition rate, determined by either the internal generator or external triggering, controls both channels A and B. Synchronous gating effectively turns the instrument on and off and in the asynchronous mode the repetition rate generator continues to run to provide a trigger output. The delay generator produces a pulse delayed with respect to the repetition rate generator and, hence, the trigger output. In the serial mode both delay generators are added making channel A the reference for channel B. Double pulses are not available in the serial mode. The pulse width circuits set up the width of the output pulses and provide differentiated spikes for processing by the integrated circuits. The input to the integrators is switchable, selecting either the width output for normal pulses from the repetition rate generator to provide the square wave output. The positive and negative pulses from the

integrator are separated by emitter followers and fed to their respective amplifiers. Either of the two amplifiers (per channel), depending on the desired pulse polarity, may be connected to the attenuator and, hence, to the output connector. A rear panel switch is provided to parallel both output amplifiers and, in the A + B mode, produce a 10 volt output at channel B connector. A dc offset facility permits the base line of each output to be set independently.

3-3 The following description explains the operation of channel A except where it is necessary to describe a common function.

3-4 REP. RATE GENERATOR

3-5 The mode of operation of the Model 8010A is established in this circuit (i.e. internal, external, or manual triggering) depending on the setting of REP RATE selector switch A12S1. Refer to the schematics, and the block diagram Figure 3-1 for the following discussion.

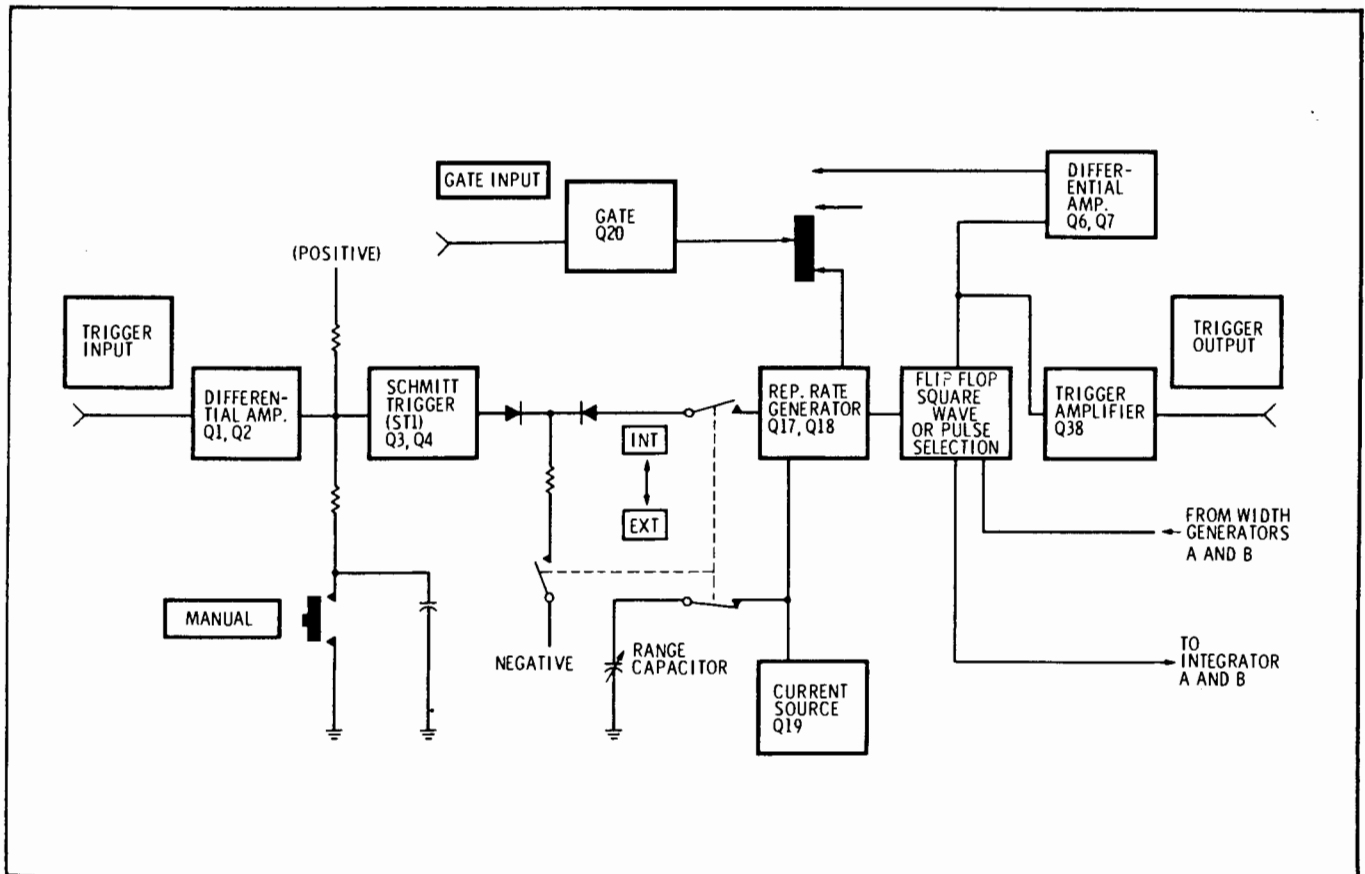

Figure 3-1. Repetition Rate and Trigger Input Block Diagram

3-6 FREE RUNNING MODE

3-7 In this mode of operation the REP. RATE is set to any of the 7 internal rate settings. Assuming a point in the cycle when the selected range capacitor is discharged, as in the case when the instrument is first switched on, the emitter of A1Q18 is effectively 0.5 volts. Transistor A1Q18 will start conducting, because its base is initially held at approximately + 0.2 volts by voltage divider A1R45/R46. As A1Q18 starts to conduct, the voltage developed across A1CR19, A1CR20, and A1R44 causes A1Q17 to conduct also. (A1CR19 and A1CR20 increase loop gain for low A1Q18 collector current). Conduction by A1Q17 raises the base potential of A1Q18 which thus conducts more heavily. Regeneration causes both transistors to saturate. When the current into the range capacitor is no longer sufficient to keep A1Q18 saturated, it ceases to conduct and regeneration turns both A1Q17 and A1Q18 off (current source A1Q19 does not draw enough current to keep A1Q18 saturated). With both A1Q17 and A1Q18 off, the range capacitor is discharged by current source A1Q19 until the emitter of A1Q18 falls again to about - 0.5 volts. Transistor A1Q18 then again turns on, and the cycle is repeated. The repetition rate is thus determined by the value of the range capacitance, selected by A12S1, and the current drawn by current source A1Q19 varied by vernier control A12R2.

3-8 The result is a negative pulse at the emitter of A1Q17, that is coupled via transistor A1Q15, which keeps the source impedance constant to effect a quick transfer, and then differentiated by LR. The resulting negative spikes are fed to the "square wave or pulse selection" circuit. In either PULSE or SQUARE mode, negative spikes are applied to emitter follower A1Q5, the output of which is inverted by A1Q38 and supplied as the positive trigger output as well as being passed by A1Q14 to differential amplifier A1Q6/Q7.

3-9 In the free-running mode, diodes A1CR3 and A1CR4 clamp the collectors of A1Q1 and A1Q2 to approximately + 11 volts, determined by Zener diode A1CR7. This ensures that no other collector voltage is developed and no signal is passed to Schmitt Trigger A1Q3/Q4, should an external trigger signal be applied to J2.

3-10 EXTERNAL TRIGGERING

3-11 In this mode of operation REP. RATE switch A12S1 is set to either EXT. - or EXT. +/MAN. With A12S1 in the EXT. - position, the Model 8010A is triggered by the negative-going slope of a negative trigger applied to J2. With A12S1 in the EXT. + position, the instrument is triggered by the positive-going slope of a positive trigger signal.

3-12 Trigger signals applied to J2 are fed to differential amplifier A1Q1/A1Q2. Diodes A1CR5 and A1CR6 protect the base-emitter junctions of A1Q1 and A1Q2 against excessive reverse voltages. With A12S1 in the EXT. - position, A1R2 is connected to + 20 volts, so A1CR 2 and A1CR3 are reverse biased (the collector of A1Q2 remains clamped at + 11 volts). When a negative trigger is applied, A1Q1 conducts less, and the increase in A1Q1 collector voltage is fed through A1CR1 to the base of A1Q3. This causes Schmitt trigger A1Q3/A1Q4 to switch, thereby generating a positive-going spike across A1L1. The negative-going spike, produced when Schmitt trigger A1Q3/A1Q4 switches back at the end of the trigger signal, is blocked by A1CR2.

3-13 With A12S1 in the EXT. + position, A1R3 is connected to + 20 volts, so A1CR1 and A1CR4 are reverse biased (the collector of A1Q1 remains clamped at + 11 V). A positive trigger signal raises the emitter voltage of A1Q1, and via A1R13 also raises the emitter voltage of A1Q2. Transistor A1Q2 thus conducts less, and the increase in its collector voltage is fed through A1CR2 to the base of A1Q3. The Schmitt trigger then behaves exactly as in the EXT. - mode described above.

3-14 In either of the two EXTERNAL positions, REP. RATE selector switch A12S1 connects A1R48 to - 25 volts. This holds the base of A1Q18 at approximately - 0.2 volt. Thus, rep. rate generator A1Q17/A1Q18 is cut off, current source A1Q19 draws all current, through A1CR32 from ground, until a positive spike from Schmitt trigger A1Q3/A1Q4 momentarily reverse-biases A1CR22. The base voltage of Q18 then rises and the rep. generator functions as in the internal mode for one cycle.

3-15 MANUAL TRIGGERING

3-16 In this mode of operation A12S1 is set to EXT. -/MAN. When the MAN button is pressed, A1C3 charges, and the voltage at the base of A1Q3 rises, causing Schmitt trigger A1Q2/A1Q4 to switch. When the button is released, A1C3 discharges, A1Q3 base voltage falls, and the Schmitt trigger returns to its original state.

3-17 GATING

3-18 With OPER. MODE switch S15 in the NORM position, + 20 volts is connected to the anode of A1CR13, turning it on. Hence, A1CR11 and A1CR12 are always reverse-biased (the base of A1Q18 reaches a maximum of about + 7 volts), and gating signals do not interfere with the rep. rate generator functions. Transistor A1Q16 is also held off, which, in turn, cuts off A1Q7, permitting A1Q6 to function as a normal amplifier.

3-19 ASYNCHRONOUS GATING

3-20 With S15 in the ASYN position, A1CR13 is reverse-biased together with A1CR12 as A1CR11 conducts. This action permits the repetition rate generator to run and connects A1Q16 to the collector of A1Q20. Transistor A1Q7 thus conducts and effectively turns off amplifier A1Q6, since it draws all available current from A1R95. A negative signal applied to J3 turns off A1Q20 which, in turn, raises the collector voltage of A1Q16 to + 20 volts. Thus, A1Q7 is switched off, A1Q6 functions normally, and output pulses are obtained for the duration of the gating signal.

3-21 SYNCHRONOUS GATING

3-22 In the SYNCHR mode A1Q16 is at ground potential, so A1Q7 is off and the A1Q6 functions as an amplifier. However, A1R17 is now connected to ground so that A1Q20 collector is at or below ground potential, A1CR12 is forward-biased, and the repetition rate generator is held off. A negative gating signal turns A1Q20 off, raises its collector voltage enough to reverse-bias A1CR12, and the repetition rate generator functions normally for the duration of the gating signal.

3-23 Since the gating takes place before the pulse width is established, i.e., while the main signal is still in form of spikes, the last output pulse before the gating signal is removed will always be completed, even if the gating pulse is stopped immediately after the output pulse has started. The gating function is always the same regardless of whether the instrument is triggered internally or externally.

3-24 The differentiated spikes at the junction of A1R40/L2 are fed to the base of A1Q30. This transistor performs two functions. Spikes are fed from the emitter to change the state of flip-flop A1Q24/Q25. The output of the flip-flop appears at the junction of diodes A1CR28/CR29. Spikes from the collector go to the junction of diodes A1CR34/35. Further signal flow is dependent upon REP RATE and SQUARE/PULSE switch positions.

3-25 In the internal PULSE mode, the + 20 volts supplied via the repetition rate switch to the base of A1Q37 holds the transistor on, which, in turn, holds A1Q28 off. Hence, A1Q31 and A1CR34 are turned on, reverse-biasing A1CR35, so that no collector signal from A1Q30 can influence A1Q22. Diode A1CR28 is reverse-biased, and the flip-flop output is routed via A1CR29 to the base of transistor A1Q22.

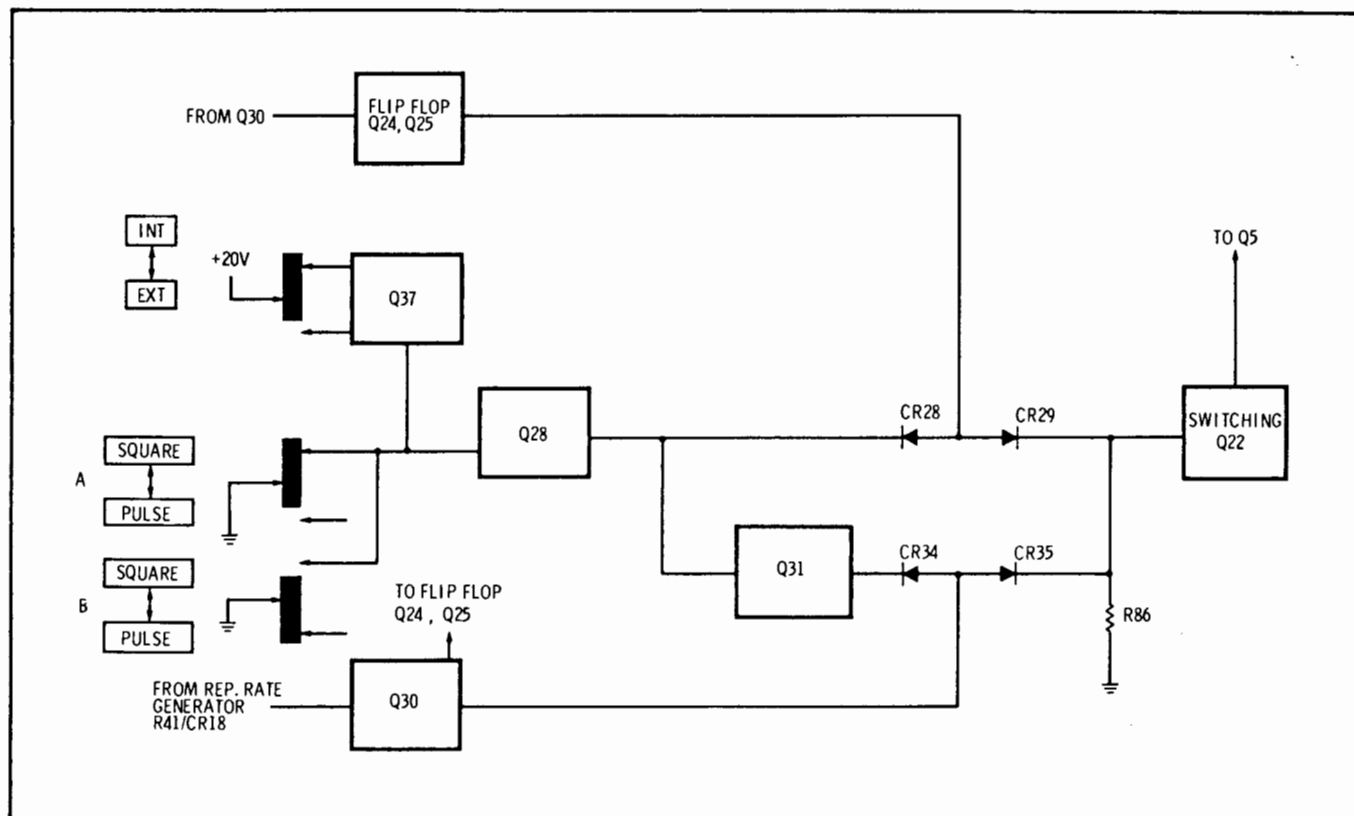

Figure 3-2. Rep. Rate Generator Output Distribution Block Diagram

3-26 The internal SQUARE mode causes no change in the circuit condition as the cathode of either diode A1CR26/A1CR27 is at ground potential holding A1Q28 off. In the external SQUARE mode A1Q37 is switched off. Transistor A1Q28 does not change state as its base is grounded by A1CR26 or A1CR27, and each external trigger pulse changes the state of the flip-flop, dividing the frequency by two.

3-27 Selection of the external PULSE mode will change the circuit conditions. Transistor A1Q37 is still off, but A1Q28 conducts. Diode A1CR28 is forward-biased creating a current path for the flip-flop. While A1CR29 is reverse-biased, the saturated A1Q28 turns off A1Q31 to reverse-bias A1CR34, and the output of the repetition rate generator is passed to the base of A1Q22. In this mode the trigger pulse by-passes the flip-flop, and no frequency division takes place.

3-28 PULSE/SQUARE WAVE SWITCHING

3-29 The SQUARE-PULSE switch position determines the operating conditions of switching transistors A1Q22/A1Q23, Figure 3-3. Irrespective of the position selected, a wave form from the repetition rate generator, either directly or from the flip-flop, always appears on the base of A1Q22. Differentiated spikes from A1Q22 emitter are fed

to A1Q5 for further processing. The base of A1Q23 receives the output of the width generator. Diodes A1CR30 through A1CR33, on the emitters of A1Q22/A1Q23, function as switching paths. In the PULSE mode A1CR30 cathode is grounded, forward-biasing the diode to provide the signal path from A1Q22 emitter to ground. Simultaneously the cathode of A1CR32 is at +25 volts and A1CR31 is forward-biased, routing the signal from A1Q23 emitter to A1Q26 and connecting the width generator output to the integrator. In the SQUARE mode, the position is reversed. The signal from A1Q23 is routed through A1CR33 to ground, and the waveform on A1Q22 emitter is fed via A1CR31 to A1Q26. Transistor A1Q26 couples the waveform, which is differentiated by A1R82/L7, to emitter followers A1Q27/A1Q29 and, hence, to the integrator. The same process occurs for channel B.

3-30 Switching transistor A1Q22 passes the output of the repetition rate generator to A1Q32 and Q33 base receives the output of channel B circuit.

3-31 PULSE DELAY

3-32 The quiescent state of the delay circuit, Figure 3-4, is as follows: A2Q4 is off, since its base is held at zero volts by A1Q6 collector. The operating state of A2Q19, and also A2Q4, is switchable. With the SEPARATE TRIG-

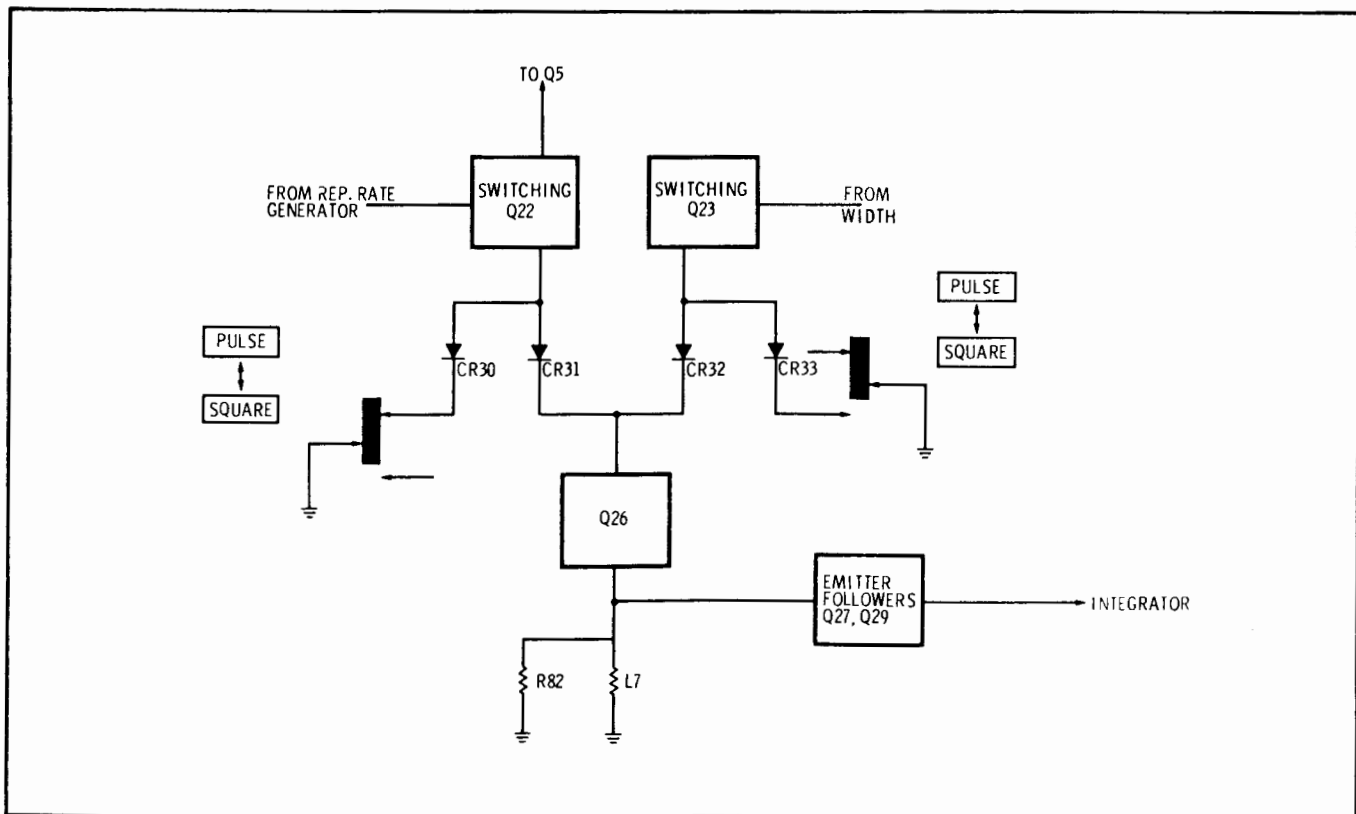

Figure 3-3. Square Wave of Pulse Selection Block Diagram

GERING switch in its off position A1CR3 is reverse-biased and A2CR2 is forward-biased. In this condition A1Q19 is held off and A1Q4 is on. Conversely, with the switch in the ON position, A1Q4 is off, and A1Q19 is on, awaiting an input from SEPARATE TRIGGERING connector J6. Bistable Schmitt trigger A2Q1/A2Q2 is in the state A2Q1 off, A2Q2 on. (The Schmitt trigger is "bistable" because the input is biased between the switching thresholds so that spikes exceeding the threshold limits will trigger the circuit into switching to the other state). Transistor A2Q7 is on, holding A2Q5 base almost at ground potential. Schmitt trigger A2Q5/A2Q6 is thus in the state A2Q5 is off, A2Q6 is on.

3-33 A positive spike from A1Q6 collector momentarily turns on A2Q4. This drops A2Q1 potential and switches Schmitt trigger A2Q1/A2Q2. Transistor switch A2Q7 is turned off, and the selected range capacitor is charged by current source A2Q3. This action results in a positive ramp on A2Q5 base - the slope determined by the value of the range capacitor (selected by DELAY switch A13S1) and the current output of the current source A2Q3 (determined by VERNIER setting A13R1). When the ramp voltage reaches about + 4 volts, Schmitt trigger A2Q5/Q6 switches, thus raising the base potential of A2Q1 above the threshold. Schmitt trigger A2Q1/Q2 switches back to its original state, A2Q7 turns on, and the range capacitor is

discharged very fast. The base voltage of A2Q5 drops back to zero volts and A2Q5/A2Q6 switches to its original state.

3-34 The overall result is a positive pulse at A2Q1 collector, differentiated by A2L1, and the positive spikes fed to the base of differential amplifier A2Q17. The negative pulse at A2Q2 collector is inverted by A2Q9, differentiated by A2R19/L2, and the resulting negative spikes further inverted by A2Q8 before being fed to A2Q10. The positive spikes arriving at the bases of A2Q10/A2Q17 are separated by the PULSE DELAY settings.

3-35 The input to both channels is derived from the collector of A1Q6, except when the DELAY MODE switch is set to SER. Then the delayed output of channel A is fed as the trigger input to channel B.

3-36 WIDTH CIRCUIT

3-37 In the SINGLE PULSE mode, A2Q17 is cut off by A2Q18. Initially off, A2Q10 turns on when the positive spike from A2Q8 (delayed w.r.t. the repetition rate generator output) is applied to its base, Figure 3-5. The preceding negative spike which is not delayed has no effect. Bistable Schmitt trigger A2Q11/A2Q12 is in the state A2Q11 off, A2Q12 on. Transistor A2Q16 is on, holding

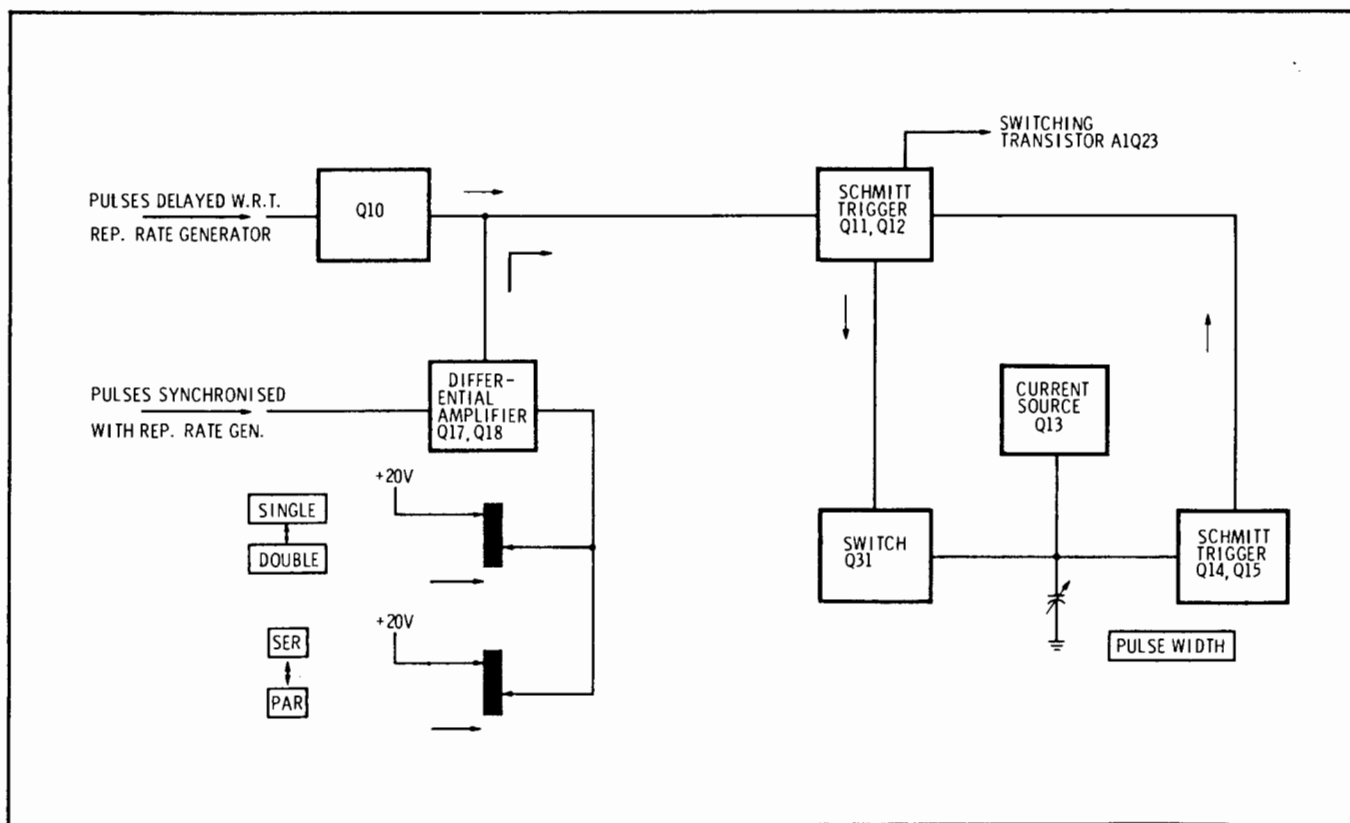

Figure 3-4. Delay Generator Block Diagram

A2Q14 base almost at ground potential, hence, A2Q14 is off, and A2Q15 is on.

3-38 When A2Q10 turns on, the base potential of A2Q11 drops and switches Schmitt trigger A2Q11/A2Q12. Transistor switch A2Q16 is turned off, and the selected range capacitor is charged by current source A2Q13. This results in a positive ramp on A2Q14 base - the slope determined by the value of the range capacitor (selected by WIDTH switch A15S1) and the current output of the current source A2Q13 (determined by VERNIER setting, A15R1). When the ramp voltage reaches about + 4 volts, Schmitt trigger A2Q14/Q15 switches, thus raising the base potential of A2Q11. Schmitt trigger A2Q11/A2Q12 switches back to its original level, A2Q16 turns on, and the range capacitor is discharged very fast. The base voltage of A2Q14 drops back to zero volts, and A2Q14/A2Q15 switches to its original state.

3-39 In the DOUBLE PULSE mode, A2Q18 is off, permitting A2Q17 to switch when a pulse is applied from A2Q1. The positive spike, corresponding to the start of the DELAY period turns A2Q17 on, producing a negative spike at its collector to switch Schmitt trigger A2Q11/Q12. Thus, output pulses are produced for both the beginning and end of the delay period, and the DELAY may be adjusted to vary the spacing between the pulses. With the DELAY MODE set to the SER position, the base potential

of A2Q18 is held at + 20 volts, turning off A2Q17 to prevent the width generator functioning in a double-pulse mode.

3-40 The output of the width circuit is applied to the base of switching transistor A1Q23 and from the differentiating network A1R82/L7 to the pulse shaping circuit when operated in the PULSE mode.

3-41 PULSE SHAPING

3-42 The positive and negative spikes from emitter follower A1Q27/A1Q29 switch Schmitt trigger A4Q1/A4Q2 on and off to form positive pulses on the collector of A4Q2. Emitter follower A4Q5 passes each pulse to the integrator circuit. Zener diode A4CR2 establishes sufficient collector voltage for A4Q6/A4Q7.

3-43 The function of switch A4Q3 is to add the RC network A4C3/R10 into the circuit to reduce the rise and fall time of the current switched in the integrator. No network is added on the 10 n range as this RC combination would slow down the rise and fall times.

3-44 INTEGRATOR

3-45 The integrator circuit establishes the rise and fall time characteristics of the pulse and forms the pulse top

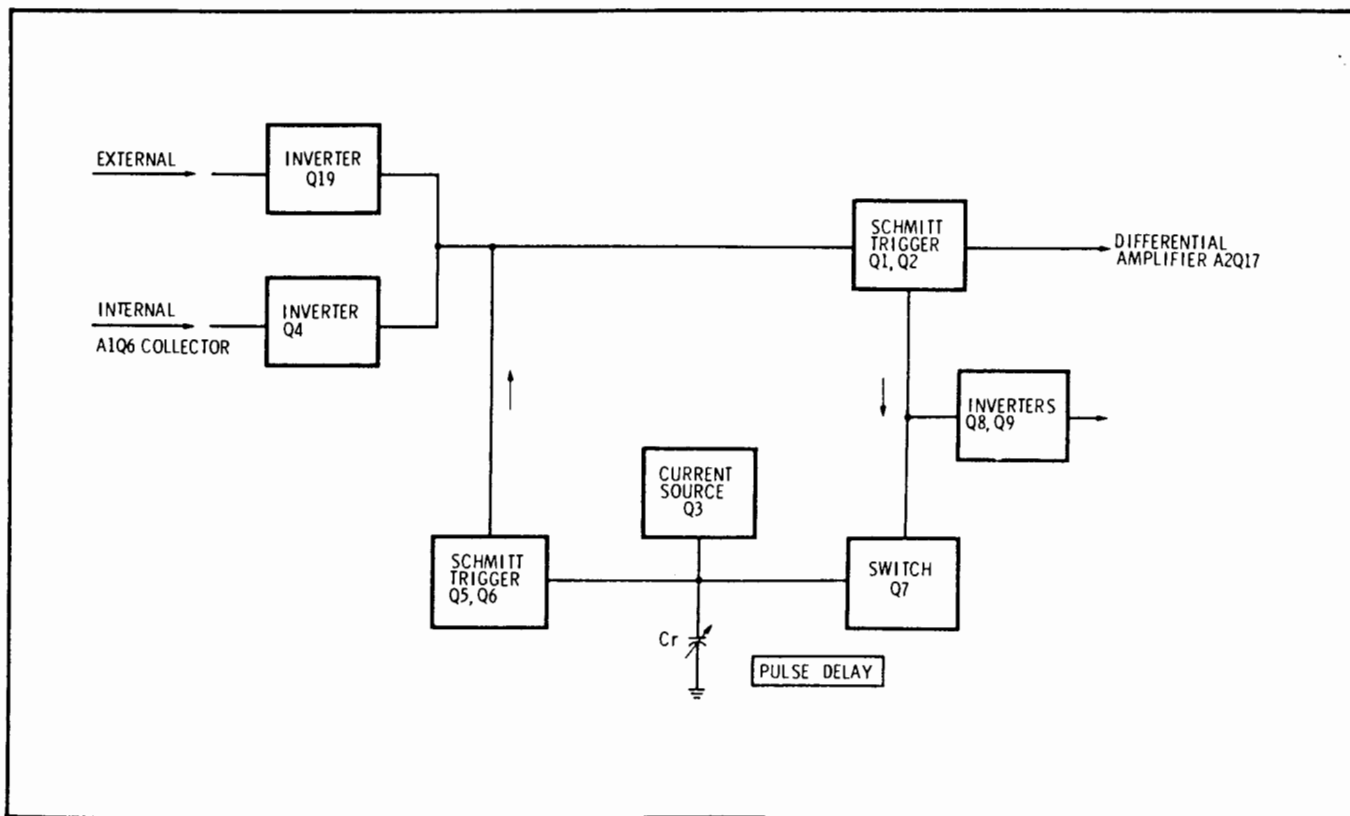

Figure 3-5. Width Generator Block Diagram

and base line. The rise and fall times are produced by the charging and discharging of the selected ramp capacitors.

3-46 The output of the pulse shaping circuit is passed to the integrator switching transistors A4Q6/A4Q7. During the time t_1 , Figure 3-6, A4Q6 is off, and the current from current source A4Q16 charges the ramp capacitor negatively. Voltage source A4Q21/A4Q22 clamps the voltage on the ramp capacitor at approximately -8.4 volts. The charging time and the clamp voltage form the rise time and pulse top respectively.

3-47 During the time t_2 switching transistor A4Q7 is off, and the current source A4Q16 flows through A4CR4. Concurrently, A4Q6 is on, diode A4CR3 is reverse-biased, and the ramp capacitor discharges through current source A4Q11. Diode A4CR9 clamps the voltage rise on the ramp capacitor at +0.7 volts. The discharging time and the clamp voltage form the fall time and the approximate base line respectively. Voltage source A4Q12 through A4Q14 and A4Q17/A4Q18 set the reverse voltage for A4CR3 and A4Q7 respectively during time t_1 . Transistors A4Q10 and A4Q15 stabilize the base voltage temperature drift of their respective current sources. Lead inductance is reduced by using switching transistors A4Q8/A4Q9 to switch the ramp capacitors. Likewise, relay contact of A4K1 is open on the 10 n range to reduce stray capacitance caused by the lead to the range switch.

3-48 EMITTER FOLLOWER AND INVERTER

3-49 The emitter follower and inverter circuit isolate the positive and negative amplifiers. After passing through emitter followers A4Q4/A4Q20, the negative pulses from the integrator are routed to the differential amplifier A6Q3/A6Q7 and emitter followers A6Q10/A6Q11. The integrator output from R91 is switchable. Rear panel switch OUTPUT AMPLIFIER, set to its PAR 10 V position, disconnects the output of channel A integrator from the base of A6Q3 and connects channel A output amplifier to channel B integrator output. This parallels both output amplifiers to provide 10 volts at output B in the A + B mode.

3-50 The output of A6Q10/A6Q11 is passed to the negative amplifier. Diode A6CR5 changes the dc level of the signal. Differential amplifier A6Q3/A6Q7 inverts the negative output from A4Q4/A4Q20, and the emitter followers A6Q8/A6Q9 pass the signal to the positive output amplifiers. The voltage source A6Q4/A6Q5 controls the collector voltage on A6Q3, setting the base line for the positive pulse.

3-51 OUTPUT AMPLIFIERS

3-52 The output amplifiers provide the necessary current to make 5 volts from a constant 50 ohm source into 50 ohms.

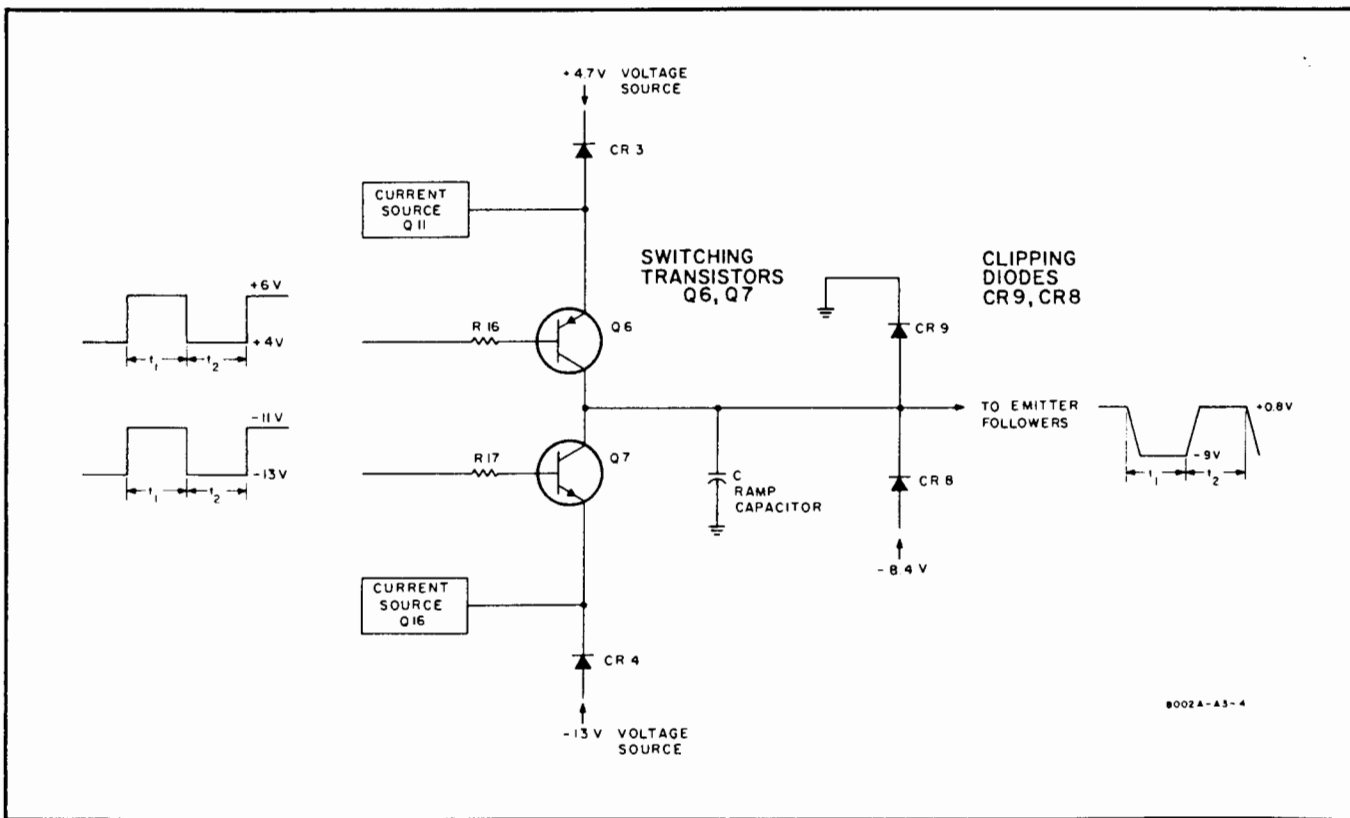

Figure 3-6. Integrator Block Diagram

3-53 Positive Amplifier

3-54 Transistors A6Q22/A6A23 form a current source controlled by A6Q21 which is switchable by the PULSE POLARITY switch to turn it on and off. In the SQUARE mode A6Q2 conducts to turn on A6Q16. This holds the current source on, irrespective of the POLARITY setting, as the positive amplifier provides the square-wave output.

3-55 The signal applied to the bases of A5Q12/A6Q15 controls the division of current between these transistors and A6Q8/A6Q11. When all the current is routed to A6Q12/A6Q15, the base line is established. The pulse top is formed when all current is routed to A6Q8/A6Q11. The base line is adjustable by A6R21 (part of the inverting differential amplifier voltage source), which varies the dc level of the signal driving A6Q12/A6Q15.

3-56 The output of the positive amplifier is passed by A6K3 relay contact to the VERNIER control. This relay is operated when PULSE POLARITY is switched to positive or whenever the SQUARE mode is selected. Selection of the SQUARE mode turns on A6Q19 to operate the relay. Additionally, transistors A6Q17 and A6Q18 are brought into operation to offset the output symmetrically to ground.

3-57 Negative Amplifier

3-58 The negative output amplifier functions in the same manner as the positive. Transistors A6Q29/A6Q30 form the current source controlled by A6Q28, which is switchable by the PULSE POLARITY switch to turn it on and off. The polarity switch also controls the relay A6K1 which is energized in the negative position. Operation in the SQUARE mode removes the ground connection from the relay and transistor A6Q28 making the negative amplifier inoperative.

3-59 The signal applied to the bases of A6Q24/A6Q27 controls the division of current between these transistors and A6Q12/A6Q14. When all current is routed to the A6Q24/A6Q27, the base line is established. The pulse top is formed when all the current is routed to A6Q12/A6Q14. Resistor A6R71 adjusts the base line by varying the base voltage of A6Q12/A6Q14. The negative output is fed to the VERNIER control.

3-60 DC OFFSET

3-61 With the OFFSET switch S10 in the OFF position, A9Q6 and A9Q8 bases are strapped together. Transistors A9Q6 and A9Q8 are off and no current flows to the attenuator assembly. With S10 in the ON position and VERNIER A9R4 set to such a position that R4 is tapped at the center, all the voltages in the circuit are symmetrical about 0 V. Collector currents from A9Q5 and A9Q7 are equal and opposite so that they cancel, and there is no current flow to the attenuator. Any unbalance of A6R4, in either direction, causes a corresponding unbalance in A9Q5/A9Q7 collector currents, and so a net current flows to the attenuator and load. The circuit is, in fact, a current source with a high source impedance so that the output pulses are not shunted.

3-62 OUTPUT SWITCHING AND ATTENUATOR

3-63 In the SEP mode, relay A7K2 is energized and A7K4 is open. Both channel outputs are fed via their respective VERNIERS to the attenuators. In the A+B mode, A7K4 is energized, A7K2 is de-energized, combining both outputs to the channel B attenuator. The 100 ohm resistors A7R1 as well as A6R1 are disconnected to maintain the 50 ohm output impedance.

3-64 The attenuator consists of three symmetrical resistive networks with attenuations of 2, 5 and 10 when fed from a 50 ohm source and terminated with a 50 ohm load. The networks are used individually or in series to yield attenuations of 2, 5, 10, 20, 50 and 100.

3-65 POWER SUPPLY

3-66 The Model 8010A operates from either 115 V or 230 V ac which is stepped down, rectified, and regulated to provide dc outputs of - 25, + 25, and + 20 volts. The two primary windings of transformer T1 are switched in parallel for 115 V operation or in series for 230 V operation by S18. The regulator circuits for the + 25 V and - 25 V supplies are identical. An error amplifier detects variations in the output voltage. The variations are inverted, amplified and applied to a series regulator via a driver. The + 20 volt output is obtained from the regulated + 25 volts by a bootstrapped voltage source.

SECTION IV
REPLACEABLE PARTS

4-1 INTRODUCTION

4-2 This section contains information for ordering replacement parts. Table 4-1 lists parts in alpha-numerical order of their reference designators and indicates the description and HP stock number of each part.

4-3 ORDERING INFORMATION

4-4 To order a replacement part, address the order or inquiry either to your authorized Hewlett-Packard sales representative or to

or, in Western Europe, to

Hewlett-Packard S.A.
Rue du Bois-du-Lan 7
1217 Meyrin-Geneva
Switzerland

4-5 Specify the following information for each part:

- Model and complete serial number of instrument
- Hewlett-Packard stock number
- Circuit reference designator
- Description

4-6 To order a part not listed in Table 4-1, give a complete description of the part and include its function and location

CUSTOMER SERVICE

Hewlett-Packard Company
333 Logue Avenue
Mountain View, California 94040

REFERENCE DESIGNATORS

A	= assembly	F	= fuse	P	= plug	V	= vacuum tube, neon bulb, photocell, etc.
B	= motor	FL	= filter	Q	= transistor	VR	= voltage regulator
BT	= battery	HR	= heater	R	= resistor	W	= cable
C	= capacitor	J	= jack	RT	= thermistor	X	= socket
CP	= coupler	K	= relay	S	= switch	Y	= crystal
CR	= diode	L	= inductor	T	= transformer		
DL	= delay line	M	= meter	TB	= terminal board		
DS	= lamp	MC	= micro-circuit	TP	= test point		

ABBREVIATIONS

A	= amperes	H	= henries	NPN	= negative-positive-negative	S-B	= slow-blow
AFC	= automatic frequency control	HEX	= hexagonal	NRFR	= not recommended for field replacement	SCHEM.	= schematic
AGC	= automatic gain control	Hg	= mercury	NSR	= not separately replaceable	Se	= selenium
BFO	= beat frequency oscillator	IF	= intermediate freq.	OBD	= order by description	SECT	= section(s)
BeCu	= beryllium copper	IMPG	= impregnated	OH	= oval head	SEMICON	= semiconductor
BH	= binder head	INCD	= incandescent	OX	= oxide	Si	= silicon
BP	= bandpass	INCL	= include(s)	P	= peak	SIL	= silver
BRS	= brass	INS	= insulation(ed)	PC	= printed circuit	SL	= slide
BWO	= backward wave oscillator	INT	= internal	pF	= picofarads = 10 ⁻¹² farads	SPG	= spring
ccw	= counter-clockwise	k	= kilo = 10 ³	PH BRZ	= phosphor bronze	SPL	= special
CER	= ceramic	LH	= left hand	PHL	= Phillips	SST	= stainless steel
CMO	= cabinet mount only	LN	= linear taper	PIV	= peak inverse voltage	SR	= split ring
COEF	= coefficient	LK WASH	= lock washer	PNP	= positive-negative-positive	STL	= steel
COM	= common	LOG	= logarithmic taper	P/O	= part of	Ta	= tantalum
COMP	= composition	LPF	= low pass filter	POLY	= polystyrene	TD	= time delay
COMPL	= complete	m	= milli = 10 ⁻³	PORC	= porcelain	TGL	= toggle
CONN	= connector	M	= meg = 10 ⁶	POS	= position(s)	THD	= thread
CP	= cadmium plate	MET FLM	= metal film	POT	= potentiometer	Ti	= titanium
CRT	= cathode-ray tube	MET OX	= metallic oxide	PP	= peak-to-peak	TOL	= tolerance
cw	= clockwise	MFR	= manufacturer	PT	= point	TQ	= total quantity
DEPC	= deposited carbon	MNAT	= minature	PWV	= peak working voltage	TRIM	= trimmer
DR	= drive	MOM	= momentary	RECT	= rectifier	TWT	= traveling wave tube
ELECT	= electrolytic	MTG	= mounting	RH	= radio frequency	VAR	= variable
ENCAP	= encapsulated	MY	= "mylar"	RH	= round head or right hand	VDCW	= dc working volts
EXT	= external	n	= nano (10 ⁻⁹)	RMO	= rack mount only	W	= watts
F	= farads	N/C	= normally closed	RMS	= root-mean square	WIV	= working inverse waveform
FH	= flat head	Ne	= neon	RS	= recommended spares	WW	= wirewound
FIL H	= fillister head	Ni PL	= nickel plate	RWV	= reverse working voltage	W/O	= without
FXD	= fixed	N/O	= normally open			μ	= micro = 10 ⁻⁶
Ge	= germanium	NPO	= negative positive zero (zero temperature coefficient)			*	= optimum value selected at factory, average value shown (part may be omitted)
GRD	= ground(ed)						

Table 4-1. Reference Designation Index

Reference Designation	HP Stock No.	Description
A 1	08010-66501	ASSY-TIMING BOARD
A 2	08010-66502	ASSY-DELAY-WIDTH BOARD CHA A
A 3	08010-66503	ASSY-DELAY-WIDTH BOARD CHA B
A 4	08010-66504	ASSY-INTEGRATOR BOARD CHA A
A 5	08010-66505	ASSY-INTEGRATOR BOARD CHA B
A 6	08010-66506	ASSY OUTPUT-AMPL BOARD CHA A
A 7	08010-66507	ASSY-OUTPUT-AMPL BOARD CHA B
A 8	08010-66508	ASSY ATTENUATOR BOARD CHA A/B
A 9	08010-66509	ASSY DC OFFSET BOARD CHA A,CHA B
A 10	08010-63401	ASSY ATTENUATORS WITH DC OFFSET BOARD
A 11	08010-66511	ASSY-POWER SUPPLY BOARD
A 12	08010-61901	ASSY REP-RATE-SWITCH
A 13	08010-61902	ASSY DELAY-SWITCH CHA.A
A 14	08010-61903	ASSY DELAY-SWITCH CHA.B
A 15	08010-61904	ASSY WIDTH-SWITCH CHA A
A 16	08010-61905	ASSY WIDTH-SWITCH CHA B
A 17	08010-63401	ASSY ATTENUATOR
A 18	08010-61906	ASSY TRANS. TIME-SWITCH CHA A
A 19	08010-61907	ASSY TRANS. TIME-SWITCH CHA B
A 1	08010-66501	ASSY-TIMING BOARD
A 1 C 1	0180-0291	C FXD TA ELECT 1 UF 10% 35VDCW
A 1 C 2	0140-0145	C FXD MICA 22 PF 5% 500VDCW
A 1 C 3	0180-0374	C FXD TA ELECT 10 UF 10% 20VDCW
A 1 C 4	0180-0291	C FXD TA ELECT 1 UF 10% 35VDCW
A 1 C 5	0140-0194	C FXD MICA 110 PF 5% 300VDCW
A 1 C 6	0150-0050	C FXD CER 1000 PF 600VDCW
A 1 C 7	0180-0291	C FXD TA ELECT 1 UF 10% 35VDCW
A 1 C 8		NUT ASSIGNED
A 1 C 9		NUT ASSIGNED
A 1 C 10	0160-2307	C FXD MICA 47 PF 5% 300VDCW
A 1 C 11	0180-0291	C FXD TA ELECT 1 UF 10% 35VDCW
A 1 C 12	0150-0050	C FXD CER 1000 PF 600VDCW
A 1 C 13	0121-0046	C VAR CER 9-35 PF
A 1 C 14	0160-2199	C FXD MICA 30 PF 5% 300VDCW
A 1 C 15	0150-0050	C FXD CER 1000 PF 600VDCW
A 1 C 16	0160-2216	C FXD MICA 820 PF 5% 300VDCW
A 1 C 17	0160-2189	C FXD MICA 12NF 5%
A 1 C 18	0160-3257	C FXD MIAL 0,15 UF 2% 125VDCW
A 1 C 19	0180-2126	C FXD TA ELECT 1.5 UF 5% 35VDCW
A 1 C 20	0180-2125	C FXD TA ELECT 15 UF 5% 20VDCW
A 1 C 21	0180-1749	C FXD TA 51 UF 5% 15VDCW
A 1 C 22	0180-0291	C FXD TA ELECT 1 UF 10% 35VDCW
A 1 C 23	0160-2204	C FXD MICA 100 PF 5% 300VDCW
A 1 C 24	0160-2204	C FXD MICA 100 PF 5% 300VDCW
A 1 C 25	0160-2150	C FXD MICA 33 PF 5% 300VDCW
A 1 C 26	0180-0291	C FXD TA ELECT 1 UF 10% 35VDCW
A 1 C 27	0180-0291	C FXD TA ELECT 1 UF 10% 35VDCW
A 1 C 28	0140-0194	C FXD MICA 110 PF 5% 300VDCW
A 1 C 29	0150-0050	C FXD CER 1000 PF 600VDCW
A 1 C 30	0180-0291	C FXD TA ELECT 1 UF 10% 35VDCW
A 1 C 31	0180-0291	C FXD TA ELECT 1 UF 10% 35VDCW
A 1 C 32	0140-0194	C FXD MICA 110 PF 5% 300VDCW
A 1 C 33		NOT ASSIGNED
A 1 C 34		NOT ASSIGNED
A 1 C 35	0180-1749	C FXD TA 51 UF 5% 15VDCW
A 1 C 36	0180-1749	C FXD TA 51 UF 5% 15VDCW
A 1 C 37	0180-0291	C FXD TA ELECT 1 UF 10% 35VDCW

Table 4-1. Reference Designation Index (cont'd)

Reference Designation	HP Stock No.	Description
A 1 C 38	0180-0291	C FXD TA ELECT 1 UF 10% 35VDCW
A 1 C 39	0180-0291	C FXD TA ELECT 1 UF 10% 35VDCW
A 1 C 40	0180-0291	C FXD TA ELECT 1 UF 10% 35VDCW
A 1 C 41	0180-0291	C FXD TA ELECT 1 UF 10% 35VDCW
A 1 C 42	0160-2204	C FXD MICA 100 PF 5% 300VDCW
A 1 CR 1	1901-0040	DIODE SILICON 30PIV 30 MA
A 1 CR 2	1901-0040	DIODE SILICON 30PIV 30 MA
A 1 CR 3	1901-0040	DIODE SILICON 30PIV 30 MA
A 1 CR 4	1901-0040	DIODE SILICON 30PIV 30 MA
A 1 CR 5	1910-0016	DIODE GERMANIUM
A 1 CR 6	1910-0016	DIODE GERMANIUM
A 1 CR 7	1902-3150	DIODE BREAKDOWN 9.09V 2% 400 MW
A 1 CR 8	1902-0049	DIODE BREAKDOWN 6.19V 5% 400 MW
A 1 CR 9	1910-0034	DIODE GERMANIUM 25 PIV 100 MA
A 1 CR 10	1901-0034	DIODE GERMANIUM 25 PIV 100MA
A 1 CR 11	1901-0040	DIODE SILICON 30PIV 30 MA
A 1 CR 12	1901-0034	DIODE GERMANIUM 25 PIV 100MA
A 1 CR 13	1901-0040	DIODE SILICON 30PIV 30 MA
A 1 CR 14	1901-0040	DIODE SILICON 30PIV 30 MA
A 1 CR 15	1901-0040	DIODE SILICON 30PIV 30 MA
A 1 CR 16		NOT ASSIGNED
A 1 CR 17	1901-0040	DIODE SILICON 30PIV 30MA THRU CR39
A 1 K 1	0490-0733	REED RELAY SPST 18VDC
A 1 L 1	9140-0111	COIL FXD RF 3.3 UH
A 1 L 2	9100-1613	COIL FXD .47 UH 20%
A 1 L 3	9170-0029	CORE FERRITE BEAD
A 1 L 4	9140-1613	COIL FXD RF 0.47uH
A 1 L 5	9140-0096	COIL FXD RF 1uH
A 1 L 6	9140-0098	COIL FXD RF 2.2 UH
A 1 L 7	9140-0098	COIL FXD RF 2.2 UH
A 1 L 8	9140-0098	COIL FXD RF 2.2 UH
A 1 Q 1	1854-0215	TRANSISTOR SILICON NPN 2N3904
A 1 Q 2	1854-0215	TRANSISTOR SILICON NPN 2N3904
A 1 Q 3	1854-0215	TRANSISTOR SILICON NPN 2N3904
A 1 Q 4	1854-0215	TRANSISTOR SILICON NPN 2N3904
A 1 Q 5	1853-0036	TRANSISTOR SILICON PNP 2N3906
A 1 Q 6	1853-0036	TRANSISTOR SILICON PNP 2N3906
A 1 Q 7	1853-0036	TRANSISTOR SILICON PNP 2N3906
A 1 Q 8		THRU Q13 NOT ASSIGNED
A 1 Q 14	1853-0036	TRANSISTOR SILICON PNP 2N3906
A 1 Q 15	1854-0215	TRANSISTOR SILICON NPN 2N3904
A 1 Q 16	1854-0215	TRANSISTOR SILICON NPN 2N3904
A 1 Q 17	1853-0036	TRANSISTOR SILICON PNP 2N3906
A 1 Q 18	1854-0260	TRANSISTOR SILICON NPN 2N3227
A 1 Q 19	1854-0053	TRANSISTOR SILICON NPN 2N2218
A 1 Q 20	1854-0260	TRANSISTOR SILICON NPN 2N3227
A 1 Q 21	1853-0036	TRANSISTOR SILICON PNP
A 1 Q 22	1854-0215	TRANSISTOR SILICON NPN 2N3904
A 1 Q 23	1854-0215	TRANSISTOR SILICON NPN 2N3904
A 1 Q 24	1854-0215	TRANSISTOR SILICON NPN
A 1 Q 25	1854-0215	TRANSISTOR SILICON NPN
A 1 Q 26	1853-0036	TRANSISTOR SILICON PNP
A 1 Q 27	1854-0215	TRANSISTOR SILICON NPN 2N3904
A 1 Q 28	1854-0329	TRANSISTOR SILICON NPN
A 1 Q 29	1853-0036	TRANSISTOR SILICON PNP 2N3906
A 1 Q 30	1853-0036	TRANSISTOR SILICON PNP 2N3906

Table 4-1. Reference Designation Index (cont'd)

Reference Designation	HP Stock No.	Description
A 1 Q 31	1854-0329	TRANSISTOR SILICON NPN
A 1 Q 32	1854-0215	TRANSISTOR SILICON NPN 2N3904
A 1 Q 33	1854-0215	TRANSISTOR SILICON NPN 2N3904
A 1 Q 34	1853-0034	TRANSISTOR SILICON PNP
A 1 Q 35	1854-0215	TRANSISTOR SILICON NPN 2N3904
A 1 Q 36	1853-0036	TRANSISTOR SILICON PNP 2N3906
A 1 Q 37	1854-0329	TRANSISTOR SILICON NPN
A 1 Q 38	1853-0036	TRANSISTOR SILICON PNP 2N3906
A 1 R 1	0757-0726	R FXD MET FLM 511 OHM 1% 1/4W
A 1 R 2	0757-0726	R FXD MET FLM 511 OHM 1% 1/4W
A 1 R 3	0757-0398	R FXD MET FLM 75 OHM 1% 1/8W
A 1 R 4	0698-4247	R FXD FLM 510 OHM 5% 1/8W
A 1 R 5	0698-3441	R FXD MET FLM 215 OHM 1% 1/8W
A 1 R 6	0757-1097	R FXD MET FLM 1200 OHM 1% 1/8W
A 1 R 7	0698-4265	R FXD FLM 3000 OHM 5% 1/8W
A 1 R 8	0757-0283	R FXD MET FLM 2000 OHM 1% 1/8W
A 1 R 9	0758-0070	R FXD FLM 1200 OHM 5% 1/4W
A 1 R 10	0757-0433	R FXD MET FLM 3320 OHM 1% 1/8W
A 1 R 11	0698-4254	R FXD FLM 1000 OHM 5% 1/8W
A 1 R 12	0758-0086	R FXD FLM 100 OHM 5% 1/4W
A 1 R 13	0698-4226	R FXD FLM 62 OHM 5% 1/8W
A 1 R 14	0757-0746	R FXD MET FLM 4750 OHM 1% 1/4W
A 1 R 15	0757-0746	R FXD MET FLM 4750 OHM 1% 1/4W
A 1 R 16	0698-4261	R FXD FLM 2000 OHM 5% 1/8W
A 1 R 17	0698-4254	R FXD FLM 1000 OHM 5% 1/8W
A 1 R 18	0698-3446	R FXD MET FLM 383 OHM 1% 1/8W
A 1 R 19	0698-4278	R FXD FLM 10K OHM 5% 1/8W
A 1 R 20	0698-4254	R FXD FLM 1000 OHM 5% 1/8W
A 1 R 21	0698-4278	R FXD FLM 10K OHM 5% 1/8W
A 1 R 22	0758-0034	R FXD MET FLM 2.4K OHM 5% 1/4W
A 1 R 23	0758-0086	R FXD FLM 100 OHM 5% 1/8W
A 1 R 24	0758-0126	R FXD FLM 51 OHM 5% 1/4W
A 1 R 25		THRU R39 NOT ASSIGNED
A 1 R 40	0757-0400	R FXD MET FLM 90.9 OHM 1% 1/8W
A 1 R 41	0757-0402	R FXD MET FLM 110 OHM 1% 1/8W
A 1 R 42	0757-0806	R FXD MET FLM 243 OHM 1% 1/2W
A 1 R 43	0698-6744	R FXD FLM 20 OHM 5% 1/8W
A 1 R 44	0757-0036	R FXD MET FLM 626 OHM 1% 1/2W
A 1 R 45	0698-3155	R FXD MET FLM 4640 OHM 1% 1/8W
A 1 R 46	0757-0395	R FXD MET FLM 56.2 OHM 1% 1/8W
A 1 R 47	0698-4254	R FXD FLM 1000 OHM 5% 1/8W
A 1 R 48	0758-0004	R FXD FLM 2700 OHM 5% 1/4W
A 1 R 49	0698-5702	R FXD FLM 30 OHM 5% 1/2W
A 1 R 50	2100-2795	R VAR CERMET 470 OHM 5W
A 1 R 51		NOT ASSIGNED
A 1 R 52	0698-4261	R FXD FLM 2000 OHM 5% 1/8W
A 1 R 53	0698-6744	R FXD FLM 20 OHM 5% 1/4W
A 1 R 54	0698-4246	R FXD FLM 470 OHM 5% 1/8W
A 1 R 55	0757-1022	R FXD MET FLM 1780 OHM 1% 1/4W
A 1 R 56	0698-4268	R FXD FLM 3.9K OHM 5% 1/8W
A 1 R 57	0698-4239	R FXD FLM 220 OHM 5% 1/8W
A 1 R 58	2100-2739	R VAR VERMET 220 OHM 20% .5W
A 1 R 59	0698-4239	R FXD FLM 220 OHM 5% 1/8W
A 1 R 60	0698-3439	R FXD MET FLM 178 OHM 1% 1/8W
A 1 R 61	0698-4245	R FXD FLM 390 OHM 5% 1/8W
A 1 R 62	0698-4249	R FXD FLM 620 OHM 5% 1/8W
A 1 R 63	0698-3439	R FXD MET FLM 178 OHM 1% 1/8W
A 1 R 64	0698-3447	R FXD MET FLM 422 OHM 1% 1/8W

Table 4-1. Reference Designation Index (cont'd)

Reference Designation	HP Stock No.	Description
A 1 R 65	0698-3447	R FXD MET FLM 422 OHM 1% 1/8W
A 1 R 66	0698-3441	R FXD MET FLM 215 OHM 1% 1/8W
A 1 R 67	0698-3440	R FXD MET FLM 196 OHM 1% 1/8W
A 1 R 68	0757-07	R FXD MET FLM 1620 OHM 1% 1/4W
A 1 R 69	0757-0180	R FXD MET FLM 31.6 OHM 1% 1/8W
A 1 R 70	0757-0737	R FXD MET FLM 1620 OHM 1% 1/4W
A 1 R 71	0698-4278	R FXD FLM 10K OHM 5% 1/8W
A 1 R 72	0698-4278	R FXD FLM 10K OHM 5% 1/8W
A 1 R 73	0698-4278	R FXD FLM 10K OHM 5% 1/8W
A 1 R 74	0698-4278	R FXD FLM 10K OHM 5% 1/8W
A 1 R 75	0698-4282	R FXD FLM 15K OHM 5% 1/8W
A 1 R 76	0757-0401	R FXD MET FLM 100 OHM 1% 1/8W
A 1 R 77	0757-0407	R FXD MET FLM 200 OHM 1% 1/8W
A 1 R 78	0698-4282	R FXD FLM 15K OHM 5% 1/8W
A 1 R 79	0698-4278	R FXD FLM 10K OHM 5% 1/8W
A 1 R 80	0758-0002	R FXD FLM 560 OHM 5% 1/4W
A 1 R 81	0698-4249	R FXD FLM 620 OHM 5% 1/8W
A 1 R 82	0698-4247	R FXD FLM 510 OHM 5% 1/8W
A 1 R 83	0698-4249	R FXD FLM 620 OHM 5% 1/8W
A 1 R 84	0698-4254	R FXD FLM 1000 OHM 5% 1/8W
A 1 R 85	0698-4238	R FXD FLM 200 OHM 5% 1/8W
A 1 R 86	0757-0416	R FXD MET FLM 511 OHM 1% 1/8W
A 1 R 87	0698-4278	R FXD FLM 10K OHM 5% 1/8W
A 1 R 88	0698-3440	R FXD MET FLM 196 OHM 1% 1/8W
A 1 R 89	0698-3440	R FXD MET FLM 196 OHM 1% 1/8W
A 1 R 90	0698-4278	R FXD FLM 10K OHM 5% 1/8W
A 1 R 91	0698-4247	R FXD FLM 510 OHM 5% 1/8W
A 1 R 92	0698-4254	R FXD FLM 1000 OHM 5% 1/8W
A 1 R 93	0698-4238	R FXD FLM 200 OHM 5% 1/8W
A 1 R 94	0698-4254	R FXD FLM 1000 OHM 5% 1/8W
A 1 R 95	0698-4246	R FXD FLM 470 OHM 5% 1/8W
A 1 R 96	0698-4254	R FXD FLM 1000 OHM 5% 1/8W
A 1 R 97	0698-4243	R FXD FLM 330 OHM 5% 1/8W
A 1 R 98	0698-4249	R FXD FLM 620 OHM 5% 1/8W
A 1 R 99	0698-4285	R FXD FLM 20K OHM 5% 1/8W
A 1 R 100	0758-0125	R FXD FLM 430 OHM 5% 1/4W
A 1 R 101	0698-6745	R FXD MET FLM 22 OHM 5% 1/4W
A 1 R 102	0698-6745	R FXD MET FLM 22 OHM 5% 1/4W
A 1 R 103	0698-6745	R FXD MET FLM 22 OHM 5% 1/4W
A 2	08010-66502	DELAY-WIDTH CHA
A 2 C 1	0180-0291	C FXD TA ELECT 1 UF 10% 35VDCW
A 2 C 2	0150-0121	C FXD CER 0.1 UF +80-20% 50VDCW
A 2 C 3	0140-0145	C FXD MICA 22 PF 5% 500VDCW
A 2 C 4	0150-0093	C FXD CER .01 UF 80-20% 100VDCW
A 2 C 5	0160-0987	C FXD MICA 12 PF 5% 500VDCW
A 2 C 6		FACTORY SELECTED
A 2 C 7		NOT ASSIGNED
A 2 C 8	0180-0294	C FXD TA ELECT 390 UF 20%
A 2 C 9	0180-1955	C FXD TA ELECT 47 UF 5% 6VDCW
A 2 C 10	0180-1954	C FXD TA ELECT 4.7 UF 5% 6VDCW
A 2 C 11	0170-0078	C FXD MYLAR .47 UF 5% 150VDCW
A 2 C 12	0160-3165	C FXD MYLAR .047 UF 2% 50VDCW
A 2 C 13	0160-2127	C FXD MICA 4600 PF 1% 300VDCW
A 2 C 14	0180-0291	C FXD TA ELECT 1 UF 10% 35VDCW
A 2 C 15	0140-0200	C FXD MICA 390 PF 5% 300VDCW
A 2 C 16	0150-0121	C FXD CER .1UF 80%-20% 50VDCW
A 2 C 17	0121-0046	C VAR CER 9-35 PF

Table 4-1

Table 4-1. Reference Designation Index (cont'd)

Reference Designation	HP Stock No.	Description
A 2 C 18		NOT ASSIGNED
A 2 C 19	0180-0291	C FXD TA ELECT 1 UF 10% 35VDCW
A 2 C 20	0150-0121	C FXD CER .1UF 80%-20% 50VDCW
A 2 C 21	0140-0145	C FXD MICA 22 PF 5% 500VDCW
A 2 C 22	0150-0093	C FXD CER .01 UF 80-20% 100VDCW
A 2 C 23	0160-0987	C FXD MICA 12 PF 5% 500VDCW
A 2 C 24		FACTORY SELECTED
A 2 C 25	0180-0294	C FXD TA ELECT 390 UF 20%
A 2 C 26		NOT ASSIGNED
A 2 C 27	0180-1955	C FXD TA ELECT 47 UF 5% 6VDCW
A 2 C 28	0180-1954	C FXD TA ELECT 47 UF 5% 6VDCW
A 2 C 29	0170-0078	C FXD MYLAR .47 UF 5% 150VDCW
A 2 C 30	0160-3165	C FXD MYLAR .047 UF 2% 50VDCW
A 2 C 31	0160-2127	C FXD MICA 4600 PF 1% 300VDCW
A 2 C 32	0150-0093	C FXD CER .01 UF 80-20% 100VDCW
A 2 C 33	0140-0177	C FXD MICA 400 PF 1% 300VDCW
A 2 C 34	0150-0121	C FXD CER .1UF 80%-20% 50VDCW
A 2 C 35		NOT ASSIGNED
A 2 C 36	0121-0061	R CER 5.5-18 PF
A 2 C 37	0150-0093	C FXD CER 0.01 UF +80-20% 100VDCW
A 2 C 38	0150-0093	C FXD CER 0.01 UF +80-20% 100VDCW
A 2 CR 1	1901-0040	DIODE SILICON 30PIV 30 MA
A 2 CR 2	1910-0016	DIODE GERMANIUM
A 2 CR 3	1910-0016	DIODE GERMANIUM
A 2 L 1	9100-1616	COIL FXD 1.5 UH
A 2 L 2	9100-1616	COIL FXD 1.5 UH
A 2 Q 1	1853-0203	TRANSISTOR SILICON PNP
A 2 Q 2	1853-0203	TRANSISTOR SILICON PNP
A 2 Q 3	1853-0034	TRANSISTOR SILICON PNP
A 2 Q 4	1854-0215	TRANSISTOR SILICON NPN 2N3904
A 2 Q 5	1854-0215	TRANSISTOR SILICON NPN 2N3904
A 2 Q 6	1854-0215	TRANSISTOR SILICON NPN 2N3904
A 2 Q 7	1854-0019	TRANSISTOR SILICON NPN
A 2 Q 8	1853-0036	TRANSISTOR SILICON PNP 2N3906
A 2 Q 9	1854-0215	TRANSISTOR SILICON NPN 2N3904
A 2 Q 10	1854-0215	TRANSISTOR SILICON NPN 2N3904
A 2 Q 11	1853-0203	TRANSISTOR PNP
A 2 Q 12	1853-0203	TRANSISTOR PNP
A 2 Q 13	1853-0034	TRANSISTOR SILICON PNP
A 2 Q 14	1854-0215	TRANSISTOR SILICON NPN 2N3904
A 2 Q 15	1854-0215	TRANSISTOR SILICON NPN 2N3904
A 2 Q 16	1854-0301	TRANSISTOR NPN
A 2 C 17	1854-0215	TRANSISTOR SILICON NPN 2N3904
A 2 Q 18	1854-0215	TRANSISTOR SILICON NPN 2N3904
A 2 Q 19	1854-0215	TRANSISTOR SILICON NPN 2N3904
A 2 R 1	0758-0127	R FXD FLM 430 OHM 5% 1/4W
A 2 R 2	0757-0736	R FXD MET FLM 1500 OHM 1% 1/4W
A 2 R 3	0757-0433	R FXD MET FLM 3320 OHM 1% 1/8W
A 2 R 4	0757-0724	R FXD MET FLM 392 OHM 1% 1/4W
A 2 R 5	0757-0817	R FXD MET FLM 750 OHM 1% 1/2W
A 2 R 6	0757-0405	R FXD MET FLM 162 OHM 1% 1/8W
A 2 R 7	0757-0338	R FXD MET FLM 1000 OHM 1% 1/4W
A 2 R 8	0757-0417	R FXD MET FLM 562 OHM 1% 1/8W
A 2 R 9	0698-4240	R FXD FLM 240 OHM 5% 1/8W
A 2 R 10	0757-0401	R FXD MET FLM 100 OHM 1% 1/8W
A 2 R 11	0757-0433	R FXD MET FLM 3320 OHM 1% 1/8W
A 2 R 12	0698-4236	R FXD FLM 160 OHM 5% 1/8W

Table 4-1. Reference Designation Index (cont'd)

Reference Designation	HP Stock No.	Description
A 2 R 13	0757-0738	R FXD MET FLM 1820 OHM 1% 1/4w
A 2 R 14	0698-4227	R FXD FLM 68 OHM 5% 1/8w
A 2 R 15	0698-4235	R FXD FLM 150 OHM 5% 1/8w
A 2 R 16	0698-6746	R FXD FLM 43 OHM 5% 1/8w
A 2 R 17	0757-0827	R FXD MET FLM 2740 OHM 1% 1/2w
A 2 R 18	0757-0354	R FXD MET FLM 3650 OHM 1% 1/4w
A 2 R 19	0698-4244	R FXD FLM 360 OHM 5% 1/8w
A 2 R 20	0698-4236	R FXD FLM 160 OHM 5% 1/8w
A 2 R 21	0758-0066	R FXD FLM 620 OHM 5% 1/4w
A 2 R 22	0698-3441	R FXD MET FLM 215 OHM 1% 1/8w
A 2 R 23	0698-4254	R FXD FLM 1000 OHM 5% 1/8w
A 2 R 24	0698-4243	R FXD FLM 330 OHM 5% 1/8w
A 2 R 25	0757-0401	R FXD MET FLM 100 OHM 1% 1/8w
A 2 R 26	0698-4242	R FXD FLM 300 OHM 5% 1/8w
A 2 R 27	0758-0127	R FXD FLM 430 OHM 5% 1/4w
A 2 R 28	0757-0736	R FXD MET FLM 1500 OHM 1% 1/4w
A 2 R 29	0757-0433	R FXD MET FLM 3320 OHM 1% 1/8w
A 2 R 30	0757-0724	R FXD MET FLM 392 OHM 1% 1/4w
A 2 R 31	0757-0817	R FXD MET FLM 750 OHM 1% 1/2w
A 2 R 32	0757-0338	R FXD MET FLM 1000 OHM 1% 1/4w
A 2 R 33	0757-0417	R FXD MET FLM 562 OHM 1% 1/8w
A 2 R 34	0757-0405	R FXD MET FLM 162 OHM 1% 1/8w
A 2 R 35	0757-0276	R FXD MET FLM 61.9 OHM 1% 1/8w
A 2 R 36	0757-0433	R FXD MET FLM 3320 OHM 1% 1/8w
A 2 R 37	0698-4236	R FXD FLM 160 OHM 5% 1/8w
A 2 R 38	0757-0738	R FXD MET FLM 1820 OHM 1% 1/4w
A 2 R 39	0698-4227	R FXD FLM 68 OHM 5% 1/8w
A 2 R 40	0757-0401	R FXD MET FLM 100 OHM 1% 1/8w
A 2 R 41	0698-6746	R FXD FLM 43 OHM 5% 1/4w
A 2 R 42	0757-0827	R FXD MET FLM 2740 OHM 1% 1/2w
A 2 R 43	0757-0354	R FXD MET FLM 3650 OHM 1% 1/4w
A 2 R 44	0698-4249	R FXD FLM 620 OHM 5% 1/8w
A 2 R 45	0698-4273	R FXD FLM 6200 OHM 5% 1/8w
A 2 R 46	0698-5703	R FXD FLM 33 OHM 5% 1/8w
A 2 R 47	0698-3445	R FXD FLM 348 OHM 1% 1/8w
A 2 R 48	0698-4242	R FXD FLM 300 OHM 5% 1/8w
A 2 R 49	0698-4261	R FXD FLM 2000 OHM 5% 1/8w
A 2 R 50	0760-0024	R FXD MET OX 100 OHM 5% 1w
A 2 R 51	0760-0024	R FXD MET OX 100 OHM 5% 1w
A 2 R 52	0698-6802	R FXD FLM 10 OHM 5% 1/8w
A 2 R 53	0698-6802	R FXD FLM 10 OHM 5% 1/8w
A 2 R 54	0698-4235	R FXD FLM 150 OHM 5% 1/8w
A 3	08010-66502	DELAY-WIDTH CH B, SAME AS A2
A 4	08010-66504	INTEGRATOR CH A
A 4 C 1	0150-0050	C FXD CER 1000 PF 600VDCW
A 4 C 2	0180-0291	C FXD TA ELECT 1 UF 10% 35VDCW
A 4 C 3	0160-2206	C FXD MICA 160 PF 5% 300VDCW
A 4 C 4	0150-0093	C FXD CER .01 UF 80-20% 100VDCW
A 4 C 5	0150-0093	C FXD CER .01 UF 80-20% 100VDCW
A 4 C 6	0150-0121	C FXD CER .1UF 80%-20% 50VDCW
A 4 C 7	0160-2143	C FXD CER 2000 PF 80-20% 100VDCW
A 4 C 8	0160-0134	C FXD MICA 220 PF 5% 300VDCW
A 4 C 9	0150-0093	C FXD CER .01 UF 80-20% 100VDCW
A 4 C 10	0150-0093	C FXD CER .01 UF 80-20% 100VDCW
A 4 C 11	0150-0121	C FXD CER .1UF 80%-20% 50VDCW
A 4 C 12	0160-2143	C FXD CER 2000 PF 80-20% 100VDCW
A 4 C 13	0160-0134	C FXD MICA 220 PF 5% 300VDCW

Table 4-1

Table 4-1. Reference Designation Index (cont'd)

Reference Designation	HP Stock No.	Description
A 4 C 14	0150-0093	C FXD CER .01 UF 880-20% 100VDCW
A 4 C 15	0160-0134	C FXD MICA 220 PF 5% 300VDCW
A 4 C 16	0180-0291	C FXD TA ELECT 1 UF 10% 35VDCW
A 4 C 17	0150-0093	C FXD CER .01 UF 880-20% 100VDCW
A 4 C 18	0160-2198	C FXD MICA 20 PF 5% 300VDCW
A 4 C 19	0160-2213	C FXD MICA 620 PF 5% 300VDCW
A 4 C 20	0160-3246	C. FXD POLYSTERENE 6.8NF 1% 250VDCW
A 4 C 21	0180-0376	C FXD TA ELECT .47 UF 10% 35VDCW
A 4 C 22	0180-0294	C. FXD TA ELECT 390 UF 20% 10 VDCW
A 4 C 23	0180-1747	C FXD TA ELECT 150UF 20% 15VDCW
A 4 C 24		SELECTED ON TEST
A 4 C 25		SELECTED ON TEST
A 4 C 26	0180-0196	C FXD TA ELECT 56 UF 10% 15VDCW
A 4 C 27	0180-1712	C FXD TA ELECT 5.6 UF 5% 35VDCW
A 4 C 28	0180-1773	C FXD TA ELECT .68 UF 5% 35VDCW
A 4 C 29	0160-2672	C FXD MYLAR .047 UF 5% 80VDCW
A 4 C 30	0150-0093	C FXD CER .01 UF 880-20% 100VDCW
A 4 C 31	0160-0194	C FXD MYLAR .015 UF 10% 200VDCW
A 4 C 32		SELECTED ON TEST
A 4 C 33	0180-0291	C FXD TA ELECT 1 UF 10% 35VDCW
A 4 C 34	0160-2139	C FXD CER 220 PF 880-20% 1000VDCW
A 4 C 35	0180-0106	C FXD TA ELECT 60 UF 20% 6VDCW
A 4 C 36	0150-0093	C FXD CER .01 UF 880-20% 100VDCW
A 4 C 37	0150-0050	C FXD CER 1000 PF 600VDCW
A 4 C 38	0160-0134	C FXD MICA 220 PF 5% 300VDCW
A 4 C 39	0150-0050	C FXD CER 1000 PF 600VDCW
A 4 CR 1	1902-0037	DIODE BREAKDOWN 9.09V 10% 400 MW
A 4 CR 2	1902-3223	DIODE BREAKDOWN 17.4V 2% 400 MW
A 4 CR 3	1901-0179	DIODE SILICON 15PIV 750 MA
A 4 CR 4	1901-0179	DIODE SILICON 15PIV 750 MA
A 4 CR 5	1902-3288	DIODE BREAKDOWN 30.9V 2% 400 MW
A 4 CR 6	1901-0044	DIODE SIL 50PIV 20 MA
A 4 CR 7	1902-3205	DIODE BREAKDOWN 15V 5% 400 MW
A 4 CR 8	1901-0179	DIODE SILICON 15PIV 750 MA
A 4 CR 9	1901-0179	DIODE SILICON 15PIV 750 MA
A 4 CR 10	1902-0594	DIODE BREAKDOWN 18.2V 5% 1W
A 4 CR 11	1902-0555	DIODE BREAKDOWN 13V 5% 1W
A 4 K 1	0490-0733	REED RELAY SPST 18VDC
A 4 L 1	9100-1613	COIL FXD .47 UH 20%
A 4 L 2	9170-0029	CORE FERRITE BEAD
A 4 L 3	9170-0029	CORE FERRITE BEAD
A 4 L 4	9170-0029	CORE FERRITE BEAD
A 4 Q 1	1853-0203	TRANSISTOR SILICON PNP
A 4 Q 2	1853-0203	TRANSISTOR SILICON PNP
A 4 Q 3	1854-0092	TRANSISTOR SILICON NPN 2N3563
A 4 Q 4	1854-0260	TRANSISTOR SILICON NPN 2N3227
A 4 Q 5	1854-0019	TRANSISTOR SILICON NPN
A 4 Q 6	5080-1044	TRANSISTOR PNP SELECTED
A 4 C 7	1854-0091	TRANSISTOR SILICON NPN
A 4 C 8	1853-0203	TRANSISTOR SILICON PNP
A 4 C 9	1853-0203	TRANSISTOR SILICON PNP
A 4 C 10	1854-0307	TRANSISTOR SILICON NPN
A 4 Q 11	1853-0034	TRANSISTOR SILICON PNP
A 4 C 12	1854-0003	TRANSISTOR SILICON NPN 2N1711
A 4 C 13	1853-0090	TRANSISTOR SILICON PNP
A 4 C 14	1854-0307	TRANSISTOR SILICON NPN
A 4 C 15	1853-0090	TRANSISTOR SILICON PNP

Table 4-1. Reference Designation Index (cont'd)

Reference Designation	HP Stock No.	Description
A 4 C 16	1854-0053	TRANSISTOR SILICON NPN
A 4 C 17	1853-0051	TRANSISTOR SILICON PNP 2N4037
A 4 C 18	1854-0307	TRANSISTOR SILICON NPN
A 4 C 19		NOT ASSIGNED
A 4 C 20	1853-0203	TRANSISTOR SILICON PNP
A 4 C 21	1854-0307	TRANSISTOR SILICON NPN
A 4 C 22	1853-0001	TRANSISTOR SILICON PNP
A 4 R 1	0698-4254	R FXD FLM 1000 OHM 5% 1/8W
A 4 R 2	0698-0083	R FXD MET FLM 1960 OHM 1% 1/8W
A 4 R 3	0757-0334	R FXD MET FLM 301 OHM 1% 1/4W
A 4 R 4	0698-4235	R FXD FLM 150 OHM 5% 1/8W
A 4 R 5	0757-0718	R FXD MET FLM 200 OHM 1% 1/4W
A 4 R 6	0698-0085	R FXD MET FLM 2610 OHM 1% 1/8W
A 4 R 7	0757-0734	R FXD MET FLM 1210 OHM 1% 1/4W
A 4 R 8	0757-0736	R FXD MET FLM 1500 OHM 1% 1/4W
A 4 R 9	0757-0418	R FXD MET FLM 619 OHM 1% 1/8W
A 4 R 10	0698-6745	R FXD MET FLM 22 OHM 5% 1/4W
A 4 R 11	0758-0034	R FXD FLM 2400 OHM 5% 1/4W
A 4 R 12	0698-4306	R FXD FLM 150K OHM 5% 1/8W
A 4 R 13	0757-0819	R FXD MET FLM 909 OHM 1% 1/2W
A 4 R 14	0758-0086	R FXD FLM 100 OHM 5% 1/4W
A 4 R 15	0698-4258	R FXD FLM 1500 OHM 5% 1/8W
A 4 R 16	0698-6745	R FXD MET FLM 22 OHM 5% 1/4W
A 4 R 17	0698-6745	R FXD MET FLM 22 OHM 5% 1/4W
A 4 R 18	0683-0515	R FXD COMP 5.1 OHM 5% 1/4W
A 4 R 19	0683-0515	R FXD COMP 5.1 OHM 5% 1/4W
A 4 R 20	0683-0515	R FXD COMP 5.1 OHM 5% 1/4W
A 4 R 21	0698-0084	R FXD MET FLM 2150 OHM 1% 1/8W
A 4 R 22	0698-4254	R FXD FLM 1000 OHM 5% 1/8W
A 4 R 23	0757-0440	R FXD MET FLM 7500 OHM 1% 1/8W
A 4 R 24	0698-4267	R FXD FLM 3600 OHM 5% 1/8W
A 4 R 25	0761-0049	R FXD MET OX 200 OHM 5% 1W
A 4 R 26	0757-0797	R FXD MET FLM 90.9 OHM 1% 1/2W
A 4 R 27	0698-4271	R FXD FLM 5100 OHM 5% 1/8W
A 4 R 28	0698-4244	R FXD FLM 360 OHM 5% 1/8W
A 4 R 29	0698-4261	R FXD FLM 2000 OHM 5% 1/8W
A 4 R 30	0698-4274	R FXD FLM 6800 OHM 5% 1/8W
A 4 R 31	2100-2795	R VAR 470 OHM
A 4 R 32	0698-4258	R FXD FLM 1500 OHM 5% 1/8W
A 4 R 33	0757-0440	R FXD MET FLM 7500 OHM 1% 1/8W
A 4 R 34	0698-0084	R FXD MET FLM 2150 OHM 1% 1/8W
A 4 R 35	0698-4254	R FXD FLM 1000 OHM 5% 1/8W
A 4 R 36	0698-4267	R FXD FLM 3600 OHM 5% 1/8W
A 4 R 37	0758-0126	R FXD FLM 51 OHM 5% 1/4W
A 4 R 38	0757-0797	R FXD MET FLM 90.9 OHM 1% 1/2W
A 4 R 39	2100-2800	R VAR CERMET 1K OHM 5W
A 4 R 40		NOT ASSIGNED
A 4 R 41	2100-2795	R VAR CERMET 470 OHM 5W
A 4 R 42	0698-4265	R FXD FLM 3000 OHM 5% 1/8W
A 4 R 43	0698-4266	R FXD FLM 3300 OHM 5% 1/8W
A 4 R 44	0698-4253	R FXD FLM 910 OHM 5% 1/8W
A 4 R 45	0698-4244	R FXD FLM 360 OHM 5% 1/8W
A 4 R 46	2100-2795	R VAR CERMET 470 OHM 5W
A 4 R 47	0698-4263	R FXD FLM 2400 OHM 5% 1/8W
A 4 R 48	0698-4269	R FXD FLM 4300 OHM 5% 1/8W
A 4 R 49	0698-4244	R FXD FLM 360 OHM 5% 1/8W
A 4 R 50	0698-4263	R FXD FLM 2400 OHM 5% 1/8W
A 4 R 51	0761-0014	R FXD MET OX 180 OHM 5% 1W

Table 4-1. Reference Designation Index (cont'd)

Reference Designation	HP Stock No.	Description
A 4 R 52	0761-0014	R FXD MET OX 180 OHM 5% 1W
A 4 R 53	0698-4247	R FXD FLM 510 OHM 5% 1/8W
A 4 R 54	0698-4286	R FXD FLM 22K OHM 5% 1/8W
A 4 R 55	0698-4261	R FXD FLM 2000 OHM 5% 1/8W
A 4 R 56	0698-4247	R FXD FLM 510 OHM 5% 1/8W
A 4 R 57	0758-0086	R FXD FLM 100 OHM 5% 1/4W
A 4 R 58	2100-2800	R VAR CERMET 1K OHM 5W
A 4 R 59	0698-4254	R FXD FLM 1000 OHM 5% 1/8W
A 4 R 60	0698-4229	R FXD FLM 75 OHM 5% 1/8W
A 4 R 61	0698-4306	R FXD FLM 150K OHM 5% 1/8W
A 4 R 62	0698-4250	R FXD FLM 680K OHM 5% 1/8W
A 5	08010-66504	INTEGRATOR CH B, SAME AS A4 EXCEPT
A 5 R 63	0758-0068	R FXD FLM 100 OHM 5% 1/8W
A 6	08010-66506	OUTPUT AMPLIFIER CH A
A 6 C 1	0180-0291	C FXD TA ELECT 1 UF 10% 35VDCW
A 6 C 2	0160-2146	C FXD CER .02 UF 880-20% 100VDCW
A 6 C 3	0180-0116	C FXD TA ELECT 6.8 UF 10% 35VDCW
A 6 C 4	0180-0291	C FXD TA ELECT 1 UF 10% 35VDCW
A 6 C 5	0150-0093	C FXD CER .01 UF 880-20% 100VDCW
A 6 C 6	0180-0291	C FXD TA ELECT 1 UF 10% 35VDCW
A 6 C 7	0150-0093	C FXD CER .01 UF 880-20% 100VDCW
A 6 C 8	0160-2139	C FXD CER 220 PF 880-20% 1000VDCW
A 6 C 9	0150-0093	C FXD CER .01 UF 880-20% 100VDCW
A 6 C 10	0180-0291	C FXD TA ELECT 1 UF 10% 35VDCW
A 6 C 11	0160-2143	C FXD CER 2000 PF 880-20% 1000VDCW
A 6 C 12	0150-0050	C FXD CER 1000 PF 600VDCW
A 6 C 13	0150-0093	C FXD CER .01 UF 880-20% 100VDCW
A 6 C 14	0140-0198	C FXD MICA 200 PF 5% 300VDCW
A 6 C 15	0150-0093	C FXD CER .01 UF 880-20% 100VDCW
A 6 C 16	0150-0093	C FXD CER .01 UF 880-20% 100VDCW
A 6 C 17	0150-0121	C FXD CER .1UF 880%-20% 50VDCW
A 6 C 18	0160-2306	C FXD MICA 27 PF 5% 300VDCW
A 6 C 19	0180-0291	C FXD TA ELECT 1 UF 10% 35VDCW
A 6 C 20	0180-0291	C FXD TA ELECT 1 UF 10% 35VDCW
A 6 C 21	0180-0291	C FXD TA ELECT 1 UF 10% 35VDCW
A 6 C 22	0180-0116	C FXD TA ELECT 6.8 UF 10% 35VDCW
A 6 C 23	0150-0093	C FXD CER .01 UF 880-20% 100VDCW
A 6 C 24	0160-2306	C FXD MICA 27 PF 5% 300VDCW
A 6 C 25	0180-0291	C FXD TA ELECT 1 UF 10% 35VDCW
A 6 C 26	0180-0291	C FXD TA ELECT 1 UF 10% 35VDCW
A 6 C 27		NOT ASSIGNED
A 6 C 28	0160-2146	C FXD CER .02 UF 880-20% 100VDCW
A 6 CR 1	1901-0044	DIODE SIL 50PIV 20 MA
A 6 CR 2	1901-0044	DIODE SIL 50PIV 20 MA
A 6 CR 3	1902-0031	DIODE BREAKDOWN 12.7V 5% 400 MW
A 6 CR 4	1902-0556	DIODE BREAKDOWN 20.0V 5% 1W
A 6 CR 5	1902-3140	DIODE BREAKDOWN 8.25V 5%
A 6 CR 6	1902-0032	DIODE BREAKDOWN 5.49V 5% 400 MW
A 6 CR 7	1902-0579	DIODE BREAKDOWN 5.11V 5% 1W
A 6 CR 8	1902-0579	DIODE BREAKDOWN 5.11V 5% 1W
A 6 CR 9	1902-0579	DIODE BREAKDOWN 5.11V 5% 1W
A 6 CR 10	1902-0579	DIODE BREAKDOWN 5.11V 5% 1W
A 6 K 1	0490-0733	REED RELAY SPST 18VDC
A 6 K 2	0490-0733	REED RELAY SPST 18VDC
A 6 K 3	0490-0733	REED RELAY SPST 18VDC

Table 4-1. Reference Designation Index (cont'd)

Reference Designation	HP Stock No.	Description
A 6 L 1	9100-1651	COIL FXD 750.0 UH 5%
A 6 L 2	9100-1630	COIL FXD 51.0 UH 5%
A 6 L 3	9100-1630	COIL FXD 51.0 UH 5%
A 6 L 4	9140-0118	COIL FXD 500 UH 5%
A 6 L 5	9170-0029	COKE FERRITE BEAD
A 6 L 6	9170-0029	CORE FERRITE BEAD
A 6 L 7	9170-0029	CORE FERRITE BEAD
A 6 Q 1	1853-0090	TRANSISTOR SILICON PNP
A 6 Q 2	1853-0090	TRANSISTOR SILICON PNP
A 6 Q 3	1854-0091	TRANSISTOR SILICON NPN
A 6 Q 4	1853-0001	TRANSISTOR SILICON PNP.
A 6 Q 5	1854-0307	TRANSISTOR SILICON NPN
A 6 Q 6	1854-0053	TRANSISTOR SILICON NPN 2N2218
A 6 Q 7	1854-0005	TRANSISTOR SILICON NPN 2N708
A 6 C 8	1854-0260	TRANSISTOR SILICON NPN 2N3227
A 6 Q 9	1853-0203	TRANSISTOR SILICON PNP
A 6 Q 10	1854-0019	TRANSISTOR SILICON NPN
A 6 C 11	1853-0203	TRANSISTOR SILICON PNP
A 6 Q 12	1853-0097	TRANSISTOR SILICON PNP
A 6 Q 13	1853-0097	TRANSISTOR SILICON PNP
A 6 Q 14	1853-0097	TRANSISTOR SILICON PNP
A 6 Q 15	1853-0097	TRANSISTOR SILICON PNP
A 6 Q 16	1854-0329	TRANSISTOR SILICON NPN
A 6 Q 17	1854-0039	TRANSISTOR SILICON NPN 2N3053
A 6 C 18	1853-0090	TRANSISTOR SILICON PNP
A 6 C 19	1854-0329	TRANSISTOR SILICON NPN
A 6 Q 20	1854-0307	TRANSISTOR SILICON NPN
A 6 Q 21	1854-0307	TRANSISTOR SILICON NPN
A 6 C 22	1853-0012	TRANSISTOR SILICON PNP 2N2904A
A 6 Q 23	1853-0012	TRANSISTOR SILICON PNP 2N2904A
A 6 Q 24	5080-1032	TRANSISTOR SILICON NPN SELECTED
A 6 C 25	5080-1032	TRANSISTOR SILICON NPN SELECTED
A 6 Q 26	5080-1032	TRANSISTOR SILICON NPN SELECTED
A 6 C 27	5080-1032	TRANSISTOR SILICON NPN SELECTED
A 6 C 28	1853-0090	TRANSISTOR SILICON PNP
A 6 Q 29	1854-0053	TRANSISTOR SILICON NPN 2N2218
A 6 C 30	1854-0053	TRANSISTOR SILICON NPN 2N2218
A 6 R 1	0698-5330	R FXD FLM 100 OHM 2% 2W
A 6 R 2	0758-0002	R FXD FLM 560 OHM 5% 1/4W
A 6 R 3	0698-5891	R FXD FLM 43 OHM 5% 1/4W
A 6 R 4	0698-5891	R FXD FLM 43 OHM 5% 1/4W
A 6 R 5	0698-4278	R FXD FLM 10K OHM 5% 1/8W
A 6 R 6	0698-4278	R FXD FLM 10K OHM 5% 1/8W
A 6 R 7	0698-4278	R FXD FLM 10K OHM 5% 1/8W
A 6 R 8	0757-0198	R FXD MET FLM 100 OHM 1% 1/2W
A 6 R 9		NCT ASSIGNED
A 6 R 10	0757-0198	R FXD MET FLM 100 OHM 1% 1/2W
A 6 R 11	0757-0411	R FXD MET FLM 332 OHM 1% 1/8W
A 6 R 12	0757-0740	R FXD MET FLM 2210 OHM 1% 1/4W
A 6 R 13	0757-0198	R FXD MET FLM 100 OHM 1% 1/2W
A 6 R 14	0698-3332	R FXD MET FLM 80.6 OHM 1% 1/2W
A 6 R 15	0698-3223	R FXD MET FLM 1.24K OHM 1% 1/8W
A 6 R 16	0757-1095	R FXD MET FLM 1440 OHM 1% 1/8W
A 6 R 17	0698-7032	R FXD FLM 100 OHM 2% 1W
A 6 R 18	0698-7032	R FXD FLM 100 OHM 2% 1W

Table 4-1. Reference Designation Index (cont'd)

Reference Designation	HP Stock No.	Description
A 6 R 19	0698-4244	R FXD FLM 360 OHM 5% 1/8W
A 6 R 20	0698-4264	R FXD FLM 2700 OHM 5% 1/8W
A 6 R 21	2100-2788	R VAR CERMET 4000 OHM
A 6 R 22	0698-4280	R FXD FLM 12K OHM 5% 1/8W
A 6 R 23	0698-4306	R FXD FLM 150K OHM 5% 1/8W
A 6 R 24	0698-4238	R FXD FLM 200 OHM 5% 1/8W
A 6 R 25	0698-4289	R FXD FLM 30K OHM 5% 1/8W
A 6 R 26	0698-4234	R FXD FLM 130 OHM 5% 1/8W
A 6 R 27	0758-0086	R FXD FLM 100 OHM 5% 1/4W
A 6 R 28	0698-4271	R FXD FLM 5100 OHM 5% 1/8W
A 6 R 29	0698-4289	R FXD FLM 30K OHM 5% 1/8W
A 6 R 30	0683-2745	R FXD COMP 270K OHM 5% 1/4W
A 6 R 31	0698-4235	R FXD FLM 150 OHM 5% 1/8W
A 6 R 32	0698-4235	R FXD FLM 150 OHM 5% 1/8W
A 6 R 33	0758-0086	R FXD FLM 100 OHM 5% 1/4W
A 6 R 34	0758-0043	R FXD FLM 1800 OHM 5% 1/4W
A 6 R 35	0698-4275	R FXD FLM 7500 OHM 5% 1/8W
A 6 R 36	0698-4254	R FXD FLM 1000 OHM 5% 1/8W
A 6 R 37	2100-2800	R VAR CERMET 1000 OHM 5%
A 6 R 38	0727-0445	R FXD CARB FLM 2 OHM 1% 1/2W
A 6 R 39	0698-4231	R FXD FLM 91 OHM 5% 1/8W
A 6 R 40	0698-4254	R FXD FLM 1000 OHM 5% 1/8W
A 6 R 41	0757-0794	R FXD MET FLM 68.1 OHM 1% 1/2W
A 6 R 42	0757-0794	R FXD MET FLM 68.1 OHM 1% 1/2W
A 6 R 43	0757-0794	R FXD MET FLM 68.1 OHM 1% 1/2W
A 6 R 44	0757-0794	R FXD MET FLM 68.1 OHM 1% 1/2W
A 6 R 45	0757-0794	R FXD MET FLM 68.1 OHM 1% 1/2W
A 6 R 46	0757-0794	R FXD MET FLM 68.1 OHM 1% 1/2W
A 6 R 47	0757-0794	R FXD MET FLM 68.1 OHM 1% 1/2W
A 6 R 48	0757-0794	R FXD MET FLM 68.1 OHM 1% 1/2W
A 6 R 49	0698-4229	R FXD FLM 75 OHM 5% 1/8W
A 6 R 50	0698-4240	R FXD FLM 240 OHM 5% 1/8W
A 6 R 51	0698-4265	R FXD FLM 3000 OHM 5% 1/8W
A 6 R 52	0757-0273	R FXD MET FLM 3010 OHM 1% 1/8W
A 6 R 53	0757-0433	R FXD MET FLM 3320 OHM 1% 1/8W
A 6 R 54	0757-0431	R FXD MET FLM 2430 OHM 1% 1/8W
A 6 R 55	0757-0440	R FXD MET FLM 7500 OHM 1% 1/8W
A 6 R 56	0758-0044	R FXD FLM 2200 OHM 5% 1/4W
A 6 R 57	0761-0041	R FXD MET 56 OHM 5% 1W
A 6 R 58	0761-0041	R FXD MET 56 OHM 5% 1W
A 6 R 59	0698-4247	R FXD FLM 510 OHM 5% 1/8W
A 6 R 60	0698-4285	R FXD FLM 20K OHM 5% 1/8W
A 6 R 61	0698-4238	R FXD FLM 200 OHM 5% 1/8W
A 6 R 62	0698-4254	R FXD FLM 1000 OHM 5% 1/8W
A 6 R 63	0757-0794	R FXD MET FLM 68.1 OHM 1% 1/2W
A 6 R 64	0757-0794	R FXD MET FLM 68.1 OHM 1% 1/2W
A 6 R 65	0757-0794	R FXD MET FLM 68.1 OHM 1% 1/2W
A 6 R 66	0757-0794	R FXD MET FLM 68.1 OHM 1% 1/2W
A 6 R 67	0757-1000	R FXD MET FLM 51.1 OHM 1% 1/2W
A 6 R 68	0757-1000	R FXD MET FLM 51.1 OHM 1% 1/2W
A 6 R 69	0757-1000	R FXD MET FLM 51.1 OHM 1% 1/2W
A 6 R 70	0698-4264	R FXD FLM 2700 OHM 5% 1/8W
A 6 R 71	2100-2795	R VAR CERMET 470 OHM 5W
A 6 R 72	0698-4238	R FXD FLM 200 OHM 5% 1/8W
A 6 R 73	0698-4264	R FXD FLM 2700 OHM 5% 1/8W
A 6 R 74	0698-4265	R FXD FLM 3000 OHM 5% 1/8W
A 6 R 75	0698-4240	R FXD FLM 240 OHM 5% 1/8W
A 6 R 76	0698-4233	R FXD FLM 120 OHM 5% 1/8W

Table 4-1. Reference Designation Index (cont'd)

Reference Designation	HP Stock No.	Description
A 6 R 77	0698-4247	R FXD FLM 510 OHM 5% 1/8W
A 6 R 78	0761-0041	R FXD MET 56 OHM 5% 1W
A 6 R 79	0761-0041	R FXD MET 56 OHM 5% 1W
A 6 R 80	0758-0044	R FXD FLM 2200 OHM 5% 1/4W
A 6 R 81	0757-0440	R FXD MET FLM 7500 OHM 1% 1/8W
A 6 R 82	0757-0431	R FXD MET FLM 2430 OHM 1% 1/8W
A 6 R 83	2100-2800	R VAR CERMET 1000 OHM 20%
A 6 R 84	0698-4254	R FXD FLM 1000 OHM 5% 1/8W
A 6 R 85	0727-0445	R FXD CARB FLM 2 OHM 1% 1/2W
A 6 R 86	0761-0054	R FXD MET OX 330 OHM 5% 1W
A 6 R 87	0761-0054	R FXD MET OX 330 OHM 5% 1W
A 6 R 88	0698-4252	R FXD FLM 820 OHM 5% 1/8W
A 6 R 89	0698-4261	R FXD FLM 2000 OHM 5% 1/8W
A 6 R 90	0698-4271	R FXD MET FLM 5110 OHM 5% 1/8W
A 6 R 91	2100-2741	R VAR VERMET 470 OHM 20% 1/2W
A 6 R 92	0698-4261	R FXD FLM 2000 OHM 5% 1/8W
A 6 R 93	0698-4261	R FXD FLM 2000 OHM 5% 1/8W
A 6 R 94		NOT ASSIGNED
A 6 R 95	0698-4261	R FXD FLM 2000 OHM 5% 1/8W
A 6 R 96	0698-4268	R FXD FLM 3.9K OHM 5% 1/8W
A 6 R 97	0698-4253	R FXD FLM 910 OHM 5% 1/8W
A 6 R 98		SELECTED ON TEST
A 6 R 99	2100-2600	R VAR CERMET 1000OHM 20% 2W
A 7	08010-66507	OUTPUT AMPLIFIER CH B, SAME AS A6 EXCEPT REED RELAY SPST 18VDCW
A 7 K 4	0490-0733	
A 7 R 21	2100-2788	R VAR CERMET 4.7K OHM
A 7 R 39	0698-5702	R FXD FLM 30 OHM 5% 1/8W
A 7 R 61	0698-4238	R FXD FLM 160 OHM 5% 1/8W
A 7 R 71	2100-2741	R VAR VERMET 470 OHM 20% 1/2W
A 8	08010-66508	ATTENUATOR ASSY, CH A
A 8 L 1	9170-0029	CORE FERRITE BEAD
A 8 L 2	9170-0029	CORE FERRITE BEAD
A 8 L 3	9170-0029	CORE FERRITE BEAD
A 8 L 4	9140-0118	CCIL FXD 500 UH 5%
A 8 R 1	0757-0801	R FXD MET FLM 150 OHM 1% 1/2W
A 8 R 2	0757-0172	R FXD MET FLM 37.4 OHM 1% 1/2W
A 8 R 3	0757-0801	R FXD MET FLM 150 OHM 1% 1/2W
A 8 R 4	0757-0795	R FXD MET FLM 75 OHM 1% 1/2W
A 8 R 5	0757-0069	R FXD MET FLM 121 OHM 1% 1/4W
A 8 R 6	0757-0795	R FXD MET FLM 75 OHM 1% 1/2W
A 8 R 7	0757-1005	R FXD MET FLM 61.11 OHM .25% 1/2W
A 8 R 8	0757-0071	R FXD MET FLM 247.5 OHM 1% 1/4W
A 8 R 9	0757-1005	R FXD MET FLM 61.11 OHM .25% 1/2W
A 8 R 10	0698-4253	R FXD FLM 910 OHM 5% 1/8W
A 8 R 11	0698-4268	R FXD FLM 3.9K OHM 5% 1/8W
A 8 S 1	3100-0530	SWITCH ROTARY
A 9	08010-66509	DC OFFSET ASSY
A 9 C 1	0180-0049	C FXD AL ELECT 20 UF 815-10% 50VDCW
A 9 C 2	0180-0291	C FXD TA ELECT 1 UF 10% 35VDCW
A 9 C 3	0180-0291	C FXD TA ELECT 1 UF 10% 35VDCW
A 9 C 4	0180-0049	C FXD AL ELECT 20 UF 815-10% 50VDCW
A 9 C 5	0180-0049	C FXD AL ELECT 20 UF 815-10% 50VDCW
A 9 C 6	0180-0291	C FXD TA ELECT 1 UF 10% 35VDCW
A 9 C 7	0180-0291	C FXD TA ELECT 1 UF 10% 35VDCW
A 9 C 8	0180-0049	C FXD AL ELECT 20 UF 815-10% 50VDCW

Table 4-1. Reference Designation Index (cont'd)

Reference Designation	HP Stock No.	Description
A 9 L 1	9170-0029	CORE FERRITE BEAD
A 9 L 2	9170-0029	CORE FERRITE BEAD
A 9 L 3	9170-0029	CORE FERRITE BEAD
A 9 L 4	9170-0029	CORE FERRITE BEAD
A 9 Q 1	1853-0051	TRANSISTOR SILICON PNP 2N4037
A 9 Q 2	1854-0329	TRANSISTOR SILICON NPN
A 9 Q 3	1854-0039	TRANSISTOR SILICON NPN 2N3053
A 9 C 4	1853-0090	TRANSISTOR SILICON PNP
A 9 C 5	1853-0051	TRANSISTOR SILICON PNP 2N4037
A 9 Q 6	1854-0329	TRANSISTOR SILICON NPN
A 9 Q 7	1854-0039	TRANSISTOR SILICON NPN 2N3053
A 9 Q 8	1853-0090	TRANSISTOR SILICON PNP
A 9 R 1	0758-0029	R FXD FLM 470 OHM 5% 1/4W
A 9 R 2	0758-0029	R FXD FLM 470 OHM 5% 1/4W
A 9 R 3	0758-0029	R FXD FLM 470 OHM 5% 1/4W
A 9 R 4	0757-0280	R FXD FLM 1000 OHM 1% 1/8W
A 9 R 5	0757-0288	R FXD FLM 9090 OHM 1% 1/8W
A 9 R 6	0698-4261	R FXD FLM 2000 OHM 5% 1/8W
A 9 R 7	0698-4247	R FXD FLM 510 OHM 5% 1/8W
A 9 R 8	0698-4247	R FXD FLM 510 OHM 5% 1/8W
A 9 R 9	0698-4261	R FXD FLM 2000 OHM 5% 1/8W
A 9 R 10	0758-0029	R FXD FLM 470 OHM 5% 1/4W
A 9 R 11	0758-0029	R FXD FLM 470 OHM 5% 1/4W
A 9 R 12	0758-0029	R FXD FLM 470 OHM 5% 1/4W
A 9 R 13	0757-0280	R FXD FLM 1000 OHM 1% 1/8W
A 9 R 14	0757-0288	R FXD FLM 9090 OHM 1% 1/8W
A 9 R 15	0758-0029	R FXD FLM 470 OHM 5% 1/4W
A 9 R 16	0758-0029	R FXD FLM 470 OHM 5% 1/4W
A 9 R 17	0758-0029	R FXD FLM 470 OHM 5% 1/4W
A 9 R 18	0757-0280	R FXD FLM 1000 OHM 1% 1/8W
A 9 R 19	0757-0288	R FXD FLM 9090 OHM 1% 1/8W
A 9 R 20	0698-4261	R FXD FLM 2000 OHM 5% 1/8W
A 9 R 21	0698-4247	R FXD FLM 510 OHM 5% 1/8W
A 9 R 22	0698-4247	R FXD FLM 510 OHM 5% 1/8W
A 9 R 23	0698-4261	R FXD FLM 2000 OHM 5% 1/8W
A 9 R 24	0758-0029	R FXD FLM 470 OHM 5% 1/4W
A 9 R 25	0758-0029	R FXD FLM 470 OHM 5% 1/4W
A 9 R 26	0758-0029	R FXD FLM 470 OHM 5% 1/4W
A 9 R 27	0757-0280	R FXD FLM 1000 OHM 1% 1/8W
A 9 R 28	0757-0288	R FXD FLM 9090 OHM 1% 1/8W
A 9 R 29	0757-0442	R FXD FLM 10K OHM 1% 1/8W
A 9 R 30	0757-0442	R FXD FLM 10K OHM 1% 1/8W
A 11	08010-66511	POWER SUPPLY ASSY
A 11 C 1	0180-0050	C FXD AL ELECT 40 UF 875-10% 50VDCW
A 11 C 2	0160-2146	C FXD CER .02 UF 880-20% 100VDCW
A 11 C 3	0180-0228	C FXD TA ELECT 22 UF 10% 15VDCW
A 11 C 4	0180-0050	C FXD AL ELECT 40 UF 875-10% 50VDCW
A 11 C 5	0160-2146	C FXD CER .02 UF 880-20% 100VDCW
A 11 C 6	0180-0228	C FXD TA ELECT 22 UF 10% 15VDCW
A 11 C 7	0160-2205	C FXD MICA 120 PF 5% 300VDCW
A 11 C 8	0180-0094	C FXD AL ELECT 100 UF 815-10% 25VDCW
A 11 CR 1	1901-0522	DIODE SILICON 100V PIV
A 11 CR 2	1901-0522	DIODE SILICON 100V PIV
A 11 CR 3	1901-0522	DIODE SILICON 100V PIV
A 11 CR 4	1901-0522	DIODE SILICON 100V PIV
A 11 CR 5	1902-0041	DIODE BREAKDOWN 5.11V 5% 400 MW
A 11 CR 6	1902-0173	DIODE BREAKDOWN 9.53V 5% 400 MW

Table 4-1. Reference Designation Index (cont'd)

Reference Designation	HP Stock No.	Description
A 11 CR 7	1901-0522	DIODE SILICON 100V PIV
A 11 CR 8	1901-0522	DIODE SILICON 100V PIV
A 11 CR 9	1901-0522	DIODE SILICON 100V PIV
A 11 CR 10	1901-0522	DIODE SILICON 100V PIV
A 11 CR 11	1902-0041	DIODE BREAKDOWN 5.11V 5% 400 MW
A 11 CR 12	1902-C173	DIODE BREAKDOWN 9.53V 5% 400 MW
A 11 Q 1	1854-0307	TRANSISTOR SILICON NPN
A 11 C 2		NOT ASSIGNED
A 11 C 3	1854-0090	TRANSISTOR SILICON NPN
A 11 Q 4	1854-0329	TRANSISTOR SILICON NPN
A 11 C 5	1854-0039	TRANSISTOR SILICON NPN 2N3053
A 11 Q 6	1854-0039	TRANSISTOR SILICON NPN 2N3053
A 11 C 7	1854-C090	TRANSISTOR SILICON NPN
A 11 C 6	1854-0329	TRANSISTOR SILICON NPN
A 11 R 1	0698-4254	R FXD FLM 1000 OHM 5% 1/8W
A 11 R 2	0698-4266	R FXD FLM 3300 OHM 5% 1/8W
A 11 R 3	0758-0124	R FXD FLM 51 OHM 5% 1/4W
A 11 R 4	0698-4278	R FXD FLM 10K OHM 5% 1/8W
A 11 R 5	0758-0043	R FXD FLM 1800 OHM 5% 1/4W
A 11 R 6	0698-4261	R FXD FLM 2000 OHM 5% 1/8W
A 11 R 7	0698-4260	R FXD FLM 1800 OHM 5% 1/8W
A 11 R 8	2100-2795	R VAR CERMET 470 OHM
A 11 R 9	0698-4254	R FXD FLM 1000 OHM 5% 1/8W
A 11 R 10	0812-0017	R FXD WW .25 OHM 5% 3W
A 11 R 11	0698-4254	R FXD FLM 1000 OHM 5% 1/8W
A 11 R 12	0698-4266	R FXD FLM 3300 OHM 5% 1/8W
A 11 R 13	0758-0124	R FXD FLM 51 OHM 5% 1/4W
A 11 R 14	0698-4278	R FXD FLM 10K OHM 5% 1/8W
A 11 R 15	0758-0043	R FXD FLM 1800 OHM 5% 1/4W
A 11 R 16	0698-4261	R FXD FLM 2000 OHM 5% 1/8W
A 11 R 17	0698-4260	R FXD FLM 1800 OHM 5% 1/8W
A 11 R 18	2100-2795	R VAR CERMET 470 OHM
A 11 R 19	0698-4254	R FXD FLM 1000 OHM 5% 1/8W
A 11 R 20	0812-0017	R FXD WW .25 OHM 5% 3W
A 11 R 21	0698-3229	R FXD CERMET 1K OHM
A 11 R 22	0698-4244	R FXD FLM 360 OHM 5% 1/8W
A 11 R 23	0757-0437	R FXD MET FLM 4750 OHM 1% 1/8W
A 11 R 24	0698-4285	R FXD FLM 20K OHM 5% 1/8W
A 12	08010-61901	ASSY REP RATE SWITCH
A 12 S 1	2100-0225	R VAR 5K OHM
A 13	08010-61902	ASSY DELAY SWITCH CH A
A 13 S 1	2100-0225	R VAR 5K OHM
A 14	08010-61903	ASSY DELAY SWITCH CH B
A 14 S 1	2100-0225	R VAR 5K OHM
A 15	08010-61904	ASSY WIDTH SWITCH CH A
A 15 S 1	2100-0225	R VAR 5K OHM
A 16	08010-61905	ASSY WIDTH SWITCH CH B
A 16 S 1	2100-0225	R VAR 5K OHM
A 17	08010-63401	ASSY ATTEN. CONTAINS ASSY'S A8/A9
A 17		ASSY'S A8 / A9

Table 4-1. Reference Designation Index (cont'd)

Reference Designation	HP Stock No.	Description
A 18	08010-61906	ASSY TRANS, TIME SWITCH CH A
A 19	08010-61907	ASSY TRANS, TIME SWITCH CH B
C 1	0180-0198	C FXD AL ELECT 1500 UF 50VDCW
C 2	0180-0198	C FXD AL ELECT 1500 UF 50VDCW
J 1	1250-0118	CONNECTOR GATE INPUT
J 2	1250-0118	CONNECTOR TRIGGER INPUT
J 3	1250-0118	CONNECTOR TRIGGER OUTPUT
J 4		NSRP OF A 17
J 5		NSRP OF A 17
J 6	1250-0118	SEPARATE TRIGGERING A
J 7	1250-0118	SEPARATE TRIGGERING B
J 8	1251-2357	AC LINE
Q 1	1854-0063	TRANSISTOR SILICCN NPN 2N3055
Q 2	1854-0063	TRANSISTOR SILICCN NPN 2N3055
Q 3	1853-0052	TRANSISTOR SILICCN PNP 2N3740
R 1	2100-2600	R VAR CERMET 100 OHM 20% 2W
R 2	2100-2600	R VAR CERMET 100 OHM 20% 2W
R 3	2100-2146	R VAR CCMP 10K OHM 20% 3/10W
R 4	2100-2146	R VAR COMP 10K OHM 20% 3/10W
R 5	2100-1577	R VAR WW DUAL 1200 OHM 10% LIN 3W
R 6	2100-1577	R VAR WW DUAL 1200 OHM 10% LIN 3W
R 7	2100-1577	R VAR WW DUAL 1200 OHM 10% LIN 3W
R 8	2100-1577	R VAR WW DUAL 1200 OHM 10% LIN 3W
S 1		NOT ASSIGNED
S 2	3101-0199	SWITCH SINGLE-DOUBLE PULSE CHA.
S 3	3101-0199	SWITCH SINGLE-DOUBLE PULSE CHB
S 4		NOT ASSIGNED
S 5		NOT ASSIGNED
S 6		NOT ASSIGNED
S 7		NOT ASSIGNED
S 8	3101-0199	SWITCH SQUARE-PULSE CHA
S 9	3101-0199	SWITCH SQUARE-PULSE CHB
S 10	3101-0199	SWITCH OFFSET ON-OFF CHA
S 11	3101-0199	SWITCH OFFSET ON-OFF CHB
S 12	3101-0199	SWITCH SEP-A+B.
S 13	3101-0199	SWITCH PULSE POLARITY CHA.
S 14	3101-0199	SWITCH PULSE POLARITY CHB
S 15	3101-1327	SWITCH SYNCH-NORM-ASYN.
S 16	3101-0124	SWITCH MAN
S 17	3101-1244	SWITCH PUSH ON-OFF
S 18	3101-0033	SWITCH LINE VOLTAGE
S 19	3101-0199	SWITCH DELAY MODE
S 20	3101-0199	SWITCH SEPARATE TRIGGERING ON-OFF CHB
S 21	3101-0199	SWITCH SEPARATE TRIGGERING ON-OFF CHA.
S 22	3101-0199	SWITCH NORM 5V-PAR 10V
	1490-0030	STAND TILT
	5000-0479	DIAL-INSERT.
	5060-0767	FOOT ASSY FM
	5060-0776	KIT 7H RACK MOUNT
	01402-23201	COUPLER, PLASTIC
	01821-01205	BRACKET SWEEP-DIAL
	08010-04001	DIAL, REP. RATE
	08010-04002	DIAL, PULSE DELAY
	08010-04003	DIAL, PULSE WIDTH
	08010-04003	DIAL, PULSE WIDTH

Table 4-1. Reference Designation Index (cont'd)

Reference Designation	HP Stock No.	Description
	08005-04101	COVER HEAT-SINK
	08010-04004	DIAL-DELAY-WIDTH-VERNIER
	08010-04005	DIAL-REP.RATE-VERNIER
	08010-04006	DIAL-VERNIER
	08010-04007	DIAL-FALL RISE-TIME
	08010-04008	DIAL-TRANSITION TIME
	08010-04009	DIAL-AMPLITUDE
	08010-04101	TOP- COVER ASSY-16LFM
	08010-61602	ATTENUATOR SET OF COAX CABLES
	08010-61603	ASSY CABLE MAIN
	08010-61605	ASSY CABLE DELAY-SWITCH CHA A
	08010-61606	ASSY CABLE DELAY-SWITCH CHA B
	08010-61607	ASSY CABLE WIDTH-SWITCH CHA A
	08010-61608	ASSY CABLE WIDTH-SWITCH CHA B
	08010-61610	ASSY CABLE TIMING
	08010-61611	ASSY CABLE SHLD.POWER
	08010-61612	ASSY CABLE COAX
	08010-67401	ASSY KNCB REP-RATE
	08010-67402	ASSY KNOB DELAY-WIDTH CHA A
	08010-67403	ASSY KNCB DELAY-WIDTH CHA B
	08010-67404	ASSY KNCB TRANS.-TIME-SWITCH CHA A
	08010-67405	ASSY KNCB TRANS.-TIME-SWITCH CHA B
	08010-67406	ASSY KNOB RISE-FALL-VERNIER CHA A
	08010-67407	ASSY KNOB RISE-FALL-VERNIER CHA B
	08010-67408	ASSY KNCB AMPLITUDE CHA A
	08010-67409	ASSY KNCB AMPLITUDE CHA B
	08010-67410	ASSY KNCB VERNIER CHA A
	08010-67411	ASSY KNCB VERNIER CHA B











SECTION V CIRCUIT DIAGRAMS

5-1 INTRODUCTION

5-2 This section contains the circuit diagrams and component location drawings necessary for the maintenance of the Model 8010A. Table 5-1 lists notes which apply to the schematic diagrams.

5-2 This section contains the circuit diagrams and component location drawings necessary for the maintenance of the Model 8010A. Table 5-1 lists notes which apply to the schematic diagrams.

Table 5-1. Schematic Diagram Notes

Refer to MIL-STD-15-1 for schematic symbols not listed in this table.												
<p>Unless otherwise indicated: capacitance in microfarads inductance in microhenries resistance in ohms</p>	<div style="display: flex; align-items: center; justify-content: center; margin-bottom: 20px;">  = Waveform test point (with number) </div> <div style="display: flex; align-items: center; justify-content: center; margin-bottom: 20px;"> <div style="display: flex; align-items: center; margin-right: 20px;">  = Front panel marking </div> <div style="text-align: center;"> <p style="margin: 0;">All switch positions shown ccw. * → indicates position.</p>  </div> </div> <div style="display: flex; align-items: center; justify-content: center; margin-bottom: 20px;"> <div style="display: flex; align-items: center; margin-right: 20px;">  = Rear panel marking </div> <div style="display: flex; align-items: center; margin-right: 20px;">  = Optimum value selected at factory </div> <div style="display: flex; align-items: center; margin-right: 20px;">  = Indicates screwdriver adj. </div> <div style="display: flex; align-items: center; margin-right: 20px;">  = Part of </div> <div style="display: flex; align-items: center; margin-right: 20px;">  = Primary signal path </div> <div style="display: flex; align-items: center; margin-right: 20px;">  = Feedback path </div> </div>	<div style="display: flex; align-items: center; justify-content: center; margin-bottom: 20px;">  = Avalanche (zener) diode </div> <p style="margin-bottom: 10px;">Numbers in box indicate wire color using resistor color code, e.g. WHT-RED-GRN is 9 2 5</p> <table style="width: 100%; border: none;"> <tr> <td style="width: 33%;">0 - Black</td> <td style="width: 33%;">5 - Green</td> </tr> <tr> <td>1 - Brown</td> <td>6 - Blue</td> </tr> <tr> <td>2 - Red</td> <td>7 - Violet</td> </tr> <tr> <td>3 - Orange</td> <td>8 - Gray</td> </tr> <tr> <td>4 - Yellow</td> <td>9 - White</td> </tr> </table>	0 - Black	5 - Green	1 - Brown	6 - Blue	2 - Red	7 - Violet	3 - Orange	8 - Gray	4 - Yellow	9 - White
0 - Black	5 - Green											
1 - Brown	6 - Blue											
2 - Red	7 - Violet											
3 - Orange	8 - Gray											
4 - Yellow	9 - White											

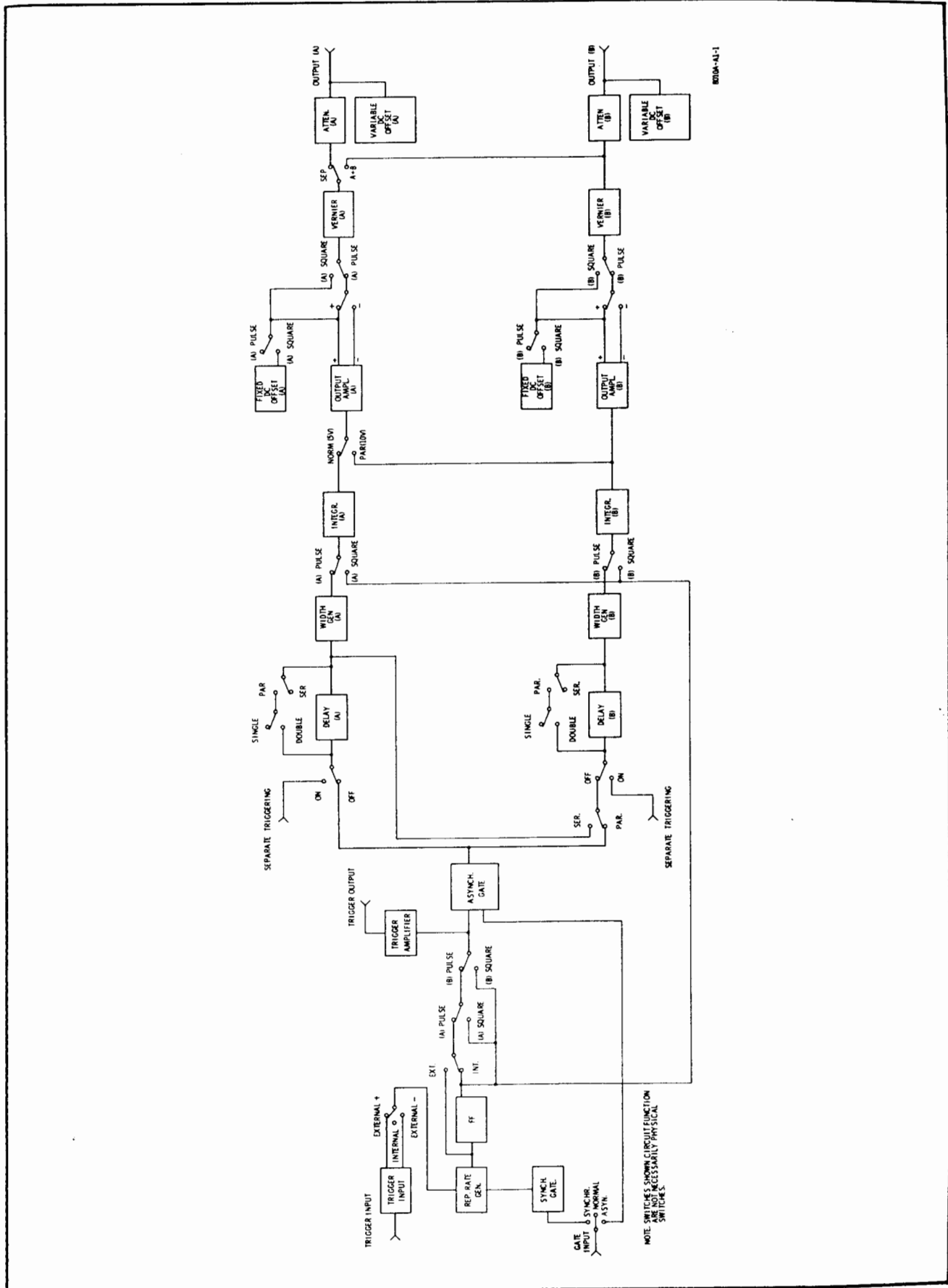

Figure 5-1. Block Diagram of 8010A

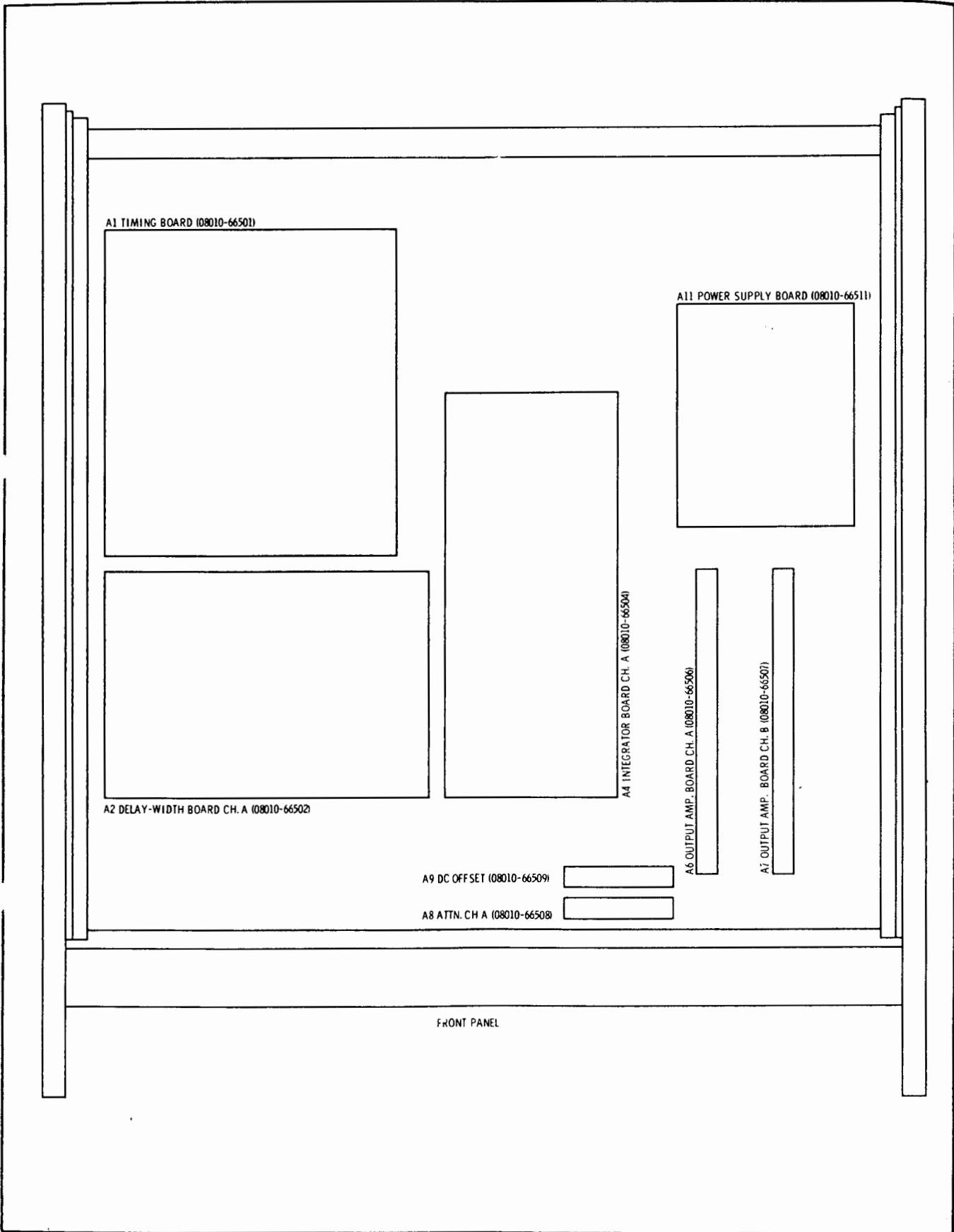

Figure 5-2. Top View

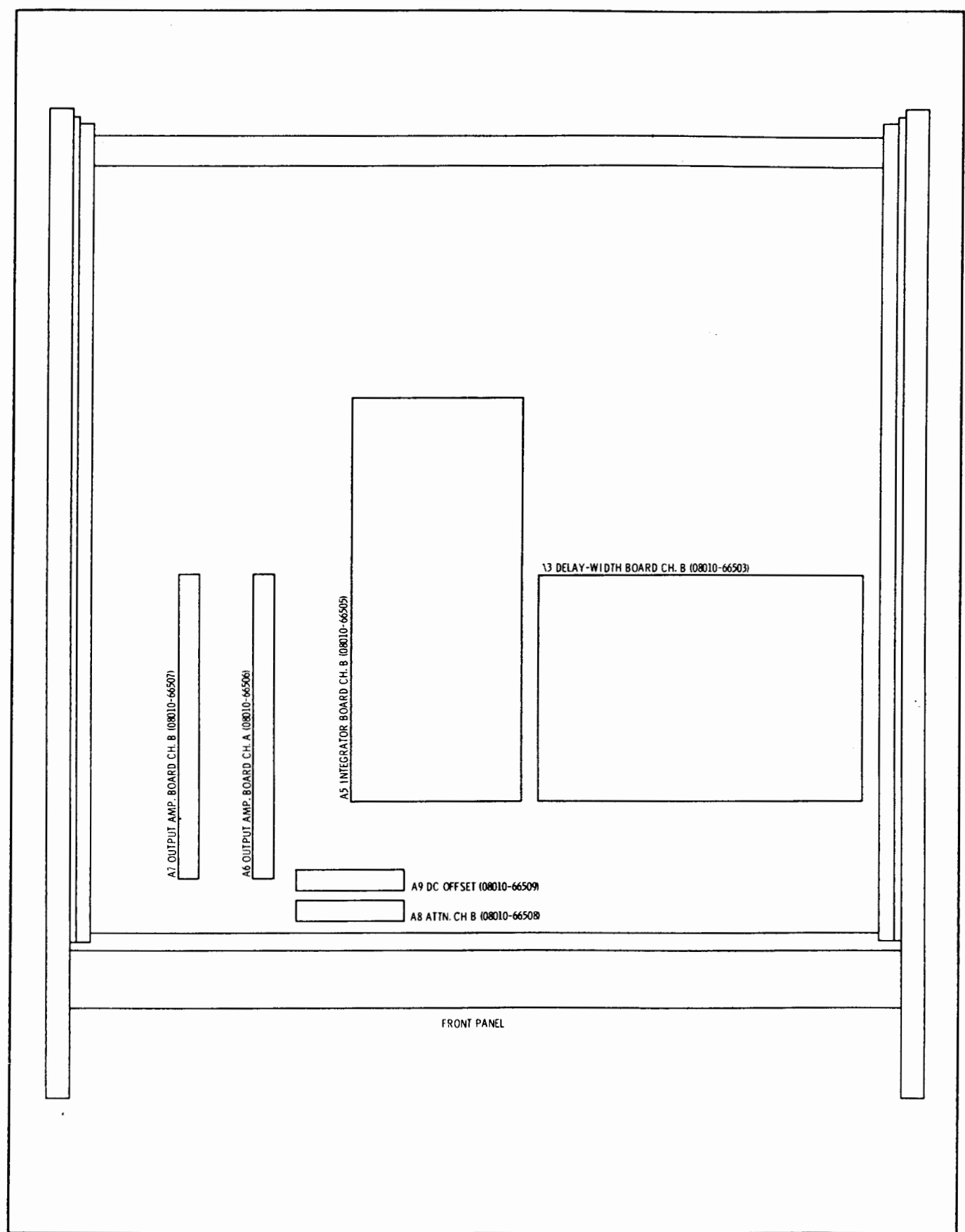
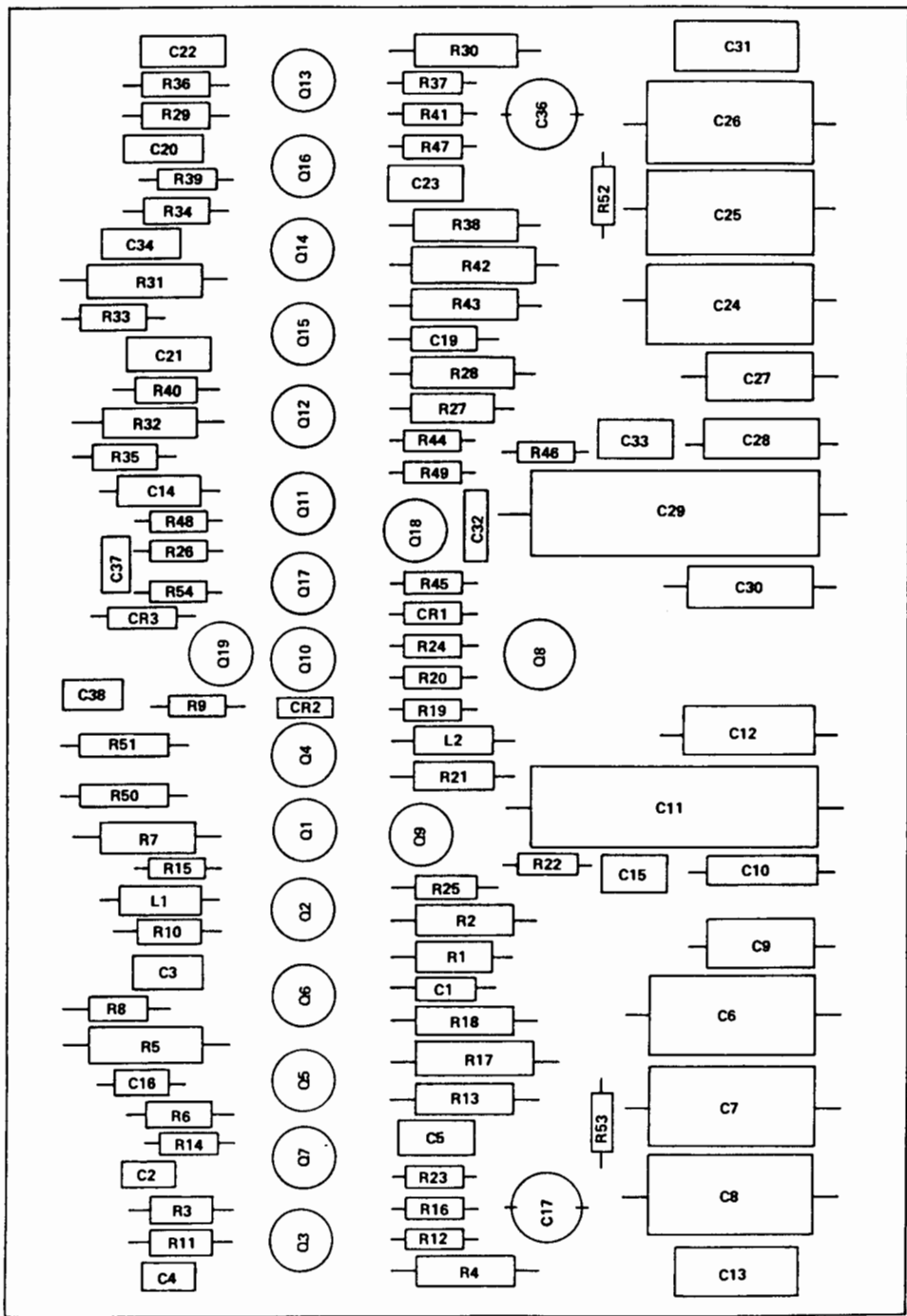

Figure 5-3. Bottom View

08010-66503
08010-66502



8010A-A3-5
8010A-A3-6

Figure 5-5. Assembly A2 and A3 Component Location

08010-66504 08010-66505

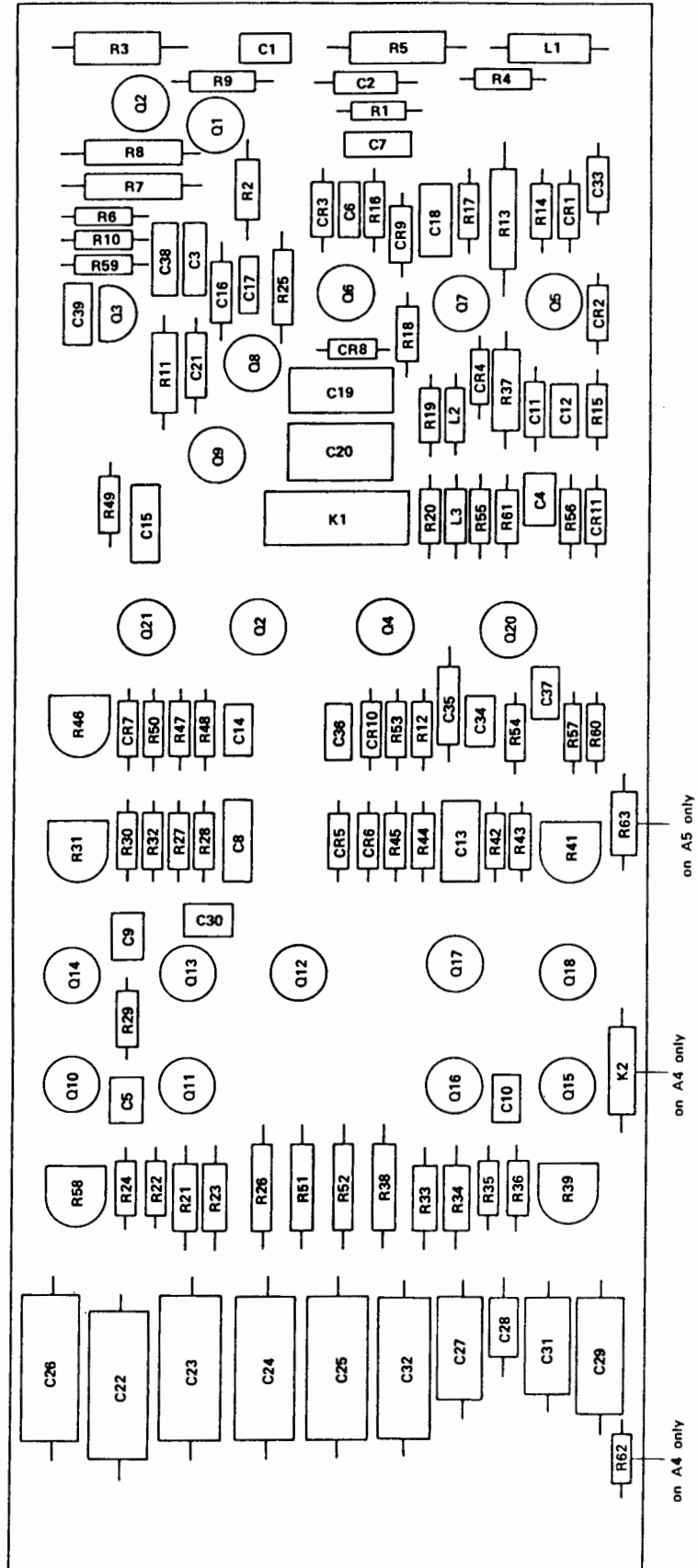
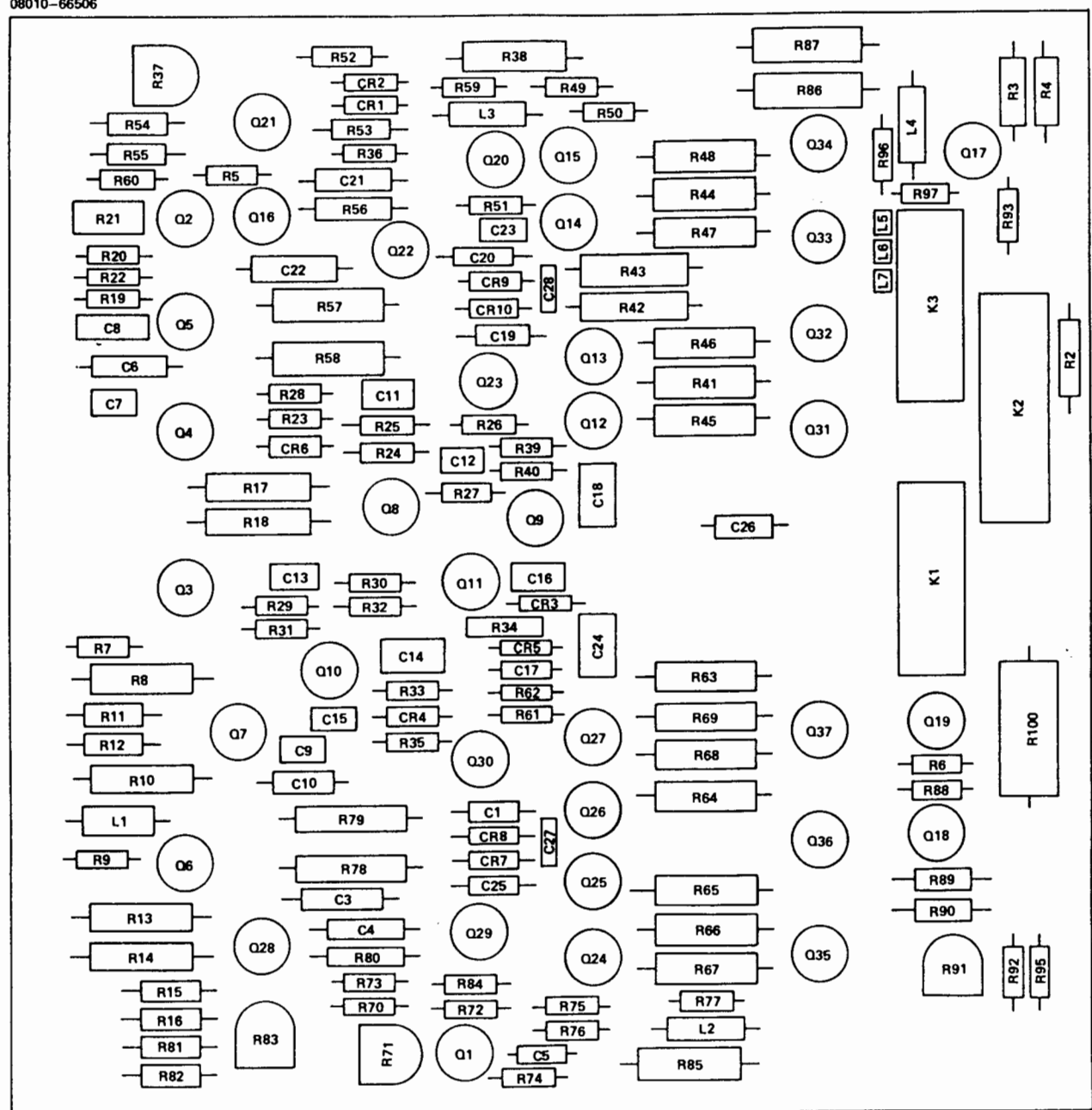

Figure 5-6. Assembly A4 and A5 Component Location

8010A-A3-8
8010A-A3-7

08010-66506



8010A-A3-9

Figure 5-7. Assembly A6 Component Location

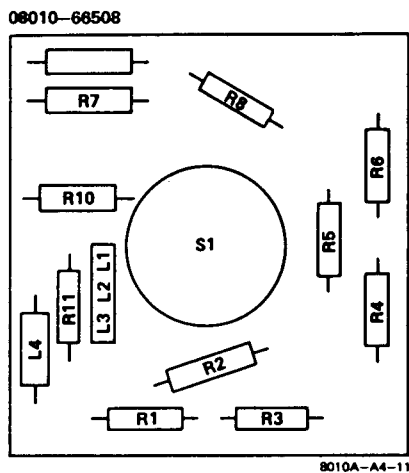

Figure 5-9. Assembly A8 Component Location

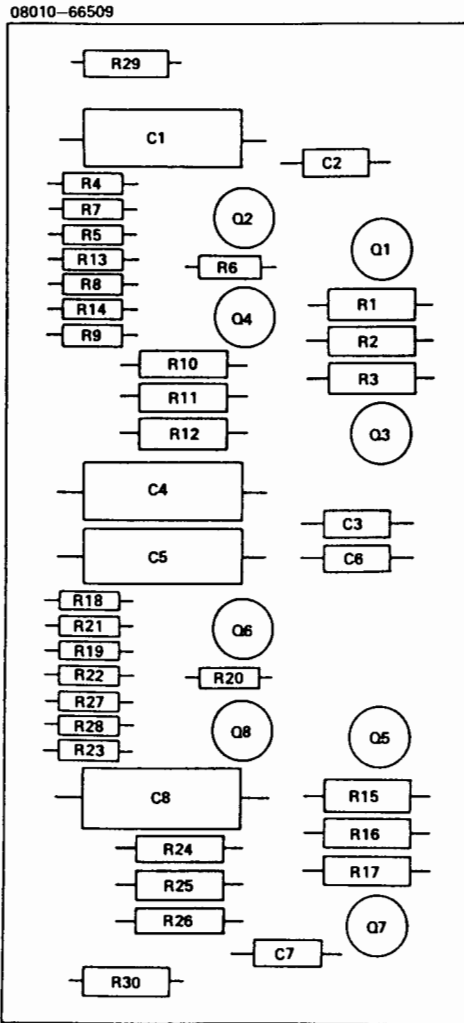
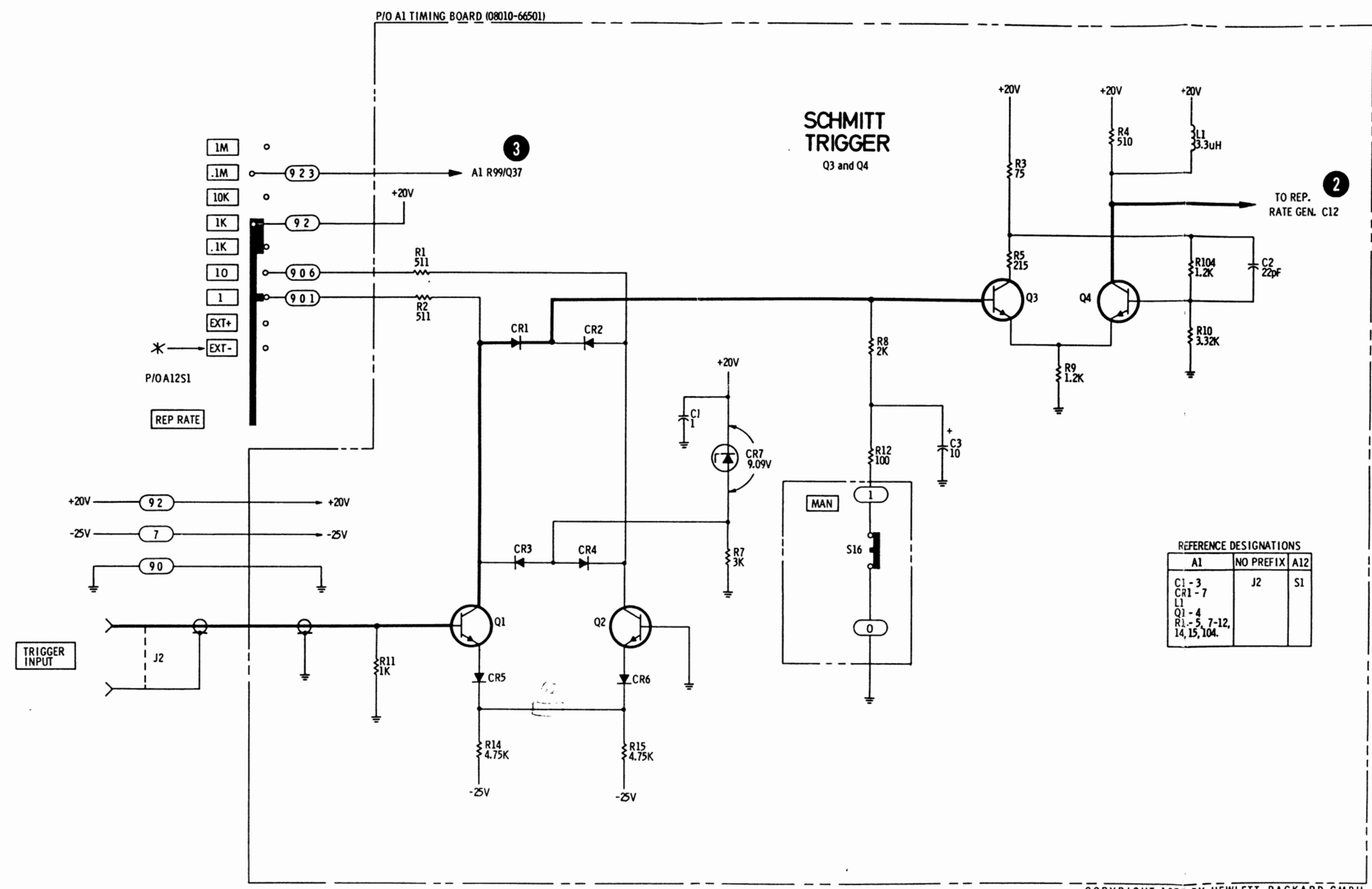

Figure 5-10. Assembly A9 Component Location



COPYRIGHT 1970 BY HEWLETT-PACKARD GMBH
8010A-TIMING BOARD-958

Figure 5-12. Trigger Input Circuit

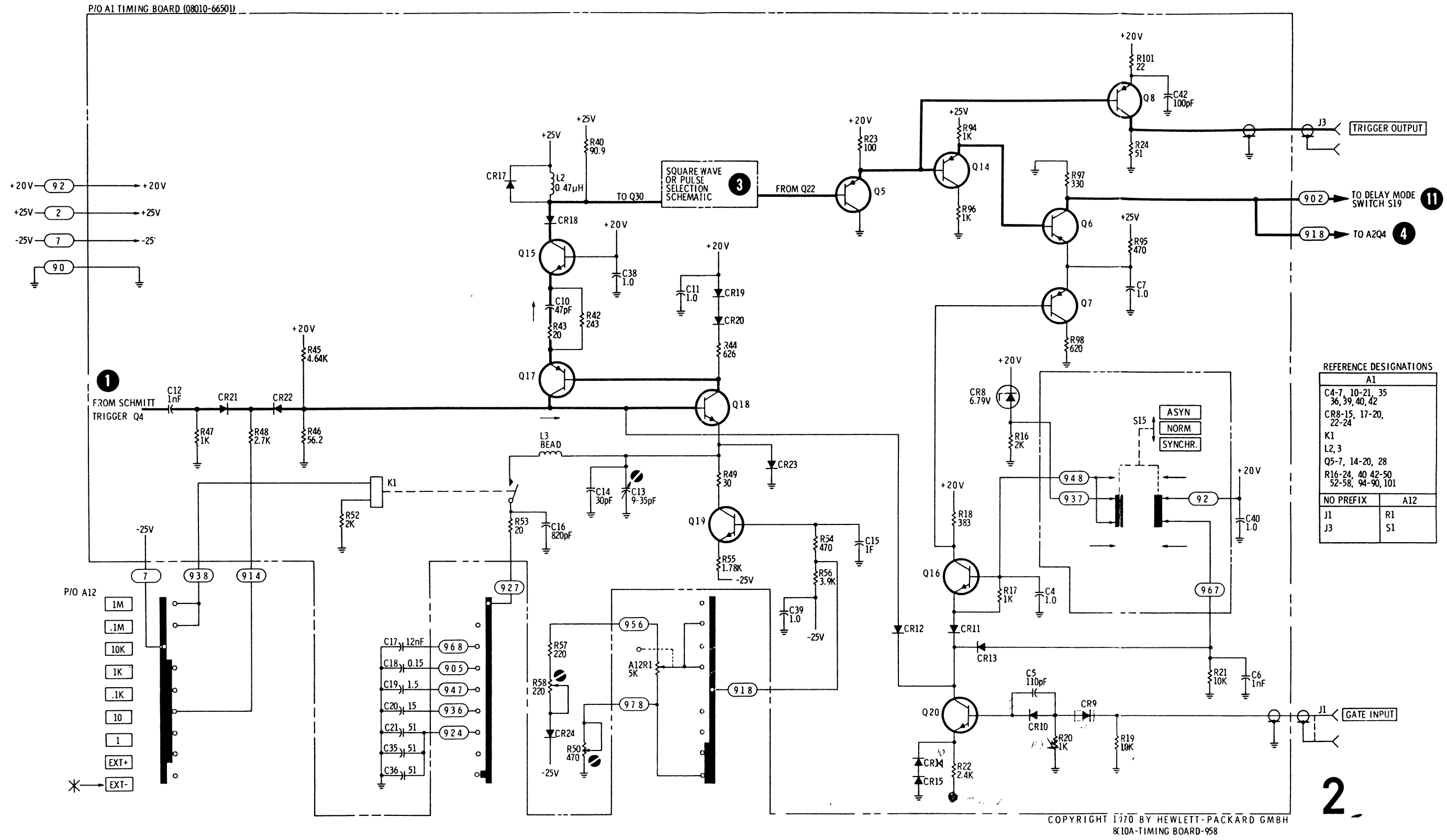

Figure 5-13. Rep. Rate and Gate Input Circuit

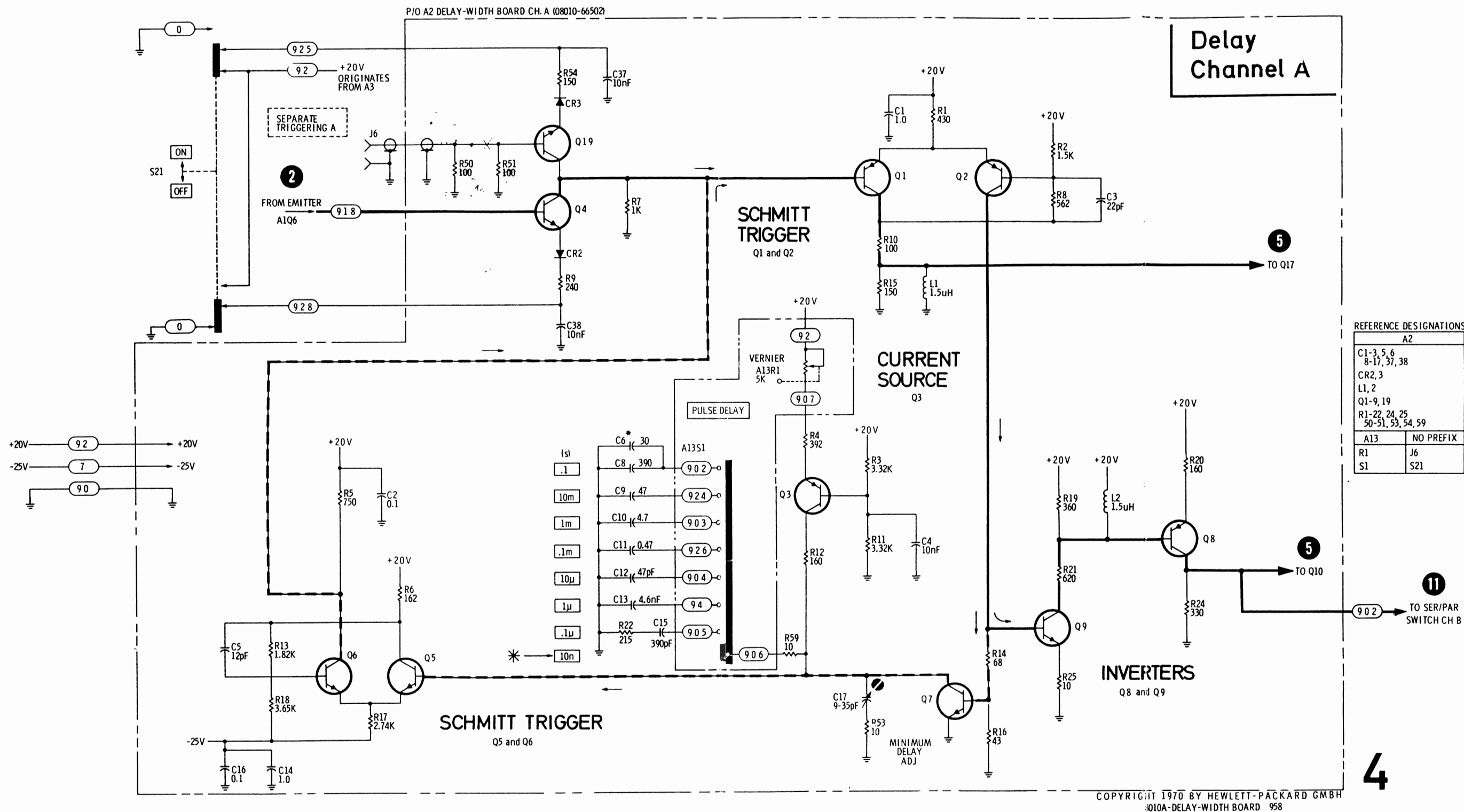

Figure 5-15. Delay Channel A Circuit

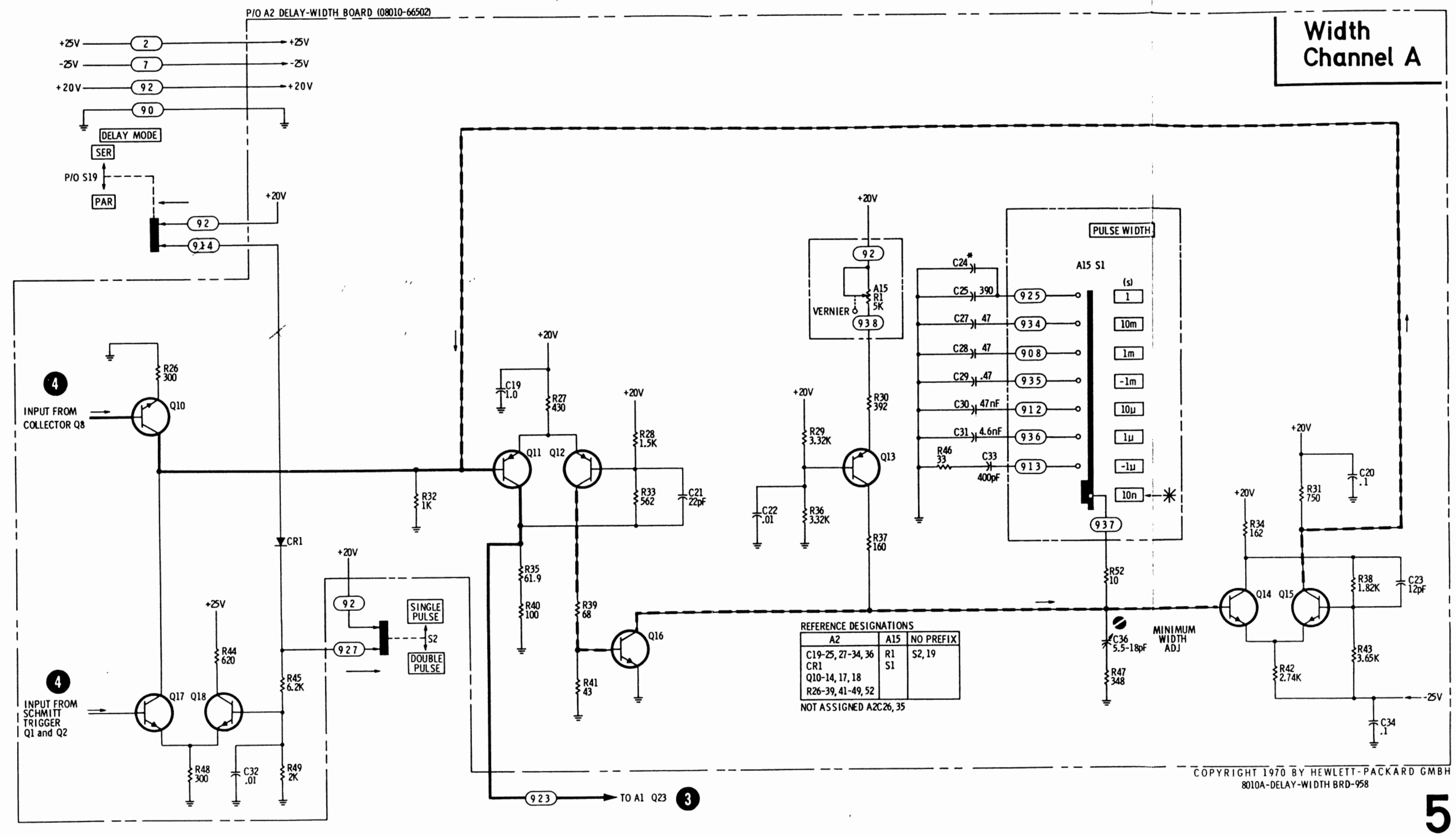
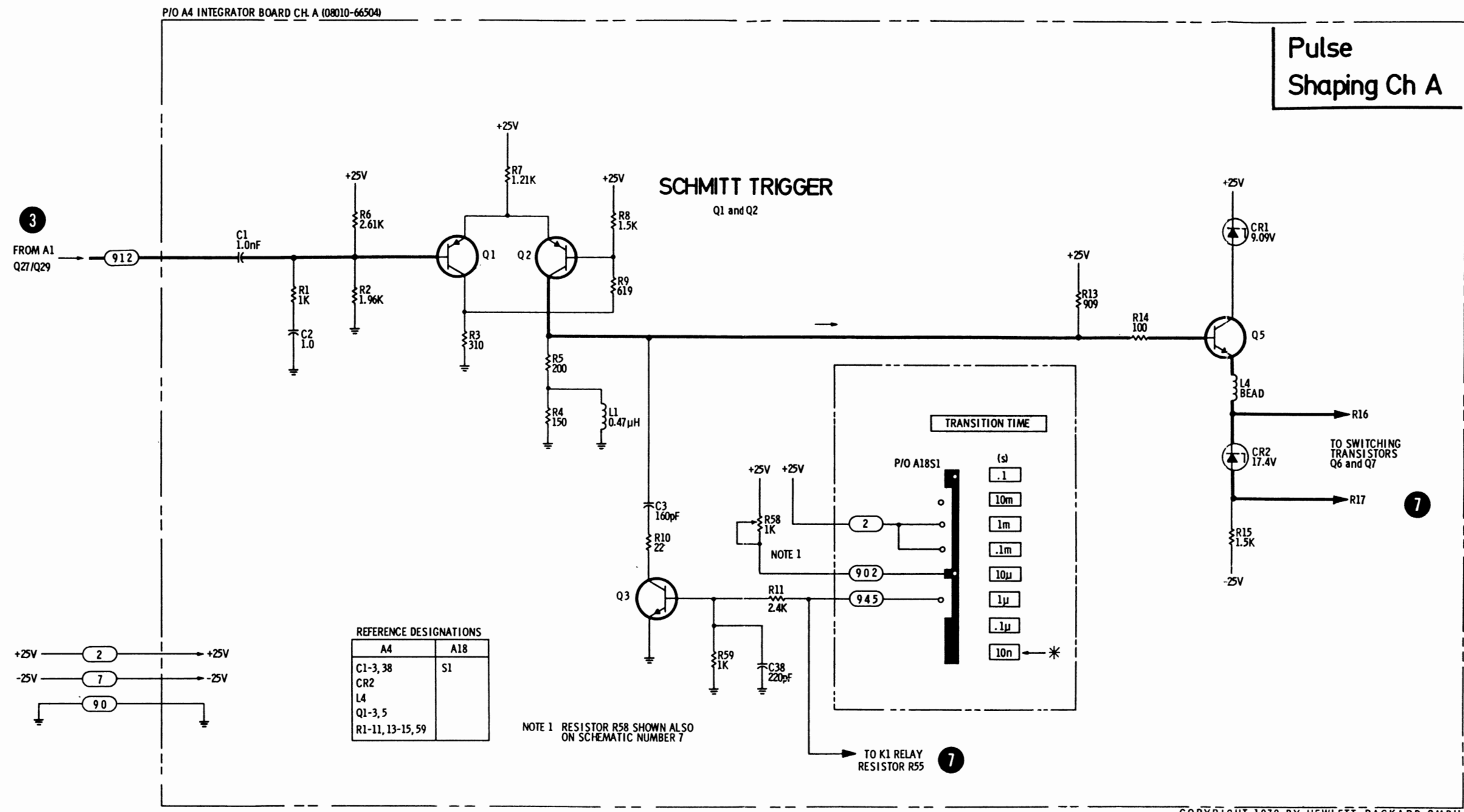
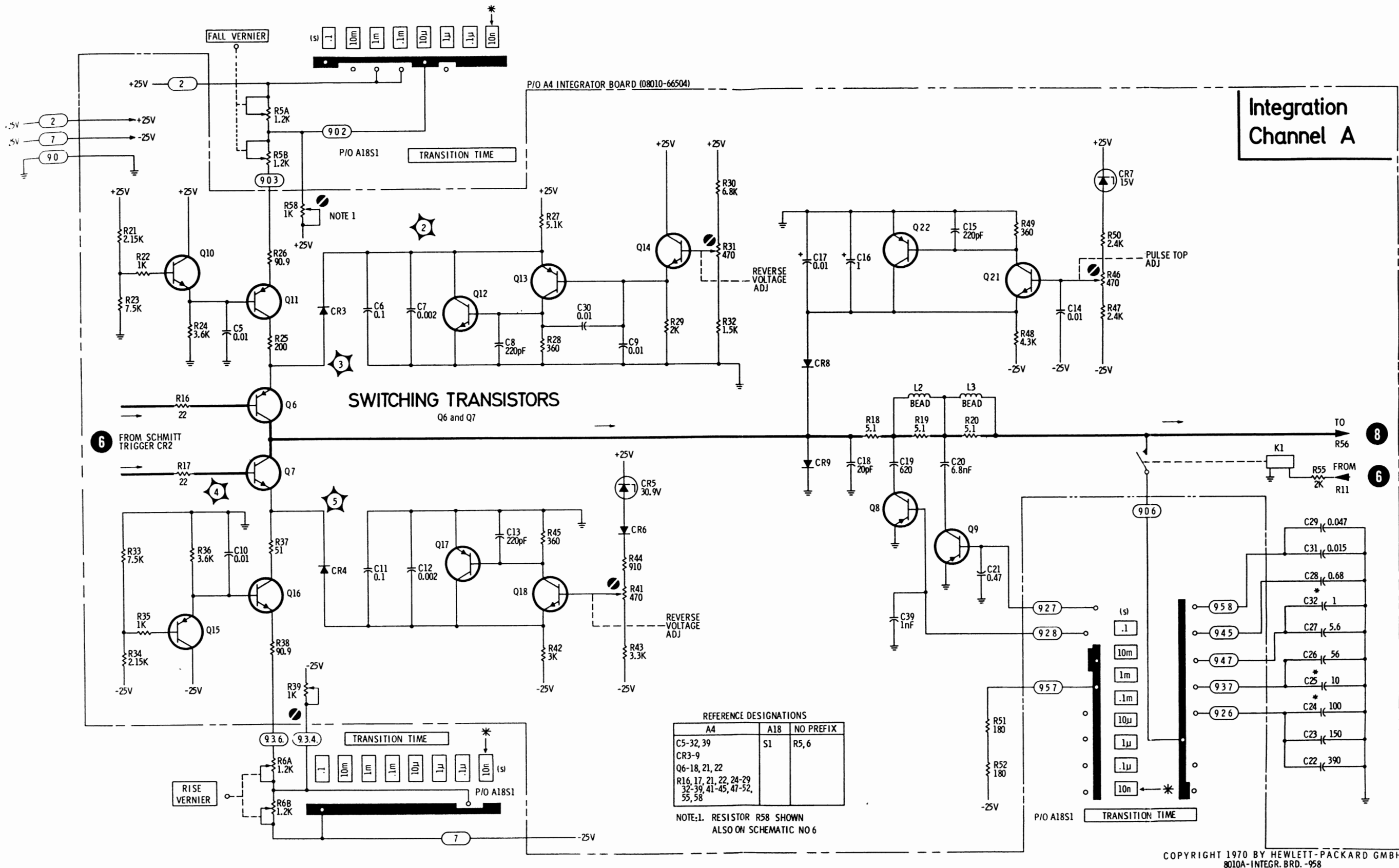

Figure 5-16. Width Channel A Circuit



COPYRIGHT 1970 BY HEWLETT-PACKARD GMBH
8010A-INTEGR. BRD -958

Figure 5-17. Pulse Shaping Channel A Circuit



COPYRIGHT 1970 BY HEWLETT-PACKARD GMBH
8010A-INTEGR. BRD. -958

Figure 5-18. Integration Channel A Circuit

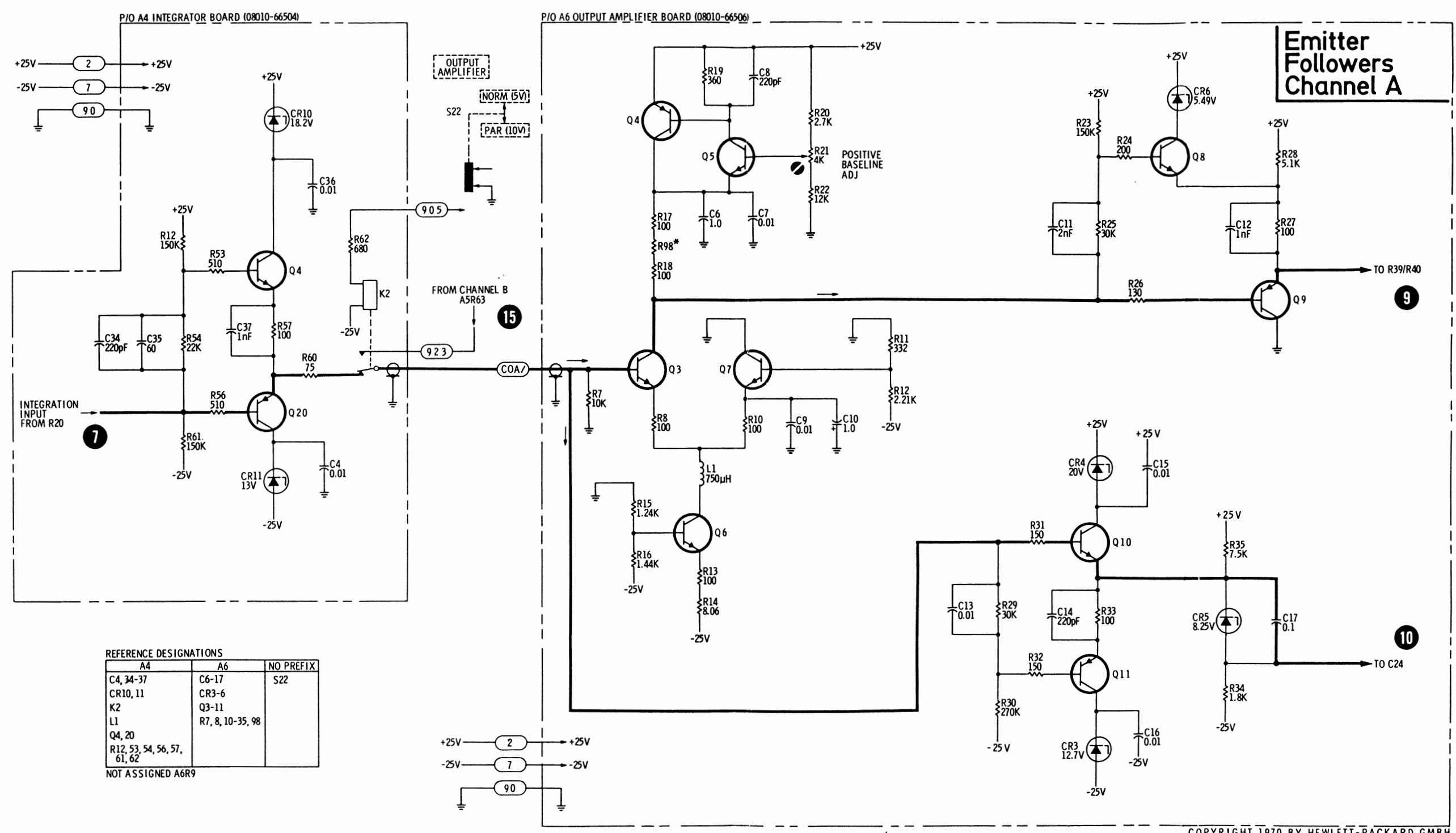

Emitter Followers Channel A

REFERENCE DESIGNATIONS

A4	A6	NO PREFIX
C4, 34-37	C6-17	S22
CR10, 11	CR3-6	
K2	Q3-11	
L1	R7, 8, 10-35, 98	
Q4, 20		
R12, 53, 54, 56, 57, 61, 62		
NOT ASSIGNED A6R9		

COPYRIGHT 1970 BY HEWLETT-PACKARD GMBH
8010A-INTEGR. AND AMP. BRD. -958

Figure 5-19. Emitter Followers Channel A Circuit

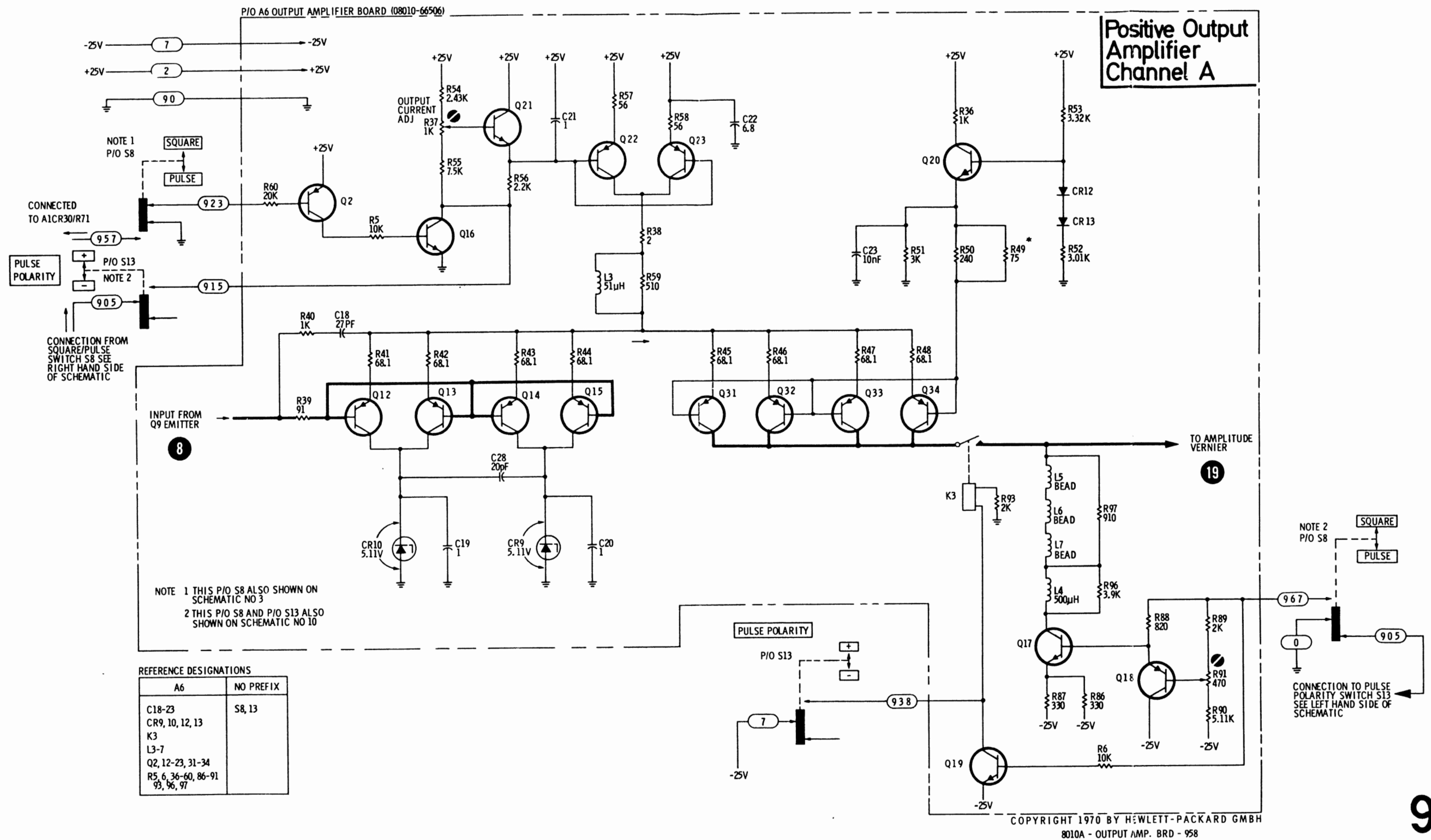
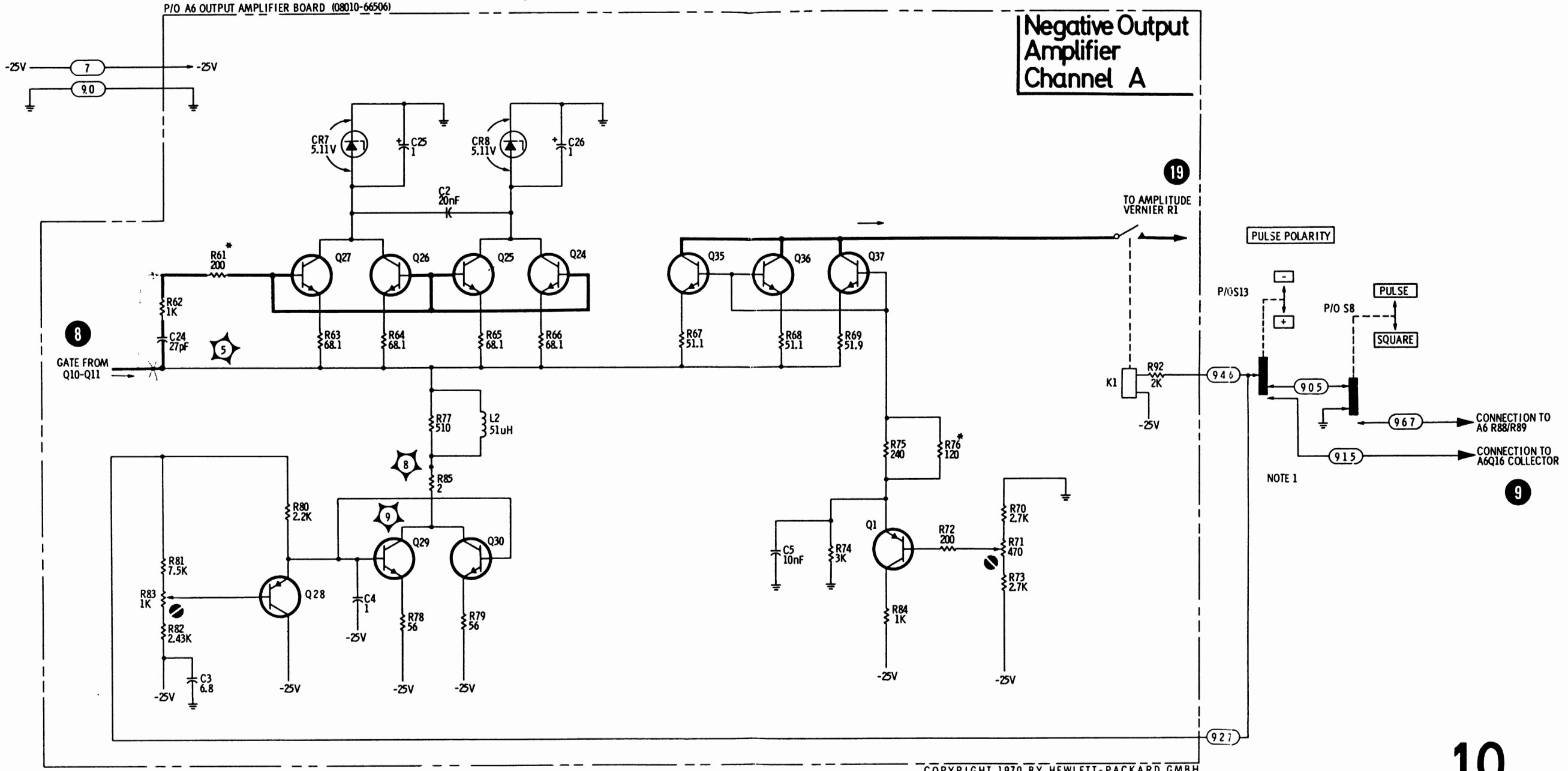

Figure 5-20. Positive Output Amplifier Channel A Circuit



REFERENCE DESIGNATIONS

A6	NO PREFIX
C2-5, 24-26	S8, 13
CR7-8	
K1	
L2	
Q1, 24-30, 35-37	
R61-85, 92	

NOTE 1 THIS P/O S8 AND P/O S13 IS ALSO SHOWN ON SCHEMATIC NO. 9

COPYRIGHT 1970 BY HEWLETT-PACKARD GMBH
8010A - OUTPUT AMP. BRD - 958

10

Figure 5-21. Negative Output Amplifier Channel A Circuit

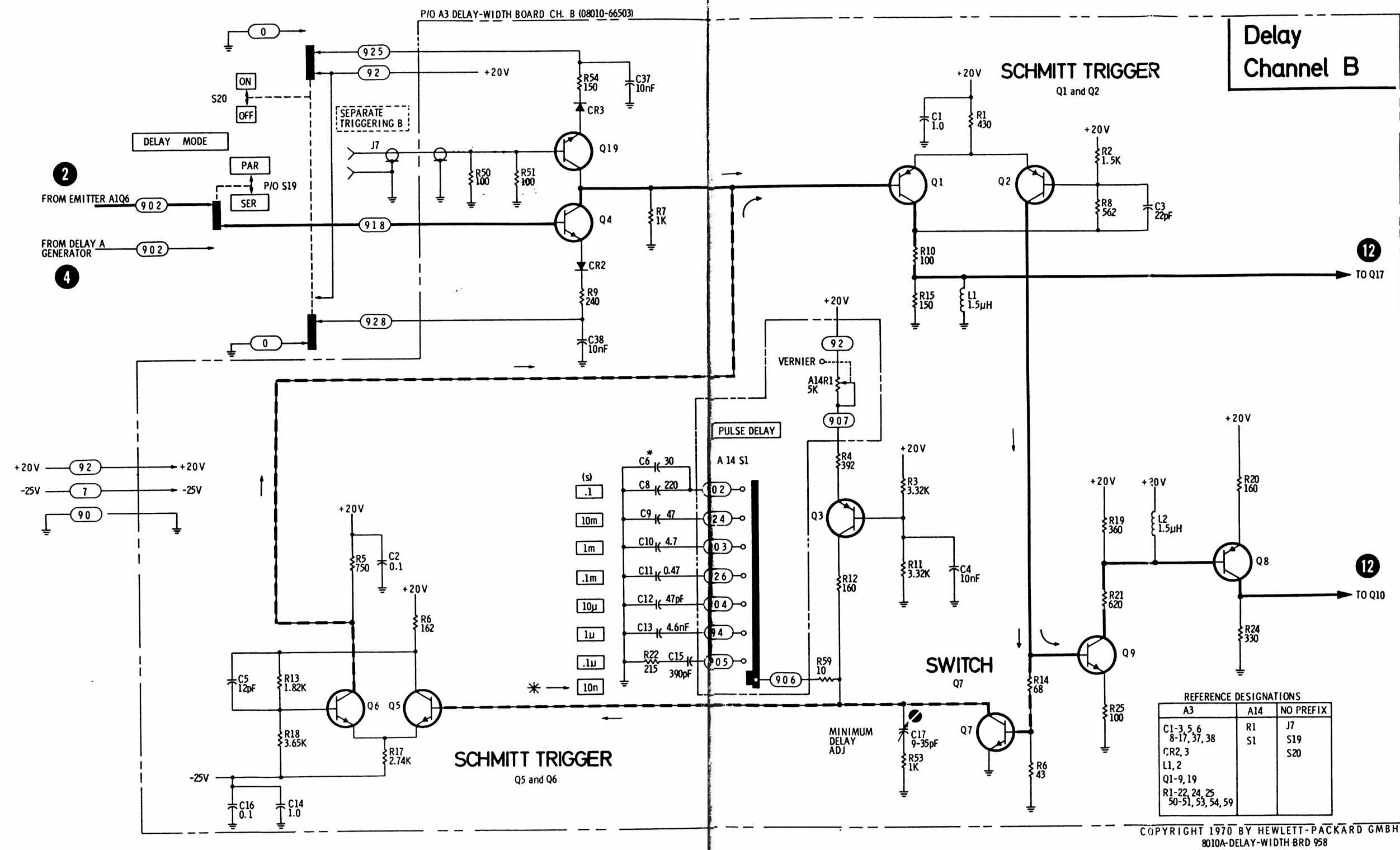

Figure 5-22. Delay Channel B Circuit

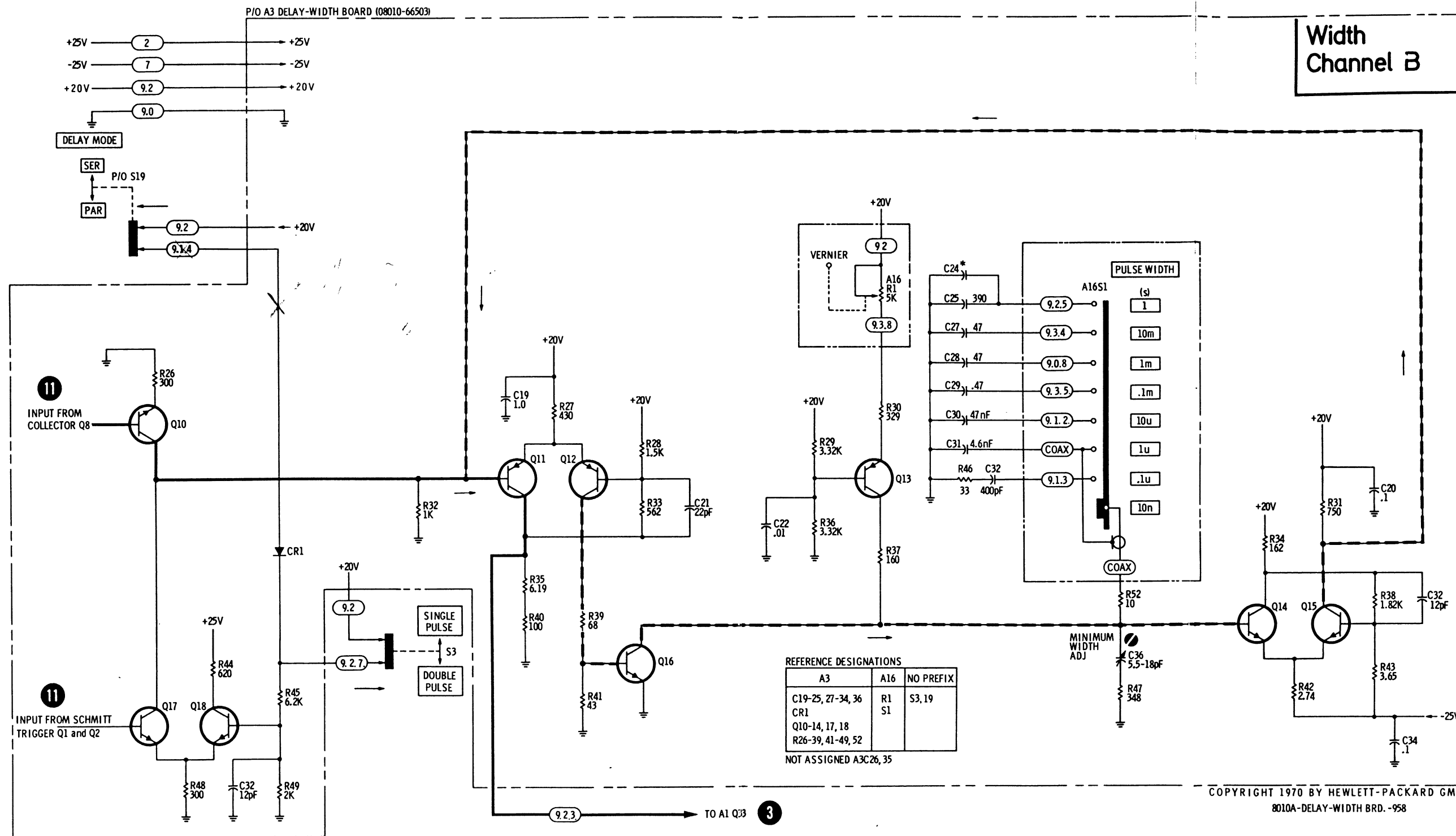

Figure 5-23. Width Channel B Circuit

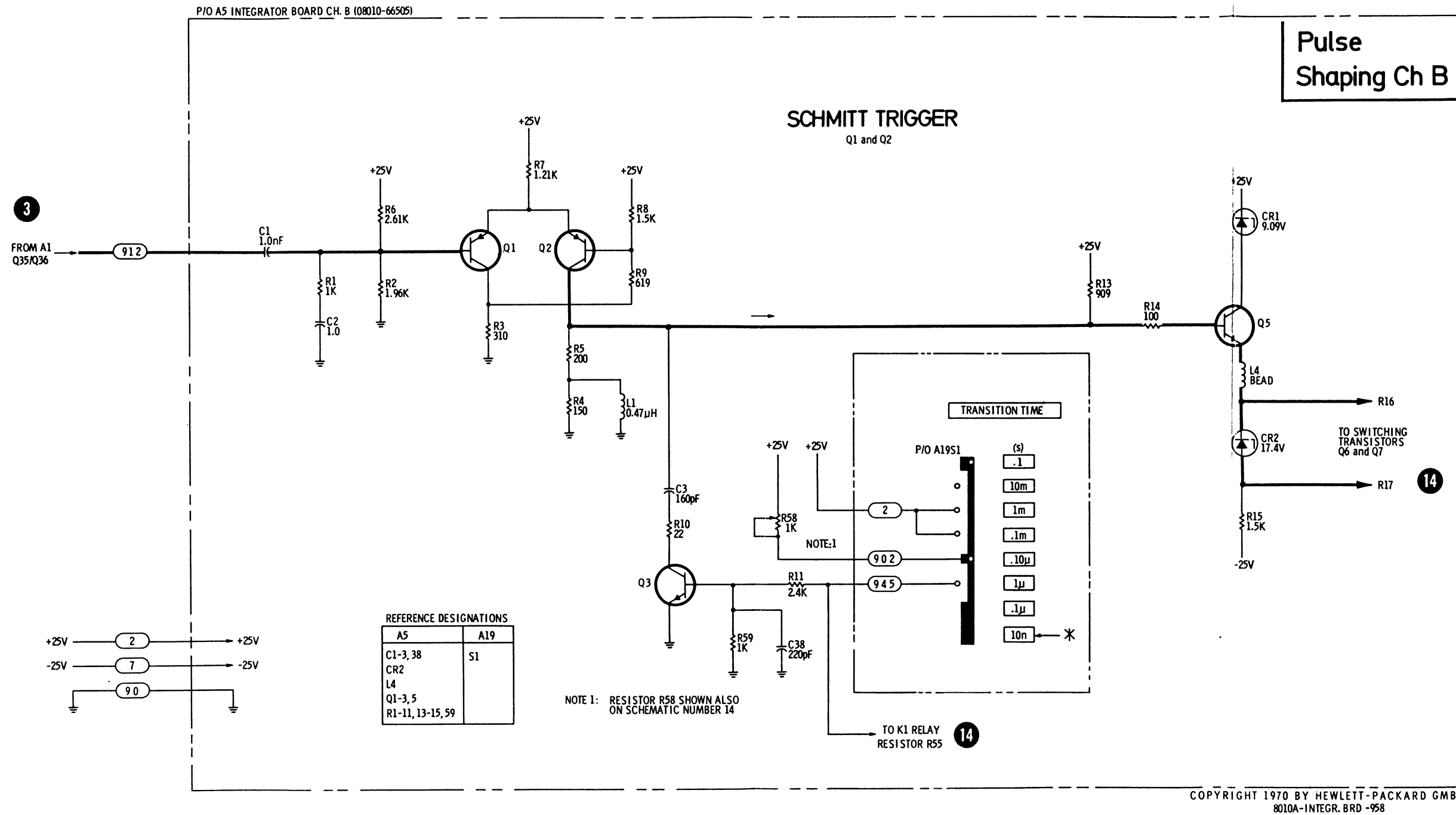

Figure 5-24. Pulse Shaping Channel B Circuit

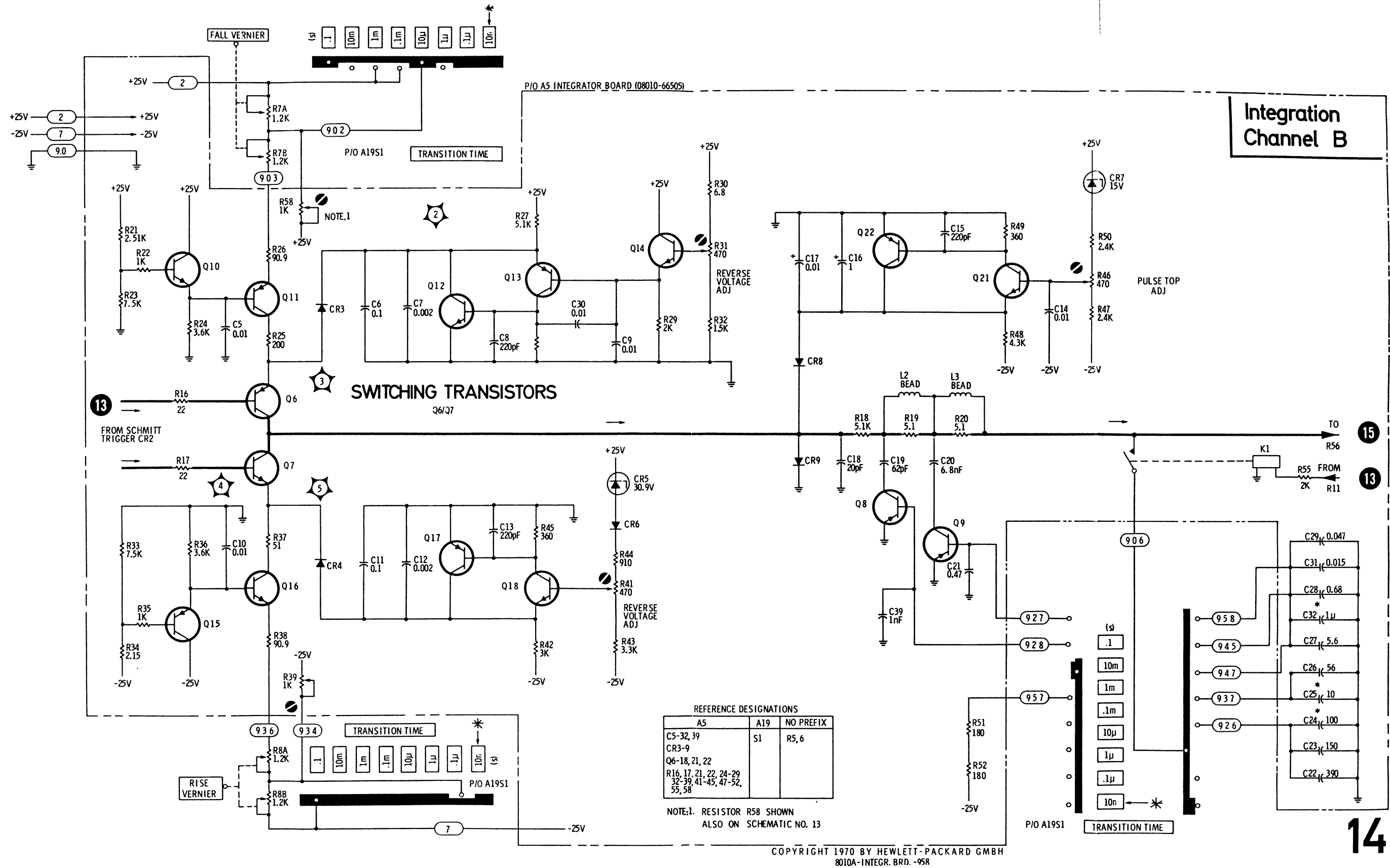

Figure 5-25. Integration Channel B Circuit

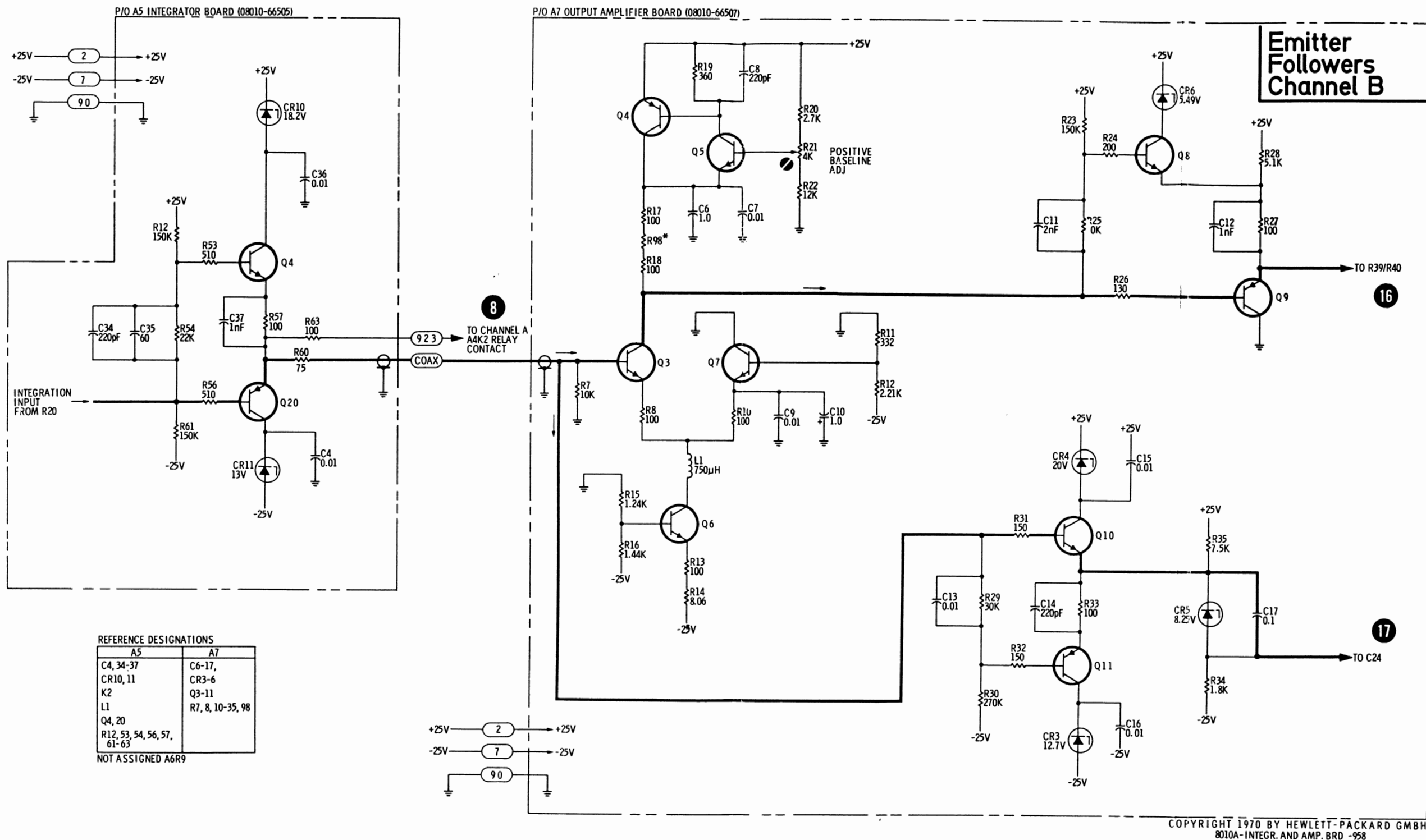

Figure 5-26. Emitter Followers Channel B Circuit

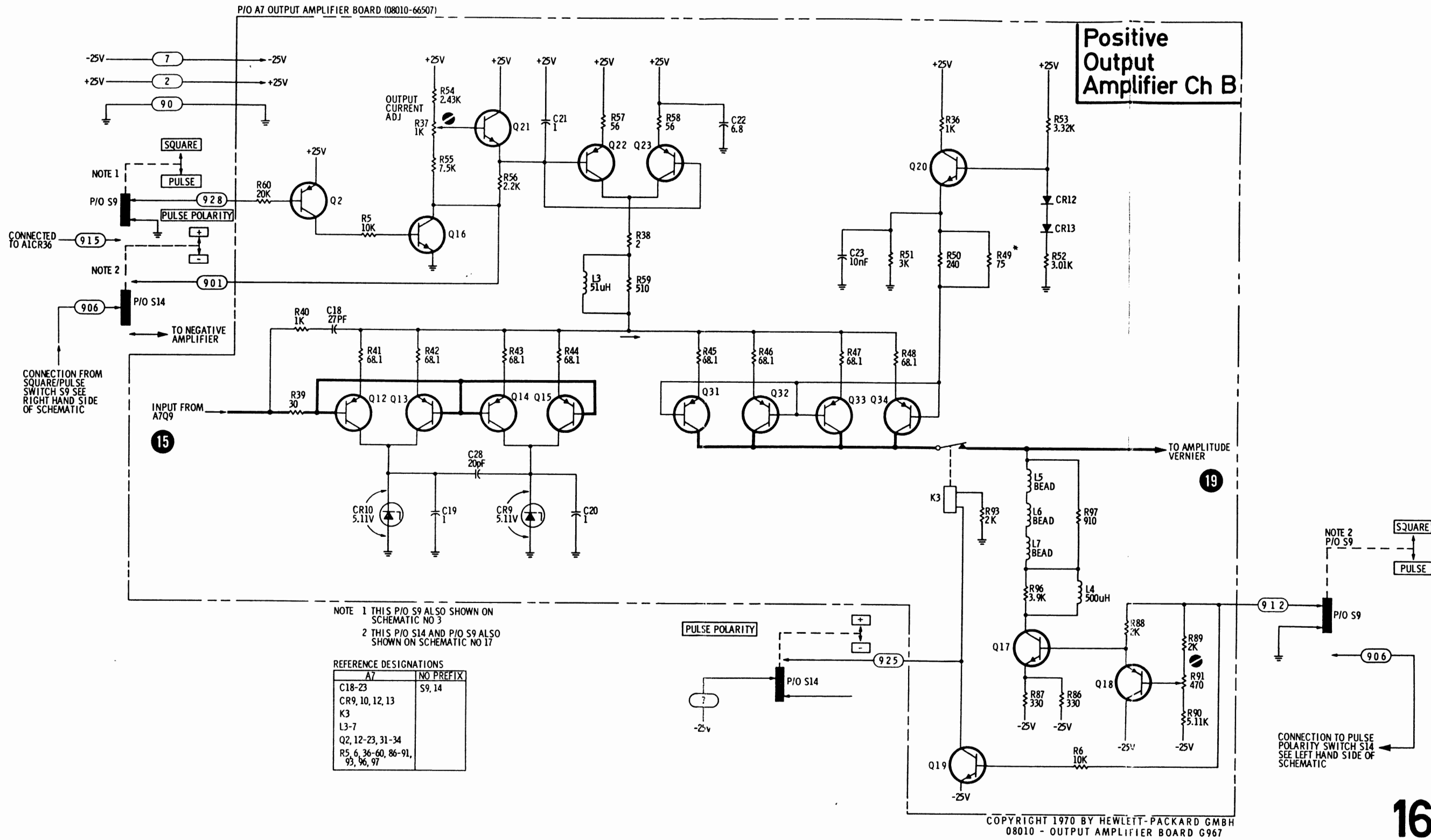
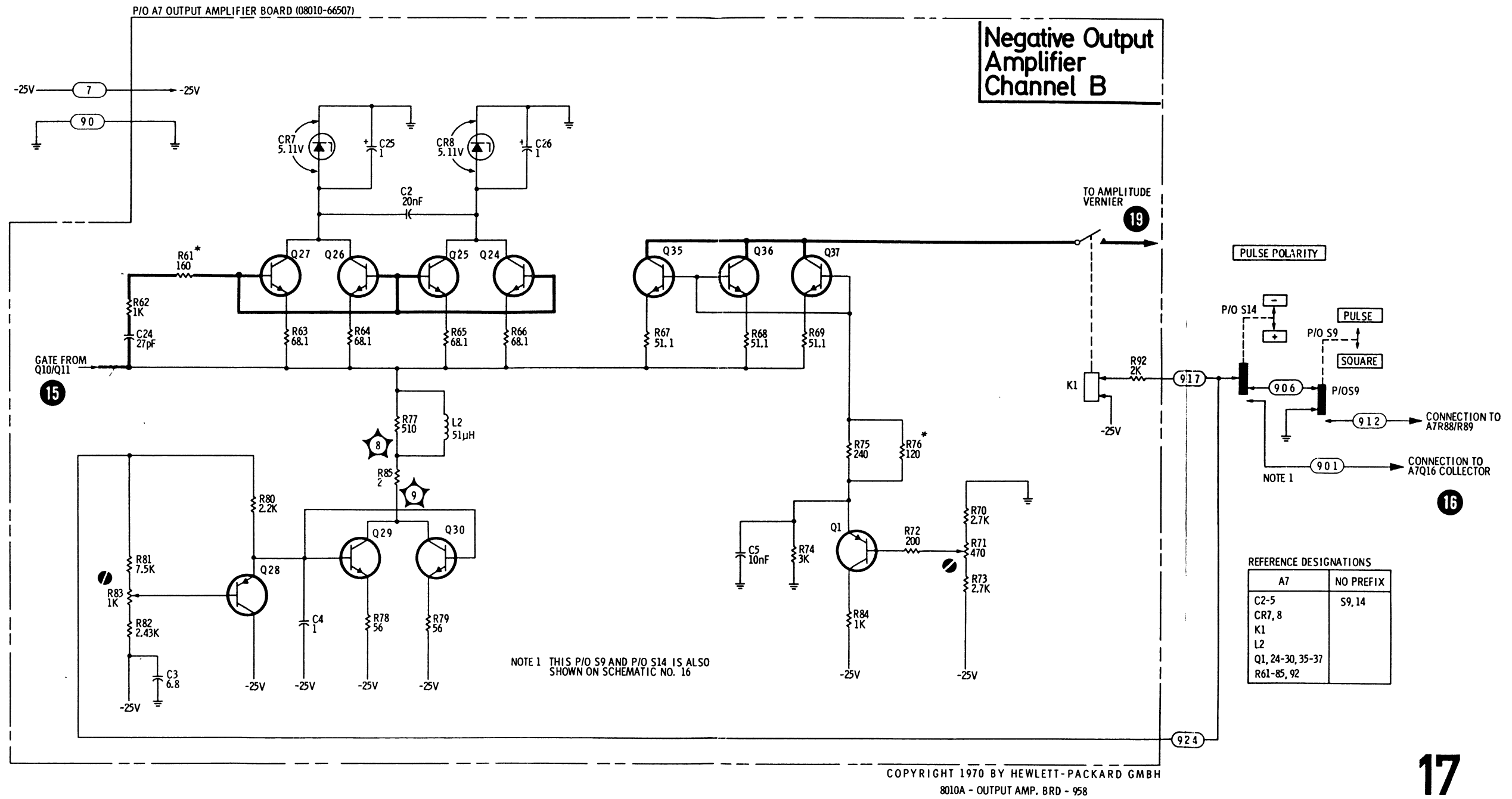

Figure 5-27. Positive Output Amplifier Channel B Circuit



17

Figure 5-28. Negative Output Amplifier Channel B Circuit

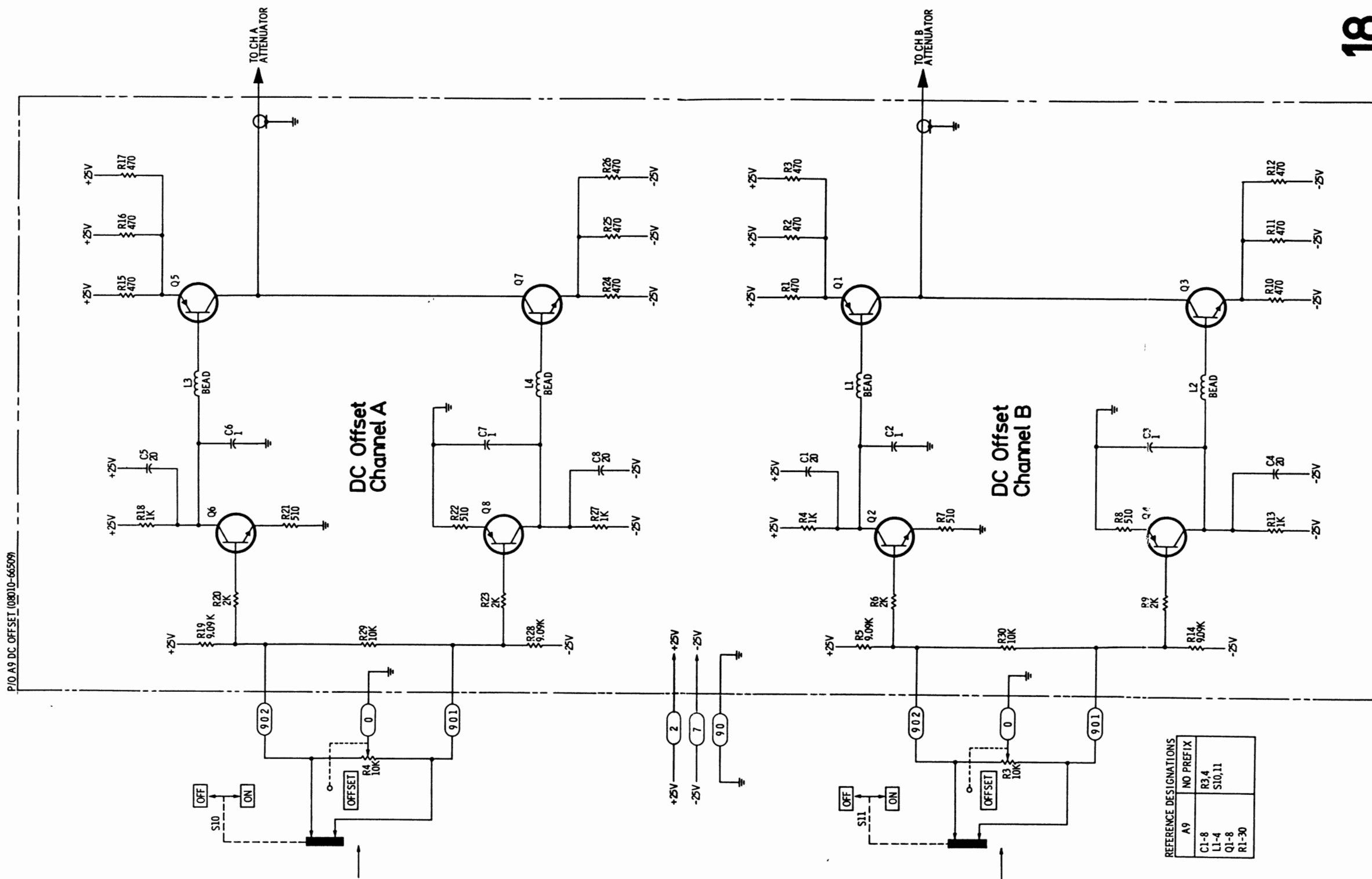

Figure 5-29. DC Offset Circuit

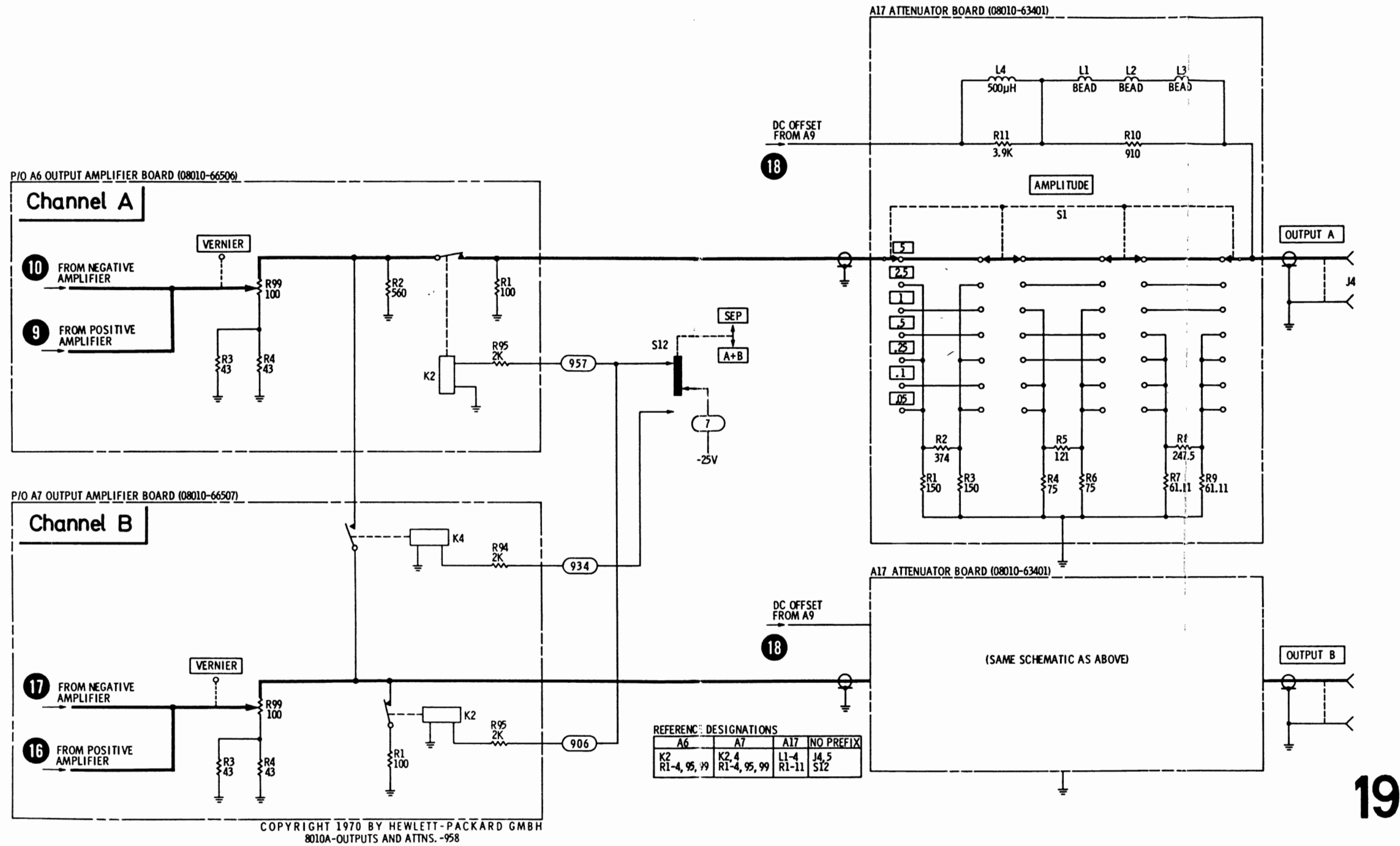
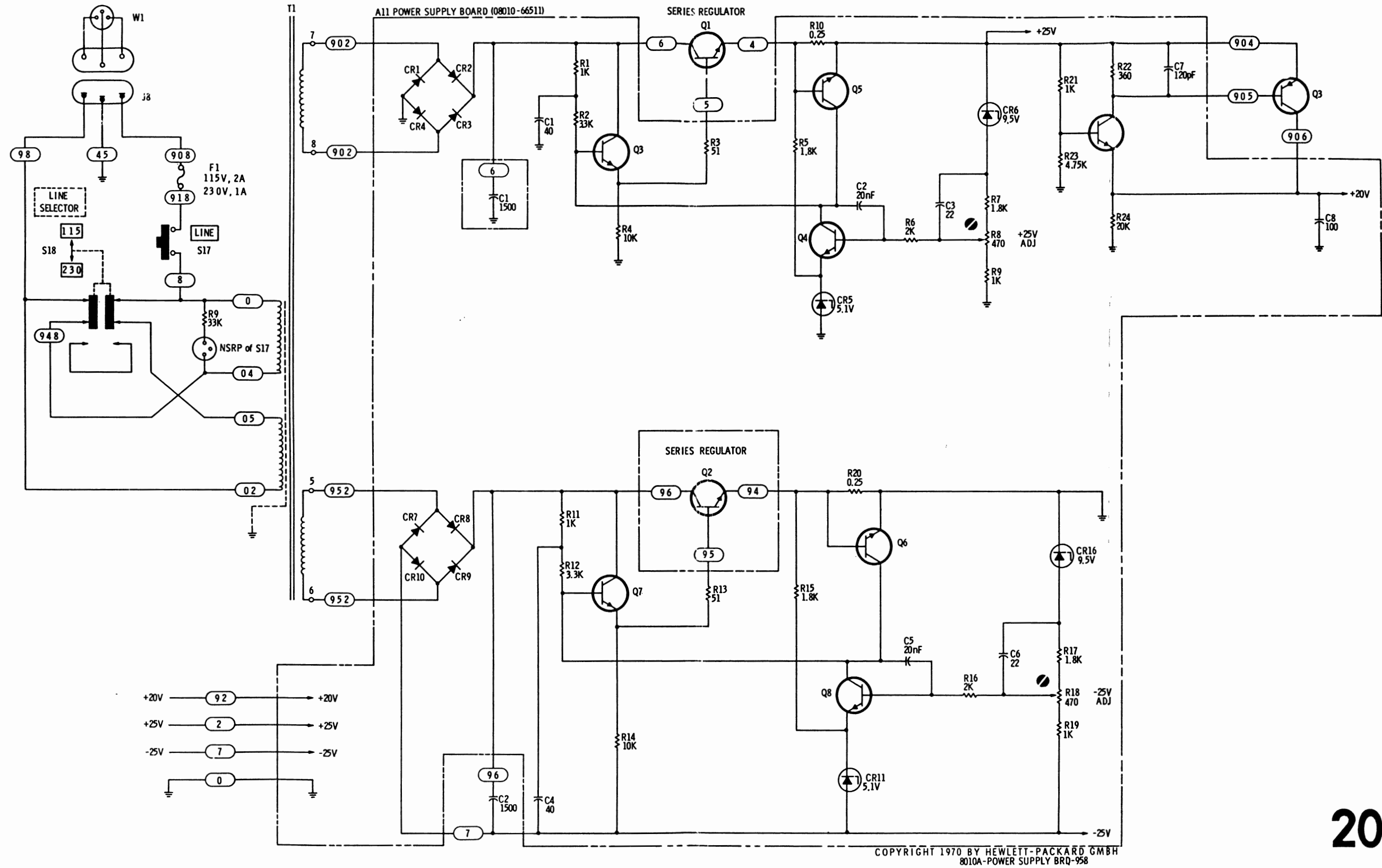

Figure 5-30. Output and Attenuator Circuit



COPYRIGHT 1970 BY HEWLETT-PACKARD GMBH
8010A-POWER SUPPLY BRQ-958

Figure 5-31. Power Supply Circuit