

Errata

Title & Document Type: 8005B Pulse Generator Operating and Service Manual

Manual Part Number: 08005-90004

Revision Date: May 1977

About this Manual

We've added this manual to the Agilent website in an effort to help you support your product. This manual provides the best information we could find. It may be incomplete or contain dated information, and the scan quality may not be ideal. If we find a better copy in the future, we will add it to the Agilent website.

HP References in this Manual

This manual may contain references to HP or Hewlett-Packard. Please note that Hewlett-Packard's former test and measurement, life sciences, and chemical analysis businesses are now part of Agilent Technologies. The HP XXXX referred to in this document is now the Agilent XXXX. For example, model number HP8648A is now model number Agilent 8648A. We have made no changes to this manual copy.

Support for Your Product

Agilent no longer sells or supports this product. You will find any other available product information on the Agilent Test & Measurement website:

www.agilent.com

Search for the model number of this product, and the resulting product page will guide you to any available information. Our service centers may be able to perform calibration if no repair parts are needed, but no other support from Agilent is available.



Agilent Technologies

8005B PULSE GENERATOR

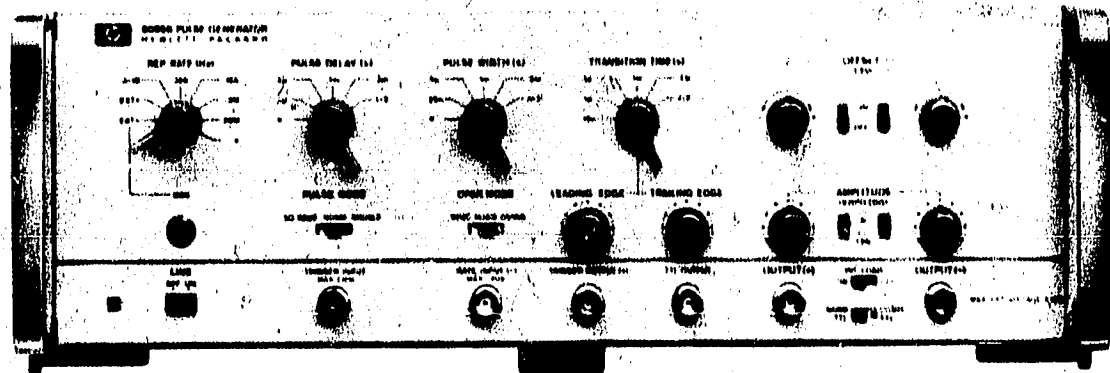

HEWLETT  PACKARD

CERTIFICATION

The Hewlett-Packard Company certifies that this instrument was thoroughly tested and inspected and found to meet its published specifications when it was shipped from the factory. The Hewlett-Packard Company further certifies that its calibration measurements are traceable to the U.S. National Bureau of Standards to the extent allowed by the Bureau's calibration facilities, or to the calibration facilities of other International Standards Organization members.

WARRANTY AND ASSISTANCE

This Hewlett-Packard product is warranted against defects in materials and workmanship. This warranty applies for one year from the date of delivery. Hewlett-Packard will repair or replace products which prove to be defective during the warranty period provided they are returned to Hewlett-Packard. No other warranty is expressed or implied. We are not liable for consequential damages.

Service contracts or customer assistance agreements are available for Hewlett-Packard products that require maintenance and repair on-site.

For any assistance, contact your nearest Hewlett-Packard Sales and Service Office. Addresses are provided at the back of this manual.

OPERATING AND SERVICE MANUAL

**8005B
PULSE GENERATOR**

SERIAL NUMBERS

This manual applies directly to instrument serial number 1627G00731.

With changes described in Section IX, this manual also applies to all earlier instruments.

For additional important information about serial numbers, see INSTRUMENTS COVERED BY MANUAL in Section I.

© HEWLETT-PACKARD GmbH 1973

Herrenbergerstr 110, D-703 Böblingen,
Federal Republic of Germany

MANUAL PART NO. 08005-90004

Microfiche Part No. 08005-90504

Printed: MAY 1977

CONTENTS

Section	Page	Section	Page
I GENERAL INFORMATION	1-1	4-3 Repetition Rate	4-1
1-1 Introduction	1-1	4-9 Gating	4-2
1-4 Specifications	1-1	4-12 Pulse - Square Selector	4-2
1-6 Safety Considerations	1-1	4-15 Pulse Delay Generator	4-3
1-9 Instruments Covered by Manual	1-1	4-18 Width Generator	4-4
1-11 Description	1-1	4-22 Pulse Defining Circuits	4-5
1-14 Options	1-1	4-24 Pulse and Double Pulse Mode	4-6
1-16 Accessories Supplied	1-1	4-27 Square Wave Mode	4-6
1-18 Recommended Test Equipment	1-2	4-31 Output Stage	4-7
II INSTALLATION	2-1	4-34 TTL Output	4-7
2-1 Introduction	2-1	4-36 DC Offset	4-7
2-3 Initial Inspection	2-1	4-38 Power Supply	4-7
2-5 Preparation for Use	2-1	V PERFORMANCE TESTS	5-1
2-6 Power Requirements	2-1	5-1 Introduction	5-1
2-8 Line Voltage Selection	2-1	5-3 Equipment Required	5-1
2-10 Power Cable	2-1	5-4 Test Record	5-1
2-13 Operating Environment	2-2	5-6 Performance Tests	5-1
2-15 Storage and Shipment	2-2	VI ADJUSTMENTS	6-1
III OPERATING INSTRUCTIONS	3-1	6-1 Introduction	6-1
3-1 General	3-1	6-4 Safety Considerations	6-1
3-3 Repetition Rate	3-1	6-10 Equipment Required	6-1
3-5 Internal Triggering	3-1	6-12 Adjustment Locations	6-1
3-7 External Triggering	3-1	6-14 Adjustments	6-1
3-9 Manual Trigger	3-1	VII REPLACEABLE PARTS	7-1
3-11 Pulse Modes	3-1	7-1 Introduction	7-1
3-13 Gating of the Rep. Rate Generator	3-2	7-3 Abbreviations	7-1
3-15 Output Controls	3-2	7-5 Replaceable Parts	7-1
3-16 Amplitude	3-2	7-8 Ordering Information	7-1
3-18 Offset	3-2	VIII SERVICE	8-1
3-20 TTL Output	3-2	8-1 Introduction	8-1
IV PRINCIPLES OF OPERATION	4-1	8-3 Recommended Test Equipment	8-2
4-1 General Description	4-1		

ILLUSTRATIONS

Figure		Page
1-1	8005B Instrument and Accessories	1-0
1-2	Rack-mount Kit, Option 908	1-0
1-3	Serial Number Plate	1-1
2-1	Power Cords	2-2
3-1	Front Panels Controls and Connectors	3-0
3-2	Single Pulse Mode - Typical Output	3-1
3-3	Double Pulse Mode - Typical Output	3-1
3-4	Square Wave Mode - Typical Output	3-1
3-5	Synchronous Gating of Rep. Rate Generator	3-2
3-6	Asynchronous Gating of Rep. Rate Generator	3-2
3-7	Output Configurations	3-2
4-1	Basic Concept	4-1
4-2	Repetition Rate Generator and Trigger Input Gating	4-2
4-3	Pulse - Square Selector Circuit	4-2
4-4	Square Wave Mode Timing Sequence	4-3
4-5	Delay Generator	4-3
4-6	Delay Generator Timing Sequence	4-4
4-7	Pulse Width Generator	4-4

Figure		Page
4-8	Width Generator Timing Sequence	4-5
4-9	Phase Defining Circuit and Integrator	4-5
4-10	Pulse Defining Timing Sequence	4-6
4-11	Output Stage	4-7
6-1	Location of Adjustments	6-1
7-1	Mainframe Parts	7-1

Diagram		Page
1	Rate Generator	6-5
2	Delay Generator	6-7
3	Width Generator	6-9
4	A3: Phase Selector	6-11
	A4: Integrator	6-11
5	Output Amps.	6-13
6	A2: DC Offset	6-15
	A3: Attenuator Vernier	6-15
7	A5: Power Supply	6-17

TABLES

Table		Page
1-1	Recommended Test Equipment	1-1
1-2	Specifications	1-2
5-1	Performance Test Record	5-2
7-1	Abbreviations for Parts List	7-1

Table		Page
7-2	Replaceable Parts	7-2
7-3	Manufacturers' Codes	7-3
8-1	Reference Designators	8-1
8-2	Schematic Diagram Notes	8-2

SAFETY SUMMARY

The following general safety precautions must be observed during all phases of operation, service, and repair of this instrument. Failure to comply with these precautions or with specific warnings elsewhere in this manual violates safety standards of design, manufacture, and intended use of the instrument. Hewlett-Packard Company assumes no liability for the customer's failure to comply with these requirements.

GENERAL – This is a Safety Class I instrument (provided with terminal for protective earthing) and has been manufactured and tested according to international safety standards.

OPERATION – BEFORE APPLYING POWER comply with the installation section. Additionally, the following shall be observed:

Do not remove instrument covers when operating.

Any interruption of the protective (grounding) conductor (inside or outside the instrument) or disconnecting the protective earth terminal is likely to make this instrument dangerous. Intentional interruption is prohibited.

Whenever it is likely that the protection has been impaired, the instrument must be made inoperative and be secured against any unintended operation.

Make sure that only fuses with the required rated current and of the specified type (normal blow, time delay, etc.) are used for replacement. The use of repaired fuses and the short-circuiting of fuseholders must be avoided.

Adjustments described in the manual are performed with power supplied to the instrument while protective covers are removed. Energy available at many points may, if contacted, result in personal injury.

Any adjustment, maintenance, and repair of the opened instrument under voltage should be avoided as much as possible, and when inevitable, should be carried out only by a skilled person who is aware of the hazard involved. Do not attempt internal service or adjustment unless another person, capable of rendering first aid and resuscitation is present. Do not replace components with power cable connected.

Do not operate the instrument in the presence of flammable gases or fumes. Operation of any electrical instrument in such an environment constitutes a definite safety hazard.

Do not install substitute parts or perform any unauthorized modification to the instrument.

Capacitors inside the instrument may still be charged even if the instrument has been disconnected from its source of supply.

SAFETY SYMBOLS



The apparatus will be marked with this symbol when it is necessary for the user to refer to the instruction manual in order to protect the apparatus against damage.



Indicates dangerous voltages.



Earth terminal (sometimes used in manual to indicate circuit common connected to grounded chassis).

WARNING

The WARNING sign denotes a hazard. It calls attention to a procedure, practice or the like, which, if not correctly performed or adhered to, could result in injury or loss of life. Do not proceed beyond a WARNING sign until the indicated conditions are fully understood and met.

CAUTION

The CAUTION sign denotes a hazard. It calls attention to an operating procedure, practice, or the like, which, if not correctly performed or adhered to, could result in damage to or destruction of part or all of the equipment. Do not proceed beyond a CAUTION sign until the indicated conditions are fully understood and met.

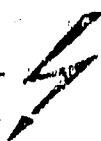

WARNING

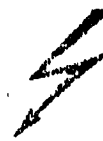

Dangerous voltages, capable of causing death, are present in this instrument.
Use extreme caution when handling, testing, and adjusting.

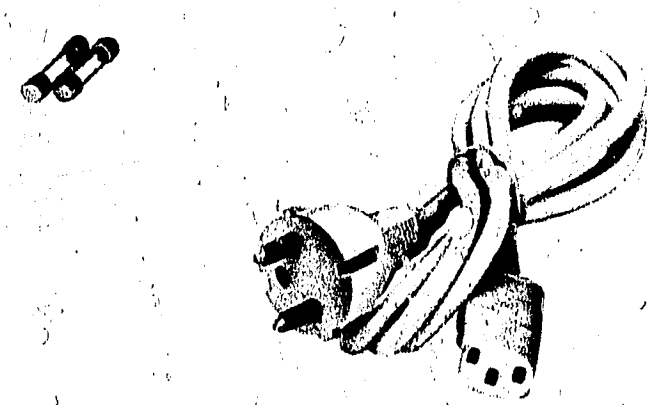
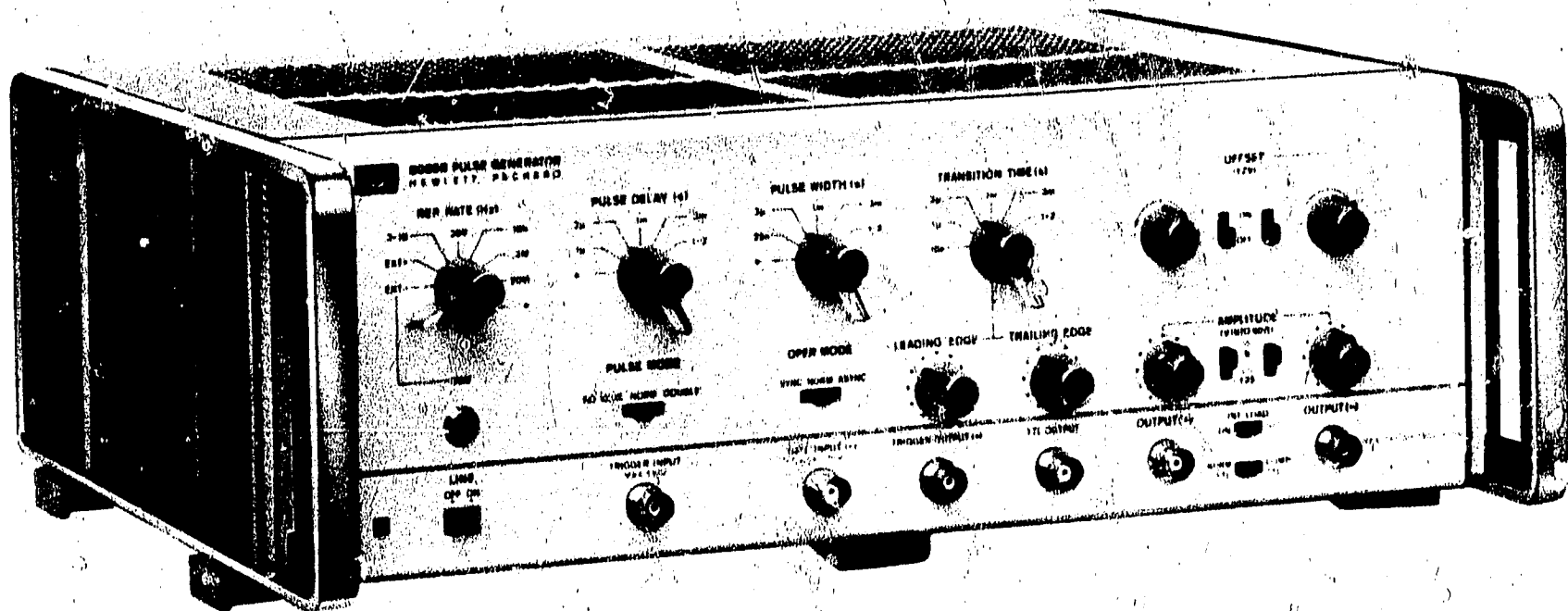

Figure 1-1. 8005B Instrument and Accessories.

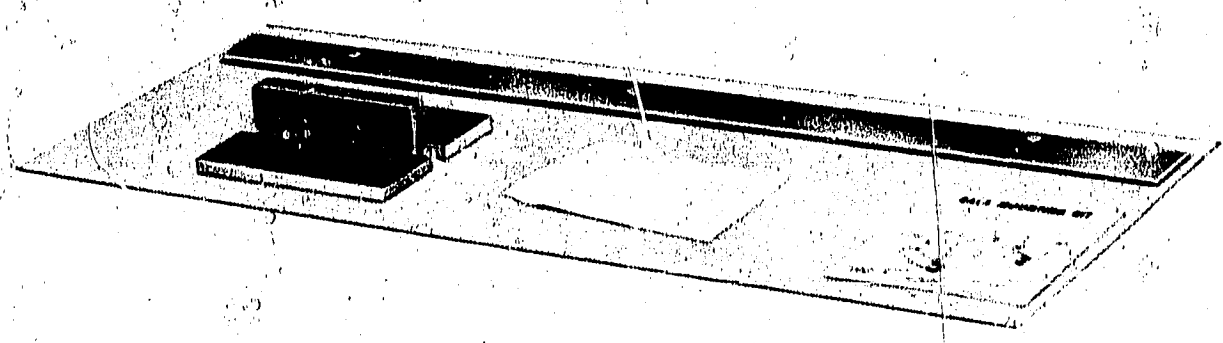

Figure 1-2. Rack-mount Kit, Option 908

SECTION I GENERAL INFORMATION

1-1 INTRODUCTION

1-2 This Operating and Service Manual contains information required to install, operate, test, adjust and service the Hewlett-Packard Model 8005B. Figure 1-1 shows the instrument and accessories supplied. This section covers instrument identification, description, accessories, specifications, and other basic information.

1-3 A microfiche version of this manual is available on 4 x 6 inch microfilm transparencies (order number on title page). Each microfilm contains up to 60 photoduplicates of the manual pages. The microfiche package also includes the latest Manual Changes supplements as well as all pertinent Service Notes.

1-4 SPECIFICATIONS

1-5 Instrument specifications are listed in Table 1-2. These specifications are the performance standards or limits against which the instrument is tested.

1-6 SAFETY CONSIDERATIONS

1-7 The Model 8005B is a Safety Class 1 instrument (it has an exposed metal chassis that is directly connected to earth via the power supply cable).

1-8 This operating and service manual contains information, cautions, and warnings which must be followed by the user to ensure safe operation and to maintain the instrument in a safe condition.

1-9 INSTRUMENTS COVERED BY MANUAL

1-10 Attached to the rear of this instrument is a serial number plate (Figure 1-3). The first four digits of the serial number only change when there is a significant change to the instrument. The last five digits are assigned to instruments sequentially. The contents of this manual apply directly to the instrument serial number quoted on the title page. For instruments with lower serial numbers, refer to the backdating information in Section IX of this manual. For instruments with higher serial numbers, refer to the Manual Change sheets at the end of this manual. In addition to change information, the Manual Change sheets may contain information for correcting errors in the manual. To keep this manual as up-to-date and accu-

rate as possible, Hewlett-Packard recommends that you periodically request the latest Manual Change supplement. The supplement for this manual is identified with this manual's print date and part number, both of which appear on this manual's title page. Complimentary copies of the supplement are available from Hewlett-Packard.

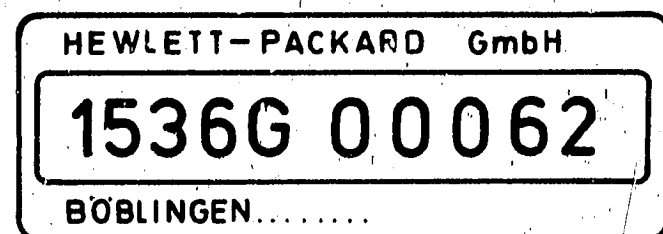

Figure 1-3. Serial Number Plate

1-11 DESCRIPTION

1-12 The Model 8005B is a versatile 20 MHz pulse generator that can deliver up to 10 volts positive and, simultaneously, 10 volts negative into a 50 ohm load from a selectable source impedance. Provision is made for external and manual triggering, synchronous and asynchronous gating, a positive trigger output and TTL output of 4.6 volts across an open circuit for positive or negative logic.

1-13 Repetition rate is variable over the range 0.3 Hz to 20 MHz, alternatively, in double pulse mode 10 MHz simulating 20 MHz or, in square wave mode, 0.15 Hz to 10 MHz. Pulse delay (with respect to the trigger output) is variable over the range < 100 ns to 3 s. Pulse width is variable over the range 25 ns to 3 s with a normal mode duty cycles of > 80% and 100% in complement mode. Transition times (pulse rise and fall) are variable from < 10 ns to 2 s with a rise and fall (or fall to rise) ratio of up to 30:1. Amplitude and base line offset of each channel is independently variable. A complete set of specifications is given in Table 1-2.

1-14 OPTIONS

1-15 The following options are available:

- Option 908 Rack-mount kit
- Option 910 Additional Copy of the Operating and Service Manual.

These options will be shipped with the instrument if ordered at the same time.

1-16 ACCESSORIES SUPPLIED

1-17 The instrument is supplied complete with the following items (see Figure 1--1).

ITEM	HP PART NUMBER
800 mA Fuse for 230V operation	2110-0020
1.6 A Fuse for 115V operation	2110-0005
Power cable	see Figure 2-1
Operating and Service Manual	08005-90004

1-18 RECOMMENDED TEST EQUIPMENT

1-19 Equipment required to maintain the model 8005B is listed in Table 1-1. Other equipment can be substituted if it meets or exceeds the critical specifications listed in the table.

Table 1-1 Recommended Test Equipment

INSTRUMENT TYPE	RECOMMENDED MODEL	REQUIRED CHARACTERISTICS	REQUIRED FOR
Oscilloscope	HP 180C with plug-ins 1805A and 1825C	Dual Channel, 50 MHz band width, 5 mV/div. sensitivity sweep speeds 5ns/div. to 2s/div. with sweep delay	PA
Sampling Oscilloscope	HP 180C with plug-in 1810A	Dual Channel, 1 GHz bandwidth, 1 mV/div. sensitivity sweep speeds 10ns/div. to 2s/div.	PA
Square Wave Generator	9013B	Capable of rep. rate of 10 kHz, 10 kHz, negative output (0 to -5V), fast rise and fall times (5ns)	P
Digital Voltmeter	34740A with 34702A	100V range to 4 significant figures. Accuracy $\pm 0.05\% \pm 1$ digit	A
AC Voltmeter	HP 3400A	Sensitivity 100 μ V to 300V rms	A
Test Oscillator	HP 651B	Frequency Range 10 Hz to 10 MHz	P
Counter	HP 5345A	0-50 MHz	PA
50 Ω cable assembly	HP 10503A	(4 required) terminated each end with BNC male connectors	PA
50 Ω Tee connector	1250-0781		PA
50 Ω Feed-through termination (2)	HP 10100C		PA
Attenuator	HP 8491A	20 dB 50 Ω , N	PA
Connector	HP 1250-0077	BNC male to N female	PA
Connector	HP 1250-0780	BNC male to N male	PA

NOTE: P = Performance Check
A = Adjustment

Table 1-2 Specifications

PULSE CHARACTERISTICS

Internal 50Ω	Ext. Load	Amplitude Range Selected	Amplitude	Offset	
				Output (+)	Output (-)
IN	50Ω	1.25V/2.5V	300mV to 1.25V	± 2V	± 2V
IN	High Z	1.25V/2.5V	800mV to 2.5V	± 4V	± 4V
OUT	50Ω	1.25V/2.5V	600mV to 2.5V	± 2V	± 2V
IN	50Ω	5V/10V	1.25V to 5V	± 2V	± 2V
IN	High Z	5V/10V	2.5V to 10V ¹	± 4V	± 4V
OUT	50Ω	5V/10V	2.5V to 10V ¹	± 2V to 0V -4V ²	± 2V in 0V/ +4V ²

1. The maximum output (amplitude + offset) is 10V.
2. Offset range with amplitude vernier CCW is ± 2V. Offset range increases to ± 4V when amplitude vernier is CW.

Transition times: ≤ 10ns to 2s in six ranges. Separate verniers provide independent control of leading and trailing edges within each range. Ranges are common for leading and trailing edges. Max. leading edge/trailing edge ratio, 1:30 or 30:1.

Linearity: for transition times > 30ns, maximum amplitude deviation from a straight line between the 10% and 90% points is less than 4% of pulse amplitude.

Overshoot, preshoot and ringing: each less than 5% of pulse amplitude.

Pulse width: < 25ns to 3s in five ranges. Vernier provides continuous adjustment within each range.

Width jitter: < 0.1% + 50 ps of any width setting.

Maximum duty cycle: > 80% for repetition rates from 0.3 Hz to 1 MHz, > 50% from 1 MHz to 20 MHz. Up to 100% when using pulse complement.

Square wave: 0.15 Hz to 10 MHz. Duty cycle: 50% ± 5% for repetition rates ≤ 1 MHz, increasing to 50% ± 15% at 10 MHz.

Pulse delay: < 100ns to 3s (with respect to trigger output) in five ranges. Vernier provides continuous adjustment within each range. Delay is inhibited in Square Wave mode.

Delay jitter: < 0.1% + 50 ps of any delay setting.

Pulse outputs: simultaneous positive, negative and TTL compatible outputs.

Maximum pulse amplitude: 5V, with internal 50 ohms and external 50 ohms. 10V with internal 50 ohms and external high impedance, or with internal high impedance and external 50 ohms.

Maximum output: (amplitude + offset) 10V.

Output protection: cannot be damaged by short circuit or application of external voltages ≤ ± 10V (at 25°C ambient) independent of control settings.

Source impedance: 50 ohms ± 10% (shunted by typ 20pF) or high impedance, switch selectable.

TTL compatible output: fixed amplitude, +4.6V, across open circuit.

Source impedance: 50 ohms typ.

Pulse formats: normal or complement, switch selectable.

REPETITION RATE AND TRIGGER

Repetition rate: 0.3 Hz to 20 MHz in five ranges. Vernier provides continuous adjustment within each range.

Period jitter: < 0.1% of any period setting.

Double pulse: 10 MHz max. Simulates 20 MHz.

Trigger output: positive pulses > 2V amplitude across external 50 ohm load.

Output Trigger pulse width: 15ns ± 7ns.

EXTERNALLY CONTROLLED OPERATION**External Triggering**

Repetition rate: dc to 20 MHz.

Delay: approximately 35ns between trigger input and trigger output.

Manual: push button for generating single pulse (two in double pulse).

Trigger Input

Input impedance: approx. 1 kohm, dc coupled

Maximum input: ± 10V.

Sensitivity: sine waves; 2Vpp. Pulses 1V peak.

Polarity: positive or negative, switch selectable.

Minimum pulse width: 10ns.

Table 1-2 Specifications (continued)

Gating

Synchronous: gate signal turns on repetition rate. Time between start of gate and first pulse defined by delay control. Last pulse is always completed even if gate ends during generation of last pulse. Synchronous trigger pulses occur for duration of gate.

Asynchronous: gate signal controls output of free running repetition rate generator.

Gate Input

Input impedance: approx. 1 kohm, dc coupled.

Gate signal polarity: negative.

Gate amplitude: 2V to 20V (max.)

GENERAL

Operating temperature range: 0°C to 55°C.

Power: 115V or 230V, +10%, -15%, 48 Hz to 440 Hz, 180VA max.

Weight: net 7 kg (16 lbs), shipping 9 kg (20 lbs).

Dimensions: 425 mm wide, 140 mm high, 336 mm deep (16 3/4 in. x 5 1/2 in. x 13 1/4 in.).

SECTION II INSTALLATION

2-1 INTRODUCTION

2-2 This section provides installation instructions for the Model 8005B Pulse Generator and its accessories. It also includes information about initial inspection and damage claims, preparation for use, and packaging, storage and shipment.

2-3 INITIAL INSPECTION

2-4 Inspect the shipping container for damage. If the container or cushioning material is damaged, it should be kept until the contents of the shipment have been checked for completeness and the instrument has been checked mechanically and electrically. The contents of the shipment should be as shown in Figure 1-1 plus any accessories that were ordered with the instrument. Procedures for checking the electrical operation are given in Section 3. If the contents are incomplete, if there is mechanical damage or defect, or if the instrument does not pass the operator's checks, notify the nearest Hewlett-Packard Sales/Service office. If the shipping container is damaged, or the cushioning material shows signs of stress, notify the carrier as well as the Hewlett-Packard office. Keep the shipping materials for carrier's inspection. The HP office will arrange for repair or replacement without waiting for settlement.

2-5 PREPARATION FOR USE

2-6 Power Requirements

2-7 The 8005B requires a power source of 115 or 230 V ac at a frequency of 48 to 66 Hz (+10%, -15%) single phase. The maximum power consumption is 70VA.

2-8 Line Voltage Selection

CAUTION

BEFORE SWITCHING ON THIS INSTRUMENT make sure that the instrument is set to the local line voltage.

2-9 The line voltage is selected by setting the voltage selector on the rear panel. Use a screwdriver to move the slider to the required position.

2-10 Power Cable

WARNING

To avoid the possibility of injury or death, the following precautions must be followed before the instrument is switched on:

- a. If this instrument is to be energized via an auto-transformer for voltage reduction, make sure that ground connection is not interrupted.
- b. The power cable plug shall only be inserted into a socket outlet provided with a protective ground contact. The protective action must not be negated by the use of an extension cord without a protective conductor.
- c. Before switching on the instrument, the protective ground terminal of the instrument must be connected to a protective conductor of the power cable. This is verified by checking that the resistance between the instrument chassis and the front panels of all modules in the instrument and the ground pin of the power cable plug is zero ohms.

2-11 In accordance with international safety standards, this instrument is equipped with a three-wire power cable. When connected to an appropriate ac power receptacle, this cable grounds the instrument cabinet. The type of power cable shipped with each instrument depends on the country of destination. Refer to Figure 2-1 for the part number of the power cords available.

2-12 If the plug on the cable supplied does not fit your power outlet, then cut the cable at the plug end and connect a suitable plug. The plug should meet local safety requirements and include the following features:

- Minimum current rating of 2A
- Ground connection
- Cable clamp

The colour coding used in the cable will depend on the cable supplied (see Figure 2-1).

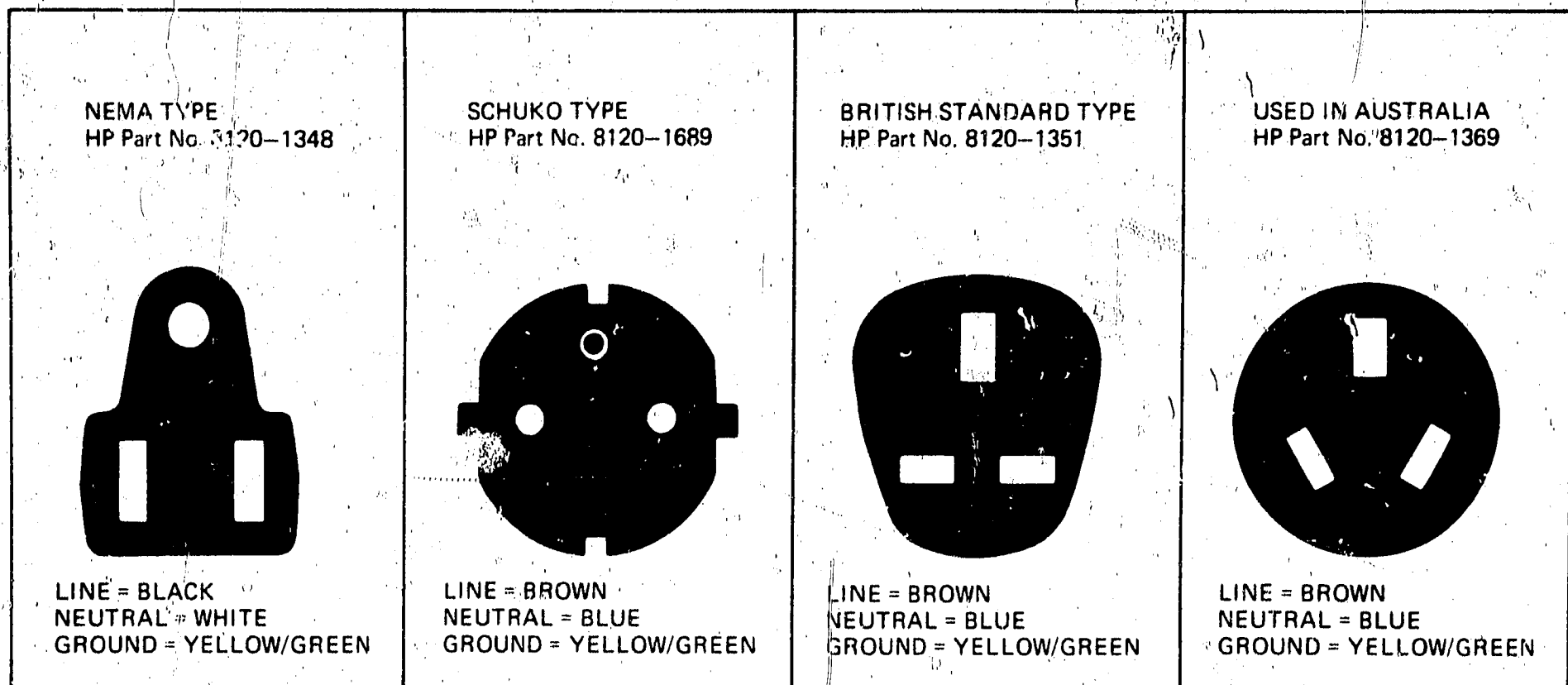

Figure 2-1. Power Cords

2-13 Operating Environment

2-14 The 8005B will operate within specifications when the ambient temperature is between 0°C and 55°C.

2-15 STORAGE AND SHIPMENT

2-16 The 8005B can be stored or shipped at temperatures between -40°C and 75°C. The instrument should be protected from temperature extremes which cause condensation within the instrument.

2-17 If the instrument is to be shipped to a Hewlett-Packard Sales/Service Office, attach a tag showing owner, return address, model number and full serial number and the type of service required. The original shipping carton and packaging material may be re-usable but the Hewlett-Packard Sales/Service office will also provide information and recommendations on materials to be used if the origi-

nal packing is not available nor re-usable. General Instructions for re-packing are as follows:

1. Wrap instrument in heavy paper or plastic.
2. Use strong shipping container. A double wall carton made of 350-pound test material is adequate.
3. Use enough shock-absorbing material (3 to 4-inch layer) around all sides of instrument to provide firm cushion and prevent movement inside container. Protect control panel with cardboard.
4. Seal shipping container securely.
5. Mark shipping container FRAGILE to encourage careful handling.
6. In any correspondence, refer to instrument by model number and serial number.

OPERATION

Operation

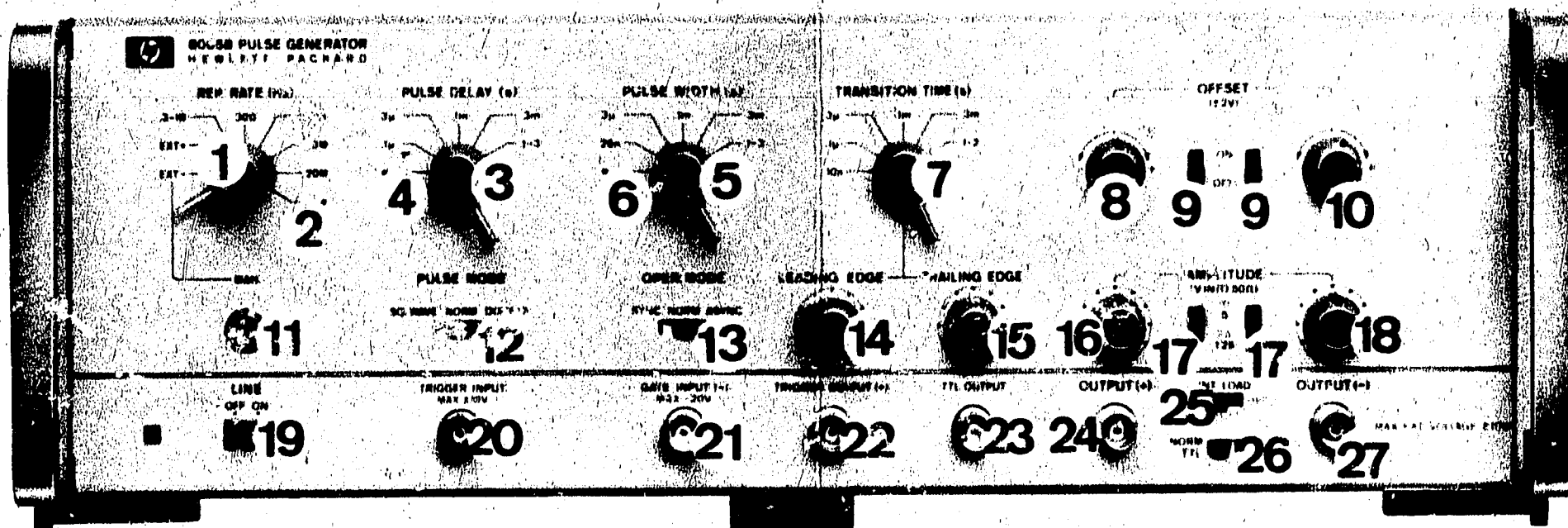

1 REP. RATE (Hz): Rotary switch selects the upper limit of the repetition rate and selects external \pm triggering or manual triggering. See note 1.

2 REP. RATE VERNIER: Provides fine control of internal repetition rate. Counter clockwise rotation of the control reduces the frequency.

3 DELAY (s): Rotary switch selects the lower limit of the range of pulse delays with respect to the trigger output. See note 1.

4 DELAY VERNIER: Provides fine control of the pulse delay. Clockwise rotation of the control increases the delay.

5 PULSE WIDTH (s): Rotary switch selects the lower limit of the range of pulse widths. See note 1.

6 PULSE WIDTH VERNIER: Provides fine control of the pulse width. Clockwise rotation of the control increases the width.

7 TRANSITION TIME: Rotary switch selects the lower limit of the range of both rise and fall times.

8 OFFSET vernier: For adjustment of the positive pulse output base line.

9 OFFSET ON/OFF: Two switches (one for each output) to turn on or off the dc baseline offset voltage.

10 OFFSET vernier: for adjustment of the negative pulse output baseline.

11 MAN.: Push button when pressed causes one pulse to be generated when the REP. RATE switch is in the EXT - MAN position.

12 PULSE MODE.: Three position switch for selecting normal, square wave or double pulse operation.

13 OPER. MODE: Three position switch for selecting synchronised gating, asynchronous gating or normal (no gating) operating modes.

14 LEADING EDGE: Provides fine control of the transition times for the leading edges of both positive and negative output pulses. Clockwise rotation of the control increases the transition time.

15 TRAILING EDGE: Provides fine control of the transition times for the trailing edges of both positive and negative output pulses. Clockwise rotation of the control increases the transition time.

16 AMPLITUDE vernier: Provides fine control of the amplitude of the positive output pulse. Counter clockwise rotation of the control reduces the amplitude.

Figure 3-1. Front Panels Controls and Connectors

3-0

17 AMPLITUDE range: Two switches for selecting the upper limits of the amplitude of the positive and negative output.

18 AMPLITUDE vernier: Provides fine control of the amplitude of the negative output pulse. Clockwise rotation of the control increases the amplitude.

19 LINE: push-for-on-push-for-off switch. The lamp adjacent to the switch indicates when power is on.

20 TRIGGER INPUT: BNC connector for applying trigger pulses to, when the REP. RATE switch is in the EXT + or EXT - position.

21 GATE INPUT (-): BNC connector to which the negative gate signal is applied when synchronously or asynchronously gating the repetition rate generator.

22 TRIGGER OUTPUT (+): BNC connector supplies positive trigger pulses.

23 TTL OUTPUT: BNC connector supplies TTL compatible voltage.

24 OUTPUT (+): BNC connector supplies positive output pulses. Maximum external voltage can be applied to this connector is $\pm 10V$.

25 INT. LOAD: Switch for connecting and disconnecting the internal 50Ω load to both positive and negative output amplifier.

26 NORM - COMPL. TTL: provides the following output formats.

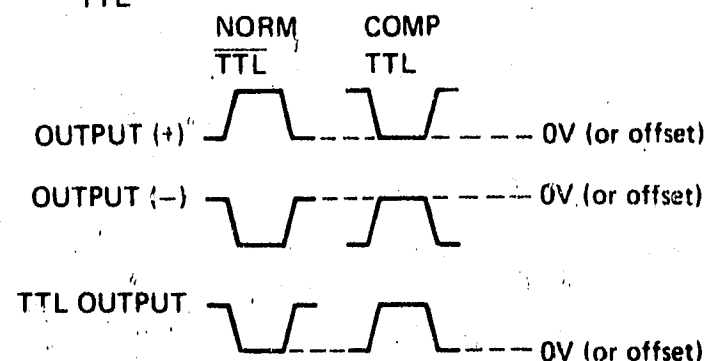

27 OUTPUT (-): BNC connector supplies positive output pulses. Maximum external voltage that can be applied to this connector is $\pm 10V$.

Note that switch positions indicated by an asterisk (*) can be used for a custom selected range.

SECTION III OPERATION

3-1 GENERAL

3-2 Figure 3-1 identifies and gives a brief description of the function of the front panel controls, adjustments, switches and connectors.

3-3 REPETITION RATE

3-4 The repetition rate can be generated internally or established externally by means of an external trigger or the MANUAL 11 push button.

3-5 Internal Triggering

3-6 The Model 8005B can establish internally any repetition rate in the range 0.3 Hz to 20 MHz. The desired repetition rate is achieved by setting the REP. RATE 1 switch to one of the five possible ranges and adjusting the REP RATE VERNIER 2 for the required frequency.

3-7 External Triggering

3-8 With the REP RATE 1 switch set to EXT+ or EXT- the repetition rate can be established by an external signal applied to the TRIGGER INPUT 20. The trigger signal may be a sine wave or pulses of either polarity (compatible with the position of the REP RATE 1 switch) with a repetition frequency up to 20 MHz. Sine waves must be of at least 2 volts peak to peak amplitude and pulses must be at least 1V peak and 15ns wide. The maximum permissible input signal is $\pm 10V$ peak.

3-9 Manual Trigger

3-10 With the REP RATE 1 switch set to the EXT - MAN position each depression of the MANUAL 11 push button will produce an output pulse (two in the DOUBLE PULSE MODE).

3-11 Pulse Modes

3-12 The 8005B is capable of operating in any one of three different pulse modes as dictated by the PULSE MODE 12 switch:

Norm: In this mode pulses are available at the output connectors. Their repetition rate, delay (with respect to trigger output), width, transition times and amplitude are determined by the front panel control settings.

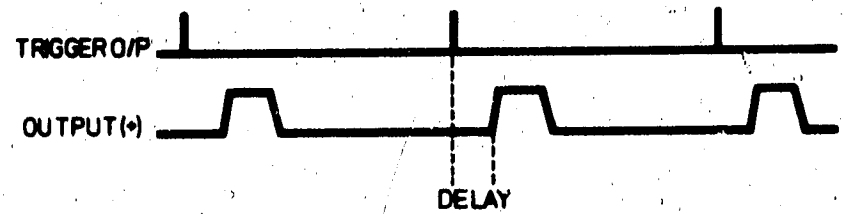

Figure 3-2. Single Pulse Mode - Typical Output

Double: In this mode the pulse rate is effectively doubled. The DELAY control determines by how much the second pulse is delayed with respect to the first.

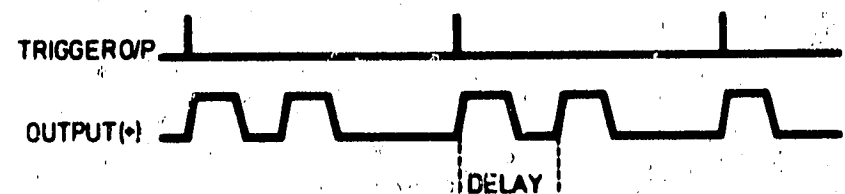

Figure 3-3. Double Pulse Mode - Typical Output

Square Wave: In this mode the repetition rate of the pulse and trigger outputs is halved.

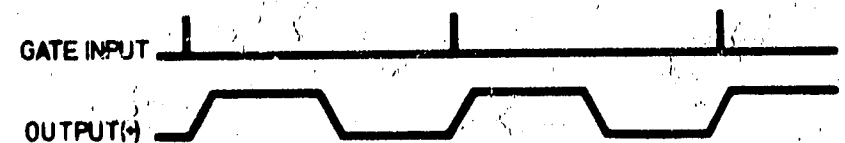

Figure 3-4. Square Wave Mode - Typical Output

3-13 Gating of the REP. RATE GENERATOR

3-14 A front panel switch 13 (OPER. MODE) selects three modes of operation; SYNCH GATED, NORM or ASYNCH GATED. In the NORM mode the 8005B functions normally and signals applied to the GATE INPUT 21 have no effect on the instrument. In the SYNCH GATED mode the rep rate generator is turned off until a negative signal is applied to the GATE INPUT 21. The first pulse is coincident with the leading edge of the gate and the last pulse is of normal width even if the gate signal ends during the pulse. In the ASYNCH GATED mode the gate pulse and the output pulses bear no time relationship. A trigger output is available continuously. Square wave is not available in the gate mode.

3-15 OUTPUT CONTROLS

3-16 Amplitude and Offset

3-17 The maximum pulse amplitude from OUTPUT (+) 24 and OUTPUT (-) 25 is 10 volts including dc offset. Figure 3-7 illustrates which combination of source and external load impedances will provide the desired amplitude. The source impedance for both OUTPUT (+) and OUTPUT (-) can be selected by means of the INT LOAD 25 switch. When operating in the 10V range, if changes are made to the settings of the AMPLITUDE verniers 16 and 18 it is necessary to reset the appropriate OFFSET vernier 8 or 10.

3-18 An advantage of the selectable internal load is that it helps overcome the problems of reflections. For example, using a 200pF capacitor to simulate the capacitance of an external load, Figure 3-7 illustrates which output configuration will produce the best results. For amplitudes up to 5 volts, reflections are more effectively absorbed when the output is developed across a 50Ω termination from a 50Ω source impedance (configuration 1). For amplitudes above 5 volts, either the 50Ω termination or the internal 50Ω load must be disconnected. In this case, reflections are more effectively absorbed by using the internal 50Ω load (configuration 2) as opposed to using only a 50Ω termination as shown in configuration 3.

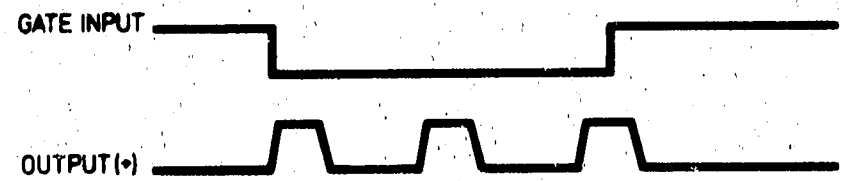

Figure 3-5. Synchronous Gating of Rep. Rate Generator

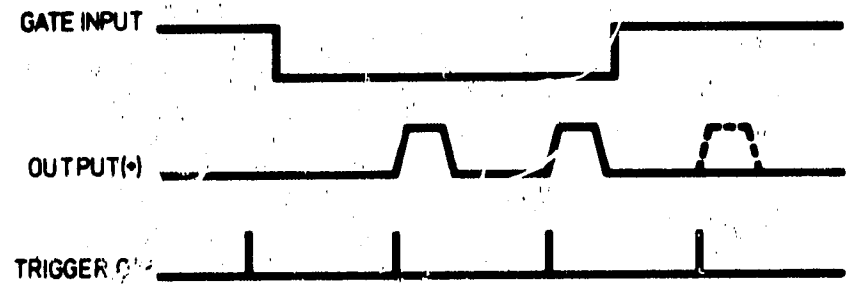

Figure 3-6. Asynchronous Gating of Rep. Rate Generator

3-19 TTL Output

3-20 The TTL OUTPUT connector supplies +4.6V open circuit voltage when the selector switch 26 is set to TTL and +4.6V complement when set to \overline{TTL} . When terminated by 50Ω the TTL voltage is +2.6 volts.

3-21 In order to minimize pulse distortion caused by interaction from unused outputs, it is necessary to terminate all unused outputs with 50Ω and, where possible, reduce the amplitude to a minimum.

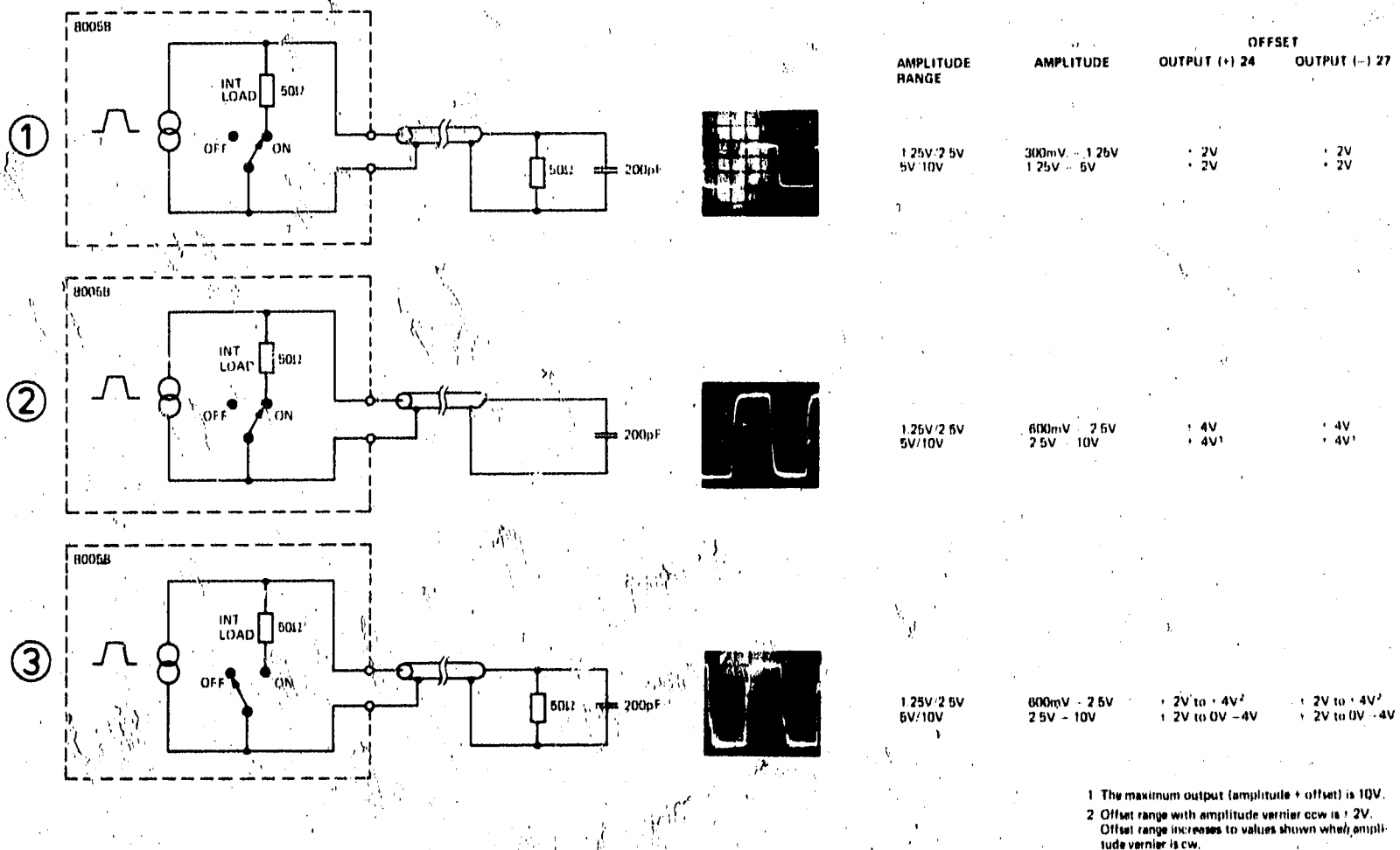

Figure 3-7. Output Configurations

THEORY

SECTION IV PRINCIPLES OF OPERATION

4-1 GENERAL DESCRIPTION

4-2 The basic concept of the Model 8005B pulse generator is shown in Figure 4-1. The pulse repetition rate is generated either internally or by an external triggering source. Gating can be effected either synchronously, by using the gate signal to start and stop the repetition rate generator, or asynchronously, by using the gate signal to control the output from the repetition rate generator. The selector circuit determines the shape and destination of the rate signal used in the pulse and square wave modes of operation. In the pulse mode, the delay generator delays, with respect to the trigger output, the output of the rep rate generator and applies it to the width generator. For each output pulse from the delay generator the width generator issues a pulse with a width as defined by the front panel control. Each pulse is processed by an integrator (with a time constant which can be varied) to achieve the desired rise and fall times. In the square wave mode the delay and width generators are not used and the square wave signal is applied directly to the integrator. The final operation involves amplifying and scaling to achieve the correct amplitude and source impedance.

4-3 REPETITION RATE

4-4 The pulse repetition rate is determined by either one of two possible methods:

- The free running state of the repetition rate generator.
- The frequency of the input pulses.

4-5 In the free running mode the repetition rate generator operates as follows:

The selected ramp capacitor discharges linearly through Q7 at a rate determined by the setting of VERIFIER R1 and the value of the capacitor. As the voltage at Q7 collector approaches zero, CR10/CR11 become forward biased causing Q5 and Q6 to conduct and rapidly recharge the ramp capacitor. CR10/CR11 become reverse biased so that Q5 and Q6 cut off and the discharge cycle resumes.

4-6 In the externally triggered mode, trigger pulses are applied to the differential amplifier Q1/Q2 which in turn switches the Schmitt trigger Q3/A4. Each trigger pulse produces a positive pulse from Q4 which is differentiated by R11/L1, and inverted by Q35. The positive spikes from Q35 cause the base of Q5 to rise so that Q5 and Q6 turn on to produce an output pulse. Each trigger pulse produces an output pulse from Q6.

4-7 In the MANUAL mode, Q3 is normally on and Q4 off. When the MAN push button is pressed, Q4 turns on and a negative spike is applied to Q35 which in turn turns Q5 and Q6 on to produce an output pulse. An output pulse is produced each time the manual push button is pushed.

4-8 In the NORM operating mode, gate Q12/Q13 is enabled by Q13 being held off. Thus, the pulses from the repetition rate generator which appear at Q12 base are inverted by Q12 and applied to the Pulse delay generator. Gating is not possible in SQ. WAVE.

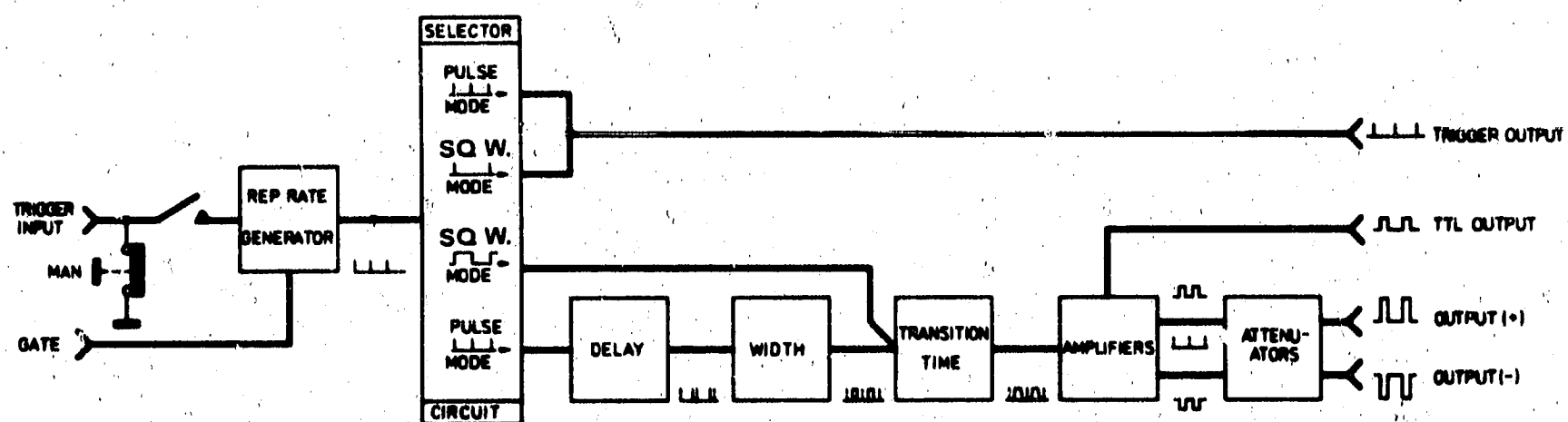

Figure 4-1. Basic Concept

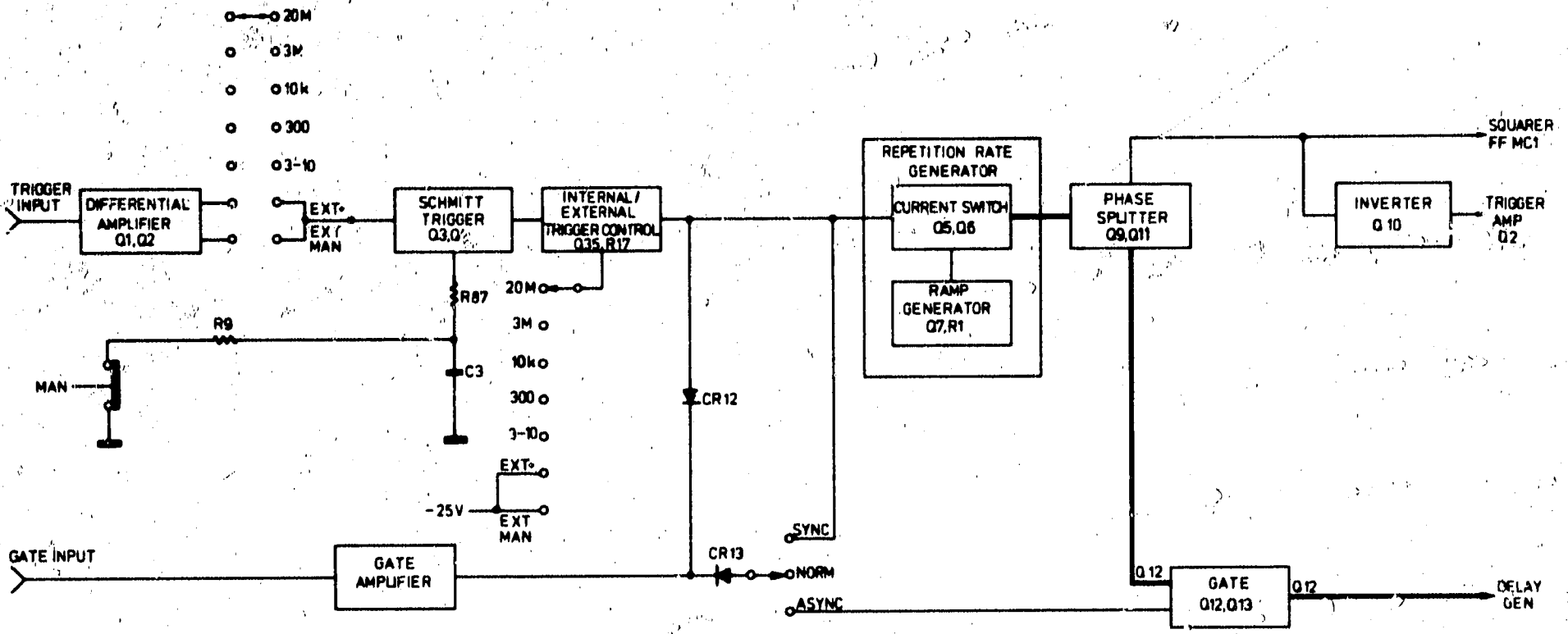

Figure 4-2. Repetition Rate Generator and Trigger Input Gating

4-9 GATING

4-10 In the ASYNCH mode, gate amplifier Q8 normally 'on' disables gate Q12/Q13 so that repetition rate pulses are blocked. A negative signal at the GATE INPUT turns Q8 off, hence gate Q12/Q13 is enabled and repetition rate

pulses are applied to the Pulse delay generator for the duration of the gate signal.

4-11 In the SYNCH operating mode gate amplifier Q8 normally on disables the repetition rate generator. A negative signal at the GATE INPUT cuts Q8 off which enables the repetition rate generator for the duration of the gate signal.

4-12 PULSE - SQUARE SELECTOR

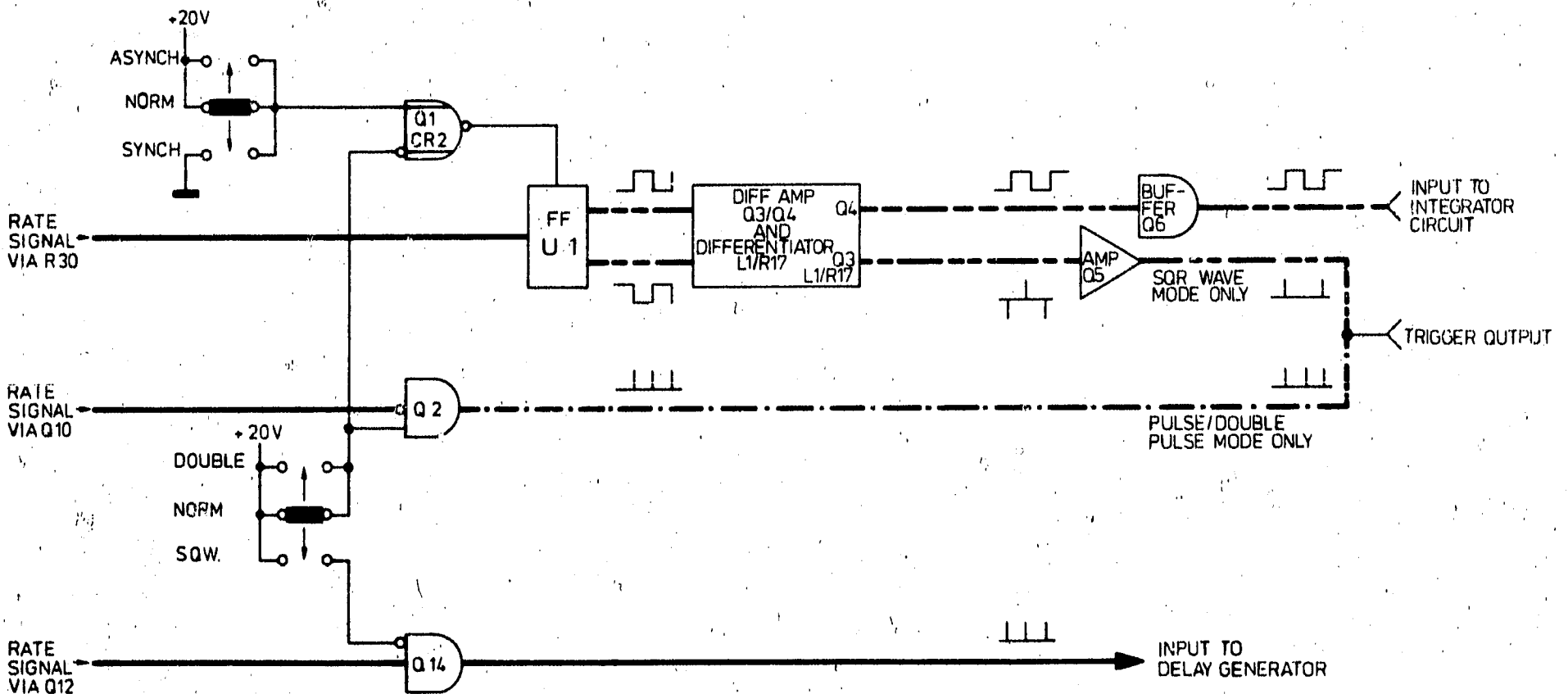

Figure 4-3. Pulse - Square Selector Circuit

4-13 The purpose of this circuit is, in NORM and DOUBLE pulse mode, to apply the rep. rate generator output to the delay generator and trigger the output amplifier. Alternatively, in SQ WAVE mode, the rep rate output is effectively disconnected from the delay generator and the trigger is established by one output from the flip-flop. The other output from the flip-flop is applied to the integrator circuits for the production of a fixed delay, fixed width pulse output. The square wave flip-flop is disabled in SYNCH gate mode.

4-14 When the PULSE MODE switch (S9) is set to NORM or DOUBLE pulse, the flip-flop (U1) is disabled. The gates Q14 and Q2 are open (Q14 off, Q2 on) thus the rate signal from Q12 is applied to the delay generator and the trigger is established via Q2. In setting S9 to SQ WAVE Q1 is turned off, the flip-flop PRESET goes high, thus the flip-flop is enabled. The complementary outputs of the flip-flop drive a differential amplifier (Q3/Q4). The output of Q3 is differentiated (L1/R17) and applied to the trigger output amplifier Q5. This is turned on only by the negative spikes and thus the positive spikes are suppressed.

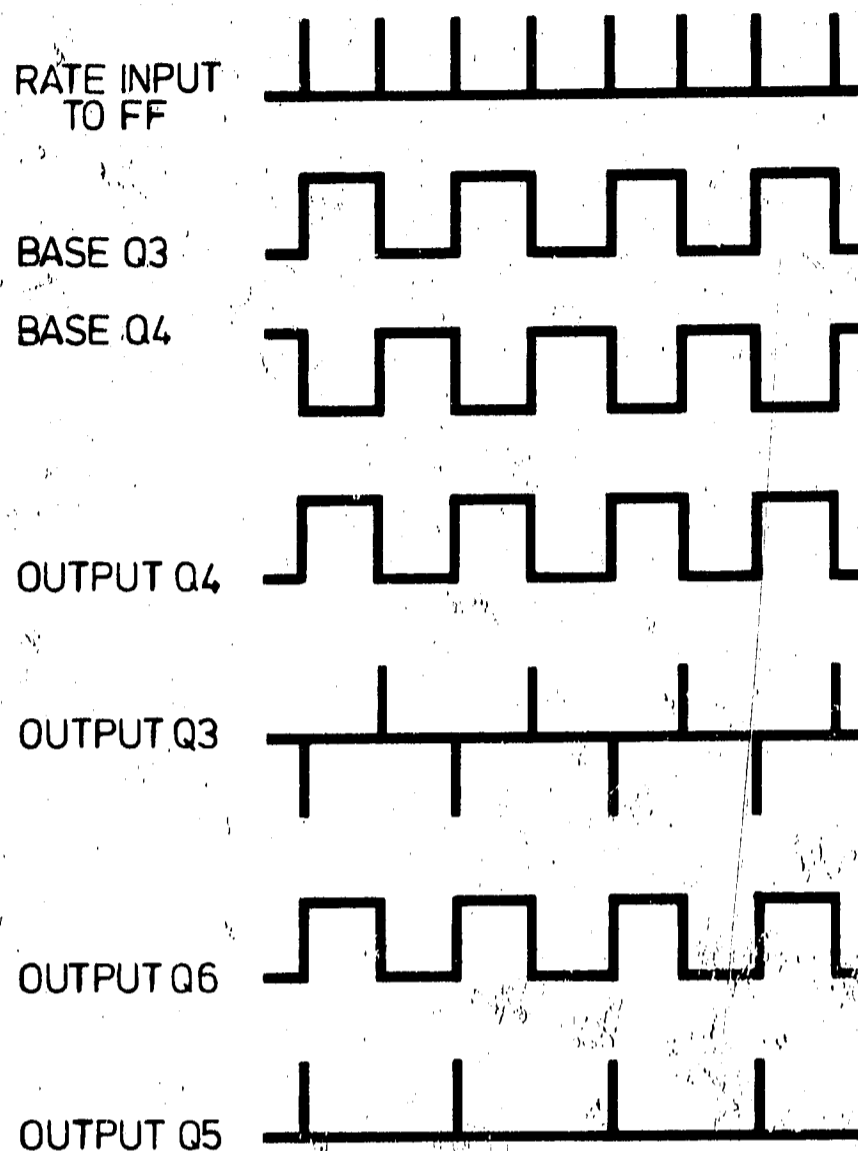

Figure 4-4. Square Wave Mode Timing Sequence

4-15 PULSE DELAY GENERATOR

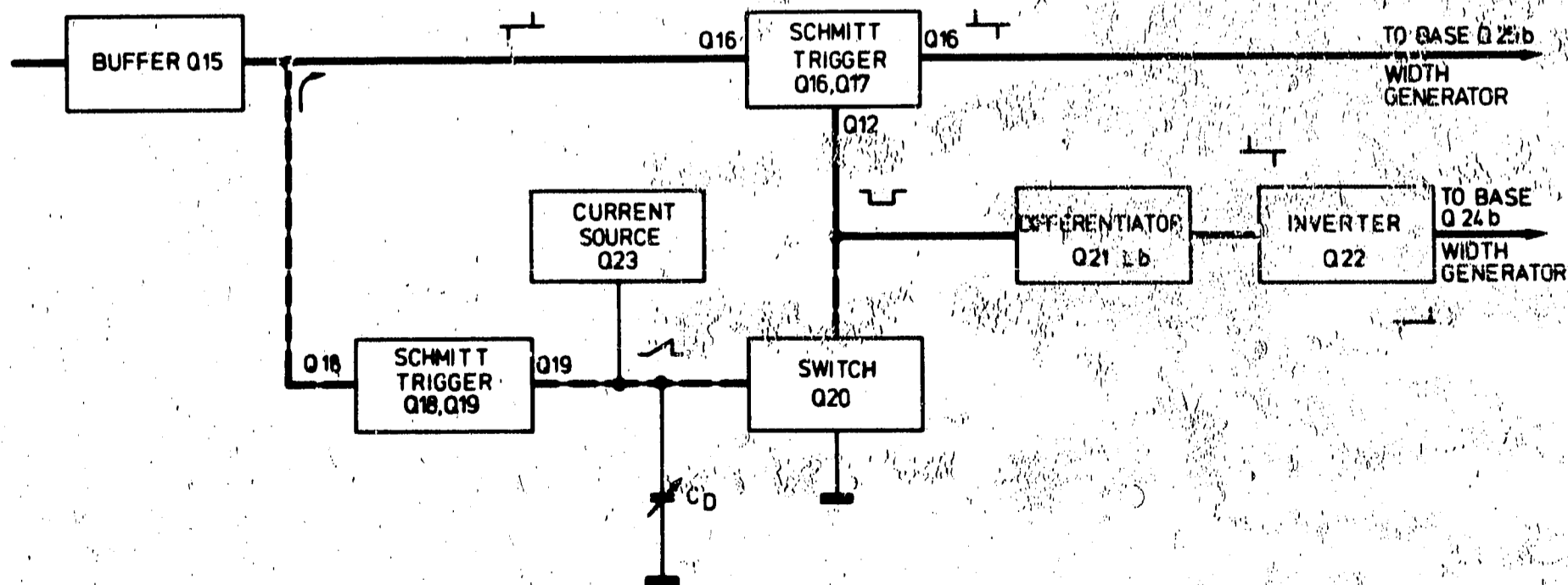

Figure 4-5. Delay Generator

4-16 The function of the Pulse delay generator is to provide pulses which are delayed with respect to the repetition rate output. Two outputs supply the width generator. One carries the delayed pulse only whilst the other carries both the in-phase and delayed pulses.

4-17 Initially Schmitt trigger Q16/Q17 holds Q20 on so that Q23 supplies Q20 with current and the selected ramp capacitor remains discharged. On receipt of a pulse from the repetition rate generator via Q15, Schmitt trigger Q16/Q17 switches and cuts off Q20. The current source now charges the selected capacitor. When the ramp reaches the threshold level of Schmitt trigger Q19/Q18, Q19/Q18 switch and reset Schmitt trigger Q16/Q17. Thus Q20 is turned on discharging the ramp capacitor and resetting Schmitt trigger Q18/Q19. It is apparent that Schmitt trigger Q16/Q17 switches first on the in-phase pulse and is reset after the required delay. Thus the outputs from Q16/Q17 are complementary pulses of duration dependent upon the delay time. The delay time range is chosen by selecting different capacitors and fine adjustment is achieved by varying the current defining resistance R3. The output from Q16 is differentiated by R41/L7 to give a positive spike coincident with the repetition rate generator output and a negative spike on completion

of the delay. The inverter Q25 responds only to the negative spike (delayed). Both the output from Q16 and the positive spike from Q25 are applied to the width generator.

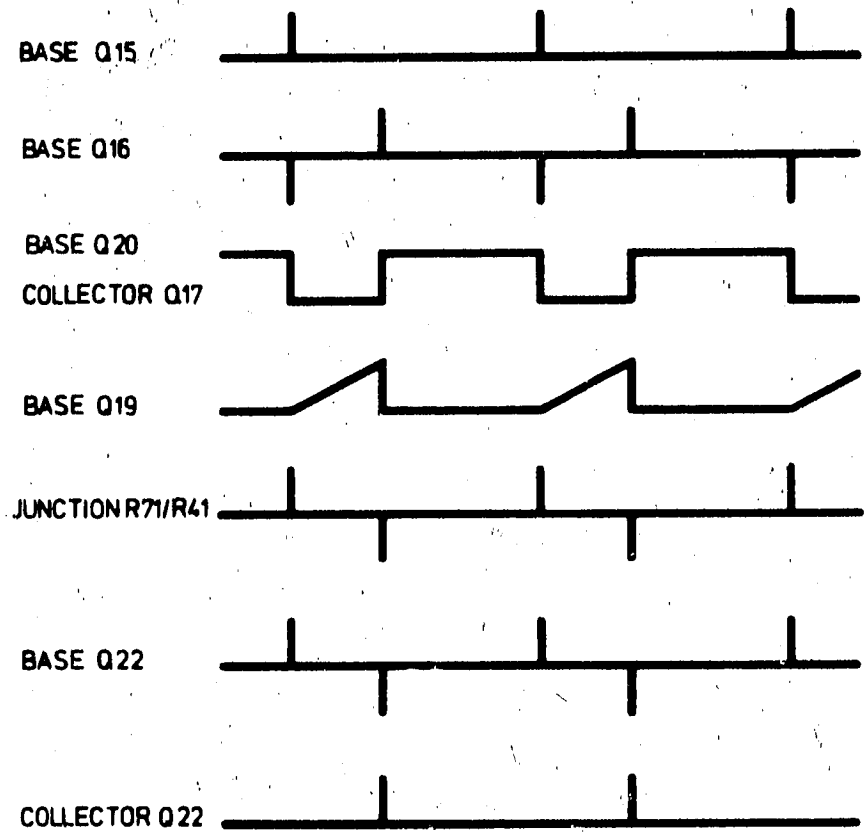

Figure 4-6. Delay Generator Timing Sequence

4-18 WIDTH GENERATOR

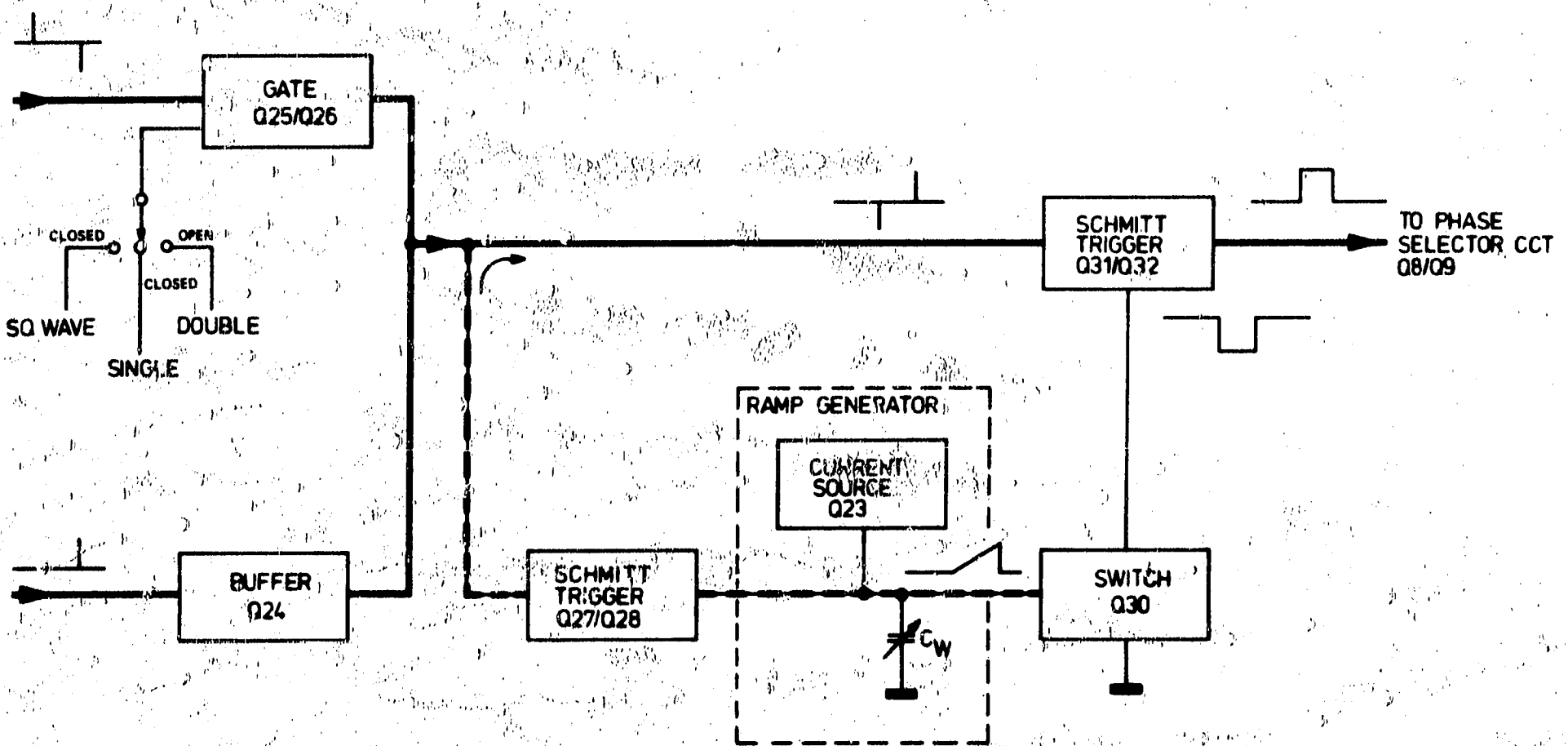

Figure 4-7. Pulse Width Generator

4-19 Operation of the width generator is similar to that of the delay generator. A Schmitt trigger (Q31/Q32) controls the operation of a ramp generator via a switch (Q30). When the ramp reaches the threshold level of Schmitt trigger Q25/Q26 the resulting change of state resets the first Schmitt trigger. This in turn resets the ramp generator which resets the second Schmitt trigger. This cycle occurs once for each input pulse to Schmitt trigger Q31/Q32.

4-20 In the SINGLE pulse mode, gate Q25/Q26 is closed so that only the delayed output from the delay generator reaches Schmitt trigger Q31/Q32 via Q24.

4-21 In the DOUBLE pulse mode Q26 is held off so that Q25 can be turned on by the in-phase output from the delay generator. Consequently, two pulses reach Schmitt trigger Q31/Q32; first the in-phase output from the delay generator via Q25 and then the delayed output via Q24.

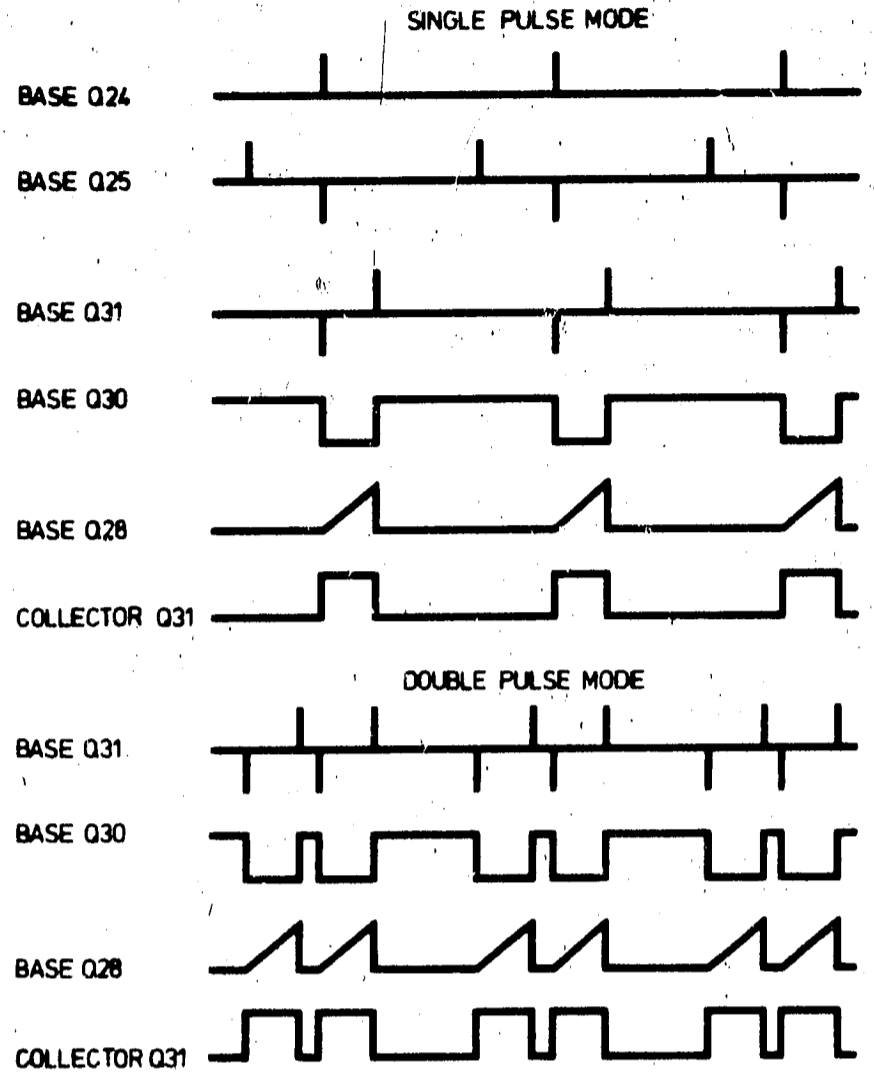

Figure 4-8. Width Generator Timing Sequence

4-22 PULSE DEFINING CIRCUITS

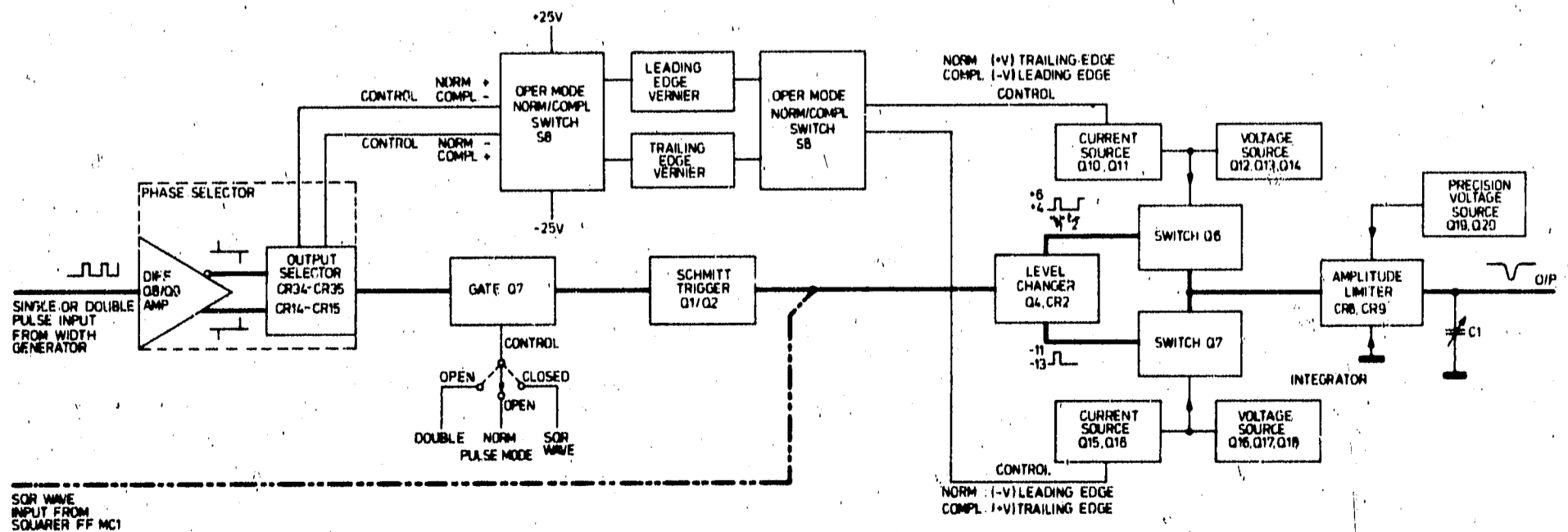

Figure 4-9. Phase Defining Circuit and Integrator

4-23 The function of the phase selector is to determine whether the leading edge of the output pulses are to be positive-going or negative-going (OPER MODE). The purpose of the integrator circuit is, in all modes of operation, to vary the rise and fall or fall and rise of the pulse LEADING EDGE and TRAILING EDGE within a selected range (TRANSITION TIME).

4-24 Pulse and Double Pulse Mode

4-25 For each positive pulse input from the width generator, a differential amplifier (Q8/Q9) produces an in-phase and an antiphase output. When the OPER. MODE switch (S8) is set to NORM, the output selector passes only the inphase signal via CR14 or, when S8 is set to COMPL, the antiphase signal via CR15. With the PULSE MODE switch 12 set to NORM or DOUBLE, the gate Q7 is open (Q7 off) and thus the selected signal (via CR14 or CR15) is applied to a Schmitt trigger (Q1/Q2).

4-26 When switched by the in-phase signal, the Schmitt trigger produces a positive pulse or, when switched by the antiphase signal (CR15), a negative pulse.

4-27 Square Wave Mode

4-28 By setting the PULSE MODE switch to SQ WAVE the gate Q7 is closed (Q7 turned on), thus the signal from the width generator is blocked and the Schmitt trigger disabled. The signals appearing at the base of Q4 in this mode are derived from the flip-flop U1 and differentiated by L1/R4.

4-29 In all modes of operation, C3 and R10 reduce ringing on all but the 10ns range where they would slow down the transition times. Q4 and CR2 convert the single pulse train to two, each with a different dc level. These two outputs control the switches Q6 and Q7. Voltage sources Q12, Q13, Q14 and Q16, Q17, Q18 define the switching potentials of Q6 and Q7 respectively. During the positive excursion Q6 is off and Q7 is on causing Q16 to draw current from the transition time capacitor (C_T) at a rate determined by the capacitance of C_T and the position of the selected transition time vernier. During the negative duration of the output from Q4, Q6 turns on and Q7 cuts off. Thus current flows from Q11 into C_T at a rate determined by C_T and the position of the selected transition time vernier. Voltage source Q19 and Q20

limits the voltage to which C_T can charge to -8.4 V whilst CR9 limits the discharge potential to +0.7V. The charging rate and negative clamp voltage define the pulse risetime whilst the discharge rate and positive clamp voltage define the pulse fall time.

4-30 When the OPER MODE switch (S8) is set to NORM, the LEADING EDGE vernier is connected to Q16 and the TRAILING EDGE vernier to Q11. When this switch is set to COMPL, the leading edge vernier is connected to Q11 and the trailing edge vernier to Q16.

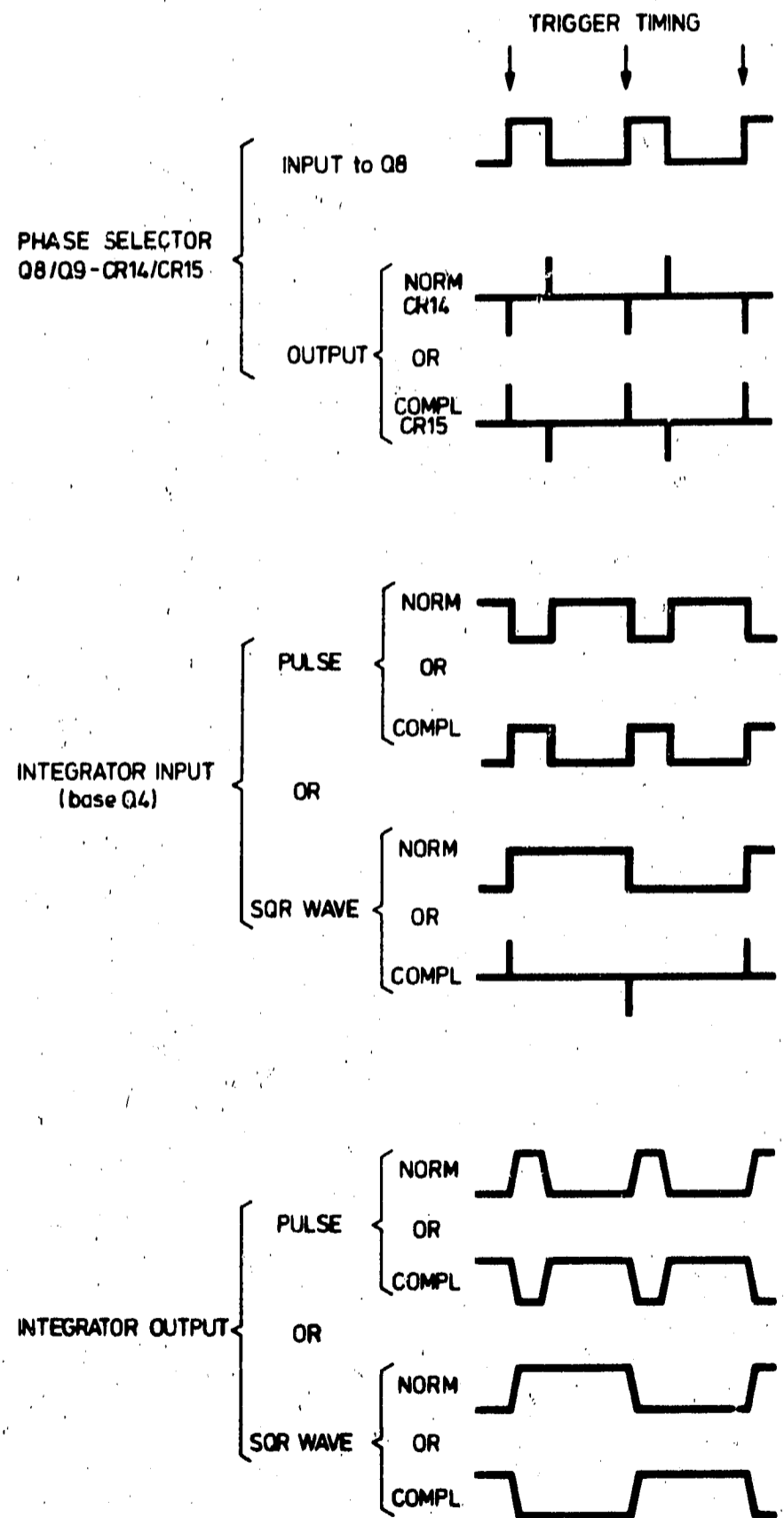

Figure 4-10. Pulse Defining Sequence

4-31 OUTPUT STAGE

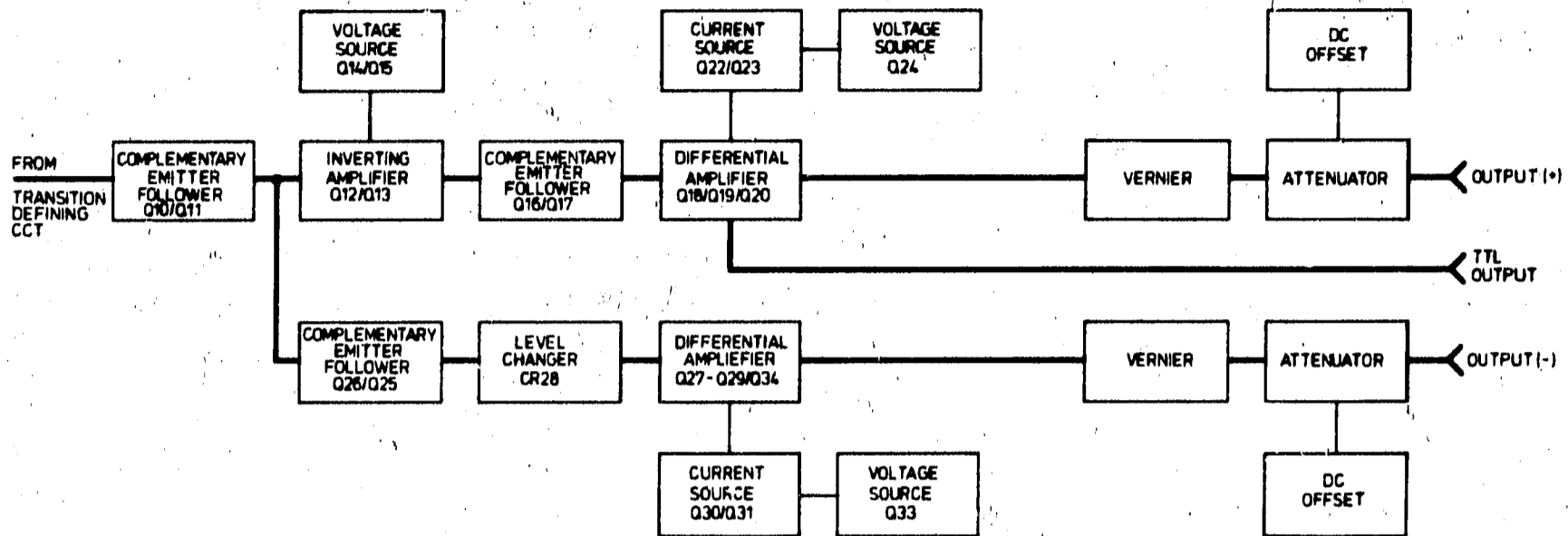

Figure 4-11. Output Stage

4-32 Complementary emitter follower Q10/Q11 functions as a buffer stage between the transition time definition circuit and the output stage. The signal from Q11 emitter supplies the positive channel (via Q12 and complementary emitter follower Q16/Q17) and the negative channel (via complementary emitter follower Q25/Q26). CR28 shifts the signal level to the negative stage by -8.25V . Voltage source Q14/Q15 sets the position of the positive channel baseline (without offset).

4-33 The output amplifier comprises two differential amplifiers one in the positive channel (Q18-Q20) and one in the negative channel (Q27-Q29 and Q34). Each amplifier is supplied from its own current source Q22/Q23 and Q30/Q31. The switching characteristics of the respective amplifier are improved by means of the diodes CR20-CR24 positive channel, and CR29-CR32 in the negative channel. The amplifiers feed the attenuators via the AMPLITUDE VERNIER.

4-34 TTL OUTPUT

4-35 The $+4.5\text{V}$ TTL output voltage is taken from the collector of Q18 and developed across a 50Ω impedance (R123/R124).

4-36 DC OFFSET

4-37 The dc offset circuits control the baseline positions of the positive and negative outputs. Both circuits operate in identical fashion, thus only the positive offset circuit is described. With the offset switch in the OFF position, the bias potential of U1 is held at 0V and the whole circuit is thus off. With the offset switch in the ON position the bias potential of U1 is dependent on the position of the OFFSET VERNIER. As the wiper of the OFFSET VERNIER is moved towards the R31 end, the output of Q3/Q4 goes positive. Similarly, as it is moved towards R32, the output of Q3/Q4 goes negative.

4-38 POWER SUPPLY

4-39 The $+25\text{V}$ and -25V power supplies are identical series regulated types. An error amplifier compares a sample of the output with the voltage of a zener diode and the resulting error signal controls the series regulator to compensate for any variations.

4-40 The $+20\text{V}$ supply is derived from the $+25\text{V}$ supply. R81, and R82 define the potential of 20V at the emitter of Q3. Q3 supplies the current.

PERFORMANCE CHECK

SECTION V PERFORMANCE TESTS

5-1 INTRODUCTION

5-2 The procedures in this section test the electrical performance of the instrument using the specifications of Table 1-2 as performance standards. All tests can be performed without access to the interior of the instrument.

5-3 EQUIPMENT REQUIRED

5-4 Equipment required for the performance tests is listed in Table 1-1, Recommended Test Equipment. Any equipment that satisfies the critical specifications given in the table may be substituted for the recommended model(s).

5-5 TEST RECORD

5-6 Results of the performance tests may be tabulated on the Test Record at the end of the test procedures. The Test Record lists all of the tested specifications and their acceptable limits. Test results recorded at incoming inspection can be used for comparison in periodic maintenance, troubleshooting, and after repairs or adjustments.

5-7 PERFORMANCE TESTS

5-8 The performance tests given in this section are suitable for incoming inspection, troubleshooting, or preventive maintenance. During any performance test, all shields and connecting hardware must be in place. The tests are designed to verify the published instrument specifications. Perform the tests in the order given and record the data on the test card and/or in the data spaces provided at the end of each procedure.

NOTE

The instrument must have a 15 min warmup time and the line voltage must be within +10%, -15% of nominal if the performance tests are to be considered valid.

5-9 Each test is arranged so that the specification is written as it appears in Table 1-2. Next, a description of the test and any special instructions or problem areas are included. Each test that requires test equipment has a setup drawing and a list of the required equipment. The initial steps of each procedure give control settings required for that particular test.

PERFORMANCE TESTS

5-10 Repetition Rate

SPECIFICATION: 0.3 Hz to 20 MHz in five ranges. Vernier provides continuous adjustment within each range.

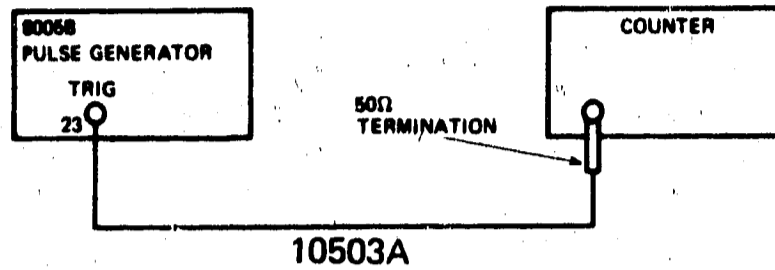

PROCEDURE:

1. Set the 8005B controls as follows:

REP RATE 1	20M
VERNIER 2	CW
PULSE DELAY 3	0.1μ
VERNIER 4	CCW
PULSE WIDTH 5	25n
VERNIER 6	CCW
TRANSITION TIME 7	10n
OFFSET VERNIER 6	-
OFFSET SWITCH 9	OFF
OFFSET VERNIER 10	-
MAN 11	-
PULSE MODE 12	NORM
OPER MODE 13	NORM
LEADING EDGE 14	CCW
TRAILING EDGE 15	CCW
AMPLITUDE VERNIER 16	CW
AMPLITUDE RANGE 17	5V
AMPLITUDE VERNIER 18	CW
INT LOAD 25	ON
NORM-COMPL 26	NORM

2. Check the repetition rate for each of the following control settings listed below.

REP RATE 1	VERNIER 2	RESULT
20M	CW	> 20 MHz
0.3M	CW	> 300 kHz
10k	CW	> 10 kHz

3. Set the counter to period measurement and continue checking rep rate

300	CW	< 3.33ms
0.3-10	CW	< 100ms

PERFORMANCE TESTS

5-11 Manual Trigger

SPECIFICATION: Push button for generating single pulse (two in double pulse mode).

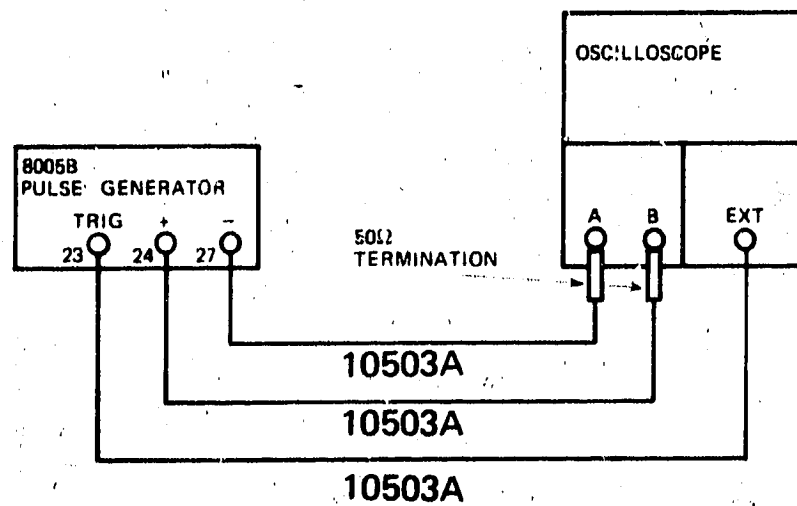

PROCEDURE:

1. Set the 8005B controls as follows:

REP RATE 1	EXT+
VERNIER 2	CCW
PULSE DELAY 3	0.1
VERNIER 4	CCW
PULSE WIDTH 5	3μ
VERNIER 6	CCW
TRANSITION TIME 7	10n
OFFSET VERNIER 8	-
OFFSET SWITCH 9	OFF
OFFSET VERNIER 10	-
MAN 11	-
PULSE MODE 12	NORM
OPER MODE 13	NORM
LEADING EDGE 14	CCW
TRAILING EDGE 15	CCW
AMPLITUDE VERNIER 16	CW
AMPLITUDE RANGE 17	5V
AMPLITUDE VERNIER 18	CW
INT LOAD 25	ON
NORM-COMPL 26	NORM

2. Press the MAN 11 push button. Check that only one pulse is generated for each depression of the MAN button. Check that no pulse occurs when the button is released.

PERFORMANCE TESTS

5-12 Pulse Width

SPECIFICATION: < 25ns to 3s in three ranges. Vernier provides continuous adjustment within each range.

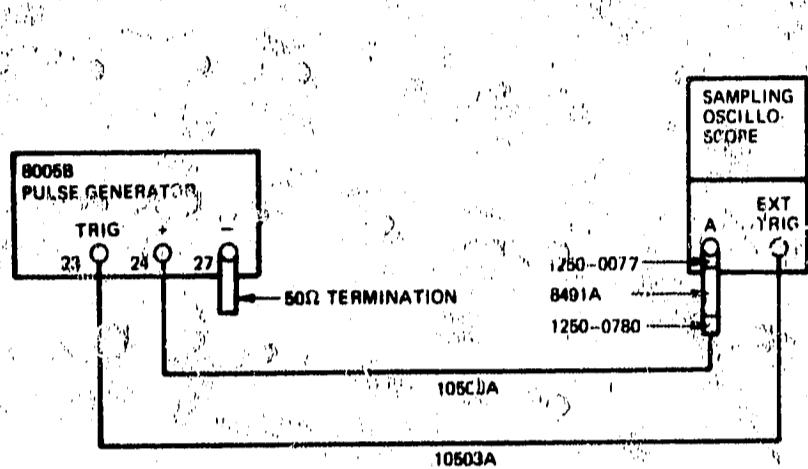

Fast Ranges

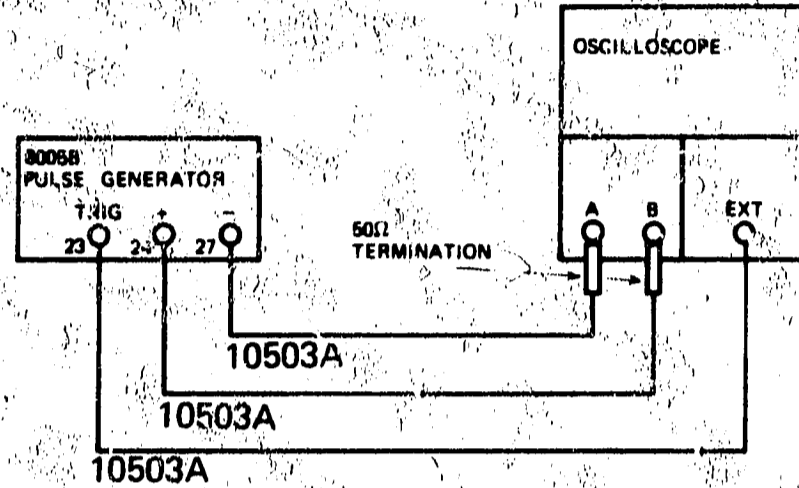

Slow Ranges

PROCEDURE:

1. Set the 8005B controls as follows:

REP RATE 1	20M
VERNIER 2	CCW
PULSE DELAY 3	0.1μ
VERNIER 4	CCW
PULSE WIDTH 5	25n
VERNIER 6	CCW
TRANSITION TIME 7	10n
OFFSET VERNIER 8	-
OFFSET SWITCH 9	OFF
OFFSET VERNIER 10	-
MAN 11	-
PULSE MODE 12	NORM
OPER MODE 13	NORM
LEADING EDGE 14	CCW
TRAILING EDGE 15	CCW
AMPLITUDE VERNIER 16	CW
AMPLITUDE RANGE 17	5V
AMPLITUDE VERNIER 18	CW
INT LOAD 25	ON
NORM-COMPL 26	NORM

PERFORMANCE TESTS

2. Using test set-up "fast ranges" check the pulse width for each control setting listed below.

REP RATE 1	PULSE WIDTH 5	VERNIER 6	RESULT
20M	25	CCW	< 25ns
0.3M	3μ	CCW	< 3μs
10K	0.1m	CCW	< 0.1ms

3. Using test set-up "slow ranges" check the pulse width for each control setting listed below.

300	3m	CCW	< 3ms
0.3-10	0.1-3	CCW	< 0.1s
Manual (switch to EXT+ and press MAN)	0.1-3	CW	> 3s

PERFORMANCE TESTS

5-13 Pulse Width Jitter

SPECIFICATION: < 0.1% of any width setting.

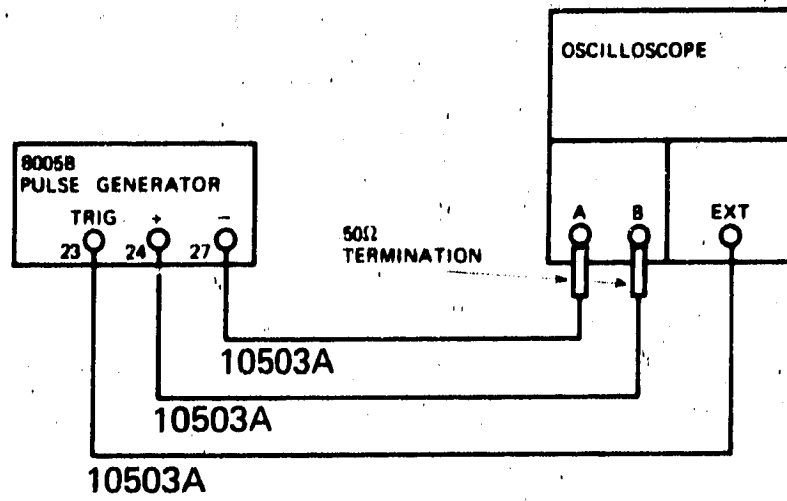

PROCEDURE:

1. Set the 8005B controls as follows:

REP RATE 1	10K
VERNIER 2	CW
PULSE DELAY 3	0.1μ
VERNIER 4	CCW
PULSE WIDTH 5	3μ
VERNIER 6	CCW
TRANSITION TIME 7	10n
OFFSET VERNIER 8	-
OFFSET SWITCH 9	OFF
OFFSET VERNIER 10	-
MAN 11	-
PULSE MODE 12	NORM
OPER MODE 13	NORM
LEADING EDGE 14	CCW
TRAILING EDGE 15	CCW
AMPLITUDE VERNIER 16	CW
AMPLITUDE RANGE 17	5V
AMPLITUDE VERNIER 18	CW
INT LOAD 25	ON
NORM-COMPL 26	NORM

2. Set the controls of scope as follows:

MAIN SWEEP	0.1ms/div.
DELAY SWEEP	0.1μs/div.
SWEEP MODE	NORM
DELAYED TRIGGER	AUTO
CM DELAY	0

3. Adjust the PULSE WIDTH VERNIER 6 for a pulse width of 0.1ms on the display.
4. Move the trailing edge of the first pulse to the centre of the display using the DELAY VERNIER 4.
5. Adjust the scope delay until the intensified spot coincides with the trailing edge of the first pulse.
6. Switch scope to DELAYED sweep display.
7. Measure the pulse width jitter.

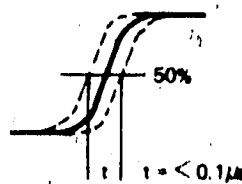

PERFORMANCE TESTS

5-14 Pulse Delay

SPECIFICATION: < 100ns to 3s in five ranges. Vernier provide continuous adjustment within each range.

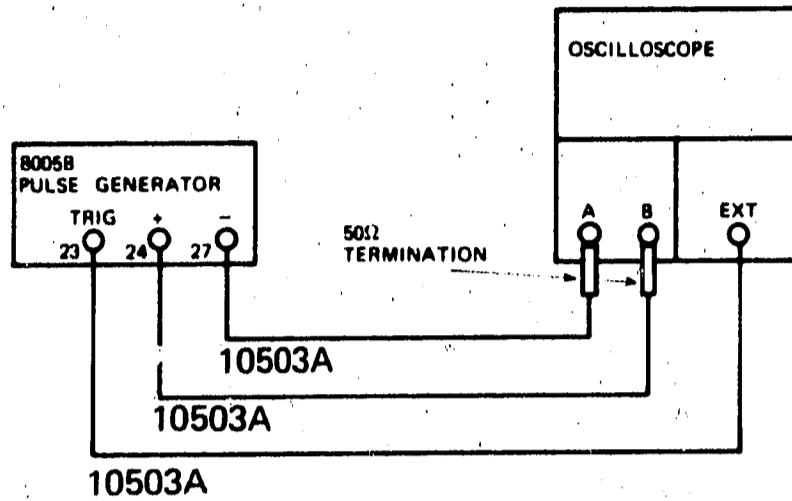

PROCEDURE:

1. Set the 8005B controls as follows:

REP RATE 1	0.3M
VERNIER 2	Mid-travel
PULSE DELAY 3	0.1μ
VERNIER 4	CW
PULSE WIDTH 5	25n
VERNIER 6	CW
TRANSITION TIME 7	10n
OFFSET VERNIER 8	CCW
OFFSET SWITCH 9	-
OFFSET VERNIER 10	OFF
MAN 11	-
PULSE MODE 12	NORM
OPER MODE 13	NORM
LEADING EDGE 14	CCW
TRAILING EDGE 15	CCW
AMPLITUDE VERNIER 16	CW
AMPLITUDE RANGE 17	5V
AMPLITUDE VERNIER 18	CW
INT LOAD 25	ON
NORM-COMPL 26	NORM

2. Set start point of trace to the left side of graticule and measure distance (delay) to the first leading edge.

RATE	DELAY	VERNIER	WIDTH	VERNIER	RESULT
0.3M	0.1μ	CW	25n	CW	> 3μs
10K	3μ	CW	3μ	CW	> 0.1ms
300	0.1m	CW	0.1m	CW	> 3ms
0.3-10	3m	CW	3m	CW	> 0.1s
EXT-MAN	0.1-3	CW	0.1-3	CW	> 3s

PERFORMANCE TESTS

5-15 Pulse Delay Jitter

SPECIFICATION: < 0.1% of any delay setting.

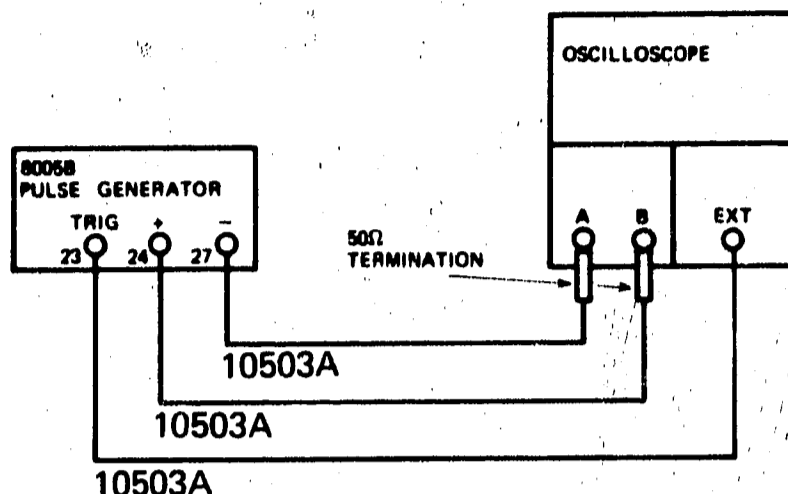

PROCEDURE:

1. Set the 8005B controls as follows:

REP RATE 1	10K
VERNIER 2	CW
PULSE DELAY 3	0.1μ
VERNIER 4	CCW
PULSE WIDTH 5	3μ
VERNIER 6	CW
TRANSITION TIME 7	10n
OFFSET VERNIER 8	-
OFFSET SWITCH 9	OFF
OFFSET VERNIER 10	-
MAN 11	-
PULSE MODE 12	NORM
OPER MODE 13	NORM
LEADING EDGE 14	CCW
TRAILING EDGE 15	CCW
AMPLITUDE VERNIER 16	CW
AMPLITUDE RANGE 17	5V
AMPLITUDE VERNIER 18	CW
INT LOAD 25	ON
NORM-COMPL 26	NORM

2. Set the controls of scope as follows:

MAIN SWEEP	0.1ms/div
DELAY TRIGGER	0.1μs/div
SWEEP MODE	NORM
DELAYED TRIGGER	AUTO
CM DELAY	0
TRIGGER	-

3. Adjust the REP RATE VERNIER 2 to obtain a 0.2ms period on the display.
4. Move the signal 0.1ms by switching the PULSE DELAY 3 to 3m and adjusting the VERNIER 4 appropriately.
5. Adjust the 1821A DELAY (DIV) until intensified spot coincides with the leading edge of the second pulse on the display.
6. Switch to MIXED sweep display on 1821A.
7. Measure the pulse delay jitter.

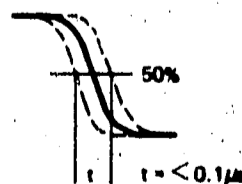

PERFORMANCE TESTS

5-16 Square Wave

SPECIFICATION

0.15 Hz to 10 MHz. Duty cycle: 50% ± 5% for repetition rates ≤ 1 MHz, increasing to 50% ± 15% at 10 MHz.

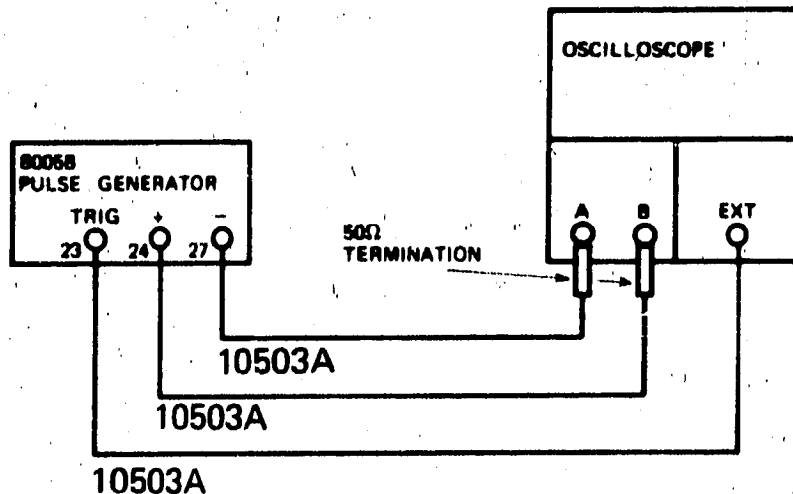

PROCEDURE:

1. Set 8005B controls as follows:

REP RATE 1	0.3-10
VERNIER 2	CCW
PULSE DELAY 3	0.1μ
VERNIER 4	CCW
PULSE WIDTH 5	25n
VERNIER 6	CCW
TRANSITION TIME 7	10n
OFFSET VERNIER 8	-
OFFSET SWITCH 9	OFF
OFFSET VERNIER 10	-
MAN 11	-
PULSE MODE 12	SQ WAVE
OPER MODE 13	NORM
LEADING EDGE 14	CCW
TRAILING EDGE 15	CCW
AMPLITUDE VERNIER 16	CW
AMPLITUDE RANGE 17	5V
AMPLITUDE VERNIER 18	CW
INT LOAD 25	ON
NORM-COMPL 26	NORM

2. For each setting of the REP RATE switch 1 given in the table below, turn the VERNIER 2 and check that the pulse width (t ON) equals the pulse off time (t OFF).

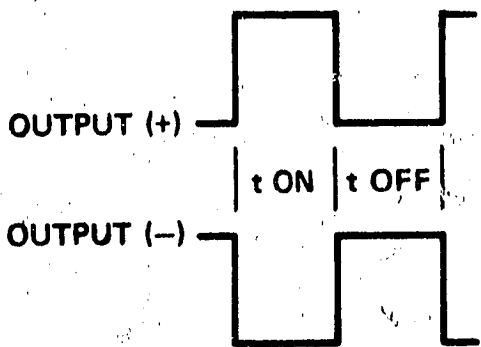

REP RATE 1

VERNIER 2

- 0.3-10
- 300
- 10K
- 0.3 MHz
- 20 MHz

- CCW
- CCW
- CCW
- CCW
- CCW

t ON = t OFF ± 5%

3.

Turn the vernier slowly CW and stop at 1 MHz

4.

Turn the vernier fully CW and measure pulse width

t ON = t OFF ± 15%

PERFORMANCE TESTS

5-17 Duty Cycle

SPECIFICATION: > 80% for repetition rates from 0.3 Hz to 1 MHz, > 50% from 1 MHz to 20 MHz. Up to 100% when using pulse complement.

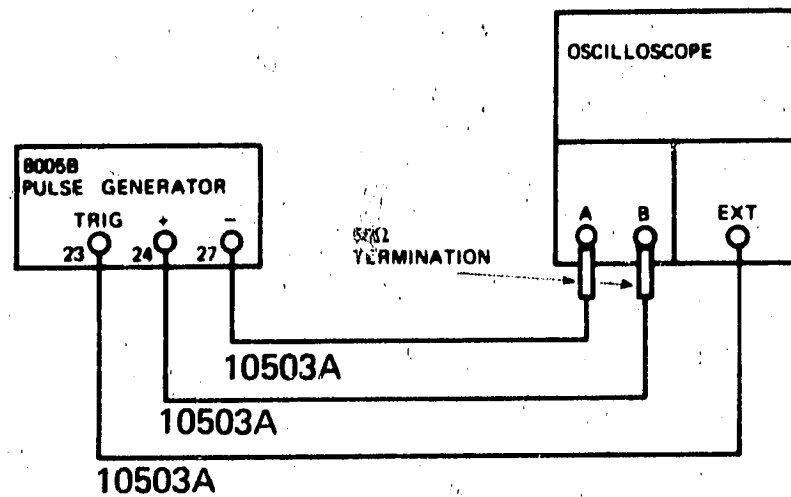

PROCEDURE:

1. Set 8005B controls as follows:

REP RATE 1	20M
VERNIER 2	CW
PULSE DELAY 3	0.1μ
VERNIER 4	CCW
PULSE WIDTH 5	25n
VERNIER 6	CCW
TRANSITION TIME 7	10n
OFFSET VERNIER 8	-
OFFSET SWITCH 9	OFF
OFFSET VERNIER 10	-
MAN 11	-
PULSE MODE 12	NORM
OPER MODE 13	NORM
LEADING EDGE 14	CCW
TRAILING EDGE 15	CCW
AMPLITUDE VERNIER 16	CW
AMPLITUDE RANGE 17	5V
AMPLITUDE VERNIER 18	CW
INT LOAD 25	ON
NORM-COMPL 26	NORM

2. Adjust the REP RATE VERNIER 2 for one complete period over the display area.
3. Turn the PULSE WIDTH VERNIER 6 slowly CW until the pulse period is affected (count down) and measure the duty cycle > 50%.
4. Set the REP RATE 1 and adjust the VERNIER 2 for frequencies under 1 MHz and repeat step 2. > 80% 'on-time'.

PERFORMANCE TESTS

5-18 Double Pulse

SPECIFICATION: 10 MHz max (simulates 20MHz) spacing: < 100ns to 3s (with respect to trigger output) in five ranges.
Vernier provides continuous adjustment within each range.

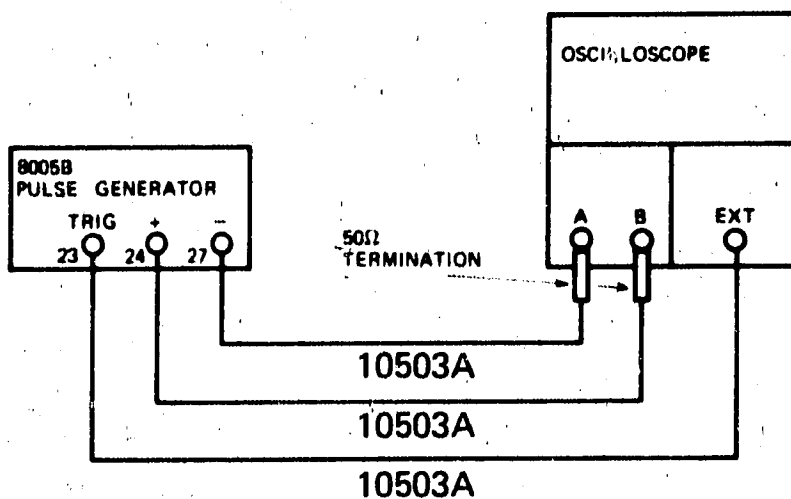

PROCEDURE:

1. Set 8005B controls as follows:

REP RATE 1	20M
VERNIER 2	CCW
PULSE DELAY 3	0.1μ
VERNIER 4	CCW
PULSE WIDTH 5	25n
VERNIER 6	CCW
TRANSITION TIME 7	10n
OFFSET VERNIER 8	-
OFFSET SWITCH 9	OFF
OFFSET VERNIER 10	-
MAN 11	-
PULSE MODE 12	DOUBLE
OPER MODE 13	NORM
LEADING EDGE 14	CCW
TRAILING EDGE 15	CCW
AMPLITUDE VERNIER 16	CW
AMPLITUDE RANGE 17	5V
AMPLITUDE VERNIER 18	CW
INT LOAD 25	ON
NORM-COMPL 26	NORM

2. Check pulse spacing.

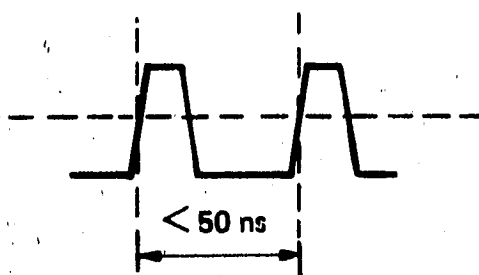

PERFORMANCE TESTS

5-19 Transition Times (Fast)

SPECIFICATION: $\leq 10\text{ns}$ to 2s in six ranges. Separate verniers provide independent control of leading and trailing edges within each range. Ranges are common for leading and trailing edges. Max. leading edge/trailing edge ratio, 1:30 or 30:1.

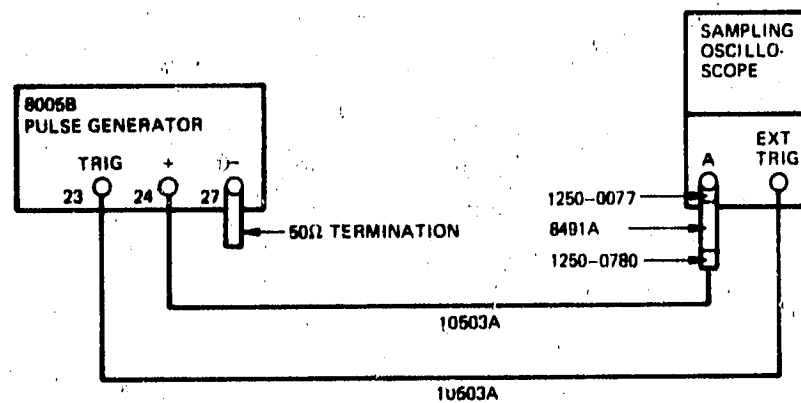

PROCEDURE:

1. Set 8005B controls as follows:

REP RATE 1	20M
VERNIER 2	CCW
PULSE DELAY 3	0.1 μ
VERNIER 4	CCW
PULSE WIDTH 5	25n
VERNIER 6	CCW
TRANSITION TIME 7	10n
OFFSET VERNIER 8	-
OFFSET SWITCH 9	OFF
OFFSET VERNIER 10	-
MAN 11	-
PULSE MODE 12	SQ WAVE
OPER MODE 13	NORM
LEADING EDGE 14	CCW
TRAILING EDGE 15	CCW
AMPLITUDE VERNIER 16	CW
AMPLITUDE RANGE 17	5V
AMPLITUDE VERNIER 18	CW
INT LOAD 25	ON
NORM-COMPL 26	NORM

2. Adjust the amplitude for a full screen display.
3. Expand the display and measure the transition times $< 10\text{ns}$.
4. Repeat the measurements for the negative output $< 10\text{ns}$.
5. Return the scope to X1 expansion.
6. Switch the TRANSITION TIME 7 switch to $0.1\mu\text{s}$.
7. Measure the transition times of both + and - outputs $< 100\text{ns}$.

PERFORMANCE TESTS

5-20 Transition Linearity

SPECIFICATION: For transition times > 30ns, maximum amplitude deviation from a straight line between the 10% and 90% points is less than 4% of pulse amplitude.

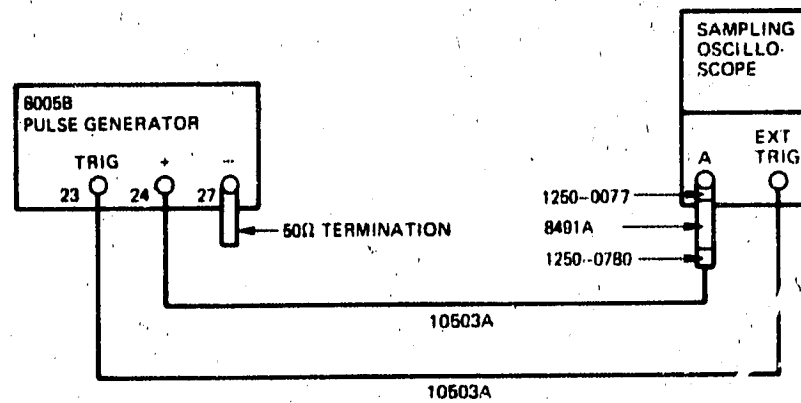

PROCEDURE:

1. Set 8005B controls as follows:

REP RATE 1	2GM
VERNIER 2	CCW
PULSE DELAY 3	0.1μ
VERNIER 4	CCW
PULSE WIDTH 5	25n
VERNIER 6	CCW
TRANSITION TIME 7	0.1μ
OFFSET VERNIER 8	-
OFFSET SWITCH 9	OFF
OFFSET VERNIER 10	-
MAN 11	-
PULSE MODE 12	SQ WAVE
OPER MODE 13	NORM
LEADING EDGE 14	CCW
TRAILING EDGE 15	CCW
AMPLITUDE VERNIER 16	CW
AMPLITUDE RANGE 17	5V
AMPLITUDE VERNIER 18	CW
INT LOAD 25	ON
NORM-COMPL 26	NORM

2. Adjust the amplitude for a full screen display.
3. Centre the leading edge of the pulse on the display.
4. With reference to the diagram check the transition linearity
Deviation to be < 4% of pulse amplitude
5. Centre the trailing edge on the display.
6. Repeat steps 2 to 4 for OUTPUT (-).

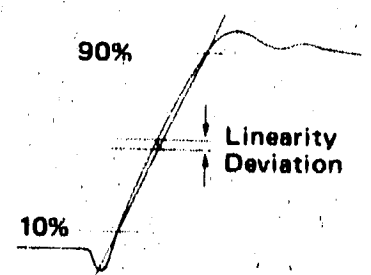

PERFORMANCE TESTS

5-21 Preshoot, Overshoot and Ringing

SPECIFICATION: overshoot, preshoot and ringing each less than 5% of pulse amplitude.

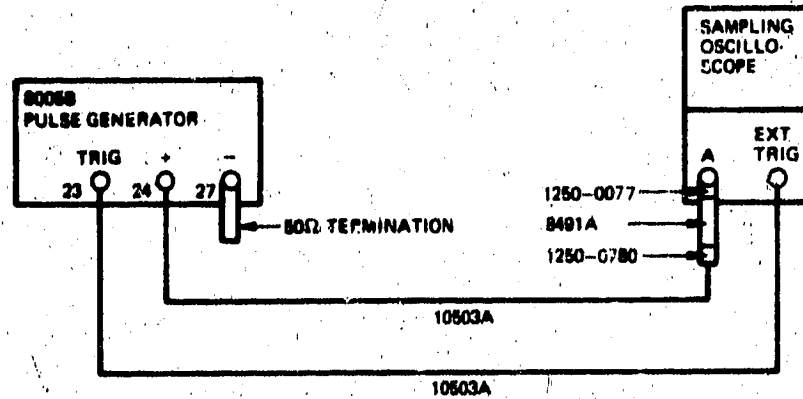

PROCEDURE:

- Set 8005B controls as follows:

REP RATE 1	20M
VERNIER 2	CCW
PULSE DELAY 3	0.1μ
VERNIER 4	CCW
PULSE WIDTH 5	25n
VERNIER 6	CCW
TRANSITION TIME 7	10n
OFFSET VERNIER 8	-
OFFSET SWITCH 9	OFF
OFFSET VERNIER 10	-
MAN 11	-
PULSE MODE 12	SQ WAVE
OPER MODE 13	NORM
LEADING EDGE 14	CCW
TRAILING EDGE 15	CCW
AMPLITUDE VERNIER 16	CW
AMPLITUDE RANGE 17	5V
AMPLITUDE VERNIER 18	CW
INT LOAD 25	ON
NORM-COMPL 26	NORM

- With reference to the diagram measure the following:

- Preshoot < 5%
- Overshoot < 5%
- Ringing < 5%

- Repeat step 1 for OUTPUT (-).

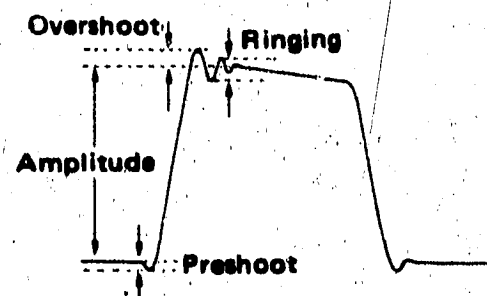

PERFORMANCE TESTS

5-22 Trigger Output

SPECIFICATION: positive pulses > 2V amplitude across external 50 ohm load.

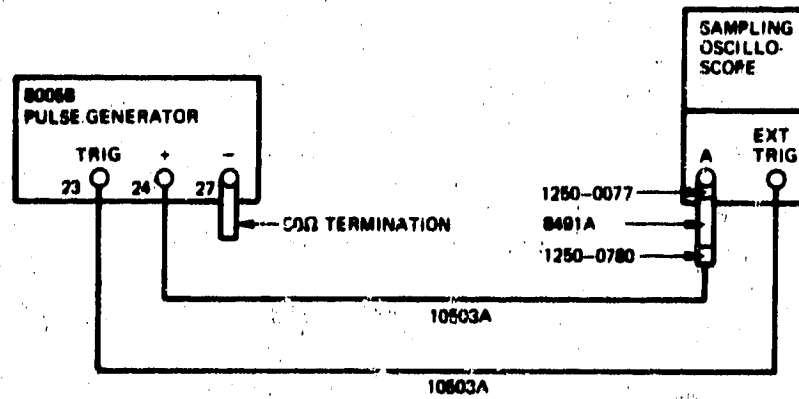

PROCEDURE:

1. Set 8005B controls as follows:

REP RATE 1	20M
VERNIER 2	CCW
PULSE DELAY 3	0.1μ
VERNIER 4	CCW
PULSE WIDTH 5	25n
VERNIER 6	CCW
TRANSITION TIME 7	10n
OFFSET VERNIER 8	-
OFFSET SWITCH 9	OFF
OFFSET VERNIER 10	-
MAN 11	-
PULSE MODE 12	NORM
OPER MODE 13	NORM
LEADING EDGE 14	CCW
TRAILING EDGE 15	CCW
AMPLITUDE VERNIER 16	CW
AMPLITUDE RANGE 17	5V
AMPLITUDE VERNIER 18	CW
INT LOAD 25	ON
NORM-COMPL 26	NORM

2. Check the amplitude (across 50Ω) > 2V
3. Check the width 15ns ± 7ns

PERFORMANCE TESTS

5-23 Transition Times (slow)

SPECIFICATION: $\leq 10\text{ns}$ to 2s in six ranges. Separate verniers provide independent control of leading and trailing edges within each range. Ranges are common for leading and trailing edges. Max. leading edge/trailing edge ratio, 1:30 or 30:1.

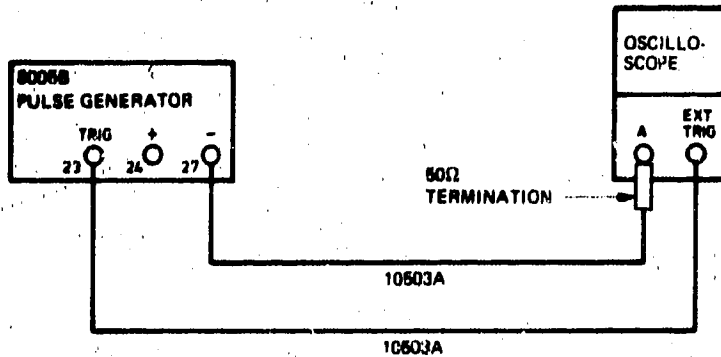

PROCEDURE:

1. Set 8005B controls as follows:

REP RATE 1	0.3M
VERNIER 2	CCW
PULSE DELAY 3	0.1 μ
VERNIER 4	CCW
PULSE WIDTH 5	25n
VERNIER 6	CCW
TRANSITION TIME 7	0.1 μ
OFFSET VERNIER 8	-
OFFSET SWITCH 9	OFF
OFFSET VERNIER 10	-
MAN 11	-
PULSE MODE 12	SQ WAVE
OPER MODE 13	NORM
LEADING EDGE 14	CW
TRAILING EDGE 15	CW
AMPLITUDE VERNIER 16	CW
AMPLITUDE RANGE 17	5V
AMPLITUDE VERNIER 18	CW
INT LOAD 25	ON
NORM-COMPL 26	NORM

2. Adjust scope sensitivity for full screen pulse display and measure leading and trailing edge between 10% and 90% of amplitude for each of the following control settings (Vary Rep rate vernier 2 to get one period on display with best resolution):

REP. RATE	TRANS. TIME	LEADING/TRAILING EDGE VERNIERS	RESULT
0.3M	3 μ	CCW	$\leq 3\mu\text{s}$
10K	0.1m	CCW	$\leq 0.1\text{m}$
300	3m	CCW	$\leq 3\text{m}$
0.3-10	0.1-2	CCW	$\leq 0.1\text{s}$

PERFORMANCE TESTS

5-24 External Triggering

SPECIFICATION: dc to 20 MHz, sensitivity 2V_{pp} (sine wave), 1V_{pk} (pulse)

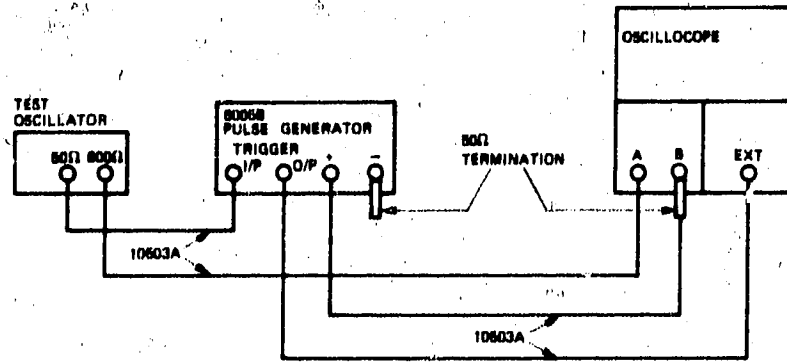

PROCEDURE:

1. Set 8005B controls as follows:

REP RATE 1	EXT+
VERNIER 2	CCW
PULSE DELAY 3	0.1μ
VERNIER 4	CCW
PULSE WIDTH 5	3μ
VERNIER 6	CCW
TRANSITION TIME 7	10n
OFFSET VERNIER 8	-
OFFSET SWITCH 9	OFF
OFFSET VERNIER 10	-
MAN 11	-
PULSE MODE 12	NORM
OPER MODE 13	NORM
LEADING EDGE 14	CCW
TRAILING EDGE 15	CCW
AMPLITUDE VERNIER 16	CW
AMPLITUDE RANGE 17	5V
AMPLITUDE VERNIER 18	CW
INT LOAD 25	ON
NORM-COMPL 26	NORM

2. Set the test oscillator for 10 kHz at 2.5V p-p. Observe that each pulse occurs during positive slope of the sine wave.
3. Change the REP RATE 1 switch on 8005B to EXT-. Observe that each pulse occurs during negative slope of the sine wave.

PERFORMANCE TESTS

5-25 Synchronous Gating

SPECIFICATION: gate signal turns on repetition rate. Time between start of gate and first pulse defined by delay control. Last pulse is always completed even if gate ends during generation of last pulse. Synchronous trigger pulses occur for duration of gate.

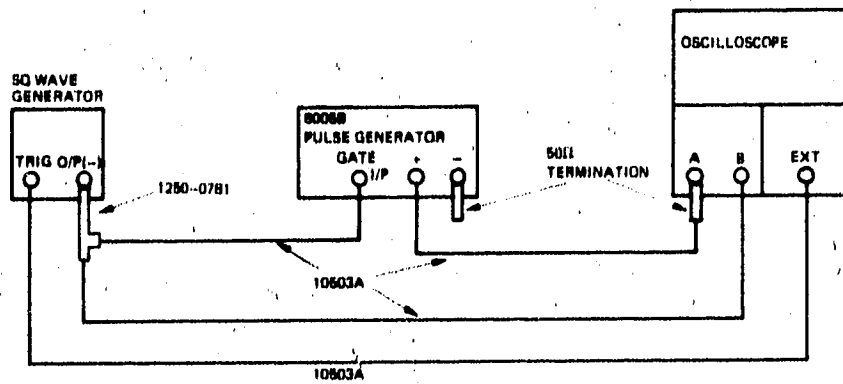

PROCEDURE:

1. Set 8005B controls as follows:

REP RATE 1	0.3M
VERNIER 2	CCW
PULSE DELAY 3	0.1μ
VERNIER 4	CCW
PULSE WIDTH 5	25n
VERNIER 6	CW
TRANSITION TIME 7	10n
OFFSET VERNIER 8	-
OFFSET SWITCH 9	OFF
OFFSET VERNIER 10	-
MAN 11	-
PULSE MODE 12	NORM
OPER MODE 13	SYNCH
LEADING EDGE 14	CCW
TRAILING EDGE 15	CCW
AMPLITUDE VERNIER 16	CW
AMPLITUDE RANGE 17	5V
AMPLITUDE VERNIER 18	CW
INT LOAD 25	ON
NORM-COMPL 26	NORM

2. Set the sq wave generator

FREQUENCY	2 kHz
WIDTH	SQ
AMPLITUDE	2V

3. Turn the 8005B REP RATE VERNIER 2 slowly CW. Check that the pulses from 8005B occur only during the 'ON' time of the gate. Check also that the first pulse is coincident with the start of the gate and the last pulse is of normal width even when the gate ends during the pulse.
4. Disconnect the gate signal at the 8005B GATE INPUT 21. Check that no pulses are generated by 8005B.

PERFORMANCE TESTS

5-26 Amplitude Normal – Complement

SPECIFICATION: 5V, with internal 50 ohms and external 50 ohms. 10V with internal 50 ohms and external high impedance and external 50 ohms. Normal or complement, switch selectable.

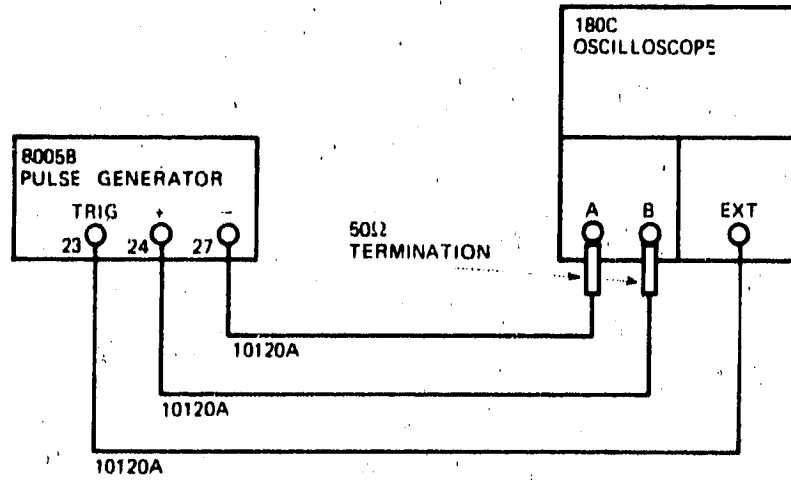

PROCEDURE:

1. Set 8005B controls as follows:

REP RATE 1	20M
VERNIER 2	CCW
PULSE DELAY 3	0.1μ
VERNIER 4	CCW
PULSE WIDTH 5	25n
VERNIER 6	CCW
TRANSITION TIME 7	10n
OFFSET VERNIER 8	-
OFFSET SWITCH 9	OFF
OFFSET VERNIER 10	-
MAN 11	-
PULSE MODE 12	SQ WAVE
OPER MODE 13	NORM
LEADING EDGE 14	CCW
TRAILING EDGE 15	CCW
AMPLITUDE VERNIER 16	CW
AMPLITUDE RANGE 17	5V
AMPLITUDE VERNIER 18	CW
INT LOAD 25	ON
NORM-COMPL 26	NORM

2. Check the normal mode output from both output channels.

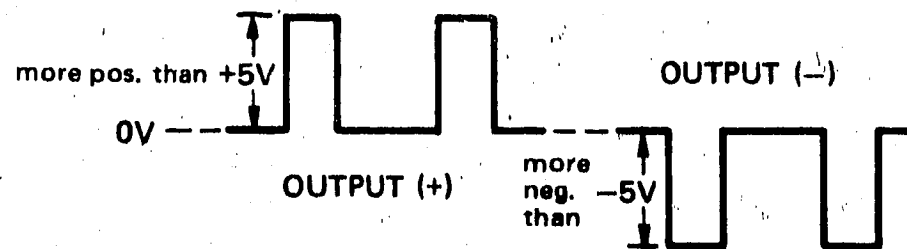

3. Set the NORM-COMPL switch 26 to COMPL and check both outputs.

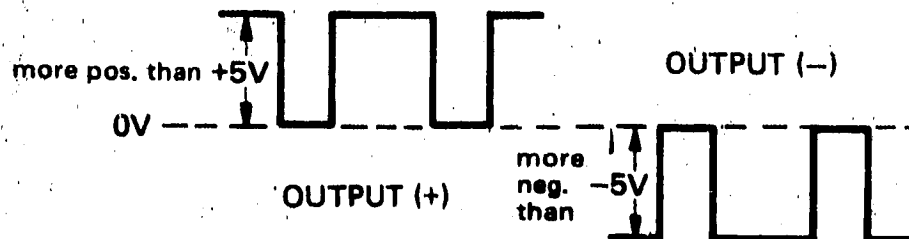

PERFORMANCE TESTS

5-27 DC Offset

SPECIFICATION: the maximum output (amplitude + offset) is 10V. Offset range with amplitude vernier CCW is $\pm 2V$. Offset range increases to values shown when amplitude vernier is CW.

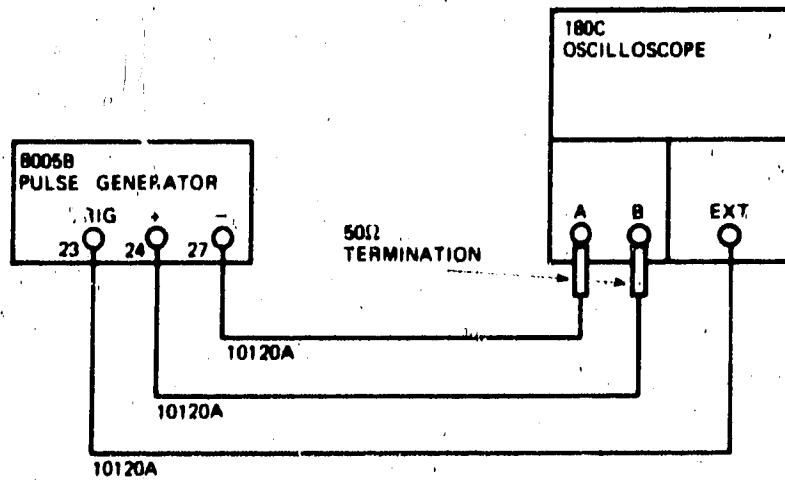

PROCEDURE:

1. Set 8005B controls as follows:

REP RATE 1	EXT+
VERNIER 2	-
PULSE DELAY 3	-
VERNIER 4	-
PULSE WIDTH 5	-
VERNIER 6	-
TRANSITION TIME 7	-
OFFSET VERNIER 8	CW
OFFSET SWITCH 9	OFF
OFFSET VERNIER 10	CW
MAN 11	-
PULSE MODE 12	NORM
OPER MODE 13	NORM
LEADING EDGE 14	-
TRAILING EDGE 15	-
AMPLITUDE VERNIER 16	CCW
AMPLITUDE RANGE 17	1.25V (2.5V)
AMPLITUDE VERNIER 18	CCW
INT LOAD 25	ON
NORM-COMPL 26	-

STEP	INSTRUCTIONS	RESULTS
1	Center trace on screen and set the OFFSET switch 9 to ON	$\geq +2V$
2	Turn the VERNIER 8 slowly from fully CW to fully CCW	+2V to -2V
3	Reset the VERNIER 8 to the CW position	$> +2V$
4	Set the INT LOAD 25 switch to OFF	
5	Turn the AMPLITUDE vernier 16 slowly to fully CW	$\geq +4V$
6	Turn VERNIER 8 slowly CCW	$> -4V$
7	Connect scope to OUTPUT (-) and repeat steps 1 to 6	

PERFORMANCE TESTS / SAFETY CHECK

5-28 TTL Output

SPECIFICATION: fixed amplitude, + 4.6V across open circuit

TEST SETUP AND PROCEDURE — as § 5-27 except apply TTL OUTPUT without load to scope input A.

Verify logic 1 level $\geq 4.6V$

Verify logic 0 level $\leq 0.2V$

5-29 Safety Check

1. Disconnect power cord from line. Visually inspect interior for any sign of abnormal internally generated heat, such as discolored printed circuit boards or components, damaged insulation, or evidence of arcing. Determine cause and remedy.
2. Check resistance from cabinet to ground pin on power plug with suitable ohmmeter. The reading must be less than one ohm. Flex the power cord while making the measurement to detect any intermittent discontinuity. Check internal ground connections on boards and frame. Also check resistance of any front or rear panel ground terminals marked 
3. Check resistance from cabinet to line and neutral (tied together) with the power switch on and the power source disconnected. The minimum acceptable resistance is two megohms. Replace any component which results in a failure or refer to production Memo or Service Note issued by product division for alternate action.
4. Check line fuse to verify that the proper value is installed.
5. Check that the plastic safety cover for the line fuse is installed.
6. Check that all coaxial and flat cables inside are properly connected. Check that all boards and the heatsink on the chassis are properly connected.
7. Inform Hewlett-Packard (internally, the responsible product division) of any repeated failures in the above tests or any other safety features.

Table 5-1. Performance Test Record

Hewlett-Packard Company Model 8005B Pulse Generator Serial Number					Tested by _____ Date _____			
Para. No.	Test Description					Results		
						Min	Actual	Max
5-10	Repetition Rate							
	Rep Rate	Vernier						
	20 MHz	CW				20 MHz	_____	
	0.3 MHz	CW				300 kHz	_____	
	10 kHz	CW				10 kHz	_____	
	300 Hz	CW					_____	3.33 ms
	10 Hz	CW					_____	100 ms
5-11	Manual Trigger							
	Press MAN button					1	_____	1
	Release MAN button					0	_____	0
5-12	Pulse Width							
	REP RATE 1	PULSE WIDTH 5	VERNIER 6					
	20M	25	CCW				_____	25 ns
	0.3M	3μ	CCW				_____	3μs
	10K	0.1m	CCW				_____	0.1 ns
	300	3m	CCW				_____	3 ms
	0.3-10	0.1-3	CCW				_____	0.1 ns
	Manual	0.1-3	CW			3s	_____	
5-13	Pulse Width Jitter						_____	0.1 μs
5-14	Pulse Delay							
	RATE 1	DELAY 3	VERNIER 4	WIDTH 5	VERNIER 6			
	0.3M	0.1μ	CW	25n	CW	3μs	_____	
	10K	3μ	CW	3μ	CW	0.1 ms	_____	
	300	0.1m	CW	0.1m	CW	3ms	_____	
	0.3-10	3m	CW	3m	CW	0.1s	_____	
	EXT-MAN	0.1-3	CW	0.1-3	CW	3s	_____	

Table 5-1. Performance Test Record

Hewlett-Packard Company Model 8005B Pulse Generator Serial Number		Tested by _____ Date _____					
Para. No.	Test Description	Results					
		Min	Actual	Max			
5-15	Pulse Delay Jitter			0.1 μs			
5-16	Square Wave 50% Duty Cycle	0.3 Hz	45%	_____	55%		
		10 Hz	45%	_____	55%		
		300 Hz	45%	_____	55%		
		10 kHz	45%	_____	55%		
		0.3 MHz	45%	_____	55%		
		1 MHz	45%	_____	55%		
		20 MHz	35%	_____	65%		
5-17	Pulse Mode Duty Cycle	above 1 MHz	50%	_____			
		below 1 MHz	80%	_____			
5-18	Double Pulse Minimum pulse spacing		_____	50 ns			
5-19	Transition Times (Fast) TRANSITION 7 LDG 14 TRLG 15	10 n	CCW	CCW	positive	_____	10 ns
					negative	_____	10 ns
		0.1 μ	CCW	CCW	positive	_____	100 ns
					negative	_____	100 ns
5-20	Transition Linearity	Positive output:	leading edge		_____	4%	
			trailing edge		_____	4%	
		Negative output:	leading edge		_____	4%	
			trailing edge		_____	4%	
5-21	Preshoot, Overshoot, and Ringing	Positive output:	preshoot		_____	5%	
			overshoot		_____	5%	
			ringing		_____	5%	
		Negative output:	preshoot		_____	5%	
			overshoot		_____	5%	
			ringing		_____	5%	

Table 5-1. Performance Test Record

Hewlett-Packard Company Model 8005B Pulse Generator Serial Number		Tested by Date		
Para. No.	Test Description	Results		
		Min	Actual	Max
5-22	Trigger Output Amplitude (across 50Ω) Width	2V 9ns	<hr/> <hr/>	21ns
5-23	Transition Times (Slow) Rep. rate 1 Transition 7 leading/trailing edge verniers 14, 15 0.3M 3μ CCW 10K 0.1m CCW 300 3 m CCW 0.3-10 0.1-2 CCW		<hr/> <hr/> <hr/> <hr/>	3μs 0.1 ms 3 ms 0.1 s
5-24	External Triggering Pulses on positive trigger slope Pulses on negative trigger slope		<input type="checkbox"/> <input type="checkbox"/>	
5-25	Synchronous Gating Output pulse only during gate on First pulse coincident with start of gate Last pulse of correct width No output		<input type="checkbox"/> <input type="checkbox"/> <input type="checkbox"/> <input type="checkbox"/>	
5-26	Amplitude Normal-Complement Amplitude, Output +, Normal Amplitude, Output -, Normal Amplitude, Output +, Complement Amplitude, Output -, Complement	+5V -5V +5V -5V	<hr/> <hr/> <hr/> <hr/>	
5-27	DC Offset Max positive offset with int 50Ω Max negative offset with int 50Ω Max positive offset without int 50Ω Max negative offset without int 50Ω	+2V -2V +4V -4V	<hr/> <hr/> <hr/> <hr/>	
5-28	TTL Output Logic 1 Logic 0	4.6V	<hr/> <hr/>	0.2V
5-29	Safety Check Interior inspection Resistance cabinet to power plug gnd Resistance cabinet to line Line fuse Line fuse safety cover Heatsinks secure	2MΩ	<hr/> <hr/> <hr/> <input type="checkbox"/> <input type="checkbox"/> <input type="checkbox"/>	1Ω

ADJUSTMENTS

SECTION VI ADJUSTMENTS

6-1 INTRODUCTION

6-2 This section describes the adjustments which will return the instrument to peak operating condition after repairs are completed.

6-3 If the adjustments are to be considered valid, the instrument must have a 15 min warmup time and the line voltage must be within +10% to -15% of nominal.

6-4 SAFETY CONSIDERATIONS

6-5 This manual contains information, cautions, and warnings which must be followed to ensure safe operation and to retain the instrument in safe condition (see Sections II and III). Service and adjustments should be performed only by qualified service personnel.

WARNING

Any interruption of the protective (grounding) conductor (inside or outside the instrument) or disconnection of the protective earth terminal is likely to make the instrument dangerous. Intentional interruption is prohibited.

6-6 Any adjustment, maintenance, and repair of the opened instrument with voltage applied should be carried out only by a skilled person who is aware of the hazard involved.

6-7 Capacitors inside the instrument may still be charged even if the instrument has been disconnected from its source of supply.

6-8 Make sure that only fuses with the required rated current and of the specified type (normal blow, time delay, etc.) are used for replacement. The use of repaired fuses and the shortcircuiting of fuseholders must be avoided.

6-9 Whenever it is likely that the protection offered by fuses has been impaired, the instrument must be made inoperative and secured against any unintended operation.

WARNING

Adjustments described herein are performed with power supplied to the instrument while protective covers are removed. Energy available at many points may, if contacted, result in personal injury.

6-10 EQUIPMENT REQUIRED

6-11 The test equipment required for the adjustment procedures is listed in Table 1-1, Recommended Test Equipment. The critical specifications of substitute test instruments must meet or exceed the standards listed in the table if the instrument is to meet the standards set forth in Table 1-2, Specifications.

6-12 ADJUSTMENT LOCATIONS

6-13 Figure 6-1 at the end of this section shows the locations of adjustment points.

6-14 ADJUSTMENTS

6-15 Power Supply

EQUIPMENT: Digital Voltmeter
ac Voltmeter

PROCEDURE:

Voltages are measured with respect to chassis.

	ADJUST	RESULT
1 Connect the digital voltmeter to +25V TP	A5R17	+25V ± 200mV
2 Connect the digital voltmeter to A5 -25V TP	A5R8	-25V ± 200mV
3 Connect the digital voltmeter to A1 +20V TP	-	+20V ± 500mV
4 Connect the ac voltmeter to A5 +25V TP and measure ripple	-	< 10mV
5 Connect the ac voltmeter to A5 -25V TP and measure ripple	-	< 10mV

ADJUSTMENTS

6-16 Timing

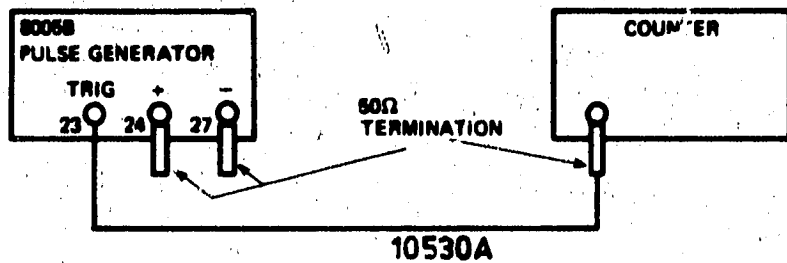

1. REP RATE SET-UP

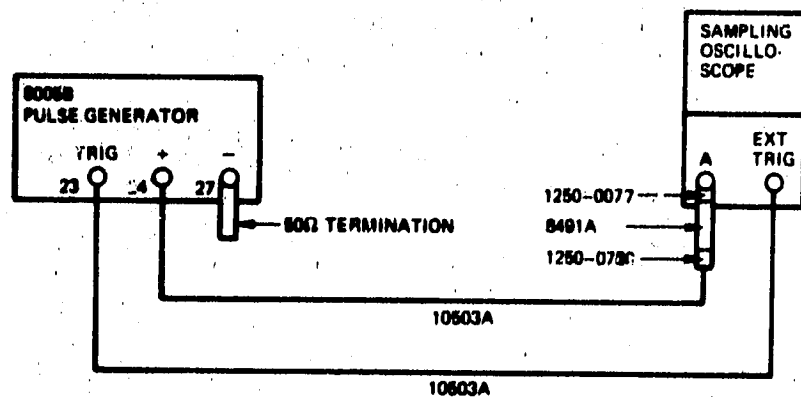

2. PULSE WIDTH SET-UP

PROCEDURE:

- Set 8005B controls as follows:

REP RATE 1	20M
VERNIER 2	CW
PULSE DELAY 3	0.1μ
VERNIER 4	CCW
PULSE WIDTH 5	25n
VERNIER 6	CCW
TRANSITION TIME 7	10n
OFFSET VERNIER 8	—
OFFSET SWITCH 9	OFF
OFFSET VERNIER 10	—
MAN 11	—
PULSE MODE 12	NORM
OPER MODE 13	NORM
LEADING EDGE 14	CCW
TRAILING EDGE 15	CCW
AMPLITUDE VERNIER 16	CW
AMPLITUDE RANGE 17	5V
AMPLITUDE VERNIER 18	CW
INT LOAD 25	ON
NORM-COMPL 26	NORM

ADJUST RESULT

- With the 8005B connected as shown in the upper diagram (1) measure rep rate
A1C9 22 MHz ± 5%
- Set Rate Vernier CCW
- With the 8005B connected as shown in the lower diagram (2) measure pulse width at 50% of amplitude
A1C33 22μs ± 10%
- Connect trigger output to scope channel A and 8005B output A to scope channel B. Set Rep Rate to 0.3M, vernier mid position delay 0.1μ vernier CW
- Measure the distance between the trigger pulse and the leading edge of the output pulse
A1C27 3.9μs ± 10%

6-17 Pulse Shape

EQUIPMENT:

Digital Voltmeter

PROCEDURE:

- Set 8005B controls as follows:

REP RATE 1	EXT+
VERNIER 2	CCW
PULSE DELAY 3	0.1μ
VERNIER 4	CCW
PULSE WIDTH 5	25n
VERNIER 6	CCW
TRANSITION TIME 7	10n
OFFSET VERNIER 8	—
OFFSET SWITCH 9	OFF
OFFSET VERNIER 10	—
MAN 11	—
PULSE MODE 12	NORM
OPER MODE 13	NORM
LEADING EDGE 14	CCW
TRAILING EDGE 15	CCW
AMPLITUDE VERNIER 16	CCW
AMPLITUDE RANGE 17	5V
AMPLITUDE VERNIER 18	CCW
INT LOAD 25	ON
NORM-COMPL 26	COMPL

ADJUSTMENTS

2 Reverse voltage adjustment — operate with DVM floating

	ADJUST	RESULT
a. Connect the DVM high terminal to TP1 and the low terminal to TP2	A4R31	+ 150mV ±50mV
b. Connect the DVM high terminal to TP3 and the low terminal to TP4	A4R41	+ 150mV ±50mV

3 Integrator adjustment

	ADJUST	RESULT
a. Set 8005B Pulse Mode 12 to SQ Wave		
b. Using DVM, measure across chassis and A4 Q6/Q7 Collector. If necessary press MAN button once to get a negative voltage	A4R46	-9.5V ±0.1V

	SQ WAVE
PULSE MODE 12	NORM
OPER MODE 13	NORM
LEADING EDGE 14	CCW
TRAILING EDGE 15	CCW
AMPLITUDE VERNIER 16	CW
AMPLITUDE RANGE 17	5V
AMPLITUDE VERNIER 18	CW
INT LOAD 25	ON
NORM-COMPL 26	NORM

	ADJUST	RESULT
2. Adjust OUTPUT(-)	A3R100	- 5.5V
3. Adjust leading and trailing edge verniers from CCW to CW for equal roll-off on both edges		
4. Adjust OUTPUT(-) roll-off	A3R95	≈ 30ns
5. With the TRAILING EDGE vernier turned fully CCW observe the position of the pulse delay point.		
6. Turn the TRAILING EDGE vernier fully CW and measure the difference between the first and second starting points. If necessary, verify S 6-17 (2).	A4R46	16ns ±2ns
7. Adjust OUTPUT(+) amplitude	A3R72	+5.5V
8. Repeat 3 for OUTPUT(+)		
9. Adjust OUTPUT(+) roll-off	A3R48	≈ 30ns
10. Repeat 2 to 7.		

6-18 Pulse Amplitude and Roll-off

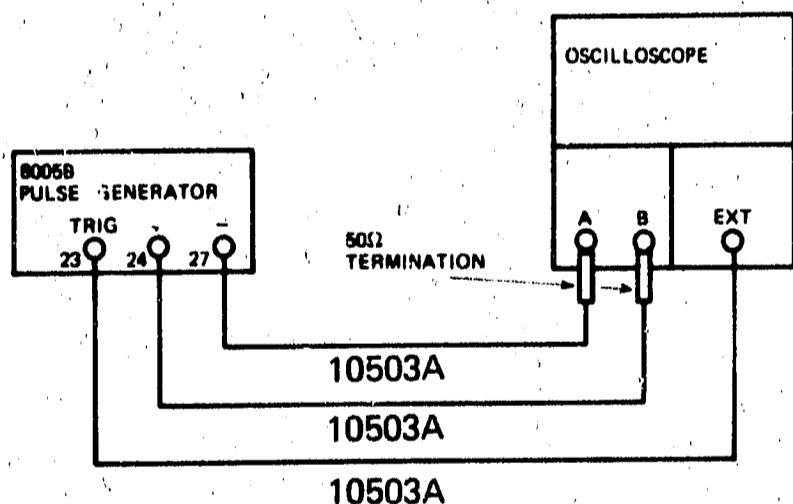

PROCEDURE:

1. Set 8005B controls as follows:

REP RATE 1	20M
VERNIER 2	CCW
PULSE DELAY 3	0.1μ
VERNIER 4	CCW
PULSE WIDTH 5	25n
VERNIER 6	CCW
TRANSITION TIME 7	10n
OFFSET VERNIER 8	-
OFFSET SWITCH 9	OFF
OFFSET VERNIER 10	-
MAN 11	-

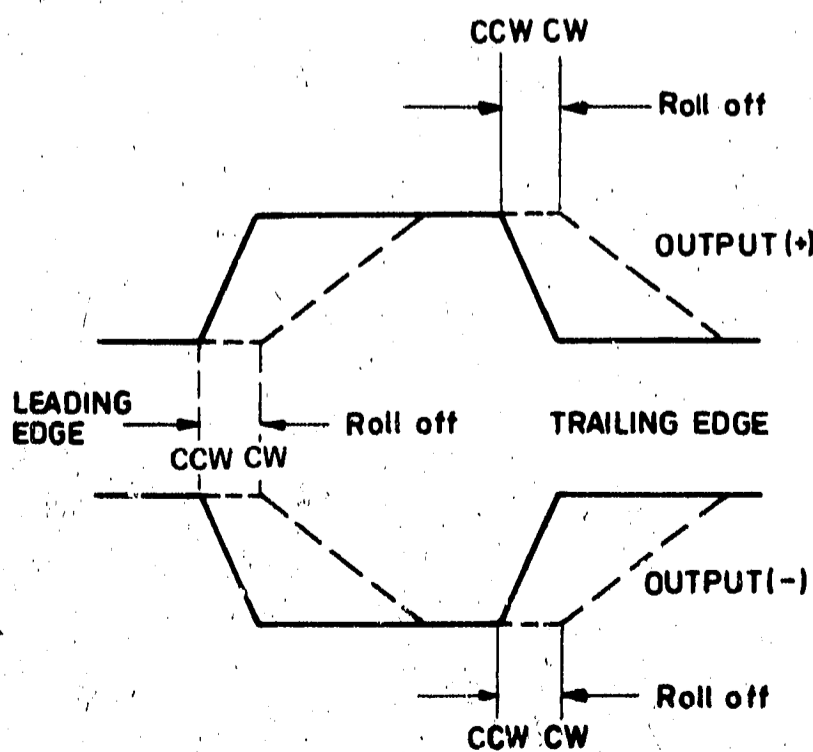

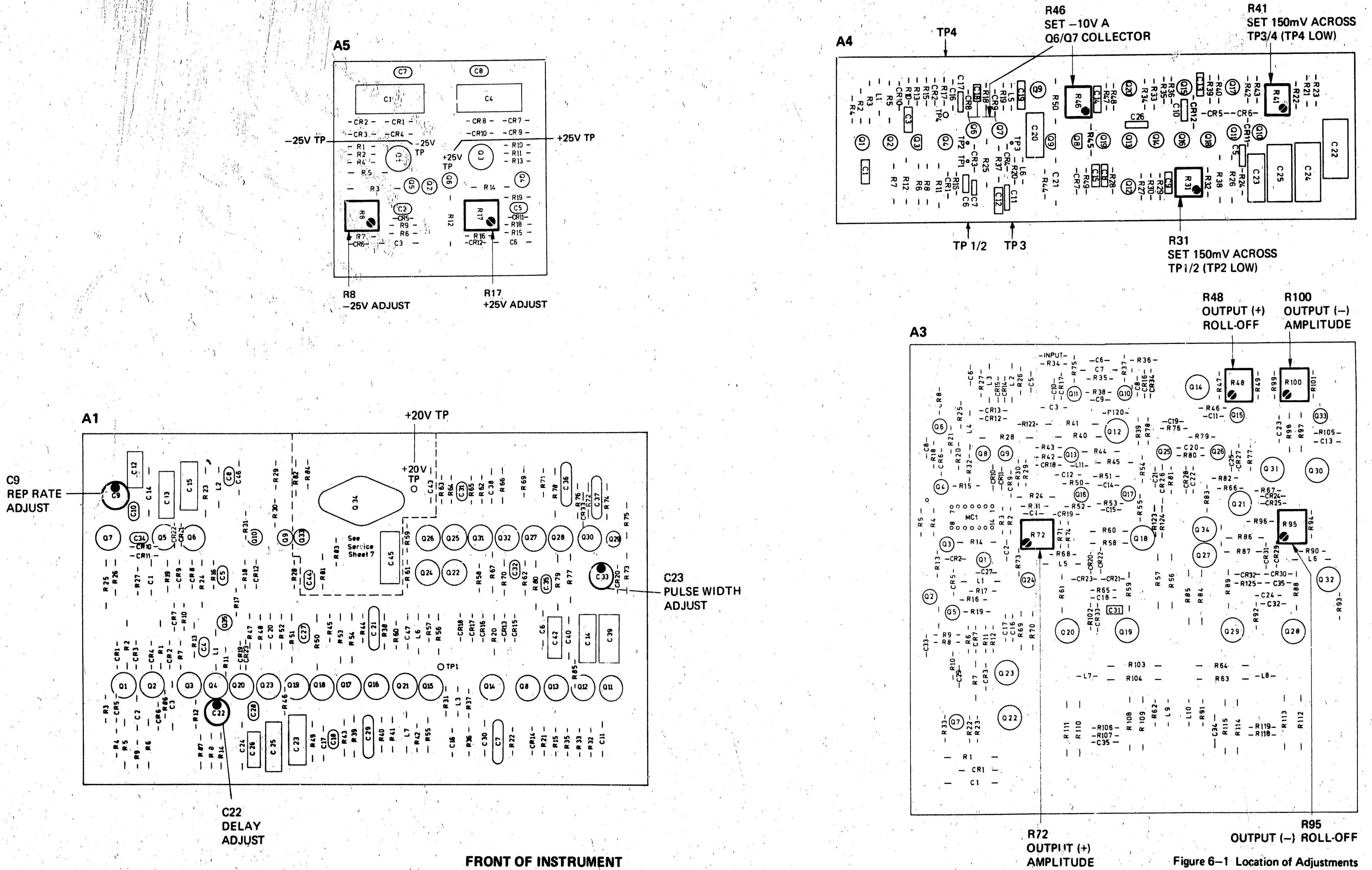

Figure 6-1 Location of Adjustments

PARTS LIST

SECTION VII REPLACEABLE PARTS

7-1 INTRODUCTION

7-2 This section contains information for ordering parts. Table 6-1 lists abbreviations used in the parts lists and elsewhere in the manual. Table 6-2 lists all replaceable parts in reference designator order. Table 6-3 contains the names and addresses that correspond to the manufacturer code numbers.

7-3 ABBREVIATIONS

7-4 Table 6-1 lists abbreviations used in the parts lists, schematics and elsewhere in the manual. In some cases two forms of the abbreviation are used, one all in capital letters, and one partial or no capitals. This occurs because the abbreviations in the parts lists are always all capitals. However, in the schematics and other parts of the manual, the same abbreviations may have upper and lower case letters.

7-5 REPLACEABLE PARTS

7-6 Table 6-2 is the list of replaceable parts and is organized as follows:

- a. Mainframe (chassis) parts in alphanumeric order by reference designation
- b. Electrical assemblies and their components in alphanumeric order by reference designation.

Reference designators are of the form A5R9 i.e. resistor 9 on assembly 5.

7-7 The information given for each part consists of the following:

- a. The Hewlett-Packard part number.
- b. The total quantity (Qty) in the instrument. This is given only once for each part - at the first appearance of the part in the list.
- c. The description of the part.
- d. A typical manufacturer of the part in a five-digit code.
- e. The manufacturer's code number for the part.

7-8 ORDERING INFORMATION

7-9 To order a part listed in the replaceable parts table, quote the Hewlett-Packard part number, indicate the quantity required, and address the order to the nearest Hewlett-Packard office (list of Sales/Service offices at the rear of this manual).

7-10 To order a part that is not listed in the replaceable parts table, include the instrument model number, instrument serial number, the description and function of parts required, address the order to the nearest Hewlett-Packard office.

Table 7-1. Abbreviations for Parts List

A	AMPERE(S)	K	KILO (10 ³)	RECT	RECTIFIER(S)
ASSY	ASSEMBLY	KG	KILOGRAM	RF	RADIO FREQUENCY
				RFI	RADIO FREQUENCY INTERFERENCE
BD	BOARD(S)	LB	POUND(S)	RH	ROUND HEAD OR
BH	BINDER HEAD	LH	LEFT HAND		RIGHT HAND
BP	BANDPASS	LIN	LINEAR TAPER	RMO	RACK MOUNT ONLY
		LOG	LOGARITHMIC TAPER	RMS	ROOT MEAN SQUARE
C	CENTI (10 ⁻²)	LPF	LOW-PASS FILTER(S)	RWV	REVERSE WORKING VOLTAGE
	CERMET	LVR	LEVER		
CAR	CARBON	M	MILLI (10 ⁻³)	S-B	SLOW-BLOW
CC	CARBON COMPOSITION	MEG	MEGA (10 ⁶)	SCR	SILICON CONTROLLED RECTIFIER
CCW	COUNTERCLOCKWISE	MET FILM	METAL FILM	SE	SELENIUM
CER	CERAMIC	MET OX	METAL OXIDE	SEC	SECOND(S)
CMO	CABINET MOUNT ONLY	MFR	MANUFACTURER	SECT	SECTION(S)
COAX	COAXIAL	MINAT	MINIATURE	SI	SILICON
COEF	COEFFICIENT	MOM	MOMENTARY	SIL	SILVER
COMP	COMPOSITION	MTG	MOUNTING	SL	SLIDE
CONN	CONNECTOR(S)	MY	MYLAR	SP	SINGLE POLE
CRT	CATHODE-RAY TUBE			SPL	SPECIAL
CW	CLOCKWISE			ST	SINGLE THROW
				STD	STANDARD
D	DECI (10 ⁻¹)	N	NANO (10 ⁻⁹)	TA	TANTALUM
DEPC	DEPOSITED CARBON	N/C	NORMALLY CLOSED	TC	TEMPERATURE COEFFICIENT
DP	DOUBLE POLE	NE	NEON	TD	TIME DELAY
DT	DOUBLE THROW	N/O	NORMALLY OPEN	TFL	TEFLON
		NOF	NEGATIVE POSITIVE ZERO (ZERO TEMPERATURE COEFFICIENT)	TGL	TOGGLE
ELECT	ELECTROLYTIC	NPN	NEGATIVE-POSITIVE-NEGATIVE	THYR	THYRISTOR
ENCAP	ENCAPSULATED	NSR	NOT SEPARATELY REPLACEABLE	TI	TITANIUM
EXT	EXTERNAL			TNLDIO	TUNNEL DIODE(S)
				TOL	TOLERANCE
F	FARAD(S), METAL FILM (FOR RESISTORS)	OBD	ORDER BY DESCRIPTION	TRIM	TRIMMER
	CARBON FILM/COMPOSITION	OH	OVAL HEAD		
FC		OX	OXIDE		
FET	FIELD-EFFECT TRANSISTOR(S)				
FT	TRANSIT FREQUENCY	P	PEAK	U	MICRO (10 ⁻⁶)
		PC	PRINTED (ETCHED) CIRCUIT(S)		
FH	FLAT HEAD	PD	POWER DISSIPATION	V	VOLTS
FIL H	FILLISTER HEAD	PF	PICOFARADS	VAR	VARIABLE
FXD	FIXED	PHL	PHILLIPS	VDCW	DC WORKING VOLT(S)
		PIV	PEAK INVERSE VOLTAGE(S)		
G	GIGA (10 ⁹)	PNP	POSITIVE-NEGATIVE-POSITIVE		
GE	GERMANIUM	P/O	PART OF	W	WATT(S)
GL	GLASS	PORC	PORCELAIN	W/	WITH
GRD	GROUNDED	POS	POSITION(S)	WIV	WORKING INVERSE VOLTAGE
		POT	POTENTIOMETER(S)	W/O	WITHOUT
H	HENRY(IES)	P-P	PEAK-TO-PEAK	WVDC	WORKING VOLTAGE DIRECT CURRENT
HG	MERCURY	PRGM	PROGRAM	WW	WIREWOUND
HP	HEWLETT-PACKARD	PS	POLYSTYRENE		
HZ	HERTZ	PWV	PEAK WORKING VOLTAGE		
IF	INTERMEDIATE FREQ.				
IMPG	IMPREGNATED				
INCD	INCANDESCENT				
INCL	INCLUDE(S)				
INS	INSULATION(ED)				
INT	INTERNAL				

Table 7-1 →

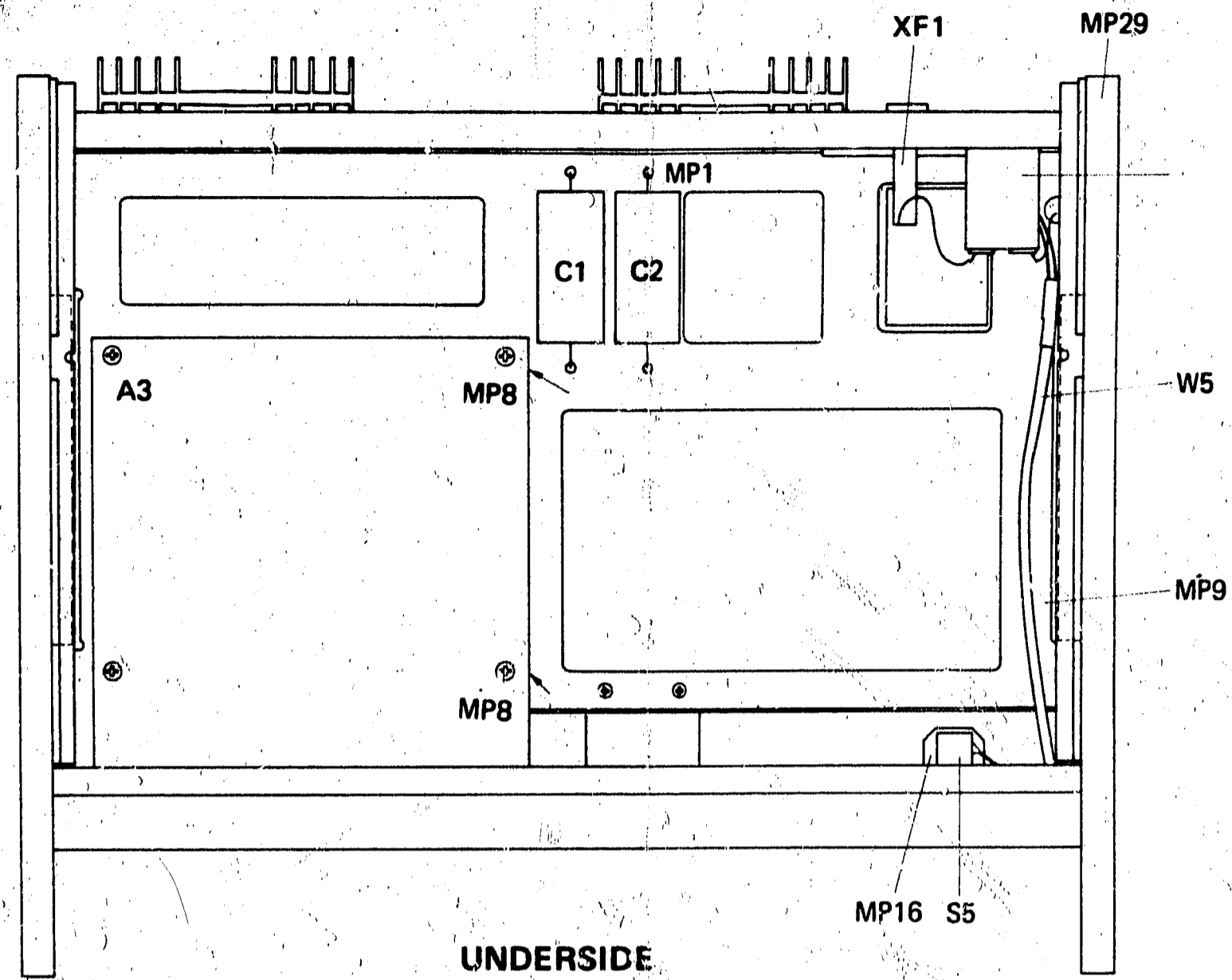

UNDERSIDE

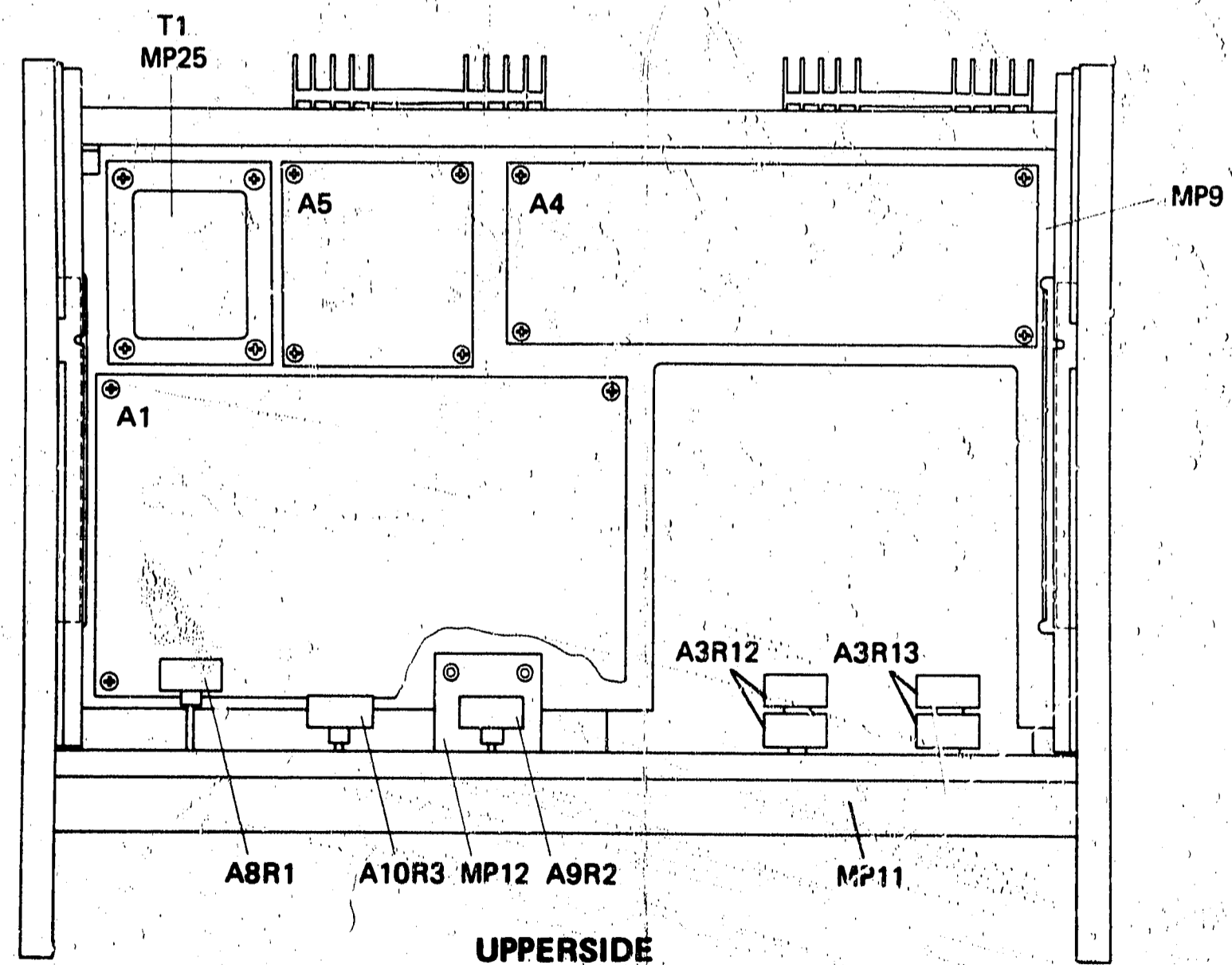

UPPERSIDE

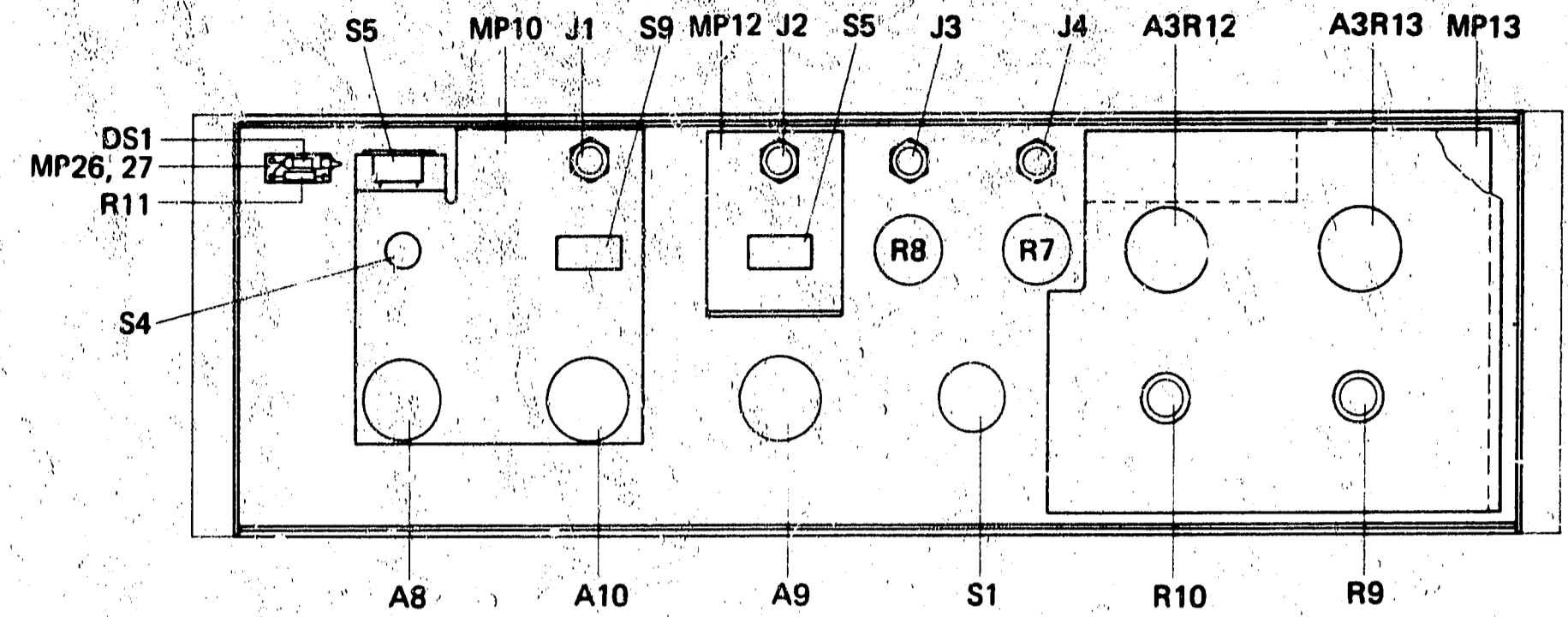

INSIDE OF FRONT PANEL

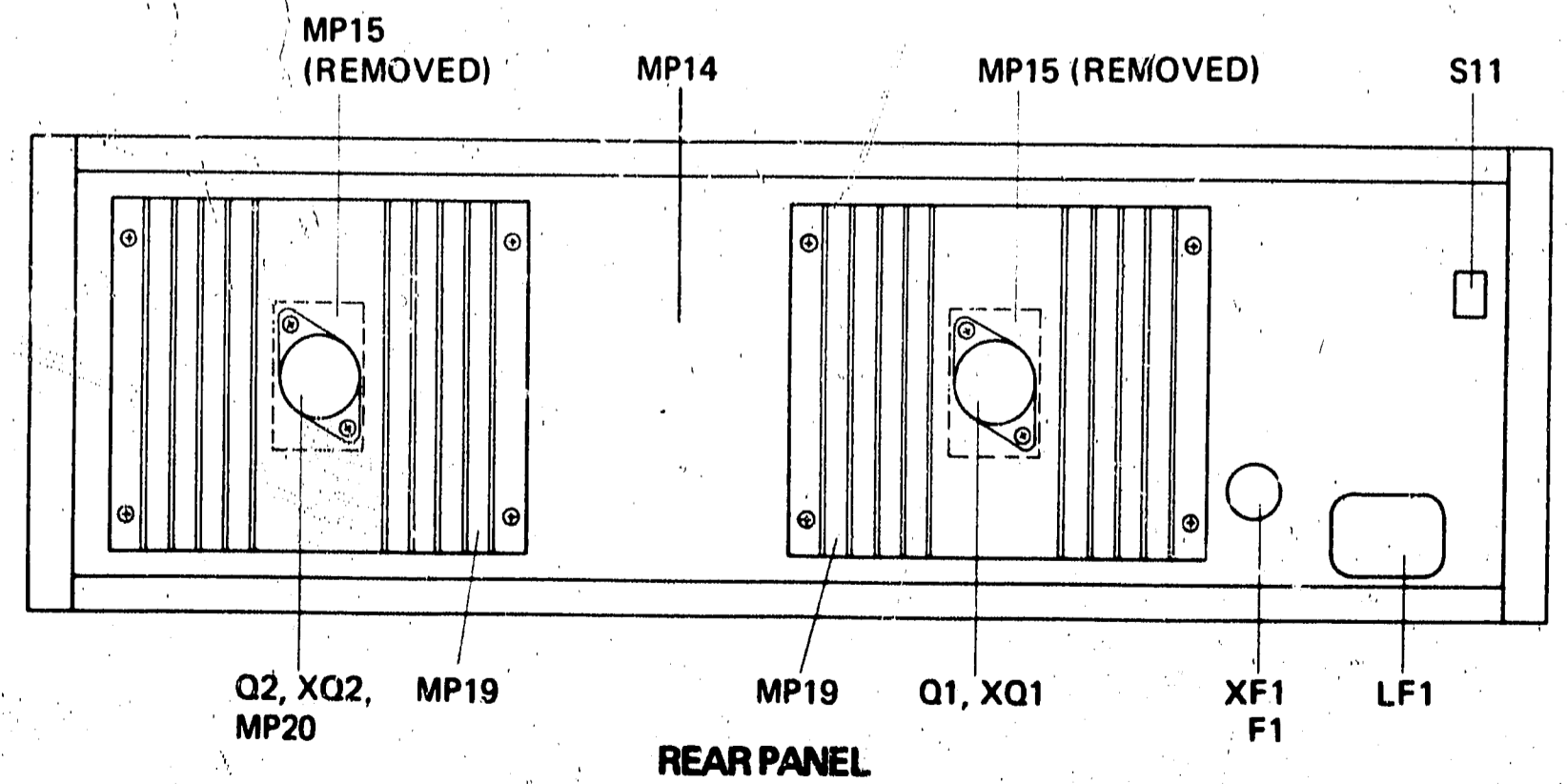
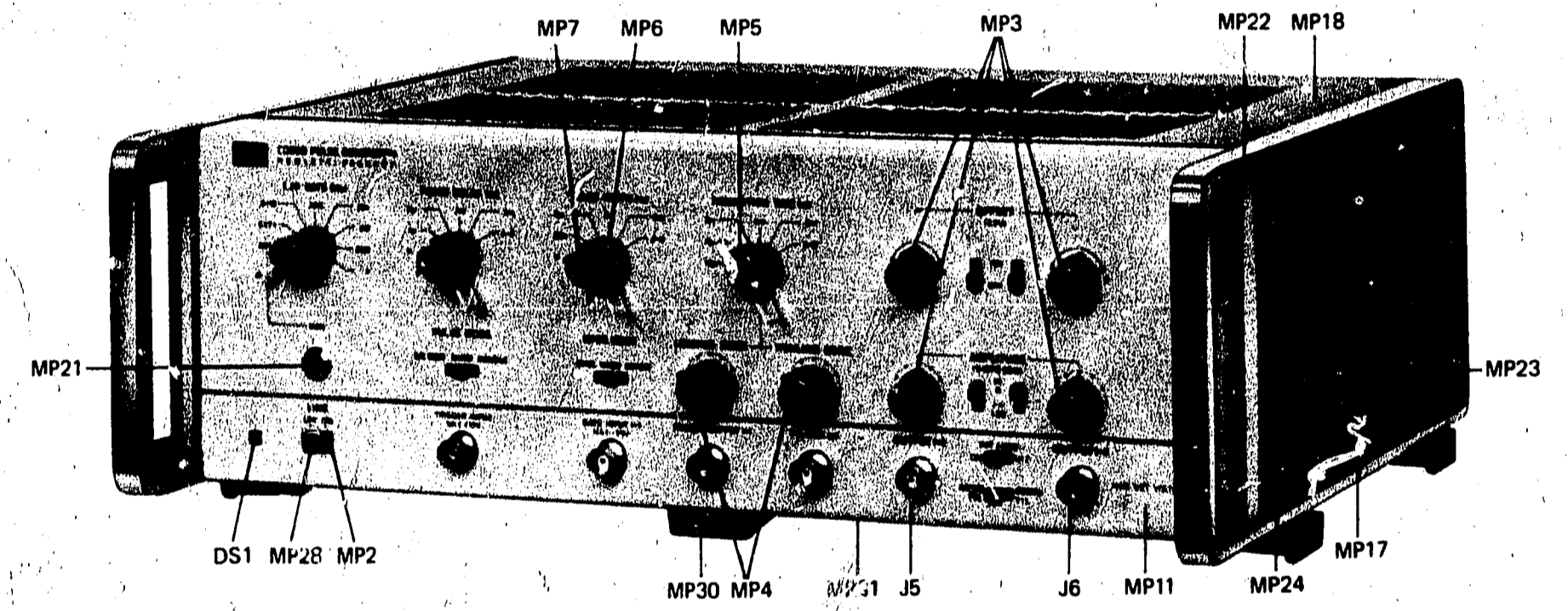

REAR PANEL

Figure 7-1 Mainframe Replaceable Parts Location

Table 7-2. Replaceable Parts

Reference Designation	HP Part Number	Qty	Description	Mfr Code	Mfr Part Number
A1	08005-66513	1	BOARD ASSEMBLY, TIMING	28480	08005-66513
A2	08005-66509	1	BOARD ASSEMBLY, MOTHER	28480	08005-66509
A3	08005-66510	1	BOARD ASSEMBLY, AMPLIFIER OUTPUT	28480	08005-66510
A4	08005-66511	1	BOARD ASSEMBLY, INTG	28480	08005-66511
A5	08005-66512	1	BOARD ASSEMBLY, POWER SUPPLY	28480	08005-66512
A6	08005-61901	1	SWITCH ASSEMBLY, RATE	28480	08005-61901
A9	08005-61902	1	SWITCH ASSEMBLY, WIDTH	28480	08005-61902
A10	08005-61903	1	SWITCH ASSEMBLY, DELAY	28480	08005-61903
C1	0180-1864	1	CAPACITOR-FXD 750UF+75-10% 75VDC AL	56289	390757G075JL4
C2	0180-1850	1	CAPACITOR-FXD 490UF+100-10% 65VDC AL	56289	D32872-0EE
D81	2140-0018	1	LAMP-GLOW T-2 BULB 58V	74276	A9A-C
F1	2110-0002	1	FUSE 1.6A 250V SLO-BLO 1.25X.25 UL	75915	31101.6
F1	2110-0020	1	FUSE .8A 250V SLO-BLO 1.25X.25 UL	71400	MDL 8/10
FL1	9100-3121	1	FILTER-LINE CEE-TERMS	28480	9100-3121
J1	1250-0118	6	CONNECTOR-RF BNC FEM SGL-HOLE-FR 50-OHM	24931	28JR128-1
J2	1250-0118		CONNECTOR-RF BNC FEM SGL-HOLE-FR 50-OHM	24931	28JR128-1
J3	1250-0118		CONNECTOR-RF BNC FEM SGL-HOLE-FR 50-OHM	24931	28JR128-1
J4	1250-0118		CONNECTOR-RF BNC FEM SGL-HOLE-FR 50-OHM	24931	28JR128-1
J5	1250-0118		CONNECTOR-RF BNC FEM SGL-HOLE-FR 50-OHM	24931	28JR128-1
J6	1250-0118		CONNECTOR-RF BNC FEM SGL-HOLE-FR 50-OHM	24931	28JR128-1
MP1	0370-0128	1	TERMINAL-STUD FXD-TUR PRESS-MTG	98291	013-3013-689
MP2	0370-0914	1	BEZEL-PUSHBUTTON KNOB, JADE GREY	28480	0370-0914
MP3	0370-1097	1	KNOB-BASE-PTR .5 IN JGK SGI-DECAL	28480	0370-1097
MP4	0370-1099	1	KNOB-BASE-PTR .5 IN JGK SGI-DECAL	28480	0370-1099
MP5	0370-1107	1	KNOB-BASE-PTR AND BAR .5 IN JGK	28480	0370-1107
MP6	0370-1108	1	KNOB-BASE-CONC PTR AND BAR .5 IN JGK	28480	0370-1108
MP7	0370-1125	1	KNOB-CONC-PTR .5 IN JGK SGI-DECAL	28480	0370-1125
MP8	0380-0008	1	SPACER-RND .5LG .18ID .250D BR3 NI-PL	28480	0380-0008
MP9	08005-00101	1	DECK, MAIN	28480	08005-00101
MP10	08005-00203	1	PANEL, SUB, LEFT	28480	08005-00203
MP11	08005-00209	1	PANEL, FRONT	28480	08005-00209
MP12	08005-00210	1	PANEL, SUB-SWITCH	28480	08005-00210
MP13	08005-00211	1	PANEL, SUB-RIGHT	28480	08005-00211
MP14	08005-00212	1	PANEL, REAR	28480	08005-00212
MP15	08005-04101	1	COVER	28480	08005-04101
MP16	08005-04102	1	COVER, SWITCH	28480	08005-04102
MP17	08007-04103	1	COVER, HANDLE	28480	08007-04103
MP18	08007-04104	1	COVER ASSEMBLY, TOP	28480	08007-04104
MP19	08010-01105	1	HEAT SINK	28480	08010-01105
MP20	1200-0087	1	INSULATOR-BSHG-FLG NYLON	28480	1200-0087
MP21	3101-0126	1	NUT-BEVD FOR 1/4-32 THD BUSHINGS) BRASS	28480	3101-0126
MP22	5000-0051	1	TRIM STRIP	28480	5000-0051
MP23	5000-8701	1	COVER:RT SIDE,REAR(OLIVE GRAY,STD)	28480	5000-8701
MP24	5000-8703	1	COVER:PT SIDE,FRONT(OLIVE GRAY,STD)	28480	5000-8703
MP25	5000-8908	1		28480	5000-8908
MP26	5040-0234	1	LAMPHOLDER	28480	5040-0234
MP27	5040-0235	1	BASE:LAMPHOLDER	28480	5040-0235
MP28	5040-1124	1		28480	5040-1124
MP29	5060-0731	1	FRAME ASSY:5 X 11 FM	28480	5060-0731
MP30	5060-0767	1	FOOT ASSY:FM	28480	5060-0767
MP31	5060-8729	1	COVER ASSEMBLY, BOTTOM	28480	5060-8729
Q1	1854-0063	2	TRANSISTOR NPN 2N3055 SI TO-3 PD=115W	28480	1854-0064
Q2	1854-0063		TRANSISTOR NPN 2N3055 SI TO-3 PD=115W	28480	1854-0064
R7	2100-1812	2	RESISTOR-VAR CONTROL CC 5K 10% 10CW	01121	J
R8	2100-1812		RESISTOR-VAR CONTROL CC 5K 10% 10CW	01121	J
R9	2100-1717	2	RESISTOR-VAR CONTROL CC 50K 20% LIN	01121	W
R10	2100-1717		RESISTOR-VAR CONTROL CC 50K 20% LIN	01121	W
R11	0758-0074	1	RESISTOR 27K 5% .25W F TC=0+-100	27167	C5
R12	2100-3104	2	RESISTOR, VAR 50 OHM 10% 5W, CC (PART OF A3, AMPLIFIER OUTPUT ASSEMBLY	01121	08D
R13	2100-3104		RESISTOR, VAR 50 OHM 10% 5W, CC (PART OF A3, AMPLIFIER OUTPUT ASSEMBLY	01121	08D
S1	3100-0519	1	SWITCH-PR SPST NC NOM	28480	3100-0519
S4	3101-0124	1	SWITCH-PB DPDT 4A 250VAC	82389	362
S5	3101-1720	1	SWITCH-PB DPDT 4A 250VAC	28480	3101-1720
S9	3101-0903	2	SWITCH-SL DP3T-NS MINTR .5A 125VAC/DC	79727	G1285-0003A
S10	3101-0903		SWITCH-SL DP3T-NS MINTR .5A 125VAC/DC	79727	G1285-0003A

See introduction to this section for ordering information

Table 7-2. Replaceable Parts

Reference Designation	HP Part Number	Qty	Description	Mfr Code	Mfr Part Number
S11	3101-1740	1	SWITCH-SL DPDT-NS STD 2A 250VAC SLDR LUG	28480	3101-1740
T1	5080-0980	1		28480	5080-0980
W1	08005-61610	1	CABLE ASSEMBLY, MAIN	28480	08005-61610
W2	08005-61611	1	CABLE ASSEMBLY, SHIELD I	28480	08005-61611
W3	08005-61612	1	CABLE ASSEMBLY, SHIELD II	28480	08005-61612
W4	08005-61613	1	CABLE ASSEMBLY, SHIELD III	28480	08005-61613
W5	08005-61614	1	CABLE ASSEMBLY, POWER	28480	08005-61614
W6	08005-61615	1	CABLE ASSEMBLY, IV	28480	08005-61615
W7	08005-61616	1	CABLE ASSEMBLY, V	28480	08005-61616
W8	8120-1689	1	POWER CORD SET	0037K	402 311
XF1A	2110-0465	1	FUSEHOLDER-EXTR POST UL/IEC .25X1.25FUSE	28480	2110-0465
XF1B	2110-0470	1	FUSEHOLDER-EXTR POST 20A 200V UL/IEC	75915	345003-010
XF1C	2110-0467	1	NUT, HEX SINGLE CHAMFER 1/2-28 THREAD	75915	903-070
XF1D	2190-0054	1	WASHER-LK INTL T NO.-1/2 .505-IN-ID	78189	1924-12
XF1E	1400-0090	1	WASHER-RUBBER 5/8" OD	00000	080
XQ1	1200-0043	2	INSULATOR-XSTR ALUMINUM	76530	322047
XQ2	1200-0043		INSULATOR-XSTR ALUMINUM	76530	322047

Table 7-2. Replaceable Parts

Reference Designation	HP Part Number	Qty	Description	Mfr Code	Mfr Part Number
A1	08005-66513		BOARD ASSEMBLY, TIMING	28480	08005-66513
A1C1	0180-0291	10	CAPACITOR-FXD 1UF+-10% 35VDC TA	56289	150D105X9035A2
A1C2	0180-0291		CAPACITOR-FXD 1UF+-10% 35VDC TA	56289	150D105X9035A2
A1C3	0180-0374	1	CAPACITOR-FXD 10UF+-10% 20VDC TA	56289	150C106X9020B2
A1C4	0140-0191	3	CAPACITOR-FXD 56PF +-5% 300WVDC MICA	72136	DM15E560J0300WV1CR
A1C5	0140-0191		CAPACITOR-FXD 56PF +-5% 300WVDC MICA	72136	DM15E560J0300WV1CR
A1C6	0180-0291		CAPACITOR-FXD 1UF+-10% 35VDC TA	56289	150D105X9035A2
A1C7	0160-4213	5	CAPACITOR-FXD .1UF +-20% 50WVDC POLYE	28480	0160-4213
A1C8	0140-0193	1	CAPACITOR-FXD 82PF +-5% 300WVDC MICA	72136	DM15E820J0300WV1CR
A1C9	0121-0046	3	CAPACITOR-V TRMR-CER 9/35PF 200V PC-MTG	00868	304322 9/35PF N650
A1C10	0140-0191	1	CAPACITOR-FXD 39PF +-5% 300WVDC MICA	72136	DM15E390J0300WV1CR
A1C11	0180-0291		CAPACITOR-FXD 1UF+-10% 35VDC TA	56289	150D105X9035A2
A1C12	0160-3714	1	CAPACITOR-FXD 5600PF +-10% 250WVDC MET	28480	0160-3714
A1C13	0160-3722	1	CAPACITOR-FXD .22UF +-10% 160WVDC MET	28480	0160-3722
A1C14	0180-0116	1	CAPACITOR-FXD 6.8UF+-10% 35VDC TA	56289	150D685X9035B2
A1C15	0180-2208	1	CAPACITOR-FXD 220UF+-10% 10VDC TA	56289	150D227X9010B2
A1C16	0160-2055	2	CAPACITOR-FXD .01UF +-80-20% 100WVDC CER	28480	0160-2055
A1C17	0180-0291		CAPACITOR-FXD 1UF+-10% 35VDC TA	56289	150D105X9035A2
A1C18	0140-0145	2	CAPACITOR-FXD 22PF +-5% 500WVDC MICA	72136	DM15C220J0500WV1CR
A1C20	0180-0291		CAPACITOR-FXD 1UF+-10% 35VDC TA	56289	150D105X9035A2
A1C21	0160-4213		CAPACITOR-FXD .1UF +-20% 50WVDC POLYE	28480	0160-4213
A1C22	0121-0046		CAPACITOR-V TRMR-CER 9/35PF 200V PC-MTG	00868	304322 9/35PF N650
A1C23	0140-2207	2	CAPACITOR-FXD 100UF+-10% 10VDC TA	56289	150D107X9010R2
A1C24	0160-2141	2	CAPACITOR-FXD 3.3UF+-10% 50VDC TA	56289	150D335X9050B2
A1C25	0160-3720	2	CAPACITOR-FXD .1UF +-10% 160WVDC MET	28480	0160-3720
A1C26	0160-3712	2	CAPACITOR-FXD 3300PF +-10% 250WVDC MET	28480	0160-3712
A1C27	0140-0201	2	CAPACITOR-FXD 12PF +-5% 500WVDC MICA	72136	DM15C120J0500WV1CR
A1C28	0160-2306	1	CAPACITOR-FXD 27PF +-5% 300WVDC MICA	28480	0160-2306
A1C29	0160-4213		CAPACITOR-FXD .1UF +-20% 50WVDC POLYE	28480	0160-4213
A1C30	0180-0291		CAPACITOR-FXD 1UF+-10% 35VDC TA	56289	150D105X9035A2
A1C31	0160-2055		CAPACITOR-FXD .01UF +-80-20% 100WVDC CER	28480	0160-2055
A1C32	0140-0145		CAPACITOR-FXD 22PF +-5% 500WVDC MICA	72136	DM15C220J0500WV1CR
A1C33	0121-0046		CAPACITOR-V TRMR-CER 9/35PF 200V PC-MTG	00868	304322 9/35PF N650
A1C34	0160-2204	1	CAPACITOR-FXD 100PF +-5% 300WVDC MICA	28480	0160-2204
A1C35	0140-0201		CAPACITOR-FXD 12PF +-5% 500WVDC MICA	72136	DM15C120J0500WV1CR
A1C36	0160-4213		CAPACITOR-FXD .1UF +-20% 50WVDC POLYE	28480	0160-4213
A1C37	0160-4213		CAPACITOR-FXD .1UF +-20% 50WVDC POLYE	28480	0160-4213
A1C38	0180-0291		CAPACITOR-FXD 1UF+-10% 35VDC TA	56289	150D105X9035A2
A1C39	0180-2207		CAPACITOR-FXD 100UF+-10% 10VDC TA	56289	150D107X9010R2
A1C40	0160-2141		CAPACITOR-FXD 3.3UF+-10% 50VDC TA	56289	150D335X9050B2
A1C41	0160-3720		CAPACITOR-FXD .1UF +-10% 160WVDC MET	28480	0160-3720
A1C42	0160-3712		CAPACITOR-FXD 3300PF +-10% 250WVDC MET	28480	0160-3712
A1C43	0180-0291		CAPACITOR-FXD 1UF+-10% 35VDC TA	56289	150D105X9035A2
A1C44	0160-2205	1	CAPACITOR-FXD 120PF +-5% 300WVDC MICA	28480	0160-2205
A1C45	0180-0358	1	CAPACITOR-FXD 50UF+-75-10% 25VDC AL	56289	30D506G025CC2
A1C46	0180-0291		CAPACITOR-FXD 1UF+-10% 35VDC TA	56289	150D105X9035A2
A1C47	0140-0191		CAPACITOR-FXD 56PF +-5% 300WVDC MICA	72136	DM15E560J0300WV1CR
A1C48	0160-2150	1	CAPACITOR-FXD 33PF +-5% 300WVDC MICA	28480	0160-2150
A1C48	0140-0202	1	CAPACITOR-FXD 15PF +-5% 500WVDC MICA	72136	DM15C150J0500WV1CR
A1CR1	1901-0040	13	DIODE-SWITCHING 30V 50MA 2NS DO-35	28480	1901-0040
A1CR2	1901-0040		DIODE-SWITCHING 30V 50MA 2NS DO-35	28480	1901-0040
A1CR3	1901-0040		DIODE-SWITCHING 30V 50MA 2NS DO-35	28480	1901-0040
A1CR4	1901-0040		DIODE-SWITCHING 30V 50MA 2NS DO-35	28480	1901-0040
A1CR5	1901-0533	2	DIODE-SCHOTTKY	28480	1901-0533
A1CR6	1901-0533		DIODE-SCHOTTKY	28480	1901-0533
A1CR8	1901-0040		DIODE-SWITCHING 30V 50MA 2NS DO-35	28480	1901-0040
A1CR9	1901-0040		DIODE-SWITCHING 30V 50MA 2NS DO-35	28480	1901-0040
A1CR10	1901-0040		DIODE-SWITCHING 30V 50MA 2NS DO-35	28480	1901-0040
A1CR11	1901-0040		DIODE-SWITCHING 30V 50MA 2NS DO-35	28480	1901-0040
A1CR12	1901-0040		DIODE-SWITCHING 30V 50MA 2NS DO-35	28480	1901-0040
A1CR13	1901-0040		DIODE-SWITCHING 30V 50MA 2NS DO-35	28480	1901-0040
A1CR14	1910-0016	2	DIODE-GE 60V 60NA 1US DO-7	28480	1910-0016
A1CR15	1910-0016		DIODE-GE 60V 60NA 1US DO-7	28480	1910-0016
A1CR16	1901-0040		DIODE-SWITCHING 30V 50MA 2NS DO-35	28480	1901-0040
A1CR17	1901-0040		DIODE-SWITCHING 30V 50MA 2NS DO-35	28480	1901-0040
A1CR18	1901-0040		DIODE-SWITCHING 30V 50MA 2NS DO-35	28480	1901-0040
A1CR22	1901-0179	1	DIODE-SWITCHING 15V 50MA 750PS DO-7	28480	1901-0179
A1CR23	1901-0533	2	DIODE-SCHOTTKY	28480	1901-0533
A1CR33	1901-0533		DIODE-SCHOTTKY	28480	1901-0533
A1L1	9140-0111	1	COIL-MLD 3.3UH 10% Q=33 .155DX.375LG	24226	15/331
A1L2	9140-0096	1	COIL-MLD 1UH 10% Q=50 .155DX.375LG	99800	1537-12
A1L3	9100-1612	1	COIL-MLD 330NH 20% Q=45 .155DX.375LG	99800	1537-04
A1L4	9170-0029	3	CORE-SHIELDING BEAD	02114	56-590-65A2/4A
A1L5	9170-0029		CORE-SHIELDING BEAD	02114	56-590-65A2/4A

See introduction to this section for ordering information

Table 7-2. Replaceable Parts

Reference Designation	HP Part Number	Qty	Description	Mfr Code	Mfr Part Number
A1L6	9100-1616	2	COIL-MLD 1.5UH 10% Q=33 .155DX.375LG	24226	15/151
A1L7	9100-1616		COIL-MLD 1.5UH 10% Q=33 .155DX.375LG	24226	15/151
A1L8	9170-0029		CORE-SHIELDING BEAD	02114	56-590-65A2/4A
A1Q1	1854-0215	13	TRANSISTOR NPN SI PD=350MW FT=300MHZ	04713	SP8 3611
A1Q2	1854-0215		TRANSISTOR NPN SI PD=350MW FT=300MHZ	04713	SP8 3611
A1Q3	1854-0215		TRANSISTOR NPN SI PD=350MW FT=300MHZ	04713	SP8 3611
A1Q4	1854-0215		TRANSISTOR NPN SI PD=350MW FT=300MHZ	04713	SP8 3611
A1Q5	1854-0630	5	TRANSISTOR NPN SI TO=52 PD=360MW	04713	892077
A1Q6	1853-0034	6	TRANSISTOR PNP SI TO=18 PD=360MW	28480	1853-0034
A1Q7	1854-0053	2	TRANSISTOR NPN 2N2218 SI TO=5 PD=800MW	04713	2N2218
A1Q8	1854-0053		TRANSISTOR NPN 2N2218 SI TO=5 PD=800MW	04713	2N2218
A1Q9	1853-0034		TRANSISTOR PNP SI TO=18 PD=360MW	28480	1853-0034
A1Q10	1854-0630		TRANSISTOR NPN SI TO=52 PD=360MW	04713	892077
A1Q11	1853-0034		TRANSISTOR PNP SI TO=18 PD=360MW	28480	1853-0034
A1Q12	1853-0036	3	TRANSISTOR PNP SI PD=310MW FT=250MHZ	28480	1853-0036
A1Q13	1853-0036		TRANSISTOR PNP SI PD=310MW FT=250MHZ	28480	1853-0036
A1Q14	1854-0630		TRANSISTOR NPN SI TO=52 PD=360MW	04713	892077
A1Q15	1854-0215		TRANSISTOR NPN SI PD=350MW FT=300MHZ	04713	SP8 3611
A1Q16	1853-0357	4	TRANSISTOR PNP SI TO=18 PD=360MW	28480	1853-0357
A1Q17	1853-0357		TRANSISTOR PNP SI TO=18 PD=360MW	28480	1853-0357
A1Q18	1854-0215		TRANSISTOR NPN SI PD=350MW FT=300MHZ	04713	SP8 3611
A1Q19	1854-0215		TRANSISTOR NPN SI PD=350MW FT=300MHZ	04713	SP8 3611
A1Q20	1854-0630		TRANSISTOR NPN SI TO=52 PD=360MW	04713	892077
A1Q21	1854-0215		TRANSISTOR NPN SI PD=350MW FT=300MHZ	04713	SP8 3611
A1Q22	1853-0036		TRANSISTOR PNP SI PD=310MW FT=250MHZ	28480	1853-0036
A1Q23	1853-0034		TRANSISTOR PNP SI TO=18 PD=360MW	28480	1853-0034
A1Q24	1854-0215		TRANSISTOR NPN SI PD=350MW FT=300MHZ	04713	SP8 3611
A1Q25	1854-0215		TRANSISTOR NPN SI PD=350MW FT=300MHZ	04713	SP8 3611
A1Q26	1854-0215		TRANSISTOR NPN SI PD=350MW FT=300MHZ	04713	SP8 3611
A1Q27	1854-0215		TRANSISTOR NPN SI PD=350MW FT=300MHZ	04713	SP8 3611
A1Q28	1854-0215		TRANSISTOR NPN SI PD=350MW FT=300MHZ	04713	SP8 3611
A1Q29	1853-0034		TRANSISTOR PNP SI TO=18 PD=360MW	28480	1853-0034
A1Q30	1854-0630		TRANSISTOR NPN SI TO=52 PD=360MW	04713	892077
A1Q31	1853-0357		TRANSISTOR PNP SI TO=18 PD=360MW	28480	1853-0357
A1Q32	1853-0357		TRANSISTOR PNP SI TO=18 PD=360MW	28480	1853-0357
A1Q33	1854-0307	1	TRANSISTOR NPN SI TO=18 PD=300MW	28480	1854-0307
A1Q34	1853-0052	1	TRANSISTOR PNP 2N3740 SI TO=66 PD=25W	04713	2N3740
A1Q35	1853-0034		TRANSISTOR PNP SI TO=18 PD=360MW	28480	1853-0034
A1R1	0757-0718	4	RESISTOR 200 1% .25W F TC=0+-100	19701	MF52C-1
A1R2	0757-0718		RESISTOR 200 1% .25W F TC=0+-100	19701	MF52C-1
A1R3	0757-0280	8	RESISTOR 1K 1% .125W F TC=0+-100	24546	C4-1/8-T0-1001-F
A1R4	0757-0390	1	RESISTOR 36.5 1% .125W F TC=0+-100	24546	C4-1/8-T0-36R5-F
A1R5	0758-0033	2	RESISTOR 2K 5% .25W F TC=0+-100	27167	C5
A1R6	0758-0033		RESISTOR 2K 5% .25W F TC=0+-100	27167	C5
A1R7	0757-0273	1	RESISTOR 3.01K 1% .125W F TC=0+-100	24546	C4-1/8-T0-3011-F
A1R8	0698-4014	1	RESISTOR 787 1% .125W F TC=0+-100	24546	C4-1/8-T0-787R-F
A1R9	0757-0401	8	RESISTOR 100 1% .125W F TC=0+-100	24546	C4-1/8-T0-101-F
A1R10	0757-0398	1	RESISTOR 75 1% .125W F TC=0+-100	24546	C4-1/8-T0-75R0-F
A1R11	0757-0407	3	RESISTOR 200 1% .125W F TC=0+-100	24546	C4-1/8-T0-201-F
A1R12	0757-0420	1	RESISTOR 750 1% .125W F TC=0+-100	24546	C4-1/8-T0-751-F
A1R13	0757-0424	1	RESISTOR 1.1K 1% .125W F TC=0+-100	24546	C4-1/8-T0-1101-F
A1R14	0757-0433	5	RESISTOR 3.32K 1% .125W F TC=0+-100	24546	C4-1/8-T0-3321-F
A1R15	0757-0442	1	RESISTOR 10K 1% .125W F TC=0+-100	24546	C4-1/8-T0-1002-F
A1R16	0757-0401		RESISTOR 100 1% .125W F TC=0+-100	24546	C4-1/8-T0-101-F
A1R17	0698-3492	1	RESISTOR 2.67K 1% .125W F TC=0+-100	24546	C4-1/8-T0-2671-F
A1R18	0757-0435	1	RESISTOR 3.92K 1% .125W F TC=0+-100	24546	C4-1/8-T0-3921-F
A1R19	0757-0284	2	RESISTOR 150 1% .125W F TC=0+-100	24546	C4-1/8-T0-151-F
A1R20	0757-0735	1	RESISTOR 1.3K 1% .125W F TC=0+-100	19701	MF52C-1
A1R21	0757-0280		RESISTOR 1K 1% .125W F TC=0+-100	24546	C4-1/8-T0-1001-F
A1R22	0757-0414	1	RESISTOR 432 1% .125W F TC=0+-100	24546	C4-1/8-T0-432R-F
A1R23	0757-0718		RESISTOR 200 1% .25W F TC=0+-100	19701	MF52C-1
A1R24	0757-0718		RESISTOR 200 1% .25W F TC=0+-100	19701	MF52C-1
A1R25	0757-0730	3	RESISTOR 750 1% .25W F TC=0+-100	19701	MF52C-1
A1R26	0698-3496	1	RESISTOR 3.57K 1% .125W F TC=0+-100	24546	C4-1/8-T0-357R-F
A1R27	0757-0426	1	RESISTOR 1.3K 1% .125W F TC=0+-100	24546	C4-1/8-T0-1301-F
A1R28	0757-0388	1	RESISTOR 30.1 1% .125W F TC=0+-100	24546	C4-1/8-T0-30R1-F
A1R29	0757-0401		RESISTOR 100 1% .125W F TC=0+-100	24546	C4-1/8-T0-101-F
A1R30	0757-0401		RESISTOR 100 1% .125W F TC=0+-100	24546	C4-1/8-T0-101-F
A1R31	0757-0410	3	RESISTOR 301 1% .125W F TC=0+-100	24546	C4-1/8-T0-301R-F
A1R32	0757-0280		RESISTOR 1K 1% .125W F TC=0+-100	24546	C4-1/8-T0-1001-F
A1R33	0757-0415	1	RESISTOR 475 1% .125W F TC=0+-100	24546	C4-1/8-T0-475R-F
A1R34	0757-0407		RESISTOR 200 1% .125W F TC=0+-100	24546	C4-1/8-T0-201-F
A1R35	0757-0416	1	RESISTOR 511 1% .125W F TC=0+-100	24546	C4-1/8-T0-511R-F
A1R36	0757-0290	2	RESISTOR 6.19K 1% .125W F TC=0+-100	19701	MF4C1/8-T0-6191-F
A1R37	0757-0280		RESISTOR 1K 1% .125W F TC=0+-100	24546	C4-1/8-T0-1001-F
A1R38	0757-0280		RESISTOR 1K 1% .125W F TC=0+-100	24546	C4-1/8-T0-1001-F
A1R39	0757-0337	2	RESISTOR 432 1% .125W F TC=0+-100	19701	MF52C-1
A1R40	0757-0417	2	RESISTOR 562 1% .125W F TC=0+-100	24546	C4-1/8-T0-562R-F

See introduction to this section for ordering information

Table 7-2. Replaceable Parts

Reference Designation	HP Part Number	Qty	Description	Mfr Code	Mfr Part Number
A1R41	0757-0401		RESISTOR 100 1X .125W F TC=0+-100	24546	C4-1/8-T0-101-F
A1R42	0757-0284		RESISTOR 150 1X .125W F TC=0+-100	24546	C4-1/8-T0-151-F
A1R43	0757-0427	2	RESISTOR 1.5K 1X .125W F TC=0+-100	24546	C4-1/8-T0-1501-F
A1R44	0757-0397	2	RESISTOR 68.1 1X .125W F TC=0+-100	24546	C4-1/8-T0-68R1-F
A1R45	0757-0392	3	RESISTOR 43.2 1X .125W F TC=0+-100	24546	C4-1/8-T0-43R2-F
A1R46	0757-0401		RESISTOR 100 1X .125W F TC=0+-100	24546	C4-1/8-T0-101-F
A1R47	0757-0433		RESISTOR 3.32K 1X .125W F TC=0+-100	24546	C4-1/8-T0-3321-F
A1R48	0757-0433		RESISTOR 3.32K 1X .125W F TC=0+-100	24546	C4-1/8-T0-3321-F
A1R49	0757-0721	2	RESISTOR 274 1X .25W F TC=0+-100	19701	MF52C-1
A1R50	0757-0627	2	RESISTOR 2.74K 1X .5W F TC=0+-100	19701	MF7C1/2-T0-2741-F
A1R51	0757-0738	2	RESISTOR 1.82K 1X .25W F TC=0+-100	19701	MF52C-1
A1R52	0757-0405	2	RESISTOR 162 1X .125W F TC=0+-100	24546	C4-1/8-T0-162R-F
A1R53	0757-0730		RESISTOR 750 1X .25W F TC=0+-100	19701	MF52C-1
A1R54	0757-0354	2	RESISTOR 3.65K 1X .25W F TC=0+-100	19701	MF52C-1
A1R55	0757-0401		RESISTOR 100 1X .125W F TC=0+-100	24546	C4-1/8-T0-101-F
A1R56	0758-0066	1	RESISTOR 620 5X .25W F TC=0+-100	27167	C5
A1R57	0698-3242	2	RESISTOR 357 1X .125W F TC=0+-100	24546	C4-1/8-T0-357R-F
A1R58	0757-0282	1	RESISTOR 221 1X .125W F TC=0+-100	24546	C4-1/8-T0-221R-F
A1R59	0757-0411	1	RESISTOR 332 1X .125W F TC=0+-100	24546	C4-1/8-T0-332R-F
A1R60	0757-0407		RESISTOR 200 1X .125W F TC=0+-100	24546	C4-1/8-T0-201-F
A1R61	0757-0410		RESISTOR 301 1X .125W F TC=0+-100	24546	C4-1/8-T0-301R-F
A1R62	0757-0410		RESISTOR 301 1X .125W F TC=0+-100	24546	C4-1/8-T0-301R-F
A1R63	0757-0280		RESISTOR 1K 1X .125W F TC=0+-100	24546	C4-1/8-T0-1001-F
A1R64	0757-0283	1	RESISTOR 2K 1X .125W F TC=0+-100	24546	C4-1/8-T0-2001-F
A1R65	0757-0290		RESISTOR 6.19K 1X .125W F TC=0+-100	19701	MF4C1/8-T0-6191-F
A1R66	0757-0286		RESISTOR 1K 1X .125W F TC=0+-100	24546	C4-1/8-T0-1001-F
A1R67	0757-0337		RESISTOR 432 1X .25W F TC=0+-100	19701	MF52C-1
A1R68	0757-0417		RESISTOR 562 1X .125W F TC=0+-100	24546	C4-1/8-T0-562R-F
A1R69	0757-0401		RESISTOR 100 1X .125W F TC=0+-100	24546	C4-1/8-T0-101-F
A1R70	0757-0427		RESISTOR 1.5K 1X .125W F TC=0+-100	24546	C4-1/8-T0-1501-F
A1R71	0757-0397		RESISTOR 68.1 1X .125W F TC=0+-100	24546	C4-1/8-T0-68R1-F
A1R72	0757-0392		RESISTOR 43.2 1X .125W F TC=0+-100	24546	C4-1/8-T0-43R2-F
A1R73	0757-0721		RESISTOR 274 1X .25W F TC=0+-100	19701	MF52C-1
A1R74	0757-0433		RESISTOR 3.32K 1X .125W F TC=0+-100	24546	C4-1/8-T0-3321-F
A1R75	0757-0433		RESISTOR 3.32K 1X .125W F TC=0+-100	24546	C4-1/8-T0-3321-F
A1R76	0757-0405		RESISTOR 162 1X .125W F TC=0+-100	24546	C4-1/8-T0-162R-F
A1R77	0757-0738		RESISTOR 1.82K 1X .25W F TC=0+-100	19701	MF52C-1
A1R78	0757-0730		RESISTOR 750 1X .25W F TC=0+-100	19701	MF52C-1
A1R79	0757-0827		RESISTOR 2.74K 1X .5W F TC=0+-100	19701	MF7C1/2-T0-2741-F
A1R80	0757-0354		RESISTOR 3.65K 1X .25W F TC=0+-100	19701	MF52C-1
A1R81	0757-0280		RESISTOR 1K 1X .125W F TC=0+-100	24546	C4-1/8-T0-1001-F
A1R82	0757-0437	1	RESISTOR 4.75K 1X .125W F TC=0+-100	24546	C4-1/8-T0-4751-F
A1R83	0698-3242		RESISTOR 357 1X .125W F TC=0+-100	24546	C4-1/8-T0-357R-F
A1R84	0757-0449	1	RESISTOR 20K 1X .125W F TC=0+-100	24546	C4-1/8-T0-2002-F
A1R86	0757-0392		RESISTOR 43.2 1X .125W F TC=0+-100	24546	C4-1/8-T0-43R2-F
A1R87	0757-0200	1	RESISTOR 5.62K 1X .125W F TC=0+-100	24546	C4-1/8-T0-5621-F
A1R88	0757-0485		RESISTOR 100 K		
A1R88	0698-3454		RESISTOR 215 K		
A1R88	0698-4543		RESISTOR 487 K		
A1R88			MAY BE OMITTED.		
A1VR7.35	1902-3149	1	DIODE-ZNR 9.09V 5% DO-7 PD=.4W TC=+.057X	04713	SZ 10939-170
A1VR19	1902-0041	3	DIODE-ZNR 5.11V 5% DO-7 PD=.4W TC=-.009X	15818	CD 35622
A1VR20	1902-0041		DIODE-ZNR 5.11V 5% DO-7 PD=.4W TC=-.009X	15818	CD 35622
A1VR21	1902-0041		DIODE-ZNR 5.11V 5% DO-7 PD=.4W TC=-.009X	15818	CD 35622

See introduction to this section for ordering information

Table 7-2. Replaceable Parts

Reference Designation	HP Part Number	Qty	Description	Mfr Code	Mfr Part Number
A2	08005-66509		BOARD ASSEMBLY, MOTHER	28480	08005-66509
A2C1	0160-0174	2	CAPACITOR-FXD .47UF +80-20% 25WVDC CER	28480	0160-0174
A2C2	0160-0174		CAPACITOR-FXD .47UF +80-20% 25WVDC CER	28480	0160-0174
A2C3	0160-2055	2	CAPACITOR-FXD .01UF +80-20% 100WVDC CER	28480	0160-2055
A2C4	0160-2055		CAPACITOR-FXD .01UF +80-20% 100WVDC CER	28480	0160-2055
A2CR7	1901-0040	2	DIODE-SWITCHING 30V 50MA 2NS DO-35	28480	1901-0040
A2CR8	1901-0040		DIODE-SWITCHING 30V 50MA 2NS DO-35	28480	1901-0040
A2CR9	1901-0050	4	DIODE-SWITCHING 80V 200MA 2NS DO-7	28480	1901-0050
A2CR10	1901-0050		DIODE-SWITCHING 80V 200MA 2NS DO-7	28480	1901-0050
A2CR11	1901-0050		DIODE-SWITCHING 80V 200MA 2NS DO-7	28480	1901-0050
A2CR12	1901-0050		DIODE-SWITCHING 80V 200MA 2NS DO-7	28480	1901-0050
A2L1	9140-0118	2	COIL-MLD 500UH 5% 0.65 .19DX.44LG	24226	19/503
A2L2	5081-1973	2	INDUCTANCE, 3-BEAD	28480	5081-1973
A2L5	9140-0118		COIL-MLD 500UH 5% 0.65 .19DX.44LG	24226	19/503
A2L6	5081-1973		INDUCTANCE, 3-BEAD	28480	5081-1973
A2U1	1853-0051	2	TRANSISTOR PNP 2N4037 SI TO-5 PD=1W	02735	2N4037
	1205-0061	2	HEAT SINK TO-5/TO-39-PKG	28480	1205-0061
A2U2	1854-0039	2	TRANSISTOR NPN 2N3053 SI TO-5 PD=1W	04713	2N3053
	1205-0033	2	HEAT SINK TO-5/TO-39-PKG	28480	1205-0033
A2U3	1853-0051		TRANSISTOR PNP 2N4037 SI TO-5 PD=1W	02735	2N4037
	1205-0033		HEAT SINK TO-5/TO-39-PKG	28480	1205-0033
A2U4	1854-0039		TRANSISTOR NPN 2N3053 SI TO-5 PD=1W	04713	2N3053
	1205-0061		HEAT SINK TO-5/TO-39-PKG	28480	1205-0061
A2R1	0698-5036	10	RESISTOR 250 1% .5W F TC=0+-100	91637	MFF-1/2-10
A2R2	0698-5036		RESISTOR 250 1% .5W F TC=0+-100	91637	MFF-1/2-10
A2R3	0698-5036		RESISTOR 250 1% .5W F TC=0+-100	91637	MFF-1/2-10
A2R4	0698-5036		RESISTOR 250 1% .5W F TC=0+-100	91637	MFF-1/2-10
A2R5	0698-5036		RESISTOR 250 1% .5W F TC=0+-100	91637	MFF-1/2-10
A2R6	0757-0811	2	RESISTOR 392 1% .5W F TC=0+-100	19701	MF7C1/2-T0-392R-F
A2R7	0757-0198	2	RESISTOR 100 1% .5W F TC=0+-100	19701	MF7C1/2-T0-101-F
A2R8	0698-4123	2	RESISTOR 499 1% .125W F TC=0+-100	24546	C4-1/8-T0-499R-F
A2R9	0698-5036		RESISTOR 250 1% .5W F TC=0+-100	91637	MFF-1/2-10
A2R10	0698-5036		RESISTOR 250 1% .5W F TC=0+-100	91637	MFF-1/2-10
A2R11	0698-5036		RESISTOR 250 1% .5W F TC=0+-100	91637	MFF-1/2-10
A2R12	0698-5036		RESISTOR 250 1% .5W F TC=0+-100	91637	MFF-1/2-10
A2R13	0698-5036		RESISTOR 250 1% .5W F TC=0+-100	91637	MFF-1/2-10
A2R14	0757-0811		RESISTOR 392 1% .5W F TC=0+-100	19701	MF7C1/2-T0-392R-F
A2R15	0757-0198		RESISTOR 100 1% .5W F TC=0+-100	19701	MF7C1/2-T0-101-F
A2R16	0698-4123		RESISTOR 499 1% .125W F TC=0+-100	24546	C4-1/8-T0-499R-F
A2R17	0757-0438	4	RESISTOR 5.11K 1% .125W F TC=0+-100	24546	C4-1/8-T0-5111-F
A2R18	0757-0438		RESISTOR 5.11K 1% .125W F TC=0+-100	24546	C4-1/8-T0-5111-F
A2R19	0757-0458	2	RESISTOR 51.1K 1% .125W F TC=0+-100	24546	C4-1/8-T0-5112-F
A2R20	0757-0453	4	RESISTOR 30.1K 1% .125W F TC=0+-100	24546	C4-1/8-T0-3012-F
A2R21	0757-0453		RESISTOR 30.1K 1% .125W F TC=0+-100	24546	C4-1/8-T0-3012-F
A2R22	0757-0283	4	RESISTOR 2K 1% .125W F TC=0+-100	24546	C4-1/8-T0-2001-F
A2R23	0757-0283		RESISTOR 2K 1% .125W F TC=0+-100	24546	C4-1/8-T0-2001-F
A2R24	0761-0014	4	RESISTOR 180 5% 1W MO TC=0+-200	11502	RG32
A2R25	0758-0030	4	RESISTOR 510 5% .25W F TC=0+-100	27167	C5
A2R26	0761-0014		RESISTOR 180 5% 1W MO TC=0+-200	11502	RG32
A2R27	0758-0030		RESISTOR 510 5% .25W F TC=0+-100	27167	C5
A2R28	0757-0431	2	RESISTOR 2.43K 1% .125W F TC=0+-100	24546	C4-1/8-T0-2431-F
A2R29	0698-3492	2	RESISTOR 2.67K 1% .125W F TC=0+-100	24546	C4-1/8-T0-2671-F
A2R30	0757-0477	2	RESISTOR 332K 1% .125W F TC=0+-100	19701	MF4C1/8-T0-3323-F
A2R31	0757-0438		RESISTOR 5.11K 1% .125W F TC=0+-100	24546	C4-1/8-T0-5111-F
A2R32	0757-0438		RESISTOR 5.11K 1% .125W F TC=0+-100	24546	C4-1/8-T0-5111-F
A2R33	0757-0458		RESISTOR 51.1K 1% .125W F TC=0+-100	24546	C4-1/8-T0-5112-F
A2R34	0757-0477		RESISTOR 332K 1% .125W F TC=0+-100	19701	MF4C1/8-T0-3323-F
A2R35	0757-0453		RESISTOR 30.1K 1% .125W F TC=0+-100	24546	C4-1/8-T0-3012-F
A2R36	0757-0453		RESISTOR 30.1K 1% .125W F TC=0+-100	24546	C4-1/8-T0-3012-F
A2R37	0757-0283		RESISTOR 2K 1% .125W F TC=0+-100	24546	C4-1/8-T0-2001-F
A2R38	0757-0283		RESISTOR 2K 1% .125W F TC=0+-100	24546	C4-1/8-T0-2001-F
A2R39	0761-0014		RESISTOR 180 5% 1W MO TC=0+-200	11502	RG32
A2R40	0758-0030		RESISTOR 510 5% .25W F TC=0+-100	27167	C5
A2R41	0761-0014		RESISTOR 180 5% 1W MO TC=0+-200	11502	RG32
A2R42	0758-0030		RESISTOR 510 5% .25W F TC=0+-100	27167	C5
A2R43	0757-0431		RESISTOR 2.43K 1% .125W F TC=0+-100	24546	C4-1/8-T0-2431-F
A2R44	0698-3492		RESISTOR 2.67K 1% .125W F TC=0+-100	24546	C4-1/8-T0-2671-F
A2R45	0757-0442	2	RESISTOR 10K 1% .125W F TC=0+-100	24546	C4-1/8-T0-1002-F
A2R46	0757-0442		RESISTOR 10K 1% .125W F TC=0+-100	24546	C4-1/8-T0-1002-F

Table 7-2. Replaceable Parts

Reference Designation	HP Part Number	Qty	Description	Mfr Code	Mfr Part Number
A291	3101-1596	6	SWITCH-SL DPDT-NS MINTR 1A 125VAC PC	28480	3101-1596
A292	3101-1596		SWITCH-SL DPDT-NS MINTR 1A 125VAC PC	28480	3101-1596
A293	3101-1596		SWITCH-SL DPDT-NS MINTR 1A 125VAC PC	28480	3101-1596
A294	3101-1596		SWITCH-SL DPDT-NS MINTR 1A 125VAC PC	28480	3101-1596
A295	3101-1596		SWITCH-SL DPDT-NS MINTR 1A 125VAC PC	28480	3101-1596
A296	3101-1596		SWITCH-SL DPDT-NS MINTR 1A 125VAC PC	28480	3101-1596
A2U1	1826-0111	1	IC MC 1458 OP AMP	04713	MC1458G
A2VR1	1902-0025	2	DIODE-ZNR 10V 5% DO-7 PD=.4W TC=+.06%	28480	1902-0025
A2VR2	1902-0025		DIODE-ZNR 10V 5% DO-7 PD=.4W TC=+.06%	28480	1902-0025
A2VR3	1902-3256	4	DIODE-ZNR 23.7V 5% DO-7 PD=.4W TC=+.076%	04713	SZ 10939-290
A2VR4	1902-3256		DIODE-ZNR 23.7V 5% DO-7 PD=.4W TC=+.076%	04713	SZ 10939-290
A2VR5	1902-3256		DIODE-ZNR 23.7V 5% DO-7 PD=.4W TC=+.076%	04713	SZ 10939-290
A2VR6	1902-3256		DIODE-ZNR 23.7V 5% DO-7 PD=.4W TC=+.076%	04713	SZ 10939-290

See introduction to this section for ordering information

Table 7-2. Replaceable Parts

Reference Designation	HP Part Number	Qty	Description	Mfr Code	Mfr Part Number
A3	0A005-66510		BOARD ASSEMBLY, AMPLIFIER OUTPUT	28480	08005-66510
A3C1	0160-1704	2	CAPACITOR-FXD .47UF +-10% 6VDC TA	56289	150D476X900082
A3C2	0160-2055	12	CAPACITOR-FXD .01UF +80-20% 100WVDC CER	28480	0160-2055
A3C3	0160-2055		CAPACITOR-FXD .01UF +80-20% 100WVDC CER	28480	0160-2055
A3C4	0160-2055		CAPACITOR-FXD .01UF +80-20% 100WVDC CER	28480	0160-2055
A3C5	0160-4213	3	CAPACITOR-FXD .1UF +-20% 50WVDC POLYE	28480	0160-4213
A3C6	0160-4213		CAPACITOR-FXD .1UF +-20% 50WVDC POLYE	28480	0160-4213
A3C7	0160-1704		CAPACITOR-FXD .47UF +-10% 6VDC TA	56289	150D476X900082
A3C8	0160-2055		CAPACITOR-FXD .01UF +80-20% 100WVDC CER	28480	0160-2055
A3C9	0160-3456	4	CAPACITOR-FXD 1000PF +-10% 1000WVDC CER	28480	0160-3456
A3C10	0160-2055		CAPACITOR-FXD .01UF +80-20% 100WVDC CER	28480	0160-2055
A3C11	0160-2139	2	CAPACITOR-FXD 220PF +80-20% 1000WVDC CER	28480	0160-2139
A3C12	0160-0291	1	CAPACITOR-FXD 1UF +-10% 35VDC TA	56289	150D105X9035A2
A3C13	0160-0174	6	CAPACITOR-FXD .47UF +80-20% 25WVDC CER	28480	0160-0174
A3C14	0160-3456		CAPACITOR-FXD 1000PF +-10% 1000WVDC CER	28480	0160-3456
A3C15	0160-3456		CAPACITOR-FXD 1000PF +-10% 1000WVDC CER	28480	0160-3456
A3C16	0160-0174		CAPACITOR-FXD .47UF +80-20% 25WVDC CER	28480	0160-0174
A3C17	0160-0174		CAPACITOR-FXD .47UF +80-20% 25WVDC CER	28480	0160-0174
A3C18	0160-0174		CAPACITOR-FXD .47UF +80-20% 25WVDC CER	28480	0160-0174
A3C19	0160-2055		CAPACITOR-FXD .01UF +80-20% 100WVDC CER	28480	0160-2055
A3C20	0160-2055		CAPACITOR-FXD .01UF +80-20% 100WVDC CER	28480	0160-2055
A3C21	0160-2055		CAPACITOR-FXD .01UF +80-20% 100WVDC CER	28480	0160-2055
A3C22	0160-4213		CAPACITOR-FXD .1UF +-20% 50WVDC POLYE	28480	0160-4213
A3C23	0160-0174		CAPACITOR-FXD .47UF +80-20% 25WVDC CER	28480	0160-0174
A3C24	0160-0174		CAPACITOR-FXD .47UF +80-20% 25WVDC CER	28480	0160-0174
A3C25	0160-2055		CAPACITOR-FXD .01UF +80-20% 100WVDC CER	28480	0160-2055
A3C26	0160-2139		CAPACITOR-FXD 220PF +80-20% 1000WVDC CER	28480	0160-2139
A3C27	0160-2055		CAPACITOR-FXD .01UF +80-20% 100WVDC CER	28480	0160-2055
A3C28	0160-2055		CAPACITOR-FXD .01UF +80-20% 100WVDC CER	28480	0160-2055
A3C29	0160-2055		CAPACITOR-FXD .01UF +80-20% 100WVDC CER	28480	0160-2055
A3C30	0160-3456		CAPACITOR-FXD 1000PF +-10% 1000WVDC CER	28480	0160-3456
A3C31	0160-2327	2	CAPACITOR-FXD 1000PF +-20% 100WVDC CER	28480	0160-2327
A3C32	0160-2327		CAPACITOR-FXD 1000PF +-20% 100WVDC CER	28480	0160-2327
A3C33	0140-0196	2	CAPACITOR-FXD 150PF +-5% 300WVDC MICA	72136	DM15F151J0300WV1CR
A3C34	0140-0196		CAPACITOR-FXD 150PF +-5% 300WVDC MICA	72136	DM15F151J0300WV12R
A3C35	0140-0193	1	CAPACITOR-FXD 82PF +-5% 300WVDC MICA	72136	DM15E820J0300WV1CR
A3C35	0160-2204	1	CAPACITOR-FXD 100PF +-5% 300WVDC MICA	28480	0160-2204
A3CR2	1910-0034	1	DIODE-GE 30V 80MA 8NS DO-7	20480	1910-0034
A3CR4	1901-0040	7	DIODE-SWITCHING 30V 50MA 2NS DO-35	28480	1901-0040
A3CR10	1901-0040		DIODE-SWITCHING 30V 50MA 2NS DO-35	28480	1901-0040
A3CR11	1901-0040		DIODE-SWITCHING 30V 50MA 2NS DO-35	28480	1901-0040
A3CR14	1901-0040		DIODE-SWITCHING 30V 50MA 2NS DO-35	28480	1901-0040
A3CR15	1901-0040		DIODE-SWITCHING 30V 50MA 2NS DO-35	28480	1901-0040
A3CR20	1901-0533	9	DIODE-SCHOTTKY	28480	1901-0533
A3CR21	1901-0533		DIODE-SCHOTTKY	28480	1901-0533
A3CR22	1901-0533		DIODE-SCHOTTKY	28480	1901-0533
A3CR23	1901-0533		DIODE-SCHOTTKY	28480	1901-0533
A3CR24	1901-0040		DIODE-SWITCHING 30V 50MA 2NS DO-35	28480	1901-0040
A3CR25	1901-0040		DIODE-SWITCHING 30V 50MA 2NS DO-35	28480	1901-0040
A3CR29	1901-0533		DIODE-SCHOTTKY	28480	1901-0533
A3CR30	1901-0533		DIODE-SCHOTTKY	28480	1901-0533
A3CR31	1901-0533		DIODE-SCHOTTKY	28480	1901-0533
A3CR32	1901-0533		DIODE-SCHOTTKY	28480	1901-0533
A3CR33	1901-0533		DIODE-SCHOTTKY	28480	1901-0533
A3L1	9140-0096	3	COIL-MLD 1UH 10% Q=50 .155DX.375LG	99800	1537-12
A3L2	9140-0096		COIL-MLD 1UH 10% Q=50 .155DX.375LG	99300	1537-12
A3L3	9140-0096		COIL-MLD 1UH 10% Q=50 .155DX.375LG	99800	1537-12
A3L4	9140-0094	1	COIL-MLD 680NH 10% Q=50 .155DX.375LG	24226	15/680
A3L5	9100-1624	2	COIL-MLD 30UH 5% Q=65 .155DX.375LG	24226	15/302
A3L6	9100-1624		COIL-MLD 30UH 5% Q=65 .155DX.375LG	24226	15/302
A3L7	9100-2247	2	COIL-FXD MOLDED RF CHOKE .1UH 10%	24226	10/100
A3L8	9100-2247		COIL-FXD MOLDED RF CHOKE .1UH 10%	24226	10/100
A3L9	9100-0346	2	COIL-FXD MOLDED RF CHOKE .05UH 20%	28480	9100-0346
A3L10	9100-0346		COIL-FXD MOLDED RF CHOKE .05UH 20%	28480	9100-0346
A3L11	9100-2251	1	COIL-FXD MOLDED RF CHOKE .22UH 10%	24226	10/220
A3Q1	1854-0630	9	TRANSISTOR NPN SI TO-52 PD=360MW	04713	832077
A3Q2	1853-0218	1	TRANSISTOR PNP SI TO-18 PD=360MW	28480	1853-0218
A3Q3	1854-0630		TRANSISTOR NPN SI TO-52 PD=360MW	04713	832077
A3Q4	1854-0630		TRANSISTOR NPN SI TO-52 PD=360MW	04713	832077
A3Q5	1853-0034	4	TRANSISTOR PNP SI TO-18 PD=360MW	28480	1853-0034

Table 7-2. Replaceable Parts

Reference Designation	HP Part Number	Qty	Description	Mfr Code	Mfr Part Number
A3Q6	1853-0034		TRANSISTOR PNP SI TO-18 PD=360MW	28480	1853-0034
A3Q7	1854-0630		TRANSISTOR NPN SI TO-52 PD=360MW	04713	892077
A3Q8	1854-0630		TRANSISTOR NPN SI TO-52 PD=360MW	04713	892077
A3Q9	1854-0630		TRANSISTOR NPN SI TO-52 PD=360MW	04713	892077
A3Q10	1854-0630		TRANSISTOR NPN SI TO-52 PD=360MW	04713	892077
A3Q11	1853-0357	1	TRANSISTOR PNP SI TO-18 PD=360MW	28480	1853-0357
A3Q12	1854-0233	3	TRANSISTOR NPN 2N3866 SI TO-39 PD=1W	02735	2N3866
A3Q13	1205-0033	6	HEAT SINK TO-5/TO-39-PKG	28480	1205-0033
A3Q14	1854-0630		TRANSISTOR NPN SI TO-52 PD=360MW	04713	892077
A3Q14	1853-0001	1	TRANSISTOR PNP SI TO-39 PD=600MW	28480	1853-0001
A3Q15	1854-0307	2	TRANSISTOR NPN SI TO-18 PD=300MW	28480	1854-0307
A3Q16	1854-0630		TRANSISTOR NPN SI TO-52 PD=360MW	04713	892077
A3Q17	1853-0034		TRANSISTOR PNP SI TO-18 PD=360MW	28480	1853-0034
A3Q18	1853-0315	3	TRANSISTOR PNP SI TO-39 PD=1W FT=1GHZ	28480	1853-0315
A3Q18	1205-0033		HEAT SINK TO-5/TO-39-PKG	28480	1205-0033
A3Q19	1853-0315		TRANSISTOR PNP SI TO-39 PD=1W FT=1GHZ	28480	1853-0315
A3Q20	1205-0061	4	HEAT SINK TO-5/TO-39-PKG	28480	1205-0061
A3Q20	1853-0315		TRANSISTOR PNP SI TO-39 PD=1W FT=1GHZ	28480	1853-0315
A3Q21	1205-0061		HEAT SINK TO-5/TO-39-PKG	28480	1205-0061
A3Q21	1854-0053	3	TRANSISTOR NPN 2N2218 SI TO-5 PD=800MW	04713	2N2218
A3Q22	1853-0027	3	TRANSISTOR PNP SI TO-39 PD=1W FT=100MHZ	28480	1853-0027
A3Q22	1205-0033		HEAT SINK TO-5/TO-39-PKG	28480	1205-0033
A3Q23	1853-0027		TRANSISTOR PNP SI TO-39 PD=1W FT=100MHZ	28480	1853-0027
A3Q23	1205-0033		HEAT SINK TO-5/TO-39-PKG	28480	1205-0033
A3Q24	1854-0307		TRANSISTOR NPN SI TO-18 PD=300MW	28480	1854-0307
A3Q25	1854-0019	1	TRANSISTOR NPN SI TO-13 PD=360MW	28480	1854-0019
A3Q26	1853-0034		TRANSISTOR PNP SI TO-18 PD=360MW	28480	1853-0034
A3Q27	1854-0233		TRANSISTOR NPN 2N3866 SI TO-39 PD=1W	02735	2N3866
A3Q28	1854-0332	2	TRANSISTOR NPN SI TO-39 PD=1W FT=800MHZ	28480	1854-0332
A3Q28	1205-0061		HEAT SINK TO-5/TO-39-PKG	28480	1205-0061
A3Q29	1854-0332		TRANSISTOR NPN SI TO-39 PD=1W FT=800MHZ	28480	1854-0332
A3Q29	1205-0061		HEAT SINK TO-5/TO-39-PKG	28480	1205-0061
A3Q30	1854-0053		TRANSISTOR NPN 2N2218 SI TO-5 PD=800MW	04713	2N2218
A3Q30	1205-0033		HEAT SINK TO-5/TO-39-PKG	28480	1205-0033
A3Q31	1854-0053		TRANSISTOR NPN 2N2218 SI TO-5 PD=800MW	04713	2N2218
A3Q31	1205-0033		HEAT SINK TO-5/TO-39-PKG	28480	1205-0033
A3Q32	1853-0027		TRANSISTOR PNP SI TO-39 PD=1W FT=100MHZ	28480	1853-0027
A3Q33	1853-0090	1	TSTRISI PNP	28480	1853-0090
A3Q34	1854-0233		TRANSISTOR NPN 2N3866 SI TO-39 PD=1W	02735	2N3866
A3R1	0761-0052	1	RESISTOR 270 5% 1W MO TC=0+-200	11502	RG32
A3R2	0757-0280	3	RESISTOR 1K 1% .125W F TC=0+-100	24546	C4-1/8-T0-1001-F
A3R3	0757-0418	1	RESISTOR 619 1% .125W F TC=0+-100	24546	C4-1/8-T0-619R-F
A3R4	0757-0401	7	RESISTOR 100 1% .125W F TC=0+-100	24546	C4-1/8-T0-101-F
A3R5	0757-0407	4	RESISTOR 200 1% .125W F TC=0+-100	24546	C4-1/8-T0-201-F
A3R7	0757-0394	2	RESISTOR 51.1 1% .125W F TC=0+-100	24546	C4-1/8-T0-51R1-F
A3R8	0757-0283	3	RESISTOR 2K 1% .125W F TC=0+-100	24546	C4-1/8-T0-2001-F
A3R9	0757-0280		RESISTOR 1K 1% .125W F TC=0+-100	24546	C4-1/8-T0-1001-F
A3R10	0757-0391	2	RESISTOR 39.2 1% .125W F TC=0+-100	24546	C4-1/8-T0-39R2-F
A3R11	0757-0273	1	RESISTOR 3.01K 1% .125W F TC=0+-100	24546	C4-1/8-T0-3011-F
A3R12	0757-0435	3	RESISTOR 3.92K 1% .125W F TC=0+-100	24546	C4-1/8-T0-3921-F
A3R13	0757-0410	3	RESISTOR 301 1% .125W F TC=0+-100	24546	C4-1/8-T0-301R-F
A3R14	0758-0094	1	RESISTOR 62 5% .25W F TC=0+-100	27167	C5
A3R15	0757-0410		RESISTOR 301 1% .125W F TC=0+-100	24546	C4-1/8-T0-301R-F
A3R16	0757-0346	5	RESISTOR 10 1% .125W F TC=0+-100	24546	C4-1/8-T0-10R0-F
A3R17	0757-0410		RESISTOR 301 1% .125W F TC=0+-100	24546	C4-1/8-T0-301R-F
A3R18	0757-0284	1	RESISTOR 150 1% .125W F TC=0+-100	24546	C4-1/8-T0-151-F
A3R19	0757-0381	5	RESISTOR 15 1% .125W F TC=0+-100	19701	MF4C1/8-T0-15R0-F
A3R20	0757-0421	1	RESISTOR 825 1% .125W F TC=0+-100	24546	C4-1/8-T0-825R-F
A3R21	0757-0438	2	RESISTOR 5.11K 1% .125W F TC=0+-100	24546	C4-1/8-T0-5111-F
A3R22	0757-0442	2	RESISTOR 10K 1% .125W F TC=0+-100	24546	C4-1/8-T0-1002-F
A3R23	0757-0280		RESISTOR 1K 1% .125W F TC=0+-100	24546	C4-1/8-T0-1001-F
A3R24	0757-0338	1	RESISTOR 1K 1% .25W F TC=0+-100	19701	MF52C-1
A3R25	0757-0407		RESISTOR 200 1% .125W F TC=0+-100	24546	C4-1/8-T0-201-F
A3R26	0757-0407		RESISTOR 200 1% .125W F TC=0+-100	24546	C4-1/8-T0-201-F
A3R27	0757-0407		RESISTOR 200 1% .125W F TC=0+-100	24546	C4-1/8-T0-201-F
A3R28	0761-0015	1	RESISTOR 1.5K 5% 1W MO TC=0+-200	11502	RG32
A3R29	0757-0440	2	RESISTOR 7.5K 1% .125W F TC=0+-100	24546	C4-1/8-T0-7501-F
A3R30	0698-3700	1	RESISTOR 715 1% .125W F TC=0+-100	24546	C4-1/8-T0-715R-F
A3R31	0757-0391		RESISTOR 39.2 1% .125W F TC=0+-100	24546	C4-1/8-T0-39R2-F
A3R32	0757-0283		RESISTOR 2K 1% .125W F TC=0+-100	24546	C4-1/8-T0-2001-F
A3R33	0757-0283		RESISTOR 2K 1% .125W F TC=0+-100	24546	C4-1/8-T0-2001-F
A3R34	0757-0469	3	RESISTOR 150K 1% .125W F TC=0+-100	24546	C4-1/8-T0-1503-F
A3R35	0757-0450	1	RESISTOR 22.1K 1% .125W F TC=0+-100	24546	C4-1/8-T0-2212-F
A3R36	0757-0469		RESISTOR 150K 1% .125W F TC=0+-100	24546	C4-1/8-T0-1503-F

See introduction to this section for ordering information

Replaceable Parts

Table 7-2. Replaceable Parts

Reference Designation	HP Part Number	Qty	Description	Mfr Code	Mfr Part Number
A3R37	0757-0410	2	RESISTOR 511 1% .125W F TC=0+-100	24546	C4-1/8-T0-511R-F
A3R38	0757-0401		RESISTOR 100 1% .125W F TC=0+-100	24546	C4-1/8-T0-101-F
A3R39	0757-0442		RESISTOR 10K 1% .125W F TC=0+-100	24546	C4-1/8-T0-1002-F
A3R40	0698-3137	1	RESISTOR 189.7 .25% .25W F TC=0+-100	24546	NA5
A3R41	0757-0804	1	RESISTOR 200 1% .5W F TC=0+-100	19701	MF7C-1/2-T0-201-F
A3R42	0757-1098	1	RESISTOR 945 1% .125W F TC=0+-100	24546	C4-1/8-T0-945R-F
A3R43	0698-4425	1	RESISTOR 1.54K 1% .125W F TC=0+-100	24546	C4-1/8-T0-1541-F
A3R44	0757-0198	2	RESISTOR 100 1% .5W F TC=0+-100	19701	MF7C1/2-T0-101-F
A3R45	0757-0198		RESISTOR 100 1% .5W F TC=0+-100	19701	MF7C1/2-T0-101-F
A3R46	0698-324E	1	RESISTOR 357 1% .125W F TC=0+-100	24546	C4-1/8-T0-357R-F
A3R47	0698-3492	1	RESISTOR 2.07K 1% .125W F TC=0+-100	24546	C4-1/8-T0-2671-F
A3R48	2100-3252	1	RESISTOR-TRMR 5K 10% C TOP-ADJ 1-TRM	73138	72-107-0
A3R49	0757-0444	1	RESISTOR 12.1K 1% .125W F TC=0+-100	24546	C4-1/8-T0-1212-F
A3R50	0757-0469		RESISTOR 150K 1% .125W F TC=0+-100	24546	C4-1/8-T0-1503-F
A3R51	0757-0453	2	RESISTOR 30.1K 1% .125W F TC=0+-100	24546	C4-1/8-T0-3012-F
A3R52	0757-0438		RESISTOR 5.11K 1% .125W F TC=0+-100	24546	C4-1/8-T0-5111-F
A3R53	0757-0401		RESISTOR 100 1% .125W F TC=0+-100	24546	C4-1/8-T0-101-F
A3R54	0757-0404	1	RESISTOR 130 1% .125W F TC=0+-100	24546	C4-1/8-T0-131-F
A3R55	0757-0346		RESISTOR 10 1% .125W F TC=0+-100	24546	C4-1/8-T0-10R0-F
A3R56	0698-3698	2	RESISTOR 47 5% 1W MO TC=0+-200	11502	RG32
A3R57	0761-0041	2	RESISTOR 56 5% 1W MO TC=0+-200	11502	RG32
A3R58	0757-0500	8	RESISTOR 30.1 1% .25W F TC=0+-100	19701	MF52C-1
A3R59	0757-0500		RESISTOR 30.1 1% .25W F TC=0+-100	19701	MF52C-1
A3R60	0757-0500		RESISTOR 30.1 1% .25W F TC=0+-100	19701	MF52C-1
A3R61	0757-0500		RESISTOR 30.1 1% .25W F TC=0+-100	19701	MF52C-1
A3R62	0683-0755	2	RESISTOR 7.5 5% .25W FC TC=-400/+500	01121	C875G5
A3R63	0761-0046	12	RESISTOR 110 5% 1W MO TC=0+-200	11502	RG32
A3R64	0761-0046		RESISTOR 110 5% 1W MO TC=0+-200	11502	RG32
A3R65	0757-0420	2	RESISTOR 750 1% .125W F TC=0+-100	24546	C4-1/8-T0-751-F
A3R66	0757-0435		RESISTOR 3.92K 1% .125W F TC=0+-100	24546	C4-1/8-T0-3921-F
A3R67	0698-3558	1	RESISTOR 4.02K 1% .125W F TC=0+-100	24546	C4-1/8-T0-4021-F
A3R68	0757-0399	2	RESISTOR 82.5 1% .125W F TC=0+-100	24546	C4-1/8-T0-82R5-F
A3R69	0698-5888	4	RESISTOR 31.6 1% .25W F TC=0+-100	27167	C5
A3R70	0698-5888		RESISTOR 31.6 1% .25W F TC=0+-100	27167	C5
A3R71	0757-0424	2	RESISTOR 1.1K 1% .125W F TC=0+-100	24546	C4-1/8-T0-1101-F
A3R72	2100-0554	3	RESISTOR-TRMR 500 10% C TOP-ADJ 1-TRM	73138	72-104-0
A3R73	0698-3496	2	RESISTOR 3.57K 1% .125W F TC=0+-100	24546	C4-1/8-T0-357R-F
A3R74	0698-4471	2	RESISTOR 7.15K 1% .125W F TC=0+-100	24546	C4-1/8-T0-7151-F
A3R75	0757-0416		RESISTOR 511 1% .125W F TC=0+-100	24546	C4-1/8-T0-511R-F
A3R76	0757-0453		RESISTOR 30.1K 1% .125W F TC=0+-100	24546	C4-1/8-T0-3012-F
A3R77	0757-0475	1	RESISTOR 274K 1% .125W F TC=0+-100	24546	C4-1/8-T0-2743-F
A3R78	0757-0422	1	RESISTOR 909 1% .125W F TC=0+-100	24546	C4-1/8-T0-909R-F
A3R79	0757-0415	1	RESISTOR 475 1% .125W F TC=0+-100	24546	C4-1/8-T0-475R-F
A3R80	0757-0401		RESISTOR 100 1% .125W F TC=0+-100	24546	C4-1/8-T0-101-F
A3R81	0757-0440		RESISTOR 7.5K 1% .125W F TC=0+-100	24546	C4-1/8-T0-7501-F
A3R82	0757-0429	1	RESISTOR 1.02K 1% .125W F TC=0+-100	24546	C4-1/8-T0-1021-F
A3R83	0757-0346		RESISTOR 10 1% .125W F TC=0+-100	24546	C4-1/8-T0-10R0-F
A3R84	0761-0041		RESISTOR 56 5% 1W MO TC=0+-200	11502	RG32
A3R85	0698-3698		RESISTOR 47 5% 1W MO TC=0+-200	11502	RG32
A3R86	0757-0500		RESISTOR 30.1 1% .25W F TC=0+-100	19701	MF52C-1
A3R87	0757-0500		RESISTOR 30.1 1% .25W F TC=0+-100	19701	MF52C-1
A3R88	0757-0500		RESISTOR 30.1 1% .25W F TC=0+-100	19701	MF52C-1
A3R89	0757-0500		RESISTOR 30.1 1% .25W F TC=0+-100	19701	MF52C-1
A3R90	0757-0399		RESISTOR 82.5 1% .125W F TC=0+-100	24546	C4-1/8-T0-82R5-F
A3R91	0683-0755		RESISTOR 7.5 5% .25W FC TC=-400/+500	01121	C875G5
A3R92	0757-0401		RESISTOR 100 1% .125W F TC=0+-100	24546	C4-1/8-T0-101-F
A3R93	0757-0420		RESISTOR 750 1% .125W F TC=0+-100	24546	C4-1/8-T0-751-F
A3R94	0757-0436	1	RESISTOR 4.32K 1% .125W F TC=0+-100	24546	C4-1/8-T0-4321-F
A3R95	2100-0554		RESISTOR-TRMR 500 10% C TOP-ADJ 1-TRM	73138	72-104-0
A3R96	0757-0435		RESISTOR 3.92K 1% .125W F TC=0+-100	24546	C4-1/8-T0-3921-F
A3R97	0698-5888		RESISTOR 31.6 1% .25W F TC=0+-100	27167	C5
A3R98	0698-5888		RESISTOR 31.6 1% .25W F TC=0+-100	27167	C5
A3R99	0757-0424		RESISTOR 1.1K 1% .125W F TC=0+-100	24546	C4-1/8-T0-1101-F
A3R100	2100-0554		RESISTOR-TRMR 500 10% C TOP-ADJ 1-TRM	73138	72-104-0
A3R101	0698-4471		RESISTOR 7.15K 1% .125W F TC=0+-100	24546	C4-1/8-T0-7151-F
A3R102	0757-0401		RESISTOR 100 1% .125W F TC=0+-100	24546	C4-1/8-T0-101-F
A3R103	0761-0046		RESISTOR 110 5% 1W MO TC=0+-200	11502	RG32
A3R104	0761-0046		RESISTOR 110 5% 1W MO TC=0+-200	11502	RG32
A3R105	0698-3496		RESISTOR 3.57K 1% .125W F TC=0+-100	24546	C4-1/8-T0-357R-F
A3R106	0757-0381		RESISTOR 15 1% .125W F TC=0+-100	19701	MF4C1/8-T0-15R0-F
A3R107	0757-0381		RESISTOR 15 1% .125W F TC=0+-100	19701	MF4C1/8-T0-15R0-F
A3R108	0761-0046		RESISTOR 110 5% 1W MO TC=0+-200	11502	RG32
A3R109	0761-0046		RESISTOR 110 5% 1W MO TC=0+-200	11502	RG32
A3R110	0761-0046		RESISTOR 110 5% 1W MO TC=0+-200	11502	RG32
A3R111	0761-0046		RESISTOR 110 5% 1W MO TC=0+-200	11502	RG32

Table 7-2. Replaceable Parts

Reference Designation	HP Part Number	Qty	Description	Mfr Code	Mfr Part Number
A3R112	0761-0046		RESISTOR 110 5% 1W MO TC=0+-200	11502	RG32
A3R113	0761-0046		RESISTOR 110 5% 1W MO TC=0+-200	11502	RG32
A3R114	0761-0046		RESISTOR 110 5% 1W MO TC=0+-200	11502	RG32
A3R115	0761-0046		RESISTOR 110 5% 1W MO TC=0+-200	11502	RG32
A3R118	0757-0381		RESISTOR 15 1% .125W F TC=0+-100	19701	MF4C1/8-T0-15R0-F
A3R119	0757-0301		RESISTOR 15 1% .125W F TC=0+-100	19701	MF4C1/8-T0-15R0-F
A3R120	0757-0346		RESISTOR 10 1% .125W F TC=0+-100	24546	C4-1/8-T0-10R0-F
A3R121	0757-0346		RESISTOR 10 1% .125W F TC=0+-100	24546	C4-1/8-T0-10R0-F
A3R122	0757-0394		RESISTOR 51.1 1% .125W F TC=0+-100	24546	C4-1/8-T0-51R1-F
A3R123	0698-3693	1	RESISTOR 30 5% 1W MO TC=0+-200	11502	RG32
A3R124	0758-0016	1	RESISTOR 300 5% .25W F TC=0+-100	27167	C5
A3R125	0757-0401		RESISTOR 100 1% .125W F TC=0+-100	24546	C4-1/8-T0-101-F
A3U1	1820-0065	1	IC-DIGITAL SN7470N TTL J-K	01295	SN7470N
A3VR1	1902-0041	3	DIODE-ZNR 5.11V 5% DO-7 PD=.4W TC=-.009%	15818	CD 35622
A3VR3	1902-0184	1	DIODE-ZNR 16.2V 5% DO-7 PD=.4W TC=+.066%	04713	SZ 10939-242
A3VR5	1902-3182	2	DIODE-ZNR 12.1V 5% DO-7 PD=.4W TC=+.064%	28480	1902-3182
A3VR6	1902-3182		DIODE-ZNR 12.1V 5% DO-7 PD=.4W TC=+.064%	28480	1902-3182
A3VR7	1902-3139	2	DIODE-ZNR 8.25V 5% DO-7 PD=.4W TC=+.053%	04713	SZ 10939-158
A3VR8	1902-0064	1	DIODE-ZNR 7.5V 5% DO-7 PD=.4W TC=+.05%	28480	1902-0064
A3VR9	1902-0041		DIODE-ZNR 5.11V 5% DO-7 PD=.4W TC=-.009%	15818	CD 35622
A3VR12	1902-0040	2	DIODE-ZNR 14V 5% DO-7 PD=.4W TC=+.056%	07263	F2 1201
A3VR13	1902-C040		DIODE-ZNR 14V 5% DO-7 PD=.4W TC=+.056%	07263	F2 1201
A3VR16	1902-0173	2	DIODE-ZNR 9.53V 5% DO-7 PD=.4W TC=+.059%	04713	SZ 10939-176
A3VR17	1902-0555	1	DIODE-ZNR 13V 5% DO-15 PD=1W TC=+.06%	28480	1902-0555
A3VR18	1902-0041		DIODE-ZNR 5.11V 5% DO-7 PD=.4W TC=-.009%	15818	CD 35622
A3VR19	1902-3104	1	DIODE-ZNR 5.62V 5% DO-7 PD=.4W TC=+.016%	15818	CD 35634
A3VR26	1902-0556	1	DIODE-ZNR 20V 5% DO-15 PD=1W TC=+.073%	28480	1902-0556
A3VR27	1902-0031	1	DIODE-ZNR 12.7V 5% DO-7 PD=.4W TC=+.061%	04713	SZ10939-212
A3VR28	1902-3140	1	DIODE-ZNR 8.25V 2% DO-7 PD=.4W TC=+.053%	04713	SZ 10939-159
A3VR34	1902-0173		DIODE-ZNR 9.53V 5% DO-7 PD=.4W TC=+.059%	04713	SZ 10939-176
A3VR35	1902-3139		DIODE-ZNR 8.25V 5% DO-7 PD=.4W TC=+.053%	04713	SZ 10939-158

See introduction to this section for ordering information

Table 7-2. Replaceable Parts

Reference Designation	HP Part Number	Qty	Description	Mfr Code	Mfr Part Number
A4	08005-66511		BOARD ASSEMBLY, INTG	28480	08005-66511
A4C1	0160-3456	4	CAPACITOR-FXD 1000PF +-10% 1000WVDC CER	28480	0160-3456
A4C3	0140-0196	1	CAPACITOR-FXD 150PF +-5% 300WVDC MICA	72136	DM15F151J0300WV1CP
A4C5	0160-2055	6	CAPACITOR-FXD .01UF +80-20% 100WVDC CER	28480	0160-2055
A4C6	0160-4213	2	CAPACITOR-FXD .1UF +-20% 50WVDC POLYE	28480	0160-4213
A4C7	0160-3456		CAPACITOR-FXD 1000PF +-10% 1000WVDC CER	28480	0160-3456
A4C8	0160-0134	3	CAPACITOR-FXD 220PF +-5% 300WVDC MICA	28480	0160-0134
A4C9	0160-2055		CAPACITOR-FXD .01UF +80-20% 100WVDC CER	28480	0160-2055
A4C10	0160-2055		CAPACITOR-FXD .01UF +80-20% 100WVDC CER	28480	0160-2055
A4C11	0160-4213		CAPACITOR-FXD .1UF +-20% 50WVDC POLYE	28480	0160-4213
A4C12	0160-3456		CAPACITOR-FXD 1000PF +-10% 1000WVDC CER	28480	0160-3456
A4C13	0160-0134		CAPACITOR-FXD 220PF +-5% 300WVDC MICA	28480	0160-0134
A4C14	0160-2055		CAPACITOR-FXD .01UF +80-20% 100WVDC CER	28480	0160-2055
A4C15	0160-0134		CAPACITOR-FXD 220PF +-5% 300WVDC MICA	28480	0160-0134
A4C16	0180-0291	1	CAPACITOR-FXD .1UF +-10% 35VDC TA	56289	150D105X9035A2
A4C17	0160-2055		CAPACITOR-FXD .01UF +80-20% 100WVDC CER	28480	0160-2055
A4C18	0160-2197	1	CAPACITOR-FXD 10PF +-5% 300WVDC MICA	28480	0160-2197
A4C19	0160-2212	1	CAPACITOR-FXD 560PF +-5% 300WVDC MICA	28480	0160-2212
A4C20	0160-3716	1	CAPACITOR-FXD .022UF +-10% 250WVDC MET	28480	0160-3716
A4C21	0160-3725	1	CAPACITOR-FXD .47UF +-10% 35VDC TA	56289	150D474X9035A2
A4C22	0160-3725	1	CAPACITOR-FXD .68UF +-10% 40WVDC MET	28480	0160-3725
A4C23	0180-0228	1	CAPACITOR-FXD 22UF +-10% 15VDC TA	56289	150D226X901502
A4C24	0180-0159	2	CAPACITOR-FXD 220UF +-20% 10VDC TA	56289	150D227X901032
A4C25	0180-0159		CAPACITOR-FXD 220UF +-20% 10VDC TA	56289	150D227X001032
A4C26	0160-2055		CAPACITOR-FXD .01UF +80-20% 100WVDC CER	28480	0160-2055
A4C27	0160-3456		CAPACITOR-FXD 1000PF +-10% 1000WVDC CER	28480	0160-3456
A4CR3	1901-0179	4	DIODE-SWITCHING 15V 50MA 750PS DO-7	28480	1901-0179
A4CR4	1901-0179		DIODE-SWITCHING 15V 50MA 750PS DO-7	28480	1901-0179
A4CR6	1901-0044	3	DIODE-SWITCHING 50V 50MA 6NS	28480	1901-0044
A4CR8	1901-0179		DIODE-SWITCHING 15V 50MA 750PS DO-7	28480	1901-0179
A4CR9	1901-0179		DIODE-SWITCHING 15V 50MA 750PS DO-7	28480	1901-0179
A4CR11	1901-0044		DIODE-SWITCHING 50V 50MA 6NS	28480	1901-0044
A4CR12	1901-0044		DIODE-SWITCHING 50V 50MA 6NS	28480	1901-0044
A4L1	9100-1613	1	COIL-MLD 470NH 20% Q=45 .155DX.375LG	24226	15/470
A4L5	9170-0029	2	CORE-SHIELDING BEAD	02114	56-590-65A2/4A
A4L6	9170-0029		CORE-SHIELDING BEAD	02114	56-590-65A2/4A
A4MP17	1205-0011	2	HEAT SINK TO-5/TO-39-PKG	28480	1205-0011
A4MP20	1205-0011		HEAT SINK TO-5/TO-39-PKG	28480	1205-0011
A4Q1	1853-0357	5	TRANSISTOR PNP SI TO-18 PD=360MW	28480	1853-0357
A4Q2	1853-0357		TRANSISTOR PNP SI TO-18 PD=360MW	28480	1853-0357
A4Q3	1854-0092	1	TRANSISTOR NPN SI PD=200MW FT=600MHZ	28480	1854-0092
A4Q4	1954-0019	1	TRANSISTOR PNP SI TO-18 PD=360MW	28480	1954-0019
A4Q6	1853-0357		TRANSISTOR PNP SI TO-18 PD=360MW	28480	1853-0357
	1205-0037	1	HEAT SINK TO-36-PKG	28480	1205-0037
A4Q7	1854-0233	1	TRANSISTOR NPN 2N3866 SI TO-39 PD=1W	02735	2N3866
A4Q8	1853-0357		TRANSISTOR PNP SI TO-18 PD=360MW	28480	1853-0357
A4Q9	1853-0357		TRANSISTOR PNP SI TO-18 PD=360MW	28480	1853-0357
A4Q10	1854-0307	3	TRANSISTOR NPN SI TO-18 PD=300MW	28480	1854-0307
A4Q11	1853-0001	2	TRANSISTOR PNP SI TO-39 PD=600MW	28480	1853-0001
A4Q12	1854-0039	1	TRANSISTOR NPN 2N3053 SI TO-5 PD=1W	04713	2N3053
A4Q13	1853-0090	2	TSTR:SI PNP	28480	1853-0090
A4Q14	1854-0329	1	TSTR:SI NPN	28480	1854-0329
A4Q15	1853-0090		TSTR:SI PNP	28480	1853-0090
A4Q16	1854-0053	1	TRANSISTOR NPN 2N2218 SI TO-5 PD=800MW	04713	2N2218
A4Q17	1853-0051	1	TRANSISTOR PNP 2N4037 SI TO-5 PD=1W	02735	2N4037
A4Q18	1854-0307		TRANSISTOR NPN SI TO-18 PD=300MW	28480	1854-0307
A4Q19	1854-0307		TRANSISTOR NPN SI TO-18 PD=300MW	28480	1854-0307
A4Q20	1853-0001		TRANSISTOR PNP SI TO-39 PD=600MW	28480	1853-0001
A4R2	0698-0083	1	RESISTOR 1.96K 1% .125W F TC=0+-100	24546	C4-1/8-TO-1961-F
A4R3	0758-0014	1	RESISTOR 180 5% .25W F TC=0+-100	27167	C5
A4R4	0757-0284	1	RESISTOR 150 1% .125W F TC=0+-100	24546	C4-1/8-TO-151-F
A4R5	0757-0718	1	RESISTOR 200 1% .25W F TC=0+-100	19701	MF52C-1
A4R6	0698-0085	1	RESISTOR 2.61K 1% .125W F TC=0+-100	24546	C4-1/8-TO-2611-F
A4R7	0757-0734	1	RESISTOR 1.21K 1% .25W F TC=0+-100	19701	MF52C-1
A4R8	0757-0726	1	RESISTOR 511 1% .25W F TC=0+-100	19701	MF52C-1
A4R10	0757-0385	2	RESISTOR 22.1 1% .125W F TC=0+-100	19701	MF4C1/8-TO-22R1-F
A4R11	0757-0741	1	RESISTOR 2.43K 1% .25W F TC=0+-100	19701	MF52C-1
A4R12	0757-0819	1	RESISTOR 909 1% .5W F TC=0+-100	19701	MF7C1/2-TO-909R-F
A4R13	0757-0401	1	RESISTOR 100 1% .125W F TC=0+-100	24546	C4-1/8-TO-101-F
A4R15	0757-0427	2	RESISTOR 1.5K 1% .125W F TC=0+-100	24546	C4-1/8-TO-1501-F
A4R16	0757-0276	1	RESISTOR 61.9 1% .125W F TC=0+-100	24546	C4-1/8-TO-6192-F
A4R17	0757-0385		RESISTOR 22.1 1% .125W F TC=0+-100	19701	MF4C1/8-TO-22R1-F
A4R18	0683-0515	3	RESISTOR 5.1 5% .25W FC TC=-400/+500	01121	CB5165

See introduction to this section for ordering information

Table 7-2. Replaceable Parts

Reference Designation	HP Part Number	Qty	Description	Mfr Code	Mfr Part Number
A4R19	0683-0515		RESISTOR 5.1 5% .25W FC TC=-400/+500	01121	C851G5
A4R20	0683-0515		RESISTOR 5.1 5% .25W FC TC=-400/+500	01121	C851G5
A4R21	0698-0084	2	RESISTOR 2.15K 1% .125W F TC=0+-100	24546	C4-1/8-T0-2151-F
A4R22	0757-0280	2	RESISTOR 1K 1% .125W F TC=0+-100	24546	C4-1/8-T0-1001-F
A4R23	0757-0440	2	RESISTOR 7.5K 1% .125W F TC=0+-100	24546	C4-1/8-T0-7501-F
A4R24	0698-3496	2	RESISTOR 3.57K 1% .125W F TC=0+-100	24546	C4-1/8-T0-357R-F
A4R25	0761-0049	1	RESISTOR 200 5% 1W MO TC=0+-200	11502	RG32
A4R26	0757-0797	2	RESISTOR 90.9 1% .5W F TC=0+-100	19701	MF7C-1/2-T0-909R-F
A4R27	0757-0438	1	RESISTOR 5.11K 1% .125W F TC=0+-100	24546	C4-1/8-T0-5111-F
A4R28	0698-3242	3	RESISTOR 357 1% .125W F TC=0+-100	24546	C4-1/8-T0-357R-F
A4R29	0757-0283	1	RESISTOR 2K 1% .125W F TC=0+-100	24546	C4-1/8-T0-2001-F
A4R30	0757-0439	1	RESISTOR 6.81K 1% .125W F TC=0+-100	24546	C4-1/8-T0-6811-F
A4R31	2100-0554	3	RESISTOR-TRMR 500 10% C TOP-ADJ 1-TRN	73138	72-104-0
A4R32	0757-0427		RESISTOR 1.5K 1% .125W F TC=0+-100	24546	C4-1/8-T0-1501-F
A4R33	0757-0440		RESISTOR 7.5K 1% .125W F TC=0+-100	24546	C4-1/8-T0-7501-F
A4R34	0698-0084		RESISTOR 2.15K 1% .125W F TC=0+-100	24546	C4-1/8-T0-2151-F
A4R35	0757-0280		RESISTOR 1K 1% .125W F TC=0+-100	24546	C4-1/8-T0-1001-F
A4R36	0698-3496		RESISTOR 3.57K 1% .125W F TC=0+-100	24546	C4-1/8-T0-357R-F
A4R37	0758-0126	1	RESISTOR 51 5% .25W F TC=0+-100	27167	C5
A4R38	0757-0797		RESISTOR 90.9 1% .5W F TC=0+-100	19701	MF7C-1/2-T0-909R-F
A4R39	0698-3242		RESISTOR 357 1% .125W F TC=0+-100	24546	C4-1/8-T0-357R-F
A4R40	0757-0273	1	RESISTOR 3.01K 1% .125W F TC=0+-100	24546	C4-1/8-T0-3011-F
A4R41	2100-0554		RESISTOR-TRMR 500 10% C TOP-ADJ 1-TRN	73138	72-104-0
A4R42	0698-3492	1	RESISTOR 2.67K 1% .125W F TC=0+-100	24546	C4-1/8-T0-2671-F
A4R43	0757-0422	1	RESISTOR 909 1% .125W F TC=0+-100	24546	C4-1/8-T0-909R-F
A4R44	0761-0014	2	RESISTOR 180 5% 1W MO TC=0+-200	11502	RG32
A4R45	0757-0431	2	RESISTOR 2.43K 1% .125W F TC=0+-100	24546	C4-1/8-T0-2431-F
A4R46	2100-0554		RESISTOR-TRMR 500 10% C TOP-ADJ 1-TRN	73138	72-104-0
A4R47	0757-0431		RESISTOR 2.43K 1% .125W F TC=0+-100	24546	C4-1/8-T0-2431-F
A4R48	0757-0436	1	RESISTOR 4.32K 1% .125W F TC=0+-100	24546	C4-1/8-T0-4321-F
A4R49	0698-3242		RESISTOR 357 1% .125W F TC=0+-100	24546	C4-1/8-T0-357R-F
A4R50	0761-0014		RESISTOR 180 5% 1W MO TC=0+-200	11502	RG32
A4VR1	1902-3149	1	DIODE-ZNR 9.09V 5% DO-7 PD=.4W TC=+.057%	04713	SZ 10939-170
A4VR2	1902-3223	1	DIODE-ZNR 17.4V 2% DO-7 PD=.4W TC=+.068%	04713	SZ 10939-252
A4VR5	1902-3288	1	DIODE-ZNR 30.9V 2% DO-7 PD=.4W TC=+.075%	28480	1902-3288
A4VR7	1902-3205	1	DIODE-ZNR 15V 5% DO-7 PD=.4W TC=+.057%	04713	SZ 10939-233
A4VR10	1902-3092	1	DIODE-ZNR 4.99V 2% DO-7 PD=.4W TC=-.012%	04713	SZ 10939-96

See introduction to this section for ordering information

Table 7-2. Replaceable Parts

Reference Designation	HP Part Number	Qty	Description	Mfr Code	Mfr Part Number
A5	09005-66512		BGARD ASSEMBLY, POWER SUPPLY	28480	09005-66512
ASC1	0160-0050	2	CAPACITOR-FXD 40UF+75-10% 50VDC AL	56289	30D406G0500D2
ASC2	0160-2146	2	CAPACITOR-FXD .02UF +80-20% 100WVDC CER	28480	0160-2146
ASC3	0160-2228	2	CAPACITOR-FXD 22UF+10% 15VDC TA	56289	150D226X901582
ASC4	0160-0050		CAPACITOR-FXD 40UF+75-10% 50VDC AL	56289	30D406G0500D2
ASC5	0160-2146		CAPACITOR-FXD .02UF +80-20% 100WVDC CER	28480	0160-2146
ASC6	0160-0228		CAPACITOR-FXD 22UF+10% 15VDC TA	56289	150D226X901582
ASC7	0160-4211	2	CAPACITOR-FXD .047UF +-20% 50WVDC POLYE	28480	0160-4211
ASC8	0160-4211		CAPACITOR-FXD .047UF +-20% 50WVDC POLYE	28480	0160-4211
ASCR1	1901-0522	8	DIODE-GEN PRP 200V 3A 2US	28480	1901-0522
ASCR2	1901-0522		DIODE-GEN PRP 200V 3A 2US	28480	1901-0522
ASCR3	1901-0522		DIODE-GEN PRP 200V 3A 2US	28480	1901-0522
ASCR4	1901-0522		DIODE-GEN PRP 200V 3A 2US	28480	1901-0522
ASCR7	1901-0522		DIODE-GEN PRP 200V 3A 2US	28480	1901-0522
ASCR8	1901-0522		DIODE-GEN PRP 200V 3A 2US	28480	1901-0522
ASCR9	1901-0522		DIODE-GEN PRP 200V 3A 2US	28480	1901-0522
ASCR10	1901-0522		DIODE-GEN PRP 200V 3A 2US	28480	1901-0522
ASQ1	1854-0039	2	TRANSISTOR NPN 2N3053 SI TO-5 PD=1W	04713	2N3053
ASQ2	1854-0329	4	TSTRISI NPN	28480	1854-0329
ASQ3	1854-0039		TRANSISTOR NPN 2N3053 SI TO-5 PD=1W	04713	2N3053
ASQ4	1854-0329		TSTRISI NPN	28480	1854-0329
ASQ5	1854-0329		TSTRISI NPN	28480	1854-0329
ASQ6	1854-0329		TSTRISI NPN	28480	1854-0329
ASR1	0757-0280	5	RESISTOR 1K 1% .125W F TC=0+-100	24546	C4-1/8-T0-1001-F
ASR2	0757-0433	2	RESISTOR 3.32K 1% .125W F TC=0+-100	24546	C4-1/8-T0-3321-F
ASR3	0811-0929	1	RESISTOR .51 5% 2W PW TC=0+-800	75042	BWH2-R51-J
ASR4	0757-0442	2	RESISTOR 10K 1% .125W F TC=0+-100	24546	C4-1/8-T0-1002-F
ASR5	0757-0738	2	RESISTOR 1.82K 1% .25W F TC=0+-100	19701	MF52C-1
ASR6	0757-0283	2	RESISTOR 2K 1% .125W F TC=0+-100	24546	C4-1/8-T0-2001-F
ASR7	0757-0429	2	RESISTOR 1.82K 1% .125W F TC=0+-100	24546	C4-1/8-T0-1821-F
ASR8	2100-0554	2	RESISTOR-TRMR 500 10% C TOP=ADJ 1-TRN	73138	72-104-0
ASR9	0757-0280		RESISTOR 1K 1% .125W F TC=0+-100	24546	C4-1/8-T0-1001-F
ASR10	0757-0280		RESISTOR 1K 1% .125W F TC=0+-100	24546	C4-1/8-T0-1001-F
ASR11	0757-0433		RESISTOR 3.32K 1% .125W F TC=0+-100	24546	C4-1/8-T0-3321-F
ASR12	0811-1746	1	RESISTOR .36 5% 2W PW TC=0+-800	75042	BWH2-36/100-J
ASR13	0757-0442		RESISTOR 10K 1% .125W F TC=0+-100	24546	C4-1/8-T0-1002-F
ASR14	0757-0738		RESISTOR 1.82K 1% .25W F TC=0+-100	19701	MF52C-1
ASR15	0757-0283		RESISTOR 2K 1% .125W F TC=0+-100	24546	C4-1/8-T0-2001-F
ASR16	0757-0429		RESISTOR 1.82K 1% .125W F TC=0+-100	24546	C4-1/8-T0-1821-F
ASR17	2100-0554		RESISTOR-TRMR 500 10% C TOP=ADJ 1-TRN	73138	72-104-0
ASR18	0757-0280		RESISTOR 1K 1% .125W F TC=0+-100	24546	C4-1/8-T0-1001-F
ASR19	0757-0280		RESISTOR 1K 1% .125W F TC=0+-100	24546	C4-1/8-T0-1001-F
ASVR5	1902-0041	2	DIODE-ZNR 5.11V 5% DO-7 PD=.4W TC=-.009%	15818	CD 35622
ASVR6	1902-3149	2	DIODE-ZNR 9.09V 5% DO-7 PD=.4W TC=+.057%	04713	SZ 10939-170
ASVR11	1902-0041		DIODE-ZNR 5.11V 5% DO-7 PD=.4W TC=-.009%	15818	CD 35622
ASVR12	1902-3149		DIODE-ZNR 9.09V 5% DO-7 PD=.4W TC=+.057%	04713	SZ 10939-170

Table 7-2. Replaceable Parts

Reference Designation	HP Part Number	Qty	Description	Mfr Code	Mfr Part Number
A8	08005-61901		SWITCH ASSEMBLY, RATE	28480	08005-61901
ABR1	2100-2684	1	RESISTOR-VAR CONTROL CC 100K 10% 10CCW	01121	J
AB51	3100-0511	1		28480	3100-0511

See introduction to this section for ordering information

Table 7-2. Replaceable Parts

Reference Designation	HP Part Number	Qty	Description	Mfr Code	Mfr Part Number
A9	08005-61902		SWITCH ASSEMBLY, WIDTH	28480	08005-61902
A9R1	0757-0365	1	RESISTOR 22.1 1% .125W F TC=0+-100	19701	MF4C1/8-T0-22R1-F
A9R2	2100-2683	1	RESISTOR-VAR CONTROL CC 100K 10% 10CW	01121	J
A9R3	0757-0427	1	RESISTOR 1.5K 1% .125W F TC=0+-100	24546	C4-1/8-T0-1501-F
A9S1	3100-0512	1		28480	3100-0512

See introduction to this section for ordering information

Table 7-2. Replaceable Parts

Reference Designation	HP Part Number	Qty	Description	Mfr Code	Mfr Part Number
A10	08005-61903		SWITCH ASSEMBLY, DELAY	28480	08005-61903
A10P1	0757-0385	1	RESISTOR 22.1 1% .125W F TC=0+-100	19701	MF4C1/8-T0-22R1-F
A10R2	0757-0274	1	RESISTOR 1.21K 1% .125W F TC=0+-100	24546	C4-1/8-T0-1213-F
A10R	2100-2683	1	RESISTOR-VAR CONTROL CC 100K 10% 10CW	01121	J
A10S1	3100-0512	1		28480	3100-0512

See introduction to this section for ordering information

Table 7-3. Manufacturer's Code Numbers

MANUFACTURERS			
8005	CODE LIST	AS OF	01/13/77
			PAGE
MFR NO.	MANUFACTURER NAME	ADDRESS	ZIP CODE
00000	NO M/F DESCRIPTION FOR THIS MFG NUMBER		
0007K	KABELMETAL		
00863	STETTNER-TRUSH INC	CAZENOVIA NY	13835
01121	ALLEN-BRADLEY CO	MILWAUKEE WI	53212
01295	TEXAS INSTR INC SEMICOND CMPNT DIV	DALLAS TX	75231
02114	FERROXCUBE CORP	SAUGERTIES NY	12477
02735	RCA CORP SOLID STATE DIV	SOMMERSVILLE NJ	08876
04713	MOTOROLA SEMICONDUCTOR PRODUCTS	PHOENIX AZ	85008
07263	FAIRCHILD SEMICONDUCTOR DIV	MOUNTAIN VIEW CA	94040
11502	TRW INC BOONE DIV	BOONE NC	28607
15818	TELEDYNE SEMICONDUCTOR	MOUNTAIN VIEW CA	94040
19701	MEPCO/ELECTRA CORP	MINERAL WELLS TX	76067
24226	GOWANDA ELECTRONICS CORP	GOWANDA NY	14070
24546	CORNING GLASS WORKS (BRADFORD)	BRADFORD PA	16701
24931	SPECIALTY CONNECTOR CO INC	INDIANAPOLIS IN	46227
27167	CORNING GLASS WORKS (WILMINGTON)	WILMINGTON NC	28401
28480	HEWLETT-PACKARD CO CORPORATE HQ	PALO ALTO CA	94304
56289	SPRAGUE ELECTRIC CO	NORTH ADAMS MA	01247
71400	BUSSMAN MFG DIV OF MCGRAW-EDISON CO	ST LOUIS MO	63017
72136	ELECTRO MOTIVE CORP SUB IEC	WILLIMANTIC CT	06226
73138	BECKMAN INSTRUMENTS INC HELIPOT DIV	FULLERTON CA	92634
74276	SIGNALITE INC	NEPTUNE NJ	07753
75042	TRW INC PHILADELPHIA DIV	PHILADELPHIA PA	19108
75915	LITTELFUSE INC	DES PLAINES IL	60016
76530	TRW ELEK CMPNT CINCH-MONADNOCK DIV	CITY OF INDUSTRY CA	91747
78189	ILLINOIS TOOL WORKS INC SHAKEPROOF	ELGIN IL	60126
79727	C-W INDUSTRIES	HARMINSTER PA	18978
82389	SWITCHCRAFT INC	CHICAGO IL	60630
91637	DALE ELECTRONICS INC	COLUMBUS NE	68601
98291	SEAELECTRO CORP	HAMARONECK NY	10544
99800	AMER PRCN IND INC DELEVAN DIV	AURORA NY	14052

SERVICE INFO

SECTION VIII SERVICE

8-1 INTRODUCTION

8-2 This section contains the component layouts and schematic diagrams for the Model. Tables listing the reference designators and schematic symbols used are also given. Refer to Section 6 for the replaceable parts information.

8-3 RECOMMENDED TEST EQUIPMENT

8-4 Test equipment and test equipment accessories required to maintain the Model 1223A are listed in table 1-1. Equipment other than that listed can be used if it meets the listed critical specifications.

Table 8-1. Reference Designators

A	= assembly	U	= micro-circuit
B	= motor	P	= plug
BT	= battery	Q	= transistor
C	= capacitor	R	= resistor
CP	= coupler	RT	= thermistor
CR	= diode	S	= switch
DL	= delay line	T	= transformer
DS	= lamp	TB	= terminal board
F	= fuse	V	= vacuum, tube, neon bulb, photocell, etc.
FL	= filter	VR	= voltage regulator
HR	= heater	W	= cable
J	= jack	X	= socket
K	= relay	Y	= crystal
L	= inductor	TP	= test point
M	= meter		

Table 8-2. Schematic Diagram Notes (1 of 2)











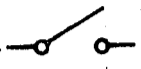
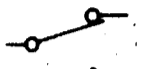
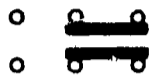

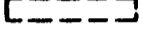
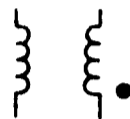











General		Components	
Units	Resistance values are in ohms, capacitance values in microfarads and inductance values in microhenries unless otherwise noted!		Normally open toggle switch. Circles (○) are used for the contacts to indicate a locking type switch.
P/O	Part of		Spring return, 2-position transfer switch. Triangles (▲) are used for the contacts to indicate a non-locking type switch.
*	Asterisk denotes a factory selected value. The value shown is the nominal value.		2-position, 2-pole slide switch.
	Encloses front panel nomenclature		Air cored inductor.
	Encloses rear panel nomenclature		Air cored transformer. The dot (●) is used, when necessary, to indicate instantaneous polarity.
	Heavy line indicates signal path		Iron core
	Heavy dashed line indicates primary feedback path		Ferrite core
<u>947</u>	Wire colour code. Same as resistor colour code. First number is wire body colour.		Ferrite bead
	Wire or plug used as link.		Varactor diode
	Test point in a circuit. Point may/may not be identified on P. C. board.		Multi-junction diode
	Used with trimmer potentiometers or capacitors to indicate screwdriver adjustment.		Diode
	Direct connection to earth.		Zener diode
	Ground connection to instrument chassis or frame.		Schottky diode
	Used when a number of common-return connections are at the same potential. If there is more than one such system in the same circuit, numbers are written in the triangles so that all connections with the same potential have the same number.		Light Emitting Diode (LED)
	Specific potential difference with respect to a potential reference level, eg. +10V		Photodiode
			Fuse
			Neon
			Filament lamp
Schematic Referencing			
			
<p>These references on a signal leaving a schematic diagram indicate the signal destination. The circle contains the signal number and the square contains the number of the schematic to which that signal goes.</p>		<p>These references on a signal entering a schematic diagram indicate the signal origin. The circle contains the signal number and the square contains the number of the schematic on which that signal originates.</p>	

Table 8-3. Schematic Diagram Notes (2 of 2)



A1 BD AY TIMING 08005-66513

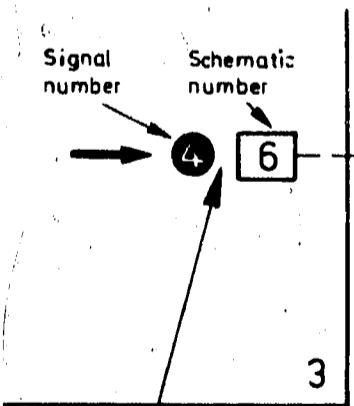
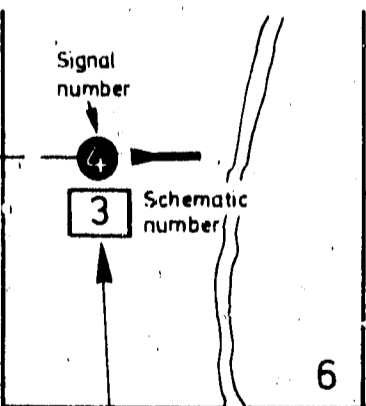
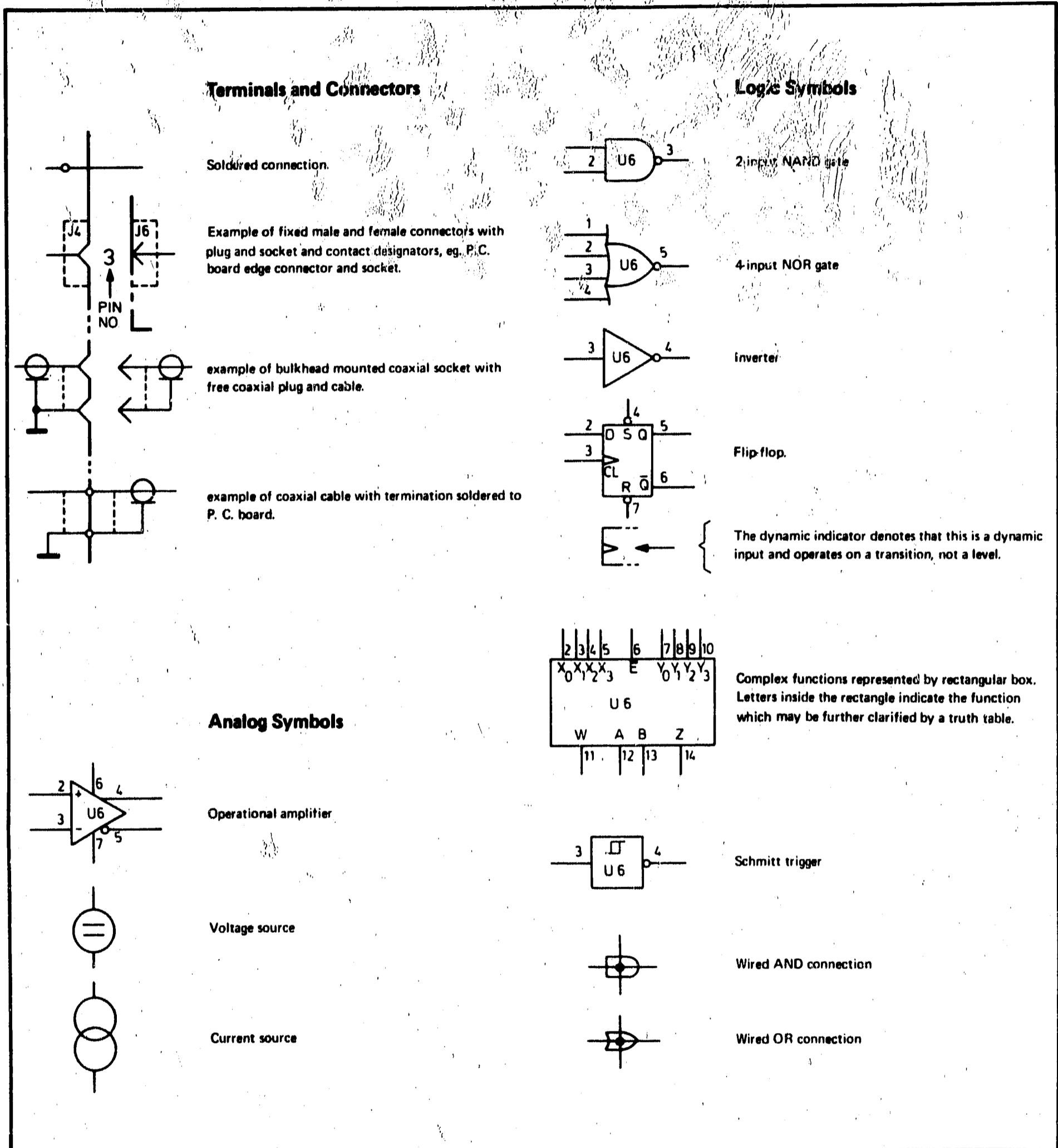
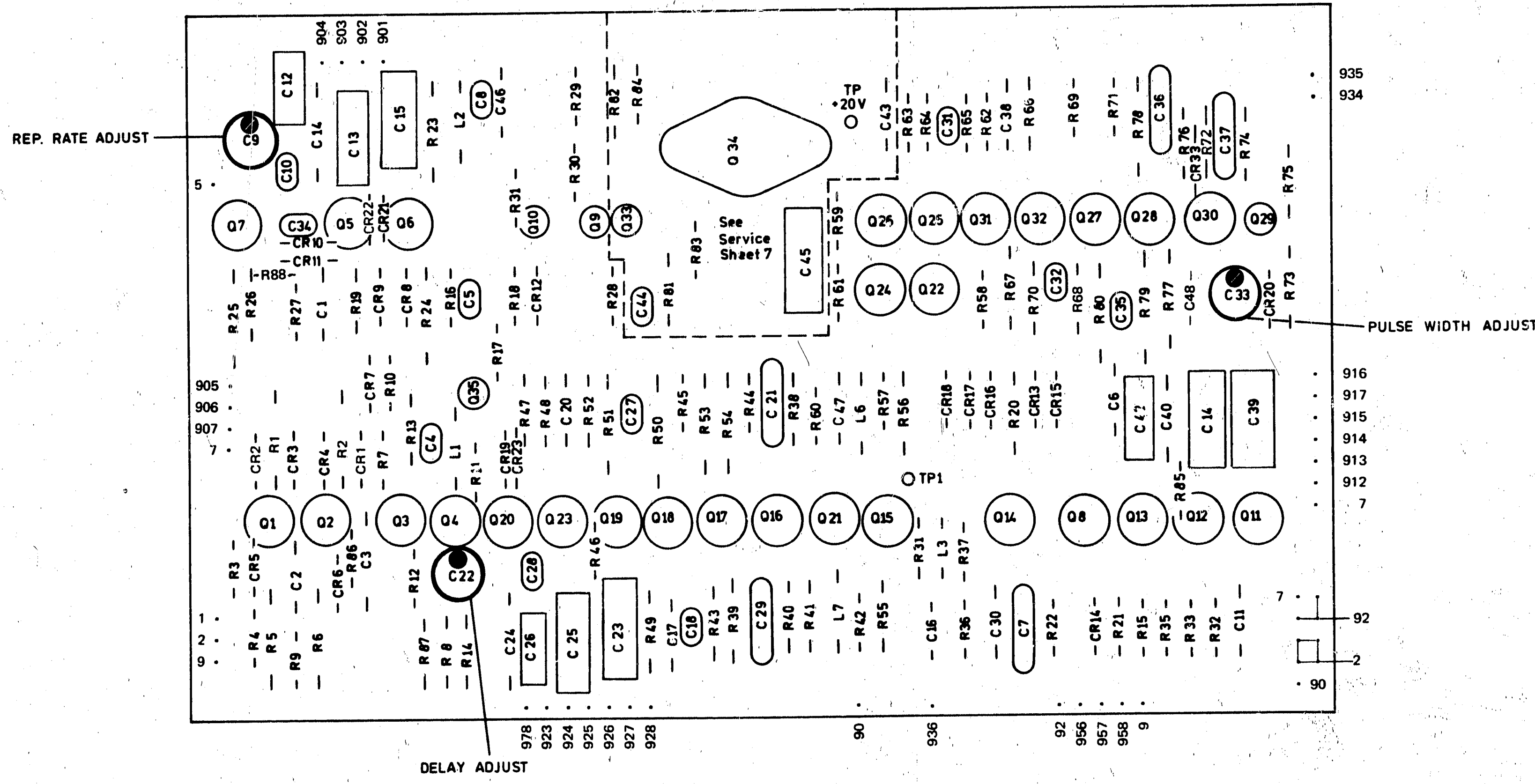

A3 BD AY AMP OUTPUT 08005-66510

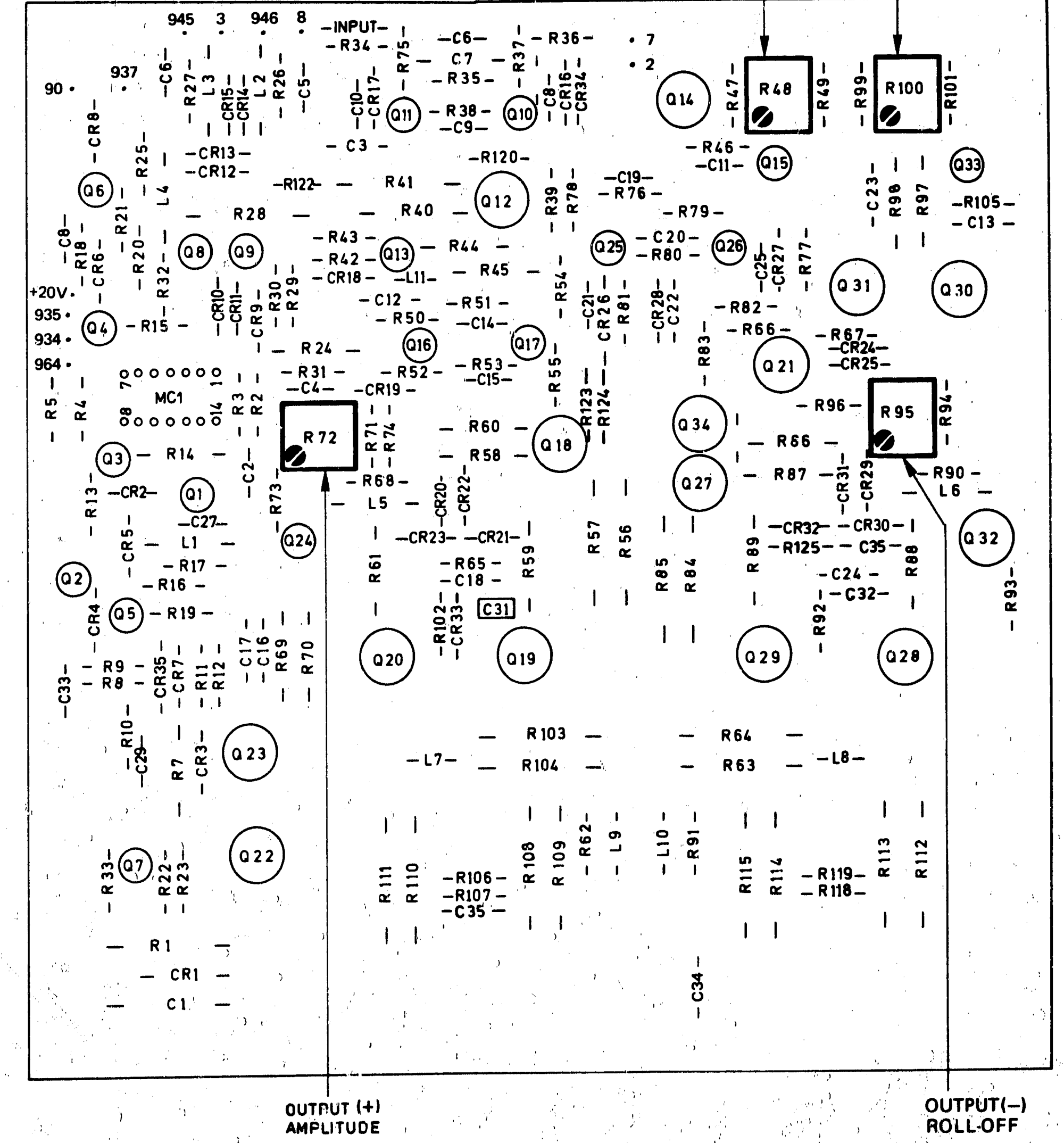

Model 8005B

EXT INPUT
0.5V/cm
1μs/cm

Q1b
0.5V/cm
1μs/cm

Q35C
2V/cm
1μs/cm

Q10C
2V/cm
1μs/cm

Q9C
2V/cm
1μs/cm

Q7C
2V/cm
1μs/cm

Q7C
2V/cm
1μs/cm

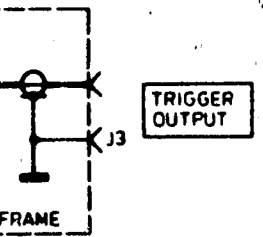
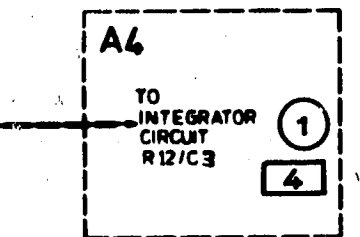
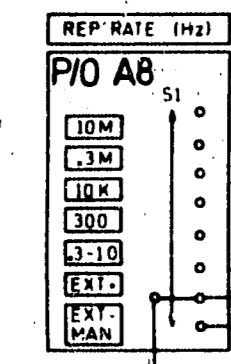
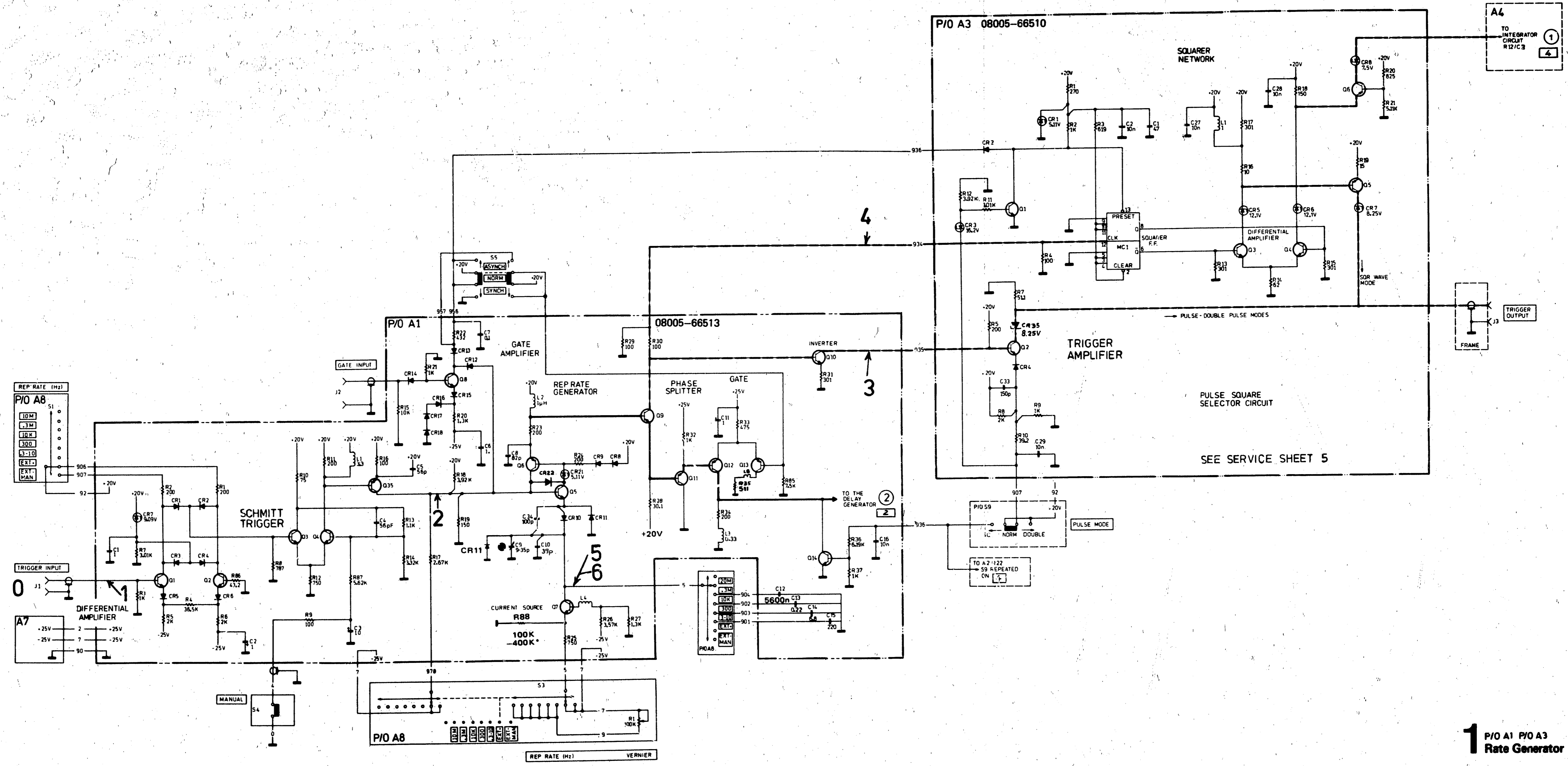

1 P/O A1 P/O A3
Rate Generator

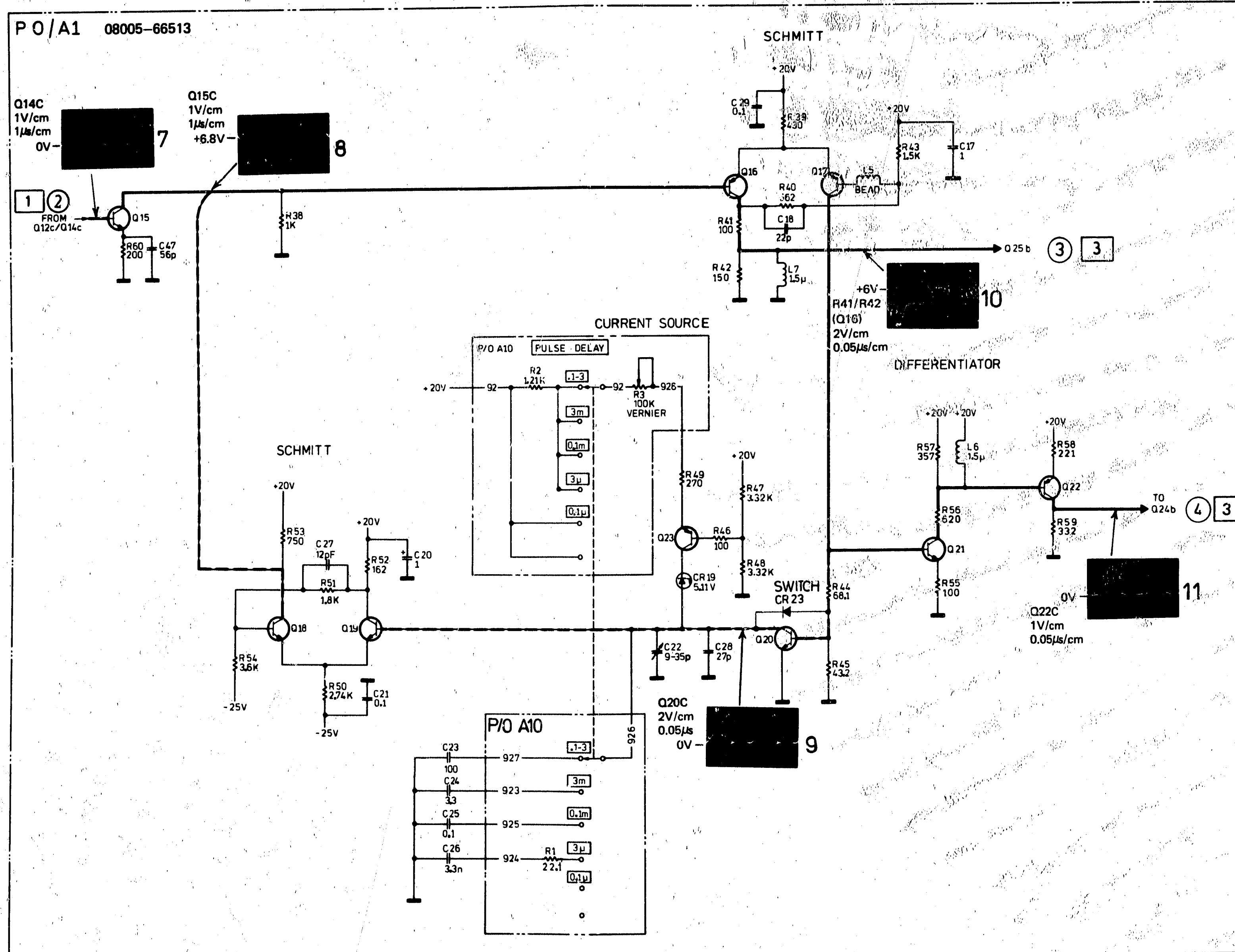

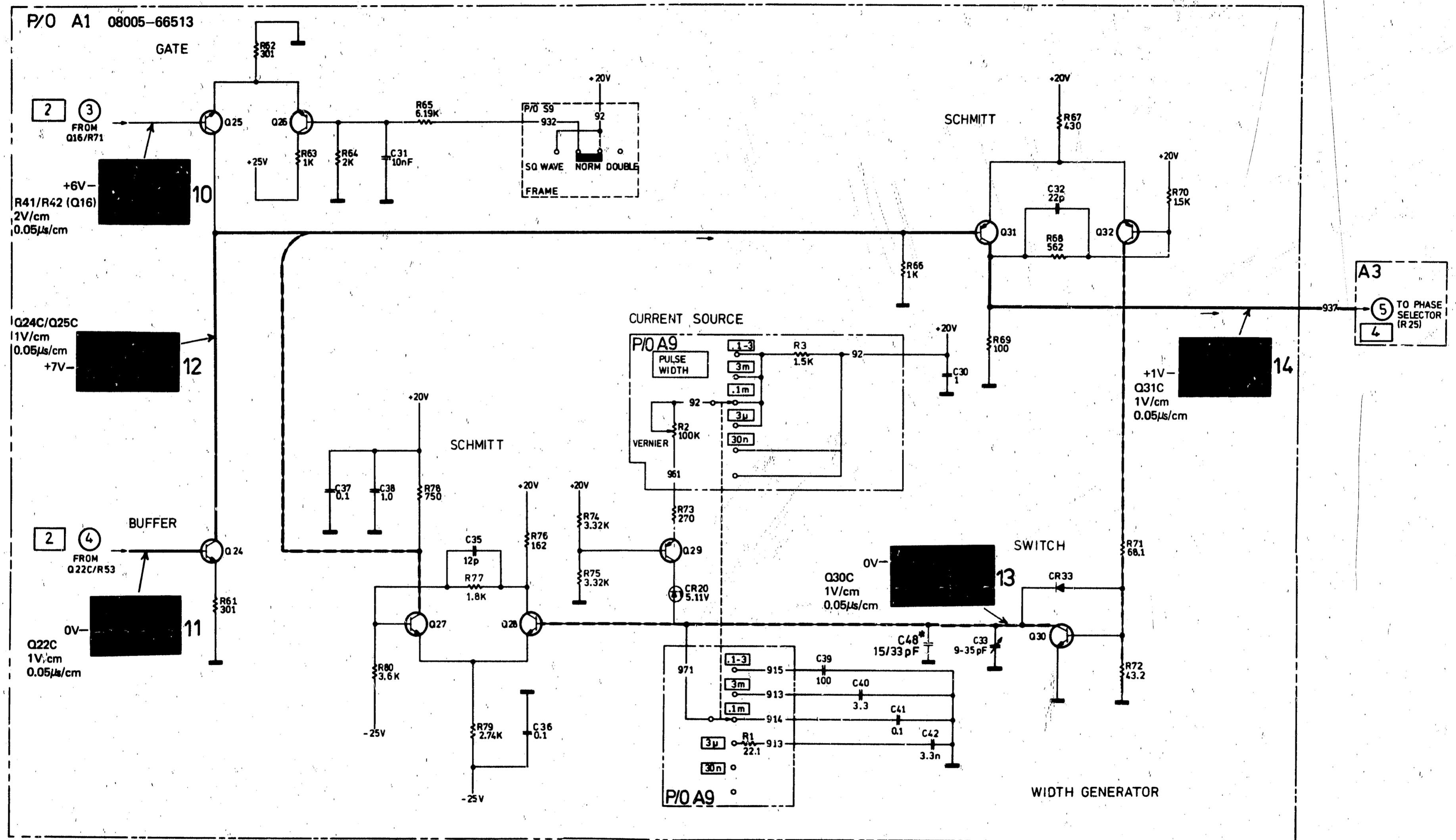

3 P/O A1 Width Generator

A3 BD AY AMP OUTPUT 08005-66510

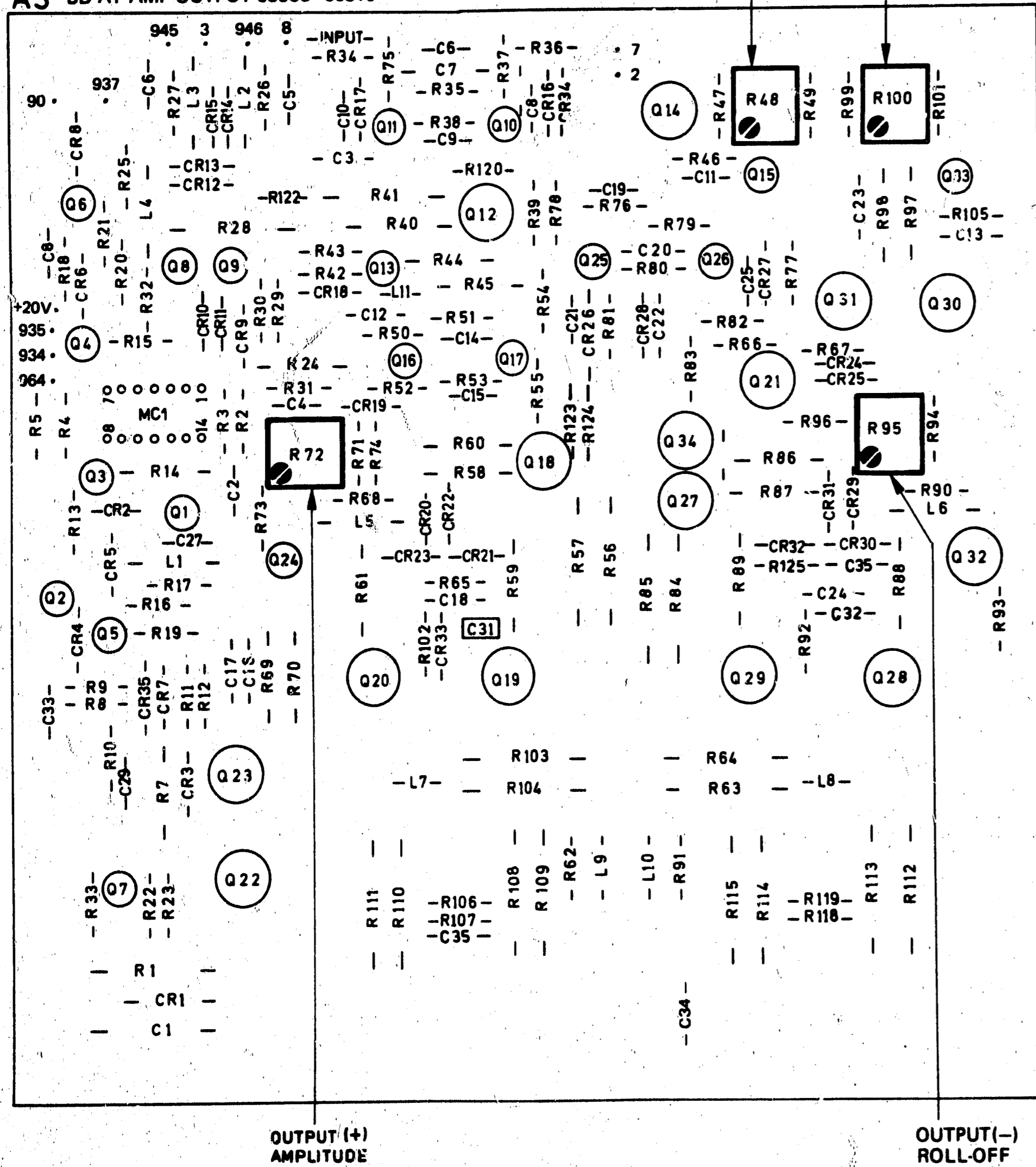

A4 BD AY INT 08005-66511

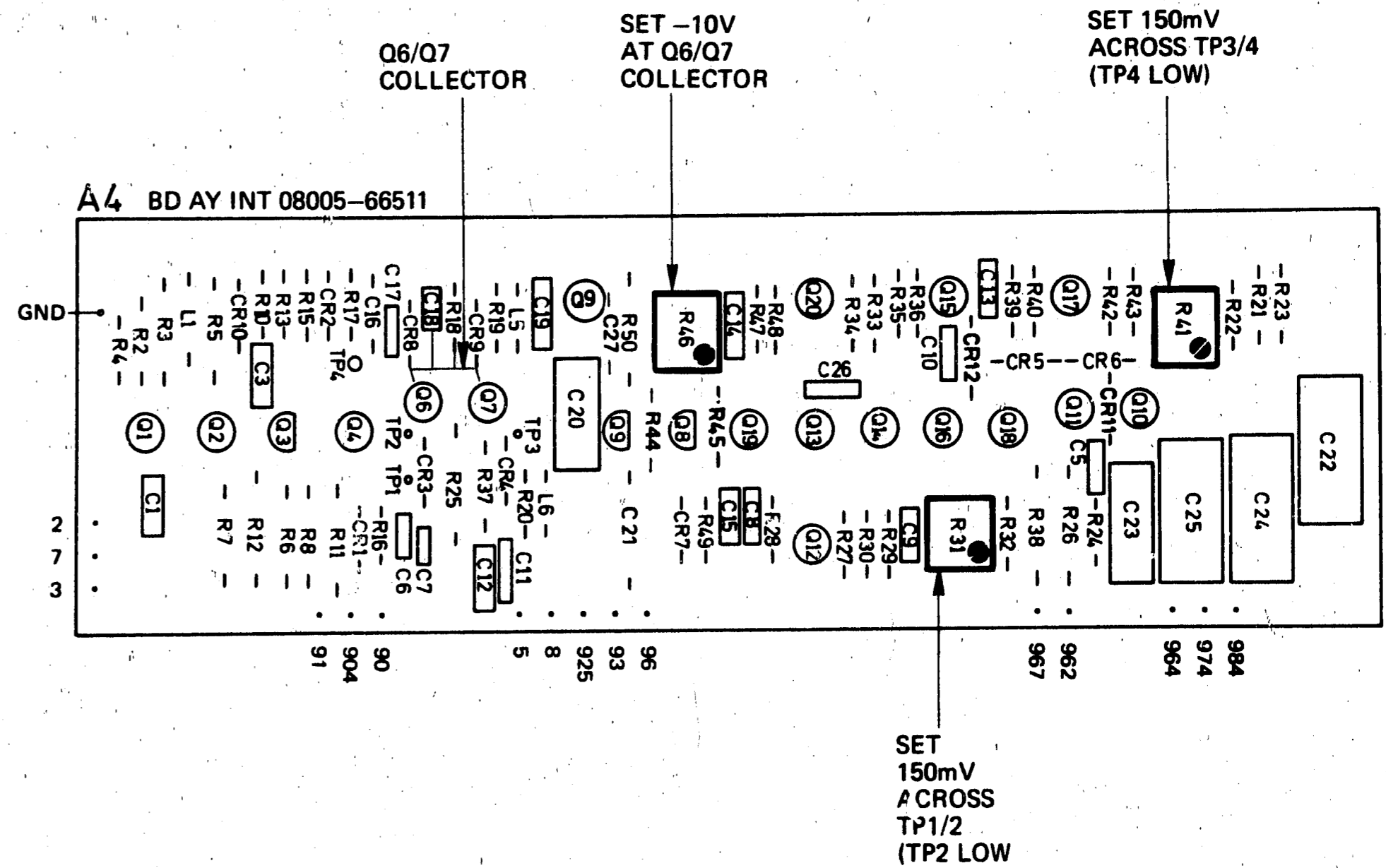

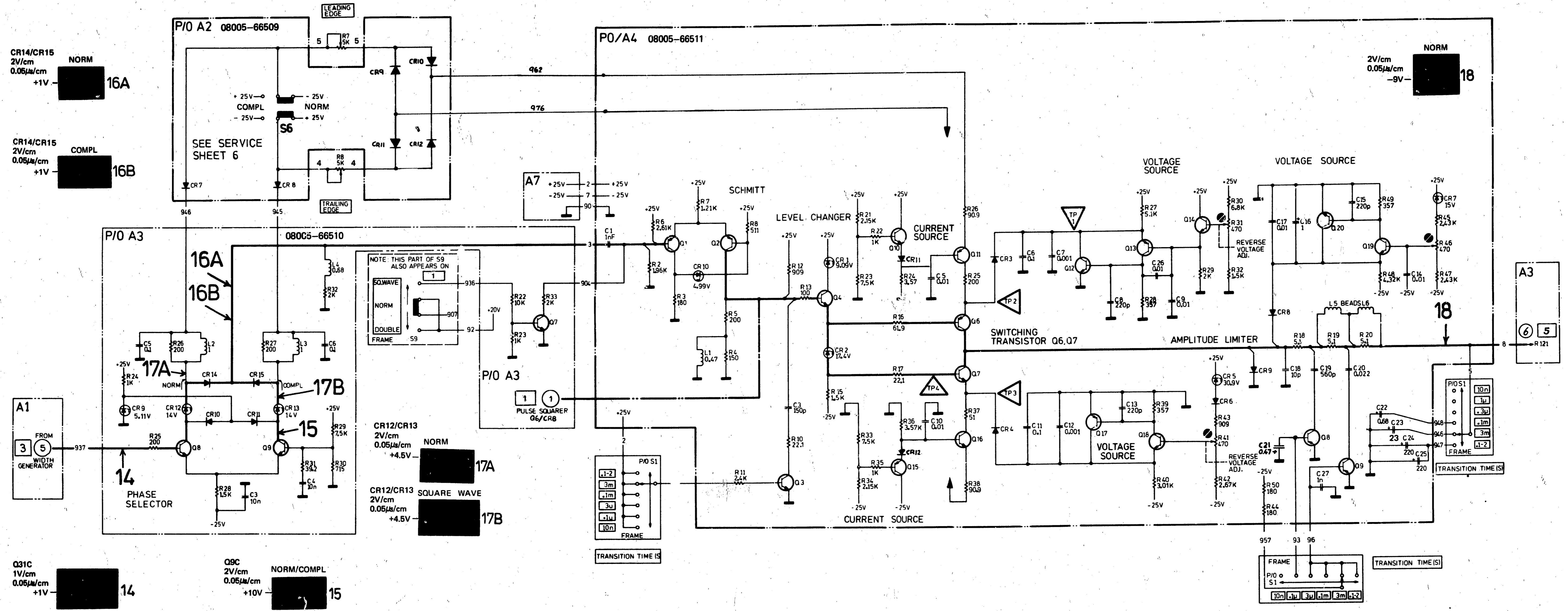

4 P/O A2
 A3: Phase Selector
 A4: Integrator

A3 BD AY AMP OUTPUT 08005-66510

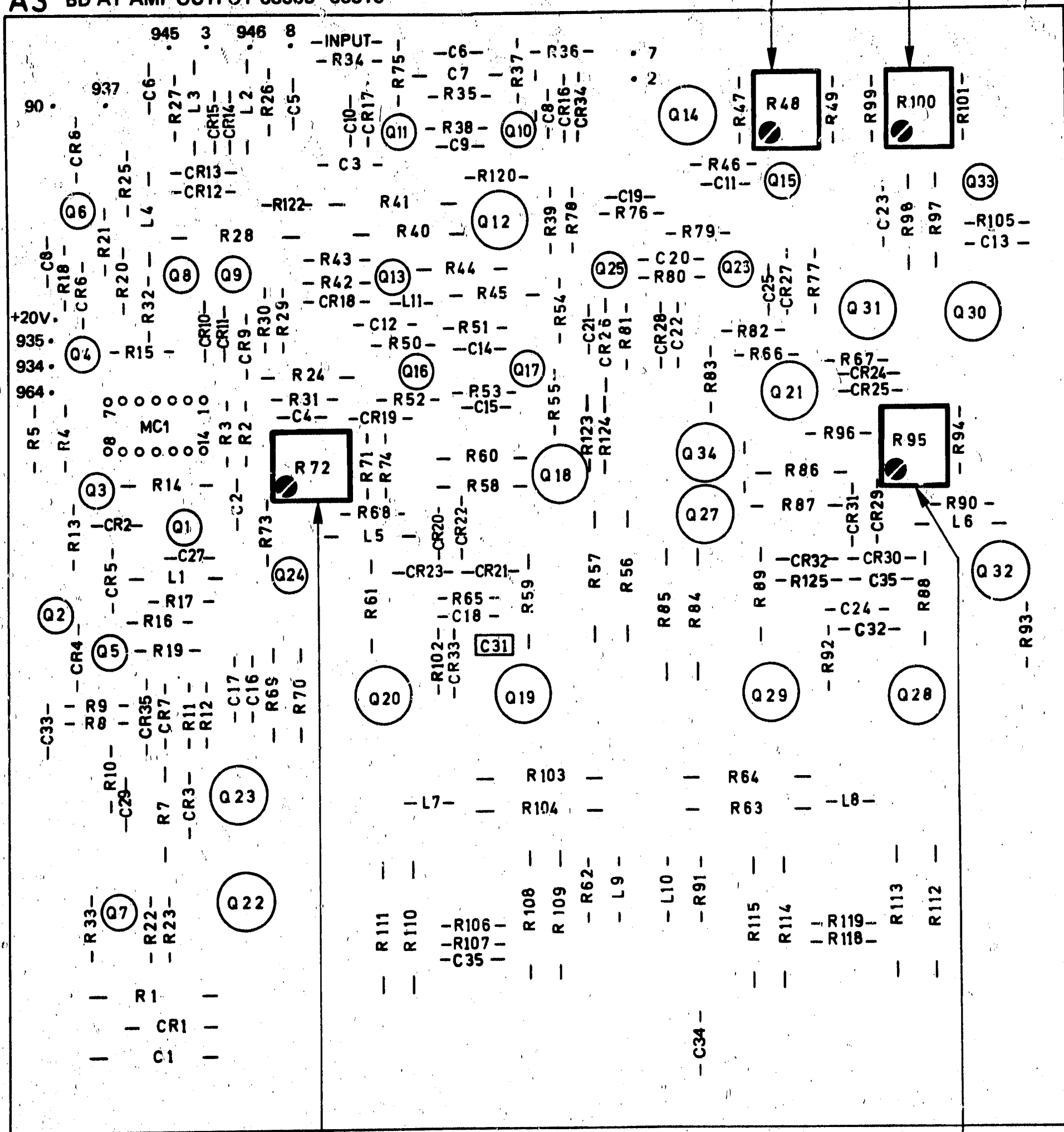

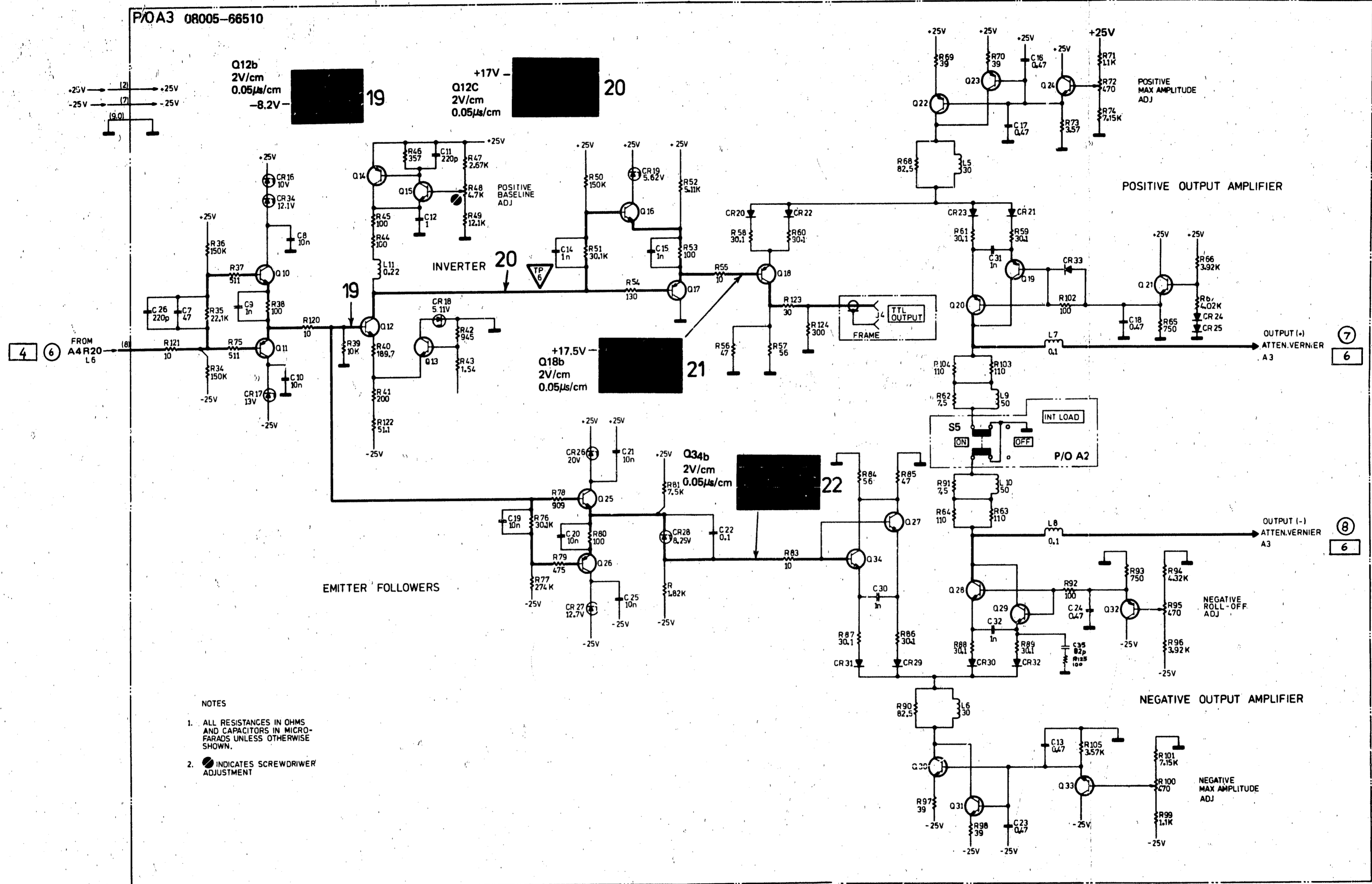

5 P/O A3
Output Amps.

A2 BD AY MOTHER 08005-66509

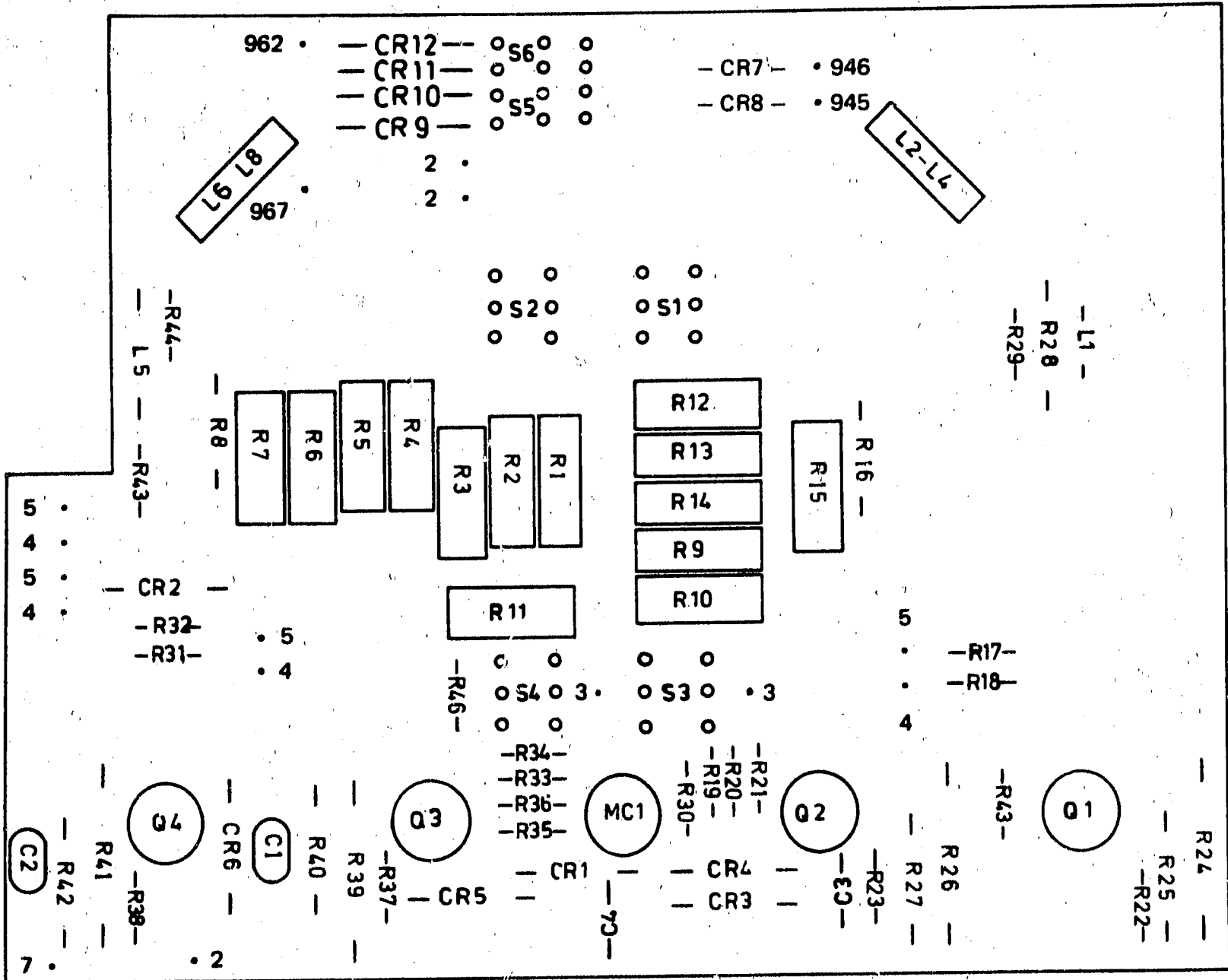

P/O A2 08005-66509

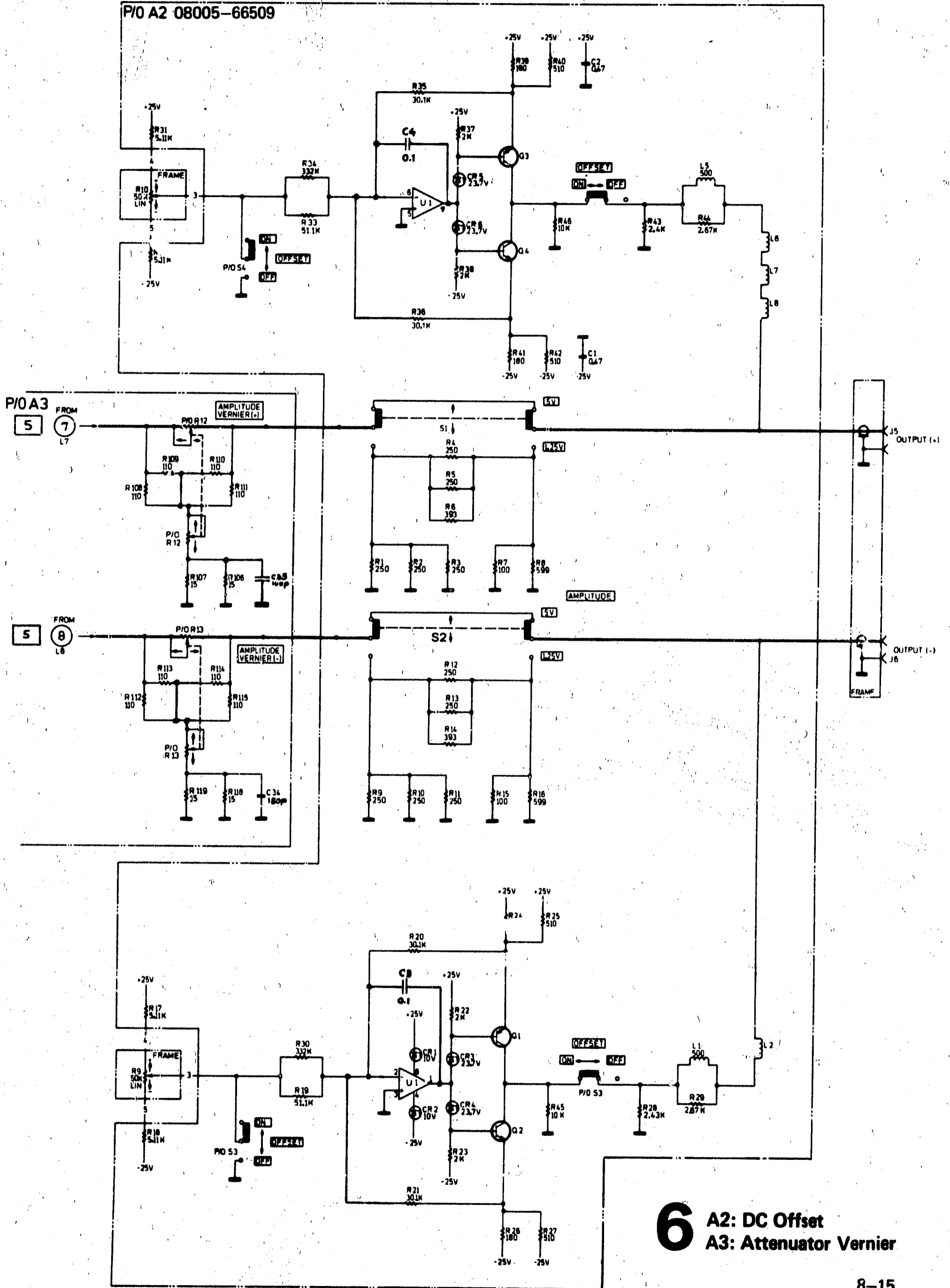

6 A2: DC Offset
A3: Attenuator Vernier

A5 BD AY POWER SUPPLY 08005-66512

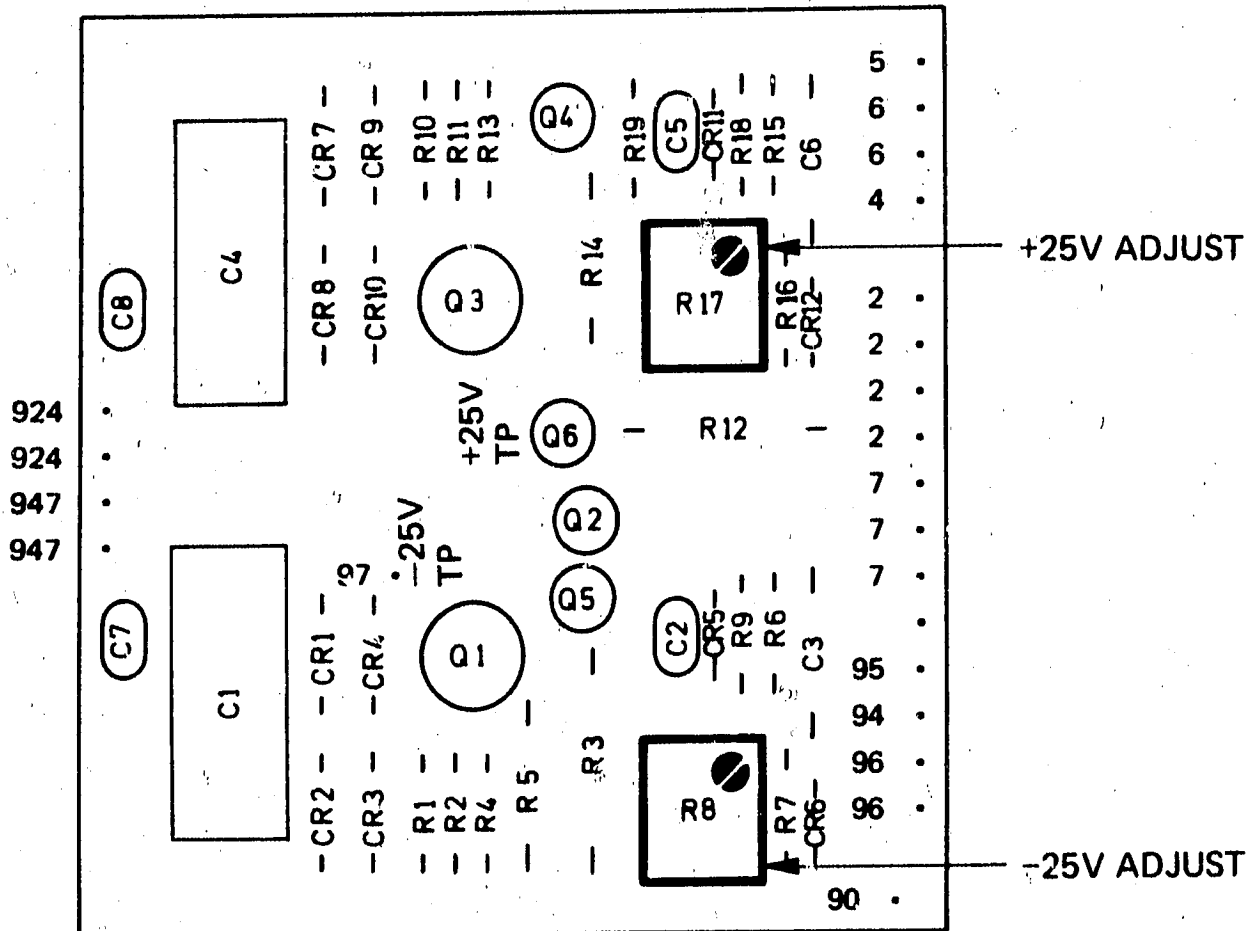

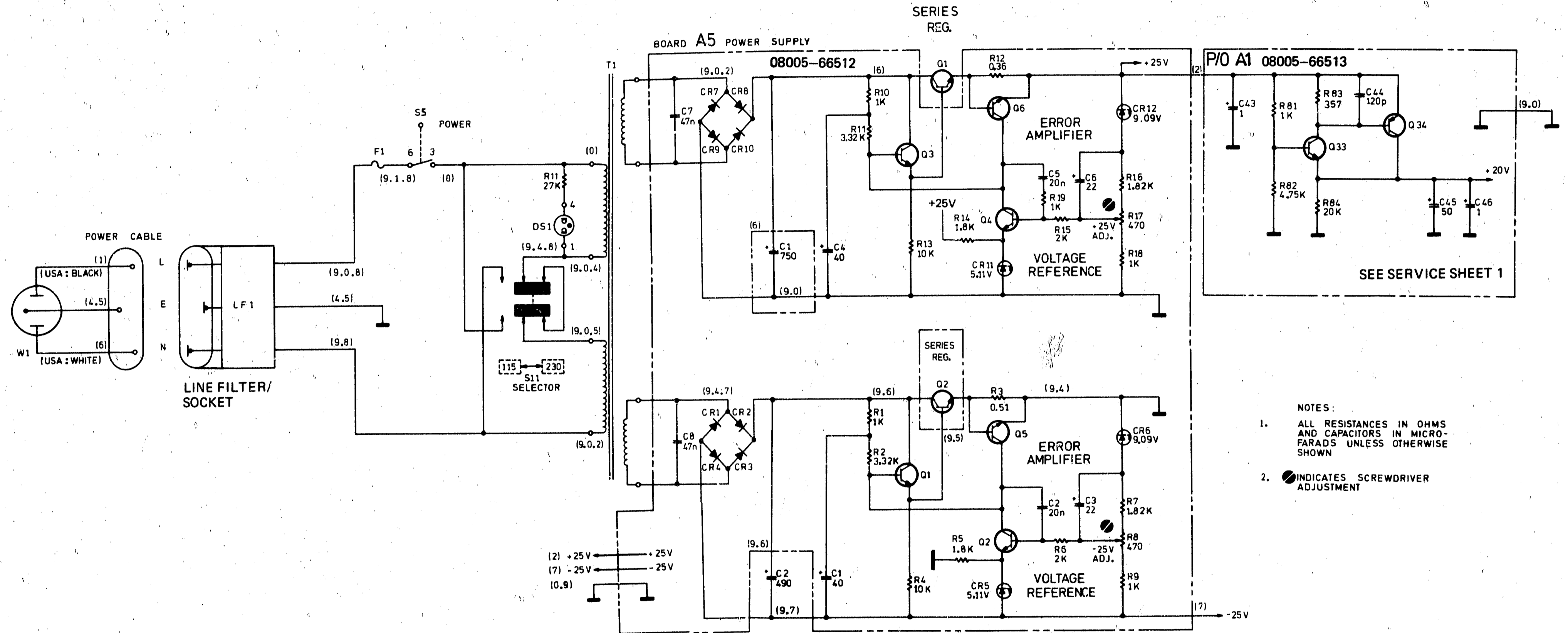

**BACK DATING
MANUAL
CHANGES**

SECTION IX BACKDATING

SERIAL NUMBERS 1341G00330 AND BELOW

Substitute Service Sheets 1, 4, 5 and layouts A2, A3 (page 9-6) and A6. Delete the following components:

A1 CR23 - Service Sheet 2
A3 C35 -) Service Sheet 5
A3 R125 -) (see Q29)
A3 C35)
A3 C34 (fitted,)
but 82pF) Service Sheet 6
A2 C3)
A2 C4)

SERIAL NUMBERS 1341G00331 TO 550

Substitute A3 layout on page 9-8. Delete the following components:

A2 C3)
A2 C4) Service Sheet 6

SERIAL NUMBERS 1341G 00730 AND BELOW

Substitute S11 part number 3101-1234.

A1 BD AY TIMING 08005-66513

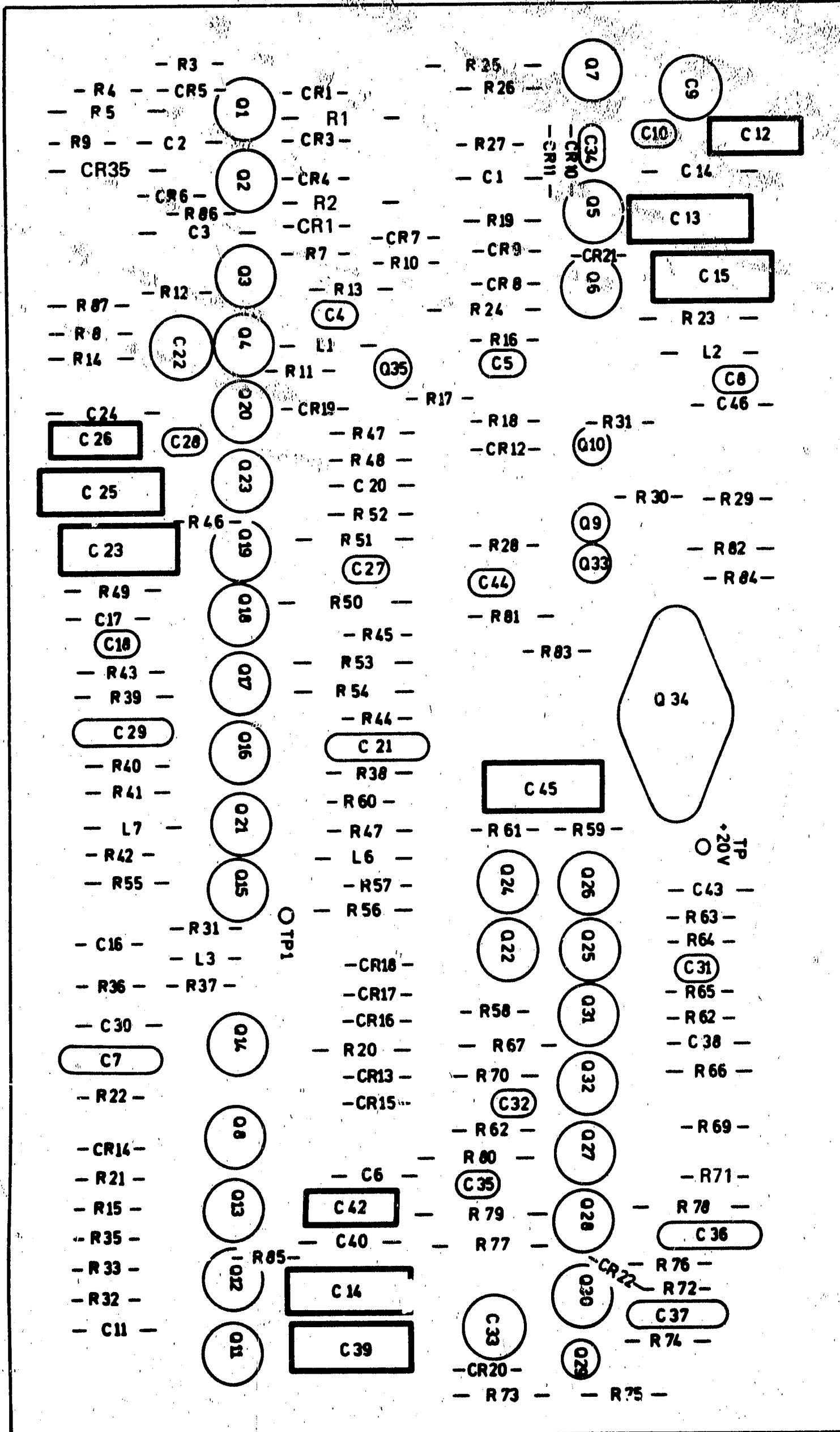

1 SERIAL NUMBERS 1341G00330 1341G00330 AND BELOW

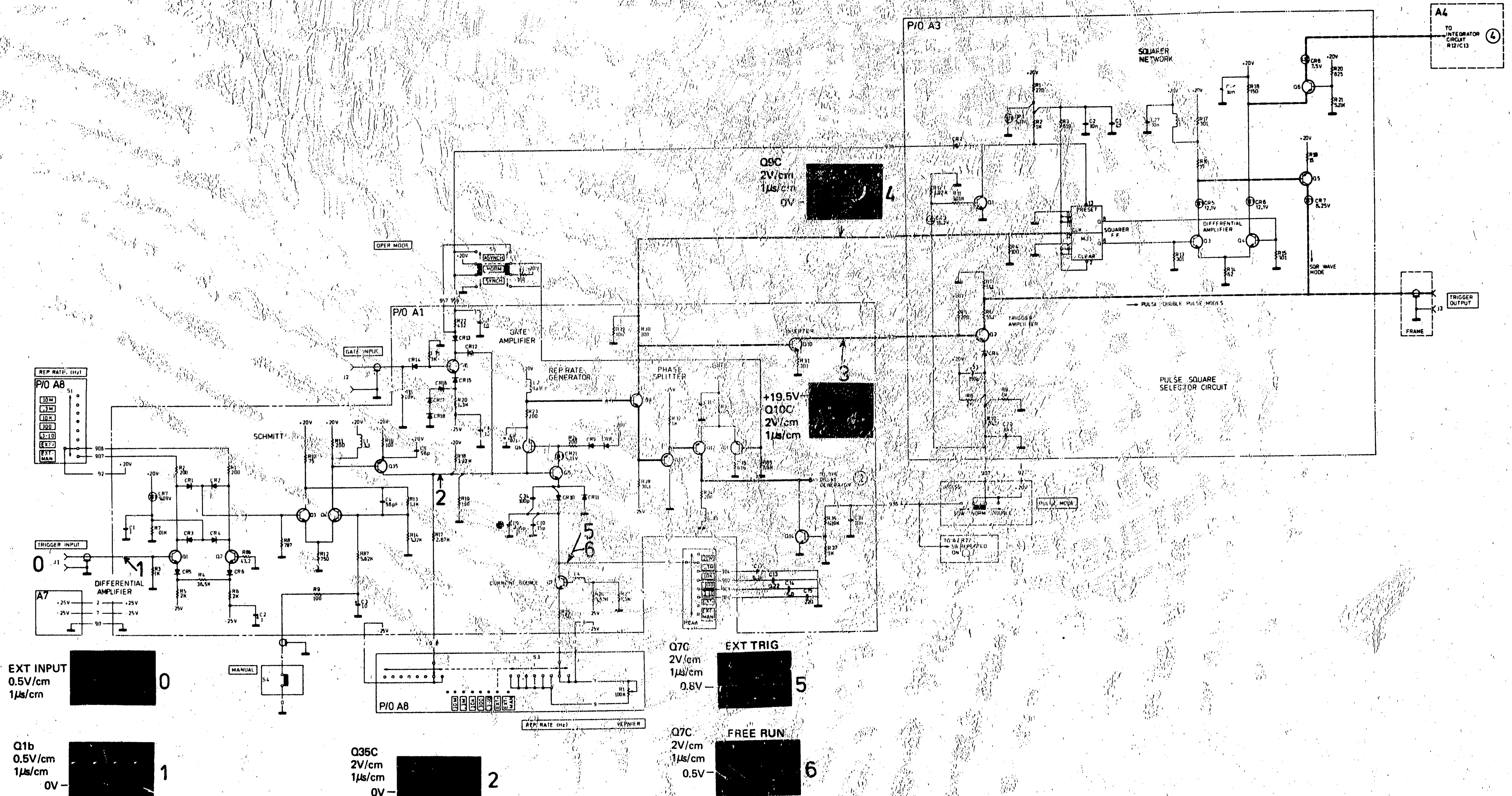

1 Rate Generator
 SERIAL NUMBERS 1341G00330 AND BELOW

A4 BD AY INTEGRATOR 08005-66511

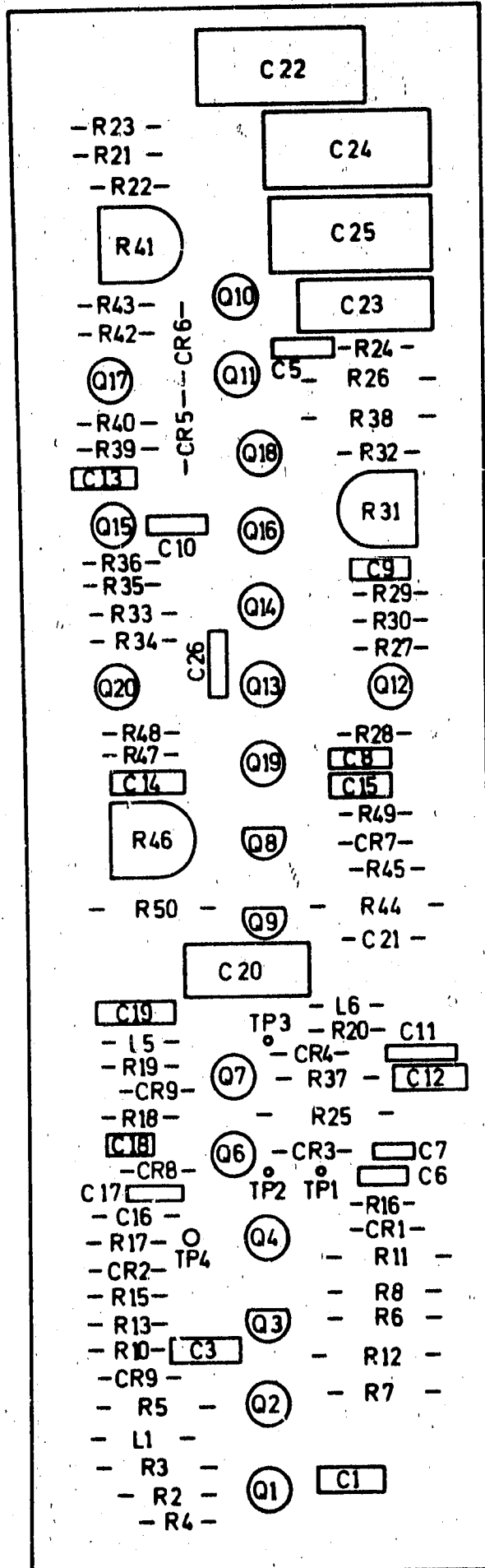

4 SERIAL NUMBERS 1341G00330 AND BELOW

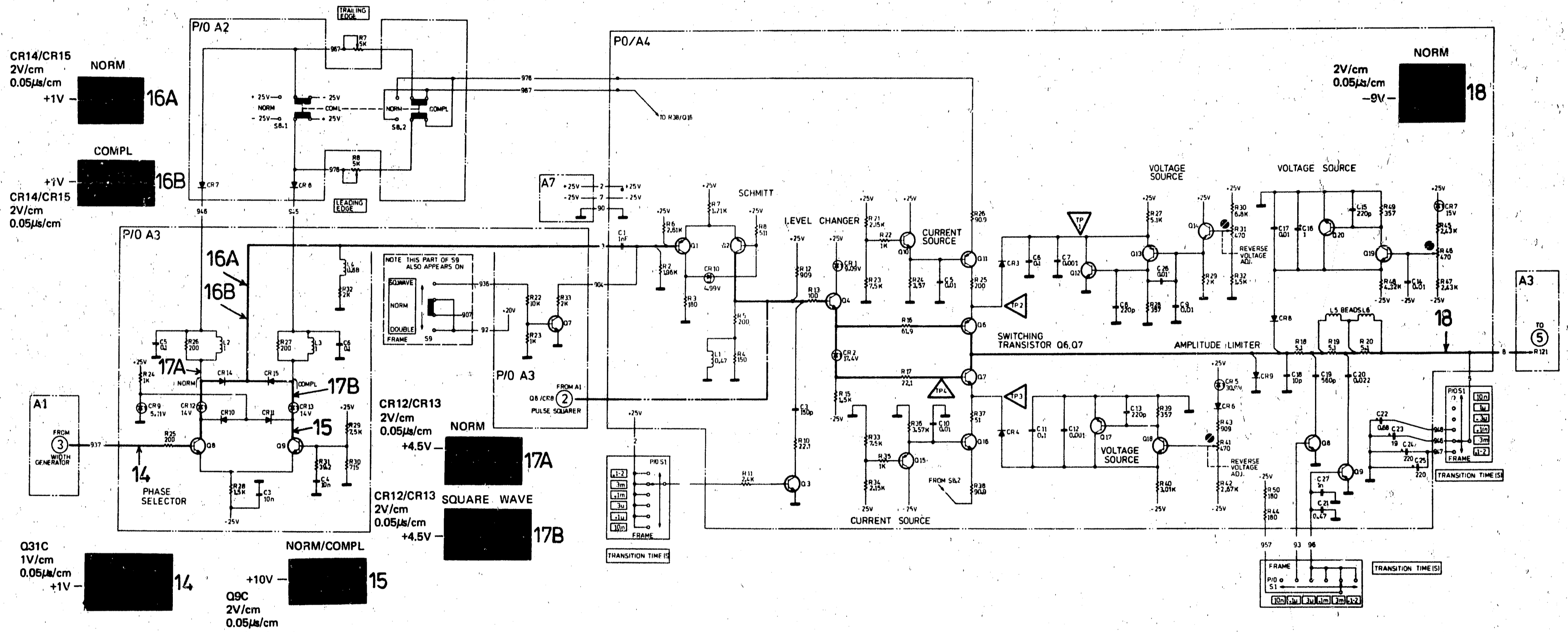

4 A3: Phase Selector
 A4: Integrator
 SERIAL NUMBERS 1341G00330 AND BELOW

A3 BD AY AMP OUTPUT 08005-66510

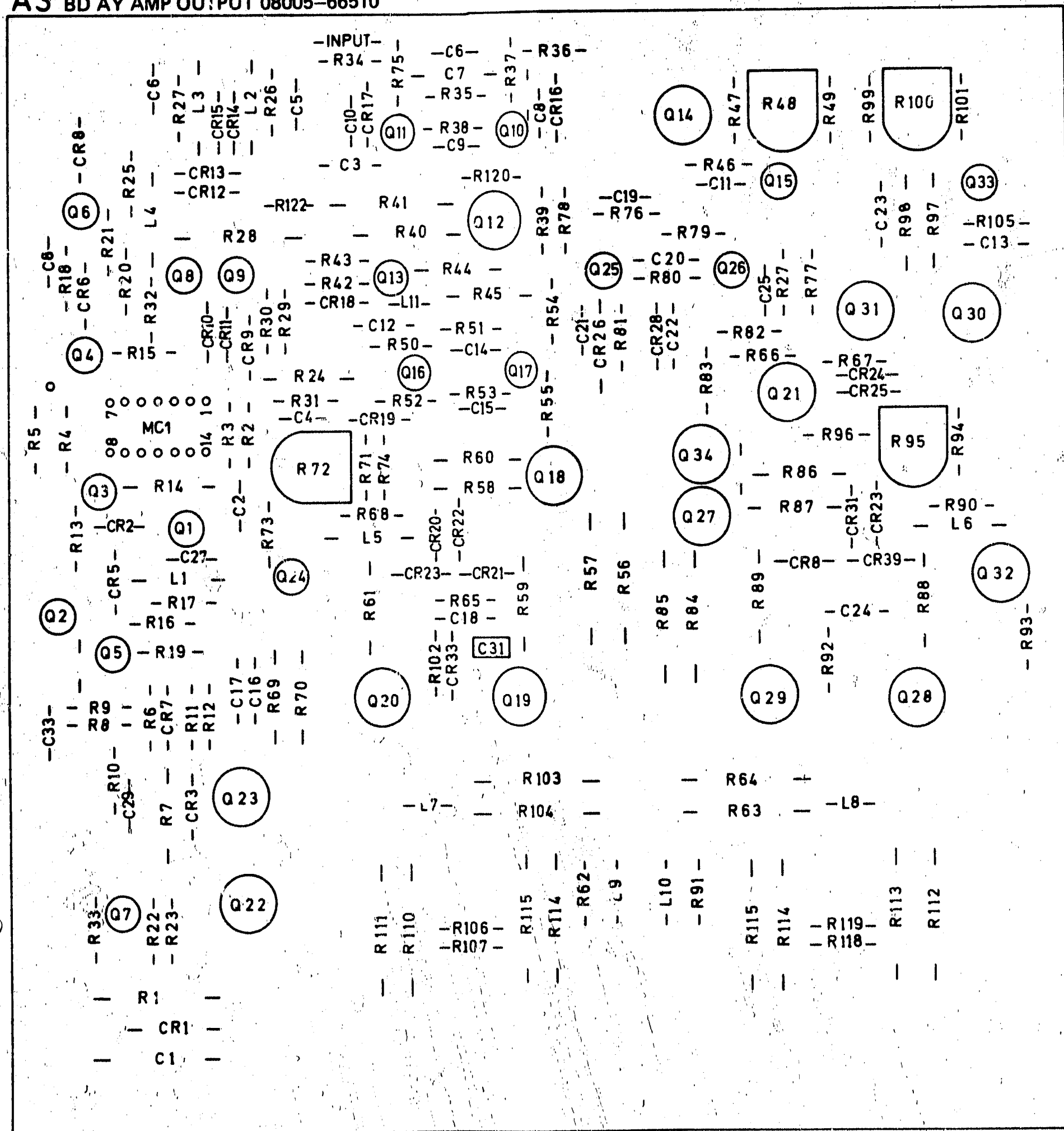

5 SERIAL NUMBERS 1341G00330 AND BELOW

A3

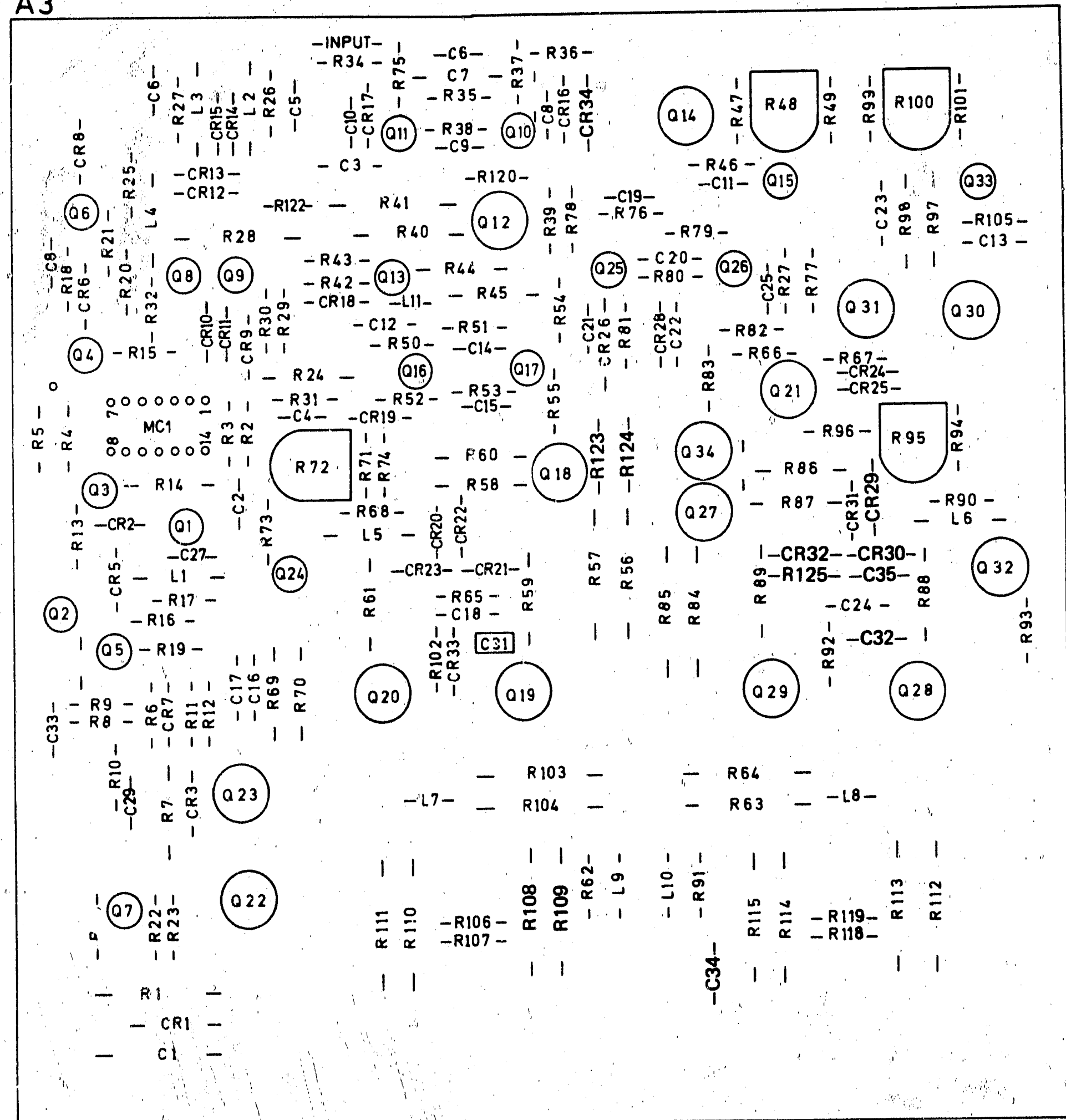

5 SERIAL NUMBERS 1341G00331 TO 00550

A2

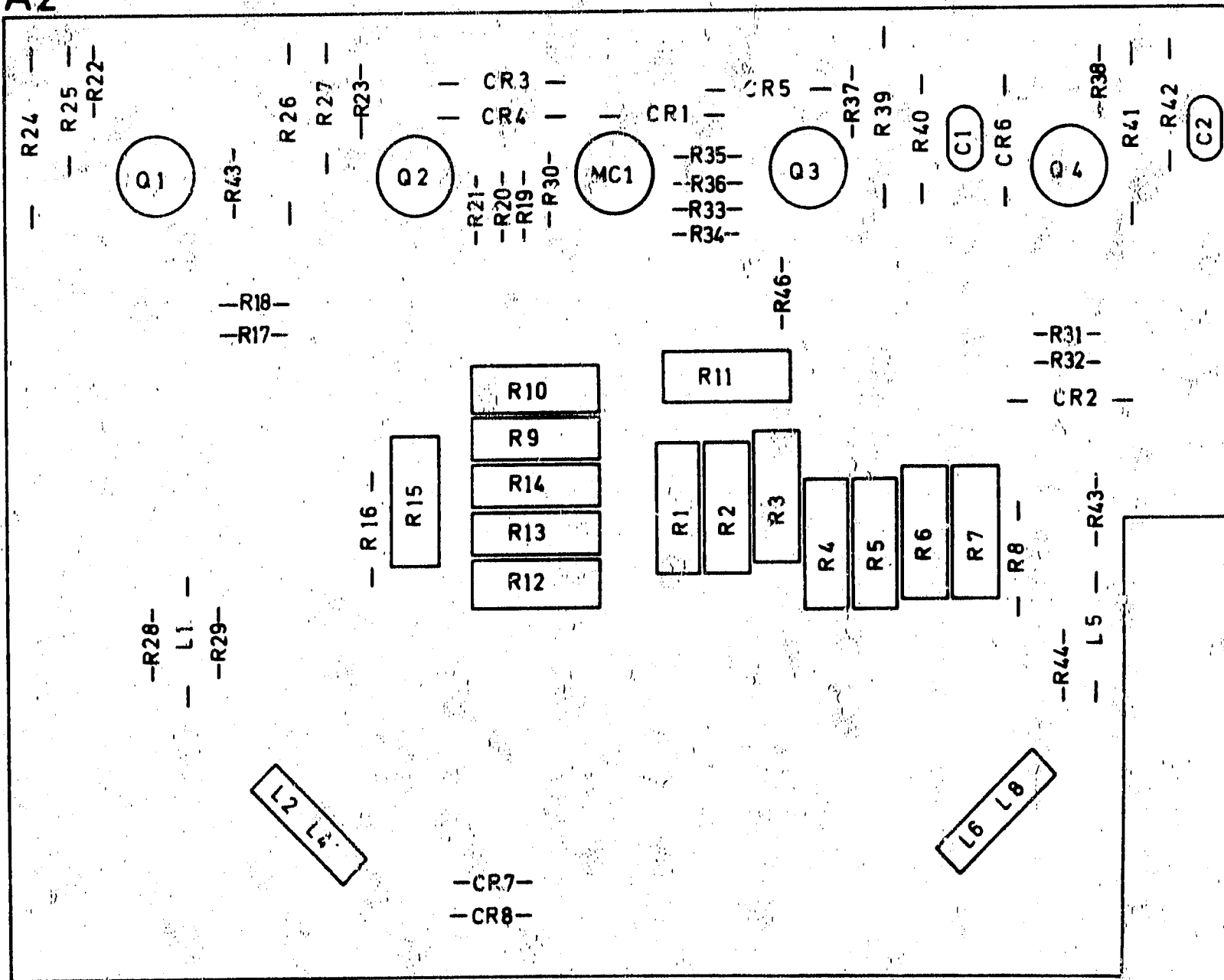

SERIAL NUMBERS 1341G00330 AND BELOW

6

9-7