

## Errata

**Title & Document Type:** 6201B DC Power Supply Operating and Service Manual

**Manual Part Number:** 06201-90001

**Revision Date:** June 1966

### About this Manual

We've added this manual to the Agilent website in an effort to help you support your product. This manual provides the best information we could find. It may be incomplete or contain dated information, and the scan quality may not be ideal. If we find a better copy in the future, we will add it to the Agilent website.

### HP References in this Manual

This manual may contain references to HP or Hewlett-Packard. Please note that Hewlett-Packard's former test and measurement, life sciences, and chemical analysis businesses are now part of Agilent Technologies. The HP XXXX referred to in this document is now the Agilent XXXX. For example, model number HP8648A is now model number Agilent 8648A. We have made no changes to this manual copy.

### Support for Your Product

Agilent no longer sells or supports this product. You will find any other available product information on the Agilent Test & Measurement website:

[www.agilent.com](http://www.agilent.com)

Search for the model number of this product, and the resulting product page will guide you to any available information. Our service centers may be able to perform calibration if no repair parts are needed, but no other support from Agilent is available.



**Agilent Technologies**

# OPERATING AND SERVICE MANUAL

DC POWER SUPPLY  
LAB SERIES, MODEL 6201B  
SERIAL NUMBER PREFIX 6A

HEWLETT  PACKARD

HEWLETT  PACKARD

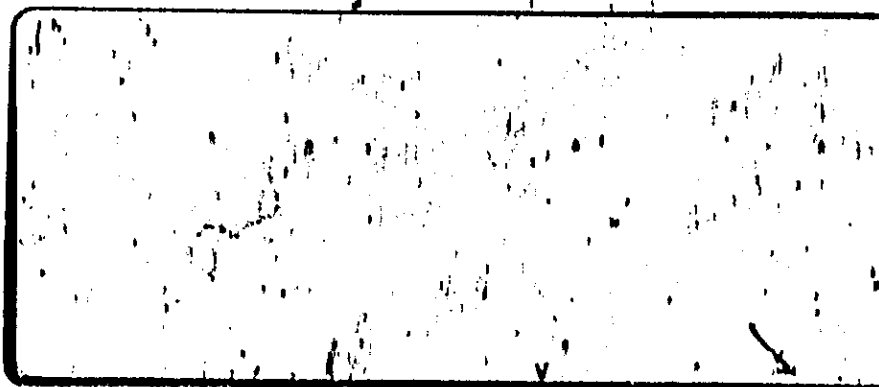

### CERTIFICATION

*The Hewlett-Packard Company certifies that this instrument was thoroughly tested and inspected and found to meet its published specifications when it was shipped from the factory. The Hewlett-Packard Company further certifies that its calibration measurements are traceable to the U.S. National Bureau of Standards to the extent allowed by the Bureau's calibration facility.*

### WARRANTY AND ASSISTANCE

All Hewlett-Packard products are warranted against defects in materials and workmanship. This warranty applies for one year from date of delivery, or in the case of certain major components listed in the operating manual, for the specified period. We will repair or replace products which prove to be defective during the warranty period provided they are returned to Hewlett-Packard. No other warranty is expressed or implied. We are not liable for consequential damages.

For any assistance contact your nearest Hewlett-Packard Sales and Service Office. Addresses are provided at the back of this manual.

DC POWER SUPPLY

LAB SERIES, MODEL 6201B

SERIAL NUMBER PREFIX 6A

Printed: June, 1966

© Stock Number 06201-90001

TABLE OF CONTENTS

Section	Page No.	Section	Page No.
<b>I GENERAL INFORMATION</b>		<b>IV PRINCIPLES OF OPERATION</b>	
1-1. Description	1-1	4-6. Series Regulator	4-3
1-7. Instrument Identification	1-1	4-8. Constant Voltage Input Circuit	4-3
1-10. Ordering Additional Manuals	1-1	4-12. Constant Current Input Circuit	4-4
		4-17. Voltage Clamp Circuit	4-5
<b>II INSTALLATION</b>		4-20. Mixer and Error Amplifiers	4-5
2-1. Initial Inspection	2-1	4-23. Reference Circuit	4-6
2-3. Mechanical Check	2-1	4-26. Meter Circuit	4-6
2-5. Electrical Check	2-1	4-32. Operation of Regulating Feedback Loop	4-7
2-7. Installation Data	2-1		
2-9. Location	2-1	<b>V MAINTENANCE</b>	
2-11. Rack Mounting	2-1	5-1. Introduction	5-1
2-15. Input Power Requirements	2-2	5-3. General Measurement Techniques	5-1
2-17. Connections for 230 Volt Operation	2-2	5-8. Test Equipment Required	5-1
2-19. Power Cable	2-3	5-10. Performance Test	5-3
2-22. Repackaging for Shipment	2-3	5-12. Constant Voltage Tests	5-4
		5-20. Output Impedance	5-6
<b>III OPERATING INSTRUCTIONS</b>		5-22. Output Inductance	5-6
3-1. Operating Controls and Indicators	3-1	5-24. Constant Current Tests	5-6
3-3. Operating Modes	3-1	5-28. Troubleshooting	5-7
3-5. Normal Operating Mode	3-1	5-30. Trouble Analysis	5-7
3-7. Constant Voltage	3-1	5-36. Repair and Replacement	5-10
3-9. Constant Current	3-1	5-40. Adjustment and Calibration	5-13
3-11. Connecting Load	3-2	5-42. Meter Zero	5-13
3-14. Optional Operating Modes	3-2	5-44. Voltmeter Tracking	5-13
3-15. Remote Programming, Constant Voltage	3-2	5-46. Ammeter Tracking	5-13
3-22. Remote Programming, Constant Current	3-2	5-48. Constant Voltage Programming	5-13
3-28. Remote Sensing	3-3	5-51. Constant Current Programming	5-14
3-33. Series Operation	3-4	5-54. Reference Circuit Adjustments	5-14
3-37. Parallel Operation	3-5	5-56. Constant Voltage Transient Response	5-14
3-40. Auto-tracking Operation	3-6		
3-43. Special Operating Considerations	3-6	<b>VI REPLACEABLE PARTS</b>	
3-44. Pulse Loading	3-6	6-1. Introduction	6-1
3-46. Output Capacitance	3-7	6-4. Ordering Information	6-1
3-49. Reverse Voltage Loading	3-7	Reference Designators	
3-51. Reverse Current Loading	3-7	Abbreviations	
		Manufacturers	
<b>IV PRINCIPLES OF OPERATION</b>		6-8. Code List of Manufacturers	6-2
4-1. Overall Block Diagram Discussion	4-1	Parts List Table	
4-4. Simplified Schematic	4-2		

## TABLE OF CONTENTS (CONTINUED)

### LIST OF TABLES

Table	Page No.	Table	Page No.
1-1 Specifications	1-2	5-6 Selected Semiconductor Characteristics	5-10
5-1 Test Equipment Required	5-2	5-7 Checks and Adjustments After Replacement of Semiconductor Devices	5-12
5-2 Reference Circuit Troubleshooting	5-8	5-8 Calibration Adjustment Summary	5-13
5-3 High Output Voltage Troubleshooting	5-8		
5-4 Low Output Voltage Troubleshooting	5-9		
5-5 Common Troubles	5-9		

### LIST OF ILLUSTRATIONS

Figure	Page No.	Figure	Page No.
2-1 Rack Mounting, Two Units	2-1	4-5 Voltage Clamp Circuit	4-5
2-2 Rack Mounting, One Unit	2-2	4-6 Mixer and Error Amplifiers, Simplified Schematic	4-5
2-8 Primary Connections	2-2	4-7 Meter Circuit, Simplified Schematic	4-6
3-1 Front Panel Controls and Indicators	3-1	4-8 Voltmeter Connections, Simplified Schematic	4-7
3-2 Normal Strapping Pattern	3-1	4-9 Ammeter Connections, Simplified Schematic	4-7
3-3 Remote Resistance Programming (Constant Voltage)	3-2	5-1 Front Panel Terminal Connections	5-1
3-4 Remote Voltage Programming (Constant Voltage)	3-2	5-2 Output Current Measurement Technique	5-1
3-5 Remote Resistance Programming (Constant Current)	3-3	5-3 Differential Voltmeter Substitute, Test Setup	5-3
3-6 Remote Voltage Programming (Constant Current)	3-3	5-4 Output Current, Test Setup	5-4
3-7 Remote Sensing	3-3	5-5 Load Regulation, Constant Voltage	5-4
3-8 Normal Series	3-4	5-6 Ripple and Noise, Constant Voltage	5-5
3-9 AUTO-Series, Two and Three Units	3-4	5-7 Transient Response, Test Setup	5-5
3-10 Normal Parallel	3-5	5-8 Transient Response, Waveforms	5-5
3-11 Auto-Parallel, Two and Three Units	3-5	5-9 Output Impedance, Test Setup	5-6
3-12 Auto-Tracking, Two and Three Units	3-6	5-10 Load Regulation, Constant Current	5-6
4-1 Overall Block Diagram	4-1	5-11 Ripple and Noise, Constant Current	5-7
4-2 Simplified Schematic	4-2	5-12 Servicing Printed Wiring Boards	5-11
4-3 Constant Voltage Input Circuit, Simplified Schematic	4-3		
4-4 Constant Current Input Circuit, Simplified Schematic	4-4		



Figure 1-1. DC Power Supply, Model 6201B

SECTION I  
GENERAL INFORMATION

1-1 DESCRIPTION

1-2 This power supply, Figure 1-1, is completely transistorized and suitable for either bench or relay rack operation. It is a compact, well-regulated, Constant Voltage / Constant Current supply that will furnish full rated output voltage at the maximum rated output current or can be continuously adjusted throughout the output range. The front panel CURRENT controls can be used to establish the output current limit (overload or short circuit) when the supply is used as a constant voltage source and the VOLTAGE controls can be used to establish the voltage limit (ceiling) when the supply is used as a constant current source.

1-3 The power supply has both front and rear terminals. Either the positive or negative output terminal may be grounded or the power supply can be operated floating at up to a maximum of 300 volts off ground.

1-4 A single meter is used to measure either output voltage or output current in one of two ranges. The voltage or current ranges are selected by a METER switch on the front panel.

1-5 The programming terminals located at the rear of the unit allow ease in adapting to the many operational capabilities of the power supply. A brief description of these capabilities is given below:

a. Remote Programming

The power supply may be programmed from a remote location by means of an external voltage source or resistance.

b. Remote Sensing

The degradation in regulation which would occur at the load because of the voltage drop in the load leads can be reduced by using the power supply in the remote sensing mode of operation.

c. Series and Auto-Series Operation

Power supplies may be used in series when a higher output voltage is required in the voltage mode of operation or when greater voltage compliance is required in the constant current mode of operation. Auto-Series operation permits one

knob control of the total output voltage from a "master" supply.

d. Parallel and Auto-Parallel Operation

The power supply may be operated in parallel with a similar unit when greater output current capability is required. Auto-Parallel operation permits one knob control of the total output current from a "master" supply.

e. Auto-Tracking

The power supply may be used as a "master" supply, having control over one (or more) "slave" supplies that furnish various voltages for a system.

1-6 Detailed Specifications for the power supply are given in Table 1-1.

1-7 INSTRUMENT IDENTIFICATION

1-8 Hewlett-Packard power supplies are identified by a three-part serial number tag. The first part is the power supply model number. The second part is the serial number prefix, which consists of a number-letter combination that denotes the date of a significant design change. The number designates the year, and the letter A through L designates the month, January through December respectively. The third part is the power supply serial number.

1-9 If the serial number prefix on your power supply does not agree with the prefix on the title page of this manual, change sheets are included to update the manual. Where applicable, backdating information is given in an appendix at the rear of the manual.

1-10 ORDERING ADDITIONAL MANUALS

1-11 One manual is shipped with each power supply. Additional manuals may be purchased from your local Hewlett-Packard field office (see list at rear of this manual for addresses). Specify the model number, serial number prefix, and stock number provided on the title page.



Table 1-1. Specifications

**INPUT:**

105-125/210-250 VAC, single phase,  
50-400 cps.

**OUTPUT:**

0-20 volts @ 1.5 amps.

**LOAD REGULATION:**

Constant Voltage -- Less than 0.01% plus 4 mv  
for a full load to no load change in output current.

Constant Current -- Less than 0.03% plus 250 $\mu$ a  
for a zero to maximum change in output voltage.

**LINE REGULATION:**

Constant Voltage -- Less than 0.01% plus 4 mv  
for any line voltage change within the input rating.

Constant Current -- Less than 0.01% plus 250 $\mu$ a  
for any line voltage change within the input rating.

**RIPPLE AND NOISE:**

Constant Voltage -- Less than 200 $\mu$ v rms.

Constant Current -- Less than 500 $\mu$ a rms.

**OPERATING TEMPERATURE RANGE:**

0 to 50°C.

**TEMPERATURE COEFFICIENT:**

Constant Voltage -- Less than 0.02% plus 1 mv  
per degree Centigrade.

Constant Current -- Less than 0.02% plus 1 ma  
per degree Centigrade.

**STABILITY:**

Constant Voltage -- Less than 0.10% plus 5 mv  
total drift for 8 hours after an initial warm-up time  
of 30 minutes at constant ambient, constant line  
voltage, and constant load.

Constant Current -- Less than 0.10% plus 5 ma  
total drift for 8 hours after an initial warm-up time  
of 30 minutes at constant ambient, constant line  
voltage, and constant load.

**INTERNAL IMPEDANCE AS A CONSTANT VOLTAGE  
SOURCE:**

Less than 0.02 ohms from DC to 1 Kc.

Less than 0.5 ohms from 1 Kc to 100 Kc.

Less than 3.0 ohms from 100Kc to 1 Mc.

**TRANSIENT RECOVERY TIME:**

Less than 50 $\mu$ sec for output recovery to within  
10 mv following a full load current change in the  
output.

**OVERLOAD PROTECTION:**

A continuously acting constant current circuit  
protects the power supply for all overloads

including a direct short placed across the terminals  
in constant voltage operation. The constant voltage  
circuit limits the output voltage in the constant cur-  
rent mode of operation.

**METER:**

The front panel meter can be used as either a  
0-24 or 0-2.4 volt voltmeter or as a 0-1.8 or  
0-0.18 amp ammeter.

**OUTPUT CONTROLS:**

Coarse and fine voltage controls and coarse and  
fine current controls.

**OUTPUT TERMINALS:**

Three "five-way" output posts are provided on  
the front panel and an output terminal strip is  
located on the rear of the chassis. All power sup-  
ply output terminals are isolated from the chassis  
and either the positive or negative terminal may be  
connected to the chassis through a separate ground  
terminal located on the output terminal strip.

**ERROR SENSING:**

Error sensing is normally accomplished at the  
front terminals if the load is attached to the front  
or at the rear terminals if the load is attached to  
the rear terminals. Also, provision is included on  
the rear terminal strip for remote sensing.

**REMOTE PROGRAMMING:**

Remote programming of the supply output at  
approximately 200 ohms per volt in constant voltage  
is made available at the rear terminals. In con-  
stant current mode of operation, the current can be  
remotely programmed at approximately 1000 ohms  
per ampere.

**COOLING:**

Convection cooling is employed. The supply  
has no moving parts.

**SIZE:**

3-1/2" H x 12-5/8" D x 8-1/2" W. Two of the  
units can be mounted side by side in a standard  
19" relay rack.

**WEIGHT:**

14 lbs. net, 19 lbs. shipping.

**FINISH:**

Light gray front panel with dark gray case.

**POWER CORD:**

A three-wire, five-foot power cord is provided  
with each unit.

## SECTION II INSTALLATION

### 2-1 INITIAL INSPECTION

2-2 Before shipment, this instrument was inspected and found to be free of mechanical and electrical defects. As soon as the instrument is unpacked, inspect for any damage that may have occurred in transit. Save all packing materials until the inspection is completed. If damage is found, proceed as described in the Claim for Damage in Shipment section of the warranty page at the rear of this manual.

### 2-3 MECHANICAL CHECK

2-4 This check should confirm that there are no broken knobs or connectors, that the cabinet and panel surfaces are free of dents and scratches, and that the meter is not scratched or cracked.

### 2-5 ELECTRICAL CHECK

2-6 The instrument should be checked against its electrical specifications. Section V includes an "in-cabinet" performance check to verify proper instrument operation.

### 2-7 INSTALLATION DATA

2-8 The instrument is shipped ready for bench operation. It is necessary only to connect the in-

strument to a source of power and it is ready for operation.

### 2-9 LOCATION

2-10 This instrument is air cooled. Sufficient space should be allotted so that a free flow of cooling air can reach the sides and rear of the instrument when it is in operation. It should be used in an area where the ambient temperature does not exceed 50°C.

### 2-11 RACK MOUNTING

2-12 This instrument may be rack mounted in a standard 19 inch rack panel either alongside a similar unit or by itself. Figures 2-1 and 2-2 show how both types of installations are accomplished.

2-13 To mount two units side-by-side, proceed as follows:

- Remove the four screws from the front panels of both units.
- Slide rack mounting ears between the front panel and case of each unit.
- Slide combining strip between the front panels and cases of the two units.
- After fastening rear portions of units together using the bolt, nut, and spacer, replace panel screws.

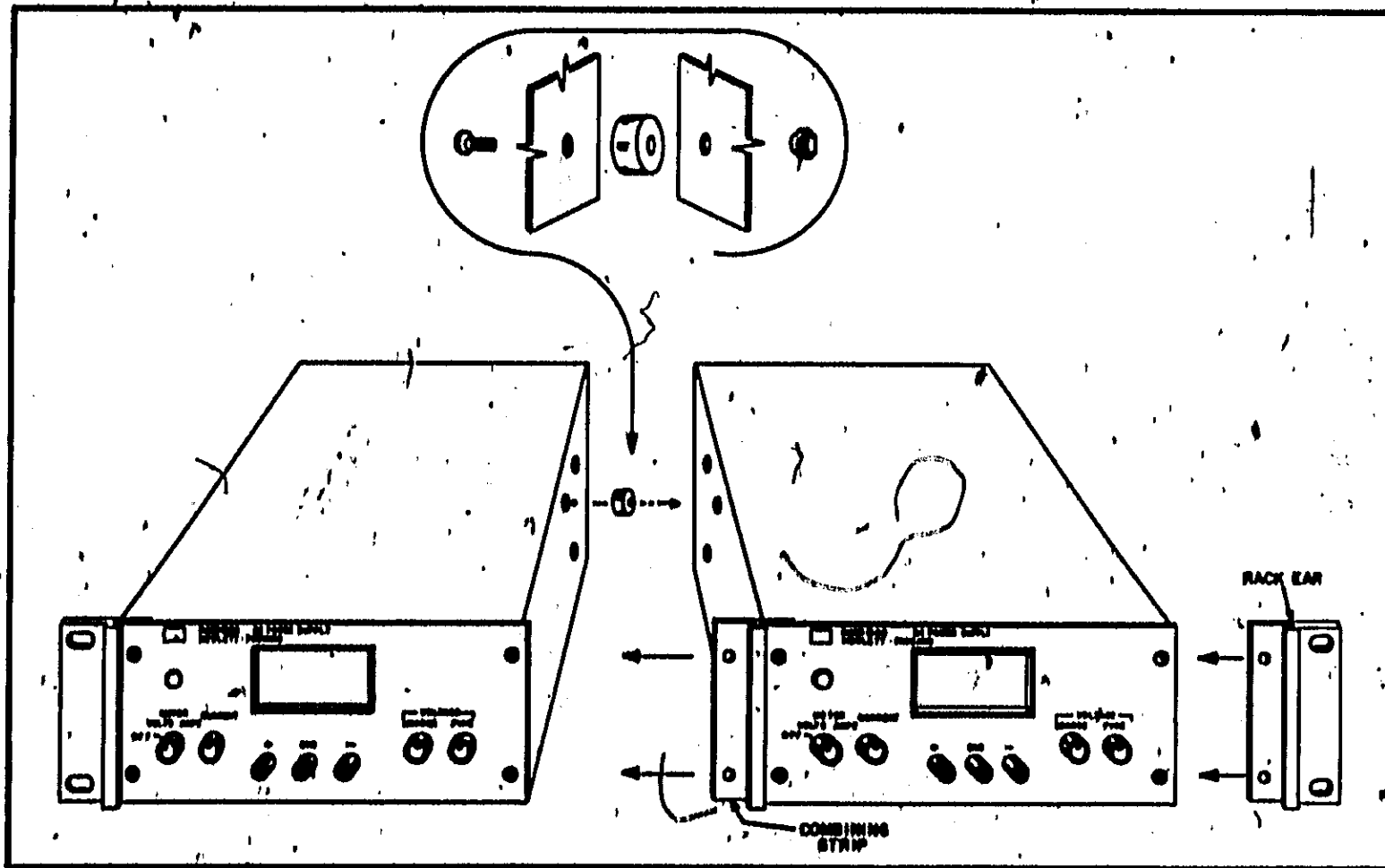

Figure 2-1: Rack Mounting, Two Units

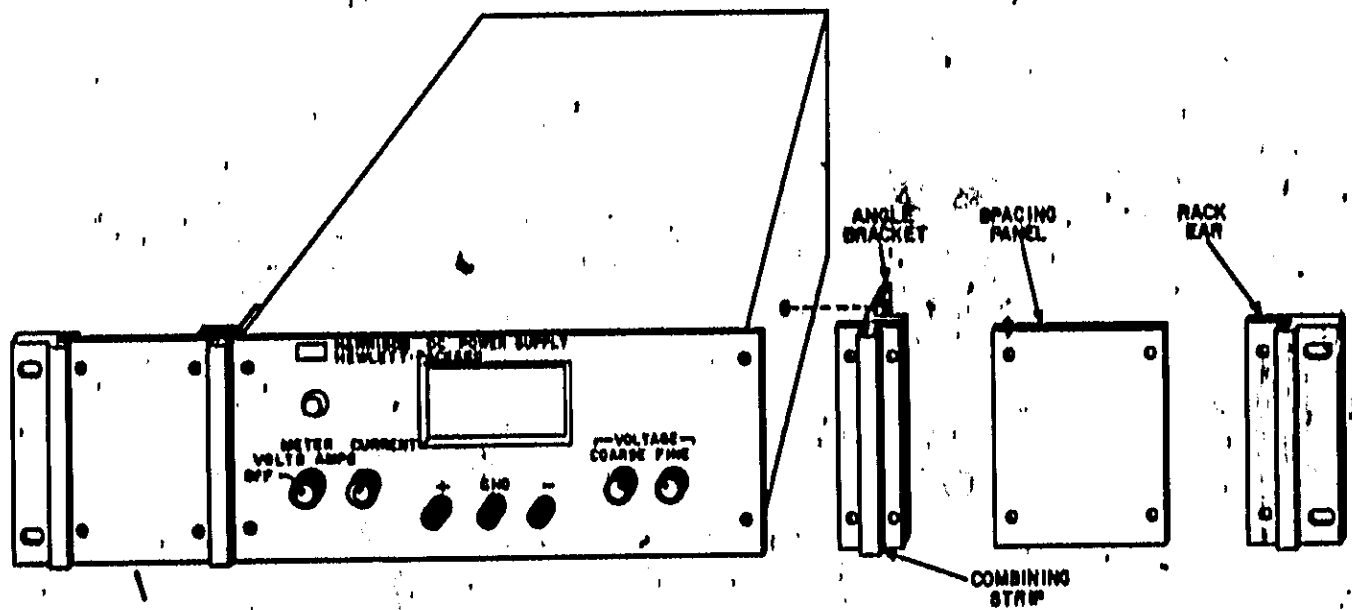

Figure 2-2. Rack Mounting, One Unit

2-14 To mount a single unit in the rack panel, proceed as follows:

- a. Bolt rack mounting ears, combining straps, and angle brackets to each side of center spacing panels. Angle brackets are placed behind combining straps as shown in Figure 2-2.
- b. Remove four screws from front panel of unit.
- c. Slide combining strips between front panel and case of unit.
- d. Bolt angle brackets to front sides of case and replace front panel screws.

#### 2-15 INPUT POWER REQUIREMENTS

2-16 This power supply may be operated from either a nominal 115 volt or 230 volt 50-500 cycle power source. The unit, as shipped from the factory, is wired for 115 volt operation. The input power required when operated from a 115 volt 60 cycle power source at full load is 70 watts and 0.85 amperes.

#### 2-17 CONNECTIONS FOR 230 VOLT OPERATION (Figure 2-3)

2-18 Normally, the two primary windings of the input transformer are connected in parallel for operation from 115 volt source. To convert the power supply to operation from a 230 volt source, the power transformer windings are connected in series as follows:

- a. Unplug the line cord and remove the unit from case.
- b. Break the copper between 54 and 55 and also between 50 and 51 on the printed circuit board. These are shown in Figure 2-3, and are labeled on copper side of printed circuit board.

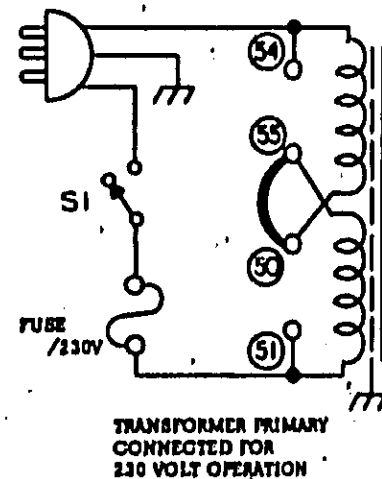
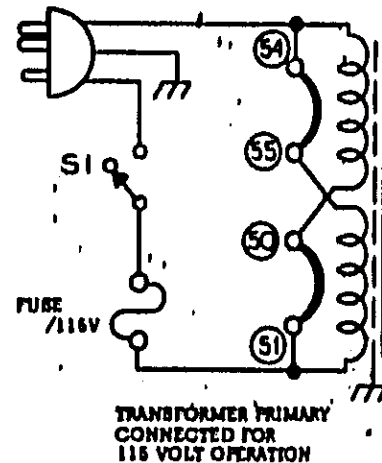

NOTE: CONNECTIONS BETWEEN 50 & 51, 54 & 55, ARE MADE WITH COPPER ON THE PRINTED CIRCUIT BOARD. THESE CONNECTIONS MUST BE REMOVED FOR 230V OPERATION. THE CONNECTIONS ON THE PRINTED CIRCUIT BOARD MUST BE BROKEN AND A SEPARATE EXTERNAL CONNECTION MADE BETWEEN POINTS 50 & 55.

Figure 2-3. Primary Connections

- c. Add strap between 50 and 55.
- d. Replace existing fuse with 1 ampere, 230 volt fuse. Return unit to case and operate normally.

## 2-19 POWER CABLE

2-20 To protect operating personnel, the National Electrical Manufacturers Association (NEMA) recommends that the instrument panel and cabinet be grounded. This instrument is equipped with a three conductor power cable. The third conductor is the ground conductor and when the cable is plugged into an appropriate receptacle, the instrument is grounded. The offset pin on the power cable three-prong connector is the ground connection.

2-21 To preserve the protection feature when operating the instrument from a two-contact outlet, use a three-prong to two-prong adapter and connect the green lead on the adapter to ground.

## 2-22 REPACKAGING FOR SHIPMENT

2-23 To insure safe shipment of the instrument, it is recommended that the package designed for the instrument be used. The original packaging material is reusable. If it is not available, contact your local Hewlett-Packard field office to obtain the materials. This office will also furnish the address of the nearest service office to which the instrument can be shipped. Be sure to attach a tag to the instrument which specifies the owner, model number, full serial number, and service required, or a brief description of the trouble.

## SECTION III OPERATING INSTRUCTIONS

### 3-1 OPERATING CONTROLS AND INDICATORS

3-2 The front panel controls and indicators, together with the normal turn-on sequence, are shown in Figure 3-1.

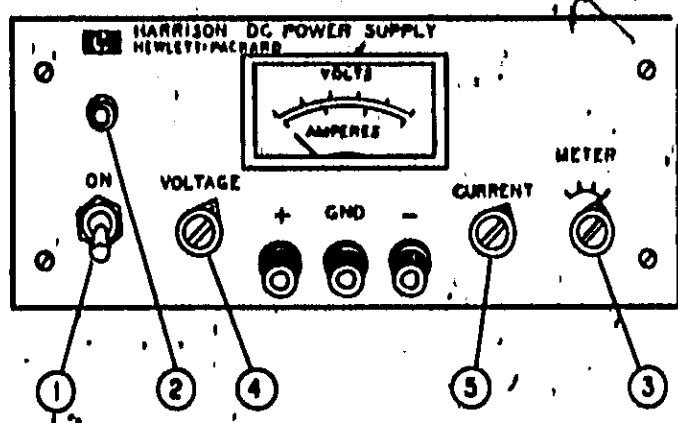

#### TURN-ON SEQUENCE

1. SET AO POWER SWITCH TO ON.
2. OBSERVE THAT PILOT LIGHT GOES ON.
3. SET METER SWITCH TO DESIRED VOLTAGE RANGE.
4. ADJUST COARSE AND FINE VOLTAGE CONTROLS UNTIL DESIRED OUTPUT VOLTAGE IS INDICATED ON METER.
5. SHORT CIRCUIT OUTPUT TERMINALS, SET METER SWITCH TO DESIRED CURRENT RANGE, AND ADJUST CURRENT CONTROLS FOR DESIRED OUTPUT CURRENT.
6. REMOVE SHORT AND CONNECT LOAD TO OUTPUT TERMINALS (FRONT OR REAR).

Figure 3-1. Front Panel Controls and Indicators

### 3-3 OPERATING MODES

3-4 The power supply is designed so that its mode of operation can be selected by making strapping connections between particular terminals on the terminal strip at the rear of the power supply. The terminal designations are stenciled in white on the power supply above their respective terminals. Although the strapping patterns illustrated in this section show the positive terminal grounded, the operator can ground either terminal or operate the power supply up to 300 vdc off ground (floating). The following paragraphs describe the procedures for utilizing the various operational capabilities of the power supply. A more theoretical description concerning the operational features of this supply is contained in a power supply Application Manual and in various Tech. Letters published by the Harrison Division. Copies of these can be obtained from your local Hewlett-Packard field office

### 3-5 NORMAL OPERATING MODE

3-6 The power supply is normally shipped with its rear terminal strapping connections arranged for Constant Voltage/Constant Current, local sensing, local programming, single unit mode of operation. This strapping pattern is illustrated in Figure 3-2. The operator selects either a constant voltage or a constant current output using the front panel controls (local programming, no strapping changes are necessary).

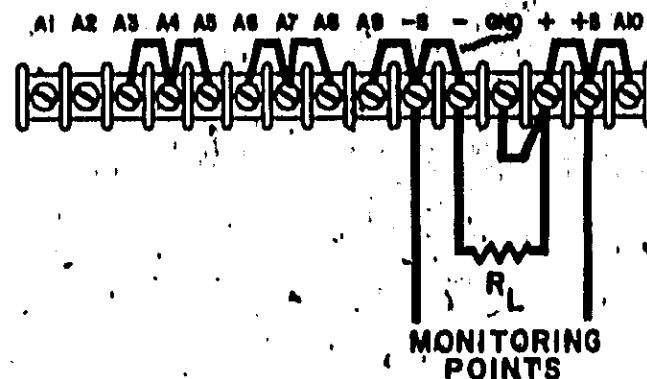

Figure 3-2. Normal Strapping Pattern

### 3-7 CONSTANT VOLTAGE

3-8 To select a constant voltage output, proceed as follows:

- a. Turn-on power supply and adjust VOLTAGE controls for desired output voltage (output terminals open).
- b. Short output terminals and adjust CURRENT controls for maximum output current allowable (current limit), as determined by load conditions. If a load change causes the current limit to be exceeded, the power supply will automatically crossover to constant current output at the preset current limit and the output voltage will drop proportionately. In setting the current limit, allowance must be made for high peak current which can cause unwanted cross-over. (Refer to Paragraph 3-44.)

### 3-9 CONSTANT CURRENT

3-10 To select a constant current output, proceed as follows:

- a. Short output terminals and adjust CURRENT controls for desired output current.

b. Open output terminals and adjust VOLTAGE controls for maximum output voltage allowable (voltage limit), as determined by load conditions. If a load change causes the voltage limit to be exceeded, the power supply will automatically crossover to constant voltage output at the preset voltage limit and the output current will drop proportionately. In setting the voltage limit, allowance must be made for high peak voltages which can cause unwanted crossover. (Refer to Paragraph 3-44).

### 3-11 CONNECTING LOAD

3-12 Each load should be connected to the power supply output terminals using separate pairs of connecting wires. This will minimize mutual coupling effects between loads and will retain full advantage of the low output impedance of the power supply. Each pair of connecting wires should be as short as possible and twisted or shielded to reduce noise pickup. (If shield is used, connect one end to power supply ground terminal and leave the other end unconnected.)

3-13 If load considerations require that the output power distribution terminals be remotely located from the power supply, then the power supply output terminals should be connected to the remote distribution terminals via a pair of twisted or shielded wires and each load separately connected to the remote distribution terminals. For this case, remote sensing should be used (Paragraph 3-28).

### 3-14 OPTIONAL OPERATING MODES

#### 3-15 REMOTE PROGRAMMING, CONSTANT VOLTAGE

3-16 The constant voltage output of the power supply can be programmed (controlled) from a remote location if required. Either a resistance or voltage source can be used for the programming device. The wires connecting the programming terminals of the supply to the remote programming device should be twisted or shielded to reduce noise pick-up. The VOLTAGE controls on the front panel are disabled according to the following procedures.

3-17 Resistance Programming (Figure 3-3). In this mode, the output voltage will vary at a rate determined by the programming coefficient -- 200 ohms per volt (i. e. the output voltage will increase 1 volt for each 200 ohms added in series with programming terminals). The programming coefficient is determined by the programming current. This current is adjusted to within 2% of 5ma at the factory. If greater programming accuracy is required, it may be achieved by changing resistor R13.

3-18 The output voltage of the power supply should be zero volts  $\pm 20$  millivolts when zero ohms is connected across the programming terminals. If

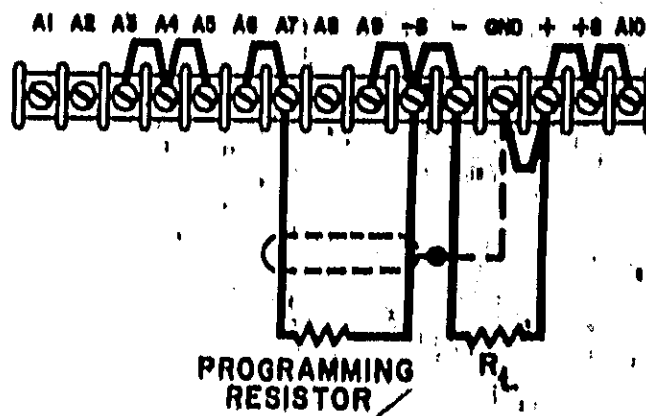

Figure 3-3. Remote Resistance Programming (Constant Voltage)

a zero ohm voltage closer than this is required, it may be achieved by changing resistor R6 or R8 as described in Paragraph 5-49.

3-19 To maintain the stability and temperature coefficient of the power supply, use programming resistors that have stable, low noise, and low temperature (less than 30ppm per degree Centigrade) characteristics. A switch can be used in conjunction with various resistance values in order to obtain discrete output voltages. The switch should have make-before-break contacts to avoid momentarily opening the programming terminals during the switching interval.

3-20 Voltage Programming (Figure 3-4). Employ the strapping pattern shown on Figure 3-4 for voltage programming. In this mode, the output voltage will vary in a 1 to 1 ratio with the programming voltage (reference voltage) and the load on the programming voltage source will not exceed 25 microamperes.

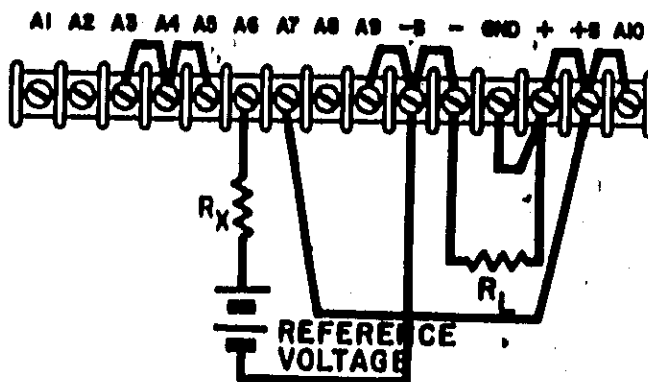

Figure 3-4. Remote Voltage Programming (Constant Voltage)

3-21 The impedance ( $R_X$ ) looking into the external programming voltage source should be approximately 1000 ohms if the temperature and stability specifications of the power supply are to be maintained.

### 3-22 REMOTE PROGRAMMING, CONSTANT CURRENT

3-23 Either a resistance or a voltage source can be used to control the constant current output of the supply. The CURRENT controls on the front panel are disabled according to the following procedures.

3-24 Resistance Programming (Figure 3-5). In this mode, the output current varies at a rate determined by the programming coefficient -- 1000 ohms per ampere for Models 6201B, 6202B, and 6200B (0-0.75 ampere range), and 500 ohms per ampere for Models 6203B and 6200B (0-1.5 ampere range).

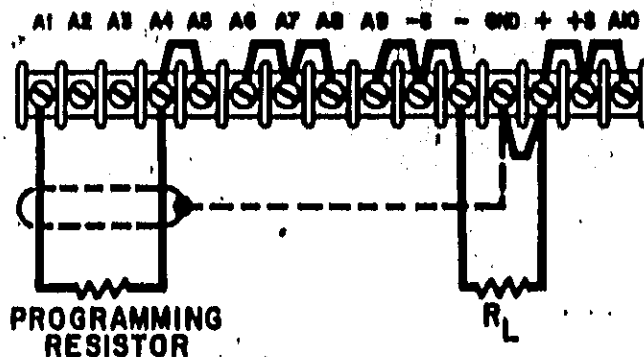

Figure 3-5. Remote Resistance Programming (Constant Current)

The programming coefficient is determined by the programming current. This current is adjusted to within 10% of 1 milliampere at the factory. If greater programming accuracy is required, it may be achieved by changing resistor R19.

3-25 Use stable, low noise, low temperature coefficient (less than 30 ppm/°C) programming resistors to maintain the power supply temperature coefficient and stability specifications. A switch may be used to set discrete values of output current. A make-before-break type of switch should be used since the output current will exceed the maximum rating of the power supply if the switch contacts open during the switching interval.

#### CAUTION

If the programming terminals (A1 and A4) should open at any time during this mode, the output current will rise to a value that may damage the power supply and/or the load. To avoid this possibility, connect a 1.5K resistor across the programming terminals and in parallel with a remote programming resistor. Like the programming resistor, the 1.5K resistor should be of the low noise, low temperature coefficient type.

3-26 Voltage Programming (Figure 3-6). In this mode, the output current will vary linearly with changes in the programming voltage. The programming voltage should not exceed 1.5 volts. Voltage in excess of 1.5 volts will result in excessive power dissipation in the instrument and possible damage.

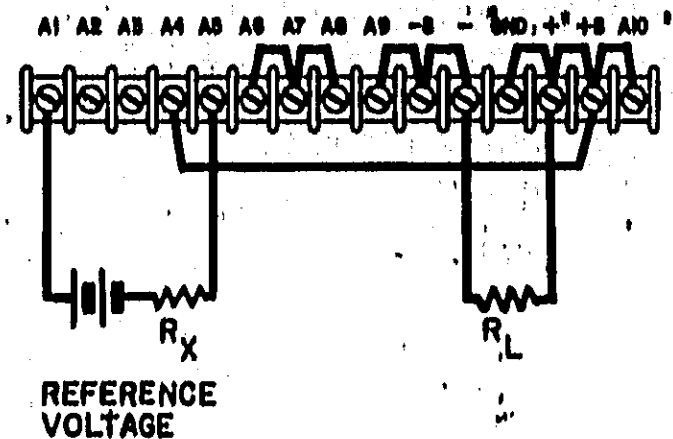

Figure 3-6. Remote Voltage Programming (Constant Current)

3-27. The output current will be the programming voltage divided by 1 ohm. The current required from the voltage source will be less than 25 microamperes. The impedance ( $R_X$ ) as seen looking into the programming voltage source should be approximately 500 ohms if the temperature coefficient and stability specifications of the power supply are to be maintained.

### 3-28 REMOTE SENSING (See Figure 3-7)

3-29 Remote sensing is used to maintain good regulation at the load and reduce the degradation of regulation which would occur due to the voltage drop in the leads between the power supply and the load. Remote sensing is accomplished by utilizing the strapping pattern shown in Figure 3-7. The power supply should be turned off before changing strapping patterns. The leads from the +S terminals to the load will carry less than 10 milliamperes of current, and it is not required that these leads be as heavy as the load leads. However, they must be twisted or shielded to minimize noise pick-up.

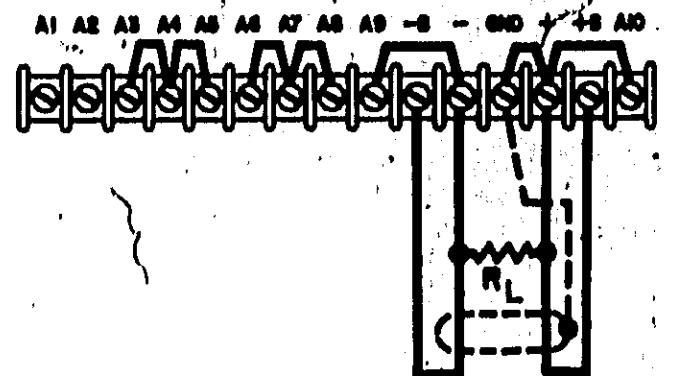

Figure 3-7. Remote Sensing

**CAUTION**

Observe polarity when connecting the sensing leads to the load.

3-30 Note that it is desirable to minimize the drop in the load leads and it is recommended that the drop not exceed 1 volt per lead if the power supply is to meet its DC specifications. If a larger drop must be tolerated, please consult a Hewlett-Packard field representative.

3-31 The procedure just described will result in a low DC output impedance at the load. If a low AC impedance is required, it is recommended that the following precautions be taken:

- a. Disconnect output capacitor C20, by disconnecting the strap between A10 and +8.
- b. Connect a capacitor having similar characteristics (approximately same capacitance, same voltage rating or greater, and having good high frequency characteristics) across the load using short leads.

3-32 Although the strapping patterns shown in Figures 3-3 through 3-6 employ local sensing, note that it is possible to operate a power supply simultaneously in the remote sensing and Constant Voltage / Constant Current remote programming modes.

**NOTE**

It is necessary to readjust the current limit when the instrument is operated in the remote sensing mode.

**3-33 SERIES OPERATION**

3-34 Normal Series Connections (Figure 3-8). Two or more power supplies can be operated in series to obtain a higher voltage than that available from a single supply. When this connection is used, the output voltage is the sum of the voltages of the individual supplies. Each of the individual supplies must be adjusted in order to obtain the total output voltage. The power supply contains a protective diode connected internally across the output which protects the supply if one power supply is turned off while its series partner(s) is on.

3-35 Auto-Series Connections (Figure 3-9). The Auto-Series configuration is used when it is desirable to have the output voltage of each of the series connected supplies vary in accordance with the setting of a control unit. The control unit is called the master; the controlled units are called slaves. At maximum output voltage, the voltage of the slaves is determined by the setting of the front panel VOLTAGE control on the master. The

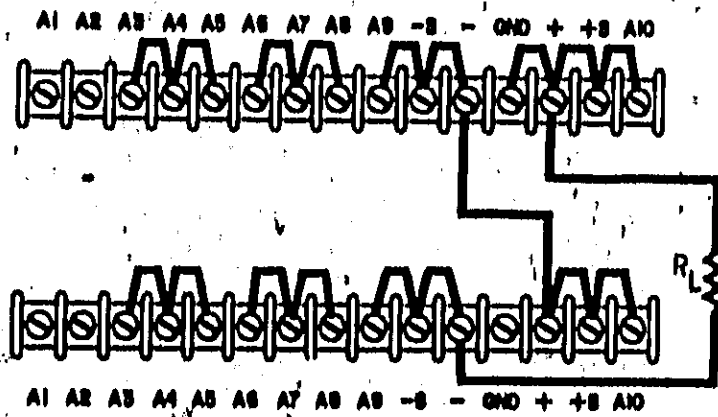

Figure 3-8. Normal Series

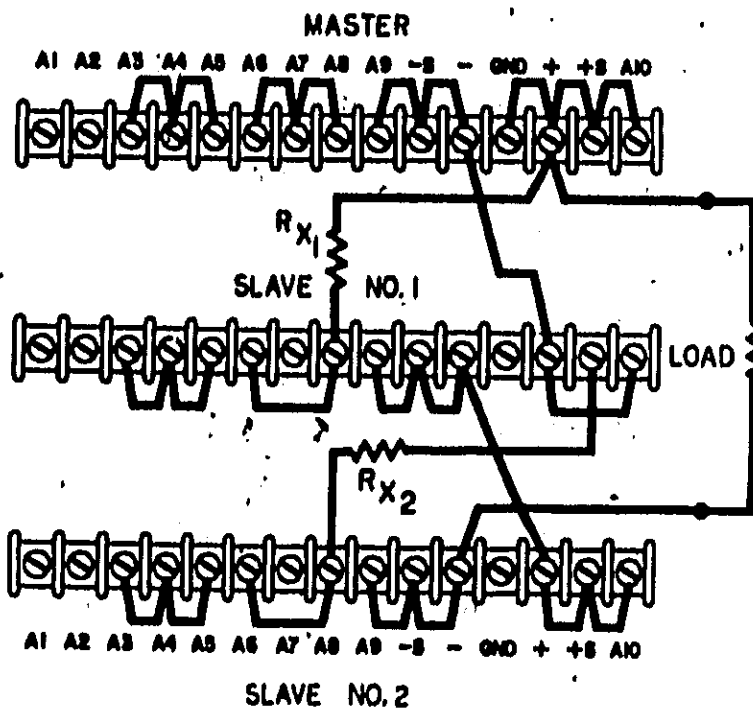
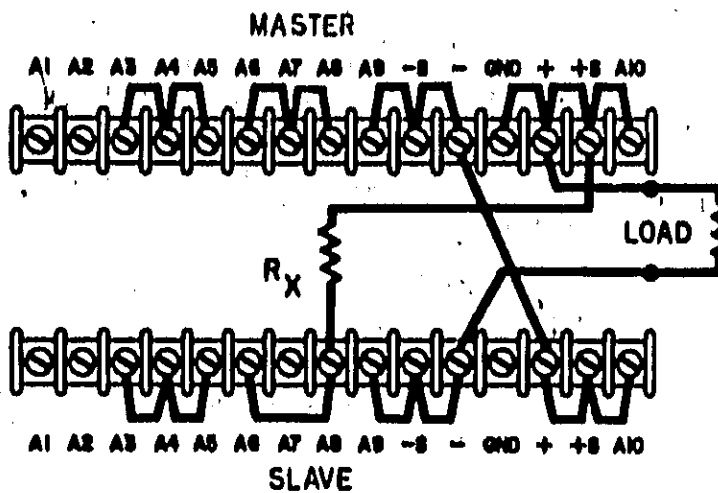

Figure 3-9. AUTO-Series, Two and Three Units



master supply must be the most positive supply of the series. The output CURRENT controls of all series units are operative and the current limit is equal to the lowest control setting. If any output CURRENT controls are set too low, automatic crossover to constant current operation will occur and the output voltage will drop. Remote sensing and programming can be used; however, the strapping arrangements shown in the applicable figures show local sensing and programming.

3-36 In order to maintain the temperature coefficient and stability specifications of the power supply, the external resistors ( $R_x$ ) shown in Figure 3-9 should be stable, low noise, low temperature coefficient (less than 30 ppm per degree Centigrade) resistors. The value of each resistor is dependant on the maximum voltage rating of the "master" supply. The value of  $R_x$  is this voltage divided by the voltage programming current of the slave supply ( $1/K_p$  where  $K_p$  is the voltage programming coefficient). The voltage contribution of the slave is determined by its voltage control setting.

### 3-37 PARALLEL OPERATION

#### 3-38 Normal Parallel Connections (Figure 3-10)

Two or more power supplies can be connected in parallel to obtain a total output current greater than that available from one power supply. The total output current is the sum of the output currents of the individual power supplies. The output CURRENT controls of each power supply can be separately set. The output voltage controls of one power supply should be set to the desired output voltage; the other power supply should be set for a slightly larger output voltage. The supply set to the lower output voltage will act as a constant voltage source; the supply set to the higher output voltage will act as a constant current source, dropping its output voltage until it equals that of the other supply.

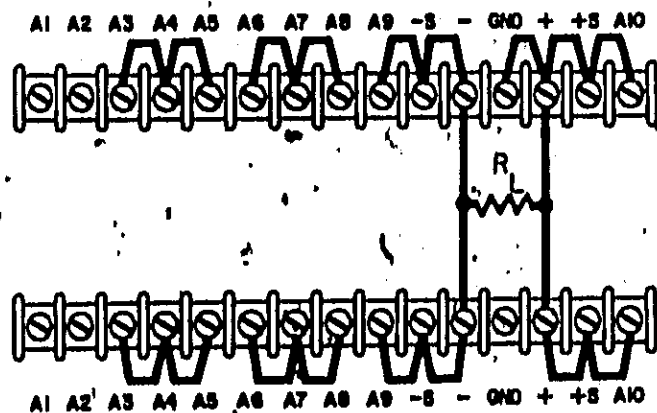

Figure 3-10. Normal Parallel

3-39 Auto-Parallel. The Strapping Patterns for Auto-Parallel operation of two and three power supplies are shown in Figure 3-11. Auto-Parallel operation permits equal current sharing under all load conditions, and allows complete control of output current from one master power supply. The output current of each slave is approximately equal to the master's. Because the output current controls of each slave are operative, they should be set to maximum to avoid having the slave revert to constant current operation; this would occur if the master output current setting exceeded the slave's.

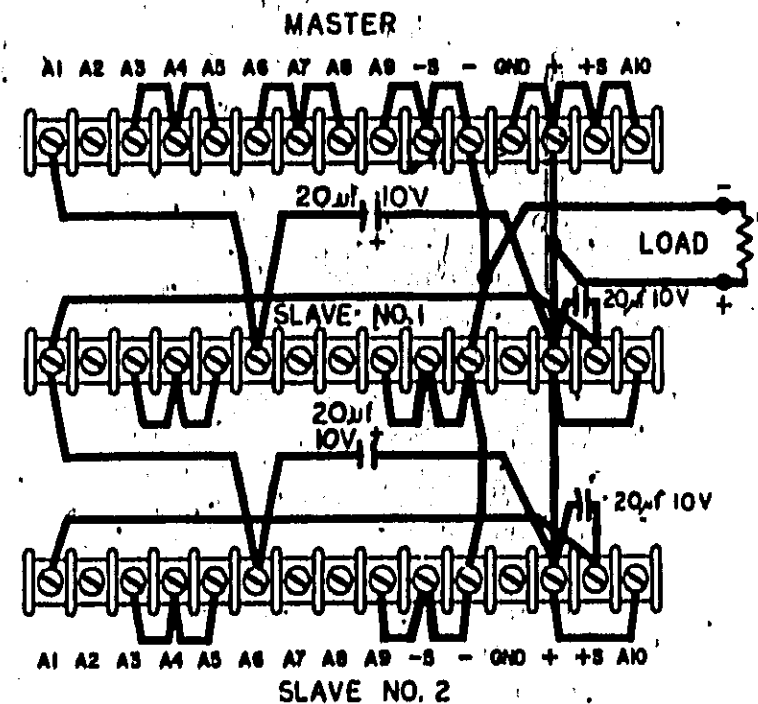
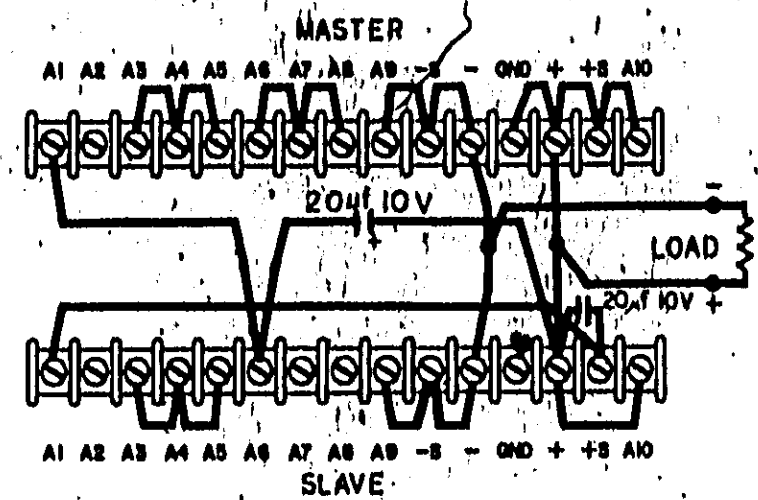

Figure 3-11. Auto-Parallel, Two and Three Units

### 3-40 AUTO-TRACKING OPERATION (See Figure 3-12)

3-41. The Auto-Tracking configuration is used when it is necessary that several different voltages referred to a common bus, vary in proportion to the setting of a particular instrument (the control or master). A fraction of the master's output voltage is fed to the comparison amplifier of the slave supply, thus controlling the slave's output. The master must have the largest output voltage of any power supply in the group (must be the most positive supply in the example shown on Figure 3-12).

3-42 The output voltage of the slave is a percentage of the master's output voltage, and is determined by the voltage divider consisting of  $R_x$  (or  $R_x$  and  $R_y$ ) and the voltage control of the slave supply,  $R_p$  where:  $E_g = R_p / (R_x + R_p)$ . Turn-on and turn-off of the power supplies is controlled by the master. Remote sensing and programming can be used, although the strapping patterns for these modes show only local sensing and programming. In order to maintain the temperature coefficient and stability specifications of the power supply, the external resistors should be stable, low noise, low temperature (less than 30ppm per °C) resistors.

### 3-43 SPECIAL OPERATING CONSIDERATIONS

#### 3-44 PULSE LOADING

3-45 The power supply will automatically cross over from constant voltage to constant current operation, or the reverse, in response to an increase (over the preset limit) in the output current or voltage, respectively. Although the preset limit may be set higher than the average output current or voltage, high peak currents or voltages (as occur in pulse loading) may exceed the preset limit and cause crossover to occur. If this crossover limiting is not desired, set the preset limit for the peak requirement and not the average.

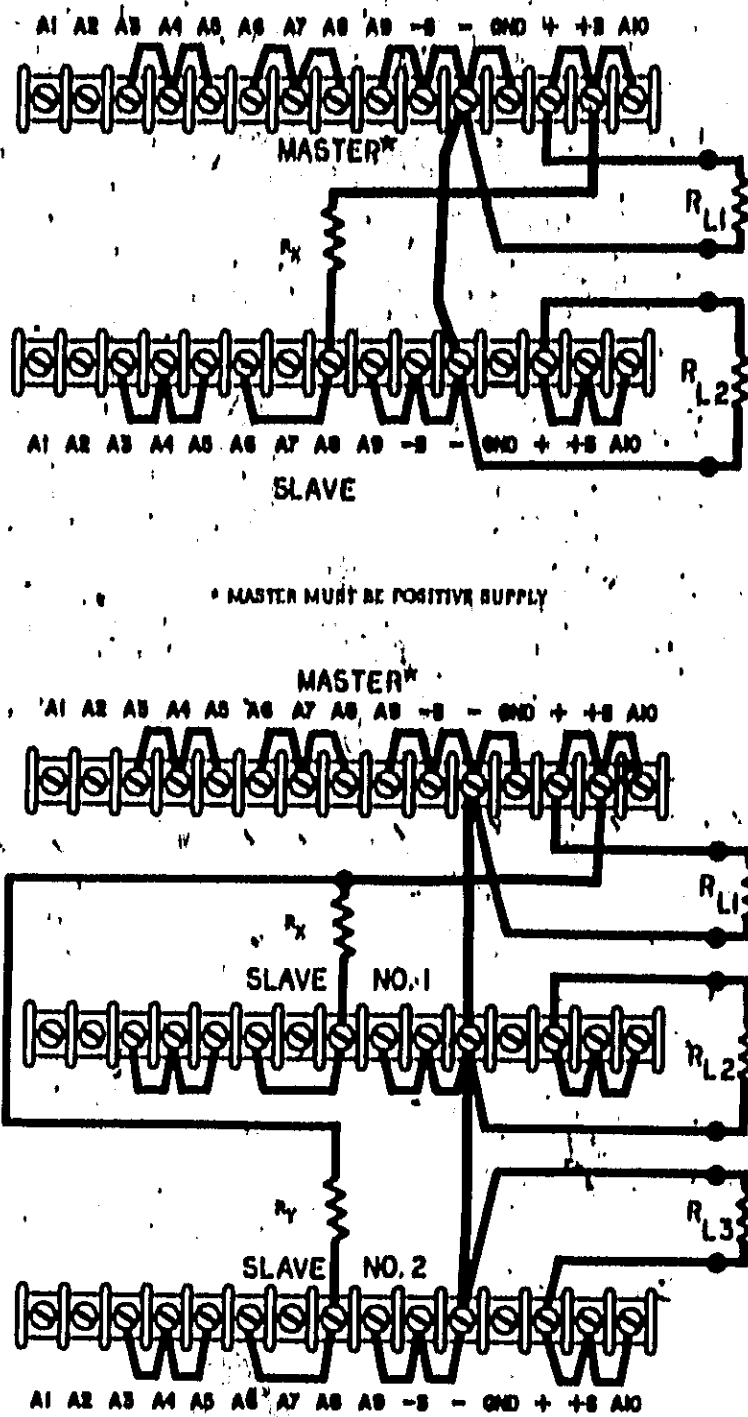

Figure 3-12. Auto-Tracking, Two and Three Units

### 3-46 OUTPUT CAPACITANCE

3-47 There is a capacitor (internal) across the output terminals of the power supply. This capacitor helps to supply high-current pulses of short duration during constant voltage operation. Any capacitance added externally will improve the pulse current capability, but will decrease the safety provided by the constant current circuit. A high-current pulse may damage load components before the average output current is large enough to cause the constant current circuit to operate.

3-48 The effects of the output capacitor during constant current operation are as follows:

- a. The output impedance of the power supply decreases with increasing frequency.
- b. The recovery time of the output voltage is longer for load resistance changes.
- c. A large surge current causing a high power dissipation in the load occurs when the load resistance is reduced rapidly.

### 3-49 REVERSE VOLTAGE LOADING

3-50 A diode is connected across the output terminals. Under normal operating conditions, the diode is reverse biased (anode connected to negative terminal). If a reverse voltage is applied to the output terminals (positive voltage applied to negative terminal), the diode will conduct, shunting current across the output terminals and limiting the voltage to the forward voltage drop of the diode. This diode protects the series transistors and the output electrolytic capacitors.

### 3-51 REVERSE CURRENT LOADING

3-52 Active loads connected to the power supply may actually deliver a reverse current to the power supply during a portion of its operating cycle. An external source cannot be allowed to pump current into the supply without loss of regulation and possible damage to the output capacitor. To avoid these effects, it is necessary to preload the supply with a dummy load resistor so that the power supply delivers current through the entire operating cycle of the load device.

SECTION IV  
PRINCIPLES OF OPERATION

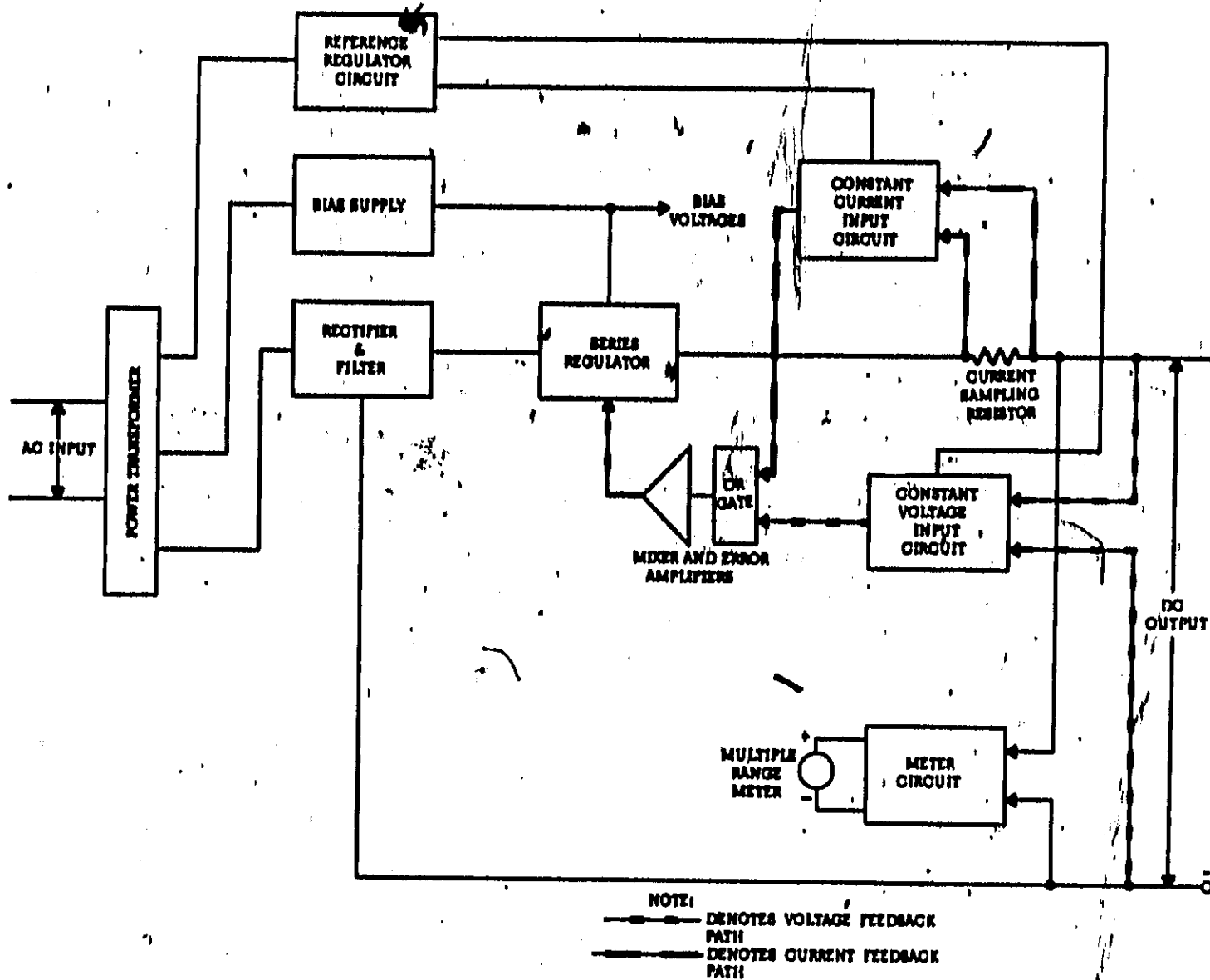

Figure 4-1. Overall Block Diagram

4-1 OVERALL BLOCK DIAGRAM DISCUSSION

4-2 The power supply, as shown on the overall block diagram on Figure 4-1, consists of a power transformer, a rectifier and filter, a series regulator, the mixer and error amplifiers, an "OR" gate, a constant voltage input circuit, a constant current input circuit, a reference regulator circuit, a bias supply, and a metering circuit.

4-3 The input line voltage passes through the power transformer to the rectifier and filter where it is converted to raw DC. The DC current passes through the series regulator to the positive output terminal via a current sampling resistor. The regulator, part of the feedback loop, is made to alter its conduction to maintain a constant output

voltage or current. The voltage developed across the current sampling resistor is the input to the constant current input circuit. The output voltage of the power supply is sampled by the voltage input circuit by means of the sensing terminals ( $\pm S$ ). Any changes in output voltage / current are detected in the constant voltage / constant current input circuit, amplified by the mixer and error amplifiers, and applied to the series regulator in the correct phase and amplitude to counteract any change in output voltage / output current. The reference circuit provides stable reference voltages which are used by the constant voltage / current input circuits for comparison purposes. The bias supply furnishes voltages which are used throughout the instrument for biasing purposes. The meter circuit provides an indication of output voltage or current.

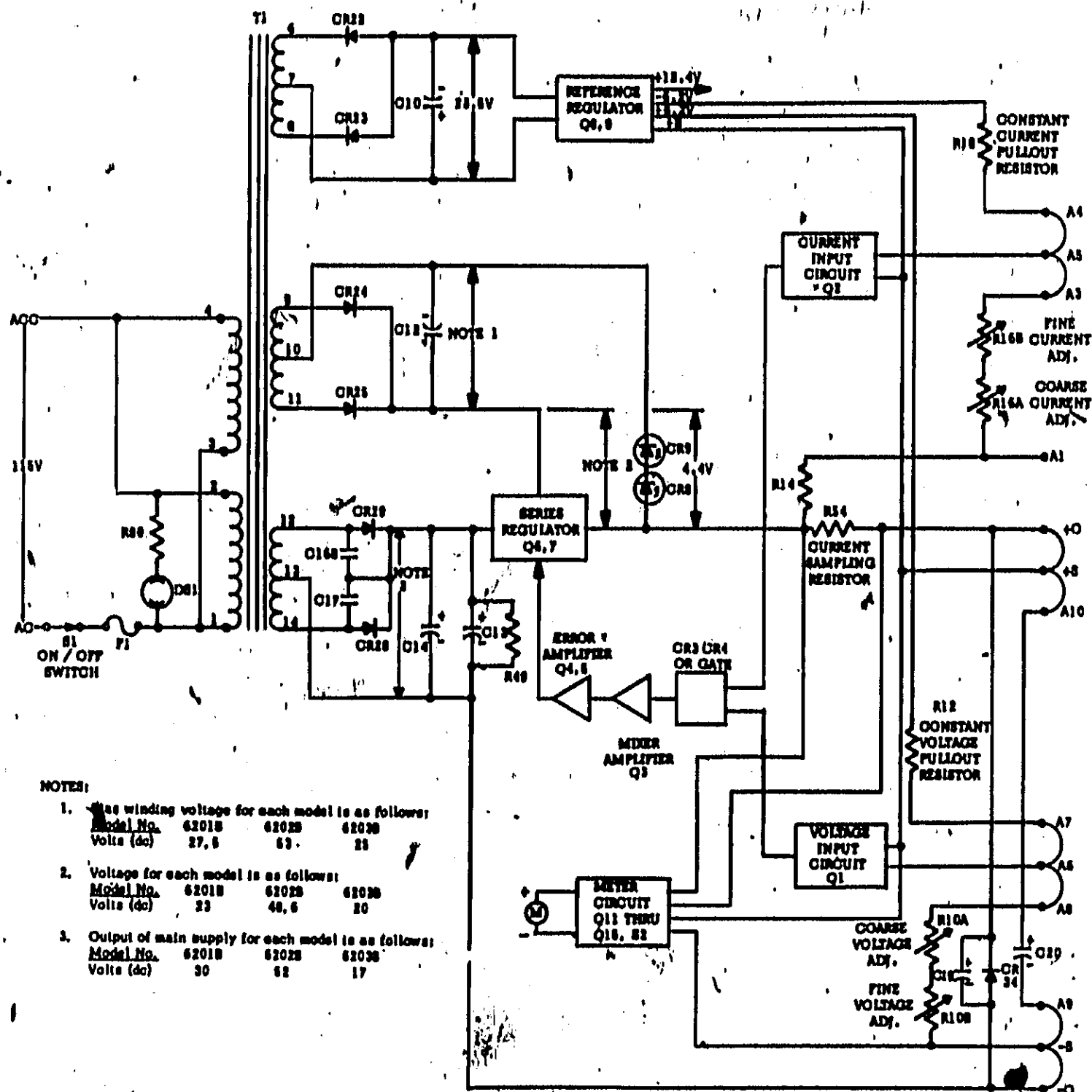

Figure 4-2. Simplified Schematic

#### 4-4 SIMPLIFIED SCHEMATIC

4-5 A simplified schematic of the power supply is shown in Figure 4-2. It shows the operating controls; the ON-off switch, the voltage programming controls (R10A and R10B), and the current programming controls (R16A and R16B). The METER switch, included in the meter circuit block on Figure 4-2, allows the meter to read output voltage or current in either of two ranges. Figure 4-2 also shows the internal sources of bias and reference voltages and their nominal magnitudes. Diode CR34, connected across the output terminals of the

power supply, is a protective device which prevents internal damage that might occur if a reverse voltage were applied across the output terminals. Output capacitor, C20, is also connected across the output terminals when the normal strapping pattern shown on Figure 4-2 is employed. Note that this capacitor can be removed if an increase in the programming speed is desired. Under these conditions, capacitor C19 serves to insure loop stability.

#### 4-6 SERIES REGULATOR

4-7 The series regulator consists of transistor stages Q6 and Q7 (see schematic at rear of manual). The transistors are connected in parallel so that approximately half of the output current flows through each one. The regulator serves as a series control element by altering its conduction so that the output voltage or current is kept constant. The conduction of the transistors is controlled by the feedback voltage from the error amplifier. Diode CR11, connected across the regulator circuit, protects the series transistors against reverse voltages that could develop across them during parallel or auto-parallel operation if one supply is turned on before the other.

#### 4-8 CONSTANT VOLTAGE INPUT CIRCUIT (Figure 4-3)

4-9 The circuit consists of the coarse and fine programming resistors (R10A and R10B), and a differential amplifier stage (Q1 and associated components). Transistor Q1 consists of two silicon transistors housed in a single package. The transistors have matched characteristics minimizing differential voltages due to mismatched stages. Moreover, drift due to thermal differentials is minimized, since both transistors operate at essentially the same temperature.

4-10 The constant voltage input circuit continuously compares a fixed reference voltage with a portion of the output voltage and, if a difference exists, produces an error voltage whose amplitude and phase is proportional to the difference. The error output is fed back to the series regulator, through an OR gate and the mixer/error amplifiers. The error voltage changes the conduction of the series regulator which, in turn, alters the output voltage so that the difference between the two input voltages applied to the differential amplifier is reduced to zero. This action maintains the output voltage constant.

4-11 Stage Q1B of the differential amplifier is connected to a common (+8) potential through impedance equalizing resistor R5. Resistor R6 and R8 are used to zero bias the input stage, offsetting minor base to emitter voltage differences in Q1. The base of Q1A is connected to a summing point at the junction of the programming resistors and the current pullout resistor R12. Instantaneous changes in output voltage result in an increase or decrease in the summing point potential. Q1A is then made to conduct more or less, in accordance with summing point voltage change. The resultant output error voltage is fed back to the series regulator via the remaining components of the feedback loop.

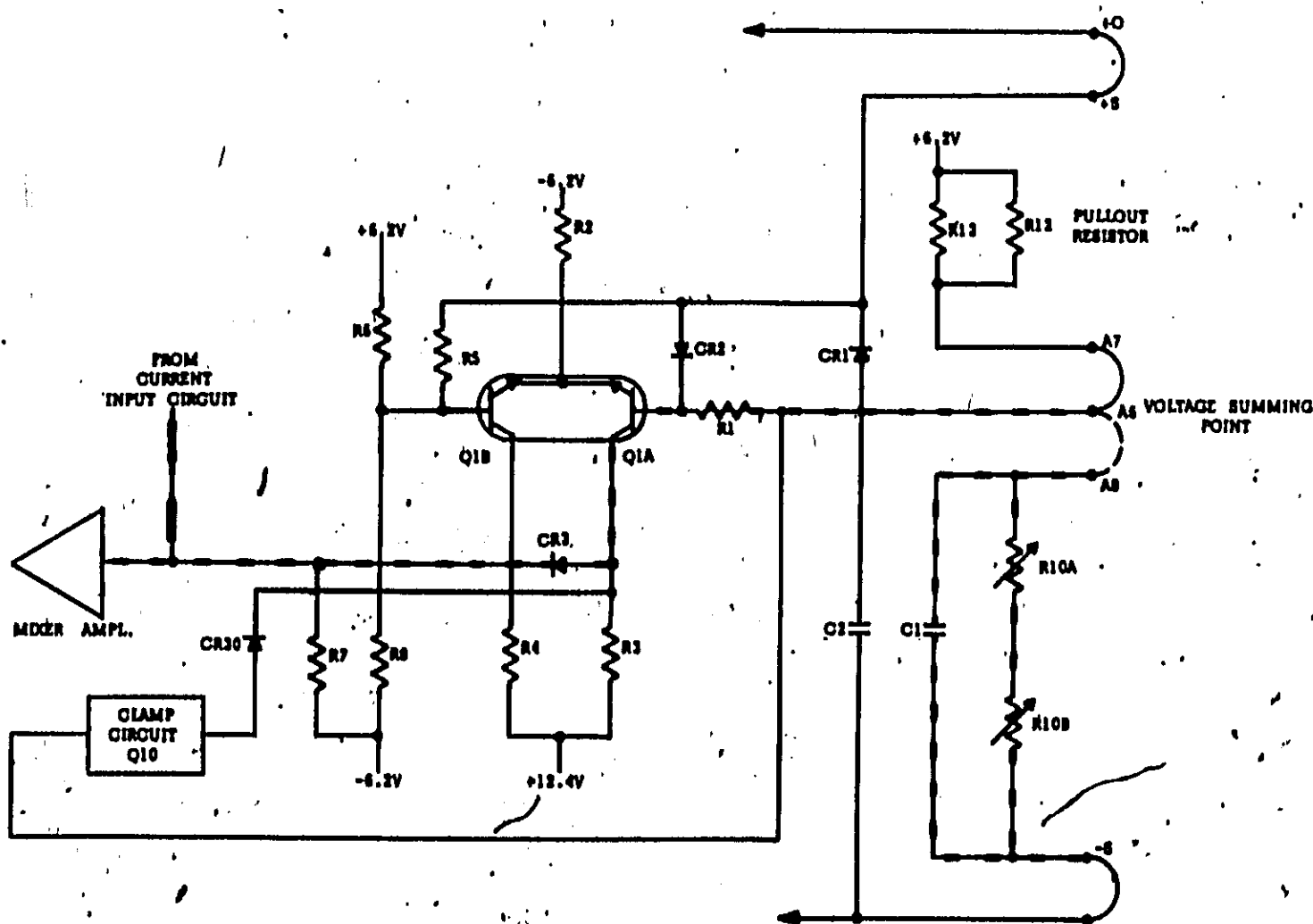

Figure 4-3. Constant Voltage Input Circuit, Simplified Schematic

Resistor R1, in series with the base Q1A, limits the current through the programming resistors during rapid voltage turn-down. Diodes CR1 and CR2 form a limiting network which prevent excessive voltage excursions from over driving stage Q1A. Capacitors C1 and C2, shunting the programming resistors, increase the high frequency gain of the input amplifier. Resistor R13, shunting pullout resistor R12, serves as a trimming adjustment for the programming current.

#### 4-12 CONSTANT CURRENT INPUT CIRCUIT (Figure 4-4)

4-13 This circuit is similar in appearance and operation to the constant voltage input circuit. It consists of the coarse and fine current programming resistors (R16A and R16B), and a differential amplifier stage (Q2 and associated components). Like transistor Q1 in the voltage input circuit, Q2 consists of two transistors, having matched characteristics, that are housed in a single package.

4-14 The constant current input circuit continuously compares a fixed reference voltage with the voltage drop across current sampling resistor R54. If a difference exists, the differential amplifier produces an error voltage which is proportional to this difference. The remaining components in the

feedback loop (amplifiers and series regulator) function to maintain the drop across the current sampling resistor, and consequently the output current, at a constant value.

4-15 Stage Q2B is connected to the +8 through impedance equalizing resistor R28. Resistors R25 and R28 are used to zero bias the input stage, offsetting minor base to emitter voltage differences in Q2. Instantaneous changes in output current on the positive line are felt at the current summing point and, hence, the base of Q2A. Stage Q2A varies its conduction in accordance with the polarity of the change at the summing point. The change in Q2A's conduction also varies the conduction of Q2B due to the coupling effects of the common emitter resistor, R22. The error voltage is taken from the collector Q2B and fed back to the series regulator through OR-gate diode CR4 and the remaining components of the feedback loop. The error voltage then varies the conduction of the regulator so that the output current is maintained at the proper level.

4-16 Resistor R20, in conjunction with R2 and C3, helps stabilize the feedback loop. Diode CR5 limits voltage excursions on the base of Q2A. Resistor R19, shunting the pullout resistor, serves as a trimming adjustment for the programming current flowing through R16A and B.

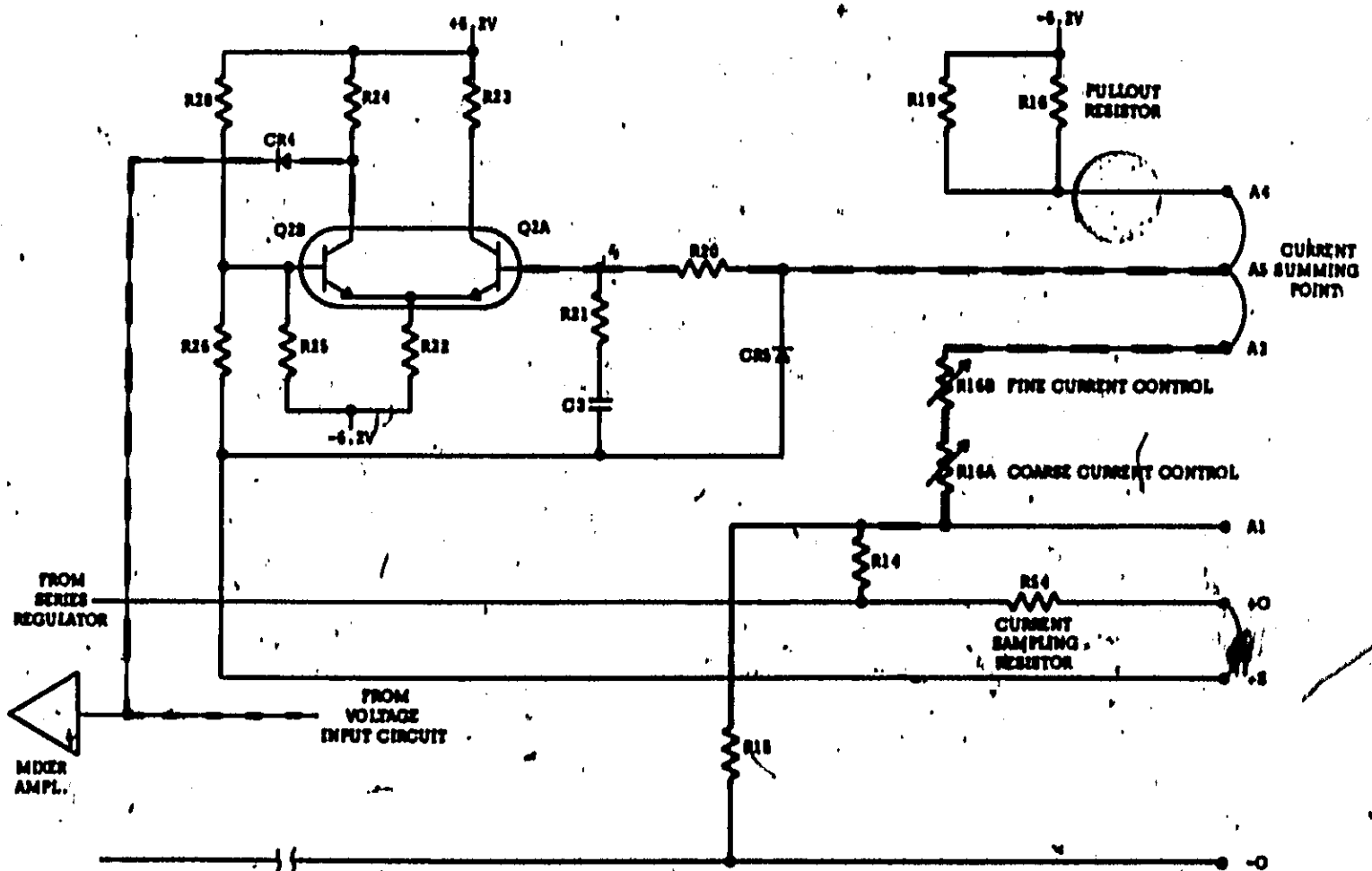

Figure 4-4. Constant Current Input Circuit, Simplified Schematic

#### 4-17 VOLTAGE CLAMP CIRCUIT (Figure 4-5)

4-18 During constant current operation the constant voltage programming resistors are a shunt load across the output terminals of the power supply. If the output voltage changed, the current through these resistors would tend to change resulting in an output current change. The clamp circuit is a return path for the voltage programming current, the current that normally flows through the programming resistors. The circuit maintains the current into the constant voltage summing point (A6) constant, thus eliminating the error due to shunting effects of the constant voltage programming resistors.

4-19 The voltage divider, R51, R52, and CR31, back biases CR30 and Q10 during constant voltage operation. When the power supply goes into constant current operation, CR30 becomes forward biased by the collector voltage of Q1A. This results in conduction of Q10 and the clamping of the summing point at a potential only slightly more negative than the normal constant voltage potential. Clamping this voltage at approximately the same potential that exists in constant voltage operation, results in a constant voltage across, and consequently a constant current through, the current pull-out resistor (R12).

#### 4-20 MIXER AND ERROR AMPLIFIERS (Figure 4-6)

4-21 The mixer and error amplifiers amplify the error signal from the constant voltage or constant current input circuit to a level sufficient to drive the series regulator transistors. The emitter bias

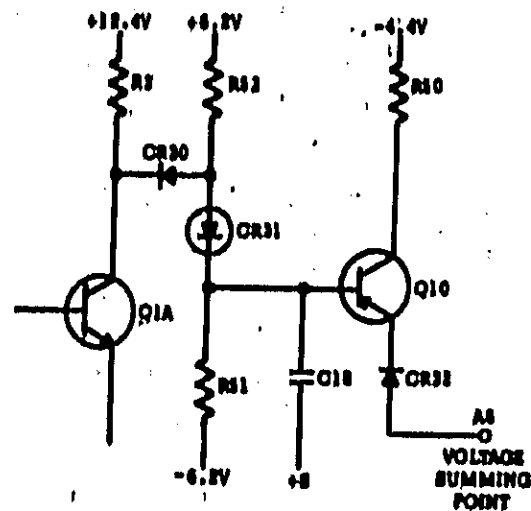

Figure 4-5. Voltage Clamp Circuit

potential for mixer amplifier Q3 is established by emitter follower Q17. Transistor Q3 receives the error voltage input from either the constant voltage or constant current circuit via the OR-gate diode (CR3 or CR4) that is conducting at the time. Diode CR3 is forward biased, and CR4 reversed biased, during constant voltage operation. The reverse is true during constant current operation.

4-22 The RC network, composed of C5 and R30, is an equalizing network which provides for high frequency roll off in the loop gain response in order to stabilize the feedback loop. Emitter follower transistors Q4 and Q5 are the error amplifiers serving as the driver and predriver elements, respectively, for the series regulator. Transistor Q4, together with diode CR17, provides a low resistance discharge path for the output capacitance of the power supply during rapid down programming.

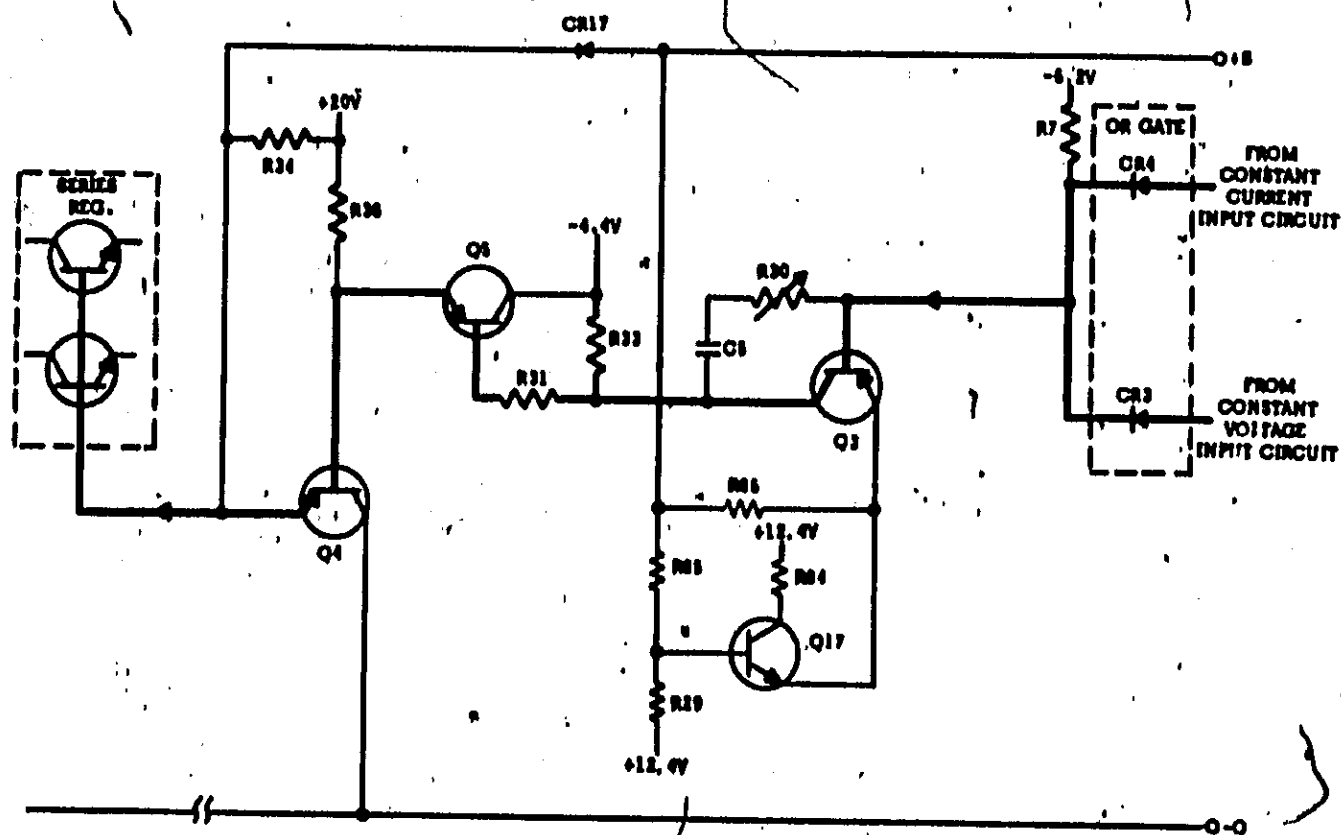

Figure 4-6. Mixer and Error Amplifiers, Simplified Schematic



#### 4-23 REFERENCE CIRCUIT

4-24 The reference circuit (see schematic) is a feedback power supply similar to the main supply. It provides stable reference voltages which are used throughout the unit. The reference voltages are all derived from smoothed dc obtained from the full wave rectifier (CR22 and CR23) and filter capacitor C10. The +6.2 and -6.2 voltages, which are used in the constant voltage and current input circuits for comparison purposes, are developed across temperature compensated Zener diodes VR1 and VR2. Resistor R43 limits the current through the Zener diodes to establish an optimum bias level.

4-25 The regulating circuit consists of series regulating transistor Q9 and error amplifier Q8. Output voltage changes are detected by Q8 whose base is

connected to the junction of a voltage divider (R41, R42) connected directly across the supply. Any error signals are amplified and inverted by Q8 and applied to the base of series transistor Q9. The series element then alters its conduction in the direction and by the amount necessary to maintain the voltage across VR1 and VR2 constant. Resistor R46, the emitter resistor for Q8, is connected in a manner which minimizes changes in the reference voltage caused by variations in the input line. Output capacitor C7 stabilizes the regulator loop.

#### 4-26 METER CIRCUIT (Figure 4-7)

4-27 The meter circuit provides continuous indications of output voltage or current on a single multiple range meter. The meter can be used either as a voltmeter or an ammeter depending upon the position of METER switch S2 on the front panel of the supply:

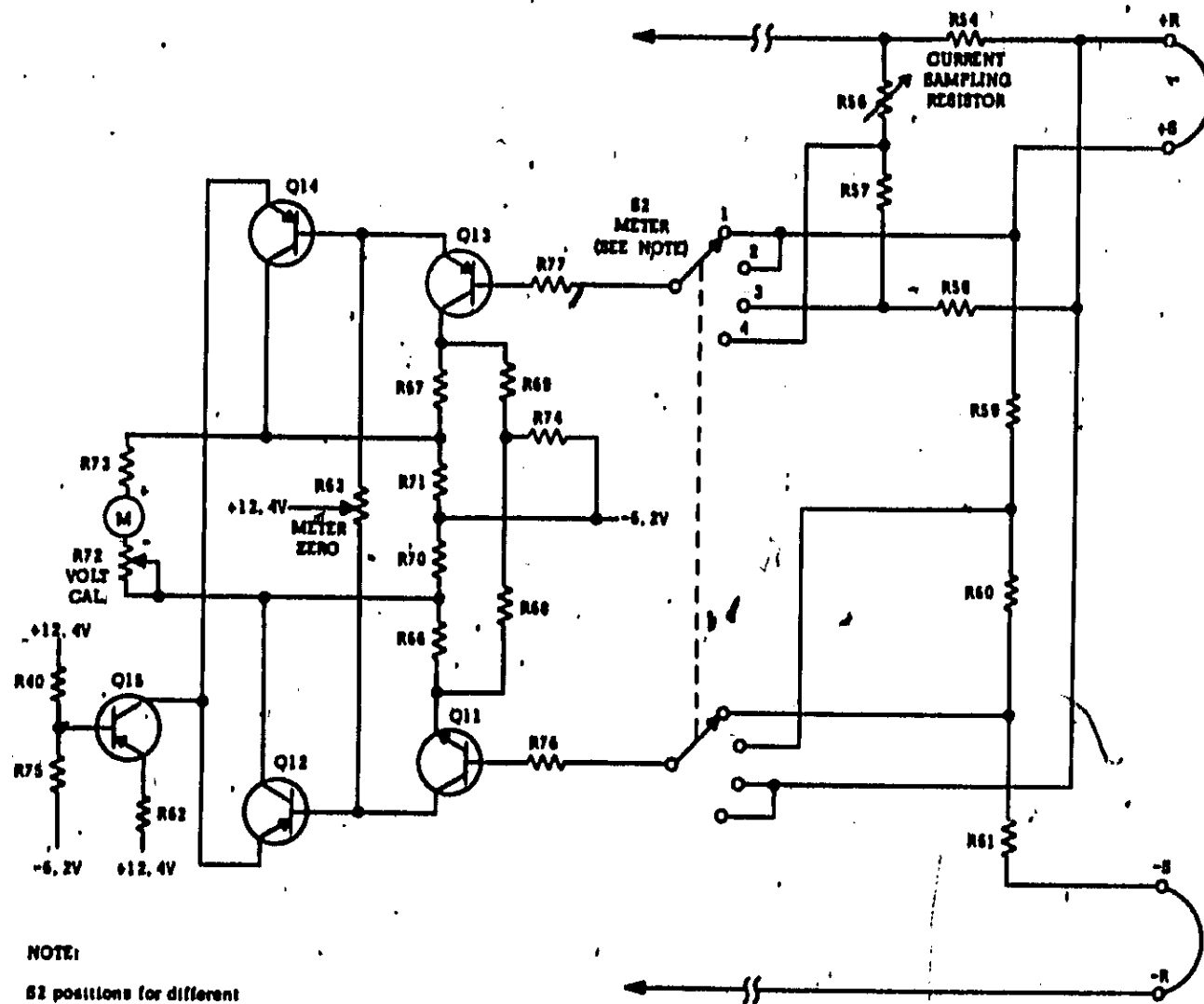

NOTE:

S2 positions for different models are shown below.

Model	S2 TERMINAL NO.			
	1	2	3	4
6201B	2.4V	24V	1.0A	10A
6202B	5V	50V	.5A	5A
6203B	9V	9V	4A	4A

Figure 4-7. Meter Circuit, Simplified Schematic

This switch also selects one of two meter ranges on each scale. The metering circuit consists basically of a selection circuit (switch S2 and associated voltage dividers), a stable differential amplifier stage (Q11 through Q14), and the meter movement.

4-28 The selection circuit determines which voltage divider is connected to the differential amplifier input. When S2 is in one of the voltage positions, the voltage across divider R58, R60, and R61 (connected across the output of the supply) is the input to the differential amplifier. When S2 is in one of the current positions, the voltage across divider R56, R57, and R58 (connected across current sampling resistor R54) is the input to the differential amplifier. The amplified output of the differential amplifier is used to deflect the meter.

4-29 The differential amplifier is a stable device having a fixed gain of ten. Stage Q11 of the differential amplifier receives a negative voltage from the applicable voltage divider when S2 is in one of the voltage positions while stage Q13 is connected to the +8 (common) terminal. With S2 in a current position, stage Q13 receives a positive voltage from the applicable voltage divider while stage Q11 is connected to the +8 terminal. The differential output of the amplifier is taken from the collectors of Q12 and Q14. Transistor Q15 is a constant current source which sets up the proper bias current for the amplifier. Potentiometer R63 permits zeroing of the meter. The meter amplifier stage contains an inherent current limiting feature which protects the meter movement against overloads. For example, if METER switch S2 is placed in position 4, (low current range) when the power supply is actually delivering a higher ampere output, the differential amplifiers are quickly driven into saturation. This action limits the current through the meter to a safe value.

4-30 Figures 4-8 and 4-9 show the meter connections when S2 is in the higher voltage and current positions, respectively. For the sake of simplicity, some of the actual circuit components are not shown on these drawings. With METER switch S2 in the higher voltage range, position (2), the voltage drop across R59 is the input to the meter amplifier and the meter indicates the output voltage across the +8 and -8 terminals. For low output voltages, S2 can be switched to position 1 resulting in the application of a larger percentage of the output voltage (drop across R59 and R60) to the meter amplifier.

4-31 With S2 in the higher current range position (Figure 4-9) the voltage drop across R58 is applied to the meter amplifier and the meter indicates the output current which flows through R54. For low values of output current, S2 can be switched to

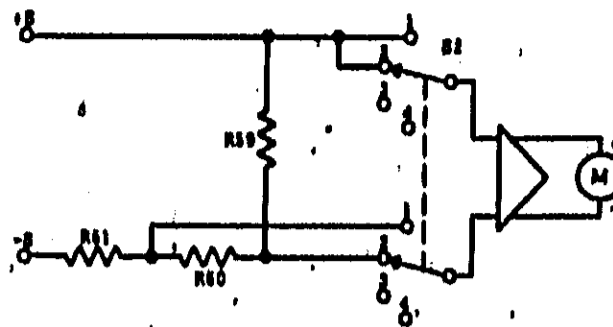

Figure 4-8. Voltmeter Connections, Simplified Schematic

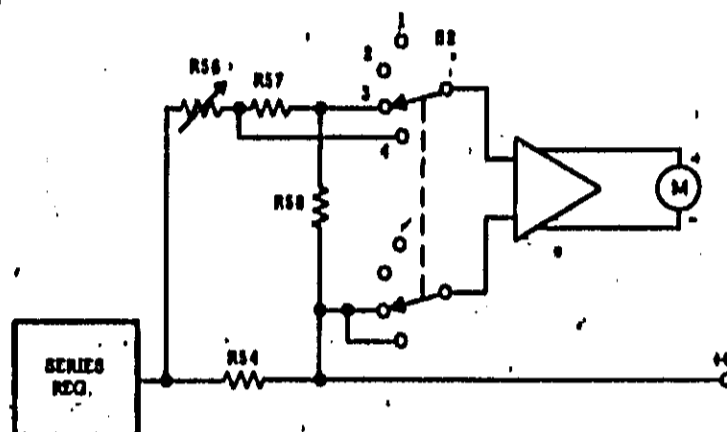

Figure 4-9. Ammeter Connections, Simplified Schematic

position 4 and the voltage drop across R57 and R58 is applied to the meter amplifier.

#### 4-32 OPERATION OF REGULATING FEEDBACK LOOP

4-33 The feedback loop functions continuously to keep the output voltage constant, during constant voltage operation, and the output current constant, during constant current operation. For purposes of this discussion, assume that the unit is in constant voltage operation and that the programming resistors have been adjusted so that the supply is yielding the desired output voltage. Further assume that the output voltage instantaneously rises (goes positive) due to a variation in the external load circuit.

4-34 Note that the change may be in the form of a slow rise in the output voltage or a positive going ac signal. An ac signal is coupled to summing point A6 through capacitor C1 and a dc voltage is coupled to A6 through R10.

4-35 The rise in output voltage causes the voltage at A6 and thus the base of Q1A to decrease (go negative). Q1A now decreases its conduction and its collector voltage rises. The positive going error voltage is amplified and inverted by Q3 and fed to

the bases of series transistors Q6 and Q7 via emitter followers Q5 and Q4. The negative going input causes Q6 and Q7 to decrease their conduction so that they drop more of the line voltage, and reduce the output voltage to its original level.

4-36 If the external load resistance is decreased to a certain crossover point, the output current increases until transistor Q2A begins to conduct. During this time, the output voltage has also decreased to a level so that the base of Q1A is at a

high positive potential. With Q1A in full conduction, its collector voltage decreases by the amount necessary to back bias OR gate diode CR3 and the supply is now in the constant current mode of operation. The crossover point at which constant current operation commences is determined by the setting of CURRENT control R16. The operation of the feedback loop during the constant current operating mode is similar to that occurring during constant voltage operation except that the input to the differential amplifier comparison circuit is obtained from current sampling resistor R54.

## SECTION V MAINTENANCE

### 5-1 INTRODUCTION

5-2 Upon receipt of the power supply, the performance check (Paragraph 5-10) should be made. This check is suitable for incoming inspection. If a fault is detected in the power supply while making the performance check or during normal operation, proceed to the troubleshooting procedure (Paragraph 5-28). After troubleshooting and repair (Paragraph 5-38), perform any necessary adjustments and calibrations (Paragraph 5-40). Before returning the power supply to normal operation, repeat the performance check to ensure that the fault has been properly corrected and that no other faults exist. Before doing any maintenance checks, turn-on power supply, allow a half-hour warm-up, and read the general information regarding measurement techniques (Paragraph 5-3).

### 5-3 GENERAL MEASUREMENT TECHNIQUES

5-4 The measuring device must be connected across the sensing leads of the supply or as close to the output terminals as possible when measuring the output impedance, transient response, regulation, or ripple of the power supply in order to achieve valid measurements. A measurement made across the load includes the impedance of the leads to the load and such lead lengths can easily have an impedance several orders of magnitude greater than the supply impedance, thus invalidating the measurement.

5-5 The monitoring device should be connected to the +B and -B terminals (see Figure 3-2) or as shown in Figure 5-1. The performance characteristics should never be measured on the front terminals if the load is connected across the rear terminals. Note that when measurements are made at the front terminals, the monitoring leads are connected at A, not B, as shown in Figure 5-1. Failure to connect the measuring device at A will result in a measurement that includes the resistance of the leads between the output terminals and the point of connection.

5-6 For output current measurements, the current sampling resistor should be a four-terminal resistor. The four terminals are connected as shown in Figure 5-2. In addition, the resistor should be of the low noise, low temperature coefficient (less than 30 ppm/°C) type and should be used at no more than 5% of its rated power so that its temperature rise will be minimized.

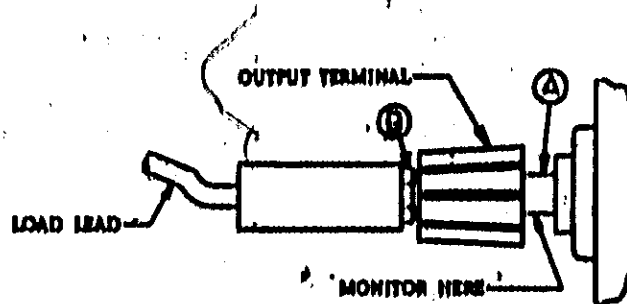

Figure 5-1. Front Panel Terminal Connections

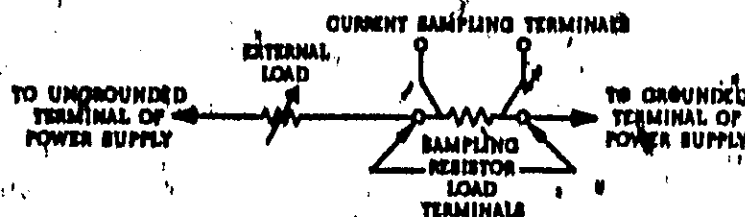

Figure 5-2. Output Current Measurement Technique

5-7 When using an oscilloscope, ground one terminal of the power supply and then ground the case of the oscilloscope to this same point. Make certain that the case is not also grounded by some other means (power line). Connect both oscilloscope input leads to the power supply ground terminal and check that the oscilloscope is not exhibiting a ripple or transient due to ground loops, pick-up, or other means.

### 5-8 TEST EQUIPMENT REQUIRED

5-8 Table 5-1 lists the test equipment required to perform the various procedures described in this Section.

Table 5-1. Test Equipment Required

TYPE	REQUIRED CHARACTERISTICS	USE	RECOMMENDED MODEL
Differential	Sensitivity: 1mv full scale (min.). Input impedance: 10 megohms (min.).	Measure dc voltages; calibration procedures	Ⓢ 3420 (See Note)
Variable Voltage Transformer	Range: 90-130 volts. Equipped with voltmeter accurate within 1 volt.	Vary AC input	----
AC Voltmeter	Accuracy: 2%. Sensitivity: 1mv full scale deflection (min.).	Measure AC voltages and ripple	Ⓢ 403B
Oscilloscope	Sensitivity: 100 $\mu$ v/cm. Differential input.	Display transient response waveforms	Ⓢ 140A plus 1400A plug in.
Oscillator	Range: 5Hz to 600KHz. Accuracy: 2%.	Impedance checks	Ⓢ 200OD
DC Voltmeter	Accuracy: 1%. Input resistance: 20,000 ohms/volt (min.).	Measure dc voltages	Ⓢ 412A
Repetitive Load Switch	Rate: 60-400Hz, 2 $\mu$ sec rise and fall time.	Measure transient response	See Figure 5-7
Resistor	Value: See Paragraph 5-14. $\pm$ 5%, 75 watts.	Load Resistor	----
Resistor	Value: See Figure 5-4. 1%, 200 watts, 20ppm, 4-Terminal.	Current sampling	----
Resistor	1K $\Omega$ $\pm$ 1%, 2 watt non-inductive	Measure impedance	----
Resistor	100 ohms, $\pm$ 5% 10 watt	Measure impedance	----
Resistor	Value: See Paragraph 5-50. $\pm$ 0.1%, 5 watt.	Calibrate programming current	----
Resistor	Value: See Paragraph 5-53. $\pm$ 0.1%, 5 watt.	Calibrate programming current	----
Capacitor	500 $\mu$ f, 50w vdc.	Measure impedance	----

Table 5-1. Test Equipment Required (Continued)

TYPE	REQUIRED CHARACTERISTICS	USE	RECOMMENDED MODEL
Decade Resistance Box	Range: 0-150K (min.). Accuracy: 0.1% plus 1 ohm. Make-before-break contacts.	Measure programming coefficients	---

**NOTE**

A satisfactory substitute for a differential voltmeter is to arrange a reference voltage source and null detector as shown in Figure 5-3. The reference voltage source is adjusted so that the voltage difference between the supply being measured and the reference voltage will have the required resolution for the measurement being made. The voltage difference will be a function of the null detector that is used. Examples of satisfactory null detectors are: 419A null detector, a dc coupled oscilloscope utilizing differential input, or a 50mv meter movement with a 100 division scale. For the latter, a 2mv change in voltage will result in a meter deflection of four divisions.

**CAUTION**

Care must be exercised when using an electronic null detector in which one input terminal is grounded to avoid ground loops and circulating currents.

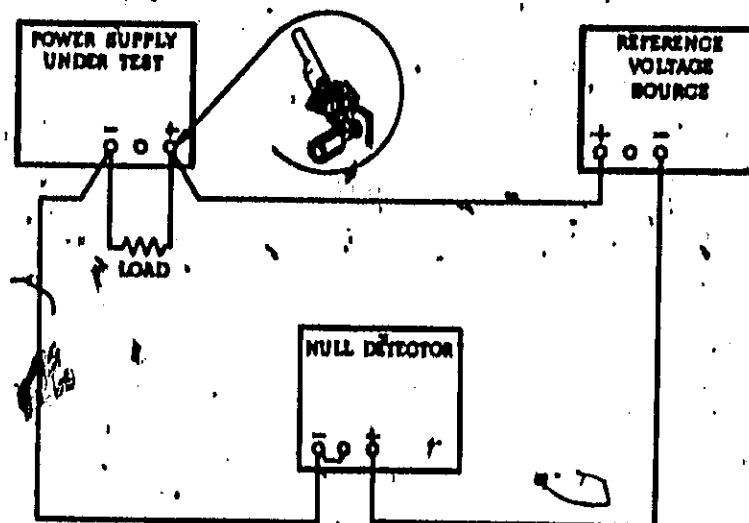

Figure 5-3. Differential Voltmeter Substitute, Test Setup

**5-10 PERFORMANCE TEST**

5-11 The following test can be used as an incoming inspection check and appropriate portions of the test can be repeated either to check the operation of the instrument after repairs or for periodic maintenance tests. The tests are performed using a 115Vac 60Hz, single phase input power source. If the correct result is not obtained for a particular check, do not adjust any controls; proceed to troubleshooting (Paragraph 5-28).

5-12 CONSTANT VOLTAGE TESTS

5-13 Rated Output and Meter Accuracy.

5-14 Voltage. Proceed as follows:

a. Connect load resistor across rear output terminals of supply. Resistor value to be as follows:

Model No.	6200B	6201B	6202B	6203B
Resistance (Ohms)	53	13	53	2.5

b. Connect differential voltmeter across +S and -S terminals of supply observing correct polarity.

c. Set METER switch to highest voltage range (and RANGE switch to 40V for Model 6200B) and turn on supply.

d. Adjust VOLTAGE controls until front panel meter indicates exactly the maximum rated output voltage.

e. Differential voltmeter should indicate maximum rated output voltage within  $\pm 2\%$ .

5-15 Current. Proceed as follows:

a. Connect test setup shown in Figure 5-4.

b. Turn CURRENT controls fully clockwise.

c. Set METER switch to highest current range (and RANGE switch to 20V mode for Model 6200B) and turn on supply.

d. Adjust VOLTAGE controls until front panel meter indicates exactly the maximum rated output current.

e. Differential voltmeter should read  $1.5 \pm 0.03$  Vdc.

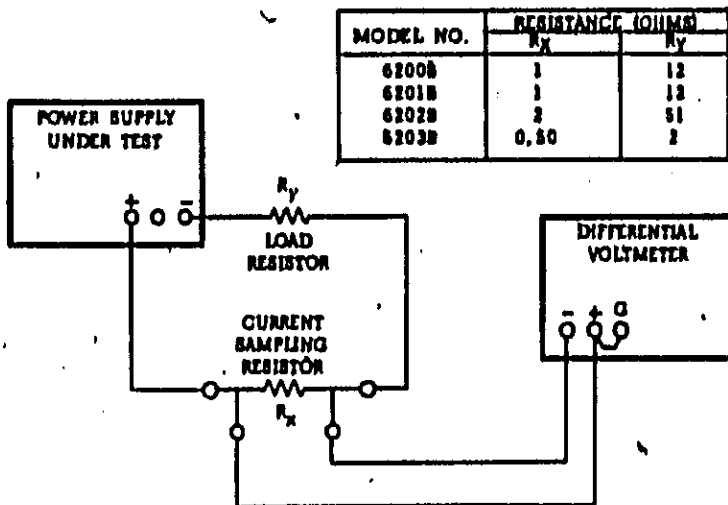

Figure 5-4. Output Current, Test Setup

5-16 Load Regulation. To check constant voltage load regulation, proceed as follows:

a. Connect test setup as shown in Figure 5-5.

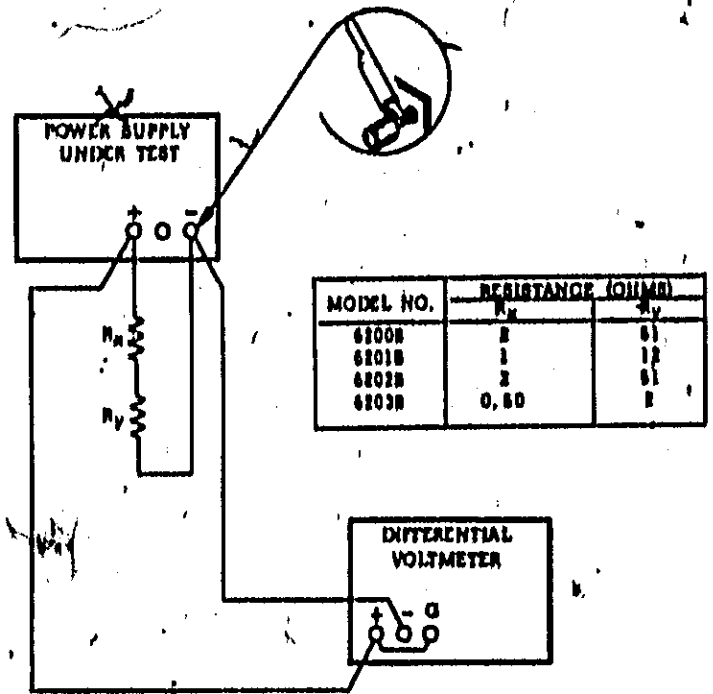

Figure 5-5. Load Regulation, Constant Voltage

b. Turn CURRENT controls fully clockwise.

c. Set METER switch to highest current range (and RANGE switch to 40V for Model 6200B) and turn on supply.

d. Adjust VOLTAGE controls until front panel meter indicates exactly the maximum rated output current.

e. Read and record voltage indicated on differential voltmeter.

f. Disconnect load resistors.

g. Reading on differential voltmeter should not vary from reading recorded in step e by more than the following:

Model No.	6200B	6201B	6202B	6203B
Variation (mvdc)	$\pm 8$	$\pm 6$	$\pm 8$	$\pm 5$

5-17 Line Regulation. To check the line regulation, proceed as follows:

a. Connect variable auto transformer between input power source and power supply power input.

b. Turn CURRENT controls fully clockwise.

c. Connect test setup shown in Figure 5-5.

d. Adjust variable auto transformer for 105 VAC input.

e. Set METER switch to highest voltage range (and RANGE switch to 40 V for Model 6200B) and turn on supply.

f. Adjust VOLTAGE controls until front panel meter indicates exactly the maximum rated output voltage.

g. Read and record voltage indicated on differential voltmeter.

h. Adjust variable auto transformer for 125 VAC input.

1. Reading on differential voltmeter should not vary from reading recorded in step g by more than the following:

Model No.	6200B	6201B	6202B	6203B
Variation (mvdc)	±8	±6	±8	±3

5-18 **Ripple and Noise.** To check the ripple and noise, proceed as follows:

- Retain test setup used for previous line regulation test except connect AC voltmeter across output terminals as shown in Figure 5-6.
- Adjust variable auto transformer for 125 VAC input.
- Set METER switch to highest current range (and RANGE switch to 40V for Model 6200B).
- Turn CURRENT controls fully clockwise and adjust VOLTAGE controls until front panel meter indicates exactly the maximum rated output current.
- AC voltmeter should read less than 0.20mv.

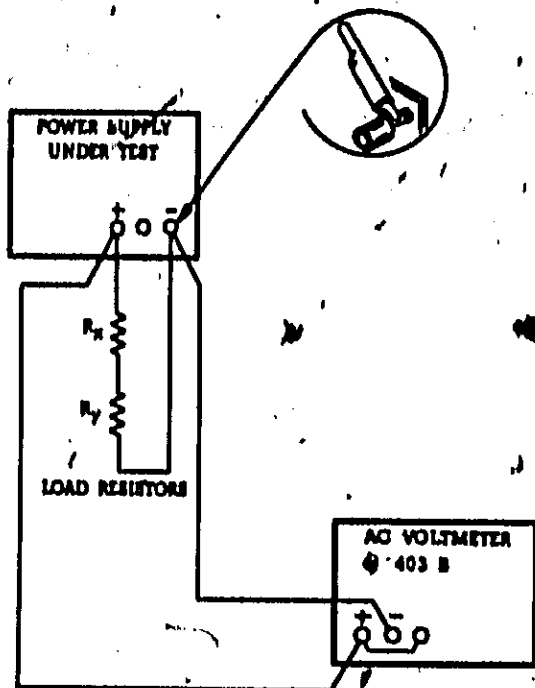

Figure 5-6. Ripple and Noise, Constant Voltage

5-19 **Transient Recovery Time.** To check the transient recovery time proceed as follows:

- Connect test setup shown in Figure 5-7.
- Turn CURRENT controls fully clockwise.
- Set METER switch to highest current range and turn on supply.
- Adjust VOLTAGE controls until front panel meter indicates exactly the maximum rated output current.

- Close line switch on repetitive load switch setup.
- Adjust 25K potentiometer until a stable display is obtained on oscilloscope. Waveform should be within the tolerances shown in Figure 5-8, (output should return to within 10 mv of original value in less than 50 microseconds).

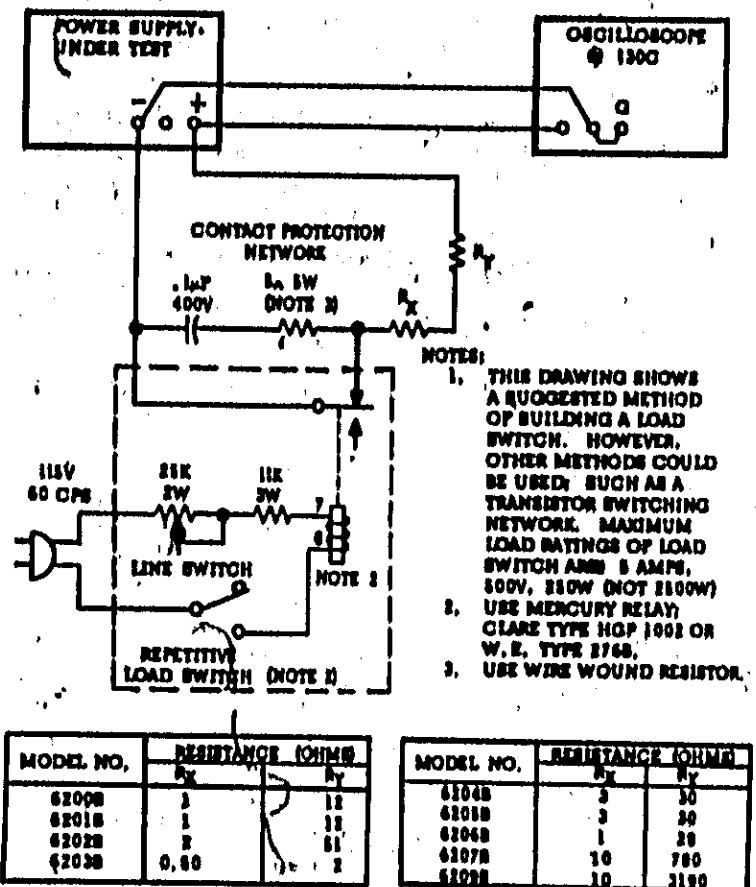

Figure 5-7. Transient Response, Test Setup

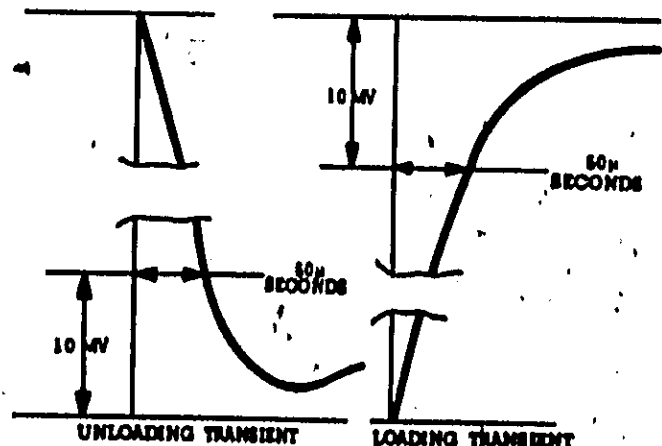

Figure 5-8. Transient Response, Waveforms



### 5-20 OUTPUT IMPEDANCE

5-21 To check the output impedance, proceed as follows:

- Connect test setup shown in Figure 5-9.
- Set METER switch to highest voltage range and turn on supply.
- Adjust VOLTAGE controls until front panel meter reads 20 volts (5 volts for Model 6203B supplies).
- Set AMPLITUDE control on Oscillator to 10 volts ( $E_{in}$ ), and FREQUENCY control to 100 Hz.
- Record voltage across output terminals of the power supply ( $E_o$ ) as indicated on AC voltmeter.
- Calculate the output impedance by the following formula:

$$Z_{out} = \frac{E_o R}{E_{in} - E_o}$$

$E_o$  = rms voltage across power supply output terminals.

$R = 1000$

$E_{in} = 10$  volts

g. The output impedance ( $Z_{out}$ ) should be less than 0.020 ohms.

h. Using formula of step f, calculate output impedance at frequencies of 50Kc and 500Kc. Values should be less than 0.5 ohm and 3.0 ohms, respectively.

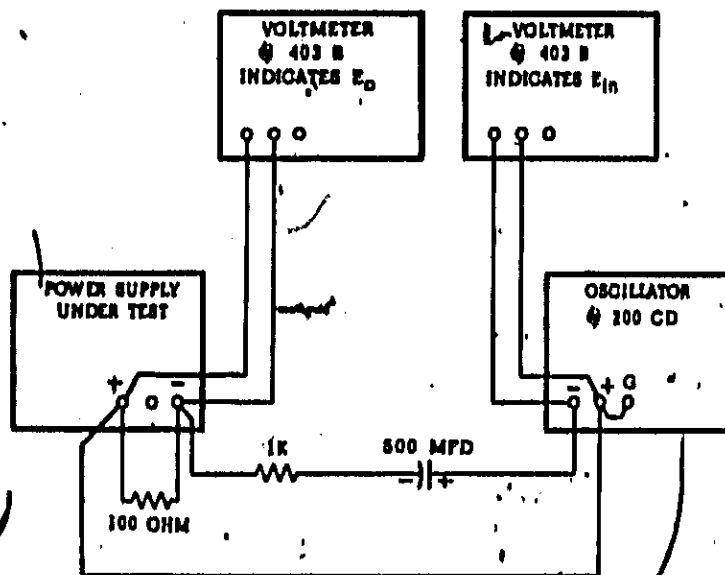

Figure 5-9. Output Impedance, Test Setup

### 5-22 OUTPUT INDUCTANCE

5-23 To check the output inductance, repeat steps a through f at frequencies of 10Kc, 50Kc and 100Kc. Calculate the output inductance ( $L$ ) using the following formula:

$$L = \frac{X_L}{2 \pi f} \text{ (See Note)}$$

The oscillator frequency is equivalent to  $f$  in the equation. The output inductance should be less than 20 microhenries.

#### NOTE

The equation assumes that  $X_L$  is much greater than  $R_{out}$  and therefore  $X_L = Z_{out}$ .

### 5-24 CONSTANT CURRENT TESTS

5-25 Load Regulation. To check the load regulation, proceed as follows:

- Connect test setup as shown in Figure 5-10.
- Turn VOLTAGE controls fully clockwise.
- Set METER switch to highest current range (and RANGE switch to 20V for Model 6200B) and turn on supply.
- Adjust CURRENT control until front panel meter reads exactly the maximum rated output current.
- Read and record voltage indicated on differential voltmeter.
- Short out load resistor by closing switch  $S_1$ .
- Reading on differential voltmeter should not vary from reading recorded in step e by more than the following:

Model No.	6200B	6201B	6202B	6203B
Variation (mvdc)	$\pm 0.70$	$\pm 0.70$	$\pm 0.950$	$\pm 0.575$

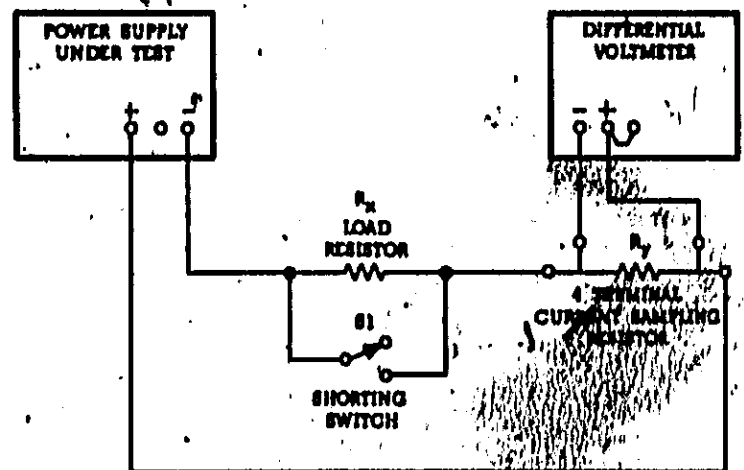

MODEL NO.	RESISTANCE (OHMS)	
	$R_x$	$R_y$
6200B	12	1
6201B	12	1
6202B	81	2
6203B	2	0.80

Figure 5-10. Load Regulation, Constant Current

5-26 **Line Regulation.** To check the line regulation proceed as follows:

- Utilize test setup shown in Figure 5-10 leaving switch S1 open throughout test.
- Connect variable auto transformer between input power source and power supply power input.
- Adjust auto transformer for 105 VAC input.
- Turn VOLTAGE controls fully clockwise.
- Set METER switch to highest current range (RANGE switch to 20V for Model 6200B) and turn on supply.
- Adjust CURRENT controls until front panel meter reads exactly the maximum rated output current.
- Read and record voltage indicated on differential voltmeter.
- Adjust variable auto transformer for 125 VAC input.
- Reading on differential voltmeter should not vary from reading recorded in step g by more than the following:

Model No.	6200B	6201B	6202B	6203B
Variation (mVdc)	±0.40	±0.40	±0.650	±0.275

5-27 **Ripple and Noise.** To check the ripple and noise, proceed as follows:

- Connect test setup shown in Figure 5-11.

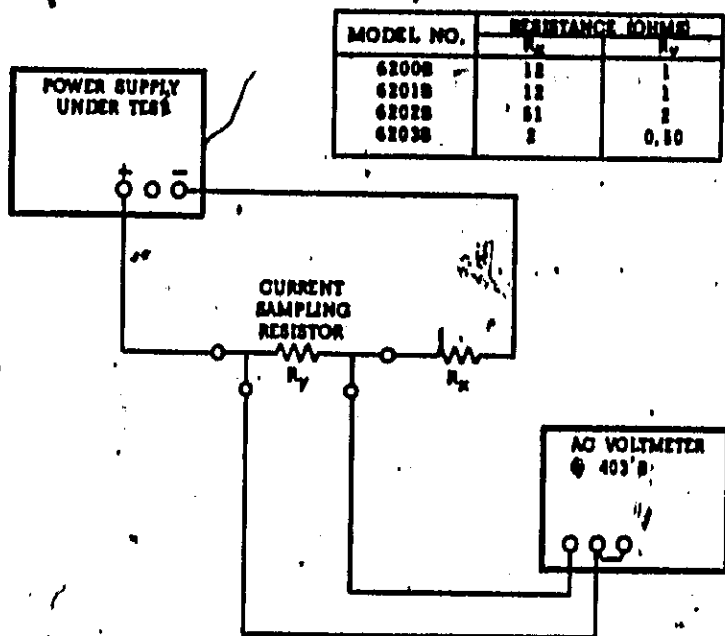

Figure 5-11. Ripple and Noise, Constant Current

- Rotate VOLTAGE controls fully clockwise.
- Set METER switch to highest current range and turn on supply.
- Adjust CURRENT controls until front panel meter indicates exactly the maximum rated output current.

e. Turn range switch on AC voltmeter to 1 mv position.

f. The AC voltmeter should read as follows:

Model No.	6200B	6201B	6202B	6203B
Reading (mVAC)	0.50	0.50	1	0.250

## 5-28 TROUBLESHOOTING

5-29 Components within Hewlett-Packard power supplies are conservatively operated to provide maximum reliability. In spite of this, parts within a supply may fail. Usually the instrument must be immediately repaired with a minimum of "down time" and a systematic approach as outlined in succeeding paragraphs can greatly simplify and speed up the repair.

## 5-30 TROUBLE ANALYSIS

5-31 **General.** Before attempting to trouble shoot this instrument, ensure that the fault is with the instrument and not with an associated circuit. The performance test (Paragraph 5-10) enables this to be determined without having to remove the instrument from the cabinet.

5-32 Once it is determined that the power supply is at fault, check for obvious troubles such as an open fuse, a defective power cable, or an input power failure. Next, remove the top and bottom covers (each held by four retaining screws) and inspect for open connections, charred components, etc. If the trouble source cannot be detected by visual inspection, follow the detailed procedure outlined in succeeding paragraphs. Once the defective component has been located (by means of visual inspection or trouble analysis) correct it and re-conduct the performance test. If a component is replaced, refer to the repair and replacement and adjustment and calibration paragraphs in this section.

5-33 A good understanding of the principles of operation is a helpful aid in troubleshooting, and it is recommended that the reader review Section IV of the manual before attempting to troubleshoot the unit in detail. Once the principles of operation are understood, logical application of this knowledge used in conjunction with the normal voltage readings shown on the schematic and the additional procedures given in the following paragraphs should suffice to isolate a fault to a component or small group of components. The normal voltages shown on the schematic are positioned adjacent to the applicable test points (identified by encircled numbers on the schematic and printed wiring boards). Additional test procedures that will aid in isolating troubles are as follows:

a. Reference circuit check (Paragraph 5-35). This circuit provides critical operating voltages for the supply and faults in the circuit could affect the overall operation in many ways.

b. Feedback loop checks (Paragraph 5-36).

c. Procedures for dealing with common troubles (Paragraph 5-37).

5-34 The test points referred to throughout the following procedures are identified on the schematic diagram by encircled numbers.

**5-35 Reference Circuit.**

a. Make an ohmmeter check to be certain that neither the positive nor negative output termi-

nal is grounded.

b. Turn front-panel VOLTAGE and CURRENT controls fully clockwise (maximum).

c. Turn-on power supply (no load connected).

d. Proceed as instructed in Table 5-2.

5-36 **Feedback Circuit.** Generally, malfunction of the feedback circuit is indicated by high or low output voltages. If one of these situations occur, disconnect the load and proceed as instructed in Table 5-3 or Table 5-4.

5-37 **Common Troubles.** Table 5-5 lists the symptoms, checks, and probable causes for common troubles.

Table 5-2. Reference Circuit Troubleshooting

STEP	METER COMMON	METER POSITIVE	NORMAL INDICATION	IF INDICATION ABNORMAL, TAKE THIS ACTION
1	+8	33	6.2 ± 0.3vdc	Check 12.4 volt bias or VR1
2	31	+8	6.2 ± 0.3vdc	Check 12.4 volt bias or VR2
3	+8	37	12.4 ± 1.0vdc	Check Q8, Q9, CR22, CR23, C10, T1

Table 5-3. High Output Voltage Troubleshooting

STEP	MEASURE	RESPONSE	PROBABLE CAUSE
1	Voltage between +8 and A6	0V to +0.8V More negative than 0V	a. Open strap between A7 and A8 b. R10 open Proceed to Step 2.
2	Voltage between +8 and 12	Less positive than +2.0V +2.0V to +3.8V	a. Q1A shorted b. Q1B open c. R3 open Proceed to Step 3.
3	Voltage between +8 and 19	More positive than -0.7V More negative than -0.7V	a. Q3 shorted b. C5 shorted Proceed to Step 4.
4	Voltage between 22 and 23	0V or negative More positive than 0V	a. Q6 and/or Q7 shorted. b. CR11 shorted c. Q4 or Q5 open b. R34 or R30 shorted or low resistance.

Table 5-4. Low Output Voltage Troubleshooting

STEP	MEASURE	RESPONSE	PROBABLE CAUSE
1	Disable Q2 by discon-	Normal output voltage.  Low output voltage.	a. Constant current circuit faulty, check CR4 and Q2A for short. b. R16 or Q2B open. Reconnect CR4 and proceed to Step 2.
2	Voltage between +8 and A6.	More negative than 0V. 0V to +0.8V.	a. Open strap A6 - A7. a. Check R10, C1, or C2 for short. b. Proceed to Step 3.
3	Voltage between +8 and 12.	More positive than +3.8V, +2V to +3.8V.	a. Q1A open. b. Q1B or R3 shorted. Proceed to Step 4.
4	Voltage between +8 and 19.	More negative than -0.7V.  More positive than -0.7V.	a. Q3 open. b. R33 shorted or low. a. Q5 shorted. b. Proceed to Step 5.
5	Voltage between 22 and 23.	More negative than 0V.  More positive than 0V.	a. R3A open. b. Q4 shorted. a. Q6 and Q7 open.

Table 5-5: Common Troubles

SYMPTOM	CHECKS AND PROBABLE CAUSES
High ripple	a. Check operating setup for ground loops. b. If output floating, connect 1 $\mu$ f capacitor between output and ground. c. Ensure that supply is not crossing over to constant current mode under loaded conditions.
Poor line regulation	a. Check reference circuit (Paragraph 5-35). b. Check reference circuit adjustment (Paragraph 5-54).
Poor load regulation (Constant Voltage)	a. Measurement technique. (Paragraph 5-16) b. Check the regulation characteristics of Zener diode VR1 as follows: (1) Connect differential voltmeter across VR1. (2) Connect appropriate load resistor (R <sub>L</sub> ), given in Figure 5-5, across (+) and (-) output terminals. (3) Perform steps b through f of Paragraph 5-16. (4) If the differential voltmeter reading varies by more than 1.8mV, replace VR1. c. Ensure that supply is not going into current limit. Check constant current input circuit.

Table 5-5. Common Troubles (Continued)

SYMPTOM	CHECKS AND PROBABLE CAUSES								
Poor load regulation (Constant Current)	<p>a. Check the regulation characteristics of Zener diode VR2 as follows:</p> <ol style="list-style-type: none"> <li>(1) Connect differential voltmeter across VR2.</li> <li>(2) Connect appropriate load resistor (<math>R_L</math>), given in Figure 5-5, across (+) and (-) output terminals.</li> <li>(3) Perform steps b through f of Paragraph 5-25.</li> <li>(4) If the differential voltmeter reading varies by more than the following, replace VR2:</li> </ol> <table style="margin-left: 40px;"> <tr> <td>6200B</td> <td>6201B</td> <td>6202B</td> <td>6203B</td> </tr> <tr> <td>1.2mV</td> <td>1.6mV</td> <td>1.2mV</td> <td>4mV</td> </tr> </table> <p>b. C19, C20, and CR34 leaky.</p> <p>c. Check clamp circuit Q10, CR30, CR31, and CR32.</p> <p>d. Ensure that supply is not going into voltage limit. Check constant voltage input circuit.</p>	6200B	6201B	6202B	6203B	1.2mV	1.6mV	1.2mV	4mV
6200B	6201B	6202B	6203B						
1.2mV	1.6mV	1.2mV	4mV						
Oscillates (Constant Voltage/Constant Current)	<p>a. Check C5 for open, adjustment of R30 (Paragraph 5-56).</p>								
Poor Stability (Constant Voltage)	<p>a. Noisy programming resistor R10.</p> <p>b. CR1, CR2 leaky.</p> <p>c. Check R1, R12, R13, C2 for noise or drift.</p> <p>d. Stage Q1 defective.</p>								
Poor Stability (Constant Current)	<p>a. Noisy programming resistor R16.</p> <p>b. CR5, CR6, C2, C3 leaky.</p> <p>c. Check R18, R19, R20, R21, C3, for noise or drift.</p> <p>d. Stage Q2 defective.</p>								

Table 5-6. Selected Semiconductor Characteristics

REFERENCE DESIGNATOR	CHARACTERISTICS	PART NO.	SUGGESTED REPLACEMENT
Q1,2	Matched differential amplifier. NPN Si Planar. 70 (min.) hFE $I_C = 1mA$ . $V_{CE} = 5V$ . $I_{CO} = 0.01\mu A$ @ $V_{CBO} = 5V$ .	1854-0229	2N2917 G.E.
Q4	PNP $I_{COX} = 0.1mA$ (max) @ $V_{CE} = 90V$ , $V_{BE} = 4V$ .	1853-0040	2N3741 Motorola
Q6,7	NPN Power hFE = 35 (min.) @ $I_C = 4A$ , $V_{CE} = 4V$ .	1854-0225	2N3055 R.C.A.
CR1-5, 20, 30, 32	Si. rectifier, 200mA, 180prv	1901-0033	1N485B Sylvania
CR8, 9, 31	Si. diode, 2.4V @ 100mA	1901-0460	1N4830 G.E.
CR11, 17, 22-25, 34	Si. rectifier, 500mA, 200prv	1901-0026	1N3253 R.C.A.
CR26-29	Si. rectifier, 900mA, 200prv.	1901-0327	1N5059 G.E.

## 5-38 REPAIR AND REPLACEMENT

5-39 Before servicing a printed wiring board, refer to Figure 5-12. Section VI of this manual contains a list of replaceable parts. Before replacing a semiconductor device, refer to Table 5-6 which lists the

special characteristics of selected semiconductors. If the device to be replaced is not listed in Table 5-6, the standard manufacturer's part number listed in Section VI is applicable. After replacing a semiconductor device, refer to Table 5-7 for checks and adjustments that may be necessary.

Excessive heat or pressure can lift the copper strip from the board. Avoid damage by using a low power soldering iron (50 watts maximum) and following these instructions. Copper that lifts off the board should be cemented in place with a quick drying acetate base cement having good electrical insulating properties.

A break in the copper should be repaired by soldering a short length of tinned copper wire across the break.

Use only high quality, rosin-core solder when repairing etched circuit boards. NEVER USE PASTE FLUX. After soldering, clean off any excess flux and coat the repaired area with a high quality electrical varnish or lacquer.

When replacing components with multiple mounting pins such as tube sockets, electrolytic capacitors, and potentiometers, it will be necessary to lift each pin slightly, working around the components several times until it is free.

**WARNING:** If the specific instructions outlined in the steps below regarding etched circuit boards without eyelets are not followed, extensive damage to the etched circuit board will result.

1. Apply heat sparingly to lead of component to be replaced. If lead of component passes through an eyelet

in the circuit board, apply heat on component side of board. If lead of component does not pass through an eyelet, apply heat to conductor side of board.



2. Reheat solder in vacant eyelet and quickly insert a small awl to clean inside of hole.

If hole does not have an eyelet, insert awl or a #57 drill from conductor side of board.

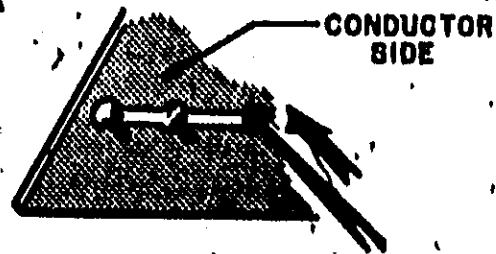

3. Bend clean tinned lead on new part and carefully insert through eyelets or holes in board.

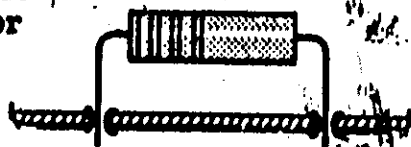

4. Hold part against board (avoid overheating) and solder leads.

Apply heat to component leads on correct side of board as explained in step 1.

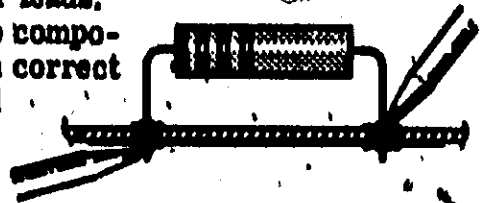

In the event that either the circuit board has been damaged or the conventional method is impractical, use method shown below. This is especially applicable for circuit boards without eyelets.

1. Clip lead as shown below.

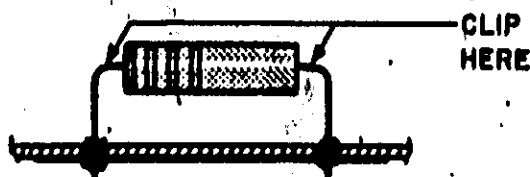

2. Bend protruding leads upward. Bend lead of new component around protruding lead.

APPLY SOLDER using a pair of long nose pliers as a heat sink.

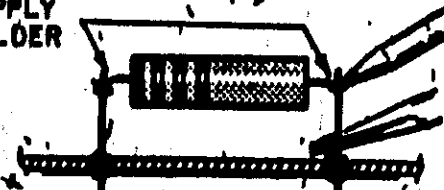

This procedure is used in the field only as an alternate means of repair. It is not used within the factory.

Figure 5-12. Servicing Printed Wiring Boards

Table 5-7. Checks and Adjustments After Replacement of Semiconductor Devices

REFERENCE	FUNCTION	CHECK	ADJUST
Q1	Constant voltage differential amplifier	Constant voltage (OV) line and load regulation, Zero volt output.	----
Q2	Constant current differential amplifier	Constant current (OC) line and load regulation, Zero current output.	----
Q3, Q4, Q5	Mixer and error amplifiers	OV load regulation, OV transient response, OC load regulation.	R30
Q6, Q7	Series regulator	OV load regulation.	----
Q8, Q9	Reference regulator	Reference circuit line regulation.	R46
Q10	Clamp circuit	OC load regulation.	----
Q11 - Q15	Meter circuit	Meter zero, Voltmeter/ammeter tracking.	R63, R72, R56
CR1, CR2	Limiting diodes	OV load regulation.	----
CR3, CR4	OR-gate diodes	OV/OC load regulation.	----
CR5	Limiting diode	OC load regulation.	----
CR8, CR9	Forward bias regulator	Voltage across each diode 2.0 to 2.4 volts.	----
CR22, CR23, CR24, CR25, CR28, CR29	Rectifier diodes	Voltage across appropriate filter capacitor.	----
CR34	Protection diode	Output voltage	----
VR1	Positive reference voltage	Positive reference voltage (+6.2V).	----
VR2	Negative reference voltage	Negative reference voltage (-6.2V).	----

Table 5-8. Calibration Adjustment Summary

ADJUSTMENT OR CALIBRATION	PARAGRAPH	CONTROL DEVICE
Meter Zero	5-42	Pointer
Voltmeter Tracking	5-44	R63 and R72
Ammeter Tracking	5-46	R56
"Zero" Volt Output	5-49	R6 or R8
"Voltage" Programming Current	5-50	R13
"Zero" Current Output	5-52	R25 or R28
"Current" Programming Current	5-53	R19
Reference Circuit Line Voltage Adjustment	5-54	R46
Transient Response	5-56	R30

**5-40 ADJUSTMENT AND CALIBRATION**

5-41 Adjustment and calibration may be required after performance testing, troubleshooting, or repair and replacement. Perform only those adjustments that affect the operation of the faulty circuit and no others. Table 5-8 summarizes the adjustments and calibrations contained in the following paragraphs.

**5-42 METER ZERO**

5-43 Proceed as follows to zero meter:

- a. Turn off instrument (after it has reached normal operating temperature) and allow 30 seconds for all capacitors to discharge.
- b. Insert sharp pointed object (pen point orawl) into the small hole at top of round black plastic disc located directly below meter face.
- c. Rotate plastic disc clockwise (cw) until meter reads zero, then rotate ccw slightly in order to free adjustment screw from meter suspension. If pointer moves, repeat steps b and c.

**5-44 VOLTMETER TRACKING**

5-45 To calibrate voltmeter tracking, proceed as follows:

- a. Set METER switch to highest current position and, with supply on and no load connected, adjust R63 until front panel meter reads zero.
- b. Connect differential voltmeter across supply, observing correct polarity.
- c. Set METER switch to highest voltage range and turn on supply. Adjust VOLTAGE control until differential voltmeter reads exactly the maximum rated output voltage.
- d. Adjust R72 until front panel meter also indicates maximum rated output voltage.

**5-46 AMMETER TRACKING**

5-47 To calibrate ammeter tracking proceed as follows:

- a. Repeat steps a through c of Paragraph 5-15.
- b. Adjust R56 until front panel meter indicates exactly the maximum rated output current.

**5-48 CONSTANT VOLTAGE PROGRAMMING CURRENT**

5-49 To calibrate the zero volt programming accuracy, proceed as follows:



a. Connect differential voltmeter between +B and -B terminals.

b. Short out voltage controls by connecting jumper between terminals A6 and -B.

c. Rotate CURRENT controls fully clockwise and turn on supply.

d. Observe reading on differential voltmeter.

e. If it is more positive than 0 volts, shunt resistor R6 with a decade resistance box (105K min).

f. Adjust decade resistance until differential voltmeter reads zero, then shunt R6 with resistance value equal to that of the decade resistance.

g. If reading of step d is more negative than 0 volts, shunt resistor R8 with the decade resistance box.

h. Adjust decade resistance until differential voltmeter reads zero then shunt R8 with a resistance value equal to that of the decade box.

5-50 To calibrate the programming current, proceed as follows:

a. Connect a 4K, 0.1% resistor between terminals -B and A6 on rear barrier strip.

b. Disconnect jumper between A7 and A8 (leaving A6 and A7 jumpered) on rear terminal barrier strip.

c. Connect a decade resistance in place of R13.

d. Connect differential voltmeter between +B and -B and turn on supply.

e. Adjust decade resistance box so that differential voltmeter indicates maximum rated output voltage within  $\pm 0.4$  volts.

f. Replace decade resistance with resistor of appropriate value in R13 position.

#### 5-51 CONSTANT CURRENT PROGRAMMING CURRENT

5-52 To calibrate the zero current programming accuracy, proceed as follows:

a. Connect differential voltmeter between +B and -B terminals.

b. Short out current controls by connecting jumper between terminals A1 and A5.

c. Rotate VOLTAGE controls fully clockwise and turn on supply.

d. Observe reading on differential voltmeter.

e. If it is more positive than 0 volts, shunt resistor R25 with a decade resistance box (105K min).

f. Adjust decade resistance until differential voltmeter reads zero, then shunt R25 with resistance value equal to that of decade resistance.

g. If reading of step d is more negative than 0 volts, shunt resistor R20 with decade resistance.

h. Adjust decade resistance until differential voltmeter reads zero, then shunt R20 with resistance value equal to that of decade box.

5-53 To calibrate the programming current, proceed as follows:

a. Connect power supply as shown in Figure 5-4.

b. Remove strap between A3 and A4 (leaving A4 and A5 jumpered).

c. Connect a 1.5K $\Omega$ , (750 $\Omega$  for Model 6200B) 0.1% resistor between A1 and A5.

d. Connect decade resistance box in place of R19.

e. Set METER switch to highest current range and turn on supply.

f. Adjust the decade resistance so that the differential voltmeter indicates  $1.5 \pm 0.030V$ .

g. Replace decade resistance with appropriate value resistor in R19 position.

#### 5-54 REFERENCE CIRCUIT ADJUSTMENTS

5-55 Line Regulation. To adjust the line regulation capabilities of the instrument proceed as follows:

a. Connect the differential voltmeter between +B (common) and 33 (positive).

b. Connect variable voltage transformer between supply and input power source.

c. Adjust line to 105Vac.

d. Connect decade resistance in place of R46.

e. Turn on supply.

f. Adjust decade resistance so that voltage indicated by differential voltmeter does not change more than 0.2 millivolts as input line voltage is varied from 105 to 125Vac.

g. Replace decade resistance with appropriate value resistor in R46 position.

#### 5-56 CONSTANT VOLTAGE TRANSIENT RESPONSE

5-57 To adjust the transient response, proceed as follows:

a. Connect test setup as shown in Figure 5-7.

b. Repeat steps a through e as outlined in Paragraph 5-19.

c. Adjust R30 so that the transient response is as shown in Figure 5-8.

## SECTION VI REPLACEABLE PARTS

### 6-1 INTRODUCTION

6-2 This section contains information for ordering replacement parts.

6-3 Table 6-4 lists parts in alpha-numerical order of the reference designators and provides the following information:

- a. Reference Designators. For abbreviations, refer to Table 6-1.
- b. Description. Refer to Table 6-2 for abbreviations.
- c. Total Quantity (TQ) used in the instrument; given only first time the part number is listed.
- d. Manufacturer's part number.
- e. Manufacturer's code number. Refer to Table 6-3 for manufacturer's name and address.
- f. Part Number.
- g. Recommended spare parts quantity (RS) for complete maintenance of one instrument during one year of isolated service.
- h. Parts not identified by a reference designator are listed at the end of Table 6-4 under Miscellaneous.

### 6-4 ORDERING INFORMATION

6-5 To order a replacement part, address order or inquiry to your local Hewlett-Packard sales office (see lists at rear of this manual for addresses).

6-6 Specify the following information for each part:

- a. Model and complete serial number of instrument.
- b. Hewlett-Packard part number.
- c. Circuit reference designator.
- d. Description.

6-7 To order a part not listed in Table 6-4, give a complete description of the part and include its function and location.

Table 6-1. Reference Designators

A = assembly	CR = diode
B = motor	DB = device, signaling (lamp)
C = capacitor	

Table 6-1. Reference Designators (Continued)

E = misc. electronic part	RT = thermistor
F = fuse	S = switch
J = jack	T = transformer
K = relay	V = vacuum tube, neon bulb, photopell, etc.
L = inductor	X = socket
M = meter	XF = fuseholder
P = plug	XDB = lampholder
Q = transistor	Z = network
R = resistor	

Table 6-2. Description Abbreviations

a = amperes	abd = order by description
c = carbon	p = peak
cer = ceramic	pcb = printed circuit board
coef = coefficient	pf = picofarads = 10 <sup>-12</sup> farads
com = common	pp = peak-to-peak
comp = composition	ppm = parts per million
conn = connection	pos = position(s)
crt = cathode-ray tube	poly = polystyrene
dep = deposited	pot = potentiometer
elect = electrolytic	prv = peak reverse voltage
encap = encapsulated	rect = rectifier
f = farads	rot = rotary
fxd = fixed	rms = root-mean-square
GE = germanium	s-b = slow-blow
grd = ground(ed)	sect = section(s)
h = henries	Si = silicon
Hg = mercury	sl = silver
impreg = impregnated	sl = slide
ins = insulation(ed)	td = time delay
K = kilo = 1000	TiO <sub>2</sub> = titanium dioxide
lin = linear taper	tog = toggle
log = logarithmic taper	tol = tolerance
mA = milli = 10 <sup>-3</sup>	trim = trimmer
M = megohms	tw = traveling wave tube
ma = milliamperes	var = variable
μ = micro = 10 <sup>-6</sup>	w/ = with
mfr = manufacturer	W = watts
mtg = mounting	w/o = without
my = mylar	omo = cabinet mount only
NC = normally closed	
Ne = neon	
NO = normally open	

Table 6-3. Code List of Manufacturers

CODE NO.	MANUFACTURER	ADDRESS	CODE NO.	MANUFACTURER	ADDRESS
00629	EBY Sales Co.	New York, N.Y.	07263	Fairchild Semiconductor Div. of	
00656	Aerovox Corp.	New Bedford, Mass.		Fairchild Camera and Instrument Corp.	Mountain View, Calif.
00853	Bangamo Electric Company,		07387	Bircher Corp., The	Los Angeles, Calif.
01121	Ordill Division (Capacitors)	Marion, Ill.	07397	Sylvania Electric Products Inc.	
01255	Allen Bradley Co.	Milwaukee, Wis.		Mountain View Operations of	
01281	Litton Industries, Inc.	Beverly Hills, Calif.		Sylvania Electronic Systems	
01295	TRW Semiconductors, Inc.	Lawndale, Calif.	07716	I. R. C. Inc.	Burlington, Iowa
01686	Texas Instruments, Inc. Semiconductor-	Dallas, Texas	07910	Continental Device Corp.	Hawthorne, Calif.
01930	Components Division		07933	Raytheon Mfg. Co., Semiconductor Div.	Mountain View, Calif.
02114	RCL Electronics, Inc.	Manchester, N.H.	08484	Breeze Corporations, Inc.	Union, N.J.
02606	Amerock Corp.	Rockford, Ill.	08530	Reliance Mica Corp.	Brooklyn, N.Y.
02660	Ferroxcube Corp. of America	Saugerties, N.Y.	08717	Sloan Company	Sun Valley, Calif.
02735	Fenwal Laboratories	Morton Grove, Ill.	08730	Vemaline Products Co.	Franklin Lakes, N.J.
03508	Amphenol-Borg Electronics Corp.	Broadview, Ill.	08863	Nylomatic Corp.	Morrisville, Pa.
03797	Radio Corp. of America, Commercial	Somerville, N.J.	09021	Airco Spear Electronic Components	Bradford, Pa.
03877	Receiving Tube and Semiconductor Div.		09182	Hewlett-Packard Co., New Jersey Div.	Berkeley Heights, N.J.
03888	G. E. Semiconductor Products Dept.	Syracuse, N.Y.	09353	C & K Components	Newton, Mass.
04009	Eldema Corp.	Compton, Calif.	09522	Bumdy Corp.	Norwalk, Conn.
04072	Transitron Electronic Corp.	Wakefield, Mass.	11234	CTS of Berne, Inc.	Berne, Ind.
04213	Pyrofilm Resistor Co.	Cedar Knolls, N.J.	11237	Chicago Telephone of California, Inc.	So. Pasadena, Calif.
04404	Arrow, Hart and Hegeman Electric Co.	Hartford, Conn.	11502	IRC Inc.	Bbons, N.C.
04713	ADC Electronics, Inc.	Harbor City, Calif.	11711	General Instrument Corp., Semiconductor	
05277	Caddell-Burns Mfg. Co. Inc.	Mineola, N.Y.	12136	Prod. Group, Rectifier Div.	Newark, N.J.
05347	Dymec Division of		12615	Philadelphia Handle Co., Inc.	Camden, N.J.
05820	Hewlett-Packard Co.	Palo Alto, Calif.	12617	U. S. Terminals, Inc.	Cincinnati, Ohio
06004	Motorola, Inc., Semiconductor		12697	Hamlin Inc.	Lake Mills, Wisconsin
06486	Products Division	Phoenix, Arizona	14493	Clarostat Mfg. Co.	Dover, N.H.
06540	Westinghouse Electric Corp.		14655	Hewlett-Packard Co.,	
06555	Semi-Conductor Dept.	Youngwood, Pa.		Loveland Division	Loveland, Colo.
06566	Ultronix, Inc.	Grand Junction, Colo.	14936	Cornell-Dubilier Elec. Corp.	Newark, N.J.
06751	Wakefield Engr. Inc.	Wakefield, Mass.	15909	General Instrument Corp., Semiconductor	
06812	The Bassick Co.	Bridgeport, Conn.	16299	Prod. Group, Semiconductor Div.	Hicksville, N.Y.
07137	IRC, Inc. Semiconductor Div.	Lynn, Mass.	16750	Davan Div. of Thos. Edison Industries,	
07138	Amathom Electronic Hardware Co., Inc.	New Rochelle, N.Y.		Mc Graw Edison Co.	Livingston, N.J.
	Beebe Electrical Instrument Co., Inc.	Penacook, N.H.	17545	Coming Glass Works,	
	General Devices Co., Inc.	Indianapolis, Ind.		Electronic Components Div.	Raleigh, N.C.
	Nuclear Corp. of America, Inc.		17803	Delco Radio Div. of General Motors	
	U. S. Semcor Div.	Phoenix, Arizona	19315	Corp.	Kokomo, Ind.
	Torrington Mfg. Co., West Div.		19701	Atlantic Semiconductors, Inc.	
	Transistor Electronics Corp.	Van Nuys, Calif.			Asbury Park, N.J.
	Westinghouse Electric Corp.	Minneapolis, Minn.		Fairchild	Mountainview, Calif.
	Electronic Tube Div.	Elmira, N.Y.		The Bendix Corp., Eclipse Pioneer Div.	Teterboro, N.J.

Table 6-3. Code List of Manufacturers (Continued)

CODE NO.	MANUFACTURER	ADDRESS	CODE NO.	MANUFACTURER	ADDRESS
21520	Fansteel Metallurgical Corp.	No. Chicago, Ill.	72699	General Instrument Corp., Capacitor Div.	Newark, N.J.
22229	Union Carbide Corp., Linde Div., Kemet Dept.	Mountain View, Calif.	72765	Drake Mfg. Co.	Chicago, Ill.
22767	ITT Semiconductors, A Division of International Telephone & Telegraph Corp.	Palo Alto, Calif.	72962	Elastic Stop Nut Corp. of America	Union, N.J.
24446	General Electric Co.	Schenectady, N.Y.	72982	Erie Technological Products, Inc.	Erie, Pa.
24455	General Electric Co., Lamp Division	Nela Park, Cleveland, Ohio	73138	Hellipot Div. of Beckman Instruments, Inc.	Fullerton, Calif.
24655	General Radio Co.	West Concord, Mass.	73168	Fenwal, Inc.	Ashland, Mass.
26982	Dynacool Mfg. Co. Inc.	Saugerties, N.Y.	73293	Hughes Components Division of Hughes Aircraft Co.	Newport Beach, Calif.
27014	National Semiconductor Corp.	Santa Clara, Calif.	73445	Amperex Electronic Co., Div. of North American Phillips Co., Inc.	Hicksville, N.Y.
28480	Hewlett-Packard Co.	Palo Alto, Calif.	73506	Bradley Semiconductor Corp.	New Haven, Conn.
28520	Heyman Mfg. Co.	Kenilworth, N.J.	73559	Carling Electric, Inc.	Hartford, Conn.
33173	G. E., Tube Dept.	Owensboro, Ky.	73734	Federal Screw Products, Inc.	Chicago, Ill.
35434	Leetrohm, Inc.	Chicago, Ill.	73978	Hardwick Hindle Co., Memcor Components Div.	Huntington, Ind.
37942	P. R. Mallory & Co., Inc.	Indianapolis, Ind.	74193	Heinemann Electric Co.	Trenton, N.J.
42190	Muter Co.	Chicago, Ill.	74545	Harvey Hubbel, Inc.	Bridgeport, Conn.
43334	New Departure-Hyatt Bearings Div., General Motors Corp.	Sandusky, Ohio	74868	FXR Div. of Amphenol-Borg Electronics Corp.	Danbury, Conn.
44655	Ohmite Manufacturing Co.	Skokie, Ill.	74970	E. P. Johnson Co.	Waseca, Minn.
46384	Penn Engr.	Doylestown, Pa.	75042	International Resistance Co.	Philadelphia, Pa.
47904	Polaroid Corp.	Cambridge, Mass.	75183	Howard B. Jones Div., of Cinch Mfg. Corp. (Use 71785)	New York, N.Y.
49956	Raytheon Mfg. Co., Microwave and Power Tube Div.	Waltham, Mass.	75382	Kulka Electric Corp.	Mt. Vernon, N.Y.
55026	Simpson Electric Co.	Chicago, Ill.	75915	Littlefuse, Inc.	Des Plaines, Ill.
56289	Sprague Electric Co.	North Adams, Mass.	76381	Minnesota Mining & Mfg. Co.	St. Paul, Minn.
58474	Superior Electric Co.	Bristol, Conn.	76493	J. W. Miller Co.	Los Angeles, Calif.
61637	Union Carbide Corp.	New York, N.Y.	76530	Cinch	City of Industry, Calif.
63743	Ward-Leonard Electric Co.	Mt. Vernon, N.Y.	76854	Oak Manufacturing Co.	Crystal Lake, Ill.
70563	Amperite Co., Inc.	Union City, N.J.	77068	Bendix Corp., Bendix-Pacific Div.	No. Hollywood, Calif.
70901	Beemer Engrg. Co.	Fort Washington, Pa.	77147	Patton Mac Guyer Co.	Providence, R.I.
70903	Belden Mfg. Co.	Chicago, Ill.	77221	Phaotron Instrument and Electronic Co.	South Pasadena, Calif.
71218	Bud Radio, Inc.	Willoughby, Ohio	77252	Philadelphia Steel and Wire Corp.	Philadelphia, Pa.
71279	Cambridge Thermionic Corp.	Cambridge, Mass.	77342	American Machine and Foundry, Potter and Brumfield Div.	Princeton, Ind.
71400	Bussmann Mfg. Div. of Mc Graw-Edison Co.	St. Louis, Mo.	77630	TRW Electronics, Components Div.	Camden, N.J.
71450	CTS Corporation	Elkhart, Ind.	77764	Resistance Products Co.	Harrisburg, Pa.
71468	I. T. T. Cannon Electric Inc.	Los Angeles, Calif.	78189	Shakeproof Div. of Illinois Tool Works	Elgin, Ill.
71590	Centralab Div. of Globe Union, Inc.	Milwaukee, Wis.	78452	Everlock Chicago, Inc.	Chicago, Ill.
71700	The Cornish Wire Co.	New York, N.Y.	78488	Stackpole Carbon Co.	St. Marys, Pa.
71707	Coto-Coll	Providence, R.I.	78526	Stanwyck Winding Co., Inc.	Newburgh, N.Y.
71744	Chicago Miniature Lamp Works	Chicago, Ill.	78553	Tinnerman Products, Inc.	Cleveland, Ohio
71785	Cinch Mfg. Co.	Chicago, Ill.			
71984	Dow Corning Corp.	Midland, Mich.			
72136	Electro-Motive Mfg. Co. Inc., The	Willimantic, Conn.			
72619	Dialight Corp.	Brooklyn, N.Y.			

Table 6-3, Code List of Manufacturers (Continued)

CODE NO.	MANUFACTURER	ADDRESS	CODE NO.	MANUFACTURER	ADDRESS
78584	Stewart Stamping Corp.	Yonkers, N.Y.	87585	Stockwell Rubber Co., Inc.	Philadelphia, Pa.
79136	Waldes Kohinoor, Inc.	L. I. C., N.Y.	87929	B. M. Tower Co., Inc.	Bridgeport, Conn.
79307	Whitehead Metal Products Co., Inc.	New York, N.Y.	88140	Outler-Hammer, Inc.	Lincoln, Ill.
79727	Continental-Wirt Electronics Corp.	Philadelphia, Pa.	89473	General Electric Distributing Corp.	Schenectady, N.Y.
80031	Mepco Div. of Sessions Clock Co.	Morristown, N.J.	91345	Miller Dial and Nameplate Co.	El Monte, Calif.
80294	Bourne, Inc.	Riverside, Calif.	91637	Dale Electronics, Inc.	Columbus, Neb.
81042	Howard Industries, Inc.	Racine, Wis.	91662	Elco Corp.	Willow Grove, Pa.
81483	International Rectifier Corp.	El Segundo, Calif.	91929	Honeywell, Inc., Micro Switch Div.	Freeport, Ill.
81751	Columbus Electronics Corp.	Yonkers, N.Y.	93332	Sylvania Electric Prod., Inc., Semiconductor Prod. Div.	Woburn, Mass.
82089	Goodyear Sundries & Mechanical Co., Inc.	New York, N.Y.	93410	Stevens Mfg. Co., Inc.	Mansfield, Ohio
82142	Airco Speer Electronic Components	Du Bois, Pa.	94144	Raytheon Co., Components Div., Industrial Components Operation	Quincy, Mass.
82219	Sylvania Electric Products, Inc., Electronic Tube Division	Emporium, Pa.	94154	Tung-Sol Electric, Inc.	Newark, N.J.
82389	Switchcraft, Inc.	Chicago, Ill.	94222	South Chester Corp.	Chester, Pa.
82647	Metals and Controls, Inc., Spencer Products	Attleboro, Mass.	94310	Tru-Ohm Products, Memcor Components Div.	Huntington, Ind.
82866	Research Products Corp.	Madison, Wis.	95263	Leecraft Mfg. Co., Inc.	Long Island City, N.Y.
82877	Rotron Mfg. Co., Inc.	Woodstock, N.Y.	95354	Methode Mfg. Co.	Chicago, Ill.
82893	Vector Electronic Co.	Glendale, Calif.	95712	Bendix Corp., Microwave Div.	Franklin, Ind.
83058	Carb Fastener Co.	Cambridge, Mass.	96791	Amphenol Controls Div. of Amphenol-Borg Electronics Corp.	Janesville, Wis.
83186	Victory Engineering Corp.	Springfield, N.J.	97464	Industrial Retaining Ring Co.	Irvington, N.J.
83298	Bendix Corp., Rod Bank Div.	Eatontown, N.J.	98291	Sealectro Corp.	Mamaroneck, N.Y.
83330	Herman H. Smith, Inc.	Brooklyn, N.Y.	98978	International Electronic Research Corp.	Burbank, Calif.
83385	Central Screw Co.	Chicago, Ill.	99934	Renbrandt, Inc.	Boston, Mass.
83501	Gavitt Wire and Cable Co., Div. of Amerace Corp.	Brookfield, Mass.			
83508	Grant Pulley and Hardware Co.	West Nyack, N.Y.			
83594	Burroughs Corp., Electronic Components Div.	Plainfield, N.J.			
83835	U. S. Radium Corp.	Morristown, N.J.			
83877	Yardeny Laboratories, Inc.	New York, N.Y.			
84171	Arco Electronics, Inc.	Great Neck, N.Y.			
84411	TRW Capacitor Div.	Ogallala, Neb.			
86684	Radio Corp. of America, Electronic Components & Devices Div.	Harrison, N.J.			
86838	Rummel Fibre Co.	Newark, N.J.			
87034	Marco Industries Co.	Anaheim, Calif.			
87216	Philco Corp. (Lansdale Div.)	Lansdale, Pa.			
<p>THE FOLLOWING H-P VENDORS HAVE NO NUMBERS ASSIGNED IN THE LATEST SUPPLEMENT TO THE FEDERAL SUPPLY CODE FOR MANUFACTURERS HANDBOOK.</p>					
0000	Cooltron	Oakland, Calif.			
00000	Plastic Ware Co.	Brooklyn, N.Y.			

Reference Designator	Description	Quantity	Mfr. Part # or Type	Mfr.	Mfr. Code	Stock No.	RS
C1, 9	fxd, elect 4.7µf 35vdc	2	150D475X9035B2	Sprague	56289	0100-0100	1
C2, 18	fxd, film .01µf 200vdc	2	192P10392	Sprague	56289	0160-0161	1
C3	fxd, film 0.1µf 200vdc	1	192P10492	Sprague	56289	0160-0168	1
C4, 6-8, 11, 15	Not Assigned	-	-	-	-	-	-
C5	fxd, film .001µf 200vdc	1	192P10292	Sprague	56289	0160-0153	1
C10	fxd, elect 100µf 50vdc	1	D32210	Sprague	56289	0180-1052	1
C12	fxd, elect 490µf 85vdc	1	D38618	Sprague	56289	0180-1000	1
C13, 14	fxd, elect 1450µf 45vdc	2	D39532	Sprague	56289	0180-1093	1
C16A	NOT USED	-	-	-	-	-	-
C16B, 17	fxd, ceramic .05µf 500vdc	2	33Q17A	Sprague	56289	0150-0052	1
C19	fxd, elect 15µf 50vdc	1	150D156X0050R2	Sprague	56289	0180-1034	1
C20	fxd, elect 80µf 300vdc	1	D39041	Sprague	56289	0180-1851	1
CR1-5, 20, 30, 32	rect. sil. 200ma 100prv	8	1N485B	Sylv.	93332	1901-0033	6
CR6, 7, 10, 12-19, 21, 33, 35	Not Assigned	-	-	-	-	-	-
CR8, 9, 31	diode, sil. 2.4v @ 100ma	3	STD-523	G.E.	11711	1901-0460	3
CR11, 17, 22-25, 34	rect. sil. 500ma 200prv	7	1N3253	R.C.A.	02735	1901-0389	6
CR26, 27	NOT USED	-	-	-	-	-	-
CR28, 29	rect. sil. 900ma 200prv	2	G100D	G.E.	11711	1901-0327	2
DS1	Indicator Light, neon	1	85BR	Sloan	08717	1450-0048	1
F1	Fuse cartridge 2a @ 250v 3AG	1	312002	Littlefuse	75915	2100-0002	5
J1, 2	STRAP (Jumpers)	2	-	-	-	-	-
Q1, 2	SS NPN diff amp sil.	2	4JX12A839	G.E.	03508	1854-0229	2
Q3, 5, 8, 10, 12, 14, 15	SS PNP sil.	7	2N2907A	Sprague	56289	1853-0099	6
Q4	SS PNP sil.	1	40362	R.C.A.	02735	1853-0041	1
Q6, 7	Power NPN	2	36616	HLAB	09182	1854-0225	2
Q9	SS NPN sil.	1	2N3417	G.E.	03508	1854-0087	1
Q11, 13, 17	SS NPN sil.	3	8K1124	T.I.	01295	1854-0071	3
Q16	Not Assigned	-	-	-	-	-	-
R1	fxd, ww 1K $\Omega$ $\pm$ 5% 3w 20ppm	1	242E1025	Sprague	56289	0813-0001	1
R2, 22, 23, 29	fxd, film 6.2K $\Omega$ $\pm$ 1% 1/8w	4	-	I.R.C.	07716	0690-5087	4
R3	fxd, film 15K $\Omega$ $\pm$ 1% 1/8w	1	-	I.R.C.	07716	0757-0446	1
R4, 64, 65	fxd, film 20K $\Omega$ $\pm$ 1% 1/8w	3	-	I.R.C.	07716	0757-0449	1
R5, 75, 76, 77	fxd, film 1.5K $\Omega$ $\pm$ 1% 1/8w	4	-	I.R.C.	07716	0757-0427	1
R6, 25	fxd, comp 360K $\Omega$ $\pm$ 5% 1/2w	2	-	A.B.	01121	0686-3645	1
R7	fxd, film 61.9K $\Omega$ $\pm$ 1% 1/8w	1	-	I.R.C.	07716	0757-0460	1
R8, 28	fxd, comp 560K $\Omega$ $\pm$ 5% 1/2w	2	-	A.B.	01121	0686-5645	1
R9, 11, 35-37, 39, 53, 79, 81-83	Not Assigned	-	-	-	-	-	-
R10	var. ww DUAL 5K $\Omega$ -50 $\Omega$	1	100149-3	HLAB	09182	2100-0996	1
R12	fxd, ww 1.3K $\Omega$ $\pm$ 5% 3w 20ppm	1	242E1325	Sprague	56289	0811-1813	1
R13, 19	fxd, comp SELECTED $\pm$ 5% 1/2w	2	-	A.B.	01121	-	-
R14	fxd, comp 3.3 $\Omega$ $\pm$ 5% 1/2w	1	-	A.B.	01121	0686-0335	1

Reference Designators	Description	Quantity	Mfr. Part # or Type	Mfr.	Mfr. Code	Stock No.	RS
R15	fxd, comp 82K $\Omega$ $\pm$ 5% $\frac{1}{2}$ w	1		A. B.	01121	0686-8235	1
R16	var. ww DUAL 1.8K $\Omega$ -20 $\Omega$	1	100149-2	HLAB	09182	2100-0995	1
R17, 55	NOT USED	-	-	-	-	-	-
R18	fxd, ww 6.5K $\Omega$ $\pm$ 5% 3w 20ppm	1	242E6525	Sprague	56289	0811-1814	1
R20, 40	fxd, film 1K $\Omega$ $\pm$ 1% $\frac{1}{2}$ w	2		I. R. C.	07716	0757-0330	1
R21	fxd, comp 39 $\Omega$ $\pm$ 5% $\frac{1}{2}$ w	1		A. B.	01121	0686-3905	1
R24	fxd, film 4.75K $\Omega$ $\pm$ 1% $\frac{1}{8}$ w	1		I. R. C.	07716	0757-0437	1
R27, 32	fxd, ww .51 $\Omega$ $\pm$ 5%	2	Type BWH	I. R. C.	07716	0811-0929	1
R30	var. ww 5K $\Omega$ (Modify)	1	Type 110-F4	C. T. S.	11236	2100-1824	1
R31	fxd, comp 1K $\Omega$ $\pm$ 5% $\frac{1}{2}$ w	1		A. B.	01121	0686-1025	1
R33	fxd, comp 10K $\Omega$ $\pm$ 5% $\frac{1}{2}$ w	1		A. B.	01121	0686-1035	1
R34	fxd, film 820 $\Omega$ $\pm$ 5% 2w	1	Type C428	Corning	16299	0698-3637	1
R38, 44	fxd, comp 47K $\Omega$ $\pm$ 5% $\frac{1}{2}$ w	2		A. B.	01121	0686-4735	1
R40, 62	fxd, film 619 $\Omega$ $\pm$ 1% $\frac{1}{2}$ w	2		I. R. C.	07716	0757-0728	1
R41	fxd, comp 12K $\Omega$ $\pm$ 5% $\frac{1}{2}$ w	1		A. B.	01121	0686-1235	1
R42	fxd, comp 6.8K $\Omega$ $\pm$ 5% $\frac{1}{2}$ w	1		A. B.	01121	0686-6825	1
R43	fxd, film 470 $\Omega$ $\pm$ 1% $\frac{1}{2}$ w	1		I. R. C.	07716	0698-3506	1
R45	fxd, comp 5.1K $\Omega$ $\pm$ 5% $\frac{1}{2}$ w	1		A. B.	01121	0686-5125	1
R46	fxd, comp 100K $\Omega$ $\pm$ 5% $\frac{1}{2}$ w	1		A. B.	01121	0686-1046	1
R47	fxd, comp 430 $\Omega$ $\pm$ 5% $\frac{1}{2}$ w	1		A. B.	01121	0686-4315	1
R49	fxd, ww 1K $\Omega$ $\pm$ 5% 5w	1	Type 5XM	W. L.	63743	0812-0099	1
R50	fxd, comp 10 $\Omega$ $\pm$ 5% $\frac{1}{2}$ w	1		A. B.	01121	0686-1005	1
R51	fxd, comp 30K $\Omega$ $\pm$ 5% $\frac{1}{2}$ w	1		A. B.	01121	0686-3035	1
R52	fxd, comp 22K $\Omega$ $\pm$ 5% $\frac{1}{2}$ w	1		A. B.	01121	0686-2235	1
R54	fxd, ww 1 $\Omega$ $\pm$ 5% 8w	1	Type T-7A	R. C. L.	01686	0811-2133	1
R56	var. ww 1K $\Omega$ (Modify)	1	Type 110-F4	C. T. S.	11236	2100-0391	1
R57, 60	fxd, film 900 $\Omega$ $\pm$ 1% $\frac{1}{8}$ w	2		I. R. C.	07716	0757-1099	1
R58, 59	fxd, film 100 $\Omega$ $\pm$ 1% $\frac{1}{8}$ w	2		I. R. C.	07716	0757-0401	1
R61	fxd, film 23K $\Omega$ $\pm$ 1% $\frac{1}{8}$ w	1		I. R. C.	07716	0698-3269	1
R63	var. ww 10K $\Omega$	1	Type 110-F4	C. T. S.	11236	2100-0396	1
R66, 67	fxd, film 3/40K $\Omega$ $\pm$ 1% $\frac{1}{2}$ w	2		I. R. C.	07716	0698-4640	1
R68, 69	fxd, film 365 $\Omega$ $\pm$ 1% $\frac{1}{2}$ w	2		I. R. C.	07716	0757-0723	1
R70, 71, 75, 84-86	fxd, film 3K $\Omega$ $\pm$ 1% $\frac{1}{8}$ w	6		I. R. C.	07716	0757-1093	2
R73	fxd, film 750 $\Omega$ $\pm$ 1% $\frac{1}{8}$ w	1		I. R. C.	07716	0757-0420	1
R74	var. ww 250 $\Omega$ (Modify)	1	Type 110-F4	C. T. S.	11236	2100-0439	1
R74	fxd, film 9.09K $\Omega$ $\pm$ 1% $\frac{1}{8}$ w	1		I. R. C.	07716	0757-0288	1
R78	STRAP	-	-	-	-	-	-
R80	fxd, comp 33K $\Omega$ $\pm$ 5% $\frac{1}{2}$ w	1		A. B.	01121	0686-3335	1
S1	Switch SPST, ON/OFF	1	T110-62	Carling	73559	3104-1055	1
S2	Switch meter rotary	1		HLAB	09182	3100-1910	1
T1	Power Transformer	1	HT6201A	HLAB	09182	9100-1817	1
VR1, 2	diode, zener 6.2v	2	1N821	N. A. Elect.	06486	1902-0761	2
	5 Way binding post (red)	1	DF21 Maroon	Superior	58474	1510-0040	1
	5 Way binding post (black)	2	DF21BC	Superior	58474	1510-0039	1
	Fastener	1	C12008-014-4	Tinnerman	89032	0510-0123	1
	Line cord, plug, PH15L 7 $\frac{1}{2}$ ft.	1	HK-4701	Beldon	70903	8120-0050	1
	Strain Relief bushing	1	SR-5P-1	Heyco	28520	0400-0013	1
	Jumper	8	422-13-11 013	Cinch	71785	0360-1143	2
	Barrier strip	1	100237-15	HLAB	09182	0360-0086	1
	Rubber bumper	4	MBS0-701	Stockwell	87575	0403-0088	1

Reference Designator	Description	Quantity	Mfr. Part # or Type	Mfr.	Mfr. Code	Block No.	RB
	Rubber bumper	3	4072	Stockwell	87875	0403-0086	1
	Knob 1/4 insert pointer 5/8 dia.	1		HLAB	09182	0370-0084	1
	Knob 17/64 insert pointer (blk.)	2		HLAB	09182	0370-0101	1
	Knob, 3/16 insert pointer (red)	2		HLAB	09182	0370-0179	1
	Meter Bezel, 1/6 Mod.	1		HLAB	09182	4040-0295	1
	Fuse Holder	1	342014	Littlefuse	75915	1400-0040	1
	Meter, 2 1/2" size, DUAL scale, 0-24V, 0-1/8A	1		HLAB	09182	1120-1227	1
	Meter Spring	4		HLAB	09182	1460-0256	1
	Fastener	8	C8091 632-4	Tinnerman	89032	0510-0275	2
	Captive nut	8	CLA-632-2	Pem Eng.	46384	0590-0393	2
	Heat Dissipator	1	TXBP-032025B	E. R. C.	98978	1205-0011	1
	Mica Insulator	2	734	Reliance	08530	0340-0174	1
	Insulator, transistor pin	4	100146-1	HLAB	09182	0340-0166	1
	Insulator	4	100151-1	HLAB	09182	0340-0168	1

OPTIONS

06	Overvoltage Crowbar	1		HLAB	09182	Model 6916A	1
07	Voltage 10-turn Potentiometer	1	Series 8400	IRC	07716	2100-1865	1
08	Current 10-turn Potentiometer	1	Series 8400	IRC	07716	2100-1864	1
09	Voltage 10-turn Potentiometer	1	Series 8400	IRC	07716	2100-1865	1
	Current 10-turn Potentiometer	1	Series 8400	IRC	07716	2100-1864	1
13	Voltage Decadal Control	1	(Includes:)				
	Voltage 10-turn Pot.	1	Series 8400	IRC	07716	2100-1865	1
	Decadal Assembly	1	RD-411	IRC	07716	1140-0020	1
14	Current Decadal Control	1	(Includes:)				
	Current 10-turn Pot.	1	Series 8400	IRC	07716	2100-1864	1
	Decadal Assembly	1	RD-411	IRC	07716	1140-0020	1



## APPENDIX A

### Option 11, Overvoltage Protection "Crowbar"

#### DESCRIPTION:

This option is installed in DC Power Supplies, 6200B, 6201B, 6202B, 6203B, 6204B, and 6206B, and tested at the factory. It consists of a printed circuit board, screwdriver-type front panel potentiometer, and six wires that are soldered to the main power supply board.

The crowbar monitors the output voltage of the power supply and fires an SCR that shorts the output when it exceeds the preset trip voltage. The trip voltage is determined by the setting of the CROWBAR ADJUST control on the front panel. The trip voltage range is as follows:

Model	6200B	6201B	6202B	6203B	6204B	6205B	6206B
Trip Voltage Range	2.5-44V	2.5-23V	2.5-44V	2.5-10V	2.5-44V	2.5-44V	2.5-65V

To prevent transients from falsely tripping the crowbar, the trip voltage must be set higher than the power supply output voltage by the following margin: 4% of the output voltage plus 2V. The margin represents the minimum crowbar trip setting for a given output voltage; the trip voltage can always be set higher than this margin.

#### OPERATION:

1. Turn the CROWBAR ADJUST fully clockwise to set the trip voltage to maximum.
2. Set the power supply VOLTAGE control for the desired crowbar trip voltage. To prevent false crowbar tripping, the trip voltage should exceed the desired output voltage by the following amount: 4% of the output voltage plus 2V.
3. Slowly turn the CROWBAR ADJUST ccw until the crowbar trips, output goes to 0 volt.
4. The crowbar will remain activated and the output shorted until the supply is turned off. To reset the crowbar, turn the supply off, then on.
5. If the CROWBAR must be completely disabled, remove the lead attached to the CROWBAR ADJUST potentiometer R5.

Table A-1. Replaceable Parts

REF. DESIG.	DESCRIPTION	TQ	MFR. PART NO.	MFR. CODE	PART NO.	RS
C1	fxd, elect 1 $\mu$ f 50Vdc	1	30D105G050BA2	56289	0180-0108	1
C2	fxd, mica 510 $\mu$ f 500Vdc	1	RCM15E511J	04062	0140-0047	1
CR1-CR3	Rect. Sl. 200mA 200prv	3	1N485B	93332	1901-0033	3
CR4	SCR 7.4A 100prv	1	C20A	03508	1884-0031	1
Q1,2	SB NPN Sl.	2	2N3417	03508	1854-0087	2
R1	fxd, met. film 10 $\Omega$ $\pm$ 1% 1/8W	1	Type CEA T-O	07716	0757-0346	1
R2	fxd, comp 2.7K $\Omega$ $\pm$ 5% 1W	1	QB-2725	01121	0698-2725	1
R3	fxd, met. film 1.21K $\Omega$ $\pm$ 1% 1/8W	1	Type CEA T-O	07716	0757-0274	1
R4	fxd, met. film 7.5K $\Omega$ $\pm$ 1% 1/8W	1	Type CEA T-O	07716	0757-0440	1
R5	var. ww 10K $\Omega$ $\pm$ 5%	1		09182	2100-1854	1
R6	fxd, ww 1K $\Omega$ $\pm$ 5% 3W	1	242E1025	56289	0813-0001	1
R7	fxd, comp 22 $\Omega$ $\pm$ 5% 1/2W	1	EB-2205	01121	0686-2205	1
R8	fxd, met. film 471 $\Omega$ $\pm$ 1% 1/8W	1	Type CEA T-O	07716	0698-5514	1
T1	Transformer, Pulse	1		09182	5080-7122	1
VR1	Diode, Zener 6.19V $\pm$ 5%	1	1N753	04713	1902-0049	1
VR2	Diode, Zener 2.37V $\pm$ 5%	1	1N4370	04713	1902-3002	1
	<b>MISCELLANEOUS</b>					
	Printed Circuit Board (Blank)	1		09182	5020-5750	
	P. C. Board (Includes Components)	1		09182	5060-6175	
	Heat Sink	1		09182	5000-6229	
	Insulator (CR4)	1		09182	0340-0462	1
	Mica Washer	1		09182	2190-0709	1
	Cable Clamp	1	T4-4	79307	1400-0330	1
	Front Panel (Modified)	1		09182	06203-60001	

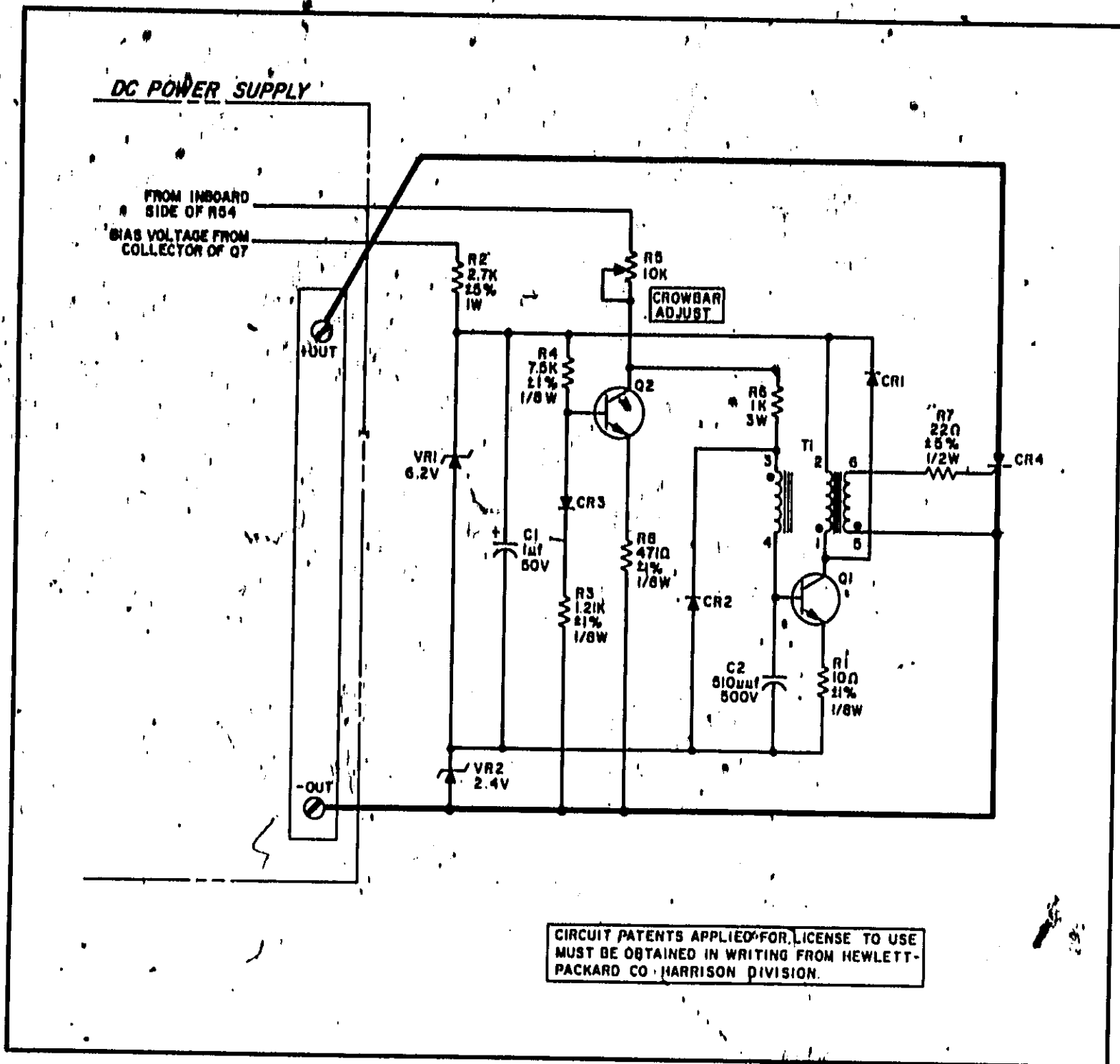
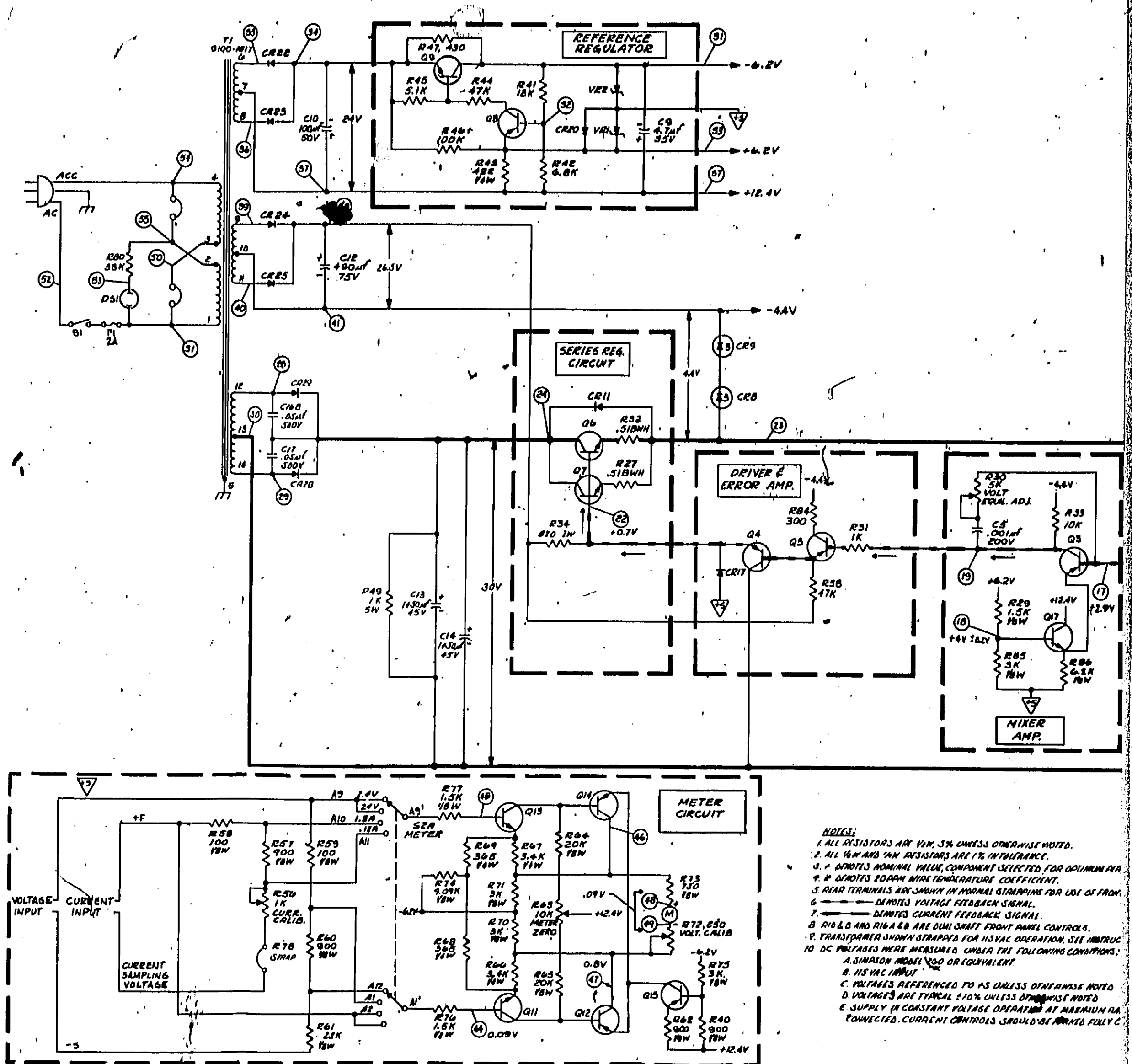
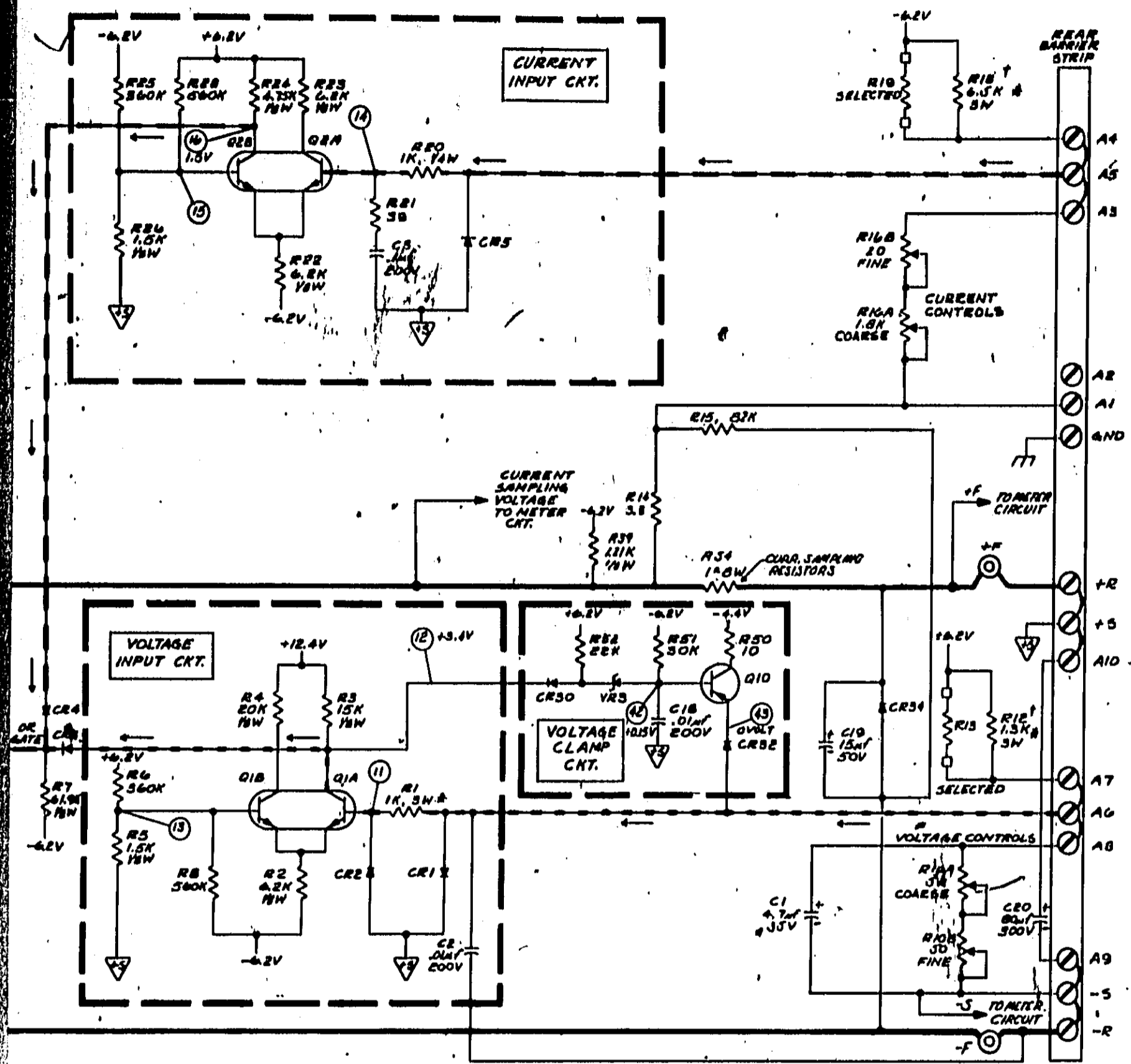

Figure A-1. Model 6201B Overvoltage Protection "Crowbar"



- NOTES:**
1. ALL RESISTORS ARE 1/2W, 5% UNLESS OTHERWISE NOTED.
  2. ALL 1/2W AND 1/4W RESISTORS ARE 1% INTOLERANCE.
  3. F DENOTES NOMINAL VALUE, COMPONENT SELECTED FOR OPTIMUM PER.
  4. M DENOTES ROOM WIRE TEMPERATURE COEFFICIENT.
  5. REAR TERMINALS ARE SHOWN IN NORMAL STRAPPINGS FOR USE OF FROM.
  6. ——— DENOTES VOLTAGE FEEDBACK SIGNAL.
  7. ——— DENOTES CURRENT FEEDBACK SIGNAL.
  8. R10 & B AND R16 A & B ARE DUAL SHAFT FRONT PANEL CONTROLS.
  9. TRANSFORMER SHOWN STRAPPED FOR 115VAC OPERATION. SEE INSTRUC.
  10. DC VOLTAGES WERE MEASURED UNDER THE FOLLOWING CONDITIONS:
    - A. SIMONSON MODEL 500 OR EQUIVALENT
    - B. 115VAC INPUT
    - C. VOLTAGES REFERENCED TO AS UNLESS OTHERWISE NOTED
    - D. VOLTAGES ARE TYPICAL  $\pm 10\%$  UNLESS OTHERWISE NOTED
    - E. SUPPLY IN CONSTANT VOLTAGE OPERATION AT MAXIMUM RA CONNECTED. CURRENT CONTROLS SHOULD BE TURNED FULLY C.



CIRCUIT PATENTS APPLIED FOR. LICENSE FEE'S MUST BE OBTAINED IN WRITING FROM HARRISON LABORATORIES.

FOR MATHS.  
 CONTROL CONTROLS.  
 FROM MANUAL FOR 110 VAC.  
 TB OUTPUT WITH NO LOAD  
 LOCKWISE.

Model 6201B, Schematic Diagram

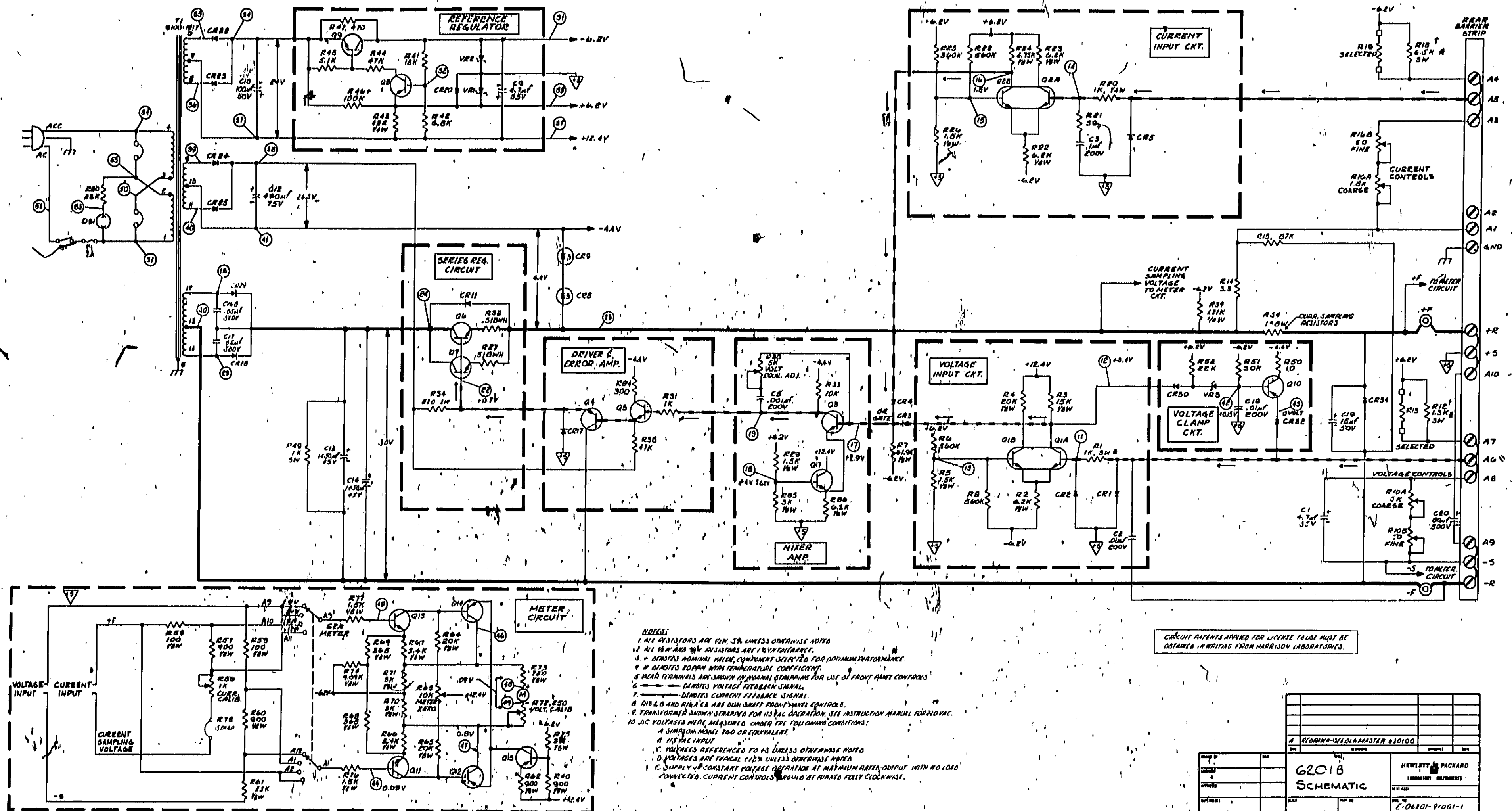

- NOTES:**
1. ALL RESISTORS ARE 1% UNLESS OTHERWISE NOTED
  2. ALL 1W AND 1/2W RESISTORS ARE 1% VOLTAGE
  3. \* DENOTES NOMINAL VALUE COMPONENT SELECTED FOR OPTIMUM PERFORMANCE
  4. # DENOTES ROOM TEMPERATURE COEFFICIENT
  5. REAR TERMINALS ARE SHOWN IN NORMAL STAMPING FOR LIST OF FRONT PANEL CONTROLS
  6. --- DENOTES VOLTAGE FEEDBACK SIGNAL
  7. --- DENOTES CURRENT FEEDBACK SIGNAL
  8. R18 & R19 ARE DUAL-SWIFT FRONT-PANEL CONTROLS
  9. TRANSFORMER SHOWN STRAPPED FOR US AC OPERATION. SEE INSTRUCTION MANUAL FOR NO. 10.
  10. AC VOLTAGES WERE MEASURED UNDER THE FOLLOWING CONDITIONS:
    - A. SIMULON MODEL 100 OR EQUIVALENT
    - B. 115 VAC INPUT
    - C. VOLTAGES REFERENCED TO AS UNLESS OTHERWISE NOTED
    - D. VOLTAGES ARE TYPICAL 1% UNLESS OTHERWISE NOTED
    - E. SUPPLY IS CONSTANT VOLTAGE OPERATION AT MAXIMUM RATED OUTPUT WITH NO LOAD CONNECTED. CURRENT CONTROLS SHOULD BE TURNED FULLY CLOCKWISE.

CIRCUIT PATENTS APPLIED FOR. LICENSE TO USE MUST BE OBTAINED IN WRITING FROM HARRISON LABORATORIES.

A. HARRISON MODEL MASTER #10100		DATE	APPROVED
6201B		DATE	APPROVED
SCHEMATIC		DATE	APPROVED
C-06201-9001-1		DATE	APPROVED

## MANUAL CHANGES

Model 6201B DC Power Supply  
Manual HP Part No. 06201-90001

Make all corrections in the manual according to errata below, then check the following table for your power supply serial number and enter any listed change(s) in the manual.

SERIAL		MAKE CHANGES
Prefix	Number	
ALL		Errata
7A	0701 - 1150	1
7A	1151 - 1550	1, 2
7A	1551 - 2030	1, 2, 3
7A	2039 - 2930	1, 2, 3, 4
1145A	2939 - up	1 thru 5

### ERRATA:

Q3, 5, 8, 10, 12, 14, 15: Change to 2N2907A, Sprague, 56209, HP Part No. 1053-0099, SS PNP SI.

### CHANGE 1:

On the Title Page change Serial Number Prefix from "6A" to "7A."

In Figure 4-5 and Paragraph 4-19, change CR31 to VR3 (zener diode).

In Figure 4-6 remove R84 from collector circuit of Q17 and connect in series with collector of Q5.

In Table 5-6, "Selected Semiconductor Characteristics", add VR3, zener diode, 4.22V, 40mW, HP Part No. 1902-3070, 1N749 Motorola.

In the replaceable parts table make the following changes:

CR31: Delete CR31.

Q4: Change to SS PNP SI., 20400, HP Part No. 1053-0063.

Q9: Change to 20400, HP Part No. 1054-0071.

R20: Change to 1.5k $\Omega$ ,  $\pm$ 1%, 1/8W, I.R.C., CEA T-0, HP Part No. 0757-0427.

R39: Add new resistor, R39, fxd, film 1.21k $\Omega$ ,  $\pm$ 1%, 1/8W, I.R.C., CEA T-0, HP Part No. 0757-0274.

R40, 62: Change to fxd, film 900 $\Omega$ , 1/8W, I.R.C., CEA T-0, HP Part No. 0757-1099,  $\pm$ 1%.

R43: Change to 422 $\Omega$ , 1/4W,  $\pm$ 1%, fxd, met. film, I.R.C., CEA T-0, HP Part No. 0698-4590.

R47: Change to 470 $\Omega$ , fxd, comp  $\pm$ 5%, 1/4W, A.B., EB-4715, HP Part No. 0686-4715.

R48: Delete R48.

R84: Change to 300 $\Omega$ ,  $\pm$ 5%, 1/4W, A.B., EB-3015, HP Part No. 0686-3015.

R86: Change to 6.2k $\Omega$  fxd, met. film  $\pm$ 1%, 1/8W, CEA T-0, I.R.C., HP Part No. 0698-5087.

### CHANGE 2:

In the replaceable parts table, delete Q11 and Q13 transistors and replace with a new single differential amplifier HP Part No. 1854-0221. Circuit References for Q11 and Q13 remain the same with Q11 serving as the "A" side and Q13 the "B" side of the new transistor. All circuit connections to Q11(A) and Q13(B) are unchanged. Also make the following changes:

R40: Delete resistor R40.

R62: Change to fxd, met. film 750 $\Omega$ ,  $\pm$ 1%, 1/8W, CEA T-0, I.R.C., HP Part No. 0757-0420.

R63: Change to var. ww 5k $\Omega$ , Type 110-F4, C.T.S., HP Part No. 2100-1824.

R64, R65: Change to fxd, met. film 12k $\Omega$ ,  $\pm$ 1%, 1/8W, CEA T-0, I.R.C., HP Part No. 0698-5088.

VR3: Add zener diode VR3, 4.22V,  $\pm$ 5%, 400mW, 20400, HP Part No. 1902-3070.

On the schematic, delete R40 in the meter circuit and connect zener diode VR3 in its place. Anode of VR3 is connected to base of Q15 and cathode to +12.4 volts.

### CHANGE 3:

In the replaceable parts table, add new resistor R83, fxd, comp 100 $\Omega$ ,  $\pm$ 5%, 1/4W, EB-1015, A.B., HP Part No. 0686-1015. On schematic connect R83 between base of Q4 and emitter of Q5. Also, change R47 to 470 $\Omega$ .

### CHANGE 4:

In the replaceable parts table, make the following changes:

T1: Change to HP Part No. 06201-80091.

Terminal Strip: Change to HP Part No. 0360-1639.

### CHANGE 5:

The Serial Prefix of this unit has been changed to 1145A. This is the only change.

11-1-71