

## Errata

**Title & Document Type:** 608E/F VHF Signal Generator Operating and Service Manual

**Manual Part Number:** 00608-90046

**Revision Date:** April 1981

### About this Manual

We've added this manual to the Agilent website in an effort to help you support your product. This manual provides the best information we could find. It may be incomplete or contain dated information, and the scan quality may not be ideal. If we find a better copy in the future, we will add it to the Agilent website.

### HP References in this Manual

This manual may contain references to HP or Hewlett-Packard. Please note that Hewlett-Packard's former test and measurement, life sciences, and chemical analysis businesses are now part of Agilent Technologies. The HP XXXX referred to in this document is now the Agilent XXXX. For example, model number HP8648A is now model number Agilent 8648A. We have made no changes to this manual copy.

### Support for Your Product

Agilent no longer sells or supports this product. You will find any other available product information on the Agilent Test & Measurement website:

[www.agilent.com](http://www.agilent.com)

Search for the model number of this product, and the resulting product page will guide you to any available information. Our service centers may be able to perform calibration if no repair parts are needed, but no other support from Agilent is available.



**Agilent Technologies**

# OPERATING AND SERVICE MANUAL

## 608E/F VHF SIGNAL GENERATOR

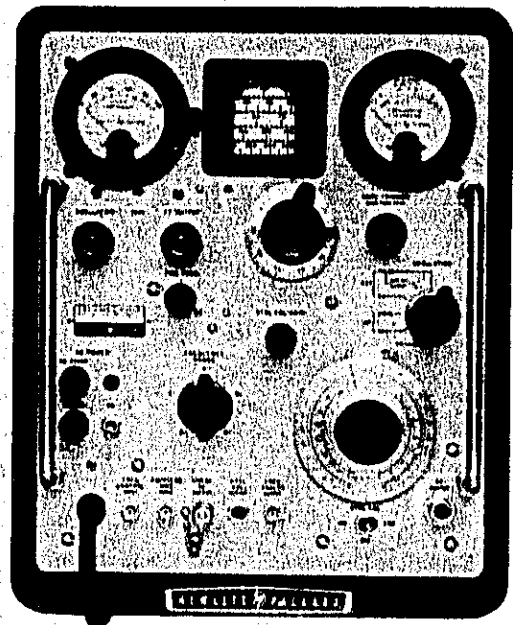
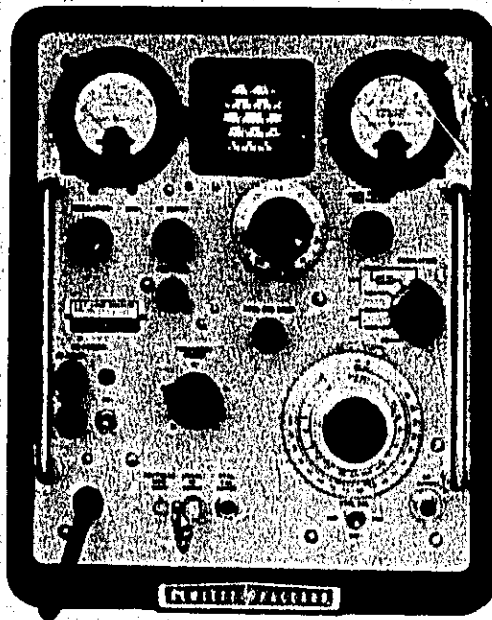

## **CERTIFICATION**

*Hewlett-Packard Company certifies that this product met its published specifications at the time of shipment from the factory. Hewlett-Packard further certifies that its calibration measurements are traceable to the United States National Bureau of Standards, to the extent allowed by the Bureau's calibration facility, and to the calibration facilities of other International Standards Organization members.*

## **WARRANTY**

This Hewlett-Packard instrument product is warranted against defects in material and workmanship for a period of one year from date of shipment. During the warranty period, Hewlett-Packard Company will, at its option, either repair or replace products which prove to be defective.

For warranty service or repair, this product must be returned to a service facility designated by HP. Buyer shall prepay shipping charges to HP and HP shall pay shipping charges to return the product to Buyer. However, Buyer shall pay all shipping charges, duties, and taxes for products returned to HP from another country.

HP warrants that its software and firmware designated by HP for use with an instrument will execute its programming instructions when properly installed on that instrument. HP does not warrant that the operation of the instrument, or software, or firmware will be uninterrupted or error free.

### **LIMITATION OF WARRANTY**

The foregoing warranty shall not apply to defects resulting from improper or inadequate maintenance by Buyer, Buyer-supplied software or interfacing, unauthorized modification or misuse, operation outside of the environmental specifications for the product, or improper site preparation or maintenance.

**NO OTHER WARRANTY IS EXPRESSED OR IMPLIED. HP SPECIFICALLY DISCLAIMS THE IMPLIED WARRANTIES OF MERCHANTABILITY AND FITNESS FOR A PARTICULAR PURPOSE.**

### **EXCLUSIVE REMEDIES**

**THE REMEDIES PROVIDED HEREIN ARE BUYER'S SOLE AND EXCLUSIVE REMEDIES. HP SHALL NOT BE LIABLE FOR ANY DIRECT, INDIRECT, SPECIAL, INCIDENTAL, OR CONSEQUENTIAL DAMAGES, WHETHER BASED ON CONTRACT, TORT, OR ANY OTHER LEGAL THEORY.**

## **ASSISTANCE**

*Product maintenance agreements and other customer assistance agreements are available for Hewlett-Packard products.*

*For any assistance, contact your nearest Hewlett-Packard Sales and Service Office. Addresses are provided at the back of this manual.*



## KEEP WITH MANUAL

### SAFETY CONSIDERATIONS

**GENERAL** — This is a Safety Class I instrument (provided with terminal for protective earthing).

**OPERATION** — BEFORE APPLYING POWER, verify that the power transformer primary is matched to the available line voltage, the correct fuse is installed, and Safety Precautions are taken (see the following warnings). In addition, note the instrument's external markings which are described under "Safety Symbols."

### WARNINGS

Servicing instructions are for use by service-trained personnel only. To avoid dangerous electric shock, do not perform any servicing unless qualified to do so.

**BEFORE SWITCHING ON THE INSTRUMENT**, the protective earth terminal of the instrument must be connected to the protective conductor of the (mains) power cord. The mains plug shall only be inserted in a socket outlet provided with a protective earth contact. The protective action must not be negated by the use of an extension cord (power cable) without a protective conductor (grounding). Grounding one conductor of a two conductor outlet is not sufficient protection.

If this instrument is to be energized via an auto-transformer (for voltage reduction) make sure the common terminal is connected to the earth terminal of the power source.

Any interruption of the protective (grounding) conductor (inside or outside the instrument) or disconnecting the protective earth terminal will cause a potential shock hazard that could result in personal injury.

Whenever it is likely that the protection has been impaired, the instrument must be made inoperative and be secured against any unintended operation.

Only fuses with the required rated current, voltage, and specified type (normal blow, time delay, etc.) should be used. Do not use repaired fuses or short circuited fuseholders. To do so could cause a shock or fire hazard.

Do not operate the instrument in the presence of flammable gases or fumes. Operation of any electrical instrument in such an environment constitutes a definite safety hazard.

Do not install substitute parts or perform any unauthorized modification to the instrument.

Adjustments described in the manual are performed with power supplied to the instrument while protective covers are removed. Energy available at many points may, if contacted, result in personal injury.

Any adjustment, maintenance, and repair of the opened instrument under voltage should be avoided as much as possible, and when inevitable, should be carried out only by a skilled person who is aware of the hazard involved.

Capacitors inside the instrument may still be charged even if the instrument has been disconnected from its source of supply.

### SAFETY SYMBOLS



Instruction manual symbol: the product will be marked with this symbol when it is necessary for the user to refer to the instruction manual in order to protect against damage to the product.



Indicates hazardous voltages.



Earth terminal (sometimes used in manual to indicate circuit common connected to grounded chassis).

### WARNING

The WARNING sign denotes a hazard. It calls attention to a procedure, practice, or the like, which, if not correctly performed or adhered to, could result in personal injury. Do not proceed beyond a WARNING sign until the indicated conditions are fully understood and met.

### CAUTION

The CAUTION sign denotes a hazard. It calls attention to an operating procedure, practice, or the like, which, if not correctly performed or adhered to, could result in damage to or destruction of part or all of the product. Do not proceed beyond a CAUTION sign until the indicated conditions are fully understood and met.



**OPERATING AND SERVICE MANUAL**

**608E/F  
VHF SIGNAL GENERATOR**

**SERIALS PREFIXED:**

This Operating and Service manual applies to HP 608E/F instruments with serial numbers prefixed 833- above 02720 (608E) and 832- above 01500 (608F).

**SERIAL PREFIXES NOT LISTED:**

For instruments with lower serial number prefixes a "Backdating" Appendix is supplied in the back of this manual.



© Copyright HEWLETT-PACKARD COMPANY 1985  
1501 PAGE MILL ROAD, PALO ALTO, CALIFORNIA, U.S.A.

**OPERATING AND SERVICE MANUAL PART NO. 00608-90046**  
Operating and Service Manual Microfiche Part No. 00608-90047

Printed: APRIL 1981

## TABLE OF CONTENTS

Section	Page	Section	Page
<b>I GENERAL INFORMATION</b> . . . . .	1-1	5-10. Purpose . . . . .	5-1
1-1. Description . . . . .	1-1	5-12. Frequency Accuracy and Resettability Test . . . . .	5-1
1-3. Frequency . . . . .	1-1	5-13. Calibrator Accuracy Test . . . . .	5-5
1-5. Modulation . . . . .	1-1	5-14. Frequency Drift Test . . . . .	5-5
1-7. RFI . . . . .	1-1	5-15. Residual FM Test . . . . .	5-5
1-9. Auxiliary Equipment . . . . .	1-1	5-16. Incidental FM Test . . . . .	5-7
1-10. Model 11509A Fuseholder . . . . .	1-1	5-17. Maximum RF Output Test . . . . .	5-7
1-12. Model 11508A Terminated Output Cable . . . . .	1-1	5-18. Frequency Response and Leveling Test . . . . .	5-8
1-14. Instrument Identification . . . . .	1-1	5-19. RF Output Accuracy Test . . . . .	5-8
<b>II INSTALLATION</b> . . . . .	2-1	5-20. Uncalibrated RF Output Test . . . . .	5-8
2-1. Incoming Inspection . . . . .	2-1	5-21. External Sine-Wave Modulation and Modulation Meter Test . . . . .	5-8
2-3. Preparation For Use . . . . .	2-1	5-22. Internal Modulation Test . . . . .	5-9
2-4. Power Requirements . . . . .	2-1	5-23. Envelope Distortion Test . . . . .	5-9
2-6. Power Cable . . . . .	2-1	5-24. External Pulse Modulation and Residual Level Test . . . . .	5-10
2-8. Repacking For Shipment . . . . .	2-1	5-25. RF Leakage Test . . . . .	5-10
<b>III OPERATION</b> . . . . .	3-1	5-26. Frequency Control Input Test (Model 608F Only) . . . . .	5-11
3-1. Introduction . . . . .	3-1	5-27. Frequency Analog Output Test (Model 608F Only) . . . . .	5-12
3-3. Controls, Indicators and Connectors . . . . .	3-1	5-28. Synchronization Test with Model 8708A Synchronizer (Model 608F) . . . . .	5-12
3-5. Pre-Operational Procedures . . . . .	3-1	5-29. Adjustment . . . . .	5-12
3-7. RF Output Loading . . . . .	3-1	5-31. Power Supply Voltage Adjustments . . . . .	5-13
3-9. Turn-On Procedures . . . . .	3-1	5-34. Modulation Meter Adjustment . . . . .	5-13
3-11. Calibration Procedures . . . . .	3-1	5-37. Calibration of Percent Modulation Meter . . . . .	5-14
3-16. Mode Operating Procedures . . . . .	3-4	5-41. Automatic Output Leveling Adjustment . . . . .	5-15
3-18. Internal Modulation . . . . .	3-4	5-42. RF Oscillator Adjustment . . . . .	5-15
3-20. External Modulation . . . . .	3-5	5-43. Uncalibrated RF Output, Minimum RF Output, and RF Amplifier Tracking Adjustment . . . . .	5-16
3-22. Phase-Lock Operation Procedures (Model 608F Only) . . . . .	3-5	5-44. RF Output Meter Accuracy Adjustment . . . . .	5-16
<b>IV PRINCIPLES OF OPERATION</b> . . . . .	4-1	5-46. RF Output Meter/Attenuator Frequency Response and Auto- matic-Leveling Output Adjustment . . . . .	5-17
4-1. Introduction . . . . .	4-1	5-47. Crystal Calibrator Adjustment . . . . .	5-17
4-3. General Description . . . . .	4-1	5-48. Troubleshooting . . . . .	5-18
4-5. RF Generator Section, Model 608E . . . . .	4-1	5-50. Isolating a Trouble to a Circuit Section . . . . .	5-18
4-7. RF Generator Section, Model 608F . . . . .	4-1	5-54. Isolating Trouble in Transistor Circuits . . . . .	5-23
4-9. Amplitude Modulation Section . . . . .	4-1	5-59. Replacement and Repair . . . . .	5-23
4-15. Attenuator Section . . . . .	4-2	5-62. Etched Circuit Board Repair . . . . .	5-23
4-17. Calibrator Section . . . . .	4-3	5-63. Component Replacement . . . . .	5-25
4-19. Modulation Meter Section . . . . .	4-3	5-64. Etched Conductor Repair . . . . .	5-25
4-21. Power Supply Section . . . . .	4-3	5-66. Transistor and Semiconductor Diode Replacement . . . . .	5-26
4-23. Detailed Description . . . . .	4-3	5-67. Replacement of Electron Tubes . . . . .	5-26
4-25. RF Generator Section, Model 608E . . . . .	4-3	5-74. Attenuator Probe Repair and Replacement . . . . .	5-29
4-33. RF Generator Section, Model 608F . . . . .	4-4	5-82. Replacement in Housing . . . . .	5-30
4-37. Amplitude Modulation Section . . . . .	4-5	5-83. Replacement of Lamp DS1 . . . . .	5-32
4-51. Attenuator Section . . . . .	4-7	5-85. Location of Parts . . . . .	5-32
4-55. Calibration Section . . . . .	4-7		
4-59. Modulation Meter Section . . . . .	4-7		
4-63. Power Supply Section . . . . .	4-8		
<b>V MAINTENANCE</b> . . . . .	5-1		
5-1. Introduction . . . . .	5-1		
5-3. Periodic Inspection . . . . .	5-1		
5-4. Cleaning . . . . .	5-1		
5-6. Lubrication . . . . .	5-1		
5-9. Performance Tests . . . . .	5-1		

**TABLE OF CONTENTS (Cont.)**

Section		Page	Section		Page
VI	REPLACEABLE PARTS	6-1	VII	SCHEMATIC DIAGRAMS	
6-1.	Introduction	6-1		COMPONENT LOCATION INFORMATION	7-1
6-3.	Replaceable Parts List	6-1	7-1.	Introduction	7-1
6-6.	Ordering Information	6-1	APPENDIX I		I-1
6-9.	Factory Selected Parts (*)	6-1	APPENDIX II		II-1

**LIST OF ILLUSTRATIONS**

Number	Title	Page	Number	Title	Page
1-1.	Model 608E and 608F VHF Signal Generators	1-0	5-18.	Frequency-Response Adjustments	5-12
3-1.	Front Panel Controls, Indicators, and Connectors	3-2	5-19.	Location of Frequency-Response and Crystal-Calibrator Adjustments	5-18
3-2.	Controls, Indicators and Connectors Used in Operation with Internally Generated Signals	3-6	5-20.	Voltage and Resistance Measure INT 1000 ~ Operation	5-19
3-3.	Controls, Indicators and Connectors Used in Operation with Externally Supplied Signals	3-8	5-21.	ALC Board Voltage and Resistance Measurements, CW and PULSE SET RF OUTPUT Operation	5-22
3-4.	Controls, Indicators, and Connectors Used in Phase-Lock Operation (Model 608F Only)	3-10	5-22.	Transistor Biasing and Operating Characteristics	5-24
4-1.	Overall Block Diagram, Models 608E and 608F	4-0	5-23.	Location of Electron Tubes	5-28
5-1.	Fabricated Test Equipment	5-3	5-24.	Replacement of Oscillator and Amplifier Tubes	5-29
5-2.	Lubrication Points, RF Tuner Drive Mechanism	5-4	5-25.	Disassembly of Attenuator Drive Cable	5-30
5-3.	Frequency Accuracy and Resetability Test Setup	5-5	5-26.	Attenuator Probe, Showing Pickup Loop and Impedance Matching Network	5-31
5-4.	Residual and Incidental FM Test Setup	5-6	5-27.	RF Generator Assembly Location of Unlabeled Parts (Side Cover Removed)	5-32
5-5.	RF Output Test Setup	5-7	5-28.	Model 608E RF Generator Assembly Showing Location of Unlabeled Parts (Top Cover Removed)	5-33
5-6.	Uncalibrated RF Output Test Setup	5-8	5-29.	Model 608F RF Generator Assembly Showing Location of Unlabeled Parts (Top Cover Removed)	5-34
5-7.	External Sine-Wave Modulation and Modulation Meter Test Setup	5-9	5-30.	Right Side View Showing Location of Unlabeled Chassis Components	5-35
5-8.	Envelope Distortion Test Setup	5-10	5-31.	Left Side View Showing Location of Unlabeled Components	5-36
5-9.	Pulse Modulation Test Setup	5-10	5-32.	Rear View Showing Location of Unlabeled Chassis Components	5-37
5-10.	RF Leakage Test Setup	5-11	5-33.	Circuit Board Parts Identification	5-38
5-11.	Frequency Control Input Test Setup	5-11	7-1.	Schematic Information Illustration	7-1
5-12.	Synchronization Test Setup	5-12	7-2.	Schematic Diagram Notes	7-2
5-13.	Location Power Supply and Modulation Meter Adjustments	5-13	7-3.	Component Identification, Modulator and ALC Board	7-3
5-14.	Modulation Meter Calibration Test Setup	5-14	7-4.	RF Generator and Modulator Schematic Diagram	7-3
5-15.	Pattern on 140 Oscilloscope at 50% modulation	5-14	7-5.	Modulation Meter, Crystal Calibration, and Power Supply Schematic Diagram	7-5
5-16.	Location of Leveling and RF Output Meter Adjustment	5-15			
5-17.	Location of RF Oscillator Adjustment	5-16			



## LIST OF TABLES

Number	Title	Page
1-1.	Specifications .....	1-2
5-1.	Test Equipment Required for Maintenance. ....	5-2
5-2.	Lubrication Chart .....	5-4
5-3.	Out-of-Circuit Transistor Resistance Measurement .....	5-25
5-4.	Safe Ohmmeter Ranges for Transistor Resistance Measurement .....	5-25
5-5.	Etched Circuit Soldering Equipment .....	5-26
5-6.	Checks Following Tube and Semiconductor Replacement .....	5-27
5-7.	608E/F Troubleshooting Procedure .....	5-40
6-1.	Reference Designations .....	6-2
6-2.	Abbreviations .....	6-2
6-3.	Replaceable Parts .....	6-4
6-4.	Code List of Manufacturers .....	6-12

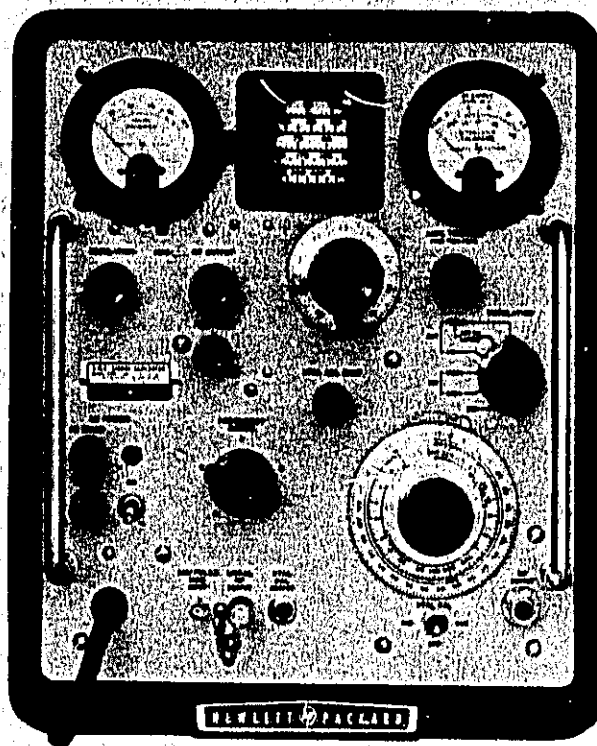

Model 608E

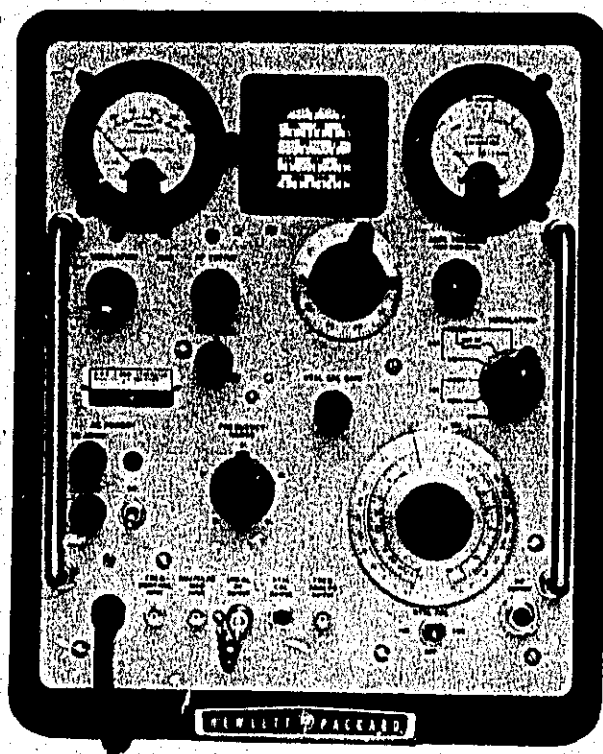

Model 608F

Figure 1-1. Model 608E and 608F VHF Signal Generators

## SECTION I

### GENERAL INFORMATION

#### 1-1. DESCRIPTION.

1-2. The Hewlett-Packard Model 608E and 608F Signal Generators (see Figure 1-1) are designed to meet the requirements of precision laboratory work, and yet to be equally useful for general applications in the VHF frequency range. The Model 608E furnishes RF signals from 0.1 microvolt to 1 volt from 10 MHz to 480 MHz, while the Model 608F supplies RF signals from 0.1 microvolt to 0.5 volt in a frequency range from 10 MHz to 455 MHz. The RF carrier can be amplitude modulated by internally generated sine-wave signals, or by externally supplied sine-wave or pulse signals. The Model 608F contains frequency control circuitry which permits the instrument to be used in phase-lock operation with the Model 8708A Synchronizer. This provision provides a stabilized output across most of the range of the instrument, with a drift factor of  $< 2 \times 10^{-7}$  per 10 minutes. The instruments can be used for troubleshooting, testing, calibrating, measuring standing-wave ratios, and checking antenna and transmission line characteristics. To preserve accuracy, equipment design holds spurious modulation to a low value under all operating conditions. Detailed specifications for both instruments are listed in Table 1-1.

#### 1-3. FREQUENCY.

1-4. The frequency of the output signal is indicated on a direct reading dial, the calibration of which is accurate to better than  $\pm 0.5\%$  for the 608E and  $\pm 1\%$  for the 608F, when the cursor and FINE FREQ are properly aligned. Calibration accuracy may be improved further by use of a built-in crystal-controlled heterodyne calibrator which furnishes 1 MHz checkpoints from 10 MHz to 270 MHz, or 5 MHz checkpoints over the entire frequency range of the instrument. At any checkpoint the calibration can be set very close to the calibrator accuracy of 0.01%, bringing overall accuracy to at least  $\pm 0.05\%$ . Frequency check point signals are obtained when a headphone set (not furnished) is plugged into the XTAL CAL OUTPUT jack. The control for the output attenuator is calibrated in both decibels and volts. When the instrument is connected to a 50-ohm resistive load and power into the output attenuator is exactly at the ATTENUATOR CALIBRATED mark (+7 dB) on the RF OUTPUT meter, the level of power or voltage applied to the RF OUTPUT connector may be read directly on the ATTENUATOR dial with an accuracy of  $\pm 1$  dB. When connected to a 50-ohm resistive load, the VSWR at the RF OUTPUT connector will not be greater than 1.2 (SWR of 1.6 dB). The signal generators feature automatic output leveling, maintaining the RF output within  $\pm 1$  dB of the adjusted output.

#### 1-5. MODULATION.

1-6. The RF output signal can be amplitude modulated by internally generated 400 or 1000-cycle sine waves,

externally applied sine waves above 1.0 volt rms over the frequency range from 20 Hz to 20 kHz, or externally applied pulses of 10 volts peak-to-peak. When pulse modulated, the signal generators are capable of producing pulses of RF energy as short as 4 microseconds at signal frequencies above 40 MHz, and pulses as short as 2 microsecond above 220 MHz. The degree of sine-wave modulation is continuously variable from 0 to 90% by a front-panel control. All sine-wave modulation of the output signal is continuously monitored and indicated in percentage on a direct reading modulation meter.

#### 1-7. RFI.

1-8. RF leakage is held to a minimum and is such that when the output signal is adjusted for 0.1 microvolt, the conducted signal leakage at any other front panel connector and the radiated leakage two inches from the instrument are each less than 1.0 microvolt.

#### 1-9. AUXILIARY EQUIPMENT.

##### 1-10. MODEL 11509A FUSEHOLDER.

1-11. To protect the output attenuator from damage, for some applications (such as transceiver testing) it is desirable to insert a fuse between the signal generators and external equipment. The 11509A is a special coaxial fuseholder which houses a type 8AG, 1/16 amp fuse which protects the output attenuator from damage in the event that an external voltage is accidentally applied to the RF OUTPUT connector. The fuseholder has an insertion loss of 0.50 dB at 200 MHz, 0.58 dB at 300 MHz, and 0.65 dB at 400 MHz; its SWR is not greater than 1.35 when connected to a 50-ohm resistive load.

##### 1-12. MODEL 11508A TERMINATED OUTPUT CABLE.

1-13. This cable assembly provides a 50-ohm termination and standard binding posts at the end of a 24-inch length of cable. The 11508A allows direct connection of the instruments to a high-impedance circuit.

#### 1-14. INSTRUMENT IDENTIFICATION.

1-15. Hewlett-Packard instruments carry a two-section, eight-digit serial number. The first three digits are a prefix. The contents of this manual apply to those instruments having the serial number prefix shown on the title page. If the serial prefix on your instrument is not mentioned on the title page, in the Appendix to this manual, or in a Manual Change Sheet enclosed with the manual, the correct information may be obtained from any Hewlett-Packard Sales and Service Office (see rear of manual for addresses).



Table 1-1. Specifications

FREQUENCY CHARACTERISTICS		input. A voltage change from -2 volts to -32 volts will change the output frequency more than 0.2% at the low end of each band and more than 1% at the high end of each band. Nominal 4 K $\Omega$ input impedance, direct coupled. Voltage limits: 0V $\leq$ applied voltage $\leq$ -50V.	
608E	608F	608E	608F
Range: 10 to 480 MHz in five bands (10-21, 21-43, 43-95, 95-215, and 215-480 MHz).	Range: 10 to 455 MHz in five bands (10-21, 21-44, 44-95, 95-210, and 210-455 MHz). 10-430 MHz when used with 8708A Synchronizer.	<b>OUTPUT CHARACTERISTICS</b>	
Accuracy: $\pm 0.5\%$ with cursor adjustment.	Accuracy: $\pm 1\%$ with cursor adjustment.	Output Level: Continuously adjustable from 0.1 $\mu$ V to 1V into a 50 $\Omega$ load. Output attenuator calibrated in V and dBm (0 dBm = 1 mW in 50 $\Omega$ ).	Output Level: Continuously adjustable from 0.1 $\mu$ V to 0.5V into a 50 $\Omega$ load. Output attenuator calibrated in V and dBm (0 dBm = 1 mW in 50 $\Omega$ ).
Drift: Less than 50 parts in 10 <sup>6</sup> per 10 min. period after 1 hr. warmup.	Drift: Less than 50 parts in 10 <sup>6</sup> per 10 min. period after 1 hr. warmup. Stability used with 8708A Synchronizer.	Accuracy: Within $\pm 1$ dB of attenuator dial reading at any frequency when RF output meter indicates "ATTENUATOR CALIBRATED."	
	5 x 10 <sup>-8</sup> /min.	Leveling: Internal feedback circuit retains "ATTENUATOR CALIBRATED" reference on RF output meter over wide frequency ranges (typically octave bands). Adjustment of front panel AMP. TRIMMER control (only) for maximum RF output indication automatically restores initial carrier level for greater frequency changes.	
	2 x 10 <sup>-7</sup> /min.	Impedance: 50 $\Omega$ ; reflection coefficient $< 0.091$ (1.2 SWR, 20.8 dB return loss) for attenuator setting below -7 dBm.	
	(0°-55°C)	RFI: Meets all conditions specified in MIL-I-6181D; permits receiver sensitivity measurements down to at least 0.1 $\mu$ V.	
	2 x 10 <sup>-7</sup> /10% line voltage change.	Auxiliary RF Output:	
Tuning Control: Frequency control mechanism provides a main dial calibrated in MHz and a vernier dial for interpolation purposes. Total scale length approximately 45 inches. Calibration: every other MHz from 130 to 270 MHz; every 5 MHz above 270 MHz.		608E	
Resettability: Main frequency control resettability better than $\pm 0.1\%$ after initial warmup. FINE FREQUENCY ADJUST provides approximately $\pm 25$ kHz settability at 480 MHz (proportionately finer adjustment at lower frequencies).		Fixed level CW signal from RF oscillator (minimum amplitude 180 mV rms into 50 $\Omega$ ) provided at front panel ENC female connector for use with external equipment (e.g., frequency counter).	
Crystal Calibrator: Provides frequency check points every 1 MHz up to 270 MHz or every 5 MHz over the range of the instrument. Headphone jack provided for audio frequency output (headphones not included). Crystal frequency accuracy better than 0.01% at normal room temperatures. Cursor on frequency dial adjustable over small range to aid in interpolation adjustment. Calibrator may be turned off when not in use.		608F	
Residual FM: $< \pm 5$ parts in 10 <sup>7</sup> in a 10 kHz post-detection bandwidth.		CW signal from RF Oscillator provided at front panel ENC female connector. Power levels into 50 $\Omega$ are as follows:	
Harmonic Output: At least 35 dB below the carrier for harmonic frequencies below 500 MHz.		10 to 215 MHz: -1.8 to +7 dBm	
Frequency Control Input: (608F only). The 608F FREQ CONTROL INPUT normally used with the 8708A Synchronizer can also be used for external frequency control by varying a dc voltage		215 to 400 MHz: +2.0 to +6 dBm	
		400 to 430 MHz: +1.0 to +5 dBm	
		Signal for use with HP 8708A Synchronizer or other external equipment (e.g., frequency counter).	

Table 1-1. Specifications (Cont.)

**MODULATION CHARACTERISTICS**

(Front-panel AMP. TRIMMER control adjusted for maximum indication of RF Output Meter and RF Output Meter set to Attenuator Calibrated.)

**Internal AM**

Frequency: 400 and 1000 Hz,  $\pm 10\%$ . Modulation signal available at front panel BNC female connector for synchronization of external equipment.

608E

608F

Modulation Level: 0 to 95% modulation at carrier levels 0.5 V and below; continuously adjustable with front-panel MOD LEVEL control.

Modulation Level: 0 to 95% modulation with Output Attenuator at 0.224 V (1 mW) or below; continuously adjustable with front-panel MOD LEVEL control.

Carrier Envelope Distortion: Less than 2% at 30% AM and less than 5% at 70% AM.

**External AM**

Frequency: 20 Hz to 20 kHz.

608E

608F

Modulation Level: 0 to 95% modulation at carrier levels 0.5 V and below; continuously adjustable with front-panel MOD LEVEL control. Input required: 1 to 10 V rms (1 k  $\Omega$  input impedance).

Modulation Level: 0 to 95% modulation with Output Attenuator at 0.224 V (1 mW) or below; continuously adjustable with front-panel MOD LEVEL control. Input required: 1 to 10 V rms (1 k  $\Omega$  input impedance).

Carrier Envelope Distortion: Less than 2% at 30% AM, less than 5% at 70% AM (modulation source distortion less than 0.5%).

External control of carrier level can be achieved through application of dc voltage in EXT AM mode.

**Modulation Meter**

Accuracy:  $\pm 5\%$  of full scale 0 to 80%,  $\pm 10\%$  from 80% to 95% (for INT AM or 20 Hz to 20 kHz EXT AM).

**Incidental Frequency Modulation (at 400 and 1000 Hz modulation)**

Less than 1000 Hz peak at 50% AM for frequencies above 100 MHz. For frequencies below 100 MHz, less than 0.001% at 30% AM.

**External Pulse Modulation**

Rise and Decay Time: From 40 MHz to 220 MHz, combined rise and decay time less than 4  $\mu$ s.

Above 220 MHz, combined rise and decay time less than 2.5  $\mu$ s.

On-Off Ratio: At least 20 dB for pulsed carrier levels of 0.5 V and above.

Input Required: Positive pulse, 10-50 V peak; input impedance 2 k  $\Omega$ .

**GENERAL**

608E and 608F

Power: 115 or 230 V  $\pm 10\%$ , 50 to 400 Hz. Approximately 220 W.

**Dimensions**

Cabinet Mount: 13-1/4 in. (337 mm) wide, 16-3/4 in. (416 mm) high, 21 in. (533 mm) deep.

Rack Mount:

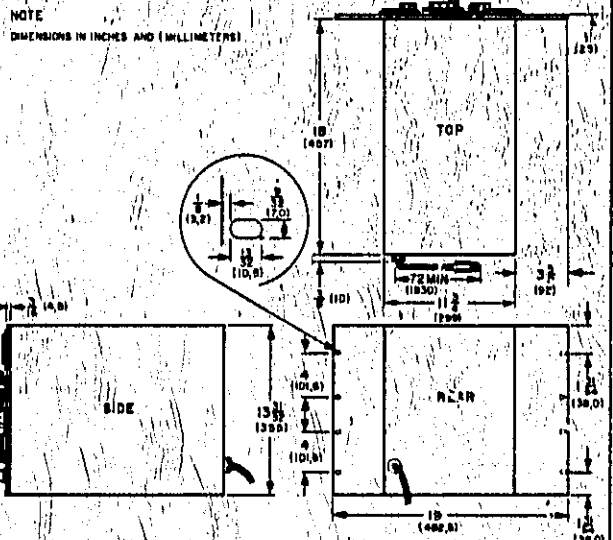

**Weight**

Cabinet Mount: Net, 62 lb (28 kg). Shipping, 74 lb (33, 4 kg).

Rack Mount: Net, 62 lb (28 kg). Shipping, 83 lb (37, 4 kg).

**Accessories Available**

11508A Output Cable provides 50- $\Omega$  termination and standard binding posts at the end of a 24-inch (610 mm) length of cable. Allows direct connection of the signal generator to high impedance circuits.

11509A Fuse Holder provides protection for the output attenuator when the 608 is used for transmitter tests.

10514A Mixer for use as nanosecond pulse modulator or balanced modulator.

10515A Doubler for extending the frequency range.

## SECTION II INSTALLATION

### 2-1. INCOMING INSPECTION.

2-2. This instrument was inspected mechanically and electrically prior to shipment. Inspect for mechanical damage received in transit and test electrical performance using procedures given in Section V. If there is damage or deficiency, or if electrical performance is not within specifications, notify the carrier and your Hewlett-Packard Sales and Service Office immediately (see list at rear of this manual.)

### 2-3. PREPARATION FOR USE.

#### 2-4. POWER REQUIREMENTS.

2-5. The VHF Signal Generator requires a power source of 115 or 230 volts ac  $\pm 10\%$ , single phase, which can supply approximately 220 watts. A two-position slide switch, on the inside rear chassis, permits operation from either a 115- or 230-volt power source. The number visible on the switch slider indicates the line voltage for which the signal generator is connected. The correct fuse rating for each line voltage is adjacent to the switch. To prepare the signal generator for operation, position the 115-230 volt switch so that the number visible on the slider corresponds to the available line voltage, and install a fuse of correct rating (marked on rear apron).

#### CAUTION

Before connecting the power cable, set the 115-230 volt switch for the line voltage to be used.

#### 2-6. POWER CABLE.

2-7. To protect operating personnel, the National Electrical Manufacturers' Association (NEMA) recommends that the instrument panel and cabinet be grounded. This instrument is equipped with a three-conductor power cable which, when plugged into an

appropriate receptacle, grounds the instrument. The off-set pin of the three-prong connector is the ground pin. To preserve the protection feature when operating the instrument from a two-contact outlet, use a three-prong to two-prong adapter (Hewlett-Packard Stock No. 1251-0049) and connect the green pigtail on the adapter to ground.

### 2-8. REPACKING FOR SHIPMENT.

2-9. If the signal generator is to be packaged for shipment use the original shipping container and packing materials. If these have been discarded or are not in condition for reuse, obtain new materials from your local Hewlett-Packard Sales and Service Office (see rear of this manual for locations), or follow these general instructions:

a. Wrap the signal generator in heavy paper or plastic. (If the signal generator is being shipped to a Hewlett-Packard service facility, attach a tag indicating type of servicing required, return address, model number, and full serial number.)

b. Use a strong shipping container. A carton made of 500-600 pound test material will usually provide adequate protection.

c. Use enough shock-absorbing material (3 to 4 inch layer) around all sides of instrument to provide firm cushion and prevent movement inside the container. Protect the control panel with cardboard. With Hewlett-Packard "floater pack" packaging, the foam blocks provide sufficient shock protection, and additional material is unnecessary.

d. Seal the shipping container securely.

e. Mark the shipping container "FRAGILE" to assure careful handling.

2-10. In any correspondence refer to the signal generator by model number and full serial number.



# OPERATION

## SECTION III OPERATION

### 3-1. INTRODUCTION.

3-2. This section provides operating instructions for the Model 608E and 608F Signal Generators. Included are a listing of controls, indicators and connectors, pre-operation procedures, mode operating procedures, and phase-lock operation procedures (Model 608F only). Controls and indicators on both instruments are nearly identical; therefore, an illustration of the Model 608F will be referenced during this discussion, with the difference between instruments identified.

### 3-3. CONTROLS, INDICATORS AND CONNECTORS.

3-4. Except for the 115/230 volt power switch, all controls, indicators, and connectors are located on the front panel. Figure 3-1 locates and provides a functional description of each front-panel mounted control, indicator and connector. The 115-230 volt power switch is located inside the rear panel and is not shown.

### 3-5. PRE-OPERATION PROCEDURES.

3-6. Prior to use, certain procedures must be completed to obtain maximum accuracy during operation of the instrument. Consideration must be given to the possibility of RF loading, and calibration of the instrument is required. During the following discussion, each control used will be identified by an item number that is referenced to Figure 3-1.

### 3-7. RF OUTPUT LOADING.

#### CAUTION

Do not connect any source of RF or dc power to the RF OUTPUT connector on the signal generator. To do so may permanently damage the impedance-matching network in the Attenuator Section. Particular care must be observed when testing transceiver-type equipment to insure that the transmitter remains inactive while the equipment is connected to the signal generator.

#### NOTE

To protect the Attenuator when there is a possibility of voltage being applied to the RF OUTPUT connector, a Model 11509A Fuseholder is recommended. The fuseholder is connected between the test cable and RF OUTPUT connector.

3-8. A resistive load of 50 ohms is used at the factory during calibration of the Attenuator Control dial. Therefore, for an accurate indication of output power the external load should be 50 ohms resistive. The internal impedance of the generator is close to 50 ohms, with a maximum VSWR of 1.2 existing when the generator is terminated in 50 ohms. This VSWR will have no important effect on the accuracy of the Attenuator Control calibration. However, a severe mismatch between the instrument and load will produce a considerable difference between the output voltage selected on the Attenuator Control dial and the actual voltage impressed across the external load. Particular care should be exercised in the selection of coaxial connectors. A coaxial connector that has been improperly assembled can produce a substantial increase in the standing-wave ratio.

### 3-9. TURN-ON PROCEDURES.

3-10. Turn-on procedures for the signal generator are as follows:

#### CAUTION

Do not obstruct the ventilating louvers on the side of the instrument cabinet. Safe operating temperature requires free air flow through the louvers.

- a. Set AC POWER switch (item 12) to the OFF position.
- b. Check position of 115-230 volt power switch (refer to paragraph 2-5) on rear of chassis.
- c. Set MODULATION selector switch (item 20) to CW position.
- d. Set RF OUTPUT control (item 5) full clockwise (maximum).
- e. Set AC POWER switch to ON position.
- f. Warmup equipment for 10 minutes prior to use. If greater frequency stability is required, extend warmup period to 60 minutes.

### 3-11. CALIBRATION PROCEDURES.

3-12. Prior to operation certain calibration of the instrument may be deemed necessary. The following discussion contains frequency and power output calibration procedures.

3-13. FREQUENCY CALIBRATION. The frequency (MEGACYCLES) dial in the signal generators are calibrated to be accurate within  $\pm 0.5\%$  for the 608E and  $\pm 1\%$  for the 608F.

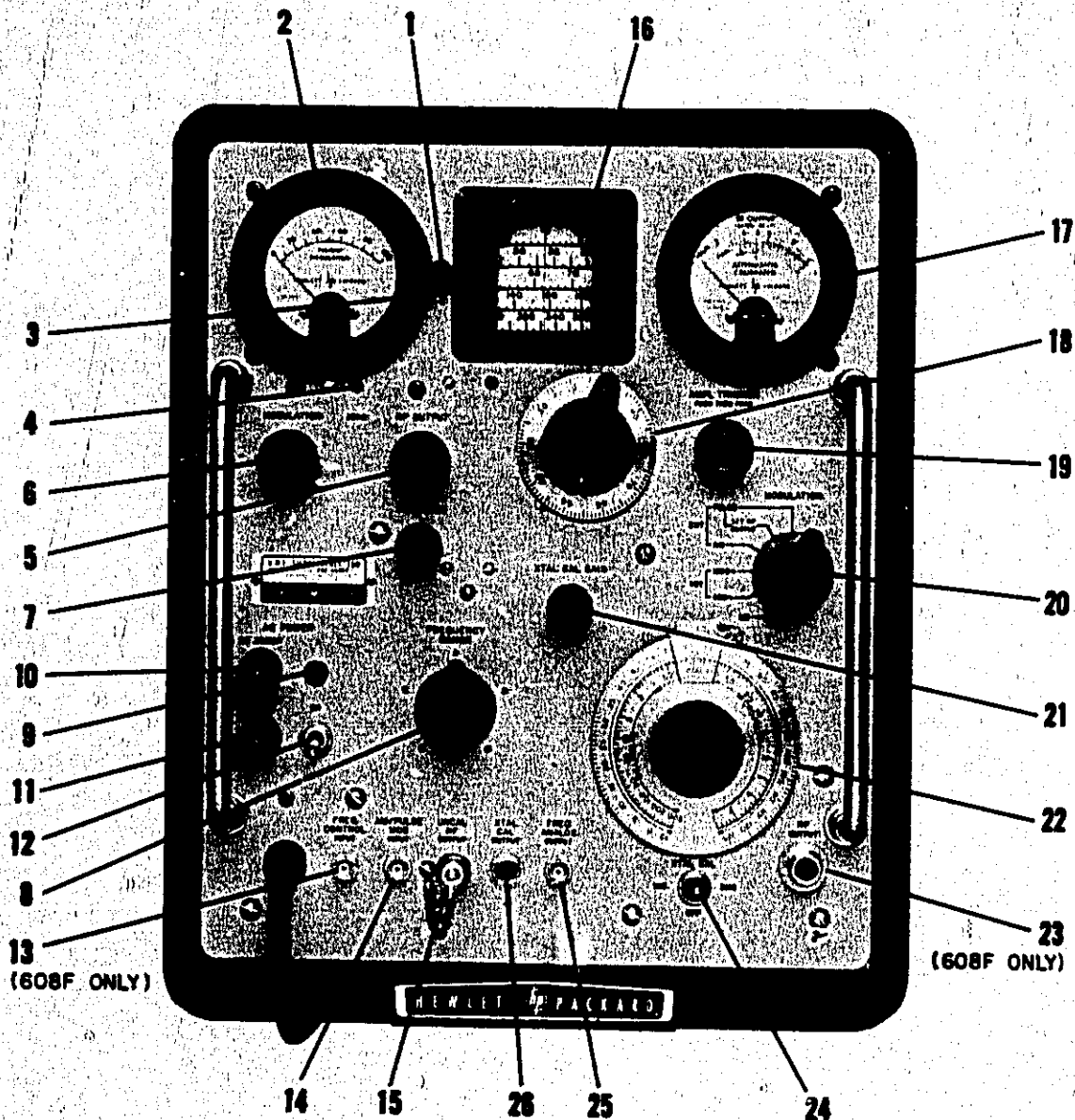

1. **Cursor knob:** Positions cursor on the MEGA-CYCLES (frequency) dial.
2. **PERCENT MODULATION meter:** Indicates the percent of modulation of the RF output signal.
3. **Panel marker:** Scribed mark for cursor alignment.
4. **ZERO control:** Screwdriver adjustment to electrically zero the PERCENT MODULATION meter.
5. **RF OUTPUT control:** Controls RF power input to the attenuator. Also controls output power levels between +7 dBm and +13 dBm in the Model 608E.

Figure 3-1. Front Panel Controls, Indicators, and Connectors



6. **MODULATION control:** Adjusts the percent of modulation of the RF output signal as observed on the PERCENT MODULATION meter.
7. **FINE FREQ control:** Used for fine frequency adjustments
8. **FREQUENCY RANGE switch:** Five-position switch used to select the desired frequency range. Also positions the range pointer on the dial. Switch positions are as follows:
- | RANGE | MODEL 608E  | MODEL 608F  |
|-------|-------------|-------------|
| A     | 10-21 MHz   | 10-21 MHz   |
| B     | 21-43 MHz   | 21-44 MHz   |
| C     | 43-95 MHz   | 44-95 MHz   |
| D     | 95-215 MHz  | 95-210 MHz  |
| E     | 215-480 MHz | 210-455 MHz |
9. **AC POWER lamp:** Indicates when ac power is applied to the instrument.
10. **DC .25 AMP fuse:** Overload protective device for the +225 Vdc power supply.
11. **AC LINE fuse:** Protective device between the instrument and the ac power source.
12. **AC POWER ON switch:** Controls application of ac power to the instrument.
13. **FREQ CONTROL INPUT connector (Model 608F only):** Input connector for the dc control voltage when the instrument is used with a Model 8708A Synchronizer.
14. **AM/PULSE MOD INPUT connector:** Input connector for AM or pulse signals during external sine-wave or pulse operation. During internal sine-wave modulation, a 400 or 1000 Hz signal is available at the connector for synchronizing external equipment.
15. **UNCAL RF OUTPUT connector:** Output connector in the 608E delivers an uncalibrated, unmodulated RF signal to external equipment. In the Model 608F used with the Model 8708A Synchronizer, output connector delivers an uncalibrated FM signal.
16. **MEGACYCLES dial:** Indicates selected frequency range and frequency in MHz.
17. **RF OUTPUT meter:** Indicates level of RF power applied to the attenuator as selected by operation of the RF OUTPUT control. Also used in conjunction with the AMPL TRIMMER control to peak the RF output signal.
18. **Frequency control:** Used to select the output frequency within a frequency range as observed on the MEGACYCLES dial.
19. **AMPL TRIMMER control:** A two-function control for peaking the RF output. During pulse modulation, the control is tuned without pushing to peak the RF output. When sine-wave or CW operations are conducted, the control is pushed and then tuned.
20. **MODULATION switch:** A six-position switch that sets the instrument mode of operation. The switch positions are identified as follows:
- PULSE:** Sets the instrument for external pulse modulation.
- PULSE SET RF OUTPUT:** Used to establish the instrument operating point for external pulse modulation.
- AM:** Sets the instrument for external sine-wave modulation.
- 1000 ~ :** Sets the instrument for internal AM modulation at 1000 Hz.
- 400 ~ :** Sets the instrument for internal AM modulation at 400 Hz.
- CW:** Sets the instrument to provide a CW output.
21. **XTAL CAL GAIN control:** Controls audio level of beat-frequency output at the XTAL CAL OUTPUT connector.
22. **Attenuator control:** Controls RF output levels of +7 dBm and below. Output levels selected by use of the Attenuator Control are accurate as long as the RF OUTPUT meter needle indicates +7 dBm (ATTENUATOR CALIBRATED).
23. **RF OUTPUT connector:** Output connector for the calibrated RF signal (refer to CAUTION, paragraph 3-7).
24. **XTAL CAL switch:** Three-position toggle switch used when performing frequency calibrations. Switch positions are as follows:
- 1 MC:** Provides 1 MHz checkpoints from 10 to 270 MHz.
- 5 MC:** Provides 5 MHz checkpoints from 10-480 MHz in the Model 608E and from 10-455 MHz in the Model 608F.
- OFF:** De-energizes oscillator circuits.
25. **FREQ ANALOG OUTPUT connector (Model 608F only):** Delivers a resistance proportional to frequency to the Model 8708A Synchronizer during phase-lock operation.
26. **XTAL CAL OUTPUT connector:** Supplies calibrating signals to an operator for frequency calibration. Accommodates an earphone plug.

Figure 3-1. Front Panel Controls, Indicators, and Connectors (Cont.)

To obtain higher accuracy, a crystal-controlled calibrator has been included to provide a means of calibrating the instrument at any multiple of 1 MHz between 10 and 270 MHz, or any multiple of 5 MHz across the frequency range of the instrument. Procedures to crystal-calibrate the instrument are as follows:

- a. Conduct turn-on procedures listed in paragraph 3-9.
- b. Connect headphones (not supplied) to the XTAL CAL OUTPUT connector (item 26).
- c. Set XTAL CAL switch (item 24) to 1 MC or 5 MC as applicable.
- d. Rotate frequency control (item 18) until MEGACYCLES dial (item 16) is set on the 1 MHz or 5 MHz checkpoint nearest the frequency to be used.
- e. Adjust XTAL CAL GAIN control (item 21) for a comfortable audio level in headphones.

## NOTE

Extraneous beat notes generated by RF harmonics may be eliminated by properly setting the RF OUTPUT control (paragraph 3-10, step d) and the XTAL CAL GAIN control (paragraph 3-13, step e).

- f. Slowly rotate frequency control around the selected checkpoint until a null (zero beat) is reached.
- g. Rotate Cursor Knob (item 3) until cursor is aligned on MEGACYCLES dial with zero-beat point achieved in step f.
- h. Rotate frequency control until selected frequency on MEGACYCLES dial appears directly under cursor.
- i. Set XTAL CAL switch to OFF.

3-14. A FINE FREQ control (item 7) is located on the instrument front panel for making minor frequency adjustments. During normal operation no adjustment of the FINE FREQ control is required, and the knob arrow should be aligned with the front-panel marker. For a precision frequency selection using a frequency counter, the FINE FREQ control is used after the frequency has been selected by use of the frequency control. Tuning the knob arrow counterclockwise from the panel marker lowers the frequency, while a clockwise rotation raises the frequency.

3-15. POWER OUTPUT CALIBRATION. The RF leveling circuit in the instrument maintains a flat RF output over wide frequency ranges with proper initial adjustments. These adjustments are conducted using the RF OUTPUT and AMPL TRIMMER controls in conjunction with the RF OUTPUT meter. The take-off point for the detected RF signal displayed on the RF OUTPUT meter is at the input circuit of the attenuator. Therefore, calibrating the RF output into the attenuator ensures that subsequent operation of the attenuator control will produce an accurate calibrated RF output from the attenuator. RF output calibration procedures are as follows:

- a. Conduct turn-on procedures listed in paragraph 3-9.
- b. Set the MODULATION switch (item 20) to the CW position.

## NOTE

For maximum accuracy, power output calibrations should be conducted with the instrument set in the CW mode.

- c. Set the FREQUENCY RANGE switch (item 8) to the desired range.
- d. Tune the frequency control (item 18) five turns in from the low end of the selected frequency range as indicated on the MEGACYCLES dial (item 16).
- e. Adjust the RF OUTPUT control (item 5) for an indication on the RF OUTPUT meter (item 17).
- f. Depress the AMPL TRIMMER control (item 19) and tune for a peak RF indication on the RF OUTPUT meter.
- g. Readjust the RF OUTPUT control until the RF OUTPUT meter pointer is aligned with the +7 dBm (ATTENUATOR CALIBRATED) mark.

## NOTES

To calibrate range "E" tune to top of band and repeat steps e through g, before proceeding on to step h.

The RF OUTPUT control may be adjusted to a value  $>+7$  dBm (RF OUTPUT meter reading); however, for maximum tube life it is recommended that the level be reduced when the higher level is not needed.

- h. Tune the frequency control across the selected frequency range. The RF OUTPUT meter pointer should remain aligned with the ATTENUATOR CALIBRATED mark.

## NOTE

If the pointer does not remain aligned with the ATTENUATOR CALIBRATED mark, the leveling circuit is not functioning properly. Stop tuning and readjust the AMPL TRIMMER control to restore leveling. The latter adjustment is made without depressing the control.

- i. Proceed with operating adjustments listed in paragraphs 3-18 and 3-20.

## 3-16. MODE OPERATING PROCEDURES.

3-17. The signal generators have four operating modes identified as CW operation, internal sine-wave modulation, external sine-wave modulation, and external pulse modulation. In addition, the RF output level

established for CW operation can be remotely controlled by an externally supplied dc control voltage. The following discussion combines locally controlled CW operation and internal sine-wave modulation into operating instructions used with internally generated signals, external sine-wave modulation, external pulse modulation and remote-controlled CW operation. These operating procedures are used with externally supplied signals.

### 3-18. INTERNAL MODULATION.

3-19. The signal generators provide internal facilities to produce a CW output, or selection of either a 400 Hz or 1000 Hz sine-wave modulated signal output. Figure 3-2 illustrates and provides instructions for proper operation of the controls, indicators, and connectors used with internally generated signals.

### 3-20. EXTERNAL MODULATION

3-21. The signal generators operate with externally supplied signals which are used to modulate the internally developed RF carrier. Also, an external dc voltage can be applied to provide remote on-off control of the RF carrier output from the instruments. Figure 3-3 illustrates and describes the operation of controls,

indicators, and connectors used in the three operations.

### 3-22. PHASE-LOCK OPERATING PROCEDURES (MODEL 608F ONLY).

3-23. The RF Generator section in the Model 608F signal generator is designed for phase-lock operation with the Model 8708A Synchronizer. This method of operation provides a highly stable output from the instrument, and requires only normal control adjustments followed by cable connections between the signal generator and synchronizer. Figure 3-4 illustrates and describes operation of controls, indicators and connectors on the Model 608F when the instrument is used in phase-lock operation.

3-24. Configuration of the RF Generator Section in the Model 608F signal generator also permits the instrument to be used in narrow-band frequency or phase modulation operations. In this application, consideration must be given to the internal bias of -22 volts dc on the FREQ CONTROL INPUT connector, and the input impedance of approximately 5K ohms. A blocking capacitor must be added to the input circuit for passing the modulating signal while preventing any change in the reference reverse bias applied to the varicap diodes.



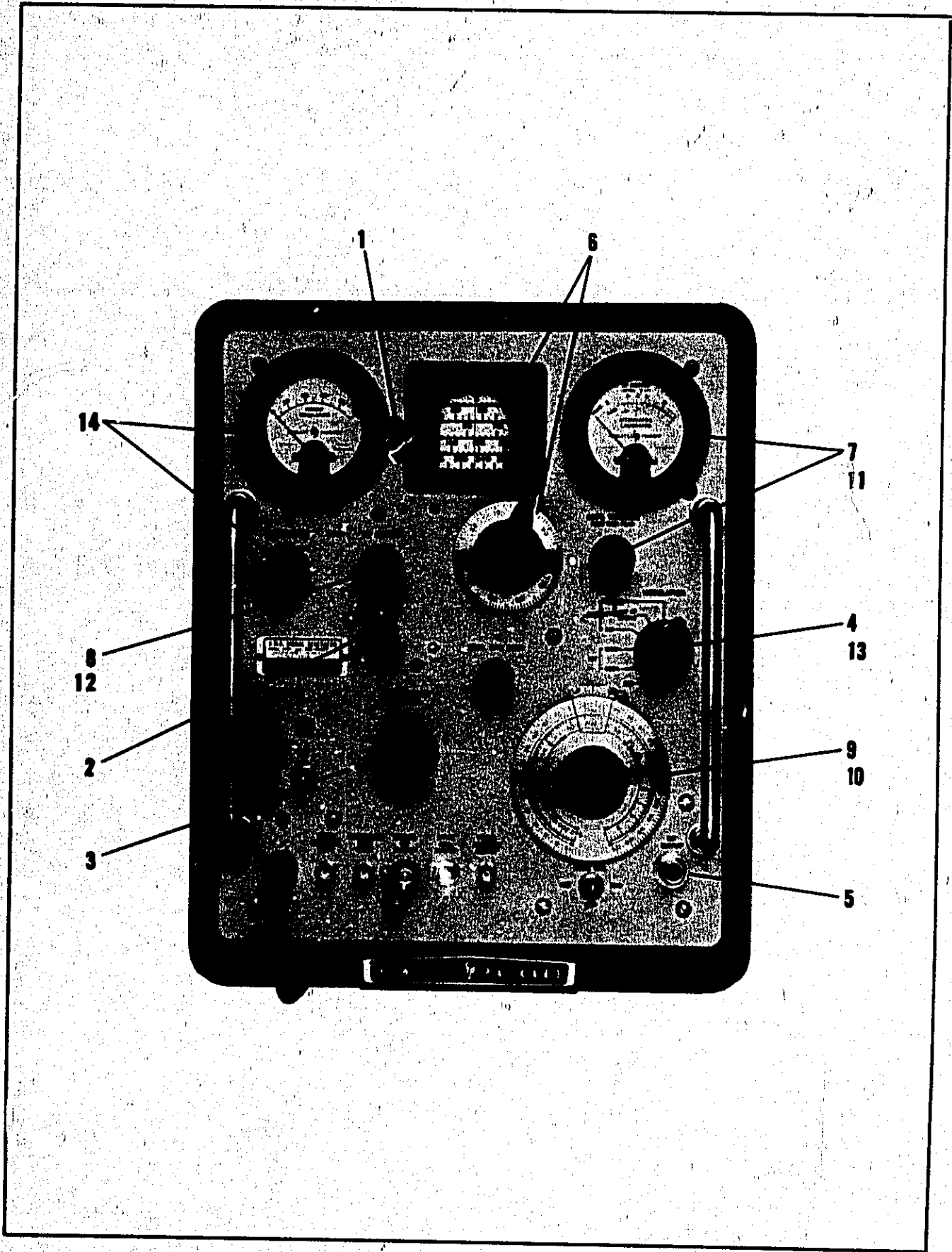

Figure 3-2. Controls, Indicators, and Connectors Used in Operation with Internally Generated Signals

**CW OPERATION****NOTE**

Perform turn-on procedures listed in paragraph 3-9.

1. Align cursor knob with panel marker.
2. Align FINE FREQ control with panel marker.
3. Set FREQUENCY RANGE switch to desired range (frequency limits for each range shown on MEGACYCLES dial housing).
4. Set MODULATION switch to the CW position.

**CAUTION**

Do not connect any source of RF or dc power to the RF OUTPUT connector on the signal generator. To do so may permanently damage the impedance-matching network in the Attenuator Section. Particular care must be observed when testing transceiver-type equipment to insure that the transmitter remains inoperative while the equipment is connected to the signal generator (refer to NOTE in paragraph 3-7).

5. Connect the equipment under test to the RF OUTPUT connector observing that the signal generator is terminated in the proper load (refer to paragraph 3-8).

**NOTE**

If deemed necessary, conduct power output calibration procedures for the selected frequency range as listed in procedural steps d. through h. in paragraph 3-15.

6. Tune the Frequency Control until MEGACYCLES dial cursor is aligned with frequency to be used as indicated on dial face.

**NOTE**

To crystal calibrate the frequency dial, refer to procedures listed in paragraph 3-13.

7. Depress and tune AMPL TRIMMER control for maximum indication on RF OUTPUT meter.
8. Adjust RF OUTPUT control until RF OUTPUT Meter pointer is aligned with +7 dBm mark (ATTENUATOR CALIBRATED).

**NOTE**

Accuracy of the Attenuator Control setting and PERCENT MODULATION meter are within specifications only when the RF OUTPUT meter is indicating ATTENUATOR CALIBRATED.

9. Adjust Attenuator Control for desired output level of +7 dBm or below.

**NOTE**

To select RF output levels from +7 dBm to +13 dBm in the Model 608E, perform steps 10 through 12. In this operation, the RF OUTPUT meter pointer is used in lieu of the Attenuator Control to indicate the power output level.

10. Adjust the Attenuator Control to the +7 dBm dial mark.
11. Check that the RF OUTPUT meter pointer indicates ATTENUATOR CALIBRATED.
12. Adjust RF OUTPUT control for desired output level above +7 dBm as indicated by the RF OUTPUT meter pointer.

**INTERNAL SINE-WAVE MODULATION****NOTE**

Steps 1 through 12, as applicable, must be completed before setting the instrument for internal sine-wave AM modulation.

13. Set MODULATION switch to 400 ~ or 1000 ~ position as desired.
14. Adjust MODULATION control for desired modulation percentage as indicated on the PERCENT MODULATION meter.

Figure 3-2. Controls, Indicators and Connectors Used in Operation with Internally Generated Signals (Cont.)

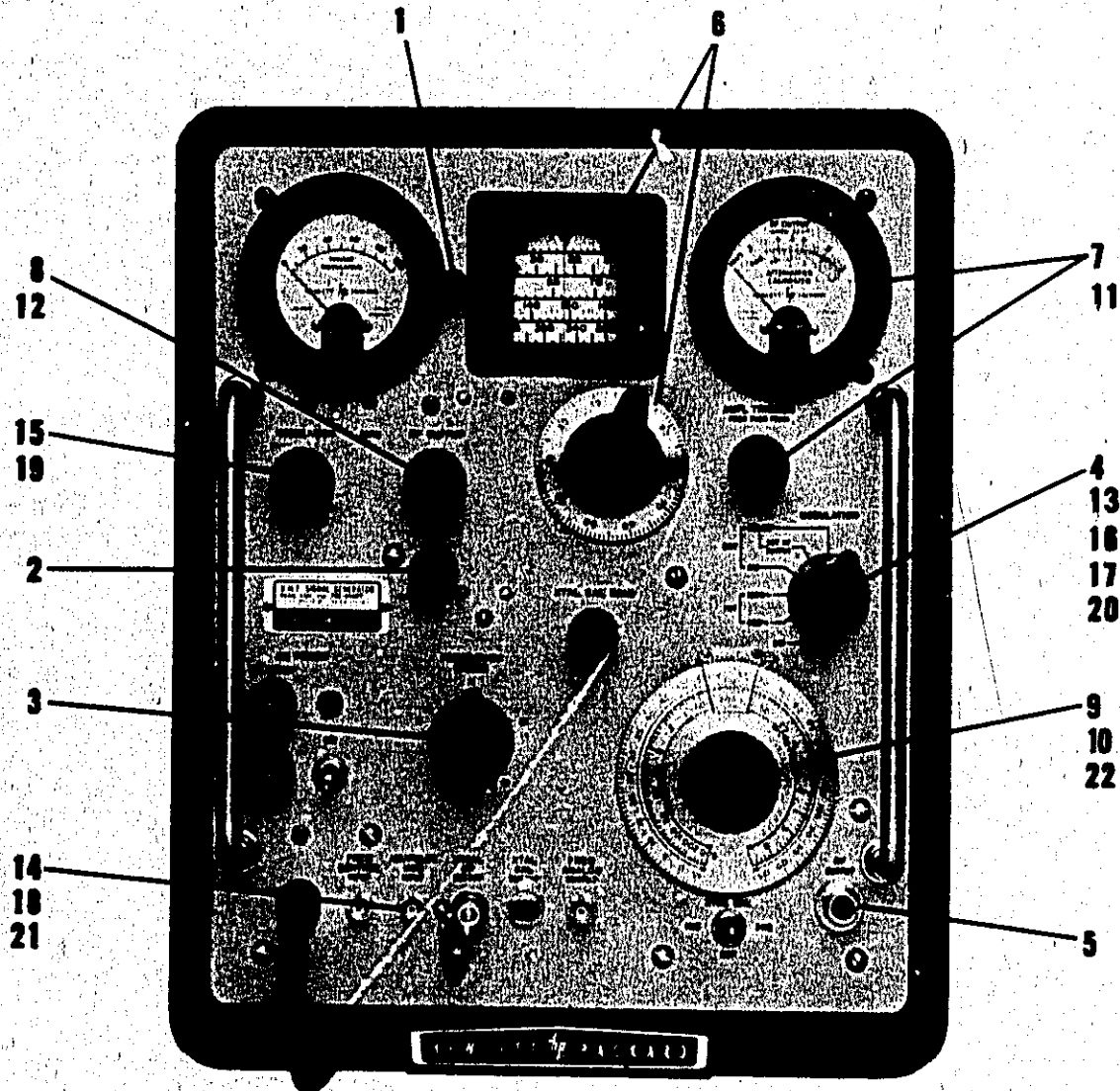

### EXTERNAL SINE-WAVE MODULATION

#### NOTE

Perform turn-on procedures listed in paragraph 3-9.

1. Align cursor knob with panel marker.
2. Align FINE FREQ control with panel marker.
3. Set FREQUENCY RANGE switch to desired range (frequency limits for each range shown on MEGACYCLES dial housing).

Figure 3-3. Controls, Indicators, and Connectors Used in Operation with Externally Supplied Signals



4. Set MODULATION switch to CW position.

**CAUTION**

Do not connect any source of RF or dc power to the RF OUTPUT connector on the signal generator. To do so may permanently damage the impedance-matching network in the Attenuator Section. Particular care must be observed when testing transceiver-type equipment to insure that the transmitter remains inoperative while the equipment is connected to the signal generator (refer to NOTE in paragraph 3-7).

5. Connect the equipment under test to the RF OUTPUT connector observing that the signal generator is terminated in the proper load (refer to paragraph 3-8).

**NOTE**

If deemed necessary, conduct power output calibration procedures for the selected frequency range as listed in procedural steps d. through h. in paragraph 3-15.

6. Tune Frequency Control until MEGACYCLES dial cursor is aligned with frequency to be used as indicated on dial face.

**NOTE**

To crystal calibrate the frequency, refer to procedures listed in paragraph 3-13.

7. Depress and tune AMPL TRIMMER control for maximum indication on RF OUTPUT meter.
8. Adjust RF OUTPUT control until RF OUTPUT meter pointer is aligned with +7 dBm mark (ATTENUATOR CALIBRATED).

**NOTE**

Accuracy of the Attenuator Control setting and PERCENT MODULATION meter are within specifications only when the RF OUTPUT meter is indicating ATTENUATOR CALIBRATED.

9. Adjust Attenuator Control for desired output level of +7 dBm or below.

**NOTE**

To select RF output levels from +7 dBm to +13 dBm in the Model 608E, perform steps 10 through 12. In this operation, the RF OUTPUT meter pointer is used to indicate the power output level in lieu of the Attenuator Control.

10. Adjust the Attenuator Control to the +7 dBm dial mark.

11. Check that the RF OUTPUT meter pointer indicates ATTENUATOR CALIBRATED.

12. Adjust the RF OUTPUT control for the desired output level above +7 dBm as indicated by the RF OUTPUT meter pointer.

13. Set the MODULATION switch to the AM position.

14. Connect the external sine-wave generator to the AM/PULSE MOD INPUT connector and set generator for a sine-wave input between 20 Hz and 20 kHz.

15. Set MODULATION control for desired percentage of modulation as observed on the PERCENT MODULATION meter.

**EXTERNAL PULSE MODULATION**

**NOTE**

Perform turn-on procedures if required, and complete steps 1 through 3.

16. Set MODULATION switch to the PULSE/SET RF OUTPUT position.

**NOTE**

Perform steps 5 through 12 as applicable.

17. Set the MODULATION switch to the PULSE position.

18. Connect the external pulse generator to the AM/PULSE MOD INPUT connector and set generator for an input pulse level above 10 volts peak-to-peak.

**EXTERNAL DC CONTROL**

**NOTE**

Perform turn-on procedures if required, and complete steps 1 through 8.

19. Set the MODULATION control to a maximum clockwise position.

20. Set MODULATION switch to the AM position.

21. Connect external power source to AM/PULSE MOD INPUT connector.

**NOTE**

Voltages required for external control of the RF carrier are +15 volts dc for full-on operation and -15 volts dc for full-off operation.

22. Adjust Attenuator Control and dc control voltage input for desired RF output level.

Figure 3-3. Controls, Indicators and Connectors Used in Operation with Externally Supplied Signals (Cont.)

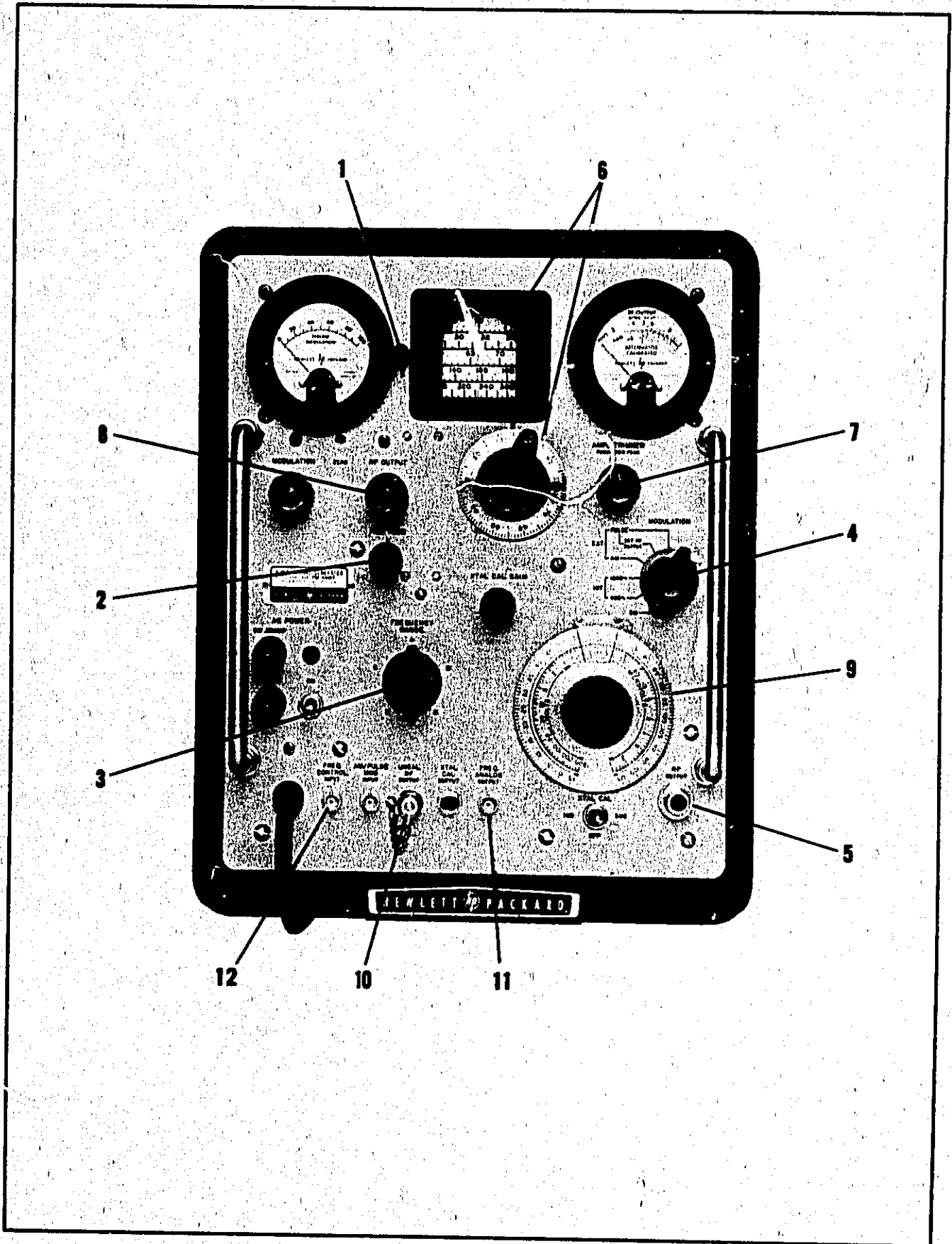

Figure 3-4. Controls, Indicators, and Connectors Used in Phase-Lock Operation (Model 608F Only)

## NOTE

Perform turn-on procedures listed in paragraph 3-9, and prepare the Model 8708A Synchronizer for use with the Model 608F using procedures contained in Section III of the Operating and Service Manual for Synchronizer 8708A.

1. Align cursor knob with panel marker.
2. Align FINE FREQ control with panel marker.
3. Set FREQUENCY RANGE switch to desired range (frequency limits for each range shown on MEGACYCLES dial housing).
4. Set MODULATION switch to the CW position.

## CAUTION

Do not connect any source of RF or dc power to the RF OUTPUT connector on the Signal Generator. To do so may permanently damage the impedance-matching network in the Attenuator Section. Particular care must be observed when testing transceiver-type equipment to insure that the transmitter remains inoperative while the equipment is connected to the signal generator (refer to NOTE in paragraph 3-7).

5. Connect the equipment under test to the RF OUTPUT connector observing that the signal generator is terminated in the proper load (refer to paragraph 3-8).

## NOTE

If deemed necessary, conduct power output calibration procedures for the selected frequency range as listed in procedural steps d. through h. in paragraph 3-15.

6. Tune the Frequency Control until MEGACYCLES dial cursor is aligned with frequency to be used as indicated on the dial face.

## NOTE

To crystal calibrate the frequency, refer to procedures listed in paragraph 3-13.

7. Depress and tune AMPL TRIMMER control for maximum indication on RF OUTPUT meter.
8. Adjust RF OUTPUT control until RF OUTPUT meter pointer is aligned with +7 dBm mark (ATTENUATOR CALIBRATED).

## NOTE

Accuracy of the Attenuator Control setting and PERCENT MODULATION meter are within specifications only when the RF OUTPUT meter is indicating ATTENUATOR CALIBRATED.

9. Adjust Attenuator Control for desired output level.
10. Connect coaxial cable between UNCAL RF OUTPUT connector on the Model 608F and the RF INPUT connector (beneath lighted lamp) on the Model 8708A Synchronizer.
11. Connect coaxial cable between FREQ ANALOG OUTPUT connector on the Model 608F and the FREQ ANALOG INPUT connector on the Model 8708A Synchronizer.
12. Connect coaxial cable between FREQ CONTROL INPUT connector on the Model 608F and the FREQ CONTROL OUTPUT connector on the Model 8708A Synchronizer.

## NOTE

With the foregoing adjustments and connections completed phase-lock operation of the Model 608F can begin. Frequency or phase modulation of the RF carrier can be accomplished using the procedures listed in Figure 3-2 of the 8708A Manual.

Figure 3-4. Controls, Indicators, and Connectors used in Phase-Lock Operation (Model 608F Only)(Cont.)



# THEORY

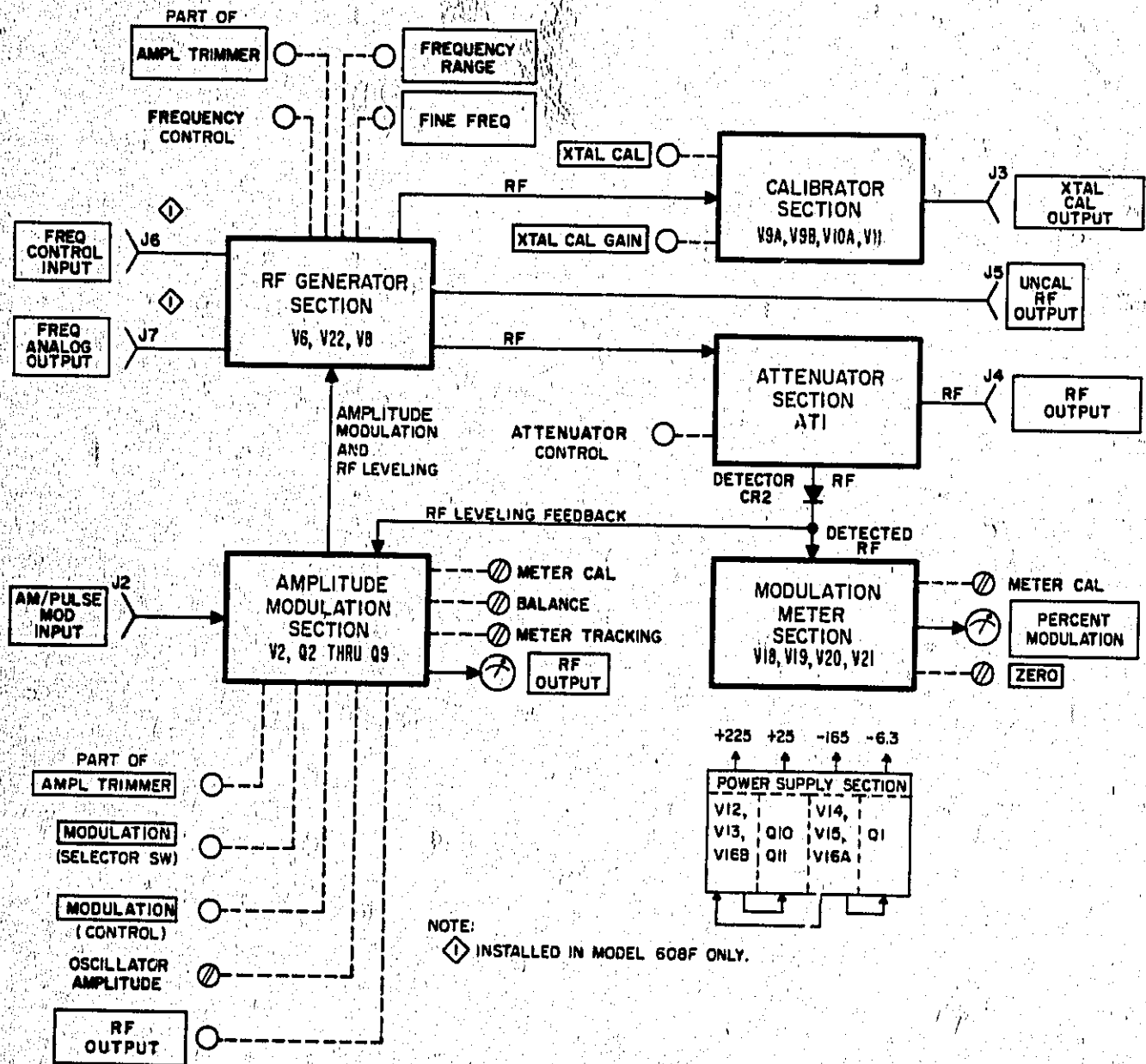

Figure 4-1. Overall Block Diagram, Models 608E and 608F

## SECTION IV

### PRINCIPLES OF OPERATION

#### 4-1. INTRODUCTION.

4-2. This section contains principles of operation for the Model 608E and Model 608F Signal Generators. Included herein is a general description of the instruments to a block diagram level, and a detailed circuit description which references the schematic diagrams. Principal dissimilarities between the Model 608E and 608F occur in the RF Generator Section; therefore, this section of each instrument will be described separately. The remaining sections in both instruments are nearly identical. These sections will be presented in a single description with the minor differences between instruments noted.

#### 4-3. GENERAL DESCRIPTION.

4-4. As illustrated in Figure 4-1, the signal generators contain a RF Generator Section, Amplitude Modulation Section, Attenuator Section, Calibrator Section, Modulation Meter Section, and Power Supply Section. Each section is described in the succeeding paragraphs.

#### 4-5. RF GENERATOR SECTION, MODEL 608E.

4-6. The RF Generator Section in the Model 608E includes RF Oscillator V6, Buffer Amplifier V22, Power Amplifier V8, and associated circuitry. The RF Oscillator generates sine-wave signals from 10 MHz to 480 MHz in five frequency bands, which are identified in Figure 3-1 (item 8). Operation of the FREQUENCY RANGE switch selects tuned circuits in both the RF Oscillator and Power Amplifier stages for the desired operating range, and the Frequency Control adjustment selects frequencies within the range. The latter control tunes the RF Oscillator and Power Amplifier simultaneously. Minor frequency adjustments can be made by use of the FINE FREQ control connected in the output circuit of RF Oscillator V8. An uncalibrated RF output signal is also provided at the output circuit of Oscillator V6. The signal is applied to UNCAL RF OUTPUT connector J5 and is available for use with a frequency counter or other external measuring equipment. Buffer Amplifier V22 isolates RF Oscillator V6 and the output stages. A connection between the output stage of Buffer Amplifier V22 and the input circuit of Power Amplifier V8 serves as the modulation point, with the modulating signal being received from the Amplitude Modulation Section. The modulated RF signal is amplified in V8 and applied to the output circuit of the stage, which has been tuned by the FREQUENCY RANGE and Frequency Control adjustments. The AMPL TRIMMER control connected in the output circuit of Power Amplifier V8 is mechanically linked to a pushbutton switch in the Amplitude Modulation section. The interconnected control permits peaking the

RF output of the instrument, and maintaining a fixed RF output across the frequency range of the instrument. Tuning the control without engaging the pushbutton provides a fine-tune adjustment, which is used in conjunction with the RF OUTPUT control to maintain a fixed, leveled RF output regardless of the selected frequency. Depressing the control and then tuning permits a sharp peak to be obtained on the RF OUTPUT meter for optimizing the RF output of Power Amplifier V8.

#### 4-7. RF GENERATOR SECTION, MODEL 608F.

4-8. The RF Generator Section in the Model 608F Signal Generator is essentially the same as the Model 608E, containing the RF Oscillator, Buffer Amplifier, and Power Amplifier stages discussed in paragraph 4-5. Frequency capability of the instrument is between 10 MHz and 455 MHz in five frequency ranges. Differences between the frequency capabilities of the Model 608F and 608E can be ascertained by reference to Figure 3-1 (item 8). Two circuits and associated input and output connectors have been added to the Model 608F to permit the unit to be used with a Model 8708A Synchronizer. This equipment arrangement provides a highly stable, phase-locked RF signal output from the Model 608F, or permits the instrument to be used in narrow-band frequency or phase modulation applications. During use with a synchronizer a connection is made between UNCAL RF OUTPUT connector J5 on the Model 608F and synchronizer to provide a sample to the uncalibrated RF signal output from RF Oscillator V6. A second connection is made between the synchronizer and FREQ CONTROL INPUT connector J6 on the Model 608F. The latter connection delivers dc control voltage to varactors connected across the tank circuit of RF Oscillator V6 in the Model 608F. This dc control voltage reflects any frequency difference between the uncalibrated RF signal output of V6 and a calibrated reference frequency developed in the synchronizer. Hence, any drift in the output of RF Oscillator V6 is detected and an offsetting control voltage is returned to the Model 608F to maintain a correct frequency output. A third connection between the Model 608F and synchronizer is made at FREQ ANALOG OUTPUT connector J7. This connection provides a resistance to the synchronizer that is inversely proportional to the frequency in use. The resistance is used to maintain constant loop gain across the frequency band during phase-lock operation.

#### 4-9. AMPLITUDE MODULATION SECTION.

4-10. The Amplitude Modulation Section consists of Modulation Oscillator V2, Differential Amplifier Q2 and Q3, Sine-Wave Amplifier Q4, Pulse Amplifier Q5, Amplifiers Q6 and Q7, Modulators Q8 and Q9, the RF OUTPUT meter, and associated circuits. Selection of



the signal generator mode of operation is made by use of the MODULATION selector switch connected in the Amplitude Modulation Section. The four modes of operation are internal sine-wave modulation (400 or 1000 Hz), external sine-wave modulation, external pulse modulation, and cw operation; these four operations are discussed in the following paragraphs.

**4-11. INTERNAL SINE-WAVE MODULATION.** To select internal modulation, the MODULATION selector switch is set to either the 400 ~ or 1000 ~ position. Modulation Oscillator V2 provides a sine-wave output of fixed amplitude established by the Oscillator Amplitude control, a screwdriver adjustment within the instrument. The sine-wave output is then applied to transistor Q3 in the differential amplifier stage, and to AM/PULSE MOD INPUT connector J2. The signal at the connector is made available for synchronizing external equipment during internal modulation operation. The second signal applied to Differential Amplifier Q2-Q3 is a detected RF output signal received from diode CR2. This leveling feedback signal, which is used to counteract variations in the RF output signal, is applied to transistor Q2. The product of Differential Amplifier Q2-Q3 is amplified in Sine-Wave Amplifier Q4, and Amplifiers Q6 and Q7, then passed to Modulators Q8 and Q9. During internal and external modulation and when CW operation is conducted, Pulse Amplifier Q5 is disabled. Signal output from the modulator stage is applied to the input circuit of Power Amplifier V8 in the RF Generator Section where modulation of the RF signal and signal leveling occur. A MODULATION control between Modulator Oscillator V2 and transistor Q3 in the differential amplifier stage provides an adjustment to select the desired percentage of modulation as observed on the PERCENT MODULATION meter discussed in paragraph 4-19. The RF OUTPUT control connected in the differential amplifier stage is used in conjunction with the Attenuator Control to calibrate RF power output from the instrument. Final selection of the desired output level up to +7 dBm is made using the Attenuator Control in both the Model 608E and 608F. In the Model 608E only, an RF output level above +7 dBm is selected by use of the RF OUTPUT control only. The AMPL TRIMMER control in the Amplitude Modulation Section is ganged to a tuning control in the output circuit of Power Amplifier V8 in the RF Generator Section. Operation of these controls is discussed in paragraph 4-5. The Meter Cal, Balance, and Meter Tracking controls are internal adjustments to set the RF OUTPUT meter and differential amplifier stage for proper operation.

**4-12. EXTERNAL SINE-WAVE MODULATION.** During external sine-wave modulation a connection is made between the external modulating equipment and AM/PULSE MODE INPUT connector J2 on the instrument, and the MODULATION selector switch is set to the AM position. The latter adjustment disables Modulation Oscillator V2, and routes the incoming modulation signal through the MODULATION control to transistor Q3 in the differential amplifier stage. Operation of the remaining circuits and controls in the Amplitude Modulation Section is identical to that described in paragraph 4-11.

4-2

**4-13. EXTERNAL PULSE MODULATION.** To set the signal generators for external pulse modulation, the desired RF output level and operating characteristics of the Amplitude Modulation Section are established with the MODULATION selector switch in the PULSE/SET RF OUTPUT position. The switch position enables Pulse Amplifier Q5 and disables Modulation Oscillator V2 and Sine-Wave Amplifier Q4. With the MODULATION switch in the PULSE/SET RF OUTPUT position, the operating characteristics of Amplifier Q7 and Modulators Q8-Q9 in the Amplitude Modulation Section are established by use of the RF OUTPUT control, and the desired RF output level from the instruments selected as observed on the RF OUTPUT meter. Fine adjustment of the RF output level can be made at this time using the AMPL TRIMMER and RF OUTPUT controls conjunctively. Upon completion of these preliminary adjustments, the MODULATION selector switch is set to the PULSE position, and the external pulse source connected to the signal generators at AM/PULSE INPUT connector J2. The input signals are amplified by transistors Q5, Q6 and Q7 then passed to Modulators Q8-Q9. The output of the Modulator stage is applied to the input circuit of Power Amplifier V8 where modulation of the RF signal occurs. During pulse modulation, the MODULATION, RF OUTPUT and AMPL TRIMMER controls should not be operated after initial adjustments are made, and the PERCENT MODULATION and RF OUTPUT meters are inoperative. To readjust the RF output level, the external modulating source must be removed at connector J2, and the MODULATION switch returned to the PULSE/SET RF OUTPUT position. Adjustment of the RF OUTPUT and AMPL TRIMMER controls can then be made as previously discussed.

**4-14. CW OPERATION.** When the instrument is set for CW operation with the MODULATION selector switch in the CW position, Modulation Oscillator V2 and transistor Q3 in the differential amplifier stage are disabled. The RF leveling signal received from diode CR2 is passed through the Amplitude Modulation Section in a normal manner, and applied to the input circuit of Power Amplifier V8 in the RF Generator Section for stabilization of the RF power output level. The RF leveling signal is also applied to the RF OUTPUT meter circuit in the Amplitude Modulation Section for RF level calibration. Operation of both the AMPL TRIMMER PUSH TO PEAK and RF OUTPUT controls is identical to that described in paragraph 4-11.

**4-15. ATTENUATOR SECTION.**

**4-16. Attenuator Section AT1** couples RF energy from Power Amplifier V8 in the RF Generator Section to the load through RF OUTPUT connector J4, and provides control over the RF output level. The previously discussed RF leveling signal developed across diode CR2 is provided by a second RF output from the Attenuator Section. The Attenuator Control is used in conjunction with the RF OUTPUT meter and RF OUTPUT control in the Amplitude Modulation Section to calibrate the RF output level of the instrument, and also to select the desired output level from the equipment after calibration procedures have been completed.

**4-17. CALIBRATOR SECTION.**

4-18. The Calibrator Section consists of 5-MHz Oscillator V9A, 1-MHz Oscillator V9B, Amplifiers V10A and V11, and the associated circuits. Operation of the oscillators is controlled by the XTAL CAL toggle switch that has three positions; OFF, 1 MC, and 5 MC. With the selector switch in either the 1 MC or 5 MC position, an output from the active oscillator is mixed with a sample RF signal from Power Amplifier V8 in the RF Generator Section to produce audio beat signals. The audio signals are passed through amplifiers V10A and V11 to a matching transformer. The transformer output is then applied to XTAL CAL OUTPUT connector J3 for use by an operator during frequency calibration operations. A XTAL CAL GAIN control connected in the output circuit of Amplifier V11 provides an audio output level adjustment.

**4-19. MODULATION METER SECTION.**

4-20. The Modulation Meter Section consists of stabilized wideband amplifiers V18 and V19, rectifier V20, and twin-triode V21 connected in a bridge circuit. Prior to operation the PERCENT MODULATION meter, also connected in the bridge circuit, is calibrated by use of the Meter Calibration control, an internal adjustment. Also, the bridge circuit is balanced to electrical zero by the ZERO adjustment located on the front panel of the instrument. The RF signal output of the Attenuator Section is detected across diode CR2 and applied to a filter network that produces the modulating signal. This signal is amplified in V18 and V19, rectified in V20, and applied to the bridge circuit. The bridge circuit is unbalanced in direct proportion to the peak amplitude of the input modulating signal; therefore, the PERCENT MODULATION meter connected across the bridge indicates the degree of unbalance in the bridge, or the percentage of modulation. The percentage of modulation is established by use of the MODULATION control in the Amplitude Modulation Section.

**4-21. POWER SUPPLY SECTION.**

4-22. The Power Supply Section consists of four series-regulated interrelated power supplies. The +225-volt power supply contains Comparison Amplifier V12 and a Series Regulator comprised of both sections of V13 and V16B. The +25-volt power supply contains Reference Amplifier Q10 and Series Regulator Q11. The -165-volt power supply consists of Reference Tube V15, Comparison Amplifier V14, and Series Regulator V16A. The -6.3 volt supply contains a reference diode and Series Regulator Q1. The -165 volt supply is used to reference both the -6.3 volt and +225 volt supplies. The +225 volt supply is used to reference the +25 volt supply. A further discussion of these power supplies is contained in the detailed circuit description that follows.

**4-23. DETAILED DESCRIPTION.**

4-24. This discussion describes the circuits in the RF Generator Section (Model 608E), RF Generator

Section (Model 608F), Amplitude Modulation Section, Attenuator Section, Calibrator Section, Modulation Meter Section, and the Power Supply Section. Figures 7-4 and 7-5 will be used as reference during the description, and where transition from one diagram to the second is required appropriate notice will be made.

**4-25. RF GENERATOR SECTION, MODEL 608E.**

4-26. The RF Generator Section in the Model 608E includes RF Oscillator V6, Buffer Amplifier V22, and Power Amplifier V8. RF Oscillator V6 is a type 4042 triode connected across the +225 and -165 Vdc supplies in a Colpitts circuit. The oscillator tank circuit contains split-stator capacitor C17A and five separate RF transformers mounted on a revolving turret assembly. Capacitor segment C17A is mechanically linked to segment C17B in the output circuit of Power Amplifier V8, and the oscillator turret assembly is linked to an amplifier turret assembly also located in the output circuit of V8. Choice of frequency band is made by operating the FREQUENCY RANGE switch located on the front panel of the instrument. This function rotates the oscillator and power amplifier turret assemblies simultaneously to the selected range (Range A through E), and sets the associated inductor (L1 through L6, and L12 through L16) into the output circuits of RF Oscillator V6 and Power Amplifier V8 respectively. Capacitors C17A and C17B are then tuned by the front-panel mounted Frequency Control to the desired frequency within the range. Minor frequency adjustments can be made by tuning capacitor C68 (FINE FREQ control) in the tank circuit of Oscillator V6.

4-27. The plate circuit of RF Oscillator V6 is series fed through resistors R246 and R247. These resistors in conjunction with resistor R43 in the cathode of the stage serve to limit plate current within safe limits. The cathode of Oscillator V6 is bypassed by capacitor C25, which is part of the tube mounting plate and is not visible when the plate is in position. Bias for the stage is developed by cathode resistor R249 and grid resistor R248, with coupling capacitor C16 returning feedback to the grid to maintain oscillation. Capacitor C59 connected across a portion of the tuned circuit is used to calibrate the high end of the frequency dial after replacing an oscillator tube. Capacitor C18, installed in the Model 608E only, is used to improve tracking characteristics of the tuned circuit at higher frequencies. Adjustment of this internal control is critical, since a compromise must be reached between tracking capabilities and optimum power output. Misadjustment of capacitor C18 can produce improved tracking capability but a loss in RF power output. The control is factory aligned, and no further adjustment should be required.

4-28. All voltages applied to RF Oscillator V6 located in the RF Generator housing assembly are regulated, and brought into the stage through RFI filters. The +225 Vdc plate voltage is received through filter FL5, the -165 Vdc supply is received through filter FL2, and a regulated -6.3 heater voltage is received through filter FL4.



4-29. The secondary windings in the oscillator turret assembly couple RF energy from RF Oscillator V6 through a coaxial cable to Buffer Amplifier V22. Resistors R240, R242, R244, and R245 located in the secondary windings of coils L2 through L5 damp undesirable resonance in the cathode of Buffer Amplifier V22. Resistors R241 and R243 connected across the secondary windings of coils L4 and L5 limit the RF drive at lower frequencies. Resistors R250, R251, and capacitor C218 form a take-off network for an uncalibrated RF output signal that is applied through coaxial cable W1 to UNCAL RF OUTPUT connector J5. Resistor R251 in the take-off network is 301 ohms in the Model 608E and 200 ohms in the Model 608F. This configuration is due to the difference in RF output level between instruments. The RF signal at connector J5 can be used with a frequency counter or other external measuring equipment. When the Model 608F is used with a Model 8708A synchronizer during phase-lock operation, the signal is used by the synchronizer.

4-30. Buffer Amplifier V22 is a type EC-8010 triode connected as a grounded-grid amplifier. The stage isolates RF Oscillator V6 and Power Amplifier V8, and reduces any incidental frequency modulation to a minimum level. Cathode resistors R255 and R253 operate with resistors R254 and R256 in the plate circuit to limit plate current to a safe value. Power to the stage is supplied through RFI filters FL2, FL4, and FL5, with the plate, cathode and filament supplies being decoupled by capacitors C222, C220, and C221 respectively. The plate circuit of Buffer Amplifier V22 is coupled to the cathode circuit of Power Amplifier V8 through a wide-band network consisting of dc blocking capacitor C224 and coil L22. Coil L20 in the plate circuit of V22 serves as an RF choke, while isolation network L11 blocks an RF signal path to the output circuit of the Amplitude Modulation Section.

4-31. Power Amplifier V8 is a grounded-grid, cathode-modulated amplifier that delivers the modulated or CW output signal to the Attenuator Section. The plate circuit of V8 contains the amplifier turret assembly which houses inductors L12 through L16. These inductors are placed into the output circuit of V8 by operation of the FREQUENCY RANGE switch discussed in paragraph 4-26. The second segment of Frequency Control capacitor C17 is also located in the plate circuit of Power Amplifier V8. Linkage between capacitor C17B and C17A in the RF Oscillator Stage permit tuning to a frequency within a range as discussed in paragraph 4-26. A second linkage between capacitor C17B and the AMPL TRIMMER control permit the capacitor to be tuned separately or in conjunction with push-to-operate switch S6 in the Amplitude Modulation Section for peaking the RF output signal. This function is discussed further in paragraph 4-45.

4-32. When the instrument is set to provide an amplitude modulated output, the modulating signal and an RF leveling signal are received at the cathode of Power Amplifier V8 from the Amplitude Modulation Section through isolation network L11. During CW operation, only the RF leveling signal is received from the

Amplitude Modulation Section. Diode CR7 connected in the signal path prevents damage to Power Amplifier V8 by limiting the negative swing of the cathode. Capacitor C32 is connected in the plate circuit of V8 in the Model 608F only, and is adjusted for improved tracking characteristics in the power amplifier stage at higher frequencies. Capacitors C30, C229, C230, and C231 connected across coils L16, L15, L14, and L13 respectively are also installed in the Model 608F only. These capacitors are selected in test to improve tracking between the power amplifier and oscillator stages. Nominal values for the capacitors are illustrated in Figure 7-4. The RF output signal from Power Amplifier V8 is inductively coupled through the amplifier turret assembly coil and applied to the Attenuator Section. This section of the instrument is discussed in paragraph 4-51.

#### 4-33. RF GENERATOR SECTION, MODEL 608F.

4-34. The RF Generator Section in the Model 608F is essentially the same as the generator section in the Model 608E, except for the addition of circuits to permit the unit to be used with a Model 8708A Synchronizer. These circuit differences occur in the tank circuit of RF Oscillator V6 and the output stage of Power Amplifier V8.

4-35. Two varactor diodes, CR31 and CR32, are connected across the oscillator tank circuit in the Model 608F. The varactors are reverse-biased junctions that act as variable capacitors, changing capacitance with a change in the applied reverse bias. In quiescent condition the diodes are biased by a voltage divider network comprised of resistors R271, R267, and R268. A change in bias, and the resultant change in capacitance, is produced by a dc control voltage received at FREQ CONTROL INPUT connector J6. During operation with a Model 8708A Synchronizer, a connection is made between UNCAL RF OUTPUT connector J5 and the synchronizer to provide a sample of the RF output from the Model 608F. A second connection is made between the synchronizer and FREQ CONTROL INPUT connector J6 to receive the dc control voltage from the synchronizer. The frequency sample sent to the synchronizer is compared to a reference frequency developed in the synchronizer. A drift tendency in RF Oscillator V6 is compared with the reference frequency, and translated into a dc control voltage for application to varactors CR31 and CR32 in the Model 608F. The varactors change capacitance in direct proportion to the detected drift holding RF Oscillator V6 on frequency.

4-36. Potentiometer R269 is installed in the Model 608F only, and is mechanically linked to Frequency Control capacitor C17B in the output circuit of Power Amplifier V8. The potentiometer output resistance varies as the Frequency Control adjustment is tuned, presenting 4K ohms at the low-frequency end of the capacitor tuning range and zero ohms at the high-frequency end. The resistance is applied through FREQ ANALOG OUTPUT connector J7 to the dc control voltage circuit in the synchronizer. This loop arrangement controls the voltage level applied to varactors CR31 and CR32, thereby assuring correct



operating conditions for the devices across a frequency range.

#### 4-37. AMPLITUDE MODULATION SECTION.

4-38. The Amplitude Modulation Section consists of Modulation Oscillator V2, a portion of the Modulator and ALC Board, a RF OUTPUT meter and control, two MODULATION controls, and the associated circuitry. The Modulator and ALC Board contains Differential Amplifier Q2-Q3, Sine-Wave Amplifier Q4, Pulse Amplifier Q5, Amplifiers Q6 and Q7, and Modulators Q8 and Q9. Four modes of operation will be discussed during the description of the Amplitude Modulation Section; these are identified as internal sine-wave modulation, external sine-wave modulation, external pulse modulation, and CW operation.

4-39. INTERNAL SINE-WAVE MODULATION. The internal sine-wave modulation mode is selected by placing MODULATION switch S7 to either the 400 - or 1000 - position (switch setting 2 or 3), which provides a  $400 \pm 40$  Hz or a  $1000 \pm 100$  Hz output from Modulation Oscillator V2. The oscillator consists of resistance-coupled amplifiers V2A and V2B connected in a Wein-Bridge circuit. At the resonant frequency, positive feedback from the plate of Amplifier V2B is applied to the grid of amplifier V2A sustaining oscillation. A change in frequency is obtained by inserting resistors R3-R5 or R4-R6 into the feedback network through two segments of MODULATION switch-wafer 2F. A negative feedback circuit consisting of resistors R7, R8 and lamp DS1 is used to stabilize the oscillator, reduce distortion, and maintain a constant output level. If the amplitude of the signal increases, current through the lamp increases thereby raising the resistance of lamp DS1; consequently, the signal amplitude is held constant. Potentiometer R7 is an internal adjustment for adjusting the amplitude of the output signal. Heater voltage to the stage is applied at all times during instrument operation; however, plate voltage is applied to V2A and V2B only when MODULATION switch-wafer 2R is in position 2 or 3.

4-40. The sine-wave signal from Modulation Oscillator V2 is applied through dc blocking capacitor C205, MODULATION switch-wafer 1F, to MODULATION control R210. A second signal path for the sine-wave is provided through resistor R262 to AM/PULSE MOD INPUT connector J2 where the signal is available for synchronizing external equipment during the internal modulation mode. The signal at the wiper of MODULATION control R210 is passed through, a frequency-compensation network consisting of resistor R261, and capacitors C203 and C204. The signal is then routed through MODULATION switch-wafer 1R to the base of transistor Q3 in the differential amplifier stage. The second input to the differential amplifier is a detected signal developed across diode CR2 and filter network C38 and R119 located in the bolometer portion of the Attenuator Section. This leveling signal, which is representative of the RF power output from the instrument, is passed through RFI filter FL8 to the base of transistor Q2. The leveling signal is also applied through resistor R201, Meter Cal potentiometer R202.

MODULATION switch-wafer 4F, and AMPL TRIMMER pushbutton switch S6 to RF OUTPUT meter M1. Operating characteristics of switch S6 and the RF OUTPUT meter are contained in paragraph: 4-45.

4-41. Balance potentiometer R203 is a board adjustment in the emitter circuit of Differential Amplifier Q2 and Q3 used to set the stage for proper operation. The RF OUTPUT control R212 connected with resistor R213 in a voltage divider network sets the operating characteristics of the differential amplifier stage, and is used in conjunction with the Attenuator Control to calibrate and control the RF output from the instrument. The output of the differential amplifier is the product of the leveling signal on the base of transistor Q2 and the modulating signal on the base of transistor Q3. This product signal is then applied to the base of Sine-Wave Amplifier Q4.

4-42. The base circuit of amplifier Q4 contains a low-frequency compensating network consisting of resistor R214 and capacitor C202. In the Model 608E resistor R214 is 200 ohms, and in the Model 608F the resistor value is 392 ohms. Amplifier Q4 is biased by voltage divider network R217 and R215, with diode CR21 installed as a protective device to maintain a safe relationship between the base and emitter circuits of Q4 during operation. The collector circuit of Q4 also contains two frequency-compensating networks consisting of resistor R219 and capacitor C208, and resistor R218 and capacitor C207. The output of amplifier Q4 is developed across resistor R216 and applied to the base circuit of Amplifier Q6.

4-43. During internal or external sine-wave modulation, Amplifier Q6 receives the leveling and modulating signals from Amplifier Q4. During CW operation, only the leveling signal is received at Amplifiers Q4 and Q6. During external pulse modulation, Amplifier Q4 is inhibited and the input pulse signals are received at Amplifier Q6 from Pulse Amplifier Q5. The external pulse modulation and CW modes of operation are discussed later in this section. The emitter of Amplifier Q6 is biased by a voltage divider network consisting of resistors R223 and R224, and during internal sine-wave operation the modulating and leveling signals are developed across load resistor R222 for application to Amplifier Q7.

4-44. Resistor R229 provides emitter bias for Amplifier Q7, while the collector voltage is developed across load resistor R228 and resistor R233. This voltage divider network also establishes the base conditions on Modulators Q8 and Q9. During the pulse modulation mode, the collector voltage on Amplifier Q7 can be controlled by operation of the RF OUTPUT control; this function is discussed in paragraph 4-47. The collector output of Amplifier Q7 is applied to the base of Modulators Q8 and Q9 connected in parallel emitter-follower configuration. The emitter bias for the stage is derived from a voltage divider network consisting of resistor R33, Zener diode CR26, and resistor R258 in the RF Generator Section. Diode CR25 is connected as a protective device between the base and emitter circuits of the stage. The modulator output is applied

through RFI filter FL6 and isolation network L11 to the cathode of Power Amplifier V8, where modulation and RF leveling occur.

4-45. A feedback path for the output of Modulators Q8 and Q9 is provided through filter network R235 and capacitor C200 which removes the modulating signal. The leveling signal is passed through MODULATION switch-wafer 4F and applied to the normally-open contacts of AMPL TRIMMER pushbutton switch S6 when the MODULATION switch is in positions 1 through 4. As previously mentioned, the AMPL TRIMMER pushbutton is mechanically linked to AMPL TRIMMER capacitor C17B in the output circuit of Power Amplifier V8. During normal operation the detected feedback from diode CR2 in the Attenuator Section is applied through resistor R201, potentiometer R202, and the normally-closed contacts of pushbutton switch S6 to RF OUTPUT meter M1; therefore, the meter normally displays the leveled RF output of the instrument. Rotation of RF OUTPUT control R212 changes the conduction level of Differential Amplifier Q2-Q3 and the signal output level of Modulators Q8-Q9. This change is reflected in the RF output of Power Amplifier V8, and displayed on RF OUTPUT meter M1. Operation of AMPL TRIMMER control C17B without engaging the pushbutton provides a fine-tune adjustment for use with the RF OUTPUT control to maintain a constant, leveled RF output across a frequency range. When AMPL TRIMMER pushbutton S6 is depressed the leveling signal feedback from Modulators Q8-Q9 is displayed on meter M1, and operation of the control permits a sharp peak to be observed on the meter. Hence, the RF output of Power Amplifier V8 can be peaked. During internal and external sine-wave operation, MODULATION control R210 controls the level of the modulation and is used in conjunction with the PERCENT MODULATION meter discussed in paragraph 4-59.

4-46. EXTERNAL SINE-WAVE MODULATION. Operation of the instruments during external sine-wave modulation is similar to the internal mode, and is established by setting MODULATION switch S7 to the AM position (switch position 4). Modulation Oscillator V2 is disabled by removing the stage plate voltage at MODULATION switch-wafer 2R, and a signal path of the external sine-wave signal is established through MODULATION switch-wafer 1F. A cable connection is made between the external source and AM/PULSE MOD INPUT connector J2, with the incoming signal being routed to MODULATION control resistor R210. The signal is then applied through the frequency-compensation network and MODULATION switch-wafer 1R to the base of transistor Q3 in the differential amplifier stage. Operation of the remaining circuits and controls in the Amplitude Modulation Section is the same as described during internal sine-wave modulation.

4-47. EXTERNAL PULSE MODULATION. During this mode of operation MODULATION switch S7 is set first to the PULSE/SET RF OUTPUT position (switch position 5) to establish operating conditions in the output circuit of the Amplitude Modulation Section, and

consequently the RF output level of the instrument. The switch is then set to the PULSE position (switch position 6) to pulse modulate the RF carrier. In both positions Modulation Oscillator V2 is disabled and the input signal path through MODULATION control resistor R210 is interrupted. The position of MODULATION switch-wafer 4F interrupts the leveling signal path through the normally-open contacts of AMPL TRIMMER pushbutton switch S6, and removes the push-to-peak function of the AMPL TRIMMER control during pulse operation. However, the detected signal from diode CR2 in the Attenuator Section is received through resistor R201 and potentiometer R202 for application to RF OUTPUT meter M1. Therefore, in the PULSE/SET RF OUTPUT position, the AMPL TRIMMER and RF OUTPUT controls can be used to set the desired RF output level as indicated on the RF OUTPUT meter. The two controls are operated only in the PULSE/SET RF OUTPUT position.

4-48. Transistor Q3 in the differential amplifier stage has an inhibiting voltage applied to the base through resistor R211 and MODULATION switch-wafer 1R. With transistor Q3 cut off, transistor Q2 conducts heavily and places a disabling voltage on the base of Amplifier Q4. This condition interrupts the leveling signal path through the Amplitude Modulation Section. Resistor R212 is removed from the circuit by the position of MODULATION switch-wafer 1R; however, the RF OUTPUT control is also connected to potentiometer R226 in the collector circuit of Amplifier Q7 for rf output level control. With the MODULATION switch in position 5, a positive voltage is applied to the base of Pulse Amplifier Q5 through resistors R220 and R225 to enable the amplifier. The position of MODULATION switch-wafer 3R forms a voltage divider network consisting of resistors R228, R226, and R270 in the collector circuit of Amplifier Q7 and the base circuits of Modulators Q8 and Q9. Operation of RF OUTPUT potentiometer R226 controls the conduction level of transistors Q7, Q8, and Q9, and the output level of Power Amplifier V8.

4-49. While the MODULATION switch is still in the PULSE/SET RF OUTPUT position, the RF OUTPUT control is adjusted for an indication on RF OUTPUT meter M1. AMPL TRIMMER control C17B in the output stage of Power Amplifier V8 is then peaked for maximum RF output. The RF OUTPUT is readjusted for an indication of +7 dBm (Attenuator Calibrated) on RF OUTPUT meter M1. With the preliminary adjustments completed, the external modulating equipment is connected to AM/PULSE MOD INPUT connector J2, and MODULATION switch S7 is set to the PULSE position (switch position 6). The incoming pulse train is passed through MODULATION switch-wafer 3F to the base of Pulse Amplifier Q5, and then routed through Amplifier Q6 and the remaining circuits of the Amplitude Modulation Section as previously described.

4-50. CW OPERATION. To set the equipment for CW operation, MODULATION switch S7 is placed to the CW position (switch position 1). Modulation Oscillator



V2 is removed from the circuit by the position of switch-wafer 2R, and the sine-wave input circuit is interrupted by the setting of switch-wafer 1F. A detected RF output signal from diode CR2 in the Attenuator Section is applied to the base of transistor Q2 in the differential amplifier stage for the development of a leveling signal as previously described. RF OUTPUT meter M1 also receives the detected signal through AMPL TRIMMER pushbutton switch S6. Transistor Q3 in the differential amplifier stage is terminated in a network consisting of resistor R263 and capacitor C206; however, RF OUTPUT control resistor R212 is connected in the circuit and controls conduction of the differential amplifier stage. Pulse Amplifier Q5 is disabled by the ground applied to the base circuit through MODULATION switch-wafer 3F. Leveling signal output of the differential amplifier stage is passed through Amplifiers Q4, Q6, Q7 and Modulators Q8-Q9 to the input circuit of Power Amplifier V8. RF OUTPUT meter M1 displays a leveled RF output from the instrument as selected by the RF OUTPUT control and Attenuator Control. AMPL TRIMMER pushbutton switch S6 is returned to operation in conjunction with AMPL TRIMMER capacitor C17B for peaking the RF output using the leveling signal feedback from Modulators Q8-Q9.

#### 4-51. ATTENUATOR SECTION.

4-52. To extract power from the RF Generator Section, a piston-type attenuator is used. The attenuator housing projects through the rear of the generator housing, and provides an open-ended termination near the power amplifier plate-circuit inductor. A single-turn pick-up loop at the end of the attenuator probe couples energy to an impedance-matching network consisting of capacitors C89 and C37, and resistors R58 and R59. Capacitor C37 is a movable slug in the probe body that is used to adjust the standing-wave ratio to a minimum value when RF OUTPUT connector J4 is terminated in a 50-ohm load.

4-53. The front-panel mounted Attenuator Control moves the probe in the attenuator housing, and controls the amount of RF energy passed to the output connector. In both the Model 608E and 608F, calibration is accomplished by adjusting the RF OUTPUT and AMPL TRIMMER controls for a steady +7 dBm (ATTENUATOR CALIBRATED) indication on the RF OUTPUT meter across the frequency range in use. An adjustment of the Attenuator Control after calibration procedures are completed provides the RF output level indicated on the control dial as long as the RF OUTPUT meter needle remains in the ATTENUATOR CALIBRATED position. In the Model 608E only, an rf output between +7 dBm and +13 dBm can be selected. The Attenuator Control is set to the +7 dBm position (maximum clockwise), and the RF OUTPUT and AMPL TRIMMER controls are adjusted for the RF OUTPUT meter indication of +7 dBm as previously discussed. The desired output level above +7 dBm is then selected by operation of the RF OUTPUT control only, and the output is read directly from the RF OUTPUT meter.

4-54. Two parallel wires crossing the open end of the attenuator housing are used to provide a sample of RF energy delivered by Power Amplifier V8. The energy is applied to the Bolometer through ferrite-bead RFC1, which provides isolation between the Bolometer and Attenuator. The Bolometer contains frequency-response coil L17, diode CR2 and resistor R60. The RF signal detected across resistor R60 and diode CR2 is passed through an RF filter consisting of capacitor C38 and resistor R119. The detected signal is then applied through RFI filter FL8 to the Modulation Meter Section discussed in paragraph 4-60, and to transistor Q2 in the Amplitude Modulation Section discussed in paragraph 4-40.

#### 4-55. CALIBRATOR SECTION.

4-56. The Calibrator Section consists of 5-MHz Oscillator V9A, 1-MHz Oscillator V9B, Harmonic Generator and Mixer CR1, Amplifiers V10A and V11, and output transformer T3. The oscillator and mixer circuits are illustrated in Figure 7-4, while the amplifiers and transformer are located on Figure 7-5.

4-57. The 5-MHz Oscillator is a crystal-controlled, electron-coupled oscillator utilizing the pentode half of a type 6U8 tube. The plate and screen circuits are tuned to the crystal frequency of 5 MHz by coils L6 and L7. Trimmer capacitor C23 is used for fine-frequency adjustment of the oscillator. The 1 MHz Oscillator consists of the triode portion of the tube, with coil L18 used to adjust the oscillator to a point where the fifth harmonic is synchronized with the 5-MHz output of Oscillator V9A. When XTAL CAL switch S4 is set to the 5-MC position, only Oscillator V9A is active. In the 1-MC position both oscillators are operating, with Oscillator V9A referencing the 1-MHz oscillator.

4-58. The output signal from Oscillators V9A or V9B is passed across dc blocking capacitor C24 to diode CR1 which acts as a harmonic generator and mixer. The anode of diode CR1 is inductively coupled to the output circuit of Power Amplifier V8 by running a lead near the plate of the amplifier. Oscillator harmonics within the diode are mixed with RF output signals to produce audio-beat frequencies across resistor R50 in the grid circuit of Amplifier V10A. The output of amplifier V10A is again amplified in V11 and applied across capacitor C36 to 600-ohm, line-matching transformer T3. The secondary of transformer T3 is connected to XTAL CAL OUTPUT connector J3 where the calibrating signals can be monitored. XTAL CAL GAIN resistor R56 provides front-panel control of the audio level output at connector J3.

#### 4-59. MODULATION METER SECTION.

4-60. The Modulation Meter Section consists of a detector network in the Bolometer portion of the Attenuator Section, Amplifiers V18 and V19, Rectifier



V20, and a balanced-bridge circuit containing PERCENT MODULATION meter M2. The Bolometer is illustrated in Figure 7-4, and the remainder of the section appears in Figure 7-5.

4-61. The output of diode CR2, capacitor C38 and resistor R119 in the Bolometer is a dc signal which is representative of the RF output level, and the modulating signal when internal or external modulation is in process. The output is passed through RFI filter FL8 and applied to blocking capacitor C39, which couples the modulating signal to Amplifier V18. The output of Amplifier V18 is amplified again in V19 and passed to the plates of Rectifier V20. A stabilization feedback circuit connects the plate of Amplifier V19 and cathode of Amplifier V18, with resistor R99 installed in the circuit for frequency compensation. C55 ac couples the plate of V19 to the cathode of V18.

4-62. Rectifier V20 is connected in a balanced-bridge detector circuit consisting of twin-triode V21, PERCENT MODULATION meter M2, and associated circuitry. With no modulating signal applied to the circuit, the steady-state dc potential at the plate of Amplifier V19 is coupled to the grids of V21A and V21B. In this condition, equal current flows on both sides of the bridge, and the PERCENT MODULATION meter reads zero. ZERO potentiometer R106 is a front-panel adjustment to compensate for variations in tube and component values. When a modulation mode of operation is in progress, the peak value of the rectified modulating signal is applied to the grid of V21B. The bridge is unbalanced accordingly, and produces an indication on the PERCENT MODULATION meter that is indirect proportion to the amplitude of the modulating signal. Triode V21A is unaffected during the detection cycle, since the modulating signal is filtered by resistors R100, R101, and capacitor C58.

#### 4-63. POWER SUPPLY SECTION.

4-64. Four series-regulated power supplies are contained in the power supply section. The power supplies provide +225, -6.3, -165, and +25 volts dc to the Model 608 Signal Generators. The four supplies are connected to a common input source through ON switch S3. A slide switch located on the rear panel of the instrument sets the generators for use with either a 115-Vac or 230-Vac power source, with AC LINE fuse F1 connected between the power supplies and source as a protective device. The supplies are illustrated in Figure 7-5 and are described in the following paragraphs.

4-65. THE +225 VOLT SUPPLY. Input ac voltage to the +225-volt supply is received across transformer

T1. The secondary contains bridge rectifier CR8 through CR11 and filter capacitor C40. The supply is series regulated through triodes V13A, V13B, and V16B, with the output connected to the load through front-panel mounted DC 0.25 AMP fuse F3. The -165 Volt Power Supply output is used as reference, being applied through a voltage divider consisting of resistors R70 through R72. Any change in the load is sensed across +225 Volts Adj potentiometer and applied to the control grid of Comparison Amplifier V12. The plate of amplifier V12 controls the conduction level of the series regulators, and holds the output voltage constant. The +225 volt supply is used to reference the +25 volt supply discussed in paragraph 4-69.

4-66. THE -6.3 VOLT SUPPLY. Input ac voltage to the -6.3-volt supply is also received across transformer T1. Rectification and filtering occur across bridge rectifier CR16 through CR19 and capacitors C75. Transistor Q1 operates as a comparison amplifier and series regulator, with the base circuit referenced by -7.5 Vdc developed from the -165 Vdc supply across resistor R260 and Zener diode CR20. The output voltage of 7.2 Vdc is applied to RFI Filter FL4 where 0.9 Vdc is dropped. The -6.3 volts is then used as a filament supply for RF Oscillator V6, Buffer Amplifier V22, and Power Amplifier V8. Filament voltage for the remaining tubes in the instrument is provided by a separate secondary winding of transformer T1. The latter winding also supplies voltage to a light behind the MEGACYCLES dial, and to the AC POWER light located on the front panel. Both lamps are lighted when switch S3 is in the ON position.

4-67. THE -165 VOLT SUPPLY. Input ac voltage to the -165 volt supply is received across transformer T1, and rectified by diodes CR12 through CR15. Triode V16A is the series regulator, with the grid controlled by the plate of Comparison Amplifier V14 whose cathode is referenced by gas tube V15. The voltage level is controlled -165 Volts Adj potentiometer R80, with the output applied to the load and to the +225 and -6.3 volt supplies for reference.

4-68. THE +25 VOLT SUPPLY. Components of the +25 volt supply are located on the Modulator and ALC Board, which also contains a portion of the Amplitude Modulation Section circuits discussed in paragraph 4-37. Ac power to the supply is received across transformer T2, and rectified by diodes CR29 and CR30. Transistor Q11 is the series regulator, with the conduction level being control by Amplifier Q10. The supply is referenced by +225 Vdc received across resistor R239.

# MAINTENANCE



## SECTION V MAINTENANCE

### 5-1. INTRODUCTION.

5-2. This section contains inspection requirements, performance and test procedures, troubleshooting techniques, and repair instructions for the Model 608E and 608F Signal Generators. Generally, maintenance procedures for both instruments are identical and will be presented in one set of instructions. Where differences occur, separate instructions for each instrument will be included. The test equipment required for maintenance is listed in Table 5-1. Test instruments other than those listed may be used if the performance equals or exceeds the minimum specification listed. Two test instruments must be fabricated; these include a 100-ohm termination and loop antenna, which are illustrated in Figure 5-1.

### 5-3. PERIODIC INSPECTION.

#### 5-4. CLEANING.

5-5. If the equipment has been subjected to unusual conditions (excessive moisture, dust, heat, vibration, etc.) it is suggested that the instrument be removed from the cabinet and inspected for dirt or moisture accumulation, loosened components, or any possible sign of damage. Forced air under medium pressure is recommended for dusting and drying, although care must be taken not to vary the settings of the internal-adjustment potentiometers and capacitors during the process.

#### 5-6. LUBRICATION.

5-7. The signal generators are thoroughly lubricated at the factory. Full-shielded ball bearings are used in many applications and require no subsequent attention. Ball bearings that are not fully shielded require only light machine oil. After prolonged use of the instrument, lubricated points should be checked for excessive dust accumulation or drying of lubricant.

5-8. This maintenance is particularly important when the instrument is operated continuously or for several hours daily. Calibration accuracy and instrument dependability can be maintained only by proper lubrication of the two worm gears in the tuning mechanism. Other rubbing surfaces and sleeve

bearings, including the small pulleys used in the attenuator drive system, should be lubricated quarterly with a light slideway oil such as Shell Tonna G. In all cases avoid over lubrication. The points to be lubricated are listed in Table 5-2 and illustrated in Figure 5-2.

### 5-9. PERFORMANCE TESTS.

#### 5-10. PURPOSE.

5-11. The following paragraphs check performance of the signal generators during incoming inspection tests, periodic instrument evaluation, troubleshooting, and during equipment calibration periods. The tests can be performed without access to the interior of the instruments. The specifications listed in Table 1-1 are the performance standards. Unless otherwise specified in the test procedures, the following controls are set to the indicated position for each test:

- MODULATION switch . . . . . CW
- Cursor knob . . . . . Aligned with panel marker
- FINE FREQ control . . . . . Aligned with panel marker
- XTAL CAL switch . . . . . OFF

#### 5-12. FREQUENCY ACCURACY AND RESETTABILITY TEST.

- a. Connect signal generator in test setup illustrated in Figure 5-3.
- b. Set FREQUENCY RANGE switch to range A.
- c. Adjust FREQ OUTPUT and attenuator controls to obtain proper triggering of electronic counter.
- d. Adjust frequency control to the low end, approximate center and high end of range A; record MEGACYCLES dial setting and electronic counter indication at each position. Electronic counter should indicate within  $\pm 1\%$  of MEGACYCLES dial setting.
- e. Retune frequency control to each MEGACYCLES dial setting recorded in step d. Electronic counter should indicate within  $\pm 0.1\%$  of indication recorded in step d.
- f. Repeat steps d. and e. for FREQUENCY RANGE B through E.



Table 5-1. Test Equipment Required for Maintenance

Instrument	Critical Specifications	Recommended Model
Electronic Counter	Frequency Range: 10 MHz to 445 MHz Accuracy: $\pm 0.005\%$	HP 5245L with 5253B plug-in unit
Power Meter	Range: 10 $\mu$ W to 10 mW Accuracy: $\pm 5\%$ of full scale	HP 432A
Thermistor Mount	Frequency Range: 10 to 480 MHz SWR: 1.6 max	HP 478A
Coaxial Attenuator Coaxial Attenuator	Attenuation: 10 dB Attenuation: 20 dB	HP 8491A HP 8492A
Oscillator	Frequency Range: 20 Hz to 30 kHz Envelope Distortion: 0.2% max Output: 1 V rms Output Impedance: 600 $\Omega$	HP 200CD
VTVM	Voltage Range: 0.1 mV to 300V Decibel Range: -72 to +52 dB Frequency Range: 20 Hz to 6 MHz	HP 400E
Distortion Analyzer	Range: 5 Hz to 600 kHz Accuracy: $\pm 3\%$	HP 334A
Deviation Meter	Frequency Range: 50 to 150 MHz Accuracy: $\pm 3\%$ Deviation Range: 0 to 5 kHz	Measurements Corp. Model 120
Power Supply	-2 to -32 V variable	HP 6217A
Oscilloscope	Vertical Bandwidth: 5 MHz Vertical Sensitivity: 5 mV/cm	HP 140A with 1402A and 1420A plug-in units
Adapter	None	UG-201A/U
Crystal Detector	Frequency Range: 10 MHz to 12.4 GHz VSWR: 1.2 max Deviation from Square Law: $< 0.5$ dB over a range of at least 30 dB Input Impedance: 50 $\Omega$ Impedance Output: 15K $\Omega$ , 10pf	HP 423A
Dummy Load	Resistance: 100 $\Omega$ $\pm 10\%$ Wattage: 1/2 W	See Figure 5-2
Pulse Generator	Pulse Width: 10 $\mu$ sec Pulse Amplitude: 10 v peak into 2K $\Omega$ Pulse Rise and Decay: 0.02 $\mu$ sec max Repetition Rate: 50 to 5000 pps	HP 214A
Loop Antenna	Special	See Figure 5-1
Spectrum Analyzer	Freq: 400 MHz Sensitivity: 1 $\mu$ V. Absolute calibration	HP 140S with 8554L and 8552A Plug-Ins.

Table 5-1. Test Equipment Required for Maintenance (Cont.)

Instrument	Critical Specifications	Recommended Model
DC Ammeter	Range: 15 to 30 mA Accuracy: $\pm 5\%$	HP 428B
SWR Meter	Sensitivity: at least $\mu v$ full scale Attenuator Range: 40 dB Attenuator Accuracy: $\pm 0.1$ dB	HP 415E
Double Balanced Mixer	Frequency Range: 10 to 480 MHz	HP 10514A
Frequency Comb Generator	Frequency Range: 10 to 480 MHz Comb Frequency: 1 MHz	HP 8406A
Filter	Cutoff Frequency: 100 kHz	
Frequency Meter/ Filter Kit	Discriminator Output: 100 kHz/V Disc. Out Accuracy: Better than 1% Internal Filter: 10 kHz, low pass	HP 5210A/10531A
Oscilloscope	Bandwidth: 0 to 20 MHz Vert Sensitivity: 50 $\mu V/cm$	HP 140 with 1406A plug-in unit
LAB Dual Range, DC Power Supply	Output: 0 to 20 Vdc	HP 6204B
Electronic Counter	Resolution: 5 digits Function: Frequency to > 350 MHz Input Impedance: 50 ohms	HP 5246L with 5252A plug-in unit
Synchronizer	Compatible with the 608F	HP 8708A

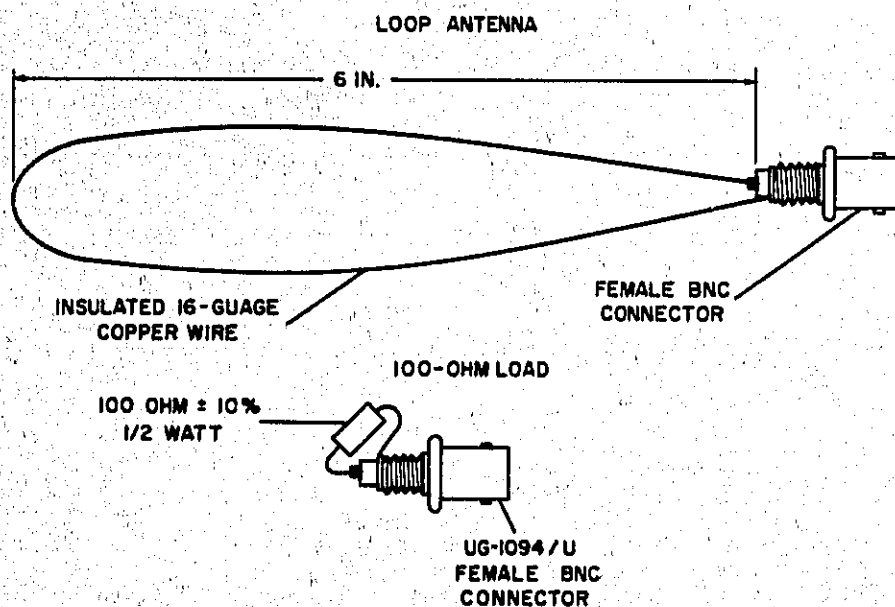

Figure 5-1. Fabricated Test Equipment

Table 5-2. Lubrication Chart

Lubrication Point (see Figure 5-2)	Lubricant
Oscillator and amplifier worm gears	"Molykote (type Z)"
AMPL TRIMMER stop mechanism	Light machine oil
AMPL TRIMMER toggle nut	Light machine oil
AMPL TRIMMER drive link	Light machine oil
Amplifier worm drive shaft	Light machine oil
RF Amplifier sliding coupler	Light machine oil
Attenuator pulleys	Light machine oil
Attenuator drive shaft bearing (front)	Light machine oil
Attenuator drive shaft bearing (rear)	Light machine oil

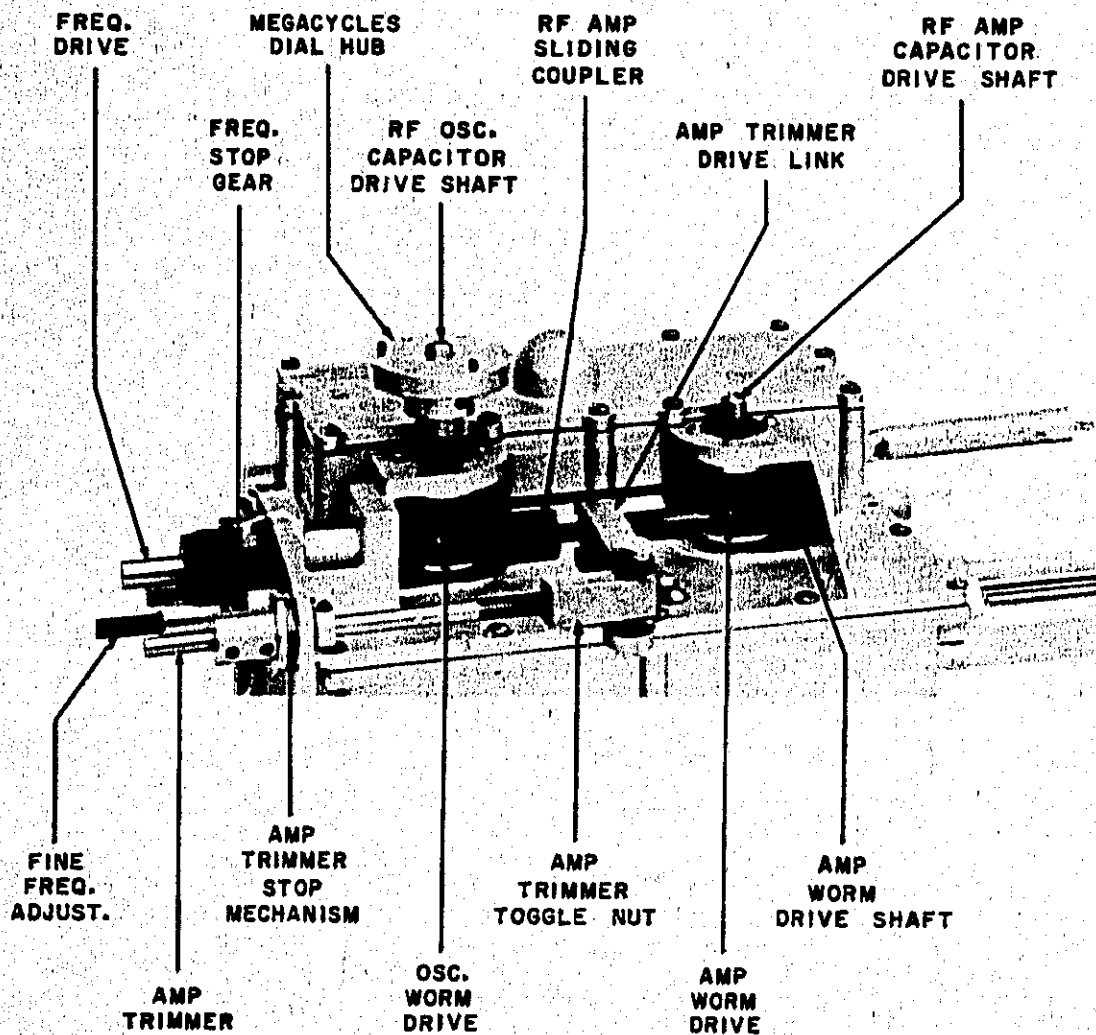

Figure 5-2. Lubrication Points, RF Tuner Drive Mechanism



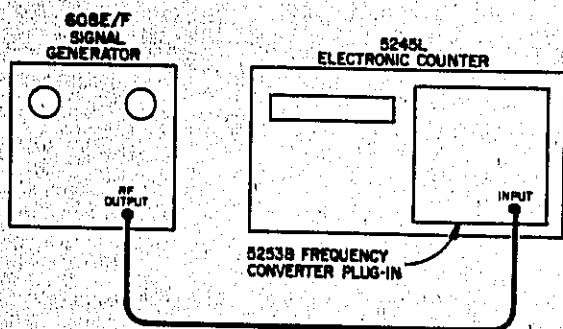

Figure 5-3. Frequency Accuracy and Resettability Test Setup

5-13. CALIBRATOR ACCURACY TEST.

- a. Connect signal generator in test setup illustrated in Figure 5-3.
- b. Set FREQUENCY RANGE switch to range E.
- c. Set XTAL CAL switch to 5 MC position.
- d. Plug headset into XTAL CAL OUTPUT connector.
- e. Adjust Model 608E frequency control for MEGACYCLES dial reading of 480 MHz, or Model 608F for MEGACYCLES dial reading of 455 MHz.
- f. Adjust RF OUTPUT and attenuator controls for proper triggering of electronic counter.
- g. Readjust frequency control for zero beat in headset. Adjust XTAL CAL GAIN control as required.
- h. Electronic counter should indicate within  $\pm 0.01\%$  ( $\pm 48$  kHz) of 480 MHz in Model 608E, or  $\pm 0.01\%$  ( $\pm 45.5$  kHz) of 455 MHz in Model 608F at zero beat in headset.
- i. Set XTAL CAL switch to 1 MC position.
- k. Adjust frequency control on Model 608E or 608F for MEGACYCLES dial reading of 270 MHz at zero beat in headset.
- l. Repeat steps f. and g. Electronic counter should indicate within  $\pm 0.01\%$  ( $\pm 27$  kHz) of 270 MHz.

5-14. FREQUENCY DRIFT TEST.

- a. Connect signal generator in test setup illustrated in Figure 5-3.
- b. Set FREQUENCY RANGE switch to range A.
- c. Adjust frequency control for a MEGACYCLES dial reading of 15 MHz.
- d. Adjust RF OUTPUT and attenuator controls for proper triggering of electronic counter. Allow signal generator to stabilize, i.e., for one hour after turn on and ~25 minutes after a frequency change.
- e. Record electronic counter indication.
- f. Wait 10 minutes and again record electronic counter indication. Frequency should be within  $\pm 0.005\%$  ( $\pm 750$  Hz) of the indication recorded in step e.
- g. Repeat steps e. and f. for the following FREQUENCY RANGE and MEGACYCLES dial settings. Allow the signal generator to stabilize for 25 minutes after changing the frequency before making the frequency drift measurement.

FREQ RANGE	FREQ.	DRIFT
B	30 MHz	$\pm 1.50$ kHz
C	75 MHz	$\pm 3.75$ kHz
D	150 MHz	$\pm 7.50$ kHz
E	340 MHz	$\pm 17.00$ kHz

5-15. RESIDUAL FM TEST.

- a. Connect signal generator in test setup illustrated in Figure 5-4.
- b. Set FREQUENCY RANGE switch to range A.
- c. Adjust frequency control for MEGACYCLES dial reading of 10 MHz.
- d. Adjust RF OUTPUT and AMPL TRIMMER controls for a +7 dBm (ATTENUATOR CALIBRATED) indication on RF OUTPUT meter.
- e. Adjust attenuator control for output setting of 0 dBm.
- f. Readjust frequency control for a 50 kHz indication on frequency meter on the 100 kHz range.

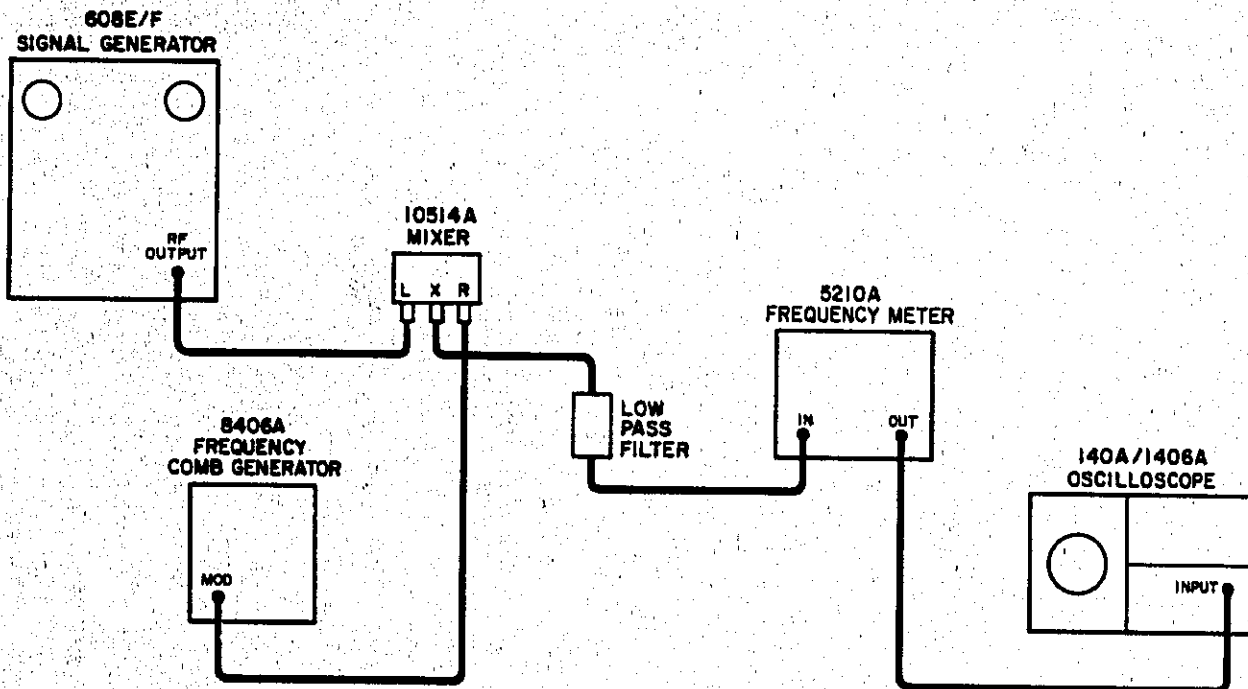

Figure 5-4. Residual and Incidental FM Test Setup

g. Measure peak-to-peak amplitude of signal displayed on oscilloscope. Measurement should not exceed 100  $\mu$ V peak-to-peak (10 Hz peak-to-peak maximum deviation).

h. Repeat steps d. through f. at the FREQUENCY RANGE and MEGACYCLES dial settings listed with applicable oscilloscope indications in the following chart.

FREQ. RANGE	FREQ.	OSCILLOSCOPE INDICATION	
		RESIDUAL FM	MAXIMUM DEV
B	30 MHz	300 $\mu$ V pk-pk	30 Hz pk-pk
C	70 MHz	700 $\mu$ V pk-pk	70 Hz pk-pk
D	150 MHz	1.5 mV pk-pk	150 Hz pk-pk
E	300 MHz	3 mV pk-pk	300 Hz pk-pk
E	400 MHz	4 mV pk-pk	400 Hz pk-pk
E	420 MHz	4.2 mV pk-pk	420 Hz pk-pk
E	450 MHz (608E)	4.5 mV pk-pk	450 Hz pk-pk
E	455 MHz (608F)	4.55 mV pk-pk	455 Hz pk-pk
E	480 MHz (608E)	4.8 mV pk-pk	480 Hz pk-pk



5-16. INCIDENTAL FM TEST.

- Connect signal generator in test setup illustrated in Figure 5-4.
- Set FREQUENCY RANGE switch to range A.
- Adjust frequency control for MEGACYCLES dial setting of 10 MHz.
- Adjust RF OUTPUT and AMPL TRIMMER controls for a +7 dBm (ATTENUATOR CALIBRATED) indication on RF OUTPUT meter.
- Set MODULATION switch to INT 1000 position.
- Adjust MODULATION control for a 50% indication on PERCENT MODULATION meter.
- Adjust attenuator control for output of 0 dBm.
- Readjust frequency control for a 50 kHz indication on frequency meter on 100 kHz range.
- Measure peak-to-peak amplitude of signal displayed on oscilloscope. Measurement should not exceed 2.0 mV peak-to-peak (200 Hz peak-to-peak maximum deviation).
- Repeat steps h. and i. at the FREQUENCY RANGE and MEGACYCLES dial settings listed with applicable oscilloscope indications in the following chart.

5-17. MAXIMUM RF OUTPUT TEST.

- Connect signal generator in test setup illustrated in Figure 5-5.
- Set FREQUENCY RANGE switch to range A.
- Adjust RF OUTPUT control to the full clockwise position.
- Adjust attenuator control to the full clockwise position.

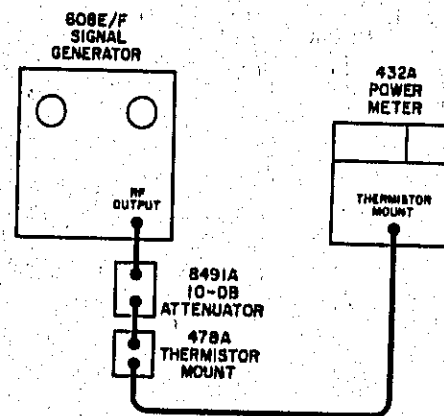

Figure 5-5. RF Output Test Setup

FREQ. RANGE	FREQ	OSCILLOSCOPE INDICATION	
		INCIDENTAL FM	MAXIMUM DEV
B	30 MHz	6 mV pk-pk	600 Hz pk-pk
C	70 MHz	14 mV pk-pk	1400 Hz pk-pk
D	150 MHz	20 mV pk-pk	2000 Hz pk-pk
E	300 MHz	20 mV pk-pk	2000 Hz pk-pk
E	400 MHz	20 mV pk-pk	2000 Hz pk-pk
E	420 MHz	20 mV pk-pk	2000 Hz pk-pk
E	450 MHz (608E)	20 mV pk-pk	2000 Hz pk-pk
E	455 MHz (608F)	20 mV pk-pk	2000 Hz pk-pk
E	480 MHz (608E)	20 mV pk-pk	2000 Hz pk-pk

- Rotate frequency control through entire limits of range A. Depress and tune AMPL TRIMMER control when necessary during tuning cycle to keep the rf output peaked.
- Observe power meter for minimum output during tuning cycle. Indication should be a minimum of +3 dBm over the range for the 608E, and -3 dBm across the range for the 608F.
- Repeat steps e. and f. for frequency ranges B through E.

5-18. FREQUENCY RESPONSE AND LEVELING TEST.

- Connect signal generator in test setup illustrated in Figure 5-5.
- Set FREQUENCY RANGE switch to range D.
- Adjust frequency control for a MEGACYCLES dial reading near center of frequency range D.
- Adjust attenuator control for a dial reading of +7 dBm.
- Adjust RF OUTPUT control approximately one-quarter turn from counter-clockwise stop.
- Adjust AMPL TRIMMER control-knob arrow to eight-o'clock position and tune (without depressing) slowly clockwise. RF OUTPUT meter needle should follow right and kick back suddenly. Stop tuning AMPL TRIMMER control when needle kicks.
- Adjust RF OUTPUT control for an RF OUTPUT meter indication of +7 dBm (ATTENUATOR CALIBRATED).

h. Vary Frequency Control a few megacycles either side of MEGACYCLES dial setting made in step c. If RF OUTPUT meter needle does not lock on +7 dBm, slowly readjust RF OUTPUT and AMPL TRIMMER controls until needle remains at +7 dBm position.

i. Vary frequency control across frequency range D. Peak-to-peak power meter variation should be less than ±1 dBm over range and RF OUTPUT meter needle should remain at +7 dBm position.

j. Repeat steps c. through i. for frequency ranges A through C and range E. The AMPLIFIER TRIMMER adjustment for leveling on bands A through D typically is the initial setting of AMPL TRIMMER plus one readjustment. Band E is typically the initial setting plus up to three readjustments.

5-19. RF OUTPUT ACCURACY TEST.

- Connect signal generator in test setup illustrated in Figure 5-5 omitting 8491A 10-DB Attenuator.

- Set FREQUENCY RANGE switch to range C.
- Adjust frequency control for MEGACYCLES dial reading of 70 MHz.
- Depress and adjust AMPL TRIMMER control for maximum indication RF OUTPUT meter.
- Adjust RF OUTPUT control for +7 dBm (ATTENUATOR CALIBRATED) indication on RF OUTPUT meter.
- Set attenuator control to 0 dBm position. Power meter should indicate 0 dBm ±1 dB.

5-20. UNCALIBRATED RF OUTPUT TEST.

- Connect signal generator in test setup illustrated in Figure 5-6.
- Model 608E should provide indication of -1.8 dBm minimum on power meter. Model 608F should provide power meter indications as follows:

10 to 215 MHz: -1.8 to +7.0 dBm  
 215 to 400 MHz: +2.0 to +6.0 dBm  
 400 to 450 MHz: +1.0 to +5.0 dBm

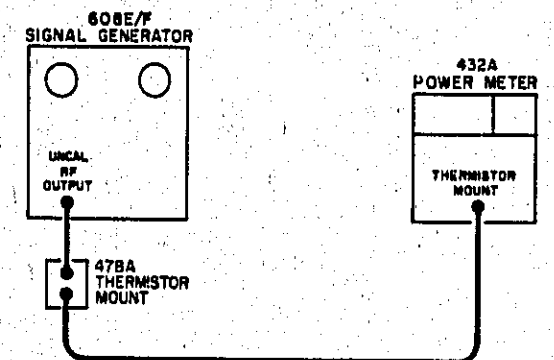

Figure 5-6. Uncalibrated RF Output Test Setup

5-21. EXTERNAL SINE-WAVE MODULATION AND MODULATION METER TEST.

- Connect signal generator in test setup illustrated in Figure 5-7.
- Set FREQUENCY RANGE switch to range A.
- Adjust frequency control for MEGACYCLES dial reading of 15 MHz.
- Adjust oscilloscope gain for envelope amplitude of 5 cm peak-to-peak.
- Set MODULATION switch to EXT AM position.



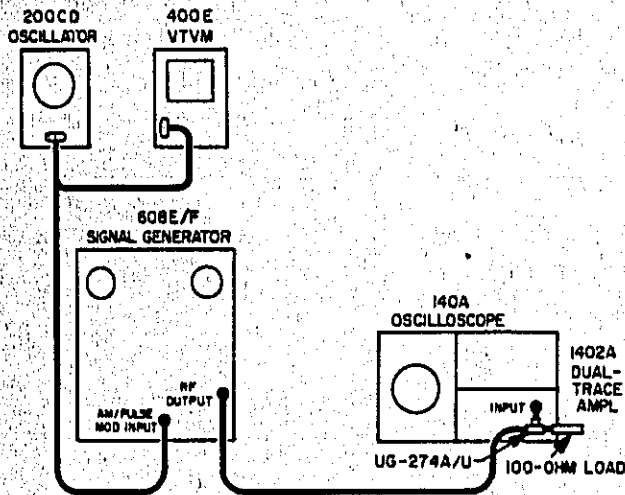

Figure 5-7. External Sine-Wave Modulation and Modulation Meter Test Setup

- f. Adjust oscillator for a 2-kHz, 1-volt rms output as observed on VTVM.
- g. Adjust MODULATION control maximum clockwise. PERCENT MODULATION meter should indicate 95% modulation.
- h. Adjust MODULATION control for 90% modulation indication on PERCENT MODULATION meter.
- i. Measure peak-to-peak amplitude (in centimeters) of modulation envelope from uppermost peak to uppermost trough. Amplitude should be  $4.5 \pm 0.5$  cm (90  $\pm$  10% modulation).
- j. Repeat steps h. and i. to test the following modulation percentages:

Percent Modulation Meter (%)	Amplitude (cm)	Equivalent Modulation Percentage (%)
80	$4.0 \pm 0.25$	$80 \pm 5$
70	$3.5 \pm 0.25$	$70 \pm 5$
60	$3.0 \pm 0.25$	$60 \pm 5$
50	$2.5 \pm 0.25$	$50 \pm 5$
40	$2.0 \pm 0.25$	$40 \pm 5$
30	$1.5 \pm 0.25$	$30 \pm 5$
20	$1.0 \pm 0.25$	$20 \pm 5$
10	$0.5 \pm 0.25$	$10 \pm 5$

5-22. INTERNAL MODULATION TEST.

- a. Set FREQUENCY RANGE switch and frequency control to any desired position.
- b. Adjust the RF OUTPUT control for ATTENUATOR CALIBRATED condition.
- c. Adjust Attenuator control for 0 dBm.
- d. Set MODULATION switch to INT 1000  $\mu$  position.
- e. Adjust MODULATION control clockwise and PERCENT MODULATION meter should indicate at least 95% modulation.
- f. Adjust MODULATION control to maximum counter-clockwise position. PERCENT MODULATION meter should indicate 0%.
- g. Set MODULATION switch to INT 400  $\mu$  position.
- h. Repeat steps e and f.

5-23. ENVELOPE DISTORTION TEST.

- a. Connect signal generator in test setup illustrated in Figure 5-8.
- b. Set FREQUENCY RANGE switch to range C and adjust frequency control for a MEGACYCLES dial reading of 70 MHz.
- c. Set MODULATION switch to CW position.
- d. Adjust RF OUTPUT control for indication on RF OUTPUT meter.
- e. Depress and tune AMPL TRIMMER control for peak indication on RF OUTPUT meter.
- f. Readjust RF OUTPUT control for +7 dBm (ATTENUATOR CALIBRATED) indication on RF OUTPUT meter.
- g. Adjust oscillator for a 10 kHz, 1 V rms, output.
- h. Set MODULATION switch to AM position.
- i. Adjust MODULATION control for 30% modulation indication on PERCENT MODULATION meter.
- j. Measure distortion using 334A Distortion Analyzer. Distortion should be <2%.
- k. Adjust MODULATION control for 70% modulation and measure distortion at desired frequencies. Distortion should be <5%.

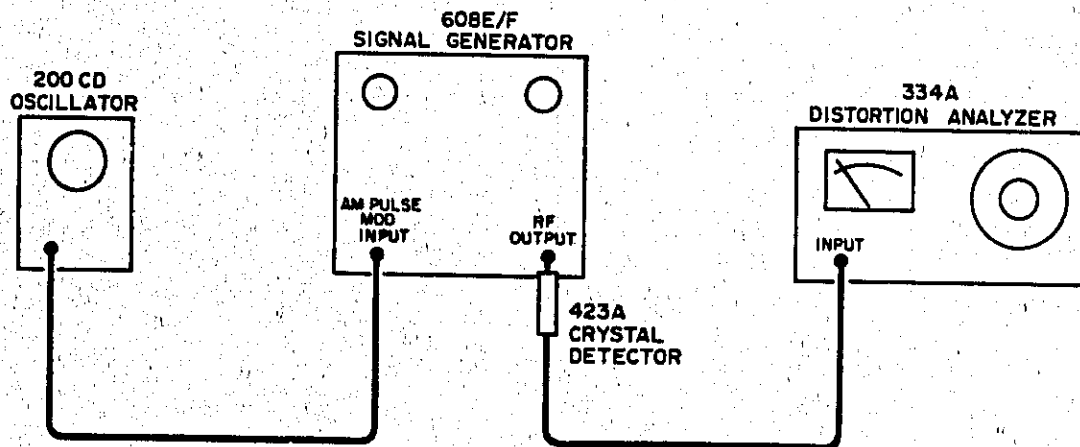

Figure 5-8. Envelope Distortion Test Setup

#### 5-24. EXTERNAL PULSE MODULATION AND RESIDUAL LEVEL TEST.

- Connect signal generator in test setup illustrated in Figure 5-9.
- Set FREQUENCY RANGE switch to range C.
- Adjust frequency control for a MEGACYCLES dial reading of 44 MHz.
- Set MODULATION switch to PULSE SET RF LEVEL position.
- Adjust RF OUTPUT control for indication on RF OUTPUT meter.
- Depress and adjust AMPL TRIMMER control for peak indication on RF OUTPUT meter.

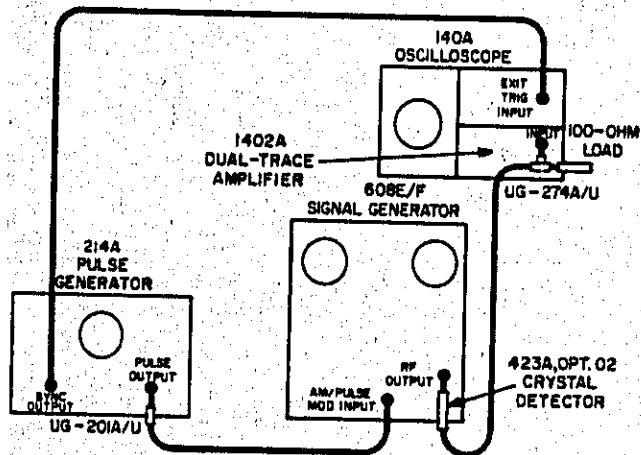

Figure 5-9. Pulse Modulation Test Setup

- Readjust RF OUTPUT control for a +7 dBm (ATTENUATOR CALIBRATED) indication on RF OUTPUT meter.
- Adjust attenuator control for output indication of +7 dBm.
- Set MODULATION switch to PULSE position.
- Adjust pulse generator for 10-volts positive output, 10  $\mu$ s wide.
- Oscilloscope should indicate a combined pulse rise and decay time of 4  $\mu$ sec maximum and a pulse width of 10  $\pm$  1.5  $\mu$ sec.
- Set FREQUENCY RANGE switch to range E.
- Adjust frequency control for MEGACYCLES dial setting of 220 MHz.
- Repeat steps d. through k.
- Connect signal generator in test setup illustrated in Figure 5-5 omitting 10-dB attenuator.
- Repeat steps d. through h.
- Set MODULATION switch to PULSE position. Power meter should indicate -13 dB minimum.

#### 5-25. RF LEAKAGE TEST.

- Connect signal generator in test setup illustrated in Figure 5-10.
- Set FREQUENCY RANGE switch to range E.
- Adjust frequency control for MEGACYCLES dial reading of 400 MHz.

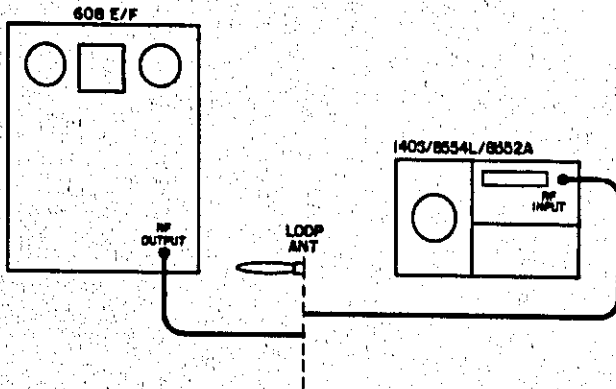

Figure 5-10. RF Leakage Test Setup

- d. Set MODULATION switch to CW position.
- e. Adjust RF output control for ATTENUATOR CALIBRATED condition.
- f. Adjust Attenuator control for  $1 \mu\text{V}$  output.
- g. Adjust spectrum analyzer for reference of  $1 \mu\text{V}$ .
- h. Disconnect the cable from signal generator RF OUTPUT connector. Set ATEN to  $0.1 \mu\text{V}$ .
- i. Connect loop antenna (see Figure 5-1) to cable.
- j. Probe with loop antenna over entire signal generator cabinet area. The spectrum analyzer indication should not exceed  $1 \mu\text{V}$ .

### 5-26. FREQUENCY CONTROL INPUT TEST (MODEL 608F ONLY),

- a. Connect signal generator in test setup illustrated in Figure 5-11.
- b. Set FREQUENCY RANGE switch to range A.
- c. Adjust frequency control for MEGACYCLES dial reading of 10 MHz.
- d. Connect power supply and adjust for  $-2 \text{ Vdc}$  at FREQ CONTROL INPUT. NOTE frequency counter reading.
- e. Adjust power supply for  $-32 \text{ Vdc}$  at FREQ CONTROL INPUT. The frequency counter should indicate a frequency change of more than 0.2%, or 20 kHz.
- f. Set frequency to high end of range A, 21 MHz.
- g. Return power supply voltage to  $-2 \text{ Vdc}$  at the FREQ CONTROL INPUT. The frequency counter should indicate a frequency change of more than 1%, or 210 kHz.
- h. Repeat this test on other bands of interest.

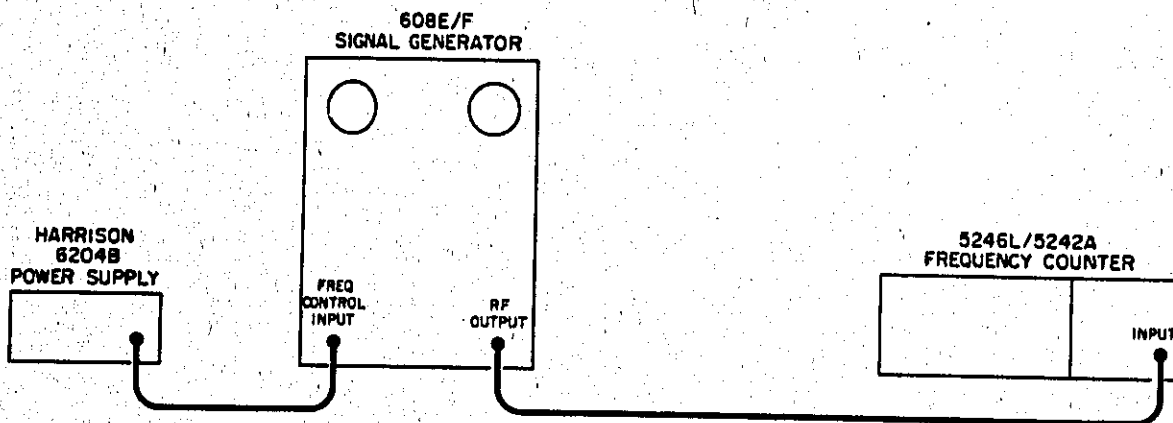

Figure 5-11. Frequency Control Input Test Setup



**5-27. FREQUENCY ANALOG OUTPUT TEST (MODEL 608F ONLY).**

- a. Connect ohmmeter to **FREQ ANALOG OUTPUT** jack on signal generator.
- b. Rotate frequency control for a **MEGACYCLES** dial reading at the extreme low end. Ohmmeter should indicate between 2500 and 3500 ohms.
- c. Rotate frequency control for a **MEGACYCLES** dial reading at the extreme high end. Ohmmeter should indicate zero ohms.

**5-28. SYNCHRONIZATION TEST WITH MODEL 8708A SYNCHRONIZER (MODEL 608F).**

- a. Connect signal generator in test setup illustrated in Figure 5-12.
- b. Set 608F and 8708A controls as follows:

608F

**FREQUENCY RANGE** . . . . . A  
**FREQUENCY** . . . . . high end of band  
**MODULATION switch** . . . . . CW

8708A

**FREQ RANGE** . . . . . A  
**FREQ TUNING** . . . . . centered  
**MODULATION** . . . . . CW

c. The 8708A meter will stop searching, indicating that phase lock is established.

d. Slowly tune 608F across band A. The 8708A meter pointer will move to left, indicating that the **FREQ CONTROL OUTPUT** voltage is changing to maintain phase lock. When end-of-lock range is reached, the 8708A meter pointer will jump to right indicating phase-lock is re-established on the next lock point. On the oscilloscope, the dc level will shift to approximately +3.0 V when the frequency is increased, and approximately -1.0 V when the frequency is decreased. The oscilloscope trace should not jump outside the the +3V and -1V limits (this indicates weak locking due to either 608F or the 8708A).

e. Repeat steps c. and d. for frequency ranges B through E.

**5-29. ADJUSTMENT.**

5-30. The following procedures list the internal adjustments necessary for proper operation of the signal generator. The test equipment required to perform the adjustments are contained in Table 5-1.

**WARNING**

Performance of the following routines require that the dust cover be removed from the signal generator. Lethal voltages exist within the unit. Exercise extreme caution when performing the procedures.

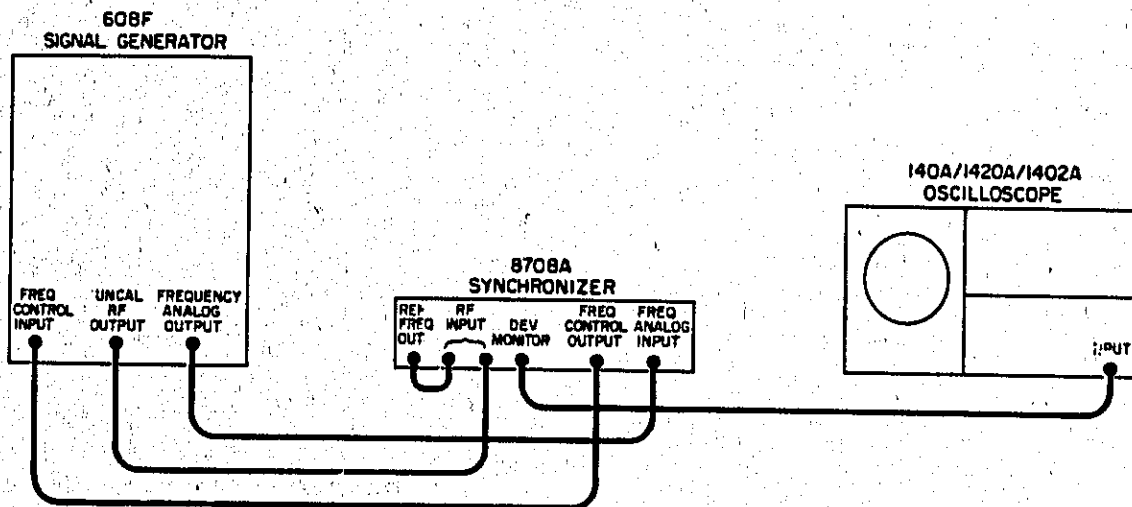

Figure 5-12. Synchronization Test Setup

**5-31. POWER SUPPLY VOLTAGE ADJUSTMENTS.**

5-32. There are four adjustable dc operating voltages: -165, +225, +25, and -6.3 volts. Adjust these voltages only if proven by accurate measurement to be outside the tolerances specified below and only if voltage error is not caused by excessive current drawn through the regulator or by inadequate voltage supplied to the regulator from the power supply rectifiers.

5-33. Because of the interdependence of these power supplies, the -165 volt regulator must be set first, the +225 volt regulator second, and the +25 and -6.3 volt regulators last. After adjusting any of these regulators, check the output voltage of each other regulator to be sure it is still within specified tolerances.

a. Connect an adjustable transformer to control line voltage applied to the signal generator.

b. Set signal generator controls as follows:

MODULATION control	max. ccw
RF OUTPUT	max. ccw
FINE FREQ	centered
Frequency	high end stop
AMPL TRIMMER	max. cw
MODULATION selector	CW
Attenuator	max. cw
Power switch	ON
XTAL CAL	OFF

c. Adjust line voltage transformer to deliver 115 (or 230) volts. Be sure 115/230 volt switch is set correctly.

d. Measure, and if necessary, adjust the following voltages:

Voltage	Adjustment (Figure 5-13)
-165 ± 5	R80
+225 ± 6	R71
+25 ± 1	Replace CR28 if necessary
-7.2 ± 0.3	Replace CR20 if necessary

**5-34. MODULATION METER ADJUSTMENT.**

5-35. **MECHANICAL ZERO.** Adjust mechanical zero as follows:

a. Set MODULATION selector to CW.

b. Connect shorting lead across PERCENT MODULATION meter terminals.

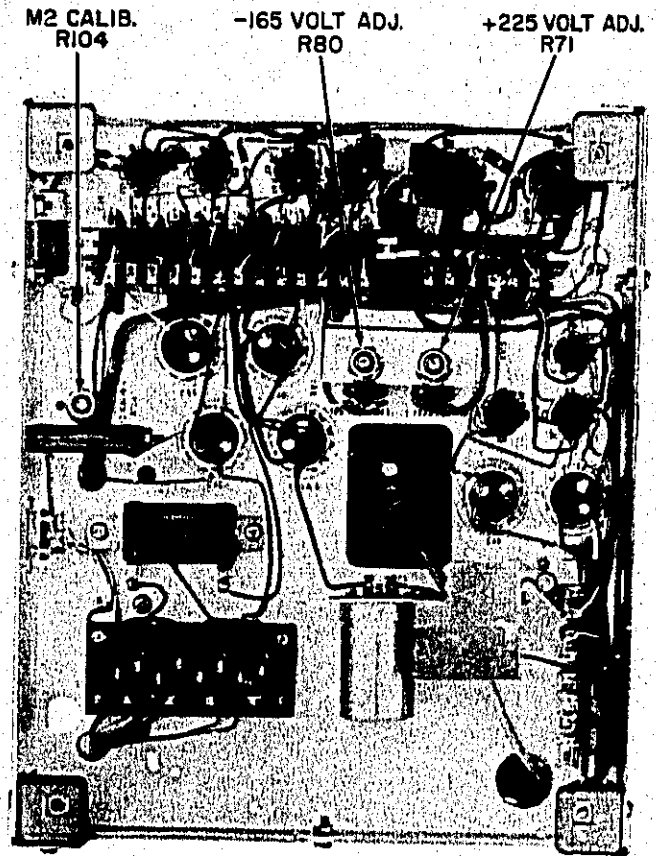

Figure 5-13. Location of Power Supply and Modulation Meter Adjustments

c. Adjust mechanical zero-adjust screw clockwise until pointer is at left of meter zero and moving towards meter zero; stop adjustment when meter needle is exactly at zero. If needle overshoots, repeat adjustment.

d. Carefully adjust mechanical zero-adjust screw a few degrees to free screw from meter suspension. If pointer moves off zero, repeat step c.

e. Remove shorting lead from meter terminals.

5-36. **ELECTRICAL ZERO.** Adjust electrical zero as follows:

a. Adjust R106 (front-panel ZERO adjustment) fully clockwise. PERCENT MODULATION meter should indicate at least 30% modulation.

b. Adjust line voltage from 102 to 128 (or 204 to 256) volts. PERCENT MODULATION meter indication should not change more than ±10% of full scale.

c. Adjust line voltage to 115 (or 230) volts. Adjust R106 for zero indication on PERCENT MODULATION meter.

**5-37. CALIBRATION OF PERCENT MODULATION METER.**

5-38. Recalibration of the PERCENT MODULATION meter may be necessary following a repair of the modulation measuring circuits (V18-V21) or after replacement of the meter itself.

**NOTE**

Be sure the mechanical and electrical zero is adjusted properly; refer to paragraph 5-34.

a. Connect 608E/F and oscilloscope as shown in Figure 5-14.

b. Set the MODULATION selector to CW.

FREQUENCY RANGE . . . . . A band  
 MEGACYCLES dial . . . . . 10 MHz  
 MOD. SELECTOR . . . . . 1000  $\omega$   
 AMP. TRIMMER . . . Adjust for maximum output  
 RF OUTPUT . . . ATTENUATOR CALIBRATED  
 MODULATION . . . . . Fully CCW

c. Set the 140/1420/1402 oscilloscope as follows:

VERT. SENS . . . . . 0.2 V/cm  
 HOR. SWEEP TIME . . . . . 0.2 ms/cm  
 TRIGGER SOURCE . . . . . + INT or - INT

d. Adjust vertical position to place pattern at center of screen.

e. Set MODULATION selector to 1000-. Adjust 608E/F Attenuator for a 4 cm pattern on screen.

**5-39. ADJUSTMENTS.**

a. Increase MODULATION control until sine wave pattern appears on oscilloscope. Adjust trigger level for stable pattern.

b. Increase MODULATION control until peak-to-peak pattern is 6 cm high, as shown in Figure 5-15. Adjust R104 (METER CAL on rear panel) for a reading of 50% on the PERCENT MODULATION meter.

c. Increase MODULATION control until the peak-to-peak pattern is 8 cm high. Adjust trigger level as necessary to keep stable pattern. The PERCENT MODULATION meter should read approximately 100%.

5-40. This check will determine if the modulation meter circuitry (V18-V21) is frequency sensitive. It will also check the relative output of the Modulation Oscillator (V2).

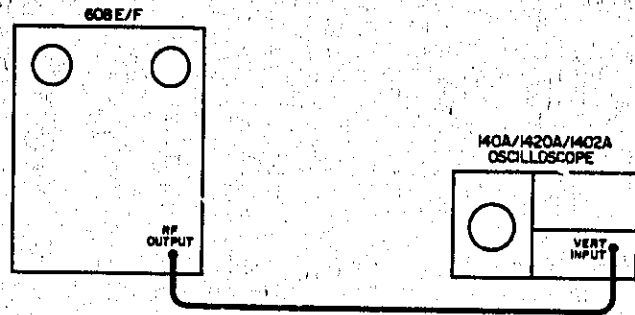

Figure 5-14. Modulation Meter Calibration Test Setup

a. Return the MODULATION control to a meter reading of 50%.

b. Turn the MOD. SELECTOR switch to 400  $\omega$ . Meter should read  $\pm 5\%$  of that obtained in step a.

**5-41. AUTOMATIC OUTPUT LEVELING ADJUSTMENT.**

a. Connect dc voltmeter (50-volt range) to junction of CR26-R235 (Figure 5-16) and ground.

b. Set RF OUTPUT control fully counterclockwise and MODULATION selector to CW.

c. Adjust R204 (Figure 5-14) to point where dc voltmeter shows no further voltage increase with adjustment of R204.

d. DC voltmeter should indicate greater than 30 volts.

e. Set MODULATION selector to 400  $\omega$ , 1000  $\omega$ , and AM position; dc voltmeter should indicate greater than 30 volts at each switch position.

f. Set MODULATION selector to PULSE/SET RF OUTPUT; voltmeter should indicate greater than 14 volts.

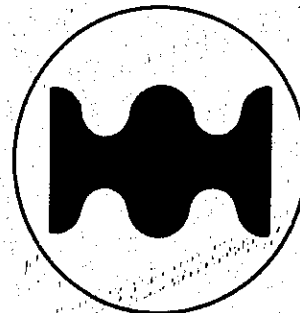

Figure 5-15. Pattern on 140 Oscilloscope at 50% Modulation



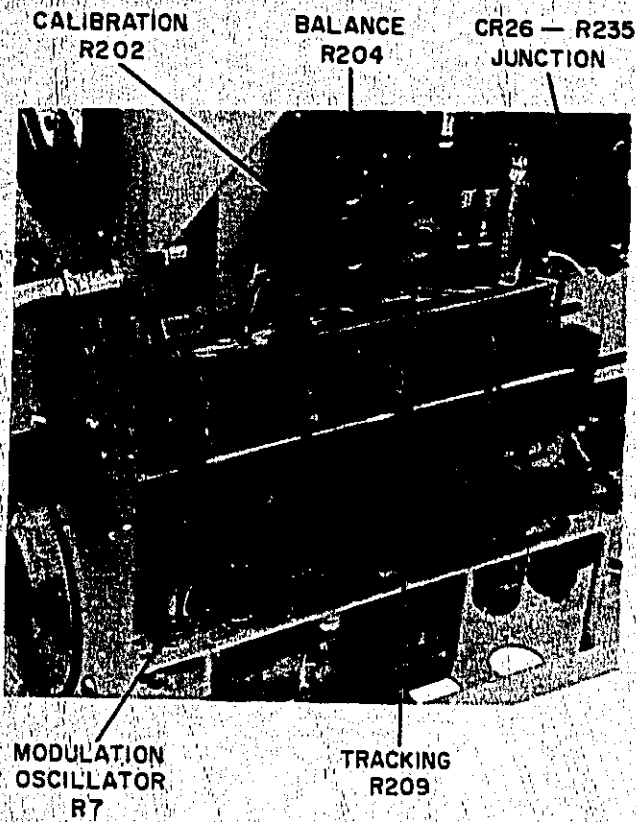

Figure 5-16. Location of Leveling and RF Output Meter Adjustments

f. Repeat steps b. through e. for each of the following frequencies, adjusting C59 for the best compromise at the listed frequencies:

Band	Frequency
B	43 MHz
C	95 MHz
D	210 MHz
E	455 MHz

5-43. UNCALIBRATED RF OUTPUT, MINIMUM RF OUTPUT, AND RF AMPLIFIER TRACKING ADJUSTMENT.

- a. Connect signal generator in test setup shown in Figure 5-5, but delete 10-dB attenuator.
- b. Set FREQUENCY RANGE switch to band A.
- c. Rotate frequency control through entire range plus one-half turn at edges of band, while adjusting AMPL TRIMMER for maximum RF output. Observe Model 432A power meter for following indications:

UNCAL RF OUTPUT (608E): -1.8 dBm minimum

RF OUTPUT (608E): 13 dBm minimum

UNCAL RF OUTPUT (608F): -1.8 dBm minimum  
10-215 MHz

+2.0 dBm minimum  
215-400 MHz

+1.0 dBm minimum  
400-430 MHz

RF OUTPUT (608F): +10 dBm minimum.

NOTE

Although Model 608F is capable of well in excess of its published specification, prolonged use at greater power levels than +7 dBm should be avoided. However, it is usable for a short time to make these adjustments.

- g. Set MODULATION selector to PULSE; voltmeter should indicate greater than 25 volts.
- h. Set RF OUTPUT control fully clockwise.
- i. Set MODULATION selector to CW and PULSE/SET RF OUTPUT positions; dc voltmeter should indicate +0.3 to +1.0 volt dc at each switch position.
- j. Set MODULATION selector to PULSE; voltmeter should indicate greater than 20 volts.

5-42. RF OSCILLATOR ADJUSTMENT.

- a. Connect signal generator in test setup shown in Figure 5-11 omitting Harrison Power Supply.
- b. Set FREQUENCY RANGE switch to band A.
- c. Center FINE FREQ and cursor controls.
- d. Adjust frequency control for 21 MHz.
- e. Check counter frequency indication; counter should indicate 21 MHz  $\pm 0.5\%$  ( $\pm 105$  kHz). If not, adjust capacitor C59 (Figure 5-17) for proper counter indication.

- d. AMPL TRIMMER control should peak with at least one-quarter turn adjustment at either end.
- e. If necessary, the power amplifier tuning coils can be adjusted to obtain the proper output at the RF OUTPUT connector as follows:

Band A: Reposition 3 or 4 turns on coil.

Bands B through D: Reposition shorted turns on coils.

Band E: Spread or compress coil loop.

- f. Repeat steps b through d for bands B through E.

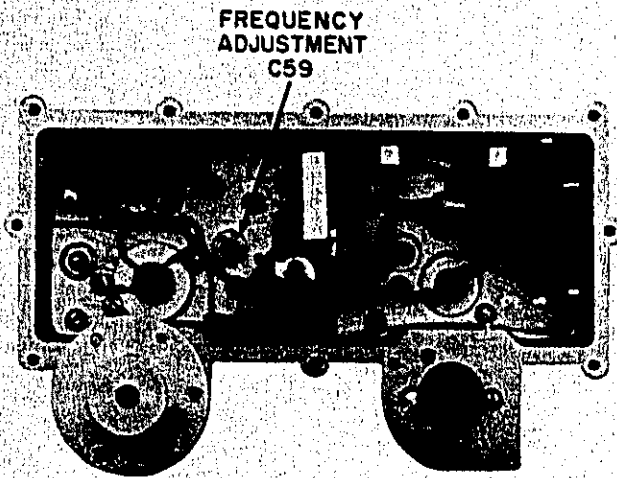

Figure 5-17. Location of RF Oscillator Adjustment

5-44. RF OUTPUT METER ACCURACY ADJUSTMENT.

5-45. MECHANICAL ZERO AND ELECTRICAL ADJUSTMENT.

- a. Adjust mechanical zero as follows:
- b. Set MODULATION selector to CW.
- c. Connect shorting leads across PERCENT MODULATION meter.
- d. Adjust mechanical zero-adjust screw clockwise until pointer is at left of meter zero and moving towards meter zero. Stop adjustment when meter needle is exactly on zero. If needle overshoots, repeat adjustment.
- e. To electrically calibrate meter, proceed as follows:
- f. Connect signal generator in test setup illustrated in Figure 5-5, omitting 10-dB attenuator.
- g. Set MODULATION switch to CW position.
- h. Set MODULATION control completely counter-clockwise.
- i. Set FREQUENCY RANGE switch to range C, and adjust frequency control to center mark on MEGACYCLES dial (approximately 75-80 MHz).
- j. Adjust RF OUTPUT control for indication on RF OUTPUT meter.
- k. Depress and adjust AMPL TRIMMER control for peak indication on RF OUTPUT meter.

m. Readjust RF OUTPUT control for +7 dBm (ATTENUATOR CALIBRATED) indication on RF OUTPUT meter.

n. Adjust Attenuator control for output of -1.0 dBm.

o. Adjust RF OUTPUT control for power meter readings shown below. Calibrate the output meter by adjusting R202 and R209 as indicated.

NOTE

In the Model 608F, the RF OUTPUT meter is calibrated using full-scale deflection when the power meter is indicating +5 dBm. During normal operation only half-scale (+7 dBm) deflection is used, indicating the maximum RF output capabilities of the instrument.

POWER OUTPUT (432A Rdg) dBm	OUTPUT METER Rdg- dB	ADJUST see Figure 5-16
+5.0	+13.0	R202
-4.0	+4.0	R209
+5.0	+13.0	R202
-4.0	+4.0	R209
+2.0	9.8-10.2	
-1.0	6.9-7.2	

5-46. RF OUTPUT METER/ATTENUATOR FREQUENCY RESPONSE AND AUTOMATIC LEVEL OUTPUT ADJUSTMENT.

- a. The following steps will indicate if an adjustment is necessary.
- b. Connect signal generator in test setup as shown in Figure 5-5, but delete the 10-dB attenuator.
- c. Adjust AMPL TRIMMER for best tracking compromise over bands A through D.
- d. Adjust RF OUTPUT control for ATTENUATOR CALIBRATED (+7 dBm) indication on meter.
- e. Vary frequency control over entire frequency range of bands A through D. The RF OUTPUT meter indication should remain constant within  $\pm 1$  dB over entire range of bands A through D. There should be no further adjustment of the AMPL TRIMMER necessary, however one readjustment is acceptable (initial setting plus one readjustment) per band.



- f. Set FREQUENCY RANGE switch to band E.
- g. Adjust frequency control to lower end of band, and adjust AMPL TRIMMER for maximum RF output.
- h. Adjust frequency control over lower half of band E. Power meter indication should remain constant within  $\pm 1$  dB over lower half of band E.
- i. Adjust frequency control to middle of band E, and adjust AMPL TRIMMER for maximum RF output.
- j. Adjust frequency control over upper half of band E and adjust AMPL TRIMMER for maximum output. Power meter indication should remain constant within  $\pm 1$  dB over upper half of band E.
- k. Set attenuator and FREQUENCY RANGE as follows and observe power meter for proper indication:

**NOTE**

When checking attenuator on band E, readjust AMPL TRIMMER for maximum RF output and then adjust RF OUTPUT control for +7 dBm on RF OUTPUT meter.

Attenuator Setting dBm	Frequency Range Band	Power Output dBm
-1.0	C	0 to -2.0
-1.0	A	0 to -2.0
-1.0	B	0 to -2.0
-1.0	D	0 to -2.0
-1.0	E	0 to -2.0
+7.0	E	+6.0 to +8.0
+7.0	D	+6.0 to +8.0
+7.0	C	+6.0 to +8.0
+7.0	B	+6.0 to +8.0
+7.0	A	+6.0 to +8.0

- m. If the power output is not within the above specified limits, proceed as follows:
- n. Setup RF OUTPUT meter adjustments as shown in paragraph 5-45.

**CAUTION**

All readings are referenced to Band C. There are several variables which have to be taken into account. The amplifier coils for bands A through D can be moved closer or further away from the attenuator probe pickup loop. In general, the power level becomes more positive by moving the coils closer to the attenuator, and more negative by moving the coils further away. THERE IS HIGH VOLTAGE ON ALL AMPLIFIER COILS, AND ON THE STATOR OF TUNING CAPACITOR C17. MAKE CERTAIN THAT THERE IS SUFFICIENT CLEARANCE BETWEEN THE COILS AND THE ATTENUATOR PROBE PICKUP LOOP. Band E presents a different problem. The amplifier coil is not adjustable, so the procedure calls for changing the bolometer response to conform to other bands.

- o. Check band C and adjust if necessary to bring into specifications.
- p. Check E band. If power output is not within specifications, adjust either coil L17 or resistor R60 (see Figures 5-18 and 5-19). After adjusting either L17 or R60, always repeat RF OUTPUT meter adjustments, as in paragraph 5-44.

**CAUTION**

Some 608E/F instruments may have a large blob of solder on the pigtail lead of R60. This was done at the factory to lessen the effects of lead inductance. This effectively shortens the pigtail lead of R60 without cutting the lead, which may at a later date prove unsatisfactory and necessitate replacement.

- q. Check and adjust, if necessary, bands D, B, and A.

**5-47. CRYSTAL CALIBRATOR ADJUSTMENT.**

- a. Remove signal generator chassis from cabinet, and remove side plate from RF generator housing.
- b. Plug headset into XTAL CAL OUTPUT jack.
- c. Set signal generator controls as follows:  
 FREQUENCY RANGE . . . . . between bands  
 XTAL CAL GAIN . . . . . max. cw  
 XTAL CAL . . . . . 1 MC
- d. Adjust L18 (Figure 5-19) in clockwise direction. Two separate beat frequencies should be heard in headset within one full turn of L18. Adjust L18 to audible null between the two beat notes.
- e. Set signal generator controls as follows:  
 FREQUENCY RANGE . . . . . band E  
 RF OUTPUT control . . . . . max. cw
- f. Set XTAL CAL to 5 MC.



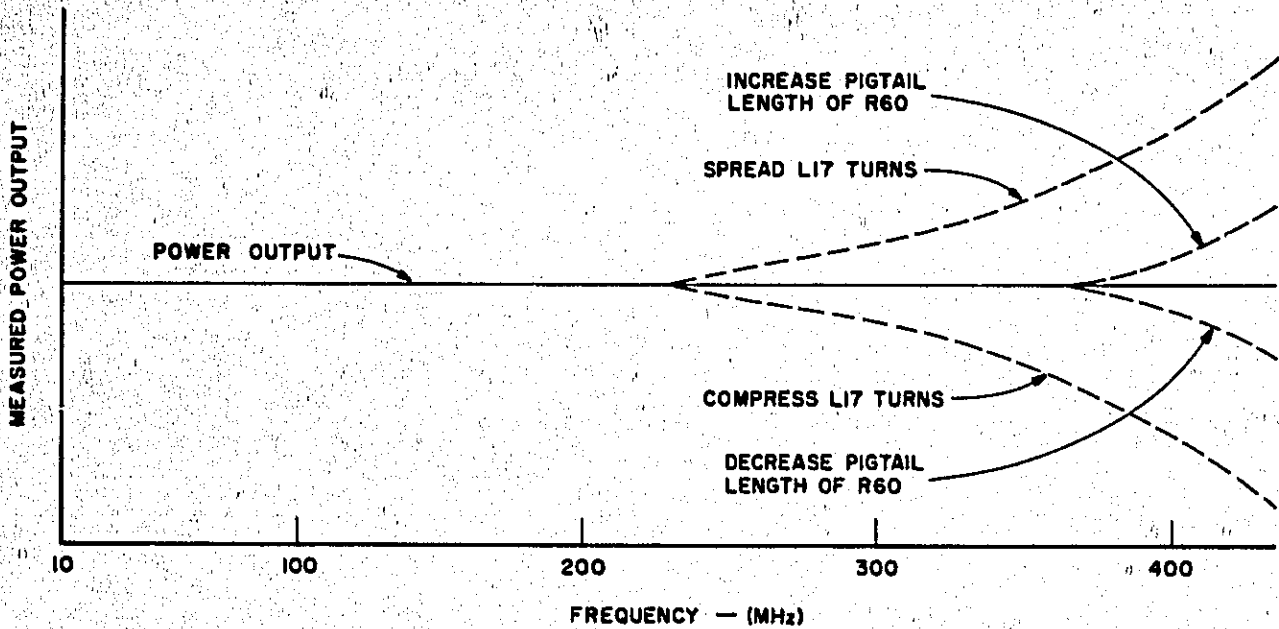
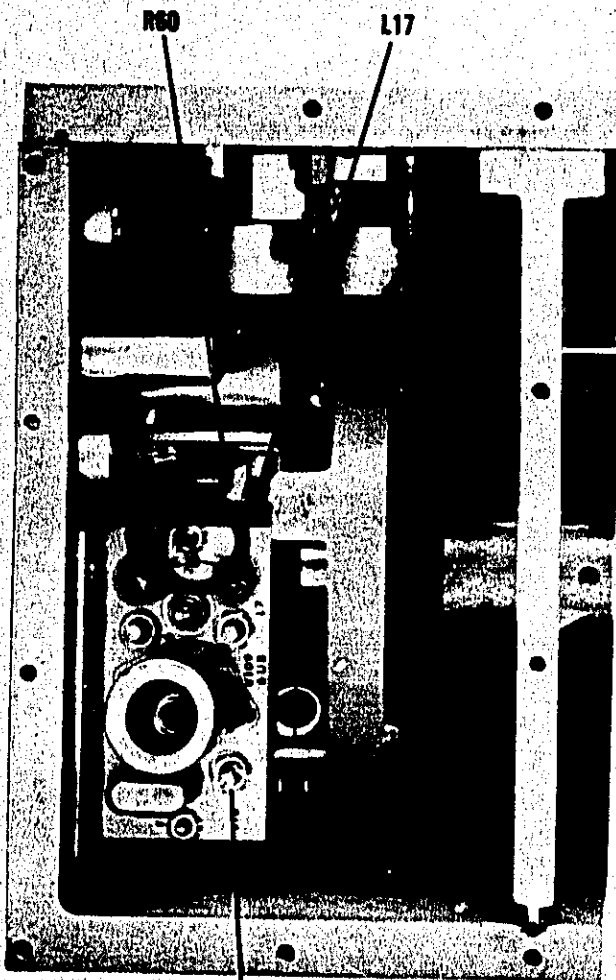

Figure 5-18. Frequency-Response Adjustments



XTAL FREQ ADJ  
L18

Figure 5-19. Location of Frequency-Response and Crystal-Calibrator Adjustments

g. Adjust frequency control from 450 to 455 MHz. Two beat notes should occur, one at 450 MHz and one at 455 MHz.

#### 5-48. TROUBLESHOOTING.

5-49. The following paragraphs contain information for troubleshooting the signal generators, and procedures for isolating troubles in transistor circuits. The procedures are not intended to correct for small out-of-tolerance conditions, but are directed toward correcting a major fault.

#### 5-50. ISOLATING A TROUBLE TO A CIRCUIT SECTION.

5-51. To isolate a trouble to a particular circuit, a troubleshooting tree (table 5-7) is presented. The tree presents five major problems that can occur during operation of the signal generators, and includes block-to-block instructions for maintenance personnel to trace a malfunction to a particular circuit. Normal shop troubleshooting practices must be employed after the trouble has been isolated to the circuit section.

5-52. As a further aid in circuit troubleshooting the instrument, voltage and resistance measurements are presented in Figures 5-20 and 5-21. Figure 5-20 lists the voltage and resistance measurements during INT 1000 ~ operation, and Figure 5-21 depicts the voltage measurements on the ALC board during CW and PULSE/SET RF OUTPUT operation.

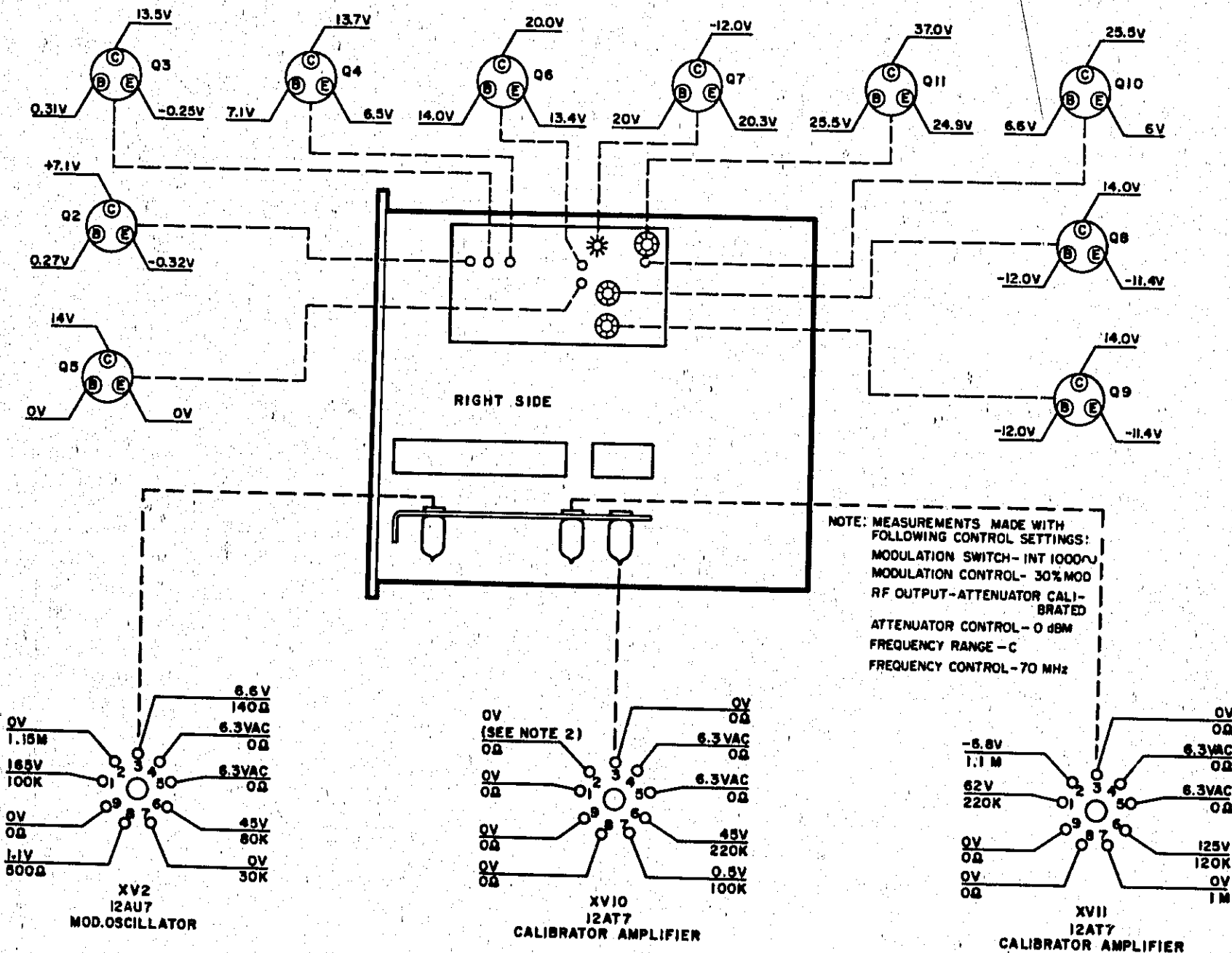

Figure 5-20. Voltage and Resistance Measurements, INT 1000 - Operation (Sheet 1 of 3)

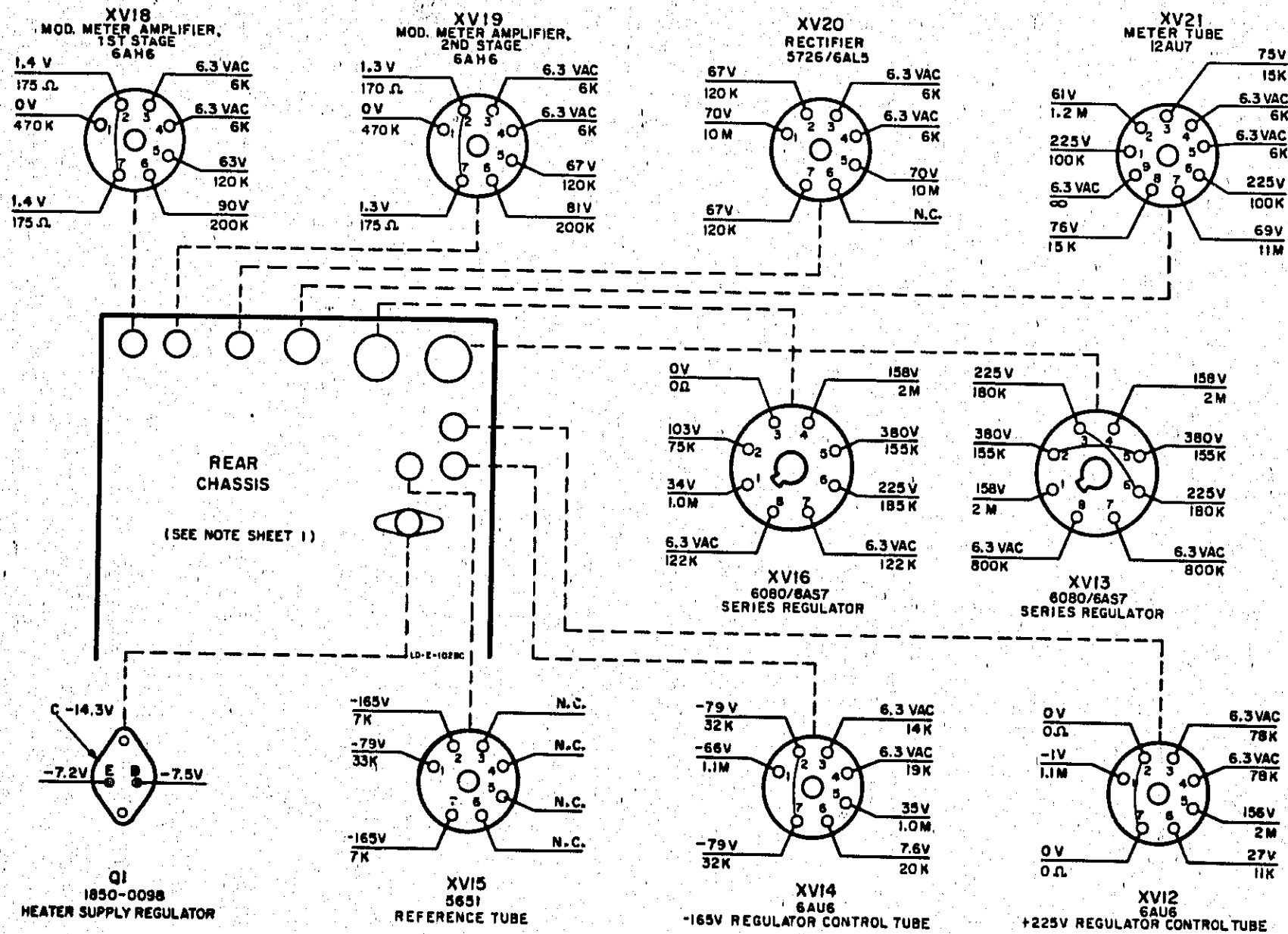
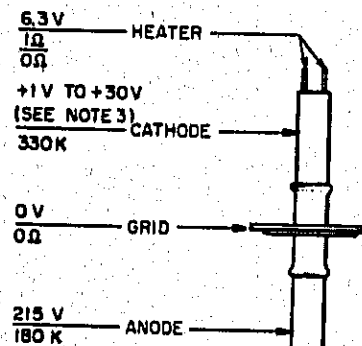

Figure 5-20. Voltage and Resistance Measurements, INT 1000 ~ Operation (Sheet 2 of 3)



V8  
RF POWER AMPLIFIER  
4043



XV22  
RF BUFFER  
EC8010

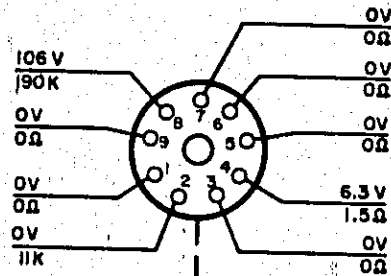

V6  
RF OSCILLATOR  
4042

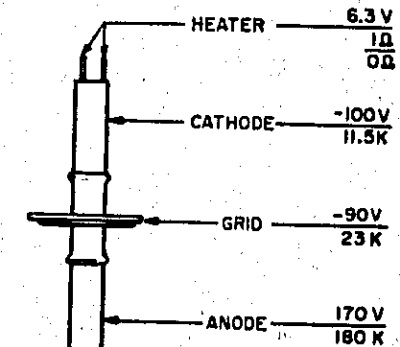

PIN NO.	XV9		6U8	
	VOLTAGE		RESISTANCE	
	1MC	5MC	1MC	5MC
1	+210	+220	100K	100K
2	-36	-40	300K	300K
3	+220	+220	100K	100K
4	0	0	0	0
5	6.3AC	6.3AC	0	0
6	+210	+220	100K	100K
7	0	0	0	0
8	0	+22	0	0
9	-50	0	30K	30K

XV9  
6U8  
(SEE CHART ABOVE)

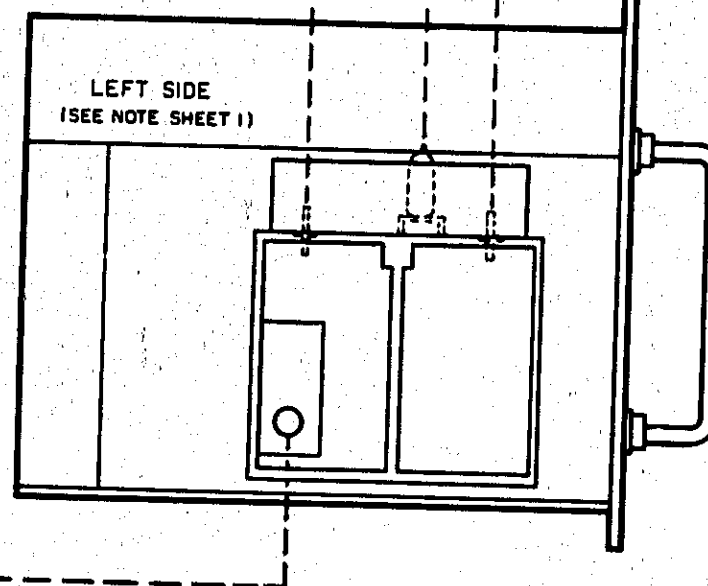
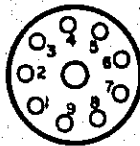
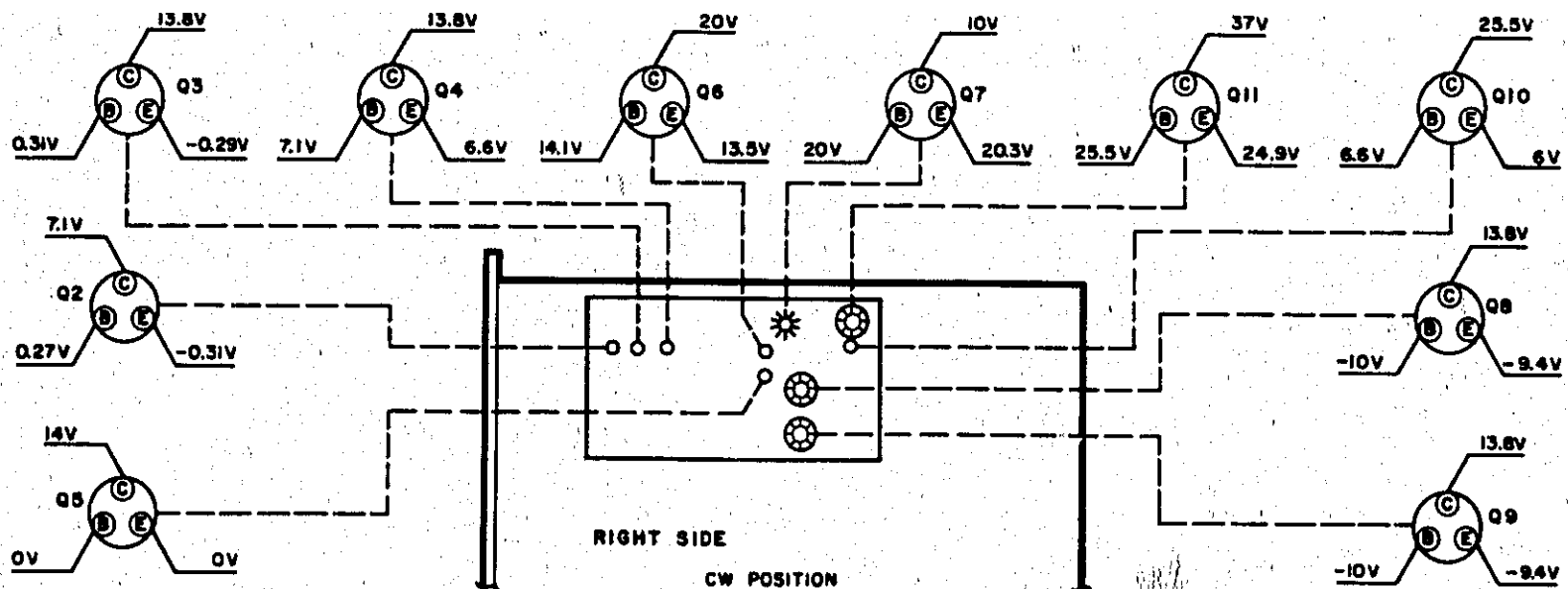

Figure 5-20. Voltage and Resistance Measurements, INT 1000 - Operation  
(Sheet 3 of 3)

Model 608E/F

Section V



NOTE: DIAL CONTROL FREQUENCY, RF OUTPUT, AND ATTENUATOR CONTROL SETTINGS SAME AS FIGURE 5-20

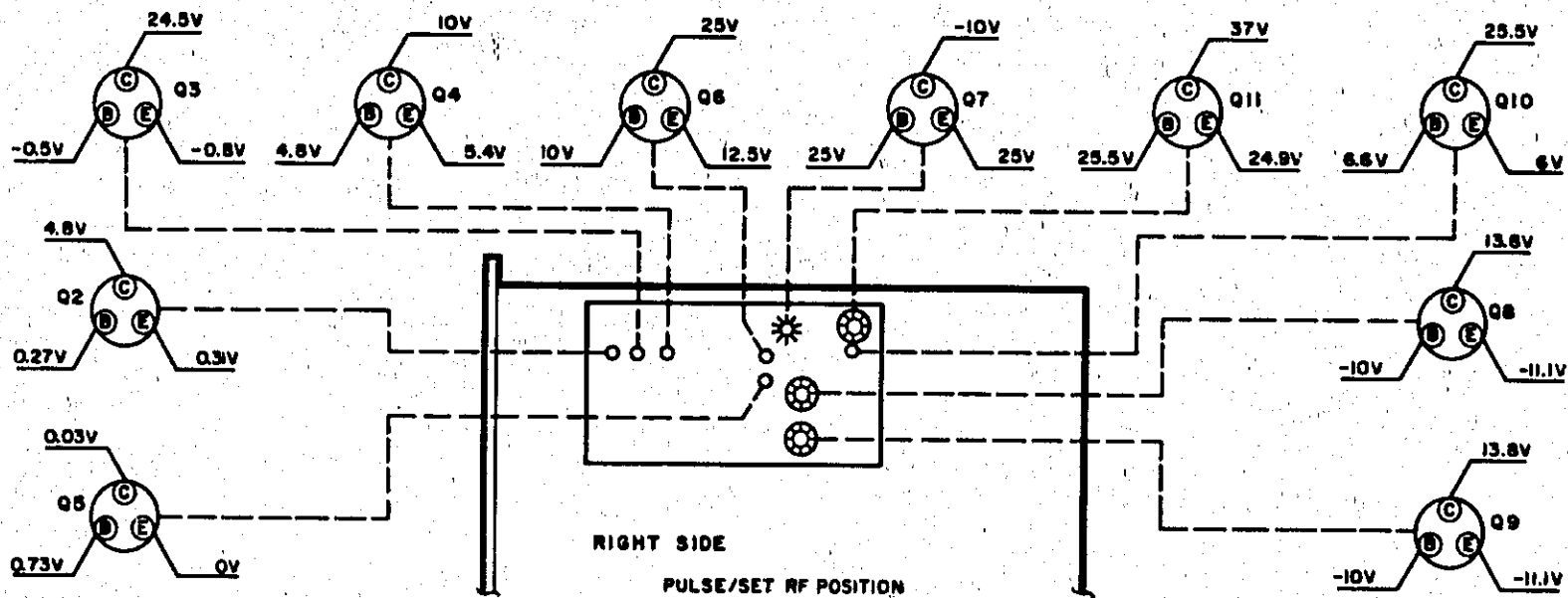

Figure 5-21 ALC Board Voltage and Resistance Measurements, CW and PULSE SET RF OUTPUT Operation

5-53. Numerous test points have been established in the signal generators and are identified by a circle-star designator on Figures 7-4 and 7-5. The dc voltages listed with the test-point designators were obtained with the instrument in an INT 1000 mode of operation.

#### 5-54. ISOLATING TROUBLE IN TRANSISTOR CIRCUITS.

5-55. The following procedures and data are given to aid in determining whether a transistor is operational. Tests are given for both in-circuit and out-of-circuit transistors.

5-56. **IN-CIRCUIT TESTING.** The common causes of transistor failures are internal short- and open-circuits. In transistor circuit testing the most important consideration is the transistor base-emitter junction. Like the control grid of a vacuum tube, this is the operational control point in the transistor. This junction is essentially a solid-state diode. For the transistor to conduct, the diode must conduct; that is, the diode must be forward biased. As with simple diodes, the forward-bias polarity is determined by the materials forming the junction. Use the transistor symbol on the schematic diagram to determine the bias polarity required to forward-bias the base-emitter junction. The A part of Figure 5-22 shows transistor symbols with terminals labeled. Notice that the emitter arrow conventionally points toward the type N material. The other two columns of the illustration compare the biasing required to cause conduction and cut-off in transistors and vacuum tubes. If the transistor base-emitter diode (junction) is forward-biased the transistor conducts. If the diode is heavily forward-biased, the transistor saturates. However, if the base-emitter diode is reverse-biased the transistor is cut-off. The voltage drop across a forward biased emitter-base diode varies with transistor collector current. For example, a germanium transistor has a typical forward-bias, base-emitter voltage of 0.2 - 0.3 volt when collector current is 1 - 10 mA, and 0.4 - 0.5 volt when collector current is 10 - 100 mA. In contrast, forward bias voltage for silicon transistors is about twice that for germanium types: about 0.5 - 0.6 volt when collector current is low, and about 0.8 - 0.9 volt when collector current is high.

5-57. Figure 5-22, part B, shows simplified versions of the three basic transistor circuits and gives the operating characteristics of each. When examining a transistor stage, first determine if the emitter-base diode is biased for conduction (forward-biased) by measuring the voltage difference between emitter and base. When using an electronic voltmeter, do not measure directly between emitter and base: there may be sufficient loop current between the voltmeter leads to damage the transistor. Instead, measure to a common point (e.g., chassis). If the emitter-base diode is forward-biased, check for amplifier action by

short-circuiting base to emitter while observing collector voltage. The short-circuit eliminates base-emitter bias and should cause the transistor to stop conducting (cut off). Collector voltage should then shift to near the supply voltage. Any difference is due to leakage current through the transistor and, in general, the smaller this current, the better the transistor. If collector voltage does not change, the transistor may have either an emitter-collector short circuit or emitter-base open circuit.

5-58. **TESTING TRANSISTORS WITH AN OHMMETER.** The two common causes of transistor failure are internal short- and open-circuits. Remove the transistor from the circuit and use an ohmmeter to measure internal resistance. See Table 5-3 for measurement data.

#### CAUTION

Most ohmmeters can supply enough current or voltage to damage a transistor. Before using an ohmmeter to measure transistor forward or reverse resistance, check open-circuit voltage and short-circuit current output **ON THE RANGE TO BE USED**. Open-circuit voltage must not exceed 1.5 volts and short-circuit current must be less than 3 ma. See Table 5-4 for safe resistance ranges for some common ohmmeters.

#### 5-59. REPLACEMENT AND REPAIR.

5-60. The following procedures contain instructions for work on etched circuit boards, replacement of electron tubes, attenuator probe replacement and repair, replacement of Lamp DS1, and diagrams for locating parts in the signal generator.

#### 5-61. ETCHED CIRCUIT BOARD REPAIR.

5-62. The etched circuit boards in the Signal Generator are of the plated-through type consisting of metallic conductors bonded to both sides of insulating material. The metallic conductors are extended through the component mounting holes by a plating process. Soldering can be done from either side of the board with equally good results. Table 5-5 lists recommended tools and materials. Following are recommendations and precautions pertinent to etched circuit repair work.

a. Avoid unnecessary component substitution; it can result in damage to the circuit board and/or adjacent components.

b. Do not use a high-power soldering iron on etched circuit boards. Excessive heat may lift a conductor or damage the board.



A. TRANSISTOR BIASING			
DEVICE	SYMBOL	CUT OFF	CONDUCTING
VACUUM TUBE			
NPN TRANSISTOR			
PNP TRANSISTOR			

B. AMPLIFIER CHARACTERISTICS			
CHARACTERISTIC	COMMON BASE	COMMON EMITTER	COMMON COLLECTOR
INPUT Z	30-50 $\Omega$	500-1500 $\Omega$	20-500K $\Omega$
OUTPUT Z	300-500K $\Omega$	30-50K $\Omega$	50-1000 $\Omega$
VOLTAGE GAIN	500-1500	300-1000	< 1
CURRENT GAIN	< 1	25-50	25-50
POWER GAIN	20-30 dB	25-40 dB	10-20 dB

Figure 5-22. Transistor Biasing and Operating Characteristics

Table 5-3. Out-of-Circuit Transistor Resistance Measurement

Transistor Type		Connect Ohmmeter		Measure Resistance (ohms)
		Pos. lead to	Neg. lead to	
PNP Germanium	Small Signal	emitter	base*	200 - 500
		emitter	collector	10K - 100K
	Power	emitter	base*	30 - 50
		emitter	collector	several hundred
NPN Silicon	Small Signal	base*	emitter	1K - 3K
		collector	emitter	very high, (might read open)
	Power	base	emitter	200 - 1000
		collector	emitter	high, often greater than 1 M

\*To test for transistor action, add collector-base short. Measured resistance should decrease.

NOTE

Axial lead components, such as resistors and tubular capacitors, can be replaced without unsoldering. Clip leads near body of defective component, remove component and straighten leads left in board. Wrap leads of replacement component one turn around original leads. Solder wrapped connection, and clip off excess lead.

5-64. ETCHED CONDUCTOR REPAIR.

5-65. A broken or burned section of conductor can be repaired by bridging the damaged section with a length of tinned copper wire. Allow adequate overlap and remove any varnish from etched conductor before soldering wire into place.

Table 5-4. Safe Ohmmeter Ranges for Transistor Resistance Measurements

Ohmmeter	Safe Range(s)	Open Ckt Voltage	Short Ckt Current	Lead	
				Color	Polarity
412A	R x 1K	1.0V	1 mA	Red	+
	R x 10K	1.0V	100 $\mu$ A	Blk	-
	R x 100K	1.0V	10 $\mu$ A		
	R x 1M	1.0V	1 $\mu$ A		
	R x 10M	1.0V	0.1 $\mu$ A		
410C	R x 1K	1.3V	0.57 mA	Red	+
	R x 10K	1.3V	57 $\mu$ A	Blk	-
	R x 100K	1.3V	5.7 $\mu$ A		
	R x 1M	1.3V	0.5 $\mu$ A		
	R x 10M	1.3V	0.05 $\mu$ A		
410B	R x 100	1.1V	1.1 mA	Blk	+
	R x 1K	1.1V	110 $\mu$ A	Red	-
	R x 10K	1.1V	11 $\mu$ A		
	R x 100K	1.1V	1.1 $\mu$ A		
	R x 1M	1.1V	0.11 $\mu$ A		
Simpson 260	R x 100	1.5V	1 mA	Red	+
				Blk	-
Simpson 269	R x 1K	1.5V	0.82 mA	Blk	+
				Red	-
Triplet 830	R x 100	1.5V	3.25 mA	Varies with Serial Number	
	R x 1K	1.5V	325 $\mu$ A		
Triplet 310	R x 10	1.5V	750 $\mu$ A		
	R x 100	1.5V	75 $\mu$ A		

c. Use a suction device (see Table 5-5) or wooden toothpick to remove solder from component mounting holes. DO NOT USE A SHARP METAL OBJECT SUCH AS AN AWL OR TWIST DRILL FOR THIS PURPOSE. SHARP OBJECTS MAY DAMAGE THE PLATED-THROUGH CONDUCTOR.

d. After soldering, remove excess flux from the soldered areas and apply a protective coating to prevent contamination and corrosion. See Table 5-5 for recommendations.

5-63. COMPONENT REPLACEMENT.

- a. Remove defective component from circuit board.
- b. Remove solder from mounting holes using a suction desoldering aid (Table 5-5) or wooden toothpick.
- c. Shape leads of replacement component to match mounting hold spacing.

d. Insert component leads into mounting holes, and position component as original was positioned. DO NOT FORCE LEADS OF REPLACEMENT COMPONENT INTO MOUNTING HOLES. Sharp leads ends may damage plated-through conductor.

Table 5-5. Etched Circuit Soldering Equipment

Item	Use	Specification	Item Recommended
Soldering Tool	Soldering Unsoldering	Wattage rating: 37.5 Tip Temp: 750-800°F Tip Size: 1/8" OD	Ungar #776 Handle with Ungar #1237 Heating Unit
Soldering Tip	Soldering	Shape: chisel	Ungar #PL113
General Purpose	Unsoldering	Size: 1/8"	
De-soldering aid	Unsoldering multi-connection components (e.g., tube sockets)	Suction device to remove molten solder from connection	Soldapult by the Edsyn Company, Arleta, California
Resin (flux) solvent	Remove excess flux from soldered area before application of protective coating	Must not dissolve etched circuit base board material or conductor bonding agent	Freon Acetone Lacquer Thinner Isopropyl Alcohol (100% dry)
Solder	Component replacement Circuit board repair Wiring	Resin (flux) core, high tin content (60/40 tin/lead), 18 gauge (SWG) preferred	
Protective Coating	Contamination, corrosion protection after soldering	Good electrical insulation, corrosion-prevention properties	Krylon #1302* Humiseal Protective Coating, Type 1B12 by Columbia Technical Corp. Woodside 77, New York
*Krylon, Inc., Norristown, Pennsylvania			

#### 5-66. TRANSISTOR AND SEMICONDUCTOR DIODE REPLACEMENT.

- a. Do not apply excessive heat. See Table 5-5 for soldering tool specifications.
- b. Use a heat sink, such as pliers, between semiconductor body and hot soldering iron.
- c. When installing a replacement semiconductor ensure sufficient lead length to dissipate heat of soldering by maintaining about the same length of exposed lead as used for original semiconductor.
- d. Refer to Table 5-6 for checks following replacement of a semiconductor.

5-26

#### 5-67. REPLACEMENT OF ELECTRON TUBES.

5-68. When replacing tubes in the Model 608E/F, it is recommended that a check be made of the operation of the instrument before and after each tube trial and, if no improvement is noted, the original tube be returned to the socket. Figure 5-23 locates all electron tubes in the equipment. Table 5-6 lists all tubes, together with the checks which should be made following tube replacement.

5-69. OSCILLATOR TUBE REPLACEMENT. Replacement of RF Oscillator tube V6 may affect the calibration of the frequency dial and the amplitude of the RF Generator heater-voltage supply. In addition,



Table 5-6. Checks Following Tube and Semiconductor Replacement

Reference Designation	Check	Paragraph
V2	Internal Modulation	5-22
V6	Frequency Accuracy	5-12
	Frequency Drift	5-14
V8	Maximum RF Output	5-17
	Uncalibrated RF Output	5-20
V9	Calibrator Accuracy	5-13
V10	Calibrator Accuracy	5-13
V11	Calibrator Accuracy	5-13
V12	Power Supply (+225)	5-31
V13	Power Supply (+225)	5-31
V14	Power Supply (-165)	5-31
V15	Power Supply (-165)	5-31
V16	Power Supply (-165)	5-31
V18	Modulation Meter Accuracy	5-21
V19	Modulation Meter Accuracy	5-21
V20	Modulation Meter Accuracy	5-21
V21	Modulation Meter Accuracy	5-21
V22	Maximum RF Output	5-17
Q1	Power Supply	5-31
Q2	Leveling	5-18
Q3	Leveling	5-18
	Internal Modulation	5-22
Q4	Leveling	5-18
	Internal Modulation	5-22
Q5	Leveling	5-18
	External Pulse Modulation	5-24
Q6	Leveling	5-18
	Internal Modulation	5-22
Q7	Leveling	5-18
	Internal Modulation	5-22
Q8	Leveling	5-18
	Internal Modulation	5-22
Q9	Leveling	5-18
	Internal Modulation	5-22
Q10	Power Supply (+25)	5-31
Q11	Power Supply (+25)	5-31
CR1	Crystal Calibrator Accuracy	5-13
CR2	Modulation Meter Accuracy	5-21
CR7	Leveling	5-18
CR8	Power Supply (+225)	5-31
CR9	Power Supply (+225)	5-31
CR10	Power Supply (+225)	5-31
CR11	Power Supply (+225)	5-31
CR12	Power Supply (-165)	5-31
CR13	Power Supply (-165)	5-31
CR14	Power Supply (-165)	5-31
CR15	Power Supply (-165)	5-31
CR16	Power Supply (-6.3)	5-31
CR17	Power Supply (-6.3)	5-31
CR18	Power Supply (-6.3)	5-31
CR19	Power Supply (-6.3)	5-31
CR20	Power Supply (-6.3)	5-31
CR21	Leveling	5-18
CR23	External Pulse Modulation	5-24
CR24	External Pulse Modulation	5-24
CR25	Leveling	5-18
CR26	Leveling	5-18
CR27	Power Supply (+25)	5-31
CR28	Power Supply (+25)	5-31
CR29	Power Supply (+25)	5-31
CR30	Power Supply (+25)	5-31

plate current requirements of type 4042 pencil triodes may differ widely from tube to tube in a given application. Therefore, when V6 is replaced, heater voltage must be checked and, if necessary, reset to the proper value; plate current must be held to between 18 and 27 milliamperes by tube selection; and calibration of the frequency dial must be checked.

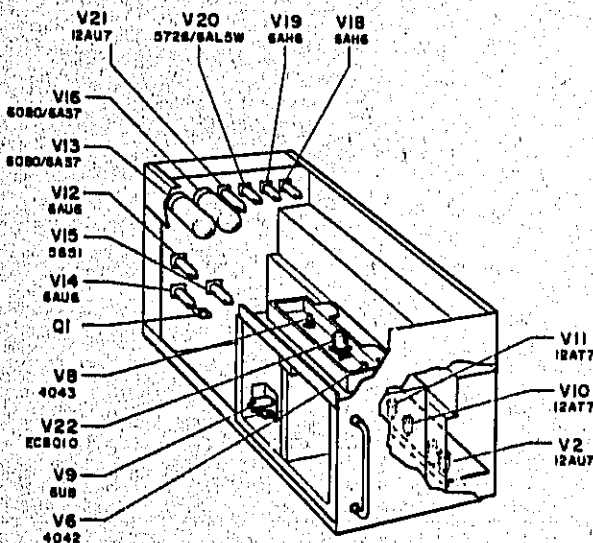

Figure 5-23. Location of Electron Tubes

5-70. To replace Oscillator V8, refer to Figure 5-24 and proceed as follows:

- Remove frequency dial and top plate from RF Generator housing to gain access to tube compartment. (The frequency dial is accurately indexed on its hub by two pins to assure exact positioning when dial is replaced on hub.)
- Remove socket from base of V8 by straight pull.
- Remove cathode clip from tube.
- Remove the two BH screws holding retainer plate, then remove plate and fiber spacer.
- Lift tube gently from hole by straight pull.
- Replace tube in reverse order of above steps.
- Connect a dc voltmeter to inside lead of FL4. Meter should indicate 6.3 Vdc. If necessary, change value of CR20 to obtain 6.3 Vdc.
- Using Model 428 DC Ammeter, measure current in lead to feed-through capacitor C15.
- Set the FREQUENCY RANGE switch to band E. Current meter should indicate between 18 and 27 mA. If meter indication is not within these limits, substitute another 4042 oscillator tube.

j. Using internal beat-frequency calibrator, check frequency calibration throughout range of signal generator, noting points that are significantly off frequency.

k. To correct calibration at the high-frequency end of all bands simultaneously, adjust trimmer capacitor C18 in the 608E, and C59 in the 608F, which is accessible in tube compartment in RF Generator housing. This adjustment has only minor effect at low-frequency ends of all ranges.

5-71. RF AMPLIFIER AND BUFFER TUBE REPLACEMENT. To remove RF Amplifier V8 and Buffer V22, refer to Figure 5-24 and proceed as follows:

#### NOTE

Replacement of the RF Amplifier and Buffer tubes can affect the amplitude of the RF generator heater-voltage supply and may limit the power output from the signal generator.

- Remove frequency dial and top plate from RF Generator housing to gain access to tube compartment.
- Replace Buffer V22.
- For Amplifier V8, remove socket from base of V8 by straight pull.
- Remove cathode clip from tube.
- Using special wrench (located on instrument chassis, near RF Generator housing), loosen threaded retainer ring which holds V8 in housing. Remove retainer ring and neoprene washer.
- Remove old tube and replace with new type 4043 tube.
- Check power output throughout full frequency range of signal generator. With AMPL TRIMMER set for maximum output at each frequency, a full-scale reading should be obtained over entire frequency range.

5-72. CRYSTAL OSCILLATOR TUBE OR QUARTZ CRYSTAL REPLACEMENT. To gain access to the Calibrator Oscillator, remove the side cover on the RF Generator housing. The entire Crystal Oscillator is mounted on a bracket on the rear wall of the amplifier compartment. Location of oscillator tube V9, crystal Y1, and associated adjustments are shown in Figure 5-27. If V9 or Y1 is replaced, the calibrator should be checked and, if necessary, adjusted.

5-73. The crystal-controlled frequency calibrator is composed of two circuits: the 5-MHz crystal-controlled oscillator, which utilizes the pentode half of a type 6U8 tube, and the 1-MHz oscillator, utilizing the triode section of the 6U8. Each section is adjustable, and both sections should be adjusted at the same time. The frequency of the crystal can only be adjusted over a range of approximately 100 Hz. The frequency of the 1-MHz oscillator then locks in with the 5-MHz frequency and is either right on frequency or is very far off. To adjust the crystal-controlled calibrator, refer to paragraph 5-47.

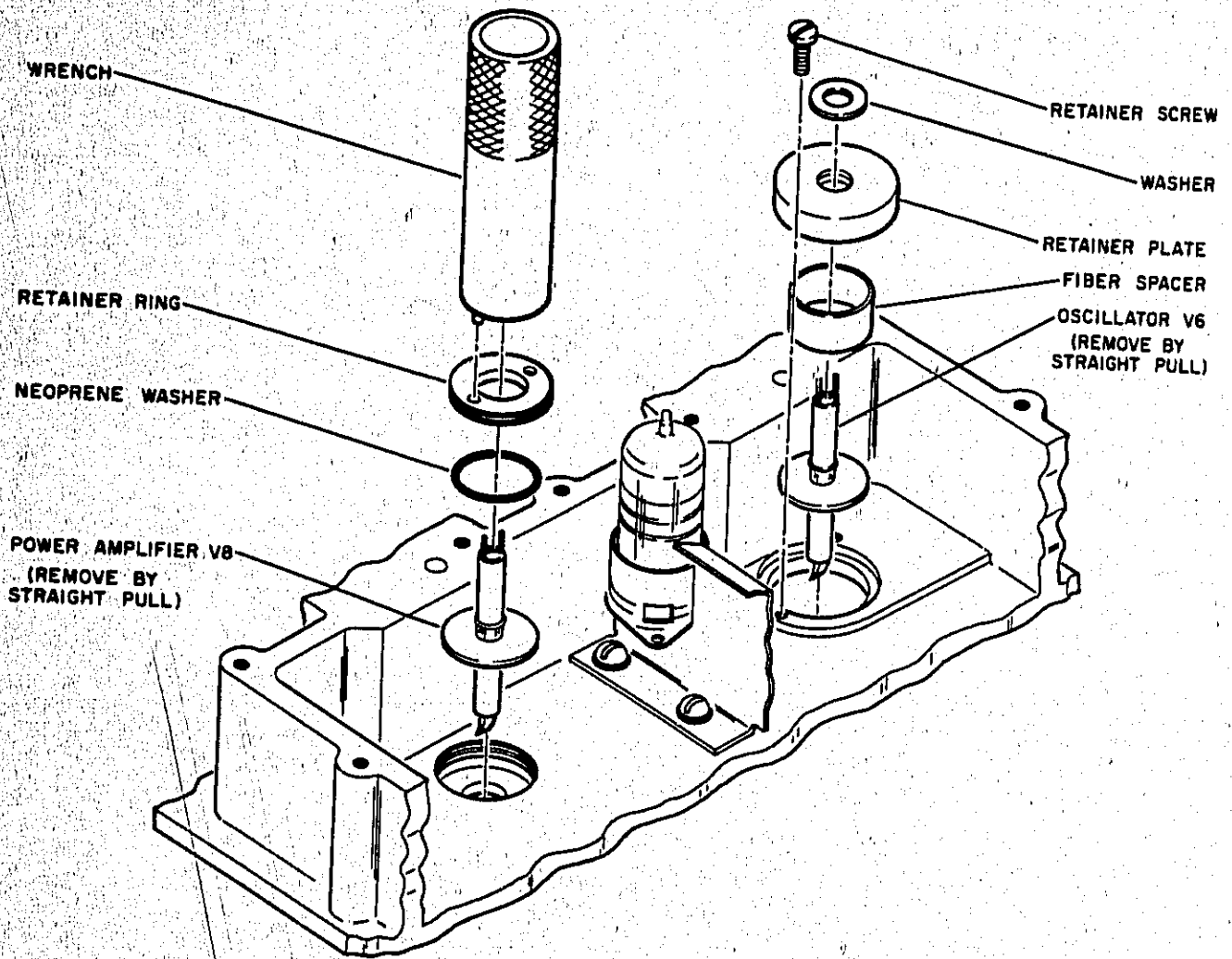

Figure 5-24. Replacement of Oscillator and Amplifier Tubes

5-74. ATTENUATOR PROBE REPAIR AND REPLACEMENT.

**CAUTION**

During removal and replacement of the probe, extreme care must be exercised. The probe consists of a cylindrical metal tube with a series of spring contact fingers around its periphery at one end. These fingers can be accidentally bent or twisted. It should be noted that one or two of the fingers are bent toward the center of the probe slightly; do not attempt to straighten them, since these fingers have been bent to assure clearance between the probe and the end of the guide slot in the attenuator housing. It

is of greatest importance to make certain that the probe is not subjected to shock. If subjected to shock, the electrical components attached to the end of the probe can be broken or their positions altered, with a consequent change in the electrical characteristics of the probe.

5-75. GENERAL. The impedance-matching network in the output attenuator can be damaged if power from an external source is applied to the RF OUTPUT connector. If electrical components of the output attenuator are damaged, repair or replacement is necessary. Damage to the impedance-matching network may be confirmed by measuring the VSWR of the attenuator at the RF OUTPUT connector.



## NOTE

Attenuator VSWR is determined by positioning of the probe variable capacitor (C37) and the relative position of the two resistors (R58 and R59) on the end of the probe. If replacement resistors are returned to their original positions, the VSWR will not be changed appreciably. However, if equipment is available for checking attenuator VSWR, such a check is advisable following replacement of resistors.

**5-76. REMOVAL FROM HOUSING.** If investigation shows an attenuator to be defective, proceed as follows:

- a. Turn attenuator control on front panel until probe reaches end of its travel at rear of attenuator housing.
- b. Remove nut and washers that hold drive cable in probe drive screw (Figure 5-25) in top of attenuator probe.
- c. Remove probe split drive screw from probe body by removing inner nut and unscrewing.
- d. Remove probe by carefully sliding it out of attenuator housing.

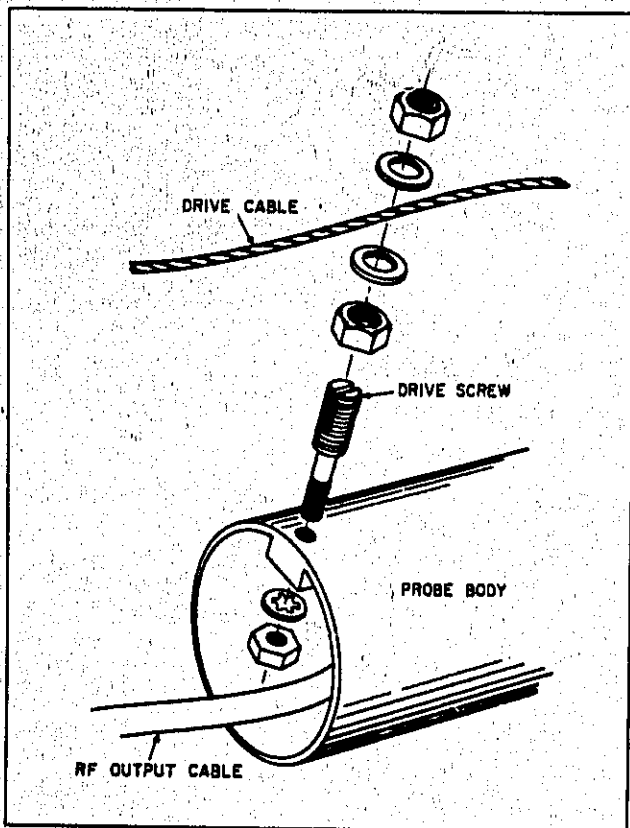

Figure 5-25. Disassembly of Attenuator Drive Cable

**5-77. PROBE REPAIR.** Capacitor C69 (Figure 5-26) is held in place by a mounting strap and a setscrew. To replace C69, unsolder the pickup loop at the capacitor end (ground slide of loop), loosen the setscrew, and slide the capacitor out of the clamp. Replace by reversing this procedure. The capacitor must be firmly seated in the hole in the end of the probe before tightening the setscrew. Be careful when tightening the setscrew; the capacitor ground lead can be cut in two if the setscrew is tightened excessively.

**5-78.** Note location of the two resistors so that new ones can be mounted as nearly as possible in the same position. Install new resistors; duplicate the original resistor mounting positions and lead lengths as closely as possible. Make connections without excessive binding or pulling on ends of resistors as they are fragile.

## CAUTION

These resistors are easily damaged by excessive heat. Use low-temperature soldering iron and solder connections as quickly as possible.

**5-79.** Measure resistors for any possible change in resistance due to soldering. The VSWR will not be changed appreciably.

**5-80.** The VSWR can be checked at several frequencies on band E, and the position of resistors R59 and R58 adjusted for optimum VSWR. Adjustment on the band E will automatically correct for minimum VSWR on the lower bands. Laboratory test equipment, such as an impedance bridge or reflectometer setup, will be required for measuring the VSWR. These VSWR checks must be made with attenuator inserted in attenuator housing in the instrument, as results obtained will be slightly different with attenuator outside of the housing.

**5-81. PROBE REPLACEMENT.** If repair is not possible, both probe and cable must be replaced. Remove the RF OUTPUT connector from the front panel, and release the cable from the clamp holding the cable to the top of the side gusset. The entire probe assembly may then be removed from the instrument. Replacement probes are complete with cable and panel connector; and require no adjustment of the impedance-matching network upon installation.

**5-82. REPLACEMENT IN HOUSING.**

- a. Insert new or repaired probe in attenuator housing. Care must be taken in starting probe into housing, since diameter at probe contact fingers is slightly greater than inner diameter of housing. Contact fingers should be depressed slightly while starting probe into its housing.

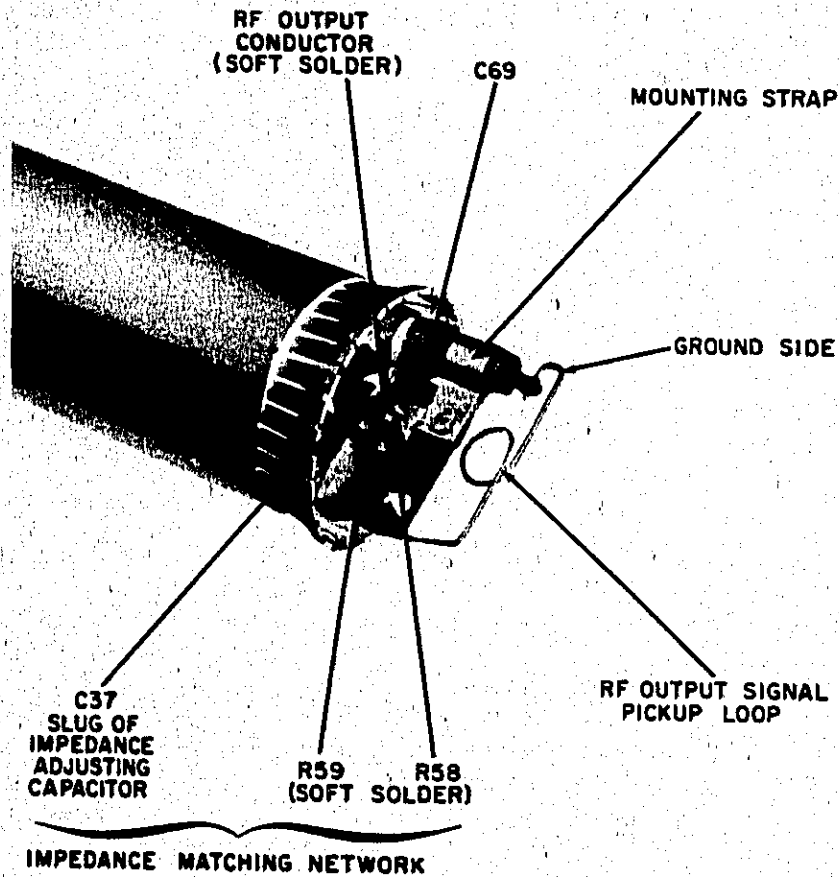

Figure 5-26. Attenuator Probe, Showing Pickup Loop and Impedance Matching Network

**CAUTION**

Under no circumstances should the probe be forced into the housing.

- b. Replace split drive screw in probe, making certain that screw slot is parallel to axis of housing.
- c. Set attenuator drive cable in screw slot and replace both washers and nut. Do not tighten nut. Cable must move freely through the slot until probe penetration has been set.
- d. Secure RF cable to clamp on side gusset.
- e. Connect instrument to a source of 115-volt for 230 volt) power, and turn on POWER switch. Unless otherwise specified, operating controls should be set as follows:

MODULATION Selector . . . . .	CW
Frequency dial . . . . .	70 MHz
FREQUENCY RANGE . . . . .	band C
AMPL TRIMMER . . . . .	Adjust for max. RF output
RF OUTPUT meter . . . . .	7 dBm
MODULATION control . . . . .	max. cw
Attenuator . . . . .	0 dBm

- f. Connect a power meter (such as Model 432A), through a thermistor mount (Model 478A or equivalent), to RF OUTPUT connector.

- g. Remove RF Generator side plate so that clearance between attenuator probe and coils of RF Amplifier tank may be observed.

**CAUTION**

The following step must be executed as carefully as possible to insure that the pickup loop does not make contact with any of the power amplifier coils. These coils are at B+ potential, and contact between any one of them and the attenuator pickup loop will damage attenuator components.

- h. With attenuator dial set exactly on 0 dBm, manually advance attenuator probe into the housing until RF output signal is exactly 1 milliwatt (0 dBm) as read on external power meter.

1. Tighten down nut on split drive screw so that probe may be actuated by its drive system. Carefully check to see that there is clearance between various amplifier coils and pickup loop when attenuator dial is set to +7 dBm.

#### 5-83. REPLACEMENT OF LAMP DS1.

5-84. Lamp DS1 acts as a positive temperature coefficient resistance, maintaining Modulator Oscillator output constant. The characteristics of the type S6 lamps used for this purpose ordinarily vary widely from lamp to lamp, causing a corresponding variation in the amplitude of the oscillator output from one Model 608E/F to another. To compensate for differences

between lamps, potentiometer R7 is provided for adjustment of the oscillator output voltage level. After lamp I1 has been replaced, the oscillator output voltage, as measured at pin 3 of V2, should be adjusted to 2 volts rms; if it cannot be adjusted to this value, another lamp must be tried.

#### 5-85. LOCATION OF PARTS.

5-86. To enable maintenance personnel to properly identify and locate replacement parts during adjustments, troubleshooting, and repair periods Figures 5-27 through 5-33 are presented at the rear of this section. A parts identification diagram for the ALC board is contained on Figures 7-3, 7-4 and 7-5.

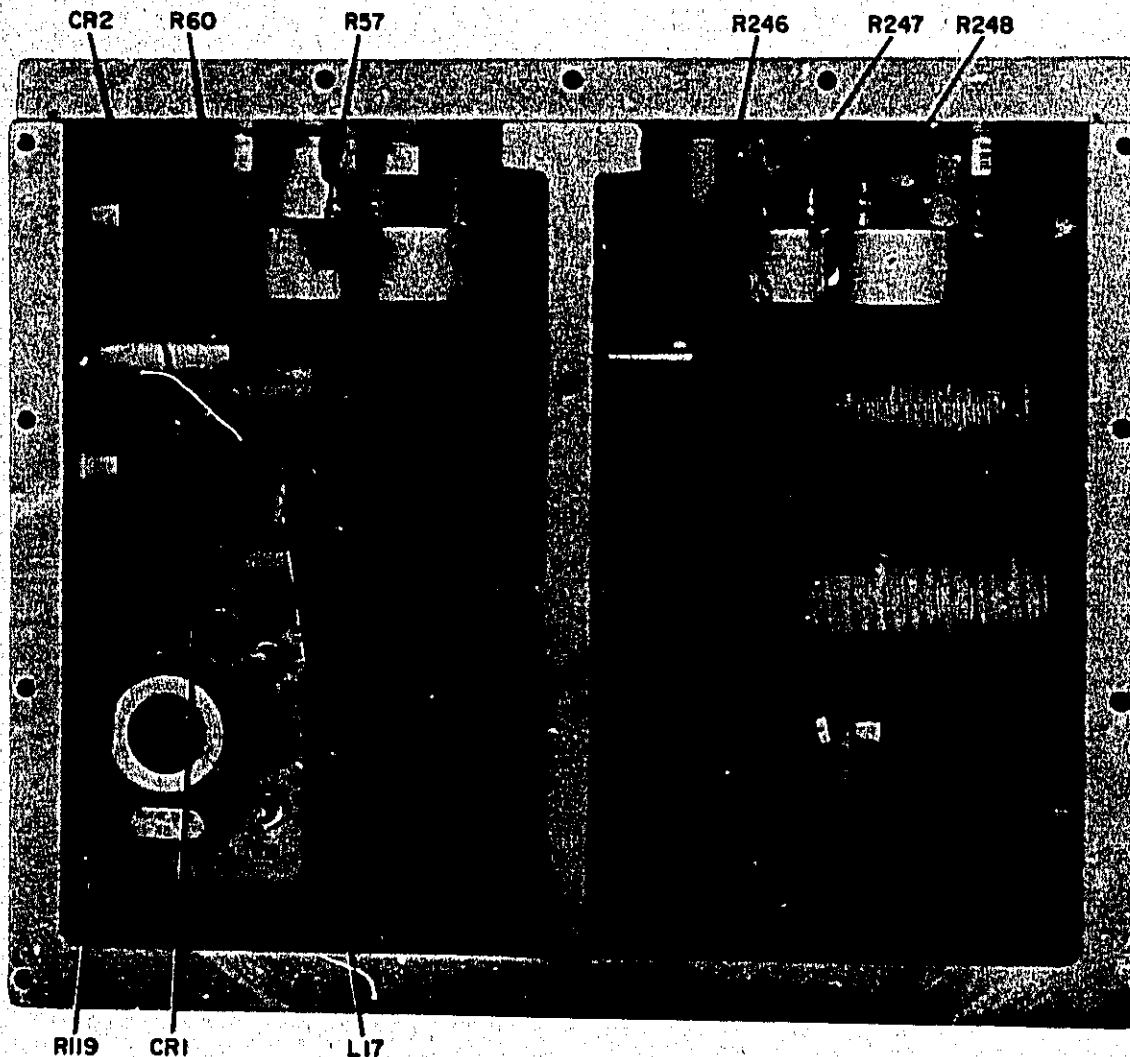

Figure 5-27. RF Generator Assembly Showing Location of Unlabeled Parts (Side Cover Removed)



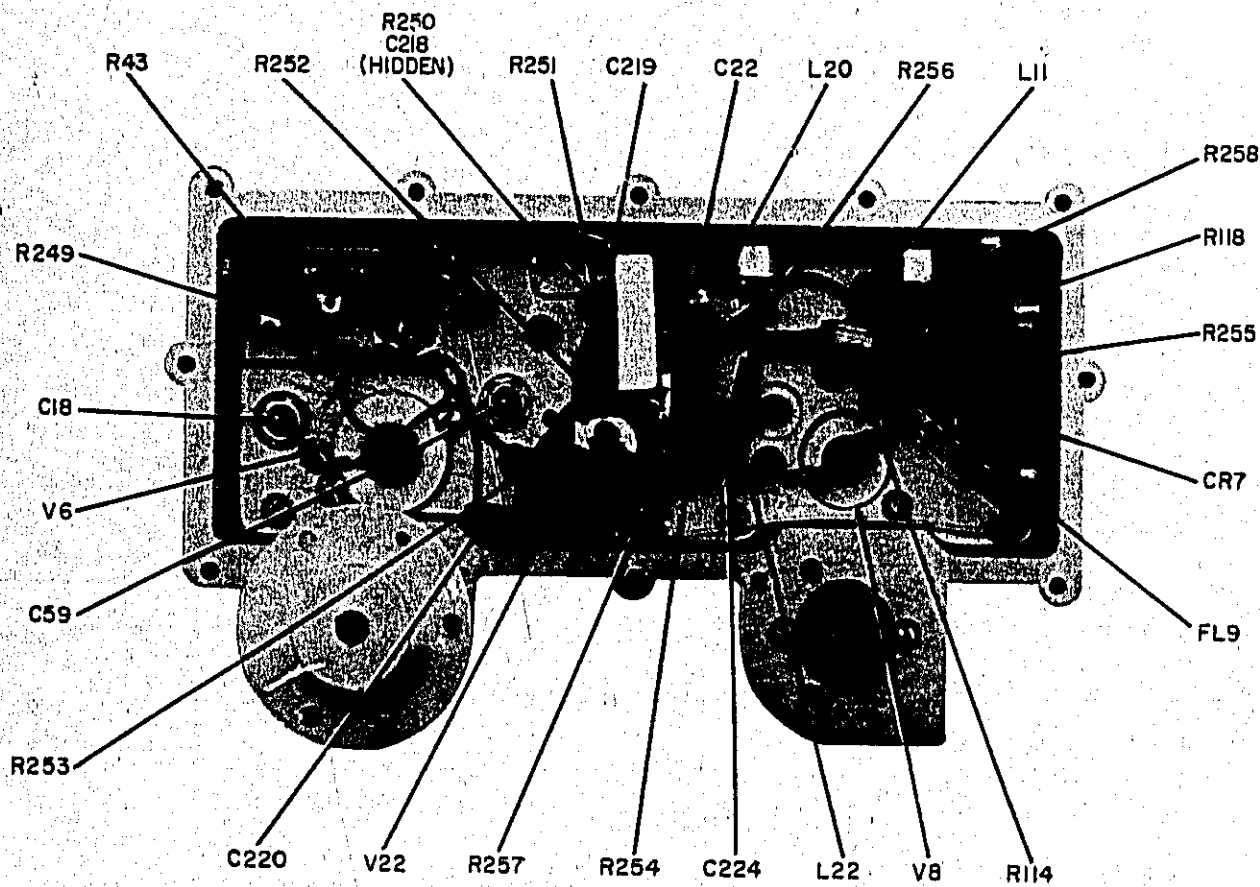

Figure 5-28. Model 608E RF Generator Assembly Showing Location of Unlabeled Parts (Top Cover Removed)

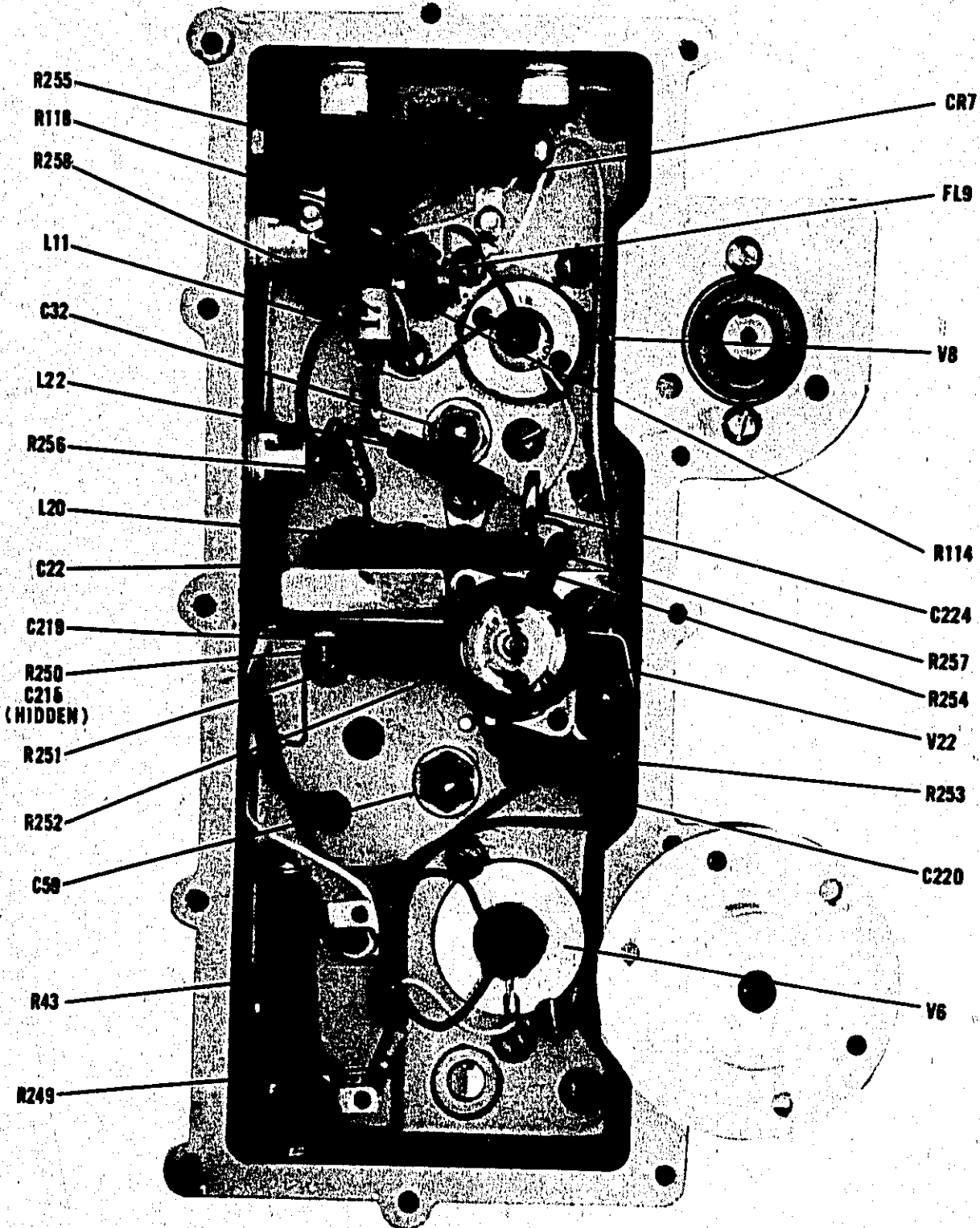

Figure 5-29. Model 608F RF Generator Assembly Showing Location of Unlabeled Parts (Top Cover Removed)

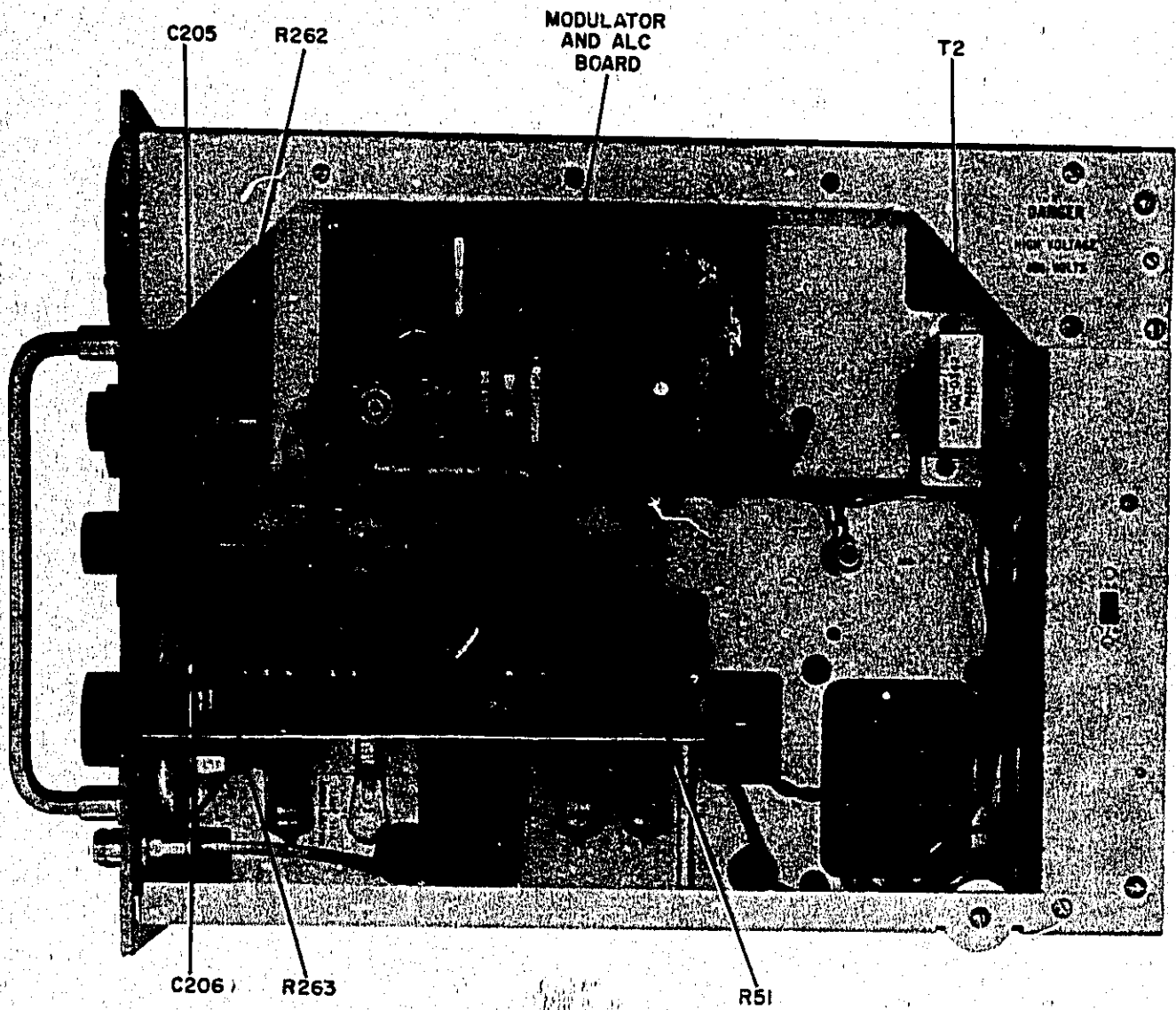

Figure 5-30. Right Side View Showing Location of Unlabeled Chassis Components



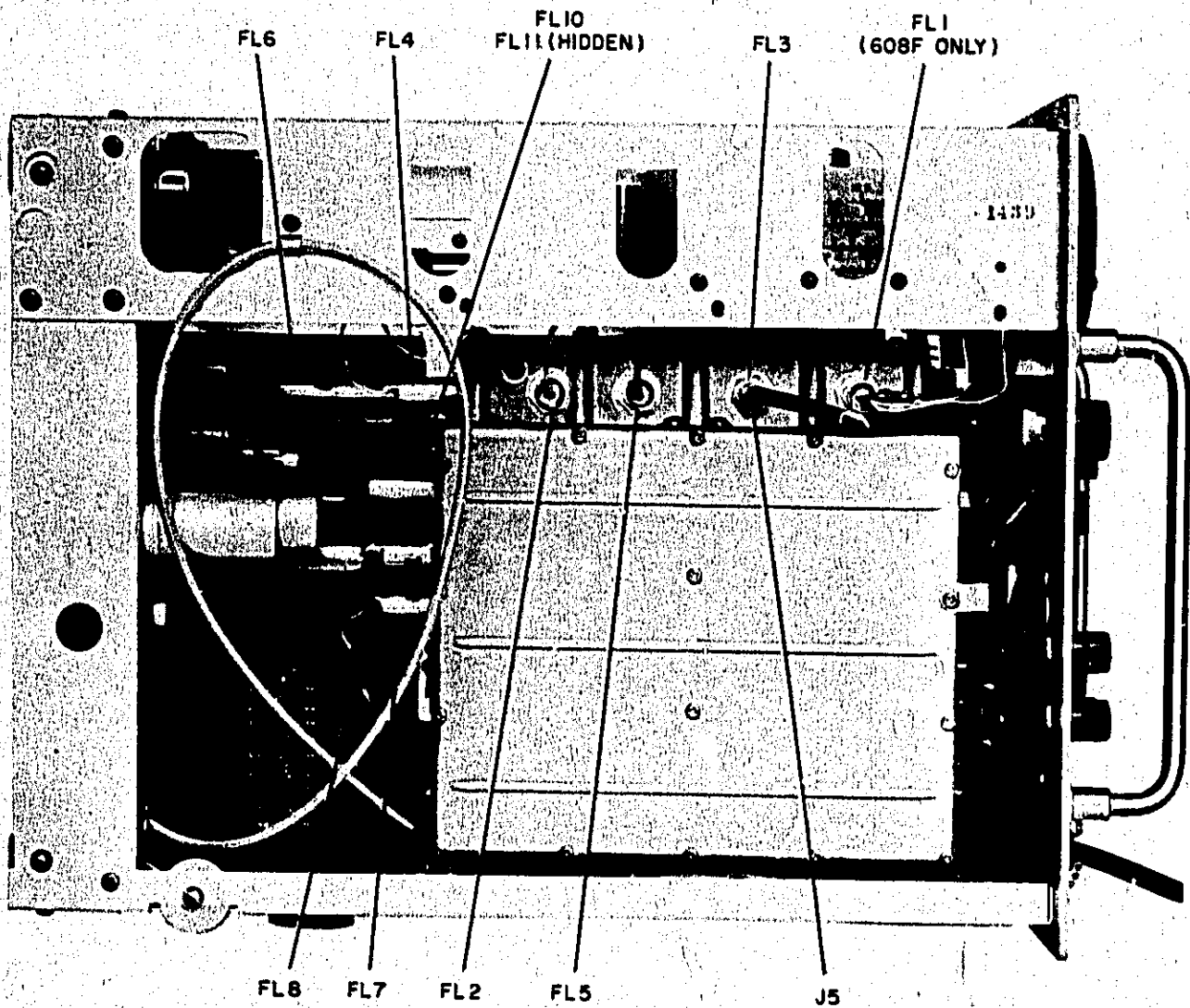

Figure 5-31. Left Side View Showing Location of Unlabeled Components

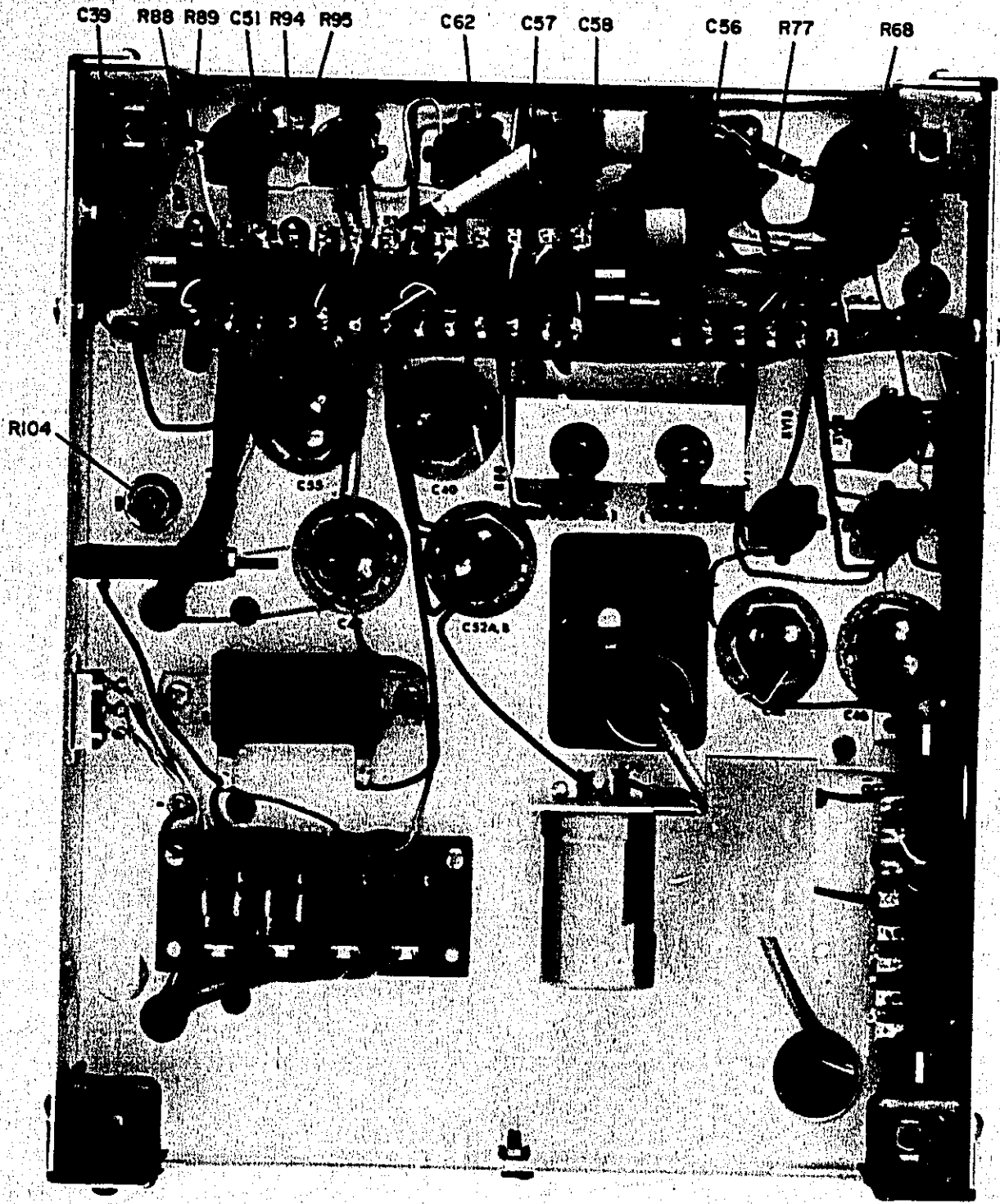
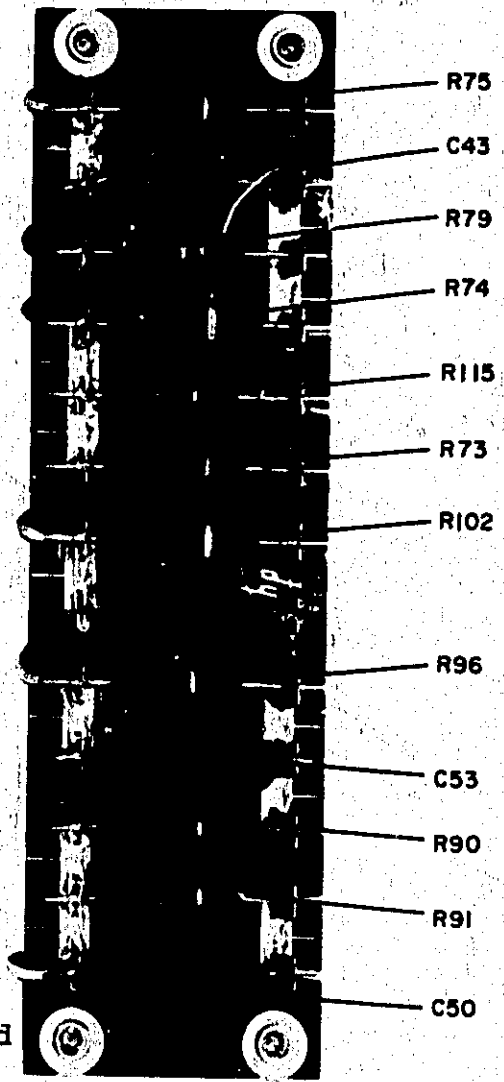
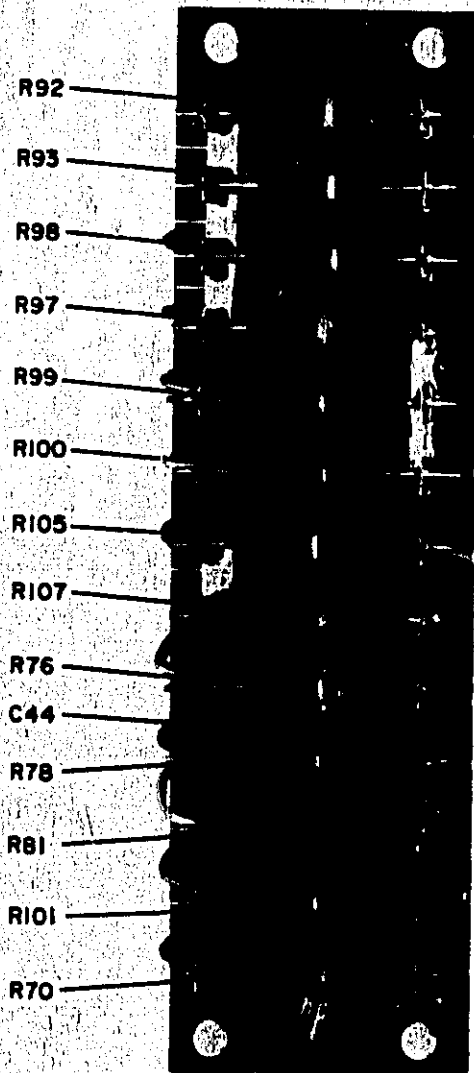
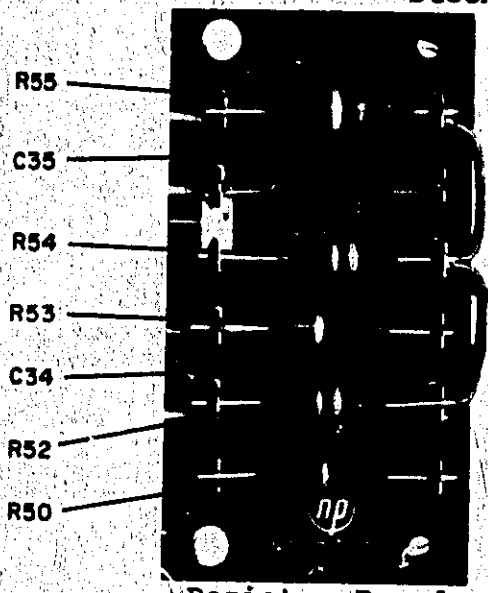

Figure 5-32. Rear View Showing Location of Unlabeled Chassis Components



Resistor Board Assembly  
Stock No. 00608-60044



Resistor Board Assembly  
Stock No. 00608-613

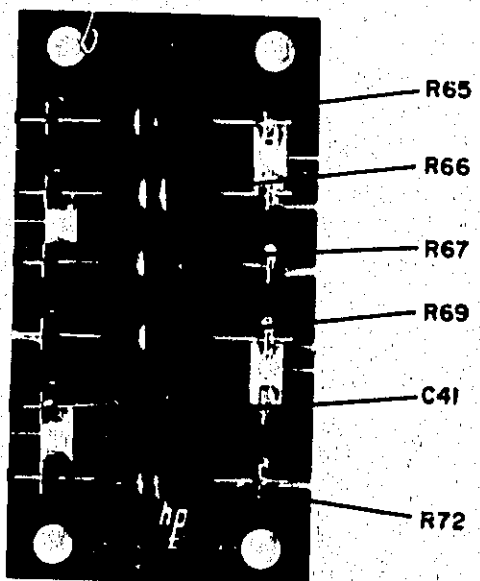

Resistor Board Assembly  
Stock No. 00608-60044

Figure 5-33. Circuit Board Parts Identification  
(Sheet 1 of 2)



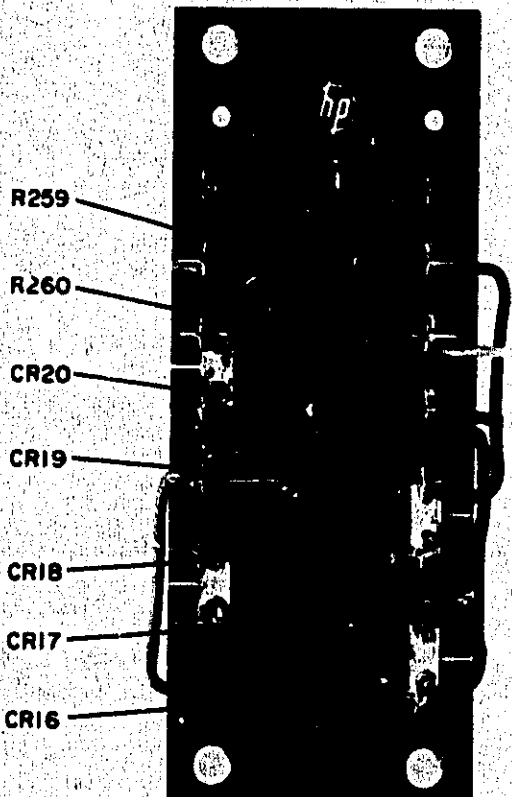

Rectifier-Resistor Board Assembly  
Stock No. 00608-604

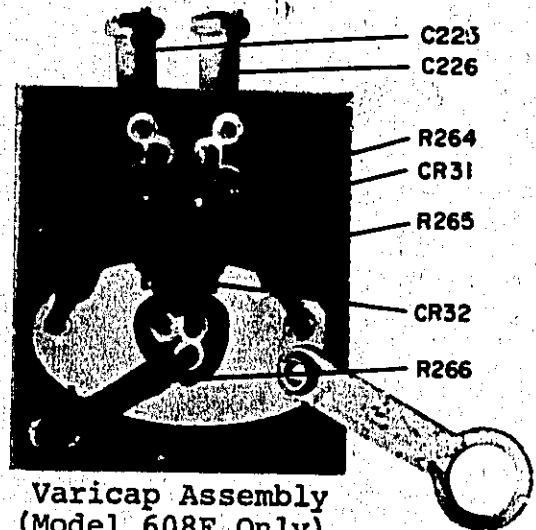

Varicap Assembly  
(Model 608F Only)  
Stock No. 00608-625

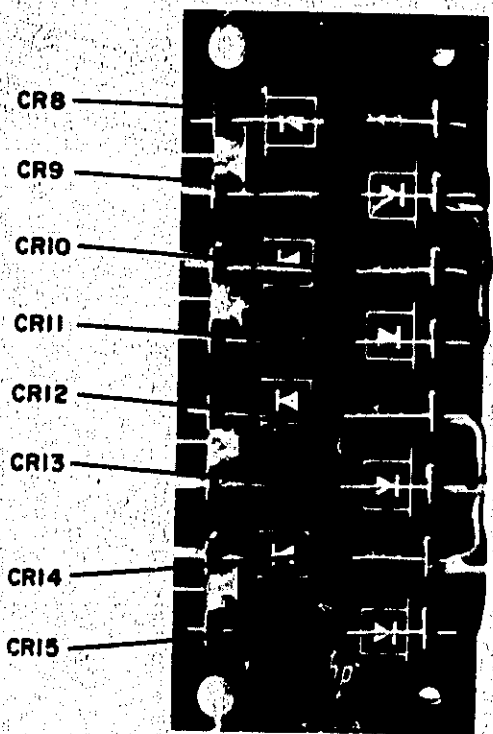

Rectifier Board Assembly  
Stock No. 00608-60046

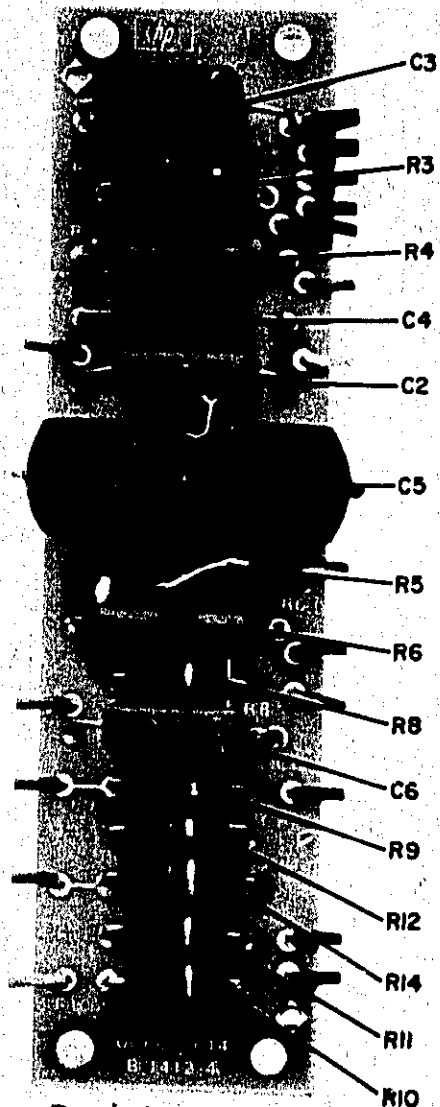

Resistor Board Assembly  
Stock No. 00608-614

Figure 5-33. Circuit Board Parts Identification  
(Sheet 2 of 2)

Section V

Model 608E/F

Table 5-7. Model 608E/F Troubleshooting Procedure

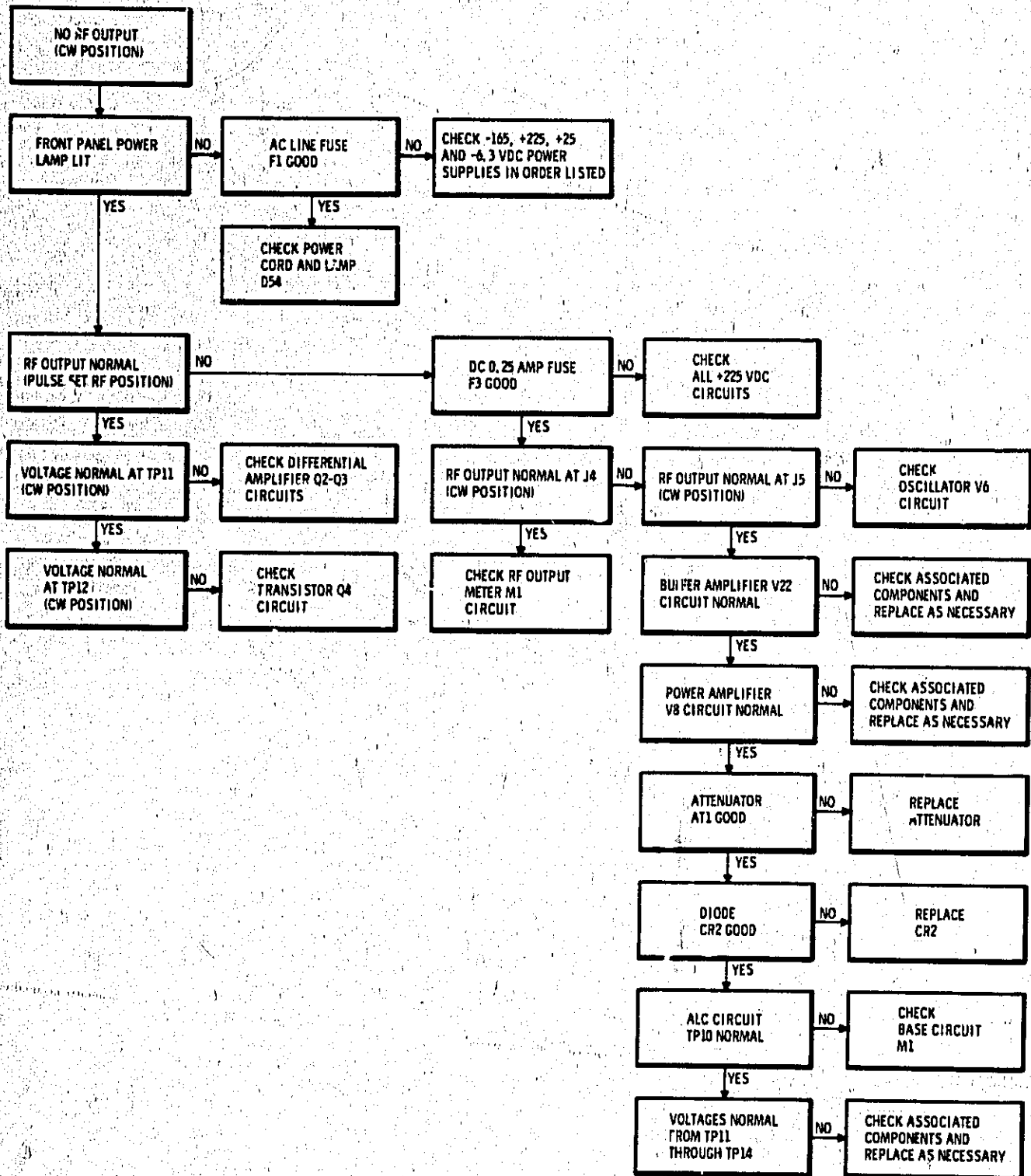
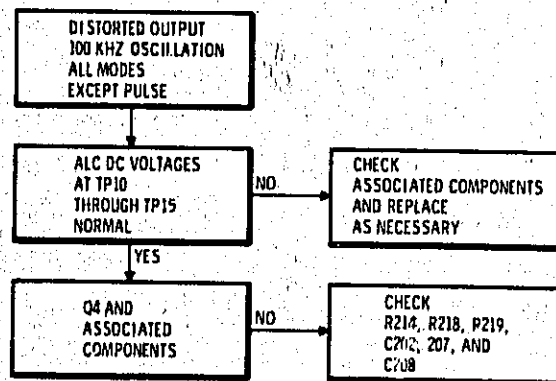
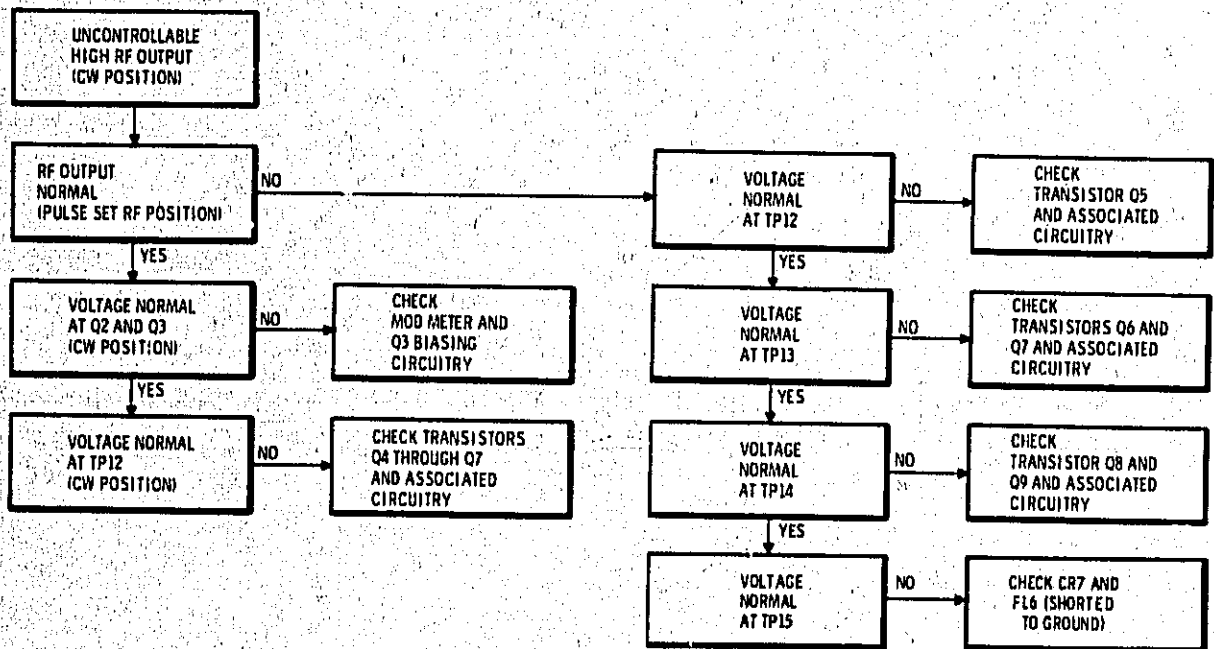

Table 5-7. Model 608E/F Troubleshooting Procedure (Continued)





Current meter should indicate between 18 and 27 mA. If meter indication is not within these limits, substitute another 4042 oscillator tube.

5-28

the 1-MHz oscillator then locks in with the 5-MHz frequency and is either right on frequency or is very far off. To adjust the crystal-controlled calibrator, refer to paragraph 5-47.

Section V

Model 608E/F

Table 5-7. Model 608E/F Troubleshooting Procedure (Continued)

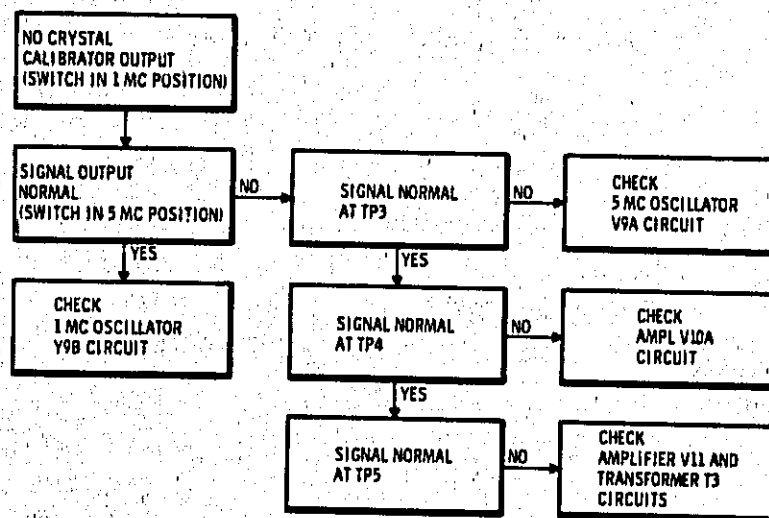
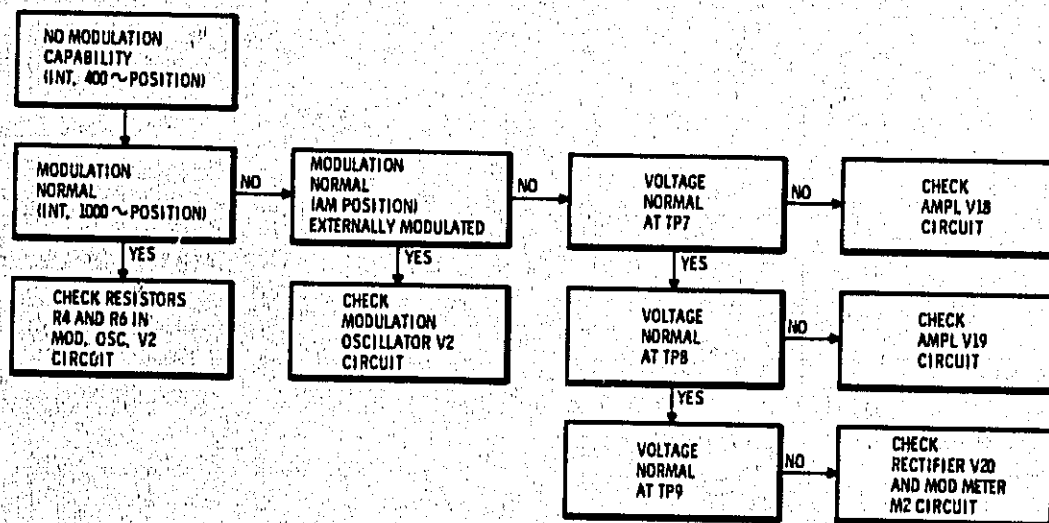

# PARTS LIST

## SECTION VI REPLACEABLE PARTS

### 6-1. INTRODUCTION

6-2. This section contains information for ordering parts. Table 6-2 lists abbreviations used in the parts list and throughout the manual. Table 6-3 lists all replaceable parts in reference designator order. Table 6-4 contains the names and addresses that correspond to the manufacturer's code numbers.

### 6-3. REPLACEABLE PARTS LIST

6-4. Table 6-3 is the list of replaceable parts and is organized as follows:

- a. Electrical assemblies and their components in alphanumeric order by reference designation.
- b. Chassis-mounted parts in alphanumeric order by reference designation.
- c. Mechanical parts.

6-5. The information given for each part consists of the following:

- a. The Hewlett-Packard part number.
- b. Part number check digit (CD).
- c. The total quantity (Qty) for the entire instrument.
- d. The description of the part.

e. A typical manufacturer of the part in a five-digit code.

f. The manufacturer's number for the part.

### 6-6. ORDERING INFORMATION

6-7. To order a part listed in the replaceable parts table, quote the Hewlett-Packard part number (with the check digit), indicate the quantity required, and address the order to the nearest Hewlett-Packard office. The check digit will ensure accurate and timely processing of your order.

6-8. To order a part that is not listed in the replaceable parts table, include the instrument model number, instrument serial number, description and function of the part, and the number of parts required. Address the order to the nearest Hewlett-Packard office.

### 6-9. FACTORY SELECTED PARTS (\*)

6-10. Parts marked with an asterisk (\*) are factory selected parts. The value listed in the parts list is the nominal value.

#### NOTE

Within the USA, it is better to order directly from the HP Parts Center in Mountain View, California. Ask your nearest HP office for information and forms for the "Direct Mail Order System".



Table 6-1. Reference Designations

REFERENCE DESIGNATIONS			
A . . . . . assembly	E . . . . . miscellaneous electrical part	P . . . . . electrical connector (movable portion); plug	U . . . . . integrated circuit; microcircuit
AT . . . . . attenuator; isolator; termination	F . . . . . fuse	Q . . . . . transistor; SCR; triode thyristor	V . . . . . electron tube
B . . . . . fan; motor	FL . . . . . filter	R . . . . . resistor	VR . . . . . voltage regulator; breakdown diode
BT . . . . . battery	H . . . . . hardware	RT . . . . . thermistor	W . . . . . cable; transmission path; wire
C . . . . . capacitor	HY . . . . . circulator	S . . . . . switch	X . . . . . socket
CP . . . . . coupler	J . . . . . electrical connector (stationary portion); jack	T . . . . . transformer	Y . . . . . crystal unit (piezo-electric or quartz)
CR . . . . . diode; diode thyristor; varactor	K . . . . . relay	TB . . . . . terminal board	Z . . . . . tuned cavity; tuned circuit
DC . . . . . directional coupler	L . . . . . coil; inductor	TC . . . . . thermocouple	
DL . . . . . delay line	M . . . . . meter	TP . . . . . test point	
DS . . . . . annunciator; signaling device (audible or visual); lamp; LED	MP . . . . . miscellaneous mechanical part		

Table 6-2. Abbreviations (1 of 2)

ABBREVIATIONS			
A . . . . . ampere	COEF . . . . . coefficient	EDP . . . . . electronic data processing	INT . . . . . internal
ac . . . . . alternating current	COM . . . . . common	ELECT . . . . . electrolytic	kg . . . . . kilogram
ACCESS . . . . . accessory	COMP . . . . . composition	ENCAP . . . . . encapsulated	kHz . . . . . kilohertz
ADJ . . . . . adjustment	COMPL . . . . . complete	EXT . . . . . external	kΩ . . . . . kilohm
A/D . . . . . analog-to-digital	CONN . . . . . connector	F . . . . . farad	kV . . . . . kilovolt
AF . . . . . audio frequency	CP . . . . . cadmium plate	FET . . . . . field-effect transistor	lb . . . . . pound
AFC . . . . . automatic frequency control	CRT . . . . . cathode-ray tube	F/F . . . . . flip-flop	LC . . . . . inductance-capacitance
AGC . . . . . automatic gain control	CTE . . . . . complementary transistor logic	FH . . . . . flat head	LED . . . . . light-emitting diode
AL . . . . . aluminum	CW . . . . . continuous wave	FIL H . . . . . fillister head	LF . . . . . low frequency
ALC . . . . . automatic level control	cm . . . . . centimeter	FM . . . . . frequency modulation	LG . . . . . long
AM . . . . . amplitude modulation	D/A . . . . . digital-to-analog	FP . . . . . front panel	LH . . . . . left hand
AMPL . . . . . amplifier	dB . . . . . decibel	FREQ . . . . . frequency	LIM . . . . . limit
APC . . . . . automatic phase control	dBm . . . . . decibel referred to 1 mW	FXD . . . . . fixed	LIN . . . . . linear taper (used in parts list)
ASSY . . . . . assembly	dc . . . . . direct current	G . . . . . gram	lin . . . . . linear
AUX . . . . . auxiliary	deg . . . . . degree (temperature interval or difference)	GE . . . . . germanium	LK WASH . . . . . lock washer
avg . . . . . average	° . . . . . degree (plane angle)	GHz . . . . . gigahertz	LO . . . . . low; local oscillator
AWG . . . . . American wire gauge	°C . . . . . degree Celsius (centigrade)	GL . . . . . glass	LOG . . . . . logarithmic taper (used in parts list)
BAL . . . . . balance	°F . . . . . degree Fahrenheit	GRD . . . . . ground(ed)	log . . . . . logarithmic
BCD . . . . . binary coded decimal	K . . . . . degree Kelvin	H . . . . . henry	LPF . . . . . low pass filter
BD . . . . . board	DEPC . . . . . deposited carbon	h . . . . . hour	LV . . . . . low voltage
BE CU . . . . . beryllium copper	DET . . . . . detector	HET . . . . . heterodyne	m . . . . . meter (distance)
BFO . . . . . beat frequency oscillator	diam . . . . . diameter	HEX . . . . . hexagonal	mA . . . . . milliamperes
BH . . . . . binder head	DIA . . . . . diameter (used in parts list)	HD . . . . . head	MAX . . . . . maximum
BKDN . . . . . breakdown	DIFF AMPL . . . . . differential amplifier	HDW . . . . . hardware	MΩ . . . . . megohm
BP . . . . . bandpass	div . . . . . division	HF . . . . . high frequency	MEG . . . . . meg (10 <sup>6</sup> ) (used in parts list)
BPF . . . . . bandpass filter	DPDT . . . . . double-pole, double-throw	HG . . . . . mercury	MET FLM . . . . . metal film
BRB . . . . . brass	DR . . . . . drive	HI . . . . . high	MET OX . . . . . metallic oxide
BWO . . . . . backward-wave oscillator	DSB . . . . . double sideband	HP . . . . . Hewlett-Packard	MF . . . . . medium frequency; microfarad (used in parts list)
CAL . . . . . calibrate	DTL . . . . . diode transistor logic	HPF . . . . . high pass filter	MFR . . . . . manufacturer
ccw . . . . . counter-clockwise	DVM . . . . . digital voltmeter	HR . . . . . hour (used in parts list)	mg . . . . . milligram
CER . . . . . ceramic	ECL . . . . . emitter coupled logic	HV . . . . . high voltage	MHz . . . . . megahertz
CHAN . . . . . channel	EMF . . . . . electromotive force	Hz . . . . . Hertz	mH . . . . . millihenry
cm . . . . . centimeter		IC . . . . . integrated circuit	mho . . . . . mho
CMO . . . . . cabinet mount only		ID . . . . . inside diameter	MIN . . . . . minimum
COAX . . . . . coaxial		IF . . . . . intermediate frequency	min . . . . . minute (time)
		IMPG . . . . . impregnated	... . . . . minute (plane angle)
		IN . . . . . inch	MINAT . . . . . miniature
		INCD . . . . . incandescent	mm . . . . . millimeter
		INCL . . . . . include(s)	
		INS . . . . . insulation	

NOTE

All abbreviations in the parts list will be in upper-case.

Table 6-2. Abbreviations (2 of 2)

MOD . . . . . modulator	OD . . . . . outside diameter	PWV . . . . . peak working voltage	TD . . . . . time delay
MOM . . . . . momentary	OH . . . . . oval head	RC . . . . . resistance-capacitance	TERM . . . . . terminal
MOS . . . . . metal-oxide semiconductor	OP AMPL . . . . . operational amplifier	RECT . . . . . rectifier	TFT . . . . . thin-film transistor
ms . . . . . millisecond	OPT . . . . . option	REF . . . . . reference	TGL . . . . . toggle
MTG . . . . . mounting	OSC . . . . . oscillator	REG . . . . . regulated	THD . . . . . thread
MTR . . . . . meter (indicating device)	OX . . . . . oxide	REPL . . . . . replaceable	THRU . . . . . through
mV . . . . . millivolt	oz . . . . . ounce	RF . . . . . radio frequency	TI . . . . . titanium
mVac . . . . . millivolt, ac	Ω . . . . . ohm	RFI . . . . . radio frequency interference	TOL . . . . . tolerance
mVdc . . . . . millivolt, dc	P . . . . . peak (used in parts list)	RH . . . . . round head; right hand	TRIM . . . . . trimmer
mVpk . . . . . millivolt, peak	PAM . . . . . pulse-amplitude modulation	RLC . . . . . resistance-inductance-capacitance	TSTR . . . . . transistor
mVp-p . . . . . millivolt, peak-to-peak	PC . . . . . printed circuit	RMO . . . . . rack mount only	TTL . . . . . transistor-transistor logic
mVrms . . . . . millivolt, rms	PCM . . . . . pulse-code modulation; pulse-count modulation	RMS . . . . . root-mean-square	TV . . . . . television
mW . . . . . milliwatt	PDM . . . . . pulse-duration modulation	RND . . . . . round	TVI . . . . . television interference
MUX . . . . . multiplex	PF . . . . . picofarad	ROM . . . . . read-only memory	TWT . . . . . traveling wave tube
MY . . . . . mylar	PH BRZ . . . . . phosphor bronze	R&P . . . . . rack and panel	U . . . . . micro (10 <sup>-6</sup> ) (used in parts list)
μA . . . . . microampere	PHL . . . . . Phillips	RWV . . . . . reverse working voltage	UF . . . . . microfarad (used in parts list)
μF . . . . . microfarad	PIN . . . . . positive-intrinsic-negative	S . . . . . scattering parameter	UHF . . . . . ultrahigh frequency
μH . . . . . microhenry	PIV . . . . . peak inverse voltage	s . . . . . second (time)	UNREG . . . . . unregulated
μmho . . . . . micromho	pk . . . . . peak	" . . . . . second (plane angle)	V . . . . . volt
μs . . . . . microsecond	PL . . . . . phase lock	S-B . . . . . slow-blow (fuse) (used in parts list)	VA . . . . . voltampere
μV . . . . . microvolt	PLO . . . . . phase lock oscillator	SCR . . . . . silicon controlled rectifier; screw	Vac . . . . . volts, ac
μVac . . . . . microvolt, ac	PM . . . . . phase modulation	SE . . . . . selenium	VAR . . . . . variable
μVdc . . . . . microvolt, dc	PNP . . . . . positive-negative-positive	SECT . . . . . sections	VCO . . . . . voltage-controlled oscillator
μVpk . . . . . microvolt, peak	P/O . . . . . part of	SEMICON . . . . . semiconductor	Vdc . . . . . volts, dc
μVp-p . . . . . microvolt, peak-to-peak	POLY . . . . . polystyrene	SHF . . . . . superhigh frequency	VDCW . . . . . volts, dc, working (used in parts list)
μVrms . . . . . microvolt, rms	POPC . . . . . porcelain	SI . . . . . silicon	V(F) . . . . . volts, filtered
μW . . . . . microwatt	POS . . . . . positive; position(s) (used in parts list)	SIL . . . . . silver	VFO . . . . . variable-frequency oscillator
nA . . . . . nanoampere	POSN . . . . . position	SL . . . . . slide	VHF . . . . . very-high frequency
NC . . . . . no connection	POT . . . . . potentiometer	SNR . . . . . signal-to-noise ratio	Vpk . . . . . volts, peak
N/C . . . . . normally closed	p-p . . . . . peak-to-peak	SPDT . . . . . single-pole, double-throw	Vp-p . . . . . volts, peak-to-peak
NE . . . . . neon	PP . . . . . peak-to-peak (used in parts list)	SPG . . . . . spring	Vrms . . . . . volts, rms
NEG . . . . . negative	PPM . . . . . pulse-position modulation	SR . . . . . split ring	VSWR . . . . . voltage standing wave ratio
nF . . . . . nanofarad	PREAMPL . . . . . preamplifier	SPST . . . . . single-pole, single-throw	VTO . . . . . voltage-tuned oscillator
NI PL . . . . . nickel plate	PRF . . . . . pulse-repetition frequency	SSB . . . . . single sideband	VTVM . . . . . vacuum-tube voltmeter
N/O . . . . . normally open	PRR . . . . . pulse repetition rate	SST . . . . . stainless steel	V(X) . . . . . volts, switched
NOM . . . . . nominal	ps . . . . . picosecond	STL . . . . . steel	W . . . . . watt
NORM . . . . . normal	PT . . . . . point	SQ . . . . . square	W/ . . . . . with
NORM . . . . . normal	PTM . . . . . pulse-time modulation	SWR . . . . . standing-wave ratio	WIV . . . . . working inverse voltage
NPN . . . . . negative-positive-negative	PWM . . . . . pulse-width modulation	SYNC . . . . . synchronize	WW . . . . . wirewound
NPO . . . . . negative-positive zero (zero temperature coefficient)		T . . . . . timed (slow-blow fuse)	W/O . . . . . without
NRFR . . . . . not recommended for field replacement		TA . . . . . tantalum	YIG . . . . . yttrium-iron-garnet
NSR . . . . . not separately replaceable		TC . . . . . temperature compensating	Z <sub>0</sub> . . . . . characteristic impedance
ns . . . . . nanosecond			
nW . . . . . nanowatt			
OBD . . . . . order by description			

NOTE

All abbreviations in the parts list will be in upper-case.

MULTIPLIERS

Abbreviation	Prefix	Multiple
T	tera	10 <sup>12</sup>
G	giga	10 <sup>9</sup>
M	mega	10 <sup>6</sup>
k	kilo	10 <sup>3</sup>
da	deka	10
d	deci	10 <sup>-1</sup>
c	centi	10 <sup>-2</sup>
m	milli	10 <sup>-3</sup>
μ	micro	10 <sup>-6</sup>
n	nano	10 <sup>-9</sup>
p	pico	10 <sup>-12</sup>
f	femto	10 <sup>-15</sup>
a	atto	10 <sup>-18</sup>

Table 6-3. Replaceable Parts

Reference Designation	HP Part Number	C D	Qty	Description	Mfr Code	Mfr Part Number
AT1	00608-610 5040-0232	0 1	1	ATTENUATOR PLUNGER ASSEMBLY WINDOW-DIAL ATTENUATOR	28480 28480	00608-610 5040-0232
C1				NOT ASSIGNED		
C2	0140-0071	3	2	CAPACITOR-FXD 5600PF +-1% 500VDC MICA	72136	DH30E562F0500WV1CR
C3	0140-0071	3		CAPACITOR-FXD 5600PF +-1% 500VDC MICA	72136	DH30E562F0500WV1CR
C4	0140-0085	9	1	CAPACITOR-FXD 470PF +-5% 500VDC MICA	72136	DH20E471J0500WV1CR
C5	0160-0018	0	1	CAPACITOR-FXD .22UF +-10% 400VDC	28480	0160-0018
C6	0140-0020	2	3	CAPACITOR-FXD 1800PF +-10% 500VDC MICA	72136	DH30E182K0500WV1CR
C7			7			
C13				NOT ASSIGNED		
C14	0150-0019	5	5	CAPACITOR-FDTHRU 1000PF 20% 500V CER	72982	327-005-X500-102M
C15	0150-0019	0		CAPACITOR-FDTHRU 1000PF 20% 500V CER	72982	327-005-X500-102M
C16	0150-0020	1	1	CAPACITOR-BTD0FF 100PF 10% 500V CER	28480	0150-0020
C17				TUNING CAPACITOR		
C10	0133-0001	4	4	THIS CAPACITOR IS NOT REPLACEABLE CAPACITOR-V TRMR-PBTN .5-3PF 500V (MODEL 608E)	28480	0133-0001
C19	0150-0014	5	1	CAPACITOR-FXD 5000PF +100-0% 500VDC CER	28480	0150-0014
C20	0150-0010	1	2	CAPACITOR-FXD 47PF +-5% 500VDC CER 0+-30	04222	81-27NPD-47-5
C21	0150-0010	1		CAPACITOR-FXD 47PF +-5% 500VDC CER 0+-30	04222	81-27NPD-47-5
C22	0150-0009	8	1	CAPACITOR-FXD 10PF +-1.5PF 500VDC CER	04222	C1-1NPD-10-1/2
C23	0133-0002	5		CAPACITOR-V TRMR-PBTN 1-12PF 500V	28480	0133-0002
C24	0150-0015	6	1	CAPACITOR-FXD 2.2PF +-10% 500VDC TI DIOX	28480	0150-0015
C25				NSR - PART OF U6		
C26	0150-0012	3	9	CAPACITOR-FXD .01UF +-20% 1KVDC CER	56289	C023A102J103MB3B
C27				NOT ASSIGNED		
C28	0150-0019	0		CAPACITOR-FDTHRU 1000PF 20% 500V CER	72982	327-005-X500-102M
C29				NOT ASSIGNED		
C30	0160-2236	8	1	CAPACITOR-FXD 1PF +-25PF 500VDC CER	28480	0160-2236
C31	0150-0019	0		CAPACITOR-FDTHRU 1000PF 20% 500V CER	72982	327-005-X500-102M
C32	0133-0001	4		CAPACITOR-V TRMR-PBTN .5-3PF 500V (MODEL 608F ONLY)	28480	0133-0001
C33	6080-82	8	1	CAPACITOR-FXD 60PF 10% 600VDCM	28480	6080-82
C34	0150-0012	3		CAPACITOR-FXD .01UF +-20% 1KVDC CER	56289	C023A102J103MB3B
C35	0150-0012	3		CAPACITOR-FXD .01UF +-20% 1KVDC CER	56289	C023A102J103MB3B
C36	0160-0013	5	4	CAPACITOR-FXD .1UF +-10% 400VDC	28480	0160-0013
C37				NSR - PART OF ATEN. PROBE ASSEMBLY		
C38	0140-0069	9	2	CAPACITOR-FDTHRU 500PF 10% 500V MICA	72982	666-034-01A4-551K
C39	0160-0013	5		CAPACITOR-FXD .1UF +-10% 400VDC	28480	0160-0013
C40	0180-0020	6	2	CAPACITOR-FXD 80UF+100-20% 450VDC AL	28480	0180-0020
C41	0150-0012	3		CAPACITOR-FXD .01UF +-20% 1KVDC CER	56289	C023A102J103MB3B
C42	0180-0020	6		CAPACITOR-FXD 80UF+100-20% 450VDC AL	28480	0180-0020
C43	0150-0012	3		CAPACITOR-FXD .01UF +-20% 1KVDC CER	56289	C023A102J103MB3B
C44	0150-0012	3		CAPACITOR-FXD .01UF +-20% 1KVDC CER	56289	C023A102J103MB3B
C45	0180-0019	3	1	CAPACITOR-FXD 45UF+50-10% 450VDC AL	28480	0180-0019
C46A	0180-0018	2	3	CAPACITOR-HLTSECT 10/10UF 450V THD MTC	28480	0180-0018
C46B				NOT USED; NSR - PART OF C46A		
C47				NOT ASSIGNED		
C48				NOT ASSIGNED		
C49	0150-0012	3		CAPACITOR-FXD .01UF +-20% 1KVDC CER	56289	C023A102J103MB3B
C50	0140-0020	2		CAPACITOR-FXD 1800PF +-10% 500VDC MICA	72136	DH30E182K0500WV1CR
C51	0150-0012	3		CAPACITOR-FXD .01UF +-20% 1KVDC CER	56289	C023A102J103MB3B
C52A	0180-0018	2		CAPACITOR-HLTSECT 10/10UF 450V THD MTC	28480	0180-0018
C52B				NSR - PART OF C52A		
C53	0140-0020	2		CAPACITOR-FXD 1800PF +-10% 500VDC MICA	72136	DH30E182K0500WV1CR
C54				NOT ASSIGNED		
C55	0180-0018	2		CAPACITOR-HLTSECT 10/10UF 450V THD MTC	28480	0180-0018
C56	0160-0013	5		CAPACITOR-FXD .1UF +-10% 400VDC	28480	0160-0013
C57	0150-0012	3		CAPACITOR-FXD .01UF +-20% 1KVDC CER	56289	C023A102J103MB3B
C58	0160-0013	5		CAPACITOR-FXD .1UF +-10% 400VDC	28480	0160-0013
C59	0133-0001	4		CAPACITOR-V TRMR-PBTN .5-3PF 500V	28480	0133-0001
C60	0150-0008	7	1	CAPACITOR-FXD 5PF +-1.5PF 500VDC CER	04222	C1-1N330-5-1/2
C61				NOT ASSIGNED		
C62	0180-0094	4	3	CAPACITOR-FXD 100UF+75-10% 25VDC AL	56289	30D107G025DD2
C63				NOT ASSIGNED		
C67				SPECIAL TRIMMER FINE FREQ. ADJUST		
C68	6080-59H	1	1		28480	6080-59H
C69				NSR - PART OF ATEN. PROBE ASSEMBLY		
C70	0150-0006	5	1	CAPACITOR-FXD 110PF +-20% 500VDC CER	04222	81-19NPD-110-20
C71	0160-4856	2	1	CAPACITOR-FXD 75PF +-1% 500VDC CER 0+-30	28480	0160-4856
C72	0150-0037	2	1	CAPACITOR-FXD 100PF +-1% 500VDC CER	28480	0150-0037
C73	0150-0032	7	1	CAPACITOR-FXD 10PF +-1PF 500VDC CER	28480	0150-0032

See Introduction to this section for ordering information  
 \*Indicates factory selected value



Table 6-3. Replaceable Parts

Reference Designation	HP Part Number	C D	Qty	Description	Mfr Code	Mfr Part Number
C74	0150-0019	0		CAPACITOR-FDTHRU 1000PF 20% 500V CER	72982	327-005-X5U0-102M
C75	0150-0057	6	1	CAPACITOR-FXD 16PF +-3% 500VDC CER 0+-30	28480	0150-0057
C76	0150-0121	5	1	CAPACITOR-FXD .1UF +80-20% 50VDC CER	28480	0150-0121
C77- C199				NOT ASSIGNED		
C200	0150-0096	3	3	CAPACITOR-FXD .05UF +80-20% 100VDC CER	28480	0150-0096
C201	0150-0096	3		CAPACITOR-FXD .05UF +80-20% 100VDC CER	28480	0150-0096
C202	0180-0094	4		CAPACITOR-FXD 100UF+75-10% 25VDC AL	56289	30D107G025DD2
C203	0180-0105	8	2	CAPACITOR-FXD 50UF+100-10% 25VDC AL SPOL	28480	0180-0105
C204	0180-0105	8		CAPACITOR-FXD 50UF+100-10% 25VDC AL SPOL	28480	0180-0105
C205	0180-0119	4	3	CAPACITOR-FXD 1UF+75-10% 25VDC AL	56289	30D105G025BA2
C206	0180-0119	4		CAPACITOR-FXD 1UF+75-10% 25VDC AL	56289	30D105G025BA2
C207	0140-0168	1	1	CAPACITOR-FXD 3400PF +-5% 500VDC MICA	72136	DM20F342J0500W1CR
C208	0180-0094	4		CAPACITOR-FXD 100UF+75-10% 25VDC AL	56289	30D107G025DD2
C209	0140-0176	9	2	CAPACITOR-FXD 100PF +-2% 300VDC MICA	72136	DM15F101G0300W1CR
C210	0160-0168	1	2	CAPACITOR-FXD .1UF +-10% 200VDC POLYE	28480	0160-0168
C211	0140-0176	9		CAPACITOR-FXD 100PF +-2% 300VDC MICA	72136	DM15F101G0300W1CR
C212	0160-0168	1		CAPACITOR-FXD .1UF +-10% 200VDC POLYE	28480	0160-0168
C213	0150-0096	3		CAPACITOR-FXD .05UF +80-20% 100VDC CER	28480	0150-0096
C214	0180-0117	2	1	CAPACITOR-FXD 2.7UF+-10% 35VDC TA	56289	1508273X9035B2
C215	0180-0059	1	1	CAPACITOR-FXD 100UF+75-10% 25VDC AL	56289	30D106G025BB2
C216	0180-1819	3	1	CAPACITOR-FXD 100UF+75-10% 50VDC AL	56289	30D107G030DH2
C217				NOT ASSIGNED		
C218	0150-0045	2	1	CAPACITOR-FXD 8.2PF +-5% 500VDC T1 DIOX	28480	0150-0045
C219	0150-0023	6	4	CAPACITOR-FXD 2000PF +-20% 1KVDC CER	72982	808-45U0-202H1KV
C220	0150-0023	6		CAPACITOR-FXD 2000PF +-20% 1KVDC CER	72982	808-45U0-202H1KV
C221	0150-0023	6		CAPACITOR-FXD 2000PF +-20% 1KVDC CER	72982	808-45U0-202H1KV
C222	0150-0023	6		CAPACITOR-FXD 2000PF +-20% 1KVDC CER	72982	808-45U0-202H1KV
C223	0180-0119	4		CAPACITOR-FXD 1UF+75-10% 25VDC AL	56289	30D105G025BA2
C224	0140-0069	9		CAPACITOR-FDTHRU 550PF 10% 500V MICA	72982	666-03A-01A4-551K
C225	0150-0089	4	2	CAPACITOR-FXD 4.7PF +- .25PF 500VDC CER (MODEL 608F ONLY)	28480	0150-0089
C226	0150-0089	4		CAPACITOR-FXD 4.7PF +- .25PF 500VDC CER (MODEL 608F ONLY)	28480	0150-0089
C227	0160-2295	9	1	CAPACITOR-FDTHRU 100PF 20% 500V CER (MODEL 608F ONLY)	28480	0160-2295
C228	0180-0089	7	1	(MODEL 608F ONLY)		
C229*	0160-2234	6	2	CAPACITOR-FXD 100F+50-10% 150VDC AL	56289	30D106F130DD2
				CAPACITOR-FXD .51PF +- .25PF 500VDC CER (MODEL 608F ONLY)VALUE SELECTED IN TEST	28480	0160-2234
C230*	0160-2235	7	1	(MODEL 608F ONLY)VALUE SELECTED IN TEST		
				CAPACITOR-FXD .75PF +- .25PF 500VDC CER	28480	0160-2235
C231*	0160-2234	6		(MODEL 608F ONLY)VALUE SELECTED IN TEST		
				CAPACITOR-FXD .51PF +- .25PF 500VDC CER	28480	0160-2234
CR1	1901-0518	8	1	DIODE-8M SIG SCHOTTKY	28480	1901-0518
CR2	1900-0017	0	1	DIODE-MICROWAVE 1N21B	17540	1N21B
CR3- CR6				NOT ASSIGNED		
CR7	1910-0002	4	1	DIODE-GE 1N334 100V 50MA DO-7	08257	1N33B
CR8	1901-0029	6	4	DIODE-PWR RECT 600V 750MA DO-29	28480	1901-0029
CR9	1901-0029	6		DIODE-PWR RECT 600V 750MA DO-29	28480	1901-0029
CR10	1901-0029	6		DIODE-PWR RECT 600V 750MA DO-29	28480	1901-0029
CR11	1901-0029	6		DIODE-PWR RECT 600V 750MA DO-29	28480	1901-0029
CR12	1901-0028	5	4	DIODE-PWR RECT 400V 750MA DO-29	28480	1901-0028
CR13	1901-0028	5		DIODE-PWR RECT 400V 750MA DO-29	28480	1901-0028
CR14	1901-0028	5		DIODE-PWR RECT 400V 750MA DO-29	28480	1901-0028
CR15	1901-0028	5		DIODE-PWR RECT 400V 750MA DO-29	28480	1901-0028
CR16	1901-0026	3	6	DIODE-PWR RECT 200V 750MA DO-29	28480	1901-0026
CR17	1901-0026	3		DIODE-PWR RECT 200V 750MA DO-29	28480	1901-0026
CR18	1901-0026	3		DIODE-PWR RECT 200V 750MA DO-29	28480	1901-0026
CR19	1901-0026	3		DIODE-PWR RECT 200V 750MA DO-29	28480	1901-0026
CR20	1902-3129	5	1	DIODE-ZNR 7.5V 2% DO-35 PD=.4W TC=+.05%	28480	1902-3129
CR21	1901-0025	2	5	DIODE-GEN PRP 100V 200MA DO-7	28480	1901-0025
CR22	1901-0050	3	1	DIODE-SWITCHING 80V 200MA 2NS DO-35	28480	1901-0050
CR23	1901-0025	2		DIODE-GEN PRP 100V 200MA DO-7	28480	1901-0025
CR24				NOT ASSIGNED		
CR25	1901-0025	2		DIODE-GEN PRP 100V 200MA DO-7	28480	1901-0025
CR26	1902-0227	8	1	DIODE-ZNR 22.6V 5% PD=1.5W TC=+.08%	28480	1902-0227
CR27	1901-0025	2		DIODE-GEN PRP 100V 200MA DO-7	28480	1901-0025
CR28	1902-0049	2	1	DIODE-ZNR 6.19V 5% DO-35 PD=.4W	28480	1902-0049
CR29	1901-0026	3		DIODE-PWR RECT 200V 750MA DO-29	28480	1901-0026
CR30	1901-0026	3		DIODE-PWR RECT 200V 750MA DO-29	28480	1901-0026
CR31	0122-0031	7	1	DIODE-VVC 15PF 20% C.1/C4-MIN=2.3 DO-14 (MODEL 608F ONLY)	12498	VA126

See Introduction to this section for ordering information  
\*Indicates factory selected value

Table 6-3. Replaceable Parts

Reference Designation	HP Part Number	C D	Qty	Description	Mfr Code	Mfr Part Number
CN32	0122-0031	7		DIODE-VVC 10PF 20% C.1/C4-MIN=2.3 DD-14 (MODEL 608F ONLY)	1249B	VA126
CN33	1901-0023	2		DIODE-GEN PRP 100V 200MA DD-7	28480	1901-0023
DB1	2140-0007	7	1	LAMP-INCAND 12VDC 8MA 8-6-BULB THERMAL RESISTOR RATING OF LAMP 12V 8MA. (LAMP MAY ALSO BE MARKED 8A/86 12V)	08806	8A/86-12V
DB2	1450-0013	1		LAMPHOLDER SCR-8-CAND-6XT BLDR-LUG-TERM NOT ASSIGNED	28480	1450-0013
DB3	2140-0009	9	2	LAMP-INCAND / 6.3VDC 150MA T-3-1/4-BULB (DIAL LIGHT)	1F556	47
DB4	1450-0009	1	1	LAMP SOCKET NINTR-9AY-8XT BLDR-LUG-TERM	28480	1450-0009
	2140-0009	1	1	LAMP-INCAND 47 6.3VDC 150MA T-3-1/4-BULB (POWER LIGHT)	1F556	47
	1450-0009	1	1	LAMP SOCKET NINTR-9AY-8XT BLDR-LUG-TERM	28480	1450-0009
F1	2110-0014	3	1	FUSE 4A 250V TD 1.25X.25 UL (FOR 115V OPERATION)	75915	313004
F1	2110-0006	3	1	FUSE 2A 250V TD 1.25X.25 UL (FOR 230V OPERATION)	71400	MDX-2
F2				NOT ASSIGNED		
F3	2110-0004	1	1	FUSE .25A 250V MTD 1.25X.25 UL	28480	2110-0004
FL1	00608-624	6	1	FILTER-VARICAP (MODEL 608F ONLY)	28480	00608-624
FL2	608A-27D	9	4	FILTER-D GREEN	28480	608A-27D
FL3				NOT ASSIGNED		
FL4	608A-27A	3	2	FILTER-A RED	28480	608A-27A
FL5	608A-27D	9		FILTER-D GREEN	28480	608A-27D
FL6	608D-27C	3	1	FILTER-RF (MOD, BLUE)	28480	608D-27C
FL7	608A-27A	3	1	FILTER-A RED	28480	608A-27A
FL8	608D-27B	1	1	FILTER-RF (WHITE)	28480	608D-27B
FL9	608D-60M	8	1	CHOKE-RF	28480	608D-60M
FL10	608A-27D	9		FILTER-D GREEN	28480	608A-27D
FL11	608A-27D	9		FILTER-D GREEN	28480	608A-27D
J1				NOT ASSIGNED		
J2	1250-0001	3	3	CONNECTOR-RF BNC FEM BCL-HOLE-FR 50-OHM (AM/PULSE MOD. INPUT)	28480	1250-0001
J3	1251-0071	9	1	CONNECTOR-TEL JACK 2-CKT .25-SHM-DIA (XTAL. CAL. OUTPUT)	28480	1251-0071
J4	1250-0099	9	1	CONNECTOR-RF N FEM (RF OUTPUT)	28480	1250-0099
J5	5021-0810	1	1	CONNECTOR-RECEPTACLE JACK CO-AXIAL TYPE NBR - PART OF W1	28480	5021-0810
	1250-0053	5	1	CAP-COAX TO FIT F-BNC NON-SHTG 2.5-CH	28480	1250-0053
J6	1250-0001	3		CONNECTOR-RF BNC FEM BCL-HOLE-FR 50-OHM (MODEL 608F ONLY) FREQ. CONTROL INPUT	28480	1250-0001
J7	1250-0001	3		CONNECTOR-RF BNC FEM BCL-HOLE-FR 50-OHM (MODEL 608F ONLY) FREQ. ANALOG OUTPUT	28480	1250-0001
	00608-603	1	1	TURRET OSCILLATOR ASSEMBLY (MODEL 608E ONLY)	28480	00608-603
	00608-623	5	1	OSCILLATOR TURRET ASSEMBLY (MODEL 608F ONLY)	28480	00608-623
L1				NBR - PART OF OSC. TURRET ASSEMBLY		
L2				NBR - PART OF OSC. TURRET ASSEMBLY		
L3				NBR - PART OF OSC. TURRET ASSEMBLY		
L4				NBR - PART OF OSC. TURRET ASSEMBLY		
L5				NBR - PART OF OSC. TURRET ASSEMBLY		
L6	9140-0008	5	1	COIL-VAR 10.5UH-20UH	28480	9140-0008
L7	9140-0035	8	1	COIL-VAR 10.5UH-20UH	28480	9140-0035
L8				NOT ASSIGNED		
L10				NOT ASSIGNED		
L11	608D-60K	4	1	CHOKE-RF	28480	608D-60K
	608C-60A	8	1	TURRET ASSEMBLY-AMP (MODEL 608E ONLY)	28480	608C-60A
	00608-626	8	1	AMPLIFIER TURRET ASSY (MODEL 608F ONLY)	28480	00608-626
L12				NBR - PART OF AMPLIFIER TURRET ASSEMBLY		
L17				NOT ASSIGNED		
L18	9140-0036	9		COIL-VAR 450UH-500UH	28480	9140-0036
L19				NOT ASSIGNED		
L20	9140-0096	1	1	INDUCTOR RF-CH-HLD 1UH 10% .166DX.385LC	28480	9140-0096
L21				NOT ASSIGNED		
L22	9140-0026	7	1	INDUCTOR 6.8UH 10% .188DX.688LC Q=60	28480	9140-0026
M1	1120-0396	4	1	METER (MODEL 608E ONLY) RF OUTPUT	28480	1120-0396
M1	1120-1505	9	1	METER, 50UA (MODEL 608F ONLY) RF OUTPUT	28480	1120-1505
M2	1120-0397	5	1	METER PERCENT MODULATION	28480	1120-0397
M2						

See Introduction to this section for ordering information  
 \*Indicates factory selected value

Table G.3. Replaceable Parts

Reference Designation	HP Part Number	C D	Qty	Description	Mfr Code	Mfr Part Number
P1	8120-0013	1	1	CABLE ABBY 18AWG 3-CNDCT BLK-JKT	28480	8120-0013
QY	1850-0087	7	1	TRANSISTOR PNP 2N1544 GE TO-3 PD=106W	28480	1850-0087
Q2	1854-0071	7	3	TRANSISTOR NPN 31 PD=300MW FT=200MHZ	28480	1854-0071
Q3	1854-0071	7	7	TRANSISTOR NPN 31 PD=300MW FT=200MHZ	28480	1854-0071
Q4	1854-0071	7	7	TRANSISTOR NPN 31 PD=300MW FT=200MHZ	28480	1854-0071
Q5	1854-0005	7	2	TRANSISTOR NPN 2N708 BI TO-18 PD=360MW	04713	2N708
Q6	1854-0005	7	7	TRANSISTOR NPN 2N708 BI TO-18 PD=360MW	04713	2N708
Q7	1853-0012	4	1	TRANSISTOR PNP 2N2904A BI TO-39 PD=600MW	01295	2N2904A
	1205-0011	0	1	HEAT SINK TO-5/TO-39-CB	28480	1205-0011
Q8	1854-0003	5	3	TRANSISTOR NPN 31 TO-39 PD=800MW	28480	1854-0003
	1205-0011	0		HEAT SINK TO-5/TO-39-CB	28480	1205-0011
Q9	1205-0011	0		HEAT SINK TO-5/TO-39-CB	28480	1205-0011
Q10	1854-0003	5		TRANSISTOR NPN 31 TO-39 PD=800MW	28480	1854-0003
Q11	1854-0037	7	1	TRANSISTOR NPN 2N3053B BI TO-39 PD=1W	01928	2N3053B
	1205-0011	0		HEAT SINK TO-5/TO-39-CB	28480	1205-0011
R1-				NOT ASSIGNED		
R2				NOT ASSIGNED		
R3	0727-0184	3	2	RESISTOR 28.4K 1% 1W CF TC=0-500	91637	MC81/2-2842-F
R4	0730-0058	7	2	RESISTOR 75K 1% 1W CF TC=0-500	91637	DC1-7502-F
R5	0727-0184	3		RESISTOR 28.4K 1% 1W CF TC=0-500	91637	MC81/2-2842-F
R6	0730-0058	7		RESISTOR 75K 1% 1W CF TC=0-500	91637	DC1-7502-F
R7	2100-0036	8	1	RESISTOR-VAR CONTROL CCP 1K 20% LHM	28480	2100-0036
R8	0690-1221	2	1	RESISTOR 1.2K 10% 1W CC TC=0+647	01121	CB1221
R9	0690-1541	9	4	RESISTOR 150K 10% 1W CC TC=0+882	01121	CB1541
R10	0690-1521	5	2	RESISTOR 1.5K 10% 1W CC TC=0+647	01121	CB1521
R11	0690-1051	6	6	RESISTOR 1M 10% 1W CC TC=0+1000	01121	CB1051
R12	0690-1541	9		RESISTOR 150K 10% 1W CC TC=0+882	01121	CB1541
R13				NOT ASSIGNED		
R14	0693-1231	0	1	RESISTOR 12K 10% 2W CC TC=0+765	01121	HB1231
R15-				NOT ASSIGNED		
R16				NOT ASSIGNED		
R17	0819-0003	0	1	RESISTOR 5K 5% 20W PW TC=0+-260	91637	HL20-02Z-20W-5001-J
R18				NOT ASSIGNED		
R19	0816-0006	7	1	RESISTOR 5K 5% 10W PW TC=0+-260	91637	HL12-02Z-10W-5001-J
R20				NOT ASSIGNED		
R21	0687-2741	6	1	RESISTOR 270K 10% .5W CC TC=0+882	01121	EB2741
R22	0687-5621	7	1	RESISTOR 5.6K 10% .5W CC TC=0+647	01121	EB5621
R23	0690-1031	2	1	RESISTOR 10K 10% 1W CC TC=0+765	01121	CB1031
R24	0687-1041	7	1	RESISTOR 100K 10% .5W CC TC=0+882	01121	EB1041
R25	0690-1241	6	2	RESISTOR 120K 10% 1W CC TC=0+882	01121	CB1241
R26	0690-1051	6		RESISTOR 1M 10% 1W CC TC=0+1000	01121	CB1051
R27	0690-1241	6		RESISTOR 120K 10% 1W CC TC=0+882	01121	CB1241
R28	0693-2731	7	1	RESISTOR 27K 10% 2W CC TC=0+765	01121	HB2731
R29	2100-0157	6	1	RESISTOR-VAR CONTROL CCP 1M 20% 10CM	28480	2100-0157
R30	0693-4711	7	1	RESISTOR 470 10% 2W CC TC=0+529	01121	HB4711
R31				NOT ASSIGNED		
R32				NOT ASSIGNED		
R33	0721-0006	6	2	RESISTOR 53.3 1% .1W CF TC=0-500	91637	DC1/10-53R3-F
R34	0721-0006	6		RESISTOR 53.3 1% .1W CF TC=0-500	91637	DC1/10-53R3-F
R35	0684-1211	7	1	RESISTOR 120 10% .25W FC TC=-400/+600	01121	CB1211
R36-				NOT ASSIGNED		
R37				NOT ASSIGNED		
R38	0690-1231	4	1	RESISTOR 12K 10% 1W CC TC=0+765	01121	CB1231
R39	0690-1541	9		RESISTOR 150K 10% 1W CC TC=0+882	01121	CB1541
R40	0690-1031	4	1	RESISTOR 10K 10% 1W CC TC=0+765	01121	CB1031
R41	0690-1021	0	3	RESISTOR 1M 10% 1W CC TC=0+1000	01121	CB1021
R42	0690-1051	6		RESISTOR 1M 10% 1W CC TC=0+1000	01121	CB1051
R43	0690-1541	9		RESISTOR 150K 10% 1W CC TC=0+882	01121	CB1541
R44	2100-0157	4	2	RESISTOR-VAR CONTROL CCP 50K 20% LHM	28480	2100-0157
R45	0690-2241	8	3	RESISTOR 220K 10% 1W CC TC=0+882	01121	CB2241
R46	0690-2731	1	1	RESISTOR 27K 10% 1W CC TC=0+765	01121	CB2731
R47	0693-6831	6	1	RESISTOR 68K 10% 2W CC TC=0+765	01121	HB6831
R48	0690-3331	9	1	RESISTOR 33K 10% 1W CC TC=0+765	01121	CB3331
R49	0690-1051	6		RESISTOR 1M 10% 1W CC TC=0+1000	01121	CB1051
R50	0690-1021	0		RESISTOR 1M 10% 1W CC TC=0+1000	01121	CB1021
R51	0690-1051	6		RESISTOR 1M 10% 1W CC TC=0+1000	01121	CB1051
R52	0690-2241	8		RESISTOR 220K 10% 1W CC TC=0+882	01121	CB2241
R53	2100-0157	4		RESISTOR-VAR CONTROL CCP 50K 20% LHM	28480	2100-0157
R54	0690-2241	8		RESISTOR 220K 10% 1W CC TC=0+882	01121	CB2241
R55				NOT ASSIGNED		
R56	0687-4741	0	2	RESISTOR 470K 10% .5W CC TC=0+882	01121	EB4741
R57	0687-5601	3	2	RESISTOR 56 10% .5W CC TC=0+412	01121	EB5601
R58	0690-8201	2	2	RESISTOR 82 10% 1W CC TC=0+412	01121	CB8201
R59	0690-8201	2	2	RESISTOR 82 10% 1W CC TC=0+412	01121	CB8201
R60	0693-2231	2	4	RESISTOR 22K 10% 2W CC TC=0+765	01121	HB2231
R61	0690-8231	8	2	RESISTOR 82K 10% 1W CC TC=0+765	01121	CB8231

See introduction to this section for ordering information  
 \*Indicates factory selected value



Table 6-3. Replaceable Parts

Reference Designation	HP Part Number	C D	Qty	Description	Mfr Code	Mfr Part Number
R94	0687-4741	0		RESISTOR 470K 10% .5W CC TC=0+882	01121	EB4741
R95	0687-5681	3		RESISTOR 56 10% .5W CC TC=0+412	01121	EB5681
R96	0690-1511	3	1	RESISTOR 150 10% 1W CC TC=0+529	01121	CB1511
R97	0693-2231	2		RESISTOR 22K 10% 2W CC TC=0+765	01121	HB2231
R98	0690-8231	8		RESISTOR 82K 10% 1W CC TC=0+765	01121	CB8231
R99	0690-1821	8	1	RESISTOR 1.8K 10% 1W CC TC=0+647	01121	CB1821
R100	0690-1061	8	1	RESISTOR 10K 10% 1W CC TC=0+1059	01121	CB1061
R101	0690-1031	6		RESISTOR 1M 10% 1W CC TC=0+1060	01121	CB1051
R102	0693-2231	2		RESISTOR 22K 10% 2W CC TC=0+765	01121	HB2231
R103				NOT ASSIGNED		
R104	2100-0156	3	2	RESISTOR-VAR CONTROL CCP 10K 20% LIN	28480	2100-0156
R105	0690-2211	2	1	RESISTOR 220 10% 1W CC TC=0+529	01121	CB2211
R106	2100-0156	3		RESISTOR-VAR CONTROL CCP 10K 20% LIN	28480	2100-0156
R107	0693-2231	2		RESISTOR 22K 10% 2W CC TC=0+765	01121	HB2231
R108				NOT ASSIGNED		
R113				NOT ASSIGNED		
R114				MR - PART OF FL9		
R115	0690-5631	6		RESISTOR 56K 10% 1W CC TC=0+765	01121	CB5631
R116				NOT ASSIGNED		
R117				NOT ASSIGNED		
R118	0690-1021	8		RESISTOR 1K 10% 1W CC TC=0+647	01121	CB1021
R119	0690-1521	5		RESISTOR 1.5K 10% 1W CC TC=0+647	01121	CB1521
R120				NOT ASSIGNED		
R121				NOT ASSIGNED		
R122	0687-1021	3	1	RESISTOR 1K 10% .5W CC TC=0+647	01121	EB1021
R123	0687-2731	4	1	RESISTOR 27K 10% .5W CC TC=0+765	01121	EB2731
R124	0818-0027	6	1	RESISTOR 60 5% 40W PM TC=0+-260	91637	HL35-08Z-40W-60R-J
R125	0819-0022	3	1	RESISTOR 50 5% 20W PM TC=0+-260	35434	CA20
R126				NOT ASSIGNED		
R128				NOT ASSIGNED		
R129	0813-0029	8	1	RESISTOR 1 3% 3W PM TC=0+-50	28480	0813-0029
R130				NOT ASSIGNED		
R199				NOT ASSIGNED		
R200	0757-0429	2	2	RESISTOR 1.82K 1% .125W F TC=0+-100	24546	C4-1/8-T0-1821-F
R201	0757-0439	4	1	RESISTOR 6.81K 1% .125W F TC=0+-100	24546	C4-1/8-T0-6811-F
R202	2100-0092	6	1	RESISTOR-VAR CONTROL CP 10K 20% LIN	28480	2100-0092
R203	0757-0854	7	2	RESISTOR 56.2K 1% .5W F TC=0+-100	28480	0757-0854
R204	2100-0151	8	1	RESISTOR-VAR CONTROL CP 500 20% LIN	28480	2100-0151
R205	0757-0442	9	4	RESISTOR 10K 1% .125W F TC=0+-100	24546	C4-1/8-T0-1002-F
R206	0757-0442	9	9	RESISTOR 10K 1% .125W F TC=0+-100	24546	C4-1/8-T0-1002-F
R207	0757-0288	3	3	RESISTOR 1K 1% .125W F TC=0+-100	24546	C4-1/8-T0-1001-F
R208	0757-0465	6	2	RESISTOR 100K 1% .125W F TC=0+-100	24546	C4-1/8-T0-1003-F
R209	2100-0281	5	1	RESISTOR-TRMR 100 20% MW TOP-ADJ 1-TRM	28480	2100-0281
R210	2100-0235	9	1	RESISTOR-VAR CONTROL CCP 500 20% LIN	28480	2100-0235
R211	0757-0477	0	1	RESISTOR 332K 1% .125W F TC=0+-100	19701	MFAC1/8-T0-3323-F
R212	2100-1619	5	2	RESISTOR-VAR DUAL 5K-20K-CC 50K-20K-CC	28480	2100-1619
R213	0757-0464	5	1	RESISTOR 90.9K 1% .125W F TC=0+-100	24546	C4-1/8-T0-9092-F
R214	0757-0407	6	2	RESISTOR 200 1% .125W F TC=0+-100 (MODEL 408E ONLY)	24546	C4-1/8-T0-201-F
R214	0757-0413	4	1	RESISTOR 392 1% .125W F TC=0+-100 (MODEL 408F ONLY)	24546	C4-1/8-T0-392R-F
R215	0757-0419	0	1	RESISTOR 681 1% .125W F TC=0+-100	24546	C4-1/8-T0-681R-F
R216	0757-0441	8	1	RESISTOR 8.25K 1% .125W F TC=0+-100	24546	C4-1/8-T0-8251-F
R217	0757-0430	5	2	RESISTOR 2.21K 1% .125W F TC=0+-100	24546	C4-1/8-T0-2211-F
R218	0757-0485	4	2	RESISTOR 162 1% .125W F TC=0+-100	24546	C4-1/8-T0-162R-F
R219	0757-0281	4	2	RESISTOR 2.74K 1% .125W F TC=0+-100	24546	C4-1/8-T0-2741-F
R220	0757-0437	2	2	RESISTOR 4.75K 1% .125W F TC=0+-100	24546	C4-1/8-T0-4751-F
R221	0757-0280	7	1	RESISTOR 5.62K 1% .125W F TC=0+-100	24546	C4-1/8-T0-5621-F
R222	0757-0281	4	4	RESISTOR 2.74K 1% .125W F TC=0+-100	24546	C4-1/8-T0-2741-F
R223	0757-0280	3	3	RESISTOR 1K 1% .125W F TC=0+-100	24546	C4-1/8-T0-1001-F
R224	0757-0280	3	3	RESISTOR 1K 1% .125W F TC=0+-100	24546	C4-1/8-T0-1001-F
R225	0757-0430	5		RESISTOR 2.21K 1% .125W F TC=0+-100	24546	C4-1/8-T0-2211-F
R226	2100-1619	5		RESISTOR-VAR DUAL 5K-20K-CC 50K-20K-CC	28480	2100-1619
R227				NOT ASSIGNED		
R228	0757-0852	5	1	RESISTOR 47.5K 1% .5W F TC=0+-100	28480	0757-0852
R229	0757-0429	2		RESISTOR 1.82K 1% .125W F TC=0+-100	24546	C4-1/8-T0-1821-F
R230	0757-0811	6	1	RESISTOR 392 1% .5W F TC=0+-100	28480	0757-0811
R231	0684-1001	3	2	RESISTOR 10 10% .25W FC TC=-400/+500	01121	CB1001
R232	0684-1001	3		RESISTOR 10 10% .25W FC TC=-400/+500	01121	CB1001
R233	0757-0444	1	1	RESISTOR 12.1K 1% .125W F TC=0+-100	24546	C4-1/8-T0-1212-F
R234				NOT ASSIGNED		
R235	0687-6841	5	1	RESISTOR 680K 10% .5W CC TC=0+882	01121	EB6841
R236	0757-0434	9	1	RESISTOR 3.65K 1% .125W F TC=0+-100	24546	C4-1/8-T0-3651-F
R237	0698-4477	2	1	RESISTOR 10.5K 1% .125W F TC=0+-100	24546	C4-1/8-T0-1052-F
R238	0757-0290	5	1	RESISTOR 6.19K 1% .125W F TC=0+-100	19701	MFAC1/8-T0-6191-F
R239	0757-0854	7		RESISTOR 56.2K 1% .5W F TC=0+-100	28480	0757-0854

See introduction to this section for ordering information  
 \*Indicates factory selected value

Table 6-3. Replaceable Parts

Reference Designation	HP Part Number	C D	Qty	Description	Mfr Code	Mfr Part Number
R240	0757-0346	2	1	RESISTOR 10 1X .125W F TC=0+-100	24546	C4-1/8-T0-18R0-F
R241	0757-0410	1	2	RESISTOR 301 1X .125W F TC=0+-100	24546	C4-1/8-T0-301R-F
R242	0694-3901	6	1	RESISTOR 39 10X .25W FC TC=-400/+500	01121	CB3901
R243	0757-0411	2	1	RESISTOR 332 1X .125W F TC=0+-100	24546	C4-1/8-T0-332R-F
R244	0698-3430	6	1	RESISTOR 21.5 1X .125W F TC=0+-100	03868	PM55-1/8-T0-21R5-F
R245	0684-1511	0	1	RESISTOR 150 10X .25W FC TC=-400/+400	01121	CB1511
R246	0757-0197	1	2	RESISTOR 1.5K 1X .5W F TC=0+-100	28480	0757-0197
R247	0757-0197	1	1	RESISTOR 1.5K 1X .5W F TC=0+-100	28480	0757-0197
R248	0757-0841	2	1	RESISTOR 12.1K 1X .5W F TC=0+-100	28480	0757-0841
R249	0757-0801	4	1	RESISTOR 150 1X .5W F TC=0+-100	28480	0757-0801
R250	0757-0276	7	1	RESISTOR 61.9 1X .125W F TC=0+-100	24546	C4-1/8-T0-6192-F
R251	0757-0410	1	1	RESISTOR 301 1X .125W F TC=0+-100 (MODEL 608E ONLY)	24546	C4-1/8-T0-301R-F
R251	0757-0407	6	1	RESISTOR 200 1X .125W F TC=0+-100 (MODEL 608F ONLY)	24546	C4-1/8-T0-201-F
R252	0757-0394	0	1	RESISTOR 51.1 1X .125W F TC=0+-100	24546	C4-1/8-T0-51R1-F
R253	0761-0021	9	1	RESISTOR 1K 5X 1W MO TC=0+-200	28480	0761-0021
R254	0761-0058	2	1	RESISTOR 750 5X 1W MO TC=0+-200	28480	0761-0058
R255	0816-0032	9	1	RESISTOR 4K 5X 10W FM TC=0+-260	91637	HL12-022-10W-4001-J
R256	0812-0058	3	1	RESISTOR 3K 5X 5W FM TC=0+-20	28480	0812-0058
R257	0727-0002	4	1	RESISTOR 3 1X .5W CF TC=0-500	28480	0727-0002
R258	0690-1841	2	1	RESISTOR 180K 10X 1W CC TC=0+892 NOT ASSIGNED	01121	CB1841
R259	0812-0038	7	1	RESISTOR 8.66K 3X 5W FM TC=0+-20	28480	0812-0038
R260	0757-0457	6	2	RESISTOR 47.5K 1X .125W F TC=0+-100	24546	C4-1/8-T0-4752-F
R262	0757-0465	6	6	RESISTOR 100K 1X .125W F TC=0+-100	24546	C4-1/8-T0-1003-F
R263	0757-0457	6	6	RESISTOR 47.5K 1X .125W F TC=0+-100	24546	C4-1/8-T0-4752-F
R264	0757-0442	9	1	RESISTOR 10K 1X .125W F TC=0+-100 (MODEL 608F ONLY)	24546	C4-1/8-T0-1002-F
R265	0757-0442	9	1	RESISTOR 10K 1X .125W F TC=0+-100 (MODEL 608F ONLY)	24546	C4-1/8-T0-1002-F
R266	0757-0437	2	1	RESISTOR 4.75K 1X .125W F TC=0+-100 (MODEL 608F ONLY)	24546	C4-1/8-T0-4751-F
R267	0698-3415	6	1	RESISTOR 19.6K 1X .5W F TC=0+-100 (MODEL 608F ONLY)	28480	0698-3415
R268	0757-0833	2	1	RESISTOR 5.11K 1X .5W F TC=0+-100 (MODEL 608F ONLY)	28480	0757-0833
R269	2100-1750	5	1	RESISTOR-VAR CONTROL CCP 4K 10X S-LIN (MODEL 608F ONLY)	28480	2100-1750
R270	0757-0485	4	1	RESISTOR 162 1X .125W F TC=0+-100	24546	C4-1/8-T0-162R-F
R271	0757-0838	7	1	RESISTOR 9.09K 1X .5W F TC=0+-100 (MODEL 608F ONLY)	28180	0757-0838
R272	0816-0002	3	1	RESISTOR 3K 5X 10W FM TC=0+-260	91637	HL12-022-10W-3001-J
RF1	9170-0029	3	1	CORE-SHIELDING BEAD	28480	9170-0029
S1				NOT ASSIGNED		
S2	3101-0033	8	1	SWITCH-8L DPDT 8TD .5A 125VAC/DC	28480	3101-0033
S3	3101-0003	2	1	SWITCH-TCL BASIC DPST 3A 250VAC/DC	04009	81024-CB
S4	3101-0012	3	1	SWITCH-TCL BASIC DPDT 10A 250VAC (XTAL CAL)	28480	3101-0012
S5				NOT ASSIGNED		
S6	3102-0006	7	1	SWITCH-SENS SPDT 8UDMIN 1A 30VDC	28480	3102-0006
S7	00608-60047	1	1	SWITCH-MOD SELECTOR ASSEMBLY (INCLUDES C205 AND R262)	28480	00608-60047
T1	9100-2289	4	1	TRANSFORMER-POWER 115/230V; FREQ NOT	28480	9100-2289
T2	9100-0342	6	1	TRANSFORMER-POWER 115/230V 50-1000HZ	28480	9100-0342
T3	9120-0018	5	1	TRANSFORMER-AUDIO PA1 1HP; 15KOHMS; SEC	28480	9120-0018
U1				NOT ASSIGNED		
U2A	1932-0066	6	1	TUBE-ELECTRON 12AU7 TRIODE-DUAL	33173	12AU7
U2B	1932-0066	6	1	NER - PART OF U2A	33173	12AU7
U3				NOT ASSIGNED		
U4	1921-0001	6	1	TUBE-ELECTRON 4042 TRIODE	28480	1921-0001
U5	1200-0010	9	2	SOCKET-TUBE 2-CONT	28480	1200-0010
U6	6080-59A-4	9	1	SOCKET-OSCILLATOR GRID	28480	6080-59A-4
U7	6080-59A-3	7	1	SOCKET-OSCILLATOR TUBE	28480	6080-59A-3
U8	612A-38A	2	2	WRENCH-TUBE	28480	612A-38A
U9				NOT ASSIGNED		
U10	1921-0002	7	1	TUBE-ELECTRON 4043 TRIODE	28480	1921-0002
U11	1200-0010	9	1	SOCKET-TUBE 2-CONT	28480	1200-0010
U12	6080-58A	6	1	CONTACT-AMP GRID	28480	6080-58A
U13	612A-38A	2	1	WRENCH-TUBE	28480	612A-38A
U14				NOT ASSIGNED		
U15	1933-0013	5	1	TUBE-ELECTRON 608A TRIODE-PENTODE	01928	608A
U16	1932-0027	9	2	TUBE-ELECTRON 12AT7 TRIODE-DUAL	24972	12AT7WA
U17				NOT USED		
U18	1200-0008	9	1	SOCKET-TUBE 9-CONT	28480	1200-0008
U19	1932-0027	9	1	TUBE-ELECTRON 12AT7 TRIODE-DUAL	24972	12AT7WA
U20	1200-0008	5	1	SOCKET-TUBE 9-CONT	28480	1200-0008

See introduction to this section for ordering information  
 \*Indicates factory selected value

Table 6-3. Replaceable Parts

Reference Designation	HP Part Number	C	D	Qty	Description	Mfr Code	Mfr Part Number
V12	1923-0021	4	2	2	TUBE-ELECTRON 6AU6A/B425A PENTODE	33173	6AU6A
	1200-0009	6	6	6	SOCKET-TUBE 7-CONT BLDR-EYE	28480	1200-0009
V13A	1932-0010	0	2	2	TUBE-ELECTRON 6080 TRIODE-DUAL	0192B	6080
V13B					NSA - PART OF V13A		
	1200-0005	2	1	1	SOCKET-TUBE 8-CONT BLDR-EYE	28480	1200-0005
V14	1923-0021	4	2	2	TUBE-ELECTRON 6AU6A/B425A PENTODE	33173	6AU6A
	1200-0009	6	6	6	SOCKET-TUBE 7-CONT BLDR-EYE	28480	1200-0009
V15	1940-0001	6	1	1	TUBE-ELECTRON 5651A DIODE-V RCLTR	0192B	5651A
	1200-0009	6	6	6	SOCKET-TUBE 7-CONT BLDR-EYE	28480	1200-0009
V16A	1932-0010	0	2	2	TUBE-ELECTRON 6080 TRIODE-DUAL	0192B	6080
V16B					NSA - PART OF V16A		
	1200-0005	2	1	1	SOCKET-TUBE 8-CONT BLDR-EYE	28480	1200-0005
V17					NOT ASSIGNED		
V18	1923-0017	8	2	2	TUBE-ELECTRON 6AH6 PENTODE	33173	6AH6
	1200-0009	6	6	6	SOCKET-TUBE 7-CONT BLDR-EYE	28480	1200-0009
V19	1923-0017	8	2	2	TUBE-ELECTRON 6AH6 PENTODE	33173	6AH6
	1200-0009	6	6	6	SOCKET-TUBE 7-CONT BLDR-EYE	28480	1200-0009
V20	1930-0013	9	1	1	TUBE-ELECTRON 6AL5 DIODE-DUAL	33173	6AL5
	1200-0009	6	6	6	SOCKET-TUBE 7-CONT BLDR-EYE	28480	1200-0009
V21A	1932-0029	1	1	1	TUBE-ELECTRON 12AU7 TRIODE-DUAL	0003J	12AU7
V21B					NSA - PART OF V21A		
	1200-0008	5	1	1	SOCKET-TUBE 9-CONT	28480	1200-0008
V22	1921-0036	7	1	1	TUBE-ELECTRON EC8010 TRIODE	28480	1921-0036
	1200-0019	8	1	1	SOCKET-TUBE 9-CONT	28480	1200-0019
W1	00608-60037	9			CABLE-UNCAL OUTPUT ASSEMBLY	28480	00608-60037
XF1	1400-0090	9	1	1	FUSEHOLDER COMPONENT FOR USE ON	28480	1400-0090
	2110-0470	5	1	1	FUSEHOLDER BODY EXTR PBT; BAYONET; TND	75915	345003-010
	2110-0465	8	1	1	FUSEHOLDER CAP EXTR PBT; BAYONET; 20A	28480	2110-0465
	2110-0467	0	1	1	FUSEHOLDER COMPONENT HEX NUT; 1/2-20	28480	2110-0467
					NOTE		
					IF ANY PART OF THE OLD FUSEHOLDER (1400-0090) NEEDS REPLACING, ALL FOUR PARTS OF THE NEW FUSEHOLDER MUST BE ORDERED. THE OLD FUSEHOLDER CAN BE IDENTIFIED BY A STRAIGHT SOLDER LUG TO WHICH THE WHITE-BLACK-GRAY WIRE ATTACHES. ON THE NEW FUSEHOLDER THE SOLDER LUG IS AT A RIGHT ANGLE TO THE BODY.		
XY1	1200-0028	9	1	1	SOCKET-XTAL, 2-CONT	28480	1200-0028
Y1	0410-0009	0	1	1	CRYSTAL-QUARTZ 5.000 MHZ	28480	0410-0009
					MISCELLANEOUS PARTS		
	608C-40A	4	1	1	ATTENUATOR DIAL ASSEMBLY	28480	608C-40A
	00608-610	0	2	2	ATTENUATOR PLUNGER ASSEMBLY	28480	00608-610
	00608-60044	8	1	1	BOARD-RESISTOR ASSEMBLY	28480	00608-60044
	00608-60045	9	1	1	BOARD-RESISTOR ASSEMBLY	28480	00608-60045
	00608-60046	0	1	1	BOARD-RECTIFIER ASSEMBLY	28480	00608-60046
	00608-60041	5	1	1	ATTENUATOR TUBE ASSEMBLY	28480	00608-60041
	00608-604	2	1	1	ASSEMBLY-RESISTOR RECTIFIER BOARD	28480	00608-604
	00608-613	3	1	1	BOARD-RESISTOR ASSEMBLY	28480	00608-613
	00608-614	4	1	1	BOARD-RESISTOR ASSEMBLY	28480	00608-614
	00608-601	9	1	1	ALC BOARD ASSEMBLY (MODEL 608E ONLY)	28480	00608-601
	00608-00024	8	1	1	WASHER-GROUNDING	28480	00608-00024
	00608-625	7	2	2	BOARD-VARICAP ASSEMBLY	28480	00608-625
	00608-625	7	1	1	BOARD-VARICAP ASSEMBLY (MODEL 608F ONLY)	28480	00608-625
	00608-602	0	1	1	BUFFER ASSEMBLY (MODEL 608E ONLY)	28480	00608-602
	00608-622	4	1	1	BUFFER ASSEMBLY (MODEL 608F ONLY)	28480	00608-622
	608D-44B	6	1	1	CABINET ASSEMBLY	28480	608D-44B
	608D-44R	8	1	1	CABINET ASSEMBLY-RACK	28480	608D-44R
	608D-16J	8	1	1	CABLE-CRYSTAL CALIBRATOR	28480	608D-16J
	608D-16R	4	1	1	CABLE-CRYSTAL CALIBRATOR ADJUST	28480	608D-16R
	00608-606	4	1	1	CABLE-POWER HARNESS	28480	00608-606
	00608-607	5	1	1	CABLE-PANEL HARNESS	28480	00608-607
	00608-611	1	1	1	CABLE-LEVELLER INPUT	28480	00608-611
	00608-612	2	1	1	CABLE-LEVELLER OUTPUT	28480	00608-612
	00608-60037	9	2	2	CABLE-UNCAL OUTPUT ASSEMBLY	28480	00608-60037
	608D-40C	0	1	1	DIAL-FREQUENCY VERNIER	28480	608D-40C
	00608-600	8	1	1	GENERATOR ASSEMBLY (MODEL 608E ONLY)	28480	00608-600
	00608-620	2	1	1	GENERATOR ASSEMBLY (MODEL 608F ONLY)	28480	00608-620
	0370-0025	4	1	1	KNOB RND;BLK;FDR .250 SHFT;1.750D (XTAL CAL GAIN)	28480	0370-0025
	0370-0026	5	1	1	KNOB RND;BLK;FDR .250 SHFT;1.1 ARO;1.750D	28480	0370-0026

See introduction to this section for ordering information  
 \*Indicates factory selected value



Table 6-3. Replaceable Parts

Reference Designation	HP Part Number	C D	Qty	Description	Mfr Code	Mfr Part Number
	0370-0028	7	1	(FINE FREQUENCY) KNOB RND:BLK:FOR .250 SHFT:1.000	28480	0370-0028
	0370-0029	8	1	(MOD METER AND RF OUTPUT) KNOB RND:BLK:FOR .250 SHFT:1 ARD:1.000 (AMPLIFIER TRIMMER)	28480	0370-0029
	0370-0035	6	1	KNOB BRTD:BAR:BLK:FOR .250SHT:1.000D (MOD SWITCH)	28480	0370-0035
	0370-0049	2	1	KNOB BRTD:BAR:BLK:FOR .375SHT:1.000D (FREQUENCY RANGE)	28480	0370-0049
	0370-0050	5	1	KNOB RND:BLK:375D:CRANK SPINNER	28480	0370-0050
	608D-83C0	7	1	WINDOW-FREQ. DIAL	28480	608D-83C0
	612A-38A	2		WRENCH-TUBE	28480	612A-38A

See introduction to this section for ordering information  
 \*Indicates factory selected value

Table 6-4. Code List of Manufactures

Mfr Code	Manufacturer Name	Address	Zip Code
00037	NIPPON ELECTRIC CO	MILWAUKEE WI	53204
01121	ALLEN-BRADLEY CO	DALLAS TX	75222
01295	TEXAS INSTR INC SEMICOND CMPNY DIV	SOMERVILLE NJ	08876
01928	NCA CORP SOLID STATE DIV	WHIPPANY NJ	07981
03888	KDI PYROFILM CORP	HARTFORD CT	06106
04089	ARROW-HART INC	MYRTLE BEACH SC	29577
04222	AVX CERAMICS CORP	PHOENIX AZ	85062
04713	MOTOROLA SEMICONDUCTOR PRODUCTS	CANOGA PARK CA	91304
08257	NPE ELECTRONICS	CLEVELAND OH	44112
08866	GE CO MINIATURE LAMP PROD DEPT	MOUNTAIN VIEW CA	94040
1F556	PRECISION LAMP INC	CAMBRIDGE MA	02148
12478	TELEDYNE INC CRYSTALONICS DIV	WOBURN MA	01801
17548	ALPHA INDUSTRIES INC	MINERAL WELLS TX	76067
19701	MEPCO/ELECTRA CORP	BRADFORD PA	16701
24546	CORNING GLASS WORKS (BRADFORD)	ENGLEWOOD NJ	07632
24772	AEG-TELEFUNKEN CORP	PALO ALTO CA	94304
28480	HEWLETT-PACKARD CO CORPORATE HQ	OMENSBORO KY	42301
33173	GE CO TUBE DEPT	CHICAGO IL	60630
35434	LECTRONM INC	NORTH ADAMS MA	01247
56289	SPRAGUE ELECTRIC CO	ST LOUIS MO	63107
71480	DUBSHAN MFG DIV OF MCGRAW-EDISON CO	WILLIAMTIC CT	06226
72136	ELECTRO MOTIVE CORP SUB IEC	ERIE PA	16512
72982	ERIE TECHNOLOGICAL PRODUCTS INC	DES PLAINES IL	60016
75915	LITTELFUSE INC	COLUMBUS NE	68601
91637	DALE ELECTRONICS INC		

# **SCHEMATIC DIAGRAMS**



## SECTION VII SCHEMATIC DIAGRAMS COMPONENT LOCATION INFORMATION

### 7-1. INTRODUCTION.

7-2. Schematic presentations in this manual show electrical circuit operation and are not intended to serve as wiring diagrams. Figure 7-1 shows an example of the schematic illustrations. Figure 7-2 lists notes which apply to the schematic diagrams.

7-3. Circuit board assemblies are shown in part on different pages. To find a specific instrument

component, refer to the "REFERENCE DESIGNATIONS" box which appears on each schematic diagram.

7-4. Component procurement information and specific component descriptions are included in Section VI. Refer to page 6-1 for information on how to order parts.

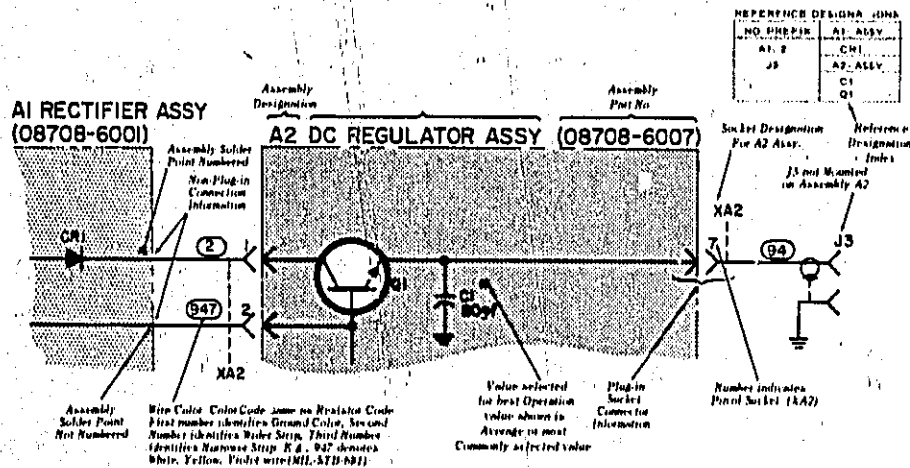

Figure 7-1. Schematic Information Illustration











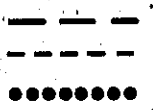

1. Resistance is in ohms, capacitance is in microfarads unless otherwise noted.
2.  Screwdriver adjustment.
-  Panel control.
3.  Encloses front panel designations.
4.  Signal path.
-  Denotes feedback paths, used in different circuits.
5.  Circuit assembly borderline.
6.  Wiper moves toward CW with clockwise rotation of control as viewed from shaft or knob.
7.  Test point. Number in circle matches TP number.
10.  Encloses wire color code. Code used (MIL-STD-681) is the same as the resistor color code. First number identifies the base color, second number the wider strip, and the third number identifies the narrow strip. E G.,  denotes white base, yellow wide stripe, violet narrow stripe.
11.  Voltage regulator (breakdown) diode.
12.  Feed-through capacitor (shunt capacitor, commonly used for bypassing high frequency currents to chassis).

Figure 7-2. Schematic Diagram Notes

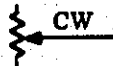
- NOTES:
- 1 INSTALLED IN MODEL 608F ONLY.
  - 2 VALUE SELECTED IN TEST-NOMINAL VALUE SHOWN.
  - 3 R214 IS 200 OHMS IN MODEL 608E AND 392 OHMS IN MODEL 608F.
  - 4 R251 IS 301 OHMS IN MODEL 608E AND 200 OHMS IN MODEL 608F.
  - 5 C25 IS NSR: PART OF V6.
  - 6 R114 IS NSR: PART OF FL9.
  - 7 C37 AND C69 ARE NSR: PART OF AT1.
  - 8 LI7 IS N.I.F. PAIR: 1/2 BOLOMETER.
  - 9 INDICATED VOLTAGES-1MC PULSE SET RF OUTPUT MODE.

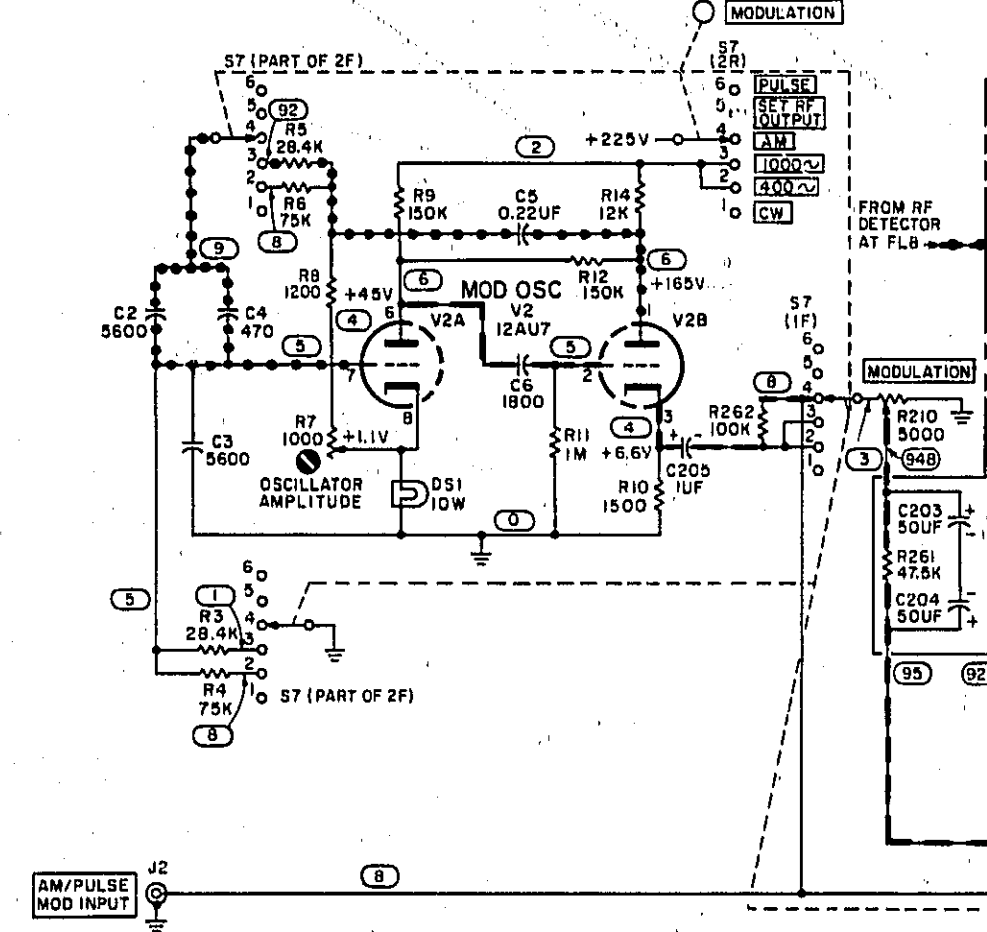
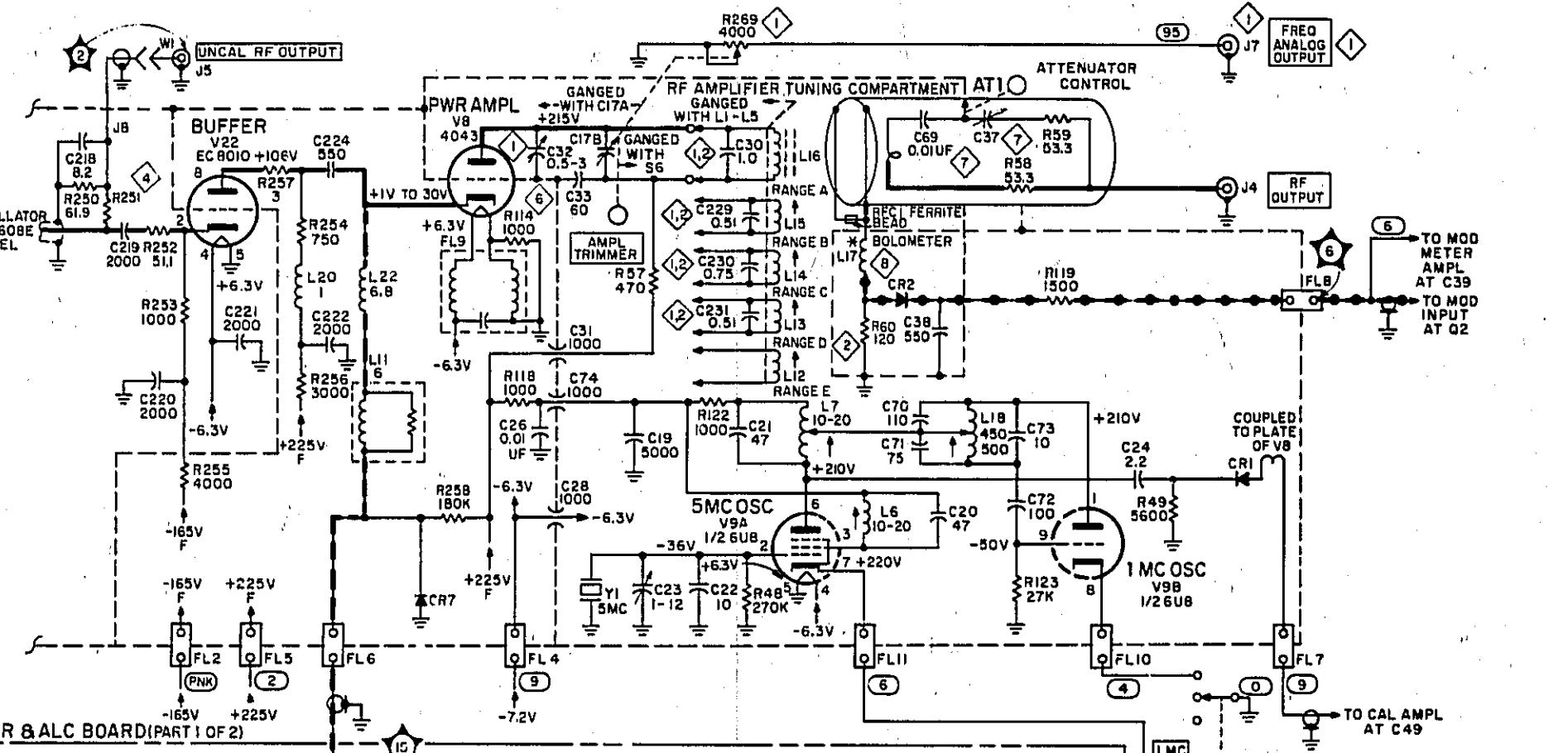
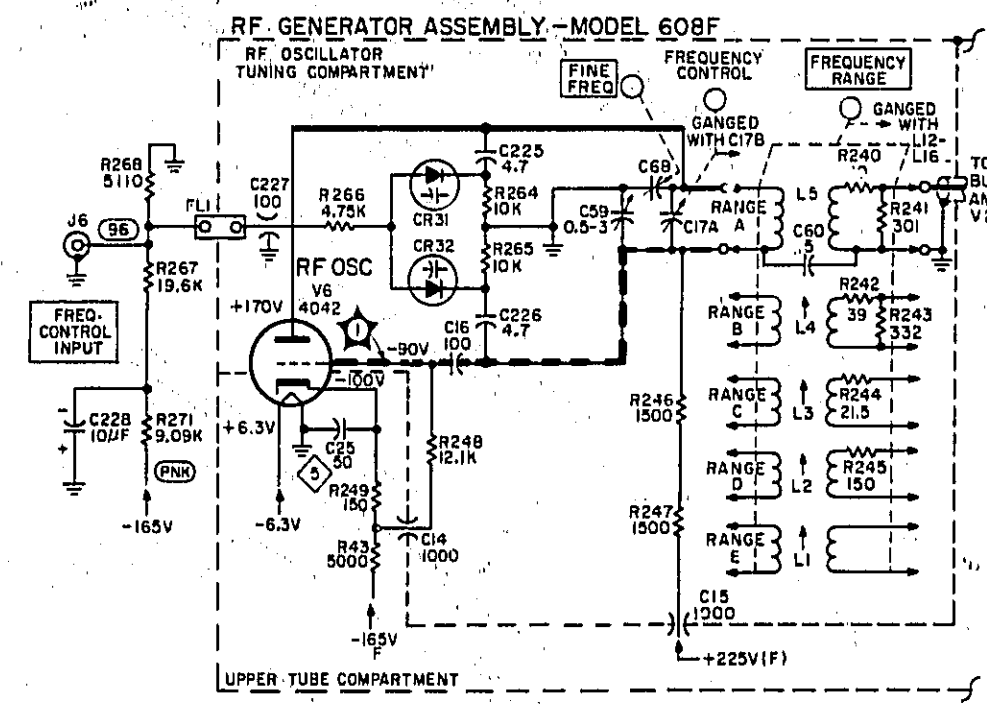
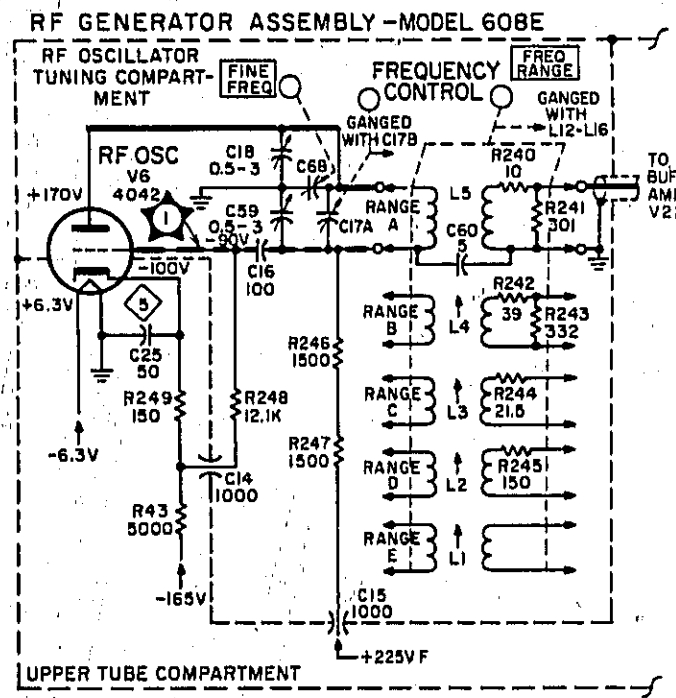

REFERENCE DESIGNATIONS

AT1	6, 14-17, 19-26, 28, 30-33, 37, 38, 59, 60
CPI	61, 68-74, 200-213, 216-227
CR1	2, 7, 21-23, 25, 26, 31-33
FL 2-II	
I1	
J2, 4, 5, 8	
L1-7, 11-18, 20, 22	
M	
M2-9	
R3-11, 14, 33, 43, 48, 49, 57-60, 114, 118, 119	
R122, 123, 200-233, 235, 240-258, 261-270	
S 4, 6, 7	
W1	
Y1	

DELETED: CR24, R227, R128

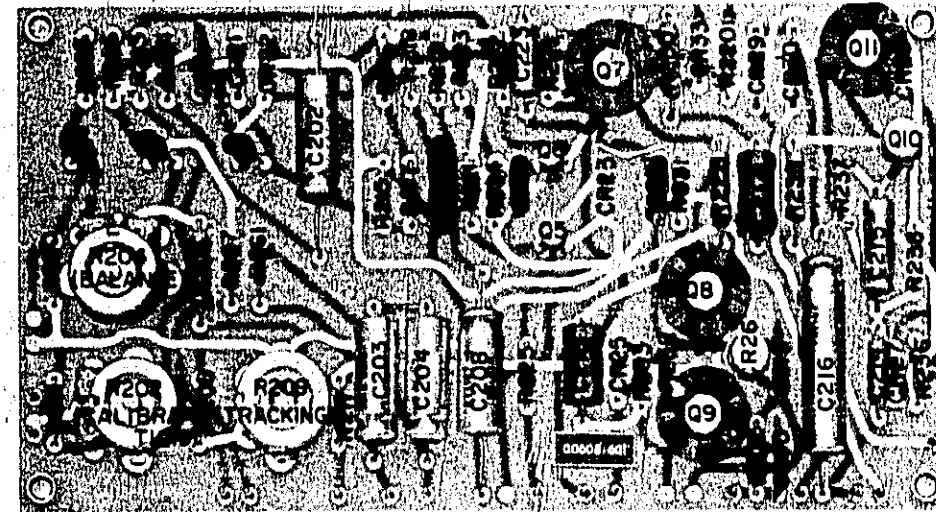
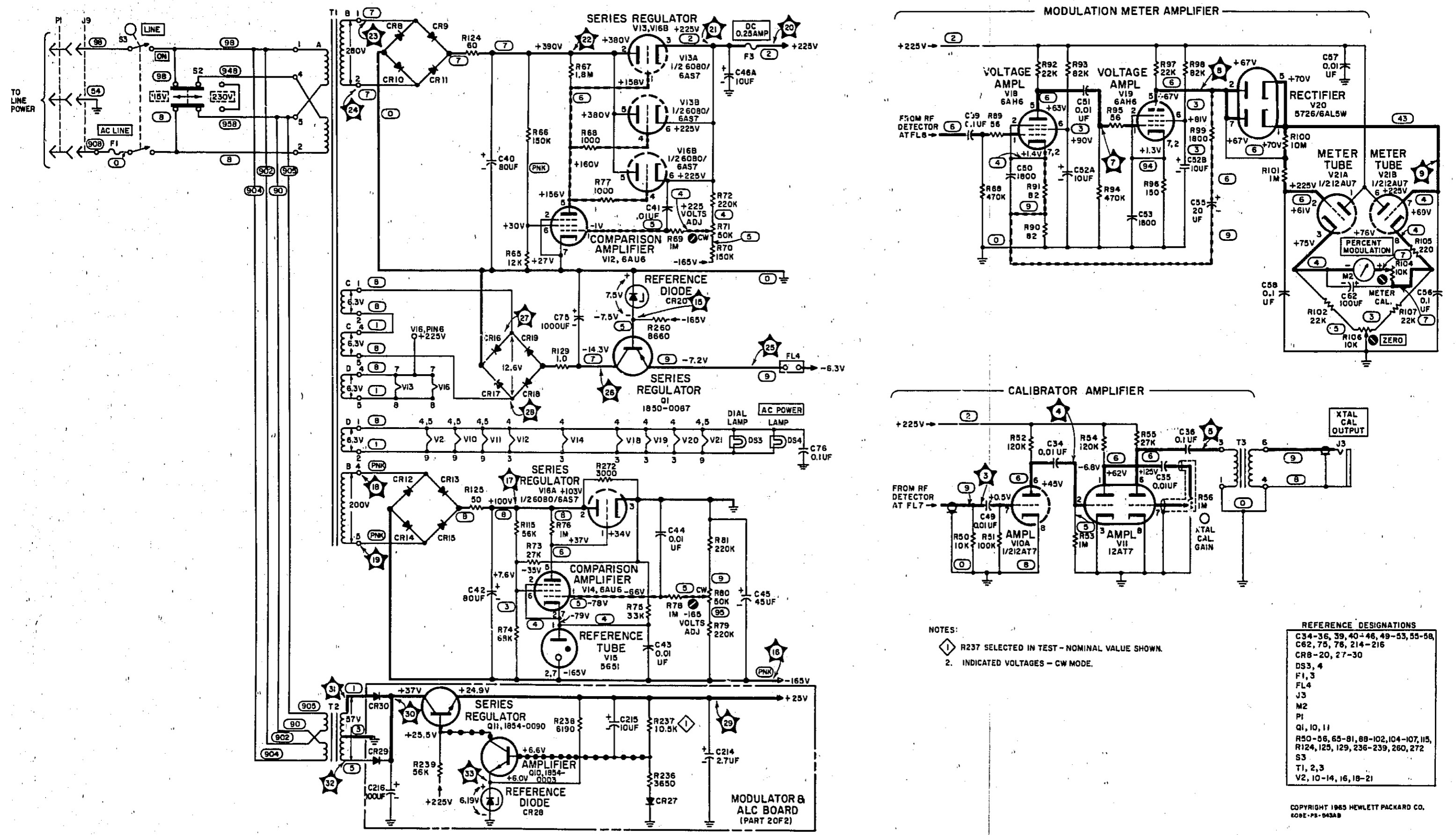

Figure 7-3. Component Identification, Modulation and ALC Board

COPYRIGHT 1965 BY HEWLETT-PACKARD CO. 638C-RF GEN-243A

Figure 7-4. RF Generator and Modulator Schematic Diagram





NOTES:  
 1. R237 SELECTED IN TEST - NOMINAL VALUE SHOWN.  
 2. INDICATED VOLTAGES - CW MODE.

REFERENCE DESIGNATIONS

C34-36, 39, 40-46, 49-53, 55-58, 62, 75, 76, 214-216
CR8-20, 27-30
DS3, 4
F1, 3
FL4
J3
M2
PI
Q1, 10, 11
R50-56, 65-81, 88-102, 104-107, 115, 124, 125, 129, 236-239, 260, 272
S3
T1, 2, 3
V2, 10-14, 16, 18-21

COPYRIGHT 1965 HEWLETT PACKARD CO.  
 608E-PS-043AB

Figure 7-5. Modulation Meter, Crystal Calibration and Power Supply Schematic Diagrams

**BACK DATING  
MANUAL  
CHANGES**

**APPENDIX I  
BACKDATING**

**MANUAL CHANGES**

Model 608E

**VHF SIGNAL GENERATOR**

Make all backdating corrections in this manual according to the changes below.

SERIAL PREFIX OR NUMBER	MAKE MANUAL CHANGES	SERIAL PREFIX OR NUMBER	MAKE MANUAL CHANGES
539- below 00120	A through M	833-	I through M
543-	B through M	833- above 01671	J, through M
610-, 637-	C through M	833- above 01821	K, L, M
637- above 00320	D through M	833- above 02121	L, M
710-	E through M	833- above 02720	M
742-	F through M		
742- above 00970	G through M		
826-	H through M		

**CHANGE A**

Figure 7-5 and Parts List:

Add (in series with emitter of Q1): R128, HP Stock No. 0812-0033, Fixed WW 7 ohm 3% 5W.  
CR20, change HP Stock No. to 1902-0037.

**CHANGE B**

Parts List:

Change Q7 to HP Stock No. 1850-0103, 2N2190 under Q7 change HP Stock No. 1205-0011 to read 1205-0012. (Change included in instruments 710-00500 and below. Recommended change for all older models).

Delete under R237 descriptions: "Factory selected part - typical value given."

Figure 7-5:

Delete asterisk (\*) after R237 denoting factory selection; typical value given.

**CHANGE C**

Figure 7-5 and Parts List:

Change T1 HP Stock No. from 9100-2289 to 9100-0047.

Change schematic to show filament wiring of T1 as follows:



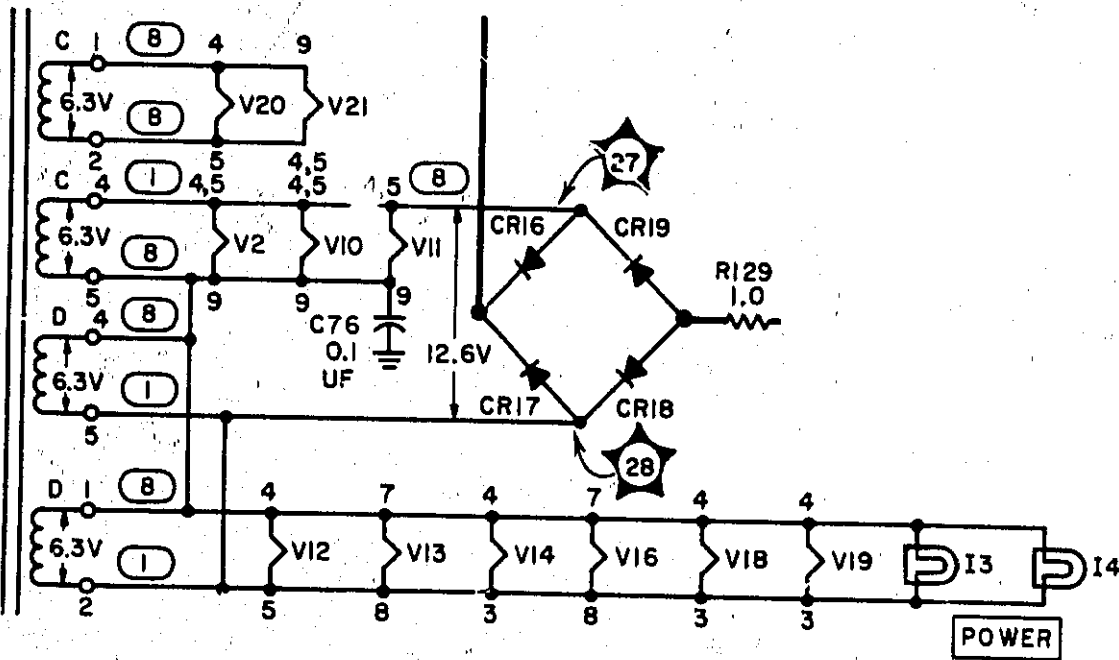

**CHANGE D**

**Parts List:**

Add the following:

- Right-angle connector, HP Stock No. 1250-0076.
- BNC connector J8, HP Stock No. 1250-0118.

Change the HP Stock No. of cable assembly W1 from 00608-60037 to 00608-605.

**CHANGE E**

**Table 1-1:**

Change second sentence of External Pulse Modulation specification to read, "From 220 MHz to 480 MHz, combined rise and decay time less than 2  $\mu$ sec.

**Paragraph 5-27, step h:**

Change test limit for "Combined pulse rise and decay times" to read, ". . . . . "2  $\mu$ sec max."

**CHANGE F**

**Figure 7-5 and Parts List:**

Change Resistor R237 typical value from 10.5K, HP Stock No. 0698-4477 to 11K, HP Stock No. 0757-0443. Delete the asterisk indicating typical value given.

**CHANGE G**

**Figure 7-4 and Parts List:**

Change MOD OSCILLATOR resistor R12 from 150K to 100K, 1W, 10%, HP Stock No. 0690-1041.

Change schematic to show R12 connected between plate of V2A (pin 6) and cathode of V2A (pin 8).

Change Tube V2 IIP Stock No. to 1932-0043.

**Parts List:**

Change F1 to:

- 2110-0013, 3.2 amp, slow-blow, for 115V operation
- 2110-0005, 1.6 amp, slow-blow, for 230V operation

**CHANGE H**

**Table 1-1:**

Change drift specification to read:

"Less than 50 parts in  $10^6$  per 10 minute period after one hour warmup.  
Less than 10 minutes to restabilize after changing frequency."

**Parts List:**

Change V2 from HP Part No. 1932-0029 to HP Part No. 1932-0066.

**CHANGE I**

**Figure 7-4 and Parts List:**

Change Resistor R7 from 1K, HP Part No. 2100-0036 to 2K,  
HF Part No. 2100-0010.

Change Resistor R8 from 1.2K, HP Part No. 0690-1221 to 680 ohms,  
HP Part No. 0690-6811.

**CHANGE J**

**Figure 7-4 and Parts List:**

Delete Ferrite Bead RFC1, HP Part No. 9170-0029.

**CHANGE K**

**Parts List:**

Change Diode CR1 from HP Part No. 1901-0518 to HP Part No. 1901-0011.

**CHANGE L**

**Figure 7-5 and Parts List:**

Change Capacitor C216 from 50 WVDC, HP Part No. 0115-1819  
to 100 MF 40V, HF Part No. 0180-0138.

**CHANGE M**

**Figure 7-3:**

Change ALC Board pictorial to show soldered connections around  
the edges, instead of plug-in pins.

# APPENDIX II BACKDATING MANUAL CHANGES

## Model 608F VHF SIGNAL GENERATOR

Make all backdating corrections in this manual according to the changes below.

SERIAL PREFIX OR NUMBER	MAKE MANUAL CHANGES	SERIAL PREFIX OR NUMBER	MAKE MANUAL CHANGES
530-	A through N	827-	I through N
608-	B through N	832-	J through N
610-, 637-	C through N	832- above 01101	K, through N
637- above 00200	D through N	832- above 01151	L, M, N
710-	E through N	832- above 01251	M, N
742-	F through N	832- above 01501	N
742- above 00850	G through N		
824-	H through N		

**CHANGE A**

Figure 7-5 and Parts List:  
Delete Resistor R129, 1 ohm, HP Stock No. 0813-0029.

**CHANGE B**

Figure 7-5 and Parts List:  
Change T1 from HP Stock No. 9100-2289 to 9100-0047.  
Change schematic to show filament wiring of T1 as follows:

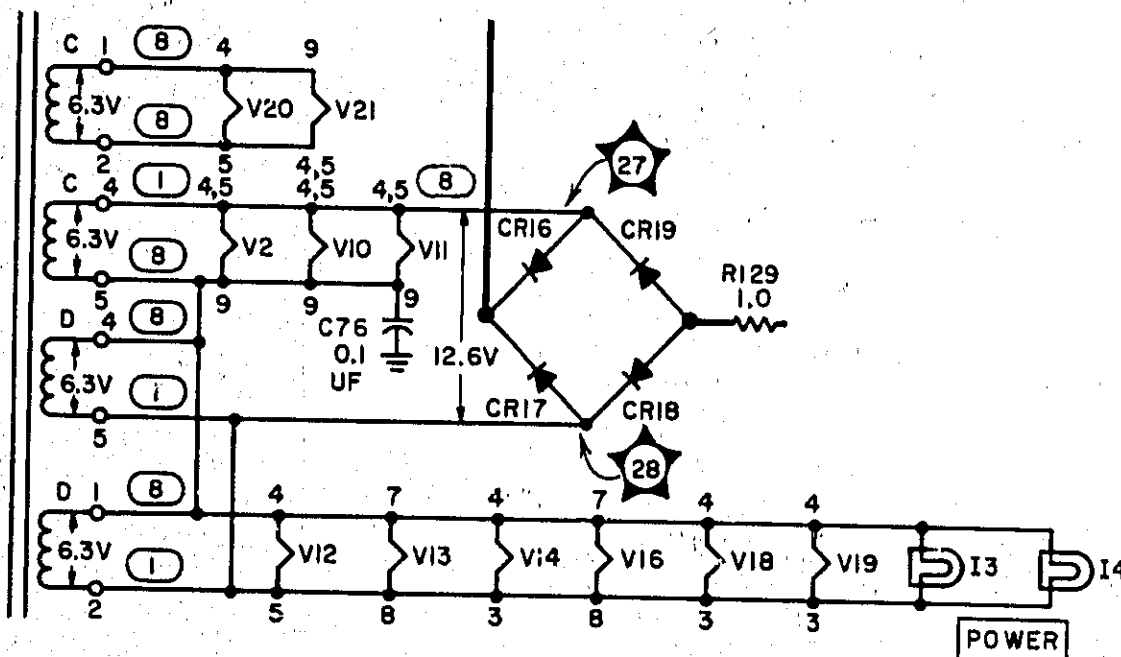



## CHANGE C

## Parts List:

Add the following:

Right-angle connector, HP Stock No. 1250-0076; BNC connector J8,  
HP Stock No. 1250-0118.

Change the HP Stock No. of cable assembly W1 from 00608-60037 to  
00608-605.

## CHANGE D

## Parts List:

Change Q7 to HP Stock No. 1850-0103, 2N2190. Under Q7 change HP Stock  
No. 1205-0011 to read 1205-0012. (Change included in instruments 710-00500  
and below. Recommended change for all older models.)

Delete under R237 description: "Factory selected part - typical value given."

## Figure 7-5:

Delete asterisk (\*) after R237 to denoting factory selection; typical value given.

## Table 1-1 (instrument serials below 710-00550):

Change Auxiliary RF Output specification to read:

"Fixed level CW signal from RF Oscillator (min amplitude 180 mv rms into  
50 ohms) provided at front panel BNC female connector for use with HP 8708A  
Synchronizer or other external equipment (e. g. frequency counter)."

## Paragraph 5-22, step b (instrument serials below 710-00550):

Change to read, "Power meter should indicate -1.8 dBm minimum."

## CHANGE E

## Table 1-1:

Change second sentence of External Pulse Modulation specification to read:

"Above 220 MHz, combined rise and decay time less than 2  $\mu$ sec."

## Paragraph 5-27 step h:

Change test limit for "Combined pulse rise and decay times" to read:

"2  $\mu$ sec max."

## CHANGE F

## Figure 7-5 and Parts List:

Change Resistor R237 typical value 10.5K, HP Stock No. 0698-4477 to 11K,  
HP Stock No. 0757-0443. Retain the asterisk to indicate typical value given.

## CHANGE G

## Parts List:

Change Meter, M1, HP Stock No. from 1120-1505 to 1120-0396.

## CHANGE H

## Figure 7-4 and Parts List:

Change Resistor R12 from 150K, HP Stock No. 0690-1541 to 100K,  
HP Stock No. 0690-1041.

Change Tube V2 HP Stock No. 1932-0043.

Change schematic to show R12 connected from V2A pin 6 to V2A pin 8.

## CHANGE I

## Table 1-1:

Change drift specification to read:

"Less than 50 parts in  $10^6$  per 10 min period after one hour warmup. Less  
than 10 min to restabilize after changing frequency.

Stability when used with 8708A Synchronizer:

$5 \times 10^{-8}$ /min;  $2 \times 10^{-7}$ /10 min;  $2 \times 10^{-6}$ /day;  $2 \times 10^{-7}/^{\circ}\text{C}$  ( $0^{\circ}$  to  $55^{\circ}\text{C}$ );

$2 \times 10^{-7}/10\%$  line voltage change."

Parts List:

Change F1 to:

2100-0014, 3.2 amp, slow blow, for 115V operation.

2100-0005, 1.6 amp, slow blow, for 250V operation.

Change V2 from HP Part No. 1932-0029 to HP Part No. 1932-0066.

CHANGE J

Figure 7-4 and Parts List:

Change Resistor R7 from 1K, HP Stock No. 2100-0036 to 2K,  
HP Stock No. 2100-0010.

Change Resistor R8 from 1.2K, HP Stock No. 0690-1221 to 680 ohms,  
HP Stock No. 0690-6811.

CHANGE K

Figure 7-4 and Parts List:

Delete Ferrite Bead RFC1, HP Stock No. 9170-0029.

CHANGE L

Parts List:

Change Diode CR1 from HP Stock No. 1901-0518 to HP Stock No. 1910-0011.

CHANGE M

Figure 7-5 and Parts List:

Change Capacitor C216 from 50 WVDC, HP Stock No. 0180-1819 to 100 MF  
40V, HP Stock No. 0180-0138.

CHANGE N

Figure 7-3:

Change ALC Board pictorial to show soldered connections around the edges,  
instead of plug-in pins.

# MANUAL CHANGES



# MANUAL CHANGES

## SIGNAL GENERATOR

### MANUAL IDENTIFICATION

Model Number: 608E/F  
 Date Printed: April 1981  
 Part Number: 00608-90046

This supplement contains important information for correcting manual errors and for adapting the manual to instruments containing improvements made after the printing of the manual.

To use this supplement:

Make all ERRATA corrections

Make all appropriate serial number related changes indicated in the tables below.

608E		608F	
Serial Prefix or Number	Make Manual Changes	Serial Prefix or Number	Make Manual Changes
All with U prefix or suffix	2	All with U prefix or suffix	1, 2
U831-00696 and above	2, 8	U831-00366 and above	1, 2, 8
U970	2, 3, 5, 8	U975	1-3, 5, 8
U975	2-9	977-01776 to 01800	4-6
983-03671 to 03770	3-8	977-01801 to 01850	4-8
983-03771 to 04470	3-9	977-01851 to 02075	4-9
1050U	2-9	1101U	1-9
1141A	4-10	1142A02076 to 02100	4-10
1150U	2-10	1142A02101 to 02125	4-11
1201A	4-10, 12	1151A	4-12
1218U, 1248U	2-10, 21	1203U	1-10
1322A, 1433A	4-10, 12, 14	1221A	4-13
1451U	2-10, 21	1324A, 1430A	4-14
1651A	4-10, 12, 14, 15		
1801A	4-10, 12, 14-16		
1822A	4-10, 12, 14-17		
1826A	5-10, 12, 14-18		
1911A	5-10, 12, 14-19		
1918A	5-10, 12, 14-20		

► NEW ITEM

### ERRATA

Page 6-5, Table 6-3:

Change C75 to 0180-0057 CD9 CAPACITOR-FXD 2000 UF 25VDC.

### NOTE

Manual change supplements are revised as often as necessary to keep manuals as current and accurate as possible. Hewlett-Packard recommends that you periodically request the latest edition of this supplement. Free copies are available from all HP offices. When requesting copies quote the manual identification information from your supplement, or the model number and print date from the title page of the manual.

5 April 1982  
 6 Pages



Printed in U.S.A.

**CHANGE 1**

Page 6-5, Table 6-3:

Change C75 to 0180-0128 CD5 CAPACITOR-FXD 2800 UF 25VDC.

**CHANGE 2**

Page 6-5, Table 6-3:

Delete C76.

Add C233, C234, 1050-0121 CD5 CAPACITOR-FXD 0.1 UF + 80 -20% 50VDC.

Add R273, R274, 0687-6811 CD9 RESISTOR 680 10%.

Page 6-9, Table 6-3:

Change R240 to 0698-3430 CD5 RESISTOR 21.5 1% .125W.

Page 7-5, Figure 7-5:

Change the figure as shown in the attached partial schematic.

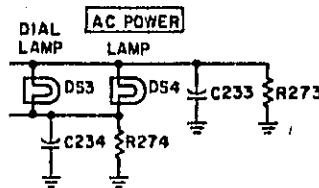

P/O Figure 7-5. Modulation Meter, Crystal Calibration and Power Supply Schematic Diagrams (P/O Change 2)

**CHANGE 3**

Page 6-9, Table 6-3:

Change S7 to 3100-2681 CD4.

**CHANGE 4**

Page 6-6, Table 6-3:

Change F1 (230V operation) to 2110-0303 CD3 Fuse: Cartridge 2 Amp Slow Blow.

Add J9, 1251-2357 CD8 Connector-ac receptacle.

Page 6-7, Table 6-3:

Change P1 to 8120-1378 CD1 Power Cable - detachable.

Page 6-9, Table 6-3:

Change S2 to 3101-1234 CD3.

Page 6-10, Table 6-3:

Add 1450-0413 CD5 Pilot Light Jewel (white).

Add 00608-00008, Bracket- Power Inlet.

Change 608D-44S to 00608-00014 CD6.

Change 608D-44R to 00608-00015 CD7.

Page 7-5/7-6, Figure 7-5:

Replace appropriate portion of schematic with attached partial schematic.

**CHANGE 4 (cont'd)**

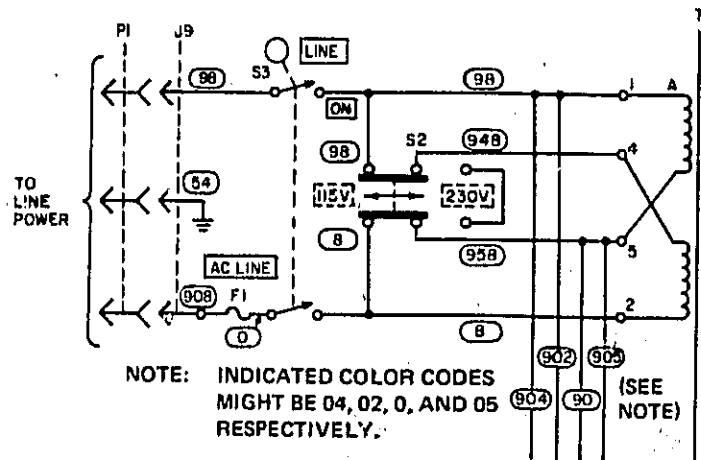

**P/O Figure 7-5. Modulation Meter, Crystal Calibration and Power Supply Schematic Diagrams (P/C Change 4)**

**CHANGE 5**

Page 6-5, Table 6-3:

Add C232, 0170-0072 CD7 Capacitor Fxd Mylar 1.0  $\mu$ F 10% 200 VDCW.

Page 7-3, Figure 7-4:

Show a SPST switch (part of S7) connected from FL6 (coax side) through C232—1.0  $\mu$ F capacitor to ground.

**CHANGE 6**

Page 6-7, Table 6-3:

Change Q11 to 1854-0090 CD0 TSTR Silicon - similar to 2N3053.

Page 7-5, Figure 7-5:

Change Q11 part number to 1854-0090.

**CHANGE 7**

Page 6-5, Table 6-3:

Change C223 to 0180-0291 CD3 Capacitor-Fxd Elect 1  $\mu$ F -10 to +100% 35 VDCW.

**CHANGE 8**

Page 6-8, Table 6-3:

Change R239 to 0761-0032 CD2 Resistor Fxd Met Ox 56K ohm 5% 1W.

Page 7-5, Figure 7-5:

Change the value of R239 to 56K.

**CHANGE 9**

Page 6-9, Table 6-3:

Change R246 and R247 to 0761-0015, Resistor 1500 5% 1W.



**CHANGE 10**

Page 6-7, Table 6-3:

Change Q8 and Q9 to 1854-0022, TSTR: SI NPN.

Page 7-3, Figure 7-4:

Change Q8 and Q9 to 1854-0022 CD8.

**CHANGE 11**

Page 6-8, Table 6-3:

Change R201 to 0757-0442 CD9 Resistor Fxd Mtl Flm 10K ohm 1% 1/8W.

Page 7-3, Figure 7-4:

Change R201 to R201\* 10K.

**CHANGE 12**

Page 6-10, Table 6-3:

Change 00608-00014 CD6 to read Cabinet Assembly (Blue Gray).

Delete 00608-00015 Cabinet Assembly: Rack (Olive Gray).

Add: 00608-00018 CD0 Cabinet Assembly (Olive Gray)

00608-00019 CD1 Cabinet Assembly: Rack (Olive Gray).

00608-00011 CD3 Front Panel (Light Gray) 608E only.

00608-00016 CD8 Front Panel (Mint Gray) 608E only.

00608-005 CD7 Front Panel: Rack (Light Gray) 608E only.

00608-00021 CD5 Front Panel: Rack (Mint Gray) 608E only.

00608-00012 CD4 Front Panel (Light Gray) 608F only.

00608-00017 CD9 Front Panel (Mint Gray) 608F only.

00608-010 CD4 Front Panel: Rack (Light Gray) 608F only.

00608-00022 CD6 Front Panel: Rack (Mint Gray) 608F only.

**CHANGE 13**

Page 1-2, Table 1-1:

In the lower right-hand corner of the page under 608F, change to read: 215 to 400 MHz: +2.0 to +7 dBm.  
400 to 430 MHz: +1.0 to 7 dBm.

**CHANGE 14**

Page 7-5, Figure 7-5:

Change the figure as shown in the attached partial schematic.

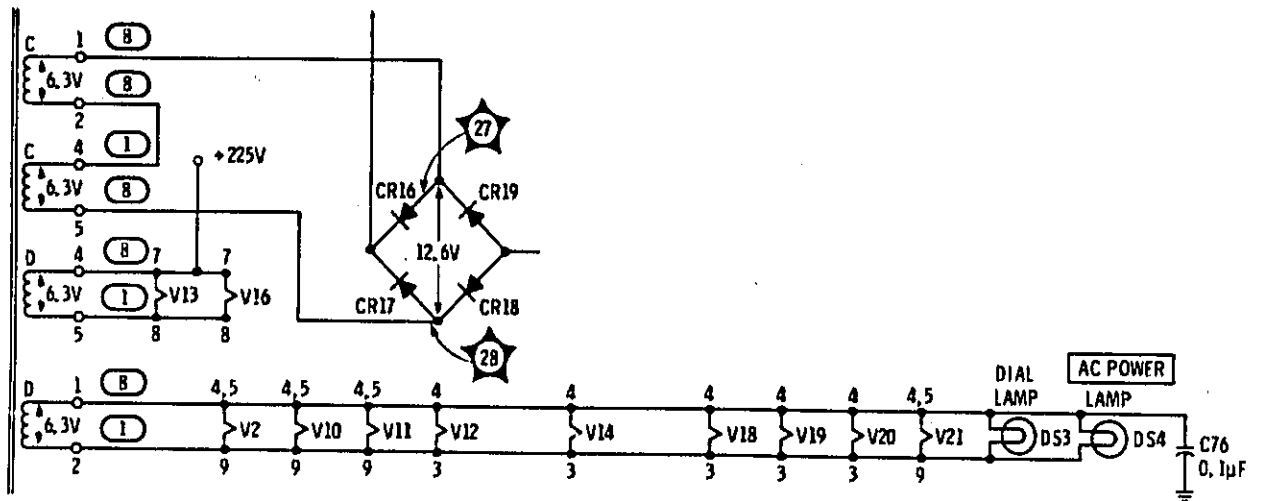

P/O Figure 7-5. Partial Schematic of Power Supply (P/O Change 14)

**CHANGE 15**

Page 6-7, Table 6-3:

- Change R58 to 0698-8914 CDO Resistor 51.1 1% 0.125W F TC-0±100 Non-Inductive.
- Change R59 to 0698-8915 CD1 Resistor 56.2 1% 0.125W F TC-0±100 Non-Inductive.

Page 7-3/7-4, Figure 7-4:

- Change R58 to 51.1Ω.
- Change R59 to 56.2Ω.

**CHANGE 16**

Page 5-32:

Add the following paragraphs:

**5-87. FACTORY SELECTED COMPONENTS**

5-88. The following paragraphs explain how to choose the values of selected components. These components are designated by an asterisk (\*) on the schematic and parts list.

**5-89. SELECTING R254**

5-90. Selected to minimize 20 MHz peaking when in the Pulse Set RF Output mode. Use the following procedure:

a. Make the following switch settings:

MODULATION . . . . .	PULSE SET RF OUTPUT
RF OUTPUT . . . . .	Full ccw
ATTENUATOR . . . . .	-1 dB

b. Adjust the AMPL TRIMMER for a peak at several frequencies between 17 and 21 MHz. Check that the RF output meter indicates less than 6.5 dBm.

c. If the power is greater than 6.5 dBm change R254 to a lower value. The value should be between 620Ω and 750Ω.

d. Perform the RF Output test described in paragraph 5-20.

Page 6-9, Table 6-3:

- Change R254 to R254\* (selected part, nominal value given).

**CHANGE 16 (cont'd)**

Page 7-3, Figure 7-4:  
Change R254 to R254\*.

**CHANGE 17**

Page 6-9, Table 6-3:  
Change S3 to 3101-2329 CD9 SWITCH-TGL BASIC DPST 2A 250 VAC/DC (ON)

**CHANGE 18**

Page 6-10, Table 6-3:  
Replace the fuseholder listing with the following parts:  
2110-0554 CD8 FUSEHOLDER BODY 12A MAX; 250V MAX 28480 2110-0564  
2110-0565 CD9 FUSEHOLDER CAP BAYONET; 12A, 250V MAX 28480 2110-0565  
2110-0569 CD3 NUT-HEX, PLASTIC 28480 2110-0569  
1400-0090 CD9 WASHER: RUBBER 5/8" OD 00000 OBD.

**CHANGE 19**

Page 6-5, Table 6-3:  
Add C77 0160-3448 CD6 CAPACITOR-FXD 1000 PF  $\pm$  10% 1 KVDC CER 28480 0160-3448.

Page 7-3, Figure 7-4:  
Draw a 1000 pF capacitor across R225. Label it C77.

**CHANGE 20**

Page 6-5, Table 6-3:  
Add C78 0160-3878 CD6 CAPACITOR-FXD CER 1000 pF  $\pm$  20% 100 VDC.  
Change CR20 to 1902-0072 CD1 DIODE BREAKDOWN 7.87V 2%.

Page 6-7, Table 6-3:  
Change Q1 to 1853-0344 CD5 TRANSISTOR SILICON 2N5876 PNP.

Page 7-5, Figure 7-5:  
Draw a 1000 pF capacitor between the collector and base of Q1. Label it C78.  
Change the CR20 voltage to 7.87.  
Change the part number of Q1 to 1853-0344.

**CHANGE 21**

Page 6-10, Table 6-3:  
Change V21 to 1932-0029 CD1.