Service Guide

Publication Number 54720-90908
First Edition, November 1992

This manual applies directly to instruments
with serial numbers having the following prefixes.

HP 54710A - 3237A, 3249A
HP 54720A - 3220A, 3237A, 3249A
HP 54717A - 3209A
HP 54718A - 3238A

For additional information about serial numbers, see
"Instruments Covered by this Service Guide" in
chapter 1.

For Safety information, Warranties, and Regulatory
information, see the pages at the back of this book.

© Copyright Hewlett-Packard Company 1992
All Rights Reserved.

HP 54710A and 54720A Oscilloscope Mainframes

The HP 54710A and 54720A Oscilloscopes

These instruments are high-performance digitizing oscilloscope mainframes. The architecture of the instruments is designed to allow versatile use of the high sample rates of its digitizing channels.

The HP 54720A has four digitizing channels and the HP 54710A has two. Both instruments have four trigger inputs in the plug-in slots.

Features

These instruments have a wide range of high-performance features:

- The HP 54720A has four slots for vertical signal conditioning plug-ins. Each slot feeds a 2 GSa/s digitizer for the vertical signal and an input for a trigger signal. The HP 54710A has only two slots with digitizers but can trigger on all four slots.
- A digital timebase with a 2 GHz reference frequency.
- Triggering functions that include edge, state, and pattern triggering, depending on the plug-in configuration.
- A color display that shows the captured signal, measurement results, and the selections for a set of softkeys.
- A 3.5 inch disk drive.
- A port for HP-IB and a parallel printer output.
- Instrument firmware that includes self calibration and failure diagnostics.

Architecture

The four slots for signal conditioning plug-ins provide the user with a variety of options. Single-slot plug-ins provide 2 GSa/s sample rate. A two-slot plug-in provides 4 GSa/s sample rate. Plug-ins include:

Model	Slots	Bandwidth	Channel	Sensitivity	Trigger
HP 54711A	1	1.5 GHz	50 Ω	2 mV/div to 1 V/div	2.5 GHz, external
HP 54712A	1	1.1 GHz	50 Ω	1 mV/div to 1 V/div	1 GHz, internal
HP 54713A	1	500 MHz	50 Ω or 1 M Ω	1 mV/div to 5 V/div	500 MHz, internal
HP 54721A	2	1.1 GHz	50 Ω	1 mV/div to 1 V/div	1 GHz, internal and external

In addition, the HP 54718A Trigger plug-in can be used in the trigger-only slots of the HP 54710A. It can also be used in any slot of the HP 54720A mainframe.

The HP 54717A plug-in is used to calibrate the HP 54710A and 54720A mainframes.

Service Policy

The service policy of this instrument is the replacement of defective assemblies. Some assemblies can be replaced on an exchange basis.

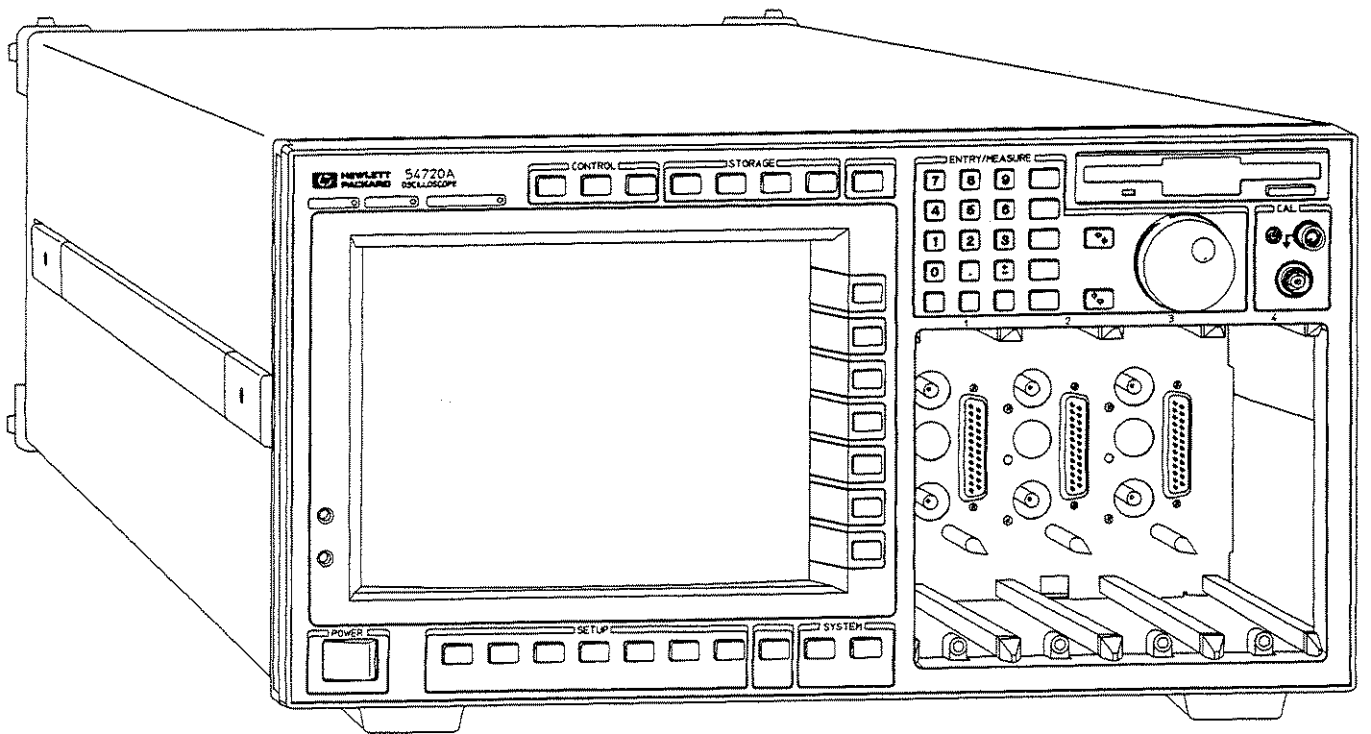

54720E36

In This Book

This book provides the service documentation for the HP 54710A and 54720A Oscilloscopes. It is divided into eight chapters.

Chapter 1 provides general information and specifications.

Chapter 2 shows you how to prepare the oscilloscope for use and gives a brief overview of operation.

Chapter 3 gives performance tests.

Chapter 4 covers calibration and adjustment procedures, how to do them and how often they need to be done.

Chapter 5 provides troubleshooting information.

Chapter 6 gives the procedures and techniques for replacing assemblies and other parts.

Chapter 7 includes a list of exchange assemblies and other replaceable parts, part ordering information, and shipping information.

Chapter 8 briefly covers the internal operation of the oscilloscope.

Chapter 9 provides service information for the HP 54717A Calibration plug-in.

Chapter 10 provides service information for the HP 54718A Trigger plug-in.

At the back of the book you will find Safety information, Warranties, and Regulatory information.

1 General Information

Instruments Covered by this Service Guide 1-2
Accessories Supplied 1-3
Accessories Available 1-3
Options Available 1-3
Specifications 1-4
Characteristics 1-4
Product Support 1-6
General Characteristics 1-6
Recommended Test Equipment 1-8

2 Preparing for Use



Setting Up the Oscilloscope 2-3
To inspect the instrument 2-3
To check power requirements 2-3
To set the line voltage selection 2-3
To install a plug-in 2-4
To clean the instrument 2-5

Operating the Oscilloscope 2-6
A Quick Tour of the Front Panel 2-6
Operating Your Oscilloscope in Five Easy Steps 2-12
In Case of Difficulty 2-21

3 Testing Performance

Testing Interval 3-2
Equipment Required 3-2
Test Record 3-2
Keystroke Conventions 3-2
Operating Hints 3-3
To test the front panel CAL signal 3-4
To test time interval accuracy 3-6

4 Calibrating and Adjusting



Equipment Required 4-2
Keystroke Conventions 4-2

Calibrating the Oscilloscope 4-3
Calibration Overview 4-3
Calibration Interval 4-5
Calibration Status Displays 4-6
To calibrate the mainframe 4-9
To calibrate the plug-ins 4-11
To calibrate for best accuracy 4-12

4 Calibrating and Adjusting (cont'd)

- Adjusting the Color CRT Module 4-14
- Equipment Required 4-14
- To prepare the instrument 4-14
- To adjust geometry 4-16
- To adjust focus, landing, and convergence 4-17
- To adjust white balance 4-24

5 Troubleshooting

- Safety 5-2
- ESD Precautions 5-2
- Keystroke Conventions 5-2
- Default Setup 5-2

- Trouble Isolation 5-3
- Tools Required 5-3
- 1, Primary Trouble Isolation 5-5
- 2, No-Display Trouble Isolation 5-11
- 3, Keyboard Trouble Isolation 5-19
- Missing Board Checks 5-22
- Interpreting Internal Self-tests 5-23
- Power Supply Distribution 5-25

- Utility Menu 5-27
- HP-IB Setup 5-27
- System Configuration 5-27
- Calibrate 5-29
- Self-test 5-30
- Firmware Support 5-30
- Service 5-31

6 Replacing Assemblies

- ESD Precautions 6-2
- Tools Required 6-2
- Instrument Structure 6-2
- To return the instrument to HP for service 6-3
- A Brief Order of Procedures 6-4
- To remove and replace
 - Front panel 6-5
 - Keyboard 6-6
 - RPG 6-7
 - Front fan 6-8
 - Disk drive assembly 6-9
 - Disk drive 6-9
 - Disk drive control 6-10

6 Replacing Assemblies (cont'd)

To remove and replace

- Rear panel 6-11
- Power supply 6-11
- CPU and display assemblies 6-12
- Time base assembly 6-12
- Clock assembly 6-14
- Acquisition assemblies 6-16
- Color CRT module 6-17
- Motherboard 6-20
- Rear fan 6-22



7 Replaceable Parts

- Ordering Replaceable Parts 3-2
- Exploded Views 3-3
- Replaceable Parts List 3-6

8 Theory of Operation

- Mainframe Block-level Theory 3-3
- Acquisition System 3-7

9 HP 54717A Plug-In Service

- General Information 10-3
- Accessories Supplied 10-3
- Specifications 10-3
- Characteristics 10-3
- General Characteristics 10-3



- Periodic Maintenance 10-4
- Functional Test 10-4
- Calibration and Adjustment 10-5

- Troubleshooting 10-6
- ESD Precautions 10-6
- Equipment Required 10-6
- Trouble Isolation 10-6

- Replacing Assemblies 10-8
- Tools Required 10-8
- To remove and replace
 - Covers 10-9
 - Front panel 10-9
 - Limiter 10-9
 - Output cable 10-10
 - PC board 10-11
 - Bus cable 10-11

9 HP 54717A Plug-In Service (cont'd)

Replaceable Parts 10-12
Mechanical View 10-12
Parts List 10-12

Theory of Operation 10-14
Signal Paths 10-14
Digital Interface 10-14
Power Supplies 10-15

10 HP 54718A Plug-In Service

General Information 10-3
Accessories Available 10-3
Specifications 10-3
Characteristics 10-4
General Characteristics 10-4

Periodic Maintenance 10-5
Performance Test 10-5
Calibration and Adjustment 10-8

Troubleshooting 10-9
ESD Precautions 10-9
Equipment Required 10-9
Trouble Isolation 10-9

Replacing Assemblies 10-11
Tools Required 10-11
To remove and replace
Covers 10-11
Input cable 10-11
Limiter and attenuator 10-12
Output cable 10-12
Bus cable 10-13
PC board 10-13

Replaceable Parts 10-14
Mechanical View 10-14
Parts List 10-14

Theory of Operation 10-16
Passive Trigger Path 10-16
Digital Interface 10-17
Probe Power 10-17
Power Supplies 10-17



Instruments Covered By this Service Guide 1-2
Accessories Supplied 1-3
Accessories Available 1-3
Options Available 1-3
Specifications 1-4
Characteristics 1-4
Product Support 1-6
General Characteristics 1-6
Recommended Test Equipment 1-8

General Information

General Information

This chapter of the Hewlett-Packard 54710A and 54720A Oscilloscope service guide gives you general information about the instrument. The following topics are covered in this chapter.

- Instrument identification
- Accessories
- Options
- Specifications and characteristics
- Test equipment requirements

Instruments Covered by this Service Guide

On the left side of the plug-in compartment of the instrument is a serial number sticker. The serial number is in the form: 0000A00000. It is composed of two parts: the first four digits and letter are the serial prefix, while the last five digits are the suffix. The prefix is the same for all identical instruments and changes only when a change has been made to the instrument. The suffix however, is assigned sequentially and is different for each instrument. The contents of this guide apply to instruments with the serial number prefixes listed under SERIAL NUMBERS on the title page.

An instrument manufactured after the printing of this guide may have a serial number prefix different than those listed on the title page. This unlisted serial number prefix indicates the instrument is different from those described in this guide. The service guide for this instrument is accompanied by a manual changes supplement. This supplement contains the necessary "change information" that explains how to adapt this guide to the newer instrument. In addition to change information, the supplement may contain information for correcting errors in this guide.

For information concerning a serial prefix number not listed on the title page or in the manual changes supplement, contact your nearest HP office.

Accessories Supplied

The following accessories are supplied with the HP 54710A and 54720A oscilloscopes.

- One 2.3 meter (7.5 feet) power cord (See chapter 7 for available power cords)
- One Operating and Programming Guide Set
- One Service Guide

Accessories Available

The following accessories are available for use with the HP 54710A and 54720A.

- HP 10087A HP 54710A to HP 54720A upgrade service
- HP 2225A ThinkJet Printer (HP-IB) or HP 2225C ThinkJet (Centronics)
- HP 3630A PaintJet Printer option 002 (HP-IB) or HP 3630A PaintJet option 004 (Centronics)
- HP C2106A DeskJet Printer (Centronics)
- HP 2228A QuietJet Printer (Centronics)
- HP 2227A QuietJet Plus (Centronics) or HP 2227B QuietJet Plus (HP-IB)
- HP 1181A system testmobile
- HP 35181A top-mounted printer stand for HP 1181A
- HP 35181C 3.5-inch drawer for HP 1181A
- HP 35181D work surface for HP 1181A

Options Available

The following options are available for the HP 54710A and 54720A.

Option 002 - Training kit including a PC board, demo guide, and power supply.

Option 907 - Rackmount kit (handles only)(HP 54710-68703) includes special long screws

Option 908 - HP Rack-mount Kit (ears only)(HP 54710-68704) includes special long screws

Option 909 - HP Rack-mount Kit (with handles)(HP 54710-68705) includes special long screws

Option 0B1 - additional Service Guide and Operating and Programming Guide Set

Other options are available. See your HP sales representative.

Specifications

The following are specifications used to test the HP 54710A and 54720A oscilloscopes. Specifications are valid after a 20 minute warm-up period.

Time base	Time-Interval Measurement Accuracy ¹ Real Time $\pm[(0.2)(\text{sample interval}) + 0.007\% \text{ of delta-time marker reading}]$. Equivalent Time (16 averages) $\pm(30 \text{ ps} + 0.007\% \text{ of delta time marker reading})$
Front Panel Calibrator	dc Output Adjustable output range $-2.5 \text{ V to } +2.5 \text{ V}$ when terminated into 50Ω . Output Delta Voltage Accuracy $\pm(0.2\% \text{ of delta voltage output})$ 1) Time interval measurement accuracy includes error sources such as time base inaccuracy, aperture uncertainty/sample clock phase jitter, reconstruction filter uncertainty (real-time only), trigger interpolation jitter, and channel-to-channel skew. Real-time time-interval accuracy applies for input rise times greater than 1.4 multiplied by the sample interval.

Characteristics

The following characteristics are typical for the HP 54710A and 54720A oscilloscopes.

Channel	ADC Input Sources (simultaneous acquisition) HP 54720A mainframe 4, each plug-in slot has its own 2 GSa/s ADC and 16,384 point acquisition memory. HP 54710A mainframe 2, each plug-in slot has its own 2 GSa/s ADC and 16,384 point acquisition memory. Best Accuracy Calibration Performing the Best Accuracy Cal on a channel just prior to a series of critical measurements will ensure the most accurate results. This calibration adjusts the channel's gain, offset, and linearity and requires a specific plug-in to stay installed in a specific mainframe slot. Channel Skew Adjustment The time skew between channels can be manually eliminated all the way to the probe tip to 1-ps resolution. Probe Calibration A probe calibration routine automatically computes the offset and the attenuation created by the probe attached to the channel input.
Time base	Time Base Scale 100 ps/div to 1 s/div (in 1-2-5 or fine steps) Time Base Position Range (auto sample rate and record length) Pretrigger 0 to -1 s or one full screen width, whichever is larger. Posttrigger 0 to 1 s or one full screen width, whichever is larger. Time Interval Measurement and Trigger Interpolator Resolution 1 ps Time Base Window Scale: 1 ps/div to the main time base scale factor. Position: The window must always stay in the time window defined by the main sweep.

Trigger

Sources All four input plug-in slots can be used for triggering. See plug-in specifications for more details.

Edge Slope Positive/negative

Holdoff Range 60 ns to 320 ms

Pattern Trigger A pattern can be specified using any channel or external trigger input (up to four bits wide). Each of the inputs can be specified as high, low, or don't care with respect to the trigger level setting for that source. Trigger occurs when that pattern is entered or exited.

Glitch Trigger This mode makes it easy to look for glitches on a single source. The user can distinguish glitches down to 3 ns ± 1 ns in width and can capture glitches as narrow as 500 ps in width, depending on the plug-in.

Time-Qualified Pattern Trigger A trigger will occur on the first edge to exit a pattern only if it meets one of these criteria: pattern present <[time], pattern present >[time], pattern present in range >[time1] and <[time2]. The time settings are adjustable from 20 ns to 160 ms [±(3% + 2 ns)] with 10 ns resolution. Filter recovery time is ≤ 12 ns.

State Trigger A pattern is specified on any three of the four inputs, with the fourth input used as a clock. Trigger occurs on the rising or falling edge of the input specified as the clock, and when the pattern is present or is not present. Setup time for the pattern with respect to the clock is 10 ns or less; hold time is zero.

Event-Delayed Trigger The trigger is qualified by an edge. The delay can be specified as a number of occurrences of a rising or falling edge of any input. After the delay, an occurrence of a rising or falling edge of any input will generate the trigger. The trigger occurrence value is selectable from 1 to 16,000,000. The maximum edge counting rate is 70 MHz. Edges occurring <30 ns after the qualifying edge may not be detected.

Time-Delayed Trigger The trigger is qualified by an edge. The delay is selectable from 30 ns to 160 ms. After the delay, an occurrence of a rising or falling edge on any one selected input will generate the trigger.

Display Update

Maximum Display Update Rate: 550 Kpixels/s

HP-IB Transfer

Maximum HP-IB Transfer Rate: 500 Kbytes/s

Throughput

This throughput data was taken in the real-time sampling mode (250 MSa/s) with 512-point records onscreen, no measurements (waveforms/s only), no interpolation, fast draw mode, infinite persistence, markers off, math off, and one channel acquisition. Vp-p does not require threshold detection, but period does.

Throughput	Waveforms/second	Measurements/second	
		Vp-p	Period
Measurement			
Front-Panel Capture and Transfer Rate	>170	>44	>39
HP-IB Capture and Transfer Rate	>50	>33	>31

**Front Panel
Calibrator**

ac Output A 2 kHz or 500 kHz square wave with approximately 1.6 ns transitions can be used for probe compensation and system calibration. The waveform levels are 0 V and 1 V when terminated into 50 Ω .

Product Support

Calibration

All instrument calibration is executed with built-in calibration routines. The mainframe calibration and plug-in calibration should be performed yearly. These calibrations are valid only if performed between 15°C and 35°C. Specifications are valid $\pm 5^\circ\text{C}$ from the calibration temperature. Perform probe calibration and best-accuracy calibration to assure the highest level of performance at the time of measurement.

Low Cost of Ownership

The HP 54720A series, including plug-ins and probes, include a one year, return to HP warranty. To minimize the mean time to repair and the calibration time, the series was designed with no periodic hardware adjustments. HP's board exchange program assures economical and timely repair of units, reducing the cost-of-ownership.

Reliability

Under normal use, estimated mean time between failures (MTBF) for the HP 54710A is 10,000 hours. The estimated MTBF of the HP 54720A is 9,000 hours.

General Characteristics

These general characteristics apply to the HP 54710A and 54720A oscilloscopes.

**Environmental
Conditions**

The instruments meet Hewlett-Packard's environmental specifications (section 750) for class B-1 products with exceptions as described for temperature and condensation. Contact your local HP field engineer for complete details.

Temperature

Operating 10°C to +40°C (50°F to +104°F)

Non-operating -40°C to +70°C (-40°F to +158°F)

Humidity

Operating up to 95% relative humidity (non-condensing) at +40°C (+104°F)

Non-operating up to 90% relative humidity at +65°C (+149°F)

Altitude

Operating up to 4,600 meters (15,000 ft)

Non-operating up to 15,300 meters (50,000 ft).

Vibration

Operating Random vibration 5-500 Hz, 10 minutes per axis, 0.3 grms

Non-operating Random vibration 5-500 Hz, 10 minute per axis, 2.41 grms; Resonant search, 5 to 500 Hz swept sine, 1 Octave/minute sweep rate, 0.75g, 5 minute resonant dwell at 4 resonances per axis.

Power Requirements Voltage 90 to 132 or 198 to 264 Vac, 48-66 Hz.

Power 1200 VA; 650 W

Weight
(approximate)

	HP 54710A	HP 54720A
Net	24.5 kg (54 lb)	26.4 kg (58 lb)
Shipping	31.8 kg (70 lb)	33.6 kg (74 lb)

Dimensions

Refer to the outline drawings to the right.

Notes

1. Dimensions are for general information only. If dimensions are required for building special enclosures, contact your HP field engineer.
2. Dimensions are in millimeters and (inches).

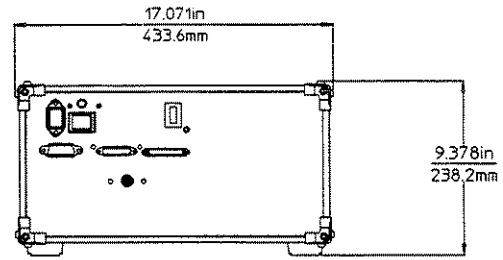
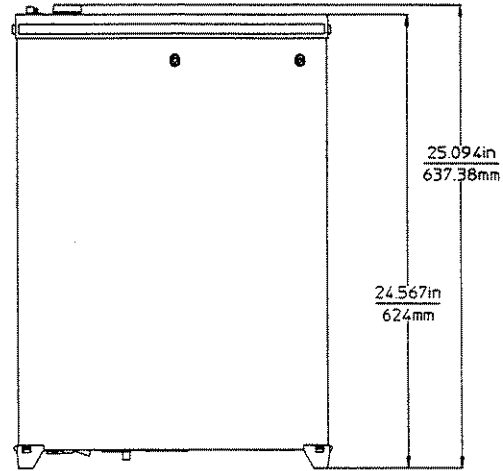

54720E07

Product Regulations

Safety	IEC 348 UL 1244 CSA Standard C22.2 No.231 (Series M-89)												
EMC	This product meets the requirement of the European Communities (EC) EMC Directive 89/336/EEC.												
Emissions	EN55011/CISPR 11 (ISM, Group 1, Class A equipment) SABS RAA Act No. 24 (1990)												
Immunity	EN50082-1												
	<table border="1"> <thead> <tr> <th></th> <th>Code¹</th> <th>Notes²</th> </tr> </thead> <tbody> <tr> <td>IEC 801-2 (ESD) 4kV CD, 8kV AD</td> <td>1</td> <td></td> </tr> <tr> <td>IEC 801-3 (Rad.) 3 V/m</td> <td>2</td> <td></td> </tr> <tr> <td>IEC 801-4 (EFT) 1kV</td> <td>1</td> <td></td> </tr> </tbody> </table>		Code ¹	Notes ²	IEC 801-2 (ESD) 4kV CD, 8kV AD	1		IEC 801-3 (Rad.) 3 V/m	2		IEC 801-4 (EFT) 1kV	1	
	Code ¹	Notes ²											
IEC 801-2 (ESD) 4kV CD, 8kV AD	1												
IEC 801-3 (Rad.) 3 V/m	2												
IEC 801-4 (EFT) 1kV	1												

¹ Performance Codes:
 1 PASS - Normal operation, no effect.
 2 PASS - Temporary degradation, self recoverable.
 3 PASS - Temporary degradation, operator intervention required.
 4 FAIL - Not recoverable, component damage.

² Notes:
(None)

Recommended Test Equipment

Table 1-1 shows a list of the test equipment required to test performance, calibrate and adjust, and troubleshoot this instrument. The table indicates the critical specification of the test equipment and for which procedure the equipment is necessary. Equipment other than the recommended model may be used if it satisfies the critical specification listed in the table.

Table 1-1

Recommended Test Equipment

Equipment Required	Critical Specifications	Recommended Model	Use *
Signal Generator	40 and 300 MHz, sine wave amplitude -12 to 2 dB frequency accuracy $\pm 0.1\%$	HP 8664A	P
RF Amplifier	40 MHz to 1 GHz, 26 dB gain	HP 8447D	P
DMM	5 1/2 digit resolution dc voltage accuracy $\pm 0.025\%$ 4-wire resistance accuracy $\pm 0.25\%$	HP 34401A	P, T
Oscilloscope	1 GHz bandwidth	HP 54720A with HP 54711A, 12A, or 21A	P, T
Calibration plug-in	No substitute	HP 54717A	C
Attenuator	20 dB ± 1 dB, BNC	HP 8490 series Opt.20 with adapters or Narda 755B-20	C
Power Splitter	>500 MHz bandwidth	HP 11667A	P
Termination (optional)	BNC 50 Ω	HP 10100C	C
Cable (2)	BNC - 3 foot	HP 10503A	P, C, T
Cable (3)	BNC - 9 inch	HP 10502A	P, C, T
Adapter (3)	N (m) to BNC (f)	HP 1250-0780	P
Adapter	BNC tee (m)(f)(f)	HP 1250-0781	P, C, T
Adapter	BNC to dual banana	HP 1251-2277	P

* P = Performance Tests, C = Calibration and adjustment, T = Troubleshooting



Setting up the Oscilloscope 2-3

To inspect the instrument 2-3

To check power requirements 2-3

To set the line voltage selection 2-3

To install a plug-in 2-4

To clean the instrument 2-5

Operating the Oscilloscope 2-6

A Quick Tour of the Front Panel 2-6

Entry Devices 2-6

Disk Drive 2-6

CAL Signal 2-6

Hardkeys 2-7

Display 2-8

Softkeys 2-9

Operating Your Oscilloscope in Five Easy Steps 2-12

Writing Conventions 2-12

Equipment Used 2-12

Step 1. Connect a signal to the oscilloscope 2-13

Step 2. Let the oscilloscope find your signal 2-14

Step 3. Modify the setup of the oscilloscope 2-15

Step 4. Make measurements on the signal 2-18

Step 5. Use the help menu 2-20

In Case of Difficulty 2-21

If the oscilloscope does not power up 2-21

If autoscale does not find the CAL signal 2-21

Preparing for Use

Preparing for Use

This chapter shows you how to prepare the HP 54710A and 54720A for use. It references the routines necessary to establish calibration levels.

Following instrument set-up is a brief section covering oscilloscope operation. If you are unfamiliar with this oscilloscope's operation and do not have the operator's manuals, this section will help you.

The following areas are covered in this chapter.

- Inspection
- Setup
- Cleaning
- Operating

Setting Up the Oscilloscope

When ordered as a system, the HP 54710A and 54720A are shipped from the factory ready to use, with the plug-ins installed and normal-accuracy calibrations done. However, if you ordered additional plug-ins and you want to change the instrument configuration, this section will help you get the instrument ready to use.

To inspect the instrument

- Inspect the shipping container for damage.

Keep a damaged shipping container or cushioning material until the contents of the shipment have been checked for completeness and the instrument has been checked mechanically and electrically.

- Check the accessories.

Accessories supplied are listed in chapter 1 of this service guide.

- If the contents are incomplete or damaged notify your HP sales office.

- Inspect the instrument.

- If there is mechanical damage or defect, or if the instrument does not operate properly or pass performance tests, notify your HP sales office.
- If the shipping container is damaged, or the cushioning materials show signs of stress, notify the carrier as well as your HP sales office. Keep the shipping materials for the carrier's inspection. The HP office will arrange for repair or replacement at Hewlett-Packard's option without waiting for claim settlement.

To check power requirements

The instrument requires a power source of 90 to 132 Vac or 198 to 264 Vac, 48 to 66 Hz, 1200 VA or 650 W maximum.

CAUTION

BEFORE CONNECTING POWER TO THIS INSTRUMENT, be sure the line voltage switch on the rear panel of the instrument is set properly. Applying a voltage excessive to the setting may open the protective fuse.

To set the line voltage selection

Before applying power, verify the setting of the LINE SELECT switch on the rear panel.

- If the switch is set incorrectly, set it to either 115 V or 230 V, whichever is appropriate for the voltage in your area.

To change the selection, remove the line voltage switch cover, turn it 180 degrees and reinstall it. The switch will change when the cover is installed.

CAUTION

The fuse requirement is different for 100 V, 115 V, and 230 V operation. The instrument was shipped with the line voltage selection and fuse appropriate for the country of destination. If you change the line voltage selection, you will need to change the fuse or the fuse may not protect the instrument properly.



WARNING

For size, type, and part number of the fuse, see the parts list in chapter 7, "Replaceable Parts."

SHOCK HAZARD!

BEFORE YOU CONNECT THIS INSTRUMENT TO MAINS POWER OR LIVE MEASURING CIRCUITS, you must provide a protective earth ground.

The Mains plug must be inserted in a socket outlet provided with a protective earth contact. Do not use an extension cord (power cable) without a protective conductor (grounding). Grounding one conductor of a two-conductor outlet does not provide an instrument ground.

Failure to provide a protective earth ground could result in a shock hazard if there is a failure in this instrument or equipment connected to it.

CAUTION

For shipments to Japan, this instrument is supplied with a heavy duty mains power cable. At lower mains voltages (approximately 90 to 100 Vac) the increased mains current will cause increased loss in the standard power cable. In such cases, be sure to use the heavy duty cable provided with this instrument.

This instrument is provided with a three-wire power cable. When connected to an appropriate ac power outlet, this cable grounds the instrument cabinet. The type of power cable plug shipped with the instrument depends on the country of destination.

To install a plug-in

There are a few things to consider when using plug-ins:

- Plug-ins may be removed and installed without turning off instrument power.
- A plug-in calibrated to normal accuracy in a calibrated mainframe will have normal accuracy in any slot of any other calibrated mainframe.

1 Install the plug-in in any empty slot of the mainframe.

Some plug-ins use more than one slot.

2 If the plug-in needs calibration, see "To calibrate the plug-ins" in chapter 4 of this service guide.

3 If Best Accuracy is desired, see "To calibrate for Best Accuracy" in chapter 4 of this service guide.

4 If you are using a probe or other attenuation device with your plug-in, you may perform the probe calibration.

- Press **Channel**, then press **Probe...**, then press **Probe cal Execute**, and follow the instructions on the screen.

See Also

"Calibration Overview" in chapter 4 of this service guide.

To clean the instrument

To clean the instrument, use a soft cloth, damp with a mild soap and water solution.

Operating the Oscilloscope

Following is a quick introduction to the oscilloscope. It is not intended as a comprehensive guide, but rather as help for people who need only a brief overview.

A Quick Tour of the Front Panel This section gives you a quick tour of the front panel in a descriptive format with examples that help to illustrate the text.

Five Easy Steps to Operating the Oscilloscope This section gives you five exercises that show you how to get the oscilloscope up and running, how to scale a waveform vertically and horizontally, and how to use the help menu.

In Case of Difficulty This section contains a few simple hints in case you are experiencing difficulty in either getting the oscilloscope to power up or to display a signal.

A Quick Tour of the Front Panel

This section describes how to use the front panel. You will find that this information will help you to gain the full use of your oscilloscope in the shortest possible time. This section divides the front panel into six areas: entry devices, disk drive, CAL signal, hardkeys, display, and softkeys.

Entry Devices

The entry devices include the knob, arrow keys, and keypad. The knob provides continuous control, while the arrow keys are step controls. The keypad allows you to enter a specific value.

Disk Drive

The disk drive is a 3-1/2 inch, high-density, MS-DOS[®] compatible drive. You can use the disk drive for loading applications, storing and loading waveforms, storing and loading instrument setups, printing waveforms to a file, or loading new system firmware.

CAL Signal

The three CAL signal choices are dc, 2-kHz square wave, and 500-kHz square wave. The CAL signal is used for mainframe calibration, plug-in calibration, probe calibration, best accuracy calibration, skew calibration, and demonstration signals. The dc output is ± 2.5 V into 50 Ω . The 2-kHz and 500-kHz square waves are 1 V into 50 Ω with about 1.6-ns edges.

MS-DOS[®] is a U.S. registered trademark of Microsoft Corporation.

Hardkeys

The two types of hardkeys are instant action and menu. Clear display and Run are examples of instant action keys because as soon as you press them, the oscilloscope changes operating states. Time base and Trigger are examples of the menu keys because pressing them causes softkey menus to come up on the right side of the display.

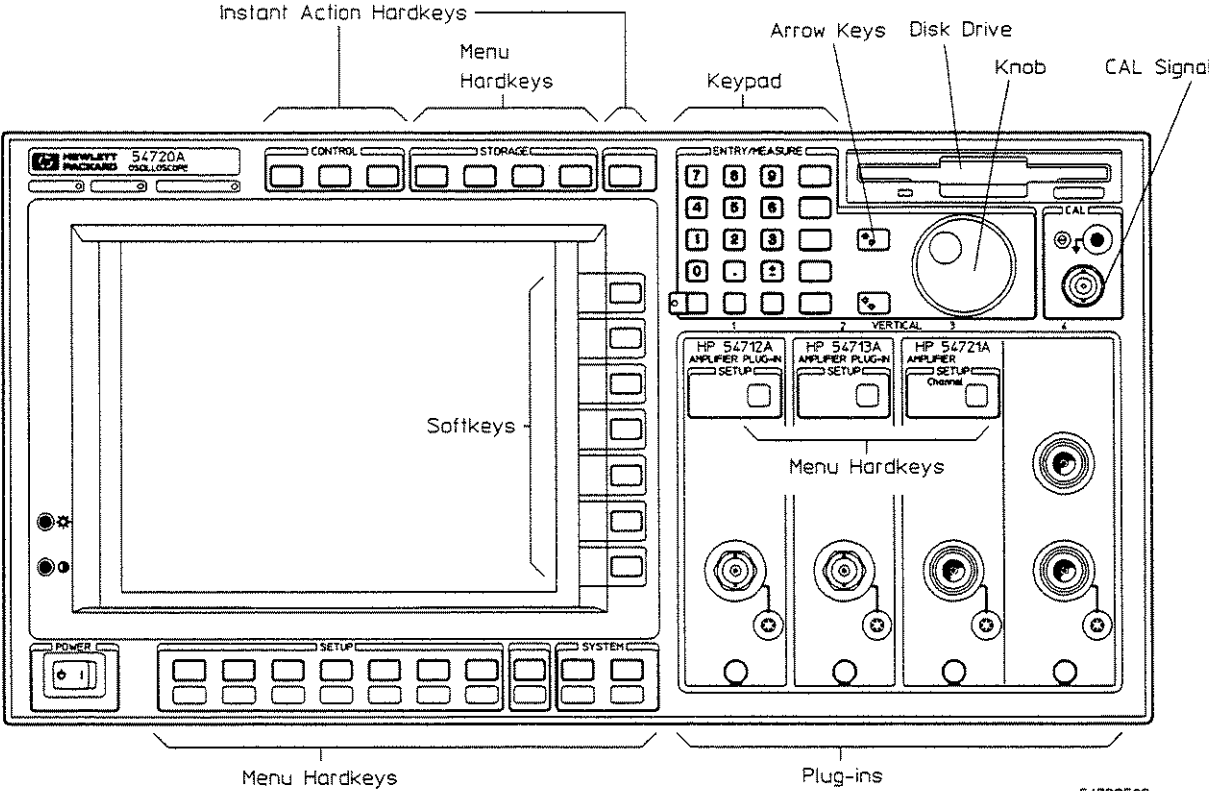

Display

The figure below shows the main areas of the display, and how you can interpret some of the oscilloscope's settings from the display.

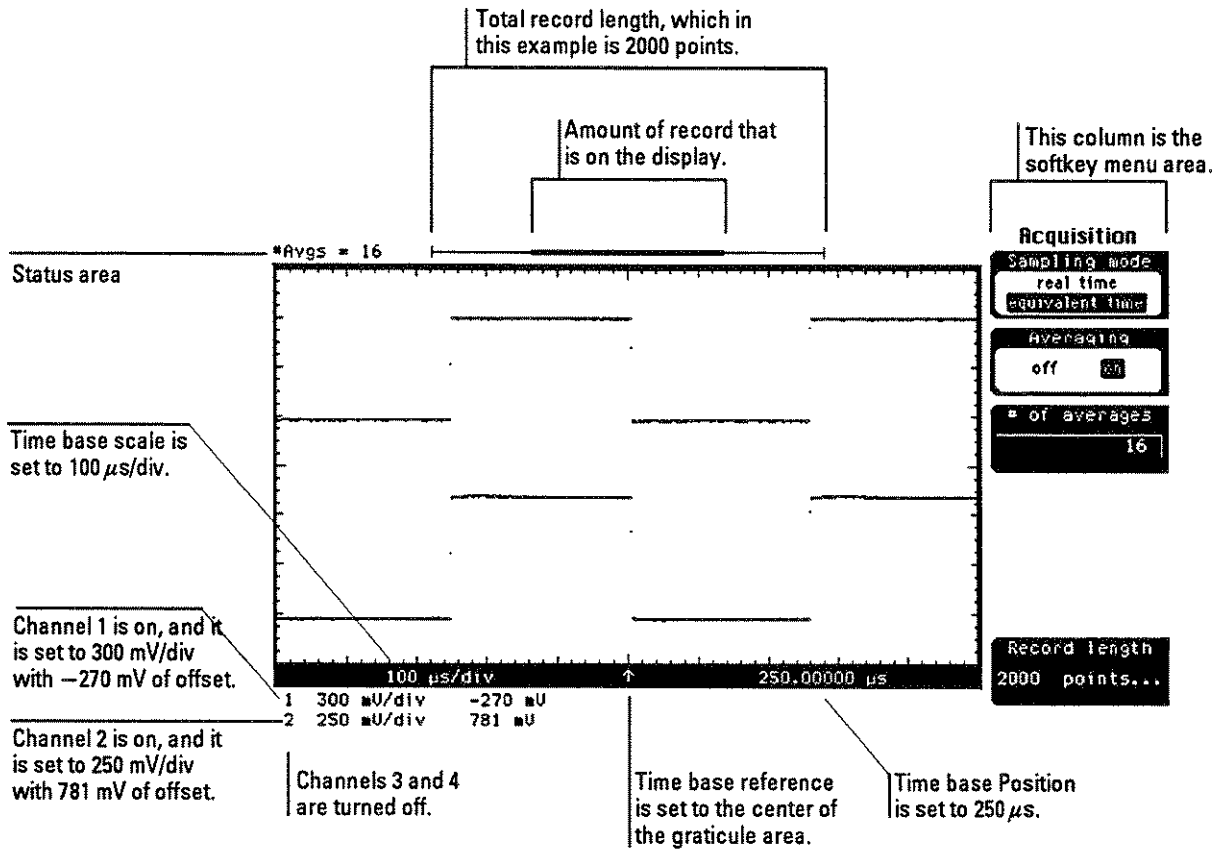

Softkeys

The softkeys are to the right of the display, and instead of placing a label on the softkey itself, the label is actually located on the display next to the softkey. These labels on the display are called menus, and which menu is on the display depends on which hardkey you press. For example, pressing Time base brings up one menu while pressing Trigger brings up a different menu.

There are five types of softkeys, and there are some differences on how each type of softkey operates. The five types of softkeys are toggle, list, continuous, menu, and single choice. Because the trigger menu contains all five types of softkeys, it is used over the next few pages to demonstrate the differences among the softkeys.

When you press the Trigger hardkey, the Trigger softkey menu comes up on the right side of the display.

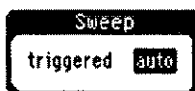
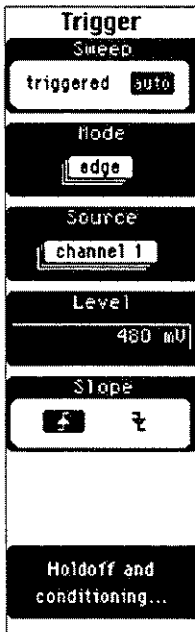

Toggle softkeys A typical example of the toggle softkeys is Sweep. It allows you to choose between two or three selections, and you change selections by pressing that same softkey. Sweep has choices of either triggered or auto. The highlighted choice is the selection that is currently active. In the example at the left, auto is highlighted, which indicates that the oscilloscope is set to auto sweep.

List softkeys A typical example of the list softkeys is Mode. It has several stacked rectangles that represents a list of choices you can choose from. The top rectangle shows the selection that is currently active. In the example at the left, edge is the current selection.



You change selections by pressing the Mode softkey which brings up a second level softkey menu on the display. Then, you use the softkeys, arrow keys, or knob to change selections. To activate that selection simply press the Enter softkey, then the display returns to the previous softkey menu. If you press the Cancel softkey, the oscilloscope returns to the previous selection.

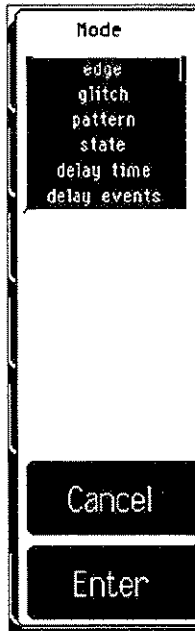

Pressing the mode softkey brings this second level menu up on the display.



Continuous softkeys A typical example of the continuous softkeys is Level. It has a range of values that you change with the keypad, arrow keys, or knob. In the example at the left, Level (trigger level) is set to 480 mV.

Because the trigger menu only has one of this type of softkey, it is active when the menu comes up on the display. You do not need to press the Level softkey when you want to change the trigger level. However, the Time base menu has two of this type softkey, Scale and Position. In this case only one of the softkeys is active at a time, and to make the other softkey active you must press the corresponding softkey. You can tell which softkey is currently active because it has a different colored background from the rest of the softkeys. When using the time base scale or channel scale, the knob and arrow keys operate in two modes. One mode is a 1-2-5 sequence, while the other mode is a fine mode that allows you to make smaller incremental changes. You activate the fine mode by pressing the blue shift key on the keypad, followed by pressing the arrow key with the word "Fine" written in blue above that key. When the fine mode is active, you'll see the word FINE at the top-right corner of the graticule area. You get out of the fine mode by simply pressing the blue shift key on the keypad, followed by pressing the arrow key with the word "Fine" written above it.

Menu softkeys

A typical example of the menu softkeys is Holdoff and conditioning... The ellipses after the word "conditioning" indicate that when you press this softkey, a new softkey menu comes up on the display that allows you to make several additional choices. To exit this menu simply press the Done softkey, then the display returns to the previous menu.

Holdoff and
conditioning...



Pressing the Holdoff
and conditioning
softkey brings this
second level menu
up on the display.

Single choice softkeys

A typical example of the single-choice softkeys is Enter. There are several variations of this type softkey throughout the many softkey menus. When you press the softkey, the oscilloscope executes that softkey command.

Enter

Operating Your Oscilloscope in Five Easy Steps

This section provides five easy steps to use to familiarize you with the operation of the oscilloscope.

You will find it easier to perform these exercises if you are at least a little familiar with how to use the front panel. The best way to learn how to use the front panel is by reading "A Quick Tour of the Front Panel." If you have not already read this, you will probably find it helpful to do so before continuing.

Keystroke Conventions

To guide you while setting up the oscilloscope the following conventions are used to represent keystrokes and other interactions with the instrument:

Text in a box, such as **Utility** or **Time base**, represents hardkeys, those defined by text on the front panel.

Bold text in a typewriter font, such as **Display** or **Calibrate...**, represents text on the CRT screen and may be a softkey you should press or a message to consider.

The blue key that has no writing on it is a shift key. It allows you to access the functions written in blue above some of the hardkeys. In this manual it is represented by a box with the word "blue" in it, like this: **(blue)**.

Equipment used in these exercises

All the pictures of the display in this book were generated using an HP 54712A Amplifier plug-in, and using the 2-kHz CAL signal from the mainframe as a signal source. If you are using a different plug-in or a different signal source, your display and oscilloscope settings may vary slightly from the pictures in this book.

For example, the HP 54712A plug-in has an internal trigger, whereas the HP 54711A plug-in has an external trigger. If you connect the signal to the HP 54711A by using a BNC Tee or power splitter to split the signal between the channel and trigger inputs, the signal on the channel connector of the plug-in will have a lower amplitude. Therefore, your channel settings and display pictures may vary slightly from what follows.

Step 1. Connect a signal to the oscilloscope

- 1 **Connect a BNC cable between the CAL output BNC on the mainframe and channel 1.**
If you are using a plug-in that uses external triggering instead of internal triggering, use a power splitter or BNC Tee to split the signal between the channel and trigger inputs. However, a power splitter maintains the signal's integrity better than a BNC Tee. Also, a BNC Tee or power splitter attenuates the signal's amplitude substantially, which may make your display results different from the pictures in this book.
- 2 Press **Setup** .
When you press the Setup hardkey, the Setup softkey menu is displayed.
- 3 Press **Default setup** (a softkey).
The default setups put the oscilloscope in a particular operating condition. This gives you a known starting point for the following exercises. The default conditions are listed in the "Setup" chapter in the User's Reference book.

Step 2. Let the oscilloscope find your signal

The purpose of this exercise is to demonstrate a feature that automatically sets up the oscilloscope to display most input signals. This feature is called Autoscale.

The pictures of the display in this book were generated using an HP 54712A Amplifier plug-in. If you are using a different plug-in, the display on your oscilloscope may vary slightly from the pictures in this book.

Also, the pictures were made with the graticule set to the frame mode. This was done to make it easier for you to see the waveform in the picture without interference from the graticule lines. However, the graticule lines on your display are dimmer than the waveform, which makes it easier for you to see the waveform on your display even though the graticule lines are also displayed.

- Press **Autoscale** .

Pressing the Autoscale key causes the oscilloscope to quickly analyze the signal. Then, it

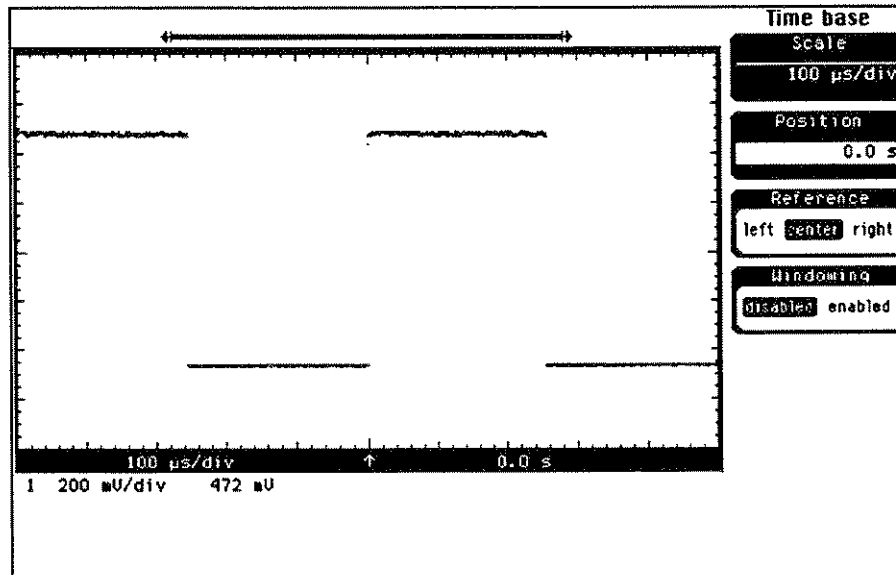

sets up the vertical, horizontal, and trigger to best display the signal. Autoscale can find repetitive signals with a frequency greater than or equal to 50 Hz, a duty cycle greater than one percent, and an amplitude greater than 50 mV p-p.

You may find situations where you pressed the Autoscale key unintentionally. When this happens, you can use the Undo Autoscale key to return the oscilloscope to the settings prior to pressing the Autoscale key.

- To undo an Autoscale, press **(blue)** , then press **Autoscale** again.

Step 3. Modify the setup of the oscilloscope

The purpose of this exercise is to show you the channel, time base, and trigger menus. This is done by having you expand the signal vertically and horizontally until it almost fills the display. You are expanding the signal because in the next exercise you will visually set markers on the signal, and it is easier to set these markers visually when the signal is expanded.

- 1 Press **channel** (located on the plug-in).
- 2 Press **scale**, then change the scaling so the vertical height of the signal is about eight divisions.

When the knob and arrow keys are not in the fine mode, they change the scaling in a 1-2-5 sequence. Changing the scaling in this sequence actually changes an attenuator setting in the plug-in. However, you can change the scaling in 1-mV increments by using the keypad, or by setting the knob and arrow keys to the fine mode.

- To set the oscilloscope to the fine mode, press **(blue)**, then press the arrow key with the word "Fine" written in blue above it.

You can tell when the fine mode is activate because you'll see the word "FINE" at the top-right corner of graticule area.

For example, when using the HP 54712A plug-in, the knob or arrow keys changes the scaling from 100 mV/div to 200 mV/div in one attenuator step. At 100 mV/div the signal is clipped, and at 200 mV/div the signal is not expanded enough to take advantage of the full vertical size of the display. However, you can use the keypad to set the scaling to 155 mV/div. The attenuator in the plug-in is still set to 200 mV/div, but the mainframe does a software expansion so that the signal is displayed at 155 mV/div.

- To set the scaling to 155 mV with the keypad, type the number **155** on the keypad. Then press **milli** for millivolts to select the unit of measure.

When you select a key with a unit of measure written on it, you do not need to press the enter key. You only press the enter key if you are entering numbers that do not require a unit of measure or that are in volts or seconds. Also, depending on the value you enter with the keypad, the oscilloscope may round the value up or down. If you tried to enter 155.5 mV/div, the oscilloscope automatically rounds the entry to 156 mV/div because 1 mV/div is the smallest increment that is allowed for vertical scaling.

- 3 Press **offset**, then vertically center the signal on the display.

Offset moves the waveform vertically on the display. Offset is similar to the vertical position on analog oscilloscopes, except that offset is calibrated. If offset is set to 480 mV, then you know that the vertical center of the graticule area is 480 mV.

You may need to readjust the scaling and offset until the signal is expanded vertically and is centered on the display.

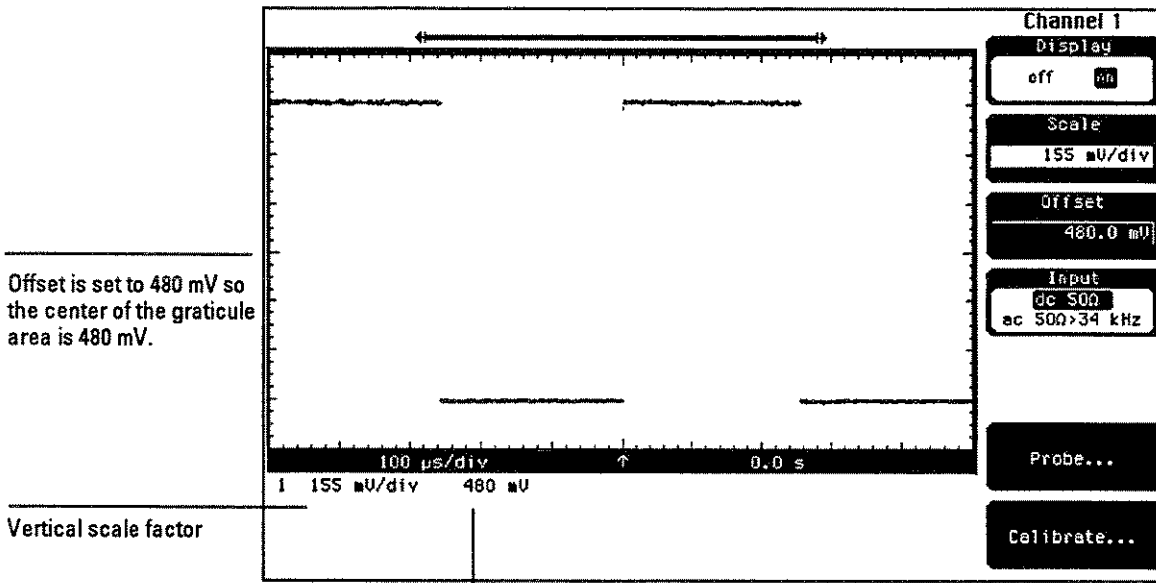

Offset is set to 480 mV so the center of the graticule area is 480 mV.

Vertical scale factor

Offset setting

- 4 Press **Time base**.
- 5 Press **Scale**, then change the scaling so that the horizontal width of the positive portion of the signal is about eight divisions.
 Again, when the knob and arrow keys are not in the fine mode, they operate in a 1-2-5 sequence, changing the scale from 20 $\mu\text{s}/\text{div}$ to 50 $\mu\text{s}/\text{div}$ in one large step. However, you can use the keypad to enter smaller values, like 31.7 $\mu\text{s}/\text{div}$, or you can use the fine mode so that you can adjust the knob and arrow keys in smaller increments.
- 6 Press **Position**, then horizontally center the signal on the display.

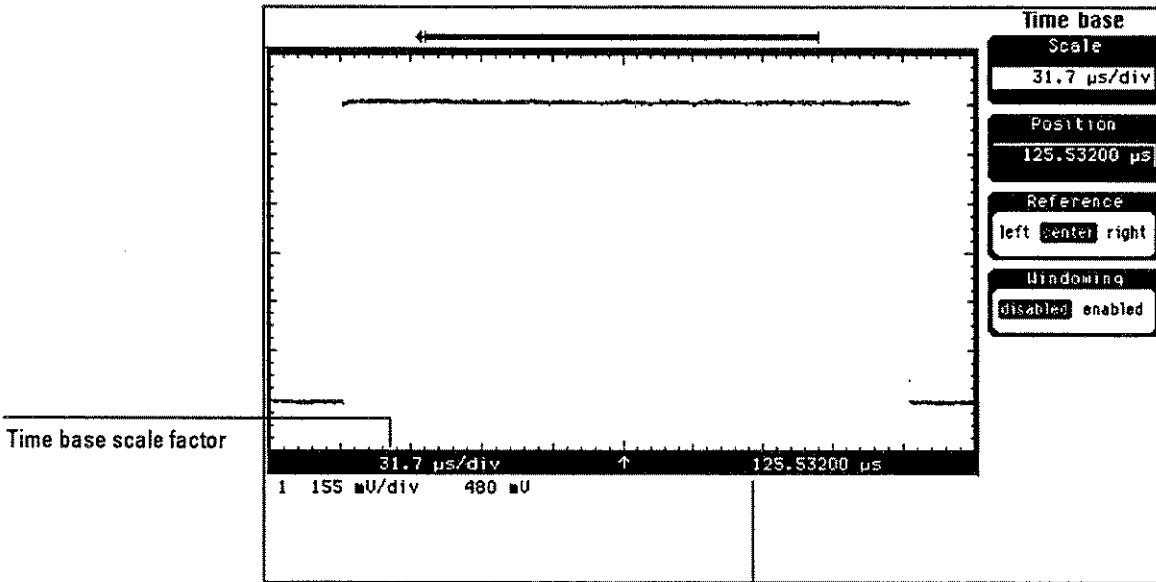

Time base scale factor

Time base position setting

Position moves the waveform horizontally on the display. (Position is sometimes referred to as delay on other oscilloscopes.) When Position is set to 0, then the trigger event occurs at the reference point. The reference point is indicated at the bottom of the display by an arrow. You can set the reference to the left, center, or right side of the graticule area by using the Reference softkey. A positive position value is the amount of time after the trigger event (posttrigger), while a negative value is the amount time before the trigger event (pretrigger). Pretrigger information is an important feature because you can see what led up to the trigger event.

7 Press **Trigger** .

8 Press **Level**, then set the trigger level near the center of the signal.

On plug-ins that have internal triggering, there is a horizontal line on the display and there is a "T" on the right side of that line. This line moves vertically as you change the trigger level and gives you a visual indicator of where the trigger level is in relation to the signal.

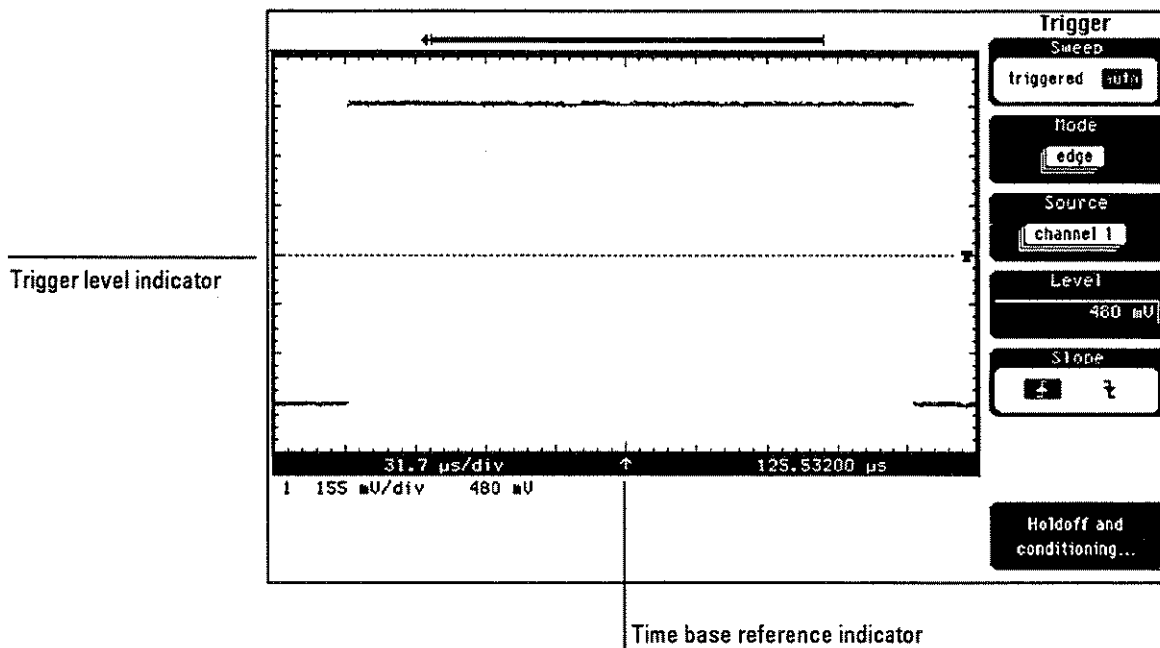

Step 4. Make measurements on the signal

The purpose of this exercise is to familiarize you with the marker menu and the automatic measurement features of the oscilloscope. You will begin by using the manual markers to make a pulse width and an amplitude measurement on channel 1. After that, you will make the same measurements by using the automatic measurement features.

- 1 Press **Marker**, then press **mode**.
- 2 Select **manual**, then press **Enter**.
 In the manual marker mode, there are two X markers and two Y markers. You can position the X markers horizontally and the Y markers vertically on the display. You use the X markers to make timing measurements and the Y markers to make voltage measurements.
 - To change the mode selection, use the knob, arrow keys, or softkeys.
- 3 Set **x1, y1 Source** to channel 1.
 - a Press **x1, y1 Source**.
 - b Select **channel 1**.
 - c Press **Enter**.
- 4 Set **x2, y2 Source** to channel 1.
 - a Press **x2, y2 Source**.
 - b Select **channel 1**.
 - c Press **Enter**.
- 5 Press **x1 Position**, then set the X1 marker to the left edge of the pulse.
- 6 Press **x2 Position**, then set the X2 marker to the right edge of the pulse.
- 7 Press **y1 Position**, then set the Y1 marker to the bottom of the pulse.
- 8 Press **y2 Position**, then set the Y2 marker to the top of the pulse.

Notice the ΔX and ΔY at the bottom of the display. The ΔX value is the width measurement, and the ΔY value is the amplitude measurement. The markers allow you to make custom measurements on signals. But, remember that they are not tied directly to the waveform data stored in memory; they are just positions on the display.

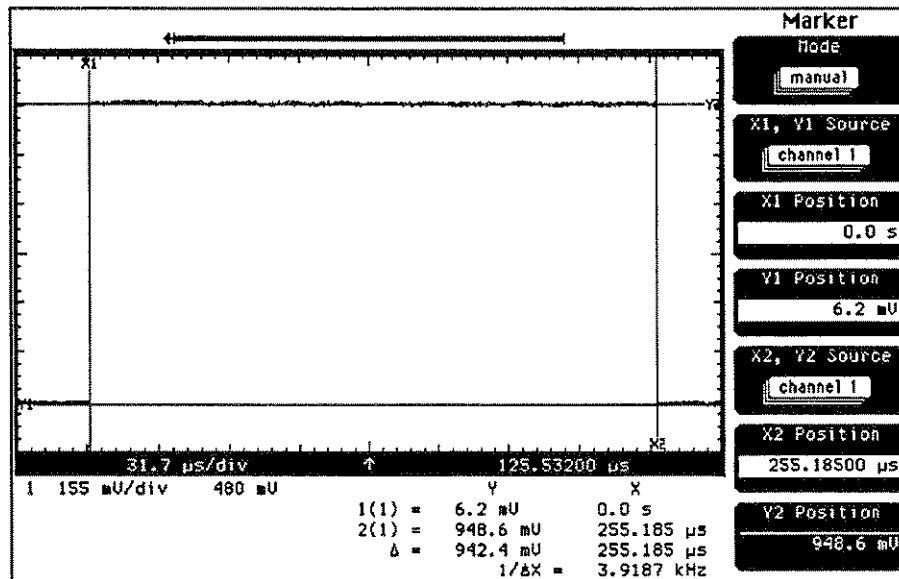

9 Make an automatic +width measurement on channel 1.

- a Press **(blue)**.
- b Press **+width**.
- c Select **channel 1**.
- d Press **Enter**.

The automatic measurement results are displayed at the bottom left of the screen.

10 Make an automatic amplitude measurement on channel 1.

- a Press **(blue)**.
- b Press **V amptd**.
- c Select **channel 1**.
- d Press **Enter**.

The IEEE pulse parameter standards are used for all of the automatic measurements, unless you make changes in the define measure menu.

Automatic measurements are the preferred measurement choice because they are faster and more repeatable than the manual marker measurements. The automatic measurements use the waveform data stored in memory for all calculations, and the waveform data in memory has a higher resolution than the resolution of the display. In comparison, the manual markers are not tied to the waveform data in memory; they are just positions on the display.

Notice that the automatic measurement results are placed on the display where the vertical scale and offset values are normally displayed.

- To redisplay the vertical scale and offset values, press **(blue)**. Then press **Clr meas**.

The automatic measurement results are replaced by the vertical scale and offset values.

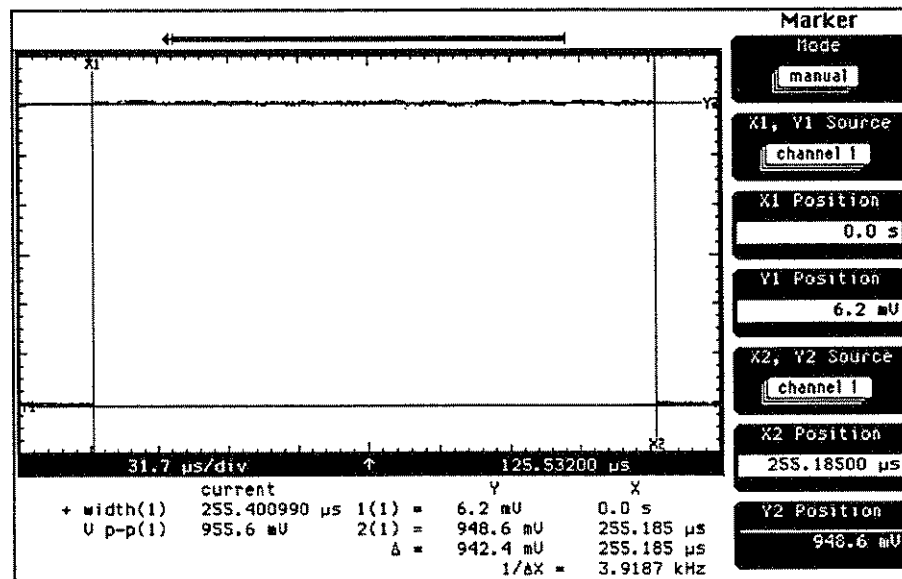

Chapter 2: Preparing for Use
Operating Your Oscilloscope in Five Easy Steps

Step 5. Use the help menu

- Press **Help**.

A three-column index appears on the display. The left column lists the features of the oscilloscope, while the middle column lists the front-panel key, and (if needed) the right column lists the softkey you press to find that feature. You can use either the knob or arrow keys to scroll through the help menu.

Feature	Hardkey	Softkey	Help
BW limit, digital (real time)	Acquisition	Digital BW lim	
CAL output control, mainframe	Utility	Calibrate...	
CAL signal control, mainframe	Utility	Calibrate...	
Calibrate plug-in	Utility	Calibrate...	
Calibrate probe	Channel	Probe...	
Calibration status	Utility	Calibrate...	
Calibration status, channel	Channel	Calibrate...	
Centronics printer selection	SHIFT Print	Destination	
Channel best accuracy cal.	Channel	Calibrate...	
Channel calibration status	Channel	Calibrate...	
Channel display	Channel	Display	Line
Channel skew adjustment	Channel	Calibrate	Channel
Channel vertical position	Channel	Offset	
Channel vertical units, V, A, M	Channel	Probe...	
Channel view	Channel	Display	
Channel, magnify	Math	Define Function	
Clear measurements from screen	SHIFT Clear		
Clear non-volatile memory	Utility	System config..	
Clear stored pixel memory	Waveform	Clear memory	
Clear waveforms (from display)	Clear display		
cm/s	Time base	Scale	
Colors, changing display	Display	Color...	
Colors, Default display	Display	Color...	
Connect waveform dots (linear)	Display	Draw waveform	Exit
Coupling, vertical input (AC,DC)	Channel	Input	

In Case of Difficulty

This section gives you a few helpful hints in case you are having trouble getting the oscilloscope to power up or display a signal. Complete service information is located in the Service Guide that is supplied with the oscilloscope.

If the oscilloscope does not power up

- Check that the line voltage switch on the rear panel is set to the correct voltage selection for your voltage source.
- Check that the outlet the power cord is plugged into has power and that the power cord is plugged into the oscilloscope.
- Check that the rear panel line switch is set to the "On" position.
- Check that the front panel power switch is set to the "On" position.

If the oscilloscope still does not power up, refer to chapter 5, "Troubleshooting" in this service guide.

If autoscale does not find the CAL signal

- Check that the CAL signal is set to 2 kHz.
 - 1 Press **Utility**.
 - 2 Press **Calibrate**....
 - 3 Press **Output**.
 - 4 Use the softkeys, arrow keys, or knob to set the output to **2 kHz**.
 - 5 Press **Enter**.
- Check that a BNC cable is connected between the channel connector and the CAL connector on the mainframe, rather than connected to a Calibration connector on a plug-in.
- If your plug-in requires an external trigger, check that the CAL signal is split between the channel connector and the trigger connector.
- Check that the plug-in is securely seated in the mainframe and that the knurled screw is finger-tightened.
- Check that the BNC cables you are using are good cables.
- Try using a different plug-in.

If the oscilloscope still cannot find a signal, refer to chapter 5, "Troubleshooting" in this service guide.

Testing Interval 3-2
Equipment Required 3-2
Test Record 3-2
Keystroke Conventions 3-2
Operating Hints 3-3
To test the front panel CAL signal 3-4
To test time interval accuracy 3-6

Testing Performance

Testing Performance

The procedures in this chapter test the instrument's electrical performance using performance specifications given in chapter 1 as performance standards. Specifications applicable to individual tests are noted at the test for reference.

Testing Interval

The performance test procedures may be performed for incoming inspection of the instrument and should be performed periodically thereafter to ensure and maintain peak performance. The recommended test interval is yearly or every 2,000 hours of operation. Amount of use, environmental conditions, and the user's experience concerning need for testing will contribute to verification requirements.

The calibration interval is covered in chapter 4 "Calibrating and Adjusting."

Equipment Required

A complete list of equipment required for the performance tests is in the Recommended Test Equipment table in chapter 1. Equipment required for individual tests is listed in the test. Any equipment satisfying the critical specifications listed may be substituted for the recommended model.

Test Record

The results of the performance tests may be tabulated on the Test Record provided at the end of this chapter. The Test Record lists the performance tests and provides an area to mark test results. The results recorded in the table at incoming inspection may be used for later comparisons of the tests during periodic maintenance, troubleshooting, and after repairs or adjustments.

Keystroke Conventions

To guide you while setting up the oscilloscope the following conventions are used to represent keystrokes and other interactions with the instrument:

Text in a box, such as `Utility` or `Time base`, represents hardkeys, those defined by text on the front panel.

Bold text in a typewriter font, such as **Display** or **Calibrate...**, represents text on the CRT screen and may be a softkey you should press or a message to consider.

The blue key that has no writing on it is a shift key. It allows you to access the functions written in blue above some of the hardkeys. In this manual it is represented by a box with the word "blue" in it, like this: `(blue)`.

Operating Hints

Some knowledge of operation of the HP 54720A is helpful; however, procedures are written so that little experience is necessary. The following two hints will speed progress of the testing.

Clear Display

When using many averages, it often takes awhile for a waveform display to stabilize after a change. When a control on the HP 54720A is changed, averaging automatically restarts. When just the input signal is changed, the instrument must average new data with the old so it takes a long time for the waveform to stabilize. If you press CLEAR DISPLAY while changing input signals, the instrument will restart averaging and give a quick indication of the result of the signal change.

Averaging

Averaging is used to assure a stable signal for measurements. It is not necessary to wait for complete stability of the signal (averaging complete) as long as the measurement is well within the limits of the test.

CAUTION

Allow the instrument to warm up for at least 20 minutes prior to beginning performance tests.

To test the front panel CAL signal

This procedure is used to test the accuracy of the front-panel calibration signal. This signal is used to perform all calibration of the instrument.

Specification

Output delta voltage accuracy -2.5 V to +2.5 V (into 50 Ω), Accuracy $\pm 0.2\%$ of delta voltage output

AC Output (all parameters are approximate), 2 kHz and 500 kHz, rise & fall times: 1.6ns, amplitude: 1 Vp-p (into 50 ohms)

NOTE: The ac output does not have specified parameters, but since its edges are used in calibration it should be checked.

Equipment Required:

Equipment	Critical Specifications	Recommended Model/Part
DMM	6 1/2 digit, 0.1mV resolution, dc accuracy 0.05% or better	HP 34401A
Oscilloscope	approximately 1 GHz bandwidth	HP 54720A with HP 54711A, 54712A, or 54721A
Cable	BNC	HP 10503A
Adapter	BNC (f) to dual banana (m)	HP 1251-2277

Check the dc accuracy

- 1 Set up the DMM to measure DC volts and use the cable and adapter to connect the DMM to the front-panel CAL output.
- 2 Press **Utility**, then **Calibrate...**, then **output**.
- 3 Select **DC** and press **Enter**.
- 4 Using either the Entry keypad or RPG knob, enter 2.5 V and record the reading.
_____ Vdc
- 5 Using either the Entry keypad or RPG knob, enter -2.5 V and record the reading.
_____ Vdc
- 6 Subtract the second reading from the first, and divide the result by 5.

Example:

(first reading, +2.498 V) - (second reading, -2.497 V) = 4.995 V

4.995 V \div 5 V = 0.999 (within specifications)

The final result should be between 0.998 and 1.002. Record the result in the Performance Test Record.

Check the ac characteristics

The following measurements are for approximate parameters. The normal accuracy vertical characteristics of the HP 54720 family are 3% and timing accuracies are much better. You can use an HP 54720A (with an HP 54711A, 54712A, or 54721A plug-in) to check the parameters of its own ac CAL signal.

If you use an HP 54711A plug-in, connect the CAL signal to both the channel and trigger inputs with short BNC cables and a BNC tee. Because the CAL signal is loaded by two 50 Ω loads, the signal amplitude will be about 67% of that shown in the test.

- 1 Press **utility** , then press **Calibrate...**, and then press **output**.
- 2 Select **2 kHz**, and press **Enter**.
- 3 Connect the CAL output to a channel of the HP 54720A or the input of another oscilloscope.
- 4 Press **Autoscale** , then measure the amplitude and frequency.
 - For amplitude, press **(blue)** , then **V amptd** , select the channel to be measured, and press **Enter**.
 - For frequency, press **(blue)** , then **Freq** , select the channel to be measured, and press **Enter**.

Read the values below the graticule. The frequency should be about 2 kHz, and amplitude should be approximately 1 V, when terminated into 50 ohms.

- 5 Change output from 2 kHz to 500 kHz.
 - a Press **Utility** , then press **Calibrate...**, and then press **output**.
 - b Select **500 kHz** and press **Enter**.
- 6 Read the frequency and amplitude below the graticule.

The frequency should be approximately 500 kHz and amplitude should be approximately 1 V, when terminated into 50 ohms.
- 7 Press **Time base** and change the **Scale** to **5.00 ns/div** and **Position** to **0.0 s**.
- 8 Measure the rise time. It should be approximately 1.6 ns.
 - Press **(blue)** then **Rise** , select the channel to be measured, then **Enter**.
- 9 Measure the fall time. It should be approximately 1.6 ns also.
 - a Press **Trigger** , then press **Slope** to set it to the negative edge.
 - b Press **(blue)** then **Fall** , select the channel to be measured, then **Enter**.

To test time interval accuracy

This test checks the accuracy of the timing measurements of the HP 54710A and 54720A.

Specification

Real Time: $\pm[(0.2)(\text{sample interval}) + 0.007\% \text{ of } \Delta\text{time marker reading}]$

Equivalent Time (16 averages): $\pm(30 \text{ ps} + 0.007\% \text{ of } \Delta\text{time marker reading})$

Equipment Required:

Equipment	Critical Specifications	Recommended Model/Part
Signal Generator	40 Mhz and 300 Mhz, frequency accuracy $\pm 0.1\%$	HP 8664A
RF Amplifier	40 MHz to 1 GHz, 26 dB gain, output rise time varies as a function of signal input amplitude	HP Model 8447D
Oscilloscope plug-in	for HP 54710, 54720 mainframe	HP 54711A, 54712A, 54713A, or 54721A
Adapter (2)	N (m) to BNC (f)	HP 1250-0780
Cable (2)	BNC, 36-inch	HP 10503A

This additional equipment is needed if you are using a 54711A plug-in

Power Splitter	>500 MHz bandwidth	HP 11667A
Cable (2)	BNC, 9-inch	HP 10502A
Adapter (3)	N (m) to BNC (f)	HP 1250-0780

Procedure

This test uses an RF signal generator with an accurate frequency specification to test timing accuracy. The signal generator overdrives an RF amplifier to give a faster edge to the signal.

If the test is made using the HP 54721A the real time results are different because the sample rate is double on that plug-in. Two result requirements are given for real time tests. Use the requirement for the plug-in you are using.

- 1 Connect the equipment.
 - a Put the plug-in into mainframe slot 1.
 - b Connect the signal generator output to the RF Amplifier input.
 - c Connect the output of the amplifier to the channel 1 input.
 - d If the plug-in is a 54711A, use the power splitter and other cables to connect the signal to the external trigger input as well.
- 2 Set the signal generator for 40 Mhz with a + 2dBm output amplitude.

- 3 Press **Setup** , then **Default setup**, then **Autoscale** , then change the oscilloscope parameters as follows:

Menu (hardkey)	Parameter	Setting
Channel	Scale	500 mV/div
	Input (54713A)	dc 50Ω
Time base	Scale	5.00 ns/div
	Position	-5.000 ns
Trigger	Level	as required for stable trigger
Acquisition	Averaging	On
	Number of averages	16
	Record length	manual, 4096 points
	Press Done	
Define meas	Press Define Δtime	
	Stop edge	rising
	Edge number	2
	Press Done	

You should have about 2 cycles of a square wave signal.

- 4 Measure the rise time of the signal to check its quality.

Press **(blue)** then **Rise** , then **Enter**.

The rise time should be between 700 ps and 900 ps. If not, vary the signal generator output amplitude to achieve this. This is a critical parameter for this test.

- 5 Measure the period of the signal.

Press **(blue)** , then **Δtime** , then **Enter**.

- 6 Read the **Δtime (1)-(1)** at the bottom of the display and record the reading in the Performance Test Record. _____ ns

The time should be 25.000 ns ±32 ps, 24.968 ns to 25.032 ns.

- 7 Press **Acquisition** then select **real time**.

- 8 Press **stop/single** to stop acquisition.

- 9 Read and record the **Δtime** in the Performance Test Record. _____ ns

With the HP 54711A/12A/13A plug-ins it should be 25.000 ns ±102 ps, 24.898 ns to 25.102 ns.

With the HP 54721A plug-in it should be 25.000 ns ±52 ps, 24.948 ns to 25.052 ns.

- 10 Press **Time base** and change the scale to 50.0 ns/div.

- 11 Press **Define meas** , then **define Δtime**.

- 12 Change the **stop edge number** from 2 to 19 and press **Done** .

- 13 Read and record the **Δtime** in the Performance Test Record. _____ ns

With the HP 54711A/12A/13A plug-ins it should be 450.000 ns ±132 ps, 449.868 ns to 450.132 ns.

With the HP 54721A plug-in it should be 450.000 ns ±82 ps, 449.918 ns to 450.082 ns.

- 14 Press Run.
- 15 Press , then select **Equivalent Time** and turn **Averaging ON**.
- 16 Read and record the Δ time in the Performance Test Record. _____ ns
It should be 450.000 ns \pm 62 ps, 449.938 ns to 450.062 ns.
- 17 Press and change the **scale** to **1.00 ns/div**.
- 18 Set up the signal generator.
 - a Change the frequency to 300 Mhz (3.333 ns period).
 - b Change the output level to -12 dBm.
 - c Press and readjust the trigger level for a stable display.
 - d Check the rise time of the signal. It is shown at the bottom of the display. If it is not shown, see step 4.
The rise time should be between 750 ps and 900 ps. If not, vary the signal generator amplitude to achieve this.
- 19 Press , then **define Δ time**.
- 20 Change the **stop edge number** to **2** and press **Done**.
- 21 Read and record the Δ time in the Performance Test Record. _____ ns
It should be 3.333 ns \pm 30 ps, 3.303 ns to 3.363 ns.
- 22 Press then select **real time**.
- 23 Press to stop acquisitions.
- 24 Read and record the Δ time in the Performance Test Record. _____ ns
With the HP 54711A/12A/13A plug-ins it should be 3.333 ns \pm 100 ps, 3.233 ns to 3.433 ns.
With the HP 54721A plug-in it should be 3.333 ns \pm 50 ps, 3.283 ns to 3.383 ns.
- 25 Press Run
- 26 Press and change the **scale** to **10.0 ns/div**.
- 27 Press , then select **Equivalent Time** and turn **Averaging ON**.
- 28 Press , then **define Δ time**.
- 29 Change the **stop edge number** to **26** and press **Done**.
- 30 Read and record the Δ time in the Performance Test Record. _____ ns
It should be 83.332 ns \pm 36 ps, 83.296 ns to 83.368 ns.

Table 3-1. Performance Test Record

	HEWLETT PACKARD	HP 54710A, 54720A Oscilloscope
Serial No. _____		Tested by _____
Recommended Test Interval - 1 Year/2000 hours		Work Order No. _____
Recommended next testing _____		Date _____
		Temperature _____

Test	Limits	Results
CAL Accuracy	1.000 ±0.002 0.998 to 1.002	_____
Time Interval Accuracy	25.000 ns ±32 ps 24.968 ns to 25.032 ns	_____
	25.000 ns ±102 ps 24.898 ns to 25.102 ns	_____
or *	25.000 ns ±52 ps 24.948 ns to 25.052 ns	_____
	450.000 ns ±132 ps 449.868 ns to 450.132 ns	_____
or *	450.000 ns ±82 ps 449.918 ns to 450.082 ns	_____
	450.000 ns ±62 ps 449.938 ns to 450.062 ns	_____
	3.333 ns ±30 ps 3.303 ns to 3.363 ns	_____
	3.333 ns ±100 ps 3.233 ns to 3.433 ns	_____
or *	3.333 ns ±50 ps 3.283 ns to 3.383 ns	_____
	83.332 ns ±36 ps 83.296 ns to 83.368 ns	_____
	* The first result of this pair is for tests using the HP 54711A, 54712A, or 54713A plug-ins. The second is for tests using the HP 54721A plug-in.	

Equipment Required 4-2
Keystroke Conventions 4-2

Calibrating the Oscilloscope 4-3

Calibration Overview 4-3

Calibration Interval 4-5

Calibration Status Displays 4-6

To calibrate the mainframe 4-9

To calibrate the plug-ins 4-11

To calibrate for best accuracy 4-12



Adjusting the Color CRT Module 4-14

Equipment Required 4-14

To prepare the instrument 4-14

To adjust geometry 4-16

To adjust focus, landing, and convergence 4-17

To adjust white balance 4-24

Calibrating and Adjusting

Calibrating and Adjusting

Calibration of the HP 54700 family is done with internally generated signals. The only other equipment required is an HP 54717A calibration module, general purpose attenuators and terminations, and cables. There is no need to remove covers for mainframe calibration. Plug-in covers must be removed for plug-in calibration (normal accuracy).

There are no adjustments in the acquisition systems of the HP 54710A and 54720A oscilloscopes. There are adjustment procedures for the color display, but these need to be done only if the display needs correction.

Equipment Required

Equipment required for these procedures is listed in the Recommended Test Equipment table in chapter 1 of this manual. Any equipment that satisfies the critical specification listed in the table may be substituted for the recommended model. Equipment for individual procedures is listed at the procedure.

Keystroke Conventions

To guide you while setting up the oscilloscope the following conventions are used to represent keystrokes and other interactions with the instrument:

Text in a box, such as `Utility` or `Time base`, represents hardkeys, those defined by text on the front panel.

Bold text in a typewriter font, such as **Display** or **Calibrate...**, represents text on the CRT screen and may be a softkey you should press or a message to consider.

The blue key that has no writing on it is a shift key. It allows you to access the functions written in blue above some of the hardkeys. In this manual it is represented by a box with the word "blue" in it, like this: `(blue)`.

Calibrating the Oscilloscope

With any exceptions noted where they apply, this section includes all procedures needed to calibrate the HP 54720A and 54710A mainframes with plug-ins. Plug-In calibration is part of the service guide for each specific plug-in. However, the prompts on the display direct the calibration details, so the procedures in this section apply to all plug-ins.

Some plug-ins, however, may require adjustment after certain repairs. See the plug-in service guide for the procedures necessary after repair.

Calibration Overview

This section briefly explains the calibration of the HP 54710A and 54720A oscilloscopes. It is intended to provide an understanding of calibration levels available and how they should be used.

The levels of accuracy provided by calibration procedures are given in the specifications and characteristics in chapter 1. Unless otherwise specified, characteristics given in the following paragraphs are typical and approximate.

There are three calibration levels:

- Normal accuracy
- Best accuracy
- Probe cal

These are accomplished by using four calibration procedures:

- Frame calibration
- Plug-In calibration
- Best-accuracy calibration
- Probe calibration

Normal accuracy

Normal accuracy is achieved by performing only the frame calibration and plug-in calibration. This is the basic level of accuracy, which provides typical vertical accuracies of $\pm 3\%$ with any calibrated plug-in installed in any front-panel slot in any calibrated mainframe. These characteristics hold for the standard calibration interval and over a $\pm 5^\circ\text{C}$ temperature range.

For instruments that use more than one mainframe slot, such as the HP 54721A, interleaving of the two slots is done during the best-accuracy calibration. Typically therefore, a real time display from these plug-ins will not be useful when only a normal accuracy calibration has been done. A Best-accuracy calibration must be done to use multiple-slot plug-ins in the real time mode.

Frame Calibration Frame calibration allows the oscilloscope to establish calibration factors for each slot, independent of plug-ins. These factors are stored in non-volatile RAM in the mainframe. These calibration factors are protected by a switch that allows calibration to be enabled or disabled. This switch can be accessed through a hole in the rear panel. The hole can be covered by a sticker if frame calibration is to be denied.

Plug-In Calibration Plug-In calibration allows the oscilloscope to establish the calibration factors for a particular plug-in independent of the frame in which it is calibrated. These calibration factors are stored in EEPROM in the plug-in, so the factors stay with the plug-in, not with the frame the plug-in was calibrated in.

Since the intent is for the oscilloscope to determine the calibration factors for the plug-in only, plug-in calibration should be done right after a frame calibration so that any drift in the frame calibration (due to time or temperature) doesn't cause drift in the calibration factors of the plug-in.

A switch in the plug-in is used to enable or disable plug-in calibration. The cover of the plug-in must be removed to gain access to the switch. A sticker can be placed over the edge of the cover to deny access to the switch.

Best Accuracy

Best-accuracy specifications require an additional calibration operation. Best-accuracy specifications are valid for a given plug-in in the same slot, for a set period of time, and for a certain temperature range. A plug-in can be best-accuracy calibrated in more than one slot but a given slot can be best-accuracy calibrated to only one plug-in.

The intention is that to insure the best measurement results, a best-accuracy calibration should be done just before critical measurements are made. The calibration is quick and easy, and requires only a short BNC cable.

The oscilloscope establishes best-accuracy calibration factors by calibrating the plug-in and the frame slot as a system. These calibration factors are stored in non-volatile RAM in the mainframe. The oscilloscope will keep these calibration factors for a plug-in/slot combination until a plug-in with a different serial number is best-accuracy calibrated in that slot. This means a plug-in that has been calibrated to best accuracy in a particular frame slot can be removed for a time, then re-installed later. The best-accuracy calibration will still be valid as long as no other plug-in was best-accuracy calibrated in that slot in the meantime, and the calibration has not been invalidated by time or a temperature difference.

A best-accuracy calibration provides the best vertical measurement results for a given channel (plug-in/slot combination). Also, plug-ins that use more than one slot must be calibrated for best accuracy to be useful in realtime mode.

Like frame calibration, best-accuracy calibration is limited by a $\pm 5^{\circ}\text{C}$ temperature range. The temperature difference since the last calibration is shown in the calibration status displays. In order for a channel to meet the best-accuracy specifications, both the Current Frame ΔTemp and the Best Accuracy ΔTemp must be between $\pm 5^{\circ}\text{C}$. In other words, the temperature of the oscilloscope must be within 5°C of the frame calibration temperature and the best-accuracy calibration temperature.

To check the instrument temperature change, see "Calibration Status Displays" in this chapter.

Probe Calibration

Probe calibration allows the oscilloscope to establish the gain and offset of a probe and apply those factors to the calibration of the channel that probe is connected to.

To achieve the most accuracy, the probe should be calibrated to a channel with a valid best-accuracy calibration. The typical vertical accuracy in this case is $\pm 2\%$. A probe calibrated to a channel with a valid normal accuracy calibration will provide typically $\pm 4\%$ vertical accuracy.

For active probes that the oscilloscope can identify through the probe power connector, such as the 54701A, the oscilloscope will automatically adjust the vertical scale factors for that channel even if a probe calibration is not done. For passive probes or other unidentified

probes, the scope will adjust the vertical scale factors only if a probe calibration is done. Without a probe calibration, the probe attenuation factor can be entered manually, through the menus.

If a probe being calibrated has an attenuation that will allow the oscilloscope to adjust its gain (in hardware) to produce even steps in the vertical scale factors, the oscilloscope will do so. If the probe being calibrated has a unusual attenuation (such as 3.75, etc) the oscilloscope may have to adjust the vertical scale factors to an unusual number (3.75V/div, etc.). Typically probes have standard attenuation factors such as $\div 10$, $\div 20$, or $\div 100$.

Calibration Interval

Calibration interval varies with the type of calibration involved.

Mainframe and Plug-In Calibration

Mainframe and plug-in calibration should be done under either of the following conditions:

- Yearly or every 2,000 hours of operation.
- If the instrument temperature is more than 5°C different than the temperature when the last calibration was done.
- If you are going to use it to calibrate plug-ins.
- If you have replaced one of the following assemblies.
 - CPU assembly (calibration factors are stored on the CPU assembly)
 - Time base assembly
 - Clock assembly
 - Acquisition assembly

Best-Accuracy Calibration

Best-accuracy calibration should be done under any of the following conditions:

- When the most accurate vertical measurements are necessary.
- If the instrument temperature is more than 5°C different than the temperature when the last calibration was done.
- If the best-accuracy time limit has expired.

For further information see "Calibration Overview" and "To calibrate for best accuracy" in this chapter.

Caution

For temperature stability, all calibration must be done with the rear panel installed. An instrument warm-up of 20 minutes is recommended before starting these procedures.

Calibration Status Displays

The calibration status displays show the current calibration status of the mainframe and plug-ins for normal accuracy and best accuracy. There are two displays, one through the Utility menu and one, specifically for each plug-in, through the channel setup menu.

The status of Calibration Memory and Best Accuracy Memory protection, and the Current Frame and plug-in Δ Temp, update only when the Cal status display is entered.

Frame Calibration Status

The following figure shows the display, and the table explains the features. This display also shows an abbreviated version of the plug-in status.

To enter this display press **Utility**, then **Calibrate...**, then press **Cal status** to turn it on.

Figure 4-1

The screenshot shows a terminal-style display with the following content:

```

Current Frame  $\Delta$ Temp : 1 °C
                    Frame
Calibration Status  : Calibrated
Last Calibration   : 12 JUN 92 16:47
Calibration Memory : Protected
Best Accuracy Memory : Unprotected

Slot  Vertical  Failure Code  Trigger  Failure Code
----  -
1     Passed
2     Passed
3     Passed
4     Passed
Other Calibration Status : Passed
Comments:

                    Plug-ins
                    Last Calibration
Slot  Model  Memory  Date  Time  Accuracy   $\Delta$ Temp
----  -
1     54711A Protected  5 JUL 92 16:34 Best Normal 0 °C
2     54713A Protected  5 JUL 92 16:36 Best Normal 0 °C
3     54721A Protected  5 JUL 92 16:39 Best Normal 0 °C
4
    
```

On the right side of the display is a control panel with the following buttons:

- Calibrate**
- Calibrate plug-in...**
- Calibrate frame**
- Cal status**
- off** (with a small icon)
- Output**
- 2 kHz**
- Exit**

Frame Calibration Status

Table 4-1

Frame Calibration Status

Frame

Current Frame ΔTemp	Displays the current internal temperature of the instrument compared to the temperature at which the frame was calibrated, in increments of one degree centigrade.
Calibration Status	Calibrated or Uncalibrated.
Last Calibration	Displays the date and time of the last frame calibration.
Calibration Memory	Shows the setting of the Frame cal memory protect switch.
Best Accuracy Memory	Shows the setting of the Best cal memory protect switch.
Slot	All front panel slots are calibrated during one calibration procedure
Vertical and Trigger	The pass/fail status of each section of the slot input. During calibration it shows Calibrating.
Failure Code	An eight digit code showing the reason for failure. These are for factory use.
Other Calibration Status	Passed, Failed, or Calibrating
Comments	This area is for text which can be programmed over the HP-IB. See "Calibrate Subsystem" in the HP 54710A and 54720A Programmer's Reference.

Plug-ins

Slot	The front panel plug-in position. A plug-in occupying more than one slot registers as the lowest numbered slot.
Model	The model number of the plug-in currently in the slot. Unfilled slots register "empty." If the mainframe does not recognize the plug-in, "--known" is displayed instead of the model number. If "--known" is displayed, refer to the User's Reference for the plug-in.
Memory	This shows the status of the calibration switch in the plug-in. It does not reflect the protection status of best-accuracy calibration. See "Plug-In Calibration Status". When calibration is disabled this shows Protected. When calibration is enabled this shows Unprotected.
Date	The date the plug-in was calibrated. This shows the date of the plug-in calibration (normal accuracy) or the date of the best-accuracy calibration.
Time	The time the plug-in was calibrated. This shows the time of the plug-in calibration (normal accuracy) or the date of the best-accuracy calibration.
Accuracy	This shows the plug-in calibration status, Uncalibrated, Normal (normal accuracy), or Best (best accuracy).
Δ Temp	The change in temperature since the best-accuracy calibration.

Plug-In Calibration Status

The following figure shows the plug-in calibration status display and the table explains the features.

To enter this display press **Channel** , then **Calibrate...**

Figure 4-2

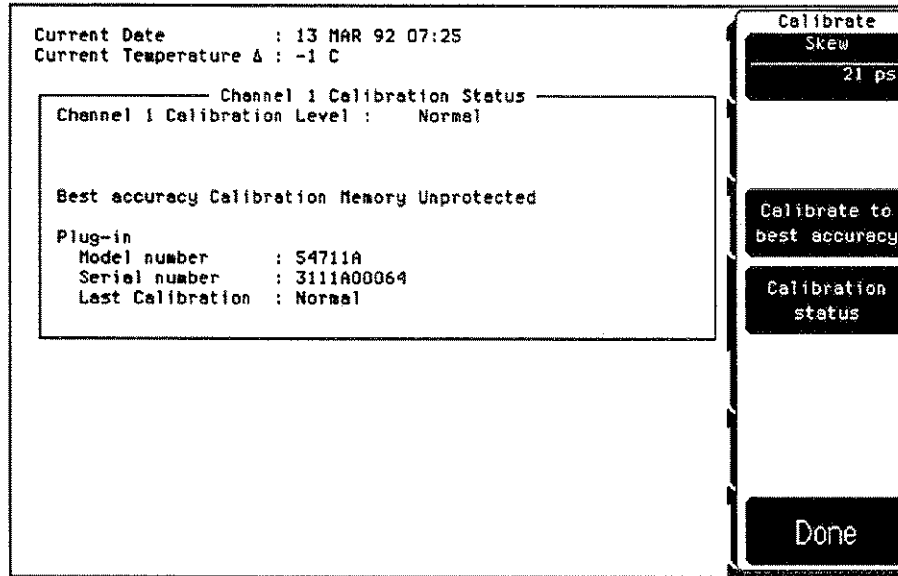

Plug-In Calibration Status

Table 4-2

Plug-In Calibration Status

Current Date	Date and time reflected by the internal clock.
Current Frame ΔTemp	The current internal temperature of the instrument compared to the temperature at which the frame was calibrated, in increments of one degree centigrade.
Channel X Calibration Level	Uncalibrated, Best, or Normal
Best Accuracy Calibration Memory	Protected or Unprotected. The Best Accuracy Calibration Memory is protected by a switch in the mainframe. See "To calibrate for best accuracy."
Plug-in	This shows other relevant plug-in data. The model number is derived from a hardware ID on the PC board The serial number is set through the Utility Service menu. Last Calibration is the date and time of the relevant calibration level. Best Accuracy ΔTemp is the change in temperature since a best-accuracy calibration.

To calibrate the mainframe

Calibration by the instrument firmware is done using the front panel CAL output. The CAL output must be performance tested before an accurate calibration can be assured.

Equipment Required

Equipment	Critical Specifications	Recommended Model/Part
Calibration module	no substitution	HP 54717A
Attenuator	20 dB, BNC	HP 8490 Series Opt 20, with adapters or Narda 755B-20
Cables (3)	BNC, 9-inch (equal length)	HP 10502A
Adapter	BNC Tee (m)(f)(f)	HP 1250-0781
Adapter (2)	Type N(m) to BNC(f)	HP 1250-0780
Termination (optional)	BNC 50 Ω	HP 10100C

Procedure

If calibration is canceled during the process, the previous calibration factors will be retained.

CAUTION

The rear panel and all rear-panel hardware must be installed when calibrating the instrument. The instrument must have warmed up for 20 minutes.

- 1 Set the mainframe calibration protect switch to the unprotected position.
 - a Find the cal protect switches on the rear panel. See the figure below.
 - b Set the left-most switch to the down position.

The protection status displayed on screen will not change unless the calibration status display is exited and re-entered.



Figure 4-3

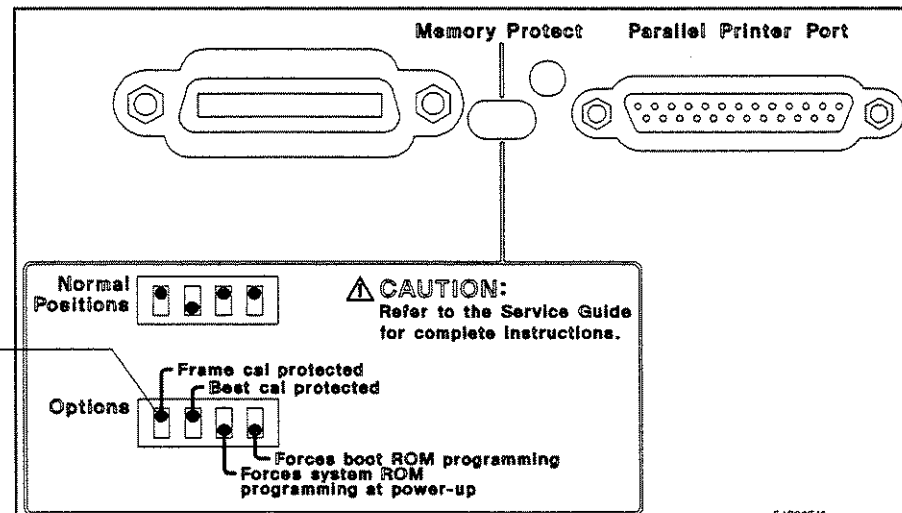

Rear-Panel Calibration Protect Switches

- 2 Press **Utility**, then **Calibrate...**, then **Calibrate frame**.
- 3 Follow the prompt on the display.
 - Remove all plug-ins.
 - Disconnect everything from the CAL output.
- 4 Press **Continue**. Monitor the calibration status bar.
- 5 When calibration is complete, follow the prompt on the display.
 - Install the HP 54717A calibration plug-in in slot 1.
- 6 Follow the prompt on the display.
 - Connect the CAL output to the plug-in Channel input.
 - Connect a termination to the Trigger input.
 - Use either the 20 dB pad or the 50 Ω feedthrough as a termination.
- 7 Press **Continue** and wait for the next prompt.
- 8 Follow the prompt on the display.
 - Connect the CAL output to the plug-in Trigger input.
 - Connect the termination to the Channel input.
- 9 Press **Continue** and wait for the next prompt.
- 10 Follow the prompt on the display.
 - Connect the CAL output through a 20 dB pad to both the Channel and Trigger inputs using a BNC tee and two short cables of equal length.
- 11 Press **Continue** and wait for the next prompt.
 - When the calibration is complete, whether passed or failed, the instrument will prompt you to calibrate the next slot.
- 12 Following the prompts on the display, calibrate the other three slots in the oscilloscope.
- 13 Return the mainframe calibration protect switch to the "protected" position.

To calibrate the plug-ins

Though plug-in calibration is not strictly part of the mainframe procedures, it is included here as a convenience to the service person.

You can calibrate any plug-in in any slot and in any mainframe. It will have normal accuracy in any other slot or mainframe. Of course, a mainframe that has just been calibrated will provide the optimal basis for a plug-in calibration. A mainframe that has drifted since its last calibration (even though it is still calibrated) may introduce skew into the plug-in calibration and provide less than optimum results. You should calibrate the mainframe just before calibrating plug-ins.

For the vertical accuracies valid after plug-in calibration, see the specifications and characteristics in chapter 1 of the plug-in service guide.

Equipment Required

Equipment	Critical Specifications	Recommended Model/Part
Cable	BNC, 12-inch	HP 8120-1838
Adapter (1) *	Type N(m) to BNC(f)	HP 1250-0780

* Adapter needed for calibrating HP 54711A only.

Procedure

CAUTION

The rear panel and all rear-panel hardware must be installed when calibrating the instrument. The instrument must have warmed up for 20 minutes.

- 1 Enable plug-in calibration.
 - a Remove the plug-in from the mainframe.
 - b With a small flat tool, remove the right-side plug-in cover by prying gently at the rear corners, lifting, and sliding it back.
 - c Set the calibration switch to the ENABLE position.
 - d Replace the cover and put the plug-in back into the mainframe.
- 2 Press `Utility`, then `Calibrate...`, then `Calibrate plug-in....`
- 3 Press `Plug-in` to select the plug-in to be calibrated.
- 4 Press `Start cal` and follow the instructions on the display.
- 5 After the instructions have been followed, press `Continue`.
The status bar will show the progress of calibration.
When calibration is complete, the display will show `Calibration completed`.
- 6 Disconnect the BNC cable, remove the plug-in, and return the calibration switch to the DISABLE position.
- 7 If desired, select the next channel to be calibrated and repeat the procedure.

To calibrate for best accuracy

The best-accuracy calibration is not part of mainframe calibration. Because of its 24-hour time limitation it is typically a user calibration. It is given here as a convenience to the service person.

A best-accuracy calibration improves the vertical characteristics of gain, offset, and linearity. For the parameters affected, see the specifications and characteristics in chapter 1 of the plug-in service guide.

Perform the best-accuracy calibration under the following circumstances:

- When you need the more accurate vertical specifications and
- When the current best-accuracy calibration is voided for one of the following reasons.
 - The 24 hour time limit on a best-accuracy calibration has expired.
 - The instrument Current Temperature Δ is more than $\pm 5^{\circ}\text{C}$.
 - In this case all of the mainframe and plug-in calibrations are void and a complete recalibration at the new temperature is necessary.
 - The temperature change since the current best-accuracy calibration is more than $\pm 5^{\circ}\text{C}$.
 - The plug-in has been moved to a mainframe slot where it does not have a valid best-accuracy calibration.

A plug-in may be best-accuracy calibrated in one or more mainframe slots. However, only one plug-in can be best-accuracy calibrated in a given slot. This last factor is dependent on the serial number of the plug-in rather than the model number.

Best-accuracy calibration factors are stored in memory in the mainframe. Calibration factors are protected by a separate switch next to the frame calibration protect switch behind the rear panel.

Equipment Required

Equipment	Critical Specifications	Recommended Model/Part
Cable	BNC, 12-inch	HP 8120-1838
Adapter (1) *	Type N(m) to BNC(f)	HP 1250-0780

* Adapter needed for calibrating HP 54711A only.

Procedure

CAUTION

The rear panel and all rear-panel hardware must be installed when calibrating the instrument. The instrument must have warmed up for 20 minutes.

- 1 On the channel to be calibrated, press , then **Calibrate**....
- 2 Check the status of the Best Accuracy Calibration Memory.
 - If it is Protected, go to the next step.
 - If it is Unprotected, skip the next step.

- 3 Set the Best cal protect switch to the unprotected position.
 - a Find the cal protect switches on the rear panel. See figure 4-3 on page 4-9.
 - b Set the second from the left switch to the down position.

The protection status displayed on screen will not change unless the calibration status display is exited and re-entered.
- 4 Press **Calibrate to best accuracy**.
- 5 Follow the instructions at the top of the display. Instructions may vary depending on the plug-in being calibrated.

To reach the channel input in slot 1 with a 9-inch cable, you must extend the cable slightly with a BNC tee or right-angle adapter.
- 6 After the instructions have been followed, press **Continue**.

The status bar will show the progress of calibration. The calibration time will vary with different models but will typically take only a few minutes.

When calibration is complete the display will show Calibration completed, the Channel X Last Calibration as Best, and the Last Calibration as the date and time reflected by the setting of the clock in the mainframe.
- 7 To calibrate other channels, press on that plug-in, then **Calibrate...**, then repeat steps 4 through 6.

Adjusting the Color CRT Module

Use these procedures to adjust the Color CRT Module to compensate for magnetic influences causing mis-convergence.

WARNING

Read the Safety Considerations at the beginning of this manual before performing adjustment procedures.

DO NOT PERFORM THESE ADJUSTMENTS AS A PART OF ROUTINE CALIBRATIONS. The following procedures are provided only for the few extreme cases where either the earth's magnetic field or the user's environment cause an unusable display due to mis-convergence which cannot be corrected by degaussing the entire CRT screen.

DO NOT continue this procedure before first degaussing the CRT screen using the rear panel degaussing switch. In extreme cases of magnetism, it may be necessary to degauss the CRT using a conventional external television-type degaussing coil.

It is recommended that these adjustments be performed only by qualified personnel who are familiar with color CRT convergence procedures.

Before starting the adjustments, mark the position where the potentiometers are set. This helps in returning the adjustments to their original positions if it becomes necessary to restart the procedure.

Equipment Required

The instrument firmware supplies the display patterns necessary for adjustment. The only tool required is a non-metallic adjustment tool:

- Sony Part Number 4-367-065-01
- HP Part Number 8710-1355

After the shields are removed, you can operate the instrument with the module connected and sitting at the front of the frame. However, the cables will be very short. You can make up a longer ribbon cable (4 feet) using the following parts.

- Ribbon cable (use 4 feet), HP Part Number 8120-1613, 3M Part Number 3365-40
- Cable connector (2 each), HP Part Number 1252-3124, 3M Part Number 3417-7600

To prepare the instrument

Note the original routing of all cabling for proper routing when the module is re-installed in the instrument. Then, re-route the cables from inside the module to the outside (left side) of the module for reconnection to the power supply for adjustments.

- 1** Remove the Color CRT Module from the instrument (see chapter 6 of this service guide).
- 2** Reconnect the instrument front panel and re-install the front panel (use two screws to temporarily hold the front panel in place).

- 3 Remove the right shield.
 - a Disconnect the display power cable from the connection in the shield.
 - b Remove the screws and slide the shield off of the module.
 - c Remove the power connector from the shield and reconnect it to the power cable from the instrument.
- 4 With the Color CRT Module placed in front of the mainframe, reconnect the module. During any of the following adjustments, the CRT module must face west.
- 5 Use the following chart to guide the procedure.

The following adjustments are broken down into adjustment groups. The adjustment group sequence must be followed in order because of interaction and dependency. The adjustment group sequence is shown in the adjustment flow diagram below. There will be cases where not all of the adjustments groups will be used. For example, if the Geometry Adjustment Group corrects the problem, this will be the only group used.

Figure 4-4

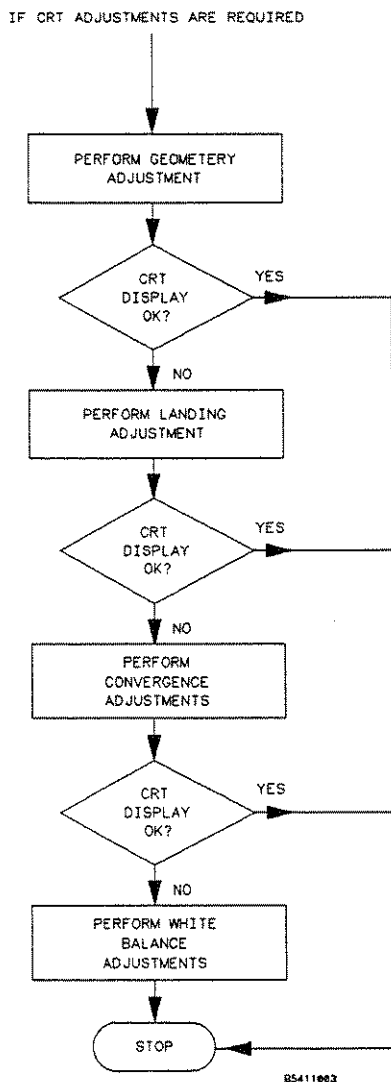

Color CRT Module Adjustment Flow Diagram

To adjust geometry

- 1 Display the white cross-hatch pattern on the CRT.
Press **Utility**, **Service**, **CRT Setup...**, then **CRT pattern on** keys to display the white cross-hatch pattern.
- 2 Preset front panel brightness control (top of the two controls to the left of the display) maximum clockwise.
- 3 Preset front panel contrast control (bottom of the two controls to the left of the display) to the mechanical center.
- 4 Preset H.SUB SHIFT (RV006) and V.SUB SHIFT (RV008), located on the bottom PC board, to the mechanical centers.

All of the following adjustment potentiometers are located on the PC board on the left side of the display.

- 5 Adjust the display size. Measure with a flexible ruler.
 - Adjust H.SIZE (RV504) for a 161 mm (6.34 in.) width.
 - Adjust V.HEIGHT (RV50) for a 120.5 mm (4.74 in.) height.
- 6 Center the pattern.
 - Adjust V.CENT (RV510) for vertical centering.
 - Adjust H.CENT (RV503) for horizontal centering.
- 7 Adjust PIN AMP (RV506) to eliminate pincushion distortion in the vertical lines of the cross-hatch pattern as shown in the next figure.

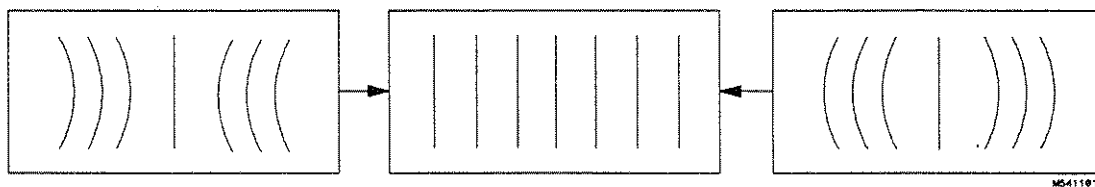

- 8 Adjust PIN PHASE (RV505) to eliminate pin phase distortion in the vertical lines of the cross-hatch pattern as shown in the next figure.

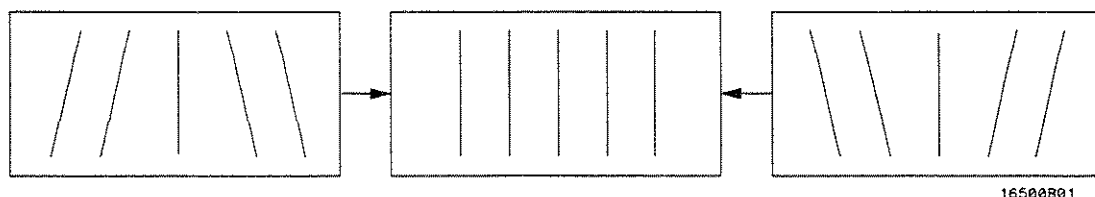

- 9 Adjust TOP PIN (RV511) so that the top horizontal line is parallel with the center horizontal line.
- 10 Adjust BOTTOM PIN (RV512) so that the bottom horizontal line is parallel with the center horizontal line.

To adjust focus, landing, and convergence

Once you have started, you will have to do all three of the procedures in this group.

Initial Preparation

- 1 Loosen the deflection yoke clamp screw.
- 2 Apply power and allow the instrument to thermally re-stabilize for 20 minutes.

Focus Adjustment

Geometry adjustments must be performed before making the focus adjustment.

- 1 Display the white cross-hatch pattern on the display.
Press **Utility**, **Service**, **CRT Setup . . .**, then **CRT pattern** keys to display the white cross-hatch pattern.
- 2 Adjust FOCUS (RV701), located on the rear PC board, for best overall focus.

Landing Adjustment

- 1 Turn the front panel BRIGHTNESS control fully clockwise.
- 2 Degauss the CRT by momentarily pressing the DEGAUSS switch located on the instrument rear panel.

In some cases, the user's environment or shipping environment may have caused high levels of magnetization in the CRT. In this case, to completely degauss the CRT it may be necessary to use a conventional television-type degaussing coil.

- 3 Set the purity magnet tabs to the mechanical center (see next figure).

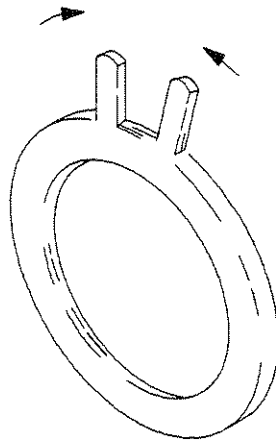

54720M06

- 4 Display a green raster on the display.

Press **Utility**, **Service**, **CRT Setup . . .**, press **Color purity** until green is highlighted then press **Enter**.

In the next steps, while moving the deflection yoke forward and rearward, rotate the yoke as necessary to keep the edges of the raster parallel to the sides of the display.

- 5 Move the deflection yoke rearward until the left edge of the raster turns red and the right side of the raster turns blue (see figure below).

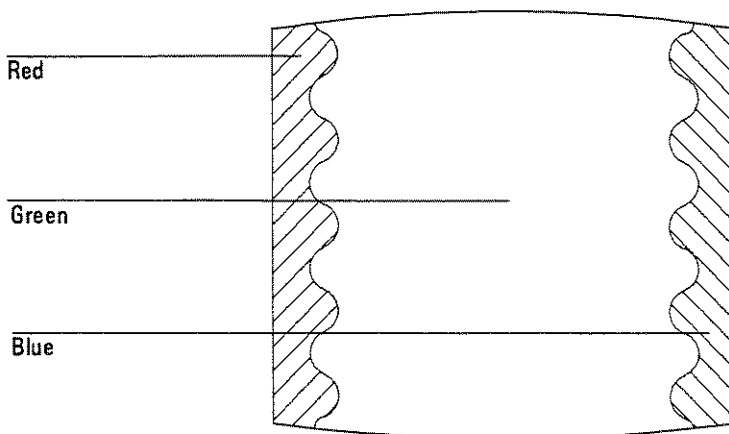

54720M07

- 6 Adjust the purity magnets until green is in the center of the raster with red and blue bands evenly distributed on the sides (see above figure).

- 7 Move the deflection yoke forward until the entire raster is green.
Landing adjustment is easier if the yoke is moved all the way forward and then moved back until the raster is completely green.
- 8 Using the Color Purity key, replace the green raster with red and then blue raster, each time checking for proper landing adjustment (color purity of each).
- 9 If the landing is not correct in step 9, repeat steps 6 through 9 for best compromise

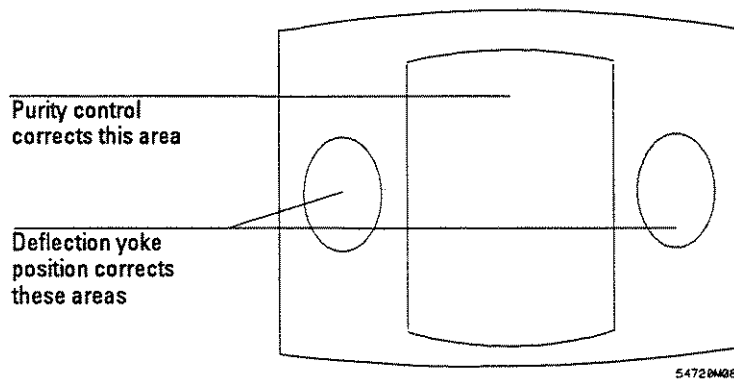

(see next figure).

- 10 If the landing is not correct in step 10, readjust purity magnets for best landing of each color.
- 11 When the landing adjustment is complete, tighten the deflection yoke clamp screw just enough to keep the yoke from moving. DO NOT over tighten.

Static Convergence

- 1 Temporarily disconnect the power from the instrument.
- 2 Remove the PC board shield cover from the rear of the Color CRT Module by prying evenly on all four sides.
- 3 Re-apply power.
- 4 Display the white cross-hatch pattern on the CRT.
Press **Utility**, **Service**, **CRT Setup . . .**, then **CRT pattern** keys to display the white cross-hatch pattern.
- 5 Preset front panel brightness control (top of the two controls to the left of the display) maximum clockwise.
- 6 Preset front panel contrast control (bottom of the two controls to the left of the display) to the mechanical center.
- 7 Check the four dots which are located around the center intersection of the cross-hatch pattern for coincidence of the blue, red and green dots.

If the dots are not coincident, adjust H.STAT (RV703) located on the rear PC board to obtain horizontal coincidence and V.STAT (RV803) located on the bottom PC board to obtain

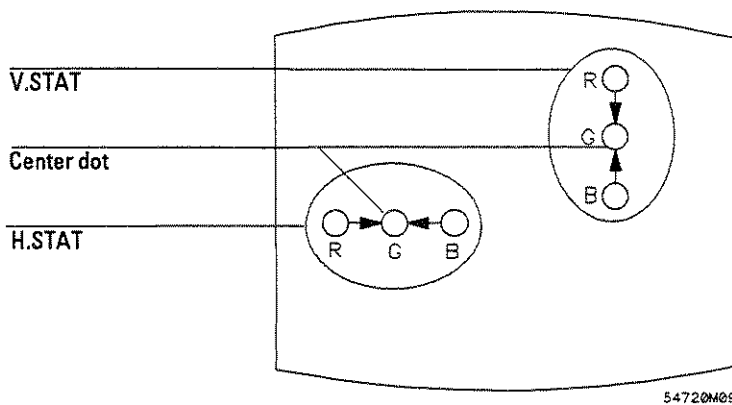

vertical coincidence (see figure below).

Due to interaction, the BEAM LANDING will need to be re-adjusted if either the H.STAT or V.STAT adjustments are made. Once the BEAM LANDING is re-adjusted, repeat step 7 above if necessary to obtain the center screen coincidence of the dots.

Dynamic Convergence

- 1 Display the white cross-hatch pattern on the CRT.

Press **Utility**, **Service**, **CRT Setup . . .**, then **CRT pattern** keys to display the white cross-hatch pattern.

- 2 Adjust Y BOW (RV805) located on the bottom PC board to eliminate red, green and blue bowing at the top and bottom of the center vertical line (see next figure).

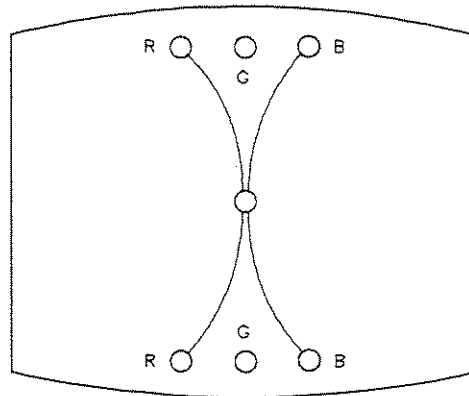

M5411005

- 3 Adjust Y CROSS (RV804) located on the bottom PC board to eliminate red green and blue orthogonal mis-alignment at the top and bottom of the center vertical line (see next figure).

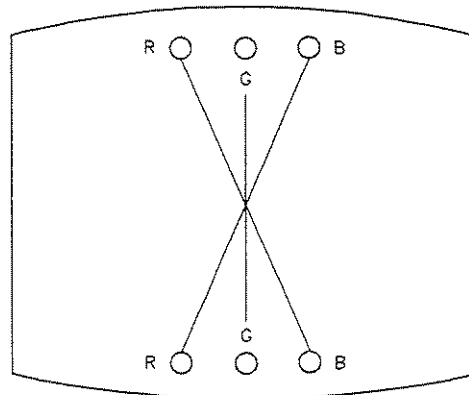

M5411006

- 4 Adjust V TOP (RV801) and V BOTTOM (RV802) located on the bottom PC board to obtain coincidence of the red, blue and green at the intersection of the top and bottom horizontal lines with the center vertical line. Use the next two figures for V TOP and V BOTTOM respectively.

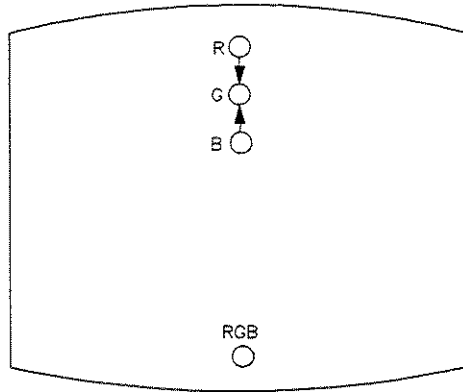

N5411007

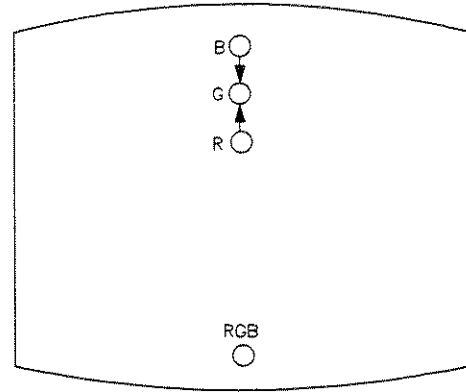

N5411008

- 5 Adjust H.AMP (RV807) located on the bottom PC board for equal amounts of mis-convergence at the right and left sides of the screen (see next figure).

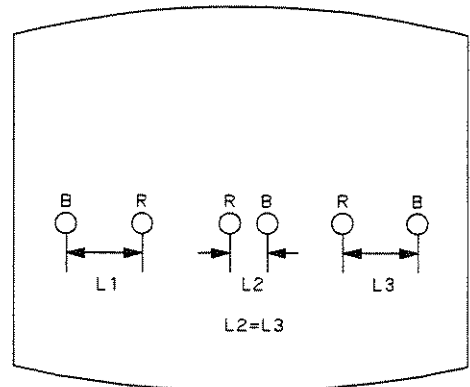
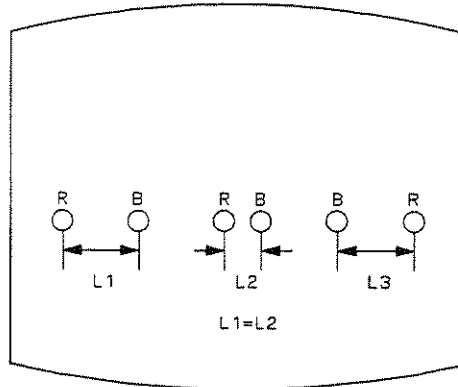

MS411009

- 6 Adjust H.TILT (RV806) located on the bottom PC board for coincidence of red, green and blue at the right and left sides of the screen (see next figure).

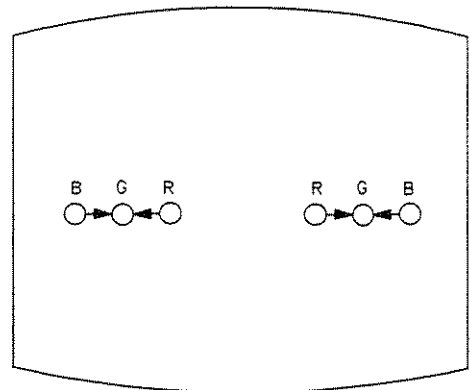
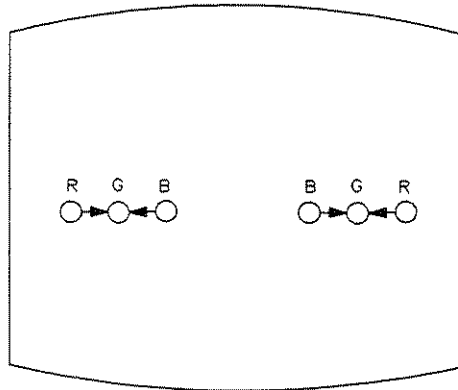

MS411018

To adjust white balance

1 Provide a blank display on the CRT.

Press **Utility**, **Service, CRT Setup . . .**, then **Color purity** key to display the black screen.

The completely blanked raster will contain the text for the function keys on the right side of the display, however, this will not affect the adjustment.

2 Preset front panel brightness and contrast controls to their mechanical centers.

3 On the bottom PC board, set the following adjustments to their mechanical centers.

- SUB BRT (RV901)
- SUB CONT (RV902)

4 On the bottom PC board, set the following adjustments to their mechanical centers.

- G. DRIVE (RV921)
- B. DRIVE (RV931)
- R. DRIVE (RV911)

5 On the rear PC board, set the following adjustments) fully counterclockwise (CCW).

- G. BKG (RV721)
- B. BKG (RV731)
- R. BKG (RV711)

6 Adjust SCREEN (RV702) located on the rear PC board until either the red, green or blue raster just starts to become visible. Note which color becomes visible first and do not adjust the background control (BKG) for that color in the next step.

7 Adjust the other two background controls for the best white balance.

8 Press Color Purity key as necessary to obtain the white raster.

9 Set the front panel brightness control to maximum.

10 On the bottom PC board, adjust the DRIVE controls (RV921, RV931 and RV911) for the best white balance.

For a white balance reference, use an average piece of white photocopy paper and compare the white on the CRT to the paper.

11 Repeat steps 1-3 and 6-10 until satisfied with the white balance.

Essentially, from this point the procedure is:

- a** With a blank screen, the front panel brightness set to center, and SCREEN (RV702) set for minimum background, adjust the BKG controls (G.-RV721, B.-RV731, and R.-RV711) for the best white balance.
- b** With a white raster and the front panel brightness set to maximum, adjust the DRIVE controls (G.-RV921, B.-RV931, and R.-RV911) for best white balance.
- c** Repeat until satisfied with the white balance.

- Safety 5-2
- ESD Precautions 5-2
- Keystroke Conventions 5-2
- Default Setup 5-2

- Trouble Isolation 5-3
- Tools Required 5-3
- 1, Primary Trouble Isolation 5-5
- 2, No-Display Trouble Isolation 5-11
- 3, Keyboard Trouble Isolation 5-19
- Missing Board Checks 5-22
- Interpreting Internal Self-tests 5-23
 - Clock 5-23
 - Acquisition 1 5-23
 - Acquisition 2 5-23
 - CPU 5-24
 - Display 5-24
 - Time Base 5-24
 - Floppy Disk 5-24
 - Front Panel 5-24
- Power Supply Distribution 5-25
 - General Supply Distribution 5-25
 - Fan Supply 5-25
 - Color CRT Module Supply 5-25
 - Power Standby Switch 5-25

- Utility Menu 5-27
- HP-IB Setup 5-27
- System Configuration 5-27
 - Time and Date 5-28
 - Declassify frame memory 5-29
 - Update system firmware 5-29
- Calibrate 5-29
- Self-test 5-30
- Firmware Support 5-30
 - Problem report 5-30
 - Firmware request 5-30
- Service 5-31
 - Plug-in 5-31
 - Frame 5-32
 - CRT setup 5-32

Troubleshooting

Troubleshooting

This section provides troubleshooting and other non-periodic maintenance information for the HP 54710A and 54720A Oscilloscopes. The service strategy of this instrument is replacement of defective assemblies. Some assemblies can be replaced on an exchange basis.

This chapter is divided into two sections.

- The Trouble Isolation section helps you find a defective assembly when the instrument fails.
- The Utility Menu section describes the various features of that menu and how to use them.

Safety

Read the Safety Summary at the front of this manual before servicing the instrument. Before performing any procedure, review it for cautions and warnings.

WARNING

Maintenance should be performed by trained service personnel aware of the hazards involved (for example, fire and electric shock). When maintenance can be performed without power applied, the power cord should be removed from the instrument.

ESD Precautions

When using any of the procedures in this chapter you should use proper ESD precautions. As a minimum you should place the instrument on a properly grounded ESD mat and wear a properly grounded ESD wrist strap.

Keystroke Conventions

To guide you while setting up the oscilloscope, the following conventions are used to represent keystrokes and other interactions with the instrument:

Text in a box, such as `Utility` or `Time base`, represents hardkeys, those defined by text on the front panel.

Bold text in a typewriter font, such as **Display** or **Calibrate...**, represents text on the CRT screen and may be a softkey you should press or a message to consider.

Default Setup

A Default Setup is provided to assure the instrument is in a known default state. The default setup prevents previous setups from interfering with the next test. The default setup also simplifies the instrument set up procedure.

To set the HP 54710A/54720A in the default state:

- 1 At the top of the instrument, press `Setup`.
- 2 At the bottom of the screen, press **Default Setup**.

Trouble Isolation

The trouble isolation information is provided to isolate a problem to a faulty assembly. When the faulty assembly has been located, the disassembly/assembly procedures in chapter 6 help direct replacement of the assembly.

The primary procedural tool in this section is the flowchart. The flowchart contains the entire troubleshooting path from failed instrument to working one. Reference letters on the flowcharts point to sections of reference text that expand on the brief prompts in the flowchart.

The flowcharts will direct you in an orderly manner through the possible failure symptoms. You will have problems if you try to troubleshoot by following only the reference text because the text is not in the correct order for troubleshooting. The flowcharts have the correct order of steps.

If you are unfamiliar with the HP 54710 and 54720, start with the Primary Trouble Isolation Flow chart on the next page.

Tools Required

Just the normal tools used when troubleshooting electronic equipment are needed. A good digital multimeter and an oscilloscope with about a 100 MHz bandwidth should be sufficient.

If you need to troubleshoot the color CRT module or plug-ins you can build extender cables using the parts listed below.

Color CRT module extender cable

This is a 40-conductor ribbon cable with 40-pin female connectors on each end. The cable should be about 4 feet long.

	Connector	Cable
3M Part No.	3417-6640	3365-40
HP Part No.	1251-8231	8120-1613

Plug-in extender cable

This is a 25 conductor cable with a 25-pin female sub-D on one end and a 25-pin male sub-D on the other. The cable should be about 2 feet long. You need to remove one conductor from the cable noted below.

	Female Connector	Male Connector	Cable
3M Part No.	8325-6000	8225-6000	3365-26
HP Part No.	1252-0048	1251-8352	8120-1506

If you need to remove and replace assemblies, you may need some of the hand tools listed in chapter 6 "Replacing Assemblies."

Figure 5-1

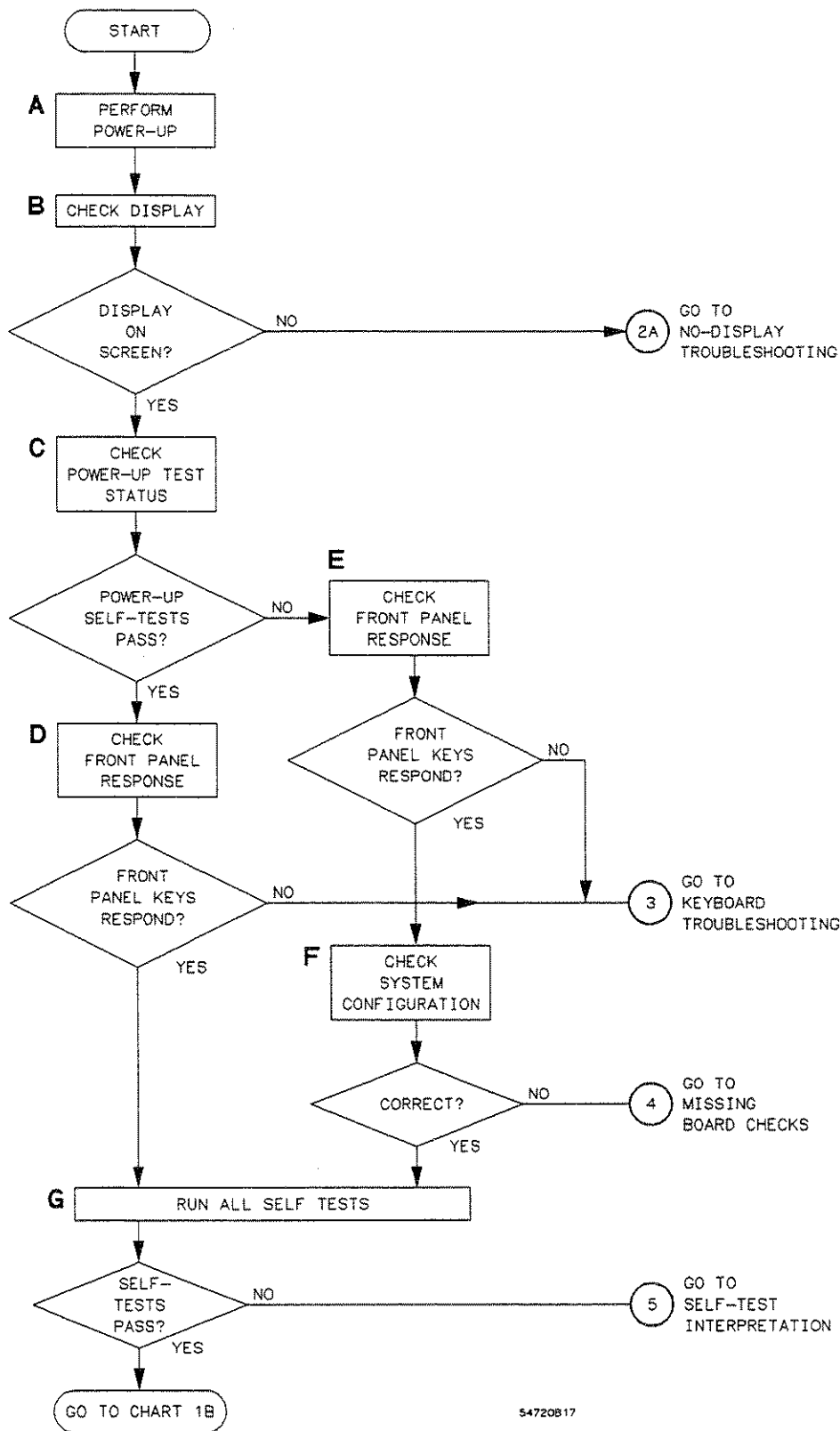

54720817

Primary Trouble Isolation Flowchart 1A

1, Primary Trouble Isolation

Except for moving the plug-ins between slots in the mainframe, the actions in the Primary Trouble Isolation Flowchart, figure 5-1, are performed without disassembling the instrument. Interaction of the front panel and other indications are used to help identify the problem area.

A letter is assigned to boxes in the flowchart. The letter corresponds to a specific section in the reference text. Be sure to use the flowchart itself for your troubleshooting path.

A Perform powerup

1 Turn on the instrument.

A few seconds after the instrument is turned on, the graticule and a function menu is displayed on the screen. The screen should look similar to Figure 5-2. Items in the softkey area will vary depending to the setup selected before the instrument was turned off.

Figure 5-2

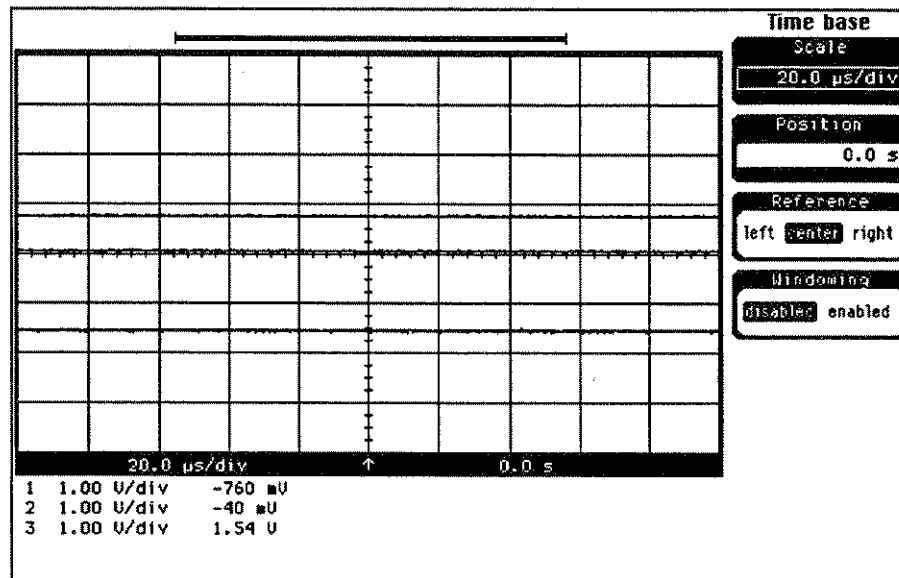

Power-Up Display, Timebase Menu

If a fault occurs on power up, the screen will display "Power-On Test FAILED!". The power-on test just runs a few essential self-tests.

2 In the Storage keys, press **Setup** , then **Default Setup**, then **Time base** .

B Check the display.

The display on screen should be similiar to Figure 5-2. If there is no display on the CRT screen after power up, go to the No-Display Trouble Isolation flowchart for further troubleshooting.

C Check power-on test status.

When the instrument is turned on the Power On Tests are performed. If the tests fail, a power-on test FAIL message will appear at the top of the CRT screen. It will stay on screen until a key is pressed. If the tests pass, no message is displayed. The Power On Test status is shown in the system configuration menu.

D/E Check the front panel response.

- Try pressing the different menu keys such as **Timebase** or **Trigger**, and the **Channel** keys on the plug-ins. Each of these keys should change the set of function keys on the right side of the screen.

F Check the system configuration

For more information about the system configuration menu, see "Utility Menus" in this chapter.

- 1 In the System keys, press **Utility** then press **System Config...**
- 2 Verify that the slots show that all the boards are installed, as in the figure below.
- 3 If the System Configuration is not showing a board in a slot, go to the "Missing Board Checks" for further trouble isolation procedures.

Figure 5-3

This assembly is not installed in the HP 54710A mainframe.

Frame					System config	
Model	:	54720A			Time	11:12:57
Serial Number	:	3207A00101			Date	15 JUL 1992
Calibration Memory	:	Protected			Declassify frame memory	
Power On Test	:	Passed			Update system firmware	
Firmware Revision	:	1.0			Exit	
Boot Revision	:	1.0				
Slot	Board	Power Statistics				
6	CPU	Total Pon Time	: 27.67 hrs			
5	Display	Length Last Poff	: 0.0 hrs			
4	Time base	Time Since Pon	: 0.44 hrs			
3	Clock	Power Cycles	: 45			
2	Acquisition					
1	Acquisition					
Plug-ins						
Slot	Model	Serial #	Analog BW	Calibration Memory		
1	S4711A	3207A00101	1.5 GHz	Protected		
2	S4713A	3207A00101	500 MHz	Protected		
3	S4721A	3207A00101	1.1 GHz	Protected		
4						

System Configuration

G Run all of the self-tests

- 1 In the System keys press **Utility**, then press **Self test...**
- 2 Toggle the **Board** softkey until **Test all boards** is highlighted, then press **Enter**.
- 3 Press **Start** and allow the instrument to run the tests.
- 4 If any of the self-tests fail, go to "Interpreting Internal Self-tests" for further information.

NOTES

Figure 5-4

1B

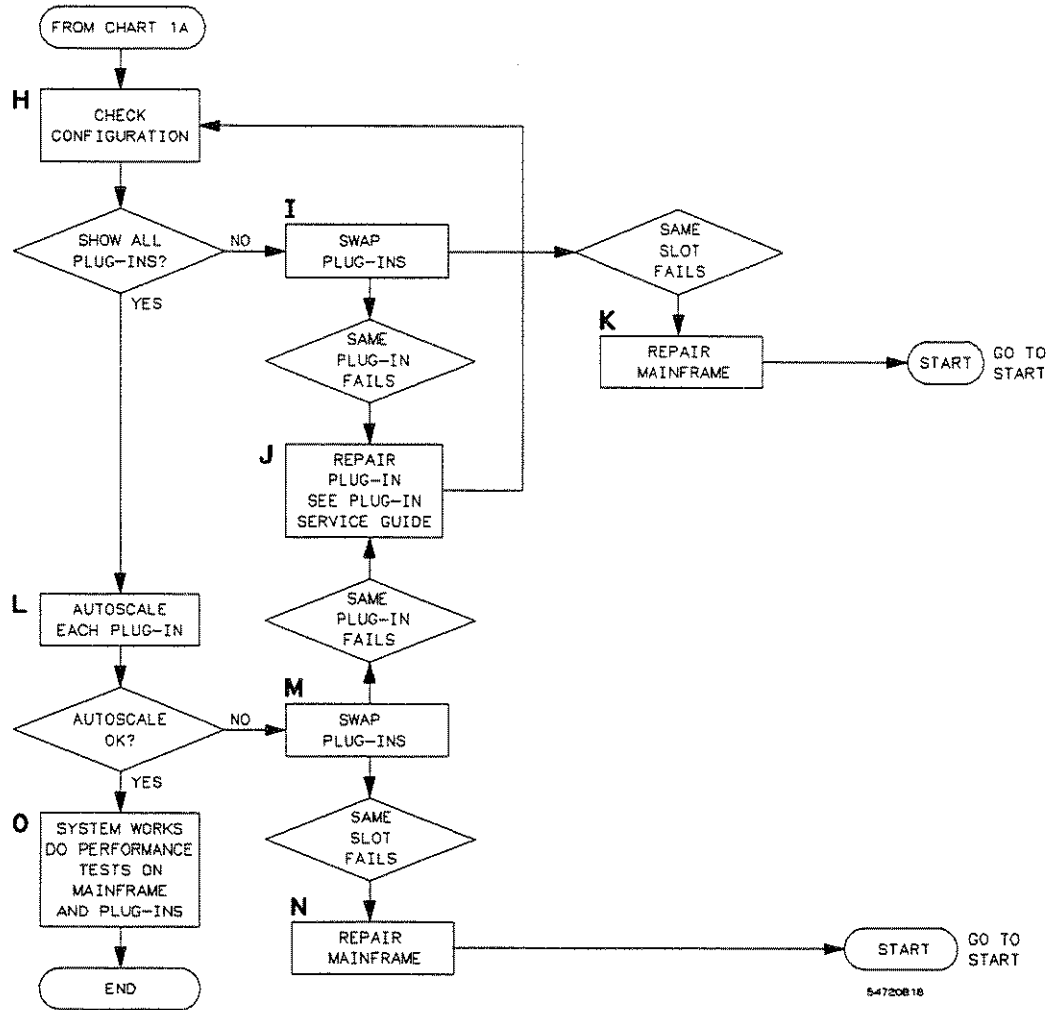

Primary Trouble Isolation Flowchart 1B

H Check instrument configuration.

- Press **Utility** , then press **System Config...**

The plug-ins are listed at the bottom of the screen. If a plug-in is not listed, it has not been recognized by the mainframe.

I Swap plug-ins.

If the mainframe does not show all of the plug-ins, swap plug-ins between a slot that recognizes a plug-in and the slot that does not.

- If the failure follows the plug-in, the plug-in needs repair.
- If the failure is in the same slot as before, there is a problem with the mainframe.

J Repair the plug-in.

- 1 Use the trouble isolation procedures in the service guide for the failed plug-in.
- 2 Reinstall the repaired plug-in and resume troubleshooting at block H of this chart.

K Repair the mainframe.

For this type of mainframe problem, first try replacing the CPU board. If that does not correct the problem, replace the motherboard.

L Autoscale test each channel.

- Connect the CAL signal to each plug in turn and press **Autoscale** .

If a plug-in is an HP 54711A, you will have to connect the signal to both the channel and trigger inputs.

M Swap the plug-ins.

If the autoscale for a plug-in is not successful, swap it with a plug-in that does autoscale and retry autoscale of both plug-ins.

N Repair the mainframe.

In this case the mainframe failure is most likely in the Acquisition assembly for that slot. Use the self-tests to determine the failure. Slots 1 and 2 are Acquisition 2 and slots 3 and 4 are Acquisition 1.

- The system is operational. Performance test the mainframe and each plug-in according to the procedures in chapter 3 of the service guides.

Figure 5-5

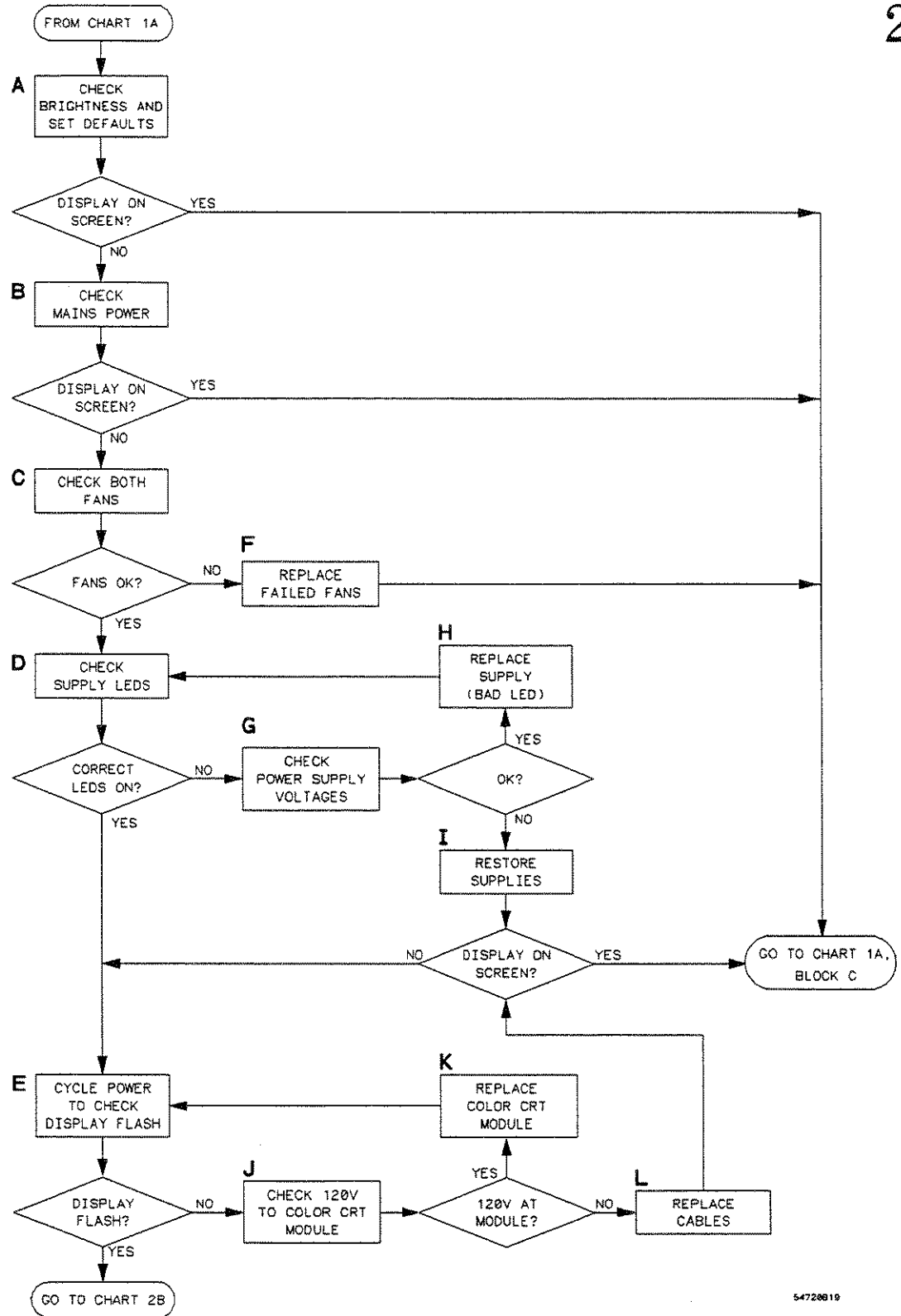

54720019

No-Display, Trouble Isolation Flowchart, 2A

2, No-Display Trouble Isolation

These trouble isolation details help isolate a problem to the assembly level when there is no display on the color module screen.

A Check brightness and set defaults.

- 1 Check that the front panel brightness control (top adjustment) is set fully clockwise.
- 2 Set up the instrument defaults. Press Setup , then the bottom softkey.

B Check mains power.

- Verify that the 54710A/54720A power cable is connected.
- Verify the rear panel line select switch is set to the proper line voltage, 115V or 230V.
- Check that the rear panel circuit breaker and the front panel Power switch are both ON.

C Check both fans.

Check that both the rear and the front fans are operating.

- The rear fan is located in the compartment directly behind the color CRT module.
- The front fan is located above the plug-in slots, behind the disk drive. To view the front fan, remove plug-ins from slots 3 and 4 and look into the area above the plug-in slots.

The power supply Remote Shut Down (RSD) circuit will shut the supply down if either fan is not connected or a fan does not start rotating immediately when power is turned on. One symptom of an inoperative fan is a particular sequence of LED indications on power-up.

- 1 Use the figure below to establish the location of the power supply LEDs. They can be viewed through the ventilation holes in the side of the instrument.

Figure 5-6

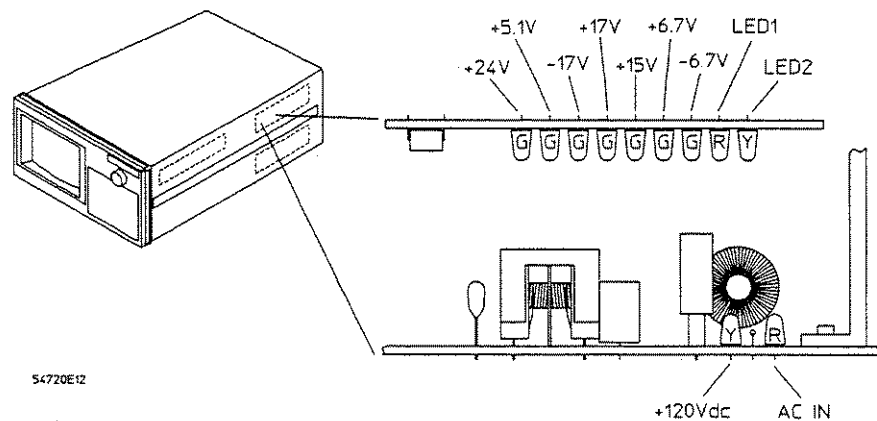

Power Supply LED Location

- 2 Cycle the power while watching the LEDs.
 - a The seven green LEDs and 120 V yellow LED light for 1-5 seconds, then go off.
 - b Then LED1 (red) and LED2 (yellow) come on.
- 3 Cycle the power while watching the fans.

If the LED sequence happens as noted in step 2, cycle the power while watching each fan in turn. A good fan should start to run as the power comes up, then stop when remote shutdown occurs. A faulty fan probably will not run at all.

D Check supply LEDs.

Verify that the correct supply LED indicators are lit. Use the figure on the previous page. An unlit LED indicates that the respective power supply voltage is missing.

- The red AC IN LED is on.
- All seven green LEDs are on.
- The yellow LED for +120 Vdc is on.

Both LED1 and LED2 are normally off and when on indicate supply failure or shutdown.

Table 5-1

Failure LED Indications

LED1 on, LED2 off	The power supply is in either Over-Load-Protection or in Over-Temperature- Protection condition. In this case, verify the vent holes are clear and allow instrument to cool if necessary. If the instrument is cool and the condition persists, suspect a short circuit on one of the supplies.
LED1 on, LED2 on	The power supply is in the Over-Voltage-Protection or the Remote-Shut-Down mode. A disconnected or non-working fan will cause the power supply to go into Remote-Shut-Down mode. See paragraph C above. The Over-Voltage-Protection condition indicates the power supply is not properly loaded or is not maintaining regulation and needs to be replaced .

E Cycle the power to check for display flash.

When there is no display, try cycling the power off, then on. If the screen flashes, the +120 Vdc supply voltage is reaching the color CRT module.

F Replace failed fan.

Replace a fan that will not attempt to run.

G Check the power supply voltages.

- 1 Five of the seven supply voltages can be checked on any of the bus connectors in the plug-in compartment. See the following figure.

Figure 5-7

	Pin #	Voltage	Approx. Resistance
	6	+17 V (17 V to 18 V)	200 Ω
	7	-17 V (-17 V to -18 V)	200 Ω
	18	+15 V (14.5 V to 16 V)	500 Ω
	19	+6.7 V (6.7 V to 7.7 V)	50 Ω
	20	-6.7 V (-6.7 V to -7.7 V)	50 Ω

Voltages Accessible on Plug-in Connectors

- 2 Set Power to Standby and measure the supply line resistance (with respect to ground) at the pins shown in the above figure. If the supply voltages are down, it can be caused by a short on an assembly.
- 3 Check the +5.1 V supply.
 - a Remove the rear panel and find the display assembly. It is the second assembly below the power supply.

- b** Apply power and measure the 5.1 V supply voltage at the decoupling capacitor visible just to left of the center of the board.

Figure 5-8

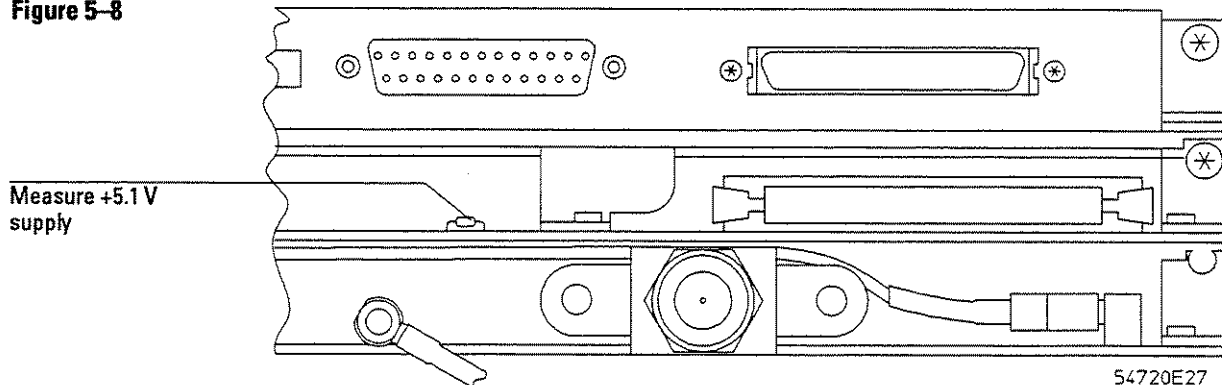

+5-V Supply Measurement Point

- c** Set Power to Standby, allow the supplies to discharge, and measure the resistance of the supply line. It should be about 20 Ω .

H Replace the supply.

Apparently the supply works but an LED is not lit. Replace the supply to correct the problem.

I Restore the supplies.

Either the power supply is faulty or an assembly is overloading the supply. Use the "Power Supply Distribution" section and other isolation techniques, removing assemblies etc., to isolate the excessive load on the supply.

J Check for 120 Vdc at the module.

If the screen does not flash when the power is cycled, extend the color CRT module (see "To remove and replace the color CRT module" in chapter 6) and check for 120 Vdc at the module. There is an intermediate cable between the module shield and the module circuitry. You will have to remove the shield to check further.

While the module shield is off, check the ribbon cable connection.

K Replace the module.

If the +120 Vdc is reaching the color CRT module but it does not flash when the power is cycled, replace it with a different one. (See "To remove and replace the color CRT module" in chapter 6).

L Replace cables.

The most likely cause of the lack of power is a bad cable. However, the 120 V comes through the motherboard. Check for 120 V at the motherboard connector. If there is no 120 V there, there is a problem on the motherboard or with the power supply connection to the motherboard.

Figure 5-9

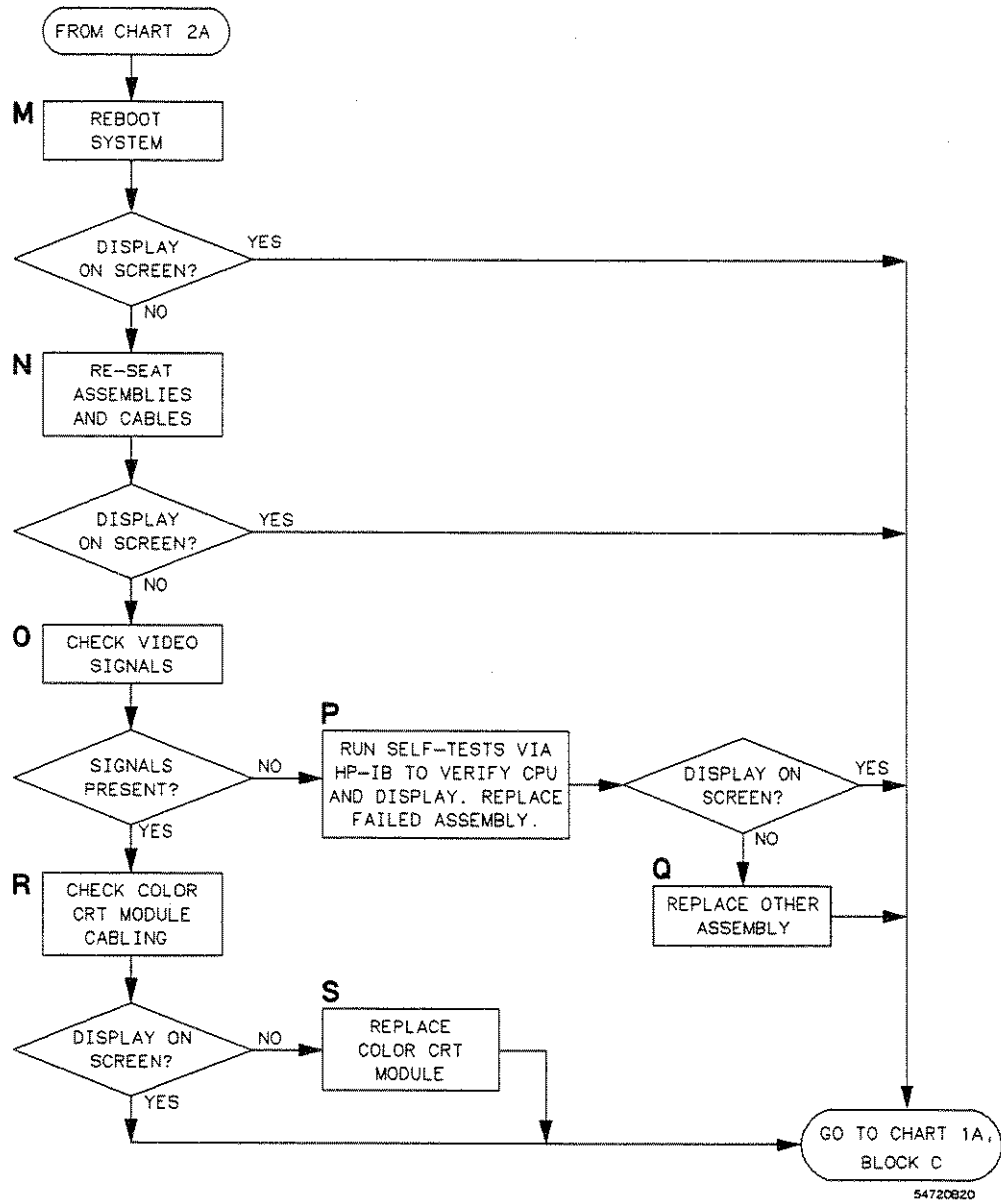

No-Display, Trouble Isolation Flowchart, 2B

M Re-boot the system.

There are three ways to force the system to load firmware when you cannot see the display.

- If the disk drive light comes on when power is applied, the instrument knows the firmware is corrupted. To load the operating system, insert the system disk and cycle the power.
- If the disk drive light does not come on, the firmware may be corrupt but the instrument is not aware of that and will not try to load new firmware. Use the following procedure.
 - a Set the rear panel system ROM switch down, as shown in the figure below.

Figure 5-10

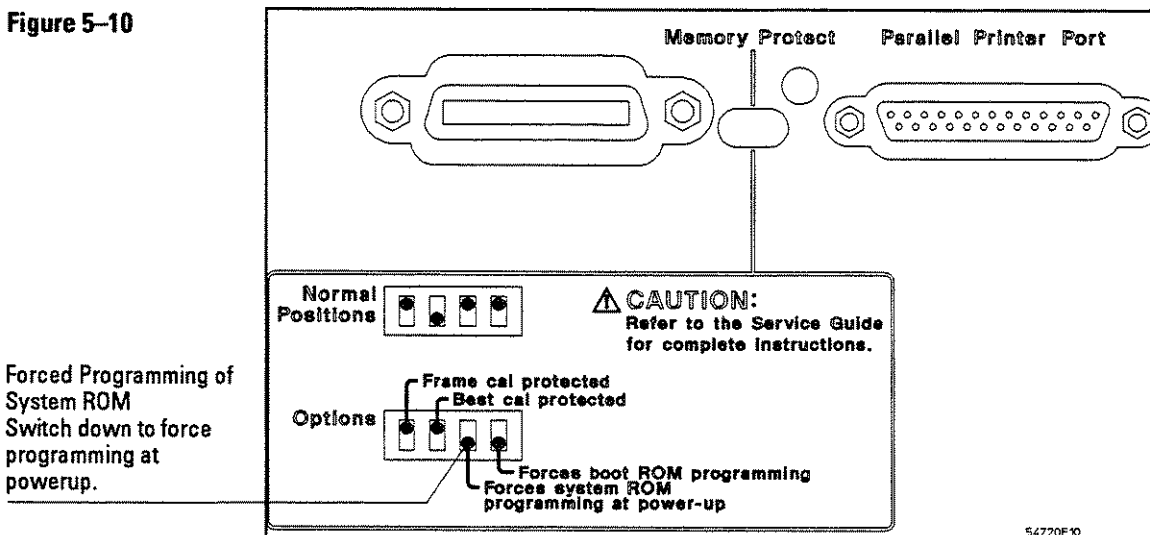

ROM Programming at Powerup

- b Install a system disk and apply power.

The operating system loading operation takes a few minutes. When finished, the disk drive light will go out.
 - c Cycle the power. The display should come up on the screen.
- If the system is operating but has no display, you can load the firmware using the front panel even if you cannot see the display.
 - a Insert the system disk.
 - b Press, in order, Utility, second softkey from the top, then the third softkey from the bottom.
 - If the oscilloscope loses its operating system when power is turned off, the battery on the CPU may be low.

N Re-seat assemblies and cables.

A no-display condition can be caused by disconnected or improperly seated connectors. Try the following:

- Check the ribbon cable connection between the display board and the color CRT module.
- Check the ribbon cable between the CPU board and the display board.
- Re-seat the CPU board and Display boards

O Check the video signals.

The video signals are conducted from the display board to the color CRT module via a wide ribbon cable. To remove parts and assemblies, refer to procedures in chapter 6.

- 1** Remove the ribbon cable from the rear of the display board. The display board is the second assembly below the power supply.
- 2** Use the following figure to locate the video signals on the PC board connector.

Figure 5-11

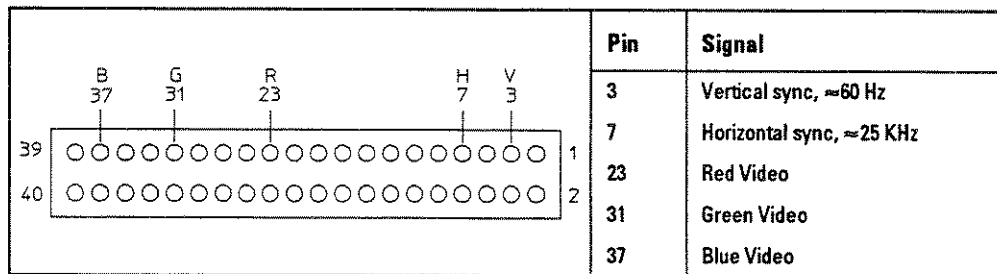

Video Signal Locations

- 3** Use another oscilloscope to check for video signals similar to the following figure.

Figure 5-12

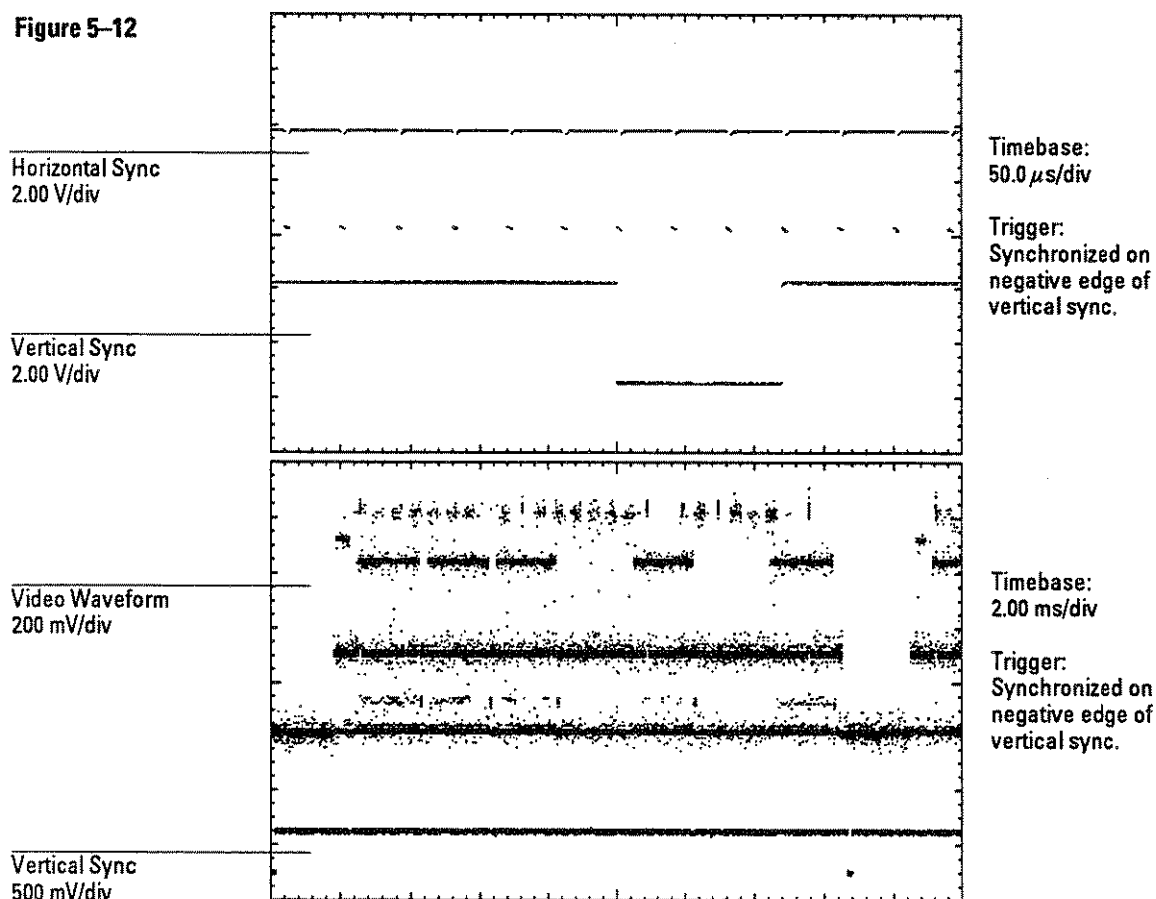

Video Signals

P Run self-tests via HP-IB.

If all the power supplies are running and there is no display, the problem may be caused by the CPU board or Display boards. Run the internal self-tests via the HP-IB to verify the CPU board and Display boards are running. The procedure gives an example program.

- 1 Connect an HP series 200/300 controller.
- 2 Set the HP-IB address on the oscilloscope.

For the following program to run, the oscilloscope address must be set to 7. Since the display is blank, you will have to do it without seeing the softkey names on the screen.

- a Press .
- b Press the top softkey.
- c Press then .

- 3 Run this program for a CPU self-test. The test takes about 3 minutes; much longer indicates the test is failing.

```

10  !This program runs 54720 self-tests via the HP-IB
20  !and prints the pass/fail result.
30  !
40  DIM Test$(100)
50  CLEAR 707                                !Clears HP-IB interface.
60  !
70  OUTPUT 707;"SELFTEST:CPU? ALL"           !Commands 54720 to run a
80                                           !self-test.
90  !
100 ENTER 707;Test$                          !Returns results of self-test.
110 PRINT Test$
120 END
:SELFTEST: CPU PASSED

```

- 4 To run a Display self-test, change the program.

- a Change line 70 so that it will run the display test. Change "CPU?" to "DISP?".

```

70  OUTPUT 707;"SELFTEST:DISP? ALL"         !Commands 54720 to run a
80                                           !self-test.

```
- b When the test is finished the instrument will return to the controller:

```

:SELFTEST: DISPLAY PASSED

```

- 5 Replace the failed assembly.

Q If the display does not show after block O, replace the assembly not replaced in block O.

R Check color CRT module cabling.

If video signals are present at the display PC board connector but there is no display, check the cabling to the module. To remove parts and assemblies, refer to procedures in chapter 6.

- 1 Remove the module from the instrument.
- 2 Remove the shields from the module.
- 3 Check the ribbon cable connection.
- 4 Connect the module cables and apply power.
- 5 If there is still no display, check for the video signals at the module end of the ribbon cable. Use the figures on the previous page.
- 6 If there are no video signals, replace the cable. If there are, replace the module.

S Replace the color CRT module.

Figure 5-13

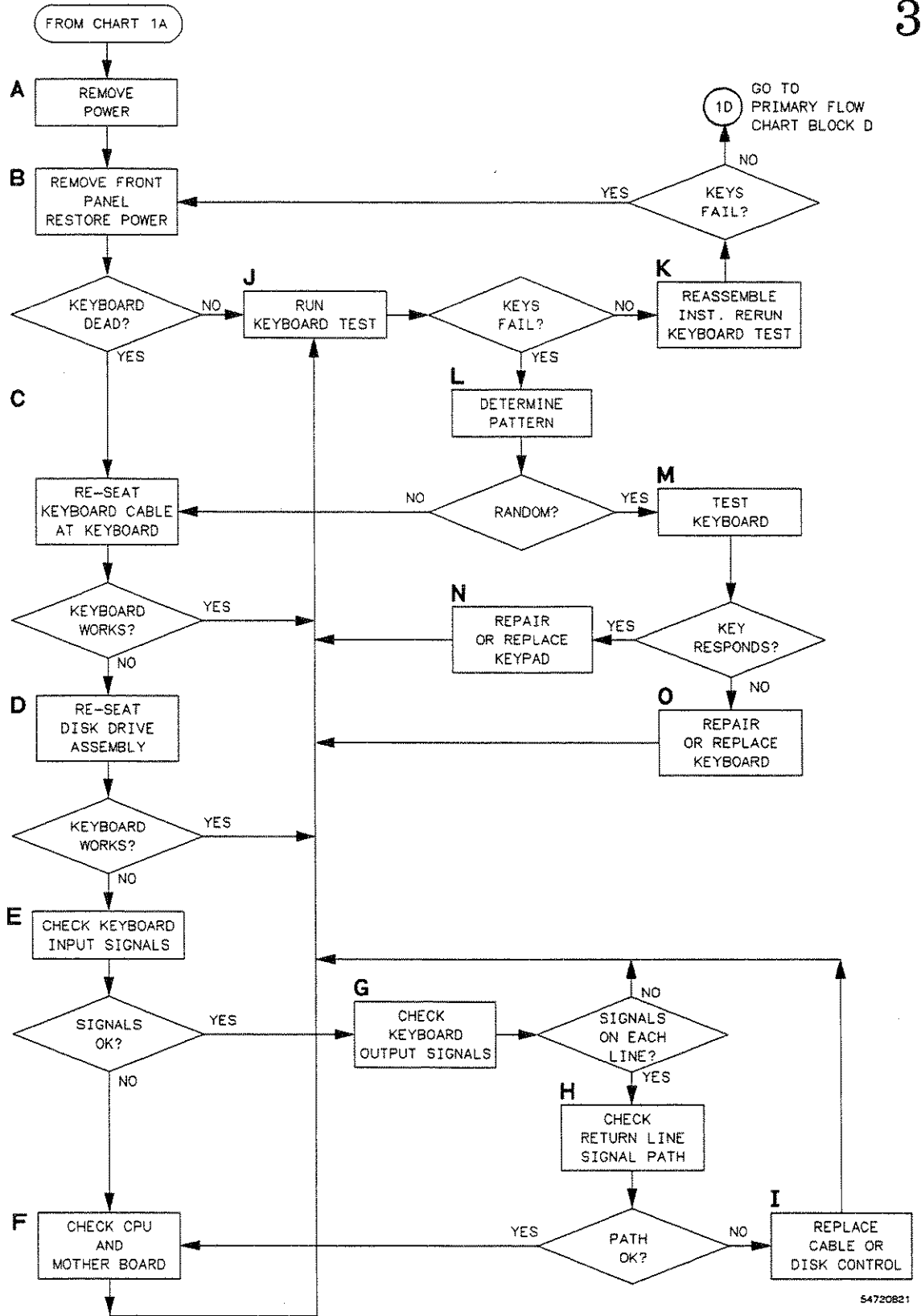

Keyboard Troubleshooting Flowchart

54720B21

3, Keyboard Trouble Isolation

Use this section to isolate keyboard problems. Such problems can usually be isolated into two groups, those that indicate complete keyboard failure and those that indicate random key failures. However, electrically the keys on the front panel are in a six by eight array, so multiple key failures may have a pattern which is masked by the layout of the keyboard.

Refer to the instrument block diagram in chapter 8 and the exploded views in chapter 7 for cable interconnect information. Notice that the front panel keyboard is connected via cable to the disk control board. The disk control board plugs into the mother board. The problem can be a disconnected cable or connector in the keyboard signal path.

CAUTION

Always remove power before removing and replacing assemblies.

- A** Turn off the power and remove the power cord.
- B** Remove the front panel.

Refer to the disassembly procedure in chapter 6.

- C** Re-seat the keyboard cable in the front panel board connector and retry instrument operation.

To remove this connector, push in the metal clips on both ends of the connector and pull the connector out.

- D** Re-seat the disk drive assembly.

1 Remove power.

2 Remove the disk drive and disk control board as a unit and re-seat all connectors.

To remove this assembly remove the one screw that holds the disk drive assembly at the front of the plug-in enclosure.

3 Re-install the disk drive assembly and retry instrument operation.

- E** Check the keyboard input signals.

Refer to the figure below and the table on the next page. The keyboard input signals consist of eight strobe lines, SL[0] through SL[7]. Each line should show a negative TTL pulse 1 ms wide at about 126 Hz (7.9 ms period).

- 1** Check the strobe signals on the keyboard connector. If the signals are good, go to block G.

Figure 5-14

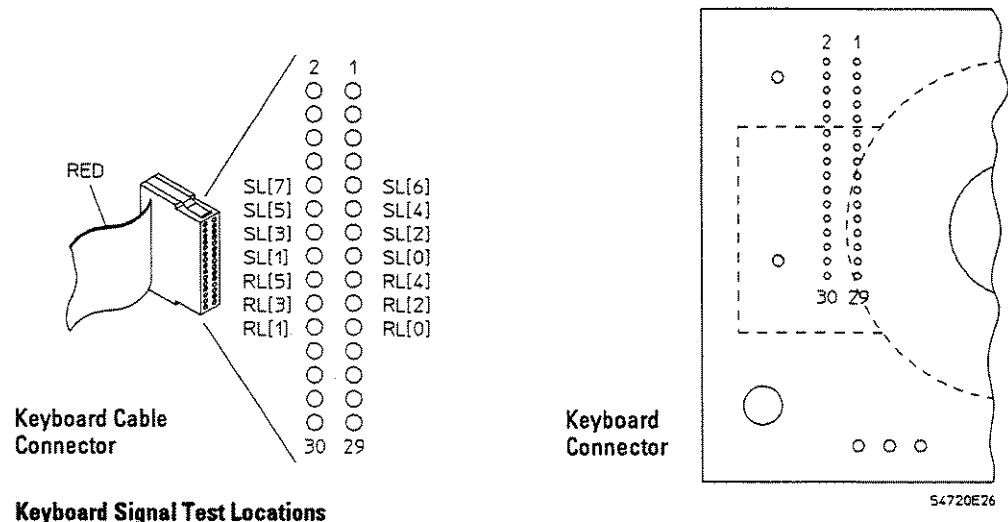

2 Check the strobe signals at the motherboard connector where the disk control board plugs in.

a Remove the disk drive assembly.

To remove this assembly remove the one screw that holds the disk drive assembly at the front of the plug-in enclosure.

b Apply power and check the signals.

When power is applied the signals should be present. However, the display will not come up because the front panel is disconnected.

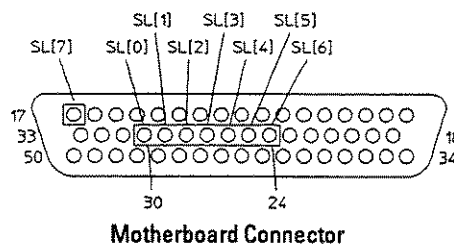

- If the signals are correct the CPU and mother board are functioning and the problem is between the motherboard and the front panel board connector. Check for continuity through the disk control assembly and keyboard cable.
- If the signals are not correct, the problem is with the CPU or mother board.

F Check the CPU and motherboard.

Try the following, in this order. Use the disassembly procedures in chapter 6.

- 1 Remove and reseat the CPU board.
- 2 Replace the CPU board.
- 3 Replace the motherboard.

Table 5-2

Keyboard Signal Lines

Return Lines (out)	Strobe Lines (input)							
	SL[7]	SL[6]	SL[5]	SL[4]	SL[3]	SL[2]	SL[1]	SL[0]
RL[0]	Time base	Trigger	Acquisition	Display	Marker	Define meas	Math	Application
RL[1]	Help	Utility	Softkey 6 (bottom)	Softkey 5	Softkey 4	Softkey 3	Softkey 2	Softkey 1
RL[2]	Clear display	Run	Stop Single	Disk	Waveform	Setup	Print	Auto-scale
RL[3]	Softkey 0 (top)	Shift (blue)	0	1	4	7	8	5
RL[4]	2	.	Clr	Eex	±	3	6	9
RL[5]	----	pico	nano	micro	milli	Enter	← ↓	↑ →

G Check the keyboard output signals.

- 1 Use the figure on the previous page and the table above.
- 2 While monitoring each output line in turn, (RL[0]–RL[5]) press a key on that line.
 You should get the same signal as the input lines, a negative TTL pulse 1 ms wide at about 126 Hz.

H Check the return line signal path (RL[0]–RL[5]).

- 1 Use the figure on the previous page, the table above, and the table on the next page.
- 2 Use an ohmmeter to check continuity between the keyboard and the disk control connector that plugs into the motherboard.

Table 5-3

Keyboard Signal Locations

Keyboard Connector Pin	Signal	Disk Control Connector Pin	Keyboard Connector Pin	Signal	Disk Control Connector Pin
1	Trig LED	8	16	SL[1]	29
2	Armed LED	9	17	SL[0]	30
3	A Trig LED	10	18	RL[5]	31
4	SW LED0 (Shift)	11	19	RL[4]	32
5	--	12	20	RL[3]	33
6	--	13	21	RL[2]	41
7	RPG A	14	22	RL[1]	42
8	RPG B	15	23	RL[0]	43
9	Grd	16	24	VCC +5.1	44
10	SL[7]	17	25	REMOTE ON/OFF	45
11	SL[6]	24	26	GND	21
12	SL[5]	25	27	+12V	47
13	SL[4]	26	28	+12 RTN	48
14	SL[3]	27	29	Background	49
15	SL[2]	28	30	Brightness	50

I Replace the keyboard cable or disk control, whichever is faulty.

J Run the Front Panel test.

1 In the SYSTEM keys press **Utility**, then press **Self test**.

2 Toggle the **Board** key until **Front Panel** is selected.

3 Press **Enter**, then press **Start**.

This brings up a diagram of the HP 54720A front panel. The individual keys will highlight as they are pressed.

4 Press all the keys to determine if keys or groups of keys are not functioning.

K Re-assemble the instrument and re-run the keyboard test.

L Determine the key failure pattern.

Use the previous table to determine whether there is a pattern to the key failures.

- If failures are grouped on a specific strobe line (SL[0]–SL[7]) or return line (RL[0]–RL[5]), the failure is likely to be off the keyboard. Go to block C.
- If failures are unrelated to a specific strobe or return line, the failure is probably on the keyboard. Note which keys have failed and go to block M.

M Test the keyboard.

On the back side of the keyboard (the side opposite the keys) at each key position is a pair of PC pads. Each pair of pads is in a small open area of the ground pattern. These PC pads, one square and one round, are connected to the key contacts on the opposite side.

- At the failed key, use a short wire or paper clip to carefully short the square and round PC pads.

N Repair or replace the keypad.

Check for contamination on the PC traces or keypads. The keypads are very simple. Contamination may prevent contact between the black contact on the pad and the board.

O Repair or replace the keyboard.

The failure may be a broken trace.

Missing Board Checks

The HP 54710A and 54720A mainframes have the following system configurations. Note that the HP 54710A mainframe uses only one Acquisition board.

Figure 5-15

Frame					System config	
Model : 54720A					Time	
Serial Number : 3207A00101					11:12:57	
Calibration Memory : Protected					Date	
Power On Test : Passed					15 JUL 1992	
Firmware Revision : 1.0					Declassify frame memory	
Boot Revision : 1.0					Update system firmware	
Slot	Board	Power Statistics			Exit	
6	CPU	Total Pon Time : 27.67 hrs				
5	Display	Length Last Poff : 0.0 hrs				
4	Time base	Time Since Pon : 0.44 hrs				
3	Clock	Power Cycles : 45				
2	Acquisition					
1	Acquisition					
Plug-ins						
Slot	Model	Serial #	Analog BW	Calibration Memory		
1	54711A	3207A00101	1.5 GHz	Protected		
2	54713A	3207A00101	500 MHz	Protected		
3	54721A	3207A00101	1.1 GHz	Protected		
4						

This assembly is not installed in the HP 54710A mainframe.

HP 54710A, 54720A System Configuration

CAUTION

Do not remove or replace PC assemblies when the instrument is powered. Doing so may cause circuit failures. Plug-ins can be removed and installed with power applied.

Use the procedures in chapter 6 for removing and replacing assemblies.

- 1 In the System keys, press **Utility** then press **System Config...** You should have the display shown above.
- 2 If the instrument appears to be missing a board in one or more slots, turn off the power and re-seat the board/assembly that is not showing.
- 3 Reapply power and check the configuration (step 1).
- 4 If there is still a missing board repeat the procedure, making the next one of the following changes at step 2 each time.
 - Re-seat the Microprocessor assembly.
 - Replace the board/assembly that is not showing.
 - Replace the Microprocessor assembly.
 - Replace the motherboard assembly.

Interpreting Internal Self-tests

The internal self-tests exercise the internal circuitry on the respective mainframe assemblies. Some of the tests require that some associated circuitry on interfacing boards is working also. These tests do not test the the plug-ins. The plug-ins are checked by checking plug-in operation in different mainframe slots and by attempting plug-in calibration.

Clock

The Clock self-test looks for the existence of the board, then checks for the presence of each required clock signal. If the self-test fails, reseal the board, then try the test again. If it still fails, replace the board.

CAUTION

Do not over-tighten the SMA semi-rigid cables! The maximum recommended torque is 5 inch-pounds. Damage to the acquisition hybrids can result from over-tightening these connectors.

Hewlett-Packard offers a special wrench socket for use on the SMA connectors in the HP 54700 family. Refer to the procedures in chapter 6 if you need to check cables or remove and replace the clock assembly. The procedures provide special instructions and cautions.

Acquisition 1

Acquisition 1 digitizes plug-in slots 3 & 4 in the HP 54720A. The HP54710A does not have Acquisition 1. The explanation of the tests and troubleshooting for Acquisition 1 is the same as for Acquisition 2 that follows. Acquisition assemblies are replaced as a set so failure of one assembly requires replacement of both.

Acquisition 2

Acquisition 2 digitizes plug-in slots 1 & 2 in the HP 54720A and 54710A. The acquisition tests check circuit groups on the acquisition board. If any test fails, check the cabling. The cabling is located in the instrument rear between the acquisition boards and the clock board. Mis-cabling and/or loose connectors can give test failures.

CAUTION

Do not over-tighten the SMA semi-rigid cables! The maximum recommended torque is 5 inch-pounds. Damage to the acquisition hybrids can result from over-tightening these connectors.

Hewlett-Packard offers a special wrench socket for use on the SMA connectors in the HP 54700 family. Refer to the procedures in chapter 6 if you need to check cables or remove and replace the acquisition assemblies. The procedures provide special instructions and cautions.

If the self-tests continue to fail, reseal the assemblies in the motherboard connectors and retry the tests. If the tests still fail, replace the acquisition assembly set.

CPU

If the CPU self-tests pass and one Display self-test passes, the CPU is tested to the 95% level. The only circuitry not tested with these tests are the interface/port drivers. These self-tests can also be run via HP-IB if the color CRT module is not functioning. See "Run self-tests via HP-IB" in the "No-Display Trouble Isolation" section.

If the self-tests fail:

- 1 Remove the CPU and Display board as a unit.
- 2 Reseat the ribbon cable between the two assemblies.
- 3 Re-install the assemblies in the mainframe.
- 4 Retry the self-test.
- 5 If the self-tests continue to fail, replace the CPU assembly.

Display

The Display self-tests check the display board circuitry to a 90% confidence level. If any of the tests fail, try re-seating the display and CPU assemblies as given in "CPU" above and re-run the tests. If the any test continues to fail, replace the display assembly.

Time Base

The Time Base tests check various circuit groups in the time base and trigger circuitry to a 85% confidence level. If any of these tests fail, try re-seating the assembly and check the rear panel cabling. If the tests continue to fail, replace the assembly.

Floppy Disk

The Floppy Disk test checks that the disk drive can be accessed by the CPU. The self-test verifies operation of the disk drive to a 90% confidence level. To check the disk drive to 100% confidence level, run the self-test and format a disk. To format a disk:

- 1 Press .
- 2 Press **Operation** to select **Format** and press **Enter**.
- 3 Press **Execute**.

Front Panel

The Front Panel test checks operation of the front panel keys and the RPG (knob). If there is a problem, check which keys are operating and refer to "Keyboard Trouble Isolation" for further procedures.

Though the front panel test is part of the list of the other self-tests, it does not run when **test all boards** is run. To run the front panel test:

- 1 Press , then **Self test...**, then press **Board** to select **front panel**.
- 2 Press **Enter** then **start** to start the test.
- 3 Press each key and turn the knob.

If they function, each key will highlight when it is pressed and the knob symbol on the display will rotate.

- 4 When you see that everything works, press **Stop/Single** until the test is exited.

Power Supply Distribution

The following discussion can be used if the power supplies are being loaded excessively and you need to know which supplies are used on each assembly.

General Supply Distribution

Power supplies are distributed through the motherboard to the assemblies shown in the table below; shading indicates use. Two other supplies are noted in following paragraphs.

Table 5-4 Power Supply Distribution

Assembly () Motherboard conn.	Supplies ¹							
	-17	-6.7	DGND	AGND	+5.1	+6.7	+15	+17
(J0) Acquisition 1	Shaded	Shaded	Shaded	Shaded		Shaded		Shaded
(J1) Acquisition 2	Shaded	Shaded	Shaded	Shaded		Shaded		Shaded
(J2) Clock	Shaded	Shaded	Shaded	Shaded		Shaded		Shaded
(J3) Timebase	Shaded	Shaded	Shaded	Shaded		Shaded		Shaded
(J4) Display	Shaded	Shaded	Shaded	Shaded		Shaded		Shaded
(J5) CPU	Shaded	Shaded	Shaded	Shaded		Shaded		Shaded
(J9) Disk Control	Shaded	Shaded	Shaded	Shaded		Shaded		Shaded
(J10-J13) Plug-ins	Shaded	Shaded	Shaded	Shaded		Shaded		Shaded
Disk Drive ²					Shaded			
Front Panel ^{2,3}								Shaded

¹ All supplies listed in the table come from the Power Supply assembly (see note 2).

² The supply for this assembly comes through the Disk Control assembly.

³ A +12-Vdc supply, used exclusively for the Background and Brightness controls, comes from the Color CRT Module through the motherboard and goes to the Front Panel assembly.

Fan Supply

The rear fan is connected directly to the power supply assembly. The front fan is connected to the same supply but through the motherboard. The power supply detects fan rotation so if a fan is not connected, the power supply will not be allowed to come up and the instrument will not function. The fans are connected to a +24-V supply, which can vary between +11 V and +27.5 V depending on the temperature within the instrument.

Color CRT Module Supply

The Color CRT Module is powered by a separate supply from the power supply assembly. This +120-Vdc supply is not distributed to any other assemblies. The +120-V supply is distributed through the motherboard.

Power Standby Switch

The front panel power switch operates as a remote control for the regulators in the power supply. To shut the supplies Off, the switch grounds a control line from the supply.

With the rear panel switch on and the front panel switch set to Standby, mains power is still applied to the power supply. The AC IN LED (red) should be lit. Power supply status LEDs are visible near the top-middle of the right side of the instrument. See figure 5-6, page 5-11.

Figure 5-16

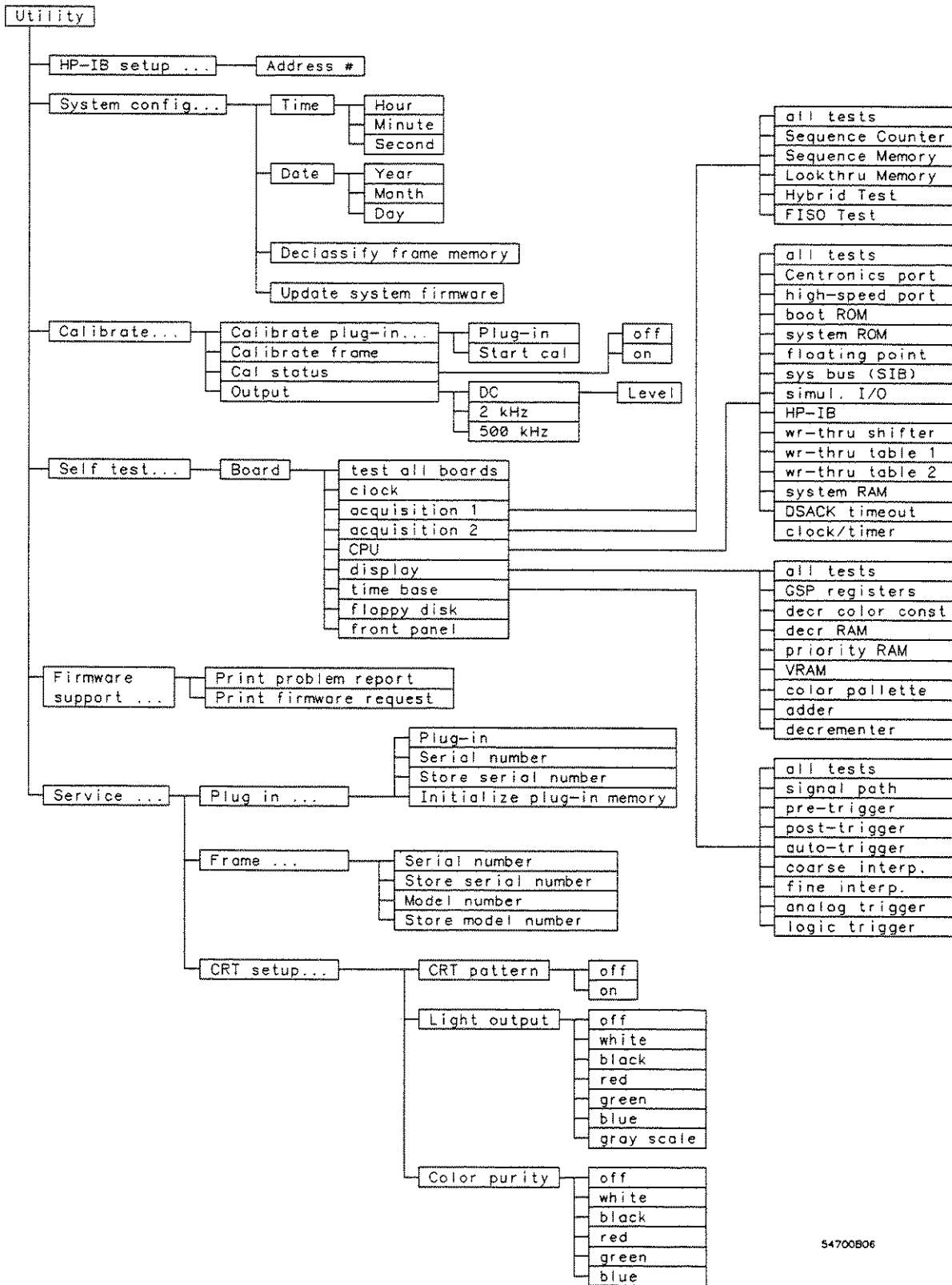

54700B06

Utility Menu

The utility menu, as shown in the figure on the previous page, gives you six additional softkey menus: HP-IB setup, System configuration, Calibrate, Self test, Firmware support, and Service.

HP-IB Setup

You may have several instruments connected by a common bus to a computer or controller. Each instrument on the bus has a separate identifying address, so that the computer or controller can communicate with only one instrument at a time. The HP-IB setup menu lets you select an address from 0 to 31. The address number you select is the address that a computer or controller uses to communicate with the oscilloscope. The default HP-IB address for oscilloscopes is 7.

System Configuration

The system configuration menu gives you information about the mainframe and plug-ins. It allows you to set the date and time on the instrument clock. It also allows you to update the system firmware and to declassify the memory in the mainframe.

Figure 5-17

This assembly is not installed in the HP 54710A mainframe.

The screenshot displays the 'System config' menu with several sections:

- Frame Information:**
 - Model : 54720A
 - Serial Number : 3207A00101
 - Calibration Memory : Protected
 - Power On Test : Passed
 - Firmware Revision : 1.0
 - Boot Revision : 1.0
- Slot and Board Information:**

Slot	Board
6	CPU
5	Display
4	Time base
3	Clock
2	Acquisition
1	Acquisition
- Power Statistics:**
 - Total Pon Time : 27.67 hrs
 - Length Last Poff : 0.0 hrs
 - Time Since Pon : 0.44 hrs
 - Power Cycles : 45
- Plug-ins Information:**

Slot	Model	Serial #	Analog BW	Calibration Memory
1	54711A	3207A00101	1.5 GHz	Protected
2	54713A	3207A00101	500 MHz	Protected
3	54721A	3207A00101	1.1 GHz	Protected
4				
- System Configuration Options (Softkeys):**
 - Time: 11:12:57
 - Date: 15 JUL 1992
 - Declassify frame memory
 - Update system firmware
 - Exit

System Configuration

Table 5-1

System Configuration

Frame

Model Number	Shows the model number of the mainframe.
Serial Number	Shows the serial number of the mainframe.
Calibration Memory	Shows the position of the Frame cal switch on the rear panel. This switch is for the memory in the mainframe that contains the calibration factors . This switch is normally set to the protected position.
Power On Test	Shows if the power-on self-tests passed or failed. These power-on tests verify that the six boards are in the mainframe (five boards in the HP 54710 mainframe). A "Failed" message indicates that at least one board is loose or defective. The power-up routine is kept simple to enable the oscilloscope to power up quickly. You can execute a more complete set of self-tests from the self-test menu.
Software Revision	Shows the revision number of the installed system firmware.
Boot Revision	Shows the boot ROM version in the mainframe. The boot ROM uncompresses files and loads new system firmware from the disk drive.
Slot and Board	Shows the rear slot number and the board (assembly) in each slot.
Power Statistics *	
Total Pon time	The total time that the oscilloscope has run since it was manufactured.
Length Last Poff	The total time that the oscilloscope was off the last time it was unpowered (On Standby or no mains power).
Time Since Pon	The total time that the oscilloscope has run since the last time it was turned on.
Power Cycles	The number of times that the oscilloscope has been turned on since manufacture.

Plug-ins

Slot	Shows the slot that the plug-in is installed in.
Model	Shows the model number of the plug-in. If there is no plug-in in a slot it reads "empty."
Serial number	Shows the serial number stored in the plug-in's nonvolatile memory.
Analog BW	Shows the maximum analog bandwidth of the plug-in/ mainframe combination.
Calibration Memory	Shows the position of the memory protect switch in the plug-in.

* Power statistics are stored in battery-backed RAM on the CPU assembly. Loss of battery power or replacement of the CPU will cause loss of the statistics.

Time and Date

The oscilloscope has a 24-hour clock and a calendar that it uses for all time references. It stamps the time and date on:

- Waveforms when they are acquired.
- Files stored to the disk drive.
- Waveforms transferred over the HP-IB.
- Waveforms that are printed. The print lists both the acquired time and the print time.
- Calibration events.
- To change the time or date, press the **Time** or **Date** softkey, then change the entry fields with the knob, arrow keys, or keypad and press Enter , then press **Done**.

Declassify frame memory

Declassify the mainframe in situations when you are concerned about the security of your work. When you declassify the memory, no one can determine what you are working on by browsing through saved setups, waveforms, and displays. Declassifying places zeros in the RAM memory. This clears:

- Setup memories
- Waveform memories
- Pixel memories
- Front-panel setups
- Channel memories
- Function memories

The following memory is not affected.

- Normal mainframe calibration
- Normal plug-in calibration (located in the plug-in)
- Best accuracy calibration
- Boot and system common variables
- Clock memory
- The part of display RAM that holds the firmware for the graphics processor

See Also

The HP 54710A and 54720A *Users Reference* for further information.

Update system firmware

The operating system is located in the system ROM. The oscilloscope does not need a disk in the disk drive in order to operate. The Update system firmware softkey loads new firmware.

To install system firmware:

- 1 Install the system disk in the disk drive.
- 2 Press, in order, **Utility**, **System config...**, and **Update System firmware**.

CAUTION

Check the display for any messages about the firmware or any special considerations before you continue.

- 3 Press **Continue**.

See Also

To re-boot the system firmware when there is a problem with the mainframe, see the "No Display Troubleshooting," specifically block L on page 5-15.

Calibrate

Calibration is covered in chapter 4 in this service guide.

Self-test

The Self-test menu is used for troubleshooting failures. With the self-test menus you can test all boards, test all of one board, or individual tests on a board. Since this instrument is repaired by replacing entire boards (assemblies), failure of any board test requires replacement of the board.

Use of self-tests is covered where applicable in the "Trouble Isolation" section.

See Also

"Interpreting Internal Self-Tests" in "Trouble Isolation" in this chapter.

Firmware Support

If you press **Firmware support...**, the instrument displays an information screen and a choice of two forms. These forms are your way of communicating directly with the factory. Because both forms are stored in memory, you can print a copy of either form whenever you like.

To print one of the forms from the oscilloscope:

1 Connect a printer to the oscilloscope.

You can connect it to the Centronics port or the HP-IB port, depending on your printer.

2 Set up the print.

a Press then .

b Press each softkey in turn and make the appropriate selections.

3 Press then **Firmware support..., then the **Print** softkey for the desired form.**

The instrument will automatically include the configuration information.

If a printer is not available, there are similar versions of the forms at the end of this chapter. Make a copy of the appropriate pages. The Problem Report Form is one page and the Firmware Notification Request Form is two pages.

- To display the instrument configuration information, press then **System config...**

Mail (or FAX) the form to the address (or phone number) on the firmware support display.

Problem report

The problem report can be used if you encounter a problem while using this oscilloscope.

Firmware request

The firmware request form is designed for those who did not sign up for the firmware notification service (option +NA0) for this oscilloscope and who would like to be notified of all future software and hardware upgrades. If you signed up for option +NA0, you do not need to fill out this form because you will automatically receive future firmware upgrades. Keep in mind that this form provides notification of upgrades only. If an upgrade has already occurred and you want a copy of the latest upgrade, you can purchase a firmware upgrade kit. Contact your nearest Hewlett-Packard Sales Office.

Service

The Service menu provides several service functions for the oscilloscope. When you press the Service softkey, the display shows the instrument configuration (the same as in the system config. menu) and several new softkeys.

Plug-in . . .

When you press **Plug-in . . .** you can program the serial number of the plug-in or initialize the plug-in memory. The plug-in data is stored in flash EEPROM in the plug-in

Store the plug-in serial number You need to re-store the plug-in serial number if:

- It is not shown in the configuration.
 - You replace the plug-in PC assembly.
 - To store the plug-in serial number:
 - 1 Remove the plug-in cover and set the protect switch to ENABLE.
 - 2 Press **Utility**, **Service . . .**, then **Plug-in . . .** to select the desired plug-in.
 - 3 Press **Serial number** to display the alpha-numeric list.
 - 4 Enter the serial number.
 - With the knob, highlight each character in turn and enter it by pressing the top softkey.
 - or
 - Enter numbers directly with the keypad but highlight letters with the knob and enter them by pressing the top softkey. (There is usually one letter in the serial number.)
- Use **Backspace** and **Delete** to help edit the number. You cannot insert a character.
- 5 Press **Done** to return to the previous menu.
 - 6 Press **Store serial number** to store the number in the plug-in.
 - 7 If you do not have to recalibrate the plug-in, set the protect switch to DISABLE and replace the cover.

Initialize the plug-in You need to initialize the plug-in if you replace the plug-in PC assembly.

- To initialize the plug-in.

CAUTION

Plug-in calibration will be lost when you initialize the plug-in.

- 1 Remove the plug-in cover and set the protect switch to ENABLE.
- 2 Press **Utility**, **Service . . .**, then **Plug-in . . .** then **Plug-in** again to select the desired plug-in.
- 3 Press **Initialize plug-in memory**.
- 4 Recalibrate the plug-in.
- 5 Set the protect switch to DISABLE and replace the cover.

Frame . . .

When you press **Frame . . .** you can enter the mainframe serial number and model number.

Store the mainframe serial number The mainframe serial number has the same status as the calibration factors. You need to re-store the mainframe serial number if:

- You replace the CPU assembly.
- The battery fails.
- To store the mainframe serial number:
 - 1 Go to the instrument rear panel and set the frame cal protect switch to the Unprotected position.
 - 2 Press **Utility**, **Service . . .**, then **Frame . . .**.
 - 3 Press **Serial number** to display the alpha-numeric list.
 - 4 Enter the serial number.
 - With the knob, highlight each character in turn and enter it by pressing the top softkey.
or
 - Enter numbers directly with the keypad but highlight letters with the knob and enter them by pressing the top softkey. (There is usually one letter in the serial number.)
Use **Backspace** and **Delete** to edit the number. You cannot insert a number.
 - 5 Press **Done** to return to the previous menu.
 - 6 Press **Store serial number** to store the number.
 - 7 If you do not have to recalibrate the mainframe, set the protect switch to the Protected position.

Store the mainframe model number The mainframe model number has the same status as the calibration factors. You need to re-store the mainframe model number if:

- You upgrade an HP 54710A to a 54720A.
- You replace the CPU assembly.
- The battery fails.
- To store the mainframe model number:
 - 1 Go to the instrument rear panel and set the frame cal protect switch to the Unprotected position.
 - 2 Press **Utility**, **Service . . .**, then **Frame . . .**.
 - 3 Press **Model number** to select the desired model.
 - 4 Press **Store model number** to store the number.
 - 5 If you do not have to recalibrate the mainframe, set the protect switch to the Protected position.

CRT setup . . .

When you press **CRT setup . . .** you are given several choices of special displays. These displays are used to adjust the Color CRT Module and check color purity. Use of these displays is covered in "Adjusting the Color CRT Module" in chapter 4 "Calibrating and Adjusting."

HP 54700-Series Oscilloscope

Problem Report Form

Your Name _____ Job Title _____

Company Name _____ Division _____

Telephone:Area/Country Code _____ Phone Number _____

Street Address _____ FAX Number _____

City _____ Prov/State _____ Mail Stop _____

Postal/Zip Code _____ Country _____ Department _____

Date _____

Problem Report Classification

_____ Hardware/Mechanical Problem

_____ Documentation Problem

_____ Software/Firmware Problem

_____ Remote Programming Problem

_____ Suggested Enhancement

Problem Description _____

System Description (Remote controller, Software, Printer, Cables) _____

Your current configuration is:

Mainframe model no. _____ Serial no. _____ Software revision _____

Plug-in 1 model no. _____ Serial no. _____

Plug-in 2 model no. _____ Serial no. _____

Plug-in 3 model no. _____ Serial no. _____

Plug-in 4 model no. _____ Serial no. _____

How would you prefer to be contacted?

_____ Mail _____ FAX _____ Phone _____ Your local HP sales representative

Return this form to Hewlett-Packard

By Mail:

By FAX

Hewlett-Packard Company

(719) 590-3505

Colorado Springs Division

Software Notification Manager

P.O. Box 2197

Colorado Springs, Colorado, 80901-2197 USA

HP 54700-Series Oscilloscope
Firmware Notification Request Form

Please complete this form and FAX or MAIL it to Hewlett-Packard to ensure that HP can contact you when firmware upgrades or new product information becomes available. If you have already signed up for the firmware notification service (option +NA0) for this product, you are already registered and you do not need to fill out this form.

Anyone responsible for the maintenance of this product, as well as the end user, may return this form. Please feel free to return the form even if you are not the original purchaser. This form may also be used to initiate a dialogue on your product needs and expectations.

Please provide as much information as possible so we will be able to contact you.

Your Name _____ Job Title _____
Company Name _____ Division _____
Telephone:Area/Country Code _____ Phone Number _____
Street Address _____ FAX Number _____
City _____ Prov/State _____ Mail Stop _____
Postal/Zip Code _____ Country _____ Department _____
Date _____

How would you prefer to be contacted?

_____ Mail _____ FAX _____ Phone _____ Your local HP sales representative

Has this product already been registered for Software Update Service?

_____ Yes _____ No _____ Not Sure

Your current configuration is:

Mainframe model no. _____ Serial no. _____ Software revision _____
Plug-in 1 model no. _____ Serial no. _____
Plug-in 2 model no. _____ Serial no. _____
Plug-in 3 model no. _____ Serial no. _____
Plug-in 4 model no. _____ Serial no. _____

Return this form to Hewlett-Packard

By Mail:

Hewlett-Packard Company
Colorado Springs Division
Software Notification Manager
P.O. Box 2197

By FAX

(719) 590-3505

Colorado Springs, Colorado, 80901-2197 USA

Optional Information

What are the most critical decisions that this oscilloscope will help you make?

What critical information do you need from the oscilloscope to make these decisions?

With the built-in disk drive and flash EPROM memory, it is possible to customize this oscilloscope to specific applications. Is this capability of interest to you?

Yes No

If you answered yes, what is the application and how could we customize the scope to the application?

What are you making measurements on?

- | | |
|--|--|
| <input type="checkbox"/> Computers | <input type="checkbox"/> Disk Drives |
| <input type="checkbox"/> Tape Drives | <input type="checkbox"/> ICs |
| <input type="checkbox"/> Lasers | <input type="checkbox"/> Fiber Optics |
| <input type="checkbox"/> Instrumentation | <input type="checkbox"/> Video |
| <input type="checkbox"/> Datacomm | <input type="checkbox"/> Telecomm |
| <input type="checkbox"/> Microprocessors (# _____) | <input type="checkbox"/> RF/Microwave Communications |
| <input type="checkbox"/> High-Energy Research | <input type="checkbox"/> TV |
| <input type="checkbox"/> Other (Please describe) | |

What is the primary application for this product?

- | | |
|---|---|
| <input type="checkbox"/> General Troubleshooting | <input type="checkbox"/> Computer Aided Test |
| <input type="checkbox"/> Digital Design and Debug | <input type="checkbox"/> Data Acquisition |
| <input type="checkbox"/> Analog Design Verification | <input type="checkbox"/> Go/No Go Measure Limit Tests |
| <input type="checkbox"/> Device Characterization/Test | <input type="checkbox"/> Go/No Go Wave Compare Tests |
| <input type="checkbox"/> Transient Waveform Capture | <input type="checkbox"/> Other (Please describe) |

ESD Precautions 6-2
Tools Required 6-2
Instrument Structure 6-2
To return the instrument to HP for service 6-3
A Brief Order of Procedures 6-4
To remove and replace
 Front panel 6-5
 Keyboard 6-6
 RPG 6-7
 Front fan 6-8
 Disk drive assembly 6-9
 Disk drive 6-9
 Disk drive control 6-10
 Rear panel 6-11
 Power supply 6-11
 CPU and display assemblies 6-12
 Time base assembly 6-12
 Clock assembly 6-14
 Acquisition assemblies 6-16
 Color CRT module 6-17
 Motherboard 6-20
 Rear fan 6-22



Replacing Assemblies

Replacing Assemblies

Procedures in this chapter should be used when removing and replacing assemblies and parts in the HP 54710A and 54720A oscilloscopes.

ESD Precautions

When using any of the procedures in this chapter you should use proper ESD precautions. As a minimum you should place the instrument on a properly grounded ESD mat and wear a properly grounded ESD wrist strap.

Tools Required

The following tools are required for these procedures. This instrument uses SMC connectors that require either a 6-mm or 1/4-inch wrench. Both connector types may be used in the instrument.

- Torx drivers: T10, T15, T20
- Nut Drivers: 5/16, 7/16
- Pozidrive screwdriver: #1
- Torque wrench, 0.565 Nm (5 in-lbs), 8 mm (5/16-inch) open end
- Torque wrench, 0.565 Nm (5 in-lbs), 1/4-inch open-end – for SMC connectors
- Torque wrench, 0.565 Nm (5 in-lbs), 6-mm (15/64-inch) open-end – for SMC connectors
- Torque driver, 0.565 Nm (5 in-lbs), 1/4-inch square male drive
- Special socket, HP part number 5081-7718 (part of HP 54717A plug-in)

Instrument Structure

The HP 54710A and 54720A are built from a welded steel cabinet with four closed sides. All assemblies are inserted from the front or the rear. At the front, behind the front panel, there are separate internal compartments for the plug-ins, color CRT module, and the front fan and disk drive. At the rear, behind the rear panel, one compartment encloses the rear fan and another comprises the card cage which holds the power supply, digital control system, and acquisition system. A motherboard, located between the plug-ins and card cage, is the main connection between the front and rear of the instrument.

To return the instrument to HP for service

Before shipping the instrument to Hewlett-Packard, contact your nearest HP sales office for additional details.

1 Write the following information on a tag and attach it to the instrument.

- Name and address of owner
- Instrument model numbers
- Instrument serial numbers
- Description of the service required or failure indications

2 Remove all accessories from the instrument.

Accessories include all cables. Do not include accessories unless they are associated with the failure symptoms.

3 Protect the instrument by wrapping it in plastic or heavy paper.

4 Pack the instrument in foam or other shock absorbing material and place it in a strong shipping container.

You can use the original shipping materials or order materials from an HP sales office. If neither are available, place 8 to 10 cm (3 to 4 inches) of shock-absorbing material around the instrument and place it in a box that does not allow movement during shipping.

5 Seal the shipping container securely.

6 Mark the shipping container as FRAGILE.

In any correspondence, refer to instrument by model number and full serial number.

A Brief Order of Procedures

In general, the procedures that follow have been placed in the order they must be used to remove a particular assembly. That is, given first are the procedures for assemblies that must be removed first. The figure below shows the general flow of procedures (from top to bottom) to remove assemblies.

CAUTION

Do not remove or replace any circuit board assemblies in this instrument while power is applied. The assemblies contain components which may be damaged if the assembly is removed or replaced while the instrument is powered.

Figure 6-1

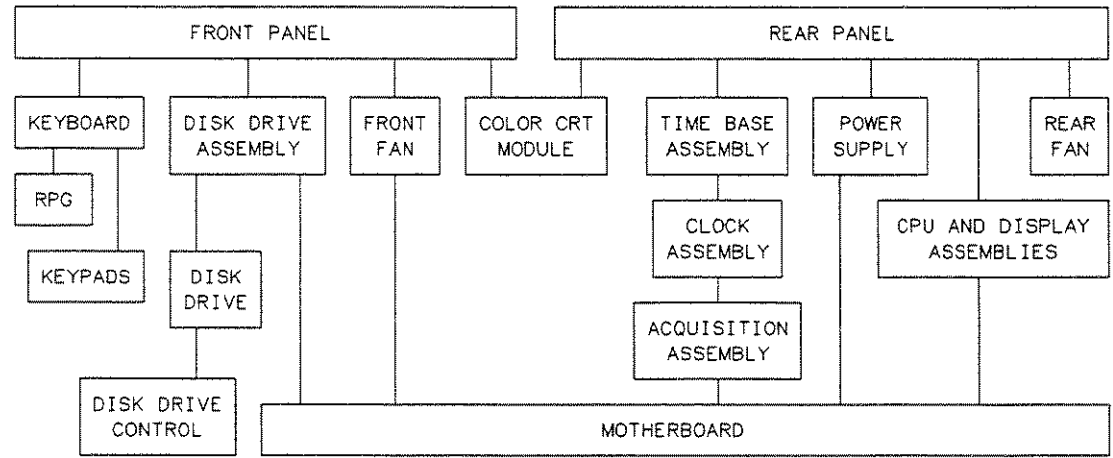

54720829

Assembly Removal Flow Diagram

To remove and replace the front panel

Removing the front panel exposes all assemblies located in the front compartments.

To Remove

Plug-ins may have been calibrated to specific slots. Record which plug-in is in each slot so you can return the instrument to its original calibrated condition.

- 1 Remove the plug-ins.
- 2 Remove all cables from the rear panel.
- 3 Place the instrument on its left side (as viewed from the front).
- 4 On the bottom of the front panel, remove the four 8 mm-long flat-head screws that hold the plug-in latches.
You may need to temporarily remove the right-front foot to remove the right side screw. Replace the foot after removing the screw.
- 5 Place the instrument in its normal operating position.
- 6 Remove the three 12 mm-long flat-head screws at the trim strips on each side of the front panel.
- 7 Pull the front panel off.

If you don't need to disconnect the panel, you can place it on top of the instrument.

- 8 To remove the keyboard cable, squeeze the metal tabs on the ends of the cable connector and pull the connector out of its receptacle.

When replacing the connector, make sure the metal tabs have latched in the keyboard connector.

To Replace

- To reassemble, reverse the above procedure. However, make note of the following:
 - Make sure the metal tabs of the keyboard cable connector have latched in the keyboard connector.
 - The plug-in guides must be inserted into holes in the back of the front panel. It may be helpful to set the instrument on its back feet while aligning the front panel.
 - While tightening the plug-in latches, hold them straight so the plug-in latching screws will align properly.

To remove and replace the keyboard

The keyboard is fastened by only two screws and the RPG shaft. However, it is held against the rubber keypads by many small tabs. Two locating pins position the PC board in the front panel. To remove the PC board, it must be lifted over the locating pins and then moved from under the tabs.

Several key reference points used during removal are marked on the PC board.

Figure 6-2

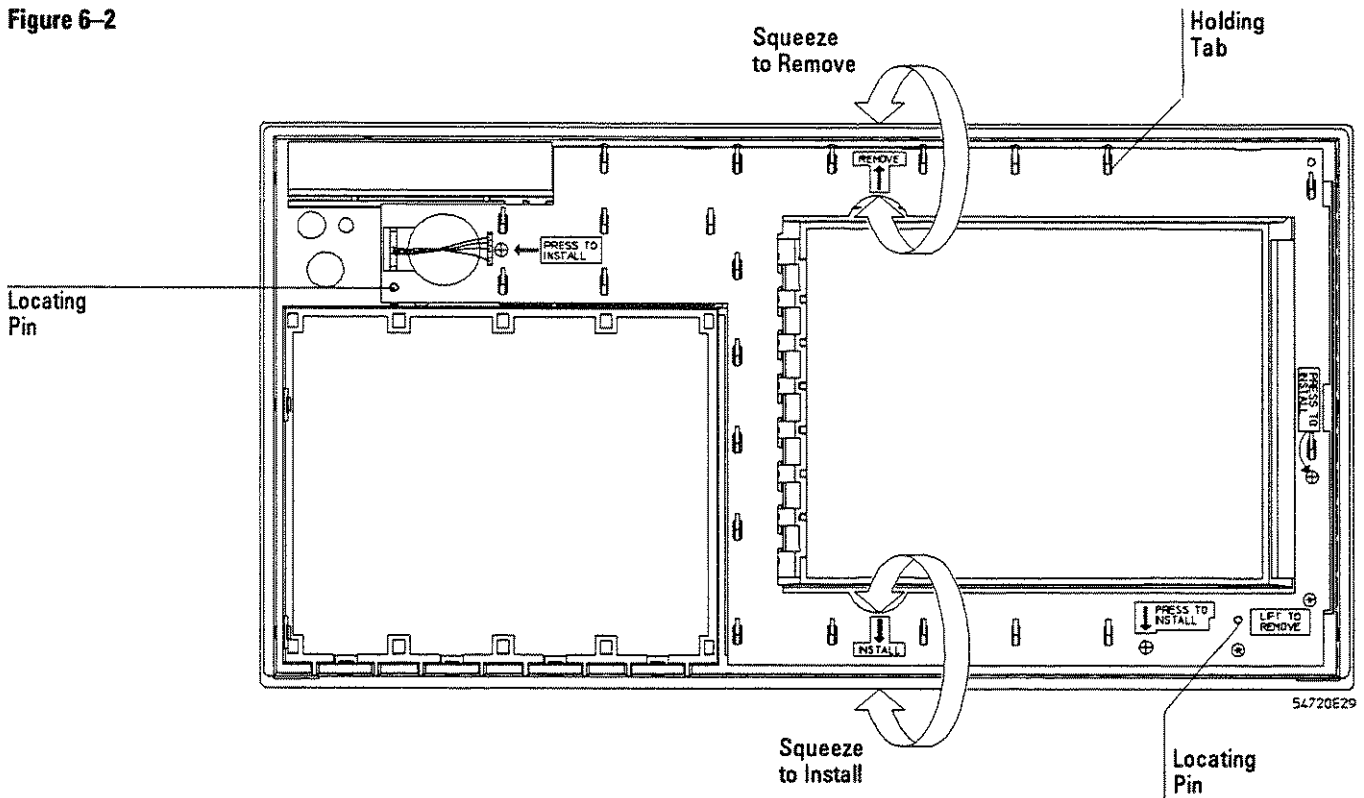

Keyboard Feature Locations

To Remove

- 1 Remove the front panel from the instrument.
- 2 Remove the knob by pulling on it firmly.
- 3 Use a 7/16 nut driver to remove the nut from the RPG bushing, then remove the curved lockwasher.
- 4 Remove the two self-tapping screws that hold the PC board at the corner near the switch.
- 5 Remove the PC board.

For this step use the finger recess at the top of the PC board. It may be helpful to turn the front panel assembly so a short side is toward you.

- a Put your thumb in the finger recess and your first finger at the top of the panel.
- b While squeezing the thumb and finger to slide the PC board toward the top of the panel, use the other hand to lift the PC board over the two locating pins. You can alternately push on the power switch and RPG from the front of the panel.

- c Lift the PC board off of the holding tabs.

CAUTION

Be careful not to contaminate the key side of the PC board or the keypads. Dust and fingerprints on these parts may cause intermittent key operation.

- 6 Remove the keypads if necessary.

To Replace

- 1 Make sure the keypads are clean and in their correct locations. They are positioned by holes in the pad and pins in the front panel.

If they look contaminated, clean them with isopropyl alcohol and a lint-free cloth.

- 2 Make sure the RPG is correctly installed on the keyboard.

- 3 Make sure the key side of the keyboard is clean.

If the key side of the keyboard is dirty, clean it with isopropyl alcohol and a lint-free cloth.

- 4 Check the green LEDs. They should be straight and perpendicular to the PC board.

- 5 Install the PC board.

For these steps use the finger recess at the bottom of the keyboard.

- a Place the keyboard over the holding tabs.

- b Put your thumb in the finger recess and your first finger at the bottom of the panel.

- c To make the PC board slide under the holding tabs, press it gently with your free hand at the points marked "Press to Install". Press first at the power switch and then near the RPG. Simultaneously, squeeze your thumb and finger to slide the PC board toward the bottom of the panel.

- d If the PC board will not slide, make sure it has dropped over all of the holding tabs.

- e Make sure the PC board has dropped over the locating pins.

- f Install the self-tapping screws in the corner of the PC board.

- 6 Place the lockwasher over the RPG bushing.

Place it on the bushing with the cupped (concave) side toward the panel.

- 7 Install the RPG nut and tighten.

- 8 Install the knob.

To remove and replace the RPG

The RPG (rotary pulse generator) is driven by the front-panel knob.

- 1 Remove the front panel from the instrument.

- 2 Remove the keyboard from the front panel.

- 3 Remove the spacer nut from the RPG bushing. It should be only finger tight so the RPG bushing can align with the hole in the panel.

- 4 Disconnect the cable and remove the RPG.

- 5 To install the RPG, reverse the procedure.

To remove and replace the front fan

The front fan is mounted on a bracket above the plug-ins. The fan power cable plugs into the motherboard at the rear of the fan compartment.

To Remove

- 1 Remove the front panel but do not disconnect the keyboard cable. Lay the front panel on top of the instrument.
- 2 Remove the top plug-in guide.
Press up on the large locking tab at the rear of the plug-in guide and pull the guide out.
- 3 Use a T15 driver to remove the screw at the front of the fan bracket.
- 4 Push the fan bracket down at the front and slide the assembly down and out.
- 5 Disconnect the fan cable.
Squeeze the locking tab on the top of the connector and pull the connector out.
- 6 To remove the fan from the bracket, remove the four 8 mm-long screws.

To Replace

- 1 Place the fan on the raised side of the bracket so that the airflow is down and the cable is on the left rear corner as shown in the figure.

Figure 6-3

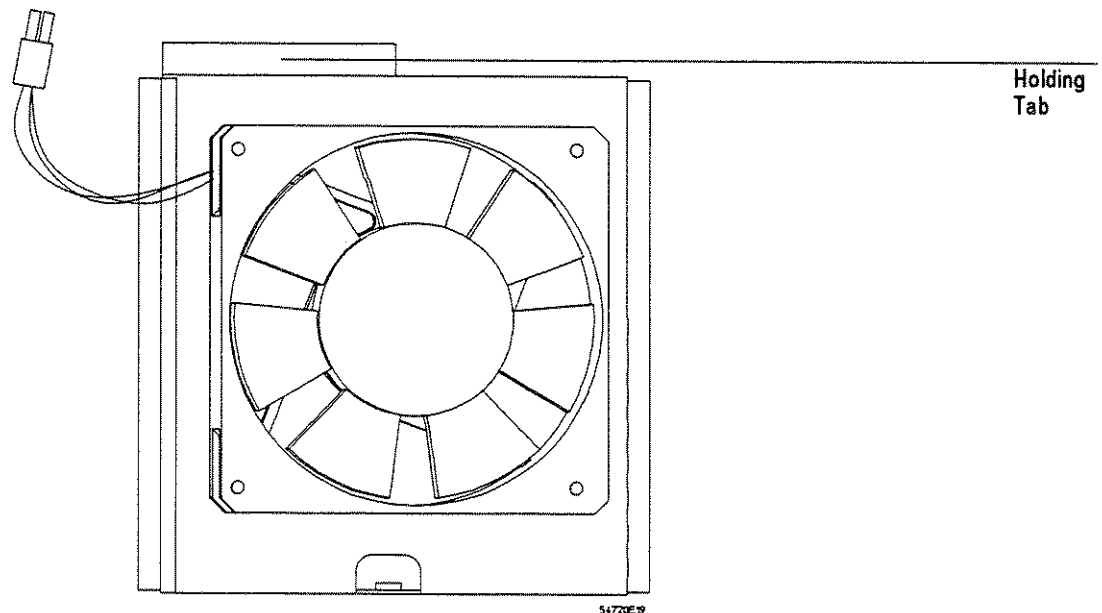

Front Fan Alignment

- 2 Install the four 8 mm-long screws.
- 3 Place the fan assembly into the plug-in compartment and connect the cable.
- 4 With the assembly sloping up at the back, slide it up and in so the holding tab (see figure) is above the ledge at the back of the compartment.
- 5 Raise the front end of the assembly into place.
- 6 Install the T15 pan-head screw at the front of the bracket.
- 7 Install the plug-in guide.
- 8 Install the front panel.

To remove and replace the disk drive assembly

The disk drive assembly includes the disk drive, disk drive control board, and the mounting bracket. It plugs into a connector at the rear of the fan compartment. The keyboard cable plugs into the disk drive control board.

To Remove

- 1 Remove the front panel, but do not disconnect the keyboard cable. Lay the front panel on top of the instrument.
- 2 Remove one screw that fastens the front strut of the disk drive bracket to the cabinet.
- 3 With a slight side-to-side motion, pull on the disk drive bracket strut and pull the assembly out.
- 4 Disconnect the keyboard cable at the disk drive control board.

To Replace

- 1 Connect the keyboard cable.
You must squeeze the metal locking tabs on the side of the connector while inserting it.
- 2 Slide the assembly most of the way into the cabinet.
- 3 Lift the back of the assembly to locate the connector into the motherboard connector.
- 4 Push on the strut or sides of the disk drive assembly to seat the connector.
- 5 Install the screw at the strut.
- 6 Install the front panel.

To remove and replace the disk drive

The disk drive is held by four screws.

- 1 Remove the disk drive assembly.
- 2 Remove four screws on the bottom of the disk drive assembly.
- 3 Separate the disk drive from the bracket slightly, and disconnect the cable from the disk drive.

The cable is soldered to the disk drive control board.

- 4 To install the disk drive, reverse the procedure.

To remove and replace the disk drive control

The disk drive control is secured to the disk drive assembly by two tabs at the end near the disk drive and two screws at the connector.

- 1 Remove the disk drive assembly from the cabinet and the disk drive from the assembly.
- 2 Remove the two flathead pozidrive screws at the sides of the large connector.
- 3 Remove the PC board by moving it as shown by the four steps in the picture below.

Figure 6-4

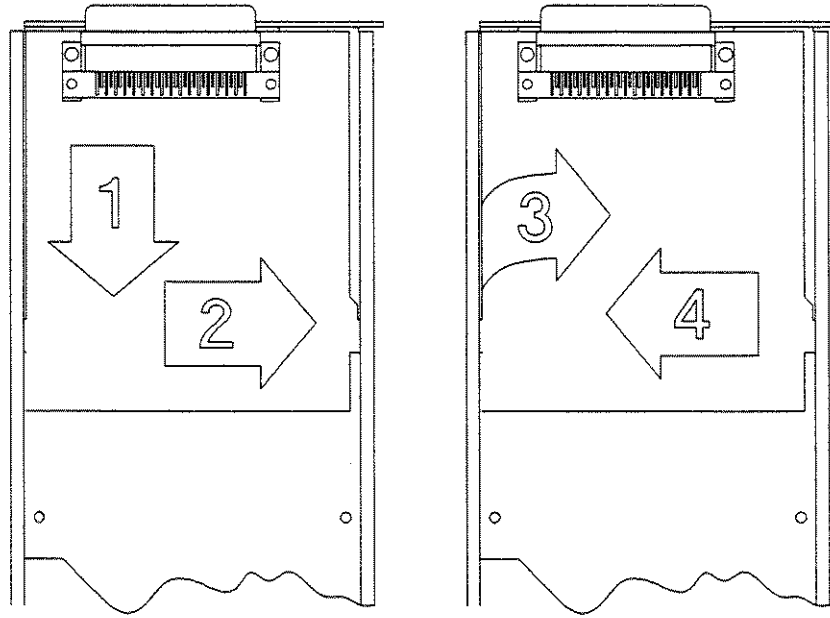

54720E20

Disk Drive Control Removal

- 4 To install the board, reverse the procedure.

To remove and replace the rear panel

Removing the rear panel provides access to the digital system, acquisition system, and rear fan.

- 1 Remove the power cord and other cables.
- 2 Remove the four rear feet. Each has a screw and flat washer.
- 3 Remove the two screws that hold the cover over the fuse.
- 4 Remove the two large screws just above and on either side of the parallel printer port.

Do not confuse these screws with the hex standoffs used to secure a printer cable.

- 5 Remove the two screws on either side of the trigger output connector.
- 6 To remove the cover, use a flat tool to gently pry at the corners.
- 7 To install the cover, reverse the procedure.

To remove and replace the power supply

CAUTION

The fuse requirement is different for 100 V, 115 V, and 230 V operation. If you will be installing a new supply you must check that the fuse on the new supply is appropriate for the line voltage that you will be using. Refer to the Replaceable Parts list for the correct fuse rating and part numbers. The wrong fuse may not protect the instrument properly.

To Remove

- 1 Remove the rear panel.
- 2 Disconnect the rear fan cable from the connector at the side of the power supply.
Consult the illustration on the inside of the rear panel.
- 3 Remove the two screws at the lower corners of the supply.

WARNING

SHOCK HAZZARD! The charge on capacitors can be lethal even after power has been disconnected. Do not touch the PC board or components until you are sure there is no danger.

- 4 Slide the supply out of the frame.
Grip the supply at the recesses on each side of the rear panel of the supply.

To Replace

- 1 To reinstall the supply, reverse the above procedure.
Slide the supply in gently to make the connection with the motherboard without bending connector pins.
- 2 If you have installed a new supply, make the following checks.
 - Check that the line voltage selection is set properly.
To change the selection, remove the line voltage switch cover, turn it 180 degrees and reinstall it. The switch will change when the cover is re-installed.
 - Check that the correct fuse is installed.

The fuse requirement is dependent on the line voltage being used; 100 V, 115 V, or 230 V. Refer to the Replaceable Parts list for the correct fuse rating and part numbers.

To remove and replace the CPU and display assemblies

The CPU and display assemblies are in the rear card cage, the second and third assemblies from the top. The display assembly is just below the CPU.

The CPU and display assemblies are connected by a short cable near the rear of the assemblies. Both assemblies must be partially removed before they can be separated.

CAUTION

Use proper ESD safety precautions.

To Remove

- 1 Remove the rear panel.
- 2 Disconnect the display cable (large ribbon cable) at the display assembly.
Push to the side the clamps on either side of the cable connector and the connector will slide out of the socket.
To get it out of the way, temporarily tuck the cable into the area beside the fan.
- 3 Remove four screws, two at either side of the CPU and display assemblies.
- 4 One at a time, and with a slight side-to-side motion, slide each assembly out until they just release at the front connector.
- 5 Slide the assemblies out together about 7 cm (3 inches).
- 6 Disconnect the ribbon cable at the center rear of the CPU.
Push to the side the clamps on either side of the cable connector and the connector will slide out of the socket.
- 7 Push the cable through the opening in the CPU assembly and remove the desired assembly.

To Replace

- 1 To reinstall the assemblies, reverse the procedure.
Slide the assemblies in gently to make the connection with the motherboard without bending connector pins.
- 2 If you have installed a new CPU or have had a battery problem, recalibrate the mainframe. The calibration factors are stored on the CPU assembly.

To remove and replace the time base assembly

The time base assembly is in the rear card cage, the fourth assembly from the top.

CAUTION

Use proper ESD safety precautions.

CAUTION

This instrument uses SMC connectors that require either a 6-mm (15/64-inch) or 1/4-inch wrench. Use the correct wrench. Using a wrench that is too large may damage the connector.

To Remove

- 1 Remove the plug-ins.
- 2 Remove the rear panel.

- 3 Disconnect the display cable (large ribbon cable) at the display assembly.
Push to the side the clamps on either side of the cable connector and it will slide out of the socket. To get the cable out of the way, temporarily tuck it into the area beside the fan.
- 4 Disconnect the CAL cable.
Use a 6-mm (15/64-inch) or 1/4-inch (as required) open-end wrench to disconnect the SMC connector and long-nose pliers to disconnect the wire connectors.
- 5 Remove 4 screws that hold the front of the time base assembly in the mainframe.
These screws are accessible through the plug-in compartment. See the figure below.
These screws have a plastic "patch lock" that comes off the threads when the screws are removed. If you use new screws when you replace the assemblies, it ensures the assemblies stay secure. For the part number, see the parts views and replaceable parts list in chapter 7.

Figure 6-5

Remove these four screws

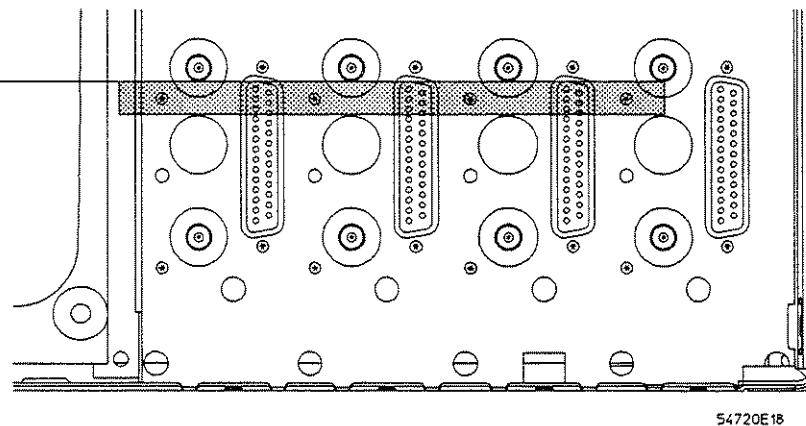

Time base Mounting Screws

- 6 Slide the time base assembly about 2.5 cm (1 inch) out of the instrument.
- 7 Disconnect the clock cable at the time base assembly.
This is the short cable that connects to the clock assembly. This is an SMC connector; use a 6-mm (15/64-inch) or 1/4-inch (as required) wrench.
- 8 Disconnect the two other SMC connectors and the two SMB connectors from the time base assembly.
- 9 Note the routing of the CAL cable in the opening in the rear bracket. Slide the cable out of the opening.
- 10 Remove the time base assembly from the instrument.

CAUTION

Be sure that all cables are out of the way so that the time base assembly and cables do not get damaged.

To Replace

The clock assembly must already be installed.

- 1 To install the time base assembly, reverse the removal procedure. However, make note of the following:
 - Tighten the SMC connectors to 0.34 Nm (3 in-lbs). Use an open-end torque wrench.
 - Slide the assemblies in gently, to make the connection with the motherboard without bending connector pins.
- 2 Recalibrate the mainframe.

To remove and replace the clock assembly

The clock assembly is in the rear card cage, the fifth assembly from the top.

CAUTION

Use proper ESD safety precautions.

CAUTION

This procedure requires removing and replacing cables in very mechanically sensitive locations. Use caution and a light touch when working with the semi-rigid cabling. Follow the procedures carefully to avoid breaking expensive parts. Careless handling may result in a broken hybrid which will be very expensive to repair.

You will need the following special tools.

- Torque screwdriver handle set to 0.565 Nm (5 in-lbs) with a 1/4-inch male drive
- Special cut-away 5/16-inch socket, 1/4-inch drive. This is a standard 5/16-inch deep socket, cut away to fit around the cables while turning. This socket is supplied with the HP 54717A calibration plug-in.

CAUTION

If you do not have these tools, do not attempt these procedures.

To Remove

Read each step completely before performing it. Refer to the appropriate procedures in this chapter for the first three steps.

- 1 Remove the plug-ins.
- 2 Remove the rear panel.
- 3 Remove the time base assembly.
- 4 Loosen the clock cable at the clock assembly so it can be moved out of the way.

This is an SMA connector; use an 8-mm (5/16-inch) open-end wrench.

CAUTION

While removing the cables in the next step you want to avoid stress to the hybrids on the acquisition assemblies. This is most easily done by just loosening the connectors with the cut-away socket and torque driver, then removing the cables the rest of the way by using just the cut-away socket held in your fingers.

The socket will only rotate part of a turn before interfering with the cable. Be sure to position it with allowance for rotation.

If the instrument is an HP 54720A there will be eight semi-rigid cables and if the instrument is an HP 54710A there will be four. The procedure is the same for both. On the HP 54710A, terminations are connected to four of the clock assembly outputs. Unless you are installing a new assembly they do not need to be removed.

- 5 With the special socket wrench and driver, loosen the semi-rigid connectors at the acquisition assemblies.
- 6 With the special socket wrench and driver, loosen the semi-rigid connectors at the clock assembly.
- 7 Working from right to left (as viewed from the rear of the instrument), remove each semi-rigid cable using your fingers or the special socket held in your fingers.

If you remove the cables in order, and set them aside in the same order, you can more easily install them in the required order.

- 8 Remove two screws that secure the clock assembly rear bracket to the acquisition assembly rear bracket.

- 9 Remove the clock assembly from the instrument.
- 10 If you are installing a new clock assembly in an HP 54710A, remove the four terminations on the unused outputs of the old assembly and install them on the same outputs of the new one.

To Replace

The acquisition assemblies must already be installed.

- 1 Slide the clock assembly into the instrument in the slot just above the acquisition assemblies.

Slide the assemblies in gently, to make the connection with the motherboard without bending connector pins.

- 2 Install two screws that secure the clock assembly rear bracket to the acquisition assembly rear bracket.

- 3 Using the drawing below, install the semi-rigid cables from left to right. Tighten the connectors gently using your fingers or the special socket held in your fingers.

- 4 Only at the clock assembly, tighten the semi-rigid coax connectors to 0.565 Nm (5 in-lbs). Use the special socket and torque driver.

When tightening the cables on the acquisition assemblies in the next step, be sure not to apply side stresses to the connectors on the hybrids. Unusual stress may break the hybrid.

- 5 On the acquisition assemblies, tighten the semi-rigid coax connectors to 0.565 Nm (5 in-lbs). Again, use the special socket and torque driver, and remember, the socket will only rotate part of a turn before interfering with the cable. Be sure to position it with allowance for rotation.

- 6 Tighten the clock cable at the clock assembly.

Be sure to position it so that the time base assembly can slide over it without damage.

- 7 Install the time base assembly, rear panel, and plug-ins.

- 8 Recalibrate the mainframe.



CAUTION



Figure 6-6

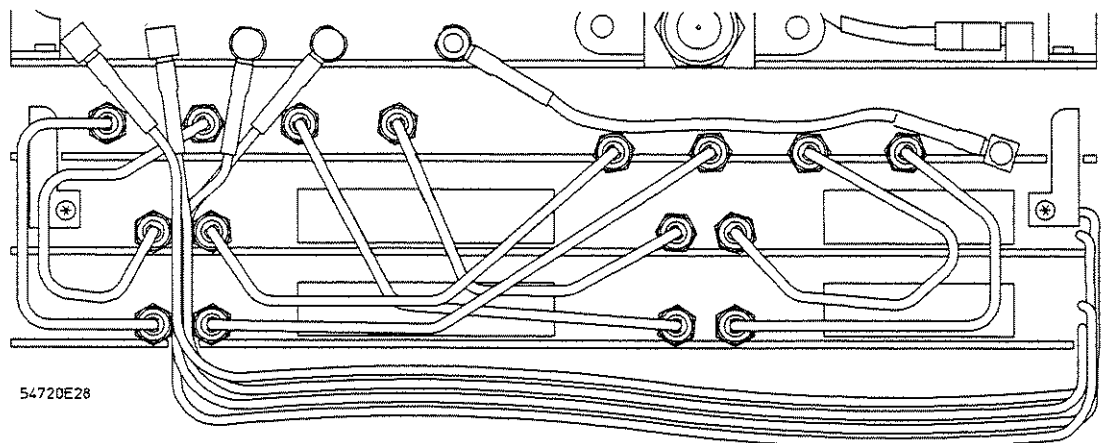

Acquisition Assembly Cabling

To remove and replace the acquisition assemblies

The acquisition assemblies are the two bottom assemblies in the rear card cage. In the HP 54710A there is only one acquisition assembly, but the procedures for removal and installation are essentially the same.

CAUTION

The ceramic hybrids to which the semi-rigid cables attach are very susceptible to breakage. Be sure to follow the procedures very carefully.

CAUTION

Use proper ESD safety precautions.

To Remove

Read each step completely before performing it. Refer to the appropriate procedures in this chapter for the first four steps.

- 1 Remove the plug-ins.
- 2 Remove the rear panel.
- 3 Remove the time base assembly and clock assembly.
- 4 Loosen the stop bars.

These hold the rear of the acquisition assemblies at each side.

- 5 Remove 4 screws that hold the front of the acquisition assemblies in the mainframe.

These screws are accessible through the plug-in compartment. See the figure below.

These screws have a plastic "patch lock" that comes off the threads when the screws are removed. If you use new screws when you replace the assemblies, it ensures the assemblies stay secure. For the part number, see the parts views and replaceable parts list in chapter 7.

Figure 6-7

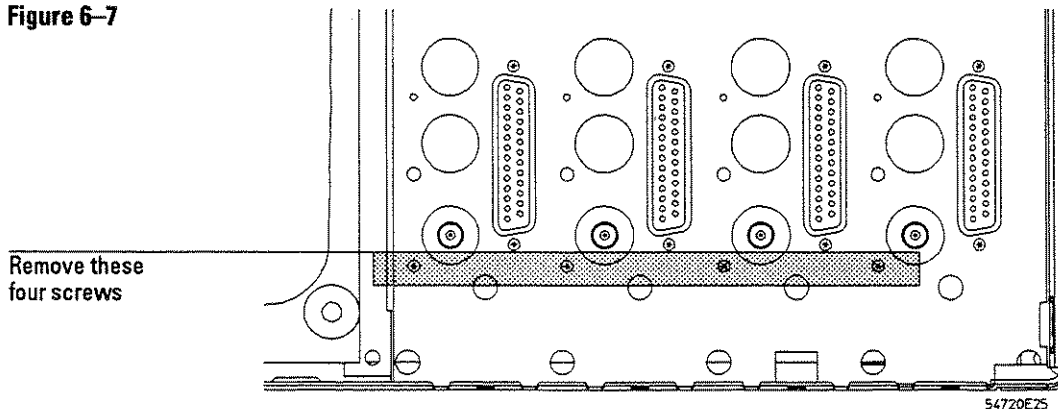

Acquisition Assembly Mounting Screws

- 6 Remove the stop bars and slide the acquisition assemblies out of the cabinet.

To Replace

- 1 To install the acquisition assemblies, reverse the removal procedure. However, make note of the following:
 - Slide the assemblies in gently to make the connection with the motherboard without bending connector pins.
- 2 Recalibrate the mainframe.

To remove and replace the color CRT module

The color CRT module is in a compartment by itself and does not need to be removed to replace any other assembly.

If you are replacing a failed color CRT module, you will have to move several parts from the failed module to the new one.

To Remove the Module

When necessary, use other procedures in this chapter to help remove the various assemblies.

- 1 Remove the rear panel.
- 2 Disconnect the ribbon cable from the display assembly.
- 3 Remove the ribbon cable from the clips that hold it in the rear fan compartment.
- 4 Remove the front panel and disconnect the keyboard cable at the keyboard.
- 5 Turn the instrument onto its left side (same side as the color CRT module).
- 6 Remove the two pan-head screws and washers, about half way back on the bottom of the cabinet.
These screws secure the color CRT module rear bracket.
- 7 Remove the two pan-head screws on the bottom of the cabinet, near the front.
- 8 Turn the instrument so that it is again right side up.
- 9 Remove the two pan-head screws on the top of the cabinet, near the front.
- 10 Slide the module part way out of the cabinet, until you can reach the power cable on the right side of the module.
- 11 Disconnect the cable at the module and remove the module from the instrument.

To Exchange Parts Between Modules

If you are installing a new or rebuilt module, you need to move several parts from the old module to the new one.

The shields and rear bracket are attached to the module with self-tapping screws. If your replacement module is a new one, the screws will tap the holes when they are installed. If the replacement module is a rebuilt one, the holes may be already tapped. Start the screws carefully so they do not cross thread the holes.

1 Move the shields.

The left shield fits around the top, left, and bottom of the module. The right shield is angled and covers the right side of the module.

- a Remove one screw from the upper-right rear of the module.

Note how tabs on the shield tuck into the front of the module frame and how the shields overlap each other at the top and bottom joints.

- b Swing the rear of the right shield away from the module and slide the front tabs out of the module frame.
- c Disconnect the cable from the module at the two places on the PC board.
- d Remove five screws from the left shield.
- e Remove the left shield and place it around the new module.
Overlap the joint between the shields as they were on the old module.
- f Install the five screws but do not tighten them at this time.

- g Take the right shield and connect the cables to the proper places on the PC board. One connector has four pins and the other has five.
- h Hold the shield at an angle and slide the front tabs of the shield about 15 mm (9/16 in) into the two slots on the module frame. (See the figure below. The bottom is the same as the top.)

Figure 6-8

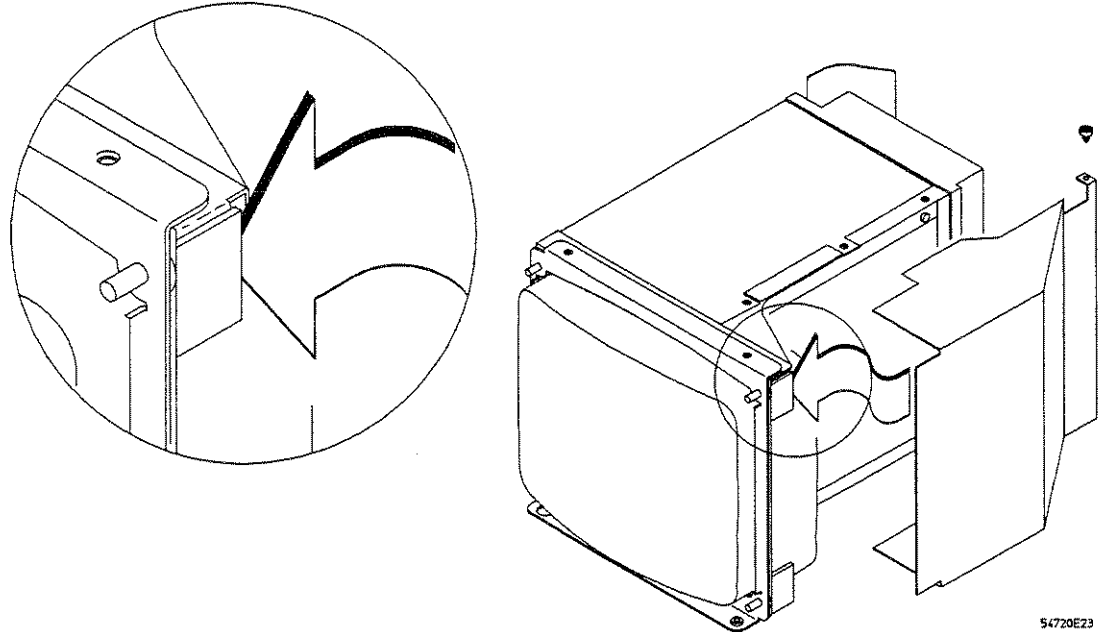

Installing Right CRT Module Shield

- i As you swing the rear of the shield toward the module, make sure the cables do not get caught between the shield and frame.
 - j Install the screw. Reposition the shield if the screw hole does not line up properly.
 - k Tighten the five screws of the left shield.
- 2 Move the front mounting bracket.
- a Remove four 5/16 nuts from the studs at the front of the replacement module.
 - b Remove the two angle rails; one is between the left pair of studs and one is between the right pair. Set the rails aside.
 - c Note the position of the front bracket on the failed module.
 - d Remove the four 5/16 nuts from the front of the failed module.
 - e Transfer the front bracket to the same position on the replacement module.
 - f Install four 5/16 nuts on the replacement module and tighten them.
 - g Install and tighten the two angle rails and 5/16 nuts on the failed module.
- 3 Note the position of the rear mounting bracket on the failed module, then remove it.
- 4 Remove the ribbon cable from the failed module (push the connector clamps to the side), and install it on the replacement module.
- 5 With the two screws and washers, install the rear bracket loosely on the replacement module.
- The bracket should be able to move only slightly. It will be tightened when the module is installed in the instrument.

To Replace the Module

- 1 Set the oscilloscope frame in its normal operating position.
- 2 Position the module in front of the mainframe and thread the ribbon cable into the slot at the bottom rear of the compartment. Make sure that it is not twisted.
- 3 Slide the module part way into the mainframe and connect the power cable to the connector on the right side of the module.
- 4 Slide the module into the mainframe. Pull the ribbon cable through the mainframe as the module slides in.

Take care not to get the ribbon cable or power cable caught between the module and mainframe. If the power cable connector gets caught between the module and frame the module may not get positioned correctly.
- 5 Install, but do not tighten, two screws in the oblong holes in the depressions at the top-front of the instrument cabinet.
- 6 Connect the keyboard cable to the front panel and install the front panel on the mainframe.
- 7 Place the instrument face down on the table with the left side (color CRT module side) toward you.

Use a couple of books under the left and right sides of the front panel so the instrument is stable and does not sit on the knob or the calibrator connectors.

In the next steps, the object is for the weight of the color CRT module to push it against the back of the front panel so there is a minimal gap between the CRT and the panel.
- 8 Install, but do not tighten, two screws in the oblong holes in the depressions at the bottom-front of the instrument cabinet.
- 9 At the module rear bracket and on the cabinet bottom are two rectangular holes with a large round hole between them. Install, but do not tighten, two screws with washers at the rectangular holes.

There is a small hole in the rear bracket, aligned with the large round hole. A pointed device can be used in the small hole to move the module bracket to insert the screws or position the module so it rests properly in the cabinet.
- 10 Tighten all of the hardware in the following sequence.
 - a Tighten the screws at the front of the instrument, those that fasten the front bracket of the module.
 - b Ensure that the rear module bracket is flush with the inside bottom of the cabinet (bottom screws are still loose).
 - c Through the two holes in the left side of the cabinet, tighten the screws that fasten the rear bracket to the module.
 - d Tighten the two rear bracket screws on the bottom of the cabinet.
- 11 Set the instrument on its bottom, look at the front, and ensure that the CRT is flush with the front panel.

If the CRT is not flush, put the instrument back on its front panel, loosen the hardware, use the access holes (side and bottom) to reposition the module, then re-tighten the hardware in the sequence in step 10.

To remove and replace the motherboard

The motherboard is located between the plug-in compartment and the card cage. It connects the card cage assemblies and the plug-ins.

1 Disassemble the instrument.

- a Remove the power cord and plug-ins.
- b Remove the front panel but leave the keyboard cable connected.
- c Remove the disk drive assembly and carefully set it on top of the front panel. You do not need to disconnect the keyboard cable.
- d Remove the front fan assembly.
- e Remove the following assemblies in order. When you start with the power supply procedure, the other procedures follow in sequence in this chapter.
 - Power supply
 - CPU and display assemblies
 - Time base assembly
 - Clock assembly
 - Acquisition assemblies

2 Remove and replace the motherboard.

The cable that provides power to the color CRT module is connected to the front of the motherboard. You must move the motherboard carefully until you can disconnect this cable from the rear. This is preferable to having to remove the color CRT module as well. Read all of the following steps before proceeding.

- a Remove the screws that hold the motherboard. See the figures on the next page.

Three things have to be considered as the motherboard is removed.

- Three tabs on the right side of the motherboard (as viewed from the rear of the instrument) fit in slots in the cabinet.
 - Eight plug-in locating pins protrude from the motherboard through the bulkhead panel.
 - The color CRT module power connector also protrudes through the bulkhead panel.
- b Swing the left side of the motherboard toward the rear until the locating pins clear the bulkhead panel.
 - c As the locating pins clear, you will be able to move the motherboard to the left slightly to clear the tabs from the slots.
 - d When the tabs are free, pull the motherboard back until the connector clears the bulkhead panel, then swing the motherboard against the right side of the card cage.
 - e Squeeze the connector locking tab at the top, and disconnect the color CRT module power cable from the upper corner of the motherboard. Do not allow the cable to fall through the opening in the bulkhead panel.
 - f If you are installing a new motherboard, use the following steps to move the torroidal springs to the new board.

CAUTION

The effect of these grounding springs is very significant, and they require care in installation. Handle the springs carefully and follow the instructions. Improper installation may cause poor operation of the oscilloscope.

- 1 One at a time, carefully remove the springs from the posts on the old motherboard and slide them half way down the posts on the new motherboard.

CAUTION

If you try to push the springs all of the way on with your fingers, they will roll and may be out of position when they come to rest on the shoulder of the pin. If they are out of position they may be crushed when the motherboard is installed or may make insufficient contact between the motherboard and the bulkhead panel.

- 2 Use the rear end of a plug-in as a tool to slide the springs down the posts. Fit the plug-in over a pair of posts, as if you were going to plug it into the motherboard, and push it until the bus connector fully mates in the motherboard.
- 3 To reassemble the instrument, reverse the procedure.
Follow the appropriate steps in all procedures.

Figure 6-9

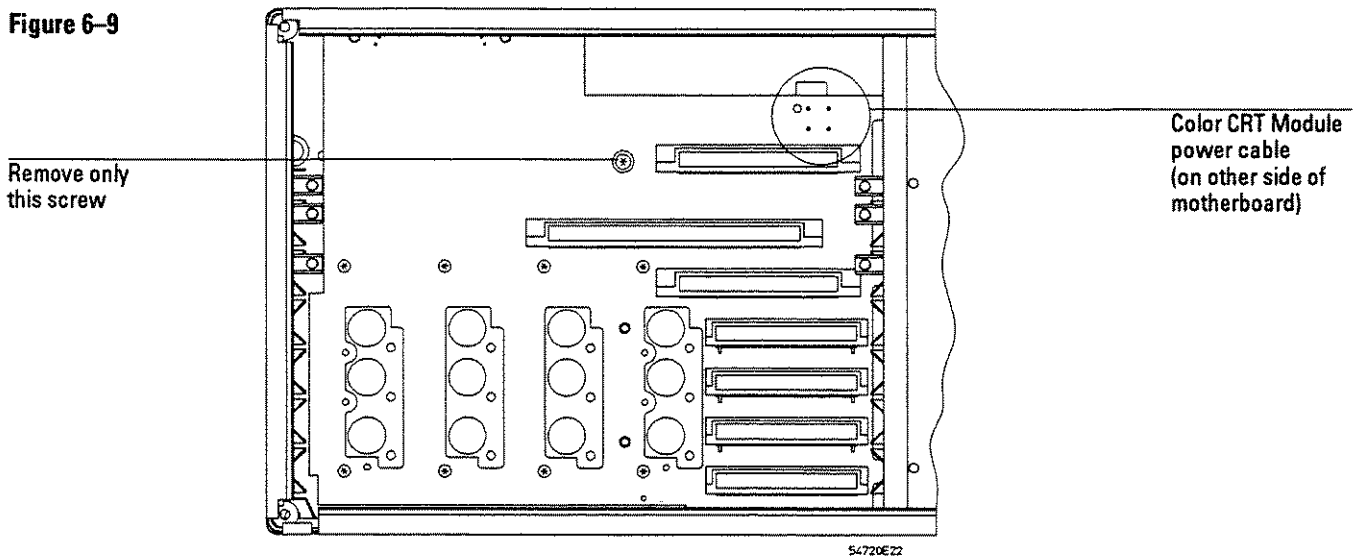

Rear Motherboard Mounting Screws

Figure 6-10

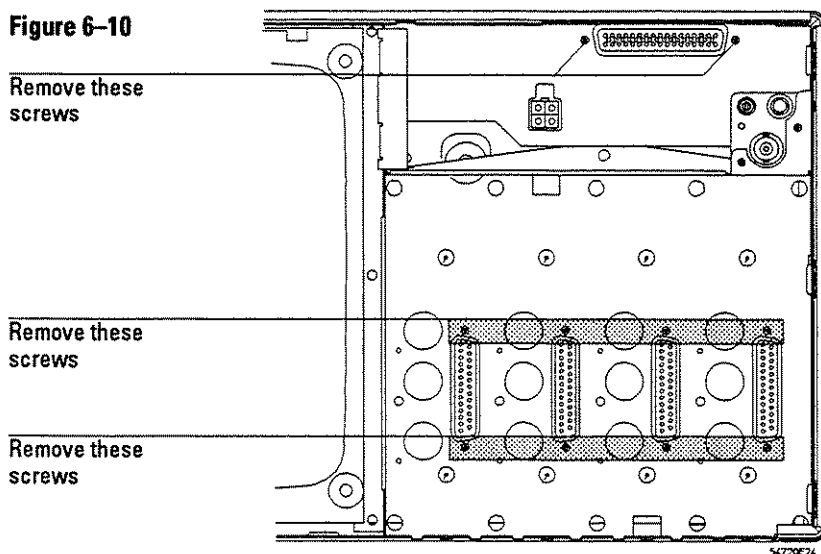

Front Motherboard Mounting Screws

To remove and replace the rear fan

The rear fan does not need to be removed to remove any other assemblies.

To Remove

The fan bracket is held in the cabinet by two pins at the front and by two screws at the rear mounting tabs.

- 1 Remove the rear panel.
- 2 Disconnect the rear fan cable from the connector at the side of the power supply.
Consult the label on the inside of the rear panel. Note the routing of the fan cable.
- 3 Remove the two screws that hold the fan bracket at the top and bottom.
- 4 Pull the fan assembly straight back about 1 cm (3/8 in) until it clears the pins at the front of the fan compartment.
- 5 Rotate the fan assembly counter-clockwise until it clears the rear mounting tabs and you can remove it completely.
- 6 Remove three screws to remove the fan from the bracket.

To Replace

- 1 Mount the fan on the bracket.
 - a Place the fan bracket on the table with the largest right-angle bend down and on the left.
 - b Place the fan on the bracket with the cable at the lower left and take note of the following:
 - Fan rotation is clockwise
 - Air flow is downAirflow and rotation are marked on the side of the fan.
 - c Install three screws.
 - left side
 - upper right
 - lower right
 - d Check that the temperature sensor is tied at the right-side hole, away from the fan bracket.
- 2 Install the fan in the instrument.
 - a Slide the fan and bracket into the cabinet with the fan to the right of the bracket.
Tilt the fan and bracket counterclockwise so that it clears the top mounting tab to the left and the bottom mounting tab to the right (as viewed from the rear).
 - b When the assembly is about 1 cm (3/8 inch) out of the cabinet, rotate it clockwise to line up with the front pins and rear tabs, then slide it the rest of the way into the cabinet.
 - c Install two screws at the rear mounting tabs.
 - d Connect the fan cable to the power supply.
- 3 When you turn on the instrument, check that the airflow is from the outside, into the cabinet.
- 4 Install the rear panel.

Ordering Replaceable Parts 7-2
Listed Parts 7-2
Unlisted Parts 7-2
Direct Mail Order System 7-2
Exchange Assemblies 7-2
Exploded Views 7-3
Replaceable Parts List 7-6

Replaceable Parts

Replaceable Parts

This chapter of the Hewlett-Packard 54720A Oscilloscope service guide includes information for ordering parts. Service support for this instrument is replacement of parts to the assembly level. The replaceable parts include assemblies and chassis parts.

Ordering Replaceable Parts

Listed Parts

To order a part in the parts list, quote the HP part number, indicate the quantity desired, and address the order to the nearest HP Sales/Service Office.

Unlisted Parts

To order a part not listed in the parts list, include the instrument part number, instrument serial number, a description of the part (including its function), and the number of parts required. Address the order to the nearest HP Sales/Service Office.

Direct Mail Order System

Within the USA, Hewlett-Packard can supply parts through a direct mail order system. There are several advantages to this system:

- Direct ordering and shipment from the HP parts center in California, USA.
- No maximum or minimum on any mail order. (There is a minimum amount for parts ordered through a local HP sales office when the orders require billing and invoicing.)
- Prepaid transportation. (There is a small handling charge for each order.)
- No invoices.

In order for Hewlett-Packard to provide these advantages, please send a check or money order with each order.

Mail order forms and specific ordering information are available through your local HP sales office. Addresses and telephone numbers are located in a separate document shipped with the manuals.

Exchange Assemblies

Some parts used in this instrument have been set up for an exchange program. This program allows the customer to exchange a faulty assembly with one that has been repaired, calibrated, and performance-verified by the factory. The cost is significantly less than that of a new part. The exchange parts have a part number in the form XXXXX-695XX.

After receiving the repaired exchange part from Hewlett-Packard, a United States customer has 30 days to return the faulty assembly. For orders not originating in the United States, contact the local HP service organization. If the faulty assembly is not returned within the warranty time limit, the customer will be charged an additional amount. The additional amount will be the difference in price between a new assembly and that of an exchange assembly.

Exploded Views

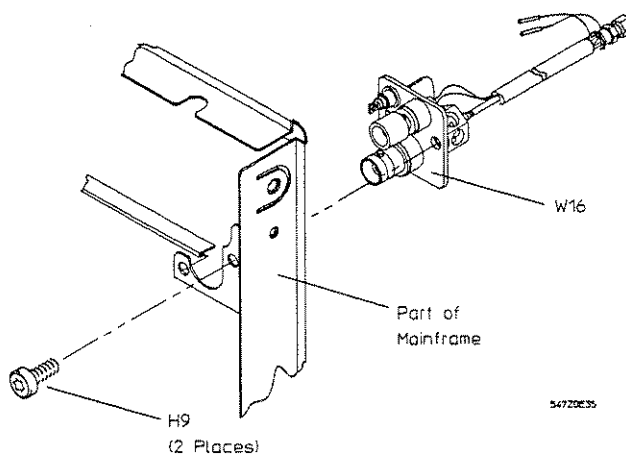
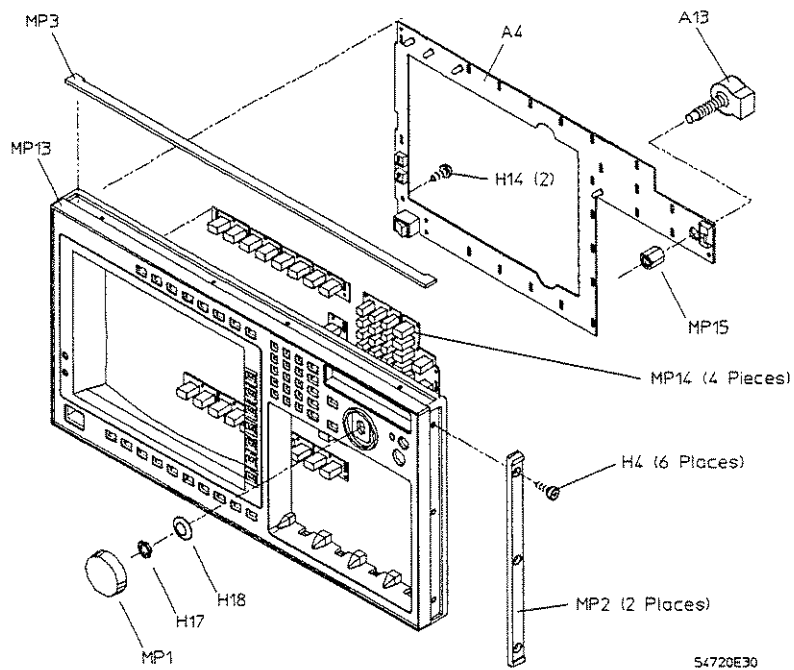

Chapter 7: Replaceable Parts
Exploded Views

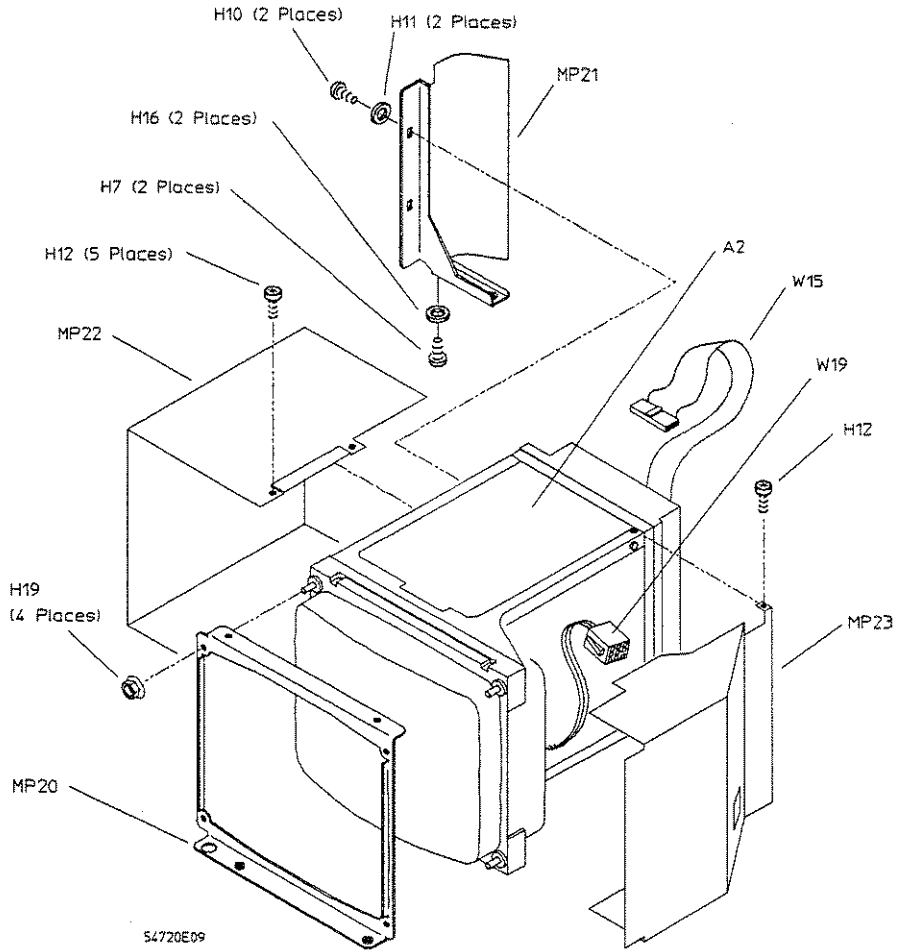

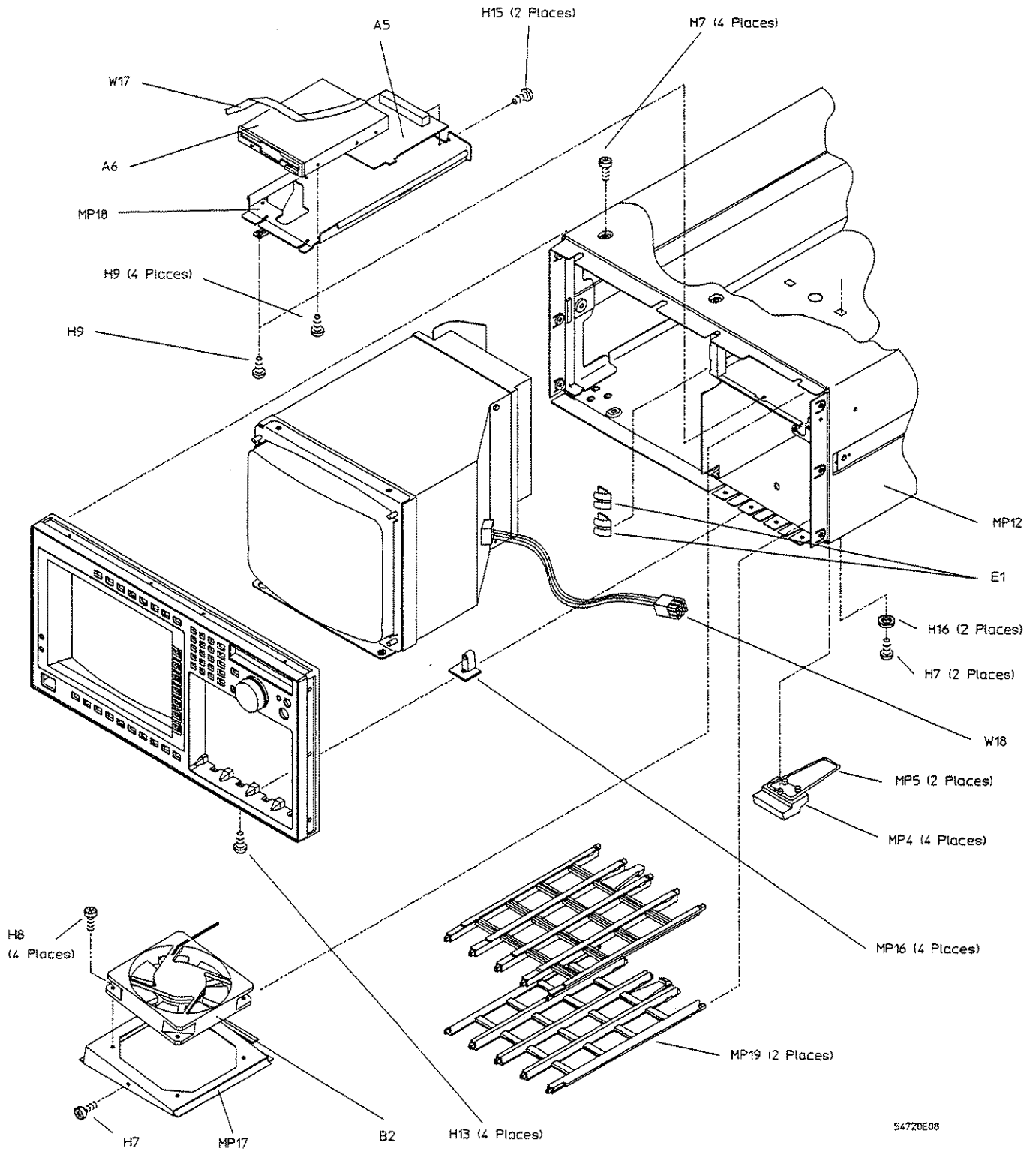

Chapter 7: Replaceable Parts
Exploded Views

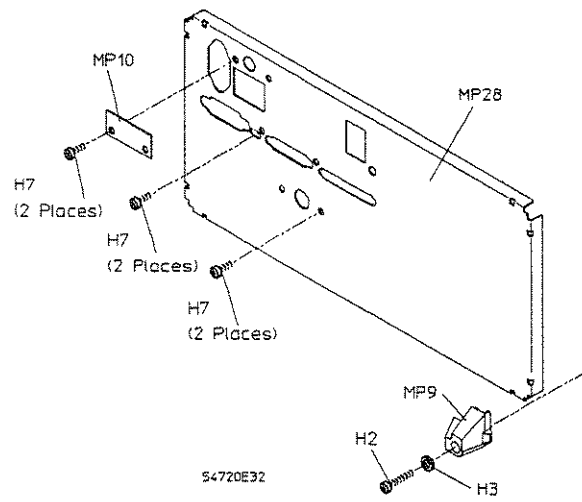
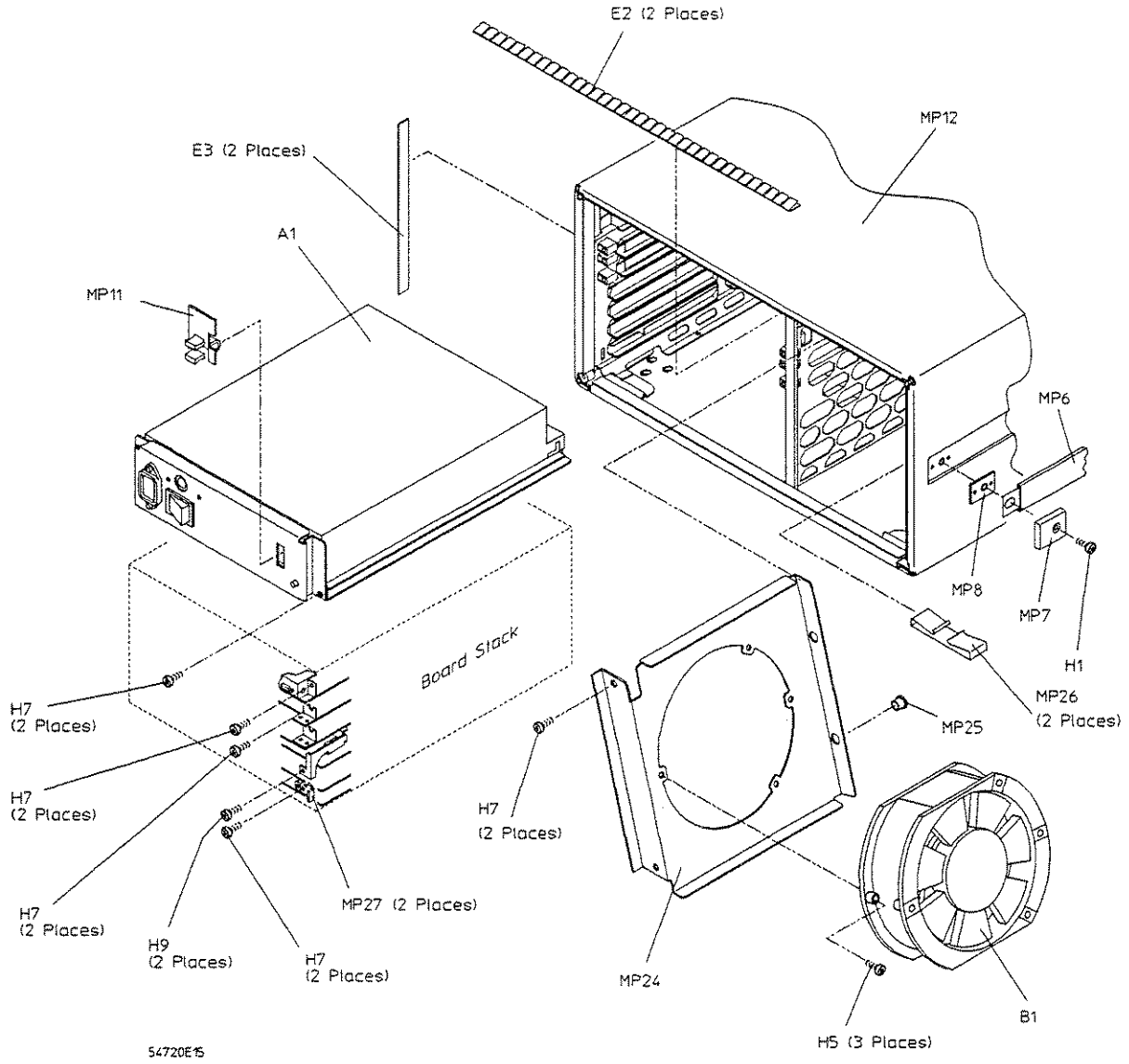

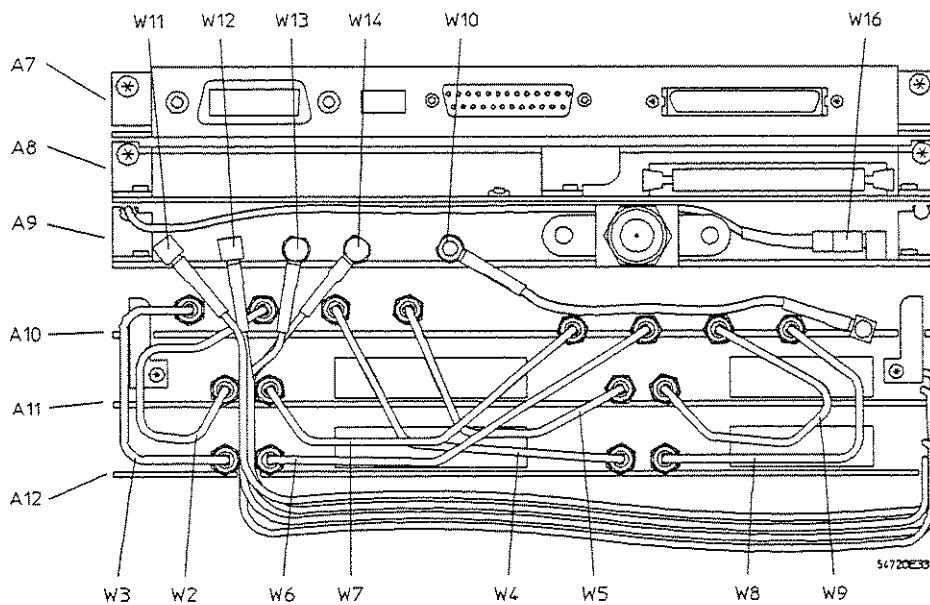
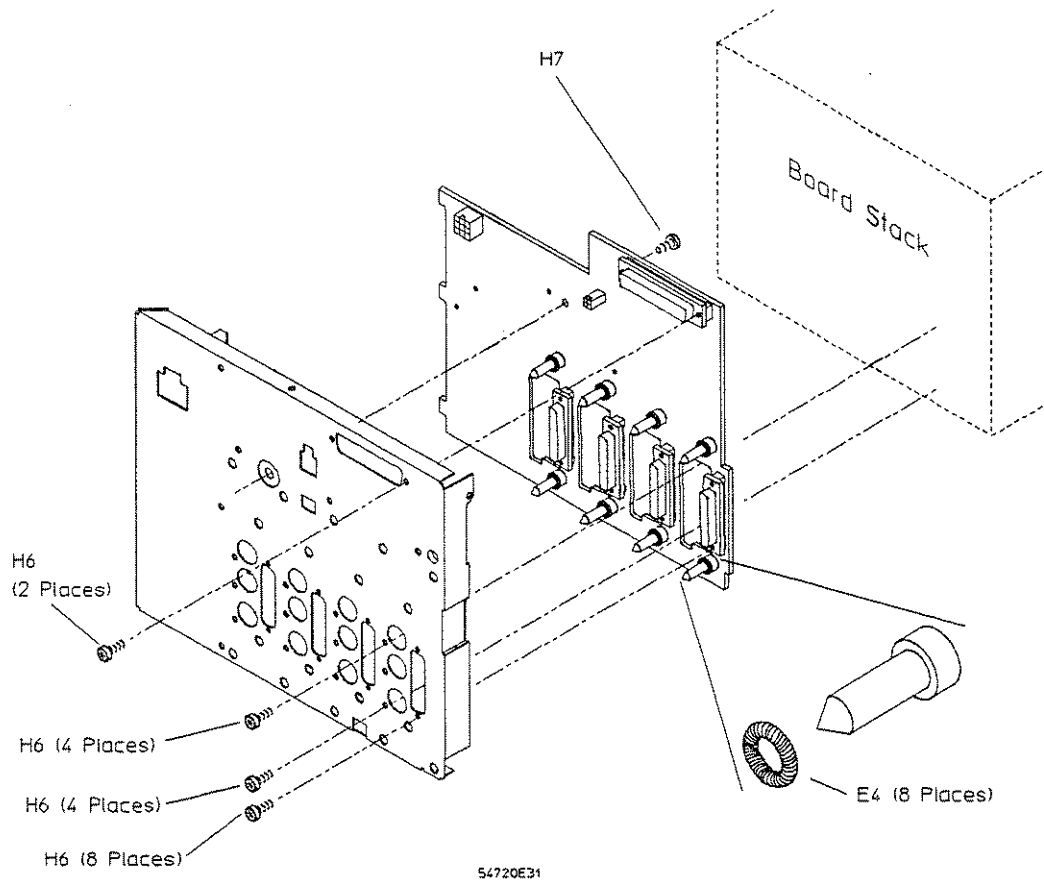

Replaceable Parts List

Table 7-1 is a list of replaceable parts and is organized as follows:

- Exchange assemblies in alphanumerical order by reference designation.
- External parts in alphanumerical order by reference designation. These parts are generally those that take the physical wear and tear of use.
- Internal parts in alphanumerical order by reference designation. Replacing these parts generally requires opening the cabinet.

The information given for each part consists of the following:

- Reference designation.
- HP part number.
- Total quantity (QTY) in instrument or on assembly. The total quantity is given once and at the first appearance of the part number in the list.
- Description of the part.

Table 7-1

HP 54720A Replaceable Parts

Ref. Des.	HP Part Number	QTY	Description
EXCHANGE ASSEMBLIES			
A2	2095-0001	1	COLOR CRT MODULE
A7	54710-69520	1	PC ASSEMBLY - CPU
A8	54710-69518	1	PC ASSEMBLY - DISPLAY
A9	54720-69509	1	PC ASSEMBLY - TIME BASE
A10	54720-69507	1	PC ASSEMBLY - CLOCK
A11	54720-69703	1	PC ASSEMBLY - ACQUISITION - 54710A ONLY (one acquisition assembly)
A11/A12	54720-69702	1	PC ASSEMBLY - ACQUISITION - 54720A ONLY (both acquisition assemblies)
EXTERNAL PARTS			
F1	2110-0342	1	FUSE 8A 250V (for 230 V operation)
F1	2110-0249	1	FUSE 12A 250V (for 115 V operation)
F1	2110-0342	1	FUSE 15A 250V (for 100 V operation)
H1	0515-2048	4	MS M5 X 0.8 12MM-LG FLAT-HD T20 (handles)
H2	0515-0383	4	MS M4 X 0.7 16MM-LG PAN-HD T10 (rear feet)
H3	3050-0065	4	WASHER - FLAT 0.203-IN-ID 0.375-IN-OD (rear feet)
H4	0515-2227	6	MS M4 X 0.7 12MM-LG FLAT-HD T15
MP1	01650-47401	1	KNOB - RPG
MP2	54710-41002	2	TRIM STRIP - SIDE
MP3	5041-8802	1	TRIM STRIP - TOP
MP4	5041-8801	4	FOOT - BOTTOM
MP5	1460-1345	2	TILT STAND
MP6	5062-3705	2	HANDLE - STRAP
MP7	54710-62501	4	CAP - HANDLE
MP8	54710-01211	4	SPACER - HANDLE
MP9	54710-41001	4	FOOT - REAR
MP10	54710-04101	1	COVER - LINE FUSE
MP11	64120-48101	1	COVER - LINE VOLTAGE SWITCH
W1	8120-1378	1	CABLE - POWER
W1	8120-1351	1	CABLE - POWER (Option 900-UK)
W1	8120-1369	1	CABLE - POWER (Option 901-AUSTL)
W1	8120-1689	1	CABLE - POWER (Option 902-EUR)
W1	8120-0698	1	CABLE - POWER (Option 904-250V USA/CANADA)
W1	8120-2104	1	CABLE - POWER (Option 906-SWIT)
W1	8120-2956	1	CABLE - POWER (Option 912-DEN)
W1	8120-4211	1	CABLE - POWER (Option 917-AFRICA)
W1	8120-4755	1	CABLE - POWER (Option 918-JAPAN)

Chapter 7: Replaceable Parts
 Replaceable Parts List

Table 7-1

HP 54720A Replaceable Parts (cont'd)

Ref. Des.	HP Part Number	QTY	Description
INTERNAL PARTS			
A1	0950-2211	1	POWER SUPPLY ASSEMBLY
A2	2090-0251	1	COLOR CRT MODULE
A3	54710-66513	1	PC ASSEMBLY - MOTHER BOARD
A4	54710-66516	1	PC ASSEMBLY - FRONT PANEL
A5	54710-66515	1	PC ASSEMBLY - DISK DRIVE CONTROL
A6	0950-2169	1	DISK DRIVE
A7	54710-66520	1	PC ASSEMBLY - CPU
A8	54710-66518	1	PC ASSEMBLY - DISPLAY
A9	54720-66509	1	PC ASSEMBLY - TIME BASE
A10	54720-66507	1	PC ASSEMBLY - CLOCK
A11			PC ASSEMBLY - ACQUISITION 2 (see parts below)
A12			PC ASSEMBLY - ACQUISITION 1 (see parts below)
	54720-68703	1	PC ASSEMBLY - ACQUISITION - 54710A ONLY (A11 only)
	54720-68702	1	PC ASSEMBLY - ACQUISITION - 54720A ONLY (A11 and A12)
A13	0960-0852	1	ROTARY PULSE GENERATOR (RPG)
B1	3160-0643	1	FAN - TUBEAXIAL (rear fan)
B2	3160-0804	1	FAN - TUBEAXIAL (front fan)
E1	8160-0718	2	GASKET - RFI FINGER STRIP (front)
E2	54710-07101	2	GASKET - RFI FINGER STRIP (rear top and bottom)
E3	54710-07102	2	GASKET - RFI FINGER STRIP (rear sides)
E4	1460-2337	8	SPRING - RFI (motherboard)
E5	54710-47601	4	TERMINATION 54710A ONLY
H5	0515-0383	3	MS M4 X 0.7 16MM-LG PAN-HD T10
H6	0515-2305	18	MS M3 X 0.5 14MM-LG PAN-HD T10
H7	0515-0433	24	MS M4 X 0.7 8MM-LG PAN-HD T15
H8	0515-0372	4	MS M3 X 0.5 8MM-LG PAN-HD T10
H9	0515-0430	9	MS M3 X 0.5 6MM-LG PAN-HD T10
H10	0515-0641	2	SCREW - THREAD-ROLLING M4 X0.7 10MM-LG PAN-HD T15
H11	3050-0065	2	WASHER - FLAT 0.203-IN-ID 0.375-IN-OD
H12	0515-1958	6	SCREW - THREAD-ROLLING M3 X 0.5 6MM-LG PAN-HD T10
H13	0515-2043	4	MS M4 X 0.7 8MM-LG FLAT-HD T15
H14	0624-0600	2	SCREW - TAPPING 4-20
H15	2200-0140	2	MS 4-40 0.27-IN-LG PAN-HD-POZI
H16	3050-0071	2	WASHER - FLAT XXXXX-IN-ID XXXXX-IN-OD
H17	2950-0043	1	NUT - HEX DBL-CHAM 3/8-32 THD .093-IN-THK
H18	3050-0188	1	WASHER - CURVED LOCK (rpg)
H19	2950-0043		NUT - HEX (part of A2, color CRT module)
MP12	54710-04401	1	CABINET
MP13	54710-60202	1	FRONT PANEL 54710A ONLY (with label)
MP13	54720-60202	1	FRONT PANEL 54720A ONLY (with label)
MP14	54710-68701	1	KEYPAD KIT (four pieces)
MP15	54710-05701	1	NUT - SPACER (for RPG)
MP16	54710-25001	4	BRACKET - PLUG-IN LATCH
MP17	54710-01220	1	BRACKET - FRONT FAN
MP18	54710-01221	1	BRACKET - DISK DRIVE
MP19	54710-43101	2	GUIDE - PLUG-IN
MP20	54710-01215	1	BRACKET - FRONT (color CRT module)

Table 7-1

HP 54720A Replaceable Parts (cont'd)

Ref. Des.	HP Part Number	QTY	Description
MP21	54710-01216	1	BRACKET - REAR (color CRT module)
MP22	5061-6197	1	SHIELD - LEFT (color CRT module)
MP23	54710-00601	1	SHIELD - RIGHT (color CRT module)
MP24	54710-01219	1	BRACKET - REAR FAN (includes plastic bushings)
MP25	0400-0269	2	BUSHING - PLASTIC (part of MP 24)
MP26	1400-1331	2	CLAMP - CABLE
MP27	54720-03701	2	STOP BAR
MP28	54710-00201	1	REAR PANEL
W2	54720-61606	1	CABLE - SEMI RIGID - 2GHZ CHAN 2
W3	54720-61605	1	CABLE - SEMI RIGID - 2GHZ CHAN 4 (54720A only)
W4	54720-61607	1	CABLE - SEMI RIGID - 2GHZ CHAN 3 (54720A only)
W5	54720-61608	1	CABLE - SEMI RIGID - 2GHZ CHAN 1
W6	54720-61610	1	CABLE - SEMI RIGID - 100MHZ CHAN 4 (54720A only)
W7	54720-61609	1	CABLE - SEMI RIGID - 100MHZ CHAN 2
W8	54720-61612	1	CABLE - SEMI RIGID - 100MHZ CHAN 3 (54720A only)
W9	54720-61611	1	CABLE - SEMI RIGID - 100MHZ CHAN 1
W10	54720-61614	1	CABLE - COAXIAL (clock to time base)
W11	54720-61615	4	CABLE - COAXIAL (time base to acquisition 1)
W12	54720-61615		CABLE - COAXIAL (time base to acquisition 2)
W13	54720-61615		CABLE - COAXIAL (time base to acquisition 1)
W14	54720-61615		CABLE - COAXIAL (time base to acquisition 2)
W15	54710-61601	1	CABLE - RIBBON (display PC assembly to color CRT module)
W16	54710-61613	1	CABLE ASSEMBLY (calibration signal)
W17	54710-61603	1	CABLE - RIBBON (keyboard)
W18	54710-61604	1	CABLE (color CRT module, outside)
W19	54710-61609	1	CABLE (color CRT module, inside)
W20	54710-61611	1	CABLE - RIBBON (CPU to display PC assembly)

Mainframe Block-Level Theory	8-3
Acquisition	8-3
Motherboard	8-3
Power Supply	8-3
Fans	8-4
CPU	8-4
Display Assembly	8-4
Color CRT Module	8-4
Disk Drive and Control	8-5
Front Panel	8-5
Acquisition System	8-7
Acquisition Assemblies	8-7
Clock	8-8
Time Base	8-8
Acquisition System Signals	8-8

Theory of Operation

Figure 8-1

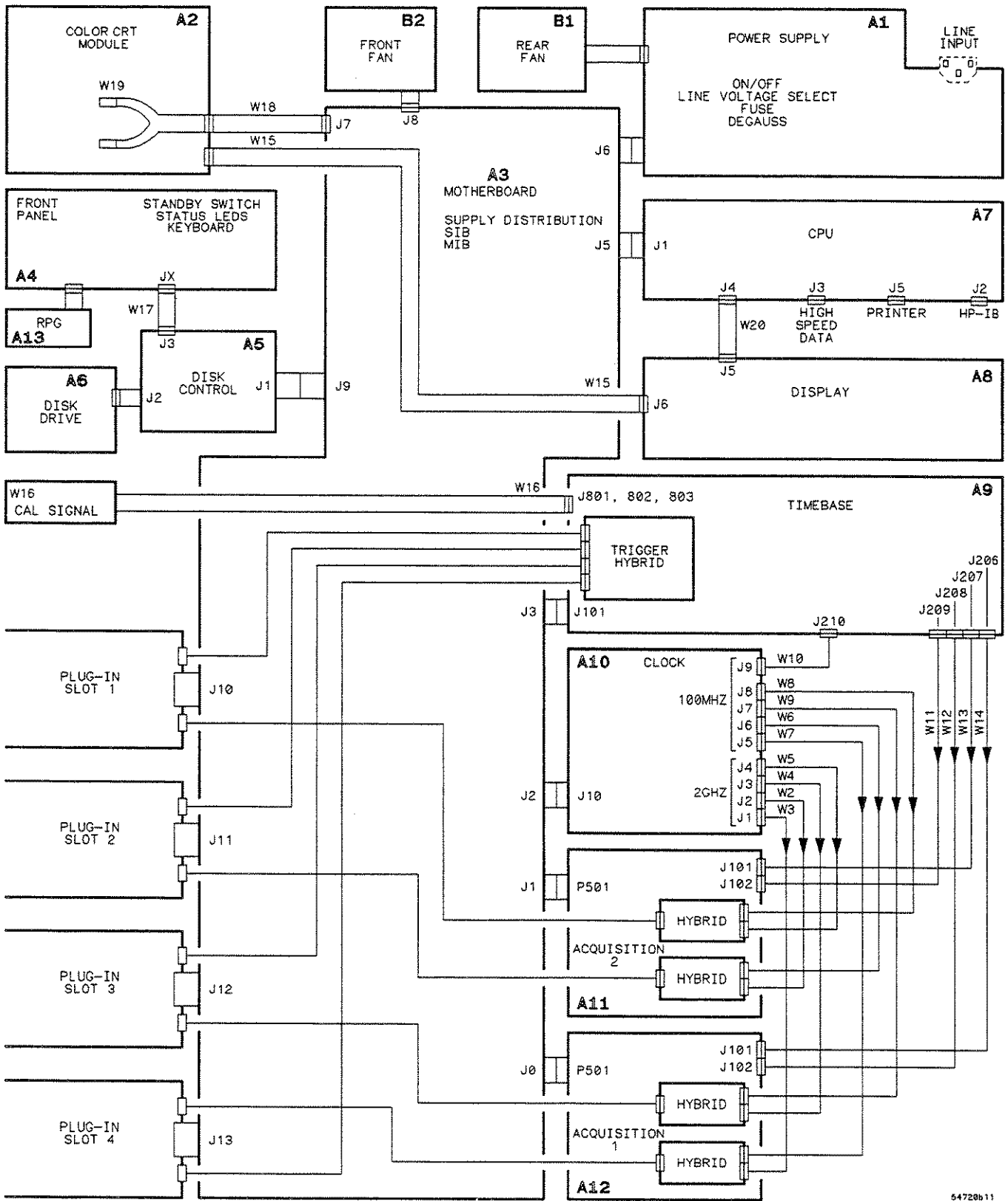

54720b11

Instrument Block Diagram

Theory of Operation

The HP 54710A and 54720A mainframes contain the sampling, digital processing, and display for a digitizing oscilloscope. Four front-panel slots accept an assortment of signal conditioning plug-ins. Seven rear-panel slots accept major assemblies of the mainframe, including the power supply and acquisition assemblies. The color CRT module (display) is a separate assembly. The front panel consists of hard and soft keys, a knob RPG (rotary pulse generator), a 3.5-inch disk drive, and the calibrator output.

The HP 54710A mainframe is identical to the HP 54720A except that it has only one acquisition assembly, acquisition 2 for plug-in slots 1 and 2. Acquisition 1 is not installed. The following theory is written to cover the HP 54720A but with minor considerations it can be applied to the HP 54710A.

Mainframe Block-Level Theory

Use the main block diagram on the previous page for the following discussion.

Acquisition

The acquisition system consist of the time base, clock, and two acquisition assemblies. They accept the conditioned vertical and trigger signals from the plug-ins in the front-panel slots.

- The plug-ins condition the input signals and provide one or more channel and/or trigger signals to the mainframe.
- The clock assembly provides 2 GHz and 100 MHz sample rates.
- The time base starts the acquisition according to the trigger conditions and trigger signals.
- The acquisition assemblies sample, digitize, and store the input signals.

Acquisition operation is covered in more detail in "Acquisition System" later in this chapter.

Motherboard

The motherboard provides most of the common connections in the mainframe. The digital interface, some acquisition control lines, and power supplies are routed through the motherboard. The vertical plug-ins, disk controller, and front fan connect to the motherboard from the front of the instrument and the other mainframe assemblies plug in from the rear.

Power Supply

The 650 W switching power supply provides eight dc voltages to the instrument. A rear-panel power switch switches both sides of the ac power input. When the rear panel power switch is on, the power supply primary circuits are energized.

The front-panel power switch is a remote control for the regulators in the supply. When the front-panel switch is set to Standby, with the rear-panel switch on, the regulators are shut down and most instrument circuitry is off.

On the rear panel is a fuse as well as a switch for changing the ac voltage input range, nominally 115 Vac or 230 Vac. The rear panel of the power supply also carries the degauss push-button switch for the CRT.

One output of the power supply is a power-on-reset signal which is distributed on the bus. This is used to initialize circuitry after all of the supplies are operating.

Fans

Fans are powered by a 24 V supply provided by the power supply assembly. The fan voltage, therefore the fan speed, varies with the internal temperature of the instrument. The power supply monitors a signal line from each fan and shuts down the supply if fan rotation stops.

CPU

The CPU assembly controls all digital functions of the instrument other than the display. It uses an MC68020 microprocessor and an MC68882 floating-point math coprocessor. A 32 MHz oscillator output is divided by two to get a 16 MHz processor clock.

The system ROM is 2 M-byte of flash ROM which can be programmed from the disk drive. One ROM IC is partitioned as a boot ROM. It is protected by a write protect switch. After power-up, pointers are set and the rest of ROM runs the instrument. The system RAM is 4M-byte of static RAM. All of the RAM has battery back-up.

The CPU assembly provides two ports to the user: an HP-IB port for instrument control and data handling, and a parallel port for a direct printer connection. Also, the hardware is present for a high-speed data port, which may be implemented with future firmware.

The CPU assembly provides separate digital interfaces to several internal functions:

- The processor sections of the system interface bus (SIB).
- The keyboard and other front panel functions.
- The display assembly.
- The digital functions of the front panel plug-ins, the module interface bus (MIB).

The CPU assembly uses a set of four switches to control firmware. One switch protects boot ROM, one protects system ROM, and two switches protect calibration factors. Use of these switches is covered wherever it is appropriate.

Display Assembly

The display assembly handles the graphics functions of the instrument. It organizes pixel-level data for the display. Special interface circuitry on the CPU assembly connects the microprocessor to a TMS34010 graphics microprocessor on the display assembly. The main display memory is 1 MByte of dynamic RAM. A 4K by 12-bit static RAM is used for variable persistence and a 16K by 8-bit static RAM is used for color mapping. Out of a possible 256K different colors, up to 256 main colors and 15 overlay colors are available at one time.

The connection to the CPU assembly is through a dedicated ribbon cable connected between the two assemblies. The connection between the display assembly and the motherboard is not used.

Color CRT Module

The color CRT module includes the color CRT and its associated driving circuitry. It uses vertical and horizontal sync and red, green, and blue video signals from the display processor. It gets power from a separate 120 Vdc supply in the power supply assembly. A switch to degauss the CRT is located on the rear panel of the power supply.

Disk Drive and Control

The disk drive is in the front panel of the instrument. Electronically however, it is not part of the front panel. The disk drive connects to the disk control, and the disk control connects to the SIB through the motherboard. The disk control assembly also passes the keyboard interface connections from the motherboard to the keyboard.

Front Panel

The front panel includes the hard keys, soft keys, knob, status LEDs, display controls, and a power switch. The knob is attached to a rotary pulse generator (RPG). The microprocessor communicates with the keyboard through a separate interface on the CPU assembly. Electrical connection between the CPU assembly and keyboard is made through the disk controller assembly and the motherboard.

Figure 8-2

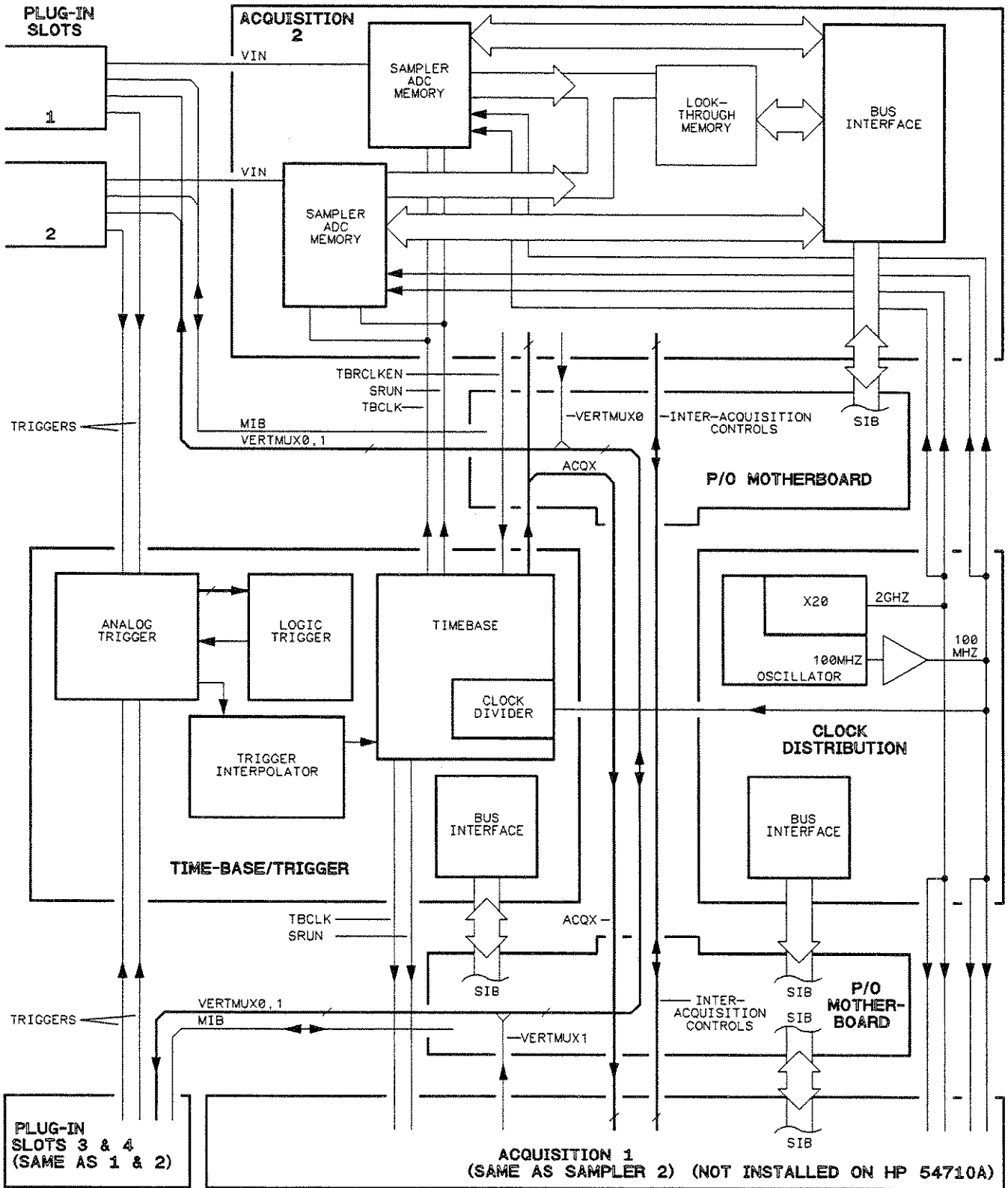

54720b-12

Acquisition Block Diagram

Acquisition System

The acquisition system samples and stores the vertical input signals and establishes a time reference between the input trigger and the stored signal. There are four assemblies in the acquisition system: a time-base assembly which includes trigger functions, a clock assembly, and two acquisition assemblies. These assemblies occupy the four lower slots in the rear-panel card cage. They connect to each other with coaxial cables. They connect to the motherboard and SIB when installed in the mainframe. In addition, the time base and acquisition assemblies provide coaxial connectors which mate directly with plug-ins installed in the front panel slots.

In the acquisition block diagram on the previous page only two channels are shown in full. The other two are identical. To accommodate the slot they are in, the samplers are programmed differently of course.

Acquisition Assemblies

Two identical acquisition assemblies receive the conditioned vertical signals from the four plug-in slots (channels) in the front panel. Two front-panel slots feed each acquisition assembly. The acquisition assemblies occupy the two lower slots in the instrument rear panel. The two acquisition assemblies are mechanically connected at the front so that all four vertical inputs can be aligned in one horizontal plane.

Each acquisition assembly holds two acquisition hybrids, one for each vertical channel. An acquisition hybrid accepts a signal of ± 80 mV and digitizes at a maximum of 2 Gsamples/s. Each acquisition hybrid consists of four groups of the three acquisition functions: sampler, analog-to-digital converter (ADC), and memory.

The four groups in one acquisition hybrid can be configured to optimize sample rate or vertical resolution. In addition, the acquisitions of two or four acquisition hybrids (in both acquisition assemblies) can be interleaved to obtain sample rates greater than 2 Gsamples/s or paralleled to obtain greater vertical resolution. This can be done when a vertical plug-in occupies two or more front-panel slots and provides the same vertical signal to more than one acquisition hybrid.

The 2 GHz sample clock is distributed from the clock assembly directly to each acquisition hybrid. Also distributed directly to each acquisition hybrid is a 100 MHz reference clock. A delay-locked-loop is used to adjust the phase relationship between the 2 GHz sample clock and the 100 MHz reference clock. This is used to eliminate phase noise and skew the sample clocks for interleaving the sample intervals.

The acquisition assemblies include the following major support functions for the acquisition hybrids:

- a look-through memory
- circuitry for interleaving acquisition data
- self test circuitry
- an interface to the SIB on the motherboard

The look-through memory serves two purposes. It maps the gray-code output of the acquisition memories to twos complement binary values. It also corrects for linearity errors in the analog path from the vertical plug-in input to the ADCs. The linearity correction is part of the self-calibration features of the instrument. During self calibration known signals are applied to the input of the plug-in. Errors in the digitized output are noted and the look-through memory is programmed to provide the correct code when the uncorrected data is read from the acquisition memory.

Clock

The clock assembly generates the 2 GHz and 100 MHz clocks. A 100 MHz oscillator generates the reference clock. In the oscillator assembly the 100 MHz frequency is multiplied by 20 to get the 2 GHz sample clock. Both clocks are distributed by semi-rigid coax directly to the acquisition hybrids on the acquisition assemblies. An additional 100 MHz signal is sent to the time base assembly where it is divided for the lower-frequency sample rates.

Time Base

The time base assembly performs several functions in the acquisition system:

- It provides analog trigger functions such as trigger level and slope.
- It provides logic trigger functions, combining the triggers of the channels.
- It determines the relationship between the trigger and acquisition memory (trigger interpolator).
- It starts and stops the acquisition process.
- It develops the sample clock for rates below 100 MHz.
- It provides clocking for reading the contents of acquisition memory.
- It provides the front-panel calibrator signals.

All triggering functions up to a frequency of 1 GHz can be provided by the time base assembly. For plug-ins requiring triggering above 1 GHz, the high-speed triggering is implemented in the plug-in. Logic triggering is not available on channels where the trigger is implemented in the plug-in.

The time base assembly occupies the fourth slot from the bottom in the rear panel card cage. The interface with the front panel plug-in slots is at the front of the assembly. Coaxial cables connect the trigger signals from the plug-ins to the trigger hybrid.

In the HP 54710A, the trigger functions are still available for plug-in slots 3 and 4 even though there is no acquisition assembly for these slots. Plug-ins in slots 3 and 4 will function only as trigger sources.

Acquisition System Signals

Signals within the acquisition system control timing between the several separate assemblies. Some are connected directly between assemblies. Others are connected through the motherboard though they are not part of the SIB. Refer to the acquisition block diagram for signals in the following table:

Acquisition System Signals

Signal	Description
ACQX	These three signals from the time base are used for acquisition control. They are connected to the acquisition assemblies through the motherboard.
Inter-Acquisition Controls	These are five signals that are used to control the readout of data from the acquisition memories. One line is used by acquisition 1 to tell acquisition 2 it has valid data to put on the SIB. the other four lines control interleaving of data. The signal at the assembly interface can be an input or output, depending on whether the board is acquisition 2 or acquisition 1. They connect the acquisition assemblies through the motherboard.

Signal	Description
MIB (Module Interface Bus)	This bus provides the connection between the CPU and the digital functions of the plug-ins. It includes two serial address/data lines (data in and data out), address/data select, and several other control and handshake lines.
SIB (System Interface Bus)	This is the primary bus between the CPU and the acquisition system. It includes bits 1 to 13 of microprocessor address, bits 16 to 31 of microprocessor data, and various status, control, and interrupt lines.
SRUN (Synchronized Run)	This is an ECL signal that gates the clocks to the FISO memories. It signals the actual start of data acquisition. It is synchronized to the 100 MHz reference clock and is conducted from the time base to the acquisition assemblies through coaxial cables.
TBCLK (Time Base Clock)	This is the acquisition write signal for sample rates 100 MHz and below. In this mode it is referenced to the 100 MHz reference clock. It is also used to increment acquisition memory when it is being read. It is conducted from the time base assembly to the acquisition assemblies by coaxial cables.
TBRCKEN (Time Base Read Clock Enable)	This signal is used by the time base to enable the memory read clock from the microprocessor. The time base will then strobe TBCLK to advance to the next memory position. This signal is distributed through the SIB.
Triggers	These are the analog trigger signals from the plug-in slots. They are conditioned in the plug-ins and conducted from the plug-in interface directly to the analog trigger hybrid through coaxial cables. If a plug-in has its own high-speed triggering circuitry, the edge of this signal represents the selected trigger point.
VERTMUX0 VERTMUX1 (Vertical Multiplexer)	These signals are used to multiplex the channels in multi-channel plug-ins. VERTMUX0 is generated on acquisition 2 and VERTMUX1 is generated on acquisition 1. Both signals are conducted to each front panel slot through the motherboard.
VIN Vertical Input	This is the conditioned vertical signal from the plug-in. It provides ± 80 mV for a full-screen vertical display. It is conducted from the plug-in interface directly to the acquisition hybrid through a "semi-flexible" cable.
100 MHz (100 MHz Reference Clock)	This is the reference clock for many of the signals from the time base. All references are to the zero crossing of the rising edge. It is conducted from the clock assembly directly to each acquisition hybrid by semi-rigid coax with SMA connectors.
2 GHz (2 GHz Sample Clock)	This is the base sample clock. It is conducted from the clock assembly directly to each acquisition hybrid by semi-rigid coax with SMA connectors.



General Information

Accessories Supplied 10-3
Specifications 10-3
Characteristics 10-3
General Characteristics 10-3

Periodic Maintenance

Functional Test 10-4
Calibration and Adjustment 10-5

Troubleshooting 10-6

ESD Precautions 10-6
Equipment Required 10-6
Trouble Isolation 10-6

Replacing Assemblies 10-8

Tools Required 10-8
To remove and replace
Covers 10-9
Front Panel 10-9
Limiter 10-9
Output Cable 10-10
PC Board 10-11
Bus Cable 10-11

Replaceable Parts 10-12

Mechanical View 10-12
Parts List 10-12

Theory of Operation 10-14

Signal Paths 10-14
Digital Interface 10-14
Power Supplies 10-14

HP 54717A Plug-In Service

HP 54717A Plug-In Service

This chapter gives service information specific to the HP 54717A oscilloscope plug-in. The chapter is divided into six sections. The following topics are covered in this chapter.

- General information – which includes specifications, characteristics, and other information
- Periodic maintenance – primarily performance testing
- Troubleshooting – to assembly level
- Replacing Assemblies – mechanical procedures
- Replaceable Parts – part views and parts list
- Theory of Operation.

For information not specific to this plug-in, refer to the following chapters in the mainframe section of this guide.

- Inspection, chapter 2
- Plug-In installation, chapter 2
- Cleaning, chapter 2
- Ordering parts, chapter 7

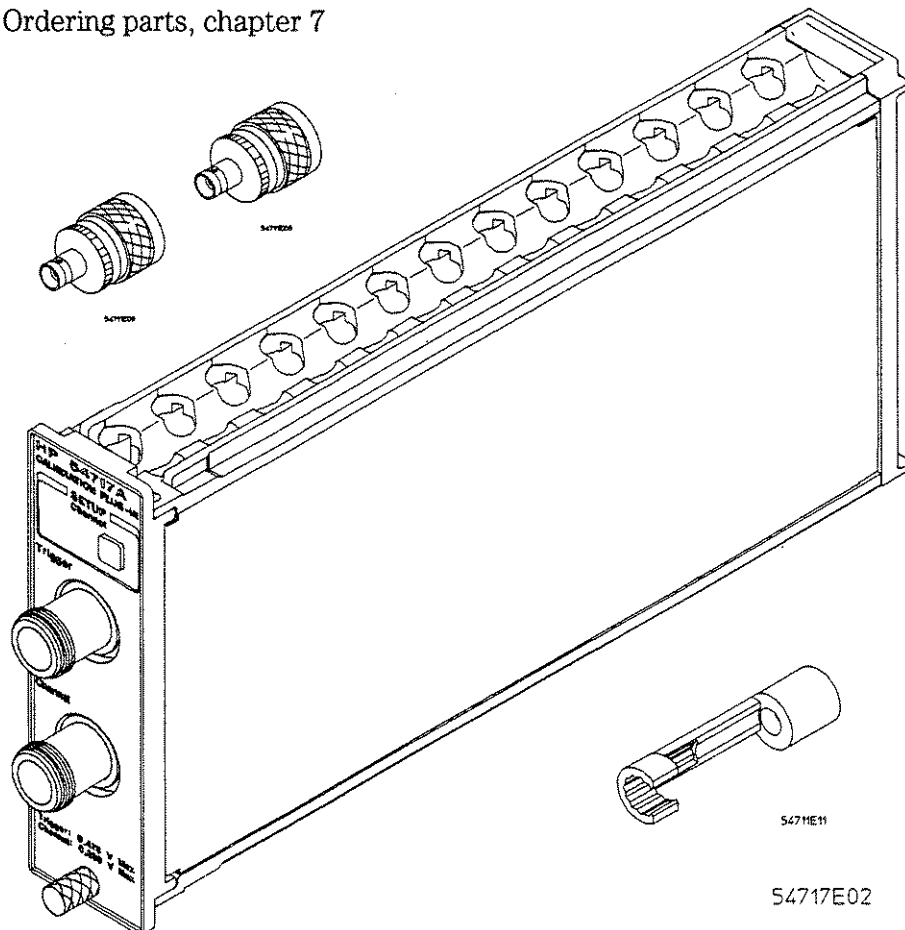

General Information

This section provides general information specific to the HP 54717A Calibration plug-in. This plug-in is used to calibrate the HP 54710A and 54720A mainframes.

Accessories Supplied

The following accessories are supplied with the HP 54717A plug-in.

- Two Type-N-to-BNC adapters (HP1250-1811)
- Special socket wrench for mainframe SMA connectors (HP 5081-7718)

Specifications

There are no specifications for the HP 54717A.

Characteristics



Maximum Safe Input Voltage (channel and trigger) ± 500 mV

General Characteristics

The following general characteristics apply to the HP 54717A oscilloscope plug-in.

Environmental Conditions

The environmental conditions are the same as for the HP 54710A and 54720A mainframes. See the environmental conditions in chapter 1 of this service guide.

Power Requirements

Supplied by mainframe.

Weight

Net approximately 0.6 kg (1.4 lb)

Shipping approximately 1.5 kg (3.4 lb)

Periodic Maintenance

The only periodic maintenance for the HP 54717A is a functional test. The HP 54717A does not require calibration or adjustment.

Functional Test

The functional test checks that the plug-in passes a signal and trigger into the mainframe.

Testing Interval

The performance test procedures may be performed for incoming inspection of the instrument and should be performed periodically thereafter to ensure and maintain peak performance. The recommended test interval is yearly or every 2,000 hours of operation. Amount of use, environmental conditions, and the user's experience concerning need for testing will contribute to test requirements.

Equipment Required

The equipment required for the trigger performance tests is listed below. Any equipment satisfying the critical specifications listed may be substituted for the recommended model. The procedures are based on the model or part number recommended.

Equipment Required

Equipment	Critical Specifications	Recommended Model/Part
Cable(2)	BNC 9-inch	HP 10502A
Attenuator	20 dB BNC	HP 8490 Series Opt. 20, with adapters or Narda 755B-20
Adapter	BNC tee (m)(f)(f)	HP 1250-0781

Procedure

- 1 Check the plug-in digital function.
 - a Install the HP 54717A Calibration plug-in in mainframe slot 1.
 - b Press **Utility**, then **System config...**

In the plug-in area of the display you should see the model and serial number of the plug-in in slot 1.

- c Press **Calibration** on the plug-in.

The calibration status display and **Calibrate frame** softkey should be displayed.

- 2 Press **Setup** then **Default Setup** to set default conditions.
- 3 Press **Math** then press **Display** to set the function display on.
- 4 Connect the CAL signal.
 - a Connect a BNC tee to the channel input and the 20 dB pad to the tee.
 - b Connect a BNC cable between the 20 dB pad and the CAL output.
 - c Connect a BNC cable between the tee and the trigger input.
- 5 Press **Time base** and set the **Scale** to 100 μ s/div.
- 6 Press **Trigger** and set the **Level** to 35 mV.

The display should show a triggered square wave, the calibrator signal.

If the tests fail
Go to "Troubleshooting" in this chapter.

Calibration and Adjustment

The HP 54717A does not require calibration or adjustment.

Troubleshooting

This section provides troubleshooting information for the HP 54717A Oscilloscope plug-in. The service strategy of this instrument is replacement of defective assemblies, so the troubleshooting is designed to isolate a failed PC assembly, limiter, or cable.

Trouble isolation of the HP 54717A plug-in requires checking the plug-in in a working HP 54710A or 54720A oscilloscope mainframe.

ESD Precautions

When using any of the procedures in this chapter, you should use proper ESD precautions. As a minimum, if you are working with the plug-in on an extender cable, you should place the instrument on a properly grounded ESD mat and wear a properly grounded ESD wrist strap.

Equipment Required

Just the normal tools used when troubleshooting electronic equipment are needed for troubleshooting. A good digital multimeter and an oscilloscope with about a 100 MHz bandwidth should be sufficient. If you want to build an extender cable for plug-in troubleshooting, see "Equipment Required" in chapter 5 of this service guide. If you need to remove and replace parts and assemblies, you may need some of the hand tools listed at "Replacing Assemblies" which follows this section.

Trouble Isolation

The trouble isolation information is provided to isolate a problem to a faulty assembly. Use the following checks to quickly isolate some major failures or be fairly certain the plug-in works. To narrow menu choices and make troubleshooting easier, it is best to have only the faulty plug-in installed in the mainframe.

A Be sure the plug-in is at fault.

When you have any problem involving a plug-in, put the suspect plug-in in a slot where you know another plug-in performs properly and check for the failure. If the problem follows the plug-in, repair it. If the plug-in works, repair the mainframe.

B Check the digital interface.

There is no interaction between the digital interface and the signal paths. Therefore the only way to check the function of the digital interface is to note how it interrelates with the mainframe.

1 Press the **Calibration** Key. You should get the calibration status display and the **Calibrate frame** softkey.

- If the response is correct, most of the digital interface in the plug-in is operating.
- If the instrument does not respond, the problem could be the keyboard, digital interface cable, or PC board.

- 2 Press **Utility** , then press **Service . . .**, and then **Plug-in . . .**.
- 3 In the Plug-ins area of the display, note the Model and Serial # fields. When the plug-in is removed and replaced, the fields should change.
If the display changes when the plug-in is installed, but the serial number or model number are incorrect, the plug-in may need to be reprogrammed. See the "Utility Menu" section of chapter 5, "Troubleshooting" in the mainframe part of this guide.

4 Enable plug-in initialization.

- a Remove the plug-in from the mainframe.
- b Remove the right-side cover.

Use a small flat-blade screwdriver. Starting at one rear corner, pry up to release one side of the cover. The other side will follow.

- c Set the calibration switch to the ENABLE position.

This is a single-pole DIP switch located near the rear.

- d Replace the cover and put the plug-in back into the mainframe.

Insert the front of the cover under the edge of the front panel. Then push one long side of the cover into the plug-in, then the other.

Replacing the cover prevents cabling from getting caught and damaged.

- 5 In the menu, the Calibration Memory should show Unprotected for the 54717A.

6 Initialize the plug-in.

Make sure the correct slot is selected (top softkey) and press **Initialize plug-in memory**.

The top of the display should show the storing message.

7 Determine the problem.

- If the mainframe can recognize the plug-in and store into it, the digital interface must work.
- If the digital interface does not work, it could be the PC board or the interface cable. Check the cable with an ohmmeter.

C Check the signal paths.

- 1 Use a four-wire resistance test to measure the resistance at the channel and trigger inputs. They should be nominally 50 Ω and 45 Ω respectively.

Unless there is a problem with a limiter, you are measuring the termination resistance of the mainframe circuitry. The trigger signal terminates on the timebase assembly and the channel signal terminates on the acquisition assembly.

- 2 The best way to check the signal path is with a TDR system. Compare the results with a known good plug-in. Also, the two signal paths in the HP 54717A can be compared against each other.

About the only part in the plug-in signal path that can fail is the limiter. If it is overloaded, the diodes in it can short, which should show up with a resistance check. If the diodes open, its characteristic impedance would change at high frequencies. The only way to check that would be with a TDR system.

Replacing Assemblies

Procedures in this section should be used when removing and replacing assemblies and parts in the HP 54717A oscilloscope plug-in.

Tools Required

The following tools are required to work on the HP 54717A. Not all tools are called out in the procedures.

- Torx driver: T10
- Open-end wrench: 8 mm (5/16 inch)
- Open-end wrench: 7/32 inch
- Socket wrench: 5/8 inch
- Pozidrive screwdriver: #1
- Connector removal tool AMP Tool No. 305141-4
- Torque wrench, 0.90 Nm (8 in-lbs), 8 mm (5/16-inch) open end – for SMA connectors

Figure 9-1

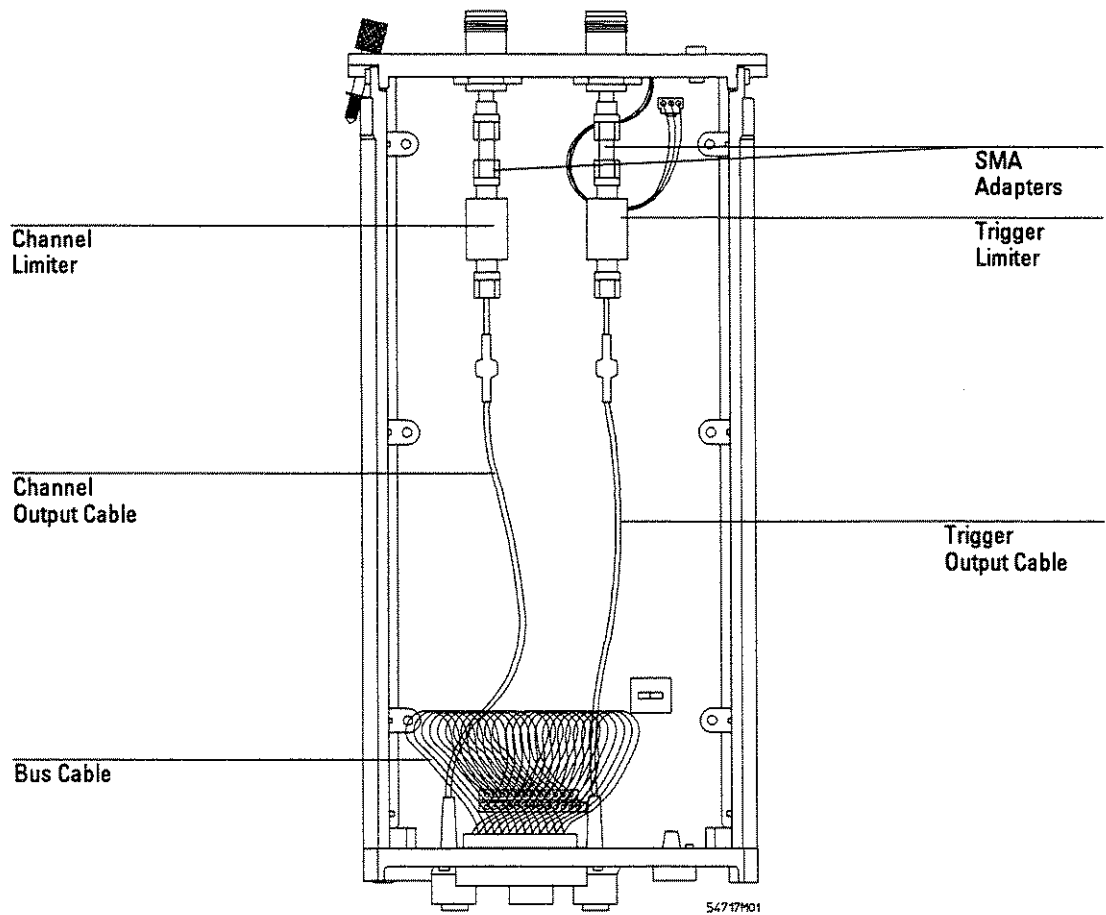

HP 54717A Parts View

To remove and replace the covers

A cover comes off more easily when it is released one edge at a time.

- 1 With a small screwdriver, pry up at one of the rear corners of the cover.
- 2 Once a corner is free, lift the cover so that nearly one entire edge is loose.
- 3 Starting at the other rear corner, lift the other side of the cover.
- 4 When both edges of the cover are loose, remove the front edge of the cover from under the edge of the front panel.
- 5 To replace the cover, reverse the procedure.

To remove and replace the front panel

You must remove the front panel to replace the keyboard.

Front Panel

- 1 Remove the covers.
- 2 Disconnect the probe power and keyboard cables that connect to the front of the PC board.
- 3 Remove the four screws that attach the front panel to the top and bottom rails.
- 4 Lay the plug-in flat on a table so it does not twist, and use a 5/16 wrench to loosen the two SMA connectors behind the front panel.
- 5 When both SMA connectors are loose, you can remove the panel.
- 6 To replace the front panel, reverse the procedure while taking note of the following.
 - To assure proper alignment, hold the front panel tight against the ends of the rails while you tighten the front panel screws.
 - Tighten the SMA connectors to 0.90 Nm (8 in-lbs) with a 5/16-in open-end torque wrench.

Keyboard

Remove the keyboard screw and lift the keyboard off the keypad.

CAUTION

Be careful not to contaminate the key side of the PC board or the keypads. Dust or fingerprints on these parts may cause intermittent key operation.

To remove and replace a limiter

The limiters are connected between an SMA(m-m) adapter at the input and the output cables.

When removing and replacing the limiter, use a 7/32-inch open-end wrench on the flats of the limiter. This prevents twisting parts when removing the connectors.

- 1 Remove the output cable from the limiter.
- 2 Remove the limiter from the SMA adapter.
- 3 To reassemble the plug-in, reverse the procedure.
 - When tightening the SMA connections, use an 8-mm (5/16-inch) torque wrench set to 0.90 Nm (8 in-lbs).

To remove and replace an output cable

You need a special tool to remove these cables from the rear panel.

- AMP Tool No. 305141-4

The coaxial output cable is held in the rear panel by a tapered snap ring that expands once it passes the shoulder in the mounting hole. The special tool compresses the snap ring and pushes the connector out of its mounting.

The connector in the rear panel is spring-loaded so it mates firmly with the connector at the rear of the plug-in compartment.

- 1 Remove the covers.**
- 2 Disconnect the SMA connection at the output of the limiter.**

Use a 7/32-inch open-end wrench on the flats of the limiter. This prevents twisting parts when removing the connectors.
- 3 Disconnect the 12 and 13 conductor bus cables.**
- 4 Remove the four screws that attach the rear panel to the top and bottom rails and remove the rear panel.**

Removing the rear panel allows the clearance needed to slide the connector out of the rear panel.
- 5 Slide the special tool over the rear of the connector.**

While pushing the tool on, rotate it slightly to slip it over the locking ring.
- 6 Push on the tool plunger to extract the connector.**

Pushing the plunger takes up the spring in the connector first, then pushes the connector past the mounting hole shoulder. A very firm force is necessary to remove the connector.
- 7 To replace the cable, re-install the cable in the rear panel.**
 - a Set the connector into the correct hole in the rear panel.**
 - b Use a blunt tool to force the connector to lock in the panel.**
 - c Make sure the connector is locked and won't fall out.**

Use the handle end of a screwdriver and push on the connector from the rear, enough to completely compress the spring tension on the connector.
- 8 Use the four screws to re-attach the rear panel.**
- 9 Connect and tighten the SMA connectors to 0.90 Nm (8 in-lbs).**

To remove and replace the PC board

Removing and replacing the PC board does not require any special techniques. It is fastened by six screws and two cables are connected to it. However, if you replace the board with a new one, you will have to store the plug-in serial number on the new board. See "Utility Menu" in chapter 5 of this service guide.

To remove and replace the bus cable

A #1 pozi-drive screwdriver is needed for replacing this cable.

The D-shell connector is designed to move freely on its mounting screws. The length of the screws is selected so they bottom in the mounting hole and allow the connector shell to float.

CAUTION

Use the correct hardware when replacing the connector. If the connector does not float it may interfere when the plug-in is installed in the mainframe and may cause damage to the mating connector.

Replaceable Parts

This section shows the replaceable parts in the HP 54717A plug-in. For ordering information and other such details, see chapter 7 in this service guide.

Mechanical View

Figure 9-2

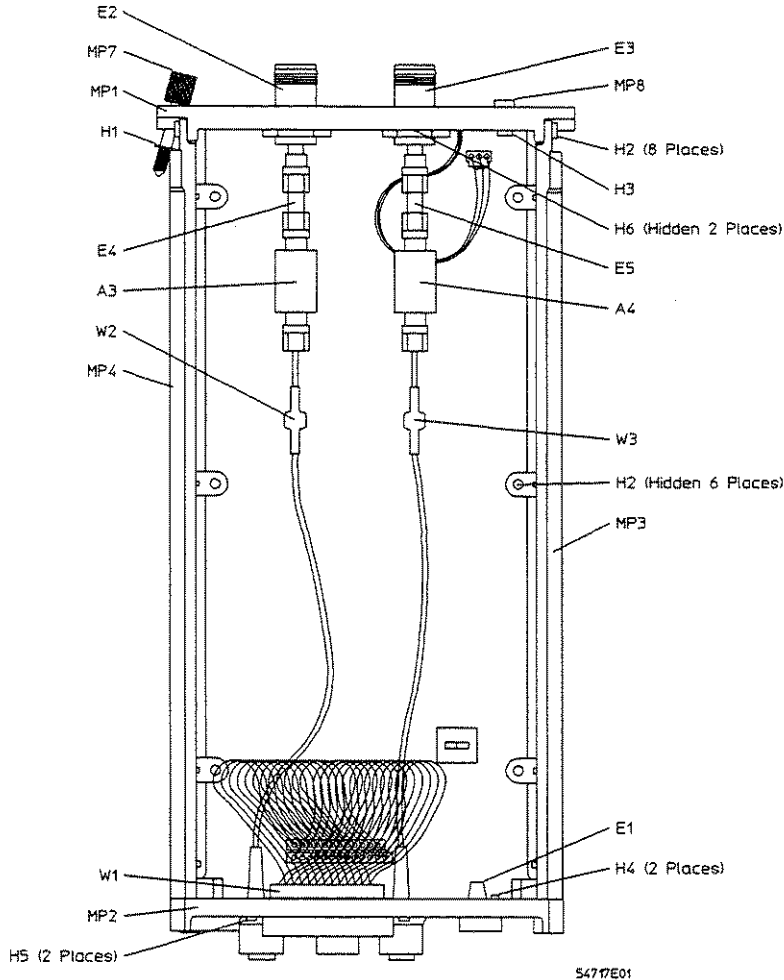

HP 54717A Mechanical View

Parts List

Table 9-1 is a list of replaceable parts and is organized as follows:

- Exchange assemblies in alphanumeric order by reference designation.
- Electrical assemblies in alphanumeric order by reference designation.
- Chassis-mounted parts in alphanumeric order by reference designation.

The information given for each part consists of the following:

- Reference designation.
- HP part number.
- Total quantity (QTY) in instrument or on assembly. For reference designators with the same part number the total quantity is given once, at the first appearance of the part number in the list.
- Description of the part.

Table 9-1

HP 54717A Replaceable Parts

Ref. Des.	HP Part Number	QTY	Description
EXCHANGE ASSEMBLIES			
A1	54717-69502	1	PC ASSEMBLY - INTERFACE
ELECTRICAL ASSEMBLIES			
A1	54717-66502	1	PC ASSEMBLY - INTERFACE
A2	54710-66512	1	PC ASSEMBLY - KEYBOARD
A3	5086-7746	2	PASSIVE LIMITER (channel)
A4	5086-7746		PASSIVE LIMITER (trigger)
CHASSIS PARTS			
E1	5001-5840	1	GROUND SPRING
E2	1250-1811	2	ADAPTER - TYPE N-TO-SMA (channel input)
E3	1250-1811		ADAPTER - TYPE N-TO-SMA (trigger input)
E4	1250-1159	2	ADAPTER - SMA (m)-to-SMA(m)
E5	1250-1159		ADAPTER - SMA (m)-to-SMA(m)
H1	0510-0166	1	RETAINER RING
H2	0515-0372	14	MS M3 8MM-LG PAN-HD T10
H3	0515-0430	1	MS M3 6MM-LG PAN-HD T10
H4	0515-0894	2	MS M2.5 6MM-LG
H5	5041-9448	2	SCREW-TAPPING 2-56 X 3/8 TORX
H6	2190-0068	2	WASHER - INTERNAL LOCK 0.505 ID 0.63 OD (part of connector)
MP1	5062-7314	1	FRONT PANEL
MP2	5062-7315	1	REAR PANEL
MP3	5062-7316	2	RAIL (top)
MP4	5062-7316		RAIL (bottom)
MP5	5062-7344	2	COVER (left side)
MP6	5062-7344		COVER (right side)
MP7	5062-7343	1	RETAINING SCREW
MP8	54714-41903	1	KEYPAD
MP9	54717-94301	1	LABEL - FRONT PANEL
MP10	5090-4464	1	LABEL - PLUG-IN BANDWIDTH
W1	5062-7322	1	CABLE ASSEMBLY - BUS INTERFACE
W2	54717-61601	2	CABLE - COAX SMA/OSP (channel output)
W3	54717-61601		CABLE - COAX SMA/OSP (trigger output)

Theory of Operation

The HP 54717A is designed to provide direct access to the channel and trigger inputs for self calibration of the HP 54710A and 54720A mainframes.

Figure 9-3

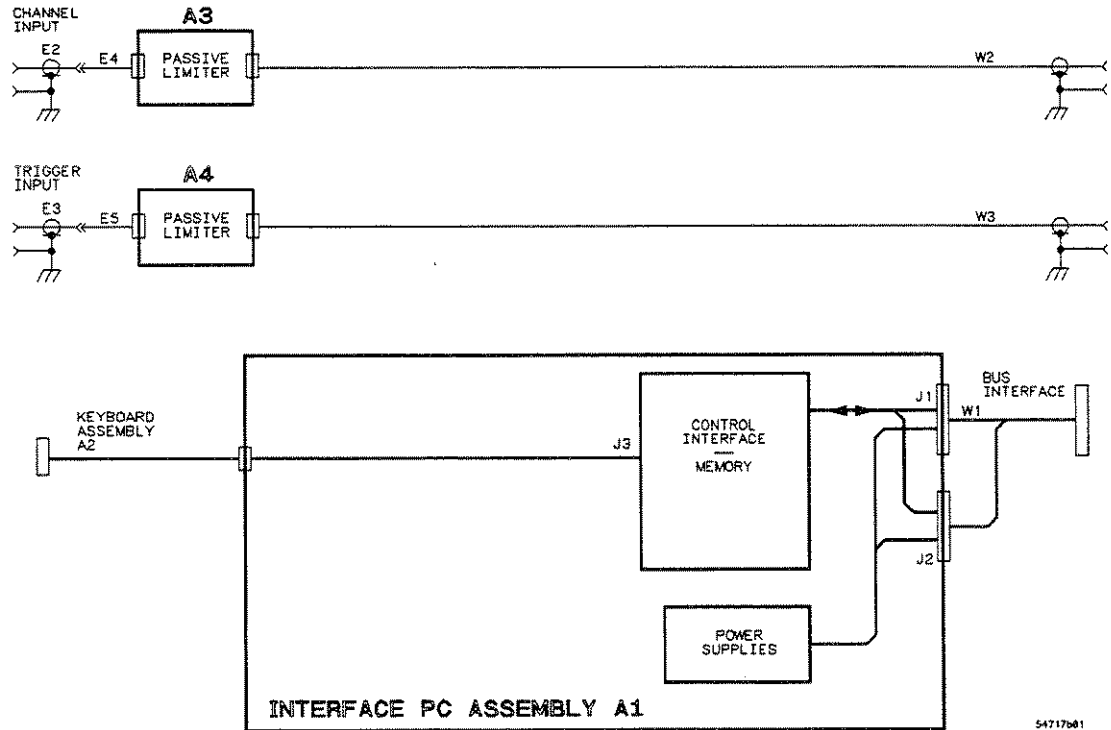

HP 54717A Block Diagram

Signal Paths

The signal path is completely passive. The front-panel inputs are fed to passive limiters. The limiters are an arrangement of Schottky and pin diodes that limit the signal into the mainframe to approximately ± 1 V. They can withstand approximately ± 1 Amp of dc current when clamped. The limiters are directional. The outputs of the limiters are fed to the channel and trigger inputs of the mainframe.

Digital Interface

The digital interface provides communication and control between the plug-in and the Module Interface Bus (MIB) in the mainframe. The interface is located on the interface PC assembly. The digital interface provides the following functions.

- **Interface Communication** The data interface with the MIB in the mainframe is serial. The digital interface converts serial data and address from the MIB to parallel for the plug-in and converts parallel data and address in the plug-in to serial for the MIB. In

addition to the two data/address lines (one for input and one for output), the HP 54717A uses several other lines to communicate with the MIB.

- **Memory** Plug-in memory is used for plug-in statistics (such as model and serial numbers). The memory IC is an 8k by 8 EEPROM.
- **Channel Key** Pressing the channel key sets a status bit in the interface which initiates an interrupt of the CPU in the mainframe.

Power Supplies

The mainframe supplies are ± 17 V, +15 V, and ± 7 V. The only supply used is the +7 V supply which is regulated into +5 V.



General Information

Accessories Available 10-3
Specifications 10-3
Characteristics 10-4
General Characteristics 10-4

Periodic Maintenance

Performance Test 10-5
Calibration and Adjustment 10-8

Troubleshooting 10-9

ESD Precautions 10-9
Equipment Required 10-9
Trouble Isolation 10-9

Replacing Assemblies 10-11

Tools Required 10-11
To remove and replace
Covers 10-11
Input Cable 10-11
Limiter and Attenuator 10-12
Output Cable 10-12
Bus Cable 10-13
PC Board 10-13

Replaceable Parts 10-14

Mechanical View 10-14
Parts List 10-14

Theory of Operation 10-16

Passive Trigger Path 10-16
Digital Interface 10-17
Probe Power 10-17
Power Supplies 10-17

HP 54718A Plug-In Service

HP 54718A Plug-In Service

This chapter gives service information specific to the HP 54718A oscilloscope plug-in. The chapter is divided into six sections. The following topics are covered in this chapter.

- General information – which includes specifications, characteristics, and other information
- Periodic maintenance – primarily performance testing
- Troubleshooting – to assembly level
- Replacing Assemblies – mechanical procedures
- Replaceable Parts – part views and parts list
- Theory of Operation.

For information not specific to this plug-in, refer to the following chapters in the mainframe section of this guide.

- Inspection, chapter 2
- Plug-In installation, chapter 2
- Cleaning, chapter 2
- Ordering parts, chapter 7

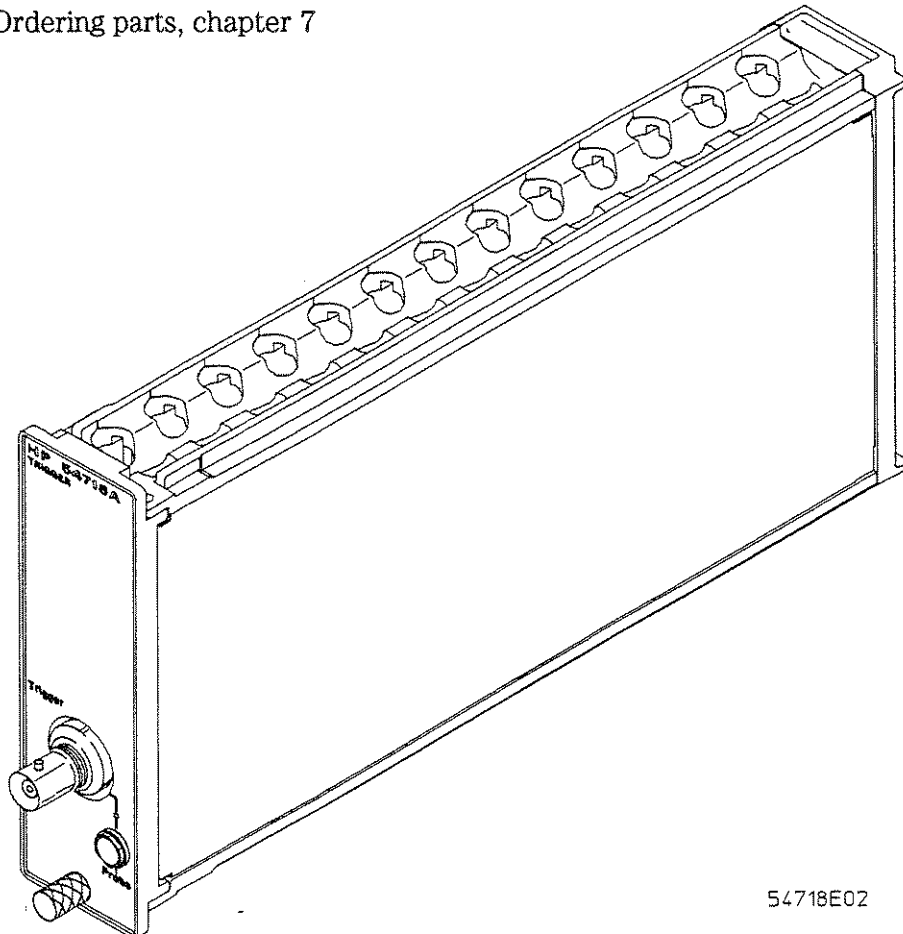

54718E02

General Information

This section provides general information specific to the HP 54718A Trigger plug-in.

The main use for the HP 54718A Trigger plug-in is to provide access to the triggers in slots 3 and 4 of the HP 54710A oscilloscope mainframe. These slots do not have channels because the HP 54710A mainframe has only one acquisition board. Slots 3 and 4 have fully functioning triggers because the triggering circuitry is on the time base assembly, which is the same in both the HP 54720A and 54710A. The HP 54718A provides the additional trigger for these slots, without the expense of a full featured plug-in. The trigger path in the HP 54718A is identical to the external trigger in the HP 54721A amplifier plug-in. A probe power connection is provided for the use of an active probe.

Accessories Available

The following accessories are available for use with the HP 54718A.

- HP 54701A 2.5 GHz Active Probe
- HP 1141A 200 MHz differential probe (needs HP 1142A probe power supply)
- HP 54006A 6 GHz passive probe

Specifications

The following are specifications used to test the HP 54718A plug-in. Specifications are valid after a 20 minute warm-up period.

Trigger Sensitivity

Normal Sensitivity 30 mV_{p-p} at 100 MHz; 90 mV_{p-p} at 1 GHz

Noise Reject 60 mV_{p-p} at 100 MHz; 150 mV_{p-p} at 1 GHz

Minimum Pulse Width at Normal Sensitivity ≤500 ps at ≥60 mV_{p-p}

Characteristics

The following characteristics are typical for the HP 54718A plug-in.

Trigger Sensitivity

High Sensitivity 6 mV_{p-p} at 100 MHz; 20 mV_{p-p} at 1 GHz

Input Resistance 50 Ω

Input Connector BNC (f)

RMS Jitter <6 ps ±0.005% of delay setting

Trigger Level Range ±1 V

Max Safe Input Voltage ±1.5 V

Probe Power Yes



General Characteristics

These general characteristics apply to the HP 54718A oscilloscope plug-in.

Environmental Conditions

The environmental conditions are the same as for the HP 54710A and 54720A mainframes. See the environmental conditions in chapter 1 of this service guide.

Power Requirements

Supplied by mainframe.

Weight

Net approximately 0.6 kg (1.4 lb)

Shipping approximately 1.5 kg (3.4 lb)

Periodic Maintenance

The only periodic maintenance for the HP 54718A is a test for triggering performance. The test uses as performance standards, the specifications given in the previous section.

The HP 54718A does not require calibration or adjustment.

Performance Test

The performance test checks the triggering sensitivity of the system.

Testing Interval

The performance test procedures may be performed for incoming inspection of the instrument and should be performed periodically thereafter to ensure and maintain peak performance. The recommended test interval is yearly or every 2,000 hours of operation. Amount of use, environmental conditions, and the user's experience concerning need for testing will contribute to test requirements.

Equipment Required

The equipment required for the tests is listed in the following table. Any equipment satisfying the critical specifications listed may be substituted for the recommended model. The procedures are based on the model or part number recommended.

Equipment Required

Equipment	Critical Specifications	Recommended Model/Part
Signal generator	100 MHz to 1.0 GHz	HP 8664A
Power Meter/Sensor	100 MHz to 1.0 GHz, $\pm 3\%$ accuracy	HP 436A/8482A
Channel plug-in	1 GHz	HP 54711A, 54712A, or 54721A
Power Splitter	50 Ω , Type-N, outputs differ by <0.25 dB	HP 11667A
Cable	Type-N	HP 11500B
Cable(2)	BNC 9-inch	HP 10502A
Adapter	N(f)-to-BNC(m)	HP 1250-0077
Adapter(2)	N(m)-to-BNC(f)	HP 1250-0780
Adapter	BNC(f)(f)	HP 1250-0080

Test Record

The results of the performance tests may be tabulated on the Performance Test Record on page 10-8. The Performance Test Record lists the tests and provides an area to mark test results. The results recorded in the table at incoming inspection may be used for later comparisons of the tests during periodic maintenance, troubleshooting, and after repairs.

Specification

Normal Sensitivity 30 mV_{p-p} at 100 MHz; 90 mV_{p-p} at 1 GHz

Procedure

This trigger test checks for triggering at two frequencies. For the low-frequency test (100 MHz) the signal is measured on the display. For the high-frequency test (1 GHz) a power meter is used to set the signal amplitude.

An additional plug-in with a channel input must be used to display the signal. When the procedure says to press **Channel**, this is the plug-in referred to.

- 1 Install the HP 54718A trigger plug-in in mainframe slot 1 and the channel plug-in in slot 2. Remove any other plug-ins.
- 2 With a Type-N cable, connect the signal generator to the power splitter input.
- 3 Using N(m)-to-BNC(f) adapters and BNC cables, connect the outputs of the power splitter to the input of the HP 54718A and the channel input of the other plug-in.
- 4 Set the signal generator to obtain a 100 MHz sine wave at approximately -20.5 dBm (about 21 mV_{rms}).
This will put about 30 mV_{p-p} at the inputs to the plug-in.
- 5 Press **Setup** then **Default setup** to set default conditions.
- 6 Press **Time base** and set the **Scale** to 5.00 ns/div.
- 7 Press **Channel** and set the **Scale** to 10 mV/div.
- 8 Press **Trigger**, select **Trigger1**, and press **Enter**.
- 9 Set the signal generator amplitude for 3 divisions as measured on the display. You can adjust the offset to position the signal for easier measurement.
- 10 Press **Trigger** and adjust the trigger **Level** for a stable trigger.
- 11 Record the result in the Performance Test Record.
- 12 Connect the N(f)-to-BNC(m) and BNC(f)(f) adapters to the input of the power sensor.
- 13 Disconnect the cable from the input of the HP 54718A and connect the power sensor to the end of the cable.
- 14 Set the power meter Cal Factor % to the 1.0 GHz value from the chart on the power sensor.
- 15 Set the signal generator frequency to 1.0 GHz and amplitude for 20.2 μ W as read on the power meter.
- 16 Disconnect the power sensor from the cable and re-connect the cable to the input of the HP 54718A.

17 Press **Time base** and set the **Scale** to **200 ps/div**.

18 Press **Channel** and set the **Scale** to **20 mV/div**

Remember, the frequency of the signal is close to the bandwidth of the plug-in, so the amplitude on the display does not reflect the true amplitude of the signal at the trigger input.

19 Press **Trigger** and adjust the trigger **Level** for a stable trigger (90 mVp-p).

20 Record the results in the Performance Test Record.

If the test fails

Failure of the trigger test can be caused by the plug-in, plug-in connectors, or the time base assembly in the mainframe. Refer to "Troubleshooting," for more information.

Table 10–1. Performance Test Record

 HEWLETT PACKARD Serial No. _____ Recommended Test Interval - 1 Year/2000 hours Recommended next testing _____		<p style="text-align: center;">HP 54718A Oscilloscope Plug-in</p> Tested by _____ Work Order No. _____ Date _____ Temperature _____						
Test	Limits	Results						
Trigger	STABLE TRIGGER ON: 30 mVp-p at 100 MHz 90 mVp-p at 1 GHz	<table style="margin: auto;"> <tr> <td style="padding: 5px;">PASS</td> <td style="padding: 5px;">FAIL</td> </tr> <tr> <td style="text-align: center;">_____</td> <td style="text-align: center;">_____</td> </tr> <tr> <td style="text-align: center;">_____</td> <td style="text-align: center;">_____</td> </tr> </table>	PASS	FAIL	_____	_____	_____	_____
PASS	FAIL							
_____	_____							
_____	_____							

Calibration and Adjustment

The HP 54718A does not require calibration or adjustment.

Troubleshooting

This section provides troubleshooting information for the HP 54718A Oscilloscope plug-in. The service strategy of this instrument is replacement of defective assemblies, so the troubleshooting is designed to isolate a failed PC assembly, attenuator, or cable.

Trouble isolation of the HP 54718A plug-in requires checking the plug-in in a working HP 54710A or 54720A oscilloscope mainframe.

ESD Precautions

When using any of the procedures in this chapter you should use proper ESD precautions. As a minimum, if you are working with the plug-in on an extender cable you should place the instrument on a properly grounded ESD mat and wear a properly grounded ESD wrist strap.

Equipment Required

Just the normal tools used when troubleshooting electronic equipment are needed for troubleshooting. A good digital multimeter and an oscilloscope with about a 100 MHz bandwidth should be sufficient. If you want to build an extender cable for plug-in troubleshooting, see "Equipment Required" in chapter 5 of this service guide. If you need to remove and replace parts and assemblies, you may need some of the hand tools listed at "Replacing Assemblies" which follows this section.

Trouble Isolation

The trouble isolation information is provided to isolate a problem to a faulty assembly. Use the following checks to quickly isolate some major failures or be fairly certain the plug-in works. To narrow menu choices and make troubleshooting easier, it is best to have only the faulty plug-in installed in the mainframe.

A Be sure the plug-in is at fault.

When you have any problem involving a plug-in, put the suspect plug-in in a slot where you know another plug-in performs properly and check for the failure. If the problem follows the plug-in, repair it. If the plug-in works, repair the mainframe.

B Check the digital interface.

There is no interaction between the digital interface and the trigger signal. Also, there is no keyboard. Therefore the only way to check the function of the digital interface is to note how it interrelates with the mainframe.

- 1 Press , then **Service . . .** , and **Plug-in . . .** .
- 2 In the Plug-ins area of the display, note an empty slot and install a plug-in in that slot.
- 3 The Model and Serial # fields should change to reflect the plug-in model and serial number.

If the display changes when the plug-in is installed, but the serial number or model number are incorrect, the plug-in may need to be reprogrammed. See the "Utility Menu" section of chapter 5, "Troubleshooting" in the mainframe part of this guide.

4 Enable plug-in calibration.

- a Remove the plug-in from the mainframe.
- b Remove the right-side cover.

Use a small flat-blade screwdriver. Starting at one rear corner, pry up to release one side of the cover. The other side will follow.

- c Set the calibration switch to the ENABLE position.

This is a single-pole DIP switch located between the attenuator and the top rail.

- d Replace the cover and put the plug-in back into the mainframe.

Insert the front of the cover under the edge of the front panel. Then push one long side of the cover into the plug-in, then the other.

Replacing the cover prevents cabling from getting caught and damaged.

5 In the System configuration menu, the Calibration Memory should show Unprotected.

6 Initialize the plug-in.

Make sure the HP54718A is selected (top softkey) and press Initialize plug-in memory. The top of the display should show the storing message.

7 Determine the problem.

- If the mainframe can recognize the plug-in and store into it, the digital interface must work.
- If the digital interface does not work, it could be the PC board or the interface cable. Check the cable with an ohmmeter.

C Check the triggering function.

The trigger signal path is a 6 dB attenuator and passive limiter between the input and output cables.

- 1 Install the HP 54718A into slot 1 and a plug-in with a channel input into another slot.
- 2 Connect a signal to the inputs of both plug-ins.
- 3 Press .
- 4 Press and check that the oscilloscope triggered on Trigger 1.

The instrument should trigger on the signal in slot 1. If it does not, there is a problem with the cables, attenuator, or passive limiter.

D Check the input resistance.

There is no specification for this parameter. The resistance is typically 50 Ω . Small bias voltages at the input of the trigger circuitry affect the reading so, reverse the DMM leads and average the two readings. For the most accuracy, make a four-wire resistance measurement. If the resistance is not correct, there could be a faulty attenuator or limiter, or an open cable.

E Check the trigger sensitivity.

If the trigger sensitivity test fails, check the following:

- 1 Check for a high-frequency problem in the trigger path.
- 2 Check the attenuation factor of the 6dB attenuator. There is no specification but it should be nominally 6 dB.
- 3 The best way to check the signal path is with a TDR system. Compare the results with a known good plug-in. The external trigger path in the HP 54721A is identical to the trigger path in the HP 54718A, so it can be used as a comparison.

If the limiter has been overloaded, the diodes in it can short, which should show up with a resistance check. If the diodes open, its characteristic impedance would change at high frequencies. The only way to check that would be with a TDR system.

Replacing Assemblies

Procedures in this section should be used when removing and replacing assemblies and parts in the HP 54718A oscilloscope plug-in.

Tools Required

The following tools are required to work on the HP 54718A. Not all tools are called out in the procedures.

- Torx driver: T10
- Open-end wrench: 10 mm – for probe power connectors
- Open-end wrench: 8 mm (5/16 inch)
- Open-end wrench: 7/32 inch
- Socket wrench: 5/8 inch
- Pozidrive screwdriver: #1
- Connector removal tool AMP Tool No. 305141-4
- Torque wrench, 0.90 Nm (8 in-lbs), 8 mm (5/16-inch) open end – for SMA connectors

To remove and replace the covers

A cover comes off more easily when it is released one edge at a time.

- 1 With a small screwdriver, pry up at one of the rear corners of the cover.
- 2 Once a corner is free, lift the cover so that nearly one entire edge is loose.
- 3 Starting at the other rear corner, lift the other side of the cover.
- 4 When both edges of the cover are loose, remove the front edge of the cover from under the edge of the front panel.
- 5 To replace the cover, reverse the procedure.

The cover with the label goes on the right side of the plug-in.

To remove and replace the input cable

- 1 Use the 5/8-inch socket wrench to remove the large nut that fastens the cable to the front panel.
- 2 Loosen the front pair of PC board screws about 5 mm so you can move the board enough to get the connector to clear.
- 3 Remove the lock washer and push the cable through the "D" hole in the panel.
- 4 Remove the attenuator/limiter assembly from the bracket.
- 5 Use one 8-mm (5/16-inch) wrench to hold the attenuator and use the other to remove the cable from the attenuator.
- 6 To replace the cable reverse the procedure.

Tighten the SMA connector to 0.90 Nm (8 in-lbs).

Figure 10-1

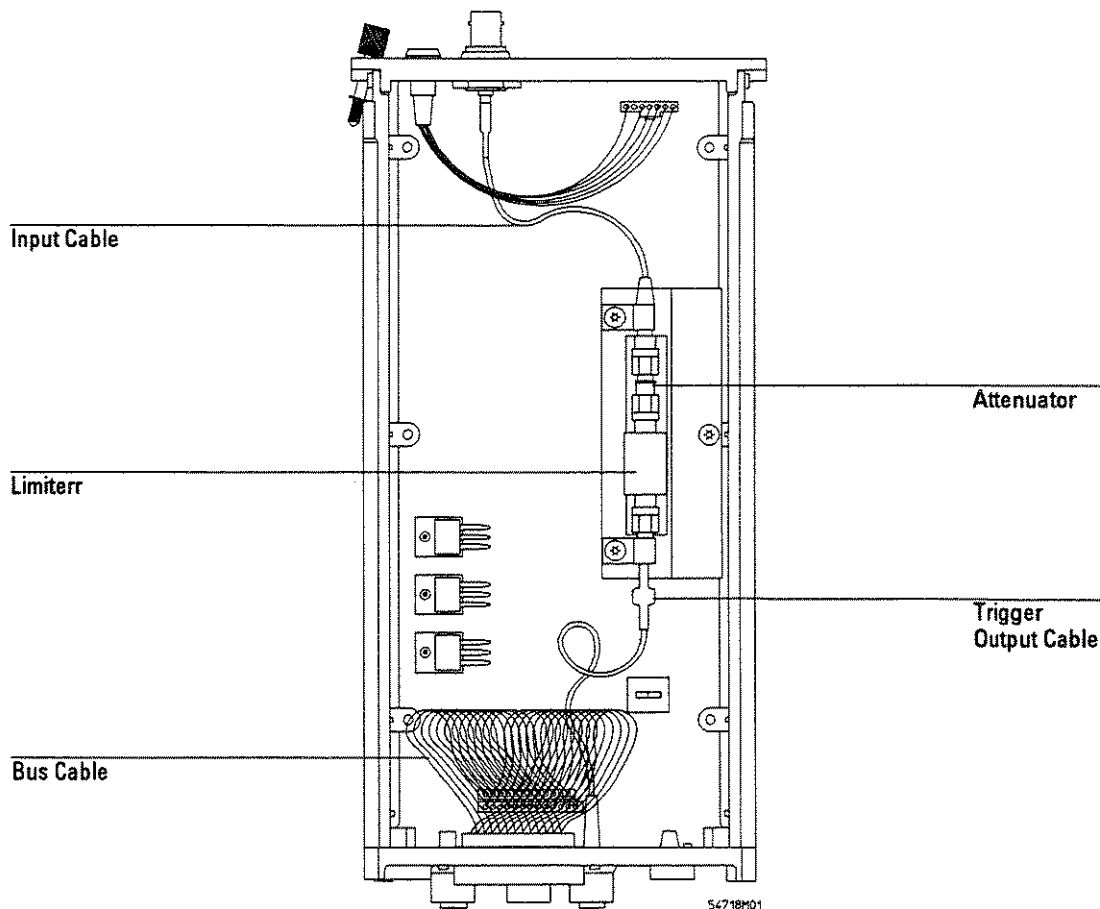

HP 54718A Parts View

To remove and replace the limiter and attenuator

The attenuator and limiter are attached to a bracket and connected between the input and output cables.

Only a few pointers are necessary when replacing these devices.

- Remove the attenuator and limiter from the bracket completely before disassembling the coaxial connectors.
- When removing and replacing these parts, use an open-end wrench on the flats of the part. Use a 7/32-inch wrench on the limiter and a 8-mm (5/16-inch) wrench on the attenuator. This prevents twisting parts when removing the connectors.
- Tighten the SMA connectors with an 8-mm (5/16-inch) torque wrench set to 0.90 Nm (8 in-lbs).

To remove and replace the output cable

You need a special tool to remove this cable from the rear casting.

- AMP Tool No. 305141-4

The coaxial output cable is held in the rear panel by a tapered snap ring that expands once it passes the shoulder in the mounting hole. The special tool compresses the snap ring and pushes the connector out of its mounting.

The connector in the rear panel is spring-loaded so it mates firmly with the connector at the rear of the plug-in compartment.

- 1 Remove the four screws that attach the rear panel to the top and bottom rails.
- 2 Pull the rear panel away from the plug-in just enough to provide clearance for the output cable as it is removed.
- 3 Slide the special tool over the rear of the connector.
While pushing the tool on, rotate it slightly to slip it over the locking ring.
- 4 Push on the tool plunger to extract the connector.
Pushing the plunger takes up the spring in the connector first, then pushes the connector past the mounting hole shoulder. A very firm force is necessary to remove the connector.
- 5 Remove two screws to remove the attenuator/limiter assembly from the bracket.
- 6 Disconnect the cable from the limiter.
Use the 7/32-inch wrench to hold the limiter at the flats next to the cable connector.
- 7 To replace the cable, connect one end of the cable to the limiter.
Use the 7/32-inch wrench to hold the limiter at the flats next to the cable connector. Tighten the SMA connector to 0.90 Nm (8 in-lbs).
- 8 Secure the attenuator/limiter assembly in the bracket.
- 9 Re-install the cable in the rear casting.
 - a Set the connector into the top hole in the rear casting.
 - b Use a blunt tool to force the connector to lock in the casting.
 - c Make sure the connector is locked and won't fall out.
Use the handle end of a screwdriver and push on the connector from the rear, enough to completely compress the spring tension on the connector.
- 10 Use the four screws to re-attach the rear casting.

To remove and replace the bus cable

A #1 pozi-drive screwdriver is needed for replacing this cable.

The D-shell connector is designed to move freely on its mounting screws. The length of the screws is selected so they bottom in the mounting hole and allow the connector shell to float.

CAUTION

Use the correct hardware when replacing the connector. If the connector does not float it may interfere when the plug-in is installed in the mainframe and may cause damage to the mating connector.

To remove and replace the PC board

To remove and replace the PC board does not require any special techniques. It is fastened by six screws and two cables are connected to it. However, if you replace the board with a new one, you will have to store the plug-in serial number on the new board. See "Utility Menu" in chapter 5 of this service guide.

Replaceable Parts

This section shows the replaceable parts in the HP 54718A plug-in. For ordering information and other such details, see chapter 7 in this service guide.

Mechanical View

Figure 10-2

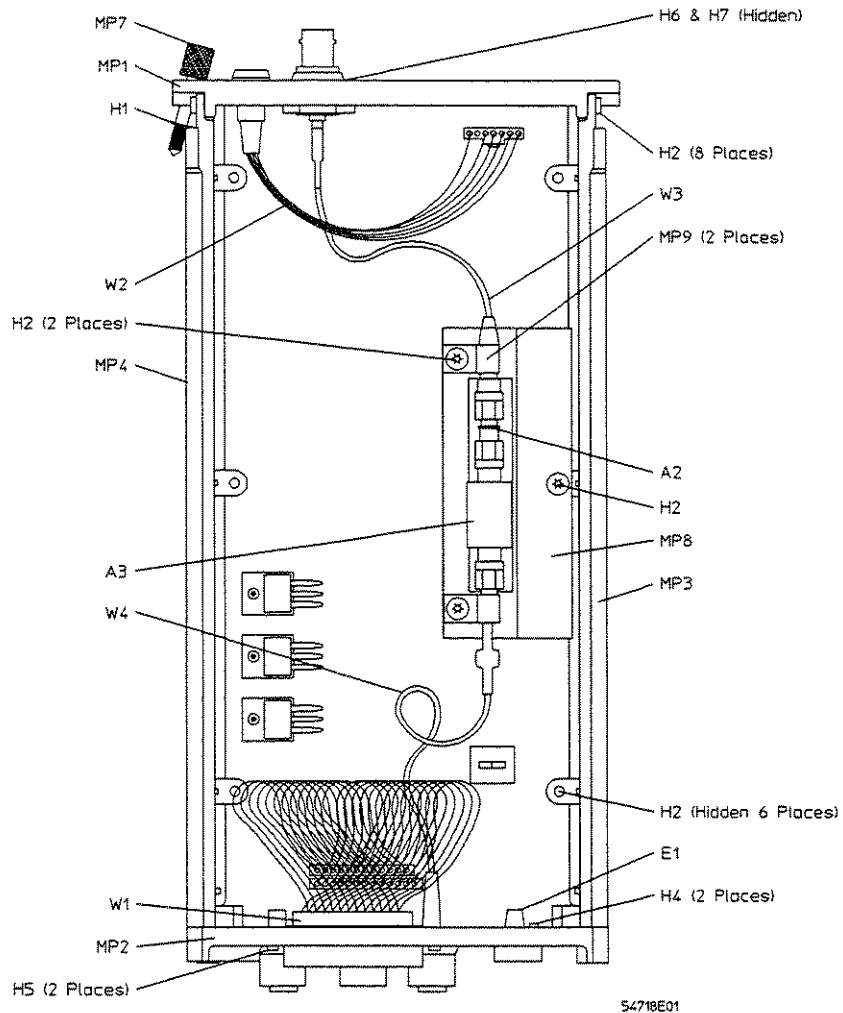

HP 54718A Mechanical View

Parts List

Table 10-2 is a list of replaceable parts and is organized as follows:

- Exchange assemblies in alphanumeric order by reference designation.
- Electrical assemblies in alphanumeric order by reference designation.
- Chassis-mounted parts in alphanumeric order by reference designation.

The information given for each part consists of the following:

- Reference designation.
- HP part number.
- Total quantity (QTY) in instrument or on assembly. For reference designators with the same part number the total quantity is given once, at the first appearance of the part number in the list.
- Description of the part.

Table 9-1

HP 54717A Replaceable Parts

Ref. Des.	HP Part Number	QTY	Description
EXCHANGE ASSEMBLIES			
A1	54718-69501	1	PC ASSEMBLY - INTERFACE
ELECTRICAL ASSEMBLIES			
A1	54718-66501	1	PC ASSEMBLY - INTERFACE
A2	0955-0587	1	ATTENUATOR - 6dB
A3	5086-7746	1	PASSIVE LIMITER
CHASSIS PARTS			
E1	5001-5840	1	GROUND SPRING
H1	0510-0166	1	RETAINER RING
H2	0515-0372	17	MS M3 8MM-LG PAN-HD T10
H3			NOT ASSIGNED
H4	0515-0894	2	MS M2.5 6MM-LG
H5	5041-9448	2	SCREW-TAPPING 2-56 X 3/8 TORX
MP1	5062-7314	1	FRONT PANEL
MP2	5062-7315	1	REAR PANEL
MP3	5062-7316	2	RAIL (top)
MP4	5062-7316		RAIL (bottom)
MP5	5062-7344	2	COVER (left side)
MP6	5062-7344		COVER (right side)
MP7	5062-7343	1	RETAINING SCREW
MP8	54718-01201	1	BRACKET - LIMITER
MP9	1400-0015	2	CLAMP - CABLE
MP10	54718-94301	1	LABEL - FRONT PANEL
MP11	5090-4464	1	LABEL - PLUG-IN BANDWIDTH
W1	5062-7322	1	CABLE ASSEMBLY - BUS INTERFACE
W2	54710-61605	1	CABLE ASSEMBLY - PROBE POWER
W3	5062-7320	1	CABLE - COAX BNC/SMA (trigger input)
W4	54717-61601	1	CABLE - COAX SMA/OSP (trigger output)

Theory of Operation

The HP 54718A is designed to provide access to only the trigger inputs of the HP 54710A and 54720A mainframes.

Figure 10-3

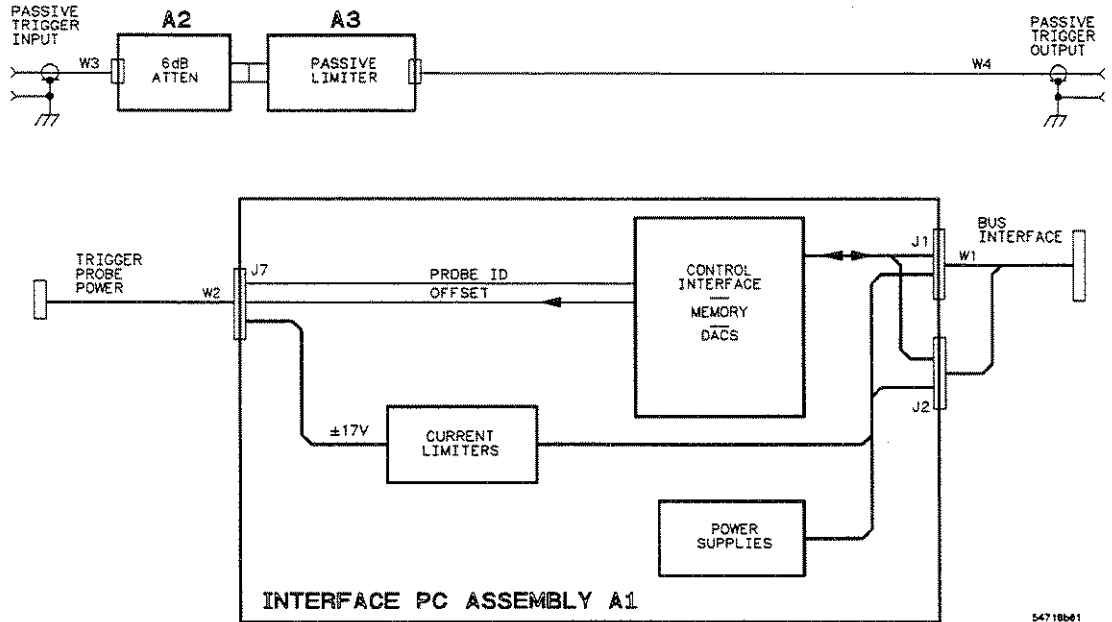

HP 54718A Block Diagram

Passive Trigger Path

The trigger path, which is completely passive, comes from the front panel through a 6 dB attenuator. The output of the attenuator is fed to a passive limiter. The limiter is an arrangement of Schottkey and pin diodes that limit the signal into the mainframe to approximately ± 1 V. It can withstand approximately ± 1 Amp of dc current when clamped. The limiter is directional. The output of the limiter is fed to the trigger input in the mainframe.

Digital Interface

The digital interface provides communication and control between the plug-in and the Module Interface Bus (MIB) in the mainframe. Along with other circuitry, the interface is located on the interface PC assembly. The digital interface provides the following functions.

- **Interface Communication** The data interface with the MIB in the mainframe is serial. The digital interface converts serial data and address from the MIB to parallel for the plug-in and converts parallel data and address in the plug-in to serial for the MIB. In addition to the two data/address lines (one for input and one for output), the HP 54718A uses several other lines to communicate with the MIB.
- **Digital-to-Analog Converters** A sixteen-bit DAC drives a current source for the probe offset. The voltage output of the DAC is converted to a current for the probe.
- **Memory** Plug-in memory is used for plug-in statistics (such as model and serial numbers). The memory IC is an 8k by 8 EEPROM.

Probe Power

There is a front panel connector for probe power. The connector provides the six lines shown below, with a seventh line as a spare.

- **Two probe identification lines** The probe pulls these lines low to inform the system of the attenuation factor of the probe. The state of each line is latched in the control interface. A change in the state of a line initiates an interrupt.

Since the circuitry senses the presence and type of probe and each probe is internally associated with a given function (channel or trigger), probes must be connected to the proper probe power connector and not switched. Switched probe power cables may cause improper setup of the channel or trigger paths.

- **An offset line** A DAC, followed by a voltage-to-current converter, provides a variable current for offset in active probes.
- **Two power supply lines** These are ± 17 V supplies for active probes. The current is limited to approximately 400 mA maximum for each supply pin on each connector.
- **Ground** This is ground for the probe power lines. Probe signal ground is through the signal coaxial cable.

Power Supplies

The mainframe supplies are ± 17 V, +15 V, and ± 7 V. The ± 17 V supplies are used for probe power and also regulated to ± 14 V. The +7 V supply is regulated into +5 V.

DECLARATION OF CONFORMITY

according to ISO/IEC Guide 22 and EN 45014

Manufacturer's Name: Hewlett-Packard Company

Manufacturer's Address: 1900 Garden of the Gods Road
Colorado Springs , CO 80901
U.S.A.

declares, that the product

Product Name: Digitizing Oscilloscope

Model Number(s): HP 54710A, 54711A, 54712A, 54713A, 54717A,
54718A, 54720A, and 54721A,

Product Options: All

conforms to the following product specifications:

Safety: IEC 348 / HD 401
UL 1244
CSA Standard C22.2 No. 231 (Series M-89)

EMC: CISPR 11:1990 /EN 55011 (1991): Group 1 Class A
IEC 801-2:1991 /EN 50082-1 (1992): 4 kV CD, 8 kV AD
IEC 801-3:1984 /EN 50082-1 (1992): 3 V/m
IEC 801-4:1988 /EN 50082-1 (1992): 1 kV

Supplementary Information:

Colorado Springs, July 24, 1992

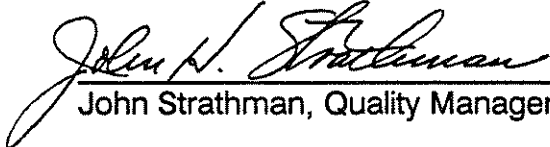
John Strathman, Quality Manager

European Contact: Your local Hewlett-Packard Sales and Service Office or Hewlett-Packard GmbH, Department ZQ / Standards
Europe, Herrenberger Straße 130, D-7030 Böblingen (FAX: +49-7031-144195)

X-RAY RADIATION NOTICE

ACHTUNG

Models HP 54111D/54112D/54120A/
54120B/54710A/54720A

WARNING

Während des Betriebs erzeugt dieses Gerät Röntgenstrahlung. Das Gerät ist so abgeschirmt, daß die Dosisleistung weniger als 36 pA/kg (0,5 mR/h) in 5cm Abstand von der Oberfläche der Kathodenstrahlröhre beträgt. Somit sind die Sicherheitsbestimmungen verschiedener Länder, u.A. der deutschen Röntgenverordnung eingehalten.

Die Stärke der Röntgenstrahlung hängt im wesentlichen von der Bauart der Kathodenstrahlröhre ab sowie von den Spannungen, welche an dieser anliegen. Um einen sicheren Betrieb zu gewährleisten, dürfen die Einstellungen des Niederspannungs- und Hochspannungsnetzteils nur nach der Anleitung in Kapitel Einstellvorschriften des Service Handbuches vorgenommen werden.

Die Kathodenstrahlröhre darf nur durch die gleiche Type ersetzt werden. (Siehe Kapitel Ersatzteile für HP-Teilenummern.)

Das Gerät ist in Deutschland zugelassen unter der Nummer: BW/218/86/ROE

When operating, this instrument emits x-rays; however, it is well shielded and meets safety and health requirements of various countries, such as the X-ray Radiation Act of Germany.

Radiation emitted by this instrument is less than 0.5 mR/hr at a distance of five (5) centimeters from the surface of the cathode-ray tube. The x-ray radiation primarily depends on the characteristics of the cathode-ray tube and its associated low-voltage and high-voltage circuitry. To ensure safe operation of the instrument, adjust both the low-voltage and high-voltage power supplies as outlined in the Adjustments Section of the Service Manual.

Replace the cathode-ray tube with an identical CRT only. Refer to the Replacement Parts Section for the proper HP part number.
Number of German License: BW/218/86/ROE

X-BAY

© Copyright Hewlett-Packard Company 1992
All Rights Reserved.

Reproduction, adaption, or translation without prior written permission is prohibited, except as allowed under the copyright laws.

Document Warranty

The information contained in this document is subject to change without notice.

Hewlett-Packard makes no warranty of any kind with regard to this material, including, but not limited to, the implied warranties of merchantability or fitness for a particular purpose.

Hewlett-Packard shall not be liable for errors contained herein or for damages in connection with the furnishing, performance, or use of this material.

Product Warranty

This Hewlett-Packard product has a warranty against defects in material and workmanship for a period of one year from date of shipment. During the warranty period, Hewlett-Packard Company will, at its option, either repair or replace products that prove to be defective.

For warranty service or repair, this product must be returned to a service facility designated by Hewlett-Packard.

For products returned to Hewlett-Packard for warranty service, the Buyer shall prepay shipping charges to Hewlett-Packard and Hewlett-Packard shall pay shipping charges to return the product to the Buyer. However, the Buyer shall pay all shipping charges, duties, and taxes for products returned to Hewlett-Packard from another country.

Hewlett-Packard warrants that its software and firmware designated by Hewlett-Packard for use with an instrument will execute its programming instructions when properly installed on that instrument. Hewlett-Packard does not warrant that the operation of the instrument software, or firmware will be uninterrupted or error free.

Limitation of Warranty

The foregoing warranty shall not apply to defects resulting from improper or inadequate maintenance by the Buyer, Buyer-supplied software or interfacing, unauthorized modification or misuse, operation outside of the environmental specifications for the product, or improper site preparation or maintenance.

No other warranty is expressed or implied. Hewlett-Packard specifically disclaims the implied warranties of merchantability or fitness for a particular purpose.

Exclusive Remedies

The remedies provided herein are the buyer's sole and exclusive remedies. Hewlett-Packard shall not be liable for any direct, indirect, special, incidental, or consequential damages, whether based on contract, tort, or any other legal theory.

Assistance

Product maintenance agreements and other customer assistance agreements are available for Hewlett-Packard products.

For any assistance, contact your nearest Hewlett-Packard Sales Office.

Certification

Hewlett-Packard Company certifies that this product met its published specifications at the time of shipment. Hewlett-Packard further certifies that its calibration measurements are traceable to the United States National Institute of Standards and Technology, to the extent allowed by the Institute's calibration facility, and to the calibration facilities of other International Standards Organization members.

Safety

This apparatus has been designed and tested in accordance with IEC Publication 348, Safety Requirements for Measuring Apparatus, and has been supplied in a safe condition. This is a Safety Class I instrument (provided with terminal for protective earthing). Before applying power, verify that the correct safety precautions are taken (see the following warnings). In addition, note the external markings on the instrument that are described under "Safety Symbols."

WARNING

- Before turning on the instrument, you must connect the protective earth terminal of the instrument to the protective conductor of the (mains) power cord. The mains plug shall only be inserted in a socket outlet provided with a protective earth contact. You must not negate the protective action by using an extension cord (power cable) without a protective conductor (grounding). Grounding one conductor of a two-conductor outlet is not sufficient protection.

- Only fuses with the required rated current, voltage, and specified type (normal blow, time delay, etc.) should be used. Do not use repaired fuses or short-circuited fuseholders. To do so could cause a shock of fire hazard.

- Service instructions are for trained service personnel. To avoid dangerous electric shock, do not perform any service unless qualified to do so. Do not attempt internal service or adjustment unless another person, capable of rendering first aid and resuscitation, is present.

- If you energize this instrument by an auto transformer (for voltage reduction), make sure the common terminal is connected to the earth terminal of the power source.

- Whenever it is likely that the ground protection is impaired, you must make the instrument inoperative and secure it against any unintended operation. The protection is likely to be impaired if, for example, the instrument shows visible damage.

- Do not operate the instrument in the presence of flammable gasses or fumes. Operation of any electrical instrument in such an environment constitutes a definite safety hazard.

- Do not install substitute parts or perform any unauthorized modification to the instrument.

- Capacitors inside the instrument may retain a charge even if the instrument is disconnected from its source of supply.

- Use caution when exposing or handling the CRT. Handling or replacing the CRT shall be done only by qualified maintenance personnel.

Safety Symbols



Instruction manual symbol: the product is marked with this symbol when it is necessary for you to refer to the instruction manual in order to protect against damage to the product.



Hazardous voltage symbol.



Earth terminal symbol: sometimes used in manual to indicate a circuit common connected to grounded chassis.

WARNING

The Warning symbol calls attention to a procedure, practice, or the like, which, if not correctly performed or adhered to, could result in personal injury. Do not proceed beyond a Warning symbol until the indicated conditions are fully understood and met.

CAUTION

The Caution symbol calls attention to an operating procedure, practice, or the like, which, if not correctly performed or adhered to, could result in damage to or destruction of part or all of the product. Do not proceed beyond a Caution symbol until the indicated conditions are fully understood or met.

Hewlett-Packard
P.O. Box 2197
1900 Garden of the Gods Road
Colorado Springs, CO 80901

About this edition

This is the first edition of the
*HP 54710A and 54720A
Oscilloscope Mainframes
Service Guide*. Edition dates are
as follows:

Preliminary edition, July, 1992
First edition, November, 1992

Publication number 54720-90908

Printed in USA.

New editions are complete
revisions of the manual. Update
packages, which are issued
between editions, contain
additional and replacement
pages to be merged into the
manual by you. The dates on the
title page change only when a
new edition is published.

A software or firmware code
may be printed before the date.
This code indicates the version
level of the software or firmware
of this product at the time the
manual or update was issued.
Many product updates and fixes
do not require manual changes;
and, conversely, manual
corrections may be done without
accompanying product changes.
Therefore, do not expect a
one-to-one correspondence
between product updates and
manual updates.

The following list of pages gives
the date of the current edition
and of any changed pages to that
edition. Within the manual, any
page changed since the last
edition is indicated by printing
the date the changes were made
on the bottom of the page. If an
update is incorporated when a
new edition of the manual is
printed, the change dates are
removed from the bottom of the
pages and the new edition date
is listed on the title page.

November 1992: All pages
original edition