

Errata

Title & Document Type: 5245L Electronic Counter Operating and Service Manual

Manual Part Number: 05245-9044

Revision Date: November 1973

About this Manual

We've added this manual to the Agilent website in an effort to help you support your product. This manual provides the best information we could find. It may be incomplete or contain dated information, and the scan quality may not be ideal. If we find a better copy in the future, we will add it to the Agilent website.

HP References in this Manual

This manual may contain references to HP or Hewlett-Packard. Please note that Hewlett-Packard's former test and measurement, life sciences, and chemical analysis businesses are now part of Agilent Technologies. The HP XXXX referred to in this document is now the Agilent XXXX. For example, model number HP8648A is now model number Agilent 8648A. We have made no changes to this manual copy.

Support for Your Product

Agilent no longer sells or supports this product. You will find any other available product information on the Agilent Test & Measurement website:

www.agilent.com

Search for the model number of this product, and the resulting product page will guide you to any available information. Our service centers may be able to perform calibration if no repair parts are needed, but no other support from Agilent is available.



HP 5245L

OPERATING AND SERVICE MANUAL

ELECTRONIC COUNTER 5245L

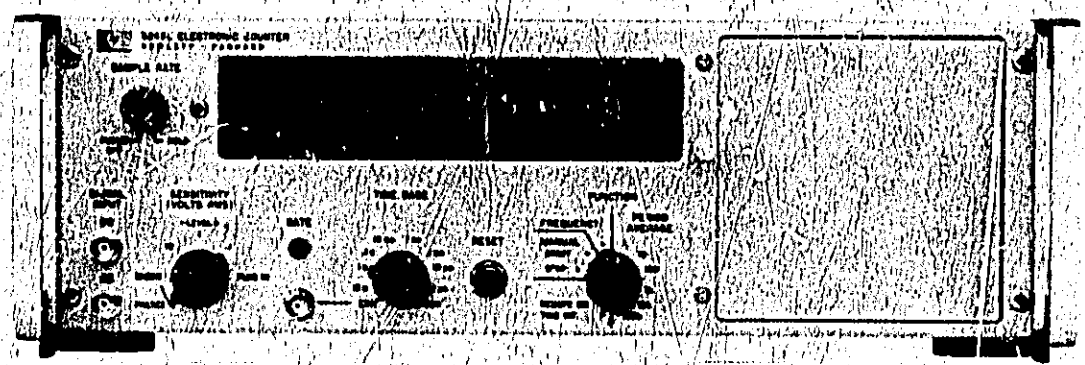

HEWLETT  PACKARD

HP 5245L

CERTIFICATION

The Hewlett-Packard Company certifies that this instrument was thoroughly tested and inspected and found to meet its published specifications when it was shipped from the factory. The Hewlett-Packard Company further certifies that its calibration measurements are traceable to the U.S. National Bureau of Standards to the extent allowed by the Bureau's calibration facilities, or to the calibration facilities of other International Standards Organization members.

WARRANTY AND ASSISTANCE

This Hewlett-Packard product is warranted against defects in materials and workmanship. This warranty applies for one year from the date of delivery. Hewlett-Packard will repair or replace products which prove to be defective during the warranty period provided they are returned to Hewlett-Packard. No other warranty is expressed or implied. We are not liable for consequential damages.

Service contracts or customer assistance agreements are available for Hewlett-Packard products that require maintenance and repair on-site.

For any assistance, contact your nearest Hewlett-Packard Sales and Service Office. Addresses are provided at the back of this manual.

ELECTRONIC COUNTER

5245L

SERIAL PREFIX: 1124A

This manual applies directly to HP Model 5245L Electronic Counters having serial prefix number 1124A.

SERIAL PREFIXES NOT LISTED

For serial prefixes above 1124A, a "Manual Changes" sheet is included with this manual. For serial prefixes below 1124A, refer to Section V, Manual Changes.

OPTIONS

This manual with changes described in Section V also applies to Options 002 and 003.

Copyright HEWLETT-PACKARD COMPANY 1966
5301 STEVENS CREEK BLVD., SANTA CLARA, CALIF. 95050

Printed: NOV 1973

MANUAL PART NO. 05245-9044
MICROFICHE PART NO. 05245-9047

PRINTED IN U.S.A.

HEWLETT  PACKARD

MANUAL CONTENT

This is a Service Manual only. Operating instructions are outlined in a separate Operating Manual. This Service Manual is supplied to help you make best use of your Model 5245L Electronic Counter. Seven sections of information are included as follows:

Section I is an introduction to the counter. This includes a table of technical specifications.

Section II discusses detailed theory for the circuits used.

Section III outlines a performance check procedure to verify operation.

Section IV lists parts for the counter.

Section V covers available options and manual changes required to backdate this manual.

Section VI contains adjustment and troubleshooting procedures which include a self check.

Section VII provides the circuit diagrams for the counter. These include block diagrams, schematic diagrams, and some waveforms and voltages.

HOW TO ORDER

To order an Operating or Service Manual for your Electronic Counter, contact the nearest Hewlett-Packard Sales and Service Office. Lists are provided at the back of this manual. Give complete 8- or 9-digit serial number and name of instrument. Comments and suggestions concerning this manual are welcome at any Sales and Service Office.

TABLE OF CONTENTS

Section	Page
I GENERAL INFORMATION	1-1
1-1. Introduction	1-1
1-6. Instrument Identification	1-1
1-9. Installation and Operation	1-1
II PRINCIPLES OF OPERATION	2-1
2-1. Introduction	2-1
2-3. The Diode	2-1
2-11. The Transistor	2-2
2-25. Basic Operation of Decimal Counter or Decade Divider	2-4
2-36. Basic Counter Functions	2-9
2-44. Time Sequence	2-10
2-49. Overall Counter Operation	2-11
2-51. Input Switch Assembly A1	2-11
2-54. Time-Base Switch Assembly A2	2-13
2-56. Function Switch Assembly A3	2-13
2-58. Mode Switch Assembly A4	2-13
2-60. Output Switch Assembly A5	2-14
2-62. Power Supply: Rectifier Assembly A6, Regulator Assembly A7	2-14
2-70. Decimal Point Assembly A8	2-15
2-73. Measurement Units Assembly A9	2-15
2-76. 600 kHz Decimal Counter Assembly A10-A15	2-15
2-78. 5 MHz Decimal Counter Assembly A16	2-15
2-80. 50 MHz Decimal Counter Assembly A17	2-15
2-84. 50 MHz Readout Assembly A18	2-18
2-88. Input Amplifier Assembly A19, A20	2-18
2-91. Function Control Assembly A21	2-19
2-95. Gate Control Assembly A22	2-20
2-99. Sampling Control Assembly A23	2-21
2-105. Oscillator and Oven A24, A25, A26	2-22
2-111. Multiplier Assembly A27	2-22
2-113. 5 MHz Decade Divider Assembly A28	2-22
2-115. Low-Frequency Decade Divider Assembly A29-A34	2-22
2-117. Time-Base Control Assembly A35	2-23
III PERFORMANCE CHECK	3-1
IV REPLACEABLE PARTS	4-1
4-1. Introduction	4-1
4-4. Ordering Information	4-1
V OPTIONS AND MANUAL CHANGES	5-1
5-1. Options	5-1
5-3. Option 002 +1248 BCD Code	5-1
5-5. Option 003 -1248 BCD Code	5-1
5-9. Specials	5-1
5-13. Manual Changes	5-1
5-14. Current Instruments	5-1
5-16. Oldex Instruments	5-1
VI ADJUSTMENT AND TROUBLESHOOTING	6-1
6-1. Introduction	6-1
6-3. Maintenance	6-1
6-7. Test Equipment	6-1
6-9. Assembly Connection Identification	6-1
6-11. Instrument Cover Removal	6-2
6-13. Assembly Location	6-2
6-15. Printed Circuit Component Replacement	6-2
6-17. Adjustments	6-2
6-18. Regulator Assembly A7	6-2

TABLE OF CONTENTS

Section	Page
VI ADJUSTMENT AND TROUBLESHOOTING Cont'd.	
6-19. Input Amplifier A19	6-3
6-21. Ratio Input Amplifier A20	6-3
6-23. Function Control A21	6-3
6-24. Oscillator Frequency Check	6-3
6-25. Time-Base Oscillator Frequency	6-3
6-28. Oscillator Calibration	6-4
6-29. Troubleshooting	6-4
6-30. Troubleshooting Aids	6-4
6-37. Troubleshooting Procedure	6-4
VII CIRCUIT DIAGRAMS	7-1
7-1. Introduction	7-1

LIST OF TABLES

Table	Page
1-1. Specifications	1-2
2-1. Four-Line Code Truth Table	2-7
2-2. Power Supplies	2-14
2-3. Basic Operation Summary of Four-Binary Counter	2-15
2-4. Normal Time Base Control	2-23
2-5. Multiplied Period Control	2-23
3-1. Recommended Test Equipment	3-1
3-2. In-Cabinet Performance Check	3-2
4-1. Reference Designation Index	4-2
4-2. Replaceable Parts	4-36
4-3. Manufacturer's Code List	4-46
5-1. Option 002 Replacement Assemblies	5-1
5-2. Option 003 Replacement Assemblies	5-1
5-3. 1248 Code Truth Table	5-1
5-4. Reference Designation Index (A18, Option 002).	5-2
5-5. Reference Designation Index (A18, Option 003).	5-5
5-6. Reference Designation Index (A15, A16, Opt. 002 & 003)	5-8
5-7. Reference Designation Index (A10-A14, Opt. 002 & 003)	5-11
5-8. Reference Designation Index (J35-5245L)	5-15
5-9. Reference Designation Index (J36-5245L)	5-17
5-10. Manual Changes	5-19
5-11. Reference Designation Index (A10-A14 DCA +1224)	5-21
5-12. Reference Designation Index (A15, A16 Opt. 002 & 003)	5-24
5-13. Modular Cabinet Parts	5-26
6-1. Fuse Replacement	6-1
6-2. Recommended Test Equipment	6-1
6-3. Assembly Designations	6-2
6-4. Power Supply Voltages	6-3
6-5. Period Average Checks with External Signal	6-7
6-6. Assembly Check	6-7
6-7. Troubleshooting "Tree"	6-12
6-8. Self Check	6-27

LIST OF ILLUSTRATIONS

1-1.	Model 5245L and Accessories	1-0
2-1.	Basic Diode Circuits	2-1
2-2.	Transistor Operation	2-2
2-3.	Basic Transistor Circuits	2-3
2-4.	Basic Operation of Decimal Counter or Decade Divider	2-4
2-5.	Basic Four Binary Counter	2-5
2-6.	Counting Sequence of Four Binary Counter	2-6
2-7.	Typical Reset Operation in Four Binary Decimal Counter	2-7
2-8.	Lamp Control	2-8
2-9.	Basic Counter Functions	2-10
2-10.	Standard Frequency Outputs	2-10
2-11.	Scaler Operation	2-11
2-12.	Time Sequence	2-11
2-13.	Model 5245L Logic Block Diagram	2-12
2-14.	Decimal Counter and Decade Divider Block Diagram	2-16
2-15.	50 MHz Counting Sequence	2-17
2-16.	50 MHz Readout and 50 MHz Counter Block Diagram	2-18
2-17.	Function Control Block Diagram	2-19
2-18.	Gate Control Block Diagram	2-20
2-19.	Sampling Control Block Diagram	2-21
4-1.	Modular Cabinet Parts	4-35
4-2.	Mechanical Parts Locations	4-45
5-1.	DP and MU with +1248 BCD Output (J35-5245L Special)	5-14
5-2.	DP and MU with -1248 BCD Output (J36-5245L Special)	5-16
5-3.	Remote Control Wiring and connectors (Special)	5-18
6-1.	Test Setups for Checking Oscillator Frequency	6-4
6-2.	Self Check	6-5
6-3.	Operating Controls (Front Panel)	6-8
6-4.	Operating Controls (Rear Panel)	6-9
6-5.	Top Internal View	6-10
6-6.	Bottom Internal View	6-11
6-7.	Frequency Measurements	6-17
6-8.	Single Period Measurements	6-19
6-9.	Multiple Period Average Measurements	6-21
6-10.	Ratio and Multiple Ratio Measurements	6-23
6-11.	Scaling	6-25
7-1.	General Notes for Schematic Diagrams	7-2
7-2.	Block Diagram	7-3
7-3.	A1 Input Switch	7-5
7-4.	A2 Time Base Switch	7-7
7-5.	A3 Function Switch	7-9
7-6.	A4, A5 Mode Switch, Output Switch	7-11
7-7.	A6, A7 Rectifier, Regulator	7-13
7-8.	A8, A9 Decimal Point/ Measurement Units	7-15
7-9.	A10-A15 Decimal Counter (5212L-4A)	7-17
7-10.	A10-A14 Decimal Counter (05212-6002, 6003) Opt. 002&003	7-19
7-11.	A16 5 MHz Decimal Counter (05232-6010)	7-21
7-12.	A15, A16 Decimal Counter (05232-6014, 6012) Opt. 002&003	7-23
7-13.	A17 Decimal Counter	7-25
7-14.	A18 Readout (5245L-4B)	7-27
7-15.	A18 Readout (05245-6001) Option 002	7-29
7-16.	A18 Readout (05245-6003) Option 003	7-31
7-17.	A19, A20 Input Amplifier	7-33
7-18.	A21 Function Control	7-35
7-19.	A22 Gate Control	7-37
7-20.	A23 Sampling Control	7-39
7-21.	A24, A25, A26 Crystal Oven, Oven Control, Oscillator	7-41
7-22.	A27 Multiplier	7-43
7-23.	A28 Decade Divider	7-45
7-24.	A29-A34 Decade Divider	7-47
7-25.	A35 Time Base Control	7-49
7-26.	J6, J11 Connectors	7-51
7-27.	A10-A14 Decimal Counters (5212L-4A)	7-53
7-28.	A15, A16 Decimal Counters (05232-6002, 6003) Opt. 002&003	7-55

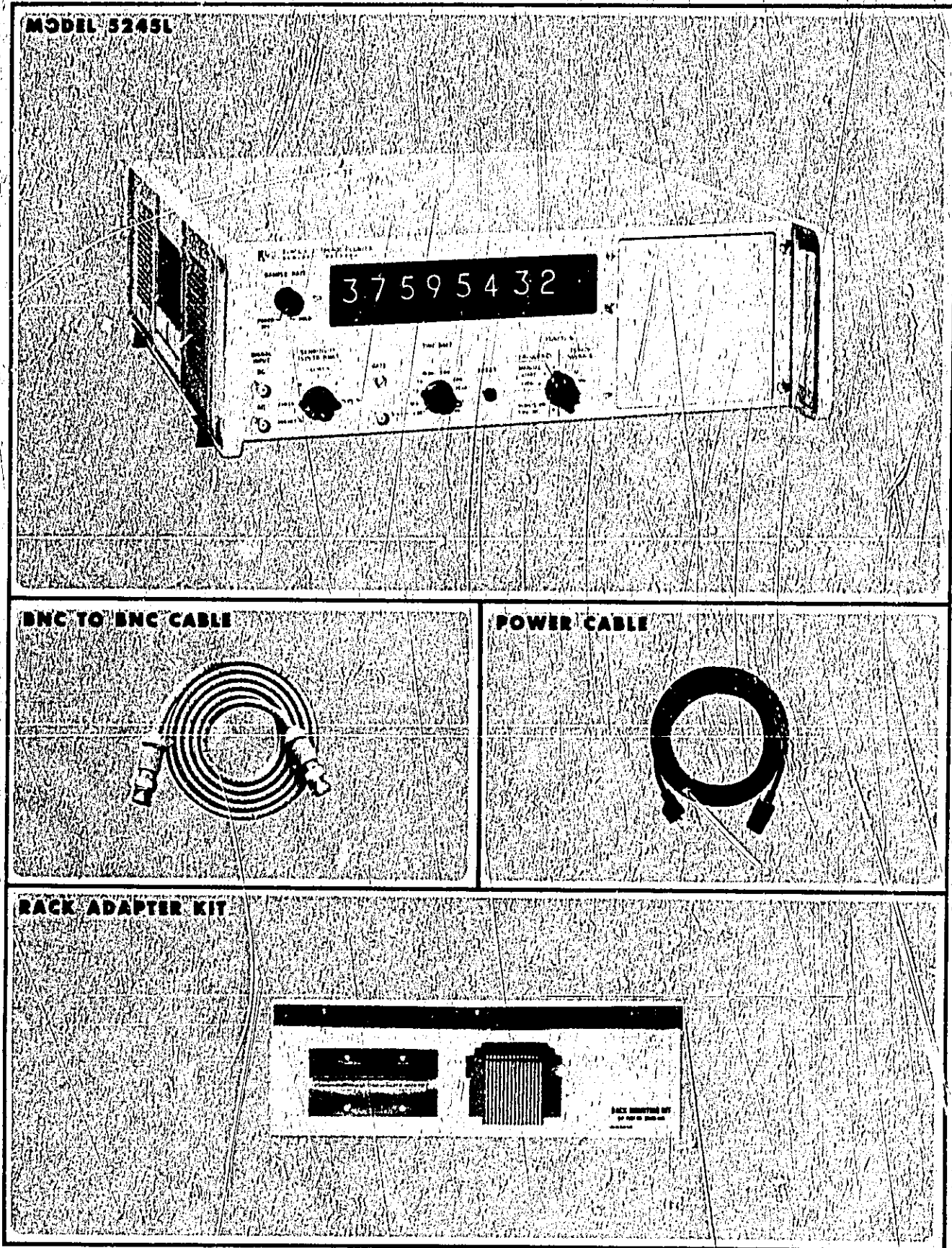

Figure 1-1. Model 5245L and Accessories

SECTION I GENERAL INFORMATION

1-1. INTRODUCTION.

1-2. DESCRIPTION.

1-3. The HP Model 5245L Electronic Counter is a high-frequency general-purpose electronic counter. The Model 5245L measures frequencies from 0 to 50 MHz, periods from 1 μ sec to 10 seconds, period averages from 10 to 100,000 periods, the ratio of two frequencies, and the multiplied ratio of two frequencies.

1-4. The HP Model 5245L provides these additional features:

- a. Decade scaling to 10^9 for any frequency to 50 MHz.
- b. Standard output frequencies from 0.1 Hz to 10 MHz in decade steps.
- c. Four-line, binary-coded-decimal output to drive digital recorder (HP Model 562A), digital to analog converter (HP Model 580A/581A), remote readout, or data processing equipment (1-2-2-4 code; 1-2-4-8 code available; see Section V).
- d. Display storage which permits reading to be displayed while new count is made.
- e. Remote control by external contact closure available (see Section V).
- f. Eight-digit display using rectangular (narrow) digital display tubes; decimal point position and measurement units displayed automatically.
- g. Operation with plug-in units which extend the basic range and performance of the counter.
- h. All electrical and mechanical specifications for the Model 5245L are given in Table 1-2.

1-5. The Model 5245L features solid state design, low power consumption, small size (5-1/4 inch panel height), light weight (32 lb), easy conversion for rack mounting, and modular plug-in circuit boards for simplified maintenance.

1-6. INSTRUMENT IDENTIFICATION.

1-7. Hewlett-Packard uses a two-section serial number mounted on the rear panel. Earlier instruments use an 8-digit serial number (000-00000). The first digits are a serial prefix number; the last five digits refer to the specific instrument. Later instruments use a 9-digit serial number (0000A00000). The first four digits are the serial prefix and the last five digits refer to the specific instrument.

1-8. If the serial prefix of your instrument differs from that listed on the title page of this manual, there are differences between this manual and your instrument. Lower serial prefixes are documented in Section VII, and higher serial prefixes are covered with manual change sheets included with the manual. If the change is missing, contact the nearest Hewlett-Packard Sales and Service Office listed on the inside rear cover of this manual.

1-9. INSTALLATION AND OPERATION.

1-10. Installation and operation procedures are covered in Sections II and III of the Model 5245L Operating Manual. An explanation of the Counter's controls and connectors and a self-check procedure is included in Section VI of this manual (see Figures 6-1, 6-2, and 6-3).

1-11. EQUIPMENT SUPPLIED.

1-12. Equipment supplied with Model 5245L is listed in Table 1-1.

Table 1-1. Equipment Supplied

Description	HP Part No.
Detachable power cord 7-1/2 feet (231 cm) long	8120-1378
Cable 4-feet (122 cm) long male BNC connectors	10503A
Rack mount kit	5243A-44A
Kit includes:	
1 Right-hand bracket	5020-0709
1 Left-hand bracket	5020-0708
1 Strip filler (gray)	05243-4001
1 Label	05243-9004
1 Circuit-board extender	05243-6022

Table 1-2. Specifications

FREQUENCY MEASUREMENTS

Range: 0 to 50 MHz (dc input), 25 Hz to 50 MHz (ac input, maximum sensitivity).

Gate Time: 1 μ sec to 10 seconds in decade steps.

Accuracy: ± 1 count \pm time base accuracy

Readout: kHz or MHz with positioned decimal point; units annunciator in line with digital display.

Self Check: counts 10 MHz for the gate time chosen by the time base selector switch.

SCALING

Frequency Range: 0 to 50 MHz.

Factor: by decades up to 10^9 , switch selected on rear panel.

Input: front panel, Signal Input.

Output: in place of time base output frequencies.

PERIOD AVERAGE MEASUREMENTS

Range: Single Period 0 to 1 MHz
Multiple Period 0 to 300 kHz

Periods Averaged: 1 period to 10^5 periods in decade steps.

Accuracy: ± 1 count \pm time base accuracy \pm trigger error.*

Frequency Counted:

1 and 10 period 1 Hz to 10 MHz in decade steps
100 period 10 Hz to 10 MHz
1,000 period 100 Hz to 10 MHz
10,000 period 1 kHz to 10 MHz
100,000 period 10 kHz to 10 MHz

Readout: sec, ms, μ s, with positioned decimal point; units annunciator in line with digital display.

Self Check: Gate time is 10 μ s to 1 sec (periods averaged of 100 kHz); counts 100 kHz from the time base.

RATIO MEASUREMENTS

Displays: (f_1/f_2) times period multiplier.

Range: f_1 - 0 to 50 MHz. f_2 - 0 to 1 MHz in single period, 0 to 300 kHz in multiple period; periods averaged 1 to 10^5 in decade steps.

Sensitivity: 0.1 v rms, each input.

*Trigger error is less than $\pm 0.3\%$ of one period \pm periods averaged for signals with 40db or better signal-to-noise ratio.

** After 72 hours of continuous operation.

Accuracy: ± 1 count of $f_1 \pm$ trigger error* of f_2 . f_1 is frequency applied to the decimal counter's (enters Time Base Ext. jack on front panel); f_2 is frequency applied to decade dividers (enters Signal Input jack).

Readout: Dimensionless; positioned decimal point for number of periods averaged.

Self Check: Period Average Self Check applies.

TIME BASE

Frequency (internal): 1 MHz.

Stability: Aging Rate - less than 3 parts in 10^9 per 24 hours. ** As a Function of Temperature: less than ± 2 parts in $10^{10}/^\circ\text{C}$ -20°C to $+55^\circ\text{C}$. As a Function of Line Voltage: less than ± 5 parts in 10^{10} for $\pm 10\%$ change in line voltage from 115v or 230 v rms.

Short Term - less than 2 parts in 10^{10} rms with measurement averaging time of one second under constant environmental and line voltage conditions.

Adjustment: Fine frequency adjustment (range approximately 4 parts in 10^8) and medium frequency adjustment (range approximately 1 part in 10^6) are available from the front panel through the plug-in hole. Coarse frequency adjustment (range approximately 1 part in 10^5) is available at the rear of the instrument.

Output Frequencies:

Rear Panel: 0.1 Hz to 10 MHz in decade steps; switch selected on rear panel; all frequencies available in manual function without interruption at reset except 100 Hz, 10 Hz, 1 Hz, and 0.1 Hz which are interrupted by manual reset; 10 kHz to 10 MHz available continuously in all functions; 1 kHz available continuously for all functions except 100K period average; stability same as internal time base; 5 volts p-p rectangular wave with 1000 ohm source impedance at 1 MHz and lower; 1 volt rms sine wave with 1000 ohm source impedance only at 10/MHz.

Front Panel: 0.1 Hz to 1 MHz in decade steps; selected by Time Base switch; availability as defined under Output Frequencies above; stability same as internal time base; 1 v p-to-p.

External Standard Frequency: 1 MHz, 1 volt, rms, into 1000 ohms required at rear panel BNC connector.

GENERAL

Registration: 8 digits in-line with rectangular Nixie[®] tubes and display storage; 99,999,999 maximum display; total width of 8 digit display including illuminated units annunciator and auto-positioned decimal point indication does not exceed 7 inches.

® Burroughs Corporation

Table 1-2. Specifications (cont'd)

GENERAL (continued)

Display Storage: Holds reading between samples; switch overrides storage.

Sample Rate: Time following a gate closing during which the gate may not be reopened is continuously variable from less than 0.2 sec. to 5 seconds in frequency mode, independent of gate time; display can be held indefinitely.

Operating Temperature Range: -20°C to +65°C.

Connectors: BNC type except for BCD output and power cable.

Signal Input:

Maximum Sensitivity - 100 mv rms.

Attenuation - Step attenuator provides ranges of 0.1, 1, and 10 volts rms.

Trigger Level Adjustment - Front panel control has ± 0.3 volt trigger level range on 0.1 volt position, ± 3 volt range on 1 volt position, and ± 30 volt range on 10 volt position. A preset position automatically centers trigger level at zero volts for all positions of attenuator.

Impedance - 1 megohm in parallel with approximately 25 pf, all ranges.

Coupling - ac or dc, separate BNC connectors. AC coupling has 600 vdc, 0.022 μ f capacitor (-3 dB at approximately 7 Hz).

Overload Protection - Diode clamps protect input circuit for up to 120 volts rms on 0.1 volt range, 250 volts rms on 1 volt range, and 500 volts rms on 10 volt range. Input resistance under overload conditions (approximately ten times minimum sensitivity) will be greater than 100K ohms on 0.1 volt range and approximately 1 megohm on other ranges.

Time Base External Input (Front Panel):

Maximum Sensitivity - 100 mv, rms.

Impedance - 10K ohms, approximately 20 pf. DC coupled.

Overload - Diode clamps protect input circuit for up to 120 volts, rms.

Output:

4-line BCD 1-2-2-4, "1" state positive. 4-line BCD 1-2-4-8, available as Option 002 ("1" state positive) and Option 003 ("1" state negative).

"0" State Level: -8v.

"1" State Level: +13v.

Impedance - 100K, each line.

Reference Levels:

Approximately +9v, 350 ohm source.

Approximately -1v, 1000 ohm source.

Output is suitable for systems use or output devices such as Model 580A and 581A Digital-to-Analog Converters and includes the decimal point and measurement unit for Model 562A Digital Recorder.

Print Command - +13v to 0v step, dc-coupled.

Cable Connector - Amphenol 50-pin 57-30500, 1 required.

Hold-off Requirement - +15v min., +25v max. from chassis ground (1000 ohm source).

Weight - Net 32 lbs (14.4 kg) with blank plug-in; shipping, 40 lbs (18.2 kg).

Power Supply - 115 or 230 volts $\pm 10\%$, 50 to 60 Hz; 95 watts (50 to 1000 Hz operation, special order).

Accessories Furnished - Model 10593A Cable, 4 feet long, male BNC connectors. Detachable power cord, 7-1/2 ft (2040 mm) long, NEMA plug. Circuit Board Extender.

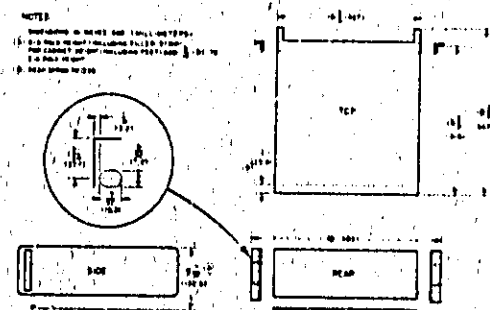
Dimensions:**OPTIONAL AND SPECIAL FEATURES**

Option 002: 4-line BCD 1-2-4-8, "1" state positive in lieu of 1-2-2-4 (identical in other respects to above Output data) for digits only.

Option 003: 4-line BCD 1-2-4-8, "1" state negative in lieu of 1-2-2-4 (identical in other respects to above Output data) for digits only.

Remote Operation: All functions which may be programmed from the front panel controls (in normal use) may be programmed from a remote location except for the "Sample Rate" (as defined above) and the sensitivity control setting. The instrument provides (through rear panel connectors) all voltages necessary for remote control. The programming voltages for Time Base and Function control are low level, -15 volts dc at 5 ma per gate. Control may also be achieved by using an external -15 volt dc supply. The position of the decimal point and measurements unit may be correctly illuminated from the remote location, using +170 volts dc from the internal or an external supply.

Cable Connector: Amphenol 36-pin 57-30360, 2 required.

THEORY

SECTION II PRINCIPLES OF OPERATION

2-1. INTRODUCTION.

2-2. This section describes how the Model 5245L operates. Basic circuits used in the counter are described first (Paragraphs 2-3 through 2-24). Operation of decimal counters and decade dividers is thoroughly discussed in Paragraphs 2-25 through 2-35. A discussion of basic counter functions is given next (Paragraphs 2-36 through 2-43). Pulse timing circuits and overall operation of the entire counter are discussed in Paragraphs 2-44 through 2-50. At the end of the section each assembly is described in order of its assembly designation (A) (Paragraphs 2-51 through 2-122.)

2-3. THE DIODE.

2-4. GENERAL. Semiconductor diodes are used in signal-handling circuits and in power supply rectifier and regulator circuits.

2-5. THE "OR" GATE. Two or more diodes are sometimes used as an OR gate. The OR gate is a multiple-input circuit which requires only one input to produce an output. Figure 2-1A shows some OR gate configuration.

2-6. THE "AND" GATE. The AND gate or coincidence circuit is a multiple-input circuit which requires the presence of all input signals to produce an output. Figure 2-1B shows an AND gate configuration in which an input signal is passed only when a properly polarized control voltage is applied.

2-7. THE "INHIBIT" GATE. The signal normally passes through an INHIBIT gate; adding a second signal closes the gate and prevents the signal from going through. One of the most common forms of the INHIBIT gate is the series gate shown in Figure 2-1C. If the diode is biased off, the gate is closed, and pulses do not reach the decade divider or decimal counter; when the diode is biased on, the pulses go through the gate and reach the decade divider or decimal counter.

2-8. LIMITER OR CLIPPER. The limiter or clipper is a circuit which removes positive or negative peaks of waveforms. It can be used either as a waveform shaping circuit or as a protective device to prevent excessive voltages from reaching a sensitive circuit. Figure 2-1D shows a limiter which prevents the negative peak of a pulse from going more negative than about -0.6 volt. Note that for a conducting silicon diode the cathode voltage is about 0.6 to 0.8 volt more negative than the anode.

2-9. CLAMPER OR DC RESTORER. The clamper or DC restorer is a circuit which establishes either the positive or negative peak of a waveform at a particular DC reference voltage; in other words, it provides a definite baseline voltage for the waveform. Figure 2-1E shows a clamper which provides a baseline of about +20 volts for a negative pulse.

2-10. REGULATOR. A diode regulator uses either the constant reverse-bias breakdown voltage characteristic of a breakdown diode or the constant forward-bias voltage drop characteristic of a silicon diode. Power supply reference voltages are generally provided by breakdown diodes which maintain a constant voltage when supplied with a reverse-bias voltage greater than their specified breakdown voltage. Regulated voltages can also be provided by a forward-biased silicon diode which maintains a constant 0.6 to 0.8 volt drop. Figure 2-1F shows connections for both types of diodes.

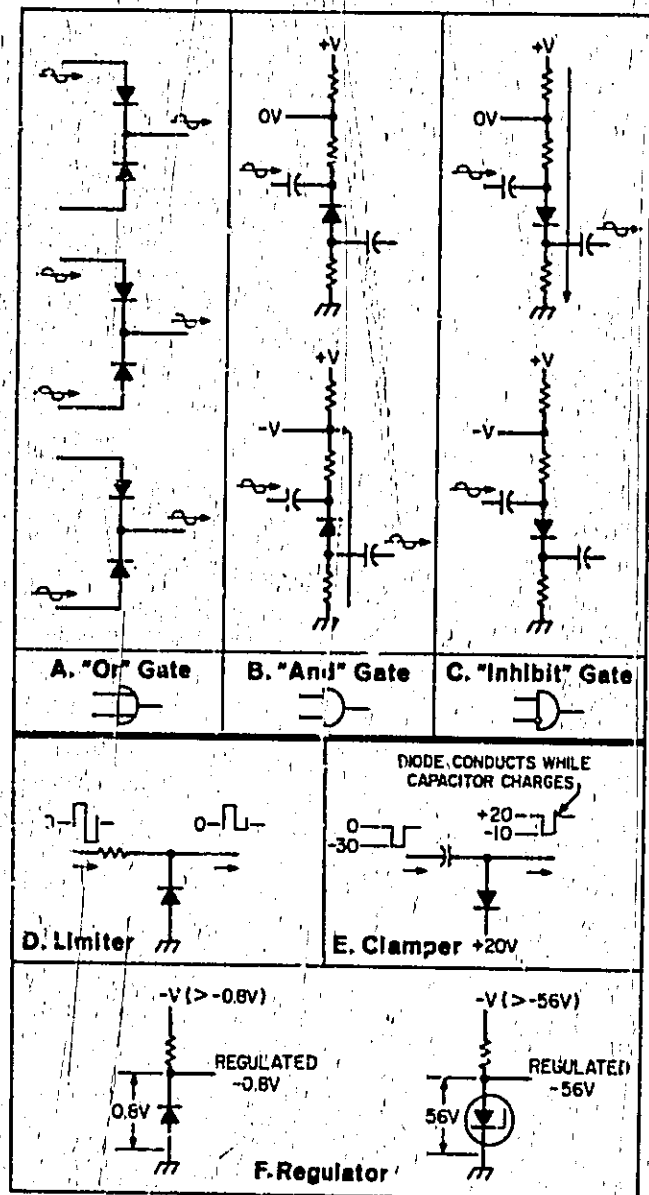

Figure 2-1. Basic Diode Circuits

2-11. THE TRANSISTOR.

2-12. GENERAL. Transistors are used throughout the counter in circuit configurations such as the amplifier, the flip-flop or binary, the trigger circuit, and the one-shot multivibrator. In the following paragraphs, basic transistor operation and a few basic transistor circuits are discussed. These paragraphs discuss the easily observed changes in currents and voltages in transistor circuits which help technicians locate circuit faults but do not attempt to describe how transistors work internally.

2-13. BIASING AND CONDUCTION. In a transistor a small base-to-emitter current controls a large collector-to-emitter current. A comparison of NPN transistor and PNP transistor operation is shown in Figure 2-2B; indicated current represents conventional flow of positive charges external to the transistor and is not intended to indicate flow of carriers inside the transistor structure. Notice that the effect of emitter-base-collector voltages is totally reversed between NPN and PNP transistors; circuits which are arranged for an NPN transistor usually function normally for a PNP transistor if supply voltages are reversed.

2-14. AMPLIFIERS. Three basic amplifier types are available (Figure 2-2A). These amplifiers may be used alone or in combination to form complex circuits.

2-15. FLIP-FLOP. The flip-flop is a bi-stable two-transistor circuit in which one transistor conducts, holding the other cut off. Each input pulse causes a reversal of states; that is, the cut off transistor is turned on and the conducting transistor is cut off. In the flip-flop shown in Figure 2-3A, Q1 is initially conducting heavily; its collector voltage is only slightly negative; a near-zero voltage is supplied to the base of Q2 (junction of R27-28 divider). The voltage drop across R24 produces a sufficiently negative voltage at the emitter of Q2 to hold Q2 cut off. With Q2 cut off the R18-R19-R20 divider delivers a negative voltage to the base of Q1 to keep it conducting.

2-16. At time t_1 the positive input pulse cuts off Q1; the Q1 collector voltage goes negative and drives Q2 into conduction (R27-R28 divider to Q2 base); the Q2 collector voltage and the Q1 base voltage (R19-R20 divider) then become considerably less negative, permitting Q1 to remain cut off. The R26-R27-R28 divider delivers a sufficiently negative voltage to the base of Q2 to drive it into conduction. In a similar manner the positive input pulse at time t_2 cuts off Q2 and starts a sequence of events which ends with Q1 conducting and Q2 cut off. Note that a positive input pulse has no effect on Q1 if it is already cut off. A negative reset pulse applied to the base of Q1 returns the flip-flop to its initial condition (Q1 conducting, Q2 cutoff). The diode CR9 removes the negative pulse from the differentiated square wave input. Without this diode, the negative pulse would drive Q1 which is cut off and the stage would switch from one state

2-2

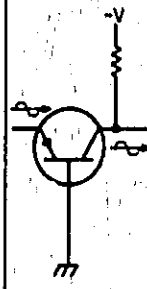
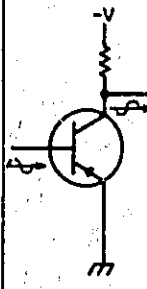
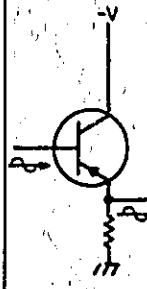
A. Amplifier Characteristics			
			
CHARACTERISTIC	COMMON BASE	COMMON EMITTER	COMMON COLLECTOR
Input Impedance	30 Ω -50 Ω	500 Ω -1500 Ω	20K Ω -500K Ω
Output Impedance	300K Ω -500K Ω	30K Ω -50K Ω	50 Ω -1000 Ω
Voltage Gain	500-1500	300-1000	<1
Current Gain	<1	25-50	25-50
Power Gain	20dB-30dB	25dB-40dB	10dB-20dB (Emitter Follower)



B. Transistor Biasing		
TYPE	CUTOFF	CONDUCTION
NPN  COLLECTOR BASE EMITTER		 MAIN CURRENT CONTROL CURRENT
PNP  COLLECTOR BASE EMITTER		 MAIN CURRENT CONTROL CURRENT

Figure 2-2. Transistor Operation

to the other but would not divide by two. The AC coupling through C2 and C3 insures fast switching. The DC coupling through R19 and R27 insures bi-stable characteristics.

2-17. BINARY CIRCUIT. In this manual a flip-flop which completes its operating cycle and produces an output pulse after receipt of two similar input pulses is called a binary circuit, since it is a counting device in a binary system. The binary circuit is driven from a single input which is connected either through a pair of resistors or through a pair of gating diodes to each transistor base.

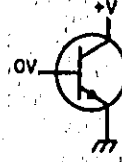
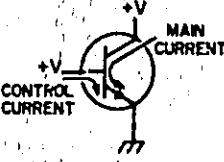
2-18. TRIGGER CIRCUIT. The trigger circuit is a limiter or squaring circuit which produces an output waveform with very fast rise and fall times. The

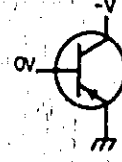
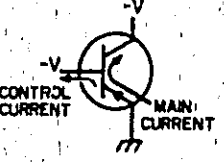
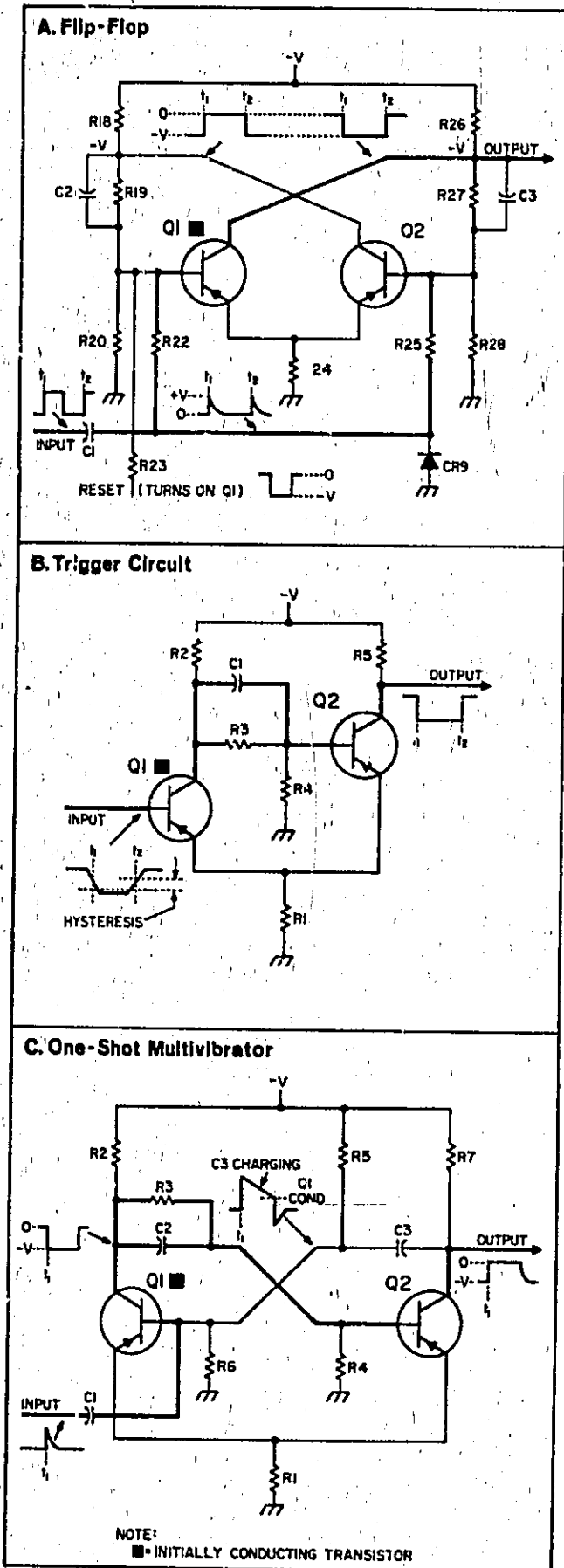

Figure 2-3. Basic Transistor Circuits

trigger circuit is similar to the flip-flop except that the RC network in one half is replaced by the input signal. Capacitor C1 bypasses R3 to couple fast changes in voltage at the Q1 collector to the base of Q2. Either Q1 or Q2 can conduct, depending on the voltage at the input. Note that there is a slight difference in input voltage (called hysteresis) between switching with a negative-going input (time t_1) and switching with a positive-going input (time t_2).

2-19. ONE-SHOT MULTIVIBRATOR. The one-shot multivibrator is a circuit which generates a pulse of some specified duration following the application of a suitable triggering pulse. The circuit is similar to the flip-flop except one DC coupling path has been removed so the circuit is stable only in the state with Q1 conducting.

2-20. In the typical one-shot multivibrator shown in Figure 2-3C the following conditions exist during the initial stable period: the R5-R6 divider delivers a sufficient negative potential to the base of Q1 to hold Q1 in saturation; the Q1 collector and Q1 emitter are therefore slightly negative; the R3-R4 divider delivers the Q2 base an even smaller negative voltage to hold Q2 cut off.

2-21. The positive triggering pulse at time t_1 reduces conduction of Q1; the resulting negative-going voltage at the Q1 collector is applied to the Q2 base through the R3-R4 divider (C2 bypasses R3 to provide coupling for the rapidly changing voltage at the Q1 collector); Q2 begins to conduct; the resulting positive-going change in Q2 collector voltage is coupled through C3 to the Q1 base to further decrease Q1 conduction. The process is regenerative and quickly results in Q1 being cut off and Q2 being saturated.

2-22. Capacitor C3 now charges at a rate mainly determined by the values of R6 and C3 (main charge path: R1-Q2-C3-R5). When the Q1 base voltage becomes sufficiently negative, Q1 begins conduction; the resulting positive-going Q1 collector voltage is coupled to the Q2 base; the Q2 collector voltage goes negative and is coupled through C3 to the Q1 base to further increase Q1 conduction. The process is regenerative and ends with the circuit in its original quiescent state, Q1 saturated and Q2 cut off.

2-23. FIELD EFFECT TRANSISTOR (FET). Field effect transistors have three terminals: source, drain, and gate which correspond in function to emitter, collector, and base of junction transistors. Source and drain leads are attached to the same block (channel) of N or P semiconductor material. A band of oppositely doped material around the channel (between the source and drain leads) is connected to the gate lead.

2-24. In normal FET operation, the gate-source voltage reverse-biases the PN junction, causing an electric field that creates a depletion region in the source-drain channel. In the depletion region the number of available current carriers is reduced as the reverse-biasing voltage increases, making source-

drain current a function of gate-source voltage. With the input (gate-source) circuit reverse-biased, the FET presents a high impedance to its signal sources (as compared with the low impedance of the forward-biased junction transistor base-emitter circuit). Because there is no input current, FET's have less noise than junction transistors. Figure 2-4 shows the schematic symbol and biasing for N channel and P channel field effect transistors.

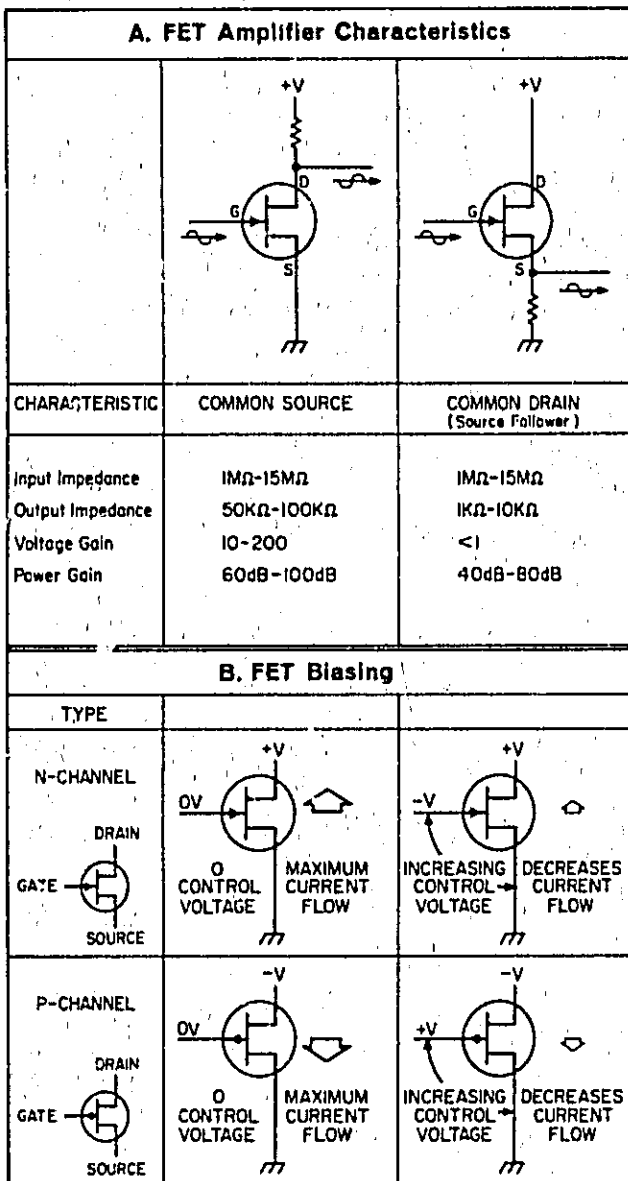

Figure 2-4. Field Effect Transistor Operation

2-25. BASIC OPERATION OF DECIMAL COUNTER OR DECADE DIVIDER

2-26. INTRODUCTION. Operation of the decimal counter circuit and the decade divider circuit is similar. The difference between the two is in function. Decimal counter circuits divide the input signal by 10 and actuate the digital display tubes, whereas the decade divider circuits are used to divide the input

signal or the output of the internal oscillator into the frequencies to be counted or frequencies to provide the various gate times. Throughout the following discussion, circuits are referred to as "counters" though the description applies equally to decade dividers. Paragraphs 2-25 through 2-29 cover general operation of the counters with emphasis on counting logic; Paragraphs 2-30 through 2-32 discuss readout circuits; and Paragraphs 2-73 through 2-86 discuss specific decimal counter assemblies and the readout assembly.

2-27. INPUT AND OUTPUT FROM BINARY. Figures 2-5A and 2-5B show a flip-flop connected for operation as a binary circuit (basic flip-flop operation is discussed in Paragraphs 2-15 and 2-16). Positive input pulses go to the bases of both transistors and cause switching by cutting off the conducting transistor. Negative reset pulses go to the base of one transistor and turn it on. Note the letter "A" near one transistor and "A̅" (read as "A bar" or "not A") near the other. The positive-going transition at the collector of the A transistor (while switching from A conducting to A̅ conducting) provides the input to the next binary circuit.

2-28. CIRCUIT ARRANGEMENT AND COUNT NOTATION. Figure 2-5C is a block diagram of a typical four-binary decimal counter. Notice that the B̅ output is applied to the D, D̅, and C̅ transistors and that the D̅ output is applied only to the C transistor. Each input pulse produces a different combination of conducting and cut-off stages; there are only 10 allowable combinations and each combination represents a decimal digit. Decimal weighting is the decimal value assigned, arbitrarily, to the output of a pair when the plain-letter transistor is conducting.

a. **Decimal Count.** Decimal weighting used in the Model 5245L counter is shown in Figure 2-5C, immediately above each of the four binary stages. The decimal weight each pair represents is present only when the plain-letter side (A, B, D, or C) is conducting; when the barred-letter side (A̅, B̅, D̅, or C̅) is conducting, the decimal weight is zero. The decimal count can be determined by adding the decimal weighting of the four stages. For example, if the A, B̅, D, and C transistors are conducting, where A=1, B̅=0, D=4, C=2, the output is 1 + 0 + 4 + 2 = 7.

b. **Binary-coded Decimals.** In binary-coded decimal notation, the output is either 1 (when the plain-letter transistor is conducting) or 0 (when the barred-letter transistor is conducting). In binary-coded decimal notation, the order of the binaries is given so that binary-coded decimals can be written with the least significant digit to the right. Thus in the system used in the Model 5245L, the binary-coded decimal notation normally is given in the order DCBA. (Counter binaries are shown in the ABDC order on the schematics and in Figure 2-5C to increase clarity in showing signal flow.) For the decimal count of 7 used as an example in Paragraph a, with D = 1, C = 1, B̅ = 0, A = 1, the binary-coded-decimal number would be 1101.

2-29. SEQUENCE. Figure 2-6 shows the counting sequence for a typical decimal counter. Initially each binary is in the "0" (reset) state (decimal count = 0, DCBA = 0000). The following action takes place when a series of input pulses is applied to the counter.

- a. The first pulse switches A to the "1" state (DCBA = 0001 = 0 + 0 + 0 + 1 = 1).
- b. The second pulse switches A to the "0" state; the output from \bar{A} causes B to switch to the "1" state (DCBA = 0010 = 0 + 0 + 2 + 0 = 2).
- c. The third pulse switches A to the "1" state (DCBA = 0011 = 0 + 0 + 2 + 1 = 3).
- d. The fourth pulse switches A to the "0" state; the output from \bar{A} switches B to the "0" state; the output from \bar{B} switches both D and C to the "1" state; the resulting signal from C is applied to \bar{B} and D to return B to the "1" state and D to the "0" state (DCBA = 0110). Although \bar{D} is connected to C, no switching occurs at C as a result of the final switching of D since C has not fully recovered from its recent switching.
- e. The fifth pulse switches A to the "1" state (DCBA = 0111 = 0 + 2 + 2 + 1 = 5).
- f. The sixth pulse switches A to the "0" state; the output from \bar{A} switches B to the "0" state; the output from \bar{B} switches D to the "1" state (DCBA = 1100 = 4 + 2 + 0 + 0 = 6).
- g. The seventh pulse switches A to the "1" state (DCBA = 1101 = 4 + 2 + 0 + 1 = 7).
- h. The eighth pulse switches A to the "0" state; the output from \bar{A} switches B to the "1" state (DCBA = 1110 = 4 + 2 + 2 + 0 = 8).
- i. The ninth pulse switches A to the "1" state (DCBA = 1111 = 4 + 2 + 2 + 1 = 9).
- j. The tenth pulse switches A to the "0" state; the output from \bar{A} switches B to the "0" state; the output from \bar{B} switches D to the "0" state; the output from \bar{D} switches C to the "0" state (DCBA = 0000). When C becomes "0", \bar{C} produces an output pulse which serves as a carry pulse to a following decimal counter assembly. The counter is now returned to its original count.

2-30. RESETTING TO ZERO. The reset pulse, (negative) is applied to the base of the "0" state transistors (\bar{A} , \bar{B} , \bar{D} , \bar{C}) in each binary circuit. If the "0" state transistor is conducting, the pulse has no effect; if the "0" state transistor is not conducting, the pulse turns it on. Thus the reset pulse ensures that all four "0" state transistors are conducting. Figure 2-7 indicates a decimal counter assembly receiving a reset pulse. The counter is in the decimal "4" state (DCBA 0110) and the reset pulse returns the decimal counter assembly to the decimal "0" state (DCBA 0000). Decade dividers can be reset as required to any desired state, since reset inputs are available at each transistor. Note the difference between a regular input pulse and a reset pulse: a regular input signal is positive, and causes a conducting transistor to cut off; a reset pulse is negative, and causes a cut-off transistor to conduct.

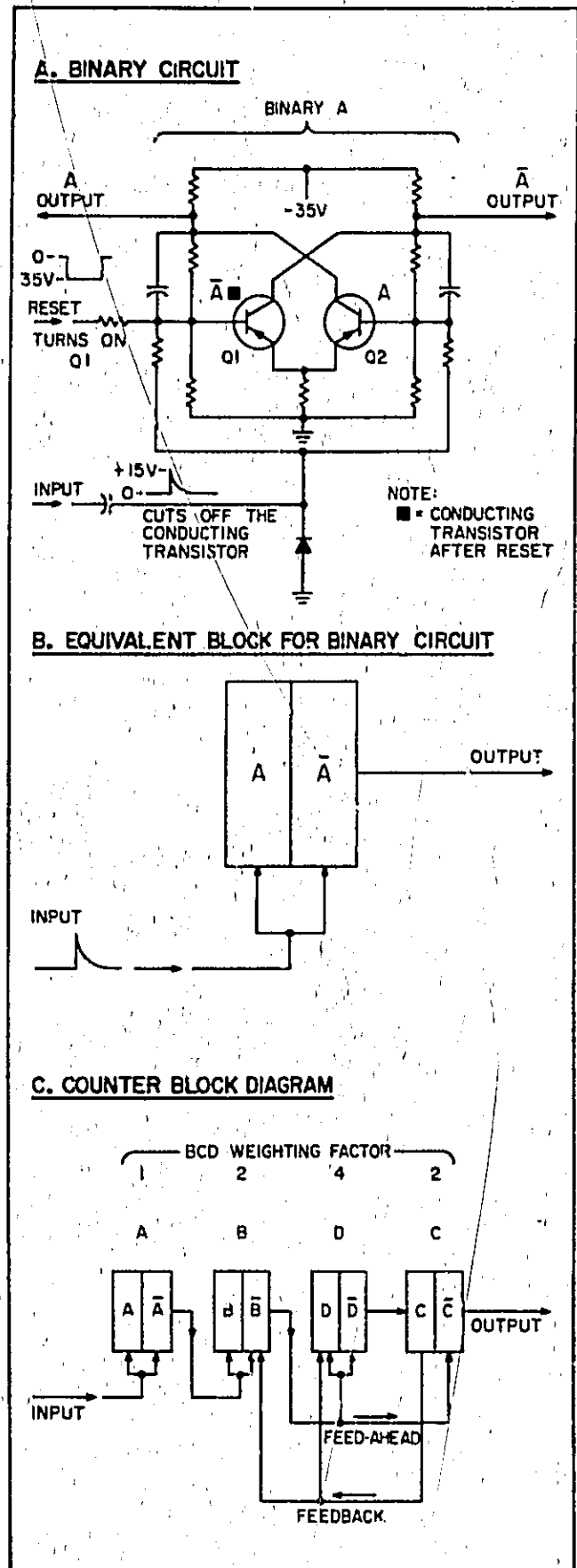

Figure 2-5. Basic Four Binary Counter

DECIMAL COUNT	COUNTER STATE (■ CONDUCTION)				4-LINE CODE			
	WEIGHTING				D	C	B	A
0	A = 1 A A	B = 2 B B	D = 4 D D	C = 2 C C	0	0	0	0
1	A A	B B	D D	C C	0	0	0	1
2	A A	B B	D D	C C	0	0	1	0
3	A A	B B	D D	C C	0	0	1	1
4	A A	B B	D D	C C	0	1	1	0
5	A A	B B	D D	C C	0	1	1	1
6	A A	B B	D D	C C	1	1	0	0
7	A A	B B	D D	C C	1	1	0	1
8	A A	B B	D D	C C	1	1	1	0
9	A A	B B	D D	C C	1	1	1	1
0	A A	B B	D D	C C	0	0	0	0

Figure 2-6. Counting Sequence of Four Binary Counter

2-31. Waveforms showing time relationships for the counter are given in Section VII; remember that a driven binary switches only when the input wave is going positive. (Diode clipping removes negative portion of input).

2-32. ELECTRICAL READOUT. A four-line binary-coded-decimal output is available from each decimal counter assembly. A voltage representing the state of each binary is taken from the collector of each of the plain-lettered transistors (A, B, C, and D). A binary "9" is represented by a relatively positive voltage on each line, and a binary "0" is represented by a relatively negative voltage on each line. Table 2-1 summarizes the ten allowable combinations which represent the decimal digits "0" through "9". To protect the binary circuit from being affected by the load, each output line includes a 100K ohm series-connected isolation resistor.

Table 2-1. Four-Line Code Truth Table

Digit	4-Line Code, 0 = negative state, 1 = positive state			
	D	C	B	A
0	0	0	0	0
1	0	0	0	1
2	0	0	1	0
3	0	0	1	1
4	0	1	1	0
5	0	1	1	1
6	1	1	0	0
7	1	1	0	1
8	1	1	1	0
9	1	1	1	1

2-33. DIGITAL DISPLAY. A display matrix, consisting of eight neon input lamps and 18 photoconductive elements is used to convert the binary-coded-representation to a digital representation. The display matrix is shown in the Decimal Counter schematics, Figures 7-9, 7-11, and 7-14.

2-34. As indicated in the schematic diagrams, Figures 7-9, 7-11, and 7-14, the circuit to each numeral in the display is brought through three series-connected photocell elements. A characteristic of the photocell element is that it is a high resistance element

(several megohms) when dark and a relatively low resistance element (less than 7000 ohms) when illuminated. Thus when the three photocell elements which constitute a circuit path are illuminated, resistance drops to about 20,000 ohms and sufficient current can flow to light the display digit. Illuminating elements for the photocells are neon lamps, one of which is connected in the collector circuit of each of the eight transistors in the counting circuit; the lamp lights when the transistor conducts. As explained in Paragraph 2-30, a four-binary counting circuit has ten states, ten combinations of conducting and nonconducting transistors, each combination corresponding to one digit. Thus there is a pattern of lighted lamps for each digit. Assigning a binary weight of 1 when the plain-letter lamp (A, B, C, or D) lights, and a weight of 0 when the bar lamp (\bar{A} , \bar{B} , \bar{C} , or \bar{D}) lights, the lamp pattern for any digit can be determined from Table 2-1. Figure 7-9 shows the counting circuit with transistors \bar{D} , \bar{C} , \bar{B} , \bar{A} conducting. The lamps associated with these circuits illuminate the photocell elements in the circuit to the digit 0 display.

2-35. The circuit sequence required to light a lamp is discussed in the following paragraphs. The sequence discussed will have more meaning if it is remembered 1) that a much higher voltage is required to fire a neon lamp than to maintain illumination in the lamp (for the lamps used in the Model 5245L, 70 volts for firing and 55 volts for maintaining illumination), and 2) that after application of the firing voltage the lamp cannot fire immediately because of the time required for ionization. Arrangement of the binary lamp circuit used in the Model 5245L is indicated in Figure 2-8B. As will be discussed later, diodes connected between the lamps make it possible for the circuit to store a previous count even though the binaries are switching during the next counting period. In decimal counter assemblies which do not have this storage feature, the display changes with each step the binaries take in setting up the circuit for a given digit. To clarify certain aspects of the lamp circuit sequence, the lamp circuit will first be discussed as though there were no diodes between the two lamps of a binary; this circuit is shown in Figure 2-8A.

a. Lamp Circuit without Diodes.

(1) As indicated in Figure 2-8A-1, the lamp associated with the conducting transistor is

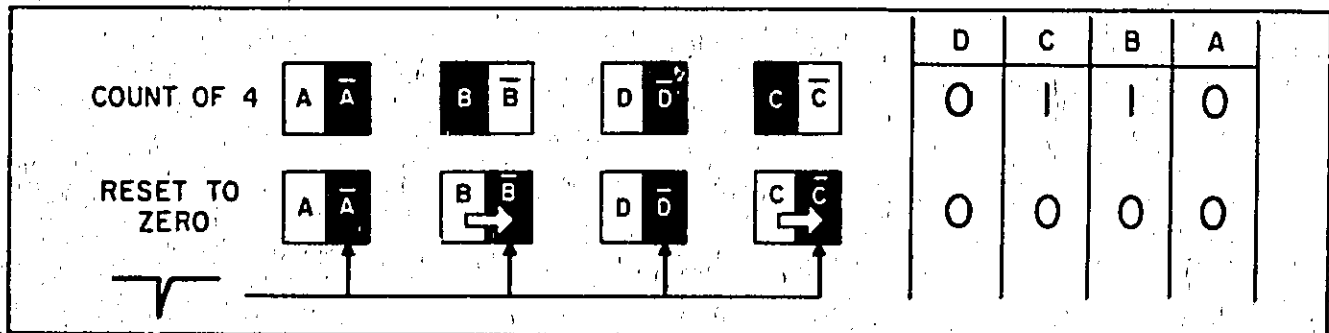

Figure 2-7. Typical Reset Operation in Four-Binary Decimal Counter Assembly

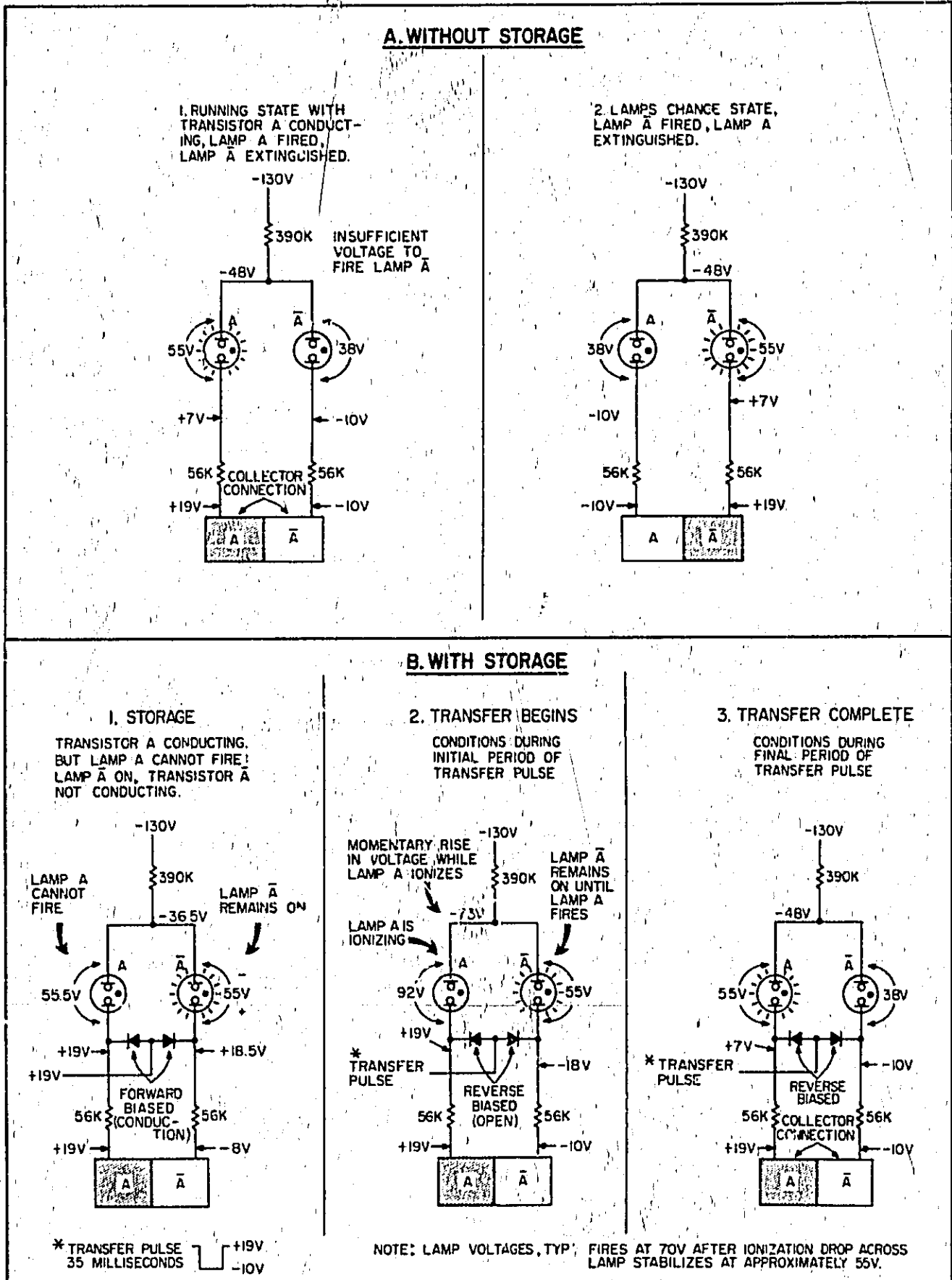

Figure 2-8. Lamp Control

lighted, the lamp associated with the nonconducting transistor is dark. Typically, voltages will be as shown. Since the transistor associated with the dark lamp is not conducting, no current is flowing in the circuit of the dark lamp, and voltage across it is established (a) by the circuit of the conducting lamp and its transistor, and (b) by the voltage on the collector of the non-conducting transistor. This voltage is not high enough to fire the dark lamp.

- (2) When the binary shown in Figure 2-8A changes state, the voltage on the collector of transistor A (now conducting) drops to -10 volts, while the voltage on the collector of nonconducting transistor A rises to +19 volts. With transistor A turned off, current through lamp A decreases, and the voltage at the junction of the two lamps rises. Since lamp A cannot fire until ionized, voltage will continue to rise until the 70-volt firing level is reached; the junction will reach approximately 73 volts during the ionization period. After the dark lamp fires, the voltage across it stabilizes at about 55 volts, and since the voltage across the other lamp is now reduced to 38 volts, the other lamp extinguishes.
- (3) Circuit state after lamp A has fired is shown in Figure 2-8A-2; it is the mirror image of that shown in Figure 2-8A-1.

b. Lamp Circuit with Diodes. The steady, or storage, state of the lamp circuit is indicated in Figure 2-8B-1. The diodes are forward-biased, effectively connecting the lamps in parallel and clamping them to approximately -1.5 volts. One lamp is conducting, the other lamp is dark. Since both lamps are clamped to -1.5 volts, regardless of the state of the binary, there will never be sufficient voltage across the dark lamp to fire it and it will remain dark until 1) the diodes are reverse-biased and 2) there is conduction through the transistor in whose collector circuit the lamp is connected.

- (1) When the gate closes at the completion of the counting period (see Paragraph 2-95) a -29 volt transfer pulse (see Paragraph 2-99) is applied to the binary diodes, reverse-biasing them. With the diodes reverse-biased, the lamps are disconnected from each other, and the circuit for each lamp is now completed through its associated transistor.
- (2) If the state of the binary is the same as that at the end of the previous counting period, the lamps "see" the voltages required to maintain them without change. If, however, the digit is such that the binary state is changed, the lamps change state. With the diodes reverse-biased, circuit action is the same as that described in subparagraph a. Condition of the circuit during the initial period of the transfer pulse when voltage across the dark lamp is increasing is indicated in Figure 2-8B-2; circuit condition after the lamp has fired is indicated in Figure 2-8B-3.

c. **Disabling the Storage.** When the function selector is set to MANUAL or the STORAGE switch on the rear panel is in the off position, the storage feature is disabled. Circuit action is then described in subparagraph a.

2-36. BASIC COUNTER FUNCTIONS.

2-37. GENERAL.

a. The basic counter circuits are arranged to provide several functional modes of operation. Each arrangement includes a main AND gate with 1) a signal input and 2) a control input, or gating signal. Following the main gate is a cascaded series of decimal counters which accumulate and display the total number of pulses which pass through the main gate. The various modes of operation are discussed in Paragraphs 2-36 through 2-41.

b. Circuit sequence in the various modes of operation is similar: pulses pass through the main gate to the decimal counters for a predetermined time, are counted and displayed. The difference between arrangements is in 1) the source of the pulses counted, and 2) the source of the gating signal which establishes the length of time during which the main gate is open to pass pulses to the decimal counters.

2-38. TOTALIZING. In the totalizing mode (see Figure 2-9A), the gate flip-flop is controlled by the FUNCTION switch when it is in the MANUAL START or MANUAL STOP positions. The decimal counters count the total number of input pulses applied while the main gate is held open with the FUNCTION switch in the MANUAL START position. Switching the FUNCTION switch to the MANUAL STOP position closes the main gate and the number of pulses which came through the main gate while it was open are displayed.

2-39. FREQUENCY MEASUREMENT. The circuit arrangement shown in Figure 2-9B permits control of the main gate by the counter time base. The gate is opened for a controlled time, therefore the accumulated count represents the number of input cycles or pulses during this time. Controlled intervals are from 10 seconds down to 1 microsecond in decade sub-multiples, selectable with the front panel TIME BASE switch. The decimal point is automatically positioned and the readout is in kilohertz or megahertz with the units in line with the digital display.

2-40. PERIOD MEASUREMENT. The arrangement shown in Figure 2-9C provides the means for measuring the period of the input signal. The period of a signal is the time required for the completion of one cycle; the counter displays the time in seconds, milliseconds or microseconds. The period measurement is obtained by making the duration of the gating signal equal to the period of the input signal, and counting a train of pulses supplied by the counter time base. The displayed count is the number of time-base pulses which occur during one period of the input signal. For multiple period measurements, Figure 2-9D, the input signal is divided by the selected decade factor so that the gating signal is the selected multiple of one

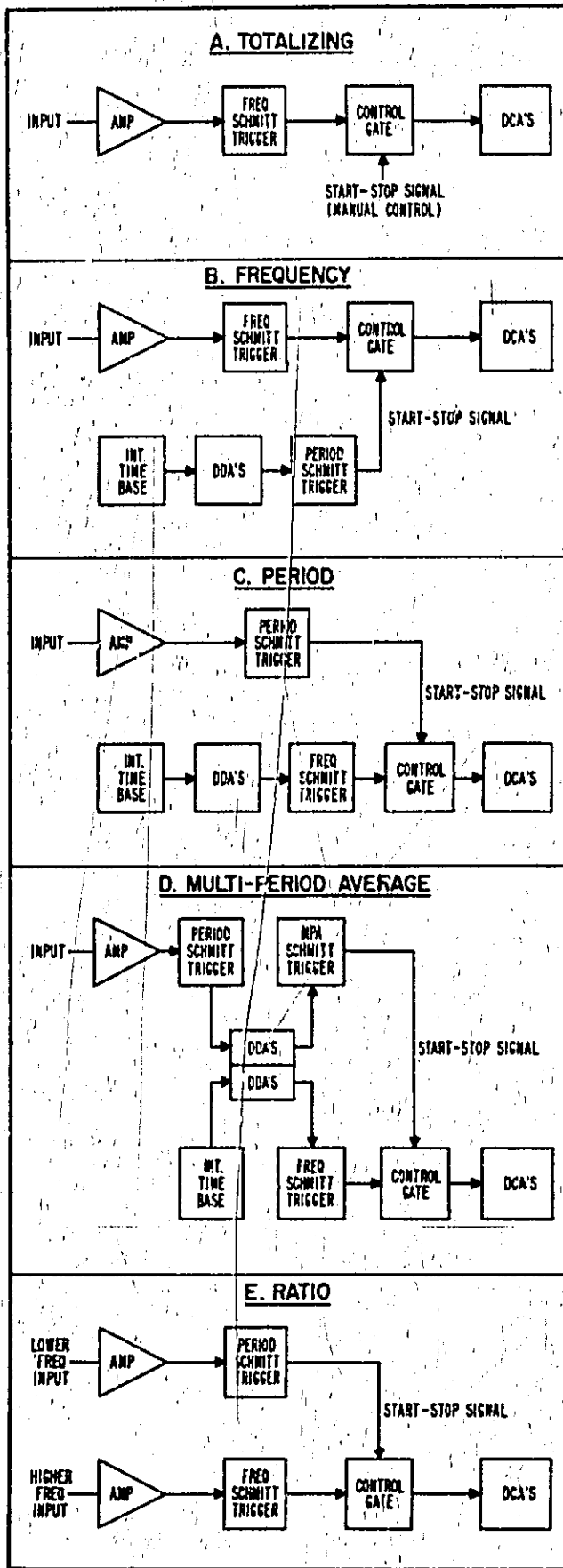

Figure 2-9. Basic Counter Functions

2-10

period. The decimal point is positioned to give the readout in seconds, milliseconds or microseconds for a single period of the input signal.

2-41. RATIO MEASUREMENT. As shown in Figure 2-9E, the frequency ratio of two inputs can be measured by a circuit arrangement similar to that used for period measurement. One input signal is applied to the main gate while the gating signal is made equal to the period (or decade multiple of the period) of the other signal. The displayed count represents the number of cycles of one input which occur during the period of one cycle (or decade multiple of one cycle) of the other input.

2-42. STANDARD FREQUENCY OUTPUTS. Multiplier and decade divider circuits connected to the internal 1MHz oscillator provide output frequencies from 10MHz to 0.1 Hz (in decade steps) using the arrangement shown in Figure 2-10.

2-43. SCALER OPERATION. An input can be scaled by a factor from 10^0 to 10^9 (in decade steps) using the arrangement shown in Figure 2-11. Note that the first two divisions are done by the high-speed decimal counters which in this case function as decade dividers.

2-44. TIME SEQUENCE.

2-45. GENERAL. Following a counter measurement there are several operations which occur in a particular sequence. The pulses which control these operations and their time relation to each other are shown in Figure 2-12. The trailing edge of the gating pulse (end of count) triggers the one-shot multivibrators (Paragraph 2-19) which generate these pulses.

2-46. TRANSFER. The transfer multivibrator is triggered at the end of the gating signal, and it produces a 35-millisecond pulse. The transfer pulse is applied to the decimal counters to transfer the new count to the display. During a measurement function the count is stored in the storage binaries until the transfer pulse allows the new count to be displayed.

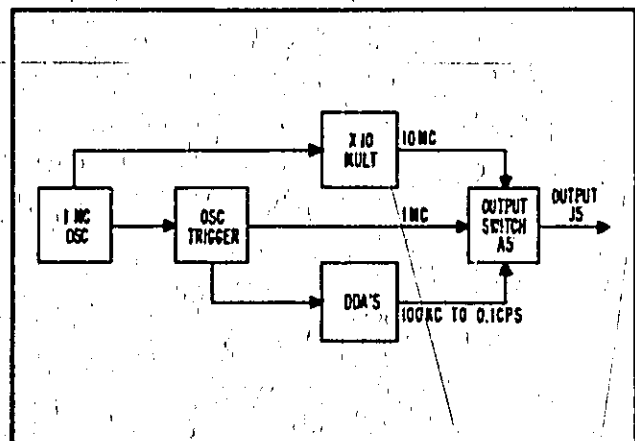

Figure 2-10. Standard Frequency Outputs

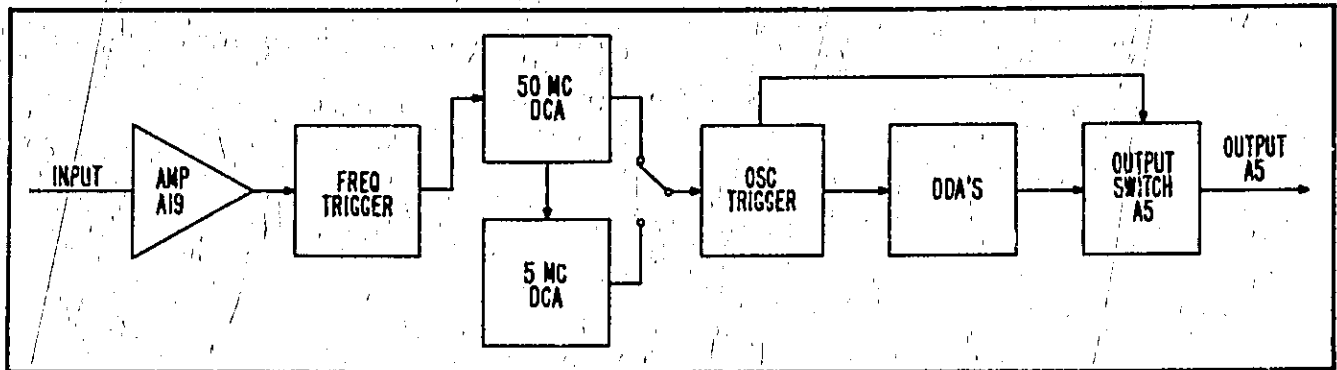

Figure 2-11. Scaler Operation

2-47. **SAMPLE RATE.** The sample-rate multivibrator is triggered at the leading edge of the transfer pulse; it produces a pulse which may be varied from 55 milliseconds to 5 seconds with the front panel **SAMPLE RATE** control. The trailing edge of the sample rate pulse is differentiated to operate the reset amplifier. The reset pulse resets the decimal counters and low-frequency decade dividers.

2-48. **HOLDOFF.** The holdoff multivibrator produces an output pulse which starts at the leading edge of the sample rate pulse and lasts until 55 milliseconds after the end of the sample-rate pulse. The holdoff pulse disables the gate flip-flop to prevent retriggering until the sample rate multivibrator timing capacitor has completed recharging. A sync pulse from the gate control circuit (collector of Q1 through C10 or when in **TIME INTERVAL** from the start line through CR7 and C11) gives the holdoff pulse a precise length

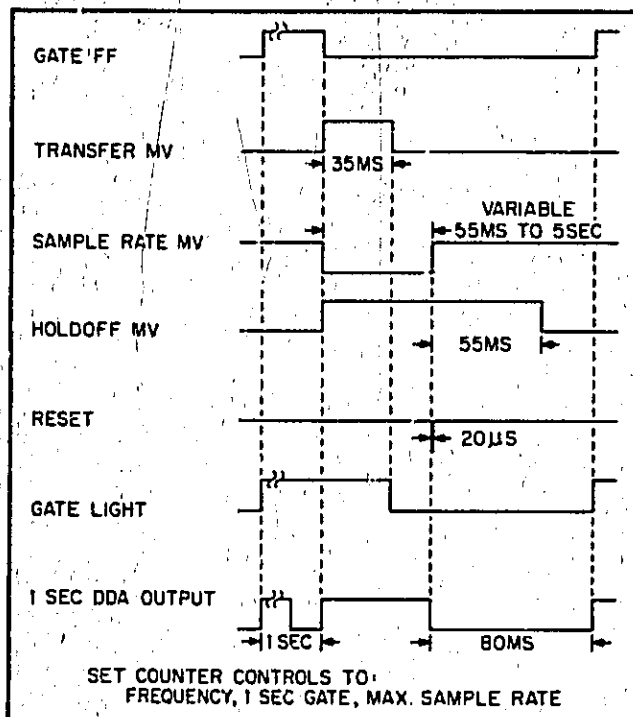

Figure 2-12. Time Sequence

and prevents the gate flip-flop from being triggered prematurely. During the slight delay between the end of the gating pulse and the start of the holdoff pulse, the gate flip-flop is disabled by an inhibit signal from the transfer multivibrator.

2-49. OVERALL COUNTER OPERATION.

2-50. The entire counter is shown in a logic block diagram in Figure 2-13. The front-panel **FUNCTION** switch applies a control voltage to selected AND gates in the function control assembly (A21) to arrange circuits for each counter function (see tabulation in Figure 7-2). The front-panel **TIME BASE** switch arranges the decade dividers (A23-A34) into two groups using gate circuits in the time-base control assembly (A35); the first group produces decade division of the oscillator (A26) output, and the second group produces decade division of the counter input during multiplied period measurements. For details of inter-connections between circuit modules (assemblies) refer to the overall diagram Figure 7-2.

2-51. INPUT SWITCH ASSEMBLY A1.

2-52. The input switch assembly, designated **SENSITIVITY (VOLTS RMS)** on front panel, is a five-position switch (**CHECK**, **10**, **1**, **.1**, and **PLUG-IN**). Refer to the schematic diagram, Figure 7-3, for circuit details. Switch functions are listed below.

a. Provides three attenuation steps (X1, X10, X100) for signal applied to the **SIGNAL INPUT** connector. The attenuator output is connected to the input amplifier A19.

b. Connects output of plug-in unit to input amplifier A19 when switched to **PLUG-IN** position.

c. Produces gate controls 1, 2, 3, 5, 6, and 27 by combining switched -15 volts from A3 (**FUNCTION** switch); distinguishes between **CHECK** and not-**CHECK** positions.

d. Combines switched -15 volts from A3 to contribute to generation of gate controls 4, 21, 22, 23, 24, 25, 26, 27, 28, and 29; distinguishes between **CHECK** and not-**CHECK** positions. Switching for these gate controls is finished in A2 (**TIME BASE** switch).

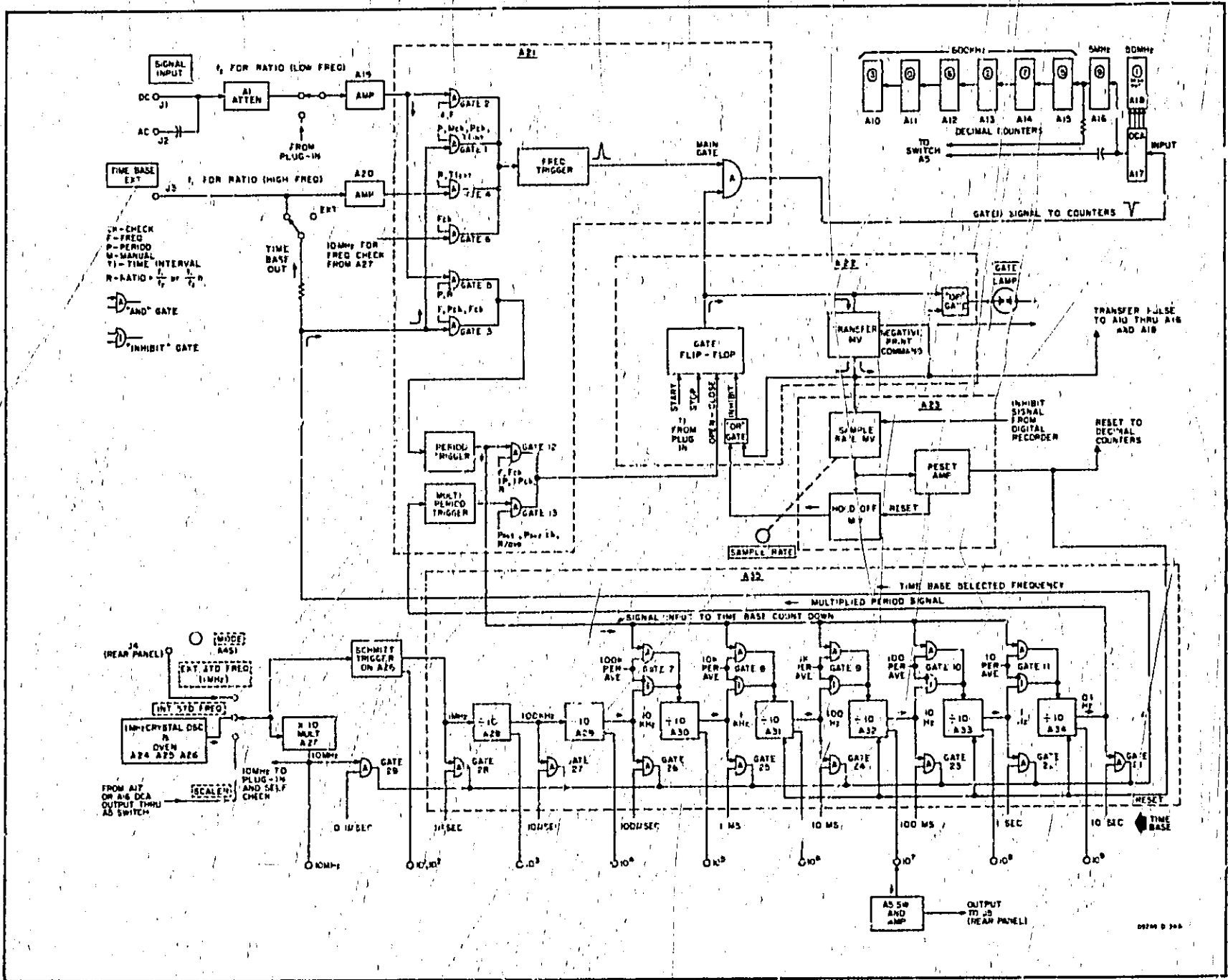

2-12

Figure 2-13. Model 5245L Logic Block Diagram

e. Switches +170 volts as first step in generating lamp control voltages (distinguishes between CHECK and not-CHECK positions). Further switching is done by A3, final switching by A2.

2-53. The level control designated -LEVEL+ on the front panel adjusts the dc input trigger level from -0.3 volts dc to +0.3 volts dc. Refer to schematic diagram Figure 7-3 and 7-4 for circuit details. This control allows the trigger level for input signals to be adjusted above or below ground potential. The level control range is increased to ± 3 volts dc when the input sensitivity switch is set at 1 volt rms, and is increased to ± 30 volts dc for the 10 volt rms setting. The maximum counterclockwise position (PRESET) closes a switch which automatically sets the trigger level at ground potential for all attenuator positions.

2-54. TIME-BASE SWITCH ASSEMBLY A2.

2-55. The time-base switch assembly (designated TIME-BASE on front panel) is a 10-position switch (EXT, 10s, 1s, .1s, 10ms, 1ms, .1ms, 10 μ s, 1 μ s, .1 μ s). Refer to the schematic diagram, Figure 7-4, for circuit details. Switch functions are listed below:

a. Produces gate controls 4, 21, 22, 23, 24, 25, 26, 27, 28, and 29 using switched -15 volts from A1 (SENSITIVITY switch).

b. Produces all decimal point control voltages using switched +170 volts from A3 (FUNCTION switch). Decimal point control voltages are connected to appropriate input terminals on decimal point assembly A8.

c. Produces all measurement units control voltages using switched +170 volts from A3. Measurement unit control voltages are connected to appropriate input terminals on measurement units assembly A9.

d. Generates reset pulses by momentarily supplying -15 volts while switch is between detent positions. This resets all counter circuits if time-base selection is changed during a measurement operation. Reset output is connected to manual reset input of sampling control assembly (pin 9 of A23).

e. Connects time-base selected frequency from A21 (function control assembly) to EXT connector on front panel when switch is not in EXT position. Disconnects selected frequency from EXT connector when switch is in EXT position.

2-56. FUNCTION SWITCH ASSEMBLY A3.

2-57. The function switch assembly (designated FUNCTION on the front panel) is a 10-position switch (MANUAL STOP; MANUAL START; FREQUENCY; PERIOD AVERAGE for 1, 10, 100, 1K, 10K, and 100K periods; and REMOTE OR TIME INT). Refer to the schematic diagram, Figure 7-5, for circuit details. Switch functions are listed below.

a. Produces gate controls 7 through 13 by switching -15 volts from power supply.

b. Contributes to generation of gate controls 1 thru 6 and 21 thru 29.

c. Contributes to generation of decimal point and measurement units controls from switched +170 volts from A1 (SENSITIVITY switch).

d. Produces start and stop input voltages (-15 volts) to gate flip-flop in the gate control assembly (pins 13 and 14 of A23) when switched to MANUAL START and MANUAL STOP.

e. Shorts sample-rate trigger pulse to ground at pin 4 of A23 when switched to either MANUAL START or MANUAL STOP. This inhibits operation of the sample rate and holdoff multivibrators, thereby preventing the reset amplifier from operating in MANUAL functions. This arrangement allows the accumulation of counts in the DCA's over several gate openings during MANUAL operation. Reset is still possible in the MANUAL function by use of the RESET push button on the front panel.

f. Opens the transfer-pulse line between the STORAGE switch on the rear panel and the decimal counters when switched to either MANUAL START or MANUAL STOP. This prevents display storage operation.

g. Opens inhibit-signal line between the DIGITAL RECORDER connector on the rear panel and pin 12 of A23 when switched to either MANUAL START or MANUAL STOP. This prevents undesired triggering of the holdoff multivibrator which could inhibit the gate flip-flop.

h. Generates reset pulses by momentarily supplying +15 volts while switch is between detent positions. This resets all counter circuits if function selection is changed during a measurement operation. Reset output is connected to manual reset input of sampling control assembly (pin 9 of A23).

2-58. MODE SWITCH ASSEMBLY A4.

2-59. The mode switch assembly (designated MODE on rear panel) is a three-position switch (EXT STD FREQ 1 MHz, INT STD FREQ, SCALER). Refer to the schematic diagram, Figure 7-6, for circuit details. Switch functions are listed below:

a. Connects external 1-MHz standard to trigger-circuit of the oscillator assembly (A26) when in EXT STD FREQ 1 MHz position.

b. Connects output of internal oscillator to trigger-circuit of oscillator assembly when in INT STD FREQ position.

c. With A5, connects output of first or second decimal counter (A16 or A17) to trigger-circuit of oscillator assembly when in SCALER position.

d. Provides AC ground through bypass capacitor for signals not selected as input for trigger-circuit of oscillator assembly.

2-60. OUTPUT SWITCH ASSEMBLY A5.

2-61. The output switch assembly (designated OUTPUT on rear panel) includes an amplifier stage and a nine-position switch (.1 Hz thru 10 MHz and 10^9 thru 10^{10} in decade steps). Circuit details are shown in the schematic diagram, Figure 7-6. Switch functions are listed below:

a. Provides standard frequency signals at OUTPUT connector from counter time base if MODE switch is not set to SCALER position. Normally provides all frequencies from .1 Hz to 10 MHz in decade steps but frequencies of 100 Hz and below are interrupted when counter is reset, and availability of frequencies of 1 kHz and below depends on setting of FUNCTION switch.

b. Provides scaling of input signals by factor of 10 to 10^9 (in decade steps) at the OUTPUT connector when MODE switch is set to SCALER and FUNCTION switch is set to MANUAL START.

c. Amplifies selected output for all selections (except standard frequencies of 1 MHz and 10 MHz and scaler ratio of 10 and 100; amplifier is disabled by +13 volt bias supplied when these outputs are selected).

2-62. POWER SUPPLY: RECTIFIER ASSEMBLY A6; REGULATOR ASSEMBLY A7.

2-63. GENERAL. Several supplies are included in the 5245L. Their characteristics are tabulated in Table 2-2.

Note

In the following discussion complete reference designations are used to identify components. This is to prevent confusion between reference designations of power-supply components located on the chassis and components located on the rectifier assembly (A6) and regulator assembly (A7). For example, "R1" would refer to a component located on the chassis, while "A7R1" would refer to a component located on the regulator assembly. Complete designations are used when confusion might exist between chassis components and circuit-board components.

Table 2-2. Power Supplies

Supply	Regulated	Remarks
-15 v	Yes	Series reg
+13 v	Yes	Series reg
+20 v	Yes	Series reg
-130 v	No	-150 v ref to +20 v
+170 v	No	+150 v ref to +20 v

2-64. PRIMARY POWER. As shown in Figure 7-7 either 115- or 230-volt AC power is connected through an LC filter (C5A, C5B, L1, L2), fuse F1 and front-panel power switch S3B (part of SAMPLE RATE control) to the primary of power transformer T1 and T2. Moving slide switch S4 on the rear panel to the left exposes "115" and connects the primaries in parallel for 115-volt operation. Moving the slide switch to the right exposes "230" and connects the primaries in series for 230-volt operation. Transformer T1 supplies power for continuous operation of the crystal-oven-heater control circuits; note that turning off the counter does not turn off the power to the crystal oven. Fan motor B1 is connected across a single primary winding; T2 functions as an autotransformer to supply 115-volts to B1 when the instrument is connected for 230-volt operation.

2-65. MINUS 15-VOLT SUPPLY. The regulated -15 volt supply consists of a full-wave rectifier (A6CR1 through A6CR4) whose output is smoothed by filter L3-C6, regulated by Q2, and further filtered by A7C2. The A7R4, A7R5, A7R6 divider supplies a sample of the regulated output to A7Q2 which amplifies and inverts variations in the sample. The A7Q2 output controls driver A7Q1 which in turn controls regulator Q2. Potentiometer A7R5 permits adjustment of the regulated output voltage by providing a means of adjusting A7Q2 bias.

2-66. REGULATOR OPERATION. Operation may be traced as follows: Suppose the output voltage tends to shift toward -14 volts. This causes the voltage at the A7Q2 base to go in a positive direction resulting in a decrease of conduction and a negative swing in A7Q2 collector voltage; driver A7Q1 increases conduction (A7Q1 emitter and Q2 base voltage go negative); regulator Q2 increases conduction and returns the output voltage to -15 volts.

2-67. OTHER REGULATOR COMPONENTS. Breakdown diode A7CR1 provides a 6.8-volt reference to the emitter of A7Q2. The A7R1-A7C1 network provides phase correction for stability during transients.

2-68. -130 VOLT AND +170 VOLT SUPPLIES. Two conventional full-wave rectifiers supply unregulated +170 volts and -130 volts. Each rectifier circuit provides a 150-volt output (filtered by C7 and C8), but the circuits are referenced to +20 volts so the actual output voltages (relative to ground) are +170 volts and

-130 volts. Note that the -130 volt supply is the source for shunt regulator A7CR2 which provides -56 volts to the -15 volt regulator circuit.

2-69. +13-VOLT AND +20-VOLT SUPPLIES. The +13-volt supply (Q3, A7C3, and A7Q4; see schematic Figure 7-7) is similar to the -15 volt supply described in Paragraph 2-65. The only significant difference is that the negative leg is grounded while the positive leg provides the regulated output. The +20 volt supply is obtained by adding a 7 volt source to the +13 volt supply. The 7 volt regulator consists of Q4 and A7Q5, both acting as emitter followers. A 7 volt zener diode and a bias adjustment circuit provide the reference voltage for this supply.

2-70. DECIMAL POINT ASSEMBLY A8.

2-71. INPUT. The decimal point assembly holds eight neon lamps which are located to the left of each digital display tube on the front panel. Lamps are designated 0 through 7 from right to left as seen looking at the front panel. The decimal point control signal consists of +170 volts applied to the desired lamp input. Control is supplied either from the TIME BASE switch or the lower REMOTE CONTROL connector on the rear panel.

2-72. OUTPUT. A group of OR gates converts the decimal point control signal from decimal form to binary-coded decimal (BCD) form which is supplied to the DIGITAL RECORDER connector on the rear panel. As an example, suppose decimal point 5 is lighted; a positive signal passes the OR gates and limiters to the A, B, and C output lines, thus providing a 0111 (in the order DCBA) output to the DIGITAL RECORDER connector. For circuit details refer to the schematic diagram, Figure 7-8.

2-73. MEASUREMENT UNITS ASSEMBLY A9.

2-74. INPUT. The measurement units assembly holds six neon lamps which are located on the front panel at the right end of the counter display. Lamps are designated MC, KC, SEC, mS, μ S, and *(asterisk). As with the decimal point assembly, the measurement units control signal consists of +170 volts applied to the desired lamp input. Control is supplied either from the TIME-BASE switch or the lower REMOTE CONTROL connector on the rear panel.

2-75. OUTPUT. A group of OR gates converts the measurement units control signal from decimal form to BCD form, just as is done in the decimal point assembly. The digit which is printed for each measurement unit is given in a table along with the schematic diagram, Figure 7-8. Print wheels are available for Hewlett-Packard recorders so that the correct measurement units symbol can be printed directly.

2-76. 600 kHz DECIMAL COUNTER ASSEMBLIES A1¹-A15.

2-77. The decimal counter is shown in block diagram form in Figure 2-14A. The input circuit to binary A includes steering diodes CR9 through CR12. These diodes gate the input pulse so that it is applied only to

the conducting transistor. For example, if the binary is in the "1" state (Q1 cut off, Q2 conducting), CR9 is reversed biased by approximately 30 volts while CR10 is slightly forward biased. The next input pulse is therefore steered to the base of conducting transistor Q2. Note the inclusion of clipper diodes CR13 and CR16 through CR18; they permit only positive pulses to be delivered to the input base of each transistor. In A15 only, CR13 also functions as the main signal gate. Operation of the basic circuits is discussed in the paragraphs listed in Table 2-3. Circuit details are given in the schematic diagram Figure 7-9.

Table 2-3. Basic Operation Summary of Four-Binary Counter

Area	Paragraph Reference
Binary circuit and counting logic	2-25 through 2-29
Resetting	2-30
Electrical readout	2-32
Digital display	2-33 through 2-35
Decimal point	2-70
Clipper diodes	2-8

2-78. 5 MHz DECIMAL COUNTER ASSEMBLY A16.

2-79. The 5 MHz decimal counter operates in a manner similar to the low frequency counter described in Paragraph 2-76. The circuits have been modified by the use of: a) high frequency transistors; b) reduced time constants in the interstage coupling network; and c) steering diodes. The input circuit to binary A includes steering diodes CR9, CR10, CR20, and CR21. These diodes gate the input pulse so that it is applied only to the conducting transistor. For example, if the binary is in the "1" state (Q1 cut off, Q2 conducting), CR9 is reversed biased by approximately 30 volts while CR10 is slightly forward biased. The next input pulse is therefore steered to the base of the conducting transistor Q2. (See Figure 7-11.)

2-80. 50 MHz DECIMAL COUNTER ASSEMBLY A17.

2-81. GENERAL. The 50 MHz decimal counter assembly is shown in Figure 2-16. Operation of basic circuits is discussed in the Paragraphs listed in Table 2-3. Circuit details are given in the schematic diagram, Figure 7-13.

2-82. GATED INPUT. Five AND gates route the input signal to the proper transistor base for each count; feedback is not used. Each of these gates is labeled to indicate the results of an input pulse passed by that gate. For example, the first input pulse is passed by gate A (diode gate A is forward biased by the negative collector voltage of transistor \bar{A}). This negative pulse turns off transistor \bar{A} which turns on transistor A. In the same way gate \bar{A} passes the second pulse turning on transistor \bar{A} . On counts 2, 4, 6, 8, and 0 (10) the input pulse passed by gate \bar{A} is amplified and applied to the inputs of gates B, \bar{B} , and C. Gate B conducts when both an input pulse is present and transistor B is not conducting (this occurs on counts 2 and 8). Gate \bar{B} conducts when both an input pulse is present and transistors \bar{B} and \bar{C} are both turned off (this

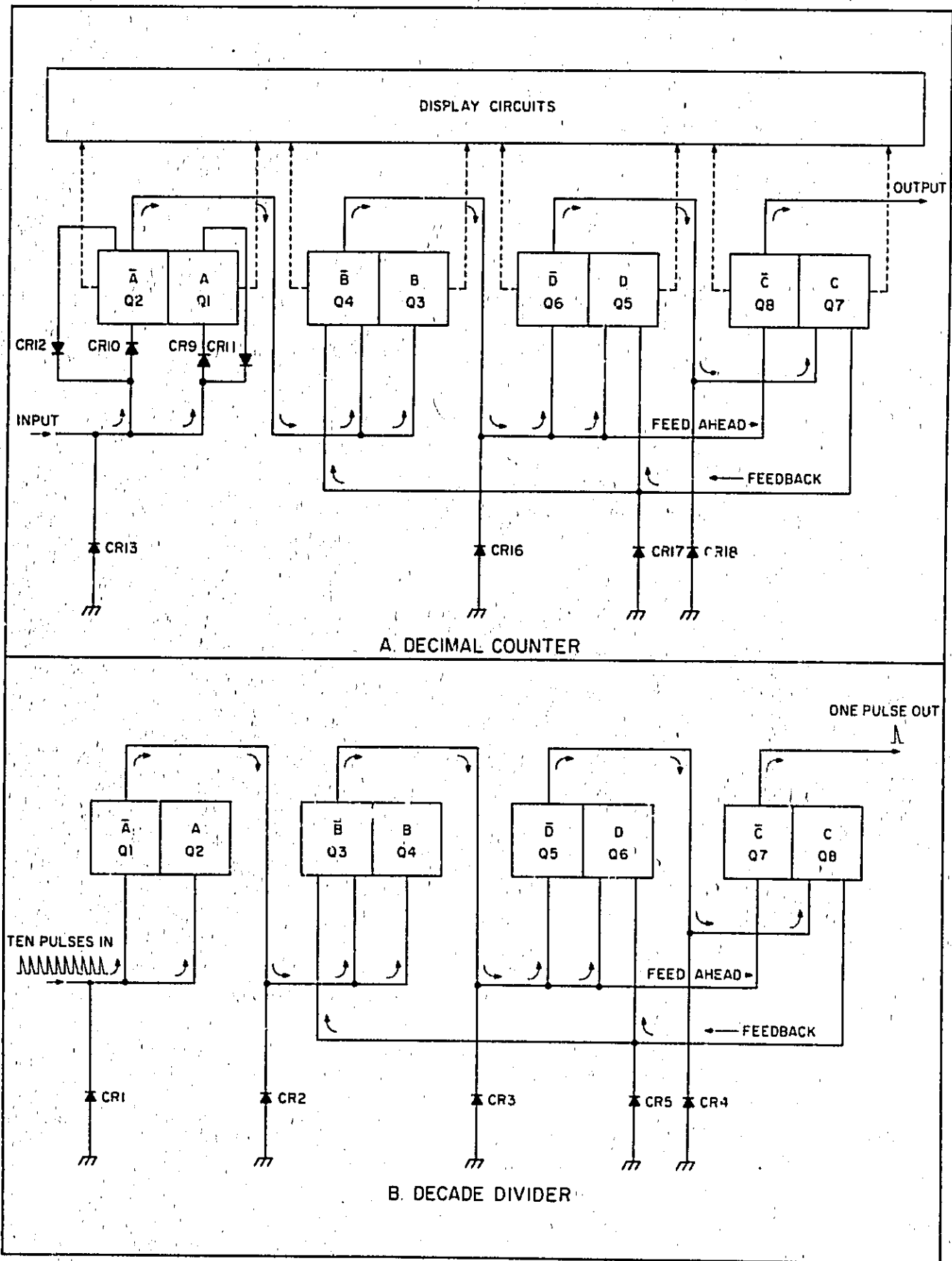

Figure 2-14. Decimal Counter and Decade Divider Block Diagram

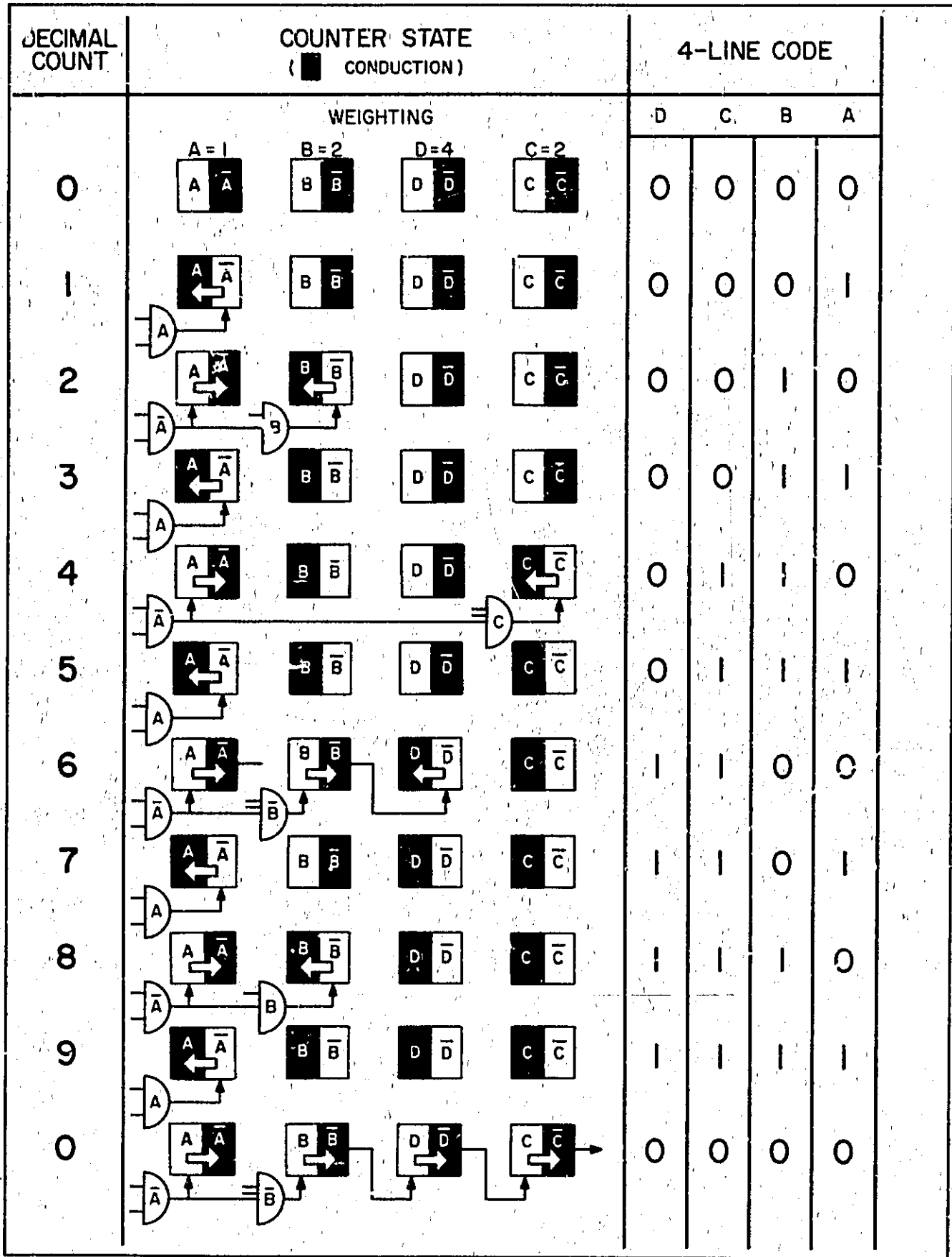

Figure 2-15. 50 MHz Counting Sequence

occurs on counts 6 and 0). Gate C conducts when an input pulse is present and transistors B and C are both turned off (count 4).

2-83. **OUTPUT.** The common emitter amplifier inverts the output and provides the voltage gain necessary to drive the 5 MHz counter assembly.

2-84. **50 MHz READOUT ASSEMBLY A18.**

2-85. **GENERAL.** The 50 MHz readout assembly (A18) receives the binary-coded decimal output from the 50 MHz decimal counter A17; it provides both front-panel digital display and amplified binary-coded-decimal signals. Circuit details are shown in the schematic diagram, Figure 7-14.

2-86. **AMPLIFIERS.** Transistors Q1 through Q8 are arranged in four pairs (amplifiers A, B, D, and C). Each amplifier pair controls a pair of neon lamps in the display matrix (for detailed discussion of digital display see Paragraphs 2-33 through 2-35).

2-87. **AMPLIFIER OPERATION.** As an example of amplifier operation, suppose that the A input became relatively negative, equivalent to binary "0", conduction through Q1 would decrease, resulting in a relatively negative voltage at the Q1 emitter and a relatively positive voltage at the Q1 collector, thus permitting the A neon lamp to light; the output of Q1, coupled to Q2 by way of emitter resistor R22 and voltage divider R20-R21, results in conduction of Q2,

the Q2 collector voltage therefore becomes relatively negative, representing binary "0", and is supplied as the A output. Operation is reversed upon receipt of a relatively positive input (binary "1") and results in lighting of the A neon lamp and supplying a relatively positive A output, representing binary "1". The B amplifier (Q3-Q4), the D amplifier (Q5-Q6), and the C amplifier (Q7-Q8) operate in a similar manner.

2-88. **INPUT AMPLIFIER ASSEMBLY A19-A20.**

2-89. Diodes CR2, CR6, CR4, and CR7 together with current source resistors R25 and R26 provides two low voltage sources that function together with limiting diodes CR1 and CR3 to provide protection while maintaining 1 megohm input resistance up to 2.8 volts peak-to-peak (same voltage as the 4 cn diodes). Since the input resistance of the limiting diodes in parallel with the temperature matched field effect transistor (FET) pair is much greater than 1 megohm, the input resistance is determined by the resistors in the attenuator A1.

2-90. The LEVEL control supplies a voltage to the second input without a gain change. Transistors Q2A and Q3 are a standard feedback pair used in differential operation with feedback pair Q2B and Q4. The feedback provides small loading on the source followers, wide bandwidth, and stable gain. The second differential pair provides gain with temperature stability and is a current source to drive the twisted pair

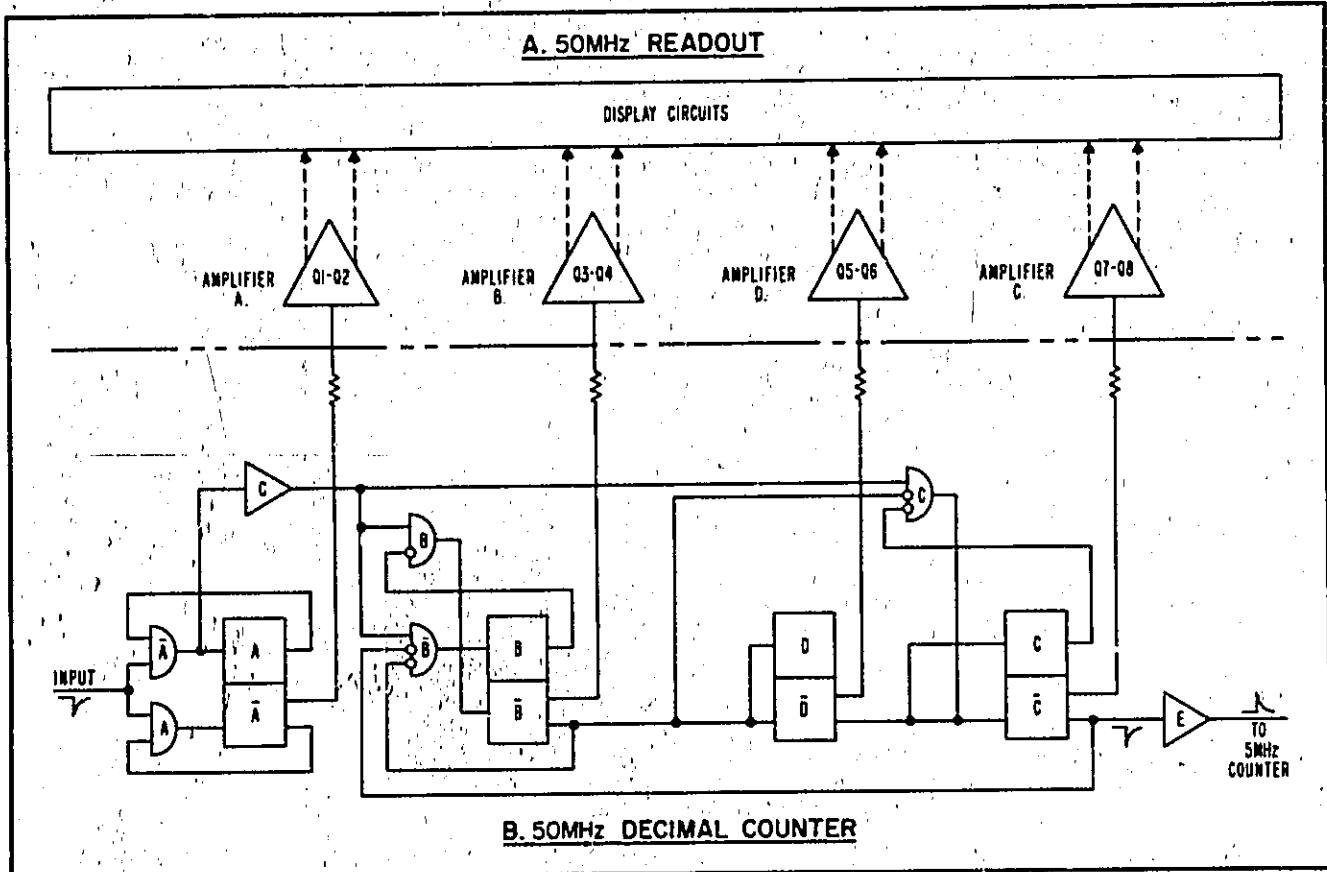

Figure 2-16. 50 MHz Readout and 50 MHz Counter Block Diagram

cable leading to the trigger on the function control assembly A21. The loaded twisted cable optimizes voltage gain, minimizes capacity effects, and isolates signal ground current. See Figure 7-17 for circuit details.

2-91. **FUNCTION CONTROL ASSEMBLY A21.**

2-92. **GENERAL.** The function control assembly, Figure 2-17, switches the counter logic circuits to perform the various counting functions. The signal which is counted by the decimal counting assemblies is switched to the high frequency trigger by one of the input gates; 1, 2, 4, or 6. The resulting pulses are gated by the main gate and then drive the 50 MHz DCA, A17. The signal to control the main gate is switched to the period trigger by input gates 3 or 5. The resulting pulses either drive the gate control assembly, A22 directly through gate 12 or are divided by the decade divider assemblies and then drive the gate control through gate 13.

2-93. **SIGNAL FLOW.** The following outline gives signal flow for each measurement function. In each case the control signal to the main gate is on during counting.

a. **MANUAL.** The input signal from A19 passes through gate 2, amplifier Q1, high frequency trigger Q3-Q4, pulse amplifier Q9, main gate Q10-Q11, and pulse amplifier Q13 to the gated signal output.

b. **MANUAL CHECK.** Same as MANUAL except gate 2 is off and gate 1 is on so that the selected fre-

quency from decade dividers passes through to gated signal output.

c. **FREQUENCY.** Input signal path same as for MANUAL. Selected frequency passes through gate 3, emitter follower Q2, period trigger Q5-Q6, and gate 12 to the gate triggering output.

d. **FREQUENCY CHECK.** Same as for FREQUENCY except gate 2 is off and gate 6 is on so that a 10 MHz signal passes to gated signal output.

e. **PERIOD.** Selected frequency from the time base control assembly A35 passes through gate 1, Q1, trigger Q3-Q4, Q9, main gate Q10-Q11, and Q13 to the gated signal output. The input signal from Q19 passes through gate 5, Q9, period trigger Q10-Q11, and gate 12 to the gate triggering outputs.

f. **PERIOD CHECK.** Same as PERIOD except that gate 5 is off and gate 3 is on so that the selected frequency (always 100 kHz for PERIOD CHECK) from the time base control assembly A35 passes to the gate triggering output.

g. **MULTI-PERIOD.** Same as PERIOD except that gate 12 is off and gate 13 is on. The output of the period trigger Q5-Q6 is divided by the chain of decade dividers. The output of the proper divider drives the multi-period trigger Q7-Q8, and passes through gate 13 to the gate triggering output.

h. **MULTI-PERIOD CHECK.** Same as MULTI-PERIOD except that gate 5 is off and gate 3 is on so

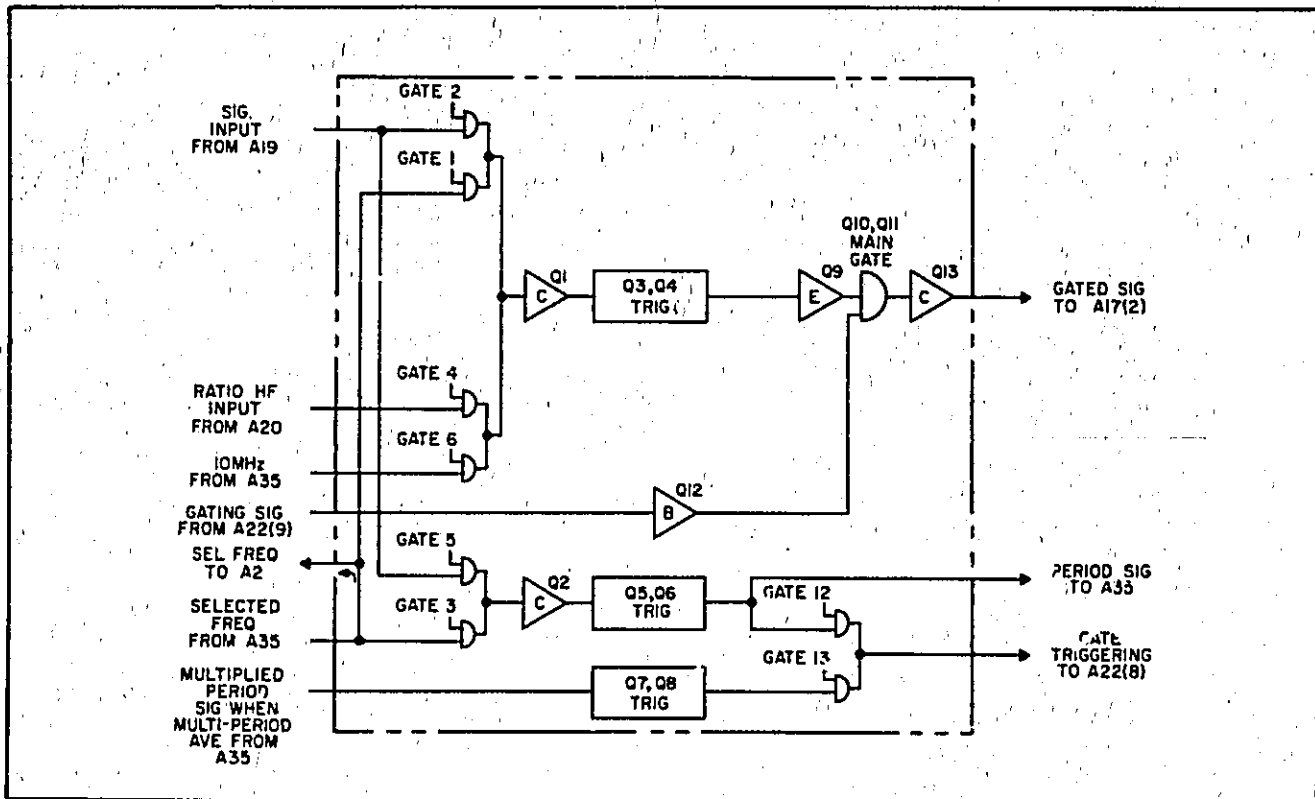

Figure 2-17. Function Control Block Diagram

that the selected frequency (always 100 kHz) from the time base control assembly A35 becomes the driving signal for the second group of decade dividers.

2-94. CIRCUIT DETAILS. Refer to the schematic diagram, Figure 7-18, for circuit details. The basic AND gate description given in Paragraph 2-6 applies to the gate circuits, but note that gates 1 through 6 consist of two diodes. The gates are turned on (signal passes) when -15 volts is applied to the control input to forward-bias the diodes; the gates are turned off (signal blocked) when the -15 volts is removed so that the fixed bias supply (from +13 volts) reverse-biases the diodes. The main gate, Q10-Q11, is open when the gating signal amplifier A12 is off, allowing the pulses from amplifier Q9 to switch the current flowing through Q10 to Q11 and to the output pulse amplifier Q13. The main gate is closed when Q12 is conducting which turns off transistors Q10 and Q11. Thus the pulses from Q9 are not allowed to drive the output pulse amplifier Q13.

2-95. GATE CONTROL ASSEMBLY A22.

2-96. GENERAL. The main function of the gate control assembly is to generate the gating signal (which controls the main gate in A21) and the sampling trigger (which starts the sample-rate multivibrator in A23). Refer to the block diagram, Figure 2-18, during the following discussion.

2-97. SIGNAL FLOW. The gate flip-flop (Q4-Q5) is normally held in its off state (in this state, it holds the main gate closed, preventing counting) by the hold-off signal from A23 which is applied through Q6. The first gate triggering pulse which occurs after the end of the holdoff pulse is amplified by Q1 and steering amplifier Q2 and operates the gate flip-flop to its on state. The next gate triggering pulse turns the gate flip-flop off through Q1 and Q3. (In MANUAL operation, -15 volts is applied as a start or stop signal thru CR1 or CR2 to turn the gate flip-flop on or off.) The gate flip-flop output (positive pulse) is amplified without inversion by split-load amplifier Q7 and passed on to A21 as the gating pulse. The trailing edge of the inverted output from Q7 triggers the transfer one-shot multivibrator (Q8-Q9) which produces a 30-millisecond output pulse; the negative pulse output is supplied directly from the multivibrator as the print command pulse (negative transition tells digital recorder to accept BCD information from counter); the positive pulse output from the multivibrator is a) immediately fed back to the gate flip-flop as a hold-off signal thru Q6 to prevent retriggering of the gate flip-flop until the regular holdoff signal from A23 is generated about a microsecond later, b) delivered to A23 for amplification as the transfer pulse, and c) amplified and inverted by Q10. The Q10 output is delivered to A23 as the sampling trigger pulse. (In MANUAL operation the sampling trigger output is shorted to ground by the FUNCTION switch). The negative pulse outputs

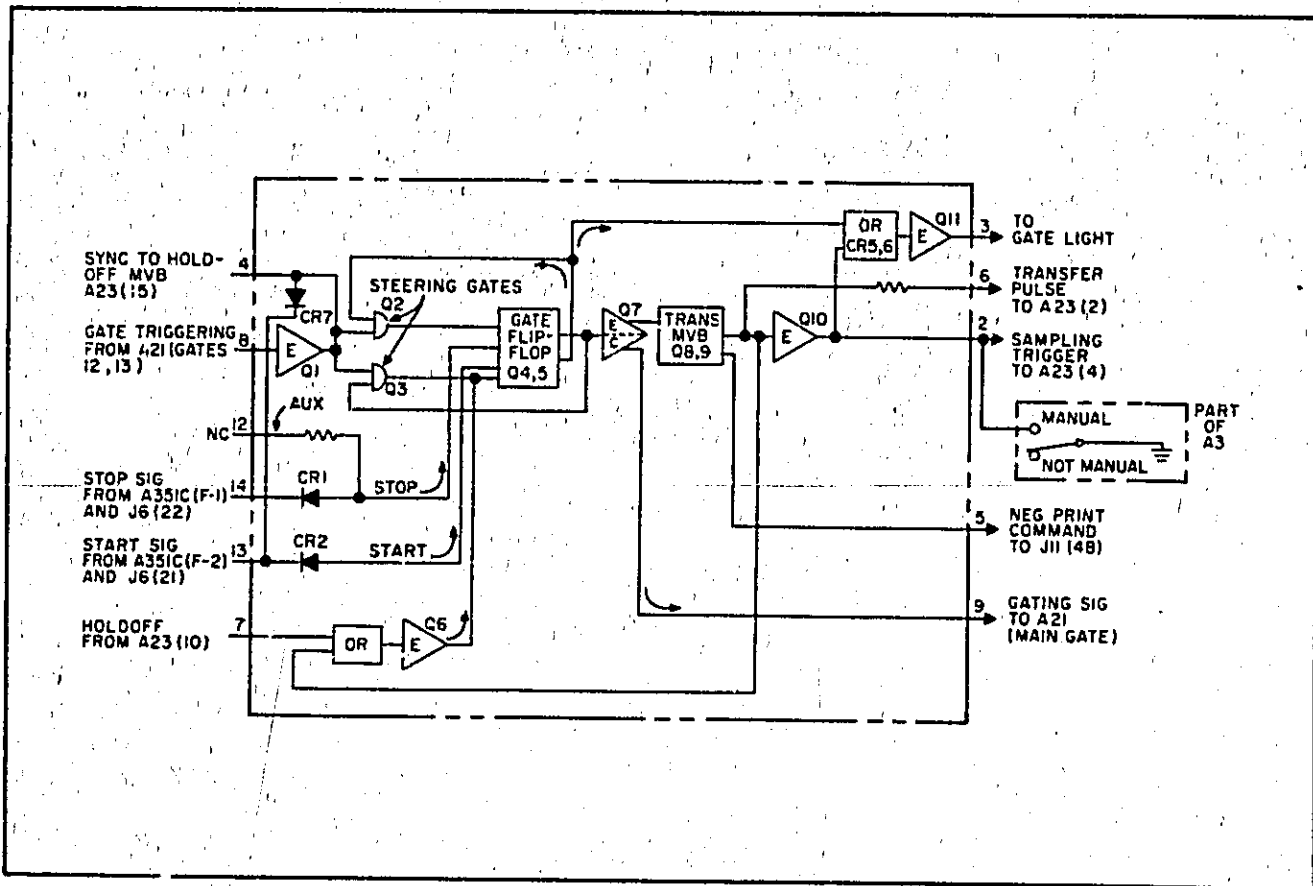

Figure 2-18. Gate Control Block Diagram

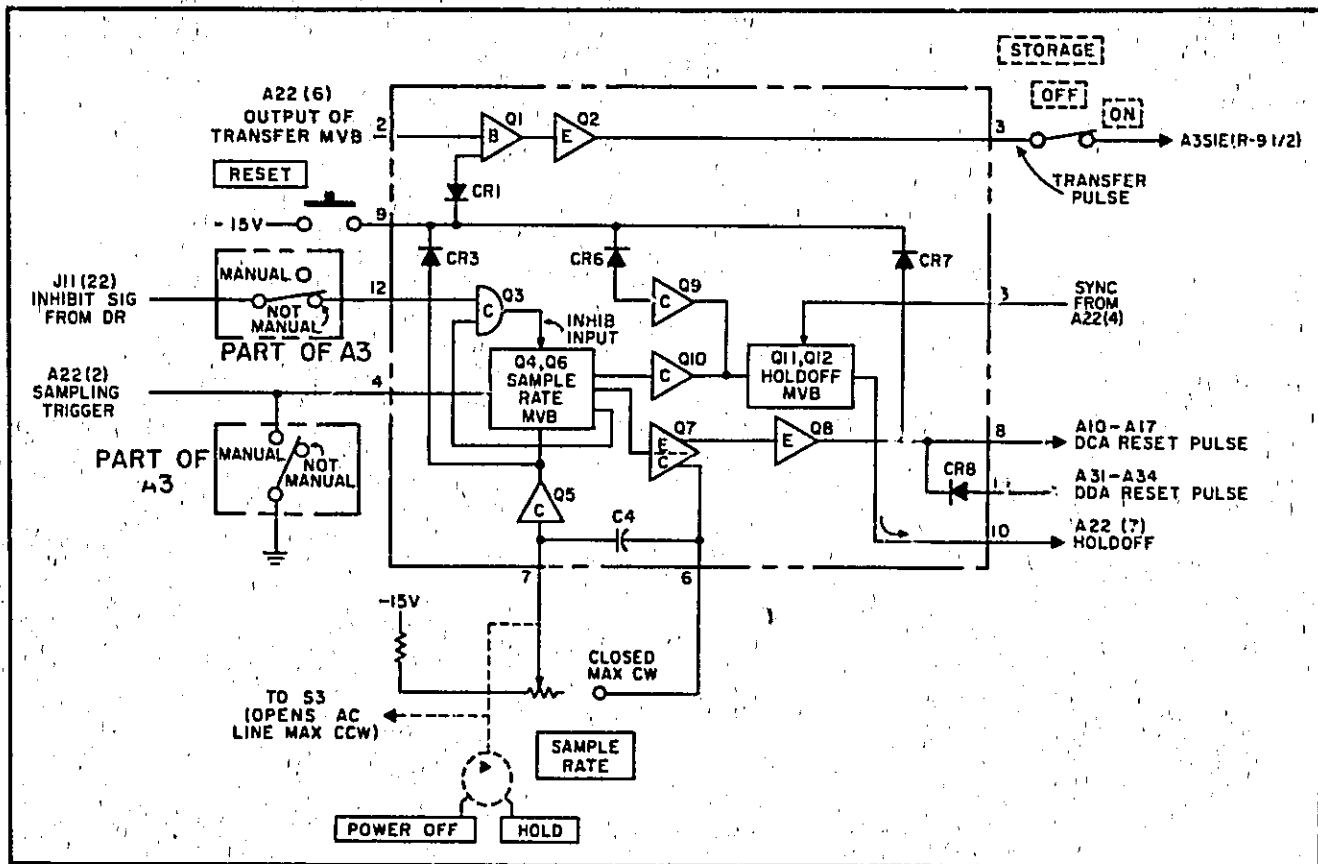

Figure 2-19. Sampling Control Block Diagram

of both the gate flip-flop and amplifier Q10 are combined, then amplified by A11 to drive the front-panel GATE lamp; the GATE lamp is therefore on during the gating signal plus 30 milliseconds; this ensures a visible flash from the lamp even for very short gates.

2-98. CIRCUIT DETAILS. Refer to the schematic diagram, Figure 7-19, for circuit details. All circuits are conventional; flip-flop operation is described in Paragraphs 2-15 and 2-16, and one-shot multivibrator operator described in Paragraphs 2-19 thru 2-22. The steering amplifiers (Q2 and Q3) are common-base amplifiers; one amplifier (whose collector is connected to the collector of the conducting flip-flop transistor) cannot operate because of low collector voltage; the other amplifier (whose collector is connected to the collector of the cut-off flip-flop transistor) amplifies the gate triggering pulse and supplies it to the receptive flip-flop transistor.

2-99. SAMPLING CONTROL ASSEMBLY A23.

2-100. GENERAL. During normal operation, the sampling control assembly receives the positive transfer pulse and the sampling trigger pulse from A22; its outputs are a) the amplified and inverted transfer pulse, b) reset pulses for the decimal counters and decade dividers, and c) the holdoff signal which prevents retriggering of the gate flip-flop in A22. Refer to the block diagram, Figure 2-19, during the following explanation.

2-101. TRANSFER PULSE. The positive transfer pulse is amplified without inversion by Q1, then amplified and inverted by Q2. During manual reset (RESET pushbutton pressed or FUNCTION or TIME-BASE switches operated) -15 volts is amplified and inverted by Q1, then amplified and inverted by Q2 to produce a manually generated equivalent of the transfer pulse. Action of other circuits resets all decimal counters to zero before the reset contacts open; then the voltage on the transfer pulse line transfers the zero count to the front-panel numerical display.

2-102. RESET. The negative transition of the sampling trigger pulse from A22 normally triggers the sample-rate one-shot multivibrator and starts operation of all sample-rate control circuits. Multivibrator feedback is through quick-recovery amplifier Q7, capacitor C4, and emitter follower Q5. The sample-rate output pulse duration is controlled by the SAMPLE RATE potentiometer and is variable between 55 milliseconds and 5 seconds. When the SAMPLE-RATE control is operated to the HOLD position (completely clockwise), the multivibrator provides a continuous output. An amplified output is taken from Q7, differentiated (leading edge is selected), amplified by Q8, and supplied as the DCA reset pulse and the DDA reset pulse. If manual reset occurs during the sample-rate multivibrator cycle, the multivibrator is quickly returned to its quiescent state as a result of the -15 volt input through CR3.

Paragraphs 2-103 to 2-116

2-103. **HOLDOFF.** A second output from the sample-rate multivibrator is amplified by Q10 to drive the holdoff one-shot multivibrator (Q11-Q12). The holdoff multivibrator output consists of a positive pulse which normally begins about 1 microsecond after the end of the gating signal and ends 55 milliseconds after the end of the sample-rate pulse. A holdoff pulse is also generated as a result of manual reset (-15 volts from manual reset line through CR6 and Q9 to Q11-Q12) so that counting cannot start until after reset switching transients have ended.

2-104. **CIRCUIT DETAILS.** Refer to the schematic diagram, Figure 7-20, for circuit details. Inhibit amplifier Q3 is in series with the Q4 collector; inhibition of the sample-rate multivibrator occurs when Q3 is cut off by a positive inhibit signal (which effectively disconnects the Q4 collector). At the end of the multivibrator cycle, recovery amplifier Q7 conducts heavily to discharge C4 rapidly in preparation for the next cycle. Refer to Paragraphs 2-19 thru 2-22 for a basic one-shot multivibrator discussion.

2-105. OSCILLATOR AND OVEN A24, A25, A26.

2-106. **GENERAL.** Crystal oven assembly A24, oven control assembly A25, and the first portion of oscillator assembly A26 provide an extremely stable 1 MHz signal. The second portion of A26 amplifies and shapes either the internally generated 1 MHz, an externally supplied 1 MHz, or, for scaler operation, the output of the decimal counter A17 or A16. Refer to the schematic diagram, Figure 7-21, during the following explanation.

2-107. **CRYSTAL OVEN ASSEMBLY A24.** The crystal oven assembly is a thermally insulated chamber which contains a heating element, a temperature sensing circuit, and a 1 MHz piezo-electric crystal.

2-108. **OVEN CONTROL ASSEMBLY A25.** The oven control assembly includes oscillator A25Q1 which produces a 3 kHz output whose amplitude is controlled by the temperature-sensing element in the oven. The oscillator output is amplified by A25Q2, detected to produce a DC level whose amplitude is inversely proportional to oven temperature. The DC level is amplified and applied to the heating element in the oven. The oven control assembly contains its own power supply which operates continuously whenever power is connected to the counter.

2-109. **OSCILLATOR ASSEMBLY A26.** The oscillator assembly includes the Q1 oscillator circuit which is connected to the 1 MHz crystal in A24. The 1 MHz oscillator output is amplified by A26Q2, A26Q3, and A26Q4. A portion of the A26Q4 output is detected and applied to A26Q1 as AGC so that power dissipation in the crystal can be held at a constant low value. Another portion of the A26Q4 output is supplied to the rear panel MODE switch where it usually is switched through to amplifier A26Q5 and trigger A26Q6-A26Q7. Outputs of 1 MHz are taken from both A26Q5 and A26Q6-A26Q7.

2-22

2-110. **CIRCUIT DETAILS.** Refer to the schematic diagram, Figure 7-21, for circuit details. The oscillator A25Q1 is controlled by the Wien bridge in A24. Positive feedback from the A25Q2 emitter through A24R1-A24C6 to the A25Q1 emitter maintains oscillation at the frequency of maximum feedback, which occurs at that frequency for which the A24R1-A24C6 phase shift equals the A24R2-A23C7 phase shift (about 3 kHz). Degenerative feedback is provided from the A25Q2 emitter and the A24R1-A24R3-A24R4 divider to the A25Q1 base; an increase in oven temperature lowers the resistance of RT1, thus increasing degenerative feedback and lowering oscillator output; likewise, a temperature decrease results in decreased degenerative feedback to produce increased oscillator output. The detector is a voltage doubler circuit; A25C2 charges fully through the negative half cycle, and then discharges through A25CR2 in series with the driving source during the positive half cycle. Capacitor A25C4 between the collector and base of A25Q4 dampens sudden DC voltage swings and filters any AC component from the detected signal. The A26Q1 oscillator is a modified Pierce oscillator; its base is maintained at a DC level from the A26R1-A26R2 junction; AGC current is supplied to its emitter from the A26CR1-A26CR2 detector (voltage doubler) which is referenced to the A26R1-A26R2 junction. Operation of the trigger circuit (A26Q6-A26Q7) is discussed in detail in Paragraph 2-18.

2-111. MULTIPLIER ASSEMBLY A27.

2-112. The 1 to 10 MHz multiplier assembly consists of X2 multiplier Q1, X5 multiplier Q2 and amplifier Q3. Circuit details are shown in the schematic diagram, Figure 7-22. Divider R4-R5 and emitter resistor R6 provide optimum DC bias to Q1 for efficient frequency doubling; likewise, divider R8-R9 and emitter resistor R10 provide optimum DC bias to Q2 for efficient fifth-harmonic generation. The interstage coupling transformers (L1-L2, L3-L4, and L5-L6) include capacitive dividers in their secondary circuits (C8-C9, C13-C14, and C19-C20) for interstage impedance matching.

2-113. 5-MHz DECADE DIVIDER ASSEMBLY A28.

2-114. The 5 MHz decade divider assembly reduces the frequency of its input by a factor of ten (normally 1 MHz to 100 kHz). Basic operation is identical to that described for the 5 MHz decimal counter (Paragraphs 2-76 through 2-79), except that there is no displayed count. Refer to the schematic diagram, Figure 7-23, for circuit details.

2-115. LOW-FREQUENCY DECADE DIVIDER ASSEMBLY A29-A34.

2-116. A block diagram of a typical decade divider is shown in Figure 2-14B. A decade divider is an arrangement of four, cascaded binaries (flip-flop) so that for every ten input pulses there is one output

pulse. Consequently, when a frequency is applied to the input of the decade divider, the first binary divides it by two (since the first pulse switches the binary to the opposite state and a second pulse is required to return it to its original state) and again by two in the second binary (making a total division by four) and so on, with an expected total division of sixteen at the output of the fourth binary. The desired division by ten is obtained by a feed-ahead pulse to the fourth binary and feedback pulses to the second and third binaries. Therefore, after the eighth input pulse is received the binaries will be in a state as if they had counted fourteen pulses. Then, when the ninth and tenth pulses are received the desired final output pulse is produced. Operation is similar to that described for the decimal counters discussed in Paragraphs 2-76 and 2-77 except that there is no display array connected to the binaries. Note that A31 through A34 are supplied with a reset input so that only a certain number of input pulses to the decade dividers are necessary after reset before an output is produced. Refer to the schematic diagram Figure 7-24, for circuit details.

2-117. TIME-BASE CONTROL ASSEMBLY A35.

2-118. GENERAL. The purpose of the time-base control is to a) lower the output impedance of the 10 MHz signal from multiplier A27; b) select a frequency between 0.1 Hz and 10 MHz as controlled by the TIME BASE switch, and c) provide a multiplied period signal when the FUNCTION switch selection is between 10 and 100K PERIOD AVERAGE. Inhibit gates 7 thru 11 (CR8, CR11, CR14, CR17, and CR20) are normally open; a control voltage to turn one of these gates off is applied only for multiplied period measurement. Multi-period gates 7 thru 11 (CR9, CR12, CR15, CR18, and CR21) are normally closed; one only is opened for multiplied period measurements. Selected frequency gates 21 thru 28 are controlled by the TIME-BASE switch.

2-119. SELECTED FREQUENCY CONTROL. For all operating functions except PERIOD AVERAGE CHECK, gates 21 thru 29 are on for the TIME BASE selections listed in Table 2-4. For example, if the TIME BASE switch is set to 1 ms, the control voltage is applied to gate 25, turning it on and permitting the 1 kHz signal from A30 to be amplified by Q11 and Q12; the amplified 1 kHz is supplied as the selected frequency to A21.

Table 2-4. Normal Time Base Control

Gate Control On	Time Base Switch
21	10 s
22	1 s
23	0.1 s
24	10 ms
25	1 ms
26	0.1 ms
27	10 μ s
28	1 μ s
29	0.1 μ s

(For PERIOD AVERAGE CHECK, gate 27 is on, regardless of TIME BASE selection, and 100 kHz is supplied as the selected frequency.)

2-120. MULTIPLIED PERIOD CONTROL. Control voltages for gates 7 through 11 are supplied only for multiplied period measurements, as listed in Table 2-5. These control voltages select one to give steps of decade division for the period signal supplied by A21. Example 1: The FUNCTION switch is set to 10-PERIOD AVERAGE; gate control 11 is on, turning off inhibit gate 11 (to prevent further division of the signal from A26) and turning on multi-period gate 11; the amplified period signal from Q1 is passed thru CR21, divided by ten in A34, and supplied thru Q10 as the multiplied period signal. Example 2: The FUNCTION switch is set to 1K-PERIOD AVERAGE; gate control 9 is on, turning off inhibit gate 9 and turning on multi-period gate 9; the amplified period signal from Q1 is passed through CR15, divided by ten in A32, passed by CR17, divided in A33, passed by CR20, divided in A34, and supplied through Q10 as the multiplied period signal.

Table 2-5. Multiplied Period Control

Gate Control On	Function Switch
7	100K PERIOD AVE
8	10K PERIOD AVE
9	1K PERIOD AVE
10	100 PERIOD AVE
11	10 PERIOD AVE

2-121. GATING CONFLICT. A few combinations of TIME BASE and FUNCTION switch selections produce overlapping decade-divider requirements. For example, a TIME BASE selection of 0.1 s and a FUNCTION selection of 10K-PERIOD AVERAGE turns on gate control 23 and gate control 8; the expected selected frequency of 10 Hz is not supplied through CR16-Q7 since the frequency-dividing chain is blocked at CR11; the counter display is therefore meaningless. An alarm for unallowed switch combinations of this sort is given by the lighting of an asterisk (*) at the right end of the front panel display. The asterisk is also used to indicate two other non-useful control combinations: 1) TIME BASE of 0.1 μ s and frequency FUNCTION, and 2) TIME BASE of 10 SEC and PERIOD function. The asterisk lamp (in A9) is controlled by switching contacts on both the TIME BASE and FUNCTION switches.

2-122. CIRCUITS. Refer to the schematic diagram, Figure 7-25, for circuit details. Most of the gates in A35 are of the type described in Paragraph 2-6, but gates 28 and 29 are two-diode AND gates, described in Paragraph 2-94. The inhibit gates (CR8, CR11, CR14, CR17, and CR20) are similar to conventional AND gates except that they are always on (forward-biased diode) in the absence of the control voltage and off (reverse-biased diode) when the control voltage is applied.

PERFORMANCE CHECK

SECTION III PERFORMANCE CHECK

3-1. GENERAL. The In-Cabinet Performance Checks, Table 3-2, and Performance Check Test Card (to be filled out during incoming inspection), pages 3-11a thru 3-11d, verify specifications and provide permanent record of the performance of each instrument. The In-Cabinet Performance Check, Table 3-2, and the Self-Check Procedure, Figure 6-1, verify proper operation of all circuits in the Model 5245L Electronic Counter and may be used:

a. as part of an incoming inspection check of instrument specifications;

b. periodically, for instruments used in systems where maximum reliability is of utmost importance;

c. as part of a troubleshooting procedure to locate malfunctioning circuits, and

d. after any repairs or adjustments, before returning instrument to regular service.

3-2. VARIABLE LINE VOLTAGE. During the Performance Check, Table 3-2, the Model 5245L should be connected to power source through a variable voltage device so that line voltage may be varied $\pm 10\%$ from nominal (115 or 230 Vac) to assure proper operation of the Counter under various supply conditions.

Table 3-1. Recommended Test Equipment

Instrument Type	Required Characteristics	Use	Instrument Recommended
Oscilloscope	50 MHz bandwidth, dual trace plug-in, ext sync capability.	Observe waveforms during troubleshooting and adjustment. Performance Check.	HP Model 175A Oscilloscope HP Model 1750B Dual Trace Vertical Amplifier HP AC-21C Voltage Divider Probe (two) HP 10003A 10:1 Probe
Test Oscillator	Continuously variable from 10 Hz to 50 MHz, 100 mV output.	Performance Check	HP Model 204B Oscillator HP Model 606A Test Oscillator
Low Frequency Generator	Continuously variable from 2 Hz to 10 Hz, 100 mV output.	Performance Check	HP Model 202A Low Frequency Function Generator
Pulse Generator	1 μ sec wide, 1 V negative, 1 kHz repetition rate.	Performance Check	HP Model 212A Pulse Generator
Primary Standard Oscillator	100 kHz or 1 MHz sine wave, accuracy of $< \pm 5 \times 10^{-10}$ per 24 hours.	Check accuracy of Counter time base Performance Check	HP Model 107BR
Variable line voltage source with meter	Variable from 103 to 127 Vac (207 to 253 Vac).	Performance Check	
DC Voltmeter	0V to ± 170 V, 10 megohm input impedance, 1% accuracy.	Troubleshooting and adjustments	HP Model 412A
Power Amplifier	DC to 10 MHz, 10 dB gain.	Performance Check	Dymec DY-2460A/ DY-2460A-M2
Power Supply	0V to ± 20 V	Performance Check	HP Model 721A

Table 3-1. Recommended Test Equipment (cont'd)

Instrument Type	Required Characteristics	Use	Instrument Recommended
Counter	10 MHz, 100 mV sensitivity, ± 1 count \pm time base.	Performance Check	HP Model 5245L
Mixer	10 MHz, 50 Ω impedance, 40 mW sensitivity max.	Performance Check	HP Model 10514A
Impedance Transformer	1000 ohms to 50 ohms	Performance Check	
Digital to Analog Converter	1-2-2-4 BCD code	Performance Check	HP Model 581A
Strip-Chart Recorder		Performance Check	Moseley 680
Low-Pass Filter	1 kHz	Performance Check	
Frequency Synthesizer	Precision signal source 0 to 50 MHz	Performance Check	HP Model 5100A/5110A
Coax Attenuator	Variable from 0 to 120 dB in 10 dB steps	Performance Check	HP Model 355D
Coax Attenuator	Variable from 0 to 12 dB in 1 dB steps	Performance Check	HP Model 355C
<p>Note: The Variable Coax Attenuators are used to adjust the output signal level of the Frequency Synthesizer and should be used with the Frequency Synthesizer for all checks.</p>			

Table 3-2. In-Cabinet Performance Check

FREQUENCY MEASUREMENTS
<p>1. RANGE: DC coupled: 0 to 50 MHz AC coupled: 25 Hz to 50 MHz</p>
<p>DC INPUT</p> <p>a. Set Counter controls as follows: SENSITIVITY to .1 VOLT SAMPLE RATE slightly clockwise out of POWER OFF TIME BASE to .1 s FUNCTION to FREQUENCY - LEVEL + to PRESET</p> <p>b. Connect output of Frequency Synthesizer to Counter DC SIGNAL INPUT and to Oscilloscope input with BNC "T" connector. The oscilloscope is used to monitor the input signal.</p> <p>c. Vary frequency of Frequency Synthesizer from 0 to 50 MHz at 0.1V rms (0.28 V peak-to-peak).</p> <p>d. To check for pulse operation, connect Pulse Generator to DC INPUT connector of Counter with normal recommended load. Set Pulse Generator for 1 μsec, 1 volt pulse of the polarity used to adjust the trigger bias with a 500 pps repetition rate. Vary -LEVEL+ control until count is obtained.</p>

Table 3-2. In-Cabinet Performance Check (cont'd)

<p>AC INPUT</p> <p>Repeat the procedure given for DC INPUT in steps a through d with the input signal connected to the AC Input. Frequency range 25 Hz to 50 MHz.</p>
<p>2. GATE TIME: selectable from 1 microsecond to 10 seconds.</p>
<p>a. Set Counter controls as follows: SENSITIVITY to .1 VOLT SAMPLE RATE slightly clockwise out of POWER OFF TIME BASE to 1 μs FUNCTION to FREQUENCY - LEVEL + to PRESET</p> <p>b. Connect Frequency Synthesizer output to Counter DC SIGNAL INPUT.</p> <p>c. Set Frequency Synthesizer for 10 MHz at 0.1 V rms.</p> <p>d. Rotate TIME BASE switch counterclockwise through 10s gate position and observe counter reading for each setting. Record results on test card.</p>
<p>3. ACCURACY: ± 1 count, \pm time base accuracy.</p>
<p>a. Set Counter controls as follows: SENSITIVITY to .1 VOLT SAMPLE RATE slightly clockwise out of POWER OFF TIME BASE to 1 μs FUNCTION to FREQUENCY - LEVEL + to PRESET</p> <p>b. Allow Counter to warm up for 72 hours. Internal crystal should be stabilized and calibrated to 1×10^8 to a primary standard.</p> <p>c. Connect output of Frequency Synthesizer (calibrated to 1×10^8 to a primary standard) to the Counter DC INPUT.</p> <p>d. Set Frequency Synthesizer to 50 MHz at 0.1V rms.</p> <p>e. With TIME BASE switch in the 1 μs position, the Counter should count 50 MHz ± 1 count. Record accuracy on test card.</p> <p>f. Change the TIME BASE switch to the 10s gate position. The Counter should count 50 MHz ± 12 counts. Record accuracy on test card.</p>
<p>4. OUTPUT DISPLAY: 8 significant figures with decimal point units of measure (kHz or MHz).</p>
<p>SELF-CHECK: counts 10 MHz for the gate time chosen by the TIME BASE switch.</p>
<p>a. Use Self-Check procedure; see Figure 6-1, page 6-4.</p> <p>b. Record results on test card.</p>
<p>SCALING</p>
<p>1. RANGE: 0 to 50 MHz</p>
<p>a. Set Counter controls as follows: SENSITIVITY to .1V SAMPLE RATE slightly clockwise out of POWER OFF TIME BASE to 10s FUNCTION to MANUAL START - LEVEL + to PRESET MODE (rear panel) to SCALER OUTPUT (rear panel) to SCALER RATIO 10</p>

Table 3-2: In-Cabinet Performance Check (cont'd)

<p>b. Connect output from rear panel SCALER RATIO OUTPUT jack to Oscilloscope or another 5245L.</p> <p>c. Connect output of Frequency Synthesizer to Counter DC SIGNAL INPUT.</p> <p>d. Set Frequency Synthesizer for 50 MHz at 0.1 V rms. The scaled output should be 5 MHz. Record results on test card.</p>
<p>2. FACTOR: by decade selectable from 10 to 10⁹.</p>
<p>a. Set Counter controls as follows</p> <p style="padding-left: 40px;">SENSITIVITY to .1 VOLT SAMPLE RATE to slightly clockwise out of POWER OFF. TIME BASE to 10 sec. FUNCTION to MAN START. - LEVEL + to PRESET MODE (rear panel) to SCALER OUTPUT (rear panel) to SCALER RATIO 10.</p> <p>b. Connect rear panel SCALER RATIO OUTPUT to the Oscilloscope or another Counter.</p> <p>c. Connect the output of the Frequency Synthesizer to the Counter DC SIGNAL INPUT.</p> <p>d. Set Frequency Synthesizer output for 50 Mhz at 0.1V rms.</p> <p>e. Rotate rear panel OUTPUT switch through SCALER RATIO positions from 10 through 10⁹. The OUTPUT should reduce by a factor of 10 for each setting. Record results on test card.</p>
<p>PERIOD MEASUREMENTS</p>
<p>1. FREQUENCY RANGE SINGLE PERIOD: 0 to 1 MHz</p>
<p>a. Set Counter controls as follows:</p> <p style="padding-left: 40px;">SENSITIVITY to .1 VOLT SAMPLE RATE to slightly clockwise out of POWER OFF TIME BASE to .1 μsec FUNCTION to 1 PERIOD AVERAGE - LEVEL + to PRESET</p> <p>b. Connect output of Frequency Synthesizer to Counter DC SIGNAL INPUT.</p> <p>c. Set Synthesizer Frequency for 1 Mhz at 0.1V rms.</p> <p>d. Counter should display 1 μs, with decimal point correctly positioned and measurement unit displayed. Record results on test card.</p>
<p>2. FREQUENCY RANGE MULTIPLE PERIOD: 0 to 300 kHz.</p>
<p>a. Set Counter controls as follows:</p> <p style="padding-left: 40px;">SENSITIVITY to .1 VOLT SAMPLE RATE to slightly clockwise out of POWER OFF TIME BASE to 10 sec. FUNCTION to PERIOD AVERAGE - LEVEL + to PRESET</p> <p>b. Connect output of Frequency Synthesizer to Counter DC SIGNAL INPUT.</p> <p>c. Set Frequency Synthesizer for 300 kHz at 0.1V rms.</p> <p>d. Rotate TIME BASE switch clockwise to .1 μs observing count. Switch FUNCTION switch to 10 PERIOD AVERAGE and rotate TIME BASE switch counterclockwise through 10 sec observing count at each setting. Repeat rotation of TIME BASE switch at each position of PERIOD AVERAGE switch. Record results on test card. This check also checks Item 5, OUTPUT DISPLAY.</p>

Table 3-2. In-Cabinet Performance Check (cont'd)

<p>3. PERIOD MEASUREMENT ACCURACY: ± 1 count \pm time base accuracy \pm trigger error where the trigger error is expressed as $\pm 0.3\%$ over 1 period divided by the number of periods averaged for signals with a signal to noise ratio of greater than 40 dB.</p>
<p>a. Set Counter controls as follows:</p> <p style="padding-left: 40px;">SENSITIVITY to .1 VOLT SAMPLE RATE to slightly clockwise out of POWER OFF TIME BASE to .1 μsec FUNCTION to 1 PERIOD AVERAGE - LEVEL + to PRESET</p> <p>b. Connect output of Frequency Synthesizer to Counter DC SIGNAL INPUT.</p> <p>c. Set Frequency Synthesizer for 1 MHz at 0.1 V rms.</p> <p>d. Counter should display $1 \mu s \pm 1$ count. Record results on test card.</p>
<p>4. PERIODS AVERAGED: 1 to 10^5 periods in decade steps.</p>
<p>a. Set Counter controls as follows:</p> <p style="padding-left: 40px;">SENSITIVITY to .1 VOLT SAMPLE RATE slightly clockwise out of POWER OFF TIME BASE to .1 μsec FUNCTION to 1 PERIOD AVERAGE - LEVEL + to PRESET</p> <p>b. Connect output of Frequency Synthesizer Counter DC SIGNAL INPUT.</p> <p>c. Set Frequency Synthesizer for 300 kHz at 0.1V rms.</p> <p>d. Rotate FUNCTION switch from 1 PERIOD AVERAGE through 100K (10^5) PERIOD AVERAGE and observe count in each setting. Record results on test card.</p>
<p>5. OUTPUT DISPLAY: 8 significant figures with decimal point and units of measure (sec, ms, or μs).</p>
<p>This is checked by Item 2, FREQUENCY RANGE MULTIPLE PERIOD. If check is satisfactory, mark test card OK.</p>
<p>6. SELF CHECK: Gate time is 10 μs to 1 sec (periods averaged of 100 kHz); counts 100 kHz from the time base.</p>
<p>Use Self Check Table 6-5, page 6-5. Record results on test card.</p>
<p>FREQUENCY RATIO MEASUREMENTS</p>
<p>1. F1 FREQUENCY RANGE: 0 to 50 MHz</p>
<p>a. Set Counter controls as follows:</p> <p style="padding-left: 40px;">SENSITIVITY to .1 VOLT SAMPLE RATE slightly clockwise out of POWER OFF TIME BASE to EXT. FUNCTION to 1 PERIOD AVERAGE - LEVEL + to PRESET</p> <p>b. Connect Frequency Synthesizer to Counter TIME BASE EXT connector and set output to 0.1V rms.</p> <p>c. Connect HP 5245L 100 Hz OUTPUT STD FREQ to Counter AC SIGNAL INPUT (F2 INPUT).</p> <p>d. Observe ratio of F/1 MHz by selecting F1 on Frequency Synthesizer as shown in table on the following page; record readings.</p>

Table 3-2. In-Cabinet Performance Check (cont'd)

F1	F2	Ratio F1/F2
50 MHz	100 Hz	500,000
10 MHz	100 Hz	100,000
1 MHz	100 Hz	10,000
100 kHz	100 Hz	1,000
10 kHz	100 Hz	100
1 kHz	100 Hz	10
500 Hz	100 Hz	5
100 Hz	100 Hz	1

2. F2 FREQUENCY RANGE: 0 to 300 kHz.

- a. Set Counter controls as follows:
 SENSITIVITY to .1 VOLT
 SAMPLE RATE to slightly clockwise out of POWER OFF
 TIME BASE to EXT.
 FUNCTION to 10 PERIOD AVERAGE.
 - LEVEL + to PRESET
- b. Connect Frequency Synthesizer set for 1 MHz (F₁) at 0.1V rms to the Counter TIME BASE EXT connector.
- c. Connect Low Frequency Generator to Counter DC SIGNAL INPUT. Vary Low Frequency Generator from 2, 5, and 10 Hz at 0.1V rms. Observe Counter display for ratio F₁/F₂. Record results on test card.
- d. Replace Low Frequency Generator with Synthesizer and set to frequencies as shown (F₂). Use 1 MHz from OUTPUT STD FREQ for F₁. Record readings on test card.

F2	Ratio F1/F2
2	500000
5	200000
10	100000
100	10000
1 kHz	1000
100 kHz	10
300 kHz	3

3. MULTIPLE PERIOD: 1 to 10⁵ in decade steps.

- a. Set Counter controls as follows:
 SENSITIVITY to .1 VOLT
 SAMPLE RATE to slightly clockwise out of POWER OFF
 TIME BASE to EXT
 FUNCTION to 1 PERIOD AVERAGE
 - LEVEL + to PRESET
- c. Connect Frequency Synthesizer set to 1 MHz (F₁) at 0.1V rms to Counter TIME BASE EXT input.
- d. Connect Oscillator set to 100 kHz at 0.1V rms to Counter DC SIGNAL INPUT.
- e. Counter should display the ratio of F₁/F₂ ± 1 count. Record results on test card.

TIME BASE: FREQUENCY (INTERNAL): 1 MHz

1. Stability: Aging Rate: Less than 3 parts in 10⁹ per 24 hours.
 As a function of line voltage: less than ± 5 parts in 10¹⁰ for changes of ± 10%.
 As a function of ambient temperature: less than ± 2 parts in 10¹⁰ per °C from -20°C to +55°C.

Table 3-2. In-Cabinet Performance Check (cont'd)

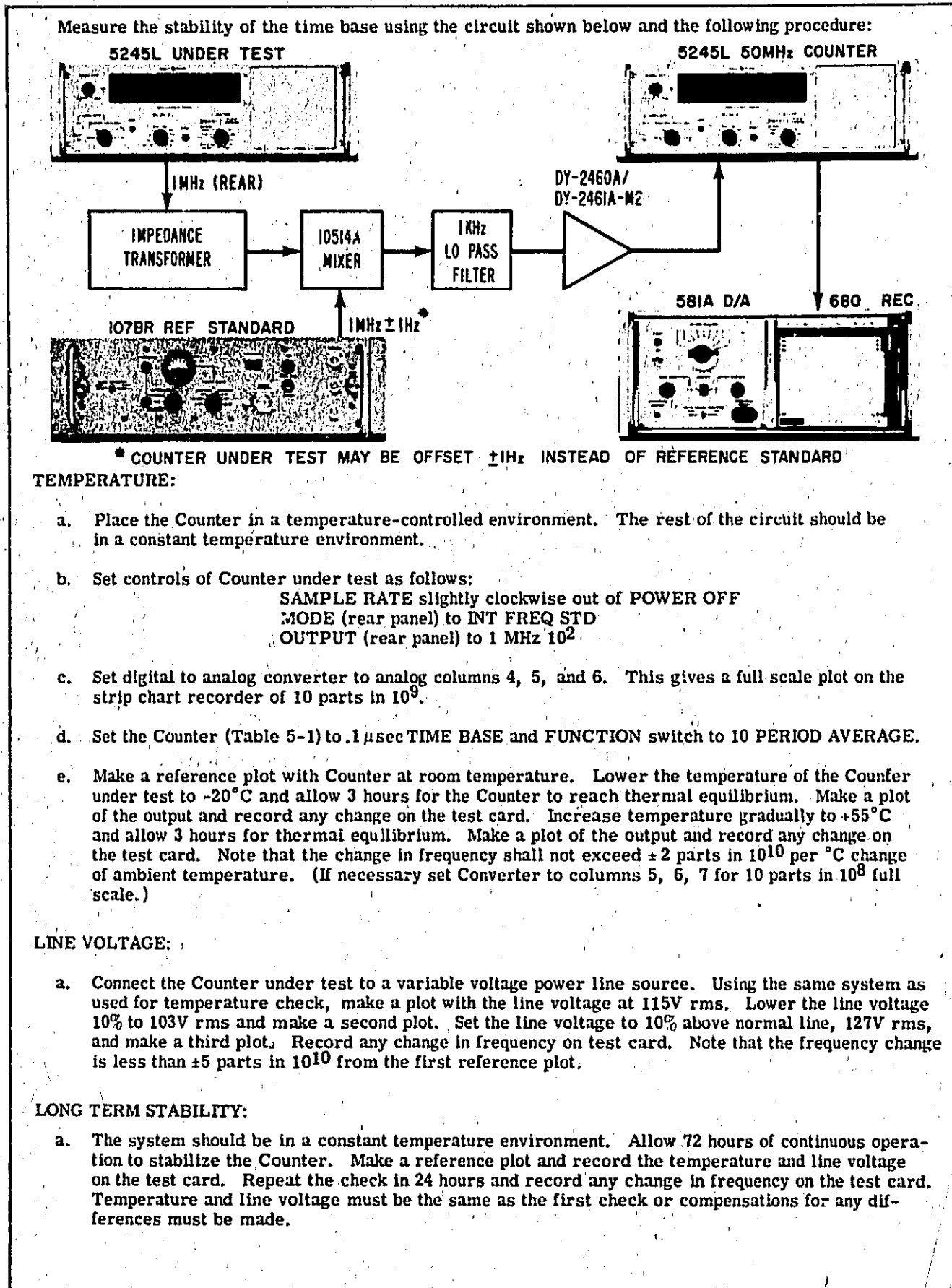

Table 3-2. In-Cabinet Performance Check (cont'd)

<p>2. TIME BASE-Output-FRONT PANEL: 0.1 Hz to 1 MHz in decade steps; 1V peak-to-peak. (See specifications Table 1-1.)</p>
<p>a. Set Counter controls as follows: SAMPLE RATE slightly clockwise out of POWER OFF TIME BASE to 1 μs FUNCTION to FREQUENCY</p> <p>b. Connect Oscilloscope to EXT input jack.</p> <p>c. Oscilloscope should display 1 MHz rectangular wave of 1V peak-to-peak. Record on test card the frequency and amplitude of the TIME BASE output.</p> <p>d. Set the TIME BASE switch to each position, 10 μs through 10s. The displayed frequency should decrease by a factor of 10 for each successive setting of the TIME BASE. The amplitude should be 1V peak-to-peak for all settings. Record on test card frequency and amplitude of TIME BASE output for each successive setting.</p>
<p>3. TIME BASE-Output-REAR PANEL: 0.1 Hz to 10 MHz in decade steps 5V peak-to-peak rectangular wave with 1000-Ω source at 1 MHz and lower; 1V rms sine wave with 1000-Ω source impedance only at 10 MHz. (See specifications Table 1-1.)</p>
<p>a. Set Counter controls as follows: SAMPLE RATE slightly clockwise out of POWER OFF MODE (rear panel) to INT STD FREQ OUTPUT (rear panel) to 10 MHz 10</p> <p>b. Connect Oscilloscope to the OUTPUT connector (J5) on the rear panel.</p> <p>c. Oscilloscope should display 10 MHz at 1V rms. Record the frequency and amplitude on test card.</p> <p>d. Set the OUTPUT switch to each position, 1 MHz 10^2 through .1 Hz 10^9. The displayed frequency should decrease by a factor of 10 for each successive setting of the OUTPUT switch.</p>
<p>INPUT ATTENUATION</p>
<p>1. Range: Three ranges 0.1, 1.0, and 10 volts.</p>
<p>a. Set Counter controls as follows: SENSITIVITY to .1 VOLT SAMPLE RATE slightly clockwise out of POWER OFF TIME BASE to .1s FUNCTION to FREQUENCY - LEVEL + to PRESET</p> <p>b. Connect Oscillator to Counter DC SIGNAL INPUT. Set Oscillator for 100 kHz at 100 mV (.1V) rms. Counter should count and display 100 kHz.</p> <p>c. Change Counter SENSITIVITY to 1.0 volt. Increase Oscillator output to 100 kHz at 1V rms. The Counter should count and display 100 kHz. Record results on test card.</p> <p>d. Change Counter SENSITIVITY to 10 volts. Increase Oscillator output to 100 kHz at 10V rms. The Counter should count and display 100 kHz. Record results on test card.</p>
<p>DISPLAY STORAGE</p>
<p>a. Set Counter controls as follows: SENSITIVITY to CHECK SAMPLE RATE slightly clockwise out of POWER OFF TIME BASE to .1s FUNCTION to FREQUENCY STORAGE (rear panel) to OFF - LEVEL - to PRESET</p>

Table 3-2. In-Cabinet Performance Check (cont'd)

<p>b. Counter should count 10,000,000 kHz. The change in count should be visible on each digital display tube.</p> <p>c. Set Counter STORAGE switch to the STORAGE position. The Counter should count, display, and hold 10,000,000 kHz count providing a continuous display of the most recent count. Record results on test card.</p>
SAMPLE RATE
<p>1. Sample Rate: Variable from less than .2 sec to greater than 5 seconds.</p>
<p>a. Set Counter controls as follows: SENSITIVITY to CHECK SAMPLE RATE to POWER OFF TIME BASE to 10 ms FUNCTION to FREQUENCY - LEVEL + to PRESET</p> <p>b. Connect Oscilloscope to J11 Pin 48.</p> <p>c. Turn the Counter SAMPLE RATE control slightly clockwise out of POWER OFF, and note that the Counter turns on.</p> <p>d. With the SAMPLE RATE control in maximum position (ccw), observe with oscilloscope the negative pulse duration between gate closing and the following gate opening; it should be less than 200 milliseconds (.2 sec).</p> <p>e. Increase the SAMPLE RATE control clockwise to minimum sample rate. Observe with Oscilloscope the negative pulse duration between gate closing and the following gate opening; it should be more than 5 seconds.</p> <p>f. Set the SAMPLE RATE control to the Hold position. The last Counter reading should remain displayed indefinitely. Record results on test card.</p>
DIGITAL OUTPUT
<p>1. Output 4 line 1-2-2-4 BCD: Impedance 100K each line "0" State Level -8V "1" State Level +18V</p>
<p>a. The impedance is determined by a fixed value 100K resistor, which can be seen in schematic diagrams Figures 7-9, 7-11, and 7-14.</p> <p>b. Set Counter controls as follows: SAMPLE RATE slightly clockwise out of POWER OFF SENSITIVITY to .1 V TIME BASE to 1 μs FUNCTION to MANUAL START MODE (rear panel) to INT STD FREQ</p> <p>c. Connect Frequency Synthesizer to Counter AC INPUT connector. Set output level at 1 V rms.</p> <p>d. Connect Oscilloscope to following points to verify "0" state and "1" state levels. Oscilloscope will display the switch from "0" state (-8 volts) to "1" state (+18 volts) as a positive 26 volts step. Check all recorder outputs for "0" state and "1" state and mark the test card ok.</p>

Table 3-2. In-Cabinet Performance Check (cont'd)

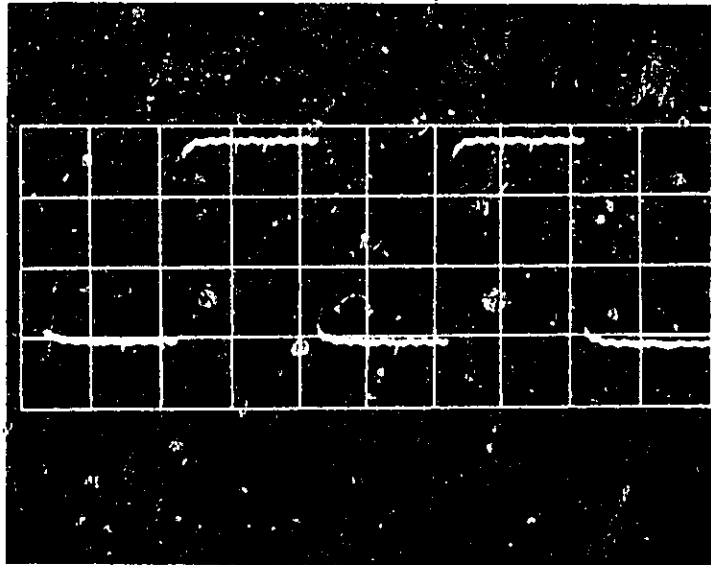

BCD Oscilloscope Display
Oscilloscope Sensitivity 10V/cm

DIGITAL RECORDER

J11 Pins

1	First DCA A18	J11	9	Fifth DCA A13
2	Set	10	10	Set
26	Frequency Synthesizer to 10 Hz	34	34	Frequency Synthesizer to 100 kHz
27	(@ 1 V rms)	35	35	(@ 1 V rms)
3	Second DCA A16	11	11	Sixth DCA A12
4	Set	12	12	Set
28	Frequency Synthesizer to 100 Hz	36	36	Frequency Synthesizer to 1 MHz
29	(@ 1 V rms)	27	27	(@ 1 V rms)
5	Third DCA A15	13	13	Seventh DCA A11
6	Set	14	14	Set
30	Frequency Synthesizer to 1 KHz	38	38	Frequency Synthesizer to 10 MHz
31	(@ 1 V rms)	39	39	(@ 1 V rms)
7	Fourth DCA A14	15	15	Eighth DCA A10
8	Set	16	16	Set
32	Frequency Synthesizer to 10 kHz	40	40	Frequency Synthesizer to 10 MHz
33	(@ 1 V rms)	41	41	(@ 1 V rms)

2. Reference Levels: approx. +9 volts, 350-ohm source impedance; approx. -1V, 1000-ohm source.

- a. Set Counter SAMPLE RATE control slightly clockwise out of POWER OFF.
- b. Connect DC Voltmeter to DIGITAL RECORDER jack (J11) pin 25 to check pos reference (+9V) and pin 24 to check neg reference (-1V). Record the amplitude of both reference voltages on test card.

Table 3-2. In-Cabinet Performance Check (cont'd)

<p>3. Print Command: Negative step from +13 volts to 0 volts, DC-coupled.</p> <p>a. Connect Oscilloscope to DIGITAL RECORDER jack (J11) pin 48.</p> <p>b. Set Counter controls as follows: SAMPLE RATE slightly clockwise out of POWER OFF SENSITIVITY to CHECK TIME BASE to 10 ms FUNCTION to FREQUENCY</p> <p>c. The Oscilloscope should display the print command step (~13 volts for each counting cycle). Record the amplitude of this negative step on test card.</p>
<p>4. Hold-Off Requirements: +15V min., +25V max. from chassis ground (1000-ohm source).</p> <p>a. Set Counter controls as follows: SAMPLE RATE slightly clockwise out of POWER OFF SENSITIVITY to CHECK TIME BASE to 10 s STORAGE (on rear panel) to non-storage FUNCTION to FREQUENCY</p> <p>b. With DC Power Supply, apply hold-off voltage, +25 volts in series with a 1000-ohm resistor to DIGITAL RECORDER jack (J11) Pin 22 on the rear panel. The Counter should stop until the hold-off voltage is removed from J11, pin 22. Record hold-off voltage on test card.</p> <p>c. Repeat step b, using +15 hold-off voltage. Record hold-off voltage on test card. Note this check can be made using any hold-off voltage from +15 volts to +25 volts.</p> <p>GATE INDICATOR. Front panel indication of main gate "open" state</p> <p>a. Set Counter controls as follows: SENSITIVITY to CHECK SAMPLE RATE slightly clockwise out of POWER OFF TIME BASE to 10 s FUNCTION to MANUAL STOP - LEVEL + to PRESET</p> <p>b. Set Counter FUNCTION switch to MANUAL START, the Counter gate lamp should turn on. Record results on test card.</p> <p>RE-SET CAPABILITY. A momentary control on the front panel that returns both the displayed and internal count to zero.</p> <p>a. Set Counter controls as follows: SENSITIVITY to CHECK SAMPLE RATE slightly clockwise out of POWER OFF TIME BASE TO 10s FUNCTION to FREQUENCY - LEVEL + to PRESET</p> <p>b. Push front panel RESET pushbutton. Counter should reset and then start a new count. Record result on test card.</p>

PERFORMANCE CHECK TEST CARD

Hewlett-Packard Model 5245L Electronic Counter Serial No. _____ - _____	Tests performed by _____ Date _____																																												
Description	Check																																												
A. FREQUENCY MEASUREMENTS. 1. RANGE: Dc coupled: 0 to 50 MHz Ac coupled: 25 Hz to 50 MHz 2. GATE TIME: selectable from 1 μ s to 10s. 3. ACCURACY: ± 1 count, \pm time base accuracy 4. OUTPUT DISPLAY: 8 significant figures with decimal point and units of measure (kHz or MHz) SELF-CHECK: counts 10 MHz for the gate time chosen by the TIME BASE switch.	<table style="width: 100%; border-collapse: collapse;"> <tr> <td style="width: 50%;"><input type="checkbox"/></td><td style="width: 50%;">0 Hz to 50 MHz</td> </tr> <tr> <td><input type="checkbox"/></td><td>25 Hz to 50 MHz</td> </tr> <tr> <td><input type="checkbox"/></td><td>00000010.</td> </tr> <tr> <td><input type="checkbox"/></td><td>0000010.0</td> </tr> <tr> <td><input type="checkbox"/></td><td>000010.00</td> </tr> <tr> <td><input type="checkbox"/></td><td>00010000.</td> </tr> <tr> <td><input type="checkbox"/></td><td>0010000.0</td> </tr> <tr> <td><input type="checkbox"/></td><td>010000.00</td> </tr> <tr> <td><input type="checkbox"/></td><td>10000.000</td> </tr> <tr> <td><input type="checkbox"/></td><td>0000.0000</td> </tr> <tr> <td><input type="checkbox"/></td><td>50 MHz ± 1 count</td> </tr> <tr> <td><input type="checkbox"/></td><td>50 MHz ± 12 counts</td> </tr> <tr> <td><input type="checkbox"/></td><td>00000010. MHz</td> </tr> <tr> <td><input type="checkbox"/></td><td>0000010.0 MHz</td> </tr> <tr> <td><input type="checkbox"/></td><td>000010.00 MHz</td> </tr> <tr> <td><input type="checkbox"/></td><td>00010000. kHz</td> </tr> <tr> <td><input type="checkbox"/></td><td>0010000.0 kHz</td> </tr> <tr> <td><input type="checkbox"/></td><td>010000.00 kHz</td> </tr> <tr> <td><input type="checkbox"/></td><td>1000.0000 kHz</td> </tr> <tr> <td><input type="checkbox"/></td><td>0000.0000 kHz</td> </tr> </table>	<input type="checkbox"/>	0 Hz to 50 MHz	<input type="checkbox"/>	25 Hz to 50 MHz	<input type="checkbox"/>	00000010.	<input type="checkbox"/>	0000010.0	<input type="checkbox"/>	000010.00	<input type="checkbox"/>	00010000.	<input type="checkbox"/>	0010000.0	<input type="checkbox"/>	010000.00	<input type="checkbox"/>	10000.000	<input type="checkbox"/>	0000.0000	<input type="checkbox"/>	50 MHz ± 1 count	<input type="checkbox"/>	50 MHz ± 12 counts	<input type="checkbox"/>	00000010. MHz	<input type="checkbox"/>	0000010.0 MHz	<input type="checkbox"/>	000010.00 MHz	<input type="checkbox"/>	00010000. kHz	<input type="checkbox"/>	0010000.0 kHz	<input type="checkbox"/>	010000.00 kHz	<input type="checkbox"/>	1000.0000 kHz	<input type="checkbox"/>	0000.0000 kHz				
<input type="checkbox"/>	0 Hz to 50 MHz																																												
<input type="checkbox"/>	25 Hz to 50 MHz																																												
<input type="checkbox"/>	00000010.																																												
<input type="checkbox"/>	0000010.0																																												
<input type="checkbox"/>	000010.00																																												
<input type="checkbox"/>	00010000.																																												
<input type="checkbox"/>	0010000.0																																												
<input type="checkbox"/>	010000.00																																												
<input type="checkbox"/>	10000.000																																												
<input type="checkbox"/>	0000.0000																																												
<input type="checkbox"/>	50 MHz ± 1 count																																												
<input type="checkbox"/>	50 MHz ± 12 counts																																												
<input type="checkbox"/>	00000010. MHz																																												
<input type="checkbox"/>	0000010.0 MHz																																												
<input type="checkbox"/>	000010.00 MHz																																												
<input type="checkbox"/>	00010000. kHz																																												
<input type="checkbox"/>	0010000.0 kHz																																												
<input type="checkbox"/>	010000.00 kHz																																												
<input type="checkbox"/>	1000.0000 kHz																																												
<input type="checkbox"/>	0000.0000 kHz																																												
B. SCALING. 1. RANGE: 0 to 50 MHz 2. FACTOR: by decades up to 10^9	TIME BASE OUTPUT JACK (J5) <table style="width: 100%; border-collapse: collapse;"> <tr> <td><input type="checkbox"/></td><td>5 MHz</td> </tr> <tr> <td><input type="checkbox"/></td><td>5 MHz in 10 MHz 10^2 position</td> </tr> <tr> <td><input type="checkbox"/></td><td>.5 MHz in 1 MHz 10^2 position</td> </tr> <tr> <td><input type="checkbox"/></td><td>50 kHz in 100 kHz 10^3 position</td> </tr> <tr> <td><input type="checkbox"/></td><td>5 kHz in 10 kHz 10^4 position</td> </tr> <tr> <td><input type="checkbox"/></td><td>.5 kHz in 1 kHz 10^5 position</td> </tr> <tr> <td><input type="checkbox"/></td><td>50 Hz in 100 Hz 10^6 position</td> </tr> <tr> <td><input type="checkbox"/></td><td>5 Hz in 10 Hz 10^7 position</td> </tr> <tr> <td><input type="checkbox"/></td><td>.5 Hz in 1 Hz 10^8 position</td> </tr> <tr> <td><input type="checkbox"/></td><td>.05 Hz in .1 Hz 10^9 position</td> </tr> </table>	<input type="checkbox"/>	5 MHz	<input type="checkbox"/>	5 MHz in 10 MHz 10^2 position	<input type="checkbox"/>	.5 MHz in 1 MHz 10^2 position	<input type="checkbox"/>	50 kHz in 100 kHz 10^3 position	<input type="checkbox"/>	5 kHz in 10 kHz 10^4 position	<input type="checkbox"/>	.5 kHz in 1 kHz 10^5 position	<input type="checkbox"/>	50 Hz in 100 Hz 10^6 position	<input type="checkbox"/>	5 Hz in 10 Hz 10^7 position	<input type="checkbox"/>	.5 Hz in 1 Hz 10^8 position	<input type="checkbox"/>	.05 Hz in .1 Hz 10^9 position																								
<input type="checkbox"/>	5 MHz																																												
<input type="checkbox"/>	5 MHz in 10 MHz 10^2 position																																												
<input type="checkbox"/>	.5 MHz in 1 MHz 10^2 position																																												
<input type="checkbox"/>	50 kHz in 100 kHz 10^3 position																																												
<input type="checkbox"/>	5 kHz in 10 kHz 10^4 position																																												
<input type="checkbox"/>	.5 kHz in 1 kHz 10^5 position																																												
<input type="checkbox"/>	50 Hz in 100 Hz 10^6 position																																												
<input type="checkbox"/>	5 Hz in 10 Hz 10^7 position																																												
<input type="checkbox"/>	.5 Hz in 1 Hz 10^8 position																																												
<input type="checkbox"/>	.05 Hz in .1 Hz 10^9 position																																												
C. PERIOD MEASUREMENTS 1. FREQUENCY RANGE SINGLE PERIOD: 0 to 1 MHz. 2. FREQUENCY RANGE MULTIPLE PERIOD: 0 to 300 kHz	<table style="width: 100%; border-collapse: collapse;"> <tr> <td colspan="2" style="text-align: center;">SINGLE PERIOD</td> </tr> <tr> <td><input type="checkbox"/></td><td>0100001.0 μs</td> </tr> <tr> <td colspan="2" style="text-align: center;">MULTIPLE PERIOD</td> </tr> <tr> <td colspan="2" style="text-align: center;">1 PERIOD AVERAGE</td> </tr> <tr> <td>.1 μs</td><td><input type="checkbox"/> 0000003.3 μs</td> </tr> <tr> <td>1 μs</td><td><input type="checkbox"/> 00000003. μs</td> </tr> <tr> <td>10 μs</td><td><input type="checkbox"/> 000000.00 ms</td> </tr> <tr> <td>.1 ms</td><td><input type="checkbox"/> 0000000.0 ms</td> </tr> <tr> <td>1 ms</td><td><input type="checkbox"/> 00000000. ms</td> </tr> <tr> <td>10 ms</td><td><input type="checkbox"/> 000000.00 sec</td> </tr> <tr> <td>.1 s</td><td><input type="checkbox"/> 0000000.0 sec</td> </tr> <tr> <td>1 s</td><td><input type="checkbox"/> 00000000. sec</td> </tr> <tr> <td>10 s</td><td><input type="checkbox"/> *</td> </tr> <tr> <td colspan="2" style="text-align: center;">10 PERIOD AVERAGE</td> </tr> <tr> <td>.1 μs</td><td><input type="checkbox"/> 000003.33 μs</td> </tr> <tr> <td>1 μs</td><td><input type="checkbox"/> 0000003.3 μs</td> </tr> <tr> <td>10 μs</td><td><input type="checkbox"/> 00000003. μs</td> </tr> <tr> <td>.1 ms</td><td><input type="checkbox"/> 000000.00 ms</td> </tr> <tr> <td>1 ms</td><td><input type="checkbox"/> 0000000.0 ms</td> </tr> <tr> <td>10 ms</td><td><input type="checkbox"/> 00000000. ms</td> </tr> <tr> <td>.1 s</td><td><input type="checkbox"/> 000000.00 sec</td> </tr> <tr> <td>10 s</td><td><input type="checkbox"/> *</td> </tr> </table>	SINGLE PERIOD		<input type="checkbox"/>	0100001.0 μ s	MULTIPLE PERIOD		1 PERIOD AVERAGE		.1 μ s	<input type="checkbox"/> 0000003.3 μ s	1 μ s	<input type="checkbox"/> 00000003. μ s	10 μ s	<input type="checkbox"/> 000000.00 ms	.1 ms	<input type="checkbox"/> 0000000.0 ms	1 ms	<input type="checkbox"/> 00000000. ms	10 ms	<input type="checkbox"/> 000000.00 sec	.1 s	<input type="checkbox"/> 0000000.0 sec	1 s	<input type="checkbox"/> 00000000. sec	10 s	<input type="checkbox"/> *	10 PERIOD AVERAGE		.1 μ s	<input type="checkbox"/> 000003.33 μ s	1 μ s	<input type="checkbox"/> 0000003.3 μ s	10 μ s	<input type="checkbox"/> 00000003. μ s	.1 ms	<input type="checkbox"/> 000000.00 ms	1 ms	<input type="checkbox"/> 0000000.0 ms	10 ms	<input type="checkbox"/> 00000000. ms	.1 s	<input type="checkbox"/> 000000.00 sec	10 s	<input type="checkbox"/> *
SINGLE PERIOD																																													
<input type="checkbox"/>	0100001.0 μ s																																												
MULTIPLE PERIOD																																													
1 PERIOD AVERAGE																																													
.1 μ s	<input type="checkbox"/> 0000003.3 μ s																																												
1 μ s	<input type="checkbox"/> 00000003. μ s																																												
10 μ s	<input type="checkbox"/> 000000.00 ms																																												
.1 ms	<input type="checkbox"/> 0000000.0 ms																																												
1 ms	<input type="checkbox"/> 00000000. ms																																												
10 ms	<input type="checkbox"/> 000000.00 sec																																												
.1 s	<input type="checkbox"/> 0000000.0 sec																																												
1 s	<input type="checkbox"/> 00000000. sec																																												
10 s	<input type="checkbox"/> *																																												
10 PERIOD AVERAGE																																													
.1 μ s	<input type="checkbox"/> 000003.33 μ s																																												
1 μ s	<input type="checkbox"/> 0000003.3 μ s																																												
10 μ s	<input type="checkbox"/> 00000003. μ s																																												
.1 ms	<input type="checkbox"/> 000000.00 ms																																												
1 ms	<input type="checkbox"/> 0000000.0 ms																																												
10 ms	<input type="checkbox"/> 00000000. ms																																												
.1 s	<input type="checkbox"/> 000000.00 sec																																												
10 s	<input type="checkbox"/> *																																												

PERFORMANCE CHECK TEST CARD (Cont'd)

Description	Check																																																																																																												
<p>MULTIPLE PERIOD CHECK (cont'd)</p>	<p>100 PERIOD AVERAGE</p> <table border="0"> <tr><td>.1 μs</td><td><input type="text"/></td><td>00003.333 μs</td></tr> <tr><td>1 μs</td><td><input type="text"/></td><td>000003.33 μs</td></tr> <tr><td>10 μs</td><td><input type="text"/></td><td>0000003.3 μs</td></tr> <tr><td>.1 ms</td><td><input type="text"/></td><td>00000003. μs</td></tr> <tr><td>1 ms</td><td><input type="text"/></td><td>000000.00 ms</td></tr> <tr><td>10 ms</td><td><input type="text"/></td><td>0000000.0 ms</td></tr> <tr><td>.1 s</td><td><input type="text"/></td><td>00000000. ms</td></tr> <tr><td>1 s</td><td><input type="text"/></td><td>*</td></tr> <tr><td>10 s</td><td><input type="text"/></td><td>*</td></tr> </table> <p>1 K PERIOD AVERAGE</p> <table border="0"> <tr><td>.1 μs</td><td><input type="text"/></td><td>0003.3333 μs</td></tr> <tr><td>1 μs</td><td><input type="text"/></td><td>00003.333 μs</td></tr> <tr><td>10 μs</td><td><input type="text"/></td><td>000003.33 μs</td></tr> <tr><td>.1 ms</td><td><input type="text"/></td><td>0000003.3 μs</td></tr> <tr><td>1 ms</td><td><input type="text"/></td><td>00000003. μs</td></tr> <tr><td>10 ms</td><td><input type="text"/></td><td>000000.00 ms</td></tr> <tr><td>.1 s</td><td><input type="text"/></td><td>*</td></tr> <tr><td>1 s</td><td><input type="text"/></td><td>*</td></tr> <tr><td>10 s</td><td><input type="text"/></td><td>*</td></tr> </table> <p>10 K PERIOD AVERAGE</p> <table border="0"> <tr><td>.1 μs</td><td><input type="text"/></td><td>003.33333 μs</td></tr> <tr><td>1 μs</td><td><input type="text"/></td><td>0003.3333 μs</td></tr> <tr><td>10 μs</td><td><input type="text"/></td><td>00003.333 μs</td></tr> <tr><td>.1 ms</td><td><input type="text"/></td><td>000003.33 μs</td></tr> <tr><td>1 ms</td><td><input type="text"/></td><td>0000003.3 μs</td></tr> <tr><td>10 ms</td><td><input type="text"/></td><td>*</td></tr> <tr><td>.1 s</td><td><input type="text"/></td><td>*</td></tr> <tr><td>1 s</td><td><input type="text"/></td><td>*</td></tr> <tr><td>10 s</td><td><input type="text"/></td><td>*</td></tr> </table> <p>100 K PERIOD AVERAGE</p> <table border="0"> <tr><td>.1 μs</td><td><input type="text"/></td><td>03.333333 μs</td></tr> <tr><td>1 μs</td><td><input type="text"/></td><td>003.33333 μs</td></tr> <tr><td>10 μs</td><td><input type="text"/></td><td>0003.3333 μs</td></tr> <tr><td>.1 ms</td><td><input type="text"/></td><td>00003.333 μs</td></tr> <tr><td>1 ms</td><td><input type="text"/></td><td>*</td></tr> <tr><td>10 ms</td><td><input type="text"/></td><td>*</td></tr> <tr><td>.1 s</td><td><input type="text"/></td><td>*</td></tr> <tr><td>1 s</td><td><input type="text"/></td><td>*</td></tr> <tr><td>10 s</td><td><input type="text"/></td><td>*</td></tr> </table>	.1 μ s	<input type="text"/>	00003.333 μ s	1 μ s	<input type="text"/>	000003.33 μ s	10 μ s	<input type="text"/>	0000003.3 μ s	.1 ms	<input type="text"/>	00000003. μ s	1 ms	<input type="text"/>	000000.00 ms	10 ms	<input type="text"/>	0000000.0 ms	.1 s	<input type="text"/>	00000000. ms	1 s	<input type="text"/>	*	10 s	<input type="text"/>	*	.1 μ s	<input type="text"/>	0003.3333 μ s	1 μ s	<input type="text"/>	00003.333 μ s	10 μ s	<input type="text"/>	000003.33 μ s	.1 ms	<input type="text"/>	0000003.3 μ s	1 ms	<input type="text"/>	00000003. μ s	10 ms	<input type="text"/>	000000.00 ms	.1 s	<input type="text"/>	*	1 s	<input type="text"/>	*	10 s	<input type="text"/>	*	.1 μ s	<input type="text"/>	003.33333 μ s	1 μ s	<input type="text"/>	0003.3333 μ s	10 μ s	<input type="text"/>	00003.333 μ s	.1 ms	<input type="text"/>	000003.33 μ s	1 ms	<input type="text"/>	0000003.3 μ s	10 ms	<input type="text"/>	*	.1 s	<input type="text"/>	*	1 s	<input type="text"/>	*	10 s	<input type="text"/>	*	.1 μ s	<input type="text"/>	03.333333 μ s	1 μ s	<input type="text"/>	003.33333 μ s	10 μ s	<input type="text"/>	0003.3333 μ s	.1 ms	<input type="text"/>	00003.333 μ s	1 ms	<input type="text"/>	*	10 ms	<input type="text"/>	*	.1 s	<input type="text"/>	*	1 s	<input type="text"/>	*	10 s	<input type="text"/>	*
.1 μ s	<input type="text"/>	00003.333 μ s																																																																																																											
1 μ s	<input type="text"/>	000003.33 μ s																																																																																																											
10 μ s	<input type="text"/>	0000003.3 μ s																																																																																																											
.1 ms	<input type="text"/>	00000003. μ s																																																																																																											
1 ms	<input type="text"/>	000000.00 ms																																																																																																											
10 ms	<input type="text"/>	0000000.0 ms																																																																																																											
.1 s	<input type="text"/>	00000000. ms																																																																																																											
1 s	<input type="text"/>	*																																																																																																											
10 s	<input type="text"/>	*																																																																																																											
.1 μ s	<input type="text"/>	0003.3333 μ s																																																																																																											
1 μ s	<input type="text"/>	00003.333 μ s																																																																																																											
10 μ s	<input type="text"/>	000003.33 μ s																																																																																																											
.1 ms	<input type="text"/>	0000003.3 μ s																																																																																																											
1 ms	<input type="text"/>	00000003. μ s																																																																																																											
10 ms	<input type="text"/>	000000.00 ms																																																																																																											
.1 s	<input type="text"/>	*																																																																																																											
1 s	<input type="text"/>	*																																																																																																											
10 s	<input type="text"/>	*																																																																																																											
.1 μ s	<input type="text"/>	003.33333 μ s																																																																																																											
1 μ s	<input type="text"/>	0003.3333 μ s																																																																																																											
10 μ s	<input type="text"/>	00003.333 μ s																																																																																																											
.1 ms	<input type="text"/>	000003.33 μ s																																																																																																											
1 ms	<input type="text"/>	0000003.3 μ s																																																																																																											
10 ms	<input type="text"/>	*																																																																																																											
.1 s	<input type="text"/>	*																																																																																																											
1 s	<input type="text"/>	*																																																																																																											
10 s	<input type="text"/>	*																																																																																																											
.1 μ s	<input type="text"/>	03.333333 μ s																																																																																																											
1 μ s	<input type="text"/>	003.33333 μ s																																																																																																											
10 μ s	<input type="text"/>	0003.3333 μ s																																																																																																											
.1 ms	<input type="text"/>	00003.333 μ s																																																																																																											
1 ms	<input type="text"/>	*																																																																																																											
10 ms	<input type="text"/>	*																																																																																																											
.1 s	<input type="text"/>	*																																																																																																											
1 s	<input type="text"/>	*																																																																																																											
10 s	<input type="text"/>	*																																																																																																											
<p>3. PERIOD MEASUREMENT ACCURACY: ± 1 count \pm time base accuracy \pm trigger error where the trigger error is expressed as $\pm 0.3\%$ over 1 period, divided by the number of periods averaged for signals with a signal-to-noise ratio of greater than 40 dB.</p>	<table border="0"> <tr> <td><input type="text"/></td> <td>0000001.0 μs \pm 1 count</td> </tr> </table>	<input type="text"/>	0000001.0 μ s \pm 1 count																																																																																																										
<input type="text"/>	0000001.0 μ s \pm 1 count																																																																																																												
<p>4. PERIODS AVERAGED: 1 to 10^5 in decade steps</p>	<p>PERIODS AVERAGED</p> <table border="0"> <tr><td>1</td><td><input type="text"/></td><td>0000003.3 μs</td></tr> <tr><td>10</td><td><input type="text"/></td><td>000003.33 μs</td></tr> <tr><td>100</td><td><input type="text"/></td><td>00003.333 μs</td></tr> <tr><td>1K</td><td><input type="text"/></td><td>0003.3333 μs</td></tr> <tr><td>10K</td><td><input type="text"/></td><td>003.33333 μs</td></tr> <tr><td>100K</td><td><input type="text"/></td><td>03.333333 μs</td></tr> </table>	1	<input type="text"/>	0000003.3 μ s	10	<input type="text"/>	000003.33 μ s	100	<input type="text"/>	00003.333 μ s	1K	<input type="text"/>	0003.3333 μ s	10K	<input type="text"/>	003.33333 μ s	100K	<input type="text"/>	03.333333 μ s																																																																																										
1	<input type="text"/>	0000003.3 μ s																																																																																																											
10	<input type="text"/>	000003.33 μ s																																																																																																											
100	<input type="text"/>	00003.333 μ s																																																																																																											
1K	<input type="text"/>	0003.3333 μ s																																																																																																											
10K	<input type="text"/>	003.33333 μ s																																																																																																											
100K	<input type="text"/>	03.333333 μ s																																																																																																											
<p>5. OUTPUT DISPLAY: 8 significant figures with decimal point and units of measure (sec, ms, or μs).</p>	<p>OUTPUT DISPLAY</p> <table border="0"> <tr> <td><input type="text"/></td> <td>See Item C-2</td> </tr> </table>	<input type="text"/>	See Item C-2																																																																																																										
<input type="text"/>	See Item C-2																																																																																																												

PERFORMANCE CHECK TEST CARD (Cont'd)

<p>6. SELF CHECK: Gate time is 10 μs to 1 sec (periods averaged of 100 kHz); counts 100 kHz from time base.</p>	<table style="width: 100%; border-collapse: collapse;"> <thead> <tr> <th style="text-align: left; border-bottom: 1px solid black;">PERIOD AVERAGE</th> <th style="border-bottom: 1px solid black;">DISPLAY</th> </tr> </thead> <tbody> <tr><td style="text-align: center;">1</td><td style="text-align: center;">00000001</td></tr> <tr><td style="text-align: center;">10</td><td style="text-align: center;">00000010</td></tr> <tr><td style="text-align: center;">100</td><td style="text-align: center;">00000100</td></tr> <tr><td style="text-align: center;">1K</td><td style="text-align: center;">00001000</td></tr> <tr><td style="text-align: center;">10K</td><td style="text-align: center;">00010000</td></tr> <tr><td style="text-align: center;">100K</td><td style="text-align: center;">00100000</td></tr> </tbody> </table>	PERIOD AVERAGE	DISPLAY	1	00000001	10	00000010	100	00000100	1K	00001000	10K	00010000	100K	00100000																																	
PERIOD AVERAGE	DISPLAY																																															
1	00000001																																															
10	00000010																																															
100	00000100																																															
1K	00001000																																															
10K	00010000																																															
100K	00100000																																															
<p>D. FREQUENCY RATIO MEASUREMENTS</p> <p>1. F1 FREQUENCY RANGE: 0 to 50 MHz</p> <p>2. F2 FREQUENCY RANGE: 0 to 300 kHz</p> <p>3. MULTIPLE PERIOD: 1 to 10⁵ in decade steps</p> <p>4. INPUT SENSITIVITY: 0.15V rms</p> <p>5. ACCURACY: ± 1 count of the larger frequency \pm the trigger error</p>	<table style="width: 100%; border-collapse: collapse;"> <thead> <tr> <th style="text-align: left; border-bottom: 1px solid black;">RATIO F1, F2</th> <th style="border-bottom: 1px solid black;">DISPLAY</th> </tr> </thead> <tbody> <tr><td style="text-align: center;">500000</td></tr> <tr><td style="text-align: center;">100000</td></tr> <tr><td style="text-align: center;">10000</td></tr> <tr><td style="text-align: center;">1000</td></tr> <tr><td style="text-align: center;">100</td></tr> <tr><td style="text-align: center;">10</td></tr> <tr><td style="text-align: center;">5</td></tr> <tr><td style="text-align: center;">1</td></tr> <tr><td style="text-align: center;">500000</td></tr> <tr><td style="text-align: center;">200000</td></tr> <tr><td style="text-align: center;">100000</td></tr> <tr><td style="text-align: center;">10000</td></tr> <tr><td style="text-align: center;">1000</td></tr> <tr><td style="text-align: center;">10</td></tr> <tr><td style="text-align: center;">3</td></tr> </tbody> </table> <p style="text-align: center;">RATIO F1/F2 = 1 MHz/100 kHz</p> <table style="width: 100%; border-collapse: collapse;"> <thead> <tr> <th style="text-align: left; border-bottom: 1px solid black;">PERIOD AVERAGE</th> <th style="border-bottom: 1px solid black;">DISPLAY</th> </tr> </thead> <tbody> <tr><td style="text-align: center;">1</td><td style="text-align: center;">00000010.</td></tr> <tr><td style="text-align: center;">10</td><td style="text-align: center;">0000010.0</td></tr> <tr><td style="text-align: center;">100</td><td style="text-align: center;">000010.00</td></tr> <tr><td style="text-align: center;">1K</td><td style="text-align: center;">00010.000</td></tr> <tr><td style="text-align: center;">10K</td><td style="text-align: center;">0010.0000</td></tr> <tr><td style="text-align: center;">100K</td><td style="text-align: center;">010.00000</td></tr> </tbody> </table> <p style="text-align: center;">RATIO F1/F2 = 1 MHz/300 kHz</p> <table style="width: 100%; border-collapse: collapse;"> <tbody> <tr><td style="text-align: center;">1</td><td style="text-align: center;">00000003.</td></tr> <tr><td style="text-align: center;">10</td><td style="text-align: center;">0000003.3</td></tr> <tr><td style="text-align: center;">100</td><td style="text-align: center;">000003.33</td></tr> <tr><td style="text-align: center;">1K</td><td style="text-align: center;">00003.333</td></tr> <tr><td style="text-align: center;">10K</td><td style="text-align: center;">0003.3333</td></tr> <tr><td style="text-align: center;">100K</td><td style="text-align: center;">003.33333</td></tr> <tr><td style="text-align: center;"> </td><td style="text-align: center;">0.1 V rms</td></tr> <tr><td style="text-align: center;"> </td><td style="text-align: center;">F1/F2 ± 1 count \pm trigger error</td></tr> </tbody> </table>	RATIO F1, F2	DISPLAY	500000	100000	10000	1000	100	10	5	1	500000	200000	100000	10000	1000	10	3	PERIOD AVERAGE	DISPLAY	1	00000010.	10	0000010.0	100	000010.00	1K	00010.000	10K	0010.0000	100K	010.00000	1	00000003.	10	0000003.3	100	000003.33	1K	00003.333	10K	0003.3333	100K	003.33333		0.1 V rms		F1/F2 ± 1 count \pm trigger error
RATIO F1, F2	DISPLAY																																															
500000																																																
100000																																																
10000																																																
1000																																																
100																																																
10																																																
5																																																
1																																																
500000																																																
200000																																																
100000																																																
10000																																																
1000																																																
10																																																
3																																																
PERIOD AVERAGE	DISPLAY																																															
1	00000010.																																															
10	0000010.0																																															
100	000010.00																																															
1K	00010.000																																															
10K	0010.0000																																															
100K	010.00000																																															
1	00000003.																																															
10	0000003.3																																															
100	000003.33																																															
1K	00003.333																																															
10K	0003.3333																																															
100K	003.33333																																															
	0.1 V rms																																															
	F1/F2 ± 1 count \pm trigger error																																															
<p>E. TIME BASE: FREQUENCY (INTERNAL) 1 MHz</p> <p>1. STABILITY:</p> <p>a. As a function of ambient temperature: less than ± 2 parts in 10¹⁰ per $^{\circ}$C from -20$^{\circ}$C to +55$^{\circ}$C</p> <p>b. As a function of line voltage: less than ± 5 parts in 10¹⁰ for changes of $\pm 10\%$.</p> <p>c. Stability: aging rate: less than 3 parts in 10⁹ per 24 hours</p>	<table style="width: 100%; border-collapse: collapse;"> <tbody> <tr><td style="text-align: center;"> </td><td style="text-align: left;">Parts in 10⁹ (frequency offset at beginning of test)</td></tr> <tr><td style="text-align: center;"> </td><td style="text-align: left;">Less than ± 2 parts in 10¹⁰ per $^{\circ}$C (stability)</td></tr> <tr><td style="text-align: center;"> </td><td style="text-align: left;">Less than ± 5 parts in 10¹⁰ (stability)</td></tr> <tr><td style="text-align: center;"> </td><td style="text-align: left;">Parts in 10⁹ (frequency offset 24 hours later at same temperature and line voltage)</td></tr> </tbody> </table>		Parts in 10 ⁹ (frequency offset at beginning of test)		Less than ± 2 parts in 10 ¹⁰ per $^{\circ}$ C (stability)		Less than ± 5 parts in 10 ¹⁰ (stability)		Parts in 10 ⁹ (frequency offset 24 hours later at same temperature and line voltage)																																							
	Parts in 10 ⁹ (frequency offset at beginning of test)																																															
	Less than ± 2 parts in 10 ¹⁰ per $^{\circ}$ C (stability)																																															
	Less than ± 5 parts in 10 ¹⁰ (stability)																																															
	Parts in 10 ⁹ (frequency offset 24 hours later at same temperature and line voltage)																																															

PERFORMANCE CHECK TEST CARD (Cont'd)

<p>2. TIME BASE: Outputs, front panel: 0.1 Hz to 1 MHz in decade steps; 1 V peak-to-peak</p> <p>3. TIME BASE: Outputs, rear panel: 0.1 Hz to 10 MHz in decade steps, 5 V peak-to-peak rectangular wave with 100-ohm source at 1 MHz and lower; 1V rms sine wave with 1000-ohm source impedance only at 10 MHz.</p>	<p>TIME BASE EXT JACK (J3)</p> <table border="0"> <tr><td><input type="checkbox"/></td><td>1 MHz (1 μs)</td><td><input type="checkbox"/></td></tr> <tr><td><input type="checkbox"/></td><td>100 kHz (10 μs)</td><td><input type="checkbox"/></td></tr> <tr><td><input type="checkbox"/></td><td>10 kHz (.1 ms)</td><td><input type="checkbox"/></td></tr> <tr><td><input type="checkbox"/></td><td>1 kHz (1 ms)</td><td><input type="checkbox"/></td></tr> <tr><td><input type="checkbox"/></td><td>1 Hz (10 ms)</td><td><input type="checkbox"/></td></tr> <tr><td><input type="checkbox"/></td><td>10 Hz (.1 s)</td><td><input type="checkbox"/></td></tr> <tr><td><input type="checkbox"/></td><td>1 Hz (1s)</td><td><input type="checkbox"/></td></tr> <tr><td><input type="checkbox"/></td><td>.1 Hz (10s)</td><td><input type="checkbox"/></td></tr> </table> <p>1 V p-p r greater</p> <p>TIME BASE OUTPUT JACK (J5)</p> <table border="0"> <tr><td><input type="checkbox"/></td><td>10 MHz (10)</td><td><input type="checkbox"/></td><td>1V rms</td></tr> <tr><td><input type="checkbox"/></td><td>1 MHz (10²)</td><td><input type="checkbox"/></td><td></td></tr> <tr><td><input type="checkbox"/></td><td>100 kHz (10³)</td><td><input type="checkbox"/></td><td></td></tr> <tr><td><input type="checkbox"/></td><td>10 kHz (10⁴)</td><td><input type="checkbox"/></td><td>5V p-p</td></tr> <tr><td><input type="checkbox"/></td><td>1 kHz (10⁵)</td><td><input type="checkbox"/></td><td></td></tr> <tr><td><input type="checkbox"/></td><td>100 Hz (10⁶)</td><td><input type="checkbox"/></td><td></td></tr> <tr><td><input type="checkbox"/></td><td>10 Hz (10⁷)</td><td><input type="checkbox"/></td><td></td></tr> <tr><td><input type="checkbox"/></td><td>1 Hz (10⁸)</td><td><input type="checkbox"/></td><td></td></tr> <tr><td><input type="checkbox"/></td><td>.1 Hz (10⁹)</td><td><input type="checkbox"/></td><td></td></tr> </table>	<input type="checkbox"/>	1 MHz (1 μ s)	<input type="checkbox"/>	<input type="checkbox"/>	100 kHz (10 μ s)	<input type="checkbox"/>	<input type="checkbox"/>	10 kHz (.1 ms)	<input type="checkbox"/>	<input type="checkbox"/>	1 kHz (1 ms)	<input type="checkbox"/>	<input type="checkbox"/>	1 Hz (10 ms)	<input type="checkbox"/>	<input type="checkbox"/>	10 Hz (.1 s)	<input type="checkbox"/>	<input type="checkbox"/>	1 Hz (1s)	<input type="checkbox"/>	<input type="checkbox"/>	.1 Hz (10s)	<input type="checkbox"/>	<input type="checkbox"/>	10 MHz (10)	<input type="checkbox"/>	1V rms	<input type="checkbox"/>	1 MHz (10 ²)	<input type="checkbox"/>		<input type="checkbox"/>	100 kHz (10 ³)	<input type="checkbox"/>		<input type="checkbox"/>	10 kHz (10 ⁴)	<input type="checkbox"/>	5V p-p	<input type="checkbox"/>	1 kHz (10 ⁵)	<input type="checkbox"/>		<input type="checkbox"/>	100 Hz (10 ⁶)	<input type="checkbox"/>		<input type="checkbox"/>	10 Hz (10 ⁷)	<input type="checkbox"/>		<input type="checkbox"/>	1 Hz (10 ⁸)	<input type="checkbox"/>		<input type="checkbox"/>	.1 Hz (10 ⁹)	<input type="checkbox"/>	
<input type="checkbox"/>	1 MHz (1 μ s)	<input type="checkbox"/>																																																											
<input type="checkbox"/>	100 kHz (10 μ s)	<input type="checkbox"/>																																																											
<input type="checkbox"/>	10 kHz (.1 ms)	<input type="checkbox"/>																																																											
<input type="checkbox"/>	1 kHz (1 ms)	<input type="checkbox"/>																																																											
<input type="checkbox"/>	1 Hz (10 ms)	<input type="checkbox"/>																																																											
<input type="checkbox"/>	10 Hz (.1 s)	<input type="checkbox"/>																																																											
<input type="checkbox"/>	1 Hz (1s)	<input type="checkbox"/>																																																											
<input type="checkbox"/>	.1 Hz (10s)	<input type="checkbox"/>																																																											
<input type="checkbox"/>	10 MHz (10)	<input type="checkbox"/>	1V rms																																																										
<input type="checkbox"/>	1 MHz (10 ²)	<input type="checkbox"/>																																																											
<input type="checkbox"/>	100 kHz (10 ³)	<input type="checkbox"/>																																																											
<input type="checkbox"/>	10 kHz (10 ⁴)	<input type="checkbox"/>	5V p-p																																																										
<input type="checkbox"/>	1 kHz (10 ⁵)	<input type="checkbox"/>																																																											
<input type="checkbox"/>	100 Hz (10 ⁶)	<input type="checkbox"/>																																																											
<input type="checkbox"/>	10 Hz (10 ⁷)	<input type="checkbox"/>																																																											
<input type="checkbox"/>	1 Hz (10 ⁸)	<input type="checkbox"/>																																																											
<input type="checkbox"/>	.1 Hz (10 ⁹)	<input type="checkbox"/>																																																											
<p>F. INPUT ATTENUATION: Three ranges 0.1, 1.0, and 10 volts.</p>	<table border="0"> <tr><td><input type="checkbox"/></td><td>0.1 volt</td></tr> <tr><td><input type="checkbox"/></td><td>1.0 volt</td></tr> <tr><td><input type="checkbox"/></td><td>10 volts</td></tr> </table>	<input type="checkbox"/>	0.1 volt	<input type="checkbox"/>	1.0 volt	<input type="checkbox"/>	10 volts																																																						
<input type="checkbox"/>	0.1 volt																																																												
<input type="checkbox"/>	1.0 volt																																																												
<input type="checkbox"/>	10 volts																																																												
<p>G. DISPLAY STORAGE: Storage off: count change visible Storage on: count change not visible</p>	<table border="0"> <tr><td><input type="checkbox"/></td><td>Storage off</td></tr> <tr><td><input type="checkbox"/></td><td>Storage on</td></tr> </table>	<input type="checkbox"/>	Storage off	<input type="checkbox"/>	Storage on																																																								
<input type="checkbox"/>	Storage off																																																												
<input type="checkbox"/>	Storage on																																																												
<p>H. SAMPLE RATE: < .2 sec to > 5 seconds</p>	<table border="0"> <tr><td><input type="checkbox"/></td><td>< .2 sec to > 5 seconds</td></tr> </table>	<input type="checkbox"/>	< .2 sec to > 5 seconds																																																										
<input type="checkbox"/>	< .2 sec to > 5 seconds																																																												
<p>I. BCD CODE:</p> <ol style="list-style-type: none"> Output 4-line 1-2-2-4 BCD: "0" State Level: approx -8 volts "1" State Level: approx +18 volts Reference Levels: approx +9 volts, 350 ohms source impedance, and approx -1 volts, 1000-ohm source impedance Print Command: negative step from +13 volts to 0 volts, dc coupled Hold-off Requirements: +15 volts min, +25 volts max from chassis ground (1000 ohm source) 	<table border="0"> <tr><td><input type="checkbox"/></td><td>"0" state approx -8 volts</td></tr> <tr><td><input type="checkbox"/></td><td>"1" state approx +18 volts</td></tr> </table> <p>DIGITAL RECORDER JACK (J11) Pins 25 and 24</p> <table border="0"> <tr><td><input type="checkbox"/></td><td>approx +9 volts</td></tr> <tr><td><input type="checkbox"/></td><td>approx -1 volts</td></tr> </table> <p>DIGITAL RECORDER JACK (J11) Pin 48</p> <table border="0"> <tr><td><input type="checkbox"/></td><td>negative step 13 volts</td></tr> </table> <p>DIGITAL RECORDER JACK (J11) Pin 22</p> <table border="0"> <tr><td><input type="checkbox"/></td><td>+15 volts</td></tr> <tr><td><input type="checkbox"/></td><td>+25 volts</td></tr> </table>	<input type="checkbox"/>	"0" state approx -8 volts	<input type="checkbox"/>	"1" state approx +18 volts	<input type="checkbox"/>	approx +9 volts	<input type="checkbox"/>	approx -1 volts	<input type="checkbox"/>	negative step 13 volts	<input type="checkbox"/>	+15 volts	<input type="checkbox"/>	+25 volts																																														
<input type="checkbox"/>	"0" state approx -8 volts																																																												
<input type="checkbox"/>	"1" state approx +18 volts																																																												
<input type="checkbox"/>	approx +9 volts																																																												
<input type="checkbox"/>	approx -1 volts																																																												
<input type="checkbox"/>	negative step 13 volts																																																												
<input type="checkbox"/>	+15 volts																																																												
<input type="checkbox"/>	+25 volts																																																												
<p>J. GATE INDICATOR: Front panel indication of main gate "open" state.</p>	<table border="0"> <tr><td><input type="checkbox"/></td><td>Gate light indicates</td></tr> </table>	<input type="checkbox"/>	Gate light indicates																																																										
<input type="checkbox"/>	Gate light indicates																																																												
<p>K. RESET CAPABILITY: Momentary control on the front panel that returns both the dis- played and internal count to zero.</p>	<table border="0"> <tr><td><input type="checkbox"/></td><td>Reset switch functions</td></tr> </table>	<input type="checkbox"/>	Reset switch functions																																																										
<input type="checkbox"/>	Reset switch functions																																																												

PARTS LIST

SECTION IV REPLACEABLE PARTS

4-1. INTRODUCTION.

4-2. This section contains information for ordering replacement parts. Table 4-1 lists parts in alpha-numerical order of their reference designators and indicates the description and HP stock number of each part, together with any applicable notes. Table 4-2 lists parts in alpha-numerical order of their HP stock number and provides the following information on each part;

- a. Description of the part (see list of abbreviations below).
- b. Typical manufacturer of the part in a five-digit code; see list of manufacturers in Table 4-5.
- c. Manufacturer's part number.
- d. Total quantity used in the instrument (TQ column).

4-3. Miscellaneous parts are listed at the end of Table 4-1.

4-4. ORDERING INFORMATION.

4-5. To obtain replacement parts, address order or inquiry to your local Hewlett-Packard Field Office (see lists at rear of this manual for addresses). Identify parts by their Hewlett-Packard stock numbers.

4-6. To obtain a part that is not listed, include:

- a. Instrument model number.
- b. Instrument serial number.
- c. Description of the part.
- d. Function and location of the part.

REFERENCE DESIGNATORS

A = assembly
B = motor
BT = battery
C = capacitor
CP = coupler
CR = diode
DL = delay line
DS = device signaling (lamp)

E = misc electronic part
F = fuse
FL = filter
J = jack
K = relay
L = inductor
M = meter
MP = mechanical part

P = plug
Q = transistor
R = resistor
RT = thermistor
S = switch
T = transformer
TB = terminal board
TP = test point

V = vacuum, tube, neon bulb, photocell, etc.
VR = voltage regulator
W = cable
X = socket
Y = crystal

ABBREVIATIONS

A = amperes
A. F. C. = automatic frequency control
AMPL = amplifier
B. F. O. = beat frequency oscillator
BE CU = beryllium copper
BH = binder head
BP = bandpass
BRS = brass
BWO = backward wave oscillator
CCW = counter-clockwise
CER = ceramic
CMO = cabinet mount only
COEF = coefficient
COM = common
COMP = composition
COMPL = complete
CONN = connector
CP = cadmium plate
CRT = cathode-ray tube
CW = clockwise
DEPC = deposited carbon
DR = drive
ELECT = electrolytic
ENCAP = encapsulated
EXT = external
F = farads
FH = flat head
FIL H = filister head
FXD = fixed
GE = germanium
GL = glass
GRD = ground(ed)

H = henries
HEX = hexagonal
HG = mercury
HR = hour(s)
IF = intermediate freq
IMPG = impregnated
INCD = incandescent
INCL = include(s)
INS = insulation(ed)
INT = internal
K = kilo = 1000
LH = left hand
LIN = linear taper
LK WASH = lock washer
LOG = logarithmic taper
LPP = low pass filter
M = milli = 10⁻³
MEG = meg = 10⁶
MET FLM = metal film
MET OX = metallic oxide
MFR = manufacturer
MINAT = miniature
MOM = momentary
MTG = mounting
MY = "mylar"
N = nano (10⁻⁹)
N/C = normally closed
NE = neon
NI PL = nickel plate
N/O = normally open
NPO = negative positive zero (zero temperature coefficient)

NPN = negative-positive-negative
NRFR = not recommended for field replacement
NSR = not separately replaceable
OBD = order by description
OH = oval head
OX = oxide
P = peak
PC = printed circuit
PF = picofarads = 10⁻¹² farads
PH BRZ = phosphor bronze
PHL = Phillips
PIV = peak inverse voltage
PNP = positive-negative-positive
P/O = part of
POLY = polystyrene
PORC = porcelain
POS = position(s)
POT = potentiometer
PP = peak-to-peak
PT = point
PWV = peak working voltage
RECT = rectifier
RF = radio frequency
RH = round head or right hand
RMO = rack mount only

RMS = root-mean square
RWV = reverse working voltage
S-B = slow-blow
SCR = screw
SE = selenium
SECT = section(s)
SEMICON = semiconductor
SI = silicon
SIL = silver
SL = slide
SPG = spring
SPL = special
SST = stainless steel
SR = split ring
STL = steel
TA = tantalum
TD = time delay
TGL = toggle
THD = thread
TI = titanium
TOL = tolerance
TRIM = trimmer
TWT = traveling wave tube
U = micro = 10⁻⁶
VAR = variable
VDCW = dc working volts
W/ = with
W = watts
WIV = working inverse voltage
WW = wirewound
W/O = without

Table 4-1. Reference Designation Index

Reference Designation	Stock No.	Description #	Note
A1	05245-6016	SWITCH ASSY:ATTENUATOR(PART OF W2)	
A1C1	0160-2262	CIFXD CER 16 PF 5% 500VDCW	
A1C2	0160-2260	CIFXD CER 13 PF 5% 500VDCW	
A1C3	0150-0069	CIFXD CER 0.001 UF +100-20% 500VDCW	
A1C4	0160-2550	CIFXD CER 1.0 PF 500VDCW	
A1C5	0160-2248	CIFXD CER 4.3 PF 500VDCW	
A1C6	0140-0169	CIFXD MICA 100 PF 5% 500VDCW	
A1C7	0150-0115	CIFXD CER 27 PF 10% 500VDCW	
A1CR1	1910-0016	SEMICON DEVICE:DIODE GERMANIUM	
A1CR2	1910-0016	DIODE:GERMANIUM 100MA AT 0.85V 60PIV	
A1CR3	1910-0016	SEMICON DEVICE:DIODE GERMANIUM	
A1CR4	1910-0016	SEMICON DEVICE:DIODE GERMANIUM	
A1CR5	1910-0016	SEMICON DEVICE:DIODE GERMANIUM	
A1L1	9100-0346	COIL:FXD 0.05 UH 20%	
A1L2	9100-0346	COIL:FXD 0.05 UH 20%	
A1R1	0683-2245	RIFXD COMP 220K OHM 5% 1/4W	
A1R2	0757-0344	RIFXD MET FLM 1 MEGOHM 1% 1/4W	
A1R3	0757-0368	RIFXD MET FLM 34 OHM 1% 1/8W	
A1R4	0757-0368	RIFXD MET FLM 34 OHM 1% 1/8W	
A1R5	0757-0972	RIFXD MET FLM 100K OHM 2% 1/6W	
A1R6	0686-1055	RIFXD COMP 1 MEGOHM 5% 1/2W	
A1R7	0757-0350	RIFXD MET FLM 909K OHM 1% 1/4W	
A1R8	0757-0972	RIFXD MET FLM 100K OHM 2% 1/8W	
A1R9		NOT ASSIGNED	
A1R10	0757-0948	RIFXD MET FLM 10K OHM 2% 1/8W	
A1R11	2100-1924	RIVAR COMP 5K OHM 20% 1/5W	
A1S1	3100-2036	SWITCH:ROTARY	
A1S2		NSR PART OF R11	
		TIME BASE	
A2		SWITCH ASSY(PART OF W2)	
A2C1	0150-01 2	CIFXD CER 2000PF 20% 500VDCW	
A2R1	0683-1045	RIFXD COMP 100K OHM 5% 1/4W	
A2S1	3100-2029	SWITCH:ROTARY	
A3		SWITCH ASSY:FUNCTION(PART OF W2)	
A3R1	0683-2025	RIFXD COMP 2000 OHM 5% 1/4W	
A3R2	0683-2025	RIFXD COMP 2000 OHM 5% 1/4W	
A3S1	3100-1874	SWITCH:ROTARY 6 SECT 10 POSITION	
A4	5245L-198	ASSY:MODE SWITCH	
A4C1	0150-0093	CIFXD CER 0.01UF +80-20 100VDCW	
A4R1	0683-1025	RIFXD COMP 1000 OHMS 5% 1/4W	
A4S1	3100-0389	SWITCH:ROT 1-SECT 3-POS HP SPEC	

= See list of abbreviations in introduction to this section

Table 4-1. Reference Designation Index (Cont'd)

Reference Designation	Stock No.	Description #	Note
A5	5245L-19A	ASSY:OUTPUT SWITCH	
A5C1	0170-0094	C:FXD MY 0.047UF 20% 50VDCW	
A5C2	0170-0094	C:FXD MY 0.047UF 20% 50VDCW	
A5CR1	1910-0016	SEMICON DEVICE:DIODE GERMANIUM	
A5Q1	1850-0062	TRANSISTOR:GERMANIUM	
A5R1	0683-3315	R:FXD COMP 330 OHMS 5% 1/4W	
A5R2	0683-4335	R:FXD COMP 43K OHM 5% 1/4W	
A5R3	0683-1025	R:FXD COMP 1000 OHMS 5% 1/4W	
A5R4	0683-1025	R:FXD COMP 1000 OHMS 5% 1/4W	
A5R5	0683-6225	R:FXD COMP 6200 OHMS 5% 1/4W	
A5C1	3100-0390	SWITCH:ROT 2-SECT 9-POS HP SPEC	
A6	5243A-65L 5243A-65L-1	ASSY:RECTIFIER BOARD:BLANK P.C.	
A6C1	0170-0040	C:FXD MY .047 UF 10% 200VDCW	
A6C2	0160-0314	C:FXD MY 0.01 UF 5% 400VDCW	
A6C3	0160-0314	C:FXD MY 0.01 UF 5% 400VDCW	
A6C4	0170-0040	C:FXD MY .047 UF 10% 200VDCW	
A6CR1	1901-0028	SEMICON DEVICE:DIODE SI 750 mA 400 PIV	
A6CR2	1901-0028	SEMICON DEVICE:DIODE SI 750 mA 400 PIV	
A6CR3	1901-0028	SEMICON DEVICE:DIODE SI 750 mA 400 PIV	
A6CR4	1901-0028	SEMICON DEVICE:DIODE SI 750 mA 400 PIV	
A6CR5	1901-0028	SEMICON DEVICE:DIODE SI 750 mA 600 PIV	
A6CR6	1901-0029	SEMICON DEVICE:DIODE SI 750 mA 600 PIV	
A6CR7	1901-0029	SEMICON DEVICE:DIODE SI 750 mA 600 PIV	
A6CR8	1901-0029	SEMICON DEVICE:DIODE SI 750 mA 600 PIV	
A6CR9	1901-0028	SEMICON DEVICE:DIODE SI 750 mA 400 PIV	
A6CR10	1901-0028	SEMICON DEVICE:DIODE SI 750 mA 400 PIV	
A6CR11	1901-0028	SEMICON DEVICE:DIODE SI 750 mA 400 PIV	
A6CR12	1901-0028	SEMICON DEVICE:DIODE SI 750 mA 400 PIV	
A6CR13	1901-0028	SEMICON DEVICE:DIODE SI 750 mA 400 PIV	
A6CR14	1901-0028	SEMICON DEVICE:DIODE SI 750 mA 400 PIV	
A6CR15	1901-0028	SEMICON DEVICE:DIODE SI 750 mA 400 PIV	
A6CR16	1901-0028	SEMICON DEVICE:DIODE SI 750 mA 400 PIV	
A7	5243A-65H 5243A-65H-1	ASSY:REGULATOR BOARD:BLANK P.C.	
A7C1	0170-0040	C:FXD MY .047 UF 10% 200VDCW	
A7C2	0180-0097	C:FXD ELECT 47 UF 10% 35VDCW	
A7C3	0170-0040	C:FXD MY .047 UF 10% 200VDCW	
A7C4	0180-0098	C:FXD ELECT 100UF 20% 20VDCW	
A7C5	0180-0098	C:FXD ELECT 100UF 20% 20VDCW	
A7CR1	1902-0017	SEMICON DEVICE:DIODE SI	
A7CR2	1902-0214	DIODE:SILICON BREAKDOWN 56.2V 10% 1.5W	
A7CR3	1902-0017	SEMICON DEVICE:DIODE SI	
A7CR4	1902-0057	SEMICON DEVICE:DIODE SILICON	
A7Q1	1853-0001	TRANSISTOR:PNP SILICON 30V 900MW	

See list of abbreviations in introduction to this section

Table 4-1. Reference Designation Index (Cont'd)

Reference Designation	Stock No.	Description #	Note
A7Q2	1850-0062	TRANSISTOR:GERMANIUM	
A7Q3	1853-0001	TRANSISTOR:PNP SILICON 30V 900MW	
A7Q4	1850-0062	TRANSISTOR:GERMANIUM	
A7Q5	1850-0048	TRANSISTOR:GERMANIUM 2N650 PNP	
A7R1	0758-0015	R:FXD MET FLM 220 OHMS 5% 1/2W	
A7R2	0686-1025	R:FXD COMP 1000 OHM 5% 1/2W	
A7R3	0686-2235	R:FXD COMP 22K OHM 5% 1/2W	
A7R4	0758-0015	R:FXD MET FLM 220 OHMS 5% 1/2W	
A7R5	2100-1412	R:VAR COMP 500 OHM 20% LIN 1/4W	
A7R6	0758-0015	R:FXD MET FLM 220 OHMS 5% 1/2W	
A7R7	0689 2035	R:FXD COMP 20K OHM 5% 1W	
A7R8	0758-0015	R:FXD MET FLM 220 OHMS 5% 1/2W	
A7R9	0686-8215	R:FXD COMP 820 OHM 5% 1/2W	
A7R10	0686-7525	R:FXD COMP 7500 OHM 5% 1/2W	
A7R11	0758-0015	R:FXD MET FLM 220 OHMS 5% 1/2W	
A7R12	2100-1412	R:VAR COMP 500 OHM 20% LIN 1/4W	
A7R13	0758-0028	R:FXD MET FLM 270 OHMS 5% 1/2W	
A7R14	0686-8215	R:FXD COMP 820 OHM 5% 1/2W	
A7R15	0686-2735	R:FXD COMP 27K OHM 5% 1/2W	
A7R16	0686-6215	R:FXD COMP 620 OHM 5% 1/2W	
A7R17	2100-1412	R:VAR COMP 500 OHM 20% LIN 1/4W	
A7R18	0686-2025	R:FXD COMP 2000 OHM 5% 1/2W	
A7R19	0686-1525	R:FXD COMP 1500 OHM 5% 1/2W	
A7R20	0683-1525	R:FXD COMP 1500 OHM 5% 1/4W	
AB	5243L-65A	ASSY:DECIMAL POINT	
ABCR1	1901-0025	SEMICON DEVICE:DIODE JUNCTION	
ABCR2	1901-0025	SEMICON DEVICE:DIODE JUNCTION	
ABCR3	1901-0025	SEMICON DEVICE:DIODE JUNCTION	
ABCR4		NOT ASSIGNED	
ABCR5	1901-0025	SEMICON DEVICE:DIODE JUNCTION	
ABCR6	1901-0025	SEMICON DEVICE:DIODE JUNCTION	
ABCR7	1901-0025	SEMICON DEVICE:DIODE JUNCTION	
ABCR8	1901-0025	SEMICON DEVICE:DIODE JUNCTION	
ABCR9	1901-0025	SEMICON DEVICE:DIODE JUNCTION	
ABCR10	1901-0025	SEMICON DEVICE:DIODE JUNCTION	
ABCR11	1901-0025	SEMICON DEVICE:DIODE JUNCTION	
ABCR12	1901-0025	SEMICON DEVICE:DIODE JUNCTION	
ABCR13	1901-0025	SEMICON DEVICE:DIODE JUNCTION	
ABCR14		NOT ASSIGNED	
ABCR15	1901-0025	SEMICON DEVICE:DIODE JUNCTION	
ABCR16	1901-0025	SEMICON DEVICE:DIODE JUNCTION	
ABCR17		NOT ASSIGNED	
ABCR18	1901-0025	SEMICON DEVICE:DIODE JUNCTION	
ABDS1 THRU			
ABDS2		NOT ASSIGNED	
ABDS3	2140-0028	LAMP:GLOW 1/15W	
ABDS4	2140-0028	LAMP:GLOW 1/15W	
ABDS5	2140-0028	LAMP:GLOW 1/15W	
ABDS6	2140-0028	LAMP:GLOW 1/15W	
ABDS7	2140-0028	LAMP:GLOW 1/15W	

See list of abbreviations in introduction to this section

Table 4-1. Reference Designation Index (Cont'd)

Reference Designation	Stock No.	Description #	Note
ABDS8	2140-0028	LAMP:GLOW 1/15W	
ABDS9	2140-0026	LAMP:GLOW 1/15W	
ABR1 THRU			
ABR2		NOT ASSIGNED	
ABR3	0683-1055	R:FXD COMP 1 MEGOHM 5% 1/4W	
ABR4	0683-6835	R:FXD COMP 68K OHM 5% 1/4W	
ABR5	0683-1055	R:FXD COMP 1 MEGOHM 5% 1/4W	
ABR6	0683-6835	R:FXD COMP 68K OHM 5% 1/4W	
ABR7	0683-1055	R:FXD COMP 1 MEGOHM 5% 1/4W	
ABR8	0683-6835	R:FXD COMP 68K OHM 5% 1/4W	
ABR9	0683-1055	R:FXD COMP 1 MEGOHM 5% 1/4W	
ABR10	0683-6835	R:FXD COMP 68K OHM 5% 1/4W	
ABR11	0683-1055	R:FXD COMP 1 MEGOHM 5% 1/4W	
ABR12	0683-6835	R:FXD COMP 68K OHM 5% 1/4W	
ABR13	0683-1055	R:FXD COMP 1 MEGOHM 5% 1/4W	
ABR14	0683-6835	R:FXD COMP 68K OHM 5% 1/4W	
ABR15	0683-1055	R:FXD COMP 1 MEGOHM 5% 1/4W	
ABR16	0683-6835	R:FXD COMP 68K OHM 5% 1/4W	
ABR17	0683-1245	R:FXD COMP 120K OHM 5% 1/4W	
ABR18	0683-1245	R:FXD COMP 120K OHM 5% 1/4W	
ABR19	0683-1245	R:FXD COMP 120K OHM 5% 1/4W	
ABR20	0683-1245	R:FXD COMP 120K OHM 5% 1/4W	
A9	5243L-65B 5243L-65B-1	ASSY:MEASUREMENT UNITS BOARD:BLANK P.C.	
A9C1	0150-0012	C:FXD CER 0.01UF 20% 1000VDCW	
A9CR1	1901-0535	SEMICON DEVICE:DIODE JUNCTION	
A9CR2	1901-0535	SEMICON DEVICE:DIODE JUNCTION	
A9CR3	1901-0535	SEMICON DEVICE:DIODE JUNCTION	
A9CR4	1901-0535	SEMICON DEVICE:DIODE JUNCTION	
A9CR5	1901-0535	SEMICON DEVICE:DIODE JUNCTION	
A9CR6	1901-0535	SEMICON DEVICE:DIODE JUNCTION	
A9CR7	1901-0535	SEMICON DEVICE:DIODE JUNCTION	
A9CR8	1901-0535	SEMICON DEVICE:DIODE JUNCTION	
A9CR9	1901-0535	SEMICON DEVICE:DIODE JUNCTION	
A9CR10	1901-0535	SEMICON DEVICE:DIODE JUNCTION	
A9CR11	1901-0535	SEMICON DEVICE:DIODE JUNCTION	
A9CR12	1901-0535	SEMICON DEVICE:DIODE JUNCTION	
A9DS1 THRU			
A9DS9		NOT ASSIGNED	
A9DS10	2140-0015	LAMP:GLOW NEON NE-2H	
A9DS11	2140-0015	LAMP:GLOW NEON NE-2H	
A9DS12	2140-0015	LAMP:GLOW NEON NE-2H	
A9DS13	2140-0015	LAMP:GLOW NEON NE-2H	
A9DS14	2140-0015	LAMP:GLOW NEON NE-2H	
A9DS15	2140-0015	LAMP:GLOW NEON NE-2H	
A9R1	0686-5135	R:FXD COMP 51K OHMS 5% 1/2W	
A9R2	0683-1055	R:FXD COMP 1 MEGOHM 5% 1/4W	
A9R3	0686-5135	R:FXD COMP 51K OHMS 5% 1/2W	

See list of abbreviations in introduction to this section

Table 4-1. Reference Designation Index (Cont'd)

Reference Designation	Stock No.	Description #	Note
A9R4	0683-1055	R:FXD COMP 1 MEGOHM 5% 1/4W	
A9R5	0686-5135	R:FXD COMP 51K OHMS 5% 1/2W	
A9R6	0683-1055	R:FXD COMP 1 MEGOHM 5% 1/4W	
A9R7	0686-5135	R:FXD COMP 51K OHMS 5% 1/2W	
A9R8	0683-1055	R:FXD COMP 1 MEGOHM 5% 1/4W	
A9R9	0686-5135	R:FXD COMP 51K OHMS 5% 1/2W	
A9R10	0683-1055	R:FXD COMP 1 MEGOHM 5% 1/4W	
A9R11	0686-5135	R:FXD COMP 51K OHMS 5% 1/2W	
A9R12	0683-1055	R:FXD COMP 1 MEGOHM 5% 1/4W	
A9R13	0683-1245	R:FXD COMP 120K OHM 5% 1/4W	
A9R14	0683-1245	R:FXD COMP 120K OHM 5% 1/4W	
A9R15	0683-1245	R:FXD COMP 120K OHM 5% 1/4W	
A9R16	0683-1245	R:FXD COMP 120K OHM 5% 1/4W	
A10	05212-6016 05212-2016 05212-6011	ASSY:DECIMAL BOARD BOARD:BLANK PC READOUT BLOCK ASSY	
A10C1	0140-0190	C:FXD MICA 39 PF 5%	
A10C2	0140-0145	C:FXD MICA 22 PF 5%	
A10C3	0140-0193	C:FXD MICA E2 PF 5%	
A10C4	0140-0193	C:FXD MICA E2 PF 5%	
A10C5	0140-0204	C:FXD MICA 47PF 5% NPO 500VDCW	
A10C6	0140-0197	C:FXD MICA 180 PF 5%	
A10C7	0160-2203	C:FXD MICA 91 PF 5%	
A10C8	0140-0192	C:FXD MICA 68 PF 5%	
A10C9	0140-0197	C:FXD MICA 180 PF 5%	
A10C10	0140-0217	C:FXD MICA 140 PF 2% 300VDCW	
A10C11	0160-2203	C:FXD MICA 91 PF 5%	
A10C12	0140-0193	C:FXD MICA 82 PF 5%	
A10C13	0160-2206	C:FXD MICA 160 PF 5%	
A10C14	0140-0195	C:FXD MICA 130 PF 5% 300 VDCW	
A10C15	0160-2206	C:FXD MICA 160 PF 5%	
A10CR1	1901-0025	DIODE:SILICON 100WV 100MA	
A10CR2	1901-0025	DIODE:SILICON 100WV 100MA	
A10CR3	1901-0025	DIODE:SILICON 100WV 100MA	
A10CR4	1901-0025	DIODE:SILICON 100WV 100MA	
A10CR5	1901-0025	DIODE:SILICON 100WV 100MA	
A10CR6	1901-0025	DIODE:SILICON 100WV 100MA	
A10CR7	1901-0025	DIODE:SILICON 100WV 100MA	
A10CR8	1901-0025	DIODE:SILICON 100WV 100MA	
A10CR9	1910-0016	DIODE:GERMANIUM 1 MICROSEC 60 WIV	
A10CR10	1910-0016	DIODE:GERMANIUM 1 MICROSEC 60 WIV	
A10CR11	1910-0016	DIODE:GERMANIUM 1 MICROSEC 60 WIV	
A10CR12	1910-0016	DIODE:GERMANIUM 1 MICROSEC 60 WIV	
A10CR13	1910-0016	DIODE:GERMANIUM 1 MICROSEC 60 WIV	
A10CR14	1910-0016	DIODE:GERMANIUM 1 MICROSEC 60 WIV	
A10CR15	1910-0016	DIODE:GERMANIUM 1 MICROSEC 60 WIV	
A10CR16	1910-0016	DIODE:GERMANIUM 1 MICROSEC 60 WIV	
A10CR17	1910-0016	DIODE:GERMANIUM 1 MICROSEC 60 WIV	
A10CR18	1910-0016	DIODE:GERMANIUM 1 MICROSEC 60 WIV	
A10DS1		NSR PART OF READOUT BLOCK ASSY	

See list of abbreviations in Introduction to this section

Table 4-1. Reference Designation Index (Cont'd)

Reference Designation	Stock No.	Description #	Note
A10D52 A10D53 A10D54 A10D55 A10D56	1970-0009	NSR PART OF READOUT BLOCK ASSY NSR PART OF READOUT BLOCK ASSY NSR PART OF READOUT BLOCK ASSY NOT ASSIGNED ELECTRON TUBE INDICATOR 10 DIGIT	
A10Q1 A10Q2 A10Q3 A10Q4 A10Q5	5080-0060 5080-0060 5080-0060 5080-0060 5080-0060	TRANSISTOR GERMANIUM PNP SELECTED TRANSISTOR GERMANIUM PNP SELECTED TRANSISTOR GERMANIUM PNP SELECTED TRANSISTOR GERMANIUM PNP SELECTED TRANSISTOR GERMANIUM PNP SELECTED	
A10Q6 A10Q7 A10Q8	5080-0060 5080-0060 5080-0060	TRANSISTOR GERMANIUM PNP SELECTED TRANSISTOR GERMANIUM PNP SELECTED TRANSISTOR GERMANIUM PNP SELECTED	
A10R1 A10R2 A10R3 THRU A10R5 A10R6 A10R7	0686-4735 0683-3945 0683-3945	RIFXD COMP 47K OHM 5% 1/2W NSR PART OF READOUT BLOCK ASSY NOT ASSIGNED RIFXD COMP 390K OHMS 5% 1/4W RIFXD COMP 390K OHMS 5% 1/4W	
A10R8 A10R9 A10R10 A10R11 A10R12	0683-3945 0683-3945 0686-7525 0683-5635 0683-5635	RIFXD COMP 390K OHMS 5% 1/4W RIFXD COMP 390K OHMS 5% 1/4W RIFXD COMP 7500 OHMS 5% 1/2W RIFXD COMP 56K OHMS 5% 1/4W RIFXD COMP 56K OHMS 5% 1/4W	
A10R13 A10R14 A10R15 A10R16 A10R17	0686-7525 0683-4735 0683-4735 0683-3925 0683-1815	RIFXD COMP 7500 OHMS 5% 1/2W RIFXD COMP 47K OHMS 5% 1/4W RIFXD COMP 47K OHMS 5% 1/4W RIFXD COMP 3900 OHM 5% 1/4W RIFXD COMP 180 OHM 5% 1/4W	
A10R18 A10R19 A10R20 A10R21 A10R22	0683-4735 0683-3925 0683-1045 0683-3025 0683-4735	RIFXD COMP 47K OHMS 5% 1/4W RIFXD COMP 3900 OHM 5% 1/4W RIFXD COMP 100K OHMS 5% 1/4W RIFXD COMP 3000 OHM 5% 1/4W RIFXD COMP 47K OHMS 5% 1/4W	
A10R23 A10R24 A10R25 A10R26 A10R27	0683-4735 0683-3025 0686-7525 0683-5635 0683-5635	RIFXD COMP 47K OHMS 5% 1/4W RIFXD COMP 3000 OHM 5% 1/4W RIFXD COMP 7500 OHMS 5% 1/2W RIFXD COMP 56K OHMS 5% 1/4W RIFXD COMP 56K OHMS 5% 1/4W	
A10R28 A10R29 A10R30 A10R31 A10R32	0686-7525 0683-4735 0683-4735 0683-3925 0683-3925	RIFXD COMP 7500 OHMS 5% 1/2W RIFXD COMP 47K OHMS 5% 1/4W RIFXD COMP 47K OHMS 5% 1/4W RIFXD COMP 3900 OHM 5% 1/4W RIFXD COMP 3900 OHM 5% 1/4W	
A10R33 A10R34 A10R35 A10R36 A10R37	0683-1815 0683-2735 0683-3925 0683-8225 0683-1045	RIFXD COMP 180 OHM 5% 1/4W RIFXD COMP 27K OHMS 5% 1/4W RIFXD COMP 3900 OHM 5% 1/4W RIFXD COMP 8200 OHMS 5% 1/4W RIFXD COMP 100K OHMS 5% 1/4W	
A10R38	0686-7525	RIFXD COMP 7500 OHMS 5% 1/2W	

See list of abbreviations in introduction to this section

Table 4-1. Reference Designation Index (Cont'd)

Reference Designation	Stock No.	Description #	Note
A10R39	0683-5635	R:FXD COMP 56K OHMS 5% 1/4W	
A10R40	0683-5635	R:FXD COMP 56K OHMS 5% 1/4W	
A10R41	0686-7525	R:FXD COMP 7500 OHMS 5% 1/2W	
A10R42	0683-4735	R:FXD COMP 47K OHMS 5% 1/4W	
A10R43	0683-4735	R:FXD COMP 47K OHMS 5% 1/4W	
A10R44	0683-8225	R:FXD COMP 2200 OHMS 5% 1/4W	
A10R45	0683-3925	R:FXD COMP 3900 OHM 5% 1/4W	
A10R46	0683-1815	R:FXD COMP 180 OHM 5% 1/4W	
A10R47	0683-4735	R:FXD COMP 47K OHMS 5% 1/4W	
A10R48	0683-3925	R:FXD COMP 3900 OHM 5% 1/4W	
A10R49	0683-1035	R:FXD COMP 10K OHM 5% 1/4W	
A10R50	0683-1045	R:FXD COMP 100K OHMS 5% 1/4W	
A10R51	0686-7525	R:FXD COMP 7500 OHMS 5% 1/2W	
A10R52	0683-5635	R:FXD COMP 56K OHMS 5% 1/4W	
A10R53	0683-5635	R:FXD COMP 56K OHMS 5% 1/4W	
A10R54	0686-7525	R:FXD COMP 7500 OHMS 5% 1/2W	
A10R55	0683-4735	R:FXD COMP 47K OHMS 5% 1/4W	
A10R56	0683-4735	R:FXD COMP 47K OHMS 5% 1/4W	
A10R57	0683-1035	R:FXD COMP 10K OHM 5% 1/4W	
A10R58	0683-3925	R:FXD COMP 3900 OHM 5% 1/4W	
A10R59	0683-1815	R:FXD COMP 180 OHM 5% 1/4W	
A10R60	0683-4735	R:FXD COMP 47K OHMS 5% 1/4W	
A10R61	0683-3925	R:FXD COMP 3900 OHM 5% 1/4W	
A10R62	0683-1035	R:FXD COMP 10K OHM 5% 1/4W	
A10R63	0683-6835	R:FXD COMP 68K OHM 5% 1/4W	
A10R64	0683-1045	R:FXD COMP 100K OHMS 5% 1/4W	
A10R65	0683-2025	R:FXD COMP 2000 OHM 5% 1/4W	
A10V1		NSR PART OF READOUT BLOCK ASSY	
A11		SAME AS A10, USE PREFIX A11	
A12		SAME AS A10, USE PREFIX A12	
A13		SAME AS A10, USE PREFIX A13	
A14		SAME AS A10, USE PREFIX A14	
A15		SAME AS A10, USE PREFIX A15	
A16	05232-6010 05232-2010 05212-6011	DECIMAL COUNTER ASSEMBLY BOARD:BLANK PC READOUT BLOCK ASSEMBLY	
A16C1	0160-0369	C:FXD MICA 17 PF 5%	
A16C2	0160-0369	C:FXD MICA 17 PF 5%	
A16C3	0140-0204	C:FXD MICA 47PF 5% NPO 500VDCW	
A16C4	0140-0204	C:FXD MICA 47PF 5% NPO 500VDCW	
A16C5	0140-0204	C:FXD MICA 47PF 5% NPO 500VDCW	
A16C6	0140-0204	C:FXD MICA 47PF 5% NPO 500VDCW	
A16C7	0140-0194	C:FXD MICA 110 PF 5% 300 VDCW	
A16C8	0140-0204	C:FXD MICA 47PF 5% NPO 500VDCW	
A16C9	0140-0204	C:FXD MICA 47PF 5% NPO 500VDCW	
A16C10	0160-2563	C:FXD CER 2000 PF 20% 500VDCW	
A16C11	0160-2563	C:FXD CER 2000 PF 20% 500VDCW	
A16C12	0140-0191	C:FXD MICA 56 PF 5% 300 VDCW	
A16C13	0160-2306	C:FXD MICA 27 PF 5%	

= See list of abbreviations in introduction to this section

Table 4-1. Reference Designation Index (Cont'd)

Reference Designation	Stock No.	Description #	Note
A16C14	0140-0190	C:FXD MICA 39 PF 5% 300 VDCW	
A16C15	0140-0190	C:FXD MICA 39 PF 5% 300 VDCW	
A16C16	0140-0191	C:FXD MICA 56 PF 5% 300 VDCW	
A16C17	0140-0191	C:FXD MICA 56 PF 5% 300 VDCW	
A16CR1	1901-0025	DIODE, JUNCTION: 100 MA AT 1V 100PIV	
A15CR2	1901-0025	DIODE, JUNCTION: 100 MA AT 1V 100PIV	
A16CR3	1901-0025	DIODE, JUNCTION: 100 MA AT 1V 100PIV	
A16CR4	1901-0025	DIODE, JUNCTION: 100 MA AT 1V 100PIV	
A16CR5	1901-0025	DIODE, JUNCTION: 100 MA AT 1V 100PIV	
A16CR6	1901-0025	DIODE, JUNCTION: 100 MA AT 1V 100PIV	
A16CR7	1901-0025	DIODE, JUNCTION: 100 MA AT 1V 100PIV	
A16CR8	1901-0025	DIODE, JUNCTION: 100 MA AT 1V 100PIV	
A16CR9	1901-0040	DIODE, SILICON: 30 MA AT 1V 30 PIV	
A16CR10	1901-0040	DIODE, SILICON: 30 MA AT 1V 30 PIV	
A16CR11	1901-0040	DIODE, SILICON: 30 MA AT 1V 30 PIV	
A16CR12	1901-0040	DIODE, SILICON: 30 MA AT 1V 30 PIV	
A16CR13	1901-0040	DIODE, SILICON: 30 MA AT 1V 30 PIV	
A16CR14	1901-0040	DIODE, SILICON: 30 MA AT 1V 30 PIV	
A16CR15	1901-0040	DIODE, SILICON: 30 MA AT 1V 30 PIV	
A16CR16	1901-0040	DIODE, SILICON: 30 MA AT 1V 30 PIV	
A16CR17	1901-0040	DIODE, SILICON: 30 MA AT 1V 30 PIV	
A16CR18	1901-0040	DIODE, SILICON: 30 MA AT 1V 30 PIV	
A16CR19	1901-0040	DIODE, SILICON: 30 MA AT 1V 30 PIV	
A16CR20	1901-0040	DIODE, SILICON: 30 MA AT 1V 30 PIV	
A16CR21	1901-0040	SEMICON DEVICE: DIODE SILICON	
A16DS1		NSR PART OF READOUT BLOCK ASSY	
A16DS2		NSR PART OF READOUT BLOCK ASSY	
A16DS3		NSR PART OF READOUT BLOCK ASSY	
A16DS4		NSR PART OF READOUT BLOCK ASSY	
A16DS5		NOT ASSIGNED	
A16DS6	1970-0009	ELECTRON TUBE: INDICATOR 10 DIGIT	
A16Q1	1853-0034	TRANSISTOR: SILICON PNP	
A16Q2	1853-0034	TRANSISTOR: SILICON PNP	
A16Q3	1853-0034	TRANSISTOR: SILICON PNP	
A16Q4	1853-0034	TRANSISTOR: SILICON PNP	
A16Q5	1853-0034	TRANSISTOR: SILICON PNP	
A16Q6	1853-0034	TRANSISTOR: SILICON PNP	
A16Q7	1853-0034	TRANSISTOR: SILICON PNP	
A16Q8	1853-0034	TRANSISTOR: SILICON PNP	
A16R1	0686-4735	R:FXD COMP 47K OHM 5% 1/2W	
A16R2		NSR PART OF READOUT BLOCK ASSY	
A16R3		NOT ASSIGNED	
A16R4			
A16R5	0683-3945	R:FXD COMP 390K OHM 5% 1/4W	
A16R6	0683-3945	R:FXD COMP 390K OHM 5% 1/4W	
A16R7			
A16R8	0683-3945	R:FXD COMP 390K OHM 5% 1/4W	
A16R9	0683-3945	R:FXD COMP 390K OHM 5% 1/4W	
A16R10	0683-5635	R:FXD COMP 56K OHM 5% 1/4W	
A16R11	0683-5635	R:FXD COMP 56K OHM 5% 1/4W	

= See list of abbreviations in introduction to this section

Table 4-1. Reference Designation Index (Cont'd)

Reference Designation	Stock No.	Description #	Note
A16R12	0683-5635	RIFXD COMP 56K OHM 5% 1/4W	
A16R13	0683-5635	RIFXD COMP 56K OHM 5% 1/4W	
A16R14	0683-5635	RIFXD COMP 56K OHM 5% 1/4W	
A16R15	0683-5635	RIFXD COMP 56K OHM 5% 1/4W	
A16R16	0683-5635	RIFXD COMP 56K OHM 5% 1/4W	
A16R17	0603-5635	RIFXD COMP 56K OHM 5% 1/4W	
A16R18	0761-0010	RIFXD MET Cx 1800 OHM 5% 1W	
A16R19	0761-0010	RIFXD MET Cx 1800 OHM 5% 1W	
A16R20	0758-0044	RIFXD MET Cx 2200 OHM 5% 1/2W	
A16R21	0758-8004	RIFXD MET FLH 2700 OHM 5% 1/2W	
A16R22	0758-0004	RIFXD MET FLH 2700 OHM 5% 1/2W	
A16R23	0758-0004	RIFXD MET FLH 2700 OHM 5% 1/2W	
A16R24	0758-0004	RIFXD MET FLH 2700 OHM 5% 1/2W	
A16R25	0758-0004	RIFXD MET FLH 2700 OHM 5% 1/2W	
A16R26	0683-1635	RIFXD COMP 16K OHM 5% 1/4W	
A16R27	0683-1635	RIFXD COMP 16K OHM 5% 1/4W	
A16R28	0683-1635	RIFXD COMP 16K OHM 5% 1/4W	
A16R29	0683-1635	RIFXD COMP 16K OHM 5% 1/4W	
A16R30	0683-1635	RIFXD COMP 16K OHM 5% 1/4W	
A16R31	0683-1635	RIFXD COMP 16K OHM 5% 1/4W	
A16R32	0683-1635	RIFXD COMP 16K OHM 5% 1/4W	
A16R33	0683-1635	RIFXD COMP 16K OHM 5% 1/4W	
A16R34	0683-1015	RIFXD COMP 100 OHM 5% 1/4W	
A16R35	0683-3925	RIFXD COMP 3900 OHM 5% 1/4W	
A16R36	0683-1835	RIFXD COMP 18K OHM 5% 1/4W	
A16R37	0683-3925	RIFXD COMP 3900 OHM 5% 1/4W	
A16R38	0683-4715	RIFXD 470 OHMS 5% 1/4W	
A16R39	0683-1015	RIFXD COMP 100 OHM 5% 1/4W	
A16R40	0683-3925	RIFXD COMP 3900 OHM 5% 1/4W	
A16R41	0683-1835	RIFXD COMP 18K OHM 5% 1/4W	
A16R42	0683-3925	RIFXD COMP 3900 OHM 5% 1/4W	
A16R43	0683-1115	RIFXD COMP 110 OHM 5% 1/4W	
A16R44	0683-1025	RIFXD COMP 1000 OHM 5% 1/4W	
A16R45	0683-3925	RIFXD COMP 3900 OHM 5% 1/4W	
A16R46	0683-1835	RIFXD COMP 18K OHM 5% 1/4W	
A16R47	0683-3925	RIFXD COMP 3900 OHM 5% 1/4W	
A16R48	0683-1045	RIFXD COMP 100K OHM 5% 1/4W	
A16R49	0683-3925	RIFXD COMP 3900 OHM 5% 1/4W	
A16R50	0683-1835	RIFXD COMP 18K OHM 5% 1/4W	
A16R51	0683-1025	RIFXD COMP 1000 OHM 5% 1/4W	
A16R52	0683-1115	RIFXD COMP 110 OHM 5% 1/4W	
A16R53	0683-3925	RIFXD COMP 3900 OHM 5% 1/4W	
A16R54	0683-1045	RIFXD COMP 100K OHM 5% 1/4W	
A16R55	0683-1025	RIFXD COMP 1000 OHM 5% 1/4W	
A16R56	0683-3625	RIFXD COMP 3600 OHM 5% 1/4W	
A16R57	0683-3625	RIFXD COMP 3600 OHM 5% 1/4W	
A16R58	0683-1025	RIFXD COMP 1000 OHM 5% 1/4W	
A16R59	0683-1045	RIFXD COMP 100K OHM 5% 1/4W	
A16R60	0683-1125	RIFXD COMP 1100 OHM 5% 1/4W	
A16R61	0683-2735	RIFXD COMP 27K OHM 5% 1/4W	
A16R62	0683-1045	RIFXD COMP 100K OHM 5% 1/4W	

= See list of abbreviations in introduction to this section

Table 4-1. Reference Designation Index (Cont'd)

Reference Designation	Stock No.	Description #	Note
A16R63	0683-1235	RIFXD COMP 12K OHM 5% 1/4W	
A16P64	0683-3025	RIFXD COMP 3000 OHM 5% 1/4W	
A16R65	0683-3935	RIFXD COMP 39K OHM 5% 1/4W	
A16V1		NSR PART OF READDUT BLOCK ASSY	
A17	5245A-65C 5245A-65C-1	ASSY:DECIMAL COUNTER BOARD:BLANK P.C.	
A17C1	0150-0093	CIFXD CER 0.01UF +80-20 100VDCW	
A17C2	0150-0050	CIFXD CER 1000PF 600 VDCW	
A17C3	0140-0196	CIFXD MICA 150 PF 5% 300 VDCW	
A17C4	0140-0034	CIFXD MICA 22 PF 5% 500 VDCW	
A17C5	0140-0210	CIFXD MICA 270PF 5% 300VDCW	
A17C6	0140-0145	CIFXD MICA 22 PF 5% 500 VDCW	
A17C7	0140-0196	CIFXD MICA 150 PF 5% 300 VDCW	
A17C8	0140-0202	CIFXD MICA 15 PF 5% 500VDCW	
A17C9	0140-0208	CIFXD MICA 680PF 5% 300VDCW	
A17C10	0140-0202	CIFXD MICA 15 PF 5% 500VDCW	
A17C11	0140-0204	CIFXD MICA 47PF 5% NPO 500VDCW	
A17C12	0140-0145	CIFXD MICA 22 PF 5% 500 VDCW	
A17C13	0140-0214	CIFXD MICA 60PF 5% 300VDCW	
A17C14	0140-0210	CIFXD MICA 270PF 5% 300VDCW	
A17C15	0140-0145	CIFXD MICA 22 PF 5% 500 VDCW	
A17C16	0140-0214	CIFXD MICA 60PF 5% 300VDCW	
A17C17	0140-0203	CIFXD MICA 30PF 5% 500VDCW	
A17C18	0140-0202	CIFXD MICA 15 PF 5% 500VDCW	
A17C19	0140-0210	CIFXD MICA 270PF 5% 300VDCW	
A17C20	0140-0202	CIFXD MICA 15 PF 5% 500VDCW	
A17C21	0140-0193	CIFXD MICA 82PF 5% 300VDCW	
A17C22	0160-0958	CIFXD MICA 390PF 5% 300VDCW	
A17C23	0140-0200	CIFXD MICA 390PF 5% 300VDCW	
A17C24	0140-0200	CIFXD MICA 390PF 5% 300VDCW	
A17C25	0150-0093	CIFXD CER 0.01UF +80-20 100VDCW	
A17C26	0150-0093	CIFXD CER 0.01UF +80-20 100VDCW	
A17C27	0150-0093	CIFXD CER 0.01UF +80-20 100VDCW	
A17C28	0150-0093	CIFXD CER 0.01UF +80-20 100VDCW	
A17C29	0150-0093	CIFXD CER 0.01UF +80-20 100VDCW	
A17CR1	1910-0022	SEMICON DEVICE:DIODE GE 100MA 6PIV 3.5NS	
A17CR2	1910-0022	SEMICON DEVICE:DIODE GE 100MA 6PIV 3.5NS	
A17CR3	1910-0022	SEMICON DEVICE:DIODE GE 100MA 6PIV 3.5NS	
A17CR4	1901-0535	SEMICON DEVICE:DIODE	
A17CR5	1910-0022	SEMICON DEVICE:DIODE GE 100MA 6PIV 3.5NS	
A17CR6	1901-0535	SEMICON DEVICE:DIODE	
A17CR7	1910-0022	SEMICON DEVICE:DIODE GE 100MA 6PIV 3.5NS	
A17CR8	1910-0022	SEMICON DEVICE:DIODE GE 100MA 6PIV 3.5NS	
A17CR9	1901-0535	SEMICON DEVICE:DIODE	
A17CR10	1901-0535	SEMICON DEVICE:DIODE	
A17CR11	1910-0022	SEMICON DEVICE:DIODE GE 100MA 6PIV 3.5NS	
A17CR12	1910-0022	SEMICON DEVICE:DIODE GE 100MA 6PIV 3.5NS	
A17CR13	1910-0022	SEMICON DEVICE:DIODE GE 100MA 6PIV 3.5NS	
A17CR14	1910-0022	SEMICON DEVICE:DIODE GE 100MA 6PIV 3.5NS	

See list of abbreviations in introduction to this section

Table 4-1. Reference Designation Index (Cont'd)

Reference Designation	Stock No.	Description #	Note
A17CR15	1901-0535	SEMICON DEVICE:DIODE	
A17CR16	1910-0022	SEMICON DEVICE:DIODE GE 100MA 6PIV 3.5NS	
A17CR17	1910-0022	SEMICON DEVICE:DIODE GE 100MA 6PIV 3.5NS	
A17CR18	1910-0022	SEMICON DEVICE:DIODE GE 100MA 6PIV 3.5NS	
A17CR19	1910-0022	SEMICON DEVICE:DIODE GE 100MA 6PIV 3.5NS	
A17CR20	1901-0025	SEMICON DEVICE:DIODE JUNCTION	
A17L1	9140-0159	COIL:FXD 0.47UH 20%	
A17L2	9140-0158	COIL:FXD 1.0UH 10%	
A17L3	9140-0159	COIL:FXD 0.47UH 20%	
A17L4	9140-0158	COIL:FXD 1.0UH 10%	
A17L5	9140-0143	COIL:FXD RF 3.3 UH	
A17L6	9140-0159	COIL:FXD 0.47UH 20%	
A17L7	9140-0159	COIL:FXD 0.47UH 20%	
A17L8	9140-0143	COIL:FXD RF 3.3 UH	
A17L9	9140-0143	COIL:FXD RF 3.3 UH	
A17Q1	1854-0009	TRANSISTOR:2N709 NPN SILICON	
A17Q2	1854-0009	TRANSISTOR:2N709 NPN SILICON	
A17Q3	1854-0009	TRANSISTOR:2N709 NPN SILICON	
A17Q4	1854-0009	TRANSISTOR:2N709 NPN SILICON	
A17Q5	1854-0009	TRANSISTOR:2N709 NPN SILICON	
A17Q6	1854-0009	TRANSISTOR:2N709 NPN SILICON	
A17Q7	1854-0009	TRANSISTOR:2N709 NPN SILICON	
A17Q8	1854-0009	TRANSISTOR:2N709 NPN SILICON	
A17Q9	1850-0158	TRANSISTOR:PNP GERMANIUM	
A17Q10	1850-0102	TRANSISTOR:GE2N2455	
A17Q11	1854-0009	TRANSISTOR:2N709 NPN SILICON	
A17Q12	1854-0009	TRANSISTOR:2N709 NPN SILICON	
A17Q13	1854-0009	TRANSISTOR:2N709 NPN SILICON	
A17R1	0683-5115	R:FXD COMP 510 OHMS 5% 1/4W	
A17R2	0683-4725	R:FXD COMP 4700 OHM 5% 1/4W	
A17R3	0683-2015	R:FXD COMP 200 OHMS 5% 1/4W	
A17R4	0683-1225	R:FXD COMP 1200 OHMS 5% 1/4W	
A17R5	0683-3315	R:FXD COMP 330 OHMS 5% 1/4W	
A17R6	0683-2025	R:FXD COMP 2000 OHMS 5% 1/4W	
A17R7	0683-3305	R:FXD COMP 33 OHMS 5% 1/4W	
A17R8	0683-2025	R:FXD COMP 2000 OHMS 5% 1/4W	
A17R9	0683-4725	R:FXD COMP 4700 OHM 5% 1/4W	
A17R10	0683-2015	R:FXD COMP 200 OHMS 5% 1/4W	
A17R11	0683-1225	R:FXD COMP 1200 OHMS 5% 1/4W	
A17R12	0683-3315	R:FXD COMP 330 OHMS 5% 1/4W	
A17R13	0683-2025	R:FXD COMP 2000 OHMS 5% 1/4W	
A17R14	0683-1035	R:FXD COMP 10K OHMS 5% 1/4W	
A17R15	0683-2225	R:FXD COMP 2.2K OHM 5% 1/4W	
A17R16	0683-3315	R:FXD COMP 330 OHMS 5% 1/4W	
A17R17	0683-1825	R:FXD COMP 1800 OHMS 5% 1/4W	
A17R18	0683-2725	R:FXD COMP 2700 OHMS 5% 1/4W	
A17R19	0683-5105	R:FXD COMP 51 OHM 5% 1/4W	
A17R20	0683-2415	R:FXD COMP 240 OHMS 5% 1/4W	
A17R21	0683-1825	R:FXD COMP 1800 OHMS 5% 1/4W	

* See list of abbreviations in introduction to this section

Table 4-1. Reference Designation Index (Cont'd)

Reference Designation	Stock No.	Description #	Note
A17R22	0683-2725	RIFXD COMP 2700 OHMS 5% 1/4W	
A17R23	0683-2225	RIFXD COMP 2.2K OHM 5% 1/4W	
A17R24	0683-2025	RIFXD COMP 2000 OHMS 5% 1/4W	
A17R25	0683-1035	RIFXD COMP 10K OHMS 5% 1/4W	
A17R26	0683-2215	RIFXD COMP 220 OHMS 5% 1/4W	
A17R27	0683-1015	RIFXD COMP 100 OHMS 5% 1/4W	
A17R28	0683-4715	RIFXD COMP 470 OHM 5% 1/4W	
A17R29	0683-2415	RIFXD COMP 240 OHMS 5% 1/4W	
A17R30	0683-1025	RIFXD COMP 1000 OHM 5% 1/4W	
A17R31	0683-8215	RIFXD COMP 820 OHMS 5% 1/4W	
A17R32	0683-3025	RIFXD COMP 3000 OHMS 5% 1/4W	
A17R33	0683-5105	RIFXD COMP 51 OHM 5% 1/4W	
A17R34	0683-2415	RIFXD COMP 240 OHMS 5% 1/4W	
A17R35	0683-1025	RIFXD COMP 1000 OHM 5% 1/4W	
A17R36	0683-8215	RIFXD COMP 820 OHMS 5% 1/4W	
A17R37	0683-3025	RIFXD COMP 3000 OHMS 5% 1/4W	
A17R38	0683-1625	RIFXD COMP 1600 OHM 5% 1/4W	
A17R39	0683-1035	RIFXD COMP 10K OHMS 5% 1/4W	
A17R40	0683-4715	RIFXD COMP 470 OHM 5% 1/4W	
A17R41	0683-3315	RIFXD COMP 330 OHMS 5% 1/4W	
A17R42	0683-1825	RIFXD COMP 1800 OHMS 5% 1/4W	
A17R43	0683-2725	RIFXD COMP 2700 OHMS 5% 1/4W	
A17R44	0683-5105	RIFXD COMP 51 OHM 5% 1/4W	
A17R45	0683-3315	RIFXD COMP 330 OHMS 5% 1/4W	
A17R46	0683-2225	RIFXD COMP 2200 OHMS 5% 1/4W (FACTORY SELECTED PART)	
A17R47	0683-2225	RIFXD COMP 2200 OHMS 5% 1/4W	
A17R48	0683-4715	RIFXD COMP 470 OHM 5% 1/4W	
A17R49	0683-2025	RIFXD COMP 2000 OHMS 5% 1/4W	
A17R50	0683-1035	RIFXD COMP 10K OHMS 5% 1/4W	
A17R51	0683-4715	RIFXD COMP 470 OHMS 5% 1/2W	
A17R52	0683-5115	RIFXD COMP 510 OHM 5% 1/4W	
A17R53	0683-0475	RIFXD COMP 4.7 OHMS 5% 1/4W	
A17R54	0683-5615	RIFXD COMP 560 OHMS 5% 1/4W	
A17R55	0683-4315	RIFXD COMP 430 OHMS 5% 1/4W	
A17R56	0683-7515	RIFXD COMP 750 OHMS 5% 1/4W	
A17R57	0683-7515	RIFXD COMP 750 OHMS 5% 1/4W	
A17R58	0683-4315	RIFXD COMP 430 OHM 5% 1/4W	
A17R59	0683-7515	RIFXD COMP 750 OHMS 5% 1/4W	
A17R60	0761-0020	RIFXD MET FLM 91 OHM 5% 1W	
A17R61	0683-1015	RIFXD COMP 100 OHMS 5% 1/4W	
A17R62	0683-6805	RIFXD COMP 68 OHMS 5% 1/4W	
A18	5245L-4B, 5243A-65A-1 05212-6011	ASSY:READOUT BOARD:ELANK P.C. READOUT BLOCK ASSEMBLY	
A18CR1	1901-0025	SEMICON DEVICE:DIODE JUNCTION	
A18CR2	1901-0025	SEMICON DEVICE:DIODE JUNCTION	
A18CR3	1901-0025	SEMICON DEVICE:DIODE JUNCTION	
A18CR4	1901-0025	SEMICON DEVICE:DIODE JUNCTION	
A18CR5	1901-0025	SEMICON DEVICE:DIODE JUNCTION	
A18CR6	1901-0025	SEMICON DEVICE:DIODE JUNCTION	

* See list of abbreviations in introduction to this section

Table 4-1. Reference Designation Index (Cont'd)

Reference Designation	Stock No.	Description #	Note
A18CR7 A18CR8	1901-0025 1901-0025	SEMICON DEVICE:DIODE JUNCTION SEMICON DEVICE:DIODE JUNCTION	
A18D51 A18D52 A18D53 A18D54 A18D55		NSR PART OF READOUT BLOCK ASSY. NSR PART OF READOUT BLOCK ASSY. NSR PART OF READOUT BLOCK ASSY. NSR PART OF READOUT BLOCK ASSY. NOT ASSIGNED	
A18D36	1970-0009	ELECTRON TUBE:INDICATOR 10 DIGIT	
A18Q1 A18Q2 A18Q3 A18Q4 A18Q5	1854-0003 1854-0003 1854-0003 1854-0003 1854-0003	TRANSISTOR:PNP SILICON TRANSISTOR:PNP SILICON TRANSISTOR:PNP SILICON TRANSISTOR:PNP SILICON TRANSISTOR:PNP SILICON	
A18Q6 A18Q7 A18Q8	1854-0003 1854-0003 1854-0003	TRANSISTOR:PNP SILICON TRANSISTOR:PNP SILICON TRANSISTOR:PNP SILICON	
A18R1 A18R2 A18R3 A18R5 A18R6	0686-4735 - - - 0683-3945	RIFXD COMP 47K OHM 5% 1/2W NSR PART OF READOUT BLOCK ASSY. NOT ASSIGNED NOT ASSIGNED RIFXD COMP 390K OHMS 5% 1/4W	
A18R7 A18R8 A18R9 A18R10 A18R11	0683-3945 0683-3945 0683-3945 0683-5635 0683-5635	RIFXD COMP 390K OHMS 5% 1/4W RIFXD COMP 390K OHMS 5% 1/4W RIFXD COMP 390K OHMS 5% 1/4W RIFXD COMP 56K OHMS 5% 1/4W RIFXD COMP 56K OHMS 5% 1/4W	
A18R12 A18R13 A18R14 A18R15 A18R16	0683-5635 0683-5635 0683-5635 0683-5635 0683-5635	RIFXD COMP 56K OHMS 5% 1/4W RIFXD COMP 56K OHMS 5% 1/4W RIFXD COMP 56K OHMS 5% 1/4W RIFXD COMP 56K OHMS 5% 1/4W RIFXD COMP 56K OHMS 5% 1/4W	
A18R17 A18R18 A18R19 A18R20 A18R21	0683-5635 0683-2025 0683-7525 0683-1545 0683-5135	RIFXD COMP 56K OHMS 5% 1/4W RIFXD COMP 2000 OHM 5% 1/4W RIFXD COMP 7500 OHMS 5% 1/4W RIFXD COMP 150K OHM 5% 1/4W RIFXD COMP 51K OHM 5% 1/4W	
A18R22 A18R23 A18R24 A18R25 A18R26	0683-6805 - 0683-7525 0683-1045 0683-2025	RIFXD COMP 68 OHM 5% 1/4W NOT ASSIGNED RIFXD COMP 7500 OHMS 5% 1/4W RIFXD COMP 100K OHM 5% 1/4W RIFXD COMP 2000 OHM 5% 1/4W	
A18R27 A18R28 A18R29 A18R30 A18R31	0683-7525 0683-1545 0683-5135 0683-9105 -	RIFXD COMP 7500 OHMS 5% 1/4W RIFXD COMP 150K OHM 5% 1/4W RIFXD COMP 51K OHM 5% 1/4W RIFXD COMP 91 OHM 5% 1/4W NOT ASSIGNED	
A18R32 A18R33 A18R34	0683-7525 0683-1045 0683-2025	RIFXD COMP 7500 OHMS 5% 1/4W RIFXD COMP 100K OHM 5% 1/4W RIFXD COMP 2000 OHM 5% 1/4W	

See list of abbreviations in introduction to this section

Table 4-1. Reference Designation Index (Cont'd)

Reference Designation	Stock No.	Description #	Note
A18R35	0683-7525	R:FXD COMP 7500 OHMS 5% 1/4W	
A18R36	0683-1545	R:FXD COMP 150K OHM 5% 1/4W	
A18R37	0683-5135	R:FXD COMP 51K OHM 5% 1/4W	
A18R38	0683-9105	R:FXD COMP 91 OHM 5% 1/4W	
A18R39		NOT ASSIGNED	
A18R40	0683-7525	R:FXD COMP 7500 OHMS 5% 1/4W	
A18R41	0683-1045	R:FXD COMP 100K OHM 5% 1/4W	
A18R42	0683-2025	R:FXD COMP 2000 OHM 5% 1/4W	
A18R43	0683-7525	R:FXD COMP 7500 OHMS 5% 1/4W	
A18R44	0683-1545	R:FXD COMP 150K OHM 5% 1/4W	
A18R45	0683-5135	R:FXD COMP 51K OHM 5% 1/4W	
A18R46	0683-9105	R:FXD COMP 91 OHM 5% 1/4W	
A18R47		NOT ASSIGNED	
A18R48	0683-7525	R:FXD COMP 7500 OHMS 5% 1/4W	
A18R49	0683-1045	R:FXD COMP 100K OHM 5% 1/4W	
A18V1		NSR PART OF READOUT BLOCK ASSY.	
A19	05245-6014 05245-2014	BOARD ASSY: INPUT AMPLIFIER BOARD: BLANK PC	
A19C1	0160-0127	C:FXD CER 1" 20% 25VDCW	
A19C2	0150-0093	C:FXD CER 0.01UF +80-20 100VDCW	
A19C3	0150-0042	C:FXD TI 4.7 PF 5% 500VDCW	
A19C4	0150-0093	C:FXD CER 0.01UF +80-20 100VDCW	
A19C5	0150-0093	C:FXD CER 0.01UF +80-20 100VDCW	
A19C6	0150-0073	C:FXD CER 100 PF 10% 500VDCW	
A19C7	0160-0127	C:FXD CER 1UF 20% 25VDCW	
A19C8	0150-0093	C:FXD CER 0.01UF +80-20 100VDCW	
A19C9	0150-0061	C:FXD CER 20 PF 10% 100VDCW	
A19C10	0150-0093	C:FXD CER 0.01UF +80-20 100VDCW	
A19CR1	1901-0376	DIODE: SILICON 35V	
A19CR2	1901-0040	SEMICON DEVICE: DIODE SILICON	
A19CR3	1901-0376	DIODE: SILICON 35V	
A19CR4	1901-0040	SEMICON DEVICE: DIODE SILICON	
A19CR5	1902-0580	DIODE BREAKDOWN: SILICON	
A19CR6	1901-0040	SEMICON DEVICE: DIODE SILICON	
A19CR7	1901-0040	SEMICON DEVICE: DIODE SILICON	
A19Q1	1855-0047	TRANSISTOR: DUAL N-CHANNEL FET	
A19Q2	1854-0249	TRANSISTOR: DUAL NP SILICON	
A19Q3	1853-0015	TRANSISTOR: SILICON PNP 2N3640	
A19Q4	1853-0015	TRANSISTOR: SILICON PNP 2N3640	
A19Q5	1854-0009	TRANSISTOR: 2N709 NPN SILICON	
A19Q6	1854-0009	TRANSISTOR: 2N709 NPN SILICON	
A19R1	0757-0898	R:FXD MET FLM 82 OHM 2% 1/8W	
A19R2	0683-1625	R:FXD COMP 1600 OHM 5% 1/4W	
A19R3	0757-0948	R:FXD MET FLM 10K OHM 2% 1/8W	
A19R4	0757-0950	R:FXD MET FLM 12K OHM 2% 1/8W	
A19R5	0757-0940	R:FXD MET FLM 4.7K OHM 2% 1/8W	
A19R6	0757-0952	R:FXD MET FLM 15K OHM 2% 1/8W	
A19R7	0757-0909	R:FXD MET FLM 240 OHM 2% 1/8W	

= See list of abbreviations in introduction to this section

Table 4-1. Reference Designation Index. (Cont'd)

Reference Designation	Stock No.	Description #	Note
A19R8	0757-0932	RIFXD MET FLM 2.2K OHM 2% 1/8W	
A19R9	0757-0936	RIFXD MET FLM 3.3K OHM 2% 1/8W	
A19R10	0757-0916	RIFXD MET FLM 470 OHM 2% 1/8W	
A19R11	0757-0900	RIFXD MET FLM 100 OHM 2% 1/8W	
A19R12	0757-0904	RIFXD MET FLM 150 OHM 2% 1/8W	
A19R13	0757-0936	RIFXD MET FLM 3.3K OHM 2% 1/8W	
A19R14	0757-0916	RIFXD MET FLM 470 OHM 2% 1/8W	
A19R15	0757-0909	RIFXD MET FLM 240 OHM 2% 1/8W	
A19R16	0757-0932	RIFXD MET FLM 2.2K OHM 2% 1/8W	
A19R17	0757-0920	RIFXD MET FLM 680 OHM 2% 1/8W	
A19R18	0757-0952	RIFXD MET FLM 15K OHM 2% 1/8W	
A19R19	0757-0972	RIFXD MET FLM 100K OHM 2% 1/8W	
A19R20	2100-1754	RIVAR WW 50 OHM 5% 1W	
A19R21	0757-0930	RIFXD MET FLM 1.8K OHM 2% 1/8W	
A19R22	0757-0914	RIFXD MET FLM 390 OHM 2% 1/8W	
A19R23	0757-0902	RIFXD MET FLM 120 OHM 2% 1/8W	
A19R24	0757-0930	RIFXD MET FLM 1.8K OHM 2% 1/8W FACTORY SELECTED PART:TYPICAL VALUE GIVEN	
A19R25	0757-0948	RIFXD MET FLM 10K OHM 2% 1/8W	
A19R26	0757-0950	RIFXD MET FLM 12K OHM 2% 1/8W	
A20		SAME AS A19:USE PREFIX A20	
A21	05245-6015 05245-2015	BOARD ASSY:FUNCTION BOARD:BLANK PC	
A21C1	0160-0127	CIFXD CER 1UF 20% 25VDCW	
A21C2	0150-0093	CIFXD CER 0.01UF +80-20 100VDCW	
A21C3	0150-0093	CIFXD CER 0.01UF +80-20 100VDCW	
A21C4	0170-0084	CIFXD MY 0.068UF 20% 50VDCW	
A21C5	0160-0127	CIFXD CER 1UF 20% 25VDCW	
A21C6	0160-0127	CIFXD CER 1UF 20% 25VDCW	
A21C7	0160-0127	CIFXD CER 1UF 20% 25VDCW	
A21C8	0160-0205	CIFXD MICA 10 PF 5%	
A21C9	0140-0203	CIFXD MICA 30PF 5% 500VDCW	
A21C10	0140-0203	CIFXD MICA 30PF 5% 500VDCW	
A21C11	0160-0205	CIFXD MICA 10 PF 5%	
A21C12	0150-0093	CIFXD CER 0.01UF +80-20 100VDCW	
A21C13	0140-0149	CIFXD MICA 470 PF 5% 300 VDCW	
A21C14	0140-0149	CIFXD MICA 470 PF 5% 300 VDCW	
A21C15	0140-0149	CIFXD MICA 470 PF 5% 300 VDCW	
A21C16	0140-0149	CIFXD MICA 470 PF 5% 300 VDCW	
A21C17	0150-0093	CIFXD CER 0.01UF +80-20 100VDCW	
A21C18	0160-0370	CIFXD MICA 20 PF 5%	
A21CR1	1910-0016	SEMICON DEVICE:DIODE GERMANIUM	
A21CR2	1910-0016	SEMICON DEVICE:DIODE GERMANIUM	
A21CR3	1910-0016	SEMICON DEVICE:DIODE GERMANIUM	
A21CR4	1910-0016	SEMICON DEVICE:DIODE GERMANIUM	
A21CR5	1910-0016	SEMICON DEVICE:DIODE GERMANIUM	
A21CR6	1910-0016	SEMICON DEVICE:DIODE GERMANIUM	
A21CR7	1910-0016	SEMICON DEVICE:DIODE GERMANIUM	
A21CR8	1910-0016	SEMICON DEVICE:DIODE GERMANIUM	
A21CR9	1901-0040	SEMICON DEVICE:DIODE SILICON	

See list of abbreviations in introduction to this section

Table 4-1. Reference Designation Index (Cont'd)

Reference Designation	Stock No.	Description #	Note
A21CR10	1910-0016	SEMICON DEVICE:DIODE GERMANIUM	
A21CR11	1910-0016	SEMICON DEVICE:DIODE GERMANIUM	
A21CR12	1910-0016	SEMICON DEVICE:DIODE GERMANIUM	
A21CR13	1901-0025	DIODE JUNCTION:100 MA AT 1V 100PIV	
A21CR14	1901-0025	DIODE JUNCTION:100 MA AT 1V 100PIV	
A21CR15	1910-0016	SEMICON DEVICE:DIODE GERMANIUM	
A21CR16	1910-0016	SEMICON DEVICE:DIODE GERMANIUM	
A21CR17	1910-0016	SEMICON DEVICE:DIODE GERMANIUM	
A21L1	9140-0146	COIL:FXD RF 10 UH	
A21L2	9140-0146	COIL:FXD RF 10 UH	
A21L3	9140-0095	COIL:FXD RF 0.27 UH	
A21L4	9140-0159	COIL:FXD RF 0.47 UH	
A21Q1	1854-0019	TRANSISTOR:SILICON NPN	
A21Q2	1854-0005	TRANSISTOR:2N708 NPN SILICON PLANAR	
A21Q3	1854-0073	TRANSISTOR:SILICON NPN	
A21Q4	1854-0073	TRANSISTOR:SILICON NPN	
A21Q5	1854-0005	TRANSISTOR:2N708 NPN SILICON PLANAR	
A21Q6	1854-0005	TRANSISTOR:2N708 NPN SILICON PLANAR	
A21Q7	1854-0005	TRANSISTOR:2N708 NPN SILICON PLANAR	
A21Q8	1854-0005	TRANSISTOR:2N708 NPN SILICON PLANAR	
A21Q9	1854-0009	TRANSISTOR:2N709 NPN SILICON	
A21Q10	1853-0015	TRANSISTOR:SILICON PNP	
A21Q11	1853-0015	TRANSISTOR:SILICON PNP 2N3640	
A21Q12	1854-0005	TRANSISTOR:2N708 NPN SILICON PLANAR	
A21Q13	1854-0019	TRANSISTOR:SILICON NPN	
A21R1	0683-1615	R:FXD COMP 160 OHM 5% 1/4W	
A21R2	0683-1615	R:FXD COMP 160 OHM 5% 1/4W	
A21R3	0683-1035	R:FXD COMP 10K OHMS 5% 1/4W	
A21R4	0683-5125	R:FXD COMP 5100 OHM 5% 1/4W	
A21R5	0683-5125	R:FXD COMP 5100 OHM 5% 1/4W	
A21R6	0683-5125	R:FXD COMP 5100 OHM 5% 1/4W	
A21R7	0683-5125	R:FXD COMP 5100 OHM 5% 1/4W	
A21R8	0683-5125	R:FXD COMP 5100 OHM 5% 1/4W	
A21R9	0683-5125	R:FXD COMP 5100 OHM 5% 1/4W	
A21R10	0683-1035	R:FXD COMP 10K OHMS 5% 1/4W	
A21R11	0683-1035	R:FXD COMP 10K OHMS 5% 1/4W	
A21R12	0683-1035	R:FXD COMP 10K OHMS 5% 1/4W	
A21R13	0683-1035	R:FXD COMP 10K OHMS 5% 1/4W	
A21R14	0683-1035	R:FXD COMP 10K OHMS 5% 1/4W	
A21R15	0683-1035	R:FXD COMP 10K OHMS 5% 1/4W	
A21R16	0683-2025	R:FXD COMP 2000 OHM 5% 1/4W	
A21R17	0683-6225	R:FXD COMP 6200 OHMS 5% 1/4W	
A21R18	0683-2025	R:FXD COMP 2000 OHM 5% 1/4W	
A21R19	0683-6225	R:FXD COMP 6200 OHMS 5% 1/4W	
A21R20	0683-1025	R:FXD COMP 1000 OHM 5% 1/4W	
A21R21	0683-1025	R:FXD COMP 1000 OHM 5% 1/4W	
A21R22	0683-1815	R:FXD COMP 180 OHM 5% 1/4W	
A21R23	0683-1815	R:FXD COMP 180 OHM 5% 1/4W	
A21R24	0683-1815	R:FXD COMP 180 OHM 5% 1/4W	
A21R25	0683-4315	R:FXD COMP 430 OHMS 5% 1/4W	

= See list of abbreviations in introduction to this section

Table 4-1. Reference Designation Index (Cont'd)

Reference Designation	Stock No.	Description #	Note
A21R26	0683-4315	R:FXD COMP 430 OHMS 5% 1/4W	
A21R27	0683-4315	R:FXD COMP 430 OHMS 5% 1/4W	
A21R28	0683-3915	R:FXD COMP 390 OHMS 5% 1/4W	
A21R29	0683-6815	R:FXD COMP 680 OHMS 5% 1/4W	
A21R30	0683-5615	R:FXD COMP 560 OHM 5% 1/4W (FACTORY SELECTED PART)	
A21R31	2100-1771	R:VAR WW 200 OHM 5% 1W	
A21R32	0683-3615	R:FXD COMP 360 OHMS 5% 1/4W (FACTORY SELECTED PART)	
A21R33	0683-6815	R:FXD COMP 680 OHMS 5% 1/4W	
A21R34	0683-3915	R:FXD COMP 390 OHMS 5% 1/4W	
A21R35	0683-1115	R:FXD COMP 110 OHM 5% 1/4W	
A21R36	0683-4715	R:FXD COMP 470 OHM 5% 1/4W	
A21R37	0683-4715	R:FXD COMP 470 OHM 5% 1/4W	
A21R38	0683-2725	R:FXD COMP 2700 OHM 5% 1/4W	
A21R39	0683-5115	R:FXD COMP 510 OHMS 5% 1/4W	
A21R40	0683-4725	R:FXD COMP 4700 OHM 5% 1/4W	
A21R41	0683-4725	R:FXD COMP 4700 OHM 5% 1/4W	
A21R42	0683-5115	R:FXD COMP 510 OHMS 5% 1/4W	
A21R43	0683-4725	R:FXD COMP 4700 OHM 5% 1/4W	
A21R44	0683-4725	R:FXD COMP 4700 OHM 5% 1/4W	
A21R45	0683-6825	R:FXD COMP 6800 OHMS 5% 1/4W	
A21R46	0683-4735	R:FXD COMP 47K OHMS 5% 1/4W	
A21R47	0683-4735	R:FXD COMP 47K OHMS 5% 1/4W	
A21R48	0683-5115	R:FXD COMP 510 OHMS 5% 1/4W	
A21R49	0683-2415	R:FXD COMP 240 OHM 5% 1/4W	
A21R50	0683-1815	R:FXD COMP 180 OHM 5% 1/4W	
A21R51	0683-3315	R:FXD COMP 330 OHM 5% 1/4W (FACTORY SELECTED PART)	
A21R52	0683-1015	R:FXD COMP 100 OHM 5% 1/4W (FACTORY SELECTED PART)	
A21R53	0683-7515	R:FXD COMP 750 OHM 5% 1/4W	
A21R54	0683-1015	R:FXD COMP 100 OHM 5% 1/4W	
A21R55	0683-6805	R:FXD COMP 68 OHMS 5% 1/4W	
A22	5243A-65R 5243A-65R-1	ASSY:GATE CONTRCL BOARD:BLANK P.C.	
A22C1	0140-0192	C:FXD MICA 68PF 5% 300VDCW	
A22C2	0140-0192	C:FXD MICA 68PF 5% 300VDCW	
A22C3	0140-0191	C:FXD MICA 56 PF 5% 300 VDCW	
A22C4	0160-0369	C:FXD MICA 17PF 5%	
A22C5	0140-0208	C:FXD MICA 680PF 5% 300VDCW	
A22C6	0180-0100	C:FXD ELECT TA 4.7UF 10% 35VDCW	
A22C7	0140-0194	C:FXD MICA 110 PF 5% 300 VDCW	
A22C8	0140-0200	C:FXD MICA 390PF 5% 300VDCW	
A22C9	0140-0159	C:FXD MICA 3000PF 300VDCW	
A22C10	0140-0201	C:FXD MICA 12PF 5% 500VDCW	
A22C11	0140-0205	C:FXD MICA 62 PF 5% 300VDCW FACTORY SELECTED PART:TYPICAL VALUE GIVEN	
A22C12	0160-0163	C:FXD MY 3300PF 10%	
A22C13	0150-0047	C:FXD TI 6.8 PF 10% 500 VDCW	
A22C14	0150-0047	C:FXD TI 6.8 PF 10% 500 VDCW	
A22CR1	1910-0034	DIODE:GERMANIUM	
A22CR2	1910-0034	DIODE:GERMANIUM	
A22CR3	1901-0040	SEMICON DEVICE:DIODE SILICON	

= See list of abbreviations in introduction to this section

Table 4-1. Reference Designation Index (Cont'd)

Reference Designation	Stock No.	Description #	Note
A22CR4	1901-0040	SEMICON DEVICE:DIODE SILICON	
A22CR5	1910-0016	SEMICON DEVICE:DIODE GERMANIUM	
A22CR6	1910-0016	SEMICON DEVICE:DIODE GERMANIUM	
A22CR7	1901-0040	SEMICON DEVICE:DIODE SILICON	
A22L1	9140-0142	COIL:FXD RF 2.2 UH	
A22L2	9140-0142	COIL:FXD RF 2.2 UH	
A22L3	9140-0142	COIL:FXD RF 2.2 UH	
A22Q1	1854-0005	TRANSISTOR:2N708 NPN SILICON PLANAR	
A22Q2	1854-0005	TRANSISTOR:2N708 NPN SILICON PLANAR	
A22Q3	1854-0005	TRANSISTOR:2N708 NPN SILICON PLANAR	
A22Q4	1854-0009	TRANSISTOR:SILICON NPN 2N709	
A22Q5	1854-0009	TRANSISTOR:SILICON NPN 2N709	
A22Q6	1854-0005	TRANSISTOR:2N708 NPN SILICON PLANAR	
A22Q7	1854-0005	TRANSISTOR:2N708 NPN SILICON PLANAR	
A22Q8	1851-0017	TRANSISTOR:2N1304	
A22Q9	1851-0017	TRANSISTOR:2N1304	
A22Q10	1651-0017	TRANSISTOR:2N1304	
A22Q11	1854-0Q22	TRANSISTOR:120V	
A22R1	0683-3325	R:FXD COMP 3300 OHM 5% 1/4W	
A22R2	0683-7535	R:FXD COMP 75K OHM 5% 1/4W	
A22R3	0683-1035	R:FXD COMP 10K OHMS 5% 1/4W	
A22R4	0683-2425	R:FXD COMP 2400 OHMS 5% 1/4W	
A22R5	0683-1035	R:FXD COMP 10K OHMS 5% 1/4W	
A22R6	0683-2425	R:FXD COMP 2400 OHMS 5% 1/4W	
A22R7	0683-1325	R:FXD COMP 1300 OHMS 5% 1/4W	
A22R8	0683-2425	R:FXD COMP 2400 OHM 5% 1/4W	
A22R9	0683-6235	R:FXD COMP 62K OHM 5% 1/4W	
A22R10	0683-6235	R:FXD COMP 62K OHM 5% 1/4W	
A22R11	0683-2425	R:FXD COMP 2400 OHM 5% 1/4W	
A22R12	0683-1325	R:FXD COMP 1300 OHMS 5% 1/4W	
A22R13	0683-1035	R:FXD COMP 10K OHMS 5% 1/4W	
A22R14	0683-3325	R:FXD COMP 3300 OHM 5% 1/4W	
A22R15	0683-4725	R:FXD COMP 4700 OHM 5% 1/4W	
A22R16	0683-3325	R:FXD COMP 3300 OHM 5% 1/4W	
A22R17	0683-4725	R:FXD COMP 4700 OHM 5% 1/4W	
A22R18	0683-1035	R:FXD COMP 10K OHMS 5% 1/4W	
A22R19	0683-1035	R:FXD COMP 10K OHMS 5% 1/4W	
A22R20	0683-1545	R:FXD COMP 150K OHMS 5% 1/4W	
A22R21	0683-2015	R:FXD COMP 200 OHMS 5% 1/4W	
A22R22	0686-9115	R:FXD COMP 910 OHMS 5% 1/2W	
A22R23	0683-1025	R:FXD COMP 1000 OHM 5% 1/4W	
A22R24	0683-1325	R:FXD COMP 1300 OHMS 5% 1/4W	
A22R25	0683-1035	R:FXD COMP 10K OHMS 5% 1/4W	
A22R26	0683-4735	R:FXD COMP 47K OHMS 5% 1/4W	
A22R27	0683-1035	R:FXD COMP 10K OHMS 5% 1/4W	
A22R28	0683-1325	R:FXD COMP 1300 OHMS 5% 1/4W	
A22R29	0683-1525	R:FXD COMP 1500 OHM 5% 1/4W	
A22R30	0683-2735	R:FXD COMP 27K OHM 5% 1/4W	
A22R31	0683-1045	R:FXD COMP 100K OHM 5% 1/4W	
A22R32	0683-1825	R:FXD COMP 1800 OHM 5% 1/4W	

= See list of abbreviations in introduction to this section

Table 4-1. Reference Designation Index (Cont'd)

Reference Designation	Stock No.	Description #	Note
A22R33	0683-2735	RIFXD COMP 27K OHM 5% 1/4W	
A22R34	0683-4725	RIFXD COMP 4700 OHM 5% 1/4W	
A22R35	0683-1625	RIFXD COMP 1600 OHMS 5% 1/4W	
A22R36	0683-4725	RIFXD COMP 4700 OHM 5% 1/4W	
A22R37	0683-9135	RIFXD COMP 91K OHM 5% 1/4W	
A22R38	0683-4725	RIFXD COMP 4700 OHM 5% 1/4W	
A23	5243A-655 5243A-655-1	ASSY: SAMPLING CONTROL BOARD: BLANK P.C.	
A23C1	0140-0159	CIFXD MICA 3000PF 300VDCW	
A23C2	0150-0093	CIFXD CER 0.01UF +80-20 100VDCW	
A23C3	0140-0156	CIFXD MICA 1500 PF 2% 300 VDCW	
A23C4	0180-0137	CIFXD ELECT TA 100 UF 20% 10VDCW	
A23C5	0180-0100	CIFXD ELECT TA 4.7UF 10% 35VDCW	
A23C6	0140-0149	CIFXD MICA 470 PF 5% 300 VDCW	
A23C7	0140-0162	CIFXD MICA 4700 PF 10% 300 VDCW	
A23C8	0180-0100	CIFXD ELECT TA 4.7UF 10% 35VDCW	
A23C9	0160-0161	CIFXD MY 0.01 UF 10% 200VDCW	
A23C10		NOT ASSIGNED	
A23C11	0140-0200	CIFXD MICA 390PF 5% 300VDCW	
A23C12	0150-0121	CIFXD CER 0.1UF +80%-20% 50VDCW	
A23C13	0150-0121	CIFXD CER 0.1UF +80%-20% 50VDCW	
A23CR1	1901-0025	SEMICON DEVICE: DIODE JUNCTION	
A23CR2	1901-0025	SEMICON DEVICE: DIODE JUNCTION	
A23CR3	1901-0040	SEMICON DEVICE: DIODE SILICON	
A23CR4	1901-0025	SEMICON DEVICE: DIODE JUNCTION	
A23CR5	1901-0025	SEMICON DEVICE: DIODE JUNCTION	
A23CR6	1901-0025	SEMICON DEVICE: DIODE JUNCTION	
A23CR7	1901-0025	SEMICON DEVICE: DIODE JUNCTION	
A23CR8	1901-0025	SEMICON DEVICE: DIODE JUNCTION	
A23CR9	1901-0040	SEMICON DEVICE: DIODE SILICON	
A23Q1	1851-0017	TRANSISTOR: 2N1304	
A23Q2	1850-0040	TRANSISTOR: GERMANIUM 2N383 PNP	
A23Q3	1850-0062	TRANSISTOR: GERMANIUM	
A23Q4	1850-0062	TRANSISTOR: GERMANIUM	
A23Q5	1853-0001	TRANSISTOR: PNP SILICON 30V 900MW	
A23Q6	1850-0101	TRANSISTOR: SPL 2N582	
A23Q7	1850-0040	TRANSISTOR: GERMANIUM 2N383 PNP	
A23Q8	1851-0024	TRANSISTOR: GE NFN 2N388A	
A23Q9	1850-0062	TRANSISTOR: GERMANIUM	
A23Q10	1850-0062	TRANSISTOR: GERMANIUM	
A23Q11	1854-0005	TRANSISTOR: SILICON NPN 2N708	
A23Q12	1851-0017	TRANSISTOR: 2N1304	
A23R1	0686-3025	RIFXD COMP 3000 OHM 5% 1/2W	
A23R2	0686-1325	RIFXD COMP 1.3K OHM 5% 1/2W	
A23R3	0686-2725	RIFXD COMP 2700 OHM 5% 1/2W	
A23R4	0686-1025	RIFXD COMP 1000 OHM 5% 1/2W	
A23R5	0686-1035	RIFXD COMP 10K OHM 5% 1/2W	
A23R6	0686-1035	RIFXD COMP 10K OHM 5% 1/2W	

= See list of abbreviations in introduction to this section

Table 4-1. - Reference Designation Index (Cont'd)

Reference Designation	Stock No.	Description #	Note
A23R7	0686-2225	RIFXD COMP 2200 OHM 5% 1/2W	
A23R8	0686-2225	RIFXD COMP 2200 OHM 5% 1/2W	
A23R9	0686-4735	RIFXD COMP 47K OHM 5% 1/2W	
A23R10	0686-1035	RIFXD COMP 10K OHM 5% 1/2W	
A23R11	0686-4735	RIFXD COMP 47K OHM 5% 1/2W	
A23R12	0686-4735	RIFXD COMP 47K OHM 5% 1/2W	
A23R13	0686-7525	RIFXD COMP 7500 OHM 5% 1/2W	
A23R14	0686-3625	RIFXD COMP 3600 OHM 5% 1/2W	
A23R15		NOT ASSIGNED	
A23R16	0686-2035	RIFXD COMP 20K OHM 5% 1/2W	
A23R17	0686-9125	RIFXD COMP 9100 OHM 5% 1/2W	
A23R18	0758-0015	RIFXD MET FLM 220 OHMS 5% 1/2W	
A23R19	0686-1025	RIFXD COMP 1000 OHM 5% 1/2W	
A23R20	0686-2225	RIFXD COMP 2200 OHM 5% 1/2W	
A23R21		NOT ASSIGNED	
A23R22	0686-1325	RIFXD COMP 1.3K OHM 5% 1/2W	
A23R23	0686-4735	RIFXD COMP 47K OHM 5% 1/2W	
A23R24	0686-2035	RIFXD COMP 20K OHM 5% 1/2W	
A23R25	0686-1035	RIFXD COMP 10K OHM 5% 1/2W	
A23R26	0686-1525	RIFXD COMP 1500 OHM 5% 1/2W	
A23R27	0758-0015	RIFXD MET FLM 220 OHMS 5% 1/2W	
A23R28	0686-1035	RIFXD COMP 10K OHM 5% 1/2W	
A23R29	0686-2225	RIFXD COMP 2200 OHM 5% 1/2W	
A23R30	0686-2225	RIFXD COMP 2200 OHM 5% 1/2W	
A23R31	0686-1225	RIFXD COMP 1200 OHM 5% 1/2W	
A23R32	0686-4725	RIFXD COMP 4700 OHM 5% 1/2W	
A23R33	0686-4725	RIFXD COMP 4700 OHM 5% 1/2W	
A23R34	0686-2735	RIFXD COMP 27K OHM 5% 1/2W	
A23R35	0686-4715	RIFXD COMP 470 OHM 5% 1/2W	
A23R36	0686-4715	RIFXD COMP 470 OHM 5% 1/2W	
A24	5243A-69A 5243A-69A-1	ASSY:CRYSTAL OVEN BOARD:BLANK P.C.	
A24C1	0130-0001	CIFXD CER 7-45PF 500VDCW	
A24C2	0160-0126	CIFXD PORC 160PF 2% 500VDCW	
A24C3	0140-0151	CIFXD MICA 820PF 2% 300VDCW	
A24C4	0140-0166	CIFXD MICA 0.017 UF 2% 300 VDCW	
A24C5	0140-0159	CIFXD MICA 3000PF 300VDCW	
A24C6	0170-0055	CIFXD MY 0.1UF 20% 200VDCW	
A24C7	0170-0040	CIFXD MY .047 UF 10% 200VDCW	
A24R1	0727-0081	RIFXD DEPC 800 OHM 1% 1/2W	
A24R2	0727-0105	RIFXD C-FLM 1200 OHM 1% 1/2W	
A24R3	0727-0387	RIFXD DEPC 442 OHM 1% 1/2W	
A24R4	2100-0354	RIVAR WW 1000 OHM 10% LIN 2W	
A24Y1		NSR:PART OF READOUT BLOCK ASSY	
A25	5243A-65T 5243A-65T-1	ASSY:OVEN CONTROL BOARD:BLANK P.C.	
A25C1	0180-0100	CIFXD ELECT TA 4.7UF 10% 35VDCW	
A25C2	0180-0100	CIFXD ELECT TA 4.7UF 10% 35VDCW	

= See list of abbreviations in introduction to this section

Table 4-1. Reference Designation Index (Cont'd)

Reference Designation	Stock No.	Description #	Note
A25C3	0180-0100	C:FXD ELECT TA 4.7UF 10% 35VDCW	
A25C4	0180-0049	C:FXD ELECT 20UF 50VDCW	
A25C5	0180-0100	C:FXD ELECT TA 4.7UF 10% 35VDCW	
A25C6	0170-0024	C:FXD MV 0.022 UF 20% 200VDCW	
A25C7	0180-0100	C:FXD ELECT 4.7 UF 10% 35VDCW	
A25CR1	1901-0025	SEMICON DEVICE:DIODE JUNCTION	
A25CR2	1901-0025	SEMICON DEVICE:DIODE JUNCTION	
A25CR3	1910-0016	SEMICON DEVICE:DIODE GERMANIUM	
A25CR4	1901-0026	SEMICON DEVICE:DIODE SI	
A25CR5	1901-0026	SEMICON DEVICE:DIODE SILICON 200PIV	
A25CR6	1901-0026	SEMICON DEVICE:DIODE SILICON 200PIV	
A25CR7	1901-0026	SEMICON DEVICE:DIODE SILICON 200PIV	
A25CR8	1901-0026	SEMICON DEVICE:DIODE SILICON 200PIV	
A25Q1	1850-0054	TRANSISTOR:GERMANIUM 2N652A PNP	
A25Q2	1853-0076	TRANSISTOR:PNP SILICON 30V 900MW	
A25Q3	1850-0054	TRANSISTOR:GERMANIUM 2N652A PNP	
A25Q4	1853-0012	TRANSISTOR:SILICON 2N2904 PNP	
A25R1	0683-4325	R:FXD COMP 4300 OHM 5% 1/4W	
A25R2	0683-4325	R:FXD COMP 4300 OHM 5% 1/4W	
A25R3	0683-8215	R:FXD COMP 620 OHM 5% 1/4W	
A25R4	0683-1535	R:FXD COMP 15K OHM 5% 1/4W	
A25R5	0683-1835	FACTORY SELECTED PART TYPICAL VALUE GIVEN R:FXD COMP 18K OHM 5% 1/4W	
A25R6	0689-0565	R:FXD COMP 5.6 OHM 5% 1W(FACTORY SELECTED PART)	
A25R7	0767-0001	R:FXD MET FLM 400 OHMS 5% 3W	
A25R8	0683-10.5	R:FXD COMP 100 OHM 5% 1/4W	
A25R9	0683-2205	R:FXD COMP 22 OHM 5% 1/4W	
A25R10	0683-1515	R:FXD COMP 150 OHM 5% 1/4W	
A26	05245-6013 05245-2008	ASSY: OSCILLATOR BOARD BOARD: BLANK PC	
A26C1	0160-0194	C:FXD MY 0.015UF 10%	
A26C2	0150-0093	C:FXD CER 0.01UF +80-20 100VDCW	
A26C3	0170-0084	C:FXD MY 0.068UF 20% 50VDCW	
A26C4	0160-0127	C:FXD CER 1UF 20% 25VDCW	
A26C5	0150-0093	C:FXD CER 0.01UF +80-20 100VDCW	
A26C6	0170-0084	C:FXD MY 0.068UF 20% 50VDCW	
A26C7	0140-0200	C:FXD MICA 39OFF 5% 300VDCW	
A26C8	0150-0093	C:FXD CER 0.01UF +80-20 100VDCW	
A26C9	0150-0093	C:FXD CER 0.01UF +80-20 100VDCW	
A26C10	0160-0194	C:FXD MY 0.015UF 10%	
A26C11	0140-0190	C:FXD MICA 39 PF 5% 300 VDCW	
A26C12	0160-0194	C:FXD MY 0.015UF 10%	
A26C13	0170-0084	C:FXD MY 0.068UF 20% 50VDCW	
A26C14	0160-0194	C:FXD MY 0.015UF 10%	
A26C15	0150-0093	C:FXD CER 0.01UF +80-20 100VDCW	
A26C16	0150-0093	C:FXD CER 0.01UF +80-20 100VDCW	
A26C17	0150-0093	C:FXD CER 0.01UF +80-20 100VDCW	
A26C18	0160-0194	C:FXD MY 0.015UF 10%	
A26C19	0150-0093	C:FXD CER 0.01UF +80-20 100VDCW	
A26C20	0150-0093	C:FXD CER 0.01UF +80-20 100VDCW	

= See list of abbreviations in introduction to this section

Table 4-1. Reference Designation Index (Cont'd)

Reference Designation	Stock No.	Description #	Note
A26C21		NOT ASSIGNED	
A26C22	0140-0152	CIFXD MICA 1000 PF 5% 300VDC	
A26C23	0150-0050	CIFXD CER 1000PF 600 VDC	
A26C24	0140-0203	CIFXD MICA 30PF 5% 500VDC	
A26C25	0150-0093	CIFXD CER 0.01UF +80-20 100VDC	
A26C26	0180-0100	CIFXD ELECT TA 4.7UF 10% 35VDC	
A26CR1	1910-0016	SEMICON DEVICE:DIODE GERMANIUM	
A26CR2	1910-0016	SEMICON DEVICE:DIODE GERMANIUM	
A26L1	9140-0138	COIL IFXD RF 180 UH	
A26L2	9140-0137	COIL IFXD RF 100 UH	
A26L3	9140-0137	COIL IFXD RF 100 UH	
A26L4	9140-0138	COIL IFXD RF 180 UH	
A26L5	9140-0138	COIL IFXD RF 180 UH	
A26Q1	1853-0009	TRANSISTOR: SILICON PNP	
A26Q2	1853-0009	TRANSISTOR: SILICON PNP	
A26Q3	1853-0009	TRANSISTOR: SILICON PNP	
A26Q4	1853-0009	TRANSISTOR: SILICON PNP	
A26Q5	1853-0009	TRANSISTOR: SILICON PNP	
A26Q6	1853-0009	TRANSISTOR: SILICON PNP	
A26Q7	1853-0009	TRANSISTOR: SILICON PNP	
A26R1	0683-1825	RIFXD COMP 1800 OHMS 5% 1/4W	
A26R2	0683-2225	RIFXD COMP 2.2K OHM 5% 1/4W	
A26R3	0683-3915	RIFXD COMP 390 OHMS 5% 1/4W	
A26R4	0683-3915	RIFXD COMP 390 OHMS 5% 1/4W	
A26R5	0683-3915	RIFXD COMP 390 OHMS 5% 1/4W	
A26R6	0683-3915	RIFXD COMP 390 OHMS 5% 1/4W	
A26R7	0683-1025	RIFXD COMP 1000 OHM 5% 1/4W	
A26R8	0683-3925	RIFXD COMP 3900 OHMS 5% 1/4W	
A26R9	0683-1535	RIFXD COMP 15K OHMS 5% 1/4W	
A26R10	0683-4725	RIFXD COMP 4700 OHM 5% 1/4W	
A26R11	0683-2725	RIFXD COMP 2700 OHMS 5% 1/4W	
A26R12	0683-2225	RIFXD COMP 2.2K OHM 5% 1/4W	
A26R13	0683-1235	RIFXD COMP 12K OHM 5% 1/4W	
A26R14	0683-2725	RIFXD COMP 2700 OHMS 5% 1/4W	
A26R15	0683-1305	RIFXD COMP 13 OHMS 5% 1/4W	
A26R16	0683-1825	RIFXD COMP 1800 OHMS 5% 1/4W	
A26R17	0683-1025	RIFXD COMP 1000 OHM 5% 1/4W	
A26R18	0683-2715	RIFXD COMP 270 OHMS 5% 1/4W	
A26R19	0683-6225	RIFXD COMP 6200 OHM 5% 1/4W	
A26R20	0683-2725	RIFXD COMP 2700 OHMS 5% 1/4W	
A26R21	0683-2215	RIFXD COMP 220 OHMS 5% 1/4W	
A26R22	0683-1025	RIFXD COMP 1000 OHM 5% 1/4W	
A26R23	0683-1525	RIFXD COMP 150 OHMS 5% 1/4W	
A26R24	0683-1015	RIFXD COMP 100 OHM 5% 1/4W	
A26R25	0683-1025	RIFXD COMP 1000 OHM 5% 1/4W	
A26R26	0683-1525	RIFXD COMP 1500 OHM 5% 1/4W	
A26R27	0683-3315	RIFXD COMP 330 OHM 5% 1/4W	
A26R28	0683-9125	RIFXD COMP 9100 OHM 5% 1/4W	
A26R29	0683-2725	RIFXD COMP 2700 OHMS 5% 1/4W	

See list of abbreviations in introduction to this section

Table 4-1. Reference Designation Index (Cont'd)

Reference Designation	Stock No.	Description #	Note
A26R30	0757-0937	RIFXD MET FLM 3.6K OHM 2% 1/8W	
A26R31	0757-0914	RIFXD MET FLM 395 OHM 2% 1/8W	
A26R32	0683-1825	RIFXD COMP 1800 OHMS 5% 1/4W	
A26R33	0683-3025	RIFXD COMP 3000 OHM 5% 1/4W	
A26R34	0683-9115	RIFXD COMP 910 OHM 5% 1/4W	
A26R35	0683-9105	RIFXD COMP 91 OHM 5% 1/4W	
A26R36	0686-8215	RIFXD COMP 820 OHM 5% 1/2W	
A26R37	0758-0014	RIFXD MET CX 180 OHM 5%	
A26R38	0683-1825	RIFXD COMP 1800 OHM 5% 1/4W	
A27	5243A-65C 5243A-65C-1	ASSY: MULTIPLIER BOARD: BLANK P.C.	
A27C1	0150-0093	CIFXD CER 0.01UF +80-20 100VDCW	
A27C2	0140-0196	CIFXD MICA 150 PF 5% 300 VDCW	
A27C3	0150-0093	CIFXD CER 0.01UF +80-20 100VDCW	
A27C4	0150-0093	CIFXD CER 0.01UF +80-20 100VDCW	
A27C5	0140-0200	CIFXD MICA 390PF 5% 300VDCW	
A27C6	0160-0194	CIFXD MY 0.015UF 10%	
A27C7	0140-0201	CIFXD MICA 12PF 5% 500VDCW	
A27C8	0140-0206	CIFXD MICA 680PF 5% 300VDCW	
A27C9	0160-0155	CIFXD MY 3360 PF 10%	
A27C10	0150-0093	CIFXD CER 0.01UF +80-20 100VDCW	
A27C11	0140-0192	CIFXD MICA 68PF 5% 300VDCW	
A27C12	0160-0194	CIFXD MY 0.015UF 10%	
A27C13	0140-0195	CIFXD MICA 130 PF 5% 300 VDCW	
A27C14	0160-0157	CIFXD MY 4760 PF 10%	
A27C15	0150-0093	CIFXD CER 0.01UF +80-20 100VDCW	
A27C16	0140-0199	CIFXD MICA 240PF 5% 300VDCW	
A27C17	0160-0194	CIFXD MY 0.015UF 10%	
A27C18	0140-0209	CIFXD MICA 5PF 10% 500VDCW	
A27C19	0140-0199	CIFXD MICA 240PF 5% 300VDCW	
A27C20	0140-0200	CIFXD MICA 390PF 5% 300VDCW	
A27L1	9140-0127	COIL: VAR 8.3-18.7 UH	
A27L2	9140-0127	COIL: VAR 8.3-18.7 UH	
A27L3	9140-0126	COIL: VAR 1.76-4.02 UH	
A27L4	9140-0126	COIL: VAR 1.76-4.02 UH	
A27L5	9140-0125	COIL: VAR 0.9-1.9 UH	
A27L6	9140-0125	COIL: VAR 0.9-1.9 UH	
A27Q1	1850-0091	TRANSISTOR: GERMANIUM 2N2048 PNP	
A27Q2	1850-0091	TRANSISTOR: GERMANIUM 2N2048 PNP	
A27Q3	1850-0091	TRANSISTOR: GERMANIUM 2N2048 PNP	
A27R1	0683-1525	RIFXD COMP 150 OHMS 5% 1/4W	
A27R2	0683-1015	RIFXD COMP 100 OHMS 5% 1/4W	
A27R3	0683-1015	RIFXD COMP 100 OHMS 5% 1/4W	
A27R4	0683-1635	RIFXD COMP 16K OHMS 5% 1/4W	
A27R5	0683-5125	RIFXD COMP 5100 OHMS 5% 1/4W	
A27R6	0683-2225	RIFXD COMP 2.2K OHM 5% 1/4W	
A27R7	0683-4715	RIFXD COMP 470 OHM 5% 1/4W	
A27R8	0683-1135	RIFXD COMP 11K OHM 5% 1/4W	
A27R9	0683-2225	RIFXD COMP 2.2K OHM 5% 1/4W	

= See list of abbreviations in introduction to this section

Table 4-1. Reference Designation Index (Cont'd)

Reference Designation	Stock No.	Description #	Note
A27R10	0683-2225	R:FXD COMP 2.2K OHM 5% 1/4W	
A27R11	0683-1015	R:FXD COMP 100 OHMS 5% 1/4W	
A27R12	0683-9125	R:FXD COMP 9100 OHMS 5% 1/4W	
A27R13	0683-2225	R:FXD COMP 2.2K OHM 5% 1/4W	
A27R14	0683-6815	R:FXD COMP 680 OHMS 5% 1/4W	
A27R15	0683-1015	R:FXD COMP 100 OHMS 5% 1/4W	
A27R16	0683-4715	R:FXD COMP 470 OHM 5% 1/4W	
A27R17	0683-1015	R:FXD COMP 100 OHMS 5% 1/4W	
A28	05232-6009	DECADE DIVIDER ASSEMBLY	
A28C1	0140-0191	C:FXD MICA 56 PF 5% 300 VDCW	
A28C2	0140-0193	C:FXD MICA 82 PF 5% 300 VDCW	
A28C3	0150-0121	C:FXD CER 0.1UF 480V-20% 50VDCW	
A28C4	0140-0191	C:FXD MICA 56 PF 5% 300 VDCW	
A28C5	0150-0122	C:FXD CER 2000PF 20% 500VDCW	
A28C6	0140-0191	C:FXD MICA 56 PF 5% 300 VDCW	
A28C7	0160-0181	C:FXD MICA 30PF 5% 300VDCW	
A28C8	0140-0192	C:FXD MICA 68PF 5% 300VDCW	
A28C9	0140-0192	C:FXD MICA 68PF 5% 300VDCW	
A28C10	0140-0193	C:FXD MICA 82 PF 5% 300 VDCW	
A28C11	0140-0193	C:FXD MICA 82 PF 5% 300 VDCW	
A28C12	0140-0195	C:FXD MICA 130 PF 5% 300 VDCW	
A28C13	0140-0193	C:FXD MICA 82 PF 5% 300 VDCW	
A28C14	0140-0193	C:FXD MICA 82 PF 5% 300 VDCW	
A28C15	0140-0176	C:FXD MICA 100 PF 2% 300 VDCW	
A28C16	0140-0195	C:FXD MICA 130 PF 5% 300 VDCW	
A28CR1	1901-0040	DIODE SILICON:30 MA AT 1V 30 PIV	
A28CR2	1901-0040	DIODE SILICON:30 MA AT 1V 30 PIV	
A28CR3	1901-0040	DIODE SILICON:30 MA AT 1V 30 PIV	
A28CR4	1901-0040	DIODE SILICON:30 MA AT 1V 30 PIV	
A28CR5	1901-0040	DIODE SILICON:30 MA AT 1V 30 PIV	
A28CR6	1901-0040	DIODE SILICON:30 MA AT 1V 30 PIV	
A28CR7	1901-0040	DIODE SILICON:30 MA AT 1V 30 PIV	
A28CR8	1901-0040	DIODE SILICON:30 MA AT 1V 30 PIV	
A28CR9	1901-0040	DIODE SILICON:30 MA AT 1V 30 PIV	
A28CR10	1901-0040	DIODE SILICON:30 MA AT 1V 30 PIV	
A28CR11	1901-0040	DIODE SILICON:30 MA AT 1V 30 PIV	
A28Q1	1853-0034	TRANSISTOR SILICON PNP	
A28Q2	1853-0009	TRANSISTOR SILICON PNP	
A28Q3	1853-0009	TRANSISTOR SILICON PNP	
A28Q4	1853-0009	TRANSISTOR SILICON PNP	
A28Q5	1853-0009	TRANSISTOR SILICON PNP	
A28Q6	1853-0009	TRANSISTOR SILICON PNP	
A28Q7	1853-0009	TRANSISTOR SILICON PNP	
A28Q8	1853-0009	TRANSISTOR SILICON PNP	
A28R1	0683-2725	R:FXD COMP 2700 OHM 5% 1/4W	
A28R2	0758-0024	R:FXD MET FLM 100 OHM 5% 1/2W	
A28R3	0758-0043	R:FXD MET FLM 1800 OHM 5% 1/2W	
A28R4	0683-1035	R:FXD COMP 10K OHM 5% 1/4 W	

= See list of abbreviations in introduction to this section

Table 4-1. Reference Designation Index (Cont'd)

Reference Designation	Stock No.	Description #	Note
A28R5	0683-3325	RIFXD COMP 3300 OHM 5% 1/4W	
A28R6	0683-2235	RIFXD COMP 22K OHM 5% 1/4W	
A28R7	0683-6205	RIFXD COMP 62 OHM 5% 1/4W	
A28R8	0683-1115	RIFXD COMP 110 OHM 5% 1/4W	
A28R9	0683-2235	RIFXD COMP 22K OHM 5% 1/4W	
A28R10	0683-6205	RIFXD COMP 62 OHM 5% 1/4W	
A28R11	0683-2235	RIFXD COMP 22K OHM 5% 1/4W	
A28R12	0758-0043	RIFXD MET FLM 1800 OHM 5% 1/2W	
A28R13	0683-1035	RIFXD COMP 10K OHM 5% 1/4W	
A28R14	0683-3325	RIFXD COMP 3300 OHM 5% 1/4W	
A28R15	0683-2735	RIFXD COMP 27K OHM 5% 1/4W	
A28R16	0758-0043	RIFXD MET FLM 1800 OHM 5% 1/2W	
A28R17	0683-1035	RIFXD COMP 10K OHM 5% 1/4W	
A28R18	0683-3325	RIFXD COMP 3300 OHM 5% 1/4W	
A28R19	0683-2235	RIFXD COMP 22K OHM 5% 1/4W	
A28R20	0683-6205	RIFXD COMP 62 OHM 5% 1/4W	
A28R21	0683-1115	RIFXD COMP 110 OHM 5% 1/4W	
A28R22	0683-1025	RIFXD COMP 1000 OHM 5% 1/4W	
A28R23	0683-6205	RIFXD COMP 62 OHM 5% 1/4W	
A28R24	0683-2235	RIFXD COMP 22K OHM 5% 1/4W	
A28R25	0758-0043	RIFXD MET FLM 1800 OHM 5% 1/2W	
A28R26	0683-1035	RIFXD COMP 10K OHM 5% 1/4W	
A28R27	0683-3325	RIFXD COMP 3300 OHM 5% 1/4W	
A28R28	0758-0004	RIFXD MET FLM 2700 OHM 5% 1/2W	
A28R29	0683-1235	RIFXD COMP 12K OHM 5% 1/4W	
A28R30	0683-2725	RIFXD COMP 2700 OHM 5% 1/4W	
A28R31	0683-2235	RIFXD COMP 22K OHM 5% 1/4W	
A28R32	0683-2205	RIFXD COMP 22 OHM 5% 1/4W	
A28R33	0683-1115	RIFXD COMP 110 OHM 5% 1/4W	
A28R34	0683-1025	RIFXD COMP 1000 OHM 5% 1/4W	
A28R35	0683-2235	RIFXD COMP 22K OHM 5% 1/4W	
A28R36	0683-4705	RIFXD COMP 47 OHM 5% 1/4W	
A28R37	0683-2235	RIFXD COMP 22K OHM 5% 1/4W	
A28R38	0758-0004	RIFXD MET FLM 2700 OHM 5% 1/2W	
A28R39	0683-1235	RIFXD COMP 12K OHM 5% 1/4W	
A28R40	0683-2725	RIFXD COMP 2700 OHM 5% 1/4W	
A28R41	0683-5635	RIFXD COMP 56K OHM 5% 1/4W	
A28R42	0683-3025	RIFXD COMP 3000 OHM 5% 1/4W	
A28R43	0758-0004	RIFXD MET FLM 2700 OHM 5% 1/2W	
A28R44	0683-1235	RIFXD COMP 12K OHM 5% 1/4W	
A28R45	0683-2725	RIFXD COMP 2700 OHM 5% 1/4W	
A28R46	0683-2235	RIFXD COMP 22K OHM 5% 1/4W	
A28R47	0683-6805	RIFXD COMP 68 OHM 5% 1/4W	
A28R48	0683-1025	RIFXD COMP 1000 OHM 5% 1/4W	
A28R49	0683-2235	RIFXD COMP 22K OHM 5% 1/4W	
A28R50	0683-2235	RIFXD COMP 22K OHM 5% 1/4W	
A28R51	0758-0004	RIFXD MET FLM 2700 OHM 5% 1/2W	
A28R52	0683-1035	RIFXD COMP 10K OHM 5% 1/4W	
A28R53	0683-3325	RIFXD COMP 3300 OHM 5% 1/4W	

= See list of abbreviations in Introduction to this section

PARTS

LIST

CON'T

Table 4-1. Reference Designation Index (Cont'd)

Reference Designation	Stock No.	Description #	Note
A29	5212A-65C 5212A-65C-1	ASSY:DECADE DIVIDER BCARU:BLANK P.C.	
A29C1	0150-0121	C:FXD CER 0.1UF 50 VDCW	
A29C2	0140-0194	C:FXD MICA 110 PF 5% 300 VDCW	
A29C3	0140-0195	C:FXD MICA 130 PF 5% 300 VDCW	
A29C4	0140-0195	C:FXD MICA 130 PF 5% 300 VDCW	
A29C5	0140-0196	C:FXD MICA 150 PF 5% 300 VDCW	
A29C6	0140-0196	C:FXD MICA 150 PF 5% 300 VDCW	
A29C7	0140-0196	C:FXD MICA 150 PF 5% 300 VDCW	
A29C8	0140-0199	C:FXD MICA 240PF 5% 300VDCW	
A29C9	0140-0195	C:FXD MICA 130 PF 5% 300 VDCW	
A29C10	0140-0195	C:FXD MICA 130 PF 5% 300 VDCW	
A29C11	0140-0193	C:FXD MICA 82 PF 5% 300 VDCW	FACTORY SELECTED VALUE
A29C12	0140-0196	C:FXD MICA 200PF 5% 300VDCW	
A29C13	0140-0196	C:FXD MICA 200PF 5% 300VDCW	
A29C14	0140-0200	C:FXD MICA 390PF 5% 300VDCW	
A29CR1	1910-0016	SEMICON DEVICE:DIODE GERMANIUM	
A29CR2	1910-0016	SEMICON DEVICE:DIODE GERMANIUM	
A29CR3	1910-0016	SEMICON DEVICE:DIODE GERMANIUM	
A29CR4	1910-0016	SEMICON DEVICE:DIODE GERMANIUM	
A29CR5	1910-0016	SEMICON DEVICE:DIODE GERMANIUM	
A29Q1	1850-0062	TRANSISTOR:GERMANIUM	
A29Q2	1850-0062	TRANSISTOR:GERMANIUM	
A29Q3	1850-0062	TRANSISTOR:GERMANIUM	
A29Q4	1850-0062	TRANSISTOR:GERMANIUM	
A29Q5	1850-0062	TRANSISTOR:GERMANIUM	
A29Q6	1850-0062	TRANSISTOR:GERMANIUM	
A29Q7	1850-0062	TRANSISTOR:GERMANIUM	
A29Q8	1850-0062	TRANSISTOR:GERMANIUM	
A29R1	0683-3915	R:FXD COMP 390 OHMS 5% 1/4W	
A29R2	0683-4735	R:FXD COMP 47K OHMS 5% 1/4W	
A29R3	0683-6825	R:FXD COMP 6800 OHMS 5% 1/4W	
A29R4	0683-4735	R:FXD COMP 47K OHMS 5% 1/4W	
A29R5	0683-1035	R:FXD COMP 10K OHMS 5% 1/4W	
A29R6	0683-3925	R:FXD COMP 3900 OHMS 5% 1/4W	
A29R7	0683-2015	R:FXD COMP 200 OHMS 5% 1/4W	
A29R8	0683-3925	R:FXD COMP 3900 OHMS 5% 1/4W	
A29R9	0683-6825	R:FXD COMP 6800 OHMS 5% 1/4W	
A29R10	0683-4735	R:FXD COMP 47K OHMS 5% 1/4W	
A29R11	0683-1035	R:FXD COMP 10K OHMS 5% 1/4W	
A29R12	0683-4735	R:FXD COMP 47K OHMS 5% 1/4W	
A29R13	0683-4735	R:FXD COMP 47K OHMS 5% 1/4W	
A29R14	0683-6825	R:FXD COMP 6800 OHMS 5% 1/4W	
A29R15	0683-4735	R:FXD COMP 47K OHMS 5% 1/4W	
A29R16	0683-8225	R:FXD COMP 8200 OHMS 5% 1/4W	
A29R17	0683-3925	R:FXD COMP 3900 OHMS 5% 1/4W	
A29R18	0683-2015	R:FXD COMP 200 OHMS 5% 1/4W	
A29R19	0683-3925	R:FXD COMP 3900 OHMS 5% 1/4W	
A29R20	0683-6825	R:FXD COMP 6800 OHMS 5% 1/4W	
A29R21	0683-4735	R:FXD COMP 47K OHMS 5% 1/4W	

= See list of abbreviations in introduction to this section

Table 4-1. Reference Designation Index (Cont'd)

Reference Designation	Stock No.	Description #	Note
A29R22	0683-1035	RIFXD COMP 10K OHMS 5% 1/4W	
A29R23	0683-4735	RIFXD COMP 47K OHMS 5% 1/4W	
A29R24	0683-6835	RIFXD COMP 68K OHM 5% 1/4W	
A29R25	0683-4735	RIFXD COMP 47K OHMS 5% 1/4W	
A29R26	0683-6825	RIFXD COMP 6800 OHMS 5% 1/4W	
A29R27	0683-4735	RIFXD COMP 47K OHMS 5% 1/4W	
A29R28	0683-1035	RIFXD COMP 10K OHMS 5% 1/4W	
A29R29	0683-3925	RIFXD COMP 3900 OHMS 5% 1/4W	
A29R30	0683-2015	RIFXD COMP 200 OHMS 5% 1/4W	
A29R31	0683-3925	RIFXD COMP 3900 OHMS 5% 1/4W	
A29R32	0683-6825	RIFXD COMP 6800 OHMS 5% 1/4W	
A29R33	0683-4735	RIFXD COMP 47K OHMS 5% 1/4W	
A29R34	0683-8225	RIFXD COMP 8200 OHMS 5% 1/4W	
A29R35	0683-4735	RIFXD COMP 47K OHMS 5% 1/4W	
A29R36	0683-4735	RIFXD COMP 47K OHMS 5% 1/4W	
A29R37	0683-6825	RIFXD COMP 6800 OHMS 5% 1/4W	
A29R38	0683-4735	RIFXD COMP 47K OHMS 5% 1/4W	
A29R39	0683-1035	RIFXD COMP 10K OHMS 5% 1/4W	
A29R40	0683-3925	RIFXD COMP 3900 OHMS 5% 1/4W	
A29R41	0683-2015	RIFXD COMP 200 OHMS 5% 1/4W	
A29R42	0683-3925	RIFXD COMP 3900 OHMS 5% 1/4W	
A29R43	0683-6825	RIFXD COMP 6800 OHMS 5% 1/4W	
A29R44	0683-4735	RIFXD COMP 47K OHMS 5% 1/4W	
A29R45	0683-1035	RIFXD COMP 10K OHMS 5% 1/4W	
A29R46	0683-4735	RIFXD COMP 47K OHMS 5% 1/4W	
A30	5212A-65C	SAME AS A29;USE PREFIX A30	
A31	5212A-65C	SAME AS A29;USE PREFIX A31	
A32	5212A-65C	SAME AS A29;USE PREFIX A32	
A33	5212A-65C	SAME AS A29;USE PREFIX A33	
A34	5212A-65C	SAME AS A29;USE PREFIX A34	
A35	5243A-65J 5243A-65J-1	ASSY:TIME-BASE CONTROL BOARD:BLANK P.C.	
A35C1	0160-0134	CIFXD MICA 220PF 5% 300VDCW	
A35C2	0160-0134	CIFXD MICA 220PF 5% 300VDCW	
A35C3	0140-0194	CIFXD MICA 110 PF 5% 300 VDCW	
A35C4	0160-0134	CIFXD MICA 220PF 5% 300VDCW	
A35C5	0160-0134	CIFXD MICA 220PF 5% 300VDCW	
A35C6	0140-0194	CIFXD MICA 110 PF 5% 300 VDCW	
A35C7	0160-0134	CIFXD MICA 220PF 5% 300VDCW	
A35C8	0160-0134	CIFXD MICA 220PF 5% 300VDCW	
A35C9	0140-0194	CIFXD MICA 110 PF 5% 300 VDCW	
A35C10	0160-0134	CIFXD MICA 220PF 5% 300VDCW	
A35C11	0160-0134	CIFXD MICA 220PF 5% 300VDCW	
A35C12	0140-0194	CIFXD MICA 110 PF 5% 300 VDCW	
A35C13	0160-0134	CIFXD MICA 220PF 5% 300VDCW	
A35C14	0160-0134	CIFXD MICA 220PF 5% 300VDCW	
A35C15	0140-0194	CIFXD MICA 110 PF 5% 300 VDCW	
A35CR1	1910-0016	SEMICON DEVICE:DIODE GERMANIUM	
A35CR2	1910-0016	SEMICON DEVICE:DIODE GERMANIUM	
A35CR3	1910-0016	SEMICON DEVICE:DIODE GERMANIUM	

= See list of abbreviations in introduction to this section

Table 4-1. Reference Designation Index (Cont'd)

Reference Designation	Stock No.	Description #	Note
A35CR4	1910-0016	SEMICON DEVICE:DIODE GERMANIUM	
A35CR5	1910-0016	SEMICON DEVICE:DIODE GERMANIUM	
A35CR6	1901-0025	SEMICON DEVICE:DIODE JUNCTION	
A35CR7	1901-0025	SEMICON DEVICE:DIODE JUNCTION	
A35CR8	1901-0025	SEMICON DEVICE:DIODE JUNCTION	
A35CR9	1901-0025	SEMICON DEVICE:DIODE JUNCTION	
A35CR10	1901-0025	SEMICON DEVICE:DIODE JUNCTION	
A35CR11	1901-0025	SEMICON DEVICE:DIODE JUNCTION	
A35CR12	1901-0025	SEMICON DEVICE:DIODE JUNCTION	
A35CR13	1901-0025	SEMICON DEVICE:DIODE JUNCTION	
A35CR14	1901-0025	SEMICON DEVICE:DIODE JUNCTION	
A35CR15	1901-0025	SEMICON DEVICE:DIODE JUNCTION	
A35CR16	1901-0025	SEMICON DEVICE:DIODE JUNCTION	
A35CR17	1901-0025	SEMICON DEVICE:DIODE JUNCTION	
A35CR18	1901-0025	SEMICON DEVICE:DIODE JUNCTION	
A35CR19	1901-0025	SEMICON DEVICE:DIODE JUNCTION	
A35CR20	1901-0025	SEMICON DEVICE:DIODE JUNCTION	
A35CR21	1901-0025	SEMICON DEVICE:DIODE JUNCTION	
A35CR22	1901-0025	SEMICON DEVICE:DIODE JUNCTION	
A35CR23	1901-0025	SEMICON DEVICE:DIODE JUNCTION	
A35E1	9170-0016	HEAD:MAGNETIC	
A35Q1	1850-0040	TRANSISTOR:GERMANIUM 2N383 PNP	
A35Q2	1854-0003	TRANSISTOR:2N708 NPN SILICON PLANAR	
A35Q3	1850-0062	TRANSISTOR:GERMANIUM	
A35Q4	1850-0062	TRANSISTOR:GERMANIUM	
A35Q5	1850-0062	TRANSISTOR:GERMANIUM	
A35Q6	1850-0062	TRANSISTOR:GERMANIUM	
A35Q7	1850-0062	TRANSISTOR:GERMANIUM	
A35Q8	1850-0062	TRANSISTOR:GERMANIUM	
A35Q9	1850-0062	TRANSISTOR:GERMANIUM	
A35Q10	1854-0003	TRANSISTOR:2N708 NPN SILICON PLANAR	
A35Q11	1854-0003	TRANSISTOR:2N708 NPN SILICON PLANAR	
A35Q12	1854-0003	TRANSISTOR:2N708 NPN SILICON PLANAR	
A35R1	0686-4715	R:FXD COMP 470 OHM 5% 1/2W FACTORY SELECTED VALUE	
A35R2	0686-3025	R:FXD MET CX 3000 OHM 5% 1/2W FACTORY SELECTED VALUE	
A35R3	0683-2025	R:FXD COMP 2000 OHMS 5% 1/4W	
A35R4	0683-3025	R:FXD COMP 3000 OHMS 5% 1/4W	
A35R5	0686-1825	R:FXD COMP 1800 OHM 5% 1/2W	
A35R6	0683-3025	R:FXD COMP 3000 OHMS 5% 1/4W	
A35R7	0683-1035	R:FXD COMP 10K OHMS 5% 1/4W	
A35R8	0683-3025	R:FXD COMP 3000 OHMS 5% 1/4W	
A35R9	0683-1035	R:FXD COMP 10K OHMS 5% 1/4W	
A35R10	0683-3025	R:FXD COMP 3000 OHMS 5% 1/4W	
A35R11	0683-1535	R:FXD COMP 15K OHMS 5% 1/4W	
A35R12	0683-1035	R:FXD COMP 10K OHMS 5% 1/4W	
A35R13	0683-3025	R:FXD COMP 3000 OHMS 5% 1/4W	
A35R14	0683-1535	R:FXD COMP 15K OHMS 5% 1/4W	
A35R15	0683-1035	R:FXD COMP 10K OHMS 5% 1/4W	
A35R16	0683-4735	R:FXD COMP 47K OHMS 5% 1/4W	

= See list of abbreviations in introduction to this section

Table 4-1. Reference Designation Index (Cont'd)

Reference Designation	Stock No.	Description #	Note
A35R17	0683-4735	RIFXD COMP 47K OHMS 5% 1/4W	
A35R18	0683-1845	RIFXD COMP 180K OHMS 5% 1/4W	
A35R19	0683-4725	RIFXD COMP 4700 OHM 5% 1/4W	
A35R20	0683-4725	RIFXD COMP 4700 OHM 5% 1/4W	
A35R21	0683-3025	RIFXD COMP 3000 OHMS 5% 1/4W	
A35R22	0683-1535	RIFXD COMP 15K OHMS 5% 1/4W	
A35R23	0683-1035	RIFXD COMP 10K OHMS 5% 1/4W	
A35R24	0683-4735	RIFXD COMP 47K OHMS 5% 1/4W	
A35R25	0683-4735	RIFXD COMP 47K OHMS 5% 1/4W	
A35R26	0683-1845	RIFXD COMP 180K OHMS 5% 1/4W	
A35R27	0683-4725	RIFXD COMP 4700 OHM 5% 1/4W	
A35R28	0683-4725	RIFXD COMP 4700 OHM 5% 1/4W	
A35R29	0683-3025	RIFXD COMP 3000 OHMS 5% 1/4W	
A35R30	0683-1535	RIFXD COMP 15K OHMS 5% 1/4W	
A35R31	0683-1035	RIFXD COMP 10K OHMS 5% 1/4W	
A35R32	0683-4735	RIFXD COMP 47K OHMS 5% 1/4W	
A35R33	0683-4735	RIFXD COMP 47K OHMS 5% 1/4W	
A35R34	0683-1845	RIFXD COMP 180K OHMS 5% 1/4W	
A35R35	0683-4725	RIFXD COMP 4700 OHM 5% 1/4W	
A35R36	0683-4725	RIFXD COMP 4700 OHM 5% 1/4W	
A35R37	0683-3025	RIFXD COMP 3000 OHMS 5% 1/4W	
A35R38	0683-1535	RIFXD COMP 15K OHMS 5% 1/4W	
A35R39	0683-1035	RIFXD COMP 10K OHMS 5% 1/4W	
A35R40	0683-4735	RIFXD COMP 47K OHMS 5% 1/4W	
A35R41	0683-4735	RIFXD COMP 47K OHMS 5% 1/4W	
A35R42	0683-1845	RIFXD COMP 180K OHMS 5% 1/4W	
A35R43	0683-4725	RIFXD COMP 4700 OHM 5% 1/4W	
A35R44	0683-4725	RIFXD COMP 4700 OHM 5% 1/4W	
A35R45	0683-3025	RIFXD COMP 3000 OHMS 5% 1/4W	
A35R46	0683-1535	RIFXD COMP 15K OHMS 5% 1/4W	
A35R47	0683-1035	RIFXD COMP 10K OHMS 5% 1/4W	
A35R48	0683-4735	RIFXD COMP 47K OHMS 5% 1/4W	
A35R49	0683-4735	RIFXD COMP 47K OHMS 5% 1/4W	
A35R50	0683-1845	RIFXD COMP 180K OHMS 5% 1/4W	
A35R51	0683-4725	RIFXD COMP 4700 OHM 5% 1/4W	
A35R52	0683-4725	RIFXD COMP 4700 OHM 5% 1/4W	
A35R53	0683-3025	RIFXD COMP 3000 OHMS 5% 1/4W	
A35R54	0683-1535	RIFXD COMP 15K OHMS 5% 1/4W	
A35R55	0683-1035	RIFXD COMP 10K OHMS 5% 1/4W	
A35R56	0683-5635	RIFXD COMP 56K OHMS 5% 1/4W	
A35R57	0683-2435	RIFXD COMP 24K OHM 5% 1/4W	
A35R58	0683-2025	RIFXD COMP 2000 OHMS 5% 1/4W	
A35R59	0683-3025	RIFXD COMP 3000 OHMS 5% 1/4W	
A35R60	0683-2025	RIFXD COMP 2000 OHMS 5% 1/4W	
A35R61	0683-4715	RIFXD COMP 470 OHM 5% 1/4W	
A35R62	0683-1025	RIFXD COMP 1000 OHM 5% 1/4W	
A35R63	0683-2025	RIFXD COMP 2000 OHMS 5% 1/4W	
A35R64	0683-2025	RIFXD COMP 2000 OHMS 5% 1/4W	
A35R65	0683-2025	RIFXD COMP 2000 OHMS 5% 1/4W	
B1	3140-0052	MOTOR: ELECTRICAL SHADED POLE 115V 3470 RPM	

= See list of abbreviations in introduction to this section

Table 4-1. Reference Designation Index (Cont'd)

Reference Designation	Stock No.	Description #	Note
C1	0170-0043	C:FXD MY 0.022 UF 10% 600VDCW	
C2	0130-0003	C:VAR CER 1.5-7 PF 500VDCW	
C3	0121-0013	C:VAR AIR 6-100.5PF	
C4	0180-0047	C:FXD ELECT 500UF 75VDCW	
C5	0150-0119	C:FXD CER 2X(0.01UF) 20% 250VDCW	
C6	0180-0129	C:FXD ELECT 975UF -10+50% 40VDCW	
C7	0180-0107	C:FXD ELECT 20UF -10/+100% 200VDCW	
C8	0180-0107	C:FXD ELECT 20UF -10/+100% 200VDCW	
C9	0180-0129	C:FXD ELECT 975UF -10+50% 40VDCW	
C10	0180-0130	C:FXD ELECT 1500UF -10+50% 15VDCW	
C11	0150-0093	C:FXD CER 0.01UF +80-20 100VDCW	
C12	0150-0093	C:FXD CER 0.01UF +80-20 100VDCW	
C13	0150-0121	C:FXD CER 0.1UF 50 VDCW	
C14	0150-0012	C:FXD CER 0.01UF 20% 1000VDCW	
C15	0160-0127	C:FXD CER 1UF 20% 25VDCW	
C18	0150-0009	C:FXD CER 10PF ±0.5PF 500 VDCW	
C16	0160-0174	C:FXD CER 0.47 UF +80-20% 25VDCW	
C17	0160-0174	C:FXD CER 0.47 UF +80-20% 25VDCW	
CR1	1902-0039	SEMICON DEVICE:DIODE 1N1597A	
DS1	1450-0049	INDICATOR:GLOW-LAMP NEON	
F1	2110-0303	FUSE:CARTRIDGE 2AMP 250V SLOW BLOW (115V OPERATION ONLY)	
F1	2110-0007	FUSE:CARTRIDGE 1 AMP 250V SLOW BLOW (230V OPERATION ONLY)	
J1	1250-0118	CONNECTOR:BNC	
J2	1250-0118	CONNECTOR:BNC	
J3	1250-0118	CONNECTOR:BNC	
J4	1250-0118	CONNECTOR:BNC	
J5	1250-0118	CONNECTOR:BNC	
J6	1251-0101	CONNECTOR:FEMALE 50-CONTACT	
J7	1250-0118	CONNECTOR:BNC	
J8	1250-0118	CONNECTOR:BNC	
J9	THRU		
J10		NOT ASSIGNED	
J11	1251-0087	CONNECTOR:FEMALE 50-PIN MINAT	
J12	1251-2357	CONNECTOR:POWER 3-PIN MALE	
L1	9140-0136	COIL:FXD RF 22 UH	
L2	9140-0136	COIL:FXD RF 22 UH	
L3	9100-2830	COIL: FXD 40 UH	
L4	9100-2830	COIL: FXD 40 UH	
L5	9140-0137	COIL:FXD RF 1000UH	
MP1	0370-0077	KNOB:1/4 BAR WITH ARROW	
MP2	0370-0077	KNOB:1/4 BAR WITH ARROW	
MP3	0370-0077	KNOB:1/4 BAR WITH ARROW	
MP4	0370-0077	KNOB:1/4 BAR WITH ARROW	
MP5A	0370-0099	KNOB:1/4 BAR WITH ARROW AND CENTER HOLE	
MP5B	0370-0134	KNOB:ROUND RED 0.5" D 0.125" SHAFT	
MP6	0370-0084	KNOB:ROUND BLACK	
MP7	0510-0123	RETAINER:PUSH-ON TYPE FASTENER	
MP8	1200-0043	INSULATOR:TRANSISTOR ANODIZED ALUMINUM	
MP9	1200-0043	INSULATOR:TRANSISTOR ANODIZED ALUMINUM	
MP10	1200-0043	INSULATOR:TRANSISTOR ANODIZED ALUMINUM	

See list of abbreviations in introduction to this section

Table 4-1. Reference Designation Index (Cont'd)

Reference Designation	Stock No.	Description #	Note
MP11	0340-0162	INSULATOR:TRANSISTOR	
MP12	1200-0081	BUSHING:INSULATOR NYLON	
MP13	1200-0081	BUSHING:INSULATOR NYLON	
MP14	1200-0081	BUSHING:INSULATOR NYLON	
MP15	1200-0081	BUSHING:INSULATOR NYLON	
MP16	1200-0081	BUSHING:INSULATOR NYLON	
MP17	1200-0081	BUSHING:INSULATOR NYLON	
MP18		NOT ASSIGNED	
MP19	1200-0092	BUSHING:TRANSISTOR	
MP20	1200-0092	BUSHING:TRANSISTOR	
MP21	1520-0001	PLATE:MOUNTING ELECTROLYTIC CAPACITOR	
MP22	1520-0001	PLATE:MOUNTING ELECTROLYTIC CAPACITOR	
MP23	1520-0001	PLATE:MOUNTING ELECTROLYTIC CAPACITOR	
MP24	1520-0001	PLATE:MOUNTING ELECTROLYTIC CAPACITOR	
MP25	1520-0003	MOUNTING PLATE:CAPACITOR	
MP26	1520-0003	MOUNTING PLATE:CAPACITOR	
MP27	2190-0046	WASHER:SPLIT LOCK	
MP28	2190-0046	WASHER:SPLIT LOCK	
MP29	2190-0046	WASHER:SPLIT LOCK	
MP30	2190-0046	WASHER:SPLIT LOCK	
MP31	2190-0046	WASHER:SPLIT LOCK	
MP32	2190-0046	WASHER:SPLIT LOCK	
MP33	2390-0015	SCREW:MACHINE	
MP34	3160-0060	FAN:IMPELLER AXIAL	
MP35	5212L-83A	SUPPORT:HEADOUT	
MP36	5212L-83B	READOUT:UNITS	
MP37	05243-6042	PANEL:PLUG-IN (MINT GRAY)	
MP38		NOT ASSIGNED	
MP39		NOT ASSIGNED	
MP40	05245-0012	BRACKET:SWITCH	
MP41	05245-0012	BRACKET:SWITCH	
MP42	05245-0012	BRACKET:SWITCH	
MP43	5243A-12E	SUPPORT:CAPACITOR	
MP44	5243A-12F	BRACKET:CRYSTAL OVEN	
MP45	5243A-20A	HOUSING:FAN	
MP46	5243A-47C	SUPPORT:PANEL	
MP47	5243A-55A	SHIELD:OSCILLATOR	
MP48	5040-0170	SUPPORT:PRINTED CIRCUIT BOARD	
MP49	5243L-12B	BRACKET:BOARD	
MP50		NOT ASSIGNED	
MP51	5243L-17A	BUSHING:LATCH	
MP52		NOT ASSIGNED	
MP53	05243-2018	HOUSING:PLUG-IN	
MP54	05243-2014	SHAFT:LATCH	
MP55		NOT ASSIGNED	
MP56	5243L-41A	PLATE:CASTING	
MP57	05245-0014	SHIELD:INPUT	
MP58	05243-2015	KNOB:PLUG-IN LATCH	
MP59		NOT ASSIGNED	
MP60	5243L-83A	HOLDER:DECIMAL	
MP61		NOT ASSIGNED	

= See list of abbreviations in introduction to this section

Table 4-1. Reference Designation Index (Cont'd)

Reference Designation	Stock No.	Description #	Note
MP62 MP63 THRU MP64 MP65 MP66 MP67	05245-4001 5243L-91A 05245-4003	INSERT:MEASUREMENT UNITS READOUT NOT ASSIGNED SPRING:LATCH NOT ASSIGNED WINDOW:READOUT AMBER	
MP68 MP69 MP70 MP71 MP72	5243L-107A 05243-2013 5243L-110A 5243L-110B	BAR:READOUT PAAL NOT ASSIGNED GUIDE:BOARD FRONT GUIDE:BOARD REAR	
MP73 MP74 MP75 MP76 MP77	 05245-2027 05245-0022 05245-0015 05243-0008	NOT ASSIGNED PANEL:FRONT (MINT GRAY) PANEL:REAR SHIELD:AMPLIFIER RETAINER:FRONT PLUG-IN PANEL	
MP78	05243-0007	RETAINER:LATCH	
Q1 Q2 Q3 Q4	1853-0052 1850-0038 1850-0038 1850-0038	TRANSISTOR:SILICON PNP 2N3740 TRANSISTOR:PNP GERMANIUM TRANSISTOR:PNP GERMANIUM TRANSISTOR:PNP GERMANIUM	
R1 R2 R3 R4 R5	0683-2235 0683-2245 0683-8235 0683-2735 2100-0318	R:FXD COMP 22K OHM 5% 1/4W R:FXD COMP 220K OHM 5% 1/4W R:FXD COMP 82K OHM 5% 1/4W R:FXD COMP 27K OHM 5% 1/4W R:VAR 250K OHM 20% 1/4W/SPST 5A	
R6 R7 R8 R9 R10	0686-1045 0686-3325 0683-6215 0683-5105 0683-1055	R:FXD COMP 100K OHM 5% 1/2W R:FXD COMP 3300 OHM 5% 1/2W R:FXD COMP 620 OHM 5% 1/4W R:FXD COMP 51 OHM 5% 1/4W R:FXD COMP 1 MEGOHM 5% 1/4W	
S1 S2 S3 S4	3101-0036 3101-0014 3101-1272	SWITCH:TOG SPST 3 AMP 125V SWITCH:PUSH SPDT NE NSR PART OF R5 SWITCH:SLIDE 4 PDT. 0.5 AMP 250 VAC	
T1 T2 W1 W1 W2 XA6 XA7 XA8 XA9 XA10 XA11	9100-0166 9100-2829 8120-1378 8120-1348 05245-6018 1251-0159 1251-0135 1251-0135 1251-0135	TRANSFORMER:POWER TRANSFORMER:POWER CABLE:POWER SVT-18-3 7.5 FT JADE GRAY CABLE:POWER SVT-18-3 7.5FT. GRAY MAIN CABLE AND SWITCH ASSY GRAY CONNECTOR:2X15 CONTACT CONNECTOR-PRINTED CIRCUIT 15 CONTACTS	
XA12 XA13 XA14 XA15 XA16	1251-0135 1251-0135 1251-0135 1251-0135 1251-0135	NOT ASSIGNED CONNECTOR-PRINTED CIRCUIT 15 CONTACTS CONNECTOR-PRINTED CIRCUIT 15 CONTACTS CONNECTOR-PRINTED CIRCUIT 15 CONTACTS CONNECTOR-PRINTED CIRCUIT 15 CONTACTS CONNECTOR-PRINTED CIRCUIT 15 CONTACTS	

= See list of abbreviations in introduction to this section

Table 4-1. Reference Designation Index (Cont'd)

Reference Designation	Stock No.	Description #	Note
XA17	1251-0135	CONNECTOR-PRINTED CIRCUIT 15 CONTACTS	
XA18	1251-0135	CONNECTOR-PRINTED CIRCUIT 15 CONTACTS	
XA19	1251-1669	CONNECTOR IFC 10 CONTACTS	
XA20	1251-1669	CONNECTOR IFC 10 CONTACTS	
XA21	1251-1670	CONNECTOR IFC 15 CONTACTS (2 REQ'D)	
XA22	1251-0135	CONNECTOR-PRINTED CIRCUIT 15 CONTACTS	
XA23	1251-0135	CONNECTOR-PRINTED CIRCUIT 15 CONTACTS	
XA24	THRU		
XA25		NOT ASSIGNED	
XA26	1251-0135	CONNECTOR-PRINTED CIRCUIT 15 CONTACTS	
XA26	1251-0158	AND CONNECTOR IFC-CONTACT	
XA27	1251-0135	CONNECTOR-PRINTED CIRCUIT 15 CONTACTS	
XA28	1251-0135	CONNECTOR-PRINTED CIRCUIT 15 CONTACTS	
XA29	1251-0135	CONNECTOR-PRINTED CIRCUIT 15 CONTACTS	
XA30	1251-0135	CONNECTOR-PRINTED CIRCUIT 15 CONTACTS	
XA31	1251-0135	CONNECTOR-PRINTED CIRCUIT 15 CONTACTS	
XA32	1251-0135	CONNECTOR-PRINTED CIRCUIT 15 CONTACTS	
XA33	1251-0135	CONNECTOR-PRINTED CIRCUIT 15 CONTACTS	
XA34	1251-0135	CONNECTOR-PRINTED CIRCUIT 15 CONTACTS	
XF1	1400-0084	FUSEHOLDER EXTRACTOR POST TYPE	
		MISCELLANEOUS	
	05243-6043	KIT: 5-1/4" RACK MOUNT	
	8500-0059	SILICONE GREASE (FOR TRANSISTOR HEAT-SINK)	
	3150-0037	AIR FILTER ASSY	
	05243-6036	PANEL: PLUG-IN (LIGHT GRAY)	

See list of abbreviations in introduction to this section

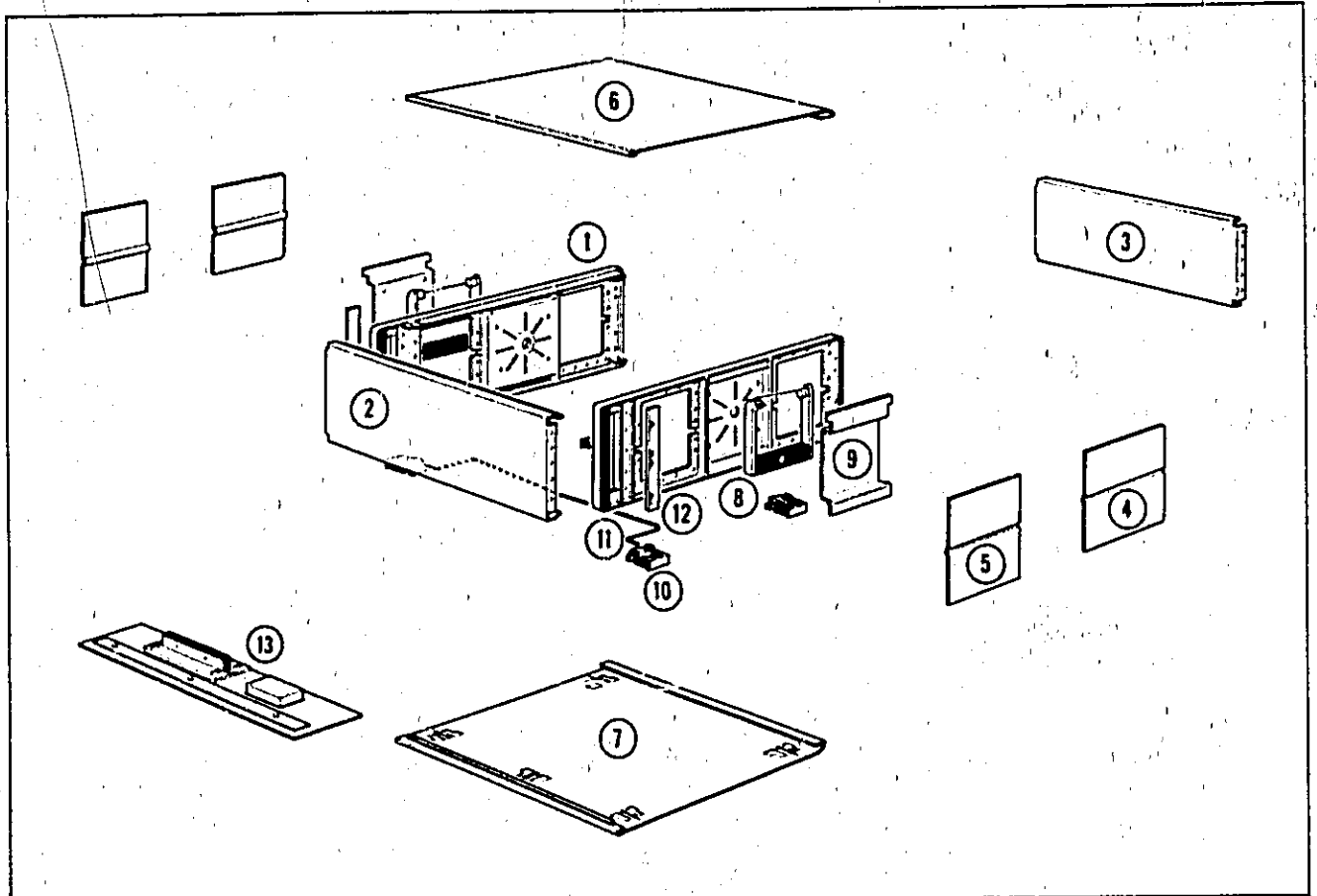

Item No.	Description	HP Part No.
1	Frame Assembly	5060-0732
2	Front Panel	05245-2027
3	Rear Panel	05245-0022
4	Cover: Rear Side	5000-8709
5	Cover: Front Side	5000-8711
6	Cover Assembly: Top	05243-0010
7	Cover Assembly: Bottom	05243-0009
8	Handle Assembly: Side	5060-0222
9	Handle Assembly: Retainer	5060-8737
10	Foot Assembly	5060-0767
11	Stand: Tilt	1490-0030
12	Plate: Fluted	5000-0051
13	Kit: Rack Mounting	05243-6043

Figure 4-1. Modular Cabinet Parts.

Table 4-2. Replaceable Parts

Stock No.	Description #	Mfr.	Mfr. Part No.	TQ
0121-0013	C:VAR AIR 6-10G.5PF	80486	08SA	1
0130-0001	C:VAR CER 7-45PF 500VDCW	72982	50300D2P0	1
0130-0003	C:VAR CER 1.5-7 PF 500VDCW	72982	503-000C0F0-10R	1
0140-0145	C:FXD MICA 22 PF 5%	28480	0140-0145	9
0140-0149	C:FXD MICA 470 PF 5% 300 VDCW	84171	DM15F471J	5
0140-0151	C:FXD MICA 820FF 2% 300VDCW	84171	DM15F821G	1
0140-0152	C:FXD MICA 300G PF 5% 300VDCW	28480	0140-0152	1
0140-0156	C:FXD MICA 150G PF 2% 300 VDCW	84171	DM19F152G 300V	1
0140-0159	C:FXD MICA 300GPF 300VDCW	84171	DM19F302G	3
0140-0162	C:FXD MICA 4700 PF 10% 300 VDCW	84171	DM2GF472K	1
0140-0166	C:FXD MICA 0.017 UF 2% 300 VDCW	84171	DM30F173G	1
0140-0169	C:FXD MICA 100 PF 5% 500VDCW	00853	M-23 CB11R0101J	1
0140-0176	C:FXD MICA 100 PF 2% 300 VDCW	84171	ROM15F101G3C	1
0140-0190	C:FXD MICA 39 PF 5%	28480	0140-0190	8
0140-0191	C:FXD MICA 56 PF 5% 300 VDCW	84171	ROM15E560J3C	7
0140-0192	C:FXD MICA 66 PF 5%	28480	0140-0192	10
0140-0193	C:FXD MICA 82 PF 5%	28480	0140-0193	21
0140-0194	C:FXD MICA 110 PF 5% 300 VDCW	84171	DM15F111J 300V	19
0140-0195	C:FXD MICA 130 PF 5% 300 VDCW	84171	DM15F131J 300V	32
0140-0196	C:FXD MICA 150 PF 5% 300 VDCW	84171	DM15F151J 300V	21
0140-0197	C:FXD MICA 160 PF 5%	28480	0140-0197	10
0140-0198	C:FXD MICA 200PF 5% 300VDCW	84171	DM15F201J 300V	12
0140-0199	C:FXD MICA 240PF 5% 300VDCW	84171	DM15F241J 300V	8
0140-0200	C:FXD MICA 390PF 5% 300VDCW	84171	DM15F391J 300V	14
0140-0201	C:FXD MICA 12PF 5% 500VDCW	84171	DM15C120J	2
0140-0202	C:FXD MICA 15 PF 5% 500VDCW	84171	DM15C150J	4
0140-0203	C:FXD MICA 30PF 5% 500VDCW	84171	DM15E300J 500V	4
0140-0204	C:FXD MICA 47PF 5% NPO 500VDCW	84171	ROM15E470J5C	12
0140-0205	C:FXD MICA 62 PF 5% 300VDCW	84171	DM15E620J	1
0140-0208	C:FXD MICA 660PF 5% 300VDCW	84171	DM15F681J	3
0140-0209	C:FXD MICA 5PF 10% 500VDCW	84171	DM15C050K 500V	1
0140-0210	C:FXD MICA 270FF 5% 300VDCW	84171	DM15F271J 300V	3
0140-0214	C:FXD MICA 60PF 5% 300VDCW	84171	DM15E600J 300V	2
0140-0217	C:FXD MICA 140 PF 2% 300VDCW	84171	DM15F141G-300V	5
0150-0009	C:FXD CER 10PF ± 0.5 PF 500 VDCW	28480	0150-0009	1
0150-0012	C:FXD CER 0.01 UF 20% 1000 VDCW	56289	H 1038	2
0150-0042	C:FXD TI 4.7 PF 5% 500VDCW	78488	TYPE GA	2
0150-0047	C:FXD TI 6.8 PF 10% 500 VDCW	78488	TYPE GA	2
0150-0050	C:FXD CER 1000PF 600 VDCW	56289	CO67B102E102ZS26-CDH	2
0150-0061	C:FXD CER 20 PF 10% 100VDCW	56289	53C47	2
0150-0069	C:FXD CER 0.001 UF +100-20% 500VDCW	72982	801-010X5G0102Z	1
0150-0073	C:FXD CER 100 PF 10% 500VDCW	56289	40C200A2	2
0150-0093	C:FXD CER 0.01UF +80-20 100VDCW	91416	TA	39
0150-0115	C:FXD CER 27 PF 10% 500VDCW	71590	CC20TCN27	1
0150-0119	C:FXD CER 2X(.01UF) 20% 250VDCW	56289	41C159A	1
0150-0121	C:FXD CER 0.1UF 50 VDCW	56289	5C50A	10
0150-0122	C:FXD CER 2000PF 20% 500VDCW	72982	801-000-Y55-202M	2
0160-0126	C:FXD PORC 160PF 2% 500VDCW	95275	VY13C161G	1
0160-0127	C:FXD CER 1UF 20% 25VDCW	56289	5C13	10
0160-0130	C:FXD MY 0.022 UF 2% 600VDCW	84411	TYPE 663-UM	1
0160-0134	C:FXD MICA 220FF 5% 300VDCW	14655	CD15F221J(300V)	10

= See list of abbreviations in introduction to this section

Table 4-2. Replaceable Parts (Cont'd)

Stock No.	Description #	Mfr.	Mfr. Part No.	TQ
0160-0155	C:FXD MY 3300 PF 10%	28480	0160-0155	1
0160-0157	C:FXD MY 4700 PF 10%	28480	0160 0157	1
0160-0161	C:FXD MY 0.01 UF 10% 200VDCW	28480	0160 0161	1
0160-0163	C:FXD MY 3300PF 10%	28480	0160-0163	1
0160-0174	C:FXD CER 0.47 UF +80-20% 25VDCW	56289	5C11B7	2
0160-0181	C:FXD MICA 30PF 5% 300VDCW	14655	RDM15E470J35	1
0160-0194	C:FXD MY 0.015UF 10%	28480	0160-0194	8
0160-0205	C:FXD MICA 10 PF 5%	28480	0160-0205	2
0160-0314	C:FXD MY 0.01 UF 5% 400VDCW	84411	TYPE 663UW	2
0160-0369	C:FXD MICA 17 PF 5%	28480	0160-0369	3
0160-0370	C:FXD MICA 20 PF 5%	28480	0160-0370	1
0160-2203	C:FXD MICA 91 PF 5%	28480	0160-2203	10
0160-2206	C:FXD MICA 160 PF 5%	28480	0160-2206	10
0160-2248	C:FXD CER 4.3 PF 500VDCW	72982	301-NP0 4.3 PF	1
0160-2260	C:FXD CER 13 PF 5% 500VDCW	72982	301-NP0 13 PF	1
0160-2262	C:FXD CER 16 PF 5% 500VDCW	72982	301-NP0 16 PF	1
0160-2306	C:FXD MICA 27 PF 5%	28480	0160-2306	1
0160-2550	C:FXD CER 1.0 PF 500VDCW	72982	301-000-C0K0-109B	1
0160-2563	C:FXD CER 2000 PF 20% 500VDCW	72982	801-012-Y5S-202M	2
0170-0024	C:FXD MV 0.022 UF 20% 200VDCW	56289	192F22302A	1
0170-0040	C:FXD MY .047 UF 10% 200VDCW	28480	0170-0040	5
0170-0055	C:FXD MY 0.1UF 20% 200VDCW	56289	192F10402	1
0170-0084	C:FXD MY 0.068UF 20% 50VDCW	84411	601FE STYLE 3	4
0170-0094	C:FXD MY 0.047UF 20% 50VDCW	84411	TYPE 602	2
0180-0047	C:FXD ELECT 500UF 75VDCW	56289	032443	1
0180-0049	C:FXD ELECT 20UF 50VDCW	56289	30D198A1	1
0180-0097	C:FXD ELECT 47 UF 10% 35VDCW	28480	0180-0097	1
0180-0098	C:FXD ELECT 100UF 20% 20VDCW	56289	150C107X0020S2	2
0180-0100	C:FXD ELECT TA 4.7UF 10% 35VDCW	56289	150C475X9035B2	9
0180-0107	C:FXD ELECT 20UF -10/+100% 200VDCW	56289	90803	2
0180-0129	C:FXD ELECT 975UF -10+50% 40VDCW	56289	537006	2
0180-0130	C:FXD ELECT 1500UF -10+50% 15VDCW	00853	PLI 505 1007 02	1
0180-0137	C:FXD ELECT TA 100 UF 20% 10VDCW	56289	150C107X0010R2	1
0370-0077	KNOB:1/4 BAR WITH ARROW	28480	0370-0077	4
0370-0084	KNOB:ROUND BLACK	28480	0370-0084	1
0370-0099	KNOB:BAR WITH CENTER HOLE	28480	0370-0099	1
0370-0134	KNOB:ROUND RED	28480	0370-0134	1
0510-0123	RETAINER:PUSH-ON TYPE FASTENER	78553	C12008-014-4	1
0683-0475	R:FXD COMP 4.7 OHMS 5% 1/4W	01121	CB 47G5	1
0683-1015	R:FXD COMP 100 OHM 5% 1/4W	01121	CB 1015	13
0683-1025	R:FXD COMP 1000 OHM 5% 1/4W	01121	CB 1025	24
0683-1035	R:FXD COMP 10K OHM 5% 1/4W	01121	CB 1035	83
0683-1045	R:FXD COMP 100K OHMS 5% 1/4W	01121	CB 1045	30
0683-1055	R:FXD COMP 1 MEGOHM 5% 1/4W	01121	CB 1055	14
0683-1115	R:FXD COMP 110 OHM 5% 1/4W	01121	CB 1115	6
0683-1125	R:FXD COMP 1100 OHM 5% 1/4W	01121	CB 1125	1
0683-1135	R:FXD COMP 11K OHM 5% 1/4W	01121	CB 1135	1
0683-1225	R:FXD COMP 1200 OHMS 5% 1/4W	01121	CB 1225	2
0683-1235	R:FXD COMP 12K OHM 5% 1/4W	01121	CB 1235	6
0683-1245	R:FXD COMP 120K OHM 5% 1/4W	01121	CB 1245	8
0683-1305	R:FXD COMP 13 OHMS 5% 1/4W	01121	CB 1305	1
0683-1325	R:FXD COMP 1300 OHMS 5% 1/4W	01121	CB 1325	4

= See list of abbreviations in introduction to this section

Table 4-2. Replaceable Parts (Cont'd)

Stock No.	Description #	Mfr.	Mfr. Part No.	TQ
0683-1515	R:FXD COMP 150 OHM 5% 1/4W	01121	CB 1515	1
0683-1525	R:FXD COMP 1500 OHM 5% 1/4W	01121	CB 1525	4
0683-1535	R:FXD COMP 15K OHMS 5% 1/4W	01121	CB 1535	8
0683-1545	R:FXD COMP 150K OHM 5% 1/4W	01121	CB 1545	5
0683-1615	R:FXD COMP 160 OHM 5% 1/4W	01121	CB 1615	2
0683-1625	R:FXD COMP 1600 OHM 5% 1/4W	01121	CB 1625	4
0683-1635	R:FXD COMP 16K OHM 5% 1/4W	01121	CB 1635	9
0683-1815	R:FXD COMP 180 OHM 5% 1/4W	01121	CB 1815	24
0683-1825	R:FXD COMP 1800 OHMS 5% 1/4W	01121	CB 1825	9
0683-1835	R:FXD COMP 18K OHM 5% 1/4W	01121	CB 1835	5
0683-1845	R:FXD COMP 180K OHMS 5% 1/4W	01121	CB 1845	5
0683-2015	R:FXD COMP 200 OHMS 5% 1/4W	01121	CB 2015	27
0683-2025	R:FXD COMP 2000 OHM 5% 1/4W	01121	CB 2025	20
0683-2205	R:FXD COMP 22 OHM 5% 1/4W	01121	CB 2205	2
0683-2215	R:FXD COMP 220 OHMS 5% 1/4W	01121	CB 2215	2
0683-2225	R:FXD COMP 2.2K OHM 5% 1/4W	01121	CB 2225	6
0683-2235	R:FXD COMP 22K OHM 5% 1/4W	01121	CB 2235	12
0683-2245	R:FXD COMP 220K OHM 5% 1/4W	01121	CB 2245	2
0683-2415	R:FXD COMP 240 OHMS 5% 1/4W	01121	CB 2415	4
0683-2425	R:FXD COMP 2400 OHMS 5% 1/4W	01121	CB 2425	4
0683-2435	R:FXD COMP 24K OHM 5% 1/4W	01121	CB 2435	1
0683-2715	R:FXD COMP 270 OHMS 5% 1/4W	01121	CB 2715	1
0683-2725	R:FXD COMP 2700 OHMS 5% 1/4W	01121	CB 2725	13
0683-2735	R:FXD COMP 27K OHM 5% 1/4W	01121	CB 2735	5
0683-3025	R:FXD COMP 3000 OHM 5% 1/4W	01121	CB 3025	26
0683-3305	R:FXD COMP 33 OHMS 5% 1/4W	01121	CB 3305	1
0683-3315	R:FXD COMP 330 OHMS 5% 1/4W	01121	CB 3315	8
0683-3325	R:FXD COMP 3300 OHM 5% 1/4W	01121	CB 3325	8
0683-3615	R:FXD COMP 360 OHM 5% 1/4W	01121	CB 3615	1
0683-3625	R:FXD COMP 3600 OHM 5% 1/4W	01121	CB 3625	2
0683-3915	R:FXD COMP 390 OHMS 5% 1/4W	01121	CB 3915	13
0683-3925	R:FXD COMP 3900 OHM 5% 1/4W	01121	CB 3925	102
0683-3935	R:FXD COMP 39K OHM 5% 1/4W	01121	CB 3935	1
0683-3945	R:FXD COMP 390K OHMS 5% 1/4W	01121	CB 3945	28
0683-4315	R:FXD COMP 430 OHMS 5% 1/4W	01121	CB 4315	5
0683-4325	R:FXD COMP 4300 OHM 5% 1/4W	01121	CB 4325	2
0683-4335	R:FXD COMP 43K OHM 5% 1/4W	01121	CB 4335	1
0683-4705	R:FXD COMP 47 OHM 5% 1/4W	01121	CB 4705	1
0683-4715	R:FXD COMP 470 OHMS 5% 1/4W	01121	CB 4715	9
0683-4725	R:FXD COMP 4700 OHM 5% 1/4W	01121	CB 4725	22
0683-4735	R:FXD COMP 47K OHMS 5% 1/4W	01121	CB 4735	179
0683-5105	R:FXD COMP 51 OHM 5% 1/4W	01121	CB 5105	4
0683-5115	R:FXD COMP 510 OHMS 5% 1/4W	01121	CB 5115	5
0683-5125	R:FXD COMP 5100 OHM 5% 1/4W	01121	CB 5125	7
0683-5135	R:FXD COMP 51K OHMS 5% 1/4W	01121	CB 5135	10
0683-5615	R:FXD COMP 560 OHMS 5% 1/4W	01121	CB 5615	1
0683-5635	R:FXD COMP 56K OHMS 5% 1/4W	01121	CB 5635	58
0683-6205	R:FXD COMP 62 OHM 5% 1/4W	01121	CB 6205	5
0683-6215	R:FXD COMP 620 OHM 5% 1/4W	01121	CB 6215	1
0683-6225	R:FXD COMP 6200 OHMS 5% 1/4W	01121	CB 6225	4

= See list of abbreviations in introduction to this section

Table 4-2. Replaceable Parts (Cont'd)

Stock No.	Description #	Mfr.	Mfr. Part No.	TQ
0683-6235	R:FXD COMP 62K OHM 5% 1/4W	01121	CB 6235	2
0683-6805	R:FXD COMP 68 OHMS 5% 1/4W	01121	CB 6805	4
0683-6815	R:FXD COMP 680 OHMS 5% 1/4W	01121	CB 6815	3
0683-6825	R:FXD COMP 6800 OHMS 5% 1/4W	01121	CB 6825	49
0683-6835	R:FXD COMP 66K OHM 5% 1/4W	01121	CB 6835	18
0683-7515	R:FXD COMP 750 OHMS 5% 1/4W	01121	CB 7515	4
0683-7525	R:FXD COMP 7500 OHMS 5% 1/4W	01121	CB 7525	8
0683-7535	R:FXD COMP 75K OHM 5% 1/4W	01121	CB 7535	1
0683-8215	R:FXD COMP 820 OHMS 5% 1/4W	01121	CB 8215	3
0683-8225	R:FXD COMP 8200 OHMS 5% 1/4W	01121	CB 8225	22
0683-8235	R:FXD COMP 82K OHM 5% 1/4W	01121	EB 8235	1
0683-9105	R:FXD COMP 91 OHM 5% 1/4W	01121	CB 9105	4
0683-9115	R:FXD COMP 910 OHM 5% 1/4W	01121	CB 9115	1
0683-9125	R:FXD COMP 9100 OHM 5% 1/4W	01121	CB 9125	2
0683-9135	R:FXD COMP 91K OHM 5% 1/4W	01121	CB 9135	1
0686-1025	R:FXD COMP 1000 OHM 5% 1/2W	01121	EB 1025	3
0686-1035	R:FXD COMP 10K OHM 5% 1/2W	01121	EB 1035	5
0686-1045	R:FXD COMP 100K OHM 5% 1/2W	01121	EB 1045	1
0686-1055	R:FXD COMP 1 MEGOHM 5% 1/2W	01121	EB 1055	1
0686-1225	R:FXD COMP 1200 OHM 5% 1/2W	01121	EB 1225	2
0686-1325	R:FXD COMP 1.3K OHM 5% 1/2W	01121	EB 1325	2
0686-1525	R:FXD COMP 1500 OHM 5% 1/2W	01121	EB 1525	1
0686-1825	R:FXD COMP 1800 OHM 5% 1/2W	01121	EB 1825	1
0686-2035	R:FXD COMP 20K OHM 5% 1/2W	01121	EB 2035	2
0686-2225	R:FXD COMP 2200 OHM 5% 1/2W	01121	EB 2225	5
0686-2235	R:FXD COMP 22K OHM 5% 1/2W	01121	EB 2235	1
0686-2725	R:FXD COMP 2700 OHM 5% 1/2W	01121	EB 2725	1
0686-2735	R:FXD COMP 27K OHM 5% 1/2W	01121	EB 2735	2
0686-3025	R:FXD COMP 3000 OHM 5% 1/2W	01121	EB 3025	1
0686-3325	R:FXD COMP 3300 OHM 5% 1/2W	01121	EB 3325	1
0686-3625	R:FXD COMP 3600 OHM 5% 1/2W	01121	EB 3625	2
0686-4715	R:FXD COMP 470 OHMS 5% 1/2W	01121	EB 4715	3
0686-4725	R:FXD COMP 4700 OHM 5% 1/2W	01121	EB 4725	2
0686-4735	R:FXD COMP 47K OHM 5% 1/2W	01121	EB 4735	11
0686-5115	R:FXD COMP 510 OHM 5% 1/2W	01121	EB 5115	1
0686-6215	R:FXD COMP 620 OHM 5% 1/2W	01121	EB 6215	1
0686-7525	R:FXD COMP 7500 OHMS 5% 1/2W	01121	EB 7525	42
0686-8215	R:FXD COMP 820 OHM 5% 1/2W	01121	EB 8215	3
0686-9115	R:FXD COMP 910 OHMS 5% 1/2W	01121	EB 9115	1
0686-9125	R:FXD COMP 9100 OHM 5% 1/2W	01121	EB 9125	1
0689-0565	R:FXD COMP 5.6 OHM 5% 1W	01121	GB 0565	1
0689-2075	R:FXD COMP 20K OHM 5% 1W	01121	GB 2035	1
0727-0081	R:FXD DEPC 600 OHM 1% 1/2W	19701	DC 1/2 AR5	1
0727-0105	R:FXD C-FLM 1200 OHM 1% 1/2W	28480	0727-0105	1
0727-0367	R:FXD DEPC 442 OHM 1% 1/2W	19701	UC 1/2A R5	1
0757-0344	R:FXD MET FLM 1 MEGOHM 1% 1/4W	28480	0757-0344	1
0757-0350	R:FXD MET FLM 909K OHM 1% 1/4W	28480	0757-0350	1
0757-0368	R:FXD MET FLM 34 OHM 1% 1/8W	28480	0757-0368	1
0757-0898	R:FXD MET FLM 62 OHM 2% 1/8W	28480	0757-0898	2

= See list of abbreviations in introduction to this section

Table 4-2. Replaceable Parts (Cont'd)

Stock No.	Description #	Mfr.	Mir. Part No.	TQ
0757-0901	RIFXD MET FLM 100 OHM 2% 1/8W	28480	0757-0900	2
0757-0902	RIFXD MET FLM 120 OHM 2% 1/8W	28480	0757-0902	2
0757-0904	RIFXD MET FLM 150 OHM 2% 1/8W	28480	0757-0904	2
0757-0909	RIFXD MET FLM 240 OHM 2% 1/8W	28480	0757-0909	4
0757-0914	RIFXD MET FLM 390 OHM 2% 1/8W	28480	0757-0914	3
0757-0916	RIFXD MET FLM 470 OHM 2% 1/8W	28480	0757-0916	4
0757-0920	RIFXD MET FLM 680 OHM 2% 1/8W	28480	0757-0920	2
0757-0930	RIFXD MET FLM 1.8K OHM 2% 1/8W	28480	0757-0930	4
0757-0932	RIFXD MET FLM 2.2K OHM 2% 1/8W	28480	0757-0932	4
0757-0936	RIFXD MET FLM 3.3K OHM 2% 1/8W	28480	0757-0936	4
0757-0937	RIFXD MET FLM 3.6K OHM 2% 1/8W	28480	0757-0937	1
0757-0940	RIFXD MET FLM 4.7K OHM 2% 1/8W	28480	0757-0940	2
0757-0948	RIFXD MET FLM 10K OHM 2% 1/8W	28480	0757-0948	5
0757-0950	RIFXD MET FLM 12K OHM 2% 1/8W	28480	0757-0950	4
0757-0952	RIFXD MET FLM 15K OHM 2% 1/8W	28480	0757-0952	4
0757-0972	RIFXD MET FLM 100K OHM 2% 1/8W	28480	0757-0972	4
0758-0004	RIFXD MET FLM 2700 OHM 5% 1/2W	28480	0758-0004	10
0758-0014	RIFXD MET OX 160 OHM 5%	28480	0758-0014	1
0758-0015	RIFXD MET FLM 220 OHMS 5% 1/2W	28480	0758-0015	7
0758-0024	RIFXD MET FLM 100 OHM 5% 1/2W	28480	0758-0024	1
0758-0028	RIFXD MET FLM 270 OHMS 5% 1/2W	28480	0758-0028	1
0758-0043	RIFXD MET FLM 1800 OHM 5% 1/2W	28480	0758-0043	4
0758-0044	RIFXD MET OX 2200 OHM 5% 1/2W	28480	0758-0044	1
0761-0010	RIFXD MET OX 1800 OHM 5% 1W	28480	0761-0010	2
0761-0020	RIFXD MET FLM 91 OHM 5% 1W	28480	0761-0020	1
0767-0001	RIFXD MET FLM 400 OHMS 5% 3W	28480	0767-0001	1
1200-0043	INSULATOR:TRANSISTOR ANCDIZED ALUMINUM	76530	294457	3
0340-0162	INSULATOR:TRANSISTOR	28480	0340-0162	1
1200-0081	BUSHING:INSULATOR NYLON	28480	1200-0081	6
1200-0092	BUSHING:TRANSISTOR	28480	1200-0092	2
1250-0118	CONNECTOR:RNC	91737	8427	7
1251-0087	CONNECTOR:FEMALE 50-PIN MINAT	02660	57-4057-40500(375)	1
1251-0101	CONNECTOR:FEMALE 50-CONTACT	02660	57-20500	1
1251-0135	CONNECTOR-PRINTED CIRCUIT 15 CONTACTS	95354	50-615UR	21
1251-2357	CONNECTOR:POWER 3-PIN MALE	82389	EAC 301	1
1251-0158	CONNECTOR:6-CONTACT	95354	CD-606S	1
1251-0159	CONNECTOR:2X15 CONTACT	95354	FD-630S	1
1251-1669	CONNECTOR:PC 10 CONTACTS	28480	1251-1669	2
1251-1670	CONNECTOR:PC 15 CONTACTS	28480	1251-1670	1
1400-0064	FUSEHOLDER:EXTRACTOR POST TYPE	75915	342014	1
1450-0049	INDICATOR:GLOW-LAMP NEON	28480	1450-0049	1
1520-0001	PLATE:COUNTING ELECTROLYTIC CAPACITOR	26480	1520-0001	4
1520-0003	MOUNTING PLATE:CAPACITOR	37942	TYPE BP2	2
1850-0038	TRANSISTOR:PMP GERMANIUM	86684	1850-0038	3
1850-0040	TRANSISTOR:GERMANIUM 2N383 PNP	94154	2N383	3
1850-0048	TRANSISTOR:GERMANIUM 2N650 PNP	04713	2N650	1
1850-0054	TRANSISTOR:GERMANIUM 2N652A PNP	04713	2N652A	2
1850-0062	TRANSISTOR:ISPL 2N404A	28480	1850-0062	94
1850-0090	TRANSISTOR:GERMANIUM 2N1183B PNP	86684	2N1183B	1

* See list of abbreviations in introduction to this section

Table 4-2. Replaceable Parts (Cont'd)

Stock No.	Description #	Mfr.	Mfr. Part No.	TQ
1850-0091	TRANSISTOR:GERMANIUM 2N2048 PNP	87216	2N2048	3
1850-0092	TRANSISTOR:GERMANIUM 2N2043A PNP	04713	2N2043	1
1850-0101	TRANSISTOR:SPL2N582	28480	1850-0101	1
1850-0102	TRANSISTOR:GE2N2455	28480	1854-0102	1
1850-0158	TRANSISTOR:PNP GERMANIUM	28480	1850-0158	1
1851-0017	TRANSISTOR:2N1304	01295	2N1304	5
1851-0024	TRANSISTOR:GE NPN 2N366A	01295	2N388A	1
1853-0001	TRANSISTOR:PNP SILICON 30V 900M μ	28480	1853-0001	4
1853-0009	TRANSISTOR:SILICON PNP	28480	1853-0009	15
1853-0015	TRANSISTOR:SILICON PNP 2N3640	07263	2N3640	6
1853-0034	TRANSISTOR:SILICON PNP	28480	1853-0034	8
1854-0003	TRANSISTOR:NPN SILICON	28480	1854-0003	8
1854-0005	TRANSISTOR:2N708 NPN SILICON PLANAR	07263	2N708	16
1854-0009	TRANSISTOR:2N709 NPN SILICON	07263	2N709	18
1854-0019	TRANSISTOR:SILICON NPN	28480	1854-0019	2
1854-0022	TRANSISTOR:120V	28480	1854-0022	1
1854-0073	TRANSISTOR:SILICON NPN	28480	1854-0073	2
1854-0249	TRANSISTOR:DUAL NPN SILICON	28480	1854-0249	2
1855-0047	TRANSISTOR:DUAL N-CHANNEL FET	28480	1855-0047	2
1901-0025	DIODE:SILICON 100WV 100MA	28480	1901-0025	113
1901-0026	SEMICON DEVICE:DIODE SI	14099	SA-783	5
1901-0029	DIODE:SILICON 60C PIV	28480	1901-0029	4
1901-0040	SEMICON DEVICE:DIODE SILICON	28480	1901-0040	38
1901-0045	SEMICON DEVICE:DIODE SI	14099	SA-788	8
1901-0049	SEMICON DEVICE:DIODE SI	14099	5C-05	4
1901-0376	DIODE:SILICON 35V	28480	1901-0376	4
1902-0017	SEMICON DEVICE:DIODE SI	28480	1902-0017	2
1902-0039	SEMICON DEVICE:DIODE 1N1597A	04713	1N1597A	1
1902-0057	SEMICON DEVICE:DIODE SILICON	28480	1902-0057	1
1902-0214	DIODE:SILICON BREAKDOWN 56.2V 10% 1.5W	28480	1902-0214	1
1902-0580	DIODE BREAKDOWN:SILICON	28480	1902-0580	2
1910-0015	SEMICON DEVICE:DIODE GERMANIUM	73293	HD-1409	5
1910-0016	DIODE:GERMANIUM 1 MICROSEC 60 μ V	28480	1910-0016	104
1910-0021	SEMICON DEVICE:DIODE	73293	HP5 1672A	5
1910-0022	SEMICON DEVICE:DIODE GE 100MA 6FIV 3.5NS	28480	1910-0022	14
1910-0034	DIODE:GERMANIUM	28480	1910-0034	2
1970-0009	ELECTRON TUBE:INDICATOR 10 DIGIT	83594	65991	8
2100-0318	RIVAR 250K OHM 20% 1/4W/SFST 5 μ	28480	210010318	1
2100-0354	RIVAR μ W 1000 OHM 10% LIN 2W	28480	2100 0354	1
2100-0737	RIVAR μ W 200 OHM 5% 1W	28480	2100-0737	1
2100-1412	RIVAR COMP 500 OHM 20% LIN 1/4W	28480	2100-1412	3
2100-1513	RIVAR μ W 50 OHM 5% 1W	28480	2100-1513	2
2100-1924	RIVAR COMP 5K OHM 20% 1/5W	28480	2100-1924	1
2110-0303	FUSE:CARTRIDGE 2AMP 125V SLOW BLOW	71400	MDL2	1
2110-0312	FUSE:CARTRIDGE 1 AMP 250V SLOW SLOW	71400	MDL 1	1
2140-0015	LAMP:GLOW NEON NE-2H	24455	NE 2H	6
2140-0628	LAMP:GLOW 1/15W	24455	NE 2E FROSTED	7
2190-0046	WASHER:SPLIT LOCK	28480	2190-0046	6
2390-0015	SCREW:MACHINE	73076	QBD	1
3100-0389	SWITCH:ROTARY 1 SECT 3 POS	28480	3100-0389	1

* See List of abbreviations in introduction to this section

Table 4-2. Replaceable Parts (Cont'd)

Stock No.	Description #	Mfr.	Mfr. Part No.	TQ
3100-0390	SWITCH:ROT 2-SECT 9-POS	28480	3100-0390	1
3100-1874	SWITCH:ROT 6-SECT 10 POS	28480	3100-1874	1
3100-2029	SWITCH:ROTARY	28480	3100-2029	1
3100-2036	SWITCH:ROTARY	28480	3100-2036	1
3101-0014	SWITCH:PUSH SPDT NE	82389	45-1106	1
3101-1272	SWITCH:SLIDE 4 PNT 0.5 AMP 125 VDC	42190	6633	1
3101-0037	SWITCH:TOG SPST 3 AMP 125V	04009	83050-A	1
3140-0052	MOTOR:ELECTRICAL SHADED POLE 115V 3470 RPM	28480	3140-0052	1
3160-0060	FAN:IMPELLER AXIAL	28480	3160-0060	1
5040-0170	SUPPORT: PRINTED CIRCUIT BOARD	28480	5040-0170	1
5080-0060	TRANSISTOR: GERMANIUM PNP SELECTED	28480	5080-0060	8
8120-0078	CABLE:POWER SVT-18-3 7.5FT.	70903	KH4147	1
8500-0059	SILICONE GREASE(FOR TRANSISTOR HEAT-SINK	71984	#5 COMPOUND	1
9100-0166	TRANSFORMER:POWER	28480	9100-0166	1
9100-0346	COIL:FXD 0.05 UH 20%	24226	9377	2
9100-2829	TRANSFORMER: POWER	28480	9100-2829	1
9100-2830	COIL: FXD 40 UH	28480	9100-2430	2
9140-0095	COIL:FXD RF 0.27 UH	28480	9140-0095	1
9140-0125	COIL:VAR 0.9-1.9 UH	28480	9140-0125	2
9140-0126	COIL:VAR 1.76-4.02 UH	28480	9140-0126	2
9140-0127	COIL:VAR 8.3-18.7 UH	28480	9140-0127	2
9140-0136	COIL:FXD PF 22 UH	28480	9140-0136	2
9140-0137	COIL:FXD RF 100 UH	28480	9140-0137	3
9140-0138	COIL:FXD RF 180 UH	28480	9140-0138	3
9140-0142	COIL:FXD RF 2.2 UH	28480	9140-0142	3
9140-0143	COIL:FXD RF 3.3 UH	28480	9140-0143	3
9140-0146	COIL:FXD RF 10 UH	28480	9140-0146	2
9140-0158	COIL:FXD 1.0UH 10%	99800	1025-20	2
9140-0159	COIL:FXD 0.47UH 20%	99800	1025-SERIES	5
9170-0016	HEAD:MAGNETIC	02114	56-590-6513B	1
05212-2016	BOARD:BLANK PC	28480	05212-2016	5
05212-6011	READOUT BLOCK ASSY	28480	05212-6011	8
05212-6016	ASSY:DECIMAL BOARD	28480	05212-6016	5
05232-2010	BOARD:BLANK PC	28480	05232-2010	1
05232-6009	DECADE DIVIDER ASSEMBLY	28480	05232-6009	1
05232-6010	DECIMAL COUNTER ASSEMBLY	28480	05232-6010	1
05243-0007	RETAINER:LATCH			1
05243-0008	RETAINER:FRONT PANEL	28480	05243-0008	1
05243-2013	PAWL	28480	05243-2013	1
05243-2014	SHAFT:LATCH	28480	05243-2014	1
05243-2015	KNOB	28480	05243-2015	1
05243-2018	HOUSING:PLUG-IN	28480	05243-2018	1
05243-6036	PANEL:PLUG-IN (LIGHT GRAY)	28480	05243-6036	1
05243-6042	PANEL:PLUG-IN (MINT GRAY)	28480	05243-6042	1
05245-2008	BOARD: BLANK PC	28480	05245-2008	1
05245-2014	BOARD:BLANK PC	28480	05245-2014	2
05245-2015	BOARD:BLANK PC	28480	05245-2015	1
05245-6013	ASSY: OSCILLATOR BOARD	28480	05245-6013	1
05245-6014	BOARD ASSY:INPUT AMPLIFIER	28480	05245-6014	2
05245-6015	BOARD ASSY:FUNCTION	28480	05245-6015	1
05245-6016	SWITCH ASSY:ATTENUATOR	28480	05245-6016	1
05245-4001	INSERT:MEASUREMENT UNITS READOUT	28480	05245-4001	
05245-4003	WINDOW:READOUT AMBER	28480	05245-4003	

= See list of abbreviations in introduction to this section

Table 4-2. Replaceable Parts (Cont'd)

Stock No.	Description #	Mfr.	Mfr. Part No.	TQ
05245-6018	MAIN CABLE AND SWITCH ASSY	28480	05245-6018	1
3150-0037	AIR FILTER ASSY	28480	3150-0037	1
5212A-63C	ASSY:DECADE DIVIDER	28480	5212A-65C	6
5212A-65C-1	BOARD:BLANK P.C.	28480	5212A-65C-1	6
5212L-83A	SUPPORT:READOUT	28480	5212A-83A	1
5212L-83B	READOUT:UNITS	28480	5212L-83B	1
5243A-12C	BRACKET:SWITCH	28480	5243A-12C	3
5243A-12E	SUPPORT:CAPACITOR	28480	5243A-12E	1
5243A-12F	BRACKET:CRYSTAL OVEN	28480	5243A-12F	1
5243A-20A	HOUSING:FAN	28480	5243A-20A	1
5243A-44A	KIT:5-1/4" RACK MOUNT	28480	5243A-44A	1
5243A-47C	SUPPORT:PANEL	28480	5243A-47C	1
5243A-55A	SHIELD:OSCILLATOR	28480	5243A-55A	1
5243A-65A-1	BOARD:BLANK P.C.	28480	5243A-65A-1	1
5243A-65C	ASSY:MULTIPLIER	28480	5243A-65C	1
5243A-65C-1	BOARD:BLANK P.C.	28480	5243A-65C-1	1
5243A-65H	ASSY:REGULATOR	28480	5243A-65H	1
5243A-65H-1	BOARD:BLANK P.C.	28480	5243A-65H-1	1
5243A-65J	ASSY:TIME-BASE CONTROL	28480	5243A-65J	1
5243A-65J-1	BOARD:BLANK P.C.	28480	5243A-65J-1	1
5243A-65L	ASSY:RECTIFIER	28480	5243A-65L	1
5243A-65L-1	BOARD:BLANK P.C.	28480	5243A-65L-1	1
5243A-65R	ASSY:GATE CONTROL	28480	5243A-65R	1
5243A-65R-1	BOARD:BLANK P.C.	28480	5243A-65R-1	1
5243A-65S	ASSY:SAMPLING CONTROL	28480	5243A-65S	1
5243A-65S-1	BOARD:BLANK P.C.	28480	5243A-65S-1	1
5243A-65T	ASSY:OVEN CONTROL	28480	5243A-65T	1
5243A-65T-1	BOARD:BLANK P.C.	28480	5243A-65T-1	1
5243A-69A	ASSY:CRYSTAL OVEN	28480	5243A-69A	1
5243A-69A-1	BOARD:BLANK P.C.	28480	5243A 69A 1	1
5243L-107A	BAR:READOUT	28480	5243L-107A	1
5243L-110A	GUIDE:BOARD FRONT	28480	5243L-110A	1
5243L-110B	GUIDE:BOARD REAR	28480	5243L-110B	1
5243L-12B	BRACKET:BOARD	28480	5243L-12B	1
5243L-17A	BUSHING:LATCH	28480	5243L-17A	1
5243L-41A	PLATE:CASTING	28480	5243L-41A	1
05245-0014	SHIELD:INPUT	28480	05245-0014	1
5243L-65A	ASSY:DECIMAL POINT	28480	5243L-65A	1
5243L-65B	ASSY:MEASUREMENT UNITS	28480	5243L-65B	1
5243L-65B-1	BOARD:BLANK P.C.	28480	5243L-65B-1	1
5243L-83A	HOLDER:DECIMAL	28480	5243L-83A	1
5243L-91A	SPRING:LATCH	28480	5243L-91A	1
5245A-65C	ASSY:DECIMAL COUNTER	28480	5245A-65C	1
5245A-65C-1	BOARD:BLANK P.C.	28480	5245A-65C-1	1

See list of abbreviations in introduction to this section

Table 4-2. Replaceable Parts (Cont'd)

Stock No.	Description #	Mfr.	Mfr. Part No.	TQ
5245L-19A	ASSY:OUTPUT SWITCH	28480	5245L-19A	1
5245L-19B	ASSY:MODE SWITCH	28480	5245L-19B	1
5245L-4B	ASSY:READOUT	28480	5245L-4B	1
05245-0015	SHIELD:AMPLIFIER	28480	05245-0015	1

= See list of abbreviations in Introduction to this section

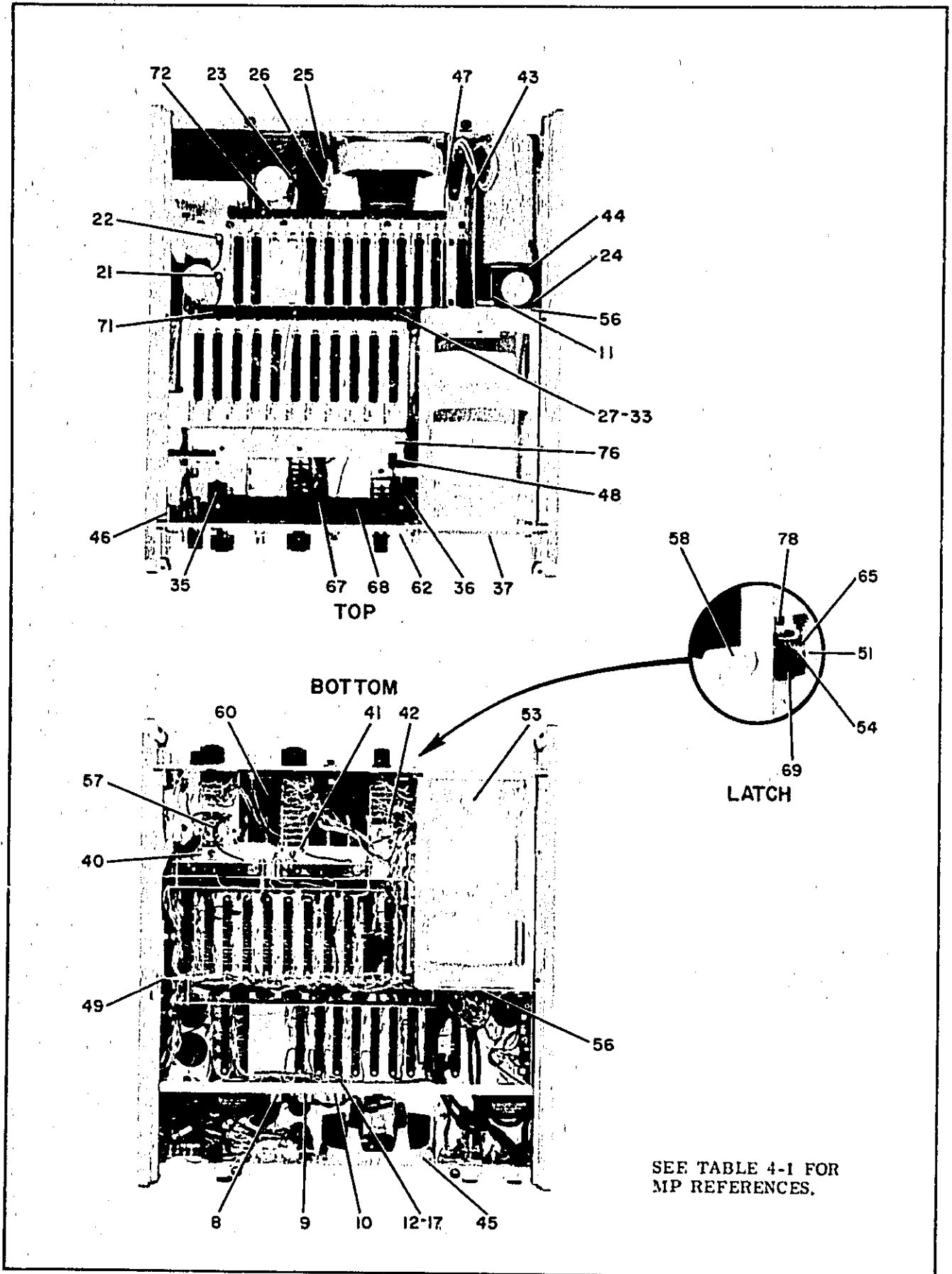

Figure 4-2. Mechanical Parts Locations

Table 4-3. Manufacturer's Code List

The following code numbers are from the Federal Supply Code for Manufacturers Cataloging Handbooks H4-1 (Name by Code) and H4-2 (Code to Name) and their latest supplements. The date of revision and the date of the supplements used appear at the bottom of each page. Alphabetical codes have been arbitrarily assigned to suppliers not appearing in the H4 Handbooks.

Code No.	Manufacturer	Address	Code No.	Manufacturer	Address	Code No.	Manufacturer	Address
00000	U. S. A. Common	Any supplier of U. S.	05347	Ultronix, Inc.	San Mateo, Cal	11236	CTS of Berne, Inc.	Berne, Ind
00136	McCoy Electronics	Mont Holly Springs, Pa.	05397	Union Carbide Corp, Elect		11237	Chicago Telephone of California, Inc.	So Pasadena, Cal.
00213	Sage Electronics Corp.	Rochester, N. Y.	05574	Viking Ind. Inc.	New York, N. Y.	11242	Day State Electronics Corp	Waltham, Mass
00287	Cemco, Inc.	Danielson, Conn	05593	Ionco Electro-Plastics Inc	Caroga Park, Cal	11317	Teledyne Inc., Microwave Div.	Palo Alto, Cal.
00334	Humidrol	Clifton, Calif.	05616	Cosmo Plastic (Electrical Spec. Co.)	Sunnyvale, Cal	11314	National Seal	Duway, Cal.
00348	Mictron, Co., Inc.	Valley Stream, N. Y.	05624	Barber Colman Co.	Cleveland, Ohio	11453	Preritation Connector Corp	Jamaica, N. Y.
00373	Garlock Inc.	Cherry Hill, N. J.	05728	Tiffen Optical Co.	Rosford, Ill.	11534	Duncan Electronics Inc	Costa Mesa, Cal.
00656	Aertron Corp.	New Bedford, Mass.	05720	Meiro-Tel Corp.	Bayside Heights, Long Island, N. Y.	11711	General Instrument Corp.	Semiconductor Division Products
00779	Amp. Inc.	Harrisburg, Pa.	05783	Stewart Engineering Co.	Westbury, N. Y.			
00781	Aircraft Radio Corp.	Bosnton, N. J.	05820	Wakefield Engineering Inc.	Santa Cruz, Cal.	11717	Imperial Electronic, Inc	Newark, N. J.
00809	Crown, Ltd.	Whitby, Ontario, Canada	06004	Wassink Co., Div. of Stewart	Wakfield, Mass.	11870	Melab, Inc.	Burns Park, Cal.
00815	Northern Engineering Laboratories, Inc.	Burlington, Wis	06090	Wayner Corp.	Bridgeport, Conn	12136	Philadelphia Handle Co	Camden, N. J.
00853	Sangamo Electric Co., Pickens Div.	Burlington, Wis Pickens, S. C.	06175	Haychem Corp.	Redwood City, Cal.	12361	Grove Mfg. Co., Inc.	Shady Grove, Pa.
00368	Goe Engineering Co.	City of Industry, Cal.	06402	Bausch and Lomb Optical Co.	Rochester, N. Y.	12574	Gulton Ind. Inc., Data System Div.	Albuquerque, N. M.
00891	Carl E. Holmes Corp.	Los Angeles, Cal.	06540	E. T. A. Products Co. of America	Chicago, Ill.	12607	Carostat Mfg. Co.	Dover, N. H.
00929	Microlab Inc.	Livingston, N. J.	06540	Amalgon Electronic Hardware Co., Inc.	New Rochelle, N. Y.	12725	Elmar Filter Corp.	W. Haven, Conn.
01002	General Electric Co., Capacitor Dept.	Hudson Falls, N. Y.	06555	Beede Electrical Instrument Co., Inc.	Penacook, N. H.	12859	Nippon Electric Co., Ltd	Tokyo, Japan
01009	Alden Products Co.	Brockton, Mass.	06555	General Devices Co., Inc.	Indianapolis, Ind.	12881	Melex Electronics Corp	Clark, N. J.
01121	Allen Bradley Co.	Milwaukee, Wis	06751	Components Inc., Ariz. Div.	Phoenix, Arizona	12930	Delta Semiconductor Inc	Newport Beach, Cal.
01254	Litton Industries, Inc.	Beverly Hills, Cal.	06812	Torrington Mfg. Co., West Div.	Van Nuys, Cal.	12954	Dickson Electronics Corp	Scottsdale, Arizona
01201	TRW Semiconductors, Inc.	Lawndale, Cal.	06860	Varian Assoc. Etric Div.	San Carlos, Cal.	13019	Airon Supply Co., Inc	Wichita, Kansas
01295	Texas Instruments, Inc., Transistor Products Div.	Dallas, Texas	07088	Kelvin Electric Co.	Van Nuys, Cal.	13061	Wilco Products	Detroit, Mich
01349	The Alliance Mfg. Co.	Alliance, Ohio	07126	Digistran Co.	Pasadena, Cal	13103	Thermolloy	Dallas, Texas
01530	Small Parts Inc.	Los Angeles, Cal.	07137	Transistor Electronics Corp.	Minneapolis, Minn.	13327	Soltron Desires Inc.	Tappan, N. Y.
01589	Parille Relays, Inc.	Van Nuys, Cal.	07138	Westinghouse Electric Corp., Electronic Tube Div.	Elmira, N. Y.	13396	Telefunken (GmbH)	Hanover, Germany
01670	Gudebrand Bros. Silk Co.	New York, N. Y.	07149	Filmohm Corp.	New York, N. Y.	14099	Sem-Tech	Kansas City, Kansas
01930	Amerock Corp.	Rockford, Ill.	07233	Cinch-Graphix Co.	City of Industry, Cal.	14193	Calli Resistor Corp	Santa Monica, Cal.
01960	Pulse Engineering Co.	Santa Clara, Cal.	07256	Silicon Transistor Corp.	Carle Place, N. Y.	14298	American Components, Inc	Conshohocken, Pa.
02114	Ferzuarube Corp. of America	Saugerties, N. Y.	07261	Avnet Corp.	Culver City, Cal	14433	ITT Semiconductor, a Div. of Int. Telephone and Telegraph Corporation	West Palm Beach, Fla
02116	Whitlock Signals, Inc.	Long Branch, N. J.	07263	Fairchild Camera & Inst. Corp., Semiconductor Div.	Mountain View, Cal.	14403	Hewlett-Packard Company	Losland, Colo
02286	Cole Rubber and Plastics Inc.	Sunnyvale, Cal.	07322	Minnesota Rubber Co.	Minneapolis, Minn.	14655	Cornell Duhler Electric Corp	Newark, N. J.
02660	Amphenol-Dork Electronics Corp.	Broadview, Ill.	07387	Birther Corp, The	Monterey Park, Cal.	14674	Corning Glass Works	Corning, N. Y.
02735	Radio Corp. of America, Semiconductor and Materials Division	Somerville, N. J.	07397	Sylvania Elect. Prod. Inc., Mt. View Operations	Mountain View, Cal.	14752	Electro Cube Inc	San Gabriel, Cal.
02771	Vocaline Co. of America, Inc.	Old Saybrook, Conn.	07700	Technical Wire Products Inc.	Cranford, N. J.	14860	Williams Mfg. Co.	San Jose, Cal.
02777	Hopkins Engineering Co.	San Fernando, Cal.	07829	Bonnie Elect. Co.	Chicago, Ill.	15106	The Sphere Co., Inc.	Little Falls, N. J.
02675	Hudson Tool & Die	Newark, N. J.	07910	Continental Device Corp.	Northorne, Cal.	15203	Webster Electronics Co	New York, N. Y.
03296	Nylon Molding Corp.	Springfield, N. J.	07933	Raytheon Mfg. Co., Semiconductor Div.	Mountain View, Cal.	15287	Scionics Corp	Northridge, Cal.
03508	G. E. Semiconductor Prod. Dept.	Syracuse, N. Y.	07980	Hewlett-Packard Co., New Jersey Division	Rorkaway, N. J.	15291	Adjustable Bushing Co	N. Hollywood, Cal.
03705	Apex Machine & Tool Co.	Dayton, Ohio	08145	U. S. Engineering Co.	Los Angeles, Cal.	15558	Mirron Electronics Garden City, Long Island N. Y.	Long Island N. Y.
03797	Fakma Corp.	Compton, Calif.	08289	Blinn, Delbert Co.	Pomona, Cal	15566	Amprobe Inst. Corp	Lybrook, N. Y.
03818	Parker Seal Co.	Los Angeles, Cal.	08358	Burgess Battery Co.	Niagara Falls, Ontario, Canada	15631	Cabletronics	Costa Mesa, Cal.
03877	Transitron Electric Corp.	Wakfield, Mass.	08524	Deutch Fastener Corp.	Los Angeles, Cal.	15772	Twentieth Century Coil Spring Co	Santa Clara, Cal.
03888	Pyrofilm Resistor Co., Inc.	Cedar Knolls, N. J.	08664	Bristol Co., The	Waterbury, Conn	15801	Fensal Elect. Inc	Framingham, Mass
03954	Singer Co., Diehl Div., Finlerno Plant	Somerville, N. J.	08717	Sloan Company	Sun Valley, Cal.	15818	Americo Inc.	Mountain View, Cal.
04009	Arrows, Hart and Hlegman Elect. Co.	Hartford, Conn.	08718	ITT Cannon Electric Inc., Phoenix Div.	Phoenix, Arizona	16037	Spruce Pine Mica Co	Spruce Pine, N. C.
04013	Taruus Corp.	Lambertville, N. J.	08727	National Radio Lab Inc.	Paramus, N. J.	16179	Omni-Spectra Inc	Detroit, Ill
04062	Arco Electronic Inc.	Great Neck, N. Y.	08792	CBS Electronics Semiconductor Operations, Div. of CBS Inc.	Lowell, Mass.	16352	Computer Diode Corp	Loth, N. J.
04217	Easen Wire	Los Angeles, Cal.	08806	General Electric Co., Miniature Lamp Dept.	Cleveland, Ohio	16554	Electroid Co.	Union, N. J.
04222	Hi-Q Division of Aertron	Myrtle Beach, S. C.	08884	Mel-Hain	Indianapolis, Ind	16585	Boots Aircraft Nut Corp.	Pasadena, Cal.
04334	Precision Paper Tube Co.	Wheeling, Ill.	09026	Babcock Relays Div.	Costa Mesa, Cal.	16688	Ideal Free Meter Co., Inc.	
04404	Palo Alto Division of Hewlett-Packard Co.	Palo Alto, Cal.	09037	Electronic Enclosures Inc.	Los Angeles, Calif.		De Jur Meter Div.	Brooklyn, N. Y.
04651	Sylvania Electric Products, Microwave Device Div.	Mountain View, Cal.	09134	Texas Capacitor Co.	Houston, Texas	16758	Delco Radio Div. of G. M. Corp	Skokomo, Ind.
04673	Dakota Engr. Inc.	Culver City, Cal.	09145	Tech. Ind. Inc. Atohm Elect.	Burbank, Cal.	17109	Thermometrics Inc.	Canoga Park, Cal.
04713	Motrola Inc. Semiconductor Prod. Div.	Phoenix, Arizona	09250	Electro Assemblies, Inc.	Chicago, Ill.	17474	Tranes Company	Mountain View, Cal.
04732	Filterco, Inc. Western Div.	Culver City, Cal.	09353	C & K Components Inc.	Newton, Mass.	17675	Hawlin Metal Products Corp	Akron, Ohio
04773	Automatic Electric Co.	Northlake, Ill.	09569	Mallory Battery Co. of Canada, Ltd.	Toronto, Ontario, Canada	17745	Angstrom Prec. Inc.	So. Hollywood, Cal.
04796	Sequoia Wire Co.	Redwood City, Cal.	09795	Pennsylvania Fluorocarbon	Chilton Heights, Penn.	17756	Siliconix Inc.	Sunnyvale, Cal.
04811	Precision Coil Spring Co.	El Monte, Cal.	09822	Burdny Corp.	Norwalk, Conn.	17870	McGraw-Edison Co	Manchester, N. H.
04870	P. M. Motor Company	Westchester, Ill.	10214	General Transistor Western Corp.	Los Angeles, Cal.	18042	Power Design Parille Inc	Palo Alto, Cal.
04919	Component Mfg. Service Co.	W. Bridgewater, Mass.	10411	Ti-Tal, Inc.	Berkeley, Cal.	18063	Chexite Corp Semiconductor Div	Palo Alto, Cal.
05006	Twentieth Century Plastics, Inc.	Los Angeles, Cal.	10646	Carborundum Co.	Niagara Falls, N. Y.	18324	Signetics Corp	Sunnyvale, Cal.
05277	Westinghouse Electric Corp. Semiconductor Dept.	Youngwood, Pa.				1876	Ty-Car Mfg. Co., Inc.	Holliston, Mass.
						18406	TRW Elect. Comp Div	Des Plaines, Ill.
						18565	Chometrics	Plainville, Mass.
						18583	Cartis Instrument, Inc	Mt. Kisco, N. Y.
						18612	Vishay Instruments Inc	Milvorn, Pa.
						18873	E. I. DuPont and Co., Inc.	Wilmington, Del.
						18911	Duran Mfg. Co.	Milwaukee, Wis
						19315	The Bendix Corp., Navigation & Control Div.	Teterboro, N. J.
						19500	Thomas A. Edison Industries, Div. of McGraw-Edison	West Orange, N. J.
						19589	Concoa	Baldwin Park, Cal.

00015-49
Revised: May, 1970

From Handbook Supplements
H4-1 Dated January 1970

Table 4-3. Manufacturer's Code List (Cont'd)

Code No	Manufacturer	Address	Code No	Manufacturer	Address	Code No	Manufacturer	Address
19644	LRC Electronics	Horseheads, N. Y.	71482	C. P. Clark & Co.	Chicago, Ill.	78452	Thompson-Brumer & Co.	Chicago, Ill.
19701	Electra Mfg. Co.	Independence, Kansas	71590	Centralab Div. of Globe Union Inc.	Milwaukee, Wis.	78471	Taney Mfg. Co.	San Francisco, Cal.
20183	General Altronics Corp.	Philadelphia, Pa.	71616	Commercial Plaster Co.	Chicago, Ill.	78488	Stackpole Carbon Co.	St. Marys, Pa.
21226	Excubator, Inc.	Long Island City, N. Y.	71707	Carmish Wire Co., The	New York, N. Y.	78493	Standard Thomson Corp.	Waltham, Mass.
21355	Fabair Bearing Co., The	New Britain, Conn.	71709	Ohio Coal Co., Inc.	Providence, R. I.	78553	Timmerman Products, Inc.	Cleveland, Ohio
21520	Fanstrel Metallurgical Corp.	N. Chicago, Ill.	71744	Chicago Miniature Lan. Works	Chicago, Ill.	78790	Transformer Engineers	San Gabriel, Cal.
23020	General Heat Co.	Metuchen, N. J.	71785	Cinch Mfg. Co.	Chicago, Ill.	78947	Union Co.	Newtownville, Mass.
23042	Tesscon Corp.	Indianapolis, Ind.		Howard B. Jones Div.	Chicago, Ill.	79136	Waldes Kohlmor Inc.	Long Island City, N. Y.
23783	British Radio Electronics Ltd.	Washington, D.C.	71984	Dow Corning Corp.	Midland, Mich.	79142	Vesler Heat Inc.	Hartford, Conn.
24455	C. E. Lamp Division, Nela Park	Cleveland, Ohio	72136	Electro-Motive Mfg. Co., Inc.	Willmar, Minn.	79251	Wesco Mfg. Co.	Chicago, Ill.
24655	General Radio Co.	West Concord, Mass.	72619	Dialight Corp.	Brooklyn, N. Y.	79727	Continental-Wirt Electronics Corp.	Philadelphia, Pa.
24681	Memcor Inc., Comp. Div.	Huntington Ind.	72656	Indiana General Corp.	Kearsey, N. J.	79963	Zurlok Mfg. Corp.	New Rochelle, N. Y.
26365	Gries Reproductor Corp.	New Rochelle, N. Y.	72709	General Instrument Corp., Cap Division	Newark, N. J.	80031	Mepro Division of Seasons Clock Co.	Morrisstown, N. J.
26402	Robert File Co. of America, Inc.	Carlstadt, N. J.	72745	Drake Mfg. Co.	Harwood Heights, Ill.	80033	Presbide Corp.	Toledo, Ohio
26851	Compar Hollister Co.	Hollister, Cal.	72825	Hugh H. Eby Inc.	Philadelphia, Pa.	80120	Schultz Alloy Products Co.	Elizabeth, N. J.
26992	Hamilton Watch Co.	Lancaster, Pa.	72928	Guldeman Co.	Chicago, Ill.	80131	Electronic Industries Association	Standard tube or semi-conductor device, any manufacturer.
28480	Howlett-Parkard Co.	Palo Alto, Cal.	72992	Elastic Shop Nut Corp.	Union, N. J.	80207	Unimax Switch, Div. Mason Electronics Corp.	Wallingford, Conn.
28520	Beyman Mfg. Co.	Smithworth, N. J.	72984	Robert M. Hatley Co.	Los Angeles, Cal.	80223	United Transformer Corp.	New York, N. Y.
30817	Instrument Specialties Co., Inc.	Little Falls, N. J.	72982	Eric Technological Products, Inc.	Eric, Pa.	80248	Oxford Electric Corp.	Chicago, Ill.
33173	G. F. Berryville Tube Dept.	Leetzbom Inc., Chicago, Ill.	73061	Hanson Mfg. Co., Inc.	Princeton, Ind.	80294	Dowdux Inc.	Irvine, Cal.
35434	Stanwyck Coil Products, Ltd.	Hawkesbury, Ontario, Canada	73075	H. M. Harper Co.	Chicago, Ill.	80411	Arco Div. of Rohm & Haas Co.	Columbus, Ohio
36196	Cunningham, W. P. & Hill Ltd.	Toronto, Ontario, Canada	73138	Helipot Div. of Beckman Inst., Inc.	Fallerton, Cal.	80486	All Star Products Inc.	Delaware, Ohio
37042	P. R. Mallory & Co., Inc.	Indianapolis, Ind.	73293	Hutches Products Division of Hutches Aircraft Co.	Newport Beach, Cal.	80509	Avery Label Co.	Monrovia, Cal.
39543	Mechanical Industries Prod. Co.	Akron, Ohio	73445	Ampac Elect. Co.	Hicksville, L. I., N. Y.	80583	Hammarlund Co., Inc.	Mary Hill, N. C.
40920	Miniature Precision Bearings, Inc.	Keene, N. H.	73506	Bradley Semi-conductor Corp.	New Haven, Conn.	80613	Sivco, Arnold, Co., Inc.	Boston, Mass.
40931	Honeywell Inc.	Chicago, Ill.	73559	Cyring Electric, Inc.	Hartford, Conn.	80630	Dimeo Gray Co.	Duxton, Ohio
42190	Mater Co.	Chicago, Ill.	73586	Cyril F. Mfg. Co.	Trenton, N. J.	81020	International Inst. Inc.	Orange, Conn.
43990	C. A. Soregen Co.	Englewood, Colo.	73682	George N. Garrett Co.	Philadelphia, Pa.	81073	Grayhill Co.	Lafayette, Ill.
4555	Ohmite Mfg. Co.	Skokie, Ill.	73734	Fed. MSL Industries, Inc.	Philadelphia, Pa.	81095	Triad Transformer Corp.	Yonkers, Cal.
46384	Penn Eng. & Mfg. Corp.	Duylstown, Pa.	73743	Fischer Special Mfg. Co.	Chicago, Ill.	81312	Winchester Elec. Div. Union Ind. Inc.	Oakville, Conn.
47904	Polaroid Corp.	Cambridge, Mass.	73793	General Industries Co., The	Elyria, Ohio	81349	Military Specification	
48620	Precision Thermometer & Inst. Co.	Southampton, Pa.	73846	Gaslan Stamping & Tool Co.	Gooson, Ind.	81483	International Berthier Corp.	El Segundo, Cal.
49956	Microware & Power Tube Div.	Waltham, Mass.	73899	ITD Electronics Corp.	Brooklyn, N. Y.	81541	Airfax Electronics, Inc.	Cambridge, Maryland
52090	Douan Controller Co.	Westminster, Md.	73905	Jennings Radio Mfg. Corp.	San Jose, Cal.	81600	Barry Controls, Div. Barry Wright Corp.	Watertown, Mass.
52983	HP Co., Met. Fltr. Div.	Waltham, Mass.	73957	Grover-Pin Corp.	Ridgely, N. J.	82042	Carter Precision Electric Co.	Skokie, Ill.
54294	Shallcross Mfg. Co.	Selma, N. C.	74276	Sunaltic Inc.	Neptune, N. J.	82047	Sperli Faraday Inc., Copper Brass Electric Div.	Hoboken, N. J.
55026	Simpson Electric Co.	Chicago, Ill.	74455	J. H. Winsor, and Sons	Winchester, Mass.	82116	Electric Regulator Corp.	Norwalk, Conn.
55030	Sontose Corp.	Elmsford, N. Y.	74868	H. F. Products Division of Amphel-Herg Electronic Corp.	Chicago, Ill.	82142	Jellers Electronics Division of Speer Controls Co.	Du Bois, Pa.
55938	Raytheon Co. Commercial Apparatus & System Div.	So. Norwalk, Conn.	74970	E. F. Johnson Co.	Danbury, Conn.	82170	Fairchild Camera & Inst. Corp. Space & Defense Systems Div.	Paramus, N. J.
56137	Squabbin Fibre Co., Inc.	Tonawanda, N. Y.	75042	International Resistance Co.	Philadelphia, Pa.	82279	Magnac Industries, Inc.	Greensboro, Conn.
56289	Syracuse Electric Co.	North Adams, Mass.	75263	Keystone Carbon Co., Inc.	St. Marys, Pa.	82219	Sylvania Electric Prod., Inc. Electronic Tube Division	Emporium, Pa.
58474	Superior Elec. Co.	Oriskany, Conn.	75378	CTS Knagler, Inc.	Sandwich, Ill.	82376	Astron Corp.	East Newark, Harrison, N. J.
58485	Telex Corp.	Tulsa, Okla.	75382	Kulka Electric Corp.	Mt. Vernon, N. Y.	82389	Sulzbach, Inc.	Chicago, Ill.
59730	Thomas & Betts Co.	Elizabeth, N. J.	75818	Leas Electric Mfg. Co.	Chicago, Ill.	82647	Metals & Controls Inc., Spencer Products	Attleboro, Mass.
60741	Triplet Electrical Inst. Co.	Hullton, Ohio	75915	Littelfuse, Inc.	Des Plaines, Ill.	82768	Phillips-Advance Control Co.	Johnst. Ill.
61775	Union Switch and Signal Div. of Westinghouse Air Brake Co.	Pittsburgh, Pa.	76005	Lord Mfg. Co.	Eric, Pa.	82866	Research Products Corp.	Madison, Wis.
62119	Universal Electric Co.	Owosso, Mich.	76433	General Instrument Corp., Micromold Division	Newark, N. J.	82877	Rollon Mfg. Co., Inc.	Woodstock, N. Y.
63763	Ward-Leonard Electric Co.	Mt. Vernon, N. Y.	76487	James Millen Mfg. Co., Inc.	Malden, Mass.	82893	Verlor Electronic Co.	Glendale, Cal.
64959	Western Electric Co., Inc.	New York, N. Y.	76493	J. W. Miller Co.	Los Angeles, Cal.	83058	Carr Fastener Co.	Cambridge, Mass.
65092	Weston Inst. Co. Weston-Newark	Newark, N. J.	76530	Cinch-Monadnock, Div. of United Carr Fastener Corp.	San Francisco, Cal.	83086	New Hampshire Ball Bearing, Inc.	Peterborough, N. H.
66295	Withak Mfg. Co.	Chicago, Ill.	76545	Mueler Electric Co.	Cleveland, Ohio	83125	General Instrument Corp., Capacitor Div.	Darlington, S. C.
66746	Minnesota Mining & Mfg. Co. Battery Mincom Div.	St. Paul, Minn.	76703	National Union	Newark, N. J.	83148	ITT Wire and Cable Div.	Los Angeles, Cal.
70276	Allen Mfg. Co.	Hartford, Conn.	76854	Oak Manufacturing Co.	Crystal Lake, Ill.	83186	Victory Eng. Corp.	Springfield, N. J.
70399	Allied Control	New York, N. Y.	77088	The Bendix Corp. Electro-dynamics Div.	N. Hollywood, Cal.	83298	Bendix Corp., Rod Blank Div.	Rod Blank, N. J.
7038	Allmetal Screw Product Co., Inc.	Garden City, N. Y.	77075	Partite Metals Co.	San Francisco, Cal.	83315	Hubbell Corp.	Mundeville, Ill.
70477	Amplex, Div. of Chrysler Corp.	Detroit, Mich.	77221	Phoosran Instrument and Electronic Co.	So. Pasadena, Cal.	83324	Rosan Inc.	Newport Beach, Cal.
7048	Atlantic India Rubber Works, Inc.	Chicago, Ill.	77252	Philadelphia Steel and Wire Corp.	Philadelphia, Pa.	83330	Smith, Herman H., Inc.	Brooklyn, N. Y.
70562	Ampelite Co., Inc.	Union City, N. J.	77342	American Machine & Foundry Co. Potter & Bramfield Div.	Princeton, Ind.	83332	Tech Labs	Palmdale Park, N. J.
70674	ADC Products Inc.	Minneapolis, Minn.	77630	TRW Electronic Components Div.	Camden, N. J.	83365	Central Screw Co.	Chicago, Ill.
70903	Belden Mfg. Co.	Chicago, Ill.	77638	General Instrument Corp., Rectifier Division	Brooklyn, N. Y.	83501	Gavitt Wire and Cable Co., Div. of Amerrace Corp.	Drewfield, Mass.
70998	Hurd Electric Corp.	Cleveland, Ohio	77764	Resistance Products Co.	Harrisburg, Pa.	83584	Burrhoughs Corp., Electronic Tube Div.	Plainfield, N. J.
71002	Hirschbach Radio Co.	New York, N. Y.	77969	Robbervall Corp. of Calif.	Torrance, Cal.	83777	Model Eng. and Mfg., Inc.	Huntington, Ind.
71034	Hilley Electric Co., Inc.	Eric, Pa.	78189	Shakproof Division of Illinois Tool Works	Elgin, Ill.	83821	Loyal Scruggs Co.	Festus, Mo.
71041	Hoston Gear Works Div. of Murray Co. of Texas	Quincey, Mass.	78277	Sigma	So. Braintree, Mass.	83942	Aeronastrical Inst. & Radio Co.	Los Angeles, N. Y.
71218	Ind. Radio, Inc.	Willoughby, Ohio	78283	Signal Indicator Corp.	New York, N. Y.	84171	Arcis Electronics Inc.	Great Neck, N. J.
71279	Cambridge Thermionics Corp.	Cambridge, Mass.	78290	Strubers-Dunn Inc.	Pitman, N. J.	84396	A. J. Glenewer Co., Inc.	San Francisco, Cal.
71286	Camloc Fastener Corp.	Paramus, N. J.				84411	TRW Capacitor Div.	Ogallala, Neb.
71313	Carroll Condenser Corp.	Lindenhurst, L. I., N. Y.						
71400	Busmann Mfg. Div. of McGraw-Edison Co.	St. Louis, Mo.						
71436	Chicago Condenser Corp.	Chicago, Ill.						
71447	Calif. Spring Co., Inc.	Pico-Rivera, Cal.						
71450	CTS Corp.	Elkhart, Ind.						
71468	ITT Cannon Electric Inc.	Los Angeles, Cal.						
71471	Cinema, Div. Aerovox Corp.	Durbank, Cal.						

00015-49
Revised: May, 1970

From Handbook Supplements
H-1 Dated January 1970

Table 4-3. Manufacturer's Code List (Cont'd)

Code No.	Manufacturer	Address	Code No.	Manufacturer	Address	Code No.	Manufacturer	Address
94870	Sarkis Tarzian, Inc.	Bloomington, Ind.	91929	Honeywell Inc., Micro Switch Division	Freeport, Ill.	96095	Hi-Q Div. of Arrows Corp.	Olean, N.Y.
95454	Bentley Molding Company	Bentley, N.J.	91961	Nalco-Bros. Spring Co.	Oakland, Cal.	96256	Thordarson-Meisner Inc.	Mt. Carmel, Ill.
95471	A. B. Boyd Co.	San Francisco, Cal.	92180	Tru-Connector Corp.	Prabody, Mass.	96296	Solar Mfg. Co.	Los Angeles, Cal.
95474	R. M. Bracamonte & Co.	San Francisco, Cal.	92367	Elge Optical Co., Inc.	Rochester, N.Y.	96396	Microwatch, Div. of	Freeport, Ill.
95660	Knitted Goods, Inc.	Hamden, Conn.	92407	Tensolite Insulated Wire Co., Inc.	Tarrytown, N.Y.	96330	Carlton Screw Co.	Chicago, Ill.
95911	Seamless Rubber Co.	Chicago, Ill.	92702	IMC Magnetics Corp.	Westbury, L.I., N.Y.	96341	Microwave Associates, Inc.	Burlington, Mass.
96174	Falmir Bearing Co.	Los Angeles, Calif.	92966	Hudson Lamp Co.	Kearney, N.J.	96501	Excel Transformer Co.	Oakland, Cal.
96197	Clifton Precision Products Co., Inc.	Clifton Heights, Pa.	93332	Sylvania Electric Prod. Inc., Semiconductor Div.	Woburn, Mass.	96506	Xcelite, Inc.	Orchard Park, N.Y.
96579	Precision Rubber Products Corp.	Dayton, Ohio	93380	Robbins & Myers Inc.	Palladas Park, N.J.	96733	San Fernando Eler. Mfg. Co.	San Fernando, Cal.
96684	Radio Corp. of America, Electronic Comp. & Devices Division	Harrison, N.J.	93410	Stemco Controls, Div. of Essex Wire Corp.	Mansfield, Ohio	96881	Thomson Ind. Inc.	Long Island, N.Y.
96928	Swastrom Mfg. Co.	Glendale, Cal.	93632	Waters Mfg. Co.	Culver City, Cal.	97464	Industrial Retaining Ring Co.	Irvine, N.J.
97034	Mareo Industries	Anaheim, Cal.	93929	G.V. Controls	Livingston, N.J.	97539	Automatic & Precision Mfg.	Englewood, N.J.
97216	Philco Corporation (Lansdale Division)	Lansdale, Pa.	94137	General Cable Corp.	Bayonne, N.J.	97979	Reon Resistor Corp.	Yonkers, N.Y.
97473	Western Fibrous Glass Products Co.	San Francisco, Cal.	94144	Raytheon Co., Comp. Div.	Quincy, Mass.	97983	Lifton Systems Inc., Adler-Wrestler Common Div.	New Rochelle, N.Y.
97664	Van Waters & Rogers Inc.	San Francisco, Cal.	94148	Scientific Electronics	Lowland, Colo.	98411	It-Tronics, Inc.	Jamaica, N.Y.
97930	Tower Mfg. Corp.	Providence, R.I.	94154	Wagner Elect. Corp., Tung-Sol Div.	Newark, N.J.	98159	Rubber Tech, Inc.	Gardena, Cal.
98140	Cutter-Hammer, Inc.	Lincoln, Ill.	94197	Curtiss-Wright Corp., Electronics Div.	East Patterson, N.J.	98220	Hewlett-Packard Co., Medical Elec. Div.	Pasadena, Cal.
98229	Gold-National Batteries, Inc.	St. Paul, Minn.	94222	South Chester Corp.	Chester, Pa.	98278	Microlite, Inc.	So. Pasadena, Cal.
98198	General Mills, Inc.	Duluth, N.Y.	94330	Wire Cloth Products, Inc.	Bellwood, Ill.	98291	Sealstro Corp.	Mamaroneck, N.Y.
98231	Granbar Electric Co.	Oakland, Cal.	94375	Automatic Metal Products Co.	Brooklyn, N.Y.	98376	Zero Mfg. Co.	Burbank, Cal.
98273	G.E. Distributing Corp.	Schenectady, N.Y.	94482	Worcester Pressed Aluminum Corp.	Worcester, Mass.	98410	Eir, Inc.	Cleveland, Ohio
98479	Security Co.	Detroit, Mich.	94896	Magnecraft Electric Co.	Chicago, Ill.	98731	General Mills Inc., Electronics Div.	Mneapolis, Minn.
99165	United Transformer Co.	Chicago, Ill.	95023	George A. Philbrick Researches, Inc.	Boston, Mass.	98734	Parent Division of Hewlett-Packard Co.	Palo Alto, Cal.
99030	United Saw Machinery Corp.	Beverly, Mass.	95146	Alco Elect. Mfg. Co.	Lawrence, Mass.	98821	North Hills Electronics, Inc.	Glen Cove, N.Y.
90179	E. S. Rubber Co., Consumer Ind. Plastics Prod. Div.	Passaic, N.J.	95238	Allris Prods. Corp.	Diana, Fla.	98978	International Electronic Research Corp.	Burbank, Cal.
90365	Belleville Speciality Tool Mfg. Inc.	Belleville, Ill.	95238	Continental Connector Corp.	Woodside, N.Y.	99109	Columbia Technical Corp.	New York, N.Y.
90763	United Carr Fastener Corp.	Chicago, Ill.	95273	Leffert Mfg. Co., Inc.	Long Island, N.Y.	99313	Variac Associates	Palo Alto, Cal.
90970	Bearing Engineering Co.	San Francisco, Cal.	95265	National Graf Co.	Beridan, Wyo.	99376	Altec Corp.	Worcester, Mass.
91146	H.T. Cannon Elect. Inc.	Salem, Mass.	95275	Vitramon, Inc.	Bridgeport, Conn.	99515	Marshall Ind., Capacitor Div.	Monrovia, Cal.
91260	Connor Spring Mfg. Co.	San Francisco, Cal.	95348	Gordos Corp.	Bloomfield, N.J.	99707	Control Switch Division, Controls Co. of Am. Inc.	El Segundo, Cal.
91345	Miller Dial & Nameplate Co.	El Monte, Cal.	95354	Method Mfg. Co.	Rolling Meadows, Ill.	99800	Debusan Electronics Corp.	East Aurora, N.Y.
91418	Radio Materials Co.	Chicago, Ill.	95586	Arnold Engineering Co.	Marango, Ill.	99848	Wilson Corporation	Indianapolis, Ind.
91506	Augat Inc.	Attleboro, Mass.	95712	Dage Electric Co., Inc.	Franklin, Ind.	99928	Drannon Corp.	Whippany, N.J.
91637	Dale Electronics, Inc.	Columbus, Ohio	95984	Simon Mfg. Co.	Wayne, Ill.	99934	Rimbrandt, Inc.	Boston, Mass.
91682	Elec. Corp.	Willow Grove, Pa.	95987	Werkhafer Co.	Chicago, Ill.	99942	Hollman Electronics Corp., Semiconductor Division	El Monte, Cal.
91673	Epiphone Inc.	New York, N.Y.	96467	Microwave Assoc. West, Inc.	Sunnyvale, Cal.	99957	Technology Instrument Corp. of California	Newbury Park, Cal.
91737	Greiner Mfg. Co., Inc.	Waverfield, Mass.						
91827	K.F. Development Co.	Redwood City, Cal.						
91866	Metro Mfg., Inc.	Chicago, Ill.						

The following HP Vendors have no number assigned in the latest supplement to the Federal Supply Code for Manufacturers Handbook

0000F	Metro Tool and Die	Los Angeles, Calif.	0000S	Hewlett-Packard Co., Colorado Springs Div.	Colorado Springs, Colorado	0000Q	Choltron	Oakland, Cal.
0000Z	Willow Leather Products Corp.	Newark, N.J.	000MM	Rubber Eng. & Development	Hayward, Cal.	0009W	California Eastern Lab.	Burlington, Cal.
000A11	ETA	England	000NN	A "N" D Mfg. Co.	San Jose, Cal.	000YY	S. K. Smith Co.	Los Angeles, Cal.
000D11	Precision Instrument Comp. Co.	Van Nuys, Cal.						

00015-49
Revised: May, 1970

From Handbook Supplements
H4-1 Dated January 1970

**BACK DATING
MANUAL
CHANGES**

SECTION V OPTIONS AND MANUAL CHANGES

5-1. OPTIONS.

5-2. The 5245L has two options available. They are Option 002, 4-line BCD 1248 "1" state positive and Option 003, 4-line BCD 1248 "1" state negative. These options change the BCD output code of the digits. The decimal point and measurement units BCD output code is 1224 "1" state positive.

5-3. OPTION 002 + 1248 BCD CODE.

5-4. Option 002 consists of changing the assemblies listed in Table 5-1. Circuit diagrams for the Option 002 assemblies are shown in Figures 7-10, 7-12, and 7-15.

Table 5-1. Option 002 Replacement Assemblies

Standard Assemblies	Option 002 Assemblies
A10-A15 DCA 05212-6016	A10-A14 DCA 05212-6002
A16 DCA 05232-6010	A15-A16 DCA 05232-6014
A18 Readout 5245L-4B	A18 Readout 05245-6001

5-5. OPTION 003 - 1248 BCD CODE.

5-6. Option 003 consists of changing the assemblies listed in Table 5-2. Circuit diagrams for the Option 003 assemblies are shown in Figures 7-10, 7-12, and 7-16.

Table 5-2. Option 003 Replacement Assemblies

Standard Assemblies	Option 003 Assemblies
A10-A15 DCA 05212-6016	A10-A14 DCA 05212-6003
A16 DCA 05232-6010	A15-A16 DCA 05232-6012
A18 Readout 5245L-4B	A18 Readout 05245-6003

5-7. The parts lists for the Option 002 and 003 assemblies are listed in Tables 5-4, 5-5, 5-6, and 5-7.

5-8. Figures 7-10 and 7-12 are used for both Option 002 + 1248 BCD output and Option 003 - 1248 BCD output. The boards are identical with one exception. The DCA's with "1" state positive BCD output have resistors marked with a double asterisk (**) connected to collectors as shown by - + - + - lines. The DCA's with "1" state negative BCD output have these resistors connected to opposite collectors as shown by - - - - - lines.

Table 5-3. 1-2-4-8 Code Truth Table

Digit	4-Line Code, 1-2-4-8			
	D = 8	C = 4	B = 2	A = 1
0	0	0	0	0
1	0	0	0	1
2	0	0	1	0
3	0	0	1	1
4	0	1	0	0
5	0	1	0	1
6	0	1	1	0
7	0	1	1	1
8	1	0	0	0
9	1	0	0	1

Option 002: Output Code: 0 = -8V, 1 = +18V
Option 003: Output Code: 1 = -8V, 0 = +18V

5-9. SPECIALS.

5-10. Decimal Point and Measurement Units assemblies with either "1" state positive or negative 1248 BCD output may be obtained by special order. Specification J35-5245L is a modified 5245L that provides a 1248 "1" state positive BCD code for all eight digits, decimal point assembly, and measurement units assembly. Specification J36-5245L is a modified 5245L that provides a 1248 "1" state negative BCD code for all eight digits, decimal point assembly, and measurement units assembly.

5-11. Circuit diagrams for these specials are shown in Figures 5-1 and 5-2. Parts lists for the specials are listed in Tables 5-8 and 5-9.

5-12. Remote control operation is also available by special order. Programming information is covered in the Model 5245L Operating Manual, Paragraphs 3-14 through 3-17, page 3-11. Circuit diagram showing additional wiring is shown in Figure 5-3.

5-13. MANUAL CHANGES.

5-14. CURRENT INSTRUMENTS.

5-15. This manual applies directly to standard Model 5245L Electronic Counter having serial prefix number 716- (refer to Paragraph 1-6).

5-16. OLDER INSTRUMENTS.

5-17. This manual applies directly to the 5245L Electronic Counters having serial prefix number 716-. This manual with the changes listed in Table 5-10 also applies to 5245L Electronic Counters having serial prefix numbers 648 and 628. For information covering 5245L Electronic Counters having serial prefix numbers 544 or below, refer to 5245L Operating and Service Manual serial prefixed 544.

Table 5-4 Reference Designation Index (A18 Option 002)

Reference Designation	Stock No.	Description #	Note
A18	05245-6001 05212-6014	50 MC +1248 READOUT ASSEMBLY READOUT BLOCK ASSY	
C1	0150-0093	CIFXD CER 0.01 UF +80-20% 100VDCW	
CR1	1901-0025	SEMICON DEVICE:DIODE JUNCTION	
CR2	1901-0025	SEMICON DEVICE:DIODE JUNCTION	
CR3	1901-0025	SEMICON DEVICE:DIODE JUNCTION	
CR4	1901-0025	SEMICON DEVICE:DIODE JUNCTION	
CR5	1901-0025	SEMICON DEVICE:DIODE JUNCTION	
CR6	1901-0025	SEMICON DEVICE:DIODE JUNCTION	
CR7	1901-0025	SEMICON DEVICE:DIODE JUNCTION	
CR8	1901-0025	SEMICON DEVICE:DIODE JUNCTION	
CR9	THRU		
CR10		NOT ASSIGNED	
CR11	1901-0025	SEMICON DEVICE:DIODE JUNCTION	
CR12	1901-0025	SEMICON DEVICE:DIODE JUNCTION	
CR13	1901-0025	SEMICON DEVICE:DIODE JUNCTION	
CR14	1901-0025	SEMICON DEVICE:DIODE JUNCTION	
CR15	1901-0025	SEMICON DEVICE:DIODE JUNCTION	
CR16	1901-0040	SEMICON DEVICE:DIODE SILICON	
CR17	1901-0040	SEMICON DEVICE:DIODE SILICON	
CR18	THRU		
CR23		NOT ASSIGNED	
CR24	1901-0025	SEMICON DEVICE:DIODE JUNCTION	
CR25	1902-0032	SEMICON DEVICE:DIODE SILICON JUNCTION	
DS1		NSR PART OF READOUT BLOCK ASSY	
DS2		NSR PART OF READOUT BLOCK ASSY	
DS3		NSR PART OF READOUT BLOCK ASSY	
DS4		NSR PART OF READOUT BLOCK ASSY	
DS5		NOT ASSIGNED	
DS6	1970-0009	ELECTRON TUBE INDICATOR 10 DIGIT	
Q1	1854-0003	TRANSISTOR NPN SILICON	
Q2	1854-0003	TRANSISTOR NPN SILICON	
Q3	1854-0003	TRANSISTOR NPN SILICON	
Q4	1854-0003	TRANSISTOR NPN SILICON	
Q5	1854-0003	TRANSISTOR NPN SILICON	
Q6	1854-0003	TRANSISTOR NPN SILICON	
Q7	1854-0003	TRANSISTOR NPN SILICON	
Q8	1854-0003	TRANSISTOR NPN SILICON	
Q9	1854-0003	TRANSISTOR NPN SILICON	
Q10	1854-0003	TRANSISTOR NPN SILICON	
Q11	1854-0003	TRANSISTOR NPN SILICON	
R1	0686-4735	RIFXD COMP 47K OHM 5% 1/2W	
R2		NSR PART OF READOUT BLOCK ASSY	
R3	THRU		
R5		NOT ASSIGNED	
R6	0683-3945	RIFXD COMP 390K OHM 5% 1/4W	
R7	0683-3945	RIFXD COMP 390K OHM 5% 1/4W	
R8	0683-3945	RIFXD COMP 390K OHM 5% 1/4W	

Table 5-4. Reference Designation Index (A18 Option 002) Cont'd

Reference Designation	Stock No.	Description #	Note
R9	0683-3945	RIFXD COMP 390K OHM 5% 1/4W	
R10	0683-5635	RIFXD COMP 56K OHM 5% 1/4W	
R11	0683-5635	RIFXD COMP 56K OHM 5% 1/4W	
R12	0683-5635	RIFXD COMP 56K OHM 5% 1/4W	
R13	0683-5635	RIFXD COMP 56K OHM 5% 1/4W	
R14	0683-5635	RIFXD COMP 56K OHM 5% 1/4W	
R15	0683-5635	RIFXD COMP 56K OHM 5% 1/4W	
R16	0683-5635	RIFXD COMP 56K OHM 5% 1/4W	
R17	0683-5635	RIFXD COMP 56K OHM 5% 1/4W	
R18	0683-2025	RIFXD COMP 2000 OHM 5% 1/4W	
R19	0683-7525	RIFXD COMP 7500 OHM 5% 1/4W	
R20	0683-1545	RIFXD COMP 150K OHM 5% 1/4W	
R21	0683-5135	RIFXD COMP 51K OHM 5% 1/4W	
R22	0683-6805	RIFXD COMP 68 OHM 5% 1/4W	
R23		NOT ASSIGNED	
R24	0683-7525	RIFXD COMP 7500 OHM 5% 1/4W	
R25		NOT ASSIGNED	
R26	0683-2025	RIFXD COMP 2000 OHM 5% 1/4W	
R27	0683-7525	RIFXD COMP 7500 OHM 5% 1/4W	
R28	0683-1545	RIFXD COMP 150K OHM 5% 1/4W	
R29	0683-5135	RIFXD COMP 51K OHM 5% 1/4W	
R30	0683-9105	RIFXD COMP 91 OHM 5% 1/4W	
R31		NOT ASSIGNED	
R32	0683-7525	RIFXD COMP 7500 OHM 5% 1/4W	
R33		NOT ASSIGNED	
R34	0683-2025	RIFXD COMP 2000 OHM 5% 1/4W	
R35	0683-7525	RIFXD COMP 7500 OHM 5% 1/4W	
R36	0683-1545	RIFXD COMP 150K OHM 5% 1/4W	
R37	0683-5135	RIFXD COMP 51K OHM 5% 1/4W	
R38	0683-9105	RIFXD COMP 91 OHM 5% 1/4W	
R39		NOT ASSIGNED	
R40	0683-7525	RIFXD COMP 7500 OHM 5% 1/4W	
R41		NOT ASSIGNED	
R42	0683-2025	RIFXD COMP 2000 OHM 5% 1/4W	
R43	0683-7525	RIFXD COMP 7500 OHM 5% 1/4W	
R44	0683-1545	RIFXD COMP 50K OHM 5% 1/4W	
R45	0683-5135	RIFXD COMP 1K OHM 5% 1/4W	
R46	0683-9105	RIFXD COMP 91 OHM 5% 1/4W	
R47		NOT ASSIGNED	
R48	0683-7525	RIFXD COMP 7500 OHM 5% 1/4W	
R49	THRU		
R50		NOT ASSIGNED	
R51	0683-4735	RIFXD COMP 47K OHM 5% 1/4W	
R52	0683-4735	RIFXD COMP 47K OHM 5% 1/4W	
R53	0683-4735	RIFXD COMP 47K OHM 5% 1/4W	
R54	0683-4735	RIFXD COMP 47K OHM 5% 1/4W	
R55	0683-4735	RIFXD COMP 47K OHM 5% 1/4W	
R56	0683-1245	RIFXD COMP 120K OHM 5% 1/4W	
R57	THRU		
R61		NOT ASSIGNED	
R62	0683-4735	RIFXD COMP 47K OHM 5% 1/4W	

Table 5-4. Reference Designation Index (A18 Option 002) Cont'd

Reference Designation	Stock No.	Description #	Note
R63		NOT ASSIGNED	
R64	0683-7525	RIFXD COMP 7500 OHM 5% 1/4W	
R65	0683-7525	RIFXD COMP 7500 OHM 5% 1/4W	
R66	0683-7545	RIFXD COMP 750K OHM 5% 1/4W	
R67	0683-7525	RIFXD COMP 7500 OHM 5% 1/4W	
R68	0683-1045	RIFXD COMP 100K OHM 5% 1/4W	
R69	0683-1045	RIFXD COMP 100K OHM 5% 1/4W	
R70	0683-1045	RIFXD COMP 100K OHM 5% 1/4W	
R71	0683-1535	RIFXD COMP 15K OHM 5% 1/4W	
R72	0683-2735	RIFXD COMP 27K OHM 5% 1/4W	
R73	0683-3335	RIFXD COMP 33K OHM 5% 1/4W	
R74	0683-2735	RIFXD COMP 27K OHM 5% 1/4W	
R75	0683-2735	RIFXD COMP 27K OHM 5% 1/4W	
R76	0683-2735	RIFXD COMP 27K OHM 5% 1/4W	
R77	0683-1835	RIFXD COMP 18K OHM 5% 1/4W	
V1		NSR PART OF READOUT BLOCK ASSY	

Table 5-5. Reference Designation Index (A18 Option 003)

Reference Designation	Stock No.	Description #	Note
A18	05245-6003 05212-6011	-1248 READOUT ASSY READOUT BLOCK ASSY	
C1 C2 C3	THRU 0150-0093	NOT ASSIGNED C:FXD CER 0.01 UF +80-20% 100VDCW	
CR1 CR2 CR3 CR4 CR5	1901-0025 1901-0025 1901-0025 1901-0025 1901-0025	DIODE JUNCTION:100 MA AT 1V 100PIV SEMICON DEVICE:DIODE JUNCTION SEMICON DEVICE:DIODE JUNCTION SEMICON DEVICE:DIODE JUNCTION SEMICON DEVICE:DIODE JUNCTION	
CR6 CR7 CR8 CR9 CR10 CR11	1901-0025 1901-0025 1901-0025 THRU 1901-0025	SEMICON DEVICE:DIODE JUNCTION SEMICON DEVICE:DIODE JUNCTION SEMICON DEVICE:DIODE JUNCTION NOT ASSIGNED SEMICON DEVICE:DIODE JUNCTION	
CR12 CR13 CR14 CR15 CR16	1901-0025 1901-0025 1901-0025 1901-0025 1901-0040	SEMICON DEVICE:DIODE JUNCTION SEMICON DEVICE:DIODE JUNCTION SEMICON DEVICE:DIODE JUNCTION SEMICON DEVICE:DIODE JUNCTION SEMICON DEVICE:DIODE SILICON	
CR17 CR18 CR19	1901-0040 1901-0025 1902-0032	SEMICON DEVICE:DIODE SILICON SEMICON DEVICE:DIODE JUNCTION SEMICON DEVICE:DIODE SILICON JUNCTION	
DS1 DS2 DS3 DS4 DS5		NSR:PART OF READOUT BLOCK ASSY NSR:PART OF READOUT BLOCK ASSY NSR:PART OF READOUT BLOCK ASSY NSR:PART OF READOUT BLOCK ASSY NOT ASSIGNED	
D56	1970-0079	ELECTRON TUBE INDICATOR 10 DIGIT	
Q1 Q2 Q3 Q4 Q5	1854-0003 1854-0003 1854-0003 1854-0003 1854-0003	TRANSISTOR NPN SILICON TRANSISTOR NPN SILICON TRANSISTOR NPN SILICON TRANSISTOR NPN SILICON TRANSISTOR NPN SILICON	
Q6 Q7 Q8 Q9 Q10	1854-0003 1854-0003 1854-0003 1854-0003 1854-0003	TRANSISTOR NPN SILICON TRANSISTOR NPN SILICON TRANSISTOR NPN SILICON TRANSISTOR NPN SILICON TRANSISTOR NPN SILICON	
Q11	1854-0003	TRANSISTOR NPN SILICON	
R1 R2 R3 R5 R6 R7 R8	0686-4735 THRU 0683-3945 0683-3945 0683-3945	R:FXD COMP 47K OHM 5% 1/2W NSR:PART OF READOUT BLOCK ASSY NOT ASSIGNED R:FXD COMP 390K OHM 5% 1/4W R:FXD COMP 390K OHM 5% 1/4W R:FXD COMP 390K OHM 5% 1/4W	

Table 5-5. Reference Designation Index (A18 Option 003) Cont'd

Reference Designation	Stock No.	Description #	Note
R9	0683-3945	RIFXD COMP 390K OHM 5% 1/4W	
R10	0683-5635	RIFXD COMP 56K OHM 5% 1/4W	
R11	0683-5635	RIFXD COMP 56K OHM 5% 1/4W	
R12	0683-5635	RIFXD COMP 56K OHM 5% 1/4W	
R13	0683-5635	RIFXD COMP 56K OHM 5% 1/4W	
R14	0683-5635	RIFXD COMP 56K OHM 5% 1/4W	
R15	0683-5635	RIFXD COMP 56K OHM 5% 1/4W	
R16	0683-5635	RIFXD COMP 56K OHM 5% 1/4W	
R17	0683-5635	RIFXD COMP 56K OHM 5% 1/4W	
R18	0683-2025	RIFXD COMP 2000 OHM 5% 1/4W	
R19	0683-7525	RIFXD COMP 7500 OHM 5% 1/4W	
R20	0683-1545	RIFXD COMP 150K OHM 5% 1/4W	
R21	0683-5135	RIFXD COMP 51K OHM 5% 1/4W	
R22	0683-6805	RIFXD COMP 68 OHM 5% 1/4W	
R23		NOT ASSIGNED	
R24	0683-7525	RIFXD COMP 7500 OHM 5% 1/4W	
R25		NOT ASSIGNED	
R26	0683-2025	RIFXD COMP 2000 OHM 5% 1/4W	
R27	0683-7525	RIFXD COMP 7500 OHM 5% 1/4W	
R28	0683-1545	RIFXD COMP 150K OHM 5% 1/4W	
R29	0683-5135	RIFXD COMP 51K OHM 5% 1/4W	
R30	0683-9105	RIFXD COMP 91 OHM 5% 1/4W	
R31		NOT ASSIGNED	
R32	0683-7525	RIFXD COMP 7500 OHM 5% 1/4W	
R33		NOT ASSIGNED	
R34	0683-2025	RIFXD COMP 2000 OHM 5% 1/4W	
R35	0683-7525	RIFXD COMP 7500 OHM 5% 1/4W	
R36	0683-1545	RIFXD COMP 150K OHM 5% 1/4W	
R37	0683-5135	RIFXD COMP 51K OHM 5% 1/4W	
R38	0683-9105	RIFXD COMP 91 OHM 5% 1/4W	
R39		NOT ASSIGNED	
R40	0683-7525	RIFXD COMP 7500 OHM 5% 1/4W	
R41		NOT ASSIGNED	
R42	0683-2025	RIFXD COMP 2000 OHM 5% 1/4W	
R43	0683-7525	RIFXD COMP 7500 OHM 5% 1/4W	
R44	0683-1545	RIFXD COMP 150K OHM 5% 1/4W	
R45	0683-5135	RIFXD COMP 51K OHM 5% 1/4W	
R46	0683-9105	RIFXD COMP 91 OHM 5% 1/4W	
R47		NOT ASSIGNED	
R48	0683-7525	RIFXD COMP 7500 OHM 5% 1/4W	
R49	THRU		
R50		NOT ASSIGNED	
R51	0683-4735	RIFXD COMP 47K OHM 5% 1/4W	
R52	0683-8235	RIFXD COMP 82K OHM 5% 1/4W	
R53	0683-8235	RIFXD COMP 82K OHM 5% 1/4W	
R54	0683-4735	RIFXD COMP 47K OHM 5% 1/4W	
R55	0683-2735	RIFXD COMP 27K OHM 5% 1/4W	
R56	0683-1245	RIFXD COMP 120K OHM 5% 1/4W	
R57	0683-2735	RIFXD COMP 27K OHM 5% 1/4W	
R58	0683-1035	RIFXD COMP 10K OHM 5% 1/4W	
R59	0683-1035	RIFXD COMP 10K OHM 5% 1/4W	

Table 5-5. Reference Designation Index (A18 Option 003) Cont'd

Reference Designation	Stock No.	Description #	Note
R60	0683-1245	RIFXD COMP 120K OHM 5% 1/4W	
R61	0683-1045	RIFXD COMP 100K OHM 5% 1/4W	
R62		NOT ASSIGNED	
R63	0683-1045	RIFXD COMP 100K OHM 5% 1/4W	
R64	0683-7525	RIFXD COMP 7500 OHM 5% 1/4W	
R65	0683-7525	RIFXD COMP 7500 OHM 5% 1/4W	
R66	0683-7545	RIFXD COMP 750K OHM 5% 1/4W	
R67	0683-7525	RIFXD COMP 7500 OHM 5% 1/4W	
R68	0683-1045	RIFXD COMP 100K OHM 5% 1/4W	
R69	0683-1045	RIFXD COMP 100K OHM 5% 1/4W	
R70	0683-1045	RIFXD COMP 100K OHM 5% 1/4W	
R71	0683-1535	RIFXD COMP 15K OHM 5% 1/4W	
VI		NSR PART OF READOUT BLOCK ASSY	

Table 5-6. Reference Designation Index (A15, A16 Options 002 & 003)

Reference Designation	Stock No.	Description #	Note
A15A16	05232-6014	ASSY:DECIMAL COUNTER(+1248)	
A15A16	05232-6012	ASSY:DECIMAL COUNTER(-1246)	
	05232-2012	BOARD:DECIMAL COUNTER BLANK	
	05212-6014	READOUT BLOCK ASSY	
C1	0140-0145	C:FXD MICA 22 PF 5% 500VDCW	
C2	0140-0145	C:FXD MICA 22 PF 5% 500VDCW	
C3	0160-0196	C:FXD MICA 24 PF 5% 500VDCW	
C4	0160-0196	C:FXD MICA 24 PF 5% 500VDCW	
C5	0160-2306	C:FXD MICA 27 PF 5%	
C6	0160-2306	C:FXD MICA 27 PF 5%	
C7	0160-0369	C:FXD MICA 17 PF 5%	
C8	0160-2306	C:FXD MICA 27 PF 5%	
C9	0160-2563	C:FXD CER 0.002 UF 20% 500VDCW	
C10	0160-0179	C:FXD MICA 33 PF 5% 300VDCW	
C11	0140-0145	C:FXD MICA 22 PF 5% 500VDCW	
C12	0160-2306	C:FXD MICA 27 PF 5%	
C13	0160-2563	C:FXD CER 0.002 UF 20% 500VDCW	
C14	0140-0190	C:FXD MICA 39 PF 5% 300VDCW	
C15	0140-0190	C:FXD MICA 39 PF 5% 300VDCW	
C16	0140-0191	C:FXD MICA 56 PF 5% 300VDCW	
C17	0160-0179	C:FXD MICA 33 PF 5% 300VDCW	
CR1	1901-0025	DIODE:SILICON 100V 100MA	
CR2	1901-0025	DIODE:SILICON 100V 100MA	
CR3	1901-0025	DIODE:SILICON 100V 100MA	
CR4	1901-0025	DIODE:SILICON 100V 100MA	
CR5	1901-0025	DIODE:SILICON 100V 100MA	
CR6	1901-0025	DIODE:SILICON 100V 100MA	
CR7	1901-0025	DIODE:SILICON 100V 100MA	
CR8	1901-0025	DIODE:SILICON 100V 100MA	
CR9	1901-0040	DIODE:SILICON	
CR10	1901-0040	DIODE:SILICON	
CR11	1901-0040	DIODE:SILICON	
CR12	1901-0040	DIODE:SILICON	
CR13	1901-0040	DIODE:SILICON	
CR14	1901-0040	DIODE:SILICON	
CR15	1901-0040	DIODE:SILICON	
CR16	1901-0040	DIODE:SILICON	
CR17	1901-0040	DIODE:SILICON	
CR18	1901-0040	DIODE:SILICON	
CR19	1901-0040	DIODE:SILICON	
CR20	1901-0040	DIODE:SILICON	
CR21	1901-0040	DIODE:SILICON	
CR22	1901-0040	DIODE:SILICON	
CR23	1901-0040	DIODE:SILICON	
DS1		NSR PART OF READOUT BLOCK ASSY	
DS2		NSR PART OF READOUT BLOCK ASSY	
DS3		NSR PART OF READOUT BLOCK ASSY	

See list of abbreviations in introduction to this section

Table 5-6. Reference Designation Index (A15, A16 Options 002 & 003) Cont'd

Reference Designation	Stock No.	Description #	Note
DS4 DS5 DS6	1970-0009	NSR PART OF READOUT BLOCK ASSY NOT ASSIGNED ELECTRON TUBE INDICATOR 10 DIGIT	
Q1 Q2 Q3 Q4 Q5	1853-0034 1853-0034 1853-0034 1853-0034 1853-0034	TRANSISTOR SILICON PNP TRANSISTOR SILICON PNP TRANSISTOR SILICON PNP TRANSISTOR SILICON PNP TRANSISTOR SILICON PNP	
Q6 Q7 Q8	1853-0034 1853-0034 1853-0034	TRANSISTOR SILICON PNP TRANSISTOR SILICON PNP TRANSISTOR SILICON PNP	
R1 R2 R3 R5 R6 R7	0686-4735 THRU 0683-3945 0683-3945	RIFXD COMP 47K OHM 5% 1/2W NSR PART OF READOUT BLOCK ASSY NOT ASSIGNED RIFXD COMP 390K OHM 5% 1/4W RIFXD COMP 390K OHM 5% 1/4W	
R8 R9 R10 R11 R12	0683-3945 0683-3945 0761-0005 0683-5635 0683-5635	RIFXD COMP 390K OHM 5% 1/4W RIFXD COMP 390K OHM 5% 1/4W RIFXD MET CX 220 OHM 5% 1W RIFXD COMP 56K OHM 5% 1/4W RIFXD COMP 56K OHM 5% 1/4W	
R13 R14 R15 R16 R17	0761-0010 0758-0004 0683-5635 0683-5635 0758-0004	RIFXD MET FLM 1800 OHM 5% 1W RIFXD MET FLM 2700 OHM 5% 1/2W RIFXD COMP 56K OHM 5% 1/4W RIFXD COMP 56K OHM 5% 1/4W RIFXD MET FLM 2700 OHM 5% 1/2W	
R18 R19 R20 R21 R22	0758-0045 0683-5635 0683-5635 0758-0045 0761-0005	RIFXD MET FLM 3.9K OHM 5% 1/2W RIFXD COMP 56K OHM 5% 1/4W RIFXD COMP 56K OHM 5% 1/4W RIFXD MET FLM 3.9K OHM 5% 1/2W RIFXD MET CX 220 OHM 5% 1W	
R23 R24 R25 R26 R27	0683-5635 0683-5635 0761-0010 0683-1635 0683-1635	RIFXD COMP 56K OHM 5% 1/4W RIFXD COMP 56K OHM 5% 1/4W RIFXD MET FLM 1800 OHM 5% 1W RIFXD COMP 16K OHM 5% 1/4W RIFXD COMP 16K OHM 5% 1/4W	
R28 R29 R30 R31 R32	0683-2035 0683-2035 0683-2735 0683-2735 0683-1635	RIFXD COMP 20K OHM 5% 1/4W RIFXD COMP 20K OHM 5% 1/4W RIFXD COMP 27K OHM 5% 1/4W RIFXD COMP 27K OHM 5% 1/4W RIFXD COMP 16K OHM 5% 1/4W	
R33 R34 R35 R36 R37	0683-1635 0683-1015 0683-3325 0683-2235 0683-5625	RIFXD COMP 16K OHM 5% 1/4W RIFXD COMP 100 OHM 5% 1/4W RIFXD COMP 3.3K OHM 5% 1/4W RIFXD COMP 22K OHM 5% 1/4W RIFXD COMP 5.6K OHM 5% 1/4W	
R38 R39 R40	0683-3025 0683-1045 0683-4705	RIFXD COMP 3K OHM 5% 1/4W RIFXD COMP 100K OHM 5% 1/4W RIFXD COMP 47 OHM 5% 1/4W	

= See list of abbreviations in introduction to this section

Table 5-6. Reference Designation Index (A15, A16 Options 002 & 003) Cont'd

Reference Designation	Stock No.	Description #	Note
R41	0683-1025	RIFXD COMP 1K OHM 5% 1/4W	
R42	0683-2235	RIFXD COMP 22K OHM 5% 1/4W	
R43	0683-3025	RIFXD COMP 3K OHM 5% 1/4W	
R44	0683-3925	RIFXD COMP 3.9K OHM 5% 1/4W	
R45	0683-1025	RIFXD COMP 1K OHM 5% 1/4W	
R46	0683-4705	RIFXD COMP 47 OHM 5% 1/4W	
R47	0683-3925	RIFXD COMP 3.9K OHM 5% 1/4W	
R48	0683-2235	RIFXD COMP 22K OHM 5% 1/4W	
R49	0683-1045	RIFXD COMP 100K OHM 5% 1/4W	
R50	0683-4715	RIFXD COMP 470 OHM 5% 1/4W	
R51	0683-2725	RIFXD COMP 2.7K OHM 5% 1/4W	
R52	0683-2235	RIFXD COMP 22K OHM 5% 1/4W	
R53	0683-1025	RIFXD COMP 1K OHM 5% 1/4W	
R54	0683-4705	RIFXD COMP 47 OHM 5% 1/4W	
R55	0683-5625	RIFXD COMP 5.6K OHM 5% 1/4W	
R56	0683-3625	RIFXD COMP 3.6K OHM 5% 1/4W	
R57	0683-4715	RIFXD COMP 470 OHM 5% 1/4W	
R58	0683-4715	RIFXD COMP 470 OHM 5% 1/4W	
R59	0683-3625	RIFXD COMP 3.6K OHM 5% 1/4W	
R60	0683-1045	RIFXD COMP 100K OHM 5% 1/4W	
R61	0683-9115	RIFXD COMP 910 OHM 5% 1/4W	
R62	0683-2735	RIFXD COMP 27K OHM 5% 1/4W	
R63	0683-1535	RIFXD COMP 15K OHM 5% 1/4W	
R64	0683-2735	RIFXD COMP 27K OHM 5% 1/4W	
R65	0683-8225	RIFXD COMP 8.2K OHM 5% 1/4W	
R66	0683-2715	RIFXD COMP 270 OHM 5% 1/4W	
R67	0683-2735	RIFXD COMP 27K OHM 5% 1/4W	
R68	0683-1045	RIFXD COMP 100K OHM 5% 1/4W	
V1		NSR PART OF READOUT BLOCK ASSY	

= See list of abbreviations in introduction to this section

Table 5-7. Reference Designation Index (A10-A14 Options 002 & 003)

Reference Designation	Stock No.	Description #	Note
A10-A14	05212-6002 05212-6003 05212-6014	+1248 DECIMAL COUNTER ASSY -1248 DECIMAL COUNTER ASSY READOUT BLOCK ASSEMBLY	
C1	0140-0194	C:FXD MICA 110 PF 5% 300 VDCW	
C2	0140-0217	C:FXD MICA 140PF 2% 300VDCW	
C3	0140-0194	C:FXD MICA 110 PF 5% 300 VDCW	
C4	0140-0197	C:FXD MICA 180 PF 5% 300 VDCW	
C5	0140-0194	C:FXD MICA 110 PF 5% 300 VDCW	
C6	0140-0194	C:FXD MICA 110 PF 5% 300 VDCW	
C7	0140-0196	C:FXD MICA 150 PF 5% 300 VDCW	
C8	0140-0194	C:FXD MICA 110 PF 5% 300 VDCW	
C9	0140-0194	C:FXD MICA 110 PF 5% 300 VDCW	
C10	0140-0196	C:FXD MICA 150 PF 5% 300 VDCW	
C11	0140-0198	C:FXD MICA 200PF 5% 300VDCW	
C12	0140-0198	C:FXD MICA 200PF 5% 300VDCW	
C13	0150-0121	C:FXD CER 0.1UF 50 VDCW	
CR1	1901-0025	SEMICON DEVICE:DIODE JUNCTION	
CR2	1901-0025	SEMICON DEVICE:DIODE JUNCTION	
CR3	1901-0025	SEMICON DEVICE:DIODE JUNCTION	
CR4	1901-0025	SEMICON DEVICE:DIODE JUNCTION	
CR5	1901-0025	SEMICON DEVICE:DIODE JUNCTION	
CR6	1901-0025	SEMICON DEVICE:DIODE JUNCTION	
CR7	1901-0025	SEMICON DEVICE:DIODE JUNCTION	
CR8	1901-0025	SEMICON DEVICE:DIODE JUNCTION	
CR9	1910-0016	SEMICON DEVICE:DIODE GERMANIUM	
CR10	1910-0016	SEMICON DEVICE:DIODE GERMANIUM	
CR11	1910-0016	SEMICON DEVICE:DIODE GERMANIUM	
CR12	1910-0016	SEMICON DEVICE:DIODE GERMANIUM	
CR13	1910-0016	SEMICON DEVICE:DIODE GERMANIUM	
CR14	1910-0016	SEMICON DEVICE:DIODE GERMANIUM	
DS1		NSR:PART OF READOUT BLOCK ASSY	
DS2		NSR:PART OF READOUT BLOCK ASSY	
DS3		NSR:PART OF READOUT BLOCK ASSY	
DS4		NSR:PART OF READOUT BLOCK ASSY	
DS5		NOT ASSIGNED	
DS6	1970-0009	ELECTRON TUBE INDICATOR 10 DIGIT	
L1	9140-0161	COIL:FXD 3600UH 5%	
Q1	5080-0060	TRANSISTOR GERMANIUM PNP SELECTED	
Q2	5080-0060	TRANSISTOR GERMANIUM PNP SELECTED	
Q3	5080-0060	TRANSISTOR GERMANIUM PNP SELECTED	
Q4	5080-0060	TRANSISTOR GERMANIUM PNP SELECTED	
Q5	5080-0060	TRANSISTOR GERMANIUM PNP SELECTED	
Q6	5080-0060	TRANSISTOR GERMANIUM PNP SELECTED	
Q7	5080-0060	TRANSISTOR GERMANIUM PNP SELECTED	
Q8	5080-0060	TRANSISTOR GERMANIUM PNP SELECTED	
R1	0686-4735	R:FXD COMP 47K OHM 5% 1/2W	
R2		NSR:PART OF READOUT BLOCK ASSY	

Table 5-7. Reference Designation Index (A10-A14 Options 002 & 003) Cont'd

Reference Designation	Stock No.	Description #	Note
R3			
R5			
R6	0683-3945	RIFXD COMP 390K OHM 5% 1/4W	
R7	0683-3945	RIFXD COMP 390K OHM 5% 1/4W	
R8	0683-3945	RIFXD COMP 390K OHM 5% 1/4W	
R9	0683-3945	RIFXD COMP 390K OHM 5% 1/4W	
R10	0683-5635	RIFXD COMP 56K OHM 5% 1/4W	
R11	0683-5635	RIFXD COMP 56K OHM 5% 1/4W	
R12	0683-5635	RIFXD COMP 56K OHM 5% 1/4W	
R13	0683-5635	RIFXD COMP 56K OHM 5% 1/4W	
R14	0683-5635	RIFXD COMP 56K OHM 5% 1/4W	
R15	0683-5635	RIFXD COMP 56K OHM 5% 1/4W	
R16	0683-5635	RIFXD COMP 56K OHM 5% 1/4W	
R17	0683-5635	RIFXD COMP 56K OHM 5% 1/4W	
R18	0686-7525	RIFXD COMP 7500 OHM 5% 1/2W	
R19	0683-4335	RIFXD COMP 43K OHM 5% 1/4W	
R20	0683-1035	RIFXD COMP 10K OHM 5% 1/4W	
R21	0683-4735	RIFXD COMP 47K OHM 5% 1/4W	
R22	0683-3925	RIFXD COMP 3900 OHM 5% 1/4W	
R23	0683-1815	RIFXD COMP 180 OHM 5% 1/4W	
R24	0683-1045	RIFXD COMP 100K OHM 5% 1/4W	
R25	0683-3925	RIFXD COMP 3900 OHM 5% 1/4W	
R26	0686-7525	RIFXD COMP 7500 OHM 5% 1/2W	
R27	0683-4335	RIFXD COMP 43K OHM 5% 1/4W	
R28	0683-1035	RIFXD COMP 10K OHM 5% 1/4W	
R29	0683-1035	RIFXD COMP 10K OHM 5% 1/4W	
R30	0686-7525	RIFXD COMP 7500 OHM 5% 1/2W	
R31	0683-4335	RIFXD COMP 43K OHM 5% 1/4W	
R32	0683-4735	RIFXD COMP 47K OHM 5% 1/4W	
R33	0683-3925	RIFXD COMP 3900 OHM 5% 1/4W	
R34	0683-1815	RIFXD COMP 180 OHM 5% 1/4W	
R35	0683-1045	RIFXD COMP 100K OHM 5% 1/4W	
R36	0683-3925	RIFXD COMP 3900 OHM 5% 1/4W	
R37	0686-7525	RIFXD COMP 7500 OHM 5% 1/2W	
R38	0683-4335	RIFXD COMP 43K OHM 5% 1/4W	
R39	0683-1035	RIFXD COMP 10K OHM 5% 1/4W	
R40	0683-1035	RIFXD COMP 10K OHM 5% 1/4W	
R41	0686-7525	RIFXD COMP 7500 OHM 5% 1/2W	
R42	0683-4335	RIFXD COMP 43K OHM 5% 1/4W	
R43	0683-4735	RIFXD COMP 47K OHM 5% 1/4W	
R44	0683-3925	RIFXD COMP 3900 OHM 5% 1/4W	
R45	0683-1815	RIFXD COMP 180 OHM 5% 1/4W	
R46	0683-1045	RIFXD COMP 100K OHM 5% 1/4W	
R47	0683-3925	RIFXD COMP 3900 OHM 5% 1/4W	
R48	0686-7525	RIFXD COMP 7500 OHM 5% 1/2W	
R49	0683-4335	RIFXD COMP 43K OHM 5% 1/4W	
R50	0683-1035	RIFXD COMP 10K OHM 5% 1/4W	
R51	0683-1035	RIFXD COMP 10K OHM 5% 1/4W	
R52	0686-7525	RIFXD COMP 7500 OHM 5% 1/2W	
R53	0683-4335	RIFXD COMP 43K OHM 5% 1/4W	
R54	0683-4735	RIFXD COMP 47K OHM 5% 1/4W	

Table 5-7. Reference Designation Index (A10-A14 Options 002 & 003) Cont'd

Reference Designation	Stock No.	Description #	Note
R55	0683-3925	RIFXD COMP 3900 OHM 5% 1/4W	
R56	0683-1815	RIFXD COMP 180 OHM 5% 1/4W	
R57	0683-1045	RIFXD COMP 100K OHM 5% 1/4W	
R58	0683-3925	RIFXD COMP 3900 OHM 5% 1/4W	
R59	0686-7525	RIFXD COMP 7500 OHM 5% 1/2W	
R60	0683-4335	RIFXD COMP 43K OHM 5% 1/4W	
R61	0683-1035	RIFXD COMP 10K OHM 5% 1/4W	
R62	0683-7525	RIFXD COMP 7500 OHM 5% 1/4W	
R63	0683-4725	RIFXD COMP 4700 OHM 5% 1/4W	
R64	0683-4335	RIFXD COMP 43K OHM 5% 1/4W	
VI		NSR:PART OF READOUT BLOCK ASSY	

Table 5-8. Reference Designation Index (J35-5245L)

Reference Designation	Stock No.	Description #	Note
A8	05245-91076	Assembly: decimal lights, with +1248 BCD output	
A8CR1 thru A8CR12	1901-0025	Semicon Device: diode junction, silicon	
A8DS1, A8DS2 A8DS3 thru A8DS9	2140-0028	Lamp: glow, 1/15W	
A8R1 A8R2		Not assigned	
A8R3	0683-1055	Not assigned	
A8R4	0683-0835	R: fxd, comp, 1 megohm 5%, 1/4W	
A8R5	0683-1055	R: fxd, comp, 68K ohms 5%, 1/4W	
		R: fxd, comp, 1 megohm 5%, 1/4W	
A8R6	0683-6835	R: fxd, comp, 68K ohms 5%, 1/4W	
A8R7	0683-1055	R: fxd, comp, 1 megohm 5%, 1/4W	
A8R8	0683-6835	R: fxd, comp, 68K ohms 5%, 1/4W	
A8R9	0683-1055	R: fxd, comp, 1 megohm 5%, 1/4W	
A8R10	0683-6835	R: fxd, comp, 68K ohms 5%, 1/4W	
A8R11	0683-1055	R: fxd, comp, 1 megohm 5%, 1/4W	
A8R12	0683-6835	R: fxd, comp, 68K ohms 5%, 1/4W	
A8R13	0683-1055	R: fxd, comp, 1 megohm 5%, 1/4W	
A8R14	0683-6835	R: fxd, comp, 68K ohms 5%, 1/4W	
A8R15	0683-1055	R: fxd, comp, 1 megohm 5%, 1/4W	
A8R16	0683-6835	R: fxd, comp, 68K ohms 5%, 1/4W	
A8R17	0683-1245	R: fxd, comp, 120K ohms 5%, 1/4W	
A8R18	0683-1245	R: fxd, comp, 120K ohms 5%, 1/4W	
A8R19	0683-1245	R: fxd, comp, 120K ohms 5%, 1/4W	
A8R20	0683-1245	R: fxd, comp, 120K ohms 5%, 1/4W	
A9	05245-91077	Assembly: measurement units, with +1248 BCD output	
A9C1	0150-0012	C: fxd, cer, 0.01 μ f 20%, 1000 vdcw	
A9CR1 thru A9CR10	1901-0025	Semicon Device: diode junction, silicon	
A9DS1 thru A9DS9		Not assigned	
A9DS10 thru A9DS15	2140-0015	Lamp: glow, neon, NE2E	
A9R1	0686-5135	R: fxd, comp, 51K ohms 5%, 1/2W	
A9R2	0683-1055	R: fxd, comp, 1 megohm 5%, 1/4W	
A9R3	0686-5135	R: fxd, comp, 51K ohms 5%, 1/2W	
A9R4	0683-1055	R: fxd, comp, 1 megohm 5%, 1/4W	
A9R5	0686-5135	R: fxd, comp, 51K ohms 5%, 1/2W	
A9R6	0683-1055	R: fxd, comp, 1 megohm 5%, 1/4W	
A9R7	0686-5135	R: fxd, comp, 51K ohms 5%, 1/2W	
A9R8	0683-1055	R: fxd, comp, 1 megohm 5%, 1/4W	
A9R9	0683-5135	R: fxd, comp, 51K ohms 5%, 1/4W	
A9R10	0683-1055	R: fxd, comp, 1 megohm 5%, 1/4W	
A9R11	0686-5135	R: fxd, comp, 51K ohms 5%, 1/2W	
A9R12	0683-1055	R: fxd, comp, 1 megohm 5%, 1/4W	
A9R13	0683-1245	R: fxd, comp, 120K ohms 5%, 1/4W	
A9R14	0683-1245	R: fxd, comp, 120K ohms 5%, 1/4W	
A9R15	0683-1245	R: fxd, comp, 120K ohms 5%, 1/4W	
A9R16	0683-1245	R: fxd, comp, 120K ohms 5%, 1/4W	

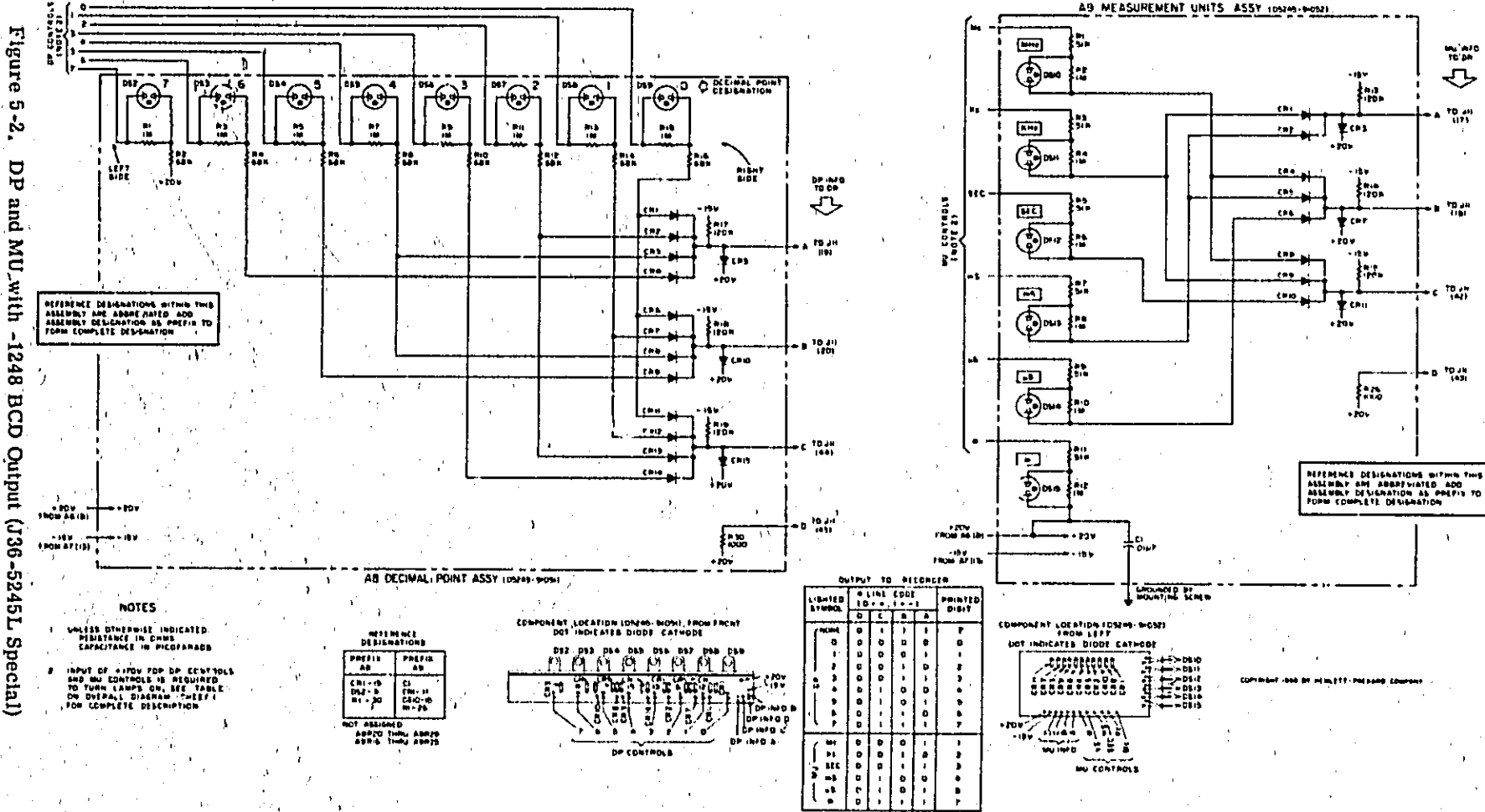

Figure 5-2. DP and MU with -1248 BCD Output (36-5245L Special)

Table 5-9. Reference Designation Index (J36-5245L)

Reference Designation	Stock No.	Description #	Note
A8	05245-91051	Assembly: decimal lights, with -1248 BCD output	
A8CR1 thru A8CR15	1901-0025	Semicon Device: diode junction, silicon	
A8DS1		Not assigned	
A8DS2	2140-0028	Lamp: glow, 1/15W	
A8R1	0683-1055	R: fxd, comp, 1 megohm 5%, 1/4W	
A8R2	0683-6835	R: fxd, comp, 68K ohms 5%, 1/4W	
A8R3	0683-1055	R: fxd, comp, 1 megohm 5%, 1/4W	
A8R4	0683-6835	R: fxd, comp, 68K ohms 5%, 1/4W	
A8R5	0683-1055	R: fxd, comp, 1 megohm 5%, 1/4W	
A8R6	0683-6835	R: fxd, comp, 68K ohms 5%, 1/4W	
A8R7	0683-1055	R: fxd, comp, 1 megohm 5%, 1/4W	
A8R8	0683-6835	R: fxd, comp, 68K ohms 5%, 1/4W	
A8R9	0683-1055	R: fxd, comp, 1 megohm 5%, 1/4W	
A8R10	0683-6835	R: fxd, comp, 68K ohms 5%, 1/4W	
A8R11	0683-1055	R: fxd, comp, 1 megohm 5%, 1/4W	
A8R12	0683-6835	R: fxd, comp, 68K ohms 5%, 1/4W	
A8R13	0683-1055	R: fxd, comp, 1 megohm 5%, 1/4W	
A8R14	0683-6835	R: fxd, comp, 68K ohms 5%, 1/4W	
A8R15	0683-1055	R: fxd, comp, 1 megohm 5%, 1/4W	
A8R16	0683-6835	R: fxd, comp, 68K ohms 5%, 1/4W	
A8R17	0683-1245	R: fxd, comp, 120K ohms 5%, 1/4W	
A8R18	0683-1245	R: fxd, comp, 120K ohms 5%, 1/4W	
A8R19	0683-1245	R: fxd, comp, 120K ohms 5%, 1/4W	
A8R20 thru A9R29		Not assigned	
A8R30	0683-1025	R: fxd, comp, 1000 ohms 5%, 1/4W	
A9	05245-91052	Assembly: measurement units, with -1248 BCD output	
A9C1	0150-0012	C: fxd, cer, 0.01 μ f 20%, 1000 vdcw	
A9CR1 thru A9CR11	1901-0025	Semicon Device: diode junction, silicon	
A9DS1 thru A9DS9		Not assigned	
A9DS10 thru A9DS15	2140-0015	Lamp: glow, neon, NE2E	
A9R1	0686-5135	R: fxd, comp, 51K ohms 5%, 1/2W	
A9R2	0683-1055	R: fxd, comp, 1 megohm 5%, 1/4W	
A9R3	0686-5135	R: fxd, comp, 51K ohms 5%, 1/2W	
A9R4	0683-1055	R: fxd, comp, 1 megohm 5%, 1/4W	
A9R5	0686-5135	R: fxd, comp, 51K ohms 5%, 1/2W	
A9R6	0683-1055	R: fxd, comp, 1 megohm 5%, 1/4W	
A9R7	0686-5135	R: fxd, comp, 51K ohms 5%, 1/2W	
A9R8	0683-1055	R: fxd, comp, 1 megohm 5%, 1/4W	
A9R9	0686-5135	R: fxd, comp, 51K ohms 5%, 1/2W	
A9R10	0683-1055	R: fxd, comp, 1 megohm 5%, 1/4W	
A9R11	0686-5135	R: fxd, comp, 51K ohms 5%, 1/2W	
A9R12	0683-1055	R: fxd, comp, 1 megohm 5%, 1/4W	
A9R13	0683-1245	R: fxd, comp, 120K ohms 5%, 1/4W	
A9R14	0683-1245	R: fxd, comp, 120K ohms 5%, 1/4W	
A9R15	0683-1245	R: fxd, comp, 120K ohms 5%, 1/4W	
A9R16 thru A9R25		Not assigned	
A9R26	0683-1025	R: fxd, comp, 1000 ohms 5%, 1/4W	

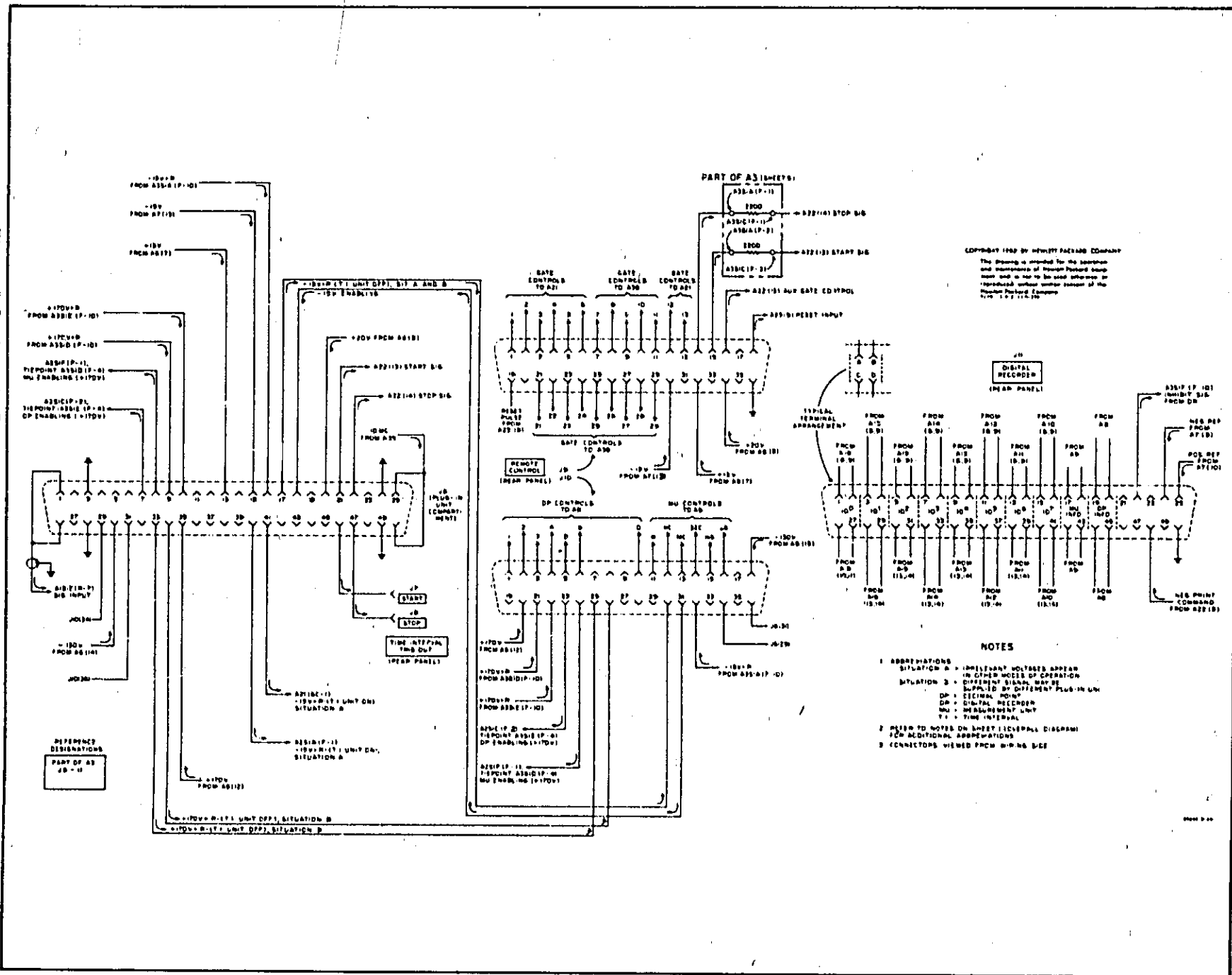

Figure 5-3. Remote Control Wiring and Connectors (Special)

Table 5-10. Manual Changes

Instrument Serial Prefix No.	Change No.
628-	1, 2, 3, 4, 5
648-	2, 3, 4, 5
716-	3, 4, 5
960-	4, 5
0980A	5

CHANGE 1

Figure 7-9, Replace Figure 7-9 A10-A15 (05212-6016) with Figure 7-27 A10-A14 (5212L-4A).

Table 4-1, Replace A10-A15 portion of Table 4-1 with Table 5-11 A10-A14. Change A15 to read A15 same as A16 prefix A15.

Figure 7-11, Change prefix designation from A16 to A15, A16.

Figure 7-12, Replace Figure 7-12 A15, A16 (05232-6014/6012) with Figure 7-28, A15, A16 (05232-6002/6003).

Table 5-6, Replace Table 5-6 (05232-6014/6012) with Table 5-12 (05232-6002/6003).

CHANGE 2

Figure 7-3, Renumber the contacts on A1S1A (FRONT) and A1S1B (FRONT) as follows:

Move contact 1 to 8

Move contact 2 to 1

Move contact 3 to 2

Move contact 4 to 3

Move contact 5 to 4

Move contact 6 to 5

Move contact 7 to 6

Move contact 8 to 7

The change is the same for both wafers.

Figure 7-4, Change contacts as indicated:

A2S1B (REAR)

Move contact 1 to 4-1/2

Move contact 2 to 2-1/2

Move contact 8 to 8-1/2

A2S1J (FRONT)

Move contact 3 to 4

A2S1I (REAR)

Move contact 2 to 1

Move contact 11 to 10

Move rotor 1 position cw

A2S1K (FRONT)

Move contact 9 to 12

Move contact 11 to 2

Move contact 12 to 3

Move rotor 90° cw

Table 4-1, Change A1S1 to HP Part No. 3100-1860.
Change A2S1 to HP Part No. 3100-0319.

CHANGE 3

Page 4-22, Table 4-1:

Change A25R6 to 0699-0013 6.8 OHM

Change A26C20 to 0150-0050 1000 PF

CHANGE 4

Page 4-18, Table 4-1:
Change A21R32 to 0683-3915 390 OHM
Change A21R30 to 0683-6215 620 OHM

Page 7-35, Figure 7-18, A21 Schematic:
Change A21R32 to 390
Change A21R30 to 620

CHANGE 5

Pages 4-31 and 4-33, Table 4-1:
Change J12 1251-2357 to 1251-0148
Change S4 3101-1272 to 3101-0034
Change W1 8120-1348 to 8120-0078
Change F1 2110-0303 to 2110-0006
Change F1 2110-0312 to 2110-0007

Page 4-40, Table 4-2:
Change 1251-2357 to 1251-0148

Page 4-41, 4-42, Table 4-2:
Change 3101-1272 to 3101-0034
Change 2110-0303 to 2110-0006

Page 7-13, Figure 7-7:
Use primary power supply schematic titled
"PRE-IEC PRIMARY SUPPLY"

Page 4-35, Figure 4-1:
Replace table of Modular Cabinet Parts with Table 5-13.

Page 4-34, Table 4-1, MISCELLANEOUS:
Delete from 05243-6036 description (LIGHT GRAY)
Delete 05243-6042 PANEL: PLUG-IN (MINT GRAY)

Page 4-42, Table 4-2:
Delete from 05243-6036 description (LIGHT GRAY)
Delete 05243-6042 PANEL: PLUG-IN (MINT GRAY);
28480; 05243-6042; TQ 1.

Page 4-33, Table 4-1:
Delete from W1 description (GRAY)
Delete W1 8120-1378 CABLE: POWER (JADE GRAY)

Table 5-11. Reference Designation Index (A10-A14 DCA +1224)

Reference Designation	Stock No.	Description #	Note
A10	5212L-4A 5212L-4A-1 05212-6011	ASSY:DECIMAL COUNTER BLANK BOARD:P.C. READOUT BLOCK ASSEMBLY	
A10C1	0140-0194	C:FXD MICA 110 PF 5% 300 VDCW	
A10C2	0140-0217	C:FXD MICA 140 PF 2% 300VDCW	
A10C3	0140-0194	C:FXD MICA 110 PF 5% 300 VDCW	
A10C4	0140-0195	C:FXD MICA 130 PF 5% 300 VDCW	
A10C5	0140-0194	C:FXD MICA 110 PF 5% 300 VDCW	
A10C6	0140-0194	C:FXD MICA 110 PF 5% 300 VDCW	
A10C7	0140-0195	C:FXD MICA 200PF 5% 300VDCW	
A10C8	0140-0194	C:FXD MICA 110 PF 5% 300 VDCW	
A10C9	0140-0194	C:FXD MICA 110 PF 5% 300 VDCW	
A10C10	0140-0195	C:FXD MICA 130 PF 5% 300 VDCW	
A10C11	0140-0195	C:FXD MICA 200PF 5% 300VDCW	
A10C12	0140-0195	C:FXD MICA 200PF 5% 300VDCW	
A10C13	0140-0199	C:FXD MICA 240PF 5% 300VDCW	
A10CR1	1901-0025	SEMICON DEVICE:DIODE JUNCTION	
A10CR1	1901-0025	DIODE JUNCTION:100 MA AT 1V 100PIV	
A10CR2	1901-0025	SEMICON DEVICE:DIODE JUNCTION	
A10CR2	1901-0025	DIODE JUNCTION:100 MA AT 1V 100PIV	
A10CR3	1901-0025	SEMICON DEVICE:DIODE JUNCTION	
A10CR3	1901-0025	DIODE JUNCTION:100 MA AT 1V 100PIV	
A10CR4	1901-0025	SEMICON DEVICE:DIODE JUNCTION	
A10CR4	1901-0025	DIODE JUNCTION:100 MA AT 1V 100PIV	
A10CR5	1901-0025	SEMICON DEVICE:DIODE JUNCTION	
A10CR5	1901-0025	DIODE JUNCTION:100 MA AT 1V 100PIV	
A10CR6	1901-0025	SEMICON DEVICE:DIODE JUNCTION	
A10CR6	1901-0025	DIODE JUNCTION:100 MA AT 1V 100PIV	
A10CR7	1901-0025	SEMICON DEVICE:DIODE JUNCTION	
A10CR7	1901-0025	DIODE JUNCTION:100 MA AT 1V 100PIV	
A10CR8	1901-0025	SEMICON DEVICE:DIODE JUNCTION	
A10CR8	1901-0025	DIODE JUNCTION:100 MA AT 1V 100PIV	
A10CR9	1910-0016	SEMICON DEVICE:DIODE GERMANIUM	
A10CR10	1910-0016	SEMICON DEVICE:DIODE GERMANIUM	
A10CR11	1910-0016	SEMICON DEVICE:DIODE GERMANIUM	
A10CR12	1910-0016	SEMICON DEVICE:DIODE GERMANIUM	
A10CR13	1910-0016	SEMICON DEVICE:DIODE GERMANIUM	
A10DS1		NSR:PART OF READOUT BLOCK ASSY	
A10DS2		NSR:PART OF READOUT BLOCK ASSY	
A10DS3		NSR:PART OF READOUT BLOCK ASSY	
A10DS4		NSR:PART OF READOUT BLOCK ASSY	
A10DS5		NCT ASSIGNED	
A10DS6	1970-0009	ELECTRON TUBE:INDICATOR 10 DIGIT	
A10Q1	1850-0062	TRANSISTOR:GERMANIUM	
A10Q2	1850-0062	TRANSISTOR:GERMANIUM	
A10Q3	1850-0062	TRANSISTOR:GERMANIUM	
A10Q4	1850-0062	TRANSISTOR:GERMANIUM	
A10Q5	1850-0062	TRANSISTOR:GERMANIUM	
A10Q6	1850-0062	TRANSISTOR:GERMANIUM	

= See list of abbreviations in introduction to this section

Section V
Table 5-11

Model 5245L

Table 5-11. Reference Designation Index (A10-A14 DCA +1224) Cont'd.

Reference Designation	Stock No.	Description #	Note
A10Q7	1850-0062	TRANSISTOR:GERMANIUM	
A10Q8	1850-0062	TRANSISTOR:GERMANIUM	
A10R1	0686-4735	RIFXD COMP 47K OHM 5% 1/2W	
A10R2		NSRIPART OF READOUT BLOCK ASSY	
A10R3			
A10R5			
A10R6			
A10R7	0683-3945	RIFXD COMP 390K OHMS 5% 1/4W	
	0683-3945	RIFXD COMP 390K OHMS 5% 1/4W	
A10R8	0683-3945	RIFXD COMP 390K OHMS 5% 1/4W	
A10R9	0683-3945	RIFXD COMP 390K OHMS 5% 1/4W	
A10R10	0683-5635	RIFXD COMP 56K OHMS 5% 1/4W	
A10R11	0683-5635	RIFXD COMP 56K OHMS 5% 1/4W	
A10R12	0683-5635	RIFXD COMP 56K OHMS 5% 1/4W	
A10R13	0683-5635	RIFXD COMP 56K OHMS 5% 1/4W	
A10R14	0683-5635	RIFXD COMP 56K OHMS 5% 1/4W	
A10R15	0683-5635	RIFXD COMP 56K OHMS 5% 1/4W	
A10R16	0683-5635	RIFXD COMP 56K OHMS 5% 1/4W	
A10R17	0683-5635	RIFXD COMP 56K OHMS 5% 1/4W	
A10R18	0686-7525	RIFXD COMP 7500 OHM 5% 1/2W	
A10R19	0683-4335	RIFXD COMP 43K OHM 5% 1/4W	
A10R20	0683-1035	RIFXD COMP 10K OHMS 5% 1/4W	
A10R21	0683-1045	RIFXD COMP 100K OHM 5% 1/4W	
A10R22	0683-4735	RIFXD COMP 47K OHMS 5% 1/4W	
A10R23	0683-3925	RIFXD COMP 3900 OHMS 5% 1/4W	
A10R24	0683-1815	RIFXD COMP 180 OHM 5% 1/4W	
A10R25	0683-3925	RIFXD COMP 3900 OHMS 5% 1/4W	
A10R26	0686-7525	RIFXD COMP 7500 OHM 5% 1/2W	
A10R27	0683-4335	RIFXD COMP 43K OHM 5% 1/4W	
A10R28	0683-1035	RIFXD COMP 10K OHMS 5% 1/4W	
A10R29	0686-7525	RIFXD COMP 7500 OHM 5% 1/2W	
A10R30	0683-4335	RIFXD COMP 43K OHM 5% 1/4W	
A10R31	0683-8225	RIFXD COMP 8200 OHMS 5% 1/4W	
A10R32	0683-1045	RIFXD COMP 100K OHM 5% 1/4W	
A10R33	0683-4735	RIFXD COMP 47K OHMS 5% 1/4W	
A10R34	0683-3925	RIFXD COMP 3900 OHMS 5% 1/4W	
A10R35	0683-1815	RIFXD COMP 180 OHM 5% 1/4W	
A10R36	0683-3925	RIFXD COMP 3900 OHMS 5% 1/4W	
A10R37	0686-7525	RIFXD COMP 7500 OHM 5% 1/2W	
A10R38	0683-4335	RIFXD COMP 43K OHM 5% 1/4W	
A10R39	0683-1035	RIFXD COMP 10K OHMS 5% 1/4W	
A10R40	0686-7525	RIFXD COMP 7500 OHM 5% 1/2W	
A10R41	0683-4335	RIFXD COMP 43K OHM 5% 1/4W	
A10R42	0683-1035	RIFXD COMP 10K OHMS 5% 1/4W	
A10R43	0683-1045	RIFXD COMP 100K OHM 5% 1/4W	
A10R44	0683-4735	RIFXD COMP 47K OHMS 5% 1/4W	
A10R45	0683-3925	RIFXD COMP 3900 OHMS 5% 1/4W	
A10R46	0683-1815	RIFXD COMP 180 OHM 5% 1/4W	
A10R47	0683-3925	RIFXD COMP 3900 OHMS 5% 1/4W	
A10R48	0686-7525	RIFXD COMP 7500 OHM 5% 1/2W	
A10R49	0683-4335	RIFXD COMP 43K OHM 5% 1/4W	

= See list of abbreviations in introduction to this section

Table 5-11. Reference Designation Index (A10-A14 DCA +1224) Cont'd.

Reference Designation	Stock No.	Description #	Note
A10R50	0663-8225	RIFXD COMP 8200 OHMS 5% 1/4W	
A10R51	0683-6835	RIFXD COMP 68K OHM 5% 1/4W	
A10R52	0666-7525	RIFXD COMP 7500 OHM 5% 1/2W	
A10R53	06E3-4335	RIFXD COMP 43K OHM 5% 1/4W	
A10R54	0663-1035	RIFXD COMP 10K OHMS 5% 1/4W	
A10R55	0663-1045	RIFXD COMP 100K OHM 5% 1/4W	
A10R56	0686 4735	RIFXD COMP 47K OHM 5% 1/2W	
A10R57	0663-3925	RIFXD COMP 3900 OHMS 5% 1/4W	
A10R58	0683-1815	RIFXD COMP 180 OHM 5% 1/4W	
A10R59	0683-3925	RIFXD COMP 3900 OHMS 5% 1/4W	
A10R60	0666-7525	RIFXD COMP 7500 OHM 5% 1/2W	
A10R61	0683-4335	RIFXD COMP 43K OHM 5% 1/4W	
A10R62	0663-1035	RIFXD COMP 10K OHMS 5% 1/4W	
A10V1		NSR:PART OF READOUT BLOCK ASSY	
A11		SAME AS A10; USE PREFIX A11	
A12		SAME AS A10; USE PREFIX A12	
A13		SAME AS A10; USE PREFIX A13	
A14		SAME AS A10; USE PREFIX A 14	

= See list of abbreviations in introduction to this section

Table 5-12. Reference Designation Index (A15, A16 Options 002 & 003)

Reference Designation	Stock No.	Description #	Note
A15-A16	05232-6002 05232-6003 05212-6014	ASSY:DECIMAL COUNTER +1248 ASSY:DECIMAL COUNTER -1248 READOUT BLOCK ASSY	
C1	0140-0203	C:FXD MICA 30PF 5% 500VDCW	
C2	0160-0178	C:FXD MICA 27PF 5% 300VDCW	
C3	0140-C191	C:FXD MICA 56 PF 5% 300 VDCW	
C4	0150-0023	C:FXD CER 2000 PF 20% 1000VDCW	
C5	0140-0203	C:FXD MICA 30PF 5% 500VDCW	
C6	0160-0179	C:FXD MICA 33PF 5% 300VDCW	
C7	0160-0178	C:FXD MICA 27PF 5% 300VDCW	
C8	0150-0023	C:FXD CER 2000 PF 20% 1000VDCW	
C9	0150-0196	C:FXD MICA 24PF 5% 300VDCW	
C10	0140-0145	C:FXD MICA 22 PF 5% 500 VDCW	
C11	0140-0214	C:FXD MICA 60PF 5% 300VDCW	
C12	0140-0214	C:FXD MICA 60PF 5% 300VDCW	
C13	0140-0204	C:FXD MICA 47PF 5% NPO 500VDCW	
C14	0140-0214	C:FXD MICA 60PF 5% 300VDCW	
C15	0140-0219	C:FXD MICA 180 PF 2% 300VDCW	
CR1	1901-0025	SEMICON DEVICE:DIODE JUNCTION	
CR2	1901-0025	SEMICON DEVICE:DIODE JUNCTION	
CR3	1901-0025	SEMICON DEVICE:DIODE JUNCTION	
CR4	1901-0025	SEMICON DEVICE:DIODE JUNCTION	
CR5	1901-0025	SEMICON DEVICE:DIODE JUNCTION	
CR6	1901-0025	SEMICON DEVICE:DIODE JUNCTION	
CR7	1901-0025	SEMICON DEVICE:DIODE JUNCTION	
CR8	1901-0025	SEMICON DEVICE:DIODE JUNCTION	
CR9	1901-0040	SEMICON DEVICE:DIODE SILICON	
CR10	1901-0040	SEMICON DEVICE:DIODE SILICON	
CR11	1901-0040	SEMICON DEVICE:DIODE SILICON	
CR12	1901-0040	SEMICON DEVICE:DIODE SILICON	
CR13	1901-0040	SEMICON DEVICE:DIODE SILICON	
CR14	1901-0040	SEMICON DEVICE:DIODE SILICON	
CR15	1901-0040	SEMICON DEVICE:DIODE SILICON	
CR16	1901-0040	SEMICON DEVICE:DIODE SILICON	
CR17	1901-0040	SEMICON DEVICE:DIODE SILICON	
CR18	1901-0040	SEMICON DEVICE:DIODE SILICON	
CR19	1901-0040	SEMICON DEVICE:DIODE SILICON	
CR20	1901-0040	SEMICON DEVICE:DIODE SILICON	
CR21	1901-0040	SEMICON DEVICE:DIODE SILICON	
CR22	1901-0040	SEMICON DEVICE:DIODE SILICON	
CR23	1901-0040	SEMICON DEVICE:DIODE SILICON	
CR24	1901-0040	SEMICON DEVICE:DIODE SILICON	
CR25	1901-0040	SEMICON DEVICE:DIODE SILICON	
CR26	1901-0040	SEMICON DEVICE:DIODE SILICON	
DS1		NSR PART OF READOUT BLOCK ASSY	
DS2		NSR PART OF READOUT BLOCK ASSY	
DS3		NSR PART OF READOUT BLOCK ASSY	
DS4		NSR PART OF READOUT BLOCK ASSY	
DS5		NOT ASSIGNED	

Table 5-12. Reference Designation Index (A15, A16 Options 002 & 003) Cont'd.

Reference Designation	Stock No.	Description #	Note
D56	1970-0009	ELECTRON TUBE INDICATOR 10 DIGIT	
Q1	1853-0009	TRANSISTOR SILICON PNP	
Q2	1853-0009	TRANSISTOR SILICON PNP	
Q3	1853-0009	TRANSISTOR SILICON PNP	
Q4	1853-0009	TRANSISTOR SILICON PNP	
Q5	1853-0009	TRANSISTOR SILICON PNP	
Q6	1853-0009	TRANSISTOR SILICON PNP	
Q7	1853-0009	TRANSISTOR SILICON PNP	
Q8	1853-0009	TRANSISTOR SILICON PNP	
R1	0686-4735	RIFXD COMP 47K OHM 5% 1/2W	
R2		NSR PART OF READOUT BLOCK ASSY	
R3			
R5		NOT ASSIGNED	
R6	0683-3945	RIFXD COMP 390K OHMS 5% 1/4W	
R7	0683-3945	RIFXD COMP 390K OHMS 5% 1/4W	
R8	0683-3945	RIFXD COMP 390K OHMS 5% 1/4W	
R9	0683-3945	RIFXD COMP 390K OHMS 5% 1/4W	
R10	0683-5635	RIFXD COMP 56K OHMS 5% 1/4W	
R11	0683-5635	RIFXD COMP 56K OHMS 5% 1/4W	
R12	0683-5635	RIFXD COMP 56K OHMS 5% 1/4W	
R13	0683-5635	RIFXD COMP 56K OHMS 5% 1/4W	
R14	0683-5635	RIFXD COMP 56K OHMS 5% 1/4W	
R15	0683-5635	RIFXD COMP 56K OHMS 5% 1/4W	
R16	0683-5635	RIFXD COMP 56K OHMS 5% 1/4W	
R17	0683-5635	RIFXD COMP 56K OHMS 5% 1/4W	
R18	0683-9115	RIFXD COMP 910 OHM 5% 1/4W	
R19	0758-0043	RIFXD MET FLM 1800 OHM 5% 1/2W	
R20	0683-1235	RIFXD COMP 12K OHM 5% 1/4W	
R21	0683-1825	RIFXD COMP 1800 OHMS 5% 1/4W	
R22	0683-1635	RIFXD COMP 16K OHMS 5% 1/4W	
R23	0683-1215	RIFXD COMP 120 OHM 5% 1/4W	
R24	0683-1045	RIFXD COMP 100K OHM 5% 1/4W	
R25	0758-0043	RIFXD MET FLM 1800 OHM 5% 1/2W	
R26	0683-1235	RIFXD COMP 12K OHM 5% 1/4W	
R27	0683-1825	RIFXD COMP 1800 OHMS 5% 1/4W	
R28	0683-4325	RIFXD COMP 4300 OHM 5% 1/4W	
R29	0758-0043	RIFXD MET FLM 1800 OHM 5% 1/2W	
R30	0683-1235	RIFXD COMP 12K OHM 5% 1/4W	
R31	0683-1825	RIFXD COMP 1800 OHMS 5% 1/4W	
R32	0683-1635	RIFXD COMP 16K OHMS 5% 1/4W	
R33	0683-1215	RIFXD COMP 120 OHM 5% 1/4W	
R34	0683-1045	RIFXD COMP 100K OHM 5% 1/4W	
R35	0758-0043	RIFXD MET FLM 1800 OHM 5% 1/2W	
R36	0683-1235	RIFXD COMP 12K OHM 5% 1/4W	
R37	0683-1825	RIFXD COMP 1800 OHMS 5% 1/4W	
R38	0683-1825	RIFXD COMP 1800 OHMS 5% 1/4W	
R39	0758-0043	RIFXD MET FLM 1800 OHM 5% 1/2W	
R40	0683-1235	RIFXD COMP 12K OHM 5% 1/4W	
R41	0683-1635	RIFXD COMP 16K OHMS 5% 1/4W	
R42	0683-1015	RIFXD COMP 100 OHM 5% 1/4W	

Table 5-12. Reference Designation Index (A15, A16 Options 002 & 003) Cont'd.

Reference Designation	Stock No.	Description #	Note
R43	0683-1045	RIFXD COMP 100K OHM 5% 1/4W	
R44	0758-0043	RIFXD MET FLM 1800 OHM 5% 1/2W	
R45	0683-1235	RIFXD COMP 12K OHM 5% 1/4W	
R46	0683-1825	RIFXD COMP 1800 OHMS 5% 1/4W	
R47	0683-1825	RIFXD COMP 1800 OHMS 5% 1/4W	
R48	0758-0043	RIFXD MET FLM 1800 OHM 5% 1/2W	
R49	0683-1235	RIFXD COMP 12K OHM 5% 1/4W	
R50	0683-1515	RIFXD COMP 150 OHM 5% 1/4W	
R51	0683-1335	RIFXD COMP 13K OHM 5% 1/4W	
R52	0683-1015	RIFXD COMP 100 OHM 5% 1/4W	
R53	0683-1045	RIFXD COMP 100K OHM 5% 1/4W	
R54	0683-1025	RIFXD COMP 1000 OHM 5% 1/4W	
R55	0758-0043	RIFXD MET FLM 1800 OHM 5% 1/2W	
R56	0683-1825	RIFXD COMP 1800 OHMS 5% 1/4W	
R57	0683-3325	RIFXD COMP 3300 OHM 5% 1/4W	
R58	0683-5125	RIFXD COMP 5100 OHM 5% 1/4W	
VI		NSR PART OF READOUT BLOCK ASSY	

Table 5-13. Modular Cabinet Parts

Item No.	Description	Part Number
1	Frame Assembly	5060-0732
2	Front Panel	05245-2017
3	Rear Panel	05245-0022
4	Cover: Rear Side, perforated	5000-0738
5	Cover: Front Side, perforated	5000-0739
6	Cover Assembly: Top	5243A-1C
7	Cover Assembly: Bottom	5243A-1B
8	Handle Assembly: Side	5060-0222
9	Handle Assembly: Retainer	5060-0766
10	Foot Assembly	5060-0767
11	Stand: Tilt	1490-0030
12	Plate: Fluted	5000-0051
13	Kit: Rack Mounting	5243A-44A

TROUBLE - SHOOTING

SECTION VI

ADJUSTMENT AND TROUBLESHOOTING

6-1. INTRODUCTION.

6-2. This section provides maintenance, adjustments, and troubleshooting information for the Model 5245L Electronic Counter.

6-3. MAINTENANCE.

6-4. **AIR FILTER.** Inspect the air filter (center of rear panel) regularly and clean it before it becomes dirty enough to restrict air flow. Proceed as follows:

- a. Remove top cover (unlock the two quarter turn fasteners and slide cover to the rear).
- b. Remove four screws holding filter in place.
- c. Wash filter in warm water and detergent.
- d. Allow filter to dry completely.

e. **DO NOT APPLY ANY COATING COMPOUND TO NON-METAL FILTERS.** Coat metal filters with light film of filter oil. We recommend No. 3 Filter Coat from Research Products Company. This adhesive is available in "Handi-Koter" sprayer cans at most heating supply stores or from your Hewlett-Packard Sales and Service Office.

6-5. **FUSE REPLACEMENT.** Table 6-1 lists fuse rating and HP Part No. for proper operation with either 115V or 230Vac.

Table 6-1. Fuse Replacement

Conversion	115 Volt	230 Volt
Slide switch	Left ("115")	Right ("230")
AC LINE FUSE	2 ampere slow-blow (HP2110-0303)	1 ampere slow-blow (HP2110-0312)

6-6. **FAN MOTOR.** Two drops of light machine oil should be applied to the fan motor shaft once a year.

6-7. TEST EQUIPMENT.

6-8. Recommended test equipment for adjustments and troubleshooting is listed in Table 6-2. Test instruments other than those listed may be used if their specifications are equal to or exceed the required characteristics.

6-9. ASSEMBLY CONNECTION IDENTIFICATION.

6-10. Throughout the manual, connections to printed circuit assemblies are referred to in abbreviated form. For example, the connection to pin 15 of assembly A6 is A6,15).

Table 6-2. Recommended Test Equipment

Instrument Type	Required Characteristics	Use	Instrument Recom.
Oscilloscope	50 MHz bandwidth, dual trace plug-in, ext sync capability	Observe waveforms during troubleshooting and adjustment. Performance Check.	HP Model 175A Oscilloscope HP Model 1750B Dual Trace Vertical Ampl HP AC-21C Voltage Divider Probe (two) HP 15003A 10:1 Probe
Test Oscillator	Continuously variable from 10 Hz to 50 MHz, 100 mV output	Performance Check Adjustments Troubleshooting	HP Model 204B Oscillator HP Model 606A Test Oscillator
Low Frequency Generator	Continuously variable from 2 Hz to 10 Hz, 100 mV output	Performance Check Troubleshooting	HP Model 202A Low Frequency Function Generator
Pulse Generator	1 μ sec wide, 1V negative, 1kHz repetition rate	Performance Check Troubleshooting	HP Model 212A Pulse Generator
DC Voltmeter	0V to \pm 170V, 10 megohm input impedance, 1% accuracy	Troubleshooting Adjustments	HP Model 412A
Digital to Analog Converter	1-2-2-4 BCD code	Performance Check Troubleshooting	HP Model 581A
Strip-Chart Recorder		Performance Check Troubleshooting	Moseley 680

6-11. INSTRUMENT COVER REMOVAL.

6-12. To remove top or bottom cover, unlock two quarter turn fasteners which secure cover to instrument. Then slide cover toward rear of instrument. To replace cover, reverse procedure.

WARNING

115/230 VAC AND DC SUPPLY WIRES ARE EXPOSED WHEN EITHER INSTRUMENT COVER IS REMOVED. EXERCISE CAUTION DURING TROUBLESHOOTING, ADJUSTMENT, OR REPAIR. REMOVE POWER FROM INSTRUMENT BEFORE REMOVING OR REPLACING COVERS OR ASSEMBLIES.

6-13. ASSEMBLY LOCATION.

6-14. Top and bottom internal views of the Counter are shown in Figures 6-5 and 6-6. These figures show the location of the assemblies, connectors, chassis parts and test points.

Table 6-3. Assembly Designations

A1	INPUT SWITCH ASSEMBLY (SENSITIVITY)
A2	TIME BASE SWITCH ASSEMBLY
A3	FUNCTION SWITCH ASSEMBLY
A4	MODE SWITCH ASSEMBLY
A5	OUTPUT SWITCH ASSEMBLY
A6	RECTIFIER ASSEMBLY
A7	REGULATOR ASSEMBLY
A8	DECIMAL POINT ASSEMBLY
A9	MEASUREMENT UNITS ASSEMBLY
A10- A14	LOW FREQUENCY DECIMAL COUNTER
A15- A16	MEDIUM FREQUENCY DECIMAL COUNTER
A17	HIGH FREQUENCY DECIMAL COUNTER
A18	HIGH FREQUENCY READOUT
A19- A20	INPUT AMPLIFIER ASSEMBLIES
A21	FUNCTION CONTROL ASSEMBLY
A22	GATE CONTROL ASSEMBLY
A23	SAMPLING CONTROL ASSEMBLY
A24	CRYSTAL OVEN ASSEMBLY
A25	OVEN CONTROL ASSEMBLY
A26	OSCILLATOR ASSEMBLY
A27	MULTIPLIER ASSEMBLY
A28	MEDIUM FREQUENCY DECADE DIVIDER
A29- A34	LOW FREQUENCY DECADE DIVIDERS
A35	TIME BASE CONTROL ASSEMBLY

6-15. PRINTED CIRCUIT COMPONENT REPLACEMENT.

6-16. Component lead holes in the Model 5245L circuit boards have plated walls to ensure good electrical contact between conductors on the opposite sides of the board. To prevent damage to this plating and to the replacement component, apply heat sparingly and work carefully. The following replacement procedure is recommended.

- a. Remove defective component.
- b. Melt solder in component lead holes. Use clean dry soldering iron to remove excess solder. Clean holes with toothpick or wooden splinter. Do not use metal tool for cleaning as this may damage through-hole plating.
- c. Bend lead of replacement component to the correct shape and insert component leads into component lead holes. Using heat and solder sparingly, solder leads in place. Heat may be applied to either side of board. A heat sink (longnose pliers, commercial heat-sink tweezers, etc) should be used when replacing transistors and diodes in order to prevent conduction of excessive heat from the soldering iron to the component.
- d. Through-hole plating breaks are indicated by the separation from the board of the round conductor pad on either side of the board. To repair breaks, press conductor pads against board and solder replacement component lead to conductor pad on both sides of the board.

6-17. ADJUSTMENTS.

6-18. REGULATOR ASSEMBLY A7.

CAUTION

When troubleshooting or adjusting the power supply, do not short supplies to ground or to each other. This will damage the diodes and transistors.

- a. Set line voltage to normal value (115 or 230 Vac).
- b. Connect dc voltmeter (Table 6-2) to buss wire between A16(11) and A18(6).
- c. Voltmeter should read +20 Vdc \pm 0.5 Vdc. If voltage is outside this range, adjust A7R17 (Figure 7-7).
- d. Vary line voltage from 103 to 127 Vac (207 to 255 Vac). The +20 Vdc supply should not vary more than 0.5 Vdc.
- e. Check all supply voltages at locations, and under conditions shown in Table 6-4.

Note

Input sensitivity levels must be rechecked if power supply voltages are readjusted.

Table 6-4. Power Supply Voltages

Test Point	Line Voltage			Adjustment
	103	115	127	
A6(15)	-117	-138	-149	None
A6(12)	+157	+179	+190	None
A7(13)	-15.0	-15.0	-15.0	R5
A7(4)	+13.0	+13.0	+13.0	R12
A16(11)	+20.0	+20.0	+20.0	R17
A7(8)	-0.83	-0.82	-0.81	*
A7(10)	+9.4	+9.5	+9.6	*

*Depends on adjustment of +20 Vdc and -15 Vdc above.

6-19. INPUT AMPLIFIER A19.

6-20. The following procedure sets the output level and checks the gain, frequency response, and sensitivity of the input amplifier.

- a. Turn counter on and set LEVEL to PRESET; SENSITIVITY to .1V.
- b. With no input connected, measure the output dc voltage at A19(6).
- c. Adjust dc voltage with A19R20 to +6.3V \pm .2V.
- d. Connect output of Test Oscillator to Counter DC INPUT connector with 50-ohm termination at Counter.
- e. Set Test Oscillator output to 50 kHz at 100 mV rms.
- f. Check output at A19(6) with Oscilloscope; output should be 1.5V p-p minimum.
- g. Increase output of Test Oscillator to 3V rms. The output at A19(6) is a symmetrically clipped waveform approximately 2V p-p.
- h. Set SENSITIVITY to .1V, TIME BASE to 10 ms, and FUNCTION to FREQUENCY.
- i. Set Test Oscillator output to 50 MHz at 100 mV rms.
- j. Adjust A19R20 until correct count appears. Reduce input signal amplitude and readjust A19R20 for maximum sensitivity.

6-21. RATIO INPUT AMPLIFIER A20.

6-22. Repeat steps a through g in Paragraph 6-20. Change A19(6) to A20(6).

- a. Set SIGNAL INPUT SENSITIVITY to 1V range, TIME BASE to EXT., and FUNCTION to 1 PERIOD AVERAGE. Set OUTPUT STANDARD FREQUENCY (rear panel) to 100 Hz. Connect a coaxial cable from OUTPUT STANDARD FREQUENCY (rear panel) to AC SIGNAL INPUT (front panel).

- b. Connect output of Test Oscillator 50 MHz at 100 mV to Counter EXT. TIME BASE through 50-ohm termination.

- c. Adjust A20R20 until correct count appears. Reduce input signal amplitude and readjust A20R20 for maximum sensitivity.

6-23. FUNCTION CONTROL A21.

- a. Set TIME BASE to .1 μ s and FUNCTION to 1 PERIOD AVERAGE.

- b. Set Test Oscillator to 1 MHz at 100 mV and connect to the Counter AC SIGNAL INPUT connector.

- c. Observe correct count on counter. Reduce the Test Oscillator output and adjust A21R31 for maximum sensitivity.

Note

Do not change the setting of the output level control A19R20.

6-24. OSCILLATOR FREQUENCY CHECK.**6-25. TIME-BASE OSCILLATOR FREQUENCY.**

6-26. GENERAL. The frequency accuracy of the oscillator may be determined by observing the rate of drift of the oscilloscope pattern (Figure 6-1). If the pattern moves to the right, counter oscillator frequency is lower than the standard frequency being used to trigger the oscilloscope. If the pattern moves to the left, oscillator frequency is high. The reciprocal of the time in seconds for the oscilloscope pattern to move the width of one cycle equals the frequency difference in parts in 10^6 with 1 MHz inputs (or parts in 10^5 with 100 kHz inputs). For example, if the oscilloscope pattern drifts to the left a rate of one cycle's width every 10 seconds with 1 MHz inputs, the oscillator frequency is 1 part in 10^7 high. If the pattern moves the width of one cycle in 100 seconds, frequency error is 1 part in 10^9 with 10 MHz inputs. If the pattern moves the width of one cycle in 10 seconds with a 10 MHz input, the frequency error is 1 part in 10^8 . Movement of the pattern may be accurately checked using an oscilloscope with calibrated sweeps by timing the movement of the point at which the oscilloscope trace crosses the base line when horizontal sweep is expanded and vertical gain is increased.

6-27. To check oscillator frequency, proceed as follows:

- a. Connect oscilloscope to OUTPUT STD FREQ BNC and set MODE switch to INT STD FREQ.
- b. Trigger oscilloscope externally with a 1 MHz signal from a standard frequency source.
- c. Set oscilloscope sweep time to .1 μ s/cm. Adjust oscilloscope controls to obtain a presentation of a 5V peak-to-peak nonsinusoidal waveform.
- d. Horizontal drift of oscilloscope display in cm/sec is difference between standard frequency and counter time-base frequency in parts in 10^7 .

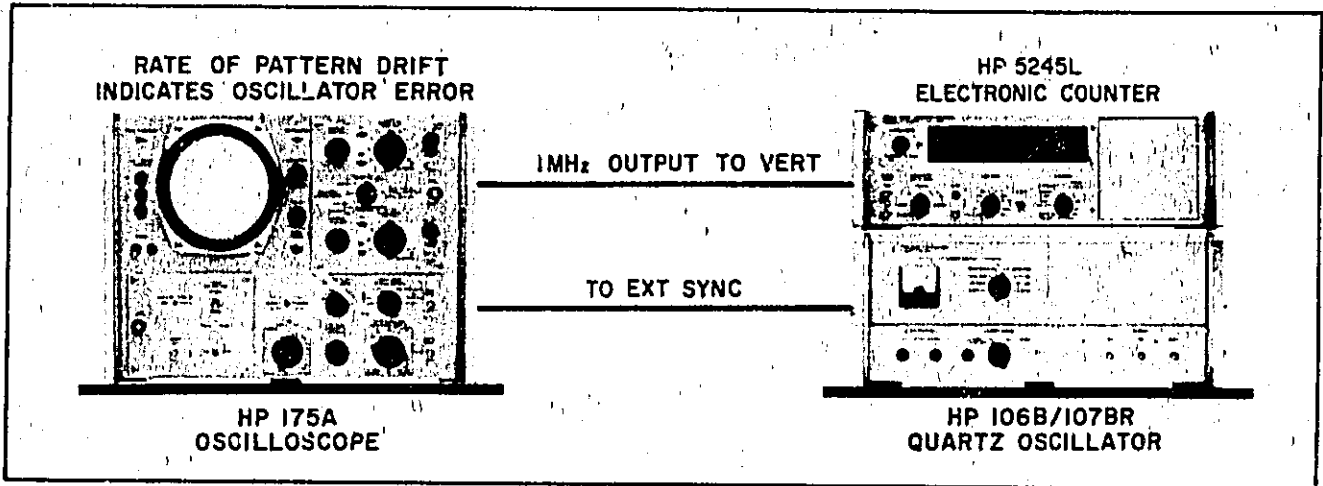

Figure 6-1. Test Setups for Checking Oscillator Frequency

e. Determine frequency difference in parts in 10^7 and record.

f. If frequency difference is excessive for the desired application of counter, see Paragraph 4-11 for time-base oscillator frequency adjustment procedure.

g. Note and record environmental temperature.

h. Repeat above steps a through g at daily intervals. Change in frequency difference between standard frequency and time-base oscillator frequency per day is frequency drift of time-base oscillator. Drift should not exceed ± 3 parts in 10^9 per day under reasonably constant environmental conditions (see Table 1-1).

6-28. OSCILLATOR CALIBRATION.

a. Connect 100 kHz output of Quartz Oscillator to EXT SYNC input on Oscilloscope.

b. Connect 1 MHz signal from OUTPUT STD FREQ BNC on rear panel of the 5245L to VERT INPUT on Oscilloscope.

c. Adjust COARSE FREQUENCY capacitor from rear panel until pattern on the oscilloscope stops drifting.

d. If necessary adjust MED or FINE FREQ ADJ (at rear of plug-in compartment) until average drift of oscilloscope pattern is zero.

6-29. TROUBLESHOOTING.

6-30. TROUBLESHOOTING AIDS.

6-31. OPERATING MANUAL. The Operating Manual provided with the HP 5245L provides general information about the instrument and its capabilities. Refer to the Operating Manual for specifications, installations, step-by-step operating procedures, and a quick operator's check of instrument operation.

6-32. PRINCIPLES OF OPERATION. Section II provides valuable information on how the instrument and its circuits function.

6-33. SCHEMATIC DIAGRAMS. Schematic diagrams and a block diagram are provided in Section VII.

6-34. COMPONENT LOCATION. Photographs are provided with the schematic diagrams to aid in locating components on switches or circuit boards.

6-35. TROUBLESHOOTING "TREE". A step-by-step troubleshooting procedure is provided on pages 6-11 through 6-14. This procedure is based on the self check feature of the instrument and makes maximum use of front panel controls and indicators.

6-36. SELF CHECK TABLES. Table 6-8 provides 33 unique combinations of Go-No-Go situations possible in the Self Check function. Circuit elements to be checked are indicated for each combination. Table 6-6 lists assemblies checked in Self Check functions.

6-37. TROUBLESHOOTING PROCEDURE.

6-38. MALFUNCTION AT TURN ON. If counter fails to turn on (no display, decimal point, or measurement units) make the following checks:

a. Line voltage switch set for power source.

b. Power cord plugged into counter and power source.

c. Line fuse good.

d. Ac power available at source.

e. Power supply (A6, A7, T2, L1, L2, C5).

6-39. MALFUNCTION DURING SELF CHECK. If counter malfunctions in some, but not all, check functions, see Table 6-8 for probable cause. If counter will not self-check for any function, see Troubleshooting "Tree", Table 6-7.

6-40. MALFUNCTION DURING OPERATION. If the counter will turn on, but malfunctions when operation is attempted, switch to Self Check for the function and time base desired. If counter will Self Check but will not function with an external signal, check setting of SENSITIVITY and LEVEL controls, input signal level, and connections to counter.

6-41. If counter will function in FREQUENCY mode but not in PERIOD (below 1 MHz) check control gate 5 (A21CR5, CR11). If counter will function in PERIOD but not in FREQUENCY, check control gate 2 (A21CR3, CR9). If counter malfunctions in both PERIOD and FREQUENCY, but self checks in both functions, check input attenuator and input amplifier.

6-42. If counter malfunctions when operation is attempted and fails to self-check in the function desired see Paragraph 6-39.

The photograph shows the front panel of a Model 5245L counter. Callout 2,3 points to the SENSITIVITY switch. Callout 5 points to the LEVEL control knob. Callout 4,6,7 points to the FUNCTION switch. Callout 5,8 points to the digital display area.

1. Turn SAMPLE RATE control clockwise from POWER OFF position to turn counter on.
2. Set SENSITIVITY switch to CHECK.
3. Set LEVEL control to PRESET.
4. Set FUNCTION switch to FREQUENCY.
5. See table below for proper display (± 1 count) for each position of TIME BASE switch.
6. Set FUNCTION switch to MANUAL START. Counter should count continuously at frequency selected on TIME BASE switch.
7. Set FUNCTION switch to 1 PERIOD AVERAGE.
8. See table below for proper display (± 1 count) for each PERIOD AVERAGE position of the FUNCTION switch.

TIME BASE	DISPLAY	PERIOD AVERAGE	DISPLAY
1 μ s	0000010. MHz	1	0000001
10 μ s	0000010.0 MHz	10	0000010
.1 ms	000010.00 MHz	100	00000100
1 ms	0001000. kHz	1K	00001000
10 ms	0010000.0 kHz	10K	00010000
.1 s	010000.00 kHz	100K	00100000
1 s	10000.000 kHz		
10 s	0000.0000 kHz		

Figure 6-2. Self Check

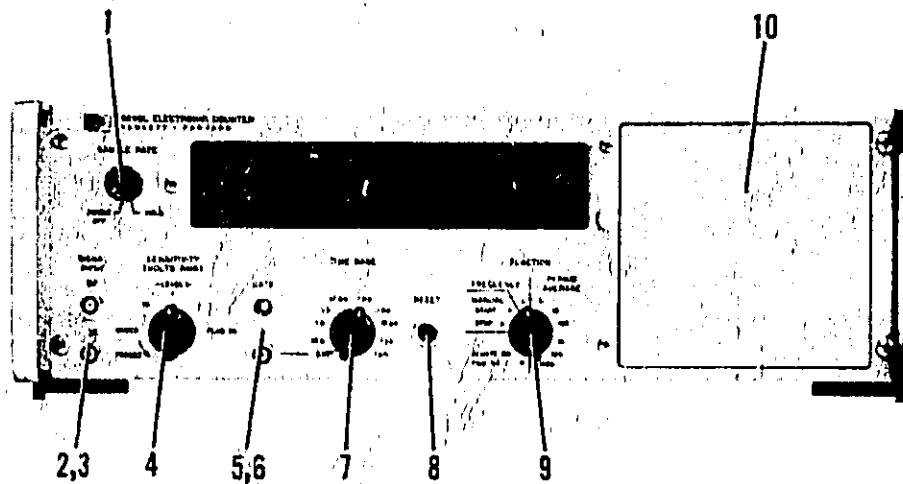

1. **SAMPLE RATE**
 - a. Controls power to all circuits except crystal oven heater; max ccw turns POWER OFF.
 - b. Controls time between measurements from 0.2 sec to 5 sec.
 - c. Causes display to HOLD indefinitely when maximum cw.
2. **DC SIGNAL INPUT** provides direct coupling to internal amplifier for most measurements.
3. **AC SIGNAL INPUT** provides coupling to internal amplifier through .022 μ f (600 vdc maximum).
4. **SIGNAL INPUT SENSITIVITY & LEVEL** control.
 - a. Controls input attenuator; set to highest position which includes signal amplitude (max overload; 50v in position 0.1, 150v in position 1; 500v in position 10).
 - b. Maximum CCW (CHECK position) gives internal self check; counts 10 MHz with selected TIME-BASE gate for FREQUENCY; 100 kHz for number of periods averaged (10 μ sec to 1 sec) for PERIOD AVERAGE, or continuously at selected TIME BASE frequency (0.1 Hz to 10 MHz) for MANUAL START.
 - c. Maximum CW (PLUG-IN position) connects output of plug-in unit directly to input amplifier.
 - d. The LEVEL control adjusts the input trigger level from -0.3V dc to +0.3V dc when attenuator is set at 0.1V rms, from -3.0V dc to +3.0V dc when attenuator is set at 1V rms, and -30V dc to +30V dc when attenuator is set at 10V rms.
 - e. Maximum counterclockwise position (PRE-SET) sets trigger level at zero volts.
5. **GATE** lamp glows during counting (main gate open).
6. **EXT** connector
 - a. Provides input for higher of two frequencies for ratio measurement (lower frequency to SIGNAL INPUT) when TIME BASE set to EXT.
 - b. Provides output frequency 0.1 Hz to 1 MHz as selected by TIME-BASE switch (see text for restrictions).
7. **TIME BASE** selects either time that main gate is on for frequency or time unit per count for period measurement.
8. **RESET** pushbutton returns both displayed and internal count to zero when pressed.
9. **FUNCTION**
 - a. Permits totalizing of pulses applied to SIGNAL INPUT when set to MANUAL START; holds accumulated count when switched to MANUAL stop.
 - b. Permits measurement of frequency applied to SIGNAL INPUT during interval selected by TIME-BASE switch when in FREQUENCY.
 - c. Permits period measurement of waveforms applied to SIGNAL INPUT averaged over 1 to 100,000 periods when set to PERIOD AVERAGE.
 - d. Removes control of TIME-BASE and FUNCTION switches when set to REMOTE or TIME INT; remote control is provided through rear connector or plug-in unit.
10. **REAR CONNECTOR** (see text for details)

Figure 6-3. Operating Controls (Front Panel)

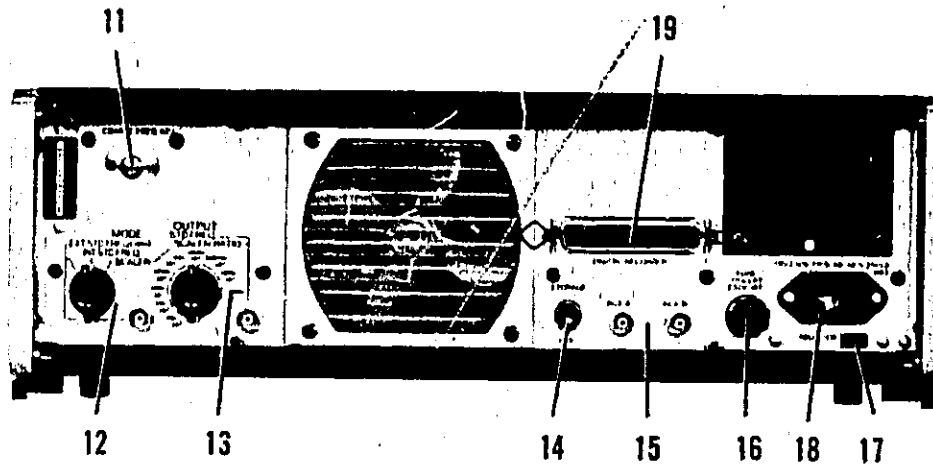

10. Plug-in compartment
- Receives plug-in unit to extend basic counter capabilities. To install plug-in (1) turn power off, (2) loosen knurled screw at side of compartment, (3) remove blank panel or plug-in unit, (4) slide desired plug-in unit into place and tighten knurled screw.
 - Permits access to fine and medium frequency controls through panel at rear of compartment; FINE FREQ ADJ has range of about 5×10^{-8} ; MED FREQ ADJ has range of about 1×10^{-6} .
11. COARSE FREQ ADJ permits adjustment of oscillator over a range of about 1×10^{-5} .
12. MODE
- Permits use of external 1-Mc frequency standard for time-base control when set to EXT STD FREQ (1 MHz).
 - Permits normal operation of counter using internal oscillator when set to INT STD FREQ.
 - Permits scaling of input signal by factors of 10 when set to SCALER.
13. OUTPUT
- Supplies selected frequency when MODE is set to INT STD FREQ (see text for restrictions).
 - Supplies scaled input frequency when MODE is set to SCALER.
14. STORAGE switch provides display storage when up; continuous display of internal count when OFF (down).
15. AUX A/AUX B (TIME INTERVAL TRIGGER OUT - START/STOP). Auxiliary plug-in outputs. See appropriate plug-in manual.
16. Fuse provides overload protection; should be 2 ampere slow-blow for 115-volt operation; 1 ampere slow-blow for 230-volt operation.
17. Line-voltage switch permits selection of either 115- or 230-vac line; insert narrow blade and slide to left for 115 v, slide to right for 230v.
18. AC LINE connector connects to flat plug on power cable.
19. DIGITAL RECORDER connector supplies BCD information to recorder, analog converter, or data processing equipment.

Figure 6-4. Operating Controls (Rear Panel)

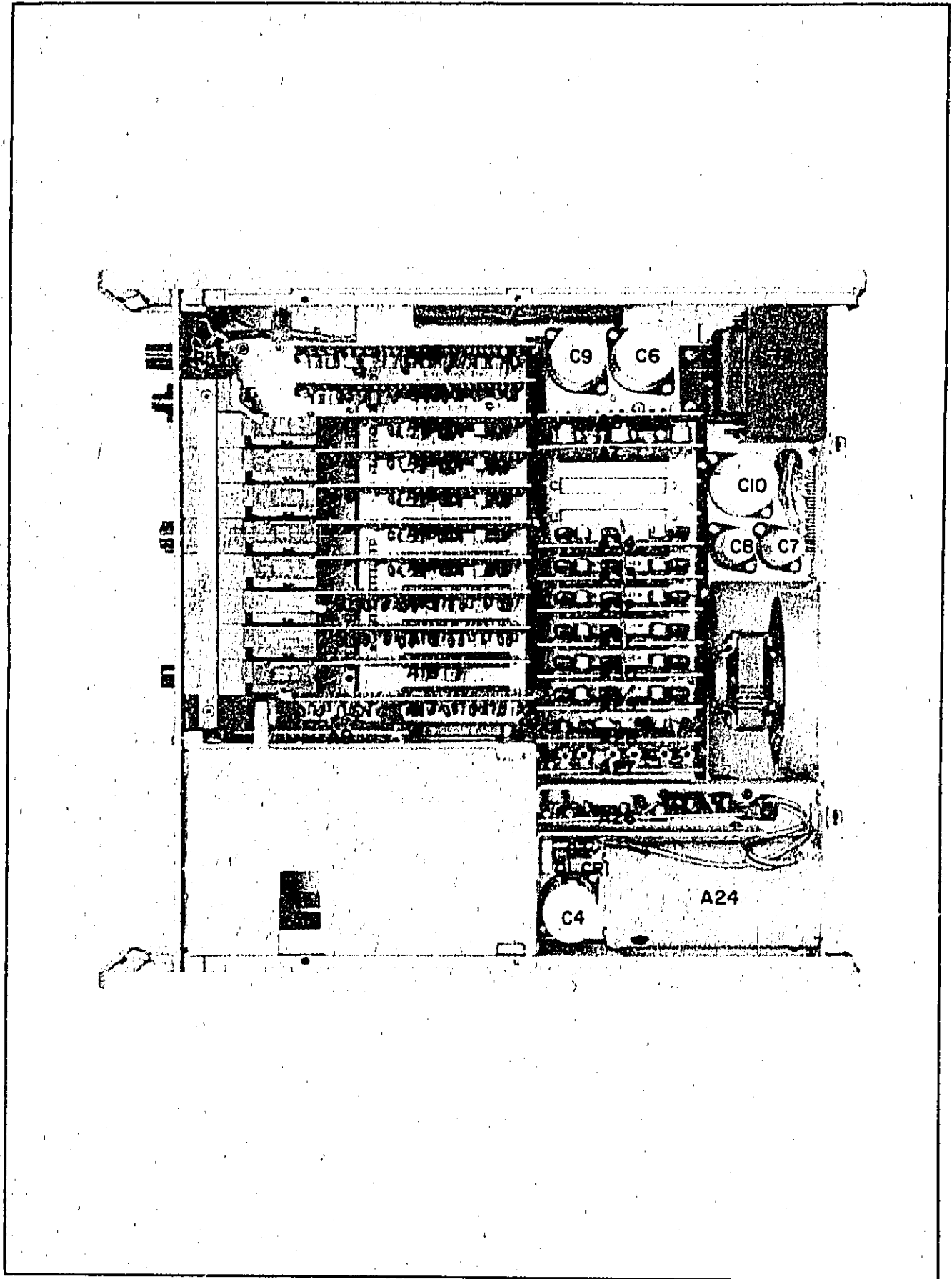

Figure 6-5. Top Internal View

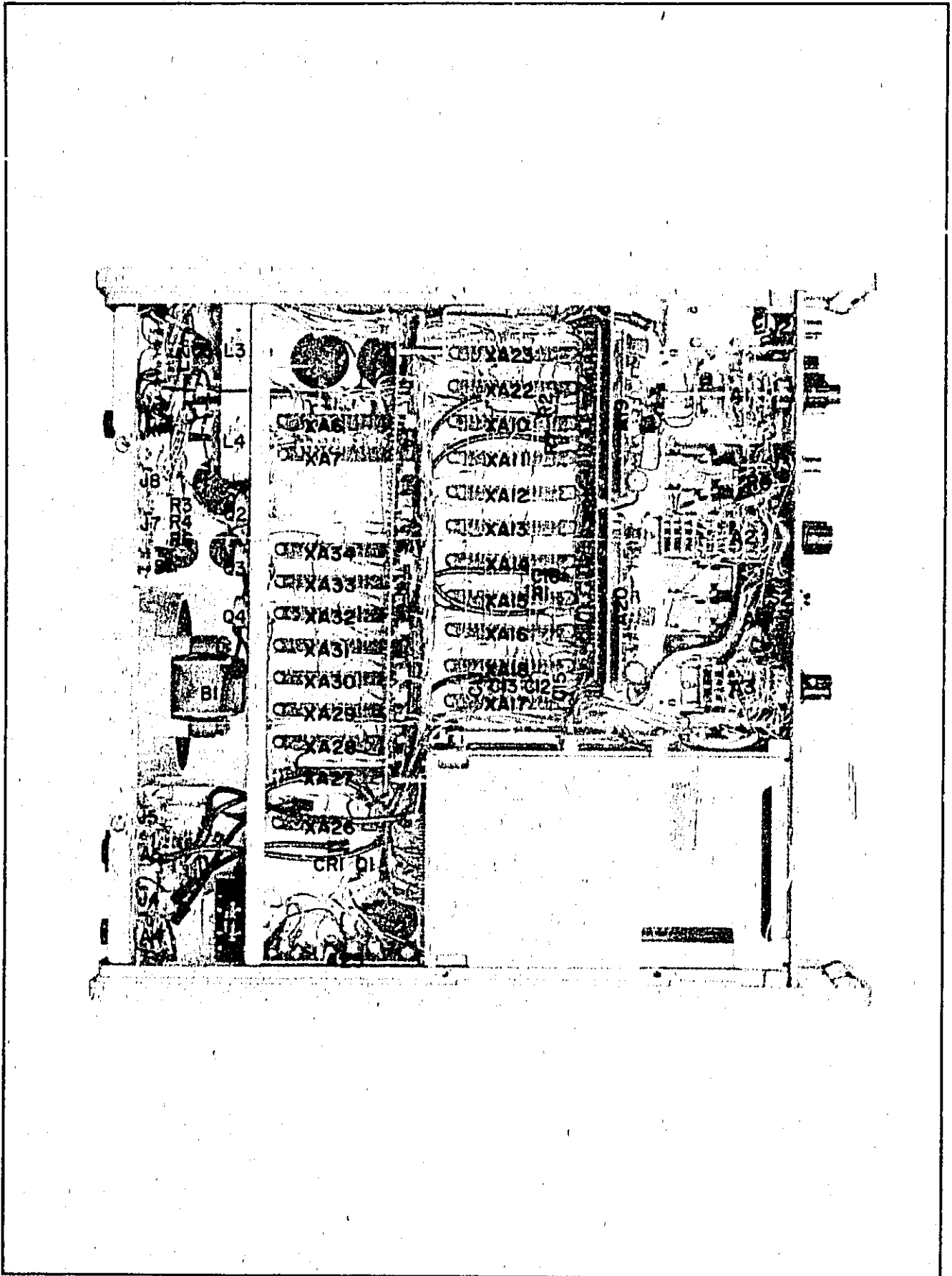

Figure 6-6. Bottom Internal View

Table 6-7. Troubleshooting "Tree".

Read Paragraphs 6-29 through 6-42.

Set Controls as follows:

MODE	INT STD FREQ
OUTPUT	1 MHz
SENSITIVITY	CHECK
TIME BASE1 μ s
FUNCTION	MANUAL START

Circled numbers indicate corresponding waveforms and the location of test points on the circuit diagrams.

Observe Gate Light

OFF Begin at 2 below
ON Begin at 3 page 6-13

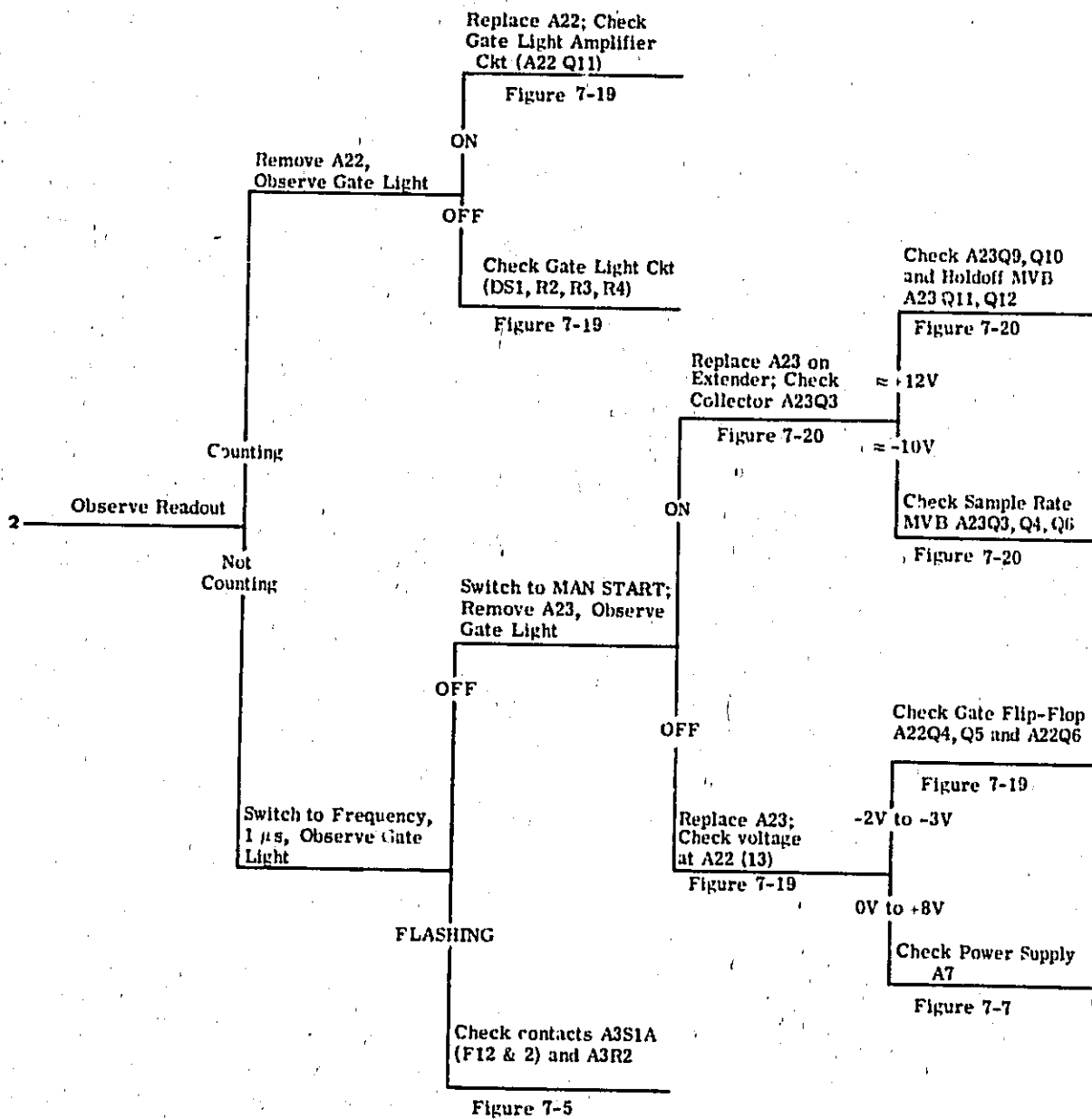
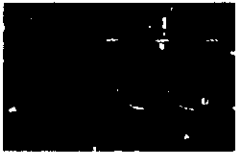
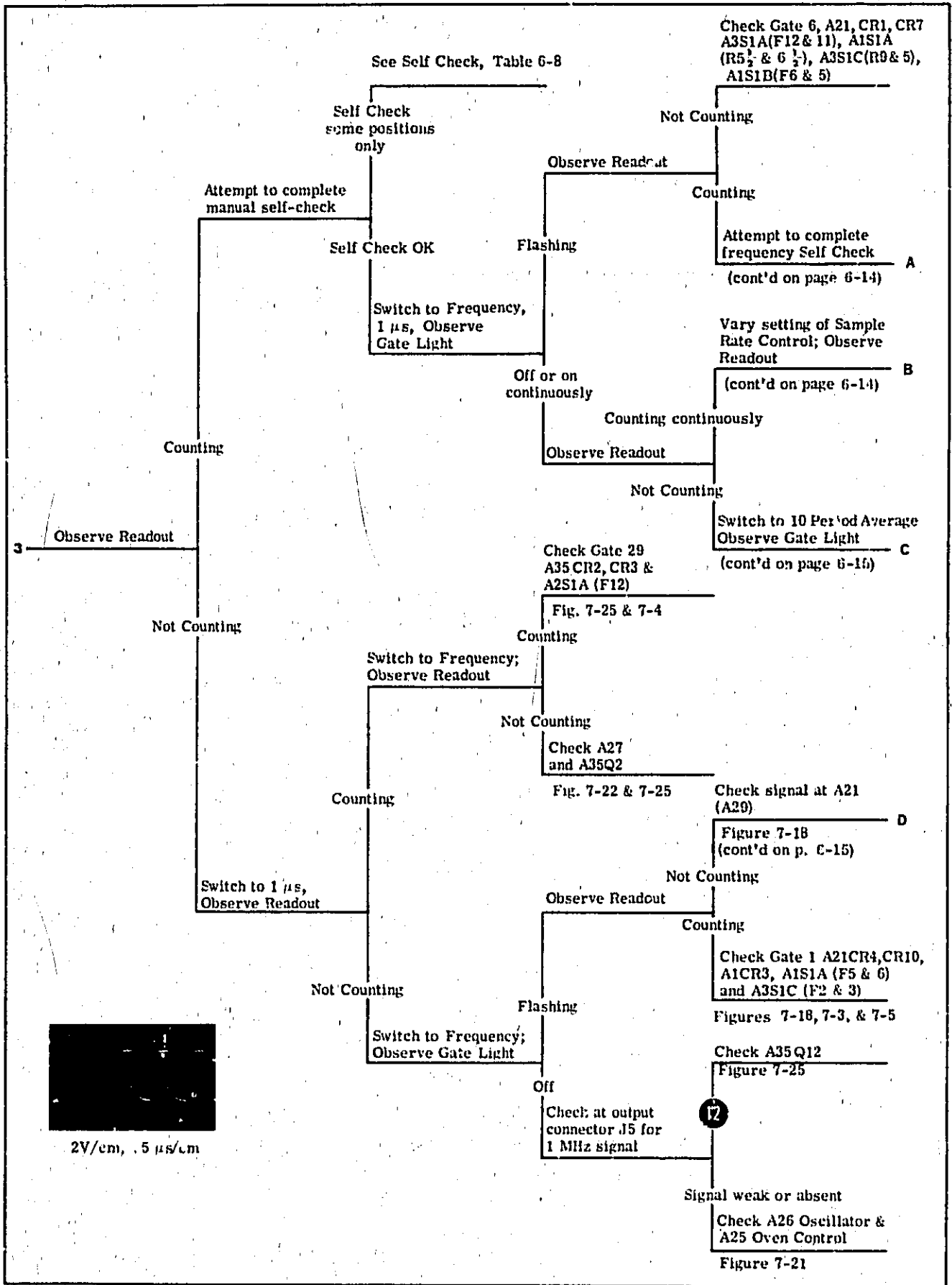

Table 6-7. Troubleshooting "Tree" Cont'd.



2V/cm, .5 μs/cm

Table 6-7. Troubleshooting "Tree" Cont'd.

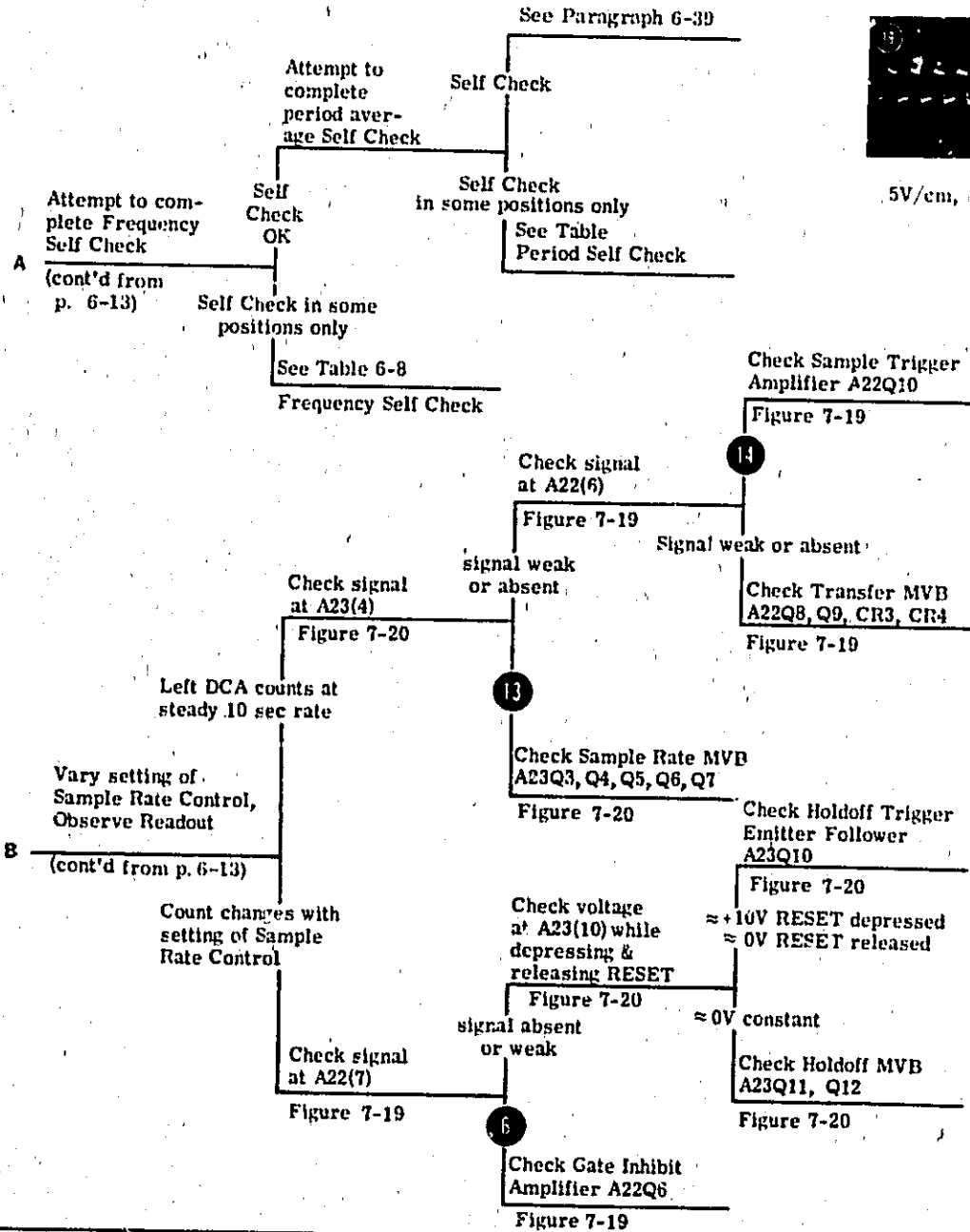
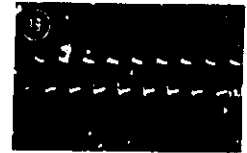
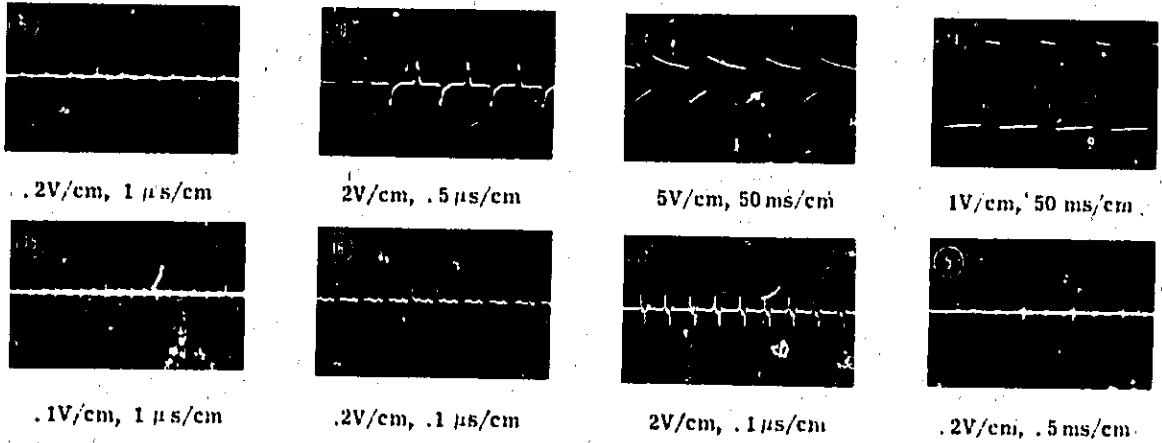
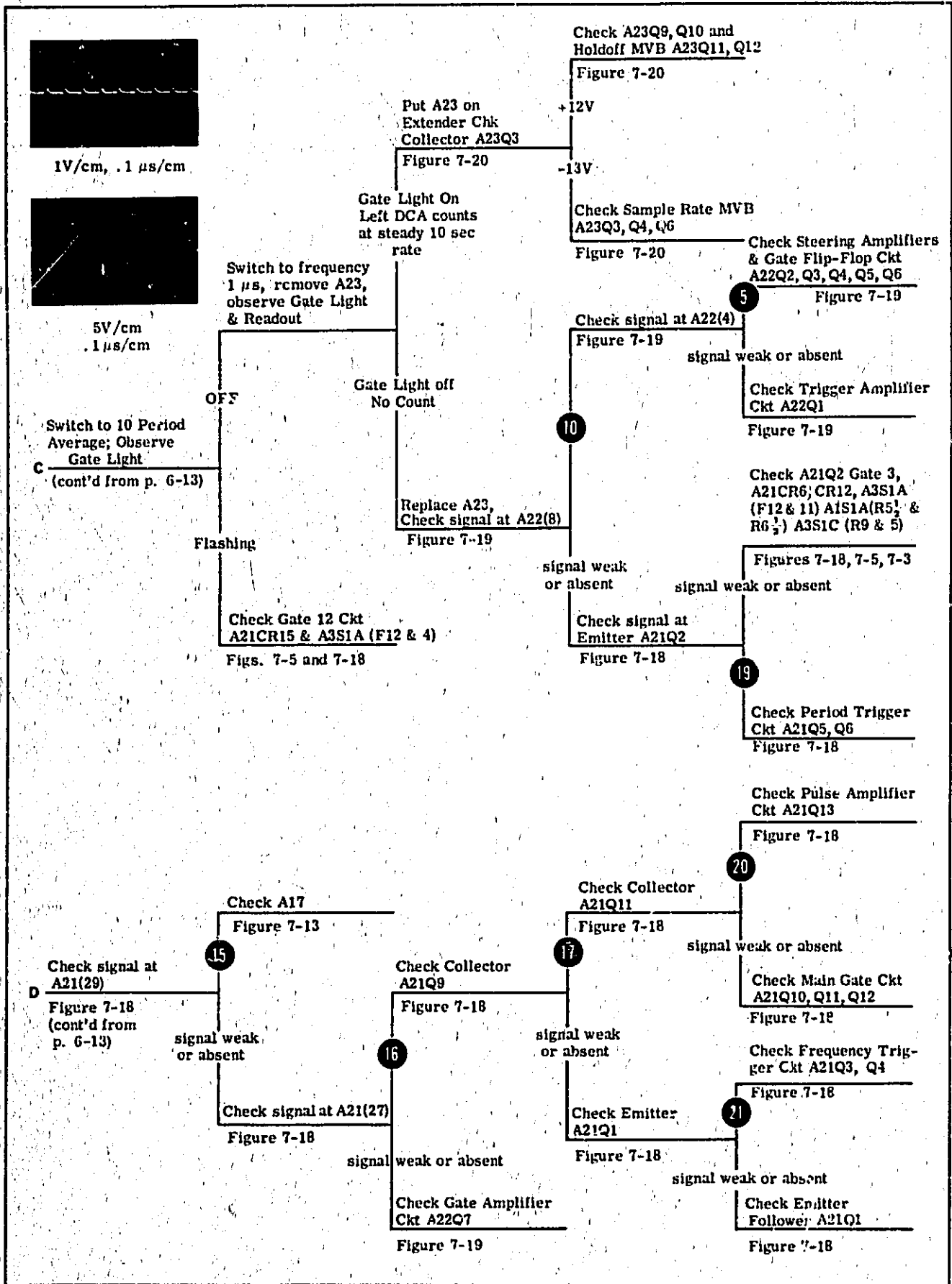

Table 6-7. Troubleshooting "Tree" Cont'd.



FREQUENCY MEASUREMENTS

Frequency is defined as the number of occurrences of a particular phenomenon in some length of time. Figure 6-7 shows the logic block diagram for a counter in the FREQUENCY mode. There are two signals that need to be traced - the input signal, or measured frequency, and the gating signal, which determines the length of time during which the DCA's are allowed to accumulate pulses.

The input signal is passed through an AND gate (which is enabled when the function switch is in the FREQUENCY mode) to a Schmitt trigger. Here it is converted into a square wave with rapid rise and fall time, then differentiated and clipped. As a result, the signal which arrives at the main gate consists of a series of pulses separated by the period of the original input signal.

All the DCA's and DDA's in μ counters with the exception of the 50 MHz DCA in the 5245L use PNP transistors. Hewlett-Packard's practice is to count pulses in these decades which will turn a conducting transistor off so that loop gain and regeneration occur immediately. The 5245L is the only counter where the pulses passed through the main gate to the first DCA are negative. The 50 MHz DCA will produce positive pulses which are counted in the next DCA.

The time base output of 1 MHz is shaped so that positive spikes 1 microsecond apart are fed through the number of DDA's required to provide the selected gate time. In the example shown, six DDA's are used for a 1 second gate. The first output pulse passes through AND gate 12 (also enabled in the FREQUENCY mode) and a Schmitt trigger to the "Gate Flip-Flop". The Gate Flip-Flop assumes a state such that an enable signal is applied to the Main gate - since this is an AND gate, the input signal pulses are allowed to enter the DCA's and are totalized. This continues until the second pulse from the DDA's arrives at the "Gate Flip-Flop". The element changes and reverts to a state which removes the enable signal from the main gate, so that it closes and no further pulses are admitted. The DCA's are now in a state which corresponds to the number of input pulses received during a precise time interval which was determined by the time base. This BCD state is then analyzed by means of a decoding matrix, converted to decimal information, and fed to the display. If an μ 562A Digital Recorder is used with the counter, the reading is fed out directly in BCD form and decoded in the recorder.

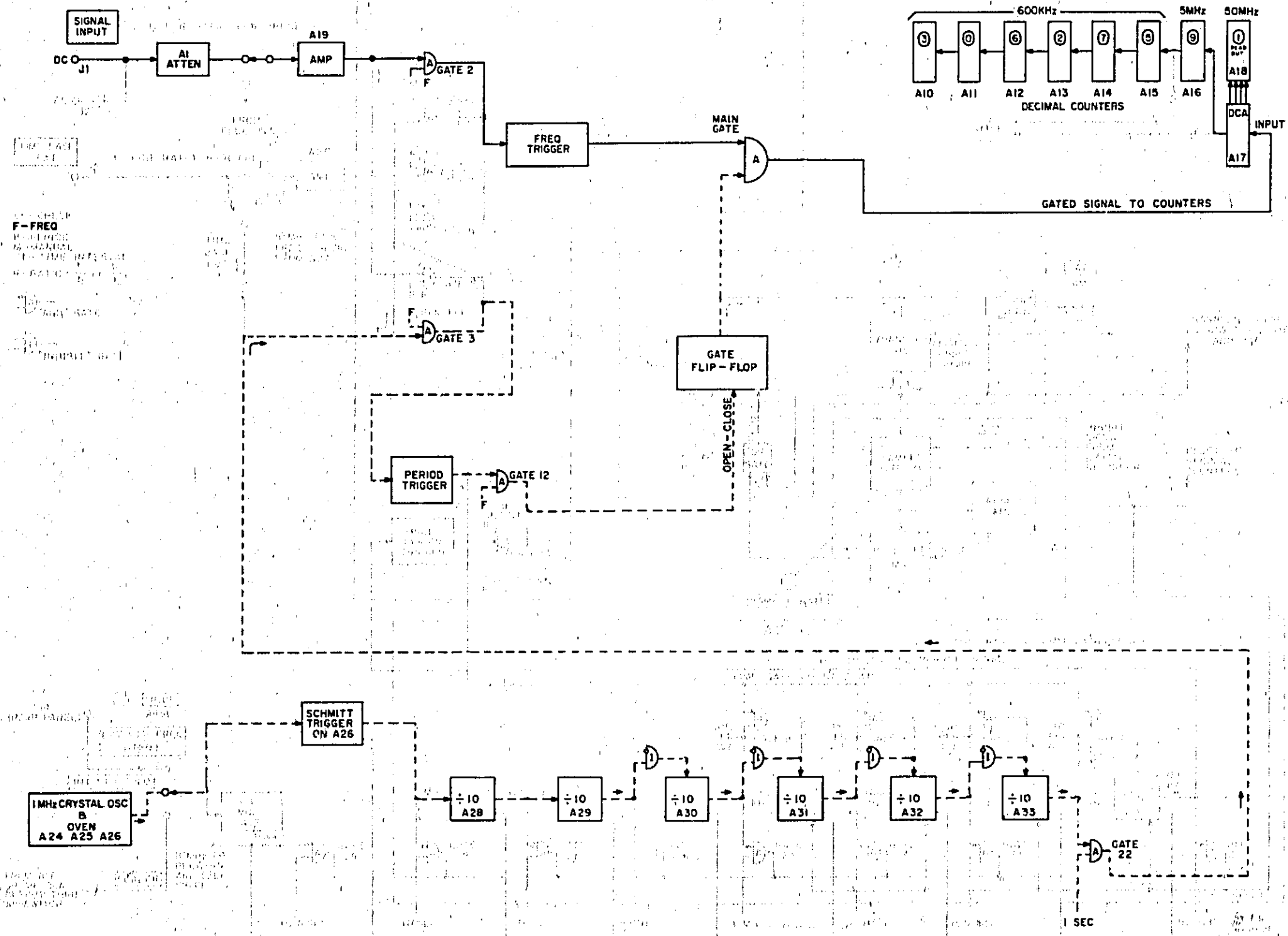

Figure 6-7. Frequency Measurements

SINGLE PERIOD MEASUREMENTS

Period is defined as the time required for one cycle to occur - literally, the inverse of a frequency measurement. Accordingly, the circuitry required for a period measurement must, in effect, reverse the counted and gated signals. Figure 6-8 shows that the gating signal is, in fact, derived from the unknown input signal. It should be noted, however, that the counted signal is not only derived from the time base but is also divided by the DDA's. This is in contrast to frequency measurements where the gating signal derived from the time base is divided in the DDA's. In short, the precisely spaced pulses from the time base are counted for one period of the unknown frequency. In our example, the time base switch is set to 1 s and the number of pulses which occur during one period of the unknown signal are counted and displayed. The gate time is always equal to the period of the unknown signal.

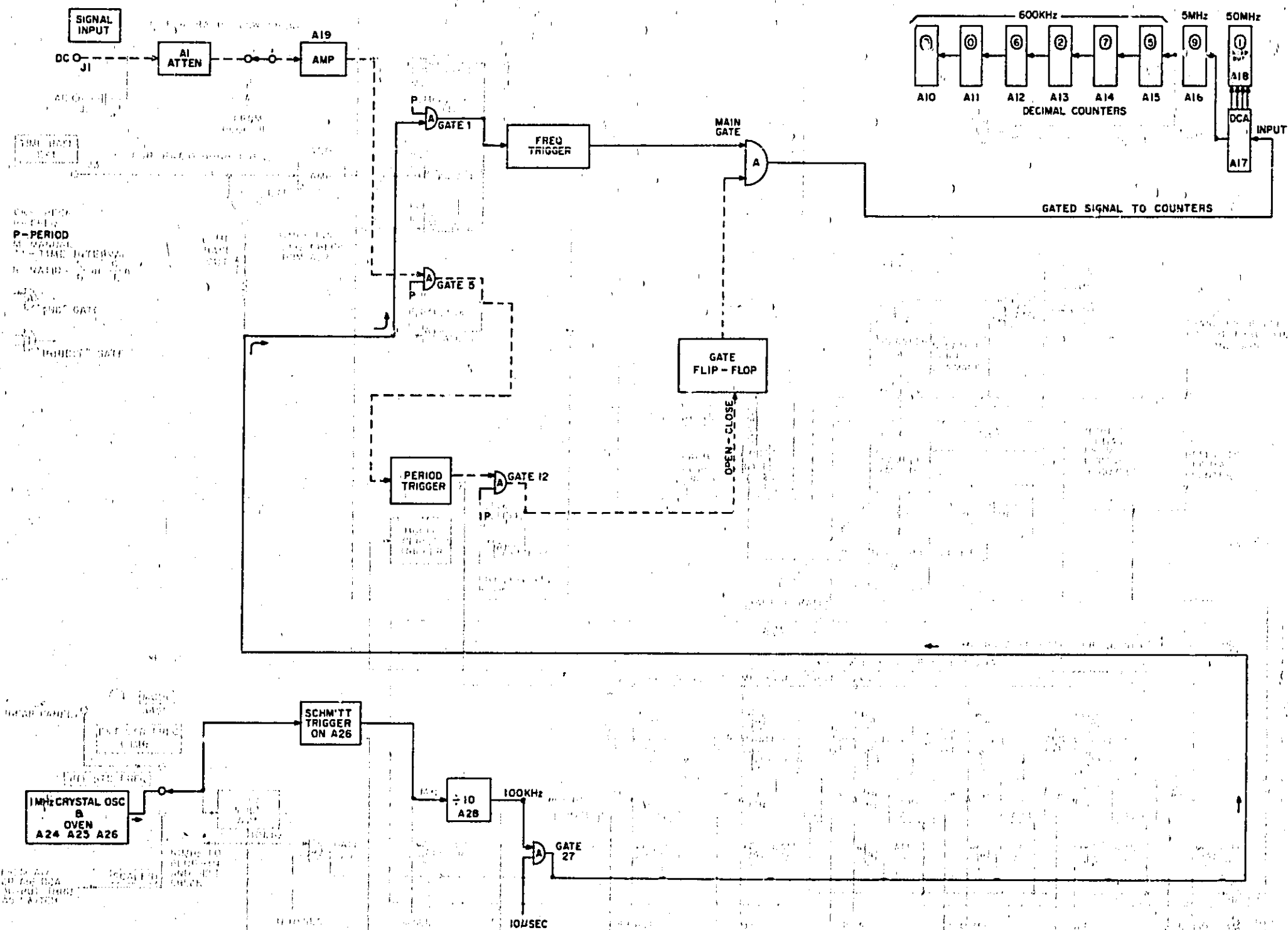

Figure 6-8. Single Period Measurements

MULTIPLE PERIOD AVERAGE MEASUREMENTS

This type of measurement is similar to a single period measurement in that the gating signal is derived from the unknown input signal and the counted signal is derived from the time base oscillator. The basic difference is that the gate may be held open for more than one period of the unknown signal. This is accomplished by the addition of an INHIBIT gate and an AND gate between selected DDA's (see Figure 6-9). This arrangement permits the unknown gating signal to be passed through certain DDA's and the counted time base signal to be passed through others. Any DDA's which are not used by the gating signal may be used to extend the separation of the counted pulses. In the example in Figure 6-9 there are seven DDA's - a maximum period average of 10^5 periods is available. The time base frequency is 1 MHz. The unknown signal is passed through suitable trigger and clipping circuits, then through the AND gate which is enabled when the Function Selector is in the 100K period average position. The signal is then passed through five DDA's so that there is one output pulse for every 10^5 input pulses; i.e., the period has been extended by a factor of 10^5 . As usual, the first output pulse enables the Main Gate and the second output pulse closes the Main Gate. The time base signal is shaped and then passed through a number of unused DDA's determined by the Time Base Selector setting. For example, if the setting is 10 microseconds, the signal will pass through one DDA. The maximum time base setting under the given circumstances is 0.1 milliseconds since the Inhibit gate will prevent the signal from passing on to the next DDA when the Function Switch is in the 100K Period Average. These precisely spaced pulses are then passed through the main gate to the DCA's. Since the 10 microsecond position was selected, the DCA's will count the number of 10 microsecond intervals which occur during 100,000 periods of the input signal. The readout logic is so designed that the decimal point will be automatically positioned to display the proper units.

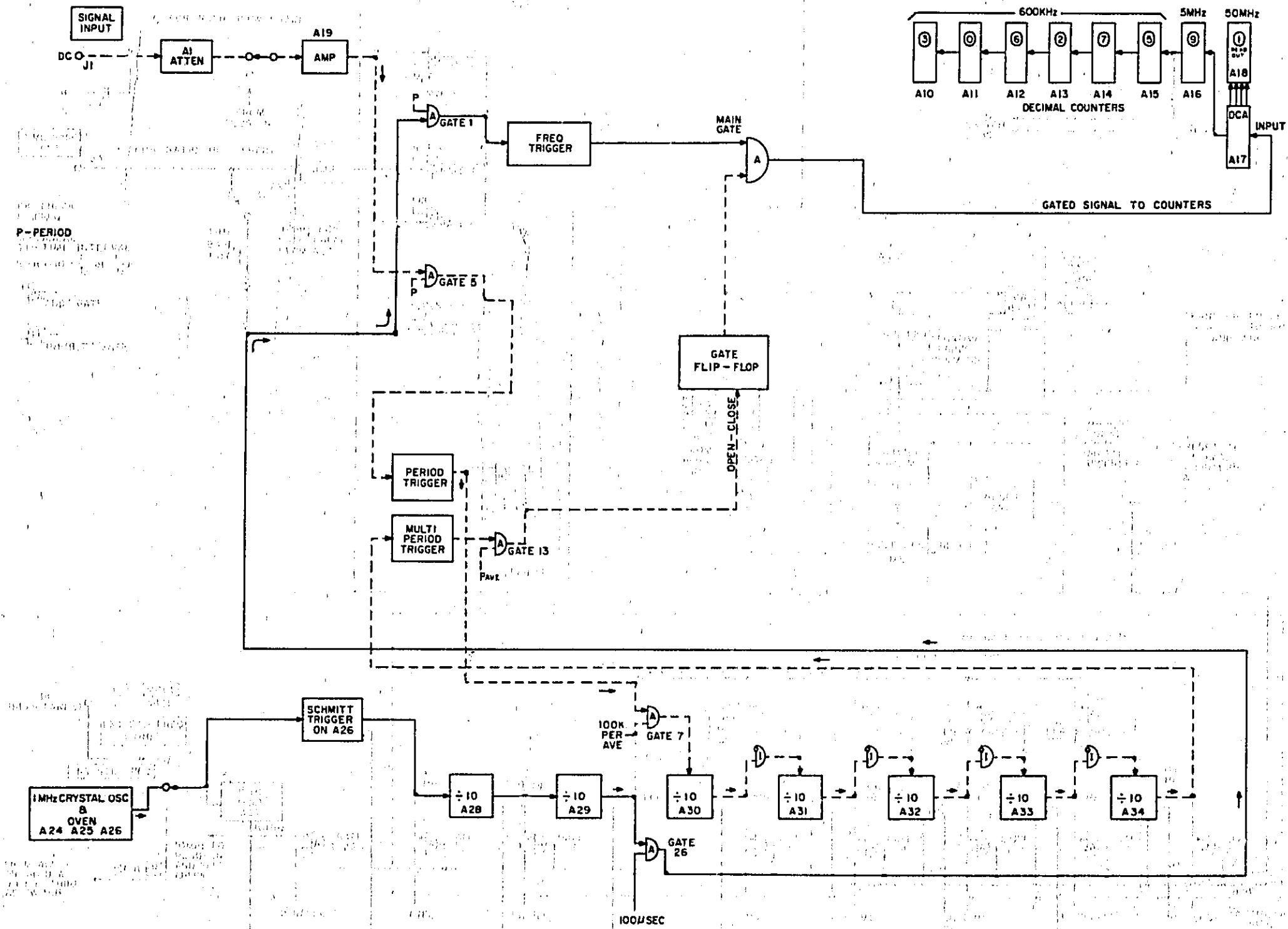

Figure 6-9. Multiple-Period Average Measurements

RATIO AND MULTIPLE RATIO MEASUREMENTS

A ratio measurement is, in effect, a period measurement with the lower of the two frequencies used as the gating signal and the higher frequency signal used as the counted signal. In other words, the higher frequency signal takes the place of the time base. The number of cycles of the higher frequency signal f_1 which occur during a period of the lower frequency f_2 is counted in the DCA's. A multiple ratio measurement simply extends the number of periods of the lower frequency to 10, 100, etc. The decimal point is automatically positioned but no units are displayed since ratio is unitless. The block diagram of Figure 6-10 applies. Note that the standard selector is in the external (E) position and f_1 takes the place of the internal oscillator.

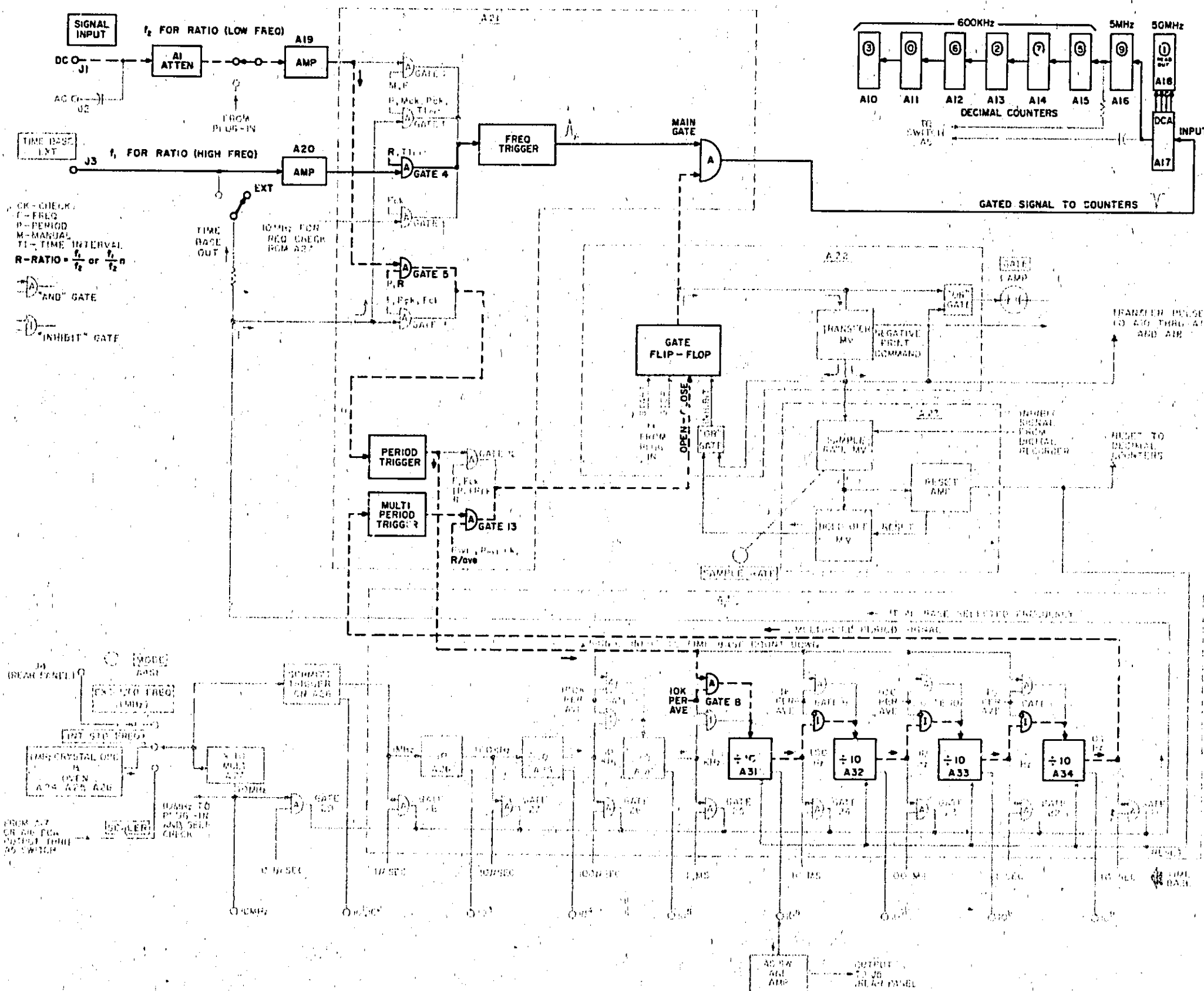

Figure 6-10. Ratio and Multiple Ratio Measurements

**TROUBLE -
SHOOTING
CON'T**

SCALING

With the Function Selector in the Manual Start position and the Mode selector on the rear of the instrument in the Scaler position, an input signal may be scaled down by factors of 10 through 1,000,000,000. The Manual Start position holds the main gate open. The input signal is converted to pulses and passed through the main gate and through the 50 MHz DCA where the first division by ten is accomplished.

With the rear panel Mode Selector in the Scaler position, and the Output Switch in the 10 position, the output of the 50 MHz DCA is passed through the time base Schmitt trigger and an amplifier and is made available at connector J5 on the rear of the instrument. With the Output Selector on any position other than 10^1 (e.g., 10^2 through 10^9) the signal is passed through both the 50 MHz and the first 5 MHz DCA to the time base Schmitt. It is then routed through a selected number of DDA's.

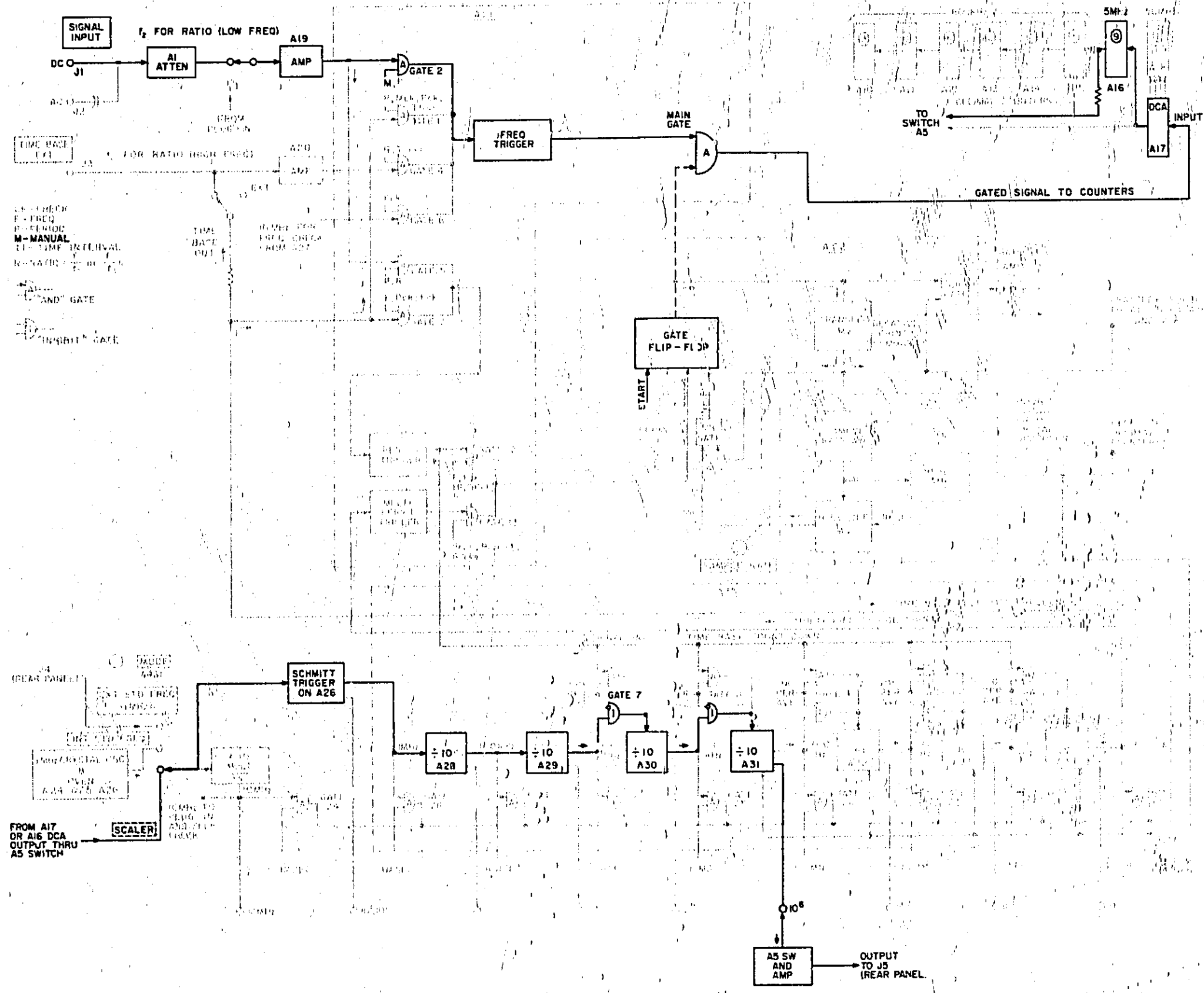

Figure 6-11. Scaling
6-25/6-26

CHECKS <input type="checkbox"/> FAILS <input type="checkbox"/>															
MANUAL START			FREQUENCY			PERIOD AVERAGE			CHECK						
.1 μs	1 μs	10 μs	.1 ms	1 ms	10 ms	.1 s	1 s	10 s	1 K	10 K	100 K	DECADE DIVIDER	GATE	SWITCH CONTACT	ASSEMBLY OR CIRCUIT
													7 A35CR9	A3S1A(F9)	
													8 A35CR12	A3S1A(F8)	
													9 A35CR15	A3S1A(F7)	
													10 A35CR18	A3S1A(F6)	
													11 A35CR21	A3S1A(F5)	
													13 A21CR16	A3S1A(R9-1/2) A3S1A(I'4) A3S1B(F12) A1S1A(F5)	A21Q7, Q8 A35Q1, Q10 A1CR1, CR2, CR3
													6 A21CR1, CR7	A1S1A(R5-1/2) A1S1B(F5) A1S1C(R5) A3S1A(F11)	
													12 A21CR15	A3S1A(F4)	
													3 A21CR6, CR12		A21Q2, Q5, Q6 A22Q1, Q2, Q3 A23
												A34	21 A35CR22, Q9	A2S1A(F4)	
													11 A35CR20		
													22 A35CR19, Q8	A2S1A(F5)	
												A33	10 A35CR17		
													23 A35CR16, Q7	A2S1A(F6)	
												A32	9 A35CR14		
													24 A35CR13, Q6	A2S1A(F7)	
												A31	8 A35CR11		
													25 A35CR10, Q5	A2S1A(F8)	
												A30	7 A35CR8		
													26 A35CR7, Q4	A2S1A(F9)	
												A29		A2S1A(F10)	
												A28	27 A35CR6, Q3		A35Q11
													28 A35CR4, CR5	A2S1A(F11)	A26Q6, Q7
													29 A35CR2, CR3	A2S1A(F12)	
													1 A21CR4, CR10	A3S1C(F2 & 3), A3S1A(F2) A1S1A(F3)	A27 A35Q2 A1CR3 A3R2

Table 6-8. Self Check

SCHEMATIC DIAGRAMS

SECTION VII CIRCUIT DIAGRAMS

7-1. INTRODUCTION.

7-2. This section includes the following:

- a. General Notes for Schematic Diagrams (Figure 7-1).
- b. Block Diagram (Figure 7-2).
- c. Schematic Diagrams and Component Location illustrations of Model 5245L circuits, assemblies and connectors in the order of their assembly designation (A1 through A35, Figures 7-3 through 7-26). These figures may also include waveforms and voltages.
- d. Schematic Diagrams and Component Location illustrations for Options 002 and 003 assemblies follow after the standard assembly they replace (Figures 7-10, 7-12, 7-15, and 7-16).

7-3. The Block Diagram or any schematic diagram, when unfolded, can be used with any other part of this manual, or with the manual closed.

7-4. DC voltages are measured with a Model 412A DC Voltmeter. Typical voltages are shown.

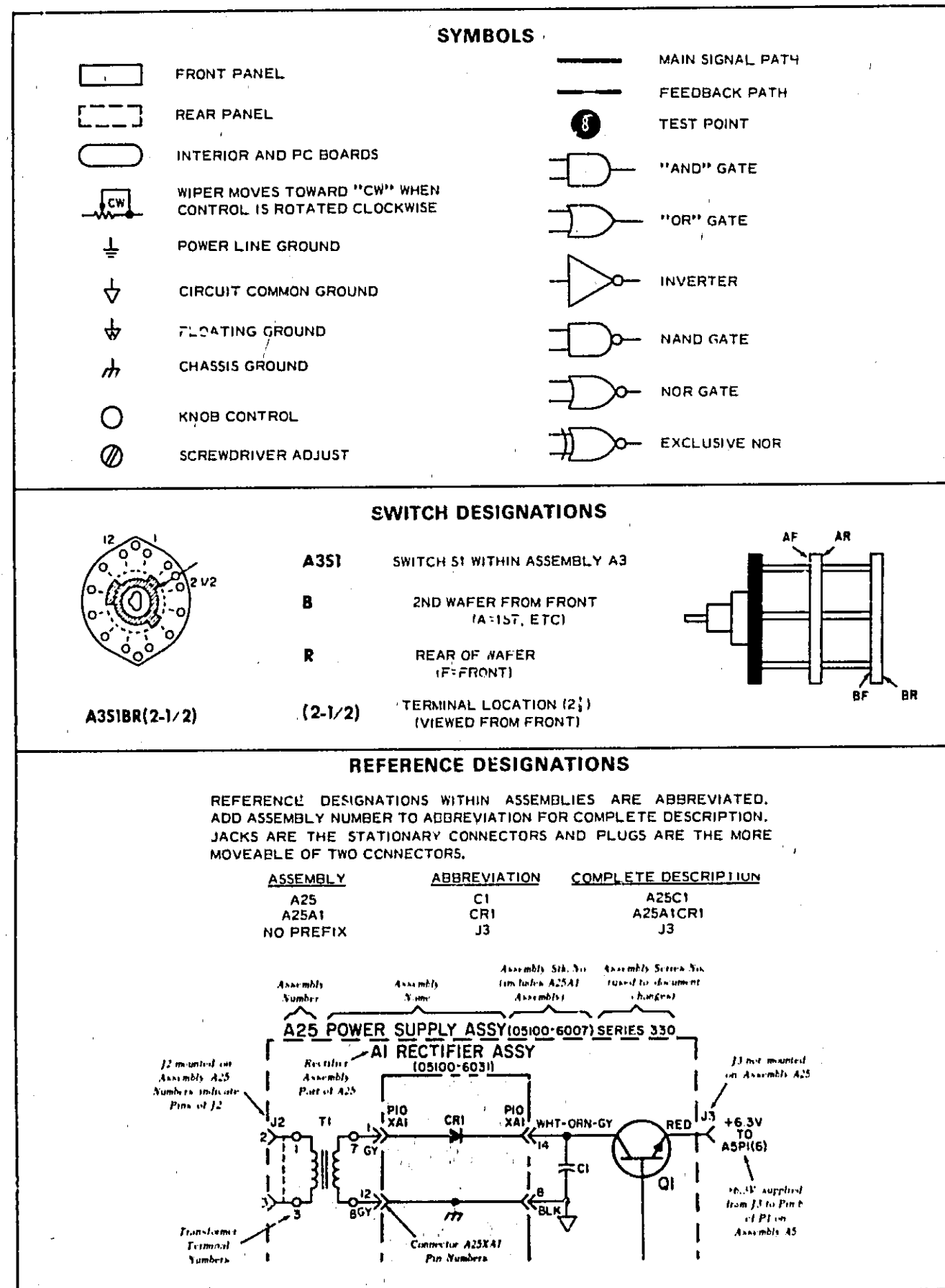

Figure 7-1. General Notes for Schematic Diagrams

Model 5245L

- NOTES**
- SYMBOLS
 - COMMON EMITTER AMPLIFIER
 - COMMON BASE AMPLIFIER
 - COMMON COLLECTOR AMPLIFIER (EMITTER FOL)
 - SPLIT LOAD AMPLIFIER
 - AND GATE, NUMBER INDICATES CONTROL ON STATE REQUIRES -15V CONTROL
 - INHIBIT GATE, OFF STATE REQUIRES -15V CONTROL
 - GENERAL ABBREVIATIONS
 - DP - DECIMAL POINT
 - DR - DIGITAL RECORDER
 - GC - GATE CONTROL
 - MU - MEASUREMENT UNIT
 - BCD - BINARY CODED DECIMAL
 - DCA - DECIMAL COUNTER ASSY
 - DDA - DECADE DIVIDER ASSY
 - MPS - MULTIPLIED PERIOD SIG
 - SWITCH SITUATION ABBREVIATIONS
 - AND
 - OR
 - INPUT SWITCH: CHECK
 - INPUT SWITCH: NOT CHECK
 - TIME BASE SWITCH: EXT
 - TIME BASE SWITCH: NOT EXT
 - FUNCTION SWITCH: FREQUENCY
 - FUNCTION SWITCH: MANUAL START OR MANUAL STOP
 - FUNCTION SWITCH: NOT (MANUAL START OR MANUAL STOP)
 - FUNCTION SWITCH: PERIOD AVERAGE (FOR ANY POSITION)
 - FUNCTION SWITCH: PERIOD AVERAGE (FOR SPECIFIC POSITION)
 - FUNCTION SWITCH: REMOTE OR TIME INT
 - FUNCTION SWITCH: NOT (REMOTE OR TIME INT)
 - DP LAMPS ARE LIGHTED D THRU 7 FOR EACH POSITION FROM RIGHT TO LEFT AS VIEWED FROM FRONT
 - DP AND MU LAMPS OPERATE TABULATED WHEN INPUT SWITCH IS NOT CHECK, LAMPS OPERATE IN CHECK CH-FUNCTION SWITCH IS SET TO FREQUENCY
 - DP AND MU LAMPS ARE LIGHTED BY +170V CONTROL SUPPLIED TO APPROPRIATE AB-3J TERMINAL FROM SWITCH OR J10
 - TIME RELATIONSHIPS
 - GATING
 - TRANSFER
 - SAMPLING RATE MV
 - HOLDOFF
 - RESET
 - LF DDA OUTPUT

GATE CONTROL SUMMARY (PAGE 3)

GATE CONTROL DESIGNATION	INTERNAL CONTROL SWITCH SITUATION FOR ON STATE (-15V) WITH (PLUG IN OFF)	SOURCE	REMOTE CONTROL (J9 PIN NO.)
1	(M-E-C)+(P-E-C)+(P-E)	A3IA (F-3)	1
2	(M-F)-E	A3IB (F-1)	2
3	(F-E)+(P-C)	A3IB (F-4)	3
4	(M-F)-E+(P-E-E)	A2SIA (F-3)	4
5	F-E-C	A3IA (F-1)	5
6	F-E-C	A3IB (F-2)	6
7	100K Pa	A3SIA (F-9)	7
8	10K Pa	A3SIA (F-8)	8
9	1K Pa	A3SIA (F-7)	9
10	100Pa	A3SIA (F-6)	10
11	10Pa	A3SIA (F-5)	11
12	F+1Pa	A3SIA (F-3,4)	12
13	ANY Pa EXCEPT 1Pa	A3SIA (R-9/2)	13
21	(10S)-(M+F+P-C)	A2SIA (F-4)	21
22	(1S)-(M+F+P-C)	A2SIA (F-3)	22
23	(10mS)-(M+F+P-C)	A2SIA (F-6)	23
24	(1mS)-(M+F+P-C)	A2SIA (F-7)	24
25	(0.1mS)-(M+F+P-C)	A2SIA (F-8)	25
26	(0.01mS)-(M+F+P-C)	A2SIA (F-9)	26
27	(10US)-(M+F+P)-(P-C)	A2SIA (F-10)	27
28	(1US)-(M+F+P)-E	A2SIA (F-11)	28
29	(1US)-(M+F+P-E)	A2SIA (F-12)	29

DECIMAL POINT SITUATIONS (NOTES 3,4,5,6)

FUNCTION SWITCH	0.1US	1US	10US	1mS	10mS	0.1S	1S	10S	EXT
M START	-	-	-	-	-	-	-	-	-
M STOP	-	-	-	-	-	-	-	-	-
F	0	1	2	0	1	2	3	4	0
10Pa	2	0	2	1	0	2	1	0	1
100Pa	3	1	0	2	1	0	-	-	2
1KPa	4	3	2	1	0	2	-	-	3
10KPa	5	4	3	2	1	-	-	-	4
100KPa	6	5	4	3	-	-	-	-	5
R	-	-	-	-	-	-	-	-	-

MEASUREMENT UNITS SITUATIONS (NOTES 3,5,6)

FUNCTION SWITCH	0.1US	1US	10US	1mS	10mS	0.1S	1S	10S	EXT
M START	-	-	-	-	-	-	-	-	-
M STOP	-	-	-	-	-	-	-	-	-
F	MHz	MHz	MHz	KHz	KHz	KHz	KHz	KHz	X
1Pa	US	US	US	mS	SEC	SEC	SEC	SEC	*
10Pa	US	US	US	mS	mS	SEC	SEC	SEC	*
100Pa	US	US	US	mS	mS	mS	*	*	*
1KPa	US	US	US	US	US	mS	*	*	*
10KPa	US	US	US	US	US	*	*	*	*
100KPa	US	US	US	US	US	*	*	*	*
R	US	US	US	US	US	*	*	*	*

SOURCE OF DP AND MU CONTROLS (NOTES 5,6)

DP DESIGNATION	INTERNAL SOURCE	REMOTE CONTROL (J10 PIN NO.)	MU DESIGNATION	INTERNAL SOURCE	REMOTE CONTROL (J10 PIN NO.)
7	A2SIB (R-2)	7	MHz	A2SIB (R-2)	13
6	A2SIE (R-5)	6	KHz	A2SIB (R-9/2)	12
5	A2SIE (R-8)	5	SEC	A2SIF (R-4)	14
4	A2SIE (F-7)	4	mS	A2SIF (R-7)	15
3	A2SID (R-6)	3	US	A2SIF (R-10)	16
2	A2SIC (F-7)	2	US	A2SIF (R-6)	11
1	A2SID (F-9)	1			
0	A2SIC (R-8)	10			

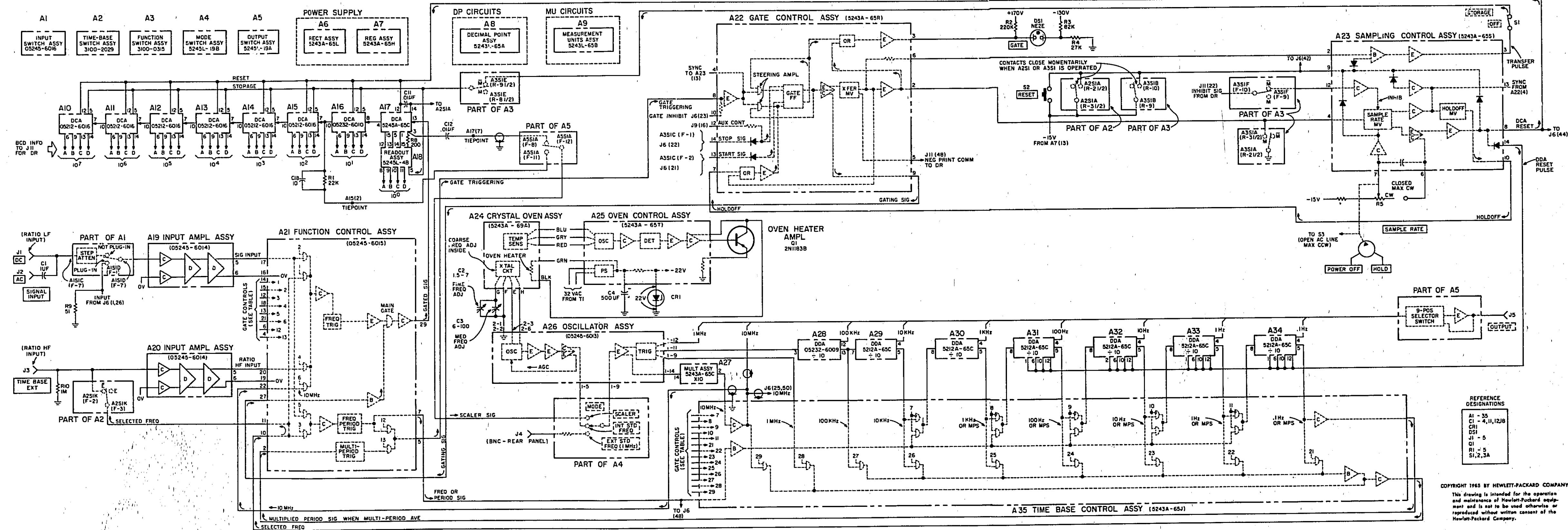

REFERENCE DESIGNATIONS
 A1 - 35
 CI - 4, 11, 12/8
 DSI
 J1 - 5
 Q1
 R1 - 5
 SI, 2, 3A

Copyright 1965 by Hewlett-Packard Company
 This drawing is intended for the operation and maintenance of Hewlett-Packard equipment and is not to be used otherwise or reproduced without written consent of the Hewlett-Packard Company.

Figure 7-2. Block Diagram
7-3/7-4

NOTES

- UNLESS OTHERWISE INDICATED: RESISTANCE IN OHMS, CAPACITANCE IN PICOFARADS
- EACH SWITCH SECTION SHOWN IN MAX CCW POSITION
- PICTORIAL DIAGRAM AS SEEN FROM FRONT OF SWITCH (KNOB END); REAR SECTION PROJECTED THRU WATER
- NUMBERED TERMINALS IN FUNCTIONAL SWITCH DIAGRAM CORRESPOND WITH NUMBERED TERMINALS IN PICTORIAL DIAGRAM
- REFER TO NOTES ON OVERALL DIAGRAM FIG. 7-2 FOR ABBREVIATIONS
- WAVEFORMS SHOWN WERE OBTAINED WITH FUNCTION SWITCH AT MANUAL START, SENSITIVITY SWITCH AT CHECK, OUTPUT SWITCH WAS ROTATED FROM 100 CPS POSITION TO 10MC POSITION

(NOTE 6)

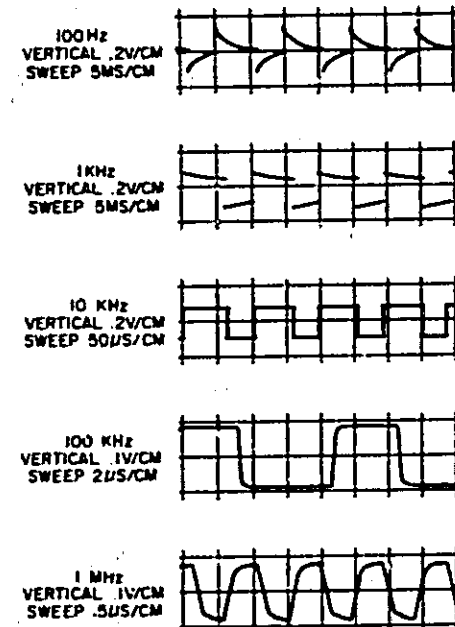

REFERENCE DESIGNATIONS

NO PREFIX	A2
L5	C1
	R1
	S1

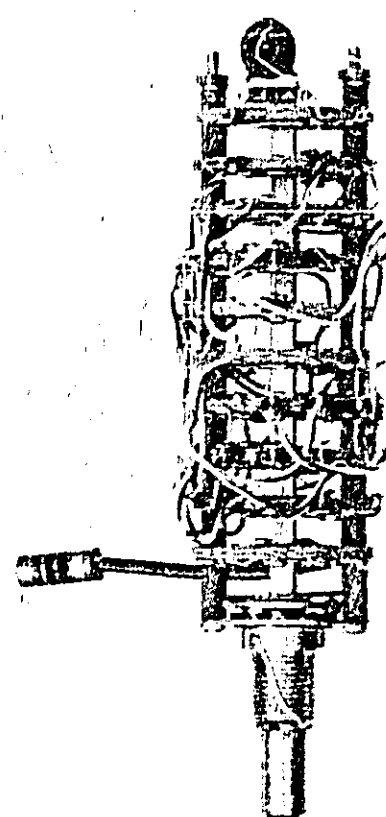

A2

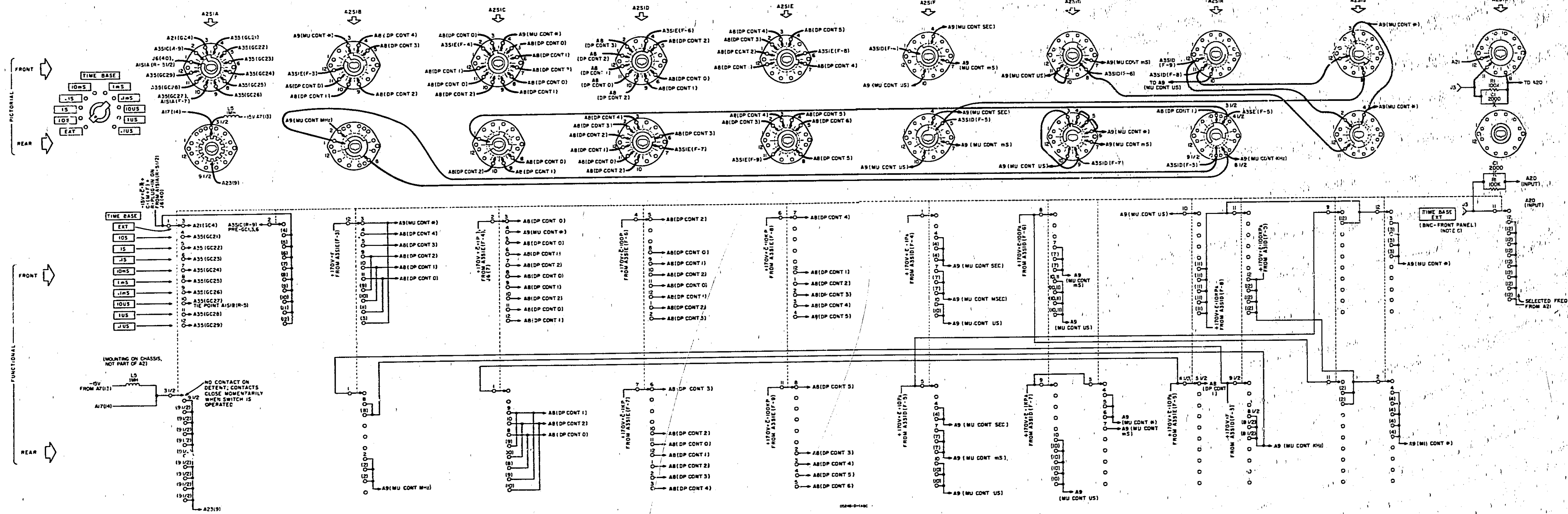
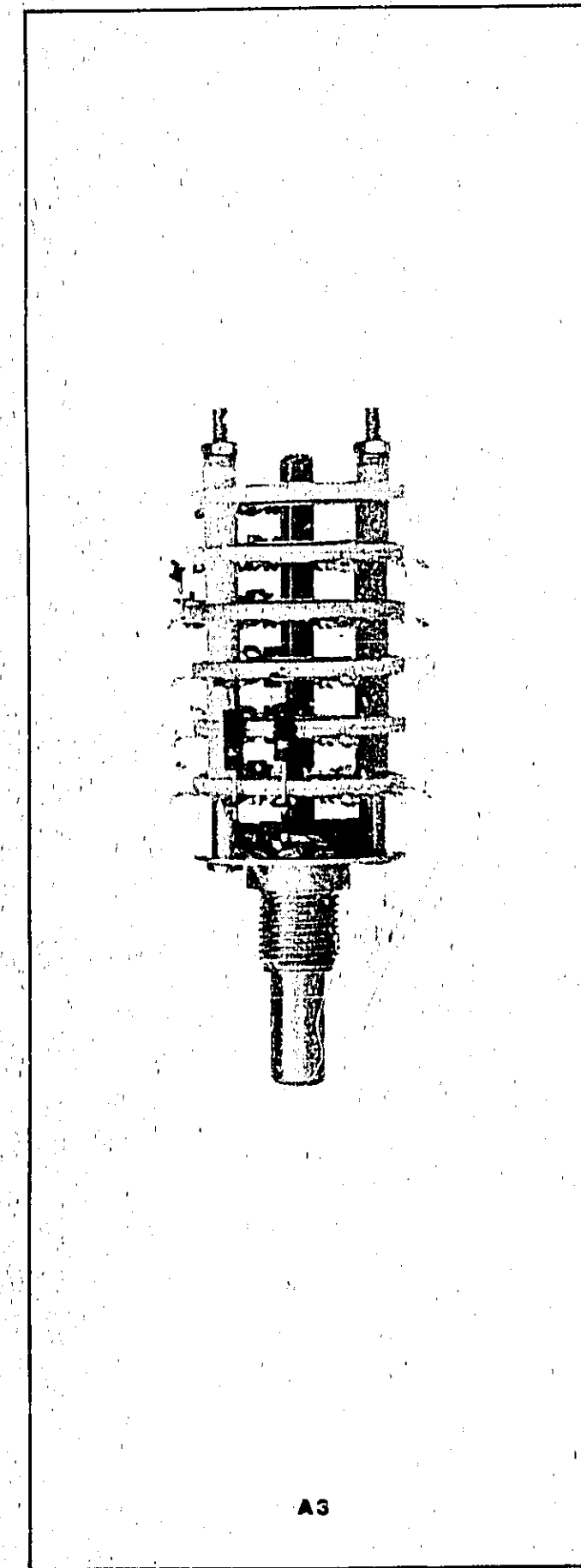

Figure 7-4. A2 Time Base Switch



A3

NOTES

- UNLESS OTHERWISE INDICATED: RESISTANCE IN OHMS.
- EACH SWITCH SECTION SHOWN IN MAX CCW POSITION
- PICTORIAL DIAGRAM AS SEEN FROM FRONT OF SWITCH (KNOB END); REAR SECTION PROJECTED THRU WAFER
- NUMBERED TERMINALS IN FUNCTIONAL SWITCH DIAGRAM CORRESPOND WITH NUMBERED TERMINALS IN PICTORIAL DIAGRAM
- REFER TO NOTES ON FIG 7-2 (OVERALL DIAGRAM) FOR ABBREVIATIONS

REFERENCE DESIGNATIONS

A3R1-2
A3S1

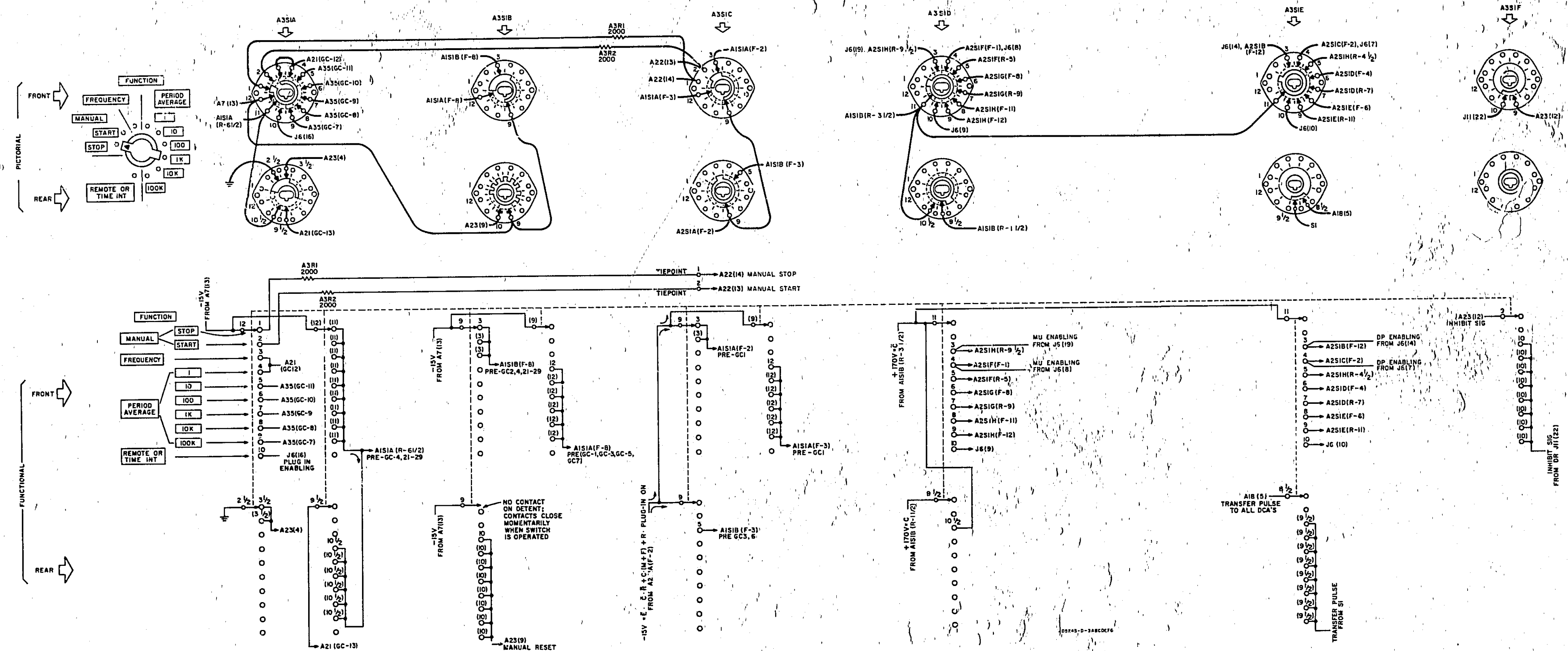

COPYRIGHT 1965 BY HEWLETT-PACKARD COMPANY

Figure 7-5. A3 Function Switch
7-9/7-10

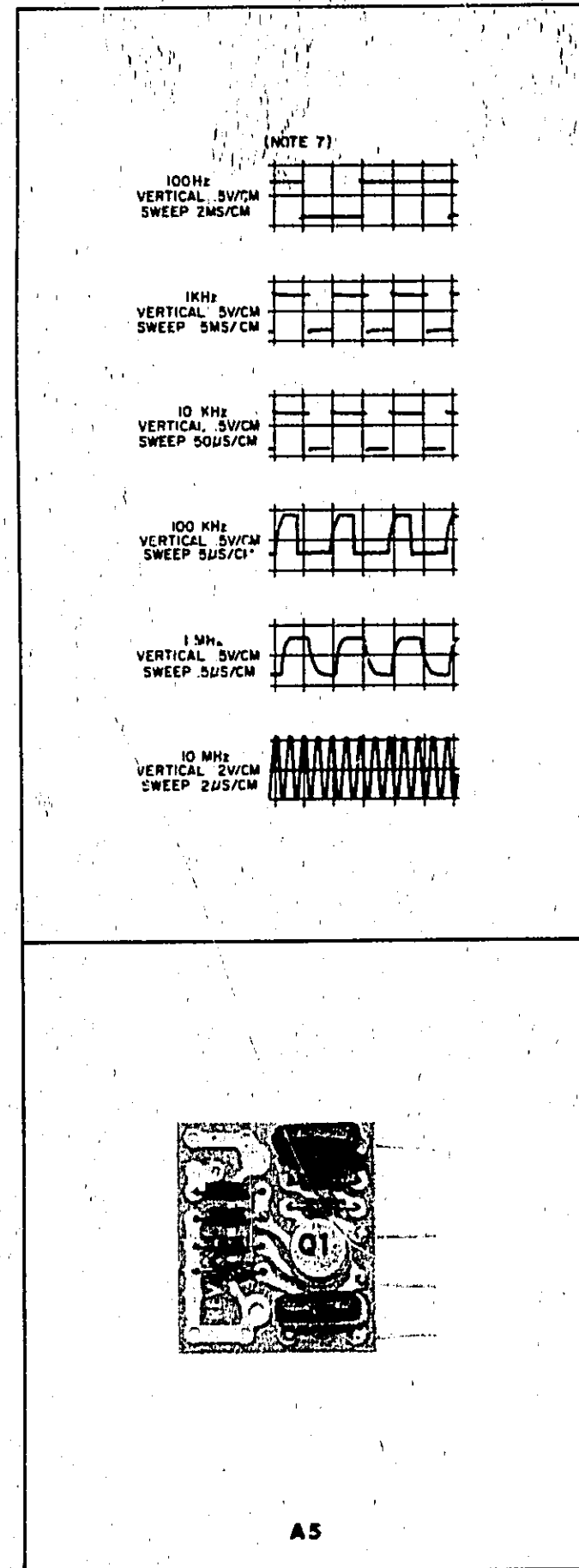

- NOTES**
- UNLESS OTHERWISE INDICATED: RESISTANCE IN OHMS, CAPACITANCE IN PICOFARADS, RESISTORS 1/4 WATT
 - EACH SWITCH SECTION SHOWN IN MAX CCW POSITION
 - PICTORIAL DIAGRAM AS SEEN FROM FRONT OF SWITCH (KNOB END); REAR SECTION PROJECTED THRU WAFER
 - NUMBERED TERMINALS IN FUNCTIONAL SWITCH DIAGRAM CORRESPOND WITH NUMBERED TERMINALS IN PICTORIAL DIAGRAM
 - REFER TO NOTES ON OVERALL DIAGRAM FOR ABBREVIATIONS
 - DOT (•) INDICATES CATHODE
 - WAVEFORMS SHOWN WERE OBTAINED WITH FUNCTION SWITCH AT MANUAL START, SENSITIVITY/SWITCH AT CHECK. OUTPUT SWITCH WAS ROTATED FROM 100Hz POSITION TO 10MHz POSITION

REFERENCE DESIGNATIONS

NO PREFIX	A4	A5
C18		C1 - 2
J4 - 5	C1	CRI
R1	R1	Q1
	S1	RI - 5
		SI

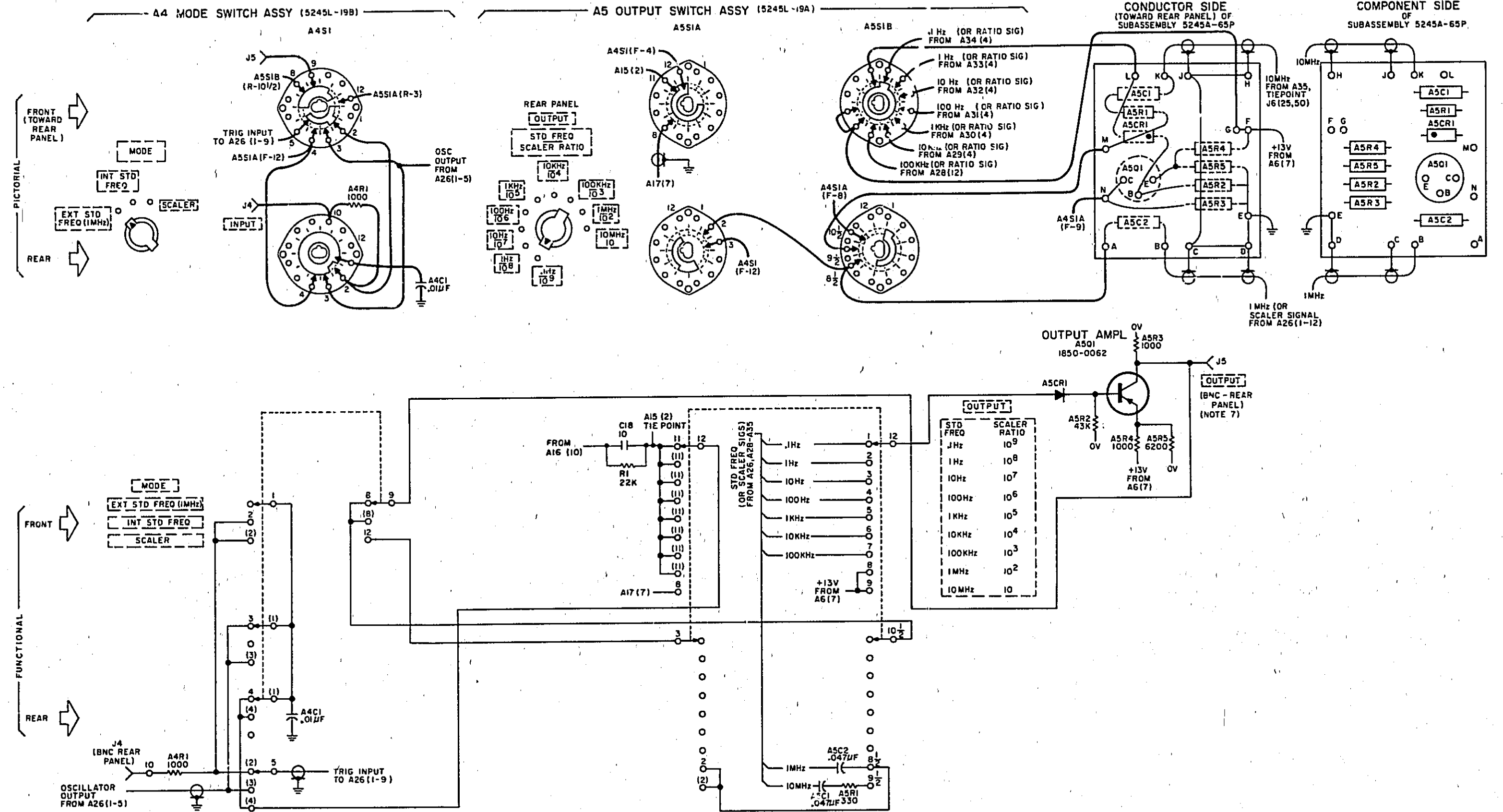
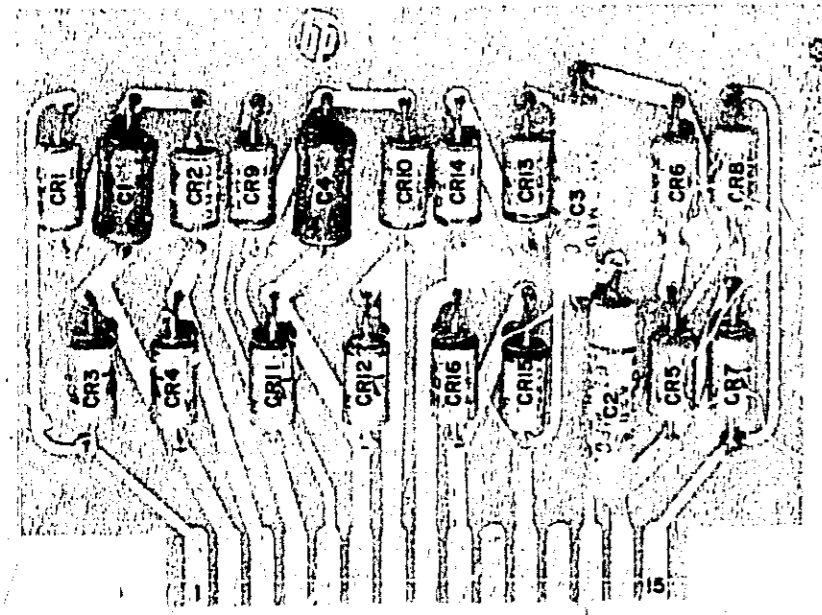
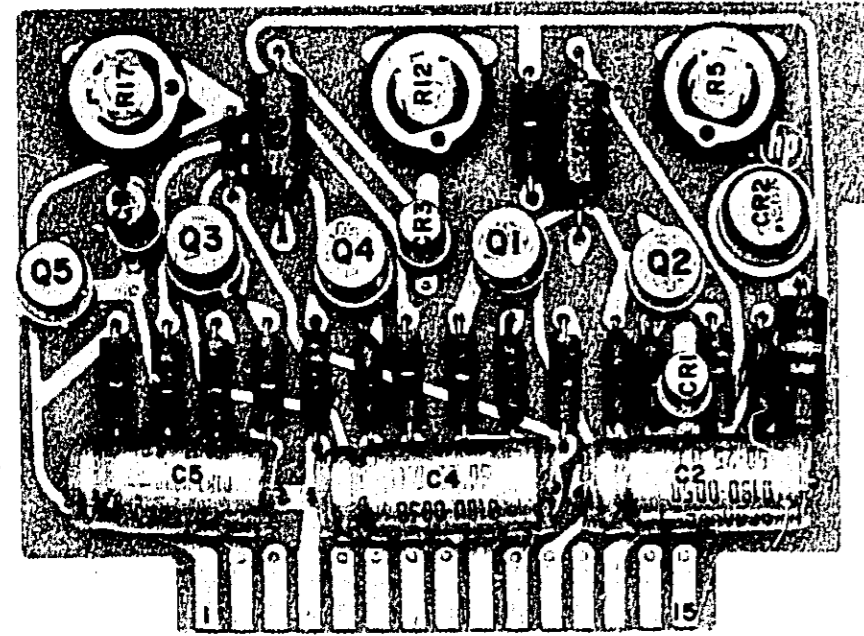

Figure 7-6. A4, A5 Mode Switch, Output Switch
7-11/7-12



A6



A7

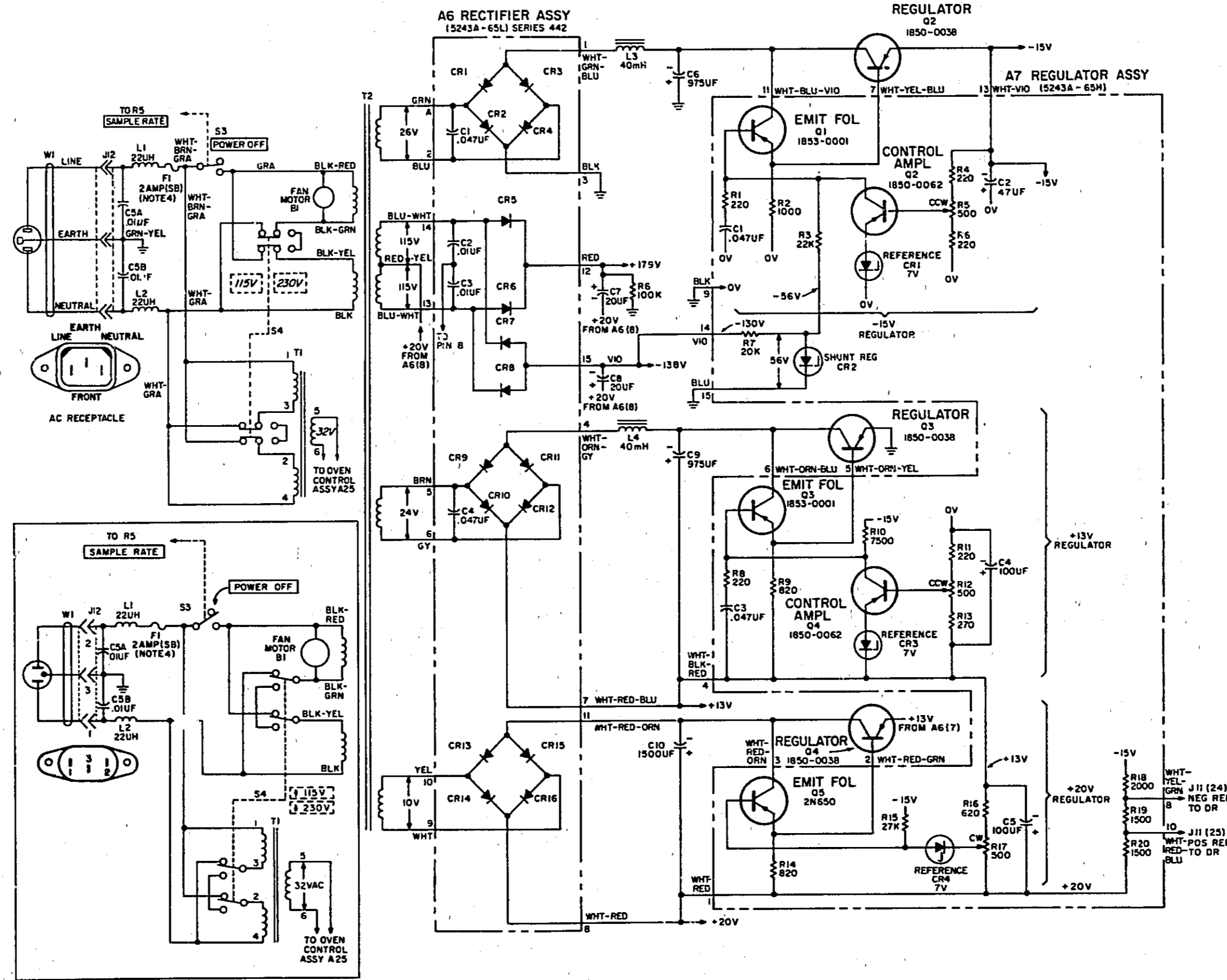

POWER DISTRIBUTION

ASSY	-15V	+13V	+20V	+170V	-130V	OV	ASSY	-15V	+13V	+20V	+170V	-130V	OV
A1	✓					✓	A19	✓	✓	✓			✓
A2	✓					✓	A20	✓	✓	✓			✓
A3	✓					✓	A21	✓	✓	✓			✓
A4	✓					✓	A22	✓	✓	✓			✓
A5	✓					✓	A23	✓	✓	✓			✓
A6						✓	A24	✓	✓	✓			✓
A7						✓	A25			(32 VAC)			✓
A8	✓	✓	✓	✓	✓	✓	A26	✓	✓	✓	✓	✓	✓
A9	✓	✓	✓	✓	✓	✓	A27	✓	✓	✓	✓	✓	✓
A10	✓	✓	✓	✓	✓	✓	A28	✓	✓	✓	✓	✓	✓
A11	✓	✓	✓	✓	✓	✓	A29	✓	✓	✓	✓	✓	✓
A12	✓	✓	✓	✓	✓	✓	A30	✓	✓	✓	✓	✓	✓
A13	✓	✓	✓	✓	✓	✓	A31	✓	✓	✓	✓	✓	✓
A14	✓	✓	✓	✓	✓	✓	A32	✓	✓	✓	✓	✓	✓
A15	✓	✓	✓	✓	✓	✓	A33	✓	✓	✓	✓	✓	✓
A16	✓	✓	✓	✓	✓	✓	A34	✓	✓	✓	✓	✓	✓
A17	✓	✓	✓	✓	✓	✓	A35	✓	✓	✓	✓	✓	✓
A18	✓	✓	✓	✓	✓	✓	J6	✓	✓	✓	✓	✓	✓
							J9	✓	✓	✓	✓	✓	✓
							J10	✓	✓	✓	✓	✓	✓

- NOTES**
- REFERENCE DESIGNATIONS WITHIN THIS ASSEMBLY ARE ABBREVIATED. ADD ASSEMBLY NUMBER TO ABBREVIATION FOR COMPLETE DESCRIPTION.
 - UNLESS OTHERWISE INDICATED: RESISTANCE IN OHMS; CAPACITANCE IN PICOFARADS; INDUCTANCE IN MICROHENRIES
 - ASTERISK(*) INDICATES SELECTED COMPONENT, AVERAGE VALUES SHOWN
 - FOR 230V OPERATION, OPERATE S4 TO 230V POSITION AND INSTALL 1AMP SLOW-BLOW FUSE (F1)

REFERENCE DESIGNATIONS

NO PREFIX	PREFIX A6	PREFIX A7
A6,7		
B1		
C5-10	C1-4	C1-5
F1	CR1-16	CR1-4
L1-L4		
Q2-4		Q1-5
R6		R1-20
S3,4		
T1,2		
W1		

COPYRIGHT 1965 BY HEWLETT-PACKARD COMPANY

02149-D-18ABDUF

Figure 7-7. A6, A7 Rectifier, Regulator

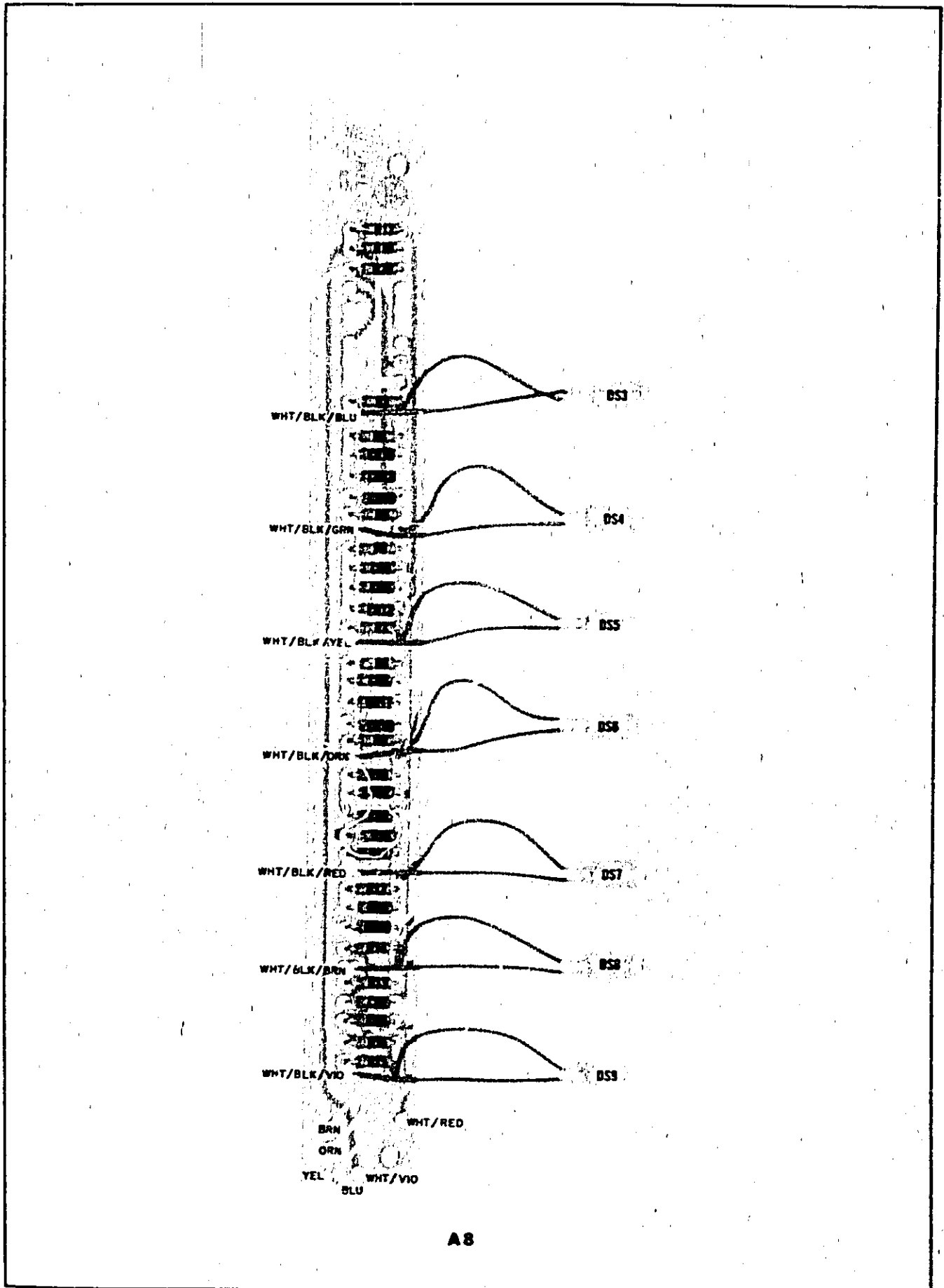

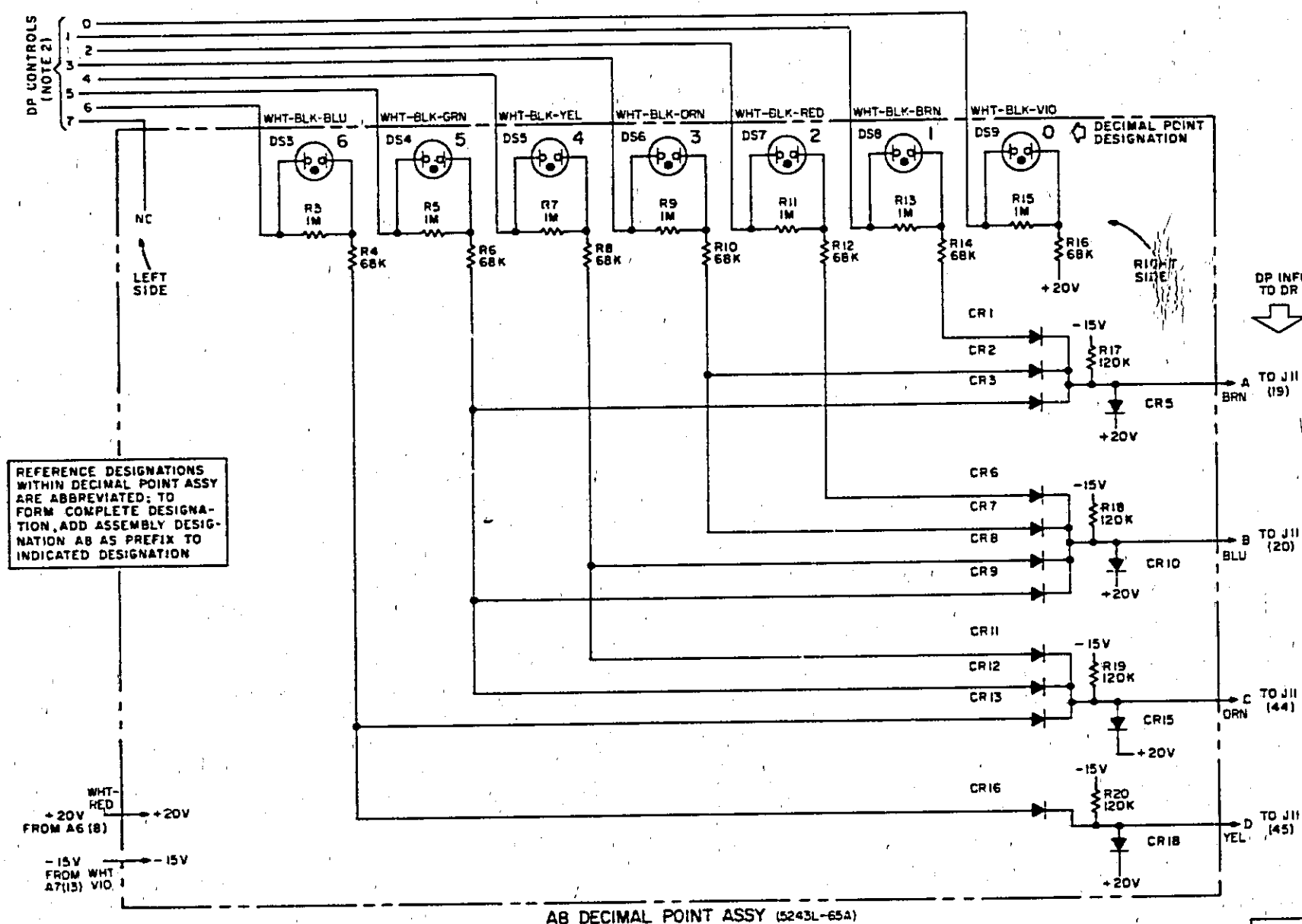
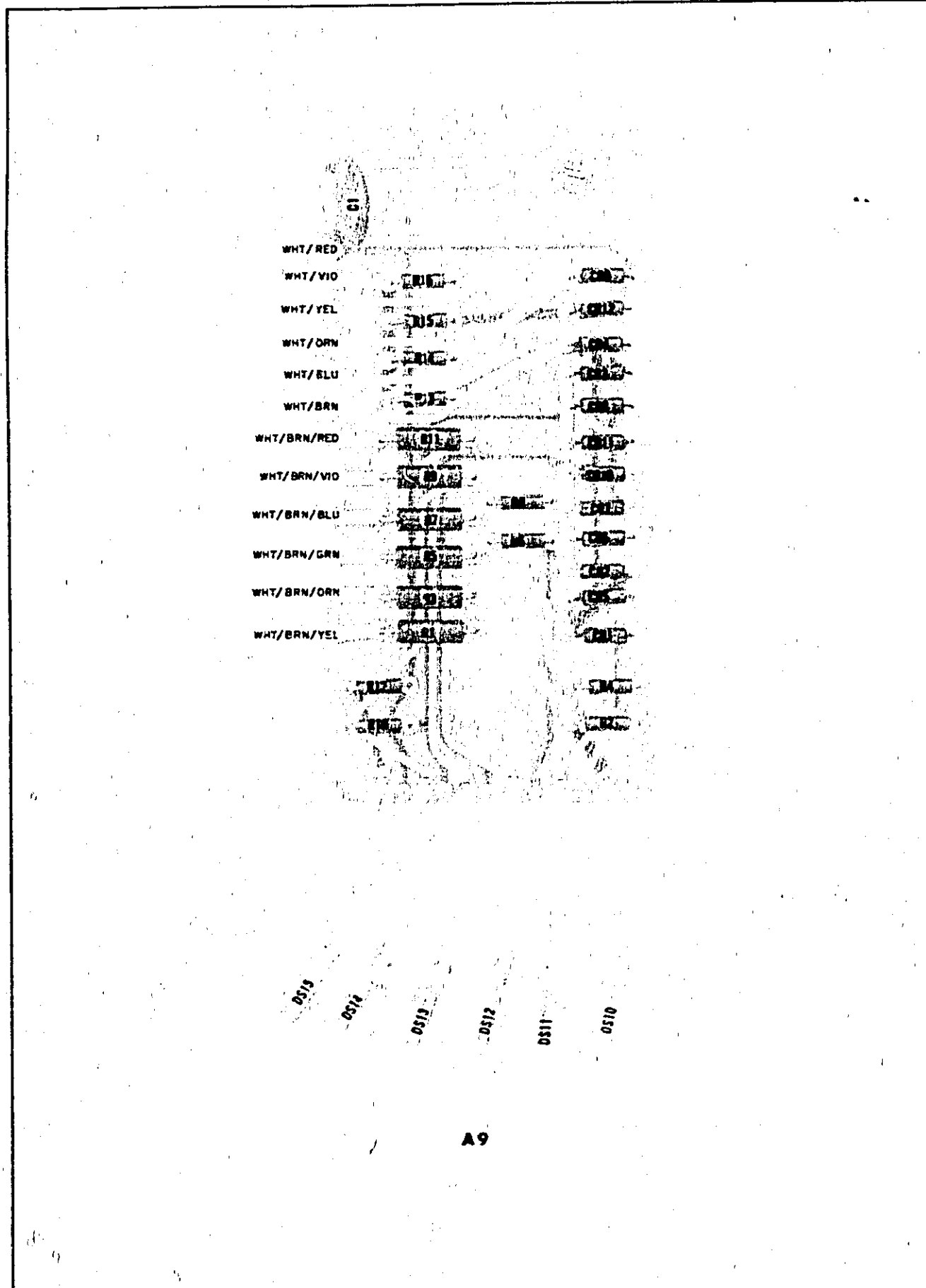

REFERENCE DESIGNATIONS WITHIN DECIMAL POINT ASSY ARE ABBREVIATED; TO FORM COMPLETE DESIGNATION, ADD ASSEMBLY DESIGNATION AS PREFIX TO INDICATED DESIGNATION

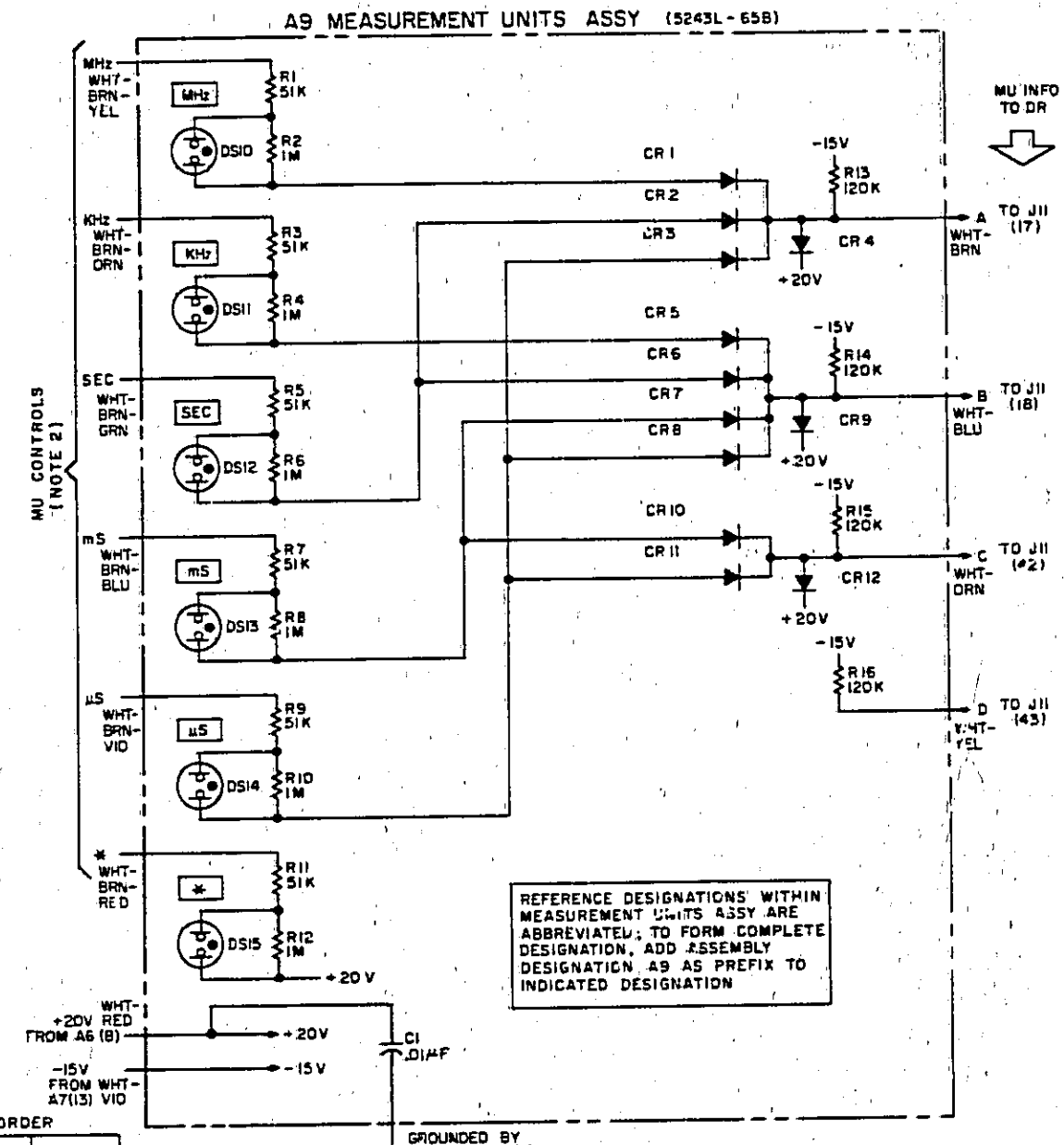

REFERENCE DESIGNATIONS WITHIN MEASUREMENT UNITS ASSY ARE ABBREVIATED; TO FORM COMPLETE DESIGNATION, ADD ASSEMBLY DESIGNATION AS PREFIX TO INDICATED DESIGNATION

NOTES

- UNLESS OTHERWISE INDICATED, RESISTANCE IN OHMS, CAPACITANCE IN PICOFARADS
- INPUT OF +170V FOR DP CONTROLS AND MU CONTROLS IS REQUIRED TO TURN LAMPS ON; SEE TABLE ON OVERALL DIAGRAM SHEET FOR COMPLETE DESCRIPTION

REFERENCE DESIGNATIONS

PREFIX A8	PREFIX A9
CR1-18	CR1-12
DS2-9	DS10-15
R1-20	R1-16

DELETED: ABCR4, CR14, CR17
ABDS2
ABR1, R2

COMPONENT LOCATION (5243L-65A), FROM FRONT

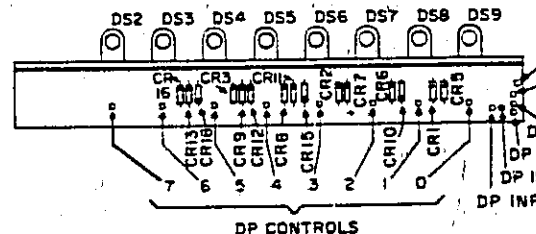

OUTPUT TO RECORDER

LIGHTED SYMBOL	4 LINE CODE (0 = -, 1 = +)				PRINTED DIGIT
	D	C	B	A	
NONE	0	0	0	0	0
0	0	0	0	1	1
1	0	0	1	0	2
2	0	0	1	1	3
3	0	1	0	0	4
4	0	1	0	1	5
5	0	1	1	0	6
6	1	0	0	0	7
7	1	0	0	1	
MHz	0	0	0	1	1
KHz	0	0	1	0	2
SEC	0	0	1	1	3
mS	0	1	0	0	4
uS	0	1	1	0	5
*	0	0	0	0	0

COMPONENT LOCATION (5243L-65B), FROM LEFT

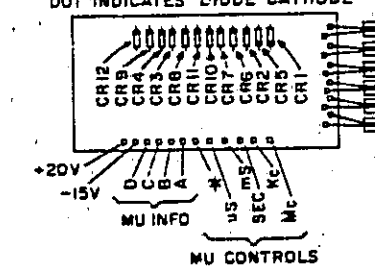

COPYRIGHT 1965 BY HEWLETT-PACKARD COMPANY
This drawing is intended for the operation and maintenance of Hewlett-Packard equipment and is not to be used otherwise or reproduced without written consent of the Hewlett-Packard Company.
5245L/DPA-A8, A9-AS/408

Figure 7-8. A8, A9 Decimal Point, Measurement Units

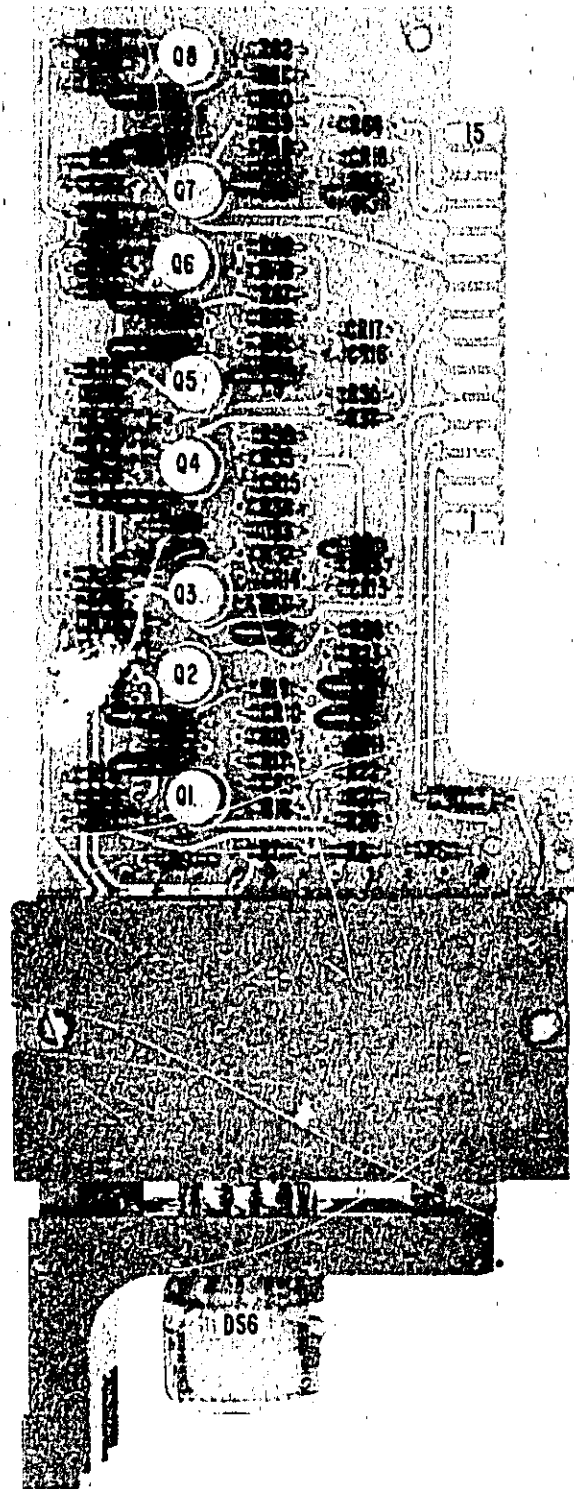

A10-A15

NOTES

- UNLESS OTHERWISE INDICATED: RESISTANCE IN OHMS, CAPACITANCE IN PICOFARADS
- REFERENCE DESIGNATIONS IN PARENTHESES INDICATE LIGHT DESIGNATION FOR DS1-DS4; LIGHT SOURCE IS NOTED NEAR EACH VI SECTION
- FOR DS1-DS4, SECTION A LIGHTS ON "1", SECTION B LIGHTS ON "0"
- FILLED SQUARE (■) INDICATES CONDUCTING ELEMENT FOR DECIMAL "0" (BCD "0000")

TRUTH TABLE

DIGIT	4 LINE CODE (0-1-+)				RELEVANT STAGES				
	D	C	B	A	VI	D	C	B	A
0	0	0	0	0	HPS				
1	0	0	0	1	DMR				
2	0	0	1	0	FNS				
3	0	0	1	1	BLR				
4	0	1	1	0	KOT				
5	0	1	1	1	JQT				
6	1	1	0	0	SPS				
7	1	1	0	1	CMR				
8	1	1	1	0	ENS				
9	1	1	1	1	ALR				

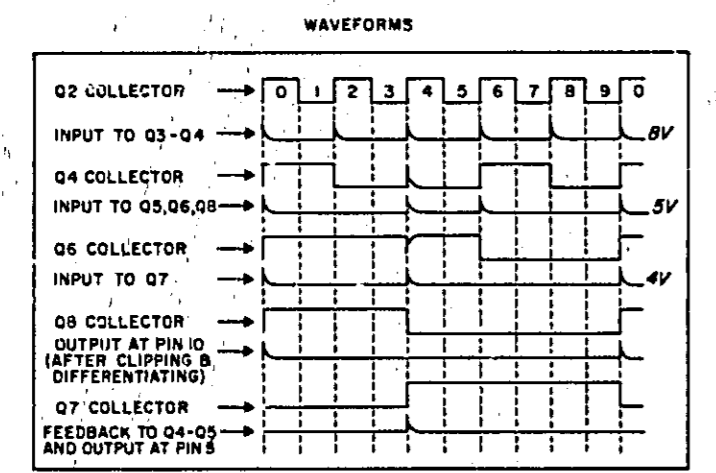
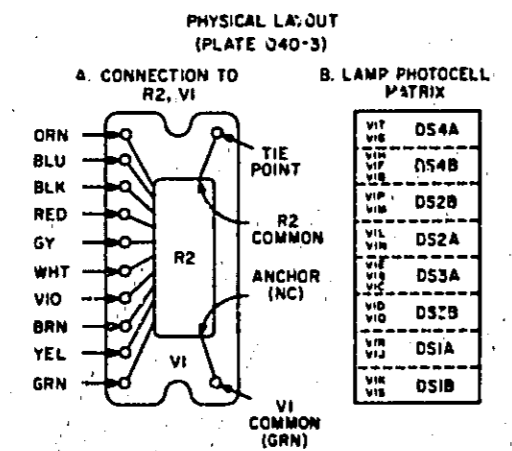

REFERENCE DESIGNATIONS

A10 - A15
C1 - 15
CR1 - 18
DS1 - 4, 6
Q1 - 8
R1 - 65

DELETED:
DS5
R5, 4, 5

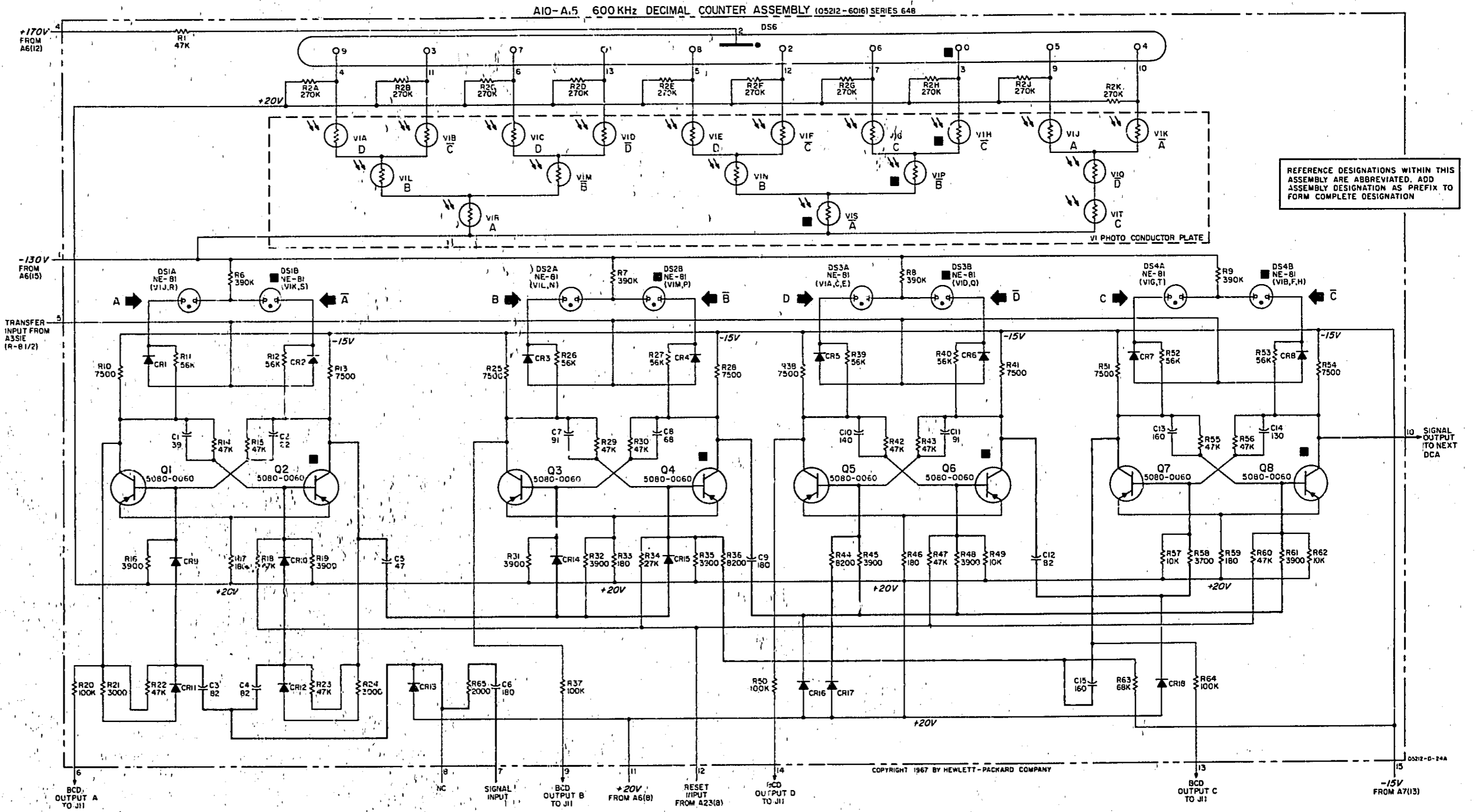

REFERENCE DESIGNATIONS WITHIN THIS ASSEMBLY ARE ABBREVIATED. ADD ASSEMBLY DESIGNATION AS PREFIX TO FORM COMPLETE DESIGNATION

Figure 7-9. A10-A15 Decimal Counter (05212-6016)

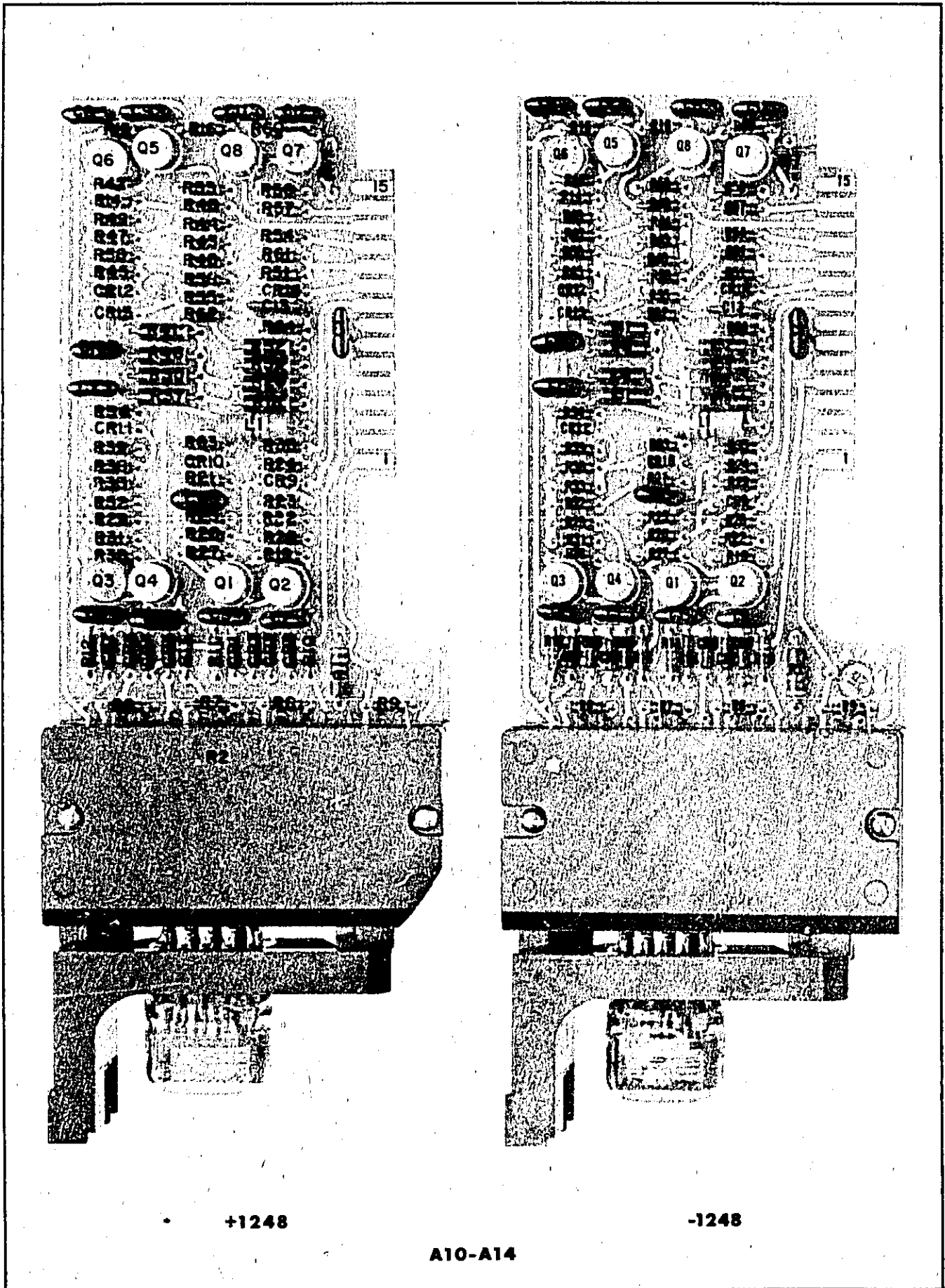

NOTES

- UNLESS OTHERWISE INDICATED: RESISTANCE IN OHMS; CAPACITANCE IN PICOFARADS
- REFERENCE DESIGNATIONS IN PARENTHESES INDICATE LIGHT DESTINATION FOR DS1-DS4. LIGHT SOURCE IS NOTED NEAR EACH VI SECTION.
- FOR DS1-DS4, SECTION A LIGHTS ON "1"; SECTION B LIGHTS ON "0"
- FILLED SQUARE (■) INDICATES CONDUCTING ELEMENT FOR DECIMAL "0" (BCD "0000")
- OUTPUT CODE:
OPTION002: 1+ +18V, 0 - 8V
OPTION003: 1+ - 8V, 0 + +18V
- THE 05212-6002 DCA'S ARE USED IN OPTION 02 INSTRUMENTS, THE 05212-6003 DCA'S ARE USED IN OPTION003 INSTRUMENTS. THIS SCHEMATIC IS FOR BOTH DCA'S. THE ASSEMBLIES ARE IDENTICAL WITH ONE EXCEPTION. THE OPTION002 DCA'S (05212-6002) WITH A "1" STATE POSITIVE BCD OUTPUT HAVE RESISTORS MARKED WITH A DOUBLE ASTERISK (**), CONNECTED TO COLLECTORS AS SHOWN BY ---+--- LINES. THE OPTION003 DCA'S (05212-6003) WITH A "1" STATE NEGATIVE BCD OUTPUT HAVE THESE RESISTORS CONNECTED TO OPPOSITE COLLECTORS AS SHOWN BY ---+--- LINE.

REFERENCE DESIGNATIONS

A10 - A14	
C	1 - 13
CR	1 - 14
DS	1 - 6
L	1 - 8
R	1 - 64
V	1

OMITTED: DS3
R3-5

TRUTH TABLE

DIGIT	4 LINE CODE				RELEVANT STAGES				
	D	C	B	A	VI	BINARY			
0	0	0	0	0	KPRT	D	C	B	A
1	0	0	0	1	FMOT				
2	0	0	1	0	HNRT				
3	0	0	1	1	EMQT				
4	0	1	0	0	JPRT				
5	0	1	0	1	DLQT				
6	0	1	1	0	GNRT				
7	0	1	1	1	CLQT				
8	1	0	0	0	BS				
9	1	0	0	1	AS				

WAVEFORMS

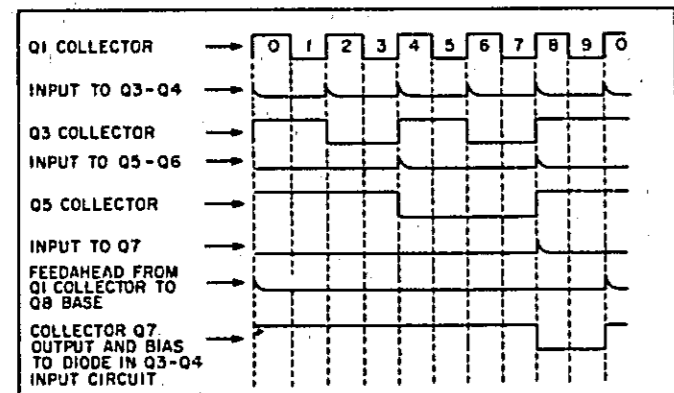

00245-D-92

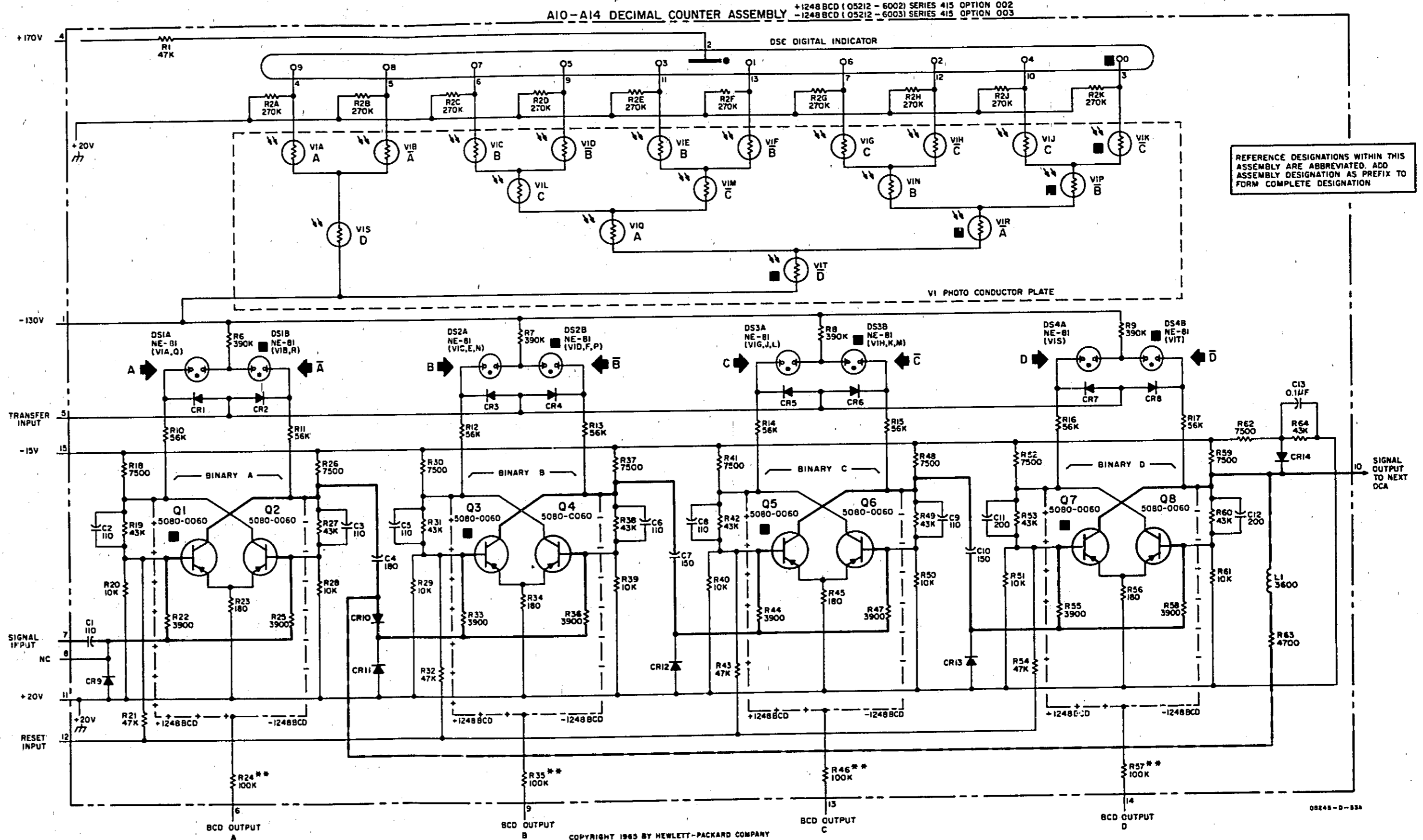

REFERENCE DESIGNATIONS WITHIN THIS ASSEMBLY ARE ABBREVIATED. ADD ASSEMBLY DESIGNATION AS PREFIX TO FORM COMPLETE DESIGNATION

Figure 7-10. A10-A14 Decimal Counter (05212-6002, 6003) Option 002, 003

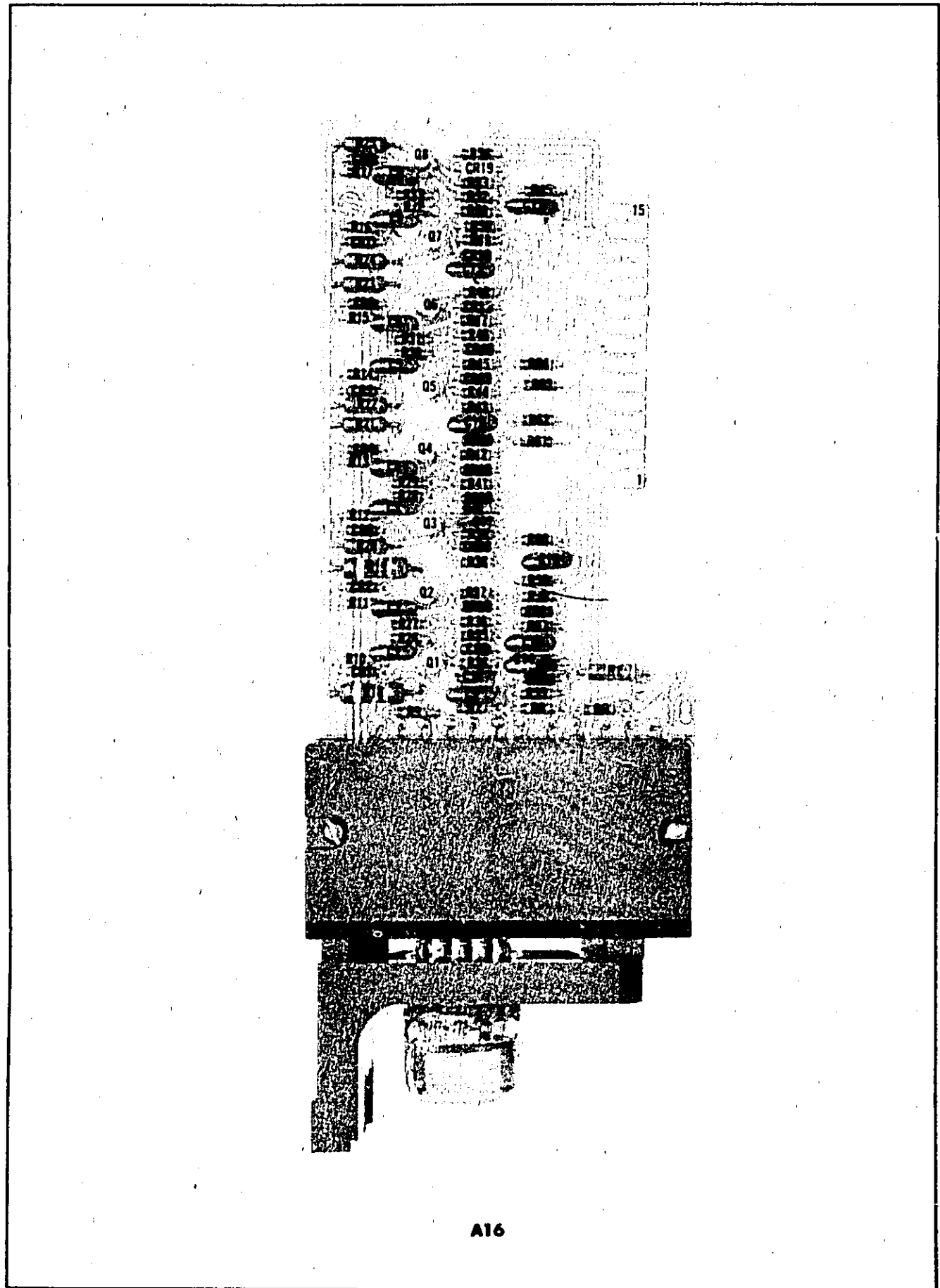

NOTES

- UNLESS OTHERWISE INDICATED: RESISTANCE IN OHMS; CAPACITANCE IN PICOFARADS
- FILLED SQUARE (■) INDICATES CONDUCTING ELEMENT FOR DECIMAL "0" (BCD "0000"); FOR DS1-DS4, SECTION "A" LIGHTS ON "1" SECTION "B" LIGHTS ON "0".

REFERENCE DESIGNATIONS

A15 (A16)	
C	1-17
CR	1-21
DS	1-6
Q	1-8
R	1-65
V	1

DELETED
DS5
R3-5

PHYSICAL LAYOUT
(PLATE O40-3)

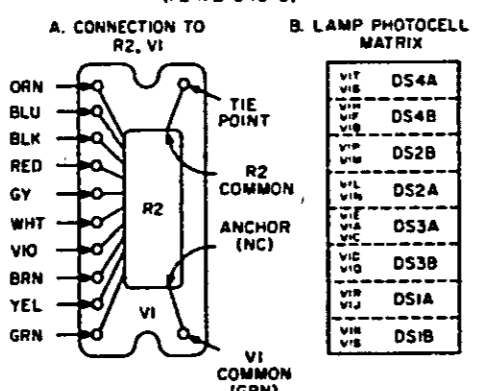

TRUTH TABLE

DIGIT	4 LINE CODE (0+--1+)				RELEVANT STAGES			
	D	C	B	A	VI BINARY			
0	0	0	0	0	HPS			
1	0	0	0	1	DMR			
2	0	0	1	0	FNS			
3	0	0	1	1	BLR			
4	0	1	0	0	KQT			
5	0	1	0	1	JOT			
6	1	0	0	0	GPS			
7	1	0	0	1	CMR			
8	1	1	0	0	ENS			
9	1	1	0	1	ALR			

WAVEFORMS

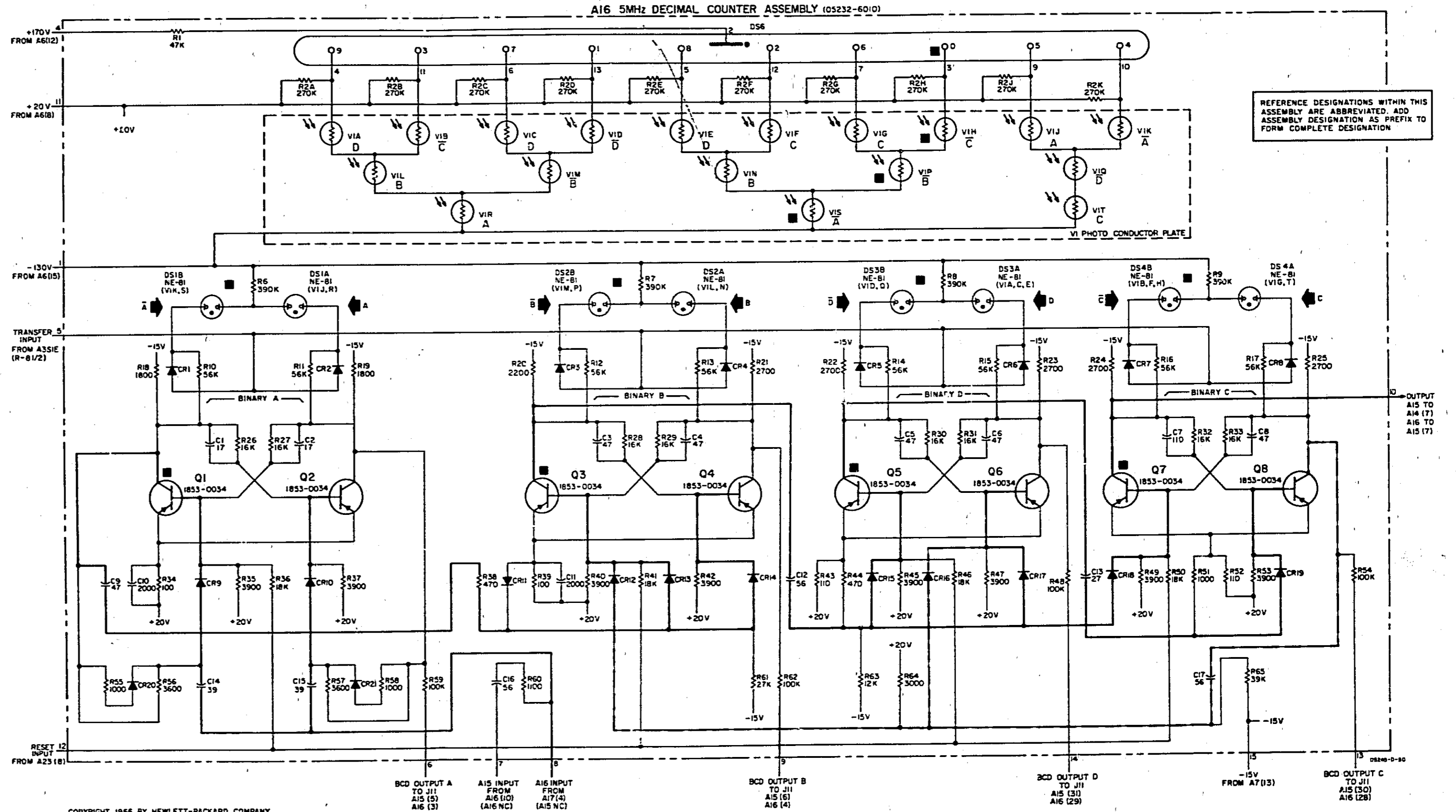
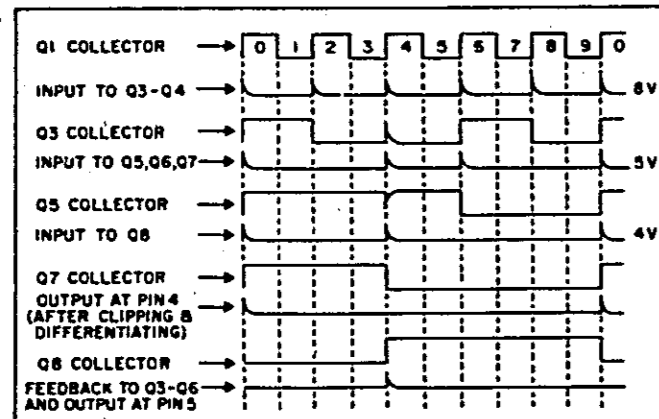

REFERENCE DESIGNATIONS WITHIN THIS ASSEMBLY ARE ABBREVIATED. ADD ASSEMBLY DESIGNATION AS PREFIX TO FORM COMPLETE DESIGNATION

COPYRIGHT 1966 BY HEWLETT-PACKARD COMPANY

Figure 7-11. A16 5 MHz Decimal Counter (05232-6010)

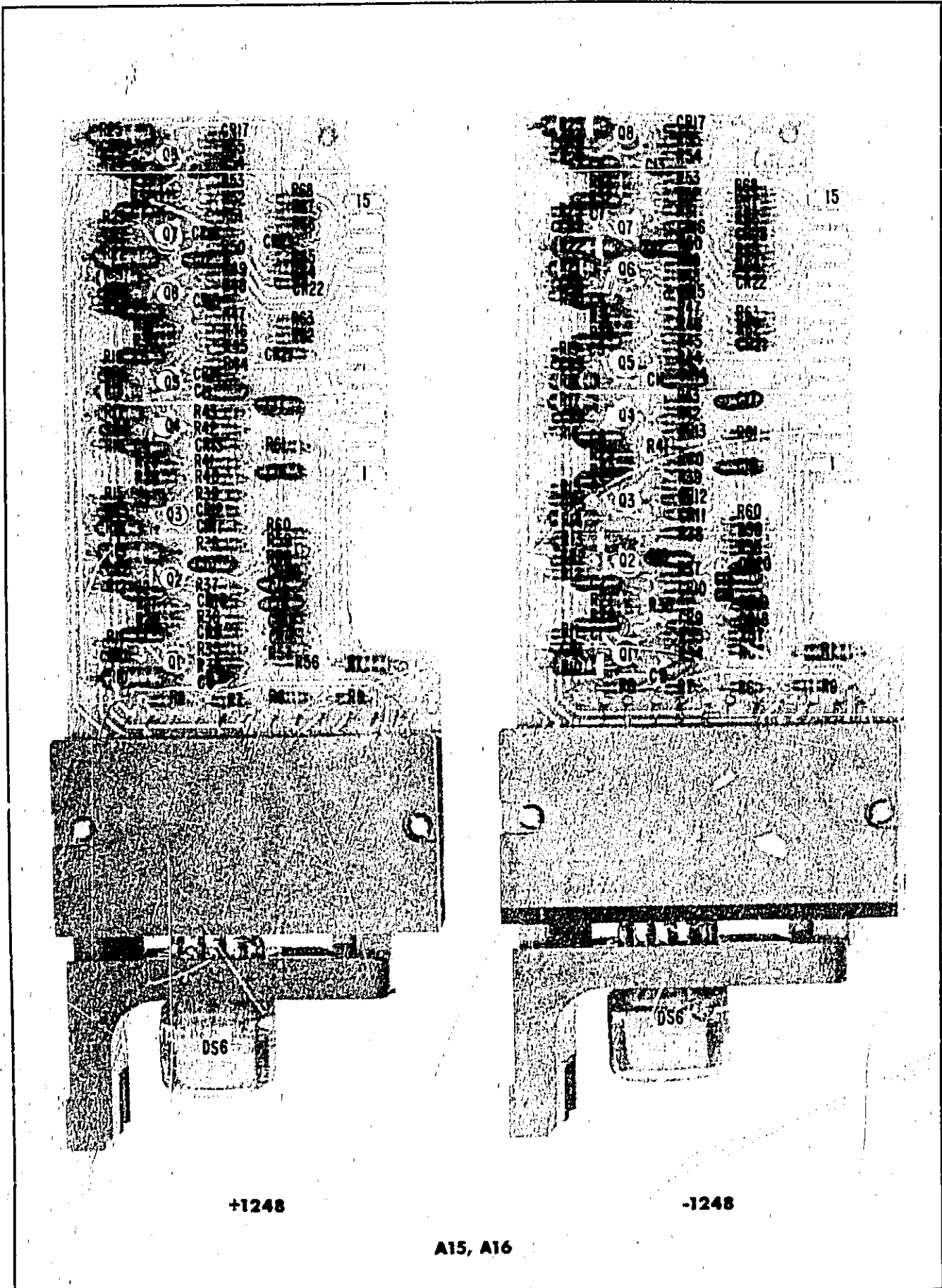

1. UNLESS OTHERWISE INDICATED:
RESISTANCE IN OHMS;
CAPACITANCE IN PICOFARADS
2. REFERENCE DESIGNATIONS IN PARENTHESES INDICATE LIGHT DESTINATION FOR DS1 - DS4. LIGHT SOURCE IS NOTED NEAR EACH VI SECTION.
3. FOR DS1 - DS4, SECTION A LIGHTS ON "I" SECTION B LIGHTS ON "O"
4. FILLED SQUARE (■) INDICATES CONDUCTING ELEMENT FOR DECIMAL "0" (BCD "0000")
5. OUTPUT CODE:
OPTION002 I = +18V, O = -8V
OPTION003 I = -8V, O = +18V

NOTES

6. THE 05232-6002 DCA'S ARE USED IN OPTION 002 INSTRUMENTS ("I" STATE POSITIVE BCD OUTPUT). THE 05232-6003 DCA'S ARE USED IN OPTION 003 INSTRUMENTS ("I" STATE NEGATIVE BCD OUTPUT). THIS SCHEMATIC IS FOR BOTH DCAs. THE ASSEMBLIES ARE IDENTICAL WITH ONE EXCEPTION, THE OPTION 002 DCAs (05232-6002) HAVE RESISTORS MARKED WITH DOUBLE ASTERISKS (**) CONNECTED TO COLLECTORS AS SHOWN BY ---+--- LINES. THE OPTION 003 DCA'S (05232-6003) HAVE THESE RESISTORS CONNECTED TO OPPOSITE COLLECTORS AS SHOWN BY -+--- LINES.

REFERENCE DESIGNATIONS

A15, A16	
C	I - 17
CR	I - 23
DS	I - 6
Q	I - 8
R	I - 68
V	I

OMITTED: DS5
R3-5

DIGIT	4 LINE CODE				RELEVANT STAGES				
	D	C	B	A	VI	D	C	B	A
0	0	0	0	0	KPRT				
1	0	0	0	1	FMOT				
2	0	0	1	0	HNRT				
3	0	0	1	1	EMOT				
4	0	1	0	0	JPRT				
5	0	1	0	1	DLDT				
6	0	1	1	0	JNRT				
7	0	1	1	1	CLDT				
8	1	0	0	0	BS				
9	1	0	0	1	AS				

WAVEFORMS

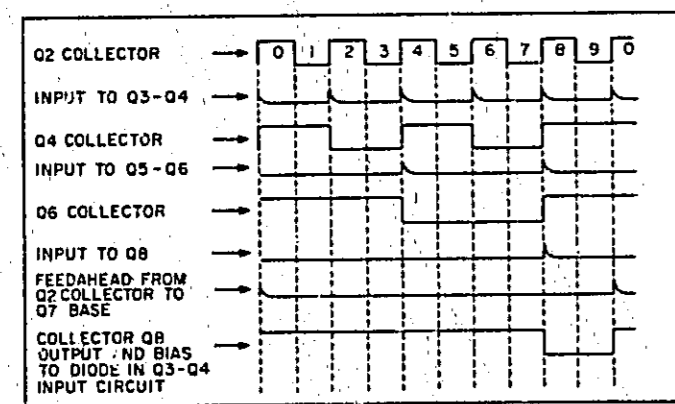

05245-0-15

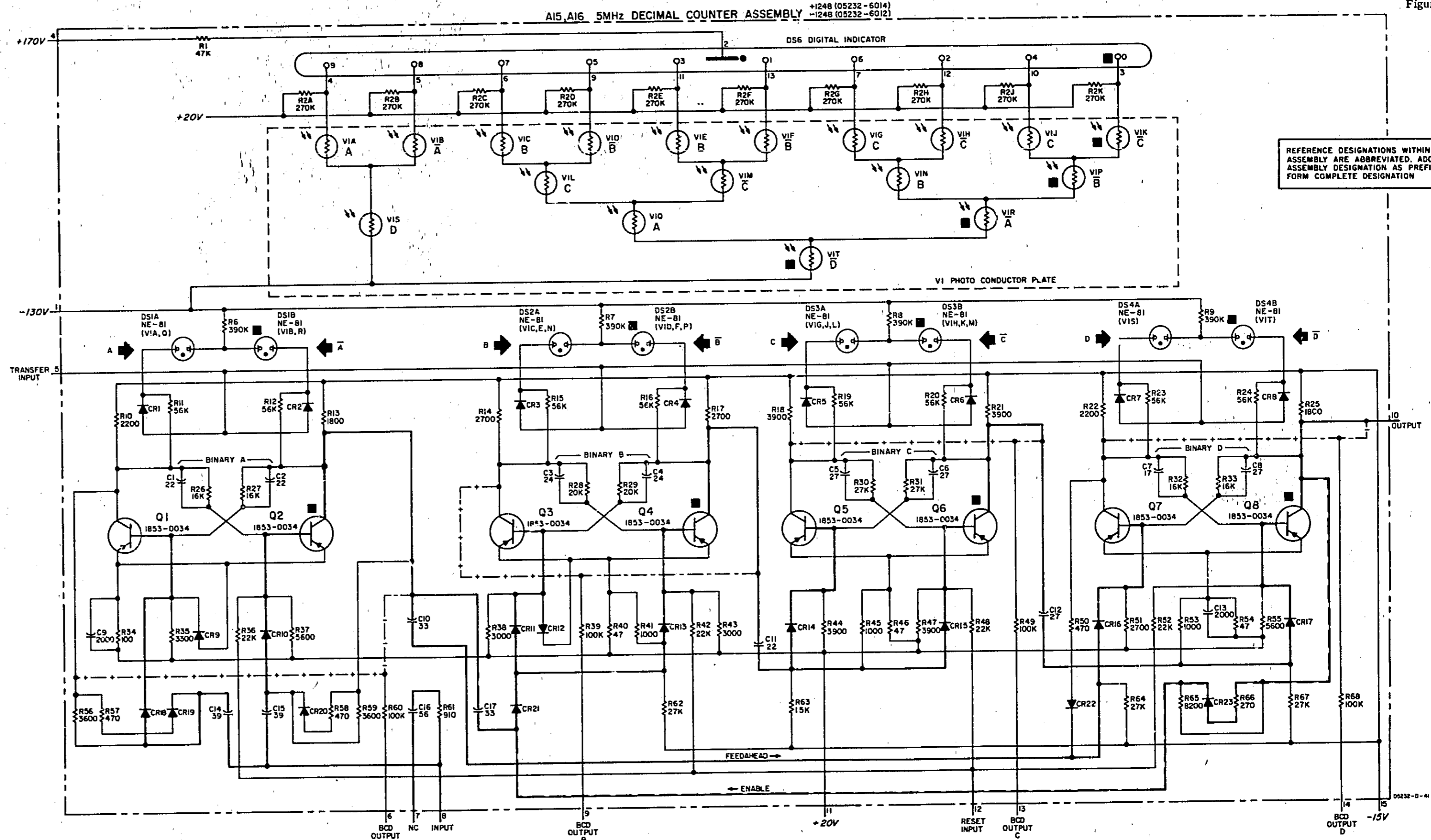

REFERENCE DESIGNATIONS WITHIN THIS ASSEMBLY ARE ABBREVIATED. ADD ASSEMBLY DESIGNATION AS PREFIX TO FORM COMPLETE DESIGNATION

Figure 7-12. A15, A16 Decimal Counter (05232-6014, 6012)
Option 002, 003

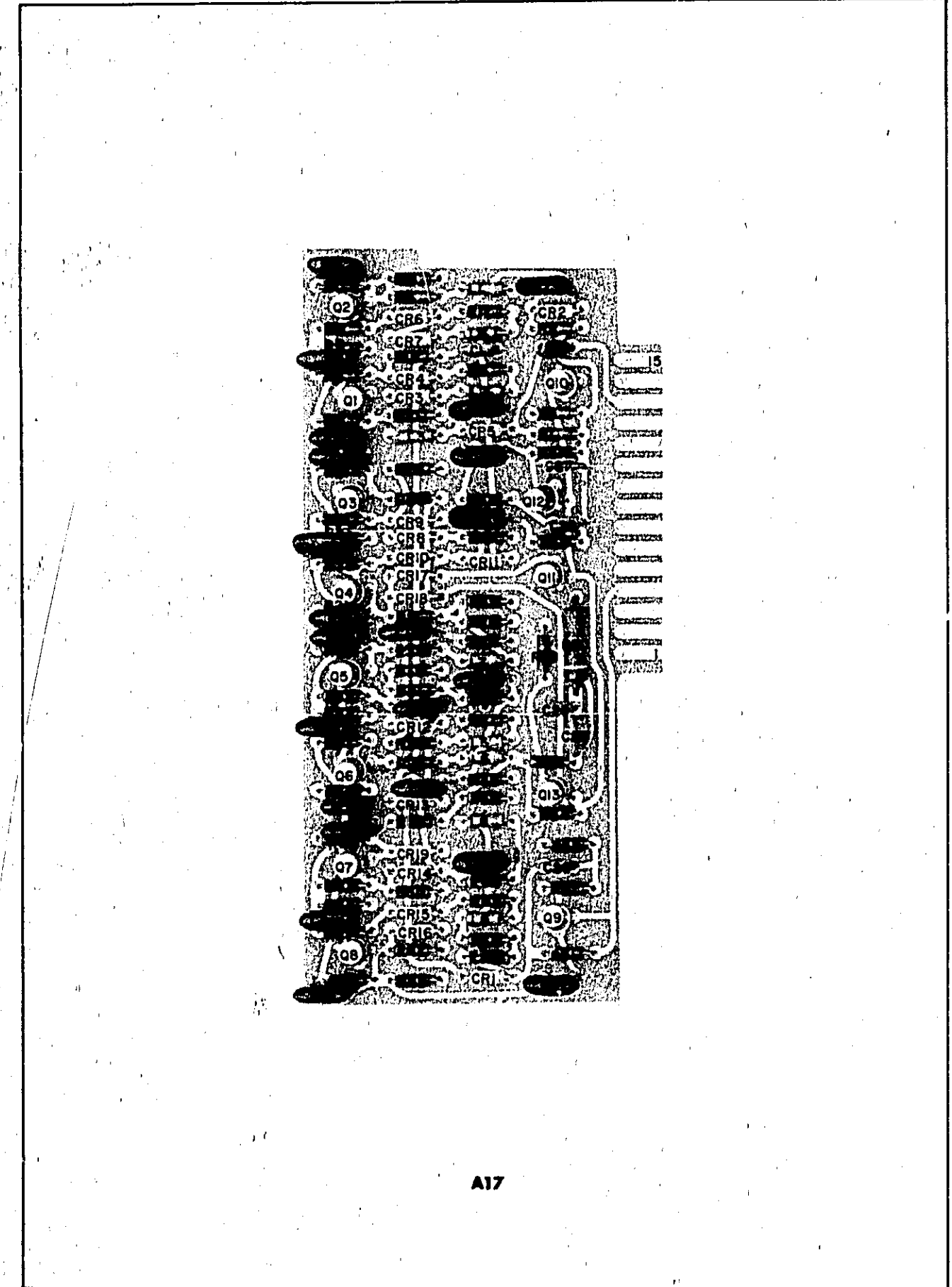

A17

- NOTES**
- UNLESS OTHERWISE INDICATED: RESISTANCE IN OHMS, CAPACITANCE IN PICOFARADS, INDUCTANCE IN MICRohenRIES
 - FILLED SQUARE (■) INDICATES CONDUCTING TRANSISTOR FOLLOWING RESET (BCD+0000)
 - ASTERISK (*) INDICATES SELECTED COMPONENT AVERAGE VALUE SHOWN

REFERENCE DESIGNATIONS

NO PREFIX	PREFIX A17
C11-13,15	C1-29
R7	CR1-20
	L1-9
	Q1-13
	R1-62

COPYRIGHT 1965 BY HEWLETT-PACKARD COMPANY

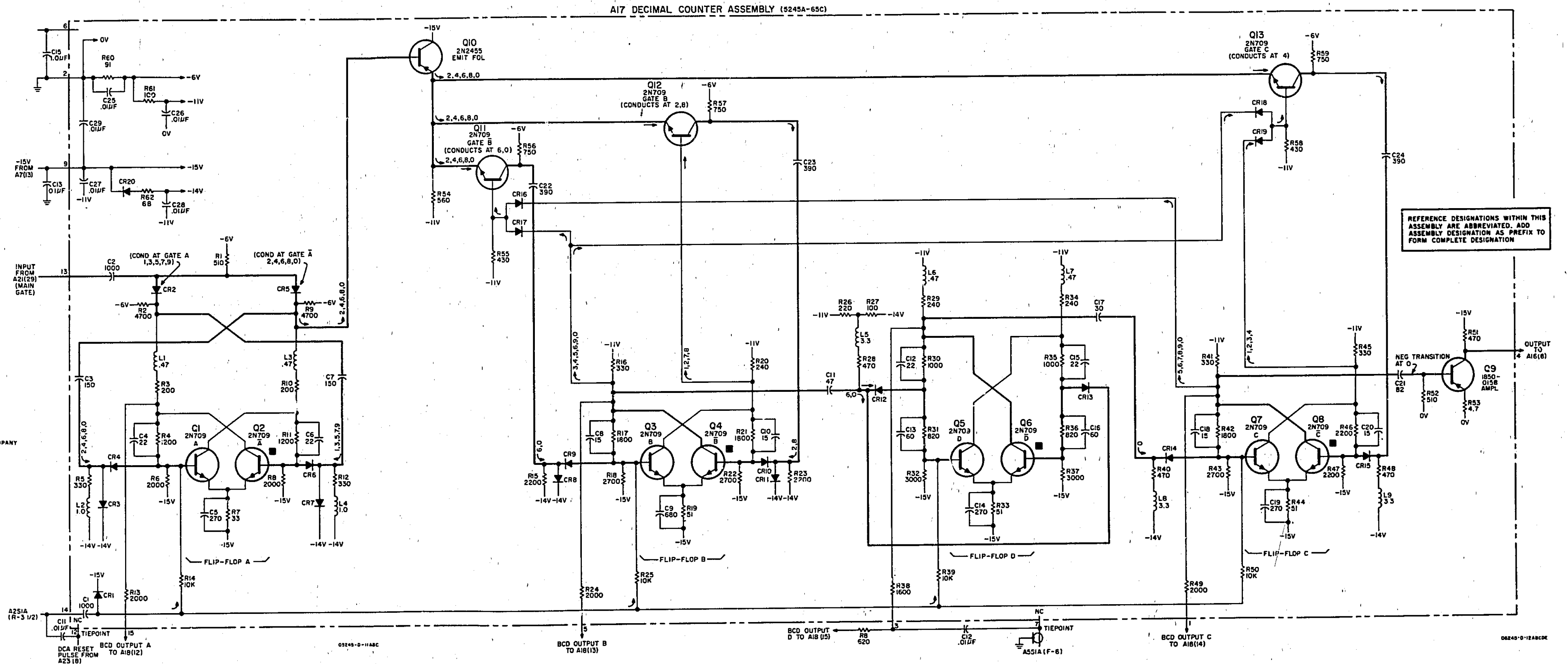

REFERENCE DESIGNATIONS WITHIN THIS ASSEMBLY ARE ABBREVIATED. ADD ASSEMBLY DESIGNATION AS PREFIX TO FORM COMPLETE DESIGNATION

Figure 7-13. A17 Decimal Counter
7-25/7-26

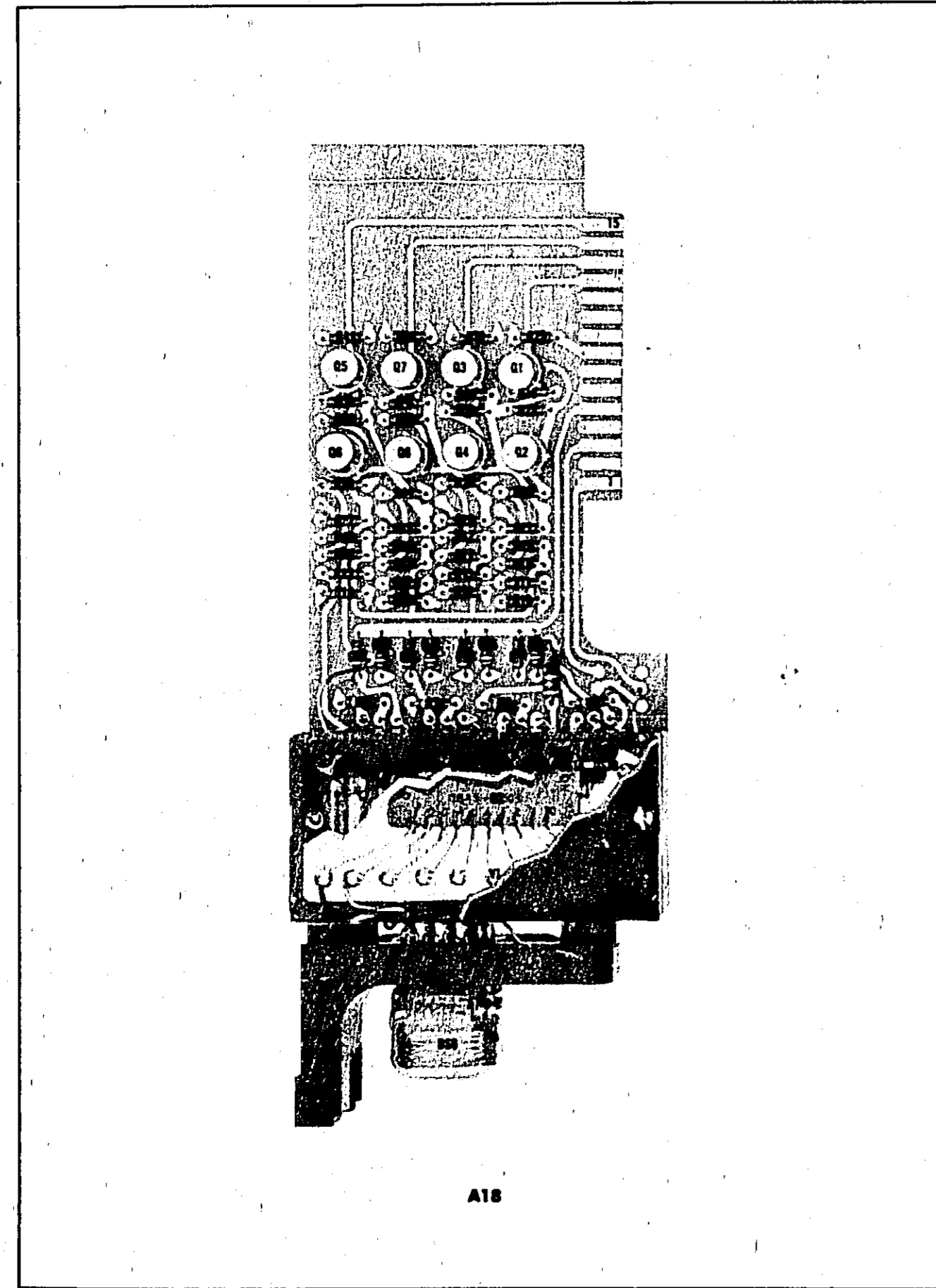

A18

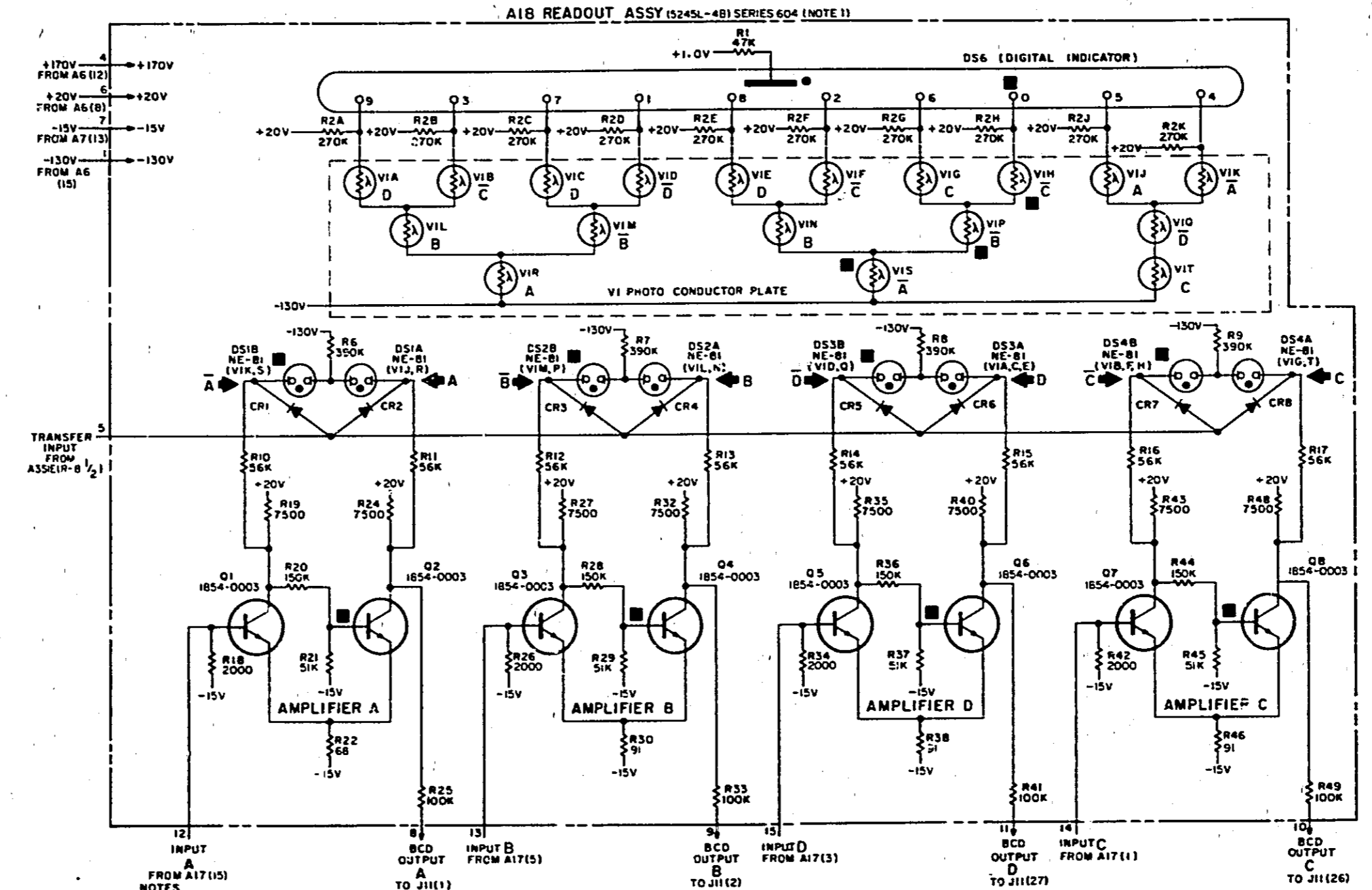

1 REFERENCE DESIGNATIONS WITHIN READ-OUT ASSEMBLY ARE INCOMPLETE; TO FORM COMPLETE REFERENCE DESIGNATION, ADD ASSEMBLY DESIGNATION A18 AS PREFIX TO INDICATED DESIGNATION.

2 UNLESS OTHERWISE INDICATED: RESISTANCE IN OHMS; CAPACITANCE IN PICOFARADS

3 REFERENCE DESIGNATIONS IN PARENTHESES INDICATE LIGHT DESTINATION FOR DS1-DS4; LIGHT SOURCE IS NOTED NEAR EACH VI SECTION.

4 FILLED SQUARE (■) INDICATES CONDUCTING ELEMENT FOR DECIMAL "0" (BCD "0000").

COPYRIGHT 1965 BY HEWLETT-PACKARD COMPANY

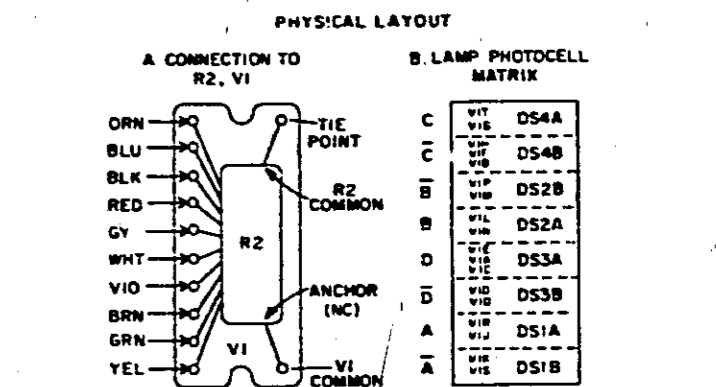
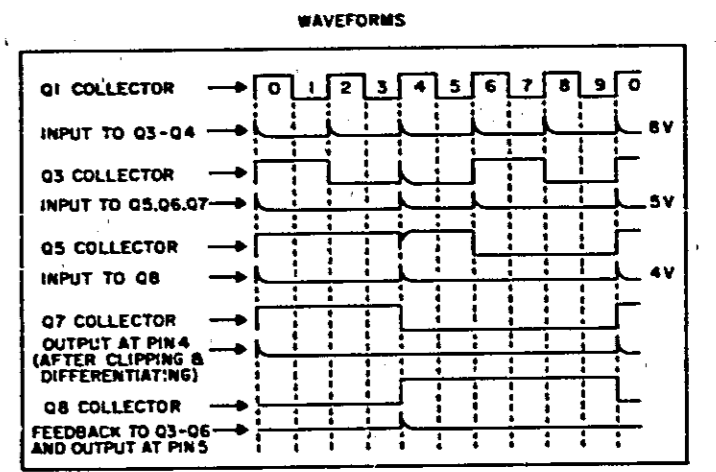

DIGIT	4 LINE CODE (0 = -, 1 = +)				RELEVANT STAGES					
	D	C	B	A	VI	AMPLIFIER	D	C	B	A
0	0	0	0	0	HPS	■	■	■	■	■
1	0	0	0	1	DMR	■	■	■	■	■
2	0	0	1	1	FWS	■	■	■	■	■
3	0	0	1	0	BLR	■	■	■	■	■
4	0	1	1	0	KOT	■	■	■	■	■
5	0	1	1	1	JOT	■	■	■	■	■
6	1	1	0	0	GPS	■	■	■	■	■
7	1	1	0	1	CMR	■	■	■	■	■
8	1	1	1	0	ENS	■	■	■	■	■
9	1	1	1	1	ALR	■	■	■	■	■

REFERENCE DESIGNATIONS

CR1 - 8
DS1 - 6
Q1 - 8
R1 - 49
VI

OMITTED:
DS5
R3-5,23,39,47

Figure 7-14. A18 Readout
7-27

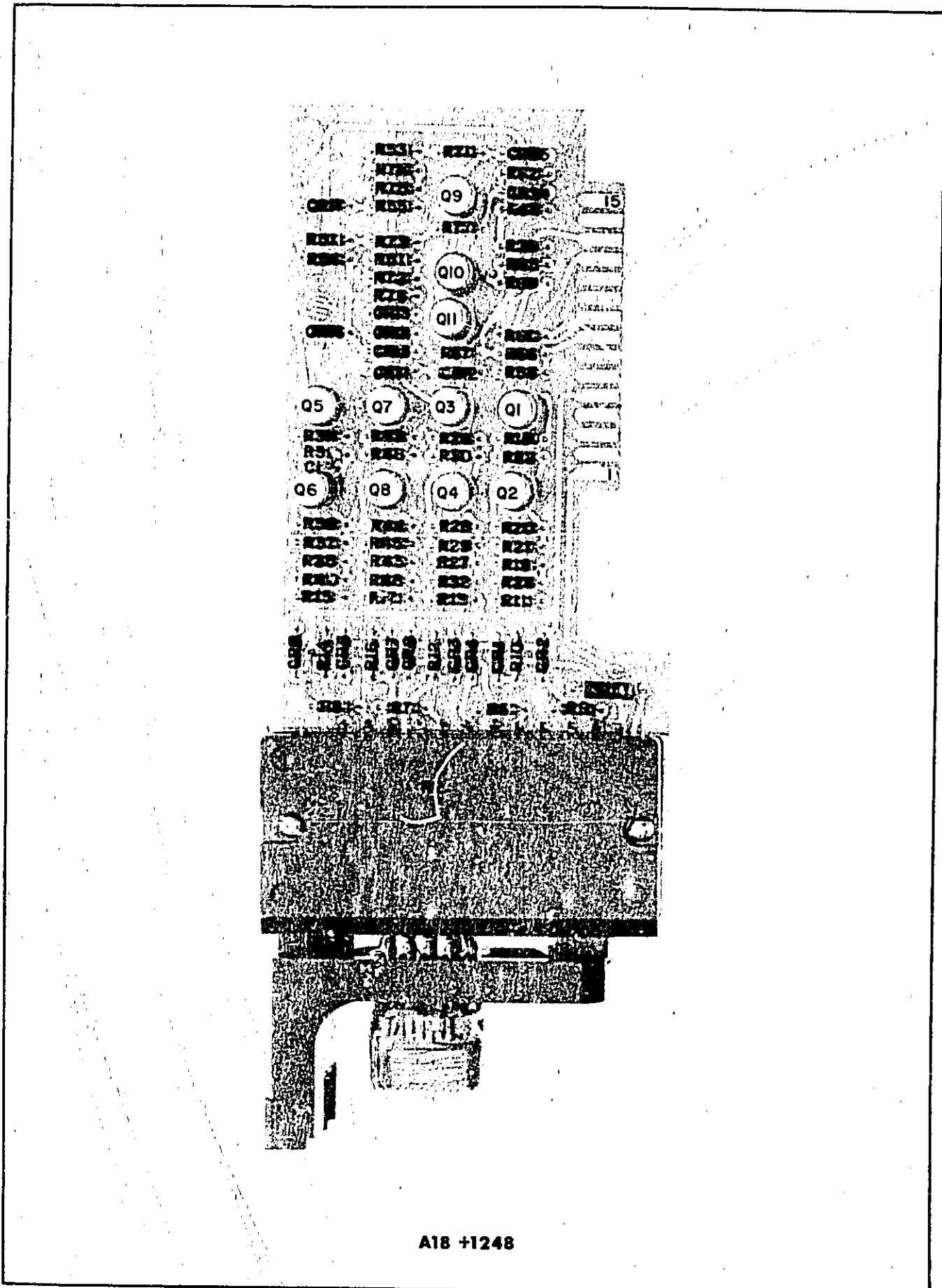

NOTES

- UNLESS OTHERWISE INDICATED:
RESISTANCE IN OHMS;
CAPACITANCE IN PICOFARADS
- REFERENCE DESIGNATIONS IN PARENTHESES
INDICATE LIGHT DESTINATION FOR DS1-DS4.
LIGHT SOURCE IS NOTED NEAR EACH VI SECTION.
- FOR DS1-DS4, SECTION A LIGHTS ON "1";
SECTION B LIGHTS ON "0"
- FILLED SQUARE (■) INDICATES CONDUCTING
ELEMENT FOR DECIMAL "0" (BCD "0000")
- OUTPUT CODE:
OPTICN002: 1 = +18V, L = -8V

REFERENCE DESIGNATIONS

A18	
C 1	
CR1 - 25	
DS1 - 6	
Q 1 - 11	
R 1 - 71	
V 1	

OMITTED:
CR9, 10, 18-23
DS5
R3 - 5, 23, 31, 39, 47
50, 57-61, 63
DELETED:
R25, 33, 41, 49

DIGIT	4 LINE CODE				V1	RELEVANT STAGES		
	10	11	12	13		D	C	A
0	0	0	0	0	KPRT			
1	0	0	0	1	FMOT			
2	0	0	1	0	HNRT			
3	0	0	1	1	EMOT			
4	0	1	0	0	JPRT			
5	0	1	0	1	DLDT			
6	0	1	1	0	GNRT			
7	0	1	1	1	CLDT			
8	1	0	0	0	BS			
9	1	0	0	1	AS			

WAVEFORMS

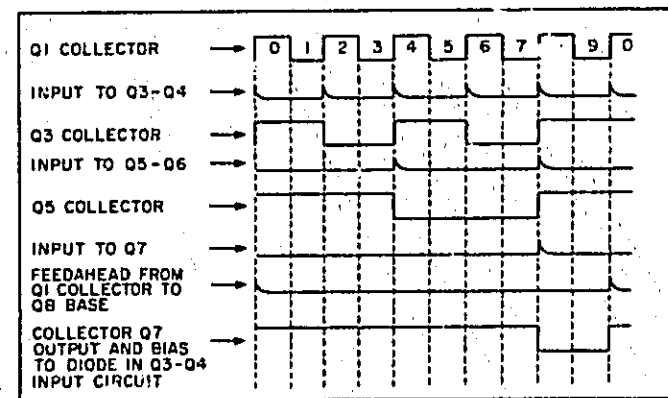

05245-D-07

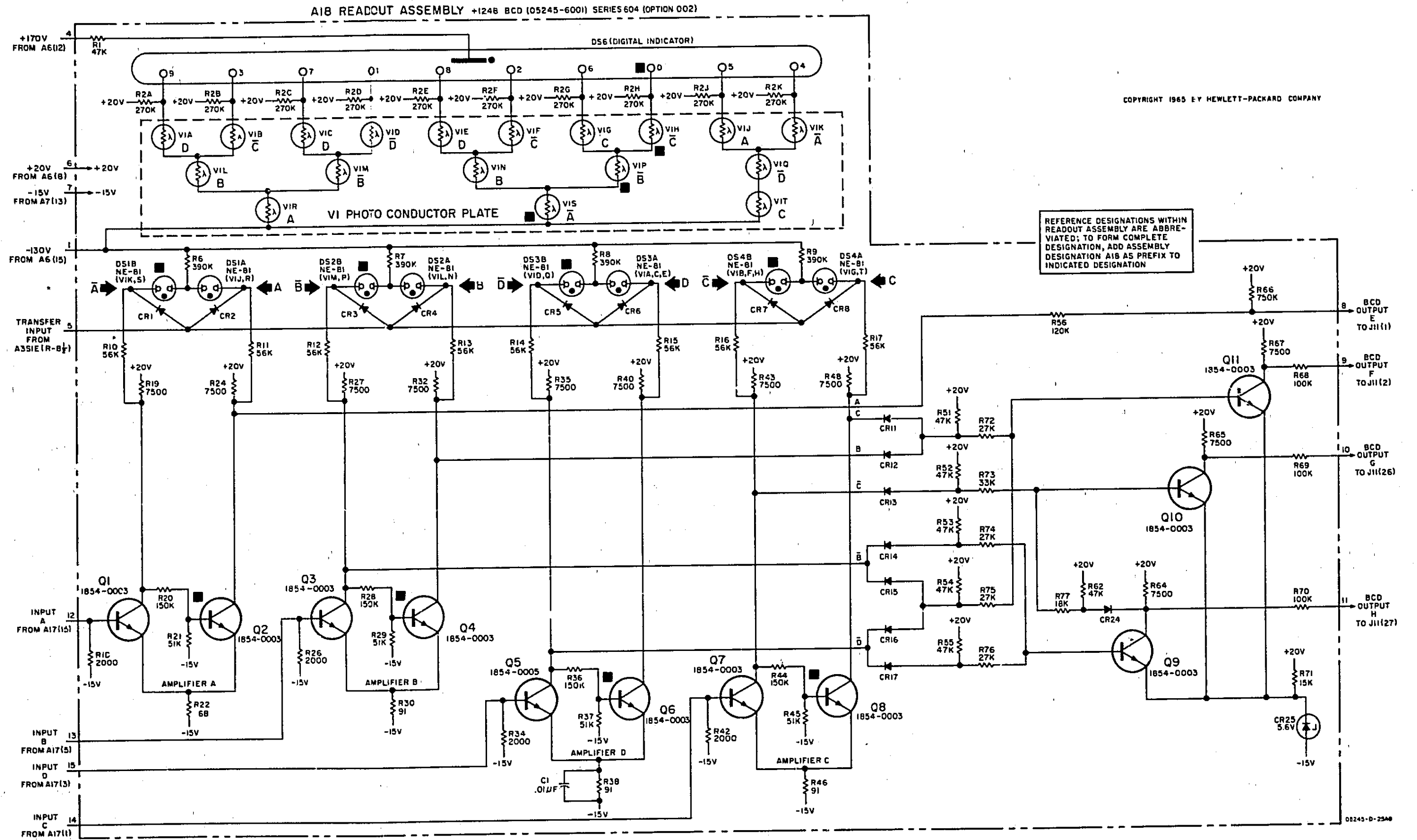

COPYRIGHT 1965 BY HEWLETT-PACKARD COMPANY

REFERENCE DESIGNATIONS WITHIN
READOUT ASSEMBLY ARE ABBRE-
VIATED: TO FORM COMPLETE
DESIGNATION, ADD ASSEMBLY
DESIGNATION A18 AS PREFIX TO
INDICATED DESIGNATION

Figure 7-15. A18 Readout (05245-6001) Option 002

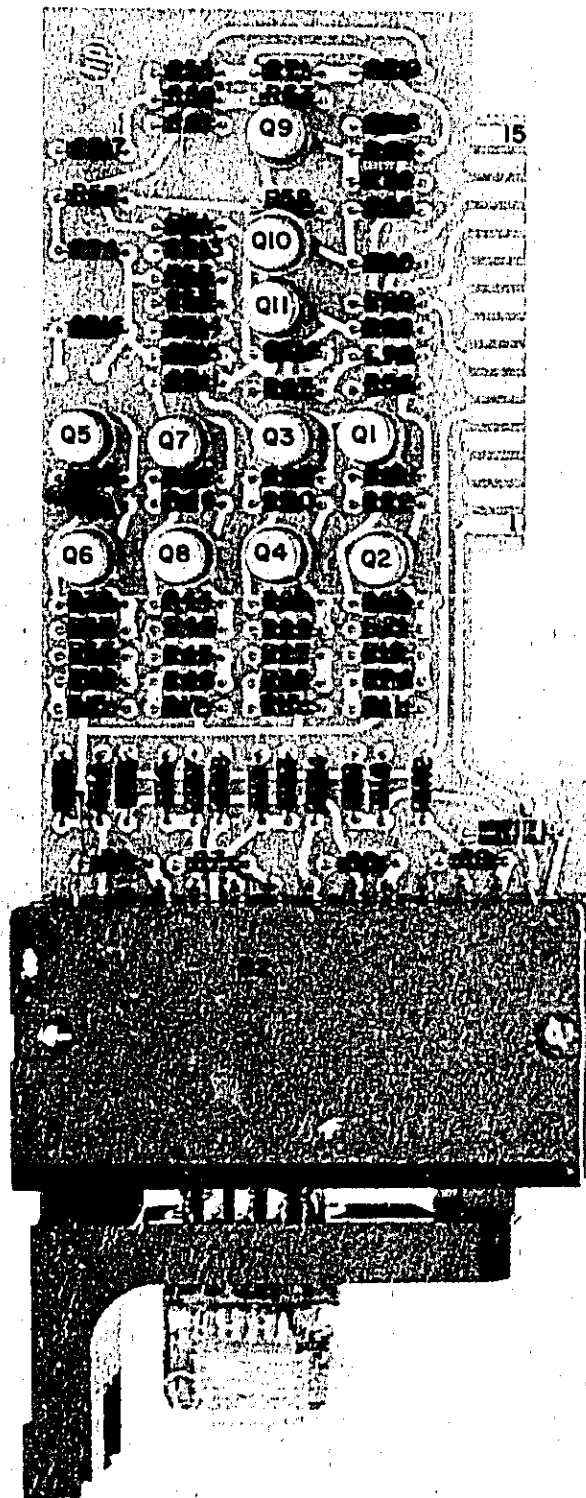

A18 -1248

NOTES

- UNLESS OTHERWISE INDICATED:
RESISTANCE IN OHMS;
CAPACITANCE IN PICOFARADS
- REFERENCE DESIGNATIONS IN PARENTHESES
INDICATE LIGHT DESTINATION FOR DS1-DS4.
LIGHT SOURCE IS NOTED NEAR EACH VI SECTION.
- FOR DS1-DS4, SECTION A LIGHTS ON "1";
SECTION B LIGHTS ON "0"
- FILLED SQUARE (■) INDICATES CONDUCTING
ELEMENT FOR DECIMAL "0" (BCD "0000")
- OUTPUT CODE:
OPTION 003: 1 = -8V, 0 = +18V

REFERENCE DESIGNATIONS

A18	
C	3
CR1-19	
DS1-6	
O	1-11
R	1-71
V	1

OMITTED:
CR9, 10
DS5
R3-5, 23, 31, 39,
47, 50, 62
DELETED:
R25, 33, 41, 49
C1, 2

TRUTH TABLE

DIGIT	4 LINE CODE (0+, 1-)				RELEVANT STAGES	BINARY			
	D	C	B	A		D	C	B	A
0	0	0	0	0	KPRT				
1	0	0	0	1	FMOT				
2	0	0	1	0	HNRT				
3	0	0	1	1	EMOT				
4	0	1	0	0	JPRT				
5	0	1	0	1	DLDT				
6	0	1	1	0	GNRT				
7	0	1	1	1	CLDT				
8	1	0	0	0	BS				
9	1	0	0	1	AS				

WAVEFORMS

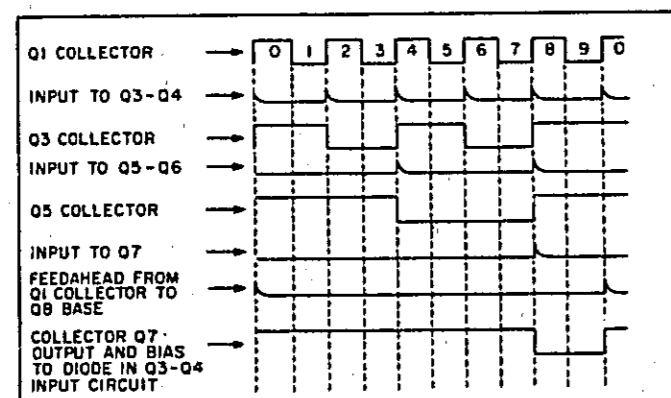

05245-D-04

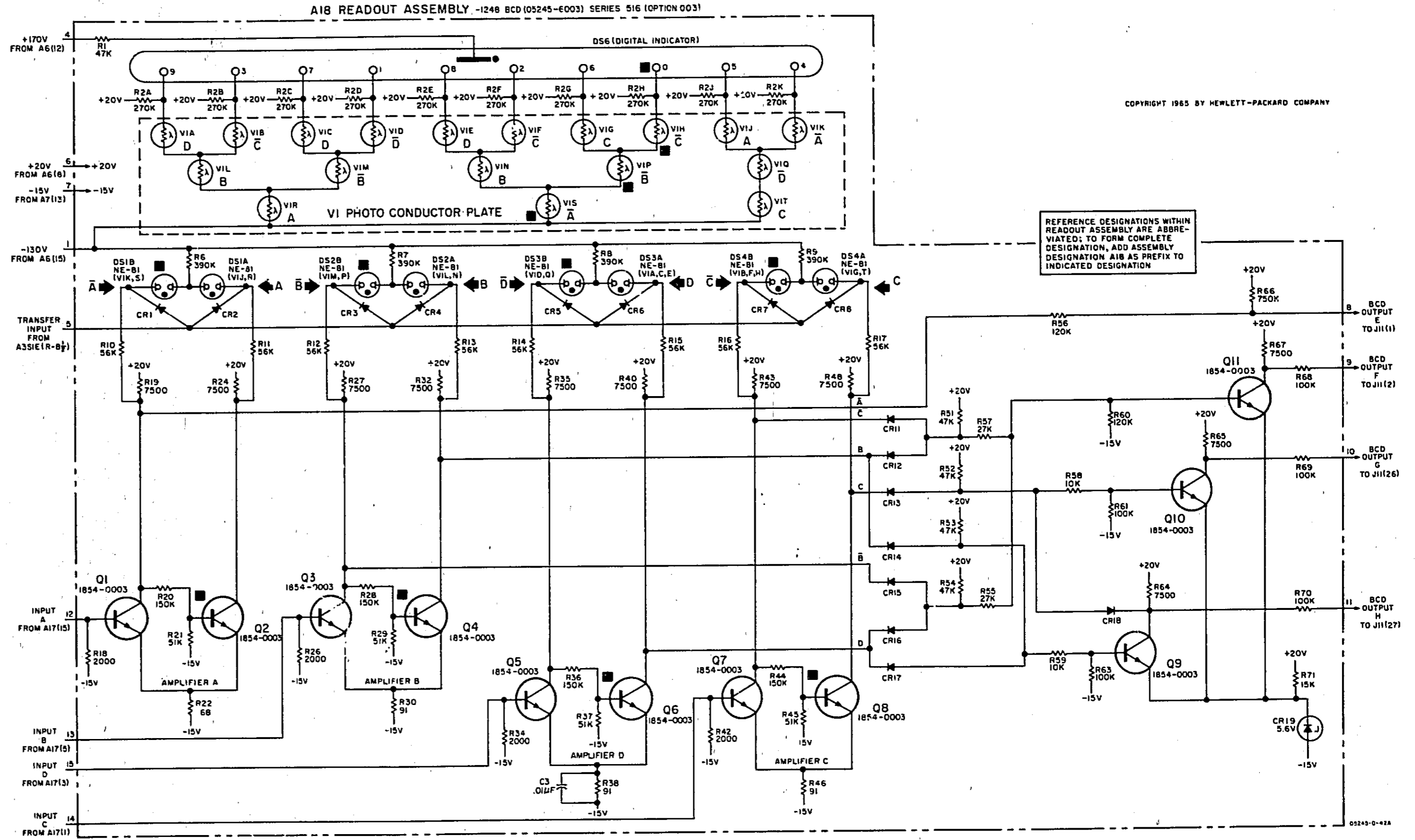

COPYRIGHT 1965 BY HEWLETT-PACKARD COMPANY

05245-D-02A

Figure 7-16. A18 Readout (05245-6003) Option 003
7-31/7-32

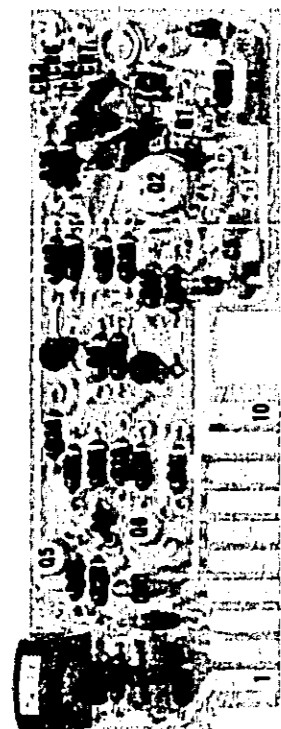

A19, A20

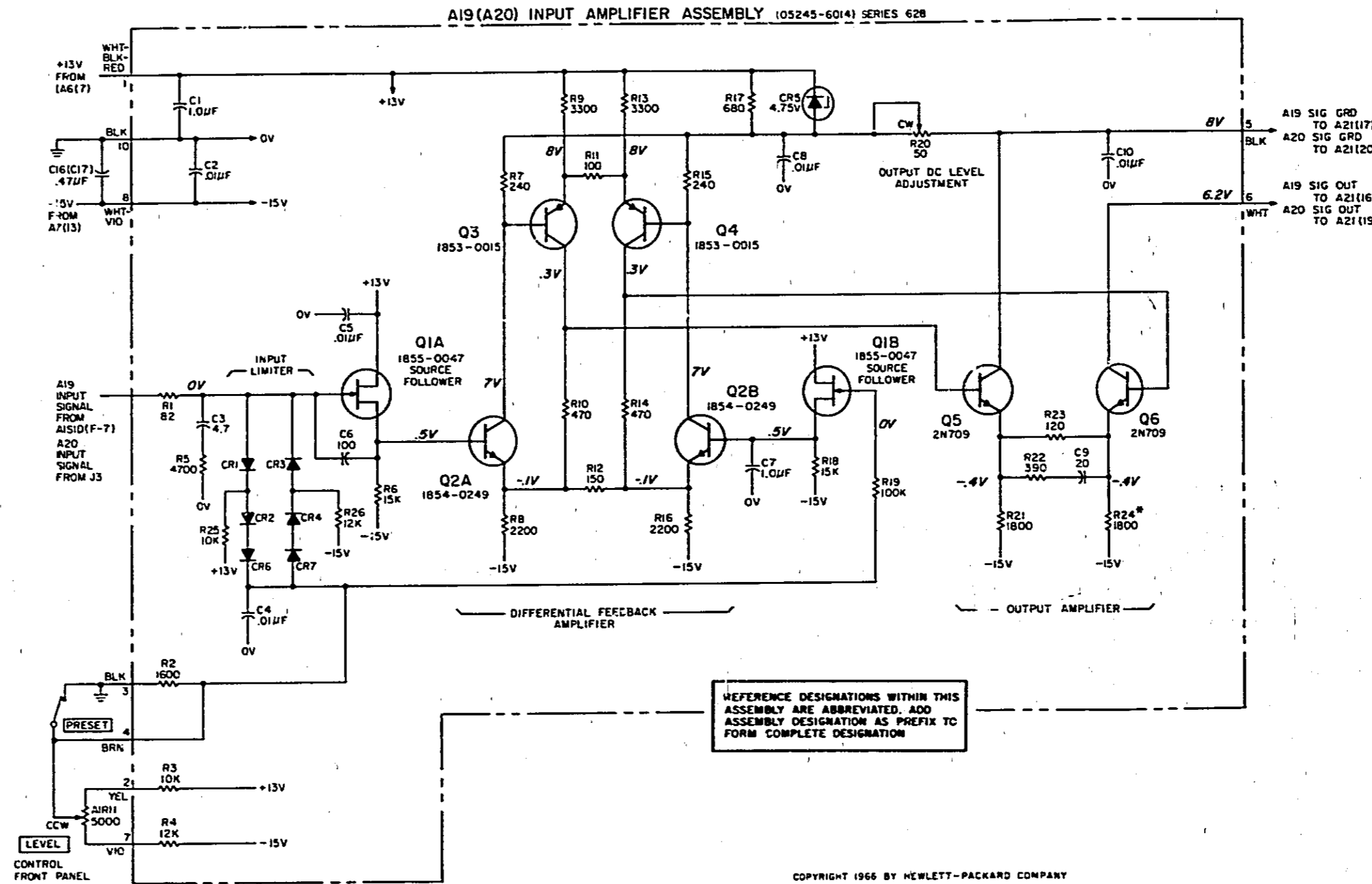

- NOTES**
- UNLESS OTHERWISE INDICATED: RESISTANCE IN OHMS; CAPACITANCE IN PICOFARADS
 - ASTERISK (*) INDICATES SELECTED COMPONENT, AVERAGE VALUES SHOWN
 - DC VOLTAGES WITH: LEVEL—PRESET TIME BASE—EXT

NO PREFIX	A1	A19 (A20)
C16(C17)		C1 - 10 C1 - 7
R11		R1 - 6 R1 - 26

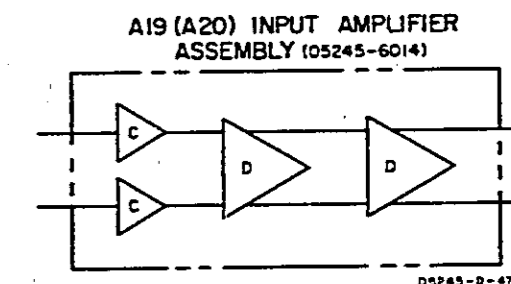

Figure 7-17. A19, A20 Input Ampl.

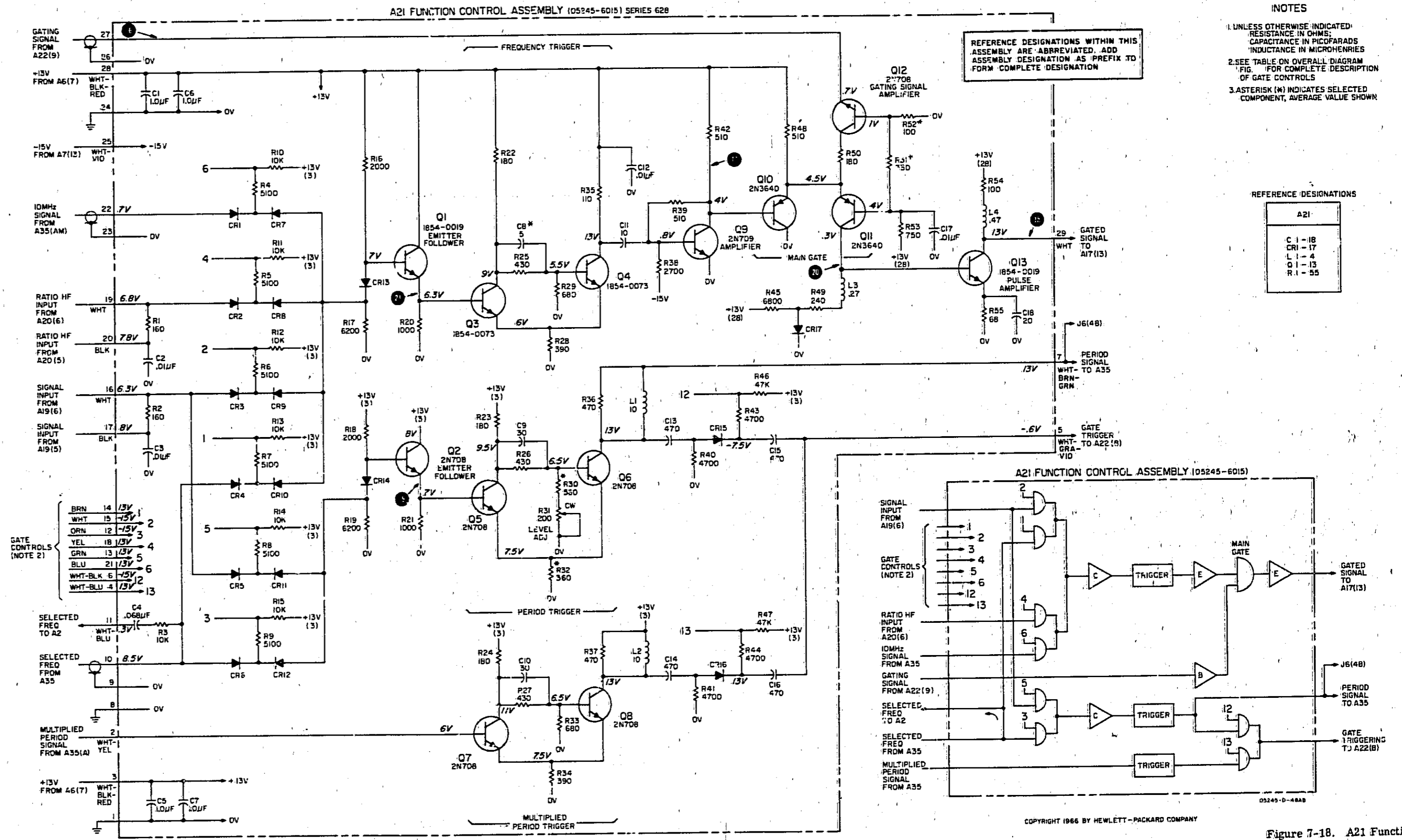
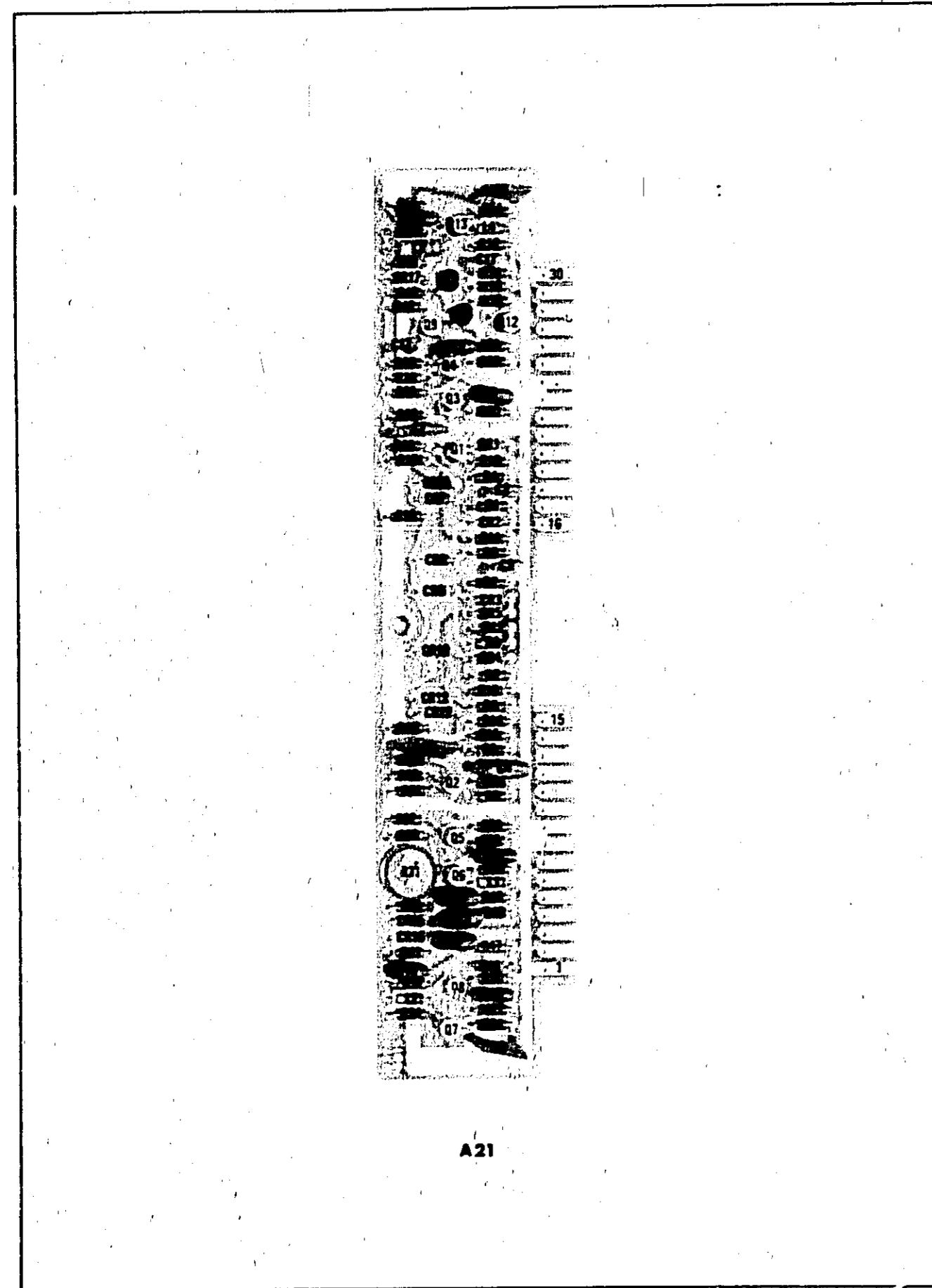
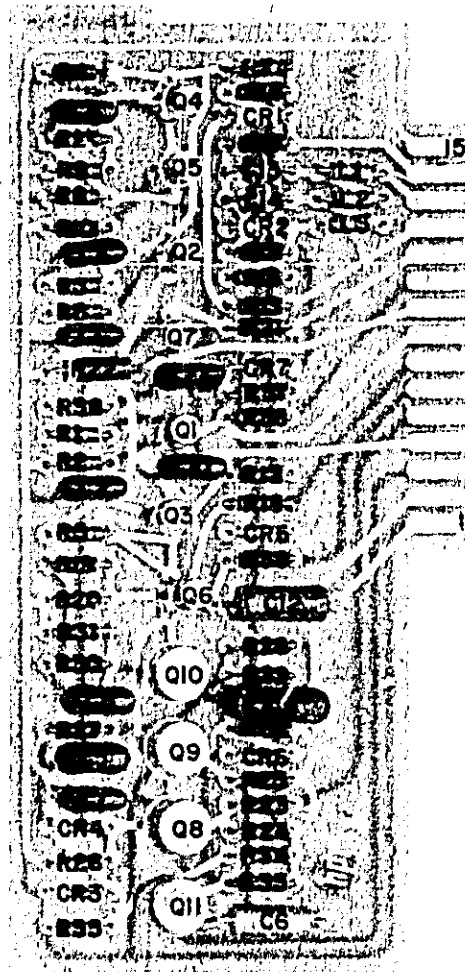
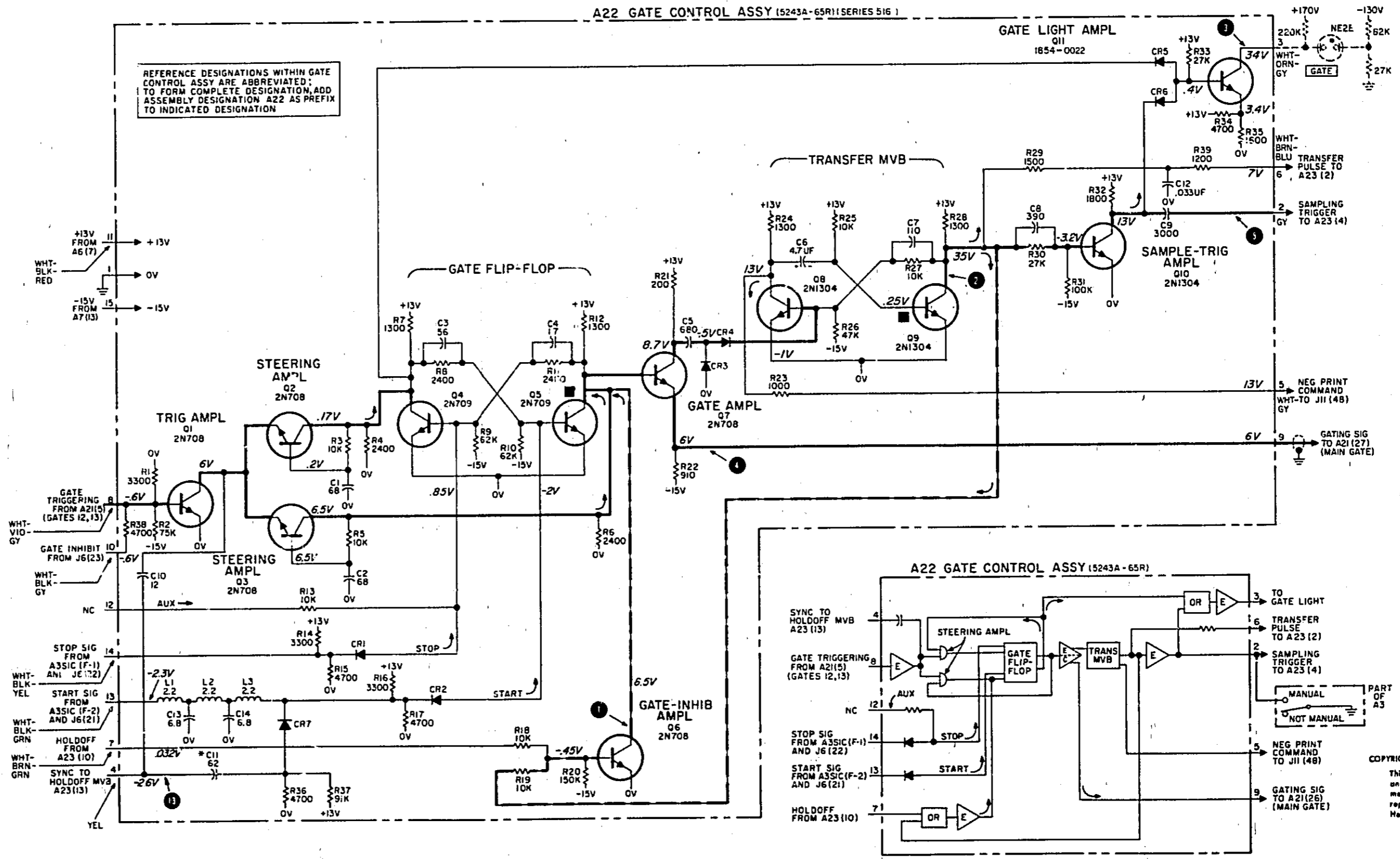
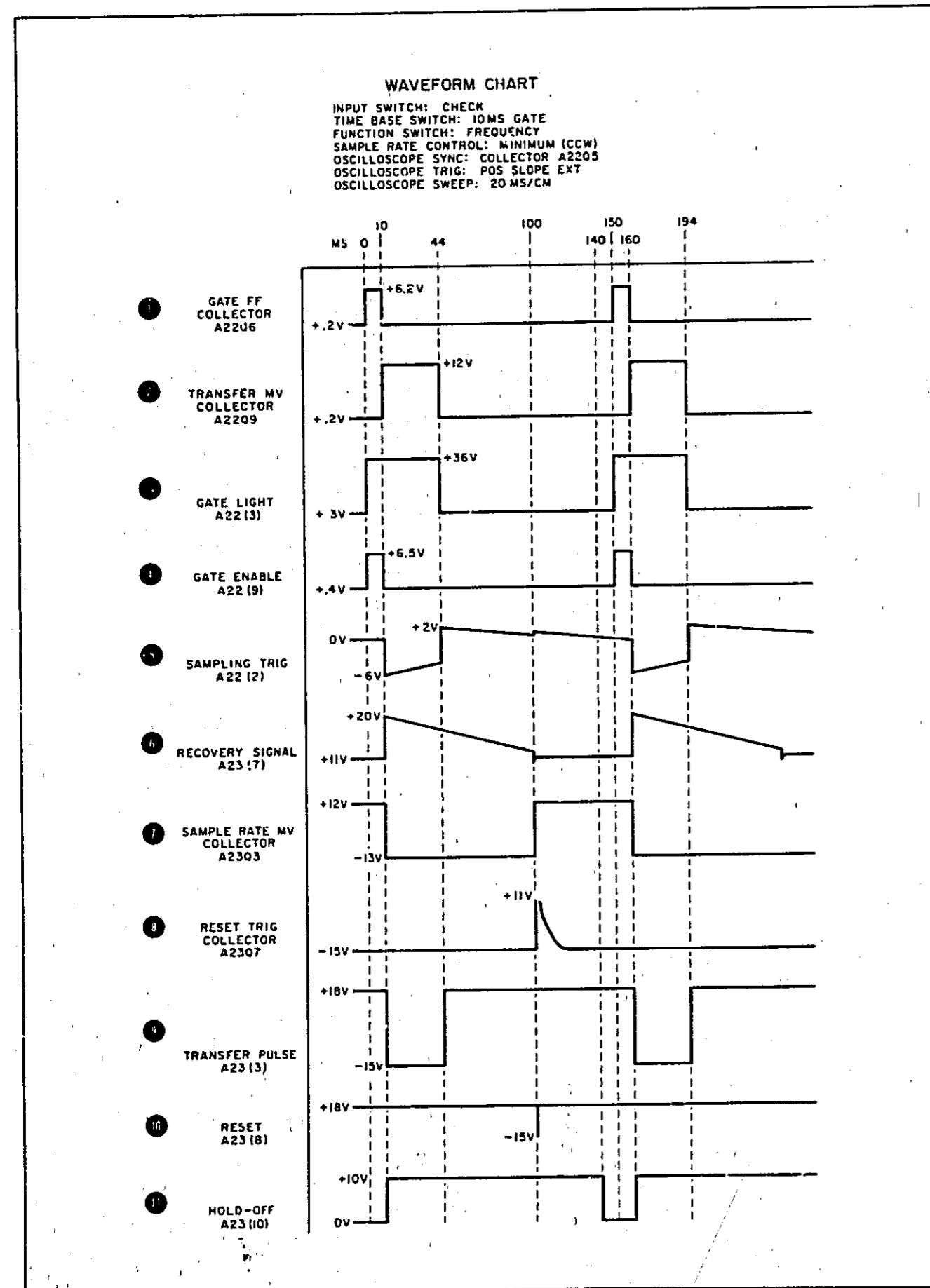

Figure 7-18. A21 Function Control



A22



COPYRIGHT 1965 BY HEWLETT-PACKARD COMPANY
This drawing is intended for the operation and maintenance of Hewlett-Packard equipment and is not to be used otherwise or reproduced without written consent of the Hewlett-Packard Company.

05245-D-28AR001

Figure 7-19. A22 Gate Control

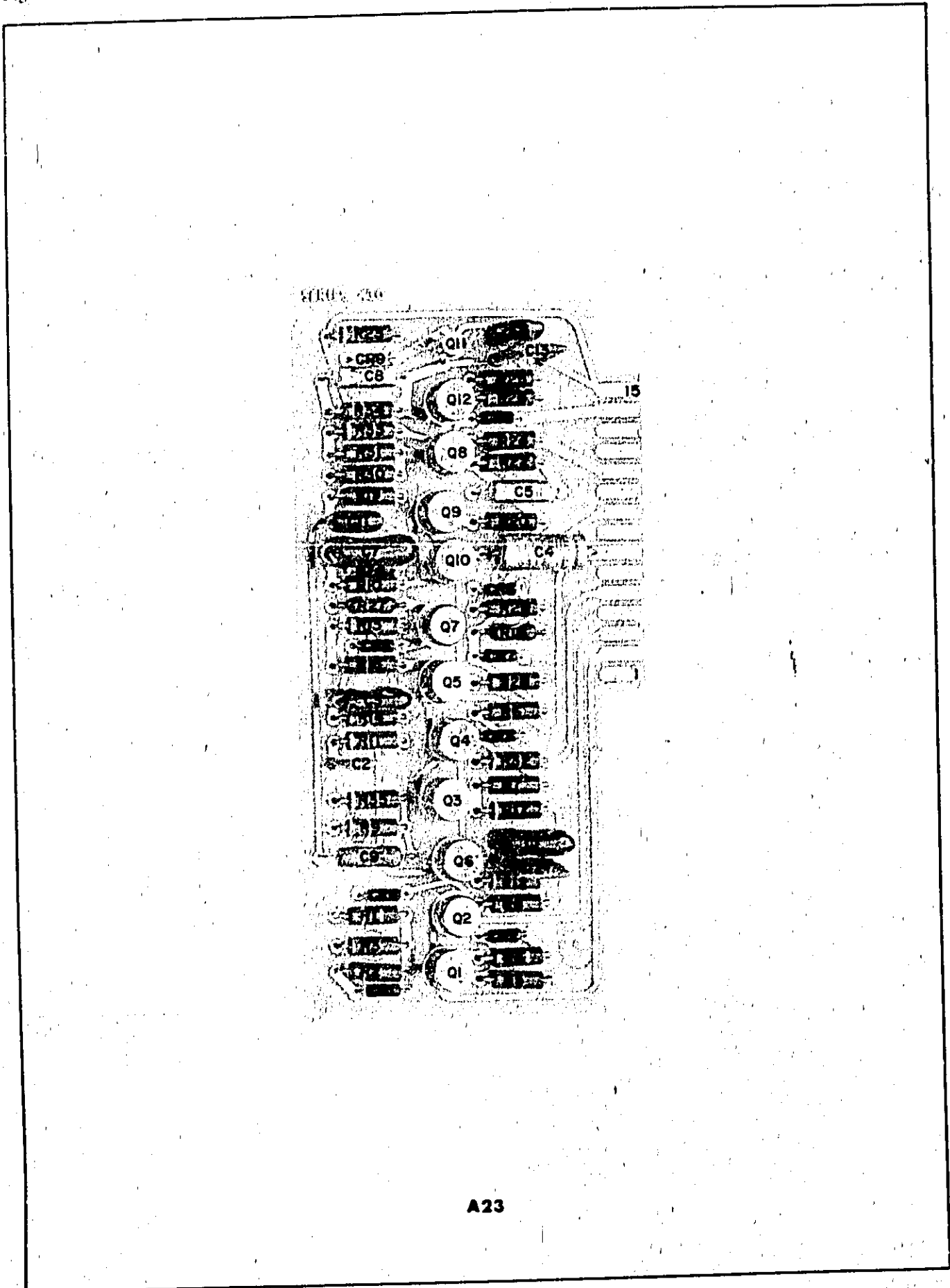

A23

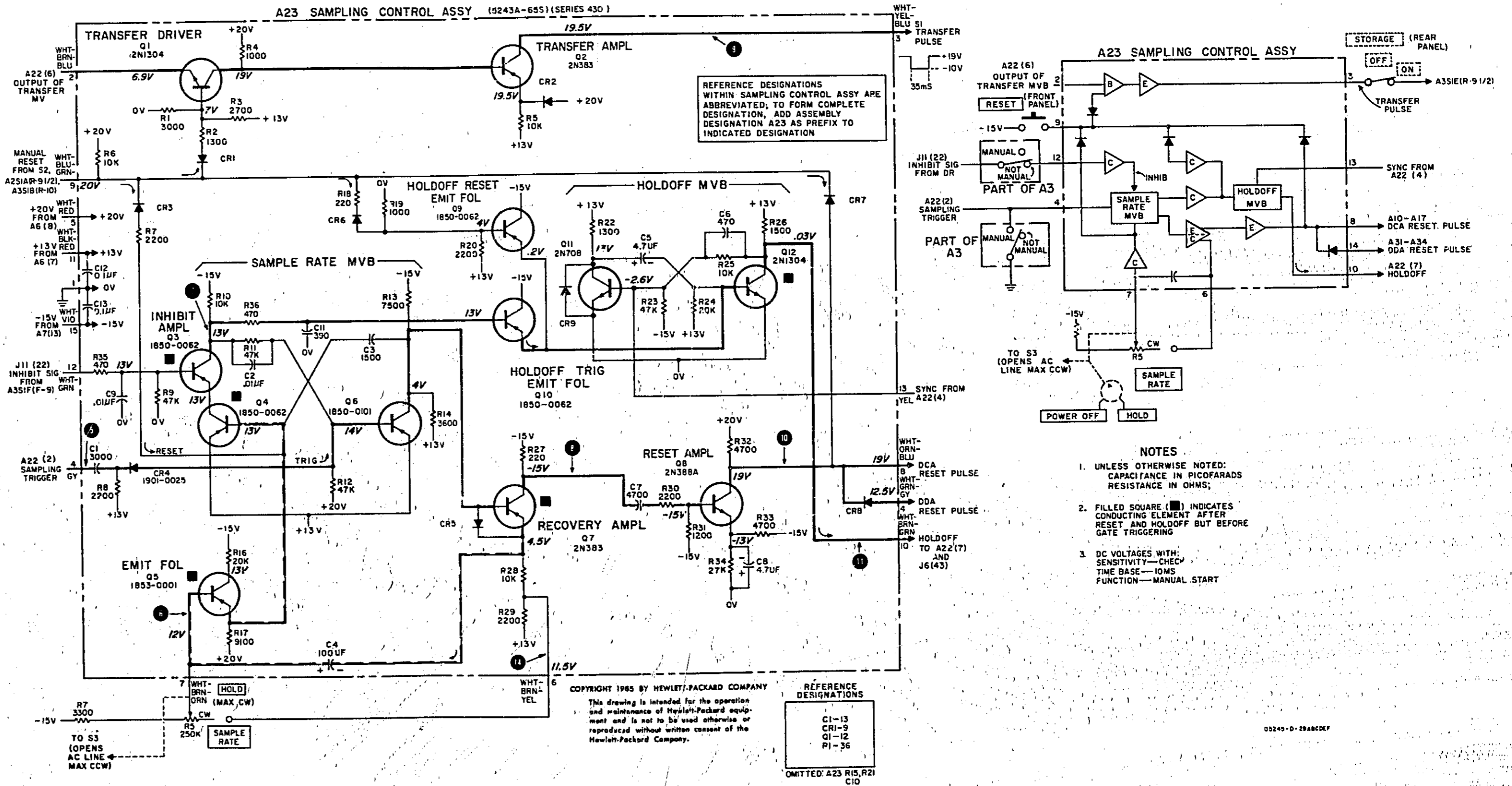
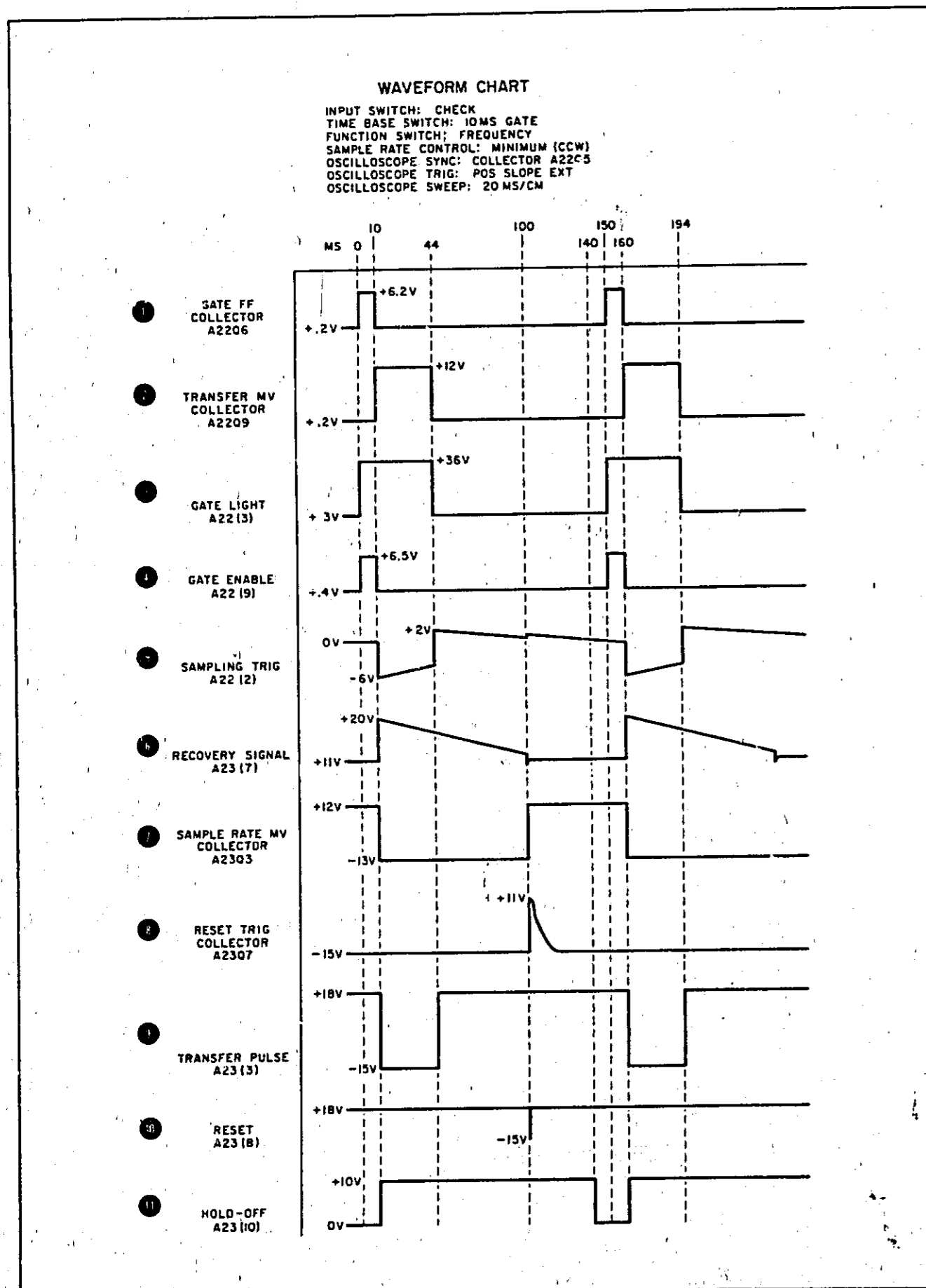

- #### NOTES
1. UNLESS OTHERWISE NOTED: CAPACITANCE IN PICOFARADS RESISTANCE IN OHMS;
 2. FILLED SQUARE (■) INDICATES CONDUCTING ELEMENT AFTER RESET AND HOLDOFF BUT BEFORE GATE TRIGGERING
 3. DC VOLTAGES WITH: SENSITIVITY—CHECK TIME BASE—10MS FUNCTION—MANUAL START

Figure 7-20. A23 Sampling Control
7-39/7-40

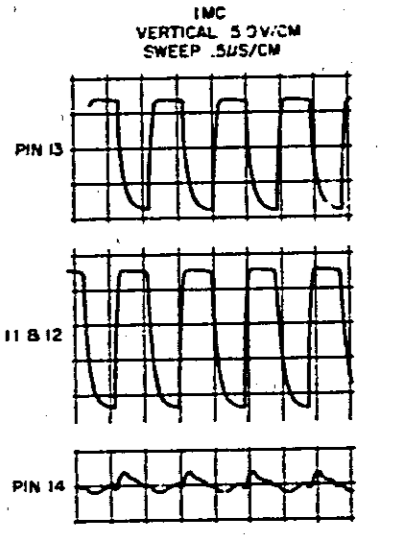
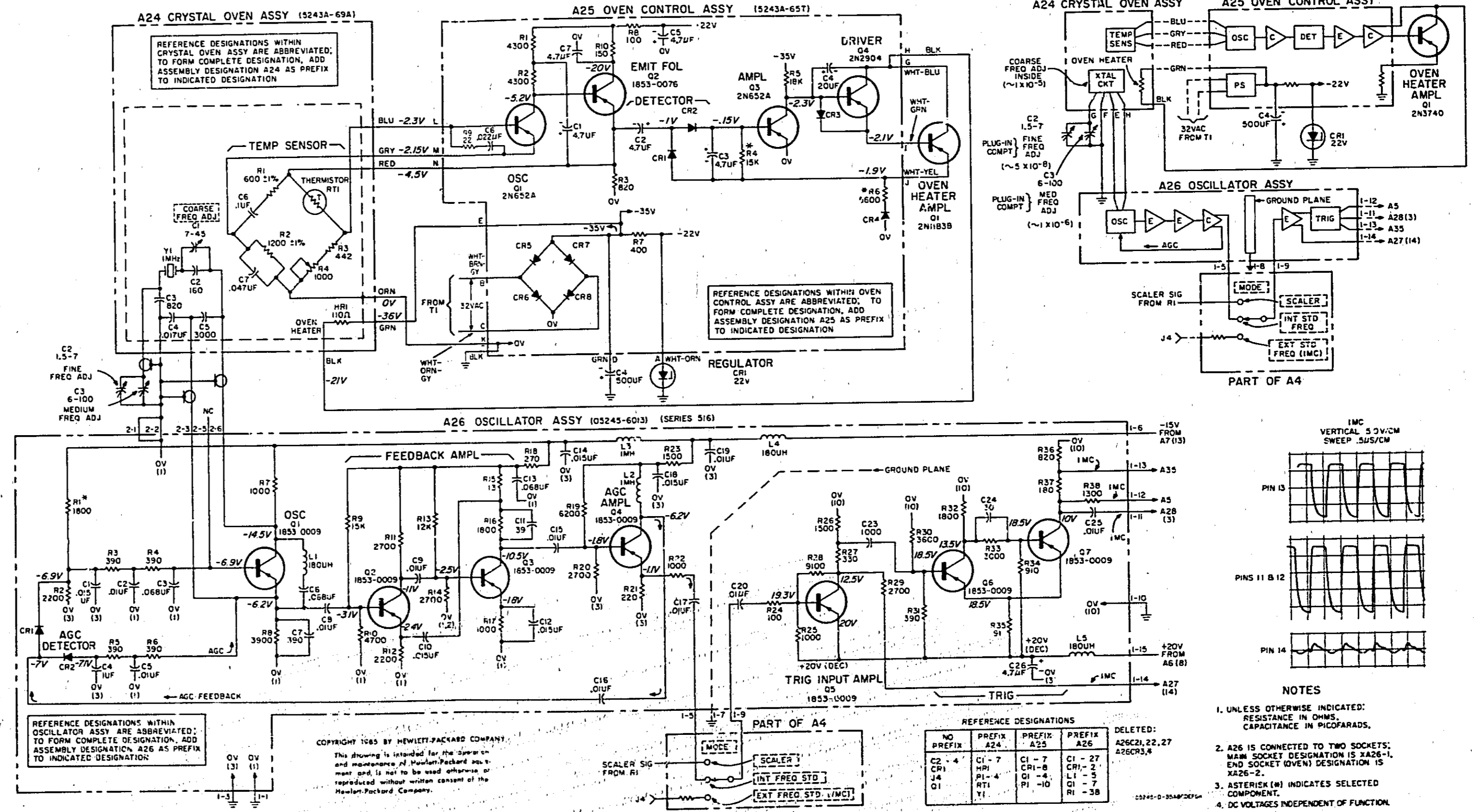
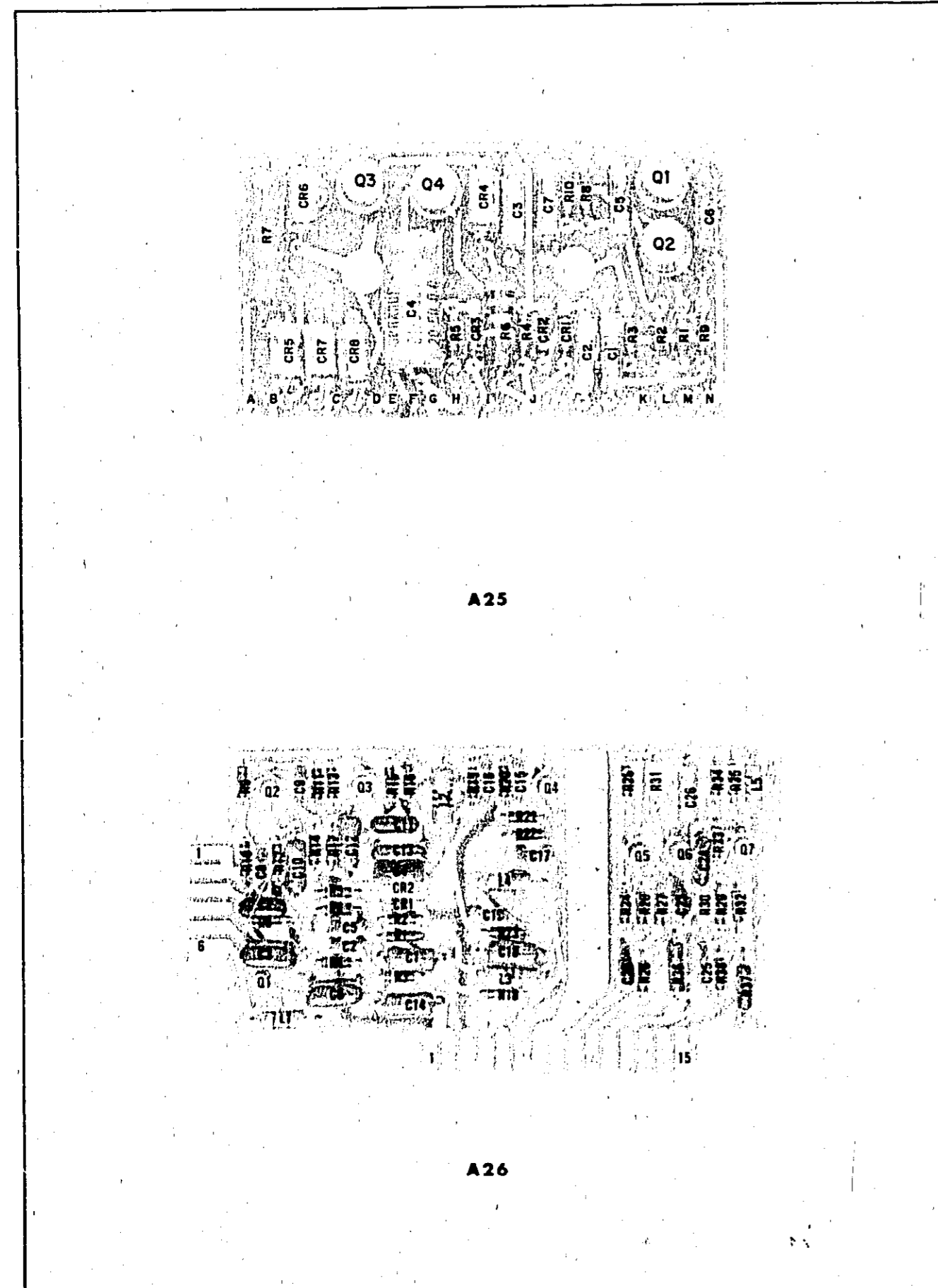
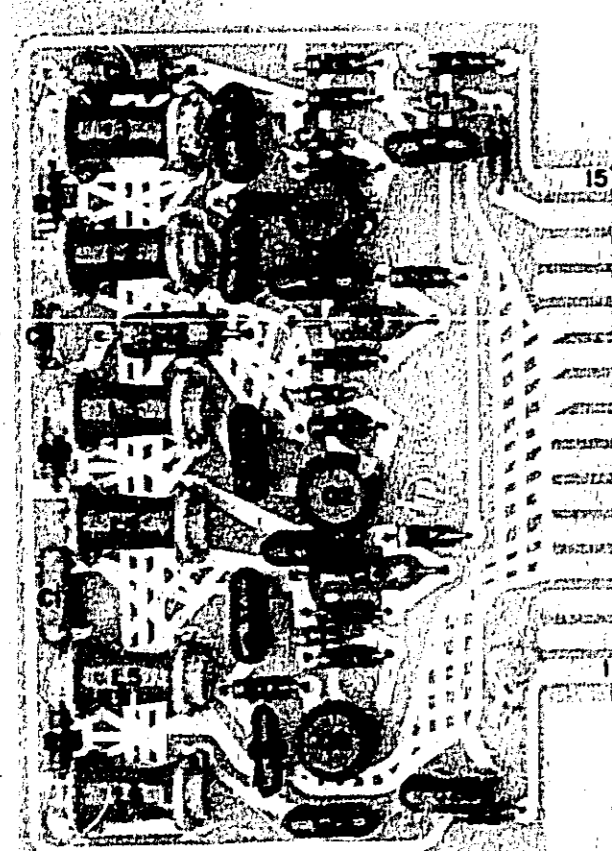
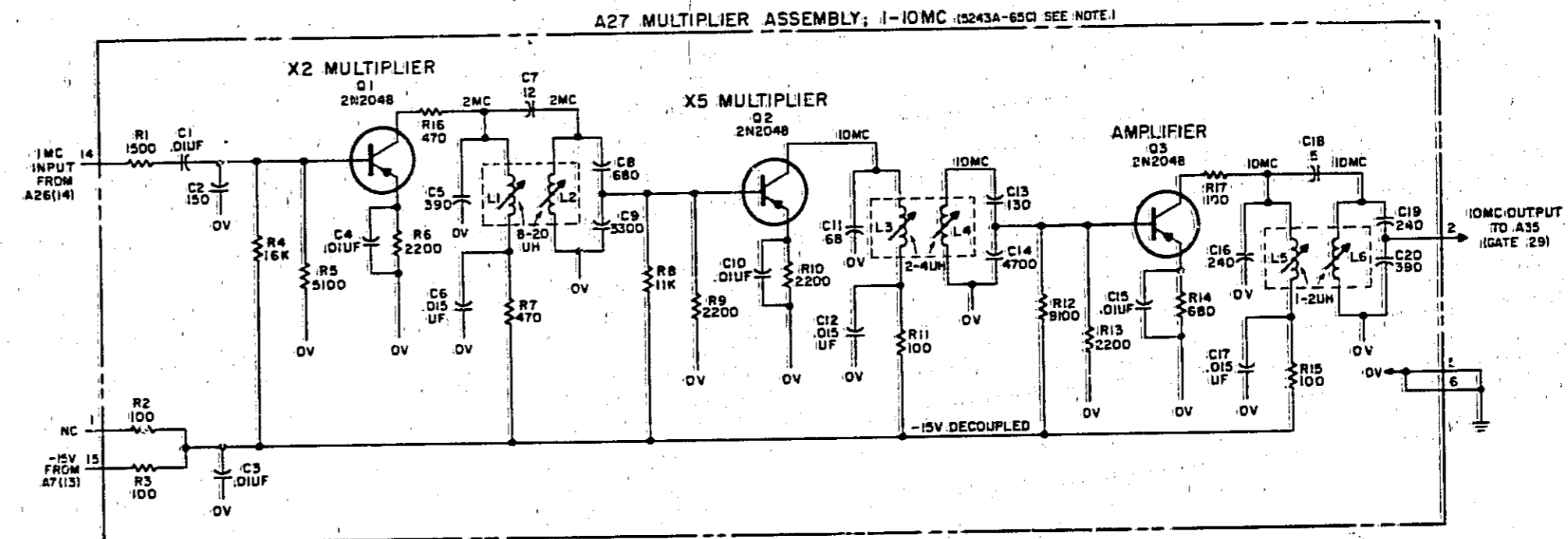

Figure 7-21. A24, A25, A26 Crystal Oven, Oven Control, Oscillator
7-41/7-42



A27



REFERENCE DESIGNATIONS

C1	-	20
L1	-	6
Q1	-	3
R1	-	17

NOTES

- 1 REFERENCE DESIGNATIONS WITHIN MULTIPLIER ASSEMBLY ARE INCOMPLETE; TO FORM COMPLETE REFERENCE DESIGNATION, ADD ASSEMBLY DESIGNATION A27 AS PREFIX TO INDICATED DESIGNATION.
- 2 L1-L2; L3-L4; L5-L6 ARE MUTUALLY COUPLED.
- 3 UNLESS OTHERWISE INDICATED:
RESISTANCE IN OHMS;
CAPACITANCE IN PICOFARADS;
RESISTORS 1/4 WATT

COPYRIGHT 1964 BY HEWLETT-PACKARD COMPANY
5245L/MULT-A27-408

05245-1-18

Figure 7-22. A27 Multiplier
7-43/7-44

SCHEMATIC DIAGRAMS

CON'T

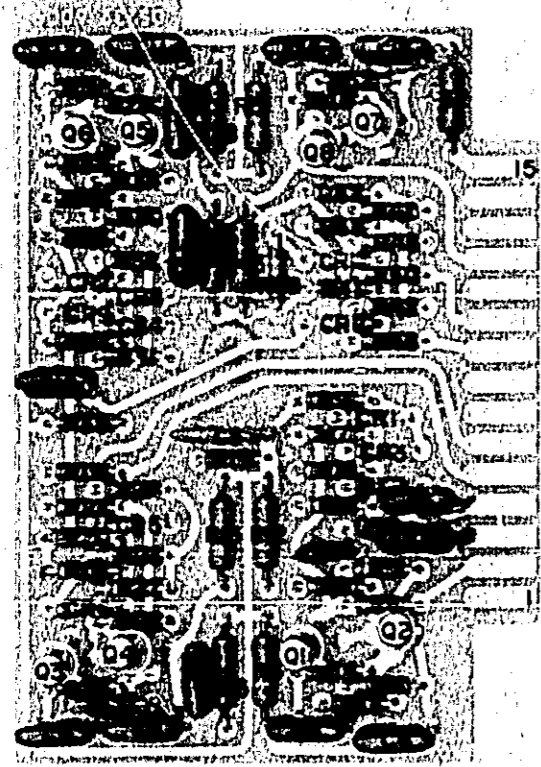

A28

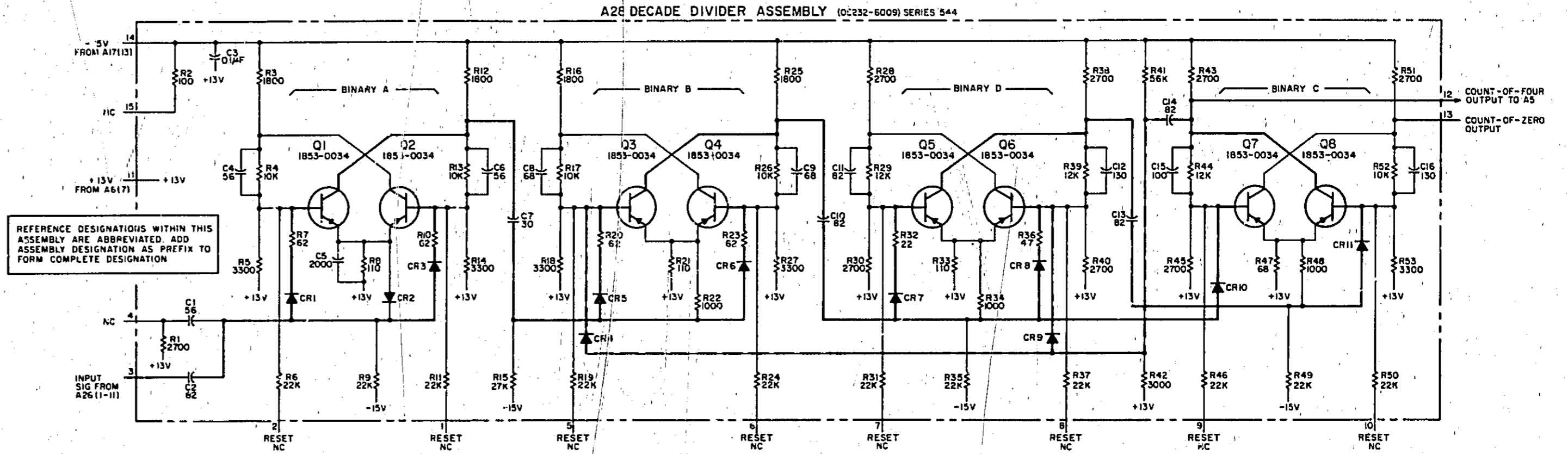

NOTES

1. UNLESS OTHERWISE INDICATED:
RESISTANCE IN OHMS;
CAPACITANCE IN PICOFARADS

REFERENCE DESIGNATIONS

A28
C1-16
CR1-11
Q1-8
R1-53

COPYRIGHT 1965 BY HEWLETT-PACKARD COMPANY
05245-D-3748C

Figure 7-23. A28 Decade Divider
7-45/7-46

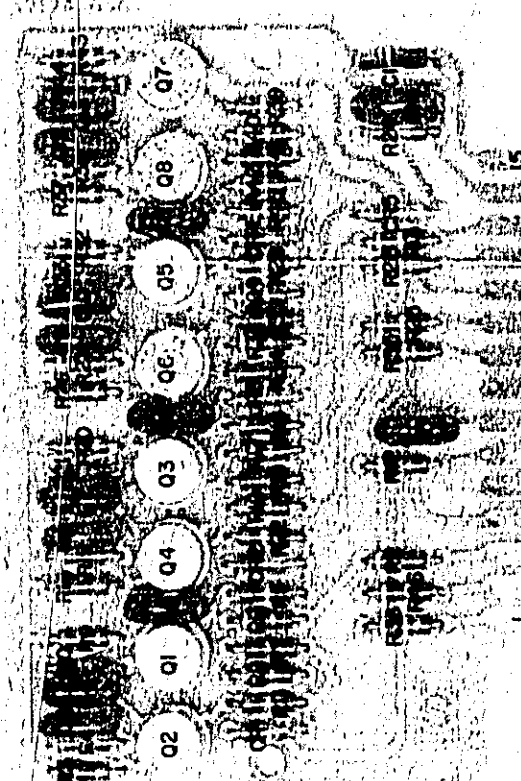

A29-A34

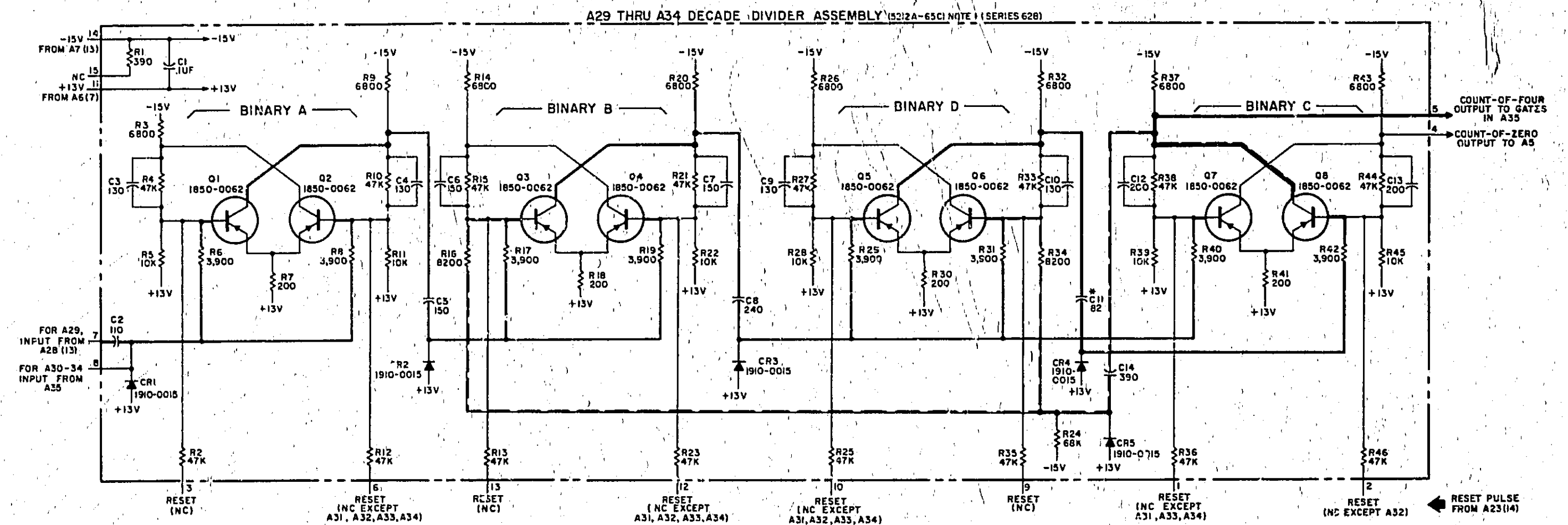

- NOTES**
- REFERENCE DESIGNATIONS WITHIN THIS ASSEMBLY ARE ABBREVIATED. ADD ASSEMBLY DESIGNATION AS PREFIX TO FORM COMPLETE DESIGNATION.
 - UNLESS OTHERWISE INDICATED: RESISTANCE IN OHMS, CAPACITANCE IN PICOFARADS.
 - ASTERISK (*) INDICATES SELECTED COMPONENT AVERAGE VALUES SHOWN.

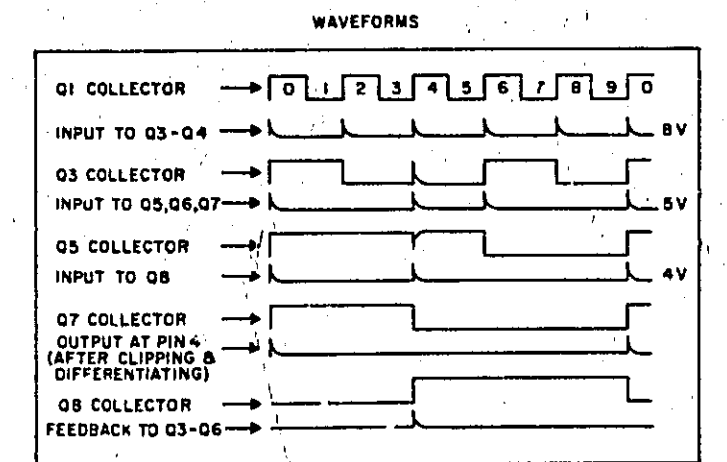

RESET WIRING

RESET NUMERAL	RESET PULSE (NEGATIVE) PIN CONNECTIONS
0	3 13 10 1
1	6 13 10 1
2	3 12 10 1
3	6 12 10 1
4	3 12 10 2
5	6 12 10 2
6	3 13 9 2
7	6 13 9 2
8	3 12 9 2
9	6 12 9 2

REFERENCE DESIGNATIONS (NOTE 1)

C1 - 14
C11 - 5
C1 - 6
R1 - 46

COPYRIGHT 1964 BY HEWLETT-PACKARD COMPANY

Figure 7-24. A29-A34 Decade Divider

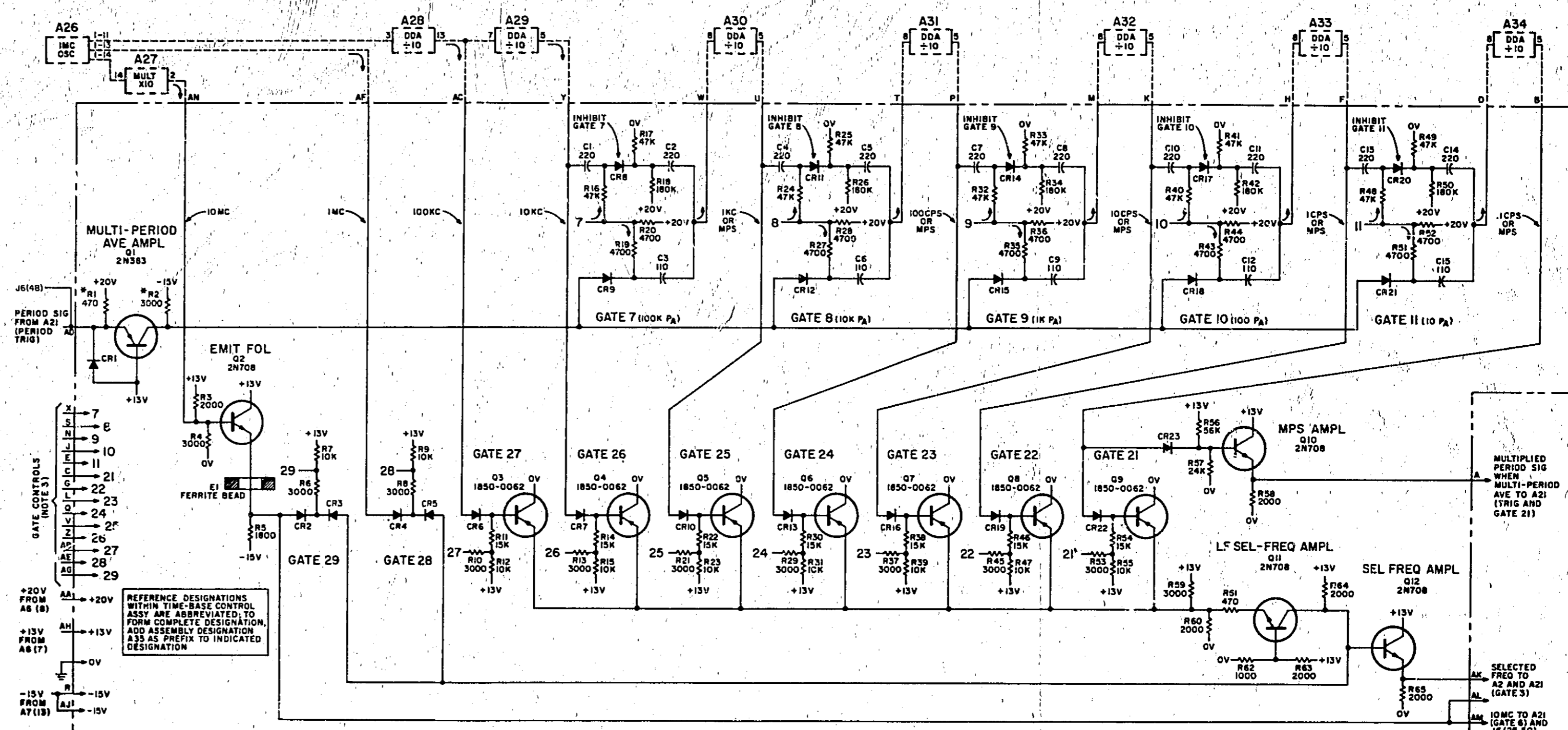
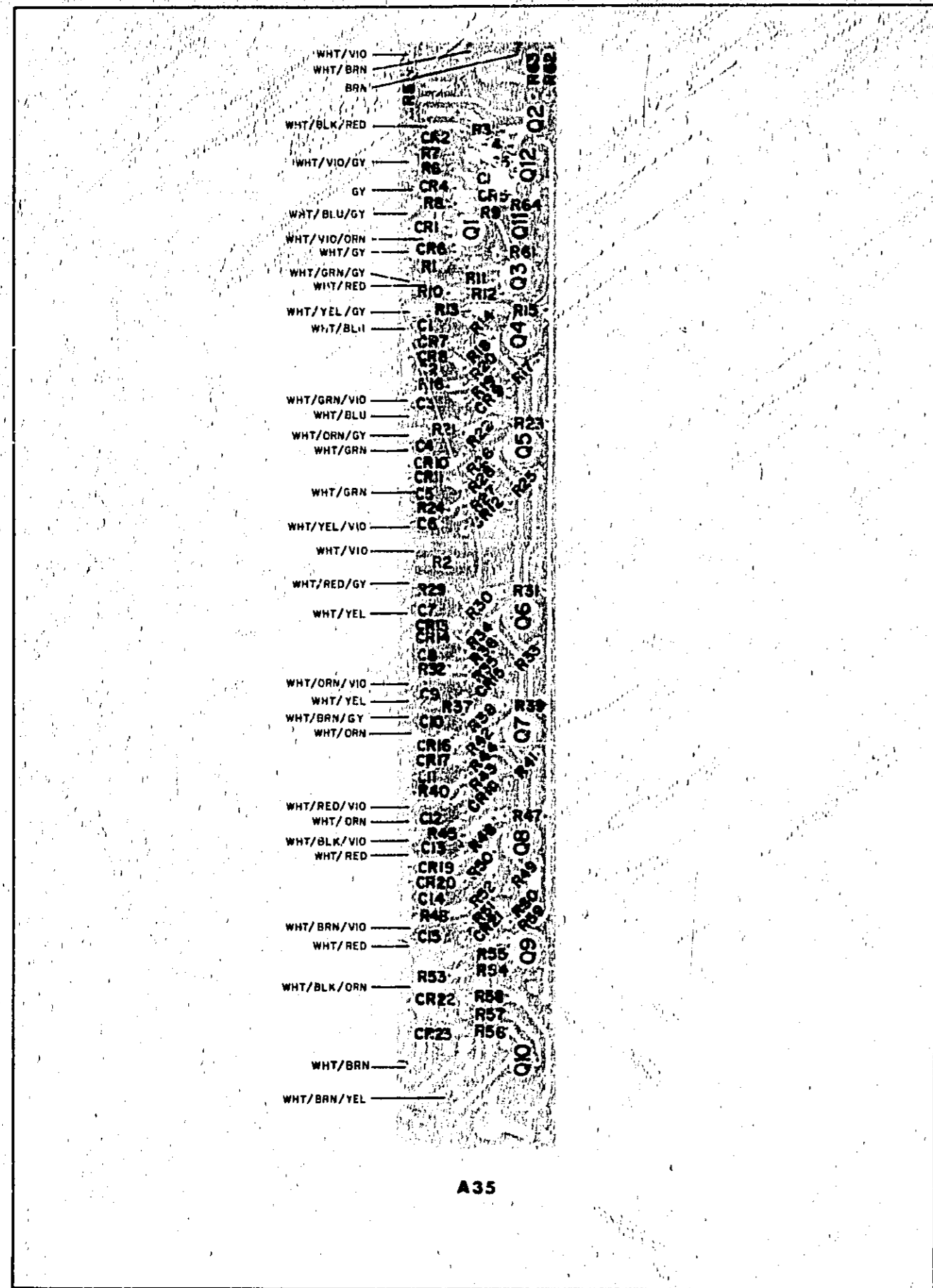

COPYRIGHT 1965 BY HEWLETT-PACKARD COMPANY

0240-D-7348C

Figure 7-25. A35 Time Base Control
7-49/7-50

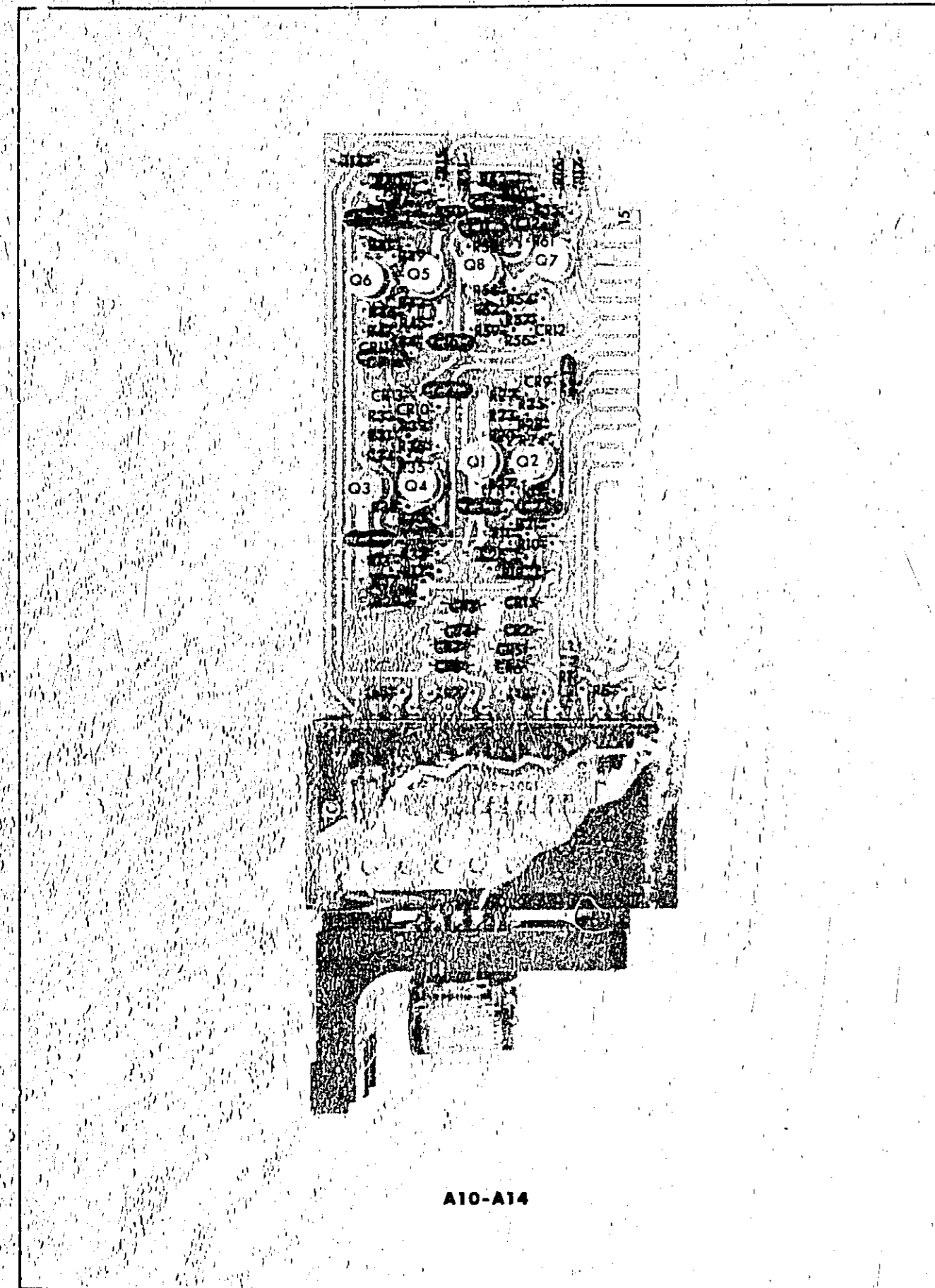

A10-A14

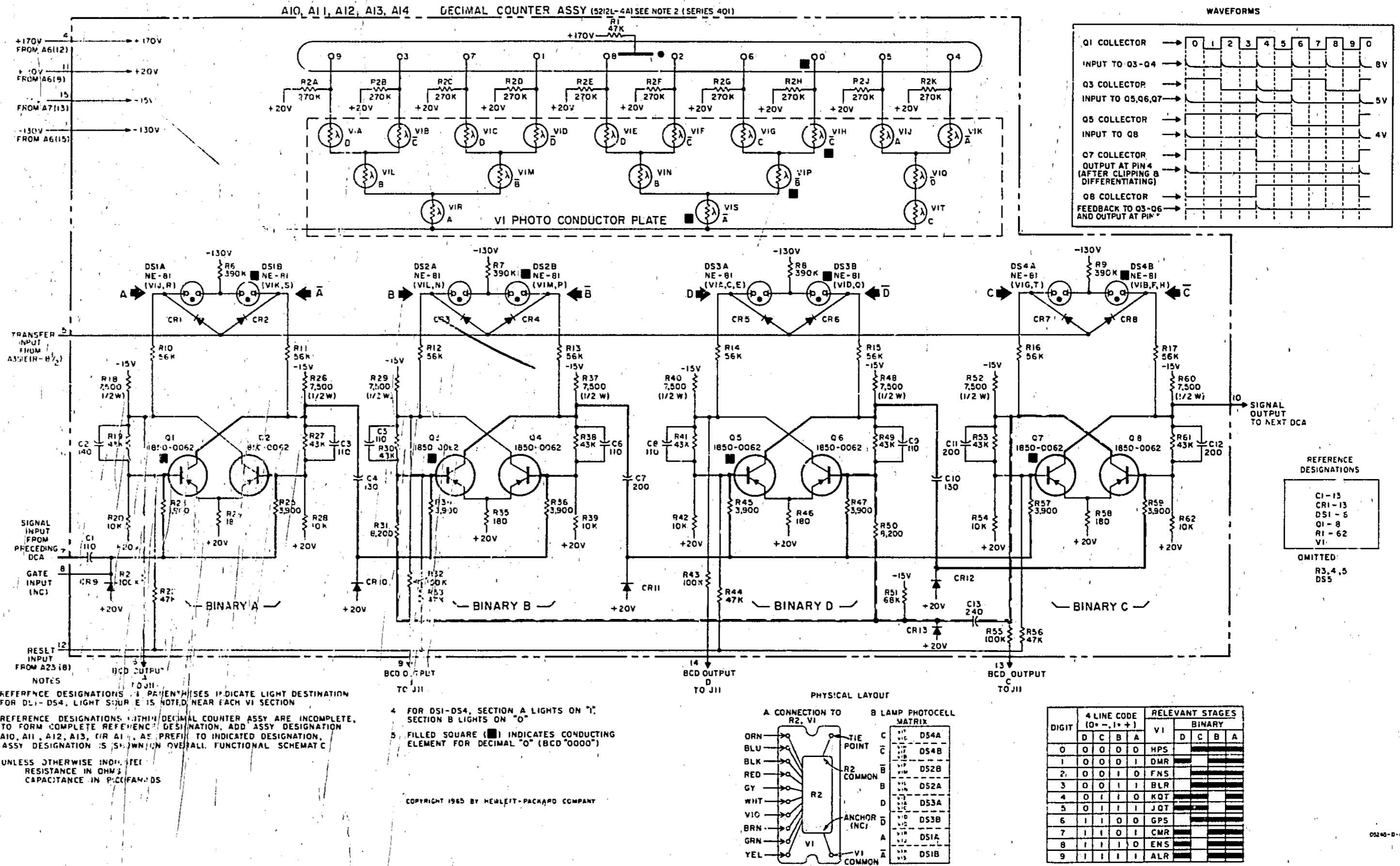
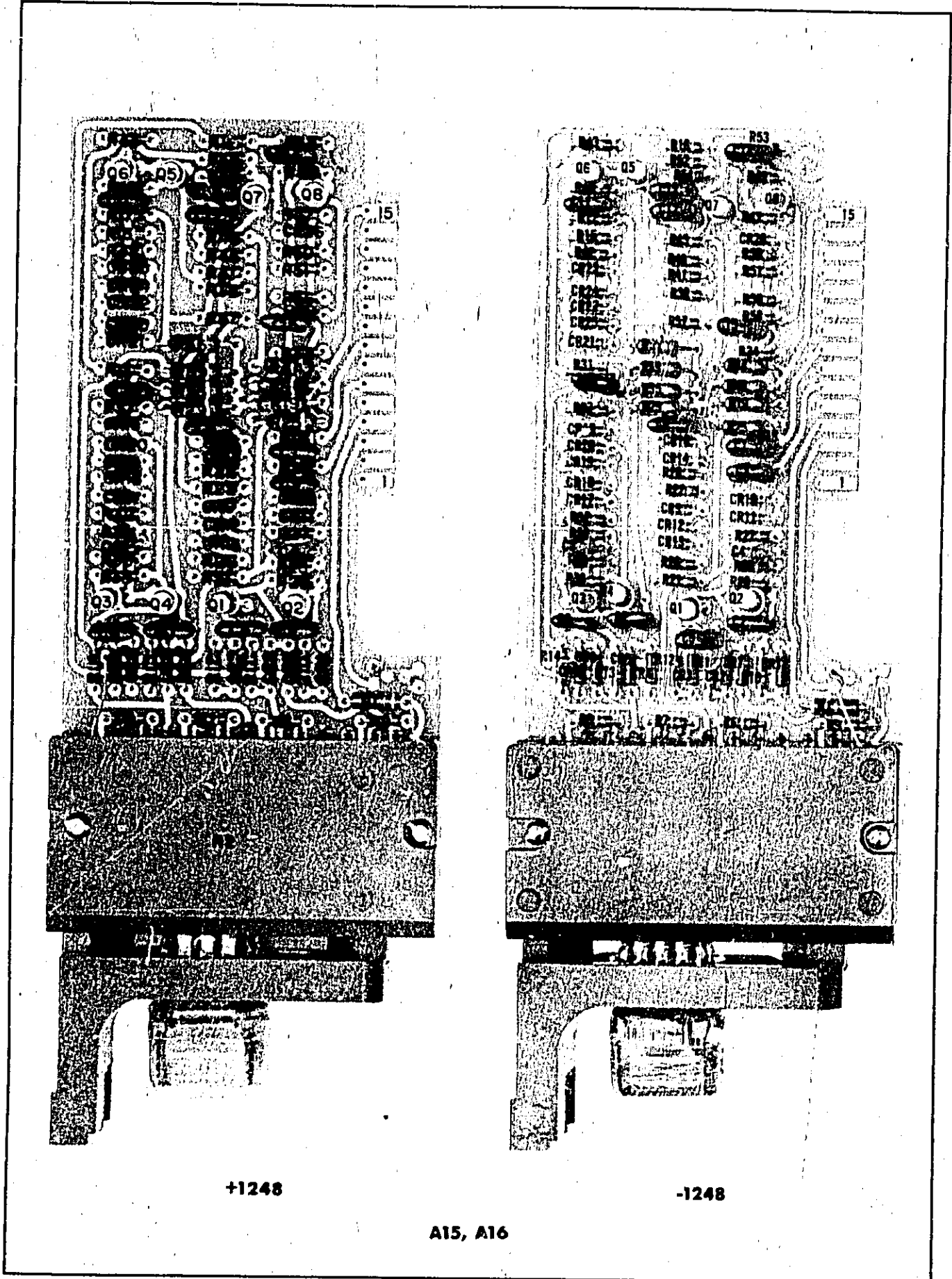

Figure 7-27. A10-A14 Decimal Counter (5212L-4A)



+1248

-1248

A15, A16

1. UNLESS OTHERWISE INDICATED: RESISTANCE IN OHMS; CAPACITANCE IN PICOFARADS
2. REFERENCE DESIGNATIONS IN PARENTHESES INDICATE LIGHT DESTINATION FOR DS1-DS4. LIGHT SOURCE IS NOTED NEAR EACH VI SECTION.
3. FOR CS1-DS4, SECTION A LIGHTS ON "1"; SECTION B LIGHTS ON "0"
4. FILLED SQUARE (■) INDICATES CONDUCTING ELEMENT FOR DECIMAL "0" (BCD "0000")
5. OUTPUT CODE:
OPTION002 1 = +18V, 0 = -8V
OPTION003 1 = -8V, 0 = +18V

NOTES

6. THE 05232-6002 DCA'S ARE USED IN OPTION 002 INSTRUMENTS ("I" STATE POSITIVE BCD OUTPUT). THE 05232-6003 DCA'S ARE USED IN OPTION 003 INSTRUMENTS ("I" STATE NEGATIVE BCD OUTPUT). THIS SCHEMATIC IS FOR BOTH DCAS. THE ASSEMBLIES ARE IDENTICAL WITH ONE EXCEPTION. THE ASSEMBLY DCA'S (05232-6002) HAVE RESISTORS MARKED WITH DOUBLE ASTERISKS (**) CONNECTED TO COLLECTORS AS SHOWN BY --- LINES. THE OPTION 003 DCA'S (05232-6003) HAVE THESE RESISTORS CONNECTED TO OPPOSITE COLLECTORS AS SHOWN BY - - - LINES.

REFERENCE DESIGNATIONS

A15, A16	
C	1-17
CR	1-23
DS	1-6
Q	1-8
R	1-68
V	1

OMITTED: DS5
R3-5

TRUTH TABLE

DIGIT	4 LINE CODE				V1	RELEVANT STAGES			
	0	C	B	A		D	C	B	A
0	0	0	0	0	KPRT				
1	0	0	0	1	FMQT				
2	0	0	1	0	MNRT				
3	0	0	1	1	EMQT				
4	0	1	0	0	JPRT				
5	0	1	0	1	DLQT				
6	0	1	1	0	GNRT				
7	0	1	1	1	CLQT				
8	1	0	0	0	BS				
9	1	0	0	1	AS				

WAVEFORMS

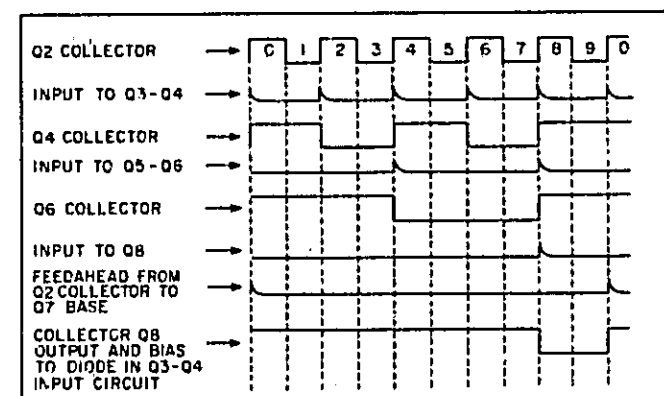

05240-D-54

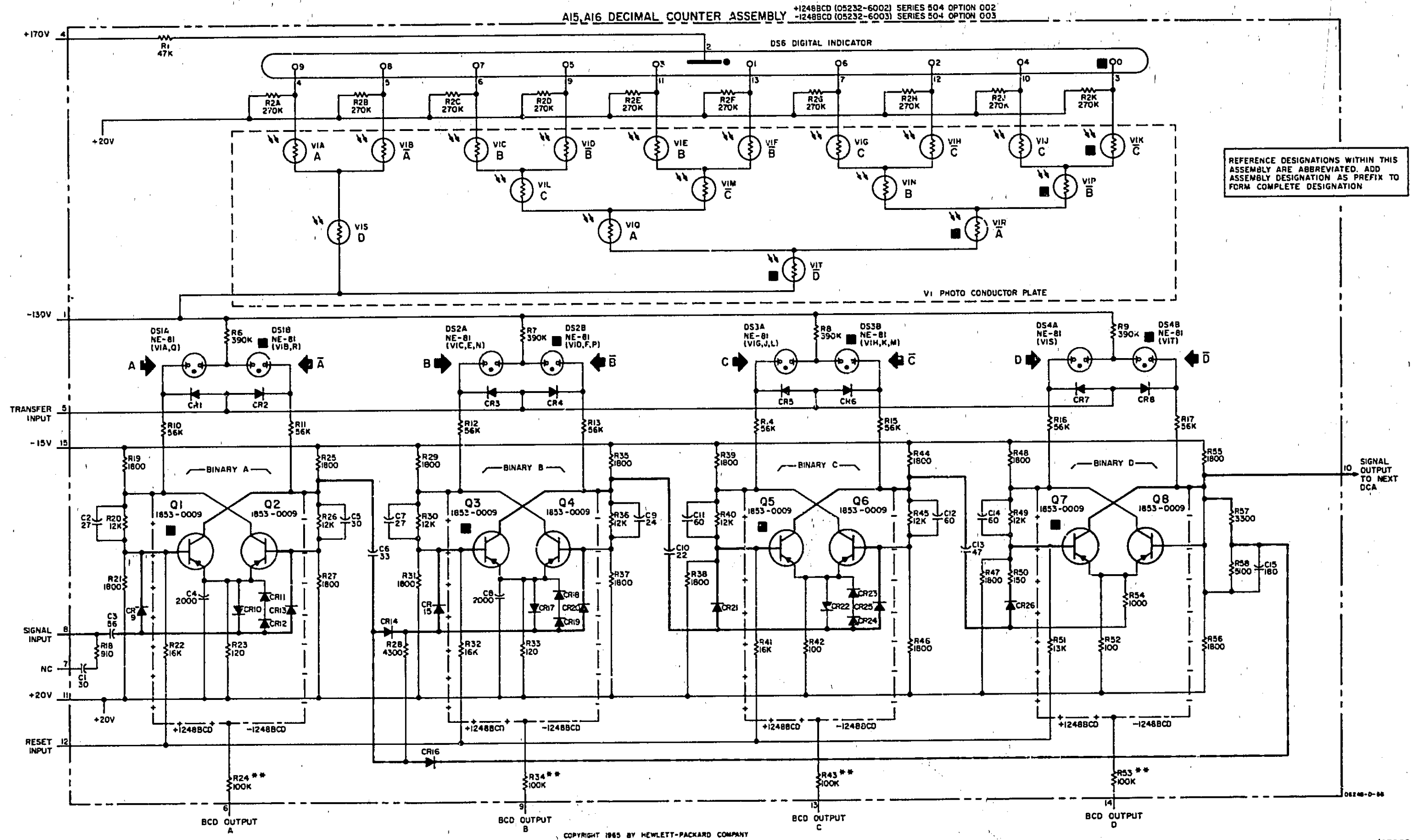

Figure 7-28, A15, A16 Decimal Counter (05232-6002, 6003) Option 002, 003

MANUAL CHANGES

MANUAL CHANGES

MANUAL DESCRIPTION

INSTRUMENT:	5245L Electronic Counter Service Manual
SERIAL PREFIX:	1124A
DATE PRINTED:	NOV 1973
HP PART NO:	05245-9044
MICROFICHE NO:	05245-9047

CHANGE DATE: April 30, 1980

(This change supersedes all earlier dated changes)

- Make all changes listed as ERRATA.
- Check the following table for your instrument's serial prefix or serial number and make listed change(s) to manual.

IF YOUR INSTRUMENT HAS SERIAL PREFIX OR SERIAL NUMBER	MAKE THE FOLLOWING CHANGES TO YOUR MANUAL	IF YOUR INSTRUMENT HAS SERIAL PREFIX OR SERIAL NUMBER	MAKE THE FOLLOWING CHANGES TO YOUR MANUAL
1336A	1	1840A	1,2,3,4,5,6,7,8,9
1412A	1,2	1904A	1 through 10
1436A	1,2,3	1912A	1 through 10
1426A26441 thru 1436A26540	1,2,3,4	1924A	1 through 12
1436A26541 thru 1436A26840	1,2,3,4,5	1932A	1 through 13
1644A	1,2,3,4,5,6	2004A	1 through 14
1720A	1,2,3,4,5,6,7	2016A	1 through 14,15
1820A	1,2,3,4,5,6,7,8		

NEW OR REVISED ITEM

The following Service Notes are available from your local HP Sales and Service Office.

Service Note No.	Description
5245L-2	Inhibit Signal Modification
5245L-3	Input Amplifier Modification
5245L-4	Fan Modification
5245L-5A	Replacement Transistor for A28Q1 thru A28Q8 in Decade Divider (05232-6009)
5245L-6	Replacement Transistor for A17Q9 in the 50 MHz Decimal Counter (5245A-85C)
5245L-7	Replacement Transistor for A25Q2 in Oven Control Assembly (5243A-85T)
5245L-9A	Oven Heater Transistor (Q1) Replacement

25R-4365-8422-8483-8083-8407-8971-8598-7034-7066-7094-7481/7485/7985-8205-8396/8414-8449-8660/
8450/9099-9459/9104/9573-9854/15-10273



HEWLETT
PACKARD

ERRATA

Page 1-1, Table 1-1, Accessories Supplied or Available:

- Change 5243A-44A to 05243-6043.
- Change 5020-0709 to 5020-7622.
- Change 5020-0718 to 5020-7621.
- Change 05243-4001 to 05580-2042.
- Change 05243-9004 to 05243-9005.
- Change 05243-6022 to 05245-6022.

Page 1-2, Table 1-2, TIME BASE, Output Frequencies:

- Change next to last line from "1000 ohm" to "100 ohm".

Page 1-3, Table 1-2, Specifications:

- Delete Options 002 and 003 listed under "OPTIONAL AND SPECIAL FEATURES".

Page 3-11d, PERFORMANCE CHECK TEST CARD, E.3, TIME BASE:

- Change fourth line from "100-ohm" to "1000-ohm".
- Change fifth line from "1000-ohm" to "100-ohm".
- Add at right hand box, TIME BASE OUTPUT JACK (J5), under 1V rms and under 5Vp-p "or greater".

Page 4-16, Table 4-1:

- Change A21CR9 from 1901-0040 to 1910-0016; change description from SILICON to GERMANIUM.

Page 4-22, Table 4-1:

- Change A25Q2 from 1553-0076 to 1853-0086.

Page 4-33, Table 4-1:

- Delete W1 8120-1348.

Page 5-1, Paragraphs 5-15 and 5-17:

- Change first sentence from "number 716-" to "number 1124A".

Page 4-40, Table 4-2, Replaceable Parts:

- Delete 1850-0090, TRANSISTOR: GERMANIUM 2N1183 PNP.
- Add 1853-0052; TRANSISTOR: SILICON 2N3740; 04713; 2N3740; 1.
- Add 0340-0162; INSULATOR: TRANSISTOR (for 2N3740); 28480; 1.

Page 4-7, Table 4-1, A10 Replaceable Parts:

- Change A10R31 and R35 from 0683-3925 (3900Ω) to 0683-8225; R: FXD COMP 8200 OHMS 5% 1/4W.

NOTE: This change is recommended for any 05212-6016 circuit with 1853-0217 silicon transistors.

Page 7-17, Figure 7-9, A10 Schematic Diagram:

- Change A10R31 and R35 from 3900 to 8200 ohms.

Page 4-20, Table 4-1, A23 (5243A-65S) Reference Designation Index:

- Change A23Q8 from 1851-0624 (NPN GER.) to 1854-0642; TRANSISTOR NPN SILICON; 28480; 1854-0642. The silicon transistor is the preferred replacement part in all 5248L instruments.

Page 4-41, Table 4-2, Replaceable Parts:

- Change 1851-0024 to 1854-0642; TRANSISTOR NPN SILICON; 28480; 1854-0642.

Page 7-39/7-40, Figure 7-20, A23 (5243A-65S) Schematic Diagram:

- Change A23Q8 from 2N388A to 1854-0642.

Page 4-33, Table 4-1, Reference Designation Index:

- Change Q2, Q3, and Q4 from 1854-0038 (PNP GER.) to 1853-0053; TRANSISTOR PNP SILICON; 28480; 1853-0053. The silicon transistor is the preferred replacement part.

Page 4-40, Table 4-2, Replaceable Parts:

- Change 1850-0038 (PNP GER.) to 1853-0053; TRANSISTOR PNP SILICON; 28480; 1853-0053.

Page 7-13, Figure 7-7, Power Supply Schematic Diagram:

- Change Q2, Q3, and Q4 from 1850-0038 to 1853-0053.

CHANGE 1 (1336A)

Page 4-6/7, Table 4-1:

Change A10CR9-18 from 1910-0016 to 1901-0040 DIODE: SILICON.

Change A10Q1-8 from 5080-0060 to 1853-0217 TRANSISTOR: PNP SILICON.

Page 4-27, Table 4-1:

Change A29CR1-5 from 1910-0016 to 1901-0040 DIODE: SILICON.

Change A29Q1-8 from 1850-0062 to 1853-0217 TRANSISTOR: PNP SILICON.

Page 5-11, Table 5-7, OPTIONS 002 and 003:

Change A10CR9-14 from 1910-0016 to 1901-0040 DIODE: SILICON.

Change A10Q1-8 from 5080-0060 to 1853-0217 TRANSISTOR: PNP SILICON.

Page 7-17/19, Figure 7-9/10:

Change A10Q1-8 from 5080-0060 to 1853-0217.

CHANGE 2 (1412A)

Page 4-13, Table 4-1:

Change A17R46 from 0683-2225 to 0683-1825 1800 OHM.

Change A17R47 from 0683-2225 to 0683-2725 2700 OHM.

With these changes A17 (5245A-65C) is SERIES 1412.

Page 4-28, Table 4-1:

Change A29R38, 44 from 0683-473F to 0683-3935 39K OHM.

Change A29R41 from 0683-2015 to 0683-1015 100 OHM.

With these changes A29 (5212A-65C) is SERIES 1412.

Page 7-25/26, Figure 7-13:

Add (at top of schematic) "A17 DECIMAL COUNTER ASSY (5245A-65C) SERIES 1412".

Change A17R46 value from 2200 to 1800 OHM; add asterisk (*).

Change A17R47 value from 2200 to 2700.

Page 7-47/48, Figure 7-24:

Change A2938, 44 value from 47K to 39K.

Change A29R41 value from 200 to 100.

Change SERIES 628 to SERIES 1412 at top of schematic.

CHANGE 3 (1436A)

Page 4-6/7, Table 4-1:

Change A10CR9-18 from 1901-0040 to 1910-0016 DIODE: GERMANIUM.

Change A10Q1-8 from 1853-0217 to 5080-0060 GERMANIUM PNP SELECTED.

Page 4-27, Table 4-1:

Change A29CR1-5 from 1901-0040 to 1910-0016 DIODE: GERMANIUM.

Change A29Q1-8 from 1853-0217 to 1850-0062 TRANSISTOR: GERMANIUM.

Page 5-11, Table 5-7, OPTIONS 002 and 003:

Change A10CR9-14 from 1901-0040 to 1910-0016 DIODE: GERMANIUM.

Change A10Q1-8 from 1853-0217 to 5080-0060 GERMANIUM PNP SELECTED.

Page 7-17/19, Figure 7-9/10:

Change A10Q1-8 from 1853-0217 to 5080-0060.

Page 7-47/48, Figure 7-24:

Change A29-A34Q1-8 from 1853-0217 to 1850-0062.

This change supersedes the applicable data in CHANGE 1.

Circuit boards 05212-6002/6003/6016 and 5212A-65C with these changes are SERIES 1436A.

CHANGE 4 (1436A26441 for 5245L)

Page 1-0, Figure 1-1, Model 5245L and Accessories:

The 5245L Electronic Counter is furnished less the RACK MOUNTING KIT and 10503A BNC-BNC Cable Assembly described in this manual in Figure 1-1 and Table 1-1. If ordered at the same time as the instrument, the RACK MOUNTING KIT described in the manual is available as Option 908 at additional cost. If not ordered with an instrument, the RACK MOUNTING KIT is available under HP Part No. 05243-6043. The BNC-BNC Model 10503A cable assembly can be ordered as an additional cost accessory. Disregard any manual references stating the instrument is supplied with a rack mounting kit or BNC to BNC cable assembly.

Page 4-34 and 4-40, Tables 4-1 and 4-2, Reference Designation Index and Replaceable Parts:

Change XF1 fuseholder from 1400-0084 to the following recommended replacement for all instruments:

Delete 1400-0084 Fuseholder for XF1.

Add 2110-0464; FUSEHOLDER BODY UL/IEC; 75915; 345002-010.

Add 2110-0465; FUSEHOLDER BAYONET CAP; 75915; 345003-020.

Add 2950-0054; NUT FUSEHOLDER MTG 1/2-28; 28480; 2950-0054.

CHANGE 5 (1436A26541 and above)

Page 4-4, Table 4-1, Reference Designation Index:

Change A7Q5 from 1850-0048 (Germanium) to 1853-0217; TRANSISTOR: PNP Silicon.

Page 4-7, Table 4-1, A10 Replaceable Parts:

Change A10Q1 thru A10Q8 from 5080-0060 to 1853-0217 TRANSISTOR: PNP Silicon.

Page 4-20, Table 4-1, Reference Designation Index:

Change A23Q6 from 1850-0101 (Germanium) to 1853-0217; TRANSISTOR: PNP Silicon.

Pages 4-40 and 4-41, Table 4-2; Replaceable Parts:

Change 1854-0048 (Ge) to 1853-0217; TRANSISTOR: PNP Si; 28480; 1853-0217.

Change 1850-0101 (Ge) to 1853-0217; TRANSISTOR: PNP Si; 28480; 1853-0217.

Page 7-13, Figure 7-7, A7 Schematic Diagram:

Change A7Q5 from 2N650 (Ge) to 1853-0217 (Si).

Page 7-17/19, Figure 7-9:

Change A10Q1-Q8 from 5080-0060 to 1853-0217.

Page 7-20, Figure 7-20, A23 Schematic:

Change A23Q6 from 2N582 (Ge) to 1853-0217 (Si).

Page 4-27, Table 4-1, A29 (5212A-65C) Reference Designation Index:

Change A29Q1 thru Q8 from 1850-0062 to 1853-0217 TRANSISTOR: PNP SILICON.

Change A29C3 and C4 from 0140-0195 (130 PF) to A29C3* and A29C4*; 0160-2203;

C: FXD MICA 91F 5% 300VDCW. FACTORY SELECTED VALUE.

Page 4-40, Table 4-2, Replaceable Parts:

Change 1850-0062 to 1853-0217; TRANSISTOR SI PNP; 28480; 1850-0062.

Page 7-47/7-48, Figure 7-24, A29-A34 Decade Divider Diagram:

Change A29Q1 thru A29Q8 to 1853-0217.

Change C3 and C4 to C3* and C4* with a value of 91 pF in place of "130".

CHANGE 6 (1644A)

Pages 4-27 and 4-28, Table 4-1, A29 (5212A-65C) Reference Designations Index:

Add "SERIES 1644" to A29 (5212A-65C) Description.

Change A29R6, R8, R17, R19, R29, R31, R40, and R42 from 0683-3925 (3900Ω) to 0683-6225;

R: FXD COMP 6200 OHMS 5% 1/4W.

NOTE — This change applies to any 5212A-65C circuit board with the transistor change described in CHANGE 5.

Page 4-38, Table 4-2, Replaceable Parts:

Change TQ for 0683-3925 to 94.

Change TQ for 0683-6225 to 12.

Page 7-47/7-48, Figure 7-24, A29-A34 Decade Divider Diagram:

Change SERIES number, at top of diagram, to SERIES 1644.

Change A29R6, R8, R17, R19, R29, R31, R40, and R42 to 6200 ohms.

CHANGE 7 (1720A)

NOTE: This change replaces crystal oven assembly A24 and oven control assembly A25 with a 10 MHz component oscillator for A24 and an oscillator control assembly for A25. The new oscillator control assembly supplies regulated voltages for the 10 MHz component oscillator and a decade divider integrated circuit to divide the 10 MHz output from A24 and provide a 1 MHz time base signal. The new component oscillator and control assembly will equal or better the stability specifications of the original assemblies which they replace.

Page 4-21, Table 4-1, Reference Designation Index:

Delete A24 Part No. 5243A-69A crystal oven assembly and all components with reference designators having a prefix of A24.

Add A24; 10544-60036: OVEN OSCILLATOR ASSY (10 MHz) shown in attached Table 1 Replaceable Parts. Field repair of this oscillator is not recommended. Exchange oscillator assemblies are available for repair.

Page 4-21 and 4-22, Table 4-1, Reference Designation Index:

Delete A25 Part No. 5243A-65T oven control assembly and all associated components with reference designations having a prefix of A25.

Add A25; 05245-60033; OSCILLATOR CONTROL ASSEMBLY and the replaceable parts listed in the attached Table 1 Replaceable Parts for the 05245-60033 assembly.

Page 4-31, Table 4-1, Reference Designation Index:

Delete part numbers for chassis mounted components C2 (0130-0003), C3 (0121-0013), and CR1 (1902-0039).

Change "Description" for C2, C3, and CR1 to NOT ASSIGNED.

Page 4-33, Table 4-1, Reference Designation Index:

Delete part number for oven heater amplifier transistor Q1 (1853-0052) and change "Description" to NOT ASSIGNED.

Page 4-34, Table 4-1, Reference Designation Index:

Add MISCELLANEOUS PARTS listed in attached Table 1 Replaceable Parts.

Page 4-36 thru 4-43, Table 4-2, Replaceable Parts:

Change Table 4-2 to reflect the above changes listed for Table 4-1.

Page 4-46, Table 4-3, Manufacturers Code List:

Add attached Table 2 Manufacturers Code List to Table 4-3.

Page 7-41/7-42, Figure 7-21, Schematic Diagram:

Delete A24 (5243-69A), A25 (5243A-65T), C2 (fine freq. adj.), C3 (medium freq. adj.), CR1 (regulator), and Q1 (oven heater amplifier).

Delete connections to 500 UF capacitor C4. This capacitor is used with the new oven control assembly to filter the positive dc output from the bridge rectifier.

Replace A24 and A25 in Figure 7-21 with A24 and A25 shown in attached diagram Figure 2.

The 1 MHz output from A25 connects to A26 pins 2-1, 2-2, and 2-3.

The 1 MHz signal from A25 is fed into the emitter of A26Q1 and is coupled to the input of A26Q2 by capacitor A26C8. This connection bypasses A26Q1 and disables the AGC feedback circuit in A26.

Replace component locator illustration for A26 with component locator for 05245-60033 shown in attached Figure 1.

OSCILLATOR ADJUSTMENT

Oscillator adjustment for the new time base oscillator requires the same procedure as the original oscillator.

The new oscillator has only two controls for adjustments in place of three. The COARSE FREQ ADJUST ($\approx 2 \times 10^{-6}$) is located under an added plug-button on the rear of the instrument. The FINE FREQ ADJUST ($\approx 5 \times 10^{-8}$) is inside the plug-in compartment in the same basic location as before.

The 10544-60036 component oscillator for A24 and the 05245-60033 oscillator control assembly for A25 will provide a 1 MHz time base with specifications equal or better than the original 1 MHz time base.

Table 1. Replaceable Parts

Reference Designation	HP Part Number	Qty	Description	Mfr Code	Mfr Part Number
A24	10544-60036	1	CRYSTAL OSCILLATOR ASSY (10 MHz) NOT RECOMMENDED FOR FIELD REPAIR OSCILLATOR IS ON THE EXCHANGE PROGRAM AS PART NUMBER 10544-60636.	28480	10544-60036
A25	05245-00033	1	BOARD ASSEMBLY, OSCILLATOR CONTROL	28480	05245-00033
A25C	0160-0574	5	CAPACITOR-FXND .1UF +-20% 50VDC CER	28480	0160-0574
A25CP	0160-0574	5	CAPACITOR-FXND .1UF +-20% 50VDC CER	28480	0160-0574
A25CE	0160-0110	1	CAPACITOR-FXND 0.01UF+-10% 35VDC TA	0420J	1500485X001582
A25CF	0160-0110	1	CAPACITOR-FXND 0.01UF+-10% 35VDC TA	0420J	1500485X001582
A25CE	0160-0110	1	CAPACITOR-FXND 0.01UF+-10% 35VDC TA	0420J	1500485X001582
A25C6	0160-1740	1	CAPACITOR-FXND .15UF+-10% 20VDC TA	0420J	1500154X002082
A25C7	0160-3400	1	CAPACITOR-FXND 100PF +-10% 1KVDC CER	28480	0160-3400
A25C8	0160-0574	1	CAPACITOR-FXND .1UF +-20% 50VDC CER	28480	0160-0574
A25C9	0160-0574	1	CAPACITOR-FXND .1UF +-20% 50VDC CER	28480	0160-0574
A25C10	0160-0574	1	CAPACITOR-FXND .1UF +-20% 50VDC CER	28480	0160-0574
A25C11	0160-0485	1	CAPACITOR-FXND 510PF +-5% 50VDC MICR0070	28480	0160-0485
A25C01	1001-0360	1	DIODE-FR BR06 400V 1A	0203E	002-10188-0
A25C02	1002-0041	1	DIODE-ZNR 5.11V 5X 00-7 PDM, 2M TCR, 0.0002	0203E	02 10030-00
A25J1	1251-2035	1	CONNECTOR-PC EDGE 15-CONT/ROW 2-ROW	0450E	250-15-30-300
A25L1	0160-1740	1	COIL-FXND NON-MOLDED HF CHOKE, .75UH	0507A	VX000-20/40
A25L2	0160-0131	1	COIL-MLD 10UH 10% 0045 .005X.25LG	0217B	04-1313-30J
A25L3	0160-2272	1	COIL-MLD 47UH 10% 0045 .005X.25LG	0217B	04-1320-3H
A2501	1444-0071	1	TRANSISTOR NPN SI PD=300mW FREQ=0.4MHz	28480	1444-0071
A2502	0603-1115	1	RESISTOR 110 OHM 5% .25W FC TCR=400/+700	0160G	CR1115
A2503	0603-2425	1	RESISTOR 2.4K 5% .25W FC TCR=400/+700	0160G	CR2425
A2504	0750-0007	1	RESISTOR 150 OHM 5% .25W F TCR=400/+700	0341B	CR51/4-Y0-151-J
A2505	0603-0025	1	RESISTOR 0.25 OHM 5% .25W FC TCR=400/+700	0160G	CR025
A2506	0750-0000	1	RESISTOR 0.025 OHM 1% .125W F TCR=400/+700	0349B	CR51/8-Y0-0021-F
A2507	0750-0030	1	RESISTOR 0.01K 1% .125W F TCR=400/+700	0349B	CR51/8-Y0-0031-F
A2508	0750-0003	1	RESISTOR 1K 5% .25W F TCR=400/+700	0341B	CR51/4-Y0-1001-J
A2509	0603-1025	1	RESISTOR 1K 5% .25W FC TCR=400/+700	0160G	CR1025
A2510	0603-3325	1	RESISTOR 3.3K 5% .25W FC TCR=400/+700	0160G	CR3325
A2511	0603-1025	1	RESISTOR 1K 5% .25W FC TCR=400/+700	0160G	CR1025
A2512	0603-1025	1	RESISTOR 1K 5% .25W FC TCR=400/+700	0160G	CR1025
A2513	0603-3325	1	RESISTOR 3.3K 5% .25W FC TCR=400/+700	0160G	CR3325
A25U1	1000-0430	1	IC V MCLR	0223C	725PC
A25U2	1000-1460	1	IC CMOS TTL 80 DECA 4BYNCR0	0140M	0474L8004
A25U3	1251-4001	1	CONNECTOR	27204	22-15-2031
			MISCELLANEOUS PARTS		
	0360-0124	3	TERMINAL-STUD 66L-PIN PRESS-VTC	28480	0360-0124
	0360-0099	2	SPACER-RVT=04 .25LG .152ID .2500 RWS	28480	0360-0099
	0360-0111	2	STANDOFF-RVT=04 .25LG 0-32TWD .2500 RWS	28480	0360-0111
P2	1251-0100	1	CONNECTOR-PC EDGE 6-CONT/ROW 1-ROW	0450E	250-06-30-210
R15	0603-0105	1	RESISTOR 51 OHM 5% .25W FC TCR=400/+700	0160G	CR0105
R16	0100-2103	1	RESISTOR-TYPR 10K 10% C SIDE-ADJ 17-TYR	7313B	040010K
U1	1000-0301	1	IC V MCLR	0340F	LM4117
W0	05245-00034	1	CABLE ASSEMBLY, OSCILLATOR OUT/P2, R15	28480	05245-00034
W1	05245-00035	1	CABLE ASSEMBLY, FINE ADJUST	28480	05245-00035
W2	05245-00037	1	CABLE ASSEMBLY, OSCILLATOR POWER SUPPLY	28480	05245-00037
Z1	0160-3447	1	ADAPTER, POT, PANEL MOUNT (FOR R16)	7313B	040
	0400-0007	1	PLUG-HOLE 00P-HND FOR 1-HOLE DRB	0421C	D-1200
	05245-00024	1	BRACKET, MOUNTING FOR A24 AND A25	28480	05245-00024

See Introduction to this section for ordering information

Table 2. Manuf. :urers Code List

MFR NO.	MANUFACTURER NAME	ADDRESS	ZIP CODE
0160G	ALLEN-BRADLEY CO	MILWAUKEE	WI
0169H	TEXAS INSTR. INC SEMICOND CMPNT DIV	DALLAS	TX
0203G	MOTOROLA SEMICONDUCTOR PRODUCTS	PHOENIX	AZ
05674	BARD-PARKER DIV BECTON DICKINSON	DANBURY	CT 06810
0217B	AIRCO SPEER ELEK DIV AIR RDCN CO	NOGALES	AZ
0223G	FAIRCHILD SEMICONDUCTOR DIV	MOUNTAIN VIEW	CA
0329B	CORNING GLASS WORKS (BRADFORD)	BRADFORD	PA
0380F	NATIONAL SEMICONDUCTOR CORP	SANTA CLARA	CA
0381B	CORNING GLASS WORKS (WILMINGTON)	WILMINGTON	NC
27268	MOLEX PRODUCTS CO	DOWNERS GROVE I	60515
28480	HP DIV 00 CORPORATE	PALO ALTO	CA
0420J	SPRAGUE ELECTRIC CO	NORTH ADAMS	MA
0421C	STIMPSON EDWIN B CO INC	BROOKLYN	NY
0450G	TRW ELEK COMPONENTS CINCH DIV	ELK GROVE VLGE	IL
7313A	RECKMAN INSTRUMENTS INC HELIPOT DIV	FULLERTON	CA 92634
28480	NO M/F DESCRIPTION FOR THIS MFG NUMBER		

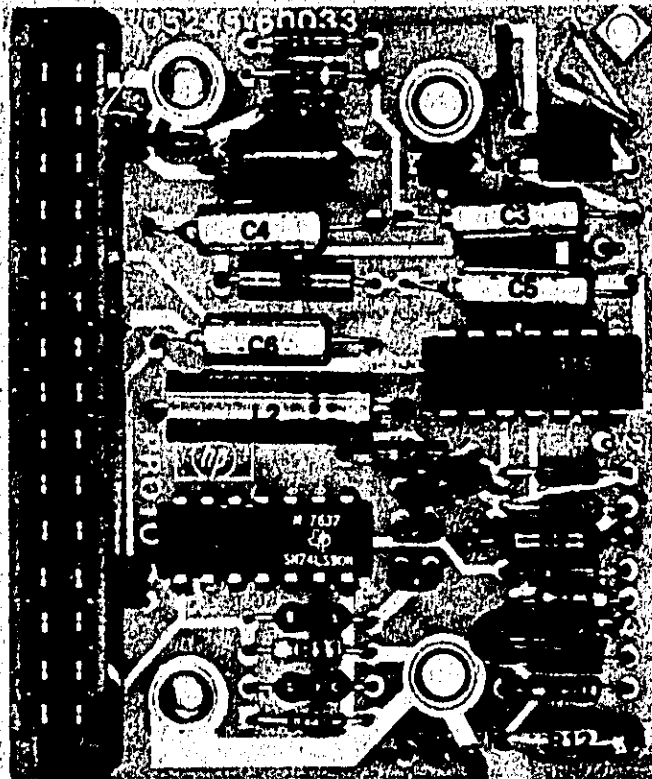
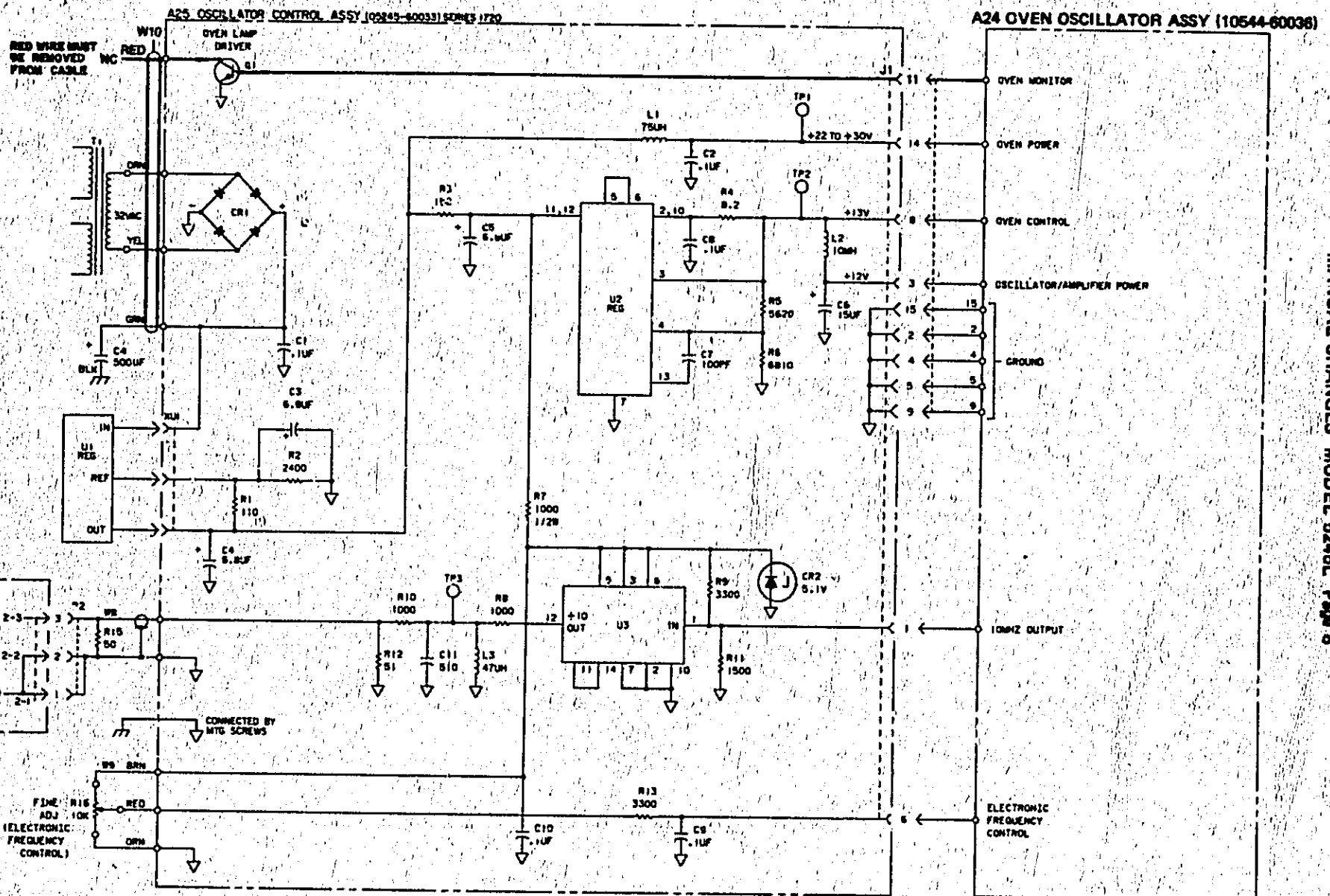

Figure 1. A25 Oscillator Control Assembly (05245-60033)

Figure 2. New A24 Oscillator (10544-60036) and A25 Oscillator Control Assembly



CHANGE 8 (1820A)

Pages 4-18 and 4-19, Table 4-1, A22 (5243A-65R) Replaceable Parts:

Add "(SERIES 1820)" to A22 circuit board description.

Change A22Q8, Q9, and Q10 from 1851-0017 (Ger. 2N1304) to 1854-0642; TRANSISTOR-NPN Si TO-9 350 MW; 28480; 1854-0642.

Page 4-20, Table 4-1, A23 (5243A-65S) Replaceable Parts:

Add "(SERIES 1820)" to A23 circuit board description.

Change A23C11 from 0140-0200 (390 PF) to 3160-2930; CAPACITOR-FXD 0.01UF +80/-20 100 VDCW CER; 28490; 016U-2930.

Change A23Q1 and Q12 from 1851-0017 (Ger. NPN) to 1854-0642; TRANSISTOR-NPN Si TO-9 350 MW; 28480; 1854-0642.

Change A23Q2 and Q7 from 1850-0040 (2N383) to 1853-0217; TRANSISTOR-PNP Si 310 MW; 28480; 1853-0217.

Change A23R10 from 0686-1035 (10K) to 0686-2725; RESISTOR-FXD 2700 5% COMP 1/2W; 01121; EB2725.

Page 4-24, Table 4-1, A27 (5243A-65C) Replaceable Parts:

Add "(SERIES 1820)" to A27 circuit board description.

Change A27Q1, Q2, and Q3 from 1850-0091 (2N2048) to 1853-0036; TRANSISTOR-PNP Si 310 MW (2N3906); 28480; 1853-0036.

Pages 4-28 and 4-29, Table 4-1, A35 (5243A-65J) Replaceable Parts:

Add "(SERIES 1820)" to A35 circuit board description.

Change A35Q1 from 1850-0040 (2N383) to 1853-0217; TRANSISTOR-PNP Si 310 MW; 28480; 1853-0217.

Page 7-37, Figure 7-19, A22 (5243A-65R) Schematic Diagram:

Change SERIES number (top of diagram) to 1820.

Change A22Q8, Q9, and Q10 to 1854-0642.

Page 7-39/7-40, Figure 7-20, A23 (5243A-65S) Schematic Diagram:

Change SERIES number (top of diagram) to 1820.

Change A23C11 from 390 pF to 0.01 UF.

Change A23Q1 and Q12 from 2N1304 to 1854-0642.

Change A23Q2 and Q7 from 2N383 to 1853-0217.

Change A23R10 from 10K to 2700 ohms.

Page 7-43/7-44, Figure 7-22, A27 (5243A-65C) Schematic Diagram:

Add "(SERIES 1820)" at top of diagram.

Change A27Q1, Q2, and Q3 from 2N2048 to 1853-0036.

Page 7-49/7-50, Figure 7-25, A35 (5243A-65J) Schematic Diagram:

Add "(SERIES 1820)" at bottom right corner of diagram.

Change A35Q1 from 2N383 to 1853-0217.

CHANGE 9 (1840A)

The following changes replace the HP Part No. 5245A-65C Decimal Counter Assembly for A17 with a new assembly (HP Part No. 05245-60039) with integrated circuits. The 05245-60039 circuit board is a direct plug-in replacement for the discontinued 5245A-65C circuit board.

Pages 4-11 thru 4-13, Table 4-1, A17 Replaceable Parts:

Deletes A17 part number 5245-65C and all associated components for this assembly.

Add A17; 05245-60039; BOARD ASSEMBLY, DECIMAL COUNTER and the replaceable parts for this assembly listed in attached Table 3.

Page 4-46, Table 4-3, Manufacturers Code List:

Add attached Table 4 Manufacturers Code List to Table 4-3.

Page 7-25/7-26, Figure 7-13, A17 (5245A-65C) Schematic and Component Locator:

Replace A17 component locator with new illustration given in attached Figure 3.

Replace A17 schematic diagram with new diagram for 05245-60039 Decimal Counter Assembly given in attached Figure 4.

Table 3. A17 Replaceable Parts

Reference Designation	HP Part Number	Qty	Description	Mfr Code	Mfr Part Number
A17	03205-0030	2	BOARD ASSEMBLY, RECIPAL COUNTER SERIES 1040	20400	03205-0030
A17C1	0100-0193	0	CAPACITOR-FXD 22PF +-5% 300VDC 11C4	72130	011920201300-0100
A17C2	0100-0170	0	CAPACITOR-FXD 150PF+-10% 20VDC 7A	50200	1500150102002
A17C3	0100-0155	0	CAPACITOR-FXD 2.2UF+-20% 20VDC 7A	50200	15002220102002
A17C4	0150-0080	0	CAPACITOR-FXD 1000PF +-50%-20% 1KVDC CER	20400	0150-0080
A17CR1	1001-0050	3	DIODE-SWITCHING 80V 200MA 2MS DG-35	20400	1001-0050
A17CR2	1001-0050	3	DIODE-SWITCHING 80V 200MA 2MS DG-35	20400	1001-0050
A17Q1	1053-0015	7	TRANSISTOR PNP SI P00210MA FT0500MAZ	20400	1053-0015
A17Q2	1050-0009	1	TRANSISTOR NPN 20700 SI T0-18 P00300MA	20400	1050-0009
A17Q3	1050-0009	1	TRANSISTOR NPN 20700 SI T0-18 P00300MA	20400	1050-0009
A17Q4	1050-0071	7	TRANSISTOR NPN SI P00300MA FT0200MAZ	20400	1050-0071
A17Q5	1053-0030	2	TRANSISTOR PNP SI P00310MA FT0200MAZ	20400	1053-0030
A17R1			NOT ASSIGNED		
A17R2	0757-0010	2	RESISTOR 470 2% .125W F TC00-100	20500	C0-170-70-0710-0
A17R3	0757-0017	3	RESISTOR 510 2% .125W F TC00-100	20500	C0-170-70-5110-0
A17R4	0757-0020	7	RESISTOR 1.0K 2% .125W F TC00-100	20500	C0-170-70-1001-0
A17R5	0757-0024	2	RESISTOR 1K 2% .125W F TC00-100	20500	C0-170-70-1001-0
A17R6	0757-0020	2	RESISTOR 1K 2% .125W F TC00-100	20500	C0-170-70-1001-0
A17R7	0757-0032	2	RESISTOR 2.2K 2% .125W F TC00-100	20500	C0-170-70-2201-0
A17R8	0757-0047	3	RESISTOR 5.0K 2% .125W F TC00-100	20500	C0-170-70-5001-0
A17R9	0757-0017	3	RESISTOR 510 2% .125W F TC00-100	20500	C0-170-70-5110-0
A17R10	0757-0030	0	RESISTOR 1.5K 2% .125W F TC00-100	20500	C0-170-70-1501-0
A17R11	0757-0032	2	RESISTOR 2.2K 2% .125W F TC00-100	20500	C0-170-70-2201-0
A17R12	0757-0043	0	RESISTOR 5.0K 2% .125W F TC00-100	20500	C0-170-70-5001-0
A17R13	0757-0020	7	RESISTOR 1.0K 2% .125W F TC00-100	20500	C0-170-70-1001-0
A17R14	0757-0043	7	RESISTOR 7.5K 2% .125W F TC00-100	20500	C0-170-70-7501-0
A17R15	0757-0047	0	RESISTOR 0.1K 2% .125W F TC00-100	20500	C0-170-70-0101-0
A17R16	0757-0048	0	RESISTOR 10K 2% .125W F TC00-100	20500	C0-170-70-1002-0
A17R17	0757-0024	2	RESISTOR 1K 2% .125W F TC00-100	20500	C0-170-70-1001-0
A17R18	0757-0037	1	RESISTOR 3.0K 2% .125W F TC00-100	20500	C0-170-70-3001-0
A17R19	0757-0020	0	RESISTOR 1.0K 2% .125W F TC00-100	20500	C0-170-70-1001-0
A17R20	0757-0030	0	RESISTOR 1.5K 2% .125W F TC00-100	20500	C0-170-70-1501-0
A17U1	1020-1010	0	IC FF TTL LS J-K NEG-EDGE-TRIG	01295	SN74LS112A
A17U2	1020-1400	3	IC FF TTL S J-K NEG-EDGE-TRIG	01295	SN74S112N
A17U3	1020-0030	1	VOLTAGE REGULATOR +5V	20400	1020-0030

✓ Part Number Check Digit

Table 4. Manufacturers Code List

Mfr No.	Manufacturer Name	Address	Zip Code
01121	Allen-Bradley Co.	Milwaukee, WI	53204
01295	Texas Instr Inc S'micond Cmpnt Div	Dallas, TX	75222
24548	Corning Glass Works (Bradford)	Bradford, PA	16701
20480	Hewlett-Packard Co Corporate Hq	Palo Alto, CA	94304
56289	Sprague Electric Co	North Adams, MA	01247
72136	Electro Motive Corp Sub IEC	Willimantic, CT	06226

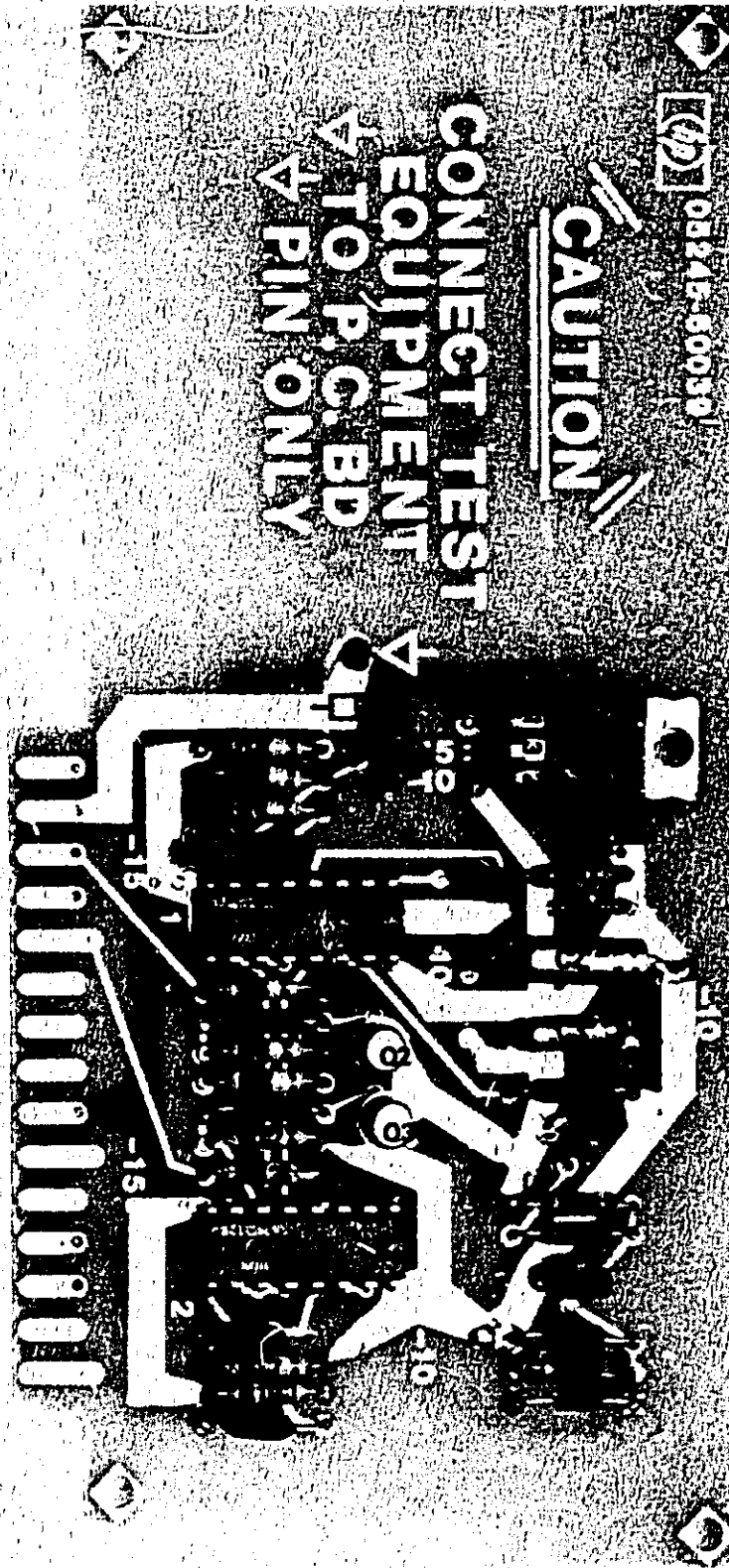

Figure 3. Component Locator for 05245-60039 DCA (SERIES 1840)
Resistor R1 added for SERIES 1904

A17 DECIMAL COUNTER ASSEMBLY (05245-60039) SERIES 1840

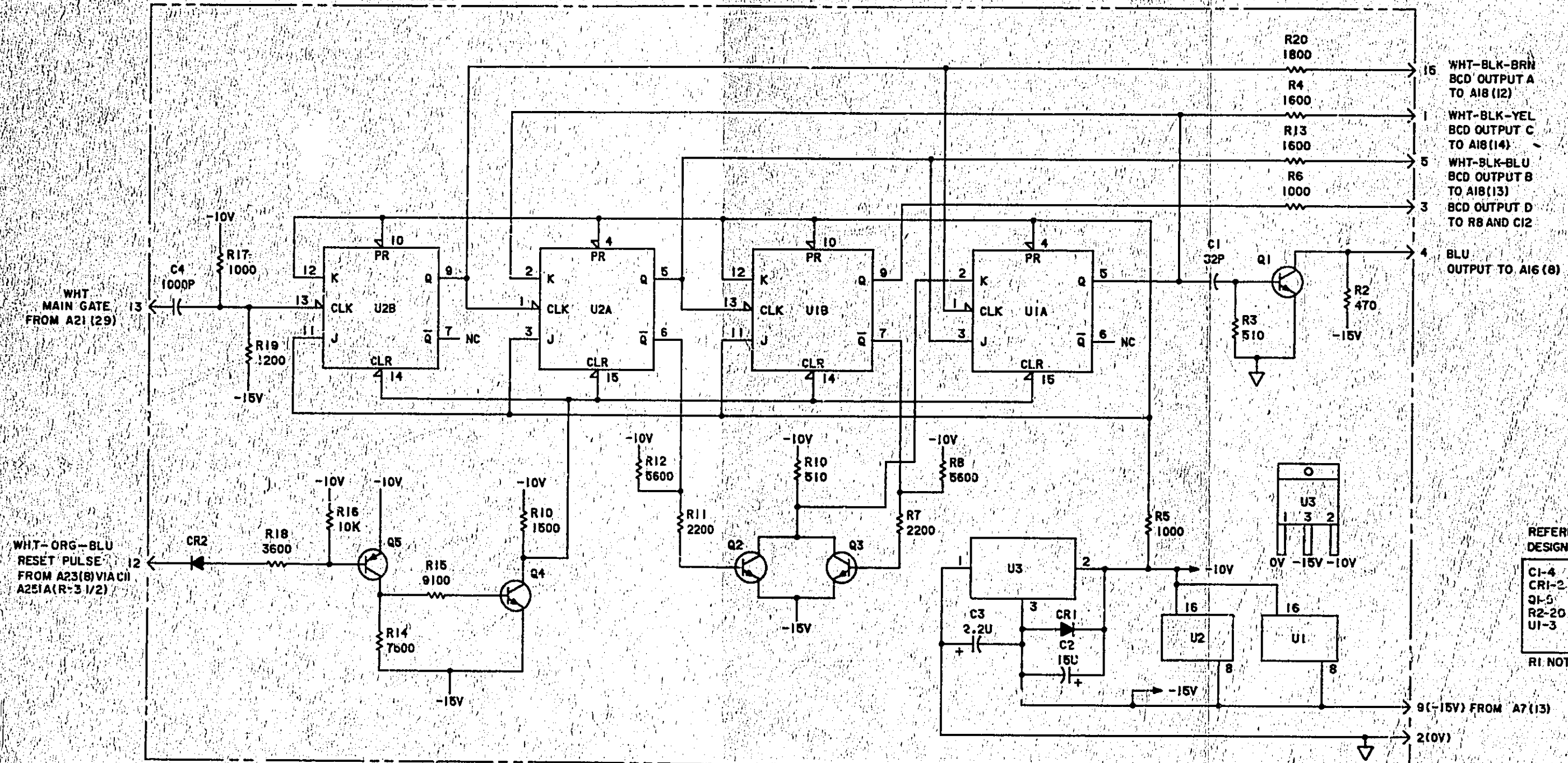

Figure 4. A17 DECIMAL COUNTER ASSEMBLY
HP PART NO. 05245-60039

CHANGE 10 (1904A)

Instrument Serial Prefix Number becomes 1904A with this change which affects Decimal Counter Assembly A17 in CHANGE 9 of these MANUAL CHANGES.

Table 3 of these MANUAL CHANGES; A17 (05245-60039) Replaceable Parts:

Change A17 series number from 1840 to 1904.

Add A17R1; 0683-0475; RESISTOR 4.7Ω 5% .25W FC TC= -400/+500; 01121; CB47G5.

Figure 3 of these MANUAL CHANGES; A17 Component Locator:

Add A17R1 in the approximate location shown in illustration for a SERIES 1904 circuit board.

Delete A17R1 for a SERIES 1840 circuit board.

Figure 4 of these MANUAL CHANGES; A17 (05245-60039) Schematic Diagram:

Change series number (top of diagram) from 1840 to 1904.

Add 4.7Ω resistor R1 in series with the emitter of transistor Q1.

Change "R2-R20" in REFERENCE DESIGNATIONS table to "R1-R20" and delete "R1 NOT USED" at bottom of this same table.

■ **CHANGE 11 (1912A)**

■ Page 4-6, Table 4-1, A10 Reference Designation Index: (See CHANGE 14.)

Delete "5212-6016 ASSY: DECIMAL BOARD" and all associated A10 components including 05212-6011 READ-OUT BLOCK ASSY.

Add 05212-6018 ASSY: DECIMAL BOARD (SERIES 1912) for A10 and A10 parts in attached Replaceable Parts Table 5.

■ Page 4-8, Table 4-1, A16 Reference Designation Index: (See CHANGE 14.)

Delete "05232-6010 DECIMAL COUNTER ASSEMBLY" and all associated A16 components including "05212-6011 READOUT BLOCK ASSEMBLY".

Add 05232-6015 DECIMAL COUNTER ASSEMBLY (SERIES 1912) for A16 and A16 parts in attached Replaceable Parts Table 6.

■ Page 4-13, Table 4-1, A18 Reference Designation Index: (See CHANGE 14.)

Delete "5245L-4B ASSY: READOUT" and all associated A18 components including "05212-6011 READOUT BLOCK ASSEMBLY".

Add 05245-60040 STANDARD +1248 READOUT ASSY (SERIES 1912) for A18 and A18 parts in attached Replaceable Parts Table 7.

Page 5-2, Table 5-4, Reference Designation Index (A18 Option 002):

Delete "05245-6001 50 KC +1248 READOUT ASSEMBLY" and all associated A18 components including the "READOUT BLOCK ASSY".

Add 05245-60041 OPTION 002 +1248 READOUT ASSY (SERIES 1912) for A18 and A18 parts in attached Replaceable Parts Table 8.

Page 5-5, Table 5-4, Reference Designation Index (A18 Option 003):

Delete "05245-6003 -1248 READOUT ASSEMBLY" and all associated A18 components including "05212-6011 READOUT BLOCK ASSY".

Add 05245-60042 OPTION 003 -1248 READOUT ASSY (SERIES 1912) for A18 and A18 parts in attached Replaceable Parts Table 9.

CHANGE 11 (1912A) (Cont'd)

- Page 7-17, Figure 7-9, A10-A15 (05212-6016) Schematic Diagram: (See CHANGE 14.)

Change "(05212-6016) SERIES 648" at top of diagram to (05212-6018) SERIES 1912.

Delete CR1 thru CR8, DS1A/B thru DS4A/B, DS6, R1, R2A thru R2K, R6 thru R9, and photoconductor V1.

Delete R12 and add "A" at top end of R11.

Delete R27 and add "B" at top end of R26.

Delete R40 and add "D" at top end of R39.

Delete R53 and add "C" at top end of R52.

Add integrated circuit U1, transistors Q12 thru Q22, digital display tube DS6, and associated components in place of above removed parts. See Figure 5 for diagram of integrated circuit readout assembly.

Connect WHT-BLK wire to A (upper end of R11).

Connect WHT-BRN wire to B (upper end of R26).

Connect WHT-RED wire to C (upper end of R52).

Connect WHT-ORN wire to D (upper end of R39).

- Page 7-21, Figure 7-11, A16 (05232-6010) Schematic Diagram: (See CHANGE 14.)

Change "(05232-6010)" at top of diagram to "(05232-6015)" SERIES 1912.

Delete CR1 thru CR8, DS1A/B thru DS4A/B, DS6, R1, R2A thru R2K, R6 thru R9, and photoconductor V1.

Delete R10 and add "A" at top end of R11.

Delete R12 and add "B" at top end of R13.

Delete R14 and add "D" at top end of R15.

Delete R16 and add "C" at top end of R17.

Add integrated circuit U1, transistors Q12 thru Q22, digital display tube DS6, and associated components in place of above removed parts. See Figure 5 for diagram of integrated circuit readout assembly.

Connect WHT-BLK wire to A (upper end of R11).

Connect WHT-BRN wire to B (upper end of R13).

Connect WHT-RED wire to C (upper end of R17).

Connect WHT-ORN wire to D (upper end of R15).

- Page 7-27, Figure 7-14, A18 (5245L-4B) Schematic Diagram: (See CHANGE 14.)

Change "(5245L-4B) SERIES 604" at top of diagram to (05245-60040) SERIES 1912.

Make same deletions and additions as given for Page 7-21, Figure 7-11 schematic diagram for A16.

- Page 7-29, Figure 7-15, A18 (05245-6001) Schematic Diagram:

Change "(05245-6001) SERIES 604" at top of diagram to (05245-60041) SERIES 1912.

Make same deletions and additions as given for Page 7-21, Figure 7-11 schematic diagram for A16.

- Page 7-31, Figure 7-16, A18 (05245-6003) Schematic Diagram:

Change "(05245-6003) SERIES 516" at top of diagram to (05245-60042) SERIES 1912.

Make same deletions and additions as given for Page 7-21, Figure 7-11 schematic diagram for A16.

CHANGE 11 (1912A) (Cont'd)

Table 5. A10-A15 Replaceable Parts

Reference Designation	HP Part Number	C	D	Qty	Description	Mfr Code	Mfr Part Number
A10	05212-0010	9		1	ASSEMBLY, DECIMAL BOARD (SERIES 1912)	20400	05212-0010
A10C1	0140-0140	7		1	CAPACITOR-FXD 30PF +-5% 300VDC MICA	72130	D015E10J0300V1C0
A10C2	0140-0145	2		1	CAPACITOR-FXD 22PF +-5% 500VDC MICA	72130	D015C220J0500V1C0
A10C3	0140-0193	0		3	CAPACITOR-FXD 82PF +-5% 300VDC MICA	72130	D015E820J0300V1C0
A10C4	0140-0193	0		1	CAPACITOR-FXD 82PF +-5% 300VDC MICA	72130	D015E820J0300V1C0
A10C5	0140-0294	0		1	CAPACITOR-FXD 87PF +-5% 300VDC MICA	72130	D015E870J0300V1C0
A10C6	0100-0197	4		2	CAPACITOR-FXD 100PF +-5% 300VDC MICA	72130	D015F101J0300V1C0
A10C7	0100-2203	0		2	CAPACITOR-FXD 91PF +-5% 300VDC MICA 0-70	20400	0100-2203
A10C8	0100-0192	0		1	CAPACITOR-FXD 68PF +-5% 300VDC MICA	72130	D015E680J0300V1C0
A10C9	0100-0197	4		4	CAPACITOR-FXD 150PF +-5% 300VDC MICA	72130	D015F151J0300V1C0
A10C10	0100-0217	0		1	CAPACITOR-FXD 100PF +-2% 300VDC MICA	72130	D015F101G0300V1C0
A10C11	0100-2203	0		0	CAPACITOR-FXD 91PF +-5% 300VDC MICA 0-70	20400	0100-2203
A10C12	0140-0193	0		0	CAPACITOR-FXD 82PF +-5% 300VDC MICA	72130	D015E820J0300V1C0
A10C13	0100-2200	2		2	CAPACITOR-FXD 100PF +-5% 300VDC MICA	20400	0100-2200
A10C14	0100-0195	2		1	CAPACITOR-FXD 130PF +-5% 300VDC MICA	72130	D015F131J0300V1C0
A10C15	0100-2200	2		2	CAPACITOR-FXD 100PF +-5% 300VDC MICA	20400	0100-2200
A10CR1 THRU A10CR8					NOT ASSIGNED		
A10CR9 THRU A10CR18	1910-0010	0		10	DIODE-GE 60V 80MA 1UB DO-7	20400	1910-0010
A10CR19 THRU A10CR25					NOT ASSIGNED		
A10CR26	1902-0025	4		1	DIODE-2HR 10V 5% DO-7 PDS, 4M TC=0.05%	20400	1902-0025
A10CR27	1902-0041	4		2	DIODE-2HR 5.11V 5% DO-7 PDS, 4M TC=0.006%	20400	1902-0041
A10CR28	1902-0041	4		2	DIODE-2HR 5.11V 5% DO-7 PDS, 4M TC=0.006%	20400	1902-0041
A10CR29	1902-0175	5		1	DIODE-2HR 100V 5% DO-15 PDS, 4M TC=0.003%	20400	1902-0175
A10DS1 THRU A10DS5					NOT ASSIGNED		
A10DS6	1970-0000	7		1	TUBE-ELECTRON 6AZ2 IAO-NUMERIC	20400	1970-0000
A10Q1 THRU A10Q8	1051-0217	1		0	TRANSISTOR PNP 01 P00310MH	04713	HP0-406A
A10Q9 THRU A10Q11					NOT ASSIGNED		
A10Q12	1050-0042	0		1	TRANSISTOR NPN 01 P00025MH JTB00MHZ	04713	HP0-417
A10Q13 THRU A10Q22	1050-0575	0		10	TRANSISTOR NPN 01 P00025MH JTB00MHZ	04713	HP0-442
A10R1 THRU A10R9					NOT ASSIGNED		
A10R10	0000-7525	2		0	RESISTOR 7.5K 5% .5W CC TC=0-047	01121	E07525
A10R11	0003-5035	5		4	RESISTOR 50K 5% .25W FC TC=000/+800	01121	C05035
A10R12					NOT ASSIGNED		
A10R13	0000-7525	2		0	RESISTOR 7.5K 5% .5W CC TC=0-047	01121	E07525
A10R14	0003-5035	0		13	RESISTOR 50K 5% .25W FC TC=000/+800	01121	C05035
A10R15	0003-5035	4		4	RESISTOR 50K 5% .25W FC TC=000/+800	01121	C05035
A10R16	0003-5035	2		7	RESISTOR 1.5K 5% .25W FC TC=000/+700	01121	C01535
A10R17	0003-1015	5		4	RESISTOR 100 5% .25W FC TC=000/+800	01121	C01015
A10R18	0003-0735	0		0	RESISTOR 47K 5% .25W FC TC=000/+800	01121	C04735
A10R19	0003-3025	2		2	RESISTOR 3.0K 5% .25W FC TC=000/+700	01121	C03025
A10R20	0003-1045	1		0	RESISTOR 100K 5% .25W FC TC=000/+800	01121	C01045
A10R21	0003-1025	3		2	RESISTOR 3K 5% .25W FC TC=000/+700	01121	C03025
A10R22	0003-0735	4		4	RESISTOR 47K 5% .25W FC TC=000/+800	01121	C04735
A10R23	0003-0735	0		0	RESISTOR 47K 5% .25W FC TC=000/+800	01121	C04735
A10R24	0003-3025	3		3	RESISTOR 3K 5% .25W FC TC=000/+700	01121	C03025
A10R25	0000-7525	2		2	RESISTOR 7.5K 5% .5W CC TC=0-047	01121	E07525
A10R26	0003-5035	5		5	RESISTOR 50K 5% .25W FC TC=000/+800	01121	C05035
A10R27					NOT ASSIGNED		
A10R28	0000-7525	2		0	RESISTOR 7.5K 5% .5W CC TC=0-047	01121	E07525
A10R29	0003-0735	4		4	RESISTOR 47K 5% .25W FC TC=000/+800	01121	C04735
A10R30	0003-0735	4		4	RESISTOR 47K 5% .25W FC TC=000/+800	01121	C04735
A10R31	0003-0225	5		0	RESISTOR 0.2K 5% .25W FC TC=000/+700	01121	C00225
A10R32	0003-5035	2		2	RESISTOR 50K 5% .25W FC TC=000/+800	01121	C05035
A10R33	0003-1015	5		5	RESISTOR 100 5% .25W FC TC=000/+800	01121	C01015
A10R34	0003-2735	0		1	RESISTOR 27K 5% .25W FC TC=000/+800	01121	C02735
A10R35	0003-0225	5		5	RESISTOR 0.2K 5% .25W FC TC=000/+700	01121	C00225
A10R36	0003-0225	5		5	RESISTOR 0.2K 5% .25W FC TC=000/+700	01121	C00225
A10R37	0003-1045	3		3	RESISTOR 100K 5% .25W FC TC=000/+800	01121	C01045
A10R38	0000-7525	2		2	RESISTOR 7.5K 5% .5W CC TC=0-047	01121	E07525
A10R39	0003-5035	5		5	RESISTOR 50K 5% .25W FC TC=000/+800	01121	C05035
A10R40					NOT ASSIGNED		
A10R41	0000-7525	2		2	RESISTOR 7.5K 5% .5W CC TC=0-047	01121	E07525
A10R42	0003-0735	4		4	RESISTOR 47K 5% .25W FC TC=000/+800	01121	C04735

CHANGE 11 (1012A) (Cont'd)

Table 5. A10-A15 Replaceable Parts (Cont'd)

Reference Designation	HP Part Number	C D	Gty	Description	Mfr Code	Mfr Part Number
A10R03	0003-0730	4		RESISTOR 47K 5% .25W FC TCR=400/+800	01121	CR0730
A10R04	0003-0220	2		RESISTOR 8.2K 5% .25W FC TCR=400/+700	01121	CR0220
A10R05	0003-1030	2		RESISTOR 3.9K 5% .25W FC TCR=400/+700	01121	CR1030
A10R06	0003-1010	5		RESISTOR 100K 5% .25W FC TCR=400/+800	01121	CR1010
A10R07	0003-0730	4		RESISTOR 47K 5% .25W FC TCR=400/+800	01121	CR0730
A10R08	0003-1030	2		RESISTOR 3.9K 5% .25W FC TCR=400/+700	01121	CR1030
A10R09	0003-1030	1		RESISTOR 10K 5% .25W FC TCR=400/+700	01121	CR1030
A10R10	0003-1000	3		RESISTOR 100K 5% .25W FC TCR=400/+800	01121	CR1000
A10R11	0003-1030	2		RESISTOR 47K 5% .25W FC TCR=400/+800	01121	CR1030
A10R12	0003-0630	5		RESISTOR 50K 5% .25W FC TCR=400/+800	01121	CR0630
A10R13				NOT ASSIGNED		
A10R14	0003-1030	1		RESISTOR 7.5K 5% .5W CC TCR=400	01121	CR1030
A10R15	0003-0730	4		RESISTOR 47K 5% .25W FC TCR=400/+800	01121	CR0730
A10R16	0003-0730	4		RESISTOR 47K 5% .25W FC TCR=400/+800	01121	CR0730
A10R17	0003-1030	1		RESISTOR 10K 5% .25W FC TCR=400/+700	01121	CR1030
A10R18	0003-1030	2		RESISTOR 3.9K 5% .25W FC TCR=400/+700	01121	CR1030
A10R19	0003-1010	5		RESISTOR 100K 5% .25W FC TCR=400/+800	01121	CR1010
A10R20	0003-1030	4		RESISTOR 47K 5% .25W FC TCR=400/+800	01121	CR1030
A10R21	0003-1030	2		RESISTOR 3.9K 5% .25W FC TCR=400/+700	01121	CR1030
A10R22	0003-1030	1		RESISTOR 10K 5% .25W FC TCR=400/+700	01121	CR1030
A10R23	0003-0630	4	1	RESISTOR 50K 5% .25W FC TCR=400/+800	01121	CR0630
A10R24	0003-1000	3	1	RESISTOR 100K 5% .25W FC TCR=400/+800	01121	CR1000
A10R25	0003-2020	1	1	RESISTOR 2K 5% .25W FC TCR=400/+700	01121	CR2020
A10R26 THRU A10R78				NOT ASSIGNED		
A10R79	0003-1000	3		RESISTOR 100K 5% .25W FC TCR=400/+800	01121	CR1000
A10R80	0003-1030	7	1	RESISTOR 10K 5% .5W CC TCR=400	01121	CR1030
A10R81	0003-1030	1		RESISTOR 10K 5% .25W FC TCR=400/+700	01121	CR1030
A10R82	0003-1030	9	1	RESISTOR 12K 5% .5W CC TCR=400	01121	CR1030
A10R83	0003-1000	3		RESISTOR 100K 5% .25W FC TCR=400/+800	01121	CR1000
A10R84 THRU A10R93	0003-1030	4	10	RESISTOR 30K 5% .25W FC TCR=400/+800	01121	CR1030
A10R84 THRU A10R97	0003-2020	5	4	RESISTOR 2K 5% .25W FC TCR=400/+700	01121	CR2020
A10U1	1200-1000	0	1	IC, CMOS 10010	0102B	CD051007
A10U1	1200-0501	1	1	SOCKET-IC 24-PIN DIP DIP-SLDR	20400	1200-0501
A11				NAME AS A10, USE PREFIX A11		
A12				NAME AS A10, USE PREFIX A12		
A13				NAME AS A10, USE PREFIX A13		
A14				NAME AS A10, USE PREFIX A14		
A15				NAME AS A10, USE PREFIX A15		

CHANGE 11 (1912A) (Cont'd)

Table 6. A16 Replaceable Parts

Reference Designation	HP Part Number	C D	Qty	Description	Mfr Code	Mfr Part Number
A16	05232-0015	7	1	DECIMAL COUNTER ASSEMBLY (SERIES 1912)	28400	05232-0015
A16C1	0100-0309	4	2	CAPACITOR-FXD 17PF +-5% 500VDC MICA	28400	0100-0309
A16C2	0100-0309	4	2	CAPACITOR-FXD 17PF +-5% 500VDC MICA	28400	0100-0309
A16C3	0100-0208	4	6	CAPACITOR-FXD 47PF +-5% 500VDC MICA	72130	D*15E470J0500AV1C
A16C4	0100-0208	4	6	CAPACITOR-FXD 47PF +-5% 500VDC MICA	72130	D*15E470J0500AV1C
A16C5	0100-0208	4	6	CAPACITOR-FXD 47PF +-5% 500VDC MICA	72130	D*15E470J0500AV1C
A16C6	0100-0208	4	6	CAPACITOR-FXD 47PF +-5% 500VDC MICA	72130	D*15E470J0500AV1C
A16C7	0100-0190	1	1	CAPACITOR-FXD 110PF +-5% 300VDC MICA	72130	D*15F111J0300AV1C
A16C8	0100-0208	4	6	CAPACITOR-FXD 47PF +-5% 500VDC MICA	72130	D*15E470J0500AV1C
A16C9	0100-0208	4	6	CAPACITOR-FXD 47PF +-5% 500VDC MICA	72130	D*15E470J0500AV1C
A16C10	0100-0208	4	2	CAPACITOR-FXD 2000PF +-20% 500VDC CER	28400	0100-0208
A16C11	0100-0208	4	6	CAPACITOR-FXD 2000PF +-20% 500VDC CER	28400	0100-0208
A16C12	0100-0191	4	3	CAPACITOR-FXD 56PF +-5% 300VDC MICA	72130	D*15E560J0300AV1C
A16C13	0100-0208	4	3	CAPACITOR-FXD 27PF +-5% 300VDC MICA	28400	0100-0208
A16C14	0100-0190	7	2	CAPACITOR-FXD 30PF +-5% 300VDC MICA	72130	D*15E300J0300AV1C
A16C15	0100-0190	7	2	CAPACITOR-FXD 30PF +-5% 300VDC MICA	72130	D*15E300J0300AV1C
A16C16	0100-0191	4	3	CAPACITOR-FXD 56PF +-5% 300VDC MICA	72130	D*15E560J0300AV1C
A16C17	0100-0191	4	3	CAPACITOR-FXD 56PF +-5% 300VDC MICA	72130	D*15E560J0300AV1C
A16CR1 THRU A16CR8				NOT ASSIGNED		
A16CR9 THRU A16CR21	1901-0000	1	13	DIODE-BRITCHING 1AV 50MA 2N8 00-35	28400	1901-0000
A16CR22 THRU A16CR25				NOT ASSIGNED		
A16CR26	1902-0025	4	1	DIODE-ZNR 10V 5% 00-7 PDM, 4M TC=+.00%	28400	1902-0025
A16CR27	1902-0001	4	2	DIODE-ZNR 5.11V 5% 00-7 PDM, 4M TC=+.00%	28400	1902-0001
A16CR28	1902-0001	4	2	DIODE-ZNR 5.11V 5% 00-7 PDM, 4M TC=+.00%	28400	1902-0001
A16CR29	1902-0175	4	1	DIODE-ZNR 100V 5% 00-15 PDM, 4M TC=+.00%	28400	1902-0175
A16DS1 THRU A16DS5				NOT ASSIGNED		
A16DS6	1970-0009	7	1	TUBE-ELECTRON 6X22 IND=NUMERIC	28400	1970-0009
A16G1 THRU A16G8	1853-0034	9	8	TRANSISTOR PNP 8I TC=18 PDM300MA	28400	1853-0034
A16G9 THRU A16G11				NOT ASSIGNED		
A16G12	1854-0042	6	1	TRANSISTOR NPN 8I PDM025MA PDM00MHZ	08713	MP8-417
A16G13 THRU A16G22	1854-0075	6	10	TRANSISTOR NPN 8I PDM025MA PDM50MHZ	08713	MP8-442
A16R1 THRU A16R10				NOT ASSIGNED		
A16R11	0603-5035	5	4	RESISTOR 50K 5% .25W FC TC=400/+500	01121	C83035
A16R12				NOT ASSIGNED		
A16R13	0603-5035	5	4	RESISTOR 50K 5% .25W FC TC=400/+500	01121	C83035
A16R14				NOT ASSIGNED		
A16R15	0603-5035	5	4	RESISTOR 50K 5% .25W FC TC=400/+500	01121	C83035
A16R16				NOT ASSIGNED		
A16R17	0603-5035	5	4	RESISTOR 50K 5% .25W FC TC=400/+500	01121	C83035
A16R18	0701-0010	4	2	RESISTOR 1.0K 5% 1W MO TC=0/+200	28400	0701-0010
A16R19	0701-0010	4	2	RESISTOR 1.0K 5% 1W MO TC=0/+200	28400	0701-0010
A16R20	0700-0044	9	1	RESISTOR 2.2K 5% .25W F TC=0/+100	24500	C5-1/4-T0-2201-J
A16R21	0700-0004	1	5	RESISTOR 2.7K 5% .25W F TC=0/+100	24500	C5-1/4-T0-2701-J
A16R22	0700-0004	1	5	RESISTOR 2.7K 5% .25W F TC=0/+100	24500	C5-1/4-T0-2701-J
A16R23	0700-0004	1	5	RESISTOR 2.7K 5% .25W F TC=0/+100	24500	C5-1/4-T0-2701-J
A16R24	0700-0004	1	5	RESISTOR 2.7K 5% .25W F TC=0/+100	24500	C5-1/4-T0-2701-J
A16R25	0700-0004	1	5	RESISTOR 2.7K 5% .25W F TC=0/+100	24500	C5-1/4-T0-2701-J
A16R26 THRU A16R33	0603-1035	7	8	RESISTOR 10K 5% .25W FC TC=400/+500	01121	C81035
A16R34	0603-1015	7	2	RESISTOR 100 5% .25W FC TC=400/+500	01121	C81015
A16R35	0603-3925	2	4	RESISTOR 3.9K 5% .25W FC TC=400/+700	01121	C83925
A16R36	0603-1035	7	4	RESISTOR 10K 5% .25W FC TC=400/+500	01121	C81035
A16R37	0603-3925	2	2	RESISTOR 3.9K 5% .25W FC TC=400/+700	01121	C83925
A16R38	0603-4715	0	2	RESISTOR 470 5% .25W FC TC=400/+500	01121	C80715
A16R39	0603-1015	7	2	RESISTOR 100 5% .25W FC TC=400/+500	01121	C81015
A16R40	0603-3925	2	2	RESISTOR 3.9K 5% .25W FC TC=400/+700	01121	C83925
A16R41	0603-1035	7	4	RESISTOR 10K 5% .25W FC TC=400/+500	01121	C81035
A16R42	0603-3925	2	2	RESISTOR 3.9K 5% .25W FC TC=400/+700	01121	C83925
A16R43	0603-1115	0	2	RESISTOR 110 5% .25W FC TC=400/+500	01121	C81115
A16R44	0603-0715	0	2	RESISTOR 870 5% .25W FC TC=400/+500	01121	C80715
A16R45	0603-3925	2	2	RESISTOR 3.9K 5% .25W FC TC=400/+700	01121	C83925
A16R46	0603-1035	7	4	RESISTOR 10K 5% .25W FC TC=400/+500	01121	C81035
A16R47	0603-3925	2	2	RESISTOR 3.9K 5% .25W FC TC=400/+700	01121	C83925
A16R48	0603-1045	3	4	RESISTOR 100K 5% .25W FC TC=400/+500	01121	C81045
A16R49	0603-3925	2	2	RESISTOR 3.9K 5% .25W FC TC=400/+700	01121	C83925

CHANGE 11 (1012A) (Cont'd)

Table 6. A16 Replaceable Parts (Cont'd)

Reference Designation	HP Part Number	C D	Qty	Description	Mfr Code	Mfr Part Number
A16A00	0001-1025	0	1	RESISTOR 10K 5% .25W FC TCR=400/+800	01121	CB1025
A16A01	0001-1025	0	3	RESISTOR 1K 5% .25W FC TCR=400/+800	01121	CB1025
A16A02	0001-1115	0	1	RESISTOR 110 5% .25W FC TCR=400/+800	01121	CB1115
A16A03	0001-1025	2	1	RESISTOR 1.0K 5% .25W FC TCR=400/+800	01121	CB1025
A16A04	0001-1045	3	1	RESISTOR 100K 5% .25W FC TCR=400/+800	01121	CB1045
A16A05	0001-1025	0	1	RESISTOR 1K 5% .25W FC TCR=400/+800	01121	CB1025
A16A06	0001-1025	0	3	RESISTOR 3.0K 5% .25W FC TCR=400/+700	01121	CB3025
A16A07	0001-1025	0	1	RESISTOR 3.0K 5% .25W FC TCR=400/+700	01121	CB3025
A16A08	0001-1025	0	1	RESISTOR 1K 5% .25W FC TCR=400/+800	01121	CB1025
A16A09	0001-1045	3	1	RESISTOR 100K 5% .25W FC TCR=400/+800	01121	CB1045
A16A00	0001-1125	0	1	RESISTOR 1.1K 5% .25W FC TCR=400/+700	01121	CB1125
A16A01	0001-0735	0	1	RESISTOR 27K 5% .25W FC TCR=400/+800	01121	CB0735
A16A02	0001-1045	3	1	RESISTOR 100K 5% .25W FC TCR=400/+800	01121	CB1045
A16A03	0001-1235	3	1	RESISTOR 12K 5% .25W FC TCR=400/+800	01121	CB1235
A16A04	0001-1025	3	1	RESISTOR 1K 5% .25W FC TCR=400/+700	01121	CB1025
A16A05	0001-0935	4	11	RESISTOR 30K 5% .25W FC TCR=400/+800	01121	CB0935
A16A06 THRU A16A70				NOT ASSIGNED		
A16A70	0001-1045	3	1	RESISTOR 100K 5% .25W FC TCR=400/+800	01121	CB1045
A16A80	0000-1035	7	1	RESISTOR 10K 5% .5W CC TCR=+700	01121	EB1035
A16A01	0001-1025	1	1	RESISTOR 10K 5% .25W FC TCR=400/+700	01121	CB1025
A16A02	0000-1235	0	1	RESISTOR 12K 5% .5W CC TCR=+700	01121	EB1235
A16A03	0001-1045	3	1	RESISTOR 100K 5% .25W FC TCR=400/+800	01121	CB1045
A16A04 THRU A16A83	0001-1025	4	1	RESISTOR 1K 5% .25W FC TCR=400/+800	01121	CB1025
A16A84 THRU A16A07	0001-2235	0	0	RESISTOR 22K 5% .25W FC TCR=400/+800	01121	CB2235
A16A01	1200-1003	C	1	IC, CMOS 14510	01020	CD051403
A16A01	1200-0501	1	1	SOCKET-IC 24-CONV DIP DIP-8LDR	00000	1200-0501

CHANGE 11 (1912A) (Cont'd)

Table 7. A18 Replaceable Parts (Standard)

Reference Designation	HP Part Number	C D	Qty	Description	Mfr Code	Mfr Part Number
STANDARD INSTRUMENT						
A18	65245-60040	5	1	*1224 READOUT ASSEMBLY (SERIES 1912)	28480	65245-60040
A18CR1 THRU A18CR25				NOT ASSIGNED		
A18CR26	1902-0025	4	1	DIODE-ZNR 10V 5% DO-7 PDS.4m TCR+.002	28480	1902-0025
A18CR27	1902-0041	4	2	DIODE-ZNR 5.11V 5% DO-7 PDS.4m TCR+.0025	28480	1902-0041
A18CR28	1902-0041	4		DIODE-ZNR 5.11V 5% DO-7 PDS.4m TCR+.0025	28480	1902-0041
A18CR29	1902-0175	5	1	DIODE-ZNR 100V 5% DO-15 PDS.1m TCR+.0035	28480	1902-0175
A18DS1 THRU A18DS5				NOT ASSIGNED		
A18DS6	1970-0000	7	1	TUBE-ELECTRON 6222 IND-NUMERIC	28480	1970-0000
A18Q1 THRU A18Q8				NOT ASSIGNED		
A18Q9 THRU A18Q12				NOT ASSIGNED		
A18Q13 THRU A18Q22				NOT ASSIGNED		
A18R1 THRU A18R10				NOT ASSIGNED		
A18R11	0603-1035	5	6	RESISTOR 50K 5% .25W FC TCR=400/+800	01121	C05035
A18R12	0603-1035	5		RESISTOR 50K 5% .25W FC TCR=400/+800	01121	C05035
A18R13	0603-1035	5		RESISTOR 50K 5% .25W FC TCR=400/+800	01121	C05035
A18R14	0603-1035	5		RESISTOR 50K 5% .25W FC TCR=400/+800	01121	C05035
A18R15	0603-1035	5		RESISTOR 50K 5% .25W FC TCR=400/+800	01121	C05035
A18R16	0603-1035	5		RESISTOR 50K 5% .25W FC TCR=400/+800	01121	C05035
A18R17	0603-1035	5		RESISTOR 50K 5% .25W FC TCR=400/+800	01121	C05035
A18R18	0603-1035	5		RESISTOR 50K 5% .25W FC TCR=400/+800	01121	C05035
A18R19	0603-1035	5		RESISTOR 50K 5% .25W FC TCR=400/+800	01121	C05035
A18R20	0603-1035	5		RESISTOR 50K 5% .25W FC TCR=400/+800	01121	C05035
A18R21	0603-1035	5		RESISTOR 50K 5% .25W FC TCR=400/+800	01121	C05035
A18R22	0603-1035	5		RESISTOR 50K 5% .25W FC TCR=400/+800	01121	C05035
A18R23	0603-1035	5		RESISTOR 50K 5% .25W FC TCR=400/+800	01121	C05035
A18R24	0603-1035	5		RESISTOR 50K 5% .25W FC TCR=400/+800	01121	C05035
A18R25	0603-1035	5		RESISTOR 50K 5% .25W FC TCR=400/+800	01121	C05035
A18R26	0603-1035	5		RESISTOR 50K 5% .25W FC TCR=400/+800	01121	C05035
A18R27	0603-1035	5		RESISTOR 50K 5% .25W FC TCR=400/+800	01121	C05035
A18R28	0603-1035	5		RESISTOR 50K 5% .25W FC TCR=400/+800	01121	C05035
A18R29	0603-1035	5		RESISTOR 50K 5% .25W FC TCR=400/+800	01121	C05035
A18R30	0603-1035	5		RESISTOR 50K 5% .25W FC TCR=400/+800	01121	C05035
A18R31	0603-1035	5		RESISTOR 50K 5% .25W FC TCR=400/+800	01121	C05035
A18R32	0603-1035	5		RESISTOR 50K 5% .25W FC TCR=400/+800	01121	C05035
A18R33	0603-1035	5		RESISTOR 50K 5% .25W FC TCR=400/+800	01121	C05035
A18R34	0603-1035	5		RESISTOR 50K 5% .25W FC TCR=400/+800	01121	C05035
A18R35	0603-1035	5		RESISTOR 50K 5% .25W FC TCR=400/+800	01121	C05035
A18R36	0603-1035	5		RESISTOR 50K 5% .25W FC TCR=400/+800	01121	C05035
A18R37	0603-1035	5		RESISTOR 50K 5% .25W FC TCR=400/+800	01121	C05035
A18R38	0603-1035	5		RESISTOR 50K 5% .25W FC TCR=400/+800	01121	C05035
A18R39	0603-1035	5		RESISTOR 50K 5% .25W FC TCR=400/+800	01121	C05035
A18R40	0603-1035	5		RESISTOR 50K 5% .25W FC TCR=400/+800	01121	C05035
A18R41	0603-1035	5		RESISTOR 50K 5% .25W FC TCR=400/+800	01121	C05035
A18R42	0603-1035	5		RESISTOR 50K 5% .25W FC TCR=400/+800	01121	C05035
A18R43	0603-1035	5		RESISTOR 50K 5% .25W FC TCR=400/+800	01121	C05035
A18R44	0603-1035	5		RESISTOR 50K 5% .25W FC TCR=400/+800	01121	C05035
A18R45	0603-1035	5		RESISTOR 50K 5% .25W FC TCR=400/+800	01121	C05035
A18R46	0603-1035	5		RESISTOR 50K 5% .25W FC TCR=400/+800	01121	C05035
A18R47	0603-1035	5		RESISTOR 50K 5% .25W FC TCR=400/+800	01121	C05035
A18R48	0603-1035	5		RESISTOR 50K 5% .25W FC TCR=400/+800	01121	C05035
A18R49	0603-1035	5		RESISTOR 50K 5% .25W FC TCR=400/+800	01121	C05035
A18R50	0603-1035	5		RESISTOR 50K 5% .25W FC TCR=400/+800	01121	C05035
A18R51	0603-1035	5		RESISTOR 50K 5% .25W FC TCR=400/+800	01121	C05035
A18R52	0603-1035	5		RESISTOR 50K 5% .25W FC TCR=400/+800	01121	C05035
A18R53	0603-1035	5		RESISTOR 50K 5% .25W FC TCR=400/+800	01121	C05035
A18R54 THRU A18R58				NOT ASSIGNED		
A18R59	0603-1035	5		RESISTOR 50K 5% .25W FC TCR=400/+800	01121	C05035
A18R60	0603-1035	5		RESISTOR 50K 5% .25W FC TCR=400/+800	01121	C05035
A18R61	0603-1035	5		RESISTOR 50K 5% .25W FC TCR=400/+800	01121	C05035
A18R62	0603-1035	5		RESISTOR 50K 5% .25W FC TCR=400/+800	01121	C05035
A18R63	0603-1035	5		RESISTOR 50K 5% .25W FC TCR=400/+800	01121	C05035
A18R64 THRU A18R68				NOT ASSIGNED		
A18R69	0603-1035	5		RESISTOR 50K 5% .25W FC TCR=400/+800	01121	C05035
A18R70 THRU A18R74				NOT ASSIGNED		
A18U1	1200-1001	8	1	IC - CMOS 14510	01420	C0451001
A18XU1	1200-0501	1	1	SOCKET-IC 24-CONT DIP DIP-8LDR	28480	1200-0501

CHANGE 11 (1912A) (Cont'd)

Table 8. A18 Replaceable Parts (Option 002)

Reference Designation	HP Part Number	C D	Qty	Description	Mfr Code	Mfr Part Number
A18 OPTION 002						
A10	05205-00001	0	1	+1200 READOUT ASSEMBLY (SERIES 1912)	20400	05205-00001
A10C1	0100-2930	0	1	CAPACITOR-PXD .01UF +50-205 100VDC CER	20400	0100-2930
A10C11 THRU A10C12 A10C13 A10C14 A10C15 A10C16 A10C17	1901-0025 1901-0025 1901-0025 1901-0025 1901-0025 1901-0025 1901-0040	2 2 2 2 2 1 1	6	NOT ASSIGNED DIODE-GEN PRP 100V 200MA DO-7 DIODE-GEN PRP 100V 200MA DO-7 DIODE-GEN PRP 100V 200MA DO-7 DIODE-GEN PRP 100V 200MA DO-7 DIODE-GEN PRP 100V 200MA DO-7 DIODE-SWITCHING 30V 50MA SMD DO-35 DIODE-SWITCHING 30V 50MA SMD DO-35	20400 20400 20400 20400 20400 20400 20400	1901-0025 1901-0025 1901-0025 1901-0025 1901-0025 1901-0040 1901-0040
A10C18 THRU A10C23	1901-0025	2	2	NOT ASSIGNED DIODE-GEN PRP 100V 200MA DO-7	20400 20400	1901-0025 1901-0025
A10C24 A10C25 A10C26 A10C27 A10C28	1902-0041 1902-0041 1902-0041 1902-0041 1902-0041	2 2 2 2 2	2	DIODE-ZNR 5.40V 5% DO-7 P00.4M TCO+.007% DIODE-ZNR 5.40V 5% DO-7 P00.4M TCO+.007% DIODE-ZNR 5.40V 5% DO-7 P00.4M TCO+.007% DIODE-ZNR 5.40V 5% DO-7 P00.4M TCO+.007% DIODE-ZNR 5.40V 5% DO-7 P00.4M TCO+.007%	20400 20400 20400 20400 20400	1902-0041 1902-0041 1902-0041 1902-0041 1902-0041
A10C29	1902-0175	0	1	DIODE-ZNR 100V 5% DO-15 P00.1M TCO+.003%	20400	1902-0175
A10C31 THRU A10C35	1970-0000	7	1	NOT ASSIGNED TUBE-ELECTRON 6X25 INO-NUMERIC	20400	1970-0000
A10Q1 THRU A10Q12 A10Q13 THRU A10Q22	1004-0003 1004-0003 1004-0070	0 0 0 0	11 1 10	TRANSISTOR NPN 51 TC-37 P000000M TRANSISTOR NPN 51 P000000M P70000M2 TRANSISTOR NPN 51 P000000M P70000M2	20400 04713 04713	1004-0003 MPS-417 MPS-442
A10R1 THRU A10R10 A10R11 A10R12 A10R13	0001-0035 0001-0035 0001-0035 0001-0035 0001-0035	0 0 0 0 0	0	NOT ASSIGNED RESISTOR 50K 5% .25W FC TCO=400/+200 RESISTOR 50K 5% .25W FC TCO=400/+200 RESISTOR 50K 5% .25W FC TCO=400/+200 RESISTOR 50K 5% .25W FC TCO=400/+200 RESISTOR 50K 5% .25W FC TCO=400/+200	01121 01121 01121 01121 01121	C00035 C00035 C00035 C00035 C00035
A10R14 A10R15 A10R16 A10R17 A10R18	0001-0035 0001-0035 0001-0035 0001-0035 0001-0035	0 0 0 0 1	4	NOT ASSIGNED RESISTOR 50K 5% .25W FC TCO=400/+200 RESISTOR 50K 5% .25W FC TCO=400/+200 RESISTOR 50K 5% .25W FC TCO=400/+200 RESISTOR 50K 5% .25W FC TCO=400/+200 RESISTOR 50K 5% .25W FC TCO=400/+200	01121 01121 01121 01121 01121	C00035 C00035 C00035 C00035 C00035
A10R19 A10R20 A10R21 A10R22 A10R23	0001-0035 0001-0035 0001-0035 0001-0035 0001-0035	0 0 0 0 0	11 4 4 3 1	RESISTOR 7.5K 5% .25W FC TCO=400/+700 RESISTOR 150K 5% .25W FC TCO=400/+700 RESISTOR 51K 5% .25W FC TCO=400/+200 RESISTOR 50K 5% .25W FC TCO=400/+200 NOT ASSIGNED	01121 01121 01121 01121 01121	C07525 C01000 C00135 C00035 C00035
A10R24 A10R25 A10R26 A10R27 A10R28	0001-0035 0001-0035 0001-0035 0001-0035 0001-0035	0 1 0 0 0	0	RESISTOR 7.5K 5% .25W FC TCO=400/+700 NOT ASSIGNED RESISTOR 5K 5% .25W FC TCO=400/+700 RESISTOR 7.5K 5% .25W FC TCO=400/+700 RESISTOR 150K 5% .25W FC TCO=400/+700	01121 01121 01121 01121 01121	C07525 C00035 C02025 C07525 C01000
A10R29 A10R30 A10R31 A10R32 A10R33	0001-0035 0001-0035 0001-0035 0001-0035 0001-0035	0 2 0 0 0	3	RESISTOR 51K 5% .25W FC TCO=400/+200 RESISTOR 7.5K 5% .25W FC TCO=400/+700 NOT ASSIGNED RESISTOR 7.5K 5% .25W FC TCO=400/+700 NOT ASSIGNED	01121 01121 01121 01121 01121	C00135 C07525 C00035 C07525 C07525
A10R34 A10R35 A10R36 A10R37 A10R38	0001-0035 0001-0035 0001-0035 0001-0035 0001-0035	1 0 0 0 2	1	RESISTOR 5K 5% .25W FC TCO=400/+700 RESISTOR 7.5K 5% .25W FC TCO=400/+700 RESISTOR 150K 5% .25W FC TCO=400/+700 RESISTOR 51K 5% .25W FC TCO=400/+200 RESISTOR 7.5K 5% .25W FC TCO=400/+700	01121 01121 01121 01121 01121	C02025 C07525 C01000 C00135 C07525
A10R39 A10R40 A10R41 A10R42 A10R43	0001-0035 0001-0035 0001-0035 0001-0035 0001-0035	0 0 1 0 0	0	NOT ASSIGNED RESISTOR 7.5K 5% .25W FC TCO=400/+700 NOT ASSIGNED RESISTOR 5K 5% .25W FC TCO=400/+700 RESISTOR 7.5K 5% .25W FC TCO=400/+700	01121 01121 01121 01121 01121	C07525 C00035 C02025 C07525 C07525
A10R44 A10R45 A10R46 A10R47 A10R48	0001-0040 0001-0035 0001-0035 0001-0035 0001-0035	0 0 0 2 0	0	RESISTOR 150K 5% .25W FC TCO=400/+700 RESISTOR 51K 5% .25W FC TCO=400/+200 RESISTOR 5K 5% .25W FC TCO=400/+700 NOT ASSIGNED RESISTOR 7.5K 5% .25W FC TCO=400/+700	01121 01121 01121 01121 01121	C01000 C00135 C00035 C00035 C07525

See introduction to this section for ordering information
*Indicates factory selected value

CHANGE 11 (1912A) (Cont'd)

Table 8. A18 Replaceable Parts (Option 002) (Cont'd)

Reference Designation	HP Part Number	C D	Qty	Description	Mfr Code	Mfr Part Number
A10029				NOT ASSIGNED		
A10030				NOT ASSIGNED		
A10031	0003-0735		4	RESISTOR 47K 5% .25W FC TCR=400/+500	01121	CR0735
A10032	0003-0735		4	RESISTOR 47K 5% .25W FC TCR=400/+500	01121	CR0735
A10033	0003-0735		4	RESISTOR 47K 5% .25W FC TCR=400/+500	01121	CR0735
A10034	0003-0735		4	RESISTOR 47K 5% .25W FC TCR=400/+500	01121	CR0735
A10035	0003-0735		2	RESISTOR 47K 5% .25W FC TCR=400/+500	01121	CR0735
A10036	0003-1045		5	RESISTOR 100K 5% .25W FC TCR=400/+500	01121	CR1045
A10037 THRU A10061				NOT ASSIGNED		
A10062	0003-0735		4	RESISTOR 47K 5% .25W FC TCR=400/+500	01121	CR0735
A10063				NOT ASSIGNED		
A10064	0003-7505		4	RESISTOR 7.5K 5% .25W FC TCR=400/+700	01121	CR7505
A10065	0003-7505		4	RESISTOR 7.5K 5% .25W FC TCR=400/+700	01121	CR7505
A10066	0003-7505		4	RESISTOR 7.5K 5% .25W FC TCR=400/+700	01121	CR7505
A10067	0003-7505		4	RESISTOR 7.5K 5% .25W FC TCR=400/+700	01121	CR7505
A10068	0003-1045		3	RESISTOR 100K 5% .25W FC TCR=400/+500	01121	CR1045
A10069	0003-1045		3	RESISTOR 100K 5% .25W FC TCR=400/+500	01121	CR1045
A10070	0003-1045		3	RESISTOR 100K 5% .25W FC TCR=400/+500	01121	CR1045
A10071	0003-1045		3	RESISTOR 100K 5% .25W FC TCR=400/+500	01121	CR1045
A10072	0003-0735		4	RESISTOR 47K 5% .25W FC TCR=400/+500	01121	CR0735
A10073	0003-3335		4	RESISTOR 33K 5% .25W FC TCR=400/+500	01121	CR3335
A10074	0003-0735		4	RESISTOR 47K 5% .25W FC TCR=400/+500	01121	CR0735
A10075	0003-0735		4	RESISTOR 47K 5% .25W FC TCR=400/+500	01121	CR0735
A10076	0003-0735		4	RESISTOR 47K 5% .25W FC TCR=400/+500	01121	CR0735
A10077	0003-1035		4	RESISTOR 10K 5% .25W FC TCR=400/+500	01121	CR1035
A10078				NOT ASSIGNED		
A10079	0003-1045		3	RESISTOR 100K 5% .25W FC TCR=400/+500	01121	CR1045
A10080	0000-1031		7	RESISTOR 10K 5% .5W CC TCR=+705	01121	CR1035
A10081	0003-1035		1	RESISTOR 10K 5% .25W FC TCR=400/+500	01121	CR1035
A10082	0000-1235		1	RESISTOR 12K 5% .5W CC TCR=+705	01121	CR1235
A10083	0003-1045		3	RESISTOR 100K 5% .25W FC TCR=400/+500	01121	CR1045
A10084 THRU A10093	0003-0735		4	RESISTOR 47K 5% .25W FC TCR=400/+500	01121	CR0735
A10094 THRU A10097	0003-0735		4	RESISTOR 47K 5% .25W FC TCR=400/+500	01121	CR0735
A10098	1000-1001		8	IC, CMOS 10B10	01920	CD05100P
A10099	1000-1001		8	IC, CMOS 10B10	01920	CD05100P
A10100	1000-0501		1	SOCKET-IC 24-CONT DIP 8LDR	20000	1200-0501

See introduction to this section for ordering information
 *Indicates factory selected value

CHANGE 11 (1812A) (Cont'd)

Table 9. A18 Replaceable Parts (Option 003)

Reference Designation	HP Part Number	C D	Qty	Description	Mfr Code	Mfr Part Number
A18 OPTION 003						
A18	05245-0002	7	1	-1245 READOUT ASSEMBLY (SERIES 1812)	20400	05245-0002
A18C1				NOT ASSIGNED		
A18C2				NOT ASSIGNED		
A18C3	0100-2930	9	1	CAPACITOR-FIXD .01UF +50-24% 100VDC CER	20400	0100-2930
A18C11 THRU				NOT ASSIGNED		
A18C11	1901-0025	2	6	DIODE-GEN PRP 100V 200MA DO-7	20400	1901-0025
A18C12	1901-0025	2	6	DIODE-GEN PRP 100V 200MA DO-7	20400	1901-0025
A18C13	1901-0025	2	6	DIODE-GEN PRP 100V 200MA DO-7	20400	1901-0025
A18C14	1901-0025	2	6	DIODE-GEN PRP 100V 200MA DO-7	20400	1901-0025
A18C15	1901-0025	2	6	DIODE-GEN PRP 100V 200MA DO-7	20400	1901-0025
A18C16	1901-0040	1	2	DIODE-SWITCHING 30V 50MA 2MS DO-18	20400	1901-0040
A18C17	1901-0040	1	2	DIODE-SWITCHING 30V 50MA 2MS DO-18	20400	1901-0040
A18C18	1901-0025	2	6	DIODE-GEN PRP 100V 200MA DO-7	20400	1901-0025
A18C19	1902-0032	3	1	DIODE-ZNR 5.49V 5% DO-7 PGM, 4N TCR, 0.005	20400	1902-0032
A18C20 THRU				NOT ASSIGNED		
A18C20	1902-0025	4	1	DIODE-ZNR 10V 5% DO-7 PGM, 4N TCR, 0.01	20400	1902-0025
A18C21	1902-0041	4	1	DIODE-ZNR 5.11V 5% DO-7 PGM, 4N TCR, 0.005	20400	1902-0041
A18C22	1902-0041	4	1	DIODE-ZNR 5.11V 5% DO-7 PGM, 4N TCR, 0.005	20400	1902-0041
A18C23	1902-0173	4	1	DIODE-ZNR 100V 5% DO-18 PGM, 1N TCR, 0.035	20400	1902-0173
A18C24 THRU				NOT ASSIGNED		
A18C24	1070-0000	7	1	TUBE-ELECTRON 6AZ5 IND-NUMERIC	20400	1070-0000
A18C25 THRU				NOT ASSIGNED		
A18C25	1054-0003	8	11	TRANSISTOR NPN 01 TC-10 PDB040M	20400	1054-0003
A18C26	1054-0003	8	11	TRANSISTOR NPN 01 PDB040M FT030M	04713	MP8-417
A18C27 THRU				NOT ASSIGNED		
A18C27	1054-0575	8	10	TRANSISTOR NPN 01 PDB040M FT030M	04713	MP8-402
A18C28 THRU				NOT ASSIGNED		
A18C28	0053-0035	5	6	RESISTOR 50K 5% .25W FC TCR=400/+500	01121	C05035
A18C29	0053-0035	5	6	RESISTOR 50K 5% .25W FC TCR=400/+500	01121	C05035
A18C30	0053-0035	5	6	RESISTOR 50K 5% .25W FC TCR=400/+500	01121	C05035
A18C31	0053-0035	5	6	RESISTOR 50K 5% .25W FC TCR=400/+500	01121	C05035
A18C32	0053-0025	1	4	RESISTOR 5K 5% .25W FC TCR=400/+700	01121	C05025
A18C33	0053-0525	6	11	RESISTOR 7.5K 5% .25W FC TCR=400/+700	01121	C07525
A18C34	0053-1545	8	4	RESISTOR 150K 5% .25W FC TCR=400/+500	01121	C01545
A18C35	0053-0135	8	4	RESISTOR 51K 5% .25W FC TCR=400/+500	01121	C05135
A18C36	0053-0005	3	1	RESISTOR 60 5% .25W FC TCR=400/+500	01121	C06005
A18C37	0053-0525	6	11	RESISTOR 7.5K 5% .25W FC TCR=400/+700	01121	C07525
A18C38	0053-0525	6	11	RESISTOR 7.5K 5% .25W FC TCR=400/+700	01121	C07525
A18C39	0053-1545	8	4	RESISTOR 150K 5% .25W FC TCR=400/+500	01121	C01545
A18C40	0053-0135	8	4	RESISTOR 51K 5% .25W FC TCR=400/+500	01121	C05135
A18C41	0053-0005	3	1	RESISTOR 60 5% .25W FC TCR=400/+500	01121	C06005
A18C42	0053-0525	6	11	RESISTOR 7.5K 5% .25W FC TCR=400/+700	01121	C07525
A18C43	0053-0525	6	11	RESISTOR 7.5K 5% .25W FC TCR=400/+700	01121	C07525
A18C44	0053-0525	6	11	RESISTOR 7.5K 5% .25W FC TCR=400/+700	01121	C07525
A18C45	0053-0525	6	11	RESISTOR 7.5K 5% .25W FC TCR=400/+700	01121	C07525
A18C46	0053-1545	8	4	RESISTOR 150K 5% .25W FC TCR=400/+500	01121	C01545
A18C47	0053-0135	8	4	RESISTOR 51K 5% .25W FC TCR=400/+500	01121	C05135
A18C48	0053-0105	2	1	RESISTOR 91 5% .25W FC TCR=400/+500	01121	C09105
A18C49	0053-0525	6	11	RESISTOR 7.5K 5% .25W FC TCR=400/+700	01121	C07525
A18C50	0053-0525	6	11	RESISTOR 7.5K 5% .25W FC TCR=400/+700	01121	C07525
A18C51	0053-0525	6	11	RESISTOR 7.5K 5% .25W FC TCR=400/+700	01121	C07525
A18C52	0053-0525	6	11	RESISTOR 7.5K 5% .25W FC TCR=400/+700	01121	C07525
A18C53	0053-1545	8	4	RESISTOR 150K 5% .25W FC TCR=400/+500	01121	C01545
A18C54	0053-0135	8	4	RESISTOR 51K 5% .25W FC TCR=400/+500	01121	C05135
A18C55	0053-0105	2	1	RESISTOR 91 5% .25W FC TCR=400/+500	01121	C09105
A18C56	0053-0525	6	11	RESISTOR 7.5K 5% .25W FC TCR=400/+700	01121	C07525
A18C57	0053-0525	6	11	RESISTOR 7.5K 5% .25W FC TCR=400/+700	01121	C07525
A18C58	0053-0525	6	11	RESISTOR 7.5K 5% .25W FC TCR=400/+700	01121	C07525
A18C59	0053-0525	6	11	RESISTOR 7.5K 5% .25W FC TCR=400/+700	01121	C07525
A18C60	0053-0525	6	11	RESISTOR 7.5K 5% .25W FC TCR=400/+700	01121	C07525
A18C61	0053-0525	6	11	RESISTOR 7.5K 5% .25W FC TCR=400/+700	01121	C07525
A18C62	0053-0525	6	11	RESISTOR 7.5K 5% .25W FC TCR=400/+700	01121	C07525
A18C63	0053-0525	6	11	RESISTOR 7.5K 5% .25W FC TCR=400/+700	01121	C07525
A18C64	0053-0525	6	11	RESISTOR 7.5K 5% .25W FC TCR=400/+700	01121	C07525
A18C65	0053-0525	6	11	RESISTOR 7.5K 5% .25W FC TCR=400/+700	01121	C07525
A18C66	0053-0525	6	11	RESISTOR 7.5K 5% .25W FC TCR=400/+700	01121	C07525
A18C67	0053-0525	6	11	RESISTOR 7.5K 5% .25W FC TCR=400/+700	01121	C07525
A18C68	0053-0525	6	11	RESISTOR 7.5K 5% .25W FC TCR=400/+700	01121	C07525
A18C69	0053-0525	6	11	RESISTOR 7.5K 5% .25W FC TCR=400/+700	01121	C07525
A18C70	0053-0525	6	11	RESISTOR 7.5K 5% .25W FC TCR=400/+700	01121	C07525
A18C71	0053-0525	6	11	RESISTOR 7.5K 5% .25W FC TCR=400/+700	01121	C07525
A18C72	0053-0525	6	11	RESISTOR 7.5K 5% .25W FC TCR=400/+700	01121	C07525
A18C73	0053-0525	6	11	RESISTOR 7.5K 5% .25W FC TCR=400/+700	01121	C07525

See introduction to this section for ordering information
 *Indicates factory selected value

CHANGE 11 (1912A) (Cont'd)

Table 9. A18 Replaceable Parts (Option 003) (Cont'd)

Reference Designation	HP Part Number	C D	Qty	Description	Mfr Code	Mfr Part Number
A1004	0603-4738	4		RESISTOR 27K 5% .25W FC TCR=400/+500	01121	C02735
A1005	0603-4738	0	2	RESISTOR 27K 5% .25W FC TCR=400/+500	01121	C02735
A1006	0603-1045	0	2	RESISTOR 100K 5% .25W FC TCR=400/+500	01121	C01045
A1007	0603-4738	0	2	RESISTOR 27K 5% .25W FC TCR=400/+500	01121	C02735
A1008	0603-1045	1	3	RESISTOR 100K 5% .25W FC TCR=400/+500	01121	C01045
A1009	0603-1045	1		RESISTOR 100K 5% .25W FC TCR=400/+500	01121	C01045
A1010	0603-1045	0		RESISTOR 100K 5% .25W FC TCR=400/+500	01121	C01045
A1011	0603-1045	3	7	RESISTOR 100K 5% .25W FC TCR=400/+500	01121	C01045
A1012				NOT ASSIGNED		
A1013	0603-1045	3		RESISTOR 100K 5% .25W FC TCR=400/+500	01121	C01045
A1014	0603-4738	0		RESISTOR 27K 5% .25W FC TCR=400/+500	01121	C02735
A1015	0603-4738	0		RESISTOR 27K 5% .25W FC TCR=400/+500	01121	C02735
A1016	0603-4738	0	1	RESISTOR 270K 5% .25W FC TCR=400/+500	01121	C07500
A1017	0603-4738	0		RESISTOR 27K 5% .25W FC TCR=400/+500	01121	C02735
A1018	0603-1045	3		RESISTOR 100K 5% .25W FC TCR=400/+500	01121	C01045
A1019	0603-1045	3		RESISTOR 100K 5% .25W FC TCR=400/+500	01121	C01045
A1020	0603-1045	3		RESISTOR 100K 5% .25W FC TCR=400/+500	01121	C01045
A1021	0603-1045	0	1	RESISTOR 10K 5% .25W FC TCR=400/+500	01121	C01045
A1022 THRU A1028				NOT ASSIGNED		
A1029	0603-1045	3		RESISTOR 100K 5% .25W FC TCR=400/+500	01121	C01045
A1030	0603-1045	7	1	RESISTOR 10K 5% .5W CC TCR=+765	01121	E01035
A1031	0603-1045	1		RESISTOR 10K 5% .25W FC TCR=400/+500	01121	C01045
A1032	0603-1234	0	1	RESISTOR 10K 5% .5W CC TCR=+765	01121	E01035
A1033	0603-1045	3		RESISTOR 100K 5% .25W FC TCR=400/+500	01121	C01045
A1034 THRU A1035	0603-1045	4	10	RESISTOR 10K 5% .25W FC TCR=400/+500	01121	C01045
A1036 THRU A1037	0603-1045	9	4	RESISTOR 22K 5% .25W FC TCR=400/+500	01121	C02235
A1041	1020-1003	0	1	IC, CMOS 14910	01020	C001007
A1041	1000-1041	1	1	SOCKET-IC 24-CONT DIP DIP-BLDR	20400	1200-0501

See introduction to this section for ordering information
 *Indicates factory selected value

CHANGE 11 (1912A) (Cont'd)

Table 10. Manufacturers Code List for Tables 5 through 9

Mfr No.	Manufacturer Name	Address	Zip Code
01121	Allen-Bradley Company	Milwaukee, WI	53204
01928	RCA Corp Solid State Division	Somerville, NJ	08876
04713	Motorola Semiconductor Products	Phoenix, AZ	85062
19701	Mepco/Electra Corp.	Mineral Wells, TX	75767
24546	Corning Glass Works (Bradford)	Bradford, PA	16701
28480	Hewlett-Packard Co. Corporate HQ	Palo Alto, CA	94304
72136	Electro Motive Corp Sub IEC	Willimantic, CT	06226

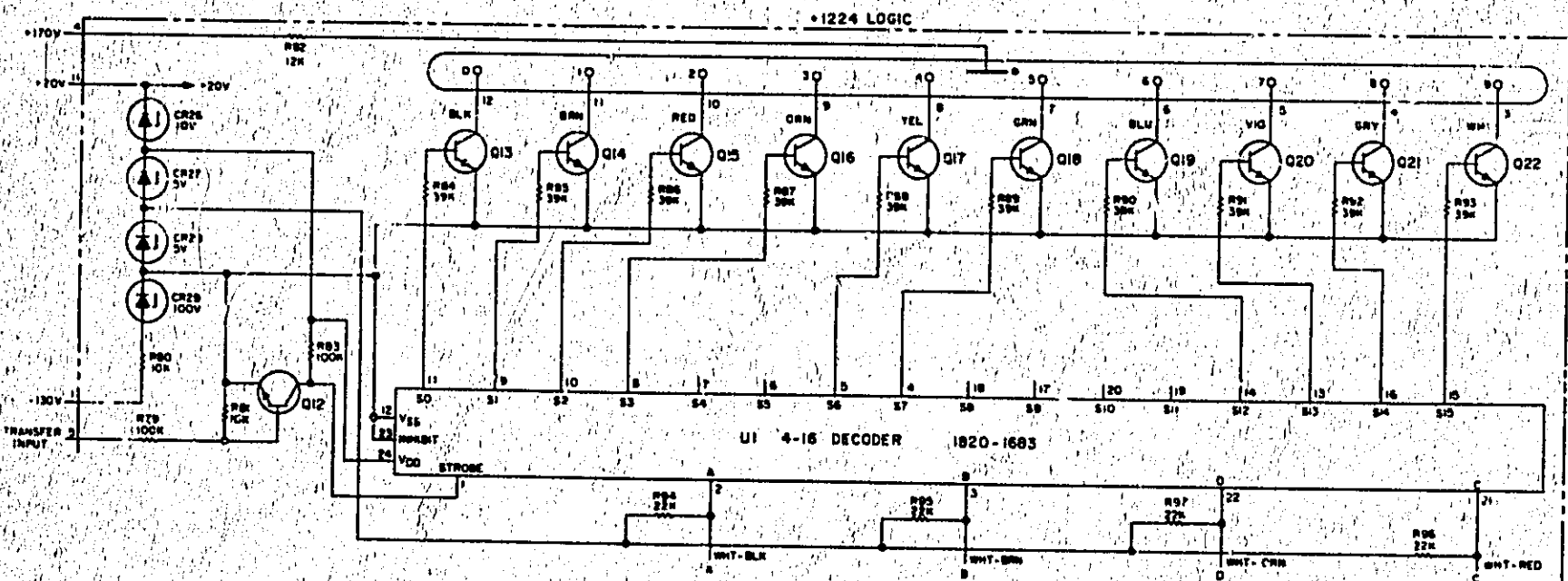

Figure 5. Integrated Circuit Readout Assembly With 1224 Logic

CHANGE 12 (1924A)

Page 4-31, Table 4-1, Reference Designation Index:

Delete HP Part No. 0150-0119 for C5 and change C5 description to NOT ASSIGNED.
 Add C19 and C20; 0160-4281; CAPACITOR-FXD 2200 pF ±20% 250VAC (RMS); Mfr Code 28480;
 Mfr Part No. 0160-4281.

Page 7-13, Figure 7-7, Schematic Diagram:

Change C5A to C19 and change value to 2200 pF.
 Change C5B to C20 and change value to 2200 pF.
 Instrument Serial Prefix number becomes 1924A with the above change.

CHANGE 13 (1932A)

Page 5-1, Tables 5-1 and 5-2, Option 002 and 003 Replacement Assemblies:

Change Table 5-1 to the following:

Table 5-1. Option 002 Replacement Assemblies

Standard Assemblies	Option 002 Assemblies
A10-A15 DCA 05212-6018 A16 DCA 05232-6015 A18 Readout 05245-60040	A10-A14 DCA 05212-6024 A15, A16 DCA 05232-6023 A18 Readout 05245-60041

Change Table 5-2 to the following:

Table 5-2. Option 003 Replacement Assemblies

Standard Assemblies	Option 003 Assemblies
A10-A15 DCA 05212-6018 A16 DCA 05232-6015 A18 Readout 05245-60040	A10-A14 DCA 05212-6025 A15, A16 DCA 05232-6022 A18 Readout 05245-60042

Page 5-8, Table 5-6, Reference Designations Index:

Delete A15/A16 Part No. 05232-6014 (+1248) and 05232-6012 (-1248) Decimal Counter assemblies and all replacement parts in Table 5-6.

Add A15/A16 replaceable parts in attached Table 10 in place of deleted parts in Table 5-6.

Page 5-11, Table 5-7, A10-A14 Reference Designations Index:

Delete A10-A14 Part No. 0512-6002 (+1248) and 05212-6003 (-1248) Decimal Counter assemblies and all replacement parts in Table 5-7.

Add A10-A14 replaceable parts in attached Table 11 in place of deleted parts in Table 5-7.

CHANGE 13 (1932A) (Cont'd)

Table 10. Replaceable Parts (A15, A16 Options 002 & 003)

Reference Designation	HP Part Number	C D	Qty	Description	Mfr Code	Mfr Part Number
A15	05232-0023	0	1	ASSEMBLY, DECIMAL COUNTER (01200) (OPTION 002) SERIES 1032	20400	05232-0023
A15	05232-0022	2	1	ASSEMBLY, DECIMAL COUNTER (01200) (OPTION 003) SERIES 1032	20400	05232-0022
A15C1	0100-0105	2	3	CAPACITOR-PXD 20PF 0-5% 500VDC MICA	72130	DM15C220J0500V1CR
A15C2	0100-0105	2	3	CAPACITOR-PXD 20PF 0-5% 500VDC MICA	72130	DM15C220J0500V1CR
A15C3	0100-0106	5	2	CAPACITOR-PXD 20PF 0-5% 500VDC MICA	20400	0100-0106
A15C4	0100-0106	5	2	CAPACITOR-PXD 20PF 0-5% 500VDC MICA	20400	0100-0106
A15C5	0100-2300	3	4	CAPACITOR-PXD 27PF 0-5% 500VDC MICA	20400	0100-2300
A15C6	0100-2300	3	4	CAPACITOR-PXD 27PF 0-5% 500VDC MICA	20400	0100-2300
A15C7	0100-2300	3	4	CAPACITOR-PXD 27PF 0-5% 500VDC MICA	20400	0100-2300
A15C8	0100-2300	3	4	CAPACITOR-PXD 27PF 0-5% 500VDC MICA	20400	0100-2300
A15C9	0100-2503	0	2	CAPACITOR-PXD 2000PF 0-20% 500VDC CER	20400	0100-2503
A15C10	0100-0170	0	2	CAPACITOR-PXD 33PF 0-5% 500VDC MICA	20400	0100-0170
A15C11	0100-0105	2	3	CAPACITOR-PXD 20PF 0-5% 500VDC MICA	72130	DM15C220J0500V1CR
A15C12	0100-2300	3	4	CAPACITOR-PXD 27PF 0-5% 500VDC MICA	20400	0100-2300
A15C13	0100-2503	0	2	CAPACITOR-PXD 2000PF 0-20% 500VDC CER	20400	0100-2503
A15C14	0100-0105	2	3	CAPACITOR-PXD 20PF 0-5% 500VDC MICA	72130	DM15C220J0500V1CR
A15C15	0100-0105	2	3	CAPACITOR-PXD 20PF 0-5% 500VDC MICA	72130	DM15C220J0500V1CR
A15C16	0100-0170	0	1	CAPACITOR-PXD 33PF 0-5% 500VDC MICA	72130	DM15C330J0500V1CR
A15C17	0100-0170	0	1	CAPACITOR-PXD 33PF 0-5% 500VDC MICA	20400	0100-0170
A15CR1 thru A15CR9				NOT ASSIGNED		
A15CR0	1901-0040	1	15	DIODE-SWITCHING 30V 50MA 2ND DO-35	20400	1901-0040
A15CR10	1901-0040	1	15	DIODE-SWITCHING 30V 50MA 2ND DO-35	20400	1901-0040
A15CR11	1901-0040	1	15	DIODE-SWITCHING 30V 50MA 2ND DO-35	20400	1901-0040
A15CR12	1901-0040	1	15	DIODE-SWITCHING 30V 50MA 2ND DO-35	20400	1901-0040
A15CR13	1901-0040	1	15	DIODE-SWITCHING 30V 50MA 2ND DO-35	20400	1901-0040
A15CR14	1901-0040	1	15	DIODE-SWITCHING 30V 50MA 2ND DO-35	20400	1901-0040
A15CR15	1901-0040	1	15	DIODE-SWITCHING 30V 50MA 2ND DO-35	20400	1901-0040
A15CR16	1901-0040	1	15	DIODE-SWITCHING 30V 50MA 2ND DO-35	20400	1901-0040
A15CR17	1901-0040	1	15	DIODE-SWITCHING 30V 50MA 2ND DO-35	20400	1901-0040
A15CR18	1901-0040	1	15	DIODE-SWITCHING 30V 50MA 2ND DO-35	20400	1901-0040
A15CR19	1901-0040	1	15	DIODE-SWITCHING 30V 50MA 2ND DO-35	20400	1901-0040
A15CR20	1901-0040	1	15	DIODE-SWITCHING 30V 50MA 2ND DO-35	20400	1901-0040
A15CR21	1901-0040	1	15	DIODE-SWITCHING 30V 50MA 2ND DO-35	20400	1901-0040
A15CR22	1901-0040	1	15	DIODE-SWITCHING 30V 50MA 2ND DO-35	20400	1901-0040
A15CR23	1901-0040	1	15	DIODE-SWITCHING 30V 50MA 2ND DO-35	20400	1901-0040
A15CR24				NOT ASSIGNED		
A15CR25				NOT ASSIGNED		
A15CR26	1902-0025	0	1	DIODE-ZNR 10V 5% DO-7 PDR, 4W TCR, 0.05%	20400	1902-0025
A15CR27	1902-0001	0	2	DIODE-ZNR 5.11V 5% DO-7 PDR, 4W TCR, 0.005%	20400	1902-0001
A15CR28	1902-0001	0	2	DIODE-ZNR 5.11V 5% DO-7 PDR, 4W TCR, 0.005%	20400	1902-0001
A15CR29	1902-0175	0	1	DIODE-ZNR 100V 5% DO-15 PDR, 1W TCR, 0.05%	20400	1902-0175
A15DS1 thru A15DS5				NOT ASSIGNED		
A15DS0	1053-0034	0	0	TRANSISTOR PNP 01 TC-10 PDR, 300mW	20400	1053-0034
A15D1	1053-0034	0	0	TRANSISTOR PNP 01 TC-10 PDR, 300mW	20400	1053-0034
A15D2	1053-0034	0	0	TRANSISTOR PNP 01 TC-10 PDR, 300mW	20400	1053-0034
A15D3	1053-0034	0	0	TRANSISTOR PNP 01 TC-10 PDR, 300mW	20400	1053-0034
A15D4	1053-0034	0	0	TRANSISTOR PNP 01 TC-10 PDR, 300mW	20400	1053-0034
A15D5	1053-0034	0	0	TRANSISTOR PNP 01 TC-10 PDR, 300mW	20400	1053-0034
A15D6	1053-0034	0	0	TRANSISTOR PNP 01 TC-10 PDR, 300mW	20400	1053-0034
A15D7	1053-0034	0	0	TRANSISTOR PNP 01 TC-10 PDR, 300mW	20400	1053-0034
A15D8	1053-0034	0	0	TRANSISTOR PNP 01 TC-10 PDR, 300mW	20400	1053-0034
A15D9	1053-0034	0	0	TRANSISTOR PNP 01 TC-10 PDR, 300mW	20400	1053-0034
A15D0	1053-0034	0	0	TRANSISTOR PNP 01 TC-10 PDR, 300mW	20400	1053-0034
A15D1 thru A15D11				NOT ASSIGNED		
A15D12	1054-0042	0	1	TRANSISTOR NPN 01 PDR, 250mW PDR, 50mW	00713	MP2-A17
A15D13	1054-0042	0	1	TRANSISTOR NPN 01 PDR, 250mW PDR, 50mW	00713	MP2-A42
A15D14	1054-0042	0	1	TRANSISTOR NPN 01 PDR, 250mW PDR, 50mW	00713	MP2-A42
A15D15	1054-0042	0	1	TRANSISTOR NPN 01 PDR, 250mW PDR, 50mW	00713	MP2-A42
A15D16	1054-0042	0	1	TRANSISTOR NPN 01 PDR, 250mW PDR, 50mW	00713	MP2-A42
A15D17	1054-0042	0	1	TRANSISTOR NPN 01 PDR, 250mW PDR, 50mW	00713	MP2-A42
A15E1 thru A15E9				NOT ASSIGNED		
A15E0	0761-0005	0	2	RESISTOR 2.2K 5% 1W MC TCR=0-200	20400	0761-0005
A15E1	0043-5033	0	5	RESISTOR 50K 5% .25W PC TCR=0-000/+500	01121	CR5033
A15E2	0761-0010	0	2	RESISTOR 1.5K 5% 1W MC TCR=0-200	20400	0761-0010
A15E3	0750-0034	0	2	RESISTOR 2.7K 5% .25W F TCR=0-100	20400	CS-1/4-TC-2701-J
A15E4	0043-5033	0	5	RESISTOR 50K 5% .25W PC TCR=0-000/+500	01121	CR5033
A15E5	0761-0010	0	2	RESISTOR 1.5K 5% 1W MC TCR=0-200	20400	0761-0010
A15E6	0750-0034	0	2	RESISTOR 2.7K 5% .25W F TCR=0-100	20400	CS-1/4-TC-2701-J
A15E7	0750-0034	0	2	RESISTOR 2.7K 5% .25W F TCR=0-100	20400	CS-1/4-TC-2701-J

CHANGE 13 (1932A) (Cont'd)

Table 10. Replaceable Parts (A15, A16 Options 002 & 003) (Cont'd)

Reference Designation	HP Part Number	C D	Qty	Description	Mfr Code	Mfr Part Number
A15R18	0700-0005	0	2	RESISTOR 3.0K 5% .25W P TCR=100	10701	HP52C1/4-70-1901-J
A15R19	0003-0035	5		RESISTOR 50K 5% .25W PC TCR=400/000 NOT ASSIGNED	01121	CS0035
A15R20						
A15R21	0700-0005	0		RESISTOR 3.0K 5% .25W P TCR=100	10701	HP52C1/4-70-1901-J
A15R22	0701-0010	0		RESISTOR 3.0K 5% 1W HO TCR=200	20000	0701-0010
A15R23	0003-0035	5		RESISTOR 50K 5% .25W PC TCR=400/000 NOT ASSIGNED	01121	CS0035
A15R24						
A15R25	0701-0010	0		RESISTOR 1.0K 5% 1W HO TCR=200	20000	0701-0010
A15R26	0003-1035	7	0	RESISTOR 10K 5% .25W PC TCR=400/000	01121	CS1035
A15R27	0003-1035	7	0	RESISTOR 10K 5% .25W PC TCR=400/000	01121	CS1035
A15R28						
A15R29	0003-2035	3	2	RESISTOR 20K 5% .25W PC TCR=400/000	01121	CS0035
A15R30	0003-2035	3		RESISTOR 20K 5% .25W PC TCR=400/000	01121	CS0035
A15R31	0003-2735	0	5	RESISTOR 27K 5% .25W PC TCR=400/000	01121	CS0735
A15R32	0003-2735	0		RESISTOR 27K 5% .25W PC TCR=400/000	01121	CS0735
A15R33	0003-1035	7		RESISTOR 10K 5% .25W PC TCR=400/000	01121	CS1035
A15R34						
A15R35	0003-1035	7		RESISTOR 10K 5% .25W PC TCR=400/000	01121	CS1035
A15R36	0003-1015	1	1	RESISTOR 100 5% .25W PC TCR=400/000	01121	CS1015
A15R37	0003-3505	0	1	RESISTOR 3.5K 5% .25W PC TCR=400/000	01121	CS0305
A15R38	0003-2235	0	2	RESISTOR 22K 5% .25W PC TCR=400/000	01121	CS0235
A15R39	0003-3005	3	2	RESISTOR 30K 5% .25W PC TCR=400/000	01121	CS0305
A15R40	0003-1045	0	0	RESISTOR 100K 5% .25W PC TCR=400/000	01121	CS1045
A15R41	0003-0705	0	3	RESISTOR 07 5% .25W PC TCR=400/000	01121	CS0705
A15R42	0003-1005	0	3	RESISTOR 10 5% .25W PC TCR=400/000	01121	CS1005
A15R43	0003-2235	0	0	RESISTOR 22K 5% .25W PC TCR=400/000	01121	CS0235
A15R44						
A15R45	0003-1005	0	3	RESISTOR 10 5% .25W PC TCR=400/000	01121	CS1005
A15R46	0003-3505	0	2	RESISTOR 3.5K 5% .25W PC TCR=400/000	01121	CS0305
A15R47	0003-3505	0	0	RESISTOR 3.5K 5% .25W PC TCR=400/000	01121	CS0305
A15R48						
A15R49	0003-2235	0	5	RESISTOR 22K 5% .25W PC TCR=400/000	01121	CS0235
A15R50	0003-1005	0	3	RESISTOR 100K 5% .25W PC TCR=400/000	01121	CS1005
A15R51	0003-0715	0	1	RESISTOR 070 5% .25W PC TCR=400/000	01121	CS0715
A15R52	0003-2735	0	1	RESISTOR 27K 5% .25W PC TCR=400/000	01121	CS0735
A15R53	0003-2235	0	5	RESISTOR 22K 5% .25W PC TCR=400/000	01121	CS0235
A15R54						
A15R55	0003-1005	0	0	RESISTOR 10 5% .25W PC TCR=400/000	01121	CS1005
A15R56	0003-0705	0	0	RESISTOR 07 5% .25W PC TCR=400/000	01121	CS0705
A15R57	0003-0005	0	2	RESISTOR 0.05K 5% .25W PC TCR=400/000	01121	CS0005
A15R58	0003-0715	0	0	RESISTOR 070 5% .25W PC TCR=400/000	01121	CS0715
A15R59						
A15R60	0003-0715	0	0	RESISTOR 070 5% .25W PC TCR=400/000	01121	CS0715
A15R61						
A15R62	0003-0715	0	0	RESISTOR 070 5% .25W PC TCR=400/000	01121	CS0715
A15R63						
A15R64	0003-1035	0	1	RESISTOR 10K 5% .25W PC TCR=400/000	01121	CS1035
A15R65	0003-2735	0	0	RESISTOR 27K 5% .25W PC TCR=400/000	01121	CS0735
A15R66	0003-0225	0	1	RESISTOR 0.2K 5% .25W PC TCR=400/000	01121	CS0225
A15R67	0003-0715	0	0	RESISTOR 070 5% .25W PC TCR=400/000	01121	CS0715
A15R68	0003-2735	0	0	RESISTOR 27K 5% .25W PC TCR=400/000	01121	CS0735
A15R69						
A15R70	0003-1045	3		RESISTOR 100K 5% .25W PC TCR=400/000	01121	CS1045
A15R71						
A15R72	0003-1045	7	1	RESISTOR 10K 5% .5W CC TCR=700	01121	CS1045
A15R73						
A15R74	0003-1035	1	1	RESISTOR 10K 5% .25W PC TCR=400/000	01121	CS1035
A15R75	0000-1735	0	1	RESISTOR 10K 5% .5W CC TCR=700	01121	CS1735
A15R76	0003-1045	0	1	RESISTOR 100K 5% .25W PC TCR=400/000	01121	CS1045
A15R77						
A15R78	0003-1035	0	10	RESISTOR 10K 5% .25W PC TCR=400/000	01121	CS1035
A15R79						
A15R80	0003-2235	5		RESISTOR 22K 5% .25W PC TCR=400/000	01121	CS0235
A15R81	0003-2235	5		RESISTOR 22K 5% .25W PC TCR=400/000	01121	CS0235
A15R82	0003-2235	5		RESISTOR 22K 5% .25W PC TCR=400/000	01121	CS0235
A15R83	0003-2235	5		RESISTOR 22K 5% .25W PC TCR=400/000	01121	CS0235
A15R84						
A15R85	1000-1003	0	1	IC DCOR CMOS 4-70-10-LINE	01020	CO0510P
A15R86						
A15R87	1000-0501	1	1	SOCKET-IC 24-CONT DIP DIP-8LDR	20000	1000-0501
A16				SAME AS A15, USE PREFIX A16		

CHANGE 13 (1932A) (Cont'd)

Table 11. Replaceable Parts (A10-A14 Options 002 & 003)

Reference Designation	HP Part Number	C D	Qty	Description	Mfr Code	Mfr Part Number
SERIES 1932 A10 THROUGH A14(OPTIONS 002 & 003)						
A10 (Option 002)	05212-0024	2	1	+1248 DECIMAL COUNTER ASSEMBLY (SERIES 1932)	20400	05212-0024
A10 (Option 003)	05212-0025	4	1	-1248 DECIMAL COUNTER ASSEMBLY (SERIES 1932)	20400	05212-0025
A10C1	0140-0190	1	4	CAPACITOR-PXD 110PF +-5% 300VDC MICA	72130	0M15P111J0300V1C8
A10C2	0140-0217	9	1	CAPACITOR-PXD 100PF +-5% 300VDC MICA	72130	0M15P101J0300V1C8
A10C3	0140-0194	1	1	CAPACITOR-PXD 110PF +-5% 300VDC MICA	72130	0M15P111J0300V1C8
A10C4	0140-0197	4	1	CAPACITOR-PXD 100PF +-5% 300VDC MICA	72130	0M15P101J0300V1C8
A10C5	0140-0190	1	1	CAPACITOR-PXD 110PF +-5% 300VDC MICA	72130	0M15P111J0300V1C8
A10C6	0140-0190	1	1	CAPACITOR-PXD 110PF +-5% 300VDC MICA	72130	0M15P111J0300V1C8
A10C7	0140-0190	3	2	CAPACITOR-PXD 100PF +-5% 300VDC MICA	72130	0M15P101J0300V1C8
A10C8	0140-0190	1	1	CAPACITOR-PXD 110PF +-5% 300VDC MICA	72130	0M15P111J0300V1C8
A10C9	0140-0194	1	1	CAPACITOR-PXD 110PF +-5% 300VDC MICA	72130	0M15P111J0300V1C8
A10C10	0140-0190	3	1	CAPACITOR-PXD 100PF +-5% 300VDC MICA	72130	0M15P101J0300V1C8
A10C11	0140-0190	5	2	CAPACITOR-PXD 200PF +-5% 300VDC MICA	72130	0M15P201J0300V1C8
A10C12	0140-0190	5	1	CAPACITOR-PXD 200PF +-5% 300VDC MICA	72130	0M15P201J0300V1C8
A10C13	0140-0121	5	1	CAPACITOR-PXD .1UF +-5% 20X 50VDC CER	20400	0140-0121
A10CR1 thru A10CR8				NOT ASSIGNED		
A10CR9	1910-0010	0	4	DIODE-GE 60V 60MA 1US DO-7	20400	1910-0010
A10CR10	1910-0010	0	1	DIODE-GE 60V 60MA 1US DO-7	20400	1910-0010
A10CR11	1910-0010	0	1	DIODE-GE 60V 60MA 1US DO-7	20400	1910-0010
A10CR12	1910-0010	0	1	DIODE-GE 60V 60MA 1US DO-7	20400	1910-0010
A10CR13	1910-0010	0	1	DIODE-GE 60V 60MA 1US DO-7	20400	1910-0010
A10CR14	1910-0010	0	1	DIODE-GE 60V 60MA 1US DO-7	20400	1910-0010
A10CR15 thru A10CR25				NOT ASSIGNED		
A10CR26	1922-0025	4	1	DIODE-TYM 10V 5% DO-7 PDM, 4M TC=0.002	20400	1922-0025
A10CR27	1922-0041	4	2	DIODE-TYM 5.11V 5% DO-7 PDM, 4M TC=0.0025	20400	1922-0041
A10CR28	1922-0041	2	1	DIODE-TYM 5.11V 5% DO-7 PDM, 4M TC=0.0025	20400	1922-0041
A10CR29	1922-0175	3	1	DIODE-TYM 100V 5% DO-15 PDM, 4M TC=0.0025	20400	1922-0175
A10D51 thru A10D65				NOT ASSIGNED		
A10D66	1070-0000	7	1	TUBE-ELECTRON 6022 IND-NUMERIC	20400	1070-0000
A10L1	0140-0101	1	1	COIL-MLD 3.0MM 5% 8070 2150X, 50LS, 20M	20400	0140-0101
A10M1	1053-0217	1	0	TRANSISTOR PNP 01 PD03104M	00713	MP0-000A
A10M2	1053-0217	1	1	TRANSISTOR PNP 01 PD03104M	00713	MP0-000A
A10M3	1053-0217	1	1	TRANSISTOR PNP 01 PD03104M	00713	MP0-000A
A10M4	1053-0217	1	1	TRANSISTOR PNP 01 PD03104M	00713	MP0-000A
A10M5	1053-0217	1	1	TRANSISTOR PNP 01 PD03104M	00713	MP0-000A
A10M6	1053-0217	1	1	TRANSISTOR PNP 01 PD03104M	00713	MP0-000A
A10M7	1053-0217	1	1	TRANSISTOR PNP 01 PD03104M	00713	MP0-000A
A10M8	1053-0217	1	1	TRANSISTOR PNP 01 PD03104M	00713	MP0-000A
A10O9 thru A10Q11				NOT ASSIGNED		
A10Q12	1050-0002	0	1	TRANSISTOR NPN 21 PD06254M FT0504M2	00713	MP0-017
A10Q13 thru A10Q22				NOT ASSIGNED		
A10R1 thru A10R8				NOT ASSIGNED		
A10R9	0003-5035	5	4	RESISTOR 50K 5% .25W FC TC=400/+800	01121	CB0635
A10R10	0003-5035	5	1	RESISTOR 50K 5% .25W FC TC=400/+800	01121	CB0635
A10R11	0003-5035	5	1	RESISTOR 50K 5% .25W FC TC=400/+800	01121	CB0635
A10R12	0003-5035	5	1	RESISTOR 50K 5% .25W FC TC=400/+800	01121	CB0635
A10R13	0003-5035	5	1	RESISTOR 50K 5% .25W FC TC=400/+800	01121	CB0635
A10R14	0003-5035	5	1	RESISTOR 50K 5% .25W FC TC=400/+800	01121	CB0635
A10R15	0003-5035	5	1	RESISTOR 50K 5% .25W FC TC=400/+800	01121	CB0635
A10R16	0003-5035	5	1	RESISTOR 50K 5% .25W FC TC=400/+800	01121	CB0635
A10R17	0003-5035	5	1	RESISTOR 50K 5% .25W FC TC=400/+800	01121	CB0635
A10R18	0006-7525	2	0	RESISTOR 7.5K 5% .5W CC TC=0.007	01121	CB0725
A10R19	0003-5035	0	0	RESISTOR 50K 5% .25W FC TC=400/+800	01121	CB0635
A10R20	0003-1035	1	0	RESISTOR 10K 5% .25W FC TC=400/+700	01121	CB1035
A10R21	0003-4735	0	0	RESISTOR 47K 5% .25W FC TC=400/+800	01121	CB0735
A10R22	0003-1725	2	0	RESISTOR 1.7K 5% .25W FC TC=400/+700	01121	CB0725
A10R23	0003-1015	5	0	RESISTOR 100 5% .25W FC TC=400/+800	01121	CB1015
A10R24	0003-1045	3	0	RESISTOR 100K 5% .25W FC TC=400/+800	01121	CB1045
A10R25	0003-3725	2	0	RESISTOR 3.7K 5% .25W FC TC=400/+700	01121	CB0725
A10R26	0006-7525	2	0	RESISTOR 7.5K 5% .5W CC TC=0.007	01121	CB0725
A10R27	0003-5035	0	0	RESISTOR 50K 5% .25W FC TC=400/+800	01121	CB0635

CHANGE 13 (1932A (Cont'd)

Table 11. Replaceable Parts (A10-A14 Options 002 & 003) (Cont'd)

Reference Designation	HP Part Number	C D	Qty	Description	Mfr Code	Mfr Part Number
A10R28	0003-1035	1		RESISTOR 10K 5% .25W PC TCR=400/+700	01121	CR1035
A10R29	0003-1035	1		RESISTOR 10K 5% .25W PC TCR=400/+700	01121	CR1035
A10R30	0003-7525	2		RESISTOR 7.5K 5% .5W CC TCR=+647	01121	CR7525
A10R31	0003-4335	0		RESISTOR 43K 5% .25W PC TCR=400/+800	01121	CR4335
A10R32	0003-4735	0		RESISTOR 47K 5% .25W PC TCR=400/+800	01121	CR4735
A10R33	0003-1925	2		RESISTOR 3.9K 5% .25W PC TCR=400/+700	01121	CR1925
A10R34	0003-1015	5		RESISTOR 100 5% .25W PC TCR=400/+800	01121	CR1015
A10R35	0003-1045	3		RESISTOR 100K 5% .25W PC TCR=400/+800	01121	CR1045
A10R36	0003-1925	2		RESISTOR 3.9K 5% .25W PC TCR=400/+700	01121	CR1925
A10R37	0003-7525	2		RESISTOR 7.5K 5% .5W CC TCR=+647	01121	CR7525
A10R38	0003-4335	0		RESISTOR 43K 5% .25W PC TCR=400/+800	01121	CR4335
A10R39	0003-1035	1		RESISTOR 10K 5% .25W PC TCR=400/+700	01121	CR1035
A10R40	0003-1035	1		RESISTOR 10K 5% .25W PC TCR=400/+700	01121	CR1035
A10R41	0003-7525	2		RESISTOR 7.5K 5% .5W CC TCR=+647	01121	CR7525
A10R42	0003-4335	0		RESISTOR 43K 5% .25W PC TCR=400/+800	01121	CR4335
A10R43	0003-4735	0		RESISTOR 47K 5% .25W PC TCR=400/+800	01121	CR4735
A10R44	0003-1925	2		RESISTOR 3.9K 5% .25W PC TCR=400/+700	01121	CR1925
A10R45	0003-1015	5		RESISTOR 100 5% .25W PC TCR=400/+800	01121	CR1015
A10R46	0003-1045	3		RESISTOR 100K 5% .25W PC TCR=400/+800	01121	CR1045
A10R47	0003-1925	2		RESISTOR 3.9K 5% .25W PC TCR=400/+700	01121	CR1925
A10R48	0003-7525	2		RESISTOR 7.5K 5% .5W CC TCR=+647	01121	CR7525
A10R49	0003-4335	0		RESISTOR 43K 5% .25W PC TCR=400/+800	01121	CR4335
A10R50	0003-1035	1		RESISTOR 10K 5% .25W PC TCR=400/+700	01121	CR1035
A10R51	0003-1035	1		RESISTOR 10K 5% .25W PC TCR=400/+700	01121	CR1035
A10R52	0003-7525	2		RESISTOR 7.5K 5% .5W CC TCR=+647	01121	CR7525
A10R53	0003-4335	0		RESISTOR 43K 5% .25W PC TCR=400/+800	01121	CR4335
A10R54	0003-4735	0		RESISTOR 47K 5% .25W PC TCR=400/+800	01121	CR4735
A10R55	0003-1925	2		RESISTOR 3.9K 5% .25W PC TCR=400/+700	01121	CR1925
A10R56	0003-1015	5		RESISTOR 100 5% .25W PC TCR=400/+800	01121	CR1015
A10R57	0003-1045	3		RESISTOR 100K 5% .25W PC TCR=400/+800	01121	CR1045
A10R58	0003-1925	2		RESISTOR 3.9K 5% .25W PC TCR=400/+700	01121	CR1925
A10R59	0003-7525	2		RESISTOR 7.5K 5% .5W CC TCR=+647	01121	CR7525
A10R60	0003-4335	0		RESISTOR 43K 5% .25W PC TCR=400/+800	01121	CR4335
A10R61	0003-1035	1		RESISTOR 10K 5% .25W PC TCR=400/+700	01121	CR1035
A10R62	0003-1035	1		RESISTOR 10K 5% .25W PC TCR=400/+700	01121	CR1035
A10R63	0003-7525	2		RESISTOR 7.5K 5% .25W PC TCR=400/+700	01121	CR7525
A10R64	0003-4735	2		RESISTOR 47K 5% .25W PC TCR=400/+800	01121	CR4735
A10R65	0003-4335	0		RESISTOR 43K 5% .25W PC TCR=400/+800	01121	CR4335
A10R66 thru A10R70	0003-1045	3		NOT ASSIGNED RESISTOR 100K 5% .25W PC TCR=400/+800	01121	CR1045
A10R71	0003-1034	7		RESISTOR 10K 5% .5W CC TCR=+705	01121	CR1034
A10R72	0003-1035	1		RESISTOR 10K 5% .25W PC TCR=400/+700	01121	CR1035
A10R73	0003-1035	1		RESISTOR 10K 5% .25W PC TCR=400/+700	01121	CR1035
A10R74	0003-1045	3		RESISTOR 100K 5% .25W PC TCR=400/+800	01121	CR1045
A10R75 thru A10R83	0003-1925	2	10	RESISTOR 39K 5% .25W PC TCR=400/+800	01121	CR1925
A10R84	0003-2235	5		RESISTOR 22K 5% .25W PC TCR=400/+800	01121	CR2235
A10R85	0003-2235	5		RESISTOR 22K 5% .25W PC TCR=400/+800	01121	CR2235
A10R86	0003-2235	5		RESISTOR 22K 5% .25W PC TCR=400/+800	01121	CR2235
A10R87	0003-2235	5		RESISTOR 22K 5% .25W PC TCR=400/+800	01121	CR2235
A10U1	1200-1003	0	1	IC 80C01 CMOS 4-70-10-LINE	01020	CR01003
A10R1	1200-0501	1	1	SOCKET-IC 28-CON DIP DIP-8LDR	28200	1200-0501
A11				SAME AS A10. USE PREFIX A11		
A12				SAME AS A10. USE PREFIX A12		
A13				SAME AS A10. USE PREFIX A13		
A14				SAME AS A10. USE PREFIX A14		

CHANGE 13 (1932A) (Cont'd)

Page 7-19, Figure 7-10, A10-A14 Decimal Counter Schematic Diagram:

Change "+1248 BCD (05212-6002) SERIES 415 OPTION 002", at top of diagram and in caption for Figure 7-10 to +1248 BCD (05212-6024) SERIES 1932 OPTION 002.

Change "-1248 BCD (05212-6003) SERIES 415 OPTION 003", at top of diagram and in caption for Figure 7-10 to -1248 BCD (05212-6025) SERIES 1932 OPTION 003.

Delete CR1 through CR8, DS1 A/B thru DS4 A/B, DS6, R1, R2A thru R2K, R6 thru R9, R11, R13, R15, R17, and photoconductor V1.

Add "A" at top end of R10.

Add "B" at top end of R12.

Add "C" at top end of R14.

Add "D" at top end of R16.

Add integrated circuit U1, transistors Q12 thru Q22, digital display tube DS6, and associated components in place of above removed parts. See Figure 6 for diagram of ± 1248 integrated circuit readout assembly.

Connect WHT-BLK wire to A (upper end of R10).

Connect WHT-BRN wire to B (upper end of R12).

Connect WHT-RED wire to C (upper end of R14).

Connect WHT-ORN wire to D (upper end of R16).

Pages 7-23/7-24, Figure 7-12, A15 and A16 Decimal Counter Schematic:

Change "+1248 (05232-6014)", at top of diagram and in caption for Figure 7-12 to +1248 (05232-6023) SERIES 1932 OPTION 002.

Change "-1248 (05232-6012)", at top of diagram and in caption for Figure 7-12 to -1248 (05232-6022) SERIES 1932 OPTION 003.

Delete CR1 thru CR8, DS1 A/B thru DS4 A/B, DS6, R1, R2A thru R2K, R6 thru R9, R12, R16, R20, R24, and photoconductor V1.

Add "A" at top end of R11.

Add "B" at top end of R15.

Add "C" at top end of R19.

Add "D" at top end of R23.

Add integrated circuit U1, transistors Q12 thru Q22, digital display tube DS6, and associated components in place of above removed parts. See Figure 6 for diagram of ± 1248 integrated circuit readout assembly.

Connect WHT-BLK wire to A (upper end of R11).

Connect WHT-BRN wire to B (upper end of R15).

Connect WHT-RED wire to C (upper end of R19).

Connect WHT-ORN wire to D (upper end of R23).

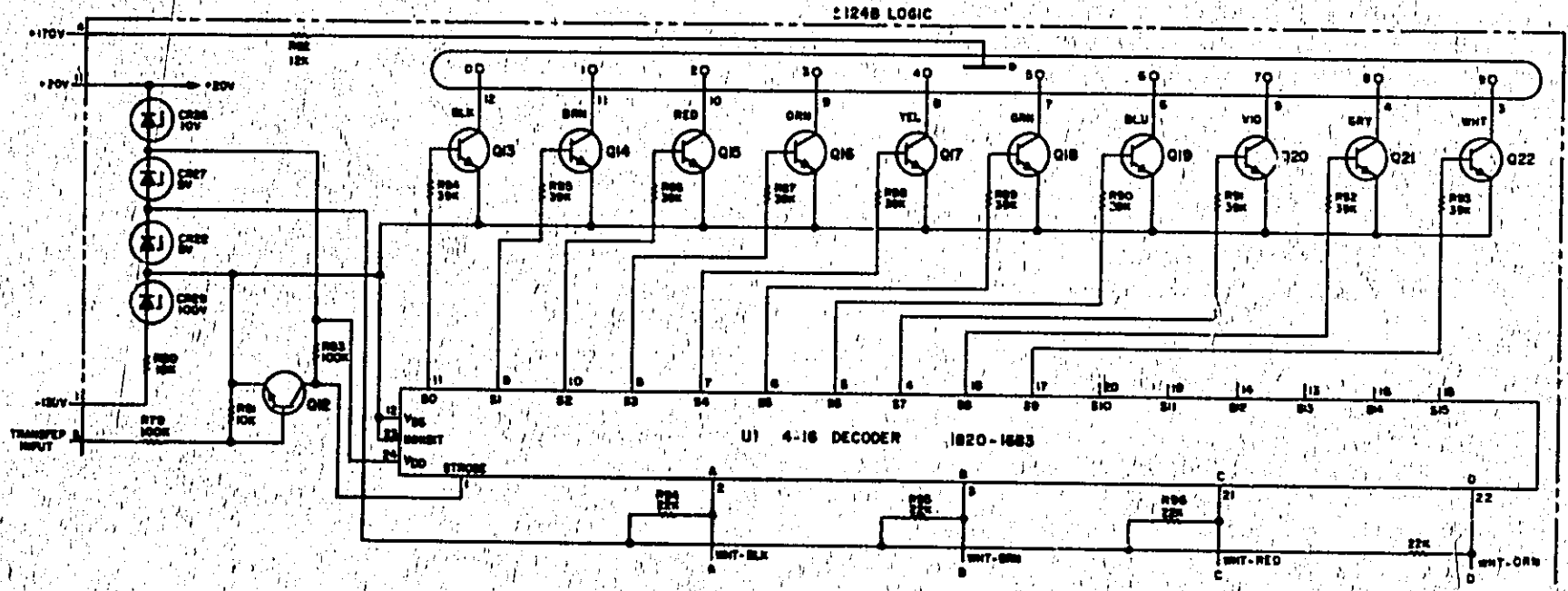

Figure 6. Integrated Circuit Readout Assembly with ± 1248 Logic

CHANGE 14 (Serial Prefix 2004A)

Page 4-20, Table 4-1, A23 Reference Designation Index:

Change A23 (05243A-65S) series number from 1820 to 2004.

Change A23Q11 from 1854-0005 (2N706) to 1854-0642; TRANSISTOR:SILICON NPN.

Pages 7-39/7-40, Figure 7-20, A23 Schematic Diagram:

Change A23 series number from 1820 to 2004.

Change "2N706" adjacent to A23Q11 to 1854-0642.

NOTE

The following part of this change negates part of the changes given in CHANGE 11.

Page 4-6, Table 4-1, A10 Reference Designation Index:

Replace 05212-6018 (SERIES 1912) Replaceable Parts (part of CHANGE 11) with HP Part No. 05212-6027 (SERIES 2004) Replaceable Parts in attached Table 12 for A10-A15 Replaceable Parts.

Page 4-8, Table 4-1, A16 Reference Designation Index:

Replace 05232-6015 (SERIES 1912) Replaceable Parts (part of CHANGE 11) with HP Part No. 05232-6024 (SERIES 2004) Replaceable Parts in attached Table 13 for A16 Replaceable Parts.

Page 4-13, Table 4-1, A18 Reference Designation Index:

Replace 05245-60040 (SERIES 1912) Replaceable Parts (part of CHANGE 11) with HP Part No. 05245-60044 (SERIES 2004) Replaceable Parts in attached Table 14 for A18 Replaceable Parts.

Page 7-16, Part of Figure 7-9, A10-A15 Component Locator:

Replace A10-A15 Component Locator illustration with new illustration for 05212-6027 in attached Figure 7.

Page 7-17, Figure 7-9, A10-A15 Schematic Diagram:

Replace A10-A15 Schematic Diagram with new diagram for 05212-6027 in attached Figure 8.

Page 7-20, Part of Figure 7-11, A16 Component Locator:

Replace A16 Component Locator illustration with new illustration for 05232-6024 in attached Figure 9.

Page 7-21, Figure 7-11, A16 Schematic Diagram:

Replace A16 Schematic Diagram with new diagram for 05232-6024 in attached Figure 10.

Page 7-27, Figure 7-14, A18 Component Locator and Schematic Diagram:

Replace A18 Component Locator illustration with new illustration for 05245-60044 in attached Figure 11.

Replace A18 Schematic Diagram with new diagram for 05245-60044 in attached Figure 12.

CHANGE 14 (2004A) (Cont'd)

Table 12 A10-A15 Replaceable Parts (Standard)

Reference Designation	HP Part Number	C D	Qty	Description	Mfr Code	Mfr Part Number
A10	05212-0027	8	1	ASSEMBLY, DECIMAL BOARD (SERIES 2004)	20400	05212-0027
A10C1	0140-0190	7	1	CAPACITOR-FIX 10PF +-5% 300VDC MICA	72130	0M15E300J0300V1C0
A10C2	0140-0195	2	1	CAPACITOR-FIX 22PF +-5% 300VDC MICA	72130	0M15E220J0300V1C0
A10C3	0140-0193	0	1	CAPACITOR-FIX 82PF +-5% 300VDC MICA	72130	0M15E80J0300V1C0
A10C4	0140-0193	0	1	CAPACITOR-FIX 82PF +-5% 300VDC MICA	72130	0M15E80J0300V1C0
A10C5	0140-0200	0	1	CAPACITOR-FIX 07PF +-5% 300VDC MICA	72130	0M15E07J0300V1C0
A10C6	0140-0197	0	2	CAPACITOR-FIX 100PF +-5% 300VDC MICA	72130	0M15P010J0300V1C0
A10C7	0140-0203	0	2	CAPACITOR-FIX 01PF +-5% 300VDC MICA 0+70	20400	0100-2205
A10C8	0140-0192	0	1	CAPACITOR-FIX 00PF +-5% 300VDC MICA	72130	0M15E00J0300V1C0
A10C9	0140-0197	0	0	CAPACITOR-FIX 100PF +-5% 300VDC MICA	72130	0M15P010J0300V1C0
A10C10	0140-0217	0	1	CAPACITOR-FIX 100PF +-5% 300VDC MICA	72130	0M15P010J0300V1C0
A10C11	0140-0202	0	0	CAPACITOR-FIX 01PF +-5% 300VDC MICA 0+70	20400	0100-2205
A10C12	0140-0193	0	0	CAPACITOR-FIX 22PF +-5% 300VDC MICA	72130	0M15E220J0300V1C0
A10C13	0140-0200	2	2	CAPACITOR-FIX 100PF +-5% 300VDC MICA	20400	0100-2200
A10C14	0140-0195	2	1	CAPACITOR-FIX 130PF +-5% 300VDC MICA	72130	0M15P013J0300V1C0
A10C15	0140-0200	2	2	CAPACITOR-FIX 100PF +-5% 300VDC MICA	20400	0100-2200
A10CR1 THRU A10CR8				NOT ASSIGNED		
A10CR9 THRU A10CR18	1910-0010	0	10	DIODE-2W 10V 5% DO-7 PWR, 4N TC00, 000Z	20400	1910-0010
A10CR19 THRU A10CR21				NOT ASSIGNED		
A10CR20	1902-0025	0	1	DIODE-ZNR 10V 5% DO-7 PWR, 4N TC00, 000Z	20400	1902-0025
A10CR27	1902-0001	0	2	DIODE-ZNR 5.11V 5% DO-7 PWR, 4N TC00, 000Z	20400	1902-0001
A10CR28	1902-0001	0	4	DIODE-ZNR 5.11V 5% DO-7 PWR, 4N TC00, 000Z	20400	1902-0001
A10CR29	1902-0175	0	1	DIODE-ZNR 100V 5% DO-15 PWR, 1N TC00, 003Z	20400	1902-0175
A10DS1 THRU A10DS5				NOT ASSIGNED		
A10DS6	1070-0000	7	1	TUBE-ELECTRON 6022 IND-NUMERIC	20400	1070-0000
A10Q1 THRU A10Q6				NOT ASSIGNED		
A10Q7 THRU A10Q11	1003-0217	1	0	TRANSISTOR PNP 01 P003100W	00715	MP0-0004
A10Q12	1003-0000	0	1	NOT ASSIGNED		
A10Q13 THRU A10Q22	1003-0000	0	10	TRANSISTOR NPN 01 P000200W P10000WZ	00715	MP0-0002
A10R1 THRU A10R0				NOT ASSIGNED		
A10R10	0000-7507	2	0	RESISTOR 7.5K 5% .5W CC TC00+047	01121	007505
A10R11	0003-0035	0	0	RESISTOR 50K 5% .25W FC TC00-000/+000	01121	C00035
A10R12				NOT ASSIGNED		
A10R13	0000-7505	2	0	RESISTOR 7.5K 5% .5W CC TC00+047	01121	007505
A10R14	0003-0735	0	10	RESISTOR 07K 5% .25W FC TC00-000/+000	01121	C00735
A10R15	0003-0735	0	0	RESISTOR 07K 5% .25W FC TC00-000/+000	01121	C00735
A10R16	0003-0735	0	7	RESISTOR 3.0K 5% .25W FC TC00-000/+000	01121	C00305
A10R17	0003-0105	0	0	RESISTOR 100 5% .25W FC TC00-000/+000	01121	C00105
A10R18	0003-0735	0	0	RESISTOR 07K 5% .25W FC TC00-000/+000	01121	C00735
A10R19	0003-0735	0	0	RESISTOR 3.0K 5% .25W FC TC00-000/+000	01121	C00305
A10R20	0003-1045	0	0	RESISTOR 100K 5% .25W FC TC00-100/+000	01121	C01045
A10R21	0003-0025	0	2	RESISTOR 3K 5% .25W FC TC00-000/+000	01121	C00025
A10R22	0003-0735	0	0	RESISTOR 07K 5% .25W FC TC00-000/+000	01121	C00735
A10R23	0003-0735	0	0	RESISTOR 07K 5% .25W FC TC00-000/+000	01121	C00735
A10R24	0003-0025	0	0	RESISTOR 3K 5% .25W FC TC00-000/+000	01121	C00025
A10R25	0000-7505	2	0	RESISTOR 7.5K 5% .5W CC TC00+047	01121	007505
A10R26	0003-0035	0	0	RESISTOR 50K 5% .25W FC TC00-000/+000	01121	C00035
A10R27				NOT ASSIGNED		
A10R28	0000-7505	2	0	RESISTOR 7.5K 5% .5W CC TC00+047	01121	007505
A10R29	0003-0735	0	0	RESISTOR 07K 5% .25W FC TC00-000/+000	01121	C00735
A10R30	0003-0735	0	0	RESISTOR 07K 5% .25W FC TC00-000/+000	01121	C00735
A10R31	0003-0735	0	0	RESISTOR 07K 5% .25W FC TC00-000/+000	01121	C00735
A10R32	0003-0735	0	0	RESISTOR 07K 5% .25W FC TC00-000/+000	01121	C00735
A10R33	0003-0105	0	0	RESISTOR 100 5% .25W FC TC00-000/+000	01121	C00105
A10R34	0003-0735	0	1	RESISTOR 07K 5% .25W FC TC00-000/+000	01121	C00735
A10R35	0003-0025	0	0	RESISTOR 3K 5% .25W FC TC00-000/+000	01121	C00025
A10R36	0003-0025	0	0	RESISTOR 3K 5% .25W FC TC00-000/+000	01121	C00025
A10R37	0003-1045	0	0	RESISTOR 100K 5% .25W FC TC00-100/+000	01121	C01045
A10R38	0000-7505	2	0	RESISTOR 7.5K 5% .5W CC TC00+047	01121	007505
A10R39	0003-0035	0	0	RESISTOR 50K 5% .25W FC TC00-000/+000	01121	C00035
A10R40				NOT ASSIGNED		
A10R41	0000-7505	2	0	RESISTOR 7.5K 5% .5W CC TC00+047	01121	007505
A10R42	0003-0735	0	0	RESISTOR 07K 5% .25W FC TC00-000/+000	01121	C00735

CHANGE 14 (3884A) (Cont'd)

Table 12. A10-A15 Replaceable Parts (Standard) (Cont'd)

Reference Designation	HP Part Number	C D	Qty	Description	Mfr Code	Mfr Part Number
A1043	0623-4725	2		RESISTOR 47K 5% .25W FC TC=400/+200	01121	CR4725
A1044	0623-4725	2		RESISTOR 47K 5% .25W FC TC=400/+200	01121	CR4725
A1045	0623-4725	2		RESISTOR 47K 5% .25W FC TC=400/+200	01121	CR4725
A1046	0623-1815	2		RESISTOR 18K 5% .25W FC TC=400/+200	01121	CR1815
A1047	0623-4725	2		RESISTOR 47K 5% .25W FC TC=400/+200	01121	CR4725
A1048	0623-1815	2		RESISTOR 18K 5% .25W FC TC=400/+200	01121	CR1815
A1049	0623-1815	1	4	RESISTOR 18K 5% .25W FC TC=400/+200	01121	CR1815
A1050	0623-1815	2		RESISTOR 18K 5% .25W FC TC=400/+200	01121	CR1815
A1051	0623-7525	2		RESISTOR 7.5K 5% .5W CC TC=400/±47	01121	CR7525
A1052	0623-5625	5		RESISTOR 56K 5% .25W FC TC=400/+200	01121	CR5625
A1053				NOT ASSIGNED		
A1054	0623-7525	2		RESISTOR 7.5K 5% .5W CC TC=400/±47	01121	CR7525
A1055	0623-4725	4		RESISTOR 47K 5% .25W FC TC=400/+200	01121	CR4725
A1056	0623-4725	4		RESISTOR 47K 5% .25W FC TC=400/+200	01121	CR4725
A1057	0623-1815	1		RESISTOR 18K 5% .25W FC TC=400/+200	01121	CR1815
A1058	0623-1815	2		RESISTOR 18K 5% .25W FC TC=400/+200	01121	CR1815
A1059	0623-1815	5		RESISTOR 18K 5% .25W FC TC=400/+200	01121	CR1815
A1060	0623-4725	4		RESISTOR 47K 5% .25W FC TC=400/+200	01121	CR4725
A1061	0623-1815	2		RESISTOR 18K 5% .25W FC TC=400/+200	01121	CR1815
A1062	0623-1815	1		RESISTOR 18K 5% .25W FC TC=400/+200	01121	CR1815
A1063	0623-5625	9	1	RESISTOR 56K 5% .25W FC TC=400/+200	01121	CR5625
A1064	0623-1815	3		RESISTOR 18K 5% .25W FC TC=400/+200	01121	CR1815
A1065	0623-1815	1		RESISTOR 18K 5% .25W FC TC=400/+200	01121	CR1815
A1066	0623-1815	1		RESISTOR 18K 5% .25W FC TC=400/+200	01121	CR1815
A1067	0623-1815	1		RESISTOR 18K 5% .25W FC TC=400/+200	01121	CR1815
A1068 THRU A1069				NOT ASSIGNED		
A1070	0623-1815	3		RESISTOR 18K 5% .25W FC TC=400/+200	01121	CR1815
A1071	0623-1815	7	1	RESISTOR 18K 5% .5W CC TC=400/±75	01121	CR1815
A1072	0623-1815	1		RESISTOR 18K 5% .25W FC TC=400/+200	01121	CR1815
A1073	0623-1815	0		RESISTOR 18K 5% .25W FC TC=400/+200	01121	CR1815
A1074	0623-1815	1		RESISTOR 18K 5% .25W FC TC=400/+200	01121	CR1815
A1075	0623-1815	3		RESISTOR 18K 5% .25W FC TC=400/+200	01121	CR1815
A1076				NOT ASSIGNED		
A1077	0623-3825	2		RESISTOR 38K 5% .25W FC TC=400/+200	01121	CR3825
A1078	0623-3825	4		RESISTOR 38K 5% .25W FC TC=400/+200	01121	CR3825
A1079 THRU A1083				NOT ASSIGNED		
A1084	0623-2225	5	4	RESISTOR 22K 5% .25W FC TC=400/+200	01121	CR2225
A1085	1810-0485	5	1	RESISTOR NETWORK 18-31P 25K/1 X3	28480	1810-0485
A1086	1820-1805	0	1	IC, CMOS 18054	01020	28481480
A1087	1200-0541	1	1	SOCKET-IC 26-COND DIP DIP-26LDR	28490	1200-0541
A11				SAME AS A10, USE PREFIX A11		
A12				SAME AS A10, USE PREFIX A12		
A13				SAME AS A10, USE PREFIX A13		
A14				SAME AS A10, USE PREFIX A14		
A15				SAME AS A10, USE PREFIX A15		

CHANGE 14 (2004A) (Cont'd)

Table 13. A16 Replaceable Parts (Standard) (Cont'd)

Reference Designation	HP Part Number	C D	Qty	Description	Mfr Code	Mfr Part Number
A1080	0003-1025	0	3	RESISTOR 10K 5% .25W FC TC=400/+000	01121	CB1025
A1081	0003-1026	0	3	RESISTOR 1K 5% .25W FC TC=400/+000	01121	CB1026
A1082	0003-1115	0	2	RESISTOR 110 5% .25W FC TC=400/+000	01121	CB1115
A1083	0003-1025	0	2	RESISTOR 3.9K 5% .25W FC TC=400/+700	01121	CB1025
A1084	0003-1045	0	3	RESISTOR 100K 5% .25W FC TC=400/+000	01121	CB1045
A1085	0003-1026	0	2	RESISTOR 1K 5% .25W FC TC=400/+000	01121	CB1026
A1086	0003-1026	0	2	RESISTOR 3.6K 5% .25W FC TC=400/+700	01121	CB1026
A1087	0003-1045	0	2	RESISTOR 3.6K 5% .25W FC TC=400/+700	01121	CB1045
A1088	0003-1025	0	2	RESISTOR 1K 5% .25W FC TC=400/+000	01121	CB1025
A1089	0003-1045	0	3	RESISTOR 100K 5% .25W FC TC=400/+000	01121	CB1045
A1090	0003-1125	0	1	RESISTOR 1.1K 5% .25W FC TC=400/+700	01121	CB1125
A1091	0003-1025	0	1	RESISTOR 27K 5% .25W FC TC=400/+000	01121	CB1025
A1092	0003-1025	0	3	RESISTOR 100K 5% .25W FC TC=400/+000	01121	CB1025
A1093	0003-1235	0	3	RESISTOR 12K 5% .25W FC TC=400/+000	01121	CB1235
A1094	0003-1025	0	3	RESISTOR 3K 5% .25W FC TC=400/+700	01121	CB1025
A1095	0003-1025	0	3	RESISTOR 30K 5% .25W FC TC=400/+000	01121	CB1025
A1096	0003-1025	0	3	RESISTOR 30K 5% .25W FC TC=400/+000	01121	CB1025
A1096 THRU				NOT ASSIGNED		
A1097	0003-1075	0	3	RESISTOR 100K 5% .25W FC TC=400/+000	01121	CB1075
A1097	0003-1075	0	3	RESISTOR 10K 5% .5W CC TC=400/+000	01121	EB1075
A1098	0003-1025	0	1	RESISTOR 10K 5% .25W FC TC=400/+700	01121	CB1025
A1099	0003-1025	0	1	RESISTOR 12K 5% .5W CC TC=400/+000	01121	EB1025
A1099	0003-1045	0	3	RESISTOR 100K 5% .25W FC TC=400/+000	01121	CB1045
A1099-A1099				NOT ASSIGNED		
A1099	0003-1025	0	4	RESISTOR 39K 5% .25W FC TC=400/+000	01121	CB1025
A1099	0003-1025	0	4	RESISTOR 3.9K 5% .25W FC TC=400/+000	01121	CB1025
A1099	0003-1025	0	4	RESISTOR 3.9K 5% .25W FC TC=400/+000	01121	CB1025
A1099 THRU				RESISTOR 22K 5% .25W FC TC=400/+000	01121	CB1025
A1099	1810-0495	0	5	RESISTOR NETWORK 16 DIP 30K X5	28480	1810-0495
A1099	1000-1001	0	6	IC, CMOS 1001	01020	CD011001
A1099	1000-1001	0	1	SOCKET-IC 24-PIN DIP DIP-BLDR	20000	1240-0541

CHANGE 14 (2004A) (Cont'd)

Table 14. A18 Replaceable Parts (Standard)

Reference Designation	HP Part Number	C D	Qty	Description	Mfr Code	Mfr Part Number
STANDARD INSTRUMENT						
A18	05245-80044	4	1	01224 READOUT ASSEMBLY SERIES 2004	20480	05245-80044
A18C1 THRU A18C25				NOT ASSIGNED		
A18C26	1902-0025	4	1	DIODE-ZNR 10V 5% 00-7 PGM, 4W TCR, 043	20480	1902-0025
A18C27	1902-0041	4	2	DIODE-ZNR 5.11V 5% 00-7 PGM, 4W TCR, 0002	20480	1902-0041
A18C28	1902-0041	4	2	DIODE-ZNR 5.11V 5% 00-7 PGM, 4W TCR, 0002	20480	1902-0041
A18C29	1902-0175	5	1	DIODE-ZNR 100V 5% 00-7 PGM, 4W TCR, 053"	20480	1902-0175
A18D1 THRU A18D55				NOT ASSIGNED		
A18D56	1078-0040	7	1	TUBE-ELECTRON 6422 IND-NUMERIC	20480	1078-0040
A18Q1 THRU A18Q5				NOT ASSIGNED		
A18Q6 THRU A18Q11	1054-0003	5	0	TRANSISTOR NPN 5% TC=3V PD=800mW	20480	1054-0003
A18Q12	1054-0042	0	1	NOT ASSIGNED TRANSISTOR NPN 5% PD=250mW FT=50MHz	04713	MP8-417
A18Q13 THRU A18Q22	1054-0078	0	10	TRANSISTOR NPN 5% PD=250mW FT=50MHz	04713	MP8-442
A18R1 THRU A18R10				NOT ASSIGNED		
A18R11	0603-0635	5	0	RESISTOR 50K 5% .25W FC TC=400/+500	01121	CB5635
A18R12				NOT ASSIGNED		
A18R13	0603-0635	5	1	RESISTOR 50K 5% .25W FC TC=400/+500	01121	CB5635
A18R14				NOT ASSIGNED		
A18R15	0603-0635	5	1	RESISTOR 50K 5% .25W FC TC=400/+500	01121	CB5635
A18R16				NOT ASSIGNED		
A18R17	0603-0635	5	1	RESISTOR 50K 5% .25W FC TC=400/+500	01121	CB5635
A18R18	0603-0635	5	1	RESISTOR 50K 5% .25W FC TC=400/+500	01121	CB5635
A18R19				NOT ASSIGNED		
A18R20	0603-7525	0	0	RESISTOR 7.5K 5% .25W FC TC=400/+700	01121	CB7525
A18R21	0603-1045	0	0	RESISTOR 100K 5% .25W FC TC=400/+500	01121	CB1045
A18R22	0603-0135	0	0	RESISTOR 51K 5% .25W FC TC=400/+500	01121	CB0135
A18R23	0603-0005	0	1	RESISTOR 40 5% .25W FC TC=400/+500	01121	CB4005
A18R24				NOT ASSIGNED		
A18R25	0603-7525	0	0	RESISTOR 7.5K 5% .25W FC TC=400/+700	01121	CB7525
A18R26	0603-1045	0	0	RESISTOR 100K 5% .25W FC TC=400/+500	01121	CB1045
A18R27	0603-0135	0	0	RESISTOR 51K 5% .25W FC TC=400/+500	01121	CB0135
A18R28	0603-0005	0	0	RESISTOR 40 5% .25W FC TC=400/+500	01121	CB4005
A18R29				NOT ASSIGNED		
A18R30	0603-0135	0	0	RESISTOR 51K 5% .25W FC TC=400/+500	01121	CB0135
A18R31	0603-0105	0	0	RESISTOR 91 5% .25W FC TC=400/+500	01121	CB0105
A18R32				NOT ASSIGNED		
A18R33	0603-7525	0	0	RESISTOR 7.5K 5% .25W FC TC=400/+700	01121	CB7525
A18R34	0603-1045	0	0	RESISTOR 100K 5% .25W FC TC=400/+500	01121	CB1045
A18R35				NOT ASSIGNED		
A18R36	0603-0225	1	1	RESISTOR 2K 5% .25W FC TC=400/+700	01121	CB0225
A18R37	0603-7525	0	0	RESISTOR 7.5K 5% .25W FC TC=400/+700	01121	CB7525
A18R38	0603-1045	0	0	RESISTOR 100K 5% .25W FC TC=400/+500	01121	CB1045
A18R39	0603-0135	0	0	RESISTOR 51K 5% .25W FC TC=400/+500	01121	CB0135
A18R40	0603-0105	0	0	RESISTOR 91 5% .25W FC TC=400/+500	01121	CB0105
A18R41				NOT ASSIGNED		
A18R42	0603-7525	0	0	RESISTOR 7.5K 5% .25W FC TC=400/+700	01121	CB7525
A18R43				NOT ASSIGNED		
A18R44	0603-0225	1	1	RESISTOR 2K 5% .25W FC TC=400/+700	01121	CB0225
A18R45	0603-7525	0	0	RESISTOR 7.5K 5% .25W FC TC=400/+700	01121	CB7525
A18R46	0603-1045	0	0	RESISTOR 100K 5% .25W FC TC=400/+500	01121	CB1045
A18R47	0603-0135	0	0	RESISTOR 51K 5% .25W FC TC=400/+500	01121	CB0135
A18R48	0603-0105	0	0	RESISTOR 91 5% .25W FC TC=400/+500	01121	CB0105
A18R49				NOT ASSIGNED		
A18R50	0603-7525	0	0	RESISTOR 7.5K 5% .25W FC TC=400/+700	01121	CB7525
A18R51				NOT ASSIGNED		
A18R52 THRU A18R78				NOT ASSIGNED		
A18R79	0603-1045	5	1	RESISTOR 100K 5% .25W FC TC=400/+500	01121	CB1045
A18R80	0603-0135	7	1	RESISTOR 10K 5% .25W FC TC=400/+500	01121	CB0135
A18R81	0603-1035	1	1	RESISTOR 10K 5% .25W FC TC=400/+700	01121	CB1035
A18R82	0603-0225	1	1	RESISTOR 2K 5% .25W FC TC=400/+700	01121	CB0225
A18R83	0603-0105	3	1	RESISTOR 100K 5% .25W FC TC=400/+500	01121	CB1045
A18R84-A18R91				NOT ASSIGNED		
A18R92	0603-3935	4	2	RESISTOR 39K 5% .25W FC TC=400/+500	01121	CB3935
A18R93	0603-3045	4	4	RESISTOR 30K 5% .25W FC TC=400/+500	01121	CB3045
A18R94-A18R97				NOT ASSIGNED		
A18R98	0603-0225	0	0	RESISTOR 2K 5% .25W FC TC=400/+700	01121	CB0225
A18R99	1810-0465	5	1	RESISTOR NETWORK 16 DIP 30K11 X8	28480	1810-0465
A18U1	1020-1005	0	1	IC- CMOS 14710	01920	CD05140P
A18U1	1200-0541	1	1	SOCKET-IC 24-COMT DIP OIP-8L08	20480	1200-0541

CHANGE 14 (2004A) (Cont'd)

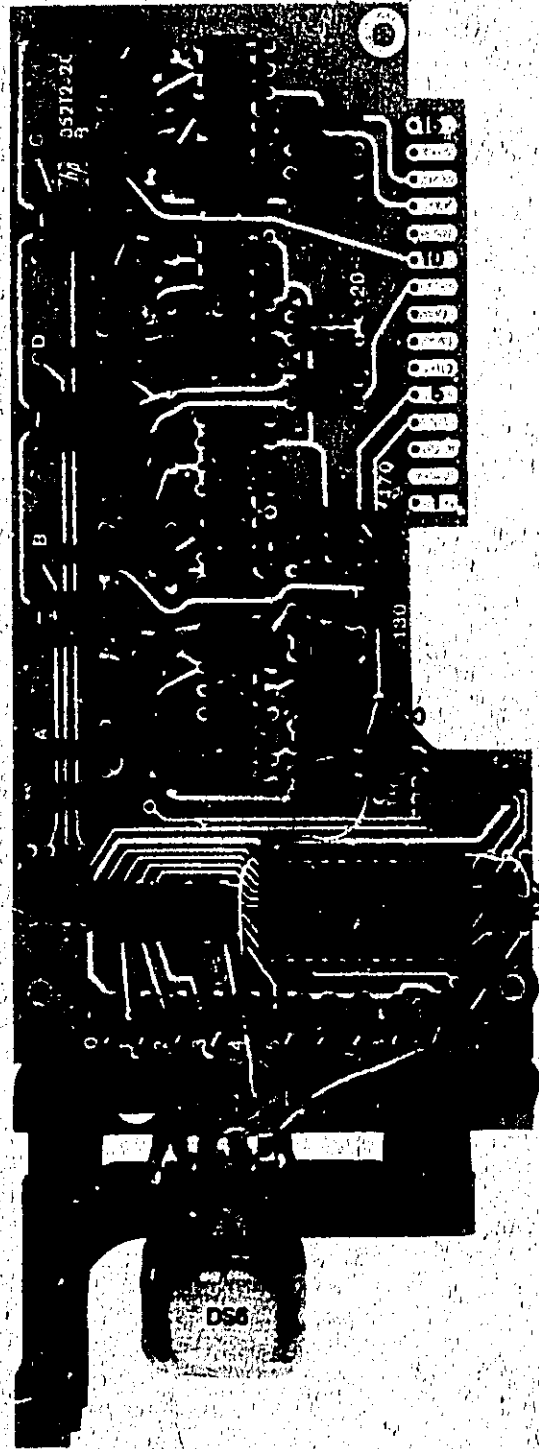
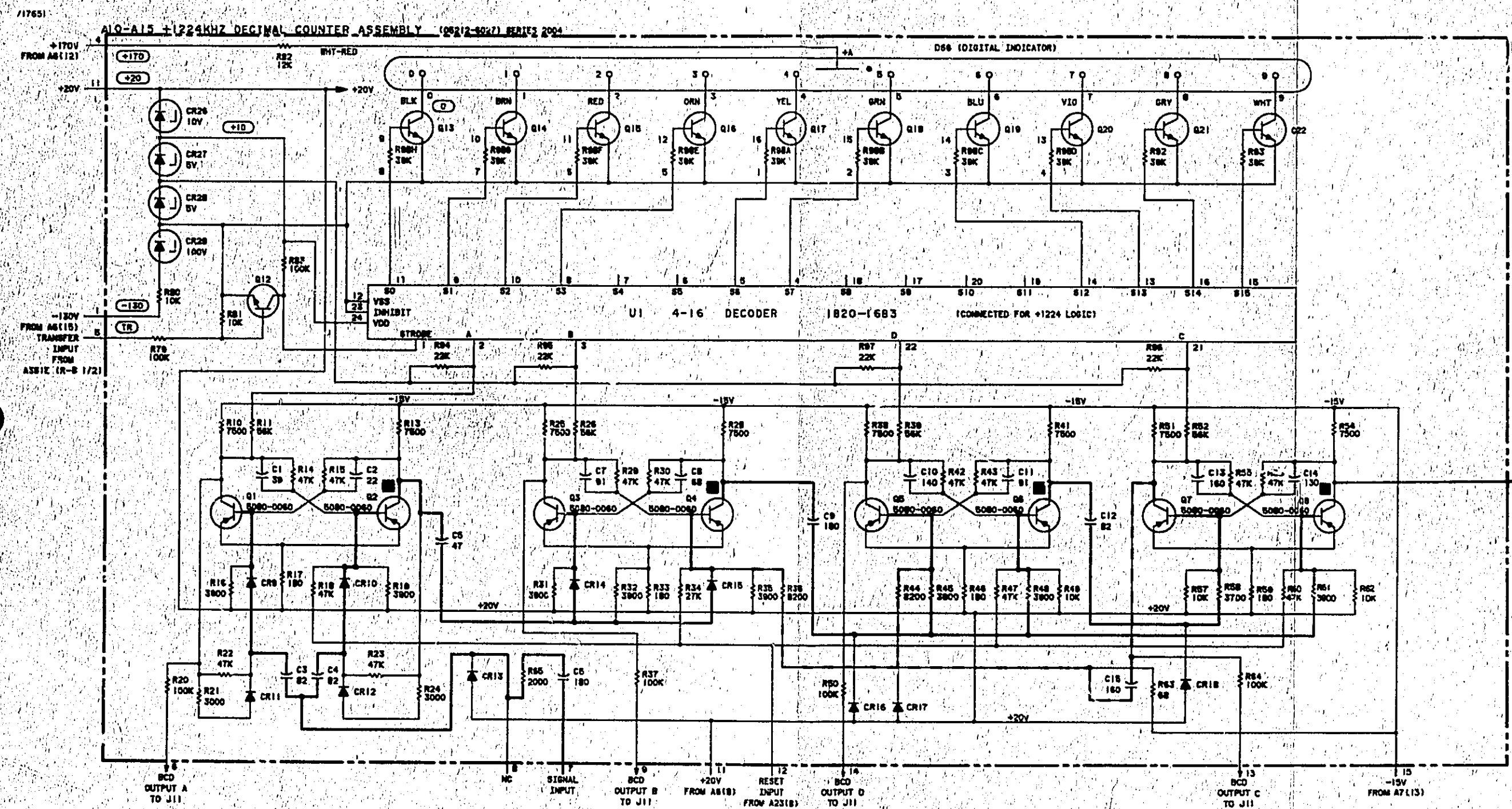

Figure 7. A10-A15 Component Locator for 05212-6027 Series 2004



- NOTES
1. REFERENCE DESIGNATIONS WITHIN HEADOUT ASSEMBLY ARE INCOMPLETE; TO FORM COMPLETE REFERENCE DESIGNATION, ADD ASSEMBLY DESIGNATION AS PREFIX TO INDICATED DESIGNATION
 2. UNLESS OTHERWISE INDICATED: RESISTANCE IN OHMS; CAPACITANCE IN PICOFARADS
 3. FILLED SQUARE (■) INDICATES CONDUCTING ELEMENT FOR DECIMAL "0" (BCD "0000")

Figure 8. A10-A15 Schematic Diagram for 05212-6027 Series 2004

CHANGE 1^A (2004A) (Cont'd)

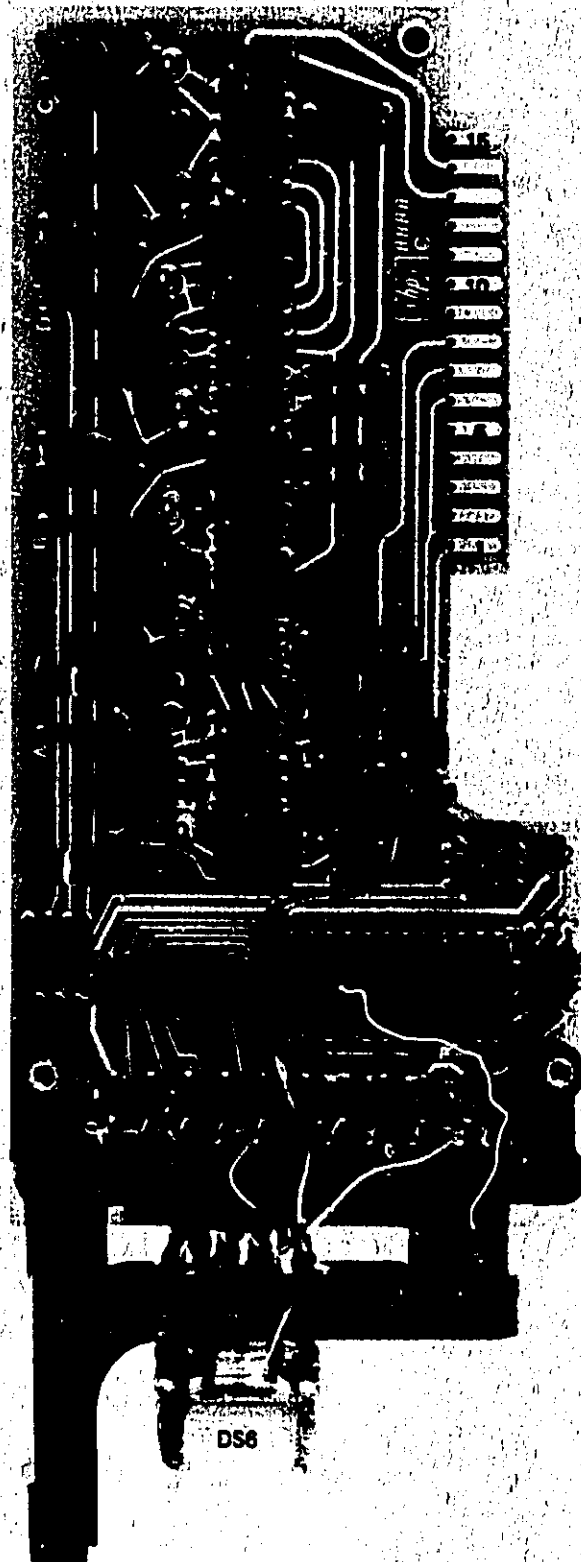
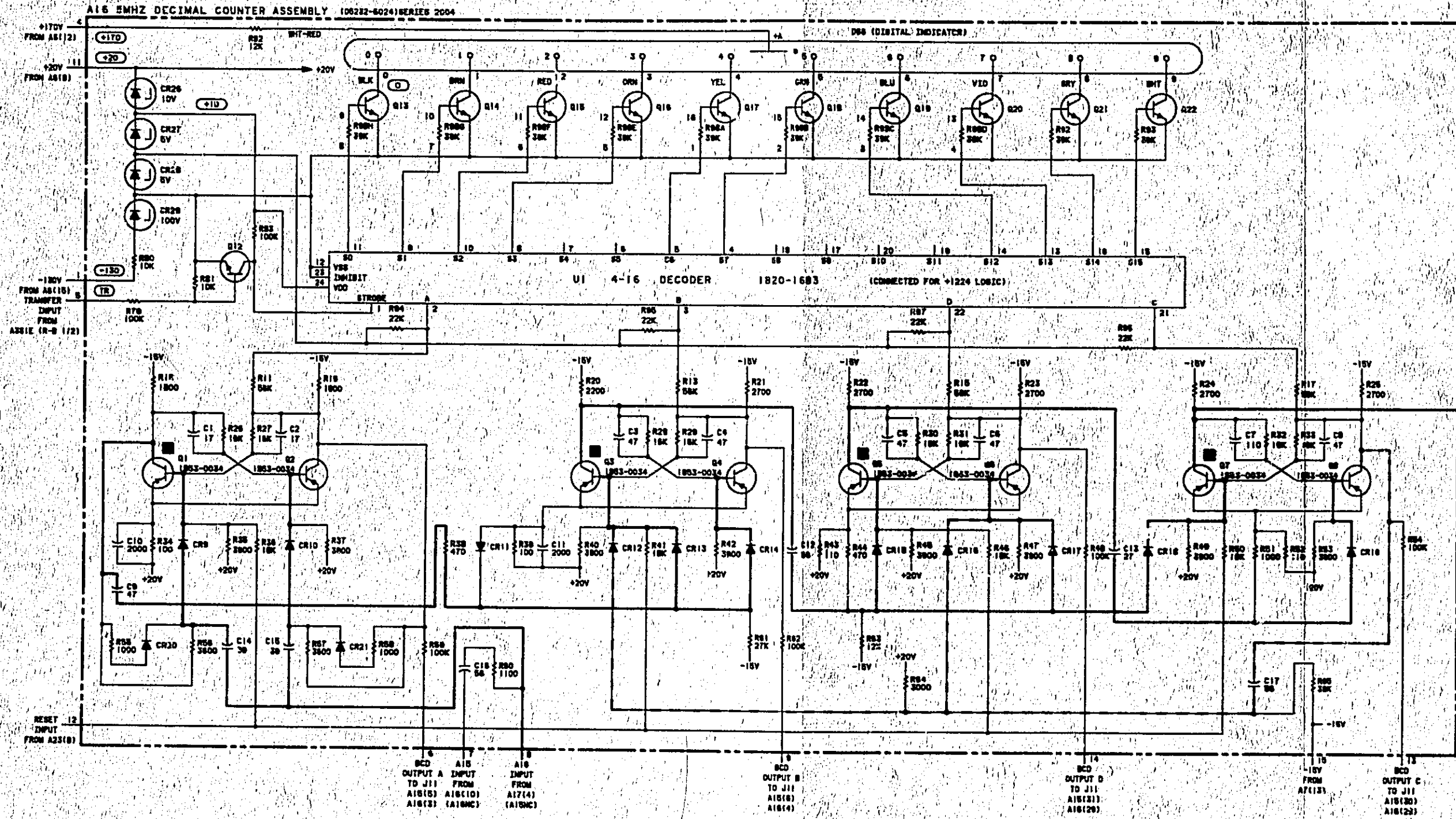
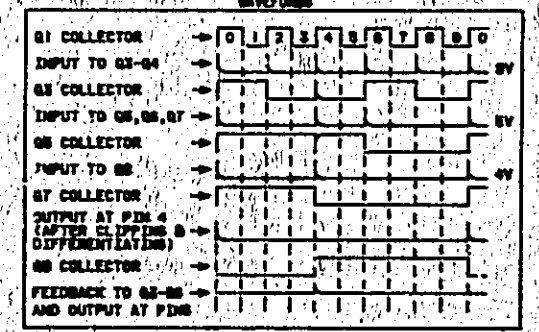

Figure 9. A16 Component Locator for 05232-6024 Series 2004.

1/17853



- NOTES
1. REFERENCE DESIGNATIONS WITHIN READOUT ASSEMBLY ARE INCOMPLETE; TO FORM COMPLETE REFERENCE DESIGNATION, ADD ASSEMBLY DESIGNATION AS PREFIX TO INDICATED DESIGNATION.
 2. UNLESS OTHERWISE INDICATED:
RESISTANCE IN OHMS
CAPACITANCE IN PICOFARADS
 3. FILLED SQUARE (■) INDICATES CONDUCTING ELEMENT FOR DECIMAL "0" (BCD "0000")



TRUTH TABLE

DIGIT	4 LINE CODE (0-100)			
	D	C	B	A
0	0	0	0	0
1	0	0	0	1
2	0	0	1	0
3	0	0	1	1
4	0	1	0	0
5	0	1	0	1
6	0	1	1	0
7	0	1	1	1
8	1	0	0	0
9	1	0	0	1

REFERENCE DESIGNATIONS

A16	(A16)
Q1-17	
CR9-26	
D98	
Q1-22	
R1-20	
NOT ASSIGNED	
CR22-25	
Q8-11	
R1-10, 12, 14, 16, 22-29	

Figure 10. A16 Schematic Diagram for 05232-6024 Series 2004

CHANGE 14 (2004A) (Cont'd)

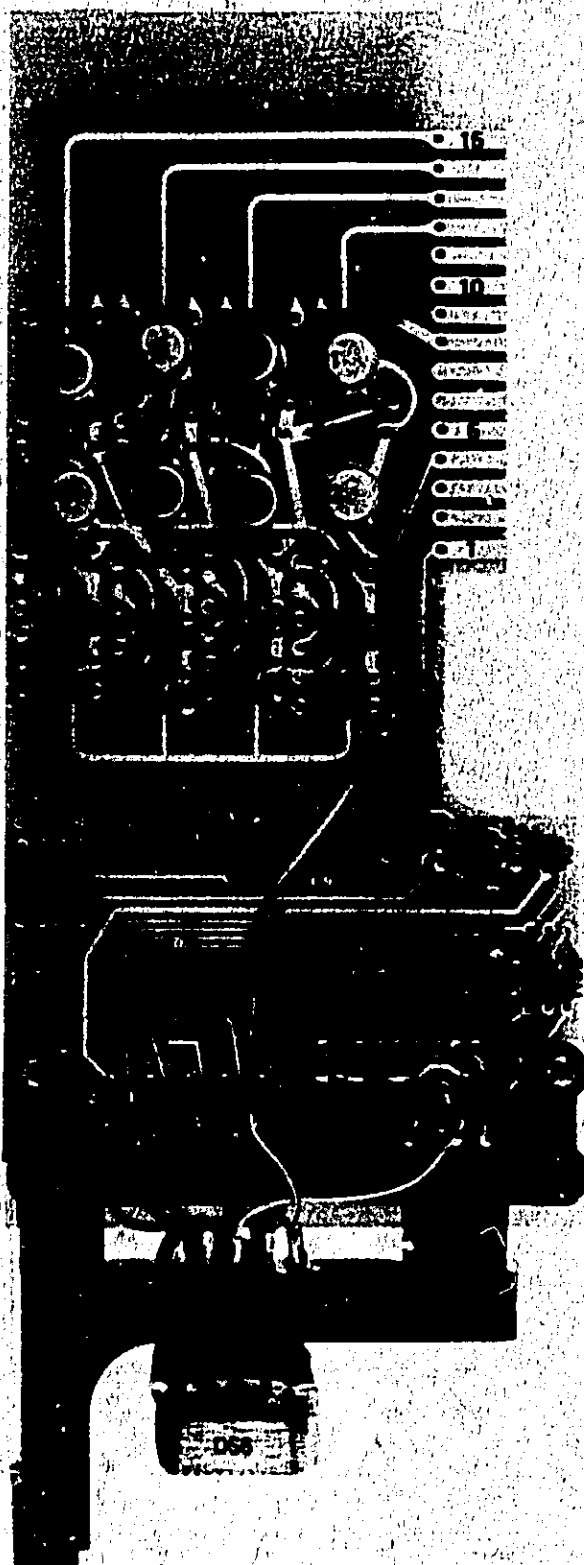
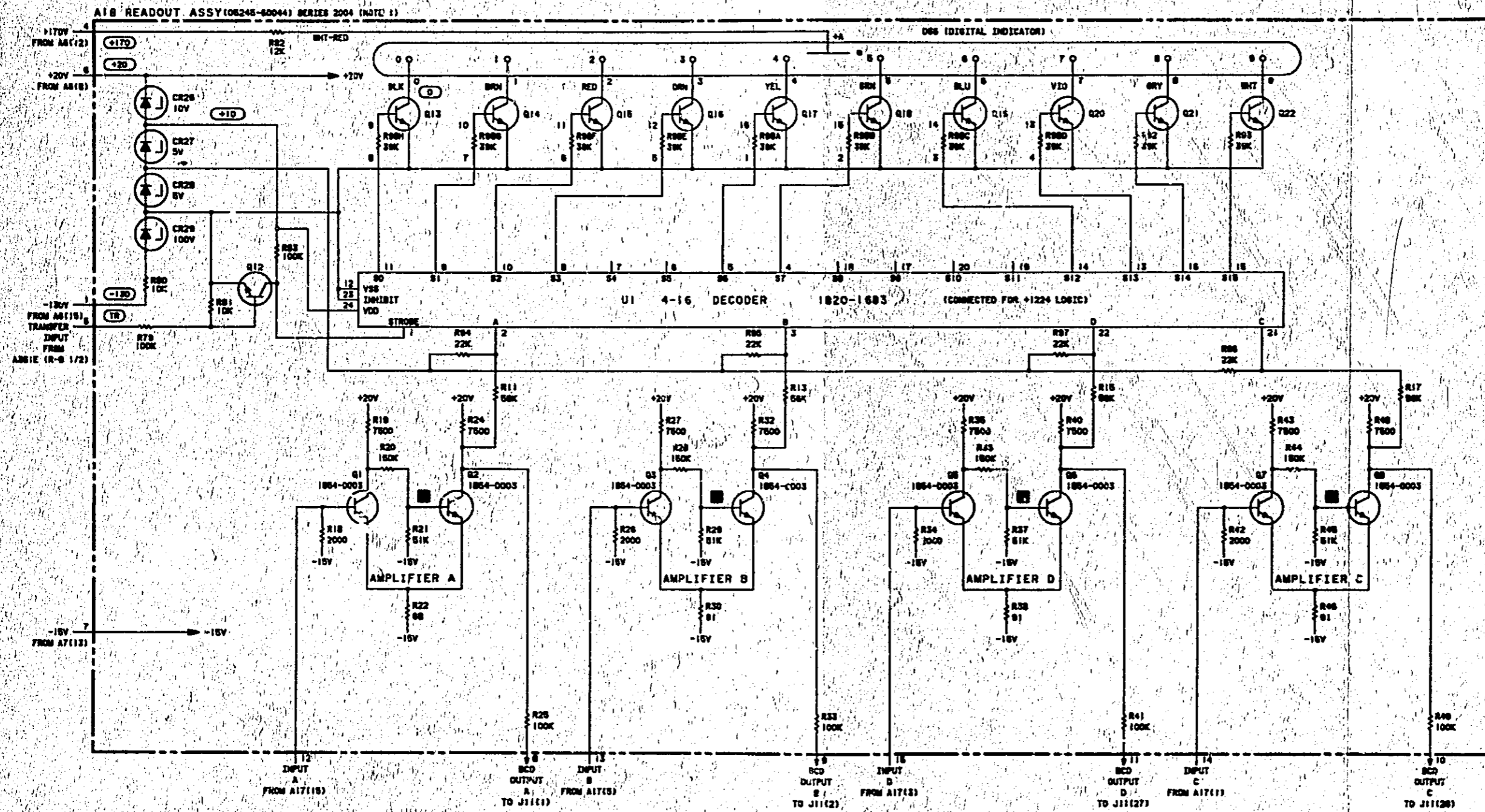
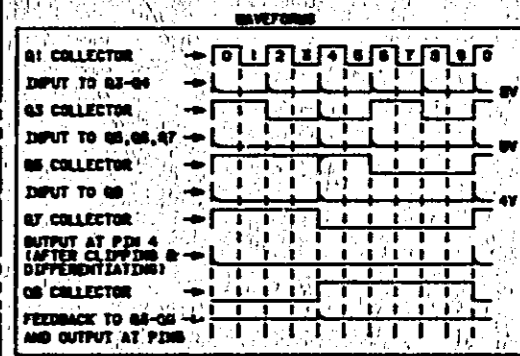

Figure 11. A18 Component Locator for 05245-60044 Series 2004

117862



- NOTES
1. REFERENCE DESIGNATIONS WITHIN READOUT ASSEMBLY ARE INCOMPLETE; TO FORM COMPLETE REFERENCE DESIGNATION, ADD ASSEMBLY DESIGNATION AS PREFIX TO INDICATED DESIGNATION
 2. UNLESS OTHERWISE INDICATED: RESISTANCE IN OHMS; CAPACITANCE IN PICOFARADS
 3. FILLED SQUARE [■] INDICATES CONDUCTING ELEMENT FOR DECIMAL "0" (BCD "0000")



TRUTH TABLE

DECIMAL	4 LINE CODE (0-1-2-3)
0	0 0 0 0
1	0 0 0 1
2	0 0 1 0
3	0 0 1 1
4	0 1 0 0
5	0 1 0 1
6	1 0 0 0
7	1 0 0 1
8	1 1 0 0
9	1 1 0 1

REFERENCE DESIGNATIONS

CR26-28
Q1-9
Q1-8
R1-88
V1
NOT ASSIGNED
U1-6
U1-10, 12, 14, 16, 22, 31, 38
U1-50-78, 84-91

Figure 12. A18 Schematic Diagram for 05245-60044 Series 2004

■ **CHANGE 15**

■ Change SERIES number of the instrument to the series prefix for CHANGE 15 in the table on page 1 of these manual changes.

■ Page 4-33, Table 4-1, Reference Designation Index:

Change R5 from 2100-0218 TO 2100-3891 R:VAR 250K OHM 20% 1/4W
Add (below R5) 0360-1632 TERMINAL-SLDR LUG LK-MTG (R5) 79963

■ Page 4-1, Table 4-2, Replaceable Parts:

Change 2100-0318 to 2100-3891 R:VAR 250K OHM 20% 1/4W 28450 2100-3891
Add (below R5) 0360-1632 TERMINAL-SLDR LUG LK-MTG (R5) 79963

■ PAGE 7-39/7-40, Figure 7-20, A23 Sample Control:

Right hand side, middle of diagram and bottom left hand corner of diagram. Change the diagram of R5 in both places to match the attached Figure 13.

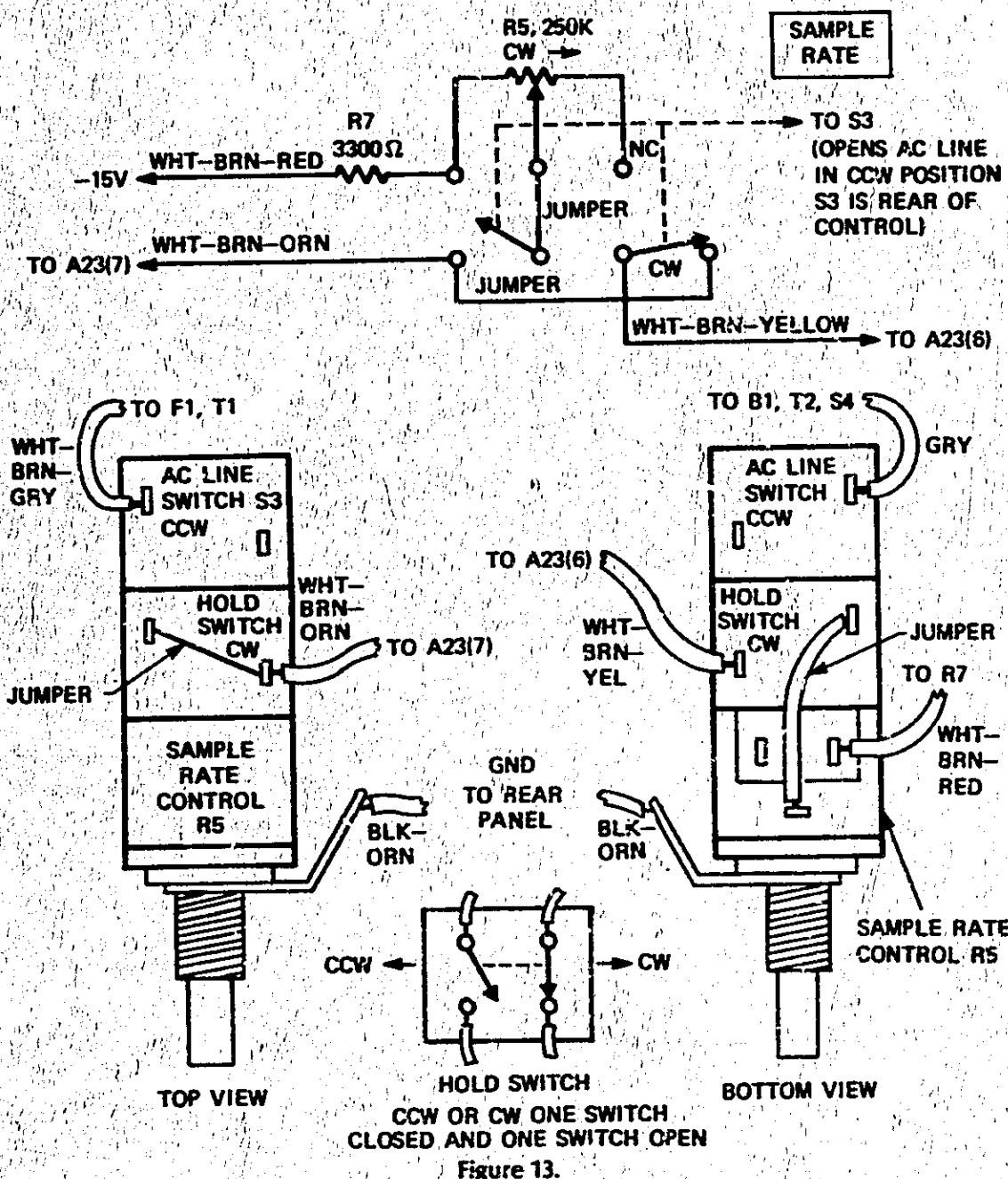

Figure 13.

MAKE ALL CORRECTIONS IN YOUR MANUAL ACCORDING TO ERRATA.

Check the following table for your instrument serial prefix and make any indicated changes to the manual:

MANUAL TITLE: 5245L Service

MANUAL PRINTED: NOV 1973

MANUAL PART NO: 05245-9044

CHANGE DATE: 23rd June, 1976.

*New or Revised item.

SERIAL PREFIX	MAKE CHANGE	SERIAL PREFIX	MAKE CHANGE	SERIAL PREFIX	MAKE CHANGE
1402U-03511	1	1402U-03591			
1402U-03561	1-2	thru 03615	1-4		
1402U-0359	1-3	1528U-03706	1-3, 5		
		1528U-03986	1-6		

ERRATA

Table 1-2

Time Base Output Frequencies

Rear Panel

Change : "5 volts p-p rectangular wave" to read "3 volts p-p minimum signal"

Front Panel

Add : 1 volts p-p "minimum"

Table 3-2 page 3-8

Add : to para 2b "... input jack "via a high impedance probe"

Change : para 2c "rectangular wave" to "signal"

Add : to para 2c 1 volt p-p "minimum"

Add : to para 2d 1 volt p-p "minimum"

Change : para 3 "5 volts p-p" to "3 volts p-p"

Add : para 3 1 volts rms "minimum"

Table 4-1

Change : W1 to part no 8120-1351 Cable Assy pwr

: All 1850-0062 Xstr to part no 1853-0217

: All 0150-0093 C Fxd to part no 0160-2930

Add : part no 0340-0162 Insulator (For Q1)

Page 1-1 Table 1-1

Change : 05243-6022 to 05245-6022

Page 1-2, Table 1-2

TIME BASE, Output Frequencies:

Change : next to last line from "1000 ohm" to "100 ohm"

Page 3-11d,

PERFORMANCE CHECK TEST CARD, E.3. TIME BASE:

Change : fourth line from "100-ohm" to "1000-ohm"

Change : fifth line from "1000-ohm" to "100-ohm"

Add : at right hand box, TIME BASE OUTPUT JACK (J5), under 1V rms and under 5Vp-p "or greater".

Page 1-3 Table 1-2, Specifications:

Delete : Options 002 and 003 listed under "OPTIONAL AND SPECIAL FEATURES".

The 5245L (SERVICE) is furnished less the RACK MOUNTING KIT described in the manual. If ordered at the same time as the instrument, the RACKING MOUNTING KIT described in the manual is available as Option 908 at additional cost. If not ordered with an instrument, the RACK MOUNTING KIT is available under HP Part No. 05245-6043. Disregard any manual references stating the instrument is supplied with a rack mounting kit.

*The cable part no 10503A is no longer supplied as an accessory. Delete all reference to this in the manual.

- CHANGE 1 Table 4-1
Change : A2306 to part no 1853-0036 XSTR PNP Si
- CHANGE 2 Table 4-1
Change : On Assy A29-A34 5212A-65C
: R41 to part no. 0683-1015 R. FXD 100Ω 5% $\frac{1}{2}$ W
: R38, 44 to part no. 0683-3935 R. Fxd $39K\Omega$ 5% $\frac{1}{2}$ W
Change : A17 R46* to part no. 0683-1825 R. Fxd $1.8K\Omega$ 5% $\frac{1}{2}$ W
A17 R47 to part no 0683-2725 R. Fxd $2.7K\Omega$ 5% $\frac{1}{2}$ W
- CHANGE 3 Table 4-1
Change : A21C13-16 to part no 0160-2210 C Fxd 470pF 300VDC
: A21C4 to part no 0160-0697 C Fxd 0.068 μ F 100VDC
: A7R5, 12, 17 to part no 2100-0554 R Var 500Ω LIN-COM
- CHANGE 4 Table 4-1
Change : A23Q2, 7 to part no 1853-0012
A23CR5 to part no 1901-0701
(note: use 1901-0025 with 1850-0040 or 1901-0701 with
1853-0012 - do not mix)
- CHANGE 5 Page 4-17, Table 4-1
Change : A21L1, L2 to 9100-2265 IND FXD 10uH
: A21L4 to 9100-2255 IND FXD .47uH
Page 4-11, Table 4-1
Change : A17L1, 3, 6, 7 to 9100-2255 IND FXD .47uH
Page 4-27/28, Table 4-1
Change : A29 R4, 10, 15, 21, 27, 33 to part no. 0683-3935 R FXD $39K\Omega$ 5% $\frac{1}{2}$ W
note this applies to A40 - A34
- **CHANGE 6** Page 4-35 Table 4-1
Delete : XF1 part no 1400-0084
Add : XF1 part no 2110-0464 Fuse Holder
XF1 part no 2110-0465 Fuse Holder Cap
1400-0090 Washer Neoprene
2950-0054 Nut Hex $\frac{1}{2}$ -28

END