

Agilent 42942A Terminal Adapter

Operation and Service Manual

Forth Edition

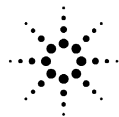

Agilent Technologies

Innovating the HP Way

Agilent Part No. 42942-90020

May 2003

Printed in: Japan

Notices

The information contained in this document is subject to change without notice.

This document contains proprietary information that is protected by copyright. All rights are reserved. No part of this document may be photocopied, reproduced, or translated to another language without the prior written consent of the Agilent Technologies.

Agilent Technologies Japan, Ltd.

Component Test PGU-Kobe

1-3-2, Murotani, Nishi-Ku, Kobe-shi, Hyogo, 651-2241 Japan

© Copyright 1999,2003 Agilent Technologies Japan, Ltd.

Manual Printing History

The manual's printing date and part number indicate its current edition. The printing date changes when a new edition is printed. (Minor corrections and updates that are incorporated at reprint do not cause the date to change.) The manual part number changes when extensive technical changes are incorporated.

April 1999 First Edition (part number: 42942-90000)

September 1999 Second Edition (part number: 42942-90010)

December 1999 Third Edition (part number: 42942-90010)

May 2003 Forth Edition (part number: 42942-90020)

Safety Summary

The following general safety precautions must be observed during all phases of operation, service, and repair of this instrument. Failure to comply with these precautions or with specific WARNINGS elsewhere in this manual may impair the protection provided by the equipment. In addition it violates safety standards of design, manufacture, and intended use of the instrument.

The Agilent Technologies assumes no liability for the customer's failure to comply with these requirements.

NOTE

42942A comply with INSTALLATION CATEGORY I and POLLUTION DEGREE 2 in IEC 1010-1. 42942A are INDOOR USE product.

- DO NOT Operate In An Explosive Atmosphere

Do not operate the instrument in the presence of flammable gasses or fumes. Operation of any electrical instrument in such an environment constitutes a definite safety hazard.

- Keep Away From Live Circuits

Operating personnel must not remove instrument covers. Component replacement and internal adjustments must be made by qualified maintenance personnel. Do not replace components with the power cable connected. Under certain conditions, dangerous voltages may exist even with the power cable removed. To avoid injuries, always disconnect power and discharge circuits before touching them.

- DO NOT Service Or Adjust Alone

Do not attempt internal service or adjustment unless another person, capable of rendering first aid and resuscitation, is present.

- DO NOT Substitute Parts Or Modify Instrument

Because of the danger of introducing additional hazards, do not install substitute parts or perform unauthorized modifications to the instrument. Return the instrument to a Agilent Technologies Sales and Service Office for service and repair to ensure that safety features are maintained.

- Dangerous Procedure Warnings

Warnings, such as the example below, precede potentially dangerous procedures throughout this manual. Instructions contained in the warnings must be followed.

WARNING

Dangerous voltages, capable of causing death, are presenting this instrument. Use extreme caution when handling, testing, and adjusting this instrument.

Certification

Agilent Technologies certifies that this product met its published specifications at the time of shipment from the factory. Agilent Technologies further certifies that its calibration measurements are traceable to the United States National Institute of Standards and Technology, to the extent allowed by the Institution's calibration facility, or to the calibration facilities of other International Standards Organization members.

Warranty

This Agilent Technologies instrument product is warranted against defects in material and workmanship for a period corresponding to the individual warranty periods of its component products. Instruments are warranted for a period of one year. Fixtures and adapters are warranted for a period of 90 days. During the warranty period, Agilent Technologies will, at its option, either repair or replace products that prove to be defective.

For warranty service or repair, this product must be returned to a service facility designated by Agilent Technologies. Buyer shall prepay shipping charges to Agilent Technologies and Agilent Technologies shall pay shipping charges to return the product to Buyer. However, Buyer shall pay all shipping charges, duties, and taxes for products returned to Agilent Technologies from another country.

Agilent Technologies warrants that its software and firmware designated by Agilent Technologies for use with an instrument will execute its programming instruction when properly installed on that instrument. Agilent Technologies does not warrant that the operation of the instrument, or software, or firmware will be uninterrupted or error free.

Limitation Of Warranty

The foregoing warranty shall not apply to defects resulting from improper or inadequate maintenance by Buyer, Buyer-supplied software or interfacing, unauthorized modification or misuse, operation outside the environmental specifications for the product, or improper site preparation or maintenance.

IMPORTANT

No other warranty is expressed or implied. Agilent Technologies specifically disclaims the implied warranties of merchantability and fitness for a particular purpose.

Exclusive Remedies

The remedies provided herein are buyer's sole and exclusive remedies. Agilent Technologies shall not be liable for any direct, indirect, special, incidental, or consequential damages, whether based on contract, tort, or any other legal theory.









Assistance

Product maintenance agreements and other customer assistance agreements are available for Agilent Technologies products.

For any assistance, contact your nearest Agilent Technologies Sales and Service Office. Addresses are provided at the back of this manual.

Safety Symbol

General definitions of safety symbols used on the instrument or in manuals are listed below.

-  Instruction Manual symbol: the product is marked with this symbol when it is necessary for the user to refer to the instrument manual.
-  Alternating current.
-  Direct current.
-  On (Supply).
-  Off (Supply).
-  In position of push-button switch.
-  Out position of push-button switch.
-  Frame (or chassis) terminal. A connection to the frame (chassis) of the equipment which normally include all exposed metal structure.

WARNING

This warning sign denotes a hazard. It calls attention to a procedure, practice, condition or the like, which, if not correctly performed or adhered to, could result in injury or death to personnel.

CAUTION

This Caution sign denotes a hazard. It calls attention to a procedure, practice, condition or the like, which, if not correctly performed or adhered to, could result in damage to or destruction of part or all of the product.

NOTE

Note denotes important information. It calls attention to a procedure, practice, condition or the like, which is essential to highlight.

Contents

1. Installation Guide	
Incoming Inspection	10
Connecting the 42942A	11
Cleaning	12
Serial Number	13
2. Overview	
Product Overview	16
Functions	17
3. Operation	
4294A Setup	20
Adapter Setup	20
Connecting Test Fixture	24
Fixture Compensation	25
Performing Open Compensation	25
Performing Short Compensation	25
Performing Load Compensation	25
Fixture Extension	27
4. Specifications	
Specifications	30
5. Service	
Maintenance	32

1 **Installation Guide**

Incoming Inspection

Inspect the shipping container for damage. If the shipping container or cushioning material is damaged, it should be kept until the contents of the shipment have been checked for completeness and the 42942A has been checked mechanically and electrically. The shipment should contain everything listed in Table 1-1. If the contents are incomplete or if there is mechanical damage or defect, notify the nearest Agilent Technologies office. If the shipping container is damaged or the cushioning material shows signs of unusual stress, notify the carrier as well as the Agilent Technologies office. Keep the shipping materials for the carrier's inspection.

Table 1-1

Contents

Description	Part Number	Qty.
42942A Terminal Adapter	-	1
OPEN ^a	04191-85302	1
SHORT ^a	04191-85300	1
LOAD ^a	04291-60043	1
Operation and Service Manual	42942-90010	1
Carrying Case	42942-60011	1

a. Furnished with Option 700.

Connecting the 42942A

Follow the steps below to connect the 42942A to the 4294A.

- Step 1.** Join the 42942A terminal adapter to the test connectors on the front panel of the 4294A by gently matching the four BNC connectors and fastening screws of the adapter with the test connectors and accessory mounting holes of the instrument until they come into complete contact.
- Step 2.** Turn the adapter's two fastening screws clockwise at the same time until the fixture is firmly secured to the instrument.

Figure 1-1 Connecting 42942A to 4294A

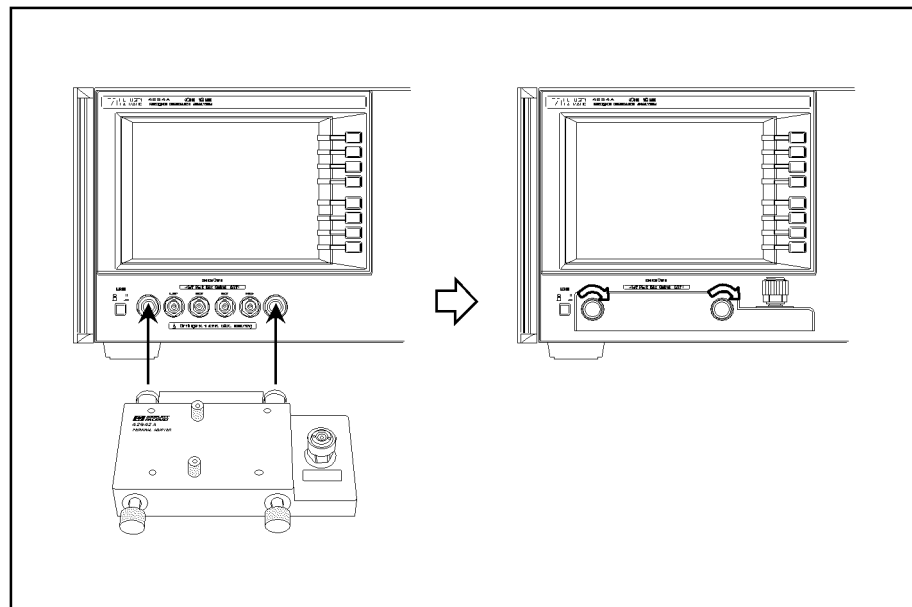

42942aaj0102

Cleaning

Even a tiny amount of dirt on the 7-mm connector of the OUTPUT port would greatly degrade the accuracy of your measurement. Use a lint-free cloth to clean the connector if it gets dirty.

Serial Number

Agilent Technologies uses a two-part, ten-character serial number that is stamped on the serial number plate (Figure 1-2) attached to the bottom of the adapter. The first four letters and one digit are the serial prefix and the last five digits are the suffix.

Figure 1-2

Serial Number Plate



2 **Overview**

Product Overview

The 42942A is an adapter equipped with a 7-mm coaxial connector that connects a test fixture furnished with the same type of connector to the 4294A Precision Impedance Analyzer.

Figure 2-1

Product Overview

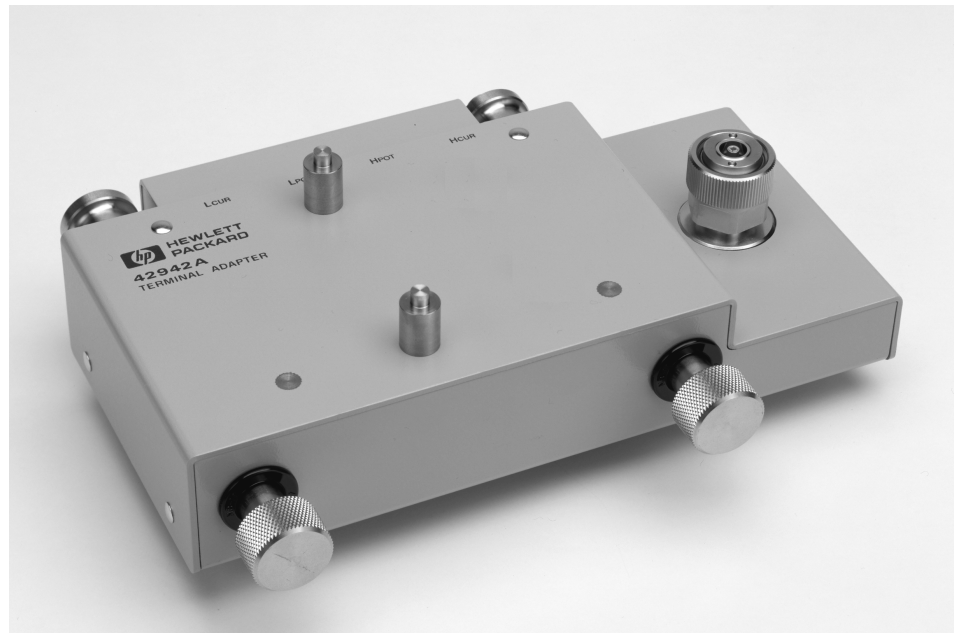

Functions

Figure 2-2 and Figure 2-3 show the names of the 42942A's parts and contents of the option 700, respectively.

Figure 2-2

42942A Parts

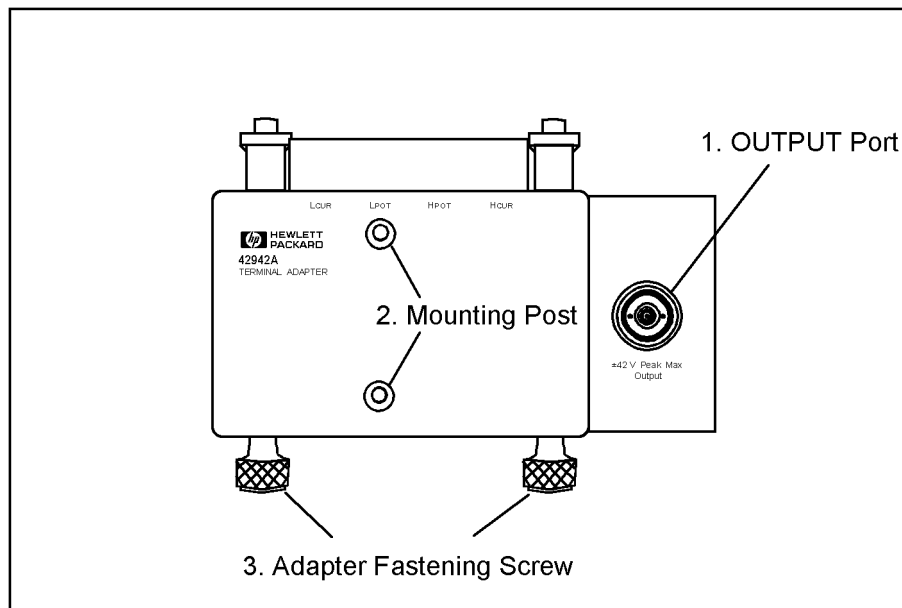

Table 2-1

42942A Function

No.	NAME	FUNCTION
1	OUTPUT Port	Contact for the test fixture furnished with a 7-mm coaxial connector.
2	Mounting Post	Guide and support post for fixture connection.
3	Adapter Fastening Screws	Secures the fixture to the 4294A.

Figure 2-3

Option 700 7-mm Open/Short/Load set

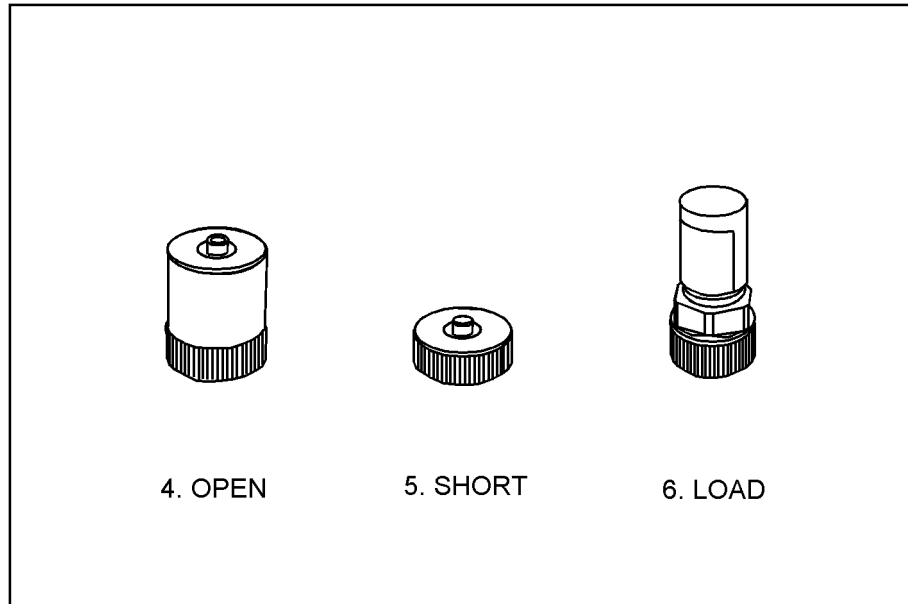

42942aoj0203

Table 2-2

Contents of the option 700

No.	NAME	FUNCTION
4	OPEN	An open device (OPEN, 0S) used for the adapter setup.
5	SHORT	A short device (SHORT, 0 Ω) used for the adapter setup.
6	LOAD	A load device (50 Ω) used for the adapter setup.

3 **Operation**

This chapter describes the proper methods for adapter setup of the 42942A, connecting a fixture, and fixture compensation.

4294A Setup

Before beginning measurements, you should perform the adapter setup. The following procedure shows adapter setup for the 42942A. Also refer to the operation manual of the 4294A for more information on adapter setup.

CAUTION

When handling the 42942A, care must be taken not to give it any mechanical shock, which may damage the adapter. Never give any mechanical shock to the upper face with the 7-mm connector's mouth. Also, do not place the 42942A with the upper face down on a hard surface.

NOTE

If the ambient temperature deviates by more than 5°C from the temperature in which the adapter setup was done, it is recommended that you again perform the adapter setup in the ambient temperature.

Adapter Setup

Connect the 42942A to the 4294A and perform the adapter setup as described below.

1. Power on the 4294A. Allow 30 minutes or longer for warm-up.
2. Press **[Cal]** key to bring up the Calibration Menu.
3. Press **ADAPTER []** key to bring up the Adapter Setup Menu. [] should indicate current settings.
4. Select **7mm 42942A**. When selected, the softkey label will be underlined.
5. Press **SETUP** key to bring up the Adapter Setup Menu.
6. Turn the 7-mm OUTPUT port connector clockwise until the connector sleeve is fully exposed.

NOTE

Even a tiny amount of dirt on the 7-mm OUTPUT port connector would greatly degrade the accuracy of your measurement. Keep the connector clean and never touch the mating plane surfaces. Use a lint-free cloth to clean the connector if it gets dirty.

CAUTION

The 7-mm OUTPUT port connector is sensitive to damage and thus requires careful handling. When not used, protect the mating plane surfaces with end caps.

Figure 3-1 Extending Connector Sleeve

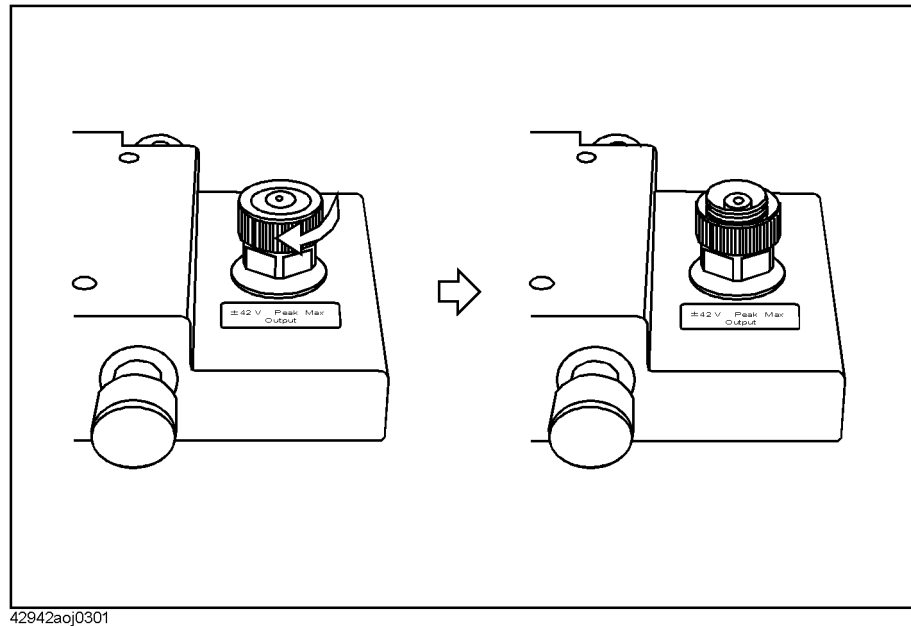

7. Connect the OPEN standard to the 7-mm OUTPUT port connector.

CAUTION

Never store the OPEN standard loosely in a box or drawer because this may result in damage to the mating plane surfaces. Do not drop the OPEN standard or give it any strong mechanical shock.

Figure 3-2 Connecting OPEN Standard

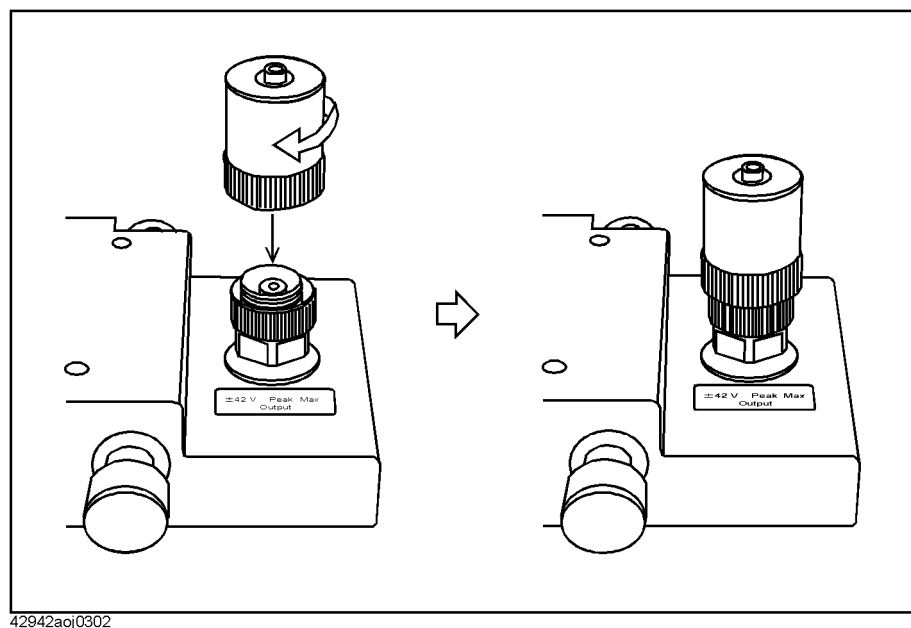

8. Press **PHASE COMP [-]** key to start the phase compensation data measurement. When the phase compensation data measurement is completed, the softkey label

Operation
4294A Setup

changes to **PHASE COMP [DONE]**.

9. Press **OPEN [-]** key to start the open data measurement. When the open data measurement is completed, the softkey label changes to **OPEN [DONE]**.
10. Remove the OPEN standard and connect the SHORT standard to the 7-mm OUTPUT port connector.

CAUTION

Never store the SHORT standard loosely in a box or drawer because this may result in damage to the mating plane surfaces. Do not drop the SHORT standard or give it any strong mechanical shock.

Figure 3-3 Connecting SHORT Standard

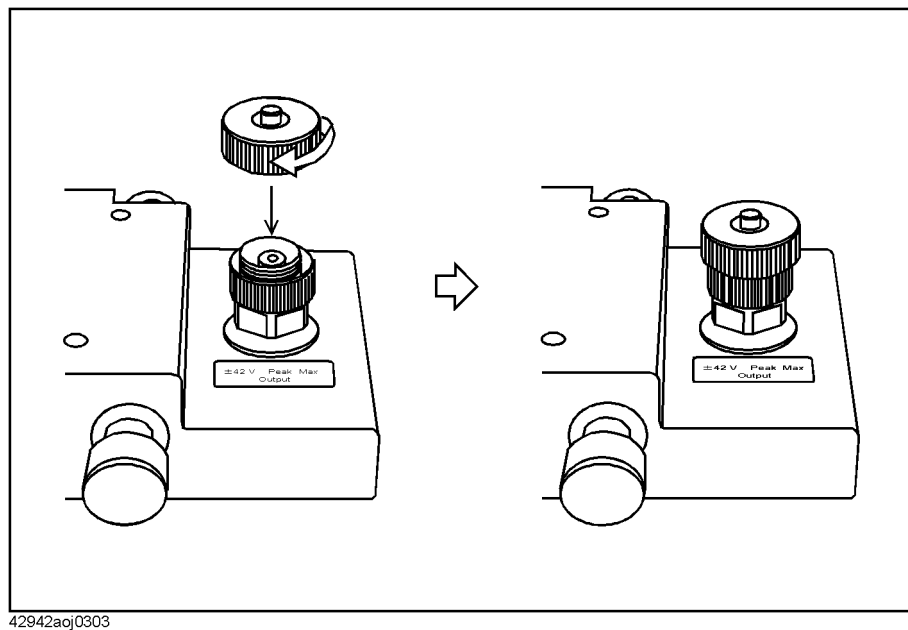

11. Press **SHORT [-]** key to start the short data measurement. When the short data measurement is completed, the softkey label changes to **SHORT [DONE]**.
12. Remove the SHORT standard from the 7-mm OUTPUT port connector of the 42942A. Then connect the LOAD standard to the 7-mm port.

CAUTION

Never store the LOAD standard loosely in a box or drawer because this may result in damage to the mating plane surfaces. Do not drop the LOAD standard or give it any strong mechanical shock. When not used, protect the mating plane surfaces with end caps.

Figure 3-4 Connecting LOAD Standard

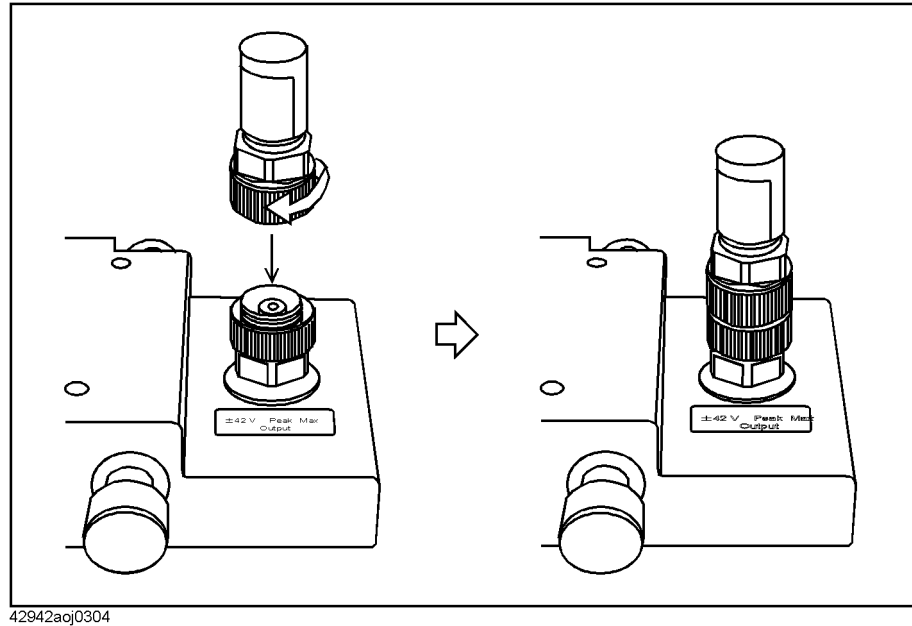

13. Press **LOAD [-]** key to start the load data measurement. When the load data measurement is completed, the softkey label changes to **LOAD [DONE]**.
14. Press **done** key.

Connecting Test Fixture

After the adapter setup, you can connect the test fixture to the terminal adapter. Refer to the manual that came with the fixture for the connection procedure. The connection procedure shown below is common to most fixtures.

1. Turn the 7-mm OUTPUT port connector on the terminal adapter counterclockwise until the connector sleeve is fully retracted.
2. Join the test fixture to the terminal adapter by keying the mounting posts and the OUTPUT port of the adapter.
3. Turn the 7-mm OUTPUT port connector on the terminal adapter counterclockwise to secure it to the connector on the lower side of the test fixture.

Figure 3-5 Connecting Test Fixture

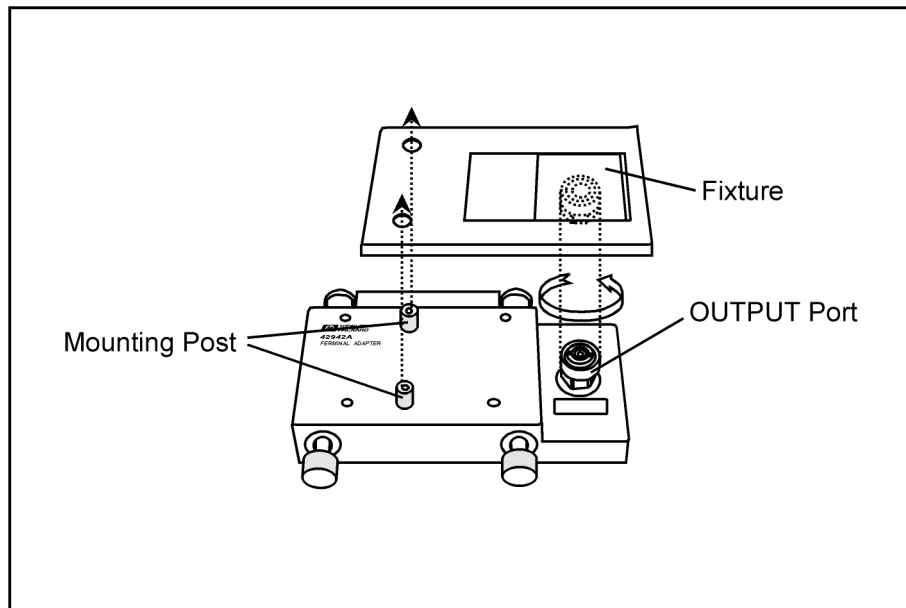

42942a0e0305

Fixture Compensation

To compensate for any residual impedance and admittance existing in the test fixture, perform fixture compensation. The fixture compensation requires measurements with the 42942A for open and short compensation data. Generally, there is no need to perform load compensation. For more information on fixture compensation, refer to the 4294A Operation Manual.

NOTE

Electrical length is noted on the test fixture and its furnished manual. There is no need to set the electrical length in the 4294A when using the 42942A. Only OPEN/SHORT compensation will eliminate the error.

Performing Open Compensation

The following procedure is for measurement of the open compensation data.

1. Be sure that the fixture is open, without any connection between the measurement terminals.
2. Press **[Cal]** key to bring up the Calibration Menu.
3. Press **FIXTURE COMPEN** key to bring up the Fixture Compensation Menu.
4. Press **OPEN** key to start the OPEN compensation data measurement. When the OPEN compensation data measurement is completed, the softkey label **OPEN on OFF** (if it is off) changes to **OPEN ON off**.

Performing Short Compensation

The following procedure is for measurement of the short compensation data.

1. Put the terminal of the test fixture into the SHORT state. For more information on shorting methods, refer to the manual that came with the fixture.
2. Press **SHORT** key to start the SHORT compensation data measurement. When the SHORT compensation data measurement is completed, the softkey label **SHORT on OFF** (if it is off) changes to **SHORT ON off**.

Performing Load Compensation

Generally, there is no need to perform load compensation. If you have any standard device or you need to keep consistency in measured data, perform the load compensation by using the device. When you perform load compensation, set the load value of the device to the instrument.

The following procedure is for the measurement of the load compensation data.

1. Connect the load device to the terminal of the test fixture. For more information on connecting methods, refer to the manual that came with the fixture.
2. Press **LOAD** key to start the LOAD compensation data measurement. When the LOAD

Operation
Fixture Compensation

compensation data measurement is completed, the softkey label **LOAD on OFF** (if it is off) changes to **LOAD ON off**.

Fixture Extension

The 42942A is designed to connect directly to the 4294A. Thus, the measurement point on the four-terminal pair cannot be extended by using four extension cables as shown in Figure 3-6 (A). The 42942A must be directly connected to the 4294A as shown in Figure 3-6 (B). For fixture extension, use a coaxial cable connected to the 7-mm OUTPUT port on the 42942A. Note that the 42942A's specified accuracy will no longer be assured with this extension. For calibration of the extended fixture, refer to the 4294A operation manual.

Figure 3-6 **Fixture Extension**

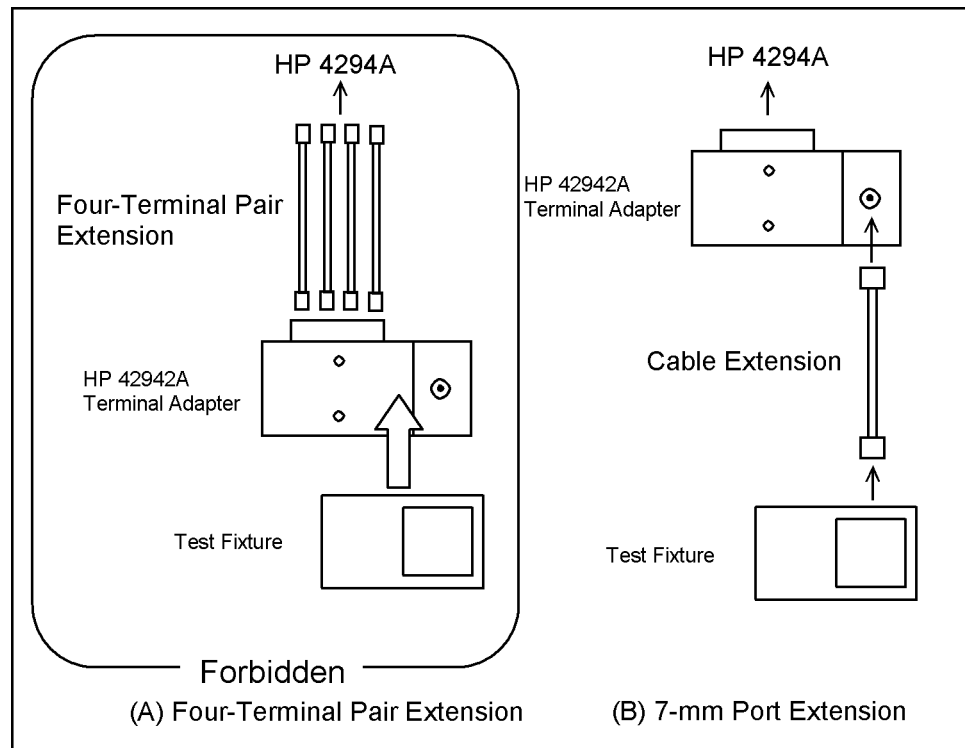

42942aoe0306

Operation
Fixture Extension

4 Specifications

This chapter provides specifications of the 42942A test fixture.

Specifications

Applicable Instruments		4294A Precision Impedance Analyzer
Frequency		40 Hz to 110 MHz
Maximum Voltage		± 42 V peak max. (AC+DC)
Operating Environment	temp.	0°C to +40°C
	humidity	15% to 95%RH (@ wet bulb temp. < 40°C)
Non-operating Environment	temp.	-40°C to +70°C
	humidity	≤ 90 % RH (@ wet bulb temp. <65°C)
Dimensions		300 (W) × 100 (H) × 280 (D) mm (Includes carrying case)
Weight		2300g (42942A body 800g)
Safety Standards		EN61010-1:1993 +A2:1995 IEC61010-1:1990 +A1:1992 +A2:1995 CSA C22.2 No.1010.1:1992 INSTALLATION CATEGORY I POLLUTION DEGREE 2 INDOOR USE

For more information on impedance measurement accuracy at the 3.5-mm port and additional error factor, refer to the 4294A Operation Manual.

Maintenance

An exploded view of the 42942A for parts identification is shown in Figure 5-1 and Figure 5-2. Do not disassemble any further than shown. Maintenance consists principally of cleaning contacts and replacing worn or damaged parts. Take special care when cleaning contacts.

To order parts, use the Agilent Technologies part numbers listed in Table 5-1 and Table 5-2. If a faulty part is located in an assembly that cannot be disassembled, order the next higher assembly or return the fixture to the nearest Agilent Technologies Sales/Service Office for repair or replacement.

Figure 5-1 Replaceable Parts (part 1 of 2)

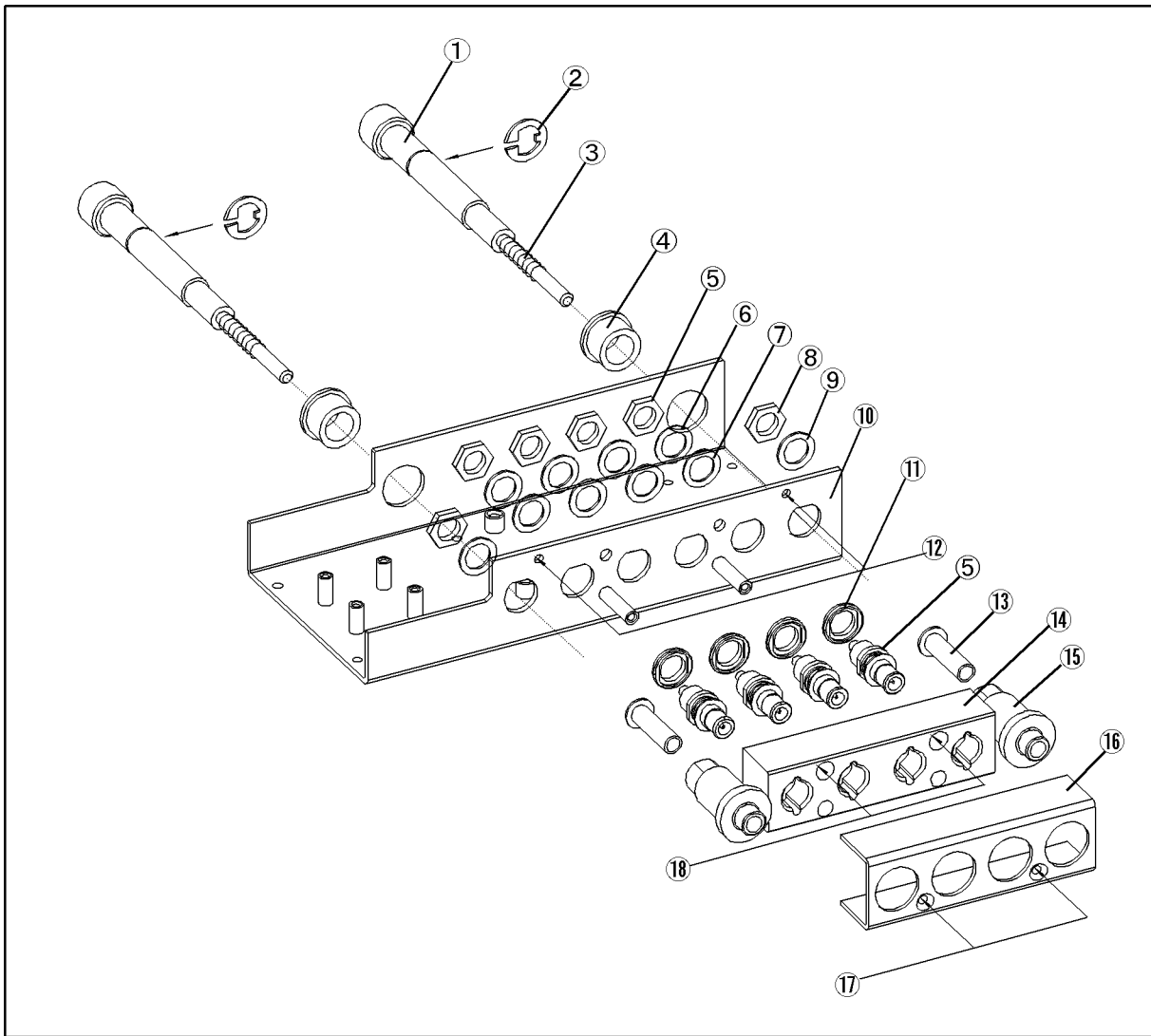

Table 5-1 **Replaceable Parts (part 1 of 2)**

Reference Designator	Part No.	Qty.	Description
1	42942-24007	2	SHAFT
2	0510-0083	2	RTNR-R
3	1460-2615	2	SPRING
4	42941-40002	2	BUSHING
5	1253-0476	4	ADPT BNC-SMB
6	3050-0067	4	WSHR-FL MTLC
7	3050-0789	4	WSHR-FL NM
8	2950-0054	2	TNUT-HEX-DBL-CHAM
9	2190-0054	2	WSHR-LK INTL
10	42942-00602	1	COVER BOTTOM
11	16047-40002	4	INSULATOR
12	0515-0914	2	SCR-MACH M3X0.5
13	42941-25002	2	SLEEVE
14	42942-25006	1	BNC-GUIDE
15	42941-24003	2	GUIDE
16	42942-00603	1	COVER
17	0515-0914	2	SCR-MACH M3X0.5
18	0515-1551	2	SCR M3-L 10 P-H

Figure 5-2 Replaceable Parts (part 2 of 2)

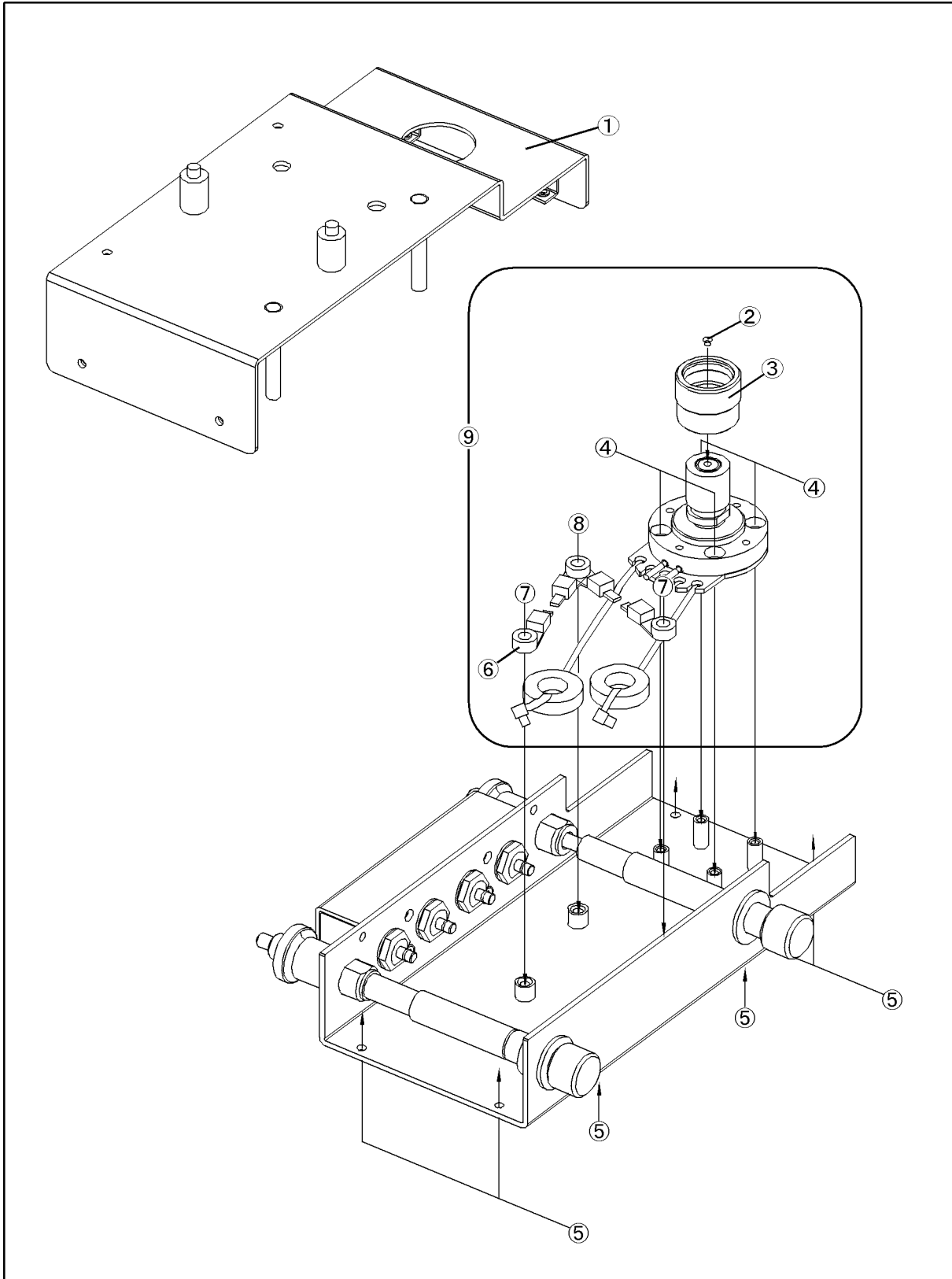

Table 5-2 **Replaceable Parts (part 2 of 2)**

Reference Designator	Part No.	Qty.	Description
1	42942-00601	1	COVER TOP
2	1250-0907	1	CONTACT CENTER
3	1250-1466	1	CONN-RF 7mm
4	0515-1550	4	SCR M3-L 8 P-H
5	0515-0914	6	SCR-MACH M3X0.5
6	1400-0719	4	CABLE TIE
7	0515-1719	2	SCR M4X10
	3050-0893	2	WSHR-FL
8	0515-1718	1	SCR M4X12
	3050-0893	1	WSHR-FL
9	42942-60001	1	7mm ASSY (exclude 4.6.7.8)

REGIONAL SALES AND SUPPORT OFFICES

For more information about Agilent Technologies test and measurement products, applications, services, and for a current sales office listing, visit our web site: <http://www.agilent.com/find/tmdir>. You can also contact one of the following centers and ask for a test and measurement sales representative. 11/29/99

United States:

Agilent Technologies
Test and Measurement Call Center
P.O.Box 4026
Englewood, CO 80155-4026
(tel) 1 800 452 4844

(fax) (61 3) 9272 0749
(tel) 0 800 738 378 (New Zealand)
(fax) (64 4) 802 6881

Canada:

Agilent Technologies Canada Inc.
5150 Spectrum Way
Mississauga, Ontario
L4W 5G1
(tel) 1 877 894 4414

Asia Pacific:

Agilent Technologies
24/F, Cityplaza One, 1111 King's Road,
Taikoo Shing, Hong Kong
(tel) (852)-3197-7777
(fax) (852)-2506-9284

Europe:

Agilent Technologies
Test & Measurement
European Marketing Organization
P.O.Box 999
1180 AZ Amstelveen
The Netherlands
(tel) (31 20) 547 9999

Japan:

Agilent Technologies Japan Ltd.
Call Center
9-1, Takakura-Cho, Hachioji-Shi,
Tokyo 192-8510, Japan
(tel) (81) 426 56 7832
(fax) (81) 426 56 7840

Latin America:

Agilent Technologies
Latin American Region Headquarters
5200 Blue Lagoon Drive, Suite #950
Miami, Florida 33126
U.S.A.
(tel) (305) 267 4245
(fax) (305) 267 4286

Australia/New Zealand:

Agilent Technologies Australia Pty Ltd
347 Burwood Highway
Forest Hill, Victoria 3131
(tel) 1-800 629 485 (Australia)

