

Agilent 42941A Impedance Probe Kit

Operation and Service Manual

Third Edition

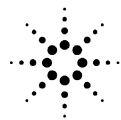

Agilent Technologies

Innovating the HP Way

Agilent Part No. 42941-90010

December 1999

Printed in: Japan

Notices

The information contained in this document is subject to change without notice.

This document contains proprietary information that is protected by copyright. All rights are reserved. No part of this document may be photocopied, reproduced, or translated to another language without the prior written consent of the Agilent Technologies.

Agilent Technologies Japan, Ltd.

Component Test PGU-Kobe

1-3-2, Murotani, Nishi-Ku, Kobe-shi, Hyogo, 651-2241 Japan

© Copyright 1999 Agilent Technologies Japan, Ltd.

Manual Printing History

The manual's printing date and part number indicate its current edition. The printing date changes when a new edition is printed. (Minor corrections and updates that are incorporated at reprint do not cause the date to change.) The manual part number changes when extensive technical changes are incorporated.

April 1999 First Edition (part number: 42941-90000)

September 1999 Second Edition (part number: 42941-90010)

December 1999 Third Edition (part number: 42941-90010)

Safety Summary

The following general safety precautions must be observed during all phases of operation, service, and repair of this instrument. Failure to comply with these precautions or with specific WARNINGS elsewhere in this manual may impair the protection provided by the equipment. In addition it violates safety standards of design, manufacture, and intended use of the instrument.

The Agilent Technologies assumes no liability for the customer's failure to comply with these requirements.

NOTE

42941A comply with INSTALLATION CATEGORY I and POLLUTION DEGREE 2 in IEC 1010-1. 42941A are INDOOR USE product.

- **DO NOT Operate In An Explosive Atmosphere**

Do not operate the instrument in the presence of flammable gasses or fumes. Operation of any electrical instrument in such an environment constitutes a definite safety hazard.

- **Keep Away From Live Circuits**

Operating personnel must not remove instrument covers. Component replacement and internal adjustments must be made by qualified maintenance personnel. Do not replace components with the power cable connected. Under certain conditions, dangerous voltages may exist even with the power cable removed. To avoid injuries, always disconnect power and discharge circuits before touching them.

- **DO NOT Service Or Adjust Alone**

Do not attempt internal service or adjustment unless another person, capable of rendering first aid and resuscitation, is present.

- **DO NOT Substitute Parts Or Modify Instrument**

Because of the danger of introducing additional hazards, do not install substitute parts or perform unauthorized modifications to the instrument. Return the instrument to a Agilent Technologies Sales and Service Office for service and repair to ensure that safety features are maintained.

- **Dangerous Procedure Warnings**

Warnings, such as the example below, precede potentially dangerous procedures throughout this manual. Instructions contained in the warnings must be followed.

WARNING

Dangerous voltages, capable of causing death, are presenting this instrument. Use extreme caution when handling, testing, and adjusting this instrument.

Certification

Agilent Technologies certifies that this product met its published specifications at the time of shipment from the factory. Agilent Technologies further certifies that its calibration measurements are traceable to the United States National Institute of Standards and Technology, to the extent allowed by the Institution's calibration facility, or to the calibration facilities of other International Standards Organization members.

Warranty

This Agilent Technologies instrument product is warranted against defects in material and workmanship for a period corresponding to the individual warranty periods of its component products. Instruments are warranted for a period of one year. Fixtures and adapters are warranted for a period of 90 days. During the warranty period, Agilent Technologies will, at its option, either repair or replace products that prove to be defective.

For warranty service or repair, this product must be returned to a service facility designated by Agilent Technologies. Buyer shall prepay shipping charges to Agilent Technologies and Agilent Technologies shall pay shipping charges to return the product to Buyer. However, Buyer shall pay all shipping charges, duties, and taxes for products returned to Agilent Technologies from another country.

Agilent Technologies warrants that its software and firmware designated by Agilent Technologies for use with an instrument will execute its programming instruction when properly installed on that instrument. Agilent Technologies does not warrant that the operation of the instrument, or software, or firmware will be uninterrupted or error free.

Limitation Of Warranty

The foregoing warranty shall not apply to defects resulting from improper or inadequate maintenance by Buyer, Buyer-supplied software or interfacing, unauthorized modification or misuse, operation outside the environmental specifications for the product, or improper site preparation or maintenance.

IMPORTANT

No other warranty is expressed or implied. Agilent Technologies specifically disclaims the implied warranties of merchantability and fitness for a particular purpose.

Exclusive Remedies

The remedies provided herein are buyer's sole and exclusive remedies. Agilent Technologies shall not be liable for any direct, indirect, special, incidental, or consequential damages, whether based on contract, tort, or any other legal theory.









Assistance

Product maintenance agreements and other customer assistance agreements are available for Agilent Technologies products.

For any assistance, contact your nearest Agilent Technologies Sales and Service Office. Addresses are provided at the back of this manual.

Safety Symbol

General definitions of safety symbols used on the instrument or in manuals are listed below.

-  Instruction Manual symbol: the product is marked with this symbol when it is necessary for the user to refer to the instrument manual.
-  Alternating current.
-  Direct current.
-  On (Supply).
-  Off (Supply).
-  In position of push-button switch.
-  Out position of push-button switch.
-  Frame (or chassis) terminal. A connection to the frame (chassis) of the equipment which normally include all exposed metal structure.

WARNING This warning sign denotes a hazard. It calls attention to a procedure, practice, condition or the like, which, if not correctly performed or adhered to, could result in injury or death to personnel.

CAUTION This Caution sign denotes a hazard. It calls attention to a procedure, practice, condition or the like, which, if not correctly performed or adhered to, could result in damage to or destruction of part or all of the product.

NOTE Note denotes important information. It calls attention to a procedure, practice, condition or the like, which is essential to highlight.

Contents

1. Installation Guide	
Incoming Inspection	10
Connecting the 42941A	11
Serial Number	12
2. Overview	
Product Overview	14
Functions	15
3. Operation	
4294A Setup	18
Adapter Setup	18
Connecting Probe Adapter	19
Connecting Pin Probe	19
Connecting Ground Lead	20
Connecting BNC Adapter	21
Fixture Compensation	22
Performing Fixture Compensation	22
DUT Measurement	24
DUT Measurement Using Pin Probe	24
DUT Measurement Using BNC Adapter	26
4. Specifications	
Specifications	28
5. Service	
Maintenance	30

1 Installation Guide

Incoming Inspection

Inspect the shipping container for damage. If the shipping container or cushioning material is damaged, it should be kept until the contents of the shipment have been checked for completeness and the 42941A has been checked mechanically and electrically. The shipment should contain everything listed in Table 1-1. If the contents are incomplete or if there is mechanical damage or defect, notify the nearest Agilent Technologies office. If the shipping container is damaged or the cushioning material shows signs of unusual stress, notify the carrier as well as the Agilent Technologies office. Keep the shipping materials for the carrier's inspection.

Table 1-1

Contents

Description	Agilent Part Number	Qty.
Probe and Four-terminal Pair Connection Block	-	1
Pin Probe	42941-60002	1
Spare Pin Set (includes 3 spare pins)	42941-60004	1
3.5-mm Short ^a	1250-2840	1
3.5-mm Load ^a	0955-1105	1
Operation and Service Manual	42941-90010	1
BNC Adapter	1250-1787	1
Clip Lead	8121-0003	1
Ground Lead	04193-61629	1
Carrying Case	42941-60011	1

a. Not furnished with Option 001.

Connecting the 42941A

Follow the steps below to connect the 42941A to the 4294A.

- Step 1.** Join the 42941A four-terminal pair connection block to the test connectors on the front panel of the 4294A by gently matching the four BNC connectors and securing screws of the block with the test connectors and accessory mounting holes of the instrument until they come into complete contact.
- Step 2.** Turn the block's two fastening screws clockwise at the same time until the four-terminal pair connection block is secured firmly to the instrument.

Figure 1-1 Connecting 42941A to 4294A

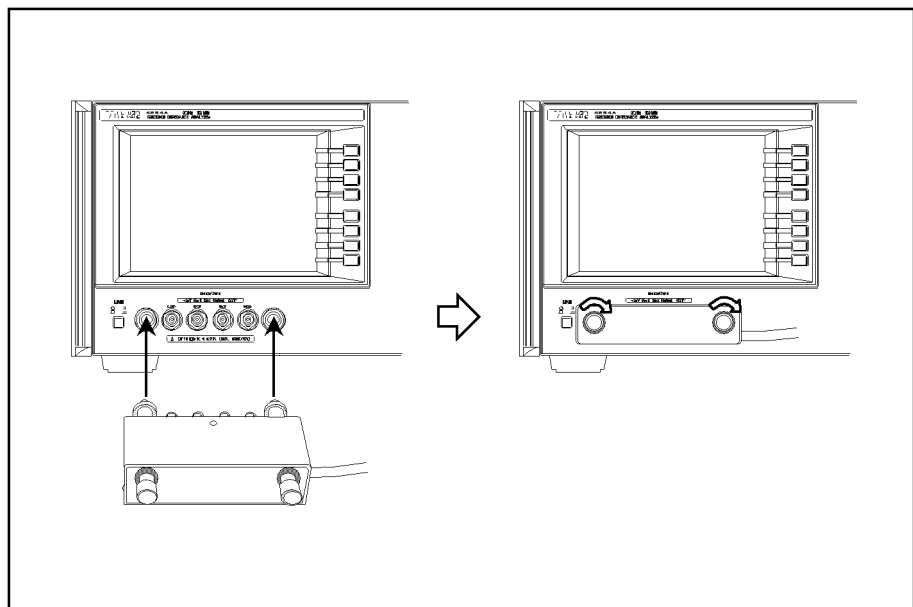

42941aj0101

Serial Number

Agilent Technologies uses a two-part, ten-character serial number that is stamped on the serial number plate (Figure 1-2) attached to the bottom of the four-terminal pair connection block. The first four letters and one digit are the serial prefix and the last five digits are the suffix.

Figure 1-2

Serial Number Plate



2 **Overview**

Product Overview

The 42941A is the impedance probe kit designed for the 4294A Precision Impedance Analyzer. When used with the 4294A, this kit allows impedance measurement and analysis in a wide frequency range of up to 110 MHz. Its 1.5-meter cable for probing allows you to evaluate implemented circuits and mounted devices.

Figure 2-1

Product Overview



Functions

Figure 2-2 and Figure 2-3 show the names of the 42941A's parts and probe adapters, respectively.

Figure 2-2 42941A Parts

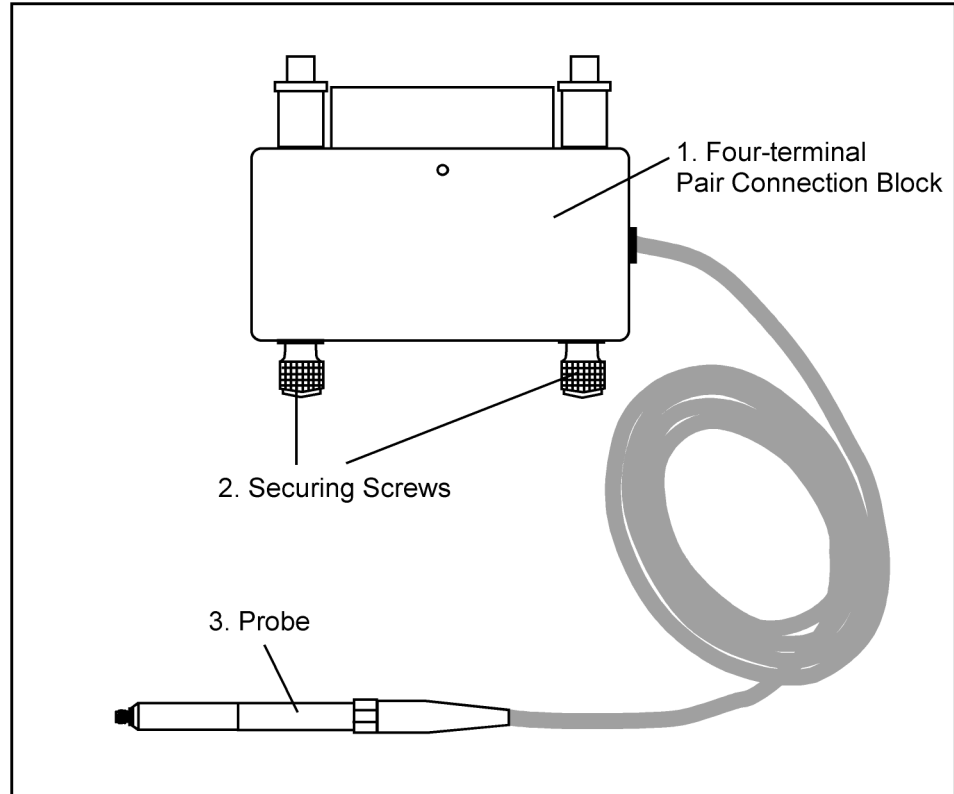

42941aoe0202

Table 2-1 42941A Function

No.	NAME	FUNCTION
1	Four-terminal Pair Connection Block	Connects the 42941A to the 4294A
2	Securing Screws	Secures the 42941A to the 4294A.
3	Probe	Attaches to various probe adapters for measurement.

Figure 2-3 **Probe Adapters**

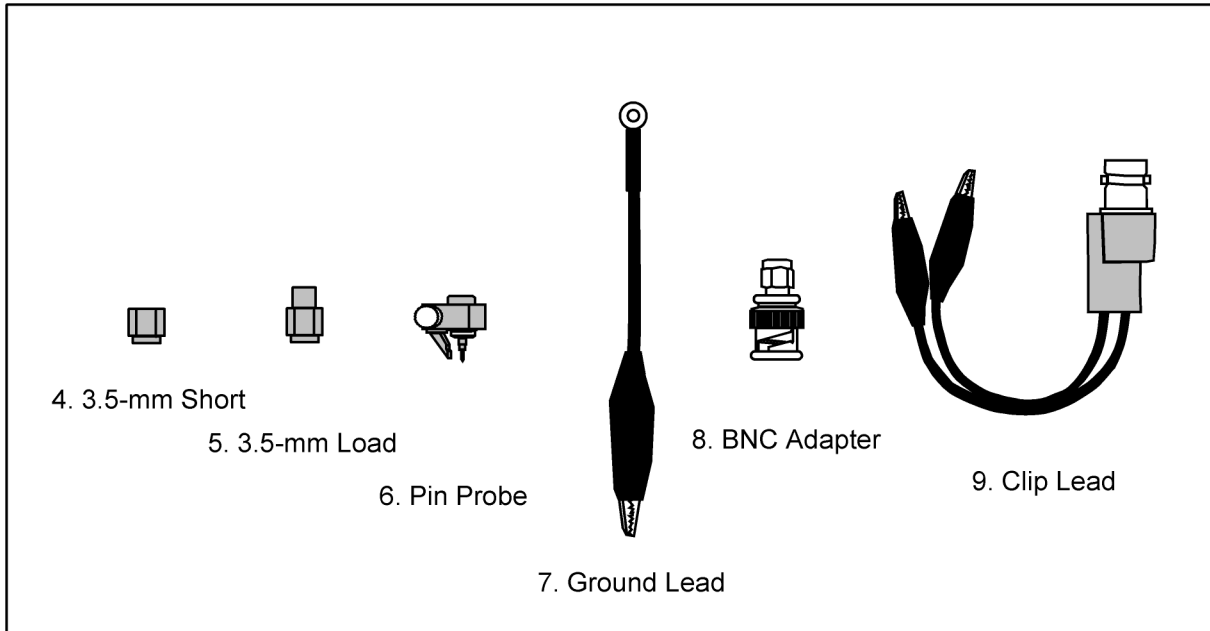

42941a0e0203

Table 2-2 **Probe Adapters**

No.	NAME	FUNCTION
4	3.5-mm Short	A short device used for the adapter setup.
5	3.5-mm Load	A load device (50 Ω) used for the adapter setup.
6	Pin Probe	Attached to the probe to measure implemented circuits, mounted devices, and printed circuit patterns.
7	Ground Lead	Attached to the pin probe to connect to the GND of the DUT.
8	BNC Adapter	Attached to the probe to measure devices and cables that have BNC connectors.
9	Clip Lead	Attached to the top of the BNC adapter by the probe to measure mounted lead components or large devices.

3 **Operation**

This chapter describes the proper methods for setting up the 4294A, connecting the probe adapter, fixture compensation with the 42941A, and DUT measurement.

4294A Setup

Before beginning measurements, you should perform the adapter setup to extend the calibration plane from the surface of the four-pair terminal to the tip of the probe. Also refer to the operation manual of the 4294A for more information on the adapter setting.

NOTE

For adapter setup, use the furnished short and load devices.

CAUTION

When handling the 42941A, care must be taken not to give it any mechanical shock, which may cause damage to the fixture. Never give any mechanical shock to the probe.

Adapter Setup

Connect the 42941A to the 4294A as shown in Figure 1-1 and perform the adapter setup described below.

1. More than 30 minutes warm-up time is required after turning on the 4294A.
2. Press **[Cal]** key to bring up the Calibration Menu.
3. Press **ADAPTER []** key to bring up the Adapter Setup Menu. [] should indicate current settings.
4. Select **PROBE 42941A**. When selected, the softkey label will be underlined.
5. Press **SETUP** key to bring up the Adapter Setup Menu.
6. Leave the 3.5-mm port of the 42941A open (no connection). There is no OPEN standard for the 42941A.
7. Press **PHASE COMP [-]** key to start the phase compensation data measurement. About 1 minute later, phase compensation data measurement is completed and the softkey label changes to **PHASE COMP [DONE]**.
8. With nothing connected to the 3.5-mm port, press **OPEN [-]** key to start open data measurement. When the open data measurement is completed, the softkey label changes to **OPEN [DONE]**.
9. Connect the SHORT to the 3.5-mm port.
10. Press **SHORT [-]** key to start the short data measurement. When the short data measurement is completed, the softkey label changes to **SHORT [DONE]**.
11. Remove the SHORT from the 3.5-mm port of the 42941A. Then connect the LOAD to the 3.5-mm port.
12. Press **LOAD [-]** key to start the load data measurement. When the load data measurement is completed, the softkey label changes to **LOAD [DONE]**.
13. Press **done** key.

Connecting Probe Adapter

Probe adapters are furnished with the 42941A to measure DUTs of various shapes and characteristics. Attach the appropriate probe adapter for your DUT.

Connecting Pin Probe

Attach the pin probe to the 3.5-mm connector top of the probe and insert the pin.

WARNING

The pin is sharp and potentially hazardous to personnel. When using or changing, handle the pin probe with care to prevent injury.

Figure 3-1

Connecting Pin Probe

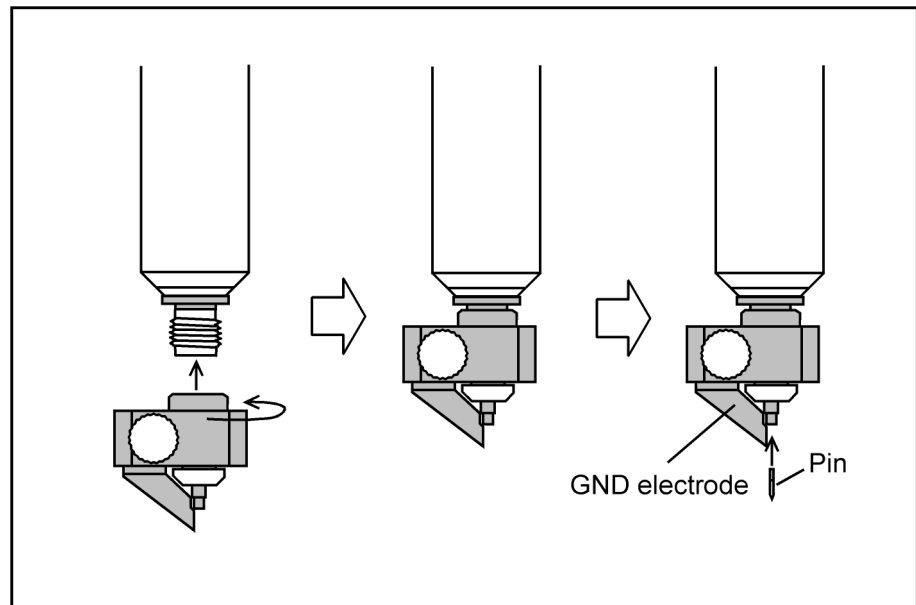

42941ace0301

Connecting Ground Lead

Remove the screw fixing the ground contact to detach the contact. Use the removed screw to attach the ground lead to the pin probe.

Figure 3-2

Connecting Ground Lead

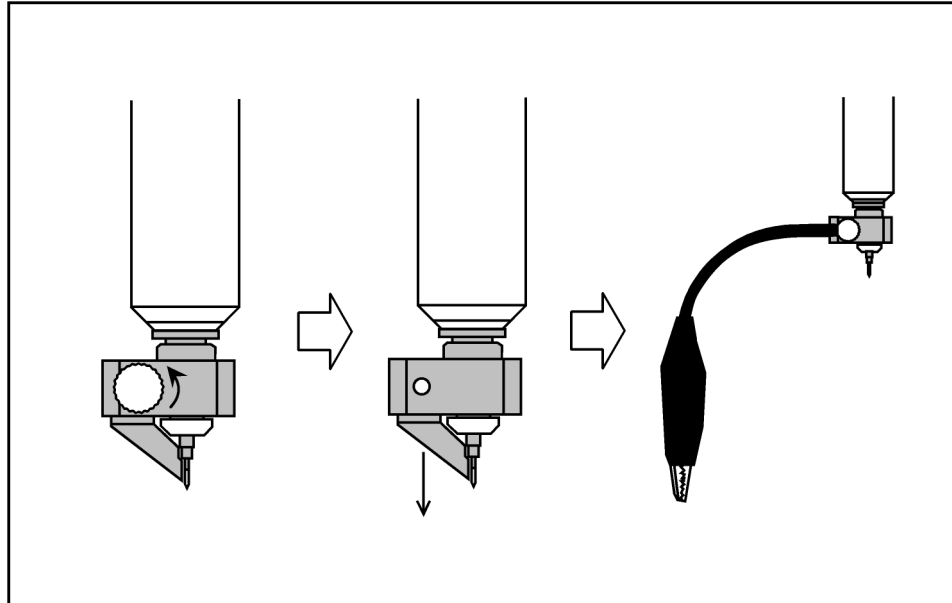

42941a0e0302

Connecting BNC Adapter

Attach the BNC adapter to the 3.5-mm connector on top of the probe.

Figure 3-3

Connecting BNC Adapter

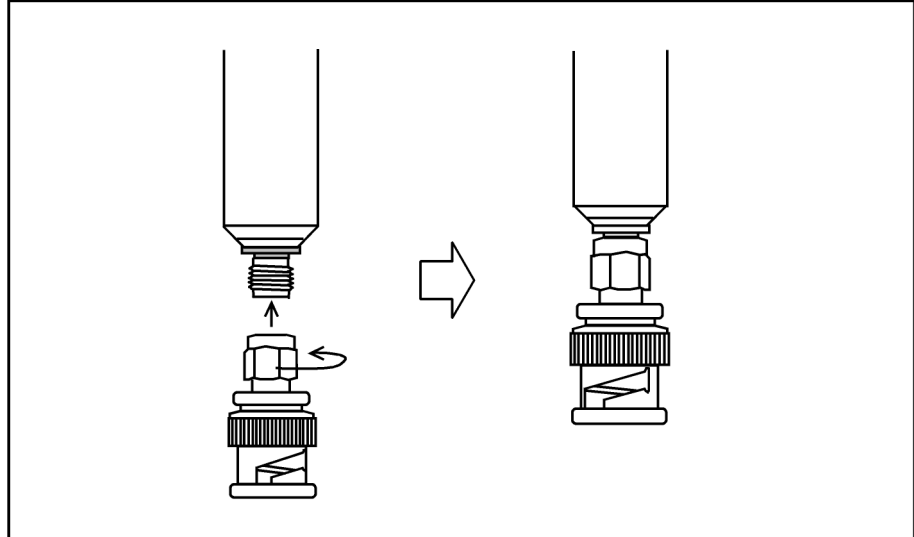

42941aee0303

Connecting Clip Lead

Attach the BNC adapter to the probe and then attach the clip lead to the adapter.

Figure 3-4

Connecting Clip Lead

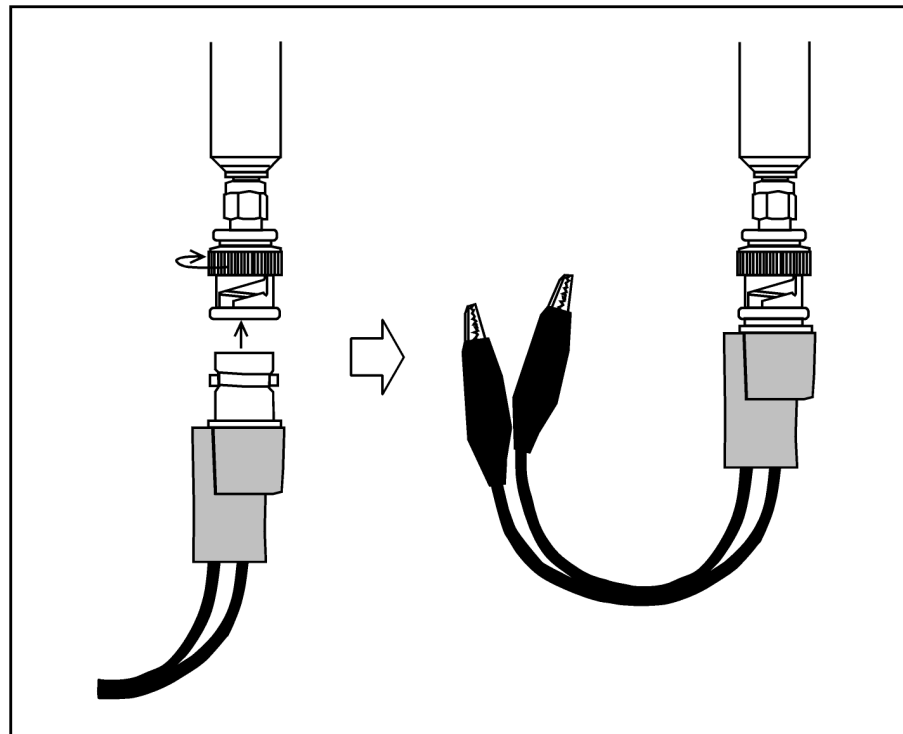

42941aee0304

Fixture Compensation

In an actual measurement, a probe adapter is attached to the probe. Fixture compensation is required for compensating residual impedance and admittance. The fixture compensation includes OPEN and SHORT compensation measurements. For more information on fixture compensation, also refer to the 4294A Operation Manual.

NOTE

Generally, there is no need to perform load compensation. However, if you have a suitable standard device and require extremely accurate measurement, perform load compensation as needed.

The following procedure is for measurement of the compensation data with the 42941A.

Performing Fixture Compensation

Attach the probe adapter to be used for your measurement and perform fixture compensation.

1. Press **[Cal]** key to bring up the Calibration Menu.
2. Press **FIXTURE COMPEN** key to bring up the Fixture Compensation Menu.

Performing Open Compensation

1. Attach the probe adapter to the probe but leave it disconnected from a device.

Figure 3-5 Performing Open Compensation

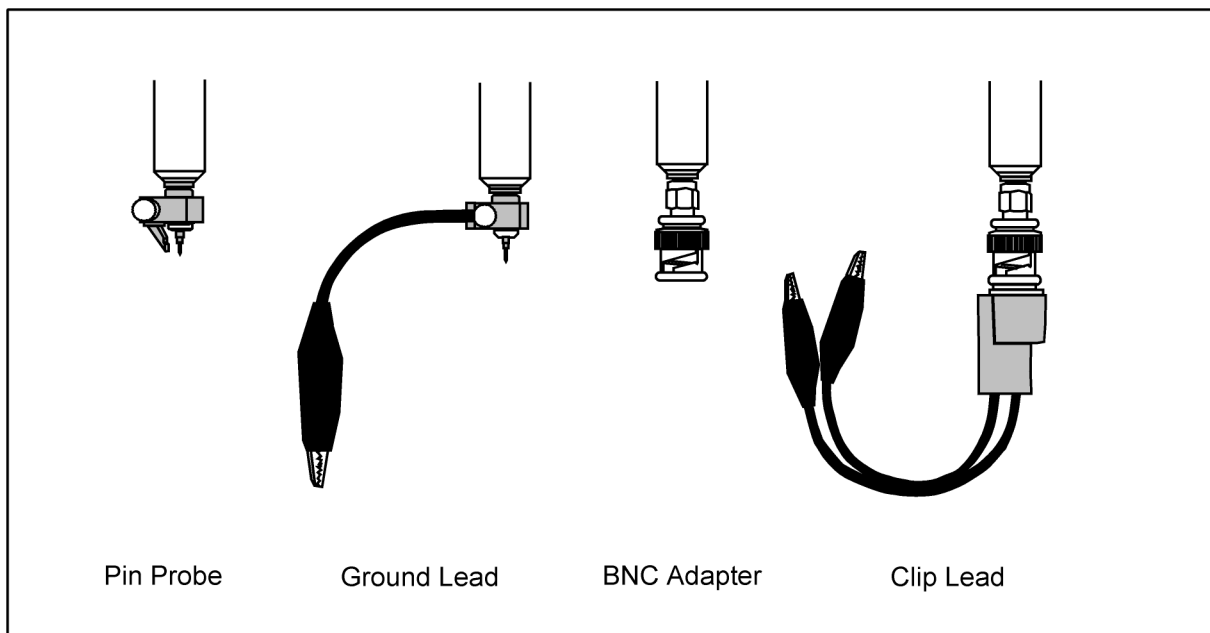

42941a0e0305

2. Press **OPEN** key to start the OPEN compensation data measurement. When the OPEN compensation data measurement is completed, the softkey label **OPEN on OFF** (if it is off) changes to **OPEN ON off**.

Performing Short Compensation

1. Put the probe adapter into the SHORTed state as shown in Figure 3-6. Use an appropriate device for shorting since no short device is supplied with the BNC adapter.

NOTE

For short compensation, we recommend using a short device with gold-plated surfaces, which provide stable contact resistance.

Figure 3-6 Performing Short Compensation

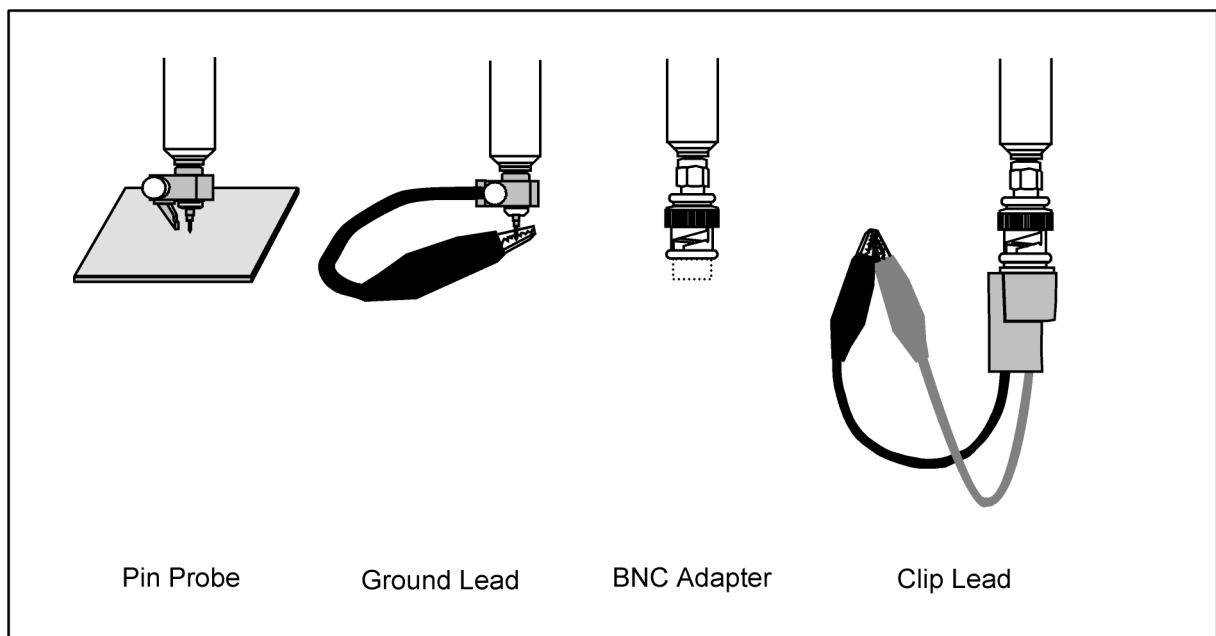

42941a0e0306

2. Press **SHORT** key to start the SHORT compensation data measurement. When the SHORT compensation data measurement is completed, the softkey label **SHORT on OFF** (if it is off) changes to **SHORT ON off**.

DUT Measurement

Before performing DUT measurement, open and short compensation should be done as described in the previous sections.

DUT Measurement Using Pin Probe

When measuring implemented circuits, mounted devices, and printed circuit patterns, use the pin probe.

Figure 3-7 DUT Measurement Using Pin Probe

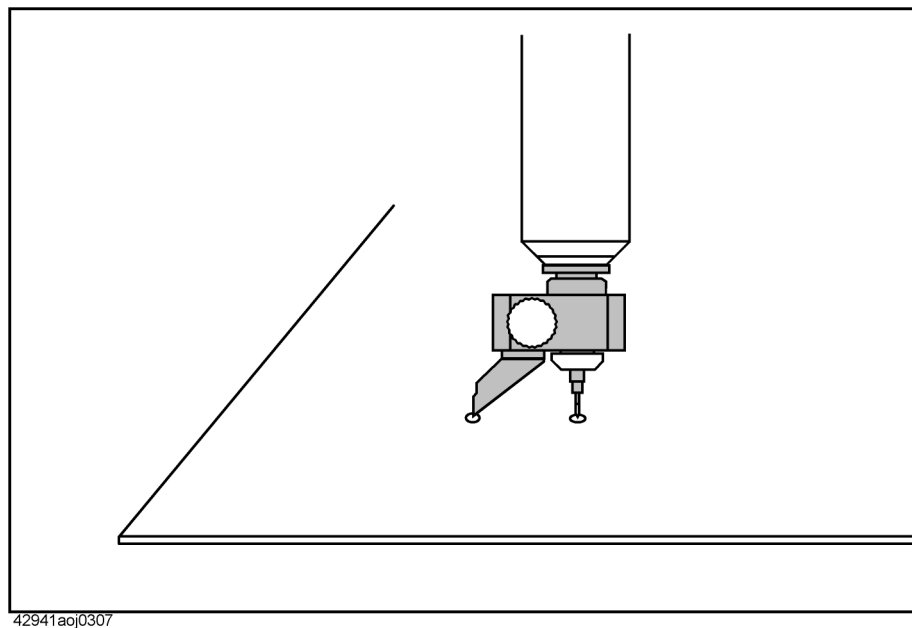

NOTE The pin of the pin probe is replaceable. Replace it when damaged or dirty.

Adjusting Pin-to-GND Gap

The gap between the pin and the GND contact is adjustable for DUT, ranging from 0.5 mm to 13.5 mm. To adjust the gap, release the screw fastening the GND contact and then rotate the contact (Figure 3-8).

CAUTION The probe is grounded 25 Ω (nominally). Do not connect the probe directly to the circuit with a DC output. If you connect a circuit with a DC output, resulting in as follows.

- It may cause the probe to be damaged.
- It may influence the circuit to not perform correctly or may damage it entirely.
- Measurement value will be incorrect.

In the case of measuring a circuit that could output a DC signal, connect an

appropriate DC-blocking capacitor to the probe.

Figure 3-8 Adjusting Pin-to-GND Gap

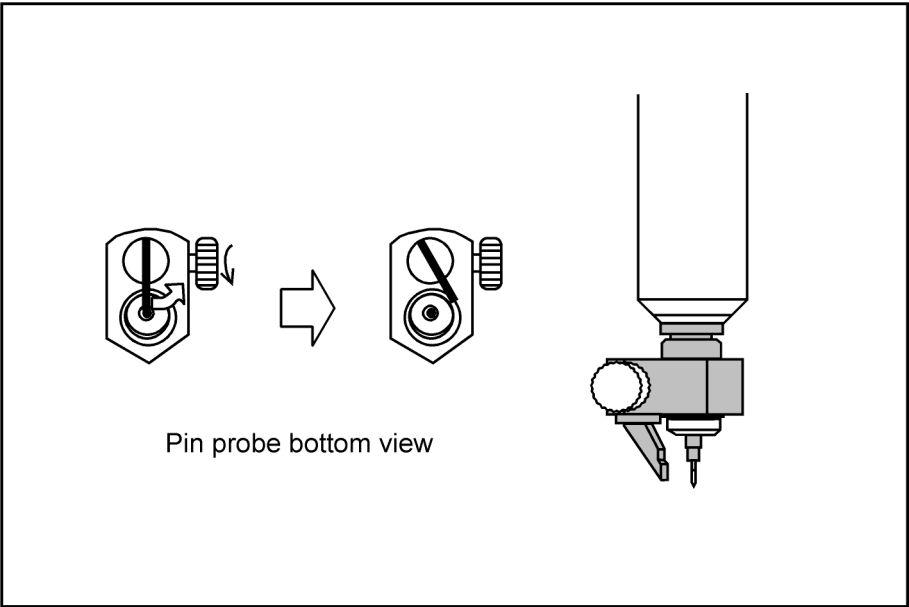

42941aee0308

DUT Measurement Using Ground Lead

Use the ground lead to ground the probe to a distant point(Figure 3-9). When you attach the ground lead to the pin probe, detach the ground contact (refer to Figure 3-2).

Figure 3-9 DUT Measurement Using Ground Lead

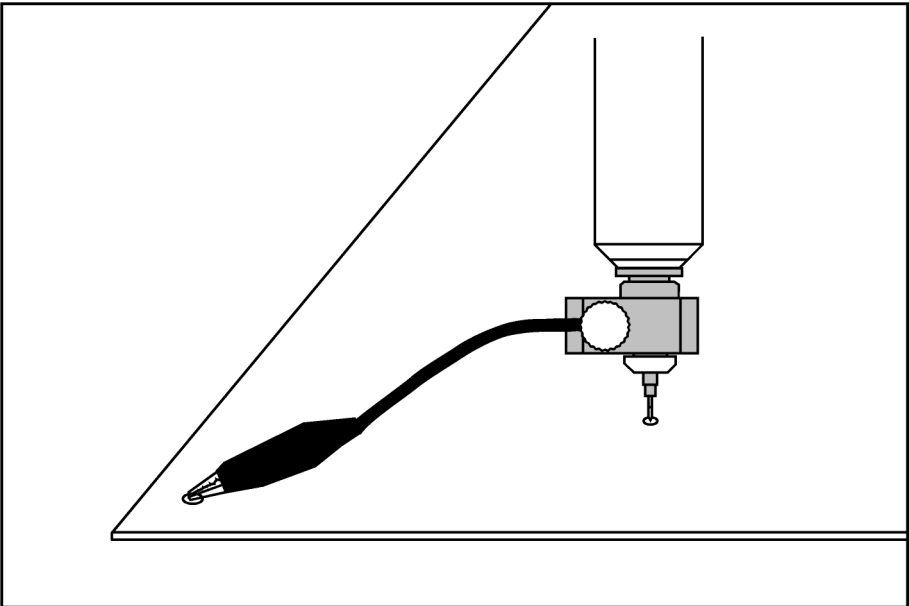

42941aaj0309

DUT Measurement Using BNC Adapter

The BNC adapter is used to measure I/O terminals or cables that have BNC connectors. It is also used as a mounting base for the alligator lead.

Figure 3-10 DUT Measurement Using BNC Adapter

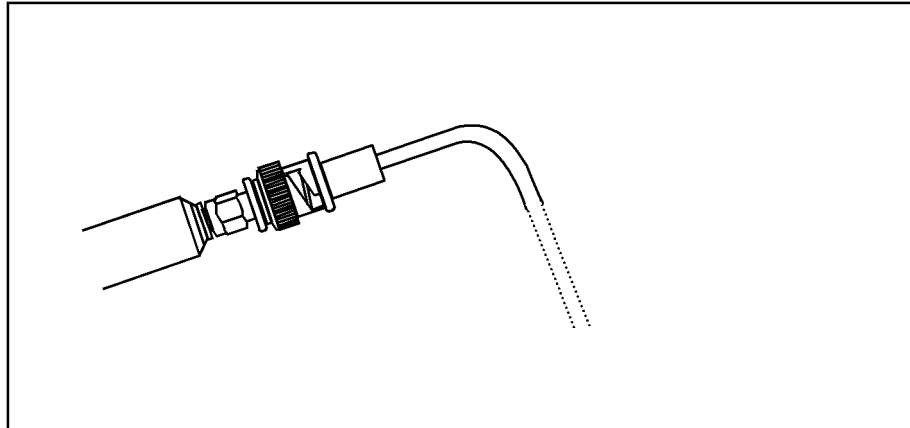

42941aoj0310

DUT Measurement Using Clip Lead

Use the clip lead to measure devices with leads that are large or mounted on the circuit board.

Figure 3-11 DUT Measurement Using Clip Lead

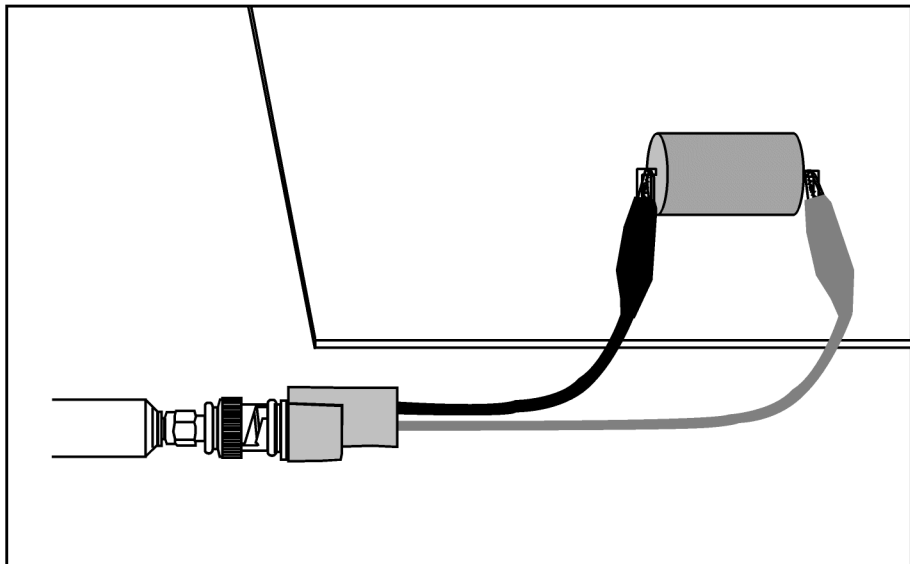

42941aoj0311

Specifications

Applicable Instruments		4294A Precision Impedance Analyzer
Frequency		40 Hz to 110 MHz
Maximum Voltage		± 42 V peak max. (AC+DC)
Output Impedance		25 Ω (Nominal) DC coupled
Operating Environment	temp.	-20°C to +75°C (except four-terminal pair connection block) 0°C to +55°C (four-terminal pair connection block)
	humidity	15% to 95%RH (@ wet bulb temp. < 40°C)
Non-operating Environment	temp.	-40°C to +70°C
	humidity	≤90 % RH (@ wet bulb temp. <65°C)
Dimensions		350 (W) × 100 (H) × 280 (D) mm (Includes carrying case)
Weight		2400g (Four-terminal pair connection block 1000g)
Safety Standards		EN61010-1:1993 +A2:1995 IEC61010-1:1990 +A1:1992 +A2:1995 CSA C22.2 No.1010.1:1992 INSTALLATION CATEGORY I POLLUTION DEGREE 2 INDOOR USE

For more information on impedance measurement accuracy at the 3.5-mm port and additional error factor, refer to the 4294A Operation Manual.

5 **Service**

This chapter provides information on servicing and proper maintenance.

Maintenance

An exploded view of the 42941A for parts identification is shown in Figure 5-1 and Figure 5-2. Do not disassemble any further than shown. Maintenance consists principally of cleaning contacts and replacing worn or damaged parts. Take special care when cleaning contacts.

To order parts, use the Agilent Technologies part numbers listed in Table 5-1 and Table 5-2. If a faulty part is located in an assembly that cannot be disassembled, order the next higher assembly or return the fixture to the nearest Agilent Technologies Sales/Service Office for repair or replacement.

Figure 5-1 Replaceable Parts (part 1 of 2)

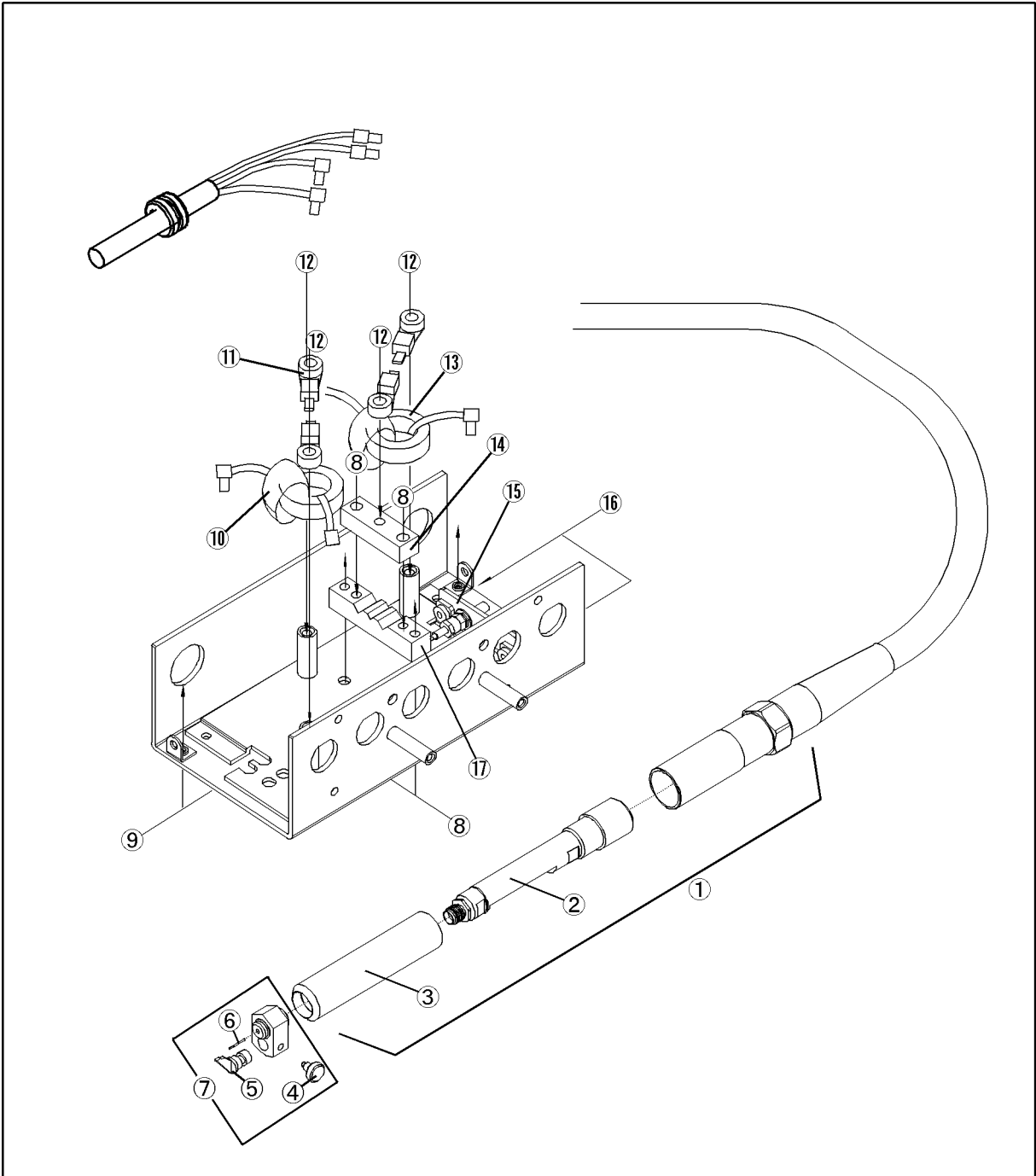

Table 5-1 **Replaceable Parts (part 1 of 2)**

Reference Designator	Part No.	Qty.	Description
1	42941-60001	1	PROBE
2	42941-65001	1	CHASSIS
3	42941-24001	1	COVER
4	42941-24015	1	KNOB
5	42941-24013	1	GND
6	-	1	CANTACT PROBE
7	42941-60002	1	CONTACT ASSY
8	0515-1718	4	SCR M4X12
9	0515-0914	2	SCR-MACH M3X0.5
10	42941-61602	1	RF CBL ASSY
11	1400-0719	4	CABLE TIE
12	0515-1718	4	SCR M4X12
	3050-0893	4	WSHR-FL
13	42941-61604	1	RF CBL ASSY
14	42941-24006	1	PLATE
15	42941-66501	1	BOARD
16	0515-1550	2	SCR M3-L 8 P-H
17	42941-24005	1	BLOCK

Figure 5-2 Replaceable Parts (part 2 of 2)

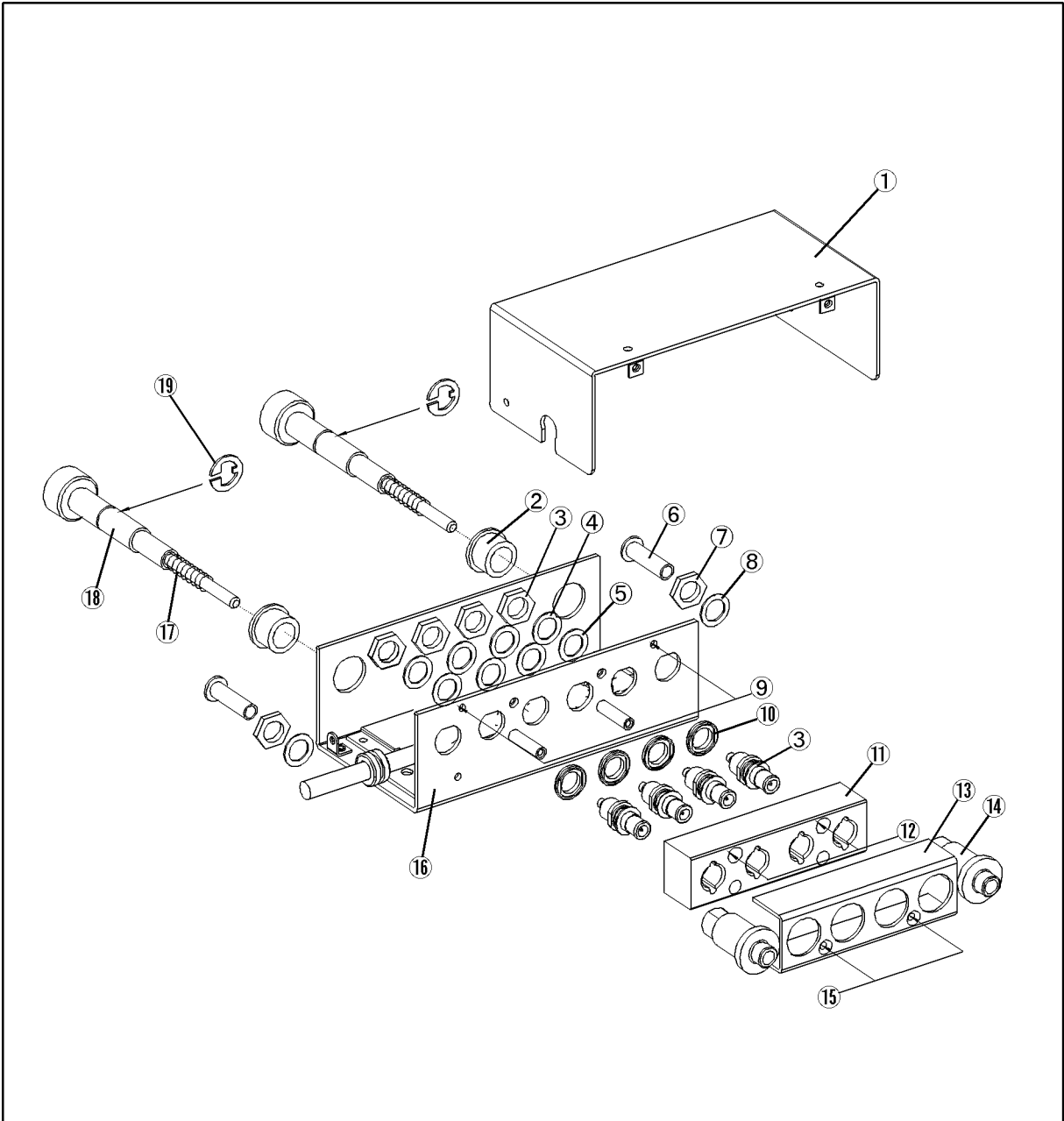

Table 5-2 **Replaceable Parts (part 2 of 2)**

Reference Designator	Part No.	Qty.	Description
1	42941-00601	1	COVER TOP
2	42941-40002	2	BUSHING
3	1253-0476	4	ADPT BNC-SMB
4	3050-0067	4	WSHR-FL MTLC
5	3050-0789	4	WSHR-FL NM
6	42941-25002	2	SLEEVE
7	2950-0054	2	NUT-HEX-DBL-CHAM
8	2190-0054	2	WSHR-LK INTL T
9	0515-0914	2	SCR-MACH M3X0.5
10	16047-40002	4	INSULATOR
11	42942-25006	1	GUIDE BNC
12	0515-1550	2	SCR M3-L 8 P-H
13	42942-00603	1	COVER
14	42941-24003	2	GUIDE
15	0515-0914	2	SCR-MACH M3X0.5
16	42941-00602	1	COVER BOTTOM
17	1460-2615	2	SPRING
18	42941-24004	2	SHAFT
19	0510-0083	2	RTNR-R