

HP 4142B Modular DC Source/Monitor Operation Manual

SERIAL NUMBERS

This manual applies directly to instruments with serial numbers 3121J- and above. With changes described in Appendix A, this manual also applies to instruments with serial numbers 2716J-, 2839J-, and 2946J-.

This literature was published years prior to the establishment of Agilent Technologies as a company independent from Hewlett-Packard and describes products or services now available through Agilent. It may also refer to products/services no longer supported by Agilent. We regret any inconvenience caused by obsolete information. For the latest information on Agilent's test and measurement products go to:

www.agilent.com find products

Or in the US, call Agilent Technologies at 1-800-452-4844 (8am-8pm EST)

HP Part No. 04142-90010
Printed in Japan March 1992

Edition 5
E0392

Copyright © Hewlett-Packard Company 1988, 1989, 1991, 1992

WARNING



HIGH VOLTAGE SHOCK HAZARD (MAX. 1000 V dc)

The HP 41423A HVU (± 1000 V), HP 41420A SMU (± 200 V), and HP 41421B SMU (± 100 V) force dangerous voltages on the FORCE, GUARD, and SENSE terminals. To prevent an electrical shock, the following safety precautions must be observed.

- ◆ Ground the HP 4142B using a three-conductor ac power cable.
- ◆ Connect the Interlock (INTLK) terminal to a switch that turns off when the shielding box access door is opened.
- ◆ For HVU, connect the OUTPUT ON/OFF STATUS terminal to a warning indicator.
- ◆ For HVU, perform the operation tests of the INTLK and OUTPUT ON/OFF STATUS circuits at least once a day, before using the HP 4142B.
- ◆ Before touching the connections of the FORCE, GUARD, and SENSE terminals, turn the HP 4142B off, and discharge any capacitors (if connected).
 - If you do not turn the HP 4142B off, perform the following four steps:
 - 1) Set the HVU and SMU output switches to off.
 - 2) For HVU, confirm that the warning indicator is not lit.
 - 3) Open the shielding box access door (open the INTLK terminal).
 - 4) Discharge any capacitors, if connected.
- ◆ Warn workers around the HP 4142B about dangerous conditions.

JAPANESE: HP 4142Bの安全上の注意



高電圧感電注意 (最大 1000 V dc)

HP 41423A HVU (± 1000 V)、HP 41420A SMU (± 200 V)、およびHP 41421B SMU (± 100 V)は、危険電圧をFORCE端子、GUARD端子、およびSENSE端子に出力します。感電事故防止のため、必ず下記の事項を実施してください。

- ◆ 3極電源ケーブルを使用して、HP 4142Bを接地する
- ◆ インターロック(INTLK)端子を、シールド・ボックスの蓋が開いたときにオープンとなるよう接続する
- ◆ OUTPUT ON/OFF STATUS端子を警告インジケータに接続する(HVU使用時)
- ◆ INTLK回路およびOUTPUT ON/OFF STATUS回路の動作テストを、1日に1回以上、使用前に行う(HVU使用時)
- ◆ FORCE端子、GUARD端子、およびSENSE端子の接続に触れる前に、HP 4142Bの電源をオフにし、キャパシタが接続されているならば、キャパシタを放電する
電源をオフにしない場合には、下記の4事項をすべて実施する
 - 1) HVUおよびSMUの出力スイッチをオフにする
 - 2) 警告インジケータが消灯していることを確認する(HVU使用時)
 - 3) シールド・ボックスの蓋をあける(INTLK端子をオープンにする)
 - 4) キャパシタが接続されているならば、キャパシタを放電する
- ◆ 周囲の他の作業者に対しても、高電圧危険に対する注意を徹底する

GERMAN: Sicherheitsmaßnahmen für den HP 4142B

WARNUNG



HOCHSPANNUNGS-BERÜHRUNGSGEFAHR (MAX. 1000 VDC)

Bei den Geräten HP 41423A HVU (± 1000 V), HP 41420A SMU (± 200 V) und HP 41421B SMU (± 100 V) gefährliche spannungen an den FORCE-, GUARD- und SENSE-Klemmen. Um einen Elektroschock zu vermeiden, sind folgende Sicherheitsmaßnahmen zu beachten.

- ◆ Gerät HP 4142B mit einem Dreileiter-AC-Starkstromkabel erden.
- ◆ Die Interlock-Klemme (INTLK) mit einem Schalter verbinden, der beim Öffnen der Abschirmkasten-Zugangstür ausgeschaltet wird.
- ◆ Bei Gerät HVU die Klemme OUTPUT ON/OFF STATUS mit einer Warnanzeige verbinden.
- ◆ Bei Gerät HVU die Funktionsprüfungen der Schaltkreise INTLK und OUTPUT ON/OFF STATUS mindestens einmal täglich durchführen, bevor HP 4142B verwendet wird.
- ◆ Vor Berühren der Verbindungen an den FORCE-, GUARD- und SENSE-Klemmen, Gerät HP 4142B ausschalten und (falls angeschlossen), die Kondensatoren entladen.
Falls HP 4142B nicht ausgeschaltet wird, sind folgende vier Schritte durchzuführen:
 - 1) Die Ausgangsschalter von HVU und SMU auf AUS stellen.
 - 2) Bei HVU kontrollieren, ob die Warnanzeige nicht leuchtet.
 - 3) Die Zugangstür des abgeschirmten Kasten öffnen (die Klemme INTLK öffnen).
 - 4) Vorhandene Kondensatoren entladen.
- ◆ Die Arbeitskräfte im Bereich des HP 4142B über die bestehende Gefahr unterrichten.

FRENCH: Consignes de sécurité relatives à l'équipement HP 4142B

DANGER D'ELECTROCUTION



HAUTE TENSION CONTINUE (JUSQU'À 1000 Vc.c.)

Les instruments HP 41423A HVU (± 1000 V), HP 41420A SMU (± 200 V) et HP 41421B SMU (± 100 V) présentent des tensions dangereuses aux bornes "FORCE", "GUARD" et "SENSE". Pour éviter tout risque d'électrocution, respecter les consignes suivantes.

- ◆ Mettre à la terre l'équipement HP 4142B en utilisant un câble secteur triphasé.
- ◆ Connecter la borne de verrouillage "INTLK" à un commutateur coupant l'alimentation lorsque la porte d'accès à la boîte blindée est ouverte.
- ◆ Pour le module HVU, connecter la borne "OUTPUT ON/OFF STATUS" à une lampe d'avertissement.
- ◆ Pour le module HVU, effectuer les essais de fonctionnement des circuits "INTLK" et "OUTPUT ON/OFF STATUS" au moins une fois par jour, avant d'utiliser l'équipement HP 4142B.
- ◆ Avant de toucher les connexions des bornes "FORCE" "GUARD" et "SENSE", mettre hors tension l'équipement HP 4142B et décharger tous les condensateurs éventuellement raccordés.
Au lieu de mettre l'équipement HP 4142B hors tension, l'on peut procéder de la manière suivante:
 - 1) Mettre les commutateurs de sortie des modules HVU et SMU en position d'arrêt.
 - 2) Pour le module HVU, s'assurer que la lampe d'avertissement est éteinte.
 - 3) Ouvrir la porte d'accès à la boîte blindée (pour mettre hors circuit la borne "INTLK").
 - 4) Décharger tous les condensateurs éventuellement raccordés.
- ◆ Avertir toute personne travaillant à proximité de l'équipement HP 4142B des dangers que présente cet équipement.

Printed in Japan 2/91
04142-90902

CERTIFICATION

Hewlett-Packard Company certifies that this product met its published specifications at the time of shipment from the factory. Hewlett-Packard further certifies that its calibration measurements are traceable to the United States National Institute of Standards and Technology (formerly National Bureau of Standards), to the extent allowed by that organization's calibration facility, or to the calibration facilities of other International Standards Organization members.

WARRANTY

This Hewlett-Packard instrument product is warranted against defects in material and workmanship for a period of one year from the date of shipment. During the warranty period, Hewlett-Packard Company will, at its option, either repair or replace products which prove to be defective.

For warranty service or repair, this product must be returned to a service facility designated by HP. Buyer shall prepay shipping charges to HP and HP shall pay shipping charges to return the product to Buyer. However, Buyer shall pay all shipping charges, duties, and taxes for products returned to HP from another country.

HP warrants that its software and firmware designated by HP for use with an instrument will execute its programming instruction when properly installed on that instrument. HP does not warrant that the operation of the instrument, or software, or firmware will be uninterrupted or error free.

LIMITATION OF WARRANTY

The foregoing warranty shall not apply to defects resulting from improper or inadequate maintenance by Buyer, Buyer-supplied software or interfacing, unauthorized modification or misuse, operation outside of the environment specifications for the product, or improper site preparation or maintenance.

NO OTHER WARRANTY IS EXPRESSED OR IMPLIED. HP SPECIFICALLY DISCLAIMS THE IMPLIED WARRANTIES OF MERCHANTABILITY AND FITNESS FOR A PARTICULAR PURPOSE.

EXCLUSIVE REMEDIES

THE REMEDIES PROVIDED HEREIN ARE BUYER'S SOLE AND EXCLUSIVE REMEDIES. HP SHALL NOT BE LIABLE FOR ANY DIRECT, INDIRECT, SPECIAL, INCIDENTAL, OR CONSEQUENTIAL DAMAGES, WHETHER BASED ON CONTRACT, TORT, OR ANY OTHER LEGAL THEORY.

ASSISTANCE

Product maintenance agreements and other customer assistance agreements are available for Hewlett-Packard products.

For any assistance, contact your nearest Hewlett-Packard Sales and Service Office. Address are provided at the back of this manual.

Herstellerbescheinigung

Hiermit wird bescheinigt, daß das Gerät HP 4142B Modular DC Source/Monitor in Übereinstimmung mit den Bestimmungen von Postverfügung 1046/84 funkentstört ist.

Der Deutschen Bundespost wurde das Inverkehrbringen dieses Gerätes angezeigt und die Berechtigung zur Überprüfung der Serie auf Einhaltung der Bestimmungen eingeräumt.

Anm: Werden Meß- und Testgeräte mit ungeschirmten Kabeln und/oder in offenen Meßaufbauten verwendet, so ist vom Betreiber sicherzustellen, daß die Funk-Entstörbestimmungen unter Betriebsbedingungen an seiner Grundstücksgrenze eingehalten werden.

Geräuschemission

Lpa < 70 dB
am Arbeitsplatz
normaler Betrieb
nach DIN 45635 T. 19

Manufacturer's Declaration

This is to certify that this product, the HP 4142B Modular DC Source/Monitor, meets the radio frequency interference requirements of directive 1046/84. The German Bundespost has been notified that this equipment was put into circulation and was granted the right to check the product type for compliance with these requirements.

Note: If test and measurement equipment is operated with unshielded cables and/or used for measurements on open setups, the user must insure that under these operating conditions, the radio frequency interference limits are met at the border of his premises.

Acoustic Noise Emission

Lpa < 70 dB
operator position
normal operation
per ISO 7779

SAFETY SUMMARY

The following general safety precautions must be observed during all phases of operation, service, and repair of this instrument. Failure to comply with these precautions or with specific **WARNINGS** given elsewhere in this manual violates safety standards of design, manufacture, and intended use of the instrument. **The Hewlett-Packard Company assumes no liability for the customer's failure to comply with these requirements.**

GROUND THE INSTRUMENT

To minimize shock hazards, the instrument chassis and cabinet must be connected to an electrical ground. The instrument is equipped with a three-conductor AC power cable. The power cable must be plugged into an approved three-contact electrical outlet or used with a three-contact to two-contact adapter with the grounding wire (**green**) firmly connected to an electrical ground (safety ground) at the power outlet. The power jack and the mating plug of the power cable meet International Electrotechnical Commission (IEC) safety standards.

DO NOT OPERATE IN AN EXPLOSIVE ATMOSPHERE

Do not operate the instrument in the presence of flammable gasses or fumes. Operation of any electrical instrument in such an environment constitutes a safety hazard.

KEEP AWAY FROM LIVE CIRCUITS

Operating personnel must not remove instrument covers. Component replacement and internal adjustments must be made by qualified maintenance personnel. Do not replace components with power cable connected. Under certain conditions, dangerous voltages may exist even with the power cable removed. To avoid injuries, always disconnect power and discharge circuits before touching them.

DO NOT SERVICE OR ADJUST ALONE

Do not attempt internal service or adjustment unless another person, capable of rendering first aid and resuscitation, is present.

DO NOT SUBSTITUTE PARTS OR MODIFY INSTRUMENT

Because of the danger of introducing additional hazards, do not substitute parts or perform unauthorized modifications to the instrument. Return the instrument to a Hewlett-Packard Sales and Service Office for service and repair to ensure the safety features are maintained.

DANGEROUS PROCEDURE WARNINGS

WARNINGS, such as the example below, precede potentially dangerous procedures throughout this manual. Instructions contained in the warnings must be followed.

WARNING

DANGEROUS VOLTAGES, CAPABLE OF CAUSING DEATH, ARE PRESENT IN THIS INSTRUMENT. USE EXTREME CAUTION WHEN HANDLING, TESTING, AND ADJUSTING THIS INSTRUMENT.

SAFETY SYMBOLS

General Definitions of Safety Symbols Used On Equipment or In Manuals.



Instruction manual symbol: the product will be marked with this symbol when it is necessary for the user to refer to the instruction manual in order to protect against damage to the instrument.



Indicates dangerous voltage (terminals fed from the interior by voltage exceeding 1000 volts must be so marked).

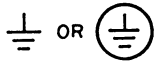

Protective conductor terminal. For protection against electrical shock in case of a fault. Used with wiring terminals to indicate the terminal which must be connected to ground before operating equipment.



Low-noise or noiseless, clean ground (earth) terminal. Used for a signal common, as well as providing protection against electrical shock in case of fault. A terminal marked with this symbol must be connected to ground in the manner described in the installation (Operating) manual, and before operating the equipment.

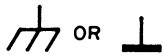

Frame or chassis terminal. A connection to the frame (chassis) of the equipment which normally includes all exposed metal structures.



Alternating current (power line).



Direct current (power line).



Alternating or direct current (power line).



A **WARNING** denotes a hazard. It calls attention to a procedure, practice, condition or the like, which, if not correctly performed or adhered to, could result in injury or death to personnel.



A **CAUTION** sign denotes a hazard. It calls attention to a procedure, practice, condition or the like, which, if not correctly performed or adhered to, could result damage to or destruction of part or all of the product.

NOTE

A **NOTE** denotes important information. It calls attention to a procedure, practice, condition or the like, which is essential to highlight.

PREFACE

This manual contains installation information, and operating and programming information for the HP 4142B. The manual consists of the following chapters and appendixes:

Chapter 1 Installation

Contains initial inspection and installation information necessary to know before applying ac power.

Chapter 2 Overview

Shows product overview.

Chapter 3 Test Device Connections

Shows how to connect the test device to the HP 4142B.

Chapter 4 Operation Guide

Shows how to turn the HP 4142B on, how to send commands to the HP 4142B, how to force and measure voltage and current, and how to retrieve measurement data. This chapter will help you quickly learn to operate the HP 4142B.

Chapter 5 Measurement Modes

Describes the types of measurements, such as spot, sweep, and pulsed measurements.

Chapter 6 Measurement Functions

Describes the functions that can be used in measurements, such as ranging, compliance, measurement averaging, automatic sweep abort function, and program memory.

Chapter 7 Miscellaneous Functions

Describes the functions that are not directly related to the measurements, such as the front and rear panels, query commands, and the functions at power-on.

Appendix A Manual Changes

Contains the information needed to use this manual with an HP 4142B that was manufactured before the printing date of this manual.

Appendix B Specifications

Contains the specification and reference data of the HP 4142B.

Appendix C Accessories and Options

Contains the accessories and options lists.

This manual does not contain detailed descriptions of each HP 4142B command, measurement data output format, and error messages. Refer to the *HP-IB Command Reference Manual* for more detailed information on these topics.

CONTENTS

CHAPTER 1 INSTALLATION

Introduction	1-1
Initial Inspection	1-1
Installing the HP 4142B	1-2
Installing the Blank Panel	1-2
Installing the Front Panel	1-2
Line Power Requirements	1-2
Line Voltage and Fuse Selection	1-3
Setting the Line Frequency FILTER Switch	1-3
Power Cables	1-4
Grounding Requirements	1-5
Changing the HP-IB Address	1-5
Connecting the HP-IB Cable	1-5
Mounting the HP 4142B	1-6
Operating Environment	1-7
Installing and Removing Plug-in Units	1-8
Storage and Shipment	1-9
Environment	1-9
Original Packaging	1-9
Other Packaging	1-9
Repair Service	1-10
Serial Number	1-10

CHAPTER 2 OVERVIEW

Introduction	2-1
Product Introduction	2-1
HP 4142B	2-1
Ground Unit (GNDU)	2-3
HP 41420A HPSMU and HP 41421B MPSMU	2-4
HP 41422A HCU	2-7
HP 41423A HVU	2-9
HP 41424A VS/VMU	2-11
HP 41425A AFU	2-13
Measurement Modes	2-14
Total Power Limitation of Plug-in Units	2-16
Panel Overview	2-17

CHAPTER 3 TEST DEVICE CONNECTIONS

Introduction	3-1
Before Connecting Test Devices	3-1
Enclose the Test Device with a Shielding Box	3-1
Connect the INTLK Terminal	3-2
Shorting Circuit Common and Chassis Ground Terminals	3-4
Connecting the Test Devices	3-5
GNDU Connections	3-5
HPSMU and MPSMU Connections	3-7
HCU Connections	3-12
HVU Connections	3-17
VS/VMU Connections	3-22

Using the Connection Accessories	3-23
Using Connector Plate Part Number 04142-60021	3-23
Using Connector Plate Part Number 04142-60032	3-24
Using Connector Plate Part Number 16087-60002	3-25
Using the HP 16088B Test Fixture	3-26
Using the HP 16058A Test Fixture	3-31
Using the HP 16087A Module Selector	3-33
Cable Reference Data	3-42
Advanced Connection Information	3-45
For High Current Measurements (Kelvin Connection)	3-45
For Low Current Measurements (Using the GUARD Terminal)	3-47
If the Test Device is Externally Grounded (Floating Measurement)	3-48
If the Test Device has Negative Resistance	3-50
Preventing Oscillation from the Test Device	3-51

CHAPTER 4 OPERATION GUIDE

Introduction	4-1
Before Applying Power	4-1
Safety Precautions	4-1
Confirming Installation	4-3
Applying Power	4-4
Self-Test	4-4
Performing Safety Tests for the HVU	4-5
Sending the HP-IB Command	4-6
Output/Input Statement	4-6
Sending an HP-IB Command	4-6
Sending an HP-IB Command to the Unit (Channel Numbers; Ch#)	4-7
Getting Data from the HP 4142B	4-7
If an Error Occurs	4-8
Reading the Error Register	4-8
Resetting the HP 4142B	4-9
Forcing and Measuring	4-10
Performing the Self-Calibration	4-10
Setting the Output Switch of the Unit to ON	4-11
Setting the Output Switch of the Unit to OFF	4-11
Forcing Constant Voltage	4-12
Forcing Constant Current	4-13
Setting the Output to 0 V	4-14
Performing the Measurement	4-15
Performing the Staircase Sweep Measurement	4-16
Specifying the Measurement Range	4-17
Measurement Program Flow	4-18
Waiting for Time	4-19

CHAPTER 5 MEASUREMENT MODES

Introduction	5-1
Spot Measurements	5-1
Commands and Parameters	5-3
Information	5-3
Spot Measurement Sample Program	5-4
Staircase Sweep Measurements	5-6
Commands and Parameters	5-10
Information	5-11
Staircase Sweep Measurement Sample Program	5-11
1ch Pulsed Spot Measurements	5-15
Commands and Parameters	5-18
Information	5-18
1ch Pulsed Spot Measurement Sample Program	5-19
Pulsed Sweep Measurements	5-21
Commands and Parameters	5-25
Information	5-26
Pulsed Sweep Measurement Sample Program	5-26
Staircase Sweep with Pulsed Bias Measurements	5-29
Commands and Parameters	5-33
Information	5-34
Staircase Sweep with Pulsed Bias Measurement Sample Program	5-34
Analog Search Measurements	5-37
Search Operation Modes	5-40
Search Measurement Modes	5-42
Commands and Parameters	5-43
AFU Monitor Port	5-44
Information	5-45
Analog Search Measurement Sample Program	5-45
2ch Pulsed Spot Measurements	5-48
Commands and Parameters	5-51
Information	5-52
2ch Pulsed Spot Measurement Sample Program	5-52
Pulsed Sweep with Pulsed Bias Measurements	5-54
Commands and Parameters	5-58
Information	5-59
Pulsed Sweep with Pulsed Bias Measurement Sample Program	5-59
Quasi-Pulsed Spot Measurements	5-63
Settling Detection Method	5-68
Commands and Parameters	5-70
Information	5-70
Quasi-pulsed Spot Measurement Sample Program	5-71
High Speed Spot Measurements	5-73
Commands and Parameters	5-75
Information	5-75
High Speed Spot Measurement Sample Program	5-76

CHAPTER 6 MEASUREMENT FUNCTIONS

Introduction	6-1
Output Ranging Mode	6-1
Allowable Ranging Mode	6-1
Auto Ranging	6-2
Limited Auto Ranging	6-3
Measurement Ranging Mode	6-4
Allowable Ranging Mode	6-4
Auto Ranging	6-5
Limited Auto Ranging	6-6
Compliance Range	6-6
Fixed Range	6-7
Note	6-8
Compliance/Limiter	6-9
V/I Compliance	6-9
Power Compliance	6-17
Limiter	6-18
Averaging	6-19
Filter	6-21
Automatic Sweep Abort Function	6-22
Output After Sweep	6-22
Measurement Data Memory	6-23
Program Memory	6-24
Using Program Memory	6-27
Program Memory Sample Program	6-28
Using the HP 4142B with External Instruments	6-30
Trigger Output and Input Function	6-30
Triggering an External Instrument	6-30
Externally Triggered HP 4142B Measurements	6-31
Waiting for Trigger Signal from TRIGGER INPUT Terminal	6-31
Waiting for Time or Trigger	6-33
Waiting for Command Execution Completion (*OPC? Command)	6-33
Relay Control (Option 300)	6-34
Module Selector Control	6-34
External Relay Control	6-35

CHAPTER 7 MISCELLANEOUS FUNCTIONS

Introduction	7-1
Front and Rear Panels	7-1
Front Panel	7-1
Rear Panel	7-8
Query Commands	7-9
HP-IB Capability	7-10
Status Byte	7-11
Status	7-11
Commands	7-12
Status Byte Sample Program	7-13
Self-Calibration/Self-Test	7-18
Self-Calibration	7-18
Auto-Calibration	7-19
Self-Test	7-20
Initial Settings	7-21
Auto Power Off Function	7-24

APPENDIXES

Appendix A, Manual Changes	A-1
Appendix B, Specifications	B-1
Appendix C, Accessories and Options	C-1

CHAPTER 1

INSTALLATION

CONTENTS

Introduction	1-1
Initial Inspection	1-1
Installing the HP 4142B	1-2
Installing the Blank Panel	1-2
Installing the Front Panel	1-2
Line Power Requirements	1-2
Line Voltage and Fuse Selection	1-3
Setting the Line Frequency FILTER Switch	1-3
Power Cables	1-4
Grounding Requirements	1-5
Changing the HP-IB Address	1-5
Connecting the HP-IB Cable	1-5
Mounting the HP 4142B	1-6
Operating Environment	1-7
Installing and Removing Plug-in Units	1-8
Storage and Shipment	1-9
Environment	1-9
Original Packaging	1-9
Other Packaging	1-9
Repair Service	1-10
Serial Number	1-10

INTRODUCTION

This chapter provides HP 4142B installation information. Included is information on initial inspection and damage claims, installing your HP 4142B, installing and removing plug-in units, storage and shipment, and repair service.

INITIAL INSPECTION

Each HP 4142B is carefully inspected before it leaves the factory. Upon receipt and before unpacking the HP 4142B, inspect the shipping container for damage. If there is any evidence of damage or mishandling, retain all packing materials and notify both the shipping carrier and the nearest Hewlett-Packard office.

When you unpack the HP 4142B, verify that the following accessories are included.

- Operation Manual (this manual)
- HP-IB Command Reference Manual
- Power Cable

If the shipment is incomplete, or if the contents show any sign of mechanical damage or other defects (scratches, dents, broken switches, etc.), notify the nearest Hewlett-Packard office (see the list at the back of this manual). HP arranges for repair or replacement without waiting for the claim settlement.

When you unpack the HP 4142B, retain all packing materials for future use. If it becomes necessary to reship the HP 4142B, repack it in the original packing materials and shipping carton.

INSTALLING THE HP 4142B

Installing the Blank Panel

CAUTION

To prevent thermal damage to HP 4142B units, be sure that Blank Panels (part number 04142-60012) are installed in all unused slots.

Installing the Front Panel

The front panel of the HP 4142B is packed separately from the mainframe. Before you connect a power cable to the HP 4142B, attach the front panel to the mainframe as instructed in the following procedure.

1. Connect the flat cable connector of the front panel to the mainframe unit connector.
2. Insert the metal flanges on the upper right and left sides of the front panel into their corresponding slots on the mainframe. With a flatblade screwdriver, tighten the two screws in the lower left and right corners of the front panel.

Line Power Requirements

The HP 4142B requires a 48 to 66 Hz, single phase power source of 100, 120, or 220 VAC $\pm 10\%$, or 240 VAC $-10\% + 5\%$. Maximum power consumption is 750 VA (Volt-Amps).

WARNING

IF THE HP 4142B IS TO BE ENERGIZED VIA AN EXTERNAL AUTO TRANSFORMER FOR VOLTAGE REDUCTION, BE SURE THE COMMON TERMINAL IS CONNECTED TO THE EARTH POLE OF THE POWER SOURCE.

Line Voltage and Fuse Selection

CAUTION

Before connecting the HP 4142B to an ac power source, verify that the **LINE VOLTAGE SELECTOR** switch is set to the correct line voltage. Be sure the correct fuse is installed for the selected line voltage.

Setting the LINE VOLTAGE SELECTOR Switch:

Disconnect the HP 4142B line power cable before changing the **LINE VOLTAGE SELECTOR** switch. With a small flatblade screwdriver, move the **LINE VOLTAGE SELECTOR** switch to the 100V/120V or the 220V/240V position in accordance with the ac line voltage of your area.

Installing the Line Power Fuse:

To install a fuse, make sure the HP 4142B power cable is disconnected. With a small flatblade screwdriver, turn the fuse holder cap counterclockwise until it pops out. The correct fuse type for each line voltage is shown in the following table.

Line Voltage Fuse

Line Voltage	Fuse Rating	Part No.
100V/200V	8 A Normal Blow	2110-0342
220V/240V	4 A Normal Blow	2110-0055

CAUTION

Use only replacement fuses of the correct current rating and of the specified type. Do not use mended fuses, and do not short circuit the fuse holder.

Insert one end of the correct fuse into the fuse cap. Insert the fuse/cap assembly into the fuse holder. Push in on the fuse cap with the screwdriver and rotate it clockwise.

The HP 4142B is shipped from the factory with the **LINE VOLTAGE SELECTOR** switch set to the line voltage used in the geographic area to which the HP 4142B is shipped, and with the corresponding fuse installed.

Setting the Line Frequency FILTER Switch

To minimize the effects of line frequency noise during measurements, set the **FILTER** switch on the HP 4142B rear panel to the ac line frequency.

Power Cables

The following figure shows the power plugs used in various countries, and provides available power cable/plug information. Also included is ordering information. If you need assistance in determining the power cable you need, contact the nearest Hewlett-Packard office.

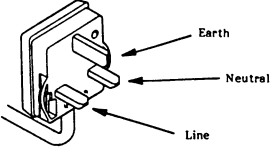
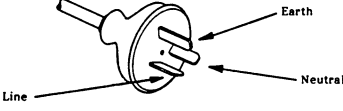
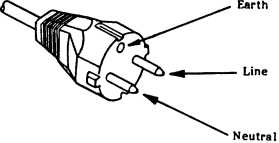
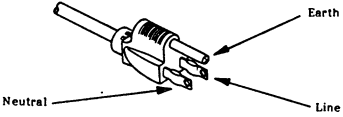
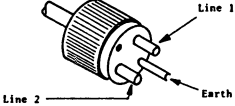
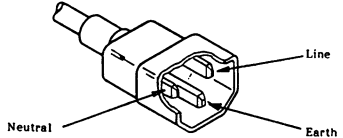
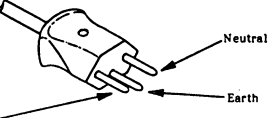
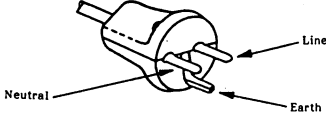
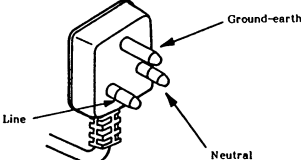
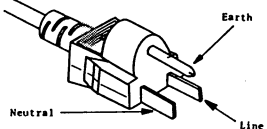
<p>OPTION 900 United Kingdom</p>  <p>Plug: BS 1363A, 250V Cable: HP 8120-1351</p>	<p>OPTION 901 Australia/New Zealand</p>  <p>Plug: NZSS 198/AS C112, 250V Cable: HP 8120-1369</p>
<p>OPTION 902 European Continent</p>  <p>Plug: CEE-VII, 250V Cable: HP 8120-1689</p>	<p>OPTION 903 U.S./Canada</p>  <p>Plug: NEMA 5-15P, 125V, 15A Cable: HP 8120-1378</p>
<p>OPTION 904 U.S./Canada</p>  <p>Plug: NEMA 6-15P, 250V, 15A Cable: HP 8120-0698</p>	<p>OPTION 905* Any country</p>  <p>Plug: CEE 22-VI, 250V Cable: HP 8120-1396</p>
<p>OPTION 906 Switzerland</p>  <p>Plug: SEV 1011.1959-24507 Type 12, 250V Cable: HP 8120-2104</p>	<p>OPTION 912 Denmark</p>  <p>Plug: DHCR 107, 220V Cable: HP 8120-2956</p>
<p>OPTION 917 India/Republic of S.Africa</p>  <p>Plug: SABS 164, 250V Cable: HP 8120-4211</p>	<p>OPTION 918 Japan</p>  <p>Plug: JIS C 8303, 125V, 15A Cable: HP 8120-4753</p>
<p>NOTE: Each option number includes a 'family' of cords and connectors of various materials and plug body configurations (straight, 90° etc.).</p> <p>* Plug option 905 is frequently used for interconnecting system components and peripherals.</p>	

Power Cables

Grounding Requirements

The HP 4142B is equipped with a three-conductor ac power cable. When plugged into the appropriate power line outlet, the cable grounds the HP 4142B cabinet, thereby protecting the user from possible shock hazards. To preserve this protection feature, the power cable must be connected to an approved three-contact electrical outlet that has its ground conductor connected to an electrical ground (safety ground).

If operating the HP 4142B from a two-contact outlet, use a three-prong to two-prong adapter, and connect the green grounding tab of the adapter to power line ground.

The HP 4142B power jack and the supplied power cable meet International Electrotechnical Commission (IEC) safety standards.

WARNING

FOR PROTECTION FROM ELECTRICAL SHOCK, THE POWER CABLE GROUND MUST NOT BE DEFEATED.

Changing the HP-IB Address

Every device on the HP-IB bus must have a unique address. If you need to change the HP-IB address of the HP 4142B, make sure the HP 4142B is turned off. With a small flatblade screwdriver, set the **HP-IB ADDRESS Switch** on the rear panel to the new address (0 to 30). The new HP-IB address is only recognized at power on.

The HP 4142B leaves the factory with the HP-IB address set to 17.

Connecting the HP-IB Cable

To connect the HP 4142B with a computer or peripheral device via HP-IB (IEEE Std. 488), connect an HP-IB cable between the HP-IB connector on the HP 4142B rear panel and the HP-IB connector on the peripheral device.

A total of 15 devices can be connected on the same HP-IB bus. The length of the HP-IB cables must not exceed 20 meters (65 feet) total, or 2 meters (6.5 feet) per device, whichever is less.

Mounting the HP 4142B

The HP 4142B comes equipped with four feet which allow it to be used as a bench instrument. There are also two retractable stands mounted on the bottom cover so you can tilt the HP 4142B. To use the stands, pull each one away from the bottom cover until it locks into position.

The HP 4142B can be rack-mounted into a cabinet. Use Option 907 to install front handles on your HP 4142B. If you're going to mount your HP 4142B into a rack, remove the retractable stands and install either Option 908 or 909. The following figure provides front handle and rack-mount flange installation information.

CAUTION

Install the HP 4142B horizontally within $\pm 20^\circ$ when you turn on and use the HP 4142B.

Option	Description	Kit Part Number
907	Handle Kit	5062-3991
908	Rack Flange Kit	5062-3979
909	Rack Flange & Handle Kit	5062-3985

Before installing the desired option, remove the adhesive-backed trim strips (1) from the right and left front sides of the HP 4142B.

HANDLE INSTALLATION (Option 907):

Attach the front handles (3) to the right and left front sides of the HP 4142B with the screws provided. Attach the trim (4) to the handles.

NOTE

To install either Option 908 or 909, remove the feet from the bottom cover by lifting the bar at the inner side of each foot and sliding the foot towards the bar.

RACK FLANGE INSTALLATION (Option 908): Attach the rack-mount flanges (2) to the right and left front sides of the HP 4142B with the screws provided.

HANDLE & RACK FLANGE INSTALLATION (Option 909): Attach the front handles (3) and the rack-mount flanges (5) to the right and left front sides of the HP 4142B with the screws provided.

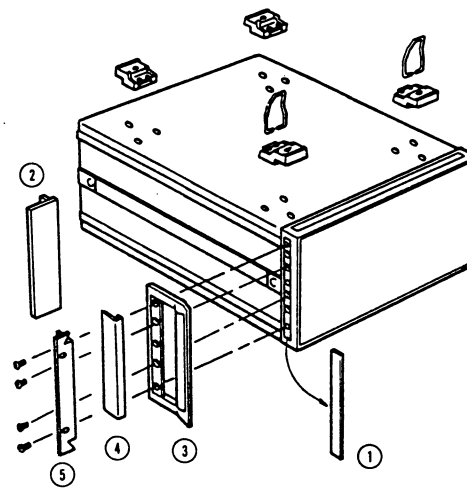

Front Handle and Rack-Mount Flange Installation

Operating Environment

To maintain the proper operating environment, operate your HP 4142B within the following limits:

Temperature: 5°C to 40°C.
Humidity: 5% to 80% RH.

Protect the HP 4142B from temperature extremes to prevent condensation from forming inside the HP 4142B.

INSTALLING AND REMOVING PLUG-IN UNITS

All HP 4142B plug-in units can be easily installed and removed. Each plug-in unit can be installed in any slot between slot #1 and #8, and all units can be retrofitted. The following procedure explains plug-in unit installation and removal.

1. Set the **POWER ON/OFF switch** or **LINE ON/OFF switch** to **OFF**.

CAUTION

To prevent damage to HP 4142B units, be sure to turn your HP 4142B OFF and wait at least 10 seconds before you remove or install units.

2. With a flatblade screwdriver, loosen the two screws located in the lower left and right corners of the front panel. Swing the front panel slightly upward, then down, until it comes loose. Disconnect the flat cable that connects the front panel to the mainframe from the mainframe unit connector.
3. **Installing units:**

Align the unit with the upper and lower slot guide rails. Push the unit into the slot until you feel the unit seat firmly into its mainframe connector. Turn the upper and lower quick-disconnect screws clockwise until they lock.

Removing units:

Turn the upper and lower quick-disconnect screws 90° counterclockwise to unlock the unit. Gently pull the unit free from its mainframe connector and remove the unit.

CAUTION

To prevent thermal damage to HP 4142B units, be sure that **Blank Panels** (part number 04142-60012) are installed in all unused slots.

4. Reconnect the front panel flat cable to the mainframe connector, and reinstall the front panel.

STORAGE AND SHIPMENT

Environment

The HP 4142B should be stored or shipped in environments within the following limits:

Temperature: -40°C to 70°C.
Humidity: Up to 90% RH at 65°C.

Protect the HP 4142B from temperature extremes to prevent condensation from forming inside the HP 4142B.

Original Packaging

When you unpack the HP 4142B, retain all packing material for future use. If it becomes necessary to reship the HP 4142B, repack it in the original packing material and shipping carton. Containers and material identical to those used in factory packaging are available from Hewlett-Packard.

Other Packaging

If you choose to package the HP 4142B in commercially available material, observe the following general instructions.

1. Wrap the HP 4142B in heavy paper or plastic.
2. Use a strong shipping container. A double-walled carton made of 159 kg (350 lb.) test material is adequate.
3. Use enough shock absorbing material, a 76 to 102 mm (3 to 4 in) layer, around all sides of the HP 4142B to provide a firm cushion and to prevent movement inside the container. Protect the front panel with cardboard.
4. Seal the shipping container securely and mark it FRAGILE to ensure careful handling.
5. In any correspondence with HP, refer to the instrument by model and serial number.

REPAIR SERVICE

You can have the HP 4142B repaired at an HP service center whether it is under warranty or not. Contact the nearest HP Sales Office for shipping instructions prior to returning the instrument. A list of Sales and Service Offices is located in the back of this manual.

Serial Number

Hewlett-Packard uses a two-serial-number system to identify the HP 4142B and each HP 4142B plug-in unit. The HP 4142B (mainframe) serial number is stamped on the serial number plate attached to the rear panel of the HP 4142B. The individual serial number of each unit is stamped on the serial number plate attached to the side panel of each unit. The HP 4142B serial number identifies the mainframe; unit serial numbers identify each individual unit. In any correspondence with Hewlett-Packard, be sure to include the serial numbers of both the HP 4142B and the unit.

CHAPTER 2

OVERVIEW

CONTENTS

Introduction	2-1
Product Introduction	2-1
HP 4142B	2-1
Ground Unit (GNDU)	2-3
HP 41420A HPSMU and HP 41421B MPSMU	2-4
HP 41422A HCU	2-7
HP 41423A HVU	2-9
HP 41424A VS/VMU	2-11
HP 41425A AFU	2-13
Measurement Modes	2-14
Total Power Limitation of Plug-in Units	2-16
Panel Overview	2-17

NOTES

INTRODUCTION

This chapter describes the basic functions and features of the HP 4142B. Included are discussions on output and measurement functions of each source and monitor unit, measurement modes, and a front/rear panel overview.

PRODUCT INTRODUCTION

HP 4142B

The HP 4142B is a high performance DC parametric measurement instrument with plug-in unit architecture designed for:

- Wide Measurement Range (10 A, 1000 V)
- High Resolution (20 fA, 4 μ V)
- High Speed (Force I or V: 4 ms, Measure I or V: 4 ms)
- High Accuracy (V: 0.05%, I: 0.2%)

All HP 4142B operations--measurement set up and execution, and measurement data receipt--are computer-controlled via the Hewlett-Packard Interface Bus (HP-IB). Up to 1023 measurement data (4095 for binary data format) can be stored in internal memory.

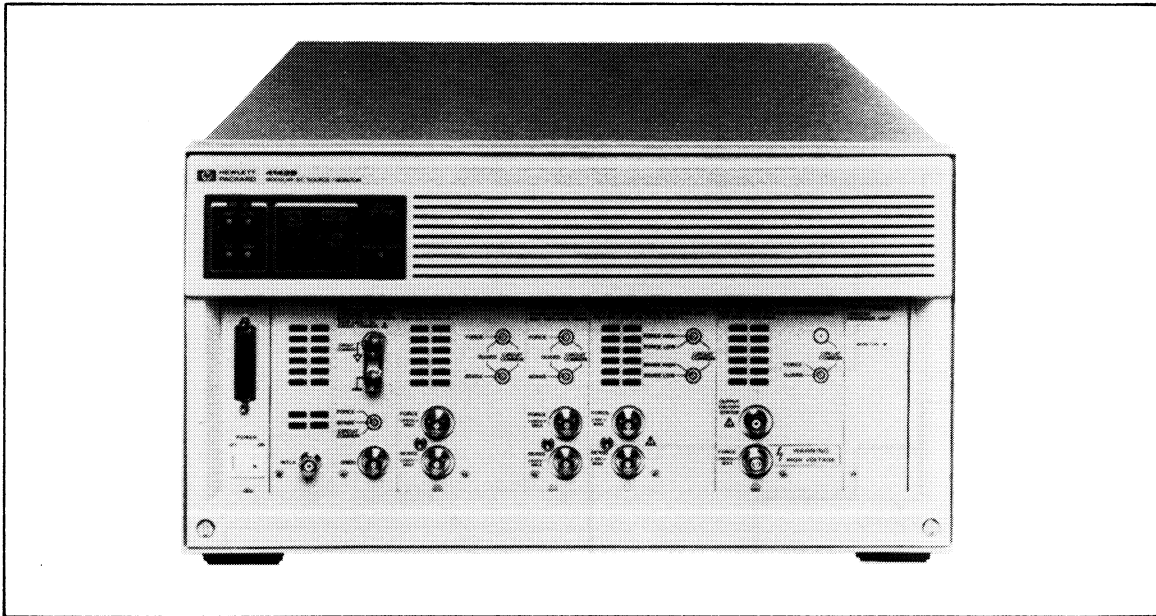

HP 4142B Modular DC Source/Monitor

As a measurement unit, the following five types of plug-in units are available, in addition to a built-in, 0 V source Ground Unit (GNDU). The plug-in units can be built-in to up to eight slots.

- HP 41420A Source/Monitor Unit, 40 μ V-200V/20fA-1A (High Power SMU, HPSMU). Occupies 2 slots.
- HP 41421B Source/Monitor Unit, 40 μ V-100V/20fA-100mA (Medium Power SMU, MPSMU). Occupies 1 slot.
- HP 41422A High Current Source/Monitor Unit, 40 μ V-10V/20nA-10A (HCU). Occupies 2 slots.
- HP 41423A High Voltage Source/Monitor Unit, 2mV-1000V/2pA-10mA (HVU). Occupies 2 slots.
- HP 41424A Voltage Source/ Voltage Monitor Unit (VS/VMU). Occupies 1 slot.
- HP 41425A Analog Feedback Unit (AFU). Occupies 1 slot. No more than one HP 41425A per mainframe.

The following figure shows the output and measurement range of plug-in units.

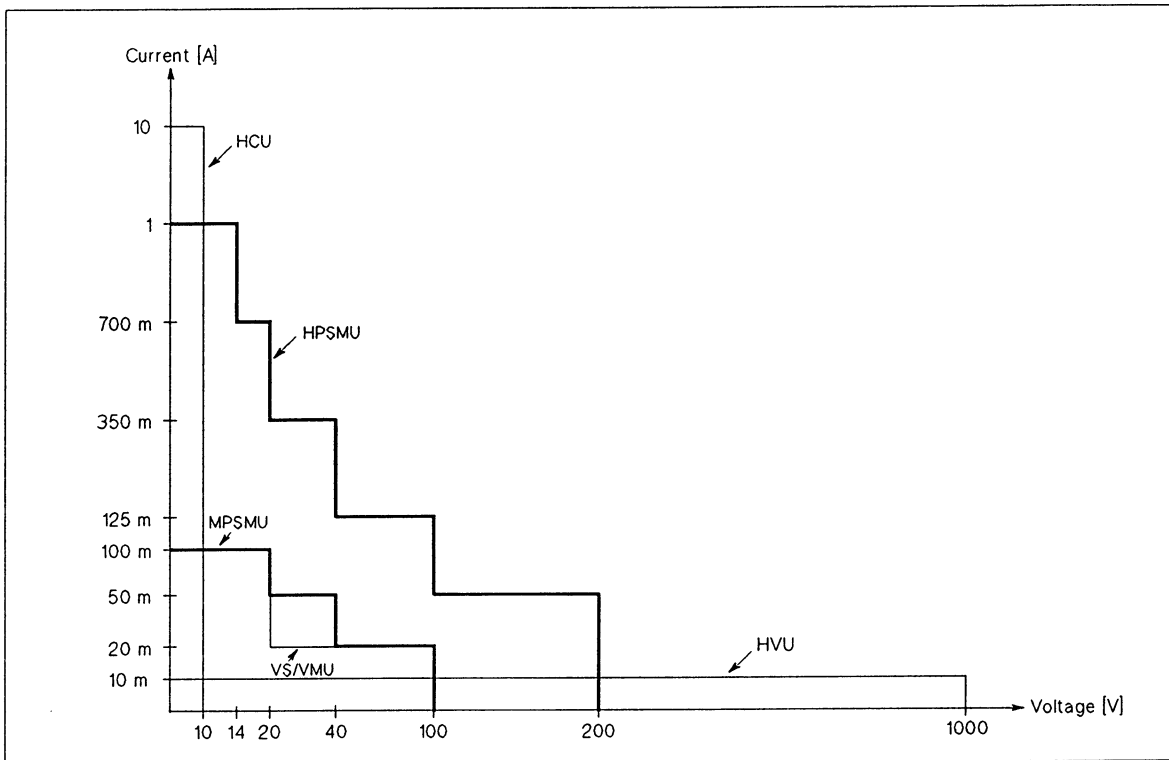

Output and Measurement Range of Plug-in Units

Ground Unit (GNDU)

The Ground Unit (GNDU) is a 0 V constant source that provides a measurement ground reference, and can sink up to ± 1.6 A. The following figure shows a simplified GNDU circuit diagram.

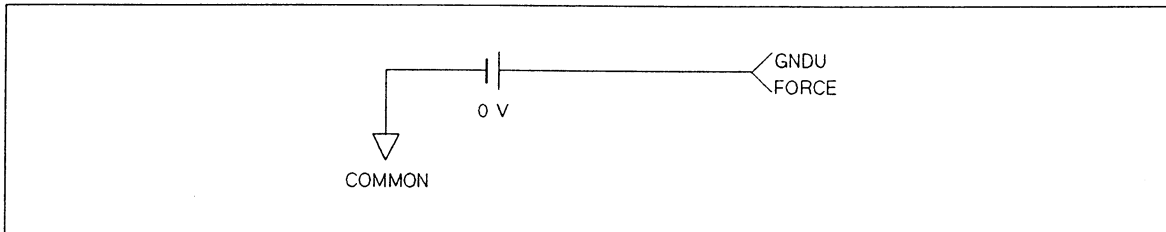

Simplified GNDU Circuit Diagram

HP 41420A HPSMU and HP 41421B MPSMU

The HP 41420A Source/Monitor Unit (High Power SMU: HPSMU) can force and measure up to ± 200 V or ± 1 A (maximum power: 14 W).

The HP 41421B Source/Monitor Unit (Medium Power SMU: MPSMU) can force and measure up to ± 100 V or ± 100 mA (maximum power: 2 W).

Each SMU functions in either of the following two modes:

- V source (constant or pulse) and I monitor
- I source (constant or pulse) and V monitor

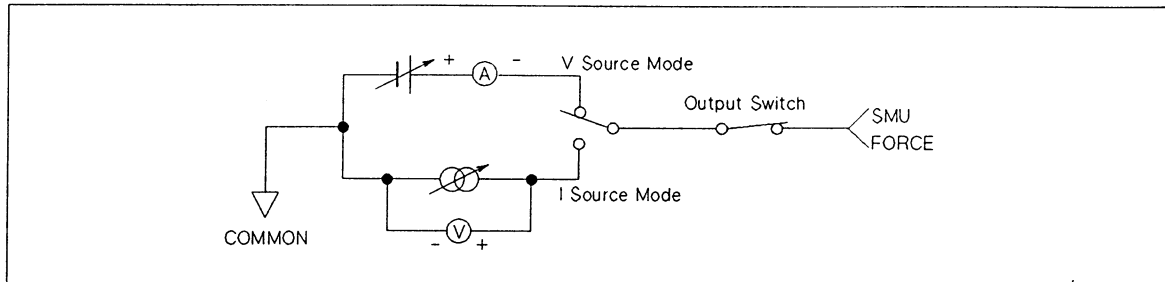

Simplified SMU Circuit Diagram

In High speed spot measurements, Analog search measurements, and Quasi-pulsed spot measurements (described later), the SMU functions in the following two modes in addition to the above two modes:

- V source (constant only) and V monitor
- I source (constant only) and I monitor

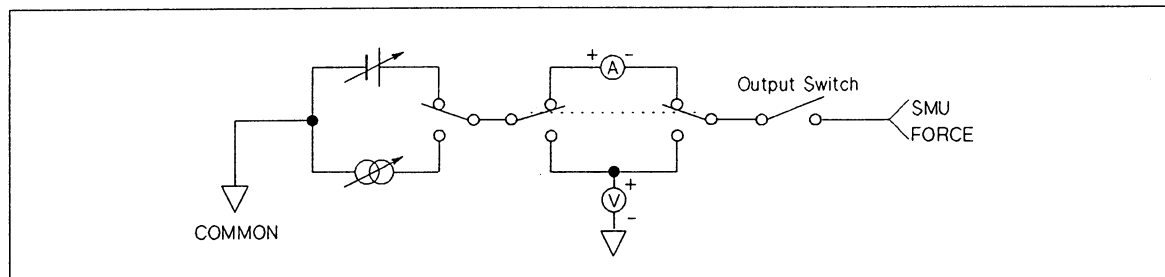

SMU Circuit Diagram

The following figure and table list HPSMU/MPSMU output and measurement ranges.

HPSMU/MPSMU Output and Measurement Ranges

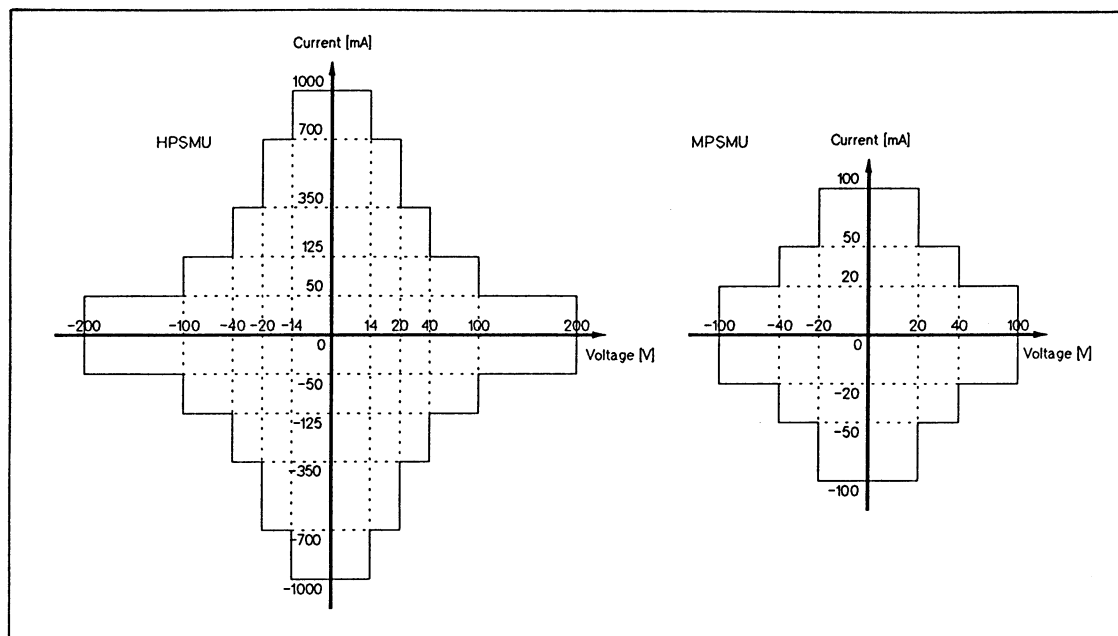

Range	Output/Measurement Value	Resolution ¹ Output/Meas.	Maximum Output	
			HPSMU	MPSMU
2 V	$0 \leq V \leq 2 \text{ V}$	100 μ V/40 μ V	$\pm 1 \text{ A}$	$\pm 100 \text{ mA}$
20 V	$0 \leq V \leq 14 \text{ V}$ $14 \text{ V} < V \leq 20 \text{ V}$	1mV/400 μ V 1mV/400 μ V	$\pm 1 \text{ A}$ $\pm 700 \text{ mA}$	$\pm 100 \text{ mA}$ $\pm 100 \text{ mA}$
40 V	$0 \leq V \leq 40 \text{ V}$	2mV/800 μ V	$\pm 350 \text{ mA}$	$\pm 50 \text{ mA}$
100 V	$0 \leq V \leq 100 \text{ V}$	5mV/2mV	$\pm 125 \text{ mA}$	$\pm 20 \text{ mA}$
200 V	$0 \leq V \leq 200 \text{ V}$	10mV/4mV	$\pm 50 \text{ mA}$	---
1 nA ²	$0 \leq I \leq 1.15 \text{ nA}$	50fA/20fA	$\pm 200 \text{ V}$	$\pm 100 \text{ V}$
10 nA ³	$0 \leq I \leq 11.5 \text{ nA}$	500fA/200fA	$\pm 200 \text{ V}^4$	$\pm 100 \text{ V}^4$
100 nA ³	$0 \leq I \leq 115 \text{ nA}$	5pA/2pA	$\pm 200 \text{ V}^4$	$\pm 100 \text{ V}^4$
1 μ A ³	$0 \leq I \leq 1.15 \text{ } \mu\text{A}$	50pA/20pA	$\pm 200 \text{ V}^4$	$\pm 100 \text{ V}^4$
10 μ A ³	$0 \leq I \leq 11.5 \text{ } \mu\text{A}$	500pA/200pA	$\pm 200 \text{ V}^4$	$\pm 100 \text{ V}^4$
100 μ A	$0 \leq I \leq 115 \text{ } \mu\text{A}$	5nA/2nA	$\pm 200 \text{ V}$	$\pm 100 \text{ V}$
1 mA	$0 \leq I \leq 1.15 \text{ mA}$	50nA/20nA	$\pm 200 \text{ V}$	$\pm 100 \text{ V}$
10 mA	$0 \leq I \leq 11.5 \text{ mA}$	500nA/200nA	$\pm 200 \text{ V}$	$\pm 100 \text{ V}$
100 mA	$0 \leq I \leq 20 \text{ mA}$ $20 \text{ mA} < I \leq 50 \text{ mA}$	5 μ A/2 μ A 5 μ A/2 μ A	$\pm 200 \text{ V}$ $\pm 200 \text{ V}$	$\pm 100 \text{ V}$ $\pm 40 \text{ V}$
1 A	$50 \text{ mA} < I \leq 115 \text{ mA}^5$ $0 \leq I \leq 50 \text{ mA}$	5 μ A/2 μ A 50 μ A/20 μ A	$\pm 100 \text{ V}$ $\pm 200 \text{ V}$	$\pm 20 \text{ V}$ ---
	$50 \text{ mA} < I \leq 125 \text{ mA}$	50 μ A/20 μ A	$\pm 100 \text{ V}$	---
	$125 \text{ mA} < I \leq 350 \text{ mA}$	50 μ A/20 μ A	$\pm 40 \text{ V}$	---
	$350 \text{ mA} < I \leq 700 \text{ mA}$	50 μ A/20 μ A	$\pm 20 \text{ V}$	---
	$700 \text{ mA} < I \leq 1 \text{ A}$	50 μ A/20 μ A	$\pm 14 \text{ V}$	---

¹ V/I Output Resolution: 1/20000, V/I Measurement Resolution: 1/50000

² The 1 nA range cannot force and measure pulse current.

³ When the pulse voltage output is in the 20 V through 200 V range, 10 nA through 10 μ A measurement ranges cannot be used.

⁴ When the pulse current output is in the 100 nA through 10 μ A range, the maximum voltage is 2 V.

⁵ For MPSMU, 100 mA

Pulse parameters are:

Pulse width: 1 ms to 50 ms, 100 μ s resolution

Pulse period: 10 ms to 500 ms, 100 μ s resolution

Maximum pulse duty (pulse width/ pulse period): 50%

Output and measurement ranges:

2 V output range: 10 nA to 1 A measurement range

20 V to 200 V output range: 100 μ A to 1 A measurement range

10 nA to 10 μ A output range: 2 V measurement range

100 μ A to 1 A output range: 2 V to 200 V measurement range

For current pulse, the pulse base current and pulse current must have the same polarity.

Each SMU includes a compliance feature that limits output voltage or current to prevent damage to your device. When the SMU forces voltage, you can specify I compliance. When the SMU forces current, you can specify V compliance. You can specify V or I compliance with the same resolution as the output voltage or current within the maximum output.

HP 41422A HCU

HP 41422A High Current Source/Monitor Unit (HCU) can force and measure up to 10 A and 10 V, and functions in either of the following two modes:

- Pulsed V source and I monitor
- Pulsed I source and V monitor

The HCU can force pulsed voltage or pulsed current, but cannot force constant voltage or constant current. When the HCU does not force a pulse value, the HCU functions as 0 V source. (Maximum current: 0.1% of the current range value. 10 mA maximum at the 10 A range.)

The following figure shows a simplified HCU circuit diagram. Although the HCU is a floating source/monitor, the LOW line of the HCU must be connected to the GNDU and fixed to 0 V. Therefore, HCU circuit (including GNDU) is equivalent to the SMU circuit.

You cannot connect an SMU, HVU, or VS in place of the GNDU.

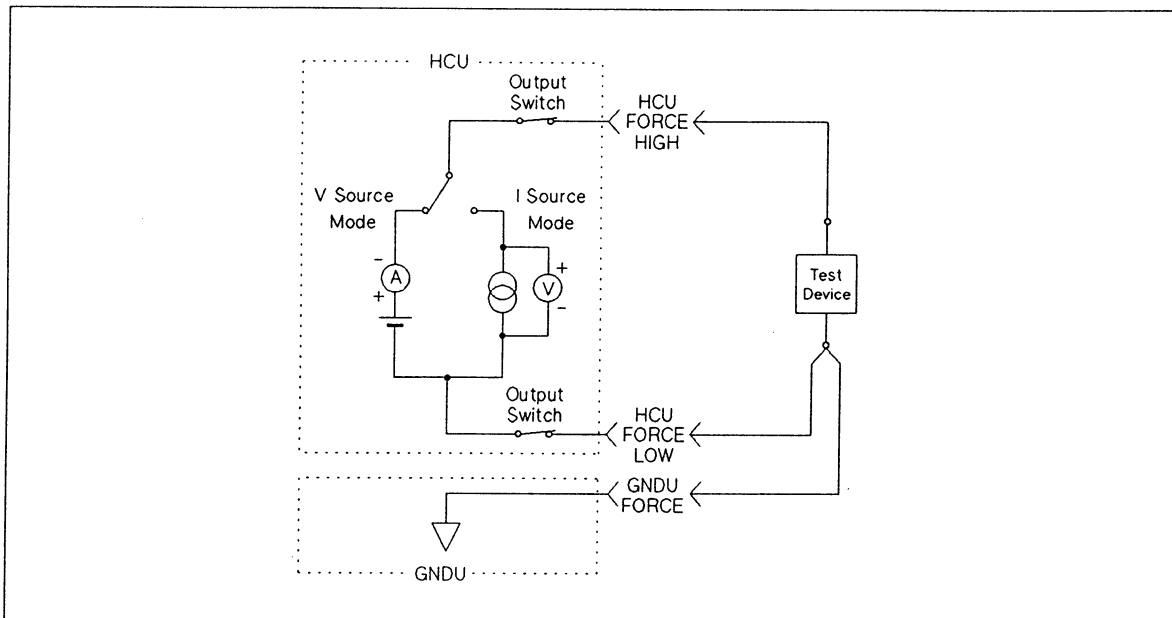

Simplified HCU Circuit Diagram

The following table shows the HCU output and measurement ranges. The HCU is a unipolar source, that is, voltage and current output are limited to the same polarity.

HCU Output/Measurement Ranges

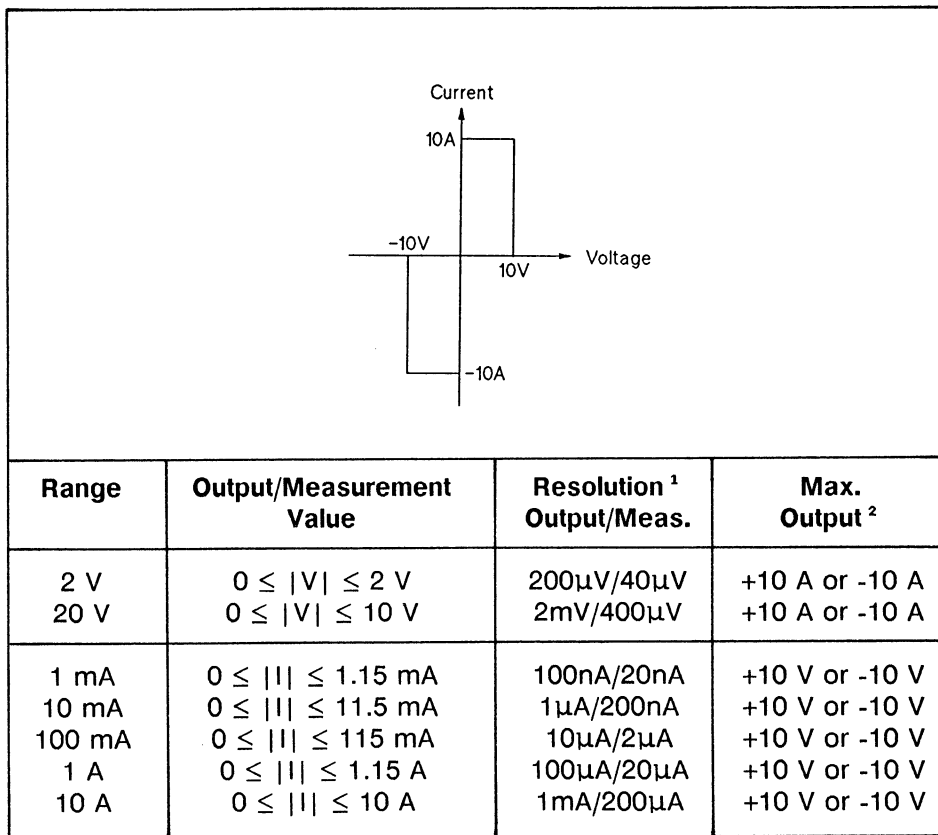

¹ V/I Output Resolution: 1/10000, V/I Measurement Resolution: 1/50000

² The polarity of maximum output is positive if the output value is positive, and negative if the output value is negative.

Pulse parameters are:

Pulse width: 100 μ s to 1 ms, 100 μ s resolution

Pulse period: 10 ms to 500 ms, 100 μ s resolution

Maximum pulse duty (pulse width/ pulse period):

10% (if output current or I compliance is 1 A or less.)

1% (if output current or I compliance is more than 1 A.)

The pulse base output is always 0 V for voltage pulse and current pulse.

An HCU includes a compliance feature that limits output voltage or current to prevent damage to your device (same as the HPSMU/MPSMUs).

HP 41423A HVU

The HP 41423A High Voltage Source/Monitor Unit (HVU) can force and measure up to ± 1000 V or ± 10 mA (maximum power: 10 W).

The HVU circuit diagram is the same as the HPSMU/MPSMU. However, the HVU cannot perform analog search measurements.

The following table shows the HVU output and measurement ranges. The HVU is a unipolar source, that is, voltage and current output are limited to the same polarity.

HVU Output/Measurement Ranges

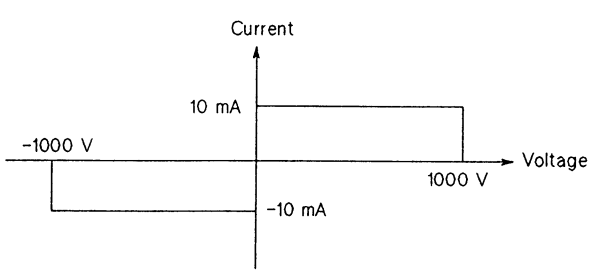

Range	Output/Measurement Value	Resolution ¹ Output/Meas.	Max. Output ²
100 V	$0 \leq V \leq 100$ V	10mV/2mV	+10 mA or -10 mA
200 V	$0 \leq V \leq 200$ V	20mV/4mV	+10 mA or -10 mA
500 V	$0 \leq V \leq 500$ V	50mV/10mV	+10 mA or -10 mA
1000 V	$0 \leq V \leq 1000$ V	100mV/20mV	+10 mA or -10 mA
100 nA	$0 \leq I \leq 115$ nA	50pA/2pA	+1000 V or -1000 V
1 μ A	$0 \leq I \leq 1.15$ μ A	500pA/20pA	+1000 V or -1000 V
10 μ A	$0 \leq I \leq 11.5$ μ A	5nA/200pA	+1000 V or -1000 V
100 μ A	$0 \leq I \leq 115$ μ A	50nA/2nA	+1000 V or -1000 V
1 mA	$0 \leq I \leq 1.15$ mA	500nA/20nA	+1000 V or -1000 V
10 mA	$0 \leq I \leq 10$ mA	5 μ A/200nA	+1000 V or -1000 V

¹ V Output Resolution: 1/10000, I Output Resolution: 1/2000, V/I Measurement Resolution: 1/50000

² The polarity of maximum output is positive if the output value is positive, and negative if the output value is negative.

Pulse parameters are:

Pulse width: 1 ms to 50 ms, 100 μ s resolution

Pulse period: 10 ms to 500 ms, 100 μ s resolution

Maximum pulse duty (pulse width/ pulse period): 50%

The pulse base value and pulse value of the HVU must have the same polarity, and the maximum voltage difference of the pulse base voltage and pulse voltage is 600 V, which is the maximum voltage difference that can be settled with a maximum pulse width of 50 ms.

An HVU includes a compliance feature that limits output voltage or current to prevent damage to your device (same as the HPSMU/MPSMUs).

HP 41424A VS/VMU

The HP 41424A V Source/V Monitor Unit (VS/VMU) provides:

- V source (constant or pulse) and I monitor (VS), 2ch
- V monitor (VM), 2ch for grounded measurement, or 1ch for differential measurement

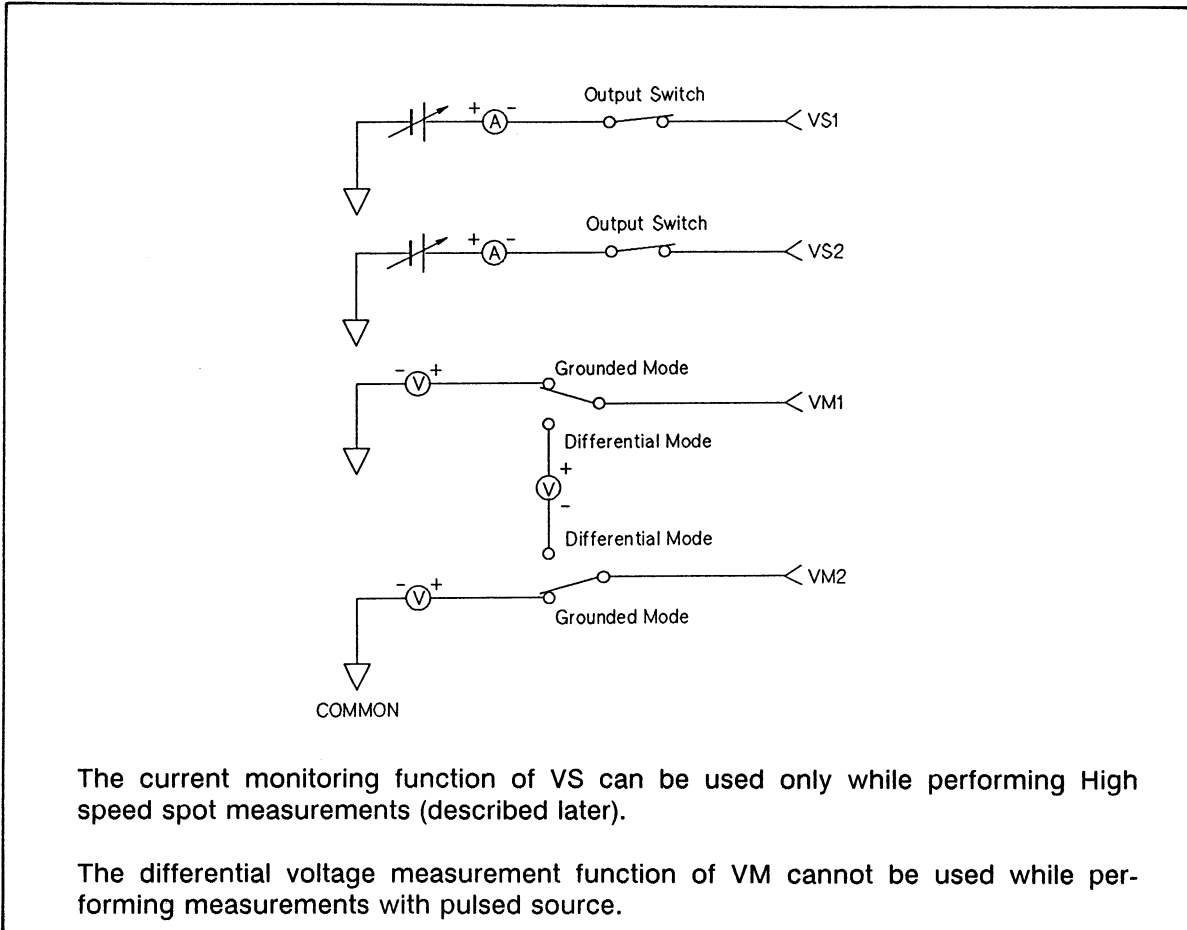

Simplified VS/VMU Circuit Diagram

VS can force up to 40 V, and VM can measure up to 40 V. The following tables show the V output range and I measurement range of VS, and the V measurement range of VM.

VS Output and Measurement Ranges

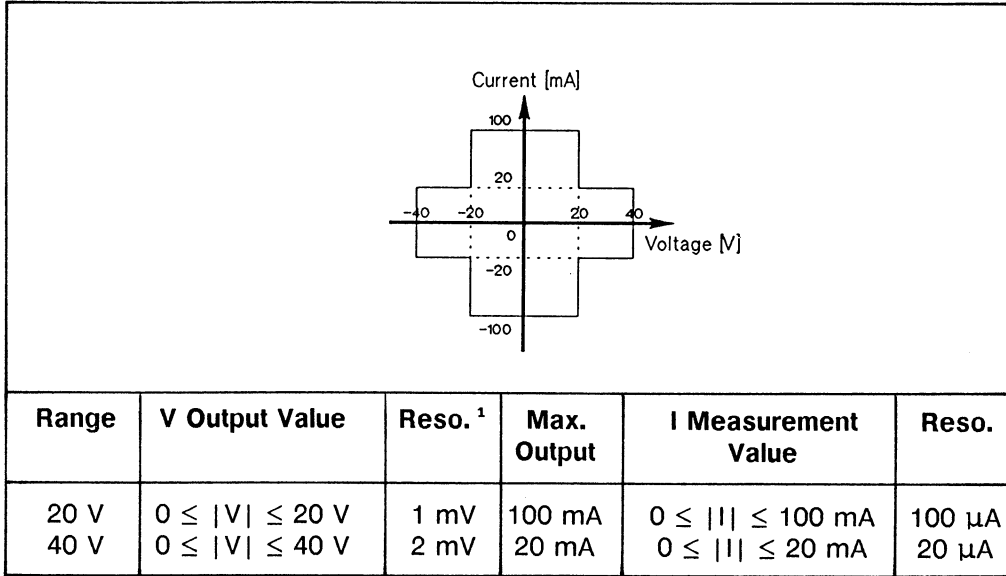

¹ V Output Resolution: 1/20000, I Measurement Resolution: 1/1000

VM Measurement Ranges

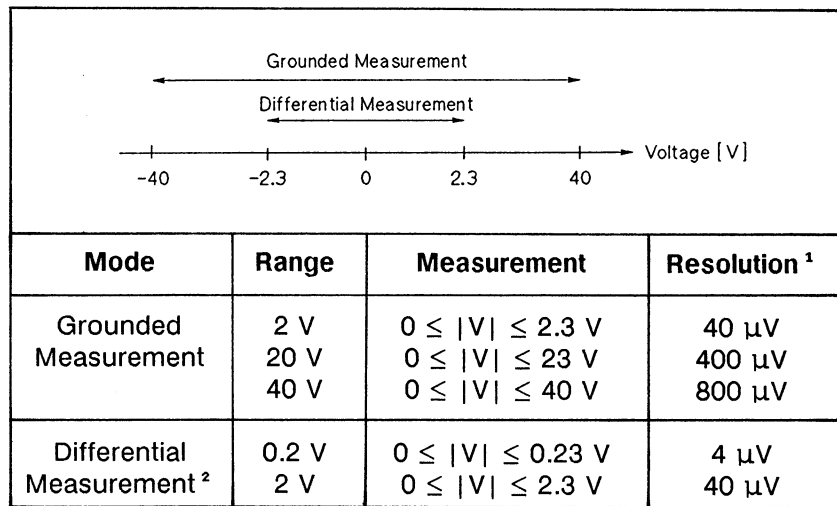

¹ V Measurement Resolution: 1/50000

² Each voltage of differential input must be within $\pm 40 \text{ V}$.

Pulse parameters are the same as the SMU:

Pulse width: 1 ms to 50 ms, 100 μs resolution

Pulse period: 10 ms to 500 ms, 100 μs resolution

Maximum pulse duty (Pulse width/ Pulse period): 50%

The VS has a current limiter. The limiter value is automatically determined by the output voltage range. If the output range is 20 V, then the current limit is 100 mA. If the output range is 40 V, then the current limit is 20 mA.

HP 41425A AFU

The HP 41425A Analog Feedback Unit (AFU) controls the output voltage of one SMU (HPSMU or MPSMU, called the search SMU), and set the monitor value of another SMU (HPSMU or MPSMU, called the sense SMU) to the specified value. The monitor is current if the sense SMU is set to V source, and it is voltage if the sense SMU is set to I source. The SMUs specified for use are automatically connected internally to the AFU. The following figure shows a simplified AFU operational diagram.

The major applications of the AFU are:

- Bipolar transistor hFE measurement at the specified collector voltage and collector current.
- MOSFET Vth measurement at the specified drain voltage and drain current.

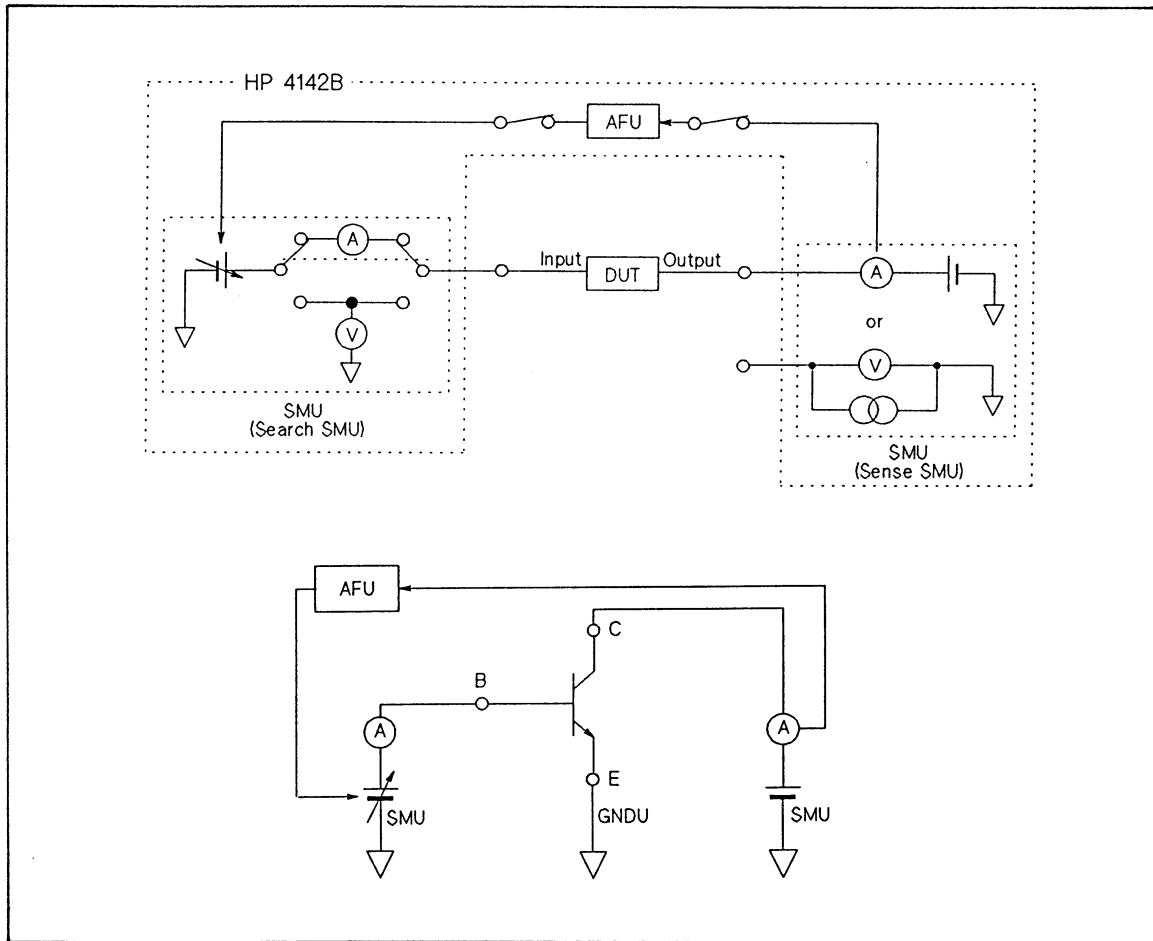

Simplified AFU Operational Diagram

Measurement Modes

By using the measurement units, you can perform the following ten types of measurements. The output waveform and available units are shown for each measurement mode in the following figure. The explanation number below corresponds to the No. in the figure.

- 1) Spot measurements
Up to 16 sources force constant voltages and currents, and up to 8 monitors measure the outputs.
- 2) Staircase sweep measurements
One source sweeps constant V or I, while up to 8 monitors measure the outputs.
Or two sources sweep constant voltages or currents at the same time, while up to 8 monitors measure the outputs.
- 3) 1ch pulsed spot measurements
One source forces pulsed V or I, and one monitor measures the output.
- 4) Pulsed sweep measurements
One source sweeps pulsed V or I, while one monitor measures the output.
- 5) Staircase sweep with pulsed bias measurements
One source sweeps constant V or I, and another source forces pulsed V or I with synchronized sweep output, while one monitor measures the output.
- 6) Analog search measurement
Searches for a specified current or voltage on one SMU by controlling the voltage output of another SMU.
The AFU is required.
- 7) 2ch pulsed spot measurements
Two sources force pulsed outputs at the same time, and one monitor measures the output.
At least one pulsed source must be an HCU.
- 8) Pulsed sweep with pulsed bias measurement
One source sweeps pulsed V or I, and another source forces pulsed V or I with synchronized sweep pulsed output, while one monitor measures the output.
At least one pulsed source must be an HCU.
- 9) Quasi-pulsed spot measurement
One source and monitor unit forces voltage and detects when the voltage is settled, then the same or another monitor measures the output. Immediately after the measurement, the source and monitor unit returns to the original voltage.
- 10) High speed spot measurement
Up to 16 sources force constant voltages and currents, and one monitor measures the outputs. You can perform the measurement with fewer commands than spot measurement.

Available Units in Each Measurement Mode

No.	Output Waveform	Source				Monitor						AFU
		SMU (V/I)	HCU (V/I)	HVU (V/I)	VS (V)	SMU (V/I)	HCU (V/I)	HVU (V/I)	VS (I)	VM		
										(V ¹)	(VD ²)	
1		●		●	●	●		●		●	●	
2		●		●	●	●		●		●	●	
		●		●	●	●		●		●	●	
3		●	●	●	●	●	●	●		●		
4		●	●	●	●	●	●	●		●		
5		●		●	●	●	●	●		●		
		●	●	●	●	●	●	●		●		
6		●				●						●
		●				●						
7		● ³	●			●	●	●		●		
		● ³	●			●	●	●		●		
8		● ³	●			●	●	●		●		
		● ³	●			●	●	●		●		
9		●		●		●		●				
10		●		●	●	●		●	●	●	●	

- ¹ Grounded measurement mode
- ² Differential measurement mode
- ³ At least one pulsed source must be an HCU.

Total Power Limitation of Plug-in Units

Total SMU, HCU, HVU, and VS power consumption must not exceed 32 W. If you do not have an HPSMU, an HCU, an HVU, or more than six VS/VMUs, total power consumption can not reach 32 W. Your HP 4142B is not limited by the total power of the units. Power consumption depends on the output settings for voltage and current, and is calculated as follows. Note that when the output switch of the unit is set to OFF, the power of that unit is 0 W.

Unit	Power ¹
SMU	2 V, 20 V range ² : 20(Iset ³) [W] 40 V range: 40(Iset) [W] 100 V range: 100(Iset) [W] 200 V range: 200(Iset) [W]
HCU	20(Iset)(pulse duty ⁴)+10 [W]
HVU	(Vset ⁵)(Iset)+10 [W]
VS	20 V range: 2.2 [W] 40 V range: 0.88 [W]

¹ Output switch set to OFF: 0 W

The power of each unit is rounded down to the nearest hundredth. For example, if the calculation result is 1.057 W, then power = 1.05 W. If 0.002 W, then power = 0 W.

² If the SMU is the I source mode, voltage range is the lowest range that includes the voltage compliance value. For example, if you set the voltage compliance to 5 V, voltage range is 20 V.

³ Iset is the specified output current value at I source mode, and is the specified current compliance value at V source mode.

⁴ The pulse duty is defined: (pulse duty) = (pulse width/ pulse period).

⁵ Vset is the specified output voltage value at V source mode, and is the specified voltage compliance value at I source mode.

Maximum value of power consumption for these units is as follows.

HPSMU: 20 W
 MPSMU: 2 W
 HCU: 12 W
 HVU: 20 W
 VS/VMU: 4.4 W

For example, if you have two HPSMUs, total maximum power consumption is 40 W (20 W + 20 W) and exceeds 32 W. You cannot force the maximum output of each unit at the same time. The maximum current of the two units is limited to 1.6 A (32W/20V).

PANEL OVERVIEW

The following figures point out important locations on the HP 4142B. The name of each part is referenced in this manual.

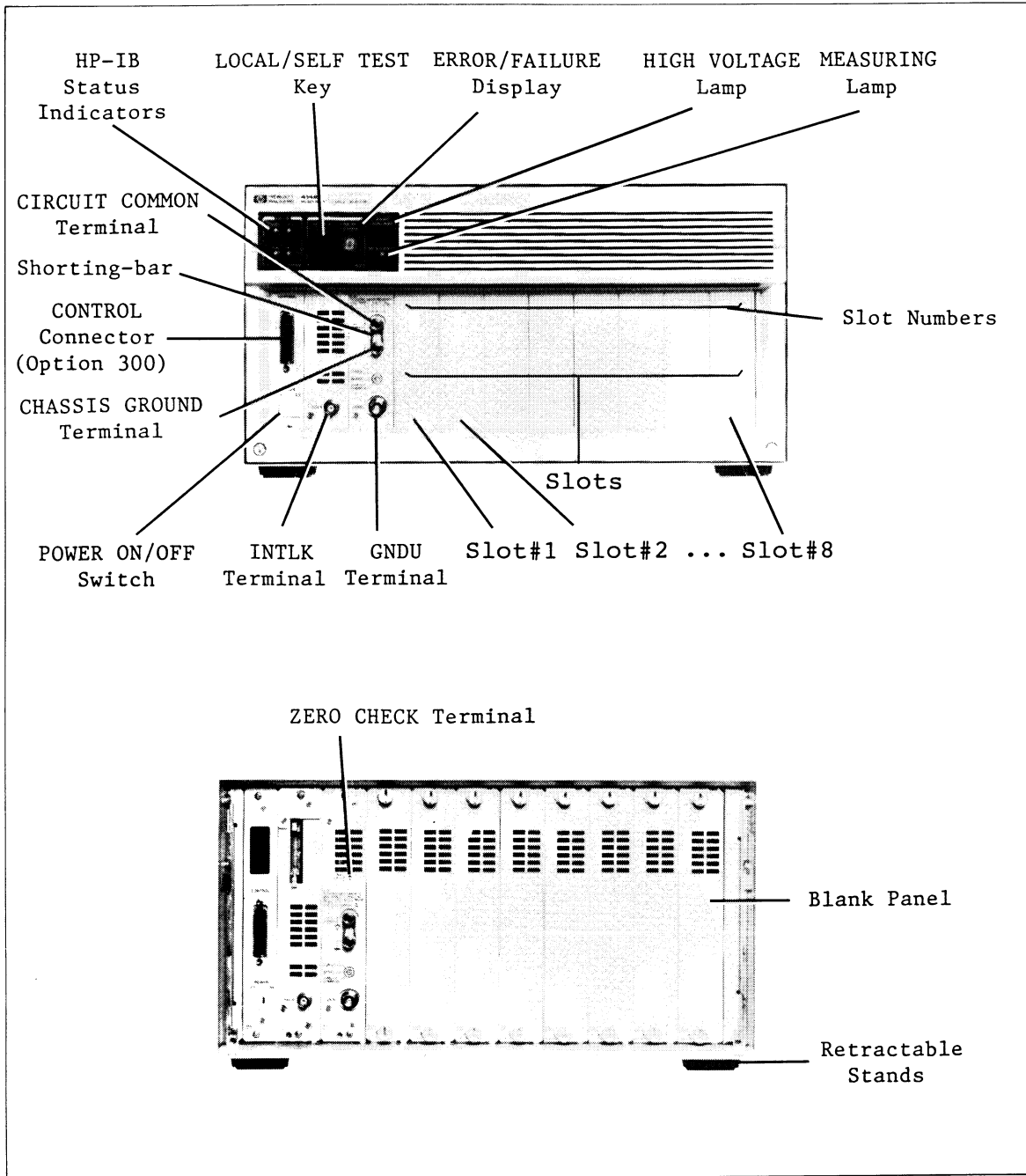

HP 4142B Panel Overview (1 of 2)

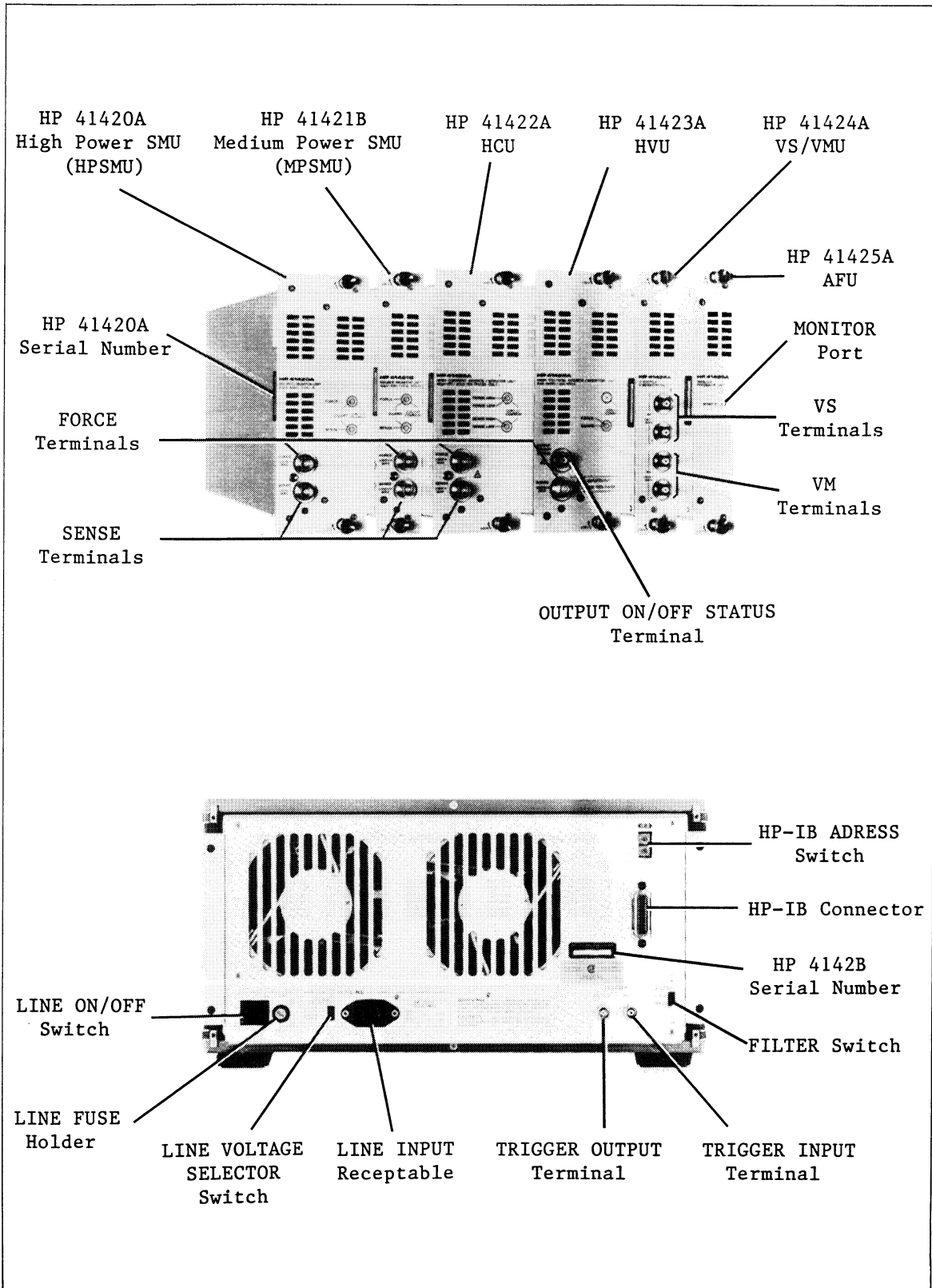

HP 4142B Panel Overview (2 of 2)

CHAPTER 3

TEST DEVICE CONNECTIONS

CONTENTS

Introduction	3-1
Before Connecting Test Devices	3-1
Enclose the Test Device with a Shielding Box	3-1
Connect the INTLK Terminal	3-2
Shorting Circuit Common and Chassis Ground Terminals	3-4
Connecting the Test Devices	3-5
GNDU Connections	3-5
HPSMU and MPSMU Connections	3-7
HCU Connections	3-12
HVU Connections	3-17
VS/VMU Connections	3-22
Using the Connection Accessories	3-23
Using Connector Plate Part Number 04142-60021	3-23
Using Connector Plate Part Number 04142-60032	3-24
Using Connector Plate Part Number 16087-60002	3-25
Using the HP 16088B Test Fixture	3-26
Using the HP 16058A Test Fixture	3-31
Using the HP 16087A Module Selector	3-33
Cable Reference Data	3-42
Advanced Connection Information	3-45
For High Current Measurements (Kelvin Connection)	3-45
For Low Current Measurements (Using the GUARD Terminal)	3-47
If the Test Device is Externally Grounded (Floating Measurement)	3-48
If the Test Device has Negative Resistance	3-50
Preventing Oscillation from the Test Device	3-51

INTRODUCTION

This chapter explains test device connection considerations and methods, and provides procedures to obtain optimum measurement results.

Be sure to observe all **WARNINGS**, **CAUTIONS**, and **NOTES** to ensure your safety and to maintain the integrity of the HP 4142B.

BEFORE CONNECTING TEST DEVICES

Before you connect the test devices to the source or monitor unit, perform the following steps.

Enclose the Test Device with a Shielding Box

When you perform measurements, enclose the test device (wafer prober or user-fabricated test fixture) with a box to prevent the operator from receiving an electric shock from the output voltage or current of the HP 4142B. Use a grounded shielding box to minimize the effects of environmental noise and ambient light. To ground the shielding box, connect it to the chassis ground of the HP 4142B by using the **CHASSIS GROUND** terminal or the outer conductor of the **INTLK** terminal.

Connect the INTLK Terminal

To prevent an operator from receiving an electric shock from the high voltage (more than ± 42 V), connect the **INTLK** (interlock) terminal to a switch that turns on when the shielding box access door is closed, and that turns off when the shielding box access door is opened. For safety, use two switches in series. The following figure shows the connections.

If the door is open (the center conductor of the **INTLK** terminal is open), the SMU can not force more than ± 42 V, the HVU output switch is not set to on, and the HVU Self-Test/Self-Calibration is not performed. If the door is opened while the SMU output is more than ± 42 V, or while the HVU output switch is set to on, the HP 4142B immediately drops the outputs of all units down to 0 V and the HVU output switch is set to off. If the door is opened during the HVU Self-Test/Self-Calibration, the HVU Self-Test/Self-Calibration is discontinued.

Conversely, if the door is closed (**INTLK** terminal is shorted, that is, the **INTLK** center conductor is set to the chassis ground), this function is disabled.

When the **INTLK** terminal is open, the voltage is 5 V. When the **INTLK** terminal is shorted, the current is about 2.8 mA ($5 \text{ V} / 1.8 \text{ k}\Omega$).

To ground the shielding box, connect it to the outer conductor (chassis ground) of the **INTLK** terminal.



DANGEROUS VOLTAGES OF UP TO THE MAXIMUM VOLTAGE OF THE SMU/HVU MAY BE PRESENT AT THE FORCE, GUARD, AND SENSE TERMINALS WHEN THE INTLK TERMINAL IS SHORTED.

EVEN IF THE INTLK TERMINAL IS OPEN, TURN THE HP 4142B OFF AND DISCHARGE ANY CAPACITORS BEFORE YOU TOUCH THE CONNECTIONS OF THESE TERMINALS. IF YOU CANNOT TURN THE HP 4142B OFF, REFER TO THE "SAFETY PRECAUTIONS" DESCRIBED IN "BEFORE APPLYING POWER," CHAPTER 4.

IF YOU DIRECTLY CONTROL AN HP 4142B THAT IS USED INSIDE A SYSTEM PRODUCT, CONFIRM THAT THE INTERLOCK FUNCTION OF THE HP 4142B WORKS BEFORE USE. FOR A SYSTEM PRODUCT, THE HP 4142B INTERLOCK FUNCTION MAY NOT BE USED BECAUSE THE SYSTEM ITSELF HAS INTERLOCK FUNCTION.

INTLK Terminal Connection Circuit Diagram:

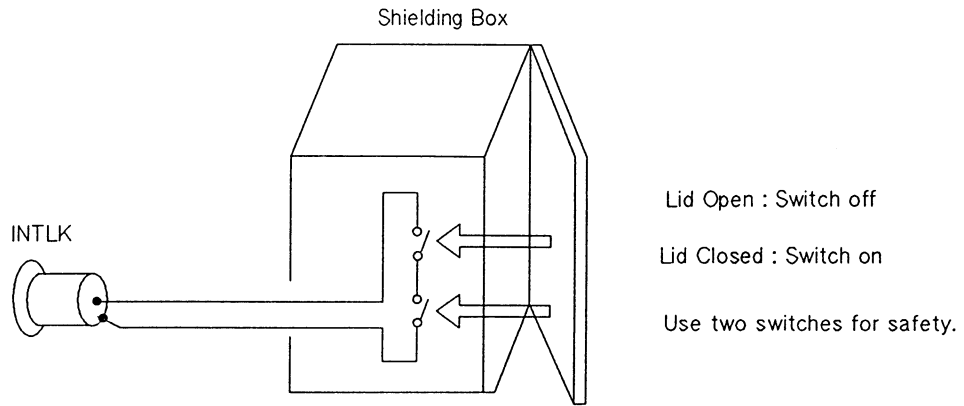

INTLK Terminal Connection:

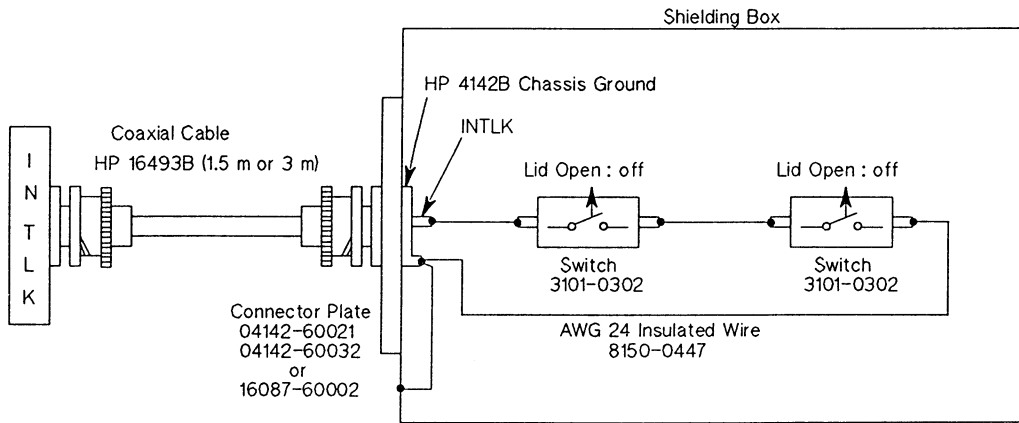

Interlock Switch (Part Number 3101-0302):

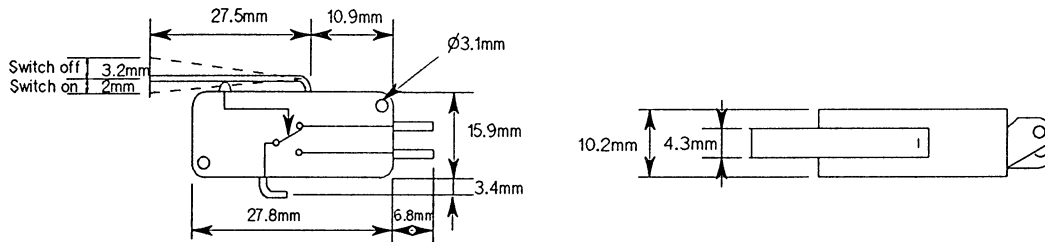

Connections of the INTLK Terminal

Shorting Circuit Common and Chassis Ground Terminals

Short the **CIRCUIT COMMON** and **CHASSIS GROUND** terminals together with the shorting-bar installed on the **CHASSIS GROUND** terminal.

WARNING

A POTENTIAL SHOCK HAZARD EXISTS IF THE CIRCUIT COMMON TERMINAL IS NOT TIED TO CHASSIS GROUND (SHORTING-BAR DISCONNECTED FOR FLOATING MEASUREMENTS). DO NOT TOUCH ANY FRONT PANEL CONNECTORS OF THE HP 4142B AT ANY TIME WHILE A FLOATING MEASUREMENT IS IN PROGRESS.

If you disconnect the shorting-bar, see "If the Test Device is Externally Grounded (Floating Measurement)" in this chapter.

CONNECTING THE TEST DEVICES

The following paragraphs discuss test device connection considerations and methods, and provide procedures for obtaining optimum measurement results.

GNDU Connections

GNDU can be connected to test devices using kelvin connections. The following figure shows and describes several GNDU/test device connection methods: one for kelvin connections, and one for non-kelvin connections.

WARNING

DO NOT USE THE HP 16493C TRIAXIAL CABLE OF THE SMU TO CONNECT THE GNDU TO A TEST DEVICE. THE GNDU CAN SINK UP TO 1.6 A, AND THE MAXIMUM CURRENT RATING OF THE CABLE IS 1 A.

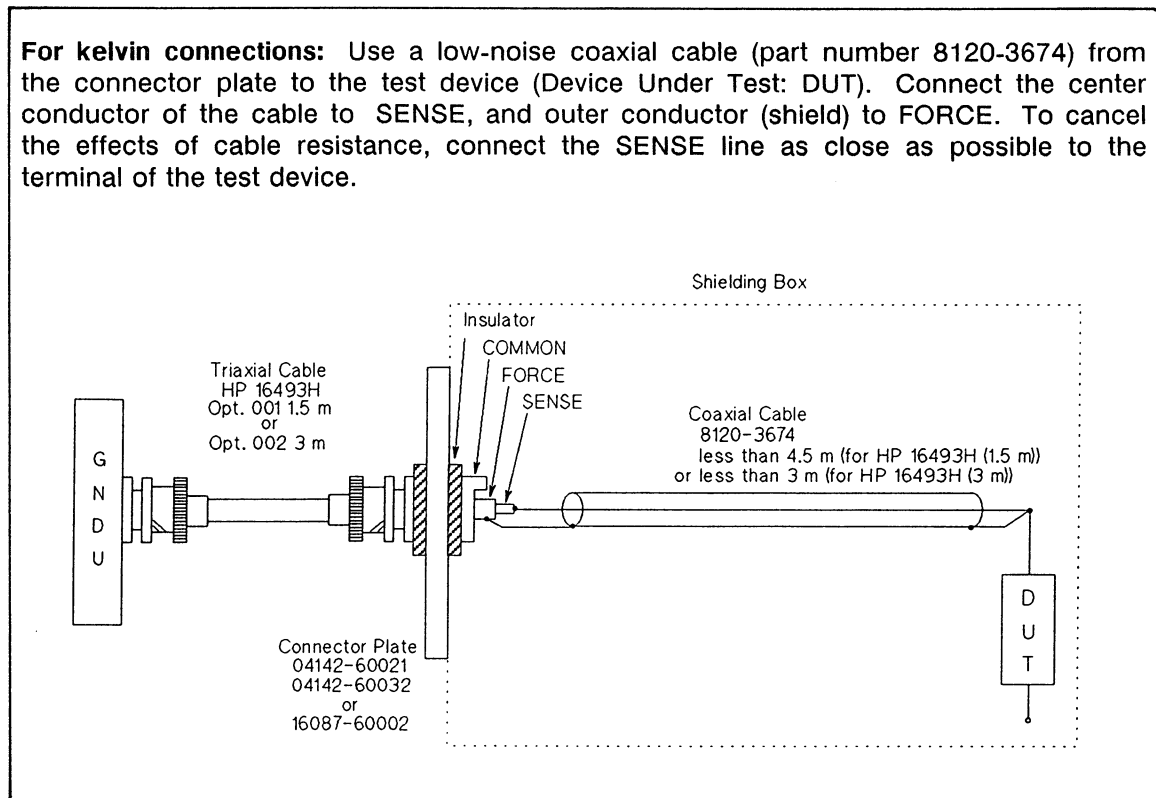

GNDU Example Connections (1 of 2)

For non-kelvin connections: Short SENSE and FORCE at the connector plate as shown. Use AWG 24 single-strand insulated wire (part number 8150-0447) from the connector plate to the test device (DUT). Measurement results include the residual resistance of the connection wire.

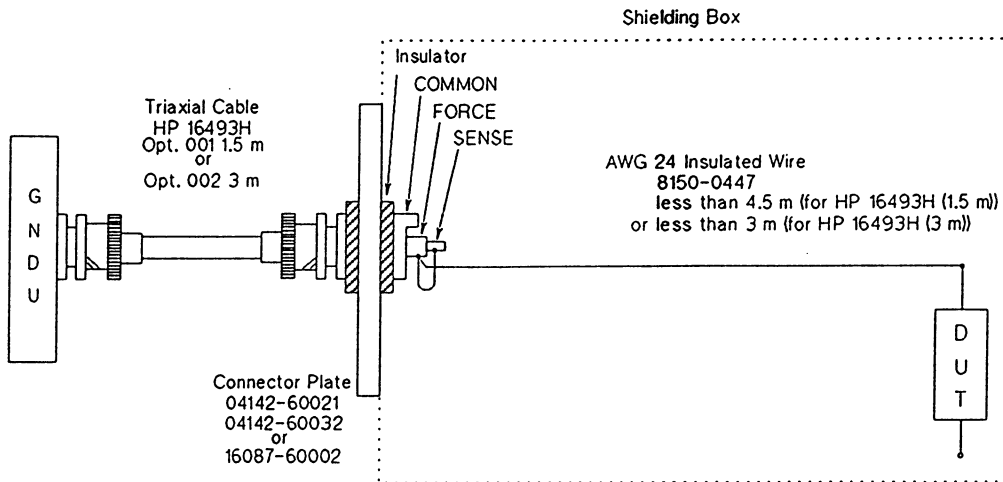

NOTE

To easily connect GNDU for a measurement in which the accuracy is not important, connect only FORCE to the test device (DUT), without shorting SENSE and FORCE.

GNDU Example Connections (2 of 2)

NOTE

If you make a kelvin connection using another cable or connection tool, make the FORCE line wiring resistance (from FORCE terminal to the sensing point) less than 1 Ω , and make the SENSE line wiring resistance (from SENSE terminal to the sensing point) less than 10 Ω .

If the wiring resistance exceeds these values, do not use a kelvin connection (SENSE terminal) because the GNDU output voltage includes a large error. Refer to the following FORCE wiring resistance.

- HP 16493H Opt. 001 1.5 m Triaxial Cable: 80 m Ω
- HP 16493H Opt. 002 3 m Triaxial Cable: 150 m Ω
- 8120-3674 Coaxial Cable: 133 m Ω /m
- 8150-0447 AWG 24 wire: 89 m Ω /m

HPSMU and MPSMU Connections

The HPSMU and MPSMU can be connected to test devices using kelvin connections. For highly accurate current forcing and measurements while minimizing leakage, the FORCE and SENSE terminals are surrounded by a GUARD terminal that has the same potential as the output. The following figure shows and describes several SMU/test device connections.

WARNING

THE SMU FORCES DANGEROUS VOLTAGES OF UP TO ± 200 V (± 100 V FOR MPSMU) AT THE FORCE, SENSE, AND GUARD TERMINALS.

TO PREVENT ELECTRICAL SHOCK, DO NOT EXPOSE THESE LINES.

BEFORE TURNING THE HP 4142B ON, CONNECT THE INTLK TERMINAL TO A SWITCH THAT TURNS OFF WHEN THE SHIELDING BOX ACCESS DOOR IS OPENED.

BEFORE YOU TOUCH THE CONNECTIONS OF THESE TERMINALS, TURN THE HP 4142B OFF AND DISCHARGE ANY CAPACITORS. IF YOU CANNOT TURN THE HP 4142B OFF, REFER TO THE "SAFETY PRECAUTIONS" DESCRIBED IN "BEFORE APPLYING POWER," CHAPTER 4.

CAUTION

NEVER connect the GUARD terminal to any output, including CIRCUIT COMMON, CHASSIS GROUND, or the GUARD terminal of any other unit. Doing so will result in SMU damage.

For kelvin connections: Use a low-noise coaxial cable (part number 8120-3674) from the connector plate to the test device. Connect the center conductor of one of the cables to FORCE, the center conductor of the other cable to SENSE, and the outer conductors (shields) of both cables to GUARD. To cancel the effects of cable resistance, connect the SENSE line as close as possible to the terminal of the test device. To prevent oscillations when making dc measurements, do not use cables longer than 1.5 m (for using HP 16493D 3 m cable) or 2.5 m (for using HP 16493D 1.5 m cable). For highly accurate current forcing and measurements while minimizing leakage, surround all FORCE and SENSE lines on the SMU by a GUARD as far as possible.

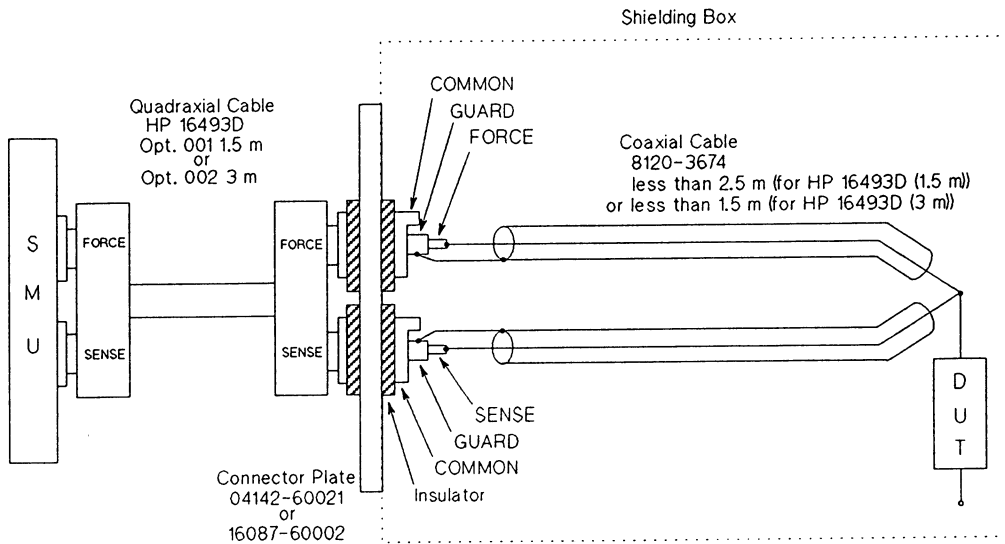

NOTE

One quadraxial cable can be replaced by two triaxial cables. If you use the HP 16493C Opt. 001 1.5 m triaxial cable, make the length of the coaxial cable less than 2 m. If you use the HP 16493C Opt. 002 3 m triaxial cable, make the length of the coaxial cable less than 75 cm.

SMU Example Connections (1 of 3)

For non-kelvin connections: The total connection cable length can be increased to 6 m by shorting SENSE and FORCE at the connector plate, as shown below. Measurement results include residual resistance from the connection wire. To enable highly accurate current forcing and measurements while minimizing leakage, surround all FORCE lines on the SMU by a GUARD as far as possible.

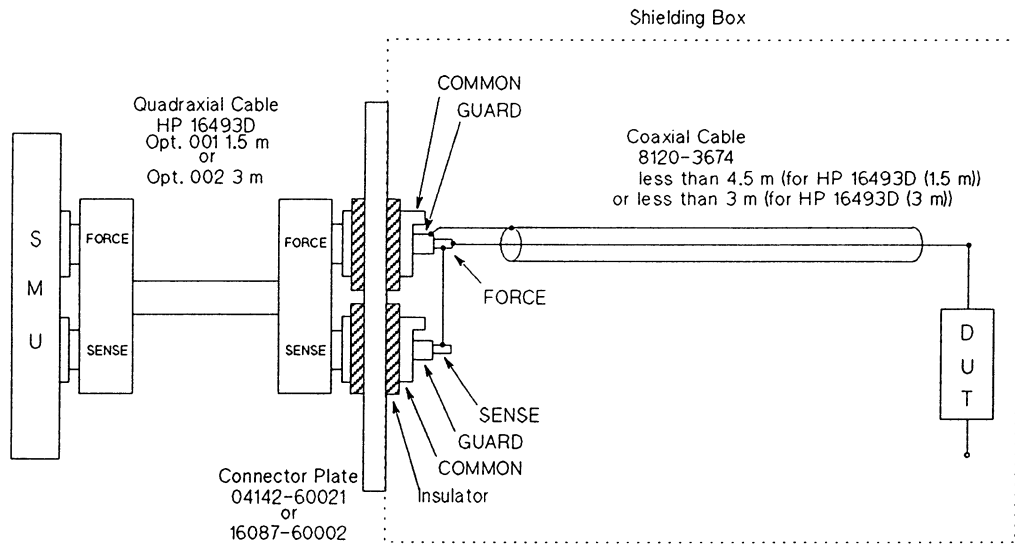

NOTE

One quadaxial cable can be replaced with two triaxial cables. If you use the HP 16493C Opt. 001 1.5 m triaxial cable, make the coaxial cable length less than 4 m. If you use the HP 16493C Opt. 002 3 m triaxial cable, make the coaxial cable length less than 1.5 m.

SMU Example Connections (2 of 3)

For non-kelvin connections: When current flow is minimum, i.e., the connection cable residual resistance is unimportant, the following connection method can be used. To use this method, be sure to connect a triax cover (part number 1250-1708) to the SENSE terminal of the SMU to provide shielding. For highly accurate current forcing and measurements while minimizing leakage, surround the FORCE line of the SMU with a GUARD as far as possible.

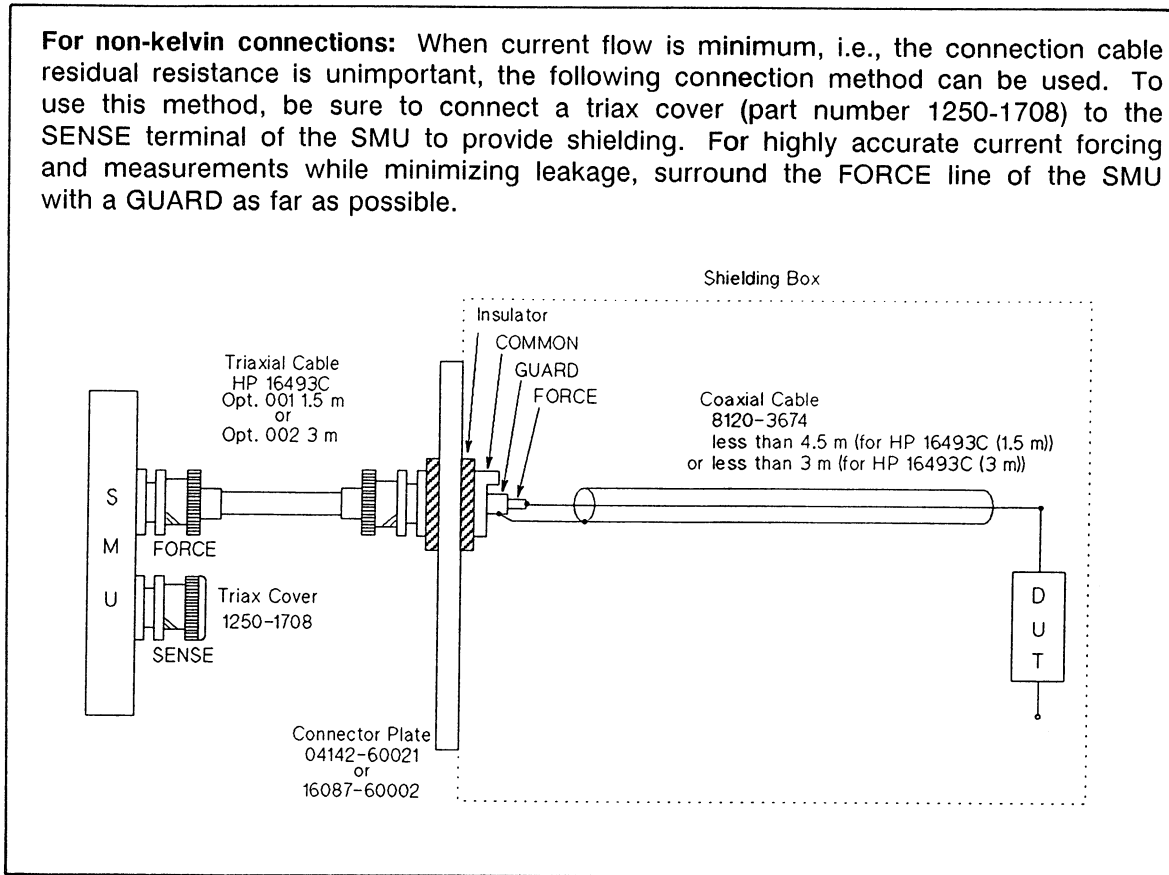

SMU Example Connections (3 of 3)

Connecting the SMU by another method

If you connect the SMU by a method that is not shown in the above figure, make the wiring capacitance and resistance as follows.

- Guard Capacitance \leq 900 pF (Recommendation: less than 600 pF)
- Shield Capacitance \leq 5000 pF
- FORCE Resistance \leq 0.7 Ω (If output current is 1 A.)
- FORCE Resistance \leq 10 Ω (If output current is less or equal to 100 mA.)
- SENSE Resistance \leq 10 Ω

- Guard Capacitance:

To prevent SMU oscillation, make the guard capacitance of the wiring cable less than 600 pF. The guard capacitance is the total cable capacitance between the FORCE and GUARD lines and between the SENSE and GUARD lines. Refer to the following guard capacitance data. For quadraxial cables, the following data is total guard capacitance.

HP 16493D Opt. 001	1.5 m Quadraxial Cable: 150 pF
HP 16493D Opt. 002	3 m Quadraxial Cable: 300 pF
HP 16493C Opt. 001	1.5 m Triaxial Cable: 120 pF
HP 16493C Opt. 002	3 m Triaxial Cable: 240 pF
8120-3674	Coaxial Cable: 77 pF/m

Do not use the GNDU cable (HP 16493H) because guard capacitance is too large (Opt. 001: 550 pF, Opt. 002: 1100 pF).

- Shield Capacitance:

To prevent SMU oscillation, make the shield capacitance of the wiring cable less than 5000 pF. The shield capacitance is the total cable capacitance between the GUARD for FORCE and CIRCUIT COMMON lines and between the GUARD for SENSE and CIRCUIT COMMON lines. Refer to the following shield capacitance data. For quadraxial cables, the following data is total shield capacitance.

HP 16493D Opt. 001	1.5 m Quadraxial Cable: 1200 pF
HP 16493D Opt. 002	3 m Quadraxial Cable: 2400 pF
HP 16493C Opt. 001	1.5 m Triaxial Cable: 900 pF
HP 16493C Opt. 002	3 m Triaxial Cable: 1800 pF

- FORCE and SENSE Resistances:

If you perform a kelvin connection, make FORCE resistance of the wiring cable less than 0.7 Ω if output current is 1 A, and less than 10 Ω if output current is less than or equal to 100 mA, and make SENSE resistance less than 10 Ω . If the cable resistance exceeds these values, do not use a kelvin connection (SENSE terminal) because the SMU output is not a specified value and the actual output voltage or current value includes a large error. Refer to the following FORCE resistance data.

HP 16493D Opt. 001	1.5 m Quadraxial Cable: 150 m Ω
HP 16493D Opt. 002	3 m Quadraxial Cable: 300 m Ω
HP 16493C Opt. 001	1.5 m Triaxial Cable: 160 m Ω
HP 16493C Opt. 002	3 m Triaxial Cable: 320 m Ω
8120-3674	Coaxial Cable: 133 m Ω /m

HCU Connections

The HCU can be connected to test devices using kelvin connections. The following figure shows several HCU/ connections.

NOTE

You can not use the HCU as a normal floating source. Whenever you use the HCU, connect GNDU to the FORCE LOW line of the HCU, and fix FORCE LOW to 0 V. Do not connect the SMU, HVU, or VS instead of the GNDU because the SMU, HVU, or VS will not operate correctly.

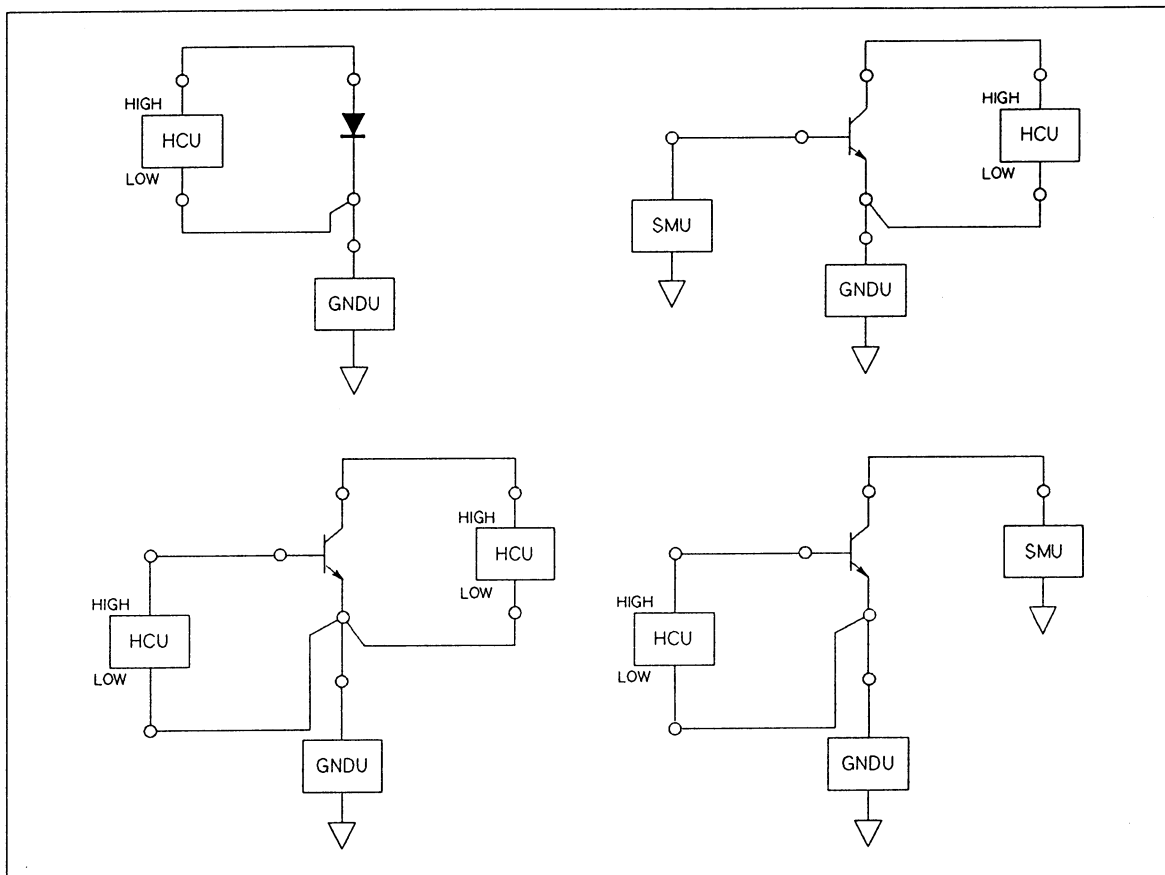

HCU Example Connection (1 of 2)

For the FORCE line connection, use an AWG 16 (1.29 mm in diameter) single-strand insulated wire (part number 8150-2605) from the connector plate to the test device. Make the wire length less than 1 m if you use 3 m wire (HP 16493E Opt. 002), and less than 1.2 m if you use 1.5 m wire (HP 16493E Opt. 001). Twist the FORCE HIGH and FORCE LOW lines together to prevent the increase of settling time and the occurrence of overshoot and noise from wire inductance. If the wire length is too short to twist the wires, tie the two wires together with string, as shown in the figure below.

For the SENSE line connection, use an AWG 24 (0.511 mm diameter) single-strand insulated wire (part number 8150-0447) from the connector plate to the test device. Make the length of the wire less than 3 m. Twist the SENSE HIGH and SENSE LOW lines together or tie the two wires together with string. To cancel the effects of residual resistance from the wire, connect the SENSE HIGH and SENSE LOW lines as close as possible to the test device.

Connect the FORCE and SENSE lines of GNDU to the same terminal of the test device (DUT) in which you connected the FORCE LOW and SENSE LOW lines of the HCU. For GNDU connections, see "GNDU Connections."

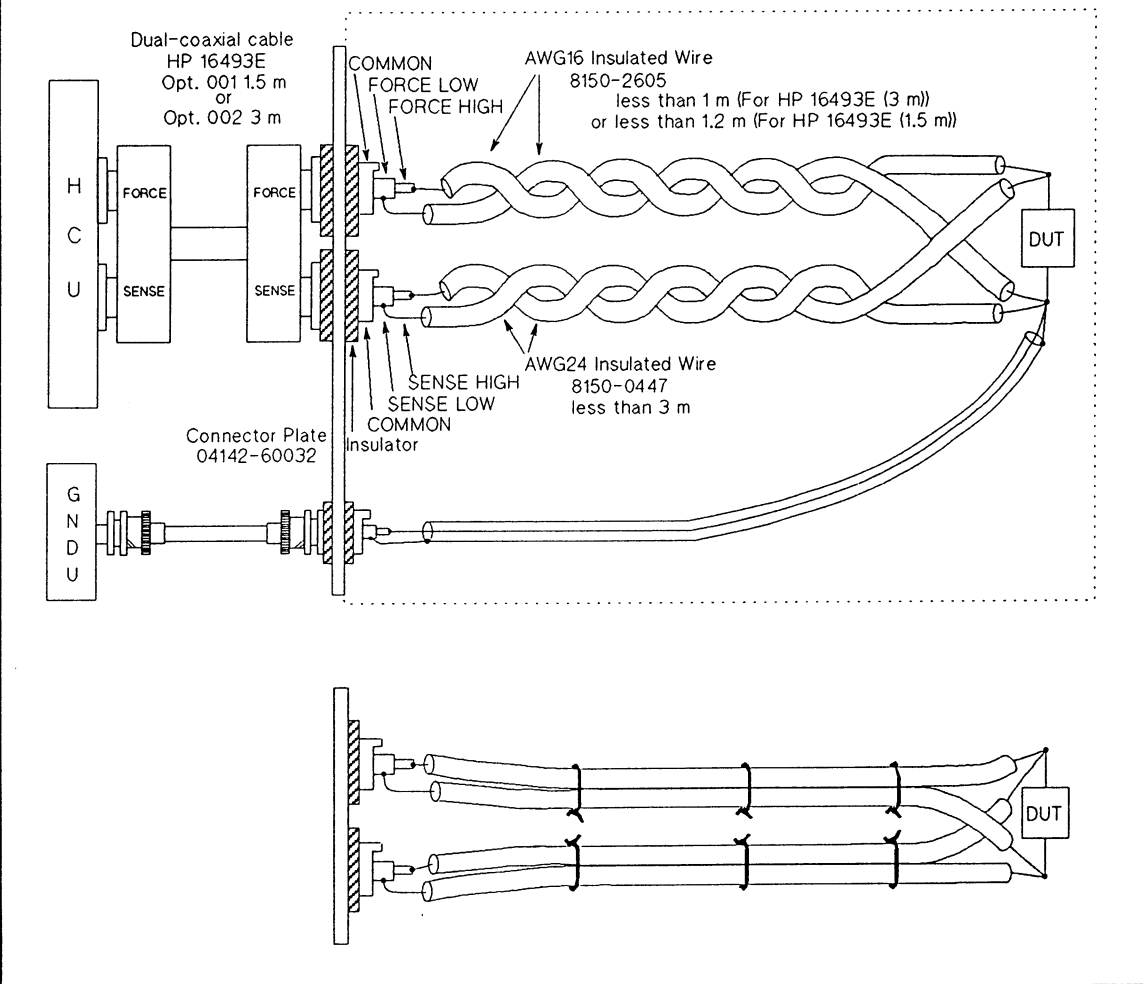

HCU Example Connection (2 of 2)

Connecting the HCU by another method

If you connect the HCU by a method that is not shown in the above figure, make the wiring resistance and inductance as follows.

- Total Resistance of FORCE HIGH and FORCE LOW $\leq 300 \text{ m}\Omega$
(If forcing 10 V and 10 A with a pulse width of 1 ms)
- SENSE HIGH or SENSE LOW Resistance $\leq 10 \text{ }\Omega$
- FORCE Inductance between HIGH and LOW $< 1000 \text{ nH}$
(If (total resistance of FORCE HIGH and FORCE LOW) $\geq 250 \text{ m}\Omega$)

- FORCE Wiring Resistance:

The FORCE wiring resistance ($R_{\text{high}} + R_{\text{low}}$) must be less than $300 \text{ m}\Omega$.

R_{high} : Wiring resistance between the HCU FORCE HIGH terminal and the test device

R_{low} : Wiring resistance between the HCU FORCE LOW terminal and the test device

Refer to the following FORCE wiring resistance data. When you use the HP 16088 Test Fixture, do not use a 3 m dual-coaxial cable (HP 16493E Opt. 002) because the wiring resistance exceeds $300 \text{ m}\Omega$.

16493E Opt. 001 1.5m Dual-coaxial Cable

65 $\text{m}\Omega$ (FORCE LOW)

40 $\text{m}\Omega$ (FORCE HIGH)

16493E Opt. 002 3 m Dual-coaxial Cable

110 $\text{m}\Omega$ (FORCE LOW)

70 $\text{m}\Omega$ (FORCE HIGH)

8120-5297 Dual-coaxial Cable

32 $\text{m}\Omega/\text{m}$ (FORCE LOW)

15.2 $\text{m}\Omega/\text{m}$ (FORCE HIGH)

8150-2605 AWG16 (1.290 mm in diameter) insulated wire

14 $\text{m}\Omega/\text{m}$

8150-2890 AWG18 (1.024 mm in diameter) insulated wire

22 $\text{m}\Omega/\text{m}$

8150-2639 AWG22 (0.634 mm in diameter) insulated wire

56 $\text{m}\Omega/\text{m}$

8150-0447 AWG24 (0.511 mm in diameter) insulated wire

89 $\text{m}\Omega/\text{m}$

Contact resistance between the Dual-coaxial cable (HP 16493E) and connector plate (04142-60032)

5 m to 10 $\text{m}\Omega$ (FORCE HIGH and FORCE LOW, respectively)

If $(R_{high} + R_{low}) > 300 \text{ m}\Omega$, the usable maximum output (10 A and 10 V) or maximum pulse width (1 ms) is limited.

The following figure shows the output limitation when the pulse width is 1 ms and $R_{high} = R_{low}$. Even if $R_{high} \neq R_{low}$, if R_{high} and R_{low} are each less than or equal to 400 m Ω , this figure applies.

If $(R_{high} + R_{low}) = 1 \text{ ohm}$, maximum output current is limited to 8 A and output voltage is limited to 5 V (at 8 A) and 7 V (at 5 A). You cannot use the HCU outside of this limitation. If you specify a value that exceeds the limitation, the HCU output is not the specified value, and the actual output voltage or current value includes a large error.

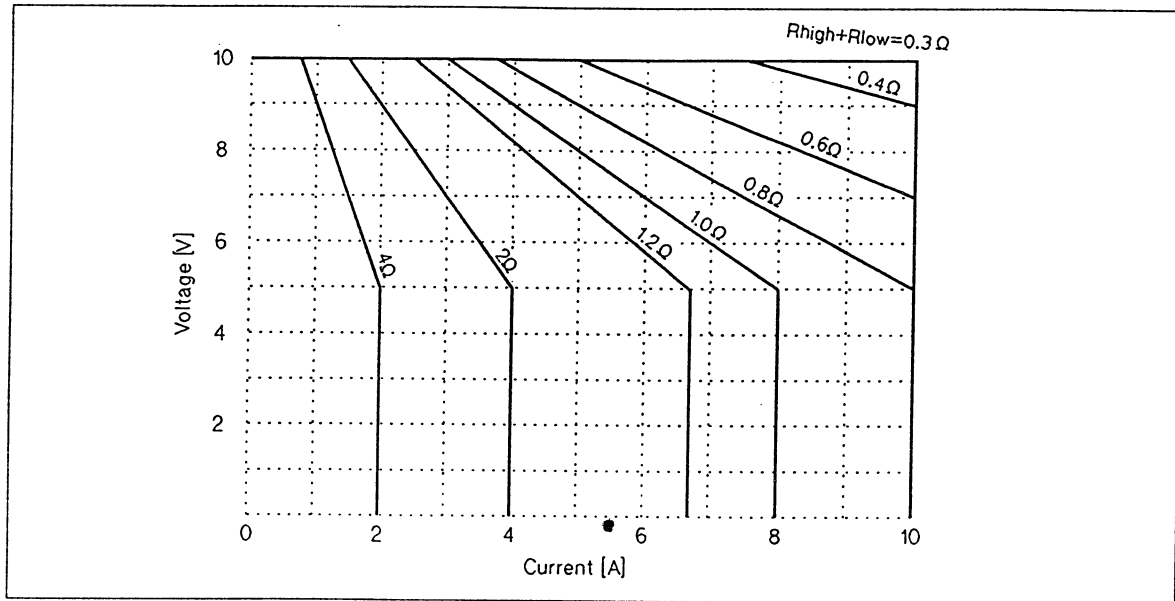

Output Limitation by Wiring Resistance (Pulse Width = 1 ms, $R_{high} = R_{low}$)

If the pulse width is less than 1 ms, the allowable FORCE resistance values for forcing 10 A and 10 V are shown in the following table.

Allowable FORCE Wiring Resistance ($R_{high} + R_{low}$) for Forcing 10 A and 10 V

Pulse Width	Allowable Resistance ($R_{high} + R_{low}$)
1 ms	300 m Ω
900 μ s	330 m Ω
800 μ s	360 m Ω
700 μ s	390 m Ω
600 μ s	420 m Ω ¹
500 μ s	450 m Ω ¹
400 μ s	480 m Ω ¹
300 μ s	510 m Ω ¹
200 μ s and less	540 m Ω ¹

¹ However, R_{high} or R_{low} must be less than or equal to 400 m Ω .

To calculate the exact output limitation, use the following equations.

- 1) $V \leq 16 - 3000t - (R_{high} + R_{low})I$
- 2) $I \leq 4/R_{high}$
- 3) $I \leq 4/R_{low}$
- 4) $I \leq 10$
- 5) $V \leq 10$

where:

- V [V]: Voltage across the test device. If the HCU forces voltage, it is the specified voltage value.
- I [A]: Current through the test device. If the HCU forces current, it is the specified current value.
- R_{high} [Ω]: Wiring resistance of FORCE HIGH
- R_{low} [Ω]: Wiring resistance of FORCE LOW
- t [s]: Specified pulse width (100E-6 to 1E-3, however if pulse width is less than 200E-6, use t = 200E-6).

Equation 1 is the limitation of maximum voltage between FORCE HIGH and FORCE LOW at the front output connectors, which is 13 V if the pulse width is 1 ms. Equation 2 and 3 are the limitations of maximum voltage between FORCE HIGH and SENSE HIGH or between FORCE LOW and SENSE LOW at the front output connectors, which is 4 V. Equation 4 and 5 are the limitations of the maximum voltage and current of HCU across the test device.

- FORCE Wiring Inductance:

To prevent slow pulsed output settling, output overshoot, and noise, make the wiring inductance of the FORCE line according to $(R_{high} + R_{low})$, as follows:

- | | |
|--|---|
| $(R_{high} + R_{low}) \geq 250 \text{ m}\Omega$: | $L < 1000 \text{ [nH]}$ |
| $250 \text{ m}\Omega > (R_{high} + R_{low}) \geq 75 \text{ m}\Omega$: | $L < 4000(R_{high} + R_{low}) \text{ [nH]}$ |
| $(R_{high} + R_{low}) < 75 \text{ m}\Omega$: | $L \leq 300 \text{ [nH]}$ |

The FORCE wiring inductance is the wiring inductance from the FORCE HIGH terminal of the HCU to the FORCE LOW terminal of the HCU, when both lines are shorted at the test device. Refer to the following FORCE wiring inductance.

- HP 16493E Opt. 001 1.5 m Dual-coaxial Cable: 100 nH
- HP 16493E Opt. 002 3 m Dual-coaxial Cable: 200 nH
- 8120-5297 Dual-coaxial Cable: 65 nH/m
- AWG 16 twisted-pair cable: 700 nH/m
- AWG 24 twisted-pair cable: 900 nH/m

When you do not use a coaxial cable, twist the FORCE HIGH and FORCE LOW lines from the connector plate to the test device so that wiring inductance decreases.

NOTE

If the wire length between the connector plate and test device exceeds 1 m (1.2 m for the HP 16493E Opt. 001), use the part number 8120-5297 Dual-coaxial Cable.

HVU Connections

The HVU FORCE terminal is surrounded by a GUARD terminal that has the same potential as the output for highly accurate current forcing and measurements while minimizing leakage. The following figure shows HVU/test device connections.

WARNING

THE HVU FORCES DANGEROUS VOLTAGES OF UP TO ± 1000 V AT THE FORCE AND GUARD TERMINALS.

TO PREVENT ELECTRICAL SHOCK, DO NOT EXPOSE THESE LINES.

BEFORE TURNING THE HP 4142B ON, CONNECT THE INTLK TERMINAL TO A SWITCH THAT TURNS OFF WHEN THE SHIELDING BOX ACCESS DOOR IS OPENED, AND CONNECT THE OUTPUT ON/OFF STATUS TERMINAL TO A WARNING INDICATOR.

BEFORE YOU TOUCH THE CONNECTIONS OF THESE TERMINALS, TURN THE HP 4142B OFF AND DISCHARGE ANY CAPACITORS. IF YOU CANNOT TURN THE HP 4142B OFF, REFER TO THE "SAFETY PRECAUTIONS" DESCRIBED IN "BEFORE APPLYING POWER," CHAPTER 4.

IF YOU MAKE A FIXTURE, MAKE THE RATED WITHSTAND VOLTAGE OF THE FIXTURE EQUAL TO OR GREATER THAN 1000 V.

CAUTION

NEVER connect the GUARD terminal to any output, including CIRCUIT COMMON, CHASSIS GROUND, or the GUARD terminal of any other unit. Doing so will result in HVU damage.

Connecting the OUTPUT ON/OFF STATUS terminal:

The **OUTPUT ON/OFF STATUS** terminal and warning indicator are used to warn that the HVU is operating (1000 V MAX). The warning indicator is lit when the HVU output switch is set to on or when the Self-Test/Self-Calibration of the HVU is being performed. Connect the warning indicator (part number 16087-60013 for English, 16087-60014 for Japanese, 16087-60015 for German) to the **OUTPUT ON/OFF STATUS** terminal.

To connect the warning indicator, perform the following steps:

1. Remove the two screws on the cover of the warning indicator and remove the cover.
2. Remove the two screws on the board and remove the board.
3. Use AWG 24 single-strand insulated wires (part number 8150-0447 for black, 8150-0449 for red, 8150-0451 for yellow, or 8150-0448 for brown). Solder one end of a wire into the hole on the board labeled "IN" and the other end of the same wire to the center conductor of the **OUTPUT ON/OFF STATUS**.
4. Solder the end of another wire into the hole labeled "COM" and the other end of the same wire into the outer conductor.
5. Install the warning indicator in a position that is highly visible for the operator.

If multiple HVUs are installed, connect the **OUTPUT ON/OFF STATUS** terminals to the warning indicator in parallel.

If you make a warning indicator, refer to the following circuit diagrams of the **OUTPUT ON/OFF STATUS** terminal and Warning Indicator.

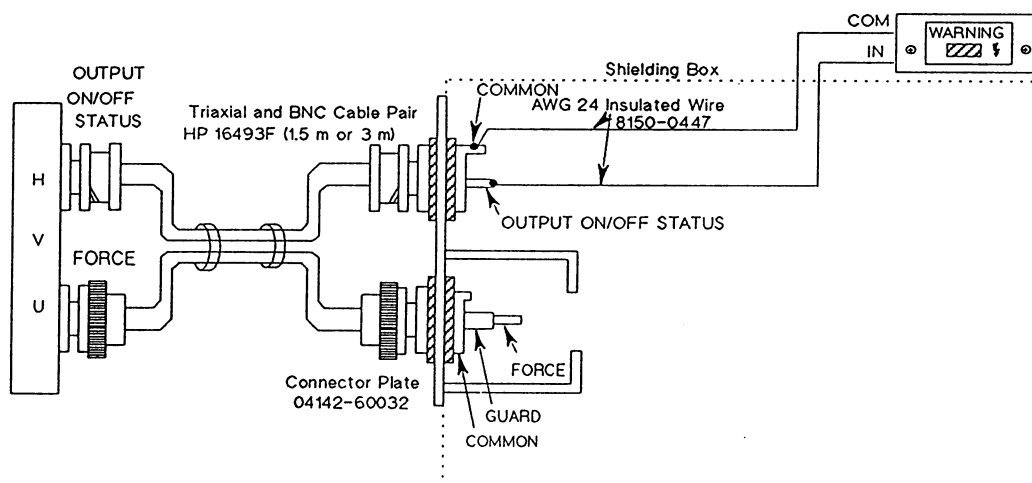

HVU Example Connections (1 of 4)

OUTPUT ON/OFF STATUS Terminal Connections for multiple HVUs :

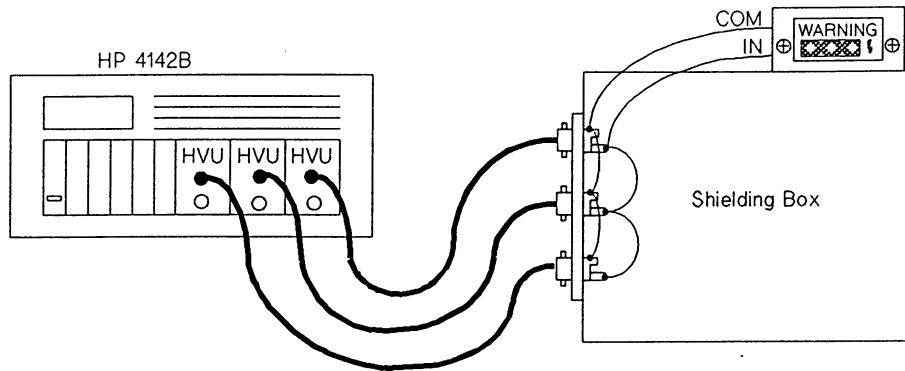

Warning Indicator Connections :

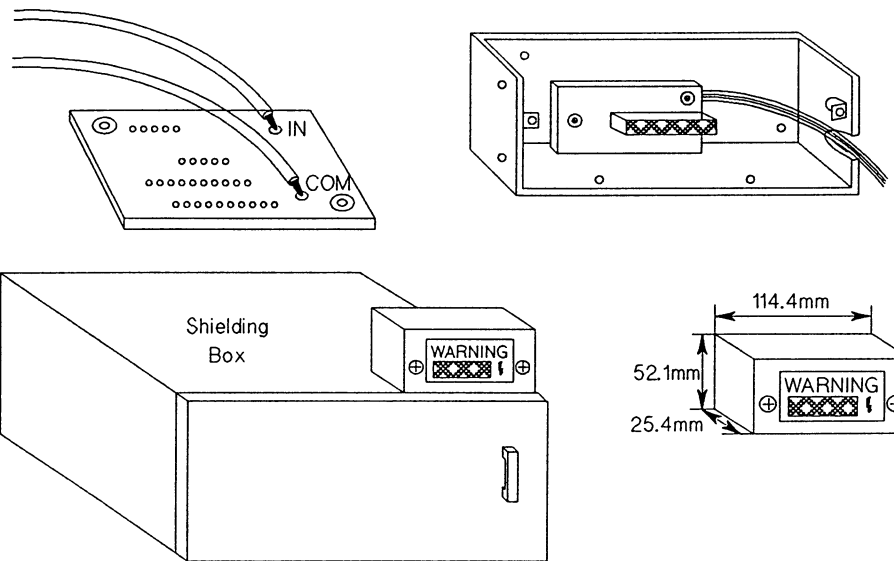

OUTPUT ON/OFF STATUS and Warning Indicator Circuit Diagrams:

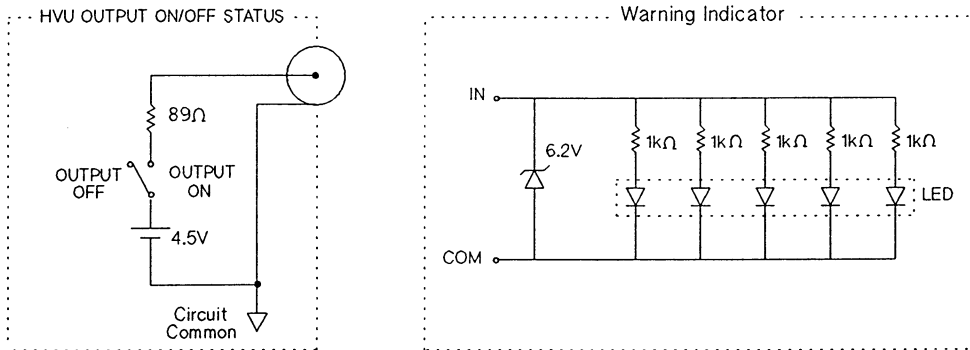

HVU Example Connections (2 of 4)

Connecting the FORCE terminal:

Use a coaxial cable (part number 8120-0122) or triaxial cable to connect the connector plate and the test device. For coaxial cable, the rated withstand voltage of the outer jacket must be greater than or equal to 1000 V (test voltage: 3000 Vrms/minute). For triaxial cable, the rated withstand voltage between GUARD and CIRCUIT COMMON lines must be greater than or equal to 1000 V. Connect the center conductor to FORCE, and the outer conductors (shields) to GUARD.

The cable length depends on the capacitance of the cable used. If you use the 8120-0122 coaxial cable, the cable length must be less than 2.3 m to use with the HP 16493F Opt. 001 (1.5 m), and less than 1.6 m to use with the HP 16493F Opt. 002 (3 m). If you use other cables, make the guard capacitance of the wiring cable less than 300 pF to prevent oscillation when making dc measurements. The guard capacitance is the cable capacitance between the FORCE and GUARD lines. Refer to the following guard capacitance data.

HP 16493F Opt. 001 (1.5 m): 70 pF
HP 16493F Opt. 002 (3 m): 140 pF
8120-0122: 100 pF/m

If you use a triaxial cable, also make the shield capacitance of the wiring cable less than 800 pF. The shield capacitance is the cable capacitance between the GUARD and CIRCUIT COMMON lines. Refer to the following shield capacitance data.

HP 16493F Opt. 001 1.5 m : 300 pF
HP 16493F Opt. 002 3 m : 600 pF

For highly accurate current forcing and measurements and to minimize leakage, surround the FORCE line on the HVU by a GUARD as far as possible.

HVU Example Connections (3 of 4)

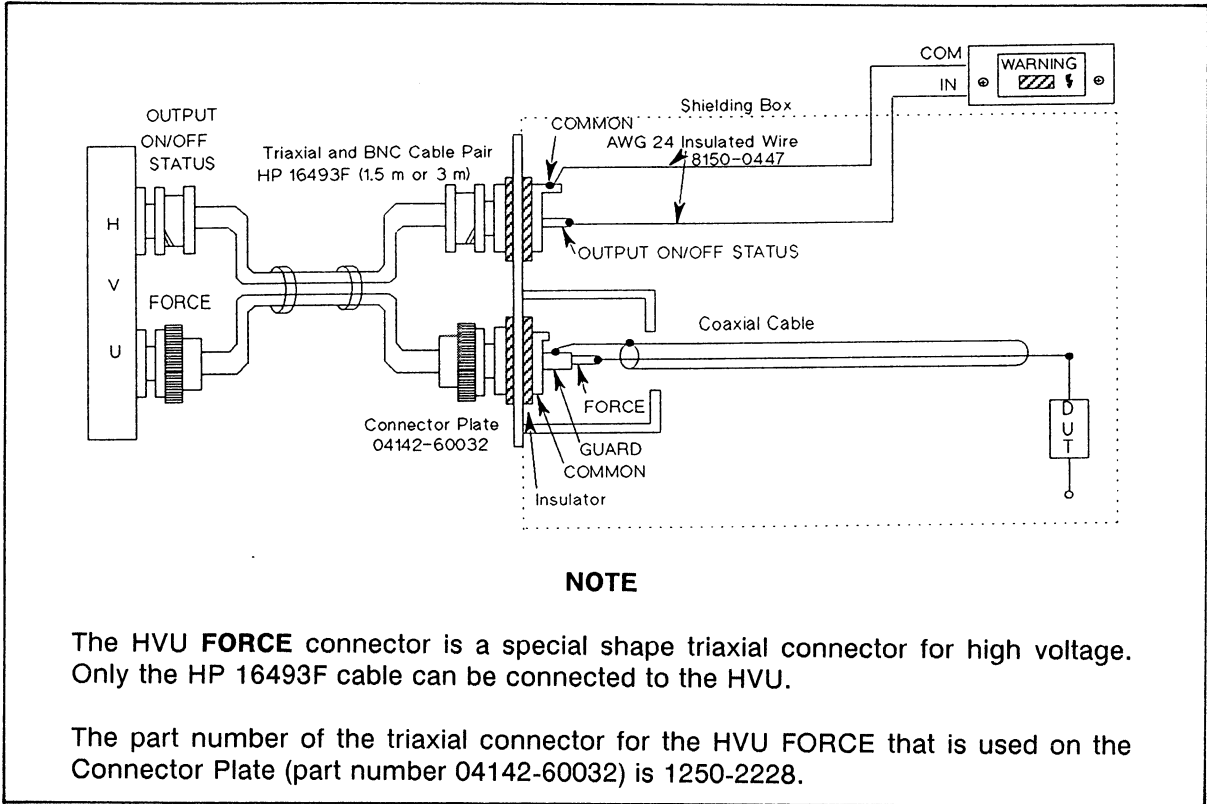

HVU Example Connections (4 of 4)

VS/VMU Connections

The following figure shows an example of a connection between VS1, VS2, VM1, or VM2 and a test device. Use AWG 24 single-strand insulated wire (part number 8150-0447) to connect the connector plate and the test device.

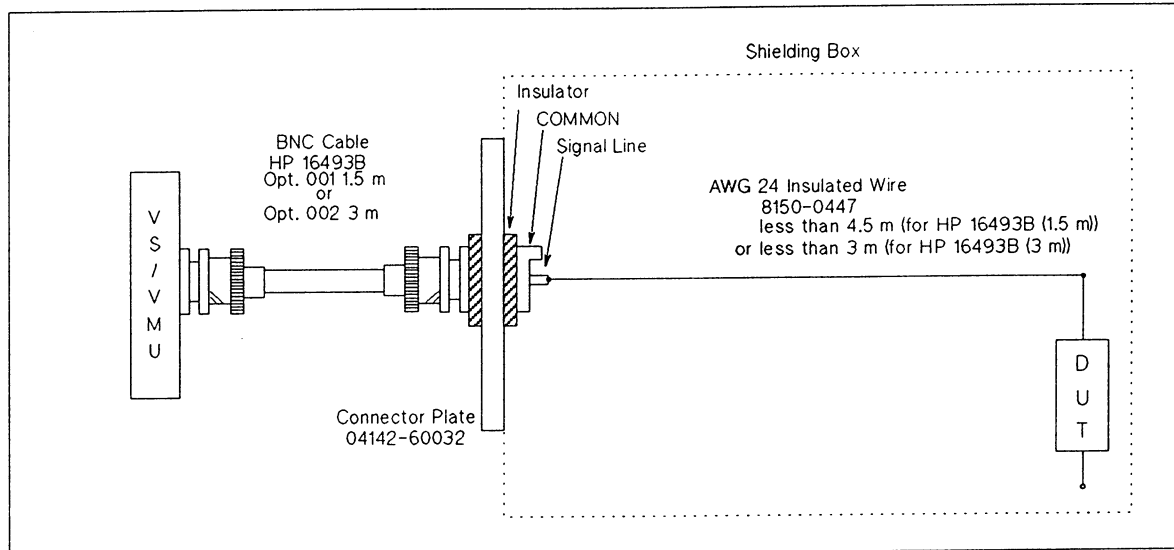

VS/VMU Example Connection

USING THE CONNECTION ACCESSORIES

Using Connector Plate Part Number 04142-60021

Connector Plate part number 04142-60021, one of the available accessories for the HP 4142B, interconnects 4 (for kelvin) to 8 (for non-kelvin) SMUs, GNDU and INTLK to test devices and a switch for INTLK via a shielding box. The following figure shows the connector assignments and connector plate dimensions.

The plate is electrically connected to the outer conductor of the INTLK connector, and is insulated from the outer conductors of the SMU and GNDU connectors for floating measurements.

To install the connector plate, drill holes to mount the connector plate onto the shielding-box, install the connector plate on the shielding-box, and ensure that there is good electrical contact between the connector plate and the shielding box.

NOTE

This connector plate cannot connect the HCU cable (HP 16493E) because the location of the screw is different from the SMU cable (HP 16493D).

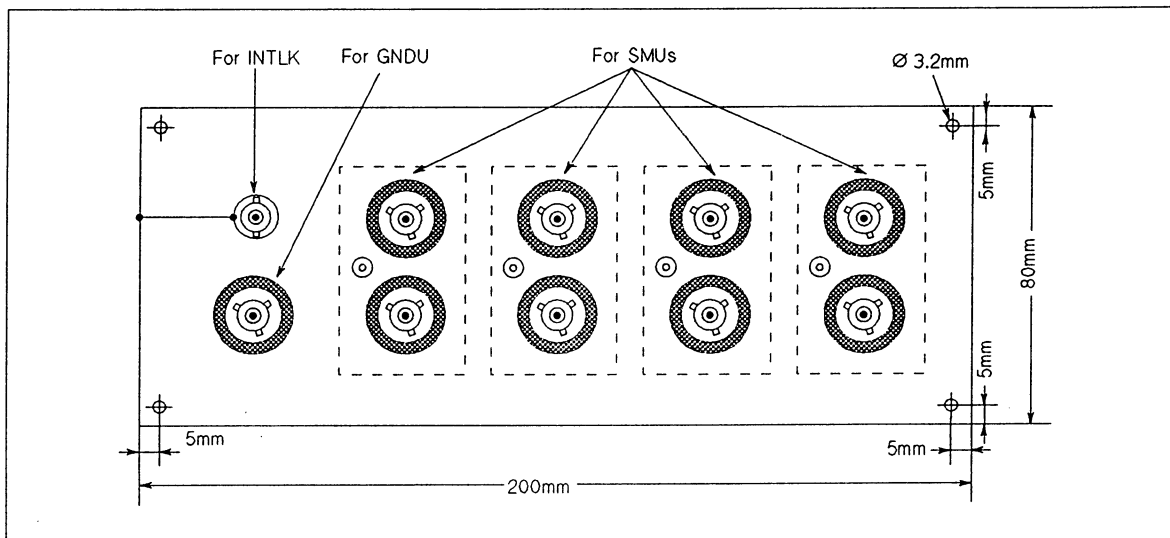

Connector Plate Part Number 04142-60021

WARNING

TO PREVENT ELECTRICAL SHOCK, BE SURE TO CONNECT THE INTLK TERMINAL TO A SWITCH THAT TURNS OFF WHEN THE SHIELDING BOX ACCESS DOOR IS OPENED.

Using Connector Plate Part Number 04142-60032

Connector Plate part number 04142-60032, one of the available accessories for the HP 4142B, interconnects two HCUs, two HVUs, VS/VMU, GNDU, and INTLK to test devices and a switch for INTLK via a shielding box. The following figure shows the connector assignment and connector plate dimensions.

The plate is electrically connected to the outer conductor of the INTLK connector, and is insulated from the outer conductors of other connectors for floating measurements.

To install the connector plate, drill holes to mount the connector plate onto the shielding-box, and install the connector plate on the shielding-box. Ensure that there is good electrical contact between the connector plate and the shielding box.

NOTE

The connector plate cannot connect the SMU cable (HP 16493D) because the location of the screw is different from the HCU cable (HP 16493E).

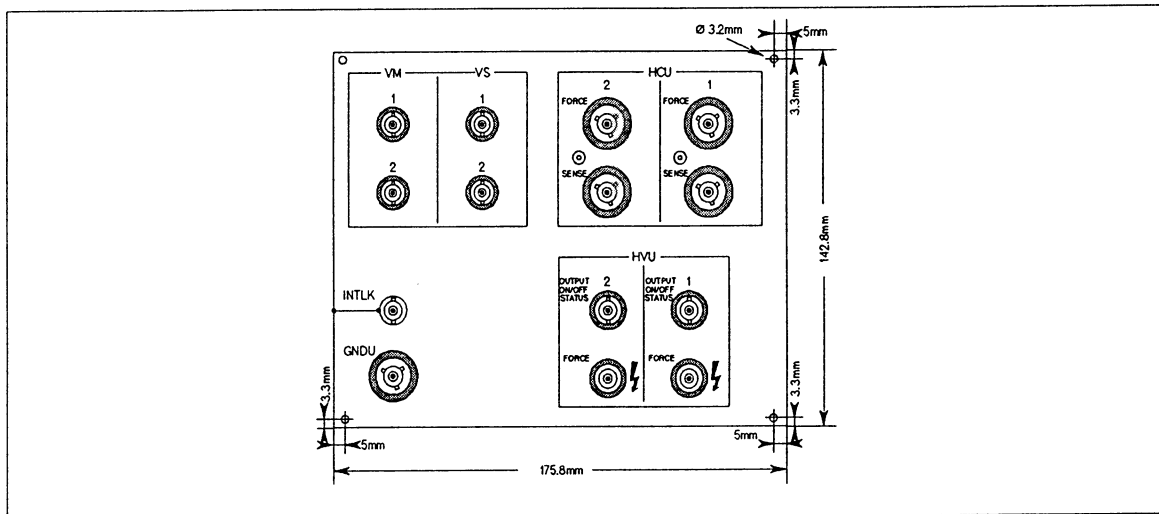

Connector Plate Part Number 04142-60032

WARNING

TO PREVENT ELECTRICAL SHOCK, BE SURE TO CONNECT THE INTLK TERMINAL TO A SWITCH THAT TURNS OFF WHEN THE SHIELDING BOX ACCESS DOOR IS OPENED.

Using Connector Plate Part Number 16087-60002

Connector Plate part number 16087-60032, one of the available accessories for the HP 4142B, interconnects two SMUs, GNDU, and INTLK to test devices and a switch for INTLK via a shielding box. The following figure shows the connector assignment and connector plate dimensions.

The plate is electrically connected to the outer conductor of the INTLK connector, and is insulated from the outer conductors of other connectors for floating measurements.

To install the connector plate, drill holes to mount the connector plate onto the shielding-box, and install the connector plate on the shielding-box. Ensure that there is good electrical contact between the connector plate and the shielding box.

NOTE

The connector plate cannot connect the HCU cable (HP 16493E) because the location of the screw is different from the SMU cable (HP 16493D).

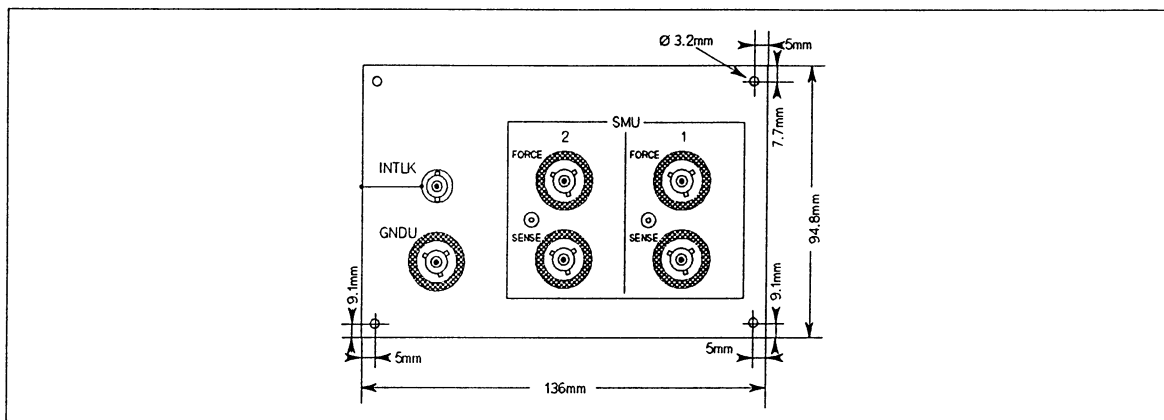

Connector Plate Part Number 16087-60002

WARNING

TO PREVENT ELECTRICAL SHOCK, BE SURE TO CONNECT THE INTLK TERMINAL TO A SWITCH THAT TURNS OFF WHEN THE SHIELDING BOX ACCESS DOOR IS OPENED.

Using the HP 16088B Test Fixture

The HP 16088B Test Fixture connects packaged test devices, such as transistors and ICs, to the following units:

SMU: 4 channel (SMU1 to SMU4, 8 channel for non-kelvin)
HCU: 2 channel (HCU1 and HCU2)
HVV: 2 channel (HVV1 and HVV2)
VS: 2 channel (VS1 and VS2)
VM: 2 channel (VM1 and VM2)
GNDU: 1 channel

For the HP 16088B with Option 300 (module selector), you can select the output of one unit from among the SMU4, HCU2, HVV2, or no selection (no output). The following figure shows the HP 16088B circuit diagrams, connections between the module selector and test device, and the module selector circuit diagram.

You can use the following cables to connect the HP 4142B and HP 16088B:

For GNDU:

HP 16493H Option 001 1.5 m Triaxial Cable
HP 16493H Option 002 3 m Triaxial Cable

For SMUs:

HP 16493D Option 001 1.5 m Quadaxial Cable
HP 16493D Option 002 3 m Quadaxial Cable
HP 16493C Option 001 1.5 m Triaxial Cable
HP 16493C Option 002 3 m Triaxial Cable

For HCUs:

HP 16493E Option 001 1.5 m Dual-coaxial Cable

For connecting the HCU and the HP 16088B, do not use 3 m Dual-coaxial cable, because the wiring resistance of the FORCE line exceeds 300 m Ω . The resistance in this case is about 330 m Ω (365 m Ω for SELECTABLE channel) for using the 16088-60007 to -60009 Socket Boards.

For HVVs:

HP 16493F Option 001 1.5 m Triaxial/BNC Cable Pair
HP 16493F Option 002 3 m Triaxial/BNC Cable Pair

For VSs, VMs, or INTLK:

HP 16493B Option 001 1.5 m BNC Cable
HP 16493B Option 002 3 m BNC Cable

For CONTROL (For Option 300)

HP 16493G Option 001 1.5 m 25pin-25pin Cable
HP 16493G Option 002 3 m 25pin-25pin Cable

WARNING

TO PREVENT ELECTRICAL SHOCK, BE SURE TO CONNECT THE HP 4142B INTLK TERMINAL TO THE HP 16088B INTLK TERMINAL.

NOTE

When you use an HCU, twist the miniature banana cables that are used in FORCE HIGH and LOW lines inside the HP 16088B to decrease wiring inductance.

Because circuit common and chassis ground are connected inside the HP 16088B Test Fixture, floating measurements cannot be performed with the HP 16088B.

For an HP 16088B with Option 300, place the HP 16088B within a $\pm 20^\circ$ horizontal angle during operation. If the angle exceeds $\pm 20^\circ$, the module selector does not operate correctly (a relay that is set to off could be set to on, and the resistance of the relay can increase).

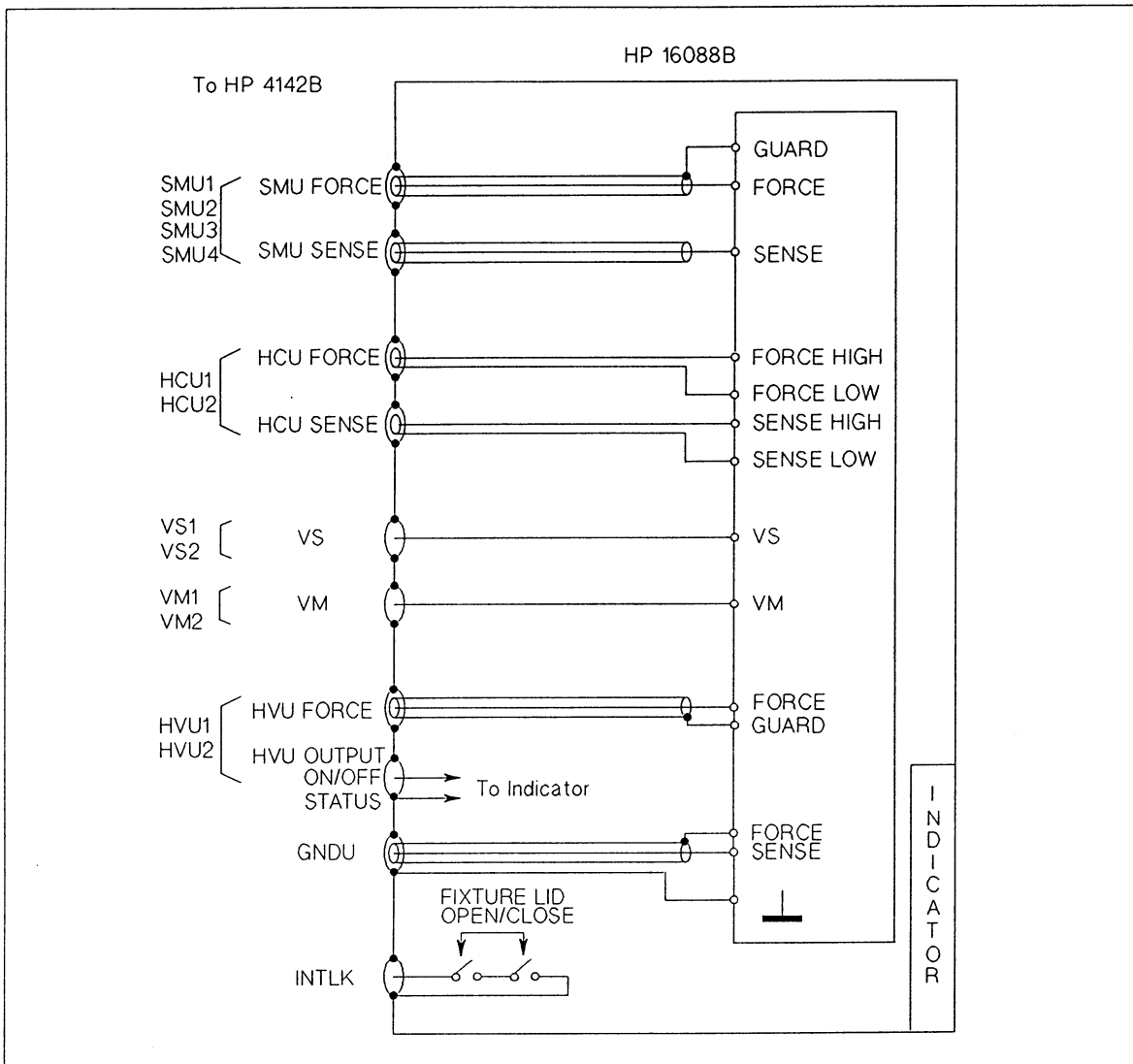

HP 16088B Circuit Diagram

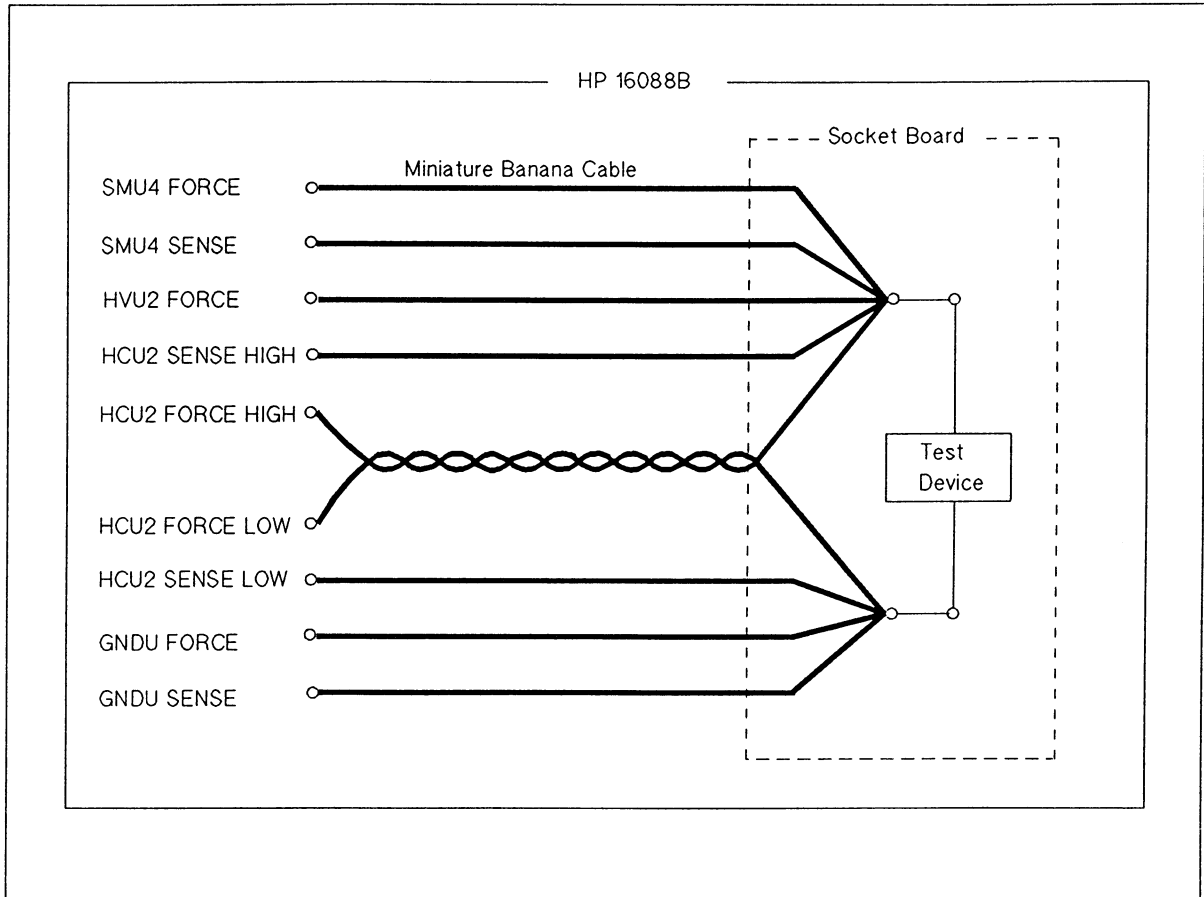

Module Selector Connections

NOTE

For an HP 16088B with Option 300, the GUARD line of the SMU4 is connected to the GUARD terminal of the HVU2 on the inner plate if you select the SMU, HCU, or No unit.

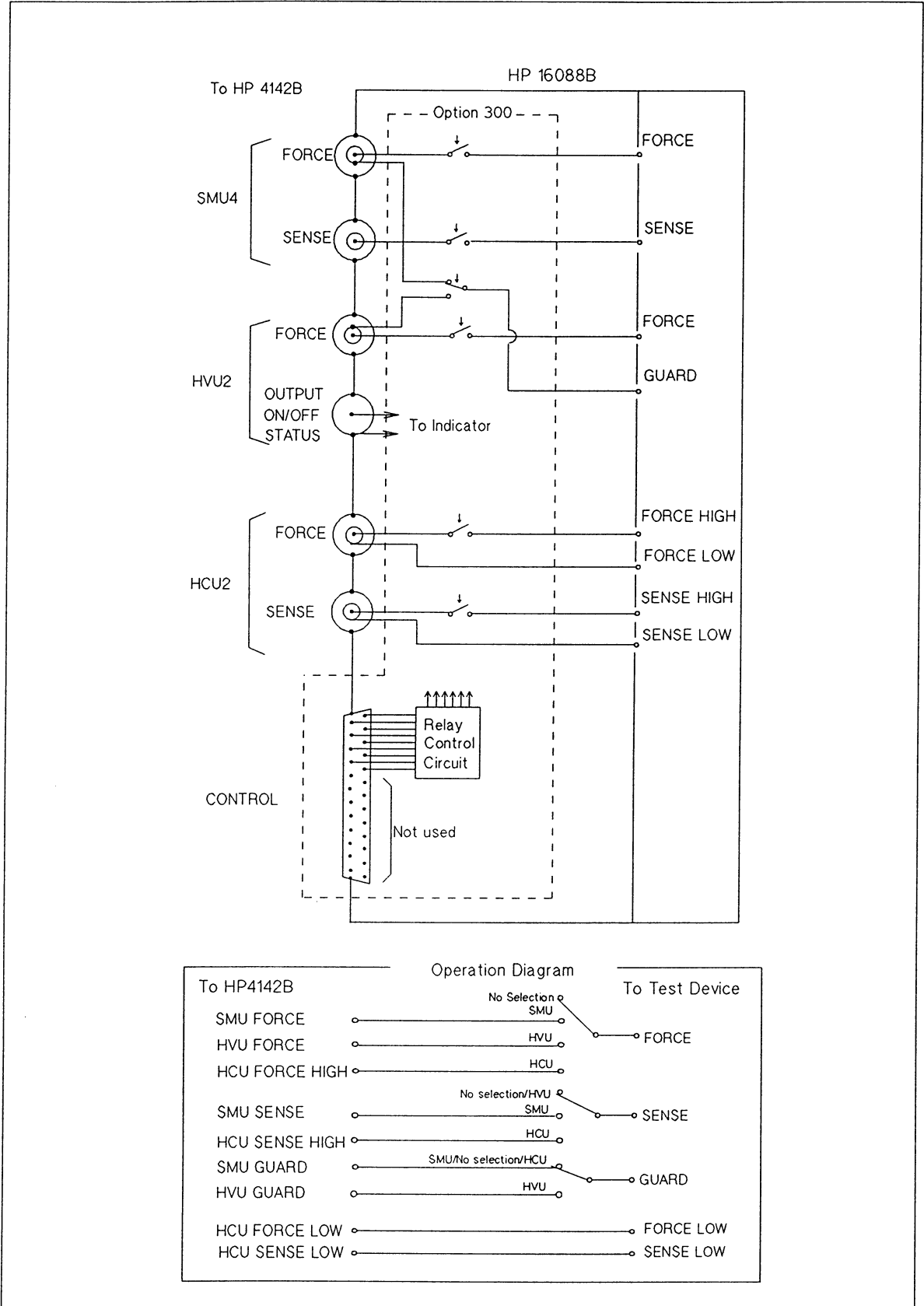

Module Selector Circuit Diagram

NOTE

The following shows the HP 16088B reference data for the connection.

For non-SELECTABLE channels:

SMU channel:

Guard capacitance: 50 pF (FORCE or SENSE)

Resistance: 100 m Ω

HCU channel:

Resistance: 150 m Ω (HIGH: 75 m Ω , LOW: 75 m Ω)

Inductance: 250 nH

HVU channel:

Guard capacitance: 40 pF

Resistance: 340 m Ω

For SELECTABLE channels (Option 300):

SMU channel:

Guard capacitance: 60 pF

Resistance: 340 m Ω

HCU channel:

Resistance: 185 m Ω (HIGH: 110 m Ω , LOW: 75 m Ω)

Inductance: 500 nH

HVU channel:

Guard capacitance: 40 pF

Resistance: 540 m Ω

The above resistance data includes resistances of the miniature banana cable (20 m Ω) and socket board (20 m Ω , for 16088-60007 to 60009). The above inductance data includes inductance of the miniature banana cables that are twisted (200 nH).

Using the HP 16058A Test Fixture

The HP 16058A Test Fixture connects packaged test devices, such as transistors and ICs, to the SMUs, VSs, and VMs of the HP 4142B. Eight interchangeable DUT Socket Boards are furnished with the HP 16058A. The following figure shows the interconnections between the HP 4142B and the HP 16058A.

NOTE

To use the GNDU with the HP 16058A, connect the GNDU to the desired HP 16058A SMU triaxial terminal, and connect the corresponding SMU **GD** (FORCE) or **GD** and **SMU** (SENSE) terminals to test device.

You can also connect the VSs and VMs of the HP 4142B to the **HIGH** and **LOW** coaxial terminals of the HP 16058A.

Because circuit common and chassis ground are connected inside the HP 16058A Test Fixture, floating measurements cannot be performed with the HP 16058A.

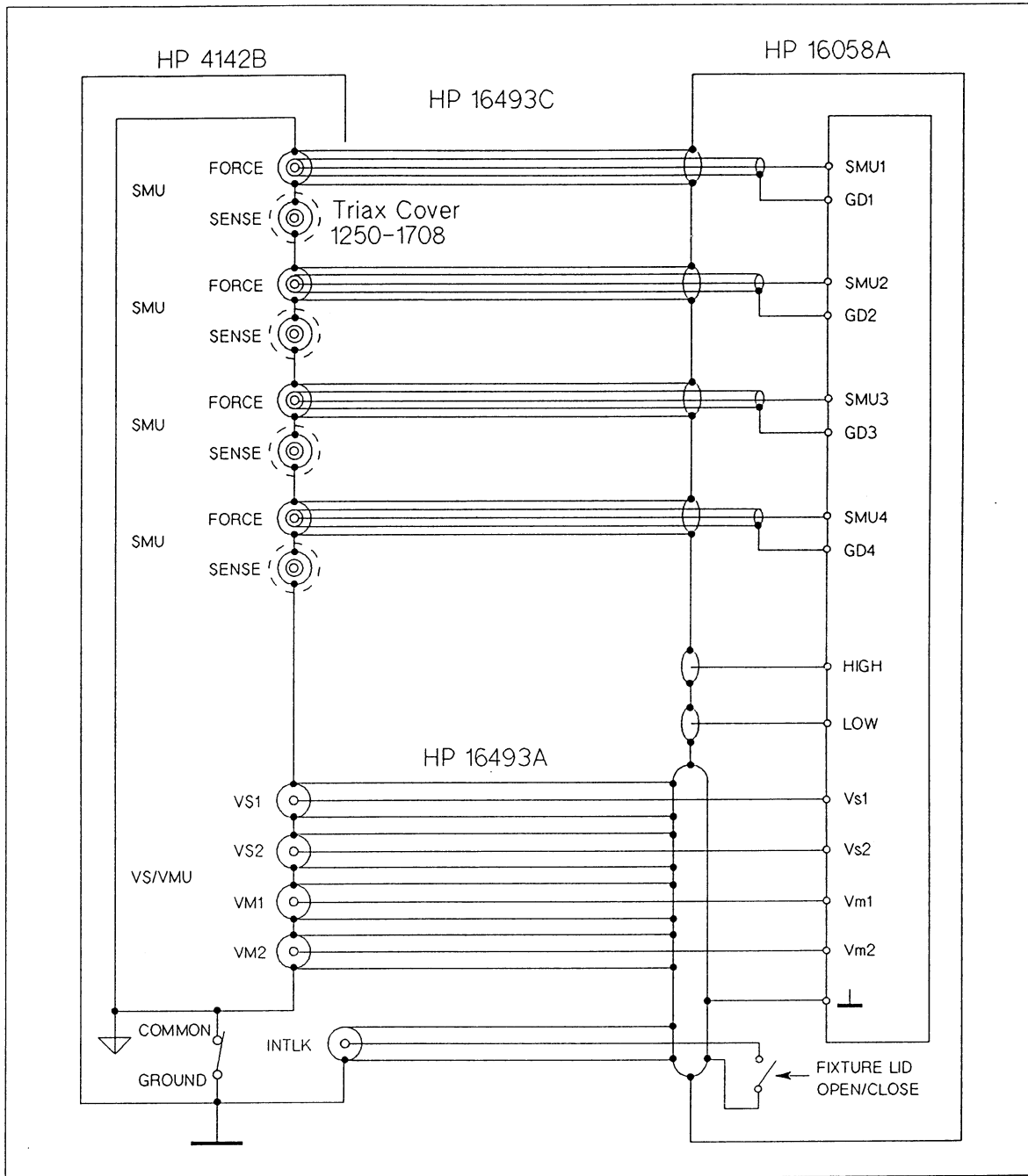

HP 4142B/16058A Interconnections Example

Using the HP 16087A Module Selector

The HP 16087A is a module selector that selects one output from among the SMU, HCU, HVU and no output. The following figure shows the HP 16087A circuit diagram.

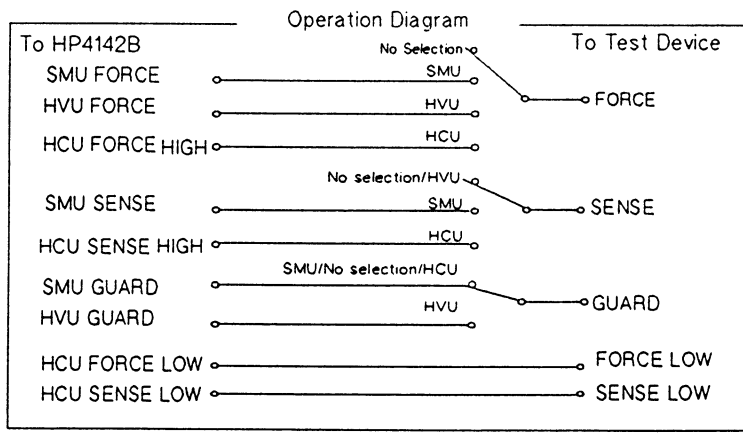
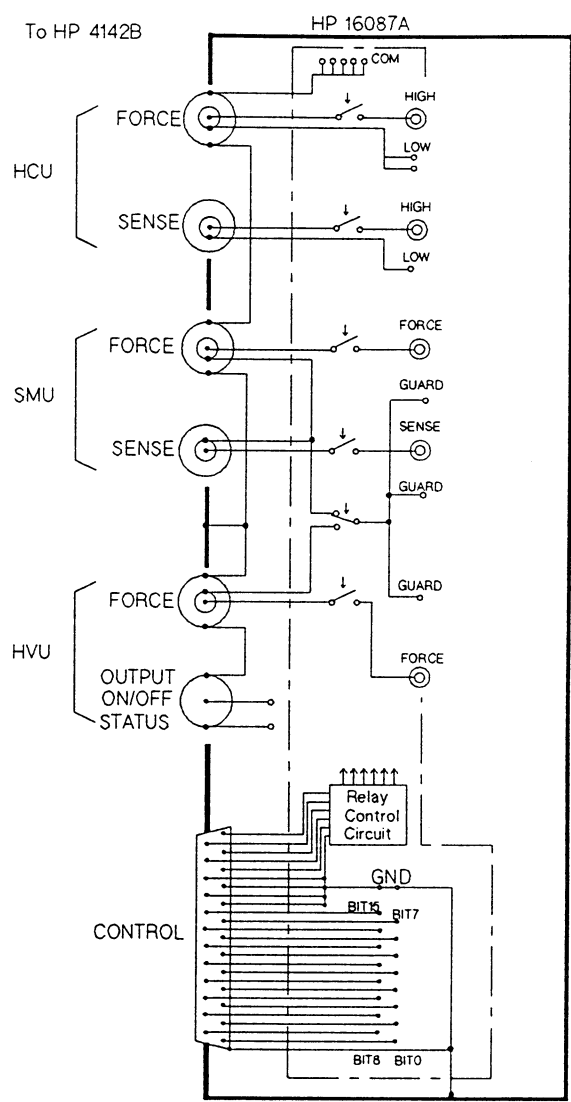

HP 16087A Circuit Diagram

The following figure shows the connections between the HP 16087A and test device. To connect the HP 4142B and HP 16087A, use the following cables.

For SMU:

HP 16493D Option 001 1.5 m Quadaxial Cable

For HCU:

HP 16493E Option 001 1.5 m Dual-coaxial Cable

For HVU:

HP 16493F Option 001 1.5 m Triaxial/BNC Cable Pair

For CONTROL

HP 16493G Option 001 1.5 m 25pin-25pin Cable

HP 16493G Option 002 3 m 25pin-25pin Cable

NOTE

When you solder a wire to the HP 16087A board, use a low hydrochloric acid solder (part number: 8090-0433) to minimize leakage current.

Install the HP 16087A within a $\pm 20^\circ$ horizontal angle during operation. If the angle exceeds $\pm 20^\circ$, the HP 16087A does not operate correctly (a relay that is set to off could be set to on, and the resistance of the relay can increase).

Connect the HP 16087A to the test device as follows:

- Use an AWG 24 wire with a voltage rating that is greater than or equal to 1000 V (part number 8150-5053 for black and 8150-5063 for red). Connect the HCU FORCE HIGH to SMU FORCE, and connect the HVU FORCE to SMU FORCE on the HP 16087A board.
- Use a coaxial cable with a voltage rating that is greater than or equal to 1000 V (part number 8120-0122) for the FORCE (FORCE HIGH) connection. Make the cable length less than 85 cm. Use an AWG 16 wire and an AWG 24 wire for the FORCE LOW connection to minimize the FORCE inductance. Make the cable length less than 1.2 m. Twist the coaxial cable, AWG 16 wire, and AWG 24 wire to minimize the FORCE inductance, and connect it to the test device. To minimize leakage current, surround the FORCE line with a GUARD as far as possible.
- Use a coaxial cable (part number 8120-0122) for the SENSE (SENSE HIGH) connection. Make the cable length less than 85 cm. Use an AWG 24 wire for the SENSE LOW connection. Make the cable length less than 1.5 m. Twist the coaxial cable and AWG 24 wire, and connect it to the test device. To minimize leakage current, surround the SENSE line with a GUARD as far as possible.

WARNING

DANGEROUS VOLTAGES OF UP TO 1000 V MAY BE PRESENT ON THE CONNECTION LINE BETWEEN THE TEST DEVICE AND HP 16087A OUTPUT (SMU FORCE/GUARD/SENSE, HCU FORCE/SENSE HIGH, AND HVU FORCE/GUARD).

USE WIRE IN WHICH THE RATED WITHSTAND VOLTAGE IS GREATER THAN OR EQUAL TO 1000 V FOR THESE CONNECTIONS.

BE SURE TO USE THE INTLK TERMINAL AND HVU OUTPUT ON/OFF STATUS TERMINAL TO PREVENT ELECTRICAL SHOCK.

EVEN IF YOU SET THE HP 16087A SELECTION TO HCU OR OPEN, ONLY THE GUARD OUTPUT OF THE HP 16087A IS EQUAL TO SMU OUTPUT (200 V MAX.).

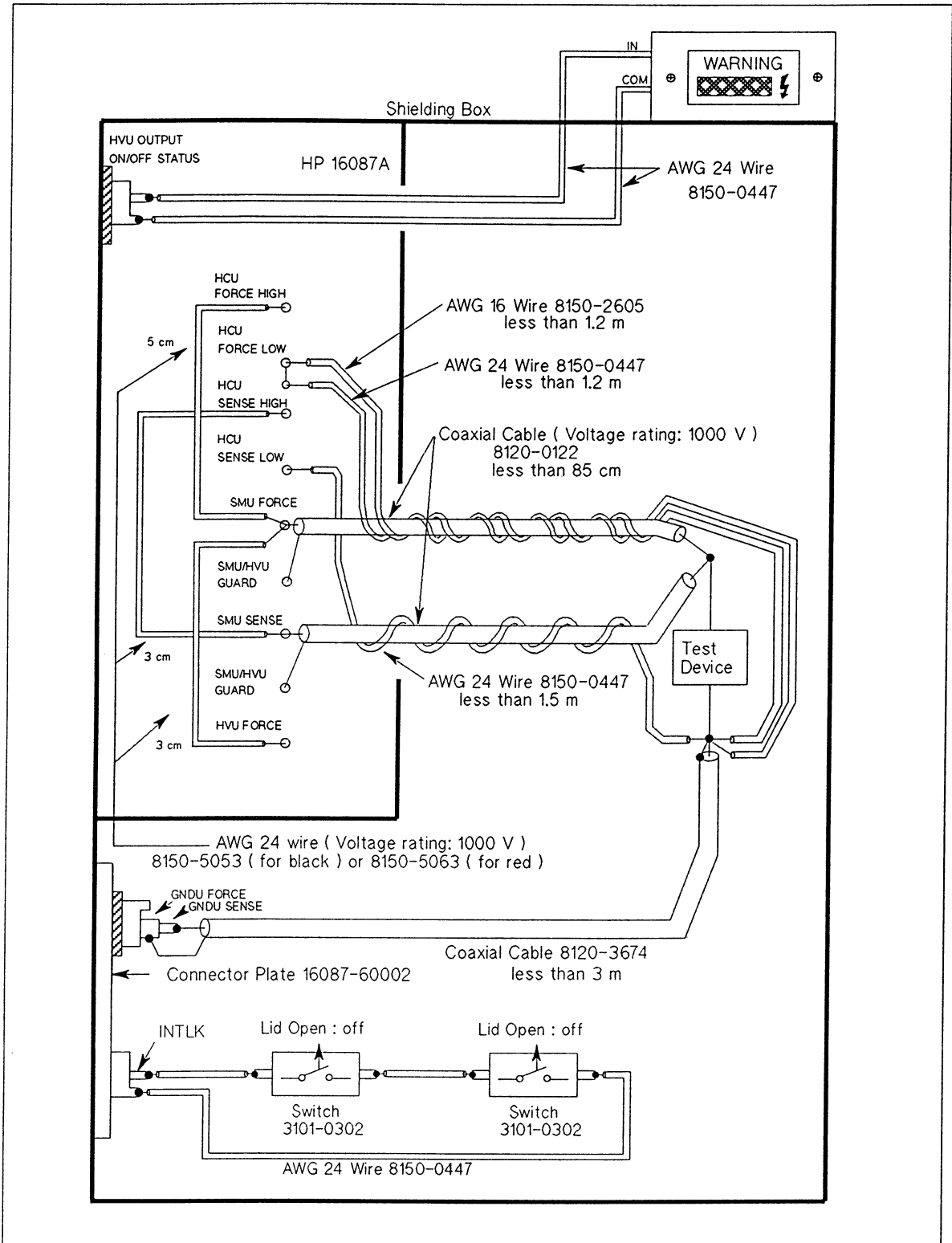

Connections between the HP 16087A and Test Device

NOTE

The FORCE wiring resistance of the HCU at the connection shown in the above figure is 269 m Ω (1.5 m cable: 105 m Ω , HP 16087A: 95 m Ω , 85 cm cable: 34 m Ω , 1.2 m cable: 15 m Ω , contact points: 20 m Ω). The FORCE wiring resistance of the SMU is 384 m Ω (1.5 m cable: 150 m Ω , HP 16087A: 95 m Ω , 85 cm cable: 34 m Ω , 1.2 m cable: 15 m Ω , contact points: 10 m Ω). If you use a prober or fixture to connect the test device, the wiring resistance, including contact resistance, may exceed the allowable values (300 m Ω for the HCU, 700 m Ω for the SMU). If you exceed these values, the maximum outputs of the HCU and SMU are limited. When you make the FORCE HIGH cable length 50 cm and the FORCE LOW cable length 70 cm, the FORCE wiring resistance of the HCU is 249 m Ω and that of the SMU is 380 m Ω .

In the above figure, if you do not use the HVU, the length of FORCE HIGH cable and SENSE HIGH cable can both be increased to 1 m.

If you use the 3 m cables (HP 16493D, HP 16493E, and HP 16493F) to connect the HP 4142B and HP 16087A, the length of the coaxial cables for FORCE and SENSE is limited to less than 50 cm. However, the FORCE wiring resistance of the HCU exceeds 300 m Ω and is 324 m Ω (3 m cable: 180 m Ω , HP 16087A: 95 m Ω , 50 cm cable: 20 m Ω , 70 cm cable: 9 m Ω , contact points: 20 m Ω).

The HP 16087A can be used for HP 4142B floating measurements by disconnecting one connection cable inside the HP 16087A. See the HP 16087A Operation Manual for the procedure.

Connecting the HP 16087A by another method

If you connect the HP 16087A by a method that is not shown in the above figure, make the connection parameters between the HP 16087A output and test device (DUT) as shown in the following table. See the sections on the connections of each unit for parameter definitions.

To connect the HP 16087A and test device, refer to the following cable data.

8120-0122 Coaxial Cable:

Voltage rating: 1900 V

Capacitance: 100 pF/m

Resistance: 40 mΩ/m

8150-5053 or 8150-5063 AWG 24 insulated wire:

Voltage rating: 1000 V

Resistance: 89.4 mΩ

8150-2605 AWG 16 insulated wire:

Voltage rating: 600 V

Resistance: 14 mΩ/m

8150-0447 AWG 24 insulated wire:

Voltage rating: 300 V

Resistance: 89 mΩ/m

Pair of AWG 16 (8150-2605) and AWG 24 (8150-0447) wires:

Total Resistance: 12 mΩ/m

Twisted-pair of coaxial cable (8120-0122), AWG 16 wire (8150-2605) and AWG 24 wire (8150-0447):

Inductance: 700 nH/m

Twisted-pair of coaxial cable (8120-0122) and AWG 16 wire (8150-2605)

Inductance: 900 nH/m

HP 4142B Connection Parameter Values Allowed for the HP 16087A

Unit	Connection Parameter	Allowed Value for Unit	Value between HP 4142B and HP 16087A Output ¹		Value Allowed between HP 16087A Output and DUT	
			1.5 m ²	3 m ³	1.5 m ²	3 m ³
SMU	Guard C ⁴	600 pF	290 pF	440 pF	310 pF (220 pF) ⁶	160 pF (0 pF) ⁷
	Shield C ⁵	5000 pF	1400 pF	2600 pF	3600 pF (3000 pF) ⁶	2400 pF (1200 pF) ⁷
	Force R	700 mΩ	350 mΩ	500 mΩ	350 mΩ (340 mΩ) ⁶	200 mΩ (180 mΩ) ⁷
HVU	Guard C ⁴	300 pF	125 pF	195 pF	175 pF	105 pF
	Shield C ⁵	800 pF	400 pF	700 pF	400 pF	100 pF
HCU	Force R	300 mΩ	190 mΩ	275 mΩ	110 mΩ	25 mΩ
	Force L	1000 nH	250 nH	350 nH	750 nH	650 nH

¹ This value is the total value of the cable between the HP 4142B and HP 16087A and the HP 16087A. The following table shows each value.

² When using 1.5 m cables (SMU: HP 16493D Opt. 001, HCU: HP 16493E Opt. 001, HVU: HP 16493F Opt. 001) for connecting the HP 4142B and HP 16087A.

³ When using 3 m cables (SMU: HP 16493D Opt. 002, HCU: HP 16493E Opt. 002, HVU: HP 16493F Opt. 002) for connecting the HP 4142B and HP 16087A.

⁴ The Guard capacitance is the total cable capacitance between the SMU FORCE and GUARD lines, between the SMU SENSE and GUARD lines, and between the HVU FORCE and GUARD lines. To minimize the Guard capacitance, connect the HVU FORCE and SMU FORCE on the HP 16087A board, and connect the SMU FORCE and test device with one coaxial cable.

⁵ If you do not use a triaxial cable to connect the HP 16087A and test device, you can ignore this parameter.

⁶ When using two HP 16493 C Opt. 001 1.5 m triaxial cables instead of an HP 16493D.

⁷ When using two HP 16493C Opt. 002 3 m triaxial cables instead of an HP 16493D.

Connection Parameters for the HP 16087A and for the HP 4142B to HP 16087A Cables

Unit	Parameter	HP 16087A	1.5 m Cable ¹	3 m Cable ²
SMU	Guard C	140 pF	150 pF (240 pF) ³	300 pF (480 pF) ⁴
	Shield C	200 pF	1200 pF (1800 pF) ³	2400 pF (3600 pF) ⁴
	Force R	200 mΩ	150 mΩ (160 mΩ) ³	300 mΩ (320 mΩ) ⁴
HVU	Guard C	55 pF	70 pF	140 pF
	Shield C	100 pF	300 pF	600 pF
HCU	Force R	95 mΩ (Hi: 60 mΩ) (Lo: 35 mΩ)	105 mΩ (Hi: 40 mΩ) (Lo: 65 mΩ)	180 mΩ (Hi: 70 mΩ) (Lo: 120 mΩ)
	Force L	150 nH	100 nH	200 nH

¹ SMU: HP 16493D Opt. 001, HCU: HP 16493E Opt. 001, HVU: HP 16493F Opt. 001

² SMU: HP 16493D Opt. 002, HCU: HP 16493E Opt. 002, HVU: HP 16493F Opt. 002

³ For using two HP 16493C Opt. 001 1.5 m triaxial cables instead of an HP 16493D.

⁴ For using two HP 16493C Opt. 002 3 m triaxial cables instead of an HP 16493D.

Cable Reference Data

The following shows the reference data of the connection cables for the HP 4142B.

HP 16493B Opt. 001 BNC Cable (1.5 m)

Capacitance: 160 pF
Resistance of center line: 220 m Ω

HP 16493B Opt. 002 BNC Cable (3 m)

Capacitance: 330 pF
Resistance of center line: 400 m Ω

HP 16493C Opt. 001 SMU Triaxial Cable (1.5 m)

Capacitance between GUARD and FORCE (or SENSE) lines (guard capacitance): 120 pF
Capacitance between GUARD and COMMON lines: 900 pF
Resistance of FORCE line: 160 m Ω
Maximum current: 1 A

HP 16493C Opt. 002 SMU Triaxial Cable (3 m)

Capacitance between GUARD and FORCE (or SENSE) lines (guard capacitance): 240 pF
Capacitance between GUARD and COMMON lines: 1800 pF
Resistance of FORCE line: 320 m Ω
Maximum current: 1 A

HP 16493D Opt. 001 SMU Quadaxial Cable (1.5 m)

Capacitance between GUARD and FORCE lines (guard capacitance): 150 pF
Capacitance between GUARD and COMMON lines: 1200 pF
Resistance of FORCE line: 150 m Ω

HP 16493D Opt. 002 SMU Quadaxial Cable (3 m)

Capacitance between GUARD and FORCE lines (guard capacitance): 300 pF
Capacitance between GUARD and COMMON lines: 2400 pF
Resistance of FORCE line: 300 m Ω

HP 16493E Opt. 001 HCU Dual-coaxial Cable (1.5 m)

Capacitance between FORCE HIGH and FORCE LOW lines: 1500 pF
Capacitance between SENSE HIGH and SENSE LOW lines: 200 pF
Inductance between FORCE HIGH and FORCE LOW lines: 100 nH
Resistance of FORCE HIGH line: 40 m Ω
Resistance of FORCE LOW line: 65 m Ω

HP 16493E Opt. 002 HCU Dual-coaxial Cable (3 m)

Capacitance between FORCE HIGH and FORCE LOW lines: 3000 pF
Capacitance between SENSE HIGH and SENSE LOW lines: 350 pF
Inductance between FORCE HIGH and FORCE LOW lines: 200 nH
Resistance of FORCE HIGH line: 70 mΩ
Resistance of FORCE LOW line: 110 mΩ

HP 16493F Opt. 001 HVU Triaxial/BNC Cable Pair (1.5 m)

Capacitance between GUARD and FORCE lines (guard capacitance): 70 pF
Capacitance between GUARD and COMMON lines: 300 pF
Resistance of FORCE line: 630 mΩ

HP 16493F Opt. 002 HVU Triaxial/BNC Cable Pair (3 m)

Capacitance between GUARD and FORCE lines (guard capacitance): 140 pF
Capacitance between GUARD and COMMON lines: 600 pF
Resistance of FORCE line: 1250 mΩ

HP 16493H Opt. 001 GNDU Triaxial Cable (1.5 m)

Capacitance between FORCE and COMMON lines: 550 pF
Resistance of FORCE line: 80 mΩ
Capacitance between FORCE and SENSE lines: 350 pF

HP 16493H Opt. 002 GNDU Triaxial Cable (3 m)

Capacitance between FORCE and COMMON lines: 1100 pF
Resistance of FORCE line: 150 mΩ
Capacitance between FORCE and SENSE lines: 700 pF

8120-3674 Coaxial Cable

Capacitance: 77 pF/m nominal
Resistance of center conductor: 133 mΩ/m maximum
Dielectric Withstand Voltage Test: 500 Vrms, 1 minute
Jacket external diameter: 3.0 mm

8120-0122 Coaxial Cable

Capacitance: 99 pF/m nominal
Resistance of Center conductor: 40 mΩ/m
Voltage Rating: 1900 Vrms
Dielectric Withstand Voltage Test: 5000 Vrms
Jacket external diameter: 5.1 mm

8120-5297 Dual-coaxial Cable

Capacitance: 1100 pF/m maximum

Resistance of Center conductor (for FORCE HIGH): 15.2 mΩ/m maximum

Resistance of Shield conductor (for FORCE LOW): 32 mΩ/m nominal

Dielectric Withstand Voltage Test: 500 Vrms, 1 minute

8150-2605 AWG 16 (1.290 mm in diameter) Insulated Wire

Resistance: 14 mΩ/m

Voltage Rating: 600 V

Color:

8150-2605: Black

8150-3358: Orange

8150-2890 AWG 18 (1.024 mm in diameter) Insulated Wire

Resistance: 22 mΩ/m

Voltage Rating: 600 V

Color:

8150-2890: Black

8150-2891: Red

8150-2639 AWG 22 (0.634 mm in diameter) Insulated Wire

Resistance: 56 mΩ/m

Voltage Rating: 600 V

Color:

8150-2639: Black

8150-2642: Red

8150-0447 AWG 24 (0.511 mm in diameter) Insulated Wire

Resistance: 89 mΩ/m

Voltage Rating: 300 V

Color:

8150-0447: Black

8150-0449: Red

8150-0451: Yellow

8150-0448: Brown

8150-5053 AWG 24 Insulated Wire

Resistance: 89.4 mΩ/m maximum

Voltage Rating: 1000 V

Dielectric Withstand Voltage Test: 3000 Vrms, 1 minute

Color:

8150-5053: Black

8150-5063: Red

ADVANCED CONNECTION INFORMATION

For High Current Measurements (Kelvin Connection)

If you perform high-current measurements using the GNDU, SMU or HCU, use the SENSE terminal for the kelvin connection, as shown in one of the following sections in this chapter: "GNDU Connections," "HPSMU and MPSMU Connections," and "HCU Connections."

The wiring between the source unit and the test device has residual resistance from the cable and contact residual resistance from the connector. For example, if you do not use the kelvin connection and you force 1 A through a cable that has a residual resistance of 100 m Ω , as shown in the following figure, the voltage drop is 100 mV. This voltage (Verror) is included in the measurement result, and the measurement result (Vmeas) becomes:

$$V_{meas} = V_{dut} + V_{error} \quad \text{where } V_{dut} \text{ is the voltage at device terminal.}$$

To eliminate the effect of residual resistance (Verror) from the FORCE line, connect the SENSE terminal as close as possible to the test device terminal. This way, V monitor is directly connected to the test device.

Because the input impedance of V monitor is high, current does not flow into the SENSE line. Therefore, measurement error does not occur if the SENSE line has a residual resistance of 10 Ω or less.

The kelvin connection is effective even when voltage is forced, because the voltage drop by wiring residual resistance is fed back to the voltage source through the SENSE line, thereby ensuring the specified voltage output at the sense point where the FORCE and SENSE lines intersect.

Because the input impedance of SENSE line is high, current does not flow into the SENSE line. Therefore, output error does not occur if the SENSE line has a residual resistance of 10 Ω or less.

I source /V monitor Mode

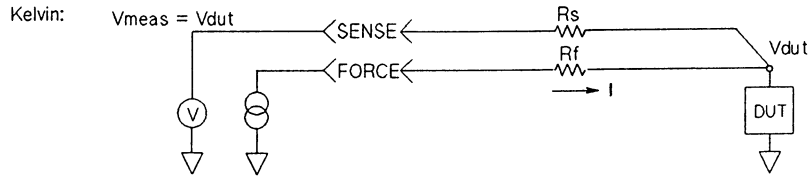
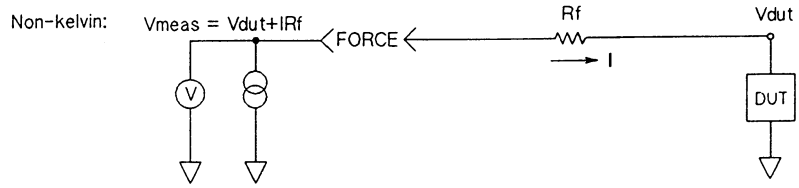

V source /I monitor Mode

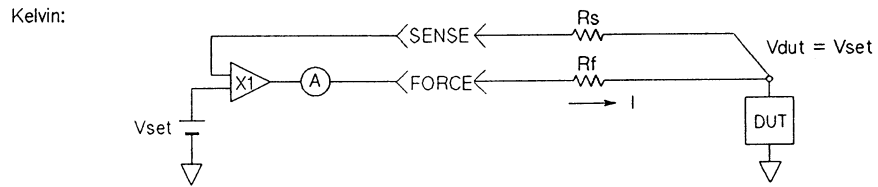
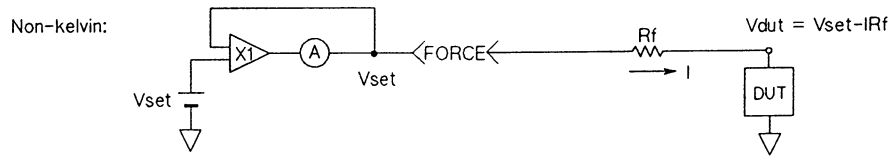

Kelvin Connection and Non-kelvin Connection Comparisons

For Low Current Measurements (Using the GUARD Terminal)

If you perform low-current measurements using an SMU or HVU, surround all FORCE and SENSE lines with the potential of GUARD as far as possible, as shown in the following figure, to minimize leakage current from the FORCE and SENSE lines. The potential of the Guard terminal is the same as FORCE and SENSE terminal voltage (the maximum difference is 1 mV).

By using GUARD, there is no potential difference between the FORCE or SENSE lines and GUARD line. Therefore, the leakage current from the FORCE and SENSE lines can not flow. The leakage current from GUARD does not affect the measurement result because it does not flow into the ammeter (I monitor).

WARNING

GUARD TERMINAL POTENTIAL IS EQUAL TO THE OUTPUT.

CAUTION

NEVER connect the GUARD terminal to any other output, including CIRCUIT COMMON, CHASSIS GROUND, or the GUARD terminal of any other unit. Doing so may result in damage to the unit.

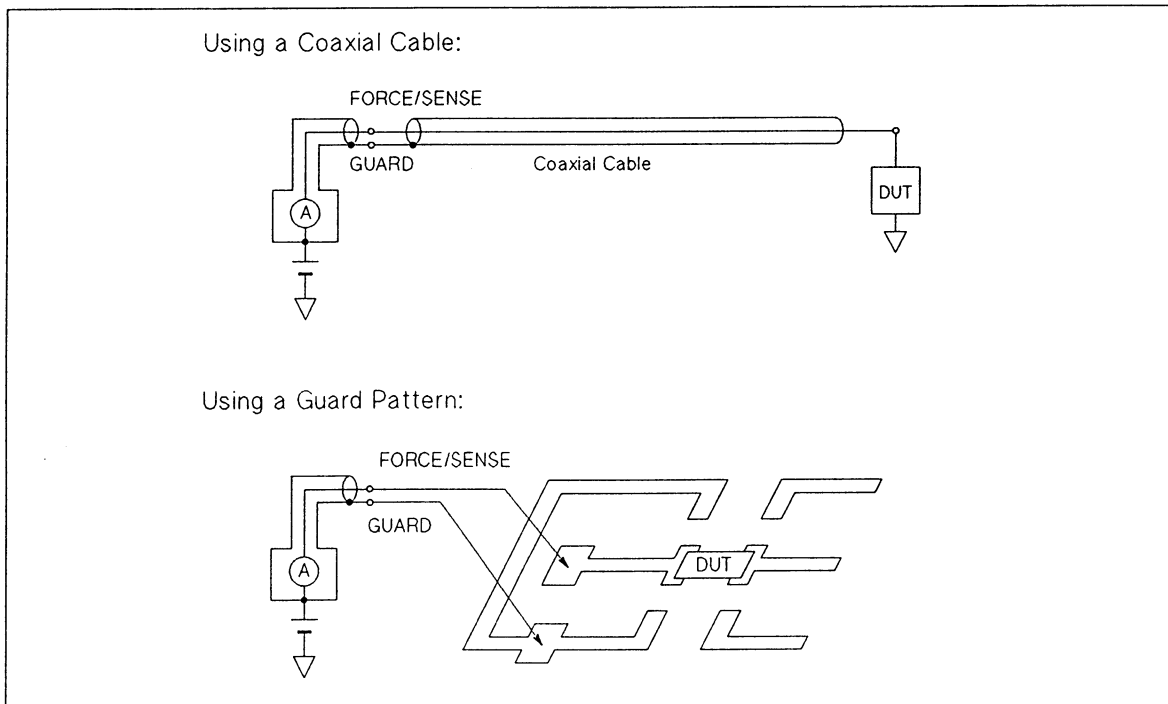

Example of GUARD Use

If the Test Device is Externally Grounded (Floating Measurement)

When the test device is grounded by the prober or is forced by the external V or I sources, the noise of ground loops may affect measurement results. To prevent this, perform the floating measurement as shown in the following procedure.

- 1) Disconnect the **CIRCUIT COMMON** terminal and **CHASSIS GROUND** terminal by removing the shorting-bar.
- 2) Connect the external ground to the **CIRCUIT COMMON** terminal. To do this, use the **CIRCUIT COMMON** terminals of the source and monitor units (GNDU, SMUs, HCU, HVUs, VSs, and VMs) on the connector plate, as shown in the following figure.

The **CIRCUIT COMMON** terminal is connected to the outer conductors of the GNDU, SMU, HCU, HVU, VS, and VM connectors. The **CHASSIS GROUND** terminal is tied to the HP 4142B chassis. With the above procedure, the HP 4142B (GNDU, SMUs, HCU, HVUs, VSs and VMs) forces and measures voltage or current referenced to external ground.

WARNING

A POTENTIAL SHOCK HAZARD EXISTS IF THE CIRCUIT COMMON TERMINAL IS NOT TIED TO CHASSIS GROUND (SHORTING-BAR DISCONNECTED FOR FLOATING MEASUREMENTS). DO NOT TOUCH ANY OF THE HP 4142B FRONT PANEL CONNECTORS AT ANY TIME WHILE A FLOATING MEASUREMENT IS IN PROGRESS.

DO NOT FLOAT THE CIRCUIT COMMON TERMINAL AT VOLTAGES GREATER THAN ± 42 V REFERENCED TO CHASSIS GROUND. FAILURE TO HEED THIS WARNING MAY RESULT IN DAMAGE TO YOUR HP 4142B.

NOTE

Because circuit common and chassis ground are connected inside the HP 16088 and HP 16058A Test Fixtures, floating measurements cannot be performed with the HP 16088 or 16058A, even if the **CIRCUIT COMMON** and **CHASSIS GROUND** terminals of the HP 4142B are not connected (shorting-bar removed).

If the **CIRCUIT COMMON** terminal is open without connecting the **CIRCUIT COMMON** terminal to the **CHASSIS GROUND** terminal or the external ground, the noise can affect the accuracy of the measurements.

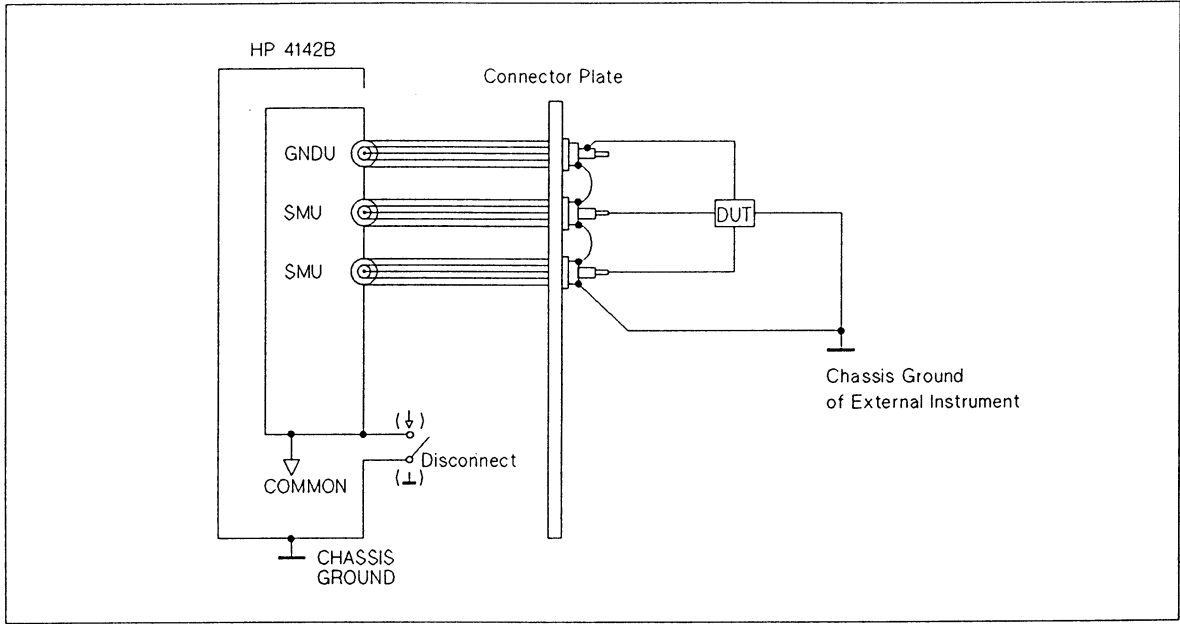

Floating Measurement Example

If the Test Device has Negative Resistance

If the test device has negative resistance characteristics (tunnel diodes or unijunction transistors), a source unit may oscillate at frequencies of 300 kHz or less because the source unit operates as a negative feedback amplifier.

The HPSMUs, the MPSMUs, or the HVUs can detect this oscillation. An "X" is indicated in data status of measurement data if the HPSMU, MPSMU, or HVU detects oscillation.

The following figure shows several examples of measurements made on negative devices.

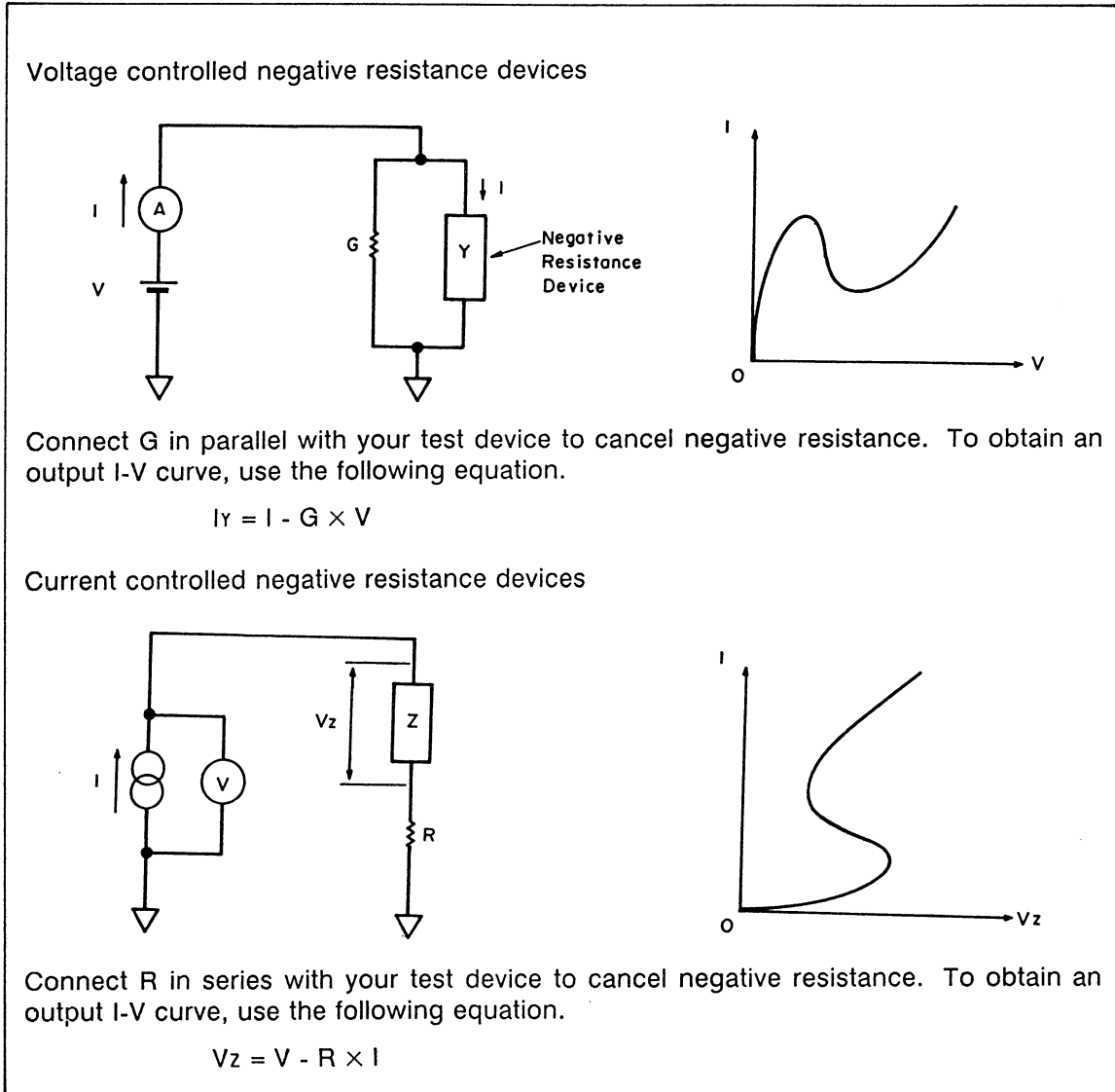

Negative Resistance Measurements

Preventing Oscillation from the Test Device

The test device itself may oscillate at high frequencies (more than 3 MHz) due to stray capacitances and residual inductances of connection cables, probe card, and test fixture. Bipolar transistors, which have a high h_{fe} (forward current transfer ratio) and a wide frequency range, and Field Effect Transistors (FETs), which have a high g_m (transconductance) and a wide frequency range, are especially likely to oscillate, and produce measurement results similar to those shown in the following figure.

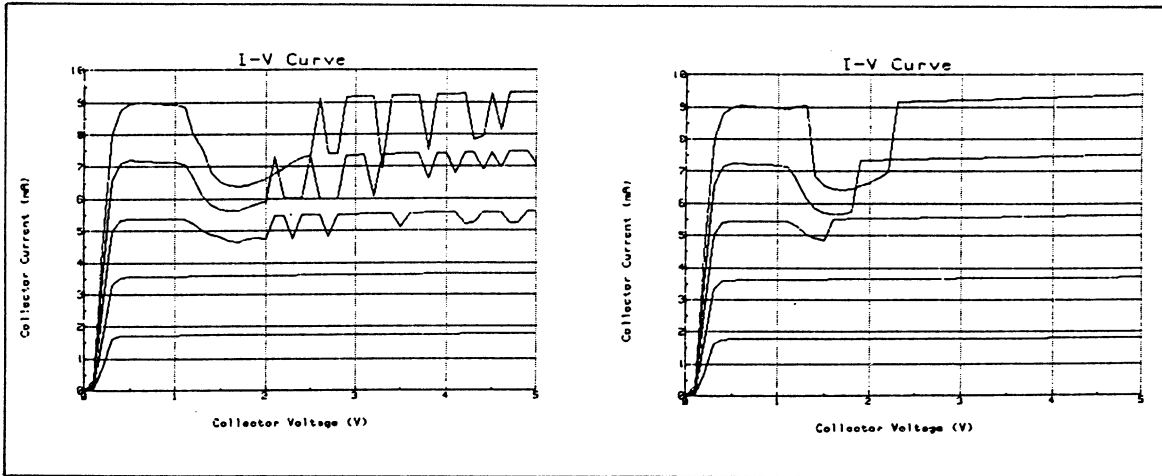

Example of an Oscillating Test Device Output I-V Curves

To prevent test device oscillation, install a ferrite bead (part number 9170-0029) to the test device leads as shown in the following figure.

Install the ferrite bead as close as possible to the test device. You may need to install more than one bead or change to a bead with a different diameter to prevent oscillation. Installing the ferrite bead to the base lead of bipolar transistors and to the gate lead of FETs is generally most effective to stop oscillation.

To minimize leakage current, do not short the ferrite beads to the case of the device, to other leads, or to the ferrite beads of other lines.

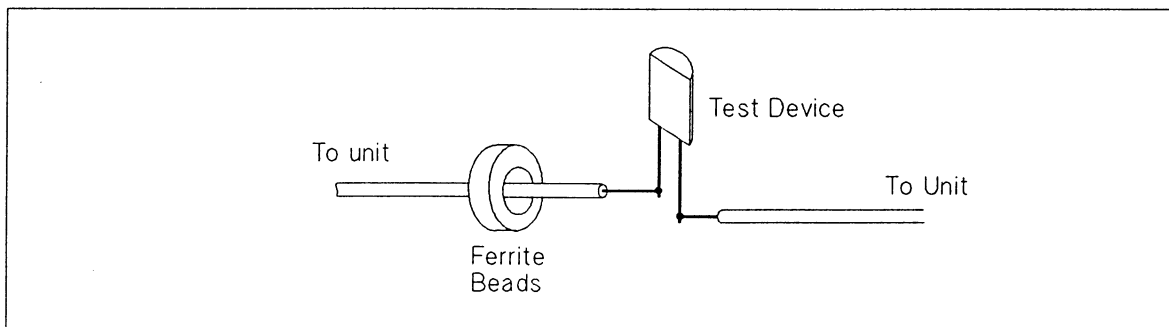

Preventing Test Device Oscillation

NOTE

Below are more suggestions to stop oscillation:

- Shorten the length of the connection cable.
- Enclose the test device with a shielding box.
- For the SMU/HVU, surround the FORCE and SENSE lines by GUARD.

This type of oscillation (more than 3 MHz) does not come from the source and monitor units. It comes from a combination of the test device and stray parameters around the test device. Oscillation of 5 MHz or more cannot be detected by the SMU or HVU.

CHAPTER 4

OPERATION GUIDE

CONTENTS

Introduction	4-1
Before Applying Power	4-1
Safety Precautions	4-1
Confirming Installation	4-3
Applying Power	4-4
Self-Test	4-4
Performing Safety Tests for the HVU	4-5
Sending the HP-IB Command	4-6
Output/Input Statement	4-6
Sending an HP-IB Command	4-6
Sending an HP-IB Command to the Unit (Channel Numbers; Ch#)	4-7
Getting Data from the HP 4142B	4-7
If an Error Occurs	4-8
Reading the Error Register	4-8
Resetting the HP 4142B	4-9
Forcing and Measuring	4-10
Performing the Self-Calibration	4-10
Setting the Output Switch of the Unit to ON	4-11
Setting the Output Switch of the Unit to OFF	4-11
Forcing Constant Voltage	4-12
Forcing Constant Current	4-13
Setting the Output to 0 V	4-14
Performing the Measurement	4-15
Performing the Staircase Sweep Measurement	4-16
Specifying the Measurement Range	4-17
Measurement Program Flow	4-18
Waiting for Time	4-19

INTRODUCTION

This chapter teaches you operating and measurement procedures. Included are how to turn the HP 4142B on, how to send commands, how to retrieve data, how to handle errors, and how to make a measurement.

BEFORE APPLYING POWER

Safety Precautions

WARNING

THE HP 4142B CAN FORCE DANGEROUS VOLTAGES (1000 V FOR HVU, 200 V FOR HPSMU, AND 100 V FOR MPSMU) AT THE FORCE, GUARD, AND SENSE TERMINALS. TO PREVENT ELECTRICAL SHOCK HAZARD, THE FOLLOWING SAFETY PRECAUTIONS MUST BE OBSERVED DURING THE USE OF THE HP 4142B.

Before Turning the HP 4142B On:

- The HP 4142B chassis and cabinet is connected to an electrical ground (safety ground) with a three-conductor ac power cable.
- Enclose all parts that have exposed voltages, such as the test device, wafer prober, fixture, and connecting points, with an insulated or grounded shielding box.
- Connect the **INTLK** terminal to a switch that turns off when the shielding box access door is opened.

If the door is opened (**INTLK** terminal is opened), the HVU output switch is set to off, and the SMU output is set to 0 V if the SMU output is more than ± 42 V.

- If the HVU is installed in your HP 4142B, connect the **OUTPUT ON/OFF STATUS** terminal to a warning indicator, and install the warning indicator in a position that is highly visible to the operator.

The warning indicator is lit when the HVU output switch is set to on, during HVU Self-Test, or during HVU Self-Calibration.

- Warn workers around the HP 4142B about dangerous conditions.

After Turning the HP 4142B On:

- If an HVU is installed in your HP 4142B: before using the HP 4142B, perform the safety tests that confirm the operation and connections of the **INTLK** and **OUTPUT ON/OFF STATUS** circuits, which are explained in this chapter. Perform the tests at least once a day.
- Whenever you do not use the source units, set the unit output switch to off.
- Before touching the connections of the FORCE, GUARD and SENSE terminals, turn the HP 4142B off and discharge any capacitors whenever possible.

If you do not turn the HP 4142B off, complete *all* of the following bulleted items, regardless of any HP 4142B settings.

- If an HVU is installed, perform the safety tests of the **INTLK** and **OUTPUT ON/OFF STATUS** circuits and confirm that the tests pass.
- Set the HVU and SMU output switches to off.
- If an HVU is installed, confirm that the warning indicator is not lit.
- Open the shielding box access door (opens the **INTLK** terminal).
- Discharge any capacitors if the capacitance is more than 0.1 μF .

For maximum safety, turn the HP 4142B off and discharge any capacitors.

Confirming Installation

Before you apply power, confirm the items in the following list.

- The HP 4142B is installed horizontally, $\pm 20^\circ$ maximum.
- The HP 4142B chassis and cabinet is connected to an electrical ground (safety ground) with a three-conductor ac power cable.
- Line voltage is within the specified tolerance.
- The **LINE VOLTAGE SELECTOR** switch is set correctly.
- The correct fuse is installed.
- The line frequency **FILTER** switch is set correctly.
- Blank panels (part number 04142-60012) are installed in all unused slots.
- Front panel is correctly installed on the HP 4142B.
- **HP-IB ADDRESS Switch** on the rear panel is set to the desired value between 0 to 30 (it is set to 17 when shipped from the factory). The new HP-IB address is recognized only at power on.

If you have any questions above, refer to Chapter 1.

- The **CIRCUIT COMMON** and **CHASSIS GROUND** terminals are shorted with the shorting-bar. Or the ground of the external devices is connected to the HP 4142B **CIRCUIT COMMON**. For details, refer to chapter 3.

APPLYING POWER

WARNING

TO PREVENT ELECTRICAL SHOCK, PERFORM THE "SAFETY PRECAUTIONS" IN THIS CHAPTER BEFORE PERFORMING THE FOLLOWING PROCEDURE.

To turn on the HP 4142B, perform the following procedure.

1. Set the front panel **POWER ON/OFF** switch to **ON**.
2. Set the rear panel **LINE ON/OFF** switch to **ON**.

NOTE

To simplify turning the HP 4142B on or off, keep the **POWER ON/OFF** switch setting to **ON** at all times, and use the **LINE ON/OFF** switch to turn the HP 4142B on or off.

Line power is applied to the HP 4142B if the rear panel **LINE ON/OFF** switch is set to **ON**, even if the front panel **POWER ON/OFF** switch is set to **OFF**. To completely power down the HP 4142B, set the rear panel **LINE ON/OFF** switch to **OFF**, regardless of the **POWER ON/OFF** switch setting.

To satisfy the specifications of the HP 4142B measurement accuracy, allow the HP 4142B to warm-up for a minimum of 40 minutes before you begin performing measurements.

Self-Test

When you turn the HP 4142B on, the HP 4142B performs Self-Test after lighting all front panel indicators momentarily. This test can also be performed by pressing the **LOCAL/SELF-TEST** key (or by sending the HP-IB command *TST?). Self-Test verifies that the HP 4142B is operating but does not verify that the output and measurement will be accurate.

When the HP 4142B starts Self-Test, a **C** (indicates Self-Test is being performed) is displayed in the **ERROR/FAILURE** display. Self-Test takes about 30 seconds. When Self-Test is finished, the **LOCAL/SELF TEST** key indicator light goes out and a **0** (No error) is displayed in the **ERROR/FAILURE** display.

If a **U** (HVU Self-Test error that indicates the **INTLK** terminal is open) is displayed, close the lid of the shielding box (that is, connect the center conductor and outer conductor of the **INTLK** terminal), then press the **LOCAL/SELF-TEST** key to perform the Self-Test again. If anything other than **0** or **U** is displayed, see Chapter 7, "Front Panel" for details.

If you keep the HP 4142B turned on for more than one day, we recommend that you perform Self-Test once a day.

PERFORMING SAFETY TESTS FOR THE HVU

WARNING

TO PREVENT ELECTRICAL SHOCK, PERFORM THE "SAFETY PRECAUTIONS" IN THIS CHAPTER BEFORE PERFORMING THE FOLLOWING PROCEDURE.

If the HVU is installed in your HP 4142B, perform the following circuit operation tests of **INTLK** terminal and **OUTPUT ON/OFF STATUS** terminals for safety before using the HVU.

- **INTLK Circuit Test:**

1. Open the shielding box access door (open the **INTLK** terminal).
2. Press the **LOCAL/SELF TEST** key to perform the Self-Test.
3. Confirm that **U** is displayed in the **ERROR/FAILURE** display after the Self-Test finishes.
4. Close the shielding box access door (short the **INTLK** terminal).
5. Press the **LOCAL/SELF TEST** key to perform the Self-Test.
6. Confirm that **0** is displayed in the **ERROR/FAILURE** display after the Self-Test finishes.

If step 3 or step 6 does not pass, correct the connections between the **INTLK** terminal and the switch on the shielding box, then perform this test again.

- **OUTPUT ON/OFF STATUS Circuit Test:**

1. Press the **LOCAL/SELF TEST** key to perform the Self-Test.
2. During Self-Test, confirm that the warning indicator connected to the **OUTPUT ON/OFF STATUS** terminal is lit for about 5 seconds for each HVU installed.
3. Confirm that the warning indicator is not lit after the Self-Test finishes.

If step 2 or step 3 does not pass, correct the connections between the **OUTPUT ON/OFF STATUS** terminal and the warning indicator, then perform this test again.

WARNING

**PERFORM THE INTLK CIRCUIT AND THE OUTPUT ON/OFF STATUS CIRCUIT TESTS AT LEAST ONCE A DAY.
IF BOTH OR EITHER OF THE TESTS DO NOT PASS, DO NOT USE THE HVU.
REMOVE THE HVU FROM YOUR HP 4142B.**

SENDING THE HP-IB COMMAND

WARNING

TO PREVENT ELECTRICAL SHOCK, PERFORM THE "SAFETY PRECAUTIONS" IN THIS CHAPTER BEFORE PERFORMING THE FOLLOWING PROCEDURE.

Output/Input Statement

The statements used to operate the HP 4142B depend on the computer and its language. In particular, you need to know the statements the computer uses to output and input information. For example, the output statement for the HP 9000 Series 200/300 BASIC language is **OUTPUT**. The input statement is **ENTER**.

Read your computer manuals to find out which statements you need to use. The examples in this manual use HP 9000 Series 200/300 BASIC language. To use the examples, load the binary (BIN) files: HPIB, IO, GRAPH, and ERR.

Sending an HP-IB Command

To send the HP 4142B an HP-IB command, combine the output statement of the computer with the HP-IB select code, the HP 4142B address, and finally, the HP 4142B HP-IB command. For example, to make the HP 4142B perform Self-Calibration, send:

```
OUTPUT 717;"CA"
```

Self-Calibration: This improves short-term accuracy for output and measurement functions, but is not a substitute for periodic calibration (adjustment) of the HP 4142B. When the HP 4142B performs Self-Test, the HP 4142B also performs Self-Calibration.

Notice that the **REM** and **LSTN** indicators of the front panel are illuminated. This means the HP 4142B is in the remote mode and has been addressed to listen (received a command).

Each HP-IB command syntax is described in the *HP-IB Command Reference Manual*.

Sending an HP-IB Command to the Unit (Channel Numbers; Ch#)

Channel Numbers (*Ch#*) are used to identify the plug-in units installed in the HP 4142B. To control each unit, you must specify the channel number of the unit. For example, to make *ch#5* of the unit perform Self-Calibration, send:

```
OUTPUT 717;"CA5"
```

Channel numbers are determined by the slot number that the unit is installed as follows. The slot number is displayed on the front panel.

- HP 41420A HPSMU, HP 41422A HCU, and HP 41423A HVU:
Ch# is the slot number that is the greater of the two slots occupied by the unit.
Example: In slot#1 and slot#2, *Ch#* is 2.
- HP 41421B MPSMU:
Ch# is the slot number in which the MPSMU is installed.
Example: In slot#3, *Ch#* is 3.
- HP 41424A VS/VMU:
VS1 and VM1:
Ch# is $1n$ or n , where n is the slot number in which the VS/VMU is installed.
Example: In slot#8, *Ch#* is 18 or 8.

VS2 and VM2:

Ch# is $2n$, where n is the slot number in which the VS/VMU is installed.
Example: In slot#8, *Ch#* is 28.

Differential Voltmeter using VM1 and VM2:

Ch# is n , $1n$, or $2n$, where n is the slot number in which the VS/VMU is installed.
Example: In slot#8, *Ch#* is 8, 18, or 28.

Getting Data from the HP 4142B

The HP 4142B is capable of sending measurement data and responses to query commands. As an example, have the HP 4142B generate a response to a query command by sending:

```
OUTPUT 717;"*IDN?"
```

The HP 4142B sends the response to its output buffer. The output buffer is a register that holds a query response or measurement data until it is read by the computer. Use the input statement of the computer to get the response from the output buffer. For example, the following program reads the response (HEWLETT-PACKARD, 4142B, 0, *ROM__version__number*) and prints it.

```
10 DIM A$(30)
20 ENTER 717;A$
30 DISP A$
40 END
```

The output format of response data to each query command and measurement data are described in the *HP-IB Command Reference Manual*.

IF AN ERROR OCCURS

The HP 4142B indicates errors in the following manner.

- The HP 4142B displays an **A, E, F, H, P, U**, or **1 to 8** in the **ERROR/FAILURE** display, which indicates the following error conditions. For more information, see Chapter 7, "Front Panel."
 - E:** Syntax error or out of the parameter range.
 - F:** Incorrect input command sequence.
 - H:** Overvoltage or overcurrent occurred. Output switches of all units are disconnected to prevent the HP 4142B damage.
 - U:** **INTLK** terminal open at the HVU Self-Test or HVU Self-Calibration.
 - 1 to 8, A, P:** Self-Test failed.
 - (C:** Performing the Self-Test or Self-Calibration)
- The HP 4142B sets Bit 5 of the status byte to one. If you remove the mask of that bit, the HP 4142B asserts the SRQ. Use this function when you handle the error in your programs. For more information, see Chapter 7, "Status Byte."

If an error occurs, you can get the error message. Refer to the next paragraph, "Reading the Error Register."

NOTE

In case of momentary power loss, overvoltage, or overcurrent, the HP 4142B may automatically turn off, keeping **LINE ON/OFF** and **POWER ON/OFF** switches **ON**, to prevent damage. If this occurs, set **LINE ON/OFF** switch to **OFF** and wait for more than 10 seconds, then set the switch to **ON**. The HP 4142B will function properly.

Reading the Error Register

Whenever an error occurs, a record of errors is stored in the error register as the error code. To read the error record, send the **ERR?** command to transfer the error codes from the error register to the output data buffer as shown below.

```
10 DIM A$(23)
20 OUTPUT 717;"ERR?"
30 ENTER 717;A$
40 PRINT A$
50 END
```

The first four error codes are printed in the order of their occurrence. For example:

```
120, 100, 0, 0
```

For error code descriptions, see *HP-IB Command Reference Manual*, "Error Messages." If no error occurs, the error register returns "0, 0, 0, 0."

When you execute the **ERR?** command, the error register and **ERROR/FAILURE** display are initialized (set to "0, 0, 0, 0" and **0**).

RESETTING THE HP 4142B

Many times during operation, you may wish to return to the power-on initial settings. The ***RST** or the HP BASIC **CLEAR** command returns you to the initial settings. To reset the HP 4142B (HP 4142B mainframe and all plug-in units), send:

```
OUTPUT 717;"*RST"
```

or

```
CLEAR 717
```

For initial settings information, see Chapter 7, "Initial Settings".

The CLEAR (Device Clear) statement resets the HP 4142B more directly than *RST command because it bypasses the HP 4142B input buffer.

FORCING AND MEASURING

WARNING

TO PREVENT ELECTRICAL SHOCK, PERFORM THE "SAFETY PRECAUTIONS" IN THIS CHAPTER BEFORE PERFORMING THE FOLLOWING PROCEDURES.

This paragraph explains the operation of measurements using a bipolar transistor as a test device.

Connect the units to the test device as follows. Refer to Chapter 3 for information on how to connect.

Emitter: GNDU
Base: HPSMU, MPSMU, or HVU
Collector: HPSMU, MPSMU, or HVU

Performing the Self-Calibration

Self-Calibration improves the short-term accuracy of the output and measurement functions. To perform Self-Calibration, send:

OUTPUT 717;"CA"

or press the **LOCAL/SELF TEST** key.

After a minimum of 40 minutes for a warm-up period and before you begin to use your HP 4142B, perform Self-Calibration. Self-Calibration should be performed every 30 minutes or if the ambient temperature changes by more than 3°C (6°F).

When the HP 4142B performs Self-Test, the HP 4142B also performs Self-Calibration.

Setting the Output Switch of the Unit to ON

Before you make the SMUs/HCUs/HVUs/VSs force or measure voltage/current, you must set the internal output switch of the unit to ON.

Even if a physical connection by a cable exists, these units are not electrically connected to a test device, because the output switches are set to OFF at power-on. To set the output switches to ON, and to connect the units to the test device electrically, send **CN** command. The syntax is:

```
CN [ch#] [,ch#] [,ch#] [,ch#] [,ch#] [,ch#] [,ch#] [,ch#]
```

Where the brackets [] mean optional parameter. If you connect three units of ch#2, ch#3, and ch#8:

```
OUTPUT 717;"CN";2,3,8
```

If you connect all units:

```
OUTPUT 717;"CN"
```

When the output switch is set to ON, 0 V is forced to the test device.

For VMs, GNDU and AFU, you do not need this operation because these units do not have output switches.

WARNING

SETTING THE OUTPUT SWITCH TO ON ENABLES THE UNIT TO FORCE DANGEROUS VOLTAGES.

EVEN IF THE OUTPUT SWITCH IS SET TO OFF, TURN THE HP 4142B OFF AND DISCHARGE ANY CAPACITORS BEFORE YOU TOUCH THE CONNECTIONS OF THE FORCE, GUARD AND SENSE TERMINALS.

IF YOU CANNOT TURN THE HP 4142B OFF, REFER TO THE "SAFETY PRECAUTIONS" IN THIS CHAPTER.

SET THE OUTPUT SWITCH TO OFF WHENEVER POSSIBLE WHEN THE UNIT IS NOT IN USE.

Setting the Output Switch of the Unit to OFF

To set the output switches to OFF, and to disconnect the units from the test device, send **CL** command. The syntax is:

```
CL [ch#] [,ch#] [,ch#] [,ch#] [,ch#] [,ch#] [,ch#] [,ch#]
```

If you disconnect three units of ch#2, ch#3, and ch#8:

```
OUTPUT 717;"CL";2,3,8
```

If you disconnect all units:

```
OUTPUT 717;"CL"
```

Forcing Constant Voltage

The **DV** command forces the specified constant voltage. Constant voltage can be forced from SMUs, HVUs, or VSs. The syntax of **DV** command is:

For SMUs or HVUs:

DV ch#, output range, output voltage, I compliance

For VSs:

DV ch#, output range, output voltage

If you force 1 V from the SMU of ch#2 with Auto ranging (*output range = 0*), and set the current compliance to 10 mA:

```
OUTPUT 717;"CN";2
OUTPUT 717;"DV";2,0,1,10E-3
```

For the HVU, if you change the output polarity (positive or negative; positive in initial setting), execute the **POL** command before sending **DV**. The syntax is:

POL ch#, output polarity

where *output polarity* is 0 for positive, 1 for negative.

If you force -1 V from the HVU of ch#8, send:

```
OUTPUT 717;"POL";8,1
OUTPUT 717;"DV";8,0,-1,10E-3
```

WARNING

THE POL COMMAND, LIKE THE CN COMMAND, SETS THE HVU OUTPUT SWITCH TO ON.

SETTING THE OUTPUT SWITCH TO ON ENABLES THE UNIT TO FORCE DANGEROUS VOLTAGES.

EVEN IF THE OUTPUT SWITCH IS SET TO OFF, TURN THE HP 4142B OFF AND DISCHARGE ANY CAPACITORS BEFORE YOU TOUCH THE CONNECTIONS OF THE FORCE, GUARD, AND SENSE TERMINALS.

IF YOU CANNOT TURN THE HP 4142B OFF, REFER TO THE "SAFETY PRECAUTIONS" IN THIS CHAPTER.

SET THE OUTPUT SWITCH TO OFF WHENEVER POSSIBLE WHEN THE UNIT IS NOT IN USE.

Forcing Constant Current

The **DI** command forces the specified constant current. Constant current can be forced from SMUs or HVUs. The syntax of **DI** command is:

DI ch#, output range, output current, V compliance

If you force 10 μA from the SMU of ch#3 with Auto ranging (*output range = 0*), and set the voltage compliance to 2 V:

```
OUTPUT 717;"CN";3
OUTPUT 717;"DI";3,0,10E-6,2
```

The current polarity is positive if current flows from the HP 4142B, and negative if it flows into the HP 4142B.

If you use an SMU or HVU as no output (open) or a voltage monitor only, set current output to 0 A.

For the HVU, if you change the output polarity, execute the **POL** command before sending **DI**.

If you force -10 μA from the HVU of ch#8, send:

```
OUTPUT 717;"POL";8,1
OUTPUT 717;"DI";8,0,-10E-6,2
```

WARNING

THE POL COMMAND, LIKE THE CN COMMAND, SETS THE HVU OUTPUT SWITCH TO ON.

SETTING THE OUTPUT SWITCH TO ON ENABLES THE UNIT TO FORCE DANGEROUS VOLTAGES.

EVEN IF THE OUTPUT SWITCH IS SET TO OFF, TURN THE HP 4142B OFF AND DISCHARGE ANY CAPACITORS BEFORE YOU TOUCH THE CONNECTIONS OF THE FORCE, GUARD AND SENSE TERMINALS.

IF YOU CANNOT TURN THE HP 4142B OFF, REFER TO THE "SAFETY PRECAUTIONS" IN THIS CHAPTER.

SET THE OUTPUT SWITCH TO OFF WHENEVER POSSIBLE WHEN THE UNIT IS NOT IN USE.

Setting the Output to 0 V

To stop forcing voltage and current, send the **DZ** command. The **DZ** command sets the specified unit(s) output to 0 V. You can send this command more easily than the **DV** command. The **DZ** command syntax is:

```
DZ [ch#] [,ch#] [,ch#] [,ch#] [,ch#] [,ch#] [,ch#] [,ch#]
```

If you specify three units of ch#2, ch#3, and ch#8:

```
OUTPUT 717;"DZ";2,3,8
```

If you specify all units:

```
OUTPUT 717;"DZ"
```

Performing the Measurement

To specify the measurement mode and measurement channel, send the **MM** command. The syntax is:

```
MM measurement mode, ch# [,ch#] [,ch#] [,ch#] [,ch#] [,ch#] [,ch#] [,ch#]
```

When the measurement unit is an SMU, HCU or HVU, an SMU/HCU/HVU set to V source mode performs an I measurement--even if output value is 0 V, and an SMU/HCU/HVU set to I source mode performs a V measurement--even if output value is 0 A. Measurements are performed in the order that you specify them with the **MM** command.

Send the measurement trigger command **XE** to start a measurement. Measurement results are stored in the HP 4142B output data buffer in ASCII format. Transfer measurement data to your computer using the **ENTER** statement.

The following program forces collector voltage (1 V) and base current (10 μ A) and measures the collector current with the spot measurement (*measurement mode* = 1).

```
10 Base=3      ! Base: ch#3, Collector: ch#2, Emitter: GNDU
20 Collector=2
30 Ib=10E-6
40 Vc=1
50 OUTPUT 717;"*RST"
60 OUTPUT 717;"CN";Base,Collector
70 OUTPUT 717;"DV";Collector,0,Vc,10E-3
80 OUTPUT 717;"DI";Base,0,Ib,2
90 OUTPUT 717;"MM";1,Collector
100 OUTPUT 717;"XE"
110 OUTPUT 717;"DZ";Base,Collector
120 OUTPUT 717;"CL";Base,Collector
130 ENTER 717;A$
140 PRINT A$
150 END
```

The measurement data *A\$* is printed as shown below:

```
NBI+02.1808E-03
```

The first three characters (NBI) are the measurement data status, which indicates measurement condition. The remainder (+02.1808E-3) is the measurement value, 2.1808 mA. For more information about the measurement data format, see the *HP-IB Command Reference Manual*.

NOTE

The HP 4142B output data buffer can store up to 1023 measurement data (4095 for binary data format). See "Measurement Data Memory" in Chapter 6 for more information. The data buffer sends measurement data in the order in which it was stored. Therefore, if you transfer the measurement data after you perform the measurement twice, the first measurement data is transferred from the HP 4142B first. Use the **BC** command to clear the output data buffer. The output data buffer is also cleared when you turn the HP 4142B on and when you execute an ***RST** command or Device Clear (**CLEAR** statement).

Performing the Staircase Sweep Measurement

You can perform staircase sweep measurements easily by using the sweep command **WV** (for voltage sweep) or **WI** (for current sweep). The following is the syntax for each:

WV ch#, sweep mode, output range, start voltage, stop voltage, number of steps [, I compliance]

WI ch#, sweep mode, output range, start current, stop current, number of steps [, V compliance]

The following program forces collector voltage (0 to 1 V, 21 steps, linear sweep (*sweep mode* = 1)) and base current (10 μ A) and measures the collector current with the staircase sweep measurement (*measurement mode* = 2).

```
10 Base=3      ! Base: ch#3, Collector: ch#2, Emitter: GNDU
20 Collector=2
30 Ib=10E-6
40 Vcstart=0
50 Vcstop=1
60 No_step=21
70 DIM A$(400)
80 OUTPUT 717;"*RST"
90 OUTPUT 717;"CN";Base,Collector
100 OUTPUT 717;"WV";Collector,1,0,Vcstart,Vcstop,No_step,10E-3
110 OUTPUT 717;"DI";Base,0,Ib,2
120 OUTPUT 717;"MM";2,Collector
130 OUTPUT 717;"XE"
140 OUTPUT 717;"DZ";Base,Collector
150 OUTPUT 717;"CL";Base,Collector
160 ENTER 717;A$
170 PRINT A$
180 END
```

The measurement data *A\$* is printed as shown below:

```
NBI+09.9696E-06,NBI+08.5332E-06,NBI+0.12334E-03,NBI+0.61556E-03,
NBI+01.4284E-03,NBI+01.9058E-03,NBI+02.0858E-03,NBI+02.1426E-03,
NBI+02.1612E-03,NBI+02.1648E-03,NBI+02.1672E-03,NBI+02.1680E-03,
NBI+02.1700E-03,NBI+02.1722E-03,NBI+02.1728E-03,NBI+02.1744E-03,
NBI+02.1756E-03,NBI+02.1764E-03,NBI+02.1778E-03,NBI+02.1780E-03,
NBI+02.1808E-03
```

For the above program, measurement data is displayed after all steps of measurements are complete. If you want to display the measurement data immediately after each step of measurements, change program lines 140 through 180 to the following:

```

140 FOR Step=1 TO No_step
150   ENTER 717 USING "#,3A,12D,X";I$,I
160   PRINT I$,I
170 NEXT Step
180 ENTER 717 USING "#,X"
190 OUTPUT 717;"DZ";Base,Collector
200 OUTPUT 717;"CL";Base,Collector
210 END

```

The measurement data *I* and *I\$* is printed as shown below:

```

NBI -9.9636E-6
NBI 8.5332E-06
NBI .00012334
NBI .00061556
NBI .0014284
NBI .0019058
:      :
:      :
NBI .002178
NBI .0021808

```

NOTE

For the HVU, if you change the output polarity, execute the **POL** command before sending **DV** or **DI** for constant output, or before sending the **XE** command for other outputs, such as a sweep output.

Specifying the Measurement Range

If you specify a measurement ranging mode or range, specify that before sending the measurement trigger command **XE**. The measurement range of each unit can be specified as follows:

- **SMU/HCU/HVU Current Measurement Range:**
RI sets *Ch#* and I measurement range. Default I measurement range at power on is Auto.
- **SMU/HCU/HVU Voltage Measurement Range:**
Set automatically, depending on the V compliance setting, to the lowest range that includes the value of V compliance. For example, if you set the V compliance of the SMU to 5 V, the 20 V measurement range is set.
- **VM (voltage) Measurement Range:**
RV sets *Ch#* and V measurement range. Default V measurement range at power on is Auto.

See "Measurement Ranging Mode" in Chapter 6 for details.

Measurement Program Flow

The following shows the basic measurement program flow. The HP-IB commands for each step are listed in parentheses.

- Step 1. Initialize the HP 4142B and perform Self-Calibration (***RST** and **CA**).
- Step 2. Set the output switch of the source unit to ON. (**CN**)
- Step 3. Specify V or I Source mode; force V or I. (**DV, DI, WV, WI, POL**, etc.)
- Step 4. Specify the measurement mode and measurement unit. (**MM**)
- Step 5. Specify the measurement range. (**RI** and **RV**)
- Step 6. Perform measurement. (**XE**)
- Step 7. Set the output to 0 V. (**DZ**)
- Step 8. Set the output switch of the source unit to OFF. (**CL**)
- Step 9. Transfer the measurement data.

In Step 3 of above, the main commands for specifying measurement conditions for Sweep, Pulsed, and Analog Search measurement are listed below.

- Staircase Sweep measurements (1ch sweep): **WV** and **WI**
- Staircase Sweep measurements (2ch sweep): **WV, WI, WSV**, and **WSI**
- 1ch Pulsed Spot measurements: **PV** and **PI**
- Pulsed Sweep measurements: **PWV** and **PWI**
- Staircase Sweep with Pulsed Bias measurements: **WV, WI, PV**, and **PI**
- Analog Search measurements: **ASV, AVI**, and **AIV**
- 2ch Pulsed Spot measurements: **PV, PI, PDV**, and **PDI**
- Pulsed Sweep with Pulsed Bias measurements: **PWV, PWI, PDV**, and **PDI**
- Quasi-pulsed spot measurements: **BDV**

Waiting for Time

You can pause command execution until the specified *wait time* has elapsed. The command is **PA**, and the syntax is:

`PA wait time`

The *wait time* setting area is from 0 to 99.9999 s (100 μ s resolution).

If you wait for 1 ms between output and measurement, send as follows:

```
:  
80 OUTPUT 717;"MM";1;Collector  
90 OUTPUT 717;"DI";Base,0,Ib,2 ! Current output  
100 OUTPUT 717;"PA";1E-3  
110 OUTPUT 717;"XE" ! Measurement Trigger  
:
```

CHAPTER 5

MEASUREMENT MODES

CONTENTS

Introduction	5-1
Spot Measurements	5-1
Commands and Parameters	5-3
Information	5-3
Spot Measurement Sample Program	5-4
Staircase Sweep Measurements	5-6
Commands and Parameters	5-10
Information	5-11
Staircase Sweep Measurement Sample Program	5-11
1ch Pulsed Spot Measurements	5-15
Commands and Parameters	5-18
Information	5-18
1ch Pulsed Spot Measurement Sample Program	5-19
Pulsed Sweep Measurements	5-21
Commands and Parameters	5-25
Information	5-26
Pulsed Sweep Measurement Sample Program	5-26
Staircase Sweep with Pulsed Bias Measurements	5-29
Commands and Parameters	5-33
Information	5-34
Staircase Sweep with Pulsed Bias Measurement Sample Program	5-34
Analog Search Measurements	5-37
Search Operation Modes	5-40
Search Measurement Modes	5-42
Commands and Parameters	5-43
AFU Monitor Port	5-44
Information	5-45
Analog Search Measurement Sample Program	5-45
2ch Pulsed Spot Measurements	5-48
Commands and Parameters	5-51
Information	5-52
2ch Pulsed Spot Measurement Sample Program	5-52
Pulsed Sweep with Pulsed Bias Measurements	5-54
Commands and Parameters	5-58
Information	5-59
Pulsed Sweep with Pulsed Bias Measurement Sample Program ...	5-59
Quasi-Pulsed Spot Measurements	5-63
Settling Detection Method	5-68
Commands and Parameters	5-70
Information	5-70
Quasi-pulsed Spot Measurement Sample Program	5-71
High Speed Spot Measurements	5-73
Commands and Parameters	5-75
Information	5-75
High Speed Spot Measurement Sample Program	5-76

INTRODUCTION

This chapter explains all ten measurement modes of the HP 4142B. Included in the description of each measurement mode are measurement method, allowable units, allowable number of source and measurement channels, HP-IB commands, and a sample program.

SPOT MEASUREMENTS

Spot measurements are performed as follows: up to 16 sources force constant voltages and currents and up to 8 monitors measure the outputs. The **DV** and **DI** commands set *output voltage* and *output current*. When using an SMU or HVU as a voltage monitor, set the *output current* of the unit to 0 A using the **DI** command. The following table and figure show HP 4142B spot measurement specifics, and an example spot measurement using two channels, respectively.

Spot Measurement Specifics

Output Mode	No. of Source Ch.	Source Mode	Source Setup Command	Allowable Units	Allowable Monitor Mode	Meas. Setup Command	No. of Meas. Ch.
Constant	0 ¹ to 16	V	DV	HPSMU MPSMU HVU	I	MM	1 to 8
		I	DI	HPSMU MPSMU HVU	V		
No Output	---	---	---	VM	V DIF. V	MM VM	

¹ When using a VM to make measurements only.

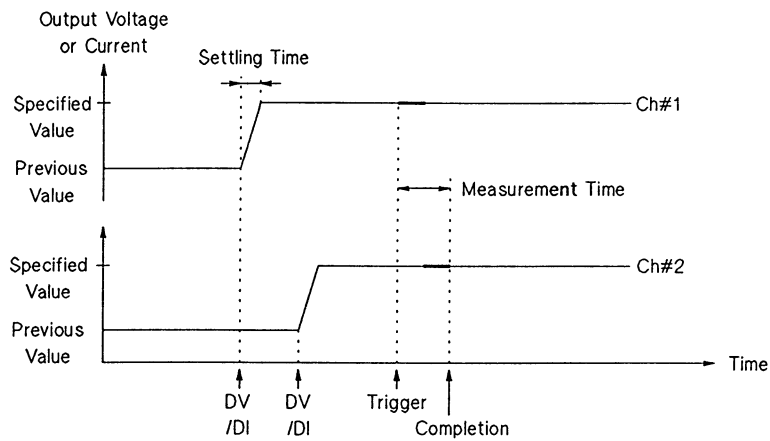

- 1) When the HP 4142B receives a **DV** or **DI** command, the source unit forces the *output voltage or current*.
- 2) When the HP 4142B receives a trigger, the measurement starts. When using more than one channel, measurements are performed in the order specified in the **MM** command. If the trigger is received during the settling time of the source unit, the measurement is performed after the settling time.
- 3) After the measurement is complete, the source unit continues to force the *output voltage or current*.

Spot Measurement Using Two Channels

Commands and Parameters

The following table lists the commands and parameters for spot measurements.

Spot Measurement Commands and Parameters

Function	Command ¹	Parameters ¹
Constant V Source	DV	<i>ch#, output range, output voltage, [I compliance], [compliance polarity mode]</i>
Constant I Source	DI	<i>ch#, output range, output current, [V compliance], [compliance polarity mode]</i>
HVU Output Polarity	[POL]	<i>ch#, output polarity</i>
Measurement	MM	<i>measurement mode, ch#</i>
	[RI]	<i>ch#, I measurement range</i>
	[RV]	<i>ch#, V measurement range</i>
	[VM]	<i>ch#, VM operation mode</i>
	[AV]	<i>averaging number, [averaging mode]</i>
Trigger	XE	-----

¹ Brackets ([]) denote optional commands and parameters.

Information

Measurement Data Output Format is explained in the *HP 4142B HP-IB Command Reference Manual*.

Output and Measurement Ranging Mode and **Averaging** are explained in chapter 6.

Spot Measurement Sample Program

The following is a sample program that measures collector saturation voltage ($V_{ce(sat)}$) and base saturation voltage ($V_{be(sat)}$) of a 2N3904 bipolar transistor by using the spot measurement function. A description of key program lines follows the program list.

Measurement Conditions

DUT Terminal	Unit	Output	Measurement
Base	SMU Ch#3	$I_b = 1 \text{ mA}$	V_{be}
Collector	SMU Ch#2	$I_c = 10 \text{ mA}$	V_{ce}
Emitter	GNDU	$V_e = 0 \text{ V}$	---

Program List

```

10  ! Vce(sat) and Vbe(sat) Measurement using Spot Function
20  !
30  INTEGER B_ch, C_ch
40  DIM A$[31]
50  ASSIGN @Hp4142 TO 717
60  OUTPUT @Hp4142;"*RST"
70  !
80  B_ch=3
90  C_ch=2
100 Ib=1.E-3
110 Ic=1.E-2
120 !
130 OUTPUT @Hp4142;"CN";B_ch, C_ch
140 OUTPUT @Hp4142;"DI";B_ch, 0, Ib, 2
150 OUTPUT @Hp4142;"DI";C_ch, 0, Ic, 2
160 OUTPUT @Hp4142;"MM";1, C_ch, B_ch
170 OUTPUT @Hp4142;"XE"
180 OUTPUT @Hp4142;"CL"
190 !
200 ENTER @Hp4142;A$
210 PRINT "Vce(sat)= ";A$[4, 15];"[V]"
220 PRINT "Vbe(sat)= ";A$[20, 31];"[V]"
230 END

```

Result

```

Vce(sat)= +0.06764E+00[V]
Vbe(sat)= +0.74692E+00[V]

```



Description

40	Defines the string variable, <i>A\$</i> , for storing measurement data.
60	Initializes the HP 4142B.
130	Sets the SMU output switches to ON.
140	Forces 1 mA to the base.
150	Forces 10 mA to the collector
160	Sets the spot measurement mode and the measurement channels.
170	Sends a trigger to start the measurement.
180	Sets the SMU output switches to OFF.
200	Enters the measurement data into the string variable, <i>A\$</i> .
210-220	Displays the measurement results.

STAIRCASE SWEEP MEASUREMENTS

Staircase sweep measurements are performed as follows: one source sweeps constant voltage or current, while up to 8 monitors measure the output for each sweep step. Or two sources sweep constant voltages or currents at the same time, while up to 8 monitors measure the outputs for each sweep step. Measurement data for each sweep step is stored in the output data buffer. The following table lists the staircase sweep measurement modes and provides an illustration of each.

Staircase Sweep Measurement Modes

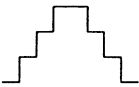
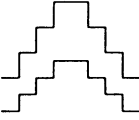
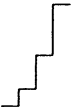
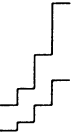
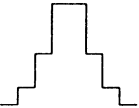
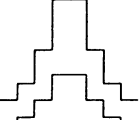
Sweep Mode	Output Waveform	
	1 Channel Sweep	2 Channel Synchronous Sweep ¹
Linear Single Staircase Sweep		
Linear Double Staircase Sweep		
Log Single Staircase Sweep		
Log Double Staircase Sweep		

¹ To perform sweep measurements using two sweep source channels, both source channels must be set to the same source mode (V source or I source).

The following table and figure show HP 4142B staircase sweep measurement specifics, and an example of a linear single staircase sweep measurement, respectively.

Staircase Sweep Measurement Specifics

Output Mode	No. of Source Ch.	Source Mode	Source Setup Command	Allowable Units	Allowable Monitor Mode	Meas. Setup Command	No. of Meas. Ch.
Staircase Sweep	1 to 2 ¹	V	1ch: WV 2ch: WV WSV	HPSMU MPSMU HVU	I	MM	1 to 8
				VS	---		
		I	1ch: WI 2ch: WI WSI	HPSMU MPSMU HVU	V		
Constant	0 to 15	V	DV	HPSMU MPSMU HVU	I		
				VS	---		
		I	DI	HPSMU MPSMU HVU	V		
No Output	---	---	---	VM	V DIF. V	MM VM	

¹ To perform sweep measurements using two sweep source channels, both source channels must be set to the same source mode (V source or I source).

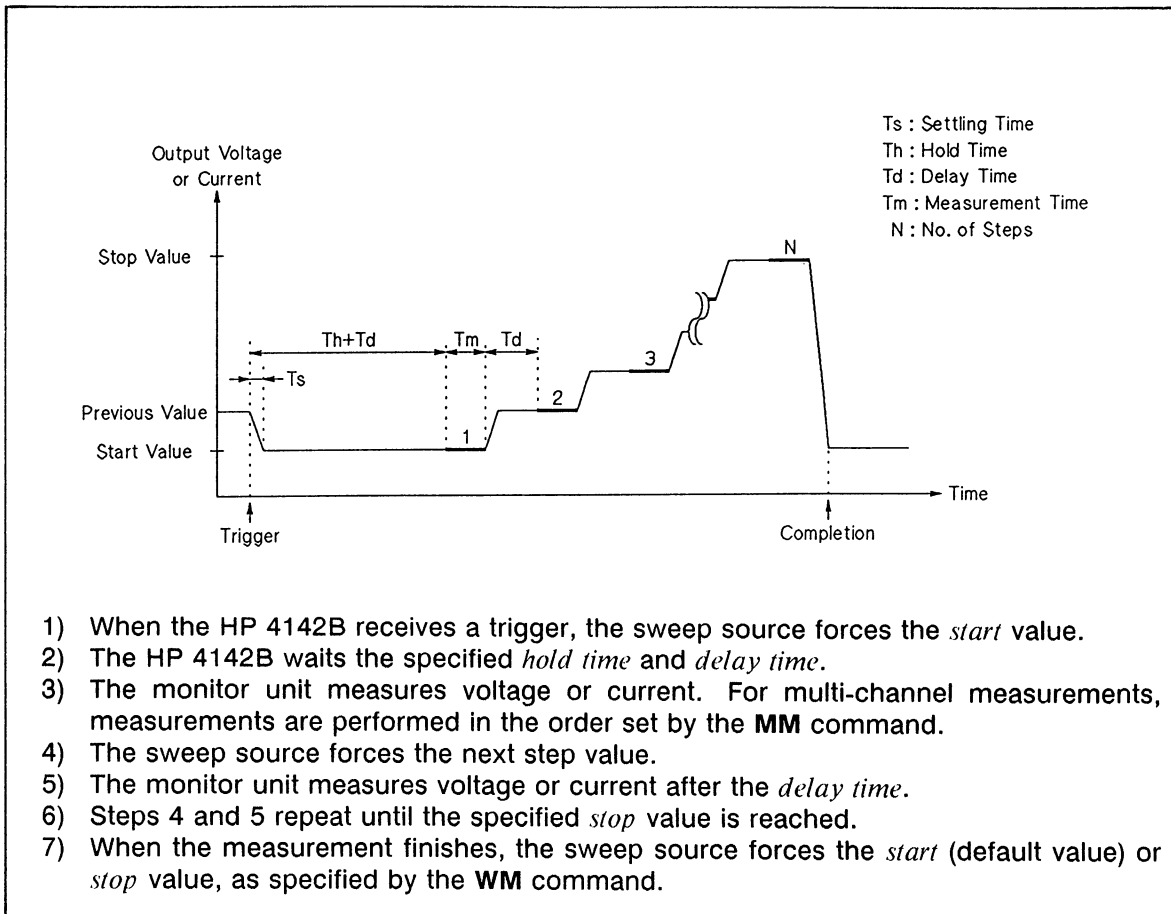

Linear Single Staircase Sweep Measurement

If you specify a *hold time* or *delay time* that is less than the settling time of the source unit, *hold time* or *delay time* is set to equal the settling time.

For linear staircase sweep, output values are calculated using the following equation.

$$k\text{th output value} = \text{start value} + (k-1)(\text{step value})$$

$$\text{where step value} = (\text{stop value} - \text{start value}) / (\text{number of steps} - 1)$$

For log staircase sweep, output values are calculated using the following equation. *Start* and *stop* values must have the same polarity, and must not be zero.

$$k\text{th output value} = (\text{start value})(\text{step value})^{(k-1)}$$

$$\text{where step value} = \text{EXP}[\{\ln(\text{stop value}/\text{start value})\} / (\text{number of steps} - 1)]$$

The following figure shows an example of a linear double staircase sweep measurement. The sweep source output is swept from the *start* value to the *stop* value, then from the *stop* value to the *start* value. The number of sweep steps is determined by the *number of steps* specified between the *start* and *stop* values. The measurement sequence is the same as a single staircase sweep. You can use the **WM** command to set the value (*start* or *stop* value) that is forced after the measurement is complete.

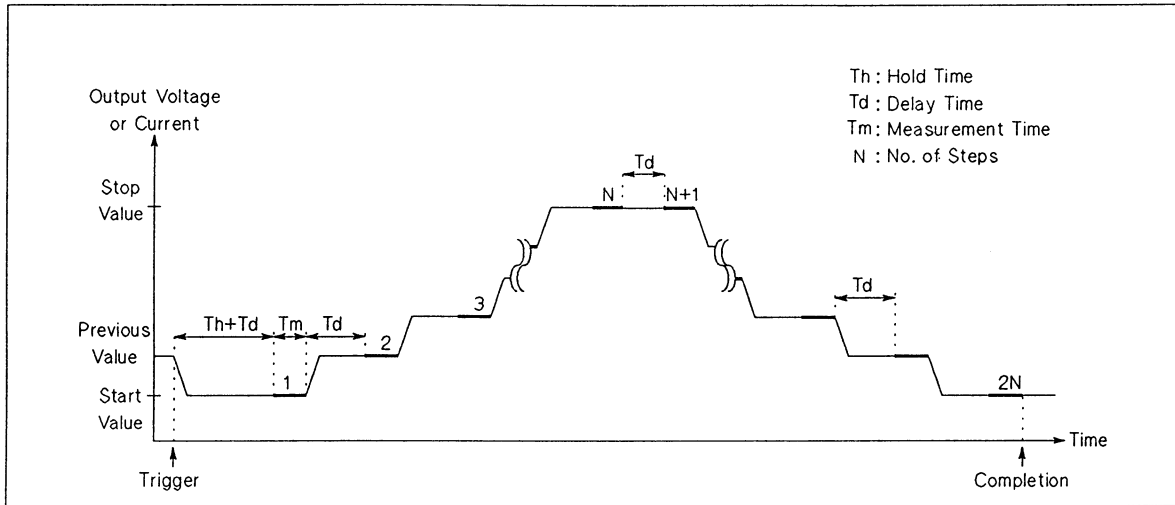

Linear Double Staircase Sweep Measurement

Commands and Parameters

The following table lists the commands and parameters for staircase sweep measurements. To perform a synchronous sweep measurement, set the main sweep source using the **WV** or **WI** commands, and set the synchronous sweep source using the **WSV** or **WSI** commands. Both sweep sources must be set to the same source mode (V source or I source).

Staircase Sweep Measurement Commands and Parameters

Function	Command ¹	Parameters ¹
Sweep V Source	WV	<i>ch#, sweep mode, output range, start voltage, stop voltage, number of steps, [I compliance], [power compliance]</i>
Sweep I Source	WI	<i>ch#, sweep mode, output range, start current, stop current, number of steps, [V compliance], [power compliance]</i>
Synchronous Sweep V Source	WSV	<i>ch#, output range, start voltage, stop voltage, [I compliance], [power compliance]</i>
Synchronous Sweep I Source	WSI	<i>ch#, output range, start current, stop current, [V compliance], [power compliance]</i>
Sweep Conditions	[WT]	<i>hold time, delay time</i>
	[WM]	<i>automatic sweep abort function, [output after sweep]</i>
Constant Source	DV	<i>ch#, output range, output voltage, [I compliance], [compliance polarity mode]</i>
	DI	<i>ch#, output range, output current, [V compliance], [compliance polarity mode]</i>
HVU Output Polarity	[POL]	<i>ch#, output polarity</i>
Measurement	MM	<i>measurement mode, ch#</i>
	[RI]	<i>ch#, I measurement range</i>
	[RV]	<i>ch#, V measurement range</i>
	[VM]	<i>ch#, VM operation mode</i>
	[AV]	<i>averaging number, [averaging mode]</i>
Trigger	XE	-----
Abort	AB	-----

¹ Brackets ([]) denote optional commands and parameters.

Information

Measurement Data Output Format is explained in the *HP 4142B HP-IB Command Reference Manual*.

Output and Measurement Ranging Mode, Averaging, Automatic Sweep Abort Function, and Power Compliance are explained in chapter 6.

Staircase Sweep Measurement Sample Program

The following is a sample program that measures static collector characteristics of a 2N3904 npn bipolar transistor by using the HP 4142B staircase sweep measurement function. This program sweeps the collector voltage while holding the base current constant, then changes the base current as a second variable. The program executes the real-time sweep measurement that plots the measurement result whenever the measurement at each sweep step is performed. A description of key program lines follows the program list, along with an example graphics display of measurement results.

This sample program minimizes range changes to optimize measurement speed.

Measurement Conditions

DUT Terminal	Unit	Output	Measurement
Base	SMU Ch#3	Ib = 10 μ , 20 μ , 30 μ A	---
Collector	SMU Ch#2	Vc = 0 to 1 V, 101 steps	Ic
Emitter	GNDU	Ve = 0 V	---

Program List

```
10 ! Ic-Vce Measurement using Staircase Sweep Function
20 !
30 OPTION BASE 1
40 INTEGER B_ch, C_ch, Vc_no_step, Ib_no_step, Var1, Var2
50 REAL Vc(101)
60 ASSIGN @Hp4142 TO 717
70 OUTPUT @Hp4142;"*RST"
80 OUTPUT @Hp4142;"FMT";5
90 !
100 B_ch=3           ! Emitter : GNDU
110 C_ch=2           ! Base   : SMU (Ch#3)
120 Vc_start=0
130 Vc_stop=1
140 Vc_no_step=101
150 Ic_comp=.01
160 Ib_start=1.E-5
170 Ib_step=1.E-5
180 Ib_no_step=3
190 !
```

```

200 Vc_step=(Vc_stop-Vc_start)/(Vc_no_step-1)
210 FOR Var1=1 TO Vc_no_step
220   Vc(Var1)=Vc_start+(Var1-1)*Vc_step
230 NEXT Var1
240 CALL lcvc_graph(Vc_start, Vc_stop, 0, 1.E-2)
250 !
260 OUTPUT @Hp4142;"CN";B_ch, C_ch
270 OUTPUT @Hp4142;"WV";C_ch, 1, 0, Vc_start, Vc_stop, Vc_no_step,
lc_comp
280 OUTPUT @Hp4142;"MM";2, C_ch
290 OUTPUT @Hp4142;"RI";C_ch, 18
300 FOR Var2=1 TO lb_no_step
310   lb=lb_start+(Var2-1)*lb_step
320   OUTPUT @Hp4142;"DI";B_ch, 0, lb, 2
330   OUTPUT @Hp4142;"XE"
340   !
350   FOR Var1=1 TO Vc_no_step
360     ENTER @Hp4142 USING "#, 3X, 12D, X";lc
370     PLOT Vc(Var1), lc
380   NEXT Var1
390   PENUP
400 NEXT Var2
410 OUTPUT @Hp4142;"CL"
420 END
430 !
440 SUB lcvc_graph(X_axis_min, X_axis_max, Y_axis_min, Y_axis_max)
450 !
460   GINIT
470   GRAPHICS ON
480   CONTROL CRT, 12;1
490   PRINT CHR$(12)
500   !
510   Xmax=100*MAX(1, RATIO)
520   Ymax=100*MAX(1,1/RATIO)
530   !
540   LORG 6
550   MOVE Xmax/2, Ymax
560   LABEL "COLLECTOR CHARACTERISTICS"
570   DEG
580   LDIR 90
590   CSIZE 4.5
600   MOVE 0, Ymax/2
610   LABEL "Ic(A)"
620   LORG 4
630   LDIR 0
640   MOVE Xmax/2, 0
650   LABEL "Vce(V)"
660   !
670   VIEWPORT .16*Xmax, .91*Xmax, .15*Ymax, .9*Ymax
680   !
690   FRAME
700   WINDOW X_axis_min, X_axis_max, Y_axis_min, Y_axis_max
710   AXES(X_axis_max-X_axis_min)/10,(Y_axis_max-Y_axis_min)/10,
X_axis_min, Y_axis_min
720   CLIP OFF
730   CSIZE 4, .5
740   LORG 6

```

```

750   FOR I=X_axis_min TO X_axis_max STEP (X_axis_max-X_axis_min)/2
760     MOVE I, Y_axis_min
770     LABEL I
780   NEXT I
790   CSIZE 3.8, .5
800   LORG 8
810   FOR I=Y_axis_min TO Y_axis_max STEP (Y_axis_max-Y_axis_min)/2
820     MOVE X_axis_min, I
830     LABEL USING "#, MD.DE";I
840   NEXT I
850   CLIP ON
860   !
870   SUBEND

```

Result

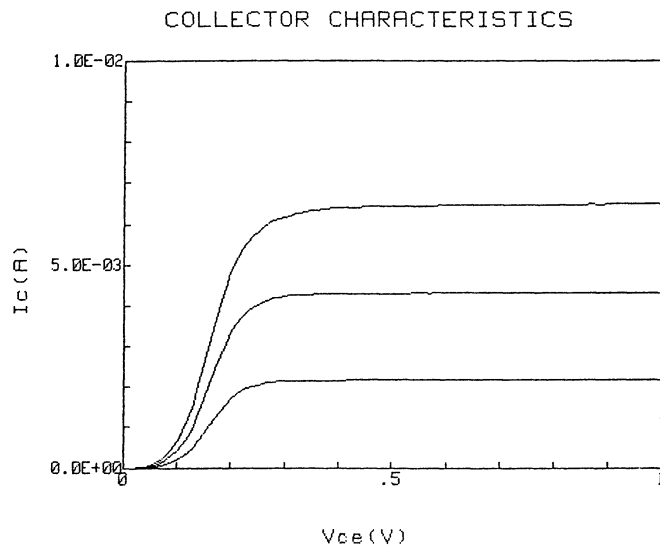

Description

30-50	Defines the variables.
70	Initializes the HP 4142B.
80	Sets the data output format to ASCII with header and comma (,) as a terminator.
100-180	Assigns the constants.
200-230	Calculates collector voltage value for each step, and stores these values in an array variable.
240	Calls subprogram to display graphics frame.
260	Sets the SMU output switches to ON.
270	Sets the <i>ch#2</i> SMU voltage sweep parameters.
280	Sets the measurement mode to staircase sweep function.
290	Sets the measurement range to 10 mA.
310-320	Sets the <i>ch#3</i> SMU current output parameters as a second sweep source.
330	Sends a trigger to start a voltage sweep measurement.

- 350-390 Enters the measurement data into the variable I_c , and displays measurement data in the graphics frame.
- 400 Sets the source base current to the next value.
- 410 Sets the SMU output switches to OFF.
- 440-870 Subprogram for displaying graphics frame.

1CH PULSED SPOT MEASUREMENTS

1 Channel Pulsed spot measurements are performed as follows: one source forces pulsed voltage or current, and one monitor measures the output. The following table lists HP 4142B pulsed spot measurement specifics. The following two figures show an example of a typical pulsed spot measurement (when *pulse period* is not specified), and an example of a repeated pulsed spot measurement (when *pulse period* is specified), respectively.

Pulsed Spot Measurement Specifics

Output Mode	No. of Source Ch.	Source Mode	Source Setup Command	Allowable Units	Allowable Monitor Mode	Meas. Setup Command	No. of Meas. Ch.
Pulse	1	V	PV	HPSMU MPSMU HCU HVU	I	MM	1
				VS	---		
Constant	0 to 15	I	PI	HPSMU MPSMU HCU HVU	V		
				V	DV		
No Output	---	---	---				

¹ Differential voltage measurements cannot be performed for pulsed measurements.

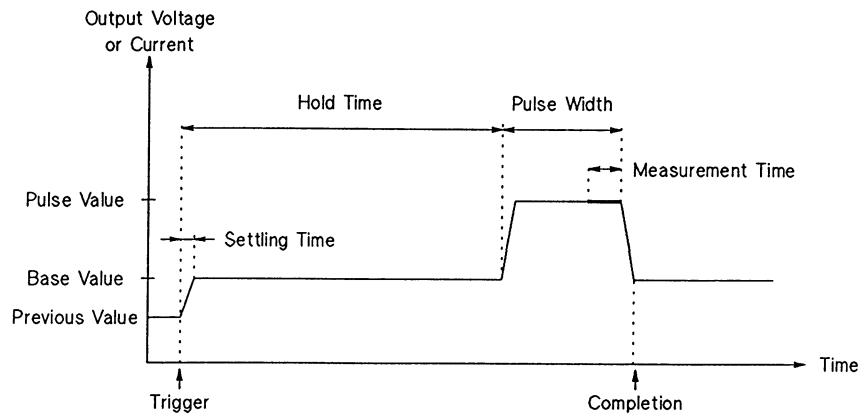

- 1) When the HP 4142B receives a trigger, the pulse source forces the *base* value.
- 2) The HP 4142B waits for the specified *hold time*. If the *hold time* is less than the settling time of the source unit, *hold time* is set equal to the settling time.
- 3) The pulse source forces the *pulse* value.
- 4) The monitor unit measures V or I before the end of pulse.
- 5) The pulse source forces the *base* value.

Pulsed Spot Measurement

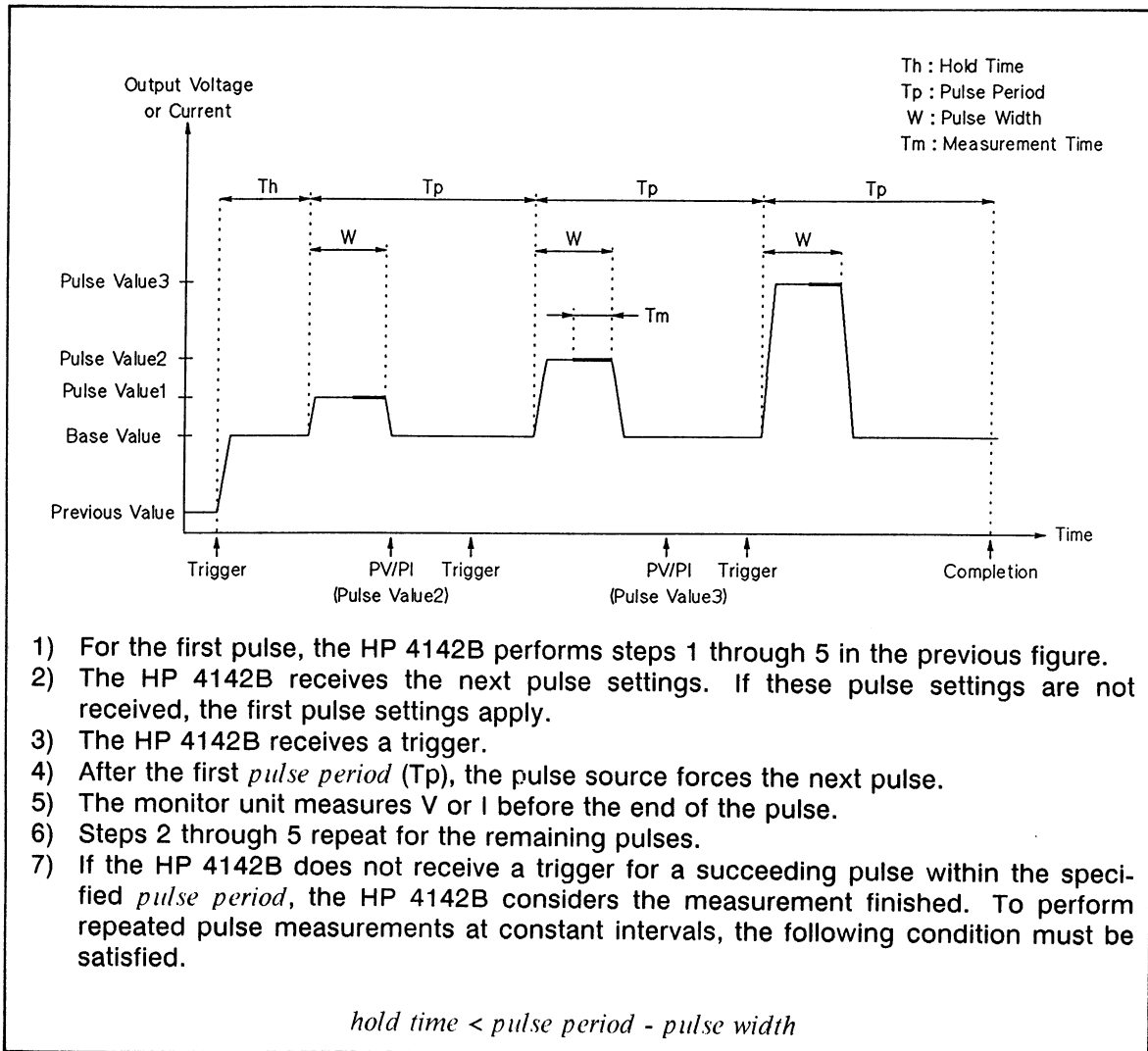

Repeated Pulsed Spot Measurement

NOTE

The HP 4142B can receive and execute commands during the *base* value output of pulsed spot measurements with *pulse period*, but other types of measurements cannot be performed until the pulsed spot measurement is complete.

Commands and Parameters

The following table lists the commands and parameters for 1ch pulsed spot measurements. To specify a voltage pulse source, use the **PV** command. To specify a current pulse source, use the **PI** command.

1ch Pulsed Spot Measurement Commands and Parameters

Function	Command ¹	Parameters ¹
Pulsed Source ²	PV	<i>ch#, output range, base voltage, pulse voltage, [I compliance]</i>
	PI	<i>ch#, output range, base current, pulse current, [V compliance]</i>
	[FL]	<i>filter, [ch#]</i>
Pulse Conditions	[PT]	<i>hold time, pulse width, [pulse period]</i>
Constant Source	DV	<i>ch#, output range, output voltage, [I compliance], [compliance polarity mode]</i>
	DI	<i>ch#, output range, output current, [V compliance], [compliance polarity mode]</i>
HVU Output Polarity	[POL]	<i>ch#, output polarity</i>
Measurement	MM	<i>measurement mode, [ch#]</i>
	[RI]	<i>ch#, I measurement range</i>
	[RV]	<i>ch#, V measurement range</i>
Trigger	XE	-----
Abort	AB	-----

¹ Brackets ([]) denote optional commands and parameters.

² When using an SMU or HVU, set Filter to OFF by using the **FL** command.

Information

Measurement Data Output Format is explained in the *HP 4142B HP-IB Command Reference Manual*.

Output and Measurement Ranging Mode and **Filter** are explained in chapter 6.

1ch Pulsed Spot Measurement Sample Program

The following is the sample program for measuring the collector saturation voltage (Vce(sat)) of a 2N3904 npn bipolar transistor by using the 1ch pulsed spot measurement function. A description of key program lines follows the program list.

Measurement Conditions

DUT Terminal	Unit	Output	Measurement
Base	SMU Ch#3	Ib = 5 mA	---
Collector	SMU Ch#2	Ic = 50 mA	Vce
Emitter	GNDU	Ve = 0 V	---

Program List

```

10 ! Vce(sat) Measurement using 1ch Pulsed Spot Function
20 !
30 INTEGER B_ch, C_ch
40 DIM A$[15]
50 ASSIGN @Hp4142 TO 717
60 OUTPUT @Hp4142;"*RST"
70 !
80 B_ch=3           Emitter      : GNDU
90 C_ch=2           ! Base       : SMU (Ch#3)
100 Ib=5.E-3       ! Collector  : SMU (Ch#2)
110 Ic=5.E-2
120 !
130 OUTPUT @Hp4142;"CN";B_ch, C_ch
140 OUTPUT @Hp4142;"FL";0, B_ch
150 OUTPUT @Hp4142;"PI";B_ch, 0, 0, Ib, 2
160 OUTPUT @Hp4142;"PT";0, 1.E-3
170 OUTPUT @Hp4142;"DI";C_ch, 0, Ic, 2
180 OUTPUT @Hp4142;"MM";3, C_ch
190 OUTPUT @Hp4142;"XE"
200 OUTPUT @Hp4142;"CL"
210 !
220 ENTER @Hp4142;A$
230 PRINT "Vce(sat)= ";A$[4, 15]
240 END

```

Result

Vce(sat)= +0.10800E+00

Description

60	Initializes the HP 4142B.
80-110	Assigns the constants.
130	Sets the SMU output switches to ON.
140	Sets the SMU Filter to OFF.
150	Sets the <i>ch#3</i> SMU current pulse parameters.
160	Sets the output pulse waveform.
170	Forces 50 mA to the collector.
180	Sets the measurement mode to 1ch pulsed spot function.
190	Sends a trigger to start the measurement.
200	Sets the SMU output switches to OFF.
220	Enters the measurement data into the string variable, <i>A\$</i> .
230	Displays the measurement results.

PULSED SWEEP MEASUREMENTS

Pulsed sweep measurements are performed as follows: one source sweeps pulsed voltage or current, while one monitor measures the output for each sweep step. Measurement data for each pulse sweep step is stored in the output data buffer. The following two tables list the pulsed sweep measurement modes and provide an illustration of each, and list the HP 4142B pulsed sweep measurement specifics, respectively.

Pulsed Sweep Measurement Modes

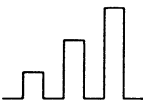
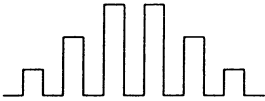
Sweep Mode	Output Waveform
Single Pulsed Sweep	
Double Pulsed Sweep	

Pulsed Sweep Measurement Specifics

Output Mode	No. of Source Ch.	Source Mode	Source Setup Command	Allowable Units	Allowable Monitor Mode	Meas. Setup Command	No. of Meas. Ch.
Pulsed Sweep	1	V	PWV	HPSMU MPSMU HCU HVU	I	MM	1
				VS	---		
		I	PWI	HPSMU MPSMU HCU HVU	V		
Constant	0 to 15	V	DV	HPSMU MPSMU HVU	I		
				VS	---		
		I	DI	HPSMU MPSMU HVU	V		
No Output	---	---	---	VM	V ¹		

¹ Differential voltage measurements cannot be performed for pulsed measurements.

The following figure shows an example of a pulsed single sweep measurement.

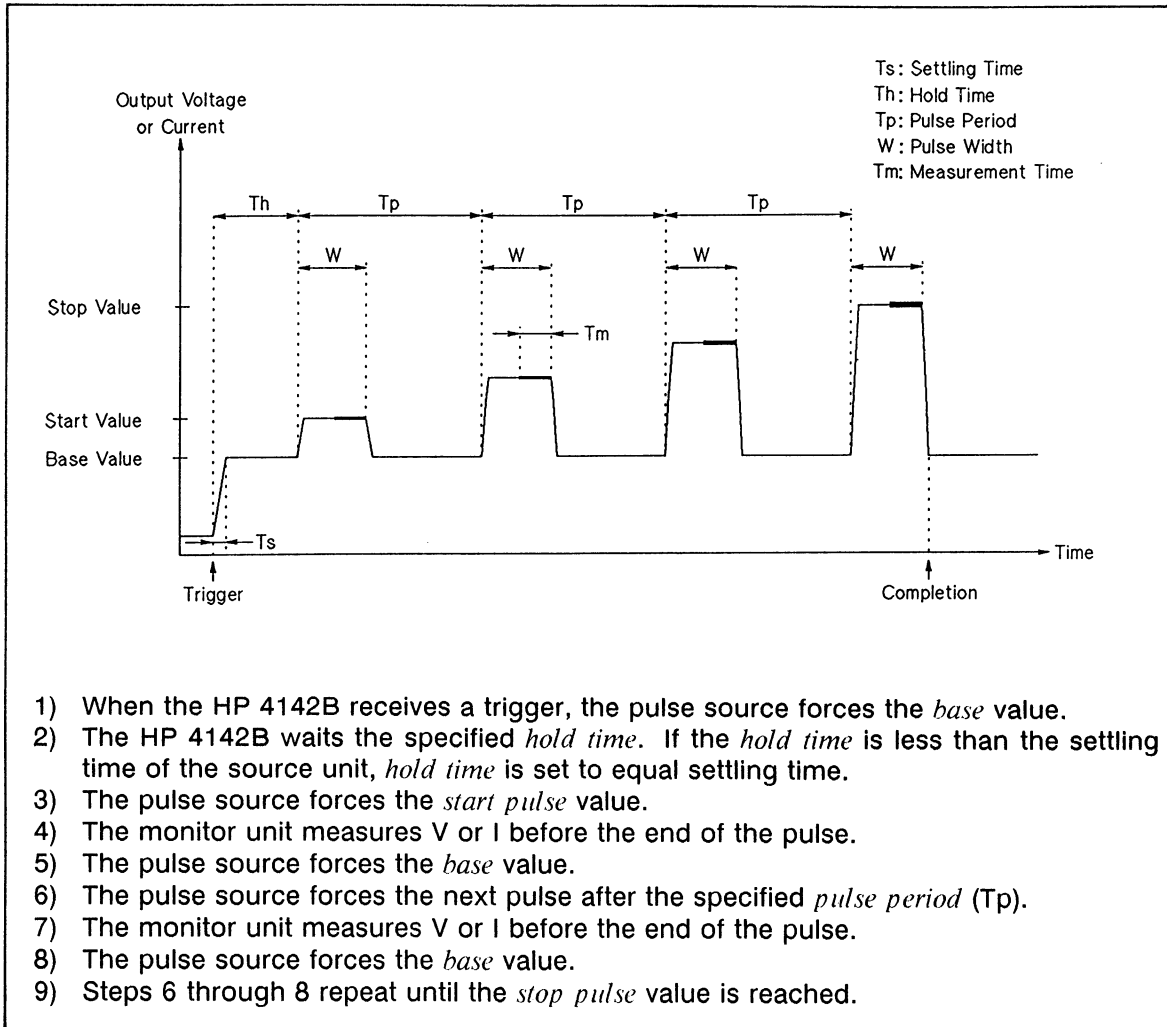

Pulsed Single Sweep Measurement

The *k*th pulse value is calculated using the following equation.

$$k\text{th pulse value} = \text{start pulse value} + (k-1)(\text{step value})$$

where $\text{step value} = (\text{stop pulse value} - \text{start pulse value}) / (\text{number of steps} - 1)$

The following figure shows an example of a pulsed double sweep measurement. Pulse sweep source output is swept from *start pulse* to *stop pulse* value, then from *stop pulse* to *start pulse*, as shown. The measurement sequence is the same as a pulsed single sweep measurement.

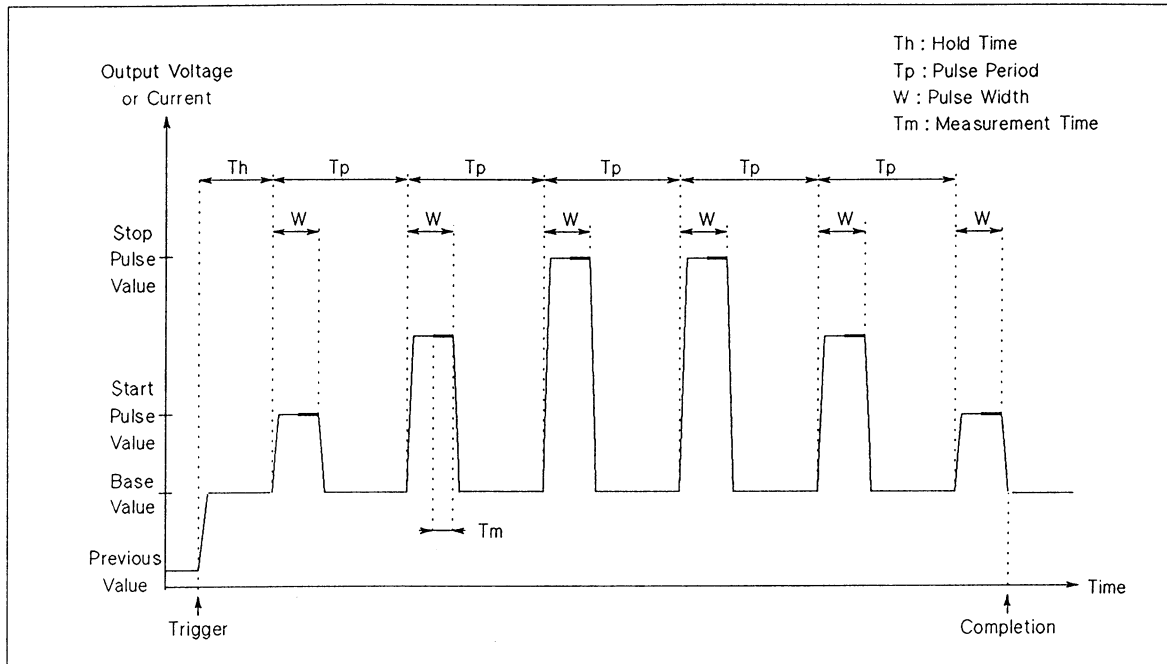

Pulsed Double Sweep Measurement

NOTE

If you set *start pulse value* = *stop pulse value*, all pulses are the same height.

Commands and Parameters

The following table lists the commands and parameters for pulsed sweep measurements. To specify a voltage pulse sweep source, use the **PWV** command. To specify a current pulse sweep source, use the **PWI** command.

Pulsed Sweep Measurement Commands and Parameters

Function	Command ¹	Parameters ¹
Pulsed Sweep Source ²	PWV	<i>ch#, sweep mode, output range, base voltage, start pulse voltage, stop pulse voltage, number of steps, [I compliance]</i>
	PWI	<i>ch#, sweep mode, output range, base current, start pulse current, stop pulse current, number of steps, [V compliance]</i>
	[FL]	<i>filter, [ch#]</i>
Pulse Conditions	[PT]	<i>hold time, pulse width, [pulse period]</i>
Sweep Conditions	[WM]	<i>automatic sweep abort function</i>
Constant Source	DV	<i>ch#, output range, output voltage, [I compliance], [compliance polarity mode]</i>
	DI	<i>ch#, output range, output current, [V compliance], [compliance polarity mode]</i>
HVU Output Polarity	[POL]	<i>ch#, output polarity</i>
Measurement	MM	<i>measurement mode, ch#</i>
	[RI]	<i>ch#, I measurement range</i>
	[RV]	<i>ch#, V measurement range</i>
Trigger	XE	-----
Abort	AB	-----

¹ Brackets ([]) denote optional commands and parameters.

² When using an SMU or HVU, set Filter to OFF by using the **FL** command.

Information

Measurement Data Output Format is explained in the *HP 4142B HP-IB Command Reference Manual*.

Output and Measurement Ranging Mode, Automatic Sweep Abort Function, and Filter are explained in chapter 6.

Pulsed Sweep Measurement Sample Program

The following is a sample program that measures the forward characteristics of a pn junction diode by using the pulsed sweep measurement function. A description of key program lines follows the program list.

Measurement Conditions

DUT Terminal	Unit	Output	Measurement
Cathode Anode	SMU Ch#2 GNDU	Vf = 0 to 0.9 V 0 V	If ---

Program List

```
10 ! Diode If-Vf Measurement using Pulsed Sweep Function
20 !
30 INTEGER A_ch, No_step, Var1
40 ASSIGN @Hp4142 TO 717
50 OUTPUT @Hp4142;"*RST"
60 OUTPUT @Hp4142;"FMT";5
70 !                                     ! Cathode : GNDU
80 A_ch=2                               ! Anode   : SMU (Ch#2)
90 Pv_start=0
100 Pv_stop=.9
110 No_step=91
120 If_comp=.1
130 !
140 CALL Ifvf_graph(Pv_start, 1, 0, If_comp)
150 Pv_step=(Pv_stop-Pv_start)/(No_step-1)
160 !
170 OUTPUT @Hp4142;"CN";A_ch
180 OUTPUT @Hp4142;"FL";0, A_ch
190 OUTPUT @Hp4142;"PWV";A_ch, 1, 0, 0, Pv_start, Pv_stop, No_step,
If_comp
200 OUTPUT @Hp4142;"PT";0, 1.E-3, 1.E-2
210 OUTPUT @Hp4142;"MM";4, A_ch
220 OUTPUT @Hp4142;"RI";A_ch, -19
230 OUTPUT @Hp4142;"XE"
240 OUTPUT @Hp4142;"CL"
250 !
```

```

260 FOR Var1=1 TO No_step
270   ENTER @HP4142 USING "#, 3X, 12D, X";If
280   Vf=Pv_start+(Var1-1)*Pv_step
290   PLOT Vf, If
300 NEXT Var1
310 PENUP
320 END
330 !
340 SUB Ifvf_graph(X_axis_min, X_axis_max, Y_axis_min, Y_axis_max)
350   !
360   GINIT
370   GRAPHICS ON
380   CONTROL CRT, 12;1
390   PRINT CHR$(12)
400   !
410   Xmax=100*MAX(1, RATIO)
420   Ymax=100*MAX(1, 1/RATIO)
430   !
440   LORG 6
450   MOVE Xmax/2, Ymax
460   LABEL "If-Vf Curve"
470   DEG
480   LDIR 90
490   CSIZE 4.5
500   MOVE 0, Ymax/2
510   LABEL "If(A)"
520   LORG 4
530   LDIR 0
540   MOVE Xmax/2, 0
550   LABEL "Vf(V)"
560   !
570   VIEWPORT .16*Xmax, .91*Xmax, .15*Ymax, .9*Ymax
580   !
590   FRAME
600   WINDOW X_axis_min, X_axis_max, Y_axis_min, Y_axis_max
610   AXES(X_axis_max-X_axis_min)/10.,(Y_axis_max-Y_axis_min)/10.,
X_axis_min, Y_axis_min
620   CLIP OFF
630   CSIZE 4, .5
640   LORG 6
650   FOR I=X_axis_min TO X_axis_max STEP (X_axis_max-X_axis_min)/2
660     MOVE I, Y_axis_min
670     LABEL I
680   NEXT I
690   CSIZE 3.8, .5
700   LORG 8
710   FOR I=Y_axis_min TO Y_axis_max STEP (Y_axis_max-Y_axis_min)/2
720     MOVE X_axis_min, I
730     LABEL USING "#, MD.DE";I
740   NEXT I
750   CLIP ON
760   !
770 SUBEND

```

Result

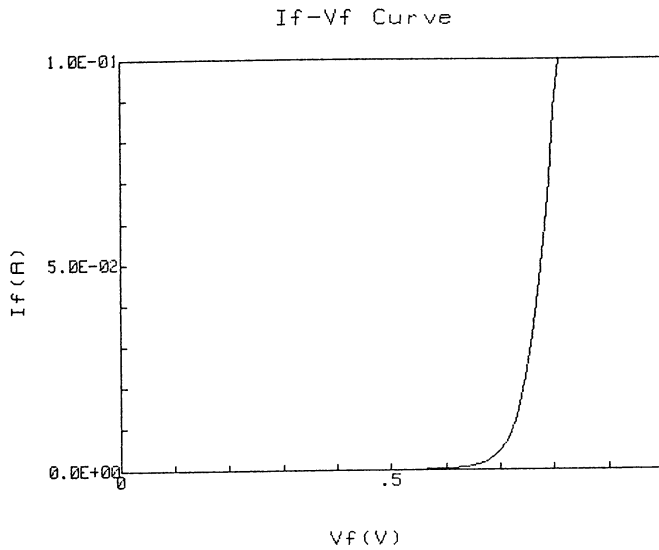

Description

- 30 Defines the variables.
- 50 Initializes the HP 4142B.
- 60 Sets the data output format to ASCII with header and comma (,) as a terminator.
- 80-120 Assigns the constants.
- 140 Calls subprogram to display graphics frame.
- 150 Calculates the pulse sweep step value.
- 170 Sets the SMU output switch to ON.
- 180 Sets the SMU Filter to OFF.
- 190 Sets the *ch#2* SMU voltage pulse sweep parameters.
- 200 Sets the output pulse sweep waveform.
- 210 Sets the measurement mode to pulsed sweep function.
- 220 Sets the current measurement range to 100 mA.
- 230 Sends a trigger to start measurement.
- 240 Sets the SMU output switch to OFF.
- 260-310 Enters the measurement data into variable *If*, and displays measurement data in the graphics frame.
- 340-770 Subprogram for displaying graphics frame.

STAIRCASE SWEEP WITH PULSED BIAS MEASUREMENTS

Staircase sweep with pulsed bias measurements are performed as follows: one source sweeps constant voltage or current, another source forces pulsed voltage or current with synchronized sweep output, while one monitor measures the output for each sweep step. Measurement data for each sweep step is stored in the output data buffer. The following two tables list the staircase sweep with pulsed bias measurement modes and provides an illustration of each, and HP 4142B staircase sweep with pulsed bias measurement specifics, respectively.

Staircase Sweep with Pulsed Bias Measurement Modes

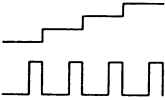
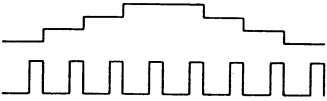
Sweep Mode	Output Waveform
<p>Linear Single Staircase Sweep with Pulsed Bias</p>	
<p>Linear Double Staircase Sweep with Pulsed Bias</p>	

Staircase Sweep with Pulsed Bias Measurement Specifics

Output Mode	No. of Source Ch.	Source Mode	Source Setup Command	Allowable Units	Allowable Monitor Mode	Meas. Setup Command	No. of Meas. Ch.
Staircase Sweep	1	V	WV	HPSMU MPSMU HVU	I	MM	1
				VS	---		
		I	WI	HPSMU MPSMU HVU	V		
Pulse	1	V	PV	HPSMU MPSMU HCU HVU	I		
				VS	---		
		I	PI	HPSMU MPSMU HCU HVU	V		
Constant	0 to 14	V	DV	HPSMU MPSMU HVU	I		
				VS	---		
		I	DI	HPSMU MPSMU HVU	V		
No Output	---	---	---	VM	V ¹		

¹ Differential voltage measurements cannot be performed for pulsed measurements.

The following figure shows an example of a single staircase sweep with pulsed bias measurement.

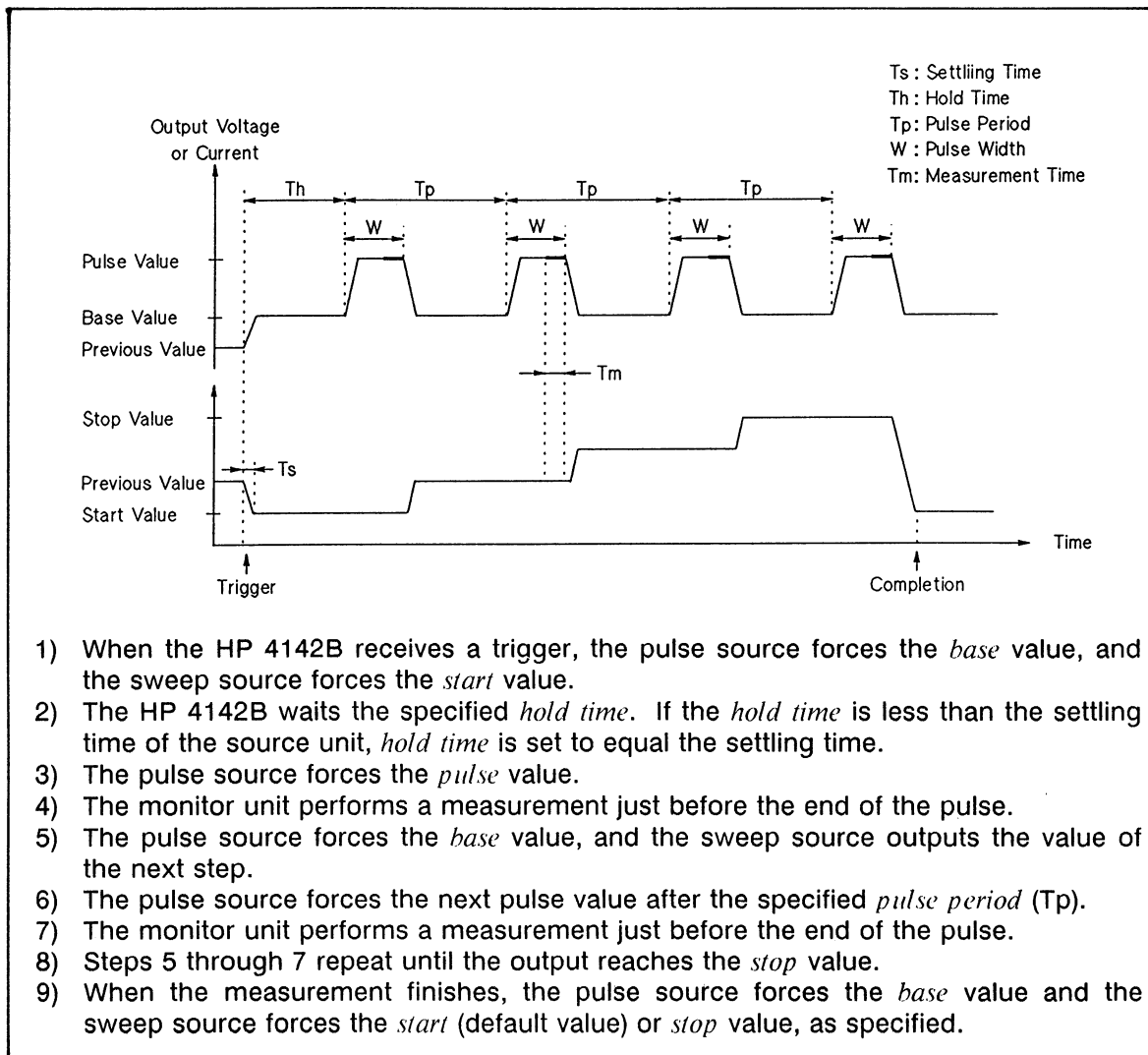

Single Staircase Sweep with Pulsed Bias Measurement

The following figure shows an example of a double staircase sweep with pulsed bias measurement. Sweep source output is swept from *start* to *stop* value, then from *stop* to *start* value, as shown. The measurement sequence is the same as a single staircase sweep measurement.

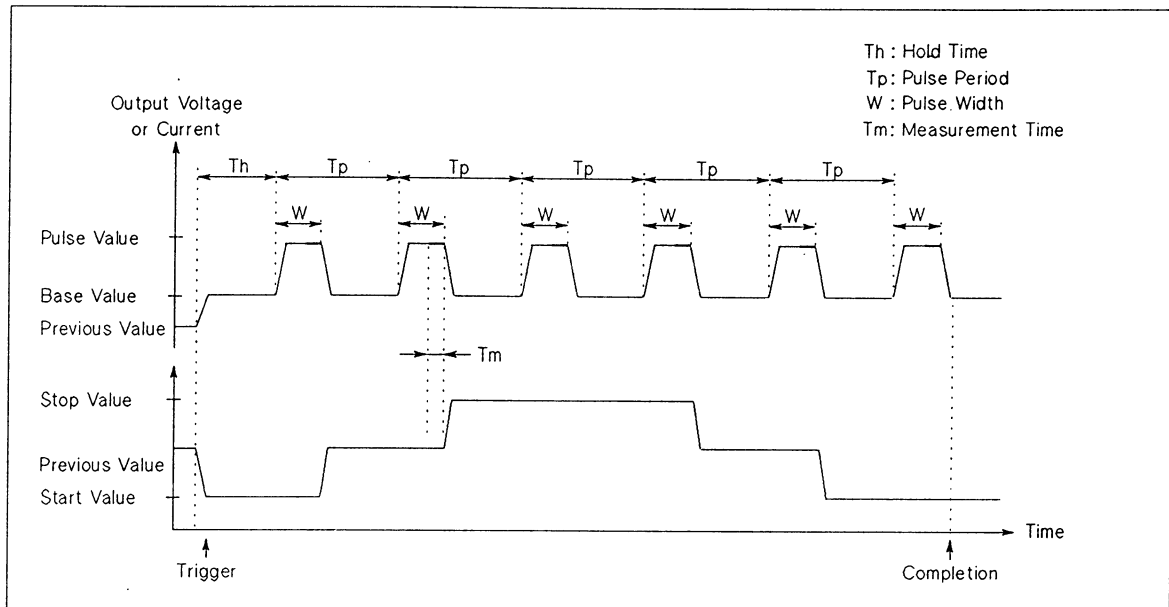

Double Staircase Sweep with Pulsed Bias Measurement

Commands and Parameters

The following table lists the commands and parameters for staircase sweep with pulsed bias measurements. To specify the staircase sweep source, use the **WV** or **WI** command. To specify the pulse source, use the **PV** or **PI** command.

Staircase Sweep with Pulsed Bias Measurement Commands and Parameters

Function	Command ¹	Parameters ¹
Sweep Source	WV	<i>ch#, sweep mode, output range, start voltage, stop voltage, number of steps, [I compliance]</i>
	WI	<i>ch#, sweep mode, output range, start current, stop current, number of steps, [V compliance]</i>
Sweep Conditions	[WM]	<i>automatic sweep abort function, [output after sweep]</i>
Pulse Source ²	PV	<i>ch#, output range, base voltage, pulse voltage, [I compliance]</i>
	PI	<i>ch#, output range, base current, pulse current, [V compliance]</i>
	[FL]	<i>filter, [ch#]</i>
Pulse Conditions	[PT]	<i>hold time, pulse width, [pulse period]</i>
Constant Source	DV	<i>ch#, output range, output voltage, [I compliance], [compliance polarity mode]</i>
	DI	<i>ch#, output range, output current, [V compliance], [compliance polarity mode]</i>
HVU Output Polarity	[POL]	<i>ch#, output polarity</i>
Measurement	MM	<i>measurement mode, [ch#]</i>
	[RI]	<i>ch#, I measurement range</i>
	[RV]	<i>ch#, V measurement range</i>
Trigger	XE	-----
Abort	AB	-----

¹ Brackets ([]) denote optional commands and parameters.

² When using an SMU or HVU, set Filter to OFF by using the **FL** command.

Information

Measurement Data Output Format is explained in the *HP 4142B HP-IB Command Reference Manual*.

Output and Measurement Ranging Modes, Automatic Sweep Abort Function, and Filter are explained in chapter 6.

Staircase Sweep with Pulsed Bias Measurement Sample Program

The following is a sample program that measures the static collector characteristics of a 2N3904 bipolar transistor by using the HP 4142B staircase sweep with pulsed bias measurement function. A description of key program lines follows the program list.

Measurement Conditions

DUT Terminal	Unit	Output	Measurement
Base	SMU Ch#3	Ib = 200 μ , 300 μ , 400 μ A	---
Collector	SMU Ch#2	Vc = 0 to 20 V, 101 steps	Ic
Emitter	GNDU	Ve = 0 V	---

Program List

```
10 ! Ic-Vce Measurement using Sweep with Pulsed Bias Function
20 !
30 OPTION BASE 1
40 INTEGER B_ch, C_ch, Vc_no_step, Ib_no_step, Var1, Var2
50 REAL Vc(101)
60 ASSIGN @Hp4142 TO 717
70 OUTPUT @Hp4142;"*RST"
80 OUTPUT @Hp4142;"FMT";5
90 !
100 B_ch=3           ! Emitter      : GNDU
110 C_ch=2           ! Base       : SMU (Ch#3)
120 Vc_start=0       ! Collector  : SMU (Ch#2)
130 Vc_stop=20
140 Vc_no_step=101
150 Ic_comp=.1
160 Ib_start=2.E-4
170 Ib_step=1.E-4
180 Ib_no_step=3
190 !
200 Vc_step=(Vc_stop-Vc_start)/(Vc_no_step-1)
210 FOR Var1=1 TO Vc_no_step
220   Vc(Var1)=Vc_start+(Var1-1)*Vc_step
230 NEXT Var1
240 CALL Icvc_graph(Vc_start, Vc_stop, 0, Ic_comp)
250 !
260 OUTPUT @Hp4142;"CN";B_ch, C_ch
270 OUTPUT @Hp4142;"WV";C_ch, 1, 0, Vc_start, Vc_stop, Vc_no_step,
Ic_comp
280 OUTPUT @Hp4142;"FL";0, B_ch
```

```

290 OUTPUT @Hp4142;"PT";0, 1.E-3, 5.0E-2
300 OUTPUT @Hp4142;"MM";5, C_ch
310 OUTPUT @Hp4142;"RI";C_ch, -19
320 FOR Var2=1 TO lb_no_step
330     lb=lb_start+lb_step*(Var2-1)
340     OUTPUT @Hp4142;"PI";B_ch, 0, 0, lb, 2
350     OUTPUT @Hp4142;"XE"
360     !
370     FOR Var1=1 TO Vc_no_step
380         ENTER @Hp4142 USING "#, 3X, 12D, X";lc
390         PLOT Vc(Var1), lc
400     NEXT Var1
410     PENUP
420 NEXT Var2
430 OUTPUT @Hp4142;"CL"
440 END
450 !
460 SUB lcvc_graph(X_axis_min, X_axis_max, Y_axis_min, Y_axis_max)
470     !
480     GINIT
490     GRAPHICS ON
500     CONTROL CRT, 12;1
510     PRINT CHR$(12)
520     !
530     Xmax=100*MAX(1, RATIO)
540     Ymax=100*MAX(1, 1/RATIO)
550     !
560     LORG 6
570     MOVE Xmax/2, Ymax
580     LABEL "COLLECTOR CHARACTERISTICS"
590     DEG
600     LDIR 90
610     CSIZE 4.5
620     MOVE 0, Ymax/2
630     LABEL "Ic(A)"
640     LORG 4
650     LDIR 0
660     MOVE Xmax/2, 0
670     LABEL "Vce(V)"
680     !
690     VIEWPORT .16*Xmax, .91*Xmax, .15*Ymax, .9*Ymax
700     !
710     FRAME
720     WINDOW X_axis_min, X_axis_max, Y_axis_min, Y_axis_max
730     AXES(X_axis_max-X_axis_min)/10,(Y_axis_max-Y_axis_min)/10,
X_axis_min, Y_axis_min
740     CLIP OFF
750     CSIZE 4, .5
760     LORG 6
770     FOR I=X_axis_min TO X_axis_max STEP (X_axis_max-X_axis_min)/2
780         MOVE I, Y_axis_min
790         LABEL I
800     NEXT I
810     CSIZE 3.8, .5
820     LORG 8
830     FOR I=Y_axis_min TO Y_axis_max STEP (Y_axis_max-Y_axis_min)/2
840         MOVE X_axis_min, I

```

```

850     LABEL USING "#, MD.DE";I
860     NEXT I
870     CLIP ON
880     !
890     SUBEND

```

Result

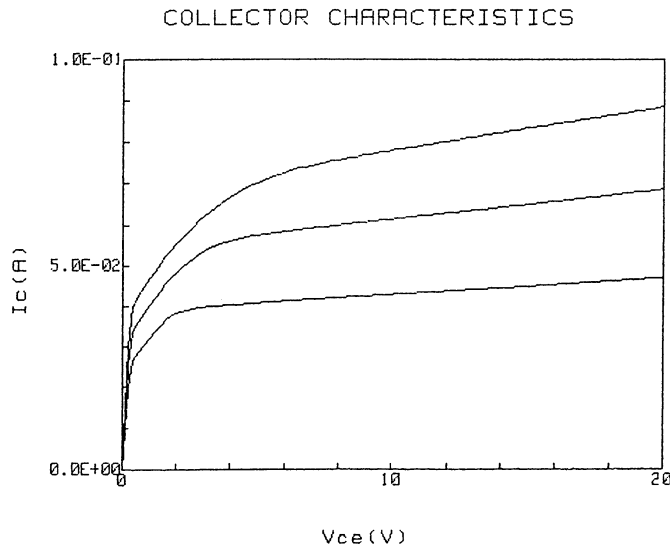

Description

30-50	Defines the variables.
70	Initializes the HP 4142B.
80	Sets the data output format to ASCII with header and comma as a terminator.
100-180	Assigns the constants.
200-230	Calculates collector voltage value for each step, and stores these values in an array variable.
240	Calls subprogram to display graphics frame.
260	Sets the SMU output switches to ON.
270	Sets the <i>ch#2</i> SMU voltage sweep parameters.
280	Sets the SMU filter to OFF.
290	Sets the output pulse waveform.
300	Sets the measurement mode to staircase sweep with pulsed bias function.
310	Sets the current measurement range to 100 mA.
320-340	Sets the <i>ch#3</i> SMU current pulsed source parameters.
350	Sends a trigger to start a voltage sweep measurement.
370-410	Enters the measurement data into variable <i>Ic</i> , and displays measurement data in the graphics frame.
420	Sets the base current to the next value.
430	Sets the SMU output switches to OFF.
460-890	Subprogram for displaying graphics frame.

ANALOG SEARCH MEASUREMENTS

Analog search measurements are performed with the Analog Feedback Unit (AFU) and two SMUs. The AFU provides precision control between the specified SMUs via a feedback loop to obtain a previously specified *target* value. The SMUs specified for use are automatically connected internally to the AFU. The following figure shows the basic analog search measurement circuit.

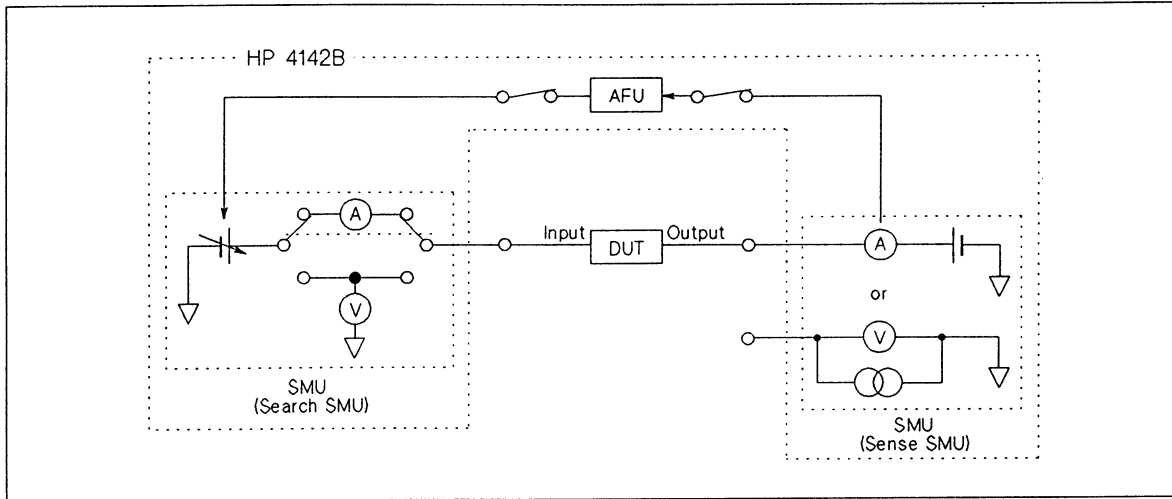

Basic Analog Search Measurement Circuit

One SMU (the search SMU) connects to the input of a test device, and forces voltage. The other SMU (the sense SMU) connects to the output of the test device, and monitors the output voltage (I source mode) or current (V source mode), depending on the specified *target* value. An error amplifier in the AFU detects the difference between the monitored test device output and the *target* value. The AFU then sends a control voltage, in proportion to the difference value, to the search SMU. This control voltage adjusts the voltage output from the search SMU to the test device, thereby adjusting test device output. This feedback process continues until the monitored test device output equals the *target* value and the specified measurements are complete.

The following figure shows the basic analog search measurement timing sequence and provides a brief description of the sequence of events.

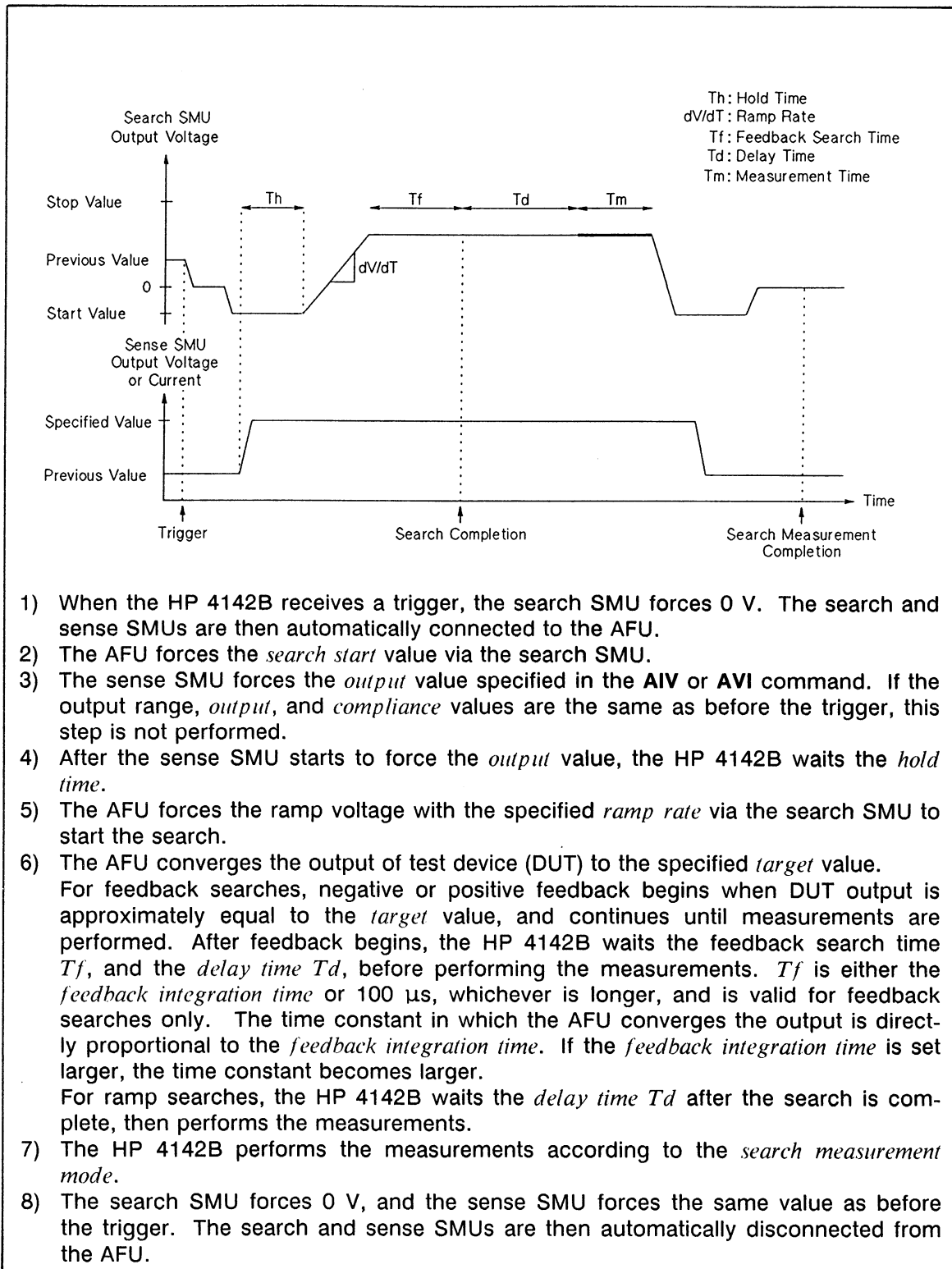

- 1) When the HP 4142B receives a trigger, the search SMU forces 0 V. The search and sense SMUs are then automatically connected to the AFU.
- 2) The AFU forces the *search start* value via the search SMU.
- 3) The sense SMU forces the *output* value specified in the AIV or AVI command. If the output range, *output*, and *compliance* values are the same as before the trigger, this step is not performed.
- 4) After the sense SMU starts to force the *output* value, the HP 4142B waits the *hold time*.
- 5) The AFU forces the ramp voltage with the specified *ramp rate* via the search SMU to start the search.
- 6) The AFU converges the output of test device (DUT) to the specified *target* value. For feedback searches, negative or positive feedback begins when DUT output is approximately equal to the *target* value, and continues until measurements are performed. After feedback begins, the HP 4142B waits the feedback search time T_f , and the *delay time* T_d , before performing the measurements. T_f is either the *feedback integration time* or 100 μs , whichever is longer, and is valid for feedback searches only. The time constant in which the AFU converges the output is directly proportional to the *feedback integration time*. If the *feedback integration time* is set larger, the time constant becomes larger. For ramp searches, the HP 4142B waits the *delay time* T_d after the search is complete, then performs the measurements.
- 7) The HP 4142B performs the measurements according to the *search measurement mode*.
- 8) The search SMU forces 0 V, and the sense SMU forces the same value as before the trigger. The search and sense SMUs are then automatically disconnected from the AFU.

Analog Search Measurement Sequence

The following table lists HP 4142B analog search measurement specifics.

Analog Search Measurement Specifics

Output Mode	No. of Source Ch.	Source Mode	Source Setup Command	Allowable Units	Allowable Monitor Mode	Meas. Setup Command	No. of Meas. Ch.
Search	1	V	ASV	HPSMU MPSMU	V, I	MM ASM	1
Sense	1	V	AVI	HPSMU MPSMU	I		0 to 1
		I	AIV	HPSMU MPSMU	V		
Constant	0 ¹ to 10	V	DV	HPSMU MPSMU HVU VS	---	---	---
		I	DI	HPSMU MPSMU HVU	---	---	---

Search Operation Modes

The AFU can perform four types of search operations: two feedback-type searches, and two ramp-wave-type searches. Feedback search operations are for performing highly accurate search measurements, where measurement speed is not as important. Ramp wave search operations are for performing high speed search measurements, where measurement accuracy is not as important.

These four search operation modes are described in the following paragraphs. Each paragraph number corresponds to the *search operation mode* number you must specify in your measurement program. The following table lists the four search operation modes and shows the basic input and output waveforms for each mode.

(1) Negative Feedback Search:

Use this search mode for measuring DUTs in which the inputs and outputs are directly related, i.e., a positive-going input causes a positive-going output, and a negative-going input causes a negative-going output.

As the measurement begins, the AFU forces a ramp voltage via the search SMU, and compares the *target* and DUT output values. When the *target* and DUT output values are nearly the same, a negative feedback search begins. If DUT output is greater than the *target* value, AFU output decreases, and vice versa. Feedback continues until the *target* value is reached, then the specified measurements are performed.

(2) Positive Feedback Search:

Use this search mode for measuring DUTs in which the inputs and outputs are inversely related, i.e., a positive-going input causes a negative-going output, and a negative-going input causes a positive-going output.

As the measurement begins, the AFU forces a ramp voltage via the search SMU, and compares the *target* and DUT output values. When the *target* and DUT output values are nearly the same, a positive feedback search begins. If DUT output is less than the *target* value, AFU output decreases, and vice versa. Feedback continues until the *target* value is reached, then the specified measurements are performed.

















(3) Ramp Wave Search (search until DUT output > target):

The AFU forces ramp voltage to the DUT input via the search SMU. Immediately (about 5 μ s) after the DUT output is greater than the *target* value, the AFU keeps the DUT input voltage constant, then performs the specified measurements.

(4) Ramp wave search (search until DUT output < target):

The AFU forces ramp voltage to the DUT input via the search SMU. Immediately (about 5 μ s) after the DUT output becomes less than the *target* value, the AFU keeps the DUT input voltage constant, then performs the specified measurements.

Search Operation Modes

Search Operation Mode	DUT Input and Output Waveform	
	$(\text{search start voltage}) < (\text{search stop voltage})$	$(\text{search start voltage}) > (\text{search stop voltage})$
Negative Feedback Search	Input Waveform:  Search Value Output Waveform:  Target Value	Input Waveform:  Search Value Output Waveform:  Target Value
Positive Feedback Search	Input Waveform:  Search Value Output Waveform:  Target Value	Input Waveform:  Search Value Output Waveform:  Target Value
Ramp Wave Search (search until DUT output > target)	Input Waveform:  Search Value Output Waveform:  Target Value	Input Waveform:  Search Value Output Waveform:  Target Value
Ramp Wave Search (search until DUT output < target)	Input Waveform:  Search Value Output Waveform:  Target Value	Input Waveform:  Search Value Output Waveform:  Target Value

Search Measurement Modes

After the *target* value is reached, the HP 4142B performs the measurements in accordance with the measurement mode you specified. The following table lists the four measurement modes.

Search Measurement Modes

Search Measurement Mode#	Number of Measurement Channels	V or I Measurement	
		Search SMU (DUT Input)	Sense SMU (DUT Output)
1	1	V	-
2	1	I	-
3	2	V	V (if <i>target</i> value is V)
			I (if <i>target</i> value is I)
4	2	I	V (if <i>target</i> value is V)
			I (if <i>target</i> value is I)

Commands and Parameters

The following table lists the commands and parameters for analog search measurements. The search SMU is set by the **ASV** command. The sense SMU is set by **AIV** (if *target* value is voltage) or by **AVI** (if *target* value is current).

Analog Search Measurement Commands and Parameters

Function	Command ¹	Parameters ¹
Search SMU	ASV	<i>ch#, search start voltage, search stop voltage, [ramp rate], [I compliance]</i>
V Sense SMU	AIV	<i>ch#, output current, target voltage, [V compliance]</i>
I Sense SMU	AVI	<i>ch#, output voltage, target current, [I compliance]</i>
Search Conditions	[ASM]	<i>search operation mode, search measurement mode, [feedback integration time]</i>
	[AT]	<i>hold time, delay time</i>
Constant Source	DV	<i>ch#, output range, output voltage, [I compliance], [compliance polarity mode]</i>
	DI	<i>ch#, output range, output current, [V compliance], [compliance polarity mode]</i>
	[POL]	<i>ch#, output polarity</i>
Measurement ²	MM	<i>measurement mode</i>
	AV	<i>number, [averaging mode]</i>
Trigger	XE	---
Abort	AB	---

¹ Brackets ([]) denote optional commands and parameters.

² Measurement channels are specified by the *search measurement mode* parameter of the **ASM** command.

NOTE

When measuring hFE or V_{th}, suitable *ramp rate*, *feedback integration time*, and *delay time* values can be obtained by using the Control Software parameter calculation subprograms, **Para_hfe** and **Para_vth**.

AFU MONITOR Port

The AFU **MONITOR** port allows you to monitor DUT output, as monitored by the sense SMU, by providing a voltage proportional to DUT output. Maximum AFU **MONITOR** port voltage is ± 8 V, as calculated using the following equations.

(1) If the target value is voltage:

$$\text{AFU MONITOR Port V} = \text{DUT Output V} / (\text{Sense SMU V Measurement Range}) (-8\text{V})$$

where the sense SMU V measurement range is the lowest range that includes *V compliance*.

(2) If the target value is current:

$$\text{AFU MONITOR Port V} = \text{DUT Output I} / (\text{Sense SMU I Measurement Range}) (8\text{V})$$

where sense SMU I measurement range is the lowest range that includes *I compliance*.

You can also observe DUT waveform patterns at the AFU **MONITOR** port using an oscilloscope to determine the validity of several analog search measurement parameters. The following table lists four waveform pattern symptoms and their related parameter(s). If you observe any of the waveform patterns listed in the following table, check the corresponding parameter(s).

AFU MONITOR Port Waveforms and Related Parameters

Waveform Pattern	Parameter To Check
If waveform does not settle before search starts	<i>hold time</i>
Excessive waveform overshoot at beginning of feedback search	<i>ramp rate</i>
Excessive waveform oscillation when a measurement is performed	<i>feedback integration time</i>
If waveform does not settle when a measurement is performed	<i>ramp rate,</i> <i>feedback integration time,</i> <i>delay time</i>

NOTE

If the sense current monitor range of the sense SMU is set to less than 10 μA range, no overshoot may be observed at the MONITOR port due to measurement circuit delay, even if overshoot occurs. Therefore, even if no overshoot is observed, do not set the *feedback integration time* too short or the *ramp rate* too high. The measurement circuit delay does not affect the measurement because it is corrected by the internal circuit of the AFU.

Information

Measurement Data Output Format is explained in the *HP 4142B HP-IB Command Reference Manual*.

Output and Measurement Ranging Mode, and Averaging are explained in chapter 6.

Analog Search Measurement Sample Program

The following figure shows a sample program that measures the hFE of a 2N3904 bipolar transistor by using the analog search measurement function. The base terminal is connected to the search SMU, and the collector terminal is connected to the sense SMU. The AFU senses the collector current via the sense SMU, and uses negative feedback to control the base voltage via the search SMU. A description of key program lines follows the program list.

Measurement Conditions

DUT Terminal	Unit	Output	Measurement
Base	SMU Ch#3	$V_b = 0 \text{ to } 1 \text{ V}$	I_b
Collector	SMU Ch#2	$V_c = 1 \text{ V}, I_c = 1 \text{ mA}$	I_c
Emitter	GNDU	$V_e = 0 \text{ V}$	---

Program List

```
10 ! hFE Measurement using Analog Search Function
20 !
30 INTEGER B_ch, C_ch
40 DIM A$(31)
50 ASSIGN @Hp4142 TO 717
60 CLEAR @Hp4142
70 !
80 B_ch=3 ! Emitter : GNDU
90 C_ch=2 ! Base : SMU (Ch#3)
100 Vb_start=0 ! Collector : SMU (Ch#2)
110 Vb_stop=1
120 Vb_rate=200
130 Ib_comp=1.15E-4
140 Vc=1
150 Ic_target=1.E-3
160 Ic_comp=1.15E-3
170 Integ_time=4.5E-4
180 Delay_time=1.E-4
190 !
200 OUTPUT @Hp4142;"CN";B_ch, C_ch
210 OUTPUT @Hp4142;"ASV";B_ch, Vb_start, Vb_stop, Vb_rate, Ib_comp
220 OUTPUT @Hp4142;"AVI";C_ch, Vc, Ic_target, Ic_comp
230 OUTPUT @Hp4142;"ASM";1, 4, Integ_time
240 OUTPUT @Hp4142;"AT";0, Delay_time
250 OUTPUT @Hp4142;"MM";6
260 OUTPUT @Hp4142;"XE"
270 OUTPUT @Hp4142;"CL"
280 !
290 ENTER @Hp4142;A$
300 Ib=VAL(A$(4, 15))
310 Ic_meas=VAL(A$(20, 31))
320 PRINT "Ib= ";Ib*1.E+6;"[uA]"
330 PRINT "Ic= ";Ic_meas*1.E+3;"[mA]"
340 Hfe=Ic_meas/Ib
350 PRINT "hFE= ";PROUND(Hfe, -2)
360 END
```

Result

```
Ib= 4.492 [uA]
Ic= .99628 [mA]
hFE= 221.79
```

Description

40	Defines the string variable <i>AS</i> for storing measurement data.
60	Initializes the HP 4142B.
100-180	Assigns the constants.
200	Sets the SMU output switches to ON.
210	Sets the parameters for the search SMU.
220	Sets the parameters for the sense SMU.
230-240	Sets the parameters for the search operation and the measurement after search.
250	Sets the measurement mode to analog search measurement function.
260	Sends a trigger to start measurement.
270	Sets the SMU output switches to OFF.
290	Enters the measurement data into string variable <i>AS</i> .
300-350	Displays the base current, collector current, and hFE.

2CH PULSED SPOT MEASUREMENTS

2 Channel Pulsed spot measurements are performed as follows: two sources force pulsed outputs at the same time, and one monitor measures the output. The following table lists 2 channel pulsed spot measurement specifics. The following two figures show an example of a typical 2 channel pulsed spot measurement (when *pulse period* is not specified), and an example of a repeated pulsed spot measurement (when *pulse period* is specified), respectively.

2ch Pulsed Spot Measurement Specifics

Output Mode	No. of Source Ch.	Source Mode	Source Setup Command	Allowable Units	Allowable Monitor Mode	Meas. Setup Command	No. of Meas. Ch.
Pulse	2	V	PDV ¹ PV ¹	HPSMU ² MPSMU ² HCU ²	I	MM	1
		I	PDI ¹ PI ¹	HPSMU ² MPSMU ² HCU ²	V		
Constant	0 to 10	V	DV	HPSMU MPSMU HVU	I		
				VS	---		
		I	DI	HPSMU MPSMU HVU	V		
No Output	---	---	---	VM	V ³		

¹ Select one command from (PDV and PDI), and one command from (PV and PI).

² One of two pulsed sources must be an HCU.

³ Differential voltage measurements cannot be performed for pulsed measurements.

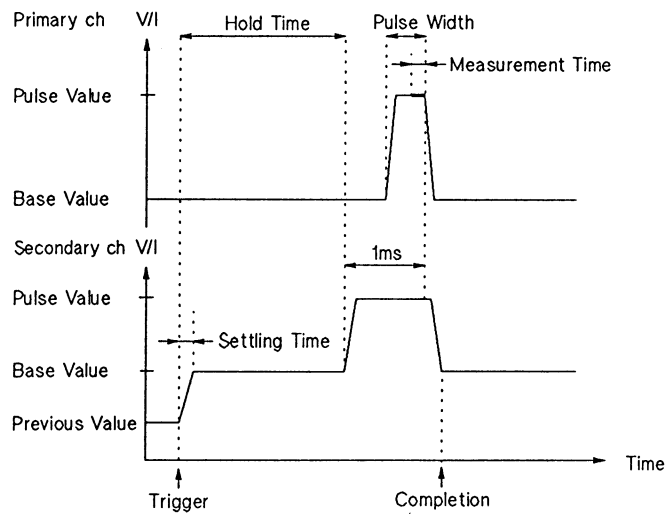

- 1) When the HP 4142B receives a trigger, the primary pulsed source forces the *base* value, and the secondary pulsed source forces the *base* value.
The primary pulsed source is automatically set to the HCU (if you use two HCUs for both pulsed sources, the primary pulsed source is specified by **PDM** command), and forces a pulse with the specified *pulse width*. The pulse width of the secondary pulsed source is set to about 1 ms, regardless of the specified *pulse width*.
- 2) After the secondary pulsed source starts to force the *base* value, the HP 4142B waits for the specified *hold time*. If the *hold time* is less than the settling time of the source unit, *hold time* is set to equal the settling time.
- 3) The secondary pulsed source forces the *pulse* value.
- 4) The primary pulsed source forces the *pulse* value.
- 5) The monitor unit measures V or I before the end of pulse.
- 6) The primary pulsed source forces the *base* value, and the secondary pulsed source forces the *base* value.

2ch Pulsed Spot Measurement Output Waveform

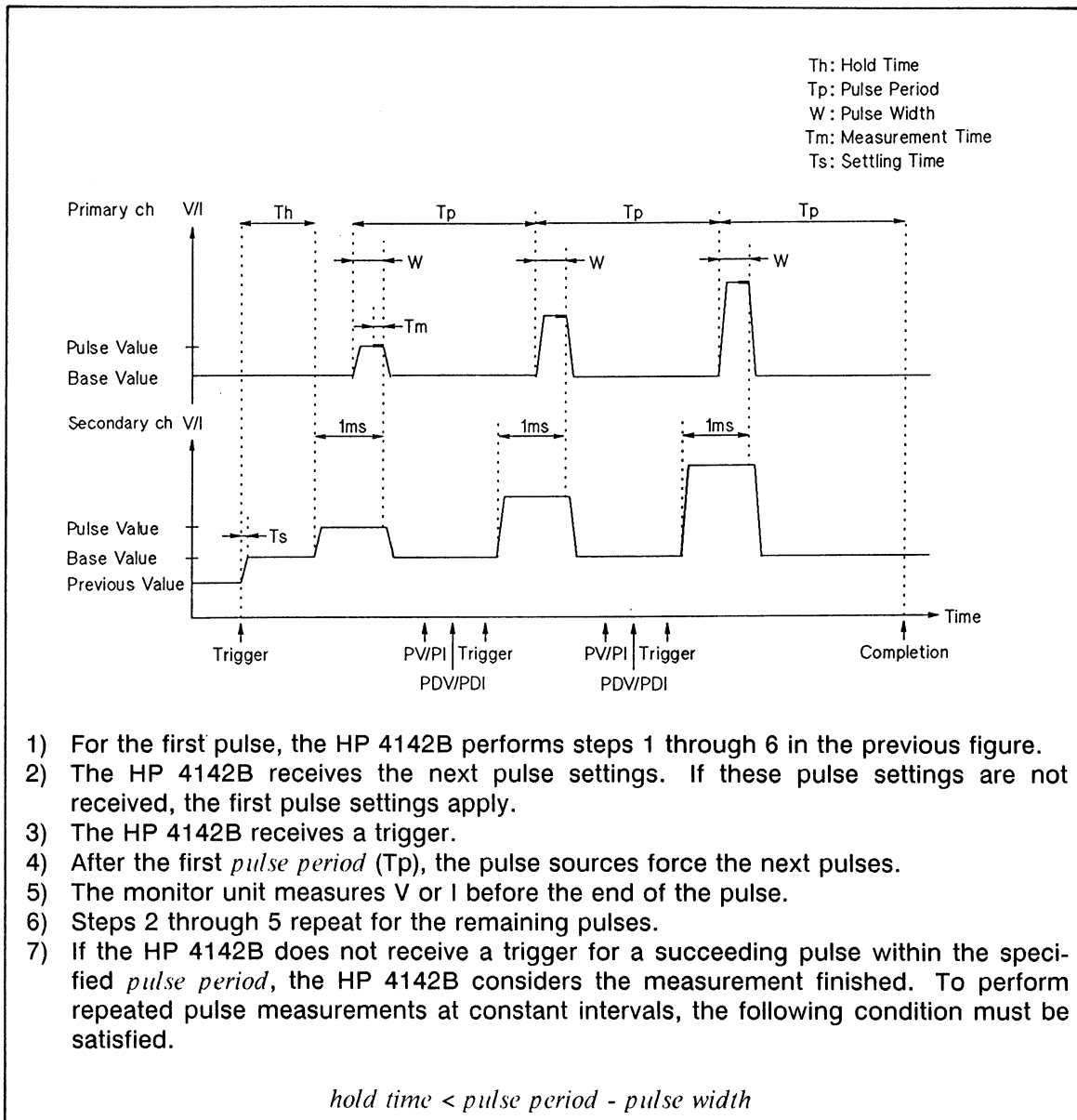

Repeated 2 ch Pulsed Spot Measurement

NOTE

The HP 4142B can receive and execute commands during *base* value output in pulsed spot measurements that *pulse period* specified, but other types of measurements cannot be performed until the pulsed spot measurement is complete.

Commands and Parameters

The following table lists the commands and parameters for 2 channel pulsed spot measurements. To specify one pulsed source, use the **PDV** or **PDI** command. To specify another pulsed source, use the **PV** or **PI** command.

2ch Pulsed Spot Measurement Commands and Parameters

Function	Command ¹	Parameters ¹
Pulsed Sources ²	PDV	<i>ch#, output range, base voltage, pulse voltage, [I compliance]</i>
	PV	<i>ch#, output range, base voltage, pulse voltage, [I compliance]</i>
	PDI	<i>ch#, output range, base current, pulse current, [V compliance]</i>
	PI	<i>ch#, output range, base current, pulse current, [V compliance]</i>
	[FL]	<i>filter, [ch#]</i>
Pulse Conditions	PT	<i>hold time, pulse width, [pulse period]</i>
	[PDM]	<i>primary pulse ch#</i>
Constant Source	DV	<i>ch#, output range, output voltage, [I compliance], [compliance polarity mode]</i>
	DI	<i>ch#, output range, output current, [V compliance], [compliance polarity mode]</i>
	[POL]	<i>ch#, output polarity</i>
Measurement	MM	<i>measurement mode, [ch#]</i>
	[RI]	<i>ch#, I measurement range</i>
	[RV]	<i>ch#, V measurement range</i>
Trigger	XE	-----
Abort	AB	-----

¹ Brackets ([]) denote optional commands and parameters.

² When using an SMU, set Filter to OFF by using the **FL** command.

Information

Measurement Data Output Format is explained in the *HP 4142B HP-IB Command Reference Manual*.

Output and Measurement Ranging Mode, and **Filter** are explained in chapter 6.

2ch Pulsed Spot Measurement Sample Program

The following is a sample program that measures the collector saturation voltage ($V_{ce(sat)}$) of a 2SC3281 npn bipolar transistor by using the 2ch pulsed spot measurement function of the HP 4142B. A description of key program lines follows the program list.

Measurement Conditions

DUT Terminal	Unit	Output	Measurement
Base	HPSMU Ch#2	Ib = 1 A	---
Collector	HCU Ch#5	Ic = 10 A	Vce
Emitter	GNDU	Ve = 0 V	---

Program List

```
10 ! Vce(sat) Measurement using 2ch Pulsed Spot Function
20 !
30 INTEGER B_ch, C_ch
40 DIM Status$[3]
50 ASSIGN @Hp4142 TO 717
60 OUTPUT @Hp4142;"*RST"
70 !
80 B_ch=2 ! Emitter : GNDU
90 C_ch=5 ! Base : HPSMU (Ch#2)
100 Ib=1 ! Collector : HCU (Ch#5)
110 Ic=10
120 !
130 OUTPUT @Hp4142;"CN";B_ch, C_ch
140 OUTPUT @Hp4142;"FL";0, B_ch
150 OUTPUT @Hp4142;"PI";B_ch, 0, 0, Ib, 2
160 OUTPUT @Hp4142;"PDI";C_ch, 0, 0, Ic, 5
170 OUTPUT @Hp4142;"PT";0, 1.E-4
180 OUTPUT @Hp4142;"MM";7, C_ch
190 OUTPUT @Hp4142;"XE"
200 OUTPUT @Hp4142;"CL"
210 !
220 ENTER @Hp4142 USING "#, 3A, 12D, 2X";Status$,Vce
230 PRINT "Vce(sat)= ";Vce;"V", "(Data status: ";Status$;)"
240 END
```

Result

Vce(sat)= .4336 V (Data status: NEV)

Description

60	Initializes the HP 4142B.
80-110	Assigns the constants.
130	Sets the output switches to ON.
140	Sets the SMU Filter to OFF.
150	Sets the <i>ch#2</i> HPSMU current pulse parameters.
160	Sets the <i>ch#5</i> HCU current pulse parameters.
170	Sets the output pulse waveform.
180	Sets the measurement mode to 2ch pulsed spot function.
190	Sends a trigger to start the measurement.
200	Sets the output switches to OFF.
220	Enters the measurement data.
230	Displays the measurement results.

PULSED SWEEP WITH PULSED BIAS MEASUREMENTS

Pulsed sweep with pulsed bias measurements are performed as follows: one source sweeps pulsed voltage or current, and another source forces pulsed voltage or current with synchronized sweep pulsed output, while one monitor measures the output for each sweep step. Measurement data for each sweep step is stored in the output data buffer. The following two tables list the pulsed sweep with pulsed bias measurement modes and provide an illustration of each, and HP 4142B pulsed sweep with pulsed bias measurement specifics, respectively.

Pulsed Sweep with Pulsed Bias Measurement Modes

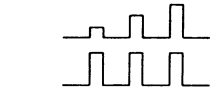
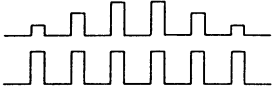
Sweep Mode	Output Waveform
Linear Single Pulsed Sweep with Pulsed Bias	
Linear Double Pulsed Sweep with Pulsed Bias	

Pulsed Sweep with Pulsed Bias Measurement Specifics

Output Mode	No. of Source Ch.	Source Mode	Source Setup Command	Allowable Units	Allowable Monitor Mode	Meas. Setup Command	No. of Meas. Ch.
Pulsed Sweep	1	V	PWV	HPSMU ¹ MPSMU ¹ HCU ¹	I	MM	1
		I	PWI	HPSMU ¹ MPSMU ¹ HCU ¹	V		
Pulsed Bias	1	V	PDV	HPSMU ¹ MPSMU ¹ HCU ¹	I		
		I	PDI	HPSMU ¹ MPSMU ¹ HCU ¹	V		
Constant	0 to 10	V	DV	HPSMU MPSMU HVU	I		
				VS	---		
		I	DI	HPSMU MPSMU HVU	V		
No Output	---	---	---	VM	V ²		

¹ One of the two pulsed sources must be an HCU.

² Differential voltage measurements cannot be performed for pulsed measurements.

The pulse period of one pulsed source (primary pulsed source) is set to the specified *pulsed width*, and the other pulsed source (secondary pulsed source) is set to about 1 ms. The following figure shows an example of a single pulsed sweep with pulsed bias measurement. Figure (a) shows the pulsed sweep source as the primary pulsed source, and the pulsed bias source as the secondary pulsed source. Figure (b) shows the pulsed sweep source as the secondary pulsed source, and the pulsed bias source as the primary pulsed source.

The primary pulsed source is automatically set to the HCU (if you use two HCUs for both pulsed sources, the primary pulsed source is specified by the **PDM** command). The secondary pulsed source is set to the other pulsed source.

(a) When pulsed sweep source is the primary pulsed source:

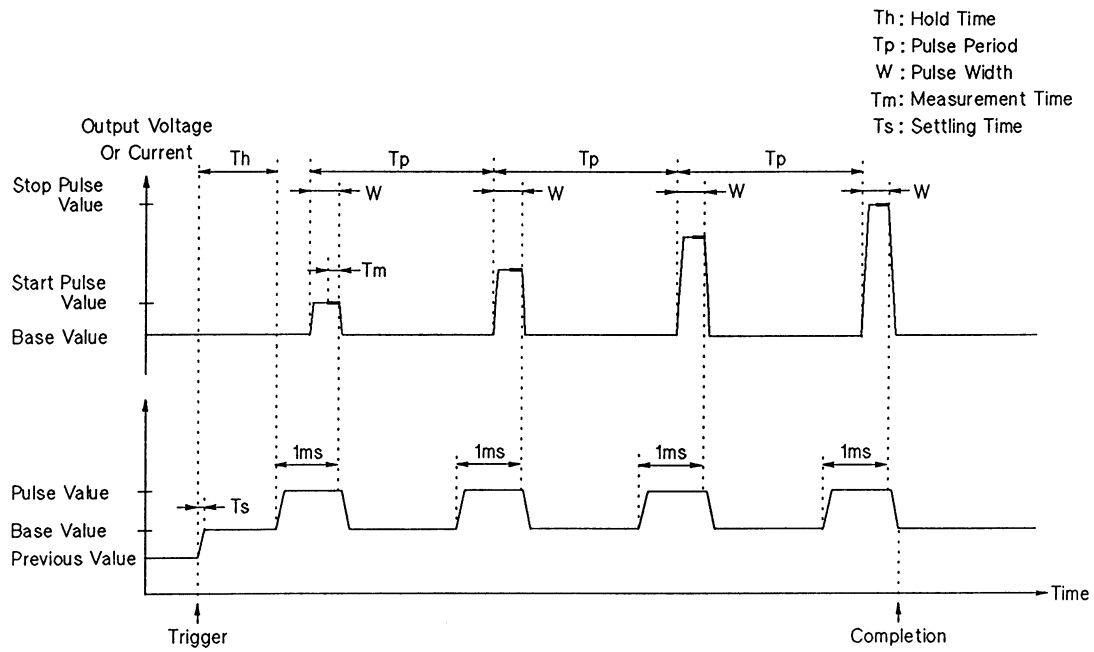

(b) When pulsed bias source is the primary pulsed source:

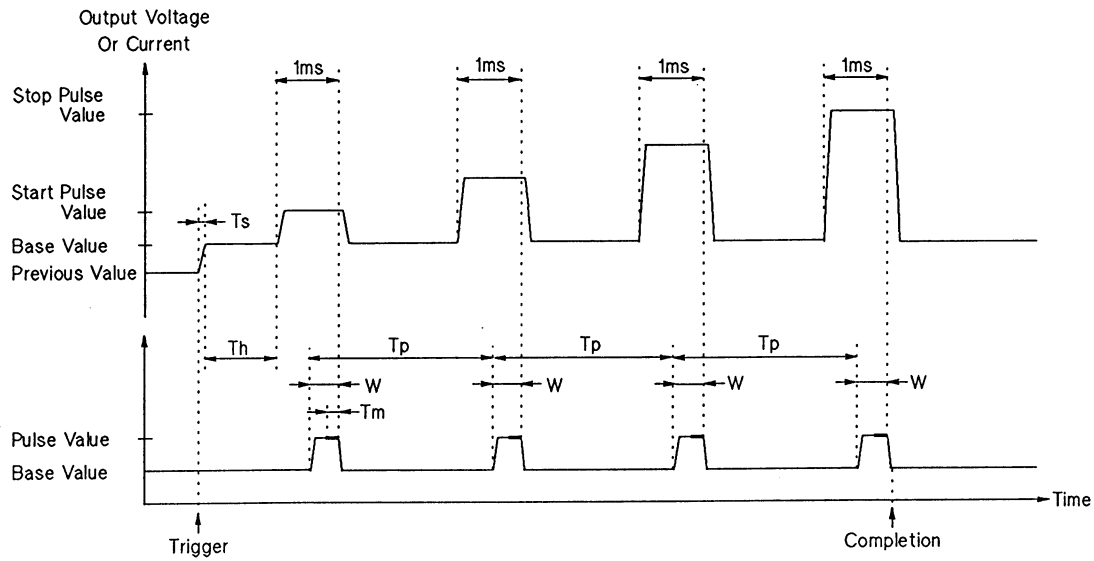

Pulsed Sweep with Pulsed Bias Measurement Output Waveform (1 of 2)

(a) When pulsed sweep source is the primary pulsed source:

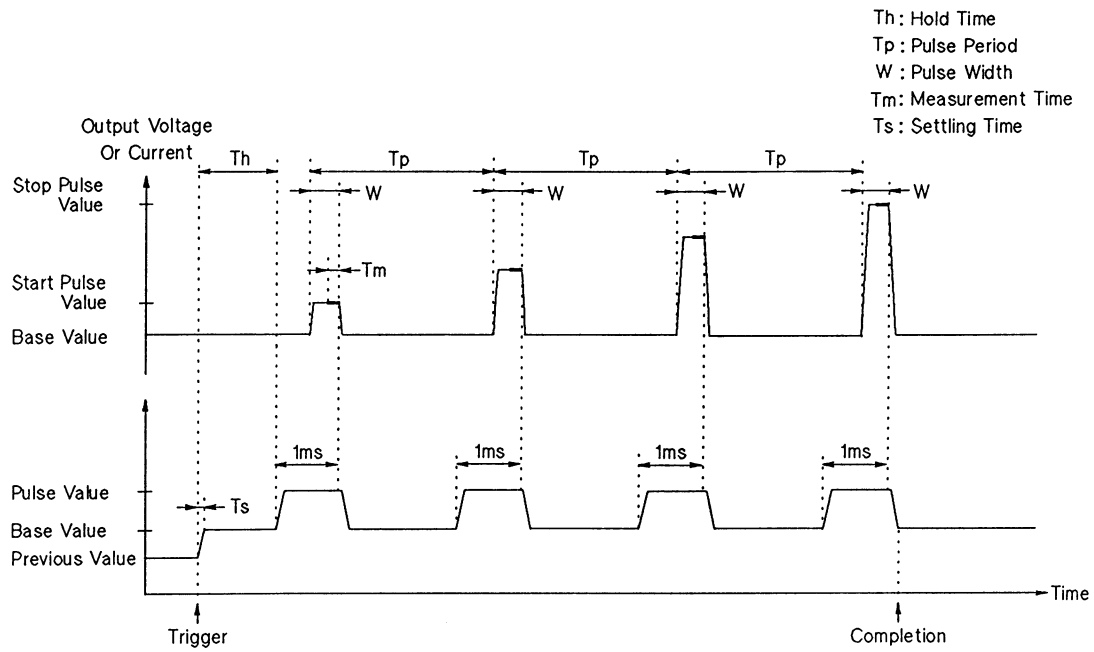

(b) When pulsed bias source is the primary pulsed source:

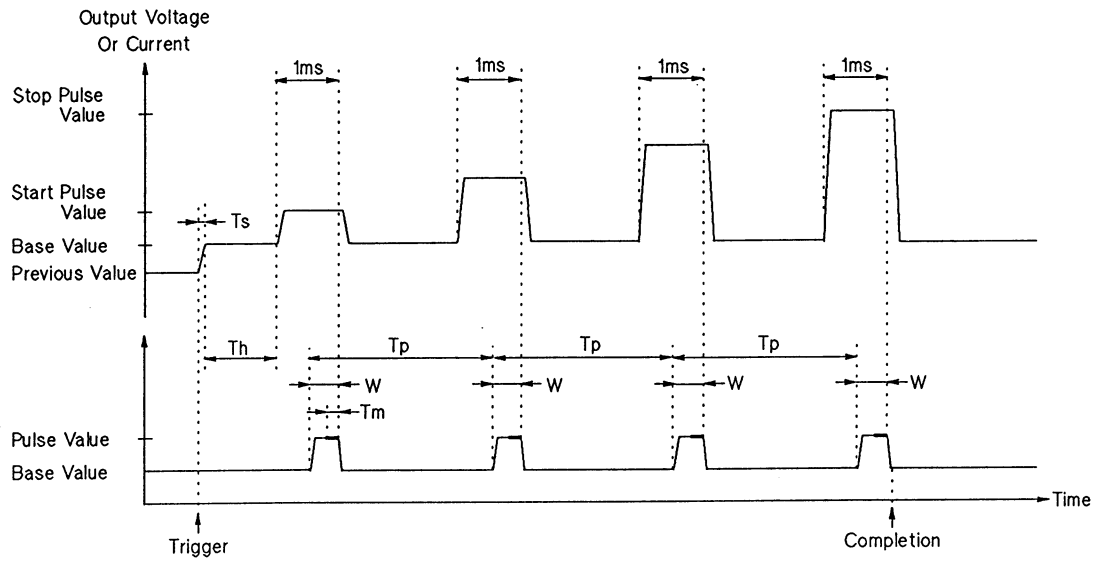

Pulsed Sweep with Pulsed Bias Measurement Output Waveform (1 of 2)

- 1) When the HP 4142B receives a trigger, the pulsed sweep source forces the *base* value, and the pulsed bias source forces the *base* value.
- 2) After the pulsed bias source starts to force the *base* value, the HP 4142B waits for the specified *hold time*. If the *hold time* is less than the settling time of the source unit, *hold time* is set to equal the settling time.
- 3) The secondary pulsed source forces the pulse, and the primary pulsed source forces the pulse.
- 4) The monitor unit measures V or I before the end of pulse.
- 5) The primary pulsed source forces the *base* value, and the secondary pulsed source forces the *base* value.
- 6) The secondary pulsed source forces the next pulse.
- 7) The primary pulsed source forces the next pulse after the specified *pulse period* (T_p).
- 8) The monitor unit measures V or I before the end of pulse.
- 9) Steps 5 through 8 repeat until the output reaches the *stop pulse* value. When the measurement finishes, both pulsed sources force the *base* value.

Pulsed Sweep with Pulsed Bias Measurement Output Waveform (2 of 2)

The following figure shows an example of a double pulsed sweep with pulsed bias measurement. Sweep source output is swept from *start* value to *stop* value, then from *stop* value to *start* value, as shown. The measurement sequence is the same as a single staircase sweep measurement.

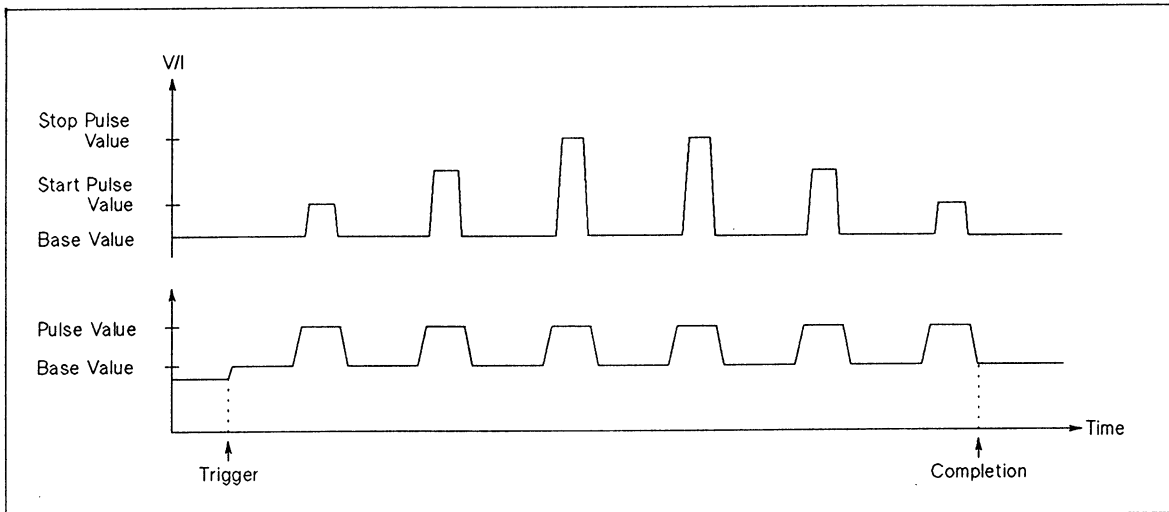

Pulsed Double Sweep Measurement

NOTE

If you set *start pulse value* = *stop pulse value*, all pulses are the same height.

Commands and Parameters

The following table lists the commands and parameters for pulsed sweep with pulsed bias measurements. To specify the pulsed sweep source, use the **PWV** or **PWI** command. To specify the pulsed bias source, use the **PDV** or **PDI** command.

Pulsed Sweep with Pulsed Bias Measurement Commands and Parameters

Function	Command ¹	Parameters ¹
Pulsed Sweep Source ²	PWV	<i>ch#, sweep mode, output range, base voltage, start pulse voltage, stop pulse voltage, number of steps, [I compliance]</i>
	PWI	<i>ch#, sweep mode, output range, base current, start pulse current, stop pulse current, number of steps, [V compliance]</i>
Pulsed Source ²	PDV	<i>ch#, output range, base voltage, pulse voltage, [I compliance]</i>
	PDI	<i>ch#, output range, base current, pulse current, [V compliance]</i>
Pulse Enable ²	[FL]	<i>filter, [ch#]</i>
Pulse Conditions	PT	<i>hold time, pulse width, [pulse period]</i>
	[PDM]	<i>primary pulse ch#</i>
Sweep Conditions	[WM]	<i>automatic sweep abort function</i>
Constant Source	DV	<i>ch#, output range, output voltage, [I compliance], [compliance polarity mode]</i>
	DI	<i>ch#, output range, output current, [V compliance], [compliance polarity mode]</i>
	[POL]	<i>ch#, output polarity</i>
Measurement	MM	<i>measurement mode, [ch#]</i>
	[RI]	<i>ch#, I measurement range</i>
	[RV]	<i>ch#, V measurement range</i>
Trigger	XE	-----
Abort	AB	-----

¹ Brackets ([]) denote optional commands and parameters.

² When using an SMU, set Filter to OFF by using the **FL** command.

Information

Measurement Data Output Format is explained in the *HP 4142B HP-IB Command Reference Manual*.

Output and Measurement Ranging Mode, Automatic Sweep Abort Function, and Filter are explained in chapter 6.

Pulsed Sweep with Pulsed Bias Measurement Sample Program

The following is a sample program that measures the static collector characteristics of a 2SC3281 bipolar transistor by using the pulsed sweep with pulsed bias measurement function of the HP 4142B. A description of key program lines follows the program list.

Measurement Conditions

DUT Terminal	Unit	Output	Measurement
Base	HPSMU Ch#2	Ib = 50 m, 100 m, 150 mA	---
Collector	HCU Ch#5	Vc = 0.1 to 10 V, 100 steps	Ic
Emitter	GNDU	Ve = 0 V	---

Program List

```
10 ! Ic-Vce Measurement using Pulsed Sweep with Pulsed Bias Function
20 !
30 OPTION BASE 1
40 INTEGER B_ch, C_ch, Vc_no_step, Ib_no_step, Var1, Var2
50 REAL Vc(100), Ic(3, 100)
60 COM Error$(100)[3], Error1(100), Error2(100), Error3(100), No_error
70 ASSIGN @Hp4142 TO 717
80 OUTPUT @Hp4142;"*RST"
90 OUTPUT @Hp4142;"FMT";5
100 !
110 B_ch=2 ! Base : HPSMU (Ch#2)
120 C_ch=5 ! Collector : HCU (Ch#5)
130 Vc_start=.1
140 Vc_stop=10
150 Vc_no_step=100
160 Ic_comp=10
170 Ib_start=5.0E-2
180 Ib_step=5.0E-2
190 Ib_no_step=3
200 !
210 Vc_step=(Vc_stop-Vc_start)/(Vc_no_step-1)
220 FOR Var1=1 TO Vc_no_step
230 Vc(Var1)=Vc_start+(Var1-1)*Vc_step
240 NEXT Var1
250 CALL Icvc_graph(0, Vc_stop, 0, Ic_comp)
260 !
```

```

270 OUTPUT @Hp4142;"CN";B_ch, C_ch
280 OUTPUT @Hp4142;"PWV";C_ch, 1, 0, 0, Vc_start, Vc_stop, Vc_no_step,
Ic_comp
290 OUTPUT @Hp4142;"FL";0, B_ch
300 OUTPUT @Hp4142;"PT";0, 2.E-4, 2.0E-2
310 OUTPUT @Hp4142;"MM";8, C_ch
320 !
330 No_error=0
340 FOR Var2=1 TO Ib_no_step
350     Ib=Ib_start+Ib_step*(Var2-1)
360     OUTPUT @Hp4142;"PDI";B_ch, 0, 0, Ib, 2
370     OUTPUT @Hp4142;"XE"
380     !
390     FOR Var1=1 TO Vc_no_step
400         ENTER @Hp4142 USING "#, 3A, 12D, X";Status$, Ic(Var2, Var1)
410         PLOT Vc(Var1), Ic(Var2, Var1)
420         IF Status$[1;1]<>"N" THEN
430             No_error=No_error+1
440             Error$(No_error)=Status$
450             Error1(No_error)=Ib
460             Error2(No_error)=Vc(Var1)
470             Error3(No_error)=Ic(Var2, Var1)
480             DISP "MEASUREMENT ERROR", Error$(No_error), Er-
ror1(No_error), Error2(No_error), Error3(No_error)
490         END IF
500     NEXT Var1
510     PENUP
520 NEXT Var2
530 OUTPUT @Hp4142;"CL"
540 END
550 !
560 SUB Icvc_graph(X_axis_min, X_axis_max, Y_axis_min, Y_axis_max)
570 !
580     GINIT
590     GRAPHICS ON
600     CONTROL CRT, 12;1
610     PRINT CHR$(12)
620     !
630     Xmax=100*MAX(1, RATIO)
640     Ymax=100*MAX(1, 1/RATIO)
650     !
660     LORG 6
670     MOVE Xmax/2, Ymax
680     LABEL "COLLECTOR CHARACTERISTICS"
690     DEG
700     LDIR 90
710     CSIZE 4.5
720     MOVE 0, Ymax/2
730     LABEL "Ic(A)"
740     LORG 4
750     LDIR 0
760     MOVE Xmax/2, 0
770     LABEL "Vce(V)"
780     !
790     VIEWPORT .16*Xmax, .91*Xmax, .15*Ymax, .9*Ymax
800     !
810     FRAME

```

```

820 WINDOW X_axis_min, X_axis_max, Y_axis_min, Y_axis_max
830 AXES(X_axis_max-X_axis_min)/10,(Y_axis_max-Y_axis_min)/10,
X_axis_min, Y_axis_min
840 CLIP OFF
850 CSIZE 4, .5
860 LOG 6
870 FOR I=X_axis_min TO X_axis_max STEP (X_axis_max-X_axis_min)/2
880 MOVE I, Y_axis_min
890 LABEL I
900 NEXT I
910 CSIZE 3.8, .5
920 LOG 8
930 FOR I=Y_axis_min TO Y_axis_max STEP (Y_axis_max-Y_axis_min)/2
940 MOVE X_axis_min, I
950 LABEL USING "#, MD.DE";I
960 NEXT I
970 CLIP ON
980 !
990 SUBEND
1000 SUB Error_disp
1010 COM Error$(*), Error1(*), Error2(*), Error3(*), No_error
1020 PRINT "STATUS", "Ib", "Vc", "Ic"
1030 FOR I=1 TO No_error
1040 PRINT Error$(I), Error1(I), Error2(I), Error3(I)
1050 NEXT I
1060 SUBEND

```

Result

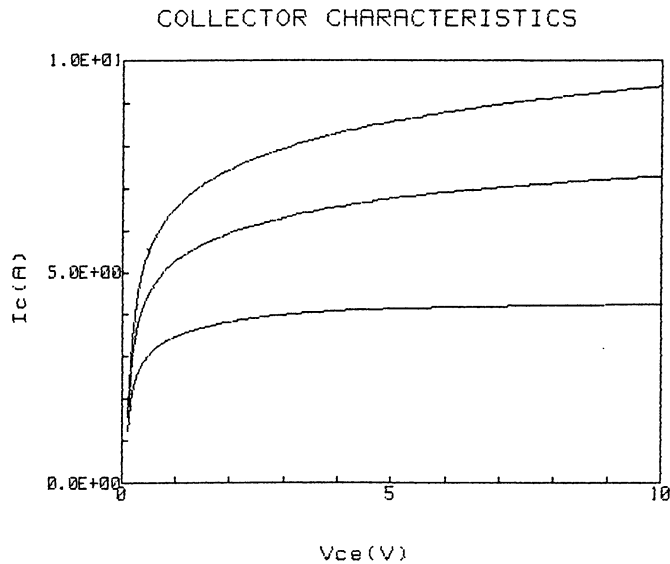

Description

30-60	Defines the variables.
80	Initializes the HP 4142B.
90	Sets the data output format to ASCII with header and comma as a terminator.
110-190	Assigns the constants.
210-240	Calculates collector voltage value for each step, and stores these values in an array variable.
250	Calls subprogram to display graphics frame.
270	Sets the output switches to ON.
280	Sets the <i>ch#5</i> HCU pulsed voltage sweep parameters.
290	Sets the SMU filter to OFF.
300	Sets the output pulse waveform.
310	Sets the measurement mode to pulsed sweep with pulsed bias function.
340-360	Sets the <i>ch#2</i> SMU current pulsed source parameters.
370	Forces a trigger to start a voltage swept measurement.
400-410	Enters the measurement data into variable <i>I_c</i> , and displays measurement data in the graphics frame.
420-490	Displays any measurement errors that may occur.
520	Sets the base current to the next value.
530	Sets the SMUs output switches to OFF.
560-990	Subprogram for displaying graphics frame.
1000-1060	Subprogram for displaying measurement errors.

QUASI-PULSED SPOT MEASUREMENTS

Quasi-pulsed spot measurements automatically perform the force, settling detection, measurement, and output down (similar to pulse measurements) to minimize the forcing time as follows: one source (HVU, HPSMU, or MPSMU) forces quasi-pulsed voltage. One monitor (HVU, HPSMU, or MPSMU) measures the output after the quasi-pulsed source detects that its output reaches the specified voltage or specified I compliance.

The detection is performed when the slew rate of the output voltage becomes less than or equal to half of the slew rate at the first part of the leading edge. To monitor the slew rate, the quasi-pulsed source continues to measure its own voltage with a constant time interval until the detection finishes.

The following figure shows the output waveform and the relationship of parameters and test device characteristics. For example, for leakage current measurement, measure the current when the voltage reaches *stop voltage*. For breakdown measurement, measure the voltage when the current reaches *I compliance*. The voltage difference of *start voltage* and *stop voltage* must be greater than or equal to 10 V if you measure the output when the voltage reaches the *stop voltage*. And the voltage difference of *start voltage* and the voltage when the current reaches the *I compliance* should be greater than or equal to 10 V for sure detection if you measure the output when the current reaches *I compliance*.

If the V source reaches the specified *I compliance*, the voltage rise stops, and the V source equals I source that forces *I compliance*.

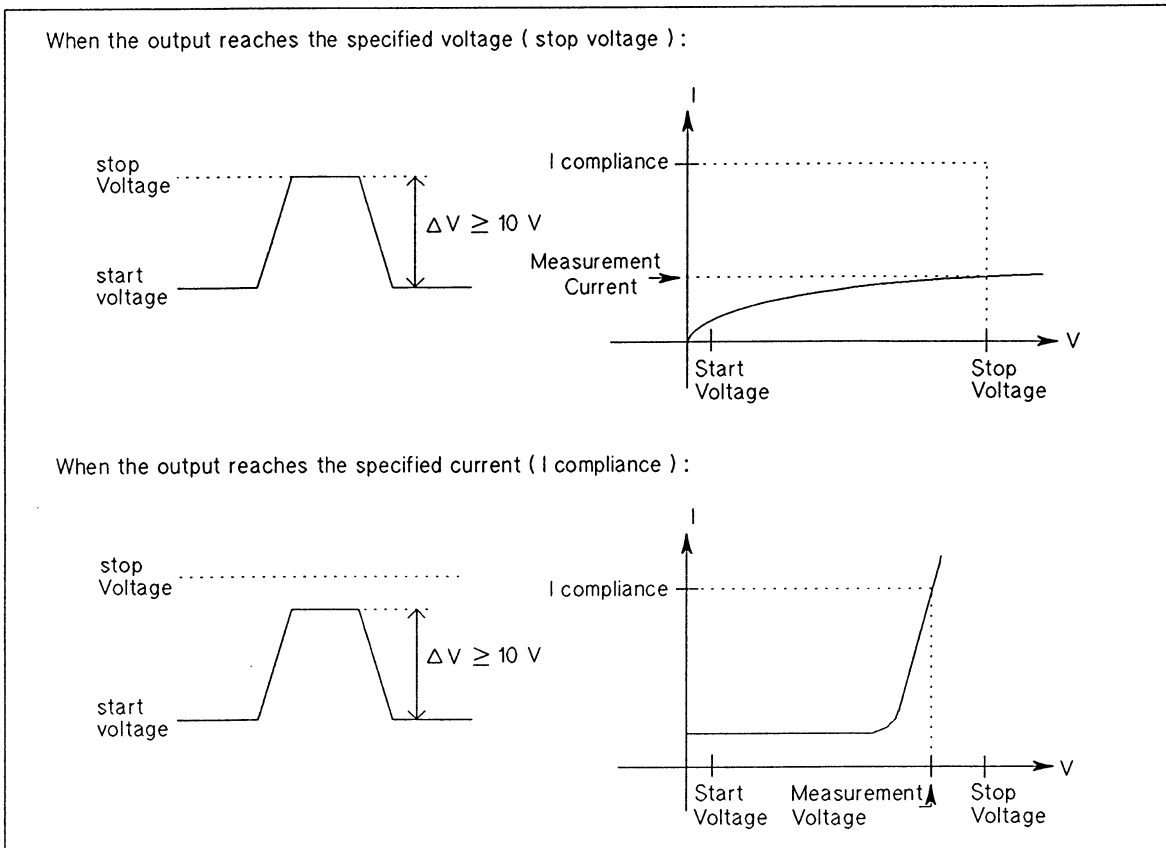

Output Waveform

The following paragraphs explain the features of this measurement.

- Short output forcing time

Voltage forcing time (except rising and falling time) is short as shown below. You can minimize the test device thermal drift and stress in high voltage measurements and breakdown measurements.

HVU: 2.1 ms to 2.4 ms when the *detection interval* is set to Short.
4.9 ms to 7.8 ms when the *detection interval* is set to Long.
SMU: 1.5 ms to 1.8 ms when the *detection interval* is set to Short.
4.2 ms to 7.1 ms when the *detection interval* is set to Long.

The conditions are:

delay time: 0 s

measurement averaging: none

measurement channel: V measurement of the quasi-pulsed source

The voltage forcing time is greater than the above values if the measurement channel is another channel or an I measurement of the quasi-pulsed source. For I measurements, the measurement range change time increases if it occurs during the measurement. For auto ranging, the time to change to next range is as follows:

Between 100 μ A and 1 A range: about 10 ms per one range up or down

Between 10 nA and 100 μ A range: about 20 ms per one range up or down

Between 1 nA and 10 nA range: about 50 ms per one range up or down

For example, if the range changes from 1 mA to 10 μ A, it takes 30 ms (= 10 ms + 20 ms).

- No need to specify delay time or pulse width

Without setting a time parameter (such as delay time and pulse width), you can perform the measurement after the output is settled, and minimize output forcing time.

You can automatically minimize the test device thermal drift and stress in high voltage measurements and breakdown measurements.

For pulsed measurements, you need to adjust the pulse width according to the output voltage to minimize forcing time because the specified pulsed width includes rising time of the pulse, and the rising time increases if the output voltage increases. The HVU needs 1 ms to change 12 V (HVU maximum slew rate: 12 V/ms for changes of 10 V or more, 300 V/ms for less than changes of 10 V; SMU maximum slew rate: 300 V/ms). If the output voltage increases 120 V, the voltage rising time increases 10 ms (0.4 ms for SMU). In this case, you must increase the pulse width by 10 ms.

If you measure multiple test devices of the same type with one measurement program, you must set the pulse width so that the maximum output voltage of the test devices is forced. Therefore, if the difference of the maximum and minimum output voltages is large, you can not minimize the voltage forcing time of all the test devices for pulsed measurements.

Without setting a delay time, you can perform a measurement in which the settling time is long, such as leakage current measurements and measurements for test devices that have capacitance (the capacitance of the test device decrease the output slew rate).

You may need to specify the delay time in the following cases:

- When the current is not settled, even if the voltage reaches the set value.
 - When the voltage is not settled, even if the voltage slew rate is half.
- Even in these cases, the delay time is slight because the output is almost settled.

- Comparison between quasi-pulsed measurement and pulsed measurement.

The quasi-pulsed measurement covers several functions that the pulsed measurement does not. The following table shows a comparison of both.

For the quasi-pulsed measurement, you can use all output and measurement ranges of the HVU, HPSMU, and MPSMU. You can perform high voltage difference measurements with minimum voltage forcing time, and high accuracy low current measurements with minimum voltage forcing time.

However, if the voltage difference is less than 10 V, use spot measurements or pulsed measurements instead because the quasi-pulsed measurements cannot be performed for a voltage difference less than 10 V.

For pulsed measurements, you can drop the forcing time (except rising time and falling time) down to 500 μ s through 1 ms by adjusting the pulse width. With the pulse width at about 1 ms through 2 ms, you can usually perform a pulsed measurement in the following cases:

HVU: (Voltage difference) < 30 V

SMU: (Current or I compliance) \geq 300 μ A

(For this case, the SMU slew rate is greater than 50 V/ms.)

Comparison of Quasi-pulsed Measurement and Pulsed Measurement

Item	Pulsed Measurement	Quasi-pulsed Measurement
Forcing time (except rising/falling time)	500 μ s to 50 ms	HVU ¹ : 2.1 ms to 2.4 ms SMU ¹ : 1.5 ms to 1.8 ms
Settling Detection	No	Yes
Voltage Difference	0 to 600 V ²	10 to 1000 V
Range Not Allowed	SMU: 1 nA to 10 μ A ³ HVU: None	None
Maximum Settling Time Allowed	50 ms (Maximum pulse width)	6.5535 s
I Measurement Ranging Allowed	Compliance	Auto, Ltd auto, Fixed, Compliance
Measurement Averaging	No	Yes

¹ For *detection interval*: short, *delay time*: 0 s, measurement averaging: none, and measurement channel: V measurement of quasi-pulsed source.

² When the pulse width is set to a maximum of 50 ms (slew rate: 12 V/ms maximum).

³ Only the 1 nA range is not allowed when the voltage range is set to 2 V.

The following table lists quasi-pulsed spot measurement specifics. The following figure shows an example of a typical quasi-pulsed spot measurement.

Quasi-pulsed Spot Measurement Specifics

Output Mode	No. of Source Ch.	Source Mode	Source Setup Command	Allowable Units ¹	Allowable Monitor Mode	Meas. Setup Command	No. of Meas. Ch.
Quasi-Pulse	1	V	BDV	HPSMU MPSMU HVU	V, I	MM BDM	1
Constant	0 to 14	V	DV	HPSMU MPSMU HVU	V, I		
		I	DI	HPSMU MPSMU HVU	V, I		
				VS	---		

¹ The VM and HCU cannot be used to measure for this measurement.

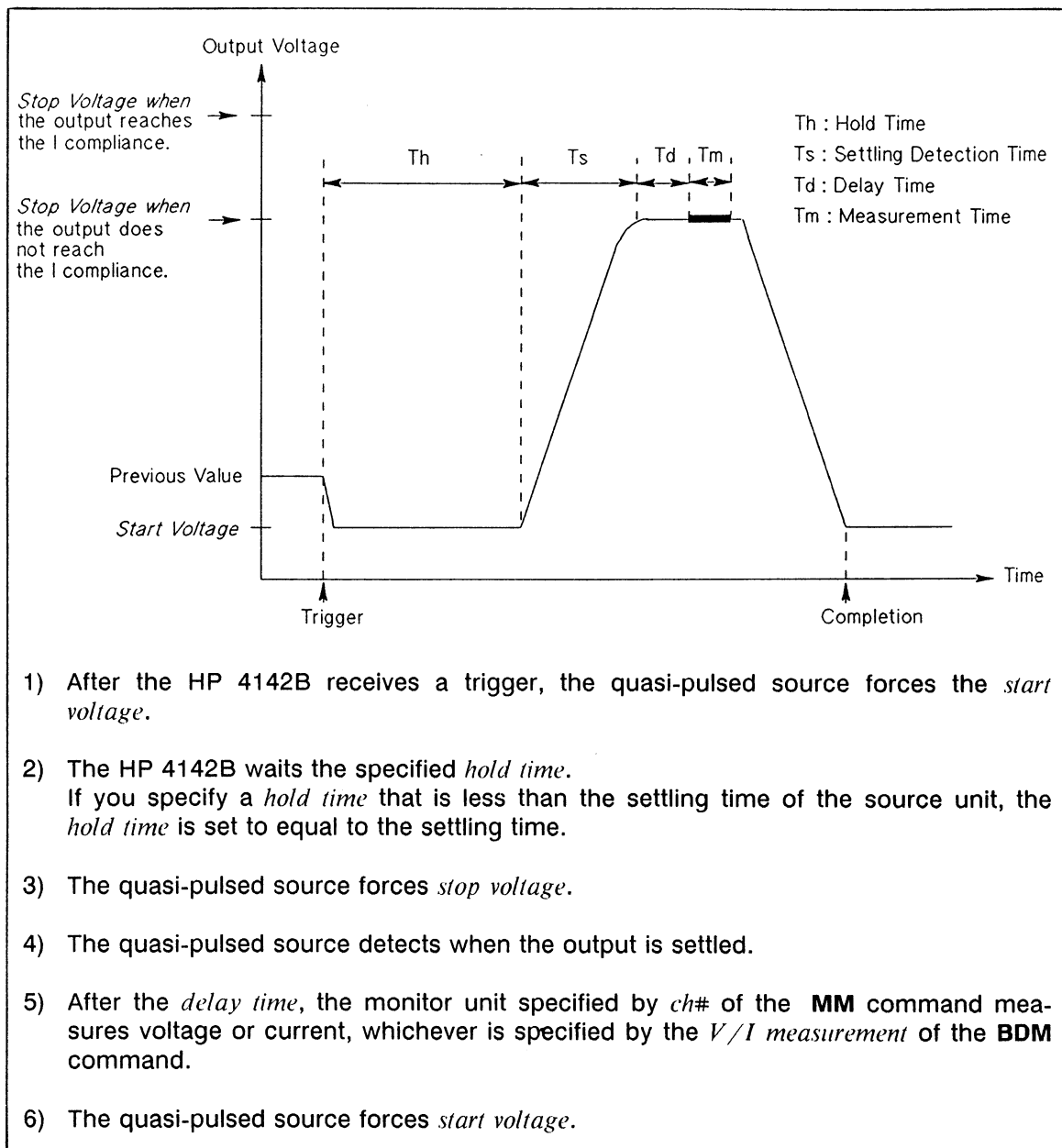

Quasi-pulsed Spot Measurement

If the output reaches the *stop voltage*, the measurement data status is **N**. If the output reaches the *I compliance*, the measurement data status is **C** for the measurement data of the quasi-pulsed source, and **T** for that of the other unit. Therefore, if you measure the voltage when the output reaches *I compliance*, the measurement data status shows **C** or **T** when the measurement succeeded.

NOTE

Status **C** or **T** occurs even if the quasi-pulsed source and the other constant source(s) reach compliance. To confirm that only the quasi-pulsed source reaches compliance, measure the outputs of all units and confirm that status **C** occurs for the quasi-pulsed source only.

Settling Detection Method

This measurement judges that the settling is complete when the slew rate of the output voltage becomes half of the slew rate at the first part of the rising edge. If the detection finishes, the output generally reaches *stop voltage* or *I compliance*.

To monitor the slew rate, the quasi-pulsed source performs the following: After the quasi-pulsed source starts to force the *stop voltage*, the quasi-pulsed source continues to measure its own voltage with a constant time interval until the detection finishes as shown in the following figure. If the voltage difference (dV_n) of two adjacent voltage measurements is less than or equal to half of the voltage difference (dV_1) of the first two adjacent voltage measurements, the quasi-pulsed source finishes the detection.

The *detection interval* parameter has two modes: Short and Long. The initial condition is Short. When the *detection interval* of the **BDM** command is set to Short, measurement samples for detection are performed every 250 μs (360 μs for Long). The number of measurement samples per measurement data is 1 (8 for Long; time per measurement data is 360 $\mu\text{s} \times 8 = 2.9 \text{ ms}$), regardless of **AV** command setting. However, the measurement after the detection is performed with the number of samples is specified by the **AV** command.

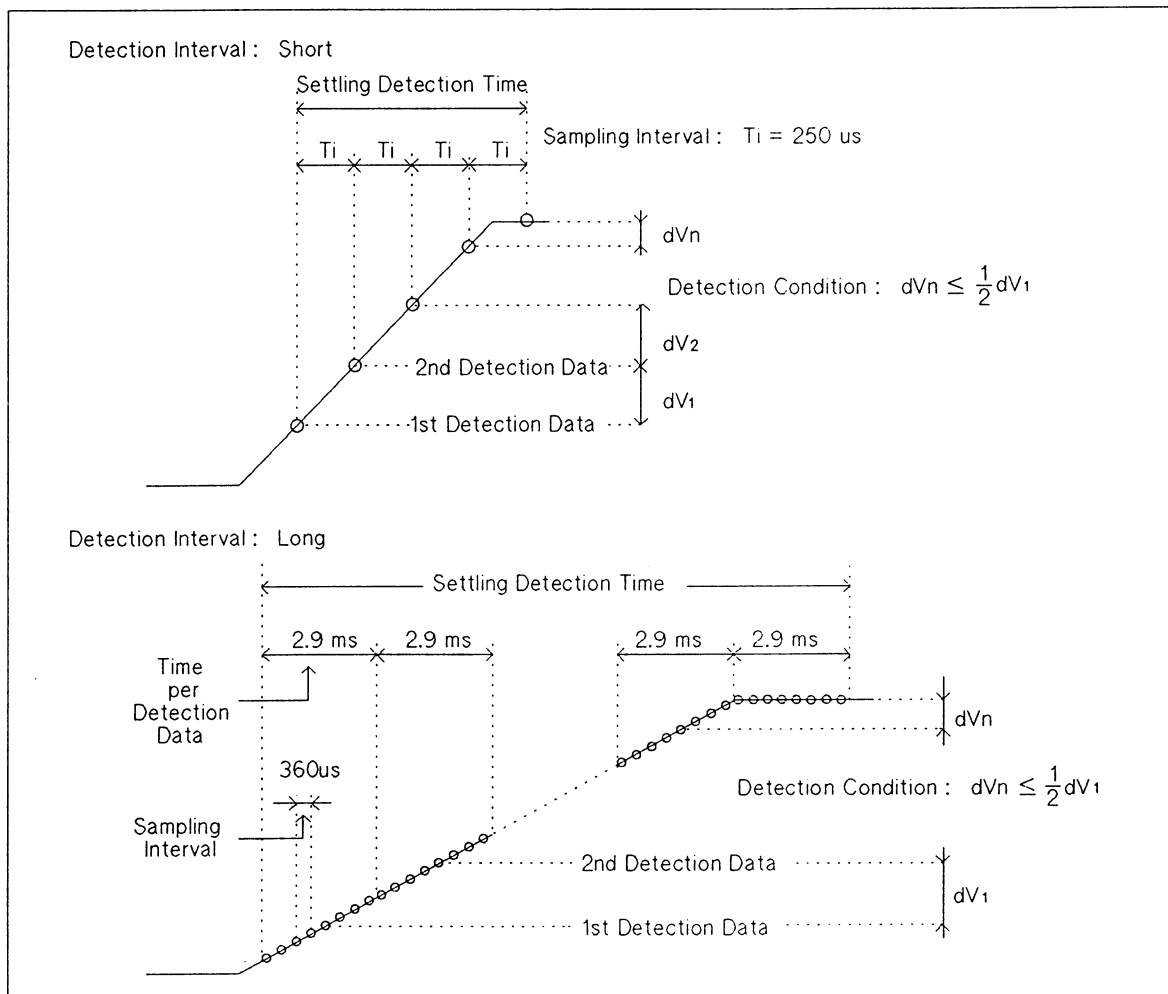

Settling Detection Method

Detection also finishes in the following cases:

- The first slew rate $dV_1/250\mu s$ ($dV_1/2.9ms$ for Long) is less than or equal to 1 V/ms (0.1 V/ms for Long). Therefore, the voltage difference of the first two measurements is less than or equal to 0.25 V (0.29 V for Long). In this case, the measurement data status shows **S**.
- The detection time exceeds 3 s (12 s for Long). In this case, the measurement data status shows **G**.

As described above, the *detection interval* parameter changes the condition of the first slew rate (1 V/ms or 0.1 V/ms), the number of measurement samples for detection (1 or 8), and the time out condition (3 s or 12 s). If you use the Short mode and an **S** status occurs, use the Long mode. The following cases can cause the **S** status to occur because the output slew rate is slow.

- If the *I compliance* is less than about 1 μA .
- If the test device has parasitic capacitance.

If you use the Long mode and an **S** status occurs, you can not use this measurement. Use the spot measurement by constant source instead.

NOTE

The **S** status does not occur in the following cases:

- When the voltage reaches *stop voltage* before the start of settling detection. In this case, the status shows **N** (Normal).
- When the current reaches *I compliance* before the start of settling detection, and when the voltage increase from *start voltage* is greater than 10 V. In this case, the status shows **C** for the measurement data of the quasi-pulsed source, and **T** for that of the other unit.

Commands and Parameters

The following table lists the commands and parameters for quasi-pulsed spot measurements.

Quasi-pulsed Spot Measurement Command and Parameters

Function	Command ¹	Parameters ¹
Quasi-pulsed Source	BDV	<i>ch#, output range, start voltage, stop voltage, [I compliance]</i>
Measurement Conditions	[BDT]	<i>hold time, delay time</i>
	[BDM]	<i>detection interval, [V/I measurement]</i>
Constant Source	DV	<i>ch#, output range, output voltage, [I compliance], [compliance polarity mode]</i>
	DI	<i>ch#, output range, output current, [V compliance], [compliance polarity mode]</i>
HVU Output Polarity	[POL]	<i>ch#, output polarity</i>
Measurement	MM	<i>measurement mode, [ch#]</i>
	[RI]	<i>ch#, I measurement range</i>
	[AV]	<i>averaging number, [averaging mode]</i>
Trigger	XE	-----
Abort	AB	-----

¹ Brackets ([]) denote optional commands and parameters.

Information

Measurement Data Output Format is explained in the *HP-IB Command Reference Manual*.

Output and Measurement Ranging Mode, and **Averaging** are explained in chapter 6.

Quasi-pulsed Spot Measurement Sample Program

The following is a sample program that measures the collector-emitter breakdown voltage of a 2N5551 bipolar transistor by using the quasi-pulsed spot measurement function. A description of key program lines follows the program list.

Measurement Conditions

DUT Terminal	Unit	Output	Measurement
Base	SMU Ch#3	Ib = 0 A	---
Collector	HVU Ch#7	Ic = 100 μ A (Vc = 220 V Max.)	Vc
Emitter	GNDU	Ve = 0 V	---

Program List

```

10  ! Collector-Emitter Breakdown Voltage Measurement using Quasi-pulse
20  !
30  INTEGER B_ch, C_ch
40  DIM Status$[3]
50  ASSIGN @Hp4142 TO 717
60  CLEAR @Hp4142
70  !
80  B_ch=3           ! Emitter      : GNDU
90  C_ch=7           ! Base        : SMU (Ch#3)
100 Ib=0            ! Collector   : HVU (Ch#7)
110 Ic=100E-6
120 Vc_start=0
130 Vc_stop=220
140 !
150 OUTPUT @Hp4142;"CN";B_ch, C_ch
160 OUTPUT @Hp4142;"DI";B_ch, 0, Ib, 2
170 OUTPUT @Hp4142;"BDV";C_ch, 0, Vc_start, Vc_stop, Ic
180 OUTPUT @Hp4142;"MM";9, C_ch
190 OUTPUT @Hp4142;"XE"
200 ENTER @Hp4142 USING "3A, 12D"; Status$, Bvceo
210 !
220 PRINT "BVceo= ";Bvceo;"[V]";TAB(23);"(Status: ";Status$;")"
230 OUTPUT @Hp4142;"CL"
240 END

```

Result

BVceo= 203.45 [V] (Status: CGV)

Description

60	Initializes the HP 4142B.
100-130	Assigns the constants.
150	Sets the output switches to ON.
160	Forces 0 A to the base.
170	Sets the HVU quasi-pulsed source parameters.
180	Sets the measurement mode to quasi-pulsed spot measurement.
190	Measures the collector voltage.
200	Enters the measurement data and the status.
220	Displays the result.
230	Sets the output switches to OFF.

HIGH SPEED SPOT MEASUREMENTS

You can make high speed spot measurements by using the **TV** or **TI** commands. These commands make a V or I measurement independently of the source mode setting (V or I). Measurements are faster because trigger, *measurement mode*, *measurement ch#*, and *measurement range* are all combined into one command. However, you are limited to one measurement channel. The **TV** command (for V measurements) is used instead of the **MM**, **RV**, and **XE** commands. The **TI** command (for I measurements) is used instead of the **MM**, **RI**, and **XE** commands. The following two tables list measurement functions that can only be performed using the high speed spot measurement function, and high speed spot measurement specifics, respectively.

High Speed Spot Measurement Special Functions

Measurement Function	Equivalent Circuit
VS current measurement	<p>The diagram shows a voltage source labeled 'VS' connected in series with an ammeter labeled 'A'. The circuit is connected to a ground symbol on the left and an open terminal on the right.</p>
Voltage measurement by SMU/HVU set to V source mode	<p>The diagram shows a voltage source labeled 'SMU or HVU' connected in parallel with a voltmeter labeled 'V'. The circuit is connected to a ground symbol on the left and an open terminal on the right.</p>
Current measurement by SMU/HVU set to I source mode	<p>The diagram shows a current source labeled 'SMU or HVU' connected in series with an ammeter labeled 'A'. The circuit is connected to a ground symbol on the left and an open terminal on the right.</p>

High Speed Spot Measurement Specifics

Output Mode	No. of Source Ch.	Source Mode	Source Setup Command	Allowable Units	Allowable Monitor Mode	Meas. Setup Command	No. of Meas. Ch.
Constant	0 ¹ to 16	V	DV	HPSMU MPSMU HVU	V, I	V: TV I: TI	1
				VS	I	TI	
		I	DI	HPSMU MPSMU HVU	V, I	V: TV I: TI	
No Output	---	---	---	VM	V DIF. V	TV VM	

¹ When using a VM to make a measurement only.

Commands and Parameters

The following table lists high speed spot measurement commands and parameters.

High Speed Spot Measurement Commands and Parameters

Function	Command ¹	Parameters ¹
Constant Source	DV	<i>ch#, output range, output voltage, [I compliance], [compliance polarity mode]</i>
	DI	<i>ch#, output range, output current, [V compliance], [compliance polarity mode]</i>
HVU Output Polarity	[POL]	<i>ch#, output polarity</i>
Measurement and Trigger	TV	<i>ch#, [V measurement range]</i>
	TI	<i>ch#, [I measurement range]</i>
Measurement	[VM]	<i>ch#, VM operation mode</i>
	[AV]	<i>number, [averaging mode]</i>

¹ Brackets ([]) denote optional commands and parameters. Optional parameters and optional command parameters have default values.

Information

Measurement Data Output Format is explained in the *HP 4142B HP-IB Command Reference Manual*.

Output and Measurement Ranging Mode and Averaging are explained in chapter 6.

High Speed Spot Measurement Sample Program

The following is a sample program that measures collector current for two collector-to-emitter voltage values using the high speed spot measurement function. Saturation I_c - V_{ce} values are then used to calculate Early Voltage. A description of key program lines follows the program list.

Measurement Conditions

DUT Terminal	Unit	Output	Measurement
Base	SMU Ch#3	$I_b = 20 \mu A$	---
Collector	SMU Ch#2	$V_c = 2, 6 V$	I_c
Emitter	GNDU	$V_e = 0 V$	---

Program List

```

10  ! Early Voltage Measurement using High Speed Spot Function
20  !
30  INTEGER B_ch, C_ch
40  DIM Ic1$[15], Ic2$[15]
50  ASSIGN @Hp4142 TO 717
60  OUTPUT @Hp4142;"*RST"
70  !
80  B_ch=3
90  C_ch=2
100 Ib=2.E-5
110 Vc1=2
120 Vc2=6
130 !
140 OUTPUT @Hp4142;"CN";B_ch, C_ch
150 OUTPUT @Hp4142;"DI";B_ch, 0, Ib, 2
160 OUTPUT @Hp4142;"DV";C_ch, 0, Vc1, 1.E-2
170 OUTPUT @Hp4142;"T1";C_ch
180 ENTER @Hp4142;Ic1$
190 OUTPUT @Hp4142;"DV";C_ch, 0, Vc2
200 OUTPUT @Hp4142;"T1";C_ch
210 ENTER @Hp4142;Ic2$
220 OUTPUT @Hp4142;"CL"
230 !
240 Ic1=VAL(Ic1$[4, 15])
250 Ic2=VAL(Ic2$[4, 15])
260 Va=(Vc1*Ic2-Ic1*Vc2)/(Ic2-Ic1)
270 PRINT "Early Voltage= ";PROUND(Va, -2);"[V]"
280 END

```

Result

Early Voltage= -155.44[V]

Description

60	Initializes the HP 4142B.
100-120	Assigns the constants.
140	Sets the SMUs output switches to ON.
150	Forces 20 μ A to the base.
160	Forces 2 V to the collector.
170	Measures the collector current.
180	Enters the measurement data into string variable <i>Ic1\$</i> .
190	Forces 6 V to the collector.
200	Measures the collector current.
210	Enters the measurement data into string variable <i>Ic2\$</i> .
220	Sets the SMUs output switches to OFF.
240-250	Converts the string expression into a numeric value to obtain the collector current values.
260	Calculates the Early Voltage value.
270	Displays the result.

CHAPTER 6

MEASUREMENT FUNCTIONS

CONTENTS

Introduction	6-1
Output Ranging Mode	6-1
Allowable Ranging Mode	6-1
Auto Ranging	6-2
Limited Auto Ranging	6-3
Measurement Ranging Mode	6-4
Allowable Ranging Mode	6-4
Auto Ranging	6-5
Limited Auto Ranging	6-6
Compliance Range	6-6
Fixed Range	6-7
Note	6-8
Compliance/Limiter	6-9
V/I Compliance	6-9
Power Compliance	6-17
Limiter	6-18
Averaging	6-19
Filter	6-21
Automatic Sweep Abort Function	6-22
Output After Sweep	6-22
Measurement Data Memory	6-23
Program Memory	6-24
Using Program Memory	6-27
Program Memory Sample Program	6-28
Using the HP 4142B with External Instruments	6-30
Trigger Output and Input Function	6-30
Triggering an External Instrument	6-30
Externally Triggered HP 4142B Measurements	6-31
Waiting for Trigger Signal from TRIGGER INPUT Terminal	6-31
Waiting for Time or Trigger	6-33
Waiting for Command Execution Completion (*OPC? Command)	6-33
Relay Control (Option 300)	6-34
Module Selector Control	6-34
External Relay Control	6-35

INTRODUCTION

This chapter explains the functions that can be used in measurements, such as ranging, compliance, measurement averaging, automatic sweep abort function and program memory.

OUTPUT RANGING MODE

Allowable Ranging Mode

The following table lists the allowable output ranging mode for each source.

Allowable Output Ranging Mode

Output Mode	Output Setup Command	Auto Ranging	Limited Auto Ranging
Constant V/I Source	DV/DI	YES	YES
Staircase Sweep V/I Source	WV/WI, WSV/WSI	YES	YES
Pulsed V/I Source	PV/PI, PDV/PDI	YES	YES
Pulsed Sweep V/I Source	PWV/PWI	YES	YES
Search	ASV	YES	---
V/I Sense (Constant I/V Source)	AVI/AIV	YES	---
Quasi-pulsed Source	BDV	YES	YES

Auto Ranging

For Auto ranging, the output of the source unit is forced at the lowest range that includes the Range Determination Value shown in the following table.

Range Determination Value	
Output Setup Command	Range Determination Value ¹
DV	<i>output voltage</i>
DI	<i>output current</i>
WV	$\text{MAX}(\text{start voltage}, \text{stop voltage})^2 \ ^3$
WSV	$\text{MAX}(\text{start voltage}, \text{stop voltage})^2 \ ^3$
WI (For linear sweep)	$\text{MAX}(\text{start current}, \text{stop current})^2$
WI (For log sweep)	each step output current ⁴
WSI (For linear sweep)	$\text{MAX}(\text{start current}, \text{stop current})^2$
WSI (For log sweep)	each step output current ⁴
PV	$\text{MAX}(\text{base voltage}, \text{pulse voltage})$
PI	$\text{MAX}(\text{base current}, \text{pulse current})$
PWV	$\text{MAX}(\text{base voltage}, \text{start pulse voltage}, \text{stop pulse voltage})^2$
PWI	$\text{MAX}(\text{base current}, \text{start pulse current}, \text{stop pulse current})^2$
ASV	$\text{MAX}(\text{search start voltage}, \text{search stop voltage}, (\text{search stop voltage} - \text{search start voltage}))^2$
AVI	<i>output voltage</i>
AIV	<i>output current</i>
BDV	$\text{MAX}(\text{start voltage}, \text{stop voltage})$

¹ Each parameter value means an absolute value.

² During a sweep, the output range does not change.

³ However, if you specify *power compliance* for the SMU of the staircase sweep V source, and the I compliance value at some step (smaller value of (*power compliance*)/ (step output voltage) and *I compliance*) is greater than the maximum current for the V output range selected by the Auto ranging or Limited Auto ranging, then the V output range at this step is changed according to the output voltage, as follows.

⁴ During a log I sweep, the output range changes so that each step current is forced at the lowest range that includes the step current.

Unit	Step Voltage	Output Range
SMU	$0 \text{ V} \leq V \leq 20 \text{ V}$	20 V
	$20 \text{ V} < V \leq 40 \text{ V}$	40 V
	$40 \text{ V} < V \leq 100 \text{ V}$	100 V

NOTE

If the V output range or V compliance range changes, the output of the unit is momentarily set to 0 V.

The following table lists the lowest output range that includes the Range Determination Value, that is, the range set by Auto ranging.

Output Range Set by Auto Ranging

Unit	Range Determination Value	Output Range
HPSMU MPSMU	$0 \leq V \leq 2 \text{ V}$ $2 \text{ V} < V \leq 20 \text{ V}$ $20 \text{ V} < V \leq 40 \text{ V}$ $40 \text{ V} < V \leq 100 \text{ V}$ $100 \text{ V} < V \leq 200 \text{ V}$	2 V 20 V 40 V 100 V 200 V
HCU	$0 \leq V \leq 2 \text{ V}$ $2 \text{ V} < V \leq 10 \text{ V}$	2 V 20 V
HVU	$0 \leq V \leq 100 \text{ V}$ $100 \text{ V} < V \leq 200 \text{ V}$ $200 \text{ V} < V \leq 500 \text{ V}$ $500 \text{ V} < V \leq 1000 \text{ V}$	100 V 200 V 500 V 1000 V
VS	$0 \leq V \leq 20 \text{ V}$ $20 \text{ V} < V \leq 40 \text{ V}$	20 V 40 V
HPSMU MPSMU	$0 \leq I \leq 1.15 \text{ nA}$ $1.15 \text{ nA} < I \leq 11.5 \text{ nA}$ $11.5 \text{ nA} < I \leq 115 \text{ nA}$ $115 \text{ nA} < I \leq 1.15 \text{ }\mu\text{A}$ $1.15 \text{ }\mu\text{A} < I \leq 11.5 \text{ }\mu\text{A}$ $11.5 \text{ }\mu\text{A} < I \leq 115 \text{ }\mu\text{A}$ $115 \text{ }\mu\text{A} < I \leq 1.15 \text{ mA}$ $1.15 \text{ mA} < I \leq 11.5 \text{ mA}$ $11.5 \text{ mA} < I \leq 115 \text{ mA}$ $115 \text{ mA} < I \leq 1 \text{ A}$	1 nA 10 nA 100 nA 1 μA 10 μA 100 μA 1 mA 10 mA 100 mA 1 A
HCU	$0 \leq I \leq 1.15 \text{ mA}$ $1.15 \text{ mA} < I \leq 11.5 \text{ mA}$ $11.5 \text{ mA} < I \leq 115 \text{ mA}$ $115 \text{ mA} < I \leq 1.15 \text{ A}$ $1.15 \text{ A} < I \leq 10 \text{ A}$	1 mA 10 mA 100 mA 1 A 10 A
HVU	$0 < I \leq 115 \text{ nA}$ $115 \text{ nA} < I \leq 1.15 \text{ }\mu\text{A}$ $1.15 \text{ }\mu\text{A} < I \leq 11.5 \text{ }\mu\text{A}$ $11.5 \text{ }\mu\text{A} < I \leq 115 \text{ }\mu\text{A}$ $115 \text{ }\mu\text{A} < I \leq 1.15 \text{ mA}$ $1.15 \text{ mA} < I \leq 10 \text{ mA}$	100 nA 1 μA 10 μA 100 μA 1 mA 10 mA

Limited Auto Ranging

For Limited Auto ranging, the output of the source unit is forced at the specified range, if this range includes the Range Determination Value described in "Auto Ranging." If not, the output is forced at the same range as Auto ranging.

MEASUREMENT RANGING MODE

Allowable Ranging Mode

The following table lists the allowable V measurement ranging mode for each monitor unit.

Unit	V/I Meas.	Allowable Ranging Mode ¹ (Ranging Mode Setup Command)		
		Constant V/I Meas.	Pulsed V/I Meas.	Search Meas.
HPSMU MPSMU	V Meas.	Comp ²	Comp	Comp ²
HCU HVU	I Meas.	Auto, Ltd, Fix, Comp ² (RI, TI)	Comp, Fix (RI, TI)	Comp
VM	V Meas.	Auto, Fix (RV, TV)	Fix (RV, TV)	---
VS	I Meas.	³	---	---

¹ Auto: Auto ranging, Ltd: Limited Auto ranging, Comp: Compliance range, Fix: Fixed range

Constant V/I Meas.: For Spot, Staircase sweep, Quasi-pulsed spot, or High speed spot measurements.

Pulsed V/I Meas.: 1ch pulsed spot, 2ch pulsed spot, Pulsed sweep, Pulsed sweep with pulsed bias, or staircase sweep with pulsed bias measurements.

Search Meas.: Analog search measurements

² If the unit is the V source and V monitor, or I source and I monitor, the measurement range is set to the same as output range, regardless of the shown ranging mode.

³ If VS output range is set to 20 V, VS I measurement range is automatically set to the 100 mA range. If VS output range is set to 40 V, VS I measurement range is automatically set to the 20 mA range. VS I measurement is only available for High speed spot measurements.

Auto Ranging

The monitor unit measures at the range that provides the highest resolution. The range changes to the next higher range if the measurement value is greater than 114% of the present range. The range changes to the next lower range if the measurement value is less than 10% of the present range.

The following table lists the auto ranging measurement area for each range.

Auto Ranging Measurement Area

Unit	Range	Meas. Area	Auto Ranging Meas. Area
VM (Grounded measurement)	2 V	0 to ± 2.3 V	$0 \text{ V} \leq V \leq 2.28 \text{ V}$
	20 V	0 to ± 23 V	$2 \text{ V} \leq V \leq 22.8 \text{ V}$
	40 V	0 to ± 40 V	$4 \text{ V} \leq V \leq 40 \text{ V}$
VM (Differential measurement)	0.2 V	0 to ± 0.23 V	$0 \leq V \leq 0.228 \text{ V}$
	2 V	0 to ± 2.3 V	$0.2 \text{ V} \leq V \leq 2.3 \text{ V}$
HPSMU MPSMU	1 nA	0 to 1.15 nA	$0 \text{ A} \leq I \leq 1.14 \text{ nA}$
	10 nA	0 to 11.5 nA	$1 \text{ nA} \leq I \leq 11.4 \text{ nA}$
	100 nA	0 to 115 nA	$10 \text{ nA} \leq I \leq 114 \text{ nA}$
	1 μ A	0 to 1.15 μ A	$100 \text{ nA} \leq I \leq 1.14 \mu\text{A}$
	10 μ A	0 to 11.5 μ A	$1 \mu\text{A} \leq I \leq 11.4 \mu\text{A}$
	100 μ A	0 to 115 μ A	$10 \mu\text{A} \leq I \leq 114 \mu\text{A}$
	1 mA	0 to 1.15 mA	$100 \mu\text{A} \leq I \leq 1.14 \text{ mA}$
	10 mA	0 to 11.5 mA	$1 \text{ mA} \leq I \leq 11.4 \text{ mA}$
	100 mA	0 to 115 mA ¹	$10 \text{ mA} \leq I \leq 114 \text{ mA}^1$
1 A	0 to 1 A	$100 \text{ mA} \leq I \leq 1 \text{ A}$	
HVU	100 nA	0 to 115 nA	$0 \text{ A} \leq I \leq 114 \text{ nA}$
	1 μ A	0 to 1.15 μ A	$100 \text{ nA} \leq I \leq 1.14 \mu\text{A}$
	10 μ A	0 to 11.5 μ A	$1 \mu\text{A} \leq I \leq 11.4 \mu\text{A}$
	100 μ A	0 to 115 μ A	$10 \mu\text{A} \leq I \leq 114 \mu\text{A}$
	1 mA	0 to 1.15 mA	$100 \mu\text{A} \leq I \leq 1.14 \text{ mA}$
	10 mA	0 to 10 mA	$1 \text{ mA} \leq I \leq 10 \text{ mA}$

¹ For MPSMU, 100 mA

Limited Auto Ranging

The monitor unit measures at the range that provides the highest resolution in the specified range and higher. The range changes to the next higher range if the measurement value is greater than 114% of the present range. The range changes to the next lower range if the present range is higher than the specified range and the measurement value is less than 10% of the present range. If you do not need to measure at the lower I range, specify the higher range at this ranging mode. You can reduce the measurement time of Auto Ranging with Limited Auto Ranging because the number of range changes decreases.

However, if the specified range is greater than the lowest range that includes *I compliance*, the measurement range is not set by Limited Auto ranging and is set to Compliance range (see next paragraph, "Compliance Range"). Therefore, if you specify the 1 A Limited Auto ranging for HPSMU, and the 100 mA Limited Auto ranging for MPSMU, then the measurement range is always set to Compliance range regardless of *I compliance*.

Compliance Range

For V measurement, the monitor unit measures at the lowest range that includes *V compliance*. If you also specify *power compliance*, the unit measures at the lowest range that includes *V compliance*, or $(\text{power compliance})/(\text{step output current})$, whichever range is lower.

For I measurement, the monitor unit measures at the lowest range that includes *I compliance*. If you also specify *power compliance*, the unit measures at the lowest range that includes *I compliance*, or $(\text{power compliance})/(\text{step output voltage})$, whichever range is lower.

Compliance range performs measurements fastest because the ranging is performed when you set the compliance and the range does not change for each measurement.

The following table lists the measurement range for Compliance range.

NOTE

If you specify the I measurement ranging mode as follows, the I measurement range of the unit is set to Compliance range.

HPSMU: 1 A Limited Auto ranging or 1 A Fixed range
MPSMU: 100 mA Limited Auto ranging or 100 mA Fixed range
HVU: 10 mA Limited Auto ranging or 10 mA Fixed range

Measurement Range for Compliance Range

Unit	V compliance/ I compliance	Measurement Range
HPSMU MPSMU	$0\text{ V} \leq V \leq 2\text{ V}$ $2\text{ V} < V \leq 20\text{ V}$ $20\text{ V} < V \leq 40\text{ V}$ $40\text{ V} < V \leq 100\text{ V}$ $100\text{ V} < V \leq 200\text{ V}$	2 V 20 V 40 V 100 V 200 V
HCU	$0\text{ V} \leq V \leq 2\text{ V}$ $2\text{ V} < V \leq 10\text{ V}$	2 V 20 V
HVU	$0\text{ V} \leq V \leq 100\text{ V}$ $100\text{ V} < V \leq 200\text{ V}$ $200\text{ V} < V \leq 500\text{ V}$ $500\text{ V} < V \leq 1000\text{ V}$	100 V 200 V 500 V 1000 V
HPSMU MPSMU	$0 \leq I \leq 1.15\text{ nA}$ $1.15\text{ nA} < I \leq 11.5\text{ nA}$ $11.5\text{ nA} < I \leq 115\text{ nA}$ $115\text{ nA} < I \leq 1.15\text{ }\mu\text{A}$ $1.15\text{ }\mu\text{A} < I \leq 11.5\text{ }\mu\text{A}$ $11.5\text{ }\mu\text{A} < I \leq 115\text{ }\mu\text{A}$ $115\text{ }\mu\text{A} < I \leq 1.15\text{ mA}$ $1.15\text{ mA} < I \leq 11.5\text{ mA}$ $11.5\text{ mA} < I \leq 115\text{ mA}$ $115\text{ mA} < I \leq 1\text{ A}$	1 nA 10 nA 100 nA 1 μA 10 μA 100 μA 1 mA 10 mA 100 mA 1 A
HCU	$0 \leq I \leq 1.15\text{ mA}$ $1.15\text{ mA} < I \leq 11.5\text{ mA}$ $11.5\text{ mA} < I \leq 115\text{ mA}$ $115\text{ mA} < I \leq 1.15\text{ A}$ $1.15\text{ A} < I \leq 10\text{ A}$	1 mA 10 mA 100 mA 1 A 10 A
HVU	$0 < I \leq 115\text{ nA}$ $115\text{ nA} < I \leq 1.15\text{ }\mu\text{A}$ $1.15\text{ }\mu\text{A} < I \leq 11.5\text{ }\mu\text{A}$ $11.5\text{ }\mu\text{A} < I \leq 115\text{ }\mu\text{A}$ $115\text{ }\mu\text{A} < I \leq 1.15\text{ mA}$ $1.15\text{ mA} < I \leq 10\text{ mA}$	100 nA 1 μA 10 μA 100 μA 1 mA 10 mA

Fixed Range

The monitor unit measures at the specified range only.

However, the I measurement range is set to the Compliance range if the specified range is greater than the lowest range that includes I compliance. For example, if you specify the 1 A range for HPSMU and the 100 mA range for MPSMU, then the measurement range is always set to the Compliance range, regardless of I compliance.

If the measurement value exceeds the specified measurement range, the measurement data is dummy data (199.999E+99).

Note

The V measurement range is set to the same range as the V output range or V compliance range if the V output range or V compliance range is changed at the **DV**, **DI**, **XE**, or **CL** command execution. Similarly, the I measurement range is set to the same range as I output range or I compliance range if the I output range or I compliance range is changed at the **DV**, **DI**, **XE**, **DZ**, or **CL** command execution. At the measurements, the measurement range is changed according to the specified ranging mode. If you specify compliance range, the measurement range does not change at the measurements.

If the V output range or V compliance range changes, the output of the unit is momentarily set to 0 V.

COMPLIANCE/LIMITER

V/I Compliance

Allowable Units:

HPSMU, MPSMU, HCU, HVU

To prevent damage to the test device due to overcurrent or overvoltage, you can set the HPSMU, MPSMU, HCU, and HVU to I or V compliance. I and V compliance are limiters that can be set with the same resolution and accuracy as output current or output voltage. When using a unit in the V source mode, specify *I compliance*. When using a unit in the I source mode, specify *V compliance*. The following tables list the compliance area and compliance resolution, respectively.

If an output reaches *I* or *V compliance*, that unit acts as a constant I or V source, respectively, and output is maintained at the specified compliance level.

To check whether a source unit reaches *I* or *V compliance* during a measurement, check the measurement data status byte. Refer to the *HP-IB Command Reference Manual* for more details.

When setting compliance, observe the following precautions:

- Do not set *I compliance* too low.
The lower that *I compliance* is, the longer it takes for the settling time.
- Do not set *V compliance* too high, even if you think that damaging high voltage can not occur. A unit will reach *V compliance* if it cannot force the specified current by the following current limitations:
 - 1) Test device.
 - 2) Compliance/limiter of another unit.
 - 3) Limitation of maximum current at the I measurement range of another unit, if the I measurement range is lower than the compliance range. However, this limitation is momentary because the I measurement range automatically changes to the compliance range immediately after this limitation occurs.
- The V measurement range (that is, V measurement resolution) is determined by *V compliance*, and set to the Compliance range.

V/I compliance **Setting Area**

Unit	Output Range	V/I compliance
HPSMU	2 V 20 V ($0 \leq V \leq 14$ V) 20 V ($14 < V \leq 20$ V) 40 V 100 V 200 V	1 pA ¹ to 1 A 1 pA ² to 1 A 1 pA ² to 700 mA 1 pA ² to 350 mA 1 pA ² to 125 mA 1 pA ² to 50 mA
	1 nA ³ 10 nA to 10 μ A 100 μ A to 10 mA 100 mA ($0 \leq I \leq 50$ mA) 100 mA (50 mA $\leq I \leq 115$ mA) 1 A ($0 \leq I \leq 50$ mA) 1 A (50 mA $< I \leq 125$ mA) 1 A (125 mA $< I \leq 350$ mA) 1 A (350 mA $< I \leq 700$ mA) 1 A (700 mA $< I \leq 1$ A)	0 to 200 V 0 to 200 V ⁴ 0 to 200 V 0 to 200 V 0 to 100 V 0 to 200 V 0 to 100 V 0 to 40 V 0 to 20 V 0 to 14 V
MPSMU	2 V 20 V 40 V 100 V	1 pA ¹ to 100 mA 1 pA ² to 100 mA 1 pA ² to 50 mA 1 pA ² to 20 mA
	1 nA ³ 10 nA to 10 μ A 100 μ A to 10 mA 100 mA ($0 \leq I \leq 20$ mA) 100 mA (20 mA $< I \leq 50$ mA) 100 mA (50 mA $< I \leq 100$ mA)	0 to 100 V 0 to 100 V ⁴ 0 to 100 V 0 to 100 V 0 to 40 V 0 to 20 V
HCU	2 V to 20 V	1 μ A to 10 A
	1 mA to 10 A	0 to 10 V
HVU	100 V to 1000 V	1 nA to 10 mA
	100 nA to 10 mA	0 to 1000 V

¹ 2 nA when performing pulsed measurements.

² 20 μ A when performing pulsed measurements.

³ 1 nA range not available when performing pulsed measurements.

⁴ 2 V when performing pulsed measurements.

V/I compliance Resolution

Unit	<i>V/I compliance</i>	Resolution
HPSMU MPSMU	$0 \leq V \leq 2 \text{ V}$ $2 \text{ V} < V \leq 20 \text{ V}$ $20 \text{ V} < V \leq 40 \text{ V}$ $40 \text{ V} < V \leq 100 \text{ V}$ $100 \text{ V} < V \leq 200 \text{ V}$	100 μV 1 mV 2 mV 5 mV 10 mV
	$1 \text{ pA} \leq I \leq 1.15 \text{ nA}$ $1.15 \text{ nA} < I \leq 11.5 \text{ nA}$ $11.5 \text{ nA} < I \leq 115 \text{ nA}$ $115 \text{ nA} < I \leq 1.15 \text{ }\mu\text{A}$ $1.15 \text{ }\mu\text{A} < I \leq 11.5 \text{ }\mu\text{A}$ $11.5 \text{ }\mu\text{A} < I \leq 115 \text{ }\mu\text{A}$ $115 \text{ }\mu\text{A} < I \leq 1.15 \text{ mA}$ $1.15 \text{ mA} < I \leq 11.5 \text{ mA}$ $11.5 \text{ mA} < I \leq 115 \text{ mA}$ $115 \text{ mA} < I \leq 1 \text{ A}$	50 fA 500 fA 5 pA 50 pA 500 pA 5 nA 50 nA 500 nA 5 μA 50 μA
HCU	$0 \leq V \leq 2 \text{ V}$ $2 \text{ V} < V \leq 10 \text{ V}$	200 μV 2 mV
	$1 \text{ }\mu\text{A} < I \leq 1.15 \text{ mA}$ $1.15 \text{ mA} < I \leq 11.5 \text{ mA}$ $11.5 \text{ mA} < I \leq 115 \text{ mA}$ $115 \text{ mA} < I \leq 1 \text{ A}$	100 nA 1 μA 10 μA 100 μA
HVU	$0 \leq V \leq 100 \text{ V}$ $100 \text{ V} < V \leq 200 \text{ V}$ $200 \text{ V} < V \leq 5000 \text{ V}$ $500 \text{ V} < V \leq 1000 \text{ V}$	10 mV 20 mV 50 mV 100 mV
	$1 \text{ nA} \leq I \leq 115 \text{ nA}$ $115 \text{ nA} < I \leq 1.15 \text{ }\mu\text{A}$ $1.15 \text{ }\mu\text{A} < I \leq 11.5 \text{ }\mu\text{A}$ $11.5 \text{ }\mu\text{A} < I \leq 115 \text{ }\mu\text{A}$ $115 \text{ }\mu\text{A} < I \leq 1.15 \text{ mA}$ $1.15 \text{ mA} < I \leq 10 \text{ mA}$	50 pA 500 pA 5 nA 50 nA 500 nA 5 μA

NOTE

For HCU, the specified *V* or *I compliance* is set only during pulse value output. When the HCU forces a base value, the output is fixed to 0 V and the *I compliance* is fixed to 0.1% of the range value of *I* range, regardless of the pulsed *V* or *I* source. The *I* range is the lowest range that includes the *I compliance* for pulsed *V* source, or is the *I* output range for the pulsed *I* source.

Polarity of Compliance

The HP 4142B automatically sets *I compliance* polarity to the same polarity as the output voltage, regardless of the specified *I compliance* polarity.

The HP 4142B automatically sets *V compliance* polarity to the same polarity as the output current, regardless of the specified *V compliance* polarity.

The following figure shows the compliance and output area.

NOTE

The only time V/I compliance automatic polarity setting mode is not valid is when you use the HPSMU or MPSMU and you set *compliance polarity mode* to MANUAL using the **DV** or **DI** command. See the following paragraph, "Manual Setting of Compliance Polarity."

For I compliance, current with the opposite polarity of *I compliance* is limited also. For HPSMU and MPSMU, this opposite polarity value is greater than $|I\ compliance|$ by an amount that is 2% to 10% of the range value in the lowest range that includes *I compliance*.

For HCU, the opposite polarity value is 0.1% of the range value for I range (maximum value is 10 mA at 10 A range). I range is the lowest range that includes *I compliance* for pulsed V source, or is the I output range for pulsed I source.

For HVU, the opposite polarity value is greater than $|I\ compliance|$ by an amount that is 2% of the range value in the lowest range that includes *I compliance*. However, the maximum opposite polarity value is 1 mA.

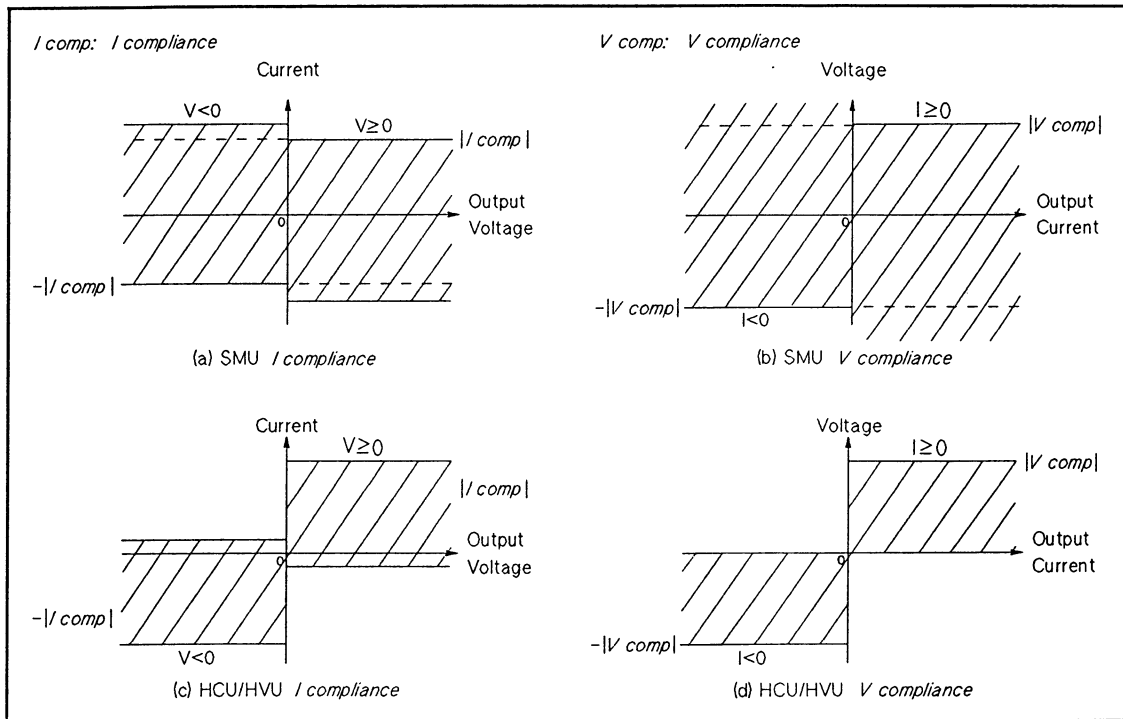

Output Area

The following table lists the compliance polarity for each command.

Compliance Polarity

Source	Setup Command	Compliance Polarity ¹
Constant	DV DI	Same as <i>output voltage</i> ² Same as <i>output current</i> ²
Staircase sweep	WV, WSV WI, WSI	Same as each step voltage Same as each step current
Pulse	PV, PDV PI, PDI	Same as <i>pulse voltage</i> Same as <i>pulse current and base current</i>
Pulsed sweep	PWV	SMU: Same as <i>start pulse voltage</i> HCU: Same as each step pulse voltage
	PWI	SMU: Same as <i>start pulse current and base current</i> HCU: Same as each step pulse current
Search	ASV	Same as <i>search stop voltage</i>
Sense	AVI AIV	Same as <i>output voltage</i> Same as <i>output current</i>
Quasi-Pulse	BDV	Same as <i>stop voltage</i>

¹ For HVU, the compliance polarity is always the same as the output polarity specified by the **POL** command.

For SMU or HCU, if the parameter value(s) = 0, the compliance polarity is positive for the SMU, and the same as the previous polarity for the HCU.

² If you set *compliance polarity mode* to MANUAL, the I compliance polarity you specified is used, regardless of the polarity of the parameter. See the following paragraph, "Manual Setting of Compliance Polarity."

Manual Setting of Compliance Polarity

When you execute the **DI** or **DV** command for the HPSMU or the MPSMU, you can set compliance to the polarity of a specified V or I compliance, regardless of the output voltage polarity. Set the compliance polarity mode to MANUAL. The following figure shows the MANUAL mode compliance and output areas.

In figure (c), $V_{compliance} \geq 0$. If the specified *output current* < 0 , then $V_{compliance}$ is the minimum allowed positive voltage. Negative voltages are not allowed. If the specified *output current* ≥ 0 , then $V_{compliance}$ is the maximum allowed positive voltage. Negative voltages are not limited. In figure (d), $V_{compliance} < 0$. If the specified *output current* < 0 , then $V_{compliance}$ is the maximum allowed negative voltage. Positive voltage is not limited. If the specified *output current* ≥ 0 , then $V_{compliance}$ is the minimum allowed negative voltage. Positive voltages are not allowed.

The following figure shows a measurement example using MANUAL mode.

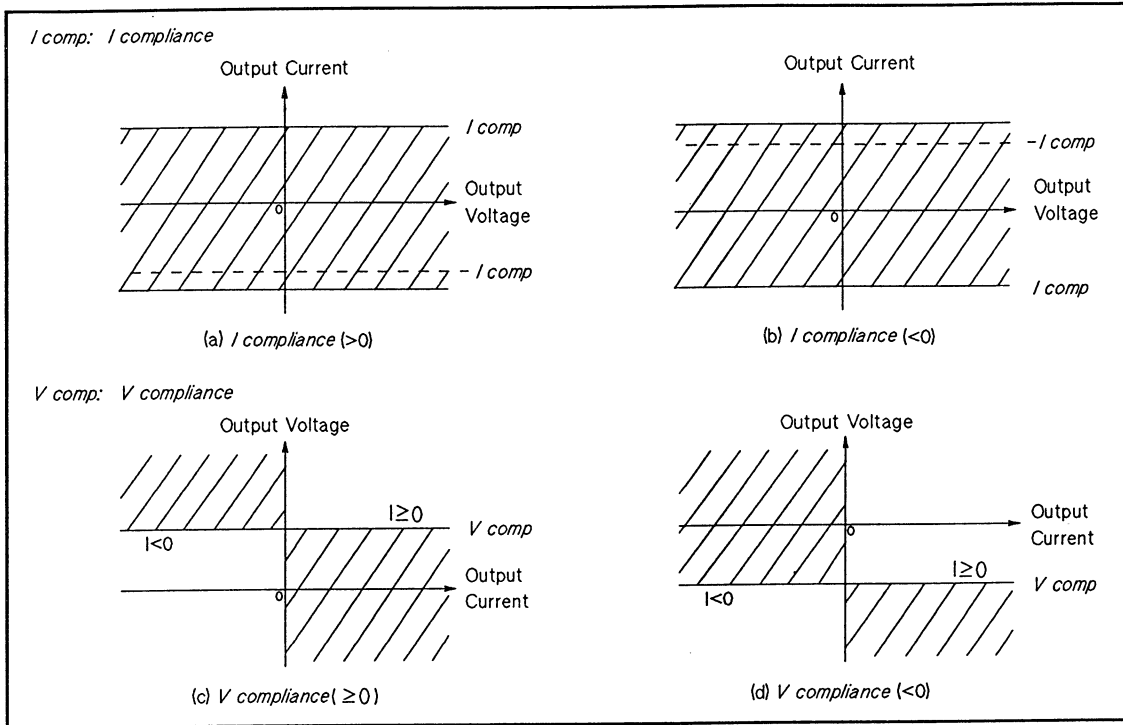

SMU Output Area for Manual Mode Compliance

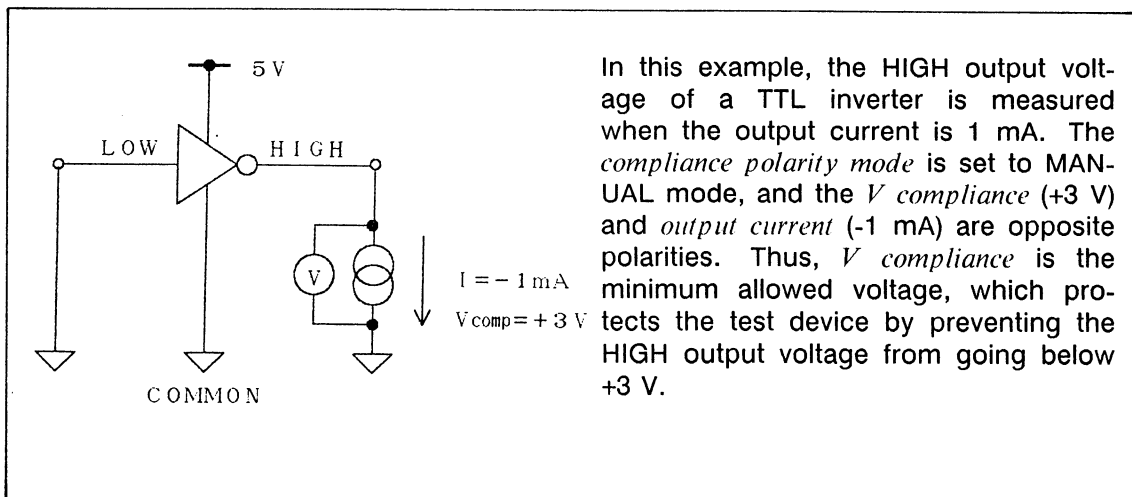

Compliance Polarity MANUAL Mode V Measurement Example

MANUAL MODE V COMPLIANCE CONSIDERATIONS

If you set the *compliance polarity mode* of the DI command to MANUAL, set *V compliance* (Vcomp) as follows. If *V compliance* is not set as follows, the SMU output may be an undesired opposite polarity current (Irev), instead of the desired *output current* (Iset).

- 1) If the specified Iset is positive or zero, set Vcomp more positive than Vrev.
- 2) If the specified Iset is negative, set Vcomp less positive than Vrev.

Vrev is the voltage that occurs at the SMU output terminal when Irev is forced to a test device. $|I_{rev}| = |I_{set}| + |\Delta I|$, where ΔI is 2% to 10% range value of I output range.

The following figure shows the allowable *V compliance* values when the test device (DUT) is a resistor.

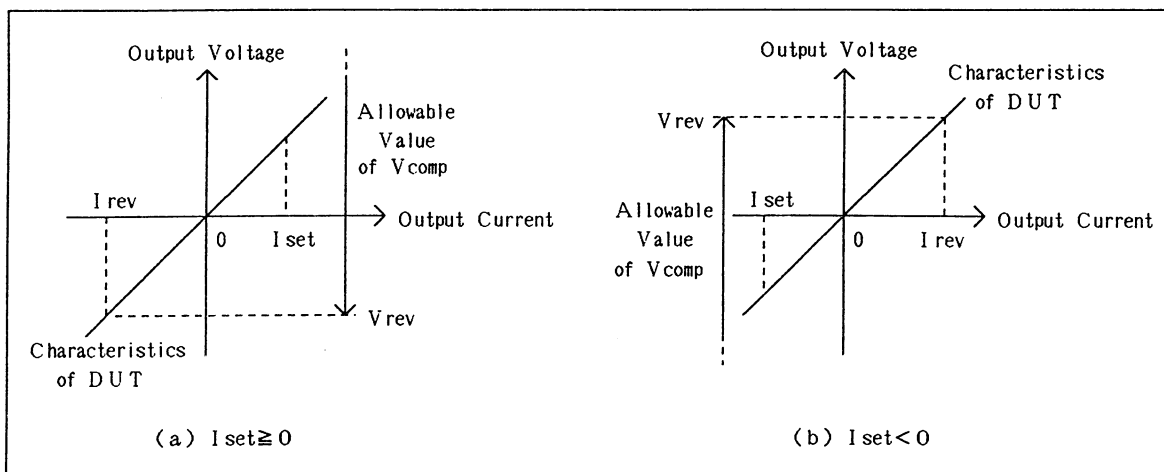

Allowable *V compliance* Values

In the I source mode, the I-V characteristics curve of an SMU is determined by the specified Iset and Vcomp, and consists of the Iset, Vcomp, and Irev lines as shown in the following figure. SMU output depends on the intersection of the I-V characteristic curves of the SMU and the DUT. An SMU forces Iset, Vcomp, or Irev depending on the intersection. To achieve the desired SMU output, specify Vcomp as shown in the above figure.

The following second figure shows how changing Vcomp affects the SMU output when the specified Iset is greater than 0, and the DUT is a resistor:

- (1) If $V_{comp} > V_{rev}$, and the intersection is on the Iset line, as shown in figure (a), the SMU forces Iset.
- (2) If $V_{comp} > V_{rev}$, and the intersection is on the Vcomp line, as shown in figure (b), the SMU forces Vcomp.
- (3) If $V_{comp} < V_{rev}$, and the intersection is on the Irev line, as shown in figure (c), the SMU forces undesirable current Irev.

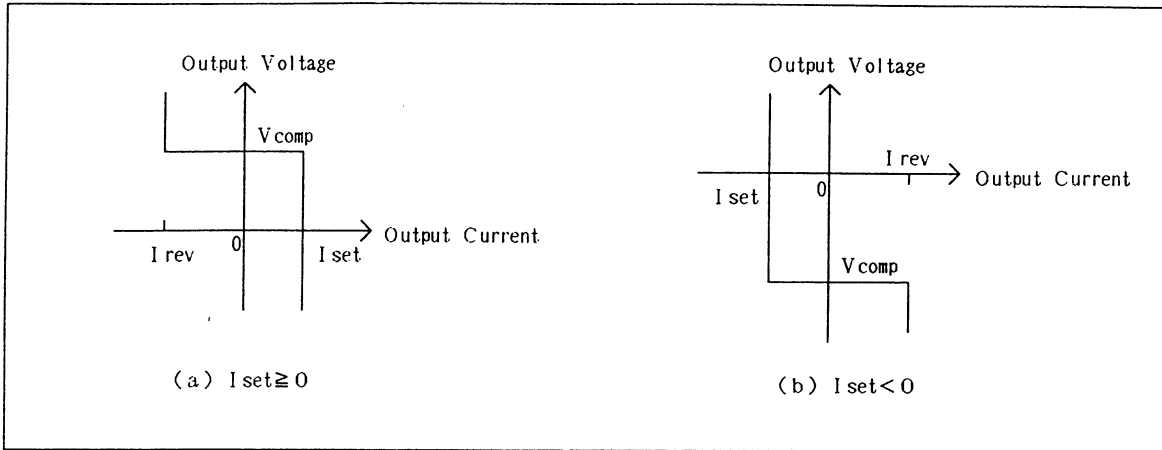

SMU I-V Characteristics Curve

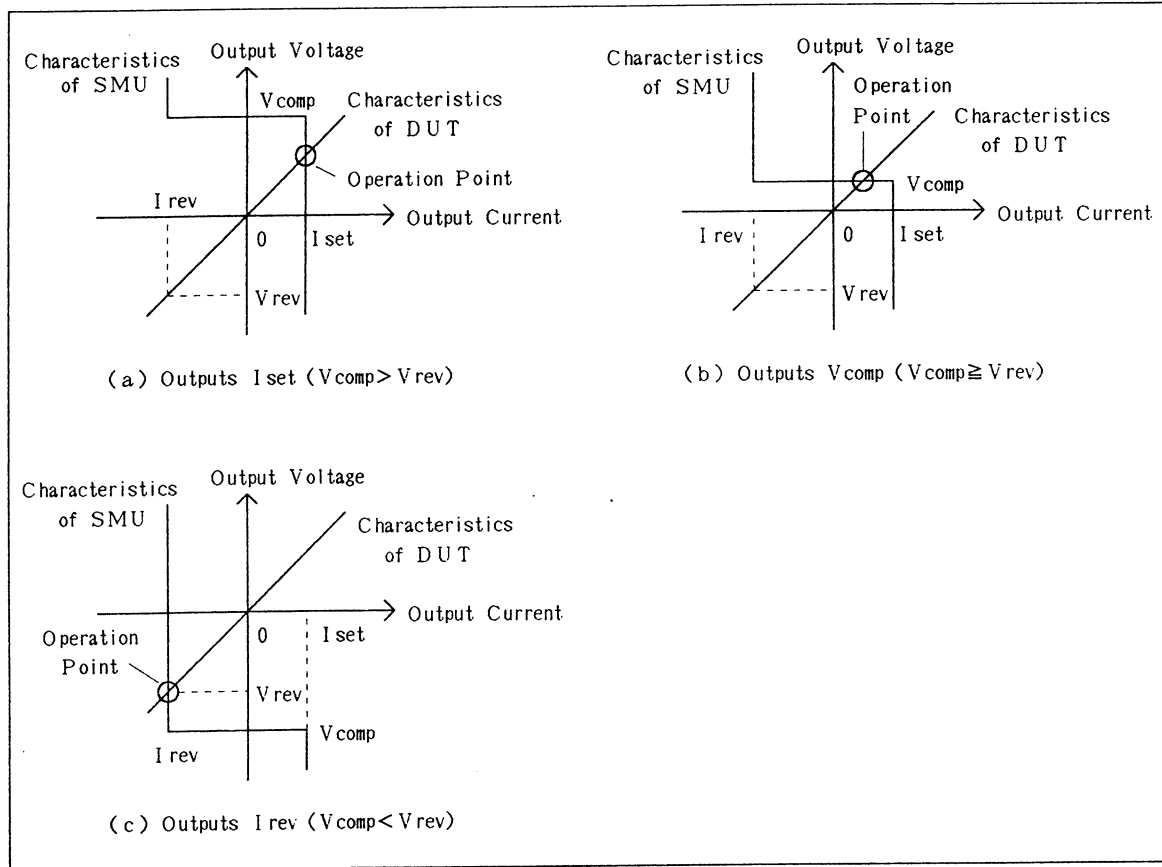

V compliance and SMU Operation

Power Compliance

Allowable Unit:

HPSMU, MPSMU, HVU

Allowable Measurement Mode:

Staircase sweep measurements

When using an SMU or HVU as a staircase sweep source, you can specify *power compliance* in addition to *V compliance* or *I compliance*.

If you specify *I compliance* and *power compliance* for a staircase sweep V source, the HP 4142B changes the I compliance at every voltage step. The I compliance is set to the smaller value of *I compliance* and $(\text{power compliance})/(\text{step voltage})$, as shown in the following figure (a).

If you specify *V compliance* and *power compliance* for a staircase sweep I source, the HP 4142B changes the V compliance at every current step. The V compliance is set to the smaller value of *V compliance* and $(\text{power compliance})/(\text{step current})$ as shown in figure (b).

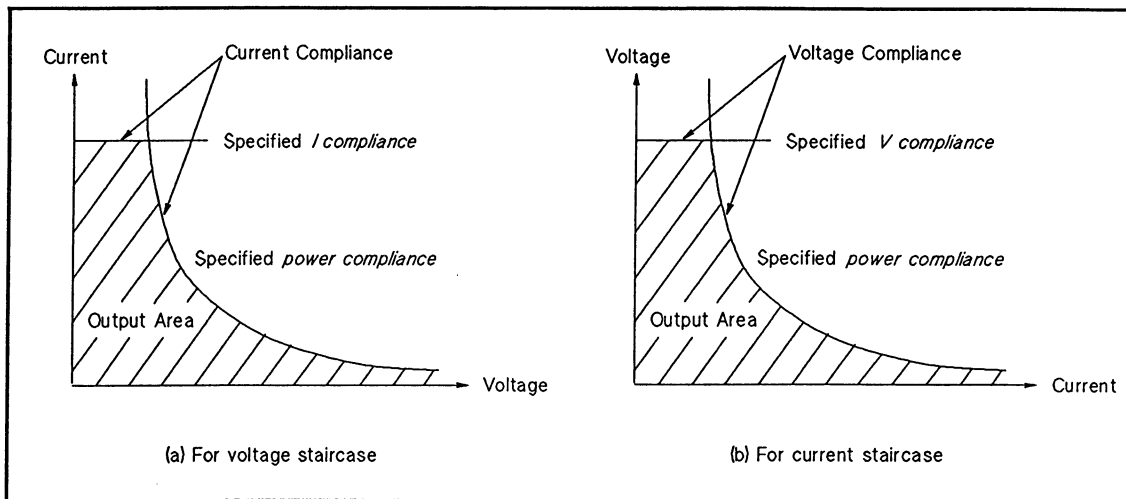

Staircase Sweep Source Power Compliance

If you specify *power compliance* and the staircase sweep source output reaches compliance during a sweep, the sweep stops, the specified *start* value is forced, and an F is displayed in the **ERROR/FAILURE** display. Dummy data (199.999E+99) is returned for measurement points not reached.

If the $(\text{power compliance})/(\text{output value at a step})$ is greater than the maximum SMU output, compliance is set to the maximum SMU output.

If you specify *power compliance*, SMUs can be swept at their maximum output limits because the HP 4142B changes the V output range during a V sweep and changes the V compliance (V compliance range) during an I sweep. The following figure shows an example of the difference in SMU output when *power compliance* is set and when *power compliance* is not set.

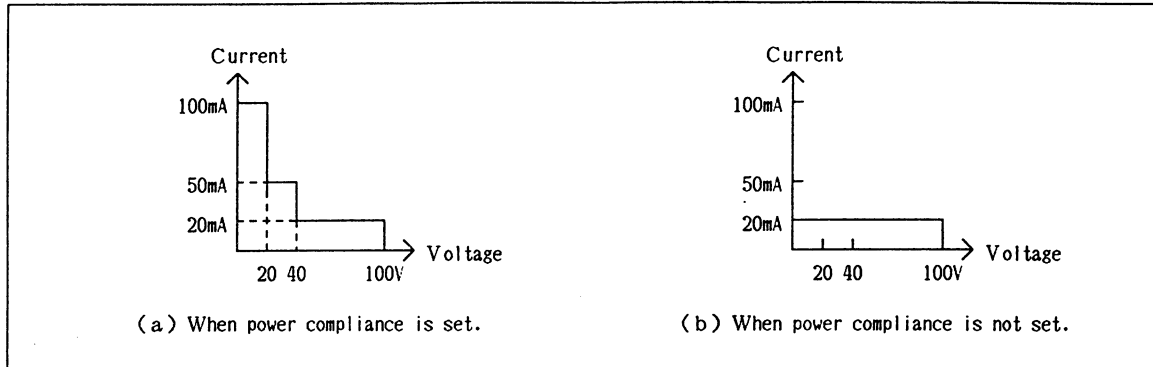

Allowable I Output when the MPSMU sweeps voltages from 0 V to 100 V

NOTE

If you specify *power compliance*, the measurement time increases slightly because the HP 4142B adjusts V or I compliance for every sweep step to accommodate *power compliance*.

If you specify *power compliance*, the V output range or V compliance range of the SMU may change during a sweep. In this case, the SMU output is momentarily set to 0 V.

Limiters

Allowable Unit:

VS

The VS has an I limiter. The limiter value is automatically determined by the V output range. If output range = 20 V, then I limit = 100 mA. If the output range = 40 V, then I limit = 20 mA.

AVERAGING

Allowable Unit:

HPSMU, MPSMU, HCU, HVU, and VM

Allowable Measurement Mode:

Spot / Staircase sweep / Analog search / Quasi-pulsed spot / High speed spot measurements

To minimize the possibility of reduced HP 4142B measurement accuracy due to line frequency noise or other environmental noise, use the **AV** command to perform averaging. The averaging function of the HP 4142B arithmetically averages the results of two or more samples (A/D conversions). The **AV** command provides three averaging modes--AUTO, MANUAL, or POWER LINE CYCLE--as described in the following paragraphs.

AUTO Mode:

In the AUTO mode, the actual number of samples taken and averaged for a measurement is determined by the following expression:

$$\text{number of samples} = (\text{required minimum samples})(\text{averaging number})$$

where *averaging number* is the value specified in the **AV** command, and the required minimum sample is the minimum number of samples required to assure an accurate HP 4142B measurement. If you specify 1 for the *averaging number*, the HP 4142B performs the required minimum samples. For V measurements, the required minimum samples is 1. For SMU or HVU I measurements, the required minimum samples depends on the V output range and I measurement range as listed in the following two tables, respectively. The initial settings for averaging are *averaging number* = 1, *averaging mode* = AUTO.

Measurement times increase approximately 240 μs for each additional sample.

Required Minimum Samples for SMU I Measurements

		V Output Range ¹		
		2 V, 20 V, 40 V	100 V	200 V
I Meas. Range	1 nA to 10 μA	4	10	25
	100 μA to 1 A	1	1	1

¹ If the SMU is in I source mode, the V output range is the lowest range that includes V compliance.

Required Minimum Samples for HVU I Measurements

		V Output Range ¹		
		100 V	200 V	500 V, 1000 V
I Meas. Range	100 nA to 10 μ A	10	25	25
	100 μ A	4	6	10
	1 mA, 10 mA	1	1	1

¹ If the HVU is in I source mode, the V output range is the lowest range that includes V compliance.

MANUAL Mode:

In the MANUAL mode, the number of samples taken and averaged for a measurement is determined by the following expression.

$$\text{number of samples} = \text{averaging number}$$

Where *averaging number* is the value specified in the **AV** command. If you specify 1 for the *averaging number*, only 1 sample is taken for the measurement. To assure an accurate HP 4142B measurement, the *averaging number* you specify should be greater than or equal to the required minimum samples defined by the AUTO mode.

In the AUTO or MANUAL mode, measurement times increase approximately 240 μ s for each additional sample.

POWER LINE CYCLE (PLC) Mode:

In the PLC mode, 32 samples are taken for each line frequency period (50 Hz: 20 ms, 60 Hz: 16.67 ms) specified in the **AV** command. To set to this mode, specify the *averaging number* with a negative number. Number of power line cycles is determined by the following expression:

$$\text{number of power line cycles} = - (\text{averaging number})$$

For example, if 3 periods are specified, 96 samples are taken and averaged for the measurement.

Before the measurements, make sure the **FILTER** switch on the rear panel is set to the correct line frequency.

NOTE

During sweep measurements, averaging settings can be changed using the **AV** command.

FILTER

Allowable Unit:

HPSMU, MPSMU, and HVU

Each SMU and HVU provides a low-pass filter (LPF) at the digital-to-analog converter (DAC) output. When the DAC output changes, a spike generally occurs. DAC output changes when the output value, compliance value, or output range changes. If the filter is ON, the spike is reduced to 1/30 of its unfiltered value.

For the SMU, the output overshoot becomes 0.03% (typically) of the range value in the range.

For the HVU, the spike is reduced to 1/30 only when the changed voltage difference is less than or equal to 10 V. When the voltage difference is greater than 10 V, there is no difference in the spike value whether the filter is on or off.

However, the unit (SMU or HVU) settling time may be longer. If the filter is ON, the unit settling time is 600 μ s to 546 ms. If the filter is OFF, the unit settling time is 50 μ s to 546 ms. The settling time of each depends on output value, output range, and compliance. The initial setting of the filter is ON, and can be set to ON or OFF using the FL command.

When a filter is ON, the output wait time is set to the unit settling time (600 μ s to 546 ms). When a filter is OFF, the output wait time is set to the unit settling time if the unit settling time (50 μ s to 546 ms) is 5 ms or less. If the unit settling time is greater than 5 ms, the output wait time is set to 5 ms. When a filter is set to OFF, wait for the unit settling time before making a measurement. Setting multi-channel output is usually much faster when filters are OFF because the maximum wait time between output settings is 5 ms versus 546 ms when the filter is on.

NOTE

- When a filter is set to OFF, the DAC output settling time is 1/40 of the filter ON value. However, the actual settling time at the output terminal is limited by the slew rate, and thus is greater than the DAC output settling time. The slew rate depends on the test device, output range, and compliance value. The filter OFF output terminal settling time is still less than the filter ON value. For example, if the two following conditions apply, the filter OFF value is less than 50% of the filter ON value.

For SMU:

Voltage difference:	less than or equal to 50 V
I Compliance:	greater than or equal to 1 mA

For HVU:

Voltage difference:	less than or equal to 10 V
I Compliance:	greater than or equal to 100 μ A

If the above conditions do not apply, the filter OFF value will be 50% to 100% of the filter ON value.

- When using an SMU or HVU as a pulse source, set the filter of that unit to OFF (to enable pulse output). The initial setting of the filter is ON.

AUTOMATIC SWEEP ABORT FUNCTION

Allowable Measurement Mode:

Staircase sweep / Staircase sweep with pulsed bias / Pulsed sweep / Pulsed sweep with pulsed bias measurements

To reduce sweep time and to prevent damage to the test device during sweep measurements, the *automatic sweep abort function* parameter of the **WM** command aborts a sweep if any of the following conditions occur:

- 1) If the output reaches *V compliance*, *I compliance*, or *I limit*.
- 2) If a measurement value exceeds the specified measurement range.
- 3) If an SMU or HVU oscillates.

If a sweep aborts, the staircase sweep source forces the specified *start value*, the pulsed source and pulsed sweep source force the specified *base* value. An **F** is displayed in the **ERROR/FAILURE** display, and dummy data (199.999E+99) is returned for measurement points not reached.

NOTE

For staircase sweep measurements: if you set *power compliance* and the output of the unit that you set *power compliance* reaches *power compliance*, *V compliance*, or *I compliance*, the HP 4142B automatically stops the measurement, even if you do not specify *automatic sweep abort function*.

If the HP 4142B receives an abort (**AB**) command, only the measurement data obtained before the sweep was aborted is stored in the output data buffer (dummy data is not stored).

OUTPUT AFTER SWEEP

Allowable Measurement Mode:

Staircase sweep / Staircase sweep with pulsed bias measurements

After staircase sweep or staircase sweep with pulsed bias measurements, you can set the output of staircase sweep source to either *start* value or *stop* value by the *output after sweep* of the **WM** command.

However, if the sweep is stopped by *power compliance*, *automatic sweep abort function*, or **AB** command, the *start* value is forced regardless of the *output after sweep* setting.

MEASUREMENT DATA MEMORY

When the HP 4142B performs a measurement, measurement data are stored in the internal output data buffer. Output data buffer size is 16383 bytes. The maximum number of data that can be stored in the output data buffer depends on the data format specified by the **FMT** command as follows.

- ASCII data with header (15 bytes) and "CR/LF^EOI" terminator (2 bytes): (default)
 - Spot measurement: Max. 963 data
 - Sweep measurement: Max. 1023 data
- ASCII data without header (12 bytes) and "," terminator (1 byte):
 - Spot measurement: Max. 1023 data
 - Sweep measurement: Max. 1023 data
- ASCII data without header (12 bytes) and "CR/LF^EOI" terminator (2 bytes):
 - Spot measurement: Max. 1170 data
 - Sweep measurement: Max. 1260 data
- BINARY data (4 bytes) and "CR/LF^EOI" terminator (2 bytes):
 - Spot measurement: Max. 2730 data
 - Sweep measurement: Max. 4095 data
- BINARY data (4 bytes) and "^EOI" terminator (0 byte):
 - Spot measurement: Max. 4095 data
 - Sweep measurement: Max. 4095 data

For more information about measurement data format, see the *HP-IB Command Reference Manual*.

The data buffer sends measurement data in the order in which it was stored. Therefore, if you transfer the measurement data after you perform the measurement twice, first measurement data is transferred from the HP 4142B first. If there is an output data buffer overflow, new measurement data is not stored and existing measurement data is maintained. Clear the output data buffer with the **BC** command. You can also clear it with the **FMT**, ***RST**, Device Clear, or by turning the HP 4142B off.

PROGRAM MEMORY

HP-IB commands can be stored locally in the internal program memory of the HP 4142B. Program memory size is 20k bytes, enabling you to store approximately 2000 commands. The commands stored in program memory can be grouped into as many as 99 programs. Because the programs are stored locally in the HP 4142B instead of in the controller, the following steps are eliminated, thus increasing execution speed.

- 1) Command transmission:
Transmission of commands from the controller to the HP 4142B.
- 2) Command validation:
Checking the syntax and content of transmitted commands.
- 3) Internal code conversion:
Conversion of commands to the internal code of the HP 4142B.

For example, **DV** command execution time can be reduced by about 1 ms if the **DV** command is stored in internal program memory. Also, if frequently used command strings are stored in internal program memory, bus/controller activity is reduced to a minimum.

The following table lists the HP-IB commands that can be stored in program memory, and the number of bytes required for each command.

HP-IB Commands Allowed in Internal Program Memory (1 of 2)

HP-IB Command	Optional Parameters	No. of Bytes ¹
AIV	0	12
	1	14
ASM	0	4
	1	6
ASV	0	10
	1	12
	2	16
AT	---	6
AV	0,1	6
AVI	0	12
	1	14
BC	---	2
BDM	---	4
BDT	---	6
BDV	0	10
	1	14
CL	0,2,4,6,8	2+n
	1,3,5,7	2+(n+1)
CN	0,2,4,6,8	2+n
	1,3,5,7	2+(n+1)
DI	0	8
	1	12
DO	0,2,4,6	4+n
	1,3,5,7	4+(n-1)
DV	0	8
	1	12
DZ	0,2,4,6,8	2+n
	1,3,5,7	2+(n+1)
ERC	---	6
FL	1,3,5,7	4+(n-1)
	0,2,4,6,8	4+n
FMT	0,1	4
IN	0,2,4,6,8	2+n
	1,3,5,7	2+(n+1)
MM	1,3,5,7	4+(n-1)
	0,2,4,6,8	4+n
OS	---	2
PA	0,1	6
PDM	0	2
	1	4
PDI	0	10
	1	14
PDV	0	10
	1	14

¹ Where *n* is the number of optional parameters used in the command.

HP-IB Commands Allowed in Internal Program Memory (2 of 2)

HP-IB Command	Optional Parameters	No. of Bytes ¹
PI	0	10
	1	14
POL	---	4
PT	0,1	8
PV	0	10
	1	14
PWI	0	14
	1	18
PWV	0	14
	1	18
RI	---	6
RU	---	4
RV	---	6
RZ	0,2,4,6,8	$2+n$
	1,3,5,7	$2+(n+1)$
TI	0,1	6
TM	---	4
TV	0,1	6
VM	---	4
WI	0	14
	1	18
	2	20
WM	0,1	4
WS	0,1	4
WSI	0	14
	1	18
	2	20
WSV	0	14
	1	18
	2	20
WT	---	6
WV	0	14
	1	18
	2	20
XE	---	2
*SRE	---	4

¹ Where n is the number of optional parameters used in the command.

Using Program Memory

The following paragraphs describe how to store, execute, list, and scratch programs using the program memory function. See *HP-IB Command Reference Manual* for details on each command.

Storing Programs

Use the **ST** and **END** commands to store a program. The **ST** command indicates the start of the program and assigns its program number (*program#* is an integer from 1 to 99). Following the **ST** command, enter the desired HP-IB commands in the order you want them executed. Use the **END** command to indicate the end of a program. The HP 4142B continues to store HP-IB commands until the **END** command is received or until a memory overflow.

NOTE

If program memory overflows while storing a program, an **F** displays on the **ERROR/FAILURE Display**.

Executing Programs

To execute a stored program, use the **RU** or **DO** command with the *program#*.

- 1) Use the **RU** command with *start program#* and *stop program#* to execute a series of programs. For example, if **RU1,5** is sent to the HP 4142B, *program#1* through *program#5* executes in sequence.
- 2) Use the **DO** command to execute programs in a specified order. For example, if **DO2,5,4** is sent to the HP 4142B, these programs execute in this order: *program#2*, *program#5*, and *program#4*. You can specify up to eight programs for each **DO** command.

Listing Programs

Use the **LST?** command with the *program#* to place a program list in the output buffer. You can then read the program list using the controller.

Scratching (Deleting) Programs

Use the **SCR** command with a *program#* to scratch a program from program memory. If you do not specify a *program#* with the **SCR** command, all programs in program memory are scratched. If you store a new program using the same *program#* as an existing program, the old program is scratched and the new program is stored.

NOTE

Program memory is cleared only by the **SCR** command and when the HP 4142B is turned OFF. ***RST** and Device Clear (HP BASIC **CLEAR**) commands do not clear program memory.

Program Memory Sample Program

The following is a sample program for using the program memory function. A description of key program lines follows the program list.

Program List

```
10  ! SAMPLE PROGRAM FOR PROGRAM MEMORY
20  !
30  OPTION BASE 1
40  INTEGER B_ch, C_ch
50  DIM A$(7)[15], Exit$(1)
60  ASSIGN @Hp4142 TO 717
70  OUTPUT @Hp4142;"*RST"
80  !
90  B_ch=3           ! Emitter      : GNDU
100 C_ch=2          ! Base        : Ch#3
110 !
120 OUTPUT @Hp4142;"ST";1
130 OUTPUT @Hp4142;"DV";B_ch, 0, -3, 1.E-7      ! Vb=-3V
140 OUTPUT @Hp4142;"DV";C_ch, 0, 30, 1.E-7     ! Vc=30V
150 OUTPUT @Hp4142;"TI";C_ch, 0                ! Icev Measurement
160 OUTPUT @Hp4142;"TI";B_ch, 0                ! Ibev Measurement
170 OUTPUT @Hp4142;"END"
180 !
190 OUTPUT @Hp4142;"ST";2
200 OUTPUT @Hp4142;"DI";C_ch, 0, 1.E-2, 2      ! Ic=10mA
210 OUTPUT @Hp4142;"DI";B_ch, 0, 1.E-3, 2     ! Ib=1mA
220 OUTPUT @Hp4142;"TV";C_ch                  ! Vce(sat) Measurement
230 OUTPUT @Hp4142;"TV";B_ch                  ! Vbe(sat) Measurement
240 OUTPUT @Hp4142;"END"
250 !
260 OUTPUT @Hp4142;"ST";3                      ! Early Voltage
Measurement
270 OUTPUT @Hp4142;"DI";B_ch, 0, 2.E-5, 2      ! Ib=20uA
280 OUTPUT @Hp4142;"DV";C_ch, 0, 2, 1.E-2     ! Vc1=2V
290 OUTPUT @Hp4142;"TI";C_ch                  ! Ic1 Measurement
300 OUTPUT @Hp4142;"DV";C_ch, 0, 6           ! Vc2=6V
310 OUTPUT @Hp4142;"TI";C_ch                  ! Ic2 Measurement
320 OUTPUT @Hp4142;"END"
330 !
340 OUTPUT @Hp4142;"ST";4
350 OUTPUT @Hp4142;"DI";B_ch, 12, 0, 2        ! Ib=0A
360 OUTPUT @Hp4142;"DI";C_ch, 0, 1.E-3, 70    ! Ic=1mA
370 OUTPUT @Hp4142;"TV";C_ch                  ! BVceo Measurement
380 OUTPUT @Hp4142;"END"
390 !
400 OUTPUT @Hp4142;"ST";5
410 OUTPUT @Hp4142;"DZ"
420 OUTPUT @Hp4142;"END"
430 !
```

```

440 OUTPUT @Hp4142;"CN";B_ch, C_ch
450 LOOP
460   OUTPUT @Hp4142;"RU";1, 5
470   ENTER @Hp4142 USING "#, 15A, 2X";A$(*)
480   PRINT "Icev=           ";A$(1)[4, 15]
490   PRINT "Ibev=           ";A$(2)[4, 15]
500   PRINT "Vce(sat)=       ";A$(3)[4, 15]
510   PRINT "Vbe(sat)=       ";A$(4)[4, 15]
520   Ic1=VAL(A$(5)[4, 15])
530   Ic2=VAL(A$(6)[4, 15])
540   Vc1=2
550   Vc2=6
560   Va=(Vc1*Ic2-Ic1*Vc2)/(Ic2-Ic1)
570   PRINT "Early Voltage=      "PROUND(Va, -2)
580   PRINT "BVceo=           "A$(7)[4, 15]
590   PRINT
600   !
610   INPUT "Set the next device and hit ""Return"" key to continue, or enter
""E"" to stop", Exit$
620   EXIT IF Exit$="E"
630   END LOOP
640   !
650   OUTPUT @Hp4142;"CL"
660   BEEP
670   END

```

Result

```

Icev=           +000.272E-09
Ibev=           -0.07796E-09
Vce(sat)=       +0.06760E+00
Vbe(sat)=       +0.74656E+00
Early Voltage=  -160
BVceo=          +058.368E+00

```

Description

```

120-170   Stores program#1 in HP 4142B memory.
190-240   Stores program#2 in HP 4142B memory.
260-320   Stores program#3 in HP 4142B memory.
340-380   Stores program#4 in HP 4142B memory.
400-420   Stores program#5 in HP 4142B memory.
440       Sets the output switches to ON.
460       Executes the the five programs.
470       Enters measurement data into the string array variable, A$.
480-590   Displays the measurement results.
610-620   Decides whether to exit or continue.
650       Sets the output switches to OFF.

```

USING THE HP 4142B WITH EXTERNAL INSTRUMENTS

The HP 4142B can perform measurements synchronized with external instruments, such as C meters, precision voltmeters/ammeters, probers, and handlers, via the rear panel **TRIGGER INPUT** and **TRIGGER OUTPUT** terminals. The following paragraphs describe how to synchronize external instruments with the HP 4142B to perform measurements.

Trigger Output and Input Function

You can trigger external instruments from the HP 4142B via the **TRIGGER OUTPUT** terminal. You can initiate HP 4142B operation via the **TRIGGER INPUT** terminal, as described in the following paragraphs. The following figure shows the connection of the HP 4142B and an external instrument. The figure also shows the trigger output waveform from the **TRIGGER OUTPUT** terminal, and the trigger input waveform conditions. For trigger input, the HP 4142B is triggered by a negative-going (HIGH to LOW) TTL level trigger.

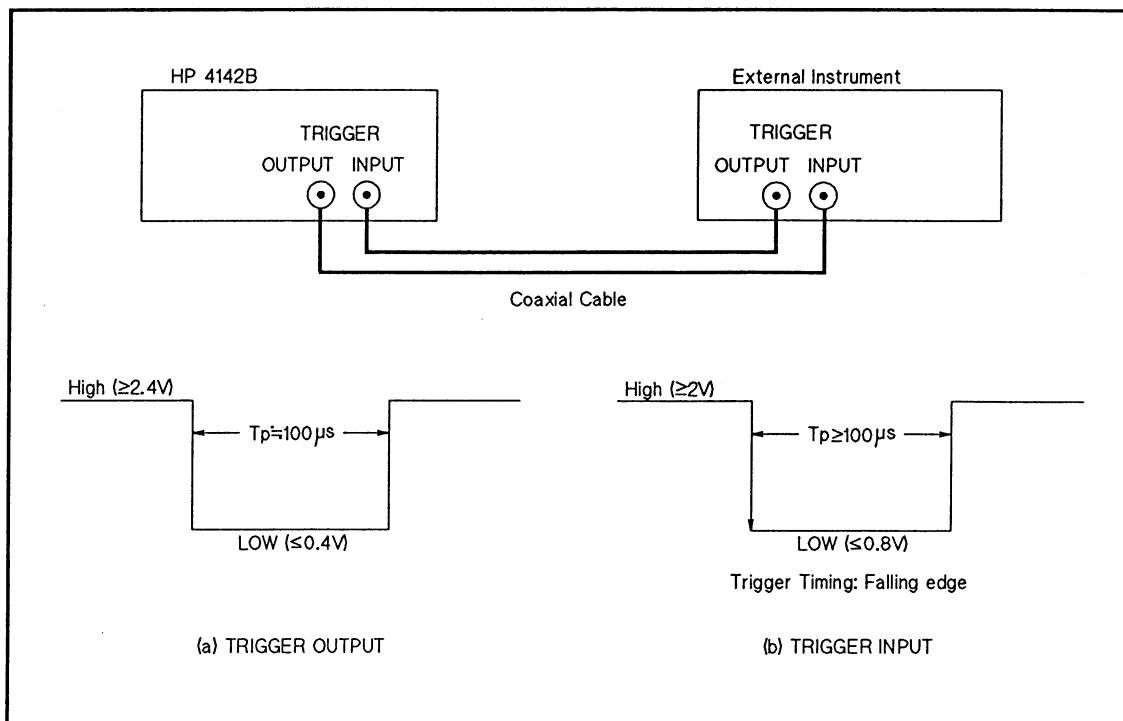

Trigger Output and Input

Triggering an External Instrument

To trigger an external instrument from the HP 4142B, execute the **OS** command. When the HP 4142B receives the **OS** command, the HP 4142B sends a trigger signal from **TRIGGER OUTPUT** terminal.

Externally Triggered HP 4142B Measurements

To externally trigger the HP 4142B to perform only measurements, set the *trigger mode* parameter of the **TM** command to 3. The HP 4142B performs a measurement when it receives a negative-going (HIGH to LOW) TTL level trigger.

To pause program execution until the HP 4142B receives a trigger and completes measurements, include an **ENTER** statement of the HP BASIC in your measurement program. The **ENTER** statement pauses program execution until measurement data is entered into the measurement data buffer. Then, the **ENTER** statement reads the data, and program execution continues.

When an externally triggered HP 4142B measurement is complete, the HP 4142B automatically sends a trigger signal from the **TRIGGER OUTPUT** terminal.

Waiting for Trigger Signal from TRIGGER INPUT Terminal

The **WAIT** state (**WS**) command waits for a negative-going (HIGH to LOW) TTL level trigger signal via the **TRIGGER INPUT** terminal.

You can cause the execution of the commands following the **WS** (for example, V/I source or measurement commands) to wait until an external instrument completes its operation and triggers the HP 4142B.

WS signals the HP 4142B CPU to check the software **TRIGGER** flag to determine whether an external trigger has been received (**TRIGGER** flag **SET**) or not (**TRIGGER** flag **RESET**). The **TRIGGER** flag is **SET** when the HP 4142B receives an external trigger. The **TRIGGER** flag is **RESET** when any of the following occur:

- If ***RST** or Device Clear executes.
- If **TM3** executes.
- If **TM** *trigger mode* is changed from 3 to another mode.
- If **OS** executes.
- After a **WS** **WAIT** state completes.
- If the trigger signal via the **TRIGGER INPUT** terminal triggers the measurements.

WS provides two **WAIT** states--*waiting mode* parameters 1 and 2--as follows:

WS1 (default):

If the **TRIGGER** flag is **SET** when **WS1** is executed, the HP 4142B continues operation without waiting. If the **TRIGGER** flag is **RESET**, HP 4142B operation waits until an external trigger is received before continuing operation.

WS2:

When **WS2** executes, the HP 4142B operation waits--regardless of whether the **TRIGGER** flag is **SET** or **RESET**--and continues operation when the next external trigger is received.

Include the **WS** command in your measurement program immediately following the **OS** command. When **OS** executes, the HP 4142B triggers an external instrument to perform its operation. When the external instrument completes an operation, it triggers the HP 4142B, which is set to a WAIT state by **WS**, to perform its operation. Using **OS** and **WS** together, therefore, ensures that the HP 4142B and external instrument operations do not overlap.

If you want to end a WAIT state, execute the **AB** or ***RST** command. If you first send any other commands while the HP 4142B is in the WAIT state, the WAIT state ending commands are not effective because the command input buffer is full. In this case, use the Device Clear (**CLEAR** command in HP BASIC) to end the WAIT state.

NOTE

An external trigger can end a WAIT state independent of the *trigger mode* set by the **TM** command. To reduce programming complexity when using the **WS** command, set the **TM** command *trigger mode* to 1, 2, or 4. In **TM3**, WAIT state programming is complex because an external trigger signal can cause either of the following to occur:

Case 1--The HP 4142B is in a WAIT state when the external trigger is received.
The HP 4142B ends the WAIT state.

Case 2--The HP 4142B is not in a WAIT state when the external trigger is received.
The HP 4142B performs the measurement.

Waiting for Time or Trigger

Use the **PA** command to pause command execution or internal memory program execution. The pause lasts until the specified *wait time* has elapsed, or until a trigger is received (**XE** command, and **MM** command, HP BASIC **TRIGGER** command, or the external trigger signal from **TRIGGER INPUT** terminal specified by the **TM** command). The trigger only releases the wait status and does not perform the measurements. The *wait time* setting area is from 0 to 99.9999s (100 μ s resolution).

If you send the **PA** command without a *wait time* parameter, you can pause until a trigger is received.

Waiting for Command Execution Completion (*OPC? Command)

Use the ***OPC?** query command to wait for the completion of the previous command execution before sending a command to the external instrument. This command tells the HP 4142B to return a **1** to the HP 4142B query buffer. The measurement program then reads the contents of the query buffer (via the **ENTER** statement). A **1** in the query buffer indicates that the HP 4142B has executed the ***OPC?** command, that is, the HP 4142B has completed the previous command execution. In effect, the ***OPC?** command serves to delay external instrument operation until the HP 4142B has completed its operation.

For example, refer to the following program segment and assume that you're forcing current from the HP 4142B, and measuring voltage via an external voltmeter, such as the HP 3457A. By including the ***OPC?** command immediately after the I forcing (**DI**) command, then by reading the contents of the query buffer with the **ENTER** statement, the measurement program waits until the query buffer is set to **1** before performing a measurement with the HP 3457A.

```
OUTPUT 717;"DI";1,0,1.0E-10,1
OUTPUT 717;"*OPC?"
ENTER 717; A$
OUTPUT Hpib;"DCV"
```

(Hpib: HP-IB address of the HP 3457A)

(**DCV** command: V measurement command of the HP 3457A)

NOTE

If you do not include the ***OPC?** command in your measurement program(s) to confirm HP 4142B operation completion, an external instrument may initiate operation prematurely.

RELAY CONTROL (OPTION 300)

This paragraph describes the **CONTROL** connector that is furnished with Option 300.

Module Selector Control

The **CONTROL** (25-pin) connector is used to connect the HP 4142B and the Module Selector (HP 16087A or HP 16088B Option 300). Each module selector selects one output from among the SMU, HCU, and HVU by the control signal from the **CONTROL** connector as follows. You can automate the measurement from low voltage/current to high voltage/current. For more information about the HP 16087A and HP 16088B, see Chapter 3.

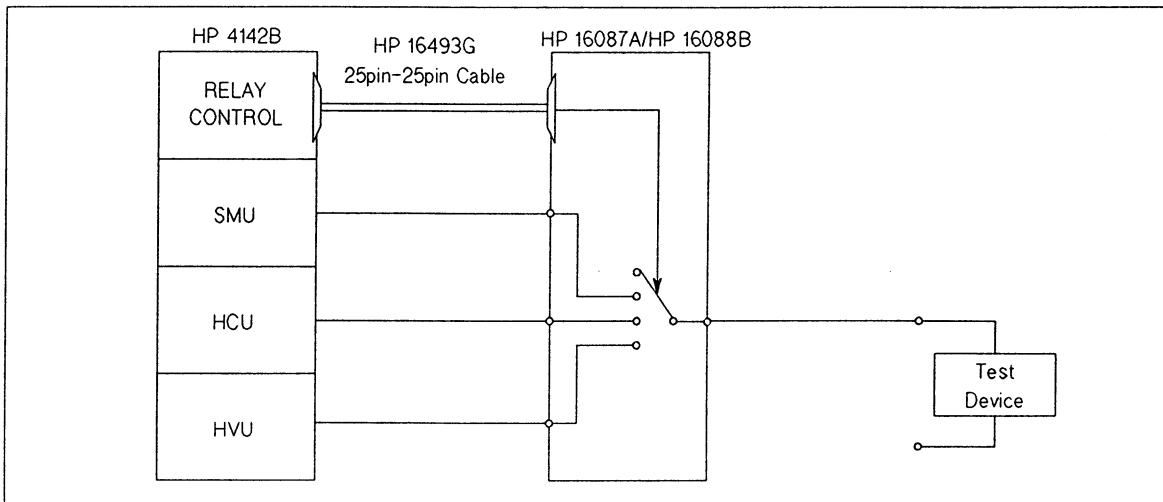

Module Selector Control

By using the **ERC** command as follows, you can select SMU, HVU, HCU, Open (no connection, initial setting).

For SMU: OUTPUT 717;"ERC";1,1
For HVU: OUTPUT 717;"ERC";1,2
For HCU: OUTPUT 717;"ERC";1,3
For Open: OUTPUT 717;"ERC";1,0

When you send the **ERC** command, the HP 4142B automatically sets all source unit outputs to zero (same as the conditions after a **DZ** command execution), changes the connection, then returns all outputs to the settings before receiving the **ERC** command.

External Relay Control

The **CONTROL** connector also has 16-bit TTL digital output pins for controlling relays. The bit(s) specified by the *control value* parameter of the **ERC** command are set to low, and not specified bit(s) are set to high. In the initial setting, all bits are high. The following figure shows the pin assignments of the **CONTROL** connector. The pins for external relay control are pin numbers 1 to 8, and 14 to 21, from Bit 0 to Bit 15. The pin numbers are marked on the **CONTROL** connector.

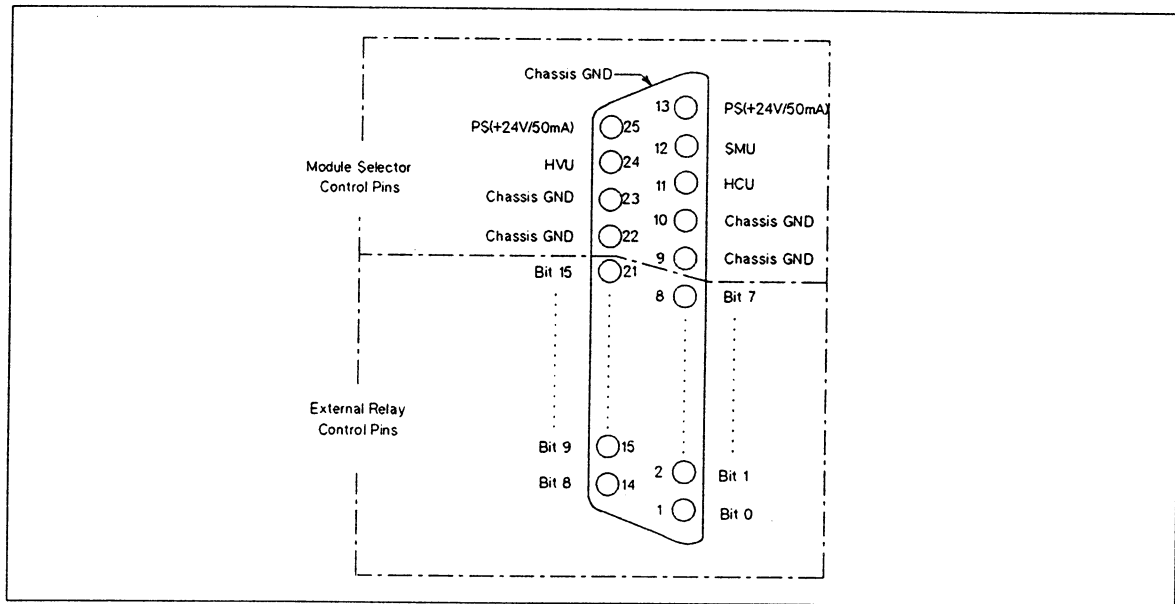

Pin Assignment of the CONTROL Connector

The following figure shows an example that switches three test devices with the relays. As a power supply (about 20 V) for driving relays, an external power supply or HP 4142B source unit (for example, VS) is required. To turn the relay on, you set the bit to low. To turn the relay off, you set the bit to high.

The figure also shows the output circuit of each bit. The specifications are:

- Maximum input voltage at high: 20 V
- Maximum input current at low: 50 mA
- Maximum output voltage at low: 0.7 V (at input current 50 mA)
- Maximum output voltage at high: 4.5 V (pull-up resistor: 10 k Ω)

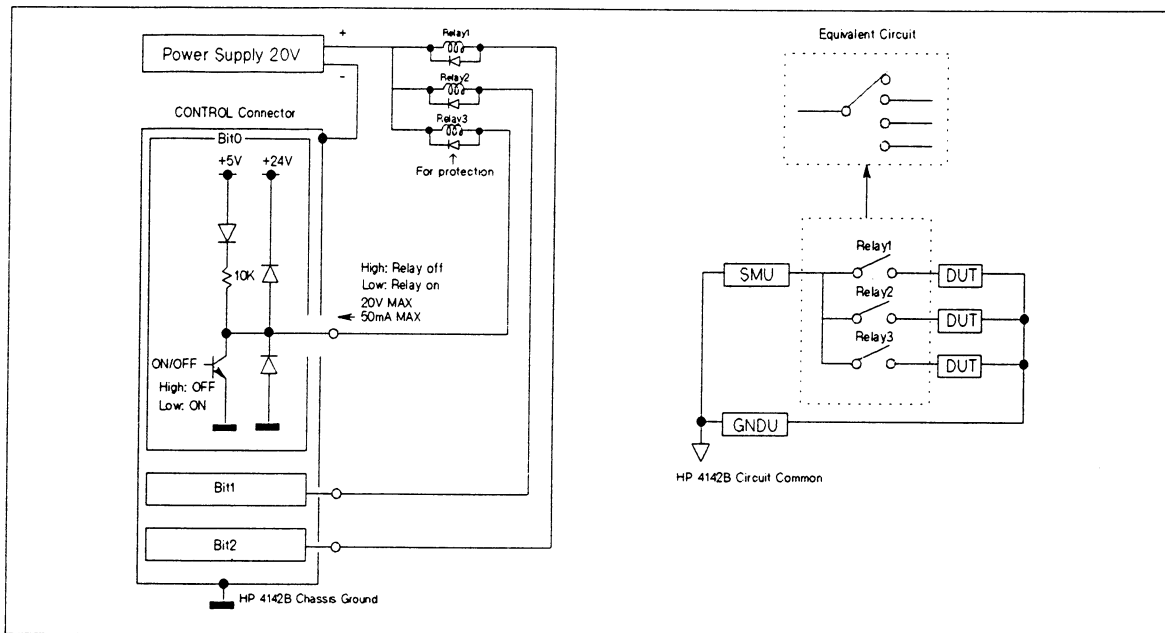

Usage Example of the External Relay Control Pins

Only when you control the 16-bit TTL digital outputs of **CONTROL** connector can you select either of the following by the *dry switching* parameter of the **ERC** command.

- Dry switching on: The HP 4142B automatically sets all outputs of source units to zero (same as the conditions after **DZ** command execution), and changes the 16-bit outputs, then returns all outputs to the outputs before receiving the **ERC** command.
- Dry switching off: Without changing all outputs of source units, the HP 4142B changes the 16-bit outputs.

NOTE

Electrically isolate the **CONTROL** outputs from the circuit in which the measurement units are connected. If the **CONTROL** outputs are not isolated and current flows between the HP 4142B Chassis Ground and Circuit Common, the measurements may not be correct. The measurement results can be altered by the following effects:

- A voltage difference occurs between the HP 4142B Chassis Ground (reference potential of the **CONTROL** outputs) and Circuit Common (reference potential of the measurement units) because of the current.
- The outputs of the source units are not stable.

CHAPTER 7

MISCELLANEOUS FUNCTIONS

CONTENTS

Introduction	7-1
Front and Rear Panels	7-1
Front Panel	7-1
Rear Panel	7-8
Query Commands	7-9
HP-IB Capability	7-10
Status Byte	7-11
Status	7-11
Commands	7-12
Status Byte Sample Program	7-13
Self-Calibration/Self-Test	7-18
Self-Calibration	7-18
Auto-Calibration	7-19
Self-Test	7-20
Initial Settings	7-21
Auto Power Off Function	7-24

7
Miscellaneous
Functions

INTRODUCTION

This chapter explains the functions that are not directly related to measurement. Included is information about front and rear panels, query commands, and the functions at power-on.

FRONT AND REAR PANELS

The following describes each key, indicator, and connector on the HP 4142B. See "Panel Overview" in chapter 2 for location on the panel of each item.

Front Panel

INTLK Terminal:

Used in conjunction with the INTERLOCK function of the HP 4142B. If the center conductor of the INTLK terminal is open, maximum SMU output is limited to ± 42 V, the HVU output switch is set to off, and the HVU Self-Test/Self-Calibration is discontinued. If the INTLK terminal is shorted (set to the Chassis Ground), the interlock function is disabled. For more information, see Chapter 3, "Before Connecting Test Devices."

WARNING

DANGEROUS VOLTAGES OF UP TO THE MAXIMUM VOLTAGE OF THE SMU/HVU MAY BE PRESENT AT THE FORCE, GUARD, AND SENSE TERMINALS WHEN THE INTLK TERMINAL IS SHORTED.

EVEN IF THE INTLK TERMINAL IS OPEN, TURN THE HP 4142B OFF AND DISCHARGE ANY CAPACITORS BEFORE YOU TOUCH THE CONNECTIONS OF THESE TERMINALS. IF YOU CANNOT TURN THE HP 4142B OFF, REFER TO THE "SAFETY PRECAUTIONS" IN CHAPTER 4.

CONNECT THE INTLK TERMINAL TO A SWITCH THAT TURNS OFF WHEN THE SHIELDING BOX ACCESS DOOR IS OPENED.

CIRCUIT COMMON - CHASSIS GROUND Terminals:

Used when making floating or grounded measurements. These terminals are shorted together for grounded measurements, and disconnected from each other (shorting-bar removed) for floating measurements. If **CIRCUIT COMMON** is disconnected from **CHASSIS GROUND** and tied to external ground, the HP 4142B forces or measures voltage or current referenced to the external ground potential. For more information, see Chapter 3, "If the Test Device is Externally Grounded (Floating Measurements)."

WARNING

A POTENTIAL SHOCK HAZARD EXISTS IF THE CIRCUIT COMMON TERMINAL IS NOT TIED TO CHASSIS GROUND (SHORTING-BAR DISCONNECTED FOR FLOATING MEASUREMENTS). DO NOT TOUCH ANY OF THE HP 4142B FRONT PANEL CONNECTORS AT ANY TIME WHILE A FLOATING MEASUREMENT IS IN PROGRESS.

DO NOT FLOAT THE CIRCUIT COMMON TERMINAL AT VOLTAGES GREATER THAN ± 42 V REFERENCED TO CHASSIS GROUND. FAILURE TO HEED THIS WARNING MAY RESULT IN DAMAGE TO YOUR HP 4142B.

HIGH VOLTAGE Lamp:

Indicates that the HP 4142B output is $> \pm 42$ V.

WARNING

DANGEROUS VOLTAGES OF UP TO THE MAXIMUM VOLTAGE OF THE SMU/HVU ARE PRESENT AT THE FORCE, GUARD, AND SENSE TERMINALS WHEN THE HIGH VOLTAGE LAMP IS LIT.

EVEN IF THE LAMP IS NOT LIT, TURN THE HP 4142B OFF AND DISCHARGE ANY CAPACITORS BEFORE YOU TOUCH THE CONNECTIONS OF THESE TERMINALS. IF YOU CANNOT TURN THE HP 4142B OFF, REFER TO THE "SAFETY PRECAUTIONS" IN CHAPTER 4.

Blank Panel:

For unused slots.

CAUTION

To prevent thermal damage to HP 4142B units, be sure that Blank Panels (part number 04142-60012) are installed in all unused slots.

ERROR/FAILURE Display:

The front panel **ERROR/FAILURE Display** indicates the status of the HP 4142B by displaying one of the following: **0** to **8**, **A**, **C**, **E**, **F**, **H**, **P**, or **U**. See the descriptions below.

- 0:** Displayed during normal operating conditions: The HP 4142B or specified plug-in unit(s) passed Self-Test or Self-Calibration.
- C:** The HP 4142B or specified plug-in unit(s) are now performing Self-Test or Self-Calibration.
- E:** The HP 4142B received an undefined command; all succeeding commands did not execute. Check for correct command syntax and out-of-range parameters.
- F:** The command or parameter value is not allowed in the present HP 4142B settings. Confirm the command execution condition or parameter value.

If you set the **INTLK** terminal to open while the output switch of an HVU is set to on, and while another HVU is performing Self-Test/Self-Calibration by the **CA** or ***TST?** command with the optional parameter *ch#*, then the HP 4142B stops the Self-Test/Self-Calibration of the unit to set the HVU output switch to off (error codes 565 and 202). In this case, the unit that is stopped from performing Self-Test/Self-Calibration loses the calibration data from Self-Calibration. Be sure to perform Self-Calibration before measurements on the unit that lost the calibration data. If a unit does not have the calibration data, the unit cannot perform outputs and measurements within the accuracy of the specifications. Note that even if the unit loses the calibration data, the unit performs measurements and no errors occur. If the command is the ***TST?**, the HP 4142B does not return the query data.

If a sweep measurement is aborted by the power compliance function or automatic sweep abort function, an **F** is displayed to indicate that the specified function works.

- H:** Output switches of all measurement units are disconnected to prevent damage to the HP 4142B from overvoltage or overcurrent, or from a momentary power loss. Check the input voltage, input current, cable connections, and ac power. Reconnect the output switches with the **CN** command.
- U:** The HVU Self-Test or HVU Self-Calibration cannot be performed because the **INTLK** terminal is open.

If the error code is 565 or 567, the HVU lost the calibration data of the Self-Calibration. Be sure to perform the HVU Self-Calibration before measurements. If the HVU loses the calibration data, the HVU cannot perform outputs and measurements within the accuracy of the specifications. Note that even if the HVU loses the calibration data, the HVU still performs measurements and no errors occur.

1 to 8, A, P:

The HP 4142B failed. If a plug-in unit failed, **1 to 8** indicates the slot # of the failed unit. **A** indicates a failure in the HP 4142B analog-to-digital conversion (ADC) section; **P** indicates a failure in the HP 4142B central processing unit (CPU). If more than one failure occurs, the **ERROR/FAILURE** display indicates the last failure detected during Self-Test or Self-Calibration. Self-Test and Self-Calibration are performed in the following order.

- 1) CPU
- 2) ADC
- 3) All plug-in units by slot # (ascending), except the AFU.
- 4) AFU

To determine whether a multiple failure occurred, execute the ***TST?** command. This command performs the Self-Test again and displays test results on the controller.

If a plug-in unit fails, remove the failed unit from slot and use a known good unit to perform your measurement. Contact the nearest Hewlett-Packard Sales and Service office for assistance.

If an **A, E, F, H, P, U,** or **1 to 8** is displayed, details about errors (error codes) are stored in the error register. Refer to *HP-IB Command Reference Manual* for error code descriptions.

The **ERROR/FAILURE Display** and error register are initialized (set to **0** and "0, 0, 0, 0", respectively) when the ***RST, ERR?**, or Device Clear (HPBASIC **CLEAR** statement) is executed. The error register is also initialized when **CA** or ***TST?** command execution begins.

POWER ON/OFF Switch:

Secondary ac Line switch. Used in conjunction with the rear panel **LINE ON/OFF** switch. Both switches must be set to **ON** to operate the HP 4142B. To simplify turning the HP 4142B on or off, keep the **POWER ON/OFF** switch setting **ON** at all times, and use the **LINE ON/OFF** switch only.

Line power is applied to the HP 4142B if the rear panel **LINE ON/OFF** switch is set to **ON**, even if the front panel **POWER ON/OFF** switch is set to **OFF**. To completely power down the HP 4142B, set the rear panel **LINE ON/OFF** switch to **OFF**, regardless of the **POWER ON/OFF** switch setting.

If you install or remove a plug-in unit, either set the **POWER ON/OFF** switch to **OFF** or set the **LINE ON/OFF** switch to **OFF**, depending on which is most accessible.

LOCAL/SELF TEST Key:

If the HP 4142B is in remote control, this key sets the HP 4142B to local control. If the HP 4142B is in local control, this key starts the HP 4142B Self-Test/Self-Calibration. If the **INTLK** terminal is open, Self-Test and Self-Calibration are performed for all units except the HVU. If the HP 4142B is set to local lockout, this key is disabled.

MEASURING Lamp:

Indicates that the HP 4142B is performing a measurement.

HP-IB Status Indicators:

These LEDs indicate HP 4142B SRQ, LISTEN, TALK, and REMOTE HP-IB status. See "Status Byte" in this chapter for more information on SRQ.

GNDU Terminal:

Triaxial GNDU output terminal. The GNDU terminal output is Circuit Common voltage (0 V). The GNDU maintains 0 V output while sinking up to ± 1.6 A.

ZERO CHECK Terminal:

Circuit Common reference terminal for checking HP 4142B output voltage.

SLOTS:

For plug-in units. The slot number is 1 to 8 from left to right. The slot numbers indicate the number of slot for each plug-in unit.

CONTROL Connector:

Furnished with Option 300. A 25-pin connector for relay control. See chapter 6, "Relay Control" for more information.

FORCE and SENSE Terminals of the HP 41420A HPSMU:

Maximum output and input is 200V/1A.

WARNING

DANGEROUS VOLTAGES OF UP TO ± 200 V MAY BE PRESENT AT THE FORCE, SENSE, AND GUARD TERMINALS. BEFORE YOU TOUCH THE CONNECTIONS OF THESE TERMINALS, TURN THE HP 4142B OFF AND DISCHARGE ANY CAPACITORS. IF YOU CANNOT TURN THE HP 4142B OFF, REFER TO THE "SAFETY PRECAUTIONS" IN CHAPTER 4.

FORCE and SENSE Terminals of the HP 41421B MPSMU:

Maximum output and input is 100V/100mA.

WARNING

DANGEROUS VOLTAGES OF UP TO ± 100 V MAY BE PRESENT AT THE FORCE, SENSE, AND GUARD TERMINALS. BEFORE YOU TOUCH THE CONNECTIONS OF THESE TERMINAL, TURN THE HP 4142B OFF AND DISCHARGE ANY CAPACITORS. IF YOU CANNOT TURN THE HP 4142B OFF, REFER TO THE "SAFETY PRECAUTIONS" IN CHAPTER 4.

FORCE and SENSE Terminals of the HP 41422A HCU:

Maximum output and input is 10V/10A.

FORCE Terminal of the HP 41423A HVU:

Maximum output and input is 1000V/10mA.

WARNING

DANGEROUS VOLTAGES OF UP TO ± 1000 V MAY BE PRESENT AT THE FORCE AND GUARD TERMINALS. BEFORE YOU TOUCH THE CONNECTIONS OF THESE TERMINAL, TURN THE HP 4142B OFF AND DISCHARGE ANY CAPACITORS. IF YOU CANNOT TURN THE HP 4142B OFF, REFER TO THE "SAFETY PRECAUTIONS" IN CHAPTER 4.

OUTPUT ON/OFF STATUS Terminal of the HP 41423A HVU:

BNC connector for connecting to a warning indicator. While the HVU output switch is set to on or while the Self-Test/Self-Calibration of the HVU is being performed, this terminal forces about 4.5 V. At any other time, this terminal is open (high impedance). See chapter 3, "HVU Connections" for more information.

WARNING

BEFORE TURNING THE HP 4142B ON, CONNECT THE OUTPUT ON/OFF STATUS TERMINAL TO A WARNING INDICATOR.

DANGEROUS VOLTAGES OF UP TO 1000 V MAY BE PRESENT AT THE FORCE AND GUARD TERMINALS WHEN THE WARNING INDICATOR IS LIT. EVEN IF THE WARNING INDICATOR IS NOT LIT, TURN THE HP 4142B OFF AND DISCHARGE ANY CAPACITORS BEFORE YOU TOUCH THE CONNECTIONS OF THESE TERMINALS. IF YOU CANNOT TURN THE HP 4142B OFF, REFER TO THE "SAFETY PRECAUTIONS" IN CHAPTER 4.

HP 41424A VS Terminal:

Maximum output is 40V/100mA.

HP 41424A VM Terminal:

Maximum input is 40 V.

MONITOR Port of the HP 41425A AFU:

See chapter 5, "Analog Search Measurements"

Rear Panel

LINE ON/OFF Switch:

Main ac line switch. Used in conjunction with the front panel **POWER ON/OFF** switch. Both switches must be set to **ON** to operate the HP 4142B. Note that line power is applied to the HP 4142B if this switch is set to **ON**, even if the front panel **POWER ON/OFF** switch is set to **OFF**.

HP-IB ADDRESS Switch:

For setting the HP-IB address (0 to 30) of the HP 4142B. The new HP-IB address is recognized only at power on.

HP-IB Connector:

24-pin connector for connecting the HP 4142B to HP-IB.

FILTER Switch:

For setting measurement integration time to minimize the effects of line-frequency noise. Set to the ac line frequency.

TRIGGER INPUT Terminal:

For triggering the HP 4142B. The HP 4142B is triggered (a measurement is performed) when a negative-going TTL level pulse (from HIGH--5 V to LOW--0 V) is applied. Trigger signals must be $\geq 100 \mu\text{s}$. See chapter 6, "Using the HP 4142B with External Instruments" for more information.

TRIGGER OUTPUT Terminal:

Sends a HIGH (5 V) TTL level signal. When the HP 4142B receives a trigger output command (**OS**), this terminal sends a LOW (0 V) TTL level pulse for approximately 100 μs . See chapter 6, "Using the HP 4142B with External Instruments" for more information.

LINE Input Receptacle:

For connecting the HP 4142B ac line cord.

LINE VOLTAGE SELECTOR Switch:

For setting the ac line voltage (100 V, 120 V, 220 V, or 240 V). See Chapter 1 for more information on power requirements.

LINE FUSE Holder:

The HP 4142B line fuse is installed in this holder. See chapter 1 for more information on the line fuse.

QUERY COMMANDS

Query commands request HP 4142B operation status data, and return status results to the query buffer. This query data can then be read by the controller. The following table lists the query commands and output data associated with each command. Refer to the *HP-IB Command Reference Manual* for details about query command syntax and output data syntax.

The HP 4142B provides two separate buffers for query data and measurement data. When you perform a data buffer read, the query buffer is always checked first. If there is no query data, a read is performed on the measurement data buffer. Only query data for the most recent query command is stored in the query buffer. Both buffers are cleared by the **BC**, **FMT**, ***RST**, or Device Clear (HP BASIC **CLEAR**) command.

Query Commands

Command	Query Command Output Data
ERR?	The first four error codes.
*IDN?	Model number (HP 4142B) and ROM version.
LOP?	Plug-in unit operation status.
*LRN?	Plug-in unit output and measurement settings.
LST?	Contents of program memory.
NUB?	Number of measurement data stored in data buffer.
*OPC?	After *OPC? executes, a "1" is placed in the query buffer.
*SRE?	Mask condition of the status byte.
*STB?	Contents of the status byte.
*TST?	Self-Test results.
UNT?	Model # and hardware version of installed plug-in units.
WNU?	Number of steps in sweep measurement.

NOTE

***OPC?** facilitates the synchronizing of HP 4142B and external instrument operations. See "Waiting for Command Execution Completion" in chapter 6 for details.

Query command output data is always stored in the query buffer in ASCII format regardless of the measurement data output format that is specified by the **FMT** command.

HP-IB CAPABILITY

The following table lists the HP-IB capabilities and functions of the HP 4142B. These functions provide the means for an instrument to receive, process, and transmit, commands, data, and status over the HP-IB bus.

HP-IB Interface Capability

Interface Function	Code	Description
Source Handshake	SH1	Complete capability
Acceptor Handshake	AH1	Complete capability
Talker	T6	Basic Talker: YES Serial Poll: YES Talk Only Mode: NO Unaddress if MLA (my listen address): YES
Listener	L4	Basic Listener: YES Unaddress if MTA (my talk address): YES Listen Only Mode: NO
Service Request	SR1	Complete capability
Remote/Local	RL1	Complete capability (with local lockout)
Parallel Poll	PP0	No capability
Device Clear	DC1	Complete capability
Device Trigger	DT1	Complete capability
Controller Function	C0	No capability
Driver Electronics	E1	Open Collector

The HP 4142B responds to the following HP BASIC statements:

- **ABORT** (IFC)
- **CLEAR** (DCL or SDC, same as *RST command)
- **LOCAL** (GTL)
- **LOCAL LOCKOUT** (LL0)
- **REMOTE**
- **SPOLL** (Serial Poll)
- **TRIGGER** (GET, same as XE command)

STATUS BYTE

Status byte bits are turned off or on (0 or 1) to represent HP 4142B operation status. When you execute a Serial Poll (HPBASIC **SPOLL**) command, the controller reads the contents of the status byte, and responds accordingly. When an unmasked status bit is set to "1", the HP 4142B sends an SRQ to the controller, causing the controller to perform an interrupt service routine.

Status

The following table lists status byte contents.

Status Byte Contents

Bit 7 (128)	Bit 6 (64)	Bit 5 (32)	Bit 4 (16)	Bit 3 (8)	Bit 2 (4)	Bit 1 (2)	Bit 0 (1)
Shut Down	RQS	Error	Set Ready	Inter-lock Open	not used	Wait	Data Ready

(): Decimal Value. Use this value when specifying a bit in a command.

A brief description of each bit follows:

- Bit 0: Data Ready**
This bit is set to "1" when measurement data or Query command response data is stored in the output data buffer. It is reset to "0" when all the stored data has been transferred to the controller, or when the HP 4142B receives a ***RST**, **BC**, **FMT**, or Device Clear (HP BASIC **CLEAR**) command.
- Bit 1: Wait**
This bit is set to "1" by the **PA** or **WS** command. It is reset to "0" when the waiting condition is complete, or when the HP 4142B receives a ***RST** or Device Clear command.
- Bit 2: not used**
This bit is always set to "0".
- Bit 3: Interlock Open**
If the HP 4142B performs the following while the **INTLK** terminal is open, or if the **INTLK** terminal is opened while the HP 4142B performs the following, then this bit is set to "1".
- Outputs a voltage that exceeds ± 42 V.
 - Sets a V compliance to greater than ± 42 V.
 - Sets the HVU output switch to on.
 - Performs the Self-Test or Self-Calibration of the HVU.
- This bit is reset to "0" when the HP 4142B receives a Serial Poll, ***RST**, or Device Clear command.

- Bit 4: Set Ready
This bit is reset to "0" when any of the following occur, and set to "1" when the corresponding operation is complete.
- 1) HP-IB command is received.
 - 2) The **SELF-TEST Key** on the front panel is pushed.
 - 3) A trigger signal is received at the **TRIGGER INPUT Terminal**.
- Bit 5: ERROR
This bit is set to "1" when an error causes **1 to 8, A, E, F, H, P, or U** to be displayed in the **ERROR/FAILURE** Display. It is reset to "0" when the HP 4142B receives a Serial Poll, ***RST, ERR?, CA, *TST?**, or Device Clear command. The **ERROR/FAILURE** Display is cleared to **0** by all these commands except the Serial Poll command.
- Bit 6: RQS (Request Service)
This bit is set to "1" whenever any other unmasked bit is set to "1". This causes the HP 4142B to send an SRQ to the controller. It is reset to "0" when the HP 4142B receives a Serial Poll, ***RST**, or Device Clear command. This bit is the only non-maskable status bit.
- Bit 7: Shut Down
This bit is set to "1" immediately before the HP 4142B automatically turns off to prevent damage, or when a momentary power loss occurs (error code 301). It is reset to "0" when the HP 4142B receives a Serial Poll, ***RST**, or Device Clear command. The **ERROR/FAILURE** Display is cleared to **0** by all these commands except the Serial Poll command.

NOTE

If Bit 3, Bit 5, or Bit 7 are masked, they are not reset to 0 by a Serial Poll command. Also, if these bits are masked, set to "1", then unmasked, a Serial Poll command does not reset them to "0".

After a masked bit is set to "1", removing the mask does not set Bit 6 to "1". That is, the HP 4142B does not send an SRQ to the controller. Therefore, if you remove a mask from a bit, it is usually best to do it at the beginning of the program.

Commands

The commands related to the status byte are listed below.

- ***STB?**
This command sends the contents of the status byte to the controller. The status byte is not cleared by this command.
- ***SRE**
This command removes the mask from the specified bits, and masks the unspecified bits. All bits except Bit 6 are masked in the initial setting.
- ***SRE?**
This command outputs data about which bits of the status byte are masked.

Status Byte Sample Program

The following is a sample program that uses Bit 3 (Interlock Open) and Bit 5 (Error) of the status byte, and a sample program that uses Bit 4 (Set Ready). A description of key program lines follows each program list.

Program List 1

```
10 ! BVceo Measurement using High Speed Spot Function
20 !
30 DIM A$[15], Err$[23]
40 ASSIGN @Hp4142 to 717
50 OUTPUT @Hp4142;"*RST"
60 !
70 B_ch=3
80 C_ch=2
90 Ib=0
100 Ic=1.E-3
110 Vc_comp=70
120 !
130 ON INTR 7 GOTO Service
140 ENABLE INTR 7;2
150 OUTPUT @Hp4142;"*SRE";40
160 !
170 OUTPUT @Hp4142;"CN";B_ch, C_ch
180 OUTPUT @Hp4142;"DI";B_ch, 12, Ib, 2
190 OUTPUT @Hp4142;"DI";C_ch, 0, Ic, Vc_comp
200 OUTPUT @Hp4142;"TV";C_ch
210 OUTPUT @Hp4142;"CL"
220 !
230 ENTER @Hp4142;A$
240 PRINT "Bvceo= ";A$[4, 15];"[V]"
250 DISABLE INTR 7
260 STOP
270 !
280 Service: !
290 OUTPUT @Hp4142;"CL"
300 Status_byte=SPOLL(@Hp4142)
310 IF BIT(Status_byte, 3)=1 THEN
320     DISP "NOT INTERLOCKED"
330 ELSE
340     OUTPUT @Hp4142;"ERR?"
350     ENTER @Hp4142;Err$
360     DISP "ERROR ";Err$
370 END IF
380 BEEP
390 END
```

Emitter	:	GNDU
! Base	:	SMU (Ch#3)
! Collector	:	SMU (Ch#2)

Description 1

130	When an SRQ interrupt is received, go to line labeled "Service."
140	Enables the interrupt.
150	Removes masks from Bit3 and Bit5.
170	Sets the SMU output switches to ON.
180-200	Forces current and performs measurement.
210	Sets the SMUs output switches to OFF.
230-240	Enters and displays measurement data.
250	Disables the interrupt.
260	Stops the program.
290	Sets the SMU output switches to OFF.
300	Enters value of the status byte.
310-370	Displays the message.

Program List 2

```
10 ! Ic-Vce Measurement using Sweep with Pulsed Bias Function
20 !
30 OPTION BASE 1
40 INTEGER B_ch, C_ch, Vc_no_step, Ib_no_step, Var1, Var2
50 INTEGER Data_no, Plot_no, X
60 DIM A$(3)[1615]
70 REAL Vc(101)
80 ASSIGN @Hp4142 TO 717
90 OUTPUT @Hp4142;"*RST"
100 !
110 B_ch=3
120 C_ch=2
130 Vc_start=0
140 Vc_stop=20
150 Vc_no_step=101
160 Ic_comp=.1
170 Ib_start=2.E-4
180 Ib_step=1.E-4
190 Ib_no_step=3
200 !
210 OUTPUT @Hp4142;"CN";B_ch, C_ch
220 OUTPUT @Hp4142;"WV";C_ch, 1, 0, Vc_start, Vc_stop, Vc_no
    _step, Ic_comp
230 OUTPUT @Hp4142;"FL";0, B_ch
240 OUTPUT @Hp4142;"PT";0, 1.E-3, 5.E-2
250 OUTPUT @Hp4142;"MM";5, C_ch
260 OUTPUT @Hp4142;"RI";C_ch, -19
270 !
280 Data_no=1
290 ON INTR 7 GOSUB Service
300 ENABLE INTR 7;2
310 OUTPUT @Hp4142;"PI";B_ch, 0, 0, Ib_start, 2
320 OUTPUT @Hp4142;"*SRE16;XE"
330 !
340 CALL Icvc_graph(Vc_start, Vc_stop, 0, Ic_comp)
350 Vc_step=(Vc_stop-Vc_start)/(Vc_no_step-1)
360 FOR Var1=1 TO Vc_no_step
370     Vc(Var1)=Vc_start+(Var1-1)*Vc_step
380 NEXT Var1
390 !
400 Plot_no=1
410 FOR Plot_no=1 TO Ib_no_step
420     LOOP
430     EXIT IF Plot_no<Data_no
440     END LOOP
450     FOR Var1=1 TO Vc_no_step
460         Ic=VAL(A$(Plot_no)[16*(Var1-1)+4;12])
470         PLOT Vc(Var1), Ic
480     NEXT Var1
490     PENUP
500 NEXT Plot_no
510 !
520 OUTPUT @Hp4142;"CL"
530 STOP
540 !
```

```
Emitter : GNDU
! Base : SMU (Ch#3)
! Collector : SMU (Ch#2)
```

```

550 Service: !
560 Status_byte=SPOLL(@Hp4142)
570 OUTPUT @Hp4142;"*SRE0"
580 !
590 ENTER @Hp4142;A$(Data_no)
600 !
610 Data_no=Data_no+1
620 IF Data_no<=lb_no_step THEN
630     lb=lb_start+(Data_no-1)*lb_step
640     ENABLE INTR 7;2
650     OUTPUT @Hp4142;"PI";B_ch, 0, 0, lb
660     OUTPUT @Hp4142;"*SRE16;XE"
670 END IF
680 RETURN
690 !
700 END
710 !
720 SUB Icvc_graph(X_axis_min, X_axis_max, Y_axis_min, Y_axis_max)
730     !
740     GINIT
750     GRAPHICS ON
760     CONTROL CRT, 12;1
770     PRINT CHR$(12)
780     !
790     Xmax=100*MAX(1, RATIO)
800     Ymax=100*MAX(1, 1/RATIO)
810     !
820     LORG 6
830     MOVE Xmax/2, Ymax
840     LABEL "COLLECTOR CHARACTERISTICS"
850     DEG
860     LDIR 90
870     CSIZE 4.5
880     MOVE 0, Ymax/2
890     LABEL "Ic(A)"
900     LORG 4
910     LDIR 0
920     MOVE Xmax/2, 0
930     LABEL "Vce(V)"
940     !
950     VIEWPORT .16*Xmax, .91*Xmax, .15*Ymax, .9*Ymax
960     !
970     FRAME
980     WINDOW X_axis_min, X_axis_max, Y_axis_min, Y_axis_max
990     AXES(X_axis_max-X_axis_min)/10,(Y_axis_max-Y_axis_min)/10,
X_axis_min, Y_axis_min
1000     CLIP OFF
1010     CSIZE 4, .5
1020     LORG 6
1030     FOR I=X_axis_min TO X_axis_max STEP (X_axis_max-X_axis_min)/2
1040         MOVE I, Y_axis_min
1050         LABEL I
1060     NEXT I

```

```

1070   CSIZE 3.8, .5
1080   LORG 8
1090   FOR I=Y_axis_min TO Y_axis_max STEP (Y_axis_max-Y_axis_min)/2
1100     MOVE X_axis_min, I
1110     LABEL USING "#, MD.DE";I
1120   NEXT I
1130   CLIP ON
1140   !
1150 SUBEND

```

Description 2

110-260	Sets up the conditions for staircase sweep with pulsed bias measurements.
280	Sets sweep data # to 1.
290	When SRQ interrupt is received, go to "Service" subroutine. In this program, the SRQ is received after measurements are performed.
300	Enables the interrupt.
310	Sets up and forces the first Base current.
320	Removes mask from Bit 4 and performs measurements.
340	Calls subprogram to display a graphics frame.
350-380	Calculates Collector voltage for each step, and stores these values in an array variable.
400	Sets sweep data plot# to 1.
410-500	Plots the sweep data. Loops between line 420 and line 440 until sweep data is ready for plotting.
530	Stops the program.
560	Clears the SRQ (resets Bit 6).
570	Disables the SRQ (masks all bits).
590	Enters the measurement data.
610	Increments the sweep data#.
620-670	If not final Base current, sets up next base current, outputs base current, enables interrupt, removes mask from Bit 4, and performs measurement.
680	Returns to main program.
720-1150	Subprogram to display a graphics frame.

SELF-CALIBRATION / SELF-TEST

Self-Calibration

To minimize output drift and measurement fluctuations caused primarily by changes in the ambient temperature, the HP 4142B provides a Self-Calibration function. Self-Calibration is performed automatically when you turn your HP 4142B on. After a minimum 40 minute warm-up period and before you begin to use your HP 4142B, perform Self-Calibration again by pressing the **LOCAL/SELF TEST** key, or by executing the **CA** command. Self-Calibration should be performed every 30 minutes, or if the ambient temperature changes by more than 3° C (6° F).

NOTE

When you perform the Self-Test/Self-Calibration, the HP 4142B first sets the unit output switch to off, then performs the test. The output switch remains off after the Self-Test/Self-Calibration.

If the output or compliance of a unit is set to more than ± 42 V, the Self-Test/Self-Calibration cannot be performed on any unit (error **F**, error code 213).

If the **INTLK** terminal is open, the Self-Test/Self-Calibration is performed on all units except the HVU (error **U**, error code 566).

If your HP 4142B has an HVU, any unit can lose the calibration data from Self-Calibration in the following three cases. Before making any measurements, be sure to perform Self-calibration or Self-Test on the unit that lost the calibration data. If a unit does not have the calibration data, the unit cannot perform outputs and measurements within the accuracy of the specifications. Note that even if the unit loses the calibration data, the unit can still perform outputs and measurements and no errors occur.

- If **INTLK** is open when the Self-Test of the HVU is performed at power-on, or if **INTLK** is opened during the Self-Test of the HVU at power-on, then the Self-Test of the HVU is skipped and goes on to the next unit (error **U**, error code 567). In this case, the HVU does not have the calibration data.
- If **INTLK** is opened while Self-Calibration/Self-Test is being performed on the HVU, then the Self-Calibration/Self-Test of HVU is skipped and goes on to the next unit (error **U**, error code 565). In this case, the HVU loses the calibration data.
- If **INTLK** is opened while the output switch of one HVU is set to on, and while another unit is performing the Self-Test/Self-Calibration by the the **CA** or ***TST?** command with the optional parameter *ch#*, then the HP 4142B stops the Self-Test/Self-Calibration of the unit to set the HVU output switch to off (error **F**, error codes 565 and 202). In this case, the unit that is stopped loses the calibration data.
If the command is the ***TST?**, the HP 4142B does not return the query data.

NOTE

If you specify one unit and perform the Self-Test/Self-Calibration while other units force output, the following power is required for Self-Test/Self-Calibration. If the total power consumption of all units exceeds 32 W, the Self-Test/Self-Calibration cannot be performed.

HPSMU:	20 W
MPSMU:	2 W
HCU:	10.02 W
HVU:	11 W
VS/VM:	2.2 W

Auto-Calibration

The Auto-Calibration function of the HP 4142B automatically performs Self-Calibration at 30 minute intervals after the output switches of all plug-in units have been set to OFF for 30 minutes. Use the **CM** command to enable or disable the Auto-Calibration function. Auto-Calibration is enabled when you turn the HP 4142B on.

Self-Test

The HP 4142B has a Self-Test function that automatically checks its basic operation when you turn your HP 4142B on.

You can also initiate the Self-Test at any time by pressing the **LOCAL/SELF TEST** key, or by executing the ***TST?** command. If you keep the HP 4142B turned on for more than one day, perform Self-Test once per day.

When the HP 4142B starts Self-Test, a **C** is displayed in the **ERROR/FAILURE** display and the **LOCAL/SELF TEST** key indicator lights. When Self-Test is finished, the **LOCAL/SELF TEST** key indicator light goes out and a **0** (No error) is displayed.

If a **1** to **8**, **A**, **P** is displayed, the HP 4142B failed Self Test. If a plug-in unit failed, **1** to **8** indicates the slot # of the failed unit. **A** indicates a failure in the HP 4142B analog-to-digital conversion (ADC) section; **P** indicates a failure in the HP 4142B central processing unit (CPU). If more than one failure occurs, the **ERROR/FAILURE** display indicates the last failure detected during Self-Test or Self-Calibration. Self-Test and Self-Calibration are performed in the following order:

- 1) CPU
- 2) ADC
- 3) All plug-in units by slot # (ascending), except the AFU.
- 4) AFU

To determine whether a multiple failure occurred, execute the ***TST?** command. This command performs the Self-Test again and displays the test results on the controller. If Self-Test is performed by pressing the **LOCAL/SELF TEST** key, the test results are not returned.

If a plug-in unit fails, remove the failed unit from the slot and use a known good unit to perform your measurement. Contact the nearest Hewlett-Packard Sales and Service office for assistance.

When the HP 4142B performs Self-Test, the HP 4142B also performs Self-Calibration.

NOTE

Units that fail Self-Test are disabled except ***TST?** command, and can only be enabled by the **RCV** command. However, the **RCV** command should be used only for servicing the HP 4142B. DO NOT use this command during normal operation.

For more information, see the **NOTE** of the previous paragraph, "Self-Calibration."

INITIAL SETTINGS

The HP 4142B is initialized at power ON, or when an *RST or Device Clear (HP BASIC CLEAR) command executes. The following table lists the initial settings of the HP 4142B.

Initial Settings (1 of 3)

Setting Item	Initial Setting		Command
SMU/HCU/HVU/VS output	open		CN and CL
SMU/HCU/HVU/VS output switch	OFF		CN and CL
SMU/HVU filter	ON		FL
VM operation mode	grounded measurement		VM
I measurement range of SMU/HCU/HVU	spot staircase sweep analog search quasi-pulsed spot	Auto	RI
	1ch pulsed spot pulsed sweep sweep with pulsed bias 2ch pulsed spot pulsed sweep with p_bias	¹	
V measurement range of VM	spot staircase sweep	Auto	RV
	1ch pulsed spot pulsed sweep sweep with pulsed bias	40V	
automatic sweep abort function	OFF		WM
output after sweep of staircase sweep source	start value		WM

¹ Compliance range

Miscellaneous Functions

Initial Settings (2 of 3)

Setting Item	Initial Setting		Command
hold time	staircase sweep	0 s	WT
	1ch pulsed spot pulsed sweep sweep with pulse bias 2ch pulsed spot pulsed sweep with p_bias	0 s	PT
	analog search	0 s	AT
	quasi-pulsed spot	0 s	BDT
delay time	staircase sweep	0 s	WT
	analog search	0 s	AT
	quasi-pulsed spot	0 s	BDT
pulse width	0.001 s		PT
pulse period	0.01 s		PT
primary pulse channel	unit specified by PDV/PDI		PDM
search operation mode	negative feedback search		ASM
search measurement mode	search SMU V measurement		ASM
feedback integration time	0.005 s		ASM
detection interval	short		BDM
V/I measurement	V measurement		BDM
trigger	XE, TV, TI, or GET ¹		TM
averaging mode	Auto		AV
averaging number	1		AV

¹ GET is the HP-IB bus trigger command. For HP BASIC, use the **TRIGGER** command.

Initial Settings (3 of 3)

Setting Item	Initial Setting	Command
auto calibration	ON	CM
measurement data output format	ASCII (with header and CR/LF)	FMT
output data buffer	cleared	BC
program memory	cleared ¹	SCR
status byte	all bits masked except Bit 6	*SRE
ERROR/FAILURE display	displays 0	---
error code register	cleared	ERR?
sweep source parameters	cleared	WV, WSV WI, WSI
pulse source parameters	cleared	PV, PI PDV, PDI
pulse sweep source parameters	cleared	PWV, PWI
search SMU parameters	cleared	ASV
sense SMU parameters	cleared	AVI, AIV
quasi-pulsed source parameters	cleared	BDV
module selector control	no module selection	ERC
control bits (16 bit)	open	ERC

¹ Only at power ON. Program memory is not cleared by an ***RST** or Device Clear (HP BASIC **CLEAR**) command.

AUTO POWER OFF FUNCTION

If an abnormal voltage or current is detected in the HP 4142B, the HP 4142B automatically turns off to prevent damage, but the **LINE ON/OFF** and **POWER ON/OFF** switches are left **ON**. Abnormal voltage or current can be caused by improper connections of the HP 4142B to the test device, overvoltage or overcurrent input, momentary power loss, HP 4142B defects, and so on. If this occurs, perform the following to turn the HP 4142B back on.

- 1) Set the **LINE ON/OFF** switch to **OFF**.
- 2) Wait for 10 seconds or more.
- 3) Set the switch to **ON**.

If no cable is connected to the connectors of the HP 4142B, and the line voltage is correct, the HP 4142B may have a defect. Contact the nearest Hewlett-Packard Sales and Service office for assistance.

APPENDIX A

MANUAL CHANGES

HP 4142Bs may vary slightly, depending on the Serial Number and the version of the ROM-based firmware. The information in this manual applies directly to an HP 4142B with the serial number prefix listed on the title page of this manual. This appendix contains information for customizing this manual, so that all the information pertains to the HP 4142B that you are using.

To customize this manual for your HP 4142B, refer to the following table, and make all of the manual changes corresponding to the serial number of your HP 4142B and version of the ROM-based firmware.

To see the version of your HP 4142B ROM-based firmware, send:

```

10  OUTPUT 717;"*IDN?"
20  ENTER 717;A, B, Version
30  DISP Version
40  END

```

Manual Changes by Serial Number

Serial Prefix or Number	ROM Version	Make Manual Changes
2716Jxxxxxx 2839Jxxxxxx	2.21, 2.40, 2.50 2.51, 2.52	1, 2, 3
	3.0, 3.1	2, 3
	4.0 and above	3
2946Jxxxxxx	3.0, 3.1	2, 3
	4.0 and above	3

• **Change 1**

Throughout this manual, delete any descriptions referring to the HP 41422A HCU, and to the 40 V, 100 V, and 200 V range of the Search SMU in the Analog feedback measurements.

You cannot use your HP 4142B with the HP 41422A HCU, and cannot use the 40 V, 100 V, and 200 V range of the Search SMU in Analog feedback Measurements.

- **Change 2**

You cannot use the following functions. Throughout this manual, delete any descriptions referring to the following.

- HP 41423A HVU
- CONTROL connector
- Quasi-pulsed spot measurement
- Optional parameter of the **UNT?** command
- **BDM, BDT, BDV, ERC, and POL** commands

Change the description as follows:

Before change: Program memory size: 20 kbyte
 After change: Program memory size: 5 kbyte

Before change: Number of program steps of the program memory: about 2000
 After change: Number of program steps of the program memory: about 500

- **Change 3**

The part numbers of the cables that you bought are changed as follows. This manual uses the new part numbers.

New Part No.	Old Part No.	Description
16493A Opt. 001	04142-61631	INTLK/VS/VMU - HP16058A Cable (1.5 m)
16493B Opt. 001	04142-61636	BNC Cable (1.5 m for INTLK or VS/VMU)
16493B Opt. 002	04145-61630	BNC Cable (3 m for INTLK or VS/VMU)
16493C Opt. 001	16058-61603	Triaxial Cable (1.5 m for SMU)
16493C Opt. 002	04145-61622	Triaxial Cable (3 m for SMU)
16493D Opt. 001	41420-61603	Quadraxial Cable (1.5 m for SMU)
16493D Opt. 002	41420-61601	Quadraxial Cable (3 m for SMU)
16493E Opt. 001	41422-61602	Dual-coaxial Cable (1.5 m for HCU)
16493E Opt. 002	41422-61601	Dual-coaxial Cable (3 m for HCU)
16493F Opt. 001	41423-60002	Triaxial/BNC Cable Pair (1.5 m for HVU)
16493F Opt. 002	41423-60001	Triaxial/BNC Cable Pair (3 m for HVU)
16493G Opt. 001	04142-61634	25pin-25pin Cable (1.5 m for CONTROL)
16493G Opt. 002	04142-61635	25pin-25pin Cable (3 m for CONTROL)
16493H Opt. 001	04142-61633	Triaxial Cable (1.5 m for GNDU)
16493H Opt. 002	04142-61632	Triaxial Cable (3 m for GNDU)

The part numbers of the HP 4142B options are as follows. These options are obsolete.

Option Number	Description	Model or Part Number
002	GNDU and INTLK cables (3 m) and Connector Plate Triaxial Cable (3 m for GNDU) Coaxial Cable (3 m for INTLK or VS/VMU) Connector Plate (for GNDU/SMUx4/INTLK)	--- 16493H Opt. 001 16493B Opt. 001 04142-60021
022	Connector Plate (for GNDU/HCUx2/VSx2/VMx2/INTLK)	04142-60031
560	IMA Software	HP 16276A/L
561	License-to-Use the HP 16276A	HP 16276L

APPENDIX B

SPECIFICATIONS

The following two tables list complete HP 4142B specifications and supplemental performance characteristics. The specifications are the performance standards or limits against which the HP 4142B is tested. When the HP 4142B is shipped from the factory, it meets the specifications. The characteristics are not specifications but are typical characteristics included as additional information for the operator.

GENERAL INFORMATION

Basic Function:

Performs high speed DC parameter measurements.

Plug-in Units:

The HP 4142B provides eight plug-in unit slots, and any combination of units can be specified.* The six types of plug-in units available, and their slot requirements, are listed below.

- HP 41420A Source/Monitor Unit (SMU), 40 μ V-200V/20fA-1A: 2 slots
- HP 41421B Source/Monitor Unit (SMU), 40 μ V-100V/20fA-100mA: 1 slot
- HP 41422A High Current Source/Monitor Unit (HCU), 40 μ V-10V/20nA-10A: 2 slots
- HP 41423A High Voltage Source/Monitor Unit (HVU), 2mV-1000V/2pA-10mA: 2 slots
- HP 41424A Voltage Source/Voltage Monitor Unit (VS/VMU): 1 slot
- HP 41425A Analog Feedback Unit (AFU)*: 1 slot

* Only one AFU can be installed per HP 4142B.

Maximum Power Consumption:

Total SMU, HCU, HVU and VS/VMU power consumption must not exceed 32W. Power consumption for these units is calculated as follows.

SMUs (HP 41420A and HP 41421B):

V Source Mode:

Voltage Range	Power
2V	20Ic
20V	20Ic
40V	40Ic
100V	100Ic
200V	200Ic

where Ic is the current compliance setting.

I Source Mode:

Voltage Compliance	Power
$V_c \leq 20$	20I _o
$20 < V_c \leq 40$	40I _o
$40 < V_c \leq 100$	100I _o
$100 < V_c \leq 200$	200I _o

where Vc is the voltage compliance setting; I_o is output current.

Output switch set to OFF: 0W

GENERAL INFORMATION (continued)

Maximum Power Consumption (continued):

HCU (HP 41422A):

V Source Mode:

$$\text{Power} = 10 + 20I_c(\text{pulse width/pulse period})$$

where I_c is the current compliance setting.

I Source Mode:

$$\text{Power} = 10 + 20I_o(\text{pulse width/pulse period})$$

where I_o is the output current.

Output switch set to OFF: 0 W

HVU (HP 41423A):

V Source Mode:

$$\text{Power} = 10 + V_o I_c$$

where V_o is the output voltage, and I_c is the current compliance setting.

I Source Mode:

$$\text{Power} = 10 + V_c I_o$$

where V_c is the voltage compliance setting, and I_o is the output current.

Output switch set to OFF: 0 W

VS/VMU (HP 41424A):

Voltage Range	Power
20 V	2.2 W
40 V	0.88 W

Output switch set to OFF: 0 W

AFU (HP 41425A): 0 W

GENERAL INFORMATION (continued)

Furnished Unit:

Ground Unit (GNDU), 0 V Output, Maximum Sink Current: 1.6 A

Measurement Modes:

Spot, Staircase Sweep, 1 ch Pulsed Spot, 2ch Pulsed Spot, Pulsed Sweep, Staircase Sweep with Pulsed Bias, Pulsed Sweep with Pulsed Bias, Quasi-pulsed spot, and Analog Search Measurements

Measurement and Output Accuracy Conditions:

Measurement and output accuracies are specified at the front panel connector terminals, referenced to the ZERO CHECK terminal (except for the HCU) under the following conditions:

1. $23^{\circ} \pm 5^{\circ}\text{C}$ --accuracies double from $5^{\circ} - 17^{\circ}\text{C}$, and $29^{\circ} - 40^{\circ}\text{C}$.
2. After a minimum 40 minute warm-up period.
3. After performing Self-calibration.
4. Averaging mode: AUTO; Averaging number: 1
5. Filter: ON (For SMUs and HVUs)
6. Kelvin connection (For SMU, HCU, and GNDU voltage accuracy)

Accuracies for the HCU are specified between the high and low sense terminals on the front panel of the HCU.

HP 4142B Modular DC Source/Monitor

Ground Unit (GNDU): 1 channel (Kelvin connection)

Maximum Sink Current: 1.6A

Output Voltage: 0V \pm 500 μ V

Maximum Voltage Between Common and Ground: \leq 42V

Plug-in Unit Control Functions:

Spot Measurement Mode: Outputs and measures voltage and current.

Staircase Sweep Measurement Mode: Outputs and measures sweep voltage and current. One channel can sweep current or voltage while up to 8 channels can measure current or voltage. A second channel can be slaved to the first channel (dual synchronous sweep). Linear or log sweeps can be performed.

Number of Steps: 2 - 1001

Hold Time: 0 - 655.35s, 10ms resolution.

Delay Time: 0 - 65.535s, 1ms resolution.

1ch Pulsed Spot Measurement Mode: Outputs and measures V and I pulses.

Pulse Width: 1ms to 50ms, 100 μ s steps (SMU, HVU, or VS).
100 μ s to 1ms, 100 μ s steps (HCU).

Pulse Period: 10ms to 500ms, 100 μ s steps.

Maximum Pulse Duty: 50% (SMU, HVU, VS)

1% (HCU, 1 A range)

10% (HCU, 1 mA to 100 mA range)

2ch Pulsed Spot Measurement Mode: Outputs and measures V and I pulses in synchronization with a pulse of another channel.

Pulse Width: 100 μ s to 800 μ s, 100 μ s steps
pulse width of another channel is set to about 1ms.

Pulse Period and Duty: same as 1ch Pulsed Spot

Pulsed Sweep Measurement Mode: Outputs and measures V and I sweep pulses.

Number of Steps and Hold Time: same as Staircase Sweep Measurement Mode.

Pulse Width, Period, and Duty: same as 1ch Pulsed Spot Measurement Mode.

Staircase Sweep with Pulse Bias Measurement Mode: Outputs sweep V or I and performs measurements in synchronization with a periodic pulse of another channel.

Number of Steps and Hold Time: same as Staircase Sweep Measurement Mode.

Pulse Width, Period, and Duty: same as 1ch Pulsed Spot Measurement Mode.

Pulsed Sweep with Pulsed Bias Measurement Mode: Outputs pulsed sweep V or I and performs measurements in synchronization with a periodic pulse of another channel.

Number of Steps and Hold Time: same as Staircase Sweep Measurement Mode.

Pulse Width, Period, and Duty: same as 1ch Pulsed Spot Measurement Mode.

Analog Search Measurement Mode: Performs measurements using the HP 41425A Analog Feedback Unit.

Quasi-pulsed Spot Measurement Mode: Performs measurements using the HVU or SMU.

HP 4142B Modular DC Source/Monitor (continued)

Pulse Measurement Restrictions (for SMU):

Current Output Range ¹: 10nA to 1A

Maximum Voltage for 10nA to 10 μ A Range ¹: 2V

Current Measurement Range:

10nA to 1A Range (when voltage output range is 2V)

100 μ A to 1A Range (when voltage output range is 20V to 200V)

Current Limit (Compliance) Minimum Setting Value ¹:

2nA (when voltage output range is 2V)

20 μ A (when voltage output range is 20V to 200V)

SMU filter: OFF

Averaging Function: Not available

¹ Not applicable if an SMU is set to constant source and does not perform measurements.

Pulse Measurement Restrictions (for HCU, HVU, and VM):

HVU filter: OFF

VM Differential Voltmeter: Not available

Averaging Function: Not available

Memory Function:

Data Memory: Measurement results can be stored. Maximum number of data are 4095 (binary) or 1023 (ASCII).

Program Memory: Program code can be stored.

Input/Output Functions:

External Trigger Input: TTL-level Negative Logic; pulse width must be > 100 μ s. For continuing a paused program when using the HP 4142B's internal program memory.

External Trigger Output: TTL-level Negative Logic; pulse width is approximately 100 μ s. For controlling peripherals when using the HP 4142B's internal program memory.

HP-IB Function: The HP 4142B may be interfaced to any HP-IB capable computer or instrument.

HP-IB Interface: SH1, AH1, T6, L4, SR1, RL1, PP0, DC1, DT1, C0, E1.

Specifications (6 of 18)

HP 41420A Source/Monitor Unit (SMU) 40 μ V-200V/20fA-1A

Measures current when operating as a voltage source; measures voltage when operating as a current source. Kelvin connections can be used. The HP 41420A's source and measurement ranges, resolution, and accuracy specifications are listed in the following table.

Voltage Range	Setting Resolution	Measurement Resolution	Accuracy	Maximum ¹ Current
$\pm 2V$	100 μ V	40 μ V	$\pm 0.05\% \pm 1mV$	1A
$\pm 20V$	1mV	400 μ V	$\pm 0.05\% \pm 10mV$	1A ($ V_o \leq 14V$)
				700mA ($14V < V_o $)
$\pm 40V$	2mV	800 μ V	$\pm 0.05\% \pm 20mV$	350mA
$\pm 100V$	5mV	2mV	$\pm 0.05\% \pm 50mV$	125mA
$\pm 200V$	10mV	4mV	$\pm 0.05\% \pm 100mV$	50mA

Current Range	Setting Resolution	Measurement Resolution	Accuracy ^{1, 2}	Maximum Voltage
$\pm 1nA$	50fA	20fA	$\pm 1\% \pm (0.1 + 0.2V_o/100)\% \pm 5pA$	200V
$\pm 10nA$	500fA	200fA		
$\pm 100nA$	5pA	2pA	$\pm 0.5\% \pm (0.1 + 0.2V_o/100)\%$	
$\pm 1\mu A$	50pA	20pA		
$\pm 10\mu A$	500pA	200pA	$\pm 0.2\% \pm (0.1 + 0.2V_o/100)\%$	
$\pm 100\mu A$	5nA	2nA		
$\pm 1mA$	50nA	20nA		
$\pm 10mA$	500nA	200nA		

¹ V_o is output voltage.

² $\pm n\%$ of specified output or measurement value, $\pm n\%$ of range value.

Specifications (7 of 18)

HP 41420A Source/Monitor Unit (SMU) 40 μ V-200V/20fA-1A (continued)

Current Range	Setting Resolution	Measurement Resolution	Accuracy ^{1, 2}	Maximum ³ Voltage
$\pm 100\text{mA}$	$5\mu\text{A}$	$2\mu\text{A}$	$\pm 0.2\% \pm (0.1 + 0.2V_o/100)\%$	200V ($ I_o \leq 50\text{mA}$)
				100V ($50\text{mA} < I_o $)
$\pm 1\text{A}$	$50\mu\text{A}$	$20\mu\text{A}$	$\pm 0.5\% \pm (0.1 + 0.2(V_o/100)\%$	200V ($ I_o \leq 50\text{mA}$)
				100V(50mA < $ I_o \leq 125\text{mA}$)
				40V(125mA < $ I_o \leq 350\text{mA}$)
				20V(350mA < $ I_o \leq 700\text{mA}$)
				14V ($700\text{mA} < I_o $)

¹ $\pm n\%$ of specified output or measurement value, $\pm n\%$ of range value.

² V_o is output voltage.

³ I_o is output current.

Current Over-Range:

15% of Range (0% at 1A range)

Current/Voltage Limiting (Compliance):

Limit Setting Range:

Current Limit: 1pA to maximum current for each voltage range.

Voltage Limit: 0V to maximum voltage for each current range.

Limit Setting Accuracy: same as V/I Setting Accuracy.

Current Limit Setting Accuracy for Opposite Polarity:

1nA to 10nA Range: V/I setting accuracy $\pm 10\%$ of range

100nA to 1A Range: V/I setting accuracy $\pm 2\%$ of range.

Specifications (8 of 18)

HP 41421B Source/Monitor Unit (SMU) 40μV-100V/20fA-100mA

Measures current when operating as a voltage source; measures voltage when operating as a current source. The following table lists the HP 41421B's source and measurement ranges, resolution, and accuracy specifications.

Voltage Range	Setting Resolution	Measurement Resolution	Accuracy	Maximum Current
±2V	100μV	40μV	±0.05%±1mV	100mA
±20V	1mV	400μV	±0.05%±10mV	
±40V	2mV	800μV	±0.05%±20mV	50mA
±100V	5mV	2mV	±0.05%±50mV	20mA

Current Range	Setting Resolution	Measurement Resolution	Accuracy ^{1, 2}	Maximum ³ Voltage
±1nA	50fA	20fA	±1%±(0.1+0.2Vo/100)%±5pA	100V
±10nA	500fA	200fA		
±100nA	5pA	2pA	±0.5%±(0.1+0.2Vo/100)%	
±1μA	50pA	20pA		
±10μA	500pA	200pA	±0.2%±(0.1+0.2Vo/100)%	
±100μA	5nA	2nA		
±1mA	50nA	20nA		
±10mA	500nA	200nA		
±100mA	5μA	2μA		100V (Io ≤ 20mA)
				40V(20mA < Io ≤ 50mA)
				20V (50mA ≤ Io)

¹ ±n% of specified output or measurement value, ±n% of range value.

² Vo is output voltage.

³ Io is output current.

HP 41421B Source/Monitor Unit (SMU) 40 μ V-100V/20fA-100mA (continued)

Current Over-Range:

15% of Range (0% at 100mA Range)

Current/Voltage Limiting (Compliance):

Limit Setting Range:

Current Limit: 1pA to maximum current for each voltage range.

Voltage Limit: 0V to maximum voltage for each current range.

Limit Setting Accuracy: same as V/I Setting Accuracy.

Current Limit Setting Accuracy for Opposite Polarity:

1nA to 10nA Range: V/I setting accuracy $\pm 10\%$ of range

100nA to 100mA Range: V/I setting accuracy $\pm 2\%$ of range.

Specifications (10 of 18)

HP 41422A High Current Source/Monitor Unit (HCU)

Measures current when operating as a pulsed voltage source; measures voltage when operating as a pulsed current source. Kelvin connections should be used and low terminals of the HCU should be connected the GNDU. The HP 41422A's source and measurement ranges, resolution, and accuracy specifications are listed in the following table.

Voltage Range	Maximum Voltage	Setting Resolution	Measurement Resolution	Accuracy ¹	Maximum ³ Current
±2V	2V	200µV	40µV	±0.5%±10mV	10A
±20V	10V	2mV	400µV	±0.5%±100mV	

Current Range	Setting Resolution	Measurement Resolution	Accuracy ^{1, 2}	Maximum ³ Voltage
±1mA	100nA	20nA	±0.5%±(0.2+0.2Vo/20)%	10V
±10mA	1µA	200nA		
±100mA	10µA	2µA		
±1A	100µA	20µA	±1%±(0.2+0.2Vo/20)%	
±10A	1mA	200µA	±2%±(0.2+0.2Vo/20)%	

¹ ±n% of specified output or measurement value, ±n% of range value.

² Vo is output voltage.

³ Polarity of the current and voltage must be same (see below).

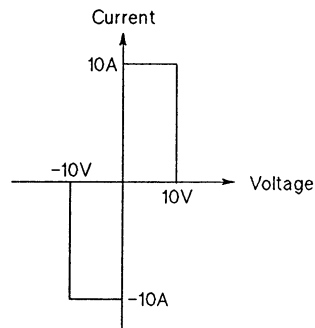

Specifications (11 of 18)

HP 41422A High Current Source/Monitor Unit (HCU)

Current Over-Range:

15% of Range (0% at 10A Range)

Current/Voltage Limiting (Compliance):

Limit Setting Range:

Current Limit: 1 μ A to 10A

Voltage Limit: 0V to 10V

Limit Setting Accuracy: same as V/I Setting Accuracy.

Specifications (12 of 18)

HP 41423A High Voltage Source/Monitor Unit (HVU)

Measures current when operating as a voltage source; measures voltage when operating as a current source.

Voltage Range	Setting Resolution	Measurement Resolution	Accuracy	Maximum ¹ Current
±100V	10mV	2mV	±0.5%±0.5V	10mA
±200V	20mV	4mV	±0.5%±1V	10mA
±500V	50mV	10mV	±0.5%±2.5V	10mA
±1000V	100mV	20mV	±0.5%±5V	10mA

Current Range	Setting Resolution	Measurement Resolution	Accuracy	Maximum ¹ Voltage
±100nA	50pA	2pA	±1%±1nA	1000V
±1µA	500pA	20pA	±1%±10nA	1000V
±10µA	5nA	200pA	±1%±100nA	1000V
±100µA	50nA	2nA	±1%±1µA	1000V
±1mA	500nA	20nA	±1%±10µA	1000V
±10mA	5µA	200nA	±1%±100µA	1000V

¹ Polarity of the current and voltage must be same (see below).

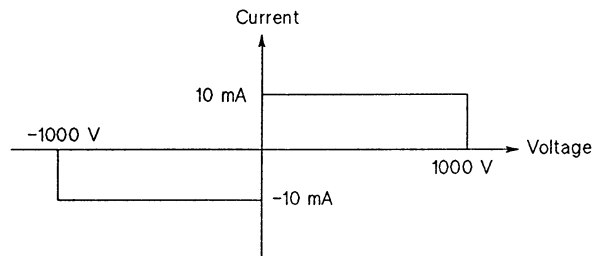

B: Specifications

Specifications (13 of 18)

HP 41423A High Voltage Source/Monitor Unit (HVU) (continued)

Current Over-Range:

15% of Range (0% at 10mA range)

Voltage Over-Range:

0%

Current/Voltage Limiting (Compliance):

Limit Setting Range:

Current Limit: 1nA to 10mA

Voltage Limit: 0V to 1000V

Limit Setting Accuracy: same as V/I Setting Accuracy.

HP 41424A Voltage Source/Voltage Measurement Unit (VS/VMU)

Provides two voltage source (VS) channels that can monitor current, and two voltage monitor (VM) channels. When used as a differential voltmeter, the two voltage monitor channels (VM1 and VM2) are used together as one channel. The HP 41424A's ranges, resolutions, and accuracies are listed in the following table.

Voltage Source:

Voltage Range	Setting Resolution	Accuracy	Maximum Current
20V	1mV	$\pm 0.1\% \pm 10\text{mV}$	100mA
40V	2mV	$\pm 0.1\% \pm 20\text{mV}$	20mA

VS Current Measurement:

Current Range	Measurement Resolution	Accuracy
20mA	20 μA	$\pm 3\% \pm 200\mu\text{A}$
100mA	100 μA	$\pm 3\% \pm 1\text{mA}$

Voltage Monitor:

Voltage Range	Measurement Resolution	Accuracy
2V	40 μV	$\pm 0.05\% \pm 1\text{mV}$
20V	400 μV	$\pm 0.05\% \pm 10\text{mV}$
40V	800 μV	$\pm 0.05\% \pm 20\text{mV}$

Differential Voltmeter:

Voltage Range	Measurement Resolution	Accuracy ¹	Max. Common Voltage
0.2V	4 μV	$\pm 0.2\% \pm 2.5 \times 10^{-6} V_{in} \pm 0.4\text{mV}$	40V
2V	40 μV	$\pm 0.1\% \pm 25 \times 10^{-6} V_{in} \pm 2\text{mV}$	

¹ V_{in} is the input voltage of VM2.

VM Over-Range:

15% of Range (0% at 40V Range)

HP 41425A Analog Feedback Unit (AFU)

Converges current or voltage on one SMU (Sense SMU) to a specified target value by controlling the output voltage of another SMU (Search SMU).

Maximum Target Voltage:

HP 41420A: 180V

HP 41421B: 90V

Maximum Target Current:

HP 41420A: 900mA

HP 41421B: 90mA

Target Value Setting Resolution:

Same as sense SMU measurement range setting resolution

Target Value Setting Over-Range:

Current: 0%

Voltage: -10%

Target Value Convergence Accuracy:

(Sense SMU measurement accuracy)

$\pm(0.1\%$ of Setting Value) $\pm(0.1\%$ of sense SMU measurement range)

Search Voltage Range:

2V,20V,40V,100V, and 200V (HP 41420A only)

Search Start Voltage Accuracy:

(0.5% of Setting) $\pm(0.5\%$ of Voltage Range)

Search Stop Voltage Accuracy:

3% of Voltage Range

Specifications (16 of 18)

HP 41425A Analog Feedback Unit (continued)

Ramp Rate Ranges and Resolution:

Search Voltage Range			
2V		20V	
Ramp Rate	Resolution	Ramp Rate	Resolution
0.5 - 5V/s	0.05V/s	5.5 - 50V/s	0.5V/s
5.5 - 50V/s	0.5V/s	55 - 500V/s	5V/s
55 - 500V/s	5V/s	550 - 5kV/s	50V/s
550 - 5kV/s	50V/s	5.5k - 50kV/s	500V/s

Search Voltage Range (continued)			
40V		100V	
Ramp Rate	Resolution	Ramp Rate	resolution
10 - 50V/s	1V/s	25 - 50V/s	2.5V/s
55 - 100V/s	5V/s	55 - 250V/s	5V/s
110 - 500V/s	10V/s	275 - 500V/s	25V/s
550 - 1kV/s	50V/s	550 - 2.5kV/s	50V/s
1.1k - 5kV/s	100V/s	2.75k - 5kV/s	250V/s
5.5k - 10kV/s	500V/s	5.5k - 25kV/s	500V/s
11k - 50kV/s	1000V/s	27.5k - 50kV/s	2500V/s
55k - 100kV/s	5000V/s	55k - 100kV/s	5000V/s

Search Voltage Range (continued)	
200V	
Ramp Rate	Resolution
55 - 500V/s	5V/s
550 - 5kV/s	50V/s
5.5k - 50kV/s	500V/s
55k - 100kV/s	5000V/s

B: Specifications

Specifications (17 of 18)

HP 41425A Analog Feedback Unit (continued)

Feedback Integration Time Ranges and Resolution:

Search Voltage Range			
2V		20V	
Integ. Time	Resolution	Integ. Time	Resolution
50 μ - 450 μ s	50 μ s	5 μ - 45 μ s	5 μ s
500 μ - 4.5ms	500 μ s	50 μ - 450 μ s	50 μ s
5m - 45ms	5ms	500 μ - 4.5ms	500 μ s
50m - 450ms	50ms	5m - 45ms	5ms

Search Voltage Range (continued)			
40V		100V	
Integ. Time	Resolution	Integ. Time	Resolution
2.5 μ - 4.5 μ s	0.5 μ s	1.0 μ - 4.5 μ s	0.5 μ s
5 μ - 45 μ s	5 μ s	5 μ - 45 μ s	5 μ s
50 μ - 450 μ s	50 μ s	50 μ - 450 μ s	50 μ s
500 μ - 4.5ms	500 μ s	500 μ - 4.5ms	500 μ s
5m - 25ms	5ms	5m - 10ms	5ms

Search Voltage Range (continued)	
200V	
Integ. Time	Resolution
0.5 μ - 4.5 μ s	0.5 μ s
5 μ - 45 μ s	5 μ s
50 μ - 450 μ s	50 μ s
500 μ - 4.5ms	500 μ s
5m	-

GENERAL SPECIFICATIONS

Self-Test Function:

At power on, the HP 4142B automatically verifies its own operational status. Self-test can be performed at any time via HP-IB.

Maximum Installation Inclination Angle:

±20° from horizontal (during operation)

Warm-up Time:

Allow the HP 4142B to warm-up for at least 40 minutes before performing measurements.

Operating Temperature Range:

5°C to 40°C

Operating Humidity Range:

5% to 80%RH

Storage Temperature Range:

-40°C to 70°C

Storage Humidity Range:

≤90%RH at 65°C

Power Requirements:

100/120/220V±10%; 240V-10%+5%, 48-66Hz (maximum 750VA)

Dimensions (in mm):

426W by 235H by 676D (approximately)

Weights (approximate):

HP 4142B Mainframe: 23kg	HP 41423A: 3kg
HP 41420A: 3kg	HP 41424A: 2kg
HP 41421B: 2kg	HP 41425A: 2kg
HP 41422A: 2.2kg	

Safety Considerations:

The HP 4142B complies with UL-1244, CSA bulletin 556B, and IEC-348 safety standards, and is shipped from the factory in a safe condition.

Supplemental Performance Characteristics (1 of 6)

The following supplemental performance characteristics are not guaranteed specifications but are typical characteristics included as additional operation information.

HP 4142B Modular DC Source/Monitor

Ground Unit (GNDU):

Capacitance Load: $\leq 10\mu\text{F}$

Cable Impedance: $\leq 1\Omega$ (Force side), $\leq 10\Omega$ (Sense side)

Plug-in Unit Control Functions:

Hold Time Setting Accuracy: $0.5\% + 1\text{ms}$

Delay Time Setting Accuracy: $0.5\% + 1\text{ms}$

Pulse Width Accuracy: $0.5\% + 100\mu\text{s}$ (SMU, HVU, or VS)
 $0.5\% + 20\mu\text{s}$ (HCU)

Pulse Period Accuracy: $0.5\% + 100\mu\text{s}$

where the pulse width is defined as below;

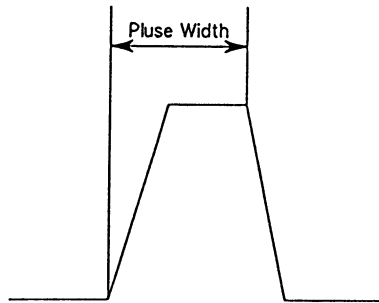

Memory Function:

Program Memory: Can store approximately 2000 program steps; up to 99 separate programs. Programs can be executed individually.

HP 41420A and 41421B SMUs

Capacitance Load: $\leq 1000\text{pF}$

Guard Capacitance: $\leq 900\text{pF}$

Shield Capacitance: $\leq 5000\text{pF}$

NOTE

When connecting cables or test devices with capacitance values greater than the allowable Capacitance Load, Guard, and Shield capacitance values, SMUs may oscillate.

Cable Impedance:

Force side: $\leq 0.7\Omega$ (when forcing 1A), $\leq 10\Omega$ (when forcing 100mA)

Sense side: $\leq 10\Omega$

NOTE

If cable impedance is greater than the allowable value when performing a measurement and using a Kelvin connection, measurement results may be invalid.

Voltage Measurement Input Resistance: $\geq 10^{12}\Omega$

Guard Voltage Offset: $\pm 1\text{mV}$

Noise Characteristics: (typical, with SMU Filter ON)

Voltage Source Noise: 0.01% of Range (rms)

Current Source Noise: 0.1% of Range (rms)

Voltage Monitor Noise: 0.02% of Range (p-p value)

Current Monitor Noise: 0.2% of Range (p-p value)

Voltage/Current Output Overshoot:

0.03% of Range (typical, with SMU Filter ON)

Maximum Slew Rate: $0.2\text{V}/\mu\text{s}$ (with SMU Filter ON)

Range Switching Transient Noise: (typically, with SMU Filter ON)

Voltage Range Switching: 250mV

Current Range Switching: 10mV

Residual Impedance when not using Kelvin connection: 0.2Ω (typical)

Measurement Time:

Force (Current or Voltage): Approximately 3.5ms

Measurement (Current or Voltage): Approximately 4ms

(When using an HP 9000 Series 300 Model 310 computer. Including data transfer time when set to the 20V and 100mA ranges.)

Supplemental Performance Characteristics (3 of 6)

HP 41422A HCU

Current Limit Setting for Opposite Polarity: 0.1% of current range

Capacitance Load: ≤ 3.5 nF

Inductance Load: ≤ 1 μ H

Cable Resistance:

FORCE side: ≤ 150 m Ω (HIGH and LOW when forcing 10 V and 10 A, respectively. See below for details.)

$$R \leq (16 - (3T/1E-3) - |V|)/(2|I|)$$

$$R \leq 4/|I|$$

$$|I| \leq 10$$

$$|V| \leq 10$$

where

R: Resistance [Ω] of HIGH or LOW FORCE cable

T: Pulse width [s], if $T < 200$ μ s then $T = 200$ μ s.

I: Output current [A] through FORCE line

V: Output voltage [V] between HIGH FORCE/SENSE and LOW FORCE/SENSE

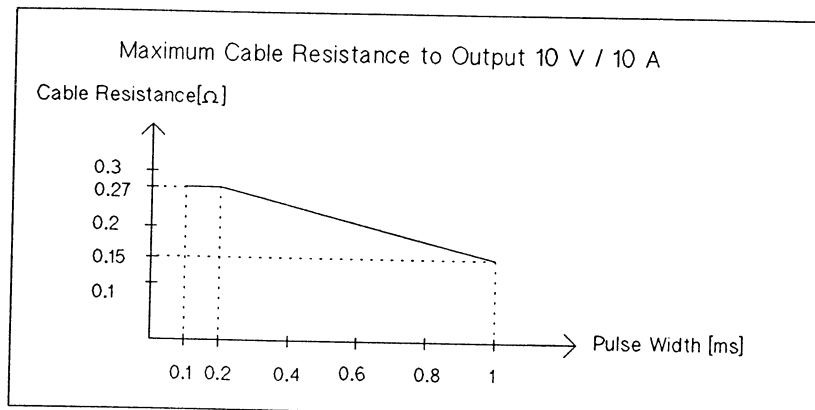

SENSE side: ≤ 10 Ω (HIGH and LOW, respectively)

NOTE

If the cable resistance is greater than the allowable value when performing a measurement and using a kelvin connection, the measurement results may be invalid.

Noise Characteristics: (typical)

Voltage Source Noise: 0.01% of Range (rms)

Current Source Noise: 0.1% of Range (rms)

Voltage Monitor Noise: 0.02% of Range (p-p value)

Current Monitor Noise: 0.2% of Range (p-p value)

Maximum slew rate: 0.3V/ μ s (typical)

Supplemental Performance Characteristics (4 of 6)

HP 41423A HVU

Opposite side I compliance: I compliance + 2% of I range (1mA max)

Capacitance Load: $\leq 1000\text{pF}$

Guard Capacitance: $\leq 300\text{pF}$

Shield Capacitance: $\leq 800\text{pF}$

NOTE

When connecting cables or test devices with capacitance values greater than the allowable Capacitance Load, Guard, and Shield capacitance values, HVUs may oscillate.

Guard Voltage Offset: $\pm 1\text{mV}$

Noise Characteristics: (typical, with HVU Filter ON)

Voltage Source Noise: 0.01% of V range (rms)

Current Source Noise: 0.1% of I range (rms)

Voltage Monitor Noise: 0.02% of Range (p-p value)

Current Monitor Noise:

1% of I range (p-p value, 10 μA range or above and 200V range)

Maximum Slew Rate: 12V/ms (typical, with HVU Filter ON)

Residual Impedance : 0.2 Ω (typical)

Measurement Time:

Force (Current or Voltage): Approximately 5.6ms

Measurement (Current or Voltage): Approximately 4.3ms

(When using an HP 9000 Series 300 Model 310 computer. Including data transfer time when set to the 100V and 10mA ranges.)

Change Polarity time: 100 ms

Channel off/on time: 100 ms

Supplemental Performance Characteristics (5 of 6)

HP 41424A VS/VMU

Voltage Source:

Output Impedance: 0.2Ω (typical)
Capacitance Load: $\leq 10\mu\text{F}$
Slew Rate: $0.2\text{V}/\mu\text{s}$
Current Limit Accuracy: +20% of Limit
Noise: (typically) 0.005% of Range (rms)

Voltage Monitor:

Input Impedance: $\geq 100\text{M}\Omega$
Leakage Current: $\leq 2\text{nA}$ (when measuring 0V)
Noise: 0.01% of Range (p - p value)
Differential Voltage Monitor Noise: 0.02% of Range (p - p value)

Measurement Time: (same as SMU measurement times, except for ranging)

Voltage Force: Approximately 3.5ms (at 20V Range)
Voltage Monitor: Approximately 4ms (at 20V Range)
Differential Voltage Monitor: Approximately 5.5ms (at 2V Range)

HP 41425A AFU

Ramp Rate Setting Accuracy:

0.5 to 5V/s: 30% of setting $\pm 0.5\text{V/s}$
5.5 to 50V/s: 30% of setting $\pm 5\text{V/s}$
55 to 500V/s: 30% of setting $\pm 50\text{V/s}$
550 to 5kV/s: 30% of setting $\pm 500\text{V/s}$
5.5k to 50kV/s: 30% of setting $\pm 5\text{kV/s}$

Feedback Integration Time Setting Accuracy: 30% of setting

Ramp Voltage Stop Delay Time: $5\mu\text{s}$ (typical)

Measurement Time:

Approximately 12ms* for detecting MOSFET threshold voltage (V_{th}) when the specified drain current is $1\mu\text{A}$, under optimum measurement setting conditions.

* From the time a measurement is triggered, until measurement results are stored in the output data buffer.

CONTROL Unit

Module Selector Control:

Output Voltage: 24 V
Current Limiter: 30 mA
Control Speed: 30 ms

16 Bit Relay Control:

Maximum Voltage: 20 V
Saturation Voltage: 0.7 V (at sink current = 50 mA)
Pull Up Voltage / Resister: 4.5 V / 10 k Ω
Control Speed: 10 ms

General Characteristics

Auto Calibration:

Automatically calibrates for offset errors (all units) every 30 minutes,.

Allowable Temperature Drift after Calibration: $\pm 3^{\circ}\text{C}$ ($\pm 6^{\circ}\text{F}$)

APPENDIX C

ACCESSORIES AND OPTIONS

ACCESSORIES

The following table shows the available accessories for the HP 4142B.

HP 4142B Available Accessories

Description	Model or Part Number
Interactive Measurement and Analysis (IMA) Software	HP 16276B/L
Test Fixture	HP 16088B
Module Selector	HP 16087A
Connector Plate (for GNDU/SMUx4/INTLK)	04142-60021
Connector Plate (for GNDU/HCUx2/HVUx2/VSx2/VMx2/INTLK)	04142-60032
Connector Plate (for GNDU/SMUx2/INTLK)	16087-60002
Warning Indicator (for HVU, English)	16087-60013
Warning Indicator (for HVU, Japanese)	16087-60014
Warning Indicator (for HVU, German)	16087-60015
Adaptor Cable (1.5 m for INTLK/VS/VMU - HP16058A)	16493A Opt. 001
BNC Cable (1.5 m for VS/VMU, or INTLK)	16493B Opt. 001
BNC Cable (3 m for VS/VMU, or INTLK)	16493B Opt. 002
Triaxial Cable (1.5 m for SMU)	16493C Opt. 001
Triaxial Cable (3 m for SMU)	16493C Opt. 002
Quadraxial Cable (1.5 m for SMU)	16493D Opt. 001
Quadraxial Cable (3 m for SMU)	16493D Opt. 002
Dual-coaxial Cable (1.5 m for HCU)	16493E Opt. 001
Dual-coaxial Cable (3 m for HCU)	16493E Opt. 002
Triaxial/BNC Cable Pair (1.5 m for HVU)	16493F Opt. 001
Triaxial/BNC Cable Pair (3 m for HVU)	16493F Opt. 002
25 pin-25 pin Cable (1.5 m for CONTROL)	16493G Opt. 001
25 pin-25 pin Cable (3 m for CONTROL)	16493G Opt. 002
Triaxial Cable (1.5 m for GNDU)	16493H Opt. 001
Triaxial Cable (3 m for GNDU)	16493H Opt. 002
Triax Cover (for SMU)	1250-1708

OPTIONS

The following tables list the options available for the HP 4142B.

HP 4142B Options Available (1 of 2)

Opt. No.	Description	Model or Part Number
001	Adaptor Cable (1.5 m for INTLK/VS/VMU - HP16058A)	16493A Opt. 001
003	GNDU and INTLK Cables (1.5 m)	---
	Triaxial Cable (1.5 m for GNDU)	16493H Opt. 001
	BNC Cable (1.5 m for INTLK or VS/VMU)	16493B Opt. 001
012	Connector Plate (for GNDU/SMUx4/INTLK)	04142-60021
032	Connector Plate and HVU Warning Indicator	---
	Connector Plate for GNDU/HCUx2/HVUx2/VSx4/INTLK	04142-60032
	Warning Indicator (for HVU)	¹
050	Line frequency filter switch is set to 50 Hz.	---
060	Line frequency filter switch is set to 60 Hz.	---
100	Line voltage switch setting and fuse for 100V/120V.	---
220	Line voltage switch setting and fuse for 220V/240V.	---
300	CONTROL Unit	---
302	25pin-25pin Cable (3 m for CONTROL)	16493G Opt. 002
303	25pin-25pin Cable (1.5 m for CONTROL)	16493G Opt. 001
400	HP 41420A SMU	HP 41420A
401	SMU Cable (1.5 m) and Triax Cover	---
	Triaxial Cable (1.5 m for SMU)	16493C Opt. 001
	Triax Cover (for SMU)	1250-1708
402	Quadraxial Cable (3 m for SMU)	16493D Opt. 002
403	Quadraxial Cable (1.5 m for SMU)	16493D Opt. 001
410	HP 41421B SMU	HP 41421B
411	SMU Cable (1.5 m) and Triax Cover	---
	Triaxial Cable (1.5 m for SMU)	16493C Opt. 001
	Triax Cover (for SMU)	1250-1708
412	Quadraxial Cable (3 m for SMU)	16493D Opt. 002
413	Quadraxial Cable (1.5 m for SMU)	16493D Opt. 001
420	HP 41422A HCU	HP 41422A
422	Dual-coaxial Cable (3 m for HCU)	16493E Opt. 002
423	Dual-coaxial Cable (1.5 m for HCU)	16493E Opt. 001
430	HP 41423A HVU	HP 41423A
432	Triaxial/BNC Cable Pair (3 m for HVU)	16493F Opt. 002
433	Triaxial/BNC Cable Pair (1.5 m for HVU)	16493F Opt. 001
440	HP 41424A VS/VMU	HP 41424A
442	Four BNC Cables (3 m for VS/VMU or INTLK)	²
443	Four BNC Cables (1.5 m for VS/VMU or INTLK)	³
450	HP 41425A AFU	HP 41425A
492	GNDU and INTLK cables (3 m)	---
	Triaxial Cable (3 m for GNDU)	16493H Opt. 002
	BNC Cable (3 m for INTLK or VS/VMU)	16493H Opt. 002

¹ 16087-60015 for Germany, 16087-60013 for other countries

² Four 16493B Opt. 002s

³ Four 16493B Opt. 001s

HP 4142B Options Available (2 of 2)

Opt. No.	Description	Model or Part Number
907	Front Handle Kit	5062-3991
908	Rack Flange Kit	5062-3979
909	Front Handle and Rack Flange Kits	5062-3985
910	Extra Manuals (English) Operation Manual HP-IB Command Reference Manual Control Software Programming Manual	
E60	Interactive Measurement and Analysis (IMA) Software and English manuals	HP 16276B with Opt. 007
E61	License-to-Use the HP 16276B and English manuals	HP 16276B
J10	Extra Manuals (Japanese) Operation Manual (Japanese) HP-IB Command Reference Manual (Japanese) Control Software Programming Manual (English)	
J32	Connector Plate and HVU Warning Indicator Connector Plate for GNDU/HCUx2/HVUx2/VSx4/INTLK Warning Indicator (for HVU, Japanese)	--- 04142-60032 16087-60014
J60	Interactive Measurement and Analysis (IMA) Software and Japanese manuals	HP 16276B with Opt. 007
J61	License-to-Use the HP 16276B and Japanese manuals	HP 16276B
W03	90 day On-site Service	

Options Available for the HP 4142B Plug-in Units

Model and Option	Description / Part Number
HP 41420A Option 401	Same as HP 4142B Option 401
Option 402	Same as HP 4142B Option 402
Option 403	Same as HP 4142B Option 403
Option W03	90 day On-site Service
HP 41421B Option 411	Same as HP 4142B Option 411
Option 412	Same as HP 4142B Option 412
Option 413	Same as HP 4142B Option 413
Option W03	90 day On-site Service
HP 41422A Option 422	Same as HP 4142B Option 422
Option 423	Same as HP 4142B Option 423
Option W03	90 day On-site Service
HP 41423A Option 432	Same as HP 4142B Option 432
Option 433	Same as HP 4142B Option 433
Option W03	90 day On-site Service
HP 41424A Option 442	Same as HP 4142B Option 442
Option 443	Same as HP 4142B Option 443
Option W03	90 day On-site Service
HP 41425A Option W03	90 day On-site Service