

## Errata

**Title & Document Type:** 37717B PDH/SDH Test Set Operating Manual

**Manual Part Number:** 37717-90083

**Revision Date:** July 1995

---

### HP References in this Manual

This manual may contain references to HP or Hewlett-Packard. Please note that Hewlett-Packard's former test and measurement, semiconductor products and chemical analysis businesses are now part of Agilent Technologies. We have made no changes to this manual copy. The HP XXXX referred to in this document is now the Agilent XXXX. For example, model number HP8648A is now model number Agilent 8648A.

### About this Manual

We've added this manual to the Agilent website in an effort to help you support your product. This manual provides the best information we could find. It may be incomplete or contain dated information, and the scan quality may not be ideal. If we find a better copy in the future, we will add it to the Agilent website.

### Support for Your Product

Agilent no longer sells or supports this product. You will find any other available product information on the Agilent Test & Measurement website:

[www.tm.agilent.com](http://www.tm.agilent.com)

Search for the model number of this product, and the resulting product page will guide you to any available information. Our service centers may be able to perform calibration if no repair parts are needed, but no other support from Agilent is available.





HP 37717B  
PDH/SDH Test Set  
Operating Manual

**HP 37717B PDH/SDH test set**  
**OPERATING MANUAL**

**SERIAL NUMBERS**

This manual applies directly to instruments  
with serial numbers GB00000101 and above.



HP Part No. 37717-90083  
Printed in U.K. July 1995

## **CERTIFICATION**

*Hewlett-Packard Company certifies that this product met its published specifications at the time of shipment from the factory. Hewlett-Packard further certifies that its calibration measurements are traceable to the United States National Bureau of Standards, to the extent allowed by the Bureau's calibration facility and to the calibration facilities of other International Standards Organization members.*

## **ASSISTANCE**

*Product maintenance agreements and other customer assistance agreements are available for Hewlett-Packard products.*

*For any assistance, contact your Hewlett-Packard Sales and Service Office.*

*Addresses are provided at the back of this manual.*

## **NOTICE**

The information contained in this document is subject to change without notice.

Hewlett-Packard shall not be liable for errors contained herein or for incidental or consequential damages in connection with the furnishing, performance or use of this material.

This document contains proprietary information which is protected by copyright. All rights are reserved. No part of this document may be photocopied or reproduced without the prior written consent of Hewlett-Packard Ltd.

## **PRINTING HISTORY**

First Edition July 1995

Copyright © Hewlett-Packard Ltd. (1995)

---

## **WARNING**

*READ THE FOLLOWING NOTES BEFORE INSTALLING OR SERVICING ANY INSTRUMENT.*

1. IF THIS INSTRUMENT IS TO BE ENERGISED VIA AN AUTO-TRANSFORMER MAKE SURE THAT THE COMMON TERMINAL OF THE AUTO-TRANSFORMER IS CONNECTED TO THE NEUTRAL POLE OF THE POWER SOURCE.
2. THE INSTRUMENT MUST ONLY BE USED WITH THE MAINS CABLE PROVIDED. IF THIS IS NOT SUITABLE, CONTACT YOUR NEAREST HP SERVICE OFFICE. THE MAINS PLUG SHALL ONLY BE INSERTED IN A SOCKET OUTLET PROVIDED WITH A PROTECTIVE EARTH CONTACT. THE PROTECTIVE ACTION MUST NOT BE NEGATED BY THE USE OF AN EXTENSION CORD (POWER CABLE) WITHOUT A PROTECTIVE CONDUCTOR (GROUNDING).
3. BEFORE SWITCHING ON THIS INSTRUMENT:
  - a. Ensure that all devices connected to this instrument are connected to the protective (earth) ground.
  - b. Ensure that the line power (mains) plug is connected to a three-conductor line power outlet that has a protective (earth) ground. (Grounding one conductor of a two-conductor outlet is not sufficient).
  - c. Check correct type and rating of the instrument fuse(s).

## Contents

---

<b>1. Getting Started</b>	
About this Manual . . . . .	1-1
About the HP 37717B . . . . .	1-2
Option Summary . . . . .	1-3
Power Requirements . . . . .	1-5
Obtaining and Modifying the HP 37717B Displays . . . . .	1-6
Other Front Panel Keys . . . . .	1-9
Status Indicators . . . . .	1-11
Connectors . . . . .	1-14
Basic Error Measurement Demonstration . . . . .	1-16
Recall Factory Default Settings . . . . .	1-16
Unstructured PDH Setup (Option UKK) . . . . .	1-17
Structured PDH Setup (Option UKJ) . . . . .	1-18
Start the Measurement and Monitor the Results . . . . .	1-19
<b>2. Making Measurements</b>	
Application Measurements . . . . .	2-1
PDH Measurements . . . . .	2-1
SDH Measurements . . . . .	2-2
ATM Measurements . . . . .	2-2
Alarm Monitoring . . . . .	2-4
Application . . . . .	2-4
Default (Known State) Settings . . . . .	2-4
Test Setup Procedure (Alarm Monitoring) . . . . .	2-4
Start the Test (Alarm Monitoring) . . . . .	2-6
Analysis of N X 64 kb/s . . . . .	2-7
Application . . . . .	2-7
Default (Known State) Settings . . . . .	2-7
Test Setup Procedure (N X 64 kb/s Analysis) . . . . .	2-7
Run the Test (N X 64 kb/s Analysis) . . . . .	2-10

BERT Testing . . . . .	2-11
Application . . . . .	2-11
Default (Known State) Settings . . . . .	2-12
Test Setup Procedure (BERT Testing) . . . . .	2-12
Start the Test (BERT Testing) . . . . .	2-14
At the End of the Test (BERT Testing) . . . . .	2-14
PDH Cross Multiplexer Testing . . . . .	2-16
Application . . . . .	2-16
Default (Known State) Settings . . . . .	2-16
PDH Cross Multiplexer Testing Test Setup Procedure . . . . .	2-16
Continuity Check . . . . .	2-19
Start the PDH Cross Multiplexer Test . . . . .	2-19
At the End of the Test (PDH Cross Multiplexer Testing) . . . . .	2-20
PDH FAS Monitoring . . . . .	2-21
Application . . . . .	2-21
Default (Known State) Settings . . . . .	2-21
Test Setup Procedure (PDH FAS Monitoring) . . . . .	2-21
Start the Test (PDH FAS Monitoring) . . . . .	2-23
Frequency Measurement . . . . .	2-24
Application . . . . .	2-24
Default (Known State) Settings . . . . .	2-24
Test Setup Procedure (Frequency Measurement) . . . . .	2-24
Run the Test (Frequency Measurement) . . . . .	2-26
At the End of the Test (Frequency Measurement) . . . . .	2-26
Frequency Offset Tolerance . . . . .	2-27
Application . . . . .	2-27
Default (Known State) Settings . . . . .	2-27
Test Setup Procedure (Frequency Offset Tolerance) . . . . .	2-28
Continuity Check . . . . .	2-29
Run the Test (Frequency Offset Tolerance) . . . . .	2-29
Multiplexer Jitter Tolerance . . . . .	2-31
Application . . . . .	2-31
Default (Known State) Settings . . . . .	2-31
Test Setup Procedure (Jitter Tolerance Test) . . . . .	2-31
Run the Test (Jitter Tolerance) . . . . .	2-34
PDH Multiplexer Testing . . . . .	2-35
Application . . . . .	2-35
Default (Known State) Settings . . . . .	2-35

PDH Multiplexer Test Setup Procedure . . . . .	2-35
Start the PDH Multiplexer Test . . . . .	2-38
At the End of the Test (PDH Multiplexer) . . . . .	2-39
Round Trip Delay . . . . .	2-40
Application . . . . .	2-40
Default (Known State) Settings . . . . .	2-40
Test Setup Procedure (Round Trip Delay) . . . . .	2-40
Continuity Check . . . . .	2-42
Start the Test (Round Trip Delay) . . . . .	2-42
Wander and Slips . . . . .	2-43
Application . . . . .	2-43
Default (Known State) Settings . . . . .	2-43
Wander and Slips Test Setup Procedure . . . . .	2-43
Run the Test (Wander and Slips) . . . . .	2-45
At the End of the Test (Wander and Slips) . . . . .	2-46
Add/Drop Multiplexer Testing . . . . .	2-47
Application . . . . .	2-47
Default (Known State) Settings . . . . .	2-47
Add/Drop Multiplexer Testing Test Setup Procedure . . . . .	2-47
Continuity Check . . . . .	2-49
Start the Add/Drop Multiplexer Test . . . . .	2-50
At the End of the Test (Add/Drop Multiplexer Testing) . . . . .	2-50
Alarm Stimulus/Response . . . . .	2-52
Application . . . . .	2-52
Default (Known State) Settings . . . . .	2-52
Alarm Stimulus/Response Test Setup Procedure . . . . .	2-52
Start the Alarm Stimulus/Response Test . . . . .	2-55
DCC Testing . . . . .	2-56
Application . . . . .	2-56
Default (Known State) Settings . . . . .	2-56
DCC Test Setup Procedure . . . . .	2-56
Start the DCC Test . . . . .	2-58
Desynchroniser Stress . . . . .	2-59
Application . . . . .	2-59
Default (Known State) Settings . . . . .	2-59
Desynchroniser Stress Test Setup Procedure . . . . .	2-59
Start the Desynchroniser Stress Test . . . . .	2-61
Frame Synchronization . . . . .	2-62



Application . . . . .	2-62
Default (Known State) Settings . . . . .	2-62
Frame Synchronization Test Setup Procedure . . . . .	2-62
Frame Error Add Test Function . . . . .	2-62
Sequence Generation Test Function . . . . .	2-62
Start the Frame Synchronization Test (Frame Error Add) . . . . .	2-64
Start the Frame Synchronization Test (Sequence Test) . . . . .	2-66
Frequency Measurement . . . . .	2-67
Application . . . . .	2-67
Default (Known State) Settings . . . . .	2-67
Test Setup Procedure (Frequency Measurement) . . . . .	2-67
Run the Test (Frequency Measurement) . . . . .	2-69
At the End of the Test (Frequency Measurement) . . . . .	2-69
Frequency Offset Tolerance . . . . .	2-70
Application . . . . .	2-70
Default (Known State) Settings . . . . .	2-70
Test Setup Procedure (Frequency Offset Tolerance) . . . . .	2-71
Continuity Check . . . . .	2-72
Run the Test (Frequency Offset Tolerance) . . . . .	2-72
SDH Jitter Transfer . . . . .	2-73
Default (Known State) Settings . . . . .	2-73
Test Setup Procedure (Jitter Transfer Test) . . . . .	2-74
Run the Test (Jitter Transfer) . . . . .	2-75
MSP Stimulus/Response . . . . .	2-76
Application . . . . .	2-76
MSP Stimulus/Response 1+1 Architecture Test Setup Procedure . . . . .	2-77
MSP Stimulus/Response 1:N Architecture . . . . .	2-78
Optical Clock Recovery Stress . . . . .	2-81
Application . . . . .	2-81
Default (Known State) Settings . . . . .	2-81
Optical Clock Recovery Stress Test Setup Procedure . . . . .	2-81
Start the Optical Clock Recovery Stress Test . . . . .	2-82
Payload Mapping/Demapping . . . . .	2-83
Application . . . . .	2-83
Default (Known State) Settings . . . . .	2-83
Payload Mapping/Demapping Test Setup Procedure . . . . .	2-83
Start the Payload Mapping/Demapping Test . . . . .	2-86

At the End of the Test (Payload Mapping/Demapping) . . .	2-86
Performance Monitor Stimulus/Response . . . . .	2-88
Application . . . . .	2-88
Default (Known State) Settings . . . . .	2-88
Performance Monitor Stimulus/Response Test Setup Procedure . . . . .	2-88
Start the Performance Monitor Stimulus/Response Test . . .	2-90
ATM Cell Performance . . . . .	2-91
Application . . . . .	2-91
Default (Known State) Settings . . . . .	2-91
ATM Cell Performance Test Setup Procedure . . . . .	2-91
Start the ATM Cell Performance Test . . . . .	2-94
At the End of the Test (ATM Cell Performance) . . . . .	2-95
Installing Upgrade Modules . . . . .	2-97
Ordering Upgrade Modules . . . . .	2-97
Transmit Static Overhead . . . . .	2-98
Path Overhead . . . . .	2-98
Path Trace . . . . .	2-98
Section Overhead . . . . .	2-100
Setting Undefined Overhead Functions . . . . .	2-100
Static Overhead Known (Default) Conditions . . . . .	2-101
Transmit Overhead Sequence . . . . .	2-102
Regenerator Section Overhead . . . . .	2-102
Multiplexer Section Overhead . . . . .	2-102
VC-4 Path Overhead . . . . .	2-102
Transmit Frame Synchronization Sequence . . . . .	2-103
Receive Overhead Monitor . . . . .	2-104
Receive Overhead Capture . . . . .	2-105
Frame by Frame Monitor of H1,H2 . . . . .	2-106
Transient Detection on A1,A1,A1,A2,A2,A2 . . . . .	2-106
Graphics . . . . .	2-107
Obtaining Graphics Results . . . . .	2-108
Recalling Previously Stored Results . . . . .	2-109
Viewing the Bar Graph Display . . . . .	2-109
Viewing the Error and Alarm Summaries . . . . .	2-111
Viewing the Stored Results Status . . . . .	2-112
Demonstration Graphs . . . . .	2-113
Printing Graphics Displays . . . . .	2-113

Logging Results . . . . .	2-115
Test Period Logging . . . . .	2-115
Error Event Logging . . . . .	2-116
HP-IB External Printer . . . . .	2-117
RS-232-C External Printer . . . . .	2-118
External HP 550C DeskJet Printer . . . . .	2-119
Connecting an HP 550C DeskJet Printer . . . . .	2-119
Internal Printer Changing Paper . . . . .	2-122
Autosetup . . . . .	2-123
Path Trace (Option US1) . . . . .	2-124
Stored Settings . . . . .	2-125
Select Settings to be Stored . . . . .	2-128
Title the Settings . . . . .	2-129
Save the Settings . . . . .	2-129
Recall Default Settings . . . . .	2-130
Recall Previously Stored Settings (Payload Mapping) . . . . .	2-130
Coupling Transmit and Receive Settings . . . . .	2-131
Time & Date . . . . .	2-132
Setting Time and Date . . . . .	2-132
Keyboard Lock . . . . .	2-133
Lock/Unlock the Keyboard . . . . .	2-133
Beep On Error . . . . .	2-134
Enable/Disable Beep On Error . . . . .	2-134
Analysis Control . . . . .	2-135
Self Test . . . . .	2-136
<b>A. Printer Messages</b>	
Printer Types . . . . .	A-1
Results Logging . . . . .	A-1
During the Measurement Period . . . . .	A-2
At the End of the Measurement Period . . . . .	A-6
Bar Graph Logging (External Printer Only) . . . . .	A-6
Graphics Text Results Logging (External Printer Only) . . . . .	A-8
Jitter Auto Tolerance Results Logging (External Printer Only) . . . . .	A-8

<b>B. Results Definitions</b>	
Trouble Scan . . . . .	B-1
Alarm Scan (Options UKJ, UKL) . . . . .	B-2
Short Term Results . . . . .	B-2
PDH Results (Options UKJ, UKK and UKL) . . . . .	B-2
SDH Results (Options US1, A1T) . . . . .	B-3
ATM Results (Option UKN) . . . . .	B-3
Cumulative Results . . . . .	B-4
PDH Results (Options UKJ, UKK and UKL) . . . . .	B-4
SDH Results (Option US1, A1T) . . . . .	B-5
ATM Results (Option UKN) . . . . .	B-5
PDH Error Analysis . . . . .	B-7
Bit Errors . . . . .	B-7
Frame (FAS) Errors . . . . .	B-8
CRC Errors . . . . .	B-9
REBE Errors . . . . .	B-10
PDH M.2100 Frame Analysis . . . . .	B-11
Structured PDH M.2110 BIS (Bring Into Service) . . . . .	B-16
Structured PDH M.2120 Circuit Maintenance . . . . .	B-17
SDH Error Analysis (Option US1, A1T) . . . . .	B-18
RS B1 BIP G.826 Analysis . . . . .	B-18
MS B2 BIP G.826 Analysis . . . . .	B-19
MS FEBE G.826 Analysis (Option A1T only) . . . . .	B-20
Path B3 G.826 BIP Analysis . . . . .	B-21
Path FEBE G.826 Analysis . . . . .	B-22
Path IEC G.826 Analysis (Option A1T only) . . . . .	B-23
TU Path BIP G.826 Analysis - 34 Mb/s Payload . . . . .	B-24
TU Path BIP G.826 Analysis - 2 Mb/s Payload . . . . .	B-25
TU Path FEBE G.826 Analysis - 34 Mb/s Payload . . . . .	B-26
TU Path FEBE G.826 Analysis - 2 Mb/s Payload . . . . .	B-27
ATM EM BIP G.826 Analysis . . . . .	B-28
ATM FEBE G.826 Analysis . . . . .	B-29
Jitter Results (Options UHN, A1M, A1N, A1P) . . . . .	B-30
Alarm Seconds . . . . .	B-31
PDH Alarm Seconds . . . . .	B-31
SDH Alarm Seconds (Options US1, A1T) . . . . .	B-32
ATM Alarm Seconds (Option UKN) . . . . .	B-33
Frequency Measurement . . . . .	B-33

**Index**

**Contents-8**

## Figures

---

1-1. HP 37717B Front Panel . . . . .	1-6
1-2. Front Panel Keys . . . . .	1-9
1-3. Front Panel Keys . . . . .	1-11
2-1. Alarm Monitoring . . . . .	2-5
2-2. N X 64 kb/s Analysis . . . . .	2-7
2-3. End-to-End Test . . . . .	2-11
2-4. Loopback Test . . . . .	2-12
2-5. PDH Cross Multiplexer Testing . . . . .	2-17
2-6. PDH FAS Monitoring . . . . .	2-22
2-7. Frequency Measurement . . . . .	2-25
2-8. Frequency Offset Tolerance . . . . .	2-27
2-9. Structured PDH Jitter Tolerance Test . . . . .	2-32
2-10. Unstructured PDH Jitter Tolerance Test . . . . .	2-32
2-11. Structured PDH Multiplexer Test . . . . .	2-36
2-12. Unstructured PDH Multiplexer Test . . . . .	2-36
2-13. Round Trip Delay . . . . .	2-40
2-14. Wander and Slips Test . . . . .	2-44
2-15. Add/Drop Multiplexer Testing . . . . .	2-48
2-16. Alarm Stimulus/Response . . . . .	2-53
2-17. DCC Testing . . . . .	2-57
2-18. Desynchroniser Stress . . . . .	2-60
2-19. Frame Synchronization . . . . .	2-63
2-20. Frequency Measurement . . . . .	2-68
2-21. Frequency Offset Tolerance . . . . .	2-70
2-22. Jitter Transfer Test . . . . .	2-73
2-23. MSP Stimulus/Response 1+1 Architecture . . . . .	2-77
2-24. Optical Clock Recovery Stress . . . . .	2-81
2-25. Payload Mapping . . . . .	2-84
2-26. Payload Demapping . . . . .	2-84
2-27. Performance Monitor Stimulus/Response . . . . .	2-89

2-28. Test Cell . . . . .	2-92
2-29. ATM Cell Performance . . . . .	2-92
2-30. Paper Feed Direction . . . . .	2-122
A-1. Logging Header . . . . .	A-1
A-2. Logging During Measurement . . . . .	A-5
A-3. Logging At End of Measurement . . . . .	A-6
A-4. Bar Graph Logging . . . . .	A-7
A-5. Text Results Logging . . . . .	A-8





## Tables

---

1-1. Option Summary . . . . .	1-3
2-1. SDH Alarms . . . . .	2-53



## Getting Started

---



### About this Manual

This Operating Manual describes control of the HP 37717B Transmission test set using the front panel keys and is arranged in two sections :

Getting Started

Making Measurements

This Getting Started section explains the following :

- How to obtain the required display using the display select keys, **TRANSMIT**; **RECEIVE**; **RESULTS**; **GRAPH**; **OTHER**
- How to modify the display information, using   and the display softkeys
- How to use the other front panel keys
- How to interpret the front panel status indicators
- How to connect to external equipment

The Making Measurements section describes in detail how to test with the HP 37717B PDH/SDH test set.

---

## About the HP 37717B

The HP 37717B is a multi-rate bit error measuring test set. It can generate and receive a range of data patterns, and provide analysis of received errors to G.821 requirements.

75 $\Omega$  unbalanced data interfaces are provided at all data rates. In addition 120  $\Omega$  balanced data interfaces are provided at 2.048 Mbit/s (and 704 kb/s in Option UKK). AMI, HDB3 or CMI coding is used depending on the selected rate.

Accurate error measurements can still be made in the presence of half-rate cable loss of up to 12 dB, and at protected monitor points.

Option UKK provides unstructured PDH measurements at standard bit rates of 704 kbit/s, 2.048 Mbit/s, 8.448 Mbit/s, 34.368 Mbit/s and 139.264 Mbit/s. Frequency offset capability of  $\pm 100$  ppm about the standard rates, is provided. At 704 kbit/s and 2.048 Mbit/s the generator timing can be recovered from the received data. In-Service FAS measurements are available at 2 Mb/s only.

Option UKJ provides structured PDH generation and measurement at standard bit rates of 2.048 Mbit/s, 8.448 Mbit/s, 34.368 Mbit/s and 139.264 Mbit/s. Sub rate testing at 64 kb/s, 2.048 Mb/s, 8.448 Mb/s and 34.368 Mb/s is provided. Frequency offset capability of  $\pm 100$  ppm about the standard rates, is provided. At 2.048 Mbit/s the generator timing can be recovered from the received data.

Option UKL provides structured PDH measurement **only** at standard bit rates of 2.048 Mbit/s, 8.448 Mbit/s, 34.368 Mbit/s and 139.264 Mbit/s. Sub rate measurement at 64 kb/s, 2.048 Mb/s, 8.448 Mb/s and 34.368 Mb/s is provided.

Option UKN provides ATM generation and measurement at the Physical and Cell layers at bit rates of 34 Mb/s and 155.52 Mb/s.

Option UHC Provides 3 additional data outputs, which are a replica of PDH Signal Out, each delayed by a defined amount.

Option US1 provides generation and analysis of mapped, 140 Mb/s, 34 Mb/s and 2 Mb/s, SDH signals at STM-1 (155.52 Mb/s). Errors can be added to the mapped payload. A frequency offset capability is provided, allowing the SDH line rate frequency to be offset from its synchronized rate. In addition the capability of generating SDH Alarms and Errors is available.

### 1-2 Getting Started

Option A1T provides the capability of US1 and allows generation of Pointer sequences and access to Overhead.

Option UH1 provides a STM-1 Optical interface to the SDH options.

Option UH2 provides a STM-1/STM-4 optical interface to the SDH options.

Option URU provides a STM-1/STM-4 optical interface at 1550 nm, for long reach applications, to the SDH options.

Option UHK Adds Jitter generation at all PDH rates except 704 kb/s, and if Option US1 or A1T is fitted adds Jitter generation at STM-1/STM-4.

Option UHN Adds PDH Jitter measurement at all PDH rates except 704 kb/s, and adds Wander and Estimated Slips measurement at 2.048 Mb/s.

Option A1M adds SDH Jitter measurement at STM-1 Electrical rate.

Option A1N adds SDH Jitter measurement at STM-1 Optical rate.

Option A1P adds SDH Jitter measurement at STM-1 and STM-4 Optical rates.

Option 1CW provides remote control via RS-232-C, and an external printer port.

Option 1A8 provides remote control via HP-IB, and an external printer port.

Option 1F7 provides remote control via a LAN (Local Area Network).

Option UHE provides a Virtual Remote capability.

### Option Summary

Table 1-1 provides a summary of the available HP 37717B options. Standard options are fitted with BNC connectors. Options identified in ( ) have Siemens connectors.

**Table 1-1. Option Summary**

Option No.	Description
UKK (USB)	Unstructured PDH generation and measurement.
UKJ (USA)	Structured PDH generation and measurement.

**Table 1-1. Option Summary (continued)**

Option No.	Description
UKL (USC)	Structured PDH measurement only.
UKN (USE)	ATM generation and measurement.
UHC (US6)	Multiple PDH outputs.
US1 (US5)	Generation and analysis of STM-1 electrical SDH signals, SDH frequency offset and Alarm/Error generation.
A1T (A1U)	As US1 plus Pointer generation and Overhead access.
UH1	STM-1 Optical interface.
UH2	STM-1 and STM-4 Optical interfaces.
URU	STM-1 and STM-4 Optical interfaces at 1550 nm.
UH4	FC/PC optical adaptor for options UH1, UH2 and URU.
UH5	DIN47256 optical adaptor for options UH1, UH2 and URU.
UH6	ST optical adaptor for options UH1, UH2 and URU.
UH7	Biconic optical adaptor for options UH1, UH2 and URU.
UH8	NEC D4 optical adaptor for options UH1, UH2 and URU.
UHK	Jitter generation.
UHN (US9)	PDH Jitter measurement, Wander and estimated Slips.
A1M (A1Q)	STM-1 Electrical Jitter measurement.
A1N (A1R)	STM-1 Optical Jitter measurement.
A1P (A1S)	STM-1 and STM-4 Optical Jitter measurement.
1CW	RS-232-C remote control and external printer port.
1A8	HP-IB remote control.
1F7	LAN remote control.
UHE	Virtual Remote capability.

**Table 1-1. Option Summary (continued)**

Option No.	Description
OB2	Provides one additional operating manual.
OBF	Provides one additional remote control manual.
OB3	Provides a service manual.
W30	Provides two additional years of hardware support beyond the standard one year warranty.

### **Power Requirements**

The HP 37717B PDH/SDH test set requires a power source of 90 V to 264 V at a frequency between 47 Hz and 63 Hz. Power consumption is 450 VA maximum.

The fuse rating for the power source is, 5A Timed 250V, HP part number 2110-1120.

## Obtaining and Modifying the HP 37717B Displays

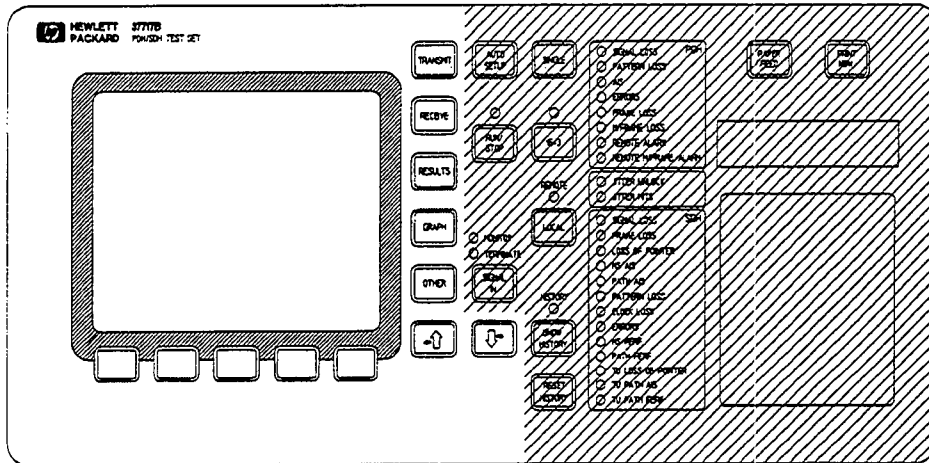

Figure 1-1. HP 37717B Front Panel

The operator interface is provided by the display and the front panel keys.



Five different display areas are obtainable using the five display keys, **TRANSMIT** ; **RECEIVE** ; **RESULTS** ; **GRAPH** and **OTHER**, immediately to the right of the display :

- TRANSMIT** Allows control of the settings associated with the generated signal.
- RECEIVE** Allows control of the settings associated with the received signal.
- RESULTS** Allows control of the Test timing and displays the selected measurement results.
- GRAPH** Allows management of the stored graphical results.
- OTHER** Allows control of Stored Settings, Settings Control, Time & Date, Keyboard Lock, Printer, COMMS Control, Beep On Error, Analysis Control, Analysis Display Mode and Self Test. A list of Options fitted is also displayed.

### Unstructured PDH (Option UKK)

1. In each of the display areas the field currently able to be changed is marked by a "highlighted cursor".

TRANSMITTER OUTPUT		[ PDH ]
SIGNAL		[ 140 Mb/s ]
CLOCK SYNC		INTERNAL
FREQUENCY OFFSET		[ OFF ]
CODE		CHI
PATTERN		[ 2^23-1 ]
TERMINATION		75Ω UNBAL
STATUS:		
140 Mb/s	34 Mb/s	8 Mb/s

2. The "highlighted cursor" is moved around the display using  and .

The "highlighted cursor" can be quickly returned to the top of the display by pressing the appropriate display key, in this example **TRANSMIT**.

3. The menu of selections available, for the highlighted field, appears at the bottom of the display : 140 Mb/s ; 34 Mb/s ; 8 Mb/s ; 2 Mb/s ; 704 kb/s. The choice from the menu is made using the display softkeys situated immediately below the display.

TRANSMITTER OUTPUT		[ PDH ]
SIGNAL		[ 140 Mb/s ]
CLOCK SYNC		INTERNAL
FREQUENCY OFFSET		[ OFF ]
CODE		CHI
PATTERN		[ 2^23-1 ]
TERMINATION		75Ω UNBAL
STATUS:		
2^15-1	2^23-1	ALL DEPOS

4. When a field has more than five choices, as in PATTERN above, a softkey labeled **MORE** is provided. When **MORE** is chosen the remainder of the menu is revealed as shown below.

RECEIVER INPUT		PDH
SIGNAL		[ 140 Mb/s ]
TEST MODE		[ OUT OF SRVC ]
CODE		CHI
PATTERN		[ 2^15-1 ]
TERMINATION		75Ω UNBAL
STATUS:		
140 Mb/s	34 Mb/s	8 Mb/s

TRANSMITTER OUTPUT		PDH
SIGNAL		[ 140 Mb/s ]
CLOCK SYNC		INTERNAL
FREQUENCY OFFSET		[ OFF ]
CODE		CHI
PATTERN		[ 2^23-1 ]
TERMINATION		75Ω UNBAL
STATUS:		
1010	1000	USER MORE

5. When the setting within a field is not enclosed in [ ] the field cannot be highlighted as no choice is available in the set up selected, as in CODE and TERMINATION above.

### Structured PDH (Option UKJ)

1. In each of the display areas the field currently able to be changed is marked by a "highlighted cursor".

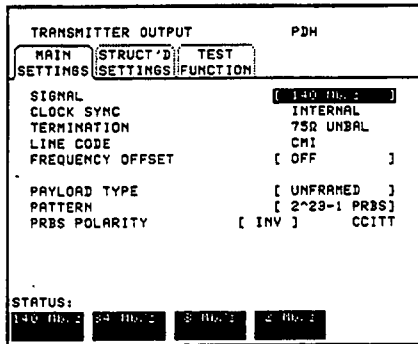

2. The "highlighted cursor" is moved around the display using  $\downarrow$  and  $\uparrow$ .

The "highlighted cursor" can be quickly returned to the top of the display by pressing the appropriate display key, in this example **TRANSMIT**.

3. The menu of selections available, for the highlighted field, appears at the bottom of the display : **140 Mb/s** ; **34 Mb/s** ; **8 Mb/s** ; **2 Mb/s**. The choice from the menu is made using the display softkeys situated immediately below the display.

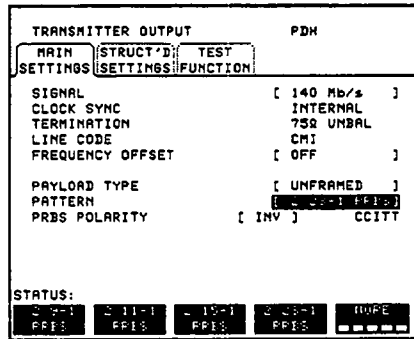

4. When a field has more than five choices, as in PATTERN above, a softkey labelled **MORE** is provided. When **MORE** is chosen the remainder of the menu is revealed as shown below.

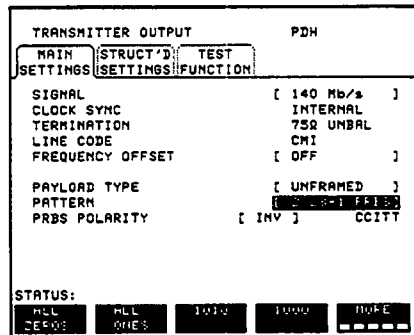
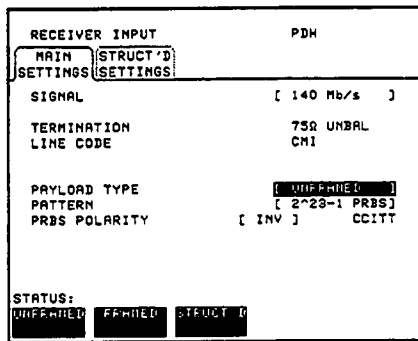

5. When the setting within a field is not enclosed in [ ] the field cannot be highlighted as no choice is available in the set up selected, as in TERMINATION and LINE CODE above.

### 1-8 Getting Started



## Other Front Panel Keys

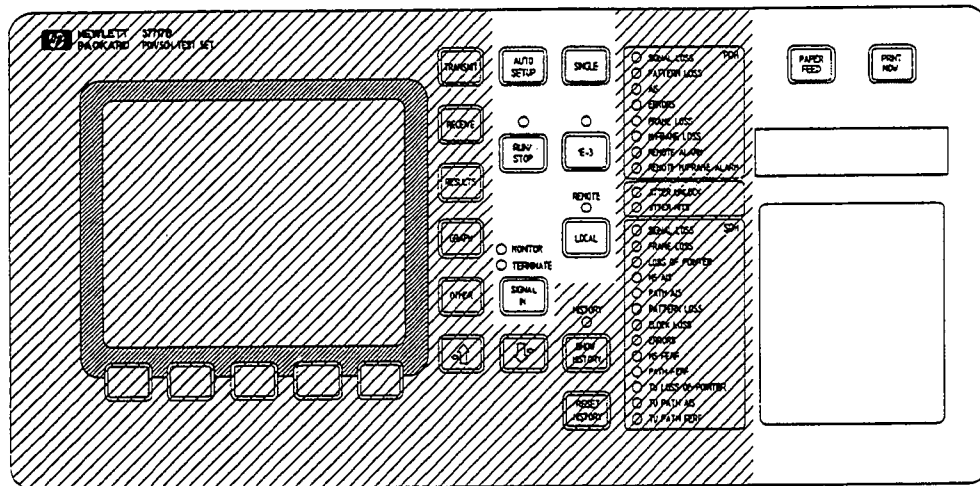





Figure 1-2. Front Panel Keys

- **AUTO SETUP** The test set attempts to match the settings to the received signal.
- **RUN/STOP** Terminates the current test period if one is in progress. Starts a new test period. The indicator above the key is lit when a test period is in progress.
- **SIGNAL IN** Determines whether the PDH IN and STM-1 IN ports function as a Monitor input or as a Terminated input. Monitor allows accurate error measurement at the line equipment protected monitor point. The indicators above the key signify the type of input selected.
- **SINGLE** Adds a single bit error to the output data pattern each time the key is pressed.
- **1E-3** Adds bit errors to the output data pattern at a rate of 1 error every 1000 data bits. The error addition continues until the key is pressed again. The indicator above the key is lit while errors are being added.
- **LOCAL** Returns the instrument from remote operation to Local (keyboard) operation. The indicator above the key is lit when the instrument is under Remote Control.

-  The selected measurement results are logged, immediately, to the selected printer.
-  The paper in the internal printer rolls up.

---

**Caution**

Do not press  while attempting to load a new roll of paper in the printer. It could result in a paper jam and disable the printer. Wait until the paper is fed through the printer rollers before pressing .

---

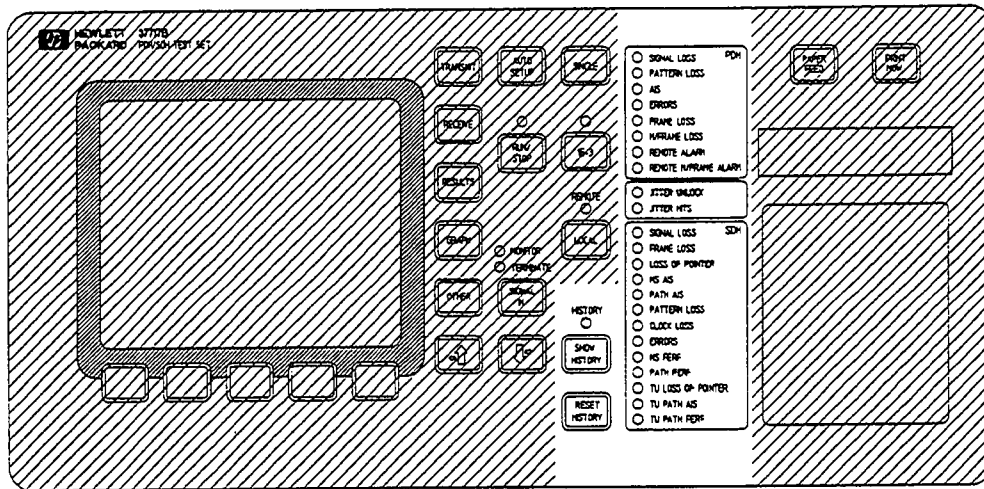

Figure 1-3. Front Panel Keys

## Status Indicators

### History Keys

The Status indicators on the front panel convey information regarding the current status of the instrument. If an alarm has occurred during the current Test Period the indicator above **SHOW HISTORY** is lit. To view which alarms have occurred press and hold **SHOW HISTORY**. When **SHOW HISTORY** is released the status indicators return to displaying the current status.

**SHOW HISTORY**

When pressed and held the Status indicators display any alarms which have been set during the current Test Period. This continues until **SHOW HISTORY** is released at which time the current status is displayed. The indicator above the key is lit to signify that an alarm has occurred during the current Test Period.

**RESET HISTORY**

Resets the history store such that the historical and present status are the same. This can also be achieved by starting a new Test Period.

**PDH Alarm Indicators** - These are active when a PDH rate is received.

- Signal Loss - No data transitions at the PDH IN port.
- Pattern Loss - The received data pattern is not in synchronization with the internally generated reference data.
- AIS - The All Ones AIS signal is detectable in the presence of a 1 in  $10^{-3}$  error rate.
- Errors - A bit or frame error has occurred.
- Frame Loss - Frame alignment lost.
- M/Frame Loss - Multiframe alignment lost.
- Remote Alarm - Remote alarm bit is set.
- Remote M/Frame - Remote Multiframe Alarm bit is set.

**SDH Alarm Indicators** - These are active when a SDH rate is received.

- Signal Loss - No data transitions at STM-1 IN port.
- Frame Loss - Loss Of Frame or Out Of Frame has been detected. Status message on bottom of display states which has occurred.
- Loss Of Pointer - Loss of AU4 pointer has been detected.
- MS AIS - Multiplexer Section AIS has been detected.
- Path AIS - Path AIS has been detected.
- Pattern Loss - The received data pattern is not in synchronization with the internally generated reference data.
- Clock Loss - The transmitter clock is not synchronized to the selected reference.
- Errors - An error has been detected. The indicator will remain lit for 100 ms.
- MS FERF - Multiplexer Section FERF has been detected.
- Path FERF - Path FERF has been detected.
- TU Loss Of Pointer - TU Loss Of Pointer has been detected. Only valid when 2 Mb/s or 34 Mb/s receiver payload is selected.

■ TU Path AIS - TU Path AIS has been detected. Only valid when 2 Mb/s or 34 Mb/s receiver payload is selected.

■ TU Path FERF - TU Path FERF has been detected. Only valid when 2 Mb/s or 34 Mb/s receiver payload is selected.

**ATM Alarm Indicators** - These are active when an ATM signal is received.

■ VP Alarm - Virtual Path AIS or FERF has been detected.

■ VC Alarm - Virtual Channel AIS or FERF has been detected.

■ Loss of Cell Sync - Cell Sync Loss has been detected.

■ Selected Cell Not RX - The selected cell has not been received.

## Connectors

<b>PDH IN</b>	PDH receiver input interface. Allows the connection of 75 $\Omega$ unbalanced data signals (all rates) and 120 $\Omega$ balanced data signals at 2 Mbit/s (and 704 kb/s Option UKK).
<b>PDH OUT</b>	PDH transmitter output interface. Provides 75 $\Omega$ unbalanced data output (all rates) and 120 $\Omega$ balanced data output at 2 Mbit/s (and 704 kb/s Option UKK).
<b>75<math>\Omega</math> OUT 1</b>	Replica of PDH OUT delayed by 4 bits at all rates except 140 Mb/s. Option UHC only.
<b>75<math>\Omega</math> OUT 2</b>	Replica of PDH OUT delayed by 8 bits at all rates except 140 Mb/s. Option UHC only.
<b>75<math>\Omega</math> OUT 3</b>	Replica of PDH OUT delayed by 12 bits at all rates except 140 Mb/s. Option UHC only.
<b>ERROR OUT</b>	Provides an ECL pulse each time an error occurs. If 2 or more errors occur within 16 clock periods only 1 pulse is output. Option UKK only.
<b>STM-1 OUT</b>	SDH transmitter output interface. Provides a 75 $\Omega$ unbalanced STM-1 electrical output. Options US1 and A1T only.
<b>STM-1 IN</b>	SDH receiver input interface. Allows the connection of 75 $\Omega$ unbalanced STM-1 electrical signals. Options US1 and A1T only.
<b>EXT MTS CLOCK</b>	Allows connection of a, 75 $\Omega$ or 120 $\Omega$ , timing reference as per CCITT G.811. The reference format may be either clock or data. Options US1 and A1T only.
<b>OPTICAL IN</b>	Allows connection of an STM-1 or STM-4 optical signal. Option UH1, UH2 and URU only. Option UH1 only accepts STM-1, Wavelength 1200 to 1600 nm, at a maximum power level of -8 dBm. Options UH2 and URU accept STM-1 or STM-4, Wavelength 1200 to 1600 nm, at a maximum power level of -8 dBm.
<b>OPTICAL OUT</b>	Provides a STM-1 or STM-4 optical signal. Option UH1, UH2 and URU only. Option UH1 provides a STM-1 optical signal, wavelength 1280 to 1330 nm, at a nominal power level of -10



dBm. Option UH2 provides a STM-1 and STM-4 optical signal, wavelength 1280 to 1330 nm, at a nominal power level of -10 dBm. Option URU provides a STM-1 and STM-4 optical signal, wavelength 1550 to 1565 nm, at a nominal power level of -1 dBm.

**HANDSET**

Allows connection of a telephone handset for communication across the network. Option UKJ only.

## Basic Error Measurement Demonstration

This simple procedure explains how to perform the following :

- Recall the factory default settings using the STORED SETTINGS function.
- Set up a simple back-to-back bit error measurement.
- Start the measurement and monitor the results.

### Recall Factory Default Settings

1. Set up the STORED SETTINGS function on the **OTHER** display as shown opposite and select STORED SETTING NUMBER [0].

Press **RECALL** to recall the factory default settings.

FUNCTION	[ STORED SETTINGS ]
STORED SETTING NUMBER	[ 0 ]
SETTING	ACTION [ RECALL ]
0	FACTORY DEFAULT SETTINGS
1	.....
2	.....
3	.....
4	.....
5	.....
6	.....
7	.....
8	.....
9	.....
STATUS:	
OFF	RECALL

The recalling of factory default settings will configure the instrument in a defined state. One important feature of the factory default settings is that the Graphics Store capability is turned off. This prevents the possibility of any previously stored graphics data being discarded.



### Unstructured PDH Setup (Option UKK)

1. Set up the **TRANSMIT** display as shown opposite.

TRANSMITTER OUTPUT	PDH
SIGNAL	[ 140 MHz ]
CLOCK SYNC	INTERNAL
FREQUENCY OFFSET	[ OFF ]
CODE	CHI
PATTERN	[ 2^23-1 ]
TERMINATION	75Ω UNBAL
STATUS:	
[ 140 MHz ]	[ 8 MHz ] [ 8 MHz ] [ 8 MHz ] [ 8 MHz ]

2. Set up the **RECEIVE** display as shown opposite.

RECEIVER INPUT	PDH
SIGNAL	[ 140 MHz ]
TEST MODE	[ OUT OF SRVC ]
CODE	CHI
PATTERN	[ 2^23-1 ]
TERMINATION	75Ω UNBAL
STATUS:	
[ 140 MHz ]	[ 8 MHz ] [ 8 MHz ] [ 8 MHz ] [ 8 MHz ]

3. Set up the **RESULTS** display as shown opposite.

Any of the other results can be viewed on the display by making a choice from the softkey menu.

RESULTS [ PDH ]	[ CUMULATIVE ]
TEST TIMING	[ MANUAL ]
STORAGE	[ OFF ]
BIT EC	
BIT ER	
CODE EC	
CODE ER	
ELAPSED TIME	
STATUS:	
SHORT TERM	CUMULATIVE ERROR ANALYSIS ALARM FREQUENCY
	ACTIVE SECONDS

## Structured PDH Setup (Option UKJ)

1. Set up the **TRANSMIT** MAIN SETTINGS display as shown below.

TRANSMITTER OUTPUT		PDH
MAIN SETTINGS	STRUCT'D SETTINGS	TEST FUNCTION
SIGNAL	[ 140 Mb/s ]	
CLOCK SYNC	INTERNAL	
TERMINATION	75Ω UNBAL	
LINE CODE	CM1	
FREQUENCY OFFSET	[ OFF ]	
PAYLOAD TYPE	[ STRUCTURED ]	
TO SET TEST SIGNAL, FIRST SET 'SETTINGS' TO 'STRUCTURED SETTINGS'		
STATUS:		
UNFRAMED	FRAMED	STRUCT'D

2. Set up the **TRANSMIT** STRUCTURED SETTINGS display as shown below.

TRANSMITTER OUTPUT		PDH
MAIN SETTINGS	STRUCT'D SETTINGS	TEST FUNCTION
TEST SIGNAL	[ 2 Mb/s ]	
2M PAYLOAD	[ PCM30 ]	
	34Mb 8Mb 2Mb	
	[ 1 ] [ 1 ] [ 1 ]	
PATTERN	[ 2 <sup>15</sup> -1 PRBS]	
PRBS POLARITY	[ INV ] CCITT	
B/G PATTERN	[ AIS ]	
STATUS:		
UNFRAMED	FRAMED	STRUCT'D
TEST FUNCTION	TEST FUNCTION	TEST FUNCTION

3. Set up the **RECEIVE** MAIN SETTINGS display as shown below.

RECEIVER INPUT		PDH
MAIN SETTINGS	STRUCT'D SETTINGS	
SIGNAL	[ 140 Mb/s ]	
TERMINATION	75Ω UNBAL	
LINE CODE	CM1	
PAYLOAD TYPE	[ STRUCTURED ]	
TO SET TEST SIGNAL, FIRST SET 'SETTINGS' TO 'STRUCTURED SETTINGS'		
STATUS:		
UNFRAMED	FRAMED	STRUCT'D

4. Set up the **RECEIVE** STRUCTURED SETTINGS display as shown below.

RECEIVER INPUT		PDH
MAIN SETTINGS	STRUCT'D SETTINGS	
TEST SIGNAL	[ 2 Mb/s ]	
2M PAYLOAD	[ PCM30 ]	
	34Mb 8Mb 2Mb	
	[ 1 ] [ 1 ] [ 1 ]	
PATTERN	[ 2 <sup>15</sup> -1 PRBS]	
PRBS POLARITY	[ INV ] CCITT	
STATUS:		
UNFRAMED	FRAMED	STRUCT'D
TEST FUNCTION	TEST FUNCTION	TEST FUNCTION

5. Set up the **RESULTS** display as shown opposite.

Any of the other results can be viewed on the display by making a choice from the softkey menu.

RESULTS [ PDH ]	[ CUMULATIVE ]			
	[ BIT ]			
TEST TIMING	[ MANUAL ]			
STORAGE	[ OFF ]			
BIT EC				
BIT ER				
ELAPSED TIME				
STATUS:				
BIT	FAS	FAS	FAS	FAS
140 NO.'s	34 NO.'s	8 NO.'s	2 NO.'s	

#### Start the Measurement and Monitor the Results

1. Connect PDH IN to PDH OUT.
2. Press **RUN/STOP** to start the measurement and monitor the **RESULTS** display.
3. Press **SINGLE** and check that the Error Results change.

## Making Measurements

---

This chapter contains a series of application orientated measurements and instrument tasks associated with the measurements.

### Application Measurements

The application measurements are arranged under the headings of PDH, SDH and ATM:

#### PDH Measurements

Alarm Monitoring	UKJ	2-4
Analysis of N X 64 kb/s	UKJ	2-7
BERT Testing	UKK or UKJ	2-11
Cross Multiplexer Testing	UKJ	2-16
FAS Monitoring	UKK or UKJ	2-21
Frequency Measurement	UKK or UKJ	2-24
Frequency Offset Tolerance	UKK or UKJ	2-27
Multiplexer Jitter Tolerance	UKK or UKJ + UHN & UHK	2-31
Multiplexer Testing	UKK or UKJ + UHC	2-35
Round Trip Delay	UKJ	2-40
Wander and Slips	UKK or UKJ + UHN	2-43

## SDH Measurements

Add/Drop Multiplexer Testing	US1 or A1T + UKK or UKJ + UH1 or UH2	2-47
Alarm Stimulus and Response	A1T	2-52
DCC Testing	A1T	2-56
De-Synchroniser Testing	A1T + UHN	2-59
Frame Synchronisation	A1T	2-62
Frequency Measurement	UKK or UKJ	2-67
Frequency Offset Tolerance	UKK or UKJ	2-70
Line Jitter Testing	UHK + A1M or A1N or A1P	2-73
MSP Stimulus and Response	A1T	2-76
Optical Clock Recovery Stress	A1T + UH1 or UH2	2-81
Payload Mapping and De-Mapping	US1 or A1T	2-83
Performance Monitoring (BIP and FEBE)	US1 or A1T	2-88

## ATM Measurements

Cell Performance	UKN	2-91
------------------	-----	------

Each measurement includes an explanation of the measurement, how and where to connect the instrument, how to configure the instrument, and how to obtain the relevant results.

## 2-2 Making Measurements

The instrument tasks associated with the measurements are :

- Installing Upgrade Modules
- Transmit Static Overhead
- Transmit Overhead Sequence
- Receive Overhead Monitor
- Graphics
- Logging Results
- Connecting an HP 550C DeskJet Printer
- Internal Printer Changing Paper
- Autosetup
- Coupling Tx and Rx Settings
- Path Trace (Option US1)
- Storing and Recalling instrument settings
- Setting Time and Date
- Enabling Keyboard Lock
- Enabling Beep On Error
- Analysis Control
- Performing an instrument Self Test

## Alarm Monitoring

### Application

Problems in the network at all levels in the hierarchy can be detected by the occurrence of alarms in each tributary of structured PDH systems.

Using the HP 37717B in a *receive only* mode, each tributary can be scanned and the state of Frame Loss, Remote (RAI) and AIS alarms viewed on the **RESULTS** display.

### Default (Known State) Settings

It can be advisable to set the HP 37717B to a known state prior to setting up to make a measurement. This clears all previous settings and provides a clearly defined instrument state. For a list of Default Settings and the procedure for accessing them see *Stored Settings*.

### Test Setup Procedure (Alarm Monitoring)

The following Option must be fitted to the HP 37717B to perform this test :

- UKJ - Structured PDH Module

This setup procedure is based on Structured PDH 140 Mb/s line traffic interfaced at the line equipment 75  $\Omega$  protected Monitor point . If a protected Monitor Point is not available then an HP 15510A Protective Probe may be used at an unprotected Monitor point.

When 120  $\Omega$  Balanced alarm monitoring is desired at an unprotected Monitor point use an HP 15511A Protective Monitor Probe.

The instrument is used in a *receive only* mode to monitor Frame Loss, AIS and Remote alarms.

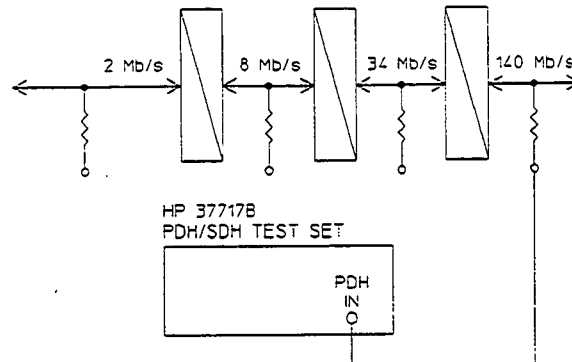

Figure 2-1. Alarm Monitoring

1. Connect the HP 37717B to the line terminal equipment protected Monitor point and set up the **RECEIVE** display MAIN SETTINGS as shown opposite.

The GAIN and EQUALIZER settings should be set to optimize the received signal.

RECEIVER INPUT		PDH
MAIN SETTINGS	STRUCT'D SETTINGS	
SIGNAL		[ 140 Mb/s ]
TERMINATION		75Ω UNBAL
LINE CODE		CM1
GAIN		[ 20 dB ]
EQUALIZER		[ OFF ]
PAYLOAD TYPE		[ STRUCTURED ]
TO SET TEST SIGNAL, FIRST SET 'SETTINGS' TO 'STRUCTURED SETTINGS'		
STATUS:		
MAIN SETTINGS	STRUCT'D SETTINGS	

2. Set up the **RECEIVE** display STRUCTURED SETTINGS as shown opposite.

2M PAYLOAD determines the Framing and selection should match that of the network equipment.

RECEIVER INPUT		[ PDH ]
MAIN SETTINGS	STRUCT'D SETTINGS	
TEST SIGNAL		[ 2 Mb/s ]
2M PAYLOAD		[ PCM30CRC ]
		34mb 8mb 2mb
		[ 3 ] [ 2 ] [ 4 ]
PATTERN		[ LIVE TRAFFIC ]
STATUS:		
MAIN SETTINGS	STRUCT'D SETTINGS	



### Start the Test (Alarm Monitoring)

1. Press **SIGNAL IN** until the MONITOR indicator is lit.
2. Set up the results display as shown opposite and select **[PDH ALM SCAN]** **ON**.

If any of the three alarms, Frame Loss, RAI or AIS has occurred the appropriate point in the hierarchy will be highlighted.

The test can be halted at any time by selecting **OFF** on the **[RESULTS]** Alarm Scan display.

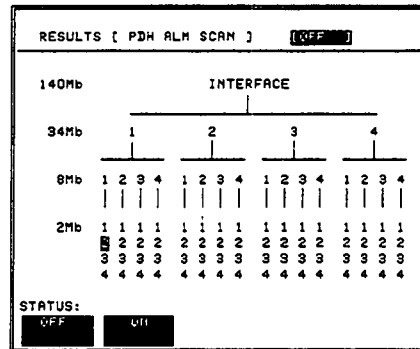

3. To determine which alarm has occurred set the **[RECEIVE]** display **STRUCTURED SETTINGS** to the tributary highlighted as shown opposite and press **RUN/STOP**.

*Example 2Mb number 2 of 8Mb number 1 of 34 Mb number 1 is highlighted.*

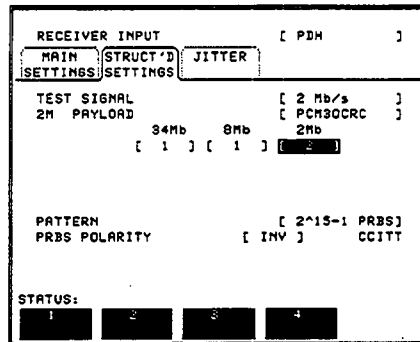

4. Now view the Alarm Seconds results on the **[RESULTS]** display to determine which alarms have occurred.

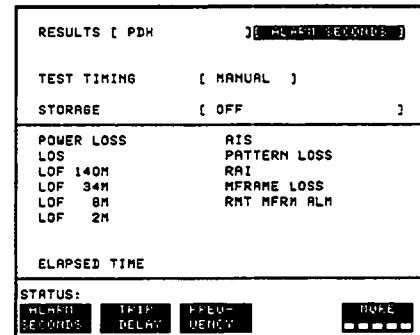

### 2-6 Making Measurements

## Analysis of N X 64 kb/s

### Application

Many customer premises receive subrate signals for example 128 Kb/s or 384 kb/s. The timeslots which make up these services may or may not be contiguous. Testing these services requires that the test set to be able to insert a pattern across the required timeslots.

Testing N X 64 kb/s channels structured within a 2 Mb/s signal can be carried out on an End to End basis using two test sets.

### Default (Known State) Settings

It can be advisable to set the HP 37717B to a known state prior to setting up to make a measurement. This clears all previous settings and provides a clearly defined instrument state. For a list of Default Settings and the procedure for accessing them see *Stored Settings*.

### Test Setup Procedure (N X 64 kb/s Analysis)

The following Option must be fitted to the HP 37717B to perform this test :

- UKJ - Structured PDH Module

This setup procedure is interfaced at 2 Mb/s, with a test signal of 6 X 64 kb/s non-contiguous timeslots. A PRBS test pattern is transmitted across the 6 timeslots. A BER measurement is performed on the received test pattern.

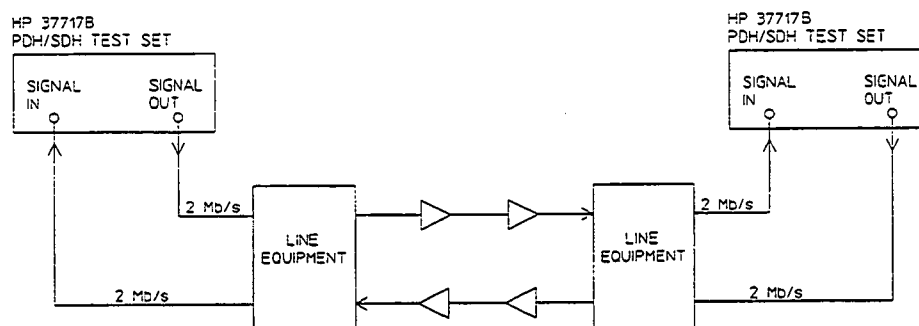

Figure 2-2. N X 64 kb/s Analysis

## HP 37717B #1

1. Set up the **OTHER SETTINGS CONTROL** display as shown opposite.

Any settings change made on the **TRANSMIT** or **RECEIVE** displays will automatically occur on the other.

```

FUNCTION          [ SETTINGS CONTROL ]

TRANSMITTER AND RECEIVER [ COUPLED ]

RECEIVER COUPLED TO TRANSMITTER

STATUS:
TRANSP: COUPLED
ERRANT:
    
```

2. Connect the HP 37717B to the line equipment and set up the **TRANSMIT MAIN SETTINGS** display as shown opposite.

The settings of SIGNAL rate and LINE CODE must match those of the network equipment.

```

TRANSMITTER OUTPUT          PDH

MAIN STRUCT'D TEST
SETTINGS SETTINGS FUNCTION

SIGNAL          [ 2 Mb/s ]
CLOCK SYNC     [ INTERNAL ]
TERMINATION     [ 75Ω UNBAL ]
LINE CODE      [ HDB3 ]
FREQUENCY OFFSET [ OFF ]

PAYLOAD TYPE    [ STRUCTURED ]

TO SET TEST SIGNAL, FIRST SET 'SETTINGS'
TO 'STRUCTURED SETTINGS'

STATUS:
MAIN STRUCT'D TEST
SETTINGS SETTINGS FUNCTION
    
```

3. Set up the **TRANSMIT STRUCTURED SETTINGS** display as shown opposite.

In this example timeslots 3, 5, 9, 25, 26 and 27 are selected.

2M PAYLOAD selects the Framing which must match that of the network equipment.

```

TRANSMITTER OUTPUT          [ PDH ]

MAIN STRUCT'D JITTER TEST
SETTINGS SETTINGS FUNCTION

TEST SIGNAL          [ Nx64 kb/s ]
2M PAYLOAD           [ PCN31CRC ]

Nx64 [ F..... ]
Cursor On Timeslot 131
Bandwidth 384 kb/s
PATTERN              [ 2^15-1 PRBS ]
PRBS POLARITY        [ NORM ] NON-CCITT

B/G PATTERN Nx64 kb/s      NUMBERED

STATUS:
DESELECT * Deselect ALL ← →
    
```

## 2-8 Making Measurements

4. Set up the **RESULTS** display as shown opposite.

The RESULTS type may be changed during the measurement without interrupting the test.

RESULTS [ PDH ]	[ G.821 ANALYSIS ]
	[ BIT ]
TEST TIMING	[ MANUAL ]
STORAGE	[ OFF ]
EC	And ES %
ES	%
EFS	%
SES	%
UNAV	%
DEG MIN	%
CODE ES	%
ELAPSED TIME	
STATUS:	
LIT	PRE
2 100%	PERE

### HP 37717B #2

1. Set up the **OTHER SETTINGS CONTROL** display as shown opposite.

Any settings change made on the **TRANSMIT** or **RECEIVE** displays will automatically occur on the other.

FUNCTION	[ SETTINGS CONTROL ]
TRANSMITTER AND RECEIVER	[ COUPLED ]
RECEIVER COUPLED TO TRANSMITTER	
STATUS:	
INTER-	COUPLED
EVIDENT	

2. Set up the **RECEIVE MAIN SETTINGS** display as shown opposite.

The settings of SIGNAL rate and LINE CODE must match those of the network equipment.

RECEIVER INPUT	PDH
DATA SETTINGS	STRUCT'D SETTINGS
SIGNAL	[ 2 Mb/s ]
TERMINATION	[ 75Ω UNBAL ]
LINE CODE	[ HDB3 ]
PAYLOAD TYPE	[ STRUCTURED ]
TO SET TEST SIGNAL, FIRST SET 'SETTINGS' TO 'STRUCTURED SETTINGS'	
STATUS:	
DATA SETTINGS	STRUCT'D SETTINGS



## BERT Testing

### Application

A transmission system must be specified for its overall error performance, measured over a period of time. Conformance to these specifications ensures that an installed system will meet the requirements of an Integrated Digital Network (IDN).

After troubleshooting, or during installation or commissioning, it is necessary to check that the transmission link meets this error performance.

This can be performed in two ways :

#### End To End

Error performance measurements are made on an end-to-end basis testing the Go and Return paths separately but simultaneously. The measurements are often performed unattended and the results and other events, alarms for example, logged on a printer and timed by a real time clock facility.

Two HP 37717B's are required for this measurement, one at each end of the link.

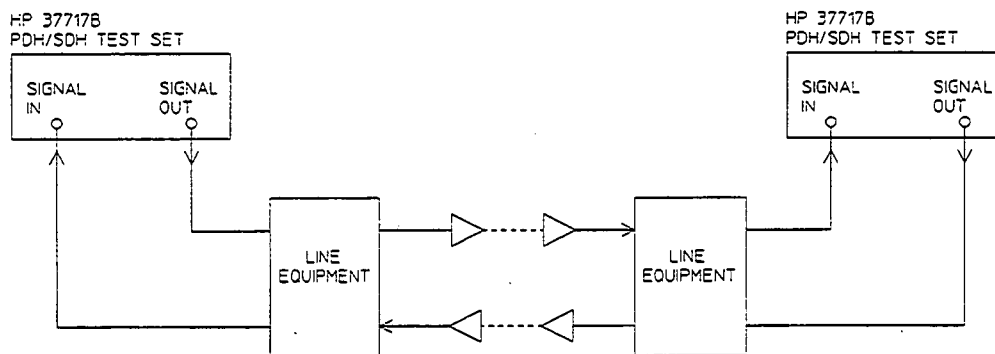
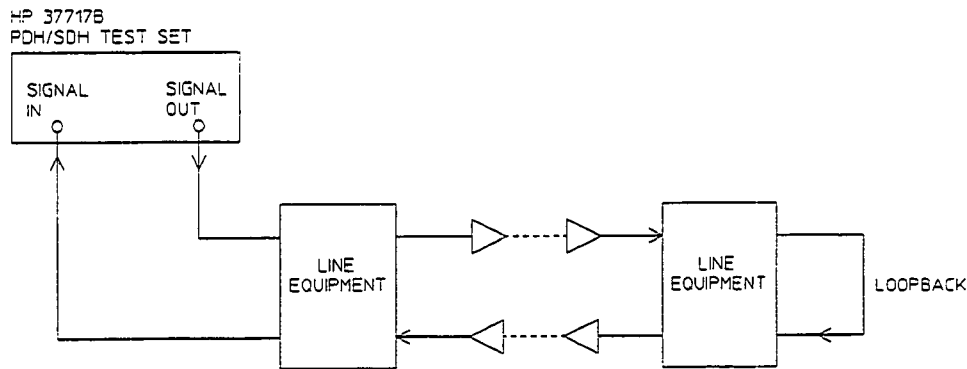

Figure 2-3. End-to-End Test

## Loopback

Error performance measurements are made via a loopback at the remote end of the system testing the combined Go and Return paths. The measurements are often performed unattended and the results and other events, alarms for example, logged on a printer and timed by a real time clock facility.



**Figure 2-4. Loopback Test**

### Default (Known State) Settings

It can be advisable to set the HP 37717B to a known state prior to setting up to make a measurement. This clears all previous settings and provides a clearly defined instrument state. For a list of Default Settings and the procedure for accessing them see *Stored Settings*.

### Test Setup Procedure (BERT Testing)

The following Option must be fitted to the HP 37717B to perform this test :

- UKJ or UKK - PDH Module

This setup procedure is based on 140 Mb/s, CMI, PRBS test data terminated in 75  $\Omega$ . A SINGLE test period of 24 HOURS is used and use of the internal printer for recording of results and alarms is included. A graphical record of the results can be viewed on the HP 37717B **GRAPH** display at the end of the test period.

## 2-12 Making Measurements

1. Set up the **OTHER SETTINGS CONTROL** display as shown opposite (on both HP 37717B's if end to end).

Any settings change made on the **TRANSMIT** or **RECEIVE** displays will automatically occur on the other.

FUNCTION [ SETTINGS CONTROL ]	
TRANSMITTER AND RECEIVER	[ COUPLED ]
RECEIVER COUPLED TO TRANSMITTER	
STATUS:	
INTER-	COUPLED
ENDENT	

2. Connect the HP 37717B to the line equipment and set up the **TRANSMIT** display as shown opposite (on both HP 37717B's if end to end).

TRANSMITTER OUTPUT	PDM
SIGNAL	[ 150 MHz ]
CLOCK SYNC	INTERNAL
FREQUENCY OFFSET	[ OFF ]
CODE	CHI
PATTERN	[ 2*28-1 ]
TERMINATION	75Ω UNBAL
STATUS:	
140 MHz	84 MHz
8 MHz	2 MHz
704 MHz	

3. Set up the **PRINTER** display as shown opposite (on both HP 37717B's if end to end).

A PRINT PERIOD selection of [USER PROGRAM] [15 MIN] provides the following :

A complete set of period and a complete set of cumulative results logged on the printer every 15 minutes.

A complete set of cumulative results logged on the printer at the end of the test period.

FUNCTION [ PRINTER ]	
PRINTER	[ INTERNAL ]
PRINTING	[ ON ]
PRINT PERIOD	[ USER PROGRAM ]
RESULTS PRINTED	[ 15 ] [ MINS ]
	[ ALL ]
PRINT ERROR SECONDS	[ OFF ]
PRINT AT END OF TEST	ALL RESULTS
STATUS:	
OFF	5 MINS
1 HOUR	24 HOURS
USER PROGRAM	



4. Set up the **RESULTS** display as shown opposite (on both HP 37717B's if end to end).

The RESULTS type can be changed during the test period without interrupting the test.

The STORAGE selection enables the graphics. To disable graphics select STORAGE [OFF].

RESULTS [ PDM ]		[ EFFUP ANALYSIS ]
TEST TIMING	[ MANUAL ]	
STORAGE	[ 1 MIN RESOL'N ]	
<b>BIT ANALYSIS</b>		
EC	And ES	%
ES		%
EFS		%
SES		%
UNAV		%
DEG MIN		%
CODE ES		
ELAPSED TIME		
STATUS:		
CUMULATIVE	SHUT	EFFUP
ACTIVE	TERM	ANALYSIS
	ALARM	SECOND
		REQUENCY

### Start the Test (BERT Testing)

1. Press **RUN/STOP** (on both HP 37717B's if end to end).

#### Note



If you do not require stored graphics results select STORAGE [OFF] on the **RESULTS** display.

The measurement results and alarms are available on the **RESULTS** display during the test period.

The graphical measurement results and alarms are stored in non volatile memory for viewing later on the **GRAPH** display.

The test can be halted at any time by pressing **RUN/STOP**.

### At the End of the Test (BERT Testing)

- The Date and Time the test started and the instrument setup are logged on the internal printer.
- All results are logged on the internal printer at 15 minute intervals.
- Any alarms which occur during the test period will be logged on the internal printer.
- At the end of the test period a complete set of cumulative results are logged on the internal printer.

- A graphical record of the results during the test period can be viewed on the **GRAPH** display. If Remote Control option 1A8 (HP-IB) or 1CW (RS-232-C) is fitted the graph results can be logged to an external printer, at a later date. See *Graphics* and *External HP 550C DeskJet Printer*.

- Results and Alarm summaries can be viewed on the **GRAPH** display.

The total graphics store capacity is normally 20,000 events. If **GRAPH STORAGE RESOLUTION [FULL]** is selected on the **OTHER MISCELLANEOUS** display the capacity reduces to 10,000 events.

The resolution, determined by the selection made under **STORAGE** on the **RESULTS** display, affects the **ZOOM** capability when viewing the bar graphs. If **1 SECOND** is selected all resolutions are available under **ZOOM**. If **1 MIN** is selected only **1 MIN/BAR**, **15 MINS/BAR** and **60 MINS/BAR** are available. If **15 MINS** is selected only **15 MINS/BAR** and **60 MINS/BAR** are available. If **1 HOUR** is selected only **60 MINS/BAR** is available.

Up to 10 sets of graphical results can be stored. If an attempt is made to store more than 10 sets of results, then a first in first out policy is operated and the oldest set of results will be lost. If graphics are enabled and a test is run which exceeds the remaining storage capacity, then some previously stored graphical results will be lost.

To prevent accidental overwriting of previously stored results the graphics capability should be disabled, when graphical results are not required, by selecting **STORAGE [OFF]** on the **RESULTS** display.

## PDH Cross Multiplexer Testing

### Application

For comprehensive testing of network equipment it is essential that the test equipment can multiplex/demultiplex the test signal.

The insertion of tributary signals into the PDH multiplexer, which are then multiplexed into the 140 Mb/s PDH structure should take place without introducing errors. The insertion and structuring process is tested by adding a test pattern to the tributary inserted at the tributary insert port. At the high rate side of the PDH multiplexer the tributary is destructured and a BER test performed.

By using a protected monitor point at the high rate side of the PDH multiplexer the mux/demux need not be taken out of service.

### Default (Known State) Settings

It is advisable to set the HP 37717B to a known state before setting up a measurement. This clears all previous settings and provides a clearly defined instrument state. For a list of Default Settings and the procedure for accessing them see *Stored Settings*.

### PDH Cross Multiplexer Testing Test Setup Procedure

The following Option must be fitted to the HP 37717B to perform this test :

- UKJ - Structured PDH Module

In this setup a 2 Mb/s Framed tributary, containing a test pattern, is inserted at the tributary insert port of the PDH multiplexer. The 140 Mb/s structured PDH signal is obtained from a protected monitor point. The 2 Mb/s tributary is destructured by the HP 37717B test set and an Error measurement is performed on the 2 Mb/s tributary test pattern.

A SINGLE test period of 24 HOURS is used and the internal printer is enabled to record results and alarms.

The HP 37717B PDH/SDH test set GRAPHICS function is enabled. The graphical results can be viewed on the **GRAPH** display



3. Set up the **RECEIVE** display MAIN SETTINGS as shown opposite.

The GAIN and EQUALIZER settings should be set to optimize the received signal.

RECEIVER INPUT		PDM
MAIN SETTINGS	STRUCT'D SETTINGS	
SIGNAL	[ 140 Mb/s ]	
TERMINATION	75Ω UNBAL	
LINE CODE	CM1	
GAIN	[ 20 dB ]	
EQUALIZER	[ OFF ]	
PAYLOAD TYPE	[ STRUCTURED ]	
TO SET TEST SIGNAL, FIRST SET 'SETTINGS' TO 'STRUCTURED SETTINGS'		
STATUS:		
MAIN SETTINGS	STRUCT'D SETTINGS	

4. Set up the **RECEIVE** display STRUCTURED SETTINGS as shown opposite.

The required 2 Mb/s test signal is selected under 34Mb : 8Mb : 2Mb

2M Payload determines the test signal framing and must match that of the network equipment.

RECEIVER INPUT		PDM
MAIN SETTINGS	STRUCT'D SETTINGS	
TEST SIGNAL	[ 2 Mb/s ]	
2M PAYLOAD	[ PCHSICRC ]	
	34Mb 8Mb 2Mb	
	[ 2 ] [ 3 ] [ 4 ]	
PATTERN	[ 2 <sup>n</sup> -1 PRBS ]	
PRBS POLARITY	[ NORM ] CCITT	
STATUS:		
1	2	3 4

5. Set up the **OTHER** display, PRINTER function, as shown opposite.

WHEN [PERIOD EC>0] ensures results are not logged on the printer when a print period is error free.

FUNCTION		[ PRINTER ]
PRINTER	[ INTERNAL ]	
PRINTING	[ ON ]	
PRINT PERIOD	[ 1 HOUR ]	
RESULTS PRINTED	[ SELECTED ]	
WHEN	[ PERIOD EC > 0 ]	
CONTENT	[ ER & AMAL ]	
	[ PER & CUMUL ]	
PRINT ERROR SECONDS	[ OFF ]	
PRINT AT END OF TEST	ALL RESULTS	
STATUS:		
PERIOD EC	PERIOD EC	0

### Continuity Check

Before running the test carry out a continuity test to verify the measurement path.

1. Set up the **RESULTS** display as shown opposite.
2. Press **RUN/STOP** to start a measurement.
3. Press error add **SINGLE** three times and check that the errors are recorded on the **RESULTS** display.
4. Press **RUN/STOP** to stop the measurement.

RESULTS [ PDH ]	[ [ CUMULATIVE ] ]
	[ BIT ]
TEST TIMING	[ MANUAL ]
STORAGE	[ OFF ]
BIT EC	
BIT ER	
ELAPSED TIME	
STATUS:	
BIT	FAS 140 Mb/s
	FAS 34 Mb/s
	FAS 8 Mb/s
	NOFE

### Start the PDH Cross Multiplexer Test

1. Set up the **RESULTS** display as shown opposite.

G.821 Analysis results are displayed but any of the other results can be viewed without affecting the measurement.

If you do not require stored graphics results select STORAGE [OFF].

2. Press **RUN/STOP** to start the measurement.

RESULTS [ PDH ]	[ [ G.821 ANALYSIS ] ]	
	[ BIT ]	
TEST TIMING	[ SINGLE ] [ [ 24 HOURS ] ]	
STORAGE	[ 15 MIN RESOL'M ]	
EC	And ES	%
ES		%
EFS		%
SES		%
UNAV		%
DES MIN		%
CODE ES		%
ELAPSED TIME		
STATUS:		
BIT	FAS 140 Mb/s	
	FAS 34 Mb/s	
	FAS 8 Mb/s	
	NOFE	

The following error results are available on the **RESULTS** display during the test period :

2 Mb/s                      FAS, CRC, REBE and BIT  
 8, 34 & 140 Mb/s        FAS

The graphical measurement results and alarms are stored in non volatile memory for viewing later on the **GRAPH** display.

The test can be halted at any time by pressing **RUN/STOP**.

### At the End of the Test (PDH Cross Multiplexer Testing)

- The Date and Time the test started and the instrument setup are logged on the internal printer.
- Results are logged on the internal printer at 1 hour intervals if the error count is greater than 0.
- Any alarms which occur during the test period will be logged on the internal printer.
- At the end of the test period a complete set of cumulative results are logged on the internal printer.
- A graphical record of the results during the test period can be viewed on the **GRAPH** display. If Remote Control option 1A8 (HP-IB) or 1CW (RS-232-C) is fitted the graph results can be logged to an external printer, at a later date. See *Graphics* and *External HP 550C DeskJet Printer*.
- Results and Alarm summaries can be viewed on the **GRAPH** display.

The total graphics store capacity is normally 20,000 events. If **GRAPH STORAGE RESOLUTION [FULL]** is selected on the **OTHER MISCELLANEOUS** display the capacity reduces to 10,000 events.

The resolution, determined by the selection made under **STORAGE** on the **RESULTS** display, affects the **ZOOM** capability when viewing the bar graphs. If **1 SECOND** is selected all resolutions are available under **ZOOM**. If **1 MIN** is selected only **1 MIN/BAR**, **15 MINS/BAR** and **60 MINS/BAR** are available. If **15 MINS** is selected only **15 MINS/BAR** and **60 MINS/BAR** are available. If **1 HOUR** is selected only **60 MINS/BAR** is available.

Up to 10 sets of graphical results can be stored. If an attempt is made to store more than 10 sets of results, then a first in first out policy is operated and the oldest set of results will be lost. If graphics are enabled and a test is run which exceeds the remaining storage capacity, then some previously stored graphical results will be lost.

To prevent accidental overwriting of previously stored results the graphics capability should be disabled, when graphical results are not required, by selecting **STORAGE [OFF]** on the **RESULTS** display.

## 2-20 Making Measurements

## PDH FAS Monitoring

### Application

Degradation in error performance can be detected by the occurrence of Frame Alignment Signal (FAS) errors in PDH systems.

Using the HP 37717B in a *receive only* mode, FAS errors can be measured and viewed on the **RESULTS** display. In addition, the results can be logged on the internal Printer for examination later.

### Default (Known State) Settings

It can be advisable to set the HP 37717B to a known state prior to setting up to make a measurement. This clears all previous settings and provides a clearly defined instrument state. For a list of Default Settings and the procedure for accessing them see *Stored Settings*.

### Test Setup Procedure (PDH FAS Monitoring)

The following Option must be fitted to the HP 37717B to perform this test :

- UKJ - Structured PDH Module

### Note



Option UKK - Unstructured PDH allows FAS Monitoring to be carried out at 2, 8, 34 and 140 Mb/s.

This setup procedure is based on Structured PDH 140 Mb/s line traffic interfaced at the line equipment protected Monitor point . If a protected Monitor Point is not available then an HP 15510A Protective Probe may be used at an unprotected Monitor point.

The instrument is used in a *receive only* mode to measure FAS Errors. A Timed Start test period is used which allows the measurement to be started at a time when the user would not normally be available.

All Error Ratio and Analysis results are logged on the internal printer at 2 hour intervals and at the end of the test period. Occurrences of error seconds and alarms are logged on the internal printer in real time.



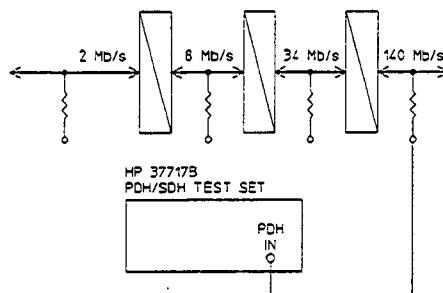

Figure 2-6. PDH FAS Monitoring

1. Connect the HP 37717B to the line terminal equipment protected Monitor point and set up the **RECEIVE** display MAIN SETTINGS as shown opposite.

When Balanced FAS monitoring is desired at an unprotected Monitor point use an HP 15511A Protective Monitor Probe.

The GAIN and EQUALIZER settings should be set to optimize the received signal.

2. Set up the **RECEIVE** display STRUCTURED SETTINGS as shown below.

RECEIVER INPUT	[ PDH ]
MAIN SETTINGS	STRUCT'D SETTINGS
TEST SIGNAL	[ 2 Mb/s ]
2M PAYLOAD	[ PCN30CRC ]
	34Mb 8Mb 2Mb
	[ 3 ] [ 2 ] [ 4 ]
PATTERN	[ LIVE TRAFFIC ]
STATUS:	
MAIN SETTINGS	STRUCT'D SETTINGS

2M PAYLOAD Framing selection should match that of the network equipment.

RECEIVER INPUT	PDH
MAIN SETTINGS	STRUCT'D SETTINGS
SIGNAL	[ 140 Mb/s ]
TERMINATION	75Ω UNBAL
LINE CODE	CM1
GAIN	[ 20 dB ]
EQUALIZER	[ OFF ]
PAYLOAD TYPE	[ STRUCTURED ]
TO SET TEST SIGNAL, FIRST SET 'SETTINGS' TO 'STRUCTURED SETTINGS'	
STATUS:	
MAIN SETTINGS	STRUCT'D SETTINGS

3. Set up the **PRINTER** display as shown below.

RESULTS [ PDH ]	[ 6.821 ANALYSIS ]
	[ FAS: 140 Mb/s ]
TEST TIMING	[ MANUAL ]
STORAGE	[ OFF ]
EC	AND ES %
ES	%
EPS	%
SES	%
UNAV	%
DES MIN	%
CODE ES	%
ELAPSED TIME	
STATUS:	
FAS: 140 Mb/s	FAS: 84 Mb/s
FAS: 8 Mb/s	FAS: 2 Mb/s
	MORE

## 2-22 Making Measurements

**Start the Test (PDH FAS Monitoring)**

1. Press **SIGNAL IN** until the MONITOR indicator is lit.
2. Set up the results display as shown opposite.

The test period will begin at the START time selected on the **RESULTS** display.

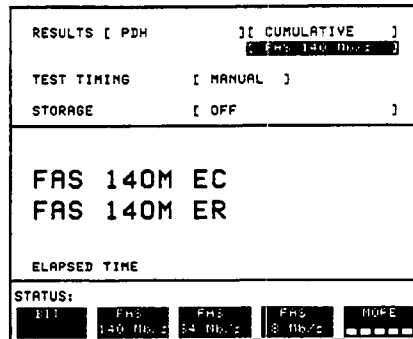

The following error types can be monitored :

- 140 Mb/s FAS (Short Term, Cumulative and G.821 Analysis)
- 34 Mb/s FAS (Short Term, Cumulative and G.821 Analysis)
- 8 Mb/s FAS (Short Term, Cumulative and G.821 Analysis)
- 2 Mb/s FAS, CRC and REBE (Short Term, Cumulative and G.821 Analysis)

Any occurrence of Alarms or Error Seconds during the test period are logged on the printer.

Cumulative and Period versions of Error Results and Analysis Results are logged on the internal printer at 2 hour intervals.

The test can be halted at any time by pressing **RUN/STOP**.

**At the End of the Test :**

- Cumulative and Period versions of Error Results and Analysis Results are logged on the internal printer.

## Frequency Measurement

### Application

The clock frequency and the amount of offset from the CCITT standard rate can be measured to give an indication of probability of errors.

The measurement can be made in out of service or monitor mode and is generally of short duration.

### Default (Known State) Settings

It can be advisable to set the HP 37717B to a known state prior to setting up to make a measurement. This clears all previous settings and provides a clearly defined instrument state. For a list of Default Settings and the procedure for accessing them see *Stored Settings*.

### Test Setup Procedure (Frequency Measurement)

If measuring frequency at PDH rates one of the following options is required.

- UKJ, UKK or UKL - PDH Module

If measuring frequency at SDH rates the following options must be fitted :

- US1 or A1T - SDH Module (STM-1 electrical)
- UH1 or UH2 or URU (STM-1 or STM-4 optical)

If measuring on live traffic the measurement is interfaced at the line terminal equipment Monitor point. The HP 37717B is used in a *receive only* mode to measure the PDH IN frequency. The PDH IN frequency is measured and compared with the internal CCITT standard frequency selected.

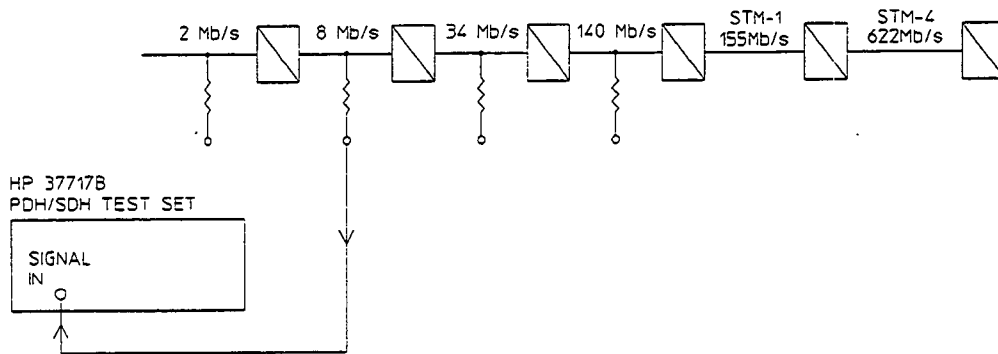

**Figure 2-7. Frequency Measurement**

1. Select SIGNAL [8 Mb/s] on the **RECEIVE** display.

For frequency measurement **PATTERN**; **TERMINATION** and **CODE** are not relevant.

RECEIVER INPUT	PDM
SIGNAL	[ 8 Mb/s ]
TEST MODE	[ OUT OF SRVC ]
CODE	[ HDB3 ]
PATTERN	[ 2 <sup>15</sup> -1 ]
TERMINATION	75Ω UNBAL
STATUS:	
140 Mb/s	84 Mb/s
8 Mb/s	2 Mb/s
2 Mb/s	0.4 Mb/s

2. Select **RESULTS** **PDM** **FREQUENCY**.

For frequency measurement **TEST TIMING** and **STORAGE** are not relevant.

RESULTS [ PDM ]	[ FREQUENCY ]
TEST TIMING	[ MANUAL ]
STORAGE	[ OFF ]
FREQUENCY	Hz
OFFSET	Hz
	ppm
STATUS:	
SHORT TERM	CORRECT
ERROR RATE	ANALYSIS
ALARM	RECORDS
FREQUENCY	RECORDS

### Run the Test (Frequency Measurement)

1. Press  until the Monitor indicator, above the key, is lit.
2. Connect the PDH IN port to the line terminal equipment monitor point.

The measured frequency and amount of offset from the internal standard is displayed.

If the PDH IN frequency is different from the selected BIT RATE the error message **Unable to recover clock** appears on the display. A **FREQ** reading is displayed but this should be ignored.

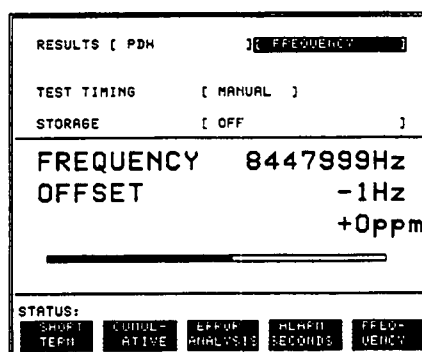

### At the End of the Test (Frequency Measurement)

Disconnect the HP 37717B from the line terminal equipment.

## Frequency Offset Tolerance

### Application

The capability of the network equipment to reliably recover the clock is tested by varying the clock rate of the generated data and checking for the occurrence of transmission errors.

The measurement can be made via a loopback or in a cross-multiplexer configuration, and is generally of short duration.

The CCITT G.703 Recommendation for Clock Tolerance is :

2048 kbit/s	$\pm 50$ ppm
8448 kbit/s	$\pm 30$ ppm
34368 kbit/s	$\pm 20$ ppm
139264 kbit/s	$\pm 15$ ppm

In SDH systems if the master timing reference is lost a standby reference within 20 ppm can be used for a limited time :

155520 kb/s (STM-1)  $\pm 20$  ppm ; 622080 kb/s (STM-4)  $\pm 20$  ppm.

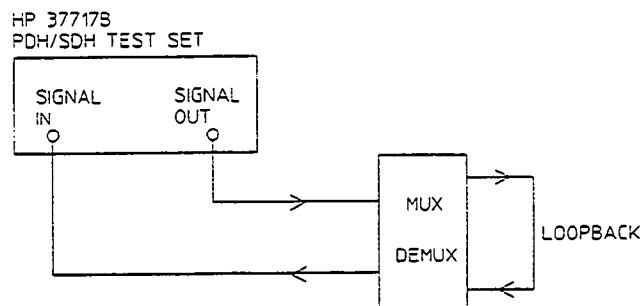

Figure 2-8. Frequency Offset Tolerance

### Default (Known State) Settings

It can be advisable to set the HP 37717B to a known state prior to setting up to make a measurement. This clears all previous settings and provides a clearly defined instrument state. For a list of Default Settings and the procedure for accessing them see *Stored Settings*.

### Test Setup Procedure (Frequency Offset Tolerance)

If checking frequency offset tolerance at PDH rates the following option is required.

- UKJ or UKK - PDH Module

If checking frequency offset tolerance at SDH rates the following options must be fitted :

- US1 or A1T - SDH Module (STM-1 electrical)
- UH1 or UH2 or URU (STM-1 or STM-4 optical)

This setup procedure tests the clock recovery capability of the line terminal equipment at 34 Mb/s using a PRBS pattern connected to the 75 Ω interface. The frequency of the generated data is offset and the data is looped back and monitored for errors.

1. Set up the **OTHER SETTINGS CONTROL** display as shown below.

FUNCTION	[ SETTINGS CONTROL ]
TRANSMITTER AND RECEIVER	[ COUPLED ]
RECEIVER COUPLED TO TRANSMITTER	
STATUS:	
INDEF- EIDENT	COUPLED

2. Set up the **RECEIVE** display as shown below.

RECEIVER INPUT	PDH
SIGNAL	[ 34 Mb/s ]
TEST MODE	[ OUT OF SRVC ]
CODE	HDB3
PATTERN	[ 2 <sup>15</sup> -1 ]
TERMINATION	75Ω UNBAL
STATUS:	
340 Mb/s	34 Mb/s
3 Mb/s	3 Mb/s
3 Mb/s	3 Mb/s
3 Mb/s	3 Mb/s

3. Set up the **RESULTS** display as shown opposite.

RESULTS [ PDM ]	[ CUMULATIVE ]
TEST TIMING	[ MANUAL ]
STORAGE	[ OFF ]
BIT EC	
BIT ER	
CODE EC	
CODE ER	
ELAPSED TIME	
STATUS:	
SHORT TERM	CUMULATIVE
ERROR ANALYSIS	RELATIVE SECONDS
	PREVIOUS MEMORY

### Continuity Check

Before running the test carry out a continuity test to verify the measurement path.

1. Connect a loopback at the desired point on the line terminal or cross-multiplexer equipment.
2. Press **RUN/STOP** to start a measurement.
3. Press error add **SINGLE** three times and check that the errors are recorded on the **RESULTS** display.
4. Press **RUN/STOP** to stop the measurement.

### Run the Test (Frequency Offset Tolerance)

1. Connect the HP 37717B to the 75  $\Omega$  interface of the multiplexer and set up the **TRANSMIT** display as shown opposite.
2. Press **RUN/STOP** to start the measurement.

TRANSMITTER OUTPUT	PDM
SIGNAL	[ 34 Mb/s ]
CLOCK SYNC	INTERNAL
FREQUENCY OFFSET	[ OFF ]
CODE	HDB3
PATTERN	[ 2 <sup>15</sup> -1 ]
TERMINATION	75 $\Omega$ UNBAL
STATUS:	
OFF	+20 PPM
	-20 PPM
	USER OFFSET

3. Select TX CLOCK OFFSET [+20ppm] and check that the Error Count and Error Ratio results are unchanged.



4. Select TX CLOCK OFFSET [-20ppm] and check that the Error Count and Error Ratio results are unchanged.

---

**Note**



The OFFSET values used above conform to CCITT G.703 Recommendation. If different values are required selection of [USER OFFSET] allows offsets of up to  $\pm 100$  ppm to be used.

---

**At the End of the Test**

1. Halt the test by pressing , and disconnect the HP 37717B.
2. Remove the loopback from the line terminal or cross-multiplexer equipment.



## Multiplexer Jitter Tolerance

### Application

It is important that network equipment can operate correctly in the presence of certain amounts of jitter. CCITT has specified tolerance masks of jitter amplitude against jitter frequency which all network equipment must be able to withstand and provide error free operation.

Jitter is applied at the CCITT specified jitter frequencies and the amplitude increased until errors occur or the mask limit is reached. These amplitude levels are plotted on the mask to determine the network elements jitter tolerance.

### Default (Known State) Settings

It can be advisable to set the HP 37717B to a known state prior to setting up to make a measurement. This clears all previous settings and provides a clearly defined instrument state. For a list of Default Settings and the procedure for accessing them see *Stored Settings*.

### Test Setup Procedure (Jitter Tolerance Test)

The following Option must be fitted to the HP 37717B to perform this test :

- UHK - Jitter Generation
- UKJ or UKK - PDH Module

This setup procedure is based on 34 Mb/s CMI, PRBS test data with jitter terminated in 75  $\Omega$ . The HP 37717B Automatic jitter tolerance feature is used and the results plotted on the CCITT mask.

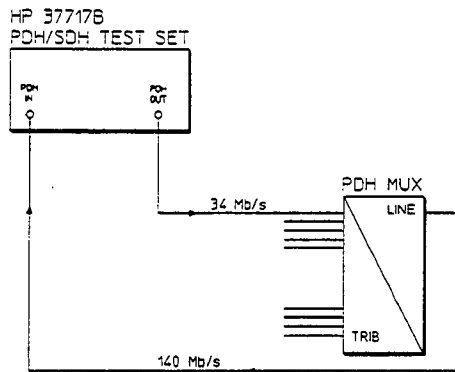
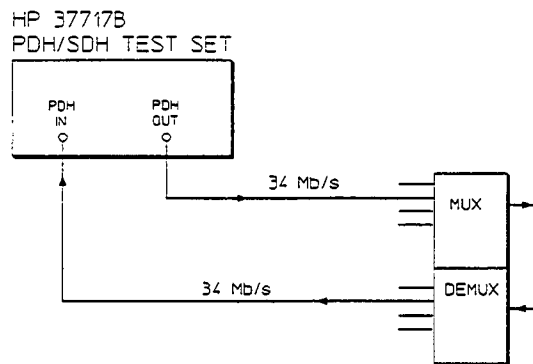

**Figure 2-9. Structured PDH Jitter Tolerance Test**

**Note**



This test can be performed using the Unstructured PDH Option UKK but the equipment configuration is slightly different as shown below.



**Figure 2-10. Unstructured PDH Jitter Tolerance Test**

60



1. Connect the HP 37717B to the network equipment, and set up the **TRANSMIT** display MAIN SETTINGS as shown below.

TRANSMITTER OUTPUT		PDH
MAIN SETTINGS	STRUCT'D SETTINGS	JITTER TEST FUNCTION
SIGNAL	[ 34 Mb/s ]	
CLOCK SYNC	INTERNAL	
TERMINATION	75Ω UNBAL	
LINE CODE	HDB3	
FREQUENCY OFFSET	[ OFF ]	
PAYLOAD TYPE	[ FRAMED ]	
PATTERN	[ 2 <sup>23</sup> -1 PRBS]	
PRBS POLARITY	[ INV ]	CCITT
STATUS:		
MAIN SETTINGS	STRUCT'D SETTINGS	JITTER TEST FUNCTION

2. Select TRANSMITTER OUTPUT SETTINGS [JITTER] and set up the display as shown below.

TRANSMITTER OUTPUT		PDH
PDH	JITTER	
JITTER	[ TOLERANCE ]	
SIGNAL FREQUENCY	34 Mb/s	
PATTERN	[ 2 <sup>23</sup> -1 ]	
0023 pattern is 2 <sup>23</sup> - 1		
PRESS <b>ENTER</b> TO BEGIN. PRESS AGAIN TO ABORT		
STATUS:		
PDH	JITTER	

3. Set up the **RECEIVE** display MAIN SETTINGS as shown below.

RECEIVER INPUT		PDH
MAIN SETTINGS	STRUCT'D SETTINGS	
SIGNAL	[ 140 Mb/s ]	
TERMINATION	75Ω UNBAL	
LINE CODE	CM1	
PAYLOAD TYPE	[ STRUCTURED ]	
TO SET TEST SIGNAL, FIRST SET 'SETTINGS' TO 'STRUCTURED SETTINGS'		
STATUS:		
MAIN SETTINGS	STRUCT'D SETTINGS	

4. Set up the **RECEIVE** display STRUCTURED SETTINGS as shown below.

RECEIVER INPUT		PDH
MAIN SETTINGS	STRUCT'D SETTINGS	JITTER
TEST SIGNAL	[ 34 Mb/s ]	
34M PAYLOAD	[ FRAMED ]	
34Mb [ 2 ]		
PATTERN	[ 2 <sup>23</sup> -1 PRBS]	
PRBS POLARITY	[ INV ]	CCITT
STATUS:		
MAIN SETTINGS	STRUCT'D SETTINGS	JITTER

### Run the Test (Jitter Tolerance)

Press **RUN/STOP** to start the measurement.

The measurement takes approximately three minutes to complete and its progress can be monitored on the **TRANSMIT** display.

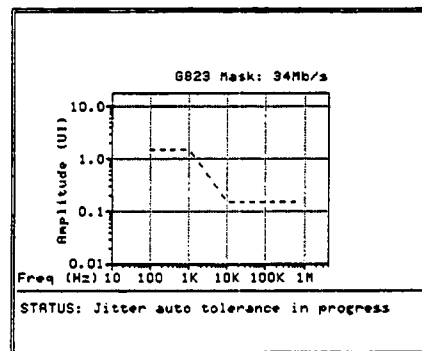

At the end of the test the results can be viewed on the **RESULTS** display.

The results on the **TRANSMIT** display are cleared when **TRANSMIT** is pressed but the **RESULTS** display remains available until the next Jitter Tolerance measurement is made.

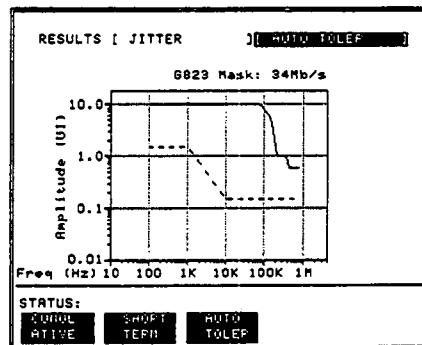

If Option 1CW, RS-232-C Remote control, or Option 1A8, HP-IB Remote Control, is fitted the Jitter Tolerance Mask results can be logged to an External printer (See *Connecting an HP 550C DeskJet Printer*). View the Jitter Tolerance results on the **RESULTS** display and press **PRINT NOW**.

## PDH Multiplexer Testing

### Application

PDH multiplexers combine four lower rate signals into a higher rate signal for transmission or further multiplexing. It is important that each multiplexer port operates error free and no "crosstalk" occurs between ports.

Multiplexing of the tributaries can be verified by performing a BER test at each of the four ports. However a more rigorous test involves loading all four ports to simulate live traffic conditions. This verifies the individual ports and detects any crosstalk problems between the ports.

### Default (Known State) Settings

It is advisable to set the HP 37717B to a known state before setting up a measurement. This clears all previous settings and provides a clearly defined instrument state. For a list of Default Settings and the procedure for accessing them see *Stored Settings*.

### PDH Multiplexer Test Setup Procedure

The following Options must be fitted to the HP 37717B to perform this test :

- UHC - Multiple Outputs
- UKJ or UKK - PDH Module

In this setup the PDH OUT signal and the three additional data outputs, from the Multiple Outputs option, load the 34 Mb/s input ports of the multiplexer. The HP 37717B (Structured PDH Option UKJ) destructures the 140 Mb/s signal and a BER test is performed on each of the 34 Mb/s signals in turn.

A SINGLE test period of 15 Minutes is used and the internal printer is enabled to record results and alarms.

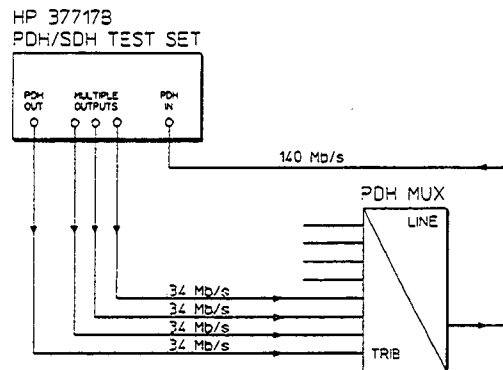
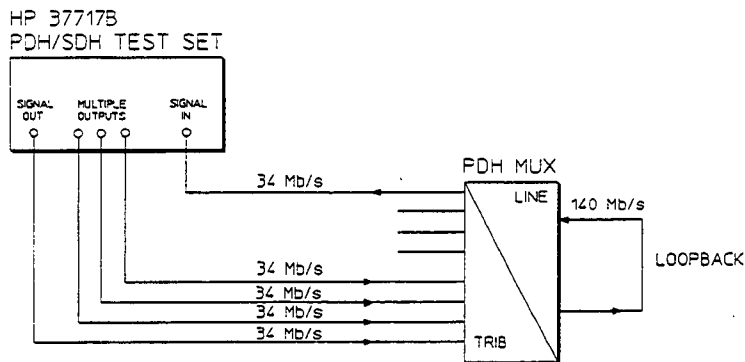

**Figure 2-11. Structured PDH Multiplexer Test**

**Note**



This test can be performed using the Unstructured PDH Option UKK but the equipment configuration is slightly different as shown below.



**Figure 2-12. Unstructured PDH Multiplexer Test**

1. Connect the HP 37717B to the network equipment and set up the **OTHER** **SETTINGS CONTROL** display as shown below.

FUNCTION [ SETTINGS CONTROL ]	
TRANSMITTER AND RECEIVER	[ INDEPENDENT ]
STATUS:	
INDEPENDENT	COUPLED

2. Set up the **TRANSMIT** display as shown below.

TRANSMITTER OUTPUT PDM	
DATA STRUCT'D: TEST	
SETTINGS SETTINGS: FUNCTION:	
SIGNAL	[ 34 Mb/s ]
CLOCK SYNC	INTERNAL
TERMINATION	75Ω UNBAL
LINE CODE	HDB3
FREQUENCY OFFSET	[ OFF ]
PAYLOAD TYPE	[ FRAMED ]
PATTERN	[ 2 <sup>15</sup> -1 PRBS ]
PRBS POLARITY	[ INV ] CCITT
STATUS:	
DATA STRUCT'D: TEST	
SETTINGS SETTINGS: FUNCTION:	

3. Set up the **RECEIVE** display MAIN **SETTINGS** as shown below.

RECEIVER INPUT PDM	
DATA STRUCT'D:	
SETTINGS SETTINGS:	
SIGNAL	[ 140 Mb/s ]
TERMINATION	75Ω UNBAL
LINE CODE	CHI
PAYLOAD TYPE	[ STRUCTURED ]
TO SET TEST SIGNAL, FIRST SET 'SETTINGS' TO 'STRUCTURED SETTINGS'	
STATUS:	
DATA STRUCT'D:	
SETTINGS SETTINGS:	

4. Set up the **RECEIVE** display **STRUCTURED SETTINGS** as shown below.

RECEIVER INPUT PDM	
DATA STRUCT'D:	
SETTINGS SETTINGS:	
TEST SIGNAL	[ 34 Mb/s ]
34M PAYLOAD	[ FRAMED ]
	34Mb
	[ 3 ]
PATTERN	[ 2 <sup>15</sup> -1 PRBS ]
PRBS POLARITY	[ INV ] CCITT
STATUS:	
DATA STRUCT'D:	
SETTINGS SETTINGS:	

The required 34 Mb/s test signal is selected under 34Mb.



5. Set up the **OTHER** display, PRINTER function, as shown opposite.

FUNCTION	[ PRINTER ]
PRINTER	INTERNAL
PRINTING	[ ON ]
PRINT PERIOD	[ OFF ]
PRINT ERROR SECONDS	[ OFF ]
PRINT AT END OF TEST	ALL RESULTS
STATUS:	
	[ OFF ] [ ON ]

### Start the PDH Multiplexer Test

1. Set up the **RESULTS** display as shown opposite.
2. Press **RUN/STOP** to start the measurement.
3. Repeat the test for the other three 34 Mb/s signals, selectable on the **RECEIVE** STRUCTURED SETTINGS display.

G.821 ANALYSIS is selected but any of the other results can be selected from the softkey menu without affecting the measurement.

RESULTS [ PDH ]	[ G.821 ANALYSIS ]
	[ BIT ]
TEST TIMING	[ SINGLE ] [ 1 HOUR ]
STORAGE	[ OFF ]
EC	And ES %
ES	%
EPS	%
SES	%
UHV	%
DES MIN	%
CODE ES	%
ELAPSED TIME	
STATUS:	
ERROR ACTIVE	SHORT TERM
D.4100 ANALYSIS	G.821 ANALYSIS
DUPE	

- The measurement results and alarms are available on the **RESULTS** display during the test period.
- The test can be halted at any time by pressing **RUN/STOP**.

**At the End of the Test (PDH Multiplexer)**

- The Date and Time the test started and the instrument setup are logged on the internal printer.
- All results are logged on the internal printer at the end of the test.
- Any alarms which occur during the test period will be logged on the internal printer.

## Round Trip Delay

### Application

In certain applications the time taken for a signal to pass through the network can be very important for example Voice Traffic where excessive delay can make speech difficult to understand. The Round Trip delay feature of the HP 37717B allows measurement of the delay at any interface or test signal rate.

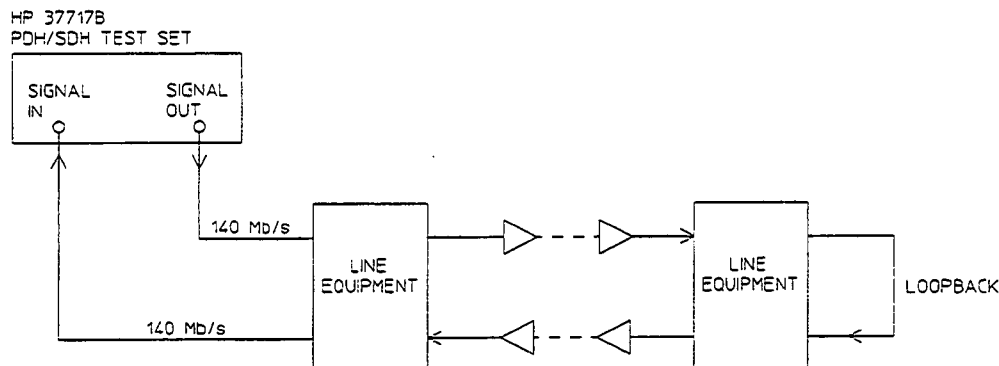

Figure 2-13. Round Trip Delay

### Default (Known State) Settings

It can be advisable to set the HP 37717B to a known state prior to setting up to make a measurement. This clears all previous settings and provides a clearly defined instrument state. For a list of Default Settings and the procedure for accessing them see *Stored Settings*.

### Test Setup Procedure (Round Trip Delay)

The following Option must be fitted to the HP 37717B to perform this test :

- UKJ - Structured PDH Module

This setup is interfaced at 140 Mb/s with a test signal of 64 kb/s. A test pattern is transmitted in the 64 kb/s slot and a timer is set running. A loopback is applied to the network equipment to return the test signal. The received pattern stops the timer and the Round Trip Delay is calculated.

## 2-40 Making Measurements

1. Connect the HP 37717B to the network equipment as shown in Figure 2-4 and set up the **OTHER SETTINGS CONTROL** display as shown opposite.

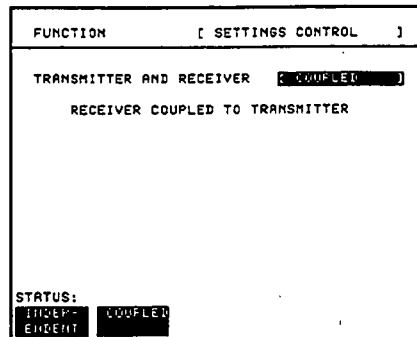

2. Set up the **TRANSMIT MAIN SETTINGS** display as shown opposite.

The SIGNAL rate and LINE CODE settings must match those of the network equipment.

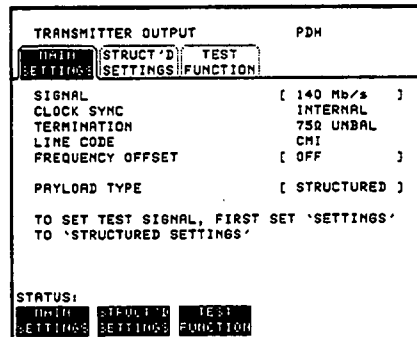

3. Set up the **TRANSMIT STRUCTURED SETTINGS** as shown opposite.

The 2M PAYLOAD selection determines the Framing which should match that of the network equipment.

The test 64 kb/s slot is selected under 34Mb ; 8Mb ; 2Mb ; 64kb.

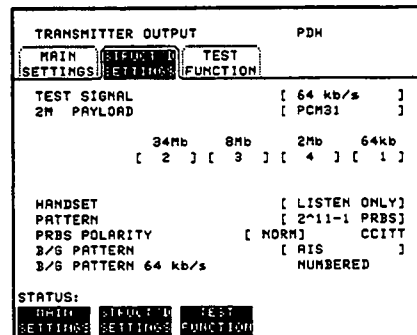

### Continuity Check

Before running the test carry out a continuity test to verify the measurement path.

1. Connect a loopback at the desired point on the line terminal equipment and set up the **RESULTS** display as shown opposite.
2. Press **RUN/STOP** to start a measurement.
3. Press error add **SINGLE** three times and check that the errors are recorded on the **RESULTS** display.
4. Press **RUN/STOP** to stop the measurement.

RESULTS [ PDH ]	[ CUMULATIVE ]
	[ BIT ]
TEST TIMING	[ MANUAL ]
STORAGE	[ OFF ]
BIT EC BIT ER	
ELAPSED TIME	
STATUS:	
ERR	FAS 140 Mb/s
	34 Mb/s
	8 Mb/s
	2 Mb/s

### Start the Test (Round Trip Delay)

1. Set up the **RESULTS** display as shown opposite.

Select ACTION [ON] to start the test.

The Round Trip Delay result is displayed in milliseconds.

RESULTS [ PDH ]	[ TRIP DELAY ]
ACTION	[ OFF ]
TEST TIMING	[ MANUAL ]
STORAGE	[ OFF ]
DELAY	0.0 msec
ELAPSED TIME 00d 00h 00m 03s	
STATUS:	
OFF	ON

The delay measurement range is up to 2 seconds. The Resolution varies according to the received rate :

- 2 Mb/s - 1 $\mu$ s
- 8, 34, 140 Mb/s - 10 $\mu$ s
- STM-1 - 0.5 ms

## Wander and Slips

### Application

The CCITT specify the frequency limits within which network equipment clocks should operate. However when network equipment from different manufacturers is connected together errors in transmission may occur due to timing differences.

To avoid this problem Master Timing sources are typically used as a reference timing source for all network equipment. The timing reference is distributed throughout the network as a 2 Mb/s signal.

Problems may arise due to wrongly configured equipment running on internal clocks or at the junction of different operators network equipment.

Because the timing sources may operate at slightly different frequencies and exhibit long term frequency drift then phase difference (Wander) may occur, between the incoming data and the network equipment. This causes "Bit Slips" in the network equipment buffers and results in frames being repeated or deleted thus reducing the efficiency of data transfer.

### Default (Known State) Settings

It is advisable to set the HP 37717B to a known state before setting up a measurement. This clears all previous settings and provides a clearly defined instrument state. For a list of Default Settings and the procedure for accessing them see *Stored Settings*.

### Wander and Slips Test Setup Procedure

The following Options must be fitted to the HP 37717B to perform this test :

- UHN - PDH Jitter receiver + Wander and Estimated Slips
- UKJ or UKK - PDH Module

This measurement is made on live traffic and is interfaced at the line terminal equipment monitor point. The HP 37717B is used in a *receive only* mode to measure the Wander and Estimated Bit Slips. A SINGLE test period of 24 HOURS is used and use of the internal printer for recording of results and alarms is included. A graphical record of the results can be viewed on the HP 37717B **GRAPH** display at the end of the test period.

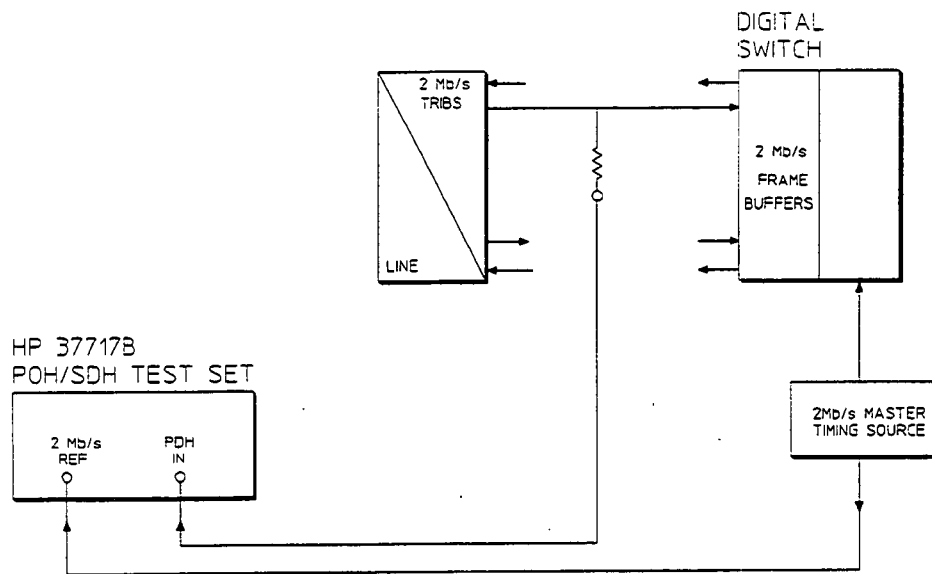

Figure 2-14. Wander and Slips Test

1. Select **RECEIVE** and set up the display as shown below.

RECEIVER INPUT	PDH
<b>PDH</b> JITTER	
SIGNAL	[ 2 Mb/s ]
TEST MODE	[ IN SERVICE ]
FRAMING	[ PCHSOCRC ]
CODE	[ HDDBS ]
PATTERN	LIVE TRAFFIC
TERMINATION	[ 75Ω UNBAL ]
STATUS:	
PDH	JITTER

2. Select **OTHER** **PRINTER** and set up the display as shown below.

FUNCTION	[ PRINTER ]
PRINTER	INTERNAL
PRINTING	[ ON ]
PRINT PERIOD	[ OFF ]
PRINT ERROR SECONDS	[ OFF ]
PRINT AT END OF TEST	[ ALL RESULTS ]
STATUS:	
OFF	ON

Selections of FRAMING and CODE should match those of the network equipment.

3. Select **RESULTS** **WANDER**.

The **STORAGE** selection enables the graphics. To disable graphics select **STORAGE [OFF]**.

**WANDER** is selected but **BIT SLIPS** or **BAR GRAPH** may be selected without affecting the measurement.

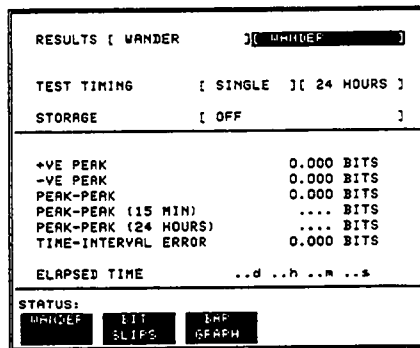

### Run the Test (Wander and Slips)

1. Press **SIGNAL IN** until the Monitor indicator, above the key, is lit.
2. Connect the PDH IN port to the line terminal equipment monitor point.
3. Connect the network master timing source to the HP 37717B 2 Mb/s REFERENCE input.

If no reference signal is connected to the HP 37717B then the status message "NO REF" is displayed.

4. Press **RUN/STOP** to start the measurement.

If **BAR GRAPH** is selected the current wander measurements are displayed in graphical form. Three positive and negative sliding bar graphs, of  $\pm 1$  UI,  $\pm 16$  UI and  $\pm 256$  UI, are displayed.

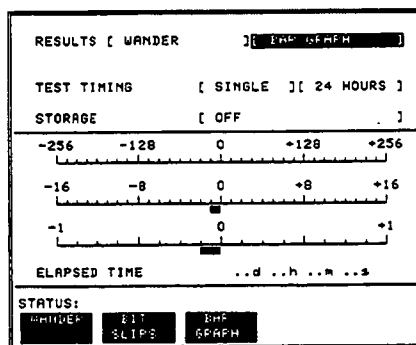

- The measurement results and alarms are available on the **RESULTS** display during the test period.



- The test can be halted at any time by pressing **RUN/STOP**.

#### At the End of the Test (Wander and Slips)

- The Date and Time the test started and the instrument setup are logged on the internal printer.
- Any alarms which occur during the test period will be logged on the internal printer.
- At the end of the test period a complete set of results are logged on the internal printer.
- A graphical record of the results during the test period can be viewed on the **GRAPH** display. If Remote Control option 1A8 (HP-IB) or 1CW (RS-232-C) is fitted the graph results can be logged to an external printer, at a later date. See *Graphics* and *External HP 550C DeskJet Printer*.
- Results and Alarm summaries can be viewed on the **GRAPH** display.

The total graphics store capacity is normally 20,000 events. If **GRAPH STORAGE RESOLUTION [FULL]** is selected on the **OTHER MISCELLANEOUS** display the capacity reduces to 10,000 events.

The resolution, determined by the selection made under **STORAGE** on the **RESULTS** display, affects the **ZOOM** capability when viewing the bar graphs. If **1 SECOND** is selected all resolutions are available under **ZOOM**. If **1 MIN** is selected only **1 MIN/BAR**, **15 MINS/BAR** and **60 MINS/BAR** are available. If **15 MINS** is selected only **15 MINS/BAR** and **60 MINS/BAR** are available. If **1 HOUR** is selected only **60 MINS/BAR** is available.

Up to 10 sets of graphical results can be stored. If an attempt is made to store more than 10 sets of results, then a first in first out policy is operated and the oldest set of results will be lost. If graphics are enabled and a test is run which exceeds the remaining storage capacity, then some previously stored graphical results will be lost.

To prevent accidental overwriting of previously stored results the graphics capability should be disabled, when graphical results are not required, by selecting **STORAGE [OFF]** on the **RESULTS** display.

## **Add/Drop Multiplexer Testing**

### **Application**

The insertion of tributary signals into the Add/Drop multiplexer, which are then mapped into the SDH signal, should take place without introducing errors. The insertion and mapping process is tested by adding a test pattern to the tributary inserted at the tributary insert port. At the SDH side of the Add/Drop multiplexer the tributary is demapped by the HP 37717B PDH/SDH test set. By using the Optical Splitter, at the optical side of the Add/Drop multiplexer, the Add/Drop multiplexer need not be taken out of service. A Bit error rate (BER) test is performed on the recovered tributary test pattern to determine whether errors have been introduced by the Add/Drop multiplexer.

### **Default (Known State) Settings**

It is advisable to set the HP 37717B to a known state before setting up a measurement. This clears all previous settings and provides a clearly defined instrument state. For a list of Default Settings and the procedure for accessing them see *Stored Settings*.

### **Add/Drop Multiplexer Testing Test Setup Procedure**

The following Options must be fitted to the HP 37717B to perform this test :

- UKJ or UKK - PDH Module
- US1 or A1T - SDH Module
- UH2 or URU- STM-1/4 Optical Interface

In this setup a 2 Mb/s payload, containing a test pattern, is inserted at the tributary insert port of the Add/Drop multiplexer. A portion of the STM4 Optical signal is tapped off by the Optical Splitter (approx 10%) and the 2 Mb/s tributary is demapped by the HP 37717B test set.

An Error measurement is performed on the demapped 2 Mb/s tributary test pattern.

A SINGLE test period of 24 HOURS is used and the internal printer is enabled to record results and alarms.

The HP 37717B PDH/SDH test set GRAPHICS function is enabled. The graphical results can be viewed on the **GRAPH** display

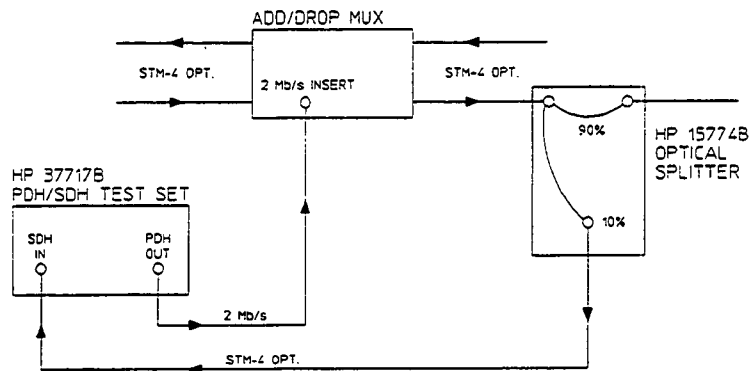

**Figure 2-15. Add/Drop Multiplexer Testing**

1. Connect the HP 37717B to the network equipment and set up the **OTHER** **SETTINGS CONTROL** display as shown opposite.

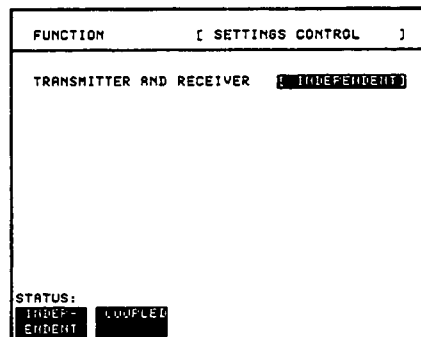

2. Set up the **TRANSMIT** display as shown opposite.

The PAYLOAD TYPE determines the Framing which is selected from the softkey menu. If Option UKK, Unstructured PDH Module, is used the Framing choice is made under FRAMING.

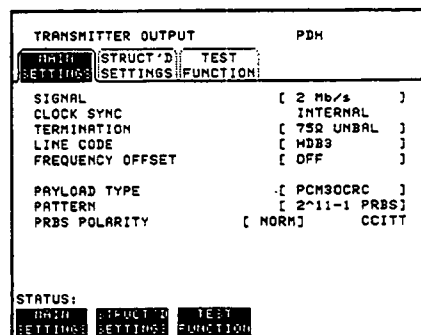

3. Set up the **RECEIVE** display as shown below.

RECEIVER INPUT [ SDH ]	
SDH	STRUCT'D: PAYLOAD
SIGNAL [ STM-4 OPT ]	
STM-1 UNDER TEST	[ 1 ]
PAYLOAD	[ ASYNC 2Mb/s ]
SELECTED 2Mb/s (TU) :	
TUGS [1]	TUG2 [1] TU [1]
PAYLOAD TYPE	[ PCS90CRC ]
PATTERN	[ 2 <sup>11</sup> -1 PRBS ]
PRBS POLARITY	[ NORM] CCITT
STATUS:	
SDH	STRUCT'D: PAYLOAD

4. Set up the **OTHER** display, PRINTER function, as shown below.

FUNCTION [ PRINTER ]	
PRINTER	[ INTERNAL ]
PRINTING	[ ON ]
PRINT PERIOD	[ 1 HOUR ]
RESULTS PRINTED	[ SELECTED ]
WHEN	[ PERIOD EC W ]
CONTENT	[ ER & AMAL ]
PRINT ERROR SECONDS	[ PER & CUMUL ]
PRINT AT END OF TEST	[ OFF ]
STATUS:	
ALPHA	PERIOD EC W

### Continuity Check

Before running the test carry out a continuity test to verify the measurement path.

1. Set up the **RESULTS** display as shown opposite.
2. Press **RUN/STOP** to start a measurement.
3. Press error add **SINGLE** three times and check that the errors are recorded on the **RESULTS** display.
4. Press **RUN/STOP** to stop the measurement.

RESULTS [ PDH PAYLOAD ]	[ CUMULATIVE ]
	[ BIT ]
TEST TIMING	[ MANUAL ]
STORAGE	[ OFF ]
BIT EC	
BIT ER	
ELAPSED TIME	
STATUS:	
BIT	ERR
CFU	PEBE

### Start the Add/Drop Multiplexer Test

1. Set up the **RESULTS** display as shown opposite.

If you do not require stored graphics results select STORAGE [OFF].

2. Press **RUN/STOP** to start the measurement.

RESULTS [ PDH PAYLOAD ] [ G.021 ANALYSIS ]		
[ EDIT ]		
TEST TIMING	[ SINGLE ]	[ 24 HOURS ]
STORAGE	[ 15 MIN RESOL'N ]	
EC	And ES	%
ES		%
EFS		%
SES		%
UNAV		%
DES MIN		%
CODE ES		%
ELAPSED TIME		
STATUS:		
ERR	FMS	CFC
0 MW/s		FEED

The measurement results and alarms are available on the **RESULTS** display during the test period.

The graphical measurement results and alarms are stored in non volatile memory for viewing later on the **GRAPH** display.

The test can be halted at any time by pressing **RUN/STOP**.

### At the End of the Test (Add/Drop Multiplexer Testing)

- The Date and Time the test started and the instrument setup are logged on the internal printer.
- Results are logged on the internal printer at 1 hour intervals if the error count is greater than 0.
- Any alarms which occur during the test period will be logged on the internal printer.
- At the end of the test period a complete set of cumulative results are logged on the internal printer.
- A graphical record of the results during the test period can be viewed on the **GRAPH** display. If Remote Control option 1A8 (HP-IB) or 1CW (RS-232-C) is fitted the graph results can be logged to an external printer, at a later date. See *Graphics* and *External HP 550C DeskJet Printer*.
- Results and Alarm summaries can be viewed on the **GRAPH** display.

### 2-50 Making Measurements

The total graphics store capacity is normally 20,000 events. If GRAPH STORAGE RESOLUTION [FULL] is selected on the **OTHER** **MISCELLANEOUS** display the capacity reduces to 10,000 events.

The resolution, determined by the selection made under STORAGE on the **RESULTS** display, affects the ZOOM capability when viewing the bar graphs. If 1 SECOND is selected all resolutions are available under ZOOM. If 1 MIN is selected only 1 MIN/BAR, 15 MINS/BAR and 60 MINS/BAR are available. If 15 MINS is selected only 15 MINS/BAR and 60 MINS/BAR are available. If 1 HOUR is selected only 60 MINS/BAR is available.

Up to 10 sets of graphical results can be stored. If an attempt is made to store more than 10 sets of results, then a first in first out policy is operated and the oldest set of results will be lost. If graphics are enabled and a test is run which exceeds the remaining storage capacity, then some previously stored graphical results will be lost.

To prevent accidental overwriting of previously stored results the graphics capability should be disabled, when graphical results are not required, by selecting STORAGE [OFF] on the **RESULTS** display.

## **Alarm Stimulus/Response**

### **Application**

SDH network elements transmit alarms in response to certain error/alarm conditions to advise upstream and downstream equipment that these conditions exist. If these alarms are not transmitted in the proper manner, at the proper time, degradations in service will occur.

Alarm testing entails transmitting an alarm signal from the PDH/SDH test set and monitoring the network equipment alarm indicators and the upstream or downstream signal for the correct response.

### **Default (Known State) Settings**

It is advisable to set the HP 37717B to a known state before setting up a measurement. This clears all previous settings and provides a clearly defined instrument state. For a list of Default Settings and the procedure for accessing them see *Stored Settings*.

### **Alarm Stimulus/Response Test Setup Procedure**

The following options must be fitted to the HP 37717B to perform this test:

- US1 or A1T - SDH module
- UH1 or UH2 or URU - STM-1 Optical interface

In this setup the PDH/SDH test set transmits MS AIS Alarm into the network. The network equipment alarm indicators are monitored for the appropriate alarms. The upstream signal is monitored for occurrences of MS FERF. The downstream signal can be monitored for occurrences of PATH AIS.

A similar procedure can be used for testing all other SDH alarms. See Table 2-1.



HP 37717B  
PDH/SDH TEST SET

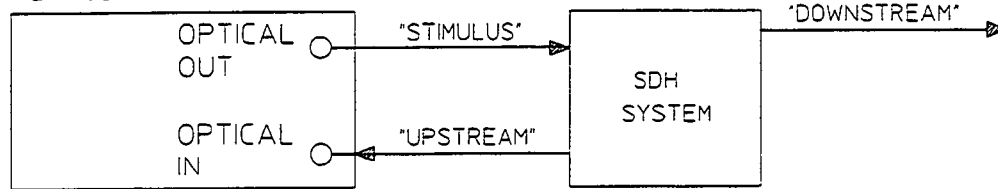

Figure 2-16. Alarm Stimulus/Response

Table 2-1. SDH Alarms

Alarm	RSTE		MSTE		PTE	
	Down	Up	Down	Up	Down	Up
Loss Of Signal	MS AIS	N/A	Path AIS	MS FERF	TU-Path AIS	TU-Path FERF
Loss Of Frame	MS AIS	N/A	Path AIS	MS FERF	TU-Path AIS	TU-Path FERF
Loss Of Pointer	N/A	N/A	Path AIS	MS FERF	TU-Path AIS	TU-Path FERF
MS AIS	N/A	N/A	Path AIS	MS FERF	TU-Path AIS	TU-Path FERF
MS FERF	N/A	N/A	N/A	N/A	N/A	N/A



1. Set up the **TRANSMIT SETTINGS CONTROL** display as shown below.

FUNCTION [ SETTINGS CONTROL ]	
TRANSMITTER AND RECEIVER [ COUPLED ]	
RECEIVER COUPLED TO TRANSMITTER	
STATUS:	
INDEF- ENDENT	COUPLED

2. Set up the **TRANSMIT MAIN SETTINGS** display as shown below.

TRANSMITTER OUTPUT [ SDH ]	
SDH	TEST OVERHEAD
FUNCTION	SETUP
SIGNAL	[ STM-16 OPT ]
CLOCK SYNC	[ INTERNAL ]
FREQUENCY OFFSET	[ OFF ]
PAYLOAD	[ 140 Mb/s ]
PAYLOAD TYPE	UNFRAMED
PATTERN	[ 2^23-1 PRBS ]
PRBS POLARITY	[ INV ] CCITT
140M OFFSET	[ 0 PPR ]
STATUS:	
SDH	TEST OVERHEAD
FUNCTION	SETUP

3. Set up the **TRANSMIT TEST FUNCTION** display as shown below.

TRANSMITTER OUTPUT [ SDH ]	
SDH	TEST OVERHEAD
FUNCTION	SETUP
TEST FUNCTION [ SDH ]	[ ERR & ALARM ]
ERROR ADD TYPE	[ A1A2 FRAME ]
RATE	[ OFF ]
ALARM TYPE	[ 15 MS ]
STATUS:	
15 MS	15 PERF
COUNT OF	ERRM
POINTER	ALARM
	TYPE

The ERROR ADD TYPE selected does not matter as long as RATE [OFF] is selected.

4. Set up the **RESULTS** display as shown below.

RESULTS [ SDH ] [ ALARM SECONDS ]	
TEST TIMING	[ MANUAL ]
STORAGE	[ OFF ]
POWER LOSS	K1/K2 CHANGE
LOS	MS FERF
LOF	PATH FERF
ODF	TU LOP
LOP	TU PATH AIS
MS AIS	TU PATH FERF
PATH AIS	
ELAPSED TIME	
STATUS:	
CONTIN	SHORT
TIME	TERM
16.826	16.826
ALARM	ALARM
SECONDS	SECONDS
	DOPE
	DOPE

ALARM SECONDS are displayed but any of the other results can be selected from the softkey menu without affecting the measurement.

**Start the Alarm Stimulus/Response Test**

1. Connect the PDH/SDH test set to the upstream port of the network equipment and press **RUN/STOP** on the HP 37717B.
2. Check that the network equipment registers MS AIS and that MS FERF alarm seconds are recorded on the **RESULTS** display.

## **DCC Testing**

### **Application**

The section overhead contains two DataCommunication Channels (DCC), Regenerator Section DCC at 192 kb/s (overhead bytes D1- D3) and Multiplexer Section DCC at 576 kb/s (overhead bytes D4 - D12). The DCC communicates network management messages between network elements and the network controller via the operations support computer system.

If the DCC is not operating correctly these network management messages will be lost and degradations in network performance will pass unnoticed. This may result in a failure condition.

Full testing of the line and section DCC's can be carried out using a protocol analyzer connected via the HP 37717B PDH/SDH test set to the appropriate overhead bytes. At the far end the HP 37717B PDH/SDH test set can drop the selected DCC to the protocol analyzer allowing the DCC integrity to be analyzed.

If you do not have access to a protocol analyzer capable of handling SDH DCC protocol, the DCC integrity can be verified by a BER test using an HP 37732A, Digital Telecomm/Datacomm Analyzer.

### **Default (Known State) Settings**

It is advisable to set the HP 37717B to a known state prior to setting up a measurement. This clears all previous settings and provides a clearly defined instrument state. For a list of Default Settings and the procedure for accessing them see *Stored Settings*.

### **DCC Test Setup Procedure**

In this procedure the HP 37717B PDH/SDH test set accepts a 576 kb/s test pattern via the protocol analyzer port, inserting the test pattern in bytes D4 - D12 of the Multiplexer Section overhead and transmitting an STM-1 optical signal. The HP 37717B PDH/SDH test set receives the STM-1 optical signal and drops the Multiplexer Section DCC, via the rear panel protocol analyzer port, to the HP 37732A which performs the BER measurement.

HP 37732A DIGITAL  
TELECOMM/DATACOMM  
ANALYSER

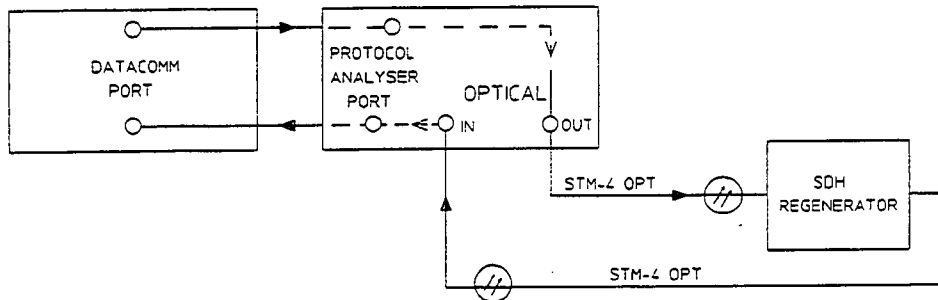
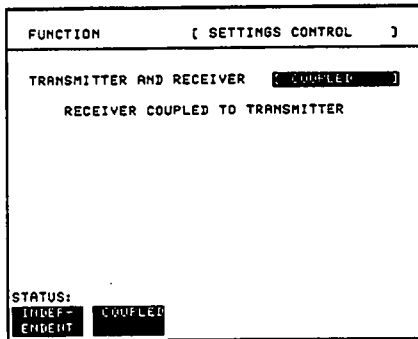
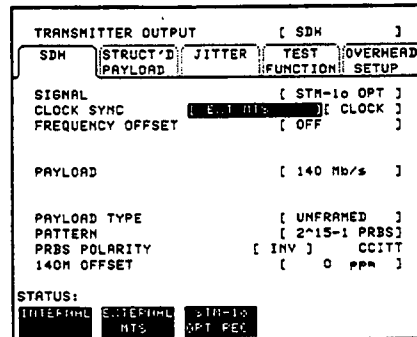

Figure 2-17. DCC Testing

1. Connect the HP 37732A and the HP 37717B to the network element, as shown and set up the **TRANSMIT** **SETTINGS CONTROL** display as shown below.



2. Set up the **TRANSMIT** **SDH** display as shown below.



The **CLOCK SYNC** selection determines the synchronization source for the **TRANSMIT** clock. If **[EXT MTS]** is selected a 2 Mb/s reference must be connected to the front panel 2M REF IN port. The format can be **CLOCK** or **DATA**.

3. Set up the **TRANSMIT TEST FUNCTION** display as shown below.

TRANSMITTER OUTPUT		[ SDH ]
SDH	STRUCT'D PAYLOAD	JITTER
TEST FUNCTION		OVERHEAD SETUP
TEST FUNCTION [ SDH ]		[ DCC INSERT ]
		[ MS DCC ]
DCC BYTE POLARITY		[ NORMAL ]
STATUS:		
RS DCC	MS DCC	
D1-D5	D3-D12	

4. Set up the **RECEIVE TEST FUNCTION** display as shown below.

RECEIVER INPUT		[ SDH ]
SDH	STRUCT'D PAYLOAD	TEST FUNCTION
		OVERHEAD MONITOR
TEST FUNCTION		[ DCC DROP ]
		[ MS DCC ]
DCC BYTE POLARITY		[ NORMAL ]
STATUS:		
SDH	STRUCT'D PAYLOAD	TEST FUNCTION
		OVERHEAD MONITOR

### Start the DCC Test

1. Select TEST SELECT **DATA COM** on the HP 37732A.
2. Set TX Clock Source and RX Clock Source to **INTERFACE** on the HP 37732A (Clock from HP 37717B protocol port).
3. Select the required pattern and monitor logic errors and frequency to verify the integrity of the DCC.

## **Desynchroniser Stress**

### **Application**

At the boundary of the SDH network the 2 Mb/s or 140 Mb/s payload is demapped from the SDH signal. Pointer adjustments in the SDH signal may cause high levels of tributary jitter in the output payload. Excessive amounts of tributary jitter will result in errors.

The desynchronizing phase lock loop of the network element should minimize the level of tributary jitter in the payload but correct operation under stress conditions must be verified.

The desynchronizing phase lock loop can be stressed by adding pointer movement sequences (defined in CCITT standard G.783) to the SDH signal such that the test VC-4 moves with respect to the SDH frame.

A jitter measurement is made to verify that the desynchroniser output jitter is within the required specification.

### **Default (Known State) Settings**

It is advisable to set the HP 37717B to a known state before setting up a measurement. This clears all previous settings and provides a clearly defined instrument state. For a list of Default Settings and the procedure for accessing them see *Stored Settings*.

### **Desynchroniser Stress Test Setup Procedure**

The following options must be fitted to the HP 37717B to perform this test:

- UKK or UKJ - PDH module
- UHN - Jitter measurement module
- A1T - SDH module
- UH1 or UH2 or URU - STM-1/4 Optical interface

The HP 37717B PDH/SDH test set transmits an STM-4 optical signal carrying 2 Mb/s payload. Pointer movement sequences are added in a controlled manner.

The desynchroniser output is returned to the HP 37717B and a jitter measurement is performed on the demapped 2 Mb/s signal.

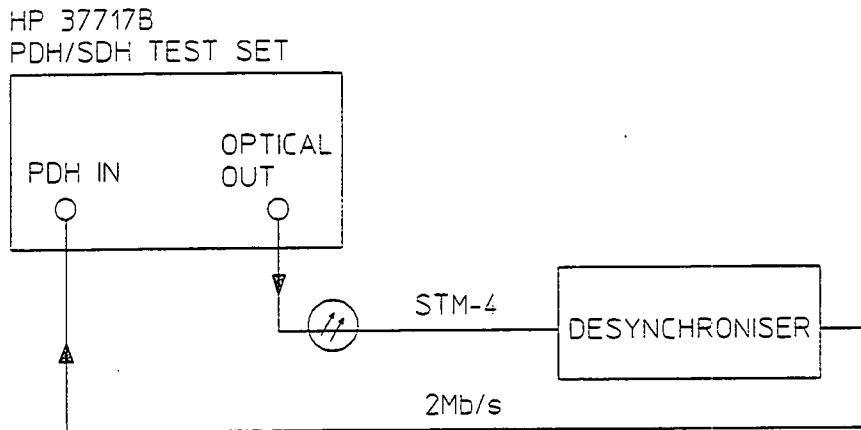

**Figure 2-18. Desynchroniser Stress**

1. Connect the HP 37717B to the network equipment and set up the **TRANSMIT** **SDH** display as shown opposite.

TRANSMITTER OUTPUT		[ SDH ]
SDH	STRUCT'D PAYLOAD	JITTER TEST OVERHEAD FUNCTION SETUP
SIGNAL	[ STM-4o OPT ]	
CLOCK SYNC	[ EXT MTS ]	[ CLOCK ]
FREQUENCY OFFSET		[ OFF ]
STM-1 UNDER TEST	[ 1 ]	
PAYLOAD	[ TU-12 ]	
TU MODE	[ ASYNC ]	
SELECTED TU	TUG3 [1] TUG2 [1] TU [1]	
TU PAYLOAD	[ UNFRAMED ]	
PATTERN	[ 2 <sup>n</sup> -15-1 PRBS ]	
PRBS POLARITY	[ INV ]	CCITT
2M OFFSET	[ 0ppm ]	SIG LABEL [ 001 ]
PATTERN IN OTHER TUs	[ 2 <sup>n</sup> -9-1 PRBS ]	
STATUS:		
INTERNAL	EXTERNAL	STM-4o OPT REF
	NTS	

The CLOCK SYNC selection determines the synchronization source for the TRANSMIT clock. If [EXT MTS] is selected a 2 Mb/s reference must be connected to the 2M REF IN port. The format can be CLOCK or DATA.

2. Set up the **TRANSMIT** **TEST** **FUNCTION** display as shown opposite.

TRANSMITTER OUTPUT		[ SDH ]
SDH	STRUCT'D PAYLOAD	JITTER TEST OVERHEAD FUNCTION SETUP
TEST FUNCTION [ SDH ] [ ADJUST PTR ]		
POINTER TYPE	[ TU POINTER ]	
	[ G.783 ]	
ADJUSTMENT TYPE	[ SINGLE ]	
	[ WITH ADDED ]	
POLARITY	[ POSITIVE ]	
INTERVAL	[ 10 ns ]	
POINTER SEQUENCES	[ STOPPED ]	
STATUS:		
NEGATIVE	POSITIVE	

Pointer adjustments are made every 10 ms with an extra ADDED adjustment as defined in CCITT standard G.783.

Pointer sequences are started by selecting **STARTED**.

3. Set up the **RECEIVE** **JITTER** display as shown opposite.

RECEIVER INPUT	[ PDH ]
MAIN STRUCT'D: JITTER	
SETTINGS: SETTINGS:	
SIGNAL FREQUENCY	2 Mb/s
RECEIVER RANGE	[ 16 UI ]
HIT THRESHOLD	[ 0.5 UI ]
FILTER	[ OFF ]
WANDER REFERENCE	[ 75Ω UNBAL ]
WANDER REF. FORMAT	[ HD39 DATA ]
STATUS:	
OFF	LF HF1 HF2 HUPB

4. Set up the **RESULTS** display as shown opposite.

Jitter Hits can be viewed without affecting the measurement.

RESULTS [ JITTER ]	[ CUMULATIVE ]
	[ AMPLITUDE ]
TEST TIMING	[ MANUAL ]
STORAGE	[ OFF ]
+VE PEAK	UI
-VE PEAK	UI
PEAK-PEAK	UI
ELAPSED TIME	
STATUS:	
HITS	AMPLITUDE

### Start the Desynchroniser Stress Test

1. Press **RUN/STOP** to start the Jitter measurement.



## Frame Synchronization

### Application

A network element should maintain synchronization even in the presence of some frame errors. If the number of frame errors exceeds the specified threshold for 3 ms, the network element will lose frame synchronization causing a new search for frame alignment to begin.

The frame synchronization process of the network element can be stressed by injecting frame errors, into the A1 and A2 framing bytes of the Regenerator Section overhead. As the frame error injection rate is increased to the frame synchronization threshold, the network element should indicate Out Of Frame (OOF) and Loss Of Frame (LOF) conditions. As the frame error injection rate is decreased again, the network element should regain frame synchronization.

### Default (Known State) Settings

It is advisable to set the HP 37717B to a known state before setting up a measurement. This clears all previous settings and provides a clearly defined instrument state. For a list of Default Settings and the procedure for accessing them see *Stored Settings*.

### Frame Synchronization Test Setup Procedure

**Frame Error Add Test Function.** In this setup the HP 37717B PDH/SDH test set is used to insert frame errors in the A1 and A2, framing bytes of the Regenerator section overhead of an STM-1 optical signal. The STM-1 optical signal is transmitted to the network equipment. The network equipment OOF and LOF alarms are monitored as the frame error add rate is increased and decreased.

**Sequence Generation Test Function.** In this setup procedure the HP 37717B PDH/SDH test set generates a sequence of errored framing bytes to test the OOF and LOF alarm threshold criteria. The upstream STM-1 optical signal is monitored for occurrences of Multiplexer Section FERF. The downstream STM-1 optical signal can be monitored for AIS.

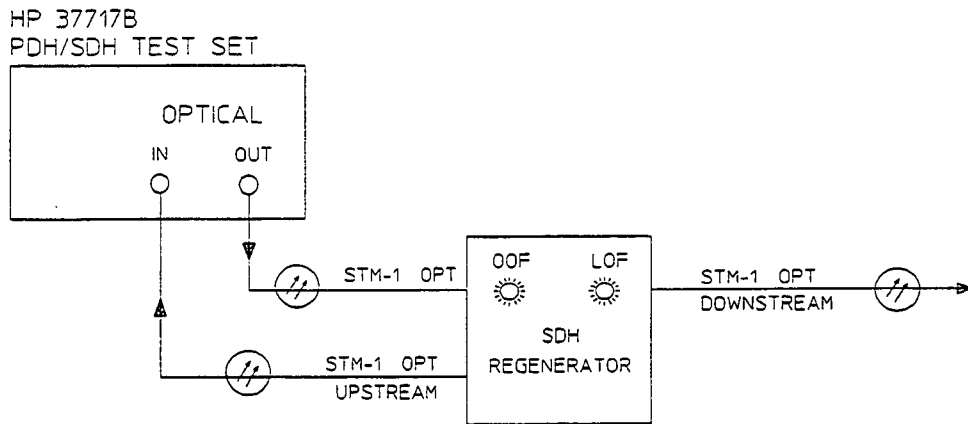

Figure 2-19. Frame Synchronization

### Frame Error Add Test Function

1. Connect the HP 37717B to the network equipment and set up the **TRANSMIT** **SETTINGS CONTROL** display as shown opposite.

FUNCTION	[ SETTINGS CONTROL ]
TRANSMITTER AND RECEIVER [ COUPLED ]	
RECEIVER COUPLED TO TRANSMITTER	
STATUS:	
TRANSMITTER	[ COUPLED ]
RECEIVER	[ COUPLED ]

2. Set up the **TRANSMIT** **SDH** display as shown opposite.

The CLOCK SYNC selection determines the synchronization source for the TRANSMIT clock. If [EXT MTS] is selected a 2 Mb/s reference must be connected to the front panel 2M REF IN port. The format can be CLOCK or DATA.

TRANSMITTER OUTPUT	[ SDH ]
[ SUM ]	[ TEST OVERHEAD ]
[ FUNCTION ]	[ SETUP ]
SIGNAL	[ STM-16 OPT ]
CLOCK SYNC	[ INTERNAL ]
FREQUENCY OFFSET	[ OFF ]
PAYLOAD	[ 140 Mb/s ]
PAYLOAD TYPE	UNFRAMED
PATTERN	[ 2 <sup>n</sup> -23-1 PRBS ]
PRBS POLARITY	[ INV ] CCITT
140M OFFSET	[ 0 ppm ]
STATUS:	
[ SUM ]	[ TEST OVERHEAD ]
[ FUNCTION ]	[ SETUP ]

### Frame Error Add Test Function (continued)

3. Set up the **RESULTS** display as shown below.

RESULTS [ SDH ] [ ALARM SECONDS ]	
TEST TIMING	[ MANUAL ]
STORAGE	[ OFF ]
POWER LOSS	K1/K2 CHANGE
LOS	MS FERF
LOF	PATH FERF
ODF	TU LOP
LOP	TU PATH AIS
MS AIS	TU PATH FERF
PATH AIS	
ELAPSED TIME	
STATUS:	
CUMUL	SHORT
ACTIVE	TEPM
ANALYSIS	ALARM
16.826	SECONDS
----	----
----	----

4. Set up the **TRANSMIT TEST FUNCTION** display as shown below.

TRANSMITTER OUTPUT [ SDH ]	
SDH	TEST OVERHEAD
FUNCTION	SETUP
TEST FUNCTION [ SDH ]	[ ERR & ALARM ]
ERROR ADD TYPE	[ R1A2 FRAME ]
RATE	[ 1 IN 4 ]
ALARM TYPE	[ OFF ]
STATUS:	
OFF	1 IN 4
	2 IN 4
	3 IN 4
	4 IN 4

### Start the Frame Synchronization Test (Frame Error Add)

1. Check that the Loss Of Frame (LOF) alarm indicator on the network element remains unlit and no occurrences of MS FERF are recorded.
2. Increase the Frame Error Add Rate to **2 IN 4** and check that the Loss Of Frame (LOF) alarm indicator on the network element remains unlit and no occurrences of MS FERF are recorded.
3. Increase the Frame Error Add Rate to **3 IN 4** and check that the Loss Of Frame (LOF) alarm indicator on the network element remains unlit and no occurrences of MS FERF are recorded.
4. Increase the Frame Error Add Rate to **4 IN 4** and check that the OOF and LOF alarm indicators on the network equipment are lit and occurrences of MS FERF are recorded.
5. Decrease the Frame Error Add Rate to **3 IN 4** and check that the OOF and LOF alarm indicators on the network equipment remain lit and occurrences of MS FERF are still being recorded.
6. Decrease the Frame Error Add Rate to **2 IN 4** and check that the OOF and LOF alarm indicators on the network equipment go off, and no further occurrences of MS FERF are recorded.

### Sequence Generation Test Function

1. Connect the HP 37717B to the network equipment and set up the **TRANSMIT** **SETTINGS CONTROL** display as shown opposite.

FUNCTION [ SETTINGS CONTROL ]	
TRANSMITTER AND RECEIVER	[ COUPLED ]
RECEIVER COUPLED TO TRANSMITTER	
STATUS:	
INDICATOR	[ COUPLED ]
EVENT	

2. Set up the **TRANSMIT** **SDH** display as shown opposite.

The **CLOCK SYNC** selection determines the synchronization source for the **TRANSMIT** clock. If [EXT MTS] is selected a 2 Mb/s reference must be connected to the front panel 2M REF IN port. The format can be **CLOCK** or **DATA**.

TRANSMITTER OUTPUT [ SDH ]	
SDH	TEST OVERHEAD
FUNCTION	SETUP
SIGNAL	[ STM-16 OPT ]
CLOCK SYNC	[ INTERNAL ]
FREQUENCY OFFSET	[ OFF ]
PAYLOAD	[ 140 Mb/s ]
PAYLOAD TYPE	UNFRAMED
PATTERN	[ 2 <sup>23</sup> -1 PRBS ]
PRBS POLARITY	[ INV ] CCITT
140M OFFSET	[ 0 pps ]
STATUS:	
SDH	TEST OVERHEAD
FUNCTION	SETUP

3. Set up the **RESULTS** display as shown below.

RESULTS [ SDH ] [ ELAPSED SECONDS ]	
TEST TIMING	[ MANUAL ]
STORAGE	[ OFF ]
POWER LOSS	K1/K2 CHANGE
LOS	RS FERF
LOF	PATH FERF
ODF	TU LOP
LOP	TU PATH AIS
RS AIS	TU PATH FERF
PATH AIS	
ELAPSED TIME	
STATUS:	
CHUNK	SHOFT
ACTIVE	TEPFI
ANALYSIS	ALARM
16.334	SECONDS
DOPE	

4. Set up the **TRANSMIT** **TEST FUNCTION** display as shown below.

TRANSMITTER OUTPUT [ SDH ]	
SDH	TEST OVERHEAD
FUNCTION	SETUP
TEST FUNCTION [ SDH ]	[ SEQUENCES ]
[ REPEAT RUN ]	[ STOPPED ] -SEQUENCE STOPPED
OVERHEAD CHANNEL	[ RSOH ] [ 3xR1,3xR2 ]
A	[ F6F6F6282828 ]
B	[ 090909D7D7D7 ]
C	[ 000000000000 ]
D	[ 000000000000 ]
E	[ 000000000000 ]
SEQUENCE	[ 15974 ] FRAMES OF [A] THEN
[ 26 ]	[B]
[ 0 ]	[C]
[ 0 ]	[D]
[ 0 ]	[E]
STATUS:	
STOPPED	STARTED

### Start the Frame Synchronization Test (Sequence Test)

1. Press **STARTED** on the **TRANSMIT TEST FUNCTION** display to start the sequence. As a result of this sequence one OOF alarm second and one LOF alarm second should occur every two seconds.
2. Check that the network element OOF and LOF alarm indicators cycle ON and OFF and that an occurrence of MS FERF is recorded every two seconds.
3. Press **STOPPED** to stop the sequence and set up the **TRANSMIT TEST FUNCTION** display as shown opposite.

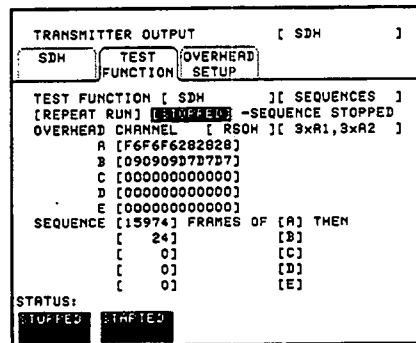

4. Press **STARTED** on the **TRANSMIT TEST FUNCTION** display to start the sequence. As a result of this sequence one OOF alarm second should occur every two seconds but LOF should not occur.
5. Check that the network element OOF alarm indicator cycles ON and OFF. The LOF alarm should not occur and no occurrences of MS FERF should be recorded.

## Frequency Measurement

### Application

The clock frequency and the amount of offset from the CCITT standard rate can be measured to give an indication of probability of errors.

The measurement can be made in out of service or monitor mode and is generally of short duration.

### Default (Known State) Settings

It can be advisable to set the HP 37717B to a known state prior to setting up to make a measurement. This clears all previous settings and provides a clearly defined instrument state. For a list of Default Settings and the procedure for accessing them see *Stored Settings*.

### Test Setup Procedure (Frequency Measurement)

The following options must be fitted :

- US1 or A1T - SDH Module (STM-1 electrical)
- UH1 or UH2 or URU - (STM-1 or STM-4 optical)

If measuring on live traffic the measurement is interfaced at the line terminal equipment Monitor point. The HP 37717B is used in a *receive only* mode to measure the SDH IN frequency. The SDH IN frequency is measured and compared with the internal CCITT standard frequency selected.

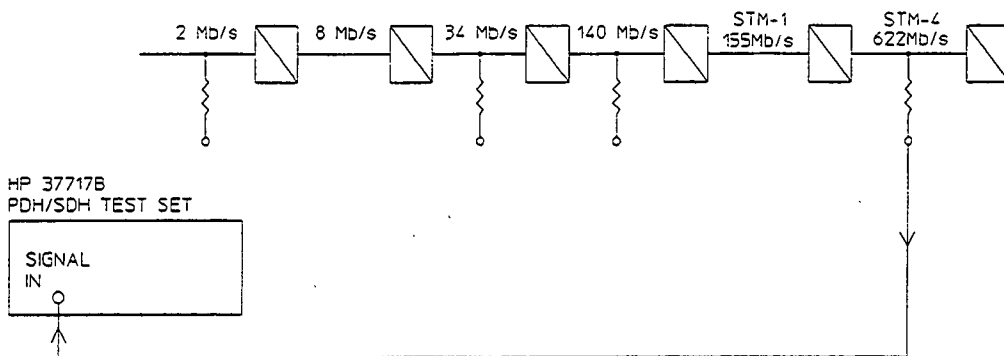
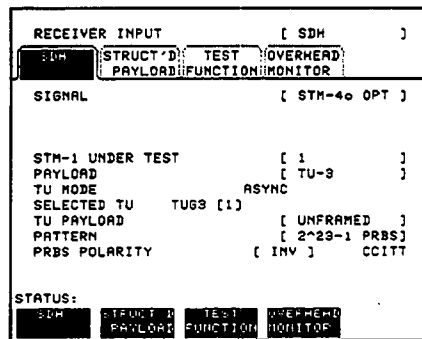

Figure 2-20. Frequency Measurement

1. Set up the **RECEIVE** **SDH** display as shown opposite.

For frequency measurement STM-1 UNDER TEST, PAYLOAD, TU MODE, SELECTED TU, TU PAYLOAD, PATTERN and PRBS POLARITY are not relevant.



2. Select **RESULTS** **SDH** **FREQUENCY**.

For frequency measurement TEST TIMING and STORAGE are not relevant.

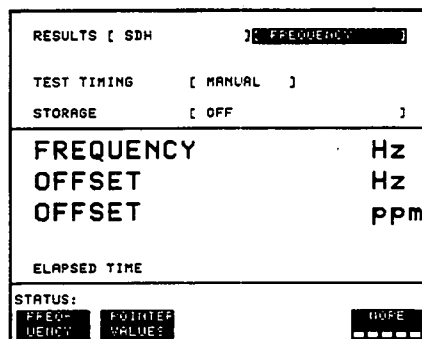

### Run the Test (Frequency Measurement)

1. Press **SIGNAL IN** until the Monitor indicator, above the key, is lit.
2. Connect the OPT IN port to the line terminal equipment monitor point.

The measured frequency and amount of offset from the internal standard is displayed.

If the SDH IN frequency is different from the selected BIT RATE the error message **Unable to recover clock** appears on the display. A **FREQ** reading is displayed but this should be ignored.

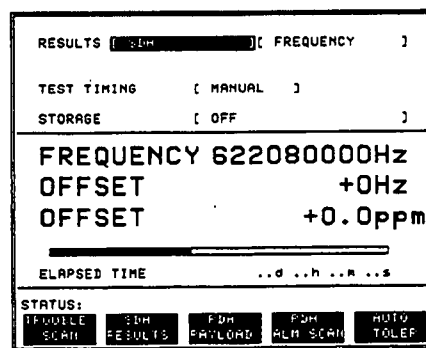

### At the End of the Test (Frequency Measurement)

Disconnect the HP 37717B from the line terminal equipment.



## Frequency Offset Tolerance

### Application

The capability of the network equipment to reliably recover the clock is tested by varying the SDH signal rate and checking for the occurrence of transmission errors.

The measurement can be made via a loopback or in a cross-multiplexer configuration, and is generally of short duration.

In SDH systems if the master timing reference is lost a standby reference within 20 ppm can be used for a limited time :  
155520 kb/s (STM-1)  $\pm$  20 ppm ; 622080 kb/s (STM-4)  $\pm$  20 ppm.

HP 37717B

PDH/SDH TEST SET

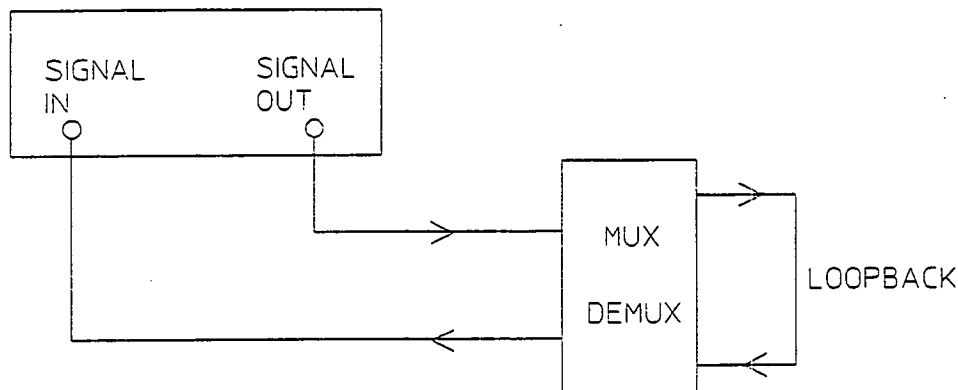

Figure 2-21. Frequency Offset Tolerance

### Default (Known State) Settings

It can be advisable to set the HP 37717B to a known state prior to setting up to make a measurement. This clears all previous settings and provides a clearly defined instrument state. For a list of Default Settings and the procedure for accessing them see *Stored Settings*.

## 2-70 Making Measurements

### Test Setup Procedure (Frequency Offset Tolerance)

The following options must be fitted :

- US1 or A1T - SDH Module (STM-1 electrical)
- UH1 or UH2 or URU - (STM-1 or STM-4 optical)

This setup procedure tests the clock recovery capability of the line terminal equipment at STM-1 optical rate. A PRBS pattern is inserted in the 140 Mb/s payload. The frequency of the STM-1 signal is offset and the payload is monitored for errors.

1. Set up the **OTHER SETTINGS CONTROL** display as shown below.

FUNCTION		[ SETTINGS CONTROL ]	
TRANSMITTER AND RECEIVER [ COUPLED ]			
RECEIVER COUPLED TO TRANSMITTER			
STATUS:			
LINE PRESENT		COUPLED	

2. Set up the **RECEIVE SDH** display as shown below.

RECEIVER INPUT				[ SDH ]	
SDH	STRUCT'D:	TEST	OVERHEAD		
	PAYLOAD:	FUNCTION	MONITOR		
SIGNAL [ STM-10 OPT ]					
PAYLOAD [ 140 Mb/s ]					
PAYLOAD TYPE [ UNFRAMED ]					
PATTERN [ 2 <sup>23</sup> -1 PRBS ]					
PRBS POLARITY [ INV ] CCITT					
STATUS:					
SDH	STRUCT'D	TEST	OVERHEAD		
	PAYLOAD	FUNCTION	MONITOR		

3. Set up the **RESULTS** display as shown opposite.

RESULTS [ PDH PAYLOAD ]		[ CUMULATIVE ]	
BIT			
TEST TIMING [ MANUAL ]			
STORAGE [ OFF ]			
BIT EC			
BIT ER			
ELAPSED TIME			
STATUS:			
LINE PRESENT	SDH	STRUCT'D	TEST
	OVERHEAD	FUNCTION	MONITOR

### Continuity Check

Before running the test carry out a continuity test to verify the measurement path.

1. Connect a loopback at the desired point on the network equipment.
2. Press **RUN/STOP** to start a measurement.
3. Press error add **SINGLE** three times and check that the errors are recorded on the **RESULTS** display.
4. Press **RUN/STOP** to stop the measurement.

### Run the Test (Frequency Offset Tolerance)

1. Connect the HP 37717B to the network equipment and set up the **TRANSMIT** **SDH** display as shown opposite.

2. Press **RUN/STOP** to start the measurement.

TRANSMITTER OUTPUT	[ SDH ]			
SDH	[ STRUCT'D ]	JITTER	TEST	
	PAYLOAD		FUNCTION	
SIGNAL	[ STM-1 OPT ]			
CLOCK SYNC	[ INTERNAL ]			
FREQUENCY OFFSET	[ ON ]			
	[ 0.0 ppm ]			
PAYLOAD	[ 140 Mb/s ]			
PAYLOAD TYPE	[ UNFRAMED ]			
PATTERN	[ 2 <sup>23</sup> -1 PRBS ]			
PRBS POLARITY	[ INV ]	CCITT		
STATUS:				
DECREASE	INCREASE	←	→	END
DIGIT	DIGIT			EDIT

3. Select FREQUENCY OFFSET [+20ppm] and check that the Error Count and Error Ratio results are unchanged.
4. Select FREQUENCY OFFSET [-20ppm] and check that the Error Count and Error Ratio results are unchanged.

### At the End of the Test

1. Halt the test by pressing **RUN/STOP**, and disconnect the HP 37717B.
2. Remove the loopback from the network equipment.

## SDH Jitter Transfer

Digital transmission systems use Regenerators to transport the signal over long distances. These Regenerators are cascaded together and it is important that each regenerator adds minimal amounts of jitter to the signal.

It is necessary during installation and maintenance to measure the degree to which jitter present at the input is amplified or attenuated by the network elements (Jitter Gain/Transfer).

The jitter transfer measurement entails measuring the input and output jitter at selected jitter frequencies within the jitter bandwidth. The jitter gain is calculated :  $\text{Jitter Gain (dB)} = 20 \text{Log} \frac{\text{Jitter out}}{\text{Jitter in}}$

When the network equipment meets CCITT specification G.823 it should be possible to connect network elements without incurring bit errors.

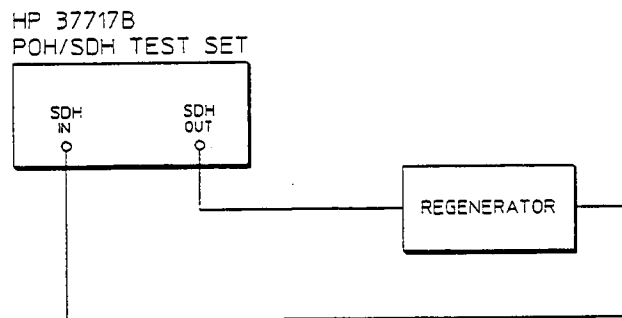

Figure 2-22. Jitter Transfer Test

### Default (Known State) Settings

It can be advisable to set the HP 37717B to a known state prior to setting up to make a measurement. This clears all previous settings and provides a clearly defined instrument state. For a list of Default Settings and the procedure for accessing them see *Stored Settings*.

### Test Setup Procedure (Jitter Transfer Test)

The following Options must be fitted to the HP 37717B to perform this test :

- UHK - Jitter Generation
- A1N or A1P - SDH Jitter Measurement
- US1 or A1T - SDH Module

This setup procedure is based on 155.52 Mb/s (STM-1), 140 Mb/s payload, PRBS test data with jitter. The Jitter frequency is varied within the jitter bandwidth and the received jitter is measured to allow calculation of the jitter gain. The internal printer is enabled for recording of results and alarms.

1. Set up the **OTHER SETTINGS CONTROL** display as shown below.

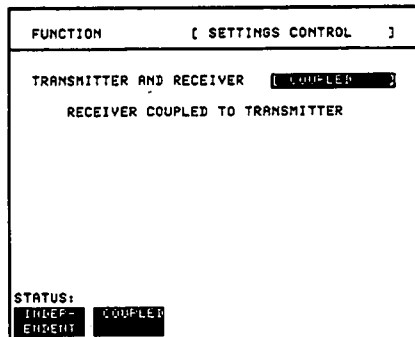

Any SDH settings change made on the **TRANSMIT** or **RECEIVE** displays will automatically occur on the other.

2. Connect the HP 37717B to the line equipment, select **TRANSMIT SDH** and set up the display as shown below.

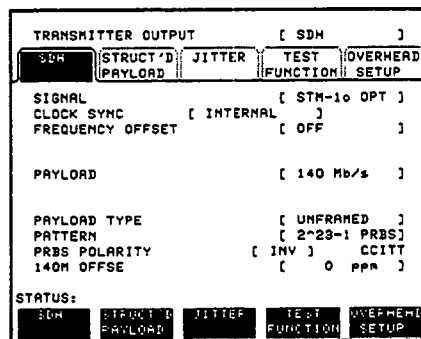

3. Select **TRANSMIT** **JITTER** and set up the display as shown below.

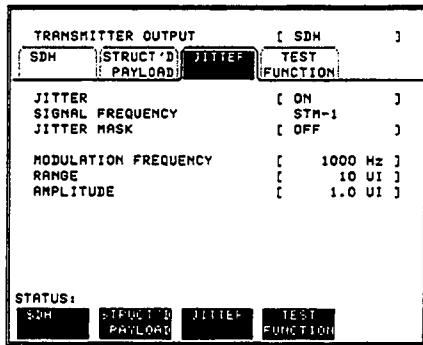

Select the required jitter MODULATING FREQUENCY and AMPLITUDE.

4. Setup the **RECEIVE** **SDH JITTER** display as shown below.

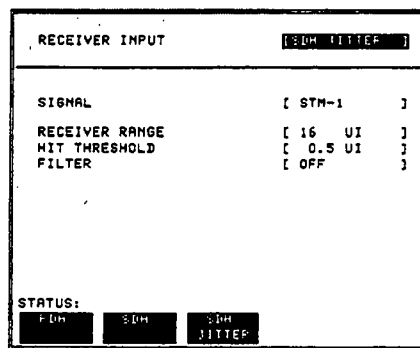

If Jitter filtering is required select from the softkey menu.

### Run the Test (Jitter Transfer)

1. Select **RESULTS** and set up the display as shown opposite.
2. Press **RUN/STOP** to start the measurement.
3. Record the Jitter Amplitude result from the **RESULTS** display.
4. Select each jitter Modulating Frequency and Amplitude in turn on the **TRANSMIT** display, press **RUN/STOP** twice and record the Jitter Amplitude result from the **RESULTS** display.

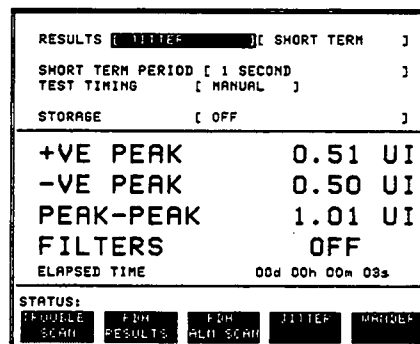

5. Calculate the Jitter gain for each frequency selected.

Jitter Gain (dB) =  $20 \text{Log} \frac{\text{Jitter out}}{\text{Jitter in}}$ . Where Jitter In is the AMPLITUDE selected on the **TRANSMIT** display.

## MSP Stimulus/Response

### Application

Multiplexer Section Protection (MSP) is an optional feature for SDH Multiplexer Section Terminating Equipment (MSTE). For those MSTE's, in which it is provided, the MSP system is standardized to ensure the interworking of MSP between MSTE's from different suppliers.

Standard messages, carried in the K1 and K2 bytes of the SDH signal transport overhead, indicate the state of the MSP.

Switching to the protection line occurs when one of the following conditions exists for a specified length of time :

- Loss Of Signal (LOS)
- Loss Of Frame (LOF)
- Signal Fail - Bit Error Ratio  $> 1 \times 10^3$
- Signal Degrade - Bit Error Ratio programmable
- MS AIS

The Signal Degrade Bit Error Ratio threshold is normally programmable in the range  $1 \times 10^5$  to  $1 \times 10^9$ .

The HP 37717B PDH/SDH test set can be used to test Multiplexer Section Protection switching by :

Generating the switching conditions listed above.

Transmitting and monitoring the K1 K2 messages.

### MSP Stimulus/Response 1+1 Architecture Test Setup Procedure

In this setup the HP 37717B PDH/SDH test set, inserted in the working line, generates MS B2 BIP errors in sufficient quantity to violate the Signal Degrade threshold of the Multiplexer Section Protection. The network equipment Service Terminal indicates that switching to the standby line has occurred. The activity on the K1 K2 bytes can be monitored on the **TRANSMIT** **TEST FUNCTION** MSP Messages display.

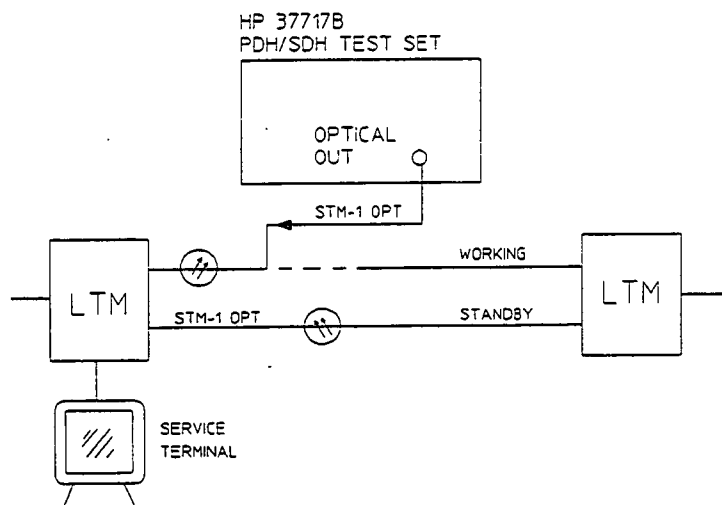

Figure 2-23. MSP Stimulus/Response 1+1 Architecture

1. Set up the **TRANSMIT** **SDH** display as shown opposite.

The **CLOCK SYNC** selection determines the synchronization source for the **TRANSMIT** clock. If **[EXT MTS]** is selected a 2 Mb/s reference must be connected to the front panel 2M REF IN port. The format can be **CLOCK** or **DATA**.

TRANSMITTER OUTPUT	[ SDH ]
<b>SDH</b> TEST OVERHEAD	<b>FUNCTION SETUP</b>
SIGNAL	[ STM-16 OPT ]
CLOCK SYNC	[ INTERNAL ]
FREQUENCY OFFSET	[ OFF ]
PAYLOAD	[ 140 Mb/s ]
PAYLOAD TYPE	UNFRAMED
PATTERN	[ 2 <sup>23</sup> -1 PRBS ]
PRBS POLARITY	[ INV ] CCITT
140M OFFSET	[ 0 PPR ]
STATUS:	
<b>SDH</b> TEST OVERHEAD	<b>FUNCTION SETUP</b>



2. Set up the **TRANSMIT TEST FUNCTION** display as shown opposite.

1530 MS B2 BIP errors in 1 second corresponds to a BER of 1 in  $10^{-5}$ .

The Service terminal should indicate switching to standby within 1 second.

TRANSMITTER OUTPUT		[ SDH ]
SDH	TEST FUNCTION	OVERHEAD SETUP
TEST FUNCTION [ SDH ] [K EPP : ALARM]		
ERROR ADD TYPE	[ MS B2 BIP ]	
RATE	[ MSP THRESLTD ]	
	[ 1530 ] ERRORS IN [ 1 s ]	
ALARM TYPE	[ OFF ]	
STATUS:		
ERRORS	ADJUST	SEQUENCE
ALARM	POINTER	TEST

### MSP Stimulus/Response 1:N Architecture

The HP 37717B PDH/SDH test set **TRANSMIT TEST FUNCTION** MSP MESSAGES can be used to transmit and monitor the K1 K2 messages.

The MSP Messages are transmitted when **DOWNLOAD** is pressed.

Two displays of K1 and K2 are provided :

1. **Current TX** - Values of K1 and K2 bytes which are currently being transmitted.
2. **Current RX** - Values of K1 and K2 bytes which are currently being received.

TRANSMITTER OUTPUT		[ SDH ]
SDH	STRUCT'D PAYLOAD	JITTER TEST OVERHEAD SETUP
TEST FUNCTION [ SDH ] [MSP MESSAGES]		
NEW TX		
K1 BITS 1->4	[ 1000: MANUAL SWITCH ]	
BITS 5->8	[ 0011: WORKING CHANNEL 3 ]	
K2 BITS 1->4	[ 0010: BRIDGED CHANNEL NO. ]	
BIT 5	[ 1 : 1:N ARCHITECTURE ]	
BITS 6->8	[ 000: RESERVED ]	
CURRENT TX		CURRENT RX
K1 .....		K1
K2 .....		K2
TRANSMIT NEW K1/K2 [ SELECT ]		
STATUS:		
SELECT	DOWN	LOAD

K1 Bits 1 ->4 Selects the MSP message to be transmitted.

**K1 Bits 1 - >4**

Selection	Message	Selection	Message
0000	NO REQUEST	1000	MANUAL SWITCH
0001	DO NOT REVERT	1001	NOT USED
0010	REVERSE REQUEST	1010	SD - Low Priority
0011	NOT USED	1011	SD - High Priority
0100	EXERCISE	1100	SF - Low Priority
0101	NOT USED	1101	SF - High Priority
0110	WAIT TO RESTORE	1110	FORCED SWITCH
0111	NOT USED	1111	LOCKOUT OF PROT

SD - High Priority and SF - High Priority are only available when K2 bit 5 is set to 1 - 1 : N architecture.

K1 Bits 5 ->8 Selects the channel used by the MSP Messages.

**K1 Bits 5 - >8**

Selection	Message	Selection	Message
0000	NULL CHANNEL	1000	WORKING CHANNEL #8
0001	WORKING CHANNEL #1	1001	WORKING CHANNEL #9
0010	WORKING CHANNEL #2	1010	WORKING CHANNEL #10
0011	WORKING CHANNEL #3	1011	WORKING CHANNEL #11
0100	WORKING CHANNEL #4	1100	WORKING CHANNEL #12
0101	WORKING CHANNEL #5	1101	WORKING CHANNEL #13
0110	WORKING CHANNEL #6	1110	WORKING CHANNEL #14
0111	WORKING CHANNEL #7	1111	EXTRA TRAFFIC CHANNEL

WORKING CHANNEL #2 through WORKING CHANNEL #14 and EXTRA TRAFFIC CHANNEL are only available when K2 Bit 5 is set to 1 : N architecture.

If K1 bits 1 >4 are set to 1111 LOCKOUT OF PROT then K1 bits 5 ->8 are fixed at 0000 NULL CHANNEL.

K2 bits 1 - >4      Selects the bridged channel used by the MSP Messages.  
Can be set in the range 0000 to 1111.

K2 bit 5            Determines the automatic protection switch architecture.  
0 - 1 + 1 architecture  
1 - 1 : N architecture

K2 bits 6 ->8      Selects the reserved bits. Can be set in the range 000 to 101.



## Optical Clock Recovery Stress

### Application

Ideally the clock recovery circuits in the network equipment optical interfaces should recover a clock even in the presence of long strings of 0's.

The optical clock recovery performance of the network equipment can be measured by increasing the length of a zero substitution block until errors occur.

### Default (Known State) Settings

It is advisable to set the HP 37717B to a known state before setting up a measurement. This clears all previous settings and provides a clearly defined instrument state. For a list of Default Settings and the procedure for accessing them see *Stored Settings*.

### Optical Clock Recovery Stress Test Setup Procedure

In this setup procedure the HP 37717B PDH/SDH test set transmits an STM-1 optical signal with zero's substituted into the payload data pattern. The length of the block of zero's is increased until the network equipment alarms are triggered.

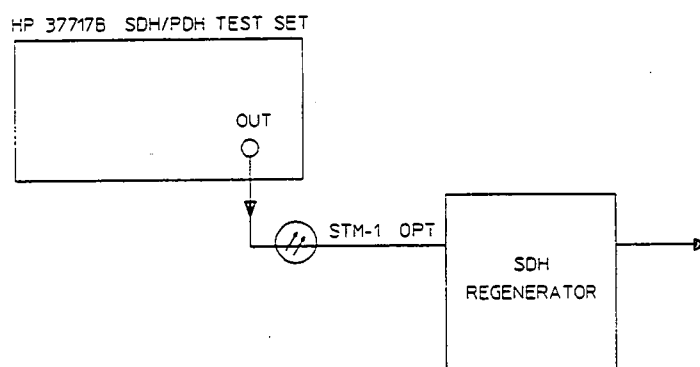

Figure 2-24. Optical Clock Recovery Stress

1. Connect the HP 37717B to the network equipment and set up the **TRANSMIT** **SDH** display as shown below.

```

TRANSMITTER OUTPUT [ SDH ]
SDH [STRUCT'D] JITTER TEST OVERHEAD
   [PAYLOAD] [FUNCTION] SETUP
SIGNAL [ STM-16 OPT ]
CLOCK SYNC [ EXT MTS ] [ CLOCK ]
FREQUENCY OFFSET [ OFF ]

PAYLOAD [ 140 Mb/s ]

PAYLOAD TYPE [ UNFRAMED ]
PATTERN [ 2^15-1 PRBS ]
PRBS POLARITY [ INV ] CCITT
140M OFFSET [ 0 ppm ]

STATUS:
2MHz CLOCK 20MHz DATA
  
```

The CLOCK SYNC selection determines the synchronization source for the TRANSMIT clock. If [EXT MTS] is selected a 2 Mb/s reference must be connected to the front panel 2M REF IN port. The format can be CLOCK or DATA.

2. Set up the **TRANSMIT** **TEST** **FUNCTION** display as shown below.

```

TRANSMITTER OUTPUT [ SDH ]
SDH [STRUCT'D] JITTER TEST OVERHEAD
   [PAYLOAD] [FUNCTION] SETUP
TEST FUNCTION [ SDH ] [ STRESS TEST ]
STRESSING PATTERN [ ALL ZEROS ]
BLOCK LENGTH [ 2 ] BYTES

STATUS:
ALL ZEROS ALL ONES 1000000
  
```

G.958 Test Pattern consists of consecutive blocks of four types of data :

- All 1's
- PRBS
- All 0's
- a data block consisting of the first row of section overhead bytes.

### Start the Optical Clock Recovery Stress Test

Increase the Block Length until the network equipment alarms are triggered.

## **Payload Mapping/Demapping**

### **Application**

The mapping and demapping of a 2 Mb/s or 140 Mb/s payload into/from the appropriate SDH containers should take place without introducing errors.

The mapping process is tested by inserting a test pattern in the 2 Mb/s or 140 Mb/s payload at the low-rate side of the terminal multiplexer. On the high-rate side of the terminal multiplexer, the payload is demapped from the SDH signal by the HP 37717B PDH/SDH test set.

The demapping process is tested by transmitting a SDH signal to the high-rate side of the multiplexer. On the low-rate side of the multiplexer the payload is received by the HP 37717B PDH/SDH test set.

A Bit error rate (BER) test is performed on the recovered payload test pattern to determine whether errors have been introduced by the SDH mapping process.

### **Default (Known State) Settings**

It is advisable to set the HP 37717B to a known state before setting up a measurement. This clears all previous settings and provides a clearly defined instrument state. For a list of Default Settings and the procedure for accessing them see *Stored Settings*.

### **Payload Mapping/Demapping Test Setup Procedure**

The following Options must be fitted to the HP 37717B to perform this test :

- US1 or A1T - SDH Module
- UH1 or UH2 or URU - STM-1/STM-4 Optical Interface

In the mapping setup a 140 Mb/s payload, containing a test pattern, is transmitted into the low-rate side of the terminal multiplexer. The 140 Mb/s payload is demapped from the STM-4 Optical signal at the high-rate side of the terminal multiplexer.

In the demapping setup an STM-4 Optical signal is transmitted into the high-rate side of the Add Drop multiplexer. The 140 Mb/s signal, on the

low-rate side of the Add Drop multiplexer, is received by the HP 37717B PDH/SDH test set.

A BER measurement is performed on the demapped 140 Mb/s payload test pattern.

A SINGLE test period of 24 HOURS is used and the internal printer is enabled to record results and alarms.

The HP 37717B PDH/SDH test set GRAPHICS function is enabled. The graphical results can be viewed on the **GRAPH** display

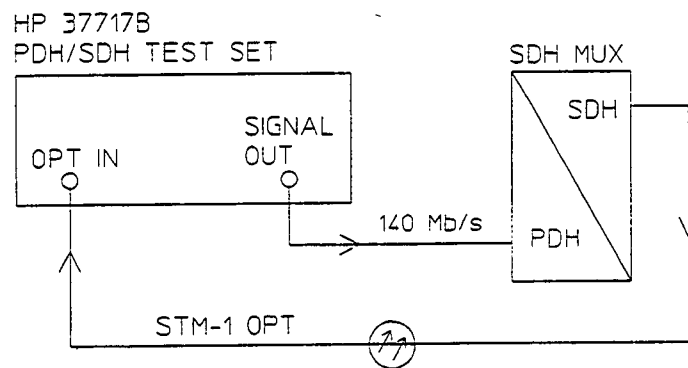

**Figure 2-25. Payload Mapping**

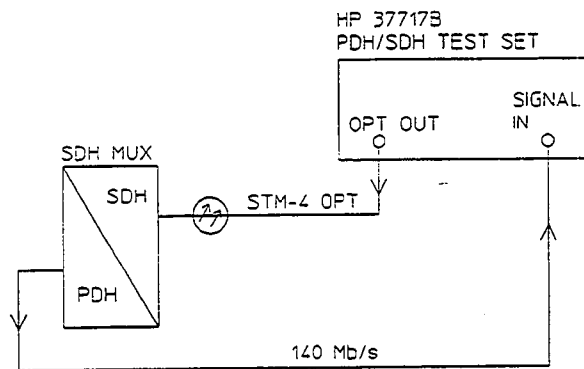

**Figure 2-26. Payload Demapping**

1. Connect the HP 37717B to the network equipment and set up the **OTHER** **SETTINGS CONTROL** display as shown opposite.

FUNCTION		[ SETTINGS CONTROL ]
TRANSMITTER AND RECEIVER		[ INDEPENDENT ]
STATUS:		
INTEP	EMERG	COUPLER

2. For Mapping set up the **TRANSMIT** display as shown below.

TRANSMITTER OUTPUT		[ PDH ]
SDH	STRUCT'D	TEST
SETTINGS	SETTINGS	FUNCTION
SIGNAL		[ 140 Mb/s ]
CLOCK SYNC		INTERNAL
TERMINATION		75Ω UNBAL
LINE CODE		CHI
FREQUENCY OFFSET		[ OFF ]
PAYLOAD TYPE		[ UNFRAMED ]
PATTERN		[ 2 <sup>23</sup> -1 PRBS ]
PRBS POLARITY		[ INV ] CCITT
STATUS:		
SDH	STRUCT'D	TEST
SETTINGS	SETTINGS	FUNCTION

2a. For Demapping set up the **TRANSMIT** display as shown below.

TRANSMITTER OUTPUT		[ SDH ]
SDH	STRUCT'D	TEST
PAYLOAD	FUNCTION	SETUP
SIGNAL		[ STM-40 OPT ]
CLOCK SYNC		[ INTERNAL ]
FREQUENCY OFFSET		[ OFF ]
STM-1 UNDER TEST		[ 3 ]
PAYLOAD		[ 140 Mb/s ]
PAYLOAD TYPE		[ UNFRAMED ]
PATTERN		[ 2 <sup>23</sup> -1 PRBS ]
PRBS POLARITY		[ INV ] CCITT
140M OFFSET		[ 0 ppm ]
STATUS:		
SDH	STRUCT'D	TEST
PAYLOAD	FUNCTION	SETUP

3. For Mapping set up the **RECEIVE** display as shown below.

RECEIVER INPUT		[ SDH ]
SDH	STRUCT'D	TEST
PAYLOAD	FUNCTION	MONITOR
SIGNAL		[ STM-10 OPT ]
PAYLOAD		[ 140 Mb/s ]
PAYLOAD TYPE		[ UNFRAMED ]
PATTERN		[ 2 <sup>23</sup> -1 PRBS ]
PRBS POLARITY		[ INV ] CCITT
STATUS:		
SDH	STRUCT'D	TEST
PAYLOAD	FUNCTION	MONITOR

3a. For Demapping set up the **RECEIVE** display as shown below.

RECEIVER INPUT		[ PDH ]
SDH	STRUCT'D	JITTER
SETTINGS	SETTINGS	
SIGNAL		[ 140 Mb/s ]
TERMINATION		75Ω UNBAL
LINE CODE		CHI
PAYLOAD TYPE		[ UNFRAMED ]
PATTERN		[ 2 <sup>15</sup> -1 PRBS ]
PRBS POLARITY		[ INV ] CCITT
STATUS:		
SDH	STRUCT'D	JITTER
SETTINGS	SETTINGS	



4. Set up the **OTHER** display, PRINTER function, as shown opposite.

All results are logged on the internal printer at 1 hour intervals.

Any alarms which occur during the test period will be logged on the internal printer.

FUNCTION [ PRINTER ]	
PRINTER	INTERNAL
PRINTING	[ ON ]
PRINT PERIOD	[ 1 HOUR ]
RESULTS PRINTED	[ SELECTED ]
WHEN	[ ALWAYS ]
CONTENT	[ EP & CURUL ]
PRINT ERROR SECONDS	[ ON ]
PRINT AT END OF TEST	ALL RESULTS
STATUS:	
ERROR RESULTS	ANALYSIS

### Start the Payload Mapping/Demapping Test

1. Set up the **RESULTS** display as shown opposite.

If you do not require stored graphics results select STORAGE [OFF].

2. Press **RUN/STOP** to start the measurement.

RESULTS [ PDH PAYLOAD ] [ ERROR ANALYSIS ]	
TEST TIMING	[ SINGLE ] [ 24 HOURS ]
STORAGE	[ 1 MIN RESOL'N ]
<b>BIT ANALYSIS</b>	
EC	%
ES	%
EFS	%
SES	%
UNAV	%
DES MIN	%
ELAPSED TIME	
STATUS:	
SMART TEST	CURUL ATIME
ERROR RESULTS	ALARM SECONDS

The measurement results and alarms are available on the **RESULTS** display during the test period.

The graphical measurement results and alarms are stored in non volatile memory for viewing later on the **GRAPH** display.

The test can be halted at any time by pressing **RUN/STOP**.

### At the End of the Test (Payload Mapping/Demapping)

- The Date and Time the test started and the instrument setup are logged on the internal printer.
- All results are logged on the internal printer at 1 hour intervals.

- Any alarms which occur during the test period will be logged on the internal printer.
- At the end of the test period a complete set of cumulative results are logged on the internal printer.
- A graphical record of the results during the test period can be viewed on the **GRAPH** display. If Remote Control option 1A8 (HP-IB) or 1CW (RS-232-C) is fitted the graph results can be logged to an external printer, at a later date. See *Graphics* and *External HP 550C DeskJet Printer*.
- Results and Alarm summaries can be viewed on the **GRAPH** display.

The total graphics store capacity is normally 20,000 events. If **GRAPH STORAGE RESOLUTION [FULL]** is selected on the **OTHER MISCELLANEOUS** display the capacity reduces to 10,000 events.

The resolution, determined by the selection made under **STORAGE** on the **RESULTS** display, affects the **ZOOM** capability when viewing the bar graphs. If **1 SECOND** is selected all resolutions are available under **ZOOM**. If **1 MIN** is selected only **1 MIN/BAR**, **15 MINS/BAR** and **60 MINS/BAR** are available. If **15 MINS** is selected only **15 MINS/BAR** and **60 MINS/BAR** are available. If **1 HOUR** is selected only **60 MINS/BAR** is available.

Up to 10 sets of graphical results can be stored. If an attempt is made to store more than 10 sets of results, then a first in first out policy is operated and the oldest set of results will be lost. If graphics are enabled and a test is run which exceeds the remaining storage capacity, then some previously stored graphical results will be lost.

To prevent accidental overwriting of previously stored results the graphics capability should be disabled, when graphical results are not required, by selecting **STORAGE [OFF]** on the **RESULTS** display.

## Performance Monitor Stimulus/Response

### Application

Performance monitors built into the SDH network equipment count BIP errors, and communicate the results to the network controller via the DataCommunication Channel (DCC). Performance monitors in Path Terminating Equipment (PTE) also communicate with the upstream equipment.

If the performance monitors are not operating correctly, degradations in network performance will pass unnoticed and may result in a failure condition.

The performance monitors can be tested by the PDH/SDH test set transmitting BIP errors in the appropriate byte of the overhead and monitoring upstream for the correct response :

Regenerator Section (RS) - B1 Byte of regenerator section overhead

Multiplexer Section (MS) - B2 Bytes of multiplexer section overhead

PATH - B3 Byte of path overhead

### Default (Known State) Settings

It is advisable to set the HP 37717B to a known state before setting up a measurement. This clears all previous settings and provides a clearly defined instrument state. For a list of Default Settings and the procedure for accessing them see *Stored Settings*.

### Performance Monitor Stimulus/Response Test Setup Procedure

The following Options must be fitted to the HP 37717B to perform this test :

- US1 or A1T - SDH Module
- UH1 or UH2 or URU - STM-1/STM-4 Optical Interface

In this setup the HP 37717B PDH/SDH test set inserts PATH BIP errors in byte B3 of the path overhead of the SDH signal. The upstream signal is monitored to provide a measure of the FEBE (Far End Block Error) count.

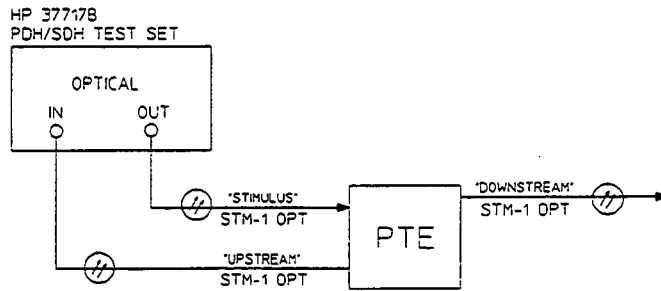
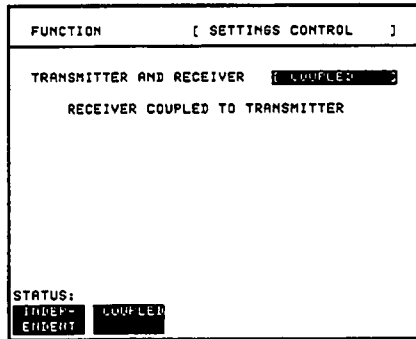
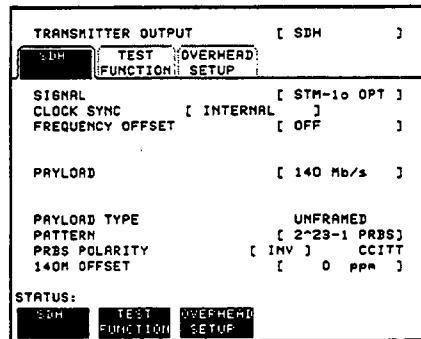

Figure 2-27. Performance Monitor Stimulus/Response

1. Connect the HP 37717B to the network equipment and set up the **TRANSMIT** **SETTINGS CONTROL** display as shown below.



2. Set up the **TRANSMIT** **MAIN SETTINGS** display as shown below.



The **CLOCK SYNC** selection determines the synchronization source for the **TRANSMIT** clock.

3. Set up the **RESULTS** display as shown below.

RESULTS [ SDH ]	[ CUMULATIVE ]
TEST TIMING [ MANUAL ]	[ PATH FEBE ]
STORAGE [ OFF ]	
FEBE EC	
FEBE ER	
ELAPSED TIME	
STATUS:	
PATH FEBE	PATH B3 BIP
PATH B3 BIP	PATH FEBE
PATH FEBE	PATH B3 BIP
PATH B3 BIP	PATH FEBE

PATH FEBE ERROR RESULTS are displayed but any of the other results can be selected from the softkey menu without affecting the measurement.

4. Set up the **TRANSMIT TEST FUNCTION** display as shown below.

TRANSMITTER OUTPUT [ SDH ]	
SDH	TEST FUNCTION [ OVERHEAD SETUP ]
TEST FUNCTION [ SDH ]	[ ERR & ALARM ]
ERROR ADD TYPE RATE	[ PATH B3 BIP ]
	[ 1E-4 ]
ALARM TYPE	[ OFF ]
STATUS:	
OFF	ERROR ALL
1E-4	1E-3
1E-3	1E-2
1E-2	NONE

The ERROR RATE required can be selected from the softkey menu.

### Start the Performance Monitor Stimulus/Response Test

1. Press **RUN/STOP** on the HP 37717B PDH/SDH test set.
2. Check that the PATH FEBE error rate is the same as the generated PATH B3 BIP rate.

All the measurement results are available, throughout the test, on the **RESULTS** display .

At the end of the test :

- the cumulative measurement results are available on the **RESULTS** display.
- the current results can be retained on the display by pressing **FREEZE DISPLAY**.

## **ATM Cell Performance**

### **Application**

Services carried on ATM have different sensitivities to the problems encountered on ATM.

Constant Bit Rate services, such as voice and uncompressed video conferencing, are sensitive to Cell Delay and Cell Delay variation. Vide on Demand and Cable TV are sensitive to Cell Delay Variations.

Variable Bit Rate services, such as Data Transfer and Compressed Video, are sensitive to Cell Loss.

All these parameters must be tested to verify the ATM network will carry the appropriate service error free. Similarly these parameters are used during Quality of Service tariff negotiations with customers and therefore need to be verified.

The HP 37717B can perform these measurements for both Constant Bit rate and Variable Bit Rate services. Constant Bit Rate traffic is simulated using the Foreground Channel (measurement channel) normal distribution. Variable Bit Rate traffic is simulated by adding bursts of cells using the PERIODIC and BURST features of the HP 37717B.

Three Background channels (non-measurement channels) can be independently set to give different traffic profiles for testing the ATM link under real conditions.

### **Default (Known State) Settings**

It is advisable to set the HP 37717B to a known state before setting up a measurement. This clears all previous settings and provides a clearly defined instrument state. For a list of Default Settings and the procedure for accessing them see *Stored Settings*.

### **ATM Cell Performance Test Setup Procedure**

The following Options must be fitted to the HP 37717B to perform this test :

- UKN - ATM Module

In this setup a 34 Mb/s cell stream, containing a test cell, is transmitted into the network equipment.

ATM performance measurements are performed on the recovered test cell.

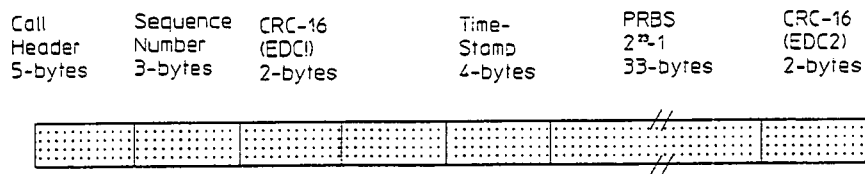
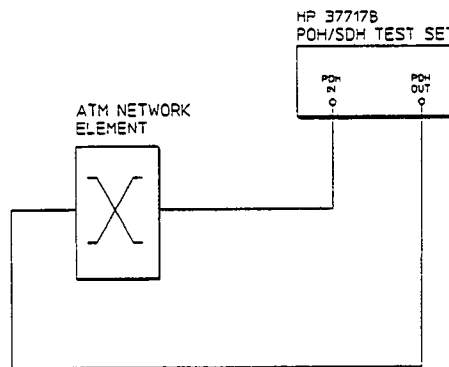

**Figure 2-28. Test Cell**

- Timestamp                      Enables delay measurements.
- Sequence Number              Enables cell misinsertion and loss measurements.
- EDC's                            Indicate cell errors.

A SINGLE test period of 24 HOURS is used and use of the internal printer for recording of results and alarms is included.

The HP 37717B PDH/SDH test set GRAPHICS function is enabled. The graphical results can be viewed on the **GRAPH** display



**Figure 2-29. ATM Cell Performance**

1. Connect the HP 37717B to the network equipment and set up the **OTHER** **SETTINGS CONTROL** display as shown below.

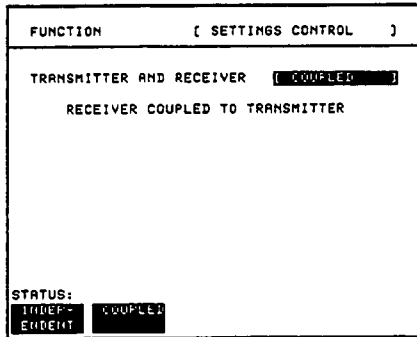

Any settings change made on the **TRANSMIT** or **RECEIVE** displays will automatically occur on the other.

3. Set up the **TRANSMIT** **ATM LAYER** **DISTRIBUTION** display as shown below.

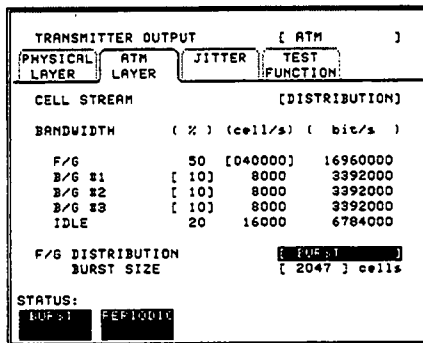

2. Set up the **TRANSMIT** **ATM** **PHYSICAL LAYER** display as shown below.

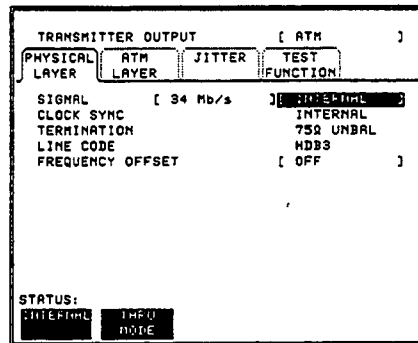

THRU MODE can be used for In-Service monitoring. Frequency Offset can be added for stress testing.

4. Set up the **TRANSMIT** **ATM LAYER** **CONTENTS** display, as shown below.

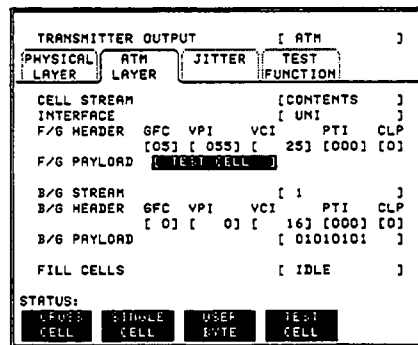

For BER testing select **CROSS CELL** or **SINGLE CELL** and required PRBS. VPI and VCI settings determine the routing of the cell stream.



5. Set up the **RECEIVE** **ATM LAYER** display as shown below.

```

RECEIVER INPUT [ ATM ]
PHYSICAL LAYER  ATM LAYER  JITTER
INTERFACE [ UNI ]
CELL SELECTED FOR TEST [ TEST CELL ]
CELL HEADER GFC VPI VCI PTI CLP
X [ X ] [ 25 ] OXX X
CELL PAYLOAD [ TEST CELL ]

STATUS:
ALL USER  MP VALUE  VC VALUE  IDLE  NONE
CELLS

```

CELL SELECTED FOR TEST allows filtering of the cells of interest.

7. Set up the **RESULTS** display, as shown opposite.

Cell Delay and Alarm Seconds results can be viewed without affecting the measurement.

If you do not require stored graphics results select STORAGE [OFF].

6. Set up the **OTHER** display, PRINTER function, as shown below.

```

FUNCTION [ PRINTER ]
PRINTER [ INTERNAL ]
PRINTING [ ON ]
PRINT PERIOD [ 1 HOUR ]
RESULTS PRINTED [ SELECTED ]
WHEN [ PERIOD EC > 0 ]
CONTENT [ ER & ANAL ]
PRINT ERROR SECONDS [ PER & CUMUL ]
PRINT AT END OF TEST [ OFF ]
ALL RESULTS

STATUS:
ALARM SECS  PERIOD EC > 0

```

WHEN [PERIOD EC>0] ensures results are not logged on the printer when a print period is error free.

```

RESULTS [ ATM ] [ CUMUL-TIME ]
[ CELL LOSS ]
TEST TIMING [ SINGLE ] [ 24 HOURS ]
STORAGE [ 1 MIN RESOL 'N ]

CELL LOSS
COUNT 0
RATIO 0

ELAPSED TIME 00d 00h 00m 17s

STATUS:
COUNT 0  SHARP 1  ALARM SECS  CELL
ACTIVE  TERM  SECONDS  DELAY

```

### Start the ATM Cell Performance Test

1. Press **RUN/STOP** to start the measurement.

The measurement results and alarms are available on the **RESULTS** display during the test period.

The graphical measurement results and alarms are stored in non volatile memory for viewing later on the **GRAPH** display.

The test can be halted at any time by pressing **RUN/STOP**.

#### **At the End of the Test (ATM Cell Performance)**

- The Date and Time the test started and the instrument setup are logged on the internal printer.
- Results are logged on the internal printer at 1 hour intervals if the error count is greater than 0.
- Any alarms which occur during the test period will be logged on the internal printer.
- At the end of the test period a complete set of cumulative results are logged on the internal printer.
- A graphical record of the results during the test period can be viewed on the **GRAPH** display. If Remote Control option 1A8 (HP-IB) or 1CW (RS-232-C) is fitted the graph results can be logged to an external printer, at a later date. See *Graphics* and *External HP 550C DeskJet Printer*.
- Results and Alarm summaries can be viewed on the **GRAPH** display.

The total graphics store capacity is normally 20,000 events. If **GRAPH STORAGE RESOLUTION [FULL]** is selected on the **OTHER MISCELLANEOUS** display the capacity reduces to 10,000 events.

The resolution, determined by the selection made under **STORAGE** on the **RESULTS** display, affects the **ZOOM** capability when viewing the bar graphs. If **1 SECOND** is selected all resolutions are available under **ZOOM**. If **1 MIN** is selected only **1 MIN/BAR**, **15 MINS/BAR** and **60 MINS/BAR** are available. If **15 MINS** is selected only **15 MINS/BAR** and **60 MINS/BAR** are available. If **1 HOUR** is selected only **60 MINS/BAR** is available.

Up to 10 sets of graphical results can be stored. If an attempt is made to store more than 10 sets of results, then a first in first out policy is operated and the oldest set of results will be lost. If graphics are enabled and a test is run which exceeds the remaining storage capacity, then some previously stored graphical results will be lost.

To prevent accidental overwriting of previously stored results the graphics capability should be disabled, when graphical results are not required, by selecting STORAGE [OFF] on the **RESULTS** display.



---

## Installing Upgrade Modules

The HP 37717B PDH/SDH test set can be upgraded to include extra modules as your test needs change. If you have suitably qualified bench service technicians, aware of ESD (Electrostatic Discharge) hazards, then the module upgrade may be performed at your premises.

If you do not have suitably qualified bench service technicians then we strongly recommend that the upgrade is performed at your nearest HP service office.

## Ordering Upgrade Modules

1. Note the Model number and Serial number.
2. Affixed to the rear panel of the HP 37717B is a BUILD STATUS label. Note the information given on this label.
3. Determine the extra modules needed using the option numbers given in the glossy data sheet.
4. Pass the information gathered in 1, 2 and 3 to your local HP Sales and Service office.

---

### Note

An upgrade module cannot be delivered unless the Serial number and Build Status information is provided.

---



## Transmit Static Overhead

It can be desirable to set an overhead byte to a known static state to aid in troubleshooting, for example, to quickly check for "stuck bits" in path overhead bytes. This capability is provided under **TRANSMIT** **SECTION OVERHEAD** and **PATH OVERHEAD**.

### Path Overhead

The value of each bit of VC4 path overhead bytes : C2, F2, G1, H4, Z3, Z4 and Z5 can be set to 0 or 1. Byte B3 cannot be set.

If **TRANSMIT** PAYLOAD [TU3] is selected the value of each bit of VC3 path overhead bytes C2, G1, F2, Z3, Z4 and Z5 can be set to 0 or 1.

If **TRANSMIT** PAYLOAD [TU2] or [TU12] is selected H4 byte is set to carry a SEQUENCE. Selection between **LONG SEQUENCE** and **SHORT SEQUENCE** is available.

### Path Trace

The path trace capability allows a user selected data message to be inserted in the appropriate J1 byte to verify the VC3 or VC-4 path connection.

#### VC3/VC-4 Path Trace

1. Press **TRANSMIT**; **SDH**; **OVERHEAD** **SETUP** and using **←**; **↓** and the display softkeys set up the **TRANSMIT** display as shown opposite.

2. Selection of **DEFAULT MESSAGE** programs the J1 byte to carry 64 ASCII Null characters.

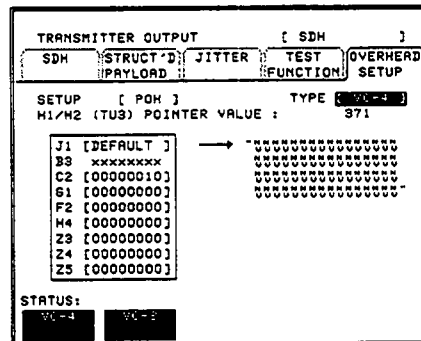

### VC3/VC-4 Path Trace (continued)

3. Selection of **TEST MESSAGE** programs the J1 byte to carry the displayed HP 37717B test message.

TRANSMITTER OUTPUT		[ SDH ]		
SDH	STRUCT'D	JITTER	TEST	OVERHEAD
	PAYLOAD		FUNCTION	SETUP
MONITOR [ POH ]		TYPE VC-4		
J1	TEST	→ "HP37717A PDH/SDH /ATM TEST SET."		
B3	XXXXXXXX	0129456789 \$b"		
C2	[00000001]			
G1	[00000000]			
F2	[00000000]			
H4	[00000000]			
Z3	[00000000]			
Z4	[00000000]			
Z5	[00000000]			
STATUS:				
DEFAULT	TEST	USER	CRC7	
MESSAGE	MESSAGE	MESSAGE	MESSAGE	

4. Selection of **USER MESSAGE** allows the user to program the message content of the J1 byte with up to 62 ASCII characters (padded out with ASCII Null characters if necessary) followed by CR LF.

TRANSMITTER OUTPUT		[ SDH ]		
SDH	STRUCT'D	JITTER	TEST	OVERHEAD
	PAYLOAD		FUNCTION	SETUP
MONITOR [ POH ]		TYPE VC-4		
J1	USER	→ [This is a simple [ example of a us [ er defined path ] [ trace message \$b]		
B3	XXXXXXXX			
C2	[00000001]			
G1	[00000000]			
F2	[00000000]			
H4	[00000000]			
Z3	[00000000]			
Z4	[00000000]			
Z5	[00000000]			
STATUS:				
DEFAULT	TEST	USER	CR LF	
MESSAGE	MESSAGE	MESSAGE	MESSAGE	

5. Selection of **CRC7 MESSAGE** allows the user to program the message content of the J1 byte with up to 15 ASCII characters (padded out with ASCII Null characters if necessary) followed by a frame marker byte with CRC7.

TRANSMITTER OUTPUT		[ SDH ]		
SDH	STRUCT'D	JITTER	TEST	OVERHEAD
	PAYLOAD		FUNCTION	SETUP
SETUP [ POH ]		TYPE [ VC-4 ]		
M1/M2 (TUS) POINTER VALUE :		371		
J1	CRCT	→ [XXXXXXXXXXXXXXXX]		
B3	XXXXXXXX			
C2	[00000010]			
G1	[00000000]			
F2	[00000000]			
H4	[00000000]			
Z3	[00000000]			
Z4	[00000000]			
Z5	[00000000]			
STATUS:				
DEFAULT	TEST	USER	CRCT	
MESSAGE	MESSAGE	MESSAGE	MESSAGE	

## Section Overhead

The value of each bit of section overhead bytes in columns 1,4,7 : A1,A2 ; C1 ; E1 ; F1 ; D1 - D3 ; K1,K2 ; D4 - D12 ; Z1 ; Z2 and E2 can be set to 0 or 1. Only bits 5 and 6 of byte H1 can be set to 0 or 1. Bytes B1, B2, H2 and H3 cannot be set at any time.

If columns 2,5,8 or 3,6,9 are selected only bytes A1,A2 ; H1 - H3 ; B2 ; Z1 and Z2 are labeled as the other overhead functions have not yet been defined. The value of each bit of section overhead bytes : A1,A2 ; H1 ; H2 ; Z1 ; Z2 and all the bits of the unlabeled functions can be set to 0 or 1. Bytes B2 and H3 cannot be set at any time.

An overhead byte cannot be set to a static value if a **TEST FUNCTION** is active in that byte, for example : If the **MSP MESSAGES** Test Function is selected then K1,K2 value will be determined by the selections made under MSP MESSAGES.

## Setting Undefined Overhead Functions

For test purposes it may be important to be able set the value of those overhead functions which are presently undefined (Z2) or unlabeled as in columns 2,5,8 and 3,6,9.

1. Press **TRANSMIT** ; **SECTION OVERHEAD** and using **←** ; **↓** set up the **TRANSMIT** display as shown opposite
2. The Z2 byte can be set in the range 00000000 to 11111111 using the display softkeys.

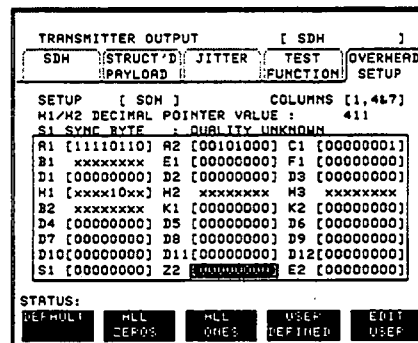

## Static Overhead Known (Default) Conditions

After testing it may be desirable to return the static overhead to the known (default) state as shown below.

TRANSMITTER OUTPUT				[ SDH ]
SDH	STRUCT'D	JITTER	TEST	OVERHEAD
PAYLOAD			FUNCTION	SETUP
MONITOR [ SDH ]				COLUMNS [ 10,400 ]
M1/M2 DECIMAL POINTER VALUE :				
S1 SYNC BYTE : QUALITY UNKNOWN				
A1	[11110110]	A2	[00101000]	C1 [00000001]
B1	xxxxxxxx	E1	[00000000]	F1 [00000000]
D1	[00000000]	D2	[00000000]	D3 [00000000]
H1	[xxxx10xx]	H2	xxxxxxxx	M3 xxxxxxxx
B2	xxxxxxxx	K1	[00000000]	K2 [00000000]
D4	[00000000]	D5	[00000000]	D6 [00000000]
D7	[00000000]	D8	[00000000]	D9 [00000000]
D10	[00000000]	D11	[00000000]	D12 [00000000]
S1	[00000000]	Z2	[00000000]	E2 [00000000]
STATUS:				
1.407	2.008	3.609		

TRANSMITTER OUTPUT				[ SDH ]
SDH	STRUCT'D	JITTER	TEST	OVERHEAD
PAYLOAD			FUNCTION	SETUP
MONITOR [ SDH ]				COLUMNS [ 8,000 ]
A1	[11110110]	A2	[00101000]	[10101010]
	[00000000]		[00000000]	[00000000]
	[00000000]		[00000000]	[00000000]
H1	[10010011]	H2	[11111111]	M3 xxxxxxxx
B2	xxxxxxxx		[00000000]	[00000000]
	[00000000]		[00000000]	[00000000]
	[00000000]		[00000000]	[00000000]
	[00000000]		[00000000]	[00000000]
Z1	[00000000]	Z2	[00000000]	[00000000]
STATUS:				
1.407	2.008	3.609		

1. Set up the STORED SETTINGS function on the **OTHER** display as shown opposite.

This returns all settings, including overhead, to the known (default) state.

FUNCTION		[ STORED SETTINGS ]
STORED SETTING NUMBER		[ 0 ]
ACTION		[ RECALL ]
SETTING	FACTORY DEFAULT SETTINGS	
0	.....	
1	.....	
2	.....	
3	.....	
4	.....	
5	.....	
6	.....	
7	.....	
8	.....	
9	.....	
STATUS:		
OFF	RECALL	



---

## Transmit Overhead Sequence

It can be desirable to insert a pattern into a functional group of overhead bytes for testing or troubleshooting purposes. This capability is provided under

**TRANSMIT** SDH TEST FUNCTION SEQUENCE.

## Regenerator Section Overhead

Sequences can be inserted into 3XA13XA2 (Framing), C1, E1, F1, and D1-D3 (DCC). The sequence is derived from 5, user defined, hexadecimal blocks of data. Each block of data can be transmitted in up to 64000 frames.

The sequence can be run once only SINGLE RUN, or on a repetitive basis REPEAT RUN.

## Multiplexer Section Overhead

Sequences can be inserted into K1K2 (MSP), D4-D12 (DCC), S1, Z1 column 2, Z1 column 3, Z2 column 4, Z2 column 5 and E2. The sequence is derived from 5, user defined, hexadecimal blocks of data. Each block of data can be transmitted in up to 64000 frames.

The sequence can be run once only SINGLE RUN, or on a repetitive basis REPEAT RUN.

## VC-4 Path Overhead

Sequences can be inserted into J1, C2, G1, F2, H4, Z3, Z4 or Z5.

If **TRANSMIT** PAYLOAD [TU2] or [TU12] is selected sequences cannot be inserted into the H4 byte using this TEST FUNCTION.

The sequence is derived from 5, user defined, hexadecimal blocks of data. Each block of data can be transmitted in up to 64000 frames.

The sequence can be run once only SINGLE RUN, or on a repetitive basis REPEAT RUN.

## Transmit Frame Synchronization Sequence

1. Press **TRANSMIT**; **SDH TEST** **FUNCTION** and using **↑**; **↓** and the display softkeys set up the display as shown opposite.

Press **REPEAT RUN** **STARTED** to start the sequence. As a result of this sequence one OOF alarm and one LOF alarm should occur every two seconds.

TRANSMITTER OUTPUT		[ SDH ]
SDH	STRUCT'D	JITTER
PAYLOAD	TEST	OVERHEAD
	FUNCTION	SETUP
TEST FUNCTION [ SDH ] SEQUENCES ]		
[ REPEAT RUN ] [ STOPPED ] -SEQUENCE STOPPED		
OVERHEAD CHANNEL [ RSOH ] [ 3xA1, 3xA2 ]		
A	[ F6F6F62828 ]	
B	[ 090909D7D7 ]	
C	[ 0000000000 ]	
D	[ 0000000000 ]	
E	[ 0000000000 ]	
SEQUENCE	[ 15974 ]	FRAMES OF [ A ] THEN
[	26]	[ B ]
[	0]	[ C ]
[	0]	[ D ]
[	0]	[ E ]
STATUS:		
[ STOPPED ]	[ STARTED ]	

## Receive Overhead Monitor

When first connecting to a SDH network a start-up confidence check can be made by viewing the behavior of all the overhead bytes. If the SDH network shows alarm indications, some diagnosis of the problem may be gained from viewing all the overhead bytes. This facility is provided on the **RECEIVE** display under **SOH MONITOR** and **POH MONITOR**.

All path overhead bytes are monitored and displayed. VC4 path overhead is shown below. If **TRANSMIT** PAYLOAD [TU3] is selected VC-3 path overhead can be monitored and displayed. If **TRANSMIT** PAYLOAD [TU12] is selected VC-12 path overhead can be monitored and displayed.

The display is updated once per second (once per 8000 frames approximately).

RECEIVER INPUT		[ SDH ]
SDH	STRUCT'D	TEST
PAYLOAD	FUNCTION	OVERHEAD
MONITOR	[ SDH ]	MONITOR
MONITOR [ SDH ]		COLUMNS [ 1,4&7 ]
S1 SYNC STATUS : RESERVED		
J1	01111000	
B3	00010111	
C2	00100110	
G1	01101001	
F2	00010100	
H4	00011101	
Z3	11110111	
Z4	10100000	
Z5	10111011	
UNKNOWN SEQUENCE		
STATUS: Loss Of Frame alarm		
SDH	POH	

All section overhead bytes are monitored and displayed as shown below.

The display is updated once per second (once per 8000 frames approximately).

RECEIVER INPUT		[ SDH ]
SDH	STRUCT'D	TEST
PAYLOAD	FUNCTION	OVERHEAD
MONITOR	[ SDH ]	MONITOR
MONITOR [ SDH ]		COLUMNS [ 1,4&7 ]
S1 SYNC STATUS : RESERVED		
A1	10101010	A2 11001100
B1	01100011	E1 01100001
D1	00011011	D2 10100111
H1	01010011	H2 00011010
B2	11101000	K1 01111001
D4	11000111	D5 10000110
D7	01100001	D8 10010010
D10	10110111	D11 10011010
S1	11101100	Z2 01001101
E2 00010100		
STATUS: Loss Of Frame alarm		
SDH	POH	

If any abnormal behavior is observed on a particular path or section overhead byte, or an associated group of bytes (3XA1,3XA2 ; D1 - D3) the **RECEIVE** **TEST FUNCTION** display of **OVERHEAD CAPTURE** can be used to "zoom" in on the suspect byte, or bytes, on a frame by frame basis.

---

## Receive Overhead Capture

Regenerator section, Multiplexer section and Path overhead provide network support functions, responding dynamically to network conditions and needs. It is therefore desirable to be able to capture overhead activity on a frame by frame basis. This capability is provided under **RECEIVE** ; **TEST FUNCTION** ; **OVERHEAD CAPTURE**.

Overhead Capture allows selection of the starting point of the capture by means of Trigger selection :

- |                |   |
|----------------|---|
| Trigger OFF    | start immediately the capture is initiated  |
| Trigger ON     | capture activity after a specified overhead state has occurred                              |
| Trigger ON NOT | capture activity after the first occurrence of a deviation from a specified overhead state. |

Trigger OFF can be used to provide a "frame by frame monitor" of the selected byte, or bytes, immediately the capture is initiated.

Trigger ON and ON NOT can be used for "transient detection" from a specified expected state.

The overhead capture feature provides up to 16 records of overhead state. Each record will represent between 1 and 64,000 frames. A capture is started by pressing **CAPTURE** **STARTED** and terminates when 16 records have been captured. The capture can be terminated sooner by pressing **STOPPED**.

## Frame by Frame Monitor of H1,H2

The frame by frame monitor capability provides a "zoom" in version of the Receive Overhead Monitor feature using the Trigger OFF condition of overhead capture.

1. Press **RECEIVE** ; **SDH** ; **TEST**  
**FUNCTION** ; **SDH** ; **OVERHEAD CAPTURE**  
and using **←** ; **↓** and the display softkeys set up the **RECEIVE** display as shown opposite.

Press **STARTED** to start the capture.

RECEIVER INPUT [ SDH ]			
SDH	STRUCT'D	TEST	OVERHEAD
PAYLOAD	FUNCTION	MONITOR	
TEST FUNCTION [ O/H CAPTURE ]			
CAPTURE OF CHANNEL [MSOH] [ H1,H2 ]			
TRIGGER [ OFF ]			
CAPTURE [ STOPPED ]			
DATA	FRAME COUNT	DATA	FRAME COUNT
6168	64000	6086	64000
6168	1610	6086	64000
9086	1	6086	57635
6086	64000	930E	1
6086	64000	630E	64000
6086	64000	630E	64000
6086	64000	630E	44106
6086	64000	911A	1
STATUS:			
STUFFED		DUMPED	

## Transient Detection on A1,A1,A1,A2,A2,A2

Under normal operating conditions the A1,A2 bytes will remain in a known stable state (F6F6F6282828). Using the Trigger ON NOT condition of the Overhead Capture, any transient deviations from that state can be detected.

1. Press **RECEIVE** ; **SDH** ; **TEST**  
**FUNCTION** ; **SDH** ; **OVERHEAD CAPTURE**  
and using **←** ; **↓** and the display softkeys set up the **RECEIVE** display as shown opposite.

Press **STARTED** to start the capture.

RECEIVER INPUT [ SDH ]			
SDH	STRUCT'D	TEST	OVERHEAD
PAYLOAD	FUNCTION	MONITOR	
TEST FUNCTION [ O/H CAPTURE ]			
CAPTURE OF CHANNEL [RSOH] [ 3xA1,3xA2 ]			
TRIGGER [ ON NOT ] [ F6F6F6282828 ]			
CAPTURE [ STOPPED ]			
DATA	FRAME COUNT	DATA	FRAME COUNT
F6F6F6282828	1		
F6F6F6282828	32909		
E6F6F6282828	1		
F6F6F6282828	64000		
F6F6F6282828	64000		
F6F6F6282828	26288		
D6F6F6282828	1		
F6F6F6282828	64000		
STATUS:			
STUFFED		DUMPED	

---

## Graphics

The Graphics function provides the following displays :

- bar graph display of the results obtained during the test period.
- display of the measurement error summary and alarm summary during the test period.
- display of the graphics Store, content and capacity.

Each of these displays can be viewed in the **GRAPH** display. The bar graph display and the error and alarm summaries can be logged on an external HP 550C DeskJet printer.

Bar Graphs of PDH Frame Count; PDH CRC Count; PDH REBE Count; PDH Code Count; Bit Error Count and PDH Alarms 1 and 2 are available.

If Option UKJ or UKL, Structured PDH, is fitted additional Bar graphs of Frame 140 Count, Frame 34 Count, Frame 8 Count and Frame 2 Count are provided.

If Option UKN, ATM measurement, is fitted additional Bar Graphs of EMBIP Count, FEBE Count, Corrected HEC Count, Non Corrected HEC Count, Cell Loss Count, Errored Cell Count and Misinserted Cell Count are provided,

If option US1 or A1T, SDH module, is fitted additional Bar Graphs of RS B1 BIP Count; MS B2 BIP Count; Path B3 BIP Count; Path FEBE Count; TU BIP Count; TU FEBE Count; Bit Error Count and SDH Alarms 1, 2 and 3 are available. Option A1T also provides MS FEBE count and A1A2 Frame count.

If option UHN, PDH Jitter measurement + Wander and Slips, is fitted additional Bar Graphs of Jitter Hit Count; Wander Bit -ve Slips; Wander Bit +ve Slips; Wander Frame -ve Slips; Wander Frame +ve Slips and Jitter Alarms are available.

Up to 10 sets of bar graphs, error summaries and alarm summaries, and the status of the stored results can be stored in non volatile memory.

The total graphics store capacity is normally 20,000 events. If **GRAPH STORAGE RESOLUTION [FULL]** is selected on the **OTHER MISCELLANEOUS** display the capacity reduces to 10,000 events.

The resolution, determined by the selection made under STORAGE on the **RESULTS** display, affects the ZOOM capability when viewing the bar graphs. If 1 MIN is selected only 1 MIN/BAR, 15 MINS/BAR and 60 MINS/BAR are available. If 15 MINS is selected only 15 MINS/BAR and 60 MINS/BAR are available. If 1 HOUR is selected only 60 MINS/BAR is available.

Up to 10 sets of graphical results can be stored. If an attempt is made to store more than 10 sets of results, then a first in first out policy is operated and the oldest set of results will be lost. If graphics are enabled and a test is run which exceeds the remaining storage capacity, then some previously stored graphical results will be lost.

To prevent accidental overwriting of graphics data the graphics capability should be disabled when graphical results are not required. To disable the graphics capability select STORAGE [OFF] on the **RESULTS** display.

### Obtaining Graphics Results

To obtain graphical results enable the graphics by selecting STORAGE [1 SEC RESOLUTION] or [1 MIN RESOLUTION] or [15 MINS RESOLUTION] or [1 HOUR RESOLUTION] on the **RESULTS** display. The resolution selected affects the ZOOM capability when viewing the bar graphs. If 1 MIN is selected only 1 MIN/BAR, 15 MINS/BAR and 60 MINS/BAR are available. If 15 MINS is selected only 15 MINS/BAR and 60 MINS/BAR are available. If 1 HOUR is selected only 60 MINS/BAR is available.

STORAGE [1 MIN RESOLUTION] enables the graphics and allows storage of the measurement results.

When a measurement is started by pressing **RUN/STOP**, graphical results will be recorded.

RESULTS [ PDB ] [ CUMULATIVE ]	
TEST TIMING	[ MANUAL ]
STORAGE	[ 1 MIN RESOL 'N ]
BIT	EC
BIT	ER
CODE	EC
CODE	ER
ELAPSED TIME	
STATUS:	
OFF	[ 1 SEC RESOL 'N ] [ 15 MINS RESOL 'N ] [ 1 HR RESOL 'N ]





3. For more detailed inspection of the bar graph, position the cursor centrally within the area of interest using  $\left(\uparrow\right)$  and  $\left(\downarrow\right)$  and select **ZOOM IN** to reduce the time axis to 15 MINS/BAR. This is only possible if the graphics results were stored with a STORAGE resolution of 1 SEC, 1 MINS or 15 MINS.

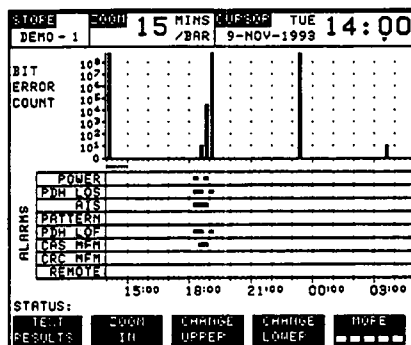

For further reduction of the time axis, to 01 MINS/BAR or 01 SECS/BAR, position the cursor centrally within the area of interest and select **ZOOM IN** until the required time axis is obtained.

The top row of the display comprises three fields :

- Store** Memory location in which the displayed bar graph data is stored. Store can only be changed when the status of stored results is displayed. Select **TEXT RESULTS** and then **STORE STATUS** and move the highlighted cursor, to the STORE location desired, using  $\left(\uparrow\right)$  and  $\left(\downarrow\right)$ .
- Zoom** The width, in minutes, of each "bar" in the bar graph, controlled by **ZOOM IN**/**ZOOM OUT**.
- Cursor** The cursor position in terms of time and date, controlled by  $\left(\uparrow\right)$  and  $\left(\downarrow\right)$ . The cursor position changes in steps of 1 minute, 15 minutes or 60 minutes dependent upon the ZOOM setting. The cursor is physically located between the two graphs.

## Viewing the Error and Alarm Summaries

The error summary or alarm summary can be viewed at any time.

1. To view the error or alarm summary associated with the current bar graphs, press **GRAPH** then **TEXT RESULTS**.

2. To view the error or alarm summary associated with previously stored bar graphs, press **GRAPH**; **TEXT RESULTS** and **STORE STATUS**. Using **←** and **↓** move the highlighted cursor to the store location which contains the required results, and select **TEXT RESULTS**.

STORE	START	12:51	STOP	12:52
LAST	TUE 28-MAR-1989		TUE 28-MAR-1989	
<b>SDH ERROR SUMMARY</b>				
		COUNT		RATIO
RS BIP		1369		3.246E-06
MS BIP		1382		3.328E-06
PATH BIP		1360		3.351E-06
PATH FEBE		0		0
TU BIP		21		3.472E-06
TU FEBE		0		0
BIT		....		....
<b>STATUS:</b>				
STORE	GRAPH	FFIIT	NEXT	ALARM
STATUS	RESULTS		SUMMARY	SUMMARY

3. To view the Alarms which have occurred during the measurement select **ALARM SUMMARY**. Use **NEXT SUMMARY** to view the PDH; JITTER; ATM and SDH Alarm Summaries in turn if applicable.

4. To view the Errors which have occurred during the measurement select **ERROR SUMMARY**. Use **NEXT SUMMARY** to view the PDH; JITTER; ATM and SDH Error Summaries in turn if applicable.

The top row of the display comprises three fields :

- Store Memory location in which the bar graphs, error summary and alarm summary are stored. Store can only be changed when the status of stored results is displayed. Select **STORE STATUS** and move the highlighted cursor, to the STORE location desired, using **←** and **↓**.
- Start The start time and date of the test, which produced the displayed results.
- Stop The stop time and date of the test, which produced the displayed results.

## Viewing the Stored Results Status

Select **TEXT RESULTS** ; **STORE STATUS** if viewing the bar graph display.

Select **STORE STATUS** if viewing the error or alarm summary.

**GRAPH RESULTS** displays the bar graphs from the highlighted store location.



**TEXT RESULTS** displays the error or alarm summary from the highlighted store location.

**DELETE STORE** deletes the results in the highlighted store location.

STORE	START DATE	START TIME	TEST DURATION	STORE USE
-9				
-8				
-7				
-6				
-5				
-4				
-3				
MEMO	20-MAR-1995	09:15	00h 02m 26s	<1%
DEMO	20-MAR-1995	09:21	00h 02m 10s	<1%
DEMO	20-MAR-1995	09:21	00h 01m 40s	<1%
FREE STORE 11972: EVENTS			TOTAL USED	<1%
			FREE	99%
STATUS:				
GRAPH RESULTS	TEXT RESULTS	DELETE STORE	DELETE ALL	

If **DELETE ALL** is selected, a **CONFIRM DELETE** ; **ABORT DELETE** choice is provided to prevent accidental deletion of all the stored results.

The top row of the display comprises five fields :

- Store Memory location in which the displayed bar graph data is stored. Move the highlighted cursor, to the STORE location desired, using  and .
- Start Date The start date of the test, which produced the stored results.
- Start Time The start time of the test, which produced the stored results.
- Test Duration The duration of the test, which produced the stored results. The storage capacity of the graphics capability is expressed in days, hours and minutes. The percentage (%) of storage capacity used and the percentage still available for use is given at the bottom of the TEST DURATION column under TOTAL USED and FREE respectively.
- Store Use The percentage (%) of the overall storage capacity occupied by each set of stored results. The percentage used and the percentage still available is provided at the bottom of the STORE USE column.

## Demonstration Graphs

Select **ENABLE DEMO** to enable the demonstration function of the graphics capability.

Select **DEMO** to construct a set of bar graphs. These bar graphs can be used as an operators training aid but it should be noted that the demonstration bar graphs require part of the graphics store capacity.

Select **DISABLE DEMO** to disable the demonstration function of the graphics capability and therefore protect any currently stored graphics data.

Demo bar graph construction takes approximately 20 seconds and uses a portion of the graphics storage capacity.

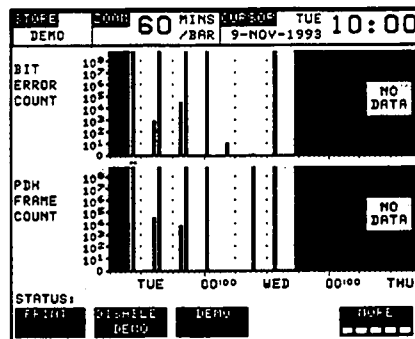

## Printing Graphics Displays

If Option 1A8, HP-IB Remote Control, or Option 1CW, RS-232-C Remote Control, is fitted the bar graphs and error and alarm summary can be logged to an external HP 550C DeskJet printer at the end of the test period. If a printer is not immediately available the graphics results remain in memory and can be logged at a later time when a printer becomes available.

To print a graphics display on an external HP 550C DeskJet printer :

1. Connect an external RS-232-C HP 550C DeskJet printer to the HP 37717B RS232 port or an external HP-IB HP 550C DeskJet printer to the HP 37717B HP-IB port . See *External HP 550C DeskJet Printer*.
2. Make the required selections on the **OTHER PRINTER** display : **PRINTER** [EXTERNAL] and **PRINTING** [ON].
3. Obtain the graphics display required and select **PRINT**.

Select **PRINT** on the bar graph display to log The Error and Alarm summaries, the displayed Bar graphs and the Alarm graph to the printer.

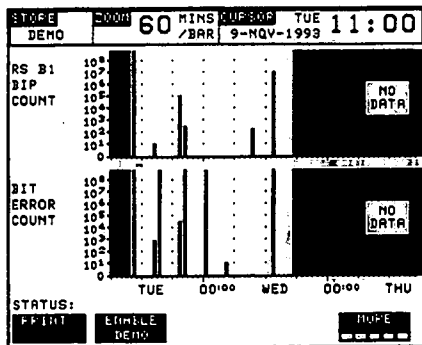

Select **PRINT** on the Text Results display to log the selected Error and Alarm summaries to the printer.

STORE	START	STOP
LAST	TUE 28-MAR-1989	TUE 28-MAR-1989

SDH ALARM SUMMARY		
POWER LOSS	0 PATH AIS	0
LOS	5 MS FERF	0
LOF	5 PATH FERF	N/A
ODF	5	N/A
LOP	5	N/A
MS AIS	0 PATTERN LOSS	N/A
	0	
TU LOP		
TU PATH AIS		
TU PATH FERF		

STATUS:				
STORE	GRAPH	PRINT	NEXT	ERROR
STATUS	RESULTS		SUMMARY	SUMMARY

---

## Logging Results

The results obtained during the test are retained in memory until they are overwritten by the next set of results. The results can be logged on the internal printer at any time during the test period and at the end of the test period.

Any Alarm occurrence results in a timed and dated message being logged on the internal printer.

BER and Analysis results can be selected by the user.

Cumulative and Period versions of the results are calculated and can be selected by the user.

**Period**            The results obtained over a set period of time during the test. The Period is defined by the PRINT PERIOD selection.

**Cumulative**      The results obtained over the time elapsed since the start of the test.

---

### Note



1. A full list of results and events available for logging is contained in Appendix A, Printer Messages.

2. Definitions of all the results is contained in Appendix B, Results.

---

## Test Period Logging

If degradations in system performance can be observed at an early stage, then the appropriate remedial action can be taken to maximize circuit availability and avoid system crashes. Period logging allows you to monitor the error performance of your circuit. At the end of the test period the selected results are logged on the printer. Results can be logged at regular intervals during the test period by selecting a PRINT PERIOD of shorter duration than the test period.

Without affecting the test in progress an instant summary of the results can be demanded by pressing .

PRINTING [ON] enables the printing of ALARM conditions.

PRINT PERIOD determines how regularly the results are logged.

RESULTS PRINTED [ALL] provides a complete set of, Cumulative, BER and Analysis results at the end of each print period and at the end of the test period.

FUNCTION [ PRINTER ]	
PRINTER	INTERNAL
PRINTING	[ ON ]
PRINT PERIOD	[ 1 HOUR ]
RESULTS PRINTED	[ ALL ]
PRINT ERROR SECONDS	[ OFF ]
PRINT AT END OF TEST	ALL RESULTS
STATUS:	
ALL	SELECTED

## Error Event Logging

Manual tracing of intermittent faults is time consuming. Error event logging allows you to carry out unattended long term monitoring of the circuit. Each occurrence of the selected error event is logged on the printer.

PRINTING [ON] enables the printing of ALARM conditions.

PRINT ERROR SECONDS [ON] determines that each time an error second is detected, a timed and dated message will be logged on the printer.

PRINT PERIOD [OFF] provides a complete set of, cumulative, BER and Analysis results at the end of the test period.

FUNCTION [ PRINTER ]	
PRINTER	[ INTERNAL ]
PRINTING	[ ON ]
PRINT PERIOD	[ OFF ]
PRINT ERROR SECONDS	[ ON ]
PRINT AT END OF TEST	ALL RESULTS
STATUS:	
OFF	5 MIN 1 HOUR 24 HOURS 100%

When making long term out-of-service bit error measurements it is often desirable only to log results when an error has occurred.

WHEN [PERIOD BEC>0] determines the action taken at the end of the selected Print Period. If the bit error count during a Print Period is greater than 0 then the selected results for that period only, are logged. If the bit error count is 0 then the message *NO BIT ERRORS* is logged at the end of the Print Period. A complete set of the selected results are logged on the printer at the end of the test period.

FUNCTION	[ PRINTER ]
PRINTER	[ INTERNAL ]
PRINTING	[ ON ]
PRINT PERIOD	[ 1 HOUR ]
RESULTS PRINTED	[ SELECTED ]
WHEN	[ PERIOD EC>0 ]
CONTENT	[ ER & ANAL ]
PRINT ERROR SECONDS	[ ON ]
PRINT AT END OF TEST	[ ALL RESULTS ]
STATUS:	
ERROR	MINI-315
RESULTS	HP 11

CONTENT [ER & ANAL] provides both BER and Analysis results at the end of each Print Period and at the end of the test period.

CONTENT [PER & CUMUL] provides both Period and Cumulative results at the end of each Print Period.

PRINT ERROR SECONDS [ON] determines that each time an error second is detected, a timed and dated message will be logged on the printer.

### HP-IB External Printer

If Option 1A8, HP-IB Remote Control, is fitted the results can be logged to an External printer connected to the HP-IB port.

An HP-IB External printer or the internal printer can be used for logging results.

Selection of HP-IB External printer prevents the use of HP-IB Remote Control.

FUNCTION	[ PRINTER ]
PRINTER	[ HP-IB ]
PRINTING	[ ON ]
PRINT PERIOD	[ 1 HOUR ]
RESULTS PRINTED	[ ALL ]
PRINT ERROR SECONDS	[ ON ]
PRINT AT END OF TEST	[ ALL RESULTS ]
STATUS:	
INTERNAL	HP 11



## RS-232-C External Printer

If Option 1CW, RS-232-C Remote Control, is fitted the results can be logged to an External printer connected to the RS-232-C port. The user interface is slightly modified as a result.

An HP RS-232-C External printer eg. 550C DeskJet, an alternate manufacturers RS-232-C External printer or the internal printer can be used for logging results.

Selection of an External printer prevents the use of RS-232-C Remote Control.

FUNCTION	[ PRINTER ]
PRINTER	[ EXTERNAL ]
PRINTING	[ ON ]
PRINT PERIOD	[ 1 HOUR ]
RESULTS PRINTED	[ ALL ]
PRINT ERROR SECONDS	[ ON ]
PRINT AT END OF TEST	[ ALL RESULTS ]
STATUS:	
INTERNAL	EXTERNAL
ALT.	RS232

The PRINTER BAUD RATE must be selected on the **OTHER COMMS** display.

The HP RS232 external printer flow control is always Xon/Xoff.

FUNCTION	[ COMMS CONTROL ]
COMMUNICATIONS PORT	RS232
PORT FUNCTION	[ PRINTER ]
PRINTER SET TO	EXTERNAL
FLOW CONTROL	XON/XOFF
PRINTER BAUD RATE	[ 9600 BAUD ]
PARITY (8 BIT DATA)	NONE
STATUS:	
300 BAUD	600 BAUD
1200 BAUD	2400 BAUD
4800 BAUD	9600 BAUD

The ALT RS232 PRINT MODE can be selected as NORMAL (80 column) or COMPRESS (40 column).

The PRINTER BAUD RATE must be selected on the **OTHER COMMS** display.

The ALT RS232 external printer flow control is always DTR.

FUNCTION	[ COMMS CONTROL ]
COMMUNICATIONS PORT	RS232
PORT FUNCTION	[ PRINTER ]
PRINTER SET TO	ALT. RS232
PRINT MODE	[ NORMAL ]
FLOW CONTROL	DTR
PRINTER BAUD RATE	[ 9600 BAUD ]
PARITY (8 BIT DATA)	NONE
STATUS:	
NORMAL	COMPRESS

---

## External HP 550C DeskJet Printer

If Option 1CW, RS-232-C Remote Control, is fitted the HP 37717B has the capability of interfacing with an RS-232-C HP 550C DeskJet printer or, an alternative suppliers RS-232-C printer, via the RS-232-C port.

If Option 1A8, HP-IB Remote Control, is fitted the HP 37717B has the capability of interfacing with an HP 550C DeskJet printer via the Centronics port.

The choice between internal and external is available on the **OTHER** **PRINTER** display.

---

### Note



Selection of an External printer prevents the use of Remote Control.

---

## Connecting an HP 550C DeskJet Printer

1. The cabling required depends upon the Remote Control option fitted to the HP 37717B.

RS-232-C If Option 1CW, RS-232-C Remote Control, is fitted, connect the HP 37717B RS-232-C port to the HP 550C DeskJet RS-232-C port.

HP-IB If Option 1A8, HP-IB Remote Control, is fitted, connect the HP 37717B HP-IB port to the HP 550C DeskJet Centronics port via an HP-IB to Centronics Converter. (Intelligent Interfaces, MICROPRINT 45CH.)

---

### Note



The MICROPRINT 45CH Configuration switches are located alongside the DC power input. To change the switch settings, use a pen or pencil to set the switches in the desired (off or on) position. After each change in settings cycle the power to establish the new settings.

---

2. If Option 1CW, RS-232-C remote Control, is fitted, proceed to step 4.  
 If Option 1A8, HP-IB Remote Control, is fitted set the MICROPRINT 45CH configuration switches as follows :

S1	S2	S3	S4	Description
ON	ON	ON	ON	DeskJet Listen Always

S5	S6	S7	S8	Description
OFF	OFF	OFF	OFF	DeskJet Default resolution (300 dpi).

3. Cycle the power to the the MICROPRINT 45CH to establish the new settings.

**Note**



The DeskJet Mode Configuration switches are located on the printers front base, under the IN tray. To change the switch settings, use a pen or pencil to set the switches in the desired (up or down) position. After each change in settings press **RESET** on the printer to establish the new settings.

4. Set the DeskJet Configuration switches as follows :

A1	A2	A3	A4	A5	A6	A7	A8
Down	Down	Down	Down	Down	Down	Down	Up

B1	B2	B3	B4	B5	B6	B7	B8
Up	Down	Down	Down	Down	Down	Down	Down

5. Press **RESET** on the printer to establish the new settings.

6. Select [FONT] - PORTRAIT on the printer.

7. Switches B5 and B6 match the instrument Baud rate to the printer Baud rate. The settings listed above are for 9600 Baud. To change the Baud rate setting of the printer set B5 and B6 as follows :

B5	B6	Baud Rate
Down	Down	9600 Baud
Up	Down	2400 Baud
Up	Up	1200 Baud

---

**Note**

Parity is not selectable on the HP 37717B Printer interface and as a result B7 and B8 are set to Parity NONE - both switches down.

---

---

## Internal Printer Changing Paper

The internal printer is housed in a compartment, beneath **PAPER FEED** and **PRINT NOW** which is accessible from the front panel. A plastic cover is fitted to prohibit dust from the printer mechanism and retain the printer paper.

---

**Caution** Do not press **PAPER FEED** while attempting to feed the paper into the Printer.



---

To change the internal printer paper proceed as follows :

1. Remove the printer compartment cover by pushing the cover catch upwards and lifting the cover off.
2. Remove any paper remaining from the old roll by gently pulling.
3. Undo the new roll of paper and place in the printer compartment such that the paper feeds up the open end of the compartment (See Figure 2-30).
4. Using scissors cut the first 2 inches of the paper as shown in Figure 2-30.
5. Feed the paper into the slot behind the cylindrical printer head located at the top of the compartment and keep feeding until the point of the paper appears between the tear-off "teeth".
6. Pull the paper through until a full width of paper appears and then tear-off as required.

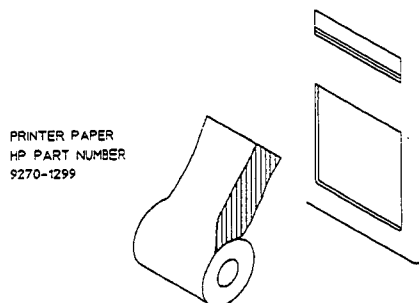

**Figure 2-30. Paper Feed Direction**

---

## Autosetup

The Autosetup function of the HP 37717B can speed up the setting up of the instrument when making PDH or SDH measurements.

This featured is activated by pressing **AUTO SETUP** when the PDH or SDH signal is connected to the HP 37717B. If both a PDH and SDH signal are connected the PDH signal will take priority and the HP 37717B will attempt Autosetup on the PDH signal.

### PDH Input

The HP 37717B will attempt to match the receiver settings of: Pattern, Signal Level, Rate, Code, Framing type and Multiframe type to those of the received signal.

If the PDH signal is STRUCTURED Autosetup will fail to lock on to the received signal.

If the PDH signal is LIVE TRAFFIC Autosetup will fail to lock on to the received signal.

### SDH Input

The HP 37717B will attempt to match the receiver settings of: Pattern, Rate and Payload type to those of the received signal.

It is possible to have both the receive and transmit settings configured by Autosetup by selecting **COUPLED** on the **OTHER SETTINGS CONTROL** display before pressing **AUTO SETUP**.



If the Payload signal is STRUCTURED Autosetup will fail to lock on to the received signal.

If the Payload signal is LIVE TRAFFIC Autosetup will fail to lock on to the received signal.

---

## Path Trace (Option US1)

The Path Trace capability allows the fixed data message provided by the PDH/SDH test set to be captured thus verifying the VC4 or TU3 path connection.

1. Press **RESULTS** ; **SDH RESULTS** and using  ,  and the display softkeys setup the display as shown opposite.

The unique path trace message including the PDH/SDH test set serial number will be displayed if the path connection is good.

RESULTS [ SDH ]	[ PATH TRACE ]
TEST TIMING	[ MANUAL ]
STORAGE	[ OFF ]
VC4 PATH TRACE	
"HEWLETT-PACKARD, HP87714R PDH/SDH FIELD TEST SET, 000000000 00000000"	
ELAPSED TIME	00d 01h 00m 00s
STATUS:	
SHOW [ ]	CONTROL [ ]
TEST [ ]	ACTIVE [ ]
ANALYSIS [ ]	ALARM [ ]
SECONDS [ ]	MODE [ ]

## Stored Settings

It is often desirable to store measurement settings which are used regularly and be able to recall those settings at a moments notice. This capability is provided in the HP 37717B on the **OTHER STORED SETTINGS** display.

One preset store is provided which cannot be overwritten, STORED SETTING NUMBER [0], and is used to set the HP 37717B to a known state. The known state is the FACTORY DEFAULT SETTINGS as listed below.

### **TRANSMIT** display (UPDH Option UKK)

Signal	140 Mb/s	Clock Sync	Internal
Code	CMI	Pattern	2 <sup>23</sup> -1
Termination	75 Ω Unbal		

### **TRANSMIT** display (SPDH Option UKJ)

Settings	Main	Signal	140 Mb/s
Clock Sync	Internal	Termination	75 Ω Unbal
Line Code	CMI	Frequency Offset	Off
Payload Type	Unframed	Pattern	2 <sup>23</sup> -1
PRBS Polarity	INV	Test Signal	34 Mb/s
34M Payload	Unframed	2M Payload	Unframed
2M Payload	Unframed	34 Mb	1
8 Mb	1	2 Mb	1
64 kb	1	BG Pattern	AIS
User Word	1111111111111111	Error Add	Bit
Error Add Rate	None		

### **TRANSMIT** display (SDH)

Signal	STM-1	Clock Sync	Internal
Payload	140 Mb/s	Payload Pattern	2 <sup>23</sup> -1
TUG3	1	TUG2	1
TU	1	2 Mb/s Pattern	2 <sup>15</sup> -1



**TRANSMIT display (ATM Option UKN)**

Signal	34 Mb/s, Internal	Clock Sync	Internal
Code	HDB3	Termination	75 Ω Unbal
Cell Stream	Distribution	F/G Bandwidth	80,000 c/s
B/G 1 Bandwidth	0	B/G 2 Bandwidth	0
B/G 3 Bandwidth	0	F/G Distribution	Burst
Burst Size	1 Cell	Interface	UNI
F/G Payload	Cross Cell, 2 <sup>15</sup> -1	B/G Stream	1
B/G Payload	00000001	Fill Cells	Idle

**RECEIVE display (UPDH Option UKK)**

Signal	140 Mb/s	Test Mode	Out of Service
Code	CMI	Pattern	2 <sup>23</sup> -1
Termination	75 Ω Unbal		

**RECEIVE display (SPDH Option UKJ, UKL)**

Settings	Main	Signal	140 Mb/s
Termination	75 Ω Unbal	Line Code	CMI
Gain	20 dB	Equalizer	Off
Payload Type	Unframed	Pattern	2 <sup>23</sup> -1
PRBS Polarity	INV	Test Signal	34 Mb/s
34M Payload	Unframed	8M Payload	Unframed
2M Payload	Unframed	34 Mb	1
8 Mb	1	2 Mb	1
64 kb	1		

**RECEIVE display (SDH)**

Signal	STM-1	Payload	140 Mb/s
Payload Pattern	2 <sup>23</sup> -1	TUG3	1
TUG2	1	TU	1

**RECEIVE display (ATM Option UKN)**

Signal	34 Mb/s	Termination	75 $\Omega$ Unbal
Code	HDB3	Interface	UNI
Test Cell	All User	Cell Payload	Cross Cell, 2 <sup>15</sup> -1

**RESULTS display**

Results	Trouble Scan	Short Term Period	1 Second
Test Timing	Manual	Single Test Duration	1 Hour
Storage	OFF	SDH Results	Short Term, RS B1 BIP
PDH Results	Short Term		

**OTHER display**

Stored Setting Lock	On	Stored Setting Number	0
Printer	Internal	Printing	Off
Print Period	OFF	Print Error Seconds	OFF
Print Mode	Normal	Print Speed	9600 Baud
Clock Mode	Run	Keyboard lock	OFF
Beep On Error	OFF	Analysis Display Mode	G.821
Suspend Test on LOS	OFF	Self Test	All Tests
Settings Control	Independent		

The use of the STORED SETTINGS function is illustrated by carrying out the following tasks :

- Select the settings used in the payload mapping measurement.
- TITLE the settings as payload mapping
- SAVE the settings as Stored Setting Number [1]
- RECALL the factory default settings from Stored Setting Number [0]
- RECALL the payload mapping settings from Stored Setting Number [1]

## Select Settings to be Stored

1. Set up the **OTHER SETTINGS CONTROL** display as shown below.

FUNCTION [ SETTINGS CONTROL ]	
TRANSMITTER AND RECEIVER	[ INDEPENDENT ]
STATUS:	
LINE	[ COUPLED ]
EVENT	[ ]

2. Set up the **TRANSMIT** display as shown below.

TRANSMITTER OUTPUT [ FDM ]	
SIGNAL	[ 140 Mb/s ]
CLOCK SYNC	[ INTERNAL ]
FREQUENCY OFFSET	[ OFF ]
CODE	[ CHI ]
PATTERN	[ 2 <sup>15</sup> -1 ]
TERMINATION	[ 75Ω UNBAL ]
STATUS:	
FDM	[ SDH ]

3. Set up the **RECEIVE** display as shown below.

RECEIVER INPUT [ SDH ]	
SIGNAL	[ STM-4 OPT ]
STM-1 UNDER TEST	[ 1 ]
PAYLOAD	[ 140 Mb/s ]
PATTERN	[ 2 <sup>23</sup> -1 ]
STATUS:	
STM-1	[ STM-1 OPTICAL ]
	[ STM-4 OPTICAL ]

4. Set up the **OTHER PRINTER** display, as shown below.

FUNCTION [ PRINTER ]	
PRINTER	[ INTERNAL ]
PRINTING	[ ON ]
PRINT PERIOD	[ 1 HOUR ]
RESULTS PRINTED	[ SELECTED ]
WHEN	[ ALWAYS ]
CONTENT	[ PER & CUMUL ]
PRINT ERROR SECONDS	[ ON ]
PRINT AT END OF TEST	[ ALL RESULTS ]
STATUS:	
RESULTS	[ ANALYSIS ]

5. Set up the **RESULTS** display as shown opposite.

RESULTS [ PDM PAYLOAD ] [ ERROR ANALYSIS ]	
TEST TIMING	[ SINGLE ] [ 24 HOURS ]
STORAGE	[ 1 MIN RESOL'N ]
<b>BIT ANALYSIS</b>	
EC	
ES	%
EFS	%
SES	%
UNAV	%
DEG MIN	%
ELAPSED TIME	
STATUS:	
SHORT TEST	LOAD ACTIVE
ERROR ANALYSIS	ALPHA SECONDS

### Title the Settings

1. Select the **STORED SETTINGS** function on the **OTHER** display.

To Title settings LOCK [OFF] must be selected.

2. Using **UP**; **JUMP**; **PREVIOUS CHAR**; **NEXT CHAR**; **RIGHT** and **LEFT** title the settings as shown opposite.

FUNCTION [ STORED SETTINGS ]	
STORED SETTING NUMBER	[ 1 ]
LOCK	[ OFF ]
ACTION	[ OFF ]
<b>SETTING</b>	
0	FACTORY DEFAULT SETTINGS
1	[ PAYLOAD..MAPPING..... ]
2	[ ..... ]
3	[ ..... ]
4	[ ..... ]
5	[ ..... ]
6	[ ..... ]
7	[ ..... ]
8	[ ..... ]
9	[ ..... ]
STATUS:	
JUMP	PREVIOUS CHAR
NEXT CHAR	← →

### Save the Settings

1. Set up the display as shown opposite.

Press **SAVE** to save the settings.

The payload mapping settings are now stored in STORED SETTING NUMBER [1].

FUNCTION [ STORED SETTINGS ]	
STORED SETTING NUMBER	[ 1 ]
LOCK	[ OFF ]
ACTION	[ SAVE ]
<b>SETTING</b>	
0	FACTORY DEFAULT SETTINGS
1	[ PAYLOAD..MAPPING..... ]
2	[ ..... ]
3	[ ..... ]
4	[ ..... ]
5	[ ..... ]
6	[ ..... ]
7	[ ..... ]
8	[ ..... ]
9	[ ..... ]
STATUS:	
OFF	RECALL
	SAVE

## Recall Default Settings

1. Set up the display as shown opposite.

Press **RECALL** to recall the settings in STORED SETTING NUMBER [0].

To verify that the instrument has adopted the factory default settings, view the **TRANSMIT**; **RECEIVE**; **RESULTS** and **OTHER** displays.

FUNCTION		[ STORED SETTINGS ]
STORED SETTING NUMBER	[ 0 ]	
	ACTION	[ RECALL ]
SETTING		
0	FACTORY DEFAULT SETTINGS	
1	[PAYLOAD..MAPPING.....]	
2	[.....]	
3	[.....]	
4	[.....]	
5	[.....]	
6	[.....]	
7	[.....]	
8	[.....]	
9	[.....]	
STATUS:		
	OFF	RECALL

## Recall Previously Stored Settings (Payload Mapping)

1. Set up the display as shown opposite and press **RECALL** to recall the settings in STORED SETTING NUMBER [1].

To verify that the instrument has adopted the payload mapping settings, view the **TRANSMIT**; **RECEIVE** and **RESULTS** displays.

Settings can be recalled when LOCK [ON] is selected but to save settings or title settings LOCK [OFF] must be selected.

FUNCTION		[ STORED SETTINGS ]
STORED SETTING NUMBER	[ 1 ]	
LOCK	[ OFF ]	
	ACTION	[ RECALL ]
SETTING		
0	FACTORY DEFAULT SETTINGS	
1	[PAYLOAD..MAPPING.....]	
2	[.....]	
3	[.....]	
4	[.....]	
5	[.....]	
6	[.....]	
7	[.....]	
8	[.....]	
9	[.....]	
STATUS:		
	OFF	RECALL
		SAVE

## Coupling Transmit and Receive Settings

When generating and measuring at the same interface level it is useful to have the transmit and receive settings coupled together. Any settings change made on the transmit display will automatically occur on the receive display. Any settings change made on the receive display will automatically occur on the transmit display. This function is available on the **OTHER** **SETTINGS CONTROL** display.

FUNCTION	[ SETTINGS CONTROL ]
TRANSMITTER AND RECEIVER	<input checked="" type="checkbox"/> COUPLED
RECEIVER COUPLED TO TRANSMITTER	
STATUS:	
INDEFINITE	<input checked="" type="checkbox"/> COUPLED

## Time & Date

When making Bit error measurements and recording results it is desirable to have certain events timed chronologically for example, Alarms ; Error Seconds.

The capability to set the Time and Date is provided on the **OTHER** display under the TIME & DATE function.

### Setting Time and Date

1. Set up the **OTHER** display as shown opposite.

Set the Time and Date as required using

**↑**; **↓**; **←**; **→**; **INCREASE DIGIT**;  
**DECREASE DIGIT**.

FUNCTION	[ TIME & DATE ]
CLOCK MODE	[ SETUP ]
TIME	[ 14:35:28 ]
DATE	[ 31-JAN-94 ]
STATUS:	
DECREASE DIGIT	INCREASE DIGIT
	<b>←</b> <b>→</b>

2. Using **↑** and **↓** move the highlighted bar to **SETUP** as shown opposite.





Select **RUN** to complete the setting of Time and Date.

FUNCTION	[ TIME & DATE ]
CLOCK MODE	[ <b>SETUP</b> ]
TIME	[ 14:35:28 ]
DATE	[ 31-JAN-94 ]
STATUS:	
<b>RUN</b>	SETUP

## Keyboard Lock

It is often desirable to protect the measurement settings from interference, during a test. This facility is provided in the HP 37717B on the **OTHER** **MISCELLANEOUS** display.

The following keys are not affected by Keyboard Lock :

- Display keys **TRANSMIT** ; **RECEIVE** ; **RESULTS** ; **GRAPH** ; **OTHER**
- cursor keys  ; 
- 
- 

The following display functions are not affected by Keyboard Lock :

- RESULTS type on the results display
- KEYBOARD LOCK on the other display

## Lock/Unlock the Keyboard

1. Set up the **OTHER** display as shown opposite.

To Lock the keyboard select [ON].

To Unlock the keyboard select [OFF].

FUNCTION	[ MISCELLANEOUS ]
KEYBOARD LOCK	[ ON ]
BEEP ON RECEIVED ERROR	[ OFF ]
<b>ANALYSIS CONTROL</b>	
SUSPEND TEST ON SIGNAL LOSS	[ OFF ]
ANALYSIS DISPLAY MODE	[ 6.821 ]
STATUS:	
OFF	ON



---

## Beep On Error

It is sometimes desirable to have an audible indication of an error particularly when the display on the test set is hidden from view. This function is provided in the HP 37717B on the **OTHER** **MISCELLANEOUS** display.

### Enable/Disable Beep On Error

1. Set up the **OTHER** display as shown opposite.

FUNCTION	[ MISCELLANEOUS ]
KEYBOARD LOCK	[ OFF ]
BEEP ON RECEIVED ERROR	[ ON ]
ANALYSIS CONTROL	
SUSPEND TEST ON SIGNAL LOSS	[ OFF ]
ANALYSIS DISPLAY MODE	[ 6.821 ]
STATUS:	
OFF	ON

---

## Analysis Control

The HP 37717B allows a choice of Analysis results when testing and this choice is selected under ANALYSIS DISPLAY MODE.

This function is provided on the **OTHER** **MISCELLANEOUS** display.

1. Set up the **OTHER** display as shown opposite.

Select the analysis results required either G.821 or M.2100.

FUNCTION	[ MISCELLANEOUS ]
KEYBOARD LOCK	[ OFF ]
BEEP ON RECEIVED ERROR	[ OFF ]
<u>ANALYSIS CONTROL</u>	
PDM ANALYSIS DISPLAY MODE	[ G.821 ]
GRAPH STORAGE RESOLUTION	[ COMPRESS ]
NOTE: storing graph results with full resolution will reduce storage capacity by 50%	
STATUS:	
G.821	M.2100

---

## Self Test

Before using the HP 37717B to make measurements it may be desirable to run Self Test to ascertain the integrity of the HP 37717B. These tests take approximately 15 minutes to complete.

Before activating Self Test both the 75Ω and 120Ω Signal In ports must be connected to the corresponding Signal Out ports.

If Option 1CW, RS-232-C Remote Control, is fitted an RS-232-C loopback connector (HP Part Number 5060-4462) must be connected to the RS-232-C Port.

If Option US1 or A1T, SDH module, is fitted the STM-1 IN port must be connected to the STM-1 OUT port.

If Option UH1, STM-1 Optical Interface, or Option UH2, STM-1/STM-4 Optical Interface, is fitted the IN port must be connected to the OUT Port.

---

### Note

If any or all of these connections are not made the HP 37717B will FAIL Self Test.



1. Set up the **OTHER** display as shown opposite using **OTHER**, **MORE** and **SELF TEST**.
2. Connect 75Ω Signal In to 75Ω Signal Out.
3. Connect 120Ω Signal In to 120Ω Signal Out.

FUNCTION	[ SELF TEST ]
TEST TYPE	[ ALL TESTS ]
TEST NUMBER	..
SUBTEST NUMBER	..
TEST STATUS	
PRESS THE <b>FUNCTION</b> KEY TO START TESTING.	
THIS SELECTION WILL RUN ALL SELF-TESTS.	
FOLLOW SETUP INSTRUCTIONS FOR EACH INDIVIDUAL SELF-TEST.	
STATUS:	
ALL TESTS	CPU TESTS
FIN TESTS	SDH TESTS

4. If Option 1CW, RS-232-C Remote Control/Printer, is fitted connect an RS-232-C Loopback connector (HP Part Number 5060-4462) to the rear panel RS232 port.
5. If Option US1 or A1T, SDH module, is fitted connect the STM-1 IN port to the STM-1 OUT port.
6. If Option UH1, STM-1 Optical Interface, or Option UH2, STM-1/STM-4 Optical Interface, is fitted connect the IN port to the OUT Port.

2-136 Making Measurements

7. Press **[RUN/STOP]** to activate the Self Test. TEST STATUS [RUNNING] will be displayed. The information pertaining to TEST TYPE, TEST NUMBER and SUBTEST NUMBER will change as the Self Test progresses

If the HP 37717B is functioning correctly, after approximately 15 minutes, TEST STATUS [PASSED] is displayed.

If TEST STATUS [FAIL nnn] is displayed the HP 37717B should be returned to a service office for repair.

FUNCTION	[ SELF TEST ]
TEST TYPE	[ SDH TESTS ]
TEST NUMBER	8
SUBTEST NUMBER	--
TEST STATUS	<b>PASSED</b>
PRESS THE <b>[RUN/STOP]</b> KEY TO START TESTING.	
CONNECT STM-1 OUT TO STM-1 IN.	
STATUS:	
SELF TEST	CALLER- RATION
	DOPE

---

**Note**



1. FAIL Error Numbers are listed and defined in the HP 37717B Service Manual (HP part number 37717-90000) and are intended for use by Service personnel.

---

# A

## Printer Messages

---

### Printer Types

The internal printer is a standard feature and is included in all instruments. Graphics results cannot be logged to the internal printer.

If Option 1A8, HP-IB Remote Control, is fitted an External HP-IB 550C DeskJet printer can be used for results logging.

If Option 1CW, RS-232-C Remote Control, is fitted an External RS-232-C 550C DeskJet printer or an alternative suppliers RS-232-C printer can be used for results logging. The alternative RS-232-C printer can be 40 column width or 80 column width. If a 40 column width printer is used Graphics results cannot be logged.

### Results Logging

Header and results are logged to the selected printer when :

- **PRINT NOW** is pressed.
- If PRINTING [ON] is selected on the **OTHER PRINTER** display and a measurement is started by pressing **RUN/STOP**.

```
=====
                        Hewlett Peckard HP37714A
                        Instrument Configuration
=====
RECEIVER :
Bit Rate   : 8 Mb/s           Pattern   : 2^15-1
Code      : HDB3             Interface  : 75ohm Unbal
Tx Clk Offset : Off
MEASUREMENT STARTED 24 Nov 93 07:25:17      Print Period 5 Minutes
=====
```

Figure A-1. Logging Header

If **PRINT NOW** is pressed the cumulative results are logged. If a measurement is in progress the current results are logged. If a measurement is not in progress the cumulative results for the last measurement are logged.

### **During the Measurement Period**

If PRINT ERROR SECOND [ON] is selected on the **OTHER** **PRINTER** display all occurrences of an Error Second will be logged :

- Bit
- Code (PDH)
- Frame (PDH)
- CRC (PDH)
- REBE (PDH)
- A1A2 FRAME (SDH Option A1T only)
- RS B1 BIP (SDH)
- MS B2 BIP (SDH)
- MS FEBE (SDH Option A1T only)
- Path B3 BIP (SDH)
- Path FEBE (SDH)
- Path IEC (SDH Option A1T only)
- TU Path BIP (SDH)
- TU Path FEBE (SDH)
- Jitter Hit (PDH Jitter)
- EM BIP (ATM)
- FEBE (ATM)
- Corrected HEC (ATM)
- Non Corrected HEC (ATM)
- Cell Loss (ATM)
- Errored Cells (ATM)

### **A-2 Printer Messages**



- Misinserted Cells (ATM)

All Alarm occurrences will be logged both when set and cleared :

- Signal Loss
- AIS (PDH & ATM)
- Pattern Sync Loss (PDH & ATM)
- Loss Of Frame (PDH & ATM)
- Multiframe (PDH)
- Remote Loss (PDH)
- Remote Multiframe Loss (PDH)
- Frame Loss (SDH)
- Loss of Pointer (SDH)
- MS AIS (SDH)
- Path AIS (SDH)
- Pattern Loss (SDH)
- Clock Loss (SDH)
- MS FERF (SDH)
- Path FERF (SDH)
- K1K2 Change (SDH Option A1T only)
- H4 Multiframe Loss (SDH)
- TU Loss of Pointer (SDH)
- TU AIS (SDH)
- TU Path FERF (SDH)
- Jitter Lock Loss (Option UHN)
- Excess Jitter (Option UHN)
- Excess Wander (Option UHN)

- Wander Ref Loss (Option UHN)
- Wander Signal Loss (Option UHN)
- FERF (ATM)
- Loss of Cell Sync (ATM)
- Selected Cell Not Received (ATM)
- Congestion Experienced (ATM)
- Test Cell Loss (ATM)
- VP AIS (ATM)
- VP FERF (ATM)
- VC AIS (ATM)
- VC FERF (ATM)

In addition the following events are logged :

- All Alarms Clear
- Power Failure
- Power Restored
- New Day
- Squelched
- Unsquelched
- Print Demanded - if  is pressed.
- Print Period - if selected on   display.
- Printing Enabled - if Printer enabled during a measurement.
- Measurement Complete

#### A-4 Printer Messages



ERROR SEC		Code	Bit
23:56:35		0	63604
ERROR SEC		Code	Bit
23:56:36		0	139264
ERROR SEC		Code	Bit
23:56:37		0	139264
ERROR SEC		Code	Bit
23:56:38		0	139264
ERROR SEC		Code	Bit
23:56:39		0	139264
ERROR SEC		Code	Bit
23:56:40		0	139264
ERROR SEC		Code	Bit
23:56:41		0	139264
ERROR SEC		Code	Bit
23:56:42		0	139264
ERROR SEC		Code	Bit
23:56:43		0	139264
ERROR SEC		Code	Bit
23:56:44		0	139264
23:56:45	SQUELCHED		
23:56:48	UNSQUELCHED		
23:56:54	AIS Alarm	SET	
23:56:54	Pattern Sync Loss	SET	
23:56:55	AIS Alarm	CLEAR	
23:56:55	Pattern Sync Loss	CLEAR	
ERROR SEC		Code	Bit
23:56:55		??05393	0
ERROR SEC		Code	Bit
23:56:56		0	276785
=====			
26-Nov-93   NEW DAY			
=====			

Figure A-2. Logging During Measurement

### At the End of the Measurement Period

A complete set of measurement results are logged.

```
ERROR SEC |=====|
MEASUREMENT COMPLETE : 26 Nov 93 00:01:59 Elapsed Time : 00d 00h 06m 11s
|=====|
                        Cumulative Results
Error Results :
Error Count          CODE      BIT
Error Ratio          6.221E+07  2.882E+06
                    1.204E-03  5.578E-05
Frequency: 139263992 Hz      Offset:  -0.06 Hz      Offset:  -8 ppm
Analysis Results :
G.821 Analysis
CODE      BIT
ES                1      24
ZES              6.4690
ZES (Annex D)    6.469
EFS              347
ZEFS            93.5310
SES              1
ZSES            0.2695
DM               2
ZDM            28.5714
UNAV            0
ZUNAV          0.0000
|=====|
```

Figure A-3. Logging At End of Measurement

### Bar Graph Logging (External Printer Only)

To log the Bar Graphs select **PRINTER [EXTERNAL]** and **PRINTING [ON]** on the **OTHER PRINTER** display. Display the Bar Graphs required on the Bar Graph display and press **PRINT**. The Error Summary, the Alarm Summary, the selected Bar Graphs and the Alarms Graph are logged.

Hewlett Packard HP37714A  
Graphical Text Results

MEASUREMENT STARTED : 09:25 26-NOV-1993  
TEST DURATION : 00d 01h 00m

Error Summary		Count	Ratio	CODE	Count	Ratio
BIT		1.406E+06	2.805E-06		1.559E+08	3.109E-04
Alarm Summary						
Power Loss		0				
LOS		1				
AIS		5				
PSL		5				

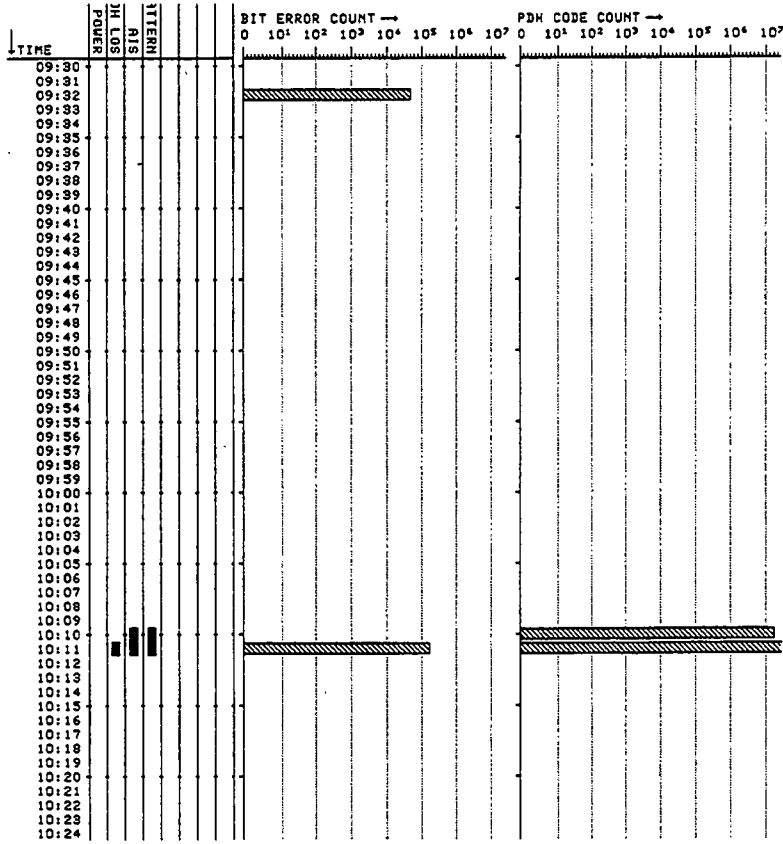

Figure A-4. Bar Graph Logging

### Graphics Text Results Logging (External Printer Only)

To log the Text Results select PRINTER [EXTERNAL] and PRINTING [ON] on the **OTHER** **PRINTER** display. Display the results (SDH or PDH) required on the Text Results display and press **PRINT**. The Error Summary and Alarm Summary are logged.

```
=====
                                Hewlett Packard HP37714A
                                Graphical Text Results
MEASUREMENT STARTED : 13:10 23-NOV-1993
TEST DURATION       : 00d 01h 01m

Error Summary
Count      Ratio      CODE      Count      Ratio
BIT        157791    5.198E-06
Alarm Summary
Power Loss          3
LOS                 4
RIS                  0
PSL                  6
=====
```

Figure A-5. Text Results Logging

### Jitter Auto Tolerance Results Logging (External Printer Only)

To log the Jitter Auto tolerance plot select PRINTER [EXTERNAL] and PRINTING [ON] on the **OTHER** **PRINTER** display. Select RESULTS [JITTER] [AUTO TOLER] on the Results display and press **PRINT NOW**.

## Results Definitions

### Trouble Scan

All possible error sources and alarms are scanned simultaneously. If any error counts are not zero then these are displayed. Up to 4 non-zero error counts are displayed in priority order :

UPDH (Option UKK)	SDH (Option US1, A1T)	SPDH (Options UKJ, UKL)	ATM (Option UKN) + SDH	ATM (Option UKN) + SPDH
<ul style="list-style-type: none"> <li>■ CRC</li> <li>■ BIT</li> <li>■ CODE</li> <li>■ FRAME</li> <li>■ REBE</li> </ul>	<ul style="list-style-type: none"> <li>■ RS B1 BIP</li> <li>■ MS B2 BIP</li> <li>■ PATH B3 BIP</li> <li>■ VC3 PATH BIP</li> <li>■ TU2 BIP</li> <li>■ TU12 BIP</li> <li>■ A1A2 FRAME</li> <li>■ MS FEBE</li> <li>■ PATH FEBE</li> <li>■ PATH IEC</li> <li>■ VC3 PATH FEBE</li> <li>■ TU2 FEBE</li> <li>■ TU12 FEBE</li> <li>■ BIT</li> </ul>	<ul style="list-style-type: none"> <li>■ CRC</li> <li>■ BIT</li> <li>■ CODE</li> <li>■ FAS 140M</li> <li>■ FAS 34M</li> <li>■ FAS 8M</li> <li>■ FAS 2M</li> <li>■ REBE</li> </ul>	<ul style="list-style-type: none"> <li>■ RS B1 BIP (SDH only)</li> <li>■ MS B2 BIP (SDH only)</li> <li>■ PATH B3 BIP (SDH only)</li> <li>■ Non Corrected HEC</li> <li>■ Corrected HEC</li> <li>■ Lost Cells</li> <li>■ Misinserted Cells</li> <li>■ Path FEBE</li> <li>■ Bit</li> <li>■ Errored Cells</li> </ul>	<ul style="list-style-type: none"> <li>■ EM BIP</li> <li>■ Non Corrected HEC</li> <li>■ Corrected HEC</li> <li>■ Lost Cells</li> <li>■ Misinserted Cells</li> <li>■ EM FEBE</li> <li>■ Bit</li> <li>■ Errored Cells</li> </ul>

If any alarms are active "ALARMS ACTIVE" is displayed.  and the alarm led's can be used to determine which alarms are active.

If no alarms are active and no non-zero error counts are detected then "NO TROUBLE" is displayed.

---

## Alarm Scan (Options UKJ, UKL)

Frame Loss, AIS and Remote Alarm at the interface rate and all lower levels of the hierarchy are displayed in graphical form as shown opposite.

The graphical display does not show which of the three possible alarms has occurred for each rate. However the alarmed rate can be selected and an analysis of the alarm state obtained.

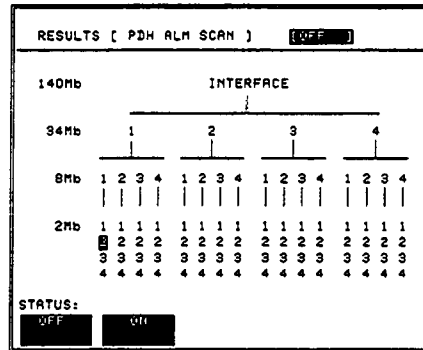

---

## Short Term Results

Displays period results obtained during the measurement. The period is user-defined under SHORT TERM PERIOD on the **RESULTS** display.

### PDH Results (Options UKJ, UKK and UKL)

<b>BIT EC</b>	Counts Bit errors occurring during the Short Term Period.
<b>BIT ER</b>	Calculates the ratio of Bit errors to the number of clocks in the Short Term Period.
<b>CODE EC</b>	Counts Code errors occurring during the Short Term Period.
<b>CODE ER</b>	Calculates the ratio of Code errors to the number of clocks in the Short Term Period.
<b>FRAME (FAS)</b>	Compares the received FAS word with the correct value.
<b>CRC</b>	Compares the received CRC4 with the calculated CRC4 (2 Mb/s only).
<b>REBE</b>	Detects Bit 1 of the NFAS word in frames 13 and 15 being set to 0 (2 Mb/s only).

### B-2 Results Definitions

## **SDH Results (Options US1, A1T)**

Error Count and Error Ratio results for the following error sources are available :

<b>A1A2 FRAME</b>	Compares the received Framing bytes with the known value. (Option A1T only)
<b>RS B1 BIP</b>	Compares the received B1 with the recalculated value.
<b>MS B2 BIP</b>	Compares the received B2 with the recalculated value.
<b>MS FEBE</b>	Calculated from the FEBE bits in the received M1 overhead byte. (Option A1T only)
<b>PATH B3 BIP</b>	Compares the received B3 with the recalculated value.
<b>PATH FEBE</b>	Calculated from the FEBE bits in the received G1 overhead byte.
<b>PATH IEC</b>	Calculated from the PIEC bits in the received Z5 Path overhead byte. (Option A1T only)

If a Payload of 34 Mb/s is selected, Error Count and Error Ratio results for the following additional error sources are also available :

<b>TU PATH BIP</b>	Compares the received VC3, B3 with the recalculated value.
<b>TU PATH FEBE</b>	Calculated from the FEBE bits in the received VC3, G1 overhead byte.

If a Payload of 2 Mb/s is selected, Error Count and Error Ratio results for the following additional error sources are also available :

<b>TU PATH BIP</b>	Compares the received V5, BIP-2 in the TU12 selected for test with the recalculated value.
<b>TU PATH FEBE</b>	Calculated from the FEBE bits in the V5 overhead byte of the TU12 selected for test.

## **ATM Results (Option UKN)**

Error Count and Error Ratio results for the following error sources are available :

<b>EM BIP</b>	Compares the received BIP with the recalculated value.
<b>FEBE</b>	Calculated from the received FEBE bits.
<b>Corrected HEC</b>	Errors in Cell Headers which have been corrected by the HEC algorithm.

<b>Non Corrected HEC</b>	Errors in Cell Headers which have not been corrected by the HEC algorithm..
<b>Received Cells</b>	Counts received cells which match the receiver cell filter.
<b>Errored Cells</b>	PRBS Cell containing one or more bit errors, or a Test Cell containing incorrect EDC's.
<b>Bit</b>	Bit by Bit comparison of the received data with the internal reference pattern.
<b>Cell Loss</b>	A discontinuity in the Test Cell sequence number indicating cells have been lost.
<b>Misinserted Cells</b>	Errors in the Test Cell sequence number implying a misinserted cell.

---

## Cumulative Results

Provides a cumulative display of the results during the measurement period.

## PDH Results (Options UKJ, UKK and UKL)

<b>BIT EC</b>	Counts Bit errors occurring during the Short Term Period.
<b>BIT ER</b>	Calculates the ratio of Bit errors to the number of clocks in the Short Term Period.
<b>CODE EC</b>	Counts Code errors occurring during the Short Term Period.
<b>CODE ER</b>	Calculates the ratio of Code errors to the number of clocks in the Short Term Period.
<b>FRAME (FAS)</b>	Compares the received FAS word with the correct value.
<b>CRC</b>	Compares the received CRC4 with the calculated CRC4 (2 Mb/s only).
<b>REBE</b>	Detects Bit 1 of the NFAS word in frames 13 and 15 being set to 0 (2 Mb/s only).



## **SDH Results (Option US1, A1T)**

Error Count and Error Ratio results for the following error sources are available :

<b>A1A2 FRAME</b>	Compares the received Framing bytes with the known value. (Option A1T only)
<b>RS B1 BIP</b>	Compares the received B1 with the recalculated value.
<b>MS B2 BIP</b>	Compares the received B2 with the recalculated value.
<b>MS FEBE</b>	Calculated from the FEBE bits in the received M1 overhead byte. (Option A1T only)
<b>PATH B3 BIP</b>	Compares the received B3 with the recalculated value.
<b>PATH FEBE</b>	Calculated from the FEBE bits in the received G1 overhead byte.
<b>PATH IEC</b>	Calculated from the PIEC bits in the received Z5 Path overhead byte. (Option A1T only)

If a Payload of 34 Mb/s is selected, Error Count and Error Ratio results for the following additional error sources are also available :

<b>TU PATH BIP</b>	Compares the received VC3, B3 with the recalculated value.
<b>TU PATH FEBE</b>	Calculated from the FEBE bits in the received VC3, G1 overhead byte.

If a Payload of 2 Mb/s is selected, Error Count and Error Ratio results for the following additional error sources are also available :

<b>TU PATH BIP</b>	Compares the received V5, BIP-2 in the TU12 selected for test with the recalculated value.
<b>TU PATH FEBE</b>	Calculated from the FEBE bits in the V5 overhead byte of the TU12 selected for test.

## **ATM Results (Option UKN)**

Error Count and Error Ratio results for the following error sources are available :

<b>EM BIP</b>	Compares the received BIP with the recalculated value.
<b>FEBE</b>	Calculated from the received FEBE bits.
<b>Corrected HEC</b>	Errors in Cell Headers which have been corrected by the HEC algorithm.

<b>Non Corrected HEC</b>	Errors in Cell Headers which have not been corrected by the HEC algorithm..
<b>Received Cells</b>	Counts received cells which match the receiver cell filter.
<b>Errored Cells</b>	PRBS Cell containing one or more bit errors, or a Test Cell containing incorrect EDC's.
<b>Bit</b>	Bit by Bit comparison of the received data with the internal reference pattern.
<b>Cell Loss</b>	A discontinuity in the Test Cell sequence number indicating cells have been lost.
<b>Misinserted Cells</b>	Errors in the Test Cell sequence number implying a misinserted cell.



---

## PDH Error Analysis

Analysis results are calculated for the following error sources :

### Option UKK

Out of Service            G.821 Bit (All Rates)

In-Service                FRAME (Not 704 kb/s), CRC and REBE (2 Mb/s,  
CRC Framing only).

### Option UKJ & UKL

G.821 Bit and FAS (All Rates), CRC and REBE (2 Mb/s, CRC Framing  
only).

G.826 (All Rates)

## Bit Errors

These result from a bit by bit comparison of the received pattern and the  
internal reference pattern.

### PDH G.821 - Bit Analysis

Display	Definition
EC	Error Count - Cumulative Bit error count during the measurement period.
ES	Error Second - Cumulative count of seconds within available time that contain at least 1 Bit error. Percentage Error Seconds is also displayed - error seconds expressed as a percentage of the available time.
% Ann. D ES	Percentage Annex D Error Seconds - As % ES, only error second is normalised to 64 kb/s rate as per CCITT G.821 Annex D.
EFS	Error Free Seconds - Cumulative count of seconds within available time that contain zero errors. Percentage Error Free Seconds is also displayed - error free seconds expressed as a percentage of the available time.
SES	Severely Errored Seconds - Cumulative count of seconds within available time in which the Bit Error Ratio is $> 1$ in $10^3$ . Percentage Severely Errored Seconds is also displayed - severely errored seconds expressed as a percentage of the available time.

**PDH G.821 - Bit Analysis (continued)**

Display	Definition
UNAV	Unavailable Seconds - Cumulative count of unavailable seconds. A period of unavailability begins at the start of 10 or more consecutive seconds in which the Bit Error Ratio is $> 1$ in $10^{-3}$ , and ends at the start of 10 or more consecutive seconds in which the Bit Error Ratio is $< 1$ in $10^{-3}$ . Percentage Unavailable Seconds is also displayed - unavailable seconds expressed as a percentage of the total elapsed time.
DEG MIN	Degrade Minutes - Cumulative count of degraded minutes. Available seconds, excluding Severely Errored Seconds, are packaged into 1 minute blocks. The Bit Error Ratio for the packaged block is measured and if it exceeds $1$ in $10^{-6}$ a Degrade Minute is registered. Percentage Degraded Minutes is also displayed - degraded minutes expressed as a percentage of the total number of packaged 1 minute blocks.
CODE ES	Code Errored Second - Cumulative count of seconds with available time that contain at least 1 Code error.

**Frame (FAS) Errors**

These result from a bit by bit comparison of the received FAS word with the correct value, once frame alignment has been achieved.

**PDH G.821 - Frame (FAS) Analysis (Not 704 kb/s)**

Display	Definition
EC	Error Count - Cumulative Frame error count during the measurement period.
ES	Error Second - Cumulative count of seconds within available time that contain at least 1 Frame error. Percentage Error Seconds is also displayed - error seconds expressed as a percentage of the available time.
% Ann. D ES	Percentage Annex D Error Seconds - As % ES, only error second is normalised to 64 kb/s rate as per CCITT G.821 Annex D.
EFS	Error Free Seconds - Cumulative count of seconds within available time that contain zero errors. Percentage Error Free Seconds is also displayed - error free seconds expressed as a percentage of the available time.
SES	Severely Errored Seconds - Cumulative count of seconds within available time in which the Bit Error Ratio is $> 1$ in $10^{-3}$ . Percentage Severely Errored Seconds is also displayed - severely errored seconds expressed as a percentage of the available time.

**B-8 Results Definitions**

**PDH G.821 - Frame (FAS) Analysis (Not 704 kb/s) (continued)**

Display	Definition
UNAV	Unavailable Seconds - Cumulative count of unavailable seconds. A period of unavailability begins at the start of 10 or more consecutive seconds in which the Bit Error Ratio is $> 1$ in $10^{-3}$ , and ends at the start of 10 or more consecutive seconds in which the Bit Error Ratio is $< 1$ in $10^{-3}$ . Percentage Unavailable Seconds is also displayed - unavailable seconds expressed as a percentage of the total elapsed time.
DEG MIN	Degrade Minutes - Cumulative count of degraded minutes. Available seconds, excluding Severely Errored Seconds, are packaged into 1 minute blocks. The Bit Error Ratio for the packaged block is measured and if it exceeds $1$ in $10^{-6}$ a Degrade Minute is registered. Percentage Degraded Minutes is also displayed - degraded minutes expressed as a percentage of the total number of packaged 1 minute blocks.
CODE ES	Code Errored Second - Cumulative count of seconds with available time that contain at least 1 Code error.

**CRC Errors**

These result from a comparison of the received CRC4 with the calculated CRC4.

**PDH G.821 - CRC Analysis (2 Mb/s, CRC Framing)**

Display	Definition
EC	Error Count - Cumulative CRC error count during the measurement period.
ES	Error Second - Cumulative count of seconds within available time that contain at least 1 CRC error. Percentage Error Seconds is also displayed - error seconds expressed as a percentage of the available time.
% Ann. D ES	Percentage Annex D Error Seconds - As % ES, only error second is normalised to 64 kb/s rate as per CCITT G.821 Annex D.
EFS	Error Free Seconds - Cumulative count of seconds within available time that contain zero errors. Percentage Error Free Seconds is also displayed - error free seconds expressed as a percentage of the available time.
SES	Severely Errored Seconds - Cumulative count of seconds within available time in which the Bit Error Ratio is $> 1$ in $10^{-3}$ . Percentage Severely Errored Seconds is also displayed - severely errored seconds expressed as a percentage of the available time.

**PDH G.821 - CRC Analysis (2 Mb/s, CRC Framing) (continued)**

Display	Definition
UNAV	Unavailable Seconds - Cumulative count of unavailable seconds. A period of unavailability begins at the start of 10 or more consecutive seconds in which the Bit Error Ratio is $> 1$ in $10^{-3}$ , and ends at the start of 10 or more consecutive seconds in which the Bit Error Ratio is $< 1$ in $10^{-3}$ . Percentage Unavailable Seconds is also displayed - unavailable seconds expressed as a percentage of the total elapsed time.
DEG MIN	Degrade Minutes - Cumulative count of degraded minutes. Available seconds, excluding Severely Errored Seconds, are packaged into 1 minute blocks. The Bit Error Ratio for the packaged block is measured and if it exceeds $1$ in $10^{-6}$ a Degrade Minute is registered. Percentage Degraded Minutes is also displayed - degraded minutes expressed as a percentage of the total number of packaged 1 minute blocks.
CODE ES	Code Errored Second - Cumulative count of seconds with available time that contain at least 1 Code error.

**REBE Errors**

These are calculated from bit 1 of the NFAS word in frames 13 and 15 of the received 2 Mb/s.

**PDH G.821 - REBE Analysis (2 Mb/s, CRC Framing)**

Display	Definition
EC	Error Count - Cumulative REBE error count during the measurement period.
ES	Error Second - Cumulative count of seconds within available time that contain at least 1 REBE error. Percentage Error Seconds is also displayed - error seconds expressed as a percentage of the available time.
% Ann. D ES	Percentage Annex D Error Seconds - As % ES, only error second is normalised to 64 kb/s rate as per CCITT G.821 Annex D.
EFS	Error Free Seconds - Cumulative count of seconds within available time that contain zero errors. Percentage Error Free Seconds is also displayed - error free seconds expressed as a percentage of the available time.
SES	Severely Errored Seconds - Cumulative count of seconds within available time in which the Bit Error Ratio is $> 1$ in $10^{-3}$ . Percentage Severely Errored Seconds is also displayed - severely errored seconds expressed as a percentage of the available time.

**B-10 Results Definitions**

**PDH G.821 - REBE Analysis (2 Mb/s, CRC Framing) (continued)**

Display	Definition
UNAV	Unavailable Seconds - Cumulative count of unavailable seconds. A period of unavailability begins at the start of 10 or more consecutive seconds in which the Bit Error Ratio is $> 1$ in $10^{-3}$ , and ends at the start of 10 or more consecutive seconds in which the Bit Error Ratio is $< 1$ in $10^{-3}$ . Percentage Unavailable Seconds is also displayed - unavailable seconds expressed as a percentage of the total elapsed time.
DEG MIN	Degrade Minutes - Cumulative count of degraded minutes. Available seconds, excluding Severely Errored Seconds, are packaged into 1 minute blocks. The Bit Error Ratio for the packaged block is measured and if it exceeds $1$ in $10^{-6}$ a Degrade Minute is registered. Percentage Degraded Minutes is also displayed - degraded minutes expressed as a percentage of the total number of packaged 1 minute blocks.
CODE ES	Code Errored Second - Cumulative count of seconds with available time that contain at least 1 Code error.

**PDH M.2100 Frame Analysis**

For Option UKK, Analysis results based on CCITT G.821 or M.2100 can be selected on the **OTHER MISCELLANEOUS** display under RESULTS DISPLAY MODE.

M.2100 Analysis is based on Frame errors.

**PDH M.2100 - Frame (FAS) Analysis (Not 704 kb/s)**

Display	Definition
RX ES	Receive Error Seconds - Cumulative count of seconds within available time that contain at least 1 FAS error. 2 Mb/s, CRC Framing - Cumulative count of seconds within available time that contain at least 1 CRC4 error.
TX ES	Transmit Error Seconds - 2 Mb/s, CRC Framing only. Cumulative count of seconds within available time that contain at least 1 REBE error.

**PDH M.2100 - Frame (FAS) Analysis (Not 704 kb/s) (continued)**

Display	Definition
RX SES	Receive Severely Errored Seconds - Cumulative count of seconds within available time in which the error ratio exceeds a threshold. The threshold changes according to the selected rate as follows : 140 Mb/s - $\geq$ 568 Frame Bit errors 34 Mb/s - $\geq$ 223 Frame Bit errors 8 Mb/s - $\geq$ 99 Frame Bit errors 2 Mb/s (Non CRC4) - $\geq$ 28 Frame Bit errors 2 Mb/s (CRC4) - $\geq$ 830 CRC4 errors
TX SES	Transmit Severely Errored Seconds - 2 Mb/s, CRC Framing only. Cumulative count of seconds within available time that contain $\geq$ 830 REBE errors.
UNAV	Unavailable Seconds - Cumulative count of unavailable second. A period of unavailability begins at the start of 10 or more consecutive Severely Errored Seconds, and ends at the start of 10 or more non Severely Errored Seconds.

**SPDH G.826 Analysis - 2 Mb/s CRC4 Framed (PCM30CRC, PCM31CRC)**

Display	Definition
RX ES	Receive Error Second - Cumulative count of seconds within available time that contain at least 1 G.703 Code error or 1 CRC error.
TX ES	Transmit Error Second - Cumulative count of seconds within available time that contains at least 1 REBE error.
RX SES	Receive Severely errored Seconds - Cumulative count of 1 second periods within available time that contain at least 805 CRC errors or a DEFECT. Defects are LOS, LOF and AIS.
TX SES	Transmit Severely errored Seconds - Cumulative count of 1 second periods within available time that contain at least 805 REBE errors or RAI has occurred for 2 consecutive 100 ms periods. Near-end occurrences of LOS, LOF and AIS are not included in the cumulative result.
ESR	Error Second Ratio - The ratio of errored seconds to the total seconds of available time. A period of unavailability begins at the start of 10 or more consecutive Severely Errored Seconds, and ends at the start of 10 or more non Severely Errored Seconds.
SESR	Severely Errored Second Ratio - The ratio of severely errored seconds to the total seconds of available time.



**SPDH G.826 Analysis - 2 Mb/s CRC4 Framed (PCM30CRC,  
PCM31CRC) (continued)**

Display	Definition
UAS	Unavailable Seconds - Cumulative count of unavailable seconds. A period of unavailability begins at the start of 10 or more consecutive severely errored seconds and ends at the start of 10 or more consecutive non severely errored seconds.
EB	Errored Block count - An errored block is a CRC4 with one or more bits in error.
BBE	Background Block Error count - Cumulative count of errored blocks excluding those in severely errored seconds.
BBER	Background Block Error Ratio - The ratio of errored blocks to total blocks. Total blocks excludes severely errored seconds and periods of unavailability.
PUAS	Path Unavailable Second count - Logical OR of the Near and Far end unavailable seconds.

**SPDH G.826 Analysis - 2 Mb/s Framed - Not CRC4**

Display	Definition
RX ES	Receive Error Second - Cumulative count of seconds within available time that contain at least 1 G.703 Code error or 1 Frame error or 1 bit error.
TX ES	Transmit Error Second - Cumulative count of seconds within available time where RAI occurs for 2 consecutive 100 ms periods.
RX SES	Receive Severely errored Seconds - Cumulative count of 1 second periods within available time that contain at least 28 Frame errors or BER $1 \times 10^{-3}$ , or a DEFECT. Defects are LOS, LOF, PSL and AIS.
TX SES	Transmit Severely errored Seconds - Cumulative count of 1 second periods within available time where RAI occurs for 2 consecutive 100 ms periods. Near-end occurrences of LOS, LOF and AIS are not included in the cumulative result.
ESR	Error Second Ratio - The ratio of errored seconds to the total seconds of available time. A period of unavailability begins at the start of 10 or more consecutive Severely Errored Seconds, and ends at the start of 10 or more non Severely Errored Seconds.
SESR	Severely Errored Second Ratio - The ratio of severely errored seconds to the total seconds of available time.
UAS	Unavailable Seconds - Cumulative count of unavailable seconds. A period of unavailability begins at the start of 10 or more consecutive severely errored seconds and ends at the start of 10 or more consecutive non severely errored seconds.

### SPDH G.826 Analysis - 2 Mb/s Unframed

Display	Definition
ES	Error Second - Cumulative count of seconds within available time that contain at least 1 G.703 Code error.
SES	Severely errored Seconds - Cumulative count of 1 second periods within available time that contain a DEFECT. Defects are LOS and AIS.
ESR	Error Second Ratio - The ratio of errored seconds to the total seconds of available time. A period of unavailability begins at the start of 10 or more consecutive Severely Errored Seconds, and ends at the start of 10 or more non Severely Errored Seconds.
SESR	Severely Errored Second Ratio - The ratio of severely errored seconds to the total seconds of available time.
UAS	Unavailable Seconds - Cumulative count of unavailable seconds. A period of unavailability begins at the start of 10 or more consecutive severely errored seconds and ends at the start of 10 or more consecutive non severely errored seconds.

### SPDH G.826 Analysis - 8 Mb/s Framed

Display	Definition
RX ES	Receive Error Second - Cumulative count of seconds within available time that contain at least 1 Frame error or 1 Bit error.
TX ES	Receive Error Second - Cumulative count of seconds within available time where RAI occurs for 2 consecutive 100 ms periods.
RX SES	Receive Severely errored Seconds - Cumulative count of 1 second periods within available time that contain at least 41 Frame errors or BER $1 \times 10^{-3}$ or a DEFECT. Defects are LOS, LOF, AIS and PSL.
TX SES	Transmit Severely errored Seconds - Cumulative count of 1 second periods within available time where RAI occurs for 2 consecutive 100 ms periods. Near-end occurrences of LOS, LOF and AIS are not included in the cumulative result.
ESR	Error Second Ratio - The ratio of errored seconds to the total seconds of available time. A period of unavailability begins at the start of 10 or more consecutive Severely Errored Seconds, and ends at the start of 10 or more non Severely Errored Seconds.
SESR	Severely Errored Second Ratio - The ratio of severely errored seconds to the total seconds of available time.
UAS	Unavailable Seconds - Cumulative count of unavailable seconds. A period of unavailability begins at the start of 10 or more consecutive severely errored seconds and ends at the start of 10 or more consecutive non severely errored seconds.

#### B-14 Results Definitions

### SPDH G.826 Analysis - 34 Mb/s Framed

Display	Definition
RX ES	Receive Error Second - Cumulative count of seconds within available time that contain at least 1 Frame error or 1 Bit error.
TX ES	Receive Error Second - Cumulative count of seconds within available time where RAI occurs for 2 consecutive 100 ms periods.
RX SES	Receive Severely errored Seconds - Cumulative count of 1 second periods within available time that contain at least 52 Frame errors or a DEFECT. Defects are LOS, LOF, AIS and PSL.
TX SES	Transmit Severely errored Seconds - Cumulative count of 1 second periods within available time where RAI occurs for 2 consecutive 100 ms periods. Near-end occurrences of LOS, LOF and AIS are not included in the cumulative result.
ESR	Error Second Ratio - The ratio of errored seconds to the total seconds of available time. A period of unavailability begins at the start of 10 or more consecutive Severely Errored Seconds, and ends at the start of 10 or more non Severely Errored Seconds.
SESR	Severely Errored Second Ratio - The ratio of severely errored seconds to the total seconds of available time.
UAS	Unavailable Seconds - Cumulative count of unavailable seconds. A period of unavailability begins at the start of 10 or more consecutive severely errored seconds and ends at the start of 10 or more consecutive non severely errored seconds.

### SPDH G.826 Analysis - 140 Mb/s Framed

Display	Definition
RX ES	Receive Error Second - Cumulative count of seconds within available time that contain at least 1 Frame error.
TX ES	Receive Error Second - Cumulative count of seconds within available time where RAI occurs for 2 consecutive 100 ms periods.
RX SES	Receive Severely errored Seconds - Cumulative count of 1 second periods within available time that contain at least 69 Frame errors or a DEFECT. Defects are LOS, LOF, AIS.
TX SES	Transmit Severely errored Seconds - Cumulative count of 1 second periods within available time where RAI occurs for 2 consecutive 100 ms periods. Near-end occurrences of LOS, LOF and AIS are not included in the cumulative result.
ESR	Error Second Ratio - The ratio of errored seconds to the total seconds of available time. A period of unavailability begins at the start of 10 or more consecutive Severely Errored Seconds, and ends at the start of 10 or more non Severely Errored Seconds.

**SPDH G.826 Analysis - 140 Mb/s Framed (continued)**

Display	Definition
SESR	Severely Errored Second Ratio - The ratio of severely errored seconds to the total seconds of available time.
UAS	Unavailable Seconds - Cumulative count of unavailable seconds. A period of unavailability begins at the start of 10 or more consecutive severely errored seconds and ends at the start of 10 or more consecutive non severely errored seconds.

**SPDH G.826 Analysis - 8, 34 and 140 Mb/s Unframed**

Display	Definition
ES	Error Second - Cumulative count of seconds within available time that contain at least 1 DEFECT. Defects are LOS and AIS.
SES	Severely errored Seconds - Cumulative count of 1 second periods within available time that contain a DEFECT. Defects are LOS and AIS.
ESR	Error Second Ratio - The ratio of errored seconds to the total seconds of available time. A period of unavailability begins at the start of 10 or more consecutive Severely Errored Seconds, and ends at the start of 10 or more non Severely Errored Seconds.
SESR	Severely Errored Second Ratio - The ratio of severely errored seconds to the total seconds of available time.
UAS	Unavailable Seconds - Cumulative count of unavailable seconds. A period of unavailability begins at the start of 10 or more consecutive severely errored seconds and ends at the start of 10 or more consecutive non severely errored seconds.

**Structured PDH M.2110 BIS (Bring Into Service)**

Provides a 2 Hour, 24 Hour and 7 Day PASS, FAIL, - indication for BIS testing as described in M.2110. The ES and SES results are compared to the S1 and S2 thresholds and indicate PASS, FAIL or - (uncertain). If - is displayed the next longest test will be carried out.

The S1 and S2 thresholds can be set in two different ways:

1. **USER PROGRAM** - S1 and S2 values are input by the user.
2. **PATH ALLOCATION** - The HP 37717B calculates the S1 and S2 values, from the user entered Path Allocation value, according to M.2110.

**B-16 Results Definitions**

### **Structured PDH M.2120 Circuit Maintenance**

Provides a threshold report when any of the relevant thresholds are exceeded within a 15 Minute (TR1 ES & SES) or 24 Hour period (TR2 ES & SES).

The TR1 and TR2 thresholds can be set in two different ways:

1. **USER PROGRAM** - TR1 ES & SES and TR2 ES & SES values are input by the user.
2. **PATH ALLOCATION** - The HP 37717B calculates the TR1 and TR2 values, from the user entered Path Allocation and Maintenance Factor values, according to M.2120.

---

## SDH Error Analysis (Option US1, A1T)

Analysis results are calculated for the following error sources :

RS B1 BIP ; MS B2 BIP ; Path B3 BIP and Path FEBE. If a Payload of 34 Mb/s or 2 Mb/s is selected additional error sources of TU Path BIP and TU Path FEBE are also available.

### RS B1 BIP G.826 Analysis

These calculations are based on "Errored Blocks". A Block is a set of consecutive bits associated with the Path. Each bit belongs to one and only one block. If an STM-4 interface is selected an errored block is a BIP with one or more bits in error.

Display	Definition
ES	Errored Seconds - Cumulative count of 1 second periods that contain at least 1 Errored Block.
EB	Errored Block count - cumulative count of errored blocks.
SES	Severely errored Seconds - Cumulative count of 1 second periods with $\geq 2400$ Errored Blocks, or containing a "defect". Defects are LOS and LOF.
UNAV	Unavailability - Cumulative count of unavailable seconds. A period of unavailability begins at the start of 10 or more consecutive severely errored seconds, and ends at the start of 10 or more consecutive non severely errored seconds.
ESR	Error Second Ratio - The ratio of errored seconds to the total seconds of available time. A period of unavailability begins at the start of 10 or more consecutive Severely Errored Seconds, and ends at the start of 10 or more non Severely Errored Seconds.
SESR	Severely Errored Second Ratio - The ratio of severely errored seconds to the total seconds of available time.
BBEC	Background Block error count - Cumulative count of errored blocks which occur outwith a severely errored second.
BBER	Background Block error Ratio - The ratio of errored blocks to total blocks. Total blocks excludes severely errored seconds and periods of unavailability.

## MS B2 BIP G.826 Analysis

These calculations are based on "Errored Blocks". A Block is a set of consecutive bits associated with the Path. Each bit belongs to one and only one block. If an STM-4 interface is selected an errored block is a BIP with one or more bits in error.

Display	Definition
ES	Errored Seconds - Cumulative count of 1 second periods that contain at least 1 Errored Block.
EB	Errored Block count - cumulative count of errored blocks.
SES	Severely errored Seconds - Cumulative count of 1 second periods with $\geq 2400$ Errored Blocks, or containing a "defect". Defects are LOS, LOF and MS AIS.
UNAV	Unavailability - Cumulative count of unavailable seconds. A period of unavailability begins at the start of 10 or more consecutive severely errored seconds, and ends at the start of 10 or more consecutive non severely errored seconds.
ESR	Error Second Ratio - The ratio of errored seconds to the total seconds of available time. A period of unavailability begins at the start of 10 or more consecutive Severely Errored Seconds, and ends at the start of 10 or more non Severely Errored Seconds.
SESR	Severely Errored Second Ratio - The ratio of severely errored seconds to the total seconds of available time.
BBEC	Background Block error count - Cumulative count of errored blocks which occur outwith a severely errored second.
BBER	Background Block error Ratio - The ratio of errored blocks to total blocks. Total blocks excludes severely errored seconds and periods of unavailability.

## MS FEBE G.826 Analysis (Option A1T only)

These calculations are based on "Errored Blocks". A Block is a set of consecutive bits associated with the Path. Each bit belongs to one and only one block. If an STM-4 interface is selected an errored block is a FEBE with one or more bits in error.

Display	Definition
ES	Errored Seconds - Cumulative count of 1 second periods that contain at least 1 Errored Block.
EB	Errored Block count - cumulative count of errored blocks.
SES	Severely errored Seconds - Cumulative count of 1 second periods with $\geq$ 2400 Errored Blocks, or MS FERF.
UNAV	Unavailability - Cumulative count of unavailable seconds. A period of unavailability begins at the start of 10 or more consecutive severely errored seconds, and ends at the start of 10 or more consecutive non severely errored seconds.
ESR	Error Second Ratio - The ratio of errored seconds to the total seconds of available time. A period of unavailability begins at the start of 10 or more consecutive Severely Errored Seconds, and ends at the start of 10 or more non Severely Errored Seconds.
SESR	Severely Errored Second Ratio - The ratio of severely errored seconds to the total seconds of available time.
BBEC	Background Block error count - Cumulative count of errored blocks which occur outwith a severely errored second.
BBER	Background Block error Ratio - The ratio of errored blocks to total blocks. Total blocks excludes severely errored seconds and periods of unavailability.

### Note



Near End Failures of LOS, LOF and MS AIS produce "dead time" in the MS FEBE measurement such that result accumulation is suspended.



### Path B3 G.826 BIP Analysis

These calculations are based on "Errored Blocks". A Block is a set of consecutive bits associated with the Path. Each bit belongs to one and only one block.

Display	Definition
ES	Errored Seconds - Cumulative count of 1 second periods that contain at least 1 Errored Block.
EB	Errored Block count - cumulative count of errored blocks.
SES	Severely errored Seconds - Cumulative count of 1 second periods with $\geq 2400$ Errored Blocks, or containing a "defect". Defects are LOS, LOF, MS AIS, LOP and Path AIS.
UNAV	Unavailability - Cumulative count of unavailable seconds. A period of unavailability begins at the start of 10 or more consecutive severely errored seconds, and ends at the start of 10 or more consecutive non severely errored seconds.
ESR	Error Second Ratio - The ratio of errored seconds to the total seconds of available time. A period of unavailability begins at the start of 10 or more consecutive Severely Errored Seconds, and ends at the start of 10 or more non Severely Errored Seconds.
SESR	Severely Errored Second Ratio - The ratio of severely errored seconds to the total seconds of available time.
BBEC	Background Block error count - Cumulative count of errored blocks which occur outwith a severely errored second.
BBER	Background Block error Ratio - The ratio of errored blocks to total blocks. Total blocks excludes severely errored seconds and periods of unavailability.
PUAS	Path Unavailable Second count - Logical OR of the Near and Far end unavailable seconds.

## Path FEBE G.826 Analysis

These calculations are based on "Errored Blocks". A Block is a set of consecutive bits associated with the Path. Each bit belongs to one and only one block.

Display	Definition
ES	Errored Seconds - Cumulative count of 1 second periods that contain at least 1 Errored Block.
EB	Errored Block count - cumulative count of errored blocks.
SES	Severely errored Seconds - Cumulative count of 1 second periods with $\geq 2400$ Errored Blocks, or Path FERF.
UNAV	Unavailability - Cumulative count of unavailable seconds. A period of unavailability begins at the start of 10 or more consecutive severely errored seconds, and ends at the start of 10 or more consecutive non severely errored seconds.
ESR	Error Second Ratio - The ratio of errored seconds to the total seconds of available time. A period of unavailability begins at the start of 10 or more consecutive Severely Errored Seconds, and ends at the start of 10 or more non Severely Errored Seconds.
SESR	Severely Errored Second Ratio - The ratio of severely errored seconds to the total seconds of available time.
BBEC	Background Block error count - Cumulative count of errored blocks which occur outwith a severely errored second.
BBER	Background Block error Ratio - The ratio of errored blocks to total blocks. Total blocks excludes severely errored seconds and periods of unavailability.
PUAS	Path Unavailable Second count - Logical OR of the Near and Far end unavailable seconds.

### Note



Near End Failures of LOS, LOF, MS AIS, LOP and Path AIS produce "dead time" in the Path FEBE measurement such that result accumulation is suspended.

## Path IEC G.826 Analysis (Option A1T only)

These calculations are based on "Errored Blocks". A Block is a set of consecutive bits associated with the Path. Each bit belongs to one and only one block.

Display	Definition
ES	Errored Seconds - Cumulative count of 1 second periods that contain at least 1 Errored Block.
EB	Errored Block count - cumulative count of errored blocks.
SES	Severely errored Seconds - Cumulative count of 1 second periods with $\geq 2400$ Errored Blocks, or containing a "defect". Defects are LOS, LOF, MS AIS, LOP, Path AIS and Path FERF.
UNAV	Unavailability - Cumulative count of unavailable seconds. A period of unavailability begins at the start of 10 or more consecutive severely errored seconds, and ends at the start of 10 or more consecutive non severely errored seconds.
ESR	Error Second Ratio - The ratio of errored seconds to the total seconds of available time. A period of unavailability begins at the start of 10 or more consecutive Severely Errored Seconds, and ends at the start of 10 or more non Severely Errored Seconds.
SESR	Severely Errored Second Ratio - The ratio of severely errored seconds to the total seconds of available time.
BBEC	Background Block error count - Cumulative count of errored blocks which occur outwith a severely errored second.
BBER	Background Block error Ratio - The ratio of errored blocks to total blocks. Total blocks excludes severely errored seconds and periods of unavailability.
PUAS	Path Unavailable Second count - Logical OR of the Near and Far end unavailable seconds.

### Note



Near End Failures of LOS, LOF, MS AIS, LOP and Path AIS produce "dead time" in the Path IEC measurement such that result accumulation is suspended.

## TU Path BIP G.826 Analysis - 34 Mb/s Payload

These calculations are based on "Errored Blocks". A Block is a set of consecutive bits associated with the Path. Each bit belongs to one and only one block.

Display	Definition
ES	Errored Seconds - Cumulative count of 1 second periods that contain at least 1 Errored Block.
EB	Errored Block count - cumulative count of errored blocks.
SES	Severely errored Seconds - Cumulative count of 1 second periods with $\geq 2400$ Errored Blocks, or containing a "defect". Defects are LOS, LOF, MS AIS, LOP, Path AIS, H4 LOM, TU3 Path AIS and TU3 LOP.
UNAV	Unavailability - Cumulative count of unavailable seconds. A period of unavailability begins at the start of 10 or more consecutive severely errored seconds, and ends at the start of 10 or more consecutive non severely errored seconds.
ESR	Error Second Ratio - The ratio of errored seconds to the total seconds of available time. A period of unavailability begins at the start of 10 or more consecutive Severely Errored Seconds, and ends at the start of 10 or more non Severely Errored Seconds.
SESR	Severely Errored Second Ratio - The ratio of severely errored seconds to the total seconds of available time.
BBEC	Background Block error count - Cumulative count of errored blocks which occur outwith a severely errored second.
BBER	Background Block error Ratio - The ratio of errored blocks to total blocks. Total blocks excludes severely errored seconds and periods of unavailability.
PUAS	Path Unavailable Second count - Logical OR of the Near and Far end unavailable seconds.

## TU Path BIP G.826 Analysis - 2 Mb/s Payload

These calculations are based on "Errored Blocks". A Block is a set of consecutive bits associated with the Path. Each bit belongs to one and only one block.

Display	Definition
ES	Errored Seconds - Cumulative count of 1 second periods that contain at least 1 Errored Block.
EB	Errored Block count - cumulative count of errored blocks.
SES	Severely errored Seconds - Cumulative count of 1 second periods with $\geq 600$ Errored Blocks, or containing a "defect". Defects are LOS, LOF, MS AIS, LOP, Path AIS, H4 LOM, TU Path AIS and TU LOP.
UNAV	Unavailability - Cumulative count of unavailable seconds. A period of unavailability begins at the start of 10 or more consecutive severely errored seconds, and ends at the start of 10 or more consecutive non severely errored seconds.
ESR	Error Second Ratio - The ratio of errored seconds to the total seconds of available time. A period of unavailability begins at the start of 10 or more consecutive Severely Errored Seconds, and ends at the start of 10 or more non Severely Errored Seconds.
SESR	Severely Errored Second Ratio - The ratio of severely errored seconds to the total seconds of available time.
BBEC	Background Block error count - Cumulative count of errored blocks which occur outwith a severely errored second.
BBER	Background Block error Ratio - The ratio of errored blocks to total blocks. Total blocks excludes severely errored seconds and periods of unavailability.
PUAS	Path Unavailable Second count - Logical OR of the Near and Far end unavailable seconds.

## TU Path FEBE G.826 Analysis - 34 Mb/s Payload

These calculations are based on "Errored Blocks". A Block is a set of consecutive bits associated with the Path. Each bit belongs to one and only one block.

Display	Definition
ES	Errored Seconds - Cumulative count of 1 second periods that contain at least 1 Errored Block.
EB	Errored Block count - cumulative count of errored blocks.
SES	Severely errored Seconds - Cumulative count of 1 second periods with $\geq 2400$ Errored Blocks, or TU3 Path FERF.
UNAV	Unavailability - Cumulative count of unavailable seconds. A period of unavailability begins at the start of 10 or more consecutive severely errored seconds, and ends at the start of 10 or more consecutive non severely errored seconds.
ESR	Error Second Ratio - The ratio of errored seconds to the total seconds of available time. A period of unavailability begins at the start of 10 or more consecutive Severely Errored Seconds, and ends at the start of 10 or more non Severely Errored Seconds.
SESR	Severely Errored Second Ratio - The ratio of severely errored seconds to the total seconds of available time.
BBEC	Background Block error count - Cumulative count of errored blocks which occur outwith a severely errored second.
BBER	Background Block error Ratio - The ratio of errored blocks to total blocks. Total blocks excludes severely errored seconds and periods of unavailability.
PUAS	Path Unavailable Second count - Logical OR of the Near and Far end unavailable seconds.

### Note



Near End Failures of LOS, LOF, MS AIS, LOP, Path AIS, H4 LOM, TU LOP and TU Path AIS produce "dead time" in the TU Path FEBE measurement such that result accumulation is suspended.

## TU Path FEBE G.826 Analysis - 2 Mb/s Payload

These calculations are based on "Errored Blocks". A Block is a set of consecutive bits associated with the Path. Each bit belongs to one and only one block.

Display	Definition
ES	Errored Seconds - Cumulative count of 1 second periods that contain at least 1 Errored Block.
EB	Errored Block count - cumulative count of errored blocks.
SES	Severely errored Seconds - Cumulative count of 1 second periods with $\geq 600$ Errored Blocks, or TU Path FERF and TU LOP.
UNAV	Unavailability - Cumulative count of unavailable seconds. A period of unavailability begins at the start of 10 or more consecutive severely errored seconds, and ends at the start of 10 or more consecutive non severely errored seconds.
ESR	Error Second Ratio - The ratio of errored seconds to the total seconds of available time. A period of unavailability begins at the start of 10 or more consecutive Severely Errored Seconds, and ends at the start of 10 or more non Severely Errored Seconds.
SESR	Severely Errored Second Ratio - The ratio of severely errored seconds to the total seconds of available time.
BBEC	Background Block error count - Cumulative count of errored blocks which occur outwith a severely errored second.
BBER	Background Block error Ratio - The ratio of errored blocks to total blocks. Total blocks excludes severely errored seconds and periods of unavailability.
PUAS	Path Unavailable Second count - Logical OR of the Near and Far end unavailable seconds.

### Note



Near End Failures of LOS, LOF, MS AIS, LOP, Path AIS, H4 LOM, TU LOP and TU Path AIS produce "dead time" in the TU Path FEBE measurement such that result accumulation is suspended.

## ATM EM BIP G.826 Analysis

These calculations are based on "Errored Blocks". A Block is a set of consecutive bits associated with the Path. Each bit belongs to one and only one block.

Display	Definition
ES	Errored Seconds - Cumulative count of 1 second periods that contain at least 1 Errored Block.
EB	Errored Block count - cumulative count of errored blocks.
SES	Severely errored Seconds - Cumulative count of 1 second periods with > 30% Errored Blocks, or containing a "defect". Defects are LOS, LOF, AIS.
UNAV	Unavailability - Cumulative count of unavailable seconds. A period of unavailability begins at the start of 10 or more consecutive severely errored seconds, and ends at the start of 10 or more consecutive non severely errored seconds.
ESR	Error Second Ratio - The ratio of errored seconds to the total seconds of available time. A period of unavailability begins at the start of 10 or more consecutive Severely Errored Seconds, and ends at the start of 10 or more non Severely Errored Seconds.
SESR	Severely Errored Second Ratio - The ratio of severely errored seconds to the total seconds of available time.
BBEC	Background Block error count - Cumulative count of errored blocks which occur outwith a severely errored second.
BBER	Background Block error Ratio - The ratio of errored blocks to total blocks. Total blocks excludes severely errored seconds and periods of unavailability.
PUAS	Path Unavailable Second count - Logical OR of the Near and Far end unavailable seconds.



## ATM FEBE G.826 Analysis

These calculations are based on "Errored Blocks". A Block is a set of consecutive bits associated with the Path. Each bit belongs to one and only one block.

Display	Definition
ES	Errored Seconds - Cumulative count of 1 second periods that contain at least 1 Errored Block.
EB	Errored Block count - cumulative count of errored blocks.
SES	Severely errored Seconds - Cumulative count of 1 second periods with > 30% Errored Blocks, or containing a "defect". Defects are LOS, LOF, AIS, FERF.
UNAV	Unavailability - Cumulative count of unavailable seconds. A period of unavailability begins at the start of 10 or more consecutive severely errored seconds, and ends at the start of 10 or more consecutive non severely errored seconds.
ESR	Error Second Ratio - The ratio of errored seconds to the total seconds of available time. A period of unavailability begins at the start of 10 or more consecutive Severely Errored Seconds, and ends at the start of 10 or more non Severely Errored Seconds.
SESR	Severely Errored Second Ratio - The ratio of severely errored seconds to the total seconds of available time.
BBEC	Background Block error count - Cumulative count of errored blocks which occur outwith a severely errored second.
BBER	Background Block error Ratio - The ratio of errored blocks to total blocks. Total blocks excludes severely errored seconds and periods of unavailability.
PUAS	Path Unavailable Second count - Logical OR of the Near and Far end unavailable seconds.

---

## Jitter Results (Options UHN, A1M, A1N, A1P)

Jitter Hits and Jitter Amplitude results are provided. In addition Wander results are provided at 2 Mb/s for Option UHN.

### Jitter Results (Options UHN, A1M, A1N, A1P)

Result	Options	Description
+ve PEAK	UHN	Highest value of positive Jitter during measurement period.
-ve PEAK	UHN	Highest value of negative Jitter during measurement period.
PEAK-PEAK	UHN	Highest value of pk_pk Jitter during measurement period.

### Wander Results (Option UHN)

Result	Options	Description
+ve PEAK	UHN	Cumulative amount of positive Wander during measurement period.
-ve PEAK	UHN	Cumulative amount of negative Wander during measurement period.
PEAK-PEAK	UHN	Cumulative amount of pk_pk Wander during measurement period.
PEAK-PEAK (15 MIN)	UHN	Cumulative amount of pk_pk Wander during 15 Minute period.
PEAK-PEAK (24 HOURS)	UHN	Cumulative amount of pk_pk Wander during 24 Hour period.
TIME INTERVAL ERROR	UHN	Cumulative
ESTIMATED BIT SLIPS	UHN	Cumulative count of Bit Slips during measurement Period.
ESTIMATED FRAME SLIPS	UHN	Cumulative count of Frame Slips during measurement Period.

---

## Alarm Seconds

### PDH Alarm Seconds

Alarm	Options	Description
Power Loss	UKJ, UKK, UKL	All rates
Loss of Signal	UKJ, UKK, UKL	All rates
AIS	UKJ, UKK, UKL	All rates
Pattern Loss	UKJ, UKK, UKL	All rates
LOF 140M	UKJ, UKL	140 Mb/s Frame Loss
LOF 34M	UKJ, UKL	34 Mb/s Frame Loss
LOF 8M	UKJ, UKL	8 Mb/s Frame Loss
LOF 2M	UKJ, UKL	2 Mb/s Frame Loss
Frame Loss	UKK	2 Mb/s In Service Only
Remote Alarm	UKJ, UKK, UKL	Not 704 kb/s
Multiframe Loss	UKJ, UKK, UKL	2 Mb/s, CAS or CRC Framing
Remote M'Frame Alarm	UKJ, UKK, UKL	2 Mb/s, CAS Framing Only

### SDH Alarm Seconds (Options US1, A1T)

Alarm	140 Mb/s Payload	34 Mb/s Payload	2 Mb/s Payload
Power Loss	Yes	Yes	Yes
Loss of Signal (LOS)	Yes	Yes	Yes
Loss of Frame (LOF)	Yes	Yes	Yes
Out of Frame (OOF)	Yes	Yes	Yes
Loss of Pointer (LOP)	Yes	Yes	Yes
MS AIS	Yes	Yes	Yes
K1K2 Change (A1T only)	Yes	Yes	Yes
Path AIS	Yes	Yes	Yes
MS FERF	Yes	Yes	Yes
Path FERF	Yes	Yes	Yes
H4 Multiframe Loss	No	Yes	Yes
TU LOP	No	Yes	Yes
TU Path AIS	No	Yes	Yes
TU Path FERF	No	Yes	Yes

### ATM Alarm Seconds (Option UKN)

Alarm	SDH	PDH	Description
Power Loss	Yes	Yes	Loss of Power
LOS	Yes	Yes	Loss of Signal
LOF	Yes	Yes	Loss of Frame
AIS	No	Yes	PDH, Physical Layer AIS
FERF	No	Yes	PDH, Physical Layer FERF
Pattern Loss	Yes	Yes	Pattern Sync Loss
Loss of Cell Sync	Yes	Yes	Cell Sync Loss
Sel Cell Not RX	Yes	Yes	Selected Cell Not Received
Test Cell Loss	Yes	Yes	Test Cell Loss
Congestion EXP	Yes	Yes	Congestion experienced
VP AIS	Yes	No	Virtual Path AIS
VP FERF	Yes	No	Virtual Path FERF
VC AIS	Yes	No	Virtual Channel AIS
VC FERF	Yes	No	Virtual Channel FERF
OOF	Yes	No	Out of Frame
LOP	Yes	No	Loss of Pointer
MS AIS	Yes	No	Multiplexer Section AIS
Path AIS	Yes	No	Path AIS
MS FERF	Yes	No	Multiplexer Section FERF
Path FERF	Yes	No	Path FERF
TU LOP	Yes	No	Tributary Loss of Pointer
TU Path AIS	Yes	No	Tributary Path AIS
TU Path FERF	Yes	No	Tributary Path FERF

---

### Frequency Measurement

Frequency measurement is available at standard PDH and SDH rates.

The measured frequency is displayed in Hz with 1 Hz resolution.

Offset from the standard rate is displayed in Hz and ppm (parts per million).

## Index

---

### 1

(1E-3), 1-9

### A

Add/Drop Multiplexer Testing, 2-47-51

Alarm Monitoring, 2-4-7

Alarm Stimulus/Response, 2-52-55

Analysis Control, 2-135

Analysis Display Mode, 2-135

Analysis of N X 64 kb/s, 2-7-10

(AUTO SETUP), 1-9

ATM Alarms, 1-13

Loss of Cell Sync, 1-13

Selected Cell Not Received, 1-13

VC Alarm, 1-13

VP Alarm, 1-13

ATM Cell Performance, 2-91-96

### B

Beep On Error, 2-134

BERT Testing, 2-11-15

### C

Coupling, 2-131

Cross Multiplexer Testing, 2-16-20

### D

DCC Testing, 2-56-58

Default Settings, 2-125

Desynchroniser Stress, 2-59-61

### E

Error Event Logging, 2-116

### F

FAS Monitoring, 2-21

Frame Synchronization, 2-62-66

Frequency Measurement, 2-24-26,  
2-67-69

Frequency Offset Tolerance, 2-27-30,  
2-70-72

### G

Graphics, 2-107-114

Demonstration Graphs, 2-113

Obtaining Results, 2-108

Printing Displays, 2-113

Recall Results, 2-109

Viewing Alarm Summary, 2-111

Viewing Bar Graphs, 2-109

Viewing Error Summary, 2-111

Viewing Stored Results Status, 2-112

### H

History

Reset, 1-11

Show, 1-11

### I

Installing Upgrade Modules, 2-97

Internal Printer

Paper change, 2-122

## J

Jitter Tolerance, 2-31-34

## K

Keyboard Lock, 2-133

## L

**LOCAL**, 1-9

Logging Results, 2-115-118

## M

Miscellaneous, 2-133-135

MSP Stimulus/Response, 2-76-80

## N

Network Stress Testing

Desynchroniser Stress, 2-59

N X 64 kb/s Analysis, 2-7

## O

Optical Clock Recovery Stress, 2-81-82

Ordering Upgrade Modules, 2-97

Overhead Capture, 2-105

Overhead Monitor, 2-104

Overhead Sequence Generation, 2-102

## P

Paper Change

Internal Printer, 2-122

Payload Mapping/Demapping, 2-83-87

PDH Alarms, 1-12

AIS, 1-12

Errors, 1-12

Frame Loss, 1-12

M/Frame Loss, 1-12

Pattern Loss, 1-12

Remote Alarm, 1-12

Remote M/Frame, 1-12

Signal Loss, 1-12

PDH FAS Monitoring, 2-21-23

PDH Multiplexer Testing, 2-35-39

Performance Monitor

Stimulus/Response, 2-88-90

**PRINT NOW**, 1-10

Power Requirements, 1-5

Printer

Change Paper, 2-122

Printer Messages, A-1-8

## R

Recall Settings, 2-130

Receive Overhead Capture, 2-105-107

Receive Overhead Monitor, 2-104-105

Results Definitions, B-1-33

**RESET HISTORY**, 1-11

Round Trip Delay, 2-40-42

**RUN/STOP**, 1-9

## S

Save Settings, 2-129

SDH Alarms, 1-12-13

Clock Loss, 1-12

Errors, 1-12

Frame Loss, 1-12

Loss Of Pointer, 1-12

MS AIS, 1-12

MS FERF, 1-12

Path AIS, 1-12

Path FERF, 1-12

Pattern Loss, 1-12

Signal Loss, 1-12

TU Loss Of Pointer, 1-12

TU Path AIS, 1-13

TU Path FERF, 1-13

Self Test, 2-136

Settings Control, 2-131

**SHOW HISTORY**, 1-11

**SIGNAL IN**, 1-9

**SINGLE**, 1-9

Status

Indicators, 1-11

**Index-2**

Reset History, 1-11  
Show History, 1-11  
Stored Settings, 2-125-130  
  Recall, 2-130  
  Save, 2-129  
  Title, 2-129  
Suspend Test On Signal Loss, 2-135

**T**

Test Period Logging, 2-115

Time & Date, 2-132  
Title Settings, 2-129  
Transmit Overhead Sequence, 2-102-103  
Transmit Static Overhead, 2-98-101

**U**

Upgrade Modules, 2-97

**W**

Wander and Slips, 2-43-46