

Errata

Title & Document Type: 3750A Attenuator Operating Note

Manual Part Number: 03750-90001

Revision Date: October 1970

About this Manual

We've added this manual to the Agilent website in an effort to help you support your product. This manual provides the best information we could find. It may be incomplete or contain dated information, and the scan quality may not be ideal. If we find a better copy in the future, we will add it to the Agilent website.

HP References in this Manual

This manual may contain references to HP or Hewlett-Packard. Please note that Hewlett-Packard's former test and measurement, life sciences, and chemical analysis businesses are now part of Agilent Technologies. The HP XXXX referred to in this document is now the Agilent XXXX. For example, model number HP8648A is now model number Agilent 8648A. We have made no changes to this manual copy.

Support for Your Product

Agilent no longer sells or supports this product. You will find any other available product information on the Agilent Test & Measurement website:

www.agilent.com

Search for the model number of this product, and the resulting product page will guide you to any available information. Our service centers may be able to perform calibration if no repair parts are needed, but no other support from Agilent is available.



Agilent Technologies

OPERATING NOTE

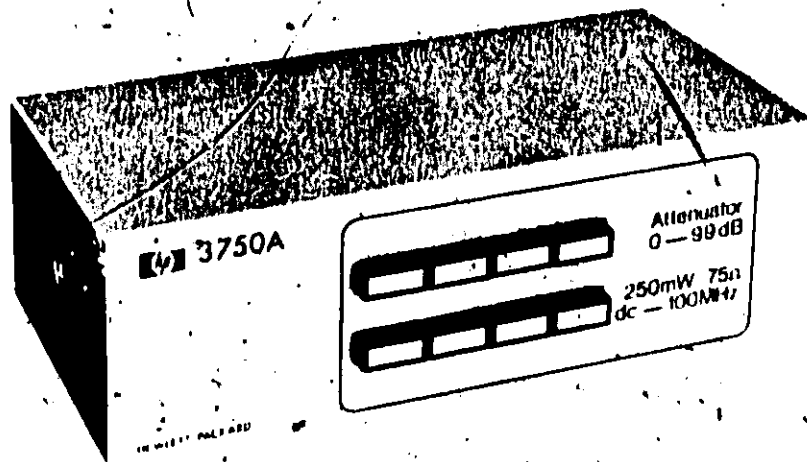

ATTENUATOR

3750A

1 DESCRIPTION

1-1 The *hp* Model 3750A Attenuator is designed for use in a frequency range from 0 (dc) to 100MHz. Attenuation of 0 to 99dB, 75Ω impedance, is provided in 1dB steps by the operation of pushbutton switches.

1-2 Although the Model 3750A is a general purpose attenuator, it is particularly suitable for large value attenuation of radio frequency signals.

1-3 A controlled range of attenuation, over the band of frequencies specified, is provided by a configuration of resistors selected in and out of the circuit by means of pushbutton switches.

1-4 The Model 3750A Attenuator has symmetrical attenuation properties so that it can be used with either terminal as input and the other as output.

1-5 The attenuator is contained in a sheet metal housing as shown in the photograph above. (The attenuator, consisting of the castings and attenuator boards and switches, is shown in Figure 3.)

2 SPECIFICATIONS

Attenuation: 0 to 99dB in 1dB steps

Frequency Range: 0 to 100MHz (see Table 1)

Accuracy: (see Table 1)

Characteristic Impedance: 75Ω

Power Rating: 250mW (+24dBm)

Return Loss: 28dB minimum

Connections: BNC, 75Ω

Temperatures: Operating: 0° to +50°C

Storage: -40° to +65°C

Overall Dimensions: 8in x 4in x 2 1/2in (203mm x 102mm x 64mm)

Weight: 3lb (1.4kg)

Table 1

FREQUENCY RANGE AND ACCURACY				
COMBINATION		DC - 100MHz	100 - 200MHz	200 - 400MHz
Units		$\pm 0.1\text{dB}$	$\pm 0.2\text{dB}$	$\pm 0.2\text{dB}$
Tens		$\pm 0.2\text{dB}$	$\pm 1.0\text{dB}$	$\pm 1.0\text{dB}$
Cumulative	to 79dB	$\pm 0.5\text{dB}$	$\pm 2.0\text{dB}$	$\pm 2.0\text{dB}$
	to 89dB	$\pm 1.0\text{dB}$	$\pm 2.0\text{dB}$	Not usable
	to 99dB	$\pm 2.0\text{dB}$	Not usable	Not usable

3 OPERATION

3-1 The Model 3750A Attenuator is operated by 8 pushbutton switches marked 1, 2, 3, 3, 10, 20, 30 and 30(dB). When any switch is pressed, that amount of attenuation in dB is inserted between the input and output connections. By pressing a suitable combination of switches, any value of attenuation, in 1dB steps, can be obtained from zero to 99dB.

EXAMPLES

- 5dB Press 2 and 3
- 28dB Press 2, 3, 3 and 20
- 79dB Press 1, 2, 3, 3, 10, 30 and 30

3-2 The pushbuttons are of the latching type, that is to say, they hold when pressed once and release when pressed again.

3-3 The characteristic impedance of the attenuator is 75Ω . If the attenuator is used with a system having a characteristic impedance other than 75Ω , an impedance converter should be used.

3-4 All connections should be made with male BNC terminated 75Ω coaxial leads. The leads should be as short as possible.

4 PERFORMANCE CHECKS

4-1 To check the performance of the Model 3750A Attenuator, test equipment equivalent to the following will be required:

- 2 - hp 3200B VHF Oscillators
- 1 - hp 10514A Mixer
- 1 - P R D Electronics Inc 915 B Attenuation Calibrator
- 2 - 10dB Attenuators, 75Ω
- 1 - 6dB Attenuator, 75Ω
- 1 - hp 180A/1801A/1821A Oscilloscope
- 1 - hp Model 15526A Accessory Kit
- 1 - hp Model 461A Amplifier
- 1 - hp Model 423A Detector
- 1 - hp Model 8601A Option 008 Sweep Oscillator
- 1 - hp Model 3750A Attenuator

4-2 To check the accuracy of the attenuator, proceed as follows:

- 1 Connect equipment as shown in Figure 1.
- 2 Set signal and local oscillators output level to maximum.
- 3 Set signal oscillator to 100MHz
Set local oscillator to 130MHz
Set Attenuator under test to 0dB
- 4 Set P R D Attenuator Calibrator controls as follows:

REFERENCE ATTENUATOR 0
 REFERENCE POWER LEVEL..... mid-position
 METER SWITCH ZERO
 A.F.C. METER SWITCH A.F.C.
 A.F.C. OFF

5. Zero NULL METER. Switch meter to NORMAL. Set VIDEO SET to read 5 on VIDEO meter. Tune local oscillator to give a large deflection positive and negative on the A.F.C. DEVIATION METER, then finally set it for zero reading between these deflections.
6. Switch reference generator POWER LEVEL off and disconnect signal oscillator from the 10dB attenuator. Adjust NOISE BALANCE to give null on NULL METER.
7. Reconnect signal oscillator and switch on reference generator. Set signal oscillator power level to give null on the NULL METER.
8. Insert 1dB in attenuator under test. Adjust reference attenuator for null reading on the NULL METER.
9. Reference attenuator should read 1 ± 0.1 dB
10. Repeat for each individual step of attenuator

ator under test.

11. Readings on the reference attenuator should be the settings of the attenuator under test within the following limits:

Units	± 0.1 dB
Tens	± 0.2 dB
Cumulative	± 0.5 dB to 79 dB
	± 1.0 dB to 89 dB
	± 2.0 dB to 99 dB

NOTE steps 1 to 14, above, comprise a test to measure the accuracy of the attenuator at 100MHz. Accuracy at other frequencies can be determined by setting the desired frequency on the signal oscillator (step 3) and the desired frequency plus 30MHz on the local oscillator.

12. Remove all attenuation from attenuator under test. Adjust reference attenuator for null. Remove attenuator under test and link the two 10dB attenuators. Re adjust reference attenuator for null.
13. The difference between the settings of the reference attenuator in step 12 is the insertion loss of the attenuator under test and should be less than 0.6dB
14. Disconnect equipment.

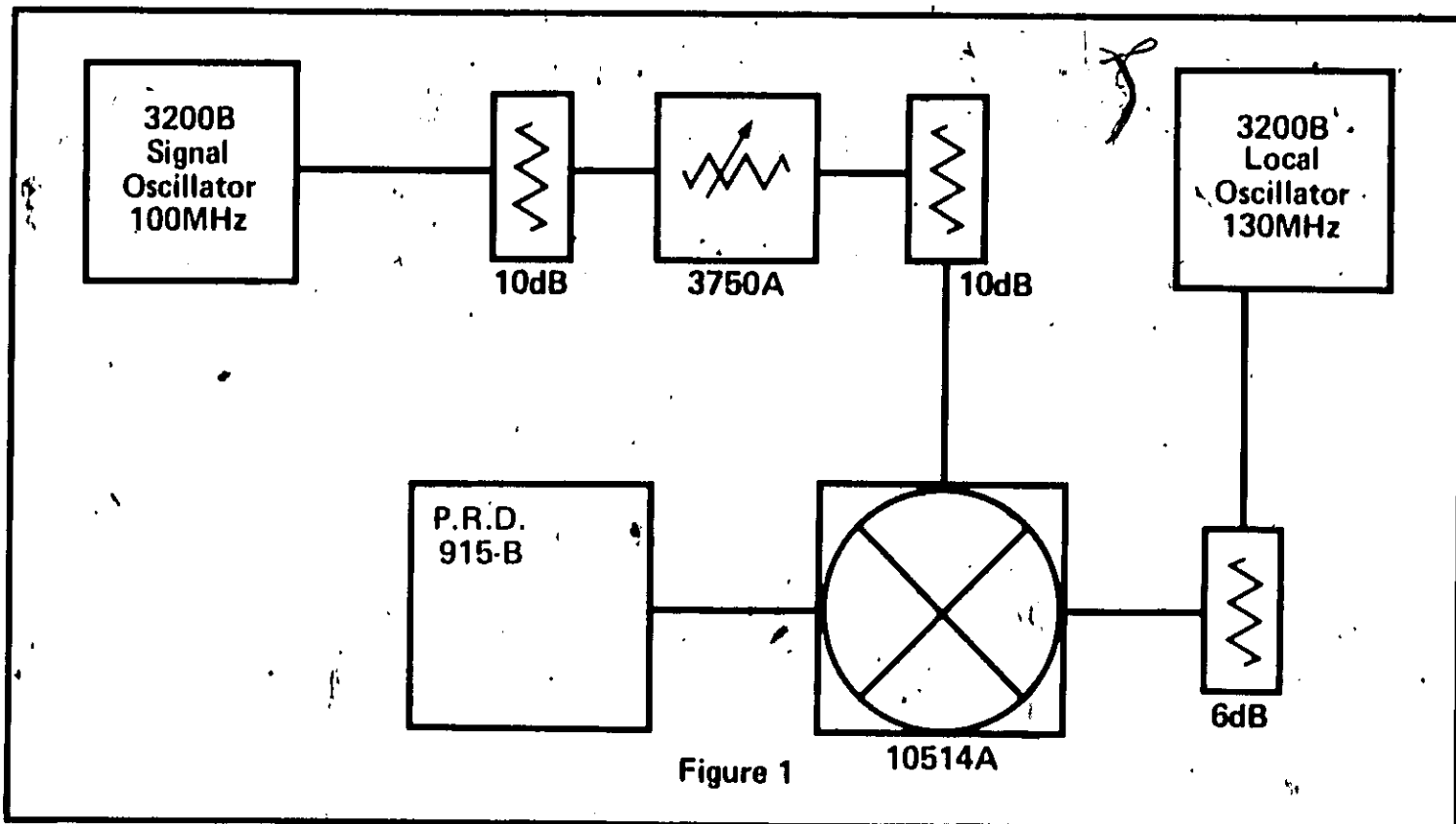

Figure 1

- 15 Connect equipment as shown in Figure 2.
- 16 Set controls as follows:

Oscilloscope
 Vertical 5mV/cm
 Horizontal EXTERNAL, adjust for 10 division display

8601A Sweep Oscillator
 SWEEP VIDEO
 FREQUENCY 95MHz
 SWEEP MODE FREE and FAST
 1kHz MOD OFF
 OUTPUT LEVEL MAXIMUM
 RANGE 110MHz

- 17 The return loss versus frequency will be displayed on the screen of the oscilloscope. Generally return loss increases down the screen. It may be necessary to adjust the vertical sensitivity and position controls to obtain a display on the oscilloscope

screen. NOTE: the frequency range of the hp Model 15520A Hybrid is 45 to 95MHz and the Model 8601A Sweep Oscillator sweeps from 1MHz to the FREQUENCY dial setting. The part of the trace below a frequency of 45MHz should be ignored.

- 18 Select the worst point on the trace (between 45 and 95MHz) and move it to a reference point on the screen. Insert and then remove 30dB on the equipment 3750A Attenuator. The trace should move up and then down thereby indicating sensitivity for the test.
- 19 Remove connection between hybrid and input of attenuator under test. Connect 17dB mismatch to hybrid.
- 20 Use equipment 3750A Attenuator to return trace to reference point.
- 21 Return loss is calculated by adding 17dB to attenuation inserted in step 20 and should be greater than 28dB.

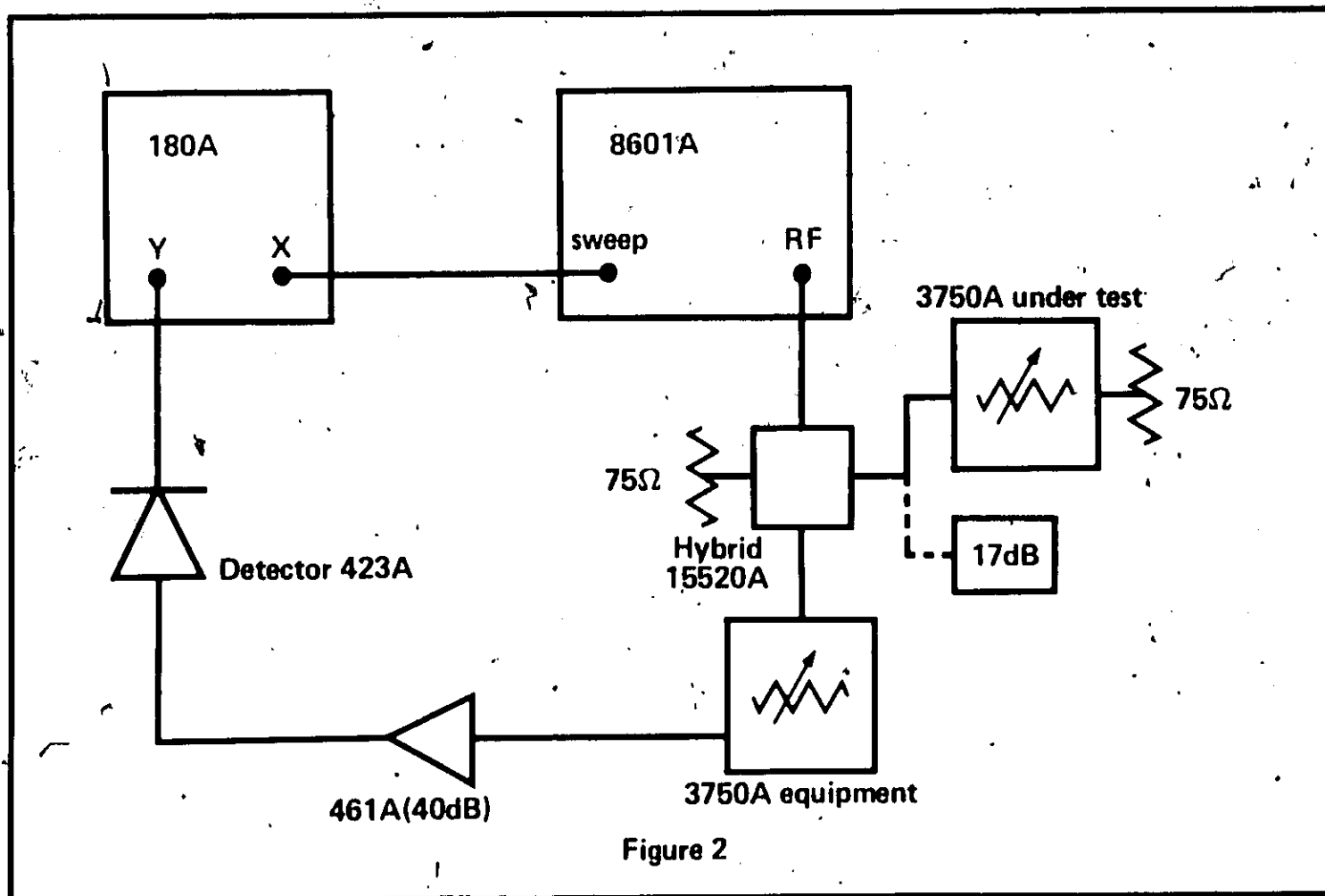

Figure 2

5 MAINTENANCE

5-1 The pushbutton switches are prepacked with silicone grease during manufacture and no routine maintenance is required.

6 REPAIRS

6-1 If it should be necessary to dismantle the Model 3750A Attenuator for repair, refer to Figure 3 and proceed as follows:

1. Depress all pushbuttons fully.
2. Remove 8 small plastic plugs.
3. Release BNC connectors by removing lock nuts.
4. Remove the 2 screws holding each side cover and remove the side covers.
5. Remove the 4 screws on the base of the attenuator housing.
6. Slide attenuator casting and its base from the sheet metal housing.
7. Remove 3 screws, nuts, lockwashers and plain washers holding the attenuator to its base.
8. To gain access to either the 'units' (1, 2, 3 and 3) or 'tens' (10, 20, 30 and 30) circuit boards and switches, remove the 4 screws in the corners of the casting from either the top or the bottom as required.
9. To remove the switch and circuit board, remove 11 screws (6 larger and 5 smaller) holding the assembly to the casting. If it is required to separate the circuit board entirely from the casting, remove the bolt down coaxial connector by removing the 2 screws from the circuit side of the circuit board.
10. To replace a faulty resistor, ensure that the replacement is of the correct power rating (250mW) and also of the correct ohmic value and tolerance. Lead lengths should be

as short as possible and care should be taken to avoid applying excessive heat to the circuit board when soldering the replacement in position.

11. The circuit board and switches are supplied as a complete sub-assembly and cannot be replaced separately.
12. When replacing the BNC connectors, ensure that the centre conductor is properly connected and that the outer conductor is solidly earthed.

6-2 After effecting any repair, check the performance as described in Section 4.

7 REPLACEABLE PARTS

7-1 In the following parts list, the abbreviations used are:

ASSY	assembly
CARB FLM	carbon film
COAX	coaxial
C/S	countersunk
LH	left hand
MET FLM	metal film
NSR	not separately replaceable
PC	printed circuit
QTY	quantity
R	resistor
RH	right hand
W	watt

7-2 To order a replacement part, address the order to the nearest Hewlett Packard Sales and Service Office. Specify the following information for each part:

- a. Model and full Serial Number of Attenuator
- b. Reference Designation
- c. Hewlett Packard Part Number
- d. Description

Reference Designation	hp Part No	Description
MP1	0050-0609	HOUSING: TOP
MP2	0050-0608	HOUSING: BOTTOM
MP3	0050-0610	PLATE: DIVISION
MP4	2360-0213	SCREW: 6-32 x 1 C/S HEAD (QTY 8)
MP5	2360-0193	SCREW: 6-32 x 1/4 PAN HEAD (QTY 12)
MP6	2200-0139	SCREW: 4-40 x 1/4 PAN HEAD (QTY 10)
MP7	2190-0622	WASHER: CRINKLE NO. 6 (QTY 12)
MP8	3050-0016	WASHER: PLAIN NO. 6 (QTY 4)
MP9	2190-0003	WASHER: SPLIT NO. 4 (QTY 10)
MP10	0370-0608	PUSHBUTTON (QTY 8)
MP11	03750-703	ASSY: COAX CABLE
MP12	03750-703	ASSY: COAX CABLE
MP13	03701-746	ASSY: COAX CABLE (CONNECTS A1 & A2)
MP14	5020-4119	LABEL: NUMERAL 1
MP15	5020-4120	LABEL: NUMERAL 2
MP16	5020-4121	LABEL: NUMERAL 3 (QTY 2)
MP17	5020-4123	LABEL: NUMERAL 10
MP18	5020-4124	LABEL: NUMERAL 20
MP19	5020-4125	LABEL: NUMERAL 30 (QTY 2)
MP20	03750-101	CASE: ATTENUATOR
MP21	03750-102	PLATE: SUPPORT
MP22	03750-103	ENDPLATE: LH
MP23	03750-104	ENDPLATE: RH
MP24	7120-0607	PLATE: SERIAL
MP25	7120-1254	STUDBACK: TRADEMARK
A1	03701-720 03701-307	ASSY: RESISTOR BOARD AND SWITCH BOARD: BLANK PC (NSR)
A1R1	0698-7017	R: FXD MET FLM 1305 OHM 1/2% 1/4W
A1R2	0698-6760	R: FXD MET FLM 8.58 OHM 1/2% 1/4W
A1R3	0698-7017	R: FXD MET FLM 1305 OHM 1/2% 1/4W
A1R4	0698-7015	R: FXD MET FLM 654 OHM 1/2% 1/4W
A1R5	0698-7002	R: FXD MET FLM 17.4 OHM 1/2% 1/4W
A1R6	0698-7015	R: FXD MET FLM 654 OHM 1/2% 1/4W
A1R7	0698-7013	R: FXD MET FLM 438 OHM 1/2% 1/4W
A1R8	0698-7004	R: FXD MET FLM 26.6 OHM 1/2% 1/4W
A1R9	0698-7013	R: FXD MET FLM 438 OHM 1/2% 1/4W
A1R10	0698-7013	R: FXD MET FLM 438 OHM 1/2% 1/4W
A1R11	0698-7004	R: FXD MET FLM 26.6 OHM 1/2% 1/4W
A1R12	0698-7013	R: FXD MET FLM 438 OHM 1/2% 1/4W
A1S1	3101-0610	ASSY: PUSHBUTTON SWITCH MECHANISM (NSR)
A1MP1	0520-0127	SCREW: 2-56 x 3/16 PAN HEAD (QTY 4)
A1MP2	2190-0103	WASHER: SHAKEPROOF NO. 2 (QTY 4)
A2	03701-721 03701-307	ASSY: RESISTOR BOARD & SWITCH BOARD: BLANK PC (NSR)
A2R1	0698-7009	R: FXD MET FLM 144.2 OHM 1/2% 1/4W
A2R2	0698-7008	R: FXD MET FLM 106.8 OHM 1/2% 1/4W
A2R3	0698-7009	R: FXD MET FLM 144.2 OHM 1/2% 1/4W
A2R4	0698-7006	R: FXD CARB FLM 91.5 OHM 1/2% 1/4W
A2R5	0698-7012	R: FXD CARB FLM 371 OHM 1/2% 1/4W
A2R6	0698-7006	R: FXD CARB FLM 91.5 OHM 1/2% 1/4W
A2R7	0698-7005	R: FXD CARB FLM 79.8 OHM 1/2% 1/4W
A2R8	0698-7016	R: FXD CARB FLM 1186 OHM 1/2% 1/4W
A2R9	0698-7005	R: FXD CARB FLM 79.8 OHM 1/2% 1/4W
A2R10	0698-7005	R: FXD CARB FLM 79.8 OHM 1/2% 1/4W
A2R11	0698-7016	R: FXD CARB FLM 1186 OHM 1/2% 1/4W
A2R12	0698-7005	R: FXD CARB FLM 79.8 OHM 1/2% 1/4W
A2S1	3101-0610	ASSY: PUSHBUTTON SWITCH MECHANISM (NSR)
A2MP1	0520-0127	SCREW: 2-56 x 3/16 PAN HEAD (QTY 4)
A2MP2	2190-0103	WASHER: SHAKEPROOF NO. 2 (QTY 4)

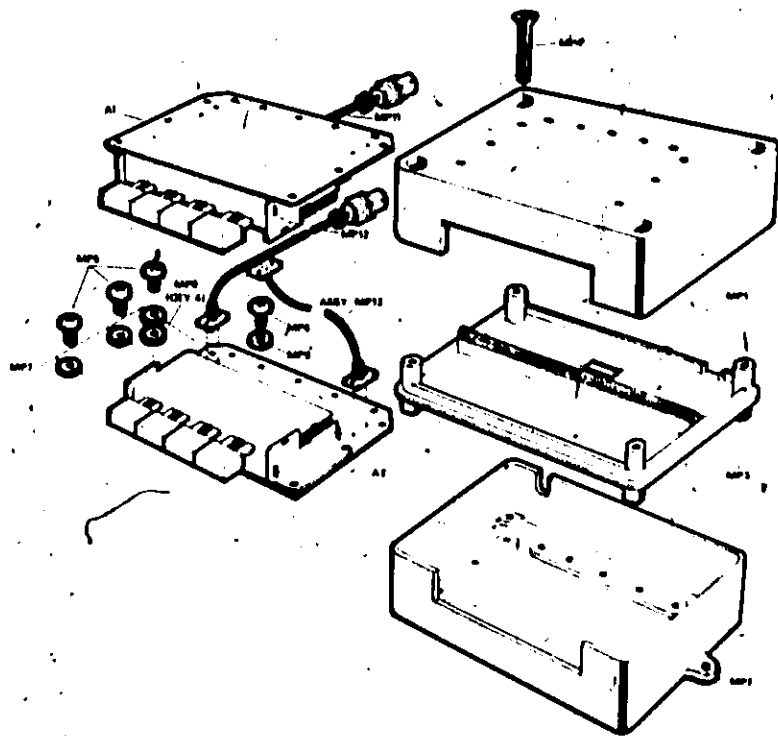

3750A ATTENUATOR

R1 R2 R3 R4 R5 R6 R7 R8 R9 R10 R11 R12

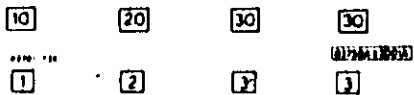

R1 R2 R3 R4 R5 R6 R7 R8 R9 R10 R11 R12

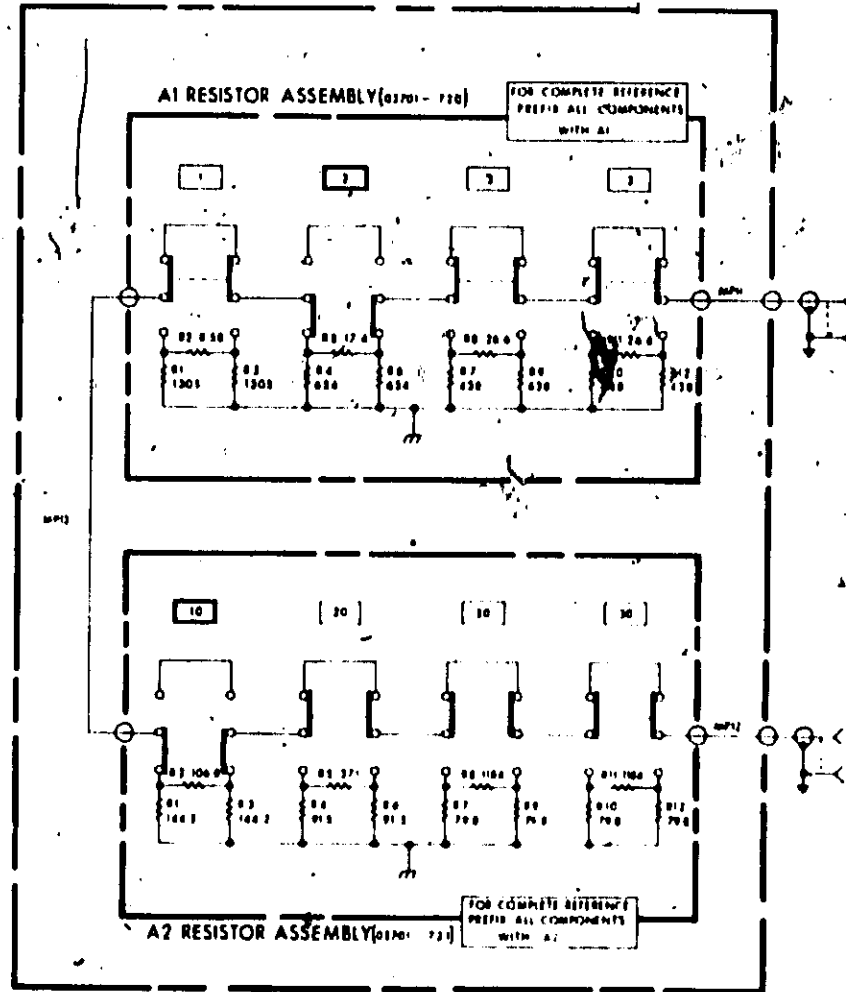

(01701-720)

Figure 3