

## Errata

**Title & Document Type:** 3577B Network Analyzer Service Manual

**Manual Part Number:** 03577-90040

**Revision Date:** May 1995

---

### HP References in this Manual

This manual may contain references to HP or Hewlett-Packard. Please note that Hewlett-Packard's former test and measurement, semiconductor products and chemical analysis businesses are now part of Agilent Technologies. We have made no changes to this manual copy. The HP XXXX referred to in this document is now the Agilent XXXX. For example, model number HP8648A is now model number Agilent 8648A.

### About this Manual

We've added this manual to the Agilent website in an effort to help you support your product. This manual provides the best information we could find. It may be incomplete or contain dated information, and the scan quality may not be ideal. If we find a better copy in the future, we will add it to the Agilent website.

### Support for Your Product

Agilent no longer sells or supports this product. You will find any other available product information on the Agilent Test & Measurement website:

[www.tm.agilent.com](http://www.tm.agilent.com)

Search for the model number of this product, and the resulting product page will guide you to any available information. Our service centers may be able to perform calibration if no repair parts are needed, but no other support from Agilent is available.



**Service Manual**  
**HP 3577B**  
**Network Analyzer**

**Serial Numbers**  
3419A01010 and above



**HP Part Number 03577-90040**  
**Microfiche Part Number 03577-90240**  
**Printed in U.S.A.**

**Print Date: May 1995**

©Hewlett-Packard Company, 1990, 1994-95. All rights reserved.  
8600 Soper Hill Road Everett, Washington 98205-1298 U.S.A.

## Warranty

The information contained in this document is subject to change without notice.

**Hewlett-Packard makes no warranty of any kind with regard to this material, including, but not limited to, the implied warranties or merchantability and fitness for a particular purpose.**

Hewlett-Packard shall not be liable for errors contained herein or for incidental or consequential damages in connection with the furnishing, performance, or use of this material.

## Safety Summary

The following general safety precautions must be observed during all phases of operation, service, and repair of this instrument. Failure to comply with these precautions or with specific warnings elsewhere in this manual violates safety standards of design, manufacture, and intended use of the instrument. Hewlett-Packard Company assumes no liability for the customer's failure to comply with these requirements. This is a Safety Class 1 instrument.

### Ground the Instrument

To minimize shock hazard, the instrument chassis and cabinet must be connected to an electrical ground. The instrument is equipped with a three-conductor ac power cable. The power cable must either be plugged into an approved three-contact electrical outlet or used with a three-contact to two-contact adapter with the grounding wire (green) firmly connected to an electrical ground (safety ground) at the power outlet. The power jack and mating plug of the power cable meet International Electrotechnical Commission (IEC) safety standards.

### Do Not Operate in an Explosive Atmosphere

Do not operate the instrument in the presence of flammable gases or fumes. Operation of any electrical instrument in such an environment constitutes a definite safety hazard.

### Keep Away from Live Circuits

Operating personnel must not remove instrument covers. Component replacement and internal adjustments must be made by qualified maintenance personnel. Do not replace components with power cable connected. Under certain conditions, dangerous voltages may exist even with the power cable removed. To avoid injuries, always disconnect power and discharge circuits before touching them.

### Do Not Service or Adjust Alone

Do not attempt internal service or adjustment unless another person, capable of rendering first aid and resuscitation, is present.

### Do Not Substitute Parts or Modify Instrument

Because of the danger of introducing additional hazards, do not install substitute parts or perform any unauthorized modification to the instrument. Return the instrument to a Hewlett-Packard Sales and Service Office for service and repair to ensure the safety features are maintained.

### Dangerous Procedure Warnings

Warnings accompany potentially dangerous procedures throughout this manual. Instructions contained in the warnings must be followed.

## Safety Symbols

The following safety symbols are used throughout this manual and in the instrument. Familiarize yourself with each symbol and its meaning before operating this instrument.

### General Definitions of Safety Symbols Used on Equipment or in Manuals



Instruction manual symbol. The product is marked with this symbol when it is necessary for the user to refer to the instruction manual to protect against damage to the instrument.



Indicates dangerous voltage (terminals fed from the interior by voltage exceeding 1000 volts must be so marked).



Protective ground (earth) terminal. Used to identify any terminal which is intended for connection to an external protective conductor for protection against electrical shock in case of a fault, or to the terminal of a protective ground (earth) electrode.



Low-noise or noiseless, clean ground (earth) terminal. Used for a signal common, as well as providing protection against electrical shock in case of a fault. A terminal marked with this symbol must be connected to ground in the manner described in the installation (operating) manual, and before operating the equipment.



Frame or chassis terminal. A connection to the frame (chassis) of the equipment which normally includes all exposed metal structures.



Alternating current (power line).



Direct current (power line).



Alternating or direct current (power line).

### Warning

The warning sign denotes a hazard. It calls attention to a procedure, practice, condition or the like, which if not correctly performed or adhered to, could result in injury or death to personnel.

### Caution

The caution sign denotes a hazard. It calls attention to an operating procedure, practice, condition or the like, which, if not correctly performed or adhered to, could result in damage to or destruction of part or all of the product or the user's data.



## SAFETY SUMMARY

The following general safety precautions must be observed during all phases of operation, service, and repair of this instrument. Failure to comply with these precautions or with specific warnings elsewhere in this manual violates safety standards of design, manufacture, and intended use of the instrument. Hewlett-Packard Company assumes no liability for the customer's failure to comply with these requirements. This is a Safety Class 1 instrument.

## GROUND THE INSTRUMENT

To minimize shock hazard, the instrument chassis and cabinet must be connected to an electrical ground. The instrument is equipped with a three-conductor ac power cable. The power cable must either be plugged into an approved three-contact electrical outlet or used with a three-contact to two-contact adapter with the grounding wire (green) firmly connected to an electrical ground (safety ground) at the power outlet. The power jack and mating plug of the power cable meet International Electrotechnical Commission (IEC) safety standards.

## DO NOT OPERATE IN AN EXPLOSIVE ATMOSPHERE

Do not operate the instrument in the presence of flammable gases or fumes. Operation of any electrical instrument in such an environment constitutes a definite safety hazard.

## KEEP AWAY FROM LIVE CIRCUITS

Operating personnel must not remove instrument covers. Component replacement and internal adjustments must be made by qualified maintenance personnel. Do not replace components with power cable connected. Under certain conditions, dangerous voltages may exist even with the power cable removed. To avoid injuries, always disconnect power and discharge circuits before touching them.

## DO NOT SERVICE OR ADJUST ALONE

Do not attempt internal service or adjustment unless another person, capable of rendering first aid and resuscitation, is present.

## DO NOT SUBSTITUTE PARTS OR MODIFY INSTRUMENT

Because of the danger of introducing additional hazards, do not install substitute parts or perform any unauthorized modification to the instrument. Return the instrument to a Hewlett-Packard Sales and Service Office for service and repair to ensure the safety features are maintained.

## DANGEROUS PROCEDURE WARNINGS

Warnings, such as the example below, precede potentially dangerous procedures throughout this manual. Instructions contained in the warnings must be followed.

Warning



Dangerous voltages, capable of causing death, are present in this instrument. Use extreme caution when handling, testing, and adjusting.





## SAFETY SYMBOLS

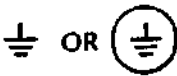
General Definitions of Safety Symbols Used On Equipment or In Manuals.



Instruction manual symbol: the product will be marked with this symbol when it is necessary for the user to refer to the instruction manual in order to protect against damage to the instrument.



Indicates dangerous voltage (terminals fed from the interior by voltage exceeding 1000 volts must be so marked.)



Protective conductor terminal. For protection against electrical shock in case of a fault. Used with field wiring terminals to indicate the terminal which must be connected to ground before operating equipment.



Low-noise or noiseless, clean ground (earth) terminal. Used for a signal common, as well as providing protection against electrical shock in case of a fault. A terminal marked with this symbol must be connected to ground in the manner described in the installation (operating) manual, and before operating the equipment.



Frame or chassis terminal. A connection to the frame (chassis) of the equipment which normally includes all exposed metal structures.



Alternating current (power line.)



Direct current (power line.)



Alternating or direct current (power line.)

---

### Warning



The **WARNING** sign denotes a hazard. It calls attention to a procedure, practice, condition or the like, which if not correctly performed or adhered to, could result in injury or death to personnel.

---

### Caution



The **CAUTION** sign denotes a hazard. It calls attention to an operating procedure, practice, condition or the like, which, if not correctly performed or adhered to, could result in damage to or destruction of part or all of the product.

---

### Note



The **NOTE** sign denotes important information. It calls attention to procedure, practice, condition or the like, which is essential to highlight.

---

# Table of Contents

---

## Section I: General Information

1-1 Introduction	1-1
1-2 Manual/Instrument Identification	1-3
1-3 Accessories Supplied	1-3
1-4 Description	1-3
1-5 Options	1-4
1-6 Specifications	1-4
1-7 Safety Considerations	1-5
1-8 Grounding	1-5
1-9 Recommended Test Equipment	1-5
1-10 Operator Maintenance	1-6
Table 1-1 Specifications	1-7
Source Characteristics	1-7
Frequency Characteristics	1-7
Output Characteristics	1-7
Sweep Characteristics	1-7
Receiver Characteristics	1-8
Input Characteristics	1-8
Magnitude Characteristics	1-9
Phase Characteristics (A/R,B/R,A/B):	1-10
Polar Characteristics	1-11
Real/Imaginary Characteristics	1-11
Delay Characteristics	1-11
Display Characteristics	1-13
Programming Characteristics	1-14
General Characteristics	1-16
Table 1-1 Specifications	1-1
HP Digital Display Performance Specifications	1-18

## Section II: Fault Isolation

2-1 Introduction	2-1
2-2 Safety Considerations	2-2
2-3 Recommended Test Equipment	2-2
2-4 Troubleshooting Hints	2-3
2-5 Getting Started	2-3
2-6 Overall Instrument Description	2-4

## Table of Contents Continued

2-7 Power-on Self Tests	2-7
Self Test Number #1, LED Test	2-8
Self Test Number #2, Main Processor-Controller ROM Test	2-8
Self Test Number #3, Main Processor-Controller Ram Test	2-8
Self Test Number #4, Total Main Processor-Controller RAM Test	2-9
Self Test Number #5, Keyboard Cable Test	2-9
Self Test Number #6, Timer Interrupt Test	2-9
Self Test Number #7, Trace Memory Test	2-9
Self Test Number #8, 1 MHz Test	2-10
Self Test Number #9, 8 kHz Test	2-10
Self Test Number #10, Fast Processor Self Test	2-10
2-8 Continuously Monitored Diagnostics	2-11
Oscillator Unlocked, Assembly A5, A6 or A17	2-12
10 MHz Reference Unlock	2-12
Main Processor Hardware Error	2-12
Fast Processor/System Errors	2-13
Keyboard	2-15
2-9 Confidence Tests	2-16
Confidence Test Number #1, Log Sweep Flatness Test	2-17
Confidence Test Number #2, Linear Sweep Flatness Test	2-18
Confidence Test Number #3, Synthesizer and L.O. Test	2-19
Confidence Test Number #4, Source Amplitude Test	2-20
Confidence Test Number #5, Output Limiter Test	2-21
Confidence Test Number #6, Impedance and Attenuator Tests	2-22
2-10 Service Diagnostics	2-23
Leveling On/Off	2-23
Settling On/Off	2-23
Syn Diag On/Off	2-24
Test Pattern	2-24
TRC Mem Test	2-24
Fastspoc Test	2-24
Fast Bus Int (Interface) Test	2-24
Disp Mem Test	2-24
Disp HP-IB Test	2-25
HP-IB SA	2-25
2-11 Covers Off Board Level Fault	2-26

### Section III: Performance Tests

3-1 Introduction	3-1
3-2 Equipment Required	3-1
3-3 Test Record	3-1
3-4 Calibration Cycle	3-1
3-5 Operational Verification Tests	3-2
HP Digital Display Operational Verification	3-2
3-6 Initial Control Settings	3-4
3-7 Receiver Residuals And Noise Test	3-5
Specifications:	3-5
3-8 On-Carrier Return Loss Test	3-8
Specifications:	3-8

3-9 Magnitude And Phase Dynamic Accuracy Test . . . . .	3-11
Specifications: . . . . .	3-11
3-10 Magnitude vs. Phase Test . . . . .	3-16
Specifications: . . . . .	3-16
3-11A Receiver Level Flatness And Absolute Accuracy Test . . . . .	3-18
Specifications: . . . . .	3-18
3-11B Alternate Receiver Level Flatness And Absolute Accuracy Test . . . . .	3-25
Specifications: . . . . .	3-25
Flatness And Absolute Accuracy Test (50W). . . . .	3-29
Flatness And Absolute Accuracy Test (1MW) . . . . .	3-34
3-12 Receiver Ratio Amplitude And Phase Accuracy . . . . .	3-36
Specifications: . . . . .	3-36
3-13 Receiver Crosstalk Test . . . . .	3-42
Specifications: . . . . .	3-42
3-14 Receiver Return Loss Test . . . . .	3-44
Specifications: . . . . .	3-44
3-15A Source Flatness And Absolute Accuracy Test . . . . .	3-47
Specifications: . . . . .	3-47
3-15B Alternate Source Flatness and Absolute Accuracy Test . . . . .	3-52
Specifications: . . . . .	3-52
3-16 Source Attenuator Accuracy Test . . . . .	3-56
Specifications: . . . . .	3-56
3-17 Source Distortion And Spur Test . . . . .	3-58
Specifications: . . . . .	3-58
3-18 Source Phase Noise Test . . . . .	3-60
Specifications: . . . . .	3-60
3-19 Api Spur Test . . . . .	3-62
Specifications: . . . . .	3-62
3-20 Frequency Stability Test (with Option 001 only) . . . . .	3-64
3-21 I/O Port Test . . . . .	3-66
Specifications: . . . . .	3-66
3-22 EPM-1 Flatness Test . . . . .	3-69
Specifications: $\leq 0.13$ dB . . . . .	3-69
Performance Test Record . . . . .	3-73
Test Equipment: . . . . .	3-74
Measurement Uncertainty . . . . .	3-78

**Section IV: Semiautomated Performance Test Guide**

Introduction . . . . .	4-1
Safety Considerations . . . . .	4-2
Features of the Semiautomated Test Program . . . . .	4-2
Overview . . . . .	4-3
Semiautomated Tests Versus Manual Tests . . . . .	4-4
Recommended Test Equipment . . . . .	4-5
Program Controlled Test Equipment . . . . .	4-5
How to Load the ITM Program . . . . .	4-6
Using an HP 9000 Series 200 or Series 300 Computer . . . . .	4-6
Using an Option 1C2 (HP Instrument BASIC) . . . . .	4-7

## Table of Contents Continued

How to Use the ITM Program . . . . .	4-8
Softkey Descriptions . . . . .	4-9
ITM Main Menu . . . . .	4-9
Start Testing Menu . . . . .	4-10
Test Configuration Menu . . . . .	4-11
Equipment Configuration Menu . . . . .	4-12
Title Page Menu . . . . .	4-13
Tests Requiring Equipment Connection Changes . . . . .	4-14
Measurement Uncertainty . . . . .	4-15

### Section V: Adjustments

5-1 Introduction . . . . .	5-1
5-2 Equipment Required . . . . .	5-1
5-3 Safety Considerations . . . . .	5-2
5-4 Related Adjustments . . . . .	5-3
5-5 Power Supply Adjustments . . . . .	5-9
5-6 Reference Board 10 MHz Oscillator Adjustment . . . . .	5-12
5-7 300 MHz Output Level Peaking Adjustment . . . . .	5-13
5-8 CPU Clock Adjustment . . . . .	5-14
5-9 Oven Heater Shutdown Adjust (Option 001 only) . . . . .	5-15
5-10 Offset Board Oscillator Tuning Range Adjustment . . . . .	5-16
5-11 Synthesizer Tuning Range Adjustment . . . . .	5-17
5-12 Synthesizer 100 kHz Null Adjustment . . . . .	5-19
5-13A 300 MHz Band Pass Filter Adjustment . . . . .	5-20
5-13B Local Oscillator 300 MHz Filter Adjustments . . . . .	5-21
5-14 Local Oscillator 200 MHz Filter Adjustments . . . . .	5-23
5-15 Local Oscillator Leveling Loop/Flatness Adjustment . . . . .	5-25
5-16 Source Output Board Filter Adjustment . . . . .	5-27
5-17 Source Amplitude And Step Adjustments . . . . .	5-29
5-18 Source Flatness Adjustment . . . . .	5-30
5-19 Input 250 kHz Filter Adjustment . . . . .	5-31
5-20 Input Notch Filter Adjustment . . . . .	5-34
5-21 Input Variable Gain Amplifier DC Offset Adjustment . . . . .	5-36
DC Offset Adjustment Program . . . . .	5-38
5-22 Input 1 MW Capacitance Adjustment . . . . .	5-39
5-23 Input 1 MW Attenuator Adjustment . . . . .	5-41
5-24 Input Local Oscillator Feedthrough Adjustment . . . . .	5-43
5-25 Receiver Return Loss Adjustment . . . . .	5-44
5-26 Input 50W Gain Adjustment . . . . .	5-46
5-27 Input 1 MW Gain Adjustment . . . . .	5-47
5-28 Input Level Flatness Adjustment . . . . .	5-49
Receiver flatness Adjustment Program . . . . .	5-50
5-29 Input Phase Zero Adjustment . . . . .	5-55
5-30 On Carrier Return Loss Adjustment . . . . .	5-58
5-31 API (Analog Phase Interpolation) Adjustments . . . . .	5-60

5-32 Oven Board 10 MHz Reference Frequency Adjustment(Option 001 only)	5-62
5-33 HP Digital Display Adjustments	5-63
Safety Considerations	5-63
Equipment Required	5-64
Removing the HP Digital Display	5-65
Adjustment Procedures	5-67
Low Voltage Power Supply Adjustments	5-69
High Voltage Power Supply Adjustments	5-73
Pattern Adjustments	5-76
Stroke Generator Adjustments	5-78
Stroke Intensity Adjustments	5-81
Final Focus Adjustments	5-83
Auxiliary X-Y-Z Output Check	5-89

**Section VI: Replaceable Parts**

6-1 Introduction	6-1
6-2 Replaceable Parts List	6-1
6-3 Ordering Information	6-2
6-4 Direct Mail Order System	6-2
6-5 Special Handling	6-2

**Section VII: Manual Backdating**

7-1 Introduction	7-1
7-2 Manual Changes Supplement	7-1
7.3 Manual Changes Instructions	7-2
Change A (Serial Number 3232A00680 and lower)	7-2
Change B (Serial Number 3232A00730 and lower)	7-2

**Section VIII: Circuit Descriptions**

8-1 Introduction	8-1
8-2 A4 Local Oscillator Board	8-2
Circuit Board Description	8-2
10 dB/20 dB Buffer	8-2
300 MHz LPF	8-2
Mixer	8-2
200 MHz LPF	8-2
20 dB/14 dB Amplifiers	8-2
Leveling Loop	8-2
20 dB Amplifier/Power Splitter	8-2
20 dB Amplifiers	8-3
8-3 A5 250 kHz Offset Board	8-4
Circuit Board Description	8-4
6 MHz Divider	8-4
Phase Detector/Loop Filter/Oscillator Unlock Detector	8-4
250 kHz Filter	8-4
300.25 MHz VCO	8-4
300.25 MHz Buffer	8-4
Mixer Driver	8-4

Table of Contents Continued

Mixer Buffer	8-5
300 MHz Buffer	8-5
Mixer	8-5
250 kHz Amplifier	8-5
<b>8-4 A6 Frequency Reference Board</b>	<b>8-6</b>
Circuit Board Description	8-6
External Reference Path, Oven Path, and Differentiator	8-6
External Reference Detector	8-6
Phase Detector and Switchable Loop Filter/Reference Lock Detector	8-6
10 MHz Reference VCXO	8-7
10 MHz Buffers	8-7
100 kHz Dividers	8-7
Phase Detector and Loop Filter/300 MHz Lock Detector	8-7
300 MHz VCO	8-7
Prescaler	8-7
÷ 2.5, ÷ 5, ÷ 3, ÷ 2 Dividers	8-7
÷ 50 & ÷ 30 Dividers and Phase Initialization	8-7
<b>8-5 A18 Output Board</b>	<b>8-8</b>
Circuit Board Description	8-8
Mixer Buffer	8-8
Variable Limiter	8-8
300 MHz Low Pass Filter	8-8
Mixer	8-8
200 MHz Low Pass Filters/20 dB Amplifiers	8-8
15 dB Amplifier	8-9
Low Frequency Gain Error Correction	8-9
Amplitude Leveling	8-9
Amplitude Reference	8-9
60 dB Step Attenuator	8-10
Private 5 Volt Supplies	8-10
<b>8-6 A15 Keyboard</b>	<b>8-11</b>
Circuit Board Description	8-11
Key Matrix	8-11
Read/Write Control	8-11
LED Annunciators	8-11
RPG Control	8-11
Instrument Preset	8-11
<b>8-7 A16 HP-IB Board</b>	<b>8-12</b>
Circuit Board Description	8-12
HP-IB Interface	8-12
Interrupt	8-12
Reset	8-12
Register Select	8-12
Read/Write	8-13
5 MHz Clock	8-13
Data Input/Output	8-13
<b>8-8 A17 Synthesizer Board</b>	<b>8-14</b>
Circuit Board Description	8-14
Fractional-N Control	8-14
Fractional-N	8-14
÷ N Counter	8-15
API (Analog Phase Interpolation) & Bias Current Sources	8-15



Phase Detector . . . . .	8-15
Integrator/Sample and Hold . . . . .	8-15
PLL Unlock Detector . . . . .	8-16
500 kHz Filter . . . . .	8-16
300.25 – 500.25 MHz VCO . . . . .	8-16
Prescaler . . . . .	8-16
+ 5 API Supply . . . . .	8-16
<b>8-9 A20 Motherboard . . . . .</b>	<b>8-17</b>
<b>Circuit Board Description . . . . .</b>	<b>8-17</b>
<b>8-10 A21 Main Power Supply Board . . . . .</b>	<b>8-18</b>
<b>Circuit Board Description . . . . .</b>	<b>8-18</b>
Line Filter . . . . .	8-18
Turn On . . . . .	8-18
Power On Preset (POP) . . . . .	8-18
Bias Supply . . . . .	8-18
FET Power . . . . .	8-18
FET Drive . . . . .	8-18
Pulsewidth Modulator (PWM) . . . . .	8-19
Primary Current Limit (PCL) . . . . .	8-19
+ 5V Output . . . . .	8-19
+ 5V Current Limit (+ 5 CL) . . . . .	8-19
Loop Shaping (Loop S.) . . . . .	8-19
+ 15V . . . . .	8-19
- 15V . . . . .	8-19
Isolated Supply . . . . .	8-20
+ 8V . . . . .	8-20
±15V Current Limit (LMT) . . . . .	8-20
Overvoltage . . . . .	8-20
Hi Temp . . . . .	8-20
Connector (Conn.) . . . . .	8-20
<b>8-11 A31 Oven Board (Option 001 only) . . . . .</b>	<b>8-21</b>
<b>Circuit Board Description . . . . .</b>	<b>8-21</b>
Threshold Detector . . . . .	8-21
Oven Assembly . . . . .	8-21
Buffer . . . . .	8-21
Switchable Filter . . . . .	8-21
<b>8-12 A61 Fast Processor Board . . . . .</b>	<b>8-22</b>
<b>Circuit Board Description . . . . .</b>	<b>8-22</b>
Input Data Buffer . . . . .	8-22
Data Immediate . . . . .	8-22
Dynamic Clock . . . . .	8-22
Bit/Slice ALU (Arithmetic Logic Unit) . . . . .	8-22
Output Data Registers . . . . .	8-22
Read/Write Control . . . . .	8-23
Micro Program ROM . . . . .	8-23
Micro Program Sequencer . . . . .	8-23
Timing . . . . .	8-23
Sweep Control Counter . . . . .	8-23
<b>8-13 A62/63 Main Processor-Controller Board . . . . .</b>	<b>8-24</b>
<b>Circuit Board Description . . . . .</b>	<b>8-24</b>
Interrupt Encoding . . . . .	8-24
Reset . . . . .	8-24



Table of Contents Continued

Data/Address Bus Buffer	8-24
Trigger	8-24
Address Decoding	8-25
Beeper	8-25
10 MHz Clock Phase-Locked Loop (PLL)	8-25
Display Interface	8-25
I/O	8-25
ROM/RAM	8-25
Fast Bus Interface	8-26
Battery Back-up	8-26
Chip Select and Read/Write Control (DECODING)	8-26
<b>8-14 A19 Input Board</b>	<b>8-27</b>
Circuit Board Description	8-27
50/1M W Input Attenuator	8-27
Buffer Amplifier	8-27
First Mixer	8-27
Overload Detection	8-27
250 kHz Bandpass Filter	8-28
Second Mixer	8-28
IF Amplifier	8-28
10 kHz Active Bandpass Filter	8-28
Sample and Hold	8-28
Variable Gain Amplifier	8-28
Analog to Digital (A - D) Converter	8-28
Look Up Table Variable Gain Amplifier	8-29
Digital Filters	8-29
32 mS Timer	8-29
Algorithmic State Machine	8-29
Look Up Table For Control	8-29
I/O Port	8-29
<b>8-15 HP Digital Display Circuit Descriptions</b>	<b>8-30</b>
Signal Line Definitions	8-31
A82 Vector Processor Control Board	8-32
A81 Stroke Generator, X-Y Output Amplifiers	8-34
X-Y Amplifiers	8-36
Z-Axis Intensity Amplifier	8-37
Focus Amplifier	8-37
A80, A83 Voltage Power Supplies	8-38
A84 Memory Circuit Option Assembly	8-39
Memory Control	8-39

**Section IX: Service**

9-1 Introduction	9-1
9-2 Recommended Test Equipment	9-2
9-3 Logic Conventions	9-2
9-4 Logic Symbology	9-2
9-5 Safety Considerations	9-8
9-6 Schematic List	9-9
9-7 Service Group A4, Local Oscillator Assembly	9-10
Initial Conditions	9-10
Troubleshooting Hints	9-11

9-8 Service Group A5, 250 kHz Assembly . . . . .	9-21
Initial Conditions . . . . .	9-21
Troubleshooting Hints . . . . .	9-22
9-9 Service Group A6, Frequency Reference Assembly . . . . .	9-27
Initial Conditions . . . . .	9-27
Troubleshooting Hints . . . . .	9-28
9-10 Service Group A15, Keyboard Assembly . . . . .	9-35
Troubleshooting Hints . . . . .	9-35
9-11 Service Group A16, HP-IB Assembly . . . . .	9-39
Initial Conditions . . . . .	9-39
Troubleshooting Hints . . . . .	9-40
9-12 Service Group A17, Synthesizer Assembly . . . . .	9-45
Initial Conditions . . . . .	9-45
Troubleshooting Hints . . . . .	9-46
Analog Troubleshooting . . . . .	9-47
Digital Troubleshooting . . . . .	9-48
API Troubleshooting . . . . .	9-49
Counter Troubleshooting . . . . .	9-52
9-13 Service Group A18, Output Assembly . . . . .	9-63
Initial Conditions . . . . .	9-63
Troubleshooting Hints . . . . .	9-64
Troubleshooting Procedure . . . . .	9-64
Low Frequency Gain Error Correction Troubleshooting Procedure . . . . .	9-65
Peak Detector (CR22 and CR23) Troubleshooting Procedure . . . . .	9-66
Amplitude Leveling Troubleshooting Procedure . . . . .	9-67
Limiting Mixer (U700) Troubleshooting Procedure . . . . .	9-69
9-14 Service Group A19, Input Assembly . . . . .	9-75
Initial Conditions . . . . .	9-75
Troubleshooting Hints . . . . .	9-76
Digital Filter Test . . . . .	9-77
A/D Test . . . . .	9-80
Signature Analysis Tests . . . . .	9-81
Dynamic Accuracy Troubleshooting (Option 002 only) . . . . .	9-82
Variable Gain Amplifier Troubleshooting . . . . .	9-84
9-15 Service Group A20, Motherboard Assembly . . . . .	9-99
How to Use A20 Motherboard Table (P/N 03577-66520) . . . . .	9-99
9-16 Service Group A21, Main Power Supply Assembly . . . . .	9-101
Initial Conditions . . . . .	9-102
Troubleshooting Hints . . . . .	9-103
Protection Circuits . . . . .	9-105
Turn On/Pop Troubleshooting Procedure . . . . .	9-106
Primary Current Limit Troubleshooting Procedure . . . . .	9-107
+ 5 V Current Limit Troubleshooting Procedure . . . . .	9-109
+ 15 V Current Limit Troubleshooting Procedure . . . . .	9-110
- 15 V Current Limit Troubleshooting Procedure . . . . .	9-111
+ 5 V Overvoltage Troubleshooting Procedure . . . . .	9-112
+ 15 V Overvoltage Troubleshooting Procedure . . . . .	9-114
- 15 V Overvoltage Troubleshooting Procedure. . . . .	9-115
High Temp Troubleshooting Procedure . . . . .	9-116
Bias Supply Troubleshooting Procedure . . . . .	9-117
FET Drive Troubleshooting . . . . .	9-117

Table of Contents Continued

FET Switching Troubleshooting Procedure . . . . .	9-118
FET Power Troubleshooting Procedure . . . . .	9-120
+ 5 V Control Loop Troubleshooting Procedure . . . . .	9-121
+ 15 V Overvoltage Troubleshooting Procedure . . . . .	9-123
-15 V Overvoltage Troubleshooting Procedure . . . . .	9-124
Loop Shaping/Pulse Width Modulator Troubleshooting Procedure . . . . .	9-125
+ 15 V and - 15 V Output Regulator Troubleshooting Procedure . . . . .	9-127
Final Power Supply Adjustments . . . . .	9-127
9-17 Service Group A31, Oven Assembly (Option 001 only) . . . . .	9-133
Initial Conditions . . . . .	9-133
Troubleshooting Hints . . . . .	9-134
9-18 Service Group A51/61, Fast Processor Assembly . . . . .	9-137
Initial Conditions . . . . .	9-137
Troubleshooting Hints . . . . .	9-138
9-19 Service Group A62/63, Main Processor-Controller Assembly . . . . .	9-157
Initial Conditions . . . . .	9-158
Troubleshooting Hints . . . . .	9-158
9-20 HP Digital Display . . . . .	9-191
Preventive Maintenance . . . . .	9-191
How to Use This Section . . . . .	9-192
Description . . . . .	9-196
Self Test . . . . .	9-196



# Section I

## General Information

---

### 1-1 Introduction

This service manual contains all the information required by service personnel to test, adjust and service the HP 3577B Network Analyzer.

Listed in the title page of this manual is a microfiche part number. This number can be used to order 4 by 6 inch microfilm transparencies of the manual. Each microfiche contains up to 96 photoduplicates of the manual pages. The microfiche package also includes the latest manual change supplements.

The manual is divided into nine sections. Each section and topic is listed below.

Section	Topic	Includes
I	General Information	Specifications Test Equipment Options
II	Fault Isolation	Power-On Self Tests Confidence Tests Isolation to Board Level.
III	Performance Tests	Verifies specifications in table 1-1.
IV	Semiautomated Performance Tests	Verifies specifications in table 1-1. Each test meets the 4:1 uncertainty ratio given in MIL STD 45662A.
V	Adjustments	Adjusts to specifications in table 1-1.
VI	Replaceable Parts	Lists HP 3577B parts.
VII	Backdating	Lists changes which adapt the manual to older units.
VIII	Circuit Descriptions	Explains theory of operation.
IX	Service	Gives individual circuit board troubleshooting data.

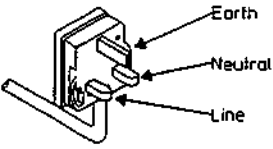
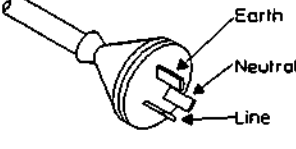
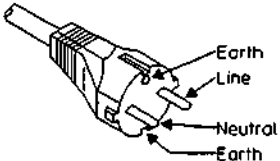
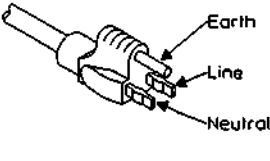
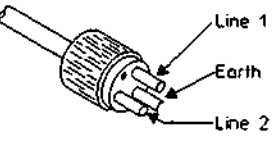
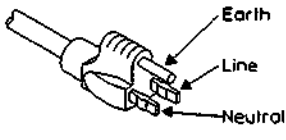
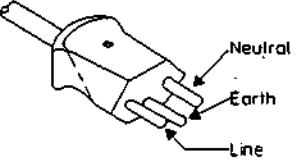
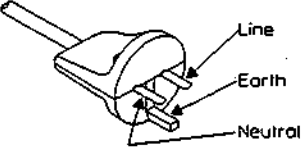
<p>United Kingdom Option 900</p>  <p>PLUG*: BS 1363A CABLE*: HP 5041-5807</p> <p>220V-5A OPERATION</p>	<p>Australia/New Zealand Option 901</p>  <p>PLUG*: NZSS 198/AS C112 CABLE*: HP 5041-5808</p> <p>220V-6A OPERATION</p>
<p>Continental Europe Option 902</p>  <p>PLUG*: CEE7-V11 CABLE*: HP 5041-5809</p> <p>220V-6A OPERATION</p>	<p>North America Option 903</p>  <p>PLUG*: NEMA 5-15P CABLE*: HP 5041-5819</p> <p>125V-10A** OPERATION</p>
<p>North America Option 904</p>  <p>PLUG*: NEMA-G-15P CABLE*: HP 5041-5806</p> <p>250V-5A** OPERATION</p>	<p>Japan Option 918</p>  <p>PLUG*: MITI 41-9692 CABLE*: HP 5041-5840</p> <p>125V-12A OPERATION</p>
<p>Switzerland Option 906</p>  <p>PLUG*: SEV 1011.1959-24507 TYPE 12 CABLE*: HP 5041-5812</p> <p>220V-6A OPERATION</p>	<p>Denmark Option 912</p>  <p>PLUG*: DHCR 107 CABLE*: HP 5041-5814</p> <p>220V-6A OPERATION</p>

Figure 1-1. HP 3577B Network Analyzer  
 Accessories Supplied

## 1-2 Manual/Instrument Identification

The instrument identification serial number is located on the rear panel of the instrument. Hewlett-Packard uses a two-section serial number consisting of a four digit prefix and a five digit suffix separated by a letter designating the country in which the instrument was manufactured (A = U.S.A; G = West Germany; J = Japan; U = United Kingdom.). The prefix is the same for all identical instruments and changes only when a major instrument change is made. The suffix, however, is assigned sequentially and is unique to each instrument.

This manual applies to instruments with serial numbers indicated on the title page. If changes have been made since this manual was printed, a yellow "Manual Change" supplement will define the changes and explain how to adapt the manual to the newer instruments. In addition, backdating information contained in Section VII adapts the manual for instruments with serial numbers lower than those listed on the title page.

## 1-3 Accessories Supplied

The following accessories are supplied with the HP 3577B Network Analyzer.

Line Power Cord.	see figure 1-1
Type N male to BNC female Adapters (3 each) *	HP 1250-0780

\* 4 each with Option 002

## 1-4 Description

The HP 3577B measures network performance in the frequency range of 5 Hz to 200 MHz. Each of the receiver inputs provides 100 dB of dynamic range. A "line stretcher" is available with a readout in length or time. The line stretcher enables the electrical length of any channel to be changed as required. This allows compensation for differences in test cable lengths and measurement of the electrical length of networks under test.

Each of the receiver inputs can be displayed on one or both traces. The traces are labeled Trace 1 and Trace 2. Trace data for each trace is digitally stored as complex data in a trace memory. This results in the ability to display the same data in any of eight display formats. The HP 3577B display has no etched lines. The graticule is drawn as a part of the display operation. No screen overlays are required for polar or Smith charts.

The twelve trace storage registers allow the HP 3577B to perform complex trace arithmetic and one port correction routines. Other features include adjustable receiver bandwidth, complex trace averaging, limit lines, discrete sweep, HP Instrument BASIC (optional), and automatic plot routines.

The HP 3577B source output frequencies can be swept from 5 Hz to 200 MHz. The same reference drives both the source and input channel tuners, whereby the source and receiver are always tuned to the same frequency. The source and receiver frequencies are coupled, therefore only linear devices can be characterized. The source output level can be set between +15 dBm and -49 dBm. The source amplitude level can also be swept.

The HP 3577B features menu-driven operation, using eight "softkeys." The menus are accessed by pressing the labeled hardkeys, and the appropriate softkeys select the desired parameters for the hardkey function. Marker and sweep parameters are presented on the HP 3577B display.

---

## 1-5 Options

The following table lists the options available for the HP 3577B. These options are available when the instrument is ordered. For later installation, use the HP part number when ordering.

For the HP 3577B

Option	Description	HP Part Number
001	Add High Stability Frequency Reference	03577-88801
002	Add 3rd Receiver	HP 3577B Option K02
1C2	Add HP Instrument BASIC and 640 kBytes RAM	03577-88812
907	Front Handle Kit	5062-3991
908	Rack Mounting Kit	5062-3979
909	Front Handle & Rack Mount Kit	5062-3965
910	Additional Operating Manual & Service Manual	03577-90035 03577-90040
911	Additional HP Instrument BASIC Programming Reference	E2083-90000 03577-90030

---

## 1-6 Specifications

The HP 3577B specifications are listed in table 1-1, Specifications. The specifications describe the instrument's warranted performance. Specifications apply after a warm up period of one hour except as noted otherwise. Supplemental characteristics are intended to provide information useful in applying the instrument by giving typical, but non-warranted, performance specifications. Supplemental characteristics are denoted as "typical," "nominal," or "approximately."



---

## 1-7 Safety Considerations

The HP 3577B is a Safety Class 1 instrument (provided with a protective earth terminal). The instrument and manuals should be reviewed for safety markings and instructions before operation.

---

## 1-8 Grounding

The following connections on the HP-IB connector are tied to Protective Earth Ground: pins 12 and 18 through 24 of the edge connector, and the HP-IB cable shield. The instrument frame, chassis, covers, and all exposed metal surfaces are connected to the protective earth terminal. The output and receiver N-connector outer conductors are at earth ground.

---

### Warning



**DO NOT interrupt the protective earth ground or "float" the HP 3577B. This action could expose the operator to potentially hazardous voltages!**

---

## 1-9 Recommended Test Equipment

The equipment required to maintain the HP 3577B is listed in table 1-2, Recommended Test Equipment. Other equipment may be substituted for the recommended model if it meets or exceeds the listed critical specifications. When substitutions are made, the user may have to modify the performance and adjustment procedures to accommodate the different operating characteristics.

---

## 1-10 Operator Maintenance

Operator maintenance is limited to replacing the line fuse, and cleaning the fan filter. There are no operator controls inside the HP 3577B.

---

### Warning



To avoid serious injury, be sure that the ac line power cord is disconnected before removing or installing the ac line fuse.

---

Only service trained personnel should perform any instrument repair.

---

### Warning



Under no circumstances should an operator remove any covers, screws, shields, or in any other way enter the HP 3577B. There are no operator controls inside the HP 3577B Network Analyzer.

---

Refer to the Safety Symbol chart in the preface section for all applicable instrument and manual safety symbols.

Table 1-1 Specifications

**Source Characteristics****■ Frequency Characteristics****Frequency Range:** 5 Hz to 200 MHz.**Frequency Resolution:** 0.001 Hz.**Stability:** for Option 001,  $\pm 5 \times 10^{-8}$ /day, 0 to 55° C  
(Applicable for instrument on continuously  $\geq$  48 hours.)**■ Output Characteristics****Level Range:** +15 dBm to -49 dBm  
(1.26 Vrms to 793  $\mu$ Vrms; 2 dBV to -62 dBV) into a 50 $\Omega$  load.**Resolution:** 0.1 dB.**Entry Units:** dBm, dBV, V.**Accuracy:**  $\pm 1$  dB at +15 dBm and 100 kHz.  
Below +15 dBm, add the greater of  $\pm 0.02$  dB/dB or 0.2 dB.**Flatness:** 1.5 dBpp from 5 Hz to 200 MHz.**Impedance:** 50 $\Omega$ ; > 20 dB return loss at all levels.**RF Output Connector:** 50 $\Omega$  Type N female.**Spectral Purity:****Phase Noise (in 1 Hz Bandwidth):**

&lt; -70 dBc at offset frequencies from carrier of 100 Hz to 20 kHz.

Harmonics: &lt; -25 dBc.

Non-Harmonic Spurious Signals:

&lt; -50 dBc or -70 dBm whichever is greater.

**Reverse Power Protection:** Output is automatically opened at a signal level of approximately +22 dBm (50 $\Omega$ ), or  $\pm 4$  Vdc, or greater applied to the source output. Source output is reconnected with the Clear Trip function.**■ Sweep Characteristics****Linear Frequency:**

Range: 5 Hz to 200 MHz.

Entry: Start/stop or center/span frequencies.

Span: 0 Hz or 0.01 Hz to 200 MHz, phase continuous.

Sweep Time: 100 ms/span to 6553 s/span.

Direction: Increasing or decreasing frequency.

**Log Frequency (segmented linear approximation):**

Range: 5 Hz to 200 MHz.

Entry: Start/stop frequencies.

Span: 0.01 Hz to 200 MHz, phase continuous.

Log Accuracy: 2%.

Sweep Time: 200 ms/span to 6553 s/span.

Sweep Direction: Increasing frequency.

**Alternate Frequency:** Sweep alternates between two separate start/stop frequencies using linear sweep only.**CW:** Frequency is fixed. Data is updated with a selectable sample time from 1 ms to 16 s.**Discrete:** From 2 to 51 discrete frequencies at points of interest. Resolution bandwidth and settling time are individually settable. The minimum measurement time for each frequency is typically 10 ms. The discrete sweep table becomes part of the instrument state.

Sweep Direction: Increasing or decreasing frequency.

**Log Amplitude (fixed frequency):**

Range: +15 dBm to -49 dBm.

Entry: Start/stop level in dBm or dBV.

Sweep Time: 1 ms/step to 16 s/step. Total sweep time/span depends upon total number of steps and time/step.

**Sweep Modes:** Continuous, single, manual.**Trigger Modes:** Free run, immediate, line, external.

## Receiver Characteristics

### Input Characteristics

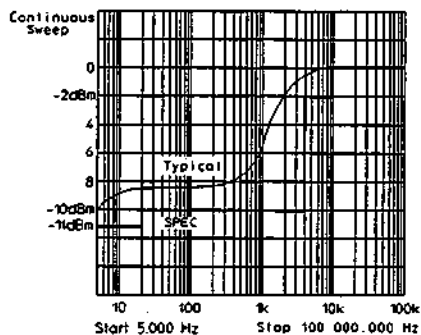
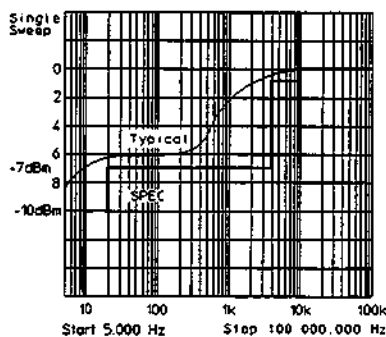
**Frequency Range:** 5 Hz to 200 MHz.

**Inputs:** Two receiver inputs (A and R). Option 002 provides input B.

**Input Impedance:** Selectable 50Ω with > 25 dB return loss, or 1 MΩ in parallel with approximately 30 pF.

**Full Scale Input Level:**

Input Impedance	Input Attenuation	
	0 dB	20 dB
50Ω	- 20 dBm	0 dBm
1 MΩ	- 33 dBV (22.4 mV)	- 13 dBV (224 mV)



**Input Damage Level (approximate):**

50Ω: +30 dBm or 25 Vdc

1 MΩ: +16.9 dBV (7 Vrms) or 25 Vdc. The 50Ω input impedance automatically switches to 1 MΩ at approximately +20 dBm, and can be reset with the clear trip function.

**Input Connectors:** 50Ω Type N female.

**Resolution Bandwidth:** Selectable 1 kHz, 100 Hz, 10 Hz, or 1 Hz.

**Sensitivity due to noise and internal crosstalk between source and receiver:**

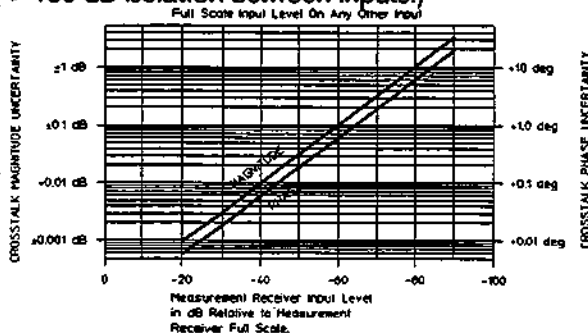
Sensitivity*					
Resolution Bandwidth	Minimum Freq.	Min. Freq. - 30 kHz (50 Ω)		30 kHz - 200 MHz (50Ω)	
		Min. Freq. - 300 kHz (1 MΩ)		300 kHz - 20 MHz (1 MΩ)	
		Full Scale Input		Full Scale Input	
		0 dBm - 13 dBm (20 dB Atten)	- 20 dBm - 33 dBV (0 dB Atten)	0 dBm - 13 dBV (20dB Atten)	- 20 dBm - 33 dBV (0 dB Atten)
1 Hz	100 Hz	- 110 dBm	- 130 dBm	- 110 dBm	- 130 dBm
10 Hz	100 Hz	- 100 dBm	- 120 dBm	- 110 dBm	- 130 dBm
100 Hz	500 Hz	- 90 dBm	- 110 dBm	- 105 dBm	- 125 dBm
1 kHz	5 kHz	- 80 dBm	- 100 dBm	- 95 dBm	- 115 dBm

\*For 1 MΩ inputs, add 5 dB to the table.

**Residual Responses:** > 100 dB below full scale input, except for crosstalk error limits, L.O. feedthrough, and ac line and fan related spurious signals.

**Crosstalk Error Limits:**

(> 100 dB isolation between inputs.)



**L.O. Feedthrough:** < -33 dB below maximum input level.

**AC Line and Fan Related Spurious Signals:**

< -100 dBm, frequency < 1kHz.

**Electrical Length/Reference Plane Extension:**

Provides equivalent electrical line length, or delay at inputs A, R, and B (B for Option 002 only).

Range:  $-3 \times 10^8$  m to  $+3 \times 10^8$  m, or -1 s to +1 s.

Resolution: 5 digits or 0.1 cm (3.3 ps) whichever is greater.

Accuracy:  $\pm 0.1$  cm or  $\pm 0.02\%$  whichever is greater.

**Magnitude Characteristics**

**Range:** Full Scale Input Level to Sensitivity.

**Resolution:**

**Marker:** 0.001 dB (log); 5 digits (linear).

**Display:** 0.01 dB/div to 20 dB/div (log absolute);

0.01 dB/div to 200 dB/div (log ratio);

0.1 nV/div to 10 V/div (linear absolute);

$10^{-10}$ /div to  $10^{20}$ /div (linear ratio).

**Display Units:** dB, dBm, dBV, V, and linear ratio.

**Accuracy (at 100 kHz, 25° C, and Full Scale Input):**

Absolute (A,B,R):  $\pm 0.2$  dB.

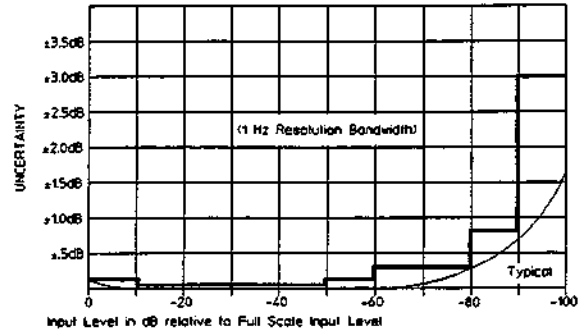
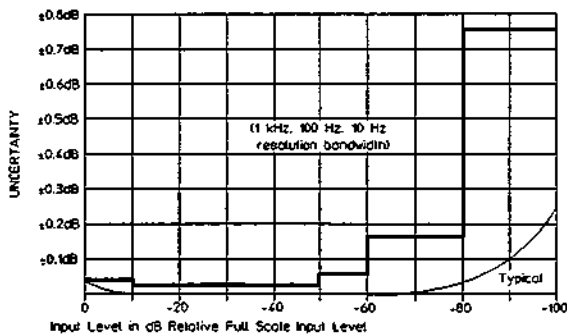
Ratio (A/R,B/R,A/B):  $\pm 0.15$  dB (50 $\Omega$ );  $\pm 0.2$  dB (1 M $\Omega$ ).

Accuracy and frequency response errors, and effects of different input attenuation can be calibrated out with normalization.

**For Frequencies  $\geq 100$  kHz:**

**Dynamic Accuracy:**

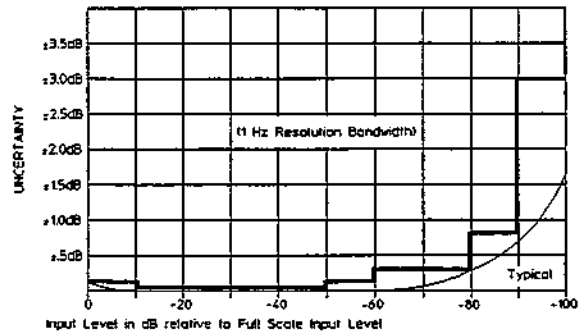
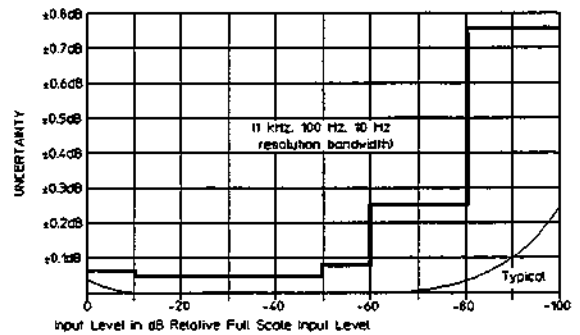
Error		Input Level Relative to Full Scale Input
Resolution Bandwidth		
1 kHz, 100 Hz, 10 Hz	1 Hz	
$\pm .04$ dB	$\pm .04$ dB	0 dB to - 10 dB
$\pm .02$ dB	$\pm .02$ dB	- 10 dB to - 50 dB
$\pm .05$ dB	$\pm .05$ dB	- 50 dB to - 60 dB
$\pm .15$ dB	$\pm .25$ dB	- 60 dB to - 80 dB
$\pm .75$ dB	$\pm .75$ dB	- 80 dB to - 90 dB
$\pm .75$ dB	$\pm 3.00$ dB	- 90 dB to - 100 dB



**For Frequencies < 100 kHz:**

**Dynamic Accuracy:**

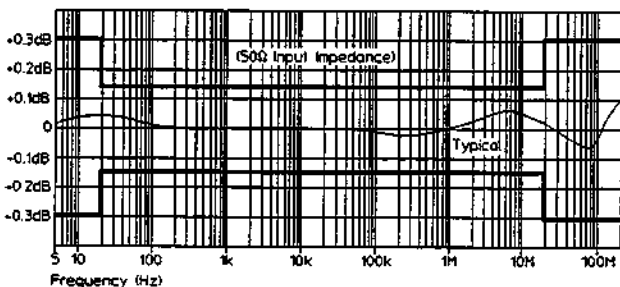
Error		Input Level Relative to Full Scale Input
Resolution Bandwidth		
1 kHz, 100 Hz, 10 Hz	1 Hz	
$\pm .07$ dB	$\pm .07$ dB	0 dB to - 10 dB
$\pm .06$ dB	$\pm .06$ dB	- 10 dB to - 50 dB
$\pm .08$ dB	$\pm .08$ dB	- 50 dB to - 60 dB
$\pm .25$ dB	$\pm .30$ dB	- 60 dB to - 80 dB
$\pm .75$ dB	$\pm .75$ dB	- 80 dB to - 90 dB
$\pm .75$ dB	$\pm 3.00$ dB	- 90 dB to - 100 dB



**Frequency Response:** Specifications apply when inputs are driven from a 50Ω source impedance.

**Absolute (A,B,R):**

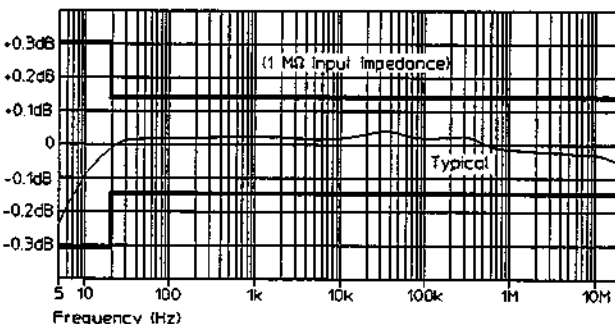
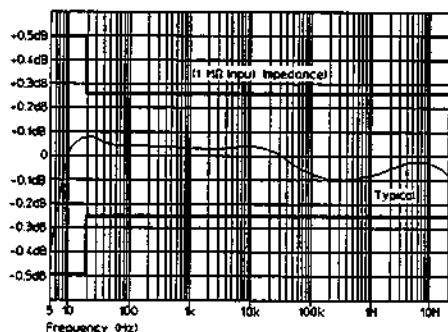
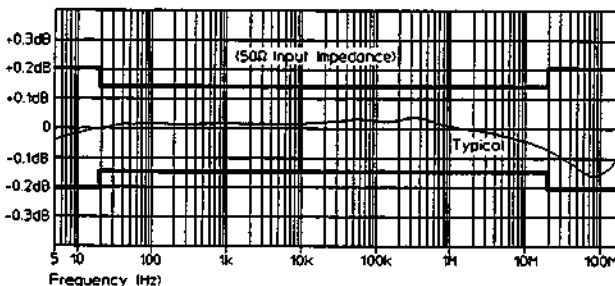
Frequency	Error	
	50Ω Input	1 MΩ Input
20 Hz to 20 MHz	.3 dB pp	.5 dB pp
5 Hz to 200 MHz	.6 dB pp	—
5 Hz to 20 MHz	—	1 dB pp



**Ratio (A/R,B/R,A/B):**

Frequency	Error*	
	50Ω Input	1 MΩ Input
20 Hz to 20 MHz	.3 dB pp	.3 dB pp
5 Hz to 200 MHz	.4 dB pp	—
5 Hz to 20 MHz	—	.6 dB pp

\*For unequal 50Ω input attenuation add 0.15 dB pp (20 Hz to 20 MHz), 0.3 dB pp (5 Hz to 200 MHz). For unequal 1 MΩ input attenuation add 0.2 dB pp (20 Hz to 20 MHz), 0.4 dB pp (5 Hz to 20 MHz).



**Reference Level:**

- Range: -207 dBm to +33 dBm
- (-220 dBV to +20 dBV) (log absolute);
- 400 dB to +400 dB (log ratio);
- 0 V to 10 V (linear absolute);
- 0 to 10<sup>20</sup> (linear ratio).
- Resolution: 0.001 dB (log); 5 digits (linear).

**Stability:**

- Temperature: Typically < ± 0.02 dB/° C.
- Time: Typically < ± 0.05 dB/hour at 25° C.

**Phase Characteristics (A/R,B/R,A/B):**

**Range:** ± 180 deg.

**Resolution:**

Marker: 0.005 deg (0.0001 rad)  
 Display: 0.01 deg/div to 200 deg/div  
 (0.00018 rad/div to 3.49 rad/div).

**Display Units:** degrees, radians.

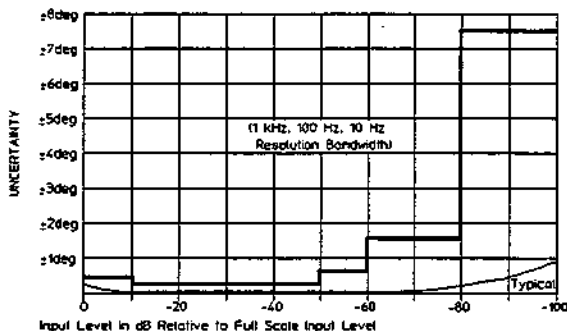
**Accuracy (at 100 kHz, 25° C, and Maximum Input Level):** ± 2.0 deg.

Accuracy and frequency response errors, and effects of different input attenuation can be calibrated out with normalization.

**Dynamic Accuracy:**

Error*	Input Level Relative to Maximum Allowable
± .4 deg	0 dB to - 10 dB
± .2 deg	- 10 dB to - 50 dB
± .5 deg	- 50 dB to - 60 dB
± 1.5 deg	- 60 dB to - 80 dB
± 7.5 deg	- 80 dB to - 100 dB

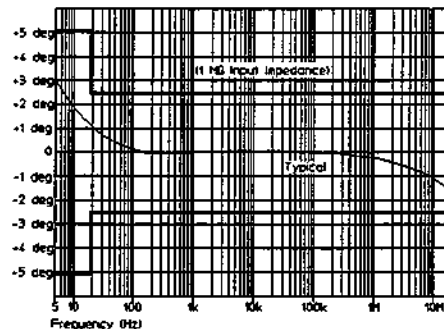
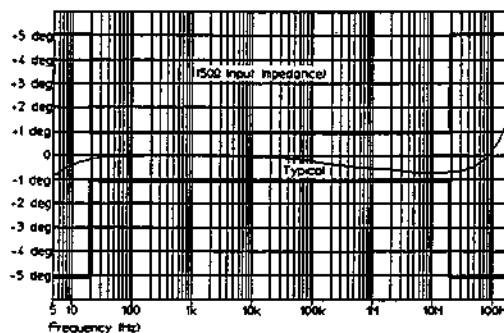
\*Specifications do not apply below - 60 dB in a 1 Hz Resolution Bandwidth.



**Frequency Response:** Specifications apply when inputs are driven from a 50Ω source impedance.

Frequency	Error *	
	50Ω Input	1 MΩ Input
20 Hz to 20 MHz	2 deg pp	5 deg pp
5 Hz to 200 MHz	10 deg pp	—
5 Hz to 20 MHz	—	10 deg pp

\*For unequal input attenuation add 8 deg pp.



**Crosstalk:** Specified under Input Characteristics.

**Reference Level:**

Range: - 500 deg to + 500 deg (- 8.7 rad to + 8.7 rad)

Resolution: 0.01 deg.

**Stability:**

Temperature: Typically < ± 0.05 deg/° C.

Time: Typically ± 0.05 deg/hour at 25° C.

**Polar Characteristics**

Range, Resolution, Display Units, Dynamic Accuracy, Frequency Response, Uncertainty, Crosstalk, Reference Level, and Stability specifications are the same as the corresponding magnitude and phase characteristics.

**Full Scale Magnitude Range:**

Absolute(A,B,R): 0.1 nV to 10V  
 Ratio (A/R,B/R,A/B): 10<sup>-10</sup> to 10<sup>20</sup>

**Real/Imaginary Characteristics**

Range, Dynamic Accuracy, Frequency Response, Uncertainty, Crosstalk, Stability specifications are the same as the corresponding magnitude and phase characteristics.



**Resolution:**

Marker: 5 digits.  
Display: 0.1 nV/div to 10 V/div for absolute;  
 $10^{-10}$  to  $10^{20}$  for ratio.

**Display Units:** V and linear ratio.

**Reference Level:**

Range:  $\pm 10$  V for absolute;  $\pm 10^{20}$  for ratio.  
Resolution: 5 digits.

■ **Delay Characteristics**

(Linear Frequency Sweep and Discrete Sweep with equal frequency point spacing; A/R, B/R, A/B; 50 $\Omega$  Input Impedance)

**Range:** Group delay is a computed parameter, defined by the equation  $t_g = -\frac{\Delta\phi}{2\pi\Delta f}$

**Minimum:** The minimum delay time is given by the expression

$$\frac{1.4 \times 10^{-5}}{\text{Aperature [Hz]}}$$

**Maximum:** The maximum delay is given by the expression  $\frac{N - 1}{2 \times \text{Span [Hz]}}$  where N = number of points per sweep (51, 101, 201, 401 for linear sweep; 3 to 51 for discrete sweep).

**Effective Range:** 1 ps to 20,000 s.

**Resolution:**

Marker: Same as minimum delay time or 5 digits, whichever is greater.  
Display: 0.01 ns/div to 1000 s/div.

**Aperture:** Selectable 0.5%, 1%, 2%, 4%, 8%, 16% of frequency span for linear sweep. For discrete sweep, aperture is two times the spacing between the first two frequency points.

**Display Units:** seconds

Accuracy:  $\frac{.13 \text{ s}}{(\text{freq [Hz]})^2} \pm 2 \text{ ns or}$

$\frac{\text{Dynamic Phase Accuracy}}{360 \times \text{Aperature [Hz]}} \pm 2 \text{ ns whichever is greater.}$

The  $\frac{.13 \text{ s}}{(\text{freq [Hz]})^2} \pm 2 \text{ ns}$

term can be calibrated out with normalization.

**Crosstalk:** Determined by the expression

$$\frac{\text{Phase Crosstalk}}{360 \times \text{Aperature [Hz]}}$$

**Reference Level:**

Range:  $\pm 10^3$  s.  
Resolution: 5 digits.

**Stability:**

Temperature: Determined by the expression

$$\frac{\text{Phase Temperature Stability}}{360 \times \text{Aperature [Hz]}}$$

Time: Determined by the expression

$$\frac{\text{Phase Time Stability}}{360 \times \text{Aperature [Hz]}}$$



## Display Characteristics

**Annotation:** Start/stop, center/span or CW frequency, source level, scale/div, reference level, delay aperture, marker data, and soft key functions.

**Graticules:** Rectangular logarithmic and linear, polar, and Smith. All graticules are electronically generated.

**Traces:** Two simultaneous traces may be present with a rectangular graticule. One trace with polar or Smith graticules.

**Markers:** Each trace has one main marker and an offset marker. Markers indicate data at corresponding trace coordinates in the same units as used to set the Reference Level. Markers can be used to modify certain display parameters. Marker resolution is the same as horizontal display resolution.

**Limit Lines:** Each trace can have separate limit lines made of up to 20 line segments. Upper and lower limit lines can be defined for each trace. The limit table for each trace becomes part of the instrument state. A Pass/Fail indicator shows the results of a limit test on the screen. Also, the FAIL line on the Programmable I/O Port is set low for a failure, or high for pass just before the EOS line is pulsed low. Limit tests typically add between 10 and 120 msec delay between sweeps.

### Reference Line Position:

Rectangular Graticule: 0% to 100% full scale deflection in 0.05% increments.

Polar/Smith Chart Graticule:  $\pm 500$  deg in 0.001 deg increments.

**Data Storage:** Measured data can be stored in vector format in twelve non-volatile storage registers X1 through X8 and D1 through D4. Stored data can be displayed again later or operated on with Vector Math.

**Vector Math:** Input magnitude and phase data, stored data, a  $j\omega$  register, and user defined constants and functions can be mathematically combined into expressions which define displayed or stored data. Mathematical operations are: add, subtract, multiply, and divide.

### Calibration:

**Normalization:** Both traces can be normalized to measured data with full accuracy, and resolution. Scale factors can be changed after normalization without affecting calibration.

**Normalize (Short):** Compensates for frequency response errors. Requires a short termination.

**One Port Part Cal:** Compensates for directivity errors and frequency response errors. Requires open and load terminations.

**One Port Full Cal:** Compensates for directivity, frequency response and source match errors. Requires open, short, and load terminations.

### Noise Averaging:

**Type:** Exponentially weighted vector averaging on successive sweep data.

**Averaging Factor:** Selectable 1 (off), 4, 8, 16, 32, 64, 128, 256.

The current trace  $A_n$  is always displayed and updated at the sweep rate according to the expression

$$A_n = S_n/F + (F - 1)(A_{n-1})/F, \text{ where } S_n = \text{current input signal, } F = \text{averaging factor, } A_{n-1} = \text{previously averaged trace.}$$

Averaging Factor is fixed at 1 in alternate sweep.

### Linear Phase Slope Compensation:

Provides linear phase slope offset in deg/span.

**Range:**  $-72,000$  deg./span to  $+72,000$  deg./span ( $-1256$  rad/span to  $+1256$  rad/span).

**Resolution:** 5 digits or 0.001 deg whichever is greater.

**Accuracy:** 0.02%.

**Autoscale:** Automatically adjusts the reference level and scale/div. of the displayed measurement.

### Measured No. of Points per Sweep:

Logarithmic frequency: 401

Linear frequency: 51, 101, 201, 401

CW frequency: 1

Discrete Sweep: between 2 and 51

**Measured No. of Steps per Sweep:**

Logarithmic Amplitude Sweep:

5, 10, 20, 50, 100, 200, 400

**Display Resolution:** Horizontal and vertical.

Rectangular: 1600 points.

Polar: 1200 points.

---

## Programming Characteristics

**HP-IB Capability:** Remote programming is via the Hewlett-Packard Interface Bus (HP-IB)\* for all HP 3577B front panel control functions except the ac line switch, display intensity, entry knob, HP-IB address and system controller on/off. The HP 35677A/B S-Parameter Test Sets are programmable through the HP 3577B interface only. The HP 3577B

**Interface Functions:** SH1,AH1,T6,TEØ, L4, LEØ,SR1,RL1,PP1,DC1,DT1,C1,C2,C3,C12,E1.

**Output Data Transfer Time:** 401 complex data points can be transferred directly to an HP 9000 Series 300 Computer in BASIC language as follows:

ASCII Mode: Typically 2800 ms.

Binary Floating Point Mode: Typically 310 ms.

**HP Instrument BASIC Capability (Option 1C2):** This option adds 640 kBytes of RAM to the HP 3577B and provides the capability to capture key sequences, customize parameter extractions, fully control the Programmable I/O Port, and control other HP-IB devices. Mass storage is accessed using a LIF or DOS disk in an external SS80 drive (subset of the CS80). One program can be in RAM at a time. Edit a program via an external controller. Load a program via an external disk drive or via HP-IB. 401 complex data points can be transferred to an HP Instrument BASIC program in 64-bit IEEE 754 binary floating-point mode in typically 130 msec.

\* HP-IB is Hewlett-Packard's implementation of IEEE Standard 488.1

Option 1C2: HP Instrument BASIC Commands

Graphics Capabilities:

Front panel commands:	Trigonometric operations	Graphics control	Clock and calendar
LIST	ACS()	GCLEAR	TIMEDATE
SECURE	ASN()		
<b>Error handling</b>	ATN()	<b>Graphics plotting</b>	<b>General device I/O</b>
ERRL()	COS()	DRAW	ASSIGN
ERRLN()	DEG	MOVE	BEEP
ERRM\$	RAD	<b>Program control</b>	CRT
ERRN	SIN()	CALL	DATA
<b>Memory allocation</b>	TAN()	CASE	DISP
COM	<b>String operations</b>	CASE ELSE	ENTER
DIM	CHR&()	CONT	IMAGE
INTEGER	DVAL\$()	DEF FN	INPUT
REAL	DVAL()	ELSE	OUTPUT
SCRATCH	IVAL\$()	END	PRINT
<b>Relation operators</b>	IVAL()	END IF	PRINTER IS
<, <=, <>, >, =	LEN()	END LOOP	PRT
<b>General math</b>	LWC\$()	END SELECT	READ
x, +, -, /, ^	NUM()	END WHILE	RESTORE
ABS()	POS()	EXIT IF	TAB()
DIV	REV\$()	FN	TABXY()
DROUND()	RPT\$()	FNEND	<b>Binary functions</b>
EXP()	TRIM\$()	FOR NEXT	BINAND()
FRACT()	UPC\$()	GOSUB	BINCMP()
INT()	VAL\$()	GOTO	BINEOR()
LET	VAL()	IF THEN	BINIOR()
LGT()	<b>HP-IB control</b>	LOOP	BIT()
LOG()	ABORT	PAUSE	ROTATE()
MAX()	CLEAR	REPEAT	SHIFT()
MAXREAL	LOCAL	UNTIL	<b>Event-initiate branching</b>
MIN()	LOCAL	RETURN	DISABLE
MINREAL	LOCKOUT	RUN	DISABLE
MOD	PASS	SELECT	INTR
MODULO	CONTROL	STOP	ENABLE
PI	REMOTE	SUB	ENABLE
PROUND()	SROLL()	SUBEND	INTR
RANDOMIZE	TRIGGER	SUBEXIT	ON/OFF
RND	<b>Mass storage</b>	WAIT	ERROR
SGN()	CAT	WHILE	ON/OFF INTR
SQR()	COPY	<b>Logical operators</b>	ON/OFF KEY
SQRT()	CREATE ASCII	AND	ON/OFF
	CREATE BDAT	EXOR	TIMEOUT
	CREATE (DOS FILE)	NOT	
	CREATE DIR (DOS FILE)	OR	
	GET		
	INITIALIZE		
	MSI		
	PURGE		
	RE-SAVE		
	RENAME		
	SAVE		

Alphanumeric Characters: 12 lines of text with 40 characters per line can be displayed character set includes alphanumerics, special characters and line vectors.

Vector Display: Trace lines and alphanumeric characters can be drawn on the display between any two points with a resolution of 2048 points along the horizontal and vertical axes.

## General Characteristics

### Compatibility:

The HP 3577B (including Options 001 and 002) is form, fit and function compatible with the HP 3577A. The HP 3577B responds to all HP 3577A HP-IB commands.

### External Reference Frequency Input:

Frequency: 10 MHz/N (N is an integer from 1 to 100).

Level: 0 dBm  $\pm$  10 dB, nominal.

Impedance: 50 $\Omega$ , nominal.

Connector: BNC female, rear panel.

### Reference Frequency Output:

Frequency: 10 MHz (nominal)

Level: Typically 0 dBm

Impedance: 50 $\Omega$ , nominal.

Connector: BNC female, rear panel.

### External Trigger:

Triggers on negative TTL transition or contact closure to ground.

Minimum Pulse Width: Typically 1  $\mu$ sec.

Impedance: 50 $\Omega$ , nominal.

Connector: BNC female, rear panel.

### Programmable Input/Output Connector:

Rear panel connector is a female D-SUB series D25. It has three dedicated outputs (EOS, EOM, and FAIL). The connector is intended to interface with non-HP-IB equipment or custom hardware. The eight input and output lines are accessible from HP Instrument BASIC or from external HP-IB control. Input and output are TTL levels. Inputs are pulled up with 10 K $\Omega$  and outputs can drive three standard LS TTL loads (typical 1.2 mA sink). They are accessible from HP Instrument BASIC or external HP-IB control.

### Plotter Control:

Directly compatible with HP-IB graphics plotters that use Hewlett-Packard Graphics Language (HP-GL). Plotter may be controlled by the HP 3577B through the HP-IB connector without an external computer. The plotter address can be set from the HP 3577B front panel. Plotted data includes trace 1, trace 2, graticule, and annotation. Additional markers can be plotted, and pen numbers, pen speed, and line type can also be selected.

### Display Adjustments:

Astigmatism, x-axis position, y-axis position, alignment, focus, and intensity.

### Save/Recall:

Front panel setups can be stored in non-volatile memory locations 1 through 5. Last state is saved when power is removed.

### Operating Conditions:

Temperature: 0° C to +55° C.

Relative Humidity: < 95% at 40° C.

Altitude: < 4,572 m (15,000 ft).

### Non-Operating Conditions:

Temperature: -40° C to +70° C.

Altitude: < 15,240 m (50,000 ft).

### Accessories Included:

3ea. Type N male to BNC female Adapter with standard. (HP Part No. 1250-0780)

4 ea. with Option 002.

1 ea. Operating Manual. (HP Part No. 03577-90029).

1 ea. Service Manual. (HP Part No. 03577-90028).

### Option 1C2 Accessories:

1 ea. *Using HP Instrument BASIC with the HP 3577B* (03577-90030)

1 ea. *HP Instrument BASIC User's Handbook* (E2083-90000)

### Hardware Options:

Option 001; Internal Oven Frequency Reference. Adds 10 MHz oven stabilized frequency reference.

Stability:  $5 \times 10^{-8}$ /day, 0 to 55° C, after 48 hour warm-up period.

Option 002; Third Receiver.

Adds third input receiver (input B).

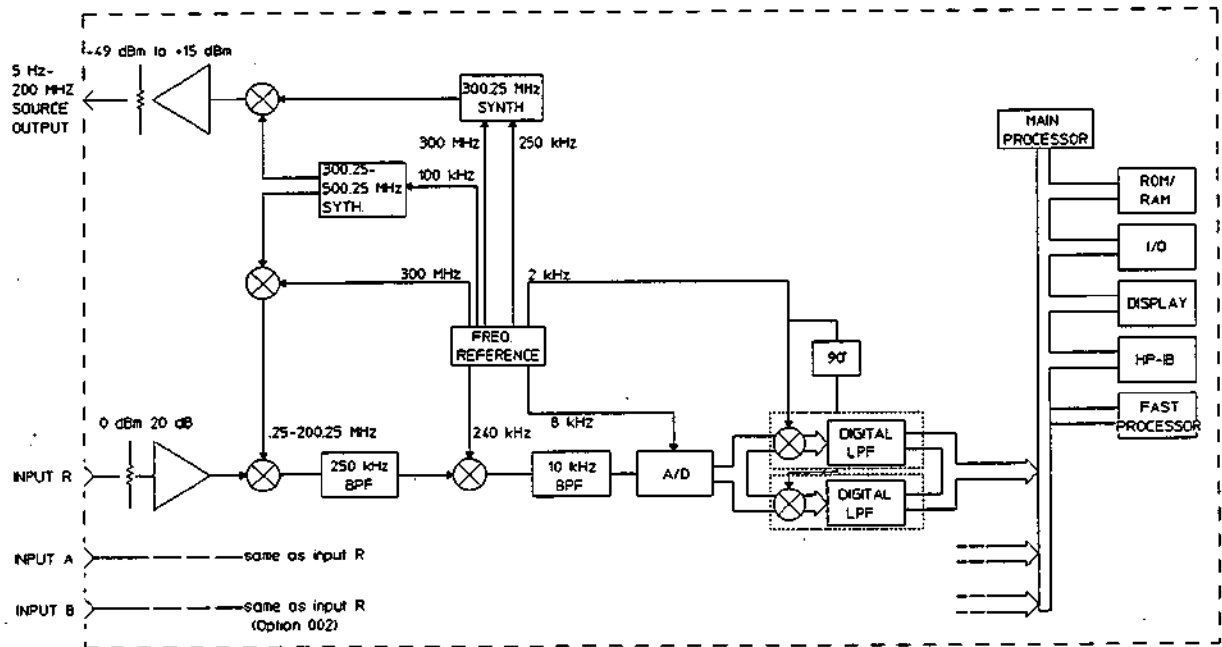
All receiver specifications apply.

Option 1C2; HP Instrument BASIC  
See description in the Programming Characteristics section.

**Power:** 115V + 10%, - 25% (47 Hz to 440 Hz), or  
230 V + 10%, - 15% (47 Hz to 66 Hz), 450 VA  
maximum.

**Weight:** 31 kg (67 lbs) net. 41 kg (90 lbs) shipping.

**Dimensions:** 222 mm H x 426 mm W x 578 mm  
D (8.75 in x 16.75 in x 22.75 in). Add 1 1/8 inch  
to depth to include front panel controls and  
connectors.



HP 3577B Block Diagram

## HP Digital Display Performance Specifications

### Interface

**General:**

16 Bit Binary.

**Signal lines:**

Pin Name	Description
D0-D15	16-Bit TTL Data Bus Pos Logic
LWR	Low Memory Write
LRD	Low Memory Read
LDS	Low Device Select
SYNC	Ext Refresh Synchronization
LXAC	Low Transfer Acknowledge
GND	Logic Ground
DISCON	Disconnect Sense. Signal connector off activates self test when allowed to float.

**Mating Connector:**

26-pin female transition connector; mating part Ansley 609-2630 (polarized).

### Analog Outputs

**General:**

X, Y, and Z analog signals to drive a slave CRT display.

**Amplitude:**

Approximately 1 Vpp open circuit.

**Output impedance:**

X, Y: 340Ω nominal.

Z: 250Ω nominal.

**Polarity:**

X – Positive-going voltage corresponds to right beam movement.

Y – Positive-going voltage corresponds to upward beam movement.

Z – Positive-going voltage corresponds to increasing luminance.

### Display Image

**Image Size:**

Factory adjusted to approximately 8.5 cm (3.35 in.) vertically by 11.2 cm (4.41 in.) horizontally.

**Resolution:**

2048 by 2048.

**Refresh rate:**

Approximately 60 Hz for displayed images containing up to 2000 vectors each 3.3 cm long and 100 characters, at maximum programmable writing speed (approximately 0.5 cm/μ sec)

**Phosphor:**

P31 (green).

**Logic Level:**

Standard TTL.

### Power

Operating Voltages		Max PP Ripple	Max Current
Voltage	Tolerance		
+15 Vdc	± 5%	10 mV	1.05A
- 15 Vdc	± 15%	10 mV	0.3A
+5 Vdc	+5 - 0%	50 mV	2.0A

**Recommended Mating Connector:**

AMP type 1-350234-9

Table 1-2. Recommended Test Equipment

Instrument	Critical Specifications	Recommended Model	Use*
Ratio Transformer	< 0.05 deg phase shift < 0.005 dB linearity 7 digit resolution	ESI DT72A†	P,S
Spectrum Analyzer	Frequency Range: 50 Hz – 1500 MHz Amplitude Measurement Range: – 100 dBm to +20 dBm Input: 50 Ω Dynamic Range: <ul style="list-style-type: none"> <li>● Harmonics: –42 dBc</li> <li>● Spurious: –62 dBc</li> <li>● Phase Noise: –82 dBc</li> </ul>	HP 8568B HP 8568A (alt.)	F,P,A,O,S
Oscilloscope	Vertical Bandwidth: DC – 100 MHz Sensitivity: 10 mV/div Horizontal Sweep Rate: 0.01 μs/div Input Coupling: AC, DC Input Impedance: 50 Ω, 1 MΩ shunted by approx. 20 pf Waveform Math: A-B Trigger: Int, Ext	HP 54503A	A,F,D
Digital Voltmeter	AC: <ul style="list-style-type: none"> <li>● Frequency Range: 5 Hz – 100 kHz</li> <li>● Accuracy: ± 0.5%</li> </ul> DC: <ul style="list-style-type: none"> <li>● Range: ± 250 V</li> <li>● Accuracy: ± 0.1%</li> <li>● Input Resistance: 10 MΩ</li> </ul> Ohms: <ul style="list-style-type: none"> <li>● Accuracy: ± 0.2%</li> </ul>	HP 3458A	F,P,A,O,D,S
Signal Generator	Frequency Range: 1 MHz – 600 MHz Amplitude Range: – 40 dBm to +10 dBm External Reference Output	HP 8662A HP 8663A (alt.) HP 8660C/D (alt.)	P,A,F,S
Synthesizer/ Level Generator	Amplitude Accuracy: ± 0.15 dB at 100 kHz, – 30 dBm	HP 3335A	A
Synthesizer	Frequency: 1.75 MHz Resolution: 0.02 Hz Amplitude: – 29 dBm DC Offset: < ± 25 mV	HP 3325B HP 3325A (alt.) HP 3326A (alt.)	P,O,F,S
Milliwatt Power Meter	± 1 V Control Voltage Output Frequency Range: 5 Hz – 200 MHz Accuracy: ± 0.05 dB at 100 kHz ± 0.075 dB at 20 Hz – 20 MHz ± 0.15 dB at 5 Hz – 200 MHz	W&G EPM-1©	P,O,St

\* P = Performance Tests; A = Adjustments; F = Fault Isolation; O = Operational Verification;  
D = Digital Display Adjustments; S = Semiautomated Performance Tests

† Alternate procedures which do not require the W&G EPM-1 power meter are included in this manual. The HP 9000 Series 300 controller, optional printer, voltmeter, and HP-IB option on the HP 436 power meter are required for the alternate tests.

© Wandel & Goltermann, Inc. 1800 Wyatt Drive, Suite 2 Santa Clara, CA 95054 (408)988-7622

‡ Electro Scientific Industries, 13900 N.W. Science Park Drive, Portland, Oregon 97229 (503) 641-4141

§ Ballantine Laboratories, Inc. P.O. Box 97 Boonton, NJ 07005(201)335-0900

© Pomona Electronics P.O. Box 2767 Pomona, CA 91769(714)623-463



**Table 1-2. Recommended Test Equipment Continued**

Instrument	Critical Specifications	Recommended Model	Use*
Power Meter	Input Range: - 10 to +20 dBm HP-IB compatible	HP 436A Opt. 022	F,O,A,P
Power Sensor	Flatness: ± 2%, 100 kHz - 200 MHz Calibration factors	HP 8482A	P,O,A,F†
Controller	HP BASIC compatible (version 3.0 or later) HP-IB interface 1/2 Mbyte program memory	HP 9000 Series 300 computer Series 200 (alt.) HP 3577B Option 1C2 (for S)	P,O,A,S†
Printer (optional)	—	compatible with controller	P,S†
Signature Multimeter	Setup time: 15 ns Maximum Clock: 25 MHz	HP 5006A	F
Power Supply	± 15 V, 50 mA +5V at 600 mA	HP 6235A	P,S
Frequency Standard	Frequency: 10 MHz The 10 MHz Frequency Standard may be derived from the National Bureau of Standards station WWVB using a Spectracom 8160A NBS Frequency Standard Receiver, an HP 105B Quartz Oscillator, and an HP 5087A Distribution Amplifier (with options to provide 10 MHz output) or equivalent.	—	P,A
Power Splitter (2 required)	3-way Frequency Range: 50 Hz - 200 MHz Impedance: 50Ω Type N female connector	HP 11850C HP 11850A (alt.)	P,O,A,S
Directional Bridge	Directivity: > 40 dB Load port: Type N, 50Ω	HP 35677-63502	P,A,S
3 dB Coaxial Attenuator	Type N, 5 Hz - 200 MHz Return Loss: > 30 dB typical	HP 8491A Opt. 003	P,A,S
20 dB Coaxial Attenuator (3 required)	Type N, 5 Hz - 200 MHz Return Loss: > 30 dB typical	HP 8491A Opt. 020	P,O,A,S
10 dB Coaxial Attenuator (2 required)	Type N, 5 Hz - 200 MHz Return Loss: > 30 dB typical	HP 8491A Opt. 010	P,A,S
Precision Termination (2 required)	Impedance: 50Ω Return Loss: > 52 dB, DC - 200 MHz Connector: N male Connector: N female	HP 909C  Opt. 200, 012 Opt. 200, 013	P,A,O

\* P = Performance Tests; A = Adjustments; F = Fault Isolation; O = Operational Verification;  
D = Digital Display Adjustments; S = Semiautomated Performance Tests

† Alternate procedures which do not require the W&G EPM-1 power meter are included in this manual. The HP 9000 Series 300 controller, optional printer, voltmeter, and HP-IB option on the HP 436 power meter are required for the alternate tests.

© Wandel & Goltermann, Inc. 1800 Wyatt Drive, Suite 2 Santa Clara, CA 95054 (408)988-7622

‡ Electro Scientific Industries, 13900 N.W. Science Park Drive, Portland, Oregon 97229 (503) 641-4141

§ Ballantine Laboratories, Inc. P.O. Box 97 Boonton, NJ 07005(201)335-0900

© Pomona Electronics P.O. Box 2767 Pomona, CA 91769(714)623-463



Table 1-2. Recommended Test Equipment Continued

Instrument	Critical Specifications	Recommended Model	Use*
50Ω Feedthrough Termination (3 required)	5 Hz – 200 MHz Return Loss > 52 dB Type N(male) Connector	HP 909C Option 012	P,O,A,S
RF Cable (4 required)	Type N, 24 inch, 50Ω	HP 11500B	F,P,O,A,S
BNC Cable (3 required)	12 inch, 50Ω	HP 8120-1838	P
Frequency Counter	Frequency Range: 8 MHz – 200 MHz Frequency Resolution: 0.1 Hz Sensitivity: 35 mV Time Base Stability: $1.25 \times 10^{-8}$ /day	HP 5384B	A,P
BNC Cable (3 required)	24 inch, 50Ω	HP 8120-1839	P,O,A
BNC Cable (3 required)	48 inch, 50Ω	HP 8120-1840	P,O,A,S
1:1 Probe	DC – 200 MHz	HP 10439A	A,F
10:1 Divider Probe (2 required)	DC – 200 MHz Input resistance: 1 MΩ	HP 10430A	A,F,D
1000:1 Divider Probe	Voltage Rating: 12 kV	HP 34111A	D
Adapter (7 required)	N male to BNC female, 50Ω	HP 1250-0780	P,O,A,S
Adapter	N female to N female, 50Ω	HP 1250-1472	P,O,A,S
Adapter (2 required)	BNC female to Banana male	HP 1251-2277	P,O,S
Adapter	BNC female to alligator	Pomona 2631®	P
Adapter	BNC Tee	HP 1250-0781	P
Adapter (2 required)	SMA male to BNC female	HP 1250-1200	P,A,S
Adapter	N male to N male (precision)	HP 1250-1475	P,S
Adapter	BNC female to BNC female	HP 1250-0080	P
Adapter	N female to BNC male	HP 1250-1477	P,S
Jumper	alligator to alligator	Pomona 3781-8®	A
Resistor	1 Meg Ω, 1%	HP 0698-7332	A
Capacitor	300 pF	HP 0160-5350	A
Error Correction Cable	—	HP 03577-61640	P,O,S

\* P = Performance Tests; A = Adjustments; F = Fault Isolation; O = Operational Verification;  
D = Digital Display Adjustments; S = Semiautomated Performance Tests

† Alternate procedures which do not require the W&G EPM-1 power meter are included in this manual. The HP 9000 Series 300 controller, optional printer, voltmeter, and HP-IB option on the HP 436 power meter are required for the alternate tests.

© Wandel & Goltermann, Inc. 1800 Wyatt Drive, Suite 2 Santa Clara, CA 95054 (408)988-7622

‡ Electro Scientific Industries, 13900 N.W. Science Park Drive, Portland, Oregon 97229 (503) 641-4141

§ Ballantine Laboratories, Inc. P.O. Box 97 Boonton, NJ 07005(201)335-0900

® Pomona Electronics P.O. Box 2767 Pomona, CA 91769(714)623-463

Table 1-2. Recommended Test Equipment Continued

Instrument	Critical Specifications	Recommended Model	Use*
Buffer Amplifier Kit	HP 3577B Performance Test Kit  Kit Contents: OP Amp (NE5534) Capacitor, 22 $\mu$ F (2 each) Resistor, 475k $\Omega$ 1 k $\Omega$ 499 $\Omega$ 100 $\Omega$ (4 each) BNC Connector (2 each) IC Socket Board Edge Connector Lug (2 each) Nut (2 each) Washer (2 each) Balun	HP 03577-84403  HP 1826-0715 HP 0180-0228 HP 0757-0481 HP 0757-0280 HP 0698-4123 HP 0757-0401 HP 1250-0083 HP 1200-0564 HP 5020-6893 HP 1251-0159 HP 0360-1190 HP 2950-0043 HP 2190-0016 HP 03577-84404	P,S
Service Accessory Kit	HP 3577B Service Kit  Kit Contents: I/O Port test connector Cable Assembly Extender(7 each) Cable Assembly Adapter (2 each) Jack to Jack Adapter PC Extender Boards: (Dual 36/25 pin) 22-pin (2 each)	HP 03577-84412  HP 03577-61683 HP 03585-61601 HP 03585-61616 HP 1250-0669 HP 03577-66541 HP 03577-66542	F,A,P,O  S

\* P = Performance Tests; A = Adjustments; F = Fault Isolation; O = Operational Verification;  
 D = Digital Display Adjustments; S = Semiautomated Performance Tests

† Alternate procedures which do not require the W&G EPM-1 power meter are included in this manual. The HP 9000 Series 300 controller, optional printer, voltmeter, and HP-IB option on the HP 436 power meter are required for the alternate tests.

© Wandel & Goltermann, Inc. 1800 Wyatt Drive, Suite 2 Santa Clara, CA 95054 (408)988-7622

‡ Electro Scientific Industries, 13900 N.W. Science Park Drive, Portland, Oregon 97229 (503) 641-4141

§ Ballantine Laboratories, Inc. P.O. Box 97 Boonton, NJ 07005(201)335-0900

© Pomona Electronics P.O. Box 2767 Pomona, CA 91769(714)623-463



## Fault Isolation

---

### 2-1 Introduction

The fault isolation procedures found in this section are designed to assist the experienced service technician. Each assembly in these procedures is referred to as a functional block, since they serve a single electrical function. Component groups within each functional block are referred to as functional sub-blocks, since they also serve a single electrical function. The goal of these procedures is to determine which functional block has failed within the HP 3577B under test. Once the faulty functional block has been found, the schematics provide sample waveforms and voltages which allow isolation to the sub-block level. The technician's experience is then used to isolate the components which have failed within the functional sub-block.

These procedures assume that all power supplies in the instrument are good. Before excessive time is spent in troubleshooting, it is strongly recommended that all power supplies be checked for correct voltage and ripple. A listing of the power supplies in the HP 3577B is shown in table 2-6.

The first tests performed in this procedure do not require inside access to the HP 3577B. Numerous self tests are performed at power-on. Additional diagnostics can be called from the self test menu under the hardkey labeled "SPCL FCTN" (SPECIAL FUNCTION). The first step should always be to run these self tests as they will isolate a majority of the problems encountered.

---

**Note**

When executing the diagnostics, refer to figures 2-3 through 2-6 (HP 3577B Overall and Functional Block Diagrams).

---

---

## 2-2 Safety Considerations

Some of the fault isolation procedures require access to the interior of the HP 3577B while power is supplied to the instrument. Extreme care should be exercised when servicing the instrument.

---

### Warning



Maintenance described herein is performed with power supplied to the instrument and protective covers removed. Such maintenance should be performed by service-trained personnel who are aware of the hazards involved (for example, fire and electrical shock). Where maintenance can be performed without power applied, the power cord should be removed.

---

---

## 2-3 Recommended Test Equipment

The test equipment required for the fault isolation procedures is listed in table 1-2. Any equipment which meets the critical specifications may be substituted for the recommended model. These procedures are designed to be performed with a minimum amount of equipment.

---

## 2-4 Troubleshooting Hints

When troubleshooting the HP 3577B, keep the following hints in mind:

- Intermittent cables can appear to be hardware failures.
- Noise or spikes on the dc power supplies can cause instrument failure.
- Interpret front panel symptoms before extensive troubleshooting.
- It is possible that one circuit board can load another circuit board resulting in an apparent failure in the first circuit board.
- Whenever possible, divide the circuit under test in half.
- Measurements made in the Fault Isolation section are approximate values unless otherwise specified. Some tests are as simple as GO/NO GO.
- Return each receiver board (A71) to its original location after troubleshooting. Some of the receiver adjustments may be dependent on the physical location of the slot in which it was initially installed.

---

## 2-5 Getting Started

Fault isolation in the HP 3577B is basically split into two separate sections; analog and digital. Digital failures quite often will prevent the HP 3577B from turning on correctly. The Fault Isolation Flow Diagram found in figure 2-2 illustrates a procedure to determine the faulty functional block if an instrument does not power up correctly. Each of the tests indicated in the procedure are described in detail in sections 2-7 through 2-11. If any of these tests fail, refer to the individual description for that test and the critical parameters checked for.

Analog failures usually will not effect the digital portions of the instrument and will show up as dead inputs or outputs, or specification failures. Fault isolation for these problems is best approached by running the Confidence Tests listed under the SPCL FCTN (SPECIAL FUNCTION) hardkey and described in Section 2-9. After running these tests, the Covers Off Board Level Fault Isolation tests listed in section 2-11 should be performed.

## 2-6 Overall Instrument Description

An overview of the entire instrument operation is given here to illustrate to the service technician the interaction of the HP 3577B's individual boards and functional blocks. The information in this section should be used in conjunction with the fault isolation and self test information. Since many of the functional blocks interact heavily, the more information known about the interaction, the easier troubleshooting becomes. Study the following section before any work is done on the instrument. By interpreting the self test data and knowing the instrument operation, many problems can be isolated to the board level quite readily.

Refer to figures 2-3 through 2-6 when reading the overall circuit description. Refer to Section VII (Circuit Descriptions) for more detailed descriptions of each board's operation.

The HP 3577B can be basically split into two sections; a signal source and a tuned receiver. There is only one area that the two overlap, and that is the source frequency is the same as the receiver tune frequency. Since the frequency generation section is common to both the source and the input, it will be explained first.

The "heart" of the frequency generation section is the frequency reference. The HP 3577B can be run from an external frequency reference by using the rear panel external reference input. The frequency reference board (A6) on a standard HP 3577B free runs if it is not driven by either the oven board (A31) (Option 001 only) or an external reference. When an external reference is sensed by the external reference detector, the shutdown line on the oven board is toggled and the oven signal is switched off using the oven board switchable filter. For Option 001, the threshold detector on the oven board senses whether the oven has warmed up. If the oven is cold, the threshold detector switches the oven signal off. When an external or oven reference signal is used, it locks a 10 MHz phase-locked loop. When the oven is not present or it is cold and no external reference is connected, the HP 3577B free runs on the uncorrected 10 MHz phase-locked loop signal. The 10 MHz phase-locked loop signal is used for two purposes. First, it is divided by 100 to form the 100 kHz signal used by the synthesizer board (A17). Second, it is used to drive a 300 MHz phase-locked loop. The 300 MHz signal is mixed and divided to form all the reference frequencies used in the HP 3577B.

The oven board (A31) of Option 001 provides a stable 10 MHz frequency reference signal. This signal is controlled by the frequency reference board (A6). When an external reference signal is used on the HP 3577B, the frequency reference board forces the control line SHUTDOWN to go low which turns off the 10 MHz oven output signal. The synthesizer board (A17) produces frequencies from 300.25 to 500.25 MHz. The reference frequency for the synthesizer is 100 kHz obtained from the frequency reference board (A6). The synthesis method used in the HP 3577B is called Fractional-N synthesis. The synthesizer board has two synthesized outputs, one for the output board (A8) and one for the local oscillator board (A4).



The 250 kHz offset board (A5) takes the 300 MHz frequency reference board (A6) signal and creates a phase-locked 300.25 MHz signal. Note that the first IF used on the input board (A71) is the 250 kHz offset frequency. The 300.25 MHz signal is used by the output board (A8). The 300.25 MHz signal is mixed with the synthesizer board (A17) 300.25 to 500.25 MHz signal to create the source output frequencies of 5 Hz to 200 MHz. This mixing scheme minimizes the number of mixings done and keeps phase noise products as low as possible.

The local oscillator board (A4) combines the 300.25 to 500.25 MHz synthesizer board (A17) signal and the 300 MHz reference board (A6) signal to produce a 0.25 to 200.25 MHz signal. This signal is used to drive the first IF mixer. Note that the local oscillator output signal and the source output (A8) signal are always 250 kHz apart, even when the source is swept. This allows for a tuned input with fixed frequency IF sections.

The output board (A8) mixes the 300.25 to 500.25 MHz synthesizer board (A17) and the 300.25 MHz offset board (A5) signals to produce a 5 Hz to 200 MHz source signal. The 300.25 MHz signal is passed through a diode limiter before the mixing to allow leveling. After mixing, the 5 Hz to 200 MHz signal is filtered and amplified. The signal level at the input to the attenuator is variable between +11 and +15 dBm in 0.1 dB increments. The increments are set using a DAC in the Amplitude Reference. The leveling circuits correct for high frequency and low frequency source flatness errors. The low frequency errors are corrected by adjusting the gain of the first 20 dB amplifier after the mixer. The high frequency errors are corrected by the Amplitude Leveling. The attenuator is capable of attenuating between 4 and 60 dB in 4 dB steps. The 60 dB Step Attenuator also has a reverse power protection circuit. Whenever the peak voltage at the output connector is greater than 4 volts, the protection circuit disconnects the attenuator from the output connector.

The HP 3577B input board (A71) is a switchable 1M/50  $\Omega$  input. Relay K1 selects the input impedance of each channel. Note that only one input channel is shown in the block diagram. This is because all input channels are electrically identical. On a standard HP 3577B, there are two input channels, A and R. Option 002 provides a third input channel B. The physical location in the instrument is the only distinguishable characteristic of each input. However each input board should be returned to its original location after troubleshooting. Relays K2 and K3 set the input attenuation for each channel. Note that the two impedance paths have separate 20 dB attenuators. The signal is then mixed with the 0.25 to 200.25 MHz local oscillator (A4) signal in the first IF section. The output of the first IF is a constant 250 kHz signal whose instantaneous amplitude and phase are the same as the input signal. The 250 kHz signal is then converted to a 10 kHz signal by the second IF section and the 240 kHz frequency reference board (A6) signal. The 10 kHz signal, with the same amplitude and phase as the input signal, is then sampled at an 8 kHz rate with a sample and hold. This creates a 2 kHz "stairstep" third IF. The 2 kHz stairstep signal undergoes two Analog to Digital conversions. The first conversion is used to set the gain on the variable gain amplifier. This conversion is an 8-bit conversion. The gain of the variable gain amplifier is then set so the A to D is as near to its full scale input as possible. The A to D then undergoes a 12-bit conversion which is passed on to the digital filters. This A to D conversion technique allows for a 20-bit dynamic range with 12-bits of resolution. Note that this A to D sequence takes place during one stairstep level. The digital quadrature filters then process the data from the A to D converters. The quadrature filters separate the "real" and "imaginary" components of the A to D converter output. The resolution bandwidths are digitally implemented here.



The central intelligence of the HP 3577B Network Analyzer is the main processor-controller board (A62/63). A62 is the board number for a standard HP 3577B.

The keyboard (A15) is constantly being monitored by the main processor-controller via the keyboard data bus. If a key is stuck for a period longer than 10 seconds, an error message will then be displayed on the CRT.

The digital display is a 16-bit TTL data bus (positive logic) display. The display provides its own test pattern. This diagnostic is accessible under the SPCL FCTN (SPECIAL FUNCTION) hardkey. This function disconnects the HP 3577B digital section (main processor-controller) from the digital display. When disconnected, the display module turns on its own resident test pattern which tests most of its display functions. This test pattern can also be shown by disconnecting the ribbon cable from the main processor-controller board (A62/63) to the display.

The HP-IB board (A16) provides an isolated link between the instrument's main processor-controller board (A62/63) and the "outside world." An HP-IB connector is provided at the rear panel of the instrument. This connector is used to connect the instrument to other instruments and controllers which have HP-IB (IEEE 488) capability.

The fast processor board (A61) performs floating point and fast numerical calculations (number crunching). The fast processor board processes data from the input boards (A71; Receivers R, A, B) and controls the sweep timing of the HP 3577B. This board contains its own firmware (Micro Program ROMs), Micro Program Sequencer, and a Bit/Slice ALU (Arithmetic Logic Unit). The fast processor controls the accessibility of the Fast Data Bus.

## 2-7 Power-on Self Tests

The tests the HP 3577B performs when power is first applied are listed in table 2-1.

As with any microprocessor based instrument, the “kernel” or microprocessor, ROM, RAM, clock, and common bus and buffers must be working for the instrument to turn on at all. At power-on, the HP 3577B tries to test its “kernel” and then gradually expands and tests the other branches of communication open to it. Please note that if the “kernel” is not functional, the HP 3577B will most likely not be able to run the self tests. On the other hand, if the HP 3577B passes the power-on self tests, there is an extremely high probability that the digital core of the instrument is functioning perfectly. The only digital sections not checked are the outermost I/O ports and buffers to the instrument measurement and control sections.

**Table 2-1. Power-on self Tests**

Self Test Number	Test Description	Test Location
#1	LED Test	Front Panel
#2	Main Processor-Controller ROM Test	A63 U20,U21,U29
#3	Main Processor-Controller RAM Test	A63 U33,U34,U133,U134, U233,U234(partial) U200,U201
#4	Total Main Processor-Controller RAM Test (Optional)	A63 U33,U34,U133,U134, U233,U234(all) U200,U201
#5	Keyboard Cable Test	A63 U90,A15J1(8)
#6	Timer Interrupt Test	A63 U60,U61 U65 – U68
#7	Trace Memory Test	A63 U45 – U48
#8	One MegaHertz Test	A63U65(8)
#9	Eight kiloHertz Test	A63 U95(2)
#10	Fast Processor Self Test	A63 U102,U103

### Self Test Number #1, LED Test

Immediately after the microprocessor (A63U1) starts its program, all front panel LEDs are turned on. The LEDs are left on until Power-On Self Test number 2 is completed.

### Self Test Number #2, Main Processor-Controller ROM Test

The main processor-controller (A62/63) computes a checksum for each ROM and compares it to a known value. Please note that if the ROMs are bad, the main processor-controller will most likely not operate. At the beginning of this test, the main processor will clear the display's memory by writing a NOP instruction to all the display's memory locations. The POP (Power On Preset) signal to the main processor-controller turns on the ROM and RAM test LEDs (A63CR20 and A63CR21, respectively). The checksums are then calculated for ROM, and if an error is found, a message will be written to the display. If all tests pass, the ROM test LED (A63CR20) will be extinguished, and the next test will be performed. If a failure occurs, the ROM test LED will be left on, the main processor-controller will pause for approximately 5 seconds, and the next test will be performed.

### Self Test Number #3, Main Processor-Controller Ram Test

The main processor-controller (A62/63) performs tests on the areas of its RAM that do not have non-volatile requirements (i.e., the dynamic stack).

RAM is tested in blocks of 16384 bytes. Before testing the first block, "RAM TEST 0016K" will be displayed on the CRT. As subsequent blocks are tested, the display is updated in a sequence such as "0032K", "0048K", "0064K", and so on. The blocks that contain non-volatile data will be skipped, unless the SAVE and RECALL hardkeys are held down. At the end of the test, the display should match the amount of memory installed (at least 0128K for the A62, or at least 0768K for the A63).

If a failure is detected, the testing will stop and either "RAM TEST FAILED: MSB", or "RAM TEST FAILED: LSB" will be displayed for about 5 seconds. If this occurs, note the memory block being tested and use the following tables to identify the IC being tested.

**A62 RAM ICs are 32K × 8-bit (256K bit):**

Block	Byte	IC Tested
0016K - 0064K	MSB	U033
0016K - 0064K	LSB	U034
0080K - 0128K	MSB	U133
0080K - 0128K	LSB	U134

**A63 RAM ICs are 128K × 8 bit (1M bit):**

Block	Byte	IC Tested
0016K – 0256K	MSB	U033
0016K – 0256K	LSB	U034
0272K – 0512K	MSB	U133
0272K – 0512K	LSB	U134
0528K – 0768K	MSB	U233
0528K – 0768K	LSB	U234

Then a marching ones test is performed on the stack area of RAM. A marching ones test pushes zeros, ones, HEX 55's and HEX AA's through RAM. If an error occurs, an error message will be displayed for approximately 5 seconds before the next test is performed. If the RAM test passes, the RAM test LED (A63CR21) will be extinguished.

**Self Test Number #4, Total Main Processor-Controller RAM Test**

This test is invoked by pressing the SAVE and RECALL hardkeys on the front panel simultaneously after a power-on and holding them down until the RAM test is complete. All RAM memory locations are checked during this test, even memory with non-volatile requirements. All saved instrument states and trace data is lost during this test. The test procedure is more thorough than the procedure in SELF TEST NUMBER 3.

**Self Test Number #5, Keyboard Cable Test**

The main processor-controller (A62/63) tests to see if the keyboard cable is connected to the motherboard. The main processor-controller looks for the keyboard MSB (Most Significant Bit) to be pulled low through A63U90. The keyboard pulls this line low at A15J1(8). If this test fails, the keyboard interconnection should be suspect.

**Self Test Number #6, Timer Interrupt Test**

The main processor-controller (A62/63) will check to see that the timer interrupt occurs, which is a divided down version of the 20 MHz from the phase-locked loop circuit (A63U60). The 20 MHz clock is divided by A63U61, U68, U66, U67, and U63 so that the main processor-controller can sense its presence. The timer interrupts are necessary for scanning the keyboard.

**Self Test Number #7, Trace Memory Test**

The main processor-controller tests the volatile portion of its trace memory section. A failed test returns a failing block number. Even block numbers correspond to A63U45. Add block numbers correspond to A63U46. If the fail message is followed by "(ROM)", an even block number corresponds to A63U47, and an odd block number corresponds to A63U48. A more exhaustive trace memory test is available using the SPECIAL FUNCTIONS menu and selecting the TRACE MEMORY test.

### **Self Test Number #8, 1 MHz Test**

This test checks to see if a divided down version of the 1 MHz clock is present. A63U91 monitors U65(8) and waits for a transition to occur. This signal is generated on the frequency reference board (A6), and should be suspect if the test fails. Also, this test will fail if the W71 jumper on the main processor board (A62/63) is left in the "1 MHz DISABLE" position.

### **Self Test Number #9, 8 kHz Test**

This test checks to see if the 8 kHz signal to the input board (A71) is present. This signal is generated on the frequency reference board (A6), and should be suspect if the test fails.

### **Self Test Number #10, Fast Processor Self Test**

The fast processor board (A61) first tests its own logic for errors. It then tests its ability to access the trace memory section of the main processor-controller board (A62/63) and the counter/receiver board interface. The following error messages are generated by this test:

#### **1. NO RESPONSE FROM FP**

This indicates that the main processor-controller board (A62/63) cannot access the fast processor board (A61). This usually indicates a serious fast processor failure.

#### **2. FP LOGIC FAILURE**

This indicates the fast processor's associated logic circuitry is not operating correctly.

#### **3. FP CNTR/RCVR FAILURE**

This indicates that the sweep timer counter and receiver board (A71) interface is not operating correctly.

#### **4. FP CANNOT ACCESS TRACE MEMORY**

The fast processor (A61) writes data to the trace memory section of the main processor-controller (A62/63) and reads the same data back. This message indicates that there is a discrepancy between the written and read data.

#### **5. FP-MP COMMUNICATION ERROR**

The main processor (A62/63) writes data to the fast processor (A61) and reads the same data back. This message indicates that there is a discrepancy between the written and read data.

## 2-8 Continuously Monitored Diagnostics

The tests listed in table 2-2 are performed continuously while the HP 3577B is operating. The tests listed in table 2-4 are obtainable from the HP 3577B front panel via the SPCL FCTN (SPECIAL FUNCTION) hardkey. For each of these tests, a test explanation is given and the suspect board identified for test failures. The continuously monitored tests are listed by the error message that is displayed on the HP 3577B.

Each of the continuously monitored diagnostics in table 2-2 is listed below by test name. This information along with the schematics in Section IX (Service) gives the service technician insight into the failure conditions.

**Table 2-2. Continuously Monitored Diagnostics**

Error Message	Test Name	Test Location	Suspect Board
Oscillator Unlocked Assembly A5, A6 or A17	Phase-Locked Loop Unlocked	A6 U9(6) A5 U50(4) A17 U6(6)	Reference (A6) Offset (A5) Synthesizer (A17)
Reference Unlocked	10 MHz Reference Unlocked	A6 U2(1)	Reference (A6)
Bus Error	Main Processor Hardware Error	A63 U1(22)	Main Processor-Controller (A62/63)
Stack Overflow  * Integer Overflow * Divide By Zero Real Math Overflow Real Math Underflow  Spurious Interrupt Interrupt 1 Interrupt 2 Illegal Instruction Escape Code x	Main Processor Hardware Error	A63 U1 Internal	Main Processor-Controller (A62/63)
System Error #x	Fast Processor/ System Errors	Software limit tests	Fast Processor (A61)
Front Panel Key Stuck	Keyboard	A15 J1(8)	Keyboard (A15)

\* Note -These error messages could be caused by data in registers D1 through D4 and X1 through X8.

\* This Proposed Floating Point Standard is explained in Chapter 4 of the Basic Programming Techniques with Extension 2.0 for the 200 Series Computers Documentation Manual. The -hp- part number for this manual is 09826-90011.

## Oscillator Unlocked, Assembly A5, A6 or A17

Each of the phase-locked loops in the HP 3577B is monitored by a loop unlock detector.

The frequency reference board (A6) is monitored by A6U10. If the output of A6U9 has an ac component, A6U10 detects the ac and pulls its output low. This causes an internal LED to turn-on and signals the main processor-controller (A62/63).

The synthesizer board (A17) phase-locked loop is monitored by A17U42. The output of the sample and hold is monitored. When the detector (A17U42) senses an out-of-range dc control voltage, it will then cause an internal LED to turn-on and interrupts the main processor-controller (A62/63). It is normal for the synthesizer to lose phase lock between sweeps due to the retrace.

The 250 kHz offset board (A5) phase-locked loop is monitored by U51. The output of the phase detector and loop filter is monitored. If an ac signal or a positive dc signal is present U51 pulls its output low. This causes an internal LED to turn-on and interrupts the main processor-controller (A62/63).

## 10 MHz Reference Unlock

The 10 MHz phase-locked loop has its own unlock detector and error message. This is because external signals can cause this loop to unlock. The 10 MHz phase-locked loop is monitored by A6CR3, CR4, and U2b. The diodes monitor the phase detector output. When an ac signal occurs at A6U2(1), the output of A6U2b runs to the positive supply voltage. This turns on an internal LED (A6CR20) and interrupts the main processor-controller (A62/63) through the inverter A6U1c.

Note that for Option 001 instruments (with internal oven frequency reference), it is normal for the instrument to beep and briefly display "REFERENCE UNLOCK" a few minutes after turn-on. This message appears when the oven has sufficiently warmed up and it switches in to drive the reference board (A6).

## Main Processor Hardware Error

The main processor-controller (A62/63) has error detection routines which are an integral part of the chip. Generally all these errors say is that something is wrong with the address or data bus. Any components connected to the bus should be suspect.

The BUS ERROR message is generated when the processor writes to ROMs, writes outside the address space available, etc. A63 U1(22) is the trigger for this error. When pin 22 is low, the main processor-controller trips. The following components are involved with the BUS ERROR decoding: A63 U70, U72, U75, U81, and U111. It should be noted, however, that this error will occur for almost all failures on the address or data bus, therefore all components connected to either bus should be suspect.

All other main processor-controller hardware errors are detected by numerical software traps within the HP 3577B operating system. These errors cannot be used to isolate hardware problems easily and indicate a fault within the HP 3577B digital system.



## Fast Processor/System Errors

The HP 3577B system errors are reported by the main processor-controller (A62/63). When the operating system senses an invalid instrument state or operation in the digital sections, a system error is generated. Since these errors are generated during a control or calculation operation, as opposed to a self test mode, the actual cause for an error cannot be exactly known. This information may be useful, along with other fault isolation data already received, for narrowing down digital failures. Each of the system errors are listed below, along with an explanation of what causes an error trip. Most of these errors indicate a problem with the fast processor (A61) and/or main processor-controller (A62/63) communication.

### Data Error #1

This error occurs when the main processor-controller gets a bad number after converting the fast processor's data from 32-bit floating point to 64-bit floating point format.

### Data Error #2

This error occurs after a bad 64-bit to 32-bit conversion in the main processor-controller resulting in a "Not A Number" error.

### Data Error #3

This error occurs after a bad 64-bit to 32-bit conversion in the main processor-controller resulting in an Underflow.

### Data Error #4

This error occurs after a bad 64-bit to 32-bit conversion in the main processor-controller resulting in an Overflow.

### Data Error #5

This error occurs after a bad 64-bit to 32-bit conversion in the main processor-controller resulting in Infinity.

### Data Error #6

This error occurs after a bad 32-bit to 64-bit conversion resulting in an Invalid Zero.

### System Error #7

This error occurs when a status interrupt occurs during the processing of a data interrupt. Possible failures include the main processor-controller interrupt decoding or the fast processor interface.

### System Error #8

This occurs when the fast processor interrupts the main processor-controller but the data given to define the interrupt does not match the valid table. The interrupt defines an overload condition at one of the receiver ports.



### **System Error #9**

This error occurs if the main processor-controller told the fast processor to start or to abort and the fast processor did not understand the command. This means the fast processor did not get the right data. This error occurs when the fast processor is in its main loop.

### **System Error #10**

This error occurs if the main processor-controller told the fast processor to start or abort and the fast processor did not understand the command. This error occurs when the fast processor is in its trigger loop.

### **System Error #11**

This error occurs if the main processor-controller told the fast processor to start or abort and the fast processor did not understand the command. This error occurs when the fast processor is in its process loop.

### **System Error #12**

This error occurs if the main processor-controller told the fast processor to start or abort and the fast processor did not understand the command. This error occurs when the fast processor is in its settling loop.

### **System Error #13**

This error occurs when the fast processor tries to execute a trace arithmetic instruction, passed it through buffers into trace memory and the data instruction received was bad.

### **System Error #14**

The fast processor is not reading the fast processor/main processor-controller interface after a command was written to the interface by the main processor-controller. Check to see if the 30 MHz fast processor clock is present.

### **System Error #15**

This error occurs when the fast processor does not acknowledge the receipt of an ABORT command from the main processor-controller. This occurs when A63U91(6) is still low.

### **System Error #16**

This error occurs when the main processor-controller has tried to send a HALT command to the fast processor and the fast processor echoed back a bit pattern which is not an appropriate response.

### **System Error #17**

This error occurs when the fast processor data and instructions create an overflow condition. This error usually indicates a fast processor communication problem.

**System Error #18**

This error occurs when the fast processor data and instructions create an underflow condition. This error usually indicates a fast processor communication problem.

**System Error #19**

This error occurs when the main processor-controller has tried to send a HALT command to the fast processor and the fast processor echoed back a bit pattern which is a valid reply but not the HALTED reply.

**System Error #20**

This command occurs when the fast processor does not allow the main processor-controller to access the interconnecting bus between fast and main processors. The BUSGNT line did not go active low.

**System Error #21**

This error occurs when the main processor-controller encounters a software error and usually indicates a main processor-controller failure.

**System Error #22**

This error occurs when the main processor-controller encounters a software error and usually indicates a main processor-controller failure.

**System Error #23**

This error occurs when the main processor-controller encounters a software terminator error in its commands. This error usually indicates a main processor-controller failure.

**System Error #24**

This error occurs if at the end of a log sweep segment the Frac N limit line, A63U93(13), was not toggled high. This usually indicates a fault in the synthesizer board (A17) or an error in the control bus and associated control lines.

**System Error #99**

This indicates an unrecoverable main processor execution error. Recovery is possible only by cycling power. This error will occur if A62 R14 or A36 R14 is loaded on the revision A version of the A62/63 board and the INSTR PRESET hardkey is pressed. R14 should not be loaded.

**Keyboard**

The main processor-controller (A62/63) scans the keyboard constantly for any inputs. If a key is held down for more than 10 seconds, the microprocessor sends an error message to the display. A pressed key is sensed through A15J1(8) by a TTL low. Due to decoding uncertainties, the keyboard ignores all inputs when it senses a key is stuck.

## 2-9 Confidence Tests

The HP 3577B has the ability to run an analog self test on its input channels and its source. These tests check that the source and input channel agree. As many single channel specifications as possible are checked in these tests. This self test does not check to the instrument specifications since a cable is required to connect the source and input channel and the characteristics of the cable can affect the measured results. Table 2-3 lists the Confidence Tests.

These tests are available under the SPCL FCTN (SPECIAL FUNCTION) hardkey on the HP 3577B front panel. To run these tests, first press the SPCL FCTN hardkey and select the CONF TEST softkey.

**Table 2-3. Confidence Tests**

Test Number	Test Name	Error Message
#1	Log Sweep Flatness Test	Is cable connected?
		FAILED: Log Sweep signal level test
		FAILED: Log Sweep flatness test
#2	Linear Sweep Flatness Test	FAILED: Linear Sweep signal level test
		FAILED: Linear Sweep flatness test
#3	Synthesizer And L.O. test	FAILED: Synthesizer and L.O. test
#4	Source Amplitude Test	FAILED: Amplitude sweep accuracy test
#5	Output Limiter Test	FAILED: Output Limiter linearity test
#6	Impedance And	FAILED: Receiver Impedance test
	Attenuator Test	FAILED: Receiver Attenuator test

Each of the Confidence Tests is described below. The description should be valuable in order to isolate any failures which occur with these tests. It is quite easy to isolate if a failure occurs on the input or output since the Confidence Tests can be run separately on each input channel. If a Confidence Test passes on one or two inputs, the problem is probably in the receiver.

The HP 3577B instrument state is also listed for each test. By repeating a test manually and varying the instrument setup, the faulty board can often be found. If repeating these tests manually, press INSTR PRESET between each test setup. If a Confidence Test fails, the test sequence stops, leaving the instrument in the failed test setup.

Due to the interactions mentioned previously, faulty boards for these tests cannot be determined in advance. The Confidence Tests are valuable when used with the overall block diagram and the overall circuit description. By running the tests manually, and varying the instrument state for each test slightly, faulty blocks can be isolated from the front panel.

**Confidence Test Number #1, Log Sweep Flatness Test****Instrument State:**

Sweep Type	Log
Display Function	Log Magnitude
Resolution Bandwidth	Auto BW On
Start Frequency	400 Hz
Stop Frequency	200 MHz
Source Amplitude	- 9.1 dBm
Sweep Time	3 seconds

**Test Procedure:**

Trigger for a single sweep

**Test Requirements:**

1. (Maximum Amplitude) - (- 9.1 dB) < 3.642 dB  
and (- 9.1 dB) - (Minimum Amplitude) < 3.642 dB  
Error message: Failed: Log Sweep signal level test
2. (Maximum Amplitude) - (Minimum Amplitude)  $\leq$  2.16 dB  
Error message: Failed: Log Sweep Magnitude flatness test
3. (Maximum Amplitude)  $\geq$  - 60 dBm  
Error message: Is cable connected?

## Confidence Test Number #2, Linear Sweep Flatness Test

### Instrument State:

Sweep Type	Linear
Display Functions	Log Magnitude
Resolution Bandwidth	1 kHz
Start Frequency	2 MHz
Stop Frequency	200 MHz
Source Amplitude	- 9.1 dBm
Sweep Time	1 second

### Test Procedure:

Trigger for a single sweep.

### Test Requirements:

1. (Maximum Amplitude) - (- 9.1 dBm) < 3.642 dB  
and (- 9.1 dB) - (Minimum Amplitude) < 3.642 dB  
Error message: Failed: Linear Sweep signal level test
2. (Maximum Amplitude) - (Minimum Amplitude) < 2.16 dB  
Error message: Failed: Sweep magnitude flatness test

**Confidence Test Number #3, Synthesizer and L.O. Test****Instrument State:**

Sweep Type	Linear
Display Functions	Log Magnitude
Resolution Bandwidth	1 kHz
Start Frequency	0 Hz
Stop Frequency	50 MHz
Source Amplitude	-9.1 dBm
Sweep Time	1 second

**Test Procedure:**

Trigger for a single sweep.

**Test Requirements:**

1. (0 Hz Marker Value) < -33 dBm  
or Absolute Value of ((50 MHz Marker Value) - (-9.1 dBm)) < 3.642 dBm  
Error message: Failed: Synthesizer and L.O. test

## Confidence Test Number #4, Source Amplitude Test

### Instrument State:

Sweep Type	Amplitude
Display Function	Log Magnitude
Source Frequency	200 MHz
Start Amplitude	- 49 dBm
Stop Amplitude	- 5.1 dBm
Steps per Sweep	50
Time per Step	100 msec
Resolution Bandwidth	1 kHz

### Test Procedure:

Trigger for a single sweep.

### Test Requirements:

1. Absolute Value of ((X Marker Value) - (Y axis Amplitude)) < 3.642 dB  
and Absolute Value of (bin N + 1 value - bin N value - 0.878 dB) < 1.28 dB  
Error Message: Failed: Amplitude Sweep accuracy test,

**Confidence Test Number #5, Output Limiter Test****Instrument State:**

Sweep Type	Amplitude
Display Function	Log Magnitude
Source Frequency	90 kHz
Start Amplitude	- 9 dBm
Stop Amplitude	- 5.1 dBm
Steps Per Sweep	20
Time Per Step	50 msec
Resolution Bandwidth	1 kHz

**Test Procedure:**

Trigger for a single sweep.

**Test Requirements and Suspect Block:**

1. Absolute Value of (bin N+1 - bin N - 0.195 dB) < 0.2 dB  
Error Message: Failed: Output Limiter linearity test.



## Confidence Test Number #6, Impedance and Attenuator Tests

### Instrument State:

Sweep Type	CW
Display Function	Log Magnitude
Source Frequency	90 kHz
Source Amplitude	- 30 dBm
Resolution Bandwidth	1 kHz

### Test Procedure:

Take a data point on 50  $\Omega$  impedance, 20 dB input attenuation

Record measured value.

Switch impedance to 1 M  $\Omega$ , 20 dB input attenuation.

Record measured value.

Switch impedance to 50  $\Omega$ , 0 dB input attenuation.

Record measured value.

### Test Requirements:

1. Absolute Value of ((1 M  $\Omega$ , 20 dB attenuation value)  
(50  $\Omega$ , 20 dB attenuation value - 6 dB)) < 0.2 dB  
Error Message: Failed: Receiver impedance test
2. (50  $\Omega$ , 20 dB value) - (50  $\Omega$ , 0 dB value) < 0.1 dB  
Error Message: Failed: Receiver attenuator test.

## 2-10 Service Diagnostics

The HP 3577B has the ability to run several diagnostic and service routines on itself. Some of these tests are a more complete version of the power-on self tests described in Section 2-6, others are servicing aides such as Signature Analysis (SA) pattern routines.

The diagnostics are accessible under the SPCL FCTN (SPECIAL FUNCTION) hardkey. To enter the diagnostic routines, press the SPCL FCTN hardkey and select the Service Diag (Diagnostics) softkey. Softkeys available under the Service Diagnostics are listed in table 2-4.

**Table 2-4. Service Diagnostics**

Softkey Number	Diagnostic Name	Test Location	Comments
1	LEVELING ON/OFF	A8U20(10)	Breaks source leveling loop for troubleshooting.
2	SETTLING ON/OFF	None	Turns off dwell time before each sweep.
3	SYN DIAG ON/OFF	None	Changes source frequency readout to read synthesizer (A17) frequency (300.25 to 500.25 MHz).
4	TEST PATTERN	Display Module	Turns on the display module test pattern.
5	TRC MEM TEST	A63U45 – U48	Tests all ROM and RAM on main processor-controller board (A62/63). Stored data is destroyed.
6	FASTPROC TEST	A61 all circuits A63U102,U103	Tests fast processor board (A61) logic and interfacing.
7	FAST BUS INT TEST	A63U102,U103	Tests bidirectional main (A62/63) and fast processor (A61) port
8	MORE	None	Selects menu listed below.
new menu 1	DISP MEM TEST	A63U50,U51	Test display module memory.
2	DISP HP-IB	A16 all circuits	Reads state of HP-IB connector pins through HP-IB IC (U21).
3	HP-IB SA	A16 all circuits	Runs signature analysis routine on HP-IB circuits.

### Leveling On/Off

This function sets the output of A8U20(10) low and turns the high frequency source leveling loop off. This feature will aid in source output board (A8) troubleshooting.

### Settling On/Off

This function turns off the settling time function implemented at the beginning of each sweep by the HP 3577B.

## **Syn Diag On/Off**

This function allows programming of the HP 3577B in direct synthesizer frequencies (300.25 to 500.25 MHz). This feature will aid in synthesizer troubleshooting by offering simpler instrument programming.

## **Test Pattern**

This function disconnects the HP 3577B digital section from the display module inside. When disconnected, the display module turns on its own resident test pattern which tests most display functions. Refer to the Digital Display Operating and Service section in this manual.

## **TRC Mem Test**

This function performs a checksum on the ROMs of the trace memory section of the main processor-controller board (A62/63). It also performs a test on the trace memory RAMs. For an explanation of the trace ROM and RAM tests, refer to Power-on Self Test Number #7 in Section 2-7.

## **Fastsproc Test**

This function performs the fast processor self test. This self test is described in detail in the Power-On Self Test Number #10 in Section 2-7.

## **Fast Bus Int (Interface) Test**

This function tests the bidirectional port between the fast processor (A61) and the main processor-controller (A62/63). This test is performed by the main processor-controller. The main processor-controller writes information to the port, and then reads back the echoed data. The test is then repeated with the fast processor performing the writing and reading.

## **Disp Mem Test**

This function thoroughly tests the memory resident in the display module in the HP 3577B. The test is about 10 seconds long, with the display blank during this time. The instrument returns from the test in an INSTRUMENT PRESET state.

**Disp HP-IB Test**

This function draws an HP-IB connector facsimile on the HP 3577B display. All connector pins are labeled. A dot is printed on the connector when the main processor-controller (A62/63) senses the pin pulled low. This connector is accessible from the rear panel of the HP 3577B. In order to display a dot on the appropriate control line, the line must be tied to logic ground (Ignd - pin 24). This diagnostic is used to test communication between the main processor-controller board (A62/63) and the HP-IB board (A16).

**HP-IB SA**

This function turns on a signature analysis routine for the HP-IB (A16) circuit board. Refer to the HP-IB service section in Section VIII for valid signatures and test points.

## 2-11 Covers Off Board Level Fault

This section includes fault isolation tests where the instrument covers are removed. Since hazardous signals are present in the HP 3577B with the covers removed, be sure to take all necessary safety precautions.

### Warning



Maintenance described herein is performed with power supplied to the instrument and protective covers removed. Such maintenance should be performed by service trained personnel who are aware of the hazards involved (for example, fire and electrical shock). Where maintenance can be performed without power applied, the power cord should be removed.

This section describes a procedure much like the factory procedure for bringing the HP 3577B to life for the first time. The procedure assumes that any board can be faulty. This procedure is written in a serial fashion but does not have to be performed in this order. If there is a strong suspicion that a particular functional area is faulty, that section of this procedure should be done first. If the HP 3577B digital self tests pass, there is a high level of confidence that the digital section is working correctly. This section includes the Main Processor-Controller (A62/63), Fast Processor (A61) and HP-IB (A16) boards. If the digital self tests fail, then the area tested in each should be repaired before continuing with the fault isolation.

Table 2-5. Board Turn-On Hierarchy

Board Description	Board Designator
1. Main Power Supply	A21
2. Digital Display	03577-60151
3. Main Processor	A62/63
4. Keyboard	A15
5. Frequency Reference	A6
6. Fast Processor	A61
7. HP-IB	A16
8. Input (R,A,B)	A71
9. Synthesizer	A17
10. Local Oscillator	A4
11. 250k Offset	A5
12. Output	A8
13. Oven (Option 001 only)	A31

Table 2-5 lists the turn-on hierarchy for the HP 3577B, given that all boards are suspect of being faulty. Table 2-6 lists all the power supplies in the HP 3577B. The power supplies should be checked before extensive troubleshooting is performed. Table 2-7 lists all input and output signals between individual boards in the HP 3577B which are available from the top of the boards by coaxial cables and test points. Signal parameters are listed for each signal. All parameters listed are required parameters unless denoted by a character. All parameters are typical performance parameters of the instrument and only serious deviations should be investigated.

**Table 2-6. Main Power supply**

Supply Name	Output Location	Return Location	Nominal Voltage	Voltage Tolerance	Ripple Tolerance
+15V	TP8	Chassis	+15V	+0.05, - 0.00	80 mVpp
- 15V	TP9	Chassis	- 15V	± 0.05	80 mVpp
+5V	TP26	Chassis	+5.1V	± 0.02	60 mVpp
+8V	TP10	Chassis	+8V	± 1	90 mVpp
+5V (HP-IB)	TP11	TP12	+5V	± 0.5	350 mVpp

Remove the HP 3577B bottom cover and check the supplies listed above with the power distribution cables connected and all circuit boards in the HP 3577B. If all supplies check good, continue with the Covers Off Board Level Fault Isolation. If any supplies are incorrect, then refer to Section VIII (Service) for troubleshooting information.

---

**Caution**



Do not remove or insert circuit boards in the HP 3577B with the power applied to the instrument. Damage may result when circuit boards are removed or inserted while instrument is powered on.

---

**Note**



The voltage levels and ripple tolerances listed above are for fully loaded supplies. When removing individual boards, the supply levels will change with the various loads. Keep this in mind when performing fault isolation.

---

Table 2-7. Fault Isolation Test Signals

Board	Connector	Signal Parameters			
		Frequency	Amplitude	Level Flatness	Harmonics
A4	J3	.25 – 200.25 MHz	≅ +7 dBm	≅ ± 1.0 dB	≅ < -10 dB
	J4	.25 – 200.25 MHz	≅ +7 dBm	≅ ± 1.0 dB	@ < -10 dB
	J5	.25 – 200.25 MHz	≅ +7 dBm	≅ ± 1.0 dB	@ < -10 dB
A5	J1	300.25 MHz	≅ +7 dBm	N/A	≅ < -18 dB
A6	J2	10 MHz	≅ 0 dBm	N/A	≅ < -40 dB
	J3	300 MHz	≅ -3 dBm	N/A	≅ < -10 dB
	J4	300 MHz	≅ -26 dBm	N/A	≅ < -15 dB
	J5	100 kHz	≅ 2 Vpp 5 Vdc offset TTL Levels	N/A	≅ < 30 ns Pulsewidth ≅ < 7 ns Risetime
	J7	30 MHz		N/A	
A17	J1	300.25 MHz – 500.25 MHz	≅ -1 dBm	≅ ± 1.5 dB	≅ < -10 dB
	J2	300.25 MHz – 500.25 MHz	≅ -1 dBm	≅ ± 1.5 dB	≅ < -10 dB
A31 (Option 001)	J1	10 MHz	≅ -0 dBm	N/A	≅ < -25 dB
AB	Front Panel	5 Hz – 200 MHz	-49 to +15 dBm	± 1.5 dB	< -30 dB

**Note**



All amplitude measurements cited here are made using an HP 436A Power Meter and an HP 8482A Power Sensor. All flatness and harmonics measurements are made using an HP 8568B Spectrum Analyzer.



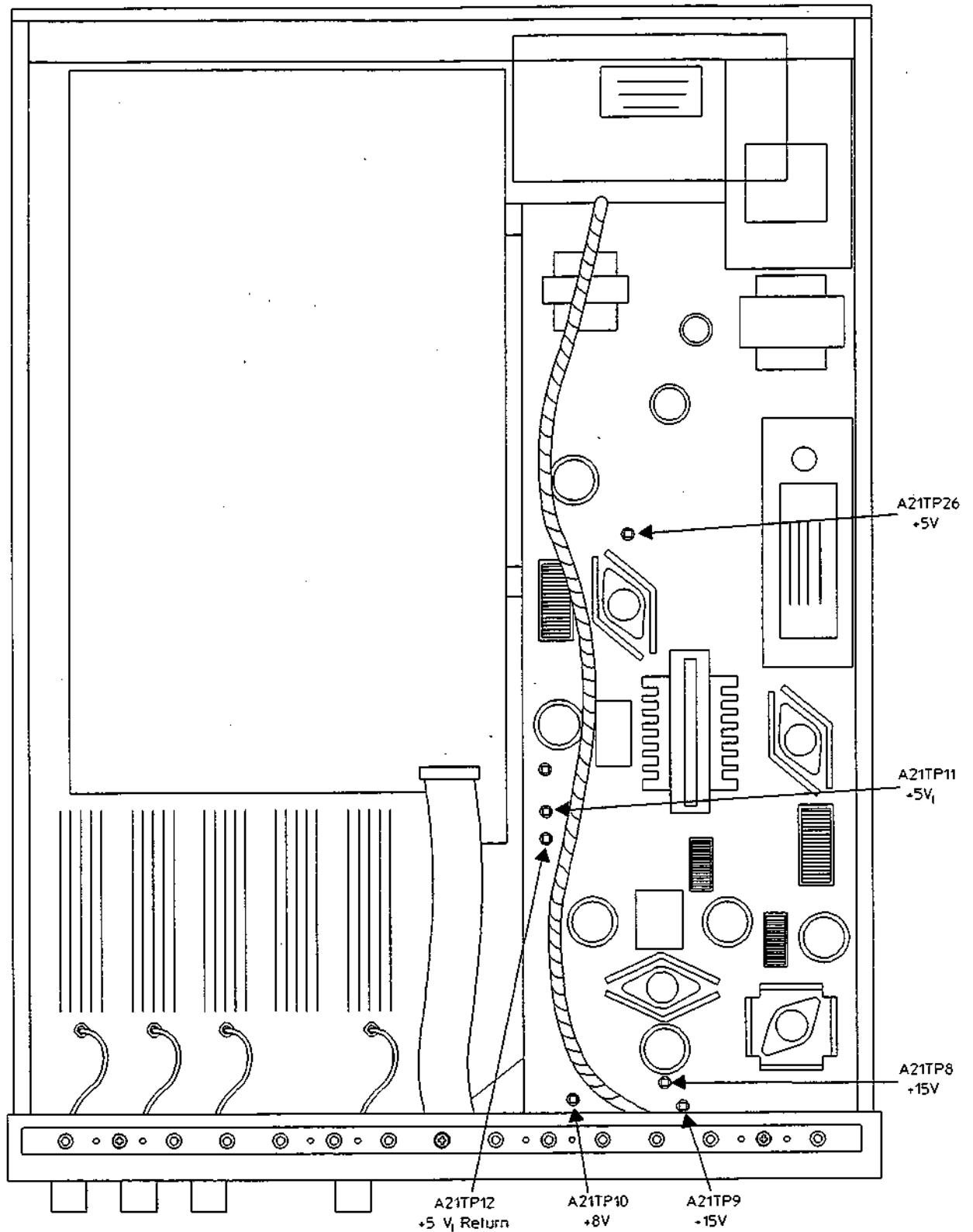
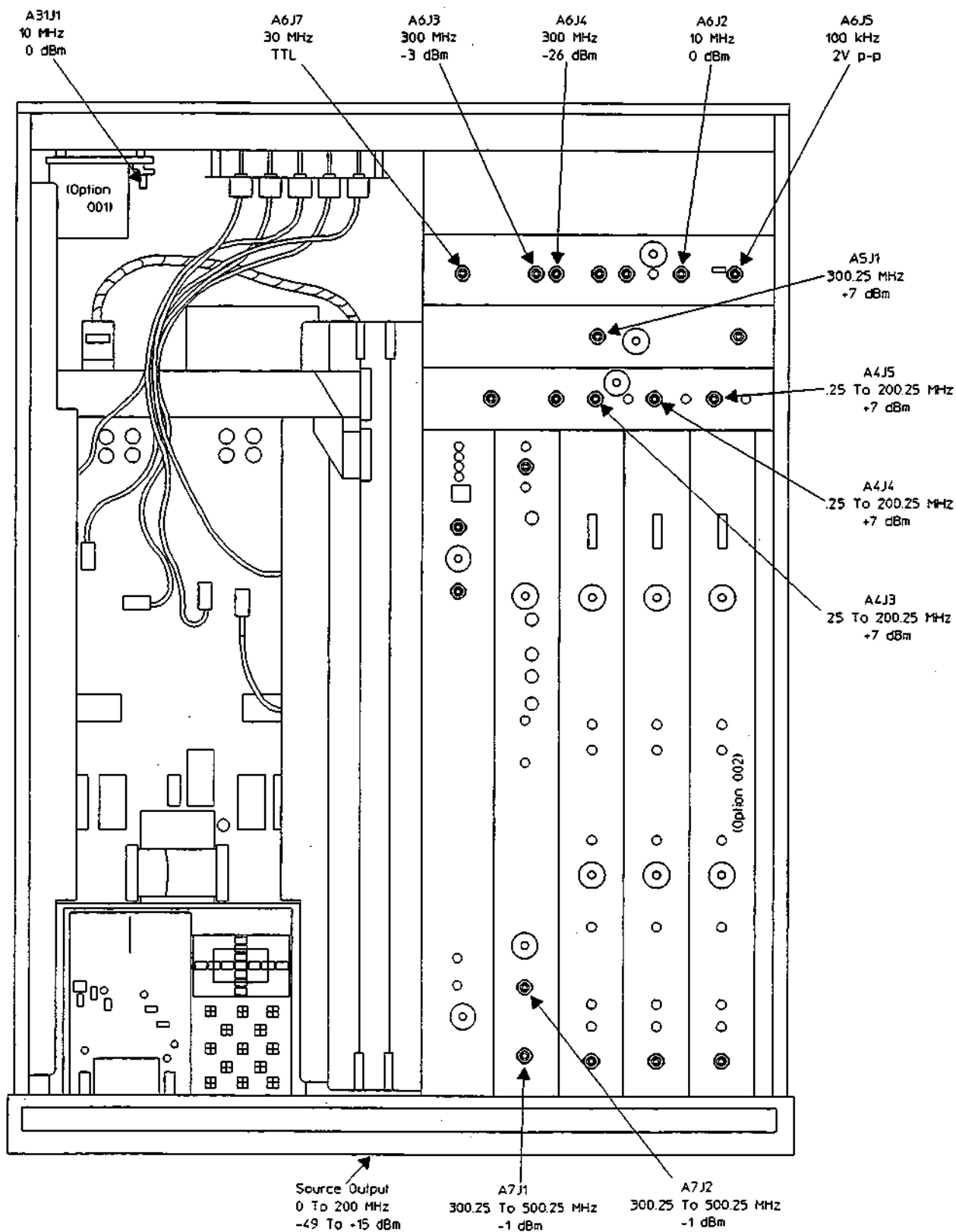


Figure 2-1. Fault Isolation Test Signal Locations

**Fault Isolation**  
**2-11 Covers Off Board Level Fault**

HP 3577B



**Figure 2-2. Fault Isolation Test Signal Locations**

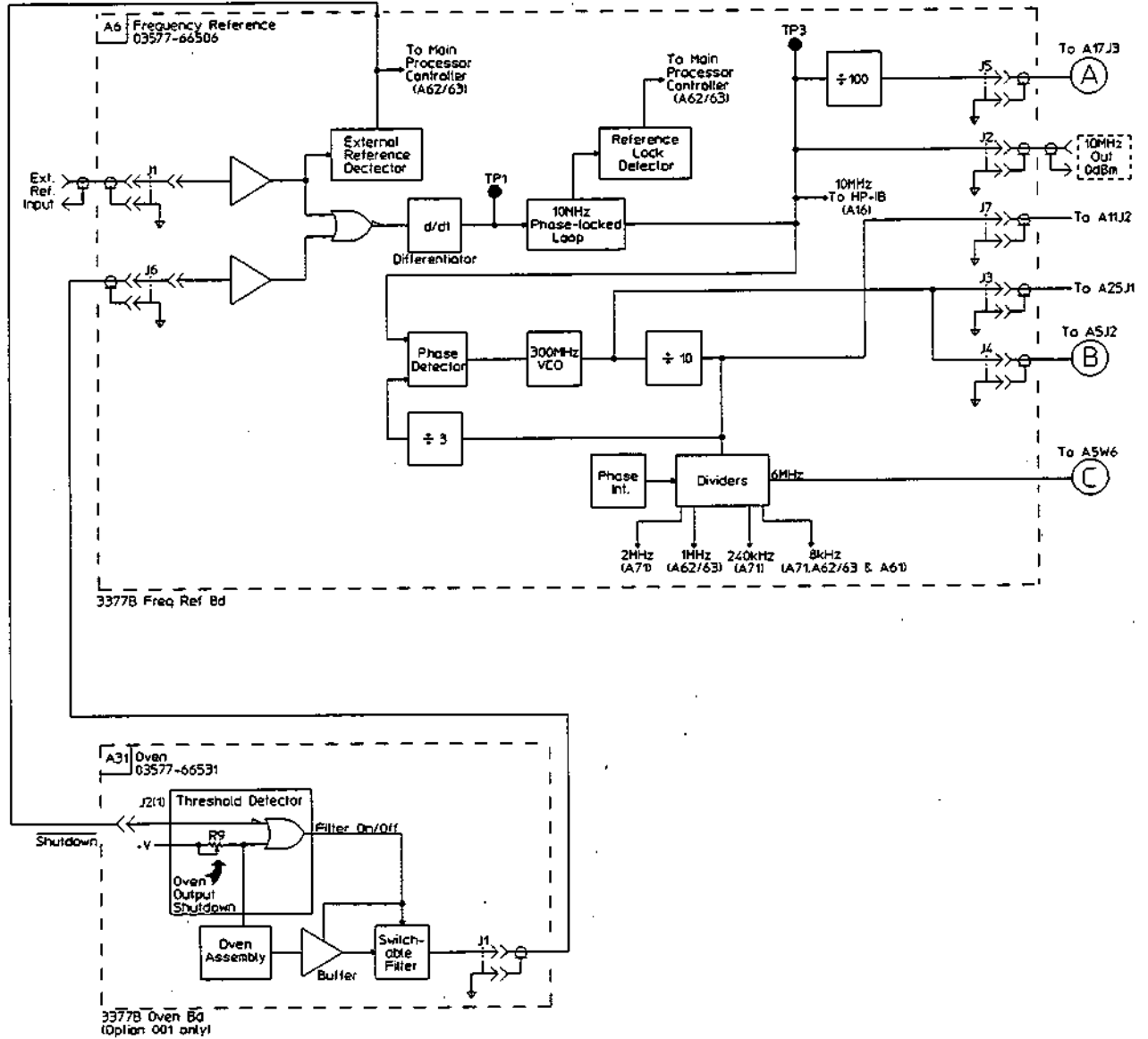


Figure 2-3. HP 3577B Functional Block Diagram (A6/A31) Part 1 of 6

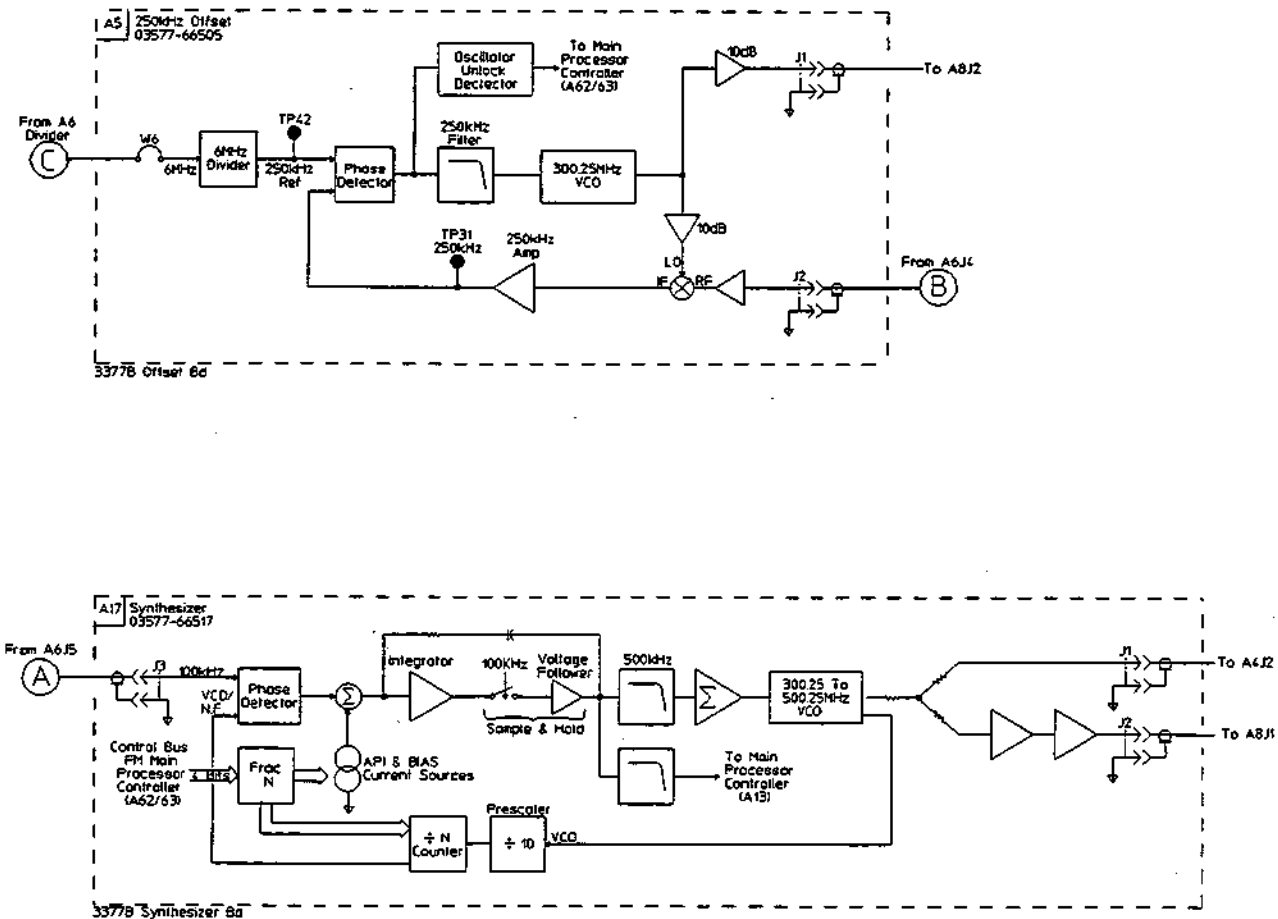


Figure 2-4. HP 3577B Functional Block Diagram  
(A5/A17) Part 2 of 6

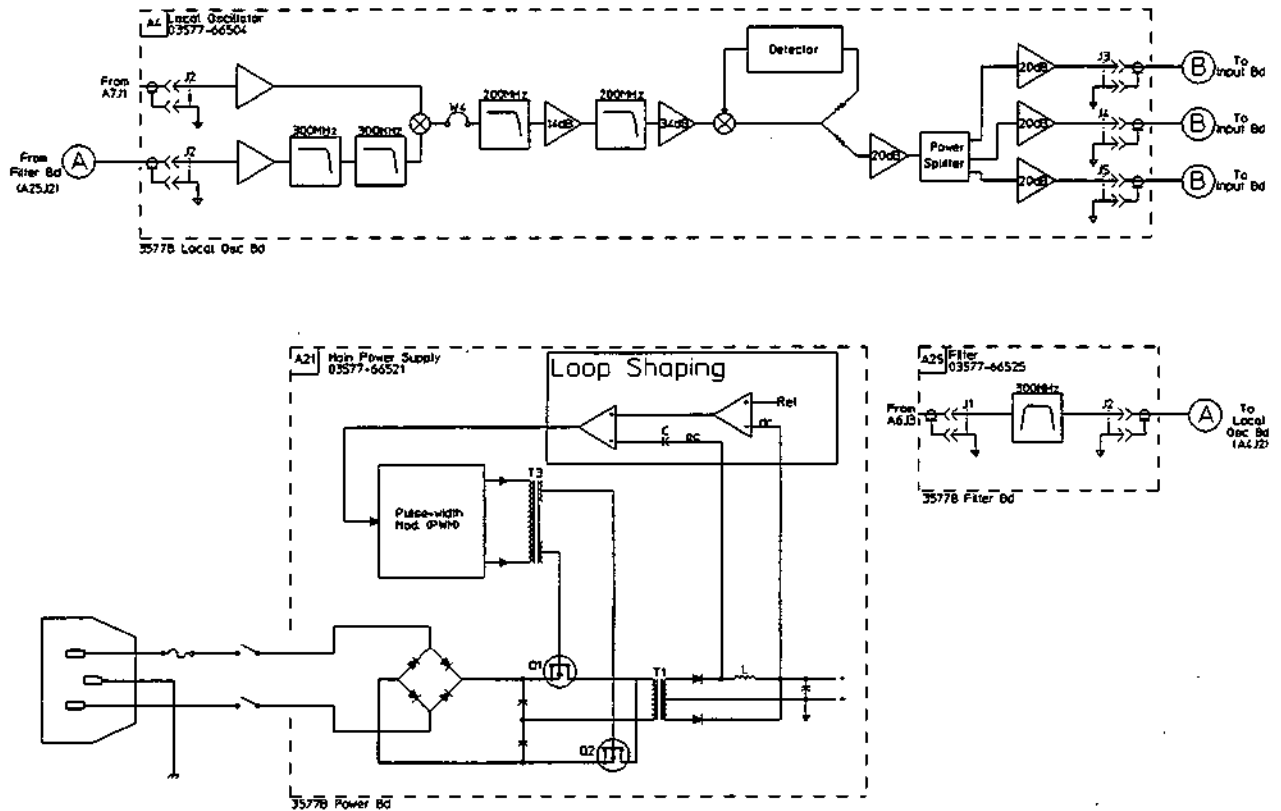


Figure 2-5. HP 3577B Functional Block Diagram, (A4/A21) Part 3 of 6

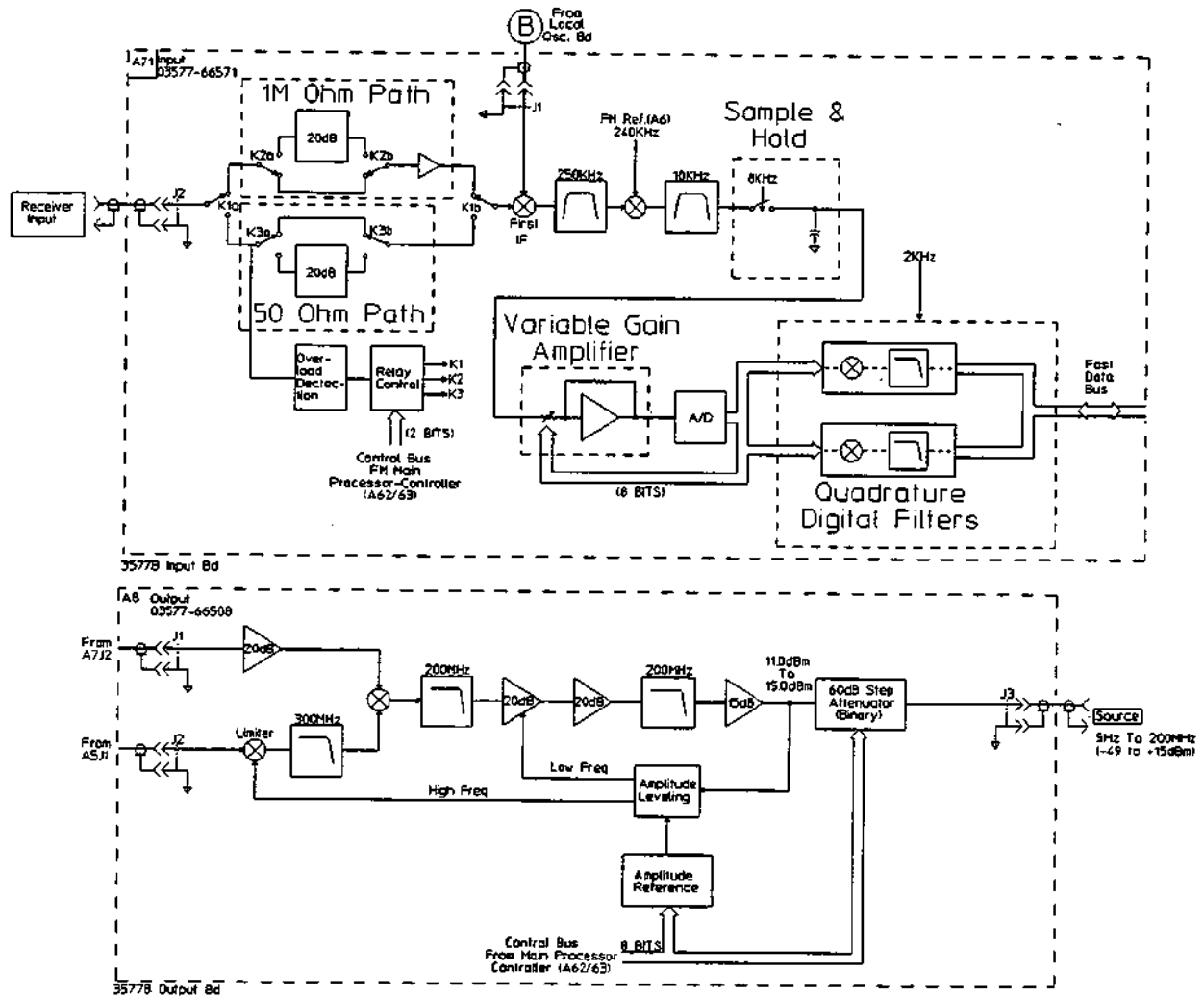


Figure 2-6. HP 3577B Functional Block Diagram, (A71/A8) Part 4 of 6

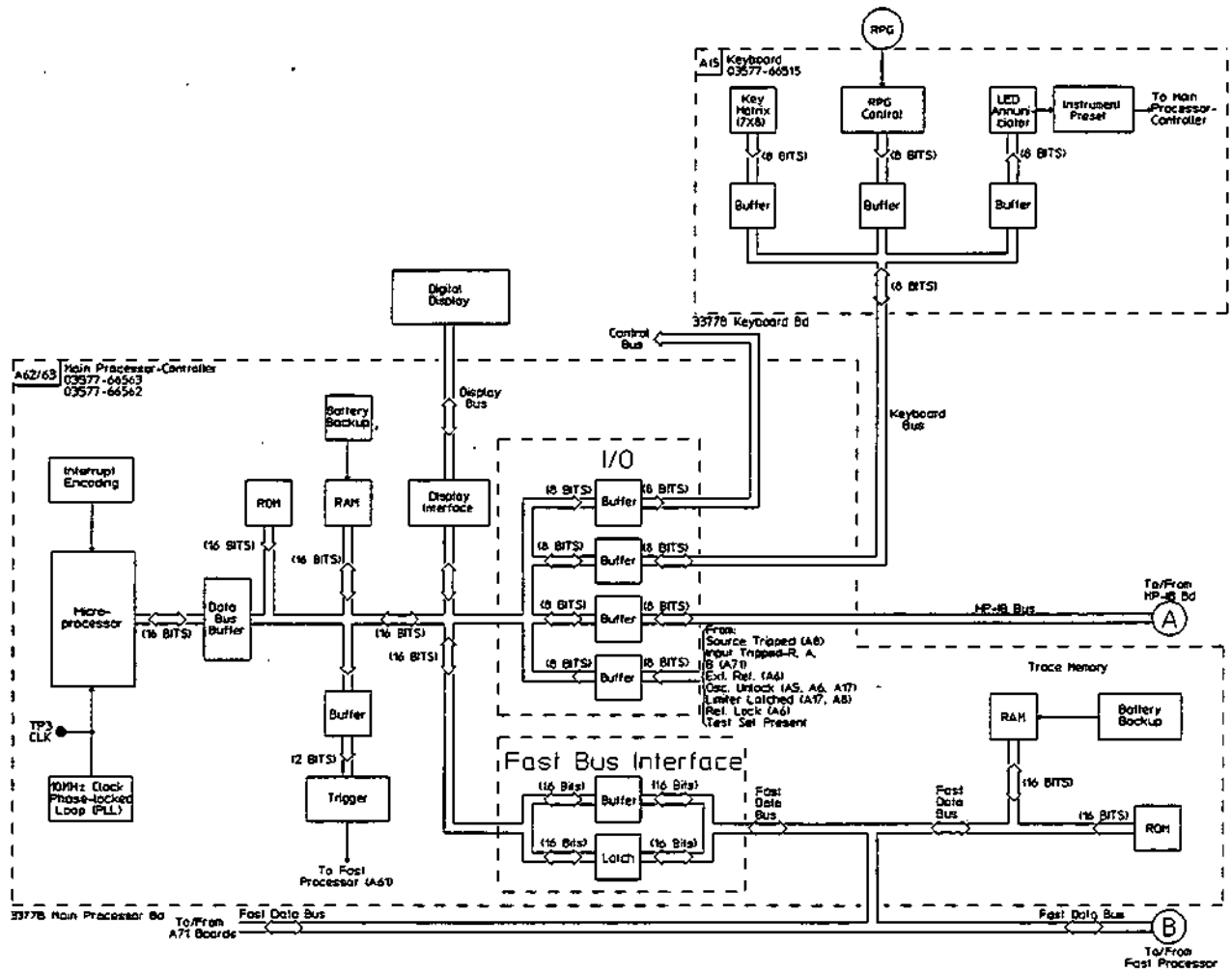


Figure 2-7. HP 3577B Functional Block Diagram, (A15/A62/63) Part 5 of 6

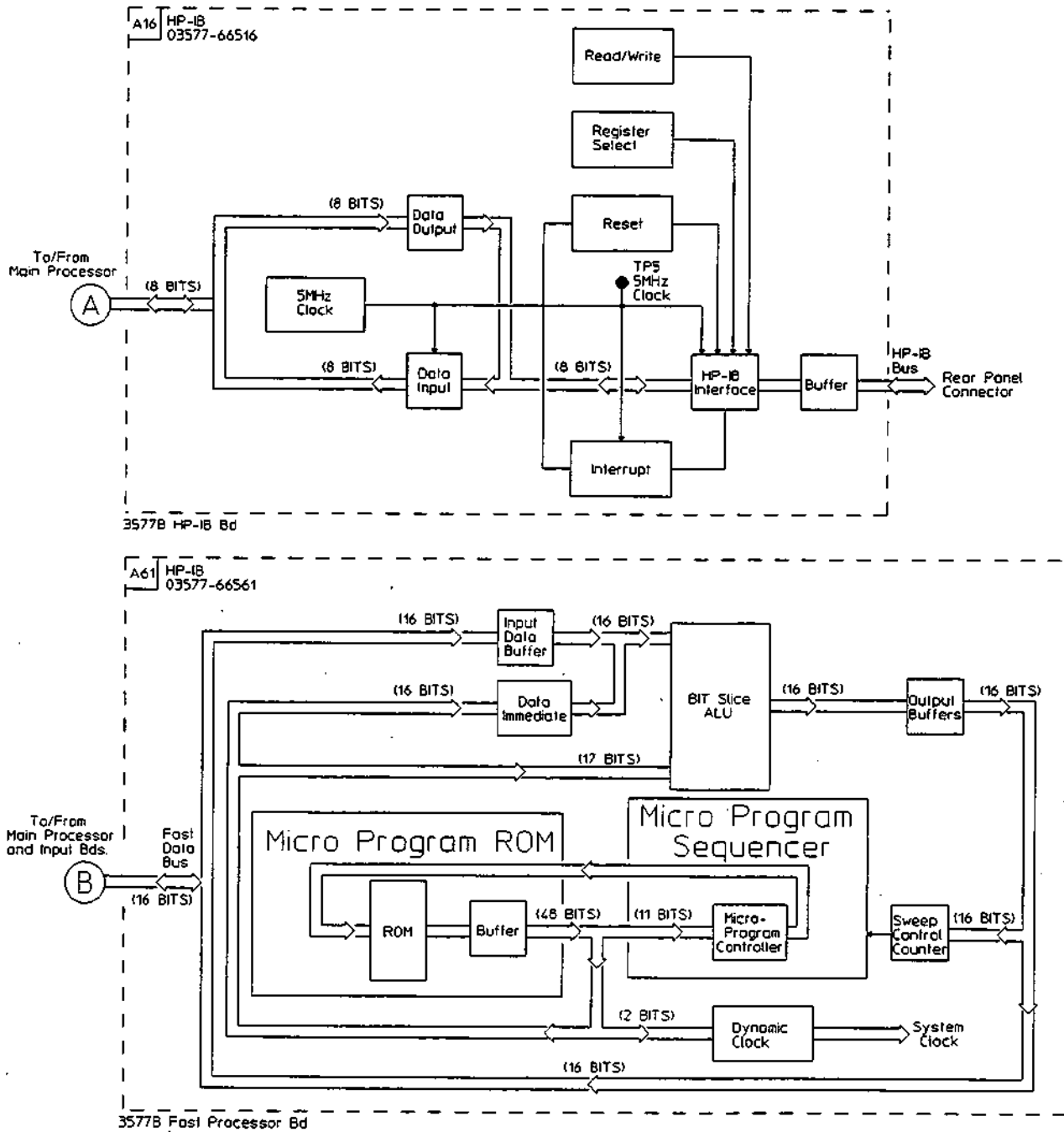


Figure 2-8. HP 3577B Functional Block Diagram, (A16/A61) Part 6 of 6



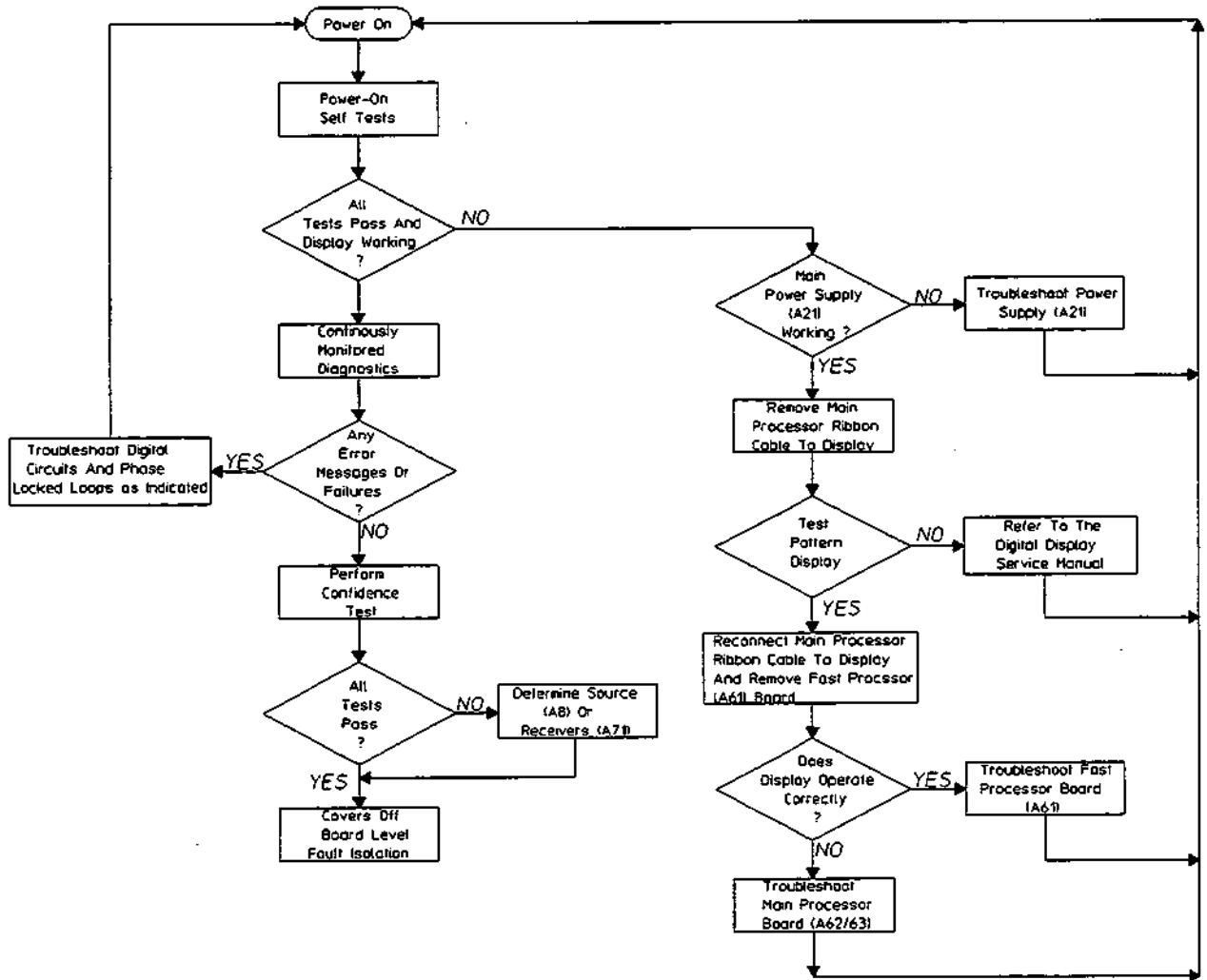


Figure 2-9. Fault Isolation Flow Diagram

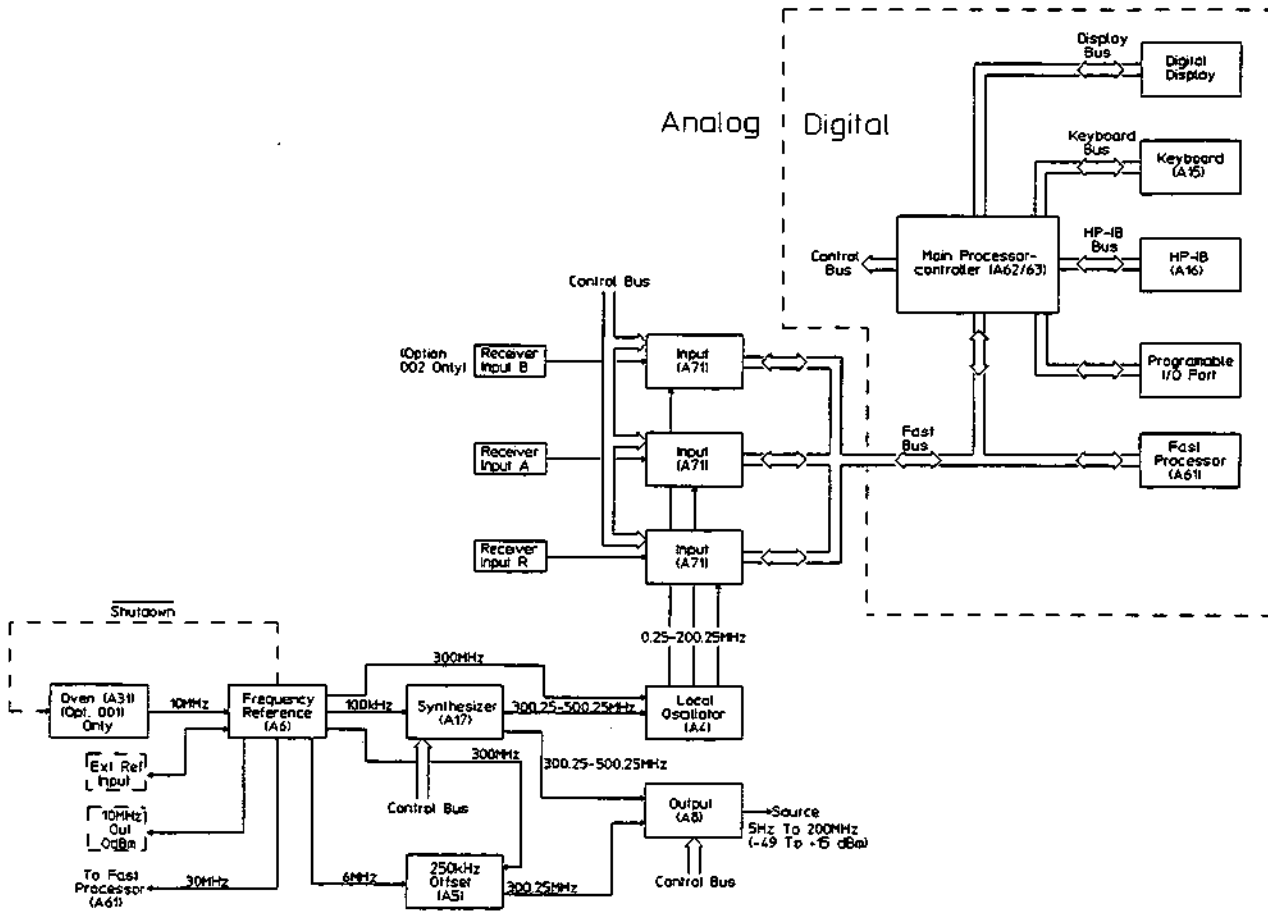


Figure 2-10. HP 3577B Overall Block Diagram



# Section III

## Performance Tests

---

### 3-1 Introduction

The procedures in this section test the electrical performance of the instrument using the specifications of table 1-1 as the performance standards. Each test meets or exceeds a 4:1 uncertainty ratio when using the recommended test equipment given in table 1-2. See the test description for the uncertainty ratio of each test in the Performance Test Record. Most tests can be performed without access to the interior of the instrument. A shorter test is included in this section under the Operational Verification Test. The performance tests must be performed in the sequence given, since some procedures rely on satisfactory results in previous tests. If a test measurement is out of tolerance, go to Section V (Adjustments).

---

### 3-2 Equipment Required

Equipment required for the performance tests is listed in table 1-2. Any equipment which meets the critical specifications given in the table may be substituted for the recommended model.

---

### 3-3 Test Record

Results of the performance tests may be tabulated on the Test Record, table 3-10, at the end of this section. The test record lists all tested specifications and acceptable limits. The test record may be removed from the manual and used as a permanent record of the incoming inspection or of routine performance verification. The performance test record may be reproduced without the written permission of Hewlett-Packard.

---

### 3-4 Calibration Cycle

This instrument requires periodic verification of performance. Depending on the use and environment the instrument is subject to, the performance tests should be performed at least every 12 months.

---

## 3-5 Operational Verification Tests

The Operational Verification Tests for the HP 3577B are designed to be run with a minimum amount of equipment. A comparison of the required equipment to run the tests is presented in table 1-2. These tests give the user a high level of confidence that the HP 3577B meets all specifications as listed in table 1-1, but do not guarantee that all specifications are met. The Operational Verification Tests require about 2 hours to perform.

Assure that the display is functioning correctly by performing the following test before attempting the instrument operational verification tests.

### HP Digital Display Operational Verification

#### Introduction:

This abbreviated test provides approximately 90% assurance of proper display operation.

#### Equipment Required:

None

#### Description:

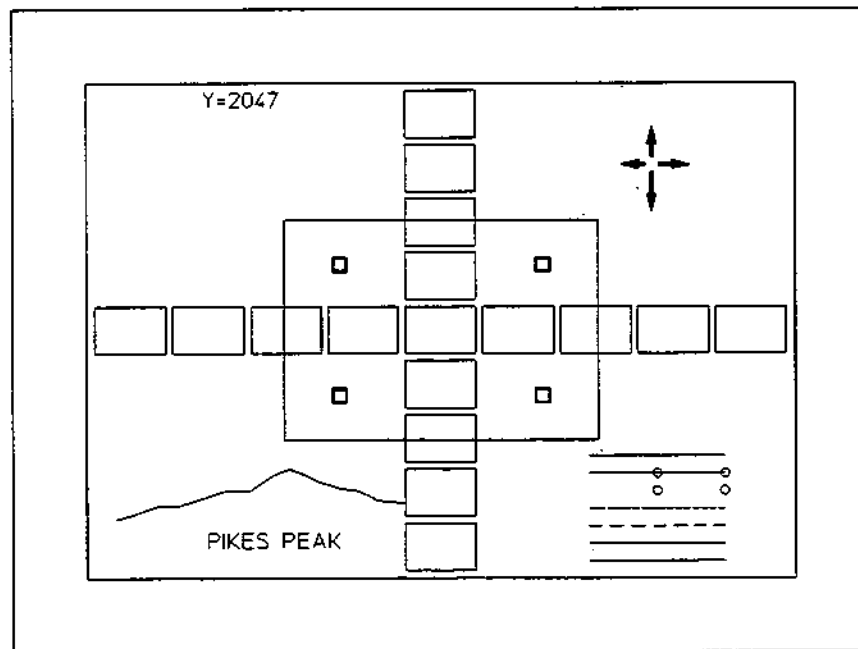
The following procedure is directed at obtaining the correct operational verification pattern on the HP Digital Display screen.

**Procedure:**

1. Press SPCL FCTN in the SYSTEM section. Then press the following softkeys:  
SERVICE DIAG  
TEST PATTERN
2. Observe the test pattern on the display. Verify that the display is legible and is centered on the screen. The corners of the outer rectangle should not have any gaps or extended lines. The sides of the smaller boxes in the display should be parallel with each other. In the lower right section of the display, 6 lines should be visible plus one row of two dots. Finally, the four smallest rectangles should have sides that are approximately equal in brightness. The test pattern should look similar to figure 3-1.
3. When done, press the green INSTR PRESET button.
4. If the display is not functioning properly refer to the Section V, Adjustments.

**Table 3-1. Operational Verification Tests**

Test Name	Paragraphs to Complete
Receiver Residuals and Noise Test	All
Magnitude vs. Phase Test	All
Source Distortion and Spur Test	All
Source Flatness and Absolute Accuracy Test	All
Confidence Test (internal)	—



**Figure 3-1. Test Pattern**

### 3-6 Initial Control Settings

Each of the following performance tests assumes an initial condition of the HP 3577B control settings. This is due to the trace arithmetic and trace input functions possible with the HP 3577B. Initial conditions can be achieved by pressing INSTR PRESET which defaults to the following settings:

INPUT	R
AMPTD	- 10 dBm
FREQ	
START FREQ	0 Hz
STOP FREQ	200 MHz
SWEEP TYPE	LIN FREQ SWEEP
SWEEP TIME	1 sec
RESOLUTION BANDWIDTH	1 kHz
SCALE	
REF LEVEL	0 dBm
dB/DIV	10 dB

## 3-7 Receiver Residuals And Noise Test

### Specifications:

#### Sensitivity\*:

Resolution Bandwidth	Minimum Freq. to 30 kHz (50 $\Omega$ ) Minimum Freq. to 300 kHz (1 M $\Omega$ )		30 kHz to 200 MHz (50 $\Omega$ ) 300 kHz to 20 MHz (1 M $\Omega$ )	
	Full Scale Input Level		Full Scale Input Level	
	0 dBm - 13 dBV (20 dB atten)	-20 dBm - 33 dBV (0 dB atten)	0 dBm - 13 dBV (20 dB atten)	-20 dBm - 33 dBV (0 dB atten)
1 Hz	- 110 dBm	- 130 dBm	-110 dBm	- 130 dBm
10 Hz	- 100 dBm	- 120 dBm	- 110 dBm	- 130 dBm
100 Hz	- 90 dBm	- 110 dBm	- 105 dBm	- 125 dBm
1 kHz	- 80 dBm	- 100 dBm	- 95 dBm	- 115 dBm

\*For 1 M $\Omega$  inputs, add 5 dB to table.

### Residual Responses:

Local Oscillator feedthrough: < - 33 dB from maximum input.

Line and Fan related spurious: < - 100 dBm.

Residual responses: > 100 dB below full scale input except for crosstalk error limits, L.O. feedthrough, and ac line and fan related spurious signals.

### Description:

The receiver inputs to the HP 3577B are terminated in 50 $\Omega$ , and the receiver residual response is measured as indicated on the HP 3577B display. Then the noise test is performed by measuring the average noise level with the inputs remaining terminated. The noise is measured by averaging the amplitude of eleven points in the linear magnitude of an amplitude sweep and converting to dBm.

Equipment:
50 $\Omega$ Termination (3 each)
N male to BNC female Adapter (3 each)



**Procedure:**

**Receiver Residuals Test**

- a. Press INSTR PRESET.
- b. Terminate the receivers of the HP 3577B with the 50Ω terminations, using N male to BNC female adapters.
- c. Set the HP 3577B controls as shown below:
 

SWEEP TYPE	CW
SWEEP TIME (SAMPLE TIME)	0.1 sec
AMPTD	48 dBm
RES BW	10 Hz
AVG	256
ATTEN (all channels)	50Ω, 20 dB
- d. **FREQ** 149.625 MHz
- e. **INPUT** R
- f. The marker MAG on the HP 3577B display should read < - 100 dBm. Enter the reading in the test record.
- g. Repeat steps e and f for inputs A and B (if receiver B is present).
- h. Repeat steps d through g for all the frequencies listed in table 3-2. For all frequencies the noise must be < - 100 dBm. For 0 Hz, the L.O. Feedthrough must be < - 33 dB.

**Table 3-2. Receiver Residual Test Points**

All frequencies listed are in MHz		
149.625	89.5	0.0080
149.875	120.0	0.0160
99.666 666 666	149.5	0.0240
99.833 333 333	180.0	0.027 777 7
74.6875	0.480	0.10
74.8125	0.960	0.20
59.7	0.0040	0.000 000 000
59.8	—	—

**Noise Test**

- i. Preset the HP 3577B.
- j. Leave the 50Ω terminations on the HP 3577B A, B, and R receivers.
- k. Set the HP 3577B controls as shown below:

SWEEP TYPE	AMPTD SWEEP
SWEEP MODE	SINGLE
SWEEP TIME	0.5 sec

AMPLITUDE	
START AMPTD	- 48 dBm
STOP AMPTD	- 48 dBm
STEPS/SWEEP	10 STEPS

RES BW	10 Hz
DISPLY FCTN	LIN MAG
SCALE	
/DIV	200 nV

- l. Press the **FREQ** hardkey and enter a **FREQ** of 100 Hz.
- m. Press the **TRIG/RESET** hardkey.
- n. Press the **INPUT** hardkey and select **R**.
- o. Use the HP 3577B **RPG** knob to measure the magnitude of the eleven points starting at the left. The **RPG** knob will move the marker directly from one point to the next. Record the magnitude of each point on the test record.
- p. Calculate the noise level using the following equation:

$$\text{Noise Level (dBm)} = -150 + 10 \log_{10} \left[ \frac{\sum_{n=1}^{11} (X_n)^2}{550} \right]$$

Where: X is the marker value in nV

- q. The noise level should be < -100 dBm (-110 dBm for 30 kHz and 199 MHz). Record the reading in the test record.
- r. Repeat steps f through h for the inputs A and B (if receiver B is present).
- s. Repeat steps c through i for the HP 3577B **FREQs** of 30 kHz and 199 MHz. The noise level for both these frequencies should be < -110 dBm.

---

## 3-8 On-Carrier Return Loss Test

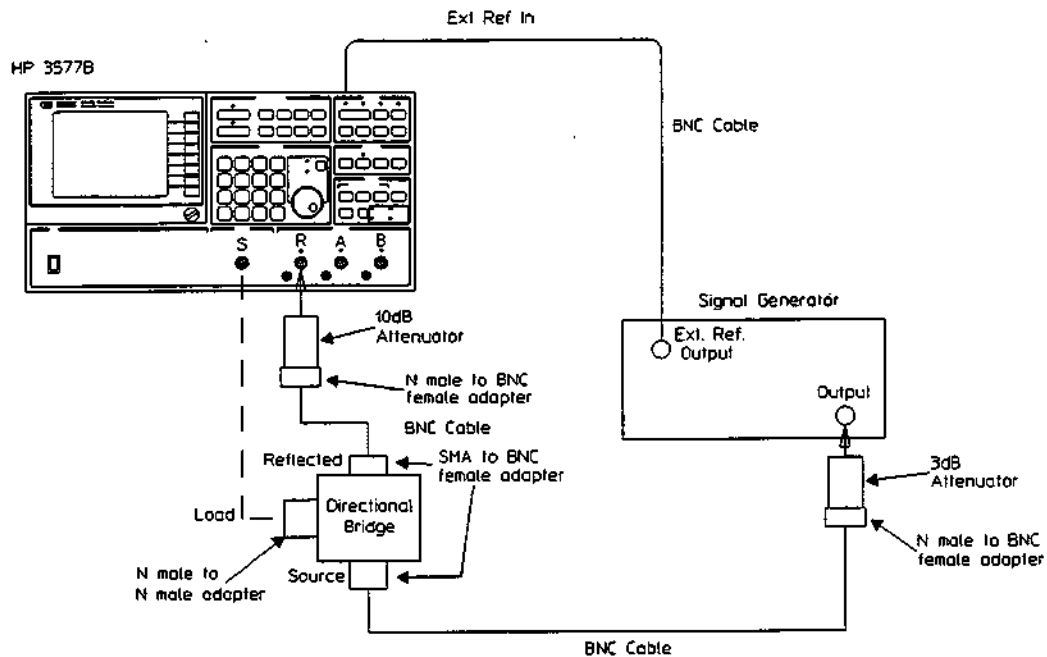
### Specifications:

Source Return Loss > 20 dB.

### Description:

The HP 3577B source return loss is measured using a signal generator (the source for the incident signal) and a directional bridge. The sum of the HP 3577B source output and the generator signal reflected from the HP 3577B source is measured by channel R. In order to distinguish the two signals, the signal generator frequency is offset from the HP 3577B frequency such that the difference frequency is within the loop bandwidth of the HP 3577B. This guarantees that the source return loss includes the effect of the leveling loop. The summation of these two signals appear as a carrier (HP 3577B output) and one sideband (generator signal reflected from the HP 3577B source). If the sideband level is 20 dB below the HP 3577B source level, the two signals can be synthesized as simultaneous AM and PM modulation of the carrier where the modulation frequency is the frequency difference between the signal generator and the HP 3577B. The display function of channel R is set to linear magnitude, so that channel R acts as an AM detector. The peak-to-peak level of the AM signal is a measure of the sideband signal (signal reflected from the source). Given the reflected signal level, the source return loss can be computed.

Equipment:
3 dB Attenuator
10 dB Attenuator
Directional Bridge
Signal Generator
SMA male to BNC female Adapter (2 each)
N male to N male Adapter
N male to BNC female Adapter (2 each)
BNC Cables-48 inch (3 each)



**Figure 3-2. On Carrier Return Loss Test Set-Up**

**Procedure:**

a. Preset the HP 3577B.

b. Set the HP 3577B as follows:

SWEEP MODE	SINGLE
FREQ	
FREQ SPAN	0 Hz
CENTER FREQ	175 MHz
AMPTD	12 dBm
RES BW	10 Hz
DISPLY FCTN	LIN MAG
SCALE	
REF POSN	50%
/DIV	10mV
SAVE	SAVE REG 1

c. Connect the equipment as shown in figure 3-2 but do not connect the HP 3577B source to the directional bridge. (HP 3577B EXT REF LED should be on.)

d. Set the signal generator frequency to the HP 3577B center frequency.

e. Set the signal generator amplitude to +10 dBm.

f. Press the TRIG/RESET hardkey.

- g. Note the marker MAG of the HP 3577B and record this reference voltage ( $V_{ref}$ ) in the test record. (The voltage should be approximately 40 mV).
- h. Set the signal generator frequency 5 Hz above the HP 3577B frequency.
- i. Connect the HP 3577B source to the directional bridge load port using an N-male to N-male adapter as shown in figure 3-2.
- j. Press the TRIG/RESET hardkey. Press the MKR → hardkey and select MKR → REF LVL.
- k. Press the SCALE hardkey and enter a /DIV of 1 mV.
- l. Press the MKR → hardkey and select MKR → MIN. Press the MKR hardkey and select ZERO MARKER. Using the HP 3577B RPG knob, set the marker to the next sinewave maximum and record this test voltage ( $V_{test}$ ) in the test record. (The voltage should be approximately 6 mV or less.)
- m. Calculate the on-carrier return loss using the following equation:

$$\text{On-CarrierReturnLoss(dB)} = - \left( 3 \text{ dB} + 20 \log_{10} \left( \frac{V_{test}}{2 V_{ref}} \right) \right)$$

The 3 dB is added to compensate for the 3 dB insertion loss of a 5 Hz signal in a 10 Hz resolution bandwidth.

- n. The on-carrier return loss should be > 20 dB. Record the value in the test record.
- o. Press the RECALL hardkey and select RECALL REG 1. Repeat steps c through n for a HP 3577B FREQ of 200 MHz.

### 3-9 Magnitude And Phase Dynamic Accuracy Test

**Specifications:**

Test or Reference Level dB from full scale input	Tolerance 1k,100,10 Hz RES BW		Tolerance 1 Hz RES BW	
	Magnitude	Phase	Magnitude	Phase
0 to -10 dB	0.07 dB	0.4 deg	0.07 dB	0.4 deg
-10 to -50 dB	0.06 dB	0.2 deg	0.06 dB	0.2 deg
-50 to -60 dB	0.08 dB	0.5 deg	0.08 dB	0.5 deg
-60 to -80 dB	0.20 dB	1.5 deg	0.30 dB	N/A
-80 to -90 dB	0.75 dB	7.5 deg	0.75 dB	N/A
-90 to -100 dB	0.75 dB	7.5 deg	3.00 dB	N/A

**Description:**

The dynamic accuracy test is a measure of receiver linearity or the ability of the receiver to measure a relative change in magnitude and/or phase. The measurement has a reference level of approximately -20 dBm (0 dBm maximum input level) at a phase of approximately 0 degrees. The test requires a source whose relative output level can be adjusted to an accuracy that exceeds the HP 3577B dynamic accuracy specification. This is done with the HP 3577B source and a ratio transformer with seven decimal place resolution.

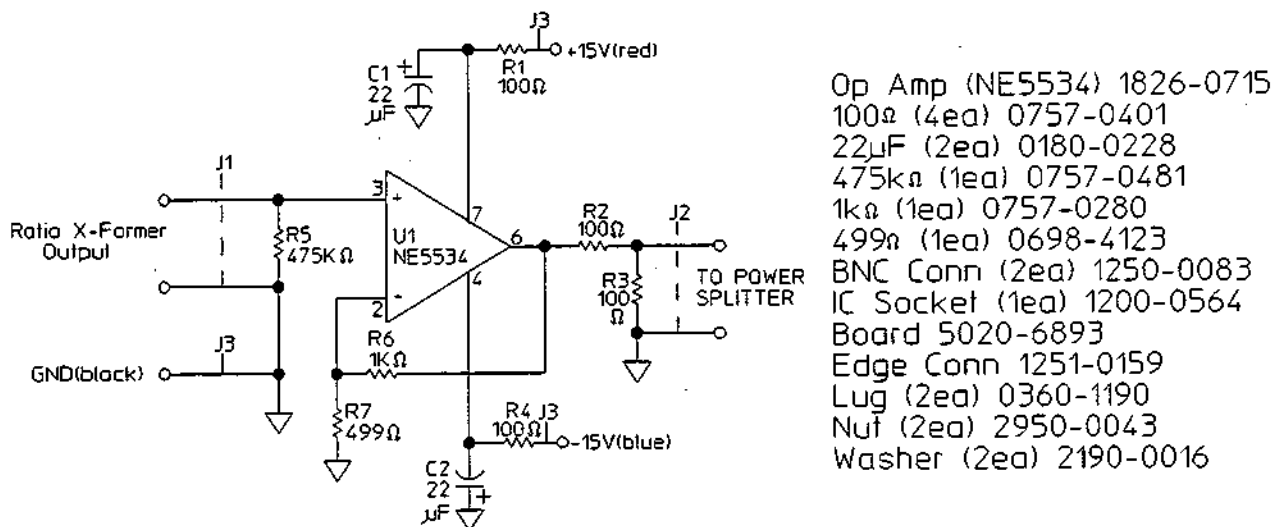


Figure 3-3. Buffer Amplifier

You will have to build a buffer amplifier to match the impedance of the ratio transformer to the 50Ω input of the HP 3577B receivers. See figures 3-3 and 3-4 for construction details.

Equipment:
Ratio Transformer
Power Splitter
Type N RF Cables-24 inch (3 each)
BNC Cables-48 inch (3 each)
N male to BNC female Adapter (2 each)
BNC female to Banana Adapter (2 each)
Power Supply
Buffer Amplifier
RF Balun
50Ω Precision Termination (if no Channel B)

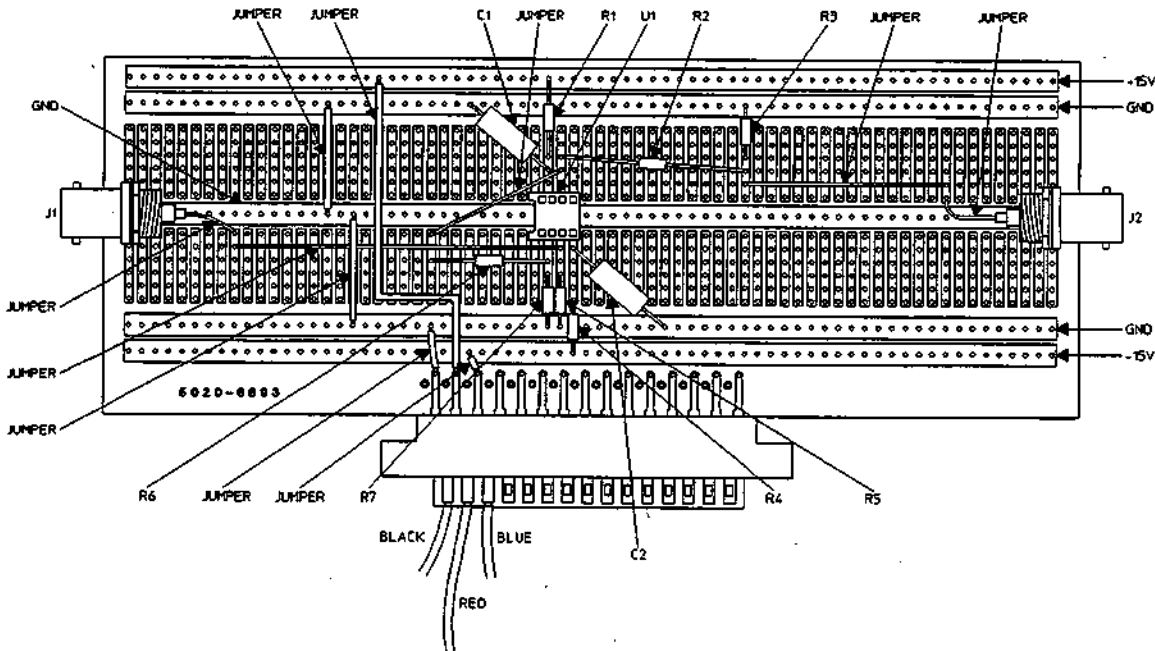


Figure 3-4. Suggested Layout for Buffer Amplifier

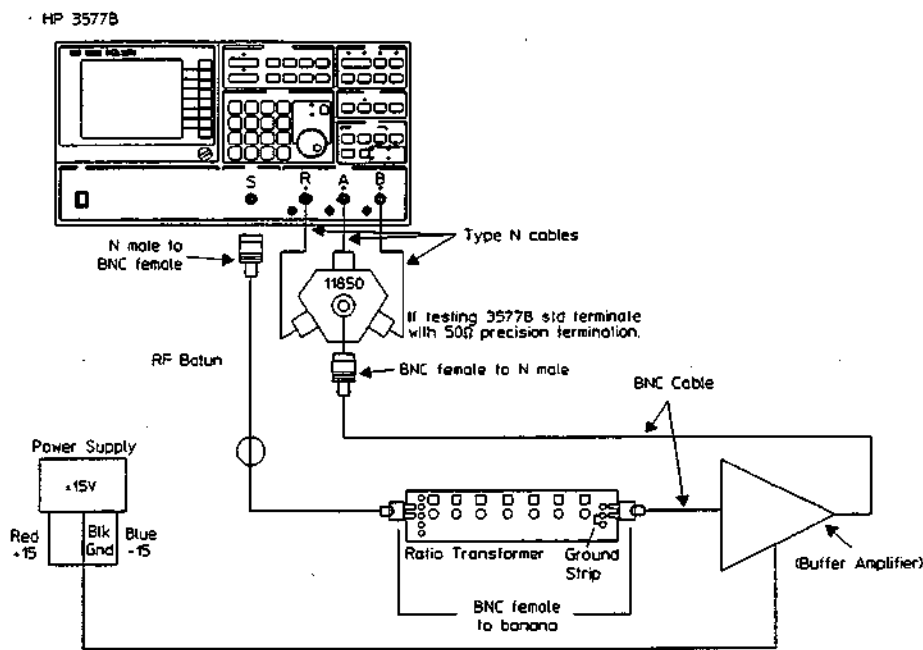


Figure 3-5. Dynamic Linearity Test Set-Up

**Procedure:**

- a. Preset the HP 3577B.
- b. Connect test equipment as shown in figure 3-5.

**Note**



Test set up as shown is essential to achieve accurate results. Do not substitute equipment.

- c. Set the HP 3577B to the following conditions:

SWEEP TYPE	CW
SWEEP TIME (SAMPLE TIME)	0.1 sec
FREQ	2.1 kHz
RES BW	10 Hz
AMPTD	6 dBm
STEP SIZE	0.1 dB

- d. Set the Ratio Transformer to 0.1 and read the marker MAG of channel R.
- e. Press the AMPTD hardkey, select AMPTD, and use the ↑ and ↓ hardkeys until the marker MAG reads -20.5 dBm ± 0.1 dBm.



f. Change the following HP 3577B conditions:

AVG	256
DEFINE MATH	
K1	
K1 REAL	0.1 UNITS
TRACE ONE	
DISPLY FCTN	LOG MAG
INPUT	
USER DEF INPUT	K1*R/D1
(select USER DEF INPUT, K__, 1, *, RAB, R, /, D__, 1, ENTER)	
SCALE	
REF LEVEL	0 dB
/DIV	20 dB

TRACE TWO

DISPLY FCTN	PHASE
INPUT	COPY Trc 1 → 2
SCALE	
/DIV	5 deg

- g. Press the SAVE hardkey and select SAVE REG 1.
- h. Press the INPUT hardkey and enter a USER DEF INPUT of  $K1 \cdot A / D2$  (select USER DEF INPUT, K\_\_, 1, \*, RAB, A, /, D\_\_, 2, ENTER).
- i. Press the TRACE 1 hardkey, then the INPUT hardkey. Select COPY Trc 2 → 1.
- j. Press the SAVE hardkey and select SAVE REG 2.
- k. Press the INPUT hardkey and enter a USER DEF INPUT of  $K1 \cdot B / D3$  (select USER DEF INPUT, K\_\_, 1, \*, RAB, B, /, D\_\_, 3, ENTER).
- l. Press the TRACE 2 hardkey, then the INPUT hardkey. Select COPY Trc 1 → 2.
- m. Press the SAVE hardkey and select SAVE REG 3.
- n. Press the RECALL hardkey, select RECALL REG 1, and wait 10 sec.
- o. Press the STORE DATA hardkey and store R into USER DEF STORE register D1 (select USER DEF STORE, RAB, R, → REG, MORE REG, → D1). Store A into D2 (and B with Option 002) into D3 in the same manner. (RECALL REG 2 for A (and RECALL REG 3 for B with Option 002).)
- p. Press the RECALL hardkey, select RECALL REG 1, and wait 5 sec.
- q. The expected value of the MAG (Trace 1) should be  $-20.000 \pm 0.003$  dB and the PHASE (Trace 2) should be  $0.00 \pm 0.05$  degrees.

**Note**

This finishes the normalization procedure. If unable to normalize, repeat steps n through p until the magnitude at step 9 is  $-20.000 \pm 0.003$  dB.

- r. Repeat steps p and q for channel A (RECALL REG 2) With Option 002 also repeat steps p and q for channel B (RECALL REG 3).
- s. Set the Ratio Transformer to 1.0.
- t. Press the RECALL hardkey, select RECALL REG 1, and wait 5 sec.
- u. The MAG should be  $0.000$  dB  $\pm 0.07$  dB and the PHASE should be  $0.0$  deg  $\pm 0.4$  deg. Record the values in the test record.
- v. Test this Ratio Transformer setting on channel A (and B with Option 002) by recalling register 2 (and 3) as in step t. Record the readings in the test record.
- w. Repeat steps s through v for the Ratio Transformer settings in table 3-3. The magnitude, phase and tolerances are listed in the table. For transformer settings below .01, wait 10 sec after recalling the registers, then press the SWEEP MODE hardkey and select SINGLE.

**Table 3-3. Ratio Transformer Settings**

Ratio Transformer	Magnitude		Phase	
	Upper Limit (dB)	Lower Limit (dB)	Upper Limit (deg)	Lower Limit (deg)
1.0	0.07	-0.07	0.4	-0.4
.31623	-9.94	-10.060	0.2	-0.2
.2	-13.912	-14.039	0.2	-0.2
.05	-25.960	-26.080	0.2	-0.2
.025	-31.981	-32.101	0.2	-0.2
.01	-39.94	-40.06	0.2	-0.2
.0031623	-49.94	-50.06	0.2	-0.2
.001	-59.92	-60.08	0.5	-0.5
.0001	-79.80	-80.20	1.5	-1.5
.00001	-99.25	-100.75	7.5	-7.5

### 3-10 Magnitude vs. Phase Test

#### Specifications:

Peak-to-peak amplitude variation: <0.04 dB.

#### Description:

The magnitude versus phase test is a measure of receiver amplitude variations as phase is varied. A reference measurement is made using a synthesizer as the input signal. The synthesizer frequency is then increased by 0.02 Hz to offset the input phase from the reference measurement. A sweep time of 50 seconds is used to allow the measurement of one complete cycle of phase.

Equipment:
Power Splitter
Synthesizer
Type N RF Cables-24 inch (3 each)
BNC Cables-48 inch (2 each)
N male to BNC female Adapter (2 each)
50Ω Precision Termination (if no Channel B)

HP 3577B

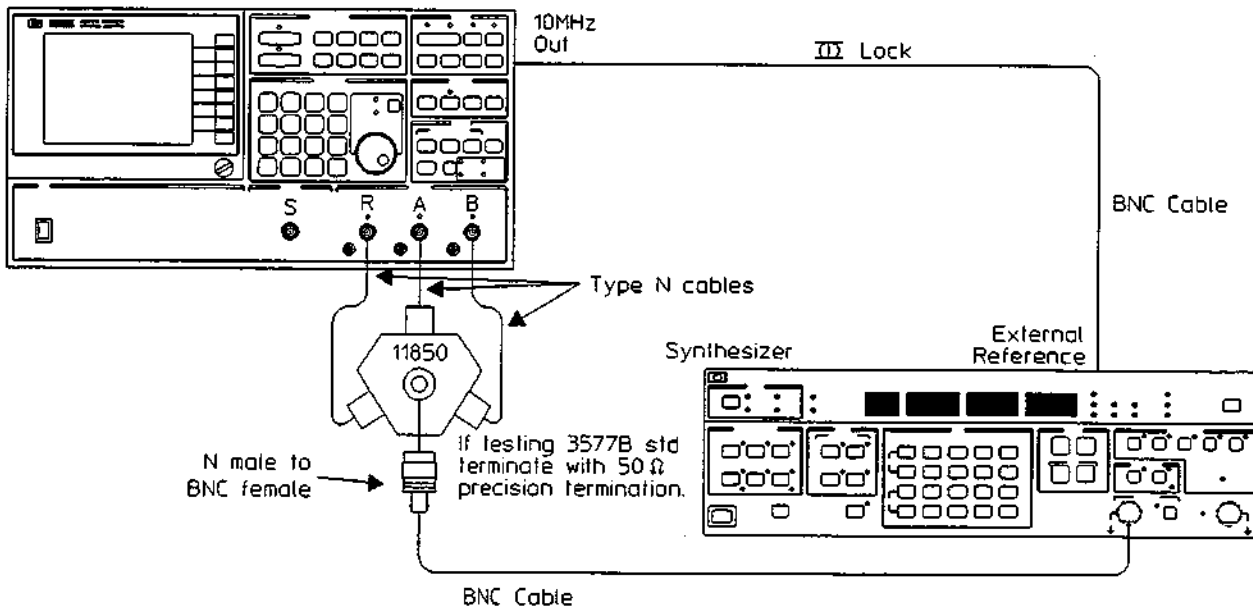


Figure 3-6. Dynamic Linearity (Magnitude vs. Phase) Test Set-Up

**Procedure:**

- a. Set up the equipment as shown in figure 3-6. Make sure the HP 3577B 10 MHz OUT is connected to the synthesizer external reference input. The EXT REF LED on the front panel of the synthesizer should be on.
- b. Preset the HP 3577B.
- c. Set the HP 3577B to the following conditions:
 

SWEEP MODE	SINGLE
SWEEP TIME	50 sec
FREQ	
START FREQ	1.75 MHz
STOP FREQ	1.75 MHz
AMPTD	- 48 dBm
RES BW	10 Hz
SCALE	
REF POSN	50%
- d. Set the synthesizer amplitude to - 29 dBm and frequency to 1.75 MHz.
- e. Press the TRIG/RESET hardkey and let the HP 3577B complete a sweep.
- f. The marker MAG on the HP 3577B should read approximately - 39 dBm.
- g. Press the SCALE hardkey and select AUTO SCALE.
- h. Increase the synthesizer frequency by 0.02 Hz.
- i. Press TRIG/RESET on the HP 3577B and let the HP 3577B complete a sweep.
- j. Press the MKR → hardkey and select MKR → MIN. Press the MKR hardkey and select ZERO MARKER. Press the MKR → hardkey and select MKR → MAX.
- k. The marker MAG should read <0.04 dB. Record the reading in the test record.
- l. Repeat step j and k for channel A (and B with Option 002).

---

## 3-11A Receiver Level Flatness And Absolute Accuracy Test

---

**Note**



Perform test 3-11A using a W&G EPM-1 power meter or perform test 3-11B using an HP 436A Power Meter (Option 022) and a HP 3458A voltmeter.

---

**Specifications:**

Absolute (at 100 kHz and full scale input): A B R Mode:  $\pm 0.2$  dB.

Flatness (at full scale input):

Input	Mode	20 Hz to 20 MHz	5 Hz to 20 MHz	5 Hz to 200 MHz
50 $\Omega$	A B R	0.3 dB pp	N/A	0.6 dB pp
1 M $\Omega$	A B R	0.5 dB pp	1.0 dB pp	N/A

---

**Note**



If test results at 5-10 Hz do not meet specifications, refer to the EPM-1 flatness test described in this test 3-22.

---

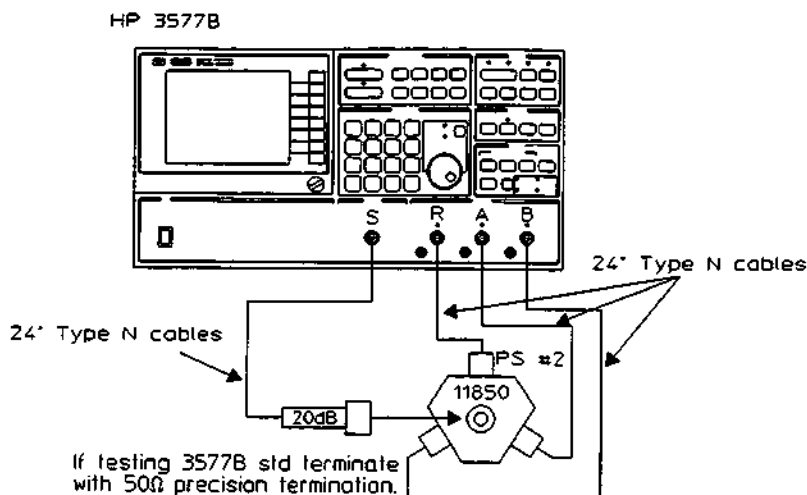
**Description:**

The flatness and absolute accuracy of each receiver (R, A, and B) is verified by leveling the HP 3577B source to a known accuracy and splitting the output with a three-port power splitter, each port driving a receiver channel. The HP 3577B source is externally leveled, using a W&G EPM-1 power meter as detector and reference level. The EPM-1 outputs an error correction signal to the source through connector W6 on the source board, maintaining 0 dBm at the EPM-1 power head. The 50 $\Omega$  three-way resistive power splitter provides equal incident power at each port. Assuming all ports are terminated in 50 $\Omega$  (reflected power is 0), the power delivered to the other two power splitter ports is equal to the power delivered to the EPM-1 port. The second power splitter divides the source into three equal outputs which become the test level inputs for each of the receivers. Knowing the transmission loss from the output of power splitter #1 (PS #1) to each receiver port allows the user to normalize the receiver input level to the EPM-1 level of PS #1. Because the transmission loss for each channel is equal (assuming a symmetrical power splitter), it is necessary to find only the transmission loss from PS #1 to channel R of PS #2 to normalize the receiver level for all channels. The transmission loss is stored in register D1 for the 5 Hz to 200 MHz frequency span and in register D2 for the 5 Hz to 20 MHz span.

Following calibration, the receiver input levels are normalized to the EPM-1 level, and the receiver input levels are measured and compared to the calibrated level. This procedure verifies the flatness and absolute accuracy for receiver input impedances of 50 $\Omega$ . The Hi-Z (1 M $\Omega$ ) response is verified by installing a 50 $\Omega$  feedthrough termination at each receiver input and repeating the procedure.

Because the HP 3577B receivers take data simultaneously, only one frequency sweep is necessary to verify receiver performance at a selected input level (0 dBm or -20 dBm). Therefore to measure the complete absolute frequency performance of the three receivers, it is necessary to complete only four sweeps — from 5 Hz to 200 MHz for each input level (50 $\Omega$  input impedance) and from 5 Hz to 20 MHz for each input level (1 M $\Omega$  input impedance).

Equipment:
Milliwatt Power Meter
Power Splitter (2 each)
Type N RF Cables-24 inch (4 each)
50 $\Omega$ Precision Termination (2 each)
Error Correction Cable
20 dB Attenuator
N-male to N-male Adapter
50 $\Omega$ Feedthrough Termination (3 each)
N male to BNC female Adapter (6 each)
BNC Cables-12 inch (3 each)



**Figure 3-7. Calibration of Transmission Loss**

**Procedure:**

**Note**



All information related to 1 MΩ test conditions in steps d through ff is in parentheses.

- a. Preset the HP 3577B.
- b. Connect the EPM-1 power head to the port marked OUTPUT on the front panel of the power meter and adjust the CAL potentiometer for a 0 dBm level (red scale) on the EPM-1 meter. This calibrates the EPM-1.
- c. Connect a 24-inch type N cable from the HP 3577B source to receiver R.

d. Set the HP 3577B controls for the following settings:

SWEEP TYPE	LOG FREQ SWEEP
SWEEP MODE	SINGLE
SWEEP TIME for 50 $\Omega$	20 sec
(SWEEP TIME for 1 M $\Omega$ )	15 sec)
FREQ	
START FREQ	5 Hz
STOP FREQ for 50 $\Omega$	200 MHz
(STOP FREQ for 1 M $\Omega$ )	20 MHz)
RES BW	100 Hz
SCALE	
REF POSN	50%

e. Press the TRIG/RESET hardkey and let the HP 3577B complete a sweep.

f. Press the MEASR CAL hardkey and select NORMALIZE.

g. Disconnect the 24-inch cable from receiver R and connect it to the 20 dB attenuator. Connect the equipment as shown in figure 3-7.

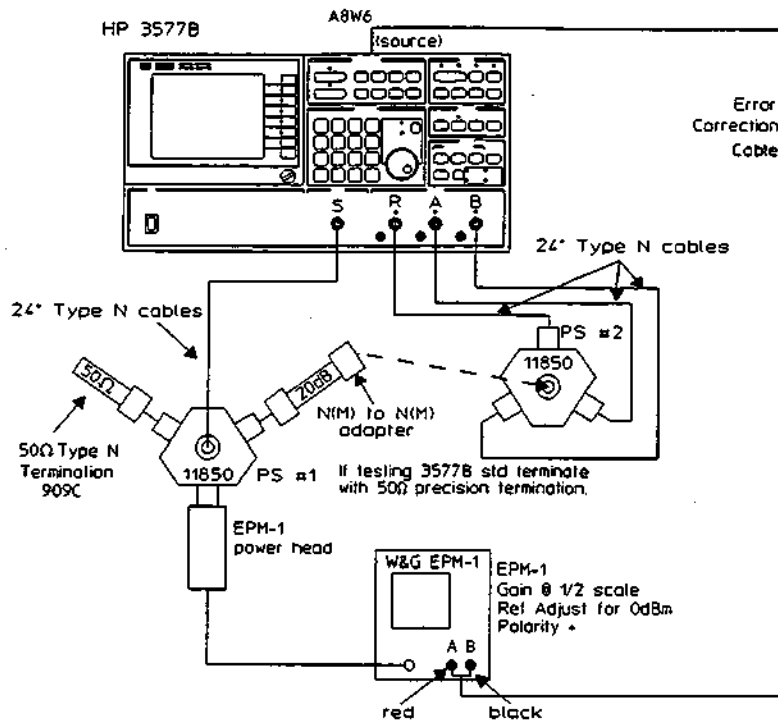
h. Press the SCALE hardkey and set the/DIV to 0.5 dB and the REF LEVEL to - 29.5 dB.

i. Press the TRIG/RESET hardkey to trigger a second sweep and store the data in register D1 (register D2 for 1 M $\Omega$ ). The transmission loss should be approximately - 30 dB.

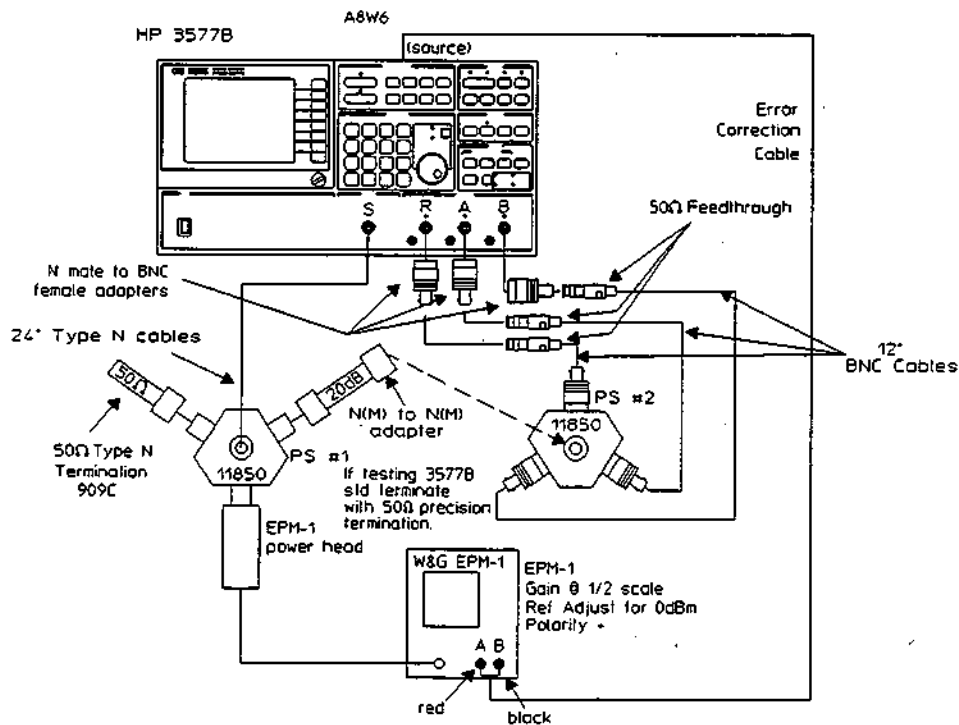
j. Press AMPTD hardkey and enter AMPTD of +10 dBm.

k. Connect the equipment as shown in figure 3-8 (figure 3-9 for 1 M $\Omega$ ). The EPM-1 Error Correction Cable connects to W6 at the top of the HP 3577B source board, A8, after removing the jumper. The EPM-1 power meter level will swing from - 0.2 dBm to +0.2 dBm several times and settle to some level between the two points. Adjust the reference control on the front panel of the EPM-1 until the meter reads 0 dBm.





**Figure 3-8. Receiver Flatness and Absolute Accuracy Test Set-Up (50 Ω)**



**Figure 3-9. Receiver Flatness and Absolute Accuracy Test Set-Up (1 MΩ)**

l. Preset the HP 3577B.

m. Set the HP 3577B controls to the following conditions:

SWEEP TYPE	LOG FREQ SWEEP
SWEEP MODE	SINGLE
SWEEP TIME for 50 $\Omega$	100 sec
(SWEEP TIME for 1 M $\Omega$ )	120 sec)
FREQ	
START FREQ	5 Hz
STOP FREQ for 50 $\Omega$	200 Mz
(STOP FREQ for 1 M $\Omega$ )	20 MHz)
ATTEN for 50 $\Omega$	50 $\Omega$ for IMPED R, A (and B with Option 002)
(ATTEN for 1 M $\Omega$ )	1 M $\Omega$ for IMPED R, A, (and B with Option 002))
AMPTD	+8 dBm
RES BW for 50 $\Omega$	10 Hz
(RES BW for 1 M $\Omega$ )	1 Hz)
SCALE	
REF POSN	50%
/DIV	0.2 dB

- n. Press the DEFINE MATH hardkey and enter a value of 4.472 UNITS for K1 real.
- o. Press the INPUT hardkey and enter a USER DEF INPUT of K1 \* R/D1 (K1 \*R/D2 for 1 M $\Omega$ ).
- p. Press the TRIG/RESET hardkey and follow the sweep marker. When the sweep marker reaches approximately 10 MHz, enter a longer sweep time by pressing the SWEEP TIME hardkey and then the  $\uparrow$  hardkey twice. This increases the sweep time to 500 seconds for the remainder of the sweep. (This is not necessary for the 1 M $\Omega$  impedance.)
- q. Disregarding the "Sweep Rate Uncalibrated" message which may appear at the completion of the sweep, set the SWEEP TIME back to 100 sec. (Skip this step for 1 M $\Omega$  impedance.)
- r. Move the marker to approximately 100 kHz. The marker MAG should read  $0 \pm 0.2$  dB. Record the reading in the test record.
- s. Press the MKR  $\rightarrow$  hardkey and select MKR  $\rightarrow$  MIN.
- t. Press the MKR hardkey and select ZERO MARKER.
- u. Press the MKR  $\rightarrow$  hardkey and select MKR  $\rightarrow$  MAX.
- v. The marker MAG should read 0.6 dB peak to peak (1.0 dB peak to peak for 1 M $\Omega$ ). This is the flatness for channel R for the frequency range of 5 Hz to 200 MHz (frequency range of 5 Hz to 20 MHz for 1 M $\Omega$ ). Record the reading in the test record.
- w. Press the MKR hardkey and turn the MKR OFFSET off.
- x. Move the marker to approximately 20 Hz.

## 3-11A Receiver Level Flatness And Absolute Accuracy Test

- y. Press the MKR hardkey and select ZERO MARKER.
- z. Move the marker within the frequency range of 20 Hz to 20 MHz and find a minimum.
- aa. Press the MKR hardkey and select ZERO MARKER.
- ab. Move the marker within the frequency range of 20 Hz to 20 MHz and find a maximum — should be close to 20 MHz.
- ac. The marker MAG should read  $< 0.3$  dB peak-to-peak (0.5 dB peak-to-peak for 1 M $\Omega$ ). Record the reading in the test record for the 20 Hz to 20 MHz range.
- ad. Press the MKR hardkey and turn MKR OFFSET off.
- ae. Select a USER DEF INPUT of K1\*A/D1 (K1 \* A/D2 for 1 M $\Omega$ ) and repeat steps r through ad for channel A.
- af. Select a USER DEF INPUT of K1\*B/D1 (K1 \* B/D2 for 1 M $\Omega$ ) and repeat steps r through ad for channel B with Option 002.
- ag. Press the ATTEN hardkey and change the attenuation of channels R and A (also B with Option 002) to the 0 dB mode.
- ah. Repeat steps o through af. All specifications remain the same.
- ai. Repeat steps a through ah for 1 M $\Omega$  input impedance. Remember to replace the jumper on the source board for steps a through j. All settings will be the same except for those with a 1 M $\Omega$  option in parentheses.

**3-11B Alternate Receiver Level Flatness And Absolute Accuracy Test**

(EPM-1 Power Meter Not Required.)

**Note**

Perform test 3-11A using W&G EPM-1 Power Meter or perform test 3-11B using an HP 436 Power Meter (Option 022) and a HP 3458A voltmeter.  
Test 3-11B is an alternate test and should be used for operation verification only.

**Specifications:**

Absolute (at 100 kHz and full scale input): A B R Mode:  $\pm 0.2$  dB.

Flatness (at full scale input):

Input	Mode	20 Hz To 20 MHz	5 Hz To 20 MHz	5 Hz To 200 MHz
50 $\Omega$	A B R	0.3 dB pp	N/A	0.6 dB pp
1 M $\Omega$	A B R	0.5 dB pp	1.0 dB pp	N/A

**Description:**

This procedure is an alternate approach for verifying HP 3577B receiver performance. The EPM-1 power meter is replaced by a voltmeter up to 100 kHz and an HP 436A power meter at frequencies above 100 kHz. Discrete measurements must be made rather than the swept measurements possible with the EPM-1. The input signal can be computed once the source output is measured. The difference between the computed level and the measured level is the absolute error of the receiver. This method is essentially the same as that in section 3-11A except that the source level at the output port of the first power splitter is not held constant at 0 dBm. Therefore, the computed receiver input level must be adjusted for the varying source level. Since manual computation for each measurement is tedious, the test procedure includes a short program which performs the following.

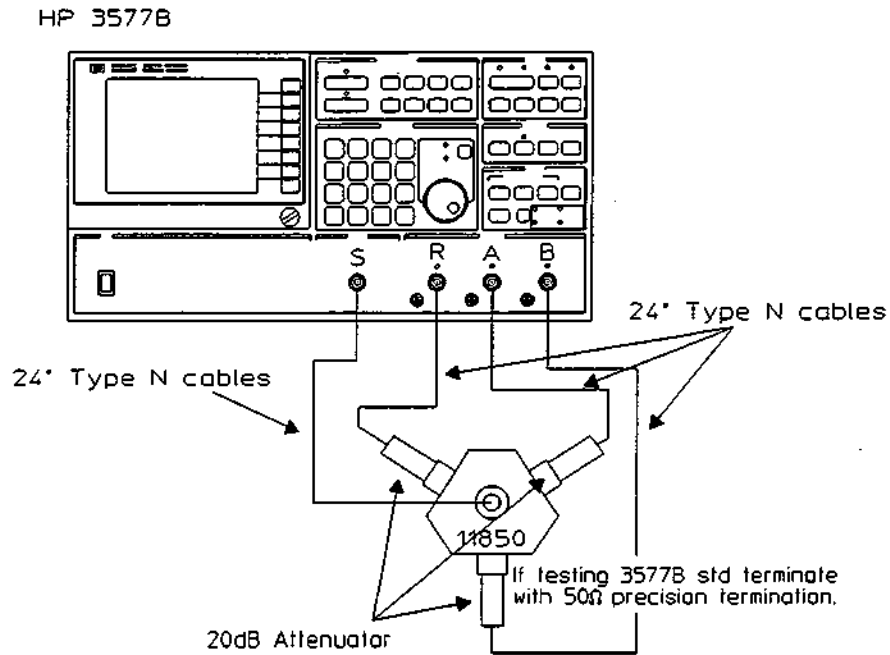
1. Reads the source level
2. Computes a source correction constant
3. Outputs the correction constant to the HP 3577B
4. Reads each receiver level
5. Outputs the results to a computer display and a printer.

## 3-11B Alternate Receiver Level Flatness And Absolute Accuracy Test

The program is written in HP BASIC (3.0) and requires the user to input the verification frequency in MHz.

Before measuring receiver performance the power splitter transmission loss must be calibrated. The voltmeter dBm function is used to read amplitudes up to 100 kHz. Transmission loss from the second power splitter input to each receiver input is measured and stored in registers D1, D2, and D3 for channels R, A, and B respectively.

<b>Equipment:</b>
Controller
Printer (optional)
Voltmeter
Power Meter
Power Head
Power Splitter (2 each)
Type N RF Cables-24 inch (4 each)
BNC Cables-12 inch (3 each)
BNC Cables-48 inch (2 each)
20 dB Attenuator (3 each)
BNC to dual banana plug Adapter
N male to BNC female Adapter (7 each)
N male to N male Adapter
Precision Termination, 50Ω (2)
BNC female to BNC female Adapter
Feedthrough Termination



**Figure 3-10. Receiver Power Splitter Calibration**

**Procedure:**

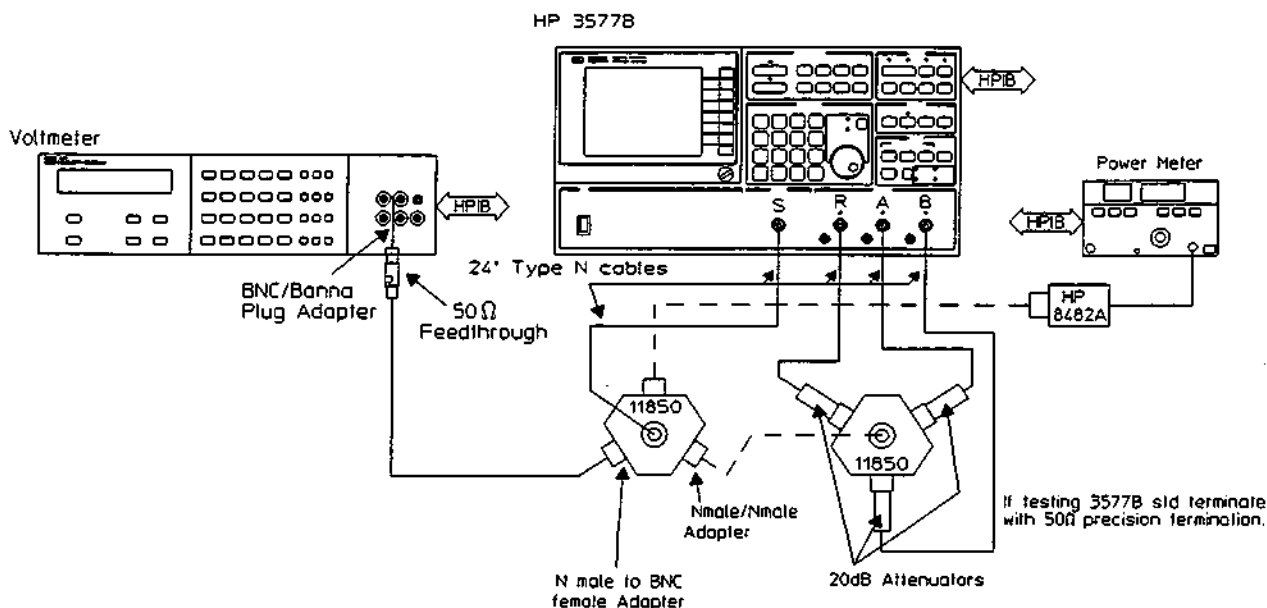
**Calibrate Receiver Power Splitter**

- a. Preset HP 3577B. Connect the HP 3577B source output to receiver R using a 24-inch type N cable.
- b. Set the HP 3577B to the following conditions:
 

SWEEP TYPE	CW
FREQ	1 MHz
RES BW	1 Hz
- c. After the MAG reading on the HP 3577B has settled, store the R input level in register D1 (press STORE DATA hardkey, select MORE REG then STORE REG D1).
- d. Disconnect the cable from receiver R and connect it to receiver A. Press the INPUT hardkey and select A.
- e. Repeat step c, storing the A input level in register D2.
- f. If receiver B is installed, disconnect the cable from receiver A and connect it to receiver B. Press the INPUT hardkey and select B.
- g. Repeat step c, storing the B input level in register D3.
- h. Connect the equipment as shown in figure 3-10. Make sure the same cable used in steps a through g is used to connect the HP 3577B source to the power splitter.

## 3-11B Alternate Receiver Level Flatness And Absolute Accuracy Test

- i. After the marker MAG reading has settled, store R/D1 in register D1 (press the STORE DATA hardkey and USER DEF STORE, RAB, R, → REG, MORE REG, → D1).
- j. Store A/D2 in register D2 and if receiver B is installed, store B/D3 in register D3 as in step i.
- k. Check the normalization data for receiver R by pressing the INPUT hardkey and selecting DATA REG and D1. The marker MAG should be  $-29.5 \text{ dB} \pm .3 \text{ dB}$ .
- l. Check the normalization data for receivers A and B (if installed) as in step k, selecting D2 for A and D3 for B.  
VOLTMETER SETUP
- m. Connect a  $50 \Omega$  feedthrough to the voltmeter using an adapter and press  
OHM  
SHIFT (blue key) S  
and press the DOWN key until SMATH is displayed.
- n. Press  
10 (RES register)  
ENTER  
ACV  
SHIFT (blue key) S  
and press the DOWN key until SETACV is displayed.
- o. Press  
3 (sync)  
ENTER  
SHIFT T  
and press the DOWN key until ACBAND is displayed.
- p. Press  
5,1000000  
ENTER
- q. Press  
SHIFT L  
and press the DOWN key until MATH is displayed.
- r. Press  
5 (dBm)  
ENTER.



**Figure 3-11. Absolute Accuracy and Flatness Test Set-Up (50Ω)**

**Flatness And Absolute Accuracy Test (50Ω).**

- s. Set the CAL FACTOR on the power meter to the value found for 100 kHz on the power head. Set the power meter to the dBm mode and press SENSOR ZERO.
- t. Connect the test equipment as shown in figure 3-11. Also connect via HP-IB the voltmeter, power meter, HP 3577B, and an HP 9000 Series 200 or 300 Computer. The following addresses are used in the program:

Instrument	HP-IB Address
HP 3577B	711
Voltmeter	722
Power Meter	713
Printer	701 (optional; if printout not desired, set print address to 1 by changing line 40 to "ASSIGN @ Prn to 1")



## 3-11B Alternate Receiver Level Flatness And Absolute Accuracy Test

- u. Load and run the following test program on the HP 9000 Series 300 computer. This program is included on your Semiautomated Performance Test Disk as "ALT\_FLAT":

```

10 ! RE-SAVE "ALT_INP_FLAT"
20 DIM Model$(100)
30 ASSIGN @Dut TO 711
40 ASSIGN @Prn TO 701
50 ASSIGN @Pm TO 713
60 ASSIGN @Dvm TO 722
70 INPUT "ENTER THE POWER METER CALIBRATION READING AT 100kHz (DBM)...",Pm_100khz
80 INPUT "ENTER THE VOLTMETER READING AT 100kHz...",Vm_100khz
90 Pm_100khz = Pm_100khz - Vm_100khz
100 OUTPUT @Dut;"ID?"
110 ENTER @Dut;Model$
120 IF POS(Model$,"3577A") THEN
130   Ch_b = 1
140 ELSE
150   OUTPUT @Dut;"DMB"
160   ENTER @Dut;Ch_b
170 END IF
180 OUTPUT @Pm USING "#,@"
190 OUTPUT @Pm USING "#,3/"
200 OUTPUT @Pm;"      FREQ (MHZ)  CHANNEL R (DB)  CHANNEL A (DB)";
210 IF Ch_b THEN
220   OUTPUT @Pm;"      CHANNEL B (DB)"
230 ELSE
240   OUTPUT @Pm;"
250 END IF
260 OUTPUT @Pm;"
270 Freq$ = ".1"
280 LOOP
290 OUTPUT 2 USING "#,K";Freq$;" H"
300 INPUT "ENTER THE FREQUENCY IN MHZ...",Freq$
310 OUTPUT @Dut;"SFR"&Freq$&"MHZ"
320 WAIT 10
330 IF VAL(Freq$) < .2 THEN
340   ENTER @Dvm;Vm
350   K1 = 10 ^ (-Vm/20)*SQR(20)
360   IF VAL(Freq$) < .0001 THEN
370     OUTPUT @Dut;"BW1"
380   ELSE
390     OUTPUT @Dut;"BW2"
400   END IF
410 ELSE
420   OUTPUT @Pm;"9D-V"
430   ENTER @Pm;Pm
440   K1 = 10 ^ ((-Pm - Pm_100khz)/20)*SQR(20)
450   PRINT TABXY(8,9),"SET THE POWER HEAD CALIBRATION FACTOR ON THE 436A.."
460 END IF
470 OUTPUT @Dut;"KR1"&VAL$(K1)&";"
480 OUTPUT @Dut;"UDI K1*R/D1; TKM"
490 GOSUB Marker_dump
500 R = Marker
510 PRINT TABXY(5,11),"CHANNEL R ACCURACY AT "&Freq$&"MHZ IS "&VAL$(PROUND(Marker,-3))&"DB
520 OUTPUT @Dut;"UDI K1*A/D2; TKM"
530 GOSUB Marker_dump
540 A = Marker
550 PRINT TABXY(5,13),"CHANNEL A ACCURACY AT "&Freq$&"MHZ IS "&VAL$(PROUND(Marker,-3))&"DB
560 IF Ch_b THEN
570   OUTPUT @Dut;"UDI K1*B/D3; TKM"
580   GOSUB Marker_dump
590   B = Marker
600   PRINT TABXY(5,15),"CHANNEL B ACCURACY AT "&Freq$&"MHZ IS "&VAL$(PROUND(Marker,-3))&"DB
610 END IF
620 GOSUB Print_result
630 END LOOP

```

```

640 Marker_dump:OUTPUT @Dut;"DM1"
650 ENTER @Dut;Marker
660 RETURN
670 Print_result: !
680 IMAGE 10X,7A,7X,MD.DDD,15X,MD.DDD,17X,#
690 IMAGE MD.DDD
700 OUTPUT @Prn USING 690;Freq$,R,A
710 IF Ch_b THEN
720 OUTPUT @Prn USING 690;B
730 ELSE
740 OUTPUT @Prn;"
750 END IF
760 RETURN
770 END

```

**Note**

The "H" at the end of step 290 is actually entered as "SHIFT CTL←" simultaneously on the controller.

v. Preset the HP 3577B.

w. Set the HP 3577B to the following conditions:

SWEEP TYPE	CW
FREQ	100 kHz
AMPTD	
AMPTD	9.5 dBm
STEP SIZE	1 dB
RES BW	10 Hz
INPUT	K1*R/D1

- x. Press the HP 3577B AMPTD hardkey, select AMPTD, and vary the amplitude using the ↑ and ↓ keys until the power meter reads  $0 \text{ dBm} \pm 0.1$ . The HP 3577B source amplitude should be  $9.5 \text{ dBm} \pm 0.5 \text{ dB}$ . The voltmeter should read  $0 \text{ dB} \pm 0.0500$ . Record the HP 3577B source amplitude level, the power meter reading, and the voltmeter reading in the test record.
- y. Press RUN or type RUN and press RETURN on the HP 9000 Series 200 or 300 controller and enter the reading of the power meter and of the voltmeter as directed by the program.
- z. Disconnect the power head from the power splitter and terminate the power splitter port with a  $50\Omega$  precision termination.

aa. Enter a frequency of 0.1 MHz on the controller (all frequencies must be entered in MHz).

**Note**



Each measurement takes approximately 10 seconds to complete. This allows time for the power meter, and voltmeter to settle.

- ab. Record the readings for channels R and A (and B with Option 002) in the test record as the absolute level at 100 kHz. The readings should be  $0.0 \pm .2$  dB.
- ac. Enter each of the frequencies in table 3-4 on the controller, recording the readings for channels R and A (and B with Option 002) in the test record or attach printout to the test record.

**Table 3-4. Voltmeter Test Frequencies**

.000005 MHz	.005 MHz
.00002 MHz	.01 MHz
.0001 MHz	.02 MHz
.001 MHz	.05 MHz
.002 MHz	.1 MHz

- ad. Disconnect the precision termination from the power splitter. Reconnect the power head to the power splitter. Disconnect the voltmeter and terminate the power splitter with a precision termination.
- ae. Enter each frequency from table 3-5 on the controller. Set the CAL FACTOR on the power meter to the value found for each frequency.
- af. Record the readings for channels R, A, and B (if installed) in the test record for each frequency or attach a printout to test record.

**Table 3-5. Power Meter Test Frequencies**

0.2 MHz	20 MHz	140 MHz
0.5 MHz	30 MHz	160 MHz
1 MHz	50 MHz	170 MHz
2 MHz	75 MHz	180 MHz
5 MHz	100 MHz	190 MHz
10 MHz	120 MHz	200 MHz

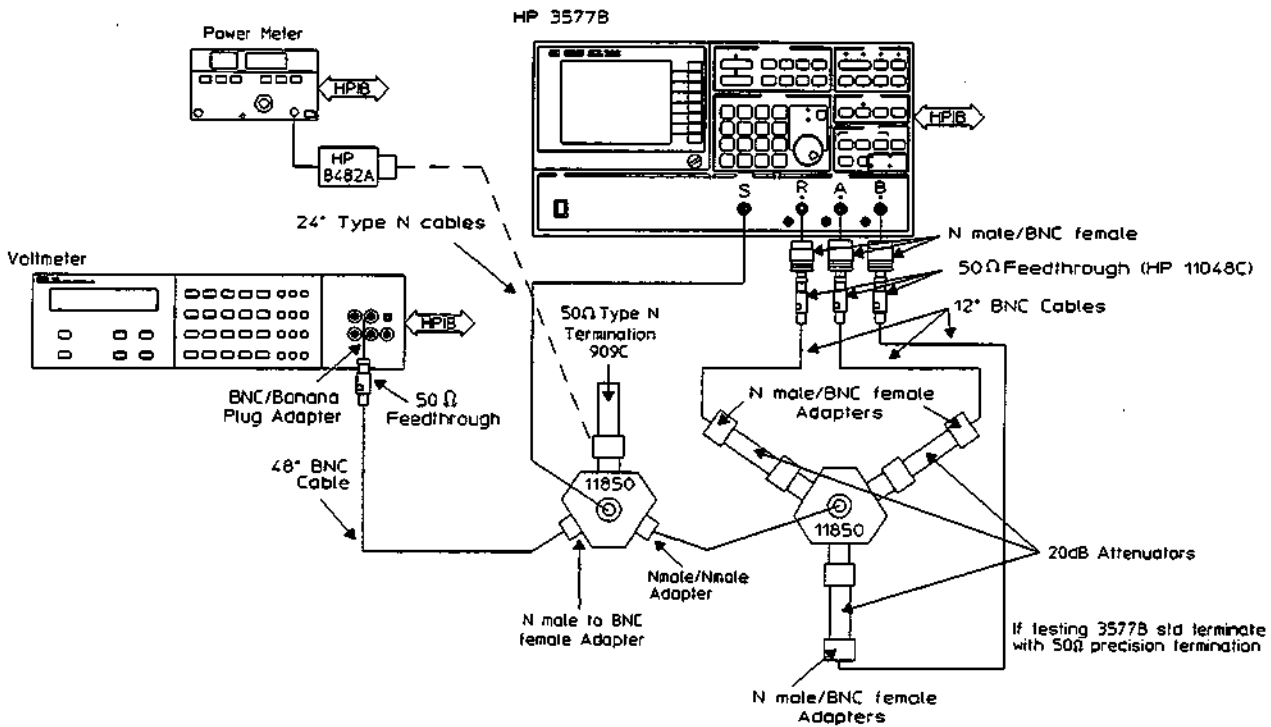
- ag. To calculate the flatness from 5 Hz to 200 MHz for each channel, find the maximum reading in the test record column for that channel. Subtract the minimum reading from the maximum reading in the same column and record the result as the flatness (in dB) for that channel from 5 Hz to 200 MHz. The results should be  $< .6$  dB.
- ah. To calculate the flatness from 20 Hz to 20 MHz for each channel, find the maximum reading between 20 Hz (.00002 MHz) and 20 MHz in the test record column. Subtract the minimum reading from the maximum reading in the frequency range and record the result as the flatness for that channel from 20 Hz to 20 MHz. The results should be  $< .3$  dB.
- ai. Press the LCL hardkey and set the HP 3577B input attenuation for all channels to 0 dB (press the ATTEN hardkey and select ATTEN R 0 dB, ATTEN A 0 dB, and ATTEN B 0 dB, if receiver B is installed).
- aj. Connect the voltmeter and 50 $\Omega$  feedthrough to the power splitter. Repeat steps z through ah of this section.

**Flatness And Absolute Accuracy Test (1MΩ)**

**Note**



If this test is performed independent of the preceding 50Ω test, the receiver power splitter must be calibrated (steps a through r of the Calibrate Receiver Power Splitter section). If the receiver power splitter has been calibrated for the 50Ω test, it need not be recalibrated for the 1 MΩ test. The program in step u must also be entered into the controller if the 1 MΩ test is run independently.



**Figure 3-12. Absolute Accuracy and Flatness Test Set-Up ( 1 MΩ )**

ak. Connect the test equipment as shown in figure 3-12.

al. Preset the HP 3577B.

am. Set the HP 3577B to the following conditions:

<b>SWEEP TYPE</b>	CW
<b>FREQ</b>	100 kHz
<b>AMPTD</b>	level from step c of this section
<b>RES BW</b>	10 Hz
<b>ATTEN</b>	
<b>IMPED</b>	1 MΩ for channels R, A, and B (if B is installed)

- an. Press RUN or type RUN and press RETURN on the controller. Enter the power meter reading from step x of this section when the program asks for the power meter reading. Enter the voltmeter reading from step x of this section when the program asks for the voltmeter reading.
- ao. Enter a frequency of 0.1 MHz on the controller. Record the receiver measurements in the test record as the absolute accuracy at 100 kHz. The reading should be  $0.0 \pm 0.2$  dB.
- ap. Enter each frequency from table 3-4 on the controller and record the receiver measurements at each frequency in the test record or attach a printout to the test record.
- aq. Repeat steps ad to af for frequencies up to 20 MHz.
- ar. To calculate the flatness from 5 Hz to 20 MHz for each channel, find the maximum reading in the test record column for that channel. Subtract the minimum reading from the maximum reading in the column and record the result in the test record. The flatness should be  $< 1.0$  dB.
- as. To calculate the flatness from 20 Hz to 20 MHz for each channel, find the maximum reading between 20 Hz (.00002 MHz) and 20 MHz in the test record column. Subtract the minimum reading from the maximum reading in the frequency range and record the result in the test record. The flatness should be  $< 0.5$  dB.
- at. Press the LCL hardkey. Set the HP 3577B input attenuation for all channels to 0 dB.
- au. Repeat steps ao through as for input attenuation of 0 dB.

## 3-12 Receiver Ratio Amplitude And Phase Accuracy

### Specifications:

#### Flatness And Absolute Accuracy:

Absolute (at 100 kHz and full scale input):

Ratio: A/R B/R A/B Mode: 50Ω input ± 0.15 dB

1 MΩ input ± 0.2 dB

Flatness (at full scale input):

Same Attenuator settings for ratio mode (column 1 of tables 3-6, 3-7, and 3-8):

Input	Mode	20 Hz to 20 MHz	5 Hz to 20 MHz	5 Hz to 200 MHz
50Ω	A/R,B/R,A/B	0.3 dB pp	N/A	0.4 dB pp
1 MΩ	A/R,B/R,A/B	0.3 dB pp	0.6 dB pp	N/A

Different Attenuator settings for ratio mode (column 2 tables 3-6 , 3-7, and 3-8):

50Ω mode: add 0.15 dB to above for 20 Hz to 20 MHz

add 0.30 dB to above for 5 Hz to 200 MHz

1 MΩ mode: add 0.20 dB to above for 20 Hz to 20 MHz

add 0.40 dB to above for 5 Hz to 20 MHz

#### Phase:

Absolute: ± 2 degree at 100 kHz

#### Flatness:

Same attenuator settings for ratio mode:

Frequency	50Ω Input	1 MΩ Input
20 Hz to 20 MHz	2 deg pp	5 deg pp
5 Hz to 200 MHz	10 deg pp	N/A
5 Hz to 20 MHz	N/A	10 deg pp

Different Attenuator settings for ratio mode: add 8 deg to above.

**Description:**

Ratio amplitude and phase accuracy are verified by sweeping each receiver input separately with the source for both attenuator settings. The data is stored into registers and the ratios of these data registers are displayed to measure the amplitude and phase ratios of the receivers. The ratio performance will be verified for two frequency ranges: 5 Hz to 200 MHz and 20 Hz to 20 MHz. Two sweeps will be made for each frequency span: one at 20 dB input attenuation and the other at 0 dB. Ratio performance will be checked with equal and unequal input attenuators.

<b>Equipment:</b>
Type N RF Cable-24 inch (1 each)
20 dB Attenuator

**Procedure:**

**5 Hz - 200 MHz Setup:**

- a. Connect the source to input "R" using the type N cable.
- b. Preset the HP 3577B.
- c. Set the HP 3577B controls for the following settings:

SWEEP TYPE	LOG FREQ SWEEP
SWEEP MODE	SINGLE
FREQ	
START FREQ	5 Hz
STOP FREQ	200 MHz
SWEEP TIME	25 SEC
RES BW	100 Hz
AMPTD	-30 dBm

**Data Collection Procedure:**

- d. Wait four seconds for the instrument to settle, then press the TRIG/RESET hardkey and let the HP 3577B complete a sweep.
- e. Press STORE DATA, MORE REG, STORE REG D2.
- f. Press the ATTEN hardkey and set R to 0 dB.
- g. Wait four seconds for the instrument to settle, then press the TRIG/RESET hardkey and wait for the analyzer to complete a sweep.
- h. Press STORE DATA, MORE REG, STORE REG D1.
- i. Connect the source to input "A" using the same cable (and attenuator for 1 MΩ input)
- j. Press INPUT                    A



- k. Wait four seconds for the instrument to settle, then press the TRIG/RESET hardkey and let the HP 3577B complete a sweep.
- l. Press STORE DATA, MORE REG, STORE REG D4.
- m. Press the ATTEN hardkey and set A to 0 dB.
- n. Wait four seconds for the instrument to settle, then press the TRIG/RESET hardkey and wait for the analyzer to complete a sweep.
- o. Press STORE DATA, MORE REG, STORE REG D3.
- p. Change the following HP 3577B settings:
  - SCALE
  - /DIV                      0.2 dB
  - REF POSN                 50%
- q. Perform the steps listed in the following two Verification sections, for each set of inputs listed in table 3-6 below. The D1 and D3 registers are for the 0 dB attenuator mode and D2 and D4 are for the 20 dB attenuator mode.

**Table 3-6. Ratio Performance Inputs**

Equal Input Attenuators	Unequal Input Attenuators
D4/D2 (20,20) - A/R	D3/D2 (0,20) - a/R
D3/D1 (0,0) - a/r	D4/D1 (20,0) - A/r

**Input Selection**

An example of how to retrieve data from registers follows. For this example we will select the first selection in table 3-6 (D4/D2):

Press the following keys on the HP 3577B:

```

INPUT
  USER DEF INPUT
  D_           4
  /
  D_           2
  ENTER
    
```

**Verification (100 kHz):**

- r. Move the marker to approximately 100 kHz.
- s. Enter the reading in the test record for 100 kHz amplitude for the input and impedance selected.
- t. Press the DISPLY FCTN hardkey and select PHASE.
- u. Press the SCALE hardkey and change /DIV to 5 deg.
- v. Enter the reading in the test record for 100 kHz phase for the input and impedance selected.

**Verification (full span):**

- w. Press the MKR → hardkey and select MKR → MIN. Press the MKR hardkey and select ZERO MARKER. Press the MKR → hardkey and select MKR → MAX.
- x. Enter the phase reading in the test record for the input and impedance selected.
- y. Press the DISPLY FCTN hardkey and select LOG MAG.
- z. Measure the amplitude flatness using the MKR → and MKR hardkeys as in step w
- aa. Enter the MAG reading in the test record for the input and impedance selected.
- ab. Press the MKR hardkey and turn MKR OFFSET off.

If Option 002 is not installed skip the following section (Procedure for Input B) and resume testing at Procedure for 20 Hz to 20 MHz Range, step ak.

**Procedure for Input B:**

- ac. Connect the source to input "B" using the same cable (and attenuator for 1 MΩ inputs)
- ad. Press INPUT                      B
- ae. Wait four seconds for the instrument to settle, then press the TRIG/RESET hardkey and let the HP 3577B complete a sweep.
- af. Repeat the steps in the Input Selection and Verification sections, steps r through ab, for the inputs in table 3-7.

**Table 3-7. Ratio Performance Inputs**

Equal Input Attenuators	Unequal Input Attenuators
B/D2 (20,20) - B/R	B/D1 (20,0) - B/r
D4/B (20,20) - A/B	D3/B (0,20) - a/B

- ag. Press the ATTN hardkey and set B to 0 dB.
- ah. Press INPUT                      B
- ai. Wait four seconds for the instrument to settle, then press the TRIG/RESET hardkey and wait for the analyzer to complete a sweep.
- aj. Repeat the steps in the Input Selection and Verification sections, steps r through ab, for the inputs in table 3-8.

**Table 3-8. Ratio Performance Inputs**

Equal Input Attenuators	Unequal Input Attenuators
B/D1 (0,0) - b/r	B/D2 (0,20) - b/R
D3/B (0,0) - a/b	D4/B (20,0) - A/b

**Procedure for 20 Hz to 20 MHz range:**

- ak. Connect the source to input "R" using the same cable (and attenuator for 1 MΩ input)
- al. Preset the HP 3577B

am. Change the HP 3577B settings as follows:

SWEEP TYPE	LOG FREQ SWEEP
SWEEP MODE	SINGLE
FREQ	
START	20 Hz
STOP	20 MHz
SWEEP TIME	30 sec
RES BW	10 Hz
AMPTD	- 30 dBm

- an. If testing the 1 MΩ inputs press ATTN and change IMPED settings to 1 MΩ
- ao. Repeat the Data Collection procedure steps d through p
- ap. Select an input from table 3-6

**Verification (20 Hz to 20 MHz):**

- aq. Press the DISPLY FCTN hardkey and select PHASE.
- ar. Press the SCALE hardkey and change /DIV to 5 deg.
- as. Press the MKR → hardkey and select MKR → MIN. Press the MKR hardkey and select ZERO MARKER. Press the MKR → hardkey and select MKR → MAX
- at. Enter the phase reading in the test record for the selected input and impedance

au. Press the DISPLY FCTN hardkey and select LOG MAG.

av. Change the following HP 3577B settings:

SCALE	
/DIV	0.2 dB
REF POSN	50%

aw. Measure the amplitude flatness using the MKR → and MKR hardkeys as in step as

ax. Enter the MAG reading in the test record for the selected input and impedance

Repeat the steps in Verification (20 Hz to 20 MHz) for all inputs in table 3-6.

Perform the Procedure for Input B section if Option 002 is installed. Use the Verification (20 Hz to 20 MHz) procedure in place of Input Selection, Verification (100 kHz), and Verification (full span).

#### Verifying 1 MΩ Inputs:

ay. Connect the 20 dB attenuator to input R

az. Connect the source output to the attenuator using the type N cable.

ba. Preset the HP 3577B

bb. Change the HP 3577B settings as follows:

SWEEP TYPE	LOG FREQ SWEEP
SWEEP MODE	SINGLE
SWEEP TIME	30 sec
RES BW	10 Hz
AMPTD	- 30 dBm
ATTEN	
IMPED R	1 MΩ
IMPED A	1 MΩ
IMPED B	1 MΩ (with Option 002)
FREQ	
START FREQ	5 Hz
STOP FREQ	20 MHz

bc. Repeat the test procedure beginning at Data Collection Procedure and ending at Verifying 1MΩ Inputs.

## 3-13 Receiver Crosstalk Test

### Specifications:

Channel isolation > 100 dB below maximum input level.

### Description:

The HP 3577B source is input to one channel at a time and the isolation measured on the other two channels.

Equipment:
Type N RF cable-24 inch (1 each)

### Procedure:

- a. Preset the HP 3577B.
- b. Connect an RF cable between the HP 3577B source and receiver R.
- c. Set the HP 3577B to the following conditions:

<b>SWEEP TYPE</b>	<b>LOG FREQ SWEEP</b>
<b>SWEEP TIME</b>	20 sec
<b>FREQ</b>	
<b>START FREQ</b>	10 kHz
<b>AMPTD</b>	-1 dBm
<b>RES BW</b>	10 Hz
<b>SCALE</b>	
<b>REF POSN</b>	50%
<b>REF LEVEL</b>	-100 dBm
<b>AVG</b>	256
<b>INPUT</b>	A

- d. Save these instrument conditions in Register 1. (Press hardkey SAVE, select SAVE REG1.)
- e. Allow the HP 3577B to complete two sweeps, then set SWEEP MODE to SINGLE.
- f. The noise level at all points across the sweep should be < -100 dBm. Press the MKR → hardkey and select MKR → MAX. Record the marker MAG reading in the test record.

Perform steps g and h only if *Option 002* is installed:

- g. Select an INPUT of B.
- h. Find the maximum level as in step f; enter the value in the test record.
- i. Move the RF cable from receiver R to receiver A.

- j. Press the RECALL hardkey and select RECALL REG 1. (This resets the HP 3577B to the conditions set up in step c.)
- k. Select an INPUT of R.
- l. Allow the HP 3577B to complete two sweeps, then set SWEEP MODE to SINGLE.
- m. Find the maximum level as in step f; enter the value in the test record.

Perform steps n through u only if *Option 002* is installed:

- n. Select an INPUT of B.
- o. Find the maximum level as in step f; enter the value in the test record.
- p. Move the RF cable from receiver A to receiver B.
- q. Press the RECALL hardkey and select RECALL REG 1.
- r. Allow the HP 3577B to complete two sweeps, then set SWEEP MODE to SINGLE.
- s. Find the maximum level as in step f; enter the value in the test record.
- t. Select an INPUT of R.
- u. Find the maximum level as in step f; enter the value in the test record.

### 3-14 Receiver Return Loss Test

#### Specifications:

Return loss: Channels A, B, and R > 25 dB.

#### Description:

A manual partial port calibration is performed to improve the accuracy of the measurements. Channels A and B are measured, using channel R as the reference. Channel A is then used as a reference to measure channel R.

Equipment:
Directional Bridge
BNC Cables-24 inch (2 each)
10 dB Attenuator
Precision Termination
SMA male to BNC female adapter (2 each)
N male to BNC female adapter (2 each)
N male to N male adapter

HP 3577B

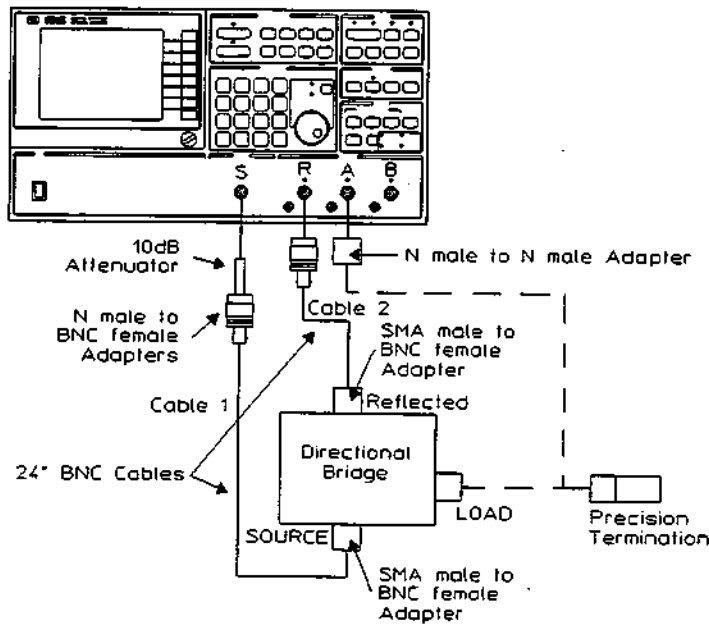


Figure 3-13. Receiver Return Loss Test Set-Up

**Procedure:**

- a. Preset the HP 3577B.
- b. Connect the equipment as shown in figure 3-13, leaving the load port of the directional bridge unconnected.
- c. Set the HP 3577B to the following conditions:
 

SWEEP TIME	5 sec
FREQ	
START FREQ	100 kHz
AMPTD	-15 dBm
RES BW	100 Hz
ATTEN	ATTEN R 0dB
INPUT	R
- d. Allow the HP 3577B to complete one sweep.
- e. Press the STORE hardkey and select MORE REG and STORE REG D1.
- f. Terminate the directional bridge load port with the precision 50 $\Omega$  termination.
- g. Allow the HP 3577B to complete one sweep.
- h. Press the STORE DATA hardkey and select MORE REG and STORE REG D2.
- i. Remove the precision termination and connect the directional bridge load port to HP 3577B receiver A using the N male to N male adapter.
- j. Press the INPUT hardkey and enter a USER DEF INPUT of (R-D2)/D1 (select USER DEF INPUT, (,RAB, R, -, D\_, 2,), /, D\_, 1, ENTER).
- k. Allow the HP 3577B to complete one sweep.
- l. Press the MKR  $\rightarrow$  hardkey and select MKR  $\rightarrow$  MAX.
- m. The marker MAG should read < -25 dB; enter the reading in the test record.
- n. Press the ATTEN hardkey and select ATTEN A 0 dB.
- o. Repeat steps k through m.



Perform steps p and q if *Option 002* is installed:

- p. Connect the directional bridge load port to HP 3577B receiver B.
- q. Repeat steps k through o, selecting ATTEN B 0 dB in step n.
- r. Move cable 2 from receiver R to receiver A and disconnect the directional bridge load port from the receiver input.
- s. Press the INPUT hardkey and select A.
- t. Press the ATTEN hardkey and set ATTEN R to 20 dB.
- u. Repeat steps d through o for channel R using channel A as a reference. Use channel A whenever channel R is called out, even in the equation of step j, and use channel R whenever channel A is called out.

---

## 3-15A Source Flatness And Absolute Accuracy Test

---

**Note**

Perform test 3-15A using a W&G EPM-1 Power Meter or perform test 3-15B using an HP 436 Power Meter and a voltmeter.

---

**Specifications:**

Absolute Accuracy:  $\pm 1$  dB at +15 dBm and 100 kHz.

Flatness: 1.5 dB peak-to-peak from 5 Hz to 200 MHz.

---

**Note**

If test results at 5-10 Hz do not meet specifications, refer to the EPM-1 flatness test described in section 3-22.

---

**Description:**

Source flatness and absolute accuracy are verified using channel R (calibrated receiver) to measure the source error directly. Before proceeding with the source verification, channel R is calibrated to remove its frequency response errors. Channel R error correction terms are stored in register D1 and test system error correction terms are stored in registers D2 (error correction for the transmission loss from the power splitter to channel R) and D3 (error correction terms for cable loss of the source cable).

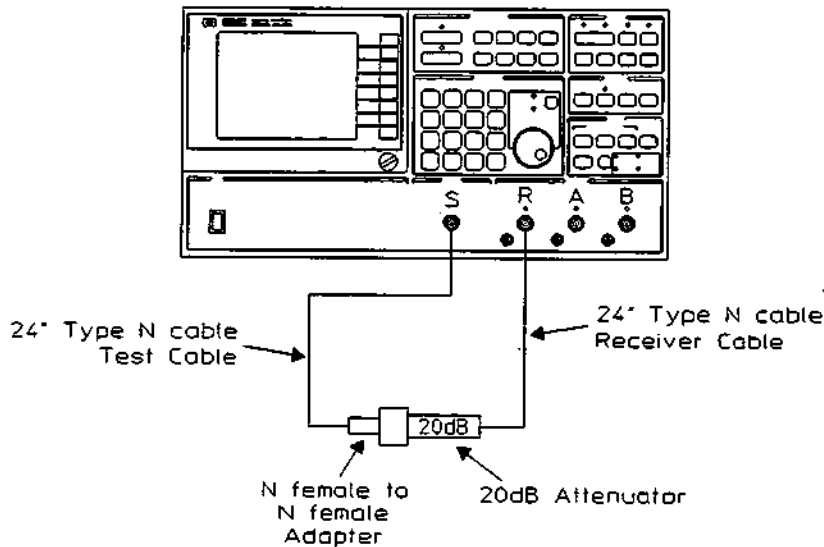
The test configuration used for calibration of channel R is very similar to that used for the receiver performance test. The EPM-1 power meter levels the HP 3577B source, maintaining an output of 0 dB at each of the power splitter ports. One output of the power splitter is attenuated by 20 dB and input to channel R. A single sweep is made and the error response of channel R is displayed after error correction for the transmission loss from the attenuator to channel R [Chan-R-error(freq)]. The results are stored in register D1. The final sweep is the source accuracy and flatness measurement, which is made without the EPM-1 (figure 3-18) and is the product of the source and receiver error response [Source-error X Chan-R-error]. The ratio of the final sweep with the receiver calibration sweep is the source amplitude error.

$$\text{Source-error}(@ \text{freq}) = [\text{Source-error} \times \text{Chan-R-error}] / \text{Chan-R-error}(@ \text{freq})$$

Flatness and absolute accuracy of the source are read directly from the HP 3577B display.

Equipment:
Milliwatt Power Meter
20 dB Attenuator
Error Correction Cable
Power Splitter
Precision Termination (2 each)
RF Cables-24 inch (2 each)
N female to N female adapter

HP 3577B



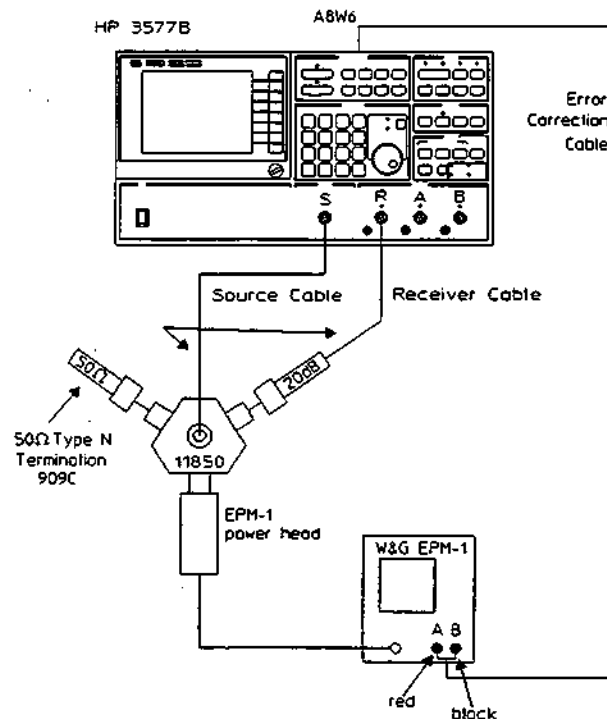
**Figure 3-14. Calibration of Transmission Loss from Power Splitter to Channel R**

**Procedure:**

- a. Preset the HP 3577B.
- b. Set the HP 3577B controls to the following settings:

SWEEP TYPE	LOG FREQ SWEEP
SWEEP MODE	SINGLE
SWEEP TIME	20 sec
FREQ	
START FREQ	5 Hz
STOP FREQ	200 MHz
RES BW	
SCALE	
REF POSN	50%
/DIV	0.2 dB

- c. Connect a 24-inch cable between the source and receiver R. This is labeled the "test" cable.
- d. Press the TRIG/RESET hardkey to trigger a sweep and let the HP 3577B complete the sweep.
- e. Press the MEASR CAL hardkey and select NORMALIZE.
- f. Connect another 24-inch cable between the first cable and receiver R, using an N female to N female adapter between the two cables. This second cable is labeled the "source" cable.
- g. Press the TRIG/RESET hardkey and let the HP 3577B complete a sweep.
- h. Press the STORE DATA hardkey and select MORE REG and STORE REG D3. This is the cable loss of the source cable.
- i. Connect the equipment as shown in figure 3-14.
- j. Press the SCALE hardkey and set the REF LEVEL to  $-20$  dB.
- k. Press the TRIG/RESET hardkey and let the HP 3577B complete a sweep.
- l. Press the STORE DATA hardkey and select MORE REG and STORE REG D2. This is the transmission loss from the output of the power splitter to receiver R.
- m. Connect the equipment as shown in figure 3-15.



**Figure 3-15. Channel R Calibration for Source Flatness and Accuracy**

n. Change only the following HP 3577B settings:

SWEEP TIME	100 sec
RES BW	10 Hz
AMPTD	+ 10 dBm
SCAL	
/DIV	0.5 dB
REF LEVEL	0 dB
INPUT	K1*R/D2
DEFINE MATH	
K1	
K1 REAL	4.472 UNITS

o. Set the EPM-1 controls for the following settings:

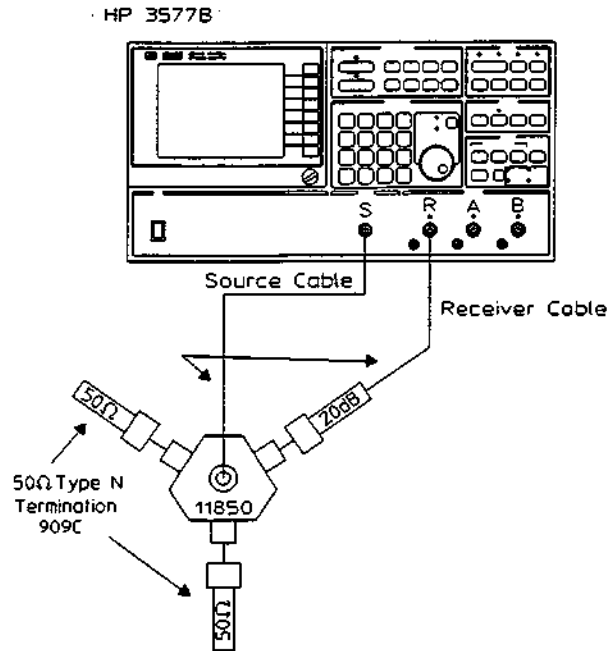
RANGE	0 dBm (red scale)
POLARITY SWITCH	POS
GAIN	Adjust to approximately half scale
REFERENCE	Adjust for 0 dBm meter reading

p. Wait until EPM-1 settles at approximately 0 dBm and press the HP 3577B TRIG/RESET hardkey. When the sweep marker reaches approximately 20 MHz, enter a longer sweep time by pressing the SWEEP TIME hardkey and then the  $\uparrow$  hardkey twice. This increases the sweep time to 500 seconds for the remainder of the sweep.

q. At the completion of the sweep, set the sweep rate back to 100 seconds. (Disregard the "Sweep Rate Uncalibrated" message which may appear.)

r. Press the STORE DATA hardkey and select MORE REG and STORE REG D1.

s. Disconnect the EPM-1 (including the Error Correction Cable — remember to reinstall the factory installed jumper). Set up the equipment as shown in figure 3-16.



**Figure 3-16. Source Flatness and Absolute Accuracy Test Set-Up**

- t. Press the **DEFINE MATH** hardkey and enter a value of 2.3823 UNITS for K1 REAL.
- u. Press the **INPUT** hardkey and enter a USER DEF INPUT of K1 \*R/D1/D2/D3 (select USER DEF INPUT, K\_\_, 1, \*, RAB, R,/, D\_\_, 1,/, D\_\_, 2,/, D\_\_, 3, ENTER).
- v. Press **AMPTD** hardkey and enter an AMPTD of + 15 dBm.
- w. Press the **TRIG/RESET** hardkey. When the sweep marker reaches approximately 20 MHz, enter a longer sweep by pressing the **SWEEP TIME** hardkey and then the **↑** hardkey twice. This increases the sweep time to 500 seconds for the remainder of the sweep.
- x. Move the marker to approximately 100 kHz. The marker MAG should read  $< \pm 1.0$  dB. Enter the reading in the test record.
- y. Press the **MKR →** hardkey and select **MKR → MIN**. Press the **MKR** hardkey and select **ZERO MARKER**. Press the **MKR →** hardkey and select **MKR → MAX**. The marker MAG should read  $< 1.5$  dB peak-to-peak. Enter the reading in the test record (5 Hz – 200 MHz).

---

## 3-15B Alternate Source Flatness and Absolute Accuracy Test

---

**Note**



Perform test 3-15A using a W&G EPM-1 Power Meter or perform test 3-15B using an HP 436 Power Meter and a voltmeter.

---

**Specifications:**

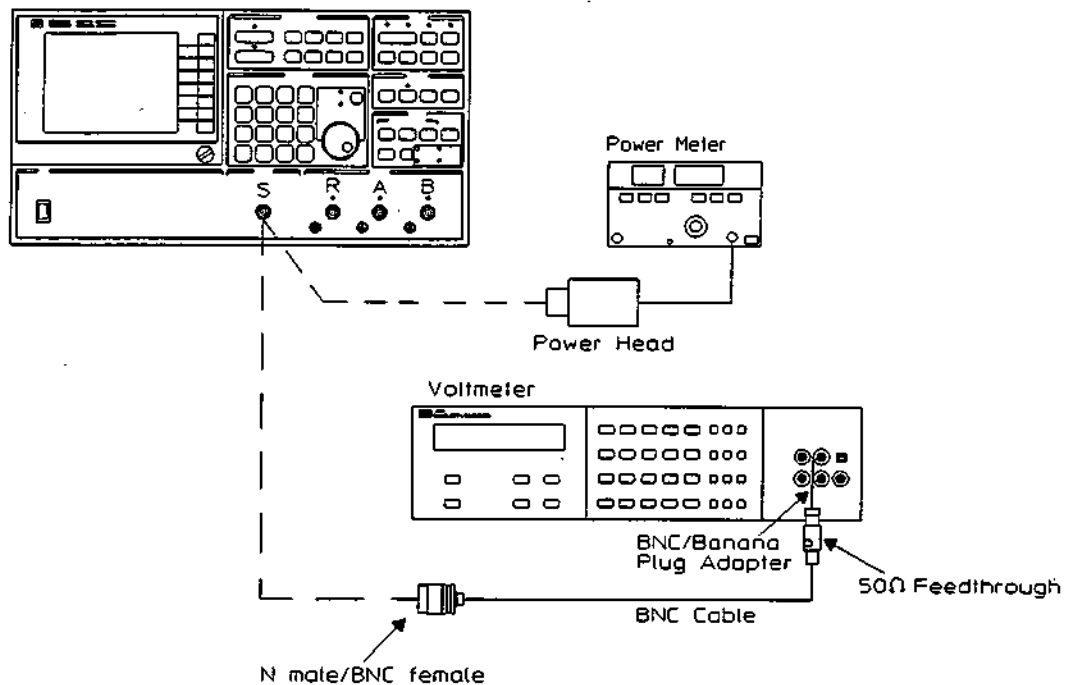
Absolute Accuracy:  $\pm 1$  dB at +15 dBm and 100 kHz  
Flatness: 1.5 dB peak-to-peak from 5 Hz to 200 MHz

**Description:**

This procedure is an alternate approach for verifying the HP 3577B source accuracy using a voltmeter and HP 436A power meter rather than the EPM-1 power meter. Discrete measurements must be made rather than the swept measurements possible with the EPM-1. For frequencies less than 200 kHz, the source level is verified by measuring the voltage across an 11048C 50 $\Omega$  feedthrough using an HP 3458A voltmeter. For frequencies of 200 kHz and above the levels are measured using an HP 436A power meter.

Equipment:
Power Meter
Power Head
Voltmeter
BNC Cable-48 inch
Feedthrough Termination
N male to BNC female adapter
BNC female to dual banana male adapter

HP 3577B



**Figure 3-17. Alternate Source Flatness and Absolute Accuracy Test Set-Up**

**Procedure:**

- a. Preset the HP 3577B.
- b. Set the HP 3577B to the following conditions:
 

SWEEP TYPE	CW
FREQ	100 kHz
AMPTD	+ 15 dBm
VOLTMETER SETUP	
- c. Connect a 50  $\Omega$  feedthrough to the voltmeter using an adapter and press  
OHM  
SHIFT (blue key) S  
and press the DOWN key until SMATH is displayed.
- d. Press  
10 (RES register)  
ENTER  
ACV  
SHIFT (blue key) S  
and press the DOWN key until SETACV is displayed.



- e. Press  
3 (sync)  
ENTER  
SHIFT T  
and press the DOWN key until ACBAND is displayed.
- f. Press  
5,10000000  
ENTER
- g. Press  
SHIFT L  
and press the DOWN key until MATH is displayed.
- h. Press  
5 (dBm)  
ENTER.
- i. Connect the voltmeter to the HP 3577B source output using a BNC cable, feedthrough termination, and N male to BNC female adapter as shown in figure 3-17.
- j. The voltmeter display should read 15 dBm  $\pm$  1 dB. Record the displayed value in the test record.
- k. Enter the following frequencies on the HP 3577B and record the voltmeter reading for each frequency in the test record:
  - 5 Hz
  - 10 Hz
  - 100 Hz
  - 1 kHz
  - 10 kHz
  - 20 kHz
  - 50 kHz
- l. Enter a frequency of 200 kHz on the HP 3577B. Disconnect the voltmeter from the HP 3577B source.
- m. Set the HP 436A function to dBm and the CALIBRATION FACTOR to the 200 kHz value found on the HP 8482A power head. Press SENSOR ZERO on the HP 436A.
- n. Connect the HP 8482A power head to the HP 3577B source as shown in figure 3-17.
- o. Record the HP 436A reading in the test record for 200 kHz.

- p. Enter each frequency from table 3-9 on the HP 3577B, set the 436A CALIBRATION FACTOR to the level found on the calibration curve on the HP 8482A power head for each frequency, and enter the 436A reading on the test record.

**Table 3-9. Source Flatness Test Frequencies**

	1 MHz	10 MHz	100 MHz	160 MHz
200 kHz	2 MHz	20 MHz	120 MHz	180 MHz
500 kHz	5 MHz	50 MHz	140 MHz	200 MHz

- q. To calculate the source flatness, find the maximum level from 5 Hz to 200 MHz and subtract from this level the minimum level in the frequency range. Enter the result in the test record as the flatness from 5 Hz to 200 MHz. The result should be  $< 1.5$  dB.

## 3-16 Source Attenuator Accuracy Test

### Specifications:

Attenuator Accuracy:  $\pm 0.02$  dB/dB or  $\pm 0.2$  dB, whichever is greater.

### Description:

The HP 3577B R channel receiver is used to measure the attenuation of the source.

Equipment:
Type N RF Cable-24 inches (1 each)
20 dB Attenuator
3 dB Attenuator

### Procedure:

- a. Preset the HP 3577B.
- b. Connect the HP 3577B source to HP 3577B receiver R using the RF Cable and both attenuators.
- c. Set the HP 3577B to the following conditions:

SWEEP TIME	5 sec
FREQ	
START FREQ	1 kHz
AMPTD	+ 12 dBm
RES BW	100 Hz
- d. Allow the HP 3577B to complete a sweep. Press the MEASR CAL hardkey and select NORMALIZE.
- e. Press the AMPTD hardkey and enter an AMPTD of +8 dBm. This sets the attenuator to the 4 dB position without disturbing the leveling loop settings.
- f. Press the MKR → hardkey and select MKR → MAX. The marker MAG on the HP 3577B display should read  $-4$  dB  $\pm 0.2$  dB. Record the reading in the test record.
- g. Press the MKR → hardkey and select MKR → MIN. The marker MAG on the HP 3577B display should read  $-4$  dB  $\pm 0.2$  dB. Record the reading in the test record.
- h. Repeat steps e through g for the amplitude and attenuation settings as listed in table 3-10. The marker MAG in steps f and g should read the attenuation value  $\pm$  the attenuation accuracy.

**Table 3-10. Source Attenuator Accuracy Tests**

<b>Amplitude (dBm)</b>	<b>Upper Limit (dB)</b>	<b>Lower Limit (dB)</b>
+8	-3.8	-4.2
+4	-7.8	-8.2
-4	-15.68	-16.32
-20	-31.36	-32.64
-36B	-47.04	-48.96

## 3-17 Source Distortion And Spur Test

### Specifications:

Harmonic Distortion:  $< -25$  dB

Non-harmonic Spurious:  $< -50$  dBc or  $< -70$  dBm, whichever is greater.

### Description:

The HP 3577B is connected to a spectrum analyzer and the spurious signals measured.

Equipment:
Spectrum Analyzer
Type N RF Cable-24 inches (1 each)

### Procedure:

- a. Preset the HP 3577B.
- b. Connect the HP 3577B source to the spectrum analyzer input.
- c. Press the SWEEP TYPE hardkey and select CW. Set the HP 3577B FREQ to the following frequencies, verifying that all harmonics are at least 25 dB below the fundamental:

250 kHz	10 MHz	150 MHz
459 kHz	100 MHz	200 MHz

Record the level of the largest harmonic for each frequency in the test record.

- d. Set the HP 3577B FREQ to 50 MHz.
- e. Adjust the spectrum analyzer to observe the frequencies listed in table 3- for the 50 MHz HP 3577B frequency. These are spurious frequencies generated in the HP 3577B. While checking these frequencies, be sure to note any other spurious signals. All spurious signals other than harmonics should be  $< -50$  dBc or  $< -70$  dBm. Record the levels for the listed frequencies in the test record.
- f. Repeat steps d and e for all HP 3577 frequencies in table 3-11.

Table 3-11 . Source Distortion Test Points

HP 3577B Frequency	Spectrum Analyzer Frequency	Maximum Allowable Level
50 MHz	250.25 MHz	- 50 dBc
	200.25 MHz	- 50 dBc
	100.25 MHz	- 50 dBc
	150.25 MHz	- 50 dBc
100 MHz	200.25 MHz	- 50 dBc
	100.25 MHz	- 50 dBc
	99.75 MHz	- 50 dBc
	200.50 MHz	- 50 dBc
	0.25 MHz	- 50 dBc
150 MHz	150.25 MHz	- 50 dBc
	0.25 MHz	- 50 dBc
	150.50 MHz	- 50 dBc
	0.50 MHz	- 50 dBc
	151.00 MHz	- 50 dBc
	149.75 MHz	- 50 dBc
200 MHz	100.25 MHz	- 50 dBc
	99.75 MHz	- 50 dBc
	0.50 MHz	- 50 dBc
	199.50 MHz	- 50 dBc
	201.00 MHz	- 50 dBc
	199.00 MHz	- 50 dBc
0.75 MHz	300.25 MHz	- 50 dBc
	301.00 MHz	- 50 dBc
99.75 MHz	400.00 MHz	- 50 dBc

## 3-18 Source Phase Noise Test

### Specifications:

SSB Phase Noise (1 Hz bandwidth, excluding spurious)	
Offset Frequency	Level
100 Hz to 20 kHz	< - 70 dBc

### Description:

The HP 3577B source phase noise is measured normalized to a 1 Hz bandwidth using the noise level function of the HP 8568B spectrum analyzer. Measurements are made with three offsets for each of two HP 3577B frequencies.

Equipment:
Spectrum Analyzer
Type N RF Cable-24 inch (1 each)
BNC Cable-48 inch

### Procedure:

- a. Preset HP 3577B.
- b. Connect the RF cable from the HP 3577B source to the spectrum analyzer input 2.  
Connect the 10 MHz REF OUT from the spectrum analyzer to the HP 3577B EXT REF IN. The EXT REF LED on the HP 3577B front panel should be on.
- c. Set the HP 3577B to the following conditions:

SWEEP TYPE	CW
SWEEP TIME(SAMPLE TIME)	10 sec
FREQ	1.75 MHz
- d. Preset spectrum analyzer.
- e. Set spectrum analyzer to the following conditions:

CENTER FREQUENCY	same as HP 3577B FREQ
FREQUENCY SPAN	1 kHz
- f. Press the NORMAL key on the spectrum analyzer to obtain the marker mode.
- g. After one complete sweep press PEAK SEARCH on the spectrum analyzer.
- h. Select MKR → REF LEVEL on spectrum analyzer.
- i. Press shift key (blue key) then NORMAL key in the marker mode block (this is the noise level key).

- j. Move the spectrum analyzer marker to 100 Hz offset (first graticule to the right of center). Record the marker reading and the ref level reading in the test record.
- k. Calculate the noise level using the following equation: Noise Level (dBc) = marker reading – ref level reading
- l. The noise level should be < - 70 dBc. Record the calculated value in the test record.
- m. Repeat steps j through l for spectrum analyzer frequency spans of 10 kHz (1 kHz offset in step j) and 100 kHz (10 kHz offset in step j)
- n. Repeat steps d through m for a HP 3577B frequency of 199.75 MHz.



### 3-19 Api Spur Test

#### Specifications:

Fractional N spurs < - 50 dBc.

#### Description:

The API performance of the HP 3577B is verified by a measurement made with an spectrum analyzer to which the HP 3577B is phase locked.

Equipment:
Spectrum Analyzer
RF Cable-24 inch
BNC Cable-48 inch

#### Procedure:

- a. Preset the HP 3577B to its initial conditions.
- b. Connect the HP 3577B source to input 2 of the spectrum analyzer with the RF cable. Also connect the 10 MHz REF OUT from the spectrum analyzer to the HP 3577B EXT REF IN. The EXT REF LED on the HP 3577B front panel should be on.
- c. Set the HP 3577B to the following conditions:  
SWEEP TYPE                      CW  
FREQUENCY                        1.7636 MHz
- d. Preset the spectrum analyzer.
- e. Set the spectrum analyzer to the following conditions:  
CENTER FREQUENCY      HP 3577B frequency  
FREQUENCY SPAN        10 kHz  
CENTER FREQ STEP SIZE 1360 Hz
- f. In the marker block on the front panel of the spectrum analyzer press the following hardkey sequence: NORMAL, PEAK SEARCH, Δ
- g. Increase the spectrum analyzer center frequency 1360 Hz by pressing the CENTER FREQUENCY hardkey followed by the ↑ hardkey, and set the FREQUENCY SPAN to 100 Hz.
- h. Let the spectrum analyzer complete the sweep.
- i. Press the PEAK SEARCH hardkey in the marker block on the spectrum analyzer.

- j. Record the marker value in the test record in the 1360 Hz offset column.
- k. Increase the spectrum analyzer center frequency another 1360 Hz by pressing the CENTER FREQUENCY hardkey followed by the  $\uparrow$  hardkey (total offset 2720 Hz).
- l. Let the spectrum analyzer complete a sweep, then press the PEAK SEARCH hardkey in the marker block.
- m. Record this value in the test record in the 2760 Hz offset column. The larger of the two offset columns is the API level for this frequency (test limit  $< -50$  dBc).
- n. Set the HP 3577B FREQUENCY to 199.7636 MHz and repeat steps d through m.

---

## 3-20 Frequency Stability Test (with Option 001 only)

---

### Note



The HP 3577B must be powered up for a minimum of one hour before testing.

---

### Description:

The HP 3577B is set up to generate a 200 MHz signal from its source output. The frequency is then measured as a reference. After at least four hours the frequency is measured again and the fractional stability is calculated using the following equation:

$$\frac{\text{Freq(ref)} - \text{Freq(test)}}{\text{time(hours)}} < \pm 0.4167$$

The frequency stability is defined as the drift rate after one day and is equal to 24 times the fractional stability.

<b>Equipment:</b>
Frequency Counter
Type N RF cable-24 inch (1 each)

### Procedure:

- a. Disconnect any external reference from the HP 3577B rear panel.
- b. Preset the HP 3577B
- c. Set the HP 3577B to the following conditions:

SWEEP TYPE	CW
FREQ	200 MHz
AMPTD	0 dBm
- d. Connect the HP 3577B source output to the counter input.
- e. Record the frequency reading of the counter as the reference frequency in the test record.
- f. Allow the HP 3577B to age for at least four hours.

- g. Record the frequency reading of the counter as the test frequency in the test record.
- h. Record the number of hours between measurements in the test record.
- i. Calculate the fractional stability using the following formula:

$$\frac{\text{Freq(ref)} - \text{Freq(test)}}{\text{time(hours)}} < \pm 0.4167$$

## 3-21 I/O Port Test

### Specifications:

Pass/fail test

### Description:

This test verifies the operation of the programmable I/O port.

<b>Equipment:</b>
Controller
I/O Port Test Connector

### Procedure:

- a. Connect the I/O port test connector to the I/O port on the rear panel of the HP 3577B.
- b. Load and run the I/O port test program into the computer. The program is included on the Semiautomated Performance Test Disk as "IO\_PORT". This program can also be executed by HP Instrument BASIC in instruments with Option 1C2. The program listing follows:

```
10 ASSIGN @Dut TO 711
11 CLEAR SCREEN
20 CALL lo_port(@Dut)
30 END
40 !-----
50 lo_port:SUB lo_port(@Dut)
60 DIM Byte_in$(40),Byte_out$(40),Address(3,2),Di0_to_d14$(40)
70 INTEGER Byte_out,Byte_in,Addr_lo,Addr_hi,Control_line,Bit
80 Y=1
90 OUTPUT @Dut;"ID?"
100 ENTER @Dut;Model$
110 IF POS(Model$,"HP3577A") THEN
120 PRINT "I/O Port test skipped for HP3577A"
140 SUBEXIT
150 END IF
160 PRINT "Connect the test connector to the I/O port"
161 PRINT "Press continue when ready"
162 PAUSE
170 !****Checking for outputs pulled high at instrument preset****
180 OUTPUT @Dut;"IPR SM2 RST TRG"
190 WAIT .1
200 LOOP
210 Ser_poll = SPOLL(@Dut)
220 EXIT IF BINAND(Ser_poll,4)
230 END LOOP
240 OUTPUT @Dut;"DIO"
250 ENTER @Dut;Byte_in
260 IF Byte_in < > 255 THEN
270 Byte_in$ = DVAL$(Byte_in,2)
280 PRINT RPT$("-",46)
290 PRINT " At Instrument Preset"
300 PRINT " Expected byte = 11111111 (255)"
310 PRINT " Byte read = ";Byte_in$(25,32);" ("&VAL$(Byte_in)&")"
320 Y=0
330 END IF
340 !****Checking D00 to D07 and D10 to D14****
```

```

350 RESTORE
360 FOR I = 1 TO 8
370   READ Byte_out
380   Byte_out$ = DVAL$(Byte_out,2)
390   OUTPUT @Dut;"LIO"
400   OUTPUT @Dut;Byte_out
410   OUTPUT @Dut;"DIO"
420   ENTER @Dut;Byte_in
430   Byte_in$ = DVAL$(Byte_in,2)
440   Di_0$ = VAL$(VAL(Byte_out$(32,32)) AND VAL(Byte_out$(30,30)))
450   Di_1$ = VAL$(VAL(Byte_out$(31,31)) AND VAL(Byte_out$(29,29)))
460   Di_2$ = VAL$(VAL(Byte_out$(28,28)) AND VAL(Byte_out$(26,26)))
470   Di_3$ = Byte_out$(27,27)
480   Di_4$ = Byte_out$(25,25)
490   Di0_to_di4$ = Di_4$&Di_3$&Di_2$&Di_1$&Di_0$
500   IF Byte_in$(28,32) <> Di0_to_di4$ THEN
510     PRINT RPT$(" ",46)
520     PRINT " Byte written to DO 0-7 = "&Byte_out$(25,32)&" ("&VAL$(
      (Byte_out)&")"
530     PRINT " Expected Byte from DI 0-4 = "&Di0_to_di4$&" ("&VAL$(
      (IVAL(Di0_to_di4$,2))&")"
540     PRINT " Byte read from DI 0-4 = " ";Byte_in$(28,32)&" ("&VAL$(
      (IVAL(Byte_in$(28,32),2))&")"
550   Y = 0
560   END IF
570   NEXT I
580   DATA 67,28,0,255,42,170,213,85 ! Bytes to be written to DO
590   !****Checking control lines and DI5 to DI7****
600   Address(1,1) = 40           !FAIL hi byte
610   Address(1,2) = 3181        !FAIL low byte
620   Address(2,1) = 40           !EOM hi byte
630   Address(2,2) = 3101        !EOM low byte
640   Address(3,1) = 40           !EOS hi byte
650   Address(3,2) = 3141        !EOS low byte
660   FOR Control_line = 1 TO 3
670     FOR Bit = 0 TO 1
680       Addr_lo = DVAL(VAL$(Address(Control_line,2)),16)
690       Addr_hi = DVAL(VAL$(Address(Control_line,1)),16)
700       OUTPUT @Dut;"WTM #!";
710       ASSIGN @Dut;FORMAT OFF
720       OUTPUT @Dut;Addr_hi;Addr_lo
730       OUTPUT @Dut;CHR$(Bit),END
740       ASSIGN @Dut;FORMAT ON
750       OUTPUT @Dut;"DIO"
760       ENTER @Dut;Byte_in
770       Byte_in$ = DVAL$(Byte_in,2)
780       SELECT Control_line
790         CASE 1
800           Control$ = "/FAIL"
810           Bit_pos = 27
820           Data_line$ = "DI 5"
830         CASE 2
840           Control$ = "/EOM "
850           Bit_pos = 26
860           Data_line$ = "DI 6"
870         CASE 3
880           Control$ = "/EOS "
890           Bit_pos = 25
900           Data_line$ = "DI 7"
910       END SELECT
920       IF VAL(Byte_in$(Bit_pos,Bit_pos)) <> Bit THEN
930         PRINT RPT$(" ",46)
940         PRINT " Control line "&Control$&" = ";Bit
950         PRINT "   "&Data_line$&"      = "&Byte_in$(Bit_pos,Bit_pos)
960         Y = 0
970       END IF
980     NEXT Bit

```

Performance Tests  
3-21 I/O Port Test

HP 3577B

990 NEXT Control\_line  
1000 SUBEND  
1010 !\_\_\_\_\_

### 3-22 EPM-1 Flatness Test

**Specifications:**  $\leq 0.13$  dB

**Description:**

The EPM-1 is not specified from 5-10 Hz. The following test must be performed before doing performance test 3-11 and 3-15.

<b>Equipment:</b>
Milliwatt Power Meter
Precision Termination
Power Splitter
Voltmeter
Error Correction Cable
RF Cable-24 inch (1 each)
Feedthrough Termination
N male to BNC female adapter
BNC Cable - 48 inch
BNC female to dual banana male adapter



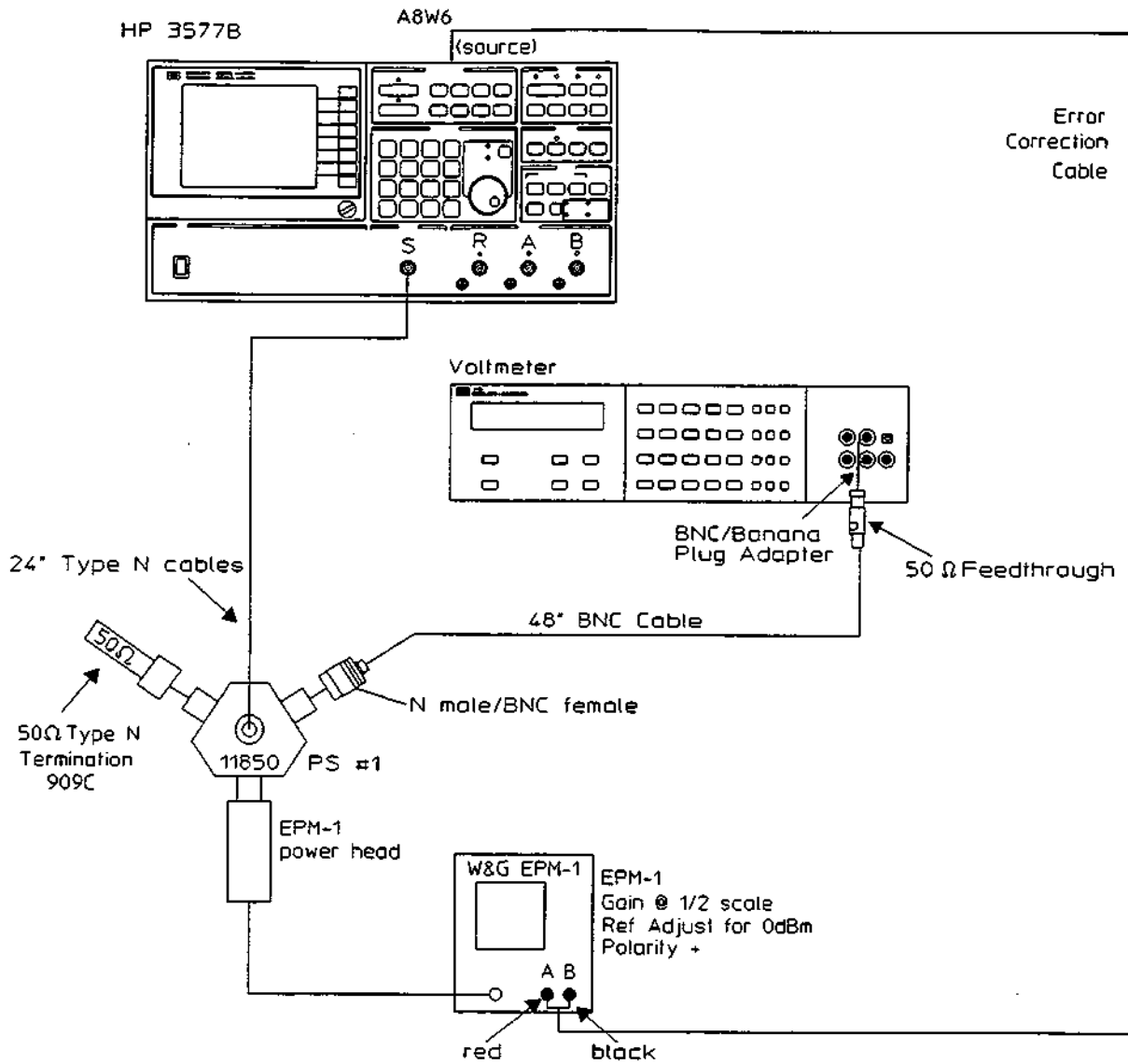


Figure 3-18. EPM-1 Flatness Test Setup

**Procedure:**

- a. Set up the HP 3458A Voltmeter as follows:

**VOLTMETER SETUP**

- i. Connect a 50  $\Omega$  feedthrough to the voltmeter using an adapter and press  
OHM  
SHIFT (blue key) S  
and press the DOWN key until SMATH is displayed.
  - ii. Press  
10 (RES register)  
ENTER  
ACV  
SHIFT (blue key) S  
and press the DOWN key until SETACV is displayed.
  - iii. Press  
3 (sync)  
ENTER  
SHIFT T  
and press the DOWN key until ACBAND is displayed.
  - iv. Press  
5,1000000  
ENTER
  - v. Press  
SHIFT L  
and press the DOWN key until MATH is displayed.
  - vi. Press  
5 (dBm)  
ENTER.
- b. Set up the equipment as shown in figure 3-18.
- c. Set the HP 3577B controls as shown below:

INSTR PRESET		
SWEEP TYPE	LOG	FREQ SWEEP
AMPTD		10 dBm
SWEEP MODE	MANUAL	5 Hz

- d. Read and record DVM reading at 5 Hz
- e. Enter 10 Hz on the HP 3577B
- f. Read and record DVM reading at 10 Hz
- g. Calculate the flatness as follows:  
Maximum reading—minimum reading = EPM– 1 flatness at 5-10 Hz.  
The EPM-1 flatness needs to measure less than 0.13 dB for performance tests 3-11 and 3-15 to meet or exceed a 4:1 accuracy ratio.

---

**Note**



This measurement should be recorded and kept with the EPM-1 for future reference.

---

---

**Performance Test Record**

Calibration Entity and Address \_\_\_\_\_

Test Performed By \_\_\_\_\_

Report Number \_\_\_\_\_

Customer \_\_\_\_\_

Trace Number \_\_\_\_\_

Installed Options \_\_\_\_\_

Test Date \_\_\_\_\_

Temperature \_\_\_\_\_

Humidity \_\_\_\_\_

Power Line Frequency \_\_\_\_\_

**Test Equipment:**

**Ratio Transformer**

Model \_\_\_\_\_

Trace Number \_\_\_\_\_

Calibration Due Date \_\_\_\_\_

**Spectrum Analyzer**

Model \_\_\_\_\_

Trace Number \_\_\_\_\_

Calibration Due Date \_\_\_\_\_

**Oscilloscope**

Model \_\_\_\_\_

Trace Number \_\_\_\_\_

Calibration Due Date \_\_\_\_\_

**Digital Voltmeter**

Model \_\_\_\_\_

Trace Number \_\_\_\_\_

Calibration Due Date \_\_\_\_\_

**Signal Generator**

Model \_\_\_\_\_

Trace Number \_\_\_\_\_

Calibration Due Date \_\_\_\_\_

**Synthesizer**

Model \_\_\_\_\_

Trace Number \_\_\_\_\_

Calibration Due Date \_\_\_\_\_

**Milliwatt Power Meter**

Model \_\_\_\_\_

Trace Number \_\_\_\_\_

Calibration Due Date \_\_\_\_\_

**Power Meter**

Model \_\_\_\_\_

Trace Number \_\_\_\_\_

Calibration Due Date \_\_\_\_\_

**Power Sensor**

Model \_\_\_\_\_

Trace Number \_\_\_\_\_

Calibration Due Date \_\_\_\_\_

**Frequency Standard**

Model \_\_\_\_\_

Trace Number \_\_\_\_\_

Calibration Due Date \_\_\_\_\_

**Power Splitter**

Model \_\_\_\_\_

Trace Number \_\_\_\_\_

Calibration Due Date \_\_\_\_\_

**Directional Bridge**

Model \_\_\_\_\_

Trace Number \_\_\_\_\_

Calibration Due Date \_\_\_\_\_

**3 dB Coaxial Attenuator**

Model \_\_\_\_\_

Trace Number \_\_\_\_\_

Calibration Due Date \_\_\_\_\_

**20 dB Coaxial Attenuator**

Model \_\_\_\_\_

Trace Number \_\_\_\_\_

Calibration Due Date \_\_\_\_\_

**10 dB Coaxial Attenuator**

Model \_\_\_\_\_

Trace Number \_\_\_\_\_

Calibration Due Date \_\_\_\_\_

**Precision Termination**

Model \_\_\_\_\_

Trace Number \_\_\_\_\_

Calibration Due Date \_\_\_\_\_

**Feedthrough Termination**

Model \_\_\_\_\_

Trace Number \_\_\_\_\_

Calibration Due Date \_\_\_\_\_



### Measurement Uncertainty

Performance Test	Using Recommended Test Equipment		Using Other Test Equipment	
	Measurement Uncertainty	Ratio	Measurement Uncertainty	Ratio
3-7. Receiver residuals Receiver noise	$\pm 0.75$ dB $\pm 0.75$ dB	NA <sup>1</sup>		NA <sup>1</sup>
3-8. On Carrier Return Loss	$\pm 1.00$ dB	NA <sup>1</sup>		NA <sup>1</sup>
3-9A. Magnitude and Phase Dynamic Accuracy Magnitude with ratio transformer setting:				
1.0	$\pm 2.205$ ppm	>10:1		
0.31623	$\pm 2.205$ ppm	>10:1		
0.2	$\pm 2.205$ ppm	>10:1		
0.05	$\pm 1.603$ ppm	>10:1		
0.025	$\pm 1.147$ ppm	>10:1		
0.01	$\pm 0.741$ ppm	>10:1		
0.0031623	$\pm 0.436$ ppm	>10:1		
0.001	$\pm 0.265$ ppm	>10:1		
0.0001	$\pm 0.114$ ppm	>10:1		
0.00001	$\pm 0.066$ ppm	>10:1		
Phase	$\pm 50 \mu$ deg.	>10:1		
3-10. Magnitude vs. Phase	$\pm 0.001$ dB	>10:1		
3-11A. Receiver Level Flatness and Absolute Accuracy				
50 $\Omega$ Flatness				
@ 100 kHz	$\pm 0.535$ dB	0.54:1		
20Hz-20 MHz	$\pm 0.535$ dB	0.26:1		
5Hz-200 MHz				
5Hz-10 Hz	3			
10Hz-50 MHz	$\pm 0.535$ dB	0.51:1		
50MHz-100 MHz	$\pm 0.545$ dB	0.5:1		
100MHz-200 MHz	$\pm 0.56$ dB	0.49:1		
1 M $\Omega$ Flatness				
@ 100 kHz	$\pm 0.535$ dB	0.54:1		
20Hz-20, MHz	$\pm 0.535$ dB	0.43:1		
5Hz-20 MHz				
5Hz-10 Hz	3			
10Hz-20 MHz	$\pm 0.535$ dB	0.83:1		

<sup>1</sup> open-ended specification order to meet test specification

<sup>2</sup> root-sum-squares calculation method

<sup>3</sup> check amplitude flatness of EPM-1 in

Performance Test	Using Recommended Test Equipment		Using Other Test Equipment	
	Measurement Uncertainty	Ratio	Measurement Uncertainty	Ratio
3-11B. Alternate Receiver Level Flatness and Absolute Accuracy				
50Ω Flatness				
@ 100kHz	± 0.52 dB	0.35:1		
20Hz-20MHz				
20Hz-50kHz	± 0.51 dB	0.27:1		
50kHz-100kHz	± 0.52 dB	0.27:1		
200kHz	± 0.70 dB	0.19:1		
500kHz-2MHz	± 0.61 dB	0.23:1		
5MHz-20MHz	± 0.59 dB	0.23:1		
5Hz-200MHz				
5Hz-50kHz	± 0.51 dB	0.54:1		
50kHz-100kHz	± 0.52 dB	0.52:1		
200kHz	± 0.70 dB	0.38:1		
500kHz-2MHz	± 0.61 dB	0.44:1		
5MHz-20MHz	± 0.59 dB	0.46:1		
50MHz-75MHz	± 0.59 dB	0.46:1		
100MHz-200MHz	± 0.60 dB	0.45:1		
1 MΩ Flatness				
@ 100kHz	± 0.52 dB	0.35:1		
20Hz-20MHz				
20Hz-50kHz	± 0.51 dB	0.45:1		
50kHz-100kHz	± 0.52 dB	0.44:1		
200kHz	± 0.70 dB	0.32:1		
500kHz-2MHz	± 0.61 dB	0.37:1		
5MHz-20MHz	± 0.59 dB	0.39:1		
5Hz-20MHz				
5Hz-50kHz	± 0.51 dB	0.87:1		
50kHz-100kHz	± 0.52 dB	0.85:1		
200kHz	± 0.70 dB	0.62:1		
500kHz-2MHz	± 0.61 dB	0.72:1		
5MHz-20MHz	± 0.59 dB	0.75:1		
3-12. Receiver Ratio Amplitude and Phase Accuracy	± 0.02 dB ± 0.2 deg.	> 10:1 > 10:1		
3-13. Receiver Crosstalk	± 0.75 dB	NA <sup>1</sup>		NA <sup>1</sup>
3-14. Receiver Return Loss	± 1.75 dB	NA <sup>1</sup>		NA <sup>1</sup>
3-15A. Source Flatness and absolute accuracy				
@100kHz	± 0.285 dB	3:1		
5Hz-200MHz				
5Hz-10Hz	<sup>3</sup>			
10Hz-50MHz	± 0.285 dB	2.3:1		
50Hz-100MHz	± 0.295 dB	2.3:1		
100Hz-200MHz	± 0.31 dB	2.1:1		

<sup>1</sup> open-ended specification order to meet test specification

<sup>2</sup> root-sum-squares calculation method

<sup>3</sup> check amplitude flatness of EPM-1 in

Performance Test	Using Recommended Test Equipment		Using Other Test Equipment	
	Measurement Uncertainty	Ratio	Measurement Uncertainty	Ratio
3-15B. Alternate Source Flatness and Absolute Accuracy @ 100kHz 5Hz-200MHz 5Hz-100kHz 200kHz 500kHz-2MHz 5MHz-100MHz 100MHz-200MHz	± 0.01 dB	>10:1		
	± 0.01 dB	>10:1		
	± 0.20 dB	3.3:1		
	± 0.11 dB	6.2:1		
	± 0.09 dB	7.7		
	± 0.10 dB	6.9		
3-16. Source Attenuator Accuracy 4 dB atten 8 dB atten 16 dB atten 32 dB atten 48 dB atten	± 0.02 dB	9.75:1		
	± 0.02 dB	9.75:1		
	± 0.02 dB	>10:1		
	± 0.02 dB	>10:1		
	± 0.05 dB	>10:1		
3-17. Source Distortion and spurs	± 2.5 dB	NA <sup>1</sup>		NA <sup>1</sup>
3-18. Source Phase Noise	± 1.5 dB <sup>2</sup>	NA <sup>1</sup>		NA <sup>1</sup>
3-19. API Spur	± 2.5 dB	NA <sup>1</sup>		NA <sup>1</sup>
3-20. Frequency Stability (with Option 001 only)	± 1x10 <sup>-7</sup> /mo. +0.1 Hz	7.9:1		
3-21. I/O Port	N/A	N/A	N/A	N/A

<sup>1</sup> open-ended specification order to meet test specification

<sup>2</sup> root-sum-squares calculation method

<sup>3</sup> check amplitude flatness of EPM-1 in

**Table 3-12 Performance Test Record**

HP 3577B Network Analyzer Serial Number		Tested by Date		
<b>3-7 Receiver Residual And Noise Test Residual Response Test</b>				
Frequency	Receiver			Tolerance
	R	A	B	
149.625 MHz				< - 100 dBm
149.875 MHz				< - 100 dBm
99.666 666 666 MHz				< - 100 dBm
99.833 333 333 MHz				< - 100 dBm
74.687 5 MHz				< - 100 dBm
74.812 5 MHz				< - 100 dBm
59.7 MHz				< - 100 dBm
59.8 MHz				< - 100 dBm
89.5 MHz				< - 100 dBm
120.0 MHz				< - 100 dBm
149.5 MHz				< - 100 dBm
180.0 MHz				< - 100 dBm
0.480 MHz				< - 100 dBm
0.960 MHz				< - 100 dBm
0.004 0 MHz				< - 100 dBm
0.008 0 MHz				< - 100 dBm
0.016 0 MHz				< - 100 dBm
0.024 0 MHz				< - 100 dBm
0.027 777 700 MHz				< - 100 dBm
0.10 MHz				< - 100 dBm
0.20 MHz				< - 100 dBm
0.000 000 000 MHz				< - 33 dBm

■ Noise Test					
Frequency		Receiver			Tolerance
		R	A	B	
100 Hz	Magnitude point 1				
	Magnitude point 2				
	Magnitude point 3				
	Magnitude point 4				
	Magnitude point 5				
	Magnitude point 6				
	Magnitude point 7				
	Magnitude point 8				
	Magnitude point 9				
	Magnitude point 10				
	Magnitude point 11				
	AvgNoise Level				< - 100 dBm
$- 150 + 10 \log_{10} \left[ \frac{\sum_{n=1}^{11} (X_n^2)}{n+1} \right]$		X = magnitude of each point in nV			
Frequency		Receiver			Tolerance
		R	A	B	
30 kHz	Magnitude point 1				
	Magnitude point 2				
	Magnitude point 3				
	Magnitude point 4				
	Magnitude point 5				
	Magnitude point 6				
	Magnitude point 7				
	Magnitude point 8				
	Magnitude point 9				
	Magnitude point 10				
	Magnitude point 11				
	Avg Noise Level				< - 110 dBm

Frequency		Receiver			Tolerance
		R	A	B	
$150 + 10 \log_{10} \left[ \frac{\sum_{n=1}^{11} (X_n^2)}{n+1} \right]$		X = magnitude of each point in nV			
199 MHz	Magnitude point 1				
	Magnitude point 2				
	Magnitude point 3				
	Magnitude point 4				
	Magnitude point 5				
	Magnitude point 6				
	Magnitude point 7				
	Magnitude point 8				
	Magnitude point 9				
	Magnitude point 10				
	Magnitude point 11				
	Avg Noise Level				< - 110 dBm
$150 + 10 \log_{10} \left[ \frac{\sum_{n=1}^{11} (X_n^2)}{n+1} \right]$		X = magnitude of each point in nV			
<b>3-8 On - Carrier Return Loss Test</b>					
Test Frequency	Vref	Vtest	Return Loss	Tolerance	
			- [3 dB + 20 log <sub>10</sub> ( $\frac{V_{test}}{2V_{ref}}$ )]		
175 MHz				> 20 dB	
200 MHz				> 20 dB	

3-9 Magnitude And Phase Dynamic Accuracy Test						
■ Dynamic Linearity Test						
Ratio Transformer	Magnitude/Phase	Upper Limit	Receiver			Lower Limit
			R	A	B	
1.0	Magnitude	+ 0.07 dB				- 0.07 dB
	Phase	+ 0.4 deg				0.4 deg
.31623	Magnitude	- 9.94 dB				- 10.06 dB
	Phase	+ 0.2 deg				0.2 deg
.2	Magnitude	- 13.912 dB				- 14.039 dB
	Phase	+ 0.2 deg				0.2 deg
.05	Magnitude	- 25.96 dB				- 26.08 dB
	Phase	+ 0.2 deg				0.2 deg
.025	Magnitude	- 31.981 dB				- 32.101 dB
	Phase	+ 0.2 deg				0.2 deg
.01	Magnitude	- 39.94 dB				- 40.06 dB
	Phase	+ 0.2 deg				0.2 deg
.0031623	Magnitude	- 49.94 dB				- 50.06 dB
	Phase	+ 0.2 deg				0.2 deg
.001	Magnitude	- 59.92 dB				- 60.08 dB
	Phase	+ 0.5 deg				0.5 deg
.0001	Magnitude	- 79.80 dB				- 80.200 dB
	Phase	+ 1.5 deg				1.5 deg
.00001	Magnitude	- 99.250 dB				- 100.750 dB
	Phase	+ 7.5 deg				7.5 deg
3-10 Magnitude Vs Phase Test						
			Receiver			Tolerance
			R	A	B	
						< 0.04 dB

3-11A Receiver Level Flatness And Absolute Accuracy Test					
■ Input Mode: 50Ω, 20 dB					
Frequency	Upper Limit	Receiver			Lower Limit
		R	A	B	
100 kHz	+ 0.2 dB				- 0.2 dB
5 Hz - 200 MHz	+ 0.6 dB				- 0.6 dB
20 Hz - 20 MHz	+ 0.3 dB				- 0.3 dB
■ Input Mode: 50Ω, 0 dB					
Frequency	Upper Limit	Receiver			Lower Limit
		R	A	B	
100 kHz	+ 0.2 dB				- 0.2 dB
5 Hz - 200 MHz	+ 0.6 dB				- 0.6 dB
20 Hz - 20 MHz	+ 0.3 dB				- 0.3 dB
■ Input Mode: 1 MΩ, 20 dB					
Frequency	Upper Limit	Receiver			Lower Limit
		R	A	B	
100 kHz	+ 0.2 dB				- 0.2 dB
5 Hz - 200 MHz	+ 1.0 dB				- 1.0 dB
20 Hz - 20 MHz	+ 0.5 dB				- 0.5 dB
■ Input Mode: 1 MΩ, 0 dB					
Frequency	Upper Limit	Receiver			Lower Limit
		R	A	B	
100 kHz	+ 0.2 dB				- 0.2 dB
5 Hz - 200 MHz	+ 1.0 dB				- 1.0 dB
20 Hz - 20 MHz	+ 0.5 dB				- 0.5 dB



**3-11B Alternate Receiver Level Flatness And Absolute Accuracy Test**

Flatness and absolute accuracy

	Upper Limit	Reading	Lower Limit
HP 3577B source AMPTD	10 dBm		9 dBm
Power meter reading at 10 MHz	0.01 dBm		-0.01 dBm
Voltmeter reading at 10 MHz	0.05 dBm		-0.05 dBm

Input impedance = 50Ω attenuation = - 20 dB

Frequency	Receiver			Tolerance
	R	A	B	

Voltmeter measurements (enter readings or attach printout)

Absolute level at .1 MHz				0.0 dBm ±0.2 dB
.000005 MHz				
.00002 MHz				
.0001 MHz				
.001 MHz				
.002 MHz				
.005 MHz				
.01 MHz				
.02 MHz				
.05 MHz				
.1 MHz				

Power meter measurements (enter readings or attach printout)

.2 MHz				
.5 MHz				
1 MHz				
2 MHz				
5 MHz				
10 MHz				
15 MHz				
20 MHz				
50 MHz				
75 MHz				
100 MHz				
120 MHz				
140 MHz				

160 MHz				
170 MHz				
180 MHz				
190 MHz				
200 MHz				
<input type="checkbox"/> Flatness (maximum - minimum)				
5 Hz-200 MHz				< 0.6 dB
20 Hz-20 MHz				< 0.3 dB
<input type="checkbox"/> Input impedance = 50Ω attenuation = 0 dB				
Frequency	Receiver			Tolerance
	R	A	B	
<input type="checkbox"/> Voltmeter measurements (enter readings or attach printout)				
Absolute level at .1 MHz				0.0 dBm ± 0.2. dB
.000005 MHz				
.00002 MHz				
.0001MHz				
.001 MHz				
.002 MHz				
.005 MHz				
.01 MHz				
.02 MHz				
.05 MHz				
.1 MHz				
<input type="checkbox"/> Power meter measurements (enter readings or attach printout)				
.2 MHz				
1 MHz				
2 MHz				
5 MHz				
10 MHz				
15 MHz				
20 MHz				
30 MHz				
50 MHz				
75 MHz				
100 MHz				
120 MHz				

140 MHz				
160 MHz				
170 MHz				
180 MHz				
190 MHz				
200 MHz				
<input type="checkbox"/> Flatness (maximum - minimum)				
	5 Hz - 200 MHz			< 0.6 dB
	20 Hz - 20 MHz			< 0.3 dB
<input type="checkbox"/> Input impedance = 1 M $\Omega$ attenuation = - 20 dB				
Frequency	Receiver			Tolerance
	R	A	B	
<input type="checkbox"/> Voltmeter measurements (enter readings or attach printout)				
Absolute level at .1 MHz				0.0 dBm $\pm$ 0.2 dB
.000005 MHz				
.00002 MHz				
.0001 MHz				
.001 MHz				
.002 MHz				
.005 MHz				
.01 MHz				
.02 MHz				
.05 MHz				
.1 MHz				
<input type="checkbox"/> Power meter measurements (enter readings or attach printout)				
.2 MHz				
.5 MHz				
1 MHz				
2 MHz				
5 MHz				
10 MHz				
15 MHz				
20 MHz				
<input type="checkbox"/> Flatness (maximum - minimum)				
5 Hz-20 MHz				< 1.0 dB
20 Hz-20 MHz				< 0.5 dB

<input type="checkbox"/> Input impedance = 1 MΩ attenuation = 0 dB				
Frequency	Receiver			Tolerance
	R	A	B	
<input type="checkbox"/> Voltmeter measurements (enter readings or attach printout)				
Absolute level at 1 MHz				0.0 dBm ± 0.2 dB
.000005 MHz				
.00002 MHz				
.0001 MHz				
.001 MHz				
.002 MHz				
.005 MHz				
.01 MHz				
.02 MHz				
.05 MHz				
.1 MHz				
<input type="checkbox"/> Power meter measurements (enter readings or attach printout)				
.2 MHz				
.5 MHz				
1 MHz				
2 MHz				
5 MHz				
10 MHz				
15 MHz				
20 MHz				
<input type="checkbox"/> Flatness (maximum - minimum)				
5 Hz - 20 MHz				< 1.0 dB
20 Hz - 20 MHz				< 0.5 dB

3-12 Receiver Level Ratio Amplitude And Phase Accuracy Test							
■ Input Impedance = 50 Ω							
Frequency = 100 kHz, Equal Attenuators							
Amplitude	D4/D2	D3/D1	B/D2	D4/B	B/D1	D3/B	Limit
							0 dBm ± 0.15 dB
Phase							0 ± 2.0 deg
Frequency = 5 Hz - 200 MHz, Equal Attenuators							
Amplitude	D4/D2	D3/D1	B/D2	D4/B	B/D1	D3/B	Limit
							< 0.4 dB pp
Phase							< 10 deg pp
Frequency = 100 kHz, Unequal Attenuators							
Amplitude	D3/D2	D4/D1	B/D1	D3/B	B/D2	D4/B	Limit
							0 dBm ± 0.15 dB
Phase							0 ± 2.0 deg
Frequency = 5 Hz - 200 MHz, Unequal Attenuators							
Amplitude	D3/D2	D4/D1	B/D1	D3/B	B/D2	D4/B	Limit
							< 0.7 dB pp
Phase							< 18 deg pp
Frequency = 20 Hz - 20 MHz, Equal Attenuators							
Amplitude	D4/D2	D3/D1	B/D2	D4/B	B/D1	D3/B	Limit
							< 0.3 dB pp
Phase							< 2 deg pp
Frequency = 20 Hz - 20 MHz, Unequal Attenuators							
Amplitude	D3/D2	D4/D1	B/D1	D3/B	B/D2	D4/B	Limit
							< 0.45 dB pp
Phase							< 10 deg pp

Input Impedance = 1 M $\Omega$							
Frequency = 100 kHz, Equal Attenuators							
	<b>D4/D2</b>	<b>D3/D1</b>	<b>B/D2</b>	<b>D4/B</b>	<b>B/D1</b>	<b>D3/B</b>	<b>Limit</b>
Amplitude							0 dBm $\pm$ 0.2 dB
Phase							0 $\pm$ 2.0 deg
Frequency = 5 Hz - 20 MHz, Equal Attenuators							
	<b>D4/D2</b>	<b>D3/D1</b>	<b>B/D2</b>	<b>D4/B</b>	<b>B/D1</b>	<b>D3/B</b>	<b>Limit</b>
Amplitude							< 0.6 dB pp
Phase							< 10 deg pp
Frequency = 100 kHz, Unequal Attenuators							
	<b>D3/D2</b>	<b>D4/D1</b>	<b>B/D1</b>	<b>D3/B</b>	<b>B/D2</b>	<b>D4/B</b>	<b>Limit</b>
Amplitude							0 dBm $\pm$ 0.2 dB
Phase							0 $\pm$ 2.0 deg
Frequency = 5 Hz - 20 MHz, Unequal Attenuators							
	<b>D3/D2</b>	<b>D4/D1</b>	<b>B/D1</b>	<b>D3/B</b>	<b>B/D2</b>	<b>D4/B</b>	<b>Limit</b>
Amplitude							< 1.0 dB pp
Phase							< 18 deg pp
Frequency = 20 Hz - 20 MHz, Equal Attenuators							
	<b>D4/D2</b>	<b>D3/D1</b>	<b>B/D2</b>	<b>D4/B</b>	<b>B/D1</b>	<b>D3/B</b>	<b>Limit</b>
Amplitude							< 0.3 dB pp
Phase							< 5 deg pp
Frequency = 20 Hz - 20 MHz, Unequal Attenuators							
	<b>D3/D2</b>	<b>D4/D1</b>	<b>B/D1</b>	<b>D3/B</b>	<b>B/D2</b>	<b>D4/B</b>	<b>Limit</b>
Amplitude							< 0.5 dB pp
Phase							< 13 deg pp

3-13 Receiver Crosstalk Test			
Input Channel	Receivers		Maximum
R	A	B	< - 100 dB
A	B	R	< - 100 dB
B	A	R	< - 100 dB
3-14 Receiver Return Loss Test			
Receiver	Actual		Maximum
A	atten 0 dB		< - 25 dB
	atten 20 dB		
R	atten 0 dB		< - 25 dB
	atten 20 dB		
B	atten 0 dB		< - 25 dB
	atten 20 dB		
3-15A Source Flatness And Absolute Accuracy Test			
Frequency	Actual		Tolerance
100 kHz (Absolute)			± 1.0 dB
5 Hz - 200 MHz (Flatness)			< 1.5 dB pp
3-15B Alternate Source Flatness And Absolute Accuracy Test			
Frequency	Amplitude		Tolerance
<input type="checkbox"/> Voltmeter measurements (enter readings or attach printout)			
	5 Hz		
	10 Hz		
	100 Hz		
	1 kHz		
	10 kHz		
	20 kHz		
	50 kHz		
	100 kHz		

■ Power Meter measurements				
200 kHz				
500 kHz				
1 MHz				
2 MHz				
5 MHz				
10 MHz				
20 MHz				
50 MHz				
100 MHz				
120 MHz				
140 MHz				
160 MHz				
180 MHz				
200 MHz				
Flatness (max. - min.)				< 1.5 dB
3-16 Source Attenuator Accuracy				
Amplitude	Upper limit	Max	Min	Lower limit
+12 dBm		Ref	Ref	
+8 dBm	- 3.8 dB			- 4.2 dB
+4 dBm	- 7.8 dB			- 8.2 dB
4 dBm	- 15.68 dB			- 16.32 dB
20 dBm	- 31.36 dB			- 32.64 dB
36 dBm	- 47.04 dB			- 48.96 dB
3-17 Source Distortion And Spur Test				
Harmonics HP 3577B Frequency	Actual	Maximum		
250 kHz		< - 25 dB		
459 kHz		< - 25 dB		
10 MHz		< - 25 dB		
100 MHz		< - 25 dB		
150 MHz		< - 25 dB		
200 MHz		< - 25 dB		



HP 3577B Frequency	Test Frequency	Actual	Maximum
50 MHz	250.25 MHz		< - 50 dBc
	200.25 MHz		< - 50 dBc
	100.25 MHz		< - 50 dBc
	150.25 MHz		< - 50 dBc
100 MHz	200.25 MHz		< - 50 dBc
	100.25 MHz		< - 50 dBc
	99.75 MHz		< - 50 dBc
	200.50 MHz		< - 50 dBc
150 MHz	0.25 MHz		< - 50 dBc
	150.25 MHz		< - 50 dBc
	150.50 MHz		< - 50 dBc
	0.50 MHz		< - 50 dBc
200 MHz	151.00 MHz		< - 50 dBc
	149.75 MHz		< - 50 dBc
	100.25 MHz		< - 50 dBc
	99.75 MHz		< - 50 dBc
0.75 MHz	0.50 MHz		< - 50 dBc
	199.50 MHz		< - 50 dBc
	201.00 MHz		< - 50 dBc
	199.00 MHz		< - 50 dBc
99.75 MHz	300.25 MHz		< - 50 dBc
	301.00 MHz		< - 50 dBc
10.75 MHz	400.00 MHz		< - 50 dBc
98.75 MHz	11.25 MHz		< - 50 dBc
198.75 MHz	99.25 MHz		< - 50 dBc
	190.25 MHz		< - 50 dBc

3-18 Source Phase Noise Test					
HP 3577B Source Frequency	Offset Frequency	Marker Reading	Ref Level	Noise Level	Maximum Level
1.75 MHz	100 Hz		-	=	< - 70 dBc
	1 kHz		-	=	< - 70 dBc
	10 kHz		-	=	< - 70 dBc
199.75 MHz	100 Hz		-	=	< - 70 dBc
	1 kHz		-	=	< - 70 dBc
	10 kHz		-	=	< - 70 dBc
3-19 API SPUR TEST					
HP 3577B Frequency	1360 Hz Offset	2720 Hz Offset	Maximum Level		
1.7636 MHz			< - 50 dBc		
199.7636 MHz			< - 50 dBc		
3-20 TIMEBASE TEST Actual Maximum Opt. 001 only					
Freq (ref)					
Freq (test)					
Time (hours)					
Calculated stability = $\frac{\text{Freq(Ref)} - \text{Freq(Test)}}{\text{Time(Hours)}}$			Limit	< ± 0.4167	



## Semiautomated Performance Test Guide

---

### Introduction

This guide contains installation and operating information for the Semiautomated Performance Test Disk. The performance test disk contains a program that semiautomates the operation verification tests and performance tests for HP 3577B Network Analyzer. The disk also contains the programs printed in this manual. Whenever possible, the semiautomated performance test program follows the manual performance test procedures.

---

#### Note



The Semiautomated Performance Test Program meets or exceeds 4:1 uncertainty ratios when using the recommended test equipment given in table 4-1.

---

## Safety Considerations

Although the HP 3577B Network Analyzer is designed in accordance with international safety standards, this manual contains information, cautions, and warnings that must be followed to ensure safe operation and to keep the unit in safe condition. The operation verification and performance test procedures must be performed by trained service personnel who are aware of the hazards involved (such as fire and electrical shock).

---

### Warning



**Any interruption of the protective (grounding) conductor inside or outside the unit, or disconnection of the protective earth terminal can expose operators to potentially dangerous voltages.**

**Under no circumstances should an operator remove any covers, screws, shields or in any other way access the interior of the HP 3577B Network Analyzer. There are no operator controls inside the analyzer.**

---

## Features of the Semiautomated Test Program

- The program can reduce performance test time from 8 hours to 3 hours and the operation verification test time from 2 hours to 1 hour.
- Since this is an HP BASIC language program, the program can operate on an HP 9000 Series 200 or 300 computer, or on an HP 3577B Option 1C2 Network Analyzer (HP Instrument BASIC).
- The program is designed to use any of the recommended test equipment listed in table 4-2. Other equipment may be used if it meets or exceeds the listed critical specifications.
- The program can automatically create a printout similar to the Performance Test Record.
- The program can "beep" when equipment connections need to be changed.
- The program can start the test sequence at any test in the operation verification or performance test list.
- The program can stop after each measurement or alternatively, only if a failure occurs.

## Overview

This program consists of five files, ITM3577, OP\_VER\_2CH, OP\_VER\_3CH, PERF\_2CH, and PERF\_3CH.

ITM3577 is the HP Instrument BASIC Test Manager program. ITM3577 contains the test program and manages its execution. Since ITM3577 reads the OP\_VER\_2CH, OP\_VER\_3CH, PERF\_2CH, and PERF\_3CH procedure files, the disk must remain in the disk drive during testing and the disk drive must be connected to HP-IB.

OP\_VER\_2CH is the operation verification procedure for a standard HP 3577B.

OP\_VER\_3CH is the operation verification procedure for an HP 3577B Option 002 (adds third receiver).

PERF\_2CH is the performance test procedure for a standard HP 3577B.

PERF\_3CH is the performance test procedure for an HP 3577B Option 002.

All four files contain an ordered list of tests, and each test contains one or more measurements.

## Semiautomated Tests Versus Manual Tests

The semiautomated tests differ from the manual tests in the following ways.

- The Receiver Residuals and Noise Test in the service manual is split into two tests in the semiautomated tests; the Receiver Residuals Test and the Receiver Noise Test.
- The Receiver Level Flatness and Absolute Accuracy Test in the service manual is divided into two tests; the 50  $\Omega$  Flatness and Accuracy Test and the 1 M $\Omega$  Flatness and Accuracy Test. The test method for each test has also been modified. The semiautomated test corrects for the error of the cables, attenuators, and power splitter. It also verifies the flatness of the W&G EPM-1 Power Meter in the 5 to 10 Hz frequency range using the method in test 3-22. In the 1 M $\Omega$  Flatness and Accuracy Test, the impedance of the attenuators is measured and is used to calculate the absolute amplitude levels.
- The Alternate Receiver Level Flatness and Absolute Accuracy Test in the service manual which eliminates the required use of the W&G EPM-1 Power Meter is not included in the semiautomated tests.
- The semiautomated Source Flatness and Absolute Accuracy Test corrects for errors due to the power splitter, cables, and attenuators.
- The Alternate Source Flatness and Absolute Accuracy Test in the service manual which uses a voltmeter and an HP 436A Power Meter instead of a W&G EPM-1 Power Meter is not included in the semiautomated tests.
- The Frequency Stability Test in the service manual is not included in the semiautomated test.

## Recommended Test Equipment

The equipment required to run the semiautomated test is listed in table 1-2. Other equipment may be substituted for the recommended model if it meets or exceeds the listed critical specifications.

In addition to the recommended test equipment, you need either an HP 3577B Option 1C2 ( HP Instrument BASIC) and a disk drive, or an HP 9000 Series 200 or Series 300 computer with a disk drive, HP BASIC 5.0 or greater, 1/2 megabyte of program memory, and the IO and CRTX binaries.

Also, if you want the test record to be automatically printed, you need an HP-IB printer.

### Note



If you want the printer to automatically leave top and bottom margins on every page, enable perforation skip mode (see your printer's manual for directions).

## Program Controlled Test Equipment

This program can automatically control the following instruments. If you use a test instrument other than those shown here, the program prompts you to set the instrument state during testing.

**Table 4-1. Recommended HP-IB Equipment**

Test Equipment	Recommended Model
Frequency Synthesizer	HP 3325B HP 3325A HP 3326A
Digital Voltmeter	HP 3458A
Signal Generator	HP 8662A HP 8660C HP 8660D HP 8663A
Spectrum Analyzer	HP 8568B HP 8568A



## How to Load the ITM Program

### Using an HP 9000 Series 200 or Series 300 Computer

1. Using HP-IB cables, connect the HP 3577B Network Analyzer to the test instruments, printer, and computer.
  2. Load BASIC.
  3. Insert the Semiautomated Performance Test Disk into the computer's disk drive. Make sure the disk drive is the current Mass Storage IS device.
- 

**Note**



If you want to remove the softkey typing aids, type SCRATCH KEY.

---

4. Type GET "ITM3577" and then type or press RUN.
- 

**Note**



If you are using an HP 9000 Series 300 computer, you may need to press the Shift-User and Menu keys to display the ITM program softkeys.

---

5. On the HP 3577B Network Analyzer, press the following keys:

[ LCL ]

[ ANALYZER ADDRESS ]

6. Record the analyzer's HP-IB address for later use.

## Using an HP 3577B Option 1C2 (HP Instrument BASIC)

7. Using HP-IB cables, connect the HP 3577B Network Analyzer to the test instruments, disk drive, and printer.
8. Insert the Semiautomated Performance Test Disk into the disk drive connected to the analyzer.
9. Press the following keys:

[ LCL ]

[ DISK ADDRESS ]

Enter the disk drive address using the numeric keypad (e.g. 4 if the HP-IB address is 704).

[ DISK UNIT ]

Enter the drive number of the disk drive using the numeric keypad (e.g. 0 or 1).

Toggle to

[ SYS CTLR ON OFF ]

[ RECALL ]

[ GET PROGRAM ]

key in

I T M 3 5 7 7

[ ENTER ]

10. After the get program is loaded, press the following keys:

[ SPCL FCTN ]

[ RUN PROGRAM ]

## How to Use the ITM Program

1. Review "Softkey Descriptions."
2. Press [ TITLE PAGE ] and enter the information for the title page of the test record.
3. Press [ EQUIP CONFIG ] and enter the calibration due date, HP-IB address, model and trace number for each test instrument.
4. Press [ TEST CONFIG ] and enter the procedure, stop conditions, beeper prompt, and HP-IB address for the analyzer and for the printer.
5. Press [ START TESTING ] and then press [ START BEGINNING ], [ START MIDDLE ], or [ ONE TEST ] and follow the directions on the display.

---

### Note



If you are using an HP 3577B with HP Instrument BASIC and you want to pause the program and return the analyzer to front panel control, press [ SPCL FCTN ]. To continue the program, press:

[ SPCL FCTN ]  
[ CONTINUE PROGRAM ].

---

---

## Softkey Descriptions

---

### Note



If you are running the program on an HP 3577B Network Analyzer with HP Instrument BASIC and you are prompted to enter names or numbers, use the numeric key pad and the knob to select characters.

---

### ITM Main Menu

Load and run the ITM program to display the following softkeys:

- |                   |  |
|-------------------|--|
| [ START TESTING ] | Press [ START TESTING ] to display a menu that allows you to start testing with any test or to select just one test in the list. Before pressing this softkey, use [ TEST CONFIG ] and [ EQUIP CONFIG ]. |
| [ TEST CONFIG ]   | Press [ TEST CONFIG ] to display the test configuration and a menu that allows you to enter the procedure, stop conditions, beeper prompt, and HP-IB address for the analyzer and printer.               |
| [ EQUIP CONFIG ]  | Press [ EQUIP CONFIG ] to display the test equipment configuration and a menu that allows you to enter the model number, calibration due date, trace number, and HP-IB address for each test instrument. |
| [ TITLE PAGE ]    | Press [ TITLE PAGE ] to display the test record title page information and a menu that allows you to enter information for the analyzer.   |
| [ STOP ITM ]      | Press [ STOP ITM ] to stop the ITM program.  |

## Start Testing Menu

Press [ START TESTING ] to display the following softkeys:

- |                     |  |
|---------------------|--|
| [ START BEGINNING ] | Press [ START BEGINNING ] to print the test record title page information and to start the selected test procedure at the beginning.   |
| [ START MIDDLE ]    | Press [ START MIDDLE ] to display a list of all the tests in the selected procedure. Testing starts with the test you select and continues through the remainder of the tests in the list. |
| [ ONE TEST ]        | Press [ ONE TEST ] to display all the tests in the selected procedure. The test you select is the only test performed.   |
| [ RETURN ]          | Press [ RETURN ] to return to the ITM main menu.   |

Start a test to display the following softkeys:

- |                  |   |
|------------------|---|
| [ STOP TESTING ] | Press [ STOP TESTING ] to stop the test and return to the ITM main menu.                    |
| [ RESTART TEST ] | Press [ RESTART TEST ] to start the current test over. Any connection prompts are repeated. |
| [ RESTART MEAS ] | Press [ RESTART MEAS ] to start the current measurement again.                              |

The following softkeys also appear when the program is waiting for you to press [ CONTINUE ]:

- |                  |   |
|------------------|---|
| [ STOP BEEPING ] | Press [ STOP BEEPING ] to turn off the beeper prompt for the remainder of this measurement. |
| [ CONTINUE ]     | Press [ CONTINUE ] to continue testing after following the directions on the display.       |

## Test Configuration Menu

---

### Note



Use the following to determine HP-IB addresses:

$$100 \times (\text{interface select code}) + (\text{primary address})$$

When using HP Instrument BASIC, the internal interface select code for the HP 3577B analyzer is 8 and the primary address is ignored. Since the analyzer's primary address is ignored, use 800 for its HP-IB address. The interface select code for the printer and test equipment is 7 (for example, if the primary address is 8, the HP-IB address is 708).

---

Press [ TEST CONFIG ] to display the test configuration and the following softkeys:

- |                     |   |
|---------------------|---|
| [ DUT ADDRESS ]     | Press [ DUT ADDRESS ] to enter the HP-IB address for the HP 3577B Network Analyzer.   |
| [ PRINTER ADDRESS ] | Press [ PRINTER ADDRESS ] to enter the HP-IB address for the printer. To disable the printer, set the printer address to 0.   |
| [ PROCEDURE ]       | Press [ PROCEDURE ] to select operation verification tests (OP_VER_2CH and OP_VER_3CH) or performance tests (PERF_2CH and PERF_3CH).  |
| [ STOP AFTER ]      | Press [ STOP AFTER ] to select "stop after limit failure", "stop after each measurement", or "do not stop after a measurement". If [ Limit Failure ] is selected, the program stops after the failing measurement is displayed, but before it is printed. At this point you can continue on and print the failing measurement or restart the measurement. |
| [ BEEPER ]          | Press [ BEEPER ] to toggle the beeper on and off. When the beeper is on, the program beeps approximately every 2 minutes while waiting for you to follow the directions on the display and press [ CONTINUE ].  |
| [ RETURN ]          | Press [ RETURN ] to return to the ITM main menu.  |

## Equipment Configuration Menu

Press [ EQUIP CONFIG ] to display the test equipment configuration and the following softkeys:

---

### Note



If you select [ Other ] for model, the program prompts you to type in a model, trace number, and calibration due date but not an HP-IB address.

---

- |                 |  |
|-----------------|--|
| [ ANALYZER ]    | Press [ ANALYZER ] to enter the model, trace number, HP-IB address, and calibration due date for the spectrum analyzer.        |
| [ SYNTHESIZER ] | Press [ SYNTHESIZER ] to enter the model, trace number, HP-IB address, and calibration due date for the frequency synthesizer. |
| [ SIG GEN ]     | Press [ SIG GEN ] to enter the model, trace number, HP-IB address, and calibration due date for the signal generator.          |
| [ RATIO XFMR ]  | Press [ RATIO XFMR ] to enter the model, trace number, and calibration due date.   |
| [ VOLTMETER ]   | Press [ VOLTMETER ] to enter the model, trace number, HP-IB address, and calibration due date for the voltmeter.               |
| [ POWER METER ] | Press [ POWER METER ] to enter the model, trace number, and calibration due date for the power meter.                          |
| [ RETURN ]      | Press [ RETURN ] to return to the ITM main menu.   |

## Title Page Menu

Press [ TITLE PAGE ] to display the title page information and the following softkeys:

---

### Note



The title page information is printed at the beginning of the test procedure.

---

[ CAL ENTITY ]	Press [ CAL ENTITY ] to enter the name or number of the testing entity.
[ ENTITY ADDRESS ]	Press [ ENTITY ADDRESS ] to enter the address of the testing entity.
[ TESTED BY ]	Press [ TESTED BY ] to enter the name or identification number of the person performing the test.
[ REPORT NUMBER ]	Press [ REPORT NUMBER ] to enter the analyzer's report number.
[ CUSTOMER ]	Press [ CUSTOMER ] to enter the name or identification number of the person requesting the test.
[ MORE ]	Press [ MORE ] to display the next page.
[ RETURN ]	Press [ RETURN ] to return to the ITM main menu.
[ TRACE NUMBER ]	Press [ TRACE NUMBER ] to enter the analyzer's trace number.
[ OPTIONS ]	Press [ OPTIONS ] to enter the analyzer's options.
[ DATE ]	Press [ DATE ] to enter the test date.
[ TEMP ]	Press [ TEMP ] to enter the temperature of the environment during the test.
[ HUMIDITY ]	Press [ HUMIDITY ] to enter the humidity of the environment during the test.
[ LINE FREQUENCY ]	Press [ LINE FREQUENCY ] to enter the power line frequency.
[ MORE ]	Press [ MORE ] to display the first page.



## Tests Requiring Equipment Connection Changes

The following tables show which tests require you to change the equipment connections relative to the connections for the previous test. The tests are listed in the order they are performed.

**Table 4-2. Equipment Connections for Operation Verification Tests**

Test Name	New Setup
1. Self Tests	yes
2. I/O Port	yes
3. Receiver Residuals	yes
4. Receiver Noise	no
5. Mag. vs. Phase	yes
6. Source Distortion and Spurs	yes
7. Source Flatness and Accuracy	yes

**Table 4-3. Equipment Connections for Performance Tests**

Test Name	New Setup
1. Self Tests	yes
2. I/O Port	yes
3. Receiver Crosstalk	yes
4. Receiver Ratio Amplitude and Phase	yes
5. Source Attenuator Accuracy	yes
6. Receiver Residuals	yes
7. Receiver Noise	no
8. Receiver Return Loss	yes
9. On Carrier Return Loss	yes
10. Dynamic Accuracy	yes
11. Mag. vs. Phase	yes
12. Source Distortion and Spurs	yes
13. Source Phase Noise	no
14. API Spurs	no
15. 50 Ohm Flatness and Accuracy	yes
16. 1 MOhm Flatness and Accuracy	yes
17. Source Flatness and Accuracy	yes

## Measurement Uncertainty

Performance Test	Using Recommended Test Equipment		Using Other Test Equipment	
	Measurement Uncertainty	Ratio	Measurement Uncertainty	Ratio
1. Self Tests	NA	NA	NA	NA
2. VO Port	NA	NA	NA	NA
3. Receiver Crosstalk	± 0.75 dB	NA <sup>1</sup>		NA <sup>1</sup>
4. Receiver Ratio Amplitude and Phase	± 0.02 dB ± 0.2 deg.	> 10:1 > 10:1		
5. Source Attenuator Accuracy				
4 dB atten	± 0.02 dB	9.75:1		
8 dB atten	± 0.02 dB	9.75:1		
16 dB atten	± 0.02 dB	> 10:1		
32 dB atten	± 0.02 dB	> 10:1		
48 dB atten	± 0.05 dB	> 10:1		
6. Receiver residuals	± 0.75 dB	NA <sup>1</sup>		NA <sup>1</sup>
7. Receiver noise	± 0.75 dB	NA <sup>1</sup>		NA <sup>1</sup>
8. Receiver Return Loss	± 1.75 dB	NA <sup>1</sup>		NA <sup>1</sup>
9. On Carrier Return Loss	± 1.00 dB	NA <sup>1</sup>		NA <sup>1</sup>
10. Dynamic Accuracy				
Magnitude with ratio transformer setting:				
1.0	± 2.205 ppm	> 10:1		
0.31623	± 2.205 ppm	> 10:1		
0.2	± 2.205 ppm	> 10:1		
0.05	± 1.603 ppm	> 10:1		
0.025	± 1.147 ppm	> 10:1		
0.01	± 0.741 ppm	> 10:1		
0.0031623	± 0.436 ppm	> 10:1		
0.001	± 0.265 ppm	> 10:1		
0.0001	± 0.114 ppm	> 10:1		
0.00001	± 0.066 ppm	> 10:1		
Phase	± 50 m deg.	> 10:1		
11. Mag. vs. Phase	± 0.001 dB	> 10:1		
12. Source Distortion and spurs	± 2.5 dB	NA <sup>1</sup>		NA <sup>1</sup>
13. Source Phase Noise	± 1.5 dB <sup>2</sup>	NA <sup>1</sup>		NA <sup>1</sup>
14. API Spur	± 2.5 dB	NA <sup>1</sup>		NA <sup>1</sup>
15. 50Ω Flatness and Accuracy				
@100 KHz	± 0.035 dB	5.6:1		
20 Hz-20 MHz	± 0.035 dB	8.2:1		
5 Hz-200 MHz				
5 Hz-10 Hz	± 0.13 dB	4:1		
10 Hz-50 MHz	± 0.035 dB	> 10:1		
50 MHz-100 MHz	± 0.045 dB	> 10:1		
100 MHz-200 MHz	± 0.06 dB	9.3:1		

<sup>1</sup> open-ended specification

<sup>2</sup> root-sum-squares calculation method

Measurement Uncertainty Continued

Performance Test	Using Recommended Test Equipment		Using Other Test Equipment	
	Measurement Uncertainty	Ratio	Measurement Uncertainty	Ratio
16. 1 M $\Omega$ Flatness and Accuracy @100 KHz 20 Hz-20 MHz 5 Hz-20 MHz 5 Hz-10 Hz 10 Hz-20 MHz	$\pm 0.035$ dB $\pm 0.035$ dB $\pm 0.013$ dB $\pm 0.035$ dB	5.6:1 >10:1 6.8:1 >10:1		
17. Source Flatness and Accuracy @100 KHz 5 Hz to 200 MHz 5 Hz to 10 Hz 10 Hz to 50 MHz 50 Hz to 100 MHz 100 Hz to 200 MHz	$\pm 0.035$ dB $\pm 0.13$ dB $\pm 0.035$ dB $\pm 0.045$ dB $\pm 0.06$ dB	>10:1 9.6:1 >10:1 >10:1 >10:1		

<sup>1</sup> open-ended specification

<sup>2</sup> root-sum-squares calculation method



## Adjustments

---

### 5-1 Introduction

This section describes adjustments and checks required to bring the instrument within the specifications listed in table 1-1. Perform these procedures only if the specifications of table 1-1 are not met, if instructed to do so in the troubleshooting section, or after replacing a component. Do not perform these procedures as a routine maintenance procedure.

Table 5-1 lists the adjustment procedure and it's description in tabular form. Table 5-2 lists all interrelated adjustments. Table 5-3 lists possible solutions for failing performance tests.

---

#### Note



Before performing any adjustments, allow the instrument to warm up for 1 hour. Adjustments must be made with all internal shields and covers in place and the instrument in thermal equilibrium.

---

### 5-2 Equipment Required

Table 1-2 lists the equipment required for the adjustment procedures. Any equipment which meets the critical specifications given in the table may be substituted for the recommended model.

---

## 5-3 Safety Considerations

Although the HP 3577B is designed in accordance with international safety standards, this manual contains information, cautions, and warnings which must be followed to ensure operation and to keep the unit in safe condition. Service and adjustments should be performed only by qualified personnel who are aware of the hazards involved.

---

### Warning



**Any interruption of the protective (grounding) conductor inside or outside the unit, or disconnection of the protective earth terminal is likely to make the unit hazardous. Capacitors inside the HP 3577B may still be charged even though the HP 3577B has been removed from mains supply.**

**Only fuses with the required rated current and specified type should be used for replacement. The use of repaired fuses and short circuiting of fuse holders is not permitted. Whenever it is likely that the protection offered by the fuse has been impaired, the HP 3577B must be made inoperative and secured against unintended operation.**

**Adjustments described in this section are performed with the protective covers removed and power applied. Energy available at many points can, if contacted, result in personal injury.**

---

## 5-4 Related Adjustments

The following adjustment procedures are written so that all interactive adjustments are described together. Adjustment procedures which interact with other adjustment procedures are listed in table 5-2. Also listed in table 5-2 are the Performance Tests which should be run after an adjustment assure the instrument meets the specifications listed in table 1-1. Table 5-3 lists adjustment procedures, possible problems, and padding parts to correct failing performance tests. Performance tests which are also included in the Semiautomated Performance Test are indicated by the footnote in table 5-3.

**Table 5-1. Adjustments List**

Adjustment Name	Reference Designator	Adjustment Paragraph	Service Sheet	Description
	A71R44	5-21		VGA DC Offset
	A71C112	5-22		Input Capacitance
	A71C114	5-23		20 dB Attenuation
PHASE ADJ	A71R74	5-29		Input Phase Zero
RTN LOSS ADJ	A71R172	5-25		Return Loss
FLATNESS ADJ	A71R173	5-28		Level Flatness
LO FEED THRU ADJ	A71R141	5-24		L.O. Feedthrough
	A71L3	5-19		250 kHz Filter
	A71L4	5-19		250 kHz Filter
	A71L5	5-19		250 kHz Filter
50Ω GAIN ADJ	A71R71	5-26		50Ω Gain
HIGH IMPED GAIN ADJ	A71 R76	5-27		HI Z Gain
	A71 C26	5-20		10 kHz Filter
	A71 C20	5-20		10 kHz Filter
R PHASE ADJ	A4 C50	5-15		R Channel LO Output Level
A PHASE ADJ	A4 C70	5-15		A Channel LO Output Level
B PHASE ADJ	A4 C90	5-15		B Channel LO Output level
	A25 L1	5-13A		200 MHz Bandpass 1
	A4 L2	5-13B		300 MHz Filter 1
	A4 L3	5-13B		300 MHz Filter 1
	A4 L4	5-13B		300 MHz Filter 2
	A4 L5	5-13B		300 MHz Filter 2
	A4 L7	5-14		200 MHz Filter Zero
	A4 L8	5-14		200 MHz Filter Zero
	A4 L9	5-14		200 MHz Filter Flatness
	A4 L100	5-14		200 MHz Filter Zero
	A4 L101	5-14		200 MHz Filter Zero
	A4 L102	5-11		200 MHz Filter Flatness
	A5 R9	5-10		Offset Tuning Range
10 MHz ADJ	A6 R12	5-6		10 MHz Tuning Range
	A6 L33	5-7		300 MHz peaking

Table 5-1. Adjustments List Continued

Adjustment Name	Reference Designator	Adjustment Paragraph	Service Sheet	Description
	A71R44	5-21		VGA DC Offset
API 1 ADJ	A17R76	5-31		API 1
API 2 ADJ	A17 R74	5-31		API 2
API 3 ADJ	A17 R73	5-31		API 3
API 4 ADJ	A17 R88	5-31		API 4
	A17 R161	5-11		VCO Tuning Range
100 kHz NULL ADJ	A17 R107	5-12		100 kHz Pedestal Null
STEP 1	A8 R142	5-17		Step Cal 1
LVL 1	A8 R144	5-17		Level Cal 1
STEP 2	A8 R157	5-17		Step Cal 2
LVL 2	A8 R156	5-17		Level Cal 2
HIGH FREQ	A8 C155	5-18		Source Flatness
RTN LOSS	A8 C71	5-30		Output Return Loss
	A8 L11	5-16		200 MHz Filter 1
	A8 L12	5-16		200 MHz Filter 1
	A8 L13	5-16		200 MHz Filter 1
	A8 L14	5-16		200 MHz Filter 2
	A8 L15	5-16		200 MHz Filter 2
	A8 L123	5-16		300 MHz Filter 2
	A8 L124	5-16		300 MHz Filter 2
	A8 L223	5-16		300 MHz Filter 1
	A8 L224	5-16		300 MHz Filter 1
+15 V ADJ	A21 R122	5-5		+15 V Output Level
- 15 V ADJ	A21 R124	5-5		- 15 V Output Level
+5 V ADJ	A21 R22	5-5		+5 V Output Level
OVEN SHUT OFF	A31 R9	5-9		Shutdown Level
FINE FREQ ADJ	A31 R2	5-32		Fine Frequency
	A31 U1	5-32		Coarse Frequency
CPU CLOCK ADJ	A63 C605	5-8		CPU CLOCK PLL FREE-RUN FREQUENCY



Table 5-2. Post Repair/Interactive Adjustments

Repaired/Adjusted sub-block	Recommended Performance Check and/or Adjustment procedure	Paragraph Number
All A71 board analog repairs	<ol style="list-style-type: none"> <li>1. All receiver adjustments</li> <li>2. All receiver performance tests</li> </ol>	5-19 through 5-29 3-7 & 3-9 through 3-14
All A71 board digital repairs	<ol style="list-style-type: none"> <li>1. All Operational Verification tests for the receiver board</li> <li>2. Input 50<math>\Omega</math> Gain Adjustment</li> <li>3. Input 1 M<math>\Omega</math> Gain Adjustment</li> </ol>	3-5  5-26 5-27
All A4 board repairs	<ol style="list-style-type: none"> <li>1. Receiver Level Flatness</li> <li>2. Input 50<math>\Omega</math> Gain Adjustment</li> <li>3. Input 1 M<math>\Omega</math> Gain Adjustment</li> <li>4. Input Phase Zero Adjustment</li> </ol>	3-13 5-26 5-27 5-29
All A5 board repairs	<ol style="list-style-type: none"> <li>1. Check A5 Fault Isolation Signals</li> <li>2. Source Distortion &amp; Spur Test</li> </ol>	2-11 3-17
All A6 board	<ol style="list-style-type: none"> <li>1. Check A6 Fault Isolation Signals</li> </ol>	2-11 repairs
All A17 API and VCO repairs and adjustments	<ol style="list-style-type: none"> <li>1. Receiver Residuals &amp; Noise Test</li> <li>2. Source Distortion and Spur Test</li> <li>3. Source Phase Noise Test</li> <li>4. API Spur Test</li> <li>5. Synthesizer 100 kHz Null Adjustment</li> <li>6. API Adjustments</li> </ol>	3-7 3-17 3-18 3-19 5-12 5-31
All A8 Filter and Amplifier repairs and adjustments	<ol style="list-style-type: none"> <li>1. Source Distortion and Spur Test</li> <li>2. Source Flatness and Absolute Accuracy Test</li> <li>3. Source Amplitude and Step Adjustments</li> <li>4. Source Flatness Adjustment</li> </ol>	3-17 3-15  5-17 5-18
A8 Freq Gain Error Correction and Amplitude leveling repairs	<ol style="list-style-type: none"> <li>1. Source Flatness and Absolute Accuracy Test</li> <li>2. On Carrier Return Loss Test</li> <li>3. Source Amplitude and Step Adjustments</li> <li>4. On Carrier Return Loss Adjustment</li> </ol>	3-15 3-8 5-17 5-30

**Table 5-2. Post Repair/Interactive Adjustments Continued**

<b>Repaired/Adjusted sub-block</b>	<b>Recommended Performance Check and/or Adjustment procedure</b>	<b>Paragraph Number</b>
All A61 board repairs	1. All Power On Self Tests 2. All Service Diagnostics	2-7 2-10
All A62/63 board repairs	1. CPU clock adjustment 2. All Power On Self Tests 3. All Service Diagnostics	5-8 2-10
All A16 board repairs	1. DISP HP-IB Service Diagnostic	2-10
All A21 board repairs	1. Main Power Supply Fault Isolation 2. Power Supply Adjustments	2-11 5-5
All A31 board repairs (Option 001 only)	1. Frequency Stability Test 2. Oven Board 10 MHz Reference Frequency Adjustment	3-20 5-32

**Table 5-3. Performance Test Adjustments**

Failing Performance Test	Adjustment Procedure	Possible Problem or Padding Part
<b>3-7 Receiver Residuals Test*</b> step h: frequency 0.0277777 MHz 0.000 MHz Other	5-24 5-31 5-24	A17 R76  Low output from A4, A71 first IF mixer
<b>Receiver Noise Test*</b> step s: frequency 100 Hz 30 kHz 199 MHz		A71 before the first mixer A11U61  Boards not screwed into card nest improperly seated input shield on receiver board Broken RF cables 60 dB attenuator on A8
<b>3-8 On Carrier Return Loss Test*</b>	5-30	
<b>3-9 Dynamic Accuracy Test*</b> step u.: magnitude  lower ratio transformer settings	5-21	A71 first IF to (mixer, op amps in 10 kHz IF) A4 local oscillator levels  Check for ground loops before doing any adjustments. Set up must be as specified in figure 3- 3 Low power supply
<b>3-10 Mag. vs. Phase Test*</b> step l	A71 R44 adj. until the test passes or do adj. 5-21	
<b>3-11A Receiver Level Flatness and Absolute Accuracy Test*</b> step r: 50Ω Flatness & Accuracy Test*	5-26	
step r: 1 MΩ Flatness & Accuracy Test*	5-27	A71 input buffer relay A71 input buffer A71 first mixer A4 low local osc. levels
step v: 50 Ω Flatness & Accuracy Test (5 Hz – 200 MHz)*	5-28	A71 first mixer to input connector inclusive A71 R140
step v: 1 MΩ Flatness & Accuracy Test (5 Hz – 20 MHz)* frequencies < 10 MHz	5-23	

\*Semi-automated Test provided.

**Table 5-3. Performance Test Adjustments Continued**

Failing Performance Test	Adjustment Procedure	Possible Problem or Padding Part
<b>3-11B Alternate Receiver Level Flatness and Absolute Accuracy Test*</b>		
step dd	5-26	
step ii	5-28	Same as 3-11A step v
step rr	5-27	Same as 3-11A step r
step tt: 1 M $\Omega$ frequencies MHz	5-23	
<b>3-12 Receiver Ratio Amplitude &amp; Phase*</b>		Cables in the box not properly hooked up. If parts were replaced, see Service notes HP 3577A-11/13
step s : (Magnitude 100 kHz)*	5-26	
step v : (Phase 100 kHz)*	5-29	
step x : (Phase 5 Hz – 200 MHz)* for 1 M $\Omega$ (Phase 5 Hz – 20 MHz)*		
step aa : Magnitude (5 Hz – 200 MHz)* for 1 M $\Omega$ (5 Hz – 20 MHz)*	5-13A	If parts were replaced, see Service note HP 3577A-12
step at : Phase (20 Hz – 20 MHz)*		Same as 3-12 step hh
step aw : Magnitude (20 Hz – 20 MHz)*		Vary the length of A71 R140
step at : frequencies < 100 Hz		A1 C101
<b>3-13 Receiver Crosstalk Test*</b>		A71 U43
<b>3-14 Receiver Return Loss Test*</b>	5-25	If A71 K1 or A71 K2 was replaced, lead length can affect return loss.
<b>3-15A Source Flatness &amp; Accuracy Test*</b>		
step y: Flatness (5 Hz – 200 MHz)*	5-18	
step x : Accuracy (at 100 kHz)*	5-17	
<b>3-15B Alternate Source Flatness &amp; Accuracy Test*</b>		
step j	5-17	
step k		A8
step o	5-18	
<b>3-16 Source Attenuator Accuracy Test*</b>		60 dB attenuator on A8
<b>3-17 Source Distortion &amp; Spurs Test*</b>		
step c : 2nd harmonic of 100 MHz*		A8Q45
step f : Spur*	5-11	
<b>3-18 Source Phase Noise Test*</b>	5-11	A17 voltage regulators A17 VCO
<b>3-19 API Spurs Test*</b>	5-31	

\*Semi-automated Test provided.

## 5-5 Power Supply Adjustments

### Description:

This procedure checks and adjusts all power supplies on the A21 Main Power Supply board for correct voltage and minimum line related ripple.

<b>Equipment:</b>
Digital Voltmeter

### Procedure:

#### Warning



Adjustments made to the power supply are in close proximity to terminals with AC voltages capable of causing personal injury. The main power supply filter capacitors are charged to approximately 250 V. Even with the power switch in the OFF position, these voltages may be present. Before making equipment connections to the FET POWER and FET DRIVE circuits, turn OFF the instrument's power switch, remove the power cord, and place jumpers A21W1 and A21W2 into the TEST position using insulated pliers. The jumpers must remain in the TEST position for approximately 2 minutes to insure the capacitors are fully discharged. After performing these steps, make all equipment connections and connect the instrument to the power line.

a. Turn OFF the instrument's power switch, remove the power cord, and remove the bottom cover. Connect the instrument to the power line, and turn the POWER switch ON.

b. Set the voltmeter as follows:

Function	DC
Range	AUTO
Trigger	Internal
Math	OFF
Sample Rate	Maximum

c. The switching power supply monitors the +5 V power supply, so this supply must be loaded nominally when making adjustments. Verify connection of power supply cables to A21J1, A21J2, and A21J8.

d. Connect the voltmeter negative terminal to the instrument chassis.

- e. Connect the voltmeter positive terminal to TP26. If necessary, adjust A21 R22 for  $+5.10 \pm 0.02$  V.
- 

**Note**



The + 15 V and – 15 V power supplies derive their reference from the +5 V supply. If the +5 V supply is not within specifications, do not adjust the 15 V supplies.

---

- f. Connect the voltmeter positive terminal to TP8. If necessary, adjust A21 R122 for  $+15.00 (-0.00, +0.05)$  V.
- g. Connect the voltmeter positive terminal to TP9. If necessary, adjust A21 R124 for  $-15.00 \pm 0.05$  V.
- h. Connect the voltmeter positive terminal to TP10. The voltmeter should read  $+8.0$  V  $\pm 1.0$ V.
- 

**Note**



The + 8 V power supply is not adjustable. This power supply feeds unregulated dc voltage to the A6 Reference and A17 Synthesizer boards. If the voltage is not correct, turn the POWER switch OFF and remove the A6 and A17 boards. Turn the POWER switch ON, and check the +8 V supply again. If there is no change in the supply voltage after the boards are removed, the problem is most likely on the A21 Main Power Supply board.

---

- i. Move the voltmeter negative terminal to TP12.
- 

**Note**



The isolated +5 V supply is isolated from the other instrument power supplies by transformer T1. Be sure to use the correct ground when checking this supply.

---

- j. Connect the voltmeter positive terminal to TP11. The voltmeter should read +5.00  $\pm$  0.25 V.
- 

**Note**

The isolated +5 V supply is not adjustable. If the voltage is not correct, disconnect the cable from A21J2 while monitoring the supply to determine if the A16 HP-IB board is affecting the supply. If there is no change in the supply voltage when the cable is removed, the problem is most likely on the A21 Main Power Supply board.

---

- k. This completes the adjustment. Turn OFF the instrument's power switch, remove the power cord, and return the HP 3577B to its original state.

---

## 5-6 Reference Board 10 MHz Oscillator Adjustment

### Description:

This procedure adjusts the free run frequency of the 10 MHz oscillator on the A6 Reference board. This 10 MHz oscillator either free runs or is phase locked to the 10 MHz oven (for Option 001) or to an external reference and is the source of all frequencies in the HP 3577B.

<b>Equipment:</b>
Counter
BNC Cable-48 inch

### Procedure:

- a. Turn OFF the instrument's power switch, remove the power cord, and remove the top cover. Connect the instrument to the power line, and turn the POWER switch ON.
- b. Remove the cable from A6J6 and any external reference from the rear panel.
- c. Connect the counter to the rear panel 10 MHz output.
- d. Place the jumper A6 W1 in the test position. This places the switchable loop filter in the wideband mode and allows the 10 MHz VCXO to free run.
- e. Adjust A6 R12 for a counter frequency reading of 10 MHz  $\pm$  5 Hz.
- f. This completes the adjustment. Turn OFF the instrument's power switch, remove the power cord, and return the HP 3577B to its original state.



## 5-7 300 MHz Output Level Peaking Adjustment

### Description:

This procedure adjusts the 300 MHz output filter pass element on the A6 Reference board. Adjusting the filter center frequency controls the 300 MHz output level.

<b>Equipment:</b>
Spectrum Analyzer
Service Accessory Kit

### Procedure:

- a. Turn OFF the instrument's power switch, remove the power cord, and remove the top cover.
- b. Place the A6 Reference board on the extender board.
- c. Connect the instrument to the power line, and turn the POWER switch ON.
- d. Connect the spectrum analyzer to A6J3.
- e. Adjust A6L33 for the maximum 300 MHz spectrum analyzer reading. (This adjustment is inside the shielded assembly and can be made through the top cover of the shield.) This reading should be between  $-5$  and  $-2$  dBm (check 2nd [600 MHz] harmonic to see if it is less than  $-40$  dBm).
- f. This completes the adjustment. Turn OFF the instrument's power switch, remove the power cord, and return the HP 3577B to its original state.

---

## 5-8 CPU Clock Adjustment

### Description:

This procedure adjusts the CPU clock PLL fre-run frequency. This insures that the PLL can lock to the reference board 1 MHz signal during environmental extremes.

Equipment:
Counter
10:1 Probe

### Procedure:

- a. Move A62 or A63 W71 to 1MHz DISABLE position.
- b. Press the A62 or A63 SW1 RESET.
- c. Check for a "1 MHz FAILURE" message after power up.
- d. Install a 10:1 probe in the frequency counter 1M $\Omega$  input.
- e. Connect the counter external reference to the HP 3577B EXT REF IN at the rear panel.
- f. Connect a 10:1 probe to A62 or A63 TP3 MCLK and set the counter to read out in frequency.

---

### Note



Use only a 10:1 probe with ground clip. A 1:1 probe or a BNC cable with alligator clips will capacitively load the MCLK signal and may result in erratic operation.

- 
- g. Adjust A62 or A63 C605 for a counter reading of 10 MHz  $\pm$  50 kHz (9.95 MHz-10.05 MHz).
  - h. Move A62 or A63 W71 to the 1 MHz ENABLE position. The counter should read 10 MHz  $\pm$  15 Hz.
  - i. Press A62 or A63 SW1 RESET.
  - j. Check that the "1 MHz FAILURE" message does NOT appear.

## 5-9 Oven Heater Shutdown Adjust (Option 001 only)

### Description:

This procedure adjusts the heater shutdown trip point on the A31 Oven board. (The A31 Oven board is present on option 001 only.) This trip point sets the temperature that causes the HP 3577B to disconnect from the oven reference when the oven is cold and connect when the oven has warmed up.

<b>Equipment:</b>
Spectrum Analyzer
Service Accessory Kit

### Procedure:

- a. Turn OFF the instrument's power switch, and remove the power cord. Remove the top cover, and the cover above A31. Connect the instrument to the power line, but DO NOT turn the POWER switch ON.
- b. Connect the spectrum analyzer to A31J1 and set as follows:

Center Frequency	10 MHz
Reference Level	0 dBm
Span	1 MHz
- c. Turn the HP 3577B line power ON. When the oven is cold, the 10 MHz signal on the spectrum analyzer should be approximately -100 dBm or lower. To check, set the spectrum analyzer reference level to -80 dBm and the span to 1 kHz.
- d. After approximately 20 minutes, when the oven is sufficiently warm, the 10 MHz signal on the spectrum analyzer should be approximately 0 dBm. Adjust A31 R9 until the 10 MHz signal on the spectrum analyzer drops out, then back off A31 R9 about 10 degrees or until the signal just appears.
- e. This completes the adjustment. Turn OFF the instrument's power switch, remove the power cord, and return the HP 3577B to its original state.

## 5-10 Offset Board Oscillator Tuning Range Adjustment

### Description:

This procedure adjusts the 300.25 MHz oscillator voltage controlled tuning range on the A5 Offset board. This is required to ensure that the oscillator remains phaselocked under all environmental conditions.

<b>Equipment:</b>
Spectrum Analyzer
Service Accessory Kit

### Procedure:

- a. Turn OFF the instrument's power switch, remove the power cord, and remove the top cover.
- b. Place the A5 Offset board on the extender board.
- c. Connect the instrument to the power line, and turn the POWER switch ON.
- d. Connect A5J2 to A6J4 (normal connection) using extender cables. Set A5W3 to the test position.
- e. Connect the spectrum analyzer to A5J1 and set as follows:

Center Frequency	300.25 MHz
Reference Level	+ 10 dBm
Span	50 MHz
- f. Press the Max Hold function, if available, on the spectrum analyzer. The VCO ramps over its tuning range, and the spectrum analyzer display should show a waveform similar to a bandpass filter.
- g. Adjust A5R9 (inside the shield) for a spectrum analyzer span such that the waveform is two-thirds above and one-third below 300.25 MHz. After any adjustment is performed, the spectrum analyzer Max Hold values must be reset. On the HP 8568B, this is done by pressing the Clear Write control.
- h. This completes the adjustment. Turn OFF the instrument's power switch, remove the power cord, and return the HP 3577B to its original state.

## 5-11 Synthesizer Tuning Range Adjustment

### Description:

This procedure adjusts the A17 Synthesizer board tuning range. This insures that the A17 Synthesizer can tune to all required frequencies during environmental extremes.

Equipment:
Spectrum Analyzer
BNC Cable-48 inch
Service Accessory Kit

### Procedure:

- a. Turn OFF the instrument's power switch, remove the power cord, and remove the top cover. Place the A17 Synthesizer board on the extender board. Connect the instrument to the power line, and turn the POWER switch ON.
- b. Connect the spectrum analyzer 10 MHz REF OUT to the HP 3577B EXT REF IN using a BNC cable. The EXT REF LED on the HP 3577B front panel should be lit.
- c. Check that the green LED on the A17 Synthesizer board is lit. This indicates that the +8 V power supply is operational.
- d. With J3 on the A17 board disconnected, the red Unlock LED should be lit.
- e. Connect A17J3 to A6J5 (normal connection) using the extender cable. The Unlock LED should go out.
- f. Connect the spectrum analyzer to A17J1 using the BNC to SMA cable.
- g. Set the spectrum analyzer as follows:
 

Center Frequency	400 MHz
Frequency Span	300 MHz
Reference Level	0 dBm
Input Attenuation	10 dB
Resolution Bandwidth	Auto
- h. Press and continue to hold down the reset button on the A62/63 Main Processor board. The output frequency should be  $290 \pm 8$  MHz. When the reset pushbutton is released, the signal should jump to the high end of the VCO tuning range for approximately 2 seconds.
- i. Using the spectrum analyzer, note the highest frequency of the signal when the reset pushbutton is released.

## 5-11 Synthesizer Tuning Range Adjustment

- j. Adjust A17 R161 (within the shield) for a signal frequency of  $515 \pm 10$  MHz when the pushbutton is released and the VCO is running at the high end of the frequency range.
- k. Check that the low end of the frequency range is below 298 MHz. Repeat steps h through j until both the lower and upper frequencies are within specification.
- l. Disconnect the cable at A17 J3. The frequency of the largest signal on the spectrum analyzer should be  $290 \pm 8$  MHz.
- m. This completes the adjustment. Turn OFF the instrument's power switch, remove the power cord, and return the HP 3577B to its original state.

## 5-12 Synthesizer 100 kHz Null Adjustment

### Description:

This procedure adjusts the 100 kHz synthesizer reference frequency sideband present on the synthesized signal to an acceptable level. This is required for proper signal purity of the A17 Synthesizer board.

Equipment:
Spectrum Analyzer
BNC Cable-48 inch
Service Accessory Kit

### Procedure:

- a. Turn OFF the instrument's power switch, remove the power cord, and remove the top cover. Place the A17 Synthesizer board on the extender board and connect A17 J3 to A6 J5. Connect the instrument to the power line, and turn the POWER switch ON.
- b. Connect the spectrum analyzer 10 MHz REF OUT to the HP 3577B EXT REF IN using a BNC cable. The EXT REF LED on the HP 3577B front panel should be lit.
- c. Set the HP 3577B sweep type to CW and frequency to 750 kHz.
- d. Set the spectrum analyzer as follows:
 

Center Frequency	301 MHz
Frequency Span	225 kHz
Reference Level	+5 dBm
- e. Connect the spectrum analyzer to A17 J1. Note the level measured at 301 MHz.
- f. Adjust A17 R107 until the signal levels at 300.9 MHz and 301.1 MHz are at least 65 dB below the level seen at 301 MHz.
- g. This completes the adjustment. Turn OFF the instrument's power switch, remove the power cord, and return the HP 3577B to its original state.

---

## 5-13A 300 MHz Band Pass Filter Adjustment

### Description:

This procedure adjusts the 300 MHz band pass filter on the A25 board. This filter eliminates 30 MHz harmonics.

Equipment:
Spectrum Analyzer
Service Accessory Kit

### Procedure:

- a. Turn OFF the instrument's power switch, remove the power cord, and remove the top cover. Connect the instrument to the power line, and turn the POWER switch ON.
- b. Connect the spectrum analyzer 10 MHz REF OUT to the HP 3577B EXT REF IN using a BNC cable. The EXT REF LED on the HP 3577B front panel should be lit.
- c. Remove the cable connecting A25 J2 to A4 J1 and connect the spectrum analyzer to A25 J2.
- d. Set the spectrum analyzer as follows:

Center Frequency	300 MHz
Frequency Span	0 Hz
Resolution Bandwidth	300 Hz
Video Bandwidth	300 Hz
Sweep Time	10 sec
- e. Adjust A25L1 for a maximum reading on the spectrum analyzer.
- f. This completes the adjustment. Turn OFF the instrument's power switch, remove the power cord, and return the instrument to its original state.



## 5-13B Local Oscillator 300 MHz Filter Adjustments

### Description:

This procedure adjusts both of the 300 MHz filters on the A4 Local Oscillator board. These filters eliminate upper harmonics that can interfere with the peak detecting leveling loop.

Equipment:
Signal Generator
Spectrum Analyzer
3 dB Attenuator
Service Accessory Kit
Type N(m) to BNC(f) Adapter

### Procedure:

- a. Turn OFF the instrument's power switch, remove the power cord, and remove the top cover.
- b. Remove the A4 Local Oscillator board. Remove the shield and place the A4 board on the extender board. Move jumper A4 W1 to the top right position.
- c. Connect the signal generator output to A4J1 and the spectrum analyzer input to A4 J6 through the 3 dB attenuator.
- d. Connect the instrument to the power line, and turn the POWER switch ON.
- e. Set the signal generator for a 0 dBm, 300 MHz, CW signal.
- f. Set the spectrum analyzer as follows:
 

Center Frequency	300 MHz
Frequency Span	0 Hz
Resolution Bandwidth	300 Hz
Reference Level	0 dBm
dB/Div	2 dB
Sweep Time	10 sec
- g. Adjust A4 L2 and A4 L3 for a maximum reading on the spectrum analyzer.
- h. Increase the spectrum analyzer dB/Div to 10 dB, and wait for a complete sweep. Then press Marker Normal, Marker  $\Delta$ , and increase the center frequency to 600 MHz.
- i. Increase the signal generator frequency to 600 MHz.
- j. The spectrum analyzer reading should be at least 40 dB below the reading in step g.

- k. Set jumper A4 W1 to the bottom right position and jumper A4 W2 to the bottom left position.
- l. Connect the signal generator output to A4 J6 and the spectrum analyzer input to A4 J7 through the 3 dB attenuator.
- m. Change the signal generator frequency to 300 MHz and the amplitude to +10 dBm.
- n. Change the spectrum analyzer center frequency to 300 MHz, the dB/div to 2 dB, and the reference level to +5 dBm.
- o. Adjust A4L4 and A4L5 for a maximum spectrum analyzer reading.
- p. Increase the spectrum analyzer dB/Div to 10 dB, and wait for a complete sweep. Then press Marker Normal, Marker  $\Delta$ , and increase the center frequency to 600 MHz.
- q. Increase the signal generator frequency to 600 MHz.
- r. The spectrum analyzer reading should be at least 35 dB below the reading in step o.
- s. This completes the adjustment. Turn OFF the instrument's power switch, remove the power cord, and return the HP 3577B to its original state.

## 5-14 Local Oscillator 200 MHz Filter Adjustments

### Description:

This procedure adjusts the 200 MHz filters on the A4 Local Oscillator board. These filters eliminate the upper mixer harmonics that can interfere with the peak detecting leveling loop.

Equipment:
Spectrum Analyzer
Signal Generator
3 dB Attenuator
Service Accessory Kit
Type N(m) to BNC(f) Adapter

### Procedure:

- a. Turn OFF the instrument's power switch, remove the power cord, and remove the top cover.
- b. Remove the A4 Local Oscillator board. Remove the shield and place the A4 board on the extender board. Move both A4 W4 and A4 W5 to the bottom left position.
- c. Connect the signal generator output to A4 J9 and the spectrum analyzer to A4 J10 through the 3 dB attenuator.
- d. Connect the instrument to the power line, and turn the POWER switch ON.
- e. Set the signal generator for a - 10 dB, 200 MHz, CW signal.
- f. Set the spectrum analyzer as follows:
 

Center Frequency	200 MHz
Frequency Span	0 Hz
Resolution Bandwidth	300 Hz
Reference Level	+ 5 dBm
dB/Div	2 dB
Sweep Time	10 sec
- g. Adjust A4L7 and A4L9 for a maximum reading on the spectrum analyzer.
- h. Increase the spectrum analyzer dB/Div to 10 dB, and wait for a complete sweep. Then press Marker Normal, Marker Δ, and increase the center frequency to 300 MHz.
- i. Increase the signal generator frequency to 300 MHz.
- j. Adjust A4 L8 for a minimum reading on the spectrum analyzer.
- k. Repeat steps e through j until no further improvement can be made. The final 300 MHz level should be at least 55 dB below the 200 MHz level.

- i. Set A4 W5 to the bottom right position and A4W6 to the top left position.
- m. Connect the signal generator to A4 J10 and the spectrum analyzer to A4 J11 through the 3 dB attenuator.
- n. Return the signal generator frequency to 200 MHz, and set the amplitude to +10 dBm.
- o. Change the spectrum analyzer center frequency to 200 MHz, dB/div to 1 dB, and sweep time to 10 sec.
- p. Adjust A4 L100 and A4 L102 for a maximum reading on the spectrum analyzer.
- q. Increase the spectrum analyzer dB/div to 10 dB and wait for a complete sweep. Then press Marker Normal, Marker  $\Delta$ , and increase the center frequency to 300 MHz.
- r. Increase the signal generator frequency to 300 MHz.
- s. Adjust A4L101 for a minimum reading on the spectrum analyzer.
- t. Repeat steps n through s until no further improvement can be made. The final 300 MHz level should be at least 55 dB below the 200 MHz level.
- u. Move A4 W6 to the top right position and A4 W7 to the bottom left position.
- v. Set the signal generator for - 40 dBm, 200 MHz, CW signal.
- w. Connect the signal generator to A4 J11 and the spectrum analyzer to A4 J12.
- x. Set the spectrum analyzer as follows:

Center Frequency	200 MHz
Frequency Span	0 Hz
Resolution Bandwidth	300 Hz
Video Bandwidth	300 Hz
Sweep Time	10 sec
dB/Div	2 dB
- y. Adjust A4L201 for a maximum reading. If necessary, adjust the reference level on the spectrum analyzer for a mid screen display.
- z. Increase the spectrum analyzer dB/div to 10 dB and wait for a complete sweep. Then press Marker Normal, Marker  $\Delta$  and increase the center frequency to 300 MHz.
- aa. Increase the signal generator frequency to 300 MHz.
- ab. The 300 MHz level should be at least 25 dB below the 200 MHz level.
- ac. This completes the adjustment. Turn OFF the instrument's power switch, remove the power cord, and return the HP 3577B to its original state.

## 5-15 Local Oscillator Leveling Loop/Flatness Adjustment

### Description:

This procedure adjusts the A4 Local Oscillator board output for maximum level flatness with respect to frequency. This adjustment is required by the A71 Receiver boards in order to meet the dynamic accuracy and absolute amplitude accuracy specifications.

Equipment:
Power Meter
Power Sensor
Service Accessory Kit
Type N(f) to BNC(f) adapter

### Procedure:

- a. Turn OFF the instrument's power switch, remove the power cord, and remove the top cover.
- b. Place the A4 Local Oscillator board on the extender board. Leave all interconnecting cables disconnected unless instructed to do otherwise in this procedure.
- c. Connect A4 J1 to A6 J3 (normal connection), A4 J2 to A17 J1 (normal connection), and A6 J5 to A17 J3 (normal connection) using extender cables.
- d. Connect the power sensor to A4J4 using the proper adapters. Terminate A4 J3 and A4 J5 into their normal A71 connections.
- e. Connect the instrument to the power line, and turn the POWER switch ON.
- f. Set the HP 3577B sweep type to CW and frequency to 1 MHz.
- g. With the proper cal factor selected on the power meter, adjust A4 R49 for a power meter reading of  $+7.00 \text{ dBm} \pm 0.05 \text{ dB}$ . Record the final amplitude measured.
- h. Connect the power sensor to A4 J3 and terminate A4 J4 into its normal connection. Record the power meter reading. It should be  $+7.0 \text{ dBm} \pm 0.2 \text{ dB}$ .
- i. Connect the power sensor to A4 J5 and terminate A4 J3 into its normal connection. Record the power meter reading. It should be  $+7.0 \text{ dBm} \pm 0.2 \text{ dB}$ .

## 5-15 Local Oscillator Leveling Loop/Flatness Adjustment

- j. Turn OFF the instrument's power switch, remove the power cord, and place the A4 Local Oscillator board back into the instrument.

**Caution**

**DO NOT** insert or remove the circuit boards from the HP 3577B with power applied to the instrument. Power surges to circuit boards may cause unknown instrument states and/or damage the circuitry.

- k. Connect the instrument to the power line, and turn the POWER switch ON.
- l. Set the HP 3577B sweep type to CW and frequency to 200 MHz.
- m. Connect the power sensor to A4 J4. Terminate A4 J3 and A4 J5 into their normal A71 board connections.
- n. With the proper cal factor selected on the power meter, adjust A4 C70 for the same amplitude  $\pm 0.05$  dB as read at 1 MHz in step g above.
- o. Connect the power sensor to A4 J3 and terminate A4 J4 into its normal connection.
- p. Adjust A4 C50 for the same amplitude  $\pm 0.05$  dB as read at 1 MHz in step h above.
- q. Connect the power sensor to A4 J5 and terminate A4 J3 into its normal connection.
- r. Adjust A4 C90 for the same amplitude  $\pm 0.05$  dB as read at 1 MHz in step i above.
- s. This completes the adjustment. Turn OFF the instrument's power switch, remove the power cord, and return the HP 3577B to its original state.

## 5-16 Source Output Board Filter Adjustment

### Description:

This procedure adjusts the 200 and 300 MHz low pass filters on the A8 Source board. These filters are required for the specified spectral purity of the output and for the peak detectors in the amplitude leveling loop.

Equipment:
Power Meter
Power Sensor
Service Accessory Kit
Signal Generator
Spectrum Analyzer
3 dB Attenuator
Type N(m) to BNC(f) adapter (Qty. 2)

### Procedure:

- a. Turn OFF the instrument's power switch, remove the power cord, and remove the top cover.
- b. Remove the A8 Source circuit board shields and place the board on the extender board. Connect A17 J2 to A8 J1 and A5 J1 to A8 J2 using extender cables.
- c. Connect the power meter to A8 J3.
- d. Set the HP 3577B as follows:
 

SWEEP TYPE	CW
FREQ	99 kHz
AMPTD	+15 dBm
- e. Adjust A8 L124 and A8 L123 for a maximum reading on the power meter. These adjustments interact, so repeat until a common maximum is obtained.
- f. Adjust A8 L224 and A8 L223 for a maximum reading on the power meter. These adjustments interact, so repeat until a common maximum is obtained.
- g. Increase the HP 3577B frequency to 200 MHz. Press the SPCL FCTN hardkey and the SERVICE DIAG softkey. Toggle LEVELING to the OFF state.
- h. Adjust A8 L14 and A8 L15 for a maximum reading on the power meter.

## 5-16 Source Output Board Filter Adjustment

- i. Set A8 W5 to the bottom right position. Connect the spectrum analyzer to A8 J8 through the 3 dB attenuator.
- j. Move A8 W4 to the bottom left position, and connect the output of the signal generator to A8 J7.
- k. Set the signal generator for a 0 dBm, 200 MHz, CW signal.
- l. Set the spectrum analyzer as follows:

Center Frequency	200 MHz
Frequency Span	0 Hz
Resolution Bandwidth	300 Hz
dB/Div	1 dB
Sweep Time	10 sec
- m. Adjust A8 L11 and A8 L13 for a maximum spectrum analyzer reading.
- n. Change the spectrum analyzer dB/div to 10 dB. Wait for a complete sweep, then press Marker Normal, Marker  $\Delta$ . Increase the center frequency to 300 MHz.
- o. Increase the signal generator frequency to 300 MHz.
- p. Adjust A8 L12 for a minimum reading on the spectrum analyzer.
- q. Repeat steps k through p until the adjustments cannot be improved. With the final adjustment, the 300 MHz spectrum analyzer reading in step p should be at least 55 dB below the 200 MHz reading in step m.
- r. This completes the adjustment. Turn OFF the instrument's power switch, remove the power cord, and return the HP 3577B to its original state.



## 5-17 Source Amplitude And Step Adjustments

### Description:

This procedure adjusts the A8 Source board leveling circuits. The step adjustment sets the increments of the DAC controlled "vernier." These adjustments are necessary for the instrument to meet output level specifications.

<b>Equipment:</b>
Power Meter
Power Sensor

### Procedure:

- a. Turn OFF the instrument's power switch, remove the power cord, and remove the top cover. Connect the instrument to the power line, and turn the POWER switch ON.
- b. Connect the power sensor to the A8 Source Output.
- c. Adjust the cal factor on the power meter for 100 kHz.
- d. Set the HP 3577B as follows:
 

SWEEP TYPE	CW
FREQ	101 kHz
AMPTD	+ 11 dBm
- e. Adjust A8 R144, LVL 1, for a power meter reading of 11.00 dBm  $\pm$  0.01 dB.
- f. Increase the HP 3577B amplitude to +15 dBm.
- g. Adjust A8 R142, STEP 1, for a power meter reading of +15.00 dBm  $\pm$  0.01 dB.
- h. Decrease the HP 3577B amplitude to +11 dBm and the frequency to 99 kHz.
- i. Adjust A8 R156, LVL 2, for a power meter reading of +11.00 dBm  $\pm$  0.01 dB.
- j. Increase the HP 3577B amplitude to +15.00 dBm.
- k. Adjust A8 R157, STEP 2, for a power meter reading of +15.00 dBm  $\pm$  0.01 dB.
- l. This completes the adjustment. Turn OFF the instrument's power switch, remove the power cord, and replace the top cover.

## 5-18 Source Flatness Adjustment

### Description:

This procedure adjusts the source output level flatness with respect to frequency on the A8 Source board.

<b>Equipment:</b>
Power Meter
Power Sensor

### Procedure:

- a. Turn OFF the instrument's power switch, remove the power cord, and remove the top cover. Connect the instrument to the power line, and turn the POWER switch ON.
- b. Connect the power sensor to the A8 Source Output.
- c. Adjust the cal factor on the power meter for 1 MHz.
- d. Set the HP 3577B as follows:

Sweep Type	CW
AMPTD	0dBm
FREQ	1 MHz
- e. Press dB[REF] on the power meter.
- f. Increase the HP 3577B frequency to 200 MHz.
- g. Adjust the cal factor on the power meter for 200 MHz.
- h. Adjust A8 C155 for 0.00 dB(REF)  $\pm$  0.02 dB on the power meter.
- i. This completes the adjustment. Turn OFF the instrument's power switch, remove the power cord, and replace the top cover.

---

## 5-19 Input 250 kHz Filter Adjustment

### Description:

This procedure adjusts the 250 kHz filter shape on the A71 Receiver board. This filter rejects upper mixer products after the first IF mixing. This is required for the Receiver to meet absolute level and flatness specifications.

Equipment:
1:1 Probe
10:1 Probe
BNC female to N male Adapter (2 each).

### Procedure:

---

#### Note



This procedure requires that one of the A71 Receiver boards is operating within specifications. This minimizes the required equipment list and simplifies the adjustment procedure.

---

- a. Turn OFF the instrument's power switch, remove the power cord, and remove the top cover.
- b. Place the A71 Receiver board, which requires adjustment, on an extender board. Note each Receiver board's original position.
- c. Connect the instrument to the power line, and turn the POWER switch ON.
- d. Connect the Source Output to A71 TP3 on the receiver under test (RUT) using the 1:1 probe.
- e. Connect a 10:1 probe to one of the other receiver inputs. This input is referred to as the measurement input for the rest of this procedure.
- f. Connect the measurement input to A71 TP4 on the RUT using the 10:1 probe.

g. Set the HP 3577B as follows:

INPUT	Measurement Input
AMPTD	+10 dBm
ATTEN	
ATTEN	
(of measurement input)	0 dBm
IMPED	
(of measurement input)	1 M $\Omega$
SWEEP TYPE	CW
FREQ	230 kHz

- h. Adjust A71 L4 of RUT for a minimum marker reading.
- i. Change the HP 3577B frequency to 250 kHz. Press the MKR → hardkey and the MKR → REF LVL softkey. Press the SCALE hardkey and enter a REF POSN of 50% and a /DIV of 0.1 dB.
- j. Adjust A71 L3 and A71 L5 of RUT for a maximum as read by the marker readout.
- k. Connect both the 1:1 and 10:1 probes to A71 TP3 (on RUT).
- l. Press the HP 3577B DISP FCTN hardkey and the PHASE softkey. Press the MEASR CAL hardkey and the NORMALIZE softkey.
- m. Move the 10:1 probe to A71 TP4 (on RUT). Note the phase reading on the marker readout.
- n. Adjust A71 L5 (on RUT) for a marker phase reading halfway between the value noted in step m and 90°. Adjust A71 L3 for a marker reading of 90 degrees.

---

**Note**



This adjusts A71 L3 and A71 L5 for exactly the same value which is necessary if the A71 Receiver board is to meet its phase specifications.

---

- o. Move the 10:1 probe to A71 TP3 (of RUT).

p. Make the following changes to the HP 3577B.

SWEEP TYPE	LIN FREQ
FREQ	
FREQ SPAN	100 kHz
CENTER FREQ	250 kHz
DISPLY FCTN	LOG MAG
SCALE	
REF LEVEL	3 dB
/DIV	6 dB
REF POSN	100%
MEASR CAL	NORMALIZE

q. Move the 10:1 probe to A71 TP4 (of RUT). The HP 3577B display should be similar to that shown in figure 5- 1.

r. Repeat this procedure for all A71 Receiver boards requiring adjustment.

s. This completes the adjustment. Turn OFF the instrument's power switch, remove the power cord, and return the instrument to its original state.

REF LEVEL	/DIV	MARKER 230	250.000Hz
3.000dB	6.000dB	MAG(UDF)	-43.652dB

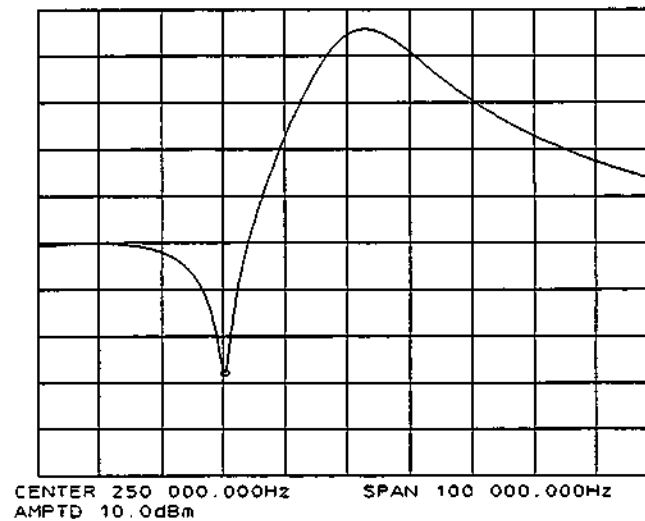


Figure 5-1. Input 250kHz Filter Frequency Response

## 5-20 Input Notch Filter Adjustment

### Description:

This procedure adjusts the 10 kHz IF filter notch on the A71 Receiver board. This filter rejects input image and noise signals. This is required for the A71 Receiver board to meet the flatness and dynamic accuracy specifications.

Equipment:
1:1 Probe
10:1 Probe
BNC female to N male Adapter (2 each)

### Procedure:

#### Note



This procedure requires that one of the A71 Receiver boards is operating within specification. This minimizes the required equipment list and simplifies the adjustment procedure.

- a. Turn OFF the instrument's power switch, remove the power cord, and remove the top cover.
- b. Place the receiver under test (RUT) which requires adjustment on an extender board. Note each receiver board's original position in the unit.
- c. Connect a 10:1 probe to one of the other receiver inputs. This input will be called the measurement input for the rest of this procedure.
- d. Connect the instrument to the power line, and turn the POWER switch ON.

INPUT	Measurement Input
ATTEN	
IMPED	
(of measurement input)	1 M $\Omega$
FREQ	
CENTER FREQ	14 kHz
FREQ SPAN	5 kHz

- e. Connect the A8 Source Output to A71 TP5 (of RUT) using the 1:1 probe.
- f. Connect the measurement input to A71 TP12 (of RUT) using the 10:1 probe.

- g. Set the 10 kHz filter adjust, A71 C20 (of RUT), for a null at 14 kHz.
- h. Move the 1:1 Probe to A71 TP12 and the 10:1 probe to A71TP6 (of RUT).
- i. Move A71 W9 (of RUT) to the test position.
- j. Set the 10 kHz filter adjust, A71 C26 (of RUT) for a null at 14 kHz.
- k. Move the 1:1 probe to A71TP5 (of RUT).
- l. Change the HP 3577B frequency span to 15 kHz, resolution bandwidth to 100 Hz, and sweep time to 2 sec.
- m. Move A71 W9 (of RUT) to the normal position.
- n. The HP 3577B display should resemble the wave shape shown in figure 5- 2. The most critical part of this filter is that the 14 kHz response should be at least 70 dB below the response at 10 kHz.
- o. Repeat this procedure for all A71 Receiver boards requiring adjustment.
- p. This completes the adjustment. Turn OFF the instrument's power switch, remove the power cord, and return the instrument to its original state.

REF LEVEL /DIV MARKER 13 662.500Hz  
0.000dBm 10.000dB MAG(R) -96.884dBm

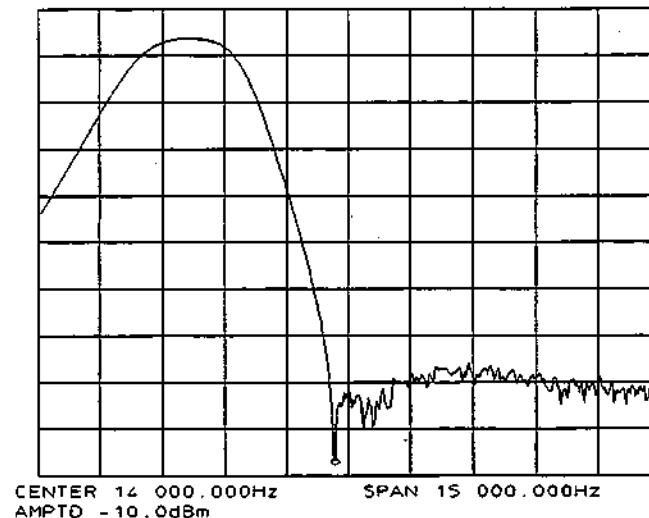


Figure 5-2. 14kHz Filter Response

## 5-21 Input Variable Gain Amplifier DC Offset Adjustment

### Description:

This procedure adjusts the DC offset for the variable gain amplifier and the sample and hold output on the A71 Receiver board. A71 R44 is adjusted for an equal DC offset in both the A/D converter and the variable gain amplifier. A71R187 is adjusted for an offset of  $\pm$  LSB so that the transition point of the MSB is not 0 V input. This adjustment is necessary for the instrument to meet the dynamic accuracy specifications.

Equipment:
Computer
Jumper
300 pF Capacitor
Service Accessory Kit

### Procedure:

- a. Turn OFF the instrument's power switch, remove the power cord, and remove the top cover.
- b. Remove the A71 Receiver board requiring adjustment. Move A71W2 and A71W3 to the test position. Solder the 300 pF capacitor between pins two and six of A71U15 and place a jumper across A71C30. Place the A71 Receiver board on an extender board.
- c. Connect the instrument to the power line, and turn the POWER switch ON.
- d. Connect the HP-IB cable from the computer to the HP 3577B
- e. Load and run the DC offset adjustment program. This program is included on the Semiautomated Performance Test disk and is named "VGA\_DC\_ADJ".
- f. Enter the A71 Receiver board channel you wish to adjust when prompted.
- g. Adjust A71 R44 for center screen (if measurement jumps erratically, try connecting a jumper from A71 ground to the chassis.
- h. Press the softkey START OVER on the computer and turn the HP 3577B OFF.
- i. Remove the jumper across A71C30 and the capacitor across A71U15.



- j. Turn the instrument on and select the channel to be adjusted using the computer keyboard.
- k. Adjust A71R187 for three divisions above or below the reference level.
- l. Repeat this procedure for all A71 Receiver boards requiring adjustment.
- m. This completes the adjustment. Turn OFF the instrument's power switch, remove the power cord, and return the instrument to its original state.

## 5-21 Input Variable Gain Amplifier DC Offset Adjustment

## DC Offset Adjustment Program

```

10! RE-SAVE "VGA_DC_ADJ"
20 COM /Flag/ Exit_flag
30 DIM Input_data(0:1),Output_data(0:1)
40 ON ERROR RECOVER Addr
50 Addr:INPUT "Enter 3577 address",Net_ani
60 ASSIGN @Net_ani TO Net_ani
70 ASSIGN @O TO Net_ani;FORMAT OFF
80 OFF ERROR
90 Start:LOOP
100 CLEAR SCREEN
110 PRINT "Place channel under test on extender board"
120 PRINT "Move W2 and W3 to TEST"
130 INPUT "Enter the channel under test (R, A, or B ).",Input$
140 Input$ = TRIM$(Input$)
150 CLEAR SCREEN
160 PRINT "R44 must be adjusted before adjusting R187"
170 PRINT "Response to adjustments will be slow"
180 PRINT " due to averaging"
190 PRINT "Connect a jumper across C30 and"
200 PRINT "a 300pf cap from U15 pin 2 to U15 pin 6"
210 PRINT "Adjust R44 to reference line"
220 PRINT "Remove jumper and cap"
230 PRINT "Adjust R187 to three divisions"
240 PRINT "above or below reference line"
250 PRINT "Press softkey START OVER to change channel"
260 OUTPUT @Net_ani;"UDS A/R TD1 ID1 DF3 ST5 SM2 MSR .5MSC "
270 OUTPUT @Net_ani;"REF 2048; DIV 1; FM2 BP0 "
280 Read_ad: !
290 Const = 2.05669908*2048
300 Mask = -32768.
310 OUTPUT @Net_ani;"BP0 FM2 SE0"
320 REPEAT
330 ON KEY 5 LABEL "START OVER" CALL Flag
340 ON KEY 8 LABEL "QUIT" RECOVER Quit
350 OUTPUT @Net_ani;"DR"&Input$
360 ENTER @O USING "#,2(A)";Dummy$;Dummy2$
370 ENTER @O;Input_data(*)
380 A_d = Const*Input_data(0)
390 WAIT .2
400 A_d = 16*A_d
410 A_d = BINEOR(Mask,A_d)
420 A_d = A_d/16
430 A_d = 2048 + A_d
440 IF Avg_ad < 2040 OR Avg_ad > 2055 THEN
450   Avg_ad = .5*Avg_ad + .5*A_d
460 ELSE
470   Avg_ad = .95*Avg_ad + .05*A_d
480 END IF
490 OUTPUT @O USING "#,K";"LD1#I"
500 Output_data(0) = Avg_ad
510 OUTPUT @O;Output_data(*)
520 OUTPUT @Net_ani;"TKM"
530 UNTIL Exit_flag > 0
540 Exit_flag = 0
550 END LOOP
560 Quit: CLEAR SCREEN
570 END
580 SUB Flag
590 COM /Flag/ Exit_flag
600 Exit_flag = 1
610 SUBEND

```

## 5-22 Input 1 M $\Omega$ Capacitance Adjustment

### Description:

The procedure adjusts the input capacitance of the 1 M $\Omega$  input mode on the A71 Receiver board. There is only a typical specification for input capacitance, but lower capacitance allows better high impedance, high frequency measurements.

Equipment:
BNC female to N male Adapter (qty. 2)
1 M $\Omega$ Series Resistor
Service Accessory Kit
BNC cable, 24 inch

### Procedure:

- a. Turn OFF the instrument's power switch, remove the power cord, and remove the top cover.
- b. Connect the 1 M $\Omega$  series resistor to the A8 Source Output with the adapter.

### Note



Return the receiver to its original position after completing the adjustment.

- c. Connect A71J2 to the 1 M $\Omega$  series resistor with a cable and adapter. Place the Receiver under test on an extender board. Connect A71 J1 to A4J3, J4, or J5 using an extender cable.
- d. Connect the instrument to the power line, and turn the POWER switch ON.
- e. Set the HP 3577B as follows: (RUT = Receiver Under Test)

INPUT	(RUT)
SWEEP TYPE	CW
AMPTD	- 25 dBm
FREQ	10 kHz
ATTEN	
ATTEN(RUT)	0 dB
IMPED (RUT)	1 M $\Omega$
RES BW	10 Hz
SCALE	
Ref Posn	50%

- f. Allow the HP 3577B to settle, then press the MEASR CAL hardkey and the NORMALIZE softkey. Press the ATTEN hardkey and select an ATTEN (RUT) of 20 dB.

- g. Adjust A71 C112 for 0 dB.
- h. Repeat steps c through g for all A71 Receiver boards requiring adjustment. Remember to disconnect power to the HP 3577B before removing a Receiver board.
- i. This completes the adjustment. Turn OFF the instrument's power switch, remove the power cord, and return the instrument to its original state.

---

**Note**



The 1 M $\Omega$  Capacitance and 1 M $\Omega$  Attenuator Adjustments interact. For best results, repeat both tests several times to obtain the optimum settings.

---

## 5-23 Input 1 M $\Omega$ Attenuator Adjustment

### Description:

This procedure adjusts the attenuation value of the 1 M $\Omega$ , 20 dB attenuator on the A71 Receiver board.

Equipment:
BNC female to N male Adapter
50 $\Omega$ Feedthrough Termination
Service Accessory Kit
BNC cable 24 inch

### Procedure:

- a. Turn OFF the instrument's power switch, remove the power cord, and remove the top cover.
- b. Connect the feedthrough termination to the A8 Source Output with the adapter.

### Note



Return the receiver to its original position after completing the adjustment.

- c. Connect A71 J2 to the feedthrough termination with the proper cable and adapter. Place the Receiver under test on an extender board. Connect A71 J1 to A4J3, J4, or J5 using an extender cable.
- d. Connect the instrument to the power line, and turn the POWER switch ON.
- e. Set the HP 3577B as follows: (RUT = Receiver Under Test)

INPUT	(RUT)
SWEEP TYPE	CW
AMPLITUDE	- 25 dBm
FREQ	100 kHz
ATTEN	
ATTEN(RUT)	0 dB
IMPED (RUT)	1 M $\Omega$
RES BW	10 Hz
SCALE	
Ref Posn	50%

5-23 Input 1 M $\Omega$  Attenuator Adjustment

- f. Allow the HP 3577B to settle, then press the MEASR CAL hardkey and the NORMALIZE softkey. Press the ATTEN hardkey, and select an ATTEN (RUT) of 20 dB.
- g. Adjust A71 C114 for  $0.00 \pm 0.03$  dB.
- h. Repeat steps c through g for all A71 Receiver boards requiring adjustment. Remember to disconnect power to the HP 3577B before removing a A71 Receiver board.
- i. This completes the adjustment. Turn OFF the instrument's power switch, remove the power cord, and return the instrument to its original state.

---

**Note**

The 1 M $\Omega$  Capacitance and 1 M $\Omega$  Attenuator Adjustments interact. For best results, repeat both tests several times to obtain the optimum settings.

---

## 5-24 Input Local Oscillator Feedthrough Adjustment

### Description:

This procedure adjusts the local oscillator feedthrough for the first IF mixer on the A71 Receiver board. This adjustment is necessary for the instrument to meet the receiver level flatness and dynamic accuracy specification.

### Equipment:

None

### Procedure:

- a. Turn OFF the instrument's power switch, remove the power cord, and remove the top cover. Connect the instrument to the power line, and turn the POWER switch ON.
- b. Set the HP 3577B as follows: (RUT = Receiver under test)

INPUT	(RUT)
SWEEP TYPE	CW
FREQ	0 Hz
- c. Adjust A71 R141 (of RUT), LO feedthrough adjust, for a minimum marker amplitude reading. This reading must be  $< -33$  dBm.
- d. Repeat steps b and c for all Receiver boards requiring adjustment.
- e. This completes the adjustment. Turn OFF the instrument's power switch, remove the power cord, and replace the top cover.

## 5-25 Receiver Return Loss Adjustment

### Description:

This procedure adjusts the A71 Receiver board return loss. An external return loss bridge, driven by the A8 Source board and measured by the A71 Receiver board in channel R, is used to verify the Receivers in channels A and B. The Receiver in channel R is then verified using the Receiver in channel A as the measurement channel.

Equipment:
Directional Bridge
RF Cable-24 inch
10 dB Attenuator
Precision Termination (female)
SMA(m) to BNC(f) adapter (2)
BNC cable

### Procedure:

- a. Turn OFF the instrument's power switch, remove the power cord, and remove the top cover. Connect the instrument to the power line, and turn the POWER switch ON.
- b. Connect the A8 Source Output to the source input of the directional bridge through the 10 dB attenuator.
- c. Set the HP 3577B as follows:

FREQ	
START FREQ	100 kHz
AMPTD	0 dBm
- d. Connect the reflected output port on the directional bridge to Receiver Input R. Connect an RF cable to the load port on the directional bridge and leave the other end of the RF cable open.
- e. Press the INPUT hardkey and select the R channel softkey.
- f. Allow the HP 3577B to make 2 complete sweeps. Press the STORE DATA, MORE REG, STORE REG D2. This is the load port open reference.
- g. Connect the precision termination to the end of the load port cable.
- h. Allow the HP 3577B to make two sweeps and store the display in register D1.
- i. Press the INPUT hardkey and enter a USER DEFINED input of (R-D1)/D2. This is the one port partial cal error correction for the directional bridge.
- j. Connect the load port cable to Receiver Input A.



- k. Allow the HP 3577B to make two sweeps. Press the ATTEN hardkey and toggle the channel being adjusted to 0 dB. Press the MKR → hardkey and the MKR → MAX softkey. Adjust A71 R172 for a minimum overall level.
- l. Repeat steps j and k for Receiver Input B.
- m. Repeat steps d through k for Receiver Input R. All control settings will be the same except Input A must be used whenever Input R is specified (even in equations).
- n. This completes the adjustment. Turn OFF the instrument's power switch, remove the power cord, and replace the top cover.

## 5-26 Input 50Ω Gain Adjustment

### Description:

This procedure adjusts the A71 Receiver board IF gain when the input is in the 50Ω termination mode. This is necessary for the instrument to meet absolute amplitude accuracy specifications.

Equipment:
Synthesizer/Level Generator
BNC Cables-48 inch (2 each)
BNC female to N male Adapter

### Procedure:

- a. Turn OFF the instrument's power switch, remove the power cord, and remove the top cover. Connect the instrument to the power line, and turn the POWER switch ON.
- b. Connect the HP 3335A 10 MHz REF OUT to the HP 3577B EXT REF IN using a BNC cable. The EXT REF LED on the HP 3577B front panel should be lit.

- c. Set the synthesizer as follows:

Input	50Ω
Frequency	100 kHz
Amplitude	- 30 dBm

- d. Set the HP 3577B as follows: (RUT = Receiver under test)

INPUT	(RUT)
SWEEP TYPE	CW
FREQ	100 kHz
SCALE	
REF LEVEL	- 30 dBm
REF POSN	50%
/DIV	0.1 dB
ATTEN	
(all receiver inputs)	0 dBm
RES BW	10 Hz

- e. Connect the synthesizer output to Receiver Input (RUT) using a BNC cable and adapter.
- f. Adjust A71 R71 for a marker reading of - 30.00 dBm ± 0.01 dB.
- g. Repeat steps d through f for all A71 Receiver boards requiring adjustment.
- h. This completes the adjustment. Turn OFF the instrument's power switch, remove the power cord, and replace the top cover.

## 5-27 Input 1 M $\Omega$ Gain Adjustment

### Description:

This procedure adjusts the A71 Receiver board IF gain when the input is in 1 M $\Omega$  terminate mode. This is necessary for the instrument to meet absolute amplitude specifications.

Equipment:
Synthesizer/Level Generator
BNC Cables-48 inch (2 each)
BNC female to N male Adapter
50 $\Omega$ Feedthrough Termination

### Procedure:

- a. Turn OFF the instrument's power switch, remove the power cord, and remove the top cover. Connect the instrument to the power line, and turn the POWER switch ON.
- b. Connect the spectrum analyzer 10 MHz REF OUT to the HP 3577B EXT REF IN using a BNC cable. The EXT REF LED on the HP 3577B front panel should be lit.
- c. Set the synthesizer as follows:

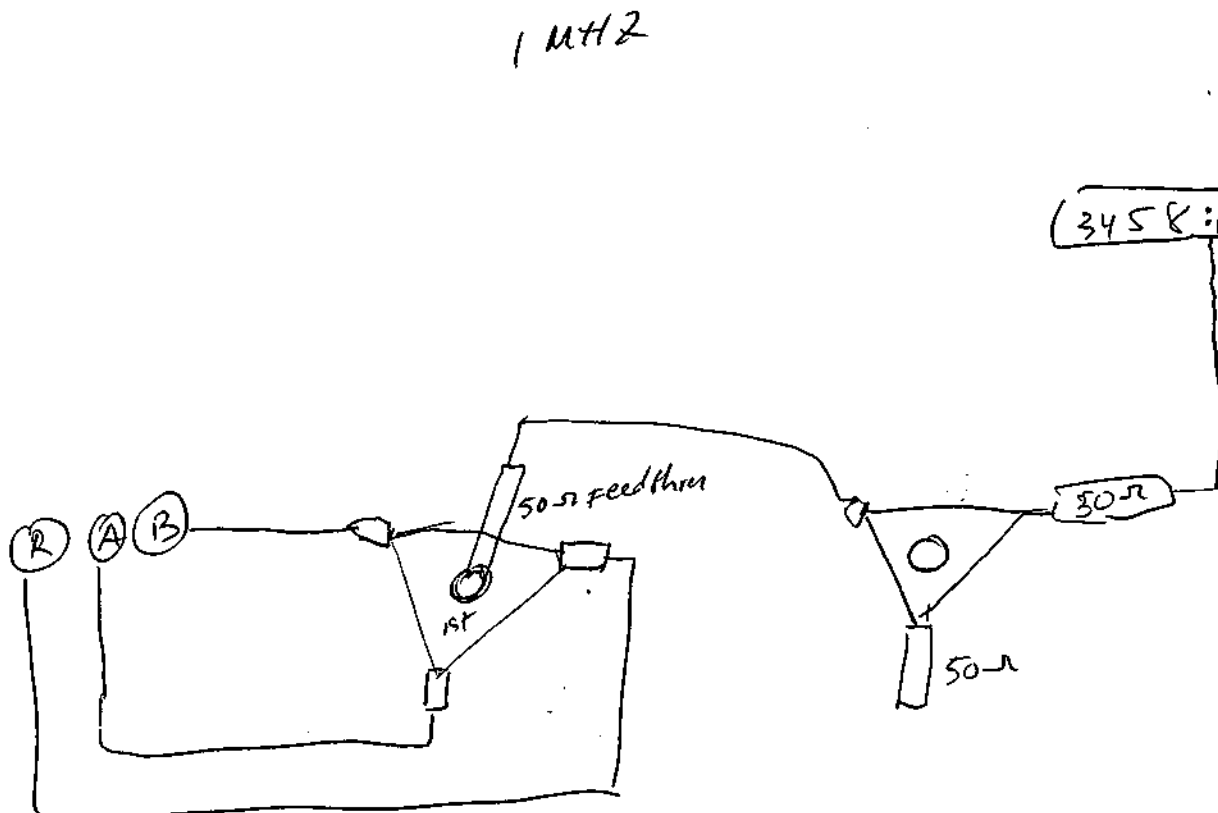
Output	50 $\Omega$
Frequency	100 kHz
Amplitude	- 30 dBm

- d. Set the HP 3577B as follows: (RUT = Receiver under test)

INPUT	(RUT)
SWEEP TYPE	CW
FREQ	100 kHz
SCALE	
REF LEVEL	- 30 dBm
REF POSN	50%
/DIV	0.1 dB
ATTEN (all receiver inputs)	
ATTEN	0 dBm
IMPED	1 M $\Omega$
RES BW	10 Hz

## 5-27 Input 1 MΩ Gain Adjustment

- e. Connect a cable from the synthesizer output to the feedthrough termination. Connect the open end of the feedthrough termination to Receiver Input (RUT) using an adapter.
- f. Adjust the 1 MΩ level adjust, A71 R76, for a marker reading of  $-30 \text{ dBm} \pm 0.01 \text{ dB}$ .
- g. Repeat steps d through f for all A71 Receiver boards requiring adjustment.
- h. This completes the adjustment. Turn OFF the instrument's power switch, remove the power cord, and replace the top cover.



## 5-28 Input Level Flatness Adjustment

### Description:

This procedure adjusts the A71 Receiver board amplitude flatness with respect to frequency. The source output and power splitter are calibrated using a power meter. The calibration data is then stored into a data register in the HP 3577B. This allows you to display the receiver flatness on the HP 3577B.

Equipment:
Computer
Power Meter
Power Sensor
Power Splitter
20 dB Attenuator
N female to N female Adapter
RF Cables-24 inch (4 each)

### Procedure:

- a. Turn OFF the instrument's power switch, remove the power cord, and remove the top cover. Connect the instrument to the power line, and turn the POWER switch ON.
- b. Set the power meter cal factor for 1 MHz and press SENSOR ZERO. (The power sensor must have a flatness of two percent or less from 1 MHz to 200 MHz.)
- c. Connect the equipment as shown in figure 5-3.
- d. Load and run the receiver flatness adjustment program. This program is included in the Semiautomated Performance Test disk under the name "FLAT\_ADJ".

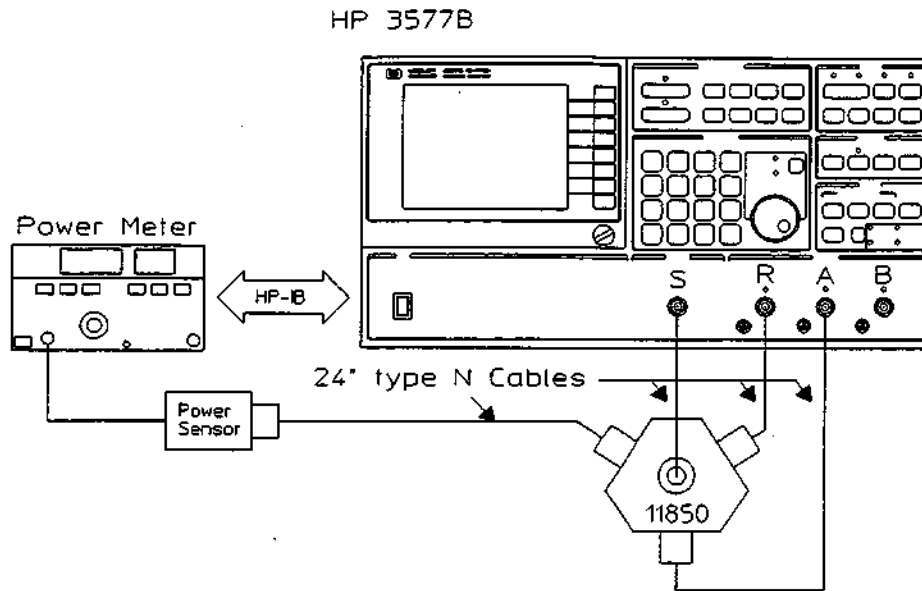


Figure 5-3. Input Level Calibration Test Set-up

### Receiver flatness Adjustment Program

```
10 ! RE-SAVE "FLAT_ADJ"
20 DIM Sour_amptd(0:101)
30 COM /Atten/ Atten_label$(10)
40 COM /Input/ Input$(10)
50 COM /Pm/ Pm_model$(40),Pm_addr,@Pm
60 COM /Dut/ @Dut
70 COM /Ch_b/ Ch_b
80 Bin=0
90 Atten_label$="ATTEN_OUT"
100 Input$="R"
110 CLEAR SCREEN
120 ON ERROR RECOVER Addr_77
130 Addr_77:INPUT "Enter 3577 address",Dut_addr
140 ASSIGN @Dut TO Dut_addr
150 OFF ERROR
160 INPUT "Power meter model ?",Pm_model$
170 IF POS(Pm_model$,"436") THEN
180   Pm_model$="HP436A"
190 ELSE
200   IF POS(Pm_model$,"438") THEN
210     Pm_model$="HP438A"
220   ELSE
230     Pm_model$="Other"
240   END IF
250 END IF
260 IF Pm_model$ <> "Other" THEN
270   ON ERROR RECOVER Addr_pm
280 Addr_pm:INPUT "Power meter address?",Pm_addr
290   ASSIGN @Pm TO Pm_addr
300   OFF ERROR
310 END IF
320 DIM Id$(80)
330 OUTPUT @Dut;"ID?"
340 ENTER @Dut;Id$
350 IF POS(Id$,"3577A") THEN
360   Ch_b=1
370 ELSE
```

```

380 OUTPUT @Dut;"DMB"
390 ENTER @Dut;Ch_b
400 END IF
410 OUTPUT @Dut;"IFR ST5 BW3 SAM0DBM SFR1MHZ"
420 PRINT "Connect:"
430 PRINT "3577 source to input of power splitter"
440 PRINT "Power meter to an output of power splitter"
450 PRINT " thru a Type-N cable"
460 PRINT "Remaining two outputs to inputs R and A"
470 PRINT "Set the power meter cal factor for 1 MHz"
480 PRINT "Press softkey CONTINUE when ready"
490 CALL Wait_for_key("CONTINUE")
500 CLEAR SCREEN
510 PRINT
520 PRINT "Calibrating source output"
530 FOR Freq = 1. TO 200 STEP 3.98
540 OUTPUT @Dut;"SFR";Freq;"MHZ"
550 WAIT .2
560 FOR N = 1 TO 5
570 WAIT .2
580 Pm_level = FNRead_pm
590 Sour_amptd(Bin) = 10 ^ (Pm_level/10) + Sour_amptd(Bin)
600 NEXT N
610 Sour_amptd(Bin) = SQR(Sour_amptd(Bin)/5)
620 Bin = Bin + 2
630 NEXT Freq
640 CLEAR SCREEN
650 OUTPUT @Dut;"ST1 RS1 SWT5SEC FRA1MHZ FRB200MHZ UDIR/D1"
660 OUTPUT @Dut;"FM1 LD1"
670 OUTPUT @Dut;Sour_amptd(*)
680 OUTPUT @Dut;"DIV.1DBR RPS50%"
690 PRINT "Install a 20 dB pad between"
700 PRINT " the 3577 source and the cable"
710 IF Ch_b THEN
720 PRINT "Move the cable from the power meter"
730 PRINT " to input B"
740 END IF
750 PRINT "Press softkey CONTINUE when ready"
760 CALL Wait_for_key("CONTINUE")
770 CLEAR SCREEN
780 OUTPUT @Dut;"TKM MTR RST"
790 CALL Delta
800 PRINT "Adjust A1R173 of selected input for <0.6 dB"
810 PRINT "Check ratio for <0.4 dB, adjust as needed"
820 PRINT "Use softkeys to:"
830 PRINT " Change selected input"
840 PRINT " Change attenuator position"
850 PRINT " Exit program"
860 LOOP
870 ON KEY 1 LABEL " R " CALL Input_r
880 ON KEY 2 LABEL " A " CALL Input_a
890 IF Ch_b THEN
900 ON KEY 3 LABEL " B " CALL Input_b
910 ELSE
920 OFF KEY 3
930 END IF
940 ON KEY 4 LABEL " A/R " CALL Input_ar
950 IF Ch_b THEN
960 ON KEY 5 LABEL " B/R " CALL Input_br
970 ON KEY 6 LABEL " A/B " CALL Input_ab
980 ELSE
990 OFF KEY 5
1000 OFF KEY 6
1010 END IF
1020 ON KEY 7 LABEL Atten_label$ CALL Atten
1030 ON KEY 8 LABEL " EXIT " RECOVER Exit
1040 END LOOP

```

Adjustments  
5-28 Input Level Flatness Adjustment

HP 3577B

```
1050 Exit: CLEAR SCREEN
1060 END
1070 !-----
1080 Input_r: SUB Input_r
1090 COM /Input/ Input$
1100 COM /Dut/ @Dut
1110 DISP "PLEASE WAIT..."
1120 OUTPUT @Dut;"UDIR/D1;TKM MTR"
1130 Input$ = "R"
1140 CALL Delta
1150 SUBEND
1160 !-----
1170 Input_a: SUB Input_a
1180 COM /Input/ Input$
1190 COM /Dut/ @Dut
1200 DISP "PLEASE WAIT..."
1210 OUTPUT @Dut;"UDIA/D1;TKM MTR"
1220 Input$ = "A"
1230 CALL Delta
1240 SUBEND
1250 !-----
1260 Input_b: SUB Input_b
1270 COM /Input/ Input$
1280 COM /Dut/ @Dut
1290 DISP "PLEASE WAIT..."
1300 OUTPUT @Dut;"UDIB/D1;TKM MTR"
1310 Input$ = "B"
1320 CALL Delta
1330 SUBEND
1340 !-----
1350 Input_ar: SUB Input_ar
1360 COM /Input/ Input$
1370 COM /Dut/ @Dut
1380 OUTPUT @Dut;"IAR MTR"
1390 Input$ = "A/R"
1400 CALL Delta
1410 SUBEND
1420 !-----
1430 Input_br: SUB Input_br
1440 COM /Input/ Input$
1450 COM /Dut/ @Dut
1460 OUTPUT @Dut;"IBR MTR"
1470 Input$ = "B/R"
1480 CALL Delta
1490 SUBEND
1500 !-----
1510 Input_ab: SUB Input_ab
1520 COM /Input/ Input$
1530 COM /Dut/ @Dut
1540 OUTPUT @Dut;"UDIA/B;MTR"
1550 Input$ = "A/B"
1560 CALL Delta
1570 SUBEND
1580 !-----
1590 Delta: SUB Delta
1600 COM /Input/ Input$
1610 COM /Dut/ @Dut
1620 OUTPUT @Dut;"MTN ZMK MTX DM1"
1630 ENTER @Dut;Marker_delta
1640 DISP "Input ";Input$;" = ";Marker_delta;"dB"
1650 SUBEND
1660 !-----
1670 Atten: SUB Atten
1680 COM /Atten/ Atten_label$
1690 COM /Dut/ @Dut
1700 COM /Ch_b/ Ch_b
1710 SELECT Atten_label$
```



```

1720 CASE "ATTEN_IN"
1730   OUTPUT @Dut;"AR2 AA2"
1740   IF Ch_b THEN OUTPUT @Dut;"AB2"
1750   Atten_label$="ATTEN_OUT"
1760 CASE "ATTEN_OUT"
1770   OUTPUT @Dut;"AR1 AA1"
1780   IF Ch_b THEN OUTPUT @Dut;"AB1"
1790   Atten_label$="ATTEN_IN"
1800 END SELECT
1810 OUTPUT @Dut;"RST"
1820 DISP "PLEASE WAIT..."
1830 WAIT 5.5
1840 CALL Delta
1850 SUBEND
1860 !-----
1870 Wait_for_key:SUB Wait_for_key(Klabel$)
1880 !labels one softkey and waits for it to be pressed.
1890 !Other softkeys may also be active.
1900 ON KEY 8 LABEL (Klabel$) GOTO Key_pressed
1910 DISP "Press a softkey"
1920 LOOP
1930 END LOOP
1940 Key_pressed: !
1950 DISP
1960 SUBEND
1970 !-----
1980 Read_pm:DEF FNRead_pm
1990   COM /Pm/ Pm_model$,Pm_address,@Pm
2000   IF Pm_address=0 THEN
2010     GOSUB Do_other
2020   ELSE
2030     SELECT Pm_model$
2040     CASE "HP436A"
2050       GOSUB Drive_436
2060     CASE "HP438A"
2070       GOSUB Drive_438
2080     CASE ELSE
2090       GOSUB Do_other
2100     END SELECT
2110   END IF
2120   RETURN Dbm_reading
2130 Do_other: !-----
2140   CLEAR SCREEN
2150   PRINT
2160   PRINT "Set the power meter to the dBm mode."
2170   PRINT
2180   PRINT "Enter the power meter reading in dBm."
2190   INPUT Dbm_reading
2200   CLEAR SCREEN
2210   RETURN
2220 Drive_436: !-----
2230   CLEAR SCREEN
2240   OUTPUT @Pm;"9D-V"
2250   ENTER @Pm;Dbm_reading
2260   LOCAL @Pm
2270   RETURN
2280 Drive_438: !-----
2290   CLEAR @Pm
2300   LOCAL @Pm
2310   OUTPUT @Pm;"AP;LG;RA"
2320   ENTER @Pm;Dbm_reading
2330   LOCAL @Pm
2340   RETURN
2350 FNEND
2360 !-----

```

- e. After the calibration data has been collected, connect the equipment as shown in figure 5-4.
- f. Adjust A71 R173 on the selected Receiver for the flattest response. (Normally 200 MHz level equal to the 1 MHz level.) Absolute flatness must be less than 0.6 dB peak-to-peak.
- g. Verify that all ratios meet a flatness of less than 0.4 dB peak-to-peak and adjust if necessary.
- h. Repeat steps f and g until all specs are met.
- i. This completes the adjustment. Turn OFF the instrument's power switch, remove the power cord, and replace the top cover.

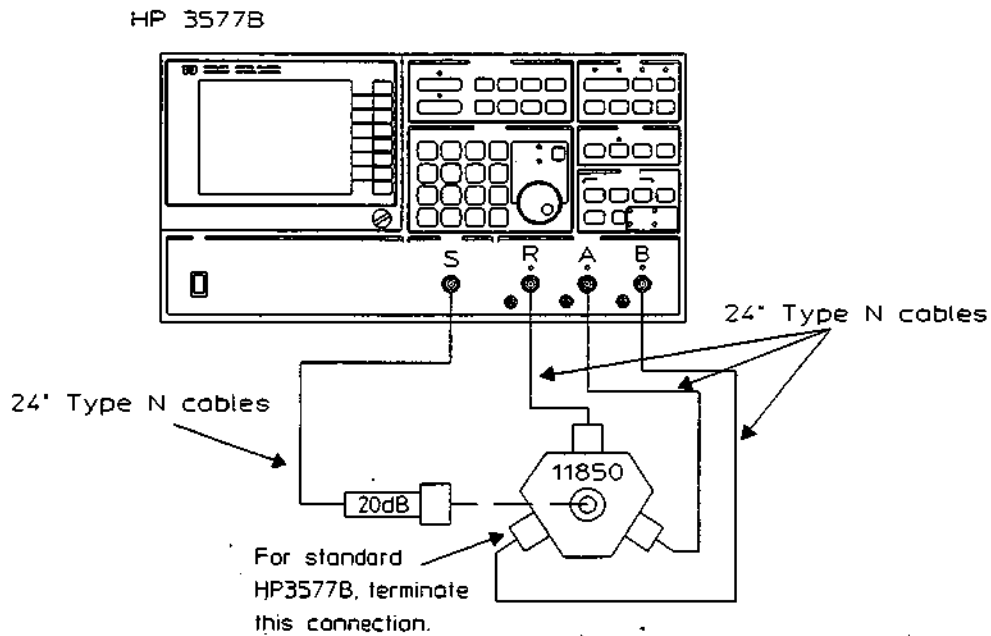


Figure 5-4.

## 5-29 Input Phase Zero Adjustment

### Description:

This procedure adjusts the A71 Receiver board phase circuits for a zero phase reference. This is required for the A71 Receiver board to meet phase specifications.

Equipment:
N male to BNC female Adapter (2 each)
BNC Cable-24 inch

### Procedure:

- a. Turn OFF the instrument's power switch, remove the power cord, and remove the top cover. Connect the instrument to the power line, and turn the POWER switch ON.

### Note



All Receivers must be adjusted for the HP 3577B to meet the channel-to-channel ratio specifications.

- b. Set the HP 3577B as follows:

INPUT	R
SWEEP TYPE	CW
FREQ	100 kHz
DISP FCTN	PHASE

SCALE	
/DIV	0.5 deg

- c. Using a short cable, connect the Source Output to Receiver Input R.
- d. Adjust the Phase Adjust, A71 R74, for a marker phase reading of  $0.0 \pm 0.5$  degrees.
- e. Repeat steps b through d for Receiver Inputs A and B.
- f. This completes the adjustment. Turn OFF the instrument's power switch, remove the power cord, and return the instrument to its original state.

**Note**



If you were unable to adjust the phase to zero, use the following procedure to select the switch setting in the phase initialization circuit on the A6 board (see steps 1 through 6).

1. Set the Phase Adjust, A71 R74, on the Receiver in channel R for a midrange, multiple of 30 degrees phase reading. Note the Receiver R phase reading.
2. Turn OFF the instrument's power switch, remove the power cord, and remove the A6 Reference board.
3. Determine the current phase offset by comparing the A6S1 switch setting to table 5-4.

**Table 5-4. Reference Board Phase Offset**

Switch Number				
4	3	2	1	
0	0	0	0	0
0	1	0	1	0
0	0	1	0	30
1	1	1	0	30
0	0	1	1	60
1	1	1	1	60
1	1	0	0	90
1	1	0	1	120
1	0	1	0	150
1	0	1	1	180
1	0	0	0	210
1	0	0	1	240
0	1	1	0	270
0	1	1	1	300
0	1	0	0	330
0	0	0	1	Not a valid setting

KEY 0 = closed 1 = open  
 No. 4 switch is at the bottom of A6S1  
 No. 1 switch is at the top of A6S1

4. Compute the new phase offset by subtracting the Receiver R phase reading from the current phase offset.  
 $(\text{current phase offset}) - (\text{R phase reading}) = \text{new phase offset}$
5. Use the table to determine the new switch setting and set A6S1 accordingly. An example follows:
  - Receiver R phase reading is approximately  $-30$  degrees. A6S1 is presently set at "1 0 1 1" or 180 degrees of phase offset.
  - $(\text{current phase offset}) - (\text{R phase reading}) = \text{new phase offset}$   $(180) - (-30) = 210$
  - Match the new phase offset of 210 degrees to table 5-4, and set A6S1 to the corresponding "1 0 0 0" switch number.
6. Replace the A6 Reference board and connect the instrument to the power line. Return to step b.

## 5-30 On Carrier Return Loss Adjustment

### Description:

This procedure adjusts the A8 Source board output impedance.

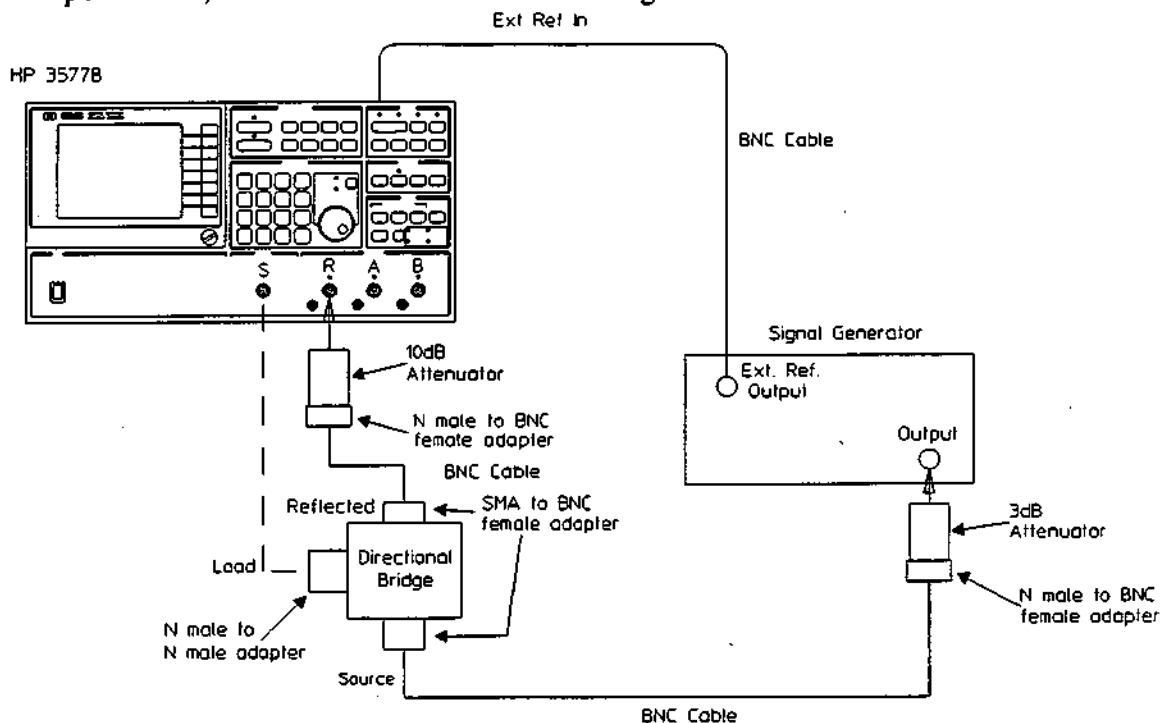
Equipment:
Signal Generator
Directional Bridge
3 dB Attenuator
10 dB Attenuator
SMA male to BNC female Adapter (2 each)
N male to BNC female Adapter (2 each)
N male to N male Adapter
BNC Cables-48 inch (3 each)

### Procedure:

- a. Turn OFF the instrument's power switch, remove the power cord, and remove the top cover. Connect the instrument to the power line, and turn the POWER switch ON.
- b. Connect the equipment as shown in figure 5- 5 except leave the A8 Source Output to the directional bridge unconnected.
- c. Set the HP 3577B as follows:

FREQ	
FREQ SPAN	0 Hz
CENTER FREQ	200 MHz
AMPTD	12 dBm
RES BW	10 Hz
DISPLY FCTN	LIN MAG
SCALE	
REF POSN	50%
/DIV	10mV
- d. Set the signal generator for a 200 MHz, 5 Hz step size, +10 dBm, CW signal.
- e. Note the MARKER MAG on the HP 3577B. It should read approximately 33 mV.
- f. Step the signal generator frequency up 5 Hz.
- g. Connect the A8 Source Output to the directional bridge load port using a N male to N male adapter.

- h. Change the HP 3577B scale/div to 1 mV. Press the MKR → hardkey and the MKR → REF LVL softkey.
- i. Adjust A8C71 for a minimum peak-to-peak sine wave (must be less than 2.5 mV peak-to-peak). Press MKR → REF LVL if necessary to keep the signal on the screen.
- j. This completes the adjustment. Turn OFF the instrument's power switch, remove the power cord, and return the HP 3577B to its original state.



**Figure 5-5. On Carrier Return Loss Adjustment Test Set-up**

## 5-31 API (Analog Phase Interpolation) Adjustments

### Description:

This procedure adjusts the API circuits on the A17 Synthesizer board. This is required for proper operation of the fractional N circuits.

Equipment:
Signal Generator
BNC Cable-48 inch
N male to BNC female Adapter (2 each)

### Procedure:

- a. Turn OFF the instrument's power switch, remove the power cord, and remove the top cover. Connect the instrument to the power line, and turn the POWER switch ON.
- b. Connect the signal generator 10 MHz REF OUT to the HP 3577B EXT REF IN. The EXT REF LED on the HP 3577B front panel should be lit.
- c. Set the HP 3577B as follows:

Sweep Type	CW
Res BW	1 Hz
FREQ	1.75038 MHz
- d. Set the signal generator as follows:

Amplitude	- 5 dBm
Frequency	1.75038 MHz
- e. Connect the signal generator output to Receiver Input R.
- f. Press the MKR hardkey and the MKR ZERO softkey.
- g. Increase the signal generator frequency to 1.750418 MHz in 38 Hz increments.
- h. Adjust A17 R218 (API 1) for a marker level at least 50 dB below the reference level set in step f. Do not fine tune this if the level is in spec, as it may throw the API circuit out of balance and many adjustments may have to be made.
- i. Increase the signal generator frequency 38 Hz twice and verify that the marker level is at least 50 dB below the reference level set in step f. The two check frequencies are 1.750456 MHz and 1.750494 MHz. Adjust A17 R218 only as necessary.



- j. Repeat steps c through i for 199.75038 MHz. The reference frequencies and test frequencies for both HP 3577B frequencies are listed below.

HP 3577B Frequency	Reference Frequency	First Test Frequency	Second Test Frequency	Third Test Frequency
1.75038	1.75038	1.750418	1.750456	1.750494
199.75038	199.75038	199.750418	199.750456	199.750494

- k. Repeat steps c through i for the following frequencies, but increase the signal generator in steps of 1.36 kHz rather than 38 Hz. Adjust A17R218 only when necessary.

HP 3577B Frequency	Reference Frequency	First Test Frequency	Second Test Frequency	Third Test Frequency
1.7636	1.7636	1.76496	1.76632	1.76768
199.7636	199.7636	199.76496	199.76632	199.76768

- l. Repeat steps c through k as necessary until the HP 3577B meets specification for all frequencies listed without adjustment.

**Note**

This adjustment is a compromise for each HP 3577B frequency and test frequency. The adjustment must be made so that all test points meet specifications simultaneously.

- m. Set the signal generator frequency to 98.750038 MHz.
- n. Change the HP 3577B frequency to 98.750038 MHz. Press the MKR hardkey and the MKR ZERO softkey. Increase the frequency 38 Hz to 98.750076 MHz.
- o. Adjust API 2, A17R223, for a marker reading of less than - 50 dB (typically - 53 dB).
- p. Increase the frequency 380 Hz from the value in step n to 98.750418 MHz.
- q. Adjust API 3, A17R222, for a marker reading of less than - 50 dB.
- r. Increase the frequency 3800 Hz from the value in step n to 98.753838 MHz.
- s. Adjust API 4, A17R350, for a marker reading of less than - 50 dB.
- t. This completes the adjustment. Turn OFF the instrument's power switch, remove the power cord, and return the HP 3577B to its original state.

## 5-32 Oven Board 10 MHz Reference Frequency Adjustment (Option 001 only)

### Description:

This procedure adjusts the absolute frequency of the 10 MHz A31 Oven board (Option 001 only). This is the absolute frequency reference in the HP 3577B (option 001).

<b>Equipment:</b>
Oscilloscope
Frequency Standard

### Procedure:

- a. Turn OFF the instrument's power switch, remove the power cord, and remove the top cover. Connect the instrument to the power line, and turn the POWER switch ON. **NOTE. THE HP 3577B MUST BE WARMED UP FOR AT LEAST 48 HOURS BEFORE THE ADJUSTMENT IS MADE.**
- b. Connect the frequency standard to the oscilloscope external trigger connector. Terminate the frequency standard as required.
- c. Connect the HP 3577B REF OUT, located on the rear panel, to the oscilloscope channel 1 input. Terminate the channel 1 input in 50Ω. Disconnect any external reference to the HP 3577B rear panel.
- d. Set the oscilloscope time/div control to 0.1μ s per division.
- e. Remove the screw on A31 U1 and set the coarse frequency adjust for a stable (i.e. not moving) display as seen on the oscilloscope.
- f. Set the oscilloscope time/div control to 10 ns per division.
- g. Set the fine frequency adjust (A31 R2) for a stable display as seen on the oscilloscope.
- h. This completes the adjustment. Turn OFF the instrument's power switch, remove the power cord, and return the HP 3577B to its original state.

---

## 5-33 HP Digital Display Adjustments

This section describes adjustments and checks required to return the HP Digital Display unit to peak operating capabilities when repairs have been made. Included in this section are equipment setups and adjustment procedures.

### Safety Considerations

The HP 3577B is a Safety Class 1 instrument (provided with a protective earth terminal). Although this instrument has been designed in accordance with international safety standards, this manual contains information, cautions and warnings which must be followed to ensure safe operation and retain the HP 3577B and the HP Digital Display in safe operating condition. Service and adjustments should be performed only by qualified personnel who are aware of the hazards involved.

---

#### Warning



Any interruption of the protective (ground) conductor inside or outside the unit, or disconnection of the protective earth terminal can expose operators to potentially dangerous voltages.

Only fuses of the rated current and specified type should be used for replacement. The use of repaired fuses and short circuiting of fuse holders is not permitted. Whenever fuse protection has been impaired, the HP 3577B must be made inoperative.

Adjustments performed in this section are performed with power applied and the protective covers removed. These adjustments should be performed only by trained service personnel who are aware of the hazards involved (such as fire and electrical shock).

Under no circumstances should an operator remove any covers, screws, shields or in any other way access the interior of the HP 3577B. There are no operator controls inside the instrument.

---

## Equipment Required

A complete list of required test equipment is given in Section I, table 1-2. Test equipment equivalent to that recommended may be substituted, provided it meets the required characteristics. For best results, use recently calibrated test equipment.

### Note



The adjustment procedures are arranged in a recommended sequence of adjustments. While some adjustments may be made independent of other adjustments, it is recommended that adjustments be made sequentially as a number of adjustments are directly related to preceding or following adjustments.

Allow the display unit to warm up for 15 minutes before making adjustments.

The display must be removed from the instrument for most adjustments. Refer to "Removing the HP Digital Display" procedure later in this section.

**Table 5-5. Sequence of Adjustments**

Order of Adjustment	Adjustment Procedure
1	External Adjustments
2	Low Voltage Power Supply
3	High Voltage Power Supply
4	Pattern
5	Stroke Generator
6	Stroke Intensity
7	Final Focus
8	Auxiliary X-Y-Z Output

## Removing the HP Digital Display

1. Disconnect the main power cord from the rear panel and remove the top cover.
2. Remove both internal shields covering the display unit.
3. Remove the screws holding the external adjustment pots to the rear panel.
4. Remove the trim strips from the top and left side of the front frame.
5. Remove the front frame and side panel screws as shown in figure 5-6.
6. Remove the screw which attaches the display to the instrument bottom deck and display bracket as shown in figure 5-6.
7. Disconnect the display power cable and the display interface cable. Then pull the display out of the front of the unit.

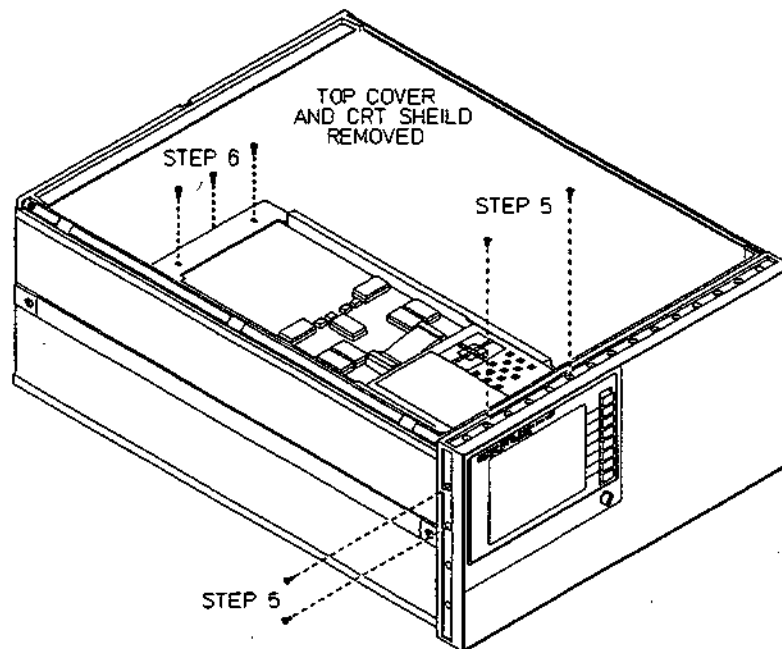
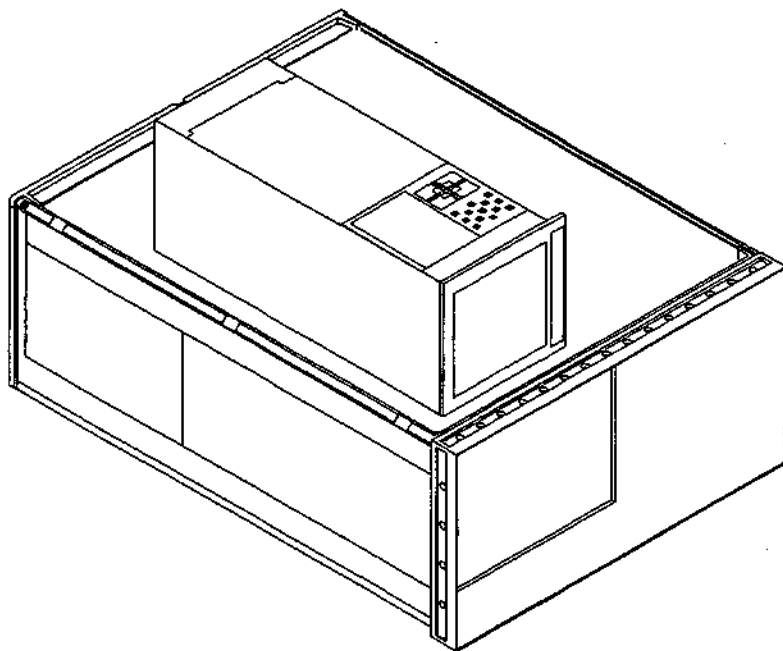


Figure 5-6. Removing the Display



**Figure 5-7. The HP Digital Display  
Ready for Adjustment**

## Adjustment Procedures

---

### Warning



Protective covers are not provided and internal hazardous voltages are exposed when power is applied. Voltages up to 10 kV are present around the CRT and HVPS areas and are capable of causing serious injury or death. Component replacement, including fuses, and internal adjustments must be made by qualified maintenance personnel.

---

### External Adjustments

1. Turn off the power to the HP 3577B.
2. Disconnect the HP 3577B power cable and the data cable to the display assembly.
3. Refer to figure 5-8 and center the five external adjustments:
  - a. FOCUS
  - b. ALIGN
  - c. HORIZ
  - d. VERT
  - e. ASTIG

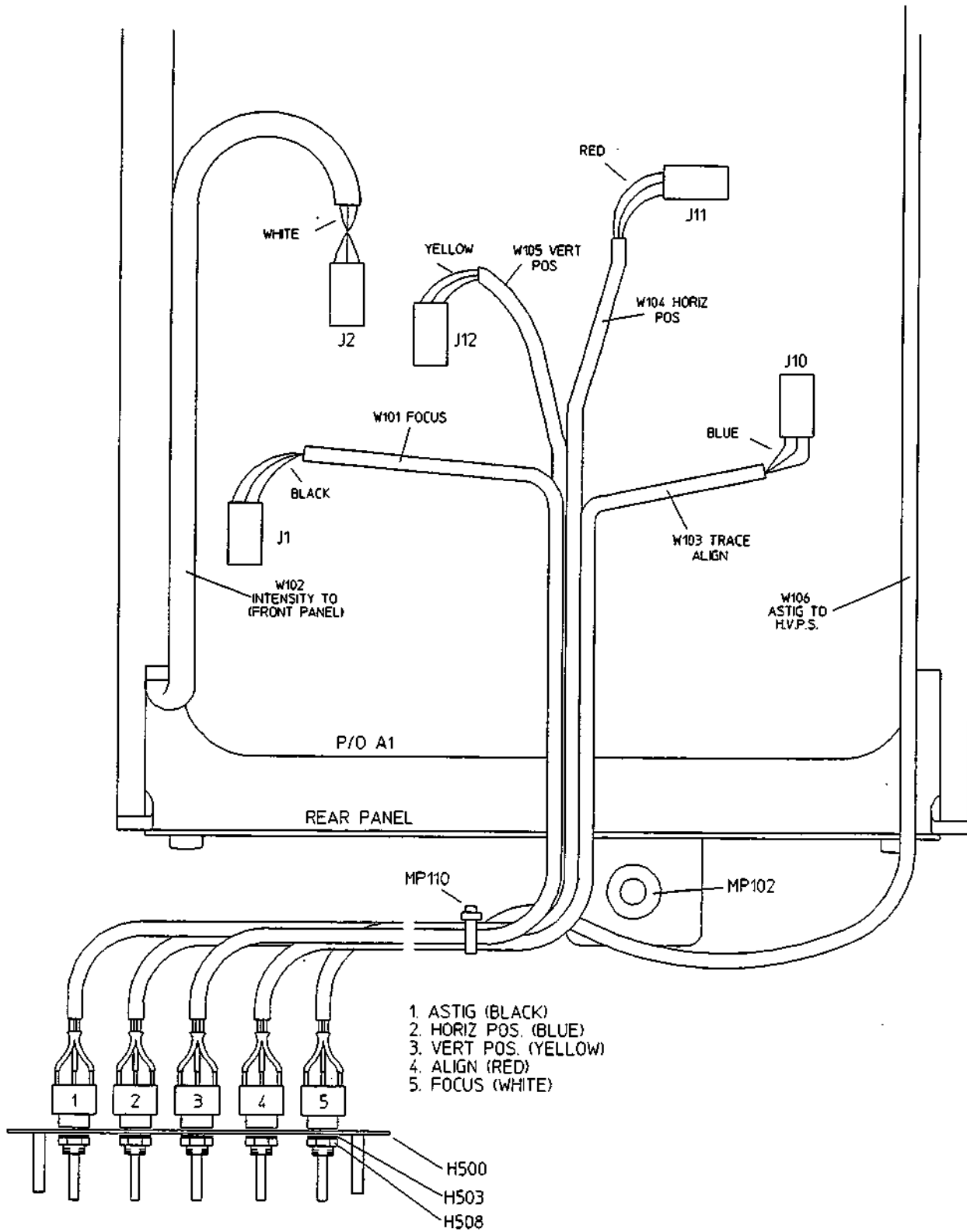


Figure 5-8. External Control Connections



## Low Voltage Power Supply Adjustments

### Description:

In this procedure, the input power supplies are verified and the 105V power supply is adjusted to  $105V \pm 250 \text{ mV}$ .

### Equipment:

Digital Voltmeter  
Power Supply (to the HP 3577B)

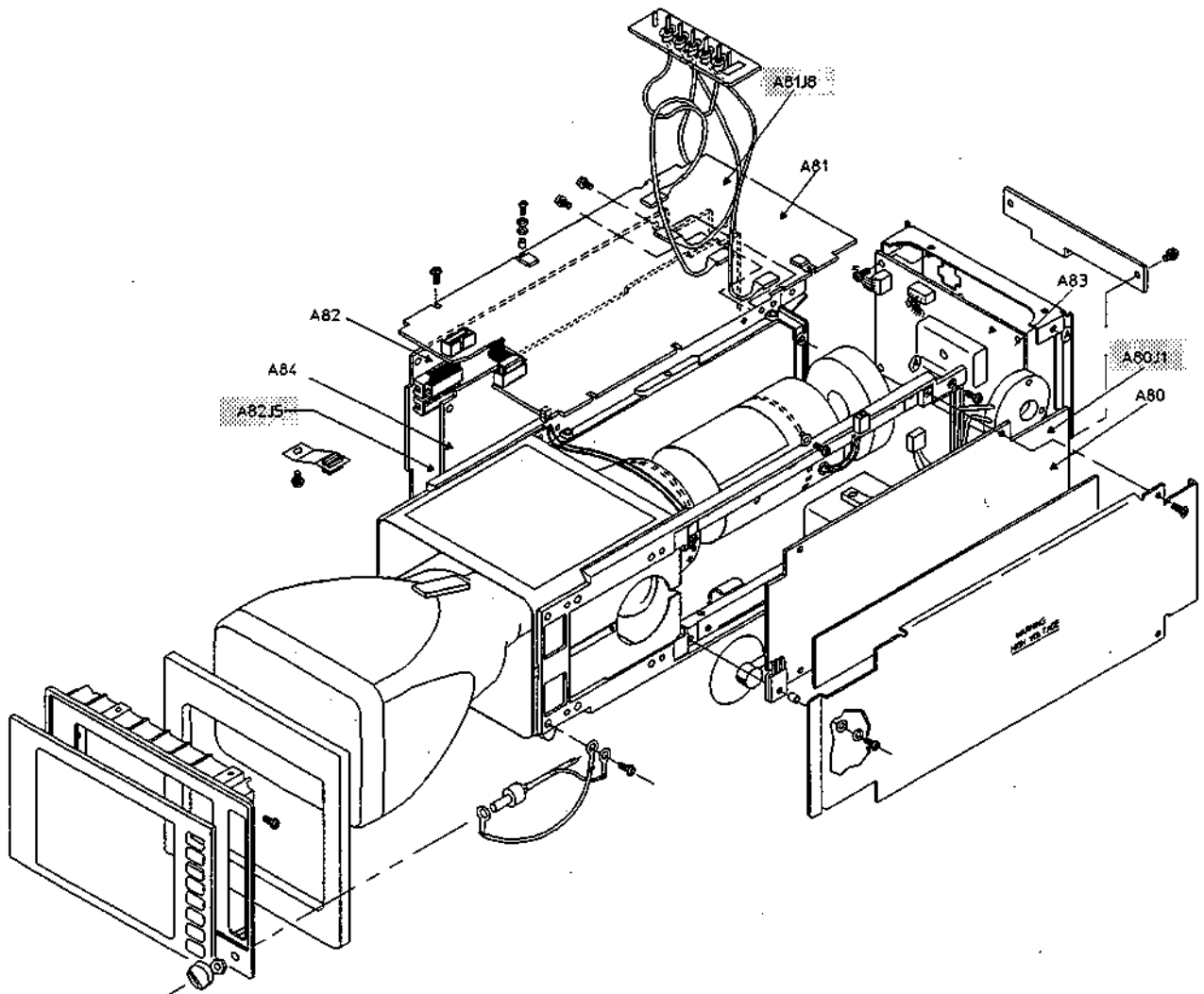


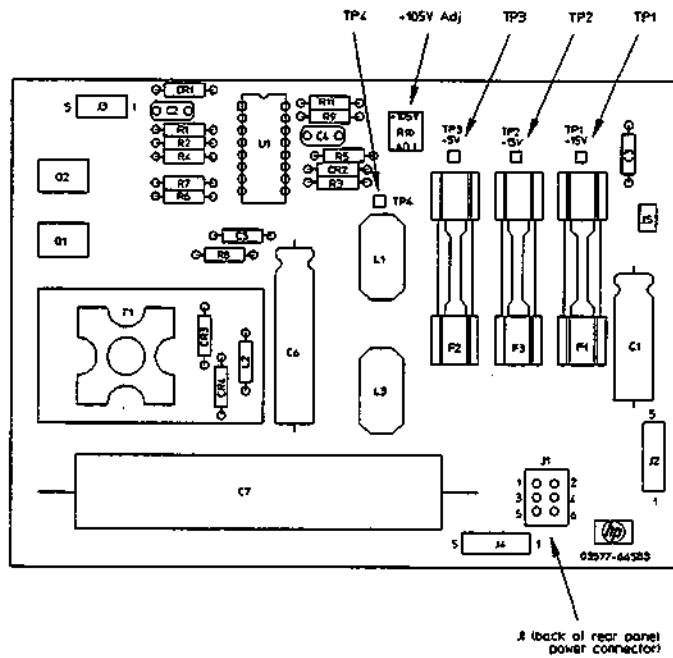
Figure 5-9. Power Plug Locations  
A80J1, A81J8, A82J5

**Procedure**

- a. Apply power to the rear panel power connector and check input power supplies as indicated in table 5-6. Refer to figure 5-10

**Table 5-6**

Monitor	Supply	Test Limits
A83 TP1	+15V	$\pm 750$ mV
A83 TP2	- 15V	$\pm 750$ mV
A83 TP3	+5V	+250 mV - 0mV



**Figure 5-10. A83 Adjustment Locations for Low Voltage Power Supply**

- b. Monitor A83TP4 and adjust the +105V (A83R10) Power Supply for  $105V \pm 250$  mV.
- c. Monitor internally regulated power supplies as indicated in table 5-7. Refer to figure 5-11.

Table 5-7

Monitor	Supply	Test Limits
A81TP15	+15V	± 750 mV
A81VR4	+10V	± 500 mV
A81U33 PIN 2	+7V	± 350 mV
A81VR5	-3.1V	± 150 mV
A81U30 PIN 3	-8V	± 400 mV
A81TP16	-15V	± 750 mV

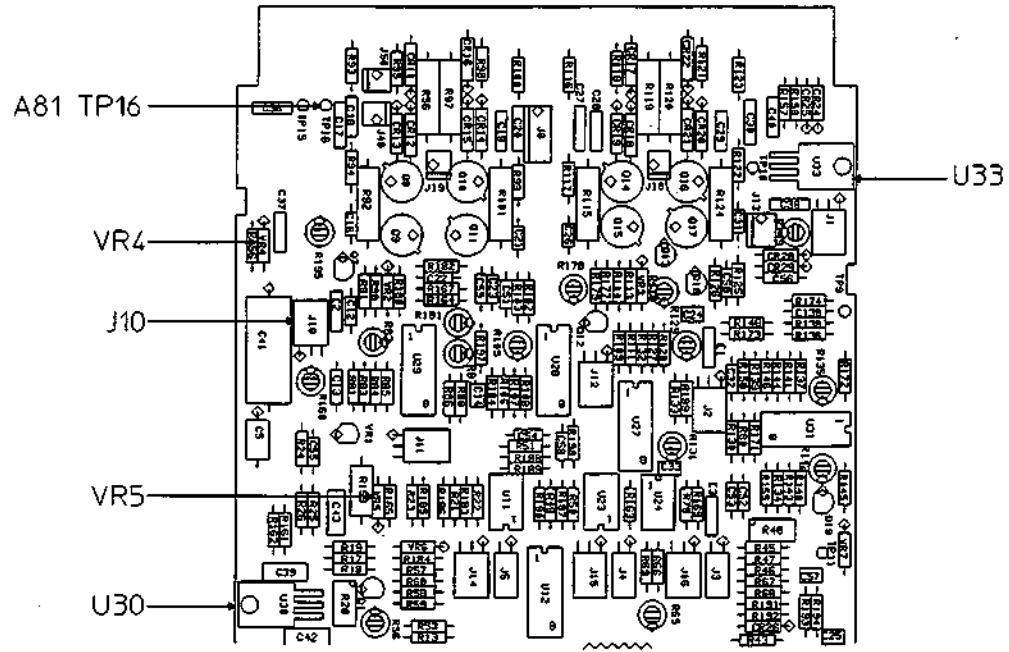
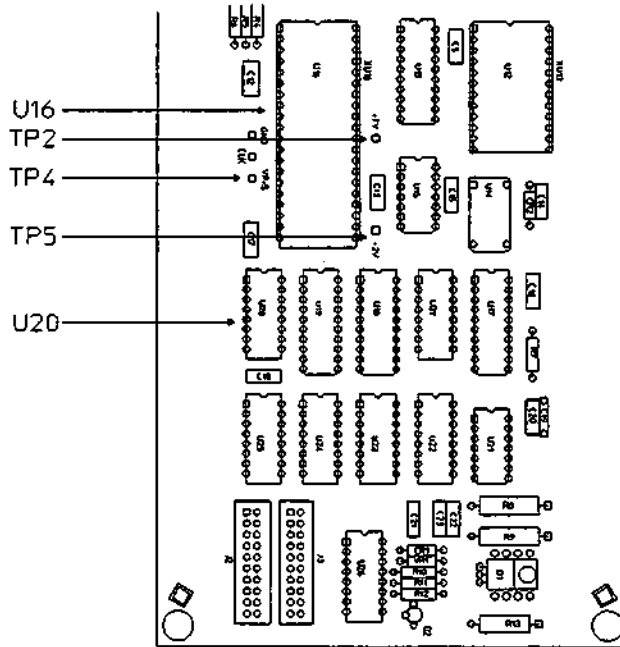


Figure 5-11. A81 Adjustment Locations for Low Voltage Power Supply

1. Monitor internally regulated power supplies as indicated in table 5-8. Refer to figure 5-12

**Table 5-8**

Monitor	Supply	Test Limits	Test Point Label
A82U16 PIN 34	+7V	± 350 mV	A82TP2 +7V
A82U20 PIN 16	+5V	± 250 mV	—
A82U16 PIN 14	+5V (peak)	± 250 mV	A82TP4 +5V
A82U16 PIN 21	-2.18V	± 100 mV	A82TP5 -2V



**Figure 5-12. A82 Adjustment Locations  
 for Low Voltage Power Supply**

## High Voltage Power Supply Adjustments

### Description:

This procedure describes the Cathode Voltage adjustment. The Cathode Voltage is set to agree with the Cathode Voltage label on the High Voltage Power Supply Board (A80), circuit side. This voltage should be within the range of  $-2300\text{V}$  to  $-2600\text{V}$ .

### Equipment Required:

Digital Voltmeter

1000:1 Divider Probe (For best results, this probe should be calibrated for 1% accuracy at 2500 Vdc.)

Power Supply (to the HP 3577B)

### Procedure:

- a. Turn off the power supply to the display.

### Warning



Extremely dangerous voltages can remain on the High Voltage Power Supply assembly (A80) even when the display assembly is turned off or unplugged. Injury or death may result if an uninsulated tool or object is placed on the board.

- b. Remove the protective aluminum cover over the A80 High Voltage Power Supply on the right side of the display assembly.
- c. Set the front panel INTENSITY control and the Beam Cut-Off control (A81 R129) both to the CCW stops. Refer to figure 5-13.

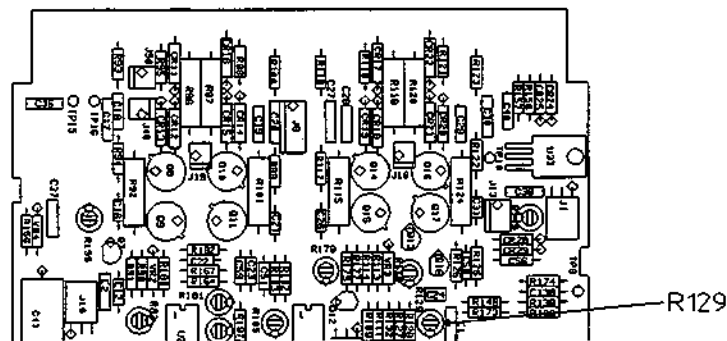


Figure 5-13. A81 Adjustment Locations  
for High Voltage Power Supply

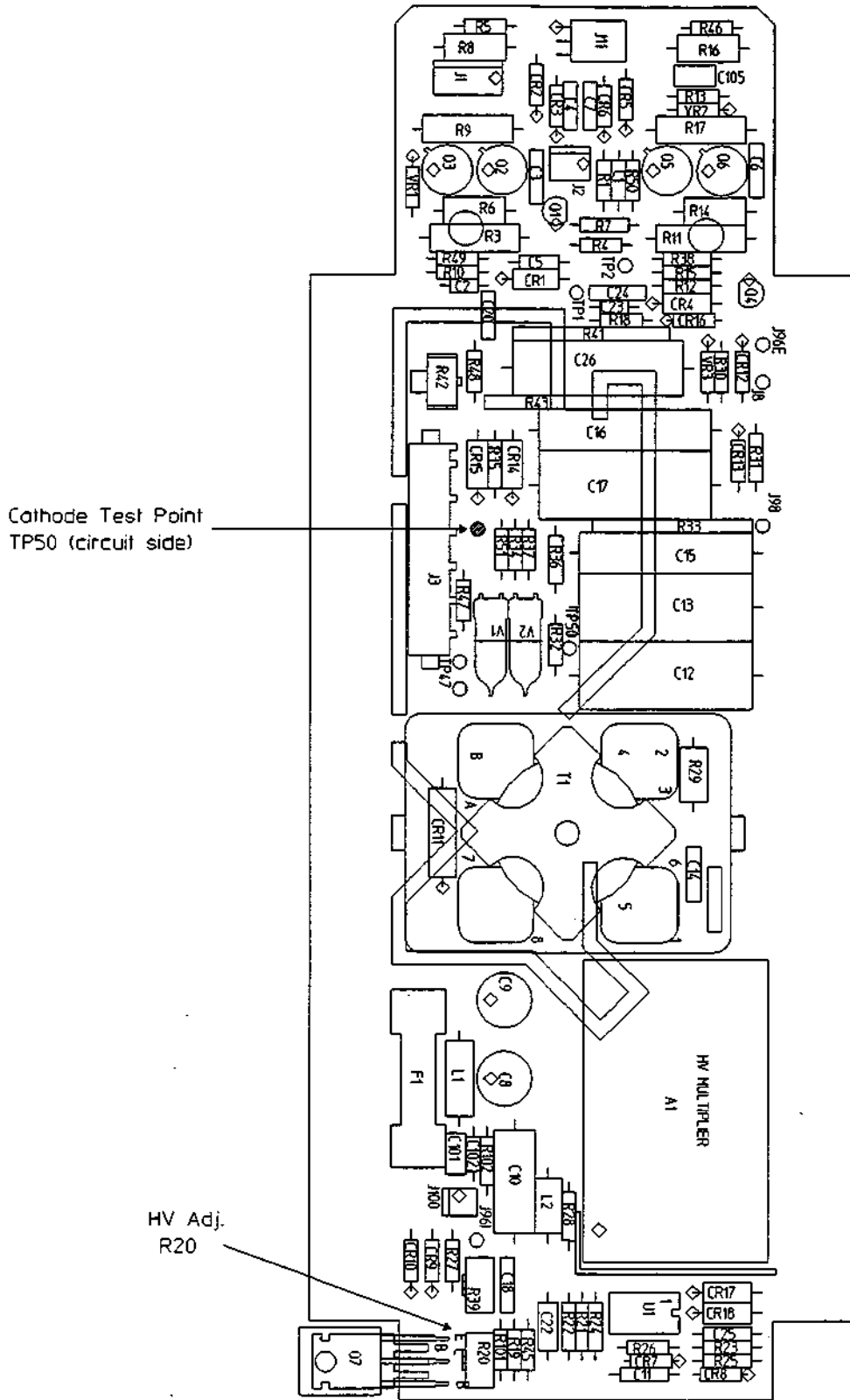


Figure 5-14. A80 Adjustment Locations  
for High Voltage Power Supply

## Pattern Adjustments

1. Refer to figure 5-15 for adjustment locations.
2. Set XGAIN and XOFFS (A81 R87, R82), and YGAIN and YOFFS (R110, R105), for a centered test pattern display that measures 112mm (4.4") wide and 85mm (3.3") tall. Adjust the external ROTATION control and the ORTHOG adjustment (A81 R195) as needed to obtain a proper rectangular display.

### Note



Figure 5-16 may be photocopied onto transparency material and used as a template for this adjustment.

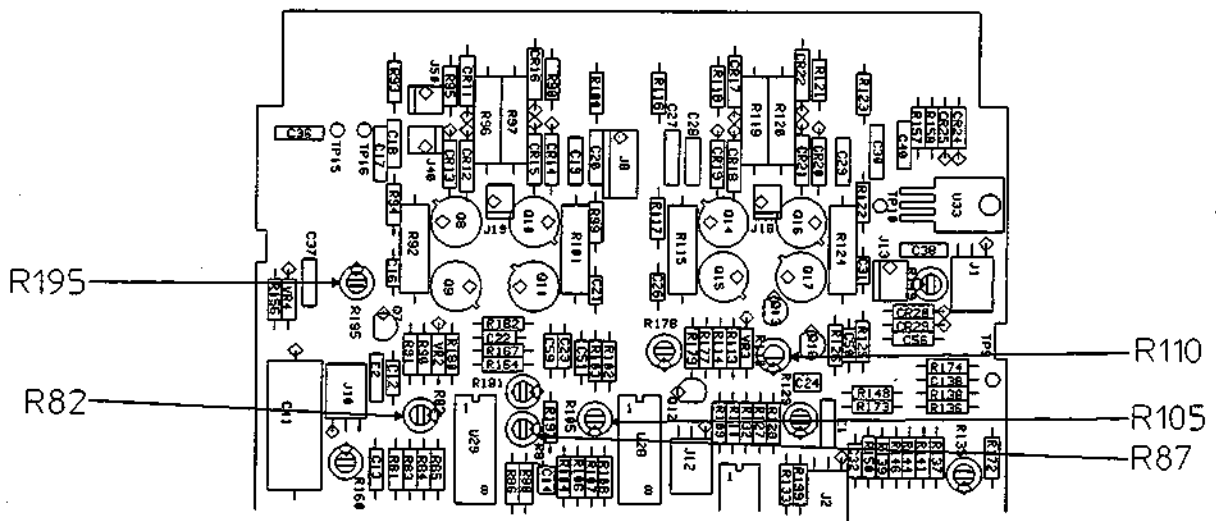
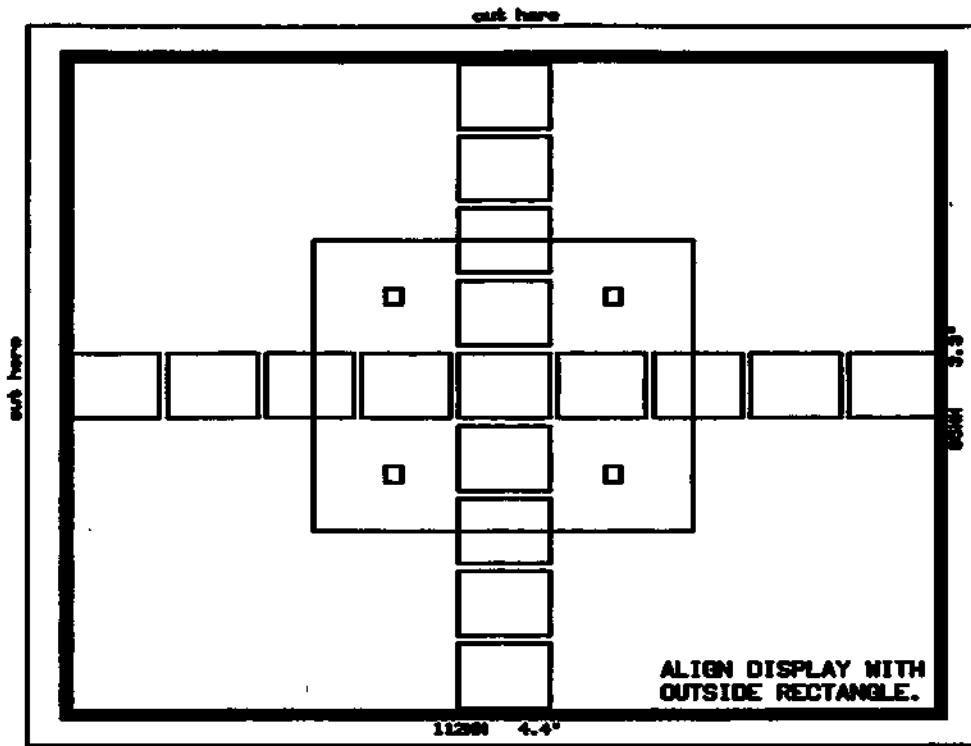


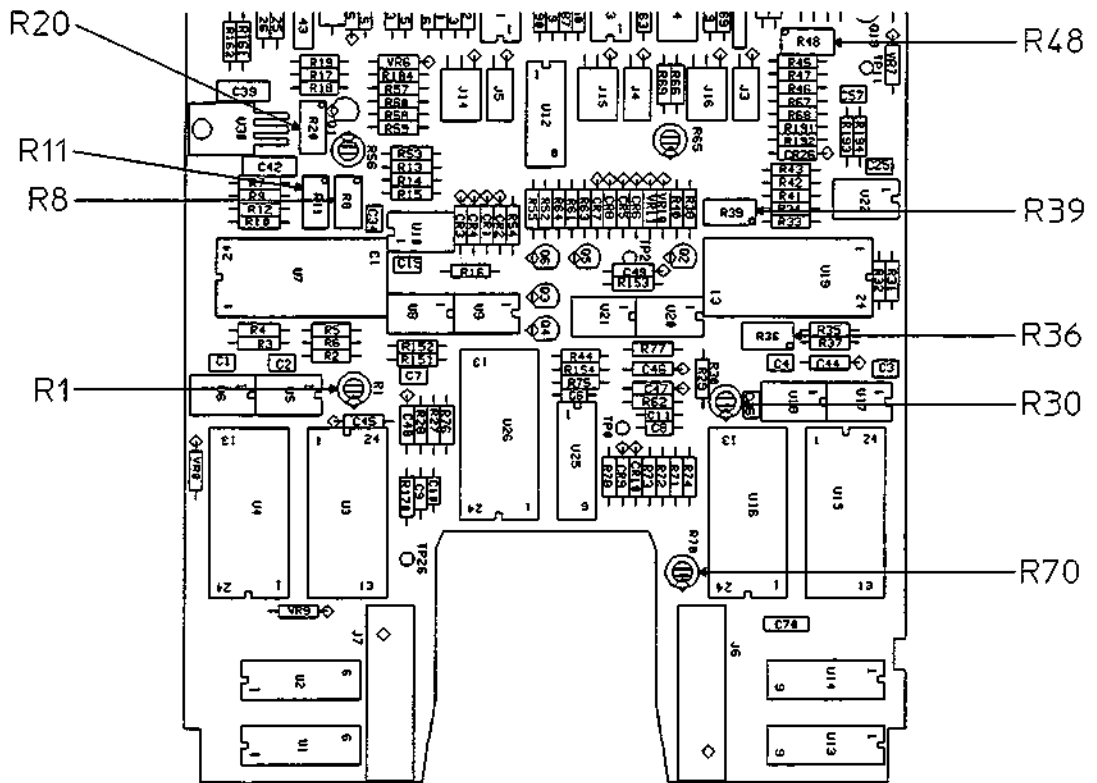
Figure 5-15. A81 Adjustment Locations



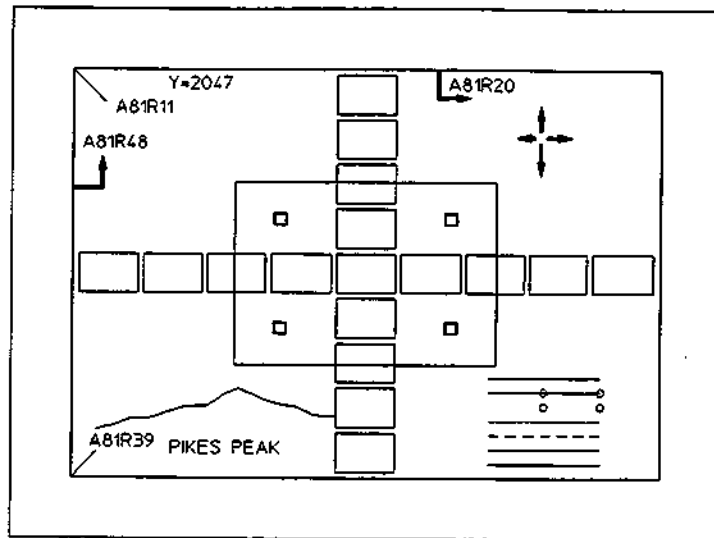
**Figure 5-16. Adjustment Template**

**Copy onto transparency material and use for adjustments**





**Figure 5-18. A81 Adjustment Locations  
for Stroke Generator and Stroke Length**



**Figure 5-19. Stroke Length Adjustment Test Pattern**

- h. Adjust A81R39 so that the left vertical line of the pattern starts at exactly the bottom horizontal line in the test pattern.
- i. Adjust A81R48 so that the left vertical line ends at exactly the top horizontal line in the test pattern.
- j. Adjust A81R11 so that the top horizontal line originates at exactly the left vertical line in the test pattern.
- k. Adjust A81R20 so that the top horizontal line ends at exactly the right vertical line in the test pattern.
- l. The outside box of the pattern should now be closed properly. If not, recheck steps 8 through 11.

## Stroke Intensity Adjustments

### Description:

This procedure describes the adjustments necessary to ensure equal intensity of all vectors.

### Equipment Required:

Power Supply (to the HP 3577B)

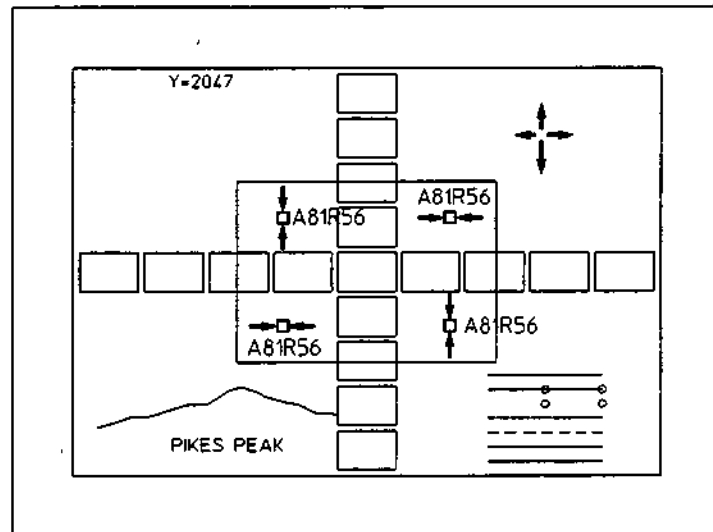


Figure 5-20. Stroke Intensity Adjustment Test Pattern

### Procedure:

1. Turn on power and obtain primary test pattern on screen.
2. Refer to figure 5-21. Adjust A81R56 so that the horizontal lines of the four small boxes in the test pattern are of equal intensity.
3. Adjust A81R65 so that the vertical lines of the four small boxes in the test pattern are of equal intensity.

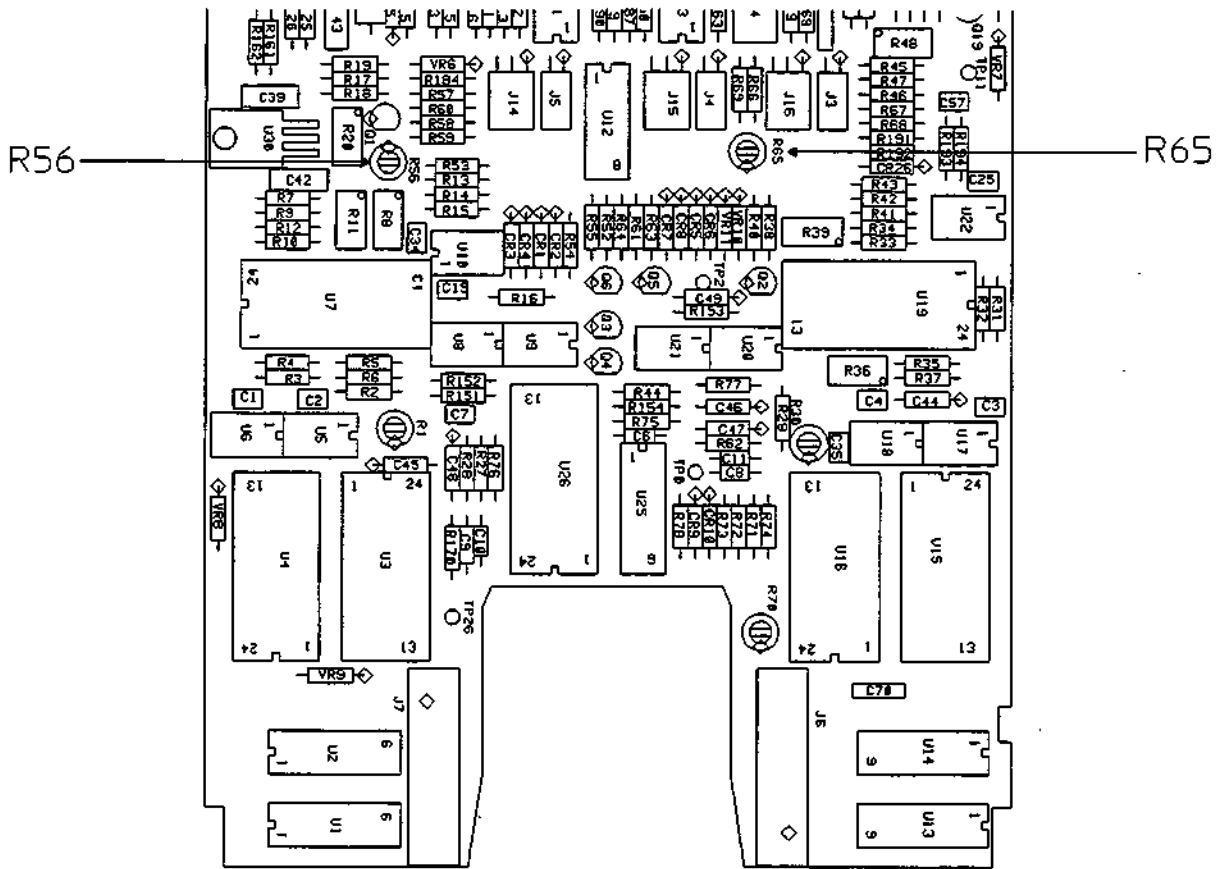


Figure 5-21. A81 Adjustment Locations  
for Stroke Intensity

## Final Focus Adjustments

### Description:

These procedures provide the necessary adjustments for optimum focus of the display. To obtain an accurate resolution check, follow the steps in the same sequence as described below. The Focus Adjustment and Resolution Check consists of two parts:

- Adjusting Focus using the Secondary Test Pattern.
- Verify Resolution using the Secondary Test pattern.

### Equipment Required:

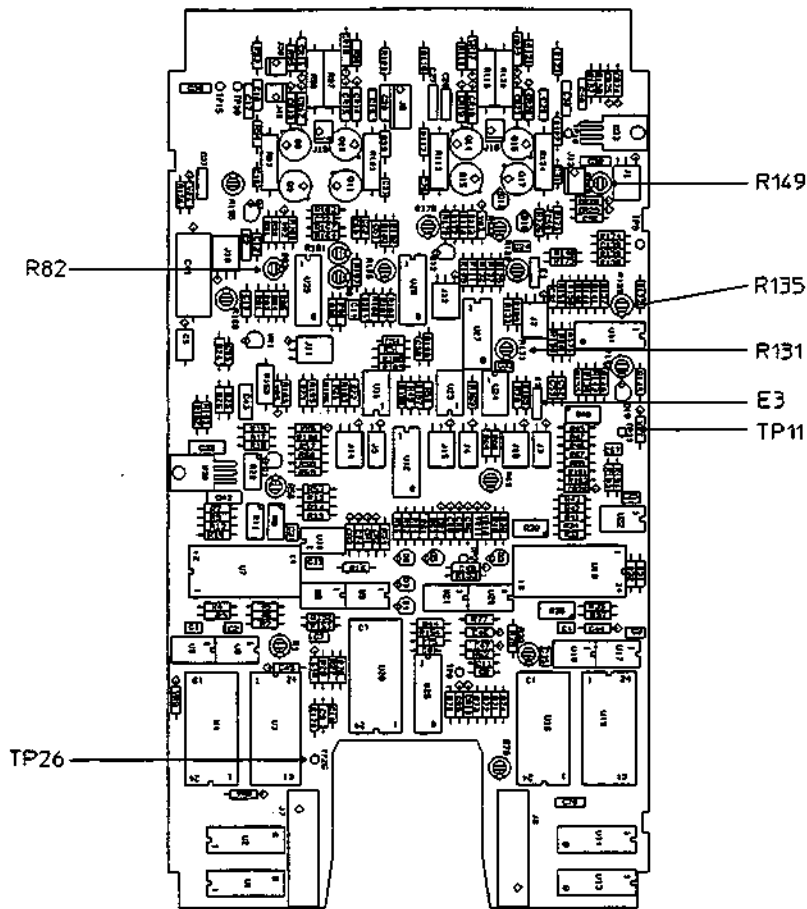
Power Supply (to the HP 3577B)  
Oscilloscope  
10:1 Divider Probe

### Procedure:

- a. Set the oscilloscope vertical gain and offset to observe a 1 Vpp signal riding on 7 Vdc using a 10:1 probe and dc coupling:

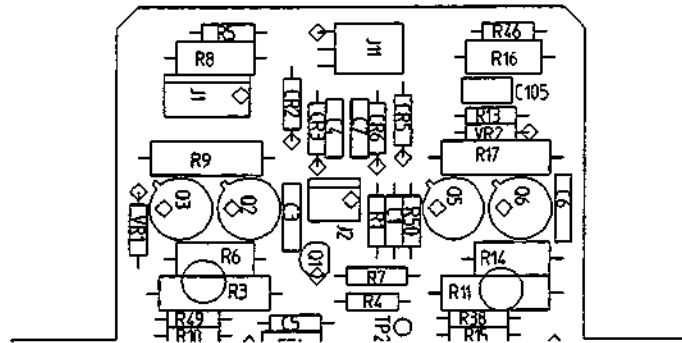
Vertical	0.1
Horizontal	100 $\mu$ sec/Div

- b. Refer to figure 3-22. Trigger the scope at A81 TP26 (/RESET) on the positive slope, dc coupled.



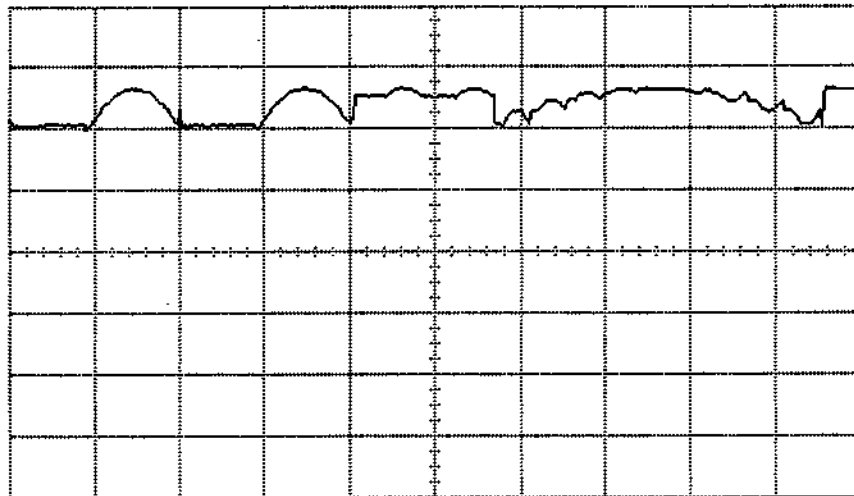
**Figure 5-22. A81 Adjustment Locations for Final Focus**

- c. Connect the 10:1 probe to A81TP11 (XFOC) and adjust X GAIN-ZERO (XGZ) control, A81 R135, so that the signal peaks at about 6.5V.
- d. Adjust A81 R142 (XFOC) to maximize the peak-peak signal swing.



**Figure 5-23. A80 Adjustment Locations for Final Focus**

- e. Adjust the X balance (XBAL), A81 R82, so that the arch seen in the oscilloscope display is made symmetric: with the end points at the same voltage. See figure 5-24.



**Figure 5-24. XFOC Testpoint 11**  
Vertical attenuator = 1 V/Div  
Sweep = 100  $\mu$ s/Div

- f. Rotate A81R142 (XFOC) back and forth. If the Peak of the arch does not stay at the same voltage (<0.2 Major Divisions), readjust R135 (XGZ) until the peak position remains stable for all settings of XFOC.
- g. Set the front panel INTENSITY control to the full on position (CW).

If the display is not visible, adjust the BEAM CUT-OFF (A81R131) until the display is visible.

---

**Warning**

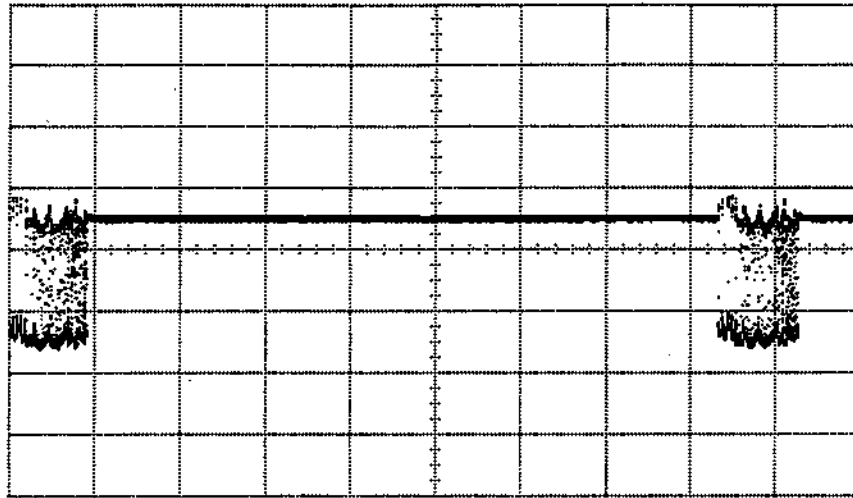


**The voltages present on the high voltage power supply assembly (A80) can cause serious injury or death. Never touch an uninsulated conductive tool or object to this assembly.**

---

- h. Adjust the HV FOCUS pot (A80R42) using a non-conductive tool and adjust the ASTIG control to bring the display into focus.
- i. Re-adjust A81R131 (beam cut-off) to the point just past where the extraneous dots and lines on the screen are extinguished. Particularly, look at the dot over the "Y=2047" in the pattern. Shade the CRT face to make sure that these dots are not visible. If R131 does not have sufficient effect, A81R149 may need to be readjusted to eliminate any dot in the lower left corner.
- j. Set the oscilloscope to show a 0 to 105V signal:
  - Vertical                      2 V/Div (10:1 probe)
  - Horizontal                  2 mSec/Div
- k. Trigger the scope at A81TP26 (/RESET) on the positive slope, ac coupled.
- l. Connect the 10:1 probe to A80 TP1 (FOCUS). Refer to figure 5-23.
- m. Set intensity to bright (fully CW). Adjust the focus-window A81R149 (FOCWIN) so that the signal can be offset by the external focus control as it is turned from one extreme to the other (see figure 5-25). Note that the waveform may be clipped at both rotation extremes.





**Figure 5-25. Focus A80 TP1 Normal Operation  
with Centered Focus Pot**  
Vertical attenuator = 20V/Div  
Sweep = 2 ms/Div  
Offset = 70V  
Input = DC

- n. Center the focus control so that the upper baseline is at 80V (figure 5-25).
- o. Rotate the intensity knob and verify that the focus signal does not clip while the display is visible. If clipping occurs, slightly readjust A81R149 (FOCWIN) so that no clipping occurs for all visible intensities.
- p. Short A82 J6 (see figure 5-26), accessible from the rear of the display, to display the focus test pattern (figure 5-27). Jumper A81 E3 may be removed and used to short A82J6.

---

**Warning**


The voltages present on the High Voltage Power Supply Assembly (A80) can cause serious injury or death. Never touch an uninsulated conductive tool or object to this assembly.

---

- q. Carefully observe the central test pattern. Adjust A80 R42 (HV FOCUS) and the external ASTIG control to get the test lines at the center of the display as narrow as possible but while keeping them all at an equal width.
- r. Adjust A81 R142 (XFOC) to obtain the best focus on the right and left sides of the screen, including the corners. The lines should be of equal width and as narrow as possible.

- s. Re-adjust HV FOCUS (A81 R42) and the external ASTIG adjustments as needed to get the best overall focus.
- t. Turn off the Display Unit, disconnect the power cable to the display assembly. Disconnect all probes. If jumper A81 E3 was used to short A82 J6, replace it on A81 E3 position "BC", now. This completes the display adjustments.

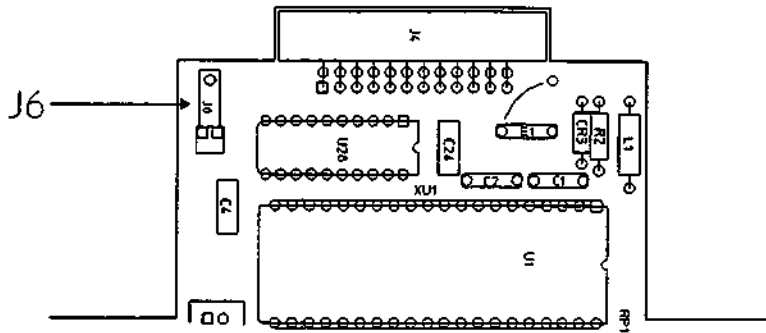


Figure 5-26. A82 Locator for Final Focus Adjustments

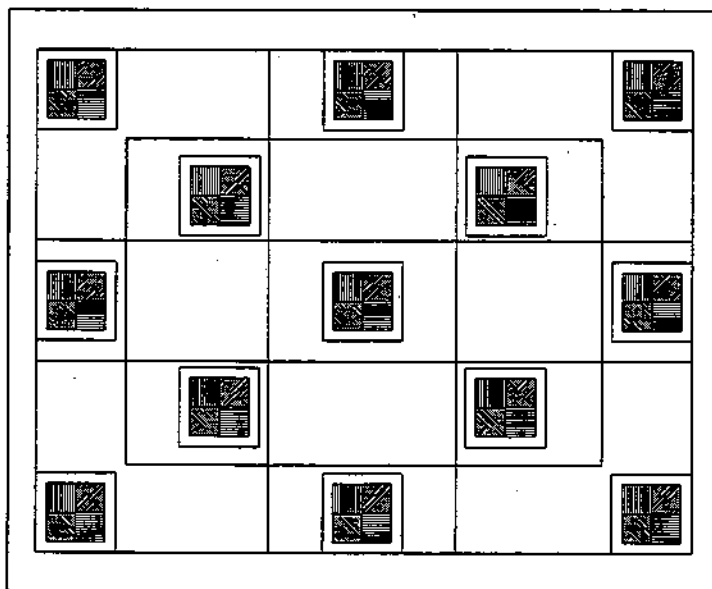


Figure 5-27. Focus Adjustment Test Pattern

## Auxiliary X-Y-Z Output Check

### Description:

This test verifies the auxiliary X-Y-Z Outputs.

### Equipment Required:

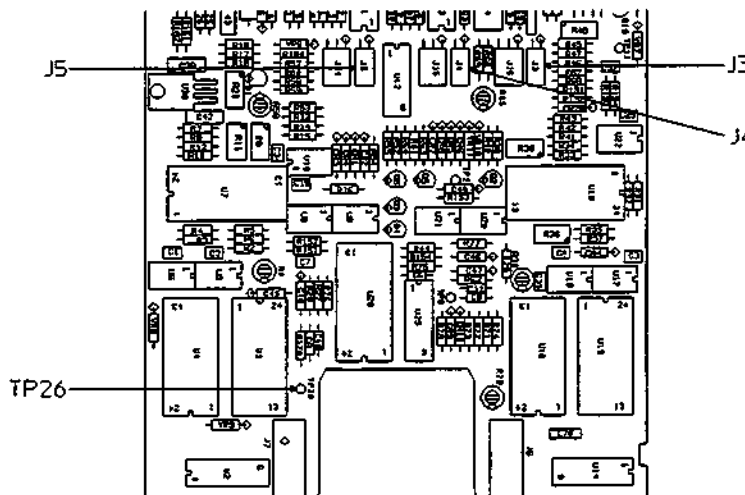
Power Supply (to the HP 3577B)

Oscilloscope

10:1 Divider Probe

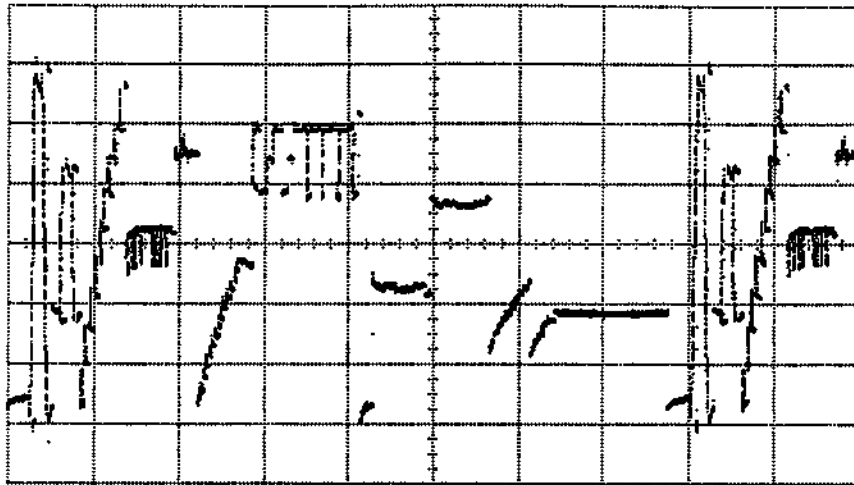
### Procedure:

- a. Turn on power and obtain primary test pattern on screen.



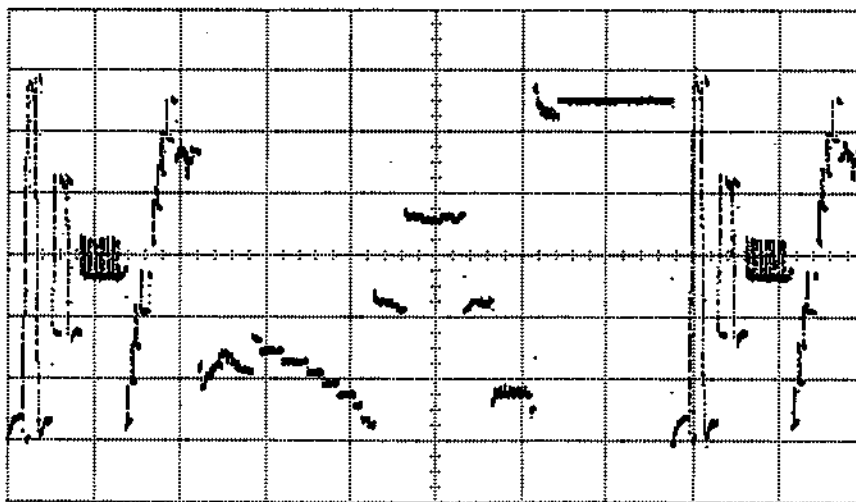
**Figure 5-28. A81 Adjustment Location for Auxiliary XYZ Output Check**

- b. Refer to figure 5-28. Trigger the scope at A81 TP26 (/RESET) on positive slope, ac coupled.
- c. Connect oscilloscope to A81 J5 pin 2 and check for a display as shown in figure 5-29.



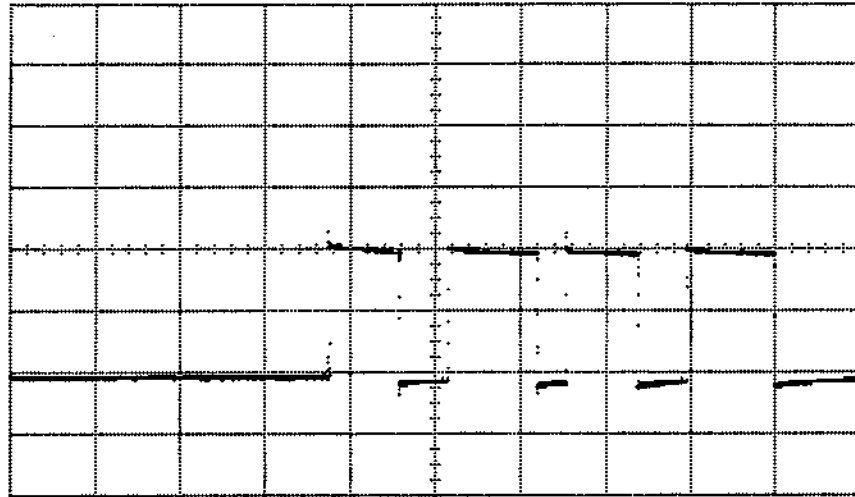
**Figure 5-29. X-Amplifier Auxiliary Output**  
Vertical attenuator = 200 mV/Div  
Sweep = 2 ms/Div

d. Monitor A81 J4 Pin 2 and check oscilloscope for a display as shown in figure 5-30.



**Figure 5-30. Y-Amplifier Auxiliary Output**  
Vertical attenuator = 200 mV/Div  
Sweep = 2 ms/Div

1. Monitor A81 J3 Pin 2 and check for a display on the oscilloscope as shown in figure 5-31.



**Figure 5-31. Z-Amplifier Auxiliary Output**  
Vertical attenuator =  $500 \mu\text{V}/\text{Div}$   
Sweep =  $100 \mu\text{s}/\text{Div}$



## Replaceable Parts

---

### 6-1 Introduction

This section contains information for ordering parts. Table 6-1 lists abbreviations used in table 6-3 (Replaceable Parts and throughout this manual). Table 6-2 lists the manufacturer's name and address by manufacturer's code numbers.

---

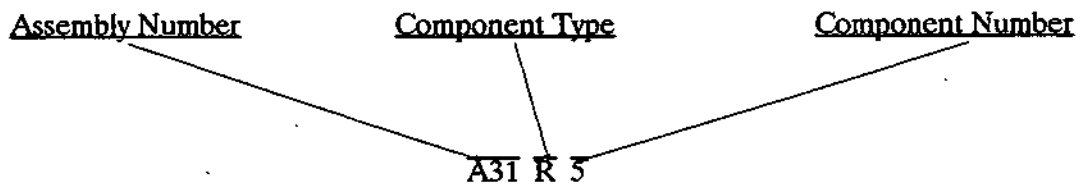
### 6-2 Replaceable Parts List

In table 6-3, the Replaceable Parts List is organized as follows:

1. PC Board Assemblies: A4, A5, A6, . . .
2. Chassis Mounted Components
3. Chassis Components
4. Hardware

Table 6-3 headings include:

1. REFERENCE DESIGNATION



2. HP PART NUMBER
3. CD – The Check Digit is used by -hp- to verify the order has been transmitted correctly.
4. QTY – The total quantity in the instrument.
5. DESCRIPTION – The -HP- description of the part.
6. MFR CODE – The manufacturer's code (see table 6-2).
7. MFR PART NUMBER – The manufacturer's part number.

---

## 6-3 Ordering Information

To order a part listed in table 6-3, quote the HP part number, check digit, quantity required and address the order to the nearest Hewlett-Packard Sales and Service Office.

To order a part that is not listed in table 6-3, describe the part, its function, the instrument model and serial number, the quantity required and address the order to the nearest Hewlett-Packard Sales and Service Office.

---

## 6-4 Direct Mail Order System

Within the U.S.A., Hewlett-Packard can supply parts through a direct mail order system.

Advantages of using this system are:

- Direct ordering and shipment from the HP Parts Center in Mountain View, California.
- No maximum or minimum on any mail order. There is a minimum order amount for parts ordered through a local HP sales and service office when the orders require billing and invoicing.
- Transportation charges are prepaid. A small handling charge is added to each order.
- No invoicing. A check or money order must accompany each order.

Mail order forms and specific ordering information are available through your local Hewlett-Packard sales and service office.

---

## 6-5 Special Handling

The HP 3577B contains many static sensitive components. Use the appropriate precautions when removing, handling and installing all parts to avoid unnecessary damage.



Table 6-1. Abbreviations Used

Abbreviations			
Ag	silver	NPO	negative positive zero (zero temperature coefficient)
Al	aluminum	ns	nanosecond(s) = $10^{-9}$ seconds
A	ampere(s)	nsr	not separately replaceable
Au	gold	obd	order by description
cer	ceramic	OD	outside diameter
coef	coefficient	p	peak
com	common	pc	printed circuit
conn	connection	pF	picofarad(s) $10^{-12}$ farads
dep	deposited	piv	peak inverse voltage
DPDT	double-pole double-throw	p/o	part of
DPST	double-pole single-throw	pos	position(s)
elect	electrolytic	poly	polystyrene
encap	encapsulated	pot	potentiometer
F	farad(s)	p-p	peak-to-peak
FET	field effect transistor	ppm	parts per million
fxd	fixed	prec	precision (temperature coefficient long term stability and/or tolerance)
GaAs*	gallium arsenide	R	resistor
GHz	gigahertz = $10^{+9}$ hertz	Rh	rhodium
Gd	guard(ed)	rms	root-mean-square
Ge	germanium	rot	rotary
gnd	ground(ed)	Se	selenium
H	henry(ies)	sect	section(s)
Hg	mercury	Si	silicon
Hz	hertz (cycle(s) per second)	sl	slide
ID	inside diameter	SPDT	single-pole double-throw
impq	impregnated	SPST	single-pole single-throw
incd	incandescent	Ta	tantalum
ins	insulation(ed)	TC	temperature coefficient
k $\Omega$	kilohm(s) = $10^{+3}$ ohms	TiO <sub>2</sub>	titanium dioxide
kHz	kilohertz = $10^{+3}$ hertz	tog	toggle
L	inductor	tol	tolerance
lin	linear taper	trim	trimmer
log	logarithmic taper	TSTR	transistor
mA	milliampere(s) = $10^{-3}$ amperes	V	volt(s)
MHz	megahertz = $10^{+6}$ hertz	vacw	alternating current working voltage
M $\Omega$	megohms(s) = $10^{+6}$ ohms	var	variable
met film	metal film	vdcw	direct current working voltage
mfr	manufacturer	W	watts
ms	microsecond	w/	with
mtg	mounting	wiv	working inverse voltage
mV	millivolt(s) = $10^{-6}$ volts	w/o	without
$\mu$ F	microfarad(s)	ww	wirewound
$\mu$ s	microsecond(s)		
$\mu$ V	microvolt(s) = $10^{-6}$ volts		
my	Mylar®		
nA	nanoampere(s) = $10^{-9}$ amperes		
NC	normally closed		
Ne	neon		
NO	normally open		

\* optimum value selected at factory average value shown (part may be omitted)

\*\*no standard type assigned selected or special type

® Dupont de Nemours

**Table 6-1. Abbreviations Used (continued)**

Designators			
A	assembly	Q	transistor
B	motor	QCR	transistor-diode
BT	battery	R	resistor
C	capacitor	RT	thermistor
CR	diode or thyristor	S	switch
DL	delay line	T	transformer
DS	lamp	TB	terminal board
E	misc electronic part	TC	thermocouple
F	fuse	TP	test point
FL	filter	TS	terminal strip
HR	heater	U	microcircuit
IC	integrated circuit	V	vacuum tube
J	jack	W	cable jumper
K	relay	X	socket
L	inductor	XDS	lampholder
M	meter	XF	fuseholder
MP	mechanical part	Y	crystal
P	plug	Z	network

\* optimum value selected at factory average value shown (part may be omitted)

\*\*no standard type assigned selected or special type

® Dupont de Nemours

Table 6-2 . Manufacturers Code List

Mfr #	Manufacturer Name	Address		Zip code
H9027	Schurter A G H	Luzern	SW	
01121	Allen-Bradley Co	Milwaukee	WI	53204
01295	Texas Instr Inc Semicond Cmpnt Div	Dallas	TX	75222
02111	Spectrol Electronics Corp	City of ind	CA	91745
03508	GE Co Semiconductor Prod Dept	Auburn	NY	13201
03888	K D I Pyrofilm Corp	Whippany	NJ	07981
04713	Motorola Semiconductor Products	Phoenix	AZ	85008
06665	Precision Monolithics Inc	Santa Clara	CA	95050
07263	Fairchile Semiconductor Div	Mountain View	CA	94042
11236	CTS of Berne inc	Berne	IN	46711
13103	Thermalloy Co	Dallas	TX	75234
13606	Sprague Elect Co Semiconductor Div	Concord	NH	03301
14099	Semtech Corp	Newbury Park	CA	91320
15454	Ametek/Rodan Div	Anaheim	CA	92806
17856	Siliconix Inc	Santa Clara	CA	95054
18324	Signetics Corp	Sunnyvale	CA	94086
19701	Mepco/Electra Corp	Mineral Wells	TX	76067
20932	Emcon Div ITW	San Diego	CA	92129
24546	Corning Glass Works (Bradford)	Bradford	PA	16701
25403	N.V. Philips-Elcoma Department	Eindhoven	HL	02876
27014	National Semiconductor Corp	Santa Clara	CA	95051
27167	Corning Glass Works (Wilmington)	Wilmington	NC	28401
28480	Hewlett-Packard Co Corporate HQ	Palo Alto	CA	94304
3L585	RCA Corp Solid State Div	Somerville	NJ	
32997	Bourns inc Trimpot Prod Div	Riverside	CA	92507
34335	Advanced Micro Devices inc	Sunnyvale	CA	94086
34371	Harris Semicon Div Harris-Intertype	Melbourne	FL	32901
52063	Exar Integrated Systems inc	Sunnyvale	CA	94086
56289	Sprague Electric Co	North Adams	MA	01247
72136	Electro Motive Corp	Florence	SC	06226
72982	Erie Technological Products Inc	Erie	PA	16512
73138	Beckman Instruments Inc Helipot Div	Fullerton	CA	92634
75915	Littelfuse Inc	Des Plaines	IL	60016
84411	TRW Capacitor Div	Ogallala	NE	69153
91637	Dale Electronics Inc	Columbus	NE	68601

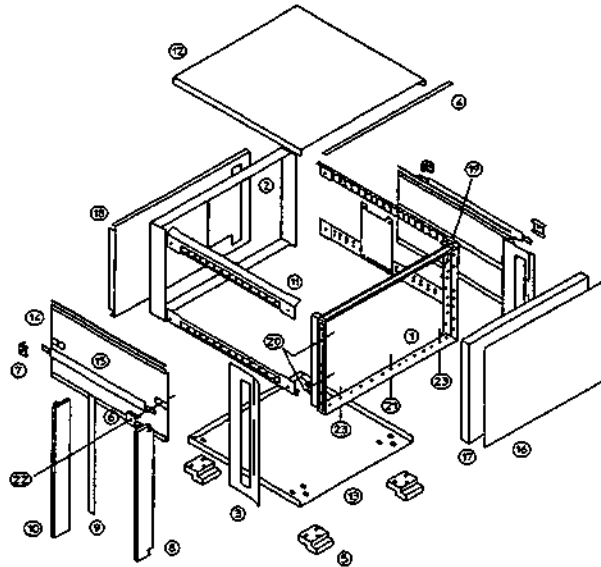
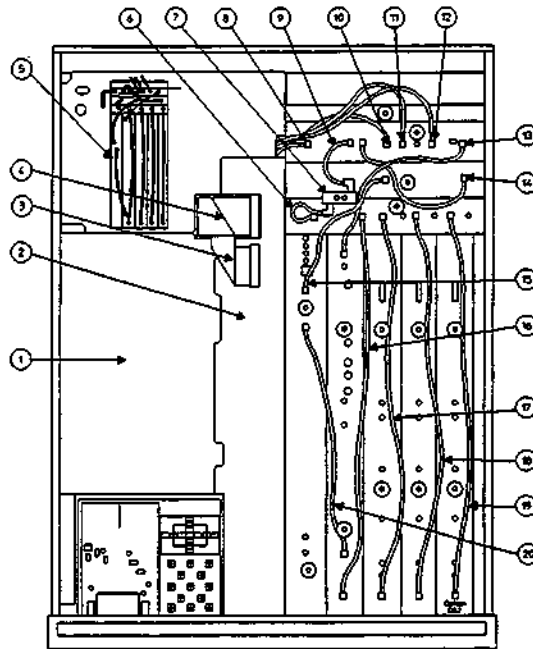


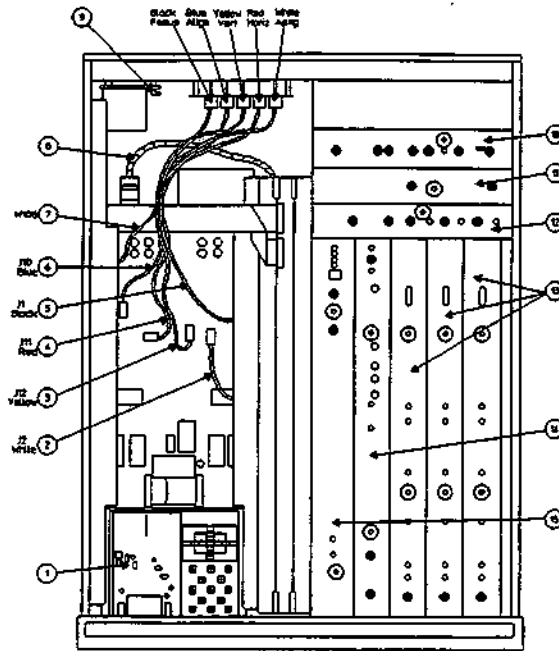
Figure 6-1. Cabinet Parts, Exploded View

Figure #	Description	Qty	Current(metric)
1	Front frame	1	5021-8407
2	Rear frame	1	5021-5808
3	Front handle kit (optional)	2	5062-3991
4	Top frame plastic piece	1	5041-8802
5	Fr feet	4	5041-8801
6	Front handle cover piece	2	5041-8819
7	Rear handle cover piece	2	5041-8820
8	Rt angle rack MT piece	2	5062-3985
9	side frame vinyl piece	2	5001-0541
10	Rack mount piece	2	5061-9679
11	Side strut	4	5021-5838
12	Top cover	1	5062-3736
13	Bottom cover	1	5062-3748
14	Side panel	2	5062-3848
15	Handle assy	2	5062-3705
16	Front panel	1	03577-64381 std (2 chan) 03577-64382 opt 002 (3 chan)
17	Front sub panel	1	03577-00282
18	Rear panel	1	03577-00283
19	Strut/Frame corner screws	8	0515-2086
20	Side frame screws	4	0515-1234
21	Botton center screw to Fr frame	1	0515-1234
	Flat washer	1	3050-0596
22	Side screws to frame	4	0515-1132
23	Botton side screws to Fr frame	5	0515-1234



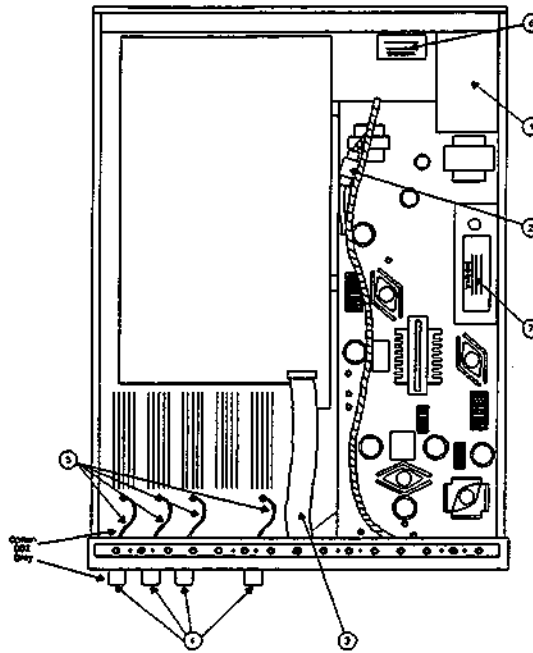
Reference Designation	HP Part Number	Qty	Description
1	03577-04187	1	Cover - Display
2	03577-04180	1	Cover - Processors
3	03577-61602	1	Display Digital Cable
4	03577-61682	1	8 Bit IO cable
5	03577-04118	1	Cover - Rear
6	03585-61602	1	Cable - Filter to LO
7	03577-66525	1	Filter Board
8	03585-61602	1	Cable - Ref to FP
9	03585-61602	1	Cable - Ref to Filter
10	03586-61674	1	Cable - Ext Ref
11	03585-61605	1	Cable - Oven to Ref
12	03586-61674	1	Cable - Ext Ref
13	03577-61622	1	Cable - Ref to Syn
14	03577-61641	1	Cable - Ref to Ofs
15	03577-61623	1	Cable - Ofs to Out
16	03577-61620	1	Cable - Syn to LO
17	03577-61620	1	Cable - Side LO to Receiver
18	03577-61624	1	Cable - Center LO to Receiver
19	03577-61620	1	Cable - Side LO to Receiver
20	03577-61621	1	Cable - Syn to Out

Figure 6-2. Mechanical Parts Identification, Cables and Shields



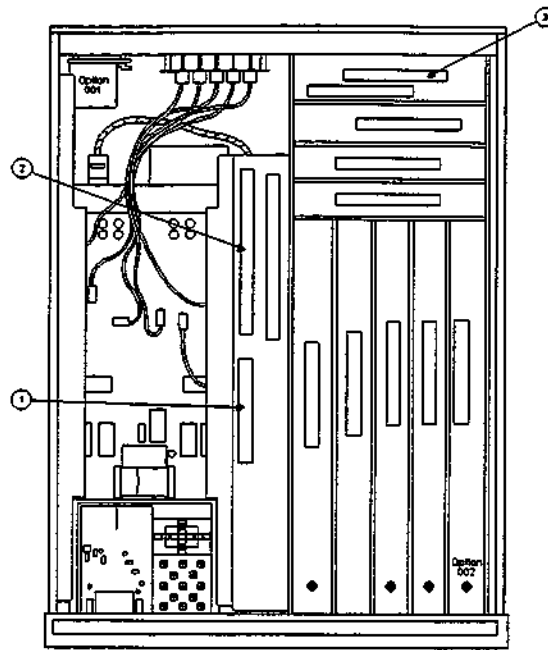
Reference Designation	HP Part Number	Qty	Description
1	03577-60151	1	Display 4K Memory
2	01345-61627	1	Cable - Display, Vertical
3	01345-61628	1	Cable - Display, Horizontal
4	01345-61630	1	Cable - Display, Focus
5	01345-61629	1	Cable - Display, Alignment and Pot
6	01345-61631	1	Cable - Display, Astig and Pot
7	03577-61603	1	Cable - Display Power
8	01345-01203	1	Mounting Bracket - Potentiometer
9	01345-61626	1	Cable - Intensity
10	03577-04106	1	Cover, Reference
11	03577-04105	1	Cover, Offset
12	03577-04104	1	Cover, Local Oscillator
13	03577-04137	3	Cover, Receiver Boards
14	03577-04127	1	Cover, Synthesizer
15	03577-04108	1	Cover, Output

Figure 6-3. Mechanical Parts Identification, Covers



Reference Designation	HP Part Number	Qty	Description
1	9135-0225	1	Line Filter
2	03577-61638	1	5V Supply Cable
3	03577-61608	1	Keyboard Cable
4	1250-1811	4	Adapter – Coax
5	03577-61626	4	Front Panel Cable
6	03577-04116	1	Guard – Fuseholder
7	03577-04115	1	Guard – Switching Transistor

Figure 6-4. Mechanical Parts Identification, Bottom



Reference Designation	HP Part Number	Qty	Description
1	1251-2915	1	Main Processor Small Edge Connector
2	1251-5160	2	Processor Large Edge Connector
3	1251-1365	10	Analog Edge Connector

Figure 6-5. Mechanical Parts Identification, Chassis



Table 6-3. Replaceable Parts

Ref.Des.	HP Part Number	CD	Qty	Description	Mfr. Code	Mfr. Part Number
	3577B	8	1	NETWORK ANALYZER 'X01'	28480	3577B
A4	03577-66504	5	1	PCASSY LO BOARD	28480	03577-66504
A4C1	0180-6508	5	8	C-F 22PF 5% 200V CERMLr	28480	RPE121-978C0G220J200V
A4C2	0160-6521	2	5	C-F 2.2PF -% 200V CERMLr	28480	RPE121-978C0G2R2C200V
A4C3	0160-6511	0	6	C-F 15PF 5% 200V CERMLr	28480	RPE121-978C0G150J200V
A4C4	0160-6508	5		C-F 22PF 5% 200V CERMLr	28480	RPE121-978C0G220J200V
A4C5	0160-6521	2		C-F 2.2PF -% 200V CERMLr	28480	RPE121-978C0G2R2C200V
A4C6	0160-6511	0		C-F 15PF 5% 200V CERMLr	28480	RPE121-978C0G150J200V
A4C7-C8	0160-6508	5		C-F 22PF 5% 200V CERMLr	28480	RPE121-978C0G220J200V
A4C10	0160-6507	4	15	C-F 1000PF 20% 100V CERMLr	28480	RPE121-978X7R102M100V
A4C11	0160-0376	5	46	CAPACITOR-FXD .1UF +-20% 50VDC CER	04222	SR205C104MAAH
A4C12-C13	0160-6507	4		C-F 1000PF 20% 100V CERMLr	28480	RPE121-978X7R102M100V
A4C14	0160-0576	5		CAPACITOR-FXD .1UF +-20% 50VDC CER	04222	SR205C104MAAH
A4C15-C16	0160-6507	4		C-F 1000PF 20% 100V CERMLr	28480	RPE121-978X7R102M100V
A4C17	0160-0576	5		CAPACITOR-FXD .1UF +-20% 50VDC CER	04222	SR205C104MAAH
A4C18-C20	0160-6507	4		C-F 1000PF 20% 100V CERMLr	28480	RPE121-978X7R102M100V
A4C21	0160-0576	5		CAPACITOR-FXD .1UF +-20% 50VDC CER	04222	SR205C104MAAH
A4C22	0180-3768	5	22	C-F 3.3UF 20% 35V TADPDr	12340P02	T350D335M035AS
A4C23	0160-0576	5		CAPACITOR-FXD .1UF +-20% 50VDC CER	04222	SR205C104MAAH
A4C24	0180-0553	0	7	CAPACITOR-FXD 22UF +-20% 25VDC TA	12340P02	T354H226M025AS
A4C25	0160-6507	4		C-F 1000PF 20% 100V CERMLr	28480	RPE121-978X7R102M100V
A4C26	0160-0576	5		CAPACITOR-FXD .1UF +-20% 50VDC CER	04222	SR205C104MAAH
A4C27	0180-3768	5		C-F 3.3UF 20% 35V TADPDr	12340P02	T350D335M035AS
A4C28	0160-0576	5		CAPACITOR-FXD .1UF +-20% 50VDC CER	04222	SR205C104MAAH
A4C29	0160-6523	4	2	C-F 1PF -% 200V CERMLr	28480	RPE121-978C0G010C200V
A4C30	0160-0576	5		CAPACITOR-FXD .1UF +-20% 50VDC CER	04222	SR205C104MAAH
A4C31	0180-3768	5		C-F 3.3UF 20% 35V TADPDr	12340P02	T350D335M035AS
A4C32	0160-0576	5		CAPACITOR-FXD .1UF +-20% 50VDC CER	04222	SR205C104MAAH
A4C33	0180-3768	5		C-F 3.3UF 20% 35V TADPDr	12340P02	T350D335M035AS
A4C34	0160-0576	5		CAPACITOR-FXD .1UF +-20% 50VDC CER	04222	SR205C104MAAH
A4C35	0180-3768	5		C-F 3.3UF 20% 35V TADPDr	12340P02	T350D335M035AS
A4C36	0160-0576	5		CAPACITOR-FXD .1UF +-20% 50VDC CER	04222	SR205C104MAAH
A4C37	0180-0553	0		CAPACITOR-FXD 22UF +-20% 25VDC TA	12340P02	T354H226M025AS
A4C38	0160-0576	5		CAPACITOR-FXD .1UF +-20% 50VDC CER	04222	SR205C104MAAH
A4C39	0180-3768	5		C-F 3.3UF 20% 35V TADPDr	12340P02	T350D335M035AS
A4C40	0160-0576	5		CAPACITOR-FXD .1UF +-20% 50VDC CER	04222	SR205C104MAAH
A4C41	0160-3768	5		C-F 3.3UF 20% 35V TADPDr	12340P02	T350D335M035AS
A4C42	0160-0576	5		CAPACITOR-FXD .1UF +-20% 50VDC CER	04222	SR205C104MAAH
A4C43	0180-3768	5		C-F 3.3UF 20% 35V TADPDr	12340P02	T350D335M035AS
A4C44	0121-0512	7	3	CAPACITOR-V TRMR-CER 2.5PF 100V PC-MTG	59660	518-002 A 2-5
A4C45	0160-6521	2		C-F 2.2PF -% 200V CERMLr	28480	RPE121-978C0G2R2C200V
A4C46	0160-0576	5		CAPACITOR-FXD .1UF +-20% 50VDC CER	04222	SR205C104MAAH
A4C47	0180-3710	7	4	C-F 15UF 20% 25V TADPDr	12340P02	T350G156M025AS
A4C48	0160-0576	5		CAPACITOR-FXD .1UF +-20% 50VDC CER	04222	SR205C104MAAH
A4C49	0160-0576	5		CAPACITOR-FXD .1UF +-20% 50VDC CER	04222	SR205C104MAAH
A4C50	0180-3768	5		C-F 3.3UF 20% 35V TADPDr	12340P02	T350D335M035AS
A4C51	0160-0576	5		CAPACITOR-FXD .1UF +-20% 50VDC CER	04222	SR205C104MAAH
A4C52	0180-0553	0		CAPACITOR-FXD 22UF +-20% 25VDC TA	12340P02	T354H226M025AS
A4C53	0160-0576	5		CAPACITOR-FXD .1UF +-20% 50VDC CER	04222	SR205C104MAAH
A4C54	0180-3768	5		C-F 3.3UF 20% 35V TADPDr	12340P02	T350D335M035AS
A4C55	0160-0576	5		CAPACITOR-FXD .1UF +-20% 50VDC CER	04222	SR205C104MAAH
A4C56	0180-0553	0		CAPACITOR-FXD 22UF +-20% 25VDC TA	12340P02	T354H226M025AS
A4C57	0160-0576	5		CAPACITOR-FXD .1UF +-20% 50VDC CER	04222	SR205C104MAAH
A4C58	0180-3768	5		C-F 3.3UF 20% 35V TADPDr	12340P02	T350D335M035AS
A4C59	0160-6523	4		C-F 1PF -% 200V CERMLr	28480	RPE121-978C0G010C200V
A4C60	0160-0576	5		CAPACITOR-FXD .1UF +-20% 50VDC CER	04222	SR205C104MAAH
A4C61	0180-3710	7		C-F 15UF 20% 25V TADPDr	12340P02	T350G156M025AS
A4C62	0160-0576	5		CAPACITOR-FXD .1UF +-20% 50VDC CER	04222	SR205C104MAAH
A4C63	0180-3768	5		C-F 3.3UF 20% 35V TADPDr	12340P02	T350D335M035AS
A4C64	0160-0576	5		CAPACITOR-FXD .1UF +-20% 50VDC CER	04222	SR205C104MAAH
A4C65	0160-0576	5		CAPACITOR-FXD .1UF +-20% 50VDC CER	04222	SR205C104MAAH
A4C66	0180-0553	0		CAPACITOR-FXD 22UF +-20% 25VDC TA	12340P02	T354H226M025AS
A4C67	0160-0576	5		CAPACITOR-FXD .1UF +-20% 50VDC CER	04222	SR205C104MAAH
A4C68	0180-3768	5		C-F 3.3UF 20% 35V TADPDr	12340P02	T350D335M035AS
A4C69	0121-0512	7		CAPACITOR-V TRMR-CER 2.5PF 100V PC-MTG	59660	518-002 A 2-5

See introduction to this section for ordering information  
 \*Indicates factory selected values

Table 6-3. Replaceable Parts

Ref.Des.	HP Part Number	CD	Qty	Description	Mfr. Code	Mfr. Part Number
A4C71	0160-6521	2		C-F 2.2PF -% 200V CERMLR	28480	RPE121-978C0G2R2C200V
A4C72	0160-0576	5		CAPACITOR-FXD .1UF +-20% 50VDC CER	04222	SR205C104MAAH
A4C73	0180-3710	7		C-F 15UF 20% 25V TADPDr	12340P02	T350G156M025AS
A4C74	0160-0576	5		CAPACITOR-FXD .1UF +-20% 50VDC CER	04222	SR205C104MAAH
A4C75	0180-3768	5		C-F 3.3UF 20% 35V TADPDr	12340P02	T350D335M035AS
A4C76	0160-0576	5		CAPACITOR-FXD .1UF +-20% 50VDC CER	04222	SR205C104MAAH
A4C77	0180-0553	0		CAPACITOR-FXD 22UF +-20% 25VDC TA	12340P02	T354H226M025AS
A4C78	0160-0576	5		CAPACITOR-FXD .1UF +-20% 50VDC CER	04222	SR205C104MAAH
A4C79	0180-3768	5		C-F 3.3UF 20% 35V TADPDr	12340P02	T350D335M035AS
A4C80	0160-0576	5		CAPACITOR-FXD .1UF +-20% 50VDC CER	04222	SR205C104MAAH
A4C81	0180-3768	5		C-F 3.3UF 20% 35V TADPDr	12340P02	T350D335M035AS
A4C88	0180-0576	5		CAPACITOR-FXD .1UF +-20% 50VDC CER	04222	SR205C104MAAH
A4C89	0180-3768	5		C-F 3.3UF 20% 35V TADPDr	12340P02	T350D335M035AS
A4C90	0121-0512	7		CAPACITOR-V TRMR-CER 2-5PF 100V PC-MTG	59660	518-002 A 2-5
A4C91	0160-6521	2		C-F 2.2PF -% 200V CERMLR	28480	RPE121-978C0G2R2C200V
A4C92	0160-0576	5		CAPACITOR-FXD .1UF +-20% 50VDC CER	04222	SR205C104MAAH
A4C93	0180-3710	7		C-F 15UF 20% 25V TADPDr	12340P02	T350G156M025AS
A4C94	0160-0576	5		CAPACITOR-FXD .1UF +-20% 50VDC CER	04222	SR205C104MAAH
A4C95	0180-3768	5		C-F 3.3UF 20% 35V TADPDr	12340P02	T350D335M035AS
A4C96	0160-0576	5		CAPACITOR-FXD .1UF +-20% 50VDC CER	04222	SR205C104MAAH
A4C97	0180-0583	0		CAPACITOR-FXD 22UF +-20% 25VDC TA	12340P02	T354H226M025AS
A4C98	0160-0576	5		CAPACITOR-FXD .1UF +-20% 50VDC CER	04222	SR205C104MAAH
A4C99	0180-3768	5		C-F 3.3UF 20% 35V TADPDr	12340P02	T350D335M035AS
A4C101	0160-6515	4	4	C-F 10PF -% 200V CERMLR	28480	RPE121-978C0G100D200V
A4C102	0160-4381	8	2	CAPACITOR-FXD 1.5PF +-25PF 200VDC CER	54583	FD11C0G2D1R5C
A4C103	0160-6508	5		C-F 22PF 5% 200V CERMLR	28480	RPE121-978C0G220J200V
A4C104	0160-6524	5	2	C-F 6.8PF -% 200V CERMLR	28480	RPE121-978C0G6R8D200V
A4C105	0160-6508	5		C-F 22PF 5% 200V CERMLR	28480	RPE121-978C0G220J200V
A4C107	0160-6515	4		C-F 10PF -% 200V CERMLR	28480	RPE121-978C0G100D200V
A4C108	0160-0576	5		CAPACITOR-FXD .1UF +-20% 50VDC CER	04222	SR205C104MAAH
A4C111	0160-0576	5		CAPACITOR-FXD .1UF +-20% 50VDC CER	04222	SR205C104MAAH
A4C112	0180-3768	5		C-F 3.3UF 20% 35V TADPDr	12340P02	T350D335M035AS
A4C113	0160-6507	4		C-F 1000PF 20% 100V CERMLR	28480	RPE121-978X7R102M100V
A4C114	0180-0553	0		CAPACITOR-FXD 22UF +-20% 25VDC TA	12340P02	T354H226M025AS
A4C115-C116	0160-0576	5		CAPACITOR-FXD .1UF +-20% 50VDC CER	04222	SR205C104MAAH
A4C117	0180-3768	5		C-F 3.3UF 20% 35V TADPDr	12340P02	T350D335M035AS
A4C120	0160-6515	4		C-F 10PF -% 200V CERMLR	28480	RPE121-978C0G100D200V
A4C121	0160-4381	8		CAPACITOR-FXD 1.5PF +-25PF 200VDC CER	54583	FD11C0G2D1R5C
A4C122	0160-6508	5		C-F 22PF 5% 200V CERMLR	28480	RPE121-978C0G220J200V
A4C123	0160-6524	5		C-F 6.8PF -% 200V CERMLR	28480	RPE121-978C0G6R8D200V
A4C124	0160-6508	5		C-F 22PF 5% 200V CERMLR	28480	RPE121-978C0G220J200V
A4C125	0160-6515	4		C-F 10PF -% 200V CERMLR	28480	RPE121-978C0G100D200V
A4C130	0160-6507	4		C-F 1000PF 20% 100V CERMLR	28480	RPE121-978X7R102M100V
A4C148	0160-6507	4		C-F 1000PF 20% 100V CERMLR	28480	RPE121-978X7R102M100V
A4C150-C151	0160-0576	5		CAPACITOR-FXD .1UF +-20% 50VDC CER	04222	SR205C104MAAH
A4C152	0180-4133	0	4	C-F 15UF 10% 20V TATBSA	12340P02	T322D156K020AS
A4C153	0160-0576	5		CAPACITOR-FXD .1UF +-20% 50VDC CER	04222	SR205C104MAAH
A4C154	0180-4133	0		C-F 15UF 10% 20V TATBSA	12340P02	T322D156K020AS
A4C155-C156	0160-0576	5		CAPACITOR-FXD .1UF +-20% 50VDC CER	04222	SR205C104MAAH
A4C157-C158	0180-4133	0		C-F 15UF 10% 20V TATBSA	12340P02	T322D156K020AS
A4C160	0160-6507	4		C-F 1000PF 20% 100V CERMLR	28480	RPE121-978X7R102M100V
A4C161	0160-0576	5		CAPACITOR-FXD .1UF +-20% 50VDC CER	04222	SR205C104MAAH
A4C162	0180-3768	5		C-F 3.3UF 20% 35V TADPDr	12340P02	T350D335M035AS
A4C163	0160-0576	5		CAPACITOR-FXD .1UF +-20% 50VDC CER	04222	SR205C104MAAH
A4C164	0180-3914	1	1	CAPACITOR-FXD .01UF +-10% 100VDC CER	04222	SR201C103KAAH
A4C166	0160-0576	5		CAPACITOR-FXD .1UF +-20% 50VDC CER	04222	SR205C104MAAH
A4C167	0160-0127	2	1	CAPACITOR-FXD 1UF +-20% 25VDC CER	04222	SR835E105MAAH
A4C168	0160-0576	5		CAPACITOR-FXD .1UF +-20% 50VDC CER	04222	SR205C104MAAH
A4C180	0160-6507	4		C-F 1000PF 20% 100V CERMLR	28480	RPE121-978X7R102M100V
A4C190	0160-6507	4		C-F 1000PF 20% 100V CERMLR	28480	RPE121-978X7R102M100V
A4C200-C201	0160-6511	0		C-F 15PF 5% 200V CERMLR	28480	RPE121-978C0G150J200V
A4C202	0160-4382	9	1	CAPACITOR-FXD 3.3PF +-25PF 200VDC CER	28480	RPE121-105C0G3R3C200V

See introduction to this section for ordering information

\*Indicates factory selected values

Table 6-3. Replaceable Parts

Ref.Des.	HP Part Number	CD	Qty	Description	Mfr. Code	Mfr. Part Number
A4C203	0160-6511	0		C-F 15PF 5% 200V CERMLr	28480	RPE121-878COG150J200V
A4C205	0160-6511	0		C-F 15PF 5% 200V CERMLr	28480	RPE121-878COG150J200V
A4C207	0180-3768	5		C-F 3.3UF 20% 35V TADPr	12340P02	T350D335M035AS
A4C208	0160-0576	5		CAPACITOR-FXD .1UF + .20% 50VDC CER	04222	SR205C104MAAH
A4CR1-CR4	1901-0518	8	4	DIODE-SCHOTTKY SM SIG	28480	1901-0518
A4CR5	1902-1329	3	1	ICV RGLTR-V-REF-FXD 6.6/7.2V TO-46 PKG	27014	LM329CH
A4E30	9170-0894	0	5	CORE-SHIELDING BEAD	06337P01	56-590-65/4A6
A4E50	9170-0894	0		CORE-SHIELDING BEAD	06337P01	56-590-65/4A6
A4E60	9170-0894	0		CORE-SHIELDING BEAD	06337P01	56-590-65/4A6
A4E70	9170-0894	0		CORE-SHIELDING BEAD	06337P01	56-590-65/4A6
A4E90	9170-0894	0		CORE-SHIELDING BEAD	06337P01	56-590-65/4A6
A4J1-J5	1250-2142	7	5	CON-SMB	74970	131-3701-341
A4J6-J7	1250-2215	5	6	CON-SMB STRAIGHT	74970	131-1701-201
A4J8-J12	1250-2215	5		CON-SMB STRAIGHT	74970	131-1701-201
A4L2-L5	9140-0814	1	4	COIL-VAR 20NH-25NH Q=50 PC-MTG	24226	8272
A4L6	9140-0144	0	11	INDUCTOR RF-CH-MLD 4.7UH 10% .105DX.26LG	99800	1025-36
A4L7	9140-0815	2	5	COIL-VAR 50.6NH-41.4NH PC-MTG	24226	8273
A4L8	9140-0813	0	2	COIL-VAR 23NH-52NH Q=65 PC-MTG	24226	8271
A4L9	9140-0815	2		COIL-VAR 50.6NH-41.4NH PC-MTG	24226	8273
A4L10-L13	9140-0144	0		INDUCTOR RF-CH-MLD 4.7UH 10% .105DX.26LG	99800	1025-36
A4L20	9140-0144	0		INDUCTOR RF-CH-MLD 4.7UH 10% .105DX.26LG	99800	1025-36
A4L30	9140-0144	0		INDUCTOR RF-CH-MLD 4.7UH 10% .105DX.26LG	99800	1025-36
A4L50	9140-0144	0		INDUCTOR RF-CH-MLD 4.7UH 10% .105DX.26LG	99800	1025-36
A4L60	9140-0144	0		INDUCTOR RF-CH-MLD 4.7UH 10% .105DX.26LG	99800	1025-36
A4L70	9140-0144	0		INDUCTOR RF-CH-MLD 4.7UH 10% .105DX.26LG	99800	1025-36
A4L90	9140-0144	0		INDUCTOR RF-CH-MLD 4.7UH 10% .105DX.26LG	99800	1025-36
A4L100	9140-0815	2		COIL-VAR 50.6NH-41.4NH PC-MTG	24226	8273
A4L101	9140-0813	0		COIL-VAR 23NH-52NH Q=65 PC-MTG	24226	8271
A4L102	9140-0815	2		COIL-VAR 50.6NH-41.4NH PC-MTG	24226	8273
A4L150-L152	9140-0607	0	3	INDUCTOR RF-CH-MLD 3.3UH 10% .20X.45LG	24226	18M331K
A4L153-L154	9100-1618	1	2	INDUCTOR RF-CH-MLD 5.6UH 10%	99800	1537-30
A4L201	9140-0815	2		COIL-VAR 50.6NH-41.4NH PC-MTG	24226	8273
A4LB1	7121-4611	2	1	LABEL-INFORMATION .15-IN-WD .6-IN-LG	28480	LO1003
A4MP1-MP4	03577-00902	9	4	ETCH SPRING-GROUNDING BECLUGD	07466P01	
A4MP1A	3050-0873	5	9	WASHER-FL NM NO. 2 .092-IN-ID .125-IN-OD	51506	
A4MP1B	3050-0873	5		WASHER-FL NM NO. 2 .092-IN-ID .125-IN-OD	51506	
A4MP1C-MPA2	3050-0873	5		WASHER-FL NM NO. 2 .092-IN-ID .125-IN-OD	51506	
A4MP2B	3050-0873	5		WASHER-FL NM NO. 2 .092-IN-ID .125-IN-OD	51506	
A4MP2C	3050-0873	5		WASHER-FL NM NO. 2 .092-IN-ID .125-IN-OD	51506	
A4MP4A	3050-0873	5		WASHER-FL NM NO. 2 .092-IN-ID .125-IN-OD	51506	
A4MP4B	3050-0873	5		WASHER-FL NM NO. 2 .092-IN-ID .125-IN-OD	51506	
A4MP4C	3050-0873	5		WASHER-FL NM NO. 2 .092-IN-ID .125-IN-OD	51506	
A4MP5	0340-1169	6	1	NSLT BSNQ .038TK TO-72 NYLNA	32559	118-055
A4MP20	2260-0002	6	1	NUT-HEX-DBL-CHAM 4-40-THD .062-IN-THK	13962P01	
A4MP21-MP22	3050-0229	5	2	WASHER-FL MTLG NO. 4 .125-IN-ID	66928	
A4MP100	03577-04104	1	1	SHTF CVR-LO. BD ALSK	13588P02	
A4MP100	0370-2595	7	1	KNOB-RVTRN 12.7MMD BRS	28480	
A4MP103A-MPA105	2950-0078	9	3	NUT-HEX-DBL-CHAM 10-32-THD .067-IN-THK	98291	40001-18-030-156
A4MP103B-MPB105	2190-0124	4	3	WASHER-LK INFL T NO. 10 .195-IN-ID	98291	3002-26
A4MP150	1205-0543	3	1	HEAT SINK SGL TO-220-CS	28480	5751C
A4MP151	0535-0004	9	1	NUT-HEX DBL-CHAM M3 X 0.5 2.4MM-THK	28480	
A4MP152	0515-0886	3	1	SCREW-MACH M3 X 0.5 6MM-LG PAN-HD	83486	
A4Q30	1854-0591	6	5	TRANSISTOR NPN SI PD=180MW FT=4GHZ	04713	BFR90
A4Q31	1854-0720	3	5	TRANSISTOR NPN SI PD=500MW FT=4GHZ	18324	BFR96S/02
A4Q50	1854-0591	6		TRANSISTOR NPN SI PD=180MW FT=4GHZ	04713	BFR90
A4Q61	1854-0720	3		TRANSISTOR NPN SI PD=500MW FT=4GHZ	18324	BFR96S/02
A4Q60	1854-0591	6		TRANSISTOR NPN SI PD=180MW FT=4GHZ	04713	BFR90
A4Q61	1854-0720	3		TRANSISTOR NPN SI PD=500MW FT=4GHZ	18324	BFR96S/02
A4Q70	1854-0591	6		TRANSISTOR NPN SI PD=180MW FT=4GHZ	04713	BFR90
A4Q71	1854-0720	3		TRANSISTOR NPN SI PD=500MW FT=4GHZ	18324	BFR96S/02
A4Q90	1854-0591	6		TRANSISTOR NPN SI PD=180MW FT=4GHZ	04713	BFR90
A4Q91	1854-0720	3		TRANSISTOR NPN SI PD=500MW FT=4GHZ	18324	BFR96S/02
A4R1	0699-2054	9	2	R-F 100 OHM 1% 1/20W HF04 TO	91637	CMF-501000FT-1

See introduction to this section for ordering information

\*Indicates factory selected values

Table 6-3. Replaceable Parts

Ref.Des.	HP Part Number	CD	Qty	Description	Mfr. Code	Mfr. Part Number
A4R2	0699-1988	2	1	R-F 68.1 OH 1% 1/20W HF04 T0	91637	CMF-5068R1FT-1
A4R3	0699-2054	9		R-F 100 OHM 1% 1/20W HF04 T0	91637	CMF-501000FT-1
A4R4	0698-7214	1	4	RESISTOR 121 1% .05W F TC=0+-100	91637	CMF-501210FT-1
A4R5	0699-1903	5	15	R-F 51.1 OH 1% 1/20W HF04 T0	91637	CMF-5051R1FT-1
A4R6-R7	0698-7214	1		RESISTOR 121 1% .05W F TC=0+-100	91637	CMF-501210FT-1
A4R8	0699-1903	5		R-F 51.1 OH 1% 1/20W HF04 T0	91637	CMF-5051R1FT-1
A4R9	0698-7214	1		RESISTOR 121 1% .05W F TC=0+-100	91637	CMF-501210FT-1
A4R10	0698-3445	2	2	RESISTOR 348 1% .125W F TC=0+-100	05524P03	CMF-553480FT-1
A4R11-R12	0698-3132	4	4	RESISTOR 281 1% .125W F TC=0+-100	05524P03	CMF-552810FT-1
A4R13	0698-7230	1	2	RESISTOR 562 1% .05W F TC=0+-100	91637	CMF-55620FT-1
A4R14	0699-1902	4	1	R-F 10 OHM 1% 1/20W HF04 T0	91637	CMF-5010R0FT-1
A4R15	0698-7230	1		RESISTOR 562 1% .05W F TC=0+-100	91637	CMF-55620FT-1
A4R16-R17	0698-3132	4		RESISTOR 261 1% .125W F TC=0+-100	05524P03	CMF-552610FT-1
A4R18	0698-7223	2	17	RESISTOR 287 1% .05W F TC=0+-100	91637	CMF-502870FT-1
A4R19	0699-2030	1	6	R-F 17.8 OH 1% 1/20W HF04 T0	91637	CMF-5017R8FT-1
A4R20	0698-7223	2		RESISTOR 287 1% .05W F TC=0+-100	91637	CMF-502870FT-1
A4R21	0698-3443	0	2	RESISTOR 287 1% .125W F TC=0+-100	91637	CMF-552870FT-1
A4R22	0698-7223	2		RESISTOR 287 1% .05W F TC=0+-100	91637	CMF-502870FT-1
A4R23	0699-2030	1		R-F 17.8 OH 1% 1/20W HF04 T0	91637	CMF-5017R8FT-1
A4R24	0698-7223	2		RESISTOR 287 1% .05W F TC=0+-100	91637	CMF-502870FT-1
A4R25	0698-3443	0		RESISTOR 287 1% .125W F TC=0+-100	91637	CMF-552870FT-1
A4R26	0698-3445	2		RESISTOR 348 1% .125W F TC=0+-100	05524P03	CMF-553480FT-1
A4R27	0683-1025	9	6	RESISTOR 1K 5% .25W CF TC=0-400	77902	R-25J
A4R30	0698-1903	5		R-F 51.1 OH 1% 1/20W HF04 T0	91637	CMF-5051R1FT-1
A4R31	0683-1025	9		RESISTOR 1K 5% .25W CF TC=0-400	77902	R-25J
A4R32	0683-4715	0	5	RESISTOR 470 5% .25W CF TC=0-400	77902	R-25J
A4R33	0683-2415	3	5	RESISTOR 240 5% .25W CF TC=0-400	77902	R-25J
A4R34	0698-7223	2		RESISTOR 287 1% .05W F TC=0+-100	91637	CMF-502870FT-1
A4R35	0698-1964	8	6	R-F 14.7 OH 1% 1/20W HF04 T0	91637	CMF-5014R7FT-1
A4R36	0683-1215	9	2	RESISTOR 120 5% .25W CF TC=0-400	77902	R-25J
A4R37-R39	0699-1903	5		R-F 51.1 OH 1% 1/20W HF04 T0	91637	CMF-5051R1FT-1
A4R40	0698-7216	3	4	RESISTOR 147 1% .05W F TC=0+-100	91637	CMF-501470FT-1
A4R41	0699-1947	7	2	R-F 38.3 OH 1% 1/20W MFHF T0	91637	CMF-5038R3FT-1
A4R42	0698-7216	3		RESISTOR 147 1% .05W F TC=0+-100	91637	CMF-501470FT-1
A4R43	0699-1903	5		R-F 51.1 OH 1% 1/20W HF04 T0	91637	CMF-5051R1FT-1
A4R44	0698-3159	5	2	RESISTOR 26.1K 1% .125W F TC=0+-100	05524P03	CMF-552612FT-1
A4R45-R46	0757-0449	6	2	RESISTOR 20K 1% .125W F TC=0+-100	05524P03	CMF-55-1
A4R47	0698-3159	5		RESISTOR 26.1K 1% .125W F TC=0+-100	05524P03	CMF-552612FT-1
A4R48	0757-0443	0	1	RESISTOR 11K 1% .125W F TC=0+-100	05524P03	CMF-55-1
A4R49	2100-0554	5	1	RESISTOR-TRMR 500 10% C TOP-ADJ 1-TRN	32997	3386P-Y46-501
A4R50	0699-1903	5		R-F 51.1 OH 1% 1/20W HF04 T0	91637	CMF-5051R1FT-1
A4R51	0683-1025	9		RESISTOR 1K 5% .25W CF TC=0-400	77902	R-25J
A4R52	0683-4715	0		RESISTOR 470 5% .25W CF TC=0-400	77902	R-25J
A4R53	0683-2415	3		RESISTOR 240 5% .25W CF TC=0-400	77902	R-25J
A4R54	0698-7223	2		RESISTOR 287 1% .05W F TC=0+-100	91637	CMF-502870FT-1
A4R55	0699-1964	8		R-F 14.7 OH 1% 1/20W HF04 T0	91637	CMF-5014R7FT-1
A4R56	0698-4417	0	6	RESISTOR 174 1% .125W F TC=0+-100	91637	CMF-55-1
A4R57	0699-1903	5		R-F 51.1 OH 1% 1/20W HF04 T0	91637	CMF-5051R1FT-1
A4R58	0698-4417	0		RESISTOR 174 1% .125W F TC=0+-100	91637	CMF-55-1
A4R60	0699-1903	5		R-F 51.1 OH 1% 1/20W HF04 T0	91637	CMF-5051R1FT-1
A4R61	0683-1025	9		RESISTOR 1K 5% .25W CF TC=0-400	77902	R-25J
A4R62	0683-4715	0		RESISTOR 470 5% .25W CF TC=0-400	77902	R-25J
A4R63	0683-2415	3		RESISTOR 240 5% .25W CF TC=0-400	77902	R-25J
A4R64	0698-7223	2		RESISTOR 287 1% .05W F TC=0+-100	91637	CMF-502870FT-1
A4R65	0699-1964	8		R-F 14.7 OH 1% 1/20W HF04 T0	91637	CMF-5014R7FT-1
A4R66	0683-1215	9		RESISTOR 120 5% .25W CF TC=0-400	77902	R-25J
A4R67	0699-1903	5		R-F 51.1 OH 1% 1/20W HF04 T0	91637	CMF-5051R1FT-1
A4R70	0699-1903	5		R-F 51.1 OH 1% 1/20W HF04 T0	91637	CMF-5051R1FT-1
A4R71	0683-1025	9		RESISTOR 1K 5% .25W CF TC=0-400	77902	R-25J
A4R72	0683-4715	0		RESISTOR 470 5% .25W CF TC=0-400	77902	R-25J
A4R73	0683-2415	3		RESISTOR 240 5% .25W CF TC=0-400	77902	R-25J
A4R74	0698-7223	2		RESISTOR 287 1% .05W F TC=0+-100	91637	CMF-502870FT-1

See introduction to this section for ordering information

\*Indicates factory selected values



Table 6-3. Replaceable Parts

Ref.Des.	HP Part Number	CD	Qty	Description	Mfr. Code	Mfr. Part Number
A4R75	0699-1964	8		R-F 14.7 OH 1% 1/20W HF04 T0	91637	CMF-5014R7FT-1
A4R76	0698-4417	0		RESISTOR 174 1% .125W F TC=0+-100	91637	CMF-55-1
A4R77	0699-1903	5		R-F 51.1 OH 1% 1/20W HF04 T0	91637	CMF-5051R1FT-1
A4R78	0698-4417	0		RESISTOR 174 1% .125W F TC=0+-100	91637	CMF-55-1
A4R90	0699-1903	5		R-F 51.1 OH 1% 1/20W HF04 T0	91637	CMF-5051R1FT-1
A4R91	0683-1025	9		RESISTOR 1K 5% .25W CF TC=0-400	77902	R-25J
A4R92	0683-4715	0		RESISTOR 470 5% .25W CF TC=0-400	77902	R-25J
A4R93	0683-2415	3		RESISTOR 240 5% .25W CF TC=0-400	77902	R-25J
A4R94	0698-7223	2		RESISTOR 287 1% .05W F TC=0+-100	91637	CMF-502870FT-1
A4R95	0699-1964	8		R-F 14.7 OH 1% 1/20W HF04 T0	91637	CMF-5014R7FT-1
A4R96	0698-4417	0		RESISTOR 174 1% .125W F TC=0+-100	91637	CMF-55-1
A4R97	0699-1903	5		R-F 51.1 OH 1% 1/20W HF04 T0	91637	CMF-5051R1FT-1
A4R98	0698-4417	0		RESISTOR 174 1% .125W F TC=0+-100	91637	CMF-55-1
A4R100	0698-7223	2		RESISTOR 287 1% .05W F TC=0+-100	91637	CMF-502870FT-1
A4R101	0699-2030	1		R-F 17.8 OH 1% 1/20W HF04 T0	91637	CMF-5017R8FT-1
A4R102	0698-7223	2		RESISTOR 287 1% .05W F TC=0+-100	91637	CMF-502870FT-1
A4R105-R108	0699-1968	0	4	R-F 28.1 OH 1% 1/20W HF04 T0	91637	CMF-50-21
A4R109	0698-7218	5	6	RESISTOR 178 1% .05W F TC=0+-100	91637	CMF-501780FT-1
A4R110	0699-2163	1	3	R-F 31.8 OH 1% 1/20W HF04 T0	91637	CMF-5031R8FT-1
A4R111-R112	0698-7218	5		RESISTOR 178 1% .05W F TC=0+-100	91637	CMF-501780FT-1
A4R113	0699-2163	1		R-F 31.8 OH 1% 1/20W HF04 T0	91637	CMF-5031R8FT-1
A4R114-R115	0698-7218	5		RESISTOR 178 1% .05W F TC=0+-100	91637	CMF-501780FT-1
A4R116	0699-2163	1		R-F 31.8 OH 1% 1/20W HF04 T0	91637	CMF-5031R8FT-1
A4R117	0698-7218	5		RESISTOR 178 1% .05W F TC=0+-100	91637	CMF-501780FT-1
A4R120	0757-0280	3	1	RESISTOR 1K 1% .125W F TC=0+-100	05524P03	CMF-55-1
A4R150	0698-7223	2		RESISTOR 287 1% .05W F TC=0+-100	91637	CMF-502870FT-1
A4R151	0699-2030	1		R-F 17.8 OH 1% 1/20W HF04 T0	91637	CMF-5017R8FT-1
A4R152	0698-7223	2		RESISTOR 287 1% .05W F TC=0+-100	91637	CMF-502870FT-1
A4R170	0698-7223	2		RESISTOR 287 1% .05W F TC=0+-100	91637	CMF-502870FT-1
A4R171	0699-2030	1		R-F 17.8 OH 1% 1/20W HF04 T0	91637	CMF-5017R8FT-1
A4R172	0699-7223	2		RESISTOR 287 1% .05W F TC=0+-100	91637	CMF-502870FT-1
A4R190	0699-7223	2		RESISTOR 287 1% .05W F TC=0+-100	91637	CMF-502870FT-1
A4R191	0699-2030	1		R-F 17.8 OH 1% 1/20W HF04 T0	91637	CMF-5017R8FT-1
A4R192	0698-7223	2		RESISTOR 287 1% .05W F TC=0+-100	91637	CMF-502870FT-1
A4R201	0698-7216	3		RESISTOR 147 1% .05W F TC=0+-100	91637	CMF-501470FT-1
A4R202	0699-1947	7		R-F 38.3 OH 1% 1/20W MFHF T0	91637	CMF-5038R3FT-1
A4R203	0698-7216	3		RESISTOR 147 1% .05W F TC=0+-100	91637	CMF-501470FT-1
A4R204	0699-1964	8		R-F 14.7 OH 1% 1/20W HF04 T0	91637	CMF-5014R7FT-1
A4TP1-TP4	1251-0600	0	4	CONNECTOR-SGL CONT PIN 1.14-MM-BSC-SZ SQ	27264	16-06-0034
A4TP5-TP6	0360-0124	3	2	CONNECTOR-SGL CONT PIN .04-IN-BSC-SZ RND	13309P01	
A4U1	1813-0216	6	2	ICWIDEBAND AMPL TO-39 PKG	04713	MWA230
A4U10	1813-0215	5	2	ICWIDEBAND AMPL TO-39 PKG	04713	MWA220
A4U11	1813-0216	6		ICWIDEBAND AMPL TO-39 PKG	04713	MWA230
A4U20	03577-87904	3	1	MIX MWAV MD-1171	02788P01	MD-1171
A4U21-U22	1813-0212	2	2	ICWIDEBAND AMPL TO-39 PKG	04713	MWA120
A4U23	0955-0194	8	1	MIX MWAV SRA-1-1 500MHZ 8	16239	SRA-1-1
A4U24	1813-0215	5		ICWIDEBAND AMPL TO-39 PKG	04713	MWA220
A4U25	1826-0043	4	1	ICOP AMP GP TO-99 PKG	28480	1826-0043
A4U150	1826-0147	9	1	ICV RGLTR-FXD-POS 11.5/12.5V TO-220 PKG	04713	MC7812CT
A4W1A	1251-1636	4	18	CONNECTOR-SGL CONT SKT .04-IN-BSC-SZ RND	06776	PS-40-823-TG30
A4W1-W2	1258-0214	6	6	CON-JUMPER WIRE PLUG-SHORTING	12355P01	461-2872-01-03-16
A4W2	1251-1636	4		CONNECTOR-SGL CONT SKT .04-IN-BSC-SZ RND	06776	PS-40-823-TG30
A4W4-WA7	1251-1836	4		CONNECTOR-SGL CONT SKT .04-IN-BSC-SZ RND	06776	PS-40-823-TG30
A4W4-W7	1258-0214	6		CON-JUMPER WIRE PLUG-SHORTING	12355P01	461-2872-01-03-16
A4	0515-1643	2	12	SCR-MCH M3.0 22MMLG PHPZ SST *	83486	
A4	03577-04109	6	1	SHTF CVR-SHLD AL	13588P02	
A4	03577-20601	7	1	CSTG-SHIELD-CIRCUIT SIDE AL	13599P01	03577-20601
A4	03577-20605	1	1	CSTG MCHO SHIELD-SLOTTED AL	13599P01	03577-20605

See introduction to this section for ordering information

\*Indicates factory selected values

Table 6-3. Replaceable Parts

Ref.Des.	HP Part Number	CD	Qty	Description	Mfr. Code	Mfr. Part Number
A5	03577-66505	6	1	PCASSY OFFSET	28480	03577-66505
ASC1	0160-6510	9	4	C-F .1UF 20% 50V CERMLr	28480	RPE121-978X7R104M50V
ASC2-C3	0160-6511	0	2	C-F 15PF 5% 200V CERMLr	28480	RPE121-978C0G150J200V
ASC4*	0160-4774	3		CAPACITOR-FXD 16PF +2% 200VDC CER 0+ -30	28480	RPE121-105C0G160G200V
ASC4*	0160-4887	9		CAPACITOR-FXD 25PF +2% 200VDC CER 0+ -30	28480	RPE121-105C0G250G200V
ASC4+	0160-4775	4	1	CAPACITOR-FXD 24PF +2% 200VDC CER 0+ -30	54583	FD12C0G2D240G
ASC5	0160-6507	4	18	C-F 1000PF 20% 100V CERMLr	28480	RPE121-978X7R102M100V
ASC6	0160-4133	0	13	C-F 15UF 10% 20V TATBSA	12340P02	T322D156K020AS
ASC7	0160-4571	8	1	CAPACITOR-FXD .1UF +80-20% 50VDC CER	04222	SA105E104ZAAH
ASC8	0160-6507	4		C-F 1000PF 20% 100V CERMLr	28480	RPE121-978X7R102M100V
ASC9	0160-4133	0		C-F 15UF 10% 20V TATBSA	12340P02	T322D156K020AS
ASC10	0160-6507	4		C-F 1000PF 20% 100V CERMLr	28480	RPE121-978X7R102M100V
ASC11	0160-0576	5	23	CAPACITOR-FXD .1UF + -20% 50VDC CER	04222	SR205C104MAAH
ASC12-C13	0160-6510	9		C-F .1UF 20% 50V CERMLr	28480	RPE121-978X7R104M50V
ASC14-C17	0160-6507	4		C-F 1000PF 20% 100V CERMLr	28480	RPE121-978X7R102M100V
ASC16	0160-0576	5		CAPACITOR-FXD .1UF + -20% 50VDC CER	04222	SR205C104MAAH
ASC19	0160-6523	4	1	C-F 1PF -% 200V CERMLr	28480	RPE121-978C0G010C200V
ASC21	0160-0576	5		CAPACITOR-FXD .1UF + -20% 50VDC CER	04222	SR205C104MAAH
ASC23-C24	0160-6507	4		C-F 1000PF 20% 100V CERMLr	28480	RPE121-978X7R102M100V
ASC25	0160-0576	5		CAPACITOR-FXD .1UF + -20% 50VDC CER	04222	SR205C104MAAH
ASC26	0160-6507	4		C-F 1000PF 20% 100V CERMLr	28480	RPE121-978X7R102M100V
ASC30-C31	0160-0576	5		CAPACITOR-FXD .1UF + -20% 50VDC CER	04222	SR205C104MAAH
ASC32	0160-4133	0		C-F 15UF 10% 20V TATBSA	12340P02	T322D156K020AS
ASC33	0160-0576	5		CAPACITOR-FXD .1UF + -20% 50VDC CER	04222	SR205C104MAAH
ASC34-C35	0160-4133	0		C-F 15UF 10% 20V TATBSA	12340P02	T322D156K020AS
ASC36-C39	0160-0576	5		CAPACITOR-FXD .1UF + -20% 50VDC CER	04222	SR205C104MAAH
ASC40-C43	0160-4832	4	5	CAPACITOR-FXD .01UF + -10% 100VDC CER	04222	SA101C103KAAH
ASC44	0160-6525	6	1	C-F 47PF 5% 200V CERMLr	28480	RPE121-978C0G470J200V
ASC82-C53	0160-0576	5		CAPACITOR-FXD .1UF + -20% 50VDC CER	04222	SR205C104MAAH
ASC54	0160-2414	4	1	CAPACITOR-FXD .022UF + -5% 200VDC POLYE	15766	HEW238T
ASC55	0160-4832	4		CAPACITOR-FXD .01UF + -10% 100VDC CER	04222	SA101C103KAAH
ASC56-C57	0160-0576	5		CAPACITOR-FXD .1UF + -20% 50VDC CER	04222	SR205C104MAAH
ASC60-C62	0160-0576	5		CAPACITOR-FXD .1UF + -20% 50VDC CER	04222	SR205C104MAAH
ASC63-C64	0160-4133	0		C-F 15UF 10% 20V TATBSA	12340P02	T322D156K020AS
ASC65	0160-4135	2	1	C-F 33 UF 10% 10V TATBSA	12340P02	T322D336K010AS
ASC66-C69	0160-4133	0		C-F 15UF 10% 20V TATBSA	12340P02	T322D156K020AS
ASC70-C71	0160-6507	4		C-F 1000PF 20% 100V CERMLr	28480	RPE121-978X7R102M100V
ASC72	0160-0576	5		CAPACITOR-FXD .1UF + -20% 50VDC CER	04222	SR205C104MAAH
ASC73	0160-6507	4		C-F 1000PF 20% 100V CERMLr	28480	RPE121-978X7R102M100V
ASC74-C75	0160-4133	0		C-F 15UF 10% 20V TATBSA	12340P02	T322D156K020AS
ASC76	0160-6510	9		C-F .1UF 20% 50V CERMLr	28480	RPE121-978X7R104M50V
ASC77	0160-6507	4		C-F 1000PF 20% 100V CERMLr	28480	RPE121-978X7R102M100V
ASC83-C84	0160-6507	4		C-F 1000PF 20% 100V CERMLr	28480	RPE121-978X7R102M100V
ASC85	0160-0576	5		CAPACITOR-FXD .1UF + -20% 50VDC CER	04222	SR205C104MAAH
ASC90	0160-6521	2	1	C-F 2.2PF -% 200V CERMLr	28480	RPE121-978C0G2R2C200V
ASC91-C92	0160-6515	4	2	C-F 10PF -% 200V CERMLr	28480	RPE121-978C0G100D200V
ASC93	0160-0576	5		CAPACITOR-FXD .1UF + -20% 50VDC CER	04222	SR205C104MAAH
ASC94-C95	0160-6507	4		C-F 1000PF 20% 100V CERMLr	28480	RPE121-978X7R102M100V
ASC100	0160-2940	1	1	CAPACITOR-FXD 470PF + -5% 300VDC MICA	09023	CD15FC471J03
ASC101	0140-0197	4	1	CAPACITOR-FXD 180PF + -5% 300VDC MICA	09023	CD15FC181J03
ASC102	0160-0154	5	1	CAPACITOR-FXD 2200PF + -10% 200VDC POLYE	06337P01	
ASC103	0160-0362	7	1	CAPACITOR-FXD 510PF + -5% 300VDC MICA	09023	CD15FC511J03
ASC104	0160-0156	7	2	CAPACITOR-FXD 3900PF + -10% 200VDC POLYE	15766	HEW238T
ASC105	0140-0199	6	1	CAPACITOR-FXD 240PF + -5% 300VDC MICA	09023	CD15FC241J03
ASC106	0160-0156	7		CAPACITOR-FXD 3900PF + -10% 200VDC POLYE	15766	HEW238T
ASC110-C111	0160-0576	5		CAPACITOR-FXD .1UF + -20% 50VDC CER	04222	SR205C104MAAH
ASC112	0160-0128	3	1	CAPACITOR-FXD 2.2UF + -20% 50VDC CER	04222	SR515E225MAAH
ASCR1	1901-0040	1	5	DIODE-SWITCHING 30V 50MA 2NS DO-35	27014	
ASCR2	0122-0085	1	2	DIODE-VVC 2.2PF 7% C3/C25-MIN = 4.5	S0545	1S2208(B)

See introduction to this section for ordering information

\*Indicates factory selected values

Table 6-3. Replaceable Parts

Ref.Des.	HP Part Number	CD	Qty	Description	Mfr. Code	Mfr. Part Number
A5CR3	1901-0040	1		DIODE-SWITCHING 30V 50MA 2NS DO-35	27014	
A5CR4	0122-0085	1		DIODE-VVC 2.2PF 7% C3/C25-MIN = 4.5	50545	1S2208(B)
A5CR50	1901-0040	1		DIODE-SWITCHING 30V 50MA 2NS DO-35	27014	
A5CR51	1990-1125	2	1	OPT LED LMP R XX LMP1002 TT1H	28480	1890-1125
A5CR52-CR53	1901-0040	1		DIODE-SWITCHING 30V 50MA 2NS DO-35	27014	
A5J1-J2	1250-2142	7	2	CON-SMB	74970	131-3701-341
ASL1	9140-0748	0	5	INDUCTOR 250UH 25% .25DX.5LG Q=3	24226	CA-253-5
ASL2	9140-0144	0	12	INDUCTOR RF-CH-MLD 4.7UH 10% .105DX.26LG	99800	1025-36
ASL3	03577-20301	4	1	IND 30.5MM	00848P01	
ASL4	9100-2891	4	1	INDUCTOR RF-CH-MLD 50NH 10% .105DX.26LG	24226	10M050K-1
ASL5	9140-0748	0		INDUCTOR 250UH 25% .25DX.5LG Q=3	24226	CA-253-5
ASL7	9140-0144	0		INDUCTOR RF-CH-MLD 4.7UH 10% .105DX.26LG	99800	1025-36
ASL10	9140-0144	0		INDUCTOR RF-CH-MLD 4.7UH 10% .105DX.26LG	99800	1025-36
ASL21-L22	9140-0144	0		INDUCTOR RF-CH-MLD 4.7UH 10% .105DX.26LG	99800	1025-36
ASL30-L31	9140-0144	0		INDUCTOR RF-CH-MLD 4.7UH 10% .105DX.26LG	99800	1025-36
ASL32	9140-0210	1	1	INDUCTOR RF-CH-MLD 100UH 5% .166DX.385LG	99800	1537-76
ASL40	9140-0144	0		INDUCTOR RF-CH-MLD 4.7UH 10% .105DX.26LG	99800	1025-36
ASL60-L62	9140-0748	0		INDUCTOR 250UH 25% .25DX.5LG Q=3	24226	CA-253-5
ASL63-L64	9100-1618	1	2	INDUCTOR RF-CH-MLD 5.6UH 10%	99800	1537-30
ASL70	9140-0144	0		INDUCTOR RF-CH-MLD 4.7UH 10% .105DX.26LG	99800	1025-36
ASL77	9140-0144	0		INDUCTOR RF-CH-MLD 4.7UH 10% .105DX.26LG	99800	1025-36
ASL79	9140-0158	6	1	INDUCTOR RF-CH-MLD 1UH 10% .105DX.26LG	32159	1A1002M +-10%
ASL81	9140-0144	0		INDUCTOR RF-CH-MLD 4.7UH 10% .105DX.26LG	99800	1025-36
ASL90	9135-0074	4	1	INDUCTOR RF-CH-MLD 47NH 4% .102DX.26LG	24226	
ASL91	9140-0144	0		INDUCTOR RF-CH-MLD 4.7UH 10% .105DX.26LG	99800	1025-36
ASL100	9100-1649	7	1	INDUCTOR RF-CH-MLD 560UH 5% .2DX.45LG	99800	2500-16
ASL101	9100-1650	1	1	INDUCTOR RF-CH-MLD 680UH 5% .2DX.45LG	99800	2500-20
ASL102	9140-0118	8	1	INDUCTOR RF-CH-MLD 500UH 5% .2DX.45LG	99800	2500-14
ASLB1	7121-4811	2	1	LABEL-INFORMATION .15-IN-WD .6-IN-LG	28480	L01003
ASMP601-MP602	0515-0897	9	2	SCREW-MACH M3 X 0.5 8MM-LG PAN-HD	83486	
ASMP603-MP604	0535-0004	6	2	NUT-HEX DBL-CHAM M3 X 0.5 2.4MM-THK	28480	
ASMP605-MP606	2180-0824	1	2	WASHER-LK INTL T NO. 3 .102-IN-ID	73734	99401
ASMP607-MP608	0515-0805	7	2	SCREW-MACH M2.5 X 0.45 6MM-LG PAN-HD	83486	
ASMP609-MP610	2190-0124	4	2	WASHER-LK INTL T NO. 10 .195-IN-ID	98291	3002-26
ASMP611-MP612	2950-0078	9	2	NUT-HEX-DBL-CHAM 10-32-THD .067-IN-THK	98291	40001-18-030-156
ASMP613-MP624	0515-1643	2	12	SCR-MCH M3.0 22MMLG PHPZ SST *	83486	
ASMP701	03577-04105	2	1	SHTF CVR-OFFSET BD ALSK	13588P02	
ASMP701	0361-0230	4	2	RVT-STB OVHD .123D .18LG BRSTN	12014	R-3682
ASMP701	1400-0964	6	2	BRACKET-RTANG STL ZINC/CLEAR CHROMATE	28480	1400-0964
ASMP701	0370-2595	7	1	KNOB-RVTN 12.7MMD BRS	28480	
ASMP702	03577-04103	0	1	SHTF SHLD-OFFSET CVR ALSK	13588P02	
ASMP703	03577-20601	7	1	CSTG-SHIELD-CIRCUIT SIDE AL	13599P01	03577-20601
ASMP704	03577-20602	8	1	CSTG SHIELD-COMPONENT SD AL	13599P01	03577-20602
ASP1-P3	1258-0141	8	3	CON-JUMPER REM .025P	00779	530153-2
ASQ1	1854-0345	8	3	TRANSISTOR NPN 2N5179 SI TO-72 PD=200MW	04713	2N5179
ASQ2	1853-0007	7	1	TRANSISTOR PNP 2N3251 SI TO-18 PD=360MW	04713	2N3251
ASQ10-Q11	1854-0591	6	2	TRANSISTOR NPN SI PD=180MW FT=4GHZ	04713	BFF80
ASQ20	1854-0345	8		TRANSISTOR NPN 2N5179 SI TO-72 PD=200MW	04713	2N5179
ASQ80	1854-0345	8		TRANSISTOR NPN 2N5179 SI TO-72 PD=200MW	04713	2N5179
ASR1-R2	0683-1035	1	15	RESISTOR 10K 5% .25W CF TC=0-400	77902	R-25J
ASR3	0683-1015	7	2	RESISTOR 100 5% .25W CF TC=0-400	77902	R-25J
ASR4	0683-1515	2	2	RESISTOR 150 5% .25W CF TC=0-400	77902	R-25J
ASR5	0683-3325	6	1	RESISTOR 3.3K 5% .25W CF TC=0-400	77902	R-25J
ASR6	0683-1035	1		RESISTOR 10K 5% .25W CF TC=0-400	77902	R-25J
ASR7	0683-1515	2		RESISTOR 150 5% .25W CF TC=0-400	77902	R-25J
ASR8	0683-4735	4	1	RESISTOR 47K 5% .25W CF TC=0-400	77902	R-25J
ASR9	2100-3253	7	1	RESISTOR-TRMR 50K 10% C TOP-ADJ 1-TRIN	32997	3386P-Y46-503
ASR10	0699-2072	1	1	R-F 34.8 OH 1% 1/20W HF04 T0	91637	CMF-5034R8FT-1
ASR11	0683-1025	9	3	RESISTOR 1K 5% .25W CF TC=0-400	77902	R-25J
ASR12	0683-4715	0	1	RESISTOR 470 5% .25W CF TC=0-400	77902	R-25J
ASR13	0696-7221	0	2	RESISTOR 237 1% .05W F TC=0+-100	91637	CMF-502370FT-1
ASR14	0699-2163	1	1	R-F 31.6 OH 1% 1/20W HF04 T0	91637	CMF-5031R6FT-1

See introduction to this section for ordering information

\*Indicates factory selected values

Table 6-3. Replaceable Parts

Ref.Des.	HP Part Number	CD	Qty	Description	Mfr. Code	Mfr. Part Number
A5R15	0699-1903	5	7	R-F 51.1 OH 1% 1/20W HF04 T0	91637	CMF-5051R1FT-1
A5R16	0699-7221	0		RESISTOR 237 1% .05W F TC=0+-100	91637	CMF-502370FT-1
A5R17	0699-1903	5		R-F 51.1 OH 1% 1/20W HF04 T0	91637	CMF-5051R1FT-1
A5R21-R22	0699-7249	2	4	RESISTOR 3.48K 1% .05W F TC=0+-100	91637	CMF-503481FT-1
A5R23	0699-1965	9	2	R-F 21.5 OH 1% 1/20W HF04 T0	91637	CMF-50-21
A5R24	0683-5615	1	2	RESISTOR 560 5% .25W CF TC=0-400	77902	R-25J
A5R26	0699-1903	5		R-F 51.1 OH 1% 1/20W HF04 T0	91637	CMF-5051R1FT-1
A5R30	0699-1903	5		R-F 51.1 OH 1% 1/20W HF04 T0	91637	CMF-5051R1FT-1
A5R31-R32	0683-1035	1		RESISTOR 10K 5% .25W CF TC=0-400	77902	R-25J
A5R33	0699-7236	7	1	RESISTOR 1K 1% .05W F TC=0+-100	05524P03	CMF-501001FT-1
A5R34-R35	0683-1035	1		RESISTOR 10K 5% .25W CF TC=0-400	77902	R-25J
A5R36	0683-1025	9		RESISTOR 1K 5% .25W CF TC=0-400	77902	R-25J
A5R40	0683-1035	1		RESISTOR 10K 5% .25W CF TC=0-400	77902	R-25J
A5R41	0683-1025	9		RESISTOR 1K 5% .25W CF TC=0-400	77902	R-25J
A5R42-R43	0683-1035	1		RESISTOR 10K 5% .25W CF TC=0-400	77902	R-25J
A5R50-R53	0683-1035	1		RESISTOR 10K 5% .25W CF TC=0-400	77902	R-25J
A5R54	0699-4467	0	1	RESISTOR 1.05K 1% .125W F TC=0+-100	91637	CMF-55-1
A5R55	0757-0465	6	1	RESISTOR 100K 1% .125W F TC=0+-100	05524P03	CMF-55-1
A5R56	0683-2025	1	1	RESISTOR 2K 5% .25W CF TC=0-400	77902	R-25J
A5R57	0683-1035	1		RESISTOR 10K 5% .25W CF TC=0-400	77902	R-25J
A5R58	0683-3345	0	1	RESISTOR 330K 5% .25W CF TC=0-800	77902	R-25J
A5R59	0699-3449	3	1	RESISTOR 28.7K 1% .125W F TC=0+-100	05524P03	CMF-552872FT-1
A5R70	0699-7216	6	2	RESISTOR 147 1% .05W F TC=0+-100	91637	CMF-501470FT-1
A5R71	0699-1947	7	1	R-F 36.3 OH 1% 1/20W MFHF T0	91637	CMF-5036R3FT-1
A5R72	0699-7216	3		RESISTOR 147 1% .05W F TC=0+-100	91637	CMF-501470FT-1
A5R76	0683-2715	6	2	RESISTOR 270 5% .25W CF TC=0-400	77902	R-25J
A5R78	0683-1015	7		RESISTOR 100 5% .25W CF TC=0-400	77902	R-25J
A5R80	0699-1903	5		R-F 51.1 OH 1% 1/20W HF04 T0	91637	CMF-5051R1FT-1
A5R81-R82	0699-7249	2		RESISTOR 3.48K 1% .05W F TC=0+-100	91637	CMF-503481FT-1
A5R83	0699-1965	9		R-F 21.5 OH 1% 1/20W HF04 T0	91637	CMF-50-21
A5R84	0683-5615	1		RESISTOR 560 5% .25W CF TC=0-400	77902	R-25J
A5R86	0699-1903	5		R-F 51.1 OH 1% 1/20W HF04 T0	91637	CMF-5051R1FT-1
A5R91	0699-7214	1	2	RESISTOR 121 1% .05W F TC=0+-100	91637	CMF-501210FT-1
A5R92	0699-1903	5		R-F 51.1 OH 1% 1/20W HF04 T0	91637	CMF-5051R1FT-1
A5R93	0699-7214	1		RESISTOR 121 1% .05W F TC=0+-100	91637	CMF-501210FT-1
A5R94	0683-2715	6		RESISTOR 270 5% .25W CF TC=0-400	77902	R-25J
A5R102	0683-5125	8	1	RESISTOR 5.1K 5% .25W CF TC=0-400	77902	R-25J
A5R103	0683-1535	6	1	RESISTOR 15K 5% .25W CF TC=0-400	77902	R-25J
A5R104	0683-1525	4	1	RESISTOR 1.5K 5% .25W CF TC=0-400	77902	R-25J
A5R105	0683-2015	9	1	RESISTOR 200 5% .25W CF TC=0-400	77902	R-25J
A5R106	0699-3243	8	1	RESISTOR 178K 1% .125W F TC=0+-100	05524P03	CMF-551783FT-1
A5TP1	1251-0600	0	12	CONNECTOR-SGL CONT PIN 1.14-MM-BSC-SZ SQ	27264	16-06-0034
A5TP31	1251-0600	0	0	CONNECTOR-SGL CONT PIN 1.14-MM-BSC-SZ SQ	27264	16-06-0034
A5TP42-TP43	1251-0600	0	0	CONNECTOR-SGL CONT PIN 1.14-MM-BSC-SZ SQ	27264	16-06-0034
A5TP51-TP52	1251-0600	0	0	CONNECTOR-SGL CONT PIN 1.14-MM-BSC-SZ SQ	27264	16-06-0034
A5TP61-TP66	1251-0600	0	0	CONNECTOR-SGL CONT PIN 1.14-MM-BSC-SZ SQ	27264	16-06-0034
A5TP67-TP68	0360-0124	3	2	CONNECTOR-SGL CONT PIN .04-IN-BSC-SZ RND	13309P01	
ASU20	0955-0095	8	1	MX MWAV SRA-1-85 500MHZ 8	16239	SRA-1-85
ASU30-U31	1820-0270	7	2	ICWIDEBAND AMPL VID TO-100 PKG	28480	1820-0270
ASU40	1820-1425	6	1	ICSchMITT-TRIG TTL LS NAND QUAD 2-INP	01295	SN74LS132N
ASU41	1820-1112	8	1	ICFF TTL LS D-TYPE POS-EDGE-TRIG	01295	SN74LS74AN
ASU42	1820-1430	3	1	ICCNTR TTL LS BIN SYNCHRO POS-EDGE-TRIG	01295	SN74LS161AN
ASU43	1820-1282	3	1	ICFF TTL LS J-K BAR POS-EDGE-TRIG	01295	SN74LS109AN
ASU50	1826-0222	1	1	ICOP AMP GP QUAD 14-DIP-P PKG	07993	RC4136DB
ASU51	1826-0412	1	1	ICCOMPARATOR PRCN DUAL 8-DIP-P PKG	27014	LM393N
ASU60	1826-0147	9	1	ICV RGLTR-FXD-POS 11.5/12.5V TO-220 PKG	04713	MC7812CT
ASU61	1826-0221	0	1	ICV RGLTR-FXD-NEG 11.5/12.5V TO-220 PKG	04713	MC7912CT
ASU70	1813-0215	5	2	ICWIDEBAND AMPL TO-39 PKG	04713	MWA220
ASU90	1813-0215	5		ICWIDEBAND AMPL TO-39 PKG	04713	MWA220
ASW1-W3	1251-4822	6	3	CONN-POST TYPE .100-PIN-SPCG 3-CONT	27264	22-03-2031
A5	2190-0003	8	2	WASHER-LK HLCL NO. 4 .115-IN-ID	73734	
A5	0515-1056	1	2	SCREW-MACH M2.5 X 0.45 4MM-LG PAN-HD	83486	

See introduction to this section for ordering information

\*Indicates factory selected values



Table 6-3. Replaceable Parts

Ref.Des.	HP Part Number	CD	Qty	Description	Mfr. Code	Mfr. Part Number
A6	03577-66506	7	1	PCASSY REFERENCE BD	28480	03577-66506
A6C1	0180-2817	3	3	CAPACITOR-FXD 47UF +-20% 10VDC TA	12340P02	T354H476M010AS
A6C2-C3	0180-0553	0	8	CAPACITOR-FXD 22UF +-20% 25VDC TA	12340P02	T354H226M025AS
A6C5	0160-4571	8	14	CAPACITOR-FXD .1UF +80-20% 50VDC CER	04222	SA105E104ZAAH
A6C7	0160-4571	8	8	CAPACITOR-FXD .1UF +80-20% 50VDC CER	04222	SA105E104ZAAH
A6C8	0160-2206	2	1	CAPACITOR-FXD 160PF +-5% 300VDC MICA	09023	CD15FC161J03
A6C9	0160-6505	2	18	C-F .01UF 20% 100V CERMLR	28480	RPE121-978X7R103M100V
A6C10	0160-6510	9	18	C-F .1UF 20% 50V CERMLR	28480	RPE121-978X7R104M50V
A6C12	0160-6518	8	2	C-F 220PF 20% 100V CERMLR	28480	RPE121-978X7R221M100V
A6C13	0160-6505	2	2	C-F .01UF 20% 100V CERMLR	28480	RPE121-978X7R103M100V
A6C14	0180-3370	5	1	CAPACITOR-FXD 22UF +-20% 25VDC AL NPOL	06360P01	SMBP(D)25V822(M)
A6C15-C16	0160-0127	2	4	CAPACITOR-FXD 1UF +-20% 25VDC CER	04222	SR835E105MAAH
A6C17-C19	0160-4571	8	8	CAPACITOR-FXD .1UF +80-20% 50VDC CER	04222	SA105E104ZAAH
A6C20	0180-0553	0	0	CAPACITOR-FXD 22UF +-20% 25VDC TA	12340P02	T354H226M025AS
A6C21	0160-6518	7	7	C-F 220PF 20% 100V CERMLR	28480	RPE121-978X7R221M100V
A6C22-C23	0160-4935	8	2	CAPACITOR-FXD 510PF +-1% 100VDC CER	04222	SR201A511FAAH
A6C24	0160-6513	2	1	C-F 68PF 5% 200V CERMLR	28480	RPE121-978COG680J200V
A6C25	1460-2201	4	1	WFRM ROLLED TEST POINT	L0121P01	1460-2201
A6C27-C28	0160-4571	8	8	CAPACITOR-FXD .1UF +80-20% 50VDC CER	04222	SA105E104ZAAH
A6C30	0180-2817	3	3	CAPACITOR-FXD 47UF +-20% 10VDC TA	12340P02	T354H476M010AS
A6C32-C34	0160-6505	2	2	C-F .01UF 20% 100V CERMLR	28480	RPE121-978X7R103M100V
A6C35	0160-4840	2	2	CAPACITOR-FXD .1UF +-10% 100VDC	06337P01	712A1BB104PK101LA
A6C36	0160-6510	9	9	C-F .1UF 20% 50V CERMLR	28480	RPE121-978X7R104M50V
A6C37	0160-4840	2	2	CAPACITOR-FXD .1UF +-10% 100VDC	06337P01	712A1BB104PK101LA
A6C38	0160-6507	4	13	C-F 1000PF 20% 100V CERMLR	28480	RPE121-978X7R102M100V
A6C39	0160-6505	2	2	C-F .01UF 20% 100V CERMLR	28480	RPE121-978X7R103M100V
A6C40	0160-6510	9	9	C-F .1UF 20% 50V CERMLR	28480	RPE121-978X7R104M50V
A6C41	0140-0181	8	1	CAPACITOR-FXD 58PF +-5% 300VDC MICA	09023	CD15EC560J03
A6C42	0160-4832	4	2	CAPACITOR-FXD .01UF +-10% 100VDC CER	04222	SA101C103KAAH
A6C43-C44	0160-6505	2	2	C-F .01UF 20% 100V CERMLR	28480	RPE121-978X7R103M100V
A6C45	0160-6507	4	4	C-F 1000PF 20% 100V CERMLR	28480	RPE121-978X7R102M100V
A6C46	0160-6505	2	2	C-F .01UF 20% 100V CERMLR	28480	RPE121-978X7R103M100V
A6C47	0160-6507	4	4	C-F 1000PF 20% 100V CERMLR	28480	RPE121-978X7R102M100V
A6C48	0160-6515	4	3	C-F 10PF +-% 200V CERMLR	28480	RPE121-978COG100D200V
A6C49	0160-6507	4	4	C-F 1000PF 20% 100V CERMLR	28480	RPE121-978X7R102M100V
A6C51	0160-6510	9	9	C-F .1UF 20% 50V CERMLR	28480	RPE121-978X7R104M50V
A6C52	0160-6507	4	4	C-F 1000PF 20% 100V CERMLR	28480	RPE121-978X7R102M100V
A6C53	0160-6505	2	2	C-F .01UF 20% 100V CERMLR	28480	RPE121-978X7R103M100V
A6C54	0160-6510	9	9	C-F .1UF 20% 50V CERMLR	28480	RPE121-978X7R104M50V
A6C55	0160-6505	2	2	C-F .01UF 20% 100V CERMLR	28480	RPE121-978X7R103M100V
A6C56	0160-6507	4	4	C-F 1000PF 20% 100V CERMLR	28480	RPE121-978X7R102M100V
A6C57	0160-0553	0	0	CAPACITOR-FXD 22UF +-20% 25VDC TA	12340P02	T354H226M025AS
A6C58-C59	0160-6510	9	9	C-F .1UF 20% 50V CERMLR	28480	RPE121-978X7R104M50V
A6C61-C62	0160-0553	0	0	CAPACITOR-FXD 22UF +-20% 25VDC TA	12340P02	T354H226M025AS
A6C63	0160-6507	4	4	C-F 1000PF 20% 100V CERMLR	28480	RPE121-978X7R102M100V
A6C64	0160-4832	4	4	CAPACITOR-FXD .01UF +-10% 100VDC CER	04222	SA101C103KAAH
A6C65-C66	0160-6505	2	2	C-F .01UF 20% 100V CERMLR	28480	RPE121-978X7R103M100V
A6C68	0160-6510	9	9	C-F .1UF 20% 50V CERMLR	28480	RPE121-978X7R104M50V
A6C69	0180-3768	5	4	C-F 3.3UF 20% 35V TADPDY	12340P02	T350D335M035AS
A6C70	0160-6510	9	9	C-F .1UF 20% 50V CERMLR	28480	RPE121-978X7R104M50V
A6C71	0160-0127	2	2	CAPACITOR-FXD 1UF +-20% 25VDC CER	04222	SR835E105MAAH
A6C72	0160-0553	0	0	CAPACITOR-FXD 22UF +-20% 25VDC TA	12340P02	T354H226M025AS
A6C75-C77	0160-6507	4	4	C-F 1000PF 20% 100V CERMLR	28480	RPE121-978X7R102M100V
A6C78	0160-6505	2	2	C-F .01UF 20% 100V CERMLR	28480	RPE121-978X7R103M100V
A6C79	0180-4133	0	1	C-F 15UF 10% 20V TATBSA	12340P02	T322D156K020AS

See introduction to this section for ordering information

\*Indicates factory selected values

Table 6-3. Replaceable Parts

Ref.Des.	HP Part Number	CD	Qty	Description	Mfr. Code	Mfr. Part Number
A6C80-C81	0180-3768	5		C-F 3.3UF 20% 35V TADPDr	12340P02	T350D335M035AS
A6C82-C83	0160-6505	2		C-F .01UF 20% 100V CERMLr	28480	RPE121-878X7R103M100V
A6C85	0180-2817	3		CAPACITOR-FXD 47UF + -20% 10VDC TA	12340P02	T354H478M010AS
A6C90-C93	0160-6510	9		C-F .1UF 20% 50V CERMLr	28480	RPE121-878X7R104M50V
A6C95-C96	0160-4571	6		CAPACITOR-FXD .1UF + 80-20% 50VDC CER	04222	SA105E104ZAAH
A6C99	0160-0576	5	4	CAPACITOR-FXD .1UF + -20% 50VDC CER	04222	SR205C104MAAH
A6C100	0160-2208	4	1	CAPACITOR-FXD 330PF +-5% 300VDC MICA	09023	CD15FC331J03
A6C101	0160-2009	3	1	CAPACITOR-FXD 820PF +-5% 300VDC MICA	09023	CD15FC821J03
A6C102-C104	0160-0576	5		CAPACITOR-FXD .1UF + -20% 50VDC CER	04222	SR205C104MAAH
A6C105	0160-4788	9	1	CAPACITOR-FXD 18PF +-5% 100VDC CER 0+-30	04222	SA102A180JAAH
A6C106	0160-6895	1	1	C-F .01UF 10% 100V CERMLr	28480	RPE121-878X7R103K100V
A6C107-C108	0160-6510	9		C-F .1UF 20% 50V CERMLr	28480	RPE121-878X7R104M50V
A6C109-C112	0160-4571	8		CAPACITOR-FXD .1UF + 80-20% 50VDC CER	04222	SA105E104ZAAH
A6C113-C114	0160-6505	2		C-F .01UF 20% 100V CERMLr	28480	RPE121-878X7R103M100V
A6C115	0180-3768	5		C-F 3.3UF 20% 35V TADPDr	12340P02	T350D335M035AS
A6C116	0180-6553	0		CAPACITOR-FXD 22UF +-20% 25VDC TA	12340P02	T354H226M025AS
A6C117	0160-6507	4		C-F 1000PF 20% 100V CERMLr	28480	RPE121-878X7R102M100V
A6C120	0160-4571	8		CAPACITOR-FXD .1UF + 80-20% 50VDC CER	04222	SA105E104ZAAH
A6C121	0160-6510	9		C-F .1UF 20% 50V CERMLr	28480	RPE121-878X7R104M50V
A6C122-C123	0160-6507	4		C-F 1000PF 20% 100V CERMLr	28480	RPE121-878X7R102M100V
A6C124	0160-4382	9	1	CAPACITOR-FXD 3.3PF +-25PF 200VDC CER	28480	RPE121-105C0G3R3C200V
A6C125	0160-6515	4		C-F 10PF -% 200V CERMLR	28480	RPE121-878C0G100D200V
A6C126	0160-6521	2	1	C-F 2.2PF -% 200V CERMLr	28480	RPE121-878C0G2R2C200V
A6C127	0160-6515	4		C-F 10PF -% 200V CERMLR	28480	RPE121-878C0G100D200V
A6C128	0160-3814	1	1	CAPACITOR-FXD .01UF +-10% 100VDC CER	04222	SR201C103KAAH
A6C129	0180-3113	4	1	CAPACITOR-FXD 330UF +50-10% 25VDC AL	43744	ECEB1EU331
A6C130	0160-0127	2		CAPACITOR-FXD 1UF +-20% 25VDC CER	04222	SR635E106MAAH
A6C131	0180-4132	9	1	C-F 6.8UF 10% 35V TATBSA	12340P02	T322D685K035AS
A6CR2	0122-0162	5	1	DIODE-VVC 28PF 10% BVR=30V	18324	BB809
A6CR3-CR4	1801-0040	1	13	DIODE-SWITCHING 30V 50MA 2NS DO-35	27014	
A6CR5	1902-1329	3	1	ICV RGLTR-V-REF-FXD 6.6/7.2V TO-46 PKG	27014	LM329CH
A6CR7	1802-3149	9	2	DIODE-ZNR 9.09V 5% DO-35 PD = .4W	04713	SZ30016-170
A6CR8-CR9	1801-0040	1		DIODE-SWITCHING 30V 50MA 2NS DO-35	27014	
A6CR11	1902-0041	4	2	DIODE-ZNR 5.11V 5% DO-35 PD = .4W	04713	SZ30016-98
A6CR12	1901-0040	1		DIODE-SWITCHING 30V 50MA 2NS DO-35	27014	
A6CR13-CR14	0122-0085	1	2	DIODE-VVC 2.2PF 7% C3/C25-MRN = 4.5	S0545	1S2208(B)
A6CR15	1901-0040	1		DIODE-SWITCHING 30V 50MA 2NS DO-35	27014	
A6CR16-CR17	1901-0376	6	2	DIODE-GEN PRP 35V 50MA DO-35	11946P01	S303
A6CR20	1990-1125	2	3	OPT LED LMP R XX LMP1002 TT1H	28480	1990-1125
A6CR21	1901-0040	1		DIODE-SWITCHING 30V 50MA 2NS DO-35	27014	
A6CR23	1990-1125	2		OPT LED LMP R XX LMP1002 TT1H	28480	1990-1125
A6CR24-CR25	1901-0040	1		DIODE-SWITCHING 30V 50MA 2NS DO-35	27014	
A6CR26	1902-0041	4		DIODE-ZNR 5.11V 5% DO-35 PD = .4W	04713	SZ30016-98
A6CR27	1990-1125	2		OPT LED LMP R XX LMP1002 TT1H	28480	1990-1125
A6CR28-CR29	1901-0040	1		DIODE-SWITCHING 30V 50MA 2NS DO-35	27014	
A6CR31	1902-3149	9		DIODE-ZNR 9.09V 5% DO-35 PD = .4W	04713	SZ30016-170
A6CR32	1901-0040	1		DIODE-SWITCHING 30V 50MA 2NS DO-35	27014	
A6CR33	1902-0958	2	1	DIODE-ZNR 10V 5% DO-35 PD = .4W TC = +.075%	04713	SZ30035-1
A6CR34	1801-0040	1		DIODE-SWITCHING 30V 50MA 2NS DO-35	27014	
A6L1-J7	1250-2142	7	7	CON-SMB	74970	131-3701-341
A6L1-L3	9140-0748	0	7	INDUCTOR 250UH 25% .25DX.5LG Q=3	24226	CA-253-5
A6L4	9100-2279	2	2	INDUCTOR RF-CH-MLD 180UH 10% .105DX.26LG	24226	10M163K
A6L5-L6	9140-0144	0	10	INDUCTOR RF-CH-MLD 4.7UH 10% .105DX.26LG	99800	1025-36
A6L7	03577-20301	4	1	IND 30.5MM	00848P01	
A6L8	9100-2891	4	1	INDUCTOR RF-CH-MLD 50NH 10% .105DX.26LG	24226	10M050K-1
A6L10-L12	9140-0144	0		INDUCTOR RF-CH-MLD 4.7UH 10% .105DX.26LG	99800	1025-36
A6L14	9100-3551	5	2	INDUCTOR RF-CH-MLD 1UH 5% .166DX.385LG	24226	15M101J
A6L15-L17	9140-0144	0		INDUCTOR RF-CH-MLD 4.7UH 10% .105DX.26LG	99800	1025-36
A6L18	9140-0748	0		INDUCTOR 250UH 25% .25DX.5LG Q=3	24226	CA-253-5
A6L19-L20	9140-0144	0		INDUCTOR RF-CH-MLD 4.7UH 10% .105DX.26LG	99800	1025-36
A6L22-L23	9140-0748	0		INDUCTOR 250UH 25% .25DX.5LG Q=3	24226	CA-253-5
A6L24	9100-3551	5		INDUCTOR RF-CH-MLD 1UH 5% .166DX.385LG	24226	15M101J

See introduction to this section for ordering information

\*Indicates factory selected values

Table 6-3. Replaceable Parts

Ref.Des.	HP Part Number	CD	Qty	Description	Mfr. Code	Mfr. Part Number
A6L25	9140-0748	0		INDUCTOR 250UH 25% .25DX.5LG Q=3	24226	CA-253-5
A6L26	9140-0210	1	1	INDUCTOR RF-CH-MLD 100UH 5% .166DX.385LG	99800	1537-76
A6L28	9100-2279	2		INDUCTOR RF-CH-MLD 180UH 10% .105DX.26LG	24226	10M183K
A6L29-L31	9100-3345	5	3	INDUCTOR RF-CH-MLD 2UH 5% .166DX.385LG	24226	15M201J
A6L32	9140-0398	6	1	INDUCTOR RF-CH-MLD 12UH 5% .188DX.385LG	24226	15M122J
A6L33	9140-0814	1	1	COIL-VAR 20NH-25NH Q=50 PC-MTG	24226	8272
A6LB1	7121-4811	2	1	LABEL-INFORMATION .15-IN-WD .6-IN-LG	28480	L01003
A6Q1	1855-0420	2	1	TRANSISTOR J-FET 2N4391 N-CHAN D-MODE	17856	2N4391
A6Q2	1854-0345	8	3	TRANSISTOR NPN 2N5179 SI TO-72 PD=200MW	04713	2N5179
A6Q4	1855-0410	0	1	TRANSISTOR J-FET N-CHAN D-MODE TO-18 SI	27014	
A6Q5	1855-0081	1	1	TRANSISTOR J-FET N-CHAN D-MODE SI	03171P01	
A6Q6	1853-0448	0	2	TRANSISTOR PNP SI TO-92 PD=625MW	04713	MPSH81
A6Q7	1854-0345	8		TRANSISTOR NPN 2N5179 SI TO-72 PD=200MW	04713	2N5179
A6Q8	1853-0007	7	1	TRANSISTOR PNP 2N3251 SI TO-18 PD=360MW	04713	2N3251
A6Q9-Q10	1854-0591	6	2	TRANSISTOR NPN SI PD=180MW FT=4GHZ	04713	BFR90
A6Q11	1854-0345	8		TRANSISTOR NPN 2N5179 SI TO-72 PD=200MW	04713	2N5179
A6Q12	1853-0448	0		TRANSISTOR PNP SI TO-92 PD=625MW	04713	MPSH81
A6Q13-Q14	1853-0038	2	2	TRANSISTOR PNP SI PD=310MW FT=250MHZ	04713	2N3906(SEL)
A6R1	0683-6805	3	2	RESISTOR 68 5% .25W CF TC=0-400	77902	R-25J
A6R2	0683-1015	7	3	RESISTOR 100 5% .25W CF TC=0-400	77902	R-25J
A6R3	0683-1545	8	2	RESISTOR 150K 5% .25W CF TC=0-800	77902	R-25J
A6R4	0683-5105	4	1	RESISTOR 51 5% .25W CF TC=0-400	77902	R-25J
A6R5	0757-0281	4	1	RESISTOR 2.74K 1% .125W F TC=0+-100	05524P03	CMF-55-1
A6R7	0698-4423	8	1	RESISTOR 1.37K 1% .125W F TC=0+-100	05524P03	CMF-551371FT-1
A6R8	0683-1025	9	7	RESISTOR 1K 5% .25W CF TC=0-400	77902	R-25J
A6R9	0757-0273	4	1	RESISTOR 3.01K 1% .125W F TC=0+-100	05524P03	CMF-55-1
A6R10	0683-1025	9		RESISTOR 1K 5% .25W CF TC=0-400	77902	R-25J
A6R11	0683-3325	6	1	RESISTOR 3.3K 5% .25W CF TC=0-400	77902	R-25J
A6R12	2100-3274	2	1	RESISTOR-TRMR 10K 10% C SIDE-ADJ 1-TRN	32997	3386X-Y46-103
A6R13	0757-0453	2	1	RESISTOR 30.1K 1% .125W F TC=0+-100	05524P03	CMF-55-1
A6R14	0757-0449	6	1	RESISTOR 20K 1% .125W F TC=0+-100	05524P03	CMF-55-1
A6R15	0757-0482	7	1	RESISTOR 511K 1% .125W F TC=0+-100	91637	CMF-55-1
A6R16	0757-0283	6	2	RESISTOR 2K 1% .125W F TC=0+-100	05524P03	CMF-55-1
A6R17	0683-1045	3	4	RESISTOR 100K 5% .25W CF TC=0-400	77902	R-25J
A6R18	0683-1055	5	4	RESISTOR 1M 5% .25W CF TC=0-800	77902	R-25J
A6R19	0698-3492	9	1	RESISTOR 2.67K 1% .125W F TC=0+-100	05524P03	CMF-552671FT-1
A6R20	0683-1045	3		RESISTOR 100K 5% .25W CF TC=0-400	77902	R-25J
A6R21	0683-2055	7	1	RESISTOR 2M 5% .25W CF TC=0-900	77902	R-25J
A6R22	0683-1055	5		RESISTOR 1M 5% .25W CF TC=0-800	77902	R-25J
A6R23	0683-4715	0	1	RESISTOR 470 5% .25W CF TC=0-400	77902	R-25J
A6R24	0757-0415	6	1	RESISTOR 475 1% .125W F TC=0+-100	05524P03	CMF-55-1
A6R25	0683-1025	9		RESISTOR 1K 5% .25W CF TC=0-400	77902	R-25J
A6R26	0683-1035	1	4	RESISTOR 10K 5% .25W CF TC=0-400	77902	R-25J
A6R27	0698-0063	4	1	RESISTOR 5.23K 1% .125W F TC=0+-100	05524P03	CMF-555321FT-1
A6R28	0698-4440	9	1	RESISTOR 3.4K 1% .125W F TC=0+-100	91637	CMF-553401FT-1
A6R29	0757-0282	5	1	RESISTOR 221 1% .125W F TC=0+-100	05524P03	CMF-55-1
A6R30	0683-2025	1	2	RESISTOR 2K 5% .25W CF TC=0-400	77902	R-25J
A6R32	0698-3458	7	1	RESISTOR 348K 1% .125W F TC=0+-100	05524P03	CMF-553483FT-1
A6R34	0683-4705	8	3	RESISTOR 47 5% .25W CF TC=0-400	77902	R-25J
A6R35*	0683-3035	5		RESISTOR 30K 5% .25W CF TC=0-400	77902	R-25J
A6R35+	0757-0199	3	1	RESISTOR 21.5K 1% .125W F TC=0+-100	05524P03	CMF-55-1
A6R36	0698-3497	4	1	RESISTOR 6.04K 1% .125W F TC=0+-100	05524P03	CMF-556041FT-1
A6R37	0683-1055	5		RESISTOR 1M 5% .25W CF TC=0-800	77902	R-25J
A6R38	0698-3279	0	4	RESISTOR 4.99K 1% .125W F TC=0+-100	05524P03	CMF-554991FT-1
A6R40	0683-1025	9		RESISTOR 1K 5% .25W CF TC=0-400	77902	R-25J
A6R44	0683-1025	9		RESISTOR 1K 5% .25W CF TC=0-400	77902	R-25J
A6R45-F47	0699-1903	5	3	R-F 51.1 OH 1% 1/20W HF04 T0	91637	CMF-5061R1FT-1
A6R48	0699-7231	2	1	RESISTOR 619 1% .05W F TC=0+-100	91637	CMF-506190FT-1
A6R49	0683-1025	9		RESISTOR 1K 5% .25W CF TC=0-400	77902	R-25J
A6R50	0698-7221	0	2	RESISTOR 237 1% .05W F TC=0+-100	91637	CMF-502370FT-1
A6R51	0699-1965	9	4	R-F 21.5 OH 1% 1/20W HF04 T0	91637	CMF-50-21
A6R52	0757-0409	8	1	RESISTOR 274 1% .125W F TC=0+-100	05524P03	CMF-55-1
A6R54-R56	0699-1965	9		R-F 21.5 OH 1% 1/20W HF04 T0	91637	CMF-50-21

See introduction to this section for ordering information

\*Indicates factory selected values

Table 6-3. Replaceable Parts

Ref.Des.	HP Part Number	CD	Qty	Description	Mfr. Code	Mfr. Part Number
A6R57	0683-1525	4	1	RESISTOR 1.5K 5% .25W CF TC = 0-400	77902	R-25J
A6R59	0683-1035	1		RESISTOR 10K 5% .25W CF TC = 0-400	77902	R-25J
A6R60	0698-4507	9	1	RESISTOR 76.8K 1% .125W F TC = 0+-100	91637	CMF-557682FT-1
A6R61	0683-3625	9	1	RESISTOR 3.6K 5% .25W CF TC = 0-400	77902	R-25J
A6R62	0683-1135	2	1	RESISTOR 11K 5% .25W CF TC = 0-400	77902	R-25J
A6R63	0683-1515	2	1	RESISTOR 150 5% .25W CF TC = 0-400	77902	R-25J
A6R64	0683-1015	7		RESISTOR 100 5% .25W CF TC = 0-400	77902	R-25J
A6R65	0683-1035	1		RESISTOR 10K 5% .25W CF TC = 0-400	77902	R-25J
A6R67	0698-7224	3	1	RESISTOR 316 1% .05W F TC = 0+-100	91637	CMF-503160FT-1
A6R68	0698-3700	2	1	RESISTOR 715 1% .125W F TC = 0+-100	05524P03	CMF-557150FT-1
A6R69	0698-4498	7	1	RESISTOR 53.6K 1% .125W F TC = 0+-100	05524P03	CMF-55-1
A6R70	0757-0272	3	1	RESISTOR 52.3K 1% .125W F TC = 0+-100	05524P03	CMF-55-1
A6R71	0698-3439	4	1	RESISTOR 178 1% .125W F TC = 0+-100	05524P03	CMF-551780FT-1
A6R72	0698-4014	3	1	RESISTOR 787 1% .125W F TC = 0+-100	91637	CMF-557870FT-1
A6R73	0757-0442	9	3	RESISTOR 10K 1% .125W F TC = 0+-100	05524P03	CMF-55-1
A6R74	0698-3280	3	1	RESISTOR 63.4K 1% .125W F TC = 0+-100	91637	CMF-556342FT-1
A6R75	0698-7221	0		RESISTOR 237 1% .05W F TC = 0+-100	91637	CMF-502370FT-1
A6R76	0757-0290	3	2	RESISTOR 1K 1% .125W F TC = 0+-100	05524P03	CMF-55-1
A6R77	0698-7234	5	1	RESISTOR 825 1% .05W F TC = 0+-100	91637	CMF-508250FT-1
A6R81	0698-3132	4	1	RESISTOR 261 1% .125W F TC = 0+-100	05524P03	CMF-552610FT-1
A6R82	0683-7505	2	1	RESISTOR 75 5% .25W CF TC = 0-400	77902	R-25J
A6R85	0683-1005	5	1	RESISTOR 10 5% .25W CF TC = 0-400	77902	R-25J
A6R86	0683-1035	1		RESISTOR 10K 5% .25W CF TC = 0-400	77902	R-25J
A6R87	0683-2035	3	1	RESISTOR 20K 5% .25W CF TC = 0-400	77902	R-25J
A6R88	0757-0427	0	1	RESISTOR 1.5K 1% .125W F TC = 0+-100	05524P03	CMF-55-1
A6R91	0683-1065	5		RESISTOR 1M 5% .25W CF TC = 0-600	77902	R-25J
A6R92	0683-2025	1		RESISTOR 2K 5% .25W CF TC = 0-400	77902	R-25J
A6R93	0683-1025	9		RESISTOR 1K 5% .25W CF TC = 0-400	77902	R-25J
A6R94	0683-1045	3		RESISTOR 100K 5% .25W CF TC = 0-400	77902	R-25J
A6R95	0698-3512	4	1	RESISTOR 1.18K 1% .125W F TC = 0+-100	91637	CMF-55-1
A6R96	0757-0280	3		RESISTOR 1K 1% .125W F TC = 0+-100	05524P03	CMF-55-1
A6R97-R99	0698-3279	0		RESISTOR 4.99K 1% .125W F TC = 0+-100	05524P03	CMF-554991FT-1
A6R100-R101	0683-4705	8		RESISTOR 47 5% .25W CF TC = 0-400	77902	R-25J
A6R102	0698-3444	1	1	RESISTOR 316 1% .125W F TC = 0+-100	05524P03	CMF-553160FT-1
A6R103	0698-4399	7	1	RESISTOR 88.7 1% .125W F TC = 0+-100	91637	CMF-55-1
A6R104	0698-3447	4	1	RESISTOR 422 1% .125W F TC = 0+-100	05524P03	CMF-554220FT-1
A6R110	0683-6805	3		RESISTOR 68 5% .25W CF TC = 0-400	77902	R-25J
A6R111	0683-1015	7		RESISTOR 100 5% .25W CF TC = 0-400	77902	R-25J
A6R112	0683-1545	8		RESISTOR 150K 5% .25W CF TC = 0-800	77902	R-25J
A6R115	0698-4429	4	1	RESISTOR 1.87K 1% .125W F TC = 0+-100	91637	CMF-55-1
A6R116	0757-0283	8		RESISTOR 2K 1% .125W F TC = 0+-100	05524P03	CMF-55-1
A6R117-R118	0757-0442	9		RESISTOR 10K 1% .125W F TC = 0+-100	05524P03	CMF-55-1
A6R120	0757-0394	0	1	RESISTOR 51.1 1% .125W F TC = 0+-100	05524P03	CMF-55-1
A6R121	0683-1045	3		RESISTOR 100K 5% .25W CF TC = 0-400	77902	R-25J
A6R122	0757-0472	5	1	RESISTOR 200K 1% .125W F TC = 0+-100	05524P03	CMF-55-1
A6R123	0698-4473	8	1	RESISTOR 8.06K 1% .125W F TC = 0+-100	05524P03	CMF-558061FT-1
A6R124	0757-0437	2	1	RESISTOR 4.75K 1% .125W F TC = 0+-100	05524P03	CMF-55-1
A6S1	3101-2063	8	1	SWITCH-RKR DIP-RKR-ASSY 4-1A .05A 30VDC	81073	76YY23444S
A6TP1-TP14	1251-0600	0	14	CONNECTOR-SGL CONT PIN 1.14-MM-BSC-SZ SQ	27264	16-06-0034
A6TP15-TP22	0360-0124	3	8	CONNECTOR-SGL CONT PIN .04-IN-BSC-SZ RND	13309P01	
A6U1	1820-2634	1	1	ICINV TTL ALS HEX	01295	SN74ALS04BN
A6U2	1826-0522	4	1	ICOP AMP LOW-BIAS-H-IMPD QUAD 14-DIP-P	01295	TL074CN
A6U3	1820-0321	9	2	ICCOMPARATOR GP TO-99 PKG	27014	LM710CH
A6U4-U5	1820-1279	8	2	ICCNTR TTL LS DECD UP/DOWN SYNCHRO	04713	SN74LS190N
A6U6	1820-1420	1	1	ICCNTR TTL LS DIV-X-12 ASYNCHRO	01295	SN74LS92N
A6U7	1820-2779	5	1	ICCNTR TTL ALS BIN SYNCHRO	01295	SN74ALS163BN
A6U8	1820-1199	1	1	ICINV TTL LS HEX 1-INP	01295	SN74LS04N
A6U9	1826-0081	0	1	ICOP AMP WB TO-99 PKG	27014	LM318H
A6U10	1826-0412	1	1	ICCOMPARATOR PRON DUAL 8-DIP-P PKG	27014	LM393N
A6U11	1820-0630	3	1	ICMISC TTL	04713	MC4044P
A6U13	1820-1453	0	1	ICCNTR TTL S BIN SYNCHRO POS-EDGE-TRIG	01295	SN74S163N
A6U14	1820-1888	5	1	ICPRESOR ECL	04713	MC12013P

See introduction to this section for ordering information

\*Indicates factory selected values



Table 6-3. Replaceable Parts

Ref.Des.	HP Part Number	CD	Qty	Description	Mfr. Code	Mfr. Part Number
A6U15	1820-1202	7	1	ICGATE TTL LS NAND TPL 3-INP	01295	SN74LS10N
A6U16	1820-1430	3	1	ICCNTR TTL LS BIN SYNCHRO POS-EDGE-TRIG	01295	SN74LS161AN
A6U17	1820-1991	1	1	ICCNTR TTL LS DECD DUAL 4-BIT	01295	SN74LS390N
A6U18	1820-1282	3	1	ICFF TTL LS J-K BAR POS-EDGE-TRIG	01295	SN74LS109AN
A6U19	1826-0147	9	1	ICV RGLTR-FXD-POS 11.5/12.5V TO-220 PKG	04713	MC7812CT
A6U20	1826-0418	7	1	ICV RGLTR-FXD-NEG 12.4/11.6V TO-220 PKG	27014	LM320T-12
A6U21	1820-0321	9	1	ICCOMPARATOR GP TO-89 PKG	27014	LM710CH
A6U22	1820-1144	6	1	ICGATE TTL LS NOR QUAD 2-INP	01295	SN74LS02N
A6U23	1826-0122	0	1	ICV RGLTR-FXD-POS 4.8/5.2V TO-220 PKG	27014	LM340T-5
A6U24	1820-1994	4	1	ICDRVR TTL LS LINE DRVR OCTL	01295	SN74LS243N
A6U25	1826-0762	4	1	ICCOMPARATOR HS TO-100 PKG	28480	1826-0762
A6W1	1251-4047	7	1	CONN-POST TYPE .100-PIN-SPOG 3-CONT	27284	22-05-2031
A6W1A	1258-0141	8	1	CON-JUMPER REM .025P	00779	530153-2
A6Y1	0410-0437	8	1	CRYSTAL-QUARTZ 9.89830 MHZ	33096	
A6	0515-1643	2	12	SCR-MCH M3.0 22MMLG PHPZ SST *	83488	
A6	2190-0124	4	7	WASHER-LK INTL T NO. 10 .185-IN-ID	98291	3002-26
A6	2950-0078	9	7	NUT-HEX-DBL-CHAM 10-32-THD .067-IN-THK	98291	40001-18-030-156
A6	0340-1169	6	4	NSLT BSNG .038TK TO-72 NYLNA	32559	118-055
A6	0515-0897	6	3	SCREW-MACH M3 X 0.5 8MM-LG PAN-HD	83488	
A6	0535-0004	9	3	NUT-HEX DBL-CHAM M3 X 0.5 2.4MM-THK	28480	
A6	2190-0363	3	2	WASHER-FL NM NO. 2 .09-IN-ID .15-IN-OD	04757P02	2-1185108
A6	03577-04108	3	1	SHTF CVR-REF BD ALSK	13588P02	
A6	03577-04119	8	1	SHTF CVR-REF BD SHLD ALSK	13588P02	
A6	03577-20601	7	1	CSTG-SHIELD-CIRCUIT SIDE AL	13589P01	03577-20601
A6	03577-20602	8	1	CSTG SHIELD-COMPONENT SD AL	13589P01	03577-20602
A15	03577-66515	8	1	PCASSY KEYBOARD	28480	03577-66515
A15C1-C10	0160-4571	8	10	CAPACITOR-FXD .1UF +80-20% 50VDC CER	04222	SA105E104ZAAH
A15CR1	1890-0485	5	1	LED-LAMP LUM-INT = 2MCD IF = 30MA-MAX BVR = 5V	28480	1890-0485
A15CR2-CR4	1890-0486	6	3	LED-LAMP LUM-INT = 2MCD IF = 25MA-MAX BVR = 5V	28480	1890-0486
A15CR5-CR18	1890-0487	7	12	LED-LAMP LUM-INT = 2MCD BVR = 5V	28480	1890-0487
A15J1	1251-8473	1	1	CONN-POST TYPE .100-PIN-SPOG 20-CONT	04726P04	2520-5002UB
A15J2	1251-5041	3	1	CONN-POST TYPE .100-PIN-SPOG 5-CONT	03206P01	68000-605
A15LB1	7121-4611	2	1	LABEL-INFORMATION .15-IN-WD .6-IN-LG	28480	L01003
A15MP1-MP16	05328-40003	8	16	MOLD STAND-LED	28480	05328-40003
A15R1	0683-1035	1	1	RESISTOR 10K 5% .25W CF TC = 0-400	77902	R-25J
A15R2	0683-1315	0	1	RESISTOR 130 5% .25W CF TC = 0-400	77902	R-25J
A15R3-R6	0683-3915	0	4	RESISTOR 390 5% .25W CF TC = 0-400	77902	R-25J
A15RP1-RP2	1810-0279	5	2	NETWORK-RES 10-SIP 4.7K OHM X 9	05524P03	MSP10A01-472G
A15RP3-RP4	1810-0271	7	2	NETWORK-RES 10-SIP 200.0 OHM X 9	91637	MSP10A01
A15SW1-SW52	5060-9436	7	52	MOLD PB BILL WEST	31918	5560-9436
A15TP1-TP2	1251-0600	0	2	CONNECTOR-SGL CONT PIN 1.14-MM-BSC-SZ SQ	27284	16-06-0034
A15U1-U2	1820-2024	3	2	ICDRVR TTL LS LINE DRVR OCTL	01295	SN74LS244N
A15U3	1820-1208	3	1	ICGATE TTL LS OR QUAD 2-INP	01295	SN74LS32N
A15U4	1820-1997	7	3	ICFF TTL LS D-TYPE POS-EDGE-TRIG PRL-IN	27014	DM74LS374N
A15U5	1820-1194	6	1	ICCNTR TTL LS BIN UP/DOWN SYNCHRO	01295	SN74LS193N
A15U6	1820-1112	8	1	ICFF TTL LS D-TYPE POS-EDGE-TRIG	01295	SN74LS74AN
A15U7-U8	1820-1197	9	2	ICGATE TTL LS NAND QUAD 2-INP	01295	SN74LS00N
A15U9-U10	1820-1997	7	1	ICFF TTL LS D-TYPE POS-EDGE-TRIG PRL-IN	27014	DM74LS374N

See introduction to this section for ordering information

\*Indicates factory selected values

Table 6-3. Replaceable Parts

Ref.Des.	HP Part Number	CD	Qty	Description	Mfr. Code	Mfr. Part Number
A18	03577-66516	9	1	PCASSY HPIB	28480	03577-66516
A16C1	0160-4571	8	9	CAPACITOR-FXD .1UF +80-20% 50VDC CER	04222	SA105E104ZAAH
A16C2	0180-4133	0	2	C-F 15UF 10% 20V TATBSA	12340P02	T322D156K020AS
A16C3	0160-4832	4	5	CAPACITOR-FXD .01UF +-10% 100VDC CER	04222	SA101C103KAAH
A16C4-C6	0160-6518	5	22	C-F .022UF 20% 100V CERMLr	28480	RPE121-978X7R223M100V
A16C8	0160-4571	8		CAPACITOR-FXD .1UF +80-20% 50VDC CER	04222	SA105E104ZAAH
A16C9	0160-6519	8	1	C-F 470PF 20% 100V CERMLr	28480	RPE121-978X7R471M100V
A16C10-C12	0160-6516	5		C-F .022UF 20% 100V CERMLr	28480	RPE121-978X7R223M100V
A16C13	0180-4133	0		C-F 15UF 10% 20V TATBSA	12340P02	T322D156K020AS
A16C14	0160-4571	8		CAPACITOR-FXD .1UF +80-20% 50VDC CER	04222	SA105E104ZAAH
A16C15	0160-4832	4		CAPACITOR-FXD .01UF +-10% 100VDC CER	04222	SA101C103KAAH
A16C16-C23	0160-6516	5		C-F .022UF 20% 100V CERMLr	28480	RPE121-978X7R223M100V
A16C24-C25	0160-4571	8		CAPACITOR-FXD .1UF +80-20% 50VDC CER	04222	SA105E104ZAAH
A16C26-C29	0160-6516	5		C-F .022UF 20% 100V CERMLr	28480	RPE121-978X7R223M100V
A16C30	0160-4571	8		CAPACITOR-FXD .1UF +80-20% 50VDC CER	04222	SA105E104ZAAH
A16C31	0160-4832	4		CAPACITOR-FXD .01UF +-10% 100VDC CER	04222	SA101C103KAAH
A16C32	0160-4571	8		CAPACITOR-FXD .1UF +80-20% 50VDC CER	04222	SA105E104ZAAH
A16C33-C36	0160-6516	5		C-F .022UF 20% 100V CERMLr	28480	RPE121-978X7R223M100V
A16C37-C38	0160-4571	8		CAPACITOR-FXD .1UF +80-20% 50VDC CER	04222	SA105E104ZAAH
A16C39-C40	0160-4832	4		CAPACITOR-FXD .01UF +-10% 100VDC CER	04222	SA101C103KAAH
A16C41	0160-6507	4	1	C-F 1000PF 20% 100V CERMLr	28480	RPE121-978X7R102M100V
A16CR1-CR2	1990-1122	9	2	OFT LED LMP G GP LMP1503 TT1H	28480	1990-1122
A16E1	03577-04114	3	1	SMTF PLT-HPIB CVR AL	13598P02	
A16E1	0580-1088	7	2	NUT-PRSN M3.0 1.4MM PNL STLZN	46384	S-M3-2-ZI
A16H1-H2	03577-24701	6	2	MCHD SPACER	28480	
A16J1	1251-8517	4	1	CONN-RECT MICROBPN 24-CKT 24-CONT	00779	554194-2
A16J3	1251-5202	8	1	CONN-POST TYPE .125-PIN-SPOG 5-CONT	03206P01	65580-105
A16L1-L2	9100-1791	1	2	CORE-FERRITE CHOKE-WIDEBAND;IMP:360	06337P01	VK200-19/4B
A16R1	0698-0083	8	3	RESISTOR 1.96K 1% .125W F TC=0+-100	05524P03	CMF-551961FT-1
A16R2	0698-0084	9	3	RESISTOR 2.15K 1% .125W F TC=0+-100	05524P03	CMF-552151FT-1
A16R3-R4	0683-4715	0	3	RESISTOR 470 5% .25W CF TC=0-400	77902	R-25J
A16R5	0698-0084	9		RESISTOR 2.15K 1% .125W F TC=0+-100	05524P03	CMF-552151FT-1
A16R6-R7	0698-0083	8		RESISTOR 1.96K 1% .125W F TC=0+-100	05524P03	CMF-551961FT-1
A16R8	0698-0084	9		RESISTOR 2.15K 1% .125W F TC=0+-100	05524P03	CMF-552151FT-1
A16R9	0683-4725	2	2	RESISTOR 4.7K 5% .25W CF TC=0-400	77902	R-25J
A16R10	0683-1025	9	1	RESISTOR 1K 5% .25W CF TC=0-400	77902	R-25J
A16R11-R12	0683-2215	1	2	RESISTOR 220 5% .25W CF TC=0-400	77902	R-25J
A16R20	0683-4715	0		RESISTOR 470 5% .25W CF TC=0-400	77902	R-25J
A16R21	0683-4725	2		RESISTOR 4.7K 5% .25W CF TC=0-400	77902	R-25J
A16RP1-RP6	1810-0722	3	6	R-N 120 OHMx4 2% SIP	91837	MSPO8A03-121G
A16TP1-TP5	1251-0600	0	5	CONNECTOR-SGL CONT PIN 1.14-MM-BSC-SZ SQ	27264	16-06-0034
A16U1	1820-2024	3	4	ICDRVR TTL LS LINE DRVR OCTL	01295	SN74LS244N
A16U2-U3	1820-1112	8	3	ICFF TTL LS D-TYPE POS-EDGE-TRIG	01295	SN74LS74AN
A16U4	9100-4394	6	6	XFM WIREWIND PLS DIP PKG	97722	EP8847
A16U5-U6	1820-1440	5	7	ICLCH TTL LS QUAD	01295	SN74LS279AN
A16U7	9100-4394	6		XFM WIREWIND PLS DIP PKG	97722	EP8847
A16U8	1820-2024	3		ICDRVR TTL LS LINE DRVR OCTL	01295	SN74LS244N
A16U9	1820-1112	8		ICFF TTL LS D-TYPE POS-EDGE-TRIG	01295	SN74LS74AN
A16U10	1820-1198	8	1	ICFF TTL LS D-TYPE POS-EDGE-TRIG COM	01295	SN74LS174N
A16U11	1820-1794	2	2	ICBFR TTL LS NON-INV OCTL	27014	DM74LS465N
A16U12	1820-1997	7	2	ICFF TTL LS D-TYPE POS-EDGE-TRIG PRL-IN	27014	DM74LS374N
A16U13	1820-2024	3		ICDRVR TTL LS LINE DRVR OCTL	01295	SN74LS244N
A16U14	9100-4394	6		XFM WIREWIND PLS DIP PKG	97722	EP8847
A16U15-U16	1820-1440	5		ICLCH TTL LS QUAD	01295	SN74LS279AN
A16U17	9100-4394	6		XFM WIREWIND PLS DIP PKG	97722	EP8847
A16U18	1820-2024	3		ICDRVR TTL LS LINE DRVR OCTL	01295	SN74LS244N
A16U19	1820-1432	5	1	ICCNTR TTL LS BIN SYNCHRO POS-EDGE-TRIG	01295	SN74LS163AN
A16U20	1820-1440	5		ICLCH TTL LS QUAD	01295	SN74LS279AN
A16U21	5180-5425	0	1	IC9914	28480	5180-5425
A16U22	1820-6045	6	1	ICD ALS181N OC TNCVR P20	01295	SN75ALS161N

See introduction to this section for ordering information

Table 6-3. Replaceable Parts

Ref.Des.	HP Part Number	CD	Qty	Description	Mfr. Code	Mfr. Part Number
A16U23	1820-8170	8	1	ICD ALS160N OC TNCVR P20	01295	SN75ALS160N
A16U24	9100-4394	6		XFM WIREWIND PLS DIP PKG	97722	EP8847
A16U25-U26	1820-1440	5		ICLCH TTL LS QUAD	01295	SN74LS279AN
A16U27	9100-4394	6		XFM WIREWIND PLS DIP PKG	97722	EP8847
A16U28	1820-1897	7		ICFF TTL LS D-TYPE POS-EDGE-TRIG PRL-IN	27014	DM74LS374N
A16U29	1820-1794	2		ICBFR TTL LS NON-INV OCTL	27014	DM74LS465N
A16U30	1990-0545	8	1	OFTO-ISOLATOR LED-PCIO/XSTR IF - 40MA-MAX	28480	1990-0545
A16	2190-0918	4	2	WASHER-LK HLCL NO. 6 .141-IN-ID	73734	
A16	1480-0116	6	2	PIN-GRV .062-IN-DIA .25-IN-LG STL	73957	G24-062 X 250-17
A16	0535-0007	2	2	NUT-HEX DBL-CHAM M3.5 X 0.6 2.8MM-THK	28480	
A16	7121-4611	2	1	LABEL-INFORMATION .15-IN-WD .6-IN-LG	28480	L01003
A17C1	0160-6731	6	13	C-F 1000PF 10% 50VDC CERML SMD	54583	C3216X7R1H102K
A17C2	0160-5790	5	25	CAPACITOR-FXD .1UF + -20% 25VDC CER	54583	C3216X7R1E104M
A17C3-C5	0160-6731	6		C-F 1000PF 10% 50VDC CERML SMD	54583	C3216X7R1H102K
A17C8	0160-5790	5		CAPACITOR-FXD .1UF + -20% 25VDC CER	54583	C3216X7R1E104M
A17C7-C8	0160-6731	6		C-F 1000PF 10% 50VDC CERML SMD	54583	C3216X7R1H102K
A17C9	0160-5790	5		CAPACITOR-FXD .1UF + -20% 25VDC CER	54583	C3216X7R1E104M
A17C10-C11	0160-6731	6		C-F 1000PF 10% 50VDC CERML SMD	54583	C3216X7R1H102K
A17C12	0160-6518	7	1	C-F 220PF 20% 100V CERML	28480	RPE121-878X7R221M100V
A17C13	0160-6731	6		C-F 1000PF 10% 50VDC CERML SMD	54583	C3216X7R1H102K
A17C14	0160-5790	5		CAPACITOR-FXD .1UF + -20% 25VDC CER	54583	C3216X7R1E104M
A17C15	0180-3847	1	23	C-F 22UF 10% 25V TADPDR	12340P02	T398H226K025AS
A17C16	0160-6731	6		C-F 1000PF 10% 50VDC CERML SMD	54583	C3216X7R1H102K
A17C17-C19	0160-5790	5		CAPACITOR-FXD .1UF + -20% 25VDC CER	54583	C3216X7R1E104M
A17C20	0180-3847	1		C-F 22UF 10% 25V TADPDR	12340P02	T398H226K025AS
A17C21	0160-4502	5	1	CAPACITOR-FXD 390PF + -5% 100VDC CER	04222	SR201A391JAAH
A17C22-C23	0160-6731	6		C-F 1000PF 10% 50VDC CERML SMD	54583	C3216X7R1H102K
A17C24	0160-5790	5		CAPACITOR-FXD .1UF + -20% 25VDC CER	54583	C3216X7R1E104M
A17C25	0180-3847	1		C-F 22UF 10% 25V TADPDR	12340P02	T398H226K025AS
A17C26-C28	0160-5790	5		CAPACITOR-FXD .1UF + -20% 25VDC CER	54583	C3216X7R1E104M
A17C29	0160-4640	2	3	CAPACITOR-FXD .1UF + -10% 100VDC	06337P01	712A1BB104PK101LA
A17C30	0160-4787	8	4	CAPACITOR-FXD 22PF + -5% 100VDC CER 0 + -30	04222	SA102A220JAAH
A17C31-C32	0160-5790	5		CAPACITOR-FXD .1UF + -20% 25VDC CER	54583	C3216X7R1E104M
A17C33	0180-3847	1		C-F 22UF 10% 25V TADPDR	12340P02	T398H226K025AS
A17C34	0160-5790	5		CAPACITOR-FXD .1UF + -20% 25VDC CER	54583	C3216X7R1E104M
A17C35	0180-3847	1		C-F 22UF 10% 25V TADPDR	12340P02	T398H226K025AS
A17C36-C37	0160-5790	5		CAPACITOR-FXD .1UF + -20% 25VDC CER	54583	C3216X7R1E104M
A17C50	0160-6731	6		C-F 1000PF 10% 50VDC CERML SMD	54583	C3216X7R1H102K
A17C51-C55	0160-5790	5		CAPACITOR-FXD .1UF + -20% 25VDC CER	54583	C3216X7R1E104M
A17C56	0180-3849	3	9	C-F 47UF 10% 10V TATBSa	12340P02	T398H476K010AS
A17C100-C103	0160-6736	1	42	C-F .01UF 10% 50VDC CER SMD	54583	C3216X7R1H103K
A17C104	0180-3849	3		C-F 47UF 10% 10V TATBSa	12340P02	T398H476K010AS
A17C105-C112	0160-6736	1		C-F .01UF 10% 50VDC CER SMD	54583	C3216X7R1H103K
A17C113	0160-4811	9	1	CAPACITOR-FXD 270PF + -5% 100VDC CER	04222	SA101A271JAAH
A17C114-C116	0160-6736	1		C-F .01UF 10% 50VDC CER SMD	54583	C3216X7R1H103K
A17C117	0160-4804	0	3	CAPACITOR-FXD 56PF + -5% 100VDC CER 0 + -30	04222	SA102A560JAAH
A17C118	0160-5790	5		CAPACITOR-FXD .1UF + -20% 25VDC CER	54583	C3216X7R1E104M
A17C119	0180-3552	5	1	C-F 4.7UF 10% 20V TATBSA	12340P02	T322B475K020AS
A17C120-C125	0160-6736	1		C-F .01UF 10% 50VDC CER SMD	54583	C3216X7R1H103K
A17C126	0180-3847	1		C-F 22UF 10% 25V TADPDR	12340P02	T398H226K025AS
A17C200-C201	0160-6736	1		C-F .01UF 10% 50VDC CER SMD	54583	C3216X7R1H103K
A17C202	0180-3849	3		C-F 47UF 10% 10V TATBSa	12340P02	T398H476K010AS
A17C203	0160-5790	5		CAPACITOR-FXD .1UF + -20% 25VDC CER	54583	C3216X7R1E104M
A17C204	0180-4133	0	11	C-F 15UF 10% 20V TATBSA	12340P02	T322D156K020AS

See introduction to this section for ordering information

\*Indicates factory selected values

Table 6-3. Replaceable Parts

Ref.Das.	HP Part Number	CD	Qty	Description	Mfr. Code	Mfr. Part Number
A17C205-C206	0160-6736	1		C-F .01UF 10% 50VDC CER SMD	54583	C3216X7R1H103K
A17C207	0180-4133	0		C-F 15UF 10% 20V TATBSA	12340P02	T322D156K020AS
A17C208	0160-6736	1		C-F .01UF 10% 50VDC CER SMD	54583	C3216X7R1H103K
A17C209	0160-5790	5		CAPACITOR-FXD .1UF + -20% 25VDC CER	54583	C3216X7R1E104M
A17C250	0180-3847	1		C-F 22UF 10% 25V TADPDR	12340P02	T398H226K025AS
A17C251	0160-6736	1		C-F .01UF 10% 50VDC CER SMD	54583	C3216X7R1H103K
A17C252	0180-3849	3		C-F 47UF 10% 10V TATBSa	12340P02	T398H476K010AS
A17C253	0160-6736	1		C-F .01UF 10% 50VDC CER SMD	54583	C3216X7R1H103K
A17C254	0160-4804	0		CAPACITOR-FXD 56PF + -5% 100VDC CER 0+ -30	04222	SA102A560JAAH
A17C255	0180-3849	3		C-F 47UF 10% 10V TATBSa	12340P02	T398H476K010AS
A17C256	0160-5790	5		CAPACITOR-FXD .1UF + -20% 25VDC CER	54583	C3216X7R1E104M
A17C257	0160-4804	0		CAPACITOR-FXD 56PF + -5% 100VDC CER 0+ -30	04222	SA102A560JAAH
A17C258	0180-3847	1		C-F 22UF 10% 25V TADPDR	12340P02	T398H226K025AS
A17C259	0160-6736	1		C-F .01UF 10% 50VDC CER SMD	54583	C3216X7R1H103K
A17C260	0180-3849	3		C-F 47UF 10% 10V TATBSa	12340P02	T398H476K010AS
A17C300	0160-6689	3	1	C-F 2.2UF 20% 50V CERMLR	28480	RPE114-807Z5U225M50V
A17C350-C351	0160-6736	1		C-F .01UF 10% 50VDC CER SMD	54583	C3216X7R1H103K
A17C352-C354	0180-3847	1		C-F 22UF 10% 25V TADPDR	12340P02	T398H226K025AS
A17C355	0160-6736	1		C-F .01UF 10% 50VDC CER SMD	54583	C3216X7R1H103K
A17C356	0180-3847	1		C-F 22UF 10% 25V TADPDR	12340P02	T398H226K025AS
A17C357	0180-4129	4	1	C-F 1UF 10% 35V TATBSA	12340P02	T322B105K035AS
A17C358	0180-3847	1		C-F 22UF 10% 25V TADPDR	12340P02	T398H226K025AS
A17C400	0160-4787	8		CAPACITOR-FXD 22PF + -5% 100VDC CER 0+ -30	04222	SA102A220JAAH
A17C401-C402	0160-6736	1		C-F .01UF 10% 50VDC CER SMD	54583	C3216X7R1H103K
A17C450	0160-4797	0	1	CAPACITOR-FXD 3.3PF +- .25PF 100VDC CER	04222	MA101A3R3CAA
A17C451-C452	0160-6736	1		C-F .01UF 10% 50VDC CER SMD	54583	C3216X7R1H103K
A17C453-C454	0160-4461	5	2	CAPACITOR-FXD 150PF +-2.5% 630VDC POLYP	06121P01	B33062/150PF/2.5%/630V
A17C455-C456	0180-3847	1		C-F 22UF 10% 25V TADPDR	12340P02	T398H226K025AS
A17C500	0160-4787	8		CAPACITOR-FXD 22PF + -5% 100VDC CER 0+ -30	04222	SA102A220JAAH
A17C501-C502	0160-6736	1		C-F .01UF 10% 50VDC CER SMD	54583	C3216X7R1H103K
A17C503-C504	0180-3847	1		C-F 22UF 10% 25V TADPDR	12340P02	T398H226K025AS
A17C550	0160-4787	8		CAPACITOR-FXD 22PF + -5% 100VDC CER 0+ -30	04222	SA102A220JAAH
A17C551-C552	0160-6736	1		C-F .01UF 10% 50VDC CER SMD	54583	C3216X7R1H103K
A17C553	0180-3847	1		C-F 22UF 10% 25V TADPDR	12340P02	T398H226K025AS
A17C554	0180-3941	6	1	C-F 100UF 10% 100V TADPDR	12340P02	T396J107K010AS
A17C555	0180-3847	1		C-F 22UF 10% 25V TADPDR	12340P02	T398H226K025AS
A17C556	0180-3849	3		C-F 47UF 10% 10V TATBSa	12340P02	T398H476K010AS
A17C600	0160-4810	8	1	CAPACITOR-FXD 330PF + -5% 100VDC CER	04222	SA101A331JAAH
A17C601-C602	0160-4640	2		CAPACITOR-FXD .1UF +-10% 100VDC	06337P01	712A1BB104PK101LA
A17C603-C604	0160-6736	1		C-F .01UF 10% 50VDC CER SMD	54583	C3216X7R1H103K
A17C605	0160-4808	4	1	CAPACITOR-FXD 470PF + -5% 100VDC CER	04222	SA101A471JAAH
A17C606	0160-4798	1	1	CAPACITOR-FXD 2.7PF + .25PF 100VDC CER	04222	MA101A2R7CAA
A17C607-C609	0180-4133	0		C-F 15UF 10% 20V TATBSA	12340P02	T322D156K020AS
A17C650	0160-5405	9	1	CAPACITOR-FXD 130PF + -5% 100VDC CER	28480	RPA10C0G131J100V
A17C651	0160-5719	8	1	CAPACITOR-FXD 620PF + -5% 100VDC CER	54583	SA201A621JAAH
A17C652	0160-4824	4	1	CAPACITOR-FXD 680PF + -5% 100VDC CER	04222	SA101A681JAAH
A17C653	0160-4802	8	1	CAPACITOR-FXD 82PF + -5% 100VDC CER 0+ -30	04222	SA102A820JAAH
A17C654	0160-4812	0	1	CAPACITOR-FXD 220PF + -5% 100VDC CER	04222	SA101A221JAAH
A17C700	0180-4131	8	3	C-F 4.7UF 10% 35V TATBSA	12340P02	T322C475K035AS
A17C701-C702	0180-3849	3		C-F 47UF 10% 10V TATBSa	12340P02	T398H476K010AS
A17C703-C704	0180-3847	1		C-F 22UF 10% 25V TADPDR	12340P02	T398H226K025AS
A17C705-C706	0180-4133	0		C-F 15UF 10% 20V TATBSA	12340P02	T322D156K020AS
A17C707	0180-3847	1		C-F 22UF 10% 25V TADPDR	12340P02	T398H226K025AS
A17C708-C709	0180-4133	0		C-F 15UF 10% 20V TATBSA	12340P02	T322D156K020AS
A17C710	0180-4131	8		C-F 4.7UF 10% 35V TATBSA	12340P02	T322C475K035AS
A17C711	0180-3847	1		C-F 22UF 10% 25V TADPDR	12340P02	T398H226K025AS
A17C712-C713	0180-4133	0		C-F 15UF 10% 20V TATBSA	12340P02	T322D156K020AS
A17C714	0180-4131	8		C-F 4.7UF 10% 35V TATBSA	12340P02	T322C475K035AS
A17CR1-CR2	0122-0162	5	2	DIODE-VVC 28PF 10% EVR = 30V	18324	8B809
A17CR3	1902-0945	7	1	DIODE-ZNR 3V 5% DO-35 PD = .4W TC = -.043%	04713	SZ0035-3FL
A17CR4	1901-0040	1	12	DIODE-SWITCHING 30V 50MA 2NS DO-35	27014	
A17CR150	1990-1122	9	1	OPT LED LMP G GP LMP1503 TT1H	28480	1990-1122
A17CR200-CR202	1901-0040	1		DIODE-SWITCHING 30V 50MA 2NS DO-35	27014	

See introduction to this section for ordering information

\*Indicates factory selected values



Table 6-3. Replaceable Parts

Ref.Des.	HP Part Number	CD	Qty	Description	Mfr. Code	Mfr. Part Number
A17CR250-CR251	1901-0040	1		DIODE-SWITCHING 30V 50MA 2NS DO-35	27014	
A17CR252	1901-0539	3	4	DIODE-SCHOTTKY SM SIG	28480	1901-0539
A17CR300	1990-1123	0	1	OPT LED LMP R AP LMP1301 TT1H	28480	1990-1123
A17CR301	1901-0040	1		DIODE-SWITCHING 30V 50MA 2NS DO-35	27014	
A17CR350-CR351	1902-0777	3	3	DIODE-ZNR 1N825 8.2V 5% DO-7 PD = .4W	04713	1N825
A17CR352	1901-0040	1		DIODE-SWITCHING 30V 50MA 2NS DO-35	27014	
A17CR400-CR402	1901-0539	3		DIODE-SCHOTTKY SM SIG	28480	1901-0539
A17CR550	1902-0777	3		DIODE-ZNR 1N825 8.2V 5% DO-7 PD = .4W	04713	1N825
A17CR551-CR553	1901-0040	1		DIODE-SWITCHING 30V 50MA 2NS DO-35	27014	
A17CR600	1901-0040	1		DIODE-SWITCHING 30V 50MA 2NS DO-35	27014	
A17CR601	1902-0847	9	1	DIODE-ZNR 3.6V 5% DO-35 PD = .4W TC = -.036%	04713	SZ30035-5
A17CR700	1902-1337	3	1	DIODE-ZNR 13V 2% DO-7 PD = .4W	12954	
A17H1A-HA2	1258-0141	8	2	CON-JUMPER REM .025P	00779	530153-2
A17J1-J3	1250-2142	7	3	CON-SMB	74870	131-3701-341
A17L1-L3	9140-0144	0	16	INDUCTOR RF-CH-MLD 4.7UH 10% .105DX.26LG	99800	1025-36
A17L4	9100-2251	0	2	INDUCTOR RF-CH-MLD 220NH 10% .105DX.26LG	24226	10M220K
A17L5-L6	9140-0144	0		INDUCTOR RF-CH-MLD 4.7UH 10% .105DX.26LG	99800	1025-36
A17L7	9140-1414	9	1	IND RF CHOKE VAR 17-19NH	01886P01	
A17L8	9100-2251	0		INDUCTOR RF-CH-MLD 220NH 10% .105DX.26LG	24226	10M220K
A17L9-L18	9140-0144	0		INDUCTOR RF-CH-MLD 4.7UH 10% .105DX.26LG	99800	1025-36
A17L50	9100-1791	1	1	CORE-FERRITE CHOKE-WIDEBAND;IMP:360	06337P01	VK200-19/48
A17L51	9140-0144	0		INDUCTOR RF-CH-MLD 4.7UH 10% .105DX.26LG	99800	1025-36
A17L52	9140-0748	0	10	INDUCTOR 250UH 25% .25DX.5LG Q = 3	24226	CA-253-5
A17L100	9140-0210	1	11	INDUCTOR RF-CH-MLD 100UH 5% .166DX.385LG	99800	1537-76
A17L101-L102	9140-0748	0		INDUCTOR 250UH 25% .25DX.5LG Q = 3	24226	CA-253-5
A17L200-L201	9140-0210	1		INDUCTOR RF-CH-MLD 100UH 5% .166DX.385LG	99800	1537-76
A17L250	9140-0748	0		INDUCTOR 250UH 25% .25DX.5LG Q = 3	24226	CA-253-5
A17L350	9140-0748	0		INDUCTOR 250UH 25% .25DX.5LG Q = 3	24226	CA-253-5
A17L450-L451	9140-0210	1		INDUCTOR RF-CH-MLD 100UH 5% .166DX.385LG	99800	1537-76
A17L550-L551	9140-0210	1		INDUCTOR RF-CH-MLD 100UH 5% .166DX.385LG	99800	1537-76
A17L600	9140-0210	1		INDUCTOR RF-CH-MLD 100UH 5% .166DX.385LG	99800	1537-76
A17L601	9140-0748	0		INDUCTOR 250UH 25% .25DX.5LG Q = 3	24226	CA-253-5
A17L650	9100-1652	3	1	INDUCTOR RF-CH-MLD 820UH 5% .2DX.45LG	99800	2500-24
A17L651	9100-1645	4	1	INDUCTOR RF-CH-MLD 390UH 5% .2DX.45LG	99800	2500-08
A17L700-L702	9140-0748	0		INDUCTOR 250UH 25% .25DX.5LG Q = 3	24226	CA-253-5
A17L703-L704	9100-1618	1	3	INDUCTOR RF-CH-MLD 5.6UH 10%	99800	1537-30
A17L705	9140-0748	0		INDUCTOR 250UH 25% .25DX.5LG Q = 3	24226	CA-253-5
A17L706-L708	9140-0210	1		INDUCTOR RF-CH-MLD 100UH 5% .166DX.385LG	99800	1537-76
A17L709	9100-1618	1		INDUCTOR RF-CH-MLD 5.6UH 10%	99800	1537-30
A17Q1	1854-0247	9	1	TRANSISTOR NPN SI TO-39 PD = 1W FT = 800MHZ	04713	SS3802
A17Q2	1854-1083	3	2	XTR NPN SGL MMBR5179 S23 SMD	04713	MMBR5179LT1
A17Q100	1853-0448	0	4	TRANSISTOR PNP SI TO-82 PD = 625MW	04713	MPSH81
A17Q200-Q202	1853-0640	4	5	XTR SML1PNP**	27014	2N4917
A17Q203-Q205	1854-1028	6	10	TRANSISTOR NPN SI PD = 350MW FT = 300MHZ	04713	2N3904
A17Q206-Q207	1855-0747	6	4	XTR J-FET N-CHAN	04713	SPF819-2
A17Q250	1854-1083	3		XTR NPN SGL MMBR5179 S23 SMD	04713	MMBR5179LT1
A17Q251-Q253	1853-0448	0		TRANSISTOR PNP SI TO-82 PD = 625MW	04713	MPSH81
A17Q350-Q351	1854-1028	6		TRANSISTOR NPN SI PD = 350MW FT = 300MHZ	04713	2N3904
A17Q400	1855-0689	5	2	XTR SML1JFET	04713	2N5461
A17Q450	1855-0308	5	1	TRANSISTOR JFET DUAL N-CHAN D-MODE SI	17856	
A17Q500	1855-0689	5		XTR SML1JFET	04713	2N5461
A17Q550	1854-1028	6		TRANSISTOR NPN SI PD = 350MW FT = 300MHZ	04713	2N3904
A17Q600-Q601	1854-1028	6		TRANSISTOR NPN SI PD = 350MW FT = 300MHZ	04713	2N3904
A17Q602-Q603	1855-0747	6		XTR J-FET N-CHAN	04713	SPF819-2
A17Q604-Q605	1853-0640	4		XTR SML1PNP**	27014	2N4917
A17Q606-Q607	1854-1028	6		TRANSISTOR NPN SI PD = 350MW FT = 300MHZ	04713	2N3904
A17Q700	1853-0320	7	1	TRANSISTOR PNP 2N4032 SI TO-5 PD = 800MW	27014	2N4032
A17R1-R3	0699-2699	8	3	R-F 16.5 1% 1/8W SMD	91637	CRCW1206-16.5FRT2
A17R4	0699-2702	4	7	R-F 84.5 1% 1/8W SMD	91637	CRCW1206-84.5FRT2
A17R5	0683-2215	1	4	RESISTOR 220 5% .25W CF TC = 0-400	77902	R-25J
A17R6-R7	0699-2544	2	4	R-F 93.1 1% 1/8W SMD	91637	CRCW120693R1F
A17R8-R10	0699-2702	4		R-F 84.5 1% 1/8W SMD	91637	CRCW1206-84.5FRT2

See introduction to this section for ordering information

\*Indicates factory selected values

Table 6-3. Replaceable Parts

Ref.Des.	HP Part Number	CD	Qty	Description	Mfr. Code	Mfr. Part Number
A17R11-R13	0683-2215	1		RESISTOR 220 5% .25W CF TC = 0-400	77902	R-25J
A17R14	0699-2700	2	3	R-F 60.4 1% 1/8W SMD	91637	CRCW1206-60.4FRT2
A17R15-R16	0699-1415	4	2	RESISTOR 100 1% .125W F TC = 0+-100	91637	CRCW12061000F
A17R17	0699-2700	2		R-F 60.4 1% 1/8W SMD	91637	CRCW1206-60.4FRT2
A17R18-R20	0699-2702	4		R-F 84.5 1% 1/8W SMD	91637	CRCW1206-84.5FRT2
A17R21	0699-1318	6	1	RESISTOR 1K 1% .125W F TC = 0+-100	91637	CRCW12061001F
A17R22	0699-2544	2		R-F 93.1 1% 1/8W SMD	91637	CRCW120693R1F
A17R23	0699-1372	2	1	RESISTOR 1.47K 1% .125W F TC = 0+-100	91637	CRCW12061471F
A17R24-R26	0699-1433	6	3	RESISTOR 562 1% .125W F TC = 0+-100	91637	CRCW12065620F
A17R27	0699-2544	2		R-F 93.1 1% 1/8W SMD	91637	CRCW120693R1F
A17R28	0699-2701	3	1	R-F 71.5 1% 1/8W SMD	91637	CRCW1206-71.5FRT2
A17R29-R32	0699-1370	0	4	RESISTOR 1.21K 1% .125W F TC = 0+-100	91637	CRCW12061211F
A17R33	2100-3252	6	1	RESISTOR-TRMR 5K 10% C TOP-ADJ 1-TRN	32997	3386P-Y46-502
A17R34	0757-0274	5	1	RESISTOR 1.21K 1% .125W F TC = 0+-100	05524P03	CMF-55-1
A17R35	0757-0465	6	3	RESISTOR 100K 1% .125W F TC = 0+-100	05524P03	CMF-55-1
A17R36	0699-4207	6	1	RESISTOR 44.2K 1% .125W F TC = 0+-100	91637	CMF-554422FT-1
A17R37	0757-0410	1	1	RESISTOR 301 1% .125W F TC = 0+-100	05524P03	CMF-55-1
A17R38	0757-0438	3	2	RESISTOR 5.11K 1% .125W F TC = 0+-100	05524P03	CMF-55-1
A17R39	0757-0283	6	1	RESISTOR 2K 1% .125W F TC = 0+-100	05524P03	CMF-55-1
A17R40	0699-4515	9	1	RESISTOR 107K 1% .125W F TC = 0+-100	91637	CMF-551073FT-1
A17R41	0757-0454	3	1	RESISTOR 33.2K 1% .125W F TC = 0+-100	05524P03	CMF-55-1
A17R50	0699-1427	8	2	RESISTOR 316 1% .125W F TC = 0+-100	91637	CRCW12063160F
A17R51	0699-2700	2		R-F 60.4 1% 1/8W SMD	91637	CRCW1206-60.4FRT2
A17R52	0699-1427	8		RESISTOR 316 1% .125W F TC = 0+-100	91637	CRCW12063160F
A17R53-R55	0683-1035	1	14	RESISTOR 10K 5% .25W CF TC = 0-400	77902	R-25J
A17R100-R105	0683-1035	1		RESISTOR 10K 5% .25W CF TC = 0-400	77902	R-25J
A17R106	0683-1015	7	2	RESISTOR 100 5% .25W CF TC = 0-400	77902	R-25J
A17R107	0683-1035	1		RESISTOR 10K 5% .25W CF TC = 0-400	77902	R-25J
A17R108	0699-3132	4	1	RESISTOR 261 1% .125W F TC = 0+-100	05524P03	CMF-552610FT-1
A17R109	0757-0398	4	1	RESISTOR 75 1% .125W F TC = 0+-100	05524P03	CMF-55-1
A17R110	0683-1035	1		RESISTOR 10K 5% .25W CF TC = 0-400	77902	R-25J
A17R111	0683-3325	6	2	RESISTOR 3.3K 5% .25W CF TC = 0-400	77902	R-25J
A17R112	0683-2025	1	2	RESISTOR 2K 5% .25W CF TC = 0-400	77902	R-25J
A17R113	0699-4440	9	1	RESISTOR 3.4K 1% .125W F TC = 0+-100	91637	CMF-553401FT-1
A17R114	0699-0064	5	2	RESISTOR 9.31K 1% .125W F TC = 0+-100	05524P03	CMF-55-1
A17R150	0683-1315	0	1	RESISTOR 130 5% .25W CF TC = 0-400	77902	R-25J
A17R200	0683-1035	1		RESISTOR 10K 5% .25W CF TC = 0-400	77902	R-25J
A17R201	0699-4469	2	1	RESISTOR 1.15K 1% .125W F TC = 0+-100	05524P03	CMF-551151FT-1
A17R202	0699-3178	8	1	RESISTOR 487 1% .125W F TC = 0+-100	91637	CMF-554870FT-1
A17R203	0699-4464	7	1	RESISTOR 887 1% .125W F TC = 0+-100	91637	CMF-55-1
A17R204	0683-4705	8	14	RESISTOR 47 5% .25W CF TC = 0-400	77902	R-25J
A17R205	0699-0064	5		RESISTOR 9.31K 1% .125W F TC = 0+-100	05524P03	CMF-55-1
A17R206	0699-3225	6	1	RESISTOR 1.43K 1% .125W F TC = 0+-100	05524P03	CMF-551431FT-1
A17R207	0699-3515	7	1	RESISTOR 5.8K 1% .125W F TC = 0+-100	05524P03	CMF-555801FT-1
A17R208	0757-0418	9	1	RESISTOR 619 1% .125W F TC = 0+-100	05524P03	CMF-55-1
A17R209-R210	0757-0428	2	2	RESISTOR 1.82K 1% .125W F TC = 0+-100	91637	CMF-55-1
A17R211	0757-0280	3	6	RESISTOR 1K 1% .125W F TC = 0+-100	05524P03	CMF-55-1
A17R212	0699-0083	8	5	RESISTOR 1.96K 1% .125W F TC = 0+-100	05524P03	CMF-551961FT-1
A17R213	0757-0280	3		RESISTOR 1K 1% .125W F TC = 0+-100	05524P03	CMF-55-1
A17R214	0757-0281	4	3	RESISTOR 2.74K 1% .125W F TC = 0+-100	05524P03	CMF-55-1
A17R215	0699-0083	8		RESISTOR 1.96K 1% .125W F TC = 0+-100	05524P03	CMF-551961FT-1
A17R216	0757-0280	3		RESISTOR 1K 1% .125W F TC = 0+-100	05524P03	CMF-55-1
A17R217	0757-0281	4		RESISTOR 2.74K 1% .125W F TC = 0+-100	05524P03	CMF-55-1
A17R218	2100-3611	1	1	RESISTOR-TRMR 50K 10% C SIDE-ADJ 17-TRN	04568P02	67XR
A17R219	0699-0083	8		RESISTOR 1.96K 1% .125W F TC = 0+-100	05524P03	CMF-551961FT-1
A17R220	0757-0280	3		RESISTOR 1K 1% .125W F TC = 0+-100	05524P03	CMF-55-1
A17R221	0757-0281	4		RESISTOR 2.74K 1% .125W F TC = 0+-100	05524P03	CMF-55-1
A17R222	2100-3354	9	1	RESISTOR-TRMR 50K 10% C SIDE-ADJ 1-TRN	32997	3386X-Y46-503
A17R223	2100-3352	7	1	RESISTOR-TRMR 1K 10% C SIDE-ADJ 1-TRN	32997	3386X-Y46-102
A17R224	0683-0275	9	1	RESISTOR 2.7 5% .25W CF TC = 0-400	77902	R-25J
A17R225	0757-0442	9	1	RESISTOR 10K 1% .125W F TC = 0+-100	05524P03	CMF-55-1
A17R250	0699-3441	8	1	RESISTOR 215 1% .125W F TC = 0+-100	05524P03	CMF-552150FT-1
A17R251	0683-4705	8		RESISTOR 47 5% .25W CF TC = 0-400	77902	R-25J

See introduction to this section for ordering information

\*Indicates factory selected values

Table 6-3. Replaceable Parts

Ref.Des.	HP Part Number	CD	Qty	Description	Mfr. Code	Mfr. Part Number
A17R252	0689-4390	6	1	RESISTOR 45.3 1% .125W F TC=0+-100	91637	CMF-55-1
A17R253	0757-0317	7	2	RESISTOR 1.33K 1% .125W F TC=0+-100	05524P03	CMF-55-1
A17R254	0757-0419	0	2	RESISTOR 681 1% .125W F TC=0+-100	05524P03	CMF-55-1
A17R255	0683-4705	8		RESISTOR 47 5% .25W CF TC=0-400	77902	R-25J
A17R256	0757-0395	1	1	RESISTOR 56.2 1% .125W F TC=0+-100	91637	CMF-55-1
A17R257	0683-4705	8		RESISTOR 47 5% .25W CF TC=0-400	77902	R-25J
A17R258	0757-0419	0		RESISTOR 681 1% .125W F TC=0+-100	05524P03	CMF-55-1
A17R259	0757-0317	7		RESISTOR 1.33K 1% .125W F TC=0+-100	05524P03	CMF-55-1
A17R260	0683-4715	0	4	RESISTOR 470 5% .25W CF TC=0-400	77902	R-25J
A17R261	0683-2205	9	1	RESISTOR 22 5% .25W CF TC=0-400	77902	R-25J
A17R262	0683-4705	8		RESISTOR 47 5% .25W CF TC=0-400	77902	R-25J
A17R263	0757-0436	3		RESISTOR 5.11K 1% .125W F TC=0+-100	05524P03	CMF-55-1
A17R264	0686-3440	7	1	RESISTOR 196 1% .125W F TC=0+-100	05524P03	CMF-551960FT-1
A17R265	0757-0417	8	1	RESISTOR 562 1% .125W F TC=0+-100	05524P03	CMF-55-1
A17R266	0683-4705	8		RESISTOR 47 5% .25W CF TC=0-400	77902	R-25J
A17R267	0683-4715	0		RESISTOR 470 5% .25W CF TC=0-400	77902	R-25J
A17R268	0683-4705	8		RESISTOR 47 5% .25W CF TC=0-400	77902	R-25J
A17R269	0683-3325	6		RESISTOR 3.3K 5% .25W CF TC=0-400	77902	R-25J
A17R270	0683-4715	0		RESISTOR 470 5% .25W CF TC=0-400	77902	R-25J
A17R271	0757-0401	0	2	RESISTOR 100 1% .125W F TC=0+-100	05524P03	CMF-55-1
A17R300	0683-1525	4	1	RESISTOR 1.5K 5% .25W CF TC=0-400	77902	R-25J
A17R301	0686-4307	7	1	RESISTOR 14.3K 1% .125W F TC=0+-100	05524P03	CMF-551432FT-1
A17R302	0683-2035	3	1	RESISTOR 20K 5% .25W CF TC=0-400	77902	R-25J
A17R350	2100-0552	3	1	RESISTOR-TRMR 50 10% C SIDE-ADJ 1-TRN	32997	3388X-Y46-500
A17R351	0683-1035	1		RESISTOR 10K 5% .25W CF TC=0-400	77902	R-25J
A17R352	0757-0401	0		RESISTOR 100 1% .125W F TC=0+-100	05524P03	CMF-55-1
A17R353	0683-4715	0		RESISTOR 470 5% .25W CF TC=0-400	77902	R-25J
A17R354	0683-3625	9	1	RESISTOR 3.8K 5% .25W CF TC=0-400	77902	R-25J
A17R355	0683-2025	1		RESISTOR 2K 5% .25W CF TC=0-400	77902	R-25J
A17R356	0683-1015	7		RESISTOR 100 5% .25W CF TC=0-400	77902	R-25J
A17R357	0686-3495	2	1	RESISTOR 866 1% .125W F TC=0+-100	05524P03	CMF-55660FT-1
A17R358	0686-4125	7	1	RESISTOR 953 1% .125W F TC=0+-100	91637	CMF-559530FT-1
A17R359	0683-4705	8		RESISTOR 47 5% .25W CF TC=0-400	77902	R-25J
A17R360	0686-8981	7	1	RESISTOR 909K 1% .125W F TC=0+-100	77902	C8B25-FX-9093
A17R361	0683-1065	7	1	RESISTOR 10M 5% .25W CC TC=-900/+1100	01121	C81065
A17R362	0683-1005	5	1	RESISTOR 10 5% .25W CF TC=0-400	77902	R-25J
A17R363	0757-0439	4	2	RESISTOR 6.81K 1% .125W F TC=0+-100	05524P03	CMF-55-1
A17R364	0686-4424	9	1	RESISTOR 1.4K 1% .125W F TC=0+-100	05524P03	CMF-55-1
A17R365	0757-0465	6		RESISTOR 100K 1% .125W F TC=0+-100	05524P03	CMF-55-1
A17R450	0757-0450	9	1	RESISTOR 22.1K 1% .125W F TC=0+-100	05524P03	CMF-55-1
A17R451	0683-1025	9	8	RESISTOR 1K 5% .25W CF TC=0-400	77902	R-25J
A17R452-R453	0686-3156	2	2	RESISTOR 14.7K 1% .125W F TC=0+-100	05524P03	CMF-551472FT-1
A17R500	0686-3484	9	1	RESISTOR 6.65K 1% .125W F TC=0+-100	05524P03	CMF-556651FT-1
A17R501	0757-0280	3		RESISTOR 1K 1% .125W F TC=0+-100	05524P03	CMF-55-1
A17R502	0686-4394	2	1	RESISTOR 76.8 1% .125W F TC=0+-100	05524P03	CMF-55768FT-1
A17R503	0757-0436	1	1	RESISTOR 4.32K 1% .125W F TC=0+-100	91637	CMF-55-1
A17R550	0757-0420	3	1	RESISTOR 750 1% .125W F TC=0+-100	05524P03	CMF-55-1
A17R551	0757-0465	6		RESISTOR 100K 1% .125W F TC=0+-100	05524P03	CMF-55-1
A17R552	0757-0451	0	1	RESISTOR 24.3K 1% .125W F TC=0+-100	91637	CMF-55-1
A17R553	0683-1025	9		RESISTOR 1K 5% .25W CF TC=0-400	77902	R-25J
A17R600	0686-0083	8		RESISTOR 1.96K 1% .125W F TC=0+-100	05524P03	CMF-551961FT-1
A17R601	0683-1025	9		RESISTOR 1K 5% .25W CF TC=0-400	77902	R-25J
A17R602	0757-0439	4		RESISTOR 6.81K 1% .125W F TC=0+-100	05524P03	CMF-55-1
A17R603-R604	0683-4705	8		RESISTOR 47 5% .25W CF TC=0-400	77902	R-25J
A17R605	0757-0416	7	2	RESISTOR 511 1% .125W F TC=0+-100	05524P03	CMF-55-1
A17R606	0683-4705	8		RESISTOR 47 5% .25W CF TC=0-400	77902	R-25J
A17R607	0757-0421	4	2	RESISTOR 825 1% .125W F TC=0+-100	05524P03	CMF-55-1
A17R608	0683-4705	8		RESISTOR 47 5% .25W CF TC=0-400	77902	R-25J
A17R609-R610	0683-1025	9		RESISTOR 1K 5% .25W CF TC=0-400	77902	R-25J
A17R611	0683-1835	9	1	RESISTOR 18K 5% .25W CF TC=0-400	77902	R-25J
A17R612	0757-0416	7		RESISTOR 511 1% .125W F TC=0+-100	05524P03	CMF-55-1
A17R613	0683-4705	8		RESISTOR 47 5% .25W CF TC=0-400	77902	R-25J

See introduction to this section for ordering information

\*Indicates factory selected values

Table 6-3. Replaceable Parts

Ref.Des.	HP Part Number	CD	Qty	Description	Mfr. Code	Mfr. Part Number
A17R614	0683-1035	1		RESISTOR 10K 5% .25W CF TC = 0-400	77902	R-25J
A17R615	0683-1025	9		RESISTOR 1K 5% .25W CF TC = 0-400	77902	R-25J
A17R616	0683-4705	8		RESISTOR 47 5% .25W CF TC = 0-400	77902	R-25J
A17R617	0683-1045	3	1	RESISTOR 100K 5% .25W CF TC = 0-400	77902	R-25J
A17R618	2100-3759	8	1	RESISTOR-TRMR 2K 10% C SIDE-ADJ 17-TRN	04566P02	67XR
A17R619	0698-0063	8		RESISTOR 1.96K 1% .125W F TC = 0+-100	05524P03	CMF-551961FT-1
A17R620	0757-0421	4		RESISTOR 825 1% .125W F TC = 0+-100	05524P03	CMF-55-1
A17R650	0757-0280	3		RESISTOR 1K 1% .125W F TC = 0+-100	05524P03	CMF-55-1
A17R700	0683-1025	8		RESISTOR 1K 5% .25W CF TC = 0-400	77902	R-25J
A17R701	0683-6815	5	1	RESISTOR 680 5% .25W CF TC = 0-400	77902	R-25J
A17R702	0683-1025	9		RESISTOR 1K 5% .25W CF TC = 0-400	77902	R-25J
A17TP100-TP110	1251-0600	0	28	CONNECTOR-SGL COINT PIN 1.14-MM-BSC-SZ SQ	27264	16-06-0034
A17TP200-TP201	1251-0600	0		CONNECTOR-SGL COINT PIN 1.14-MM-BSC-SZ SQ	27264	16-06-0034
A17TP250-TP252	1251-0600	0		CONNECTOR-SGL COINT PIN 1.14-MM-BSC-SZ SQ	27264	16-06-0034
A17TP400	1251-0600	0		CONNECTOR-SGL COINT PIN 1.14-MM-BSC-SZ SQ	27264	16-06-0034
A17TP450	1251-0600	0		CONNECTOR-SGL COINT PIN 1.14-MM-BSC-SZ SQ	27264	16-06-0034
A17TP550	1251-0600	0		CONNECTOR-SGL COINT PIN 1.14-MM-BSC-SZ SQ	27264	16-06-0034
A17TP600	1251-0600	0		CONNECTOR-SGL COINT PIN 1.14-MM-BSC-SZ SQ	27264	16-06-0034
A17TP700-TP707	1251-0600	0		CONNECTOR-SGL COINT PIN 1.14-MM-BSC-SZ SQ	27264	16-06-0034
A17U1-U4	1826-2066	5	4	ICL AMP MSA 0386 .3DB SO4	28480	1826-2066
A17U4	1826-2066	5	1	ICL AMP MSA 0386 .3DB SO4	28480	1826-2066
A17U5	1826-0715	7	4	ICOP AMP LOW-NOISE 8-DIP-P PKG	18324	NE5534AN
A17U50	1820-3517	1	1	ICDVR ECL VAR-MODULE	01590P01	SP8680BDG
A17U51-U53	1820-0629	0	8	ICFF TTL S J-K NEG-EDGE-TRIG	01295	SN74S112AN
A17U52-U53	1820-0629	0	7	ICFF TTL S J-K NEG-EDGE-TRIG	01295	SN74S112AN
A17U53	1820-0629	0	6	ICFF TTL S J-K NEG-EDGE-TRIG	01295	SN74S112AN
A17U100-U102	1820-0629	0	0	ICFF TTL S J-K NEG-EDGE-TRIG	01295	SN74S112AN
A17U101-U102	1820-0629	0	4	ICFF TTL S J-K NEG-EDGE-TRIG	01295	SN74S112AN
A17U102	1820-0629	0	3	ICFF TTL S J-K NEG-EDGE-TRIG	01295	SN74S112AN
A17U103	1820-1208	3	1	ICGATE TTL LS OR QUAD 2-INP	01295	SN74LS32N
A17U105-U106	1820-0629	0	0	ICFF TTL S J-K NEG-EDGE-TRIG	01295	SN74S112AN
A17U108	1820-0629	0	1	ICFF TTL S J-K NEG-EDGE-TRIG	01295	SN74S112AN
A17U107	1820-0681	4	3	ICGATE TTL S NAND QUAD 2-INP	01295	SN74S00N
A17U108	1820-0683	6	1	ICINV TTL S HEX 1-INP	01295	SN74S04N
A17U109	1820-0693	8	1	ICFF TTL S D-TYPE POS-EDGE-TRIG	01295	SN74S74N
A17U110	1820-1322	2	1	ICGATE TTL S NOR QUAD 2-INP	01295	SN74S02N
A17U111	1820-0681	4	4	ICGATE TTL S NAND QUAD 2-INP	01295	SN74S00N
A17U112	1820-1279	8	2	ICCNTR TTL LS DECD UP/DOWN SYNCHRO	04713	SN74LS190N
A17U114	1820-0681	4		ICGATE TTL S NAND QUAD 2-INP	01295	SN74S00N
A17U115	1820-1144	6	1	ICGATE TTL LS NOR QUAD 2-INP	01295	SN74LS02N
A17U116	1820-1112	8	2	ICFF TTL LS D-TYPE POS-EDGE-TRIG	01295	SN74LS74AN
A17U120	1820-1279	8		ICCNTR TTL LS DECD UP/DOWN SYNCHRO	04713	SN74LS190N
A17U121-U122	1820-1196	8	3	ICFF TTL LS D-TYPE POS-EDGE-TRIG COM	01295	SN74LS174N
A17U122	1820-1196	8	2	ICFF TTL LS D-TYPE POS-EDGE-TRIG COM	01295	SN74LS174N
A17U123	5180-5429	4	1	ICC ANLG FRAC-N	28480	5180-5429
A17U124	1820-2102	8	1	ICLCH TTL LS D-TYPE OCTL	01295	SN74LS373N
A17U200	1820-1112	8		ICFF TTL LS D-TYPE POS-EDGE-TRIG	01295	SN74LS74AN
A17U201	1820-1196	8		ICFF TTL LS D-TYPE POS-EDGE-TRIG COM	01295	SN74LS174N
A17U202	1810-0294	4	1	NETWORK-RESISTOR 16 PIN DIP; RES	28480	1810-0294
A17U250	1820-0817	8	1	ICFF ECL D-M/S DUAL	04713	MC10131P
A17U251	1826-0122	0	3	ICV RGLTR-FXD-POS 4.8/5.2V TO-220 PKG	27014	LM340T-5
A17U300	1826-0412	1	1	ICCOMPARATOR PRCN DUAL 8-DIP-P PKG	27014	LM393N
A17U350	1821-0001	4	1	TRANSISTOR ARRAY 14-PIN PLSTC DIP	34371	CA3046
A17U351	1826-0773	7	1	ICOP AMP GP TO-99 PKG	27014	LM10CH
A17U400	1826-0715	7		ICOP AMP LOW-NOISE 8-DIP-P PKG	18324	NE5534AN
A17U450	1826-0700	0	1	ICOP AMP WB 14-DIP-C PKG	34371	HA1-5195-5
A17U500	1826-0715	7		ICOP AMP LOW-NOISE 8-DIP-P PKG	18324	NE5534AN
A17U550	1826-0715	7		ICOP AMP LOW-NOISE 8-DIP-P PKG	18324	NE5534AN
A17U600	1826-0021	8	1	ICOP AMP GP TO-99 PKG	27014	LM310H
A17U601	1826-0221	0	1	ICV RGLTR-FXD-NEG 11.5/12.5V TO-220 PKG	04713	MC7912CT
A17U700	1826-0122	0		ICV RGLTR-FXD-POS 4.8/5.2V TO-220 PKG	27014	LM340T-5
A17U701	1826-0147	9	3	ICV RGLTR-FXD-POS 11.5/12.5V TO-220 PKG	04713	MC7912CT
A17U702	1826-0122	0		ICV RGLTR-FXD-POS 4.8/5.2V TO-220 PKG	27014	LM340T-5

See introduction to this section for ordering information

\*Indicates factory selected values



Table 6-3. Replaceable Parts

Ref.Des.	HP Part Number	CD	Qty	Description	Mfr. Code	Mfr. Part Number
A17U703-U704	1828-0147	9		ICV RGLTR-FXD-POS 11.5/12.5V TO-220 PKG	04713	MC7812CT
A17U704	1828-0147	9	1	ICV RGLTR-FXD-POS 11.5/12.5V TO-220 PKG	04713	MC7812CT
A17W1-W3	1251-4822	6	3	CONN-POST TYPE .100-PIN-SPOG 3-CONT	27264	22-03-2031
A17XQ1	1200-0185	9	1	INSULATOR-XSTR NYLON	13103	7717-88N RED
A17	0515-1643	2	17	SCR-MCH M3.0 22MMLG PHPZ SST *	83486	
A17	1205-0639	8	7	STMP HEATSINK	28480	576802B03100
A17	2190-0824	1	4	WASHER-LK INTL T NO. 3 .102-IN-ID	73734	89401
A17	0515-0905	7	4	SCREW-MACH M2.5 X 0.45 6MM-LG PAN-HD	83486	
A17	2190-0124	4	3	WASHER-LK INTL T NO. 10 .185-IN-ID	98291	3002-26
A17	2850-0078	9	3	NUT-HEX-OBL-CHAM 10-32-THD .087-IN-THK	98291	40001-18-030-156
A17	03577-04127	8	1	SHTF CVR-R-SYNTHSZR ALSK	13588P02	
A17	03577-04130	3	1	SHTF CVR-SYNTHSZR SHLD ALSK	13588P02	
A17	03577-20601	7	1	CSTG-SHIELD-CIRCUIT SIDE AL	13599P01	03577-20601
A17	03577-20602	6	1	CSTG-SHIELD-COMPONENT SD AL	13599P01	03577-20602
A17	03577-40603	1	1	CSTG-SHIELD-COVER AL	13599P01	03577-40603
A17	03577-40604	2	1	CSTG-SHIELD-TOP AL	13599P01	03577-40604
A18	03577-66518	1	1	PCASSY OUTPUT	28480	03577-66518
A18C20	0160-8757	6	6	C-F 100PF 5% 50V COG 1206 SMT	28480	GRM42-602C0G101J050C
A18C21	0160-8736	1	6	C-F .01UF 10% 50VDC CER SMD	54583	C3216X7R1H103K
A18C22*	0121-0512	7		CAPACITOR-V TRMR-CER 2-5PF 100V PC-MTG	59680	518-002 A 2-5
A18C23	0160-5790	5	80	CAPACITOR-FXD .1UF +-20% 25VDC CER	54583	C3216X7R1E104M
A18C24*	0160-7279	9		C-F 1pF -% 50V CERML SMD	04222	C1206C0G1R0C100LR
A18C25*	0121-0512	7		CAPACITOR-V TRMR-CER 2-5PF 100V PC-MTG	59680	518-002 A 2-5
A18C26-C28	0160-5790	5		CAPACITOR-FXD .1UF +-20% 25VDC CER	54583	C3216X7R1E104M
A18C29	0160-8736	1		C-F .01UF 10% 50VDC CER SMD	54583	C3216X7R1H103K
A18C31	0160-8736	1		C-F .01UF 10% 50VDC CER SMD	54583	C3216X7R1H103K
A18C50-C51	0160-5790	5		CAPACITOR-FXD .1UF +-20% 25VDC CER	54583	C3216X7R1E104M
A18C52	0180-4136	3	6	C-F 10UF 10% 20V TATBSA	12340P02	T322C106K020AS
A18C53	0180-3845	9	3	C-F 4.7UF 10% 35V TADPDR	04222	TAL475K035
A18C54	0160-8731	6	8	C-F 1000PF 10% 50VDC CERML SMD	54583	C3216X7R1H102K
A18C55	0160-5790	5		CAPACITOR-FXD .1UF +-20% 25VDC CER	54583	C3216X7R1E104M
A18C56	0160-8731	6		C-F 1000PF 10% 50VDC CERML SMD	54583	C3216X7R1H102K
A18C57	0180-4136	3		C-F 10UF 10% 20V TATBSA	12340P02	T322C106K020AS
A18C58-C63	0160-5790	5		CAPACITOR-FXD .1UF +-20% 25VDC CER	54583	C3216X7R1E104M
A18C64*	0160-7096	8		C-F 8PF 5% 50VDC SMD	28480	GRH42-6C0G60D50VET
A18C65*	0160-7096	8		C-F 8PF 5% 50VDC SMD	28480	GRH42-6C0G60D50VET
A18C66-C67	0160-6757	6		C-F 100PF 5% 50V COG 1206 SMT	28480	GRM42-602C0G101J050C
A18C100	0180-3845	9		C-F 4.7UF 10% 35V TADPDR	04222	TAL475K035
A18C101	0160-5790	5		CAPACITOR-FXD .1UF +-20% 25VDC CER	54583	C3216X7R1E104M
A18C104	0180-3831	3	4	C-F 10UF 10% 35V TADPDR	12340P02	T398G106K035AS
A18C105-C106	0160-5790	5		CAPACITOR-FXD .1UF +-20% 25VDC CER	54583	C3216X7R1E104M
A18C107	0180-3831	3		C-F 10UF 10% 35V TADPDR	12340P02	T398G106K035AS
A18C150	0180-3831	3		C-F 10UF 10% 35V TADPDR	12340P02	T398G106K035AS
A18C151-R506	0160-5790	5		CAPACITOR-FXD .1UF +-20% 25VDC CER	54583	C3216X7R1E104M
A18C153	0180-3831	3		C-F 10UF 10% 35V TADPDR	12340P02	T398G106K035AS
A18C156	0160-5790	5		CAPACITOR-FXD .1UF +-20% 25VDC CER	54583	C3216X7R1E104M
A18C157	0180-3845	9		C-F 4.7UF 10% 35V TADPDR	04222	TAL475K035
A18C200	0160-6515	4	2	C-F 10PF -% 200V CERMLR	28480	RPE121-878C0G100D200V
A18C201	0160-4381	8	1	CAPACITOR-FXD 1.5PF +-25PF 200VDC CER	54583	FD11C0G2D1R5C
A18C202	0160-6508	5	6	C-F 22PF 5% 200V CERML	28480	RPE121-878C0G220J200V
A18C203	0160-6524	5	1	C-F 8.8PF -% 200V CERMLR	28480	RPE121-878C0G6R8D200V
A18C204	0160-6508	5		C-F 22PF 5% 200V CERML	28480	RPE121-878C0G220J200V
A18C205	0160-6515	4		C-F 10PF -% 200V CERMLR	28480	RPE121-878C0G100D200V

See introduction to this section for ordering information

\*Indicates factory selected values

Table 6-3. Replaceable Parts

Ref.Des.	HP Part Number	CD	Qty	Description	Mfr. Code	Mfr. Part Number
A18C300-C315	0160-5790	5		CAPACITOR-FXD .1UF +20% 25VDC CER	54583	C3216X7R1E104M
A18C350	0160-6736	1		C-F .01UF 10% 50VDC CER SMD	54583	C3216X7R1H103K
A18C351	0160-5790	5		CAPACITOR-FXD .1UF +20% 25VDC CER	54583	C3216X7R1E104M
A18C352	0160-4134	1	3	C-F 22UF 10% 15V TATBSA	12340P02	T322D226K015AS
A18C353-C354	0160-5790	5		CAPACITOR-FXD .1UF +20% 25VDC CER	54583	C3216X7R1E104M
A18C355	0160-4134	1		C-F 22UF 10% 15V TATBSA	12340P02	T322D226K015AS
A18C356	0160-4136	3		C-F 10UF 10% 20V TATBSA	12340P02	T322C106K020AS
A18C400	0160-5790	5		CAPACITOR-FXD .1UF +20% 25VDC CER	54583	C3216X7R1E104M
A18C401	0160-4136	3		C-F 10UF 10% 20V TATBSA	12340P02	T322C106K020AS
A18C402-C411	0160-5790	5		CAPACITOR-FXD .1UF +20% 25VDC CER	54583	C3216X7R1E104M
A18C412	0160-4136	3		C-F 10UF 10% 20V TATBSA	12340P02	T322C106K020AS
A18C452	0160-4136	3		C-F 10UF 10% 20V TATBSA	12340P02	T322C106K020AS
A18C453	0160-5790	5		CAPACITOR-FXD .1UF +20% 25VDC CER	54583	C3216X7R1E104M
A18C454	0160-6736	1		C-F .01UF 10% 50VDC CER SMD	54583	C3216X7R1H103K
A18C455-F828	0160-4134	1		C-F 22UF 10% 15V TATBSA	12340P02	T322D226K015AS
A18C458	0160-6757	6		C-F 100PF 5% 50V COG 1206 SMT	28480	GRM42-602C0G101J050C
A18C459	0160-5790	5		CAPACITOR-FXD .1UF +20% 25VDC CER	54583	C3216X7R1E104M
A18C500-C501	0160-5790	5		CAPACITOR-FXD .1UF +20% 25VDC CER	54583	C3216X7R1E104M
A18C550	0160-5790	5		CAPACITOR-FXD .1UF +20% 25VDC CER	54583	C3216X7R1E104M
A18C575	0160-4031	7	3	C-F 10UF 10% 35V TATBSA	12340P02	T322D106K035AS
A18C580	0160-4031	7		C-F 10UF 10% 35V TATBSA	12340P02	T322D106K035AS
A18C581-C582	0160-5790	5		CAPACITOR-FXD .1UF +20% 25VDC CER	54583	C3216X7R1E104M
A18C600	0160-5790	5		CAPACITOR-FXD .1UF +20% 25VDC CER	54583	C3216X7R1E104M
A18C601-C602	0160-6731	6		C-F 1000PF 10% 50VDC CERML SMD	54583	C3216X7R1H102K
A18C603-C604	0160-5790	5		CAPACITOR-FXD .1UF +20% 25VDC CER	54583	C3216X7R1E104M
A18C605	0160-6731	6		C-F 1000PF 10% 50VDC CERML SMD	54583	C3216X7R1H102K
A18C700	0160-6731	6		C-F 1000PF 10% 50VDC CERML SMD	54583	C3216X7R1H102K
A18C701	0160-5790	5		CAPACITOR-FXD .1UF +20% 25VDC CER	54583	C3216X7R1E104M
A18C702	0160-6508	5		C-F 22PF 5% 200V CERML	28480	RPE121-978C0G220J200V
A18C703-C704	0160-6511	0	4	C-F 15PF 5% 200V CERML	28480	RPE121-978C0G150J200V
A18C705	0160-6521	2	2	C-F 2.2PF -% 200V CERML	28480	RPE121-978C0G2R2C200V
A18C706	0160-6508	5		C-F 22PF 5% 200V CERML	28480	RPE121-978C0G220J200V
A18C707	0160-6731	6		C-F 1000PF 10% 50VDC CERML SMD	54583	C3216X7R1H102K
A18C708-C711	0160-5790	5		CAPACITOR-FXD .1UF +20% 25VDC CER	54583	C3216X7R1E104M
A18C712	0160-6731	6		C-F 1000PF 10% 50VDC CERML SMD	54583	C3216X7R1H102K
A18C713	0160-6508	5		C-F 22PF 5% 200V CERML	28480	RPE121-978C0G220J200V
A18C714	0160-6521	2		C-F 2.2PF -% 200V CERML	28480	RPE121-978C0G2R2C200V
A18C715-C716	0160-6511	0		C-F 15PF 5% 200V CERML	28480	RPE121-978C0G150J200V
A18C717	0160-6508	5		C-F 22PF 5% 200V CERML	28480	RPE121-978C0G220J200V
A18C800-C801	0160-6756	5	2	C-F 47PF 5% 50V COG SMT	28480	GRM42-602C0G470K050C
A18C802-C805	0160-5790	5		CAPACITOR-FXD .1UF +20% 25VDC CER	54583	C3216X7R1E104M
A18C807	0160-5790	5		CAPACITOR-FXD .1UF +20% 25VDC CER	54583	C3216X7R1E104M
A18C808	0160-6757	6		C-F 100PF 5% 50V COG 1206 SMT	28480	GRM42-602C0G101J050C
A18C809-C814	0160-5790	5		CAPACITOR-FXD .1UF +20% 25VDC CER	54583	C3216X7R1E104M
A18C815	0160-6736	1		C-F .01UF 10% 50VDC CER SMD	54583	C3216X7R1H103K
A18C816-C817	0160-5790	5		CAPACITOR-FXD .1UF +20% 25VDC CER	54583	C3216X7R1E104M
A18CR20-CR23	1901-0518	8		DIODE-SCHOTTKY SM SIG	28480	1901-0518
A18CR24-CR25	1901-0047	8	2	DIODE-SWITCHING 20V 75MA 10NS	27014	
A18CR26-CR27	1902-0025	4	2	DIODE-ZNR 10V 5% DO-35 PD = .4W TC = +.06%	04713	SZ30016-182
A18CR50	1902-0920	8	2	DIODE-ZNR 1N5345B 8.7V 5% PD = 5W	04713	1N5345B
A18CR51-CR52	1906-0291	4	2	DIODE-DUAL 70V	04713	MBAV99
A18CR53	1902-0920	8		DIODE-ZNR 1N5345B 8.7V 5% PD = 5W	04713	1N5345B
A18CR350	1901-0518	8		DIODE-SCHOTTKY SM SIG	28480	1901-0518
A18CR351-CR352	1901-0040	1	2	DIODE-SWITCHING 30V 50MA 2NS DO-35	27014	
A18CR353	1901-0518	8		DIODE-SCHOTTKY SM SIG	28480	1901-0518
A18CR400	1902-0041	4	1	DIODE-ZNR 5.11V 5% DO-35 PD = .4W	04713	SZ30016-98
A18CR700	1901-0025	2	2	DIODE-GEN PRP 100V 200MA DO-7	27014	FDH400 SELECTED
A18CR800	1902-1329	3	2	ICV RGLTR-V-REF-FXD 6.6/7.2V TO-46 PKG	27014	LM329CH
A18CR801	1901-0025	2		DIODE-GEN PRP 100V 200MA DO-7	27014	FDH400 SELECTED
A18CR802	1902-1329	3		ICV RGLTR-V-REF-FXD 6.6/7.2V TO-46 PKG	27014	LM329CH
A18J1	1250-1314	3	1	CONNECTOR-RF SM-SLD FEM PC 50-OHM	98291	52-054-0000-226
A18J20	1251-4484	6	11	CONN-POST TYPE .100-PIN-SPOG 4-CQNT	27264	22-03-2041
A18J100	1251-4484	6		CONN-POST TYPE .100-PIN-SPOG 4-CQNT	27264	22-03-2041

See introduction to this section for ordering information

\*Indicates factory selected values

Table 6-3. Replaceable Parts

Ref.Des.	HP Part Number	CD	Qty	Description	Mfr. Code	Mfr. Part Number
A18J150	1251-4484	6		CONN-POST TYPE .100-PIN-SPCG 4-CONT	27264	22-03-2041
A18J200-J201	1251-4484	6		CONN-POST TYPE .100-PIN-SPCG 4-CONT	27264	22-03-2041
A18J600	1250-2142	7	2	CON-SMB	74970	131-3701-341
A18J601	1251-4484	6		CONN-POST TYPE .100-PIN-SPCG 4-CONT	27264	22-03-2041
A18J700	1250-2142	7		CON-SMB	74970	131-3701-341
A18J701-J703	1251-4484	6		CONN-POST TYPE .100-PIN-SPCG 4-CONT	27264	22-03-2041
A18K1	0490-1779	1	5	REL RK1RE 12V 1C	61529	RK1RE-12V
A18K2	0490-1738	2	4	REL HIGH FREQUENCY	61529	RK1E-12V
A18K3	0490-1779	1		REL RK1RE 12V 1C	61529	RK1RE-12V
A18K4	0490-1738	2		REL HIGH FREQUENCY	61529	RK1E-12V
A18K5	0490-1779	1		REL RK1RE 12V 1C	61529	RK1RE-12V
A18K6	0490-1738	2		REL HIGH FREQUENCY	61529	RK1E-12V
A18K7	0490-1779	1		REL RK1RE 12V 1C	61529	RK1RE-12V
A18K8	0490-1738	2		REL HIGH FREQUENCY	61529	RK1E-12V
A18K9	0490-1779	1		REL RK1RE 12V 1C	61529	RK1RE-12V
A18L50-L51	9140-0144	0	13	INDUCTOR RF-CH-MILD 4.7UH 10% .105DX.26LG	99800	1025-36
A18L200-L202	9140-0815	2	3	COIL-VAR 50.6NH-41.4NH PC-MTG	24226	8273
A18L300	9140-0144	0		INDUCTOR RF-CH-MILD 4.7UH 10% .105DX.26LG	99800	1025-36
A18L400-L403	9140-0144	0		INDUCTOR RF-CH-MILD 4.7UH 10% .105DX.26LG	99800	1025-36
A18L450	9140-0144	0		INDUCTOR RF-CH-MILD 4.7UH 10% .105DX.26LG	99800	1025-36
A18L575-L577	9100-1618	1	4	INDUCTOR RF-CH-MILD 5.8UH 10%	99800	1537-30
A18L580	9100-1618	1		INDUCTOR RF-CH-MILD 5.8UH 10%	99800	1537-30
A18L600-L601	9140-0523	9	2	INDUCTOR RF-CH-MILD 510NH 9% .105DX.26LG	24226	10M510J
A18L602	9140-0144	0		INDUCTOR RF-CH-MILD 4.7UH 10% .105DX.26LG	99800	1025-36
A18L700-L701	9140-0144	0		INDUCTOR RF-CH-MILD 4.7UH 10% .105DX.26LG	99800	1025-36
A18L702-L705	9140-0814	1	4	COIL-VAR 20NH-25NH Q = 50 PC-MTG	24226	8272
A18L800-L801	9140-0144	0		INDUCTOR RF-CH-MILD 4.7UH 10% .105DX.26LG	99800	1025-36
A18LB1	7121-4611	2	1	LABEL-INFORMATION .15-IN-WD .6-IN-LG	28480	L01003
A18MP600-MP602	0515-0886	3	3	SCREW-MACH M3 X 0.5 6MM-LG PAN-HD	83486	
A18MP603	0403-0029	9	1	BUMPER FOOT-SCR .5-IN-MAX-OD.25-IN-THK	04427P01	368W
A18MP604	0515-0897	6	1	SCREW-MACH M3 X 0.5 8MM-LG PAN-HD	83486	
A18MP605-MP606	2580-0003	5	2	NUT-HEX-W/LKWR 8-32-THD .125-IN-THK	07296P01	
A18MP607	0515-0919	3	1	SCREW-MACH M3 X 0.5 25MM-LG PAN-HD	83486	
A18MP608	0535-0004	9	1	NUT-HEX DBL-CHAM M3 X 0.5 2.4MM-THK	28480	
A18MP609-MP612	3050-0032	8	4	WASHER-FL MTLCL NO. 8 .189-IN-HD	78471	
A18MP613-MP614	2850-0078	9	2	NUT-HEX-DBL-CHAM 10-32-THD .062-IN-THK	98281	40001-18-030-156
A18MP615	2190-0564	0	1	WASHER-LK HLCL 3.0 MM 3.1-MM-HD	28480	
A18MP616-MP630	0515-1643	2	15	SCR-MCH M3.0 22MMLG PHPZ SST *	83486	
A18MP631-MP635	0515-0905	7	5	SCREW-MACH M2.5 X 0.45 6MM-LG PAN-HD	83486	
A18MP636-MP640	2190-0824	1	5	WASHER-LK INTL T NO. 3 .102-IN-HD	73734	99401
A18MP641	2260-0002	6	1	NUT-HEX-DBL-CHAM 4-40-THD .062-IN-THK	13962P01	
A18MP642-MP645	0535-0031	2	4	NUT-HEX W/LKWR M3 X 0.5 2.4MM-THK	28480	
A18MP701-MP708	1252-3672	4	8	CON-SGL CONT	28480	1252-3672
A18MP711-MP716	03577-00901	8	6	ETCH SPRNG-GROUNDING BECUGD	07466P01	
A18MP717-MP719	03577-00902	9	3	ETCH SPRNG-GROUNDING BECUGD	07466P01	
A18MP720	03577-00903	0	1	ETCH BAR-GROUNDING BECUGD	07466P01	
A18MP721	03577-04109	6	1	SHTF CVR-SHLD AL	13588P02	
A18MP723	03577-21103	6	1	MCHD-HT-SINK	28480	
A18MP724	03577-20604	0	1	CSTG-SHLD-CIRCUIT SIDE	13599P01	03577-20604
A18MP724	03577-20601	7	1	CSTG-SHIELD-CIRCUIT SIDE AL	13599P01	03577-20601
A18MP725	03577-20605	1	1	CSTG MCHD SHIELD-SLOTTED AL	13599P01	03577-20605
A18MP725	03577-20602	8	1	CSTG SHIELD-COMPONENT SD AL	13599P01	03577-20602
A18MP726	03577-20606	2	1	MCHD COVER-SHIELD CAN	02875	
A18MP727	03577-20607	3	1	MCHD COVER-SHIELD CAN	02875	
A18MP800	0340-1169	6	2	NSLT BSNG .038TK TO-72 NYLNA	32559	118-055
A18MP802	0340-1169	6		NSLT BSNG .038TK TO-72 NYLNA	32559	118-055
A18P20	1258-0141	8	13	CON-JUMPER REM .025P	00779	530153-2
A18P100	1258-0141	8		CON-JUMPER REM .025P	00779	530153-2
A18P150	1258-0141	8		CON-JUMPER REM .025P	00779	530153-2
A18P200-P201	1258-0141	8		CON-JUMPER REM .025P	00779	530153-2
A18P500	1258-0141	8		CON-JUMPER REM .025P	00779	530153-2
A18P601	1258-0141	8		CON-JUMPER REM .025P	00779	530153-2

See introduction to this section for ordering information

\*Indicates factory selected values

Table 6-3. Replaceable Parts

Ref.Des.	HP Part Number	CD	Qty	Description	Mr. Code	Mr. Part Number
A18P701-P703	1258-0141	8		CON-JUMPER REM .025P	00779	530153-2
A18P800-P802	1258-0141	8		CON-JUMPER REM .025P	00779	530153-2
A18Q50	1853-0495	7	1	TRANSISTOR PNP PD = 1W FT = 1GHZ	04713	SFF2954
A18Q51	1854-1243	7	7	XTR NPN SI	18324	BFR93R
A18Q52	1855-0410	0	4	TRANSISTOR J-FET N-CHAN D-MODE TO-18 SI	27014	
A18Q53	1853-0612	0	7	XTR PNP SI 12V 35MA SMD	18324	BFT93
A18Q54	1854-0876	0	1	TRANSISTOR NPN PD = 1W FT = 1GHZ	04713	SFF2955
A18Q100	1853-0612	0		XTR PNP SI 12V 35MA SMD	18324	BFT93
A18Q101	1855-0410	0		TRANSISTOR J-FET N-CHAN D-MODE TO-18 SI	27014	
A18Q102	1854-1243	7		XTR NPN SI	18324	BFR93R
A18Q103	1853-0612	0		XTR PNP SI 12V 35MA SMD	18324	BFT93
A18Q104-Q105	1854-1243	7		XTR NPN SI	18324	BFR93R
A18Q106	1853-0612	0		XTR PNP SI 12V 35MA SMD	18324	BFT93
A18Q150	1853-0612	0		XTR PNP SI 12V 35MA SMD	18324	BFT93
A18Q151-Q152	1854-1243	7		XTR NPN SI	18324	BFR93R
A18Q153	1853-0612	0		XTR PNP SI 12V 35MA SMD	18324	BFT93
A18Q154	1854-1243	7		XTR NPN SI	18324	BFR93R
A18Q155	1855-0410	0		TRANSISTOR J-FET N-CHAN D-MODE TO-18 SI	27014	
A18Q156	1853-0612	0		XTR PNP SI 12V 35MA SMD	18324	BFT93
A18Q400	1854-0039	7	1	TRANSISTOR NPN 2N3053S SI TO-39 PD = 1W	04713	SS1782
A18Q401	1853-0531	2	1	TRANSISTOR PNP 2N3636 SI TO-39 PD = 1W	04713	2N3636
A18Q800	1855-0410	0		TRANSISTOR J-FET N-CHAN D-MODE TO-18 SI	27014	
A18R1	0699-2797	7	2	R-F FXED	91637	CRCW1206-2210F
A18R2	0699-1353	9	1	RESISTOR 23.7 1% .125W F TC = 0+-100	91637	CRCW120623R7F
A18R3	0699-2797	7		R-F FXED	91637	CRCW1206-2210F
A18R4	0699-2799	9	2	R-F FXED	91637	CRCW1206-1150F
A18R5	0699-2798	8	1	R-F FXED	91637	CRCW1206-52R30F
A18R6	0699-2799	9		R-F FXED	91637	CRCW1206-1150F
A18R7	0699-1364	2	8	RESISTOR 68.1 1% .125W F TC = 0+-100	91637	CRCW120668R1F
A18R8	0699-2815	0	3	R-F 154 OHM 1%	77902	MCR18-F-X-1540
A18R9-R10	0699-1364	2		RESISTOR 68.1 1% .125W F TC = 0+-100	91637	CRCW120668R1F
A18R11	0699-2815	0		R-F 154 OHM 1%	77902	MCR18-F-X-1540
A18R12-R13	0699-1364	2		RESISTOR 68.1 1% .125W F TC = 0+-100	91637	CRCW120668R1F
A18R14	0699-2815	0		R-F 154 OHM 1%	77902	MCR18-F-X-1540
A18R15	0699-1364	2		RESISTOR 68.1 1% .125W F TC = 0+-100	91637	CRCW120668R1F
A18R20	0757-0442	9	14	RESISTOR 10K 1% .125W F TC = 0+-100	05524P03	CMF-55-1
A18R21	0757-0465	6	4	RESISTOR 100K 1% .125W F TC = 0+-100	05524P03	CMF-55-1
A18R22	0699-4123	5	6	RESISTOR 499 1% .125W F TC = 0+-100	05524P03	CMF-554990FT-1
A18R23	0757-0401	0	5	RESISTOR 100 1% .125W F TC = 0+-100	05524P03	CMF-55-1
A18R24	0757-0465	6		RESISTOR 100K 1% .125W F TC = 0+-100	05524P03	CMF-55-1
A18R25	0699-1416	5	3	RESISTOR 110 1% .125W F TC = 0+-100	91637	CRCW12061100F
A18R26	0699-1415	4	7	RESISTOR 100 1% .125W F TC = 0+-100	91637	CRCW12061000F
A18R27-R28	0699-1344	8	5	RESISTOR 10 1% .125W F TC = 0+-100	91637	CRCW120610R0F
A18R29	0683-4745	6	3	RESISTOR 470K 5% .25W CF TC = 0-800	77902	R-25J
A18R30	0683-4725	2	3	RESISTOR 4.7K 5% .25W CF TC = 0-400	77902	R-25J
A18R31	0698-3228	9	5	RESISTOR 49.9K 1% .125W F TC = 0+-100	05524P03	CMF-554992FT-1
A18R32	0698-4123	5		RESISTOR 499 1% .125W F TC = 0+-100	05524P03	CMF-554990FT-1
A18R33	0683-4725	2		RESISTOR 4.7K 5% .25W CF TC = 0-400	77902	R-25J
A18R50-R53	0699-1430	3	16	RESISTOR 422 1% .125W F TC = 0+-100	91637	CRCW12064220F
A18R54	0757-0427	0	2	RESISTOR 1.5K 1% .125W F TC = 0+-100	05524P03	CMF-55-1
A18R55-R56	0757-0417	8	4	RESISTOR 562 1% .125W F TC = 0+-100	05524P03	CMF-55-1
A18R55	0698-0082	7		RESISTOR 464 1% .125W F TC = 0+-100	05524P03	CMF-554640FT-1
A18R55	0698-3488	3		RESISTOR 442 1% .125W F TC = 0+-100	91637	CMF-55-1
A18R55	0757-0418	7		RESISTOR 511 1% .125W F TC = 0+-100	05524P03	CMF-55-1
A18R56	0698-0082	7		RESISTOR 464 1% .125W F TC = 0+-100	05524P03	CMF-554640FT-1
A18R56	0698-3488	3		RESISTOR 442 1% .125W F TC = 0+-100	91637	CMF-55-1
A18R56	0757-0416	7		RESISTOR 511 1% .125W F TC = 0+-100	05524P03	CMF-55-1
A18R57	0699-2467	8	6	R-F 249 1% 1/8W SMD	91637	CRCW1206249F
A18R58	0699-1354	0	2	RESISTOR 26.1 1% .125W F TC = 0+-100	91637	CRCW120626R1F
A18R59	0699-1360	8	7	RESISTOR 46.4 1% .125W F TC = 0+-100	91637	CRCW120646R4F
A18R60	8159-0005	0	4	RESISTOR ZERO OHMS 22 AWG LEAD DIA	02499P02	YZO 1/4
A18R61	0699-2467	8		R-F 249 1% 1/8W SMD	91637	CRCW1206249F
A18R62	0699-1354	0		RESISTOR 26.1 1% .125W F TC = 0+-100	91637	CRCW120626R1F

See introduction to this section for ordering information

\*Indicates factory selected values



Table 6-3. Replaceable Parts

Ref.Des.	HP Part Number	CD	Qty	Description	Mfr. Code	Mfr. Part Number
A18R63-R64	0699-1360	8		RESISTOR 46.4 1% .125W F TC=0+-100	91637	CRCW120646R4F
A18R65-R66	0757-0417	8		RESISTOR 562 1% .125W F TC=0+-100	05524P03	CMF-55-1
A18R65	0698-0082	7		RESISTOR 464 1% .125W F TC=0+-100	05524P03	CMF-554640FT-1
A18R65	0698-3488	3		RESISTOR 442 1% .125W F TC=0+-100	91637	CMF-55-1
A18R65	0757-0416	7		RESISTOR 511 1% .125W F TC=0+-100	05524P03	CMF-55-1
A18R66	0698-0082	7		RESISTOR 464 1% .125W F TC=0+-100	05524P03	CMF-554640FT-1
A18R66	0698-3488	3		RESISTOR 442 1% .125W F TC=0+-100	91637	CMF-55-1
A18R66	0757-0416	7		RESISTOR 511 1% .125W F TC=0+-100	05524P03	CMF-55-1
A18R67	0757-0427	0		RESISTOR 1.5K 1% .125W F TC=0+-100	05524P03	CMF-55-1
A18R68-R71	0699-1430	3		RESISTOR 422 1% .125W F TC=0+-100	91637	CRCW12064220F
A18R72	0683-1055	5	3	RESISTOR 1M 5% .25W CF TC=0-800	77902	R-25J
A18R73	0698-4123	5		RESISTOR 499 1% .125W F TC=0+-100	05524P03	CMF-554990FT-1
A18R74	0757-0447	4	2	RESISTOR 16.2K 1% .125W F TC=0+-100	05524P03	CMF-55-1
A18R75	0698-4123	5		RESISTOR 499 1% .125W F TC=0+-100	05524P03	CMF-554990FT-1
A18R76	0757-0447	4		RESISTOR 16.2K 1% .125W F TC=0+-100	05524P03	CMF-55-1
A18R77	0698-4517	1	1	RESISTOR 127K 1% .125W F TC=0+-100	91637	CMF-551273FT-1
A18R78-R79	0699-1415	4		RESISTOR 100 1% .125W F TC=0+-100	91637	CRCW12061000F
A18R78-R79	0699-1416	5		RESISTOR 110 1% .125W F TC=0+-100	91637	CRCW12061100F
A18R78	0699-1417	8		RESISTOR 121 1% .125W F TC=0+-100	91637	CRCW12061210F
A18R78	0699-1418	7		RESISTOR 133 1% .125W F TC=0+-100	91637	CRCW1206F
A18R78	0699-1419	8		RESISTOR 147 1% .125W F TC=0+-100	91637	CRCW12061470F
A18R79	0699-1417	8		RESISTOR 121 1% .125W F TC=0+-100	91637	CRCW12061210F
A18R79	0699-1418	7		RESISTOR 133 1% .125W F TC=0+-100	91637	CRCW1206F
A18R79	0699-1419	8		RESISTOR 147 1% .125W F TC=0+-100	91637	CRCW12061470F
A18R80-R87	0699-1430	3		RESISTOR 422 1% .125W F TC=0+-100	91637	CRCW12064220F
A18R102	0699-1344	8		RESISTOR 10 1% .125W F TC=0+-100	91637	CRCW120610R0F
A18R103	0698-3228	9		RESISTOR 49.9K 1% .125W F TC=0+-100	05524P03	CMF-554992FT-1
A18R104	0683-1055	5		RESISTOR 1M 5% .25W CF TC=0-800	77902	R-25J
A18R105	0698-4496	5	4	RESISTOR 45.3K 1% .125W F TC=0+-100	05524P03	CMF-55-1
A18R106-R107	0699-1360	8		RESISTOR 46.4 1% .125W F TC=0+-100	91637	CRCW120646R4F
A18R108	0698-4496	5		RESISTOR 45.3K 1% .125W F TC=0+-100	05524P03	CMF-55-1
A18R109	0698-3228	9		RESISTOR 49.9K 1% .125W F TC=0+-100	05524P03	CMF-554992FT-1
A18R110	0683-1555	0	2	RESISTOR 1.5M 5% .25W CF TC=0-800	77902	R-25J
A18R111	0699-1425	6	4	RESISTOR 261 1% .125W F TC=0+-100	91637	CRCW12062610F
A18R112-R113	0699-1348	2	8	RESISTOR 14.7 1% .125W F TC=0+-100	91637	CRCW120614R7F
A18R114	0699-1425	6		RESISTOR 261 1% .125W F TC=0+-100	91637	CRCW12062610F
A18R115	0699-1348	2		RESISTOR 14.7 1% .125W F TC=0+-100	91637	CRCW120614R7F
A18R116	0699-2467	8		R-F 249 1% 1/8W SMD	91637	CRCW1206249F
A18R117	0699-1419	8	2	RESISTOR 147 1% .125W F TC=0+-100	91637	CRCW12061470F
A18R118	0699-2467	8		R-F 249 1% 1/8W SMD	91637	CRCW1206249F
A18R119	0699-1348	2		RESISTOR 14.7 1% .125W F TC=0+-100	91637	CRCW120614R7F
A18R148	0698-4496	5		RESISTOR 45.3K 1% .125W F TC=0+-100	05524P03	CMF-55-1
A18R149	0699-1360	8		RESISTOR 46.4 1% .125W F TC=0+-100	91637	CRCW120646R4F
A18R150	0699-1348	2		RESISTOR 14.7 1% .125W F TC=0+-100	91637	CRCW120614R7F
A18R151	0699-2467	8		R-F 249 1% 1/8W SMD	91637	CRCW1206249F
A18R152	0699-1419	8		RESISTOR 147 1% .125W F TC=0+-100	91637	CRCW12061470F
A18R153	0699-2467	8		R-F 249 1% 1/8W SMD	91637	CRCW1206249F
A18R154	0699-1348	2		RESISTOR 14.7 1% .125W F TC=0+-100	91637	CRCW120614R7F
A18R155	0698-4496	5		RESISTOR 45.3K 1% .125W F TC=0+-100	05524P03	CMF-55-1
A18R156-R157	0698-3228	9		RESISTOR 49.9K 1% .125W F TC=0+-100	05524P03	CMF-554992FT-1
A18R158	0699-1425	6		RESISTOR 261 1% .125W F TC=0+-100	91637	CRCW12062610F
A18R159-R160	0699-1348	2		RESISTOR 14.7 1% .125W F TC=0+-100	91637	CRCW120614R7F
A18R161	0699-1425	6		RESISTOR 261 1% .125W F TC=0+-100	91637	CRCW12062610F
A18R162	0699-1360	8		RESISTOR 46.4 1% .125W F TC=0+-100	91637	CRCW120646R4F
A18R165	0757-0401	0		RESISTOR 100 1% .125W F TC=0+-100	05524P03	CMF-55-1
A18R166	0683-1055	5		RESISTOR 1M 5% .25W CF TC=0-800	77902	R-25J
A18R167	0683-1555	0		RESISTOR 1.5M 5% .25W CF TC=0-800	77902	R-25J
A18R169	0699-1344	8		RESISTOR 10 1% .125W F TC=0+-100	91637	CRCW120610R0F
A18R200	0699-1433	6	2	RESISTOR 562 1% .125W F TC=0+-100	91637	CRCW12065620F
A18R201	0699-1344	8		RESISTOR 10 1% .125W F TC=0+-100	91637	CRCW120610R0F
A18R202	0699-1433	6		RESISTOR 562 1% .125W F TC=0+-100	91637	CRCW12065620F
A18R203	0699-2103	9	2	R-F 49.9 1% 1/8W SMD	91637	CRCW120649R9F

See introduction to this section for ordering information

\*Indicates factory selected values

Table 6-3. Replaceable Parts

Ref.Des.	HP Part Number	CD	Qty	Description	Mfr. Code	Mfr. Part Number
A18R300-R304	0683-3905	8	10	RESISTOR 39 5% .25W CF TC=0-400	77902	R-25J
A18R305-R306	0757-0280	3	20	RESISTOR 1K 1% .125W F TC=0+-100	05524P03	CMF-55-1
A18R308	0757-0280	3	19	RESISTOR 1K 1% .125W F TC=0+-100	05524P03	CMF-55-1
A18R307-R311	0683-3905	8		RESISTOR 39 5% .25W CF TC=0-400	77902	R-25J
A18R309	0683-3905	8		RESISTOR 39 5% .25W CF TC=0-400	77902	R-25J
A18R310-R311	0683-3905	8	2	RESISTOR 39 5% .25W CF TC=0-400	77902	R-25J
A18R311	0683-3905	8	1	RESISTOR 39 5% .25W CF TC=0-400	77902	R-25J
A18R350	0683-2725	8	1	RESISTOR 2.7K 5% .25W CF TC=0-400	77902	R-25J
A18R351	0757-0280	3		RESISTOR 1K 1% .125W F TC=0+-100	05524P03	CMF-55-1
A18R352	0698-3497	4	1	RESISTOR 6.04K 1% .125W F TC=0+-100	05524P03	CMF-556041FT-1
A18R353	0757-0442	9		RESISTOR 10K 1% .125W F TC=0+-100	05524P03	CMF-55-1
A18R354	0757-0465	6		RESISTOR 100K 1% .125W F TC=0+-100	05524P03	CMF-55-1
A18R355	0757-0442	9		RESISTOR 10K 1% .125W F TC=0+-100	05524P03	CMF-55-1
A18R356	0757-0465	6		RESISTOR 100K 1% .125W F TC=0+-100	05524P03	CMF-55-1
A18R357	0757-0442	9		RESISTOR 10K 1% .125W F TC=0+-100	05524P03	CMF-55-1
A18R400	0757-0442	9		RESISTOR 10K 1% .125W F TC=0+-100	05524P03	CMF-55-1
A18R401	0757-0442	9	9	RESISTOR 10K 1% .125W F TC=0+-100	05524P03	CMF-55-1
A18R402-R403	0698-4590	0	4	RESISTOR 422 1% .25W F TC=0+-100	91637	CMF-604220FT-1
A18R403	0698-4590	0	3	RESISTOR 422 1% .25W F TC=0+-100	91637	CMF-604220FT-1
A18R404-R408*	0757-0729	5	10	RESISTOR 681 1% .25W F TC=0+-100	91637	CMF-60-1 T-1
A18R409	0757-0280	3		RESISTOR 1K 1% .125W F TC=0+-100	05524P03	CMF-55-1
A18R410	0757-0401	0		RESISTOR 100 1% .125W F TC=0+-100	05524P03	CMF-55-1
A18R411-R412	0698-4590	0		RESISTOR 422 1% .25W F TC=0+-100	91637	CMF-604220FT-1
A18R413	0757-0401	0		RESISTOR 100 1% .125W F TC=0+-100	05524P03	CMF-55-1
A18R414-R418*	0757-0729	5		RESISTOR 681 1% .25W F TC=0+-100	91637	CMF-60-1 T-1
A18R419	8159-0005	0		RESISTOR-ZERO OHMS 22 AWG LEAD DIA	02498P02	YZO1/4
A18R450	0757-0280	3		RESISTOR 1K 1% .125W F TC=0+-100	05524P03	CMF-55-1
A18R451-R452	0757-0280	3	15	RESISTOR 1K 1% .125W F TC=0+-100	05524P03	CMF-55-1
A18R452	0757-0280	3	14	RESISTOR 1K 1% .125W F TC=0+-100	05524P03	CMF-55-1
A18R453	0698-8827	4	1	RESISTOR 1M 1% .125W F TC=0+-100	05524P03	CMF-551004FT-1
A18R454	0683-4745	6		RESISTOR 470K 5% .25W CF TC=0-600	77902	R-25J
A18R455	0757-0415	6	1	RESISTOR 475 1% .125W F TC=0+-100	05524P03	CMF-55-1
A18R456	0698-4381	7	1	RESISTOR 48.7 1% .125W F TC=0+-100	91637	CMF-55-1
A18R457	0757-0401	0		RESISTOR 100 1% .125W F TC=0+-100	05524P03	CMF-55-1
A18R500-R506	0757-0280	3		RESISTOR 1K 1% .125W F TC=0+-100	05524P03	CMF-55-1
A18R550	0757-0280	3		RESISTOR 1K 1% .125W F TC=0+-100	05524P03	CMF-55-1
A18R600	0683-5615	1	6	RESISTOR 560 5% .25W CF TC=0-400	77902	R-25J
A18R601-R602	0698-3445	2	3	RESISTOR 348 1% .125W F TC=0+-100	05524P03	CMF-553480FT-1
A18R602	0698-3445	2	2	RESISTOR 348 1% .125W F TC=0+-100	05524P03	CMF-553480FT-1
A18R603	0699-2627	2	2	R-F 294 1% 1/8W SMD	91637	CRCW12062940F
A18R604	0699-1350	6	1	RESISTOR 17.8 1% .125W F TC=0+-100	91637	CRCW120617R8F
A18R605	0699-2627	2		R-F 294 1% 1/8W SMD	91637	CRCW12062940F
A18R606-R607	0683-5615	1		RESISTOR 560 5% .25W CF TC=0-400	77902	R-25J
A18R608	0698-3445	2		RESISTOR 348 1% .125W F TC=0+-100	05524P03	CMF-553480FT-1
A18R700	0699-2103	8		R-F 49.9 1% 1/8W SMD	91637	CRCW120649R9F
A18R701	0699-1415	4		RESISTOR 100 1% .125W F TC=0+-100	91637	CRCW12061000F
A18R702	0699-1364	2		RESISTOR 68.1 1% .125W F TC=0+-100	91637	CRCW120688R1F
A18R703	0699-1415	4		RESISTOR 100 1% .125W F TC=0+-100	91637	CRCW12061000F
A18R704	0683-5615	1		RESISTOR 560 5% .25W CF TC=0-400	77902	R-25J
A18R705	0699-1415	4		RESISTOR 100 1% .125W F TC=0+-100	91637	CRCW12061000F
A18R706	0699-1364	2		RESISTOR 68.1 1% .125W F TC=0+-100	91637	CRCW120688R1F
A18R707	0699-1415	4		RESISTOR 100 1% .125W F TC=0+-100	91637	CRCW12061000F
A18R708-R709	0683-5615	1		RESISTOR 560 5% .25W CF TC=0-400	77902	R-25J
A18R800	2100-3056	8	3	RESISTOR-TRMR 5K 10% C SIDE-ADJ 17-TRN	04568P02	89PR5K
A18R801	2100-3109	2	1	RESISTOR-TRMR 2K 10% C SIDE-ADJ 17-TRN	04568P02	89PR2K
A18R802-R803	2100-3056	8		RESISTOR-TRMR 5K 10% C SIDE-ADJ 17-TRN	04568P02	89PR5K
A18R803	2100-3056	8	1	RESISTOR-TRMR 5K 10% C SIDE-ADJ 17-TRN	04568P02	89PR5K
A18R804	0698-4307	7	1	RESISTOR 14.3K 1% .125W F TC=0+-100	05524P03	CMF-551432FT-1
A18R805	0683-4725	2		RESISTOR 4.7K 5% .25W CF TC=0-400	77902	R-25J
A18R806	0698-4492	1	1	RESISTOR 32.4K 1% .125W F TC=0+-100	91637	CMF-553242FT-1
A18R807	0699-1364	6	1	RESISTOR 4.64K 1% .125W F TC=0+-100	91637	CRCW12064641F
A18R809	0757-0456	5	1	RESISTOR 43.2K 1% .125W F TC=0+-100	91637	CMF-55-1
A18R810	0757-0442	9		RESISTOR 10K 1% .125W F TC=0+-100	05524P03	CMF-55-1

See introduction to this section for ordering information

\*Indicates factory selected values

Table 6-3. Replaceable Parts

Ref.Des.	HP Part Number	CD	Qty	Description	Mfr. Code	Mfr. Part Number
A18R811	0698-3284	3	1	RESISTOR 11.8K 1% .125W F TC=0+-100	91637	CMF-55-1
A18R812-R813	0699-1318	6	6	RESISTOR 1K 1% .125W F TC=0+-100	91637	CRCW12061001F
A18R814	0683-4745	6		RESISTOR 470K 5% .25W CF TC=0-800	77902	R-25J
A18R815	0757-0442	9		RESISTOR 10K 1% .125W F TC=0+-100	05524P03	CMF-55-1
A18R816	0757-0449	6	3	RESISTOR 20K 1% .125W F TC=0+-100	05524P03	CMF-55-1
A18R817	0757-0280	3		RESISTOR 1K 1% .125W F TC=0+-100	05524P03	CMF-55-1
A18R818	0698-4123	5		RESISTOR 499 1% .125W F TC=0+-100	05524P03	CMF-554990FT-1
A18R819	0698-4123	5	1	RESISTOR 499 1% .125W F TC=0+-100	05524P03	CMF-554990FT-1
A18R820-R821	0757-0442	9		RESISTOR 10K 1% .125W F TC=0+-100	05524P03	CMF-55-1
A18R822-R823	0757-0280	3		RESISTOR 1K 1% .125W F TC=0+-100	05524P03	CMF-55-1
A18R824	0757-0449	6		RESISTOR 20K 1% .125W F TC=0+-100	05524P03	CMF-55-1
A18R825	0698-4442	1	1	RESISTOR 4.42K 1% .125W F TC=0+-100	05524P03	CMF-554421FT-1
A18R826-R828	0757-0442	9		RESISTOR 10K 1% .125W F TC=0+-100	05524P03	CMF-55-1
A18R829	0698-0083	8	1	RESISTOR 1.96K 1% .125W F TC=0+-100	05524P03	CMF-551961FT-1
A18R830	0757-0453	2	1	RESISTOR 30.1K 1% .125W F TC=0+-100	05524P03	CMF-55-1
A18R831	0757-0280	3		RESISTOR 1K 1% .125W F TC=0+-100	05524P03	CMF-55-1
A18R832	0757-0442	9		RESISTOR 10K 1% .125W F TC=0+-100	05524P03	CMF-55-1
A18R833	0757-0449	6		RESISTOR 20K 1% .125W F TC=0+-100	05524P03	CMF-55-1
A18R834	8159-0005	0		RESISTOR-ZERO OHMS 22 AWG LEAD DIA	02499P02	YZO1/4
A18R835	8159-0005	0	1	RESISTOR-ZERO OHMS 22 AWG LEAD DIA	02499P02	YZO1/4
A18R836	0699-1376	6	2	RESISTOR 2.15K 1% .125W F TC=0+-100	91637	CRCW12062151F
A18R837-R838	0699-1318	6		RESISTOR 1K 1% .125W F TC=0+-100	91637	CRCW12061001F
A18R839	0699-1376	6		RESISTOR 2.15K 1% .125W F TC=0+-100	91637	CRCW12062151F
A18R840-R841	0699-1318	6		RESISTOR 1K 1% .125W F TC=0+-100	91637	CRCW12061001F
A18R842	0757-0280	3		RESISTOR 1K 1% .125W F TC=0+-100	05524P03	CMF-55-1
A18TP300-TP304	1252-2897	3	14	CON-SINGLE CONTACT	11627P01	7-22751-8
A18TP400-TP402	1252-2897	3		CON-SINGLE CONTACT	11627P01	7-22751-8
A18TP500	1252-2897	3		CON-SINGLE CONTACT	11627P01	7-22751-8
A18TP575-TP577	1252-2897	3		CON-SINGLE CONTACT	11627P01	7-22751-8
A18TP580	1252-2897	3		CON-SINGLE CONTACT	11627P01	7-22751-8
A18TP800	1252-2897	3		CON-SINGLE CONTACT	11627P01	7-22751-8
A18U50	1826-0043	4	3	ICOP AMP GP TO-99 PKG	28480	1826-0043
A18U100	1826-0043	4		ICOP AMP GP TO-99 PKG	28480	1826-0043
A18U150	1826-0043	4		ICOP AMP GP TO-99 PKG	28480	1826-0043
A18U300	1858-0047	5	1	TRANSISTOR ARRAY 16-PIN PLSTC DIP	13307P01	ULN-2003A
A18U350	1820-1144	6	1	ICGATE TTL LS NOR QUAD 2-INP	01295	SN74LS02N
A18U351	1826-0412	1	1	ICCOMPARATOR PRCN DUAL 8-DIP-P PKG	27014	LM383N
A18U400	1826-0139	9	2	ICOP AMP GP DUAL 8-DIP-P PKG	27014	LM1458N
A18U450	1826-0139	9		ICOP AMP GP DUAL 8-DIP-P PKG	27014	LM1458N
A18U451	1826-0108	3	1	ICOP AMP WB TO-99 PKG	34371	HA2-2625-5 (SELECTED)
A18U500	1820-1211	8	1	ICGATE TTL LS EXCL-OR QUAD 2-INP	01295	SN74LS86AN
A18U501	1820-1197	9	1	ICGATE TTL LS NAND QUAD 2-INP	01295	SN74LS00N
A18U550	1820-1730	6	2	ICFF TTL LS D-TYPE POS-EDGE-TRIG COM	01295	SN74LS273N
A18U580	1826-0147	9	1	ICV RGLTR-FXD-POS 11.5/12.5V TO-220 PKG	04713	MC7812CT
A18U600	1826-2217	8	2	ICL AMP MSA 0486 .3DB S04	28480	1826-2217
A18U601	1826-2133	7	1	ICL AMP MSA 1105 BIP S04	28480	1826-2133
A18U700	0955-0095	8	1	MIX MWAV SRA-1-85 500MHZ 8	16239	SRA-1-85
A18U701	1826-2217	8		ICL AMP MSA 0486 .3DB S04	28480	1826-2217
A18U702	03577-87904	3	1	MIX MWAV MD-1171	02788P01	MD-1171
A18U800-U801	1826-0222	1	2	ICOP AMP GP QUAD 14-DIP-P PKG	07933	RC4136DB
A18U802	1820-1934	2	1	D/A 8-BIT 16-CERDIP BPLR	24355	DAC-08EQ
A18U803	1820-1730	6		ICFF TTL LS D-TYPE POS-EDGE-TRIG COM	01295	SN74LS273N
A18W500	1251-4822	6	1	CONN-POST TYPE .100-PIN-SPOG 3-CONT	27264	22-03-2031
A18W800	1251-4047	7	1	CONN-POST TYPE .100-PIN-SPOG 3-CONT	27264	22-05-2031
A18W801	1251-4484	6		CONN-POST TYPE .100-PIN-SPOG 4-CONT	27264	22-03-2041
A18W802	1251-4484	6	1	CONN-POST TYPE .100-PIN-SPOG 4-CONT	27264	22-03-2041
A18	T-224702	7	1	XTRSM11NPN-03577-18 BOARD	28480	T-224702
A18	03577-04131	4	1	SHTF COVER-OUTPUT BD ALSK	13588P02	
A18	0361-0230	4	5	RVT-STB OVHD .123D .19LG BRSTN	12014	R-3682
A18	1400-0964	6	5	BRACKET-RTANG STL ZINC/CLEAR CHROMATE	28480	1400-0964
A18	0370-2595	7	2	KNOB-RVTN 12.7MMD BRS	28480	

See introduction to this section for ordering information

\*Indicates factory selected values

Table 6-3. Replaceable Parts

Ref.Des.	HP Part Number	CD	Qty	Description	Mfr. Code	Mfr. Part Number
A19	03577-66519	2		PCASSY	28480	03577-66519
A19C1	0160-4571	8	14	CAPACITOR-FXD .1UF + 80-20% 50VDC CER	04222	SA105E104ZAAH
A19C2	0160-2724	9	2	CAPACITOR-FXD 3600PF + -2% 500VDC MICA	09023	CD19.5FD362GO3
A19C3	0140-0157	6	1	CAPACITOR-FXD 1857PF +-1% 500VDC MICA	09023	
A19C4	0160-2724	9		CAPACITOR-FXD 3600PF + -2% 500VDC MICA	09023	CD19.5FD362GO3
A19C5	0160-4571	8		CAPACITOR-FXD .1UF + 80-20% 50VDC CER	04222	SA105E104ZAAH
A19C6	0180-3845	9	8	C-F 4.7UF 10% 35V TADPDR	04222	TAL475K035
A19C7	0160-4571	8		CAPACITOR-FXD .1UF + 80-20% 50VDC CER	04222	SA105E104ZAAH
A19C8	0180-3845	9		C-F 4.7UF 10% 35V TADPDR	04222	TAL475K035
A19C11-C12	0160-4571	8		CAPACITOR-FXD .1UF + 80-20% 50VDC CER	04222	SA105E104ZAAH
A19C13	0160-5349	0	1	CAPACITOR-FXD 200PF + -5% 100VDC CER	28480	RPA10C0G201J100V
A19C14-C17	0160-6514	3	10	C-F 4700PF 1% 50V CERMLr	04222	SR255A472FAAH
A19C18	0160-4591	2	2	CAPACITOR-FXD .018UF +-1% 200VDC	15766	HEW-249
A19C19	0160-6514	3		C-F 4700PF 1% 50V CERMLr	04222	SR255A472FAAH
A19C20	0121-0491	1	2	CAPACITOR-V TRMR-CER 5-30PF 50V PC-MTG	59660	518-003 A 5-30
A19C21	0160-2646	4	2	CAPACITOR-FXD 168.9PF +-1% 300VDC MICA	09023	CD15FC(168.9)F0
A19C22-C23	0160-6514	3		C-F 4700PF 1% 50V CERMLr	04222	SR255A472FAAH
A19C24	0160-4591	2		CAPACITOR-FXD .018UF +-1% 200VDC	15766	HEW-249
A19C25	0160-6514	3		C-F 4700PF 1% 50V CERMLr	04222	SR255A472FAAH
A19C26	0121-0491	1		CAPACITOR-V TRMR-CER 5-30PF 50V PC-MTG	59660	518-003 A 5-30
A19C27	0160-4682	2	1	CAPACITOR-FXD 1000PF +-2.5% 180VDC POLYP	28480	0160-4682
A19C28-C29	0160-6513	2	2	C-F 68PF 5% 200V CERMLr	28480	RPE121-878C0G680J200V
A19C30	0180-2197	0	1	CAPACITOR-FXD 10PF +-5% 300VDC MICA	09023	CD150C100J03
A19C31-C32	0160-4571	8		CAPACITOR-FXD .1UF + 80-20% 50VDC CER	04222	SA105E104ZAAH
A19C33	0180-3845	9		C-F 4.7UF 10% 35V TADPDR	04222	TAL475K035
A19C34	0180-4535	4	3	CAPACITOR-FXD 1UF +-10% 50VDC CER	28480	RPE113-130X7R105K50V
A19C35	0180-3845	9		C-F 4.7UF 10% 35V TADPDR	04222	TAL475K035
A19C36	0180-3847	1	2	C-F 22UF 10% 25V TADPDR	12340P02	T398H226K025AS
A19C37	0180-4441	1	2	CAPACITOR-FXD .47UF +-10% 50VDC CER	04222	SR305C474KAAH
A19C38	0160-6497	1	9	C-F 0.1UF 10% 50V CERML SMT	28480	GRM42-6X7R104K050C
A19C39	0180-3847	1		C-F 22UF 10% 25V TADPDR	12340P02	T398H226K025AS
A19C40	0160-6508	5	2	C-F 22PF 5% 200V CERMLr	28480	RPE121-978C0G220J200V
A19C41	0160-4441	1		CAPACITOR-FXD .47UF +-10% 50VDC CER	04222	SR305C474KAAH
A19C42	0160-6497	1		C-F 0.1UF 10% 50V CERML SMT	28480	GRM42-6X7R104K050C
A19C43-C44	0160-4787	8	2	CAPACITOR-FXD 22PF +-5% 100VDC CER 0+-30	04222	SA102A220JAAH
A19C45	0180-3845	9		C-F 4.7UF 10% 35V TADPDR	04222	TAL475K035
A19C46	0160-4819	7	1	CAPACITOR-FXD 2200PF +-5% 100VDC CER	04222	SA301A222JAAH
A19C47-C48	0160-4571	8		CAPACITOR-FXD .1UF + 80-20% 50VDC CER	04222	SA105E104ZAAH
A19C50	0160-2646	4		CAPACITOR-FXD 168.9PF +-1% 300VDC MICA	09023	CD15FC(168.9)F0
A19C51-C52	0180-6514	3		C-F 4700PF 1% 50V CERMLr	04222	SR255A472FAAH
A19C53-C55	0160-4571	8		CAPACITOR-FXD .1UF + 80-20% 50VDC CER	04222	SA105E104ZAAH
A19C96-C99	0160-4532	1	2	CAPACITOR-FXD 1000PF +-20% 50VDC CER	04222	SA101C102MAAH
A19C100*	0160-8924	9		C-F 10pf 5% 50V SMD	28480	GRM42-602C0G100D050C
A19C101	0180-0490	4	1	CAPACITOR-FXD 68UF +-10% 6VDC TA	12340P02	T355G686K006AS
A19C102	0160-7096	8	3	C-F 6PF 5% 50VDC SMD	28480	GRH42-6C0G60D50VET
A19C103-C104	0160-0576	5	9	CAPACITOR-FXD .1UF +-20% 50VDC CER	04222	SR205C104MAAH
A19C105	0180-4129	4	1	C-F 1UF 10% 35V TATBSA	12340P02	T322B105K035AS
A19C106	0160-6654	2	1	C-F 160PF 1% 300V MICAs	09023	
A19C107	0160-0576	5		CAPACITOR-FXD .1UF +-20% 50VDC CER	04222	SR205C104MAAH
A19C108	0160-4507	0	1	CAPACITOR-FXD 1800PF +-2% 100VDC CER	28480	RPE121-151C0G182G100V
A19C109	0160-4571	8		CAPACITOR-FXD .1UF + 80-20% 50VDC CER	04222	SA105E104ZAAH
A19C110-C111	0160-6497	1		C-F 0.1UF 10% 50V CERML SMT	28480	GRM42-6X7R104K050C
A19C112	0121-0449	9	2	CAPACITOR-V TRMR-CER 3.5-10PF 63V PC-MTG	59660	528-009 C3.5-10
A19C113	0160-7279	9	2	C-F 1pF -% 50V CERML SMD	04222	C1206C0G1R0C100LR
A19C114	0121-0449	9		CAPACITOR-V TRMR-CER 3.5-10PF 63V PC-MTG	59660	528-009 C3.5-10
A19C115*	0160-7096	8		C-F 6PF 5% 50VDC SMD	28480	GRM42-6C0G60D50VET

See introduction to this section for ordering information

\*Indicates factory selected values



Table 6-3. Replaceable Parts

Ref.Des.	HP Part Number	CD	Qty	Description	Mfr. Code	Mfr. Part Number
A19C116	0160-6487	1		C-F 0.1UF 10% 50V CERML SMT	28480	GRM42-6X7R104K050C
A19C118	0180-3645	9		C-F 4.7UF 10% 35V TADPDR	04222	TAL475K035
A19C119	0160-6497	1		C-F 0.1UF 10% 50V CERML SMT	28480	GRM42-6X7R104K050C
A19C120	0160-0576	5		CAPACITOR-FXD .1UF +-20% 50VDC CER	04222	SR205C104MAAH
A19C121	0160-3829	7	1	CAPACITOR-FXD .47UF +-10% 50VDC	15766	HEW-249
A19C122	0160-0576	5		CAPACITOR-FXD .1UF +-20% 50VDC CER	04222	SR205C104MAAH
A19C123	0160-6497	1		C-F 0.1UF 10% 50V CERML SMT	28480	GRM42-6X7R104K050C
A19C124	0160-7096	8		C-F 6PF 5% 50VDC SMD	28480	GRM42-6C0G60D50VET
A19C125	0160-7279	9		C-F 1pF -% 50V CERML SMD	04222	C1206C0G1R0C100LR
A19C129	0160-7584	1	4	C-F 2.2PF .25% 50V COG SMD	54583	C3216C0G1H2F2C
A19C130	0160-6487	1		C-F 0.1UF 10% 50V CERML SMT	28480	GRM42-6X7R104K050C
A19C131	0160-5041	9	1	CAPACITOR-FXD .015UF +-10% 100VDC CER	04222	SR201C153KAA
A19C132-C133	0160-3914	1	2	CAPACITOR-FXD .01UF +-10% 100VDC CER	04222	SR201C103KAAH
A19C137	0160-7584	1		C-F 2.2PF .25% 50V COG SMD	54583	C3216C0G1H2F2C
A19C139-C140	0160-0576	5		CAPACITOR-FXD .1UF +-20% 50VDC CER	04222	SR205C104MAAH
A19C141-C142	0180-3845	9		C-F 4.7UF 10% 35V TADPDR	04222	TAL475K035
A19C143	0180-4139	0	1	C-F 15UF 10% 20V TATBSA	12340P02	T322D156K020AS
A19C144	0180-4535	4		CAPACITOR-FXD 1UF +-10% 50VDC CER	28480	RPE113-130X7R105K50V
A19C145	0180-6508	5		C-F 22PF 5% 200V CERML	28480	RPE121-878C0G220J200V
A19C146	0180-4535	4		CAPACITOR-FXD 1UF +-10% 50VDC CER	28480	RPE113-130X7R105K50V
A19C147	0160-0576	5		CAPACITOR-FXD .1UF +-20% 50VDC CER	04222	SR205C104MAAH
A19C148	0160-6497	1		C-F 0.1UF 10% 50V CERML SMT	28480	GRM42-6X7R104K050C
A19C149	0160-0576	5		CAPACITOR-FXD .1UF +-20% 50VDC CER	04222	SR205C104MAAH
A19C150	0160-6505	2	1	C-F .01UF 20% 100V CERML	28480	RPE121-878X7R103M100V
A19C200	0160-7280	2		C-F 4.7pF 5% 50V CERML SMD	04222	12061A4R7CAT A
A19C200	0180-7480	0		C-F 3.3PF 7.5% 500V CER SMT	02010P03	12067A3R3CAT A
A19C200	0160-7593	0		C-F 1.5PF +-25PF 50V	54583	C3216C0G1H1R5C
A19C200-C201	0160-7584	1		C-F 2.2PF .25% 50V COG SMD	54583	C3216C0G1H2F2C
A19C201	0160-7280	2		C-F 4.7pF 5% 50V CERML SMD	04222	12061A4R7CAT A
A19C201	0160-7460	0		C-F 3.3PF 7.5% 500V CER SMT	02010P03	12067A3R3CAT A
A19C201	0160-7593	0		C-F 1.5PF +-25PF 50V	54583	C3216C0G1H1R5C
A19CR1	1902-0953	7	6	DIODE-ZNR 6.2V 5% DO-35 PD = .4W TC = +.053%	04713	SZ30035-11RL
A19CR4	1902-0951	5	1	DIODE-ZNR 5.1V 5% DO-35 PD = .4W TC = +.035%	04713	SZ30035-9RL
A19CR5	1902-0953	7		DIODE-ZNR 6.2V 5% DO-35 PD = .4W TC = +.053%	04713	SZ30035-11RL
A19CR6-CR7	1906-0291	4	3	DIODE-DUAL 70V	04713	MBAV99
A19CR10	0122-0085	1	1	DIODE-VVC 2.2PF 7% C3/C25-MIN = 4.5	50545	1S2208(B)
A19CR12	1906-0291	4		DIODE-DUAL 70V	04713	MBAV99
A19CR13	1901-0040	1	4	DIODE-SWITCHING 30V 50MA 2NS DO-35	27014	
A19CR14-CR16	1902-0953	7		DIODE-ZNR 6.2V 5% DO-35 PD = .4W TC = +.053%	04713	SZ30035-11RL
A19CR17	1901-0040	1		DIODE-SWITCHING 30V 50MA 2NS DO-35	27014	
A19CR18	1902-0953	7		DIODE-ZNR 6.2V 5% DO-35 PD = .4W TC = +.053%	04713	SZ30035-11RL
A19CR19-CR20	1901-0040	1		DIODE-SWITCHING 30V 50MA 2NS DO-35	27014	
A19CR21	1902-0957	1	1	DIODE-ZNR 8.1V 5% DO-35 PD = .4W TC = +.069%	04713	SZ30035-1
A19CR22-CR23	1901-0179	7	2	DIODE-SWITCHING 15V 50MA 750PS	27014	FD777
A19CR24	1901-0026	3	1	DIODE-PWR RECT 200V 750MA DO-29	14089	
A19CR25	1901-0535	9	1	DIODE-SCHOTTKY SM SIG	28480	1901-0535
A19E3-E4	9170-0894	0	2	CORE-SHIELDING BEAD	06337P01	56-590-65/4A6
A19J1	1250-2142	7	1	CON-SMB	74970	131-3701-341
A19J2	1250-1314	3	1	CONNECTOR-RF SM-SLD FEM PC 50-OHM	98291	52-054-0000-226
A19K1-K4	0490-1738	2	4	REL HIGH FREQUENCY	61529	RK1E-12V
A19K5	0490-1700	8	1	REL TQ2E-12V USE ME! 35655	61529	TQ2E-12V
A19L1-L2	9140-0748	0	2	INDUCTOR 250UH 25% .25DX.5LG Q=3	24226	CA-253-5
A19L3	03577-60329	0	2	IND POT CORE VAR 101-108 UH	10890P01	
A19L4	03577-60331	4	1	IND POT CORE VAR 247-263 UH	10890P01	500 13 10040
A19L5	03577-60329	0		IND POT CORE VAR 101-108 UH	10890P01	
A19L6	9100-2275	8	1	INDUCTOR RF-CH-MLD 82UH 10% .105DX.26LG	24226	10M822K
A19L7-L8	9140-0144	0	2	INDUCTOR RF-CH-MLD 4.7UH 10% .105DX.26LG	99800	1025-36
A19L9	9100-1611	4	2	INDUCTOR RF-CH-MLD 220NH 20%	99800	1537-02
A19L10	9140-0129	1	1	INDUCTOR RF-CH-MLD 220UH 5% .166DX.365LG	99800	1537-92
A19L11	03577-67801	8	1	IND -WIRE 22GA LOOP	07466P01	
A19L12	9100-2574	0	2	INDUCTOR RF-CH-MLD 1.2MH 10%	24226	17S124K
A19L13	9100-1611	4		INDUCTOR RF-CH-MLD 220NH 20%	99800	1537-02

See introduction to this section for ordering information

\*Indicates factory selected values

Table 6-3. Replaceable Parts

Ref.Des.	HP Part Number	CD	Qty	Description	Mfr. Code	Mfr. Part Number
A18L14	9100-2574	0		INDUCTOR RF-CH-MLD 1.2MH 10%	24226	17S124K
A18LB1	7121-4611	2	1	LABEL-INFORMATION .15-IN-WD .6-IN-LG	28480	L01003
A19MP700	03577-04137	0	1	SHTF COVER-BOARD SHIELD 3577B	13588P02	
A19MP701	03577-04139	2	1	SHTF CVR-RECEIVER BOARD ALSK	13588P02	
A19MP701	0361-0230	4	6	RVT-STB OVHD .123D .18LG BRSTN	12014	R-3682
A19MP701	1400-0984	6	6	BRACKET-RTANG STL ZINC/CLEAR CHROMATE	28480	1400-0984
A19MP701	0370-2585	7	2	KNOB-RVFN 12.7MMD BRS	28480	
A19MP702	03577-20603	9	1	CSTG MCHD SHLD-CMPNT SIDE AL	13599P01	03577-20603
A19MP702	03577-20602	8	1	CSTG SHIELD-COMPONENT SD AL	13599P01	03577-20602
A19MP703	2180-0124	4	1	WASHER-LK INTL T NO. 10 .185-IN-ID	98291	3002-28
A19MP704	2950-0078	9	1	NUT-HEX-DBL-CHAM 10-32-THD .067-IN-THK	98291	40001-18-030-156
A19MP705-MP710	0515-0905	7	6	SCREW-MACH M2.5 X 0.45 6MM-LG PAN-HD	83486	
A19MP715-MP720	2180-0824	1	6	WASHER-LK INTL T NO. 3 .102-IN-ID	73734	99401
A19P1	1251-8736	9	2	CONN-POST TYPE .100-PIN-SPOG 6-COAT	00779	103240-3
A19P2	1251-4822	6	11	CONN-POST TYPE .100-PIN-SPOG 3-COAT	27264	22-03-2031
A19P3	1251-8735	8	1	CONN-POST TYPE .100-PIN-SPOG 8-COAT	00779	103240-4
A19P4	1251-8736	9	8	CONN-POST TYPE .100-PIN-SPOG 6-COAT	00779	103240-3
A19P5-P6	1251-4047	7	2	CONN-POST TYPE .100-PIN-SPOG 3-COAT	27264	22-05-2031
A19P7-P13	1251-4822	6		CONN-POST TYPE .100-PIN-SPOG 3-COAT	27264	22-03-2031
A19P15	1251-4822	6		CONN-POST TYPE .100-PIN-SPOG 3-COAT	27264	22-03-2031
A19P17-P18	1251-4822	6		CONN-POST TYPE .100-PIN-SPOG 3-COAT	27264	22-03-2031
A19P111	1251-5033	3	2	CONN-POST TYPE .100-PIN-SPOG 3-COAT	00779	103239-3
A19P113	1251-7524	1	1	CONN-POST TYPE .100-PIN-SPOG 4-COAT	03206P01	68001-604
A19P114	1251-5033	3		CONN-POST TYPE .100-PIN-SPOG 3-COAT	00779	103239-3
A19Q1-Q2	1854-1247	1	3	XTR NPN SI 15V 25MA .2W	18324	BFR92R
A19Q3	1853-0816	4	1	XTR PNP 5GHZ	18324	BFT92
A19Q4	1854-0686	0	2	TRANSISTOR NPN SI TO-72 PD = 200MW FT = 4GHZ	18324	BFO53
A19Q5	1855-0747	6	3	XTR J-FET N-CHAN	04713	SPF819-2
A19Q6	1854-1247	1		XTR NPN SI 15V 25MA .2W	18324	BFR92R
A19Q7-Q8	1853-0419	5	2	TRANSISTOR PNP SI PD = 310MW FT = 200MHZ	04713	2N4403
A19Q9-Q10	1855-0747	6		XTR J-FET N-CHAN	04713	SPF819-2
A19Q11	1855-0232	4	1	TRANSISTOR JFET DUAL 2N5565 N-CHAN	17856	2N5565
A19Q12	1853-0563	0	1	XTR SML1PNP SI 2N3906 TXXXX	04713	2N3906(SEL)
A19Q13-Q21	03577-60339	2	9	XTR JFETN ASSY SI 2N4393 T018	07797P01	
A19Q22-Q23	1855-0420	2	2	TRANSISTOR J-FET 2N4391 N-CHAN D-MODE	17856	2N4391
A19Q24	1853-0083	9	1	TRANSISTOR-DUAL PNP PD = 600MW	04713	SD4753 (SELECTED)
A19Q25	1854-0263	9	1	TRANSISTOR NPN 2N3019 SI TO-39 PD = 800MW	04713	2N3019
A19Q26	1854-0515	4	1	TRANSISTOR-DUAL NPN TO-77 PD = 600MW	34371	
A19Q27	1853-0320	7	1	TRANSISTOR PNP 2N4032 SI TO-5 PD = 800MW	27014	2N4032
A19Q28	1854-0477	7	1	TRANSISTOR NPN 2N2222A SI TO-18 PD = 500MW	04713	2N2222A
A19Q29	1854-0686	0		TRANSISTOR NPN SI TO-72 PD = 200MW FT = 4GHZ	18324	BFO53
A19Q30-Q31	1854-0404	0	2	TRANSISTOR NPN SI TO-18 PD = 360MW	04713	SS8333
A18R1	0698-4445	4	1	RESISTOR 5.76K 1% .125W F TC = 0+ -100	91637	CMF-555761FT-1
A19R2	0757-0283	6	8	RESISTOR 2K 1% .125W F TC = 0+ -100	05524P03	CMF-55-1
A19R3-R4	0757-0435	0	3	RESISTOR 3.92K 1% .125W F TC = 0+ -100	05524P03	CMF-55-1
A19R5	0757-0283	6		RESISTOR 2K 1% .125W F TC = 0+ -100	05524P03	CMF-55-1
A19R6	0698-6871	4	2	RESISTOR 10K .5% .125W F TC = 0+ -50	91637	CMF-55-1 T-2
A19R7	0698-3581	7	1	RESISTOR 13.7K 1% .125W F TC = 0+ -100	91637	CMF-55-1
A19R8	0757-0276	9	1	RESISTOR 1.78K 1% .125W F TC = 0+ -100	05524P03	CMF-55-1
A19R9	0698-3228	9	2	RESISTOR 49.9K 1% .125W F TC = 0+ -100	05524P03	CMF-554992FT-1
A19R10	0757-0283	6		RESISTOR 2K 1% .125W F TC = 0+ -100	05524P03	CMF-55-1
A19R11	0757-0290	5	1	RESISTOR 6.19K 1% .125W F TC = 0+ -100	05524P03	CMF-55-1
A19R12	0757-0283	6		RESISTOR 2K 1% .125W F TC = 0+ -100	05524P03	CMF-55-1
A19R13	0698-6965	7	1	RESISTOR 505 .1% .125W F TC = 0+ -25	91637	CMF-55-1 T-9
A19R14	0757-0288	1	1	RESISTOR 9.09K 1% .125W F TC = 0+ -100	05524P03	CMF-55-1
A19R15	0698-4489	6	1	RESISTOR 28K 1% .125W F TC = 0+ -100	91637	CMF-55-1
A19R17	0698-6362	8	2	RESISTOR 1K .1% .125W F TC = 0+ -25	05524P03	CMF-551001BT-9
A19R18	0698-6630	3	5	RESISTOR 20K .1% .125W F TC = 0+ -25	05524P03	CMF-552002BT-9
A19R19	0698-7674	7	1	RESISTOR 13.18K .1% .125W F TC = 0+ -50	91637	CMF-55-1 T-2
A19R20	0698-6805	4	1	RESISTOR 1.078K .25% .125W F TC = 0+ -50	91637	CMF-55-1 T-2
A19R21	0698-6343	5	1	RESISTOR 8K .1% .125W F TC = 0+ -25	05524P03	CMF-559001BT-9
A19R22	0698-6320	8	1	RESISTOR 5K .1% .125W F TC = 0+ -25	05524P03	CMF-555001BT-9
A19R23	0698-6630	3		RESISTOR 20K .1% .125W F TC = 0+ -25	05524P03	CMF-552002BT-9

See introduction to this section for ordering information

\*Indicates factory selected values

Table 6-3. Replaceable Parts

Ref.Des.	HP Part Number	CD	Qty	Description	Mfr. Code	Mfr. Part Number
A19R24-R25	0698-7960	4	4	RESISTOR 7.87K 1% .125W F TC=0+-25	91637	CMF-55-1 T-9
A19R26	0698-5418	3	2	RESISTOR 50 .1% .125W F TC=0+-50	91637	CMF-5550R0BT-2
A19R27	0699-0192	2	2	RESISTOR 3.894K .1% .125W F TC=0+-25	91637	CMF-55-1
A19R28	0757-0448	5	1	RESISTOR 18.2K 1% .125W F TC=0+-100	91637	CMF-55-1
A19R29	0698-6630	3		RESISTOR 20K .1% .125W F TC=0+-25	05524P03	CMF-552002BT-9
A19R30	0698-7394	8	1	RESISTOR 698 .1% .125W F TC=0+-25	91637	CMF-55-1 T-9
A19R31	0698-6362	8		RESISTOR 1K .1% .125W F TC=0+-25	05524P03	CMF-551001BT-9
A19R32	0698-6630	3		RESISTOR 20K .1% .125W F TC=0+-25	05524P03	CMF-552002BT-9
A19R33-R34	0698-7960	4		RESISTOR 7.87K 1% .125W F TC=0+-25	91637	CMF-55-1 T-9
A19R35	0698-5418	3		RESISTOR 50 .1% .125W F TC=0+-50	91637	CMF-5550R0BT-2
A19R36	0699-0192	2		RESISTOR 3.894K .1% .125W F TC=0+-25	91637	CMF-55-1
A19R36-R39	0698-3558	8	3	RESISTOR 4.02K 1% .125W F TC=0+-100	05524P03	CMF-554021FT-1
A19R40	0698-3279	0	2	RESISTOR 4.99K 1% .125W F TC=0+-100	05524P03	CMF-554991FT-1
A19R41	0698-3558	8		RESISTOR 4.02K 1% .125W F TC=0+-100	05524P03	CMF-554021FT-1
A19R42	0757-0401	0	3	RESISTOR 100 1% .125W F TC=0+-100	05524P03	CMF-55-1
A19R43	0698-3582	8	1	RESISTOR 41.2K 1% .125W F TC=0+-100	91637	CMF-554122FT-1
A19R44	2100-3356	1	1	RESISTOR-TRMR 200K 10% C SIDE-ADJ 1-TRN	32997	3386X-Y46-204
A19R45	0757-0277	8	3	RESISTOR 49.9 1% .125W F TC=0+-100	05524P03	CMF-55-1
A19R46	0757-0437	2	7	RESISTOR 4.75K 1% .125W F TC=0+-100	05524P03	CMF-55-1
A19R47	0757-0124	4	1	RESISTOR 39.2K 1% .125W F TC=0+-100	91637	CMF-55-1
A19R49	0757-0442	9	12	RESISTOR 10K 1% .125W F TC=0+-100	05524P03	CMF-55-1
A19R51	0757-0478	9	1	RESISTOR 301K 1% .125W F TC=0+-100	05524P03	CMF-55-1
A19R63-R64	0757-0437	2		RESISTOR 4.75K 1% .125W F TC=0+-100	05524P03	CMF-55-1
A19R67-R68	0698-6619	8	2	RESISTOR 15K .1% .125W F TC=0+-25	91637	CMF-551502BT-9
A19R69	0698-4441	0	1	RESISTOR 3.74K 1% .125W F TC=0+-100	05524P03	CMF-553741FT-1
A19R70	0757-0427	0	2	RESISTOR 1.5K 1% .125W F TC=0+-100	05524P03	CMF-55-1
A19R71	2100-3273	1	1	RESISTOR-TRMR 2K 10% C SIDE-ADJ 1-TRN	32997	3386X-Y46-202
A19R72-R73	0757-0465	6	2	RESISTOR 100K 1% .125W F TC=0+-100	05524P03	CMF-55-1
A19R74	2100-3274	2	1	RESISTOR-TRMR 10K 10% C SIDE-ADJ 1-TRN	32997	3386X-Y46-103
A19R75	2100-3352	7	1	RESISTOR-TRMR 1K 10% C SIDE-ADJ 1-TRN	32997	3386X-Y46-102
A19R77	0757-0161	9	1	RESISTOR 604 1% .125W F TC=0+-100	05524P03	CMF-55-1
A19R78	0757-0442	9		RESISTOR 10K 1% .125W F TC=0+-100	05524P03	CMF-55-1
A19R79	0698-7934	2	1	RESISTOR 12.1K .1% .125W F TC=0+-25	91637	CMF-551212BT-9
A19R80	0698-8706	4	1	RESISTOR 1.24K .25% .125W F TC=0+-100	91637	CMF-55-1 T-1
A19R81	0698-8191	5	1	RESISTOR 12.5K .1% .125W F TC=0+-25	91637	CMF-55-1 T-9
A19R82	0698-6630	3		RESISTOR 20K .1% .125W F TC=0+-25	05524P03	CMF-552002BT-9
A19R83	0698-5323	9	1	RESISTOR 4K .5% .125W F TC=0+-50	91637	CMF-55-1 T-2
A19R84	0699-1364	2	2	RESISTOR 68.1 1% .125W F TC=0+-100	91637	CRCW120668R1F
A19R85	0699-1405	2	1	RESISTOR 38.3K 1% .125W F TC=0+-100	91637	CRCW12063832F
A19R86	0699-1364	2		RESISTOR 68.1 1% .125W F TC=0+-100	91637	CRCW120668R1F
A19R87-R88	0757-0280	3	8	RESISTOR 1K 1% .125W F TC=0+-100	05524P03	CMF-55-1
A19R90	0699-1435	8	2	RESISTOR 681 1% .125W F TC=0+-100	91637	CRCW12068160F
A19R91	0698-3279	0		RESISTOR 4.99K 1% .125W F TC=0+-100	05524P03	CMF-554991FT-1
A19R92	0683-1015	7	1	RESISTOR 100 5% .25W CF TC=0-400	77902	R-25J
A19R93	0757-0444	1	1	RESISTOR 12.1K 1% .125W F TC=0+-100	91637	CMF-55-1
A19R94	0757-0273	4	3	RESISTOR 3.01K 1% .125W F TC=0+-100	05524P03	CMF-55-1
A19R96	0757-0442	9		RESISTOR 10K 1% .125W F TC=0+-100	05524P03	CMF-55-1
A19R97	0699-1330	2	4	RESISTOR 100K 1% .125W F TC=0+-100	91637	CRCW12061003F
A19R98	0699-1391	5	4	RESISTOR 10K 1% .125W F TC=0+-100	91637	CRCW12061002F
A19R99	0699-1369	7	2	RESISTOR 1.1K 1% .125W F TC=0+-100	91637	CRCW12061101F
A19R100	0699-1384	6	1	RESISTOR 4.64K 1% .125W F TC=0+-100	91637	CRCW12064641F
A19R101	0757-0427	0		RESISTOR 1.5K 1% .125W F TC=0+-100	05524P03	CMF-55-1
A19R102	0699-1434	7	2	RESISTOR 619 1% .125W F TC=0+-100	91637	CRCW12061960F
A19R103	0699-2467	8	2	R-F 249 1% 1/8W SMD	91637	CRCW1206249F
A19R104	0699-1434	7		RESISTOR 619 1% .125W F TC=0+-100	91637	CRCW12061960F
A19R105-R106	0699-1361	9	2	RESISTOR 51.1 1% .125W F TC=0+-100	91637	CRCW120651R1F
A19R107	0699-1320	0	1	RESISTOR 19.6K 1% .125W F TC=0+-100	91637	CRCW12061962F
A19R108	0699-1358	4	3	RESISTOR 38.3 1% .125W F TC=0+-100	91637	CRCW120638R3F
A19R109	0699-1415	4	7	RESISTOR 100 1% .125W F TC=0+-100	91637	CRCW12061000F
A19R110	0699-1382	4	1	RESISTOR 3.83K 1% .125W F TC=0+-100	91637	CRCW12063831F
A19R111	0699-1376	6	2	RESISTOR 2.15K 1% .125W F TC=0+-100	91637	CRCW12062151F
A19R112	0699-1319	6	2	RESISTOR 1K 1% .125W F TC=0+-100	91637	CRCW12061001F

See introduction to this section for ordering information

\*Indicates factory selected values

Table 6-3. Replaceable Parts

Ref.Des.	HP Part Number	CD	Qty	Description	Mfr. Code	Mfr. Part Number
A19R113	0757-0284	7	5	RESISTOR 150 1% .125W F TC=0+-100	05524P03	CMF-55-1
A19R114	0757-0277	8		RESISTOR 49.9 1% .125W F TC=0+-100	05524P03	CMF-55-1
A19R115	0699-1415	4		RESISTOR 100 1% .125W F TC=0+-100	91637	CRCW12061000F
A19R116	0699-1372	2	1	RESISTOR 1.47K 1% .125W F TC=0+-100	91637	CRCW12061471F
A19R117	0699-1415	4		RESISTOR 100 1% .125W F TC=0+-100	91637	CRCW12061000F
A19R118	0699-2103	8	4	R-F 49.9 1% 1/8W SMD	91637	CRCW120649R9F
A19R119	0757-0435	0		RESISTOR 3.92K 1% .125W F TC=0+-100	05524P03	CMF-55-1
A19R120	0699-2457	8		R-F 249 1% 1/8W SMD	91637	CRCW1206249F
A19R121	0757-0280	3		RESISTOR 1K 1% .125W F TC=0+-100	05524P03	CMF-55-1
A19R122	0699-1460	9	1	RESISTOR 825K 1% .125W F TC=0+-100	77902	MCR18-F-X-8253
A19R123	0699-1412	1	1	RESISTOR 75K 1% .125W F TC=0+-100	91637	CRCW12067502F
A19R124	0699-1358	4		RESISTOR 38.3 1% .125W F TC=0+-100	91637	CRCW120638R3F
A19R125	0699-2103	9		R-F 49.9 1% 1/8W SMD	91637	CRCW120649R9F
A19R126	0699-1327	7	1	RESISTOR 1M 1% .125W F TC=0+-100	77902	MCR18-F-X-1004
A19R127	0699-1370	0	1	RESISTOR 1.21K 1% .125W F TC=0+-100	91637	CRCW12061211F
A19R128	0699-1415	4		RESISTOR 100 1% .125W F TC=0+-100	91637	CRCW12061000F
A19R129	0699-1435	8		RESISTOR 681 1% .125W F TC=0+-100	91637	CRCW12068160F
A19R130	0699-1415	4		RESISTOR 100 1% .125W F TC=0+-100	91637	CRCW12061000F
A19R131	0699-1358	4		RESISTOR 38.3 1% .125W F TC=0+-100	91637	CRCW120638R3F
A19R132	0699-1318	6		RESISTOR 1K 1% .125W F TC=0+-100	91637	CRCW12061001F
A19R133	0699-1368	7		RESISTOR 1.1K 1% .125W F TC=0+-100	91637	CRCW12061101F
A19R134	0683-3855	8	1	RESISTOR 3.9M 5% .25W CC TC=-800/+1100	01121	CB3955
A19R135	0699-1437	0	1	RESISTOR 825 1% .125W F TC=0+-100	05524P03	CRCW12068250F
A19R136	0699-1330	2		RESISTOR 100K 1% .125W F TC=0+-100	91637	CRCW12061003F
A19R137	0699-4534	2	1	RESISTOR 309K 1% .125W F TC=0+-100	91637	CMF-553093FT-1
A19R138	0757-0401	0		RESISTOR 100 1% .125W F TC=0+-100	05524P03	CMF-55-1
A19R139	0757-0472	5	1	RESISTOR 200K 1% .125W F TC=0+-100	05524P03	CMF-55-1
A19R140	03577-67902	9	1	WIRE ASM-MAGNETIC	28480	03577-67902
A19R140	7225-0458	7	2	WIRE MAGNETIC	28480	7225-0458
A19R141	2100-3355	0	1	RESISTOR-TRMR 100K 10% C SIDE-ADJ 1-TRN	32997	3386X-Y46-104
A19R142-R143	0699-1330	2		RESISTOR 100K 1% .125W F TC=0+-100	91637	CRCW12061003F
A19R144	0699-1376	6		RESISTOR 2.15K 1% .125W F TC=0+-100	91637	CRCW12062151F
A19R145	0757-0459	8	2	RESISTOR 56.2K 1% .125W F TC=0+-100	05524P03	CMF-55-1
A19R146	0699-8827	4	2	RESISTOR 1M 1% .125W F TC=0+-100	05524P03	CMF-551004FT-1
A19R147	0757-0459	8		RESISTOR 56.2K 1% .125W F TC=0+-100	05524P03	CMF-55-1
A19R148	0699-8827	4		RESISTOR 1M 1% .125W F TC=0+-100	05524P03	CMF-551004FT-1
A19R149	0757-0273	4		RESISTOR 3.01K 1% .125W F TC=0+-100	05524P03	CMF-55-1
A19R150	0699-1356	2	1	RESISTOR 31.6 1% .125W F TC=0+-100	91637	CRCW120631R6F
A19R151	0757-0273	4		RESISTOR 3.01K 1% .125W F TC=0+-100	05524P03	CMF-55-1
A19R152-R155	0757-0437	2		RESISTOR 4.75K 1% .125W F TC=0+-100	05524P03	CMF-55-1
A19R156	0698-4461	4	2	RESISTOR 698 1% .125W F TC=0+-100	91637	CMF-556980FT-1
A19R157-R158	0757-0283	6		RESISTOR 2K 1% .125W F TC=0+-100	05524P03	CMF-55-1
A19R159	0698-3228	9		RESISTOR 49.9K 1% .125W F TC=0+-100	05524P03	CMF-554992FT-1
A19R160	0699-1415	4		RESISTOR 100 1% .125W F TC=0+-100	91637	CRCW12061000F
A19R161-R162	0699-8943	1	2	RESISTOR 20K 1% .125W F TC=0+-50	91637	CMF-55-1 T-2
A19R163	0757-0283	6		RESISTOR 2K 1% .125W F TC=0+-100	05524P03	CMF-55-1
A19R164	0699-4461	4		RESISTOR 698 1% .125W F TC=0+-100	91637	CMF-556980FT-1
A19R165	0757-0283	6		RESISTOR 2K 1% .125W F TC=0+-100	05524P03	CMF-55-1
A19R166	0757-0401	0		RESISTOR 100 1% .125W F TC=0+-100	05524P03	CMF-55-1
A19R167	0757-0389	3	1	RESISTOR 33.2 1% .125W F TC=0+-100	91637	CMF-55-1
A19R168	0699-1391	5		RESISTOR 10K 1% .125W F TC=0+-100	91637	CRCW12061002F
A19R169	0698-6871	4		RESISTOR 10K .5% .125W F TC=0+-50	91637	CMF-55-1 T-2
A19R170-R171	0757-0284	7		RESISTOR 150 1% .125W F TC=0+-100	05524P03	CMF-55-1
A19R172	2100-3207	1	1	RESISTOR-TRMR 5K 10% C SIDE-ADJ 1-TRN	32997	3386X-Y46-502
A19R173	2100-3354	9	1	RESISTOR-TRMR 50K 10% C SIDE-ADJ 1-TRN	32997	3386X-Y46-503
A19R174	0699-1415	4		RESISTOR 100 1% .125W F TC=0+-100	91637	CRCW12061000F
A19R175	0699-2103	9		R-F 49.9 1% 1/8W SMD	91637	CRCW120649R9F
A19R176	0757-0277	8		RESISTOR 49.9 1% .125W F TC=0+-100	05524P03	CMF-55-1
A19R177-R178	0699-1391	5		RESISTOR 10K 1% .125W F TC=0+-100	91637	CRCW12061002F
A19R179	0757-0280	3		RESISTOR 1K 1% .125W F TC=0+-100	05524P03	CMF-55-1
A19R180	0699-1351	7	1	RESISTOR 19.6 1% .125W F TC=0+-100	91637	CRCW120619R6F
A19R181	0699-2103	9		R-F 49.9 1% 1/8W SMD	91637	CRCW120649R9F
A19R182	0699-1430	3	1	RESISTOR 422 1% .125W F TC=0+-100	91637	CRCW12064220F

See introduction to this section for ordering information

\*Indicates factory selected values



Table 6-3. Replaceable Parts

Ref.Des.	HP Part Number	CD	Qty	Description	Mfr. Code	Mfr. Part Number
A19R183	0699-1422	3	1	RESISTOR 196 1% .125W F TC=0+-100	91637	CRCW12061960F
A19R184-R185	0757-0284	7		RESISTOR 150 1% .125W F TC=0+-100	05524P03	CMF-55-1
A19R186	0757-0407	6	1	RESISTOR 200 1% .125W F TC=0+-100	05524P03	CMF-55-1
A19R187	2100-1986	9	1	RESISTOR-TRMR 1K 10% C TOP-ADJ 1-TRN	04568P02	82P1K
A19R188	0757-0169	3	1	RESISTOR 21.5K 1% .125W F TC=0+-100	05524P03	CMF-55-1
A19R189-R196	0757-0442	9		RESISTOR 10K 1% .125W F TC=0+-100	05524P03	CMF-55-1
A19F200	0757-0442	9		RESISTOR 10K 1% .125W F TC=0+-100	05524P03	CMF-55-1
A19F201-F202	0683-6915	5	2	RESISTOR 680 5% .25W CF TC=0-400	77902	R-25J
A19F203-F206	0757-0260	9		RESISTOR 1K 1% .125W F TC=0+-100	05524P03	CMF-55-1
A19RP1	1810-0280	6	1	NETWORK-RES 10-SIP 10.0K OHM X 9	05524P03	MSP10A01-103G
A19RP2	1810-0279	5	2	NETWORK-RES 10-SIP 4.7K OHM X 9	05524P03	MSP10A01-472G
A19RP3	1QG8-0078	2	1	ICC FNLN GAIN NETWK-3577 P20	28480	1QG8-0078
A19RP4	1810-0675	5	1	NETWORK-RES 10-SIP MULTI-VALUE	13906	216CK261
A19RP5	1810-0279	5		NETWORK-RES 10-SIP 4.7K OHM X 9	05524P03	MSP10A01-472G
A19TP1-TP14	1252-2697	3	14	CON-SINGLE CONTACT	11627P01	7-22751-8
A19U1	1820-1244	7	1	ICMUXR/DATA-SEL TTL LS 4-TO-1-LINE DUAL	01295	SN74LS153N
A19U3	03577-60307	4	1	PGM PROM	28480	03577-60307
A19U3	1816-1142	5	2	IC TTL S 4096 (4K) PROM 70-NS 3-S	18324	N82S141N
A19U5	1820-1997	7	3	ICFF TTL LS D-TYPE POS-EDGE-TRIG PRL-IN	27014	DM74LS374N
A19U6-U7	1S89-0029	0	2	ICC DGTL FILTR-3577A C28 3577B	28480	1S89-0029
A19U8	03577-60308	5	1	PGM PROM	28480	03577-60308
A19U8	1816-1142	5		IC TTL S 4096 (4K) PROM 70-NS 3-S	18324	N82S141N
A19U9	1820-1997	7		ICFF TTL LS D-TYPE POS-EDGE-TRIG PRL-IN	27014	DM74LS374N
A19U10-U11	1820-1216	3	2	ICCCDR TTL LS 3-TO-8-LINE 3-INP	01295	SN74LS138N
A19U12	1820-1197	9	1	ICGATE TTL LS NAND QUAD 2-INP	01295	SN74LS00N
A19U13	1820-6748	6	1	ICD TTL 74F550 OC TNCVR 3577B	27014	74F550PC
A19U14	1813-0257	5	1	A/D 12-BIT 28-CBRZ/SDR BPLR	24355	AD574AKD
A19U15	1826-0715	7	2	ICOP AMP LOW-NOISE 8-DIP-P PKG	18324	NE5534AN
A19U16	1820-1997	7		ICFF TTL LS D-TYPE POS-EDGE-TRIG PRL-IN	27014	DM74LS374N
A19U17-U18	1826-0138	8	2	ICCOMPARATOR GP QUAD 14-DIP-P PKG	27014	LM339N
A19U19	1820-2096	9	1	ICCNTR TTL LS BIN DUAL 4-BIT	01295	SN74LS393N
A19U20	1826-0715	7		ICOP AMP LOW-NOISE 8-DIP-P PKG	18324	NE5534AN
A19U21	1826-0503	1	1	SAMPLE AND HOLD 8 -METAL	27014	LF398H
A19U22	1826-0522	4	1	ICOP AMP LOW-BIAS-H-IMPQ QUAD 14-DIP-P	01295	TL074CN
A19U23	1826-1318	9	1	ICL OPAMP 5533 BIP LN P14	18324	NE5533AN
A19U24	1820-0427	6	1	ICMODULATOR TO-100 PKG	27014	SL27624
A19U25	03577-60309	6	1	PGM PROM	28480	03577-60309
A19U25	1816-1811	3	1	ICM PROM 27S19 32X8 40NS P16	34335	AM27S19PC
A19U26	1826-0412	1	2	ICCOMPARATOR PRON DUAL 8-DIP-P PKG	27014	LM339N
A19U27	1826-0316	7	1	ICOP AMP LOW-BIAS-H-IMPQ TO-99 PKG	27014	LF398H
A19U28	1820-1202	7	1	ICGATE TTL LS NAND TPL 3-INP	01295	SN74LS10N
A19U29	1826-0302	6	1	ICOP AMP GP TO-99 PKG	34371	CA0741CT
A19U31-U32	1820-1430	3	2	ICCNTR TTL LS BIN SYNCHRO POS-EDGE-TRIG	01295	SN74LS161AN
A19U33	1826-0635	0	2	ICOP AMP LOW-OFS 8-DIP-P PKG	10858P01	OP-07CN8
A19U34	1826-0412	1		ICCOMPARATOR PRON DUAL 8-DIP-P PKG	27014	LM339N
A19U35-U36	1820-1112	8	2	ICFF TTL LS D-TYPE POS-EDGE-TRIG	01295	SN74LS74AN
A19U37	1820-1417	6	1	ICGATE TTL LS NAND QUAD 2-INP	01295	SN74LS26N
A19U38	1826-1116	4	1	ICOP AMP GP QUAD 14-DIP-P PKG	07833	RC4156N
A19U42	1826-0635	0		ICOP AMP LOW-OFS 8-DIP-P PKG	10858P01	OP-07CN8
A19U43	03577-67902	1	1	MIX MWAV MD-983 3577X	02788P01	MD-983
A19U44	1820-1199	1	1	ICINV TTL LS HEX 1-INP	01295	SN74LS04N
A19W1	1258-0223	7	2	CON-JUMPER 3 AMPS	03206P01	69145-206
A19W2	1258-0141	8	13	CON-JUMPER REM .025P	00779	530153-2
A19W3	1258-0222	6	1	CON-JUMPER 3 AMPS MULT REM 2X3	03206P01	69145-206
A19W4	1258-0223	7		CON-JUMPER 3 AMPS	03206P01	69145-206
A19W5-W13	1258-0141	8		CON-JUMPER REM .025P	00779	530153-2
A19W15	1258-0141	8		CON-JUMPER REM .025P	00779	530153-2
A19W17-W18	1258-0141	8		CON-JUMPER REM .025P	00779	530153-2
A19	0515-1643	2	12	SCR-MCH M3.0 22MMLG PHPZ SST *	83486	
A19	2190-0376	8	1	WASHER-FL MTLG NO. 4 .115-IN-ID	73734	
A19	2260-0002	6	1	NUT-HEX-DBL-CHAM 4-40-THD .062-IN-THK	13962P01	
A19	03577-20601	7	1	CSTG-SHIELD-CIRCUIT SIDE AL	13599P01	03577-20601

See introduction to this section for ordering information

\*Indicates factory selected values

Table 6-3. Replaceable Parts

Ref.Des.	HP Part Number	CD	Qty	Description	Mfr. Code	Mfr. Part Number
A20	03577-66520	5	1	PCASSY MOTHER BD	28480	03577-66520
A20C1-C2	0180-0576	5	2	CAPACITOR-FXD .1UF + -20% 50VDC CER	04222	SR205C104MAAH
A20J1-J8	1251-1365	6	10	CONNECTOR-PC EDGE 22-CONT/ROW 2-ROWS	03394P01	220-626-03
A20J11	1251-5160	7	2	CONNECTOR-PC EDGE 36-CONT/ROW 2-ROWS	54453	EXM 36 DRXN
A20J12	1251-1365	6		CONNECTOR-PC EDGE 22-CONT/ROW 2-ROWS	03394P01	220-626-03
A20J13	1251-2915	4	1	CONNECTOR-PC EDGE 25-CONT/ROW 2-ROWS	04068P01	252-25-30-301
A20J14	1251-5160	7		CONNECTOR-PC EDGE 36-CONT/ROW 2-ROWS	54453	EXM 36 DRXN
A20J15	1251-4634	8	1	CONN-POST TYPE .100-PIN-SPOG 20-CONT	03206P01	65692-072
A20J16	1251-1365	6		CONNECTOR-PC EDGE 22-CONT/ROW 2-ROWS	03394P01	220-626-03
A20J22	1251-4836	2	1	CONN-POST TYPE 2.5-PIN-SPOG 2-CONT	27264	22-12-1022
A20J26	1251-4837	3	1	CONN-POST TYPE 2.5-PIN-SPOG 4-CONT	27264	22-12-1042
A20LB1	7121-4611	2	1	LABEL-INFORMATION .15-IN-WD .6-IN-LG	28480	L01003
A21C1	0150-0012	3	1	CAPACITOR-FXD .01UF + -20% 1KVDC CER	59660	618-584 Z5U 103M
A21C2-C3	0180-3369	6	2	CAPACITOR-FXD 1200UF + 50-10% 250VDC AL	09023	DCM122T250AE2A
A21C4-C5	0180-4835	7	4	CAPACITOR-FXD .1UF + -10% 50VDC CER	04222	SA105C104KAAH
A21C6-C7	0180-4914	3	5	CAPACITOR-FXD 470PF + -10% 600VDC POLYE	09023	
A21C8-C9	0160-0314	9	2	CAPACITOR-FXD .01UF + -5% 400VDC POLYE	15766	883LW
A21C10	0160-5848	4	1	CAPACITOR-FXD 1UF + -20% 200VDC MET-POLYP	15766	TRW-35
A21C11-C12	0160-4913	2	2	CAPACITOR-FXD 1600PF + -10% 600VDC POLYE	09023	
A21C13	0180-4133	0	2	C-F 15UF 10% 20V TATBSA	12340P02	T322D156K020AS
A21C14	0160-3560	3	1	CAPACITOR-FXD 1UF + -2% 100VDC MET-POLYC	15766	HEW-249
A21C16-C18	0160-4571	8	23	CAPACITOR-FXD .1UF + 80-20% 50VDC CER	04222	SA105E104ZAAH
A21C20	0160-4571	8		CAPACITOR-FXD .1UF + 80-20% 50VDC CER	04222	SA105E104ZAAH
A21C21	0160-2414	4	1	CAPACITOR-FXD .022UF + -5% 200VDC POLYE	15766	HEW238T
A21C22	0160-0300	3	1	CAPACITOR-FXD 2700PF + -10% 200VDC POLYE	15766	HEW238T
A21C23	0160-0170	5	1	CAPACITOR-FXD .22UF + 80-20% 50VDC CER	04222	SR835E224ZAAH
A21C24	0160-0180	7	1	CAPACITOR-FXD .033UF + -5% 200VDC POLYE	15766	HEW238T
A21C25	0160-3335	0	1	CAPACITOR-FXD 470PF + -10% 100VDC CER	04222	SA102C471KAAH
A21C26-C29	0160-4571	8		CAPACITOR-FXD .1UF + 80-20% 50VDC CER	04222	SA105E104ZAAH
A21C41-C44	0160-4571	8		CAPACITOR-FXD .1UF + 80-20% 50VDC CER	04222	SA105E104ZAAH
A21C53	0160-4571	8		CAPACITOR-FXD .1UF + 80-20% 50VDC CER	04222	SA105E104ZAAH
A21C54	0180-4132	9	2	C-F 6.8UF 10% 35V TATBSA	12340P02	T322D685K035AS
A21C55	0160-4801	7	1	CAPACITOR-FXD 100PF + -5% 100VDC CER	04222	SA102A101JAAH
A21C56	0160-4682	2	1	CAPACITOR-FXD 1000PF + -2.5% 160VDC POLYP	28480	0160-4682
A21C57	0160-4571	8		CAPACITOR-FXD .1UF + 80-20% 50VDC CER	04222	SA105E104ZAAH
A21C58	0180-3552	5	1	C-F 4.7UF 10% 20V TATBSA	12340P02	T322B475K020AS
A21C59	0180-4136	3	7	C-F 10UF 10% 20V TATBSA	12340P02	T322C106K020AS
A21C60	0180-4132	9		C-F 6.8UF 10% 35V TATBSA	12340P02	T322D685K035AS
A21C61	0160-4571	8		CAPACITOR-FXD .1UF + 80-20% 50VDC CER	04222	SA105E104ZAAH
A21C62-C63	0160-4835	7		CAPACITOR-FXD .1UF + -10% 50VDC CER	04222	SA105C104KAAH
A21C70	0170-0040	9	1	CAPACITOR-FXD .047UF + -10% 200VDC POLYE	15766	HEW238T
A21C72	0160-6510	9	11	C-F .1UF 20% 50V CERML	28480	RPE121-978X7R104M50V
A21C80	0160-4915	4	1	CAPACITOR-FXD 3000PF + -5% 600VDC POLYE	09023	
A21C81-C86	0160-6510	9		C-F .1UF 20% 50V CERML	28480	RPE121-978X7R104M50V
A21C87	0160-4571	8		CAPACITOR-FXD .1UF + 80-20% 50VDC CER	04222	SA105E104ZAAH
A21C88-C89	0160-6510	9		C-F .1UF 20% 50V CERML	28480	RPE121-978X7R104M50V

See introduction to this section for ordering information

\*Indicates factory selected values

Table 6-3. Replaceable Parts

Ref.Des.	HP Part Number	CD	Qty	Description	Mfr. Code	Mfr. Part Number
A21C90-C91	0180-3366	9	4	CAPACITOR-FXD 180UF + 100-10% 60VDC AL	06360P01	674D187H060HESA
A21C92-C93	0180-4136	3		C-F 10UF 10% 20V TATBSA	12340P02	T322C106K020AS
A21C94-C95	0180-3366	9		CAPACITOR-FXD 180UF + 100-10% 60VDC AL	06360P01	674D187H060HESA
A21C96	0180-4136	3		C-F 10UF 10% 20V TATBSA	12340P02	T322C106K020AS
A21C97	0180-2976	5	1	CAPACITOR-FXD 68UF + 50-10% 100VDC AL	06360P01	674D180
A21C98	0180-2771	6	1	CAPACITOR-FXD 110UF + 100-20% 30VDC AL	06360P01	672D153
A21C99	0180-4136	3		C-F 10UF 10% 20V TATBSA	12340P02	T322C106K020AS
A21C100	0180-3367	0	1	CAPACITOR-FXD 470UF + 100-10% 40VDC AL	06360P01	674D477H040HE1A
A21C101	0160-6510	9		C-F .1UF 20% 50V CERML	28480	RPE121-978X7R104M50V
A21C102-C104	0160-4614	3		CAPACITOR-FXD 470PF + -10% 600VDC POLYE	09023	
A21C105	0160-6510	9		C-F .1UF 20% 50V CERML	28480	RPE121-978X7R104M50V
A21C107-C108	0160-4571	8		CAPACITOR-FXD .1UF + 80-20% 50VDC CER	04222	SA105E104ZAAH
A21C109	0160-0127	2	2	CAPACITOR-FXD 1UF + -20% 25VDC CER	04222	SR835E105MAAH
A21C110-C111	0160-4571	8		CAPACITOR-FXD .1UF + 80-20% 50VDC CER	04222	SA105E104ZAAH
A21C112	0160-0127	2		CAPACITOR-FXD 1UF + -20% 25VDC CER	04222	SR835E105MAAH
A21C114-C116	0160-4571	8		CAPACITOR-FXD .1UF + 80-20% 50VDC CER	04222	SA105E104ZAAH
A21C117	0180-3845	9	1	C-F 4.7UF 10% 35V TADPDR	04222	TAL475K035
A21C120	0180-3078	0	1	CAPACITOR-FXD 1000UF + 50-10% 50VDC AL	55680	UVR1J102MRA
A21C121	0160-4571	8		CAPACITOR-FXD .1UF + 80-20% 50VDC CER	04222	SA105E104ZAAH
A21C122	0180-2966	7	1	CAPACITOR-FXD 330UF + -20% 50VDC AL	06360P01	SMC50VB331M12X20
A21C123	0160-4571	8		CAPACITOR-FXD .1UF + 80-20% 50VDC CER	04222	SA105E104ZAAH
A21C124-C125	0180-4136	3		C-F 10UF 10% 20V TATBSA	12340P02	T322C106K020AS
A21C126	0180-4133	0		C-F 15UF 10% 20V TATBSA	12340P02	T322D156K020AS
A21CR2	1902-0945	7	2	DIODE-ZNR 3V 5% DO-35 PD = .4W TC = -.043%	04713	SZ0035-3RL
A21CR3	1901-0050	3	22	DIODE-SWITCHING 80V 200MA 2NS DO-35	27014	D3D2/FDH6308A
A21CR5	1902-0945	7		DIODE-ZNR 3V 5% DO-35 PD = .4W TC = -.043%	04713	SZ0035-3RL
A21CR6	1901-0050	3		DIODE-SWITCHING 80V 200MA 2NS DO-35	27014	D3D2/FDH6308A
A21CR7	1906-0080	9	1	DIODE-FW BRDG 600V 10A	12928P01	VJ847
A21CR10	1902-0777	3	1	DIODE-ZNR 1N825 6.2V 5% DO-7 PD = .4W	04713	1N825
A21CR11	1901-0050	3		DIODE-SWITCHING 80V 200MA 2NS DO-35	27014	D3D2/FDH6308A
A21CR14	1990-1124	1	4	OPT LED LMP Y AP LMP1401 TT1H	28480	1990-1124
A21CR17	1884-0317	7	7	THY XTR SCR ** THYR	11699P01	CS92A
A21CR20	1902-0953	7	2	DIODE-ZNR 6.2V 5% DO-35 PD = .4W TC = +.053%	04713	SZ30035-11RL
A21CR21	1901-0050	3		DIODE-SWITCHING 80V 200MA 2NS DO-35	27014	D3D2/FDH6308A
A21CR22	1990-1124	1		OPT LED LMP Y AP LMP1401 TT1H	28480	1990-1124
A21CR23-CR26	1901-0050	3		DIODE-SWITCHING 80V 200MA 2NS DO-35	27014	D3D2/FDH6308A
A21CR30-CR31	1902-0950	4	2	DIODE-ZNR 4.7V 5% DO-35 PD = .4W TC = +.025%	04713	SZ30035-6
A21CR33-CR36	1901-0026	3	4	DIODE-PWR RECT 200V 750MA DO-29	14099	
A21CR40	1906-0278	7	1	DIODE-CT-RECT 50V 80A	02688P03	SBT3060
A21CR41	1990-1122	9	3	OPT LED LMP G GP LMP1503 TT1H	28480	1990-1122
A21CR42	1901-0673	6	3	DIODE-PWR RECT 100V 5A 5US	03580	G3B-010
A21CR45-CR46	1901-0050	3		DIODE-SWITCHING 80V 200MA 2NS DO-35	27014	D3D2/FDH6308A
A21CR50	1906-0277	6	1	DIODE-CT-RECT 300V 30A	02688P02	UES2605
A21CR52-CR53	1901-1108	4	2	DIODE-SWITCHING 300V 3A 50NS	02688P02	UES1305
A21CR57-CR59	1901-0704	4	3	DIODE-GEN PRP 1N4002 100V 1A DO-41	14433	1N4002
A21CR60	1901-0049	0	1	DIODE-PWR RECT 50V 750MA DO-29	14099	
A21CR61	1901-0673	6		DIODE-PWR RECT 100V 5A 5US	03580	G3B-010
A21CR62	1990-1122	9		OPT LED LMP G GP LMP1503 TT1H	28480	1990-1122
A21CR63	1901-0050	3		DIODE-SWITCHING 80V 200MA 2NS DO-35	27014	D3D2/FDH6308A
A21CR64	1901-0673	6		DIODE-PWR RECT 100V 5A 5US	03580	G3B-010
A21CR65	1990-1122	9		OPT LED LMP G GP LMP1503 TT1H	28480	1990-1122
A21CR70	1901-1244	9	2	DIO PRECT	04713	MUR140
A21CR71-CR72	1901-1112	0	4	DIODE-SWITCHING 150V 2A 25NS	18324	BYV27-150
A21CR73	1901-1244	9		DIO PRECT	04713	MUR140
A21CR74-CR75	1901-1112	0		DIODE-SWITCHING 150V 2A 25NS	18324	BYV27-150
A21CR76	1902-0522	6	1	DIODE-ZNR 1N5340B 6V 5% PD = 5W IR = 1UA	04713	1N5340B
A21CR81	1902-0958	2	1	DIODE-ZNR 10V 5% DO-35 PD = .4W TC = +.075%	04713	SZ30035-1
A21CR82	1902-0589	5	2	DIODE-ZNR 10V 2% DO-35 PD = .4W TC = +.066%	28480	1902-0589
A21CR84	1990-1124	1		OPT LED LMP Y AP LMP1401 TT1H	28480	1990-1124
A21CR85	1884-0317	7		THY XTR SCR ** THYR	11699P01	CS92A
A21CR86	1901-0050	3		DIODE-SWITCHING 80V 200MA 2NS DO-35	27014	D3D2/FDH6308A
A21CR88-CR89	1901-0050	3		DIODE-SWITCHING 80V 200MA 2NS DO-35	27014	D3D2/FDH6308A

See introduction to this section for ordering information

\*Indicates factory selected values

6-45

Table 6-3. Replaceable Parts

Ref.Des.	HP Part Number	CD	Qty	Description	Mfr. Code	Mfr. Part Number
A21CR90	1902-0589	5		DIODE-ZNR 10V 2% DO-35 PD = .4W TC = +.066%	28480	1902-0589
A21CR91	1902-0953	7		DIODE-ZNR 6.2V 5% DO-35 PD = .4W TC = +.053%	04713	SZ30035-11RL
A21CR92	1990-1124	1		OPT LED LMP Y AP LMP1401 TT1H	28480	1990-1124
A21CR93	1884-0317	7		THY XTR SCR ** THYR	11699P01	CS92A
A21CR94	1801-0050	3		DIODE-SWITCHING 80V 200MA 2NS DO-35	27014	D3D2/FDH6308A
A21CR95	1990-1123	0	4	OPT LED LMP R AP LMP1301 TT1H	28480	1990-1123
A21CR96	1884-0317	7		THY XTR SCR ** THYR	11699P01	CS92A
A21CR97	1901-0050	3		DIODE-SWITCHING 80V 200MA 2NS DO-35	27014	D3D2/FDH6308A
A21CR98	1902-3160	4	1	DIODE-ZNR 10V 2% DO-35 PD = .4W TC = +.066%	04713	SZ30018-183
A21CR100	1990-1123	0		OPT LED LMP R AP LMP1301 TT1H	28480	1990-1123
A21CR101	1884-0317	7		THY XTR SCR ** THYR	11699P01	CS92A
A21CR102	1901-0050	3		DIODE-SWITCHING 80V 200MA 2NS DO-35	27014	D3D2/FDH6308A
A21CR103	1990-1123	0		OPT LED LMP R AP LMP1301 TT1H	28480	1990-1123
A21CR104	1884-0317	7		THY XTR SCR ** THYR	11699P01	CS92A
A21CR105	1901-0050	3		DIODE-SWITCHING 80V 200MA 2NS DO-35	27014	D3D2/FDH6308A
A21CR106	1990-1123	0		OPT LED LMP R AP LMP1301 TT1H	28480	1990-1123
A21CR107	1884-0317	7		THY XTR SCR ** THYR	11699P01	CS92A
A21CR110-CR113	1901-0050	3		DIODE-SWITCHING 80V 200MA 2NS DO-35	27014	D3D2/FDH6308A
A21F3-F5	2110-0001	8	3	FUSE 1A 250V NTD 1.25X.25 UL	75915	312 001
A21J1	1251-5863	7	1	CONN-POST TYPE 2.5-PIN-SPOG 5-CONT	27264	22-11-1051
A21J2	1251-5862	6	1	CONN-POST TYPE 2.5-PIN-SPOG 4-CONT	27264	22-11-1041
A21J3-J5	1251-6832	3	3	CONN-POST TYPE 2.5-PIN-SPOG 3-CONT	27264	22-11-1031
A21J6	1251-6091	5	1	CONN-POST TYPE 2.5-PIN-SPOG 2-CONT	27264	22-11-1021
A21J8	03577-61639	7	1	CBL-ASM DSC MHS/STP 085MM ML	13740P01	
A21J10	1251-6310	1	1	CONN-UTIL METMAT 6-CKT 6-CONT	00779	207583-3
A21L1	03577-60334	7	1	IND TOROID SW 50UH 21A	07797P01	
A21L2	03577-60336	1	1	IND TOROID SW 200UH 5A	07797P01	
A21L3	03577-60333	8	1	IND TOROID SW 60UH 5A	07797P01	
A21L4	03577-60337	0	1	IND TOROID SW 200UH 2A	07797P01	
A21L5	03577-60332	5	1	IND POT CORE FIX 62UH 1.5A	10890P01	
A21L8	03577-60336	9	1	IND TOROID SW 2.5MH .6A	07797P01	
A21L7-L8	03577-60335	8	2	IND TOROID SW 500UH 1A	07797P01	
A21LB1	7121-4611	2	1	LABEL-INFORMATION .15-IN-WD .6-IN-LG	28480	L01003
A21MP1-MP12	0380-1511	6	12	STANDOFF-RVT-ON 4-MM-LG M3.0 X 0.5-THD	05791	
A21MP13-MP14	0380-1674	2	2	STANDOFF-RVT-ON 51-MM-LG M3.0 X 0.5-THD	06540	19878CB-0350-14
A21MP15	03577-04115	4	1	SHTF GRD-PLSTC PLCR	13588P02	
A21MP15	7120-3416	1	1	LABEL-WARNING 1.25-IN-WD 2.75-IN-LG	28480	
A21MP16-MP17	0515-0897	6	2	SCREW-MACH M3 X 0.5 8MM-LG PAN-HD	83486	
A21MP18-MP19	0535-0004	9	2	NUT-HEX DBL-CHAM M3 X 0.5 2.4MM-THK	28480	
A21MP20	0515-1451	0	1	SCR-MCH M3.0 16MMLG PHPZ SST +	83486	
A21MP21-MP30	0515-0169	5	10	SCREW-MACHINE ASSEMBLY M3 X 0.5 10MM-LG	05610P01	
A21MP31-MP32	0515-0897	5	2	SCREW-MACH M3 X 0.5 35MM-LG PAN-HD	83486	
A21MP33-MP34	3050-0105	6	2	WASHER-FL MTL NO. 4 .125-IN-ID	78471	
A21MP35-MP38	2190-0034	5	4	WASHER-LK HLCL NO. 10 .194-IN-ID	13962P01	
A21MP39	0535-0031	2	1	NUT-HEX WALKWR M3 X 0.5 2.4MM-THK	28480	
A21MP40	03577-01205	7	1	SHTF SHM-MTG SST	28480	
A21MP41-MP42	0380-0006	2	2	SPCR RD .18ID.25D .38LG BR5NI	28480	
A21MP43-MP44	8150-4397	3	2	JMPR 22GA GRN 100MM 8X8	28480	
A21MP45-MP48	2680-0099	1	4	SCREW-MACH 10-32 .375-IN-LG PAN-HD-POZI	05610P01	
A21MP49-MP50	0515-0886	3	2	SCREW-MACH M3 X 0.5 8MM-LG PAN-HD	83486	
A21MP51-MP52	0535-0042	5	2	NUT-HEX PLSTC-LKG M3 X 0.5 4MM-THK	28480	0535-0042
A21MP53-MP58	3050-0716	5	6	WASHER-FL MTL NO. 5 .128-IN-ID	70318	NAS620-C5
A21MP59-MP60	2260-0001	5	2	NUT-HEX-DBL-CHAM 4-40-THD .094-IN-THK	28480	2260-0001
A21MP61-MP70	4330-0496	3	10	INSULATOR-BEAD GLASS	53101	KG12
A21MP71-MP73	4330-0952	6	3	INSULATOR-BEAD CERAMIC	25706	10-215A
A21MP700	1205-0289	4	5	HEAT SINK TO-3-CS	13103	6016B
A21MP701-MP702	1205-0349	7	2	HEAT SINK SGL PLSTC-PWR-CS	13103	6025B-TT
A21Q1-Q2	1855-0536	1	2	TRANSISTOR MOSFET N-CHAN E-MODE TO-3 SI	34371	IRF440
A21Q12	1853-0569	6	2	TRANSISTOR PNP SI PD = 310MW FT = 40MHZ	04713	2N5087RLR
A21Q13	1854-0283	9	1	TRANSISTOR NPN 2N3019 SI TO-39 PD = 800MW	04713	2N3019
A21Q14	1853-0320	7	1	TRANSISTOR PNP 2N4032 SI TO-5 PD = 800MW	27014	2N4032
A21Q15	1854-0210	6	1	TRANSISTOR NPN 2N2222 SI TO-18 PD = 500MW	27014	
A21Q21	1853-0405	9	1	TRANSISTOR PNP SI PD = 300MW FT = 850MHZ	27014	

See introduction to this section for ordering information

\*Indicates factory selected values



Table 6-3. Replaceable Parts

Ref.Des.	HP Part Number	CD	Qty	Description	Mfr. Code	Mfr. Part Number
A21Q22	1854-0019	3	3	TRANSISTOR NPN SI TC-18 PD = 360MW	27014	
A21Q35-Q36	1854-0019	3		TRANSISTOR NPN SI TC-18 PD = 360MW	27014	
A21Q37	1853-0569	6		TRANSISTOR PNP SI PD = 310MW FT = 40MHZ	04713	2N5067RLR
A21Q38	1854-0087	5	1	TRANSISTOR NPN SI PD = 360MW FT = 75MHZ	13307P01	
A21R1-R2	0690-6831	0	2	RESISTOR 68K 10% 1W CC TC = 0 + 785	01121	GB6831
A21R3	0699-1167	3	2	RESISTOR-FUSE 18 OHM +-1%; .5W AT 70 DEG	91637	CMF60-64
A21R4	0683-2025	1	2	RESISTOR 2K 5% .25W CF TC = 0-400	77902	R-25J
A21R5	0699-1167	3		RESISTOR-FUSE 18 OHM +-1%; .5W AT 70 DEG	91637	CMF60-64
A21R6	0683-2025	1		RESISTOR 2K 5% .25W CF TC = 0-400	77902	R-25J
A21R7-R8	0698-3624	9	2	RESISTOR 150 5% 2W MO TC = 0 + -200	02499P02	GS-3
A21R9-R10	0688-4725	8	2	RESISTOR 4.7K 5% .5W CC TC = 0 + 647	01121	EB4725
A21R12	0683-2725	8	5	RESISTOR 2.7K 5% .25W CF TC = 0-400	77902	R-25J
A21R13	0683-1025	9	3	RESISTOR 1K 5% .25W CF TC = 0-400	77902	R-25J
A21R14	0757-0465	6	1	RESISTOR 100K 1% .125W F TC = 0 + -100	05524P03	CMF-55-1
A21R15	0757-0260	3	5	RESISTOR 1K 1% .125W F TC = 0 + -100	05524P03	CMF-55-1
A21R16	0698-3558	8	1	RESISTOR 4.02K 1% .125W F TC = 0 + -100	05524P03	CMF-554021FT-1
A21R17	0698-3382	6	1	RESISTOR 5.48K 1% .125W F TC = 0 + -100	91637	CMF-555491FT-1
A21R18	0683-3035	5	10	RESISTOR 30K 5% .25W CF TC = 0-400	77902	R-25J
A21R19	0683-4725	2	4	RESISTOR 4.7K 5% .25W CF TC = 0-400	77902	R-25J
A21R20	0683-1225	1	8	RESISTOR 1.2K 5% .25W CF TC = 0-400	77902	R-25J
A21R21	0683-7515	4	1	RESISTOR 750 5% .25W CF TC = 0-400	77902	R-25J
A21R22	2100-3252	6	1	RESISTOR-TRMR 5K 10% G TOP-ADJ 1-TRN	32997	3386P-Y46-502
A21R23	0683-1535	6	2	RESISTOR 15K 5% .25W CF TC = 0-400	77902	R-25J
A21R24	0683-4325	8	1	RESISTOR 4.3K 5% .25W CF TC = 0-400	77902	R-25J
A21R25	0683-2035	3	2	RESISTOR 20K 5% .25W CF TC = 0-400	77902	R-25J
A21R26	0683-1235	3	1	RESISTOR 12K 5% .25W CF TC = 0-400	77902	R-25J
A21R27	0683-3025	3	2	RESISTOR 3K 5% .25W CF TC = 0-400	77902	R20J
A21R28	0683-1045	3	1	RESISTOR 100K 5% .25W CF TC = 0-400	77902	R-25J
A21R29-R30	0683-1335	4	3	RESISTOR 13K 5% .25W CF TC = 0-400	77902	R-25J
A21R31	0683-1035	1	8	RESISTOR 10K 5% .25W CF TC = 0-400	77902	R-25J
A21R32	0683-5635	5	1	RESISTOR 56K 5% .25W CF TC = 0-400	77902	R-25J
A21R33	0698-6362	8	2	RESISTOR 1K .1% .125W F TC = 0 + -25	05524P03	CMF-551001BT-9
A21R34	0699-0033	0	2	RESISTOR 56.84K .25% .125W F TC = 0 + -50	91637	CMF-55-1
A21R35	0698-6362	8		RESISTOR 1K .1% .125W F TC = 0 + -25	05524P03	CMF-551001BT-9
A21R36	0699-0033	0		RESISTOR 56.84K .25% .125W F TC = 0 + -50	91637	CMF-55-1
A21R37	0683-3825	9	9	RESISTOR 3.6K 5% .25W CF TC = 0-400	77902	R-25J
A21R38	0683-3035	5		RESISTOR 30K 5% .25W CF TC = 0-400	77902	R-25J
A21R39	0683-1225	1		RESISTOR 1.2K 5% .25W CF TC = 0-400	77902	R-25J
A21R40	0698-4489	8	2	RESISTOR 54.9K 1% .125W F TC = 0 + -100	91637	CMF-555492FT-1
A21R41	0698-3572	6	2	RESISTOR 60.4K 1% .125W F TC = 0 + -100	91637	CMF-556042FT-1
A21R42	0683-1535	6		RESISTOR 15K 5% .25W CF TC = 0-400	77902	R-25J
A21R50	0757-0198	2	1	RESISTOR 100 1% .5W F TC = 0 + -100	05524P03	CMF-65-2
A21R51	0683-1035	1		RESISTOR 10K 5% .25W CF TC = 0-400	77902	R-25J
A21R52	0683-3035	5		RESISTOR 30K 5% .25W CF TC = 0-400	77902	R-25J
A21R53	0757-0433	8	1	RESISTOR 3.32K 1% .125W F TC = 0 + -100	05524P03	CMF-55-1
A21R54	0683-1035	1		RESISTOR 10K 5% .25W CF TC = 0-400	77902	R-25J
A21R55	0683-4725	2		RESISTOR 4.7K 5% .25W CF TC = 0-400	77902	R-25J
A21R56	0683-1325	2	1	RESISTOR 1.3K 5% .25W CF TC = 0-400	77902	R-25J
A21R57	0698-3332	6	1	RESISTOR 80.6 1% .5W F TC = 0 + -100	91637	CMF-65-2
A21R58	0698-4840	3	1	RESISTOR 115 1% .5W F TC = 0 + -100	91637	CMF-65-2
A21R60-R81	0683-2725	8		RESISTOR 2.7K 5% .25W CF TC = 0-400	77902	R-25J
A21R83	0683-6215	9	1	RESISTOR 620 5% .25W CF TC = 0-400	77902	R-25J
A21R84	0683-1035	1		RESISTOR 10K 5% .25W CF TC = 0-400	77902	R-25J
A21R85	0683-2725	8		RESISTOR 2.7K 5% .25W CF TC = 0-400	77902	R-25J
A21R86	0698-4482	9	1	RESISTOR 17.4K 1% .125W F TC = 0 + -100	05524P03	CMF-551742FT-1
A21R87	0683-2725	8		RESISTOR 2.7K 5% .25W CF TC = 0-400	77902	R-25J
A21R88	0683-5115	6	1	RESISTOR 510 5% .25W CF TC = 0-400	77902	R-25J
A21R89	0683-1025	9		RESISTOR 1K 5% .25W CF TC = 0-400	77902	R-25J
A21R90	0683-1035	1		RESISTOR 10K 5% .25W CF TC = 0-400	77902	R-25J
A21R91	0683-3025	3		RESISTOR 3K 5% .25W CF TC = 0-400	77902	R20J
A21R92	0757-0403	2	1	RESISTOR 121 1% .125W F TC = 0 + -100	05524P03	CMF-55-1
A21R93	0757-0317	7	1	RESISTOR 1.33K 1% .125W F TC = 0 + -100	05524P03	CMF-55-1

See introduction to this section for ordering information

\*Indicates factory selected values

Table 6-3. Replaceable Parts

Ref.Des.	HP Part Number	CD	Qty	Description	Mfr. Code	Mfr. Part Number
A21R94	0757-0282	5	2	RESISTOR 221 1% .125W F TC = 0+-100	05524P03	CMF-55-1
A21R95	0757-0431	6	1	RESISTOR 2.43K 1% .125W F TC = 0+-100	05524P03	CMF-55-1
A21R96-R97	8159-0005	0	2	RESISTOR-ZERO OHMS 22 AWG LEAD DIA	02499P02	YZ01/4
A21R99-R101	0698-3615	8	4	RESISTOR 47 5% 2W MO TC = 0+-200	02499P02	GS-3
A21R102	63312-80001	4	1	R-F SENSING .005	L4458P01	
A21R103	0766-0029	7	1	RESISTOR 10 2% 3W MO TC = 0+-250	91637	FP-3
A21R104	0683-2215	1	1	RESISTOR 220 5% .25W CF TC = 0-400	77902	R-25J
A21R105-R107	0698-3618	1	3	RESISTOR 82 5% 2W MO TC = 0+-200	02499P02	GS-3
A21R108	0757-0442	9	4	RESISTOR 10K 1% .125W F TC = 0+-100	05524P03	CMF-55-1
A21R109	0757-0273	4	1	RESISTOR 3.01K 1% .125W F TC = 0+-100	05524P03	CMF-55-1
A21R110-R111	0698-3633	0	4	RESISTOR 390 5% 2W MO TC = 0+-200	02499P02	GS-3
A21R112	0812-0049	0	1	RESISTOR 500 5% 2W PW TC = 0+-20	05524P06	RS-2B-138
A21R113	0693-6811	2	1	RESISTOR 680 10% 2W CC TC = 0+529	01121	MB6811
A21R114	0698-3633	0		RESISTOR 390 5% 2W MO TC = 0+-200	02499P02	GS-3
A21R115	0699-1060	5	1	RESISTOR .05 1% 3W MFS TC = 0+-337	28480	0699-1060
A21R116	0699-1059	2	1	RESISTOR .1 1% 3W MFS TC = 0+-337	28480	0699-1059
A21R117	0698-3633	0		RESISTOR 390 5% 2W MO TC = 0+-200	02499P02	GS-3
A21R118	0757-0440	7	1	RESISTOR 7.5K 1% .125W F TC = 0+-100	05524P03	CMF-55-1
A21R119	0757-0427	0	1	RESISTOR 1.5K 1% .125W F TC = 0+-100	05524P03	CMF-55-1
A21R120	0757-0282	5		RESISTOR 221 1% .125W F TC = 0+-100	05524P03	CMF-55-1
A21R121	0698-4432	9	1	RESISTOR 2.1K 1% .125W F TC = 0+-100	05524P03	CMF-552101FT-1
A21R122	2100-3211	7	1	RESISTOR-TRMR 1K 10% C TOP-ADJ 1-TRN	32997	3386P-Y46-102
A21R123	0757-0410	1	1	RESISTOR 301 1% .125W F TC = 0+-100	05524P03	CMF-55-1
A21R124	2100-0568	1	1	RESISTOR-TRMR 100 10% C TOP-ADJ 1-TRN	32997	3386P-Y46-101
A21R125	0683-3625	9		RESISTOR 3.6K 5% .25W CF TC = 0-400	77902	R-25J
A21R126	0764-0020	4	1	RESISTOR 5.6K 5% 2W MO TC = 0+-200	02499P02	GS-3
A21R126-R129	0698-7515	0	2	RESISTOR 750 5% .5W CC TC = 0+529	01121	EB7515
A21R130	0757-0424	7	4	RESISTOR 1.1K 1% .125W F TC = 0+-100	05524P03	CMF-55-1
A21R131	0698-3162	0	1	RESISTOR 48.4K 1% .125W F TC = 0+-100	05524P03	CMF-554642FT-1
A21R132	0683-1035	1		RESISTOR 10K 5% .25W CF TC = 0-400	77902	R-25J
A21R133	0683-2035	3		RESISTOR 20K 5% .25W CF TC = 0-400	77902	R-25J
A21R134	0683-1025	9		RESISTOR 1K 5% .25W CF TC = 0-400	77902	R-25J
A21R135	0683-1035	1		RESISTOR 10K 5% .25W CF TC = 0-400	77902	R-25J
A21R136	0698-3450	9	1	RESISTOR 42.2K 1% .125W F TC = 0+-100	05524P03	CMF-554222FT-1
A21R137	0698-3228	9	1	RESISTOR 49.9K 1% .125W F TC = 0+-100	05524P03	CMF-554992FT-1
A21R138	0683-1335	4		RESISTOR 13K 5% .25W CF TC = 0-400	77902	R-25J
A21R139	0757-0280	3		RESISTOR 1K 1% .125W F TC = 0+-100	05524P03	CMF-55-1
A21R140	0683-3035	5		RESISTOR 30K 5% .25W CF TC = 0-400	77902	R-25J
A21R141	0683-3625	9		RESISTOR 3.6K 5% .25W CF TC = 0-400	77902	R-25J
A21R142	0683-1225	1		RESISTOR 1.2K 5% .25W CF TC = 0-400	77902	R-25J
A21R143	0683-1035	1		RESISTOR 10K 5% .25W CF TC = 0-400	77902	R-25J
A21R144	0757-0424	7		RESISTOR 1.1K 1% .125W F TC = 0+-100	05524P03	CMF-55-1
A21R145	0757-0442	9		RESISTOR 10K 1% .125W F TC = 0+-100	05524P03	CMF-55-1
A21R146	0698-3279	0	3	RESISTOR 4.99K 1% .125W F TC = 0+-100	05524P03	CMF-554991FT-1
A21R147	0698-3488	3	2	RESISTOR 442 1% .125W F TC = 0+-100	91637	CMF-55-1
A21R150	0698-3572	6		RESISTOR 60.4K 1% .125W F TC = 0+-100	91637	CMF-558042FT-1
A21R151	0757-0424	7		RESISTOR 1.1K 1% .125W F TC = 0+-100	05524P03	CMF-55-1
A21R152	0683-3625	9		RESISTOR 3.6K 5% .25W CF TC = 0-400	77902	R-25J
A21R153-R154	0683-3035	5		RESISTOR 30K 5% .25W CF TC = 0-400	77902	R-25J
A21R155	0683-3625	9		RESISTOR 3.6K 5% .25W CF TC = 0-400	77902	R-25J
A21R156	0683-1225	1		RESISTOR 1.2K 5% .25W CF TC = 0-400	77902	R-25J
A21R158	0698-4499	8		RESISTOR 54.9K 1% .125W F TC = 0+-100	91637	CMF-555492FT-1
A21R159	0698-4503	5	1	RESISTOR 66.5K 1% .125W F TC = 0+-100	91637	CMF-556652FT-1
A21R160	0757-0424	7		RESISTOR 1.1K 1% .125W F TC = 0+-100	05524P03	CMF-55-1
A21R162	0698-3279	0		RESISTOR 4.99K 1% .125W F TC = 0+-100	05524P03	CMF-554991FT-1
A21R163	0698-3488	3		RESISTOR 442 1% .125W F TC = 0+-100	91637	CMF-55-1
A21R164	0757-0442	9		RESISTOR 10K 1% .125W F TC = 0+-100	05524P03	CMF-55-1
A21R169	0698-3447	4	1	RESISTOR 422 1% .125W F TC = 0+-100	05524P03	CMF-554220FT-1
A21R170	0757-0280	3		RESISTOR 1K 1% .125W F TC = 0+-100	05524P03	CMF-55-1
A21R171	0698-4425	0	1	RESISTOR 1.54K 1% .125W F TC = 0+-100	91637	CMF-551541FT-1
A21R174	0698-3279	0		RESISTOR 4.99K 1% .125W F TC = 0+-100	05524P03	CMF-554991FT-1
A21R175	0757-0451	0	1	RESISTOR 24.3K 1% .125W F TC = 0+-100	91637	CMF-55-1
A21R176	0757-0442	9		RESISTOR 10K 1% .125W F TC = 0+-100	05524P03	CMF-55-1

See introduction to this section for ordering information

\*Indicates factory selected values

Table 6-3. Replaceable Parts

Ref.Des.	HP Part Number	CD	Qty	Description	Mfr. Code	Mfr. Part Number
A21R177	0757-0444	1	1	RESISTOR 12.1K 1% .125W F TC = 0+ -100	91637	CMF-55-1
A21R179-R182	0683-3035	5		RESISTOR 30K 5% .25W CF TC = 0-400	77902	R-25J
A21R183	0683-3625	9		RESISTOR 3.6K 5% .25W CF TC = 0-400	77902	R-25J
A21R184	0683-1225	1		RESISTOR 1.2K 5% .25W CF TC = 0-400	77902	R-25J
A21R193-R195	0683-3625	9		RESISTOR 3.6K 5% .25W CF TC = 0-400	77902	R-25J
A21R196-R198	0683-1225	1		RESISTOR 1.2K 5% .25W CF TC = 0-400	77902	R-25J
A21R202	0757-0456	5	1	RESISTOR 43.2K 1% .125W F TC = 0+ -100	91637	CMF-55-1
A21R203	0757-0280	3		RESISTOR 1K 1% .125W F TC = 0+ -100	05524P03	CMF-55-1
A21R204	0698-3152	8	1	RESISTOR 3.48K 1% .125W F TC = 0+ -100	91637	CMF-553481FT-1
A21R205-R208	0683-4725	2		RESISTOR 4.7K 5% .25W CF TC = 0-400	77902	R-25J
A21R207	0698-4472	7	1	RESISTOR 7.98K 1% .125W F TC = 0+ -100	05524P03	CMF-55768FT-1
A21R208	0757-0280	3		RESISTOR 1K 1% .125W F TC = 0+ -100	05524P03	CMF-55-1
A21R209	0757-0435	0	1	RESISTOR 3.92K 1% .125W F TC = 0+ -100	05524P03	CMF-55-1
A21R210	0698-3518	0	1	RESISTOR 7.32K 1% .125W F TC = 0+ -100	05524P03	CMF-557321FT-1
A21RT1	0837-0144	8	1	THERMISTOR DISC 5-OHM TC = -3.3%/C-DEG	12830P01	5DA5R0
A21RT2-RT3	0837-0215	4	2	THERMISTOR-SURGE PTCR USED AS SURGE	12830P01	SG-220S
A21S1	3103-0118	4	1	SWITCH-THRM FXD +221F 15A OPN-ON-RISE	14604	3450-83-130
A21SG1	1870-0092	8	1	TUBE-ELECTRON SURGE V PTCR	06121P01	L71-A270X
A21T1	9100-4361	7	1	TRANSFORMER-POWER PRI V:110/215 V;FOPR	02081P01	PX4903
A21T2	9100-4348	0	1	INDUCTOR-FIXED CURRENT SENSE INDUCTOR,L	09161	51719
A21T3	9100-4364	0	1	TRANSFORMER-SWITCHING GATE DRIVE XFMR	10890P01	
A21T4	9100-4360	6	1	TRANSFORMER-POWER 115/230V 47-440HZ	02081P01	PX4902
A21T5	9100-4370	8	1	XFM LAMINATE PWR	02081P01	PX4798
A21TP1-TP14	1252-2897	3	33	CON-SINGLE CONTACT	11627P01	7-22751-8
A21TP15-TP20	0360-0535	0	6	TML-STUD 1PIN .330LG BRS	13296P01	330.100-TIN PLATED
A21TP16-TP20	0360-0535	0	5	TML-STUD 1PIN .330LG BRS	13296P01	330.100-TIN PLATED
A21TP17-TP20	0360-0535	0	4	TML-STUD 1PIN .330LG BRS	13296P01	330.100-TIN PLATED
A21TP18-TP20	0360-0535	0	3	TML-STUD 1PIN .330LG BRS	13296P01	330.100-TIN PLATED
A21TP19-TP20	0360-0535	0	2	TML-STUD 1PIN .330LG BRS	13296P01	330.100-TIN PLATED
A21TP20	0360-0535	0	1	TML-STUD 1PIN .330LG BRS	13296P01	330.100-TIN PLATED
A21TP21-TP39	1252-2897	3		CON-SINGLE CONTACT	11627P01	7-22751-8
A21TP40-TP41	0360-0124	3	2	CONNECTOR-SGL CONT PIN .04-IN-BSC-SZ RND	13308P01	
A21U1	1826-1116	4	1	ICOP AMP GP QUAD 14-DIP-P PKG	07933	RC4156N
A21U2	1826-0138	8	4	ICOMPARATOR GP QUAD 14-DIP-P PKG	27014	LM339N
A21U3	1820-1288	9	1	ICDRVR TTL CLK TTL-TO-MOS 1-INP	27014	DS0026CJ
A21U4	1826-0138	8		ICOMPARATOR GP QUAD 14-DIP-P PKG	27014	LM339N
A21U5	1826-1040	3	1	ICV RGLTR-SWG 4.85/5.15V 18-DIP-C PKG	34333	SG3526J
A21U6	1826-0412	1	2	ICOMPARATOR PRCN DUAL 8-DIP-P PKG	27014	LM393N
A21U7	1826-0059	2	1	ICOP AMP GP TO-99 PKG	27014	LM201AH
A21U8	1826-0138	8		ICOMPARATOR GP QUAD 14-DIP-P PKG	27014	LM339N
A21U10	1828-0677	0	1	ICV RGLTR-ADJ-POS 1.2/32V TO-3 PKG	27014	LM338K
A21U11	1826-1585	1	1	ICL VREG 1033C BIP AN T03	10858P01	LT1033CK
A21U12	1826-0144	6	1	ICV RGLTR-FXD-POS 4.8/5.2V TO-220 PKG	04713	MC7805CT
A21U13	1826-0393	7	1	ICV RGLTR-ADJ-POS 1.2/37V TO-220 PKG	27014	LM317T
A21U14	1826-0527	9	1	ICV RGLTR-ADJ-NEG 1.2/37V TO-220 PKG	27014	LM337T
A21U15	1826-0412	1		ICOMPARATOR PRCN DUAL 8-DIP-P PKG	27014	LM393N
A21U17	1826-0138	8		ICOMPARATOR GP QUAD 14-DIP-P PKG	27014	LM339N
A21W1-W2	1258-0224	8	2	CON-JUMPER PROGRAMMING	28480	1258-0224
A21W1A	1251-1636	4	6	CONNECTOR-SGL CONT SKT .04-IN-BSC-SZ RND	06776	PS-40-823-TG30
A21W1B	1251-1636	4		CONNECTOR-SGL CONT SKT .04-IN-BSC-SZ RND	06776	PS-40-823-TG30
A21W1C-WA2	1251-1636	4		CONNECTOR-SGL CONT SKT .04-IN-BSC-SZ RND	06776	PS-40-823-TG30
A21W2	1258-0224	8	1	CON-JUMPER PROGRAMMING	28480	1258-0224
A21W2A	1251-1636	4	3	CONNECTOR-SGL CONT SKT .04-IN-BSC-SZ RND	06776	PS-40-823-TG30
A21W2B	1251-1636	4		CONNECTOR-SGL CONT SKT .04-IN-BSC-SZ RND	06776	PS-40-823-TG30
A21W2C	1251-1636	4		CONNECTOR-SGL CONT SKT .04-IN-BSC-SZ RND	06776	PS-40-823-TG30
A21X1	1205-0289	4		HEAT SINK TO-3-CS	13103	6016B
A21X2	1205-0289	4	3	HEAT SINK TO-3-CS	13103	6016B
A21X3-X5	2110-0643	4	3	FUSEHOLDER-CLIP TYPE 15A 250 V	55982	FH-8000
A21X7	1205-0353	3	1	HEAT SINK SGL PLSTC-PWR-CS	13103	6073B
A21X10	1205-0366	8	1	HEAT SINK SGL TO-3-CS	13103	6054B
A21X11	1205-0289	4		HEAT SINK TO-3-CS	13103	6016B
A21X50	1205-0289	4		HEAT SINK TO-3-CS	13103	6016B

See introduction to this section for ordering information

\*Indicates factory selected values

Table 6-3. Replaceable Parts

Ref.Des.	HP Part Number	CD	Qty	Description	Mfr. Code	Mfr. Part Number
A25	03577-66525	0	1	PCASSY R F FILTER	28480	03577-66525
A25C1-C2	0160-6853	3	2	C-F 1.5PF % 500V CERTB	59660	301 089 COX0 159C
A25C3	0160-6864	6	1	C-F 4.7PF 5% 500V CERTB	59660	301 089 COH0 479C
A25J1-J2	1250-2142	7	2	CON-SMB	74970	131-3701-341
A25L1	9140-0814	1	1	COIL-VAR 20NH-25NH Q = 50 PC-MTG	24226	8272
A25	2190-0124	4	2	WASHER-LK INTL T NO. 10 .185-IN-ID	98291	3002-26
A25	2950-0078	9	2	NUT-HEX-DBL-CHAM 10-32-THD .067-IN-THK	98291	40001-18-030-156
A25	0340-0677	9	1	INSULATOR MYLAR	22670	
A25	03577-00601	5	1	ETCH SHLD-FILTER BD	LD063P01	
A31	03577-66531	8	1	PCASSY OSC	28480	03577-66531
A31C1	0180-4170	5	1	C-F 22uF 35V TA	12340P01	T322E226K035AS
A31C2	0160-4832	4	2	CAPACITOR-FXD .01UF +-10% 100VDC CER	04222	SA101C103KAAH
A31C3-C4	0160-2222	2	2	CAPACITOR-FXD 1500PF +-5% 300VDC MICA	09023	CD19FC152J03
A31C5	0160-4832	4	4	CAPACITOR-FXD .01UF +-10% 100VDC CER	04222	SA101C103KAAH
A31C6	0160-6510	9	1	C-F .1UF 20% 50V CERMLI	28480	RPE121-878X7R104M50V
A31CR1-CR2	1901-0040	1	2	DIODE-SWITCHING 30V 50MA 2NS DO-35	27014	
A31J1	1250-2215	5	1	CON-SMB STRAIGHT	74970	131-1701-201
A31J2	1251-5971	8	1	CONN-POST TYPE 2.5-PIN-SPOG 3-COAT	27264	22-12-1032
A31L1	9100-1618	1	1	INDUCTOR RF-CH-MLD 5.6UH 10%	99800	1537-30
A31L2	9100-2486	3	1	INDUCTOR RF-CH-MLD 330NH 5% .166DX.385LG	24226	15M330J
A31L3	9140-0238	3	1	INDUCTOR RF-CH-MLD 82UH 5% .166DX.385LG	99800	1537-72
A31Q1-Q2	1853-0020	4	2	TRANSISTOR PNP SI FD = 300MW FT = 150MHZ	04713	SPS3609
A31Q3-Q4	1855-0386	9	2	TRANSISTOR J-FET 2N4392 N-CHAN D-MODE	04713	2N4392
A31R1	0757-0442	9	1	RESISTOR 10K 1% .125W F TC = 0 +-100	91637	CMF-55-1
A31R2	2100-3207	1	1	RESISTOR-TRMR 5K 10% C SIDE-ADJ 1-TRN	32997	3386X-Y46-502
A31R3	0683-2225	3	1	RESISTOR 2.2K 5% .25W CF TC = 0-400	77902	R-25J
A31R4	0683-4705	8	3	RESISTOR 47 5% .25W CF TC = 0-400	77902	R-25J
A31R5	0690-6811	6	1	RESISTOR 680 10% 1W CC TC = 0 + 529	01121	GB6811
A31R6	0683-4705	8	1	RESISTOR 47 5% .25W CF TC = 0-400	77902	R-25J
A31R7	0698-3279	0	1	RESISTOR 4.99K 1% .125W F TC = 0 +-100	91637	CMF-55-1
A31R8	0757-0449	6	1	RESISTOR 20K 1% .125W F TC = 0 +-100	91637	CMF-55-1
A31R9	2100-3351	6	1	RESISTOR-TRMR 500 10% C SIDE-ADJ 1-TRN	32997	3386X-Y46-501
A31R10	0698-4442	1	1	RESISTOR 4.42K 1% .125W F TC = 0 +-100	91637	CMF-55-1
A31R11	0698-4308	8	1	RESISTOR 16.9K 1% .125W F TC = 0 +-100	91637	CMF-55-1
A31R12	0683-1055	5	2	RESISTOR 1M 5% .25W CF TC = 0-800	77902	R-25J
A31R13	0698-4438	5	1	RESISTOR 3.09K 1% .125W F TC = 0 +-100	91637	CMF-55-1
A31R14	0683-4705	8	1	RESISTOR 47 5% .25W CF TC = 0-400	77902	R-25J
A31R15-R16	0698-4453	4	2	RESISTOR 402 1% .125W F TC = 0 +-100	91637	CMF-55-1
A31R17	0683-1055	5	1	RESISTOR 1M 5% .25W CF TC = 0-800	77902	R-25J
A31R18	0683-1035	1	1	RESISTOR 10K 5% .25W CF TC = 0-400	77902	R-25J
A31U1	0960-0465	7	1	GSKT OSC OCXO 10MHZ VCONT TTL	12020	OSC 92-12
A31U2	1826-0026	3	1	ICCOMPARATOR PRON TO-99 PKG	27014	LM311H
A31	0380-1236	2	5	STANDOFF-RVT-ON 6-MMLG M3.0 X 0.5-THD	05791	
A31	2200-0103	2	3	SCREW-MACH 4-40 .25-IN-LG PAN-HD-POZI	83486	
A31	03585-04132	5	1	SHTF NSLTR-OVEN PLCR	13588P02	
A31	7121-4611	2	1	LABEL-INFORMATION .15-IN-WD .6-IN-LG	28480	L01003

See introduction to this section for ordering information

\*Indicates factory selected values



Table 6-3. Replaceable Parts

Ref.Des.	HP Part Number	CD	Qty	Description	Mfr. Code	Mfr. Part Number
A61	03577-66561	4	1	PCASSY FAST PROCESSOR	28480	03577-66561
A61C1-C29	0160-4835	7	61	CAPACITOR-FXD .1UF +-10% 50VDC CER	04222	SA105C104KAAH
A61C30	0180-4135	2	1	C-F 33 UF 10% 10V TATBSA	12340P02	T322D336K010AS
A61C31-C32	0160-4835	7		CAPACITOR-FXD .1UF +-10% 50VDC CER	04222	SA105C104KAAH
A61C33	0160-6507	4	1	C-F 1000PF 20% 100V CERMLr	28480	RPE121-978X7R102M100V
A61C34-C63	0160-4835	7		CAPACITOR-FXD .1UF +-10% 50VDC CER	04222	SA105C104KAAH
A61J2	1250-2214	4	1	CON-SMB RTA	74970	131-3701-301
A61J3	1251-5202	6	1	CONN-POST TYPE .125-PIN-SPOG 5-CONT	03206P01	65580-105
A61L1	8100-1791	1	1	CORE-FERRITE CHOKE-WIDEBAND;IMP-360	06337P01	VK200-19/4B
A61L2	8100-3345	5	1	INDUCTOR RF-CH-MLD 2UH 5% .166DX.385LG	24226	15M201J
A61LB1	7121-4611	2	1	LABEL-INFORMATION .15-IN-WD .6-IN-LG	28480	LD1003
A61MP1	4040-0754	1	1	EXTR-PC BD BLU POLYC .062-IN-BD-THKNS	10456P01	
A61MP2	4040-0749	4	1	EXTR-PC BD BRN POLYC .062-IN-BD-THKNS	10456P01	
A61MP3-MP4	1480-0116	8	2	PIN-GRV .062-IN-DIA .25-IN-LG STL	73957	G24-062 X 250-17
A61MP5-MP7	1258-0141	8	3	CON-JUMPER REM .025P	00779	530153-2
A61R1-R4	0683-1025	9	5	RESISTOR 1K 5% .25W CF TC = 0-400	77902	R-25J
A61R5-R6	0683-2025	1	3	RESISTOR 2K 5% .25W CF TC = 0-400	77902	R-25J
A61R9-R10	0683-4725	2	9	RESISTOR 4.7K 5% .25W CF TC = 0-400	77902	R-25J
A61R11	0683-2025	1		RESISTOR 2K 5% .25W CF TC = 0-400	77902	R-25J
A61R12	0683-4725	2		RESISTOR 4.7K 5% .25W CF TC = 0-400	77902	R-25J
A61R13	0683-1035	1	2	RESISTOR 10K 5% .25W CF TC = 0-400	77902	R-25J
A61R14	0683-1025	9		RESISTOR 1K 5% .25W CF TC = 0-400	77902	R-25J
A61R17-R22	0683-4725	2		RESISTOR 4.7K 5% .25W CF TC = 0-400	77902	R-25J
A61R23	8159-0005	0	2	RESISTOR-ZERO OHMS 22 AWG LEAD DIA	02499P02	YZ01/4
A61R25	0683-1035	1		RESISTOR 10K 5% .25W CF TC = 0-400	77902	R-25J
A61R900	8159-0005	0		RESISTOR-ZERO OHMS 22 AWG LEAD DIA	02499P02	YZ01/4
A61RP1	1810-0286	4	1	NETWORK-RES 18-DIP 10.0K OHM X 15	11236	761-1-R10K
A61RP3-RP4	1810-0338	7	2	NETWORK-RES 18-DIP 100.0 OHM X 8	11236	761-3-R100
A61TP1-TP9	1252-2897	3	9	CON-SINGLE CONTACT	11627P01	7-22751-8
A61U1	03577-60352	9	1	PGM PROM	28480	03577-60352
A61U1-U6	1818-4435	9	6	ICM OTP 27C292 2X08 35NS P24	11345P01	CY7C292-35PC
A61U2	03577-60353	0	1	PGM PROM	28480	03577-60353
A61U3	03577-60354	1	1	PGM PROM	28480	03577-60354
A61U4	03577-60355	2	1	PGM PROM	28480	03577-60355
A61U5	03577-60356	3	1	PGM PROM	28480	03577-60356
A61U6	03577-60357	4	1	PGM PROM	28480	03577-60357
A61U7-U12	1820-1677	0	9	ICFF TTL S D-TYPE OCTL	01295	SN74S374N
A61U13-U14	1820-0998	6	2	ICMUXR/DATA-SEL TTL S 4-TO-1-LINE DUAL	01295	SN74S153N
A61U15	1820-3657	0	1	IC-12 BIT WIDE MICROPROGRAMMER	11345P01	CY2910APC
A61U16	1820-0694	9	1	ICGATE TTL S EXCL-OR QUAD 2-INP	01295	SN74S86N
A61U17-U18	1820-1302	8	2	ICMUXR/DATA-SEL TTL S 8-TO-1-LINE 8-INP	01295	SN74S251N
A61U19-U20	1820-2796	5	2	ICDRVR TTL F LINE DRVR OCTL	18324	74F244N
A61U21	1820-1305	1	1	ICGEN TTL S LOCK-AHD-CRY	01295	SN74S162N
A61U22	1820-2287	0	2	ICMUXR/DATA-SEL TTL S 4-TO-1-LINE DUAL	27014	DM74S253N
A61U23	1820-1677	0		ICFF TTL S D-TYPE OCTL	01295	SN74S374N
A61U24-U27	1820-4699	2	4	ICM BIT SLICE 2901	11345P01	CY7C901-31PC
A61U28	1820-1319	7	2	ICMUXR/DATA-SEL TTL S 8-TO-1-LINE 8-INP	01295	SN74S151N
A61U29	1820-0681	4	2	ICGATE TTL S NAND QUAD 2-INP	01295	SN74S00N
A61U30	1820-1072	9	1	ICDCDR TTL S 2-TO-4-LINE DUAL 2-INP	01295	SN74S139AN
A61U31	1820-1112	8	1	ICFF TTL LS D-TYPE POS-EDGE-TRIG	01295	SN74LS74AN
A61U32	1820-1491	6	1	ICBFR TTL LS NON-INV HEX 1-INP	01295	SN74LS367AN
A61U33-U34	1820-1276	7	4	ICCNTR TTL LS BIN UP/DOWN SYNCHRO	01295	SN74LS191N
A61U35	1820-1430	3	1	ICCNTR TTL LS BIN SYNCHRO POS-EDGE-TRIG	01295	SN74LS161AN
A61U36	1820-0693	8	2	ICFF TTL S D-TYPE POS-EDGE-TRIG	01295	SN74LS74N

See introduction to this section for ordering information

\*Indicates factory selected values

Table 6-3. Replaceable Parts

Ref.Des.	HP Part Number	CD	Qty	Description	Mfr. Code	Mfr. Part Number
A61U37-U39	1820-1216	3	3	ICDCDR TTL LS 3-TO-8-LINE 3-INP	01295	SN74LS138N
A61U40	1820-1322	2	1	ICGATE TTL S NOR QUAD 2-INP	01295	SN74S02N
A61U41-U42	1820-1278	7		ICCNTR TTL LS BIN UP/DOWN SYNCHRO	01295	SN74LS191N
A61U43	1820-1841	8	1	ICDRVR TTL LS BUS HEX 1-INP	01295	SN74LS365AN
A61U44	1820-0683	6	2	ICINV TTL S HEX 1-INP	01295	SN74S04N
A61U45	1820-1319	7		ICMUXR/DATA-SEL TTL S 8-TO-1-LINE 8-INP	01295	SN74S151N
A61U46-U47	1820-1794	2	2	ICBFR TTL LS NON-INV OCTL	27014	DM74LS465N
A61U48	1820-0683	6		ICINV TTL S HEX 1-INP	01295	SN74S04N
A61U49	1820-1158	2	1	ICGATE TTL S AND-OR-INV DUAL 2-INP	01295	SN74S51N
A61U50	1820-0681	4		ICGATE TTL S NAND QUAD 2-INP	01295	SN74S00N
A61U51-U52	1820-1997	7	2	ICFF TTL LS D-TYPE POS-EDGE-TRIG PRL-IN	27014	DM74LS374N
A61U53	1820-2287	0		ICMUXR/DATA-SEL TTL S 4-TO-1-LINE DUAL	27014	DM74S253N
A61U54-U55	1820-1677	0		ICFF TTL S D-TYPE OCTL	01295	SN74S374N
A61U56	1820-2897	6	1	ICSHF-RGTR TTL F MULTI-MODE	18324	74F194N
A61U57	1820-0688	1	1	ICGATE TTL S NAND DUAL 4-INP	01295	SN74S20N
A61U58	1820-1275	4	1	ICGATE TTL S NOR DUAL 5-INP	01295	SN74S260N
A61U59	1820-1470	1	1	ICMUXR/DATA-SEL TTL LS 2-TO-1-LINE QUAD	01295	SN74LS157N
A61U60	1820-0683	8		ICFF TTL S D-TYPE POS-EDGE-TRIG	01295	SN74S74N
A61U61	1820-2634	1	1	ICINV TTL ALS HEX	01295	SN74ALS04BN
A61W1-W3	1251-6515	8	3	CONN-POST TYPE .100-PIN-SPCG 6-CONT	03206P01	67996-606
A61XU1-XU6	1200-0541	1	6	SOCKET-IC 24-CONT DIP DIP-SLDR	00779	2-641604-1
A62	03577-66562	5	1	PCASSY MAIN PROCESSOR	28480	03577-66562
A62BT1	1420-0277	6	1	BATTERY 3V 1.05A-HR L/5-DIOX W-FLEX	55002	400S PC
A62C1-C4	0160-4835	7	80	CAPACITOR-FXD .1UF +-10% 50VDC CER	04222	SA105C104KAAH
A62C10-C17	0160-4835	7		CAPACITOR-FXD .1UF +-10% 50VDC CER	04222	SA105C104KAAH
A62C20-C23	0160-4835	7		CAPACITOR-FXD .1UF +-10% 50VDC CER	04222	SA105C104KAAH
A62C28	0160-4835	7		CAPACITOR-FXD .1UF +-10% 50VDC CER	04222	SA105C104KAAH
A62C33-C37	0160-4835	7		CAPACITOR-FXD .1UF +-10% 50VDC CER	04222	SA105C104KAAH
A62C38	0180-3440	0	3	CAPACITOR-FXD 47UF +-10% 10VDC TA	12340P02	T322D476K010AS
A62C45-C48	0160-4835	7		CAPACITOR-FXD .1UF +-10% 50VDC CER	04222	SA105C104KAAH
A62C50-C52	0160-4835	7		CAPACITOR-FXD .1UF +-10% 50VDC CER	04222	SA105C104KAAH
A62C54-C55	0160-4835	7		CAPACITOR-FXD .1UF +-10% 50VDC CER	04222	SA105C104KAAH
A62C56	0160-4832	4	6	CAPACITOR-FXD .01UF +-10% 100VDC CER	04222	SA101C103KAAH
A62C57	0180-3552	5	1	C-F 4.7UF 10% 20V TATBSA	12340P02	T322B475K020AS
A62C58-C59	0160-4832	4		CAPACITOR-FXD .01UF +-10% 100VDC CER	04222	SA101C103KAAH
A62C60-C61	0160-4835	7		CAPACITOR-FXD .1UF +-10% 50VDC CER	04222	SA105C104KAAH
A62C64-C67	0160-4835	7		CAPACITOR-FXD .1UF +-10% 50VDC CER	04222	SA105C104KAAH
A62C70-C71	0160-4835	7		CAPACITOR-FXD .1UF +-10% 50VDC CER	04222	SA105C104KAAH
A62C74-C75	0160-4835	7		CAPACITOR-FXD .1UF +-10% 50VDC CER	04222	SA105C104KAAH
A62C77	0160-4835	7		CAPACITOR-FXD .1UF +-10% 50VDC CER	04222	SA105C104KAAH
A62C80-C84	0160-4835	7		CAPACITOR-FXD .1UF +-10% 50VDC CER	04222	SA105C104KAAH
A62C90-C93	0160-4835	7		CAPACITOR-FXD .1UF +-10% 50VDC CER	04222	SA105C104KAAH
A62C95-C96	0160-4835	7		CAPACITOR-FXD .1UF +-10% 50VDC CER	04222	SA105C104KAAH
A62C100-C105	0160-4835	7		CAPACITOR-FXD .1UF +-10% 50VDC CER	04222	SA105C104KAAH
A62C110-C113	0160-4835	7		CAPACITOR-FXD .1UF +-10% 50VDC CER	04222	SA105C104KAAH
A62C115	0160-4832	4		CAPACITOR-FXD .01UF +-10% 100VDC CER	04222	SA101C103KAAH
A62C118	0180-3440	0		CAPACITOR-FXD 47UF +-10% 10VDC TA	12340P02	T322D476K010AS
A62C118	0160-4835	7		CAPACITOR-FXD .1UF +-10% 50VDC CER	04222	SA105C104KAAH
A62C133-C134	0160-4835	7		CAPACITOR-FXD .1UF +-10% 50VDC CER	04222	SA105C104KAAH
A62C200-C201	0160-4835	7		CAPACITOR-FXD .1UF +-10% 50VDC CER	04222	SA105C104KAAH
A62C210	0160-4835	7		CAPACITOR-FXD .1UF +-10% 50VDC CER	04222	SA105C104KAAH
A62C233-C234	0160-4835	7		CAPACITOR-FXD .1UF +-10% 50VDC CER	04222	SA105C104KAAH
A62C600-C601	0160-4832	4		CAPACITOR-FXD .01UF +-10% 100VDC CER	04222	SA101C103KAAH
A62C602-C603	0160-4835	7		CAPACITOR-FXD .1UF +-10% 50VDC CER	04222	SA105C104KAAH

See introduction to this section for ordering information

\*Indicates factory selected values

Table 6-3. Replaceable Parts

Ref.Des.	HP Part Number	CD	Qty	Description	Mfr. Code	Mfr. Part Number
A82C604	0160-4789	0	1	CAPACITOR-FXD 15PF + -5% 100VDC CER 0 + -30	04222	SA102A150JAAH
A82C605	0121-0493	3	1	CAPACITOR-V TRMR-AIR 1.7-11PF 175V	74970	187-0306-125
A82C606	0180-3440	0		CAPACITOR-FXD 47UF + -10% 10VDC TA	12340P02	T322D476K010AS
A82C700-C706	0160-4835	7		CAPACITOR-FXD .1UF + -10% 50VDC CER	04222	SA105C104KAAH
A82CR1	1890-1123	0	1	OPT LED LMP R AP LMP1301 TT1H	28480	1890-1123
A82CR20-CR21	1890-1124	1	2	OPT LED LMP Y AP LMP1401 TT1H	28480	1890-1124
A82CR30	1802-0946	8	1	DIODE-ZNR 3.3V 5% DO-35 PD = .4W TC = -.039%	04713	SZ30035-4
A82CR31	1801-0518	8	18	DIODE-SCHOTTKY SM SIG	28480	1801-0518
A82CR50-CR51	1901-0050	3	2	DIODE-SWITCHING 80V 200MA 2NS DO-35	27014	D3D2/FDH6308A
A82CR110	1802-0951	5	1	DIODE-ZNR 5.1V 5% DO-35 PD = .4W TC = +.035%	04713	SZ30035-9RL
A82CR111	1802-0944	6	1	DIODE-ZNR 2.7V 5% DO-35 PD = .4W TC = -.044%	04713	SZ30035-2
A82CR600-CR616	1901-0518	8		DIODE-SCHOTTKY SM SIG	28480	1901-0518
A82J1	1251-7229	3	2	CONN-POST TYPE .100-PIN-SPOG 26-CONT	56501	609-2607
A82J2	1251-5202	8	1	CONN-POST TYPE .125-PIN-SPOG 5-CONT	03206P01	65580-105
A82J4	1251-7229	3		CONN-POST TYPE .100-PIN-SPOG 26-CONT	56501	609-2607
A82L110	9100-1791	1	1	CORE-FERRITE CHOKE-WIDEBAND;IMP:360	06337P01	VK200-19/4B
A82LB1	7121-4611	2	1	LABEL-INFO RMATION .15-IN-WD .6-IN-LG	28480	L01003
A82LB2	8320-5528	6	1	LBL-LINE PRINTER/ADH-PS 9/RO	28480	
A82MP1	1258-0141	8	4	CON-JUMPER REM .025P	00779	530153-2
A82MP2	4040-0750	7	1	EXTR-PC BD RED POLYC .062-IN-BD-THKNS	10456P01	
A82MP3	4040-0754	1	1	EXTR-PC BD BLU POLYC .062-IN-BD-THKNS	10456P01	
A82MP4-MP5	1480-0118	8	2	PIN-GRV .062-IN-DIA .25-IN-LG STL	73957	G24-062 X 250-17
A82MP6	6960-0060	8	1	PLUG-HOLE FL-HD FOR .185-D-HOLE TFE	88291	119-0052-00-0-009
A82MP30	1258-0141	8		CON-JUMPER REM .025P	00779	530153-2
A82MP31	0360-1647	7	2	TERMINAL-STUD SGL-PIN PRESS-MTG	28480	
A82MP70-MP71	1258-0141	8		CON-JUMPER REM .025P	00779	530153-2
A82MP81	0360-1647	7		TERMINAL-STUD SGL-PIN PRESS-MTG	28480	
A82Q30	1853-0398	9	1	TRANSISTOR PNP SI PD = 15W FT = 65MHZ	04713	MJE 210
A82Q31	1854-1028	6	2	TRANSISTOR NPN SI PD = 350MW FT = 300MHZ	04713	2N3904
A82Q50	1854-1028	6		TRANSISTOR NPN SI PD = 350MW FT = 300MHZ	04713	2N3904
A82R1	0683-3315	4	5	RESISTOR 330 5% .25W CF TC = 0-400	77902	R-25J
A82R2-R9	0683-4725	2	34	RESISTOR 4.7K 5% .25W CF TC = 0-400	77902	R-25J
A82R10-R11	0683-1035	1	9	RESISTOR 10K 5% .25W CF TC = 0-400	77902	R-25J
A82R12-R13	0683-1015	7	7	RESISTOR 100 5% .25W CF TC = 0-400	77902	R-25J
A82R14	8159-0005	0		RESISTOR-ZERO OHMS 22 AWG LEAD DIA	02499P02	YZO11/4
A82R15	0683-4725	2		RESISTOR 4.7K 5% .25W CF TC = 0-400	77902	R-25J
A82R20-R21	0683-3315	4		RESISTOR 330 5% .25W CF TC = 0-400	77902	R-25J
A82R22	0683-4725	2		RESISTOR 4.7K 5% .25W CF TC = 0-400	77902	R-25J
A82R34	0683-7525	6	1	RESISTOR 7.5K 5% .25W CF TC = 0-400	77902	R-25J
A82R35	0683-8205	1	1	RESISTOR 82 5% .25W CF TC = 0-400	77902	R-25J
A82R36	0683-2015	9	1	RESISTOR 200 5% .25W CF TC = 0-400	77902	R-25J
A82R37	0757-0450	9	1	RESISTOR 22.1K 1% .125W F TC = 0 + -100	05524P03	CMF-55-1
A82R38-R39	0683-3315	4		RESISTOR 330 5% .25W CF TC = 0-400	77902	R-25J
A82R40-R41	0683-1025	9	5	RESISTOR 1K 5% .25W CF TC = 0-400	77902	R-25J
A82R42	0683-1015	7		RESISTOR 100 5% .25W CF TC = 0-400	77902	R-25J
A82R50	0698-4489	6	1	RESISTOR 28K 1% .125W F TC = 0 + -100	91637	CMF-55-1
A82R51	0698-4472	7	1	RESISTOR 7.68K 1% .125W F TC = 0 + -100	05524P03	CMF-55768FT-1
A82R52	0698-4486	3	1	RESISTOR 24.8K 1% .125W F TC = 0 + -100	05524P03	CMF-552492FT-1
A82R53-R54	0683-1035	1		RESISTOR 10K 5% .25W CF TC = 0-400	77902	R-25J
A82R60	0683-1035	9		RESISTOR 10K 5% .25W CF TC = 0-400	77902	R-25J
A82R61-R62	0683-1025	1		RESISTOR 1K 5% .25W CF TC = 0-400	77902	R-25J
A82R63	0683-4725	2		RESISTOR 4.7K 5% .25W CF TC = 0-400	77902	R-25J
A82R64	0683-1025	9		RESISTOR 1K 5% .25W CF TC = 0-400	77902	R-25J
A82R65	0683-4705	8	1	RESISTOR 47 5% .25W CF TC = 0-400	77902	R-25J
A82R68-R74	0683-4725	2		RESISTOR 4.7K 5% .25W CF TC = 0-400	77902	R-25J
A82R75-R76	0683-1015	7		RESISTOR 100 5% .25W CF TC = 0-400	77902	R-25J
A82R77	0683-4725	2		RESISTOR 4.7K 5% .25W CF TC = 0-400	77902	R-25J
A82R80-R84	0683-4725	2		RESISTOR 4.7K 5% .25W CF TC = 0-400	77902	R-25J
A82R90	0683-4725	2		RESISTOR 4.7K 5% .25W CF TC = 0-400	77902	R-25J
A82R100	0683-4725	2		RESISTOR 4.7K 5% .25W CF TC = 0-400	77902	R-25J
A82R101-R102	0683-1035	1		RESISTOR 10K 5% .25W CF TC = 0-400	77902	R-25J
A82R110-R112	0683-1045	3	4	RESISTOR 100K 5% .25W CF TC = 0-400	77902	R-25J
A82R113-R114	0683-4725	2		RESISTOR 4.7K 5% .25W CF TC = 0-400	77902	R-25J

See introduction to this section for ordering information

\*Indicates factory selected values

Table 6-3. Replaceable Parts

Ref.Des.	HP Part Number	CD	Qty	Description	Mfr. Code	Mfr. Part Number
A62R115	0683-2735	0	1	RESISTOR 27K 5% .25W CF TC = 0-400	77902	R-25J
A62R116	0683-1035	1		RESISTOR 10K 5% .25W CF TC = 0-400	77902	R-25J
A62R117	0683-1045	3		RESISTOR 100K 5% .25W CF TC = 0-400	77902	R-25J
A62R118-R120	0683-4725	2		RESISTOR 4.7K 5% .25W CF TC = 0-400	77902	R-25J
A62R200	8159-0005	0	1	RESISTOR-ZERO OHMS 22 AWG LEAD DIA	02489P02	YZO1/4
A62R600	0683-1035	1		RESISTOR 10K 5% .25W CF TC = 0-400	77902	R-25J
A62R601-R602	0683-1015	7		RESISTOR 100 5% .25W CF TC = 0-400	77902	R-25J
A62R603	0683-4725	2		RESISTOR 4.7K 5% .25W CF TC = 0-400	77902	R-25J
A62RP1	1810-0286	4	6	NETWORK-RES 16-DIP 10.0K OHM X 15	11236	761-1-R10K
A62RP50	1810-0286	4		NETWORK-RES 16-DIP 10.0K OHM X 15	11236	761-1-R10K
A62RP90	1810-0286	4		NETWORK-RES 16-DIP 10.0K OHM X 15	11236	761-1-R10K
A62RP92	1810-0286	4		NETWORK-RES 16-DIP 10.0K OHM X 15	11236	761-1-R10K
A62RP100	1810-0286	4		NETWORK-RES 16-DIP 10.0K OHM X 15	11236	761-1-R10K
A62RP600	1810-0286	4		NETWORK-RES 16-DIP 10.0K OHM X 15	11236	761-1-R10K
A62RP601-RP602	1810-0325	2	2	NETWORK-RES 16-DIP 150.0 OHM X 8	11236	761-3-R150
A62RP604	1810-0338	7	1	NETWORK-RES 16-DIP 100.0 OHM X 8	11236	761-3-R100
A62SP1	0960-0483	9	1	OSC ALRM AUDIBLE	28480	0960-0483
A62SW1	3101-2170	8	1	SWITCH-PB SPDT MOM	09353	8125-DBABEQ
A62TP1-TP8	1252-2897	3	11	CON-SINGLE CONTACT	11627P01	7-22751-8
A62TP60-TP61	1252-2897	3		CON-SINGLE CONTACT	11627P01	7-22751-8
A62TP100	1252-2897	3		CON-SINGLE CONTACT	11627P01	7-22751-8
A62U1	1820-4570	8	1	ICM MPU 88000-10 NMOS 16B P64	04713	MC6800P10
A62U2	1820-2488	3	9	ICFF TTL ALS D-TYPE POS-EDGE-TRIG	01295	SN74ALS74AN
A62U3	1820-1851	2	1	ICENCCR TTL LS	01295	SN74LS148N
A62U10	1820-3121	3	8	ICTRANSCEIVER TTL ALS BUS OCTL	01295	SN74ALS245AN
A62U12	1820-3121	3		ICTRANSCEIVER TTL ALS BUS OCTL	01295	SN74ALS245AN
A62U14-U17	1820-3707	1	10	ICD ALS 74ALS541 OC BUF P20	01295	SN74ALS541N
A62U20	03577-60340	5	1	PGM PROM	28480	03577-60340
A62U20-U21	1818-4931	0	2	ICM OTP 544000 512KB 150NP32	3S845	TC544000AP-15
A62U21	03577-60341	6	1	PGM PROM	28480	03577-60341
A62U29-U29	1820-3100	8	7	ICDCDR TTL ALS BIN 3-TO-8-LINE 3-INP	01295	SN74ALS138AN
A62U33-U34	1818-3943	2	6	ICM SRAM 62256 32KB 85NS P28	54013	HM62256ALP-8
A62U35-U36	1820-3707	1		ICD ALS 74ALS541 OC BUF P20	01295	SN74ALS541N
A62U37	1820-3185	9	1	ICSCHMITT-TRIG CMOS/74HC INV HEX	27014	MM74HC14N
A62U45-U46	1818-3943	2		ICM SRAM 62256 32KB 85NS P28	54013	HM62256ALP-8
A62U47	03577-60318	7	1	PGM PROM	28480	03577-60318
A62U47-U48	1818-1142	5	2	IC TTL S 4096 (4K) PROM 70-NS 3-S	18324	N82S141N
A62U48	03577-60311	0	1	PGM PROM	28480	03577-60311
A62U50-U51	1820-3121	3		ICTRANSCEIVER TTL ALS BUS OCTL	01295	SN74ALS245AN
A62U52	1820-1568	6	1	ICBFR TTL LS BUS QUAD	01295	SN74ALS125AN
A62U53-U54	1820-2657	8	5	ICGATE TTL ALS OR QUAD 2-INP	01295	SN74ALS32N
A62U55	1826-0205	0	1	ICTIMER TTL	18324	NE555N
A62U60	1826-1054	9	1	ICPL LOOP 16-DIP-P PKG	18324	NE564N
A62U61	1820-3222	5	1	ICCNTR TTL F BCD UP/DOWN SYNCHRO	27014	74F190PC
A62U62	1820-2635	2	2	ICGATE TTL ALS AND QUAD 2-INP	01295	SN74ALS08N
A62U63	1820-2488	3		ICFF TTL ALS D-TYPE POS-EDGE-TRIG	01295	SN74ALS74AN
A62U64	1820-3376	0	1	ICINV TTL ALS HEX	01295	SN74ALS05AN
A62U65-U67	1820-2096	9	3	ICCNTR TTL LS BIN DUAL 4-BIT	01295	SN74LS393N
A62U68	1820-2488	3		ICFF TTL ALS D-TYPE POS-EDGE-TRIG	01295	SN74ALS74AN
A62U70	1820-2657	8		ICGATE TTL ALS OR QUAD 2-INP	01295	SN74ALS32N
A62U71	1820-3145	1	6	ICDRVR TTL ALS BUS OCTL	01295	SN74ALS244BN
A62U72	1820-2657	8		ICGATE TTL ALS OR QUAD 2-INP	01295	SN74ALS32N
A62U73	1820-1433	9	2	ICSHF-RGTR TTL LS R-S SERIAL-IN PRL-OUT	01295	SN74LS164N
A62U74	1820-3391	6	1	ICMUX/DATA-SEL TTL ALS 8-TO-1-LINE	01295	SN74ALS151N
A62U75-U76	1820-2656	7	3	ICGATE TTL ALS NAND QUAD 2-INP	01295	SN74ALS00AN
A62U77	1820-3100	8		ICDCDR TTL ALS BIN 3-TO-8-LINE 3-INP	01295	SN74ALS138AN
A62U78	1820-1433	6		ICSHF-RGTR TTL LS R-S SERIAL-IN PRL-OUT	01295	SN74LS164N
A62U80	1820-2634	1	1	ICINV TTL ALS HEX	01295	SN74ALS04BN
A62U81	1820-2775	1	1	ICGATE TTL ALS NAND TPL 3-INP	01295	SN74ALS10AN
A62U82-U83	1820-3100	8		ICDCDR TTL ALS BIN 3-TO-8-LINE 3-INP	01295	SN74ALS138AN
A62U84	1820-3145	1		ICDRVR TTL ALS BUS OCTL	01295	SN74ALS244BN
A62U85-U86	1820-3100	8		ICDCDR TTL ALS BIN 3-TO-8-LINE 3-INP	01295	SN74ALS138AN

See introduction to this section for ordering information

\*Indicates factory selected values

Table 6-3. Replaceable Parts

Ref.Des.	HP Part Number	CD	Qty	Description	Mfr. Code	Mfr. Part Number
A62U90	1820-3121	3		ICTRANSCEIVER TTL ALS BUS OCTL	01295	SN74ALS245AN
A62U91-U93	1820-3145	1		ICDRVR TTL ALS BUS OCTL	01295	SN74ALS244BN
A62U94	1820-2488	3		ICFF TTL ALS D-TYPE POS-EDGE-TRIG	01295	SN74ALS74AN
A62U95	1820-3145	1		ICDRVR TTL ALS BUS OCTL	01295	SN74ALS244BN
A62U96	1820-3121	3		ICTRANSCEIVER TTL ALS BUS OCTL	01295	SN74ALS245AN
A62U100	1820-2635	2		ICGATE TTL ALS AND QUAD 2-INP	01295	SN74ALS08N
A62U101	1820-2488	3		ICFF TTL ALS D-TYPE POS-EDGE-TRIG	01295	SN74ALS74AN
A62U102-U103	1820-6748	6	2	ICD TTL 74F550 OC TNCVR 3577B	27014	74F550PC
A62U104-U105	1820-3121	3		ICTRANSCEIVER TTL ALS BUS OCTL	01295	SN74ALS245AN
A62U110	1820-2488	3		ICFF TTL ALS D-TYPE POS-EDGE-TRIG	01295	SN74ALS74AN
A62U111	1820-2739	7	1	ICGATE TTL ALS NOR QUAD 2-INP	01295	SN74ALS02AN
A62U112	1820-2488	3		ICFF TTL ALS D-TYPE POS-EDGE-TRIG	01295	SN74ALS74AN
A62U113	1826-0412	1	1	ICOMPARATOR PRCN DUAL 8-DIP-P PKG	27014	LM393N
A62U114	1820-2657	8		ICGATE TTL ALS OR QUAD 2-INP	01295	SN74ALS32N
A62U115	1820-2656	7		ICGATE TTL ALS NAND QUAD 2-INP	01295	SN74ALS00AN
A62U133-U134	1818-3943	2		1CM SRAM 62256 32KX8 65NS P28	54013	HMB2256ALP-8
A62U200	03577-60345	0	1	PGM PLD	28480	03577-60345
A62U200	1820-4755	1	2	ICD PLGC 16L8-15CN P20	01295	TIBPAL16L8-15CN UNPRGMD
A62U210	03577-60344	0	1	PGM PLD	28480	03577-60344
A62U210	1820-4755	1		ICD PLGC 16L8-15CN P20	01295	TIBPAL16L8-15CN UNPRGMD
A62U600	1820-2488	3		ICFF TTL ALS D-TYPE POS-EDGE-TRIG	01295	SN74ALS74AN
A62U601	1820-2757	9	1	ICFF TTL ALS D-TYPE POS-EDGE-TRIG OCTL	01295	SN74ALS574BN
A62U602	1820-2488	3		ICFF TTL ALS D-TYPE POS-EDGE-TRIG	01295	SN74ALS74AN
A62U603-U606	1820-3707	1		ICD ALS 74ALS541 OC BUF P20	01295	SN74ALS541N
A62W1	1251-4822	6	3	CONN-POST TYPE .100-PIN-SPOG 3-CONT	27264	22-03-2031
A62W30	1251-4822	6		CONN-POST TYPE .100-PIN-SPOG 3-CONT	27264	22-03-2031
A62W70	1251-4822	6		CONN-POST TYPE .100-PIN-SPOG 3-CONT	27264	22-03-2031
A62W71	1251-4700	9	1	CONN-POST TYPE .100-PIN-SPOG 3-CONT	03206P01	68015-603
MP213	03577-28381	8	1	LNZ-CRT FILTER 3577B	28480	
MP213	7121-4963	7	1	PLT-NAME(NEW BUG W/PINS & ADH)	28480	
	0515-1821	8	93	SCR-TPG M3.0 11MMLG HH STZN	83486	
	0515-0912	6	91	SCREW-MACH M3 X 0.5 8MM-LG PAN-HD	83486	
	0515-1079	8	41	SCREW-MACHINE ASSEMBLY M3 X 0.5 8MM-LG	13962P01	
	0515-0898	7	31	SCREW-MACH M4 X 0.7 6MM-LG PAN-HD	83486	
	0515-2086	9	16	SCR-SPC M4.0 7MMLG FHTX SST	13962P01	
	0515-1234	7	15	SCREW-MACH M3.5 X 0.8 8MM-LG	83486	
	0515-1114	2	14	SCREW-MACH M4 X 0.7 10MM-LG PAN-HD	83486	
	0515-0886	3	12	SCREW-MACH M3 X 0.5 6MM-LG PAN-HD	83486	
	0515-0885	2	8	SCREW-MACH M4 X 0.7 8MM-LG PAN-HD	83486	
	0515-0896	5	8	SCREW-MACH M4 X 0.7 10MM-LG	83486	
	5040-6967	1	8	PKG-PAD FOAM CORNER BLOCK	27463	
	5040-7278	9	8	MOLD KCAP EXT	28480	5040-7278
	5041-4850	9	8	MOLD KCAP* II+HLF 3577B	28480	5041-4850
	3050-0010	2	7	WASHER-FL MTLG NO. 6 .147-IN-ID	78471	
	0515-0887	4	6	SCREW-MACH M3.5 X 0.6 6MM-LG PAN-HD	83486	
	0535-0043	6	6	NUT-HEX W/LKWR M4 X 0.7 3.2MM-THK	28480	934KEPS-M4
	0403-0301	0	6	GUIDE-PC BD NAT NYL .07-IN-BD-THKNS	23880	1600F (NATURAL)
	1400-0249	0	6	CABLE TIE .062-.625-DIA .091-WD NYL	56501	TY-23M-8
	3050-0067	9	5	WASHER-FL MTLG 5/16 IN .375-IN-ID	73734	31-550
	3050-0604	0	4	WASHER-FL MTLG 7/16 IN .5-IN-ID	86928	5710-94-16
	0515-1132	4	4	SCREW-MACH M5 X 0.8 10MM-LG	83486	
	0515-1507	7	4	SCR-MCH M3.5 20MMLG PHPZ SST *	83486	
	0890-0025	6	4	SPIRAL WRAP .189-2-DIA POLYETH	00779	500001-2

See introduction to this section for ordering information

\*Indicates factory selected values



Table 6-3. Replaceable Parts

Ref.Des.	HP Part Number	CD	Qty	Description	Mfr. Code	Mfr. Part Number
	0535-0013	0	4	NUT-THUMB M3.5 X 0.6 5MM-THK 8.6MM-WD	28480	
	0590-0038	5	4	NUT-HEX-DBL-CHAM 1/2-32-THD .094-IN-THK	02003P01	
	5041-8801	8	4	MOLD FOOT II +	28480	5041-8801
	5021-5838	3	4	CSTG STRT-CRNR 574.0D II AL	28480	5021-5838
	2190-0018	3	3	WASHER-LK INTL T 3/8 IN .377-IN-ID	73734	
	2190-0098	2	3	WASHER-LK INTL T 7/16 IN .472-IN-ID	73734	
	6960-0041	1	3	PLUG-HOLE FL-HD FOR .5-D-HOLE NYL	03480P01	2643 (BLACK)
	2950-0035	8	3	NUT-HEX-DBL-CHAM 15/32-32-THD	07296P01	
	2950-0043	8	3	NUT-HEX-DBL-CHAM 3/8-32-THD .094-IN-THK	07296P01	
	03577-23201	9	3	MCHD GUIDE-CONNECTOR	28480	
	03577-61626	2	3	CBL-ASM RGD CNF 106MM 3577B	13740P01	
	03585-61602	4	3	CBL-ASM CXL FSMB/FSMB 76MM RD	13740P01	
	1400-0031	8	3	CLAMP-CABLE .375-DIA .5-WD NYL	03480P01	3326
	0403-0295	1	3	BUMPER FOOT-PRS-IN	04427P01	NO.12
	1250-0780	5	3	ADAPTER-COAX F-BNC M-N	24931	2BJP104-2
	1250-1811	5	3	ADAPTER-COAX STR F-N F-SMA	06860P01	34N-SMA-50-2
	2190-0108	4	2	WASHER-LK HLCL NO. 4 .115-IN-ID	07296P01	
	5001-0541	3	2	TRIM-FRT FRM SD 221.5H II + VYNL	28480	5001-0541
	0380-3001	3	2	SCR-JCK 4-40 .38X.19LG 3577B	05791	BR9412-34
	0515-0893	2	2	SCREW-MACH M3.5 X 0.6 10MM-LG PAN-HD	83486	
	5062-3848	7	2	SHTF CVR-SD RS221H574D II + ALVP	09586P01	
	5041-4834	9	2	MOLD KCAP* 6" II + FUL 3577B	28480	5041-4834
	5041-4865	6	2	MOLD KCAP*UP/DN ARROW* I3577B	28480	5041-4865
	5041-8819	8	2	MOLD STRP HDL CAP FRT II +	28480	5041-8819
	5041-8820	1	2	MOLD STRP HDL CAP RR II +	28480	5041-8820
	5060-0467	6	2	MOLD CONNECTOR PROBE	28480	
	03577-61620	6	2	CBL-ASM CXL FSMB/FSMB 3573577B	28480	
	03566-61674	1	2	CBL-ASM CXL FSMB/FBNC 2853577B	28480	
	5062-3705	5	2	ASSY-SD HNDL 574D # + SSTP	28480	5062-3705
	2190-0068	5	1	WASHER-LK INTL T 1/2 IN .505-IN-ID	73734	
	3050-0071	5	1	WASHER-FL MTLG NO. 8 .169-IN-ID	73734	
	3050-0105	6	1	WASHER-FL MTLG NO. 4 .125-IN-ID	78471	
	03577-60151	6	1	VECTOR DISP 6" P31/MEM/77B 8ZL	28480	03577-60151
	0890-0785	1	1	TUBING-HS .187-D/.093-RCVD .02-WALL	02145P02	VERSAFIT-3/16-WHT
	0890-0870	9	1	TUBING-HS .093-D/.046-RCVD .02-WALL	02145P02	VERSAFIT-3/32-CLEAR
	03577-00101	0	1	SHTF DECK-MAIN AL	13588P02	
	03577-00112	3	1	SHTF BRKT-CHSS SPRT AL	13588P02	
	03577-00204	4	1	SHTF PNL-LT SIDE AL 3577B	13588P02	
	03577-00207	7	1	SHTF DAM-CTR AIR AL 3577B	13588P02	
	03577-00208	8	1	SHTF DAM-FRT AIR AL 3577B	13588P02	
	03577-00216	8	1	SHTF PNL-CTR AL 3577B	13588P02	
	03577-00282	8	1	SHTF PNL-FRT SUB 3577B	13588P02	
	03577-00283	9	1	SHTF PANEL-REAR ALSK 3577B	13588P02	
	03577-04118	5	1	SHTF GRD-FUSE HLDK/PLCR 3577B	13588P02	
	03577-04118	7	1	SHTF CVR-REAR/ALSK 3577B	13588P02	
	03577-04190	3	1	SHTF COVER-PROCESSORS/AL 3577B	13588P02	
	03577-04181	4	1	SHTF COVER-BLANK/ALSK 3577B	13588P02	
	03577-04187	0	1	SHTF CVR-DSPL 3577B	13588P02	
	03577-61201	9	1	SHTF ASSY-UPR DSPL BRKTAL3577B	13588P02	
	0515-1115	3	1	SCREW-MACH M4 X 0.7 12MM-LG PAN-HD	83486	
	0515-1280	3	1	SCR-MCH M3.0 14MMLG PHPZ SST *	13962P01	
	3101-3014	1	1	SW-RKR	09328P01	W132/217MZ
	5062-3736	2	1	SHTF CVR-TOP FM 574D II + ALV	NEW	DIV#
	5062-3748	6	1	SHTF CVR-BTM FM 574D II + ALV	NEW	DIV#
	03577-64381	2	1	PNL-FRT DRS *3577BII + ALLM3577B	22670	
	5040-6973	9	1	PKG-COVERFRONT PLASTIC	28480	
	9211-6029	3	1	PKG-CTN RSC 275D37.5X21.4X13.0	27463	
	9220-4493	0	1	PKG-TRY COR 275D21.4X12.88	28480	
	9220-4649	8	1	PKG-TRY COR/FOAM	27463	
	5061-8008	9	1	OPT RPG DSC RPG/FHSG	28480	5061-8008
	01650-47401	7	1	MOLD RPG KNOB	10456P01	
	03577-21201	5	1	MCHD BRACE-CARDNEST 3577B	28480	

See introduction to this section for ordering information

\*Indicates factory selected values

Table 6-3. Replaceable Parts

Ref.Des.	HP Part Number	CD	Qty	Description	Mfr. Code	Mfr. Part Number
	03577-60601	1	1	MCHD CARDNEST 3577B	L1851P01	
	03577-60038	1	1	MANL-OPERATING 3577B	28480	
	03577-60039	2	1	MANL-SERVICE 3577B	28480	
	5041-0720	4	1	MOLD KCAP*INST PRESET* II HLF	28480	5041-0720
	5041-4779	1	1	MOLD KCAP*RES BW*II + HLF 3577B	28480	5041-4779
	5041-4781	5	1	MOLD KCAP*SWEEP TIME*II + HLF3577B	28480	5041-4781
	5041-4782	6	1	MOLD KCAP*ATTEN*II + HLF 3577B	28480	5041-4782
	5041-4787	1	1	MOLD KCAP*MKR* II + HLF 3577B	28480	5041-4787
	5041-4788	2	1	MOLD KCAP*MKR* - II + HLF 3577B	28480	5041-4788
	5041-4818	9	1	MOLD KCAP* LCL* II + QTR	28480	5041-4818
	5041-4829	2	1	MOLD KCAP* 1 * II + FUL 3577B	28480	5041-4829
	5041-4830	5	1	MOLD KCAP* 2 * II + FUL 3577B	28480	5041-4830
	5041-4831	6	1	MOLD KCAP* 3 * II + FUL 3577B	28480	5041-4831
	5041-4832	7	1	MOLD KCAP* 4 * II + FUL 3577B	28480	5041-4832
	5041-4833	8	1	MOLD KCAP* 5 * II + FUL 3577B	28480	5041-4833
	5041-4835	0	1	MOLD KCAP* 7 * II + FUL 3577B	28480	5041-4835
	5041-4836	1	1	MOLD KCAP* 8 * II + FUL 3577B	28480	5041-4836
	5041-4838	3	1	MOLD KCAP* 0 * II + FUL 3577B	28480	5041-4838
	5041-4839	4	1	MOLD KCAP* . * II + FUL 3577B	28480	5041-4839
	5041-4855	4	1	MOLD KCAP*SAVE* II + HLF 3577B	28480	5041-4855
	5041-4856	5	1	MOLD KCAP*RECALL* II + HLF 3577B	28480	5041-4856
	5041-4858	7	1	MOLD KCAP*SOUD COLOR* II 3577B	28480	5041-4858
	5041-4859	8	1	MOLD KCAP*TRIG/RESET* II 3577B	28480	5041-4859
	5041-4860	1	1	MOLD KCAP*PLOT* II + HLF 3577B	28480	5041-4860
	5041-4861	2	1	MOLD KCAP*SPCL FCTN*IIHLF3577B	28480	5041-4861
	5041-4862	3	1	MOLD KCAP*ENTRY OFF*II + FUL3577B	28480	5041-4862
	5041-4863	4	1	MOLD KCAP*BACK SPACE*IIHLF3577B	28480	5041-4863
	5041-4864	5	1	MOLD KCAP* - * II + FUL 3577B	28480	5041-4864
	5041-4868	7	1	MOLD KCAP*TRACE 2*II + LDH 3577B	28480	5041-4868
	5041-4867	8	1	MOLD KCAP*TRACE 1*II + LDH 3577B	28480	5041-4867
	5041-4868	9	1	MOLD KCAP SWEEP TYPE II LDH 3577B	28480	5041-4868
	5041-4869	0	1	MOLD KCAP*LENGTH* II + HLF 3577B	28480	5041-4869
	5041-4870	3	1	MOLD KCAP*AVG* II + HLF 3577B	28480	5041-4870
	5041-4871	4	1	MOLD KCAP*TRIG MODE*II + HLF3577B	28480	5041-4871
	5041-4872	5	1	MOLD KCAP*SWEEP MODE*IIHLF3577B	28480	5041-4872
	5041-4873	6	1	MOLD KCAP*DISPL FCTN*IIHLF3577B	28480	5041-4873
	5041-4874	7	1	MOLD KCAP*MEASR CAL*II + HLF3577B	28480	5041-4874
	5041-4875	8	1	MOLD KCAP*DEFINE MATH* II 3577B	28480	5041-4875
	5041-4876	9	1	MOLD KCAP*STORE DATA* II 3577B	28480	5041-4876
	5041-4877	0	1	MOLD KCAP*INPUT* II + HLF 3577B	28480	5041-4877
	5041-4878	1	1	MOLD KCAP*AMPTD* II + HLF 3577B	28480	5041-4878
	5041-4879	2	1	MOLD KCAP*FREQ* II + HLF 3577B	28480	5041-4879
	5041-4880	5	1	MOLD KCAP*SCALE* II + HLF 3577B	28480	5041-4880
	5041-6802	9	1	MOLD TRM-TOP FM II +	28480	5041-6802
	5960-5753	1	1	MISC- 1 YR WARR STMT	28480	
	5963-1298E	3	1	MISC-SUPPORT W3X BROCHURE	28480	5963-1298E
	9230-0023	5	1	MISC-6.2 X 3.5 ENVELOPE	28480	9230-0023
	9230-0325	0	1	MISC-10 X 13 ENVELOPE	11284P01	
	5959-5737	8	1	LBL-S/W BLNK; 3.5" PIN FEED	22670	
	7121-5618	1	1	LBL-CAL	13079P01	NIST1.0
	7124-2063	4	1	LABEL-WARNING 1-IN-WD 3.5-IN-LG PPR	28480	
	9135-0225	7	1	UF CORCOM F3071E 3577B	05245	F3071E
	0400-0226	2	1	GROMMET-CHAN .052-IN-GRV-WD	12324P01	GRNY-052-9
	1400-0090	9	1	FUSEHOLDER COMPONENT FOR USE ON	75915	901-002
	2110-0056	3	1	FUSE 6A 250V NTD 1.25X.25 UL	75915	312 006
	2110-0564	8	1	FUSEHOLDER BODY 12A MAX FOR UL	H9027	031.1657
	2110-0565	9	1	FUSEHOLDER CAP 12A MAX FOR UL	H9027	031.1666
	2110-0766	6	1	FUSE HX M12.7X1.5 DBLTHD	H9027	098.0026
	3150-0218	4	1	FILTER-AIR 32 STD MESH MET sCREEN	28480	LZ60
	3160-0562	2	1	FAN-GUARD	10938P01	08128
	3160-0845	4	1	FAN-ASSY W/CONN	12339P01	4715PL-05W-B30
	03577-61602	4	1	CBL-ASM RBN FHDR/FHDR 3503577B	28480	
	03577-61603	5	1	CBL-ASM DSC FHSG/STP 7303577B	13740P01	

See introduction to this section for ordering information  
 \*Indicates factory selected values

Table 6-3. Replaceable Parts

Ref.Des.	HP Part Number	CD	Qty	Description	Mfr. Code	Mfr. Part Number
	03577-61608	0	1	CBL-ASM RBN FHDR/FHDR 3303577B	28480	
	03577-61609	1	1	CBL-ASM DSC FHSG/STP 5703577B	13740P01	
	03577-61610	4	1	CBL-ASM TWS FHSG/STP 4753577B	13740P01	
	03577-61611	5	1	CBL-ASM DSC FHSG/STP 4803577B	13740P01	
	03577-61612	6	1	CBL-ASM DSC FHSG/STP 4003577B	13740P01	
	03577-61615	9	1	CBL-ASM CXL FHSG/FBNC 2703577B	13740P01	
	03577-61616	0	1	CBL-ASM DSC FHSG/STP 2703577B	13740P01	
	03577-61617	1	1	CBL-ASM DSC FHSG/STP 2853577B	13740P01	
	03577-61619	3	1	CBL-ASM DSC 4CND 48MM ML 3577B	13740P01	
	03577-61621	7	1	CBL-ASM CXL FSMB/FSMB 220MM WH	28480	
	03577-61622	8	1	CBL-ASM CXL FSMB/FSMB 160MM YL	13740P01	
	03577-61623	9	1	CBL-ASM CXL FSMB/FSMB 1353577B	28480	
	03577-61624	0	1	CBL-ASM CXL FSMB/FSMB 384MM BL	13740P01	
	03577-61634	2	1	CBL-ASM SHL SWT/FHSG 7503577B	28480	
	03577-61638	6	1	CBL-ASM DSC STP/FHSG 1803577B	13740P01	
	03577-61641	1	1	CBL-ASM CXL FSMB/FSMB 135MM OR	13740P01	
	03577-61682	0	1	CBL-ASM RBN MDSUB/FHDR 503577B	28480	
	1251-8628	8	1	CONNECTOR 4-PIN M CIRC AUDIO	82389	TB4M
	1400-0611	0	1	CLAMP-FL-CA 1-WD	04728P04	3484-1000
	5021-5808	7	1	CSTG FRM-FR FM 221.5H II AL	28480	5021-5808
	5021-8407	8	1	CSTG FRM-FRT FM 221.5H II + ALPT	28480	5021-8407
	9282-1078	1	1	BNDR-3-RING	09533P01	
	9282-1080	5	1	BNDR-2 1/2"	09533P01	
	03577-84460	0	1	AUTO PERFORMANCE TEST KIT	28480	03577-84460

See introduction to this section for ordering information

\*Indicates factory selected values



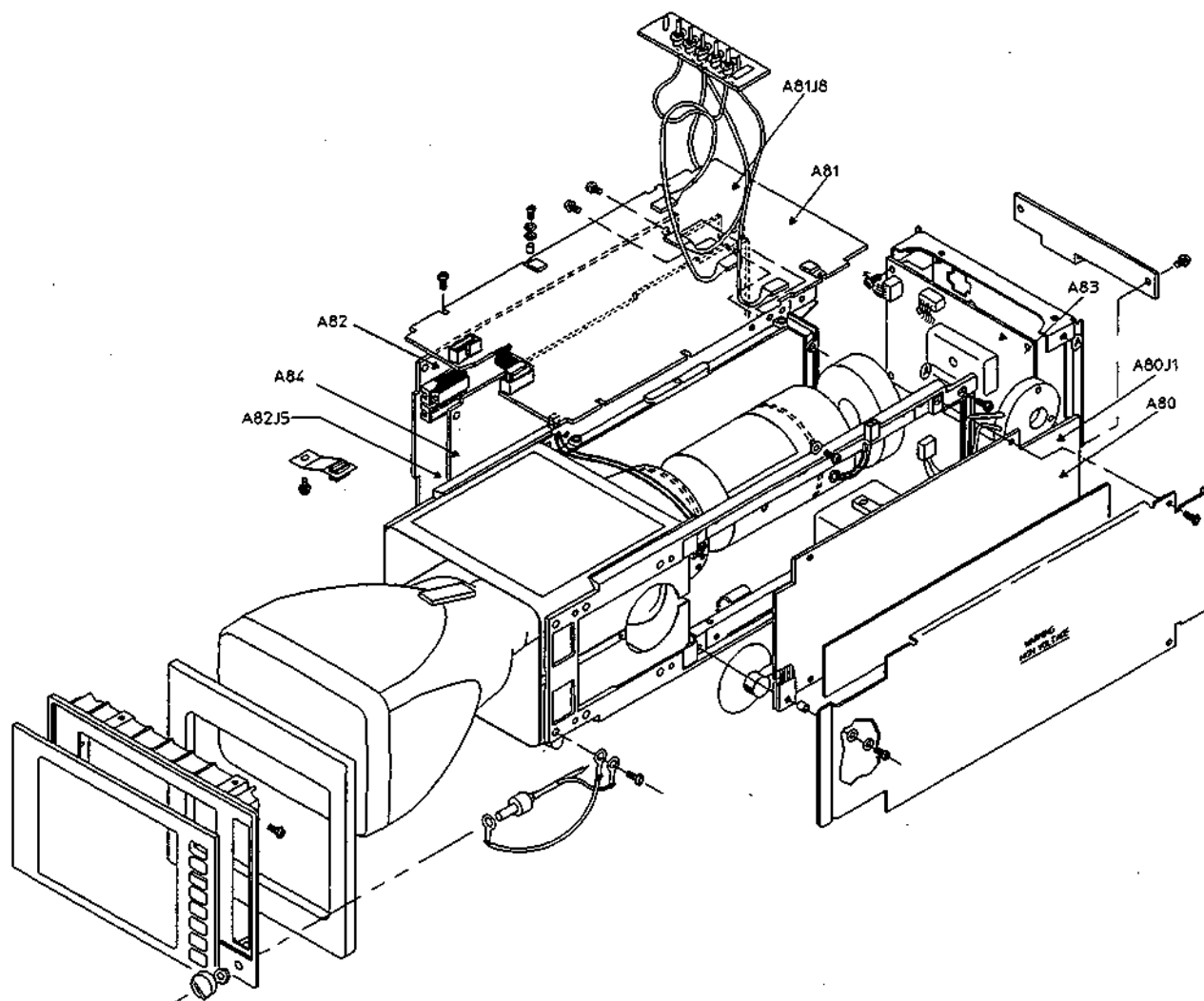


Figure 6-6. HP Digital Display Assembly Locations

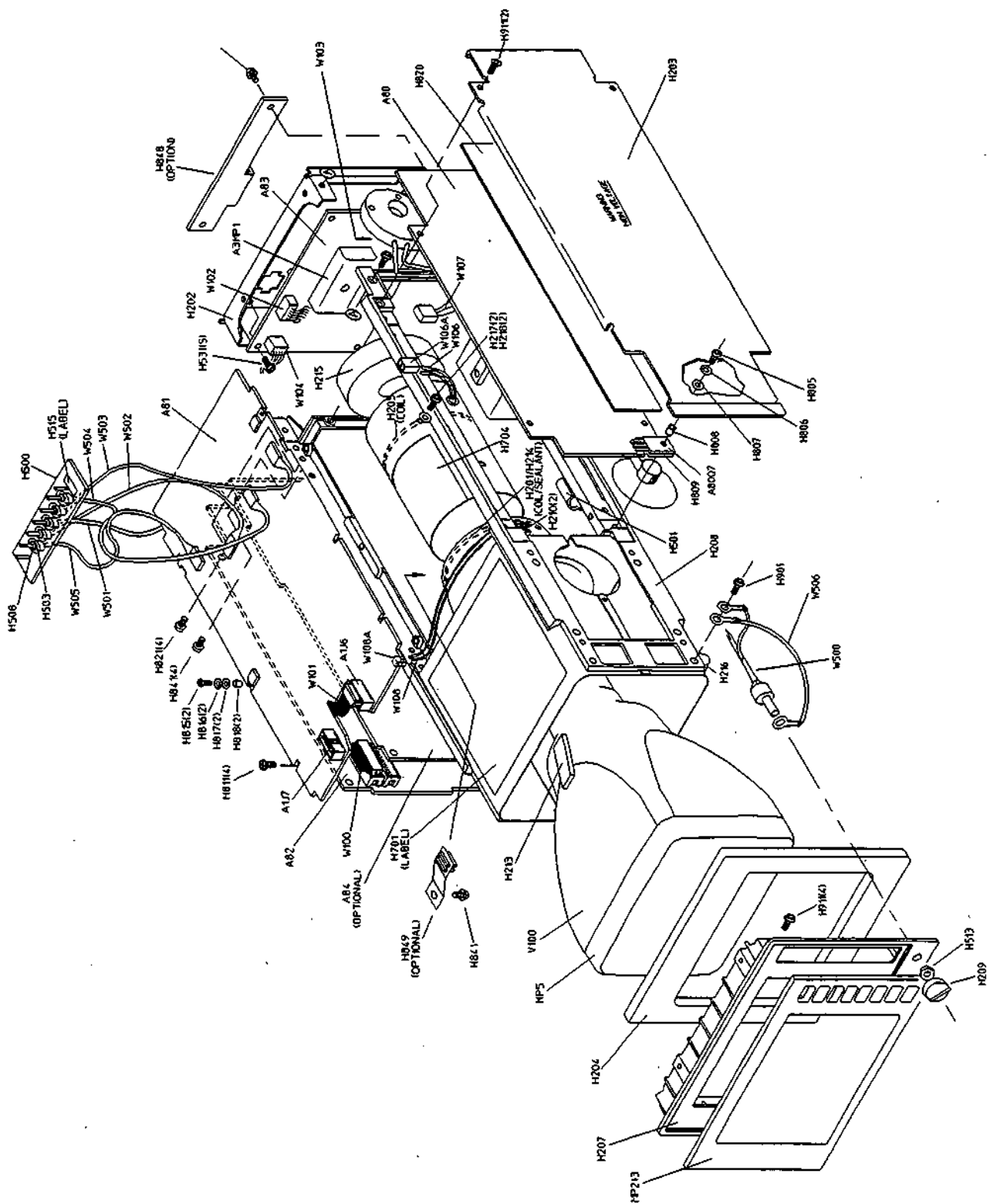


Figure 6-7. HP Digital Display Chassis Parts and Assembly Identification

Table 6-3. Replaceable Parts

Ref.Des.	HP Part Number	CD	Qty	Description	Mfr. Code	Mfr. Part Number
A80	03577-68580	7	1	HVPS BOARD	28480	03577-68580
A80A1	0960-0734	3	1	DIO MULT COLMR CS1164A1	27777	
A80C1	0160-4800	6	1	CAPACITOR-FXD 120PF +-5% 100VDC CER	04222	SA102A121JAAH
A80C2	0160-5897	3	2	CAPACITOR-FXD 1.2PF +-25PF 200VDC CER	54583	MA12C0G2D1R2C
A80C3	0160-5473	1	4	CAPACITOR-FXD .01UF +-5% 400VDC	05468P01	1677.01/J/400B
A80C4	0160-3638	6	2	CAPACITOR-FXD .22UF +-80-20% 200VDC CER	04222	SF402E224ZAAH
A80C5	0160-6623	5	3	C-F /1U +-20 50VDC	04222	SA115C104MAAH
A80C6	0160-5473	1		CAPACITOR-FXD .01UF +-5% 400VDC	05468P01	1677.01/J/400B
A80C7	0160-3638	6		CAPACITOR-FXD .22UF +-80-20% 200VDC CER	04222	SR402E224ZAAH
A80C8	0180-2735	4	2	CAPACITOR-FXD 100UF +-100-10% 63VDC AL	62643	SMVB63V100UF
A80C9	0180-2735	4		CAPACITOR-FXD 100UF +-100-10% 63VDC AL	62643	SMVB63V100UF
A80C10	0160-0165	6	1	CAPACITOR-FXD .056UF +-10% 200VDC POLYE	15766	HEW-238M
A80C11	0160-6623	5		C-F /1U +-20 50VDC	04222	SA115C104MAAH
A80C12	0160-4051	9	4	CAPACITOR-FXD .01UF +-20% 4KVDC	13606	430P103040
A80C13	0160-4051	9		CAPACITOR-FXD .01UF +-20% 4KVDC	13606	430P103040
A80C14	0160-5336	5	2	CAPACITOR-FXD 20PF +-20% 3KVDC CER	09859P01	564CP3KAA302AE200M
A80C15	0160-0684	6	2	CAPACITOR-FXD 1000PF +-20% 4KVDC	13606	430P102040
A80C16	0160-0684	6		CAPACITOR-FXD 1000PF +-20% 4KVDC	13606	430P102040
A80C17	0160-4051	9		CAPACITOR-FXD .01UF +-20% 4KVDC	13606	430P103040
A80C18	0160-5473	1		CAPACITOR-FXD .01UF +-5% 400VDC	05468P01	1677.01/J/400B
A80C20	0160-5336	5		CAPACITOR-FXD 20PF +-20% 3KVDC CER	09859P01	564CP3KAA302AE200M
A80C22	0160-4833	5	1	CAPACITOR-FXD .022UF +-10% 100VDC CER	04222	SA201C223KAAH
A80C23	0160-5897	3		CAPACITOR-FXD 1.2PF +-25PF 200VDC CER	54583	MA12C0G2D1R2C
A80C24	0160-5473	1		CAPACITOR-FXD .01UF +-5% 400VDC	05468P01	1677.01/J/400B
A80C25	0160-6623	5		C-F /1U +-20 50VDC	04222	SA115C104MAAH
A80C26	0160-4051	9		CAPACITOR-FXD .01UF +-20% 4KVDC	13606	430P103040
A80C101	0160-3670	6	2	CAPACITOR-FXD .1UF +-20% 200VDC CER	04222	SR302E104MAAH
A80C102	0160-4801	7	1	CAPACITOR-FXD 100PF +-5% 100VDC CER	04222	SA102A101JAAH
A80C105	0160-3670	6		CAPACITOR-FXD .1UF +-20% 200VDC CER	04222	SR302E104MAAH
A80CR1	1901-1065	2	10	DIODE-PWR RECT 1N4936 400V 1A 200NS	04713	1N4936
A80CR2	1901-0096	7	2	DIODE-SWITCHING 120V 50MA 100NS	9N171	1N3070
A80CR3	1901-1065	2		DIODE-PWR RECT 1N4936 400V 1A 200NS	04713	1N4936
A80CR4	1901-1065	2		DIODE-PWR RECT 1N4936 400V 1A 200NS	04713	1N4936
A80CR5	1901-0096	7		DIODE-SWITCHING 120V 50MA 100NS	9N171	1N3070
A80CR6	1901-1065	2		DIODE-PWR RECT 1N4936 400V 1A 200NS	04713	1N4936
A80CR7	1901-0040	1	2	DIODE-SWITCHING 30V 50MA 2NS DO-35	9N171	1N4148
A80CR8	1901-0040	1		DIODE-SWITCHING 30V 50MA 2NS DO-35	9N171	1N4148
A80CR9	1901-1065	2		DIODE-PWR RECT 1N4936 400V 1A 200NS	04713	1N4936
A80CR10	1901-1065	2		DIODE-PWR RECT 1N4936 400V 1A 200NS	04713	1N4936
A80CR11	1901-0683	8	1	DIODE-HV RECT 10KV 5MA 250NS	05131P01	
A80CR12	1901-1065	2		DIODE-PWR RECT 1N4936 400V 1A 200NS	04713	1N4936
A80CR13	1901-1065	2		DIODE-PWR RECT 1N4936 400V 1A 200NS	04713	1N4936
A80CR14	1901-1065	2		DIODE-PWR RECT 1N4936 400V 1A 200NS	04713	1N4936
A80CR15	1901-1065	2		DIODE-PWR RECT 1N4936 400V 1A 200NS	04713	1N4936
A80CR16	1902-0965	1	1	DIODE-ZNR 20V 5% DO-35 PD = .4W TC = +.092%	04713	
A80CR17	1902-0049	2	4	DIODE-ZNR 6.19V 5% DO-35 PD = .4W	04713	SZ30016-122RL
A80CR18	1902-0049	2		DIODE-ZNR 6.19V 5% DO-35 PD = .4W	04713	SZ30016-122RL
A80F1	2110-0001	6	1	FUSE 1A 250V NTD 1.25X.25 UL	75915	312 001
A80H1	5957-2260	2	1	LBL-MADE IN USA	28480	5957-2260
A80J1	1252-0309	2	1	CONN-PST-TY-HDR 5 CONT.	27264	22-11-2052
A80J2	1251-7775	4	1	CONN-POST TYPE .100-PIN-SPCG 3-CONT	27264	22-11-2032

See introduction to this section for information  
 \* Indicates factory selected values

Table 6-3. Replaceable Parts

Ref.Des.	HP Part Number	CD	Qty	Description	Mfr. Code	Mfr. Part Number
A80J3	1252-2105	6	1	CONN-LF UTIL MT-LK 60CONT MALE	00779	643408-1
A80J6	1251-0600	0	4	CONNECTOR-SGL CONT PIN 1.14-MM-BSC-SZ SQ	27264	16-06-0034
A80J11	1251-7933	6	1	CONN-POST TYPE .100-PIN-SPOG 3-CONT	27264	22-12-2034
A80J96E	1251-0600	0	8	CONNECTOR-SGL CONT PIN 1.14-MM-BSC-SZ SQ	27264	16-06-0034
A80J96F	1251-0600	0	8	CONNECTOR-SGL CONT PIN 1.14-MM-BSC-SZ SQ	27264	16-06-0034
A80J98	1251-0600	0	8	CONNECTOR-SGL CONT PIN 1.14-MM-BSC-SZ SQ	27264	16-06-0034
A80J100	1251-7776	5	1	CONN-POST TYPE .100-PIN-SPOG 2-CONT	27264	22-11-2022
A80L1	9140-0115	5	1	INDUCTOR RF-CH-MLD 220UH 10% .23DX.57LG	99600	2150-32
A80L2	9140-0129	1	1	INDUCTOR RF-CH-MLD 220UH 5% .166DX.385LG	99600	1537-92
A80MP1	01345-04103	6	1	STMP ASSY-HI VLT NNR CVR AL	08638P01	
A80MP2	0515-1079	8	2	SCREW-MACHINE ASSEMBLY M3 X 0.5 8MM-LG	28480	
A80MP3	0515-1079	8	2	SCREW-MACHINE ASSEMBLY M3 X 0.5 8MM-LG	28480	
A80MP4	1600-0844	5	1	STMP SHLD-50-1 BRNSI	16365	
A80Q1	1853-0563	0	2	XTR SML1PNP SI 2N3906 TXXXX	04713	2N3906(SEL)
A80Q2	1853-0038	4	2	TRANSISTOR PNP SI TO-39 PD = 1W FT = 100MHZ	04713	
A80Q3	1854-0813	5	2	TRANSISTOR NPN 2N3501S SI TO-39 PD = 1W	04713	2N3501(SEL)
A80Q4	1853-0563	0	2	XTR SML1PNP SI 2N3906 TXXXX	04713	2N3906(SEL)
A80Q5	1853-0038	4	2	TRANSISTOR PNP SI TO-39 PD = 1W FT = 100MHZ	04713	
A80Q6	1854-0813	5	2	TRANSISTOR NPN 2N3501S SI TO-39 PD = 1W	04713	2N3501(SEL)
A80Q7	1854-0456	2	1	TRANSISTOR NPN SI PD = 65W FT = 3MHZ	01295	TIP41A
A80R1	0757-0419	0	3	RESISTOR 681 1% .125W F TC = 0 + -100	19701	SFR25H
A80R3	0757-0190	4	4	RESISTOR 20K 1% .5W F TC = 0 + -100	19701	5053R
A80R4	0757-0419	0	3	RESISTOR 681 1% .125W F TC = 0 + -100	19701	SFR25H
A80R5	0757-0442	9	2	RESISTOR 10K 1% .125W F TC = 0 + -100	19701	SFR25H
A80R6	0757-0775	1	2	RESISTOR 90.9K 1% .25W F TC = 0 + -100	19701	5043R
A80R7	0683-1015	7	6	RESISTOR 100 5% .25W CF TC = 0-400	77902	R-25J
A80R8	0757-0735	3	2	RESISTOR 1.3K 1% .25W F TC = 0 + -100	19701	5043R
A80R9	0757-0190	4	4	RESISTOR 20K 1% .5W F TC = 0 + -100	19701	5053R
A80R10	0683-1015	7	6	RESISTOR 100 5% .25W CF TC = 0-400	77902	R-25J
A80R11	0757-0190	4	4	RESISTOR 20K 1% .5W F TC = 0 + -100	19701	5053R
A80R12	0757-0419	0	3	RESISTOR 681 1% .125W F TC = 0 + -100	19701	SFR25H
A80R13	0757-0442	9	2	RESISTOR 10K 1% .125W F TC = 0 + -100	19701	SFR25H
A80R14	0757-0775	1	2	RESISTOR 90.9K 1% .25W F TC = 0 + -100	19701	5043R
A80R15	0683-1015	7	6	RESISTOR 100 5% .25W CF TC = 0-400	77902	R-25J
A80R16	0757-0735	3	2	RESISTOR 1.3K 1% .25W F TC = 0 + -100	19701	5043R
A80R17	0757-0190	4	4	RESISTOR 20K 1% .5W F TC = 0 + -100	19701	5053R
A80R18	0683-1015	7	6	RESISTOR 100 5% .25W CF TC = 0-400	77902	R-25J
A80R19	0698-3266	5	1	RESISTOR 237K 1% .125W F TC = 0 + -100	19701	SFR25H
A80R20	2100-3357	2	2	RESISTOR-TRMR 500K 10% C SIDE-ADJ 1-TRN	32997	3388X-Y46-504
A80R21	0757-0465	6	2	RESISTOR 100K 1% .125W F TC = 0 + -100	19701	SFR25H
A80R22	0757-0465	6	2	RESISTOR 100K 1% .125W F TC = 0 + -100	19701	SFR25H
A80R23	0683-2265	1	1	RESISTOR 22M 5% .25W CC TC = -900/+ 1200	01121	CB2265
A80R24	0684-4731	2	1	RESISTOR 47K 10% .25W CF TC = 0-400	77902	R-25J
A80R25	0683-1015	7	6	RESISTOR 100 5% .25W CF TC = 0-400	77902	R-25J
A80R26	0683-3915	0	1	RESISTOR 390 5% .25W CF TC = 0-400	77902	R-25J
A80R27	0684-2221	1	1	RESISTOR 2.2K 10% .25W CF TC = 0-400	77902	R-25J
A80R28	0683-1025	9	2	RESISTOR 1K 5% .25W CF TC = 0-400	77902	R-25J
A80R29	0687-3941	0	1	RESISTOR 390K 10% .5W CC TC = 0 + 882	01121	EB3941
A80R30	0683-6615	5	4	RESISTOR 680 5% .25W CF TC = 0-400	77902	R-25J
A80R31	0683-6615	5	4	RESISTOR 680 5% .25W CF TC = 0-400	77902	R-25J

See introduction to this section for information  
 \* Indicates factory selected values

Table 6-3. Replaceable Parts

Ref.Des.	HP Part Number	CD	Qty	Description	Mfr. Code	Mfr. Part Number
A80R32	0684-5621	1	1	RESISTOR 5.6K 10% .25W CF TC = 0-400	77902	R-25J
A80R33	0699-0167	1	1	RESISTOR 20M 5% 1W C TC = 0 + .250	03888	FL1
A80R34	0683-6815	5		RESISTOR 680 5% .25W CF TC = 0-400	77902	R-25J
A80R35	0683-6815	5		RESISTOR 680 5% .25W CF TC = 0-400	77902	R-25J
A80R36	0683-1065	7	1	RESISTOR 10M 5% .25W CC TC = -900/ + 1100	01121	CB1085
A80R37	0683-1015	7		RESISTOR 100 5% .25W CF TC = 0-400	77902	R-25J
A80R38	0757-0449	8	1	RESISTOR 20K 1% .125W F TC = 0 + .100	19701	SFR25H
A80R39	2100-3357	2		RESISTOR-TRMR 500K 10% C SIDE-ADJ 1-TRN	32987	3386X-Y46-504
A80R41	0699-0551	7	1	RESISTOR 5.3M 5% 1W C TC = 0 + .250	03888	FL1
A80R42	2100-4238	0	1	RES TRMR 2.5 E6 OHM + 20% -0%	32987	3386U-HV1-255
A80R43	0699-0172	8	1	RESISTOR 3M 5% 1W C TC = 0 + .250	03888	FL1
A80R45	0698-4508	0	2	RESISTOR 78.7K 1% .125W F TC = 0 + .100	91637	CMF-55-1 T-1
A80R46	0698-4508	0		RESISTOR 78.7K 1% .125W F TC = 0 + .100	91637	CMF-55-1 T-1
A80R47	0698-8815	0	1	RESISTOR 1.78 1% .125W F TC = 0 + .100	91637	CMF-55-1
A80R48	0683-1855	1	1	RESISTOR 1.6M 5% .25W CF TC = 0-900	77902	R-25J
A80R49	0757-0448	5	2	RESISTOR 18.2K 1% .125W F TC = 0 + .100	19701	SFR25H
A80R50	0757-0448	5		RESISTOR 18.2K 1% .125W F TC = 0 + .100	19701	SFR25H
A80R51	0683-1025	9		RESISTOR 1K 5% .25W CF TC = 0-400	77902	R-25J
A80R101	0698-8856	2	1	RESISTOR 511K 1% .125W F TC = 0 + .100	19701	SFR25H
A80R102	0757-0481	2	1	RESISTOR 68.1K 1% .125W F TC = 0 + .100	19701	SFR25H
A80T1	01345-81101	4	1	XFC HI V	02859P01	
A80TP1	1252-2897	3	5	CONNECTOR-SINGLE CONTACT	11627P01	7-22751-8
A80TP2	1252-2897	3		CONNECTOR-SINGLE CONTACT	11627P01	7-22751-8
A80TP47A	1252-2897	3		CONNECTOR-SINGLE CONTACT	11627P01	7-22751-8
A80TP47B	1252-2897	3		CONNECTOR-SINGLE CONTACT	11627P01	7-22751-8
A80TP50	1252-2897	3		CONNECTOR-SINGLE CONTACT	11627P01	7-22751-8
A80U1	1826-0167	3	1	ICOP AMP PRGMBL TO-99 PKG	34371	CA3094AT
A80V1	2140-0018	0	2	LAMP-GLOW A9A-CT 90VDC 700UA T-2-BULB	09448P01	A9A-CT (NE2E1T)
A80V2	2140-0018	0		LAMP-GLOW A9A-CT 90VDC 700UA T-2-BULB	09448P01	A9A-CT (NE2E1T)
A80VR1	1902-0049	2		DIODE-ZNR 6.19V 5% DO-35 PD = .4W	04713	SZ30016-122RL
A80VR2	1902-0049	2		DIODE-ZNR 6.19V 5% DO-35 PD = .4W	04713	SZ30016-122RL
A80VR3	1902-3354	8	1	DIODE-ZNR 54.9V 5% DO-7 PD = .4W TC = +.081%	04713	
A80X1A	2110-0269	0	2	FUSEHOLDER-CUP TYPE.25D-FUSE	13060	
A80X1B	2110-0269	0		FUSEHOLDER-CUP TYPE.25D-FUSE	13060	
A81	03577-66581	0	1	XYZ BOARD	28480	03577-66581
A81C1	0160-6508	5	4	C-F 22PF 5% 200V CERMLr	28480	RPE121-978C0G220J200V
A81C2	0160-6508	5		C-F 22PF 5% 200V CERMLr	28480	RPE121-978C0G220J200V
A81C3	0160-6508	5		C-F 22PF 5% 200V CERMLr	28480	RPE121-978C0G220J200V
A81C4	0160-6508	5		C-F 22PF 5% 200V CERMLr	28480	RPE121-978C0G220J200V
A81C5	0160-4136	3	1	C-F 10UF 10% 20V TATBSA	13806	173D106X9020W
A81C6	0160-4801	7	3	CAPACITOR-FXD 100PF + .5% 100VDC CER	04222	SA102A101JAAH
A81C7	0160-6510	9	2	C-F .1UF 20% 50V CERMLr	28480	RPE121-978X7R104M50V
A81C8	0160-4801	7		CAPACITOR-FXD 100PF + .5% 100VDC CER	04222	SA102A101JAAH
A81C9	0160-6623	5	14	C-F /1U + .20 50VDC	04222	SA115C104MAAH
A81C10	0160-4814	2	1	CAPACITOR-FXD 150PF + .5% 100VDC CER	04222	SA101A151JAAH
A81C11	0160-4801	7		CAPACITOR-FXD 100PF + .5% 100VDC CER	04222	SA102A101JAAH
A81C12	0160-6623	5		C-F /1U + .20 50VDC	04222	SA115C104MAAH
A81C13	0160-4557	0	2	CAPACITOR-FXD .1UF + .20% 50VDC CER	04222	SA306C104MAAH
A81C14	0160-6524	5	4	C-F 6.8PF -% 200V CERMLr	28480	RPE121-978C0G6R8D200V
A81C15	0160-6524	5		C-F 6.8PF -% 200V CERMLr	28480	RPE121-978C0G6R8D200V

See introduction to this section for information  
 \* Indicates factory selected values

Table 6-3. Replaceable Parts

Ref.Des.	HP Part Number	CD	Qty	Description	Mfr. Code	Mfr. Part Number
A81C16	0160-5897	3	4	CAPACITOR-FXD 1.2PF +-25PF 200VDC CER	54583	MA12C0G2D1R2C
A81C17	0160-5473	1	4	CAPACITOR-FXD .01UF +-5% 400VDC	05466P01	1677.01/J/400B
A81C18	0160-3670	6	4	CAPACITOR-FXD .1UF +-20% 200VDC CER	04222	SR302E104MAAH
A81C19	0160-3670	6		CAPACITOR-FXD .1UF +-20% 200VDC CER	04222	SR302E104MAAH
A81C20	0160-5473	1		CAPACITOR-FXD .01UF +-5% 400VDC	05466P01	1677.01/J/400B
A81C21	0160-5897	3		CAPACITOR-FXD 1.2PF +-25PF 200VDC CER	54583	MA12C0G2D1R2C
A81C22	0160-6623	5		C-F /1U +-20 50VCD	04222	SA115C104MAAH
A81C23	0160-4557	0		CAPACITOR-FXD .1UF +-20% 50VDC CER	04222	SA305C104MAAH
A81C24	0160-6524	5		C-F 6.8PF -% 200V CERMLr	28480	RPE121-978C0G6R8D200V
A81C25	0160-6524	5		C-F 6.8PF -% 200V CERMLr	28480	RPE121-978C0G6R8D200V
A81C26	0160-5897	3		CAPACITOR-FXD 1.2PF +-25PF 200VDC CER	54583	MA12C0G2D1R2C
A81C27	0160-5473	1		CAPACITOR-FXD .01UF +-5% 400VDC	05466P01	1677.01/J/400B
A81C28	0160-3670	6		CAPACITOR-FXD .1UF +-20% 200VDC CER	04222	SR302E104MAAH
A81C29	0160-3670	6		CAPACITOR-FXD .1UF +-20% 200VDC CER	04222	SR302E104MAAH
A81C30	0160-5473	1		CAPACITOR-FXD .01UF +-5% 400VDC	05466P01	1677.01/J/400B
A81C31	0160-5897	3		CAPACITOR-FXD 1.2PF +-25PF 200VDC CER	54583	MA12C0G2D1R2C
A81C32	0160-6623	5		C-F /1U +-20 50VCD	04222	SA115C104MAAH
A81C33	0160-6510	9		C-F .1UF 20% 50V CERMLr	28480	RPE121-978X7R104M50V
A81C34	0160-6505	2	2	C-F .01UF 20% 100V CERMLr	28480	RPE121-978X7R103M100V
A81C35	0160-6505	2		C-F .01UF 20% 100V CERMLr	28480	RPE121-978X7R103M100V
A81C36	0160-6520	1	8	C-F 1UF -% 50V CERMLr	28480	RPE113-907Z5U105Z50V
A81C37	0160-6520	1		C-F 1UF -% 50V CERMLr	28480	RPE113-907Z5U105Z50V
A81C38	0160-6520	1		C-F 1UF -% 50V CERMLr	28480	RPE113-907Z5U105Z50V
A81C39	0160-6520	1		C-F 1UF -% 50V CERMLr	28480	RPE113-907Z5U105Z50V
A81C40	0160-6520	1		C-F 1UF -% 50V CERMLr	28480	RPE113-907Z5U105Z50V
A81C41	0180-0094	4	1	CAPACITOR-FXD 100UF +75-10% 25VDC AL	13606	30D107G025DD2-DSM
A81C42	0160-6520	1		C-F 1UF -% 50V CERMLr	28480	RPE113-907Z5U105Z50V
A81C43	0160-6520	1		C-F 1UF -% 50V CERMLr	28480	RPE113-907Z5U105Z50V
A81C44	0180-4130	7	6	C-F 2.2UF 10% 20V TATBSA	13606	173D225X9020V
A81C45	0180-4130	7		C-F 2.2UF 10% 20V TATBSA	13606	173D225X9020V
A81C46	0180-4130	7		C-F 2.2UF 10% 20V TATBSA	13606	173D225X9020V
A81C47	0180-4130	7		C-F 2.2UF 10% 20V TATBSA	13606	173D225X9020V
A81C48	0180-4130	7		C-F 2.2UF 10% 20V TATBSA	13606	173D225X9020V
A81C49	0180-4130	7		C-F 2.2UF 10% 20V TATBSA	13606	173D225X9020V
A81C50	0160-6623	5		C-F /1U +-20 50VCD	04222	SA115C104MAAH
A81C51	0160-6623	5		C-F /1U +-20 50VCD	04222	SA115C104MAAH
A81C52	0160-6623	5		C-F /1U +-20 50VCD	04222	SA115C104MAAH
A81C53	0160-6623	5		C-F /1U +-20 50VCD	04222	SA115C104MAAH
A81C54	0160-6623	5		C-F /1U +-20 50VCD	04222	SA115C104MAAH
A81C55	0160-6623	5		C-F /1U +-20 50VCD	04222	SA115C104MAAH
A81C56	0160-6623	5		C-F /1U +-20 50VCD	04222	SA115C104MAAH
A81C57	0160-0575	4	1	CAPACITOR-FXD .047UF +-20% 50VDC CER	04222	SR205C473MAAH
A81C58	0160-6623	5		C-F /1U +-20 50VCD	04222	SA115C104MAAH
A81C59	0160-6623	5		C-F /1U +-20 50VCD	04222	SA115C104MAAH
A81C70	0160-6520	1		C-F 1UF -% 50V CERMLr	28480	RPE113-907Z5U105Z50V
A81C138	0160-6623	5		C-F /1U +-20 50VCD	04222	SA115C104MAAH
A81CR1	1901-1068	5	8	DIODE-SCHOTTKY SM SIG	28480	1901-1068
A81CR2	1901-1068	5		DIODE-SCHOTTKY SM SIG	28480	1901-1068
A81CR3	1901-1068	5		DIODE-SCHOTTKY SM SIG	28480	1901-1068
A81CR4	1901-1068	5		DIODE-SCHOTTKY SM SIG	28480	1901-1068

See introduction to this section for information  
 \* Indicates factory selected values



Table 6-3. Replaceable Parts

Ref.Des.	HP Part Number	CD	Qty	Description	Mfr. Code	Mfr. Part Number
A81CR5	1901-1068	5		DIODE-SCHOTTKY SM SIG	28480	1901-1068
A81CR6	1901-1068	5		DIODE-SCHOTTKY SM SIG	28480	1901-1068
A81CR7	1901-1068	5		DIODE-SCHOTTKY SM SIG	28480	1901-1068
A81CR8	1901-1068	5		DIODE-SCHOTTKY SM SIG	28480	1901-1068
A81CR9	1901-0040	1	6	DIODE-SWITCHING 30V 50MA 2NS DO-35	9N171	1N4148
A81CR10	1901-0040	1		DIODE-SWITCHING 30V 50MA 2NS DO-35	9N171	1N4148
A81CR11	1901-0028	5	8	DIODE-PWR RECT 400V 750MA DO-29	04713	SR1358-9BRL
A81CR12	1901-0028	5		DIODE-PWR RECT 400V 750MA DO-29	04713	SR1358-9BRL
A81CR13	1901-0096	7	4	DIODE-SWITCHING 120V 50MA 100NS	9N171	1N3070
A81CR14	1901-0096	7		DIODE-SWITCHING 120V 50MA 100NS	9N171	1N3070
A81CR15	1901-0028	5		DIODE-PWR RECT 400V 750MA DO-29	04713	SR1358-9BRL
A81CR16	1901-0028	5		DIODE-PWR RECT 400V 750MA DO-29	04713	SR1358-9BRL
A81CR17	1901-0028	5		DIODE-PWR RECT 400V 750MA DO-29	04713	SR1358-9BRL
A81CR18	1901-0028	5		DIODE-PWR RECT 400V 750MA DO-29	04713	SR1358-9BRL
A81CR19	1901-0096	7		DIODE-SWITCHING 120V 50MA 100NS	9N171	1N3070
A81CR20	1901-0096	7		DIODE-SWITCHING 120V 50MA 100NS	9N171	1N3070
A81CR21	1901-0028	5		DIODE-PWR RECT 400V 750MA DO-29	04713	SR1358-9BRL
A81CR22	1901-0028	5		DIODE-PWR RECT 400V 750MA DO-29	04713	SR1358-9BRL
A81CR24	1901-0040	1		DIODE-SWITCHING 30V 50MA 2NS DO-35	9N171	1N4148
A81CR25	1901-0040	1		DIODE-SWITCHING 30V 50MA 2NS DO-35	9N171	1N4148
A81CR28	1902-0958	2	1	DIODE-ZNR 10V 5% DO-35 PD = .4W TC = +.075%	04713	
A81CR28	1901-0040	1		DIODE-SWITCHING 30V 50MA 2NS DO-35	9N171	1N4148
A81CR29	1901-0040	1		DIODE-SWITCHING 30V 50MA 2NS DO-35	9N171	1N4148
A81E1	1251-4670	2	3	CONN-POST TYPE .100-PIN-SPOG 3-CONT	22526	68000-603
A81E1A	1258-0141	8	3	CON-JUMPER REM .025P	22526	65474-004
A81E2	1251-4670	2		CONN-POST TYPE .100-PIN-SPOG 3-CONT	22526	68000-603
A81E2A	1258-0141	8		CON-JUMPER REM .025P	22526	65474-004
A81E3	1251-4670	2		CONN-POST TYPE .100-PIN-SPOG 3-CONT	22526	68000-603
A81E3A	1258-0141	8		CON-JUMPER REM .025P	22526	65474-004
A81H1	5957-2260	2	1	LBL-MADE IN USA	28480	5957-2260
A81J1	1251-7933	6	8	CONN-POST TYPE .100-PIN-SPOG 3-CONT	27264	22-12-2034
A81J2	1251-7933	6		CONN-POST TYPE .100-PIN-SPOG 3-CONT	27264	22-12-2034
A81J3	1251-7745	8	3	CONN-POST TYPE .100-PIN-SPOG 2-CONT	27264	22-12-2024
A81J4	1251-7745	8		CONN-POST TYPE .100-PIN-SPOG 2-CONT	27264	22-12-2024
A81J5	1251-7745	8		CONN-POST TYPE .100-PIN-SPOG 2-CONT	27264	22-12-2024
A81J6	1251-6823	1	2	CONN-POST TYPE .100-PIN-SPOG 20-CONT	56501	609-2027
A81J7	1251-6823	1		CONN-POST TYPE .100-PIN-SPOG 20-CONT	56501	609-2027
A81J8	1251-5863	7	1	CONN-POST TYPE 2.5-PIN-SPOG 5-CONT	27264	22-11-1051
A81J10	1251-7933	6		CONN-POST TYPE .100-PIN-SPOG 3-CONT	27264	22-12-2034
A81J11	1251-7933	6		CONN-POST TYPE .100-PIN-SPOG 3-CONT	27264	22-12-2034
A81J12	1251-7933	6		CONN-POST TYPE .100-PIN-SPOG 3-CONT	27264	22-12-2034
A81J13	1251-7775	4	1	CONN-POST TYPE .100-PIN-SPOG 3-CONT	27264	22-11-2032
A81J14	1251-7933	6		CONN-POST TYPE .100-PIN-SPOG 3-CONT	27264	22-12-2034
A81J15	1251-7933	6		CONN-POST TYPE .100-PIN-SPOG 3-CONT	27264	22-12-2034
A81J16	1251-7933	6		CONN-POST TYPE .100-PIN-SPOG 3-CONT	27264	22-12-2034
A81J18	1251-7776	5	4	CONN-POST TYPE .100-PIN-SPOG 2-CONT	27264	22-11-2022
A81J19	1251-7776	5		CONN-POST TYPE .100-PIN-SPOG 2-CONT	27264	22-11-2022
A81J40	1251-7776	5		CONN-POST TYPE .100-PIN-SPOG 2-CONT	27264	22-11-2022
A81J50	1251-7776	5		CONN-POST TYPE .100-PIN-SPOG 2-CONT	27264	22-11-2022
A81MP1	1600-1038	1	1	SHIELD-AMPLIFIER	08638P01	
A81Q1	1655-0052	6	2	TRANSISTOR J-FET P-CHAN D-MODE TO-92 SI	04713	

See introduction to this section for information  
 \* Indicates factory selected values

Table 6-3. Replaceable Parts

Ref.Des.	HP Part Number	CD	Qty	Description	Mfr. Code	Mfr. Part Number
A81Q2	1855-0052	6		TRANSISTOR J-FET P-CHAN D-MODE TO-92 SI	04713	
A81Q3	1853-0639	1	4	XTR	04713	MPSH81
A81Q4	1853-0639	1		XTR	04713	MPSH81
A81Q5	1853-0639	1		XTR	04713	MPSH81
A81Q6	1853-0639	1		XTR	04713	MPSH81
A81Q7	1853-0563	0	4	XTR SML1PNP SI 2N3906 TXXXX	04713	2N3906(SEL)
A81Q8	1853-0038	4	4	TRANSISTOR PNP SI TO-39 PD=1W FT=100MHZ	04713	
A81Q9	1854-0813	5	4	TRANSISTOR NPN 2N3501S SI TO-39 PD=1W	04713	2N3501(SEL)
A81Q10	1853-0038	4		TRANSISTOR PNP SI TO-39 PD=1W FT=100MHZ	04713	
A81Q11	1854-0813	5		TRANSISTOR NPN 2N3501S SI TO-39 PD=1W	04713	2N3501(SEL)
A81Q12	1853-0563	0		XTR SML1PNP SI 2N3906 TXXXX	04713	2N3906(SEL)
A81Q13	1853-0563	0		XTR SML1PNP SI 2N3906 TXXXX	04713	2N3906(SEL)
A81Q14	1853-0038	4		TRANSISTOR PNP SI TO-39 PD=1W FT=100MHZ	04713	
A81Q15	1854-0813	5		TRANSISTOR NPN 2N3501S SI TO-39 PD=1W	04713	2N3501(SEL)
A81Q16	1853-0038	4		TRANSISTOR PNP SI TO-39 PD=1W FT=100MHZ	04713	
A81Q17	1854-0813	5		TRANSISTOR NPN 2N3501S SI TO-39 PD=1W	04713	2N3501(SEL)
A81Q18	1853-0563	0		XTR SML1PNP SI 2N3906 TXXXX	04713	2N3906(SEL)
A81Q19	1853-0419	5	1	TRANSISTOR PNP SI PD=310MW FT=200MHZ	04713	2N4403
A81R1	2100-4241	5	2	RES TRMR 200 OHM +-10%	32997	3329U-1-201R
A81R2	0757-0401	0	2	RESISTOR 100 1% .125W F TC=0+-100	19701	SFR25H
A81R3	0757-0418	9	2	RESISTOR 619 1% .125W F TC=0+-100	19701	SFR25H
A81R4	0757-1094	9	2	RESISTOR 1.47K 1% .125W F TC=0+-100	19701	SFR25H
A81R5	0699-1011	6	12	RESISTOR 3.32K .1% .125W F TC=0+-25	19701	5033R
A81R6	0699-1011	6		RESISTOR 3.32K .1% .125W F TC=0+-25	19701	5033R
A81R7	0699-1011	6		RESISTOR 3.32K .1% .125W F TC=0+-25	19701	5033R
A81R8	2100-3288	8	4	RESISTOR-TRMR 50 20% C TOP-ADJ 17-TRN	73138	67WR
A81R9	0699-1011	6		RESISTOR 3.32K .1% .125W F TC=0+-25	19701	5033R
A81R10	0699-1011	6		RESISTOR 3.32K .1% .125W F TC=0+-25	19701	5033R
A81R11	2100-3288	8		RESISTOR-TRMR 50 20% C TOP-ADJ 17-TRN	73138	67WR
A81R12	0699-1011	6		RESISTOR 3.32K .1% .125W F TC=0+-25	19701	5033R
A81R13	0757-0439	4	3	RESISTOR 6.81K 1% .125W F TC=0+-100	19701	SFR25H
A81R14	0699-3154	0	6	RESISTOR 4.22K 1% .125W F TC=0+-100	19701	SFR25H
A81R15	0699-3154	0		RESISTOR 4.22K 1% .125W F TC=0+-100	19701	SFR25H
A81R16	0757-0428	1	5	RESISTOR 1.62K 1% .125W F TC=0+-100	19701	SFR25H
A81R17	0757-0433	8	4	RESISTOR 3.32K 1% .125W F TC=0+-100	19701	SFR25H
A81R18	0699-3154	0		RESISTOR 4.22K 1% .125W F TC=0+-100	19701	SFR25H
A81R19	0757-0433	8		RESISTOR 3.32K 1% .125W F TC=0+-100	19701	SFR25H
A81R20	2100-3659	7	2	RESISTOR-TRMR 20K 10% C TOP-ADJ 17-TRN	73138	67WR
A81R21	0757-0280	3	12	RESISTOR 1K 1% .125W F TC=0+-100	19701	SFR25H
A81R22	0757-0465	6	11	RESISTOR 100K 1% .125W F TC=0+-100	19701	SFR25H
A81R23	0757-0411	2	3	RESISTOR 332 1% .125W F TC=0+-100	19701	SFR25H
A81R24	0757-0415	6	1	RESISTOR 475 1% .125W F TC=0+-100	19701	SFR25H
A81R25	0757-0402	1	1	RESISTOR 110 1% .125W F TC=0+-100	19701	SFR25H
A81R26	0757-0409	8	2	RESISTOR 274 1% .125W F TC=0+-100	19701	SFR25H
A81R27	0699-3427	0	1	RESISTOR 13.3 1% .125W F TC=0+-100	91637	CMF-55-1 T-1
A81R28	0699-3443	0	1	RESISTOR 287 1% .125W F TC=0+-100	19701	SFR25H
A81R29	0757-0401	0		RESISTOR 100 1% .125W F TC=0+-100	19701	SFR25H
A81R30	2100-4241	5		RES TRMR 200 OHM +-10%	32997	3329U-1-201R
A81R31	0757-0418	9		RESISTOR 619 1% .125W F TC=0+-100	19701	SFR25H
A81R32	0757-1094	9		RESISTOR 1.47K 1% .125W F TC=0+-100	19701	SFR25H
A81R33	0699-1011	6		RESISTOR 3.32K .1% .125W F TC=0+-25	19701	5033R

See introduction to this section for information  
 \* Indicates factory selected values



Table 6-3. Replaceable Parts

Ref.Des.	HP Part Number	CD	Qty	Description	Mfr. Code	Mfr. Part Number
A81R34	0699-1011	6		RESISTOR 3.32K .1% .125W F TC = 0+ -25	19701	5033R
A81R35	0699-1011	6		RESISTOR 3.32K .1% .125W F TC = 0+ -25	19701	5033R
A81R36	2100-3288	8		RESISTOR-TRMR 50 20% C TOP-ADJ 17-TRN	73138	67WR
A81R37	0699-1011	6		RESISTOR 3.32K .1% .125W F TC = 0+ -25	19701	5033R
A81R38	0699-1011	6		RESISTOR 3.32K .1% .125W F TC = 0+ -25	19701	5033R
A81R39	2100-3288	8		RESISTOR-TRMR 50 20% C TOP-ADJ 17-TRN	73138	67WR
A81R40	0699-1011	6		RESISTOR 3.32K .1% .125W F TC = 0+ -25	19701	5033R
A81R41	0757-0439	4		RESISTOR 6.81K 1% .125W F TC = 0+ -100	19701	SFR25H
A81R42	0699-3154	0		RESISTOR 4.22K 1% .125W F TC = 0+ -100	19701	SFR25H
A81R43	0699-3154	0		RESISTOR 4.22K 1% .125W F TC = 0+ -100	19701	SFR25H
A81R44	0757-0428	1		RESISTOR 1.62K 1% .125W F TC = 0+ -100	19701	SFR25H
A81R45	0757-0433	8		RESISTOR 3.32K 1% .125W F TC = 0+ -100	19701	SFR25H
A81R46	0699-3154	0		RESISTOR 4.22K 1% .125W F TC = 0+ -100	19701	SFR25H
A81R47	0757-0433	8		RESISTOR 3.32K 1% .125W F TC = 0+ -100	19701	SFR25H
A81R48	2100-3659	7		RESISTOR-TRMR 20K 10% C TOP-ADJ 17-TRN	73138	67WR
A81R49	0757-0280	3		RESISTOR 1K 1% .125W F TC = 0+ -100	19701	SFR25H
A81R50	0757-0465	6		RESISTOR 100K 1% .125W F TC = 0+ -100	19701	SFR25H
A81R51	0757-0411	2		RESISTOR 332 1% .125W F TC = 0+ -100	19701	SFR25H
A81R52	0757-0453	2	4	RESISTOR 30.1K 1% .125W F TC = 0+ -100	19701	SFR25H
A81R53	0757-0431	6	1	RESISTOR 2.43K 1% .125W F TC = 0+ -100	19701	SFR25H
A81R54	0683-1265	9	2	RESISTOR 12M 5% .25W CC TC = -900/ + 1200	01121	CB1265
A81R55	0757-0453	2		RESISTOR 30.1K 1% .125W F TC = 0+ -100	19701	SFR25H
A81R56	2100-4240	4	10	RES TRMR 1000 OHM + -10%	32997	3329U-1-102R
A81R57	0699-3228	9	4	RESISTOR 49.9K 1% .125W F TC = 0+ -100	19701	SFR25H
A81R58	0699-4412	5	4	RESISTOR 143 1% .125W F TC = 0+ -100	91637	CMF-55-1 T-1
A81R59	0699-4412	5		RESISTOR 143 1% .125W F TC = 0+ -100	91637	CMF-55-1 T-1
A81R60	0699-3228	9		RESISTOR 49.9K 1% .125W F TC = 0+ -100	19701	SFR25H
A81R61	0757-0453	2		RESISTOR 30.1K 1% .125W F TC = 0+ -100	19701	SFR25H
A81R62	0699-3151	7	2	RESISTOR 2.87K 1% .125W F TC = 0+ -100	19701	SFR25H
A81R63	0683-1265	9		RESISTOR 12M 5% .25W CC TC = -900/ + 1200	01121	CB1265
A81R64	0757-0453	2		RESISTOR 30.1K 1% .125W F TC = 0+ -100	19701	SFR25H
A81R65	2100-4240	4		RES TRMR 1000 OHM + -10%	32997	3329U-1-102R
A81R66	0699-3228	9		RESISTOR 49.9K 1% .125W F TC = 0+ -100	19701	SFR25H
A81R67	0699-4412	5		RESISTOR 143 1% .125W F TC = 0+ -100	91637	CMF-55-1 T-1
A81R68	0699-4412	5		RESISTOR 143 1% .125W F TC = 0+ -100	91637	CMF-55-1 T-1
A81R69	0699-3228	9		RESISTOR 49.9K 1% .125W F TC = 0+ -100	19701	SFR25H
A81R70	2100-4239	1	6	RES TRMR 10000 OHM + -10%	32997	3329U-1-103R
A81R71	0757-0462	3	1	RESISTOR 75K 1% .125W F TC = 0+ -100	19701	SFR25H
A81R72	0757-0409	8		RESISTOR 274 1% .125W F TC = 0+ -100	19701	SFR25H
A81R73	0757-0459	8	1	RESISTOR 56.2K 1% .125W F TC = 0+ -100	19701	SFR25H
A81R74	0699-3151	7		RESISTOR 2.87K 1% .125W F TC = 0+ -100	19701	SFR25H
A81R75	0757-0439	4		RESISTOR 6.81K 1% .125W F TC = 0+ -100	19701	SFR25H
A81R76	0757-0406	5	1	RESISTOR 182 1% .125W F TC = 0+ -100	19701	SFR25H
A81R77	0699-3156	2	1	RESISTOR 14.7K 1% .125W F TC = 0+ -100	19701	SFR25H
A81R78	0757-0442	9	12	RESISTOR 10K 1% .125W F TC = 0+ -100	19701	SFR25H
A81R79	0757-0443	0	1	RESISTOR 11K 1% .125W F TC = 0+ -100	19701	SFR25H
A81R80	0757-0408	7	1	RESISTOR 243 1% .125W F TC = 0+ -100	19701	SFR25H
A81R81	0757-0440	7	2	RESISTOR 7.5K 1% .125W F TC = 0+ -100	19701	SFR25H
A81R82	2100-4240	4		RES TRMR 1000 OHM + -10%	32997	3329U-1-102R
A81R83	0757-0290	5	6	RESISTOR 6.18K 1% .125W F TC = 0+ -100	19701	SFR25H
A81R84	0757-0280	3		RESISTOR 1K 1% .125W F TC = 0+ -100	19701	SFR25H

See introduction to this section for information  
 \* Indicates factory selected values

Table 6-3. Replaceable Parts

Ref.Des.	HP Part Number	CD	Qty	Description	Mfr. Code	Mfr. Part Number
A81R85	0757-0428	1		RESISTOR 1.62K 1% .125W F TC=0+-100	19701	SFR25H
A81R86	0757-0280	3	4	RESISTOR 1K 1% .125W F TC=0+-100	19701	SFR25H
A81R87	2100-4240	4		RES TRMR 1000 OHM +-10%	32997	3329U-1-102R
A81R88	0757-0472	5	2	RESISTOR 200K 1% .125W F TC=0+-100	19701	SFR25H
A81R90	0757-0448	5	4	RESISTOR 18.2K 1% .125W F TC=0+-100	19701	SFR25H
A81R91	0757-0419	0	5	RESISTOR 681 1% .125W F TC=0+-100	19701	SFR25H
A81R92	0757-0847	8	8	RESISTOR 27.4K 1% .5W F TC=0+-100	19701	5053R
A81R93	0757-0290	5		RESISTOR 6.19K 1% .125W F TC=0+-100	19701	SFR25H
A81R94	0757-0465	6		RESISTOR 100K 1% .125W F TC=0+-100	19701	SFR25H
A81R95	0757-0317	7	5	RESISTOR 1.33K 1% .125W F TC=0+-100	19701	SFR25H
A81R96	0757-0847	8		RESISTOR 27.4K 1% .5W F TC=0+-100	19701	5053R
A81R97	0757-0847	8		RESISTOR 27.4K 1% .5W F TC=0+-100	19701	5053R
A81R98	0757-0317	7		RESISTOR 1.33K 1% .125W F TC=0+-100	19701	SFR25H
A81R99	0757-0465	6		RESISTOR 100K 1% .125W F TC=0+-100	19701	SFR25H
A81R100	0757-0290	5		RESISTOR 6.19K 1% .125W F TC=0+-100	19701	SFR25H
A81R101	0757-0847	8		RESISTOR 27.4K 1% .5W F TC=0+-100	19701	5053R
A81R102	0757-0419	0		RESISTOR 681 1% .125W F TC=0+-100	19701	SFR25H
A81R103	0757-0448	5		RESISTOR 18.2K 1% .125W F TC=0+-100	19701	SFR25H
A81R104	0757-0440	7		RESISTOR 7.5K 1% .125W F TC=0+-100	19701	SFR25H
A81R105	2100-4240	4		RES TRMR 1000 OHM +-10%	32997	3329U-1-102R
A81R106	0757-0290	5		RESISTOR 6.19K 1% .125W F TC=0+-100	19701	SFR25H
A81R107	0757-0280	3		RESISTOR 1K 1% .125W F TC=0+-100	19701	SFR25H
A81R108	0757-0428	1		RESISTOR 1.62K 1% .125W F TC=0+-100	19701	SFR25H
A81R109	0757-0418	7		RESISTOR 511 1% .125W F TC=0+-100	19701	SFR25H
A81R110	2100-4240	4		RES TRMR 1000 OHM +-10%	32997	3329U-1-102R
A81R111	0757-0472	5		RESISTOR 200K 1% .125W F TC=0+-100	19701	SFR25H
A81R113	0757-0448	5		RESISTOR 18.2K 1% .125W F TC=0+-100	19701	SFR25H
A81R114	0757-0419	0		RESISTOR 681 1% .125W F TC=0+-100	19701	SFR25H
A81R115	0757-0847	8		RESISTOR 27.4K 1% .5W F TC=0+-100	19701	5053R
A81R116	0757-0290	5		RESISTOR 6.19K 1% .125W F TC=0+-100	19701	SFR25H
A81R117	0757-0465	6		RESISTOR 100K 1% .125W F TC=0+-100	19701	SFR25H
A81R118	0757-0317	7		RESISTOR 1.33K 1% .125W F TC=0+-100	19701	SFR25H
A81R119	0757-0847	8		RESISTOR 27.4K 1% .5W F TC=0+-100	19701	5053R
A81R120	0757-0847	8		RESISTOR 27.4K 1% .5W F TC=0+-100	19701	5053R
A81R121	0757-0317	7		RESISTOR 1.33K 1% .125W F TC=0+-100	19701	SFR25H
A81R122	0757-0465	6		RESISTOR 100K 1% .125W F TC=0+-100	19701	SFR25H
A81R123	0757-0290	5		RESISTOR 6.19K 1% .125W F TC=0+-100	19701	SFR25H
A81R124	0757-0847	8		RESISTOR 27.4K 1% .5W F TC=0+-100	19701	5053R
A81R125	0757-0419	0		RESISTOR 681 1% .125W F TC=0+-100	19701	SFR25H
A81R126	0757-0448	5		RESISTOR 18.2K 1% .125W F TC=0+-100	19701	SFR25H
A81R127	0757-0442	9		RESISTOR 10K 1% .125W F TC=0+-100	19701	SFR25H
A81R128	0757-0442	9		RESISTOR 10K 1% .125W F TC=0+-100	19701	SFR25H
A81R129	2100-4240	4		RES TRMR 1000 OHM +-10%	32997	3329U-1-102R
A81R130	0757-0278	9	1	RESISTOR 1.78K 1% .125W F TC=0+-100	19701	SFR25H
A81R131	2100-4240	4		RES TRMR 1000 OHM +-10%	32997	3329U-1-102R
A81R132	0757-0428	9	1	RESISTOR 1.3K 1% .125W F TC=0+-100	19701	SFR25H
A81R133	0757-0317	7		RESISTOR 1.33K 1% .125W F TC=0+-100	19701	SFR25H
A81R133	0757-0420	3	1	RESISTOR 750 1% .125W F TC=0+-100	19701	SFR25H
A81R133*	0757-0280	3		RESISTOR 1K 1% .125W F TC=0+-100	19701	SFR25H
A81R134	0757-0280	3		RESISTOR 1K 1% .125W F TC=0+-100	19701	SFR25H
A81R135	2100-4239	1		RES TRMR 10000 OHM +-10%	32997	3329U-1-103R

See introduction to this section for information

\* Indicates factory selected values

Table 6-3. Replaceable Parts

Ref.Des.	HP Part Number	CD	Qty	Description	Mfr. Code	Mfr. Part Number
A81R136	0698-4502	4	1	RESISTOR 64.9K 1% .125W F TC=0+-100	91637	CMF-55-1 T-1
A81R137	0757-0280	3		RESISTOR 1K 1% .125W F TC=0+-100	19701	SFR25H
A81R138	0698-3279	0	4	RESISTOR 4.99K 1% .125W F TC=0+-100	19701	SFR25H
A81R139	0757-0283	6	2	RESISTOR 2K 1% .125W F TC=0+-100	19701	SFR25H
A81R140	0757-0283	6		RESISTOR 2K 1% .125W F TC=0+-100	19701	SFR25H
A81R141	0698-3279	0		RESISTOR 4.99K 1% .125W F TC=0+-100	19701	SFR25H
A81R142	2100-4239	1		RES TRMR 10000 OHM +-10%	32997	3328U-1-103R
A81R143	0698-3279	0		RESISTOR 4.99K 1% .125W F TC=0+-100	19701	SFR25H
A81R144	8159-0005	0		RESISTOR ZERO OHMS	19701	SFR25H
A81R145	0757-0465	6		RESISTOR 100K 1% .125W F TC=0+-100	19701	SFR25H
A81R146	0757-0442	9		RESISTOR 10K 1% .125W F TC=0+-100	19701	SFR25H
A81R148	0757-0442	9		RESISTOR 10K 1% .125W F TC=0+-100	19701	SFR25H
A81R149	2100-4239	1		RES TRMR 10000 OHM +-10%	32997	3328U-1-103R
A81R150	0757-0280	3		RESISTOR 1K 1% .125W F TC=0+-100	19701	SFR25H
A81R151	0757-0407	6	5	RESISTOR 200 1% .125W F TC=0+-100	19701	SFR25H
A81R152	0757-0407	6		RESISTOR 200 1% .125W F TC=0+-100	19701	SFR25H
A81R153	0757-0407	6		RESISTOR 200 1% .125W F TC=0+-100	19701	SFR25H
A81R154	0757-0407	6		RESISTOR 200 1% .125W F TC=0+-100	19701	SFR25H
A81R155	0757-0280	3		RESISTOR 1K 1% .125W F TC=0+-100	19701	SFR25H
A81R156	0757-0411	2		RESISTOR 332 1% .125W F TC=0+-100	19701	SFR25H
A81R157	0698-3445	2	2	RESISTOR 348 1% .125W F TC=0+-100	19701	SFR25H
A81R158	0757-0428	1		RESISTOR 1.62K 1% .125W F TC=0+-100	19701	SFR25H
A81R159	0757-0714	8	1	RESISTOR 130 1% .25W F TC=0+-100	19701	5043R
A81R160	2100-4239	1		RES TRMR 10000 OHM +-10%	32997	3328U-1-103R
A81R181	0698-3438	3	1	RESISTOR 147 1% .125W F TC=0+-100	19701	SFR25H
A81R182	0757-0421	4	1	RESISTOR 825 1% .125W F TC=0+-100	19701	SFR25H
A81R183	0757-0416	7		RESISTOR 511 1% .125W F TC=0+-100	19701	SFR25H
A81R165	0757-0465	6		RESISTOR 100K 1% .125W F TC=0+-100	19701	SFR25H
A81R167	0757-0465	6		RESISTOR 100K 1% .125W F TC=0+-100	19701	SFR25H
A81R169	8159-0005	0	3	RESISTOR-ZERO OHMS 22 AWG LEAD DIA	20940	106
A81R170	0757-0407	6		RESISTOR 200 1% .125W F TC=0+-100	19701	SFR25H
A81R171	0757-0442	9		RESISTOR 10K 1% .125W F TC=0+-100	19701	SFR25H
A81R172	0757-0442	9		RESISTOR 10K 1% .125W F TC=0+-100	19701	SFR25H
A81R173	0757-0442	9		RESISTOR 10K 1% .125W F TC=0+-100	19701	SFR25H
A81R174	0757-0485	6		RESISTOR 100K 1% .125W F TC=0+-100	19701	SFR25H
A81R177	0757-0442	9		RESISTOR 10K 1% .125W F TC=0+-100	19701	SFR25H
A81R178	2100-4240	4		RES TRMR 1000 OHM +-10%	32997	3329U-1-102R
A81R179	0698-3498	5	2	RESISTOR 8.66K 1% .125W F TC=0+-100	19701	SFR25H
A81R180	0757-0442	9		RESISTOR 10K 1% .125W F TC=0+-100	19701	SFR25H
A81R181	2100-4240	4		RES TRMR 1000 OHM +-10%	32997	3329U-1-102R
A81R182	0698-3498	5		RESISTOR 8.66K 1% .125W F TC=0+-100	19701	SFR25H
A81R183	0757-0442	9		RESISTOR 10K 1% .125W F TC=0+-100	19701	SFR25H
A81R184	0698-4195	1	2	RESISTOR 1.02K 1% .125W F TC=0+-100	19701	SFR25H
A81R185	0757-0419	0		RESISTOR 681 1% .125W F TC=0+-100	19701	SFR25H
A81R186	8159-0005	0		RESISTOR-ZERO OHMS 22 AWG LEAD DIA	20940	106
A81R187	0757-0442	9		RESISTOR 10K 1% .125W F TC=0+-100	19701	SFR25H
A81R188	0698-4195	1		RESISTOR 1.02K 1% .125W F TC=0+-100	19701	SFR25H
A81R189	0698-3445	2		RESISTOR 348 1% .125W F TC=0+-100	19701	SFR25H
A81R190	8159-0005	0		RESISTOR-ZERO OHMS 22 AWG LEAD DIA	20940	106
A81R191	0757-0465	6		RESISTOR 100K 1% .125W F TC=0+-100	19701	SFR25H

See introduction to this section for information  
 \* Indicates factory selected values

Table 6-3. Replaceable Parts

Ref.Des.	HP Part Number	CD	Qty	Description	Mfr. Code	Mfr. Part Number
A81R192	0699-3450	9	1	RESISTOR 42.2K 1% .125W F TC=0+-100	19701	SFR25H
A81R193	0757-0460	1	1	RESISTOR 61.9K 1% .125W F TC=0+-100	19701	SFR25H
A81R194	0757-0199	3	1	RESISTOR 21.5K 1% .125W F TC=0+-100	19701	SFR25H
A81R195	2100-4239	1		RES TRMR 10000 OHM +-10%	32997	3329U-1-103R
A81R197	0757-0260	3		RESISTOR 1K 1% .125W F TC=0+-100	19701	SFR25H
A81R198	0757-0442	3		RESISTOR 10K 1% .125W F TC=0+-100	19701	SFR25H
A81R199	0757-0260	9		RESISTOR 1K 1% .125W F TC=0+-100	19701	SFR25H
A81TP	1252-2897	3	8	CONNECTOR-SINGLE CONTACT	11627P01	7-22751-8
A81TP2	1252-2897	3		CONNECTOR-SINGLE CONTACT	11627P01	7-22751-8
A81TP9	1252-2897	3		CONNECTOR-SINGLE CONTACT	11627P01	7-22751-8
A81TP10	1252-2897	3		CONNECTOR-SINGLE CONTACT	11627P01	7-22751-8
A81TP11	1252-2897	3		CONNECTOR-SINGLE CONTACT	11627P01	7-22751-8
A81TP15	1252-2897	3		CONNECTOR-SINGLE CONTACT	11627P01	7-22751-8
A81TP16	1252-2897	3		CONNECTOR-SINGLE CONTACT	11627P01	7-22751-8
A81TP26	1252-2897	3		CONNECTOR-SINGLE CONTACT	11627P01	7-22751-8
A81U1	1820-1196	8	4	ICFF TTL LS D-TYPE POS-EDGE-TRIG COM	01295	SN74LS174N
A81U2	1820-1196	8		ICFF TTL LS D-TYPE POS-EDGE-TRIG COM	01295	SN74LS174N
A81U3	1826-1457	6	4	ICL DAC 566A BIP 12 B24	24355	AD 41367
A81U4	1826-1457	6		ICL DAC 566A BIP 12 B24	24355	AD 41367
A81U5	1826-1535	1	6	ICL OPAMP 3140A BIF LB P8	34371	CA3140AE
A81U6	1826-1535	1		ICL OPAMP 3140A BIF LB P8	34371	CA3140AE
A81U7	1NB4-5003	4	2	ANALOG MULT.PACK	28480	1NB4-5003
A81U8	1826-0207	2	4	ICOP AMP WB 8-DIP-P PKG	27014	LM318N
A81U9	1826-0207	2		ICOP AMP WB 8-DIP-P PKG	27014	LM318N
A81U10	1826-1535	1		ICL OPAMP 3140A BIF LB P8	34371	CA3140AE
A81U11	1826-0208	3	3	ICOP AMP GP 8-DIP-P PKG	27014	LM310N
A81U12	1826-0753	3	2	ICOP AMP LOW-BIAS-H-IMPQ QUAD 14-DIP-C	04713	MC34004BL
A81U13	1820-1196	8		ICFF TTL LS D-TYPE POS-EDGE-TRIG COM	01295	SN74LS174N
A81U14	1820-1196	8		ICFF TTL LS D-TYPE POS-EDGE-TRIG COM	01295	SN74LS174N
A81U15	1826-1457	6		ICL DAC 566A BIP 12 B24	24355	AD 41367
A81U16	1826-1457	6		ICL DAC 566A BIP 12 B24	24355	AD 41367
A81U17	1826-1535	1		ICL OPAMP 3140A BIF LB P8	34371	CA3140AE
A81U18	1826-1535	1		ICL OPAMP 3140A BIF LB P8	34371	CA3140AE
A81U19	1NB4-5003	4		ANALOG MULT.PACK	28480	1NB4-5003
A81U20	1826-0207	2		ICOP AMP WB 8-DIP-P PKG	27014	LM318N
A81U21	1826-0207	2		ICOP AMP WB 8-DIP-P PKG	27014	LM318N
A81U22	1826-1535	1		ICL OPAMP 3140A BIF LB P8	34371	CA3140AE
A81U23	1826-0208	3		ICOP AMP GP 8-DIP-P PKG	27014	LM310N
A81U24	1826-0208	3		ICOP AMP GP 8-DIP-P PKG	27014	LM310N
A81U25	1826-0818	1	1	IC16-DIP-C PKG	52063	CS283
A81U26	1NB4-5004	5	1	RAMP GENERATOR	28480	1NB4-5004
A81U27	1826-0871	6	3	ICPREAMPLIFIER 14-DIP-C PKG	01590P01	MOG-2829
A81U28	1826-0871	6		ICPREAMPLIFIER 14-DIP-C PKG	01590P01	MOG-2829
A81U29	1826-0871	6		ICPREAMPLIFIER 14-DIP-C PKG	01590P01	MOG-2829
A81U30	1826-0527	9	1	ICV RGLTR-ADJ-NEG 1.2/37V TO-220 PKG	27014	LM337T
A81U31	1826-0753	3		ICOP AMP LOW-BIAS-H-IMPQ QUAD 14-DIP-C	04713	MC34004BL
A81U33	1826-0393	7	1	ICV RGLTR-ADJ-POS 1.2/37V TO-220 PKG	27014	LM317T
A81VR1	1826-0825	0	1	ICV RGLTR-V-REF-FXD 6.6/7.3V TO-92 PKG	27014	LM399Z
A81VR2	1902-0025	4	3	DIODE-ZNR 10V 5% DO-35 PD=.4W TC=+.06%	04713	
A81VR3	1902-0025	4		DIODE-ZNR 10V 5% DO-35 PD=.4W TC=+.06%	04713	
A81VR4	1902-0025	4		DIODE-ZNR 10V 5% DO-35 PD=.4W TC=+.06%	04713	

See introduction to this section for information

\* Indicates factory selected values

Table 6-3. Replaceable Parts

Ref.Des.	HP Part Number	CD	Qty	Description	Mfr. Code	Mfr. Part Number
A81VR5	1902-3036	3	1	DIODE-ZNR 3.16V 5% DO-7 PD = .4W TC = -.064%	04713	
A81VR6	1902-0048	1	6	DIODE-ZNR 6.81V 5% DO-35 PD = .4W	04713	
A81VR7	1902-0048	1		DIODE-ZNR 6.81V 5% DO-35 PD = .4W	04713	
A81VR8	1902-0048	1		DIODE-ZNR 6.81V 5% DO-35 PD = .4W	04713	
A81VR9	1902-0048	1		DIODE-ZNR 6.81V 5% DO-35 PD = .4W	04713	
A81VR10	1902-0048	1		DIODE-ZNR 6.81V 5% DO-35 PD = .4W	04713	
A81VR11	1902-0048	1		DIODE-ZNR 6.81V 5% DO-35 PD = .4W	04713	
A81XU3	1200-1311	5	7	SOCKET-IC 24 PIN	09922	DILB24P-108T
A81XU4	1200-1311	5		SOCKET-IC 24 PIN	09922	DILB24P-108T
A81XU7	1200-1311	5		SOCKET-IC 24 PIN	09922	DILB24P-108T
A81XU15	1200-1311	5		SOCKET-IC 24 PIN	09922	DILB24P-108T
A81XU16	1200-1311	5		SOCKET-IC 24 PIN	09922	DILB24P-108T
A81XU19	1200-1311	5		SOCKET-IC 24 PIN	09922	DILB24P-108T
A81XU25	1200-1219	2	1	SOCKET-IC 16 PIN	09922	DILB16P-108T
A81XU26	1200-1311	5		SOCKET-IC 24 PIN	09922	DILB24P-108T
A82	03577-66562	6	1	VECTOR PROCESSOR BOARD	28480	03577-66562
A82C3	0160-0374	3	1	CAPACITOR-FXD 10UF +-10% 20VDC TA	13606	150D106X9020B2-DYS
A82C4	0160-6500	7	16	CAPACITOR-FXD .01UF 10%	54583	DA12X7R2A103K
A82C5	0160-6500	7		CAPACITOR-FXD .01UF 10%	54583	DA12X7R2A103K
A82C6	0160-6500	7		CAPACITOR-FXD .01UF 10%	54583	DA12X7R2A103K
A82C7	0160-6500	7		CAPACITOR-FXD .01UF 10%	54583	DA12X7R2A103K
A82C8	0160-6500	7		CAPACITOR-FXD .01UF 10%	54583	DA12X7R2A103K
A82C9	0160-6500	7		CAPACITOR-FXD .01UF 10%	54583	DA12X7R2A103K
A82C10	0160-6500	7		CAPACITOR-FXD .01UF 10%	54583	DA12X7R2A103K
A82C11	0160-6500	7		CAPACITOR-FXD .01UF 10%	54583	DA12X7R2A103K
A82C13	0160-6623	5	4	CAPACITOR-FXD .1U +-20 50VDC	04222	SA115C104MAAH
A82C14	0160-6500	7		CAPACITOR-FXD .01UF 10%	54583	DA12X7R2A103K
A82C15	0160-6500	7		CAPACITOR-FXD .01UF 10%	54583	DA12X7R2A103K
A82C16	0160-6500	7		CAPACITOR-FXD .01UF 10%	54583	DA12X7R2A103K
A82C17	0160-6500	7		CAPACITOR-FXD .01UF 10%	54583	DA12X7R2A103K
A82C18	0160-6500	7		CAPACITOR-FXD .01UF 10%	54583	DA12X7R2A103K
A82C19	0160-6623	5		CAPACITOR-FXDF .1U +-20 50VDC	04222	SA115C104MAAH
A82C20	0160-6500	7		CAPACITOR-FXD .01UF 10%	54583	DA12X7R2A103K
A82C21	0160-6500	7		CAPACITOR-FXD .01UF 10%	54583	DA12X7R2A103K
A82C22	0160-6623	5		CAPACITOR-FXDF .1U +-20 50VDC	04222	SA115C104MAAH
A82C23	0160-6623	5		CAPACITOR-FXDF .1U +-20 50VDC	04222	SA115C104MAAH
A82C24	0160-6500	7		CAPACITOR-FXD .01UF 10%	54583	DA12X7R2A103K
A82CR1	1901-0040	1	1	DIODE-SWITCHING 30V 50MA 2NS DO-35	9N171	1N4148
A82CR2	1901-1065	2	2	DIODE-PWR RECT 1N4936 400V 1A 200NS	04713	1N4936
A82CR3	1901-1065	2		DIODE-PWR RECT 1N4936 400V 1A 200NS	04713	1N4936
A82J2	1251-6823	1	2	CONN-POST TYPE .100-PIN-SPOG 20-CONT	56501	609-2027
A82J3	1251-6823	1		CONN-POST TYPE .100-PIN-SPOG 20-CONT	56501	609-2027
A82J6	1251-4836	2	1	CONN-POST TYPE 2.5-PIN-SPOG 2-CONT	27264	22-12-1022
A82L1	9100-1629	4	1	INDUCTOR RF-QH-MLD 47UH 5% .166DX.385LG	99800	1537-60
A82R2	0757-0260	3	2	RESISTOR 1K 1% .125W F TC = 0+-100	19701	SFR25H
A82R3	0683-0275	9	1	RESISTOR 2.7 5% .25W CF TC = 0-400	77902	R-25J
A82R4	0683-1035	1	1	RESISTOR 10K 5% .25W CF TC = 0-400	77902	R-25J
A82R5	0757-0273	4	1	RESISTOR 3.01K 1% .125W F TC = 0+-100	19701	SFR25H
A82R6	0757-0416	7	2	RESISTOR 511 1% .125W F TC = 0+-100	19701	SFR25H

See introduction to this section for information  
 \* Indicates factory selected values



Table 6-3. Replaceable Parts

Ref.Des.	HP Part Number	CD	Qty	Description	Mfr. Code	Mfr. Part Number
A82R7	0757-0449	6	1	RESISTOR 20K 1% .125W F TC=0+-100	19701	SFR25H
A82R8	0757-0159	5	1	RESISTOR 1K 1% .5W F TC=0+-100	19701	5053R
A82R9	0698-3394	0	1	RESISTOR 31.6 1% .5W F TC=0+-100	19701	5053R
A82R10	0757-0280	3		RESISTOR 1K 1% .125W F TC=0+-100	19701	SFR25H
A82R11	0698-3154	0	1	RESISTOR 4.22K 1% .125W F TC=0+-100	19701	SFR25H
A82R12	0757-0416	7		RESISTOR 511 1% .125W F TC=0+-100	19701	SFR25H
A82U12	01347-80012	8	1	PGM EPROM 1818-1633	28480	01347-80012
A82U12	1818-1633	3	3	ICNMOS 32768 (32K) EPROM 300-NS	34649	D2732A-3
A82VR1	1902-3126	2	1	DIODE-ZNR 7.15V 2% DO-35 PD=.4W	04713	
A82C1	0160-2264	2	2	CAPACITOR-FXD 20PF +-5% 500VDC CER 0+-30	52763	2RDPLX05020RNP0
A82C2	0160-2264	2		CAPACITOR-FXD 20PF +-5% 500VDC CER 0+-30	52763	2RDPLX05020RNP0
A82C12	0160-5468	4	1	CAPACITOR-FXD .47UF +-10% 50VDC	28480	0160-5468
A82E1	1258-0124	7	1	PIN PRG JUMPER	91506	8136-475G1
A82J1	1251-8262	6	1	CONN-POST TYPE .100-PIN-SPOG 50-CONT	04726P02	3596-6002
A82J4	1251-7229	3	1	CONN-POST TYPE .100-PIN-SPOG 26-CONT	56501	609-2607
A82J5	1251-6000	6	1	CONN-POST TYPE 2.5-PIN-SPOG 5-CONT	27264	22-12-1052
A82MP1A	1200-0475	0	3	CONNECTOR-SGL CONT SKT .017-IN-BSC-SZ	22526	75060-012
A82MP1B	1200-0475	0		CONNECTOR-SGL CONT SKT .017-IN-BSC-SZ	22526	75060-012
A82MP1C	1200-0475	0		CONNECTOR-SGL CONT SKT .017-IN-BSC-SZ	22526	75060-012
A82Q1	1854-0300	5	1	TRANSISTOR NPN SI PD=25W FT=4MHZ	04713	
A82Q2	1854-0215	1	1	TRANSISTOR NPN SI PD=350MW FT=300MHZ	04713	2N3604
A82R13	0761-0035	5	1	RESISTOR 150 5% 1W MO TC=0+-200	28480	RG32
A82RP1	1810-0205	7	1	NETWORK-RES 8-SIP 4.7K OHM X 7	32997	4308R-101
A82RP2	1810-0204	6	1	NETWORK-RES 8-SIP 1.0K OHM X 7	11236	750-81
A82TP1	0360-0535	0	5	TML-STUD 1PIN .330LG BRS	63345	
A82TP2	0360-0535	0		TML-STUD 1PIN .330LG BRS	63345	
A82TP3	0360-0535	0		TML-STUD 1PIN .330LG BRS	63345	
A82TP4	0360-0535	0		TML-STUD 1PIN .330LG BRS	63345	
A82TP5	0360-0535	0		TML-STUD 1PIN .330LG BRS	63345	
A82U1	1820-5140	0	1	ICM MCU 8048 NMOS MCU88 P40	18324	SCN8049HCEN40-CP8211
A82U2	1820-1297	0	1	ICGATE TTL LS EXCL-NOR QUAD 2-INP	01295	SN74LS266N
A82U3	1810-0307	0	2	NETWORK-CNDCT MODULE DIP; 16 PINS; 0.100	11236	SERIES 760
A82U4	1810-0307	0		NETWORK-CNDCT MODULE DIP; 16 PINS; 0.100	11236	SERIES 760
A82U5	1816-1500	9	1	IC TTL S 4096 (4K) ROM 3-S	01295	TBP28S42N PROGMD
A82U6	1820-2024	3	5	ICDRVR TTL LS LINE DRVR OCTL	01295	SN74LS244N
A82U7	1820-1198	0	1	ICGATE TTL LS NAND QUAD 2-INP	01295	SN74LS03N
A82U8	1820-2024	3		ICDRVR TTL LS LINE DRVR OCTL	01295	SN74LS244N
A82U9	1820-1432	5	4	ICCNTR TTL LS BIN SYNCHRO POS-EDGE-TRIG	01295	SN74LS163AN
A82U10	1820-1432	5		ICCNTR TTL LS BIN SYNCHRO POS-EDGE-TRIG	01295	SN74LS163AN
A82U11	1820-1432	5		ICCNTR TTL LS BIN SYNCHRO POS-EDGE-TRIG	01295	SN74LS163AN
A82U11	1818-1633	3		ICNMOS 32768 (32K) EPROM 300-NS	34649	D2732A-3
A82U13	1820-2024	3		ICDRVR TTL LS LINE DRVR OCTL	01295	SN74LS244N
A82U14	1813-0143	0	1	OSC CLK 19.6608MHZ .05% TTL5V	09235P01	F1114-19.6608MHZ
A82U15	1820-1322	2	1	ICGATE TTL S NOR QUAD 2-INP	01295	SN74S02N
A82U16	1S85-0025	8	1	VPC B2D2 PROC	28480	1S85-0025
A82U17	1820-2024	3		ICDRVR TTL LS LINE DRVR OCTL	01295	SN74LS244N
A82U18	1820-1997	7	2	ICFF TTL LS D-TYPE POS-EDGE-TRIG PRL-IN	27014	DM74LS374N
A82U19	1820-1997	7		ICFF TTL LS D-TYPE POS-EDGE-TRIG PRL-IN	27014	DM74LS374N
A82U20	1820-1444	9	1	ICMUXR/DATA-SEL TTL LS 2-TO-1-LINE QUAD	01295	SN74LS298N
A82U21	1820-1422	3	1	ICMV TTL LS MONOSTBL RETRIG	01295	SN74LS122N
A82U22	1820-1196	8	4	ICFF TTL LS D-TYPE POS-EDGE-TRIG COM	01295	SN74LS174N

See introduction to this section for information

\* Indicates factory selected values

Table 6-3. Replaceable Parts

Ref.Des.	HP Part Number	CD	Qty	Description	Mfr. Code	Mfr. Part Number
A82U23	1820-1196	8		ICFF TTL LS D-TYPE POS-EDGE-TRIG COM	01295	SN74LS174N
A82U24	1820-1196	8		ICFF TTL LS D-TYPE POS-EDGE-TRIG COM	01295	SN74LS174N
A82U25	1820-1196	8		ICFF TTL LS D-TYPE POS-EDGE-TRIG COM	01295	SN74LS174N
A82U26	1820-1432	5		ICCNTR TTL LS BIN SYNCHRO POS-EDGE-TRIG	01295	SN74LS163AN
A82U27	1820-1217	4	1	ICMUXR/DATA-SEL TTL LS 8-TO-1-LINE	01295	SN74LS151N
A82U28	1820-2024	3		ICDRVR TTL LS LINE DRVR OCTL	01295	SN74LS244N
A82XU1	1200-1310	4	2	SOCKET-IC 40 PIN	09922	DILB40P-108T
A82XU3	1200-1219	2	2	SOCKET-IC 16 PIN	09922	DILB16P-108T
A82XU4	1200-1219	2		SOCKET-IC 16 PIN	09922	DILB16P-108T
A82XU5	1200-1217	0	1	ICSOCKET-20 PIN	09922	DILB20P-108T
A82XU12	1200-1311	5	1	SOCKET-IC 24 PIN	09922	DILB24P-108T
A82XU16	1200-1310	4		SOCKET-IC 40 PIN	09922	DILB40P-108T
	3050-0367	2	1	WASHER-FL MTLG NO. 3 .105-IN-HD	28480	3050-0367
	0515-0403	0	1	SCREW-MACH M2.5 X 0.45 6MM-LG PAN-HD	28480	
	0535-0008	3	1	NUT-HEX DBL-CHAM M2.5 X 0.45 2MM-THK	28480	
	5957-2260	2	1	LBL-MADE IN USA	28480	5957-2260
	1818-1833	3		ICNMOS 32768 (32K) EPROM 300-NS	34649	D2732A-3
A65	03577-66563	0	1	POWER SUPPLY BOARD	28480	03577-66563
A83C3	0180-0106	9	1	CAPACITOR-FXD 60UF + -20% 8VDC TA	13606	150D606X0006B2-DYS
A83CR2	1901-0040	1	2	DIODE-SWITCHING 30V 50MA 2NS DO-35	9N171	1N4148
A83CR3	1901-0669	0	2	DIODE-PWR RECT 400V 1A 150NS	14099	S4F
A83CR4	1901-0669	0		DIODE-PWR RECT 400V 1A 150NS	14099	S4F
A83J2	1251-5863	7	3	CONN-POST TYPE 2.5-PIN-SPOG 5-CONT	27264	22-11-1051
A83J3	1251-5863	7		CONN-POST TYPE 2.5-PIN-SPOG 5-CONT	27264	22-11-1051
A83J4	1251-5863	7		CONN-POST TYPE 2.5-PIN-SPOG 5-CONT	27264	22-11-1051
A83L2	9140-0137	1	1	INDUCTOR RF-CH-MLD 1MH 5% .2DX.45LG Q=60	99800	2500-28
A83R1	0757-0438	3	2	RESISTOR 5.11K 1% .125W F TC=0+-100	19701	SFR25H
A83R2	0757-0438	3		RESISTOR 5.11K 1% .125W F TC=0+-100	19701	SFR25H
A83R3	0757-0449	6	1	RESISTOR 20K 1% .125W F TC=0+-100	19701	SFR25H
A83R4	0698-0085	0	1	RESISTOR 2.61K 1% .125W F TC=0+-100	19701	SFR25H
A83R6	0757-0401	0	2	RESISTOR 100 1% .125W F TC=0+-100	19701	SFR25H
A83R7	0757-0401	0		RESISTOR 100 1% .125W F TC=0+-100	19701	SFR25H
A83R9	0757-0466	7	1	RESISTOR 110K 1% .125W F TC=0+-100	19701	SFR25H
A83C1	0180-0094	4	1	CAPACITOR-FXD 100UF + 75-10% 25VDC AL	13606	30D107G025DD2-DSM
A83C2	0160-3443	1	1	CAPACITOR-FXD .1UF +80-20% 50VDC CER	04222	SR215E104ZAAH
A83C4	0160-3448	6	1	CAPACITOR-FXD 1000PF +-10% 1KVDC CER	59660	808-548 X5E 102K
A83C5	0160-0207	9	1	CAPACITOR-FXD .01UF + -5% 200VDC POLYE	15768	HEW-238M
A83C7	0160-2069	1	1	CAPACITOR-FXD 100UF +50-10% 150VDC AL	13606	39D107F150FP4-DSB
A83CR1	1901-0040	1		DIODE-SWITCHING 30V 50MA 2NS DO-35	9N171	1N4148
A83F1	2110-0303	3	1	FUSE 2A 250V TD 1.25X.25 UL	71400	MDX-2A
A83F2	2110-0367	9	1	FUSE 5A 250V TD 1.25X.25	71400	MDA-250-5
A83F3	2110-0001	8	1	FUSE 1A 250V NTD 1.25X.25 UL	75915	312 001
A83J1	1251-4308	3	1	CONN-UTIL MR 6-CKT 6-CONT	00779	840500-2
A83J5	1251-6091	5	1	CONN-POST TYPE 2.5-PIN-SPOG 2-CONT	27264	22-11-1021
A83L1	9100-3139	5	2	INDUCTOR 75UH 15% .5DX.875LG	NEW	DN#
A83L3	9100-3139	5		INDUCTOR 75UH 15% .5DX.875LG	NEW	DN#
A83MP1A	2110-0726	4	6	CLIP-FUSE	13060	1115-0597T
A83MP1B	2110-0726	4		CLIP-FUSE	13060	1115-0597T

See introduction to this section for information  
 \* Indicates factory selected values

Table 6-3. Replaceable Parts

Ref.Des.	HP Part Number	CD	Qty	Description	Mfr. Code	Mfr. Part Number
A83MP2A	2110-0726	4		CLIP-FUSE	13060	1115-0597T
A83MP2B	2110-0726	4		CLIP-FUSE	13060	1115-0597T
A83MP3A	2110-0726	4		CLIP-FUSE	13060	1115-0597T
A83MP3B	2110-0726	4		CLIP-FUSE	13060	1115-0597T
A83Q1	1854-0659	7	2	TRANSISTOR NPN SI PD = 12.5W FT = 50MHZ	04713	MJE180
A83Q2	1854-0659	7		TRANSISTOR NPN SI PD = 12.5W FT = 50MHZ	04713	MJE180
A83R5	0757-0720	6	1	RESISTOR 243 1% .25W F TC = 0+-100	19701	5043R
A83R8	0811-3283	0	1	RESISTOR .18 5% 2W PW TC = 0+-300	28480	SPH
A83R10	2100-0654	5	1	RESISTOR-T/M/R 500 10% C TOP-ADJ 1-TRN	32997	3388P-Y46-501
A83R11	0757-0431	6	1	RESISTOR 2.43K 1% .125W F TC = 0+-100	19701	SFR25H
A83T1	01345-61102	5	1	XFC HI V	02858P01	
A83TP1	0360-0535	0	4	TML-STUD 1PIN .330LG BRS	63345	
A83TP2	0360-0535	0		TML-STUD 1PIN .330LG BRS	63345	
A83TP3	0360-0535	0		TML-STUD 1PIN .330LG BRS	63345	
A83TP4	0360-0535	0		TML-STUD 1PIN .330LG BRS	63345	
A83U1	1826-0428	9	1	ICV RGLTR-SWG 1/40V 18-DIP-C PKG	34333	SG3524J
A83XU1	1200-1219	2	1	SOCKET-IC 16 PIN	09922	DILB16P-108T
A84	03577-66584	1	1	PCBOARD ASSY	28480	03577-66584
A84C1	0160-5471	9	1	CAPACITOR-FXD .1UF +-5% 50VDC MET-POLYE	06127P01	MKS2
A84C2	0160-4832	4	31	CAPACITOR-FXD .01UF +-10% 100VDC CER	04222	SA101C103KAAH
A84C4	0160-4812	0	1	CAPACITOR-FXD 220PF +-5% 100VDC CER	04222	SA101A221JAAH
A84C5	0160-0374	3	1	CAPACITOR-FXD 10UF +-10% 20VDC TA	12340P01	T110B106K020AS
A84C6-C35	0160-4832	4		CAPACITOR-FXD .01UF +-10% 100VDC CER	04222	SA101C103KAAH
A84E1	1258-0124	7	1	CON-PROG JUMPER	91506	8136-475G1
A84J1	01345-61625	7	1	CBL-ASM RBN FHSG/FHSG 82MM GY	28480	
A84J2	1251-3976	9	1	CONN-POST TYPE 2.5-PIN-SPOG 6-CONT	27284	22-03-1061
A84J3	1251-4836	2	1	CONN-POST TYPE 2.5-PIN-SPOG 2-CONT	27284	22-12-1022
A84R1	0757-0442	9	1	RESISTOR 10K 1% .125W F TC = 0+-100	91637	CMF-55-1
A84R2	0757-0467	8	1	RESISTOR 121K 1% .125W F TC = 0+-100	91637	CMF-55-1
A84R4-R5	0757-0280	3	3	RESISTOR 1K 1% .125W F TC = 0+-100	91637	CMF-55-1
A84R6-R8	8159-0005	0	3	RESISTOR-ZERO OHMS 22 AWG LEAD DIA	02499P02	YZO 1/4
A84R9	0757-0280	3		RESISTOR 1K 1% .125W F TC = 0+-100	91637	CMF-55-1
A84U1	1820-2654	5	4	ICMUXR/DATA-SEL TTL F 2-TO-1-LINE QUAD	18324	74F157AN
A84U2-U3	1820-2779	5	8	ICCNTR TTL ALS BIN SYNCHRO	01295	SN74ALS163BN
A84U4	1820-2654	5		ICMUXR/DATA-SEL TTL F 2-TO-1-LINE QUAD	18324	74F157AN
A84U5-U6	1820-2779	5		ICCNTR TTL ALS BIN SYNCHRO	01295	SN74ALS163BN
A84U9-U10	1818-3336	7	4	ICNMOS 16384 (16K) STAT RAM 45-NS 3-S	04713	MCM2018AN45
A84U11-U13	1820-3294	1	6	ICFF TTL ALS D-TYPE POS-EDGE-TRIG COM	01295	SN74ALS374AN
A84U14	1820-1416	5	2	ICSCHMITT-TRIG TTL LS INV HEX 1-INP	01295	SN74LS14N
A84U15	01345-80005	7	1	PGM PAL 1820-3614	28480	01345-80005
A84U15-U16	1820-3614	9	3	ICD PLGC 20R8A PAL 25NS P24	34335	PAL20R8ACNS UNPRGMD
A84U16	1820-3614	9		ICD PLGC 20R8A PAL 25NS P24	34335	PAL20R8ACNS UNPRGMD
A84U17	1820-2692	1	1	ICGATE TTL F EXCL-OR QUAD 2-INP	18324	74F86N
A84U18	1820-3220	3	1	ICDCDR TTL F BIN 2-TO-4-LINE DUAL	18324	74F139N
A84U19	1820-2654	5		ICMUXR/DATA-SEL TTL F 2-TO-1-LINE QUAD	18324	74F157AN
A84U20-U21	1820-2779	5		ICCNTR TTL ALS BIN SYNCHRO	01295	SN74ALS163BN
A84U22	1820-2654	5		ICMUXR/DATA-SEL TTL F 2-TO-1-LINE QUAD	18324	74F157AN
A84U23-U24	1820-2779	5		ICCNTR TTL ALS BIN SYNCHRO	01295	SN74ALS163BN
A84U25	1826-0180	0	1	ICTIMER TTL MONO/ASTBL	18324	NE555N
A84U26	1820-2488	3	2	ICFF TTL ALS D-TYPE POS-EDGE-TRIG	01295	SN74ALS74AN

See introduction to this section for information

\* Indicates factory selected values



Table 6-3. Replaceable Parts

Ref.Des.	HP Part Number	CD	Qty	Description	Mfr. Code	Mfr. Part Number
A84U27	1820-2656	7	2	ICGATE TTL ALS NAND QUAD 2-INP	01295	SN74ALS00AN
A84U28	1820-2488	3		ICFF TTL ALS D-TYPE POS-EDGE-TRIG	01295	SN74ALS74AN
A84U29	1820-1645	2	1	ICBFR TTL LS BUS QUAD	01295	SN74LS126AN
A84U32-U33	1818-3336	7		ICNMOS 16384 (16K) STAT RAM 45-NS 3-S	04713	MCM2018AN45
A84U34-U36	1820-3294	1		ICFF TTL ALS D-TYPE POS-EDGE-TRIG COM	01295	SN74ALS374AN
A84U37	1820-1416	5		ICSCHMITT-TRIG TTL LS INV HEX 1-INP	01295	SN74LS14N
A84U38	1820-2656	7		ICGATE TTL ALS NAND QUAD 2-INP	01295	SN74ALS00AN
A84U39	1820-2701	3	1	ICFF TTL F D-TYPE POS-EDGE-TRIG COM	18324	74F374N
A84W2	01345-61606	4	1	CBL-ASM DSC FHDR/ STP 63MM GB	28480	
A84XU15-XU18	1200-1107	7	2	SOCKET-IC 24-CONT DIP DIP-SLDR	00779	2-641932-1
A84Y1	1813-0126	7	1	OSC CLK 22.2464MHZ	00815	HS-103-22.2464MHZ
A84	7121-4611	2	1	LABEL-INFORMATION .15-IN-WD .6-IN-LG	28480	L01003
	3050-0367	2	2	WASHER-FL MTLG NO. 3 .105-IN-ID	28480	3050-0367
	0515-0403	0	2	SCREW-MACH M2.5 X 0.45 8MM-LG PAN-HD	28480	
	0535-0008	3	2	NUT-HEX DBL-CHAM M2.5 X 0.45 2MM-THK	28480	
	2190-0584	0	1	WASHER-LK HLCL 3.0 MM 3.1-MM-ID	28480	
	01345-04101	4	1	STMP CVR-LO VOLT XSFMR AL	08638P01	
	0515-0065	0	1	SCREW-MACH M3 X 0.5 25MM-LG PAN-HD	63486	
	0535-0004	9	1	NUT-HEX DBL-CHAM M3 X 0.5 2.4MM-THK	28480	
	5957-2260	2	1	LBL-MADE IN USA	28480	5957-2260
MISCELLANEOUS PARTS						
H204	01345-67101	8	1	GASKET-DUST	28480	
H700	03577-84302	9	1	LBL-INFORMATION	22670	
H201	01340-66001	8	1	TRALIGN COIL	02859P01	
H202	01345-00202	8	1	SHTF PNL-REAR ALSK	08638P01	
H203	01345-00601	1	1	SHTF SHLD-HI VOLT OUTER ALSK	28480	01345-00601
H205	01701-66001	5	1	INC WIREWIND HIV TRACE ALIGN	02859P01	
H206	0330-0381	1	1	INSULATION-MATERIAL .063-THK .5-WD	28480	4701-01-20062-1604 W/PSA 5944
H207	03577-44301	4	1	MOLD BEZEL 3577A (Dark Bezel)	28480	
H207	03577-44381	0	1	MOLD BEZEL 3577B (Light Bezel)	28480	
H208	03577-60622	6	1	ASSY-CRT SHLD & FRAME MU	08638P01	
H209	0370-3067	0	1	MOLD KNOB-CONCENTRIC	28480	0370-3067
H210	0400-0009	9	2	GROMMET-RND .125-IN-ID .25-IN-GRV-OD	28480	G250
H213	0460-1790	3	1	PORON .125X1 PSA	28480	0460-1790
H216	6160-0533	2	1	STMP RFI FINGERS	30817	97-538-AX
H280	03577-04121	2	1	NSTLR-DISPLAY PCRB	22670	
H500	01345-01203	1	1	SHTF BRKT-POT MTG AL	28480	01345-01203
H501	1400-1122	0	2	CLAMP-CABLE .187-DIA .735-WD NYL	34785	021-0188
H503	2190-0027	6	5	WASHER-LK INTL T 1/4 IN .256-IN-ID	73734	
H508	2950-0006	3	5	NUT-HEX-DBL-CHAM 1/4-32-THD .094-IN-THK	73734	9000
H513	2950-0072	3	1	NUT-HEX-DBL-CHAM 1/4-32-THD .062-IN-THK	12697	
H514	5958-3759	8	1	FOCUS LABEL	28480	
H601	9211-5148	5	1	CARTON-CORR	28480	9211-5148
H701	03577-00401	3	1	LBL-DISPLAY COMP LOCATOR MYLR	22670	
H702	5955-6032	4	1	LABEL X-RAY	28480	5955-6032
H703	7120-6957	1	1	LABEL-INFORMATION .5-IN-WD 1.75-IN-LG	22670	
H704	7121-2139	5	1	LABEL-INFO	28480	7121-2139
H705	7121-4137	7	1	LABEL-WARNING 2-IN-WD 3-IN-LG PPR	04351P01	

See introduction to this section for information  
 \* Indicates factory selected values

Table 6-3. Replaceable Parts

Ref.Des.	HP Part Number	CD	Qty	Description	Mfr. Code	Mfr. Part Number
H706	7121-5318	8	1	LABEL INFORMATION	22670	
H801	0515-1146	0	4	SCREW-MACHINE ASSEMBLY M3 X 0.5 8MM-LG	28480	0515-1146
H805	0515-0054	7	2	SCREW-MACH M3 X 0.5 10MM-LG PAN-HD	83486	
H806	2190-0584	0	2	WASHER-LK HLCL 3.0 MM 3.1-MM-ID	28480	
H807	3050-0105	6	2	WASHER-FL MTLG NO. 4 .125-IN-ID	78471	
H808	3050-0440	2	2	WASHER-SHLDR NO. 4 .115-IN-ID .2-IN-OD	86828	5607-45
H809	0340-0564	3	1	INSULATOR-XSTR THRM-CNCT	53285	7403-09FR-51
H811	0515-1079	8	2	SCREW-MACHINE ASSEMBLY M3 X 0.5 8MM-LG	28480	
H815	0515-0054	7		SCREW-MACH M3 X 0.5 10MM-LG PAN-HD	83486	
H816	2190-0584	0		WASHER-LK HLCL 3.0 MM 3.1-MM-ID	28480	
H817	3050-0105	6		WASHER-FL MTLG NO. 4 .125-IN-ID	78471	
H818	3050-0440	2		WASHER-SHLDR NO. 4 .115-IN-ID .2-IN-OD	86828	5607-45
H821	0515-1146	0		SCREW-MACHINE ASSEMBLY M3 X 0.5 6MM-LG	28480	0515-1146
H831	0515-1146	0		SCREW-MACHINE ASSEMBLY M3 X 0.5 6MM-LG	28480	0515-1146
H841	0515-1079	8		SCREW-MACHINE ASSEMBLY M3 X 0.5 8MM-LG	28480	
H847	0515-1146	0		SCREW-MACHINE ASSEMBLY M3 X 0.5 6MM-LG	28480	0515-1146
H848	01345-01204	2	1	SHTF BRKT-LWR DSPL AL	28480	01345-01204
H848	0580-1551	9	1	THREADED INSERT-STDF .312-IN-LG SST	46384	SOS-8169-10
H849	01345-04701	0	1	SHTF SPPT-PC BD AL	08638P01	
H901	0515-0244	7	1	SCREW-MACH M3 X 0.5 4MM-LG PAN-HD	28480	
H911	0515-0219	6	10	SCREW-MACH M3 X 0.5 6MM-LG 90-DEG-FLH-HD	28480	
V100	2080-0225	4	1	CRT 6" VECTOR GRN	08708P03	
W100	01345-61601	9	1	CBL-ASM RBN FHDR/FHDR 115MM	28480	
W101	01345-61602	0	1	CBL-ASM RBN FHDR/FHDR 185MM	28480	
W102	01345-61604	2	2	CBL-ASM DSC FHSG/FHSG 82MM ML	28480	
W103	01345-61604	2		CBL-ASM DSC FHSG/FHSG 82MM ML	28480	
W104	01345-61605	3	1	CBL-ASM DSC FHSG/FHSG 222MM ML	28480	
W105	03577-61650	2	1	CBL-ASSM CRT HARNESS	28480	03577-61650
W106	03577-61651	3	1	CBL-ASSM ORTHOGONALITY	28480	03577-61651
W106A	1251-7928	9	2	CONN-POST TYPE .100-PIN-SPOG	27264	22-01-3027
W107	03577-61652	4	1	CBL-ASSM 3 WIRE JUMP	28480	03577-61652
W108	03585-61687	5	1	CBL-ASM DSC FHSG1STP 178MM ML	28480	03585-61687
W108A	1251-7928	9		CONN-POST TYPE .100-PIN-SPOG	27264	22-01-3027
W500	01345-61626	8	1	CBL-ASM SHL FHSG/ POT 710MM GY	11882P01	
W501	01345-61627	9	1	CBL-ASM SHL FHSG/ POT 330MM GY	11882P01	
W502	01345-61628	0	1	CBL-ASM SHL FHSG/ POT 330MM GY	11882P01	
W503	01345-61629	1	1	CBL-ASM SHL FHSG/ POT 330MM GY	11882P01	
W504	01345-61630	4	1	CBL-ASM SHL FHSG/ POT 330MM GY	11882P01	
W505	01345-61831	5	1	CBL-ASM SHL FHSG/ POT 550MM GY	11882P01	
W506	01345-61632	6	1	CBL-ASM DSC LUG/ LUG 38MM BL	11882P01	

See introduction to this section for information  
 \* Indicates factory selected values



## Manual Backdating

---

### 7-1 Introduction

This section provides information necessary to modify this manual for instruments that differ from those currently being produced. The information in this section documents earlier instrument configurations and associated servicing procedures.

With the information provided in this section, this manual can be corrected so that it applies to any earlier version or configuration of the instrument. To adapt this manual to your instrument, see table -and make all the changes listed opposite your instrument serial number. Later versions of the instrument are documented in the Manual Changes Supplement.

### 7-2 Manual Changes Supplement

As Hewlett-Packard continues to improve the performance of the HP 3577B, corrections and modifications to the manual may be required. Required changes are documented by a yellow Manual Changes supplement and/or revised pages. To keep the manual up-to-date, periodically request the most recent supplement, available from the nearest Hewlett-Packard sales and service office (for office locations, see the listing at the back of this manual).

---

## 7-3 Manual Changes Instructions

Table 7-1. Manual changes

Instrument Serial Number	Make Manual Changes
3232A00680	A
3232A00730	B

### Change A

Change schematic and replaceable parts list from 03577-66518 to 03577-66508. Schematic, component locator and replaceable parts list are included in this section. Insert these pages in place of the A18 board section. Change all reference designation from A18 to A8 for A18 schematics, text and replaceable parts list, when servicing the A8 board .

### Change B

Change schematic and replaceable parts list from 03577-66519 to 03577-66571. Schematic, component locator and replaceable parts list are included in this section. Insert these pages in place of the A19 board section. Change all reference designation from A19 to A71 for A19 schematics, text and replaceable parts list, when servicing the A71 board .

---

## Service Group A8, Output Assembly

The information in this section should be used to isolate faulty functional sub-blocks when servicing the HP 3577B. All procedures assume the Fault Isolation procedures of Section II have been used to determine which functional block has failed, and the Circuit Descriptions of Section VII are understood.

---

### Warning



Service procedures described in this section are performed with the protective covers removed and power applied. Energy available at many points can, if contacted, result in personal injury.

---

### Caution



Do not insert or remove any circuit board in the HP 3577B with the line power turned on. Power transients caused by insertion or removal may damage the circuit boards.

---

### Initial Conditions

All measurements are  $\pm 10$  percent unless otherwise specified.

## Troubleshooting Hints

1. Before troubleshooting this circuit board, be sure that the fault is occurring on this board by checking the following signals using the parameters in table 2-7.

A17J2	Swept Synthesizer Output
A5J1	300.25 MHz Offset Signal Amplifier

## Troubleshooting Procedure

- a. Turn OFF the instrument's power switch, remove the power cord, and remove the top cover. Place the A8 Source board on an extender board. Connect the instrument to the power line, and turn the POWER switch ON.
- b. Set the HP 3325A Synthesizer to a frequency of 100 kHz and an amplitude of - 40 dBm.
- c. Move A8W5 to the top right position and connect the synthesizer to A8J8.
- d. Set the HP 3577B as follows:

SWEEP TYPE	CW
AMPTD	+ 15 dBm

- e. Measure the level at A8J3 with an HP 8568B Spectrum Analyzer. The level should be approximately +14.3 dBm. If it is not, use table 7-2 to determine the faulty amplifier. These levels may be measured with an HP 8568B Spectrum Analyzer and an HP 10020A 20:1 resistive divider probe, or an oscilloscope and a 1:1 probe.

Table 7-2. A8 Circuit Board, Troubleshooting Data

Junction of Q5 and Q6	0.07 V peak-to-peak	- 45 dBm
Junction of Q25 and Q26	0.64 V peak-to-peak	- 27 dBm
Junction of Q45 and Q46	6.6 V peak-to-peak	- 6 dBm
Output side of R72*	3.4 V peak-to-peak	-12 dBm

\* Connect a 50 $\Omega$  load from J3 to ground.

- f. The drop across R72 should be exactly 6 dB. If it is not, then troubleshoot the relays in the 60 dB Step Attenuator.
- g. Turn OFF the instrument's power switch, remove the power cord, and return the HP 3577B to its original state.

## Low Frequency Gain Error Correction Troubleshooting Procedure

- a. Turn OFF the instrument's power switch, remove the power cord, and remove the top cover.
- b. Lift one side of R194. Place the A8 Source board on an extender board. Connect the instrument to the power line, and turn the POWER switch ON.
- c. Set the HP 3325A Synthesizer to a frequency of 100 kHz and an amplitude of -40 dBm.
- d. Move A8W5 to the top right position and connect the synthesizer to A8J8.
- e. Set the HP 3577B as follows:

SWEEP TYPE	CW
AMPTD	+15 dBm
- f. Connect an oscilloscope to A8J3 and set its input impedance to 50 ohms.
- g. Adjust the DC offset on the synthesizer until the sine wave viewed on the oscilloscope is centered around 0 volts.
- h. If the source trips before the synthesizer can be adjusted, lift one side of R115 to disable the overload sense circuit.
- i. The synthesizer DC offset should not be greater than  $\pm 25$  mV and the output at J3 should be a 3 V peak-to-peak sine wave (non-clipped). If it is not, then the problem is in one of the amplifier stages and the bias levels at each stage should be checked.
- j. Re-install R194 and R115.
- k. Return the synthesizer DC offset to zero.
- l. Lift one side of R193 and the side of R331 connected to U4 pin 6.
- m. Set an external DC power supply to zero volts. Using the hole left by R331, connect the power supply through a 10 k $\Omega$  resistor to U4 pin 6.
- n. Monitor the junction of R181 and R182 with a dc voltmeter.
- o. Adjust the power supply output until the dc voltmeter reads  $0 \pm 0.1$  V. If unable to obtain the correct voltmeter reading, check the outputs of U4 and U190 for voltages that vary with the power supply.
- p. Turn OFF the instrument's power switch, remove the power cord, and return the HP 3577B to its original state.



## Peak Detector (CR161 and CR160) Troubleshooting Procedure

- a. Turn OFF the instrument's power switch, remove the power cord, and remove the top cover. Place the A8 Source board on an extender board. Connect the instrument to the power line, and turn the POWER switch ON.
- b. Set the HP 3325A Synthesizer to a frequency of 100 kHz and an amplitude of - 40 dBm.
- c. Move A8W5 to the top right position and connect the synthesizer to A8J8.
- d. Set the HP 3577B as follows:

SWEEP TYPE	CW
AMPTD	+15 dBm
- e. Measure the output at A8J3 with an HP 8568B Spectrum Analyzer. Adjust the synthesizer for an output reading of +15 dBm  $\pm$  0.1 dB.
- f. With an oscilloscope and a 10:1 probe, check the dc level at the junction of R149 and R150. It should be +3.5 V.
- g. Decrease the amplitude of the synthesizer by 4 dB.
- h. The DC level on the oscilloscope should be +2.5 V.
- i. If this test failed, suspect CR160 or CR161.
- j. Turn OFF the instrument's power switch, remove the power cord, and return the HP 3577B to its original state.

## Amplitude Leveling Troubleshooting Procedure

- a. Turn OFF the instrument's power switch, remove the power cord, and remove the top cover. Place the A8 Source board on an extender board. Connect A17J2 to A8J1 and A5J1 to A8J2 using extender cables. Connect the instrument to the power line, and turn the POWER switch ON.
- b. Set the HP 3577B as follows:

SWEEP TYPE	CW
REQ	100.001 kHz
STEP SIZE	2 Hz
AMPTD	+11 dBm
STEP SIZE	4 dB
- c. Adjust Level Cal 1 (R144) for approximately 1.93 V at U20 pin 2.
- d. Increase the HP 3577B amplitude to +15 dBm by pressing AMPTD ↑.
- e. Adjust Step Cal 1 (R142) for approximately 3.12 V at U20 pin 2.
- f. Ground one side of L125 and turn R156 and R157 fully clockwise.
- g. Decrease the HP 3577B frequency to 99.999 kHz by pressing FREQ ↓ and decrease the amplitude to +11 dBm by pressing AMPTD ↓.
- h. The DC voltage at U21 pin 3 should be approximately -0.275 V.
  - i. Increase the HP 3577B amplitude to +15 dBm by pressing AMPTD ↑.
  - j. The DC voltage at U21 pin 3 should be approximately -0.437 V.
- k. Remove the ground from L125.
  - l. If this test passed, then the amplitude leveling loop works. Turn OFF the instrument's power switch, remove the power cord, and return the HP 3577B to its original state. Perform adjustment 4-19, Source Amplitude and Step Adjustments.
- m. Decrease the HP 3577B amplitude to +11 dBm by pressing AMPTD ↓ (the frequency should be 99.999 kHz).

- n. Check each of the following op amp stages: The voltage at U20 pin 3 should be the same as the reference voltage on U21 Pin 12.
- The output of U20 pin 3 should be constant.
  - The output of U20 pin 4 should be approximately  $-2\text{ V}$ .
  - The output of U21 pin 10 should be  $0\text{ V}$ .
  - The Anode of CR171 should be  $0.5\text{ V}$ .
  - The output of U21 pin 4 should be  $+0.24\text{ V}$ .
- o. Ground one side of L125. The output of U21 pin 3 should now be  $-0.24\text{ V}$  providing the output of U21 pin 4 was  $+0.24\text{ V}$ .
- p. Turn OFF the instrument's power switch, remove the power cord, and return the HP 3577B to its original state. Perform adjustment 4-19 Source Amplitude and Step Adjustments.

### Limiting Mixer (U13) Troubleshooting Procedure

- a. Turn OFF the instrument's power switch, remove the power cord, and remove the top cover.
- b. Lift the side of L125 connected to CR164. Using the hole left by L125, connect the dc supply through a 10 k $\Omega$  resistor to CR164.
- c. Place the A8 Source board on an extender board. Connect A5J1 to A8J2 using extender cables. Connect the instrument to the power line, and turn the POWER switch ON.
- d. Move A8W1 to the top left position and connect the HP 8568B Spectrum Analyzer to A8J4.
- e. Adjust the dc supply to - 4 V.
- f. The 300.25 MHz signal on the spectrum analyzer should be approximately - 33.7 dBm.
- g. Change the dc supply voltage to - 7 V.
- h. The 300.25 MHz signal on the spectrum analyzer should be approximately - 29 dBm.
- i. If this test failed, replace the U13 mixer.
- j. Turn OFF the instrument's power switch, remove the power cord, and return the HP 3577B to its original state.

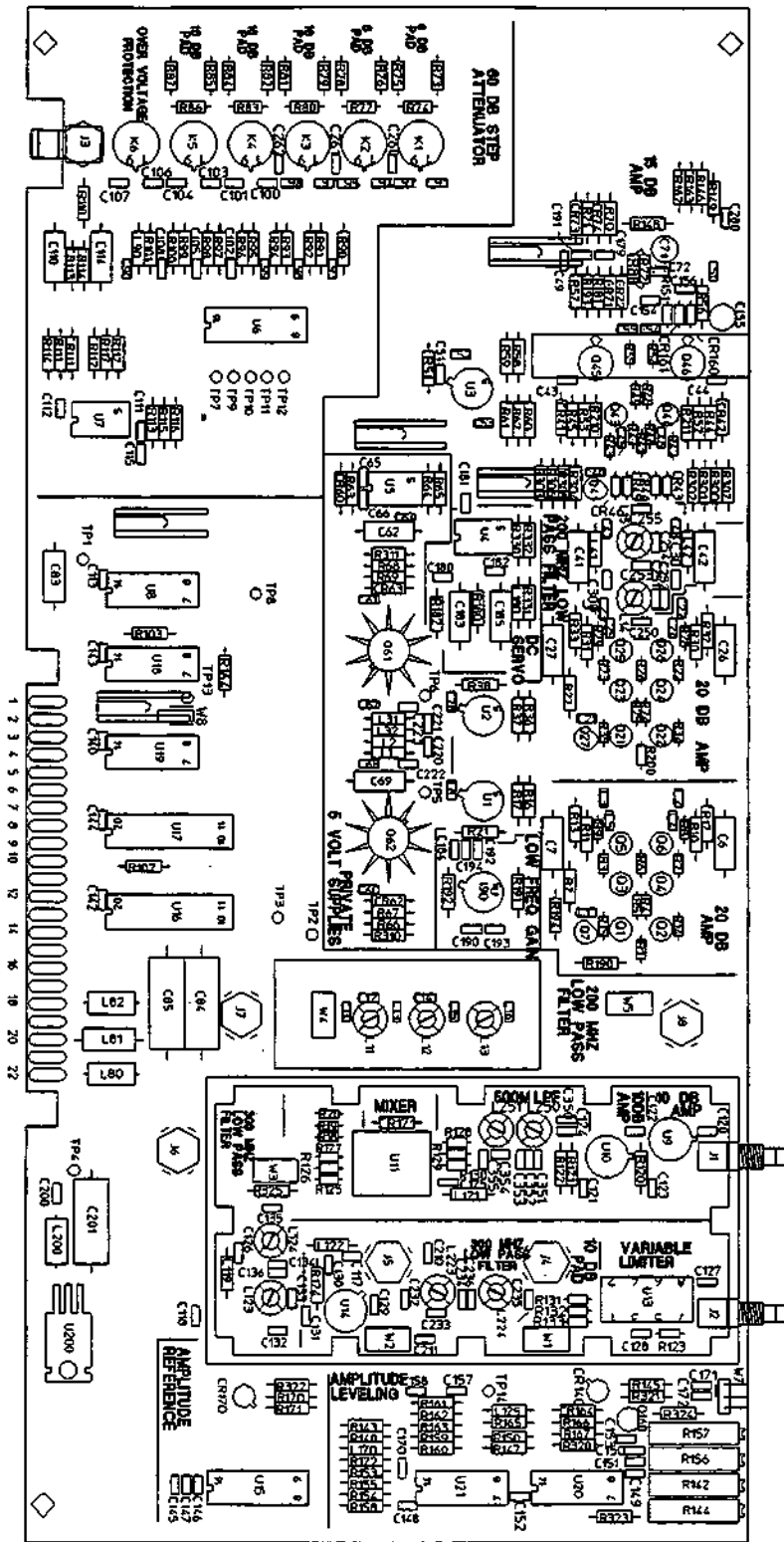


Figure 7-1. A8 Component Locator

IC	Voltage &	Gnd	Bypass Cap	
	Pin #		Desig.	Value
U1	+5V1,7			
U1	- 5V1,4			
U2	+5V2,7			
U2	- 5V2,4			
U3	+15V2,7		C52	.1
U3	- 15V2,4		C53	.1
U4	+15V2,8		C181	.1
U4	- 15V2,4		C182	.1
U5	+15V2,8	3	C65	.1
U5	- 15V2,4	3	C64	.1
U6		8		
U7	+15V2,8		C112	.1
U7	- 15V2,4		C111	.1
U8	+5V3,14	7	C113	.1
U9		3		
U10		3		
U14		3		
U15	+15V2,13	1,4	C145	.1
U15	- 15V2,3	1,4	C147	.1
U16	+5V3,20	10	C142	.1
U17	+5V3,20	10	C144	.1
U18	+5V3,14	7	C143	.1
U19	+5V3,14	7	C140	.1
U20	+15V2,11	13,14	C151	.1
U20	- 15V2,7	13,14	C149	.1
U21	+15V2,11	5,9,13	C148	.1
U21	- 15V2,7	5,9,13	C152	.1
U190	+15V2,7		C192	.1
U190	- 15V2,4		C193	.1
U200	+ 15V2,1	2		
K1		5		
K2		5		
K3		5		
K4		5		
K5		5		
K6		5		

**Attenuation Chart**

Output Level (dBm)	TP12 (4dB Pad)	TP11 (8dB Pad)	TP10 (16dB Pad)	TP9 (32dB Pad)
11.0 to 15.0	H	H	H	H
7.0 to 10.9	L	H	H	H
3.0 to 6.9	H	L	H	H
.0 to 2.9	L	L	H	H
- 5.0 to - 1.1	H	H	L	H
- 9.0 to - 5.1	L	H	L	H
- 13.0 to - 9.1	H	L	L	H
- 17.0 to - 13.1	L	L	L	H
- 21.0 to - 17.1	H	H	H	L
- 25.0 to - 21.1	L	H	H	L
- 33.0 to - 25.1	L	L	H	L
- 37.0 to - 33.1	H	H	L	L
- 41.0 to 37.1	L	H	L	L
- 45.0 to - 41.1	H	L	L	L
- 49.0 to - 45.1	L	L	L	L

TTL: H=High; L=Low

Table 7-3. Replaceable Parts

Ref.Des.	HP Part Number	CD	Qty	Description	Mfr. Code	Mfr. Part Number
A8	03577-66508	9	1	PCBOARD ASSY OUTPUT	28480	03577-66508
A8C1	0180-3768	5	3	CAPACITOR-FXD 3.3UF 20% 35V TADPD*	01760P01	202L3502335MH
A8C2-C3	0160-0576	5	82	CAPACITOR-FXD .1UF +-.20% 50VDC CER	04222	SR205C104MAAH
A8C4-C5	0160-6508	5	12	CAPACITOR-FXD 22PF 5% 200V CERML*	28480	RPE121-978C0G220J200V
A8C6-C7	0180-4136	3	10	CAPACITOR-FXD 10UF 10% 20V TATBSA	13606	173D106X9020W
A8C8	0180-0576	5		CAPACITOR-FXD .1UF +-.20% 50VDC CER	04222	SR205C104MAAH
A8C11	0160-6515	4	3	CAPACITOR-FXD 10PF --% 200V CERML*	28480	RPE121-978C0G100D200V
A8C12	0160-4381	8	4	CAPACITOR-FXD 1.5PF +-.25PF 200VDC CER	28480	RPE110-120C0G1R5C200V
A8C13	0160-6508	5		CAPACITOR-FXD 22PF 5% 200V CERML*	28480	RPE121-978C0G220J200V
A8C14	0160-6524	5	3	CAPACITOR-FXD 8.8PF --% 200V CERML*	28480	RPE121-978C0G6R8D200V
A8C15	0160-6508	5		CAPACITOR-FXD 22PF 5% 200V CERML*	28480	RPE121-978C0G220J200V
A8C16	0160-6515	4		CAPACITOR-FXD 10PF --% 200V CERML*	28480	RPE121-978C0G100D200V
A8C21	0180-3768	5		CAPACITOR-FXD 3.3UF 20% 35V TADPD*	01760P01	202L3502335MH
A8C22-C23	0180-0576	5		CAPACITOR-FXD .1UF +-.20% 50VDC CER	04222	SR205C104MAAH
A8C24-C25	0180-6508	5		CAPACITOR-FXD 22PF 5% 200V CERML*	28480	RPE121-978C0G220J200V
A8C26-C27	0180-4136	3		CAPACITOR-FXD 10UF 10% 20V TATBSA	13606	173D106X9020W
A8C28	0160-0576	5		CAPACITOR-FXD .1UF +-.20% 50VDC CER	04222	SR205C104MAAH
A8C40	0180-3768	5		CAPACITOR-FXD 3.3UF 20% 35V TADPD*	01760P01	202L3502335MH
A8C41-C42	0180-4136	3		CAPACITOR-FXD 10UF 10% 20V TATBSA	13606	173D106X9020W
A8C43-C44	0160-0576	5		CAPACITOR-FXD .1UF +-.20% 50VDC CER	04222	SR205C104MAAH
A8C45-C48	0160-6507	4	8	CAPACITOR-FXD 1000PF 20% 100V CERML*	28480	RPE121-978X7R102M100V
A8C47-C48	0180-0576	5		CAPACITOR-FXD .1UF +-.20% 50VDC CER	04222	SR205C104MAAH
A8C49-C50	0160-6505	2	6	CAPACITOR-FXD .01UF 20% 100V CERML*	28480	RPE121-978X7R103M100V
A8C51-C55	0160-0576	5		CAPACITOR-FXD .1UF +-.20% 50VDC CER	04222	SR205C104MAAH
A8C60-C61	0160-0576	5		CAPACITOR-FXD .1UF +-.20% 50VDC CER	04222	SR205C104MAAH
A8C62	0180-4136	3		CAPACITOR-FXD 10UF 10% 20V TATBSA	13606	173D106X9020W
A8C64-C68	0160-0576	5		CAPACITOR-FXD .1UF +-.20% 50VDC CER	04222	SR205C104MAAH
A8C69	0180-4136	3		CAPACITOR-FXD 10UF 10% 20V TATBSA	13606	173D106X9020W
A8C71	0121-0512	7	2	CAPACITOR-V TRMR-CER 2-5PF 100V PC-MTG	59860	518-002 A 2-5
A8C72	0160-6523	4	3	CAPACITOR-FXD 1PF --% 200V CERML*	28480	RPE121-978C0G010C200V
A8C83	0180-4136	3		CAPACITOR-FXD 10UF 10% 20V TATBSA	13606	173D106X9020W
A8C84-C85	0180-4031	7	3	CAPACITOR-FXD 10UF 10% 35V TATBSA	12340P01	T322D106K035AS
A8C90-C108	0160-0576	5		CAPACITOR-FXD .1UF +-.20% 50VDC CER	04222	SR205C104MAAH
A8C110	0180-4134	1	3	CAPACITOR-FXD 22UF 10% 15V TATBSA	13606	173D226X9015X
A8C111-C113	0160-0576	5		CAPACITOR-FXD .1UF +-.20% 50VDC CER	04222	SR205C104MAAH
A8C114	0180-4134	1		CAPACITOR-FXD 22UF 10% 15V TATBSA	13606	173D226X9015X
A8C115	0160-6505	2		CAPACITOR-FXD .01UF 20% 100V CERML*	28480	RPE121-978X7R103M100V
A8C117-C118	0160-0576	5		CAPACITOR-FXD .1UF +-.20% 50VDC CER	04222	SR205C104MAAH
A8C120	0160-6507	4		CAPACITOR-FXD 1000PF 20% 100V CERML*	28480	RPE121-978X7R102M100V
A8C121	0160-0576	5		CAPACITOR-FXD .1UF +-.20% 50VDC CER	04222	SR205C104MAAH
A8C122	0160-6507	4		CAPACITOR-FXD 1000PF 20% 100V CERML*	28480	RPE121-978X7R102M100V
A8C123	0160-0576	5		CAPACITOR-FXD .1UF +-.20% 50VDC CER	04222	SR205C104MAAH
A8C124	0160-6507	4		CAPACITOR-FXD 1000PF 20% 100V CERML*	28480	RPE121-978X7R102M100V
A8C125-C126	0160-0576	5		CAPACITOR-FXD .1UF +-.20% 50VDC CER	04222	SR205C104MAAH
A8C127	0160-6507	4		CAPACITOR-FXD 1000PF 20% 100V CERML*	28480	RPE121-978X7R102M100V
A8C128	0160-0576	5		CAPACITOR-FXD .1UF +-.20% 50VDC CER	04222	SR205C104MAAH
A8C129	0160-6507	4		CAPACITOR-FXD 1000PF 20% 100V CERML*	28480	RPE121-978X7R102M100V
A8C130	0160-0576	5		CAPACITOR-FXD .1UF +-.20% 50VDC CER	04222	SR205C104MAAH
A8C131	0160-6507	4		CAPACITOR-FXD 1000PF 20% 100V CERML*	28480	RPE121-978X7R102M100V
A8C132	0160-6508	5		CAPACITOR-FXD 22PF 5% 200V CERML*	28480	RPE121-978C0G220J200V
A8C133	0160-6521	2	6	CAPACITOR-FXD 2.2PF --% 200V CERML*	28480	RPE121-978C0G2R2C200V

See introduction to this section for information  
\* Indicates factory selected values



Table 7-3. Replaceable Parts

Ref.Des.	HP Part Number	CD	Qty	Description	Mfr. Code	Mfr. Part Number
A8C134	0180-6511	0	5	CAPACITOR-FXD 15PF 5% 200V CERMLr	28480	RPE121-978C0G150J200V
A8C135	0180-6508	5		CAPACITOR-FXD 22PF 5% 200V CERMLr	28480	RPE121-978C0G220J200V
A8C138	0180-6511	0		CAPACITOR-FXD 15PF 5% 200V CERMLr	28480	RPE121-978C0G150J200V
A8C140	0160-0576	5		CAPACITOR-FXD .1UF +20% 50VDC CER	04222	SR205C104MAAH
A8C142-C145	0180-0576	5		CAPACITOR-FXD .1UF +20% 50VDC CER	04222	SR205C104MAAH
A8C146	0180-6505	2		CAPACITOR-FXD .01UF 20% 100V CERMLr	28480	RPE121-978X7R103M100V
A8C147-C154	0180-0576	5		CAPACITOR-FXD .1UF +20% 50VDC CER	04222	SR205C104MAAH
A8C155	0121-0512	7		CAPACITOR-V TRMR-CER 2-5PF 100V PC-MTG	59860	518-002 A 2-5
A8C156	0180-0576	5		CAPACITOR-FXD .1UF +20% 50VDC CER	04222	SR205C104MAAH
A8C157	0160-6517	6	4	CAPACITOR-FXD 100PF 20% 200V CERMLr	28480	RPE121-978X7R101M200V
A8C158	0160-0576	5		CAPACITOR-FXD .1UF +20% 50VDC CER	04222	SR205C104MAAH
A8C170	0160-0576	5		CAPACITOR-FXD .1UF +20% 50VDC CER	04222	SR205C104MAAH
A8C171-C172	0180-3876	4	2	CAPACITOR-FXD 47PF +20% 200VDC CER	04222	SR202C470MAAH
A8C179-C180	0180-6505	2		CAPACITOR-FXD .01UF 20% 100V CERMLr	28480	RPE121-978X7R103M100V
A8C181-C182	0180-0576	5		CAPACITOR-FXD .1UF +20% 50VDC CER	04222	SR205C104MAAH
A8C183	0180-4134	1		CAPACITOR-FXD 22UF 10% 15V TATBSA	13606	173D226X9015X
A8C184	0160-0576	5		CAPACITOR-FXD .1UF +20% 50VDC CER	04222	SR205C104MAAH
A8C185	0180-4136	3		CAPACITOR-FXD 10UF 10% 20V TATBSA	13606	173D106X9020W
A8C190-C191	0160-6517	6		CAPACITOR-FXD 100PF 20% 200V CERMLr	28480	RPE121-978X7R101M200V
A8C182-C183	0160-0576	5		CAPACITOR-FXD .1UF +20% 50VDC CER	04222	SR205C104MAAH
A8C194	0180-6508	5		CAPACITOR-FXD 22PF 5% 200V CERMLr	28480	RPE121-978C0G220J200V
A8C200	0180-0576	5		CAPACITOR-FXD .1UF +20% 50VDC CER	04222	SR205C104MAAH
A8C201	0180-4031	7		CAPACITOR-FXD 10UF 10% 35V TATBSA	12340P01	T322D106K035AS
A8C210-C211	0160-0576	5		CAPACITOR-FXD .1UF +20% 50VDC CER	04222	SR205C104MAAH
A8C220-C223	0180-0576	5		CAPACITOR-FXD .1UF +20% 50VDC CER	04222	SR205C104MAAH
A8C232	0180-6508	5		CAPACITOR-FXD 22PF 5% 200V CERMLr	28480	RPE121-978C0G220J200V
A8C233	0180-6521	2		CAPACITOR-FXD 2.2PF --% 200V CERMLr	28480	RPE121-978C0G2R2C200V
A8C234	0180-6511	0		CAPACITOR-FXD 15PF 5% 200V CERMLr	28480	RPE121-978C0G150J200V
A8C235	0180-6508	5		CAPACITOR-FXD 22PF 5% 200V CERMLr	28480	RPE121-978C0G220J200V
A8C236	0180-6511	0		CAPACITOR-FXD 15PF 5% 200V CERMLr	28480	RPE121-978C0G150J200V
A8C250	0180-6515	4		CAPACITOR-FXD 10PF --% 200V CERMLr	28480	RPE121-978C0G100D200V
A8C251	0160-4381	8		CAPACITOR-FXD 1.5PF +-25PF 200VDC CER	28480	RPE110-120C0G1R5C200V
A8C252	0160-6524	5		CAPACITOR-FXD 6.8PF --% 200V CERMLr	28480	RPE121-978C0G6R8D200V
A8C253	0160-6508	5		CAPACITOR-FXD 22PF 5% 200V CERMLr	28480	RPE121-978C0G220J200V
A8C254	0180-6521	2		CAPACITOR-FXD 2.2PF --% 200V CERMLr	28480	RPE121-978C0G2R2C200V
A8C255	0180-6511	0		CAPACITOR-FXD 15PF 5% 200V CERMLr	28480	RPE121-978C0G150J200V
A8C260	0180-6521	2		CAPACITOR-FXD 2.2PF --% 200V CERMLr	28480	RPE121-978C0G2R2C200V
A8C261-C262	0180-6523	4		CAPACITOR-FXD 1PF --% 200V CERMLr	28480	RPE121-978C0G10C200V
A8C280	0180-6517	6		CAPACITOR-FXD 100PF 20% 200V CERMLr	28480	RPE121-978X7R101M200V
A8C300-C301	0180-0576	5		CAPACITOR-FXD .1UF +20% 50VDC CER	04222	SR205C104MAAH
A8C350	0160-4382	9	1	CAPACITOR-FXD 3.3PF +-25PF 200VDC CER	28480	RPE121-105C0G3R3C200V
A8C351-C352	0160-4381	8		CAPACITOR-FXD 1.5PF +-25PF 200VDC CER	28480	RPE110-120C0G1R5C200V
A8C353	0160-6524	5		CAPACITOR-FXD 6.8PF --% 200V CERMLr	28480	RPE121-978C0G6R8D200V
A8C354-C355	0180-6521	2		CAPACITOR-FXD 2.2PF --% 200V CERMLr	28480	RPE121-978C0G2R2C200V
A8CR41-CR42	1902-0920	8	4	DIODE-ZNR 1N5345B 8.7V 5% PD=5W	04713	1N5345B
A8CR43-CR46	1901-0025	2	6	DIODE-GEN PRP 100V 200MA DO-7	9N171	1N645
A8CR60	1902-0041	4	1	DIODE-ZNR 5.11V 5% DO-35 PD=.4W	04713	
A8CR62-CR63	1902-0920	8		DIODE-ZNR 1N5345B 8.7V 5% PD=5W	04713	1N5345B
A8CR71-CR72	1901-0047	8	2	DIODE-SWITCHING 20V 75MA 10NS	27014	
A8CR73-CR74	1902-0025	4	2	DIODE-ZNR 10V 5% DO-35 PD=.4W TC=+.06%	04713	
A8CR111-CR112	1901-0518	8	6	DIODE-SCHOTTKY SM SIG	28480	1901-0518

See introduction to this section for information  
\* Indicates factory selected values

Table 7-3. Replaceable Parts

Ref.Des.	HP Part Number	CD	Qty	Description	Mfr. Code	Mfr. Part Number
A8CR113-CR114	1901-0040	1	2	DIODE-SWITCHING 30V 50MA 2NS DO-35	9N171	1N4148
A8CR140	1902-1329	3	2	ICV RGLTR-V-REF-FXD 6.6/7.2V TO-46 PKG	27014	LM329CH
A8CR160-CR163	1901-0518	8		DIODE-SCHOTTKY SM SIG	28480	1901-0518
A8CR164	1901-0025	2		DIODE-GEN PRP 100V 200MA DO-7	9N171	1N645
A8CR170	1902-1329	3		ICV RGLTR-V-REF-FXD 6.6/7.2V TO-46 PKG	27014	LM329CH
A8CR171	1901-0025	2		DIODE-GEN PRP 100V 200MA DO-7	9N171	1N645
A8E1-E5	03577-00901	8	5	ETCH SPRNG-GROUNDING BECUGD	28480	
A8E8-E9	03577-00902	9	4	ETCH SPRNG-GROUNDING BECUGD	28480	
A8H17	03577-04108	5	1	SHTF CVR-OUTPUT 8D ALSK	28480	03577-04108
A8H17	0361-0230	4	4	RVT-STB OVHD .123D .19LG BRSTN	12014	R-3682
A8H17	1400-0964	6	4	BRACKET-RTANG STL ZINC/CLEAR CHROMATE	28480	1400-0964
A8H17	0370-2595	7	2	KNOB-RVTN 12.7MMD BRS	28480	
A8J1-J2	1250-2142	7	2	CON-SMB	74970	131-3701-341
A8J3	1250-1314	3	1	CONNECTOR-RF SM-SLD FEM PC 50-OHM	98291	52-054-0000-226
A8J4-J8	1250-2215	5	5	CON-SMB STRAIGHT	74970	131-1701-201
A8K1-K6	0490-1404	9	6	RELAY 2C 12VDC-COIL .5A 28VDC	11532	412Y-0191
A8L1-L2	9140-0144	0	13	INDUCTOR RF-CH-MLD 4.7UH 10% .105DX.26LG	99800	1025-36
A8L11	9140-0815	2	3	COIL-VAR 50.6NH-41.4NH PC-MTG	24226	8273
A8L12	9140-0813	0	2	COIL-VAR 23NH-52NH Q=65 PC-MTG	24226	8271
A8L13	9140-0815	2		COIL-VAR 50.6NH-41.4NH PC-MTG	24226	8273
A8L14	9140-0813	0		COIL-VAR 23NH-52NH Q=65 PC-MTG	24226	8271
A8L15	9140-0815	2		COIL-VAR 50.6NH-41.4NH PC-MTG	24226	8273
A8L31-L32	9140-0144	0		INDUCTOR RF-CH-MLD 4.7UH 10% .105DX.26LG	99800	1025-36
A8L41-L42	9140-0144	0		INDUCTOR RF-CH-MLD 4.7UH 10% .105DX.26LG	99800	1025-36
A8L80	9100-1618	1	3	INDUCTOR RF-CH-MLD 5.6UH 10%	99800	1537-30
A8L81	9140-0807	0	1	INDUCTOR RF-CH-MLD 3.3UH 10% .2DX.45LG	24226	18M331K
A8L82	9100-1618	1		INDUCTOR RF-CH-MLD 5.6UH 10%	99800	1537-30
A8L90	9140-0144	0		INDUCTOR RF-CH-MLD 4.7UH 10% .105DX.26LG	99800	1025-36
A8L119	9140-0144	0		INDUCTOR RF-CH-MLD 4.7UH 10% .105DX.26LG	99800	1025-36
A8L121-L122	9140-0144	0		INDUCTOR RF-CH-MLD 4.7UH 10% .105DX.26LG	99800	1025-36
A8L123-L124	9140-0814	1	4	COIL-VAR 20NH-25NH Q=50 PC-MTG	24226	8272
A8L125	9140-0144	0		INDUCTOR RF-CH-MLD 4.7UH 10% .105DX.26LG	99800	1025-36
A8L170	9140-0144	0		INDUCTOR RF-CH-MLD 4.7UH 10% .105DX.26LG	99800	1025-36
A8L180	9140-0144	0		INDUCTOR RF-CH-MLD 4.7UH 10% .105DX.26LG	99800	1025-36
A8L200	9100-1618	1		INDUCTOR RF-CH-MLD 5.6UH 10%	99800	1537-30
A8L223-L224	9140-0814	1		COIL-VAR 20NH-25NH Q=50 PC-MTG	24226	8272
A8L250-L251	9140-1070	3	2	IND RF CHOKE VAR 78.4NH	24226	8274
A8MP1	03577-21101	4	1	MCHD HEAT SINK	78654	
A8Q1	1853-0544	7	5	TRANSISTOR PNP SI PD=180MW	03334P01	BFQ51
A8Q2	1854-0591	6	5	TRANSISTOR NPN SI PD=180MW FT=4GHZ	03334P01	BFR90
A8Q3	1853-0544	7		TRANSISTOR PNP SI PD=180MW	03334P01	BFQ51
A8Q4-Q5	1854-0591	6		TRANSISTOR NPN SI PD=180MW FT=4GHZ	03334P01	BFR90
A8Q6	1853-0544	7		TRANSISTOR PNP SI PD=180MW	03334P01	BFQ51
A8Q7	1855-0410	0	4	TRANSISTOR J-FET N-CHAN D-MODE TO-18 SI	27014	
A8Q21	1853-0544	7		TRANSISTOR PNP SI PD=180MW	03334P01	BFQ51
A8Q22	1854-0591	6		TRANSISTOR NPN SI PD=180MW FT=4GHZ	03334P01	BFR90
A8Q23	1853-0544	7		TRANSISTOR PNP SI PD=180MW	03334P01	BFQ51
A8Q24	1854-0591	6		TRANSISTOR NPN SI PD=180MW FT=4GHZ	03334P01	BFR90
A8Q25	1854-0720	3	2	TRANSISTOR NPN SI PD=500MW FT=4GHZ	03334P01	
A8Q26	1853-0527	6	2	TRANSISTOR PNP SI PD=500MW FT=4GHZ	03334P01	BFQ-32
A8Q27	1855-0410	0		TRANSISTOR J-FET N-CHAN D-MODE TO-18 SI	27014	
A8Q41	1855-0410	0		TRANSISTOR J-FET N-CHAN D-MODE TO-18 SI	27014	

See introduction to this section for information  
\* Indicates factory selected values

Table 7-3. Replaceable Parts

Ref.Des.	HP Part Number	CD	Qty	Description	Mfr. Code	Mfr. Part Number
A8Q43	1853-0527	6		TRANSISTOR PNP SI PD = 500MW FT = 4GHZ	03334P01	BFQ-32
A8Q44	1854-0720	3		TRANSISTOR NPN SI PD = 500MW FT = 4GHZ	03334P01	
A8Q45	1854-0876	0	1	TRANSISTOR NPN PD = 1W FT = 1GHZ	04713	
A8Q46	1853-0495	7	1	TRANSISTOR PNP PD = 1W FT = 1GHZ	04713	
A8Q61	1853-0037	3	1	TRANSISTOR PNP SI TO-39 PD = 1W FT = 100MHZ	04713	
A8Q62	1854-0039	7	1	TRANSISTOR NPN 2N3053S SI TO-39 PD = 1W	04713	2N3053S
A8Q62	1205-0033	6	1	HEAT SINK TO-5/TO-39-CS	02123P01	207-CB
A8Q160	1855-0410	0		TRANSISTOR J-FET N-CHAN D-MODE TO-18 SI	27014	
A8R1	0699-2069	6	2	RESISTOR 13.3 1% 1/20W HF04 T0	91637	CMF-50-21
A8R2-R3	0698-7222	1	4	RESISTOR 261 1% .05W F TC = 0+-100	19701	5063J
A8R4-R5	0699-1964	8	8	RESISTOR 14.7 1% 1/20W HF04 T0	91637	CMF-50-21
A8R6	0698-7216	3	2	RESISTOR 147 1% .05W F TC = 0+-100	18701	5063J
A8R7	0698-1055	5	4	RESISTOR 1M 5% .25W CF TC = 0-800	77902	R-25J
A8R8-R9	0699-1964	8		RESISTOR 14.7 1% 1/20W HF04 T0	91637	CMF-50-21
A8R10-R11	0757-0408	7	4	RESISTOR 243 1% .125W F TC = 0+-100	19701	SFR25H
A8R12-R13	0698-4496	5	2	RESISTOR 45.3K 1% .125W F TC = 0+-100	91637	CMF-55-1 T-1
A8R14-R15	0699-1848	8	7	RESISTOR 46.4 1% 1/20W HF04 T0	91637	CMF-50-21
A8R16-R17	0698-3228	8	5	RESISTOR 49.8K 1% .125W F TC = 0+-100	19701	SFR25H
A8R18	0698-7223	2	4	RESISTOR 287 1% .05W F TC = 0+-100	19701	5063J
A8R19	0699-2030	1	2	RESISTOR 17.8 1% 1/20W HF04 T0	91637	CMF-50-21
A8R20	0698-7223	2		RESISTOR 287 1% .05W F TC = 0+-100	19701	5063J
A8R21	0683-1555	0	2	RESISTOR 1.5M 5% .25W CF TC = 0-900	77902	R-25J
A8R22-R23	0698-7222	1		RESISTOR 261 1% .05W F TC = 0+-100	19701	5063J
A8R24-R25	0699-1964	8		RESISTOR 14.7 1% 1/20W HF04 T0	91637	CMF-50-21
A8R26	0698-7216	3		RESISTOR 147 1% .05W F TC = 0+-100	19701	5063J
A8R27	0683-1055	5		RESISTOR 1M 5% .25W CF TC = 0-800	77902	R-25J
A8R28-R29	0699-1964	8		RESISTOR 14.7 1% 1/20W HF04 T0	91637	CMF-50-21
A8R30-R31	0757-0408	7		RESISTOR 243 1% .125W F TC = 0+-100	19701	SFR25H
A8R32-R33	0757-0456	5	2	RESISTOR 43.2K 1% .125W F TC = 0+-100	19701	SFR25H
A8R34-R35	0699-1948	8		RESISTOR 46.4 1% 1/20W HF04 T0	91637	CMF-50-21
A8R36-R37	0698-3228	9		RESISTOR 49.9K 1% .125W F TC = 0+-100	19701	SFR25H
A8R38	0683-1555	0		RESISTOR 1.5M 5% .25W CF TC = 0-900	77902	R-25J
A8R41-R43	0699-1948	8		RESISTOR 46.4 1% 1/20W HF04 T0	91637	CMF-50-21
A8R44-R45	0757-0427	0	2	RESISTOR 1.5K 1% .125W F TC = 0+-100	19701	SFR25H
A8R46-R47	0699-1965	9	2	RESISTOR 21.5 1% 1/20W HF04 T0	91637	CMF-50-21
A8R48-R49	0698-7221	0	2	RESISTOR 237 1% .05W F TC = 0+-100	19701	5063J
A8R51	0698-4517	1	1	RESISTOR 127K 1% .125W F TC = 0+-100	91637	CMF-55-1 T-1
A8R52-R53	0698-3446	3	4	RESISTOR 383 1% .125W F TC = 0+-100	19701	SFR25H
A8R54-R55	0699-1902	4	2	RESISTOR 10 OHM 1% 1/20W HF04 T0	91637	CMF-50-21
A8R56-R59	0698-4123	5	6	RESISTOR 499 1% .125W F TC = 0+-100	19701	SFR25H
A8R60	0683-1055	5		RESISTOR 1M 5% .25W CF TC = 0-800	77902	R-25J
A8R61-R62	0757-0447	4	2	RESISTOR 16.2K 1% .125W F TC = 0+-100	19701	SFR25H
A8R63	0683-1025	9	8	RESISTOR 1K 5% .25W CF TC = 0-400	77902	R-25J
A8R64-R65	0757-0442	9	10	RESISTOR 10K 1% .125W F TC = 0+-100	19701	SFR25H
A8R66-R69	0683-2215	1	6	RESISTOR 220 5% .25W CF TC = 0-400	77902	R-25J
A8R70-R71	0683-4725	2	3	RESISTOR 4.7K 5% .25W CF TC = 0-400	77902	R-25J
A8R72	0699-1480	3	2	RESISTOR 100 .5% .125W F TC = 0+-50	28480	PR8494-100
A8R73	0699-1483	6	2	RESISTOR 221 .5% .125W F TC = 0+-50	28480	PR8494-221
A8R74	0699-1477	8	1	RESISTOR 23.85 .5% .125W F TC = 0+-50	28480	PR8494-23.85
A8R75	0699-1483	6		RESISTOR 221 .5% .125W F TC = 0+-50	28480	PR8494-221
A8R76	0699-1481	4	2	RESISTOR 116.1 .5% .125W F TC = 0+-50	28480	PR8494-116.1
A8R77	0698-1478	9	1	RESISTOR 52.84 .5% .125W F TC = 0+-50	28480	PR8494-52.84

See introduction to this section for information  
\* Indicates factory selected values

Table 7-3. Replaceable Parts

Ref.Des.	HP Part Number	CD	Qty	Description	Mfr. Code	Mfr. Part Number
A8R78	0699-1481	4		RESISTOR 116.1 .5% .125W F TC=0+-50	28480	PR8494-116.1
A8R79	0699-1479	0	6	RESISTOR 68.83 .5% .125W F TC=0+-50	28480	PR8494-68.83
A8R80	0699-1482	5	3	RESISTOR 153.8 .5% .125W F TC=0+-50	28480	PR8494-153.8
A8R81-R82	0699-1479	0		RESISTOR 68.83 .5% .125W F TC=0+-50	28480	PR8494-68.83
A8R83	0699-1482	5		RESISTOR 153.8 .5% .125W F TC=0+-50	28480	PR8494-153.8
A8R84-R85	0699-1479	0		RESISTOR 68.83 .5% .125W F TC=0+-50	28480	PR8494-68.83
A8R86	0699-1482	5		RESISTOR 153.8 .5% .125W F TC=0+-50	28480	PR8494-153.8
A8R87	0699-1479	0		RESISTOR 68.83 .5% .125W F TC=0+-50	28480	PR8494-68.83
A8R88	0699-1480	3		RESISTOR 100 .5% .125W F TC=0+-50	28480	PR8494-100
A8R90-R101	0683-3905	8	12	RESISTOR 39 5% .25W CF TC=0-400	77902	R-25J
A8R102-R103	0683-1025	9		RESISTOR 1K 5% .25W CF TC=0-400	77902	R-25J
A8R110	0683-1035	1	5	RESISTOR 10K 5% .25W CF TC=0-400	77902	R-25J
A8R111	0683-1045	3	3	RESISTOR 100K 5% .25W CF TC=0-400	77902	R-25J
A8R112	0683-1035	1		RESISTOR 10K 5% .25W CF TC=0-400	77902	R-25J
A8R113	0698-3497	4	1	RESISTOR 8.04K 1% .125W F TC=0+-100	19701	SFR25H
A8R114	0683-1035	1		RESISTOR 10K 5% .25W CF TC=0-400	77902	R-25J
A8R115	0683-1025	9		RESISTOR 1K 5% .25W CF TC=0-400	77902	R-25J
A8R116	0683-2725	8	1	RESISTOR 2.7K 5% .25W CF TC=0-400	77902	R-25J
A8R117	0683-1045	3		RESISTOR 100K 5% .25W CF TC=0-400	77902	R-25J
A8R120	1251-5203	9	2	CONN-POST TYPE .100-PIN-SPOG 6-COINT	27284	22-10-2062
A8XR120A	0683-3615	7		RESISTOR 360 5% .25W CF TC=0-400	77902	R-25J
A8XR120B	7175-0057	5	1	RESISTOR-ZERO OHMS SOLID TINNED COPPER	09684P01	UN105-6
A8XR120C	9140-0523	9	1	INDUCTOR RF-CH-MLD 510NH 5% .105DX.26LG	24226	10M510J
A8R122	1251-5203	9		CONN-POST TYPE .100-PIN-SPOG 6-COINT	27284	22-10-2062
A8XR122A-XR122B	0683-2715	6	1	RESISTOR 270 5% .25W CF TC=0-400	77902	R-25J
A8XR122C	7175-0057	5	1	RESISTOR-ZERO OHMS SOLID TINNED COPPER	09684P01	UN105-6
A8XR122D	9140-0523	9	1	INDUCTOR RF-CH-MLD 510NH 5% .105DX.26LG	24226	10M510J
A8R123	0699-1903	5	1	RESISTOR 51.1 1% 1/20W HF04 TO	91637	CMF-50-21
A8R124	0683-3615	7	2	RESISTOR 360 5% .25W CF TC=0-400	77902	R-25J
A8R125	0699-2054	9	5	RESISTOR 100 OHM 1% 1/20W HF04 TO	91637	CMF-50-21
A8R126	0699-1968	2	2	RESISTOR 68.1 1% 1/20W HF04 TO	91637	CMF-50-21
A8R127	0699-2054	9		RESISTOR 100 OHM 1% 1/20W HF04 TO	91637	CMF-50-21
A8R128	0698-7223	2		RESISTOR 287 1% .05W F TC=0+-100	19701	5063J
A8R129	0699-2030	1		RESISTOR 17.8 1% 1/20W HF04 TO	91637	CMF-50-21
A8R130	0698-7223	2		RESISTOR 287 1% .05W F TC=0+-100	19701	5063J
A8R131	0699-2054	9		RESISTOR 100 OHM 1% 1/20W HF04 TO	91637	CMF-50-21
A8R132	0699-1968	2		RESISTOR 68.1 1% 1/20W HF04 TO	91637	CMF-50-21
A8R133	0699-2054	9		RESISTOR 100 OHM 1% 1/20W HF04 TO	91637	CMF-50-21
A8R140	0757-0449	6	3	RESISTOR 20K 1% .125W F TC=0+-100	19701	SFR25H
A8R142	2100-3056	8		RESISTOR-TRMR 5K 10% C SIDE-ADJ 17-TRN	73138	89PR5K
A8R143	0757-0449	6		RESISTOR 20K 1% .125W F TC=0+-100	19701	SFR25H
A8R144	2100-3056	8	3	RESISTOR-TRMR 5K 10% C SIDE-ADJ 17-TRN	73138	89PR5K
A8R145	0683-4725	2		RESISTOR 4.7K 5% .25W CF TC=0-400	77902	R-25J
A8R146	0757-0465	6	2	RESISTOR 100K 1% .125W F TC=0+-100	19701	SFR25H
A8R147	0757-0449	6		RESISTOR 20K 1% .125W F TC=0+-100	19701	SFR25H
A8R148	0757-0465	6		RESISTOR 100K 1% .125W F TC=0+-100	19701	SFR25H
A8R149-R150	0757-0442	9		RESISTOR 10K 1% .125W F TC=0+-100	19701	SFR25H
A8R151	0699-2054	9		RESISTOR 100 OHM 1% 1/20W HF04 TO	91637	CMF-50-21
A8R153-R155	0757-0442	9		RESISTOR 10K 1% .125W F TC=0+-100	19701	SFR25H
A8R156	2100-3109	2	1	RESISTOR-TRMR 2K 10% C SIDE-ADJ 17-TRN	73138	89PR2K
A8R157	2100-3056	8		RESISTOR-TRMR 5K 10% C SIDE-ADJ 17-TRN	73138	89PR5K

See introduction to this section for information  
\* Indicates factory selected values

Table 7-3. Replaceable Parts

Ref.Des.	HP Part Number	CD	Qty	Description	Mfr. Code	Mfr. Part Number
A8R158	0698-0083	8	1	RESISTOR 1.96K 1% .125W F TC=0+-100	19701	SFR25H
A8R159-R160	0757-0442	9		RESISTOR 10K 1% .125W F TC=0+-100	19701	SFR25H
A8R161	0757-0280	3	1	RESISTOR 1K 1% .125W F TC=0+-100	19701	SFR25H
A8R162-R163	0698-4123	5		RESISTOR 489 1% .125W F TC=0+-100	19701	SFR25H
A8R164	0757-0442	9		RESISTOR 10K 1% .125W F TC=0+-100	19701	SFR25H
A8R165	0683-4745	6	3	RESISTOR 470K 5% .25W CF TC=0-800	77902	R-25J
A8R166	0683-1045	3		RESISTOR 100K 5% .25W CF TC=0-400	77902	R-25J
A8R167	0683-1035	1		RESISTOR 10K 5% .25W CF TC=0-400	77902	R-25J
A8R170	0683-1025	9		RESISTOR 1K 5% .25W CF TC=0-400	77902	R-25J
A8R171	0683-1035	1		RESISTOR 10K 5% .25W CF TC=0-400	77902	R-25J
A8R172	0698-4442	1	1	RESISTOR 4.42K 1% .125W F TC=0+-100	91637	CMF-55-1 T-1
A8R180	0683-1055	5		RESISTOR 1M 5% .25W CF TC=0-800	77902	R-25J
A8R181-R182	0683-4745	6		RESISTOR 470K 5% .25W CF TC=0-800	77902	R-25J
A8R190	0683-1015	7	1	RESISTOR 100 5% .25W CF TC=0-400	77902	R-25J
A8R191	0698-4381	7	1	RESISTOR 48.7 1% .125W F TC=0+-100	91637	CMF-55-1 T-1
A8R182	0757-0415	6	1	RESISTOR 475 1% .125W F TC=0+-100	19701	SFR25H
A8R193	0698-3228	9		RESISTOR 49.9K 1% .125W F TC=0+-100	19701	SFR25H
A8R194	0757-0401	0	1	RESISTOR 100 1% .125W F TC=0+-100	19701	SFR25H
A8R200	0698-2069	6		RESISTOR 13.3 1% 1/20W HF04 TD	91637	CMF-50-21
A8R210-R211	0698-3446	3		RESISTOR 383 1% .125W F TC=0+-100	19701	SFR25H
A8R300-R307	0683-2015	9	8	RESISTOR 200 5% .25W CF TC=0-400	77902	R-25J
A8R310-R311	0683-2215	1		RESISTOR 220 5% .25W CF TC=0-400	77902	R-25J
A8R320	0688-3264	3	1	RESISTOR 11.8K 1% .125W F TC=0+-100	19701	SFR25H
A8R321	0698-4482	1	1	RESISTOR 32.4K 1% .125W F TC=0+-100	91637	CMF-55-1 T-1
A8R322	0757-0453	2	1	RESISTOR 30.1K 1% .125W F TC=0+-100	19701	SFR25H
A8R323	0757-0438	4	1	RESISTOR 6.81K 1% .125W F TC=0+-100	19701	SFR25H
A8R324	0698-4307	7	1	RESISTOR 14.3K 1% .125W F TC=0+-100	19701	SFR25H
A8R325	8159-0005	0	1	RESISTOR-ZERO OHMS 22 AWG LEAD DIA	20940	106
A8R330-R332	0683-1025	9		RESISTOR 1K 5% .25W CF TC=0-400	77902	R-25J
A8TP1-TP14	1251-0600	0	14	CONNECTOR-SGL CONT PIN 1.14-MM-BSC-SZ SQ	27284	16-06-0034
A8U1-U3	1826-0043	4	3	ICOP AMP GP TO-99 PKG	27014	LM307H
A8U4-U5	1826-0139	9	2	ICOP AMP GP DUAL 8-DIP-P PKG	04713	MC1458P1
A8U6	1858-0047	5	1	TRANSISTOR ARRAY 16-PIN PLSTC DIP	13606	ULN-2003A
A8U7	1826-0412	1	1	ICCOMPARATOR PRCN DUAL 8-DIP-P PKG	27014	LM393N
A8U8	1820-1144	6	1	ICGATE TTL LS NOR QUAD 2-INP	01295	SN74LS02N
A8U9	1813-0215	5	2	ICWIDEBAND AMPL TO-39 PKG	04713	MWA220
A8U10	1813-0216	6	1	ICWIDEBAND AMPL TO-39 PKG	04713	MWA230
A8U11	03577-87904	3	1	MIX MWAV MD-1171	03174P01	MD1171
A8U13	0655-0085	8	1	MIX MWAV SRA-1-85 500MHZ 8	16239	SRA-1-85
A8U14	1813-0215	5		ICWIDEBAND AMPL TO-39 PKG	04713	MWA220
A8U15	1820-1834	2	1	D/A 8-BIT 16-CERDIP BPLR	06885	DAC-08EQ
A8U16-U17	1820-1730	6	2	ICFF TTL LS D-TYPE POS-EDGE-TRIG COM	01295	SN74LS273N
A8U18	1820-1211	8	1	ICGATE TTL LS EXCL-OR QUAD 2-INP	01295	SN74LS86AN
A8U19	1820-1197	9	1	ICGATE TTL LS NAND QUAD 2-INP	01295	SN74LS00N
A8U20-U21	1826-0222	1	2	ICOP AMP GP QUAD 14-DIP-P PKG	07933	RC4136DB
A8U190	1826-0109	3	1	ICOP AMP WB TO-99 PKG	34371	HA2-2625-5 (SELECTED)
A8U200	1826-0147	9	1	ICV RGLTR-FXD-POS 11.5/12.5V TO-220 PKG	04713	UA7812UC
A8W1A	1251-1636	4	15	CONNECTOR-SGL CONT SKT .04-IN-BSC-SZ RND	06776	PS-40-832-TG30
A8W1-WA2	1251-1636	4		CONNECTOR-SGL CONT SKT .04-IN-BSC-SZ RND	06776	PS-40-832-TG30
A8W1-W5	1258-0214	6	5	CON-JUMPER WIRE PLUG-SHORTING	12355P01	461-2872-01-03-16
A8W2-WA3	1251-1636	4		CONNECTOR-SGL CONT SKT .04-IN-BSC-SZ RND	06776	PS-40-832-TG30
A8W3-WA4	1251-1636	4		CONNECTOR-SGL CONT SKT .04-IN-BSC-SZ RND	06776	PS-40-832-TG30

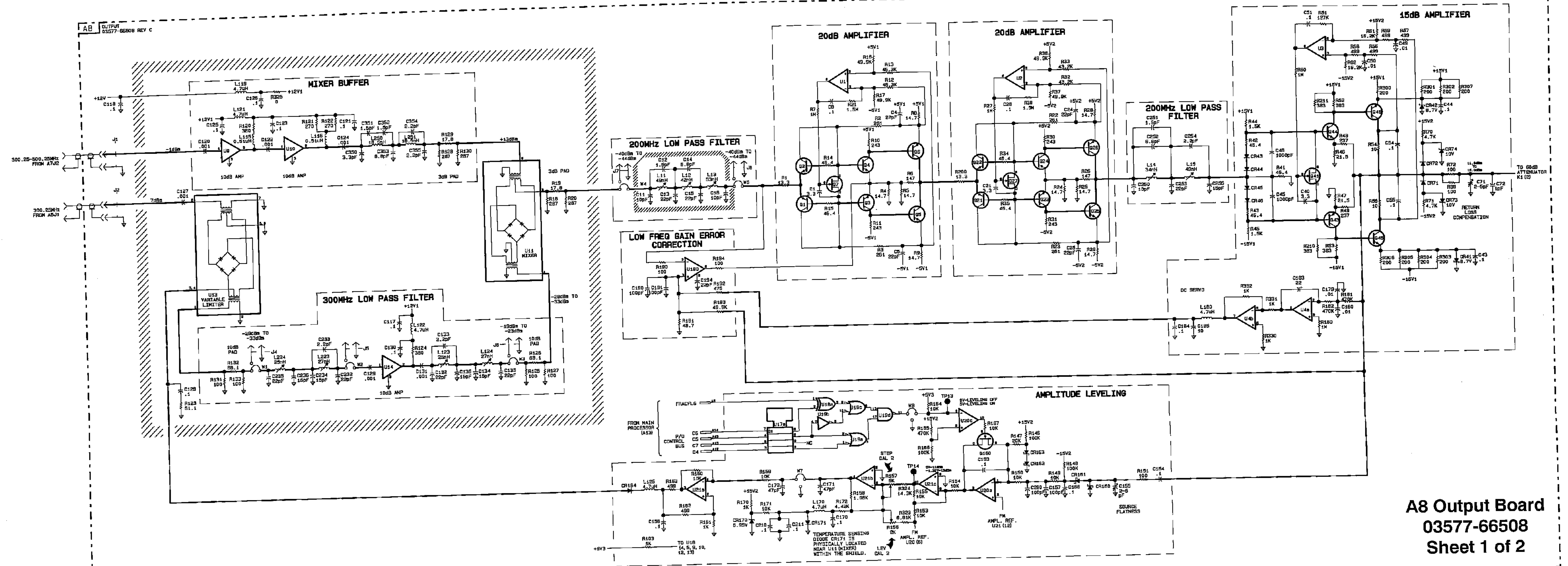
See introduction to this section for information  
\* Indicates factory selected values



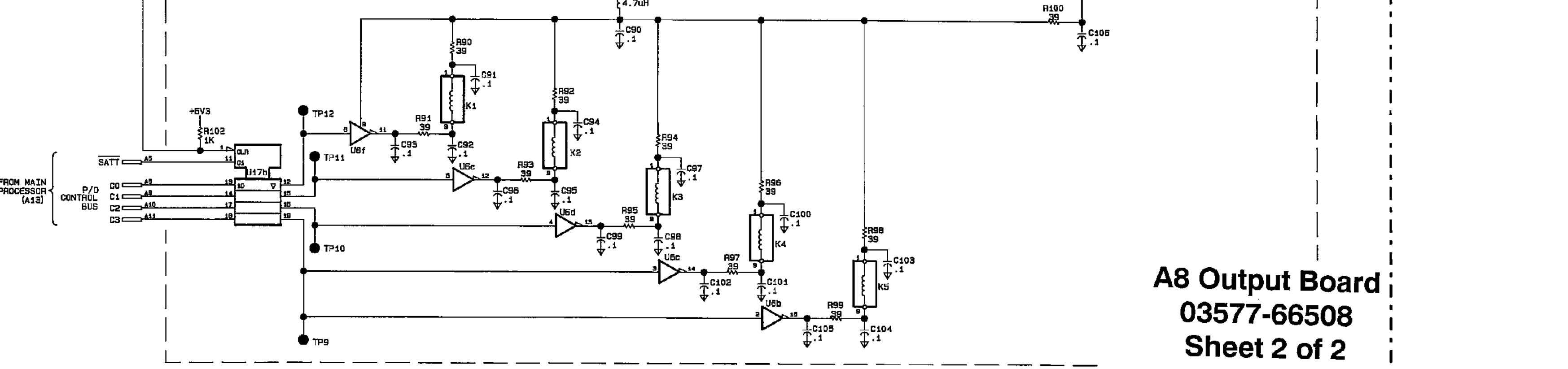
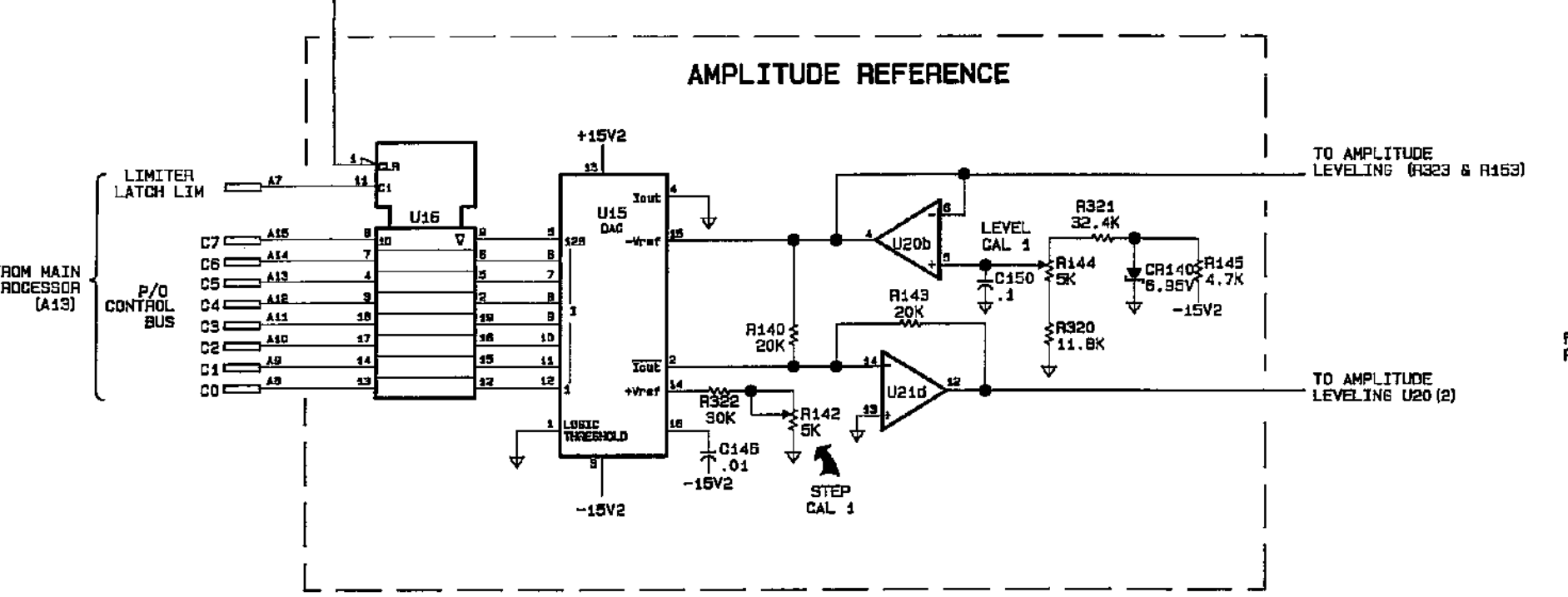
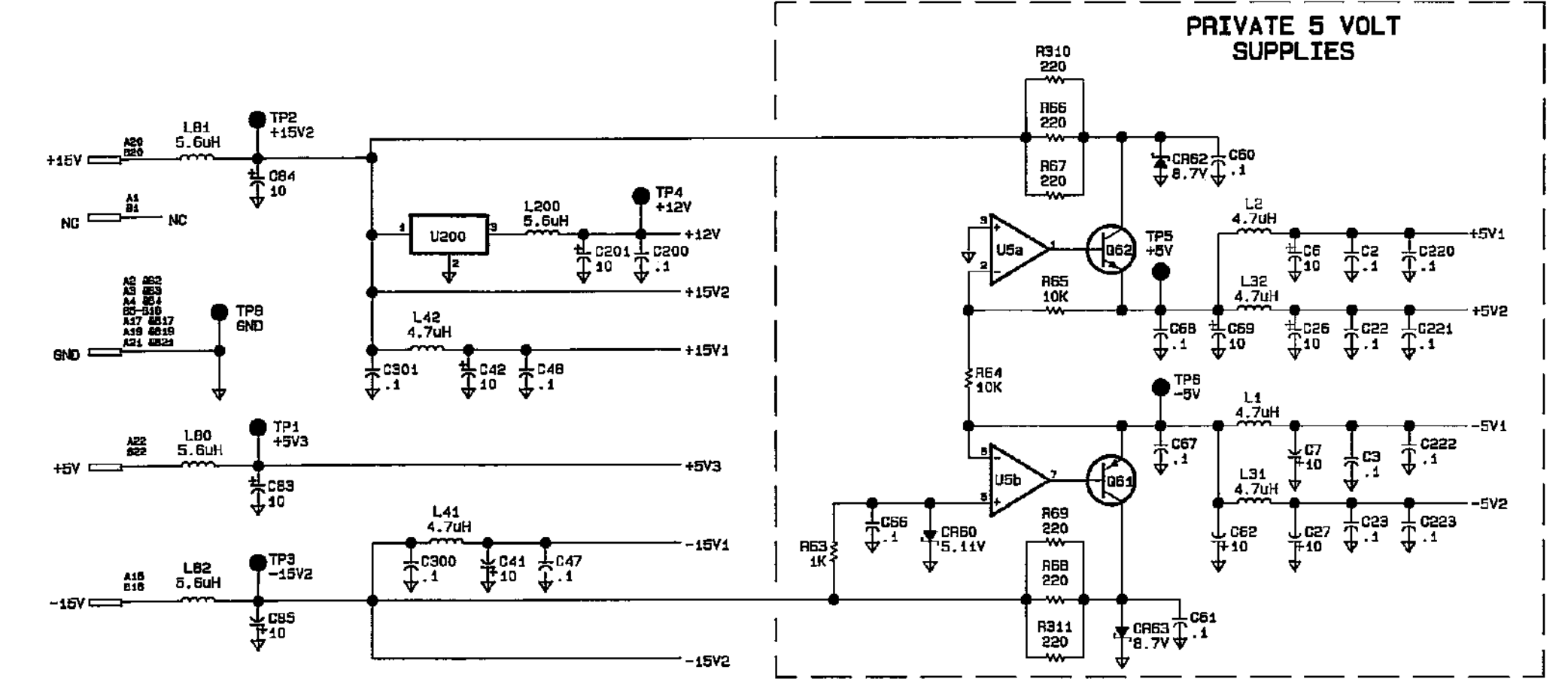
Table 7-3. Replaceable Parts

Ref.Des.	HP Part Number	CD	Qty	Description	Mfr. Code	Mfr. Part Number
A8W4-WA5	1251-1636	4		CONNECTOR-SGL CONT SKT .04-IN-BSC-SZ RND	06776	PS-40-832-TG30
A8W5	1251-1636	4		CONNECTOR-SGL CONT SKT .04-IN-BSC-SZ RND	06776	PS-40-832-TG30
A8W7	1251-4047	7	1	CONN-POST TYPE .100-PIN-SPCG 3-CONT	27264	22-05-2031
A8W8	1251-4822	6	1	CONN-POST TYPE .100-PIN-SPCG 3-CONT	27264	22-03-2031
A8X7-X8	1258-0141	8	2	CON-JUMPER REM .025P	22526	65474-004
A8	0515-1643	2	18	SCR-MCH M3.0 22MMLG PHPZ SST *	77250	
A8	4330-0498	3	12	INSULATOR-BEAD GLASS	53101	KG12
A8	3050-0159	0	8	WASHER-FL NM NO. 6 .14-IN-ID .312-IN-OD	26365	872 402
A8	3050-0873	5	6	WASHER-FL NM NO. 2 .092-IN-ID .125-IN-OD	51506	
A8	0340-1142	5	6	SPCR-SLBL .225ID .375D .030TK	32559	TO-5-03
A8	2180-0824	1	4	WASHER-LK INTL T NO. 3 .102-IN-ID	73734	98401
A8	0515-0905	7	4	SCREW-MACH M2.5 X 0.45 6MM-LG PAN-HD	28480	
A8	0515-1056	1	4	SCREW-MACH M2.5 X 0.45 4MM-LG PAN-HD	77250	
A8	0535-0004	9	2	NUT-HEX DBL-CHAM M3 X 0.5 2.4MM-THK	28480	
A8	2850-0078	9	4	NUT-HEX-DBL-CHAM 10-32-THD .067-IN-THK	98291	33002-18-00-0-156
A8	2260-0002	6	3	NUT-HEX-DBL-CHAM 4-40-THD .062-IN-THK	77250	
A8	0515-0886	3	2	SCREW-MACH M3 X 0.5 6MM-LG PAN-HD	28480	
A8	0340-1169	6	2	NSLTR-BSNG .038TK TO-72 NYLNA	32559	118-055
A8	2580-0003	5	2	NUT-HEX-W/LKWR 8-32-THD .125-IN-THK	28480	
A8	3050-0229	5	1	WASHER-FL MTLC NO. 4 .125-IN-ID	88928	
A8	03577-04109	6	1	SHTF CVR-SHLD AL	28480	03577-04109
A8	0515-0897	6	1	SCREW-MACH M3 X 0.5 8MM-LG PAN-HD	28480	
A8	0535-0004	9		NUT-HEX DBL-CHAM M3 X 0.5 2.4MM-THK	28480	
A8	03577-20606	2	1	MCHD COVER-SHIELD CAN	02875	
A8	03577-20607	3	1	MCHD COVER-SHIELD CAN	02875	
A8	03577-00903	0	1	ETCH BAR-GROUNDING BECUGD	28480	
A8	03577-20601	7	1	CSTG-SHIELD-CIRCUIT SIDE AL	01440P01	
A8	03577-20605	1	1	CSTG-MCHD SHLD-SLTDD AL	01440P01	
A8	3050-0873	5	6	WASHER-FL NM NO. 2 .092-IN-ID .125-IN-OD	51506	
A8	0340-1142	5	6	SPCR-SLBL .225ID .375D .030TK	32559	TO-5-03
A8	2180-0824	1	4	WASHER-LK INTL T NO. 3 .102-IN-ID	73734	98401
A8	0515-0905	7	4	SCREW-MACH M2.5 X 0.45 6MM-LG PAN-HD	28480	
A8	0515-1056	1	4	SCREW-MACH M2.5 X 0.45 4MM-LG PA		

See introduction to this section for information  
\* Indicates factory selected values



A8 Output Board  
03577-66508  
Sheet 1 of 2



**A8 Output Board  
03577-66508  
Sheet 2 of 2**



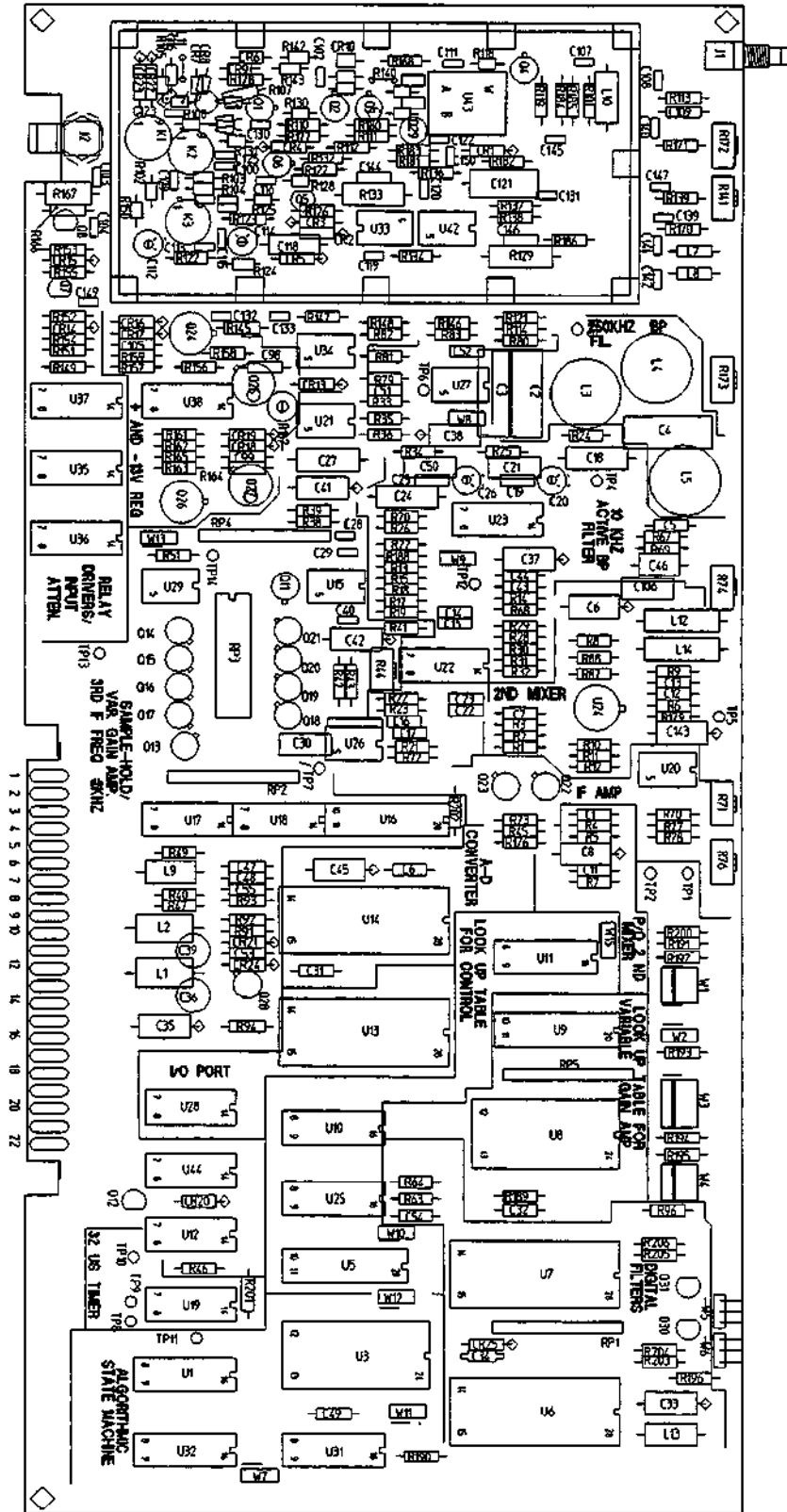


Figure 7-2. A71 Component Locator

Table 7-4. Replaceable Parts

Ref.Des.	HP Part Number	CD	Qty	Description	Mfr. Code	Mfr. Part Number
A71	03577-66571	6	2	PCBOARD ASSY INPUT	28480	03577-66571
A71C1	0160-4571	8	14	CAPACITOR-FXD .1UF +80-20% 50VDC CER	04222	SA105E104ZAAH
A71C2	0160-2724	9	2	CAPACITOR-FXD 3600PF +-2% 500VDC MICA	09023	CD19.5FD362G03
A71C3	0140-0157	6	1	CAPACITOR-FXD 1857PF +-1% 500VDC MICA	09023	
A71C4	0160-2724	9		CAPACITOR-FXD 3600PF +-2% 500VDC MICA	09023	CD19.5FD362G03
A71C5	0160-4571	8		CAPACITOR-FXD .1UF +80-20% 50VDC CER	04222	SA105E104ZAAH
A71C6	0180-0210	6	3	CAPACITOR-FXD 3.3UF +-20% 15VDC TA	13606	150D335X0015A2-OYS
A71C7	0160-4571	8		CAPACITOR-FXD .1UF +80-20% 50VDC CER	04222	SA105E104ZAAH
A71C8	0180-3552	5	3	CAPACITOR-FXD 4.7UF 10% 20V TATBSA	13606	173D475X9020V1
A71C11-C12	0160-4571	8		CAPACITOR-FXD .1UF +80-20% 50VDC CER	04222	SA105E104ZAAH
A71C13	0160-5349	0	1	CAPACITOR-FXD 200PF +-5% 100VDC CER	28480	RPA10C0G201J100V
A71C14-C17	0160-6514	3	10	CAPACITOR-FXD 4700PF 1% 50V CERMLr	04222	SR215A472FAAHTR
A71C18	0160-4591	2	2	CAPACITOR-FXD .018UF +-1% 200VDC	15766	HEW-249
A71C19	0160-6514	3		CAPACITOR-FXD 4700PF 1% 50V CERMLr	04222	SR215A472FAAHTR
A71C20	0121-0491	1	2	CAPACITOR-V TRMR-CER 5-30PF 50V PC-MTG	59660	518-003 A 5-30
A71C21	0160-2646	4	2	CAPACITOR-FXD 168.8PF +-1% 300VDC MICA	09023	CD15FD(168.8)FO
A71C22-C23	0160-6514	3		CAPACITOR-FXD 4700PF 1% 50V CERMLr	04222	SR215A472FAAHTR
A71C24	0160-4591	2		CAPACITOR-FXD .018UF +-1% 200VDC	15766	HEW-249
A71C25	0160-6514	3		CAPACITOR-FXD 4700PF 1% 50V CERMLr	04222	SR215A472FAAHTR
A71C26	0121-0491	1		CAPACITOR-V TRMR-CER 5-30PF 50V PC-MTG	59660	518-003 A 5-30
A71C27	0160-4682	2	1	CAPACITOR-FXD 1000PF +-2.5% 160VDC POLYP	06121P01	B33062-A1 102-H
A71C28-C29	0160-6513	2	2	CAPACITOR-FXD 68PF 5% 200V CERMLr	28480	RPE121-978C0G680J200V
A71C30	0160-2197	0	1	CAPACITOR-FXD 10PF +-5% 300VDC MICA	09023	CD15CD100J03
A71C31-C32	0160-4571	8		CAPACITOR-FXD .1UF +80-20% 50VDC CER	04222	SA105E104ZAAH
A71C33	0180-0210	6		CAPACITOR-FXD 3.3UF +-20% 15VDC TA	13606	150D335X0015A2-OYS
A71C34	0160-0127	2	1	CAPACITOR-FXD 1UF +-20% 25VDC CER	04222	SR835E105MAAH
A71C35	0180-3552	5		CAPACITOR-FXD 4.7UF 10% 20V TATBSA	13606	173D475X9020V1
A71C36	0180-3882	4	2	CAPACITOR-FXD 22UF 20% 25V TADPDr	12340P01	T356H226M025AS
A71C37-C38	0180-3622	0	4	CAPACITOR-FXD .1UF 10% 35V TATBSA	13606	173D104X9035U
A71C39	0180-3882	4		CAPACITOR-FXD 22UF 20% 25V TADPDr	12340P01	T356H226M025AS
A71C40	0160-6508	5	2	CAPACITOR-FXD 22PF 5% 200V CERMLr	28480	RPE121-978C0G220J200V
A71C41-C42	0180-3622	0		CAPACITOR-FXD .1UF 10% 35V TATBSA	13606	173D104X9035U
A71C43-C44	0160-4787	8	2	CAPACITOR-FXD 22PF +-5% 100VDC CER 0+-30	04222	SA102A220JAAH
A71C45	0180-3552	5		CAPACITOR-FXD 4.7UF 10% 20V TATBSA	13606	173D475X9020V1
A71C46	0160-4819	7	1	CAPACITOR-FXD 2200PF +-5% 100VDC CER	04222	SA301A222JAAH
A71C47-C48	0160-4571	8		CAPACITOR-FXD .1UF +80-20% 50VDC CER	04222	SA105E104ZAAH
A71C50	0160-2646	4		CAPACITOR-FXD 168.8PF +-1% 300VDC MICA	09023	CD15FD(168.8)FO
A71C51-C52	0160-6514	3		CAPACITOR-FXD 4700PF 1% 50V CERMLr	04222	SR215A472FAAHTR
A71C53-C55	0160-4571	8		CAPACITOR-FXD .1UF +80-20% 50VDC CER	04222	SA105E104ZAAH
A71C98-C99	0160-4532	1	2	CAPACITOR-FXD 1000PF +-20% 50VDC CER	04222	SA101C102MAAH
A71C100*	0160-6515	4		CAPACITOR-FXD 10PF -% 200V CERMLr	28480	RPE121-978C0G100D200V
A71C100*	0160-4519	4	1	CAPACITOR-FXD 9.1PF +-.5PF 200VDC CER	54583	FD12C0H2D9R1D
A71C101	0180-2616	0	1	CAPACITOR-FXD 60UF +-20% 6VDC TA	13606	166D004
A71C102	0160-6511	0	1	CAPACITOR-FXD 15PF 5% 200V CERMLr	28480	RPE121-978C0G150J200V
A71C103-C104	0160-0576	5	11	CAPACITOR-FXD .1UF +-20% 50VDC CER	04222	SR205C104MAAH
A71C105	0180-4129	4	1	CAPACITOR-FXD 1UF 10% 35V TATBSA	13606	173D105X9035V
A71C106	0160-6654	2	1	CAPACITOR-FXD 160PF 1% 300V MICAs	09023	
A71C107	0160-0576	5		CAPACITOR-FXD .1UF +-20% 50VDC CER	04222	SR205C104MAAH
A71C108	0160-4507	0	1	CAPACITOR-FXD 1800PF +-2% 100VDC CER	28480	RPE121-151C0G182G100V
A71C109	0160-4571	8		CAPACITOR-FXD .1UF +80-20% 50VDC CER	04222	SA105E104ZAAH
A71C110-C111	0160-6510	9	6	CAPACITOR-FXD .1UF 20% 50V CERMLr	28480	RPE121-978X7R104M50V

See introduction to this section for information  
\* Indicates factory selected values

Table 7-4. Replaceable Parts

Ref.Des.	HP Part Number	CD	Qty	Description	Mfr. Code	Mfr. Part Number
A71C112	0121-0449	9	2	CAPACITOR-V TRMR-CER 3.5-10PF 63V PC-MTG	52763	302-504-404
A71C113	0160-6521	2	1	CAPACITOR-FXD 2.2PF -% 200V CERML	28480	RPE121-978C0G2R2C200V
A71C114	0121-0449	9		CAPACITOR-V TRMR-CER 3.5-10PF 63V PC-MTG	52763	302-504-404
A71C115	0160-6524	5	2	CAPACITOR-FXD 6.8PF -% 200V CERML	28480	RPE121-978C0G6R8D200V
A71C116	0160-0576	5		CAPACITOR-FXD .1UF +20% 50VDC CER	04222	SR205C104MAAH
A71C118	0180-0210	6		CAPACITOR-FXD 3.3UF +20% 15VDC TA	13606	150D335X0015A2-DYS
A71C119	0160-6510	9		CAPACITOR-FXD .1UF 20% 50V CERML	28480	RPE121-978X7R104M50V
A71C120	0160-0576	5		CAPACITOR-FXD .1UF +20% 50VDC CER	04222	SR205C104MAAH
A71C121	0160-3829	7	1	CAPACITOR-FXD .47UF +10% 50VDC	15766	HEW-249
A71C122-C123	0160-0576	5		CAPACITOR-FXD .1UF +20% 50VDC CER	04222	SR205C104MAAH
A71C125	0160-6523	4	2	CAPACITOR-FXD 1PF -% 200V CERML	28480	RPE121-978C0G010C200V
A71C127	0160-0576	5		CAPACITOR-FXD .1UF +20% 50VDC CER	04222	SR205C104MAAH
A71C129	0160-6523	4		CAPACITOR-FXD 1PF -% 200V CERML	28480	RPE121-978C0G010C200V
A71C130	0160-6510	9		CAPACITOR-FXD .1UF 20% 50V CERML	28480	RPE121-978X7R104M50V
A71C131	0160-5041	9	1	CAPACITOR-FXD .015UF +10% 100VDC CER	04222	SR201C153KAA
A71C132-C133	0160-3914	1	2	CAPACITOR-FXD .01UF +10% 100VDC CER	04222	SR201C103KAAH
A71C137	0160-6524	5		CAPACITOR-FXD 6.8PF -% 200V CERML	28480	RPE121-978C0G6R8D200V
A71C139-C140	0160-0576	5		CAPACITOR-FXD .1UF +20% 50VDC CER	04222	SR205C104MAAH
A71C141-C142	0180-3767	4	2	CAPACITOR-FXD 3.3UF 20% 25V TADPD	01760P01	202L2502335MH
A71C143	0180-4133	0	1	CAPACITOR-FXD 15UF 10% 20V TATBSA	13606	173D156X9020X
A71C144	0160-6688	2	2	CAPACITOR-FXD 1UF 20% 50V CERML	28480	RPE113-907Z5U105M50V
A71C145	0160-6508	5		CAPACITOR-FXD 2.2PF 5% 200V CERML	28480	RPE121-978C0G220J200V
A71C146	0160-6688	2		CAPACITOR-FXD 1UF 20% 50V CERML	28480	RPE113-907Z5U105M50V
A71C147	0160-0576	5		CAPACITOR-FXD .1UF +20% 50VDC CER	04222	SR205C104MAAH
A71C148-C149	0160-6510	9		CAPACITOR-FXD .1UF 20% 50V CERML	28480	RPE121-978X7R104M50V
A71C150	0160-6505	2	1	CAPACITOR-FXD .01UF 20% 100V CERML	28480	RPE121-978X7R103M100V
A71C200*-C201*	0160-4381	8	2	CAPACITOR-FXD 1.5PF +-25PF 200VDC CER	28480	RPE110-120C0G1R5C200V
A71C200*-C201*	0160-6521	2		CAPACITOR-FXD 2.2PF -% 200V CERML	28480	RPE121-978C0G2R2C200V
A71C200*-C201*	0160-4382	9	1	CAPACITOR-FXD 3.3PF +-25PF 200VDC CER	28480	RPE121-105C0G3R3C200V
A71C200*-C201*	0160-3873	9	1	CAPACITOR-FXD 4.7PF +-25PF 200VDC CER	28480	RPE121-105C0G4R7C200V
A71CR1	1902-0953	7	6	DIODE-ZNR 6.2V 5% DO-35 PD=.4W TC= +.053%	04713	SZ30035-11RL
A71CR2-CR3	1901-1255	2	2	DIO 35V 50MA DO-35 **GP	34371	DE131
A71CR4	1902-0951	5	1	DIODE-ZNR 5.1V 5% DO-35 PD=.4W TC= +.035%	04713	SZ30035-9RL
A71CR5	1902-0953	7		DIODE-ZNR 6.2V 5% DO-35 PD=.4W TC= +.053%	04713	SZ30035-11RL
A71CR6	1901-0050	3	2	DIODE-SWITCHING 80V 200MA 2NS DO-35	9N171	1N4150
A71CR7-CR8	1901-1068	5	4	DIODE-SCHOTTKY SM SIG	28480	1901-1068
A71CR9	1901-0050	3		DIODE-SWITCHING 80V 200MA 2NS DO-35	9N171	1N4150
A71CR10	0122-0085	1	1	DIODE-VVC 2.2PF 7% C3/C25-MIN = 4.5	30545	1S2208(8)
A71CR11-CR12	1901-1068	5		DIODE-SCHOTTKY SM SIG	28480	1901-1068
A71CR13	1901-0040	1	4	DIODE-SWITCHING 30V 50MA 2NS DO-35	9N171	1N4148
A71CR14-CR16	1902-0953	7		DIODE-ZNR 6.2V 5% DO-35 PD=.4W TC= +.053%	04713	SZ30035-11RL
A71CR17	1901-0040	1		DIODE-SWITCHING 30V 50MA 2NS DO-35	9N171	1N4148
A71CR18	1902-0953	7		DIODE-ZNR 6.2V 5% DO-35 PD=.4W TC= +.053%	04713	SZ30035-11RL
A71CR19-CR20	1901-0040	1		DIODE-SWITCHING 30V 50MA 2NS DO-35	9N171	1N4148
A71CR21	1902-0957	1	1	DIODE-ZNR 9.1V 5% DO-35 PD=.4W TC= +.069%	04713	
A71CR22-CR23	1901-0179	7	2	DIODE-SWITCHING 15V 50MA 750PS	27014	FD777
A71CR24	1901-0026	3	1	DIODE-PWR RECT 200V 750MA DO-29	04713	
A71CR25	1901-0535	9	1	DIODE-SCHOTTKY SM SIG	28480	1901-0535
A71E3	9170-0894	0	3	CORE-SHIELDING BEAD	02995P05	56-590-65/4A6
A71E25	9170-0894	0		CORE-SHIELDING BEAD	02995P05	56-590-65/4A6
A71E27	9170-0894	0		CORE-SHIELDING BEAD	02995P05	56-590-65/4A6

See introduction to this section for information  
\* Indicates factory selected values

Table 7-4. Replaceable Parts

Ref.Des.	HP Part Number	CD	Qty	Description	Mfr. Code	Mfr. Part Number
A71J1	1250-2142	7	1	CON-SMB	74970	131-3701-341
A71J2	1250-1314	3	1	CONNECTOR-RF SM-SLD FEM PC 50-OHM	98291	52-054-0000-226
A71K1-K3	0490-1404	9	3	RELAY 2C 12VDC-DCIL .5A 28VDC	11532	412Y-0191
A71L1-L2	9140-0748	0	2	INDUCTOR 250UH 25% .25DX.5LG Q = 3	24226	CA-253-5
A71L3	03577-60329	0	2	INC POT CORE VAR 101-108 UH	10890P01	03577-60329
A71L4	03577-60331	4	1	INC POT CORE VAR 247-263 UH	10890P01	03577-60331
A71L5	03577-60329	0		INC POT CORE VAR 101-108 UH	10890P01	03577-60329
A71L6	9100-2275	8	1	INDUCTOR RF-CH-MLD 82UH 10% .105DX.26LG	24226	10M822K
A71L7-L8	9140-0144	0	2	INDUCTOR RF-CH-MLD 4.7UH 10% .105DX.26LG	99800	1025-36
A71L9	9100-1611	4	2	INDUCTOR RF-CH-MLD 220NH 20%	99800	1537-02
A71L10	9140-0129	1	1	INDUCTOR RF-CH-MLD 220UH 5% .168DX.385LG	99800	1537-92
A71L11	03577-87901	8	1	INDCTR-WIRE 22GA LOOP	28480	
A71L12	9100-2574	0	2	INDUCTOR RF-CH-MLD 1.2MH 10%	24226	17S124K
A71L13	9100-1611	4		INDUCTOR RF-CH-MLD 220NH 20%	99800	1537-02
A71L14	9100-2574	0		INDUCTOR RF-CH-MLD 1.2MH 10%	24226	17S124K
A71P1	1251-8736	9	2	CONN-POST TYPE .100-PIN-SPOG 6-CONT	22526	67997-606
A71P1A	1251-5033	3	2	CONN-POST TYPE .100-PIN-SPOG 3-CONT	22526	68001-603
A71P2	1251-4822	6	9	CONN-POST TYPE .100-PIN-SPOG 3-CONT	27264	22-03-2031
A71P3	1251-8736	8	1	CONN-POST TYPE .100-PIN-SPOG 8-CONT	22526	67997-608
A71P3A	1251-7524	1	1	CONN-POST TYPE .100-PIN-SPOG 4-CONT	22526	68001-604
A71P4	1251-8736	9		CONN-POST TYPE .100-PIN-SPOG 6-CONT	22526	67997-606
A71P4A	1251-5033	3		CONN-POST TYPE .100-PIN-SPOG 3-CONT	22526	68001-603
A71P5-P6	1251-4047	7	2	CONN-POST TYPE .100-PIN-SPOG 3-CONT	27264	22-05-2031
A71P7-P13	1251-4822	6		CONN-POST TYPE .100-PIN-SPOG 3-CONT	27264	22-03-2031
A71P15	1251-4822	6		CONN-POST TYPE .100-PIN-SPOG 3-CONT	27264	22-03-2031
A71Q1-Q2	1854-0908	9	3	TRANSISTOR NPN TO-72 FT = 2.5GHZ	04713	
A71Q3	1853-0553	8	1	TRANSISTOR PNP SI TO-72 PD = 200MW FT = 5GHZ	03334P01	A440
A71Q4	1854-0686	0	2	TRANSISTOR NPN SI TO-72 PD = 200MW FT = 4GHZ	03334P01	
A71Q5	1855-0081	1	1	TRANSISTOR J-FET N-CHAN D-MODE SI	03171P01	
A71Q6	1854-0908	9		TRANSISTOR NPN TO-72 FT = 2.5GHZ	04713	
A71Q7-Q8	1853-0418	5	2	TRANSISTOR PNP SI PD = 310MW FT = 200MHZ	04713	2N4403
A71Q11	1855-0232	4	1	TRANSISTOR-JFET DUAL 2N5565 N-CHAN	17856	2N5565
A71Q12	1853-0036	2	1	TRANSISTOR PNP SI PD = 310MW FT = 250MHZ	04713	2N3906(SEL)
A71Q13-Q21	03577-60339	2	9	XTR JFETN ASSY SI 2N4393 T018	07797P01	
A71Q22-Q23	1855-0420	2	2	TRANSISTOR J-FET 2N4391 N-CHAN D-MODE	17856	2N4391
A71Q24	1853-0083	9	1	TRANSISTOR-DUAL PNP PD = 600MW	04713	
A71Q25	1854-0263	9	1	TRANSISTOR NPN 2N3019 SI TO-39 PD = 800MW	04713	2N3019
A71Q26	1854-0515	4	1	TRANSISTOR-DUAL NPN TO-77 PD = 800MW	34371	
A71Q27	1853-0320	7	1	TRANSISTOR PNP 2N4032 SI TO-5 PD = 800MW	27014	2N4032
A71Q28Q204	1854-0477	7	1	TRANSISTOR NPN 2N2222A SI TO-18 PD = 500MW	04713	2N2222A
A71Q29	1854-0686	0		TRANSISTOR NPN SI TO-72 PD = 200MW FT = 4GHZ	03334P01	
A71Q30-Q31	1854-0404	0	2	TRANSISTOR NPN SI TO-18 PD = 360MW	04713	
A71R1	0698-4445	4	1	RESISTOR 5.76K 1% .125W F TC = 0+-100	91637	CMF-55-1 T-1
A71R2	0683-2025	1	4	RESISTOR 2K 5% .25W CF TC = 0-400	77902	R-25J
A71R3-R4	0683-3925	2	2	RESISTOR 3.9K 5% .25W CF TC = 0-400	77902	R-25J
A71R5	0683-2025	1		RESISTOR 2K 5% .25W CF TC = 0-400	77902	R-25J
A71R6	0698-6871	4	1	RESISTOR 10K .5% .125W F TC = 0+-50	19701	5033R
A71R7	0698-3581	7	1	RESISTOR 13.7K 1% .125W F TC = 0+-100	19701	SFR25H
A71R8	0757-0278	9	1	RESISTOR 1.78K 1% .125W F TC = 0+-100	19701	SFR25H
A71R9	0698-3228	9	2	RESISTOR 49.9K 1% .125W F TC = 0+-100	19701	SFR25H
A71R10	0683-2025	1		RESISTOR 2K 5% .25W CF TC = 0-400	77902	R-25J
A71R11	0683-6225	1	1	RESISTOR 6.2K 5% .25W CF TC = 0-400	77902	R-25J

See introduction to this section for information  
\* Indicates factory selected values

Table 7-4. Replaceable Parts

Ref.Des.	HP Part Number	CD	Qty	Description	Mfr. Code	Mfr. Part Number
A71R12	0683-2025	1		RESISTOR 2K 5% .25W CF TC = 0-400	77902	R-25J
A71R13	0698-6865	7	1	RESISTOR 505 .1% .125W F TC = 0+-25	19701	5033R
A71R14	0757-0288	1	1	RESISTOR 9.09K 1% .125W F TC = 0+-100	19701	SFR25H
A71R15	0698-4489	6	1	RESISTOR 28K 1% .125W F TC = 0+-100	91637	CMF-55-1 T-1
A71R17	0698-6382	8	2	RESISTOR 1K .1% .125W F TC = 0+-25	19701	5033R
A71R18	0698-6630	3	5	RESISTOR 20K .1% .125W F TC = 0+-25	19701	5033R
A71R19	0698-7874	7	1	RESISTOR 13.19K .1% .125W F TC = 0+-50	19701	5033R
A71R20	0698-6805	4	1	RESISTOR 1.078K .25% .125W F TC = 0+-50	19701	5033R
A71R21	0698-6343	5	1	RESISTOR 9K .1% .125W F TC = 0+-25	19701	5033R
A71R22	0698-6320	8	1	RESISTOR 5K .1% .125W F TC = 0+-25	91637	CMF-55-1 T-9
A71R23	0698-6630	3		RESISTOR 20K .1% .125W F TC = 0+-25	19701	5033R
A71R24-R25	0698-7960	4	4	RESISTOR 7.87K 1% .125W F TC = 0+-25	19701	5033R
A71R26	0698-5418	3	2	RESISTOR 50 .1% .125W F TC = 0+-50	19701	5033R
A71R27	0698-0182	2	2	RESISTOR 3.894K .1% .125W F TC = 0+-25	19701	5033R
A71R28	0757-0448	5	1	RESISTOR 18.2K 1% .125W F TC = 0+-100	19701	SFR25H
A71R29	0698-6630	3		RESISTOR 20K .1% .125W F TC = 0+-25	19701	5033R
A71R30	0698-7384	8	1	RESISTOR 688 .1% .125W F TC = 0+-25	19701	5033R
A71R31	0698-6362	8		RESISTOR 1K .1% .125W F TC = 0+-25	19701	5033R
A71R32	0698-6630	3		RESISTOR 20K .1% .125W F TC = 0+-25	19701	5033R
A71R33-R34	0698-7960	4		RESISTOR 7.87K 1% .125W F TC = 0+-25	19701	5033R
A71R35	0698-5418	3		RESISTOR 50 .1% .125W F TC = 0+-50	19701	5033R
A71R36	0698-0182	2		RESISTOR 3.894K .1% .125W F TC = 0+-25	19701	5033R
A71R38-R39	0698-3558	8	3	RESISTOR 4.02K 1% .125W F TC = 0+-100	19701	SFR25H
A71R40	0698-3279	0	1	RESISTOR 4.89K 1% .125W F TC = 0+-100	19701	SFR25H
A71R41	0698-3558	8		RESISTOR 4.02K 1% .125W F TC = 0+-100	19701	SFR25H
A71R42	0757-0401	0	2	RESISTOR 100 1% .125W F TC = 0+-100	19701	SFR25H
A71R43	0698-3562	8	1	RESISTOR 41.2K 1% .125W F TC = 0+-100	19701	SFR25H
A71R44	2100-3356	1	1	RESISTOR-TRMR 200K 10% C SIDE-ADJ 1-TRN	32997	3386X-Y46-204
A71R45	0757-0277	8	3	RESISTOR 49.9 1% .125W F TC = 0+-100	19701	SFR25H
A71R46	0683-6815	5	3	RESISTOR 680 5% .25W CF TC = 0-400	77902	R-25J
A71R47	0683-5825	3	1	RESISTOR 5.6K 5% .25W CF TC = 0-400	77902	R-25J
A71R48	0683-1035	1	12	RESISTOR 10K 5% .25W CF TC = 0-400	77902	R-25J
A71R51	0683-3045	7	1	RESISTOR 300K 5% .25W CF TC = 0-800	77902	R-25J
A71R63-R64	0683-4725	2	6	RESISTOR 4.7K 5% .25W CF TC = 0-400	77902	R-25J
A71R67-R68	0698-6619	8	2	RESISTOR 15K .1% .125W F TC = 0+-25	19701	5033R
A71R69	0698-4441	0	1	RESISTOR 3.74K 1% .125W F TC = 0+-100	91637	CMF-55-1 T-1
A71R70	0757-0427	0	1	RESISTOR 1.5K 1% .125W F TC = 0+-100	19701	SFR25H
A71R71	2100-3273	1	1	RESISTOR-TRMR 2K 10% C SIDE-ADJ 1-TRN	32997	3386X-Y46-202
A71R72-R73	0683-1045	3	2	RESISTOR 100K 5% .25W CF TC = 0-400	77902	R-25J
A71R74	2100-3274	2	1	RESISTOR-TRMR 10K 10% C SIDE-ADJ 1-TRN	32997	3386X-Y46-103
A71R76	2100-3352	7	1	RESISTOR-TRMR 1K 10% C SIDE-ADJ 1-TRN	32997	3386X-Y46-102
A71R77	0757-0161	9	1	RESISTOR 604 1% .125W F TC = 0+-100	19701	SFR25H
A71R78	0757-0442	9	3	RESISTOR 10K 1% .125W F TC = 0+-100	19701	SFR25H
A71R79	0698-7934	2	1	RESISTOR 12.1K .1% .125W F TC = 0+-25	19701	5033R
A71R80	0698-6706	4	1	RESISTOR 1.24K .25% .125W F TC = 0+-100	19701	5033R
A71R81	0698-8191	5	1	RESISTOR 12.5K .1% .125W F TC = 0+-25	91637	CMF-55-1 T-9
A71R82	0698-6630	3		RESISTOR 20K .1% .125W F TC = 0+-25	19701	5033R
A71R83	0698-5323	9	1	RESISTOR 4K .5% .125W F TC = 0+-50	19701	5033R
A71R87-R88	0683-1025	9	6	RESISTOR 1K 5% .25W CF TC = 0-400	77902	R-25J
A71R91	0683-5125	8	1	RESISTOR 5.1K 5% .25W CF TC = 0-400	77902	R-25J
A71R92	0683-1015	7	2	RESISTOR 100 5% .25W CF TC = 0-400	77902	R-25J
A71R93	0757-0444	1	1	RESISTOR 12.1K 1% .125W F TC = 0+-100	19701	SFR25H

See introduction to this section for information  
\* Indicates factory selected values



Table 7-4. Replaceable Parts

Ref.Des.	HP Part Number	CD	Qty	Description	Mfr. Code	Mfr. Part Number
A71R94	0757-0273	4	1	RESISTOR 3.01K 1% .125W F TC=0+-100	19701	SFR25H
A71R96	0683-1035	1		RESISTOR 10K 5% .25W CF TC=0-400	77902	R-25J
A71R100	0675-4721	1	1	RESISTOR 4.7K 10% .125W CC TC=-350/+857	01121	BB4721
A71R101	0683-1525	4	1	RESISTOR 1.5K 5% .25W CF TC=0-400	77902	R-25J
A71R102	0699-2130	2	2	RESISTOR 61.1 OH .1% 1/20W HF04 TO	91637	CMF-50-21
A71R103	0699-2131	3	1	RESISTOR 247 OHM .5% 1/20W HF04 TO	91637	CMF50-21
A71R104	0699-2130	2		RESISTOR 61.1 OH .1% 1/20W HF04 TO	91637	CMF-50-21
A71R105	0699-2075	4	2	RESISTOR 50 OHM .5% 1/20W HF04 TO	91637	CMF-50-21
A71R106	0698-3378	0	3	RESISTOR 51 5% .125W CC TC=-270/+540	01121	BB5105
A71R107	0683-2035	3	1	RESISTOR 20K 5% .25W CF TC=0-400	77902	R-25J
A71R108	0699-2071	0	1	RESISTOR 33.2 OH .5% 1/20W HF04 TO	91637	CMF-50-21
A71R109	0699-2083	4	3	RESISTOR 100 OHM .5% 1/20W HF04 TO	91637	CMF-50-21
A71R110	0683-3325	6	2	RESISTOR 3.3K 5% .25W CF TC=0-400	77902	R-25J
A71R111	0757-0283	6	5	RESISTOR 2K 1% .125W F TC=0+-100	19701	SFR25H
A71R112	0757-0419	0	1	RESISTOR 681 1% .125W F TC=0+-100	19701	SFR25H
A71R113	0683-1515	2	3	RESISTOR 150 5% .25W CF TC=0-400	77902	R-25J
A71R114	0683-5105	4	1	RESISTOR 51 5% .25W CF TC=0-400	77902	R-25J
A71R115	0699-2083	4		RESISTOR 100 OHM .5% 1/20W HF04 TO	91637	CMF-50-21
A71R116	0698-5178	2	1	RESISTOR 1.5K 5% .125W CC TC=-350/+857	01121	BB1525
A71R117	0699-2083	4		RESISTOR 100 OHM .5% 1/20W HF04 TO	91637	CMF-50-21
A71R118	0699-2075	4		RESISTOR 50 OHM .5% 1/20W HF04 TO	91637	CMF-50-21
A71R119	0683-3325	6		RESISTOR 3.3K 5% .25W CF TC=0-400	77902	R-25J
A71R121	0757-0280	3	2	RESISTOR 1K 1% .125W F TC=0+-100	19701	SFR25H
A71R122	0698-5131	7	1	RESISTOR 900K .5% .25W F TC=0+-100	19701	5043R
A71R123	0698-6879	3	1	RESISTOR 111.1K .1% .125W F TC=0+-25	19701	5033R
A71R124	0699-1947	7	2	RESISTOR 38.3 OH 1% 1/20W MFHF TO	91637	CMF-50-21
A71R125	0698-3378	0		RESISTOR 51 5% .125W CC TC=-270/+540	01121	BB5105
A71R126	0698-7332	4	1	RESISTOR 1M 1% .125W F TC=0+-100	19701	5033R
A71R127	0683-1225	1	1	RESISTOR 1.2K 5% .25W CF TC=0-400	77902	R-25J
A71R128	0698-3113	1	1	RESISTOR 100 5% .125W CC TC=-270/+540	01121	BB1015
A71R129	0698-4585	3	1	RESISTOR 348 1% .25W F TC=0+-100	91637	CMF-60-1 T-1
A71R130*	0699-1969	3		RESISTOR 90.9 OH 1% 1/20W HF04 TO	91637	CMF-50-21
A71R130*	0699-2077	6		RESISTOR 75 OHM 1% 1/20W HF04 TO	91637	CMF-50-21
A71R130+	0699-2077	6	1	RESISTOR 75 OHM 1% 1/20W HF04 TO	91637	CMF-50-21
A71R131	0699-1947	7		RESISTOR 38.3 OH 1% 1/20W MFHF TO	91637	CMF-50-21
A71R132	0698-7236	7	1	RESISTOR 1K 1% .05W F TC=0+-100	19701	5063J
A71R133	0686-4715	6	1	RESISTOR 470 5% .5W CC TC=0+529	01121	EB4715
A71R134	0683-3955	8	1	RESISTOR 3.9M 5% .25W CC TC=-900/+1100	01121	CB3955
A71R136	0698-8996	8	3	RESISTOR 100K 1% .05W F TC=0+-100	12482P01	CT3
A71R137	0698-4534	2	1	RESISTOR 309K 1% .125W F TC=0+-100	19701	SFR25H
A71R138	0757-0401	0		RESISTOR 100 1% .125W F TC=0+-100	19701	SFR25H
A71R139	0683-2045	5	1	RESISTOR 200K 5% .25W CF TC=0-800	77902	R-25J
A71R140	03577-67902	9	1	WIRE ASM-MAGNETIC	28480	
A71R140	7225-0458	7	2	WIRE MAGNETIC	28480	7225-0458
A71R141	2100-3355	0	1	RESISTOR-TRMR 100K 10% C SIDE-ADJ 1-TRN	32997	3388X-Y46-104
A71R142-R143	0698-8996	8		RESISTOR 100K 1% .05W F TC=0+-100	12482P01	CT3
A71R145	0757-0459	8	2	RESISTOR 58.2K 1% .125W F TC=0+-100	19701	SFR25H
A71R146	0683-1055	5	2	RESISTOR 1M 5% .25W CF TC=0-800	77902	R-25J
A71R147	0757-0459	8		RESISTOR 58.2K 1% .125W F TC=0+-100	19701	SFR25H
A71R148	0683-1055	5		RESISTOR 1M 5% .25W CF TC=0-800	77902	R-25J
A71R149	0683-3025	3	2	RESISTOR 3K 5% .25W CF TC=0-400	77902	R-25J

See introduction to this section for information  
\* Indicates factory selected values

Table 7-4. Replaceable Parts

Ref.Des.	HP Part Number	CD	Qty	Description	Mfr. Code	Mfr. Part Number
A71R150	0699-2163	1	1	RESISTOR 31.5 OH 1% 1/20W HF04 T0	91637	CMF-50-21
A71R151	0683-3025	3		RESISTOR 3K 5% .25W CF TC=0-400	77902	R-25J
A71R152-R155	0683-4725	2		RESISTOR 4.7K 5% .25W CF TC=0-400	77902	R-25J
A71R156	0698-4461	4	2	RESISTOR 698 1% .125W F TC=0+-100	91637	CMF-55-1 T-1
A71R157-R158	0757-0283	6		RESISTOR 2K 1% .125W F TC=0+-100	19701	SFR25H
A71R159	0698-3228	9		RESISTOR 48.8K 1% .125W F TC=0+-100	19701	SFR25H
A71R161-R162	0698-6943	1	2	RESISTOR 20K .1% .125W F TC=0+-50	19701	5033R
A71R163	0757-0283	6		RESISTOR 2K 1% .125W F TC=0+-100	19701	SFR25H
A71R164	0698-4461	4		RESISTOR 698 1% .125W F TC=0+-100	91637	CMF-55-1 T-1
A71R165	0757-0283	6		RESISTOR 2K 1% .125W F TC=0+-100	19701	SFR25H
A71R166	0683-1015	7		RESISTOR 100 5% .25W CF TC=0-400	77902	R-25J
A71R167	0686-3305	8	1	RESISTOR 33 5% .5W CC TC=0+412	01121	EB3305
A71R168	0683-1035	1		RESISTOR 10K 5% .25W CF TC=0-400	77902	R-25J
A71R170-R171	0683-1515	2		RESISTOR 150 5% .25W CF TC=0-400	77902	R-25J
A71R172	2100-3207	1	1	RESISTOR-TRMR 5K 10% C SIDE-ADJ 1-TRN	32997	3386X-Y48-502
A71R173	2100-3354	8	1	RESISTOR-TRMR 50K 10% C SIDE-ADJ 1-TRN	32997	3386X-Y48-500
A71R175	0698-3378	0		RESISTOR 51 5% .125W CC TC=-.270/+540	01121	BB5105
A71R176	0757-0277	8		RESISTOR 49.9 1% .125W F TC=0+-100	19701	SFR25H
A71R177-R178	0757-0442	9		RESISTOR 10K 1% .125W F TC=0+-100	19701	SFR25H
A71R179	0757-0280	3		RESISTOR 1K 1% .125W F TC=0+-100	19701	SFR25H
A71R180	0699-2070	9	1	RESISTOR 21 OHM 1% 1/20W HF04 T0	91637	CMF-50-21
A71R181	0757-0277	8		RESISTOR 49.9 1% .125W F TC=0+-100	19701	SFR25H
A71R182	0757-0412	3	1	RESISTOR 365 1% .125W F TC=0+-100	19701	SFR25H
A71R183	0757-0407	6	2	RESISTOR 200 1% .125W F TC=0+-100	19701	SFR25H
A71R184-R185	0757-0284	7	2	RESISTOR 150 1% .125W F TC=0+-100	19701	SFR25H
A71R186	0757-0407	6		RESISTOR 200 1% .125W F TC=0+-100	19701	SFR25H
A71R187	2100-1986	9	1	RESISTOR-TRMR 1K 10% C TOP-ADJ 1-TRN	73138	82PR1K
A71R188	0757-0199	3	1	RESISTOR 21.5K 1% .125W F TC=0+-100	19701	SFR25H
A71R189-R196	0683-1035	1		RESISTOR 10K 5% .25W CF TC=0-400	77902	R-25J
A71R200	0683-1035	1		RESISTOR 10K 5% .25W CF TC=0-400	77902	R-25J
A71R201-R202	0683-6815	5		RESISTOR 680 5% .25W CF TC=0-400	77902	R-25J
A71R203-R208	0683-1025	9		RESISTOR 1K 5% .25W CF TC=0-400	77902	R-25J
A71RP1	1810-0280	8	1	NETWORK-RES 10-SIP 10.0K OHM X 8	91637	MSP10A01
A71RP2	1810-0279	5	2	NETWORK-RES 10-SIP 4.7K OHM X 8	91637	MSP10A01
A71RP3	1Q68-0078	2	1	ICC FNLN GAIN NETWK-3577 P20	28480	1Q68-0078
A71RP4	1810-0675	5	1	NETWORK-RES 10-SIP MULTI-VALUE	13606	216CK261
A71RP5	1810-0279	5		NETWORK-RES 10-SIP 4.7K OHM X 8	91637	MSP10A01
A71TP1-TP14	1251-0600	0	14	CONNECTOR-SGL CONT PIN 1.14-MM-BSC-SZ SQ	27264	16-06-0034
A71U1	1820-1244	7	1	ICMUXR/DATA-SEL TTL LS 4-TO-1-LINE DUAL	01295	SN74LS153N
A71U3	03577-60307	4	1	PRGMD PROM	28480	03577-60307
A71U3	1816-1142	5	2	IC TTL S 4096 (4K) PROM 70-NS 3-S	18324	N82S141F
A71U5	1820-1897	7	3	ICFF TTL LS D-TYPE POS-EDGE-TRIG PRL-IN	27014	DM74LS374N
A71U6-U7	1SB9-0029	0	2	ICC DGTL FILTR-3577 C28	28480	1SB9-0029
A71U8	03577-60308	5	1	PRGMD PROM	28480	03577-60308
A71U8	1816-1142	5		IC TTL S 4096 (4K) PROM 70-NS 3-S	18324	N82S141F
A71U9	1820-1897	7		ICFF TTL LS D-TYPE POS-EDGE-TRIG PRL-IN	27014	DM74LS374N
A71U10-U11	1820-1216	3	2	ICDCDR TTL LS 3-TO-8-LINE 3-INP	01295	SN74LS138N
A71U12	1820-1197	9	1	ICGATE TTL LS NAND QUAD 2-INP	01295	SN74LS00N
A71U13	1820-6748	6	1	ICD TTL 74F550 OC TNCVR C28	27014	74F550DC
A71U14	1813-0257	5	1	A/D 12-BIT 28-CBRZ/SDR BPLR	24355	AD574AKD
A71U15	1828-0715	7	2	ICOP AMP LOW-NOISE 8-DIP-P PKG	18324	NE5534AN
A71U16	1820-1897	7		ICFF TTL LS D-TYPE POS-EDGE-TRIG PRL-IN	27014	DM74LS374N

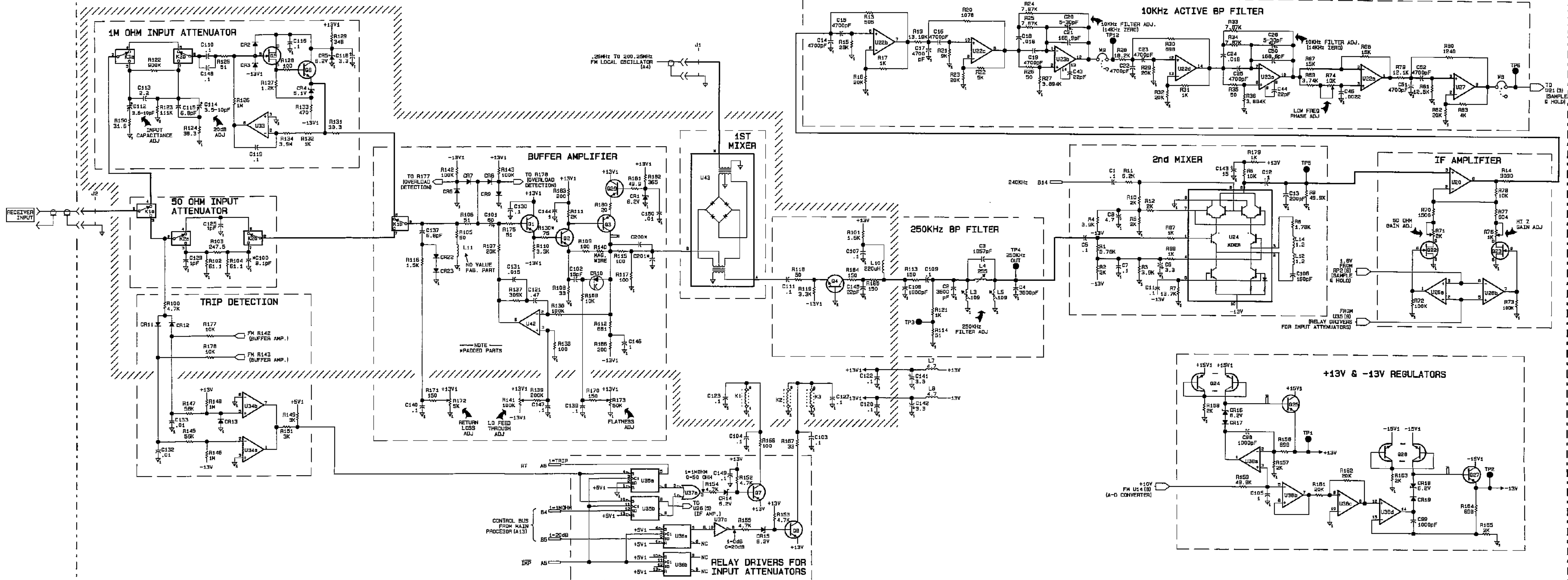
See introduction to this section for information  
\* Indicates factory selected values

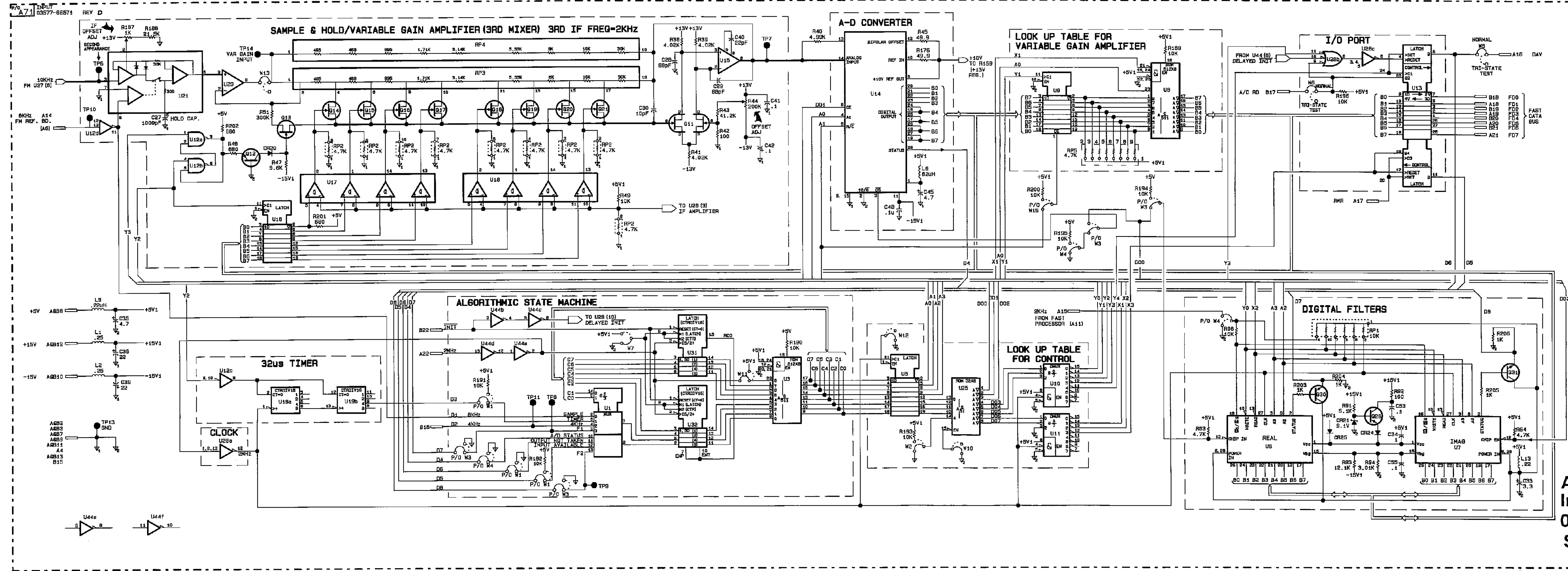
Table 7-4. Replaceable Parts

Ref.Des.	HP Part Number	CD	Qty	Description	Mfr. Code	Mfr. Part Number
A71U17-U18	1826-0138	8	2	ICCOMPARATOR GP QUAD 14-DIP-P PKG	27014	LM339N
A71U19	1820-2096	9	1	ICCNTR TTL LS BIN DUAL 4-BIT	01295	SN74LS393N
A71U20	1826-0715	7		ICOP AMP LOW-NOISE 8-DIP-P PKG	18324	NE5534AN
A71U21	1826-0503	1	1	SAMPLE AND HOLD 8 -METAL	27014	LF398H
A71U22	1826-0522	4	1	ICOP AMP LOW-BIAS-H-IMPQ QUAD 14-DIP-P	01295	TL074CN
A71U23	1826-1319	9	1	ICL OPAMP 5533 BIP LN P14	18324	NE5533AN
A71U24	1820-0427	6	1	ICMODULATOR TO-100 PKG	04713	MC1496G
A71U25	03577-60309	6	1	PRGMD PROM	28480	03577-60309
A71U25	1816-1811	3	1	ICM PROM 27S19 32x8 40NS P16	34335	AM27S19PC
A71U26	1826-0412	1	2	ICCOMPARATOR PRCN DUAL 8-DIP-P PKG	27014	LM393N
A71U27	1826-0319	7	1	ICOP AMP LOW-BIAS-H-IMPQ TO-99 PKG	27014	LF356H
A71U28	1820-1202	7	1	ICGATE TTL LS NAND TPL 3-INP	01295	SN74LS10N
A71U29	1826-0302	8	1	ICOP AMP GP TO-99 PKG	04713	MC1741SCG
A71U31-U32	1820-1430	3	2	ICCNTR TTL LS BIN SYNCHRO POS-EDGE-TRIG	01295	SN74LS161AN
A71U33	1826-0635	0	2	ICOP AMP LOW-OFS 8-DIP-P PKG	06665	OP-07CP
A71U34	1826-0412	1		ICCOMPARATOR PRCN DUAL 8-DIP-P PKG	27014	LM393N
A71U35-U36	1820-1112	8	2	ICFF TTL LS D-TYPE POS-EDGE-TRIG	01295	SN74LS74AN
A71U37	1820-1417	6	1	ICGATE TTL LS NAND QUAD 2-INP	01295	SN74LS26N
A71U38	1826-1116	4	1	ICOP AMP GP QUAD 14-DIP-P PKG	07933	RC4156DB
A71U42	1826-0635	0		ICOP AMP LOW-OFS 8-DIP-P PKG	06665	OP-07CP
A71U43	03577-87902	1	1	MX MWAV MD-983	03174P01	MD983
A71U44	1820-1188	1	1	ICINV TTL LS HEX 1-INP	01295	SN74LS04N
A71W1	1258-0223	7	2	CON-JUMPER 3 AMPS	22526	69145-206
A71W2	1258-0141	8	11	CON-JUMPER REM .025P	22526	65474-004
A71W3	1258-0222	6	1	CON-JUMPER 3 AMPS MULT REM 2x3	22526	69145-208
A71W4	1258-0223	7		CON-JUMPER 3 AMPS	22526	69145-206
A71W5-W13	1258-0141	8		CON-JUMPER REM .025P	22526	65474-004
A71W15	1258-0141	8		CON-JUMPER REM .025P	22526	65474-004
A71W16	7175-0057	5	1	RESISTOR-ZERO OHMS SOLID TINNED COPPER	09684P01	UN105-6
A71	0515-1843	2	12	SCR-MCH M3.0 22MMLG PHPZ SST *	77250	
A71	4330-0496	3	9	INSULATOR-BEAD GLASS	53101	KG12
A71	2190-0824	1	6	WASHER-LK INTL T NO. 3 .102-IN-ID	73734	99401
A71	0515-0905	7	6	SCREW-MACH M2.5 X 0.45 6MM-LG PAN-HD	28480	
A71	0515-1056	1	6	SCREW-MACH M2.5 X 0.45 4MM-LG PAN-HD	77250	
A71	0340-1169	6	3	NSLTR-BSNG .038TK TO-72 NYLNA	32559	118-055
A71	2190-0124	4	1	WASHER-LK INTL T NO. 10 .185-IN-ID	98291	3002-26
A71	2190-0378	8	1	WASHER-FL MTLC NO. 4 .115-IN-ID	73734	
A71	03577-04101	8	1	SHTF CVR-RCVR BDS ALSK	28480	03577-04101
A71	03577-04102	9	1	SHTF CVR-RCVR BD SHLD ALSK	28480	03577-04102
A71	2260-0002	6	1	NUT-HEX-DBL-CHAM 4-40-THD .062-IN-THK	77250	
A71	2950-0078	9	1	NUT-HEX-DBL-CHAM 10-32-THD .067-IN-THK	98291	33002-18-00-0-156
A71	7121-4611	2	1	LABEL-INFORMATION .15-IN-WD .6-IN-LG	28480	L01003
A71	03577-20601	7	1	CSTG-SHIELD-CIRCUIT SIDE AL	01440P01	
A71	03577-20602	8	1	CSTG-SHIELD-COMPONT SIDE AL	01440P01	
A71U35-U36	1820-1112	8	2	ICFF TTL LS D-TYPE POS-EDGE-TRIG	01295	SN74LS

See introduction to this section for information  
\* Indicates factory selected values







**A71**  
**Input Board**  
**03577-66571**  
**Sheet 2 of 2**



# Section VIII

## Circuit Descriptions

---

### 8-1 Introduction

This section provides circuit descriptions to be used along with the schematics of Section IX (Service). This information should be used after isolating faults to the functional block level. The descriptions here and the schematics in Section VIII provide information for fault isolation inside each functional block. The technician's expertise is then relied upon to isolate the faulty component(s) within the functional block.

If more general information is desired, the overall instrument operation description in Section II (Fault Isolation) gives a broader explanation of the instrument's operation.

## 8-2 A4 Local Oscillator Board

### Circuit Board Description

The local oscillator board (A4) is used to provide a signal (0.25 to 200.25 MHz) for mixing into the first IF conversion section of the input board (A19). This section has two input signals: a 300 MHz signal from the frequency reference board (A6) and a VCO signal (300.25 to 500.25 MHz) from the synthesizer board (A17).

### 10 dB/20 dB Buffer

These sections are used to provide amplification and isolation between the frequency reference (A6) and synthesizer board (A17) respectively.

### 300 MHz LPF

The 300 MHz low pass filters are used to reduce high frequency harmonic distortion.

### Mixer

The mixer multiplies the signals from the frequency reference board (A6) and the synthesizer board (A17) to produce a signal ranging from 0.25 to 200.25 MHz.

### 200 MHz LPF

The 200 MHz low pass filters are used to remove all but the difference frequency produced by the mixer.

### 20 dB/14 dB Amplifiers

These sections are used to amplify the signal (0.25 to 200.25 MHz) by 48 dB.

### Leveling Loop

The leveling loop is used to maintain a constant amplitude level regardless of the incoming frequency. The signal (0.25 to 200.25 MHz) is first sent to a 10 dB buffer amplifier via a power splitter. This signal is then peak detected. This sensed signal is then compared with a reference voltage by the servo amplifier. When an error signal has been sensed, the servo amplifier increases or decreases the current drive to the limiting mixer to maintain a constant output level.

### 20 dB Amplifier/Power Splitter

These sections take the signal from the leveling loop and amplify it by 20 dB. This signal is then distributed into three-ways by the power splitter.

## 20 dB Amplifiers

The 20 dB amplifiers provide amplification and isolation from the input boards (A19).

---

### Note



There are two (2) identical input boards (A19) for a standard HP 3577B. Receivers: R and A. Option 002 adds a third input board (receiver B) which is identical to the other input boards.

---



## 8-3 A5 250 kHz Offset Board

### Circuit Board Description

The 250 kHz offset board (A5) offsets the 300 MHz signal from the frequency reference board (A6) to 300.25 MHz. The 300.25 MHz signal converts the 300.25 to 500.25 MHz synthesizer board (A17) signal to the 5 Hz to 200 MHz output board (A18) frequency.

### 6 MHz Divider

The 6 MHz from the frequency reference board (A6) is divided by 24 to yield the 250 kHz offset frequency. This 250 kHz is the reference frequency for this board. The INIT line is from the main processor-controller board (A62/63) to insure that the divide by 24 signal is properly synchronized.

### Phase Detector/Loop Filter/Oscillator Unlock Detector

The phase detector compares the 250 kHz reference signal from the 6 MHz divider and the 250 kHz difference frequency from the mixer. The loop filter integrates the phase detector output to create a dc tuned signal. The output of the loop filter is monitored by the oscillator unlock detector. When the loop filter output is a negative voltage or is greater than +9 volts, the unlock detector trips and sets the oscillator unlock to an active low line signal. The main processor-controller board (A62/63) then displays an error message ("OSCILLATOR UNLOCKED, Assembly A5, A6 or A17").

### 250 kHz Filter

This low pass filter removes any 250 kHz harmonics feedthrough from the phase detector and loop filter. Any feedthrough shows up as residual FM on the 300.25 MHz output.

### 300.25 MHz VCO

The 300.25 MHz VCO produces a 300.25 MHz signal phase locked to the 250 kHz reference signal. Phase locking is accomplished with the phase detector and varactor diode tune voltage.

### 300.25 MHz Buffer

The 300.25 MHz buffer drives the output board (A18) with the 300.25 MHz phase locked signal. The 6 dB pad and 10 dB amplifier isolate the offset board (A5) from the output board (A18).

### Mixer Driver

The mixer driver amplifies the 300.25 MHz signal to drive the LO port of the mixer. A strong LO signal is required for good mixer translation.

### **Mixer Buffer**

The buffer filter and pad provide additional isolation between the 300.25 MHz VCO and mixer.

### **300 MHz Buffer**

The 300 MHz buffer amplifies the 300 MHz frequency reference board (A6) signal and provides isolation between the frequency reference board and the 250 kHz offset board (A5).

### **Mixer**

The mixer multiplies the 300.25 MHz VCO signal (LO port) and the frequency reference board (A6) 300 MHz signal (RF port). The 250 kHz difference signal (IF port) is used to phase lock the 300.25 MHz VCO to the 250 kHz reference signal described earlier.

### **250 kHz Amplifier**

This section amplifies the 250 kHz difference signal from the mixer. The signal is then used by the phase detector to lock the 300.25 MHz VCO to the 250 kHz reference.



## 8-4 A6 Frequency Reference Board

### Circuit Board Description

The frequency reference board (A6) generates all of the reference frequencies used in the HP 3577B. It locks to an external frequency reference of  $10 \text{ MHz}/N$ , where  $N = 1, 2, 3, \dots$  and the external frequency reference is  $\geq 100 \text{ kHz}$ . For option 001, this board is always connected to the oven board (A31). However, when an external frequency reference is connected, the oven board is automatically turned off so that the frequency reference board may lock to the external frequency reference. When the instrument is first turned on, the oven assembly is cold. The frequency reference board runs on its  $10 \text{ MHz VCXO}$  when there is no oven or external reference, or when the oven is cold.

### External Reference Path, Oven Path, and Differentiator

This section squares the signal from the external reference input or the oven (A31) input. This square wave is then fed to a differentiator which generates narrow pulses. This process is necessary in order for a  $10 \text{ MHz}$  harmonic to be generated when a sub-harmonic of  $10 \text{ MHz}$  is used as the external reference.

### External Reference Detector

The square wave generated in the previous section is sensed by the external reference detector. The detector drives an LED on the frequency reference board (A6) to indicate that an external reference is present. The external reference detector also passes this information to the main processor-controller board (A62/63) via the EXT REF line which also drives an LED on the front panel. This same line is used to shut down the oven board (A31) output when an external reference signal is detected.

### Phase Detector and Switchable Loop Filter/Reference Lock Detector

The phase detector is used to compare the external reference input signal or the oven (A31) input signal with the  $10 \text{ MHz}$  reference VCXO signal. The phase error signal generated by the phase detector is monitored by the reference lock detector. Whenever an ac signal is present at the phase detector output, this will indicate that the phase-locked loop is unlocked. During this time, the reference lock detector senses this condition and switches the switchable loop filter into a wide band configuration. The phase-locked loop captures the frequency reference by switching the loop filter to the wide band configuration. Once the loop is locked, the reference lock detector allows the switchable loop filter to switch back to a narrow band configuration. Whenever the loop is unlocked (and consequently, whenever the loop is in the wideband configuration), the detector lights up the unlock LED on the frequency reference board (A6). The reference lock detector pass this information to the main processor-controller (A62/63) via the REF LOCK line and displays on the front panel "OSCILLATOR UNLOCKED, Assembly A5, A6 or A17."

## 10 MHz Reference VCXO

The output of the switchable loop filter is fed into the 10 MHz reference VCXO and then the output is buffered and fed back to the phase detector, thus closing the loop.

## 10 MHz Buffers

This section buffers the 10 MHz output from the phase-locked loop. This signal is then fed to the HP 3577B rear panel, "10 MHz OUT, 0 dBm" connector. This section also provides an additional separate 10 MHz signal for the HP-IB board (A16).

## 100 kHz Dividers

This section takes the output of the 10 MHz phase-locked loop and divides the frequency by 100 to generate the 100 kHz signal used in the synthesizer board (A17).

## Phase Detector and Loop Filter/300 MHz Lock Detector

This section is very similar to the phase and lock detectors shown in the 10 MHz phase-locked loop section. The only difference is that the 300 MHz lock detector indicates whether or not the loop is locked (i.e., it does not switch any bandwidths in the loop filter).

## 300 MHz VCO

This section takes the output of the phase detector and uses it to control the frequency of the 300 MHz VCO. This frequency is then fed to the 250 kHz offset (A5) and output (A18) board.

## Prescaler

The output of the 300 MHz VCO is divided down in two stages. The first stage divides the 300 MHz VCO signal down to 30 MHz. This signal is then sent to the fast processor board (A61). The second stage takes the 30 MHz signal output and divides it down to 10 MHz. This signal is then fed back to the phase detector to close the loop.

### ÷ 2.5, ÷ 5, ÷ 3, ÷ 2 Dividers

The output of the first stage of the prescaler (30 MHz) is divided down appropriately to generate the necessary reference frequencies used in the HP 3577B.

### ÷ 50 & ÷ 30 Dividers and Phase Initialization

The phase initialization circuitry operates in conjunction with the divide by 15 counter to produce an 8 kHz signal. This is done by loading a start count once when the HP 3577B is initialized and thereafter allowing the counter to operate normally. Phase may be offset in 30° increments by configuring a switch in the phase initialization circuitry to change the count that is loaded initially.

## 8-5 A18 Output Board

### Circuit Board Description

The output board provides a sinusoidal signal with a frequency range of 5 Hz to 200 MHz and a amplitude level range of +15 dBm to -49 dBm. This output signal is generated by mixing the 300.25 to 500.25 MHz signal of the synthesizer board (A17) with the 300.25 signal from the 250 kHz offset board (A5).

### Mixer Buffer

The 10 dB amplifiers and 3 dB pad provide isolation between the synthesizer board (A17) and the mixer (A18U702).

### Variable Limiter

This section varies the amplitude of the 300.25 MHz signal coming from the 250 kHz offset board (A5) depending on the level signal generated by the Amplitude Leveling section.

### 300 MHz Low Pass Filter

This section reduces high frequency harmonic distortion.

### Mixer

The mixer multiplies the frequency signals from the 250 kHz offset board (A5) and the synthesizer board (A17) to produce a signal with a frequency range of 0 to 200 MHz.

### 200 MHz Low Pass Filters/20 dB Amplifiers

The output signal from the mixer (U702) is first filtered to reduce harmonic distortion, amplified by 40 dB, and then it is filtered again to reduce any harmonic distortion induced by the 20 dB amplifiers.

## 15 dB Amplifier

The output signal level of this section is maintained between 11.0 to 15.0 dBm, with 0.1 dB of resolution. At low frequencies (approximately 5 Hz and below), the DC Servo senses the dc component of that waveform. This dc signal is then sent to the Low Frequency Gain Error Correction section. Note that for frequencies above 5 Hz the DC Servo is no longer in the feedback loop.

## Low Frequency Gain Error Correction

For frequencies below 100 kHz, negative feedback is used to stabilize the gain of the amplifiers. The feedback path comes from the output of the 15 dB Amplifier and through a 60 dB voltage divider formed by R191 and R193. U451 compares the feedback signal to the output signal from the 200 MHz Low Pass Filter. The difference from these two signals drives the 20 dB Amplifier. In addition, the signal from the DC Servo is added to the input of the 20 dB Amplifier via R455 and U451.

## Amplitude Leveling

For frequencies equal to and below 100 kHz the main processor-controller board (A62/63) signals the Amplitude Leveling, via the Control Bus, to turn off. This is done by setting the voltage at U800(8) to zero, thereby forcing U800 to act like a voltage-follower. During this frequency range, the output of this section has a referenced dc voltage which is independent of the output frequency from the 15 dB Amplifier. This section obtains its dc reference from the Amplitude Reference.

For frequencies above 100 kHz, the dc reference from the Amplitude Reference is compared with the amplitude output level from the 15 dB Amplifier. This is done by peak detecting the amplitude output level from the 15 dB Amplifier and opening the switch Q800.

## Amplitude Reference

The Amplitude Reference is controlled by the main processor-controller board (A62/63) via the Control Bus. This section provides the Amplitude Leveling with a dc referenced signal. This dc referenced signal, compared with the amplitude output level from the 15 dB Amplifier, provides the necessary information to maintain an amplitude output level between 11.0 to 15.0 dBm with 0.1 dB of resolution.

### 60 dB Step Attenuator

This section attenuates the amplitude output level from the 15 dB Amplifier (11.0 to 15.0 dBm with 0.1 dB of resolution) by 60 dB. The attenuator works in the following binary sequence:

K1 & K2	4 dB
K3 & K4	8 dB
K5 & K6	16 dB
K7 & K8	32 dB
K9	OVER VOLTAGE PROTECTION

For example, if an output level between 11.0 and 15.0 (inclusive) is desired, the signal would go straight through without any attenuation. A chart is shown in Section VIII (Service) under the output board schematic demonstrating the operation of the relays pertaining to a given programmed output level. This section also provides overvoltage protection. When a voltage of 4 Vdc or greater is sensed at A18J1, the relay K9 will trip to disconnect the instrument from the "outside world." The 60 dB Step Attenuator receives its control data from the main processor-controller board (A62/63) via the Control Bus.

### Private 5 Volt Supplies

This section provides the output board (A18) with  $\pm 5$  volts. Voltage regulators are used to monitor the  $\pm 5$  supplies, U400b & Q400 and U400a & Q401, respectively.

## 8-6 A15 Keyboard

### Circuit Board Description

The keyboard is responsible for two prime functions:

- To recognize the closure of switches.
- Light up the appropriate LEDs.

The keyboard is constantly being monitored by the main processor-controller (A62/63) via the keyboard data bus lines (KB0 – KB7). If a key is stuck for a period longer than 10 seconds, an error message will then be displayed on the CRT.

### Key Matrix

A 7 X 8 keyboard matrix is used to recognize the closure of switches. This information is then buffered and sent to the main processor-controller board (A62/63).

### Read/Write Control

This section reads the data entered in the key matrix via the main processor-controller board (A62/63) and sends a command signal to LED annunciators.

### LED Annunciators

This section drives the LEDs on the front panel.

### RPG Control

The rotary pulse generator (RPG) control is used to enter data or use the marker function capabilities. This section is also buffered from the main processor-controller board (A62/63).

### Instrument Preset

This section is used to set the instrument to its turn-on preset conditions.

---

## 8-7 A16 HP-IB Board

### Circuit Board Description

This board provides an isolated link between the instrument's main processor-controller (A62/63) and the "outside world." An HP-IB connector is provided at the rear panel of the instrument. This connector is used to connect the instrument to other instruments and controllers which have HP-IB (IEEE 488) capability.

This board also provides electrical isolation between the interface bus and analog sections of the instrument. Isolated power for the interface section of this board is supplied from a separate transformer winding (A21 Main Power Supply Board). All digital signals between the isolated and non-isolated sections of this board are coupled through pulse transformers. The buffer amplifiers drive the pulse transformers and latches which convert pulses to constant signal levels.

### HP-IB Interface

The HP-IB interface section implements the IEEE 488 protocol.

### Interrupt

This section couples the HP-IB interface circuit signal  $\overline{INT}$  from the main processor bus. The interrupt circuit is activated by the HP-IB interface section whenever it requests main processor-controlled (A62/63) service.

### Reset

This section uses the instrument reset line ( $\overline{INIT}$ ) to initialize interaction of hardware.

### Register Select

This section couples the register select signals from the HP-IB interface circuitry. This section provides the register select signals necessary to perform sequential data processing.

### **Read/Write**

This section is used to instruct the HP-IB interface to accept incoming or outgoing data.

### **5 MHz Clock**

This section provides a 5 MHz clock signal necessary to run the HP-IB interface circuitry.

### **Data Input/Output**

Each of these sections handles the sequential data being sent from and to the main processor-controller board (A62/63).



## 8-8 A17 Synthesizer Board

### Circuit Board Description

The synthesizer board (A17) generates a signal in the frequency range of 300.25 to 500.25 MHz with 0.001 Hz resolution. This board uses the Fractional-N synthesis technique which will not be discussed in this manual. For a full explanation of Fractional-N, refer to the following Hewlett-Packard Service Manuals: HP 3325A Synthesizer/Function Generator, HP 3336A/B/C Synthesizer/Level Generator, and HP 3586A/B/C Selective Level Meter. The only input to this board is the 100 kHz signal from the frequency reference board (A6). This signal is used as a frequency reference by the synthesizer for phase-locked loop capabilities. The output signal of this board is sent to the source output board (A18) and the local oscillator board (A4).

### Fractional-N Control

The data and control latches of this section provide the Fractional-N chip (U123) with the appropriate data bus commands from the main processor-controller (A62/63). The following signal names are used:

1.  $\overline{\text{FDAT}}$  loads the data for the Fractional-N.
2.  $\overline{\text{FINST}}$  is used as an instruction load for the Fractional-N.
3.  $\overline{\text{FHOLD}}$  tells the Fractional-N to hold until trigger. This signal is used for synchronizing the start of a sweep.
4.  $\overline{\text{STATWR}}$  is a main processor-controller status interrupt. This signal is used to synchronize the start of a sweep. This signal comes from the fast processor board (A61).
5. The 8 kHz signal is used for final start-of-sweep. This insures that the Fractional-N, input board (A19), and the fast processor board (A61) are synchronized properly so that the appropriate data is taken.

### Fractional-N

The Fractional-N chip (U123) is the "heart" of the frequency synthesis technique. This chip controls the divide by N counter and the API & Bias Current Sources. The  $\overline{\text{FRACLMT}}$  signal is the sweep limit control which comes from the main processor controller board (A62/63). This signal is used to interface with a sweep input on the Fractional-N chip. The  $\overline{\text{FRACFLG}}$  signal is a sweep limit flag which goes to the output (A18) and main processor-controller board (A62/63). This signal indicates that the sweep frequency has exceeded the value in the limit register in the Fractional-N chip.

## ÷ N Counter

The ÷ N counter consists of the following sections:

- MSD ÷ 10 (Max)
- 2nd MSD ÷ 10 (Max)
- Least Significant Digit ÷ 5 (Max)
- 9's Complement of N Storage
- Preload One Shot
- PreLoad
- Pulse Remove Logic
- Pulse Remove Sync
- Dual Modulus Divider
- Chip Clock and Cycle Start
- VCO/N.F. Reclock

The purpose of the ÷ N counter (where N is an integer from 300 to 500) is dividing the prescaled VCO (VCO/10) by some number (N) and producing the 100 kHz signal required by the phase detector.

## API (Analog Phase Interpolation) & Bias Current Sources

The API & Bias Current Sources consist of the following sections:

- API & Bias Current Control
- Bias Current Source
- Current Sinks

These current sources discharge the integrator after it has been charged by the phase detector. By discharging (subtracting) current from the integrator, this insures that the dc control voltage from the sample and hold maintains a steady dc state.

## Phase Detector

The phase detector compares the 100 kHz from the frequency reference (A6) with the ÷ N counter output (VCO/N.F.). The output of the phase detector is a series of pulses of equal width. The width of the pulses depends on the phase difference detected between the 100 kHz reference and the VCO/N.F.

## Integrator/Sample and Hold

The integrator and sample and hold convert the phase detector output pulses, with the help of the API correction currents, to the dc control voltage required to drive the 300.25 to 500.25 MHz VCO.

### **PLL Unlock Detector**

This section determines if the phase-locked loop (PLL) is unlocked. When the detector senses an out-of-range dc control voltage, it turns on an internal LED and interrupts the main processor-controller board (A62/63). A message will then appear on the display. Refer to the Section II (Fault Isolation) for further details.

### **500 kHz Filter**

This section reduces sidebands of 100 kHz and its harmonics induced by the sample and hold.

### **300.25 – 500.25 MHz VCO**

The dc control voltage produced by the sample and hold controls the output frequency (300.25 to 500.25 MHz) of the VCO. The output frequency signal of this section is inversely proportional to the dc control voltage from the sample and hold. The output frequency of the VCO is distributed to the output board (A18), the local oscillator board (A4), and the prescaler section.

### **Prescaler**

Before the output frequency of the VCO is sent to the  $\div N$  counter the VCO is first divided by 10 (prescaled).

### **+5 API Supply**

This section provides the APIs with an isolated +5 voltage supply.

## 8-9 A20 Motherboard

### Circuit Board Description

The motherboard does not have any active or passive electrical components. The only purpose of this board is to be a common focal point where signals are distributed throughout the instrument. The signal names that are distributed via the motherboard are listed in Section IX (Service) under the mother assembly number.

## 8-10 A21 Main Power Supply Board

### Circuit Board Description

This board is an off line half-bridge switching power supply. The main power supply board provides regulated (+ 5 Vdc,  $\pm 15$  Vdc) and unregulated (+ 8 Vdc) voltages. It also has isolated supplies (HP-IB and Fan Output). MOS FET transistors provide the switching power supply capabilities. The "heart" of this switching power supply is the Pulsewidth Modulator (PWM). In addition, the power supply has the capabilities of sensing output current and overvoltage, monitoring the ac line voltage, and turning off due to excess temperature. For further details on switching power supplies, refer to *Power Supplies, An Introduction* (HP part no. 5952-0158).

### Line Filter

The line filter provides RFI isolation between the ac line voltage and the main power supply.

### Turn On

This section is used to signal the Pulsewidth Modulator (PWM) when to turn on. For example, when the instrument has been turned off due to over or under ac line voltage. This section is also used to insure that the power supply turns on in an orderly manner.

### Power On Preset (POP)

After the output voltages are up and running, this section presets the microprocessor (A63U1). This section is also used to turn-on the battery back-up circuit on the main processor-controller board (A62/63).

### Bias Supply

The bias supply provides power for the control and protection circuitry. The signal name LINE SYNC synchronizes the fast processor's (A61) sweep triggering with the ac line.

### FET Power

In this section the ac line is rectified and filtered to provide a high dc power supply. This high voltage supply is then switched across the primary of the transformer (T1) by Q1 and Q2.

### FET Drive

The FET drive takes the signal from the Pulsewidth Modulator (PWM) and develops two anti-phase signals to drive the FETs (Q1 & Q2). These transistors are used to switch the dc high voltage created in the FET power section. This section also provides isolation between the PWM, which is connected to circuit ground, and FET power, which is connected to the ac line.

### **Pulsewidth Modulator (PWM)**

The PWM is the “heart” of the switching power supply (A21). The outputs of the power supply are controlled by the PWM. The PWM takes the error signal from the Loop Shaping section and uses it to control the pulsewidth to the FET drive. The PWM contains its own internal oscillator, which has a frequency of 40 kHz and a + 5 voltage reference. The PWM also contains a soft-start circuit to prevent large current surges at turn-on. In addition, the PWM can be turned off by any of the protection circuitry, including the Turn On section, when a fault is detected.

### **Primary Current Limit (PCL)**

The PCL circuit senses the primary current via the transformer (T2) and latches off the Pulsewidth Modulator (PWM) when excess current is detected.

### **+5V Output**

The signal from the FET Drive via the transformer (T1) is first rectified and then filtered to produce a + 5 dc voltage. This section also contains a current sensing resistor for the +5V Current Limit (+5CL) section.

### **+5V Current Limit (+5 CL)**

This section senses the + 5V current and latches off the Pulsewidth Modulator (PWM) when excess current is detected.

### **Loop Shaping (Loop S.)**

The error signal from this section adjusts the pulsewidth of the Pulsewidth Modulator (PWM). This section has two inputs. One of the inputs is the dc loop, from the + 5V Output, which provides good steady state voltage accuracy. The second input is the ac loop, also from the + 5V Output, which helps improve transient responses.

### **+15V**

The signal from the FET Drive via the transformer (T1) is first rectified and then filtered to produce a +15 dc voltage. The regulator (U10) used in this section provides an accurate, low output impedance, +15 voltage. This section also contains a current sensing resistor for the ± 15V Current Limit (LMT) section.

### **- 15V**

The signal from the FET Drive via the transformer (T1) is first rectified and then filtered to produce a - 15 dc voltage. The regulator (U11) used in this section provides an accurate, low output impedance, - 15 voltage. This section also contains a current sensing resistor for the ± 15V Current Limit (LMT) section.

## **Isolated Supply**

This section provides a regulated dc supply for the HP-IB and an unregulated dc supply for the fan output. Note that these supplies are fused and are floating from chassis ground.

### **+8V**

This section provides a fused, unregulated +8 dc supply for the synthesizer (A17) and frequency reference (A6) boards .

### **± 15V Current Limit (LMT)**

The ± 15V Current LMT senses the current from the + 15V and - 15V supplies and latches off the Pulsewidth Modulator (PWM) when excess current is detected.

### **Overvoltage**

This section senses the voltage from the ± 15V and + 5V supplies and latches off the Pulsewidth Modulator (PWM) when overvoltage is detected.

### **Hi Temp**

This section senses the temperature of CR40 located in the + 5V Output section and latches off the Pulsewidth Modulator (PWM) when excess temperature is detected.

### **Connector (Conn.)**

This section distributes the power supplies throughout the entire instrument via the motherboard (A20). This section also provides probe power.

## 8-11 A31 Oven Board (Option 001 only)

### Circuit Board Description

The oven board generates a stable 10 MHz frequency reference signal, that is controlled by the frequency reference board (A6). When an external reference signal is used on the HP 3577B, the frequency reference board forces the control line "SHUTDOWN" to go low which turns off the 10 MHz oven output signal.

### Threshold Detector

At turn-on before the oven assembly warms up, large heater currents are drawn through L1 by the oven assembly. Regardless of the signal on the control line "SHUTDOWN", U2 senses this current and shuts down the oven output signal at J1 by turning off the switchable filter. During this time, the HP 3577B uses its own VCXO as a frequency reference. After the oven assembly has warmed up (i.e., frequency output is stable), the heater current through L1 is reduced which allows U2 to turn-on the switchable filter and have a 10 MHz signal present at J1. This signal is dependent upon the control input at J2(1) (SHUTDOWN: TTL HIGH = ON, TTL LOW = OFF).

### Oven Assembly

When the oven assembly has warmed up, it provides a stable 10 MHz frequency reference signal. The oven assembly takes approximately 10 minutes to warm up from room temperature.

### Buffer

The buffer provides isolation between the oven assembly and the switchable filter. In the on state (U2 is high), CR2 acts as a open and allows Q3 and Q4 to be biased separately from Q1. In the off state (U2 is low), U2 effectively grounds the emitter of Q1 and the gates of Q3 & Q4.

### Switchable Filter

In the on state, this section provides a 10 MHz low pass filter to reduce harmonic distortion. In the off state, this section provides additional isolation between the buffer and the oven output.



## 8-12 A61 Fast Processor Board

### Circuit Board Description

The fast processor board (A61) is a floating point processor. The main purpose of this board is to perform floating point and fast numerical calculations (number crunching). This is done by taking data from the input boards (A19) and controlling the sweep timing of the HP 3577B. This board contains its own firmware (Micro Program ROMs), Micro Program Sequencer, and a Bit/Slice ALU (Arithmetic Logic Unit). The ROMs provide microcode which defines the instruction steps for the fast processor board. The Micro Program Sequencer contains a microprogram controller which handles program flow. The Bit/Slice ALU provides 16-bits of data. This is where floating point and fast numerical calculations are performed.

### Input Data Buffer

This bidirectional buffer manages communication between the input (A19) and the Fast Processor Board (A61).

### Data Immediate

This section provides data to the Bit/Slice ALU when performing arithmetic constant calculations.

### Dynamic Clock

This dynamic clock is used as the system clock for the fast processor. It is controlled by the microprogram controller. The frequency of the dynamic clock is a function of the instructions executed by the fast processor.

### Bit/Slice ALU (Arithmetic Logic Unit)

This section is the "heart" of the floating point processor. The ALU provides a 16-bit word length. The functions that are performed in the ALU are:

- 16-Bit Adder/Subtractor
- 16-Bit x 16 Word RAM
- 16-Bit (Q) Register
- Shift Registers
- Multiplexers

### Output Data Registers

These tri-state registers provide isolation between the Bit/Slice ALU and the Fast Data Bus.

### **Read/Write Control**

This section is used to read and write data to the input (A19) and the main processor-controller board (A62/63). For example, the signal name BUSGNT (Bus Grant) is used to notify the main processor-controller (A62/63) that the Fast Data Bus is now available.

### **Micro Program ROM**

This section provides the fast processor with a  $2k \times 48$ -bit program storage capabilities.

### **Micro Program Sequencer**

The sequencer controls the program flow for the fast processor.

### **Timing**

This section provides the sweep control counter and the digital filters on the input board (A19) with a 4 kHz and 2 kHz reference signal, respectively.

### **Sweep Control Counter**

This section is used as a loadable counter. This counter controls the sweep time and settling time of the input board (A19).

## 8-13 A62/63 Main Processor-Controller Board

### Circuit Board Description

The central or main intelligence of the HP 3577B Network Analyzer is the main processor-controller board (A62/63). A standard HP 3577B uses an A62 main processor-controller board. An HP 3577B Option 1C2 which provides HP Instrument BASIC capability uses an A63 board. In either case, the "heart" of the main processor is a 16-bit microprocessor which runs at 10 MHz. This board contains its own firmware (ROM) and RAM. The main processor bus on this board provides all interfacing between the microprocessor and other portions of the instrument. This interfacing includes the I/O (Input/Output), Display Interface, and Fast Bus interface. The I/O section includes the Keyboard Bus, HP-IB Bus, Control Bus, and Status lines. The Display Interface section provides all display functions. The Fast Bus Interface ties the main processor-controller's communication port with that of the Fast Data Bus. The input (A19) and the fast processor (A61) boards communicate via the Fast Data Bus.

Trace memory also resides on the main processor-controller board. It provides non-volatile data storage capabilities. The ROM and RAM for trace memory is checked when the instrument is turned on. A checksum is performed for ROM and a marching ones is performed for the RAM test. Use the SPCL FCTN hardkey for a more exhaustive test. See Section II (Fault Isolation) under Service Diagnostics for more information.

### Interrupt Encoding

This section is used to interrupt the microprocessor when the HP-IB (A16) is requesting service or when the front panel INSTRUMENT PRESET key is pressed. This section is also used as a timer and fast processor (A61) interrupt.

### Reset

This section ensures that the microprocessor (A63 U1) begins its program at a initial (known) state.

### Data/Address Bus Buffer

These buffers provide the microprocessor (A63 U1) isolation from the rest of the board.

### Trigger

This section is used to trigger the sweep on the fast processor board (A61) whenever an external trigger signal is connected on the rear panel or whenever the user wants to trigger off the ac line. If neither of these two conditions are used, the fast processor board will then free run.

## Address Decoding

The address decoding is used to read/write and send control data to various boards throughout the instrument.

## Beeper

The beeper is used to inform the user that attention is required. For example, when an error message is displayed the beeper will alert the user that the main processor-controller (A62/63) has detected an unsatisfactory operating condition.

## 10 MHz Clock Phase-Locked Loop (PLL)

This section provides an 10 MHz clock signal necessary to run the microprocessor (A63 U1). This is done by multiplying the 1 MHz signal, which comes from the frequency reference board (A6), by twenty (20), and then dividing it by two to produce 10 MHz. If the 1 MHz is not present, the 20 MHz PLL will free run in order to clock the microprocessor. An error message will then appear on the display.

## Display Interface

This section is a 16-bit bidirectional data buffer. The signal name "DISCONNECT SENSE" is used to show the display's test pattern.

## I/O

The I/O section contains the Control Bus, Keyboard Bus, HP-IB Bus, and Status lines.

## ROM/RAM

The main processor ROM/RAM serves two functions. It provides instrument state storage and it provides the main processor-controller (A62/63) with 16-bits of data. The ROM/RAM for trace memory also resides on the main processor-controller board but its function is closely tied to the fast processor board (A61). The RAM for trace memory serves as a scratch pad memory for the fast processor board (A61). It also is used to store data in registers D1 through D4 and X1 through X8. To preserve data storage, only the scratch pad memory portion of the RAM is tested when the instrument is turned on. The ROM for trace memory contains the coefficients corresponding to trigonometric and logarithmic functions for the fast processor board (A61).

### **Fast Bus Interface**

This section provides the main processor-controller a means of communicating with the fast processor (A61) and input (A19) boards. In order for the main processor-controller to communicate with the input boards, the fast processor must grant the bus. The latches and buffers used in this section are bidirectional.

### **Battery Back-up**

This section provides power backup for the RAMs. If the voltage at test point 8 (+ VDD) drops below approximately 3 volts, the battery (BT1) located on the main processor-controller board (A62/63) supplies power.

### **Chip Select and Read/Write Control (DECODING)**

This section insures that trace data is received and sent by the appropriate trace memory RAM/ROM chips.

## 8-14 A19 Input Board

### Circuit Board Description

The input board (A19) is a tuned, low noise receiver. The input board is tuned to the source output (A18) frequency and tracks it as the source is swept. The receiver can be tuned from 5 Hz to 200 MHz with tuning bandwidth of 1 Hz to 1 kHz in decade values. This board processes the input signal using both analog and digital signal processing. The analog processing includes input impedance, input attenuation, and frequency conversion from the source frequency to a 10 kHz intermediate frequency (IF) with amplitude and phase information preserved. The digital signal processing includes sampling the 10 kHz IF at an 8 kHz rate, creating a 2 kHz digital IF. The real and imaginary phasor components are extracted using quadrature mixing via the digital filters. These filters also set the receiver tuning bandwidth.

A standard HP 3577B has A19 input boards for receivers A and R. Option 002 adds a third A19 input board for receiver B.

### 50/1M $\Omega$ Input Attenuator

Relay K1 & K4 select the receiver input impedance. The relaxed state for the relays are the 1 M $\Omega$  position. Relays K2 and K3 select the input attenuation, 0 or 20 dB. Each impedance path has its own 20 dB attenuator. The relaxed state for relays K2 and K3 are in the 0 dB attenuation position. Relays K2 and K3 are always switched together. The 1 M $\Omega$  path also has a buffer amplifier which is used as an impedance converter. It converts from a 1 M $\Omega$  to a 50  $\Omega$  environment where the rest of the instrument operates.

### Buffer Amplifier

The unity gain buffer amplifier consists of a 12 dB amplifier and a 12 dB attenuator. Both the amplifier and the attenuator are used to increase isolation between the first mixer and the "outside world." The buffer amplifier consists of Q1, Q2, Q3, and Q29. U42 is used in a dc servo loop to compensate for mixer feedthrough.

### First Mixer

The first mixer down converts the 5 Hz to 200 MHz source frequency to a 250 kHz IF using the 0.25 MHz to 200.25 MHz local oscillator signal from the local oscillator board (A4).

### Trip Detection

Diode CR12 detects the positive and negative peaks of the input signal. If the input signal is greater than  $\pm 1.1$  V peak, the comparators will signal an overload. This sets the input impedance relay to the 1 M $\Omega$  position and signals the main processor-controller board (A62/63) that an overload has occurred.

## 250 kHz Bandpass Filter

The 250 kHz bandpass filter rejects all higher frequency mixer products from the first mixer. This filter also provides a zero at 230 kHz. The zero is to cancel any signals at 230 kHz, which is the image frequency for the next IF (10 kHz). At the beginning of this section there is an IF buffer used (A19Q4). This buffer presents a good 50  $\Omega$  load to the mixer. A good load is required in order to obtain a flat frequency response at the output of the mixer.

## Second Mixer

The second mixer down converts the 250 kHz first IF frequency to the 10 kHz second IF. The local oscillator signal (240 kHz) is obtained from the frequency reference board (A6). L14, L12, and C106 are used to drop the gain of the mixer at input frequencies other than 250 kHz (Note: the two inductors provide magnetic field cancellation to reduce receiver-to-receiver cross talk).

## IF Amplifier

The second IF amplifier provides isolation between the second mixer and the 10 kHz bandpass filter. It also sets the overall receiver gain to unity for both the 50  $\Omega$  and 1 M $\Omega$  impedance positions.

## 10 kHz Active Bandpass Filter

The 10 kHz active bandpass filter cancels all upper frequency second mixer products. It also provides a zero at 14 kHz to cancel the 254 kHz first mixer feedthrough when the source is programmed for 4 kHz.

## Sample and Hold

The sample and hold circuit samples the 10 kHz IF at an 8 kHz rate. This sampling action effectively down converts the 10 kHz IF to a 2 kHz digital IF. The 2 kHz signal is a stairstep output.

## Variable Gain Amplifier

This section is a programmable 8-bit binary amplifier. The gain of the amplifier is variable between 1 and 128 in octave steps. The gain of the amplifier is set by the Analog to Digital converter. The A to D makes an 8-bit conversion with the amplifier set to a gain of 1.1. The conversion value is then used to program the amplifier for an A to D input voltage as close as possible to the A to D full scale input. This amplifier gives the A to D seven more bits of dynamic range.

## Analog to Digital (A - D) Converter

The Analog to Digital converts the analog 2 kHz stairstep signal to a 2 kHz digital IF. The A to D first sets the gain of the variable gain amplifier with an 8-bit conversion, and then makes a 12-bit conversion on the amplified signal. This 8-bit/12-bit cycle is repeated for every stairstep on the digital 2 kHz IF signal.

## Look Up Table Variable Gain Amplifier

This section provides optimum gain settings stored for a given 8-bit conversion in one-half of the ROM (A19U8). The other half of this section provides the number of zeros the digital filters should append to the 12-bit conversion result.

## Digital Filters

The quadrature digital filters process the A to D output values by digitally mixing the values with the 2 kHz signal from the fast processor board (A61). The output is simultaneously mixed with two filters. One of the mixers is fed with the equivalent of a 2 kHz sine wave, the other with a cosine wave. The output of the filters is a digital representation of the "real" and "imaginary" components of the input. These values are then fed to the fast processor (A61) for storage and processing.

## 32 $\mu$ S Timer

The timer is used for timeouts in the operation of the algorithmic state machine.

## Algorithmic State Machine

This is a ROM based state machine. U31 & U32 latch present state and qualifier information, which is used by the ROM (U3) to determine the next state. The multiplexer (U1) determines which qualifiers will be used in making a decision.

## Look Up Table For Control

The ROM (U25) is used to decode state information into various control signals.

## I/O Port

The bidirectional latch handshakes data to the fast processor board (A61) via the Fast Data Bus.

---

### Note



There are two (2) identical input boards (A19) for a standard HP 3577B. Receivers: R and A. Option 002 adds a third input board (receiver B) which is identical to the other input boards.

---



## 8-15 HP Digital Display Circuit Descriptions

The simplified block diagram (figure 8-1) shows the major functional stages of the HP Digital Display. The theory of operation of each stage is described below. Refer to the detailed block diagram in Section IX.

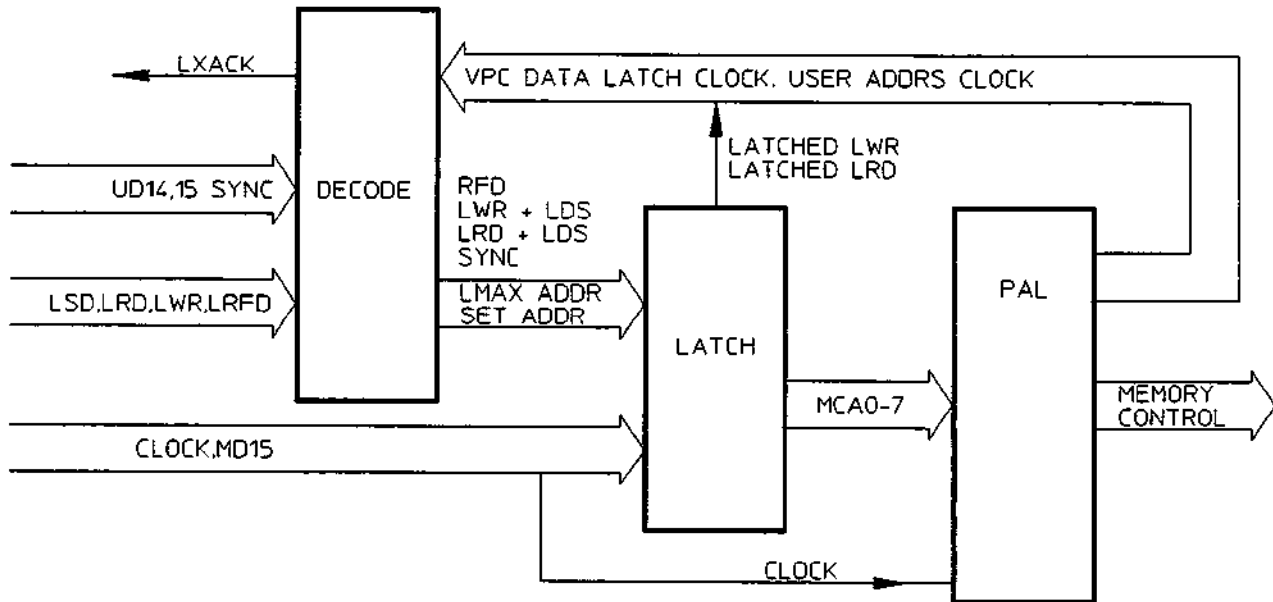


Figure 8-1. HP Digital Display  
Simplified Block Diagram

**Signal Line Definitions**

- D0 – D15** D0 through D14 are the vector data lines (TTL positive logic). D15 is used as a Vector Memory instruction. When D15 is a “1” then the input data is recognized as a memory command. When D15 is a “0” then all the input data forms the picture.
- DISCONNECT** This line must be grounded to the display chassis when the data lines are active.
- SENSE** The internal performance verification pattern will be displayed if the 26-pin connector is disconnected.
- SYNC** External display refresh synchronization signal line. Thew line provides an external refresh clock when external sync mode has been selected via a jumper wire on the Vector Memory board.
- LXACK** Acknowledge signal line. When low, this line indicates that the Vector Memory has completed the Read or Write operation requested by the user processor.
- LDS** Device Select signal line. When low this line enables the Vector Memory to communicate with the user processor (write/read).
- LWR** Memory Write signal line. When low, this line indicates that the 16-bit Data Bus contents are to be written into either the current Vector Memory location(D15=0) or into the User Address Pointer (D15=1).
- LRD** Memory Read signal line. When low, this line indicates that the contents of the current Vector Memory location (as specified by the User Address Pointer) are to be placed on the 16-bit Data Bus for transmission back to the user processor.

## **A82 Vector Processor Control Board**

The purpose of the Vector Processor Control is to convert the digital 16-bit input data to absolute coordinate vector data for the Stroke Generator (A81). This is accomplished by interfacing a host processor or refresh memory system with the circuit board. The 8048 processor (A82 U1) is used for storing the primary and secondary test pattern. The patterns are used for the "Operational Verification Procedure — (in Section III, "Performance Tests") and the adjustment procedures (Section V).

The Vector Processor Control Board contains the following primary circuits:

- Input Data Latches (A82 U6, A82 U8, A82 U13)
- Output Data Latches (A82 U22-A82 U25)
- Character Generator (A82 U5, A82 U9, A82 U10, A82 U11, A82 U12)
- Timing Circuits (A82 U14, A82 U26)
- Vector Processor (A82 U16)

### **Input Data Latches**

The Input Data Latches provide buffering for the Vector Processor (A82 U16). The input data is held in these latches until the VPC is ready for new vector data. Character data is handled by A82 U13, while vector data is handled by A82 U6 and A82 U8. The VPC controls the latching of the data by using the signal lines VECTOR and CHARACTER.

### **Output Data Latches**

The absolute X and Y vector values generated by the VPC (A82 U16), are held in output latches A82 U22-A82 U25 for use by the Stroke Generator. The vector data is transferred by the Data Latch signal into the Output Latches. Control Latches (A82 U18 and A82 U20) contain the last Set Condition commands.

### **Character Generator**

The Character Generator translates character data into vector data for the VPC. ROM A82 U12 contains the stroke information for the modified ASCII character set. The character size and rotation is processed by the VPC for proper vector generation.

### **Timing Circuit**

The clock circuit (A82 U14, A82 U26) provides two clock frequencies. A82 U14 generates the 19.66 MHz signal for the optional Memory Circuit (A84). A82 U14 divides the 19.66 MHz signal by 5 to generate the required 3.93 MHz clock for the VPC.

## Vector Processor (VPC)

The VPC is the controlling device for vector generation, using four programmable modes of operation.

- Set Condition
- Plot Absolute
- Graph Absolute
- Text
- Set Condition

When the Most Significant Bits of an input word (B14, B13), are set to "1", the VPC recognizes the Set Condition Command. The Set Condition Command controls the intensity level, the line type, and the writing speed of the vector drawn. Once a Set Condition has been defined, the data remains stored in latches A82 U18-A82 U20 until a new Set Condition Command is received.

### Plot Command

When the Most Significant Bits (B14, B13) are set to "0", the VPC is ready to process vector data. Data bits B0-B10 define X or Y coordinates. When bit B12 is set to "0" the incoming data is an X coordinate; when bit B12 is set to "1" the incoming data is a Y coordinate. The beam can be turned on or off depending on the status of bit B11. The present X-Y coordinates are latched into A82 U22-A82 U25.

### Graph Command

The Graph Command allows automatic X incrementing with each new Y coordinate input. To invoke the Graph Command, data bit B14 must be set to "0" and B13 must be set to "1". When bit B12 is set to "0", B0-B10 define the X increment. The VPC is now programmed to increment the X coordinate each time a new Y coordinate is received. Bits B0-B10 contain Y coordinate information when B12 is set to "1".

### Text Command

When bit B14 is set to "1" and B13 is set to "0", the VPC is instructed to go to the Text Mode. Bits B0-B7 define the character to be drawn. B11-B12 define the size of character to be drawn, B9-B10 determine rotation of the character. When bit B8 is set to "0" the VPC defaults to the previous size and rotation data. When set to "1" size and rotation information is determined via data bits B9-B12.

## **A81 Stroke Generator, X-Y Output Amplifiers**

The Stroke Generator converts binary data to analog deflection information. The Stroke Generator consists of the following primary circuits.

- Digital to Analog Converters (A81 U1-A81 U6, A81 U13-A81 U18)
- Analog Multiplier (A81 U7, A81 U19)
- Ramp Generator (A81 U26)
- Intensity Controller (A81 U25)

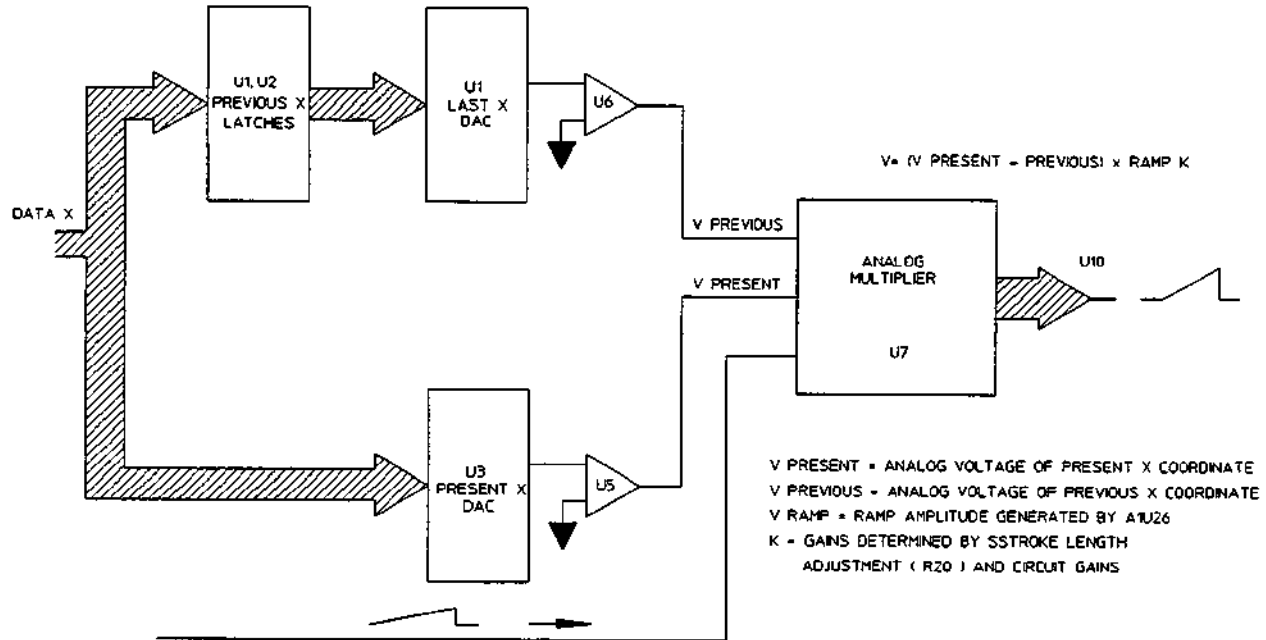
The X and Y Stroke Generator circuits are identical, therefore only the X Stroke Generator will be described below.

### **Digital to Analog Converter**

A81 U1 and A81 U2 latch the previous X coordinate for comparison with the present X coordinate data. A81 U3 and A81 U4 are 12 bit DACs that convert the binary coordinate data to a corresponding analog current. The voltage output of operational amplifiers A81 U5 and A81 U6 represents the present and previous X coordinates. The difference between these two voltages determines the next relative beam movement in the X direction.

### **Analog Multiplier**

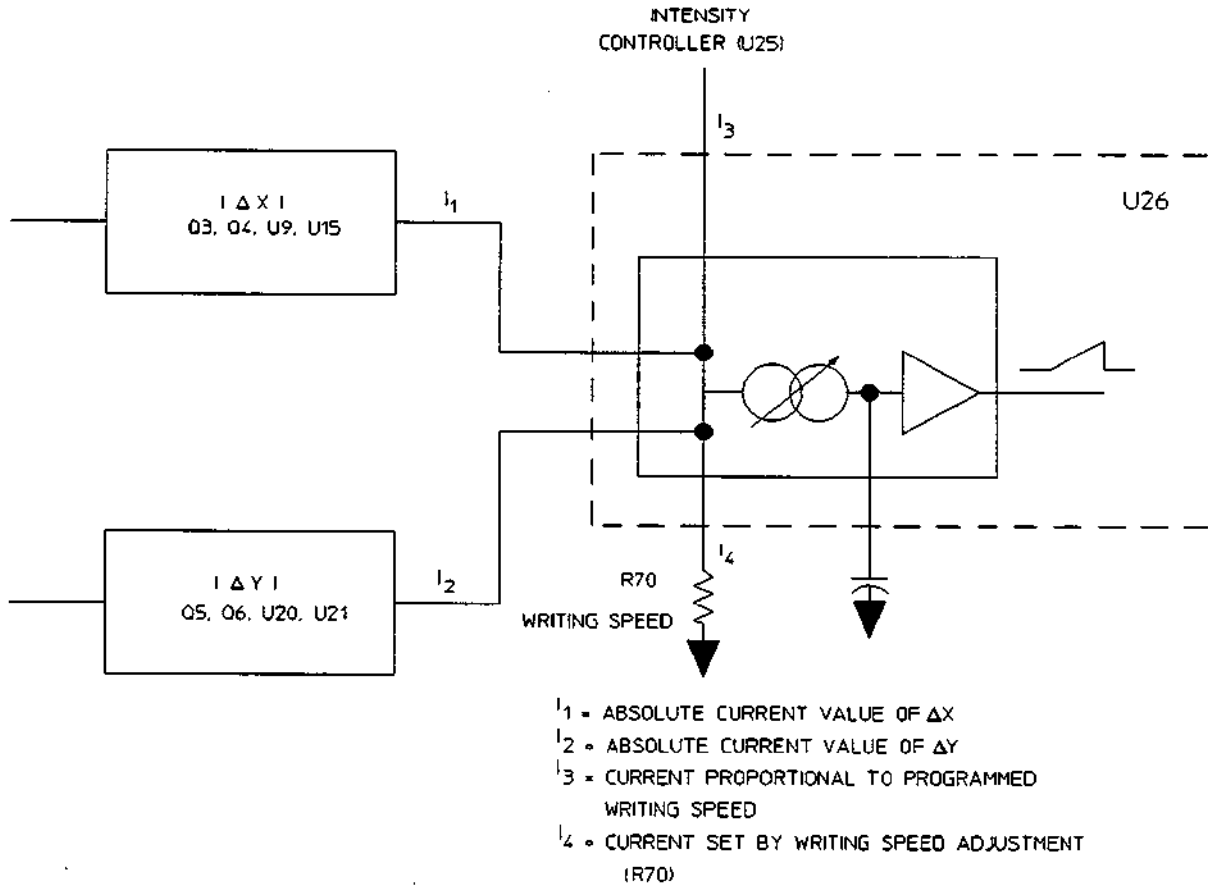
The Analog Multiplier multiplies two signals. The ramp generated by A81 U26 and the DAC outputs are multiplied. The output of A81 U10 is a ramp whose amplitude is a function of the desired relative X beam movement and whose offset is a function of screen location (see figure 8-2).



**Figure 8-2. Analog Multiplier  
Simplified Block Diagram**

### Ramp Generator

The Ramp Generator (A81 U26) provides two signals: a ramp for X-Y beam movement; the gate pulse for beam blanking. In order to maintain a constant intensity level for different vector length, the slope of the ramp (writing speed) must be held constant. The ramp slope is controlled by a combination of four inputs to A81 U26. (See figure 8-3 for the simplified block diagram).



**8-3. Ramp Generator Simplified Block Diagram**

### Intensity Controller

The Intensity Controller converts digital line, writing and intensity information to analog voltages for use by the Intensity Amplifier. The only other input to the Intensity Controller is the gate pulse for beam blanking generated by A81 U26.

### X-Y Amplifiers

The X and Y amplifiers are identical. They amplify the X and Y analog coordinates from the Analog Multiplier (A81 U7, A81 U19) to drive the CRT horizontal and vertical deflection plates. Since both amplifiers are identical, only the X amplifier will be described below.

The X amplifier consists of a preamplifier (A81 U29) and an output amplifier (A81 Q7 - A81 Q12). The differential output from preamp A81 U29 is applied to two identical amplifiers A81 Q7 - A81 Q9 and A81 Q10 - A81 Q12. The signal voltage is raised by these two amplifiers to the required level to drive the horizontal deflection plates. The gain of the output amplifier is stabilized by the negative feedback path through A81 R92 and A81 R101. The gain and balance of the X amplifier are set by A81 R86 and A81 R82 respectively.

### **Z-Axis Intensity Amplifier**

The operating potential between the CRT grid and the cathode is controlled by the Z-Axis amplifier output level. More positive levels lower the beam current. The amplifier consists of the Z-Axis preamp located on the XYZ Vector assembly (A81), and the Intensity Amplifier is on the High Voltage Power Supply assembly (A80). The one side of the preamp output A81 U27 is applied to the Dynamic Focus circuit (A81 U31), the other side goes to the Intensity Amplifier A80 Q4 - A80 Q6. Since all the signal current generated by the Z-Axis preamp goes only through the feedback resistor, A80 R11, the output signal is forced to a voltage necessary to satisfy that current. A80 CR6 provides protection for the Intensity Amplifier against negative voltage arcs and transients.

### **Focus Amplifier**

The Dynamic Focus circuit provides an optimum focus voltage across the entire display area. The amplifier uses three inputs for proper focus correction. A voltage related to the square of the instantaneous beam position is coupled from the X and Y preamps to A81 U31. The Z-Axis correction current is fed from the Z-Axis preamp and summed with the Dynamic Focus circuit current output. This combined signal is then applied to the Focus Amplifier A80 Q1 - A80 Q3. The Focus Amplifier operation is identical to that of the Intensity Amplifier, above.



## **A80, A83 Voltage Power Supplies**

### **Low Voltage Power Supply**

The Low Voltage Power Supply consists of only one primary circuit — the +105V supply. All other required operating supplies must be provided by an external supply (see table 1-1, Input Power Requirements). The +105V power supply is a switching supply consisting of A83 U1, A83 Q1, A83 Q2 and A83 T1. A83 U1 contains all the functions necessary for current limiting, regulating and switching the power transistors A83 Q1 and A83 Q2. A83 C5 and A83 R4 determine the switching frequency of the oscillator of A83 U1. A83 T1 steps up the switching voltage. A83 CR3 and A83 CR4 make up the rectifier. Filtering is accomplished by A83 L2 and A83 C7. A83 R11 adjusts the +105V supply.

### **High Voltage Power Supply**

The High Voltage Power Supply provides the high operating potentials for the CRT. The supply consists of the following primary circuits: an oscillator; the cathode rectifier and filter circuit; a regulator circuit and the level translator. The oscillator signal is stepped up by transformer A80 T1 and rectified by A80 CR11. A80 C12, A80 C13 and A80 R32 provide filtering for the cathode supply. A80 R33 and A80 U1 make up the regulator circuit.

The feedback voltage from A80 R33 is compared to the +105V reference voltage at the junction of A80 R21 and A80 R33. The resultant output voltage of A80 U1 controls the amplitude of the High Voltage Oscillator A80 Q7. The Level Translator, A80 CR14 and A80 CR15, establishes the operating potential between cathode and grid of the CRT.

## A84 Memory Circuit Option Assembly

The Vector Memory option functions as an auxiliary vector data storage for the display (static 4K × 16 bit), and provides a means for automatic display refresh in order to “free up” the controller.

The Vector Memory circuit can store all the Digital Display commands to draw a picture on the screen. The user processor can access any address in Vector Memory via the Address Pointer. This allows selected portions of a picture to be changed or sent back to the processor for checking or processing.

The Memory Circuit also has a feature whereby the user processor can suppress portions of the picture (such as graticules or labels). Suppressed information is not erased from the Vector Memory. This is done by having the Memory do an Internal Jump past the data that is not to be displayed. Suppressed data can be made part of the picture by using only a few user processor commands, thus reducing overhead time.

## Memory Control

The Memory Control section interprets the user commands and synchronizes the memory operations. The circuit is divided into three functional stages:

- Command Decode
- Memory Control Latch
- Memory Control Circuitry

## The Command Decoder

The Command Decoder monitors the status of the memory operations. The user commands (LRD, LWR, LDS) and the memory status lines specify in which of the two modes the memory is to operate. The two states are: Read/Write and Screen Refresh.

To read data from memory, control lines LDS and LRD are used. To write data into memory, control lines LDS and LWR are used. When control line LDS is set high by the user, the display will be refreshed at the sync rate according to the instructions stored in memory. Internal Sync is generated by the 60 Hz clock A84 U25 and A84 U28, unless held-off by LCLR SYNC being set low. LCLR SYNC will also hold off the LMAX ADDR line. The LMAX ADDR line indicates when the end of the display memory is reached. When User Data lines UD14 and UD15 are high, SET ADDRS is set low indicating that the Read/Write pointer is to be sent to the address defined by UD0 through UD11. USER ADDRS CLOCK clocks the status of the user commands through A84 U26 to A84 U29. The output at A84 U29 pin 3 (LXACK) is fed back to the user to acknowledge that the command has been received.

### Refresh Sync

The display refresh is synchronized by either an internal clock or by an external sync signal provided by a user clock.

### Internal Sync

When in Internal Sync mode, an onboard oscillator (A84 U25) provides sync pulses at approximately a 60 Hz rate. The user processor can send all picture producing data to the Vector Memory at one time. The Vector Memory will then continuously refresh the display screen by redrawing the picture at regular intervals. This reduces overhead time for the user processor.

### External Sync

Sync pulses (TTL) must be supplied from an external source in the user system via the SYNC input signal line at W1 pin 4.

### Memory Control Latch

On the positive edge of the 22 MHz oscillator (Y1), the status of the five state request line and the two status signals are latched into A84 U39. These seven control lines along with the XOR of LRD and LWR are then held at the Memory Control circuitry inputs MCA0 - MCA7. The five state request signals are:

- LWR+LDS
- LRD+LDS
- SET ADDR
- RFD
- MD15

The two status signals are:

- LMAX ADDR
- SYNC

## Memory Control Circuitry

The output of the Memory Control devices (A84 U15, A84 U16) are the twelve memory control signals and the four state control signals.

The Memory Control signals are:

- VPC ADDR5 LOAD
- VPC ADDR5 CLOCK
- VPC DATA LATCH CLOCK
- USER ADDR5 LOAD
- USER ADDR5 CLOCK
- USER WRITE LATCH CLOCK
- USER WRITE LATCH ENABLE
- USER READ LATCH CLOCK
- USER READ LATCH ENABLE
- VM ADDR5 MUX (H=USER/L=VPC ADDRESS SELECT)
- VM LOE
- VM LWE

The four state control signals are:

- MCA8
- MCA9
- MCA10
- MCA11

The states of the Memory Control signals are determined by the data stored in the Memory Control devices (A84 U15, A84 U16).

The Memory Control Address specified by MCA0 - MCA11 will, at the positive edge of the control clock, determine the state of the Memory Control Signals.

## Read/Write Mode

The user can do a Read/Write operation without setting the Read/Write Pointer. However, it is recommended that the user know which location in memory is being accessed (read from or written into). There are two steps in a read or write operation:

- Setting the Read/Write Pointer
- Reading from or writing into Vector Memory

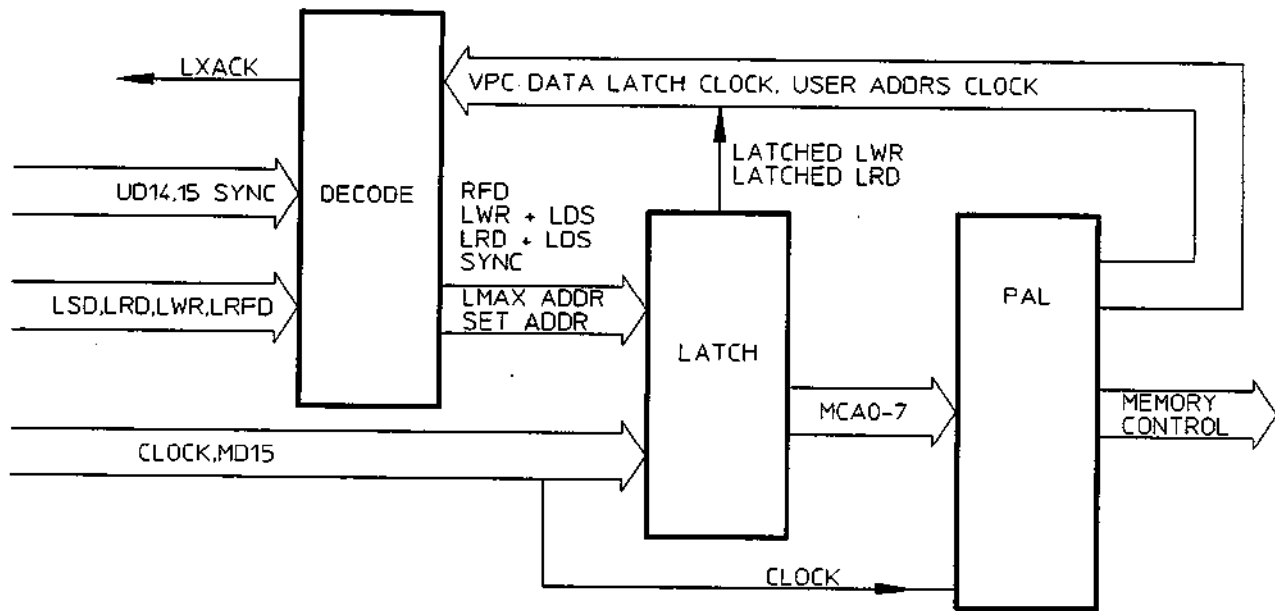


Figure 8-4. Read/Write Mode

**Set Pointer**

The value in the Read/Write Pointer specifies the next address in Vector Memory that will be written into or read from by the user processor. When the user sends a Set Pointer Command, the USER ADDRS LOAD line is set low and the data specified by bits MD0 - MD12 is preloaded into the Read/Write Pointer. The outputs of the Pointer (USER A0 - USER A12) are selected by the Address Multiplexers (A84 U1, A84 U4, A84 U19, A84 U22) as the next memory address.

**Read/Write**

After the vector memory address has been selected, a Read/Write operation can be performed. To read data from Vector Memory, the user sets LDS and LRD lines low. Control line VM LOE will set low and the information at the address specified will be placed on the Data Bus. During the time the LDS and LRD are low, the Memory Read Latches (A84 U12, A84 U35) are enabled to transfer the data from the Memory Data Bus to the User Data Bus (UD0 - UD15).

When a write operation is performed, signal lines LDS and LWR are set low, and LRD is set high. As a result, the VM LWE line is set low and the information on the Data Bus is written into Vector Memory at the address specified. The data flow through the memory write latches (A84 U13, A84 U36) is controlled by the USER WRITE LATCH ENABLE line. When this line is low, data is transferred from the User Data Bus to the Memory Data Bus.

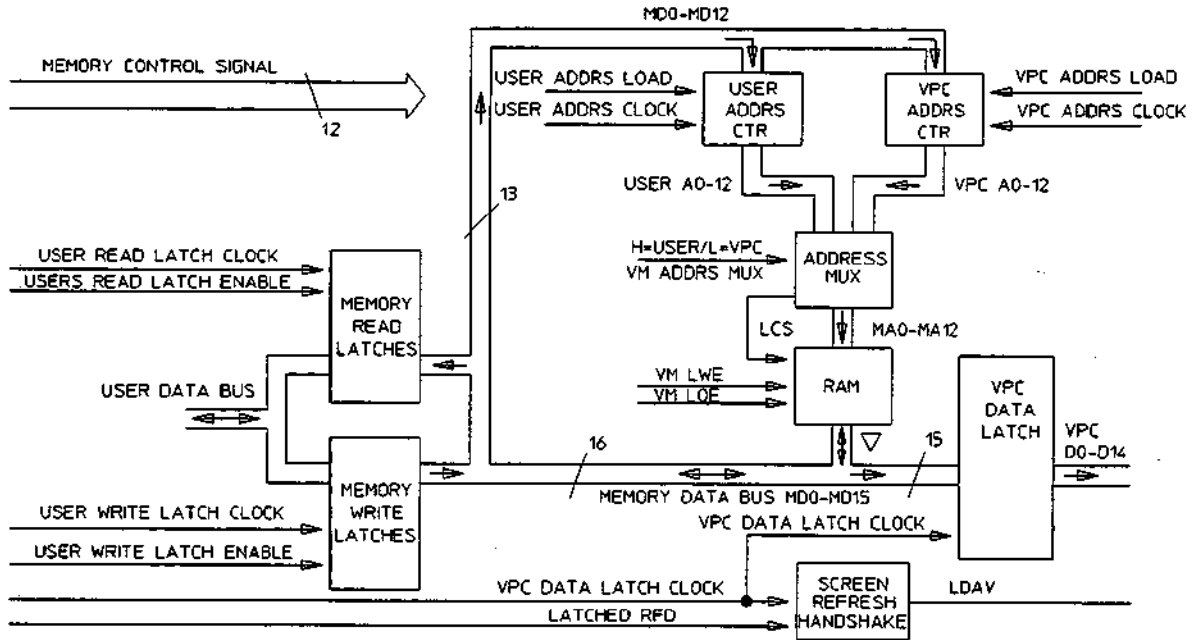


Figure 8-5. Screen Refresh Mode

**Note**



When Memory Option Assembly is installed, Jumper Packs A82 U3 and A82 U4 must be removed.



# Section IX

## Service

---

### 9-1 Introduction

This section provides information for troubleshooting and repairing the HP 3577B Network Analyzer. Circuit descriptions are provided in Section VIII to explain circuit function to the service technician, so troubleshooting time can be spent troubleshooting and not learning instrument operation.

Troubleshooting voltages and waveforms are provided on or next to the schematic diagram foldout. Parts locators are provided opposite the foldout service sheets. This section is to be used after isolating the faulty functional block using the Fault Isolation Procedures in Section II. The functional blocks are described in Section VIII (Circuit Descriptions). Fault isolation to the sub-block level is accomplished here. Each functional sub-block consists of a small number of components, and the technician's expertise is relied upon for isolating the faulty component.



---

## 9-2 Recommended Test Equipment

The recommended test equipment for troubleshooting is listed in section I table 1-2. Any item which meets or exceeds the critical requirements can be substituted for the model listed.

---

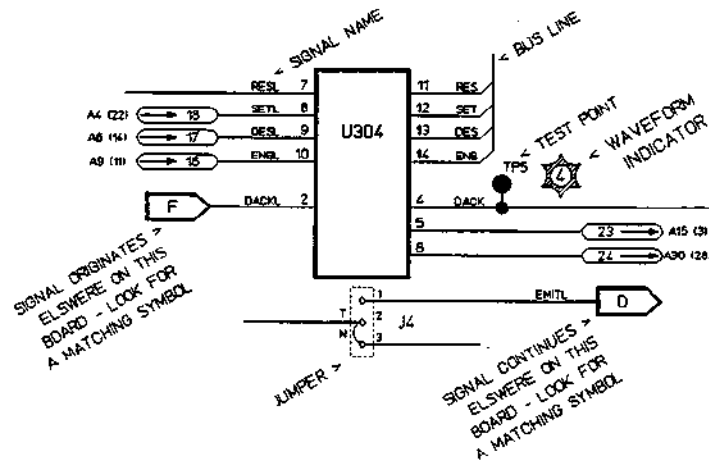
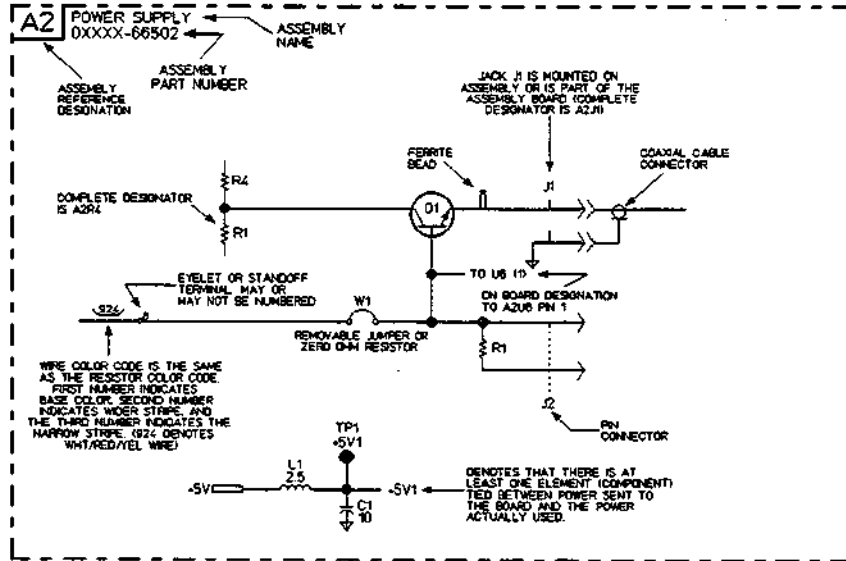
## 9-3 Logic Conventions

Positive logic convention is used in this manual unless otherwise noted. Positive logic conventions define a logic "1" or "High" as the more positive voltage and a logic "0" or "Low" as the more negative voltage.

---

## 9-4 Logic Symbology

The logic symbology used in this manual is based on ANSI Y32.14-1973. The reference designations and general schematic notes are shown in figure 9-1 and figure 9-4, respectively. Basic logic symbols and examples of symbols are shown in figure 9-5. Figure 9-3 provides an explanation of function labels used in the schematics. Refer to the *Logic Symbology Training Manual* (HP part number 5951-6116) for a full explanation of the logic symbology used in the schematics.







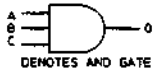
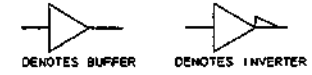
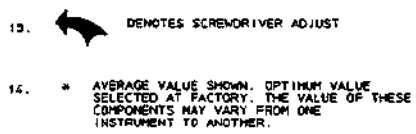
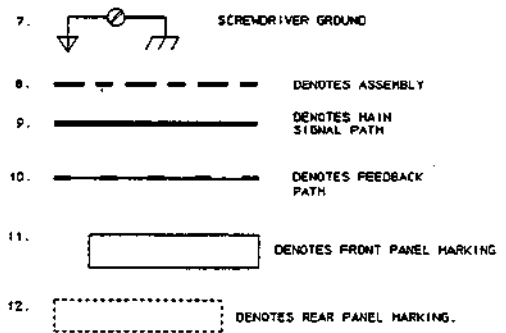
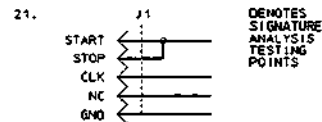
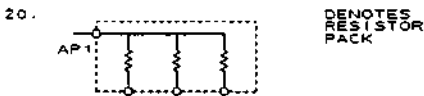
NOTE: THE SYMBOL INDICATES A PIN OF THE EDGE CONNECTOR WHICH PLUGS INTO THE MOTHER BOARD.

EXAMPLE: GRAMSTL A8 (119)

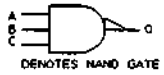
PIN 12 OF THE EDGE CONNECTOR ON THIS BOARD CARRIES THE SIGNAL GRAMSTL TO PIN 119 OF THE EDGE CONNECTOR OF THE A8 BOARD VIA THE MOTHER BOARD.

Figure 9-1. Reference Designations

1. PARTIAL REFERENCE DESIGNATIONS ARE SHOWN. PREFIX WITH ASSEMBLY DESIGNATION FOR COMPLETE DESIGNATION.
2. COMPONENT VALUES ARE SHOWN AS SHOWN AS FOLLOWS UNLESS OTHERWISE NOTED.  
RESISTANCE IN OHMS  
CAPACITANCE IN MICROFARADS  
INDUCTANCE IN MILLIHENRYS
3.  DENOTES EARTH GROUND. USED FOR TERMINALS WITH NO LESS THAN A NO. 16 GAUGE WIRE CONNECTED BETWEEN TERMINAL AND EARTH GROUND TERMINAL OF AC POWER RECEPTACLE
4.  DENOTES FRAME GROUND. USED FOR TERMINALS WHICH ARE PERMANENTLY CONNECTED WITHIN APPROXIMATELY 0.1 OHM OF EARTH GROUND.
5.  DENOTES GROUND ON PRINTED CIRCUIT ASSEMBLY (ELECTRICALLY CONNECTED TO FRAME GROUND).
6.  DENOTES ISOLATED (I) OR SINGAL(S) CIRCUIT GROUND.
16. 924 DENOTES WIRE COLOR. COLOR CODE SAME AS RESISTOR COLOR CODE. FIRST NUMBER IDENTIFIES BASE COLOR. SECOND NUMBER IDENTIFIES WIDER STRIP. THIRD NUMBER IDENTIFIES NARROWER STRIP (e.g. 924 = WHITE, RED, YELLOW).
17. ALL RELAYS ARE SHOWN DEENERGIZED. ALL ANALOG SWITCH IC'S ARE SHOWN NOT ACTIVE.
18. WAVEFORMS AND AC VOLTAGE MEASUREMENTS WERE MADE WITH RESPECT TO CHASSIS GROUND USING AN OSCILLOSCOPE WITH A 10:1 PROBE. THE VOLTAGE LEVELS SHOWN FOR THE WAVEFORMS ARE ACTUAL VOLTAGE LEVELS AND ARE NOT TO BE CONFUSED WITH OSCILLOSCOPE SETTING. THE VOLTAGE LEVELS SHOWN ARE NOMINAL AND MAY VARY FROM ONE INSTRUMENT TO ANOTHER A VARIATION OF ±10% IN MEASUREMENTS SHOULD BE ALLOWED. ALL WAVEFORMS SHOWN WERE AC-COUPLED UNLESS OTHERWISE NOTED. DC VOLTAGE LEVELS OF WAVEFORM TEST POINTS ARE INDICATED SEPARATELY.
19. DC VOLTAGE LEVELS WERE MEASURED WITH RESPECT TO CIRCUIT GROUND USING A DVM. THE VOLTAGE LEVELS SHOWN ARE NOMINAL AND MAY VARY FROM ONE INSTRUMENT TO ANOTHER DUE TO CHANGE IN TRANSISTOR CHARACTERISTICS. A VARIATION OF ±10% SHOULD BE ALLOWED.



ABC 10  
000 10  
001 10  
010 10  
011 10  
100 10  
101 10  
110 10  
111 10



ABC 0  
000 1  
001 1  
010 1  
011 1  
100 1  
101 1  
110 1  
111 1

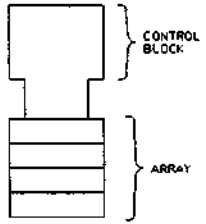


ABC 0  
000 1  
001 1  
010 1  
011 1  
100 1  
101 1  
110 1  
111 0



ABC 0  
000 1  
001 1  
010 0  
011 0  
100 0  
101 1  
110 1  
111 0

CONTROL BLOCK IS USED WHEN AN ARRAY OF RELATED LOGIC ELEMENTS SHARE COMMON CONTROL LINES



LOGIC ELEMENTS WITH COMMON CONTROL BLOCK

Figure 9-2. General Schematic Notes



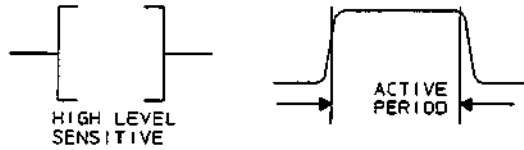
	AMPLIFIER/BUFFER
1 	MONOSTABLE MULTIVIBRATOR (ONE-SHOT)
&	AND GATE
$\cong 1$	OR GATE
$= 1$	EXCLUSIVE OR GATE
X $\dashv$ Y	ENCODER, DECODER
X MAX $\dashv$ Y	PRIORITY ENCODER
CNTR	COUNTER
DEMUX	DEMULTIPLEXER
FF	FLIP-FLOP
RAM	RANDOM-ACCESS MEMORY
REG	REGISTER
ROM	READ-ONLY MEMORY
SAR	SUCCESSIVE APPROXIMATION REGISTER
SEL	SELECTER
SREG	SHIFT REGISTER
TX/RX	TRANSMITTER/RECEIVER

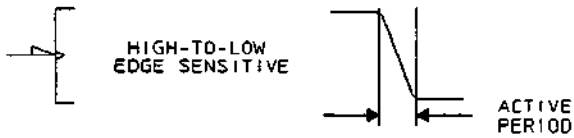
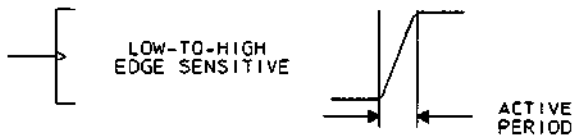
Figure 9-3. Function Labels



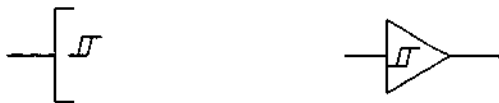
ACTIVE HIGH inputs and outputs-  
Indicated by the absence of the  
polarity indicator ( ▽ ).



ACTIVE LOW inputs and outputs-  
Indicated by the presence of the  
polarity indicator ( ▽ ).



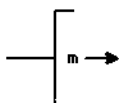
EDGE SENSITIVE (Dynamic) inputs-  
Indicated by the presence of the  
dynamic indicator symbol ( > ).



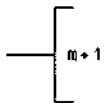
BI-THRESHOLD (Hysteresis) input  
(  $\square$  )-Input takes on internal  
high state when external signal  
exceeds high threshold value.  
State is maintained until external  
signal falls below a lower  
threshold value.



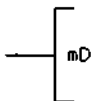
OPEN COLLECTOR output (  $\diamond$  )-  
Forms a part of a distributed  
connector.



SHIFT RIGHT (Down) input of  
register m may be other  
qualifiers or dependency  
notation.

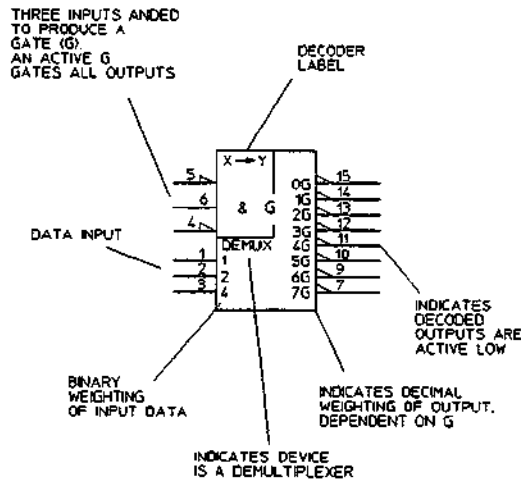


COUNT UP input of a counter.  
m may be other qualifiers or  
dependency notation.

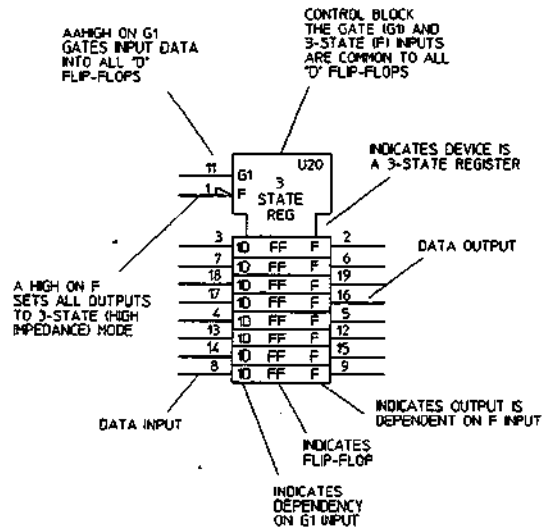


DATA input m may be other  
qualifiers or dependency  
notation.

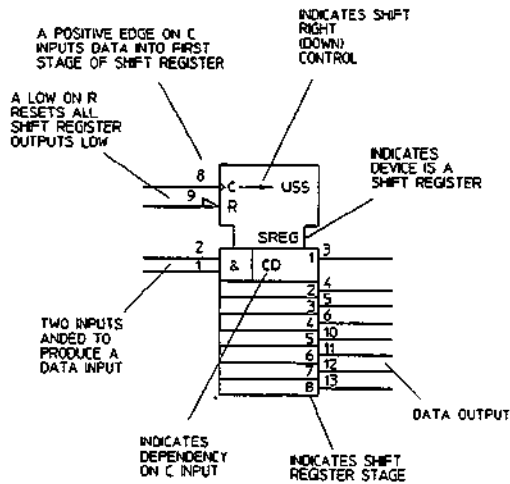
Figure 9-4. Qualifying Symbols



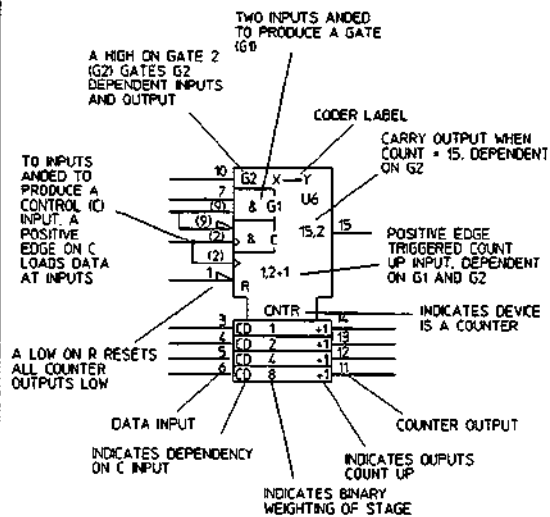
3-LINE TO 8-LINE DECODER/DEMULTIPLEXER



3-STATE OCTAL D FLIP-FLOP



8-BIT SERIAL-IN/PARALLEL-OUT SHIFT REGISTER



PRESETTABLE BINARY COUNTER

Figure 9-5. Logic Symbology

---

## 9-5 Safety Considerations

The HP 3577B is a Safety Class 1 instrument (provided with a protective earth terminal). The instrument and manuals should be reviewed for safety markings and instructions before operation. Refer to the Safety Symbol Table in the preface of this manual.

---

### Warning



Service procedures described in this section are performed with the protective covers removed and power applied. Energy available at many points can, if contacted, result in personal injury.

---

### Caution



Do not insert or remove any circuit board in the HP 3577B with the line power turned on. Power transients caused by insertion or removal may damage the circuit boards.

---

### Warning



230 Vdc is present in the main power supply board (A21) even with the line switch in the off position and the power cord removed. Be extremely careful when working in the proximity of this area. This high voltage could cause serious personal injury if contacted. To remove this voltage, remove the mains power cord from the rear panel, remove the bottom cover and set the main power supply board (A21) jumpers W1 & W2 to the test position, using insulated pliers, to discharge the capacitors (A21C2 & A21C3) holding this voltage.

---

## 9-6 Schematic List

Table 9-1 shows the service groups by assembly numbers for each schematic in the section. Note that the service group number is the same as the assembly number for each of the circuit boards.

**Table 9-1. Schematic List**

Assembly Number	Description
A4a	Local Oscillator
A4b	Local Oscillator
A5	250 kHz Offset
A6	Frequency Reference
A15	Keyboard
A16	HP-IB
A17a	Synthesizer, Analog
A17b	Synthesizer, Digital
A18a	Output
A18b	Output
A19a	Input, Analog
A19b	Input, Digital
A20	Motherboard
A21	Main Power Supply
A31	Oven (Option 001 only)
A61a	Fast Processor
A61b	Fast Processor
A62/63a	Main Processor-Controller
A62/63b	Main Processor-Controller
A62/63c	Main Processor-Controller
A80	Display, High Voltage Power Supply
A81a	Display, Analog XYZ Board
A81b	Display, Analog XYZ Board
A81c	Display, Analog XYZ Board
A82a	Display, VPC Board
A82b	Display, VPC Board
A83	Display, Low Voltage Power Supply
A84a	Display, Memory Board
A84b	Display, Memory Board







## 9-7 Service Group A4, Local Oscillator Assembly

The information in this section should be used to isolate faulty functional sub-blocks when servicing the HP 3577B. All procedures assume the Fault Isolation procedures of Section II have been used to determine which functional block has failed, and the Circuit Descriptions of Section VIII are understood.

### Warning



Service procedures described in this section are performed with the protective covers removed and power applied. Energy available at many points can, if contacted, result in personal injury.

### Caution



Do not insert or remove any circuit board in the HP 3577B with the line power turned on. Power transients caused by insertion or removal may damage the circuit boards.

### Initial Conditions

Unless otherwise stated in the troubleshooting sections of the signal table, set the HP 3577B as described below, after power on.

SWEEP TYPE	CW
AMPTD	- 49 dBm
FREQUENCY	200 MHz

All Oscilloscope waveforms are taken using a 10:1 probe but each oscilloscope display shows actual voltage. All Spectrum Analyzer waveforms connected to an SMB connector are taken through the 03577-84401 Service Kit BNC to SMB cable. All Spectrum Analyzer waveforms taken off component leads are taken through a 10:1 probe with 215Ω of series resistance.

## Troubleshooting Hints

1. Before troubleshooting this circuit board, be sure that the fault is occurring on this board by checking the following inputs using the settings in table 2-2 in the Fault Isolation Section.
  - a. A6J7 300 MHz reference output.
  - b. A17J1 300.25 to 500.25 MHz output.

If these signals check out as being good, then the problem is on the A4 Local Oscillator board.

2. SYMPTOM: Output Frequency is not correct.
  - a. The problem is due to improper conversion in the first mixer, or improper frequency input signals.
3. SYMPTOM: Output Level or harmonic/spurious distortion.
  - a. These problems could be anywhere on the circuit board. Begin troubleshooting at A4J11. Compare the Spectrum Analyzer reading with the information in table 9-2 following this description. If the signal is good, then the fault is after J11, if it is bad, then the fault is before J11. Continue with this "half splitting" procedure until the faulty functional block is found. Compare all measured signals with the information given in table 9-2.

Table 9-2. A4 Circuit Board, Troubleshooting Data

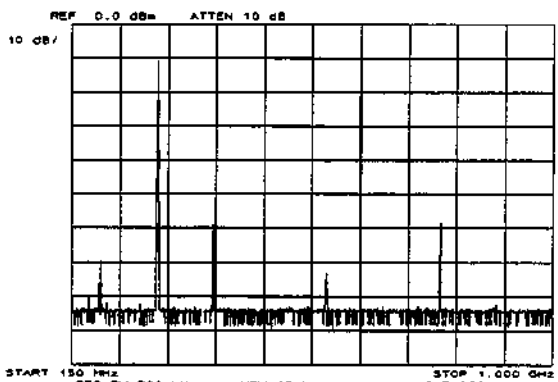
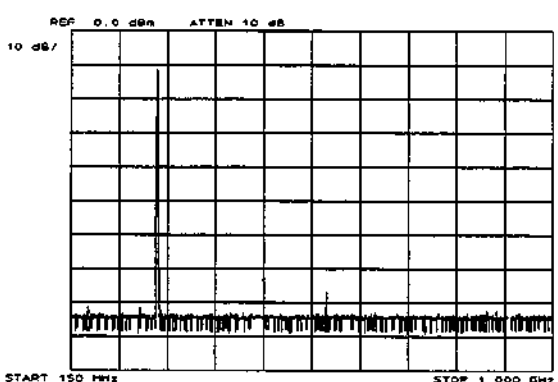
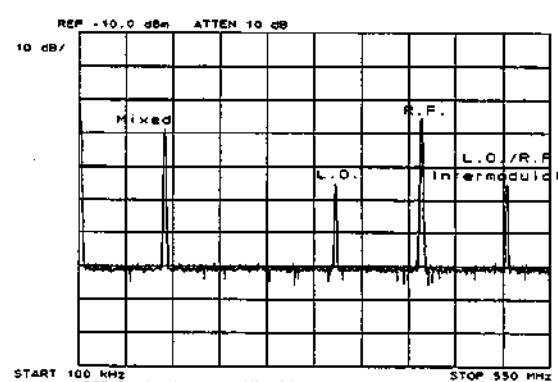
HP 3577B Set up	Measurement Set up	Waveform with Parameters
<p>Test at A4J6 Press INSTR PRESET</p> <p>Move Jumper W1 to connect signal to test jack.</p>	<p>Spectrum Analyzer</p> <p>Start 150 MHz Stop 1000 MHz Res BW 300 kHz VBW 10 kHz Ref Level 0 dBm dB/Div 10 dB</p>	<p>300 MHz amplitude harmonics.</p>  <p>#1</p>
<p>Test at A4J7 Press INSTR PRESET</p> <p>Move Jumper W2 to connect signal to test jack.</p>	<p>Spectrum Analyzer</p> <p>Start 150 MHz Stop 1000 MHz Res BW 300 kHz VBW 10 kHz Ref Level 0 dBm dB/Div 10 dB</p>	<p>300 MHz amplitude harmonics.</p>  <p>#2</p>
<p>Test at A4J9 Press INSTR PRESET</p> <p>Sweep Type CW Freq 100 MHz</p> <p>Move Jumper W4 to connect signal to test jack.</p>	<p>Spectrum Analyzer</p> <p>Start 100 kHz Stop 550 MHz Res BW 1 MHz VBW 30 kHz Ref Level -10 dBm dB/Div 10 dB</p>	<p>100.25 MHz mixed, RF feedthrough, intermodulation</p>  <p>#3</p>

Table 9-2. A4 Circuit Board, Troubleshooting Data Continued

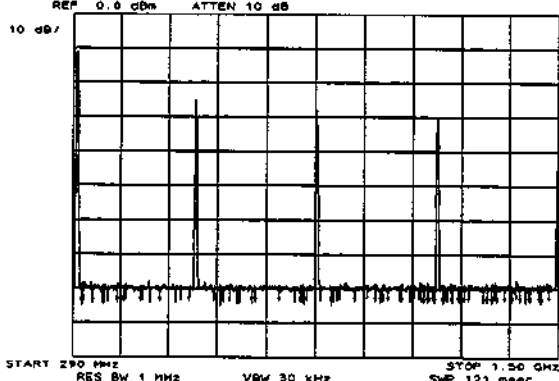
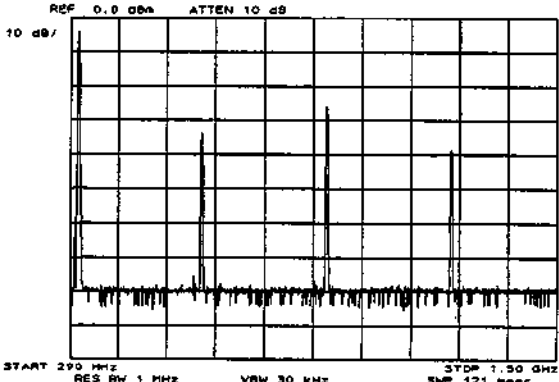
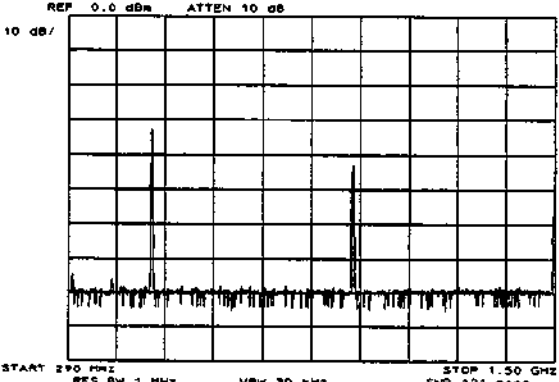
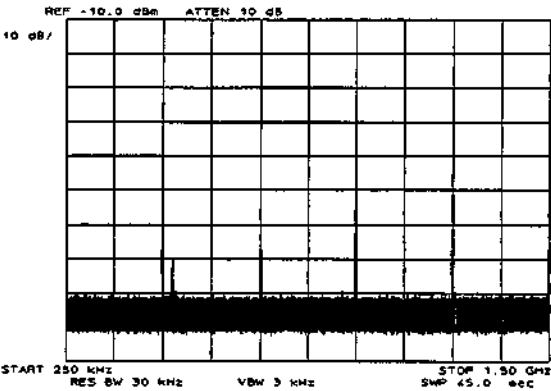
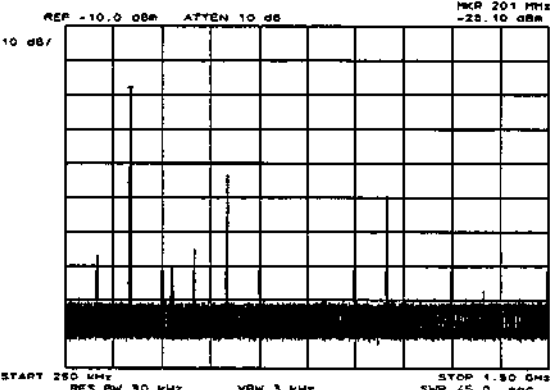
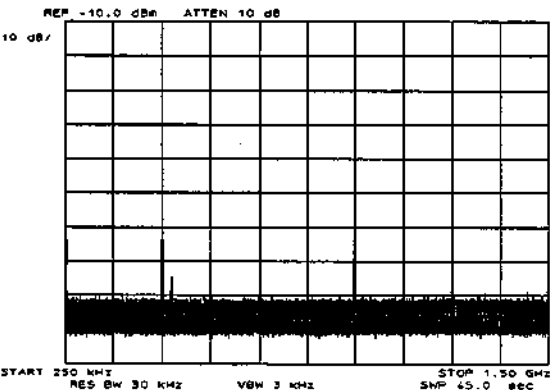
HP 3577B Set up	Measurement Set up	Waveform with Parameters
<p>Test at A4C13 Press INSTR PRESET</p> <p>Sweep Type CW Freq 5 Hz</p>	<p>Spectrum Analyzer</p> <p>Start 290 MHz Stop 1500 MHz Res BW 1 MHz VBW 30 kHz Ref Level 0 dBm dB/Div 10 dB</p>	<p>300.25 MHz synthesizer output amplitude harmonics.</p>  <p>#4</p>
<p>Test at A4C1 3 Press INSTR PRESET</p> <p>Sweep Type CW Freq 10 MHz</p>	<p>Spectrum Analyzer</p> <p>Start 290 MHz Stop 1500 MHz Res BW 1 MHz VBW 30 kHz Ref Level 0 dBm dB/Div 10dB</p>	<p>310.25 MHz synthesizer output amplitude, harmonics.</p>  <p>#4 (cont'd)</p>
<p>Test at A4C1 3 Press INSTR PRESET</p> <p>Sweep Type CW Freq 200 MHz</p>	<p>Spectrum Analyzer</p> <p>Start 290 MHz Stop 1500 MHz Res BW 1 MHz VBW 30 kHz Ref Level 0 dBm dB/Div 10 dB</p>	<p>500.25 MHz synthesizer output amplitude, harmonics</p>  <p>#4 (cont'd)</p>

Table 9-2. A4 Circuit Board, Troubleshooting Data Continued

HP 3577B Set up	Measurement Set up	Waveform with Parameters
<p>Test at A4J10 Press INSTR PRESET</p> <p>Sweep Type CW Freq 5 Hz</p> <p>Move W5 to connect signal to test jack.</p>	<p>Spectrum Analyzer</p> <p>Start 250 kHz Stop 1500 MHz Res BW 30 kHz VBW 3 kHz Ref Level -10 dBm dB/Div 10 dB</p>	<p>250 kHz amplitude, harmonics, noise</p>  <p>#5</p>
<p>Test at A4J10 Press INSTR PRESET</p> <p>Sweep Type CW Freq 200 MHz</p> <p>Move W5 to connect signal to test jack.</p>	<p>Spectrum Analyzer</p> <p>Start 250 kHz Stop 1500 MHz Res BW 30 kHz VBW 3 kHz Ref Level -10 dBm dB/Div 10 dB</p>	<p>200.25 MHz amplitude, harmonics, noise</p>  <p>#5 (cont'd)</p>
<p>Test at A4J11 Press INSTR PRESET</p> <p>Sweep Type CW Freq 5 Hz</p> <p>Move W6 to connect signal to test jack.</p>	<p>Spectrum Analyzer</p> <p>Start 250 kHz Stop 1500 MHz Res BW 30 kHz VBW 3 kHz Ref Level -10 dBm dB/Div 10 dB</p>	<p>250 kHz amplitude, harmonics, noise</p>  <p>#6</p>

**Table 9-2. A4 Circuit Board, Troubleshooting Data Continued**

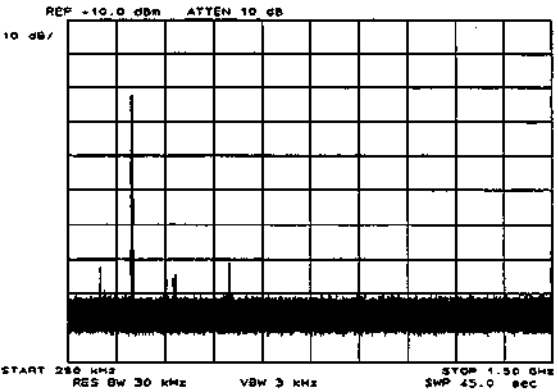
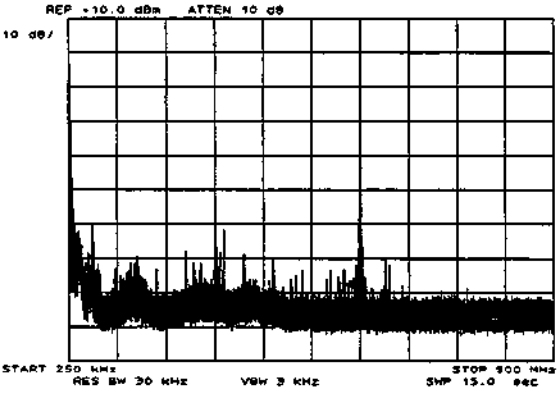
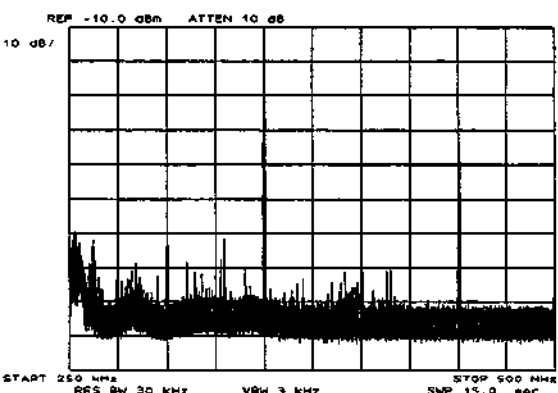
HP 3577B Set up	Measurement Set up	Waveform with Parameters
<p>Test at A4J11 Press INSTR PRESET</p> <p>Sweep Type CW                      Freq 200 MHz</p> <p>Move W6 to connect signal to test jack.</p>	<p>Spectrum Analyzer</p> <p>Start 250 kHz                      Stop 1500 MHz                      Res BW 30 kHz                      VBW 3 kHz                      Ref Level -10 dBm                      dB/Div 10 dB</p>	<p>200.25 MHz amplitude, harmonics, noise</p>  <p>#6 (cont'd)</p>
<p>Test at A4U23 Pin 8 Press INSTR PRESET</p> <p>Sweep Type CW                      Freq 5 Hz</p>	<p>Spectrum Analyzer</p> <p>Start 250 kHz                      Stop 500 MHz                      Res BW 30 kHz                      VBW 3 kHz                      Ref Level -10 dBm                      dB/Div 10 dB</p>	<p>250 kHz amplitude, harmonics, noise</p>  <p>#7</p>
<p>Test at A4U23 Pin 8 Press INSTR PRESET</p> <p>Sweep Type CW                      Freq 5 Hz</p>	<p>Spectrum Analyzer</p> <p>Start 250 kHz                      Stop 500 MHz                      Res BW 30 kHz                      VBW 3 kHz                      Ref Level -10 dBm                      dB/Div 10 dB</p>	<p>200.25 MHz amplitude, harmonics, noise</p>  <p>#7 (cont'd)</p>



Table 9-2. A4 Circuit Board, Troubleshooting Data Continued

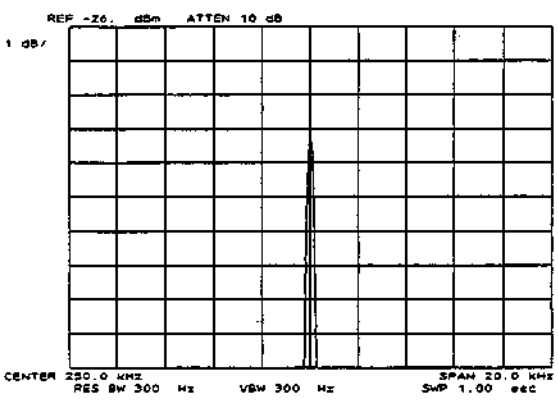
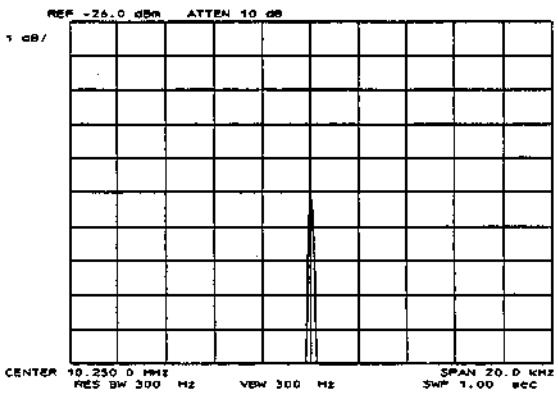
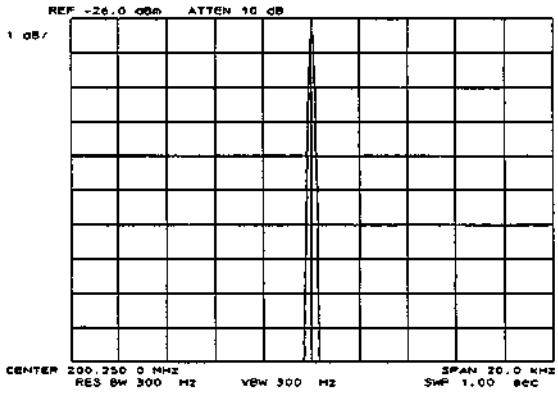
HP 3577B Set up	Measurement Set up	Waveform with Parameters
<p>Test at A4R41 and R42 Junction Press INSTR PRESET</p> <p>Sweep Type CW Freq 5 Hz</p>	<p>Spectrum Analyzer</p> <p>Center 250 kHz Span 20 kHz Res BW 300 Hz VBW 300 Hz Ref Level -26 dBm dB/Div 1 dB</p>	<p>Absolute Level</p>  <p>REF -26.0 dBm ATTEN 10 dB</p> <p>1 dB/</p> <p>CENTER 250.0 KHZ RES BW 300 HZ VBW 300 HZ SPAN 20.0 KHZ SWP 1.00 sec</p> <p>#8</p>
<p>Test at A4R41 and R42 Junction Press INSTR PRESET</p> <p>Sweep Type CW Freq 10 MHz</p>	<p>Spectrum Analyzer</p> <p>Center 10.25 MHz Span 20 kHz Res BW 300 Hz VBW 300 Hz Ref Level -26 dBm dB/Div 1 dB</p>	<p>Absolute Level</p>  <p>REF -26.0 dBm ATTEN 10 dB</p> <p>1 dB/</p> <p>CENTER 10.250 MHz RES BW 300 HZ VBW 300 HZ SPAN 20.0 KHZ SWP 1.00 sec</p> <p>#8 (cont'd)</p>
<p>Test at A4R41 and R42 Junction Press INSTR PRESET</p> <p>Sweep Type CW Freq 200 MHz</p>	<p>Spectrum Analyzer</p> <p>Center 200.25 MHz Span 20 kHz Res BW 300 Hz VBW 300 Hz Ref Level -26 dBm dB/Div 1 dB</p>	<p>Absolute Level</p>  <p>REF -26.0 dBm ATTEN 10 dB</p> <p>1 dB/</p> <p>CENTER 200.250 MHz RES BW 300 HZ VBW 300 HZ SPAN 20.0 KHZ SWP 1.00 sec</p> <p>#8 (cont'd)</p>

Table 9-2. A4 Circuit Board, Troubleshooting Data Continued


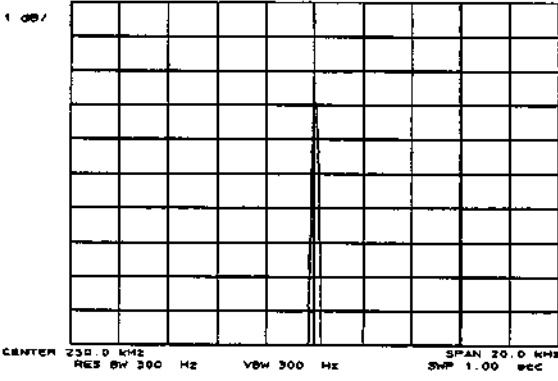
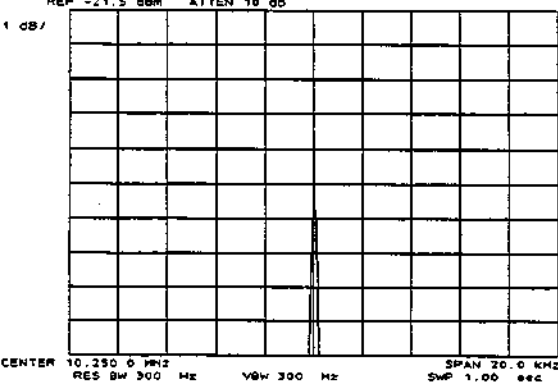
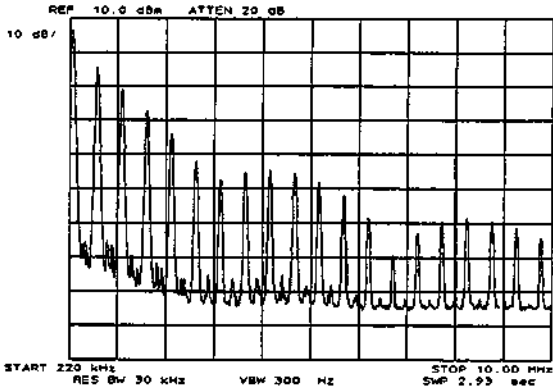
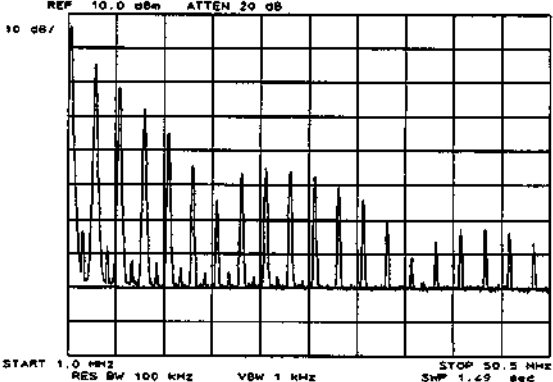
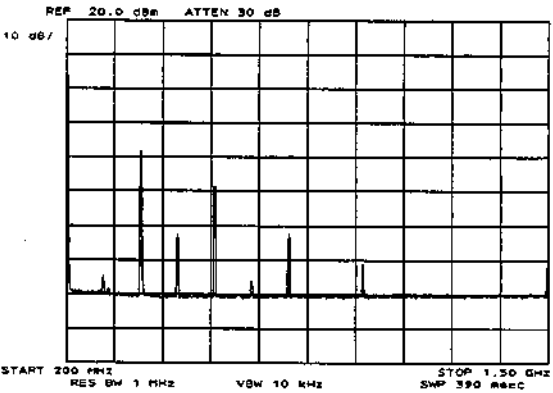
HP 3577B Set up	Measurement Set up	Waveform with Parameters
<p>Test at A4U25 Pin 6 Press INSTR PRESET</p> <p>Sweep Type CW Freq 100 MHz</p> <p>Probe 10:1</p>	<p>Oscilloscope</p> <p>CH1 Coupling AC CH1 V/Div 2 mV Time/Div 20 ns Trigger CH1</p>	<p>100 MHz Feedthrough on leveling signal.</p>  <p>CH1 CPLG=AC CH1= 2.00 mV/Div</p> <p>MT=Ch 1 Main= 20.0 ns/Div</p> <p>#9</p>
<p>Test at A4R109 Press INSTR PRESET</p> <p>Sweep Type CW Freq 5 Hz</p>	<p>Spectrum Analyzer</p> <p>Center 250 kHz Span 20 kHz Res BW 300 Hz VBW 300 Hz Ref Level -21.5 dBm dB/Div 1 dB</p>	<p>Amplitude</p>  <p>REF -21.5 dBm ATTEN 10 dB</p> <p>CENTER 250.0 KHZ RES BW 300 Hz VBW 300 Hz SPAN 20.0 KHZ SWP 1.00 sec</p> <p>#10</p>
<p>Test at A4R109 Press INSTR PRESET</p> <p>Sweep Type CW Freq 10 Hz</p>	<p>Spectrum Analyzer</p> <p>Center 10.25 MHz Span 20 kHz Res BW 300 Hz VBW 300 Hz Ref Level -21.5 dBm dB/Div 1 dB</p>	<p>Amplitude</p>  <p>REF -21.5 dBm ATTEN 10 dB</p> <p>CENTER 10.250 MHz RES BW 300 Hz VBW 300 Hz SPAN 20.0 KHZ SWP 1.00 sec</p> <p>#10 (cont'd)</p>

Table 9-2. A4 Circuit Board, Troubleshooting Data Continued

HP 3577B Set up	Measurement Set up	Waveform with Parameters
<p>Test at A4J3 Press INSTR PRESET</p> <p>Sweep Type CW Freq 5 Hz</p>	<p>Spectrum Analyzer</p> <p>Start 220 kHz Stop 10 MHz Res BW 30 kHz VBW 300 Hz Ref Level 10 dBm dB/Div 10 dB</p>	<p>250 kHz amplitude, harmonics, noise</p>  <p>#11</p>
<p>Test at A4J3 Press INSTR PRESET</p> <p>Sweep Type CW Freq 1 MHz</p>	<p>Spectrum Analyzer</p> <p>Start 1 MHz Stop 50.5 MHz Res BW 100 kHz VBW 1 kHz Ref Level 10 dBm dB/Div 10 dB</p>	<p>1 MHz amplitude, harmonics, noise</p>  <p>#11 (cont'd)</p>
<p>Test at A4J3 Press INSTR PRESET</p> <p>Sweep Type CW Freq 200 MHz</p>	<p>Spectrum Analyzer</p> <p>Start 200 MHz Stop 1500 MHz Res BW 1 MHz VBW 10 kHz Ref Level 20 dBm dB/Div 10 dB</p>	<p>200 MHz amplitude, harmonics, noise</p>  <p>#11 (cont'd)</p>

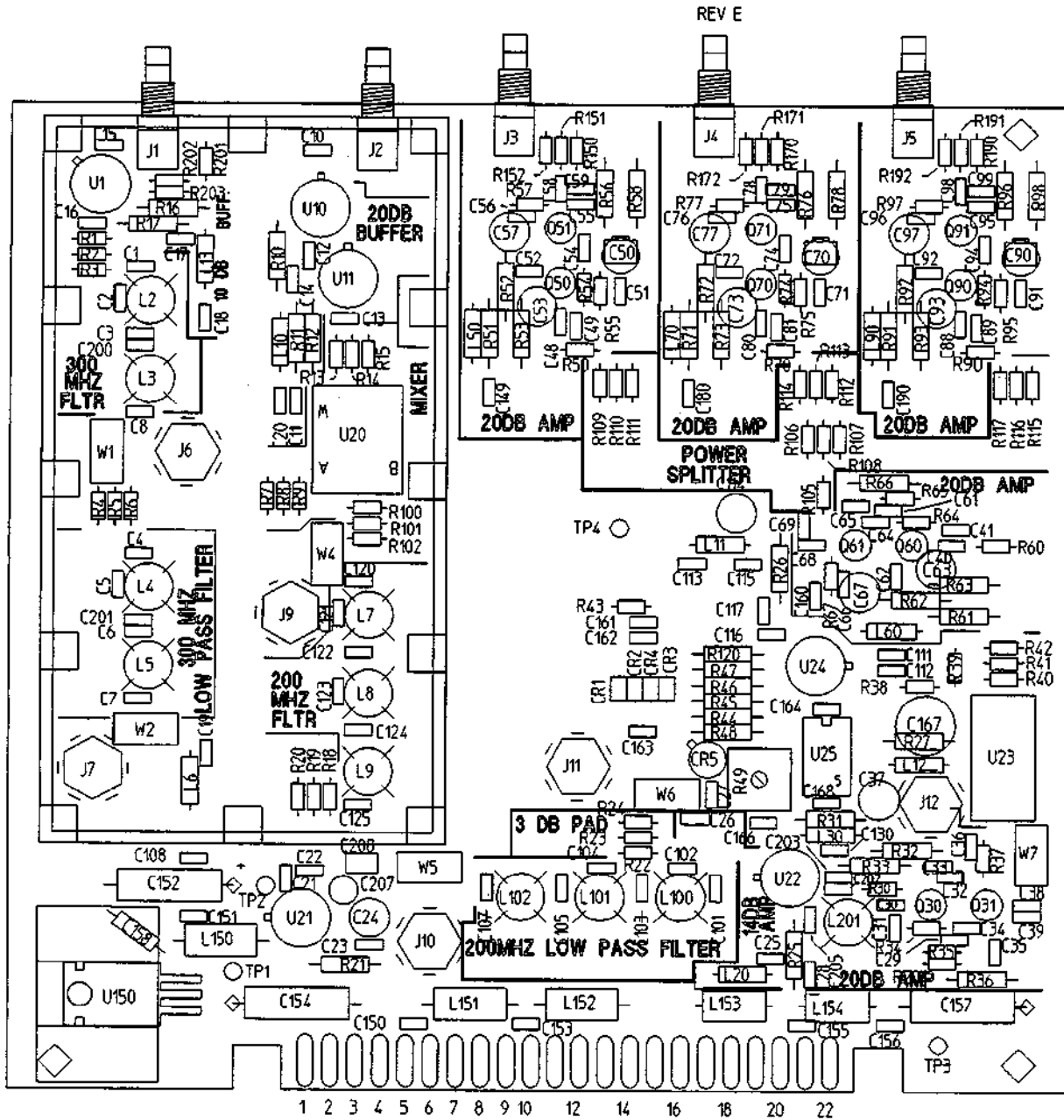
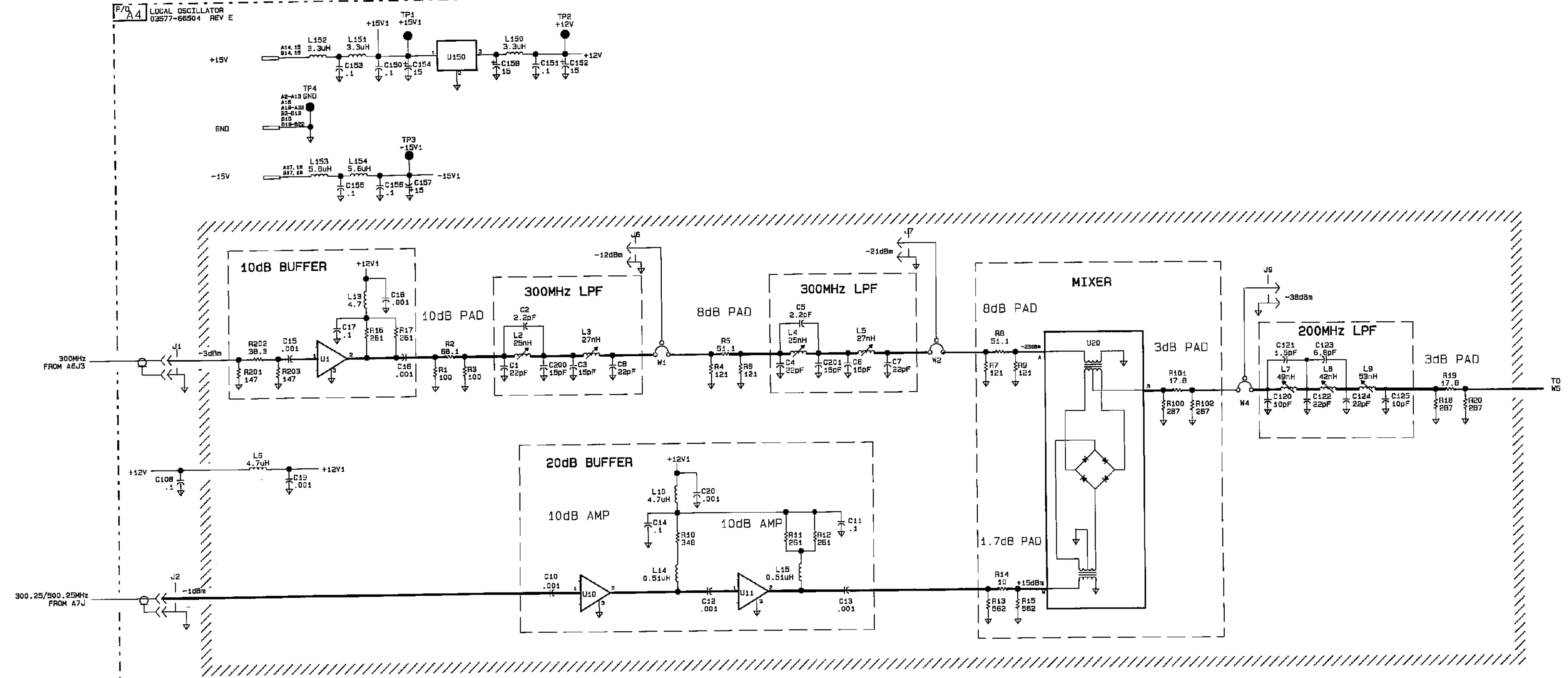
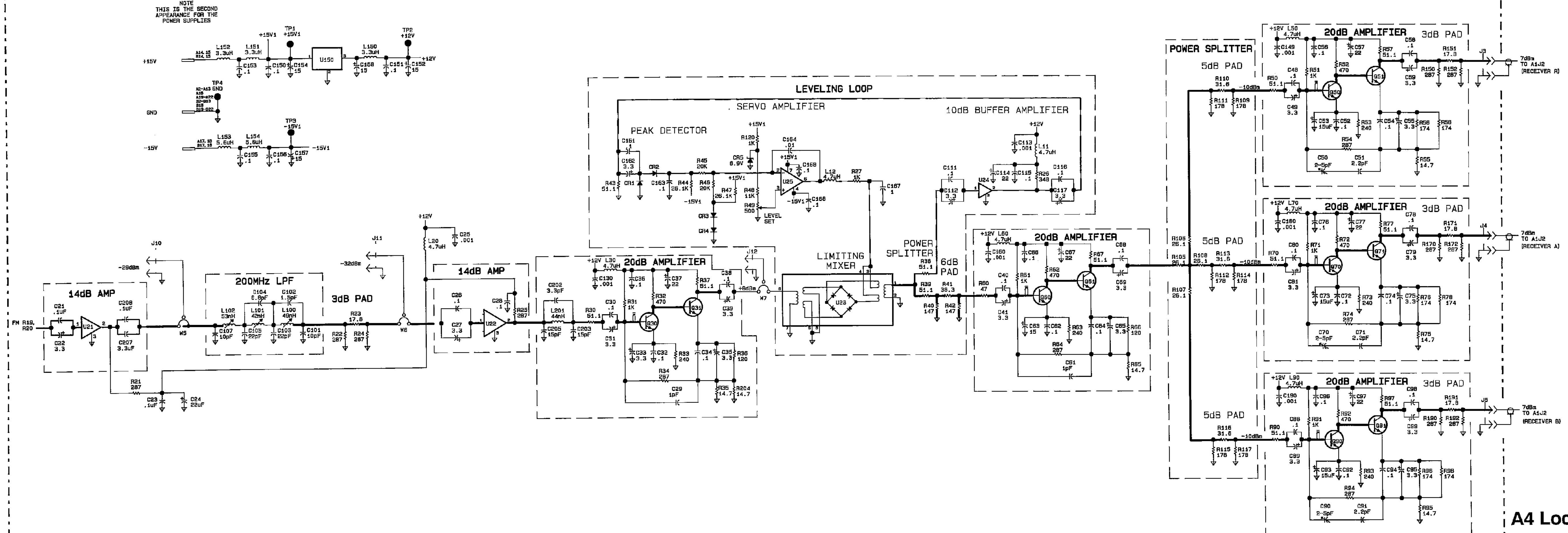


Figure 9-6. A4 Component Locator





A4 Local Oscillator  
03577-66504  
Sheet 2 of 2



## 9-8 Service Group A5, 250 kHz Assembly

The information in this section should be used to isolate faulty functional sub-blocks when servicing the HP 3577B. All procedures assume the Fault Isolation procedures of Section II have been used to determine which functional block has failed, and the circuit descriptions of Section VIII are understood.

### Warning



Service procedures described in this section are performed with the protective covers removed and power applied. Energy available at many points can, if contacted, result in personal injury.

### Caution



Do not insert or remove any circuit board in the HP 3577B with the line power turned on. Power transients caused by insertion or removal may damage the circuit boards.

### Initial Conditions

Unless otherwise stated in the troubleshooting sections of the signal table, set the HP 3577B as described below, after power on.

SWEEP TYPE	CW
AMPTD	-49 dBm
FREQUENCY	200 MHz

All Oscilloscope waveforms are taken using 10:1 probe but each oscilloscope display shows actual voltage. All Spectrum Analyzer waveforms connected to an SMB connector are taken through the 03577-84401 Service Kit BNC to SMB cable. All Spectrum Analyzer waveforms taken off component leads are taken through a 1:1 probe with 215Ω of series resistance.



## Troubleshooting Hints

1. Before troubleshooting this circuit board, be sure that the fault is occurring on this board by checking the following inputs using the settings in table 2-3 in the Fault Isolation Section.
  - a. A6 J4 300 MHz reference output
2. Test the signals listed in table 9-3 to troubleshoot the circuit to the faulty functional sub-block. The phase locked loop can be can be opened by removing jumper W2. This allows troubleshooting of the phase detector and VCO.

**Table 9-3. A5 Circuit Board, Troubleshooting**

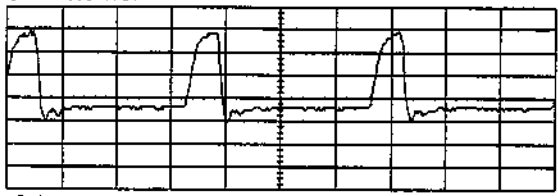
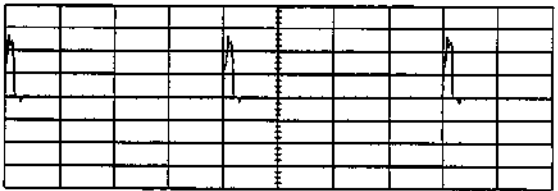
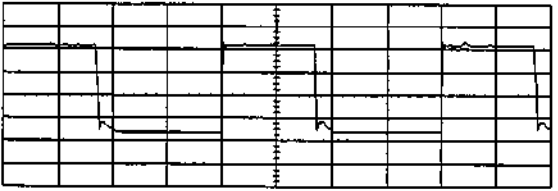
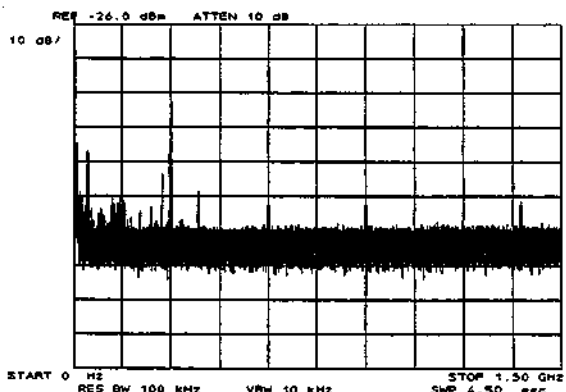
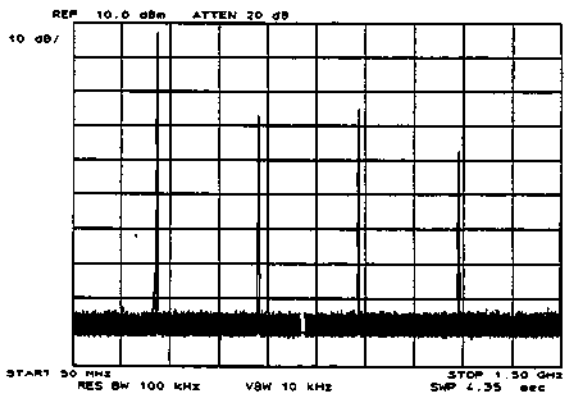
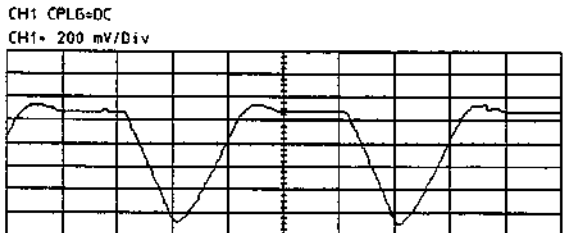
HP 3577B Set up	Measurement Set up	Waveform with Parameters
<p>Test at A5W3 Press INSTR PRESET</p> <p>Probe 10:1</p>	<p>Oscilloscope</p> <p>CH1 Coupling AC CH1 V/Div 1V Time/Div 50 ns Trigger CH1</p>	<p>Pulse shape and distortion</p>  <p>CH1 CPLG=AC CH1= 1.00 V/Div</p> <p>MT=Ch 1 Main= 50.0 ns/Div</p> <p>#1</p>
<p>Test at A5TP42 Press INSTR PRESET</p> <p>Probe 10:1</p>	<p>Oscilloscope</p> <p>CH1 Coupling AC CH1 V/Div 2V Time/Div 1 us Trigger CH1</p>	<p>Pulse shape and distortion</p>  <p>CH1 CPLG=AC CH1= 2.00 V/Div</p> <p>MT=Ch 1 Main= 1.00 us/Div</p> <p>#2</p>
<p>Test at A5TP31 Press INSTR PRESET</p> <p>Probe 10:1</p>	<p>Oscilloscope</p> <p>CH1 Coupling AC CH1 V/Div 1 V Time/Div 1 us Trigger CH1</p>	<p>Pulse shape and distortion</p>  <p>CH1 CPLG=AC CH1= 1.00 V/Div</p> <p>MT=Ch 1 Main= 1.00 us/Div</p> <p>#3</p>

Table 9-3. A5 Circuit Board, Troubleshooting Data Continued

HP 3577B Set up	Measurement Set up	Waveform with Parameters
Test at A5U20 Pin 1 Press INSTR PRESET	Spectrum Analyzer  Start            0 Hz Stop             1500 MHz Res BW          100 kHz VBW             10 kHz Ref Level       -26 dBm dB/Div          10 dB	<p style="text-align: center;"><b>300 MHz amplitude, and harmonics</b></p>  <p style="text-align: center;">#4</p>
Test at A5J1 Press INSTR PRESET  Probe 10:1	Spectrum Analyzer  Start            50 MHz Stop             1500 MHz Res BW          100 kHz VBW             10 kHz Ref Level       10 dBm dB/Div          10 dB	<p style="text-align: center;"><b>300.25 MHz amplitude and harmonics</b></p>  <p style="text-align: center;">#5</p>
Test at A5U50 Pin 12 Press INSTR PRESET  Probe 10:1	Oscilloscope  CH1 Coupling   DC CH1 V/Div      200 mV Time/Div        1 $\mu$ s Trigger          CH1	<p style="text-align: center;"><b>Pulse shape and distortion</b></p>  <p style="text-align: center;">#6</p>

**Table 9-3. A5 Circuit Board, Troubleshooting Data Continued**

HP 3577B Set up	Measurement Set up	Waveform with Parameters
Test at A5Q1 collector Press INSTR PRESET  Connect external power supply to W1 and GND	Counter	Correct Frequency  Frequency should be < 300.25 MHz with 0 V input should be > 300.25 MHz with 12V in

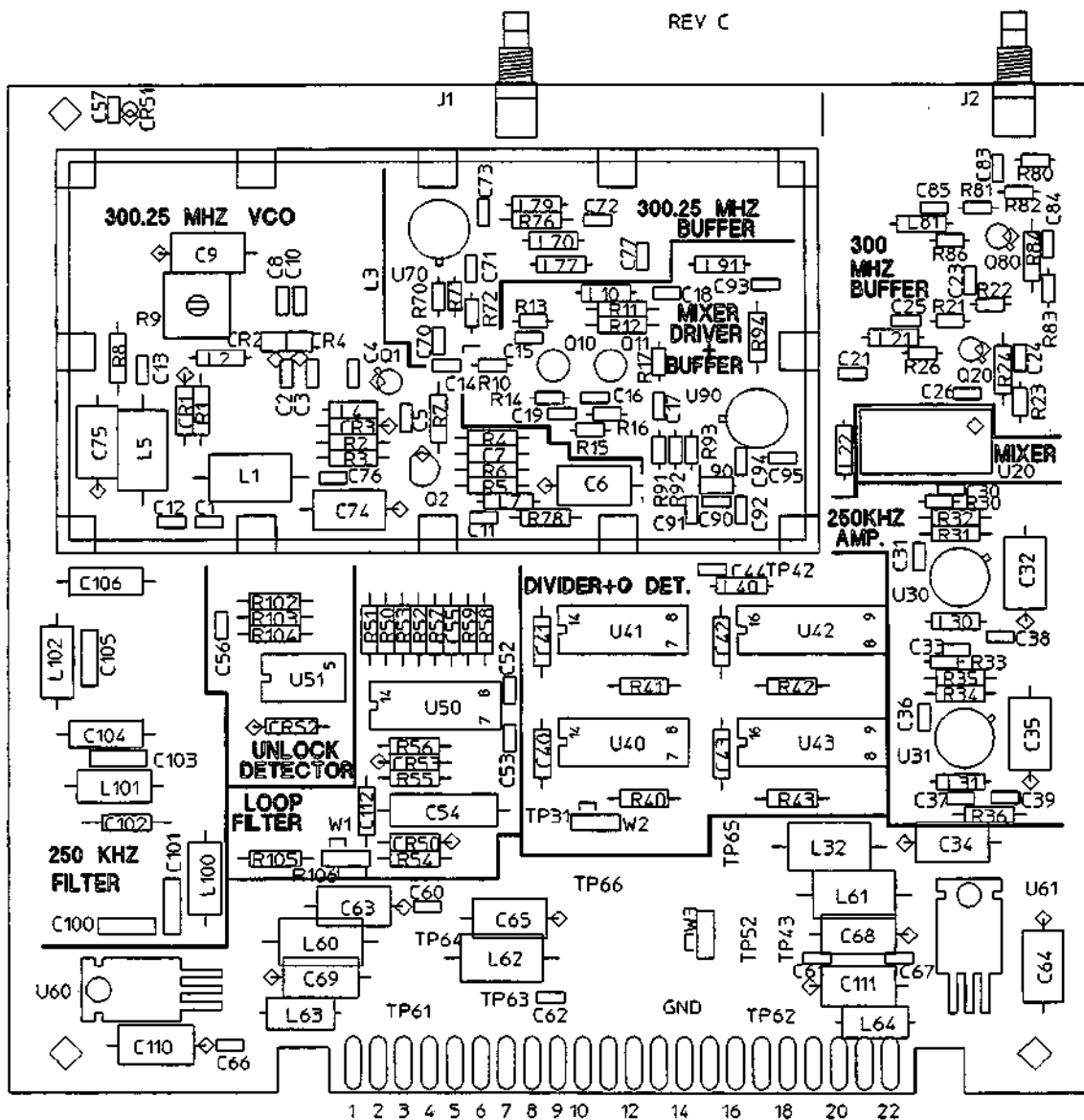
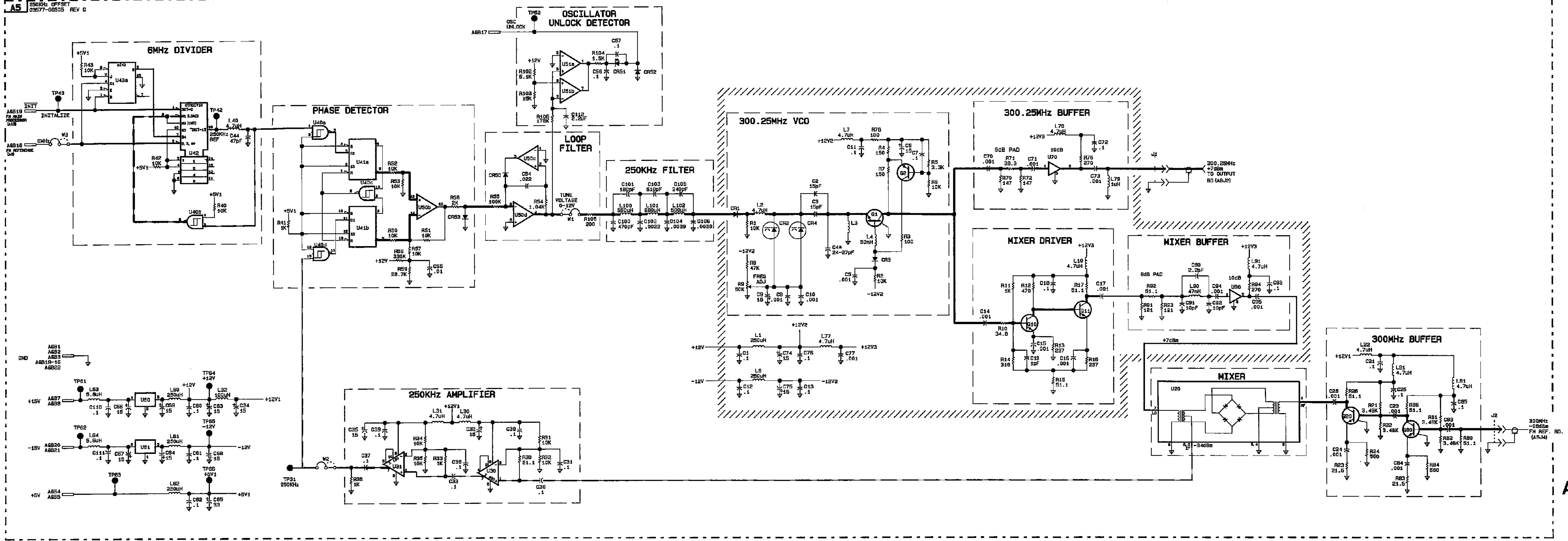


Figure 9-7. A5 Component Locator

IC	Voltage	Gnd	Bypass Cap	
	Pin #		Desig.	Value
U40	+5V1,14	7	C40	0.1
U41	+5V1,14	7	C41	0.1
U42	+5V1,14	5,6,8	C42	0.1
U43	+5V1,14	3,15	C43	0.1
U50	+12V,11	1,5	C52	0.1
U50	-12V,7	1,5,8,9	C53	0.1
U51	-12V,8	3		
U51	-12V,4	3		





## 9-9 Service Group A6, Frequency Reference Assembly

The information in this section should be used to isolate faulty functional sub-blocks when servicing the HP 3577B. All procedures assume the Fault Isolation procedures of Section II have been used to determine which functional block has failed, and the Circuit Descriptions of Section VIII are understood.

### Warning



Service procedures described in this section are performed with the protective covers removed and power applied. Energy available at many points can, if contacted, result in personal injury.

### Caution



Do not insert or remove any circuit board in the HP 3577B with the line power turned on. Power transients caused by insertion or removal may damage the circuit boards.

### Initial Conditions

Unless otherwise stated in the troubleshooting sections of the signal table, set the HP 3577B as described below, after power on.

SWEEP TYPE	CW
AMPTD	- 49 dBm
FREQUENCY	200 MHz

All Oscilloscope waveforms are taken using 10:1 probe but each oscilloscope display shows actual voltage. All Spectrum Analyzer waveforms connected to an SMB connector are taken through the 03577-84401 Service Kit BNC to SMB cable. All Spectrum Analyzer waveforms taken off component leads are taken through a 1:1 probe with 215  $\Omega$  of series resistance.



## Troubleshooting Hints

1. Before starting to troubleshoot this circuit board, be sure the fault is on this board by checking the following input signals. The signal information is listed in table 2-7 in the Fault Isolation Section.

A31J1 Oven Reference Output

### Note



The A6 Frequency Reference board of a standard HP 3577B free runs on its own 10 MHz VCXO if no external reference is present. For Option 001, the A6 Frequency Reference board runs on the A31 Oven Signal after the A31 is adequately warmed up and if no external reference signal is present. The A31 Oven Signal is not present if the oven is not adequately warmed up.

2. Check the signal at A6J2 and A6J7 to determine in which third of the circuit the fault has occurred. Refer to table 9-4 for the proper signal levels at the various test points listed.

Table 9-4. A6 Circuit Board, Troubleshooting Data

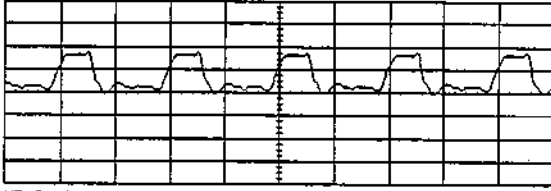
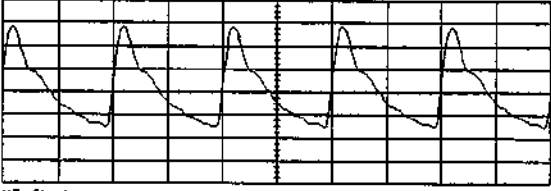
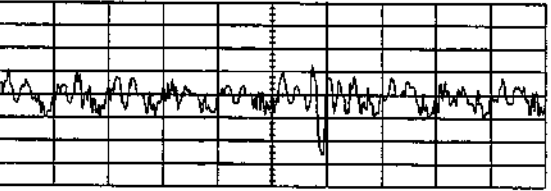
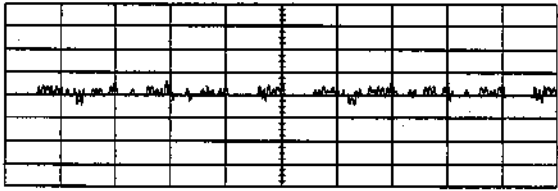
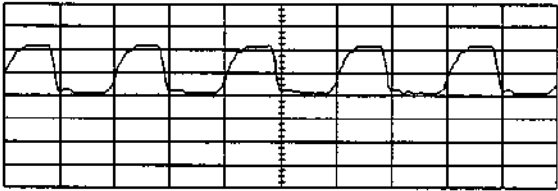
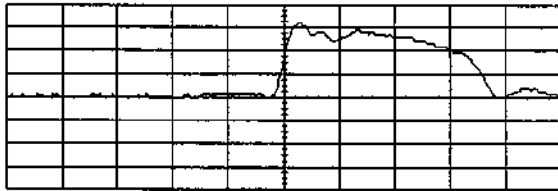
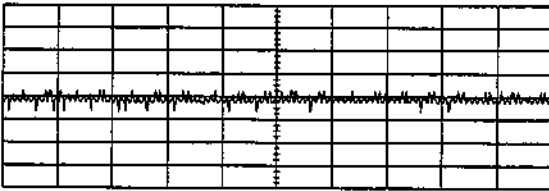
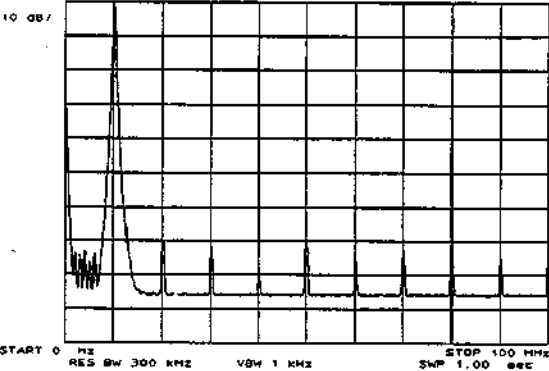
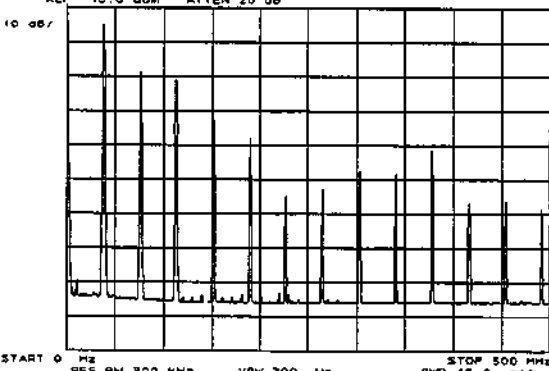
HP 3577B Set up	Measurement Set up	Waveform with Parameters
Test at A6U22 Pin 1 Press INSTR PRESET  Probe 10:1	Oscilloscope  CH1 Coupling DC CH1 V/Div 2 V Time/Div 50 ns Trigger CH1	Pulse Shape, pp amplitude  CH1 CPLG=DC CH1= 2.00 V/Div  HT=Ch 1 Main= 50.0 ns/Div  #1
Test at A6TP1 Press INSTR PRESET  Probe 10:1	Oscilloscope  CH1 Coupling AC CH1 V/Div 1 V Time/Div 50 ns Trigger CH1	Pulse Shape, pp amplitude  CH1 CPLG=AC CH1= 1.00 V/Div  HT=Ch 1 Main= 50.0 ns/Div  #2
Test at A6TP2 Press INSTR PRESET  Probe 10:1	Oscilloscope  CH1 Coupling AC CH1 V/Div 20 mV Time/Div 100 ns Trigger LF REJ CH1	Noise on VCO control voltage  CH1 CPLG=AC CH1= 20.0 mV/Div  HT=Ch 1 Main= 100 ns/Div  #3

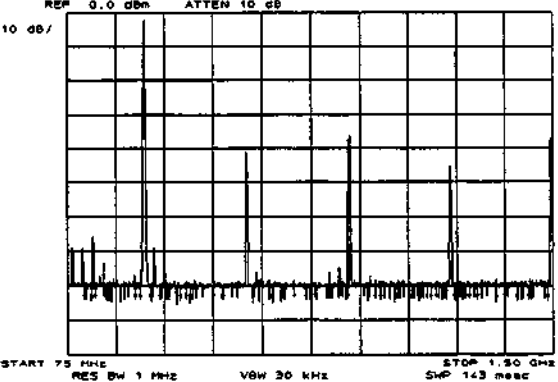
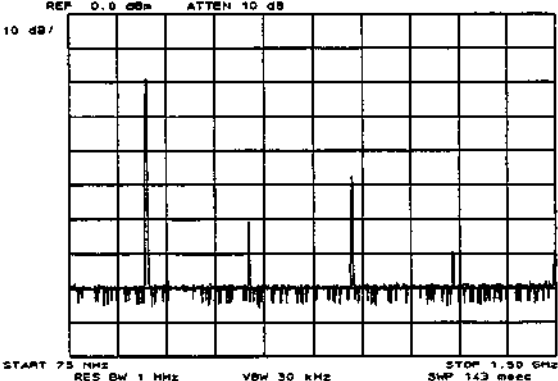
Table 9-4. A6 Circuit Board, Troubleshooting Data Continued

HP 3577B Set up	Measurement Set up	Waveform with Parameters
<p>Test at A6U2 Pin 14 Press INSTR PRESET</p> <p>Probe 10:1</p>	<p>Oscilloscope</p> <p>CH1 Coupling AC CH1 V/Div 20 mV Time/Div 100 ns Trigger LF REJ CH1</p>	<p>Noise on VCO control voltage</p> <p>CH1 CPLG=AC CH1= 20.0 mV/Div</p>  <p>MT=Ch 1 Main= 100 ns/Div</p> <p>#4</p>
<p>Test at A6TP3 Press INSTR PRESET</p> <p>Probe 10:1</p>	<p>Oscilloscope</p> <p>CH1 Coupling DC CH1 V/Div 2V Time/Div 50 ns Trigger CH1</p>	<p>Pulse Shape, pp amplitude</p> <p>CH1 CPLG=DC CH1= 2.00 V/Div</p>  <p>MT=Ch 1 Main= 50.0 ns/Div</p> <p>#5</p>
<p>Test at A6J5 Press INSTR PRESET</p> <p>Probe 10:1</p>	<p>Oscilloscope</p> <p>CH1 Coupling AC CH1 V/Div 500 mV Time/Div 2us Trigger CH1</p>	<p>Pulse Shape, pp amplitude</p> <p>CH1 CPLG=AC CH1= 500 mV/Div</p>  <p>MT=Ch 1 Main= 2.00 us/Div</p> <p>#6</p>

**Table 9-4. A6 Circuit Board, Troubleshooting Data Continued**

HP 3577B Set up	Measurement Set up	Waveform with Parameters
<p>Test at A6TP4 Press INSTR PRESET</p> <p>Probe 10:1</p>	<p>Oscilloscope</p> <p>CH1 Coupling AC CH1 V/Div 20m V Time/Div 2 us Trigger CH1</p>	<p>Pulse pp amplitude, period</p> <p>CH1 CPLG=AC CH1= 20.0 mV/Div</p>  <p>MT-Ch 1 Main= 2.00 us/Div</p> <p>#7</p>
<p>Test at A6J2 Press INSTR PRESET</p>	<p>Spectrum Analyzer</p> <p>Start 0 Hz Stop 100 MHz Res BW 300 kHz VBW 1 kHz Ref Level 0 dBm dB/Div 10 dB</p>	<p>Harmonics and noise on 10 MHz output.</p> <p>REF 0.0 dBm ATTN 10 dB</p>  <p>START 0 MHz RES BW 300 kHz VBW 1 kHz STOP 100 MHz SWP 1.00 sec</p> <p>#8</p>
<p>Test at A6J7 Press INSTR PRESET</p>	<p>Spectrum Analyzer</p> <p>Start 0 Hz Stop 500 MHz Res BW 300 kHz VBW 300 Hz Ref Level 10 dBm dB/Div 10 dB</p>	<p>Harmonics and noise on 30 MHz output</p> <p>REF 10.0 dBm ATTN 20 dB</p>  <p>START 0 MHz RES BW 300 kHz VBW 300 Hz STOP 500 MHz SWP 15.0 sec</p> <p>#9</p>

**Table 9-4. A6 Circuit Board, Troubleshooting Data Continued**

HP 3577B Set up	Measurement Set up	Waveform with Parameters
Test at A6J3 Press INSTR PRESET	Spectrum Analyzer  Start 75 MHz Stop 1500 MHz Res BW 1 MHz VBW 30 kHz Ref Level 0 dBm dB/Div 10 dB	Harmonics and noise on 300 MHz output   <p>#10</p>
Test at A6J4 Press INSTR PRESET	Spectrum Analyzer  Start 75 MHz Stop 1500 MHz Res BW 1 MHz VBW 30 kHz Ref Level 0 dBm dB/Div 10 dB	Harmonics and noise on 300 MHz output.   <p>#11</p>
Test at A6R22	Oscilloscope CH1 Coupling DC CH1 V/Div 1 V Time/Div any Trigger AUTO	See TTL Toggle Oscilloscope should show U2b toggle when an External Reference is connected and disconnected.

IC	Voltage &	Gnd	Bypass Cap	
	Pin #		Desig.	Value
U1	+5V3,14	7		
U2	+12V,4	6,9	C18	0.1
	- 12V,11		C17	0.1
U4	+5V3,11	4,5,8	C53	0.01
	+5V3,16			
U5	+5V3,11	4,5,8	C46	0.01
	+5V3,16			
U6	+5V1,5	6,7,10	C33	0.01
U7	+5V1,5	3,4,8		
	+5V1,6			
	+5V1,7			
	+5V1,10			
	+5V1,16			
U8	+5V1,14	7	C32	0.01
U9	+12V1,7			
	+12V1,4			
U10	+12V1,8	6		
	+12V,4			
U11	+5V3,14	7	C42	0.01
U13	+5V3,1	3,5,6	C43	0.01
	+5V3,4	8		
	+5V3,7			
	+5V3,10			
	+5V3,16			
U14		8,10,11 12,13		
U15	+5V2,14	7	C71	1.0
U16	+5V2,7	8	C65	0.01
	+5V2,10			
	+5V2,16			
U17	+5V2,16	8	C72	22
U18	+5V2,1	8	C66	0.01
	+5V2,14			
	+5V2,15			
	+5V2,16			
U19		2		
U20		1		
U22	+5V3,14	3,7,9,12	C120	0.1
U23		2		
U24	+5V2,1	7,8,9		
	+5V2,14	10,11		
U25	+5V3,8	4,6		
	+5V3,9		C109	0.1
	+12V,10		C107	0.1
	- 12V,3		C108	0.1

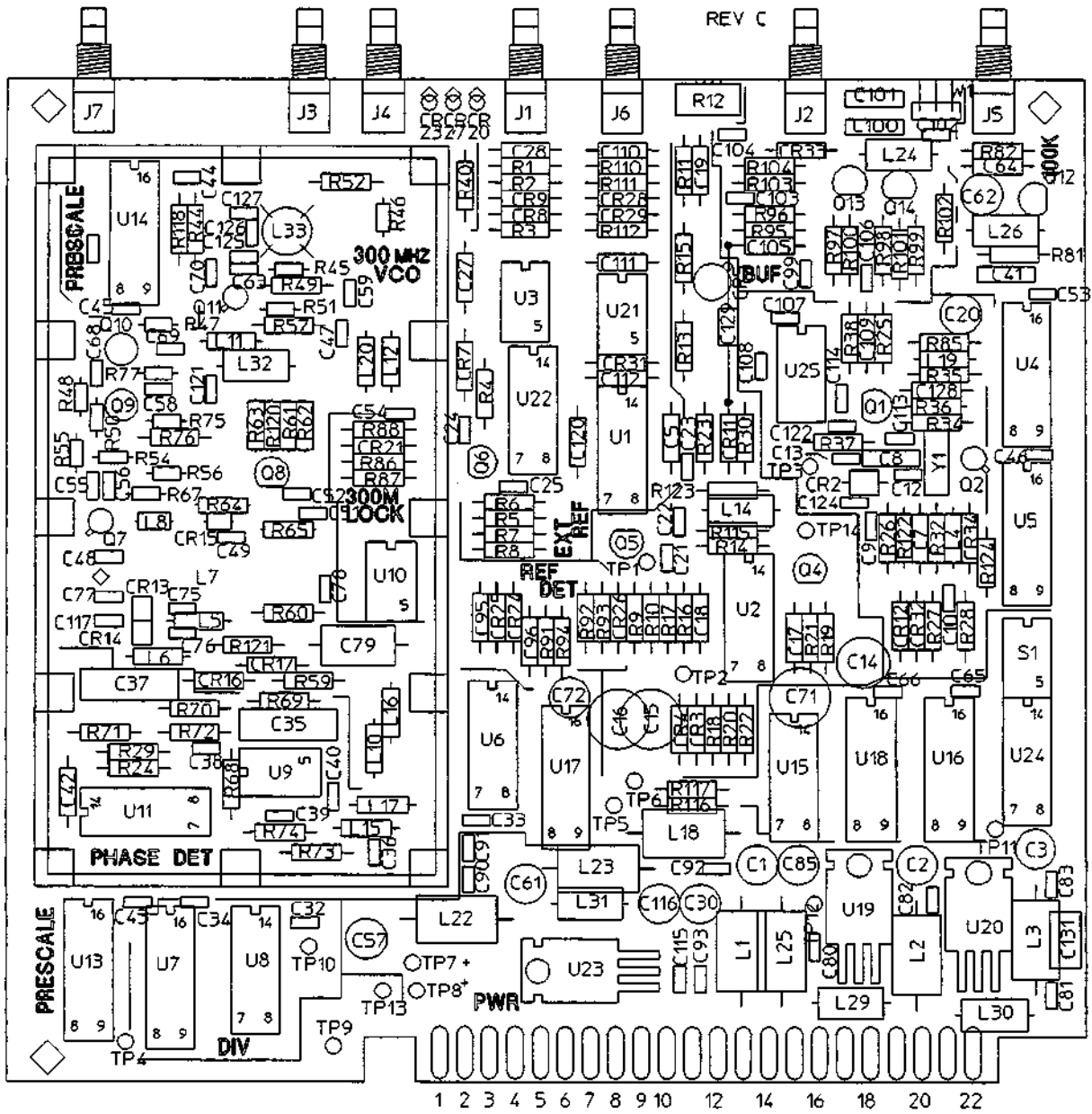
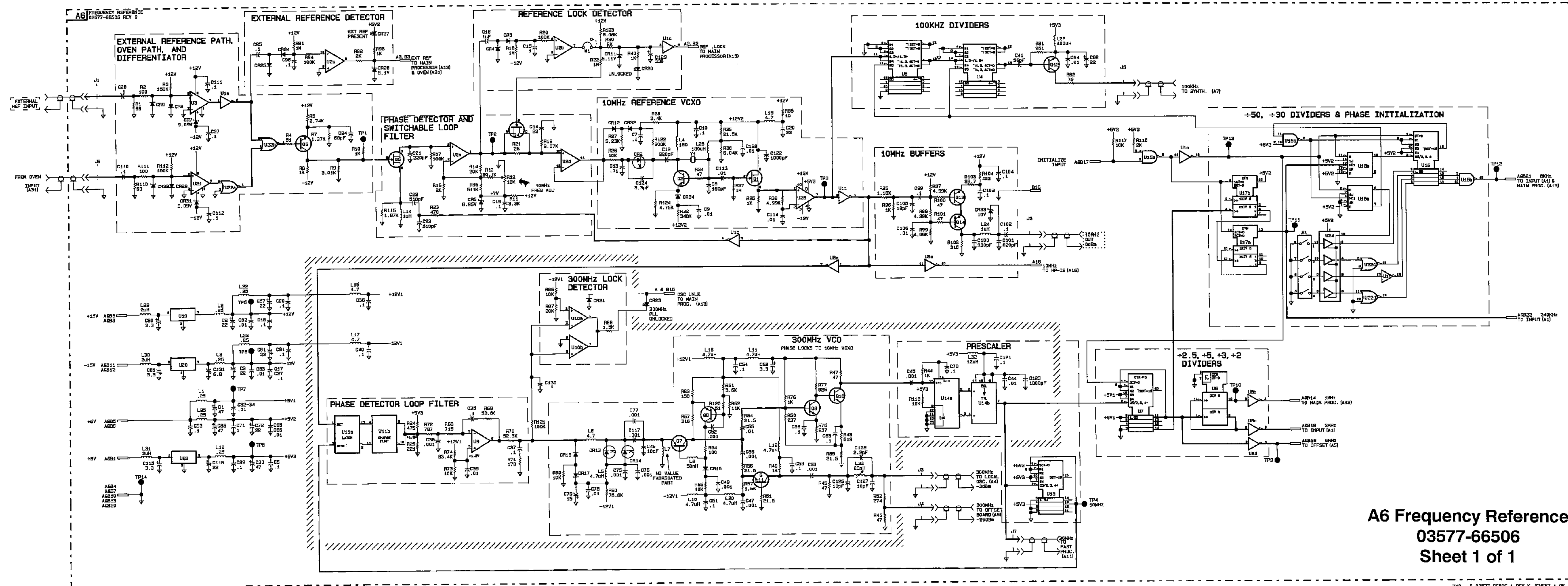


Figure 9-8. A6 Component Locator



**A6 Frequency Reference**  
**03577-66506**  
**Sheet 1 of 1**





---

## 9-10 Service Group A15, Keyboard Assembly

The information in this section should be used to isolate faulty functional sub-blocks when servicing the HP 3577B. All procedures assume the Fault Isolation procedures of Section II have been used to determine which functional block has failed, and the Circuit Descriptions of Section VIII are understood.

---

### Warning



Service procedures described in this section are performed with the protective covers removed and power applied. Energy available at many points can, if contacted, result in personal injury.

---

### Caution



Do not insert or remove any circuit board in the HP 3577B with the line power turned on. Power transients caused by insertion or removal may damage the circuit boards.

---

### Troubleshooting Hints

1. Troubleshoot at each side of the latches separating the suspect key, LED, or the RPG from the keyboard connector J1. Key closure is indicated by TTL ground.

2 LAYERS

03577-2655

2-27-85 REV C

26A-2A00.14

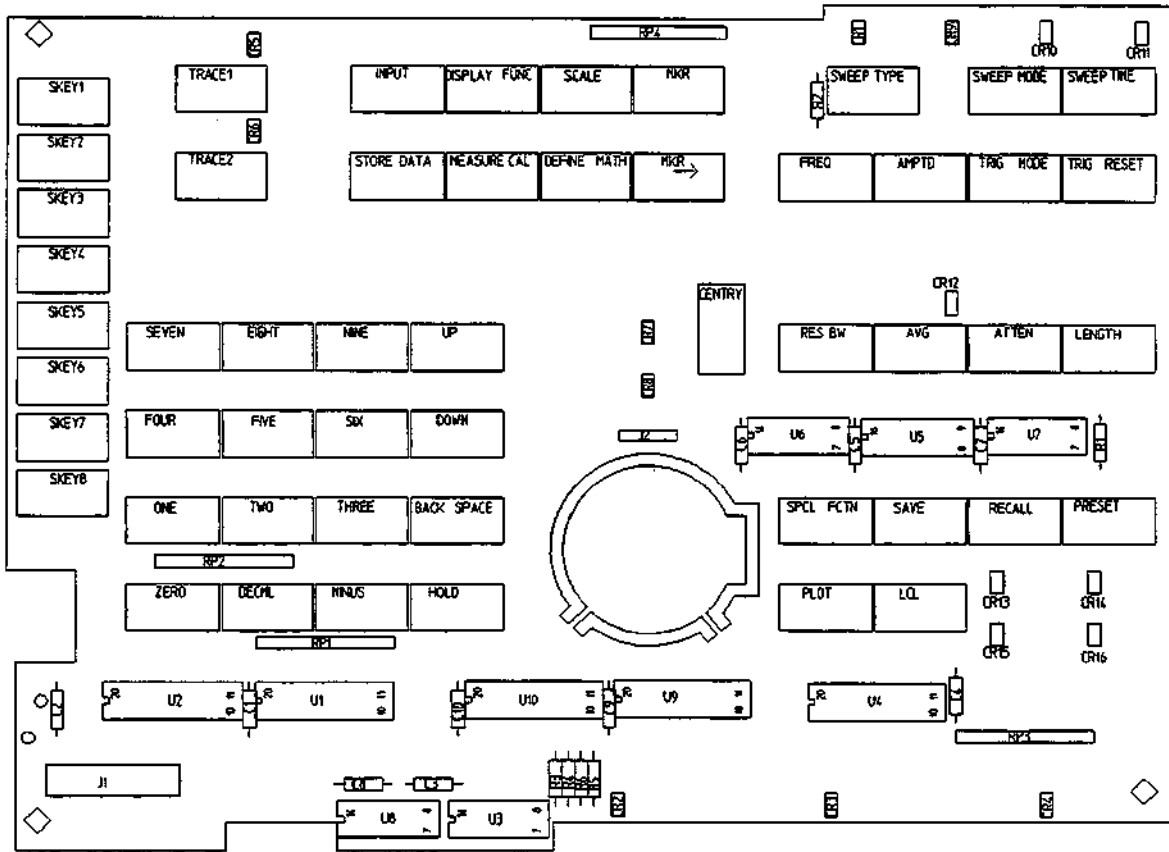
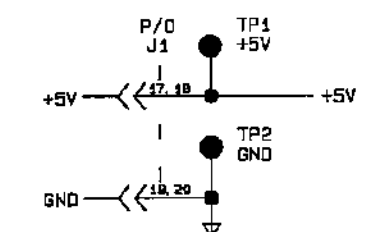
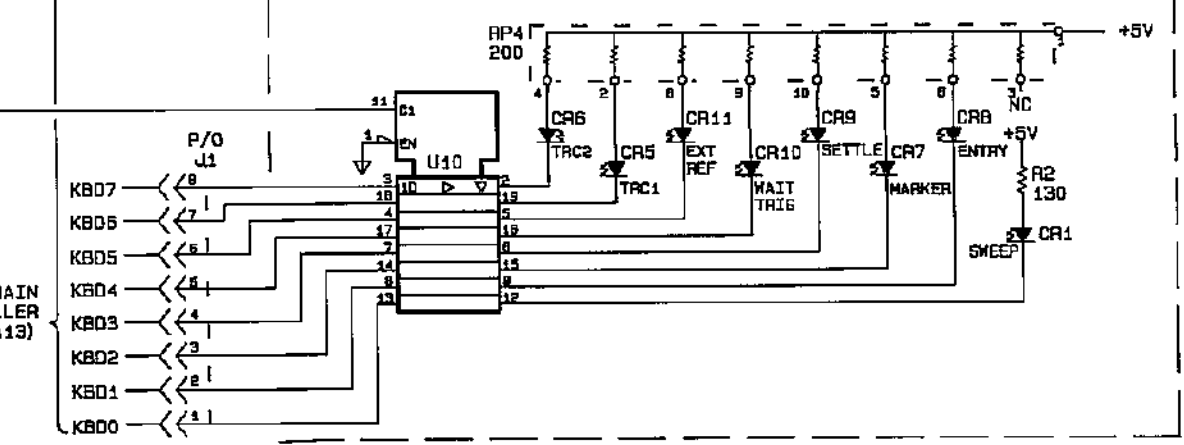
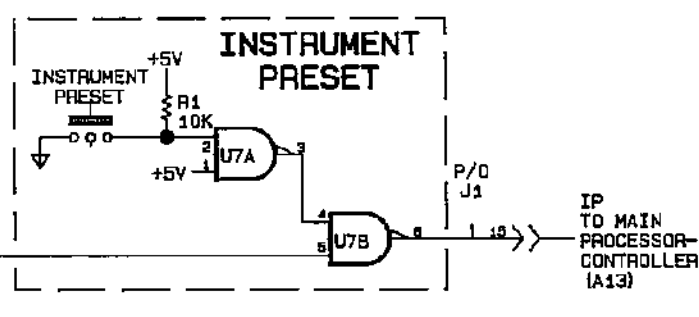
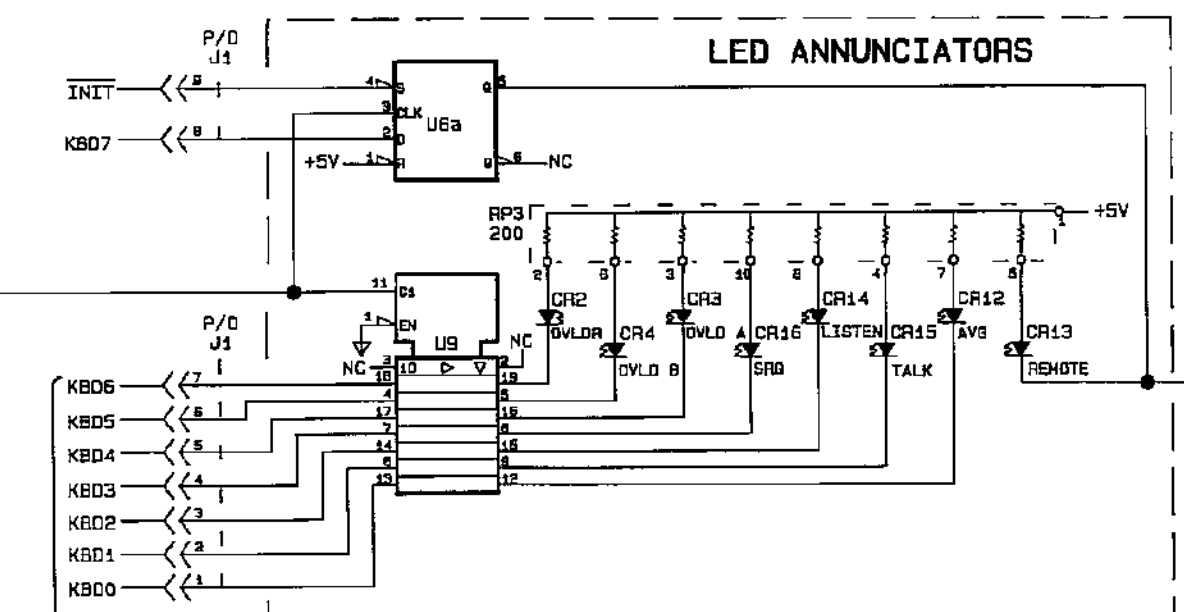
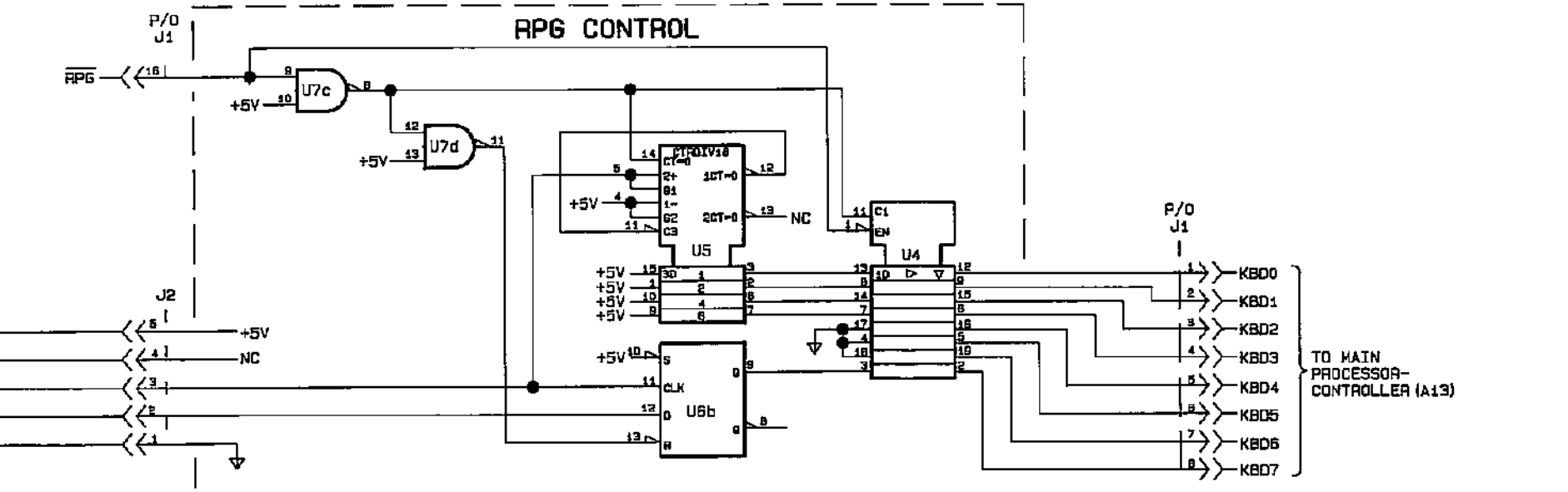
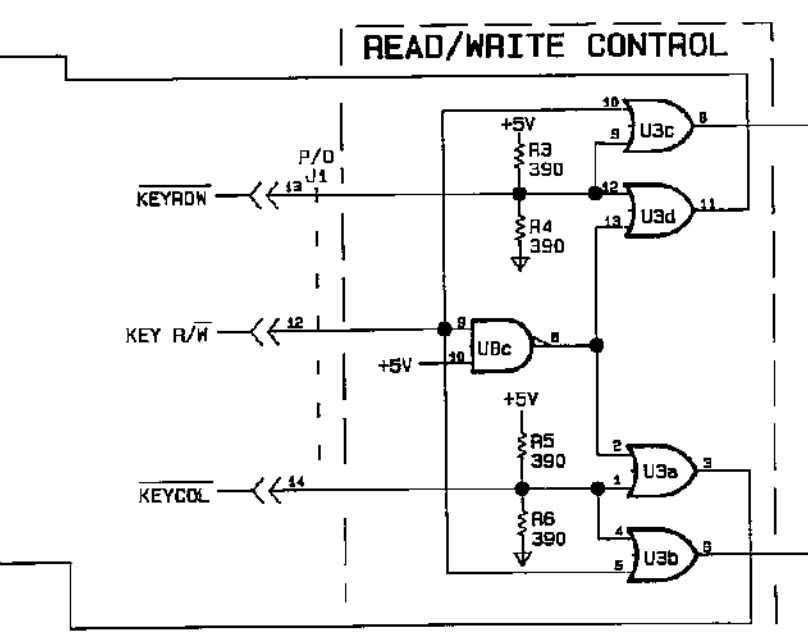
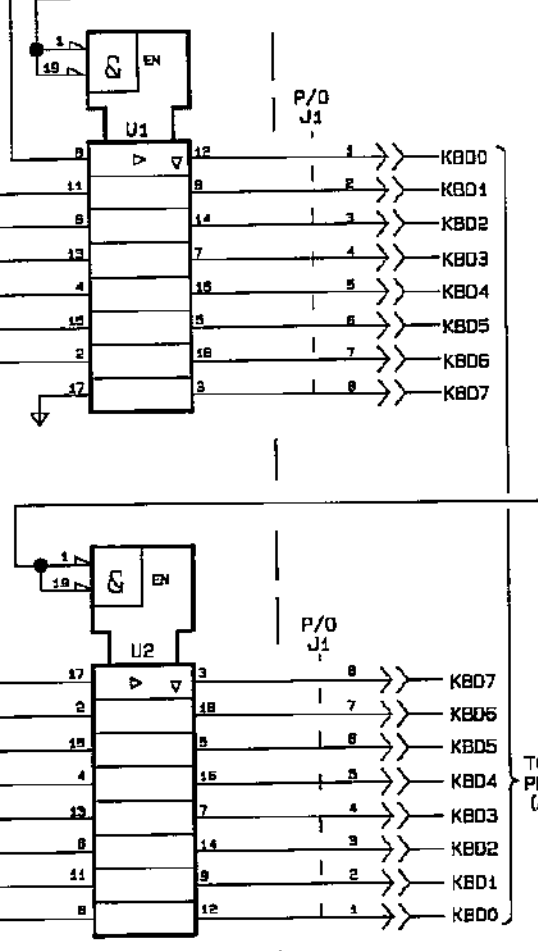
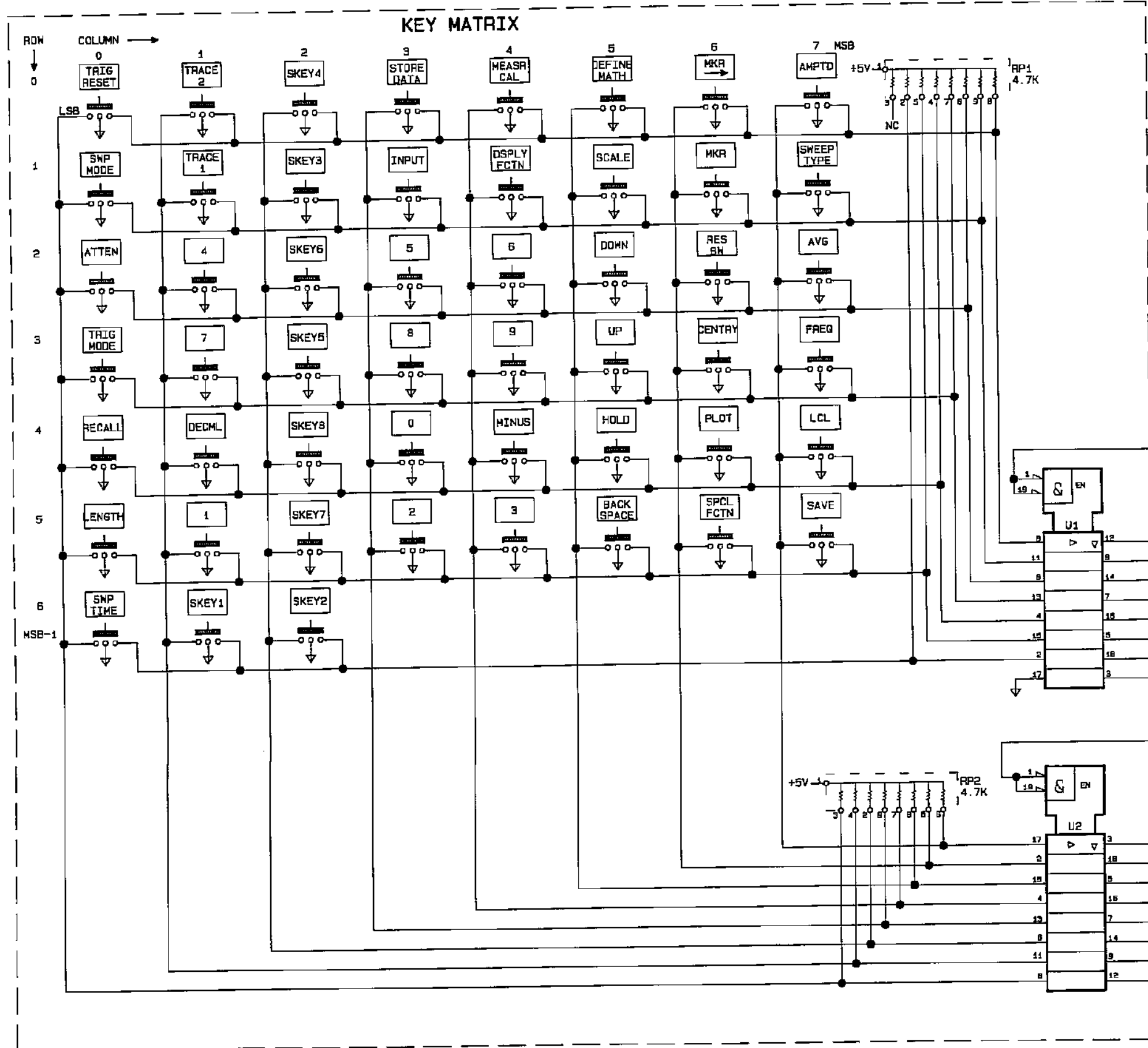


Figure 9-9. A15 Component Locator

IC	+ 5V	GND	Bypass Cap	
	PIN#		Desig.	Value
U1	20	10,17	C1	0.1
U2	20	10	C2	0.1
U3	14	7	C3	0.1
U4	20	4,10,17,18	C4	0.1
U5	1,4,9 10,15,16	8	C5	0.1
U6	1,10,14	8	C6	0.1
U7	1,10,13,14	7	C7	0.1
U8	10,14	1,4,7,13	C8	0.1
U9	20	1,10	C9	0.1
U10	20	1,10	C10	0.1

LED'S	
Diode	Description
CR1	SWEEP
CR2	OVLD R
CR3	OVLD A
CR4	OVLD B
CR5	TRC 1
CR6	TRC 2
CR7	MARKER
CR8	ENTRY
CR9	SETTLE
CR10	WAIT TRIG
CR1 1	EXT REF
CR12	AVG
CR13	REMOTE
CR14	LISTEN
CR15	TALK
CR16	SRQ







---

## 9-11 Service Group A16, HP-IB Assembly

The information in this section should be used to isolate faulty functional sub-blocks when servicing the HP 3577B. All procedures assume the Fault Isolation procedures of Section II have been used to determine which functional block has failed, and the Circuit Descriptions of Section VIII are understood.

---

### Warning



Service procedures described in this section are performed with the protective covers removed and power applied. Energy available at many points can, if contacted, result in personal injury.

---

### Caution



Do not insert or remove any circuit board in the HP 3577B with the line power turned on. Power transients caused by insertion or removal may damage the circuit boards.

---

### Initial Conditions

Unless otherwise stated in the troubleshooting sections of the signal table, set the HP 3577B as described below, after power on:

Press INSTR PRESET

All Oscilloscope waveforms are taken using a 1:1 probe and a HP 1980B Oscilloscope. All signatures were taken using a HP 5006A Signature Analyzer.

---

### Note



When running all signature analysis routines, keep the signature analyzer and the HP 3577B physically far from each other to prevent digital signal coupling.

---



## Troubleshooting Hints

---

### Note



The HP-IB signature analysis routine is run from the Main Processor-Controller. Faulty +5V1 and GNDI signatures would indicate Main Processor-Controller and HP-IB communication fault.

---

1. Run the DISP HP-IB test routine under the SPCL FCTN hardkey and SERVICE DIAG softkey. Using a small jumper, short each of the control pins to HP-IB connector ground. When each pin is grounded, the appropriate pin shown should have a dot in it.

If this test passes, and there is still an HP-IB fault, then the fault would be in either the HP-IB chip or in Main Processor-Controller servicing of the HP-IB circuit. All signal paths and buffers are checked using the above procedure.

If this test fails, then all components are still suspect. Run the HP-IB Signature Analysis routine under the SPCL FCTN hardkey and SERVICE DIAG softkey. If the Signatures are correct and there is still an HP-IB fault, then there is probably a firmware fault, and the Main Processor-Controller ROMs should be checked as described in the Power-On Selftest section of Section I.

2. To run the HP-IB signature analysis routine, press the SPCL FCTN hardkey and select the HP-IB SA softkey. Connect the Signature Analyzer to the HP 3577B as described below.

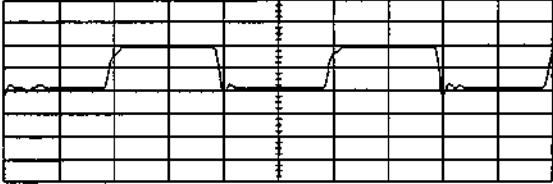
Clock	A16J3pin3
Qualify	No Connection
Start	A16J3 pin5
Stop	A16J3 pin4

Signature Analyzer set-up.

Clock	
Qualify	N/A
Start	
Stop	
+5V1, signature =	P672
GNDI, signature =	0000

Test for correct signatures as noted on A16, HP-IB Schematic. All data path signatures are identical.

**Table 9-5 . A16 Circuit Board, Troubleshooting Data**

HP 3577B Set up	Measurement Set up	Waveform with Parameters
Test at A16TP5 (Clock signal)  Probe 10:1	Oscilloscope CH1 Coupling AC CH1 V/Div 2 V Time/Div 50 ns Trigger CH1	<p style="text-align: center;">Risetime, Period</p> <p>CH1 CPLG=AC CH1= 2.00 V/Div</p>  <p>HT=Ch 1 Main= 50.0 ns/Div</p> <p style="text-align: right;">#1</p>

REVD

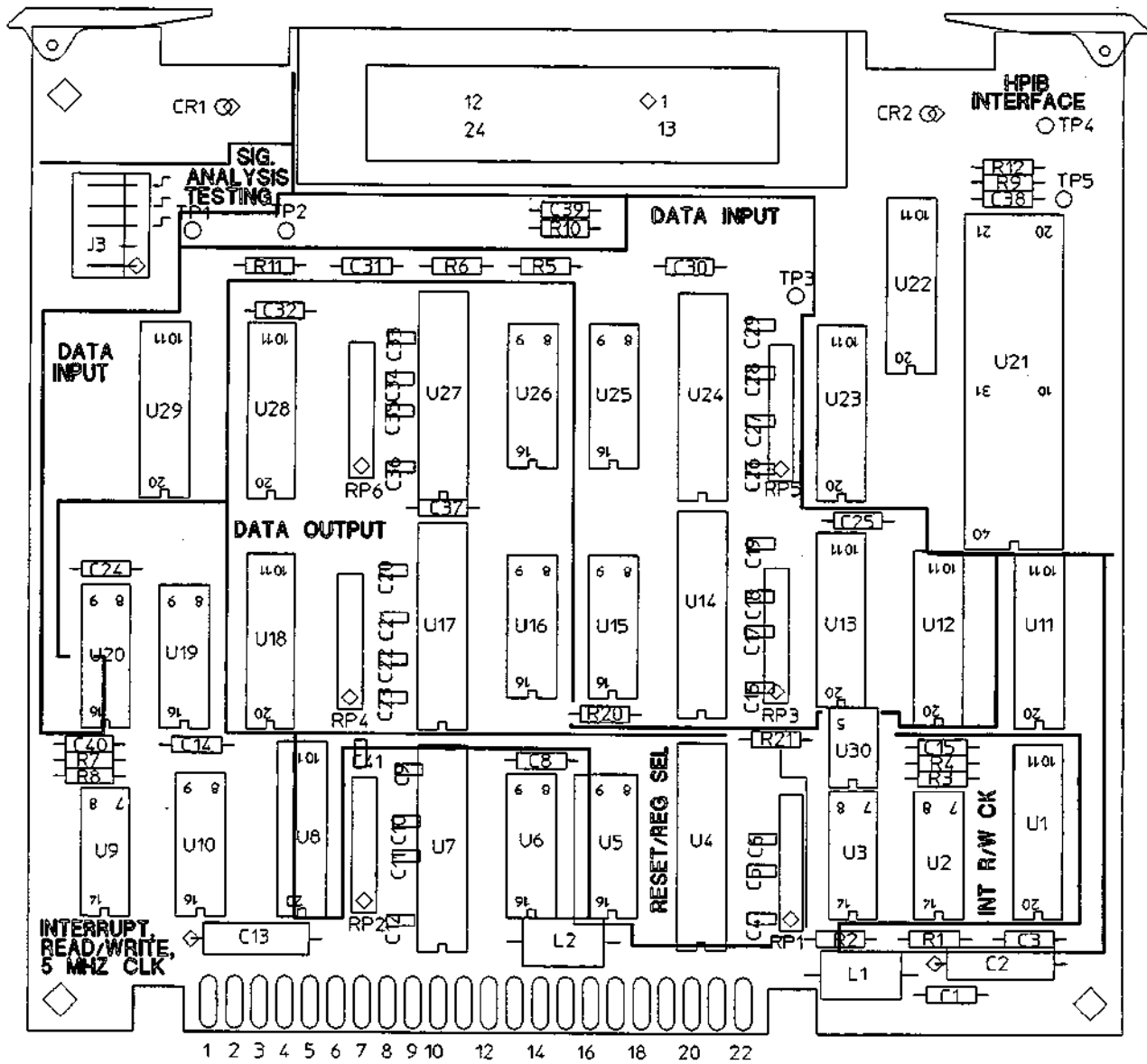
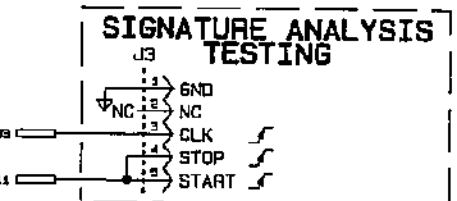
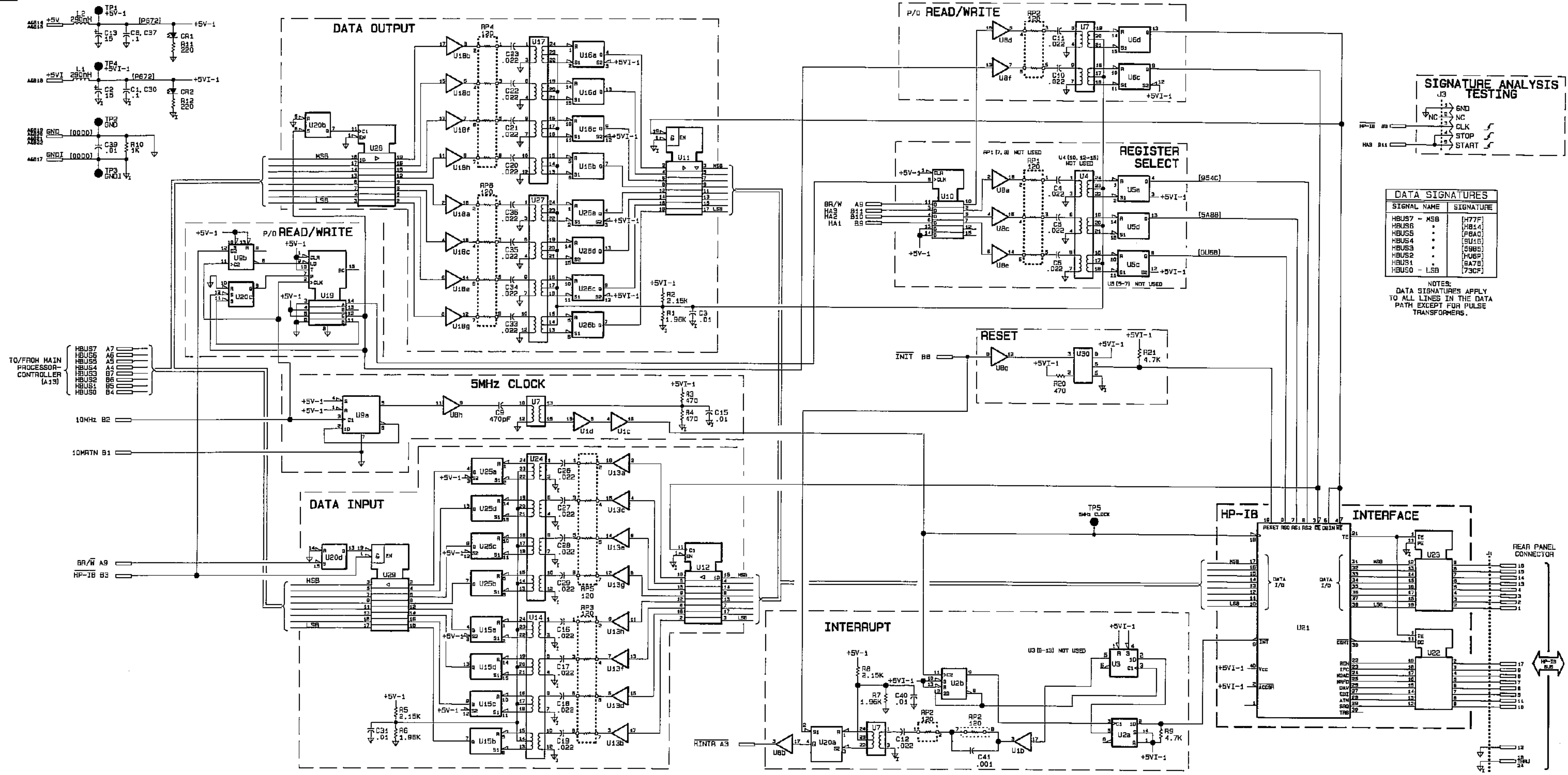


Figure 9-10. A16 Component Locator

IC	+5VI - 1	GNDI	+5VI	GND	Bypass Cap	
					Desig.	Value
U1	2,6,8 11,13,20	1,10,19				
U2	2,4,10-14	7		3,4,7,12		
U4						
U5	3,12,16	8				
U6	1,2,3,5	8				
U7				4,7,12		
U8			20	1,10,19		
U9			1,4,14	7	C14	0.1
U11	20	1,10				
U12	20	1,10				
U13	20	1,10,19			C25	0.1
U14		3,4,7,12				
U15			3,12,16	8		
U16	3,12,16	8				
U17				3,4,7,12		
U18			20	1,10,19		
U20			8,14,9	7	C24	0.1
U21	2,40	20			C38	0.1
U22	20	10				
U23	20	10,11				
U24		3,4,7,12			C30	0.1
U25			3,12,16	8		
U26	3,12,16	8				
U27				3,4,7,12	C37	0.1
U28			20	1,10	C32	0.1
U29			20	10		

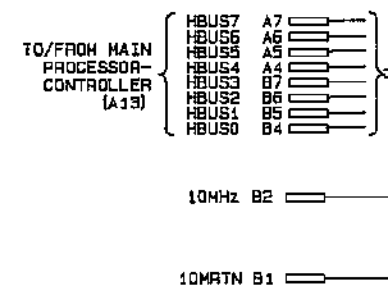




**DATA SIGNATURES**

SIGNAL NAME	SIGNATURE
HBUS7 - MSB	[H77F]
HBUS6	[H814]
HBUS5	[P8A0]
HBUS4	[S016]
HBUS3	[S805]
HBUS2	[H0E6]
HBUS1	[A78]
HBUS0 - LSB	[73CF]

NOTES:  
 DATA SIGNATURES APPLY TO ALL LINES IN THE DATA PATH EXCEPT FOR PULSE TRANSFORMERS.





## 9-12 Service Group A17, Synthesizer Assembly

The information in this section should be used to isolate faulty functional sub-blocks when servicing the HP 3577B. All procedures assume the Fault Isolation procedures of Section II have been used to determine which functional block has failed, and the Circuit Descriptions of Section VIII are understood.

### Warning



Service procedures described in this section are performed with the protective covers removed and power applied. Energy available at many points can, if contacted, result in personal injury.

### Caution



Do not insert or remove any circuit board in the HP 3577B with the line power turned on. Power transients caused by insertion or removal may damage the circuit boards.

### Initial Conditions

Unless otherwise stated in the troubleshooting sections of the signal table, set the HP 3577B as described below, after power on:

SWEEP TYPE	CW
AMPTD	- 49 dBm
FREQUENCY	200 MHz

All Oscilloscope waveforms are taken using a 10:1 probe but all oscilloscope displays shows actual voltage. All Spectrum Analyzer waveforms connected to an SMB connector are taken through the 03577-84401 Service Kit BNC to SMB cable. All Spectrum Analyzer waveforms taken off component leads are taken through a 10:1 probe with 215 $\Omega$  of series resistance.

All troubleshooting in this section takes place with the synthesizer diagnostics turned on. To turn on this diagnostic, press the SPCL FCTN hardkey and toggle the SYN DIAG to the ON mode. This causes the HP 3577B to display directly in synthesizer frequency rather than output frequency.



## Troubleshooting Hints

1. Before starting to troubleshoot this circuit board, be sure the fault is on this board by checking the following input signals. The signal information is listed in table 2-7 in the Fault Isolation Section.
  - a. A6J5 100 kHz reference signal. See table 9-4 in the A6 section for the waveform.
  - b. Run Service Diagnostics section in the Fault Isolation Section to verify that the digital circuits are operational.
  - c. This circuit board regulates the main power supplies input to it. When the fault has been isolated to a functional sub-block, first check the supplies associated with that circuit.
2. SYMPTOM: Synthesizer output frequency is bad or noisy.
  - a. Isolate whether the analog or digital circuitry is faulty by checking the signal at A17J1 with the Spectrum Analyzer. Power the instrument up with the Reset button pushed on the A62/63 Main Processor-Controller board. This keeps the main processor from programming the synthesizer, and makes the output VCO free run at the top of its frequency range. By releasing the main processor reset switch and disconnecting the 100 kHz reference signal at A17J3, the VCO will free run at the bottom of its frequency range.
  - b. If the VCO oscillates at both the top and bottom of its range, the VCO is probably operating correctly. The important aspects of these signals are the frequency range and amplitude at both frequency extremes. There must be adequate signal level for the VCO to drive the associated circuitry. If the signals are good, begin troubleshooting the digital section of this board.
  - c. If the VCO does not oscillate at all, repair the VCO circuit before continuing.
  - d. If the VCO frequency range is not wide enough, then troubleshoot the oscillator transistor and the associated bias circuits.

## Analog Troubleshooting

1. Connect the Spectrum Analyzer to A17J1 and then A17J2. Set A17W1 to the right and left positions. The output signals for both connectors should be  $-1 \text{ dBm} \pm 1.5 \text{ dB}$  for both frequency extremes.
  - a. If the signal is at A17J1 only, then the buffer circuits in the 300.25 MHz to 500.25 MHz VCO are faulty.
  - b. If 200 MHz of tuning range is available, but not centered correctly, then the adjustment of this tuning range is required. See the appropriate adjustment in Section IV.
  - c. If 200 MHz of tuning range is not available, then check all components in the schematic and physical vicinity of the oscillator transistor, A17Q161. Placement and mounting of these components is critical.
2. If the counter circuit is operational as described in the digital troubleshooting section, and the VCO is still not tuning correctly, then test for the correct signal at A17TP450. Sample waveforms for this test point are shown in step 3 of table 9-6.
  - a. If the waveform is slightly distorted or rounded, then check for proper operation of the sample and hold. Be sure the sampling FETS are not leaky. Start troubleshooting at the sample pulse input at A17TP106. See step 8 in table 9-6.
  - b. If the waveform is good, then check the following circuits in the order given to isolate the faulty functional sub-block.
    - i. The phase detector output at A17TP400 should look like the waveforms in step 2 of table 9-6.
    - ii. The voltage at A17R382 should be approximately  $-13.5 \text{ V}$ .
    - iii. The voltage at the junction of A17R356 and A17R357 should be between  $-7$  and  $-8 \text{ V}$ .
    - iv. The outputs generating the Bias and API signals should be toggling for a swept synthesizer output. If they are not present, make sure the Fractional-N IC is generating them and that the latch clock is present. There should be 14 latch clock cycles for each reference cycle.
3. If the circuitry checked above is good, then the fault lies in the API and Bias sub-blocks. Care should be taken when troubleshooting this circuitry as all the signals are small currents which are difficult to detect. Note that if the VCO Locks correctly, but there are large spurious signals present on the output, then check the diodes A17CR252, 400, 402 for opens, shorts, or excessive leakage.

## Digital Troubleshooting

1. Check that the main processor is talking to the synthesizer properly. Connect the Oscilloscope to A17 TP109. Press the SWEEP TYPE hardkey and select the CW softkey. Press the FREQ hardkey and enter a FREQUENCY of 1 MHz. Note on the Oscilloscope display that three pulses are sent to the Fractional-N IC after the MHz softkey is pressed. Repeat sending new frequencies to the A17 board until you are sure the data is present or not.
  - a. If the data is latching through from the main processor-controller and motherboard to the A17 board, then the fault is on the A17 board. Continue the digital troubleshooting.
  - b. If the data is not latching through, the input instruction decoding latches are faulty, or the main processor-controller signals are bad or missing.
2. Disconnect the jumper A17 W1 and connect the External Power Supply to the A17 W1 pins. Set the power supply for approximately 2 V. Monitor the VCO output frequency with the spectrum analyzer and adjust the power supply for a 400 MHz output signal. Press the SWEEP TYPE hardkey and select the CW softkey. With the Synthesizer Diagnostics on, press the FREQ hardkey and enter a FREQUENCY of 400 MHz. Monitor A17 TP100 with the Oscilloscope while the VCO is manually tuned. See step 5 in table 9-6. If the frequency at TP100 approaches 100 kHz (10 uS) as the output frequency approaches 400 MHz, then the entire counter digital section is working correctly. Note that this frequency will approach 100 kHz for every N number programmed into the HP 3577B and tuned for at the VCO output.
  - a. If this test passes, and the faults appear to be digitally related, check to make sure the API current sources are getting the correct signals and are not leaky.
  - b. If this test fails, troubleshoot the counter subblocks and repair as necessary. Refer to the counter troubleshooting procedure.

## API Troubleshooting

### Overall API Troubleshooting

This procedure checks the entire API current source programming section. This can be used when the API circuit in general is suspect and will determine if the digital programming or the analog current sources are faulty.

- a. Turn OFF the instrument's power switch, remove the power cord, and remove the top cover. Place the A17 board on an extender board and connect A17J3 to A6J5. Connect the instrument to the power line, and turn the POWER switch ON.
- b. Set the HP 3577B as follows:

SWEEP TYPE	CW
SPCL FCTN	
SERVICE DIAG	toggle SYN DIAG to ON
FREQ	450.000001 MHz

---

#### Note

SYN DIAG mode ON cannot be saved in the instrument state register.



- c. In this mode, the Fractional-N counter is running to correct the phase detector error for the 1 Hz offset. In this mode, the programming pattern for the API's repeats at the following rate.

Api Number	Location	Rate
1	U200 PIN 9	10 s
2	U201 PIN 15	1 s
3	U201 PIN 12	100 ms
4	U201 PIN 10	10 ms
5	U201 PIN 7	1 ms

- d. Using an oscilloscope, check for the programming pattern at the outputs of A17U4 and A17U5. If these pulses are present, then the digital section is probably operational.

#### Individual API Troubleshooting

- e. Turn OFF the instrument's power switch, remove the power cord, and remove the top cover. Place the A17 board on an extender board and connect A17J3 to A6J5. Connect the instrument to the power line, and turn the POWER switch ON.
- f. Connect the HP 8568B Spectrum Analyzer 10 MHz REF OUT to the HP 3577B EXT REF IN using a BNC cable. The FXT REF LED on the HP 3577B front panel should be lit.
- g. Connect the spectrum analyzer to A17 J1.
- h. Set the HP 3577B as follows:

SWEEP TYPE	CW
SPCL FCTN	
SERV DIAG	toggle SYN DIAG to ON
FREQ	400.1 MHz

---

#### Note



SYN DIAG mode ON cannot be saved in the instrument state register.

---

- i. Set the spectrum analyzer as follows:

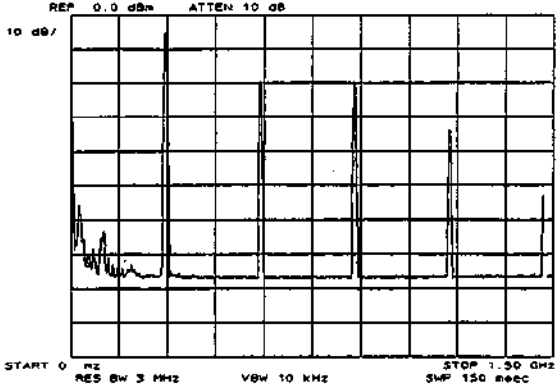
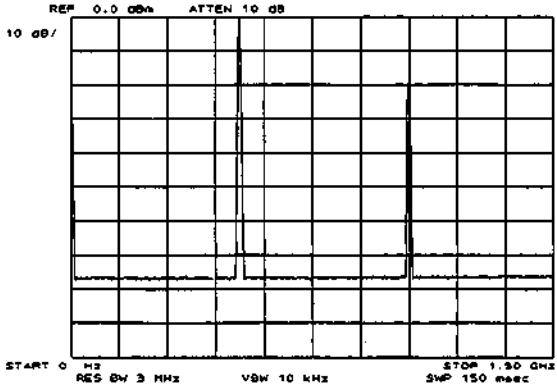
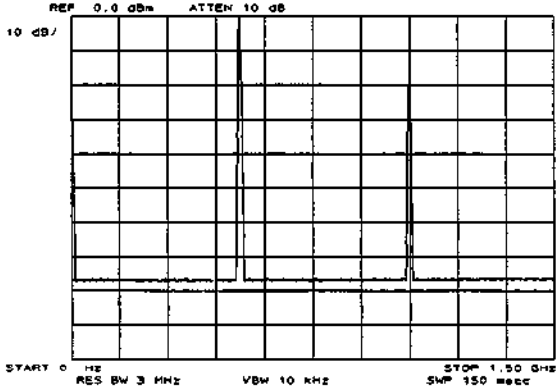
INSTR PRESET	
Center Frequency	400.1 MHz
Frequency Span	1 kHz
Ref Level	+ 5 dBm
Resolution Bandwidth	10 Hz
Sweep Time	20 sec
dB/Div	10 dB
CF Step Size	10 kHz

- j. Wait one complete sweep, then press PEAK SEARCH on the spectrum analyzer. Turn the  $\Delta$  function ON and step the center frequency up to 400.11 MHz using the  $\uparrow$  key. Wait one complete sweep, then press PEAK SEARCH.
- k. The  $\Delta$  amplitude reading on the spectrum analyzer should be  $<- 50$  dB. If it is not, then troubleshoot API 1.
- l. Set the frequency on the HP 3577B to 400.01 MHz.
- m. Set the center frequency on the spectrum analyzer to 400.01 MHz. Wait one complete sweep, then press PEAK SEARCH on the spectrum analyzer. Toggle the  $\Delta$  function until the marker  $\Delta$  reading is 0 Hz, 0 dB. Step the center frequency up to 400.02 MHz using the  $\uparrow$  key. Wait one complete sweep, then press PEAK SEARCH.
- n. The  $\Delta$  amplitude reading on the spectrum analyzer should be  $<- 50$  dB. If it is not, then troubleshoot API 2.
- o. Set the frequency on the HP 3577B to 400.001 MHz.
- p. Set the center frequency on the spectrum analyzer to 400.001 MHz. Wait one complete sweep, then press PEAK SEARCH. Toggle the  $\Delta$  function until the marker  $\Delta$  reading is 0 Hz, 0 dB. Step the center frequency up to 400.011 MHz using the  $\uparrow$  key. Wait one complete sweep, then press PEAK SEARCH.
- q. The  $\Delta$  amplitude reading on the spectrum analyzer should be  $<- 50$  dB. If it is not, then troubleshoot API 3.
- r. Set the frequency on the HP 3577B to 400.0001 MHz.
- s. Set the center frequency on the spectrum analyzer to 400.0001 MHz. Wait one complete sweep, then press PEAK SEARCH. Toggle the  $\Delta$  function until the marker  $\Delta$  reading is 0 Hz, 0 dB. Step the center frequency to 400.0101 MHz using the  $\uparrow$  key. Wait one complete sweep, then press PEAK SEARCH.
- t. The  $\Delta$  amplitude reading on the spectrum analyzer should be  $<- 50$  dB. if it is not, then troubleshoot API 4.

## Counter Troubleshooting


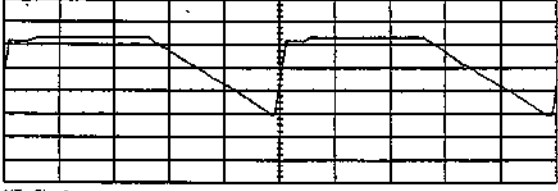
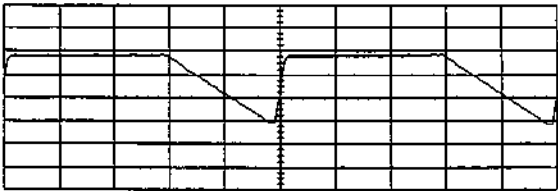
- a. Set the HP 3577B for a CW frequency at 300 MHz (the synthesizer diagnostics must be turned on). This sets the synthesizer for an integer counter divide value. Test for the proper frequencies on the nodes labeled both on the schematic and in step 9 of table 9-6. Replace all faulty components as indicated.

Table 9-6. A17 Circuit Board, Troubleshooting Data

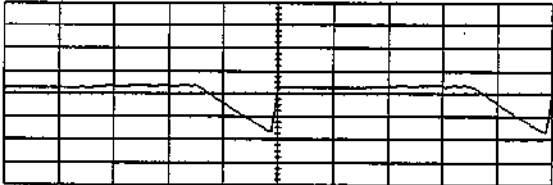


HP 3577B Set up	Measurement Set up	Waveform with Parameters
<p>Test at A17J1 Press INSTR PRESET</p> <p>Set A17W1 to + 5V</p>	<p>Spectrum Analyzer</p> <p>Start 0 Hz Stop 1500 MHz Res BW 3 MHz VBW 10 kHz Ref Level 0 dBm dB/Div 10 dB</p>	<p>Frequency, Amplitude, Harmonics</p>  <p>#1</p>
<p>Test at A17J1 Press INSTR PRESET</p> <p>Set A17W1 to GND</p>	<p>Spectrum Analyzer</p> <p>Start 0 Hz Stop 1500 MHz Res BW 3 MHz VBW 10 kHz Ref Level 0 dBm dB/Div 10 dB</p>	<p>Frequency, Amplitude, Harmonics</p>  <p>#1(cont'd)</p>
<p>Test at A17J1 Press INSTR PRESET</p> <p>Set A17W1 open</p>	<p>Spectrum Analyzer</p> <p>Start 0 Hz Stop 1500 MHz Res BW 3 MHz VBW 10 kHz Ref Level 0 dBm dB/Div 10 dB</p>	<p>Frequency, Amplitude, Harmonics</p>  <p>#1(cont'd)</p>



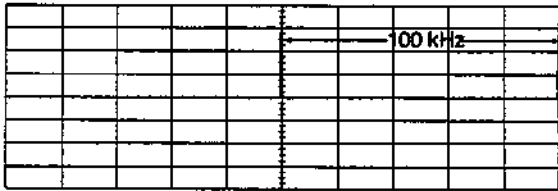
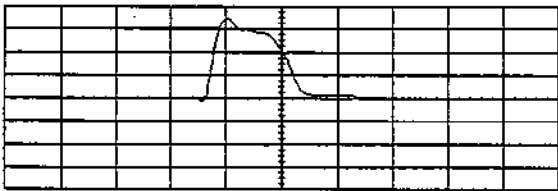
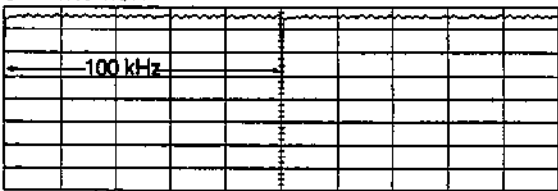
**Table 9-6. A17 Circuit Board, Troubleshooting Data Continued**

HP 3577B Set up	Measurement Set up	Waveform with Parameters
<p>Test at A17TP400 Press INSTR PRESET</p> <p>Sweep Type CW Freq 5 Hz</p> <p>Probe 10:1</p>	<p>Oscilloscope</p> <p>CH1 Coupling AC CH1 volts/Div 500mV Time/Div 2 us Trigger CH1</p>	<p>Top pulse width and reset</p> <p>CH1 CPLG=AC CH1= 500 mV/Div</p>  <p>MT=Ch 1 Main= 2.00 us/Div</p> <p>#2</p>
<p>Test at A17TP450 Press INSTR PRESET</p> <p>Sweep Type CW Freq 50 MHz</p> <p>Probe 10:1</p> <p>Press SPCL FCTN Toggle SYN DIAG to OFF mode</p>	<p>Oscilloscope</p> <p>CH1 Coupling DC CH1 Volts/Div 2 V/div Time/Div 2 us Trigger CH1</p>	<p>Top pulse width and reset.</p> <p>CH1 CPLG=DC CH1= 2.00 V/Div</p>  <p>MT=Ch 1 Main= 2.00 us/Div</p> <p>#3</p>
<p>Test at A17TP450 Press INSTR PRESET</p> <p>Sweep Type CW Freq 50 MHz</p> <p>Probe 10:1</p> <p>Press SPCL FCTN Toggle SYN DIAG to OFF mode</p>	<p>Oscilloscope</p> <p>CH1 Coupling DC CH1 Volts/Div 2V Time/Div 2 us Trigger CH1</p>	<p>Top pulse width and reset.</p> <p>CH1 CPLG=DC CH1= 2.00 V/Div</p>  <p>MT=Ch 1 Main= 2.00 us/Div</p> <p>#3 (cont'd)</p>

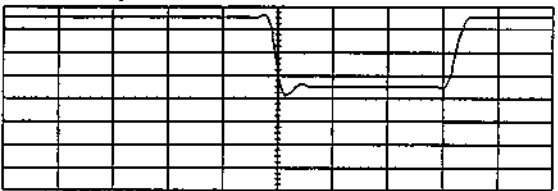
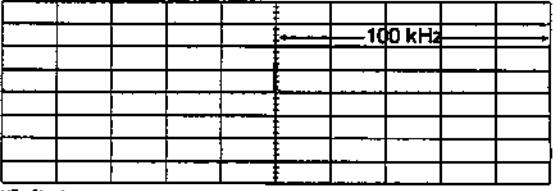
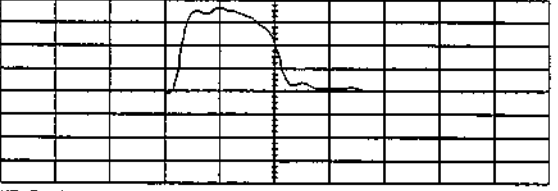
**Table 9-6. A17 Circuit Board, Troubleshooting Data Continued**

HP 3577B Set up	Measurement Set up	Waveform with Parameters
<p>Test at A17TP450 Press INSTR PRESET</p> <p>Sweep Type CW Freq 200 MHz</p> <p>Press SPCL FCTN Toggle SYN DIAG to OFF mode</p> <p>Probe 10:1</p>	<p>Oscilloscope</p> <p>CH1 Coupling DC CH1 Volts/Div 2 V Time/Div 2 us Trigger CH1</p>	<p>Pulse height and reset.</p> <p>CH1 CPLG=DC CH1- 2.00 V/Div</p>  <p>MT=Ch 1 Main= 2.00 us/Div</p> <p>#3(cont'd)</p>
<p>Test at A17W1 Press INSTR PRESET</p> <p>Press SPCL FCTN Toggle SYN DIAG to OFF mode</p> <p>Probe 10:1</p>	<p>Oscilloscope</p> <p>CH1 Coupling DC CH1 Volts/Div 2 V Time/Div 200 ms Trigger CH1</p>	<p>Pulse height and linear ramp</p> <p>CH1 CPLG=DC CH1- 2.00 V/Div</p>  <p>MT=Ch 1 Main= 200 ms/Div</p> <p>#4</p>
<p>Test at A17W1 Press INSTR PRESET</p> <p>Sweep Type log</p> <p>Press SPCL FCTN Toggle SYN DIAG to OFF mode</p> <p>Probe 10:1</p>	<p>Oscilloscope</p> <p>CH1 Coupling DC CH1 Volts/Div 2 V Time/Div 500 ms Trigger CH1</p>	<p>Pulse height and reset.</p> <p>CH1 CPLG=DC CH1- 2.00 V/Div</p>  <p>MT=Ch 1 Main= 500 ms/Div</p> <p>#4(cont'd)</p>


**Table 9-6. A17 Circuit Board, Troubleshooting Data Continued**

HP 3577B Set up	Measurement Set up	Waveform with Parameters
<p>Test at A17W1 Press INSTR PRESET</p> <p>Sweep Type CW Freq 300 MHz</p> <p>Press SPCL FCTN Toggle SYN DIAG to ON mode</p> <p>Probe 10:1</p>	<p>Oscilloscope</p> <p>CH1 Coupling DC CH1 Volts/Div 500 mV Time/Div 2 us Trigger CH1</p>	<p>Pulse height and linear ramp</p> <p>CH1 CPLG=DC CH1= 500 mV/Div</p>  <p>MT-Ch 1 Main= 2.00 us/Div</p> <p>#5</p>
<p>Test at A17W1 Press INSTR PRESET</p> <p>Sweep Type Log</p> <p>Press SPCL FCTN Toggle SYN DIAG to OFF mode</p> <p>Probe 10:1</p>	<p>Oscilloscope</p> <p>CH1 Coupling DC CH1 Volts/Div 500 mV Time/Div 20 us Trigger CH1</p>	<p>Pulse height and logarithmic ramp</p> <p>CH1 CPLG=DC CH1= 500 mV/Div</p>  <p>MT-Ch 1 Main= 20.0 ns/Div</p> <p>#5 (cont'd)</p>
<p>Test at A17TP100 Press INSTR PRESET</p> <p>Sweep Type CW Freq 300 MHz</p> <p>Press SPCL FCTN Toggle SYN DIAG to ON mode.</p> <p>Probe 10:1</p>	<p>Oscilloscope</p> <p>CH1 Coupling DC CH1 Volts/Div 1V Trigger CH1 Time/Div 2 us</p>	<p>Frequency</p> <p>CH1 CPLG=DC CH1= 1.00 V/Div</p>  <p>MT-Ch 1 Main= 2.00 us/Div</p> <p>#6</p>

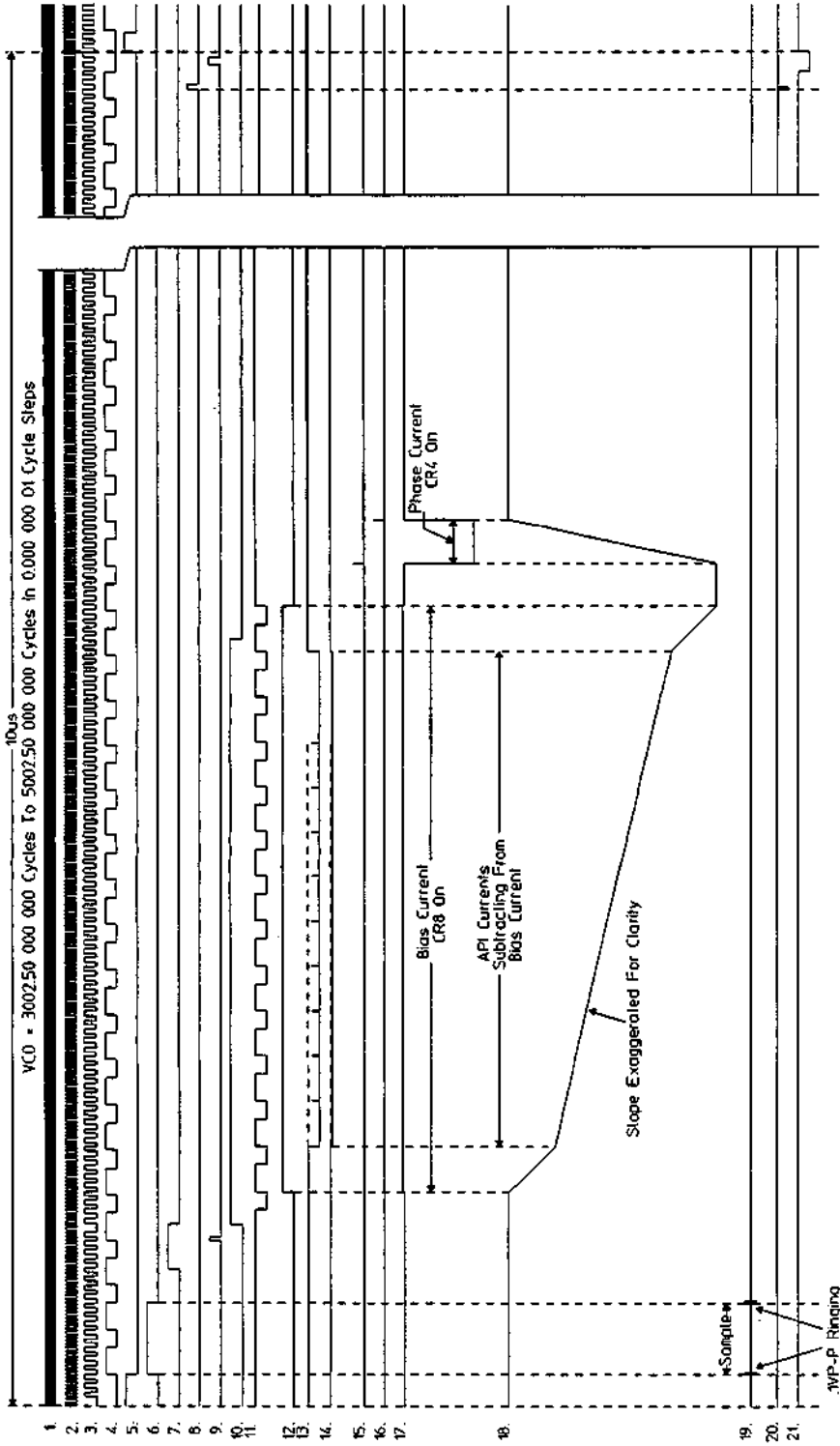
**Table 9-6. A17 Circuit Board, Troubleshooting Data Continued**

HP 3577B Set up	Measurement Set up	Waveform with Parameters
<p>Test at A17TP100 Press INSTR PRESET</p> <p>Sweep Type CW Freq 300 MHz</p> <p>Press SPCL FCTN Toggle SYN DIAG to ON mode.</p> <p>Probe 10:1</p>	<p>Oscilloscope</p> <p>CH1 Coupling DC CH1 Volts/Div 1V Trigger CH1 Time/Div 20 ns</p>	<p>Pulse height and width</p>  <p>CH1 CPLG=DC CH1= 1.00 V/Div</p> <p>MT=Ch 1 Main= 20.0 ns/Div</p> <p>#6 (cont'd)</p>
<p>Test at A17TP108 Press INSTR PRESET</p> <p>Sweep Type CW Freq 300 MHz</p> <p>Press SPCL FCTN Toggle SYN DIAG to ON mode</p> <p>Probe 10:1</p>	<p>Oscilloscope</p> <p>CH1 Coupling DC CH1 Volts/Div 500 mV Trigger CH1 Time/Div 2 ms</p>	<p>Frequency</p>  <p>CH1 CPLG=DC CH1= 500 mV/Div</p> <p>MT=Ch 1 Main= 2.00 μs/Div</p> <p>#7</p>
<p>Test at A17TP108 Press INSTR PRESET</p> <p>Sweep Type CW Freq 300 MHz</p> <p>Press SPCL FCTN Toggle SYN DIAG to ON mode</p> <p>Probe 10:1</p>	<p>Oscilloscope</p> <p>CH1 Coupling DC CH1 Volts/Div 500 mV Trigger CH1 Time/Div 20 ns</p>	<p>Pulse height and width</p>  <p>CH1 CPLG=DC CH1= 500 mV/Div</p> <p>MT=Ch 1 Main= 20.0 ns/Div</p> <p>#7 (cont'd)</p>

**Table 9-6. A17 Circuit Board, Troubleshooting Data Continued**

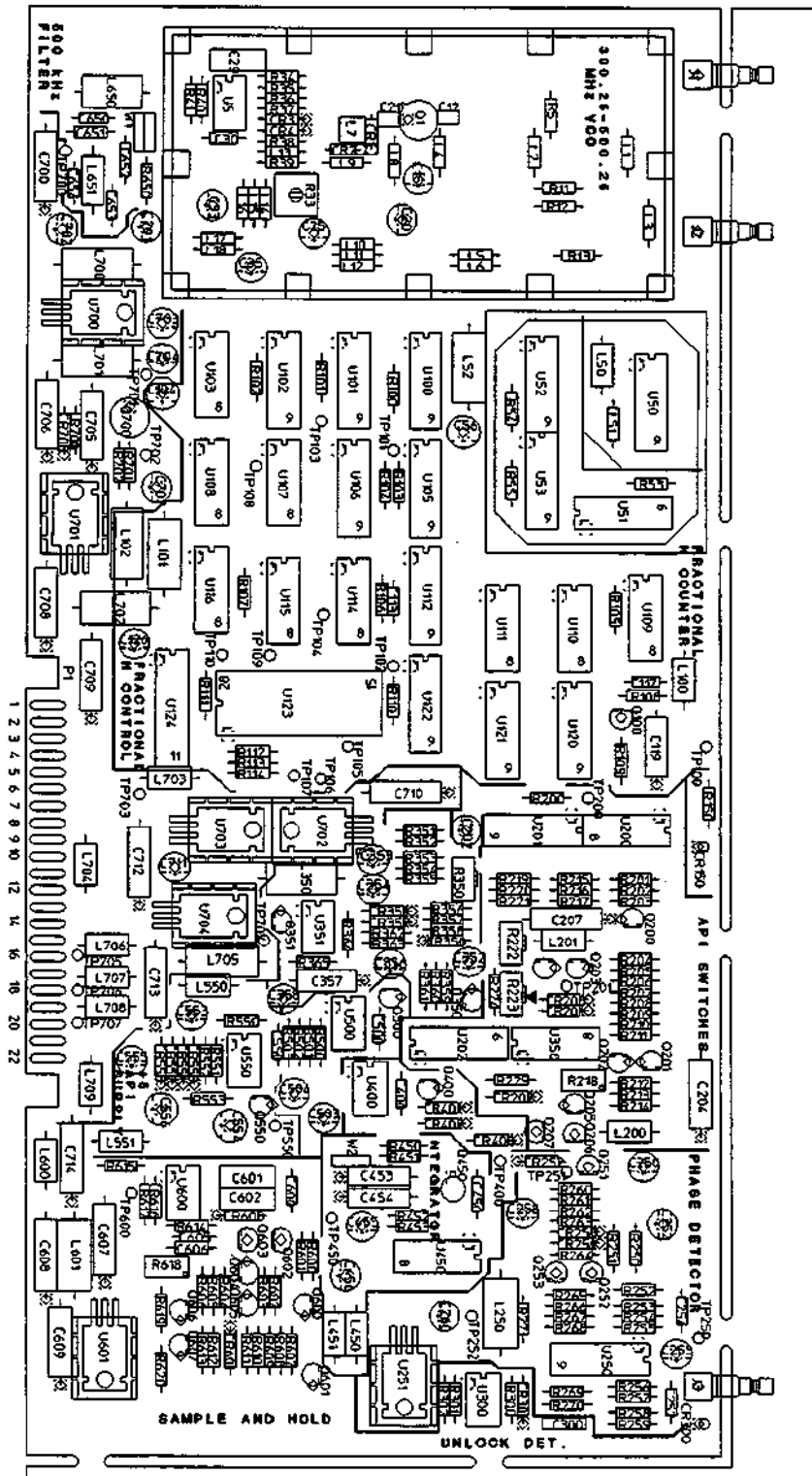
HP 3577B Set up	Measurement Set up	Waveform with Parameters
<p>Test at A17TP106                      Press INSTR PRESET                      Sweep Type CW                      Freq 300 MHz</p> <p>Press SPCL FCTN                      Toggle SYN DIAG to ON mode</p> <p>Probe 10:1</p>	<p>Oscilloscope                      CH1 Coupling DC                      CH1 Volts/Div 1 V                      Time/Div 2 us                      Trigger CH1</p>	<p>Frequency, pulse height and width.</p> <p>CH1 CPLG=DC                      CH1= 1.00 V/DIV</p>  <p>MT=Ch 1                      Main= 2.00 us/Div</p> <p>#8</p>
<p>Digital Section Tests Press INSTR PRESET</p> <p>Sweep Type CW                      Freq 300 MHz</p> <p>Press SPCL FCTN Toggle SYN DIAG to ON mode.</p>	<p>Counter</p>	<p>Frequency at each test location</p> <p>U11 (1,9,10,15) = 100 kHz                      U14 (3,4,6) = 100 kHz                      U14 (1,9) = 200 kHz                      U15 (3) = 100 kHz                      U15 (5,7,10,15) = 100 kHz                      U18 (5) = 6 MHz</p>

HP3577B Synthesizer Timing Diagram



- 1. VCO - J1, J2
- 2. VCO/10 - U50110
- 3. VCO/20 Or VCO/30 To Pulse Remove - TP1 (Exact Relationship May Vary)
- 4. Chip Clock (VCO/100) - TP3
- 5. Cycle Start (Sync To Rising Edge) - TP7
- 6. Sample And Hold - TP20
- 7. Pulse Remove (Phase Accumulator Overflow) - TP6
- 8. Sel Freq To XXX 749 999.999Hz
- 9. Pulse Remove (When N is Odd) - U109(2)
- 10. Sel Freq To XXX XXX XXX XXX Hz Where A Is 1, 3, 5, 7, 9
- 11. /2 or /3 Control - U53(2)
- 12. Bias - U123(10)
- 13. Latch Clock - U201(9)
- 14. Delayed Bias - U20(K2)
- 15. API 1 Thru API 5 Control - U200(9), U201(5), U201(12), U201(M0), U201(K7)
- 16. API 1 Thru API 5 Current - U202(7), U202(8), U202(9), R78, R77
- 17. VCO/N/F - TP3
- 18. 100kHz Reference - TP16
- 19. Phase Detector Output - TP9
- 20. Integrator Output - TP10
- 21. Sample And Hold Output - W1 (See VCO Tuning Graph For DC Voltage To Frequency)
- 22. 2ND MSD And MSD Preload - TP3
- 23. N=Odd Pulse Remove Enable
- 24. N Divider Output - TP4

Figure 9-11. Synthesizer Timing Diagram

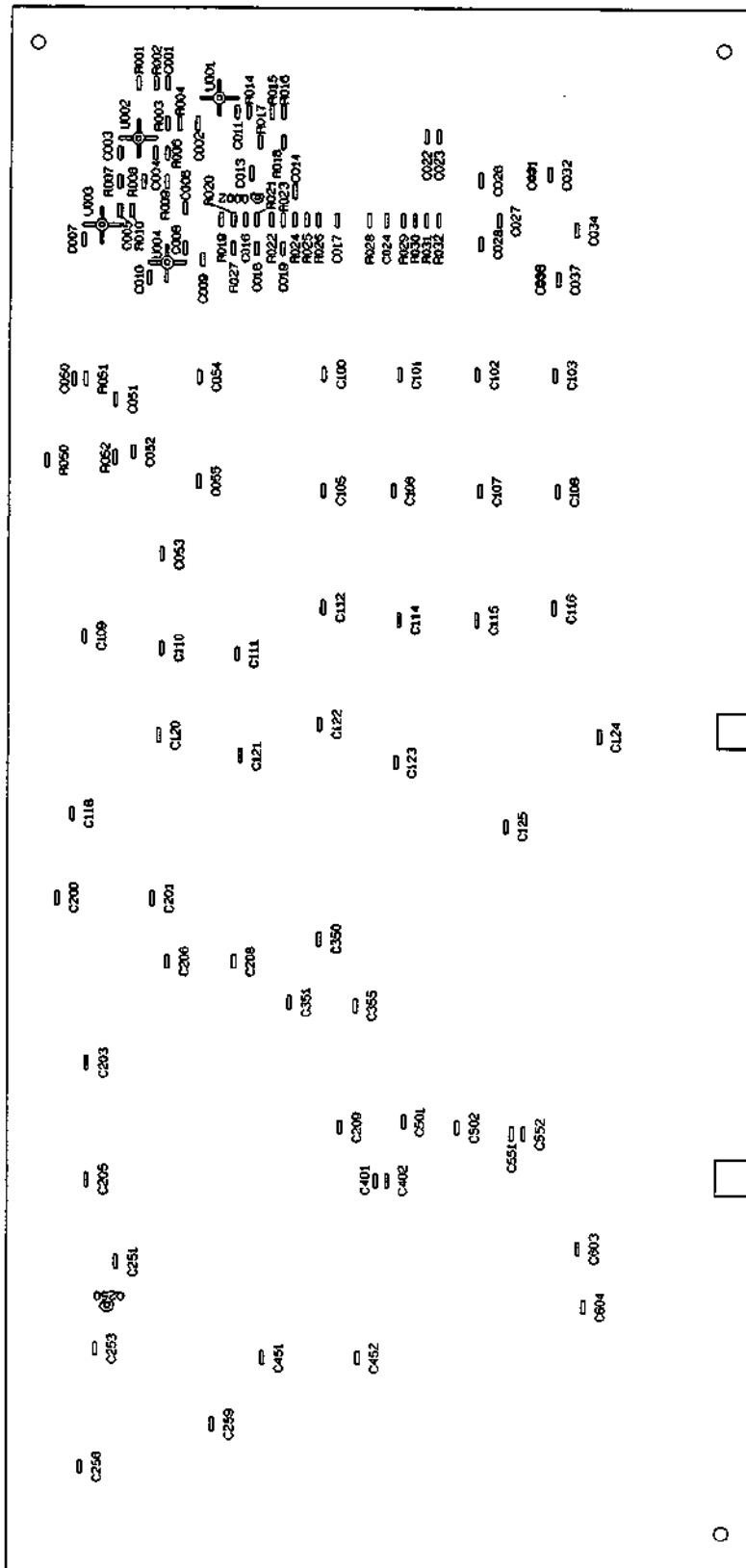


REV A

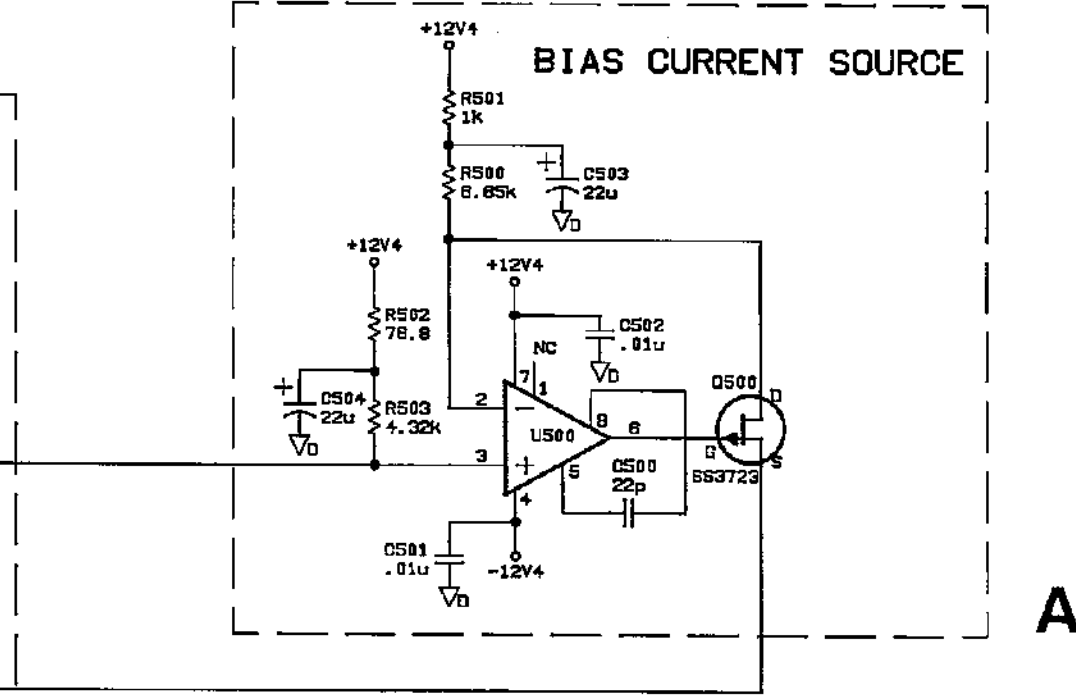
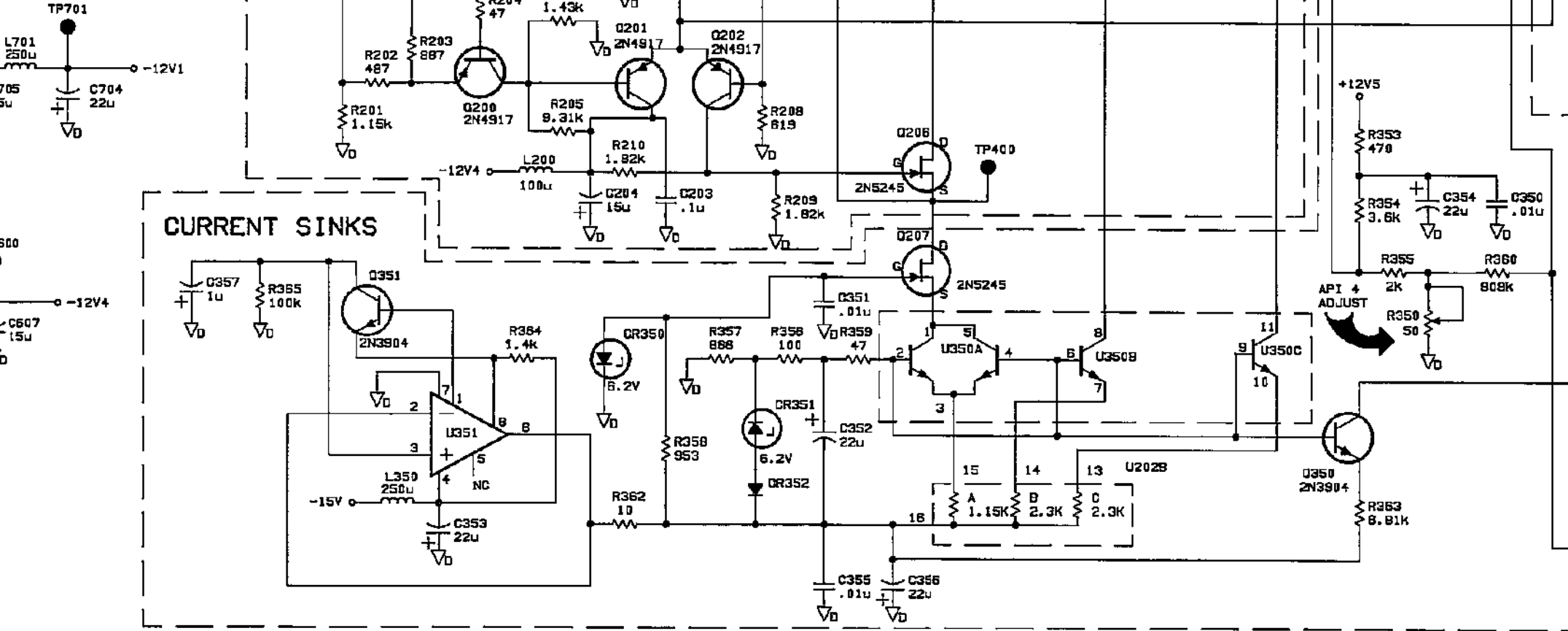
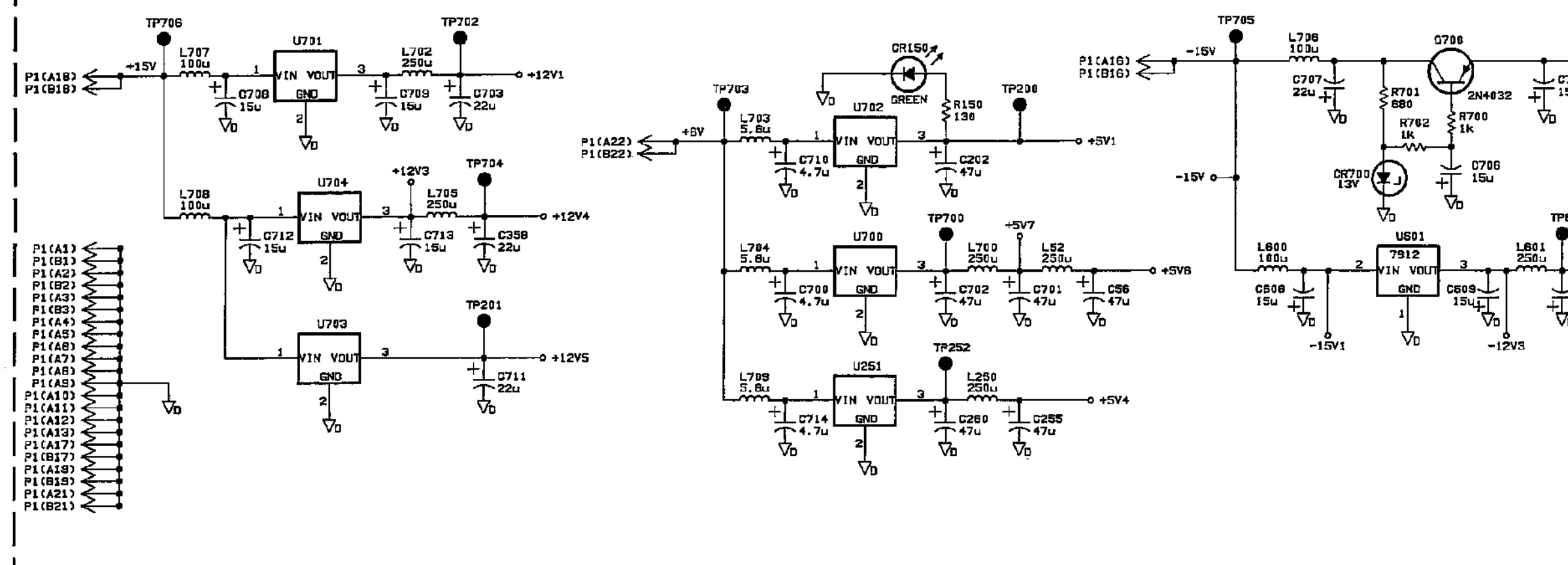
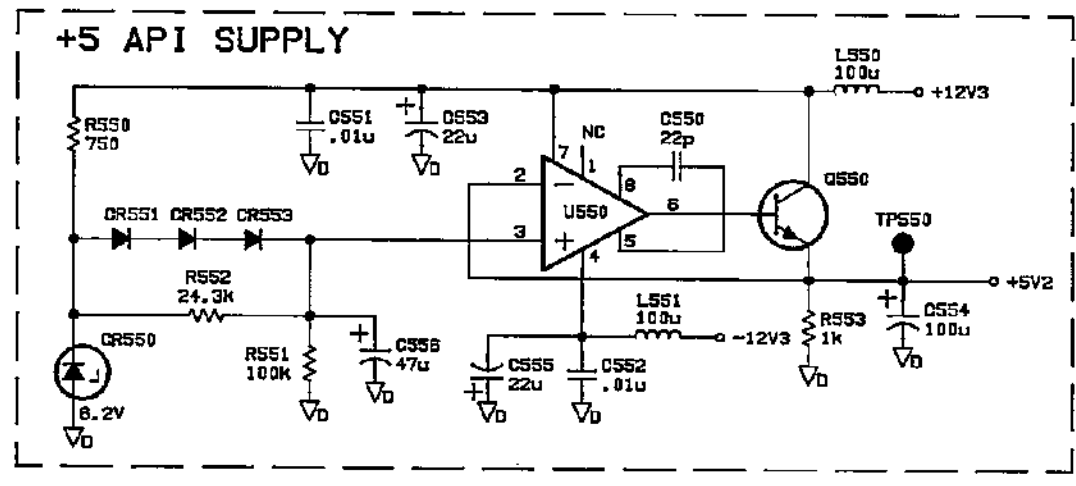
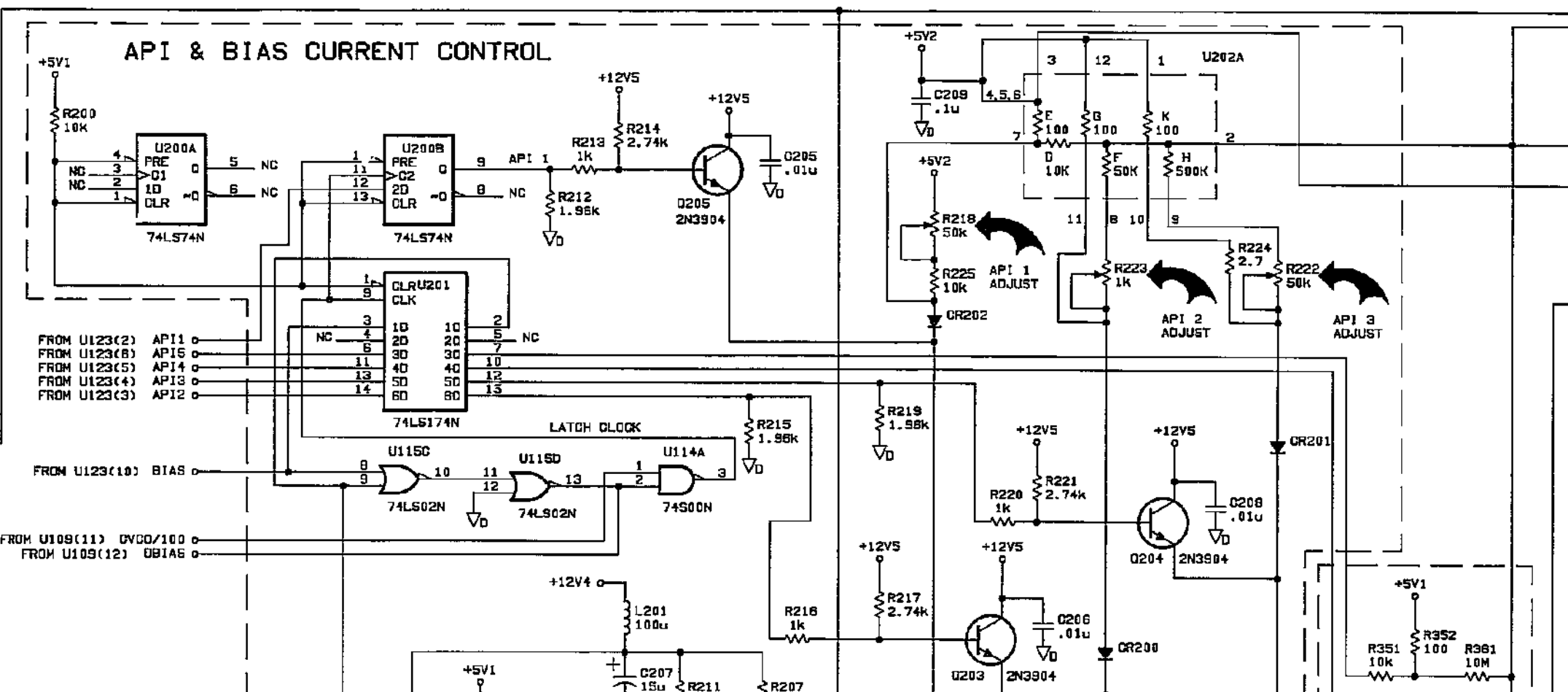
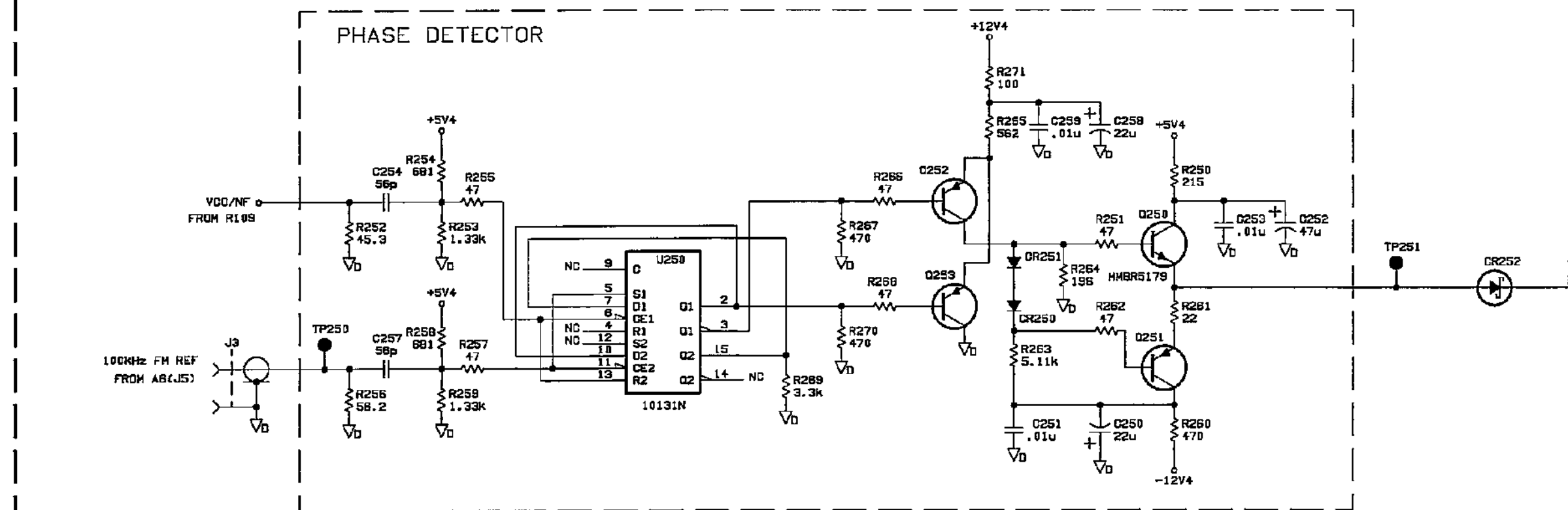
Figure 9-12. A17 Component Locator

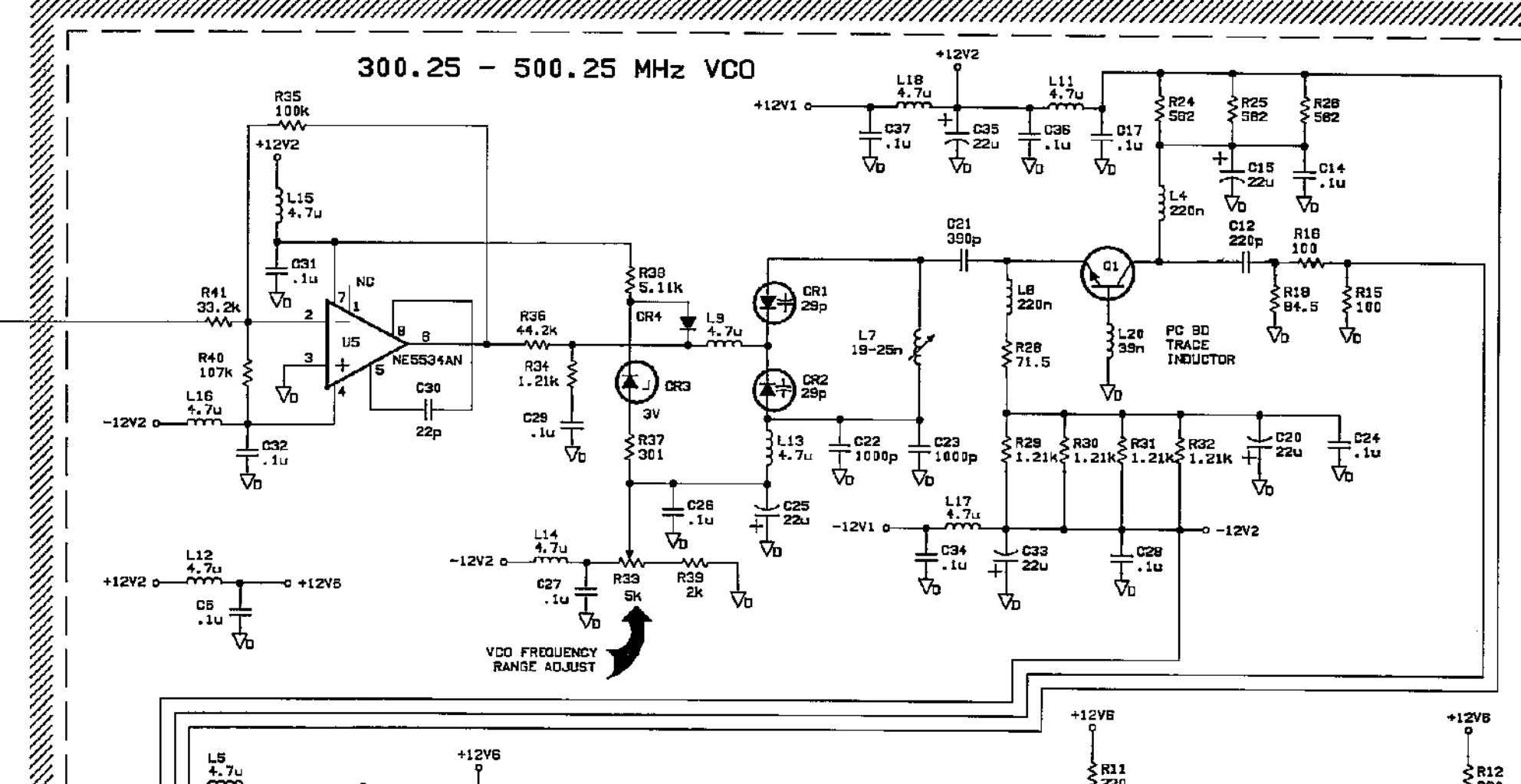
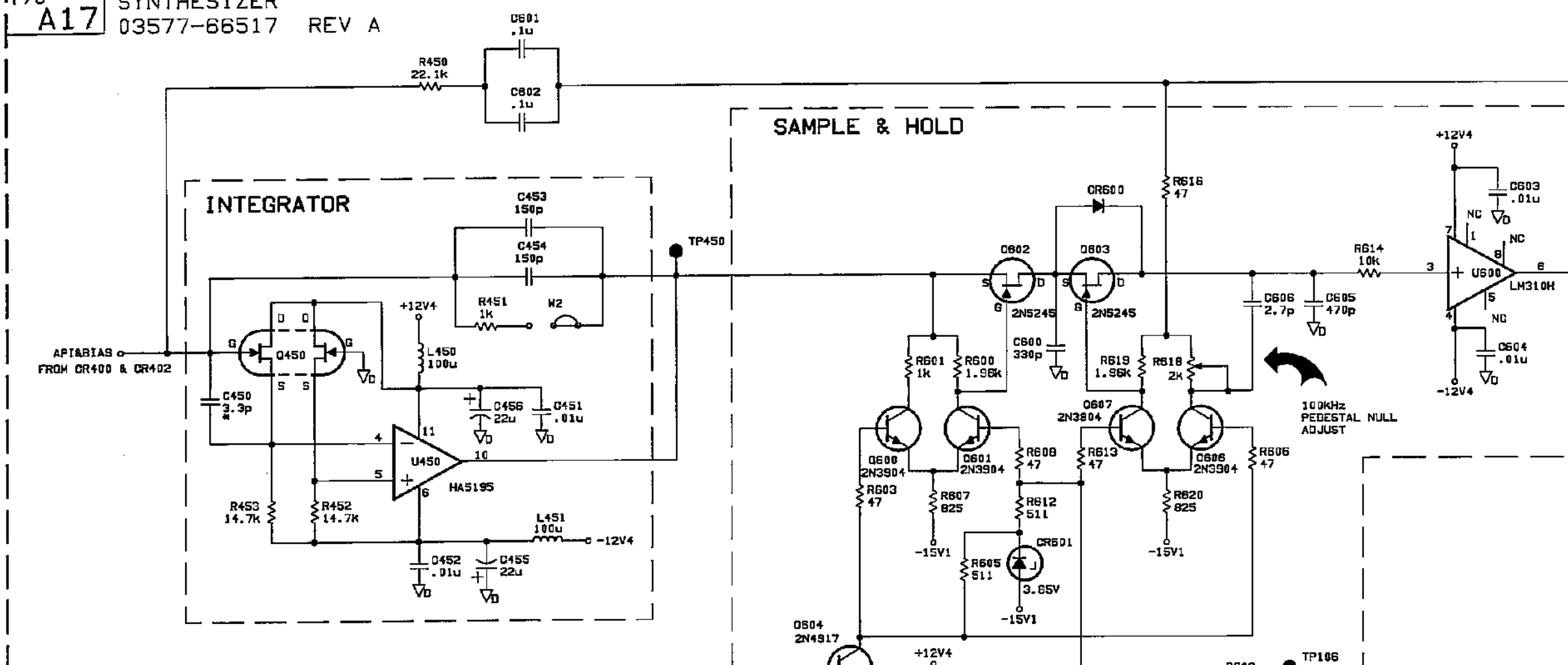
IC	Voltage	Pin	GND Pin	Bypass Cap	
				Design	Value
U7	+5V	6,,16	8	C132	0.1
U9	+5V	3	8	C116	0.01
U11	+5V	3,,16	8	C135	0.01
U12	+5V	3,,14	7	C123	0.01
U13	+5V	3,,16	8	C134	0.01
U14	+5V	3,,16	8	C137	0.01
U15	+5V	3,,16	8	C124	0.01
U17	+5V	3,,14	7	C121	0.01
U18	+5V	3,,16	8	C136	0.01
U19	+12V	3,,27	8	C141	0.01
U19	+5V	3,,9	8	C149	22
U21	+5V	3,,14	7	C146	0.01
U22	+5V	3,,14	7	C122	0.01
U23	+5V	3,,14	7	C139	0.01
U24	+5V	3,,16	8	C127	0.01
U25	+5V	3,,14	7	C148	0.01
U26	+5V	3,,14	7	C127	0.01
U27	+5V	6,,16	8	C125	0.1
U28	+5V	3,,20	10	C119	0.01
U29	+5V	3,,16	8	C128	0.01
U30	+5V	3,,16	8	C126	0.01
U31	+5V	3,,16	7	C147	0.01
U2	+5V	6,,16	8	C142	0.1
U37	+5V	3,,14	7	C130	0.01
U1	+5V	4,,16			
U5			7		
U4			8		
U10	+12V	4,,7		C46	0.01
U10	-12V	4,,4		C47	0.01
U8	-12V	4,,4		C48	0.01
U8	+12V	4,,7		C49	0.01
U6	+12V	4,,7		C23	0.01
U6	+12V	4,,4		C26	0.01





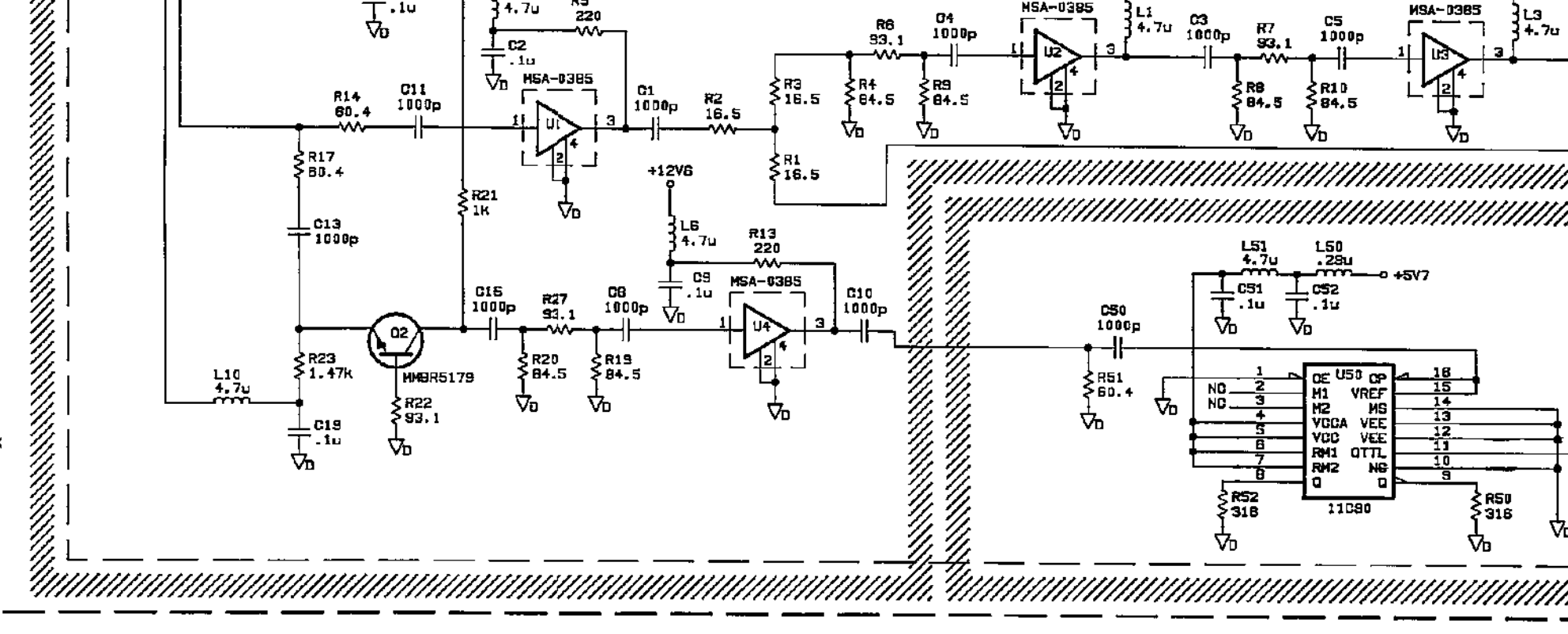
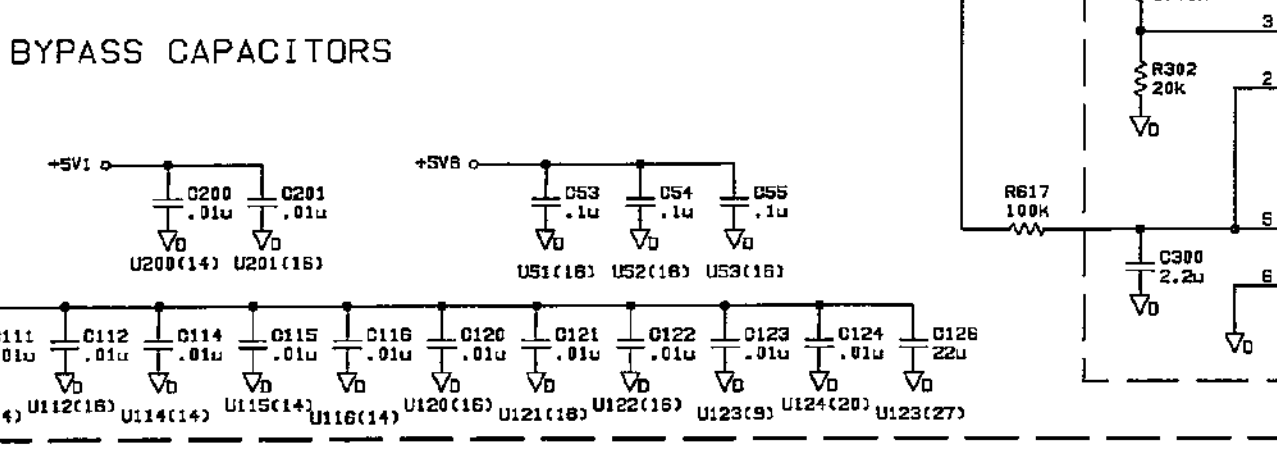
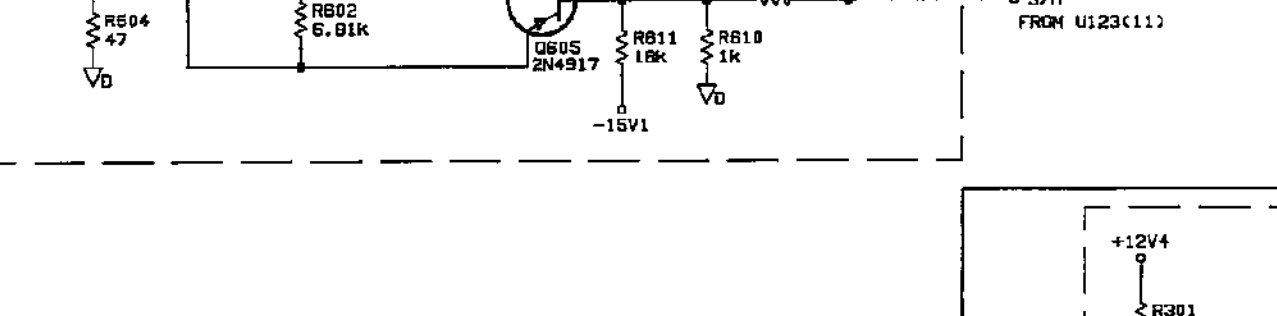
9-13. A17 Component Locator, Surface Mount Side



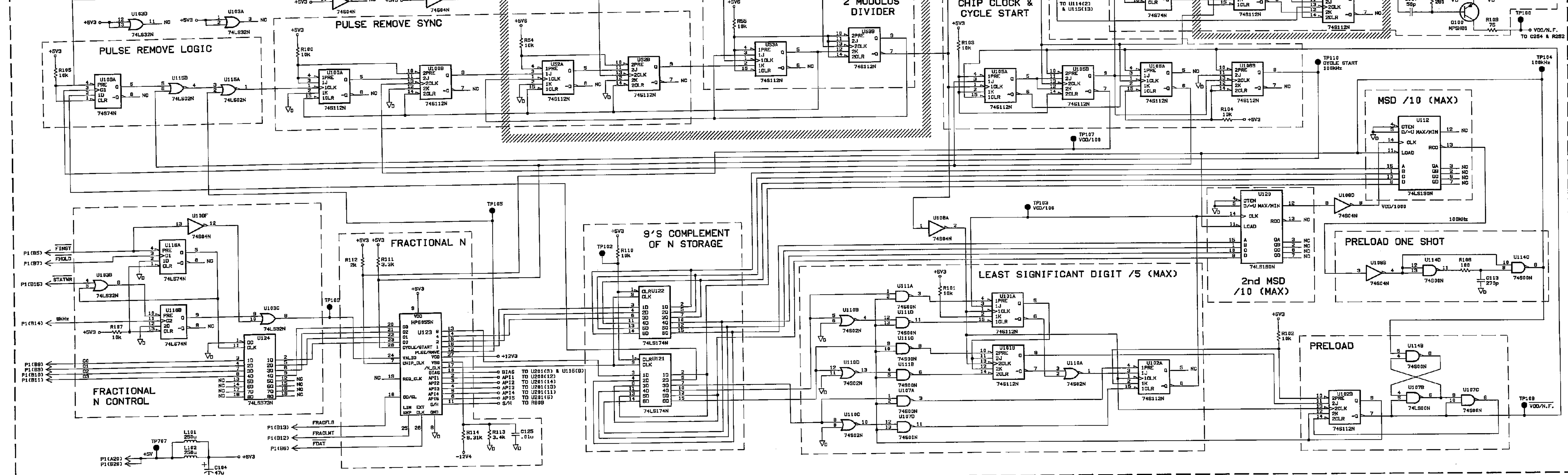


PINS CONNECTED TO EMBEDDED POWER/GROUND NETS:

Pin	Device	Value	Net
U51(8)	U51	1	VDD
U51(1)	U51	1	VDD
U51(10)	U51	1	VDD
U51(11)	U51	1	VDD
U51(12)	U51	1	VDD
U51(13)	U51	1	VDD
U51(14)	U51	1	VDD
U51(15)	U51	1	VDD
U51(16)	U51	1	VDD
U51(17)	U51	1	VDD
U51(18)	U51	1	VDD
U51(19)	U51	1	VDD
U51(20)	U51	1	VDD
U51(21)	U51	1	VDD
U51(22)	U51	1	VDD
U51(23)	U51	1	VDD
U51(24)	U51	1	VDD
U51(25)	U51	1	VDD
U51(26)	U51	1	VDD
U51(27)	U51	1	VDD
U51(28)	U51	1	VDD
U51(29)	U51	1	VDD
U51(30)	U51	1	VDD
U51(31)	U51	1	VDD
U51(32)	U51	1	VDD
U51(33)	U51	1	VDD
U51(34)	U51	1	VDD
U51(35)	U51	1	VDD
U51(36)	U51	1	VDD
U51(37)	U51	1	VDD
U51(38)	U51	1	VDD
U51(39)	U51	1	VDD
U51(40)	U51	1	VDD
U51(41)	U51	1	VDD
U51(42)	U51	1	VDD
U51(43)	U51	1	VDD
U51(44)	U51	1	VDD
U51(45)	U51	1	VDD
U51(46)	U51	1	VDD
U51(47)	U51	1	VDD
U51(48)	U51	1	VDD
U51(49)	U51	1	VDD
U51(50)	U51	1	VDD
U51(51)	U51	1	VDD
U51(52)	U51	1	VDD
U51(53)	U51	1	VDD
U51(54)	U51	1	VDD
U51(55)	U51	1	VDD
U51(56)	U51	1	VDD
U51(57)	U51	1	VDD
U51(58)	U51	1	VDD
U51(59)	U51	1	VDD
U51(60)	U51	1	VDD
U51(61)	U51	1	VDD
U51(62)	U51	1	VDD
U51(63)	U51	1	VDD
U51(64)	U51	1	VDD
U51(65)	U51	1	VDD
U51(66)	U51	1	VDD
U51(67)	U51	1	VDD
U51(68)	U51	1	VDD
U51(69)	U51	1	VDD
U51(70)	U51	1	VDD
U51(71)	U51	1	VDD
U51(72)	U51	1	VDD
U51(73)	U51	1	VDD
U51(74)	U51	1	VDD
U51(75)	U51	1	VDD
U51(76)	U51	1	VDD
U51(77)	U51	1	VDD
U51(78)	U51	1	VDD
U51(79)	U51	1	VDD
U51(80)	U51	1	VDD
U51(81)	U51	1	VDD
U51(82)	U51	1	VDD
U51(83)	U51	1	VDD
U51(84)	U51	1	VDD
U51(85)	U51	1	VDD
U51(86)	U51	1	VDD
U51(87)	U51	1	VDD
U51(88)	U51	1	VDD
U51(89)	U51	1	VDD
U51(90)	U51	1	VDD
U51(91)	U51	1	VDD
U51(92)	U51	1	VDD
U51(93)	U51	1	VDD
U51(94)	U51	1	VDD
U51(95)	U51	1	VDD
U51(96)	U51	1	VDD
U51(97)	U51	1	VDD
U51(98)	U51	1	VDD
U51(99)	U51	1	VDD
U51(100)	U51	1	VDD
U51(101)	U51	1	VDD
U51(102)	U51	1	VDD
U51(103)	U51	1	VDD
U51(104)	U51	1	VDD
U51(105)	U51	1	VDD
U51(106)	U51	1	VDD
U51(107)	U51	1	VDD
U51(108)	U51	1	VDD
U51(109)	U51	1	VDD
U51(110)	U51	1	VDD
U51(111)	U51	1	VDD
U51(112)	U51	1	VDD
U51(113)	U51	1	VDD
U51(114)	U51	1	VDD
U51(115)	U51	1	VDD
U51(116)	U51	1	VDD
U51(117)	U51	1	VDD
U51(118)	U51	1	VDD
U51(119)	U51	1	VDD
U51(120)	U51	1	VDD
U51(121)	U51	1	VDD
U51(122)	U51	1	VDD
U51(123)	U51	1	VDD
U51(124)	U51	1	VDD
U51(125)	U51	1	VDD
U51(126)	U51	1	VDD
U51(127)	U51	1	VDD
U51(128)	U51	1	VDD
U51(129)	U51	1	VDD
U51(130)	U51	1	VDD









---

## 9-13 Service Group A18, Output Assembly

The information in this section should be used to isolate faulty functional sub-blocks when servicing the HP 3577B. All procedures assume the Fault Isolation procedures of Section II have been used to determine which functional block has failed, and the Circuit Descriptions of Section VIII are understood.

---

### Warning



Service procedures described in this section are performed with the protective covers removed and power applied. Energy available at many points can, if contacted, result in personal injury.

---

### Caution



Do not insert or remove any circuit board in the HP 3577B with the line power turned on. Power transients caused by insertion or removal may damage the circuit boards.

---

### Initial Conditions

All measurements are  $\pm 10$  percent unless otherwise specified.

## Troubleshooting Hints

1. Before troubleshooting this circuit board, be sure that the fault is occurring on this board by checking the following signals using the parameters in table 2-7.

A17J2	Swept Synthesizer Output
A51J1	300.25 MHz Offset Signal Amplifier

## Troubleshooting Procedure

- a. Turn OFF the instrument's power switch, remove the power cord, and remove the top cover. Place the A18 Source board on an extender board. Connect the instrument to the power line, and turn the POWER switch ON.
- b. Set the HP 3325A Synthesizer to a frequency of 100 kHz and an amplitude of -40 dBm.
- c. Move A18J201 to the right position and connect the synthesizer to A18J001.

- d. Set the HP 3577B as follows:

SWEEP TYPE	CW
AMPTD	+15 dBm

- e. Measure the level at A18J20 with an HP 8568B Spectrum Analyzer. The level should be approximately +14.3 dBm. If it is not, use table 9-5 to determine the faulty amplifier. These levels may be measured with an HP 8568B Spectrum Analyzer and an HP 10020A 20:1 resistive divider probe, or an oscilloscope and a 1:1 probe.

Table 9-5. A18 Circuit Board, Troubleshooting Data

Junction of Q150 and Q151	0.07 V peak-to-peak	-45 dBm
Junction of Q105 and Q106	0.64 V peak-to-peak	-27 dBm
Junction of Q50 and Q54	6.6 V peak-to-peak	-6 dBm
Output side of R25*	3.4 V peak-to-peak	-12 dBm

\* Connect a 50 $\Omega$  load from J20 to ground.

- f. The drop across R25 should be exactly 6 dB. If it is not, then troubleshoot the relays in the 60 dB Step Attenuator.
- g. Turn OFF the instrument's power switch, remove the power cord, and return the HP 3577B to its original state.

**Low Frequency Gain Error Correction Troubleshooting Procedure**

- a. Turn OFF the instrument's power switch, remove the power cord, and remove the top cover.
- b. Lift one side of R165. Place the A18 Source board on an extender board. Connect the instrument to the power line, and turn the POWER switch ON.
- c. Set the HP 3325A Synthesizer to a frequency of 100 kHz and an amplitude of - 40 dBm.
- d. Move A18J201 to the top right position and connect the synthesizer to A18J001.
- e. Set the HP 3577B as follows:

SWEEP TYPE	CW
AMPTD	+15 dBm
- f. Connect an oscilloscope to A18J20 and set its input impedance to 50 ohms.
- g. Adjust the DC offset on the synthesizer until the sine wave viewed on the oscilloscope is centered around 0 volts.
- h. If the source trips before the synthesizer can be adjusted, lift one side of R351 to disable the overload sense circuit.
- i. The synthesizer DC offset should not be greater than  $\pm 25$  mV and the output at J20 should be a 3 V peak-to-peak sine wave (non-clipped). If it is not, then the problem is in one of the amplifier stages and the bias levels at each stage should be checked.
- j. Re-install R165 and R351.
- k. Return the synthesizer DC offset to zero.
  - l. Lift one side of R31 and the side of R450 connected to U450 pin 6.
- m. Set an external DC power supply to zero volts. Using the hole left by R450, connect the power supply through a 10 k $\Omega$  resistor to U450 pin 6.
- n. Monitor the junction of R29 and R454 with a dc voltmeter.
- o. Adjust the power supply output until the dc voltmeter reads  $0 \pm 0.1$  V. If unable to obtain the correct voltmeter reading, check the outputs of U450 and U451 for voltages that vary with the power supply.
- p. Turn OFF the instrument's power switch, remove the power cord, and return the HP 3577B to its original state.



### Peak Detector (CR22 and CR23) Troubleshooting Procedure

- a. Turn OFF the instrument's power switch, remove the power cord, and remove the top cover. Place the A18 Source board on an extender board. Connect the instrument to the power line, and turn the POWER switch ON.
- b. Set the HP 3325A Synthesizer to a frequency of 100 kHz and an amplitude of -40 dBm.
- c. Move A18J201 to the top right position and connect the synthesizer to A18J001.
- d. Set the HP 3577B as follows:

SWEEP TYPE	CW
AMPTD	+15 dBm
- e. Measure the output at A18J20 with an HP 8568B Spectrum Analyzer. Adjust the synthesizer for an output reading of +15 dBm  $\pm$  0.1 dB.
- f. With an oscilloscope and a 10:1 probe, check the dc level at the junction of R20 and R815. It should be +3.5 V.
- g. Decrease the amplitude of the synthesizer by 4 dB.
- h. The DC level on the oscilloscope should be +2.5 V.
- i. If this test failed, suspect CR23 or CR22.
- j. Turn OFF the instrument's power switch, remove the power cord, and return the HP 3577B to its original state.

**Amplitude Leveling Troubleshooting Procedure**

- a. Turn OFF the instrument's power switch, remove the power cord, and remove the top cover. Place the A18 Source board on an extender board. Connect A17J2 to A18J600 and A51J1 to A18J700 using extender cables. Connect the instrument to the power line, and turn the POWER switch ON.
- b. Set the HP 3577B as follows:

SWEEP TYPE	CW
REQ	100.001 kHz
STEP SIZE	2 Hz
AMPTD	+11 dBm
STEP SIZE	4 dB
- c. Adjust Level Cal 1 (R803) for approximately 1.93 V at U800 pin 5.
- d. Increase the HP 3577B amplitude to +15 dBm by pressing AMPTD ↑.
- e. Adjust Step Cal 1 (R802) for approximately 3.12 V at U800 pin 5.
- f. Ground one side of L800 and turn R800 and R801 fully clockwise.
- g. Decrease the HP 3577B frequency to 99.999 kHz by pressing FREQ ↓ and decrease the amplitude to +11 dBm by pressing AMPTD ↓.
- h. The DC voltage at U801 pin 3 should be approximately -0.275 V.
- i. Increase the HP 3577B amplitude to +15 dBm by pressing AMPTD ↑.
- j. The DC voltage at U801 pin 3 should be approximately -0.437 V.
- k. Remove the ground from L800.
- l. If this test passed, then the amplitude leveling loop works. Turn OFF the instrument's power switch, remove the power cord, and return the HP 3577B to its original state. Perform adjustment 4-19, Source Amplitude and Step Adjustments.
- m. Decrease the HP 3577B amplitude to +11 dBm by pressing AMPTD ↓ (the frequency should be 99.999 kHz).

- n. Check each of the following op amp stages: The voltage at U800 pin 3 should be the same as the reference voltage on U801 Pin 12.
  - The output of U800 pin 3 should be constant.
  - The output of U800 pin 4 should be approximately  $-2\text{ V}$ .
  - The output of U801 pin 10 should be  $0\text{ V}$ .
  - The output of U801 pin 4 should be  $+0.24\text{ V}$ .
- o. Ground one side of L800. The output of U801 pin 3 should now be  $-0.24\text{ V}$  providing the output of U801 pin 4 was  $+0.24\text{ V}$ .
- p. Turn OFF the instrument's power switch, remove the power cord, and return the HP 3577B to its original state. Perform adjustment 4-19 Source Amplitude and Step Adjustments.

**Limiting Mixer (U700) Troubleshooting Procedure**

- a. Turn OFF the instrument's power switch, remove the power cord, and remove the top cover.
- b. Lift the side of L800 connected to CR901. Using the hole left by L800, connect the dc supply through a 10 k $\Omega$  resistor to CR901.
- c. Place the A18 Source board on an extender board. Connect A51J1 to A18J700 using extender cables. Connect the instrument to the power line, and turn the POWER switch ON.
- d. Move A18W800 to the right position and connect the HP 8568B Spectrum Analyzer to A18J701.
- e. Adjust the dc supply to - 4 V.
- f. The 300.25 MHz signal on the spectrum analyzer should be approximately - 33.7 dBm.
- g. Change the dc supply voltage to - 7 V.
- h. The 300.25 MHz signal on the spectrum analyzer should be approximately - 29 dBm.
- i. If this test failed, replace the U700 mixer.
- j. Turn OFF the instrument's power switch, remove the power cord, and return the HP 3577B to its original state.

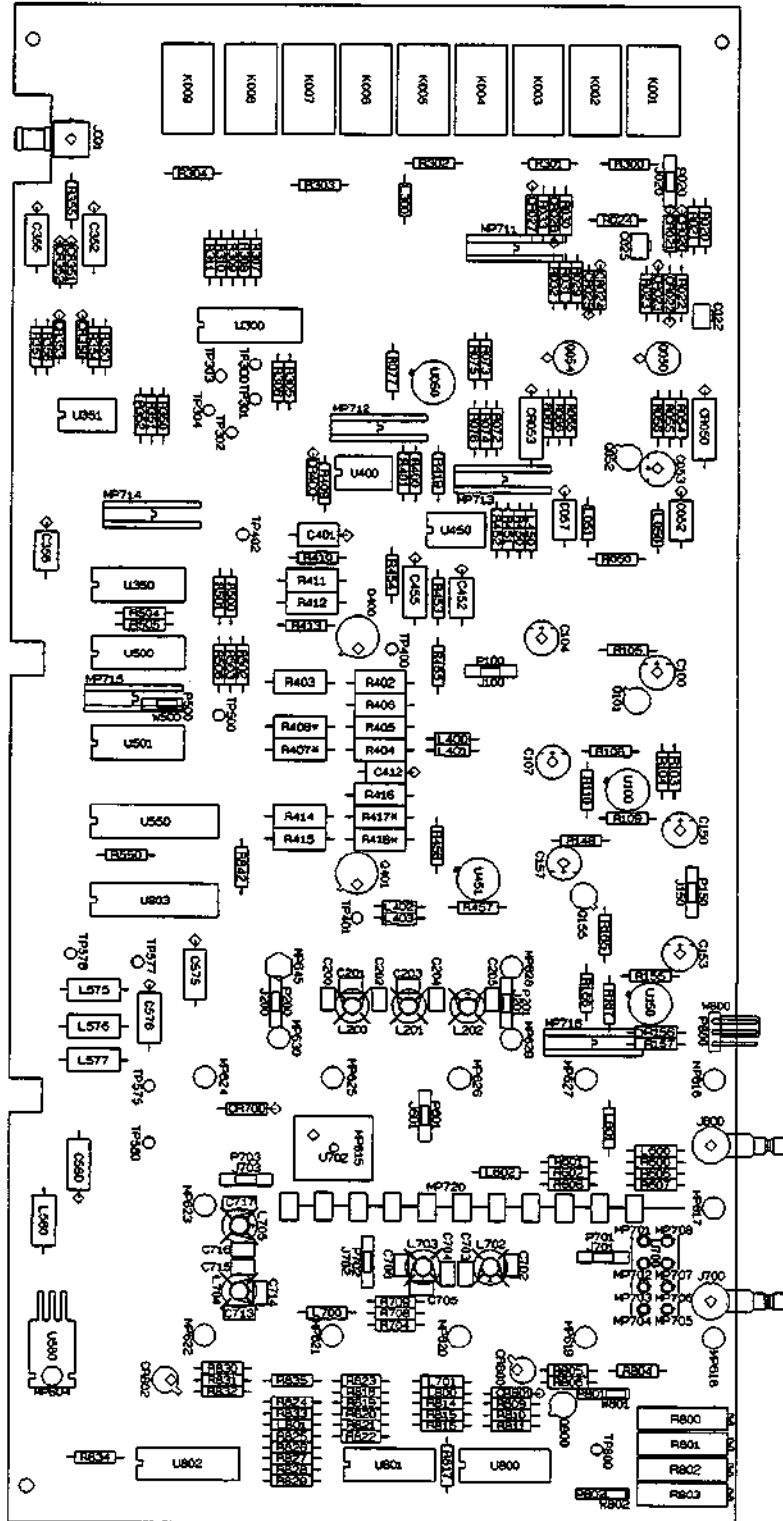


Figure 9-14. A18 Component Locator

IC	Voltage &	Gnd	Bypass Cap	
	Pin #		Desig.	Value
U150	+5V1,7			
U150	-5V1,4			
U100	+5V2,7			
U100	-5V2,4			
U50	+15V2,7		C81	.1
U50	-15V2,4		C82	.1
U450	+15V2,8		C451	.1
U450	-15V2,4		C452	.1
U400	+15V2,8	3	C405	.1
U400	-15V2,4	3	C404	.1
U300		8		
U351	+15V2,8		C354	.1
U351	-15V2,4		C353	.1
U350	+5V3,14	7	C351	.1
U600		3		
U601		3		
U701		3		
U802	+15V2,13	1,4	C818	.1
U802	-15V2,3	1,4	C817	.1
U803	+5V3,20	10	C814	.1
U550	+5V3,20	10	C550	.1
U501	+5V3,14	7	C501	.1
U551	+5V3,14	7	C501	.1
U800	+15V2,11	13,14		.1
U800	-15V2,7	13,14	C23	.1
U801	+15V2,11	5,9,13	C809	.1
U801	-15V2,7	5,9,13	C807	.1
U451	+15V2,7		C457	.1
U451	-15V2,4		C459	.1
U580	+15V2,1	2		
K1		5		
K2		5		
K3		5		
K4		5		
K5		5		
K6		5		
K7		5		
K8		5		
K9		5		

**Attenuation Chart**

Output Level (dBm)	TP12 (4dB Pad)	TP11 (8dB Pad)	TP10 (16dB Pad)	TP9 (32dB Pad)
11.0 to 15.0	H	H	H	H
7.0 to 10.9	L	H	H	H
3.0 to 6.9	H	L	H	H
.0 to 2.9	L	L	H	H
- 5.0 to - 1.1	H	H	L	H
- 9.0 to - 5.1	L	H	L	H
- 13.0 to - 9.1	H	L	L	H
- 17.0 to - 13.1	L	L	L	H
- 21.0 to - 17.1	H	H	H	L
- 25.0 to - 21.1	L	H	H	L
- 33.0 to - 25.1	L	L	H	L
- 37.0 to - 33.1	H	H	L	L
- 41.0 to 37.1	L	H	L	L
- 45.0 to - 41.1	H	L	L	L
- 49.0 to - 45.1	L	L	L	L

TTL: H=High; L=Low

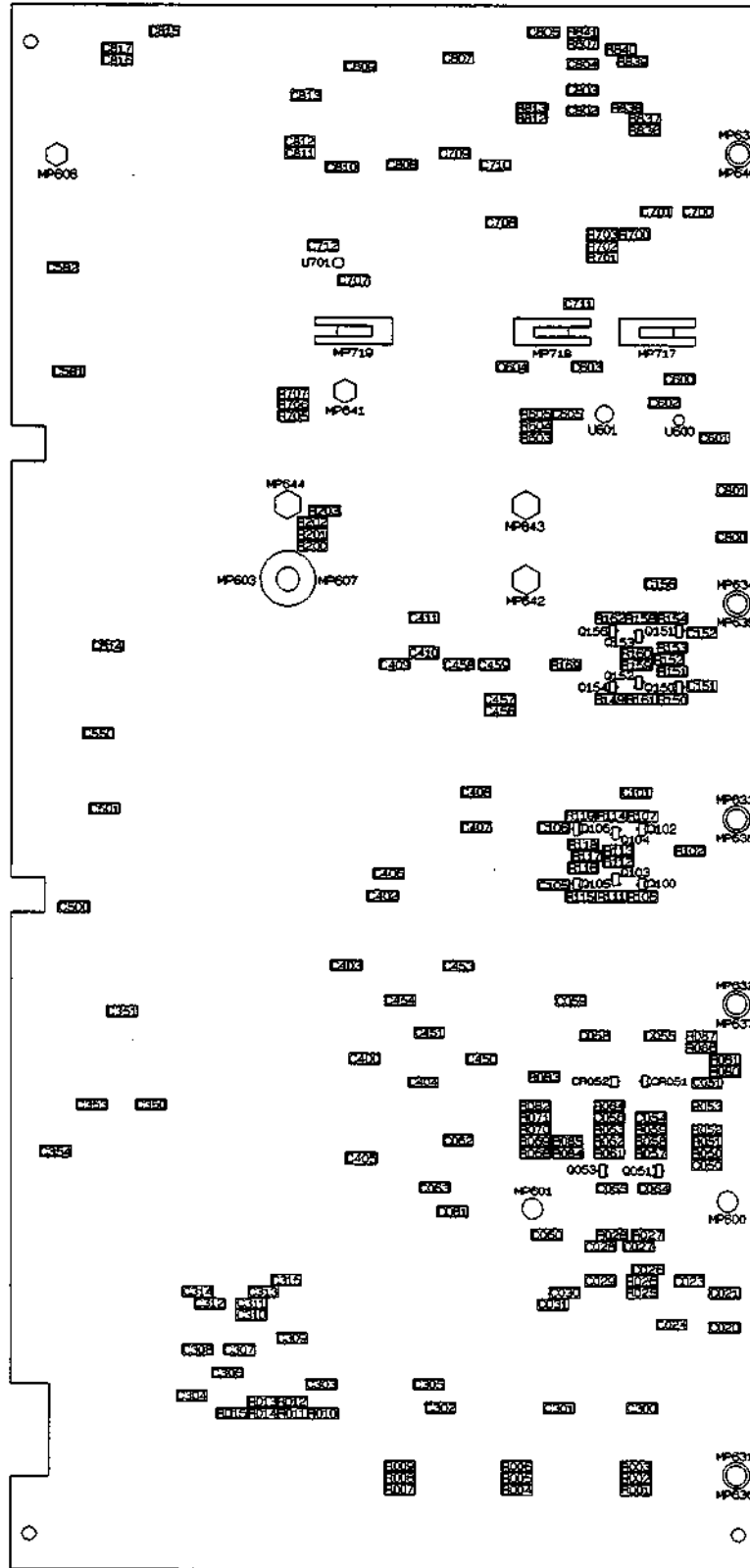
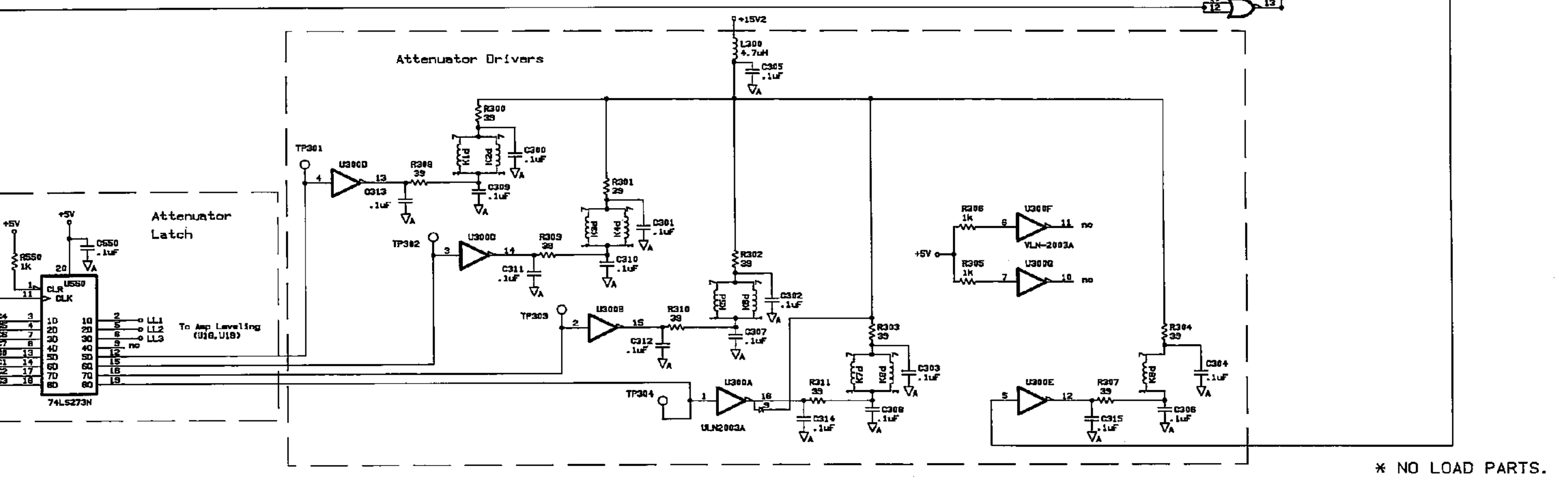
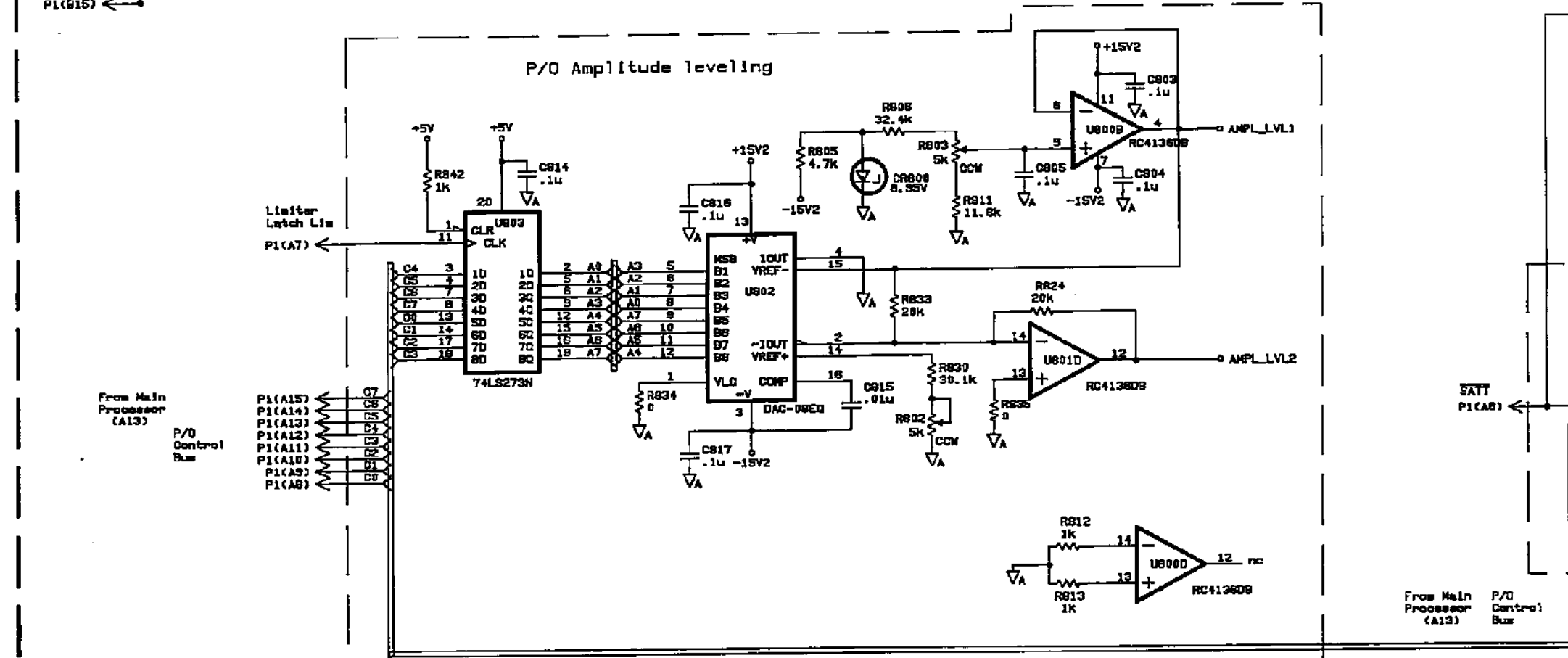
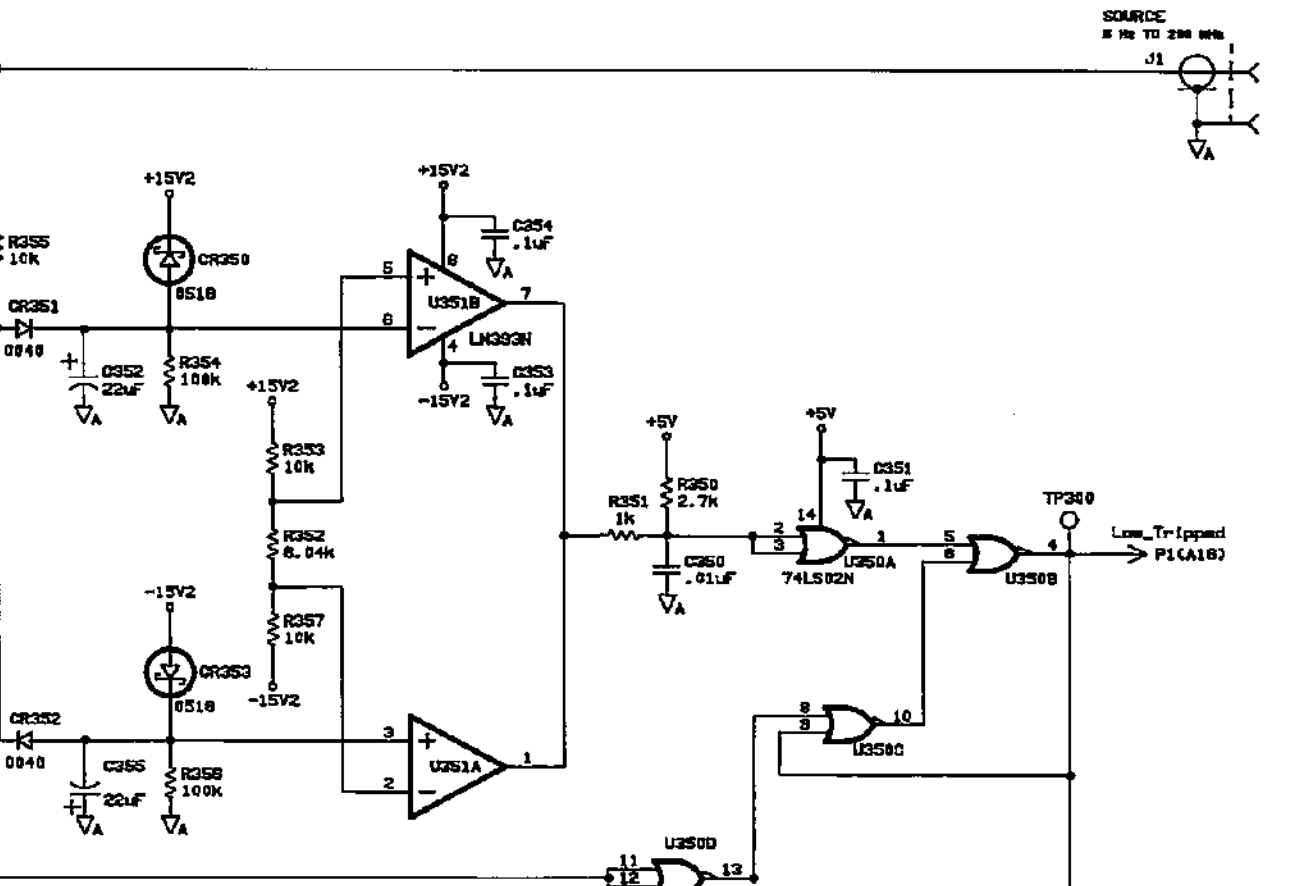
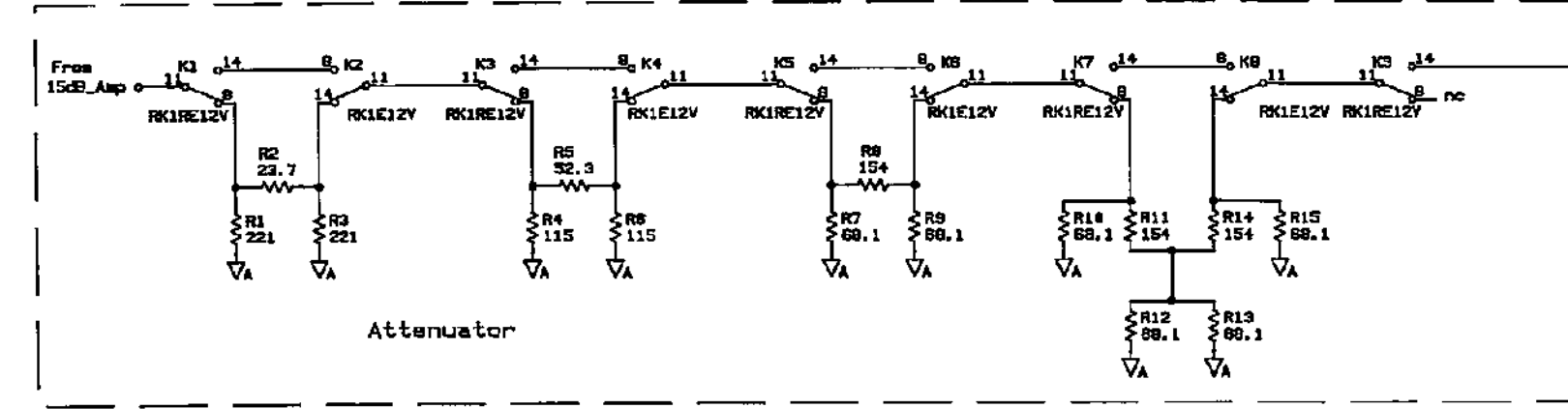
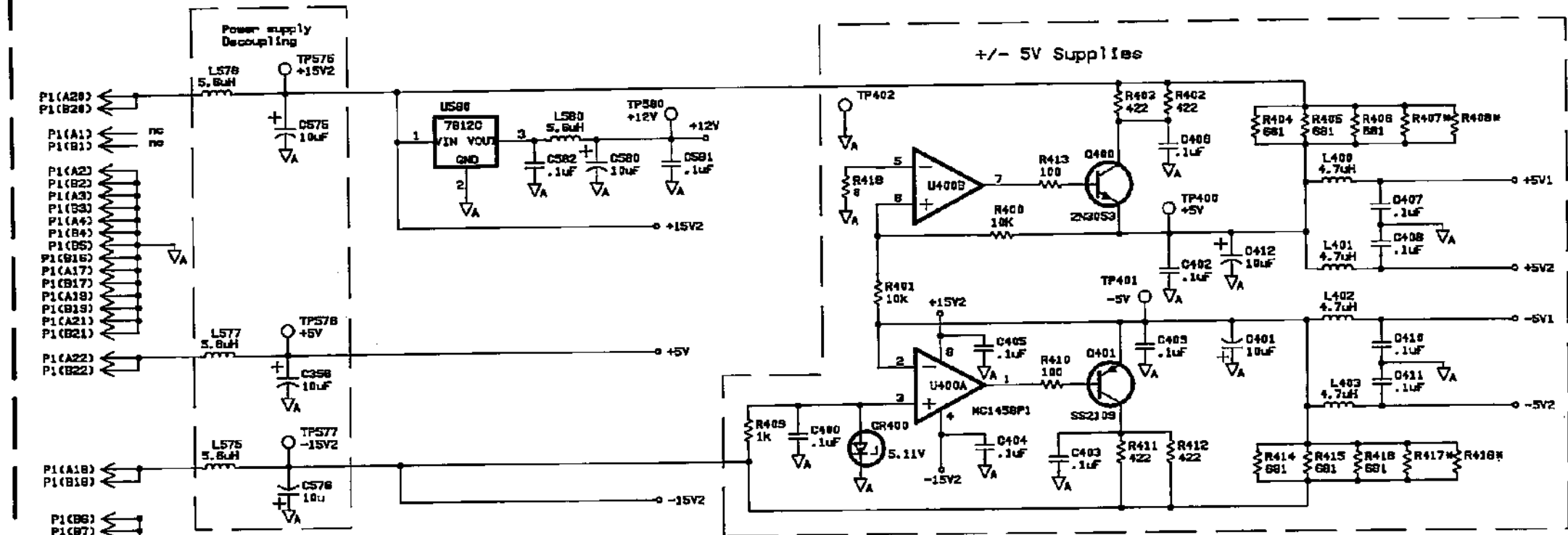
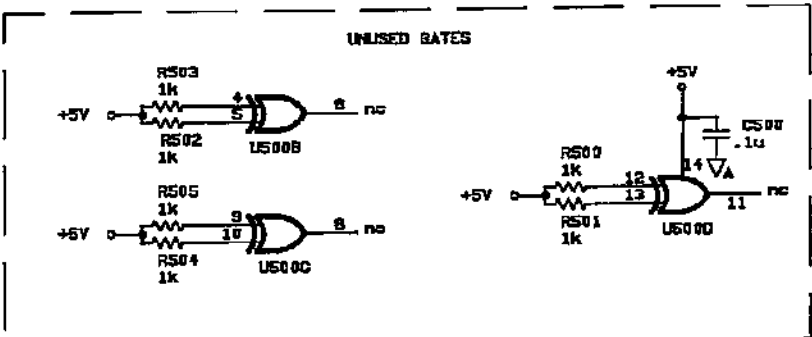
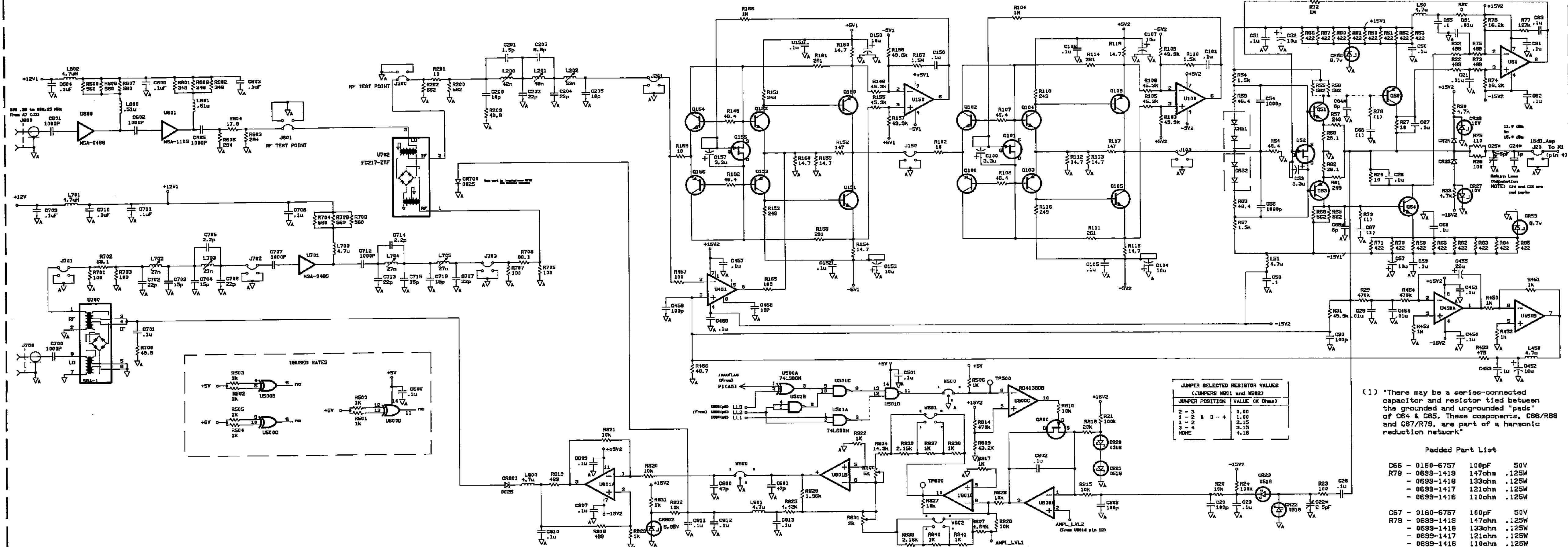


Figure 9-15. A18 Component Locator, Surface Mount Side









JUMPER SELECTED RESISTOR VALUES  
(JUMPERS M801 and M802)

JUMPER POSITION	VALUE (K Ohms)
2 - 3	8.00
1 - 2 & 3 - 4	1.00
1 - 2	2.15
3 - 4	3.15
NONE	4.15

(1) "There may be a series-connected capacitor and resistor tied between the grounded and ungrounded "pads" of C64 & C65. These components, C66/R68 and C67/R78, are part of a harmonic reduction network"

Padded Part List

- C66 - 0160-6757 100pF 50V
- R78 - 0699-1419 147ohm .125W
- 0699-1418 133ohm .125W
- 0699-1417 121ohm .125W
- 0699-1416 110ohm .125W
  
- C67 - 0160-6757 100pF 50V
- R79 - 0699-1419 147ohm .125W
- 0699-1418 133ohm .125W
- 0699-1417 121ohm .125W
- 0699-1416 110ohm .125W



## 9-14 Service Group A19, Input Assembly

The information in this section should be used to isolate faulty functional sub-blocks when servicing the HP 3577B. All procedures assume the Fault Isolation procedures of Section II have been used to determine which functional block has failed, and the circuit descriptions of Section VIII are understood.

### Warning



Service procedures described in this section are performed with the protective covers removed and power applied. Energy available at many points can, if contacted, result in personal injury.

### Caution



Do not insert or remove any circuit board in the HP 3577B with the line power turned on. Power transients caused by insertion or removal may damage the circuit boards.

### Initial Conditions

Unless otherwise stated in the troubleshooting sections of the signal table, set the HP 3577B as described below, after power on.

SWEEP TYPE	CW
AMPTD	- 10 dBm
FREQUENCY	200 MHz

All Oscilloscope waveforms are taken using 10:1 probe but each oscilloscope display shows actual voltage. All Spectrum Analyzer waveforms derived from SMB connectors are taken through the 03577-84401 Service Kit BNC to SMB cable. All Spectrum Analyzer waveforms taken off component leads are taken through a HP 10041A 10:1 Probe. This probe has 215 $\Omega$  of series resistance.

All waveforms in this section were taken with the Receiver under test connected to the HP 3577B source using a cable from the HP 11851A Cable Kit.

## Troubleshooting Hints

1. Before troubleshooting this circuit board, be sure that the fault is occurring on this circuit board by checking the following inputs using the settings in table 2-7 and table 9-7.
  - A4J3,A4J4,A4J5 (depending on R,A, or B) L.O. input
  - A19R10 240 kHz Second L.O. input.
  - A19TP10 8 kHz Third L.O. input.
  - A19U28 pin 12 2 MHz Reference input.
  - A19W4 2 kHz input.
2. Isolate the problem to either the digital or the analog circuitry by testing the signal at A19TP6 as described in step 6 of table 9-7. If this test passes, then the analog circuitry is good, and the digital circuitry is bad. If the analog circuitry is bad, then half split the analog circuitry by testing the signal at A19TP4 as described in step 5 of table 9-7. Then continue troubleshooting toward the bad signal. If the digital circuitry is indicated, follow the digital troubleshooting procedure following the troubleshooting hints.
3. SYMPTOM: Dynamic Linearity Performance Test fails.
  - Use the other channels of the HP 3577B by setting the HP 3577B to continuous wave (CW) mode and setting the output frequency to the IF frequency where testing is taking place. Follow the Dynamic Accuracy test procedure in this section.
4. SYMPTOM: Crosstalk Performance Test fails.
  - Board must be in cardnest and all receiver board screws in place.
  - The A19 L12 and A19 L14 inductors could be coupling from receiver board to receiver board. These components should suspect.
5. SYMPTOM: Receiver Noise Performance Test fails.
  - Check L.O. signals (all) for proper noise levels. DUT board must be in cardnest and all screws in place.
  - Check the + or - 13 V power supplies for correct voltage and ripple.
6. SYMPTOM: Receiver Level Flatness cannot be adjusted into specification.
  - Problem is in first mixer, L.O., input buffer, or impedance switching subblocks.
7. SYMPTOM: Receiver Phase Zero and Response out of specification.
  - Check Frequency Reference board counter preset switch for proper position if 100 kHz phase zero bad. The proper position will put the phase zero between 15 degrees.
  - Make sure L.O. output phase is good by observing a phase display when swapping the L.O. inputs to the A19 boards. If the display is constant then the L.O. is good. If the display changes, then L.O. is bad.



**8. SYMPTOM: Receiver Sensitivity Performance Test fails.**

- Jumper A19 TP6 to ground. This is the Analog/Digital halfsplit. If the receiver passes, then the Analog section is bad. If the receiver fails, then the digital section is bad.
- If the analog circuit is suspect, jumper A19TP4 to ground. This should be used as an Input/10 kHz half split.

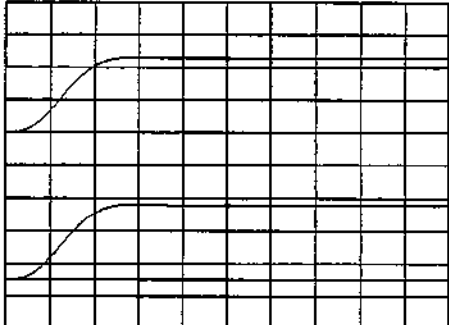
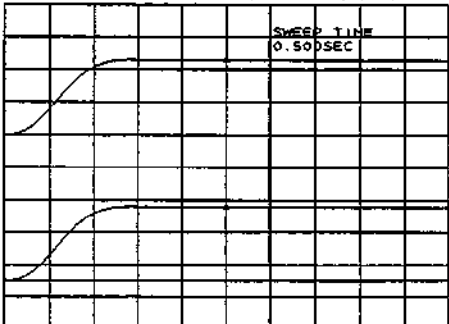
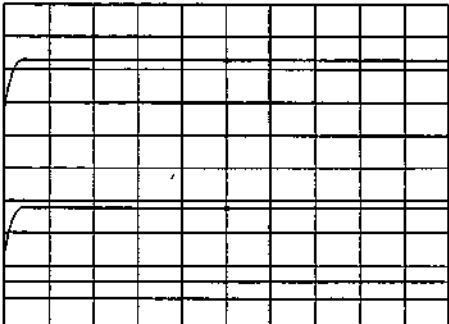
**Digital Filter Test**

- a. Disconnect the main power cord from the rear panel and remove the top cover. Place the suspect A19 receiver board on the 03577-66542 extender board.
- b. Move the Digital Filter Test jumper W4 to the TEST position. Move the TEST jumper W2 to the TEST position.
- c. Press the hardkeys listed below on the left and select the softkey, or enter the data listed on the right.

TRACE 1	
INPUT	Suspect Channel
DISP FCTN	Real
SCALE	
/Div	100 mV
Ref Pos	60%
Ref Level	0 V
TRACE 2	
INPUT	Suspect Channel
DISP FCTN	Imag
SCALE	
/Div	100mV
Ref Pos	15%
Ref Level	0 V
SPCL FCTN	
Service Diag	Settling Off
AMPTD	- 40 dBm

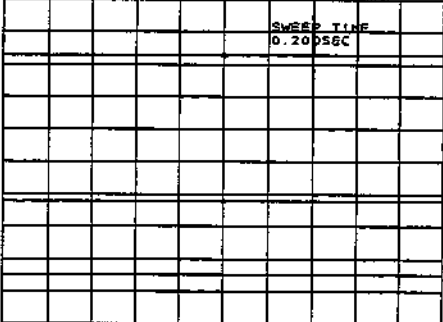
- d. Press the RES BW and SWP TIME hardkeys and select the values listed for each display shown in table 9-7. The display is the digital filter step response. If any of these displays do not pass, then the digital filters or the algorithmic state machine are faulty. If both digital filters pass, then the Algorithmic State machine, I/O, and Look Up Tables are all good. If only one digital filter fails, then the failure is probably a bad filter. If both digital filters fail, then the problem is probably a state machine problem and the Signature Analysis tests should be run before replacing the digital filters.

**Table 9-7. Digital Filter Test Waveform Table**

HP 3577B Set up	Measurement Set up	Waveform with Parameters
<p>As in step c. Sweep Time 5 sec RES BW 1 Hz</p>	<p>A19 board, W4  Digital Filter Test jumper in TEST position. A19W2 also in TEST position</p>	<p><b>Step Response and final settled output value.</b>            REF LEVEL /DIV MARKER 100 000 000.000Hz            0.00V 100.00mV REAL (R) 228.38mV            0.00V 100.00mV MARKER 100 000 000.000Hz            IMAG (R) 228.38mV</p>  <p>START 0.000Hz STOP 200 000 000.000Hz            AMPTD -40.0dBm</p> <p style="text-align: center;">#1</p>
<p>As in step c. Sweep Time.5 sec RES BW 10 Hz</p>	<p>A19 board, W4  Digital Filter Test jumper in TEST position. A19W2 also in TEST position.</p>	<p><b>Step Response and final settled output value.</b>            REF LEVEL /DIV MARKER 100 000 000.000Hz            0.00V 100.00mV REAL (R) 228.39mV            0.00V 100.00mV MARKER 100 000 000.000Hz            IMAG (R) 228.40mV</p>  <p>START 0.000Hz STOP 200 000 000.000Hz            AMPTD -40.0dBm</p> <p style="text-align: center;">#2</p>
<p>As in step c. Sweep Time.2 sec RES BW 100 Hz</p>	<p>A19 board, W4  Digital Filter Test jumper in TEST position. A19W2 also in TEST position</p>	<p><b>Step Response and final settled output value</b>            REF LEVEL /DIV MARKER 100 000 000.000Hz            0.00V 100.00mV REAL (R) 228.50mV            0.00V 100.00mV MARKER 100 000 000.000Hz            IMAG (R) 228.50mV</p>  <p>START 0.000Hz STOP 200 000 000.000Hz            AMPTD -40.0dBm</p> <p style="text-align: center;">#3</p>



**Table 9-7. Digital Filter Test Waveform Table Continued**

HP 3577B Set up	Measurement Set up	Waveform with Parameters
As in step c. Sweep Time .2 sec RES BW        1 kHz	A19 board, W4  Digital Filter Test jumper in TEST position. A19W2 also TEST position.	<p style="text-align: center;"><b>Step Response and final settled output value</b></p> <div style="display: flex; justify-content: space-between; font-size: small;"> <span>REF LEVEL    /DIV</span> <span>MARKER 100 000 000.000Hz</span> <span>SWEEP TIME</span> </div> <div style="display: flex; justify-content: space-between; font-size: x-small;"> <span>0.00V        100.00mV</span> <span>REAL (R)     228.50mV</span> <span></span> </div> <div style="display: flex; justify-content: space-between; font-size: x-small;"> <span>0.00V        100.00mV</span> <span>MARKER 100 000 000.000Hz</span> <span></span> </div> <div style="display: flex; justify-content: space-between; font-size: x-small;"> <span></span> <span>IMAG (I)     228.50mV</span> <span></span> </div> <div style="text-align: center; margin: 10px 0;">  </div> <div style="display: flex; justify-content: space-between; font-size: x-small;"> <span>START 0.000Hz</span> <span>STOP 200 000 000.000Hz</span> </div> <div style="display: flex; justify-content: space-between; font-size: x-small;"> <span>AMPTD -40.0dBm</span> <span></span> </div> <p style="text-align: center; font-weight: bold; font-size: large;">#4</p>

## A/D Test

- a. Disconnect the main power cord from the rear panel and remove the top cover. Place the suspect receiver board on the 03577-66542 extender board.
- b. Set the Test jumper W2 to the TEST position. Set the A/D Test jumper W3 to the TEST position. Set the 10 kHz in jumper W8 to the TEST position. All other jumpers should be in their NORMAL position.
- c. Connect the External Power Supply to TP6.
- d. Press the hardkeys listed on the left, and select the softkeys or enter the data listed on the right.

```
INSTR PRESET
DISP FCTN      Real
SWEEP TYPE     CW
INPUT
  User Defined Input  K3*(K1 *X - K2) X = Suspect
DEF MATH       Channel
  K1 real        15.425 Units
  K1 imag        0.0 Units
  K2 real        7.5 Units
  K2 imag        0.0 Units
  K3 real        - 1 Units
  K3 imag        0.0 Units
SCALE
  /Div          2 Units
```

- e. This set up will measure positive input voltages at TP6. Monitor the External Power Supply with the Digital Voltmeter and compare the readings. All readings should agree to within 100 mV. At near 0 V, the reading may jump suddenly to  $\pm 15V$ . This is normal and is due to the sign bit being toggled. The A/D does this because the trace math is different for the different polarities.
- f. Test the negative half of the A/D by switching the polarity of the external power supply, and setting K2 real in step d to - 7.5 Units.
- g. If these tests fail, isolate the fault to the analog or digital sections of the receiver. Run the Digital Filter test in this section. If the digital filter test passes, then the fault is most likely in the A/D converter, sample and hold, or variable gain amplifier. If the digital filter test fails, then a algorithmic state machine, look up table or digital filter is faulty and must be repaired. Repair the components as indicated in the test.

**Signature Analysis Tests**

- a. This Signature Analysis mode actually uses an Oscilloscope rather than a Signature Analyzer to check the digital sections of the A19 board.
- b. Remove power from the HP 3577B and place the suspect receiver board on the 03577-66542 Extender board.
- c. Set the following jumpers to their TEST position. All other jumpers must be the NORMAL position.

**Jumper Name:**

DIGITAL FILTER TEST	W4
A/D TEST	W3
BOARD TRI-STATE	W5 and W6
SIGNATURE ANALYSIS	W1

- d. Externally trigger the Oscilloscope on the 4 kHz signal on A19TP8.
- e. Check each of the signals as listed in table 9-7. Expand the Time/Div control and adjust the delaying timebase to view each of the signals listed in the table. If a signal is bad, it will probably show up in the burst of pulses in the first 20  $\mu$ s. Check this time frame first, then expand out to view the second burst at approximately 120  $\mu$ s.
- f. Replace each faulty component as shown from the signature data.

### Dynamic Accuracy Troubleshooting (Option 002 only)

- g. The Dynamic Accuracy Troubleshooting Procedure requires that two of the receivers in the HP 3577B are operating correctly. Therefore this procedure only applies when troubleshooting an HP 3577B Option 002 Three-Channel Network Analyzer
- h. By programming the HP 3577B output frequency for the IF frequency under test, the good receiver is tuned to the IF, and linearity tests can be made. It is assumed the Input Variable Gain Amplifier dc Offset Adjustment was performed and the unit still failed the dynamic accuracy specifications. Also, perform the A/D converter and digital filter tests in this section to isolate the fault to the analog portion of the instrument.
- i. Remove power from the HP 3577B and place the suspect receiver board on the 03577-66542 extender board. Connect the equipment as shown in figure 9-16. Use the SMB to BNC cable to connect the suspect receiver board to the Power Splitter. The set up shown is for a faulty R channel board. Adapt the set up as necessary for an A or B circuit board fault.

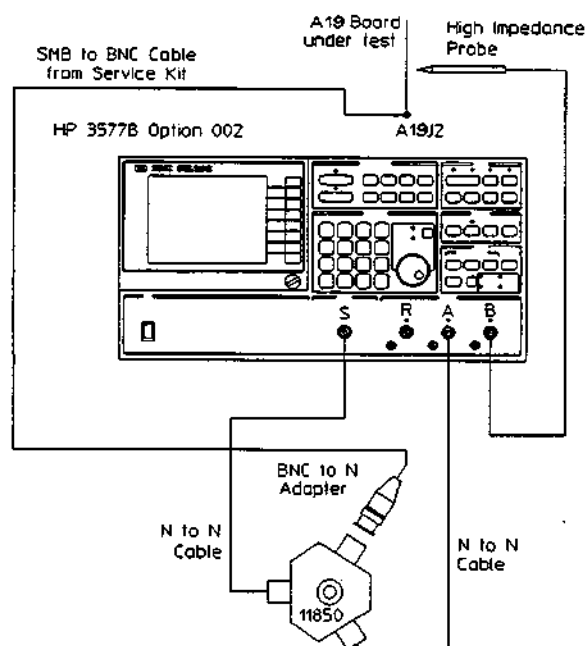


Figure 9-16. Dynamic Accuracy Troubleshooting Set Up

- j. Set the HP 3577B controls by pressing the hardkey on the left and selecting the softkey, or entering the data listed on the right. The input settings below are for an R channel fault with the test set up seen in figure 9-16. Adapt the control settings for your test set up as required by noting which channel is faulty, which is fed by the bridge and which has the 1:1 probe.

INPUT	A/B
DISP FCTN	Log Mag
SWEEP TYPE	CW
RES BW	10 Hz
ATTEN	
Receiver R	50 $\Omega$ , 20 dB
Receiver A	50 $\Omega$ , 20 dB
Receiver B	1 M $\Omega$ , 20 dB

- k. If the failure occurs at only one frequency, then the fault is isolated to the first mixer and Local Oscillator buffer amplifier. Check this conversion section by pressing the **FREQ** hardkey and entering a **FREQUENCY** of 250 kHz. Connect the 1:1 10007B Probe to A19 R118.
- l. Press the **AMPTD** hardkey and enter an amplitude of - 10 dBm.
- m. Press the **MEASR CAL** hardkey and select the **NORMALIZE** softkey.
- n. Press the **AMPTD** hardkey and enter the amplitude where the suspect receiver fails the dynamic accuracy specifications. Vary the amplitude over the range of the input board. The marker readout should read 0 dB within the dynamic accuracy specifications. These specifications are listed in table 1-1.
- o. Dynamic accuracy failures will generally be limited to the A/D converter, non-linear amplifiers, and mixers. Test each of the mixers (U24 and U43) and the intermediate amplifiers at their outputs. Test these components from the first mixer back to the A/D. Replace all components that prove to be defective. After each mixer, the HP 3577B programmed frequency will change. Each of the IF frequencies are listed below.

First IF (mixer is U43) = 250 kHz  
Second IF (mixer is U24) = 10 kHz

## Variable Gain Amplifier Troubleshooting

- a. These tests assume that the digital self tests have been run on the suspect receiver board. If these tests have not been run, then do the A/D test and the signature analysis test described in this section.
- b. With the suspect receiver on the extender board, place jumpers A19 W2, A19W13, and A19W3 into the test position. With the jumpers in this position, A19 Q13 should be turned off, and the overall gain of the variable gain amplifier set to negative one. Note that the sample and hold has been disconnected by A19W13.
  - i. Connect the External Power Supply positive terminal to A19 TP14 and the negative terminal to chassis. Monitor the Power Supply voltage with the DC Voltmeter and set it to  $5V \pm 5\text{ mV}$ .
  - ii. Connect the DC Voltmeter to A19TP7 at the variable gain amplifier output. The voltage at A19TP7 should be  $-5.0 \pm 0.1\text{ V}$ .
  - iii. If this test fails, then the variable gain amplifier or gain determining circuitry is faulty. Among the things to check for are shorted switch FETs, out of tolerance resistor ladder, faulty digital latches or buffer amplifiers. Replace all faulty components. Be sure the Variable Gain Amplifier Offset adjustment has been properly performed before replacing components.
  - iv. If this test passes, then the gain ladder can probably be assumed to be good. Continue with this procedure.
- c. Test each of the Variable Gain Amplifier gain settings by following this procedure. A dc voltage is fed to the A/D converter which then determines the optimum gain value and turns on the appropriate gain selection FET.
  - i. Place jumper A19 W13 into the test position and jumpers A19W2 and A19W3 into the normal position.
  - ii. Set the External Power Supply to  $-6.8\text{ V}$ . Connect the positive terminal to A19TP14 and the negative terminal to chassis.
  - iii. Connect the DC Voltmeter positive terminal to A19 TP14 and the negative terminal to chassis.
  - iv. Connect the Oscilloscope probe to A19 TP7. The amplitude of the square wave at A19TP7 is the voltage at A19TP14 multiplied alternately by  $-1.1$  and by the optimum gain value. If possible, the optimum gain value amplifies the voltage at A19TP7 to the range of  $+3.75$  to  $+7.5\text{ V}$  or  $-3.75$  to  $-7.5\text{ V}$ .

- v. While monitoring the Oscilloscope, slowly increase the dc voltage at A19TP14. At approximately  $-3.4$  V, a rapid change in the square wave occurs as Q20 turns on. Check all of the ranges in the following chart for a rapid change in the square wave each time the voltage at A19 TP14 approaches the next range.

Table 9-8

Approximate A19TP14 dc Voltage Range		Gain Selection FET
Lower	Upper	ON
$-6.8$	$-3.4$	Q21
$-3.4$	$-1.7$	Q20
$-1.7$	$-0.85$	Q19
$-0.85$	$-0.43$	Q18
$-0.43$	$-0.21$	Q17
$-0.21$	$-0.11$	Q16
$-0.11$	$-0.05$	Q15
$-0.05$	$+0.05$	Q14
$+0.05$	$+0.11$	Q15
$+0.11$	$+0.21$	Q16
$+0.21$	$+0.43$	Q17
$+0.43$	$+0.85$	Q18
$+0.85$	$+1.7$	Q19
$+1.7$	$+3.4$	Q20
$+3.4$	$+6.8$	Q21

- vi. If this test fails, check that the gain selection signals are getting through to the FETs and that the FETs are switching. If the signals are not getting through to the FETs, check for pulses to the driver chips (U18 and U17) and the buffer chip (U16). Note that pulses will be present rather than a steady state since the gain of the variable gain amplifier is first set to  $-1.1$  and then to the optimum gain value.
- vii. If this test passes, run the signature analysis test to verify that the digital circuitry is operational. Also verify all clock signals entering the board.

**Table 9-9. A19 Circuit Board, Troubleshooting Data**

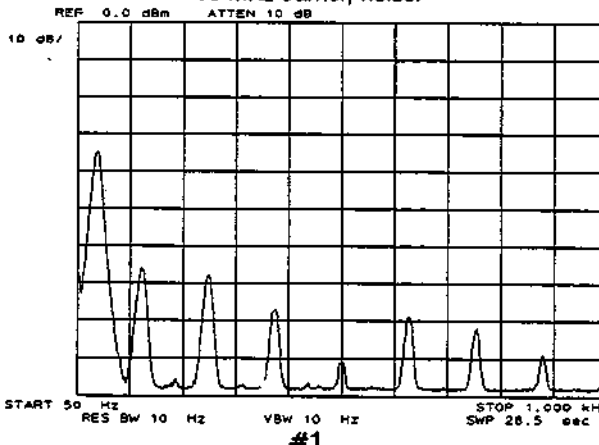
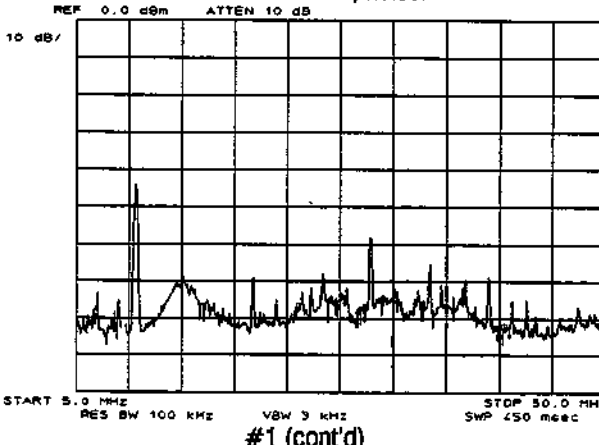
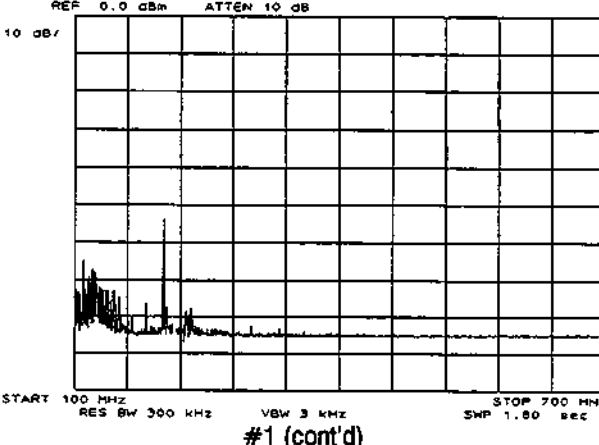
HP 3577B Set up	Measurement Set up	Waveform with Parameters
<p>Test at A19R106 Press INSTR PRESET</p> <p>AMPTD        - 20 dBm Sweep Type    CW Freq            100 Hz Atten            1 MΩ                   0 dB</p> <p>Connect source to receiver under test</p>	<p>Spectrum Analyzer</p> <p>Start            50 Hz Stop            1 kHz Res BW          10 Hz VBW            10 Hz Ref Level        0 dBm dB/Div          10 dB</p>	<p>10 MHz Carrier, noise.</p>  <p>REF 0.0 dBm    ATTEN 10 dB</p> <p>10 dB/</p> <p>START 50.0 MHz    RES BW 10.0 Hz    VBW 10.0 Hz    STOP 1.000 MHz SWP 28.5 msec</p> <p>#1</p>
<p>Test at A19R106 Press INSTR PRESET</p> <p>AMPTD        - 20 dBm Sweep Type    CW Freq            10 MHz Atten            1 MΩ                   0 dB</p> <p>Connect source to receiver under test</p>	<p>Spectrum Analyzer</p> <p>Start            5 MHz Stop            50 MHz Res BW          100 kHz VBW            3 kHz Ref Level        0 dBm dB/Div          10 dB</p>	<p>10 MHz Carrier, noise.</p>  <p>REF 0.0 dBm    ATTEN 10 dB</p> <p>10 dB/</p> <p>START 5.0 MHz    RES BW 100 kHz    VBW 3 kHz    STOP 50.0 MHz SWP 450 msec</p> <p>#1 (cont'd)</p>
<p>Test at A19R106 Press INSTR PRESET</p> <p>AMPTD        - 20 dBm Sweep Type    CW Freq            200 MHz Atten            1 MΩ                   0 dB</p> <p>Connect source to receiver under test</p>	<p>Spectrum Analyzer</p> <p>Start            100 MHz Stop            700 MHz Res BW          300 kHz VBW            3 kHz Ref Level        0 dBm dB/Div          10 dB</p>	<p>10 MHz Carrier, noise.</p>  <p>REF 0.0 dBm    ATTEN 10 dB</p> <p>10 dB/</p> <p>START 100 MHz    RES BW 300 kHz    VBW 3 kHz    STOP 700 MHz SWP 1.00 sec</p> <p>#1 (cont'd)</p>



Table 9-9. A71 Circuit Board, Troubleshooting Data Continued

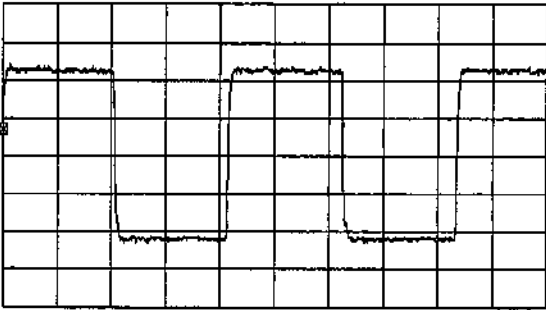
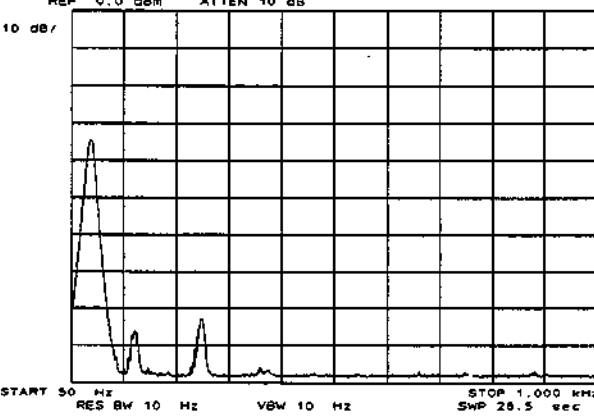
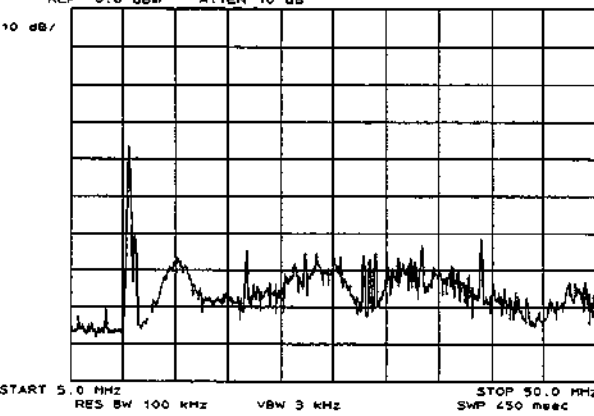
HP 3577B Set up	Measurement Set up	Waveform with Parameters
<p>Test at A19R10 Press INSTR PRESET</p> <p>Freq start            5 Hz</p>	<p>Oscilloscope</p> <p>CH1 Coupling    AC CH1 V/Div       200mV Time/Div        us Trigger         CH1</p>	<p>Waveform with Parameters</p> <p>Waveshape period, noise</p>  <p>#2</p>
<p>Test at A19R117 Press INSTR PRESET</p> <p>AMPTD            - 20 dBm Sweep Type      CW Freq              100 Hz Atten             1 MΩ                      0 dB</p> <p>Connect source to receiver under test</p>	<p>Spectrum Analyzer</p> <p>Start             50 Hz Stop              1 kHz Res BW           10 Hz VBW              10 Hz Ref Level        0 dBm dB/Div          10 dB</p>	<p>100 Hz Carrier, noise</p>  <p>#3</p>
<p>Test at A19R117 Press INSTR PRESET</p> <p>AMPTD            - 20 dBm Sweep Type      CW Freq              10 MHz Atten             1 MΩ                      0 dB</p> <p>Connect source to receiver under test</p>	<p>Spectrum Analyzer</p> <p>Start             5 MHz Stop              50 MHz Res BW           100 kHz VBW              3 kHz Ref Level        0 dBm dB/Div          10 dB</p>	<p>10 MHz Carrier, noise.</p>  <p>#3 (cont'd)</p>

Table 9-9. A71 Circuit Board, Troubleshooting Data Continued

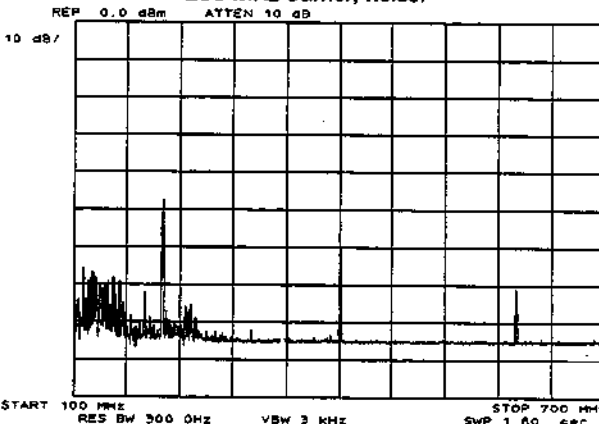
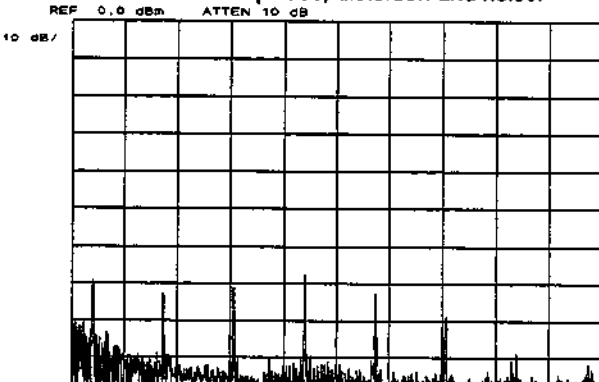
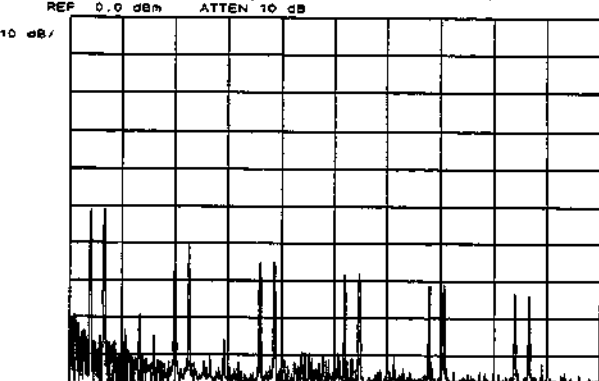
HP 3577B Set up	Measurement Set up	Waveform with Parameters
<p>Test at A19R117 Press INSTR PRESET</p> <p>AMPTD            - 20 dBm Sweep Type      CW Freq              200 MHz Atten             1 MΩ                      0 dB</p> <p>Connect source to receiver under test</p>	<p>Spectrum Analyzer</p> <p>Start             100 MHz Stop              700 MHz Res BW          300 kHz VBW              3 kHz Ref Level        0 dBm dB/Div          10 dB</p>	<p>200 MHz Carrier, noise.</p>  <p>#3 (cont'd)</p>
<p>Test at A19R118 Press INSTR PRESET</p> <p>AMPTD            - 4 dBm Sweep Type      CW Freq              20 Hz Atten             50Ω                      20 dB</p> <p>Connect source to receiver under test</p>	<p>Spectrum Analyzer</p> <p>Start             100 kHz Stop              3.85 MHz Res BW          3 kHz VBW 3            kHz Ref Level        0 dBm dB/Div          10 dB</p>	<p>250 kHz first IF amplitude, distortion and noise.</p>  <p>#4</p>
<p>Test at A19R118 Press INSTR PRESET</p> <p>AMPTD            - 4 dBm Sweep Type      CW Freq              50 kHz</p> <p>Connect source to receiver under test</p>	<p>Spectrum Analyzer</p> <p>Start             100 kHz Stop              3.85 MHz Res BW          3 kHz VBW              3 kHz Ref Level        0 dBm dB/Div          10 dB</p>	<p>250 kHz Carrier, amplitude, intermodulation, noise</p>  <p>#4 (cont'd)</p>

Table 9-9. A71 Circuit Board, Troubleshooting Data Continued

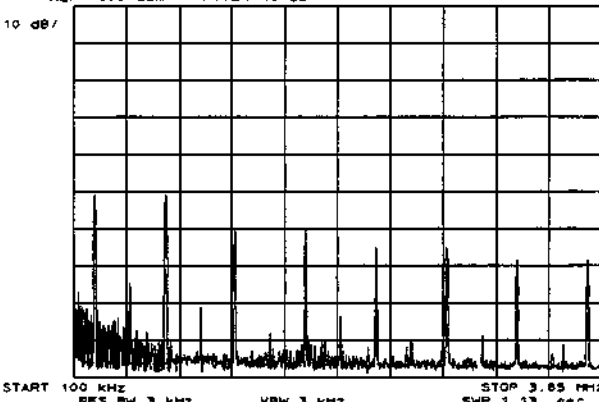
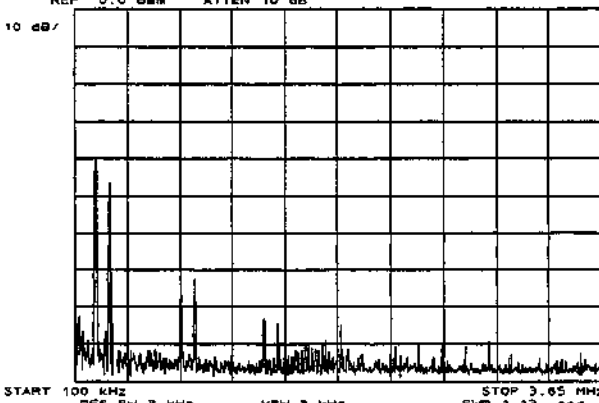
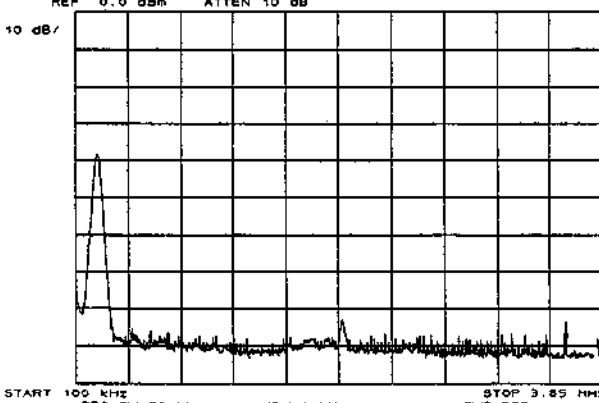
HP 3577B Set up	Measurement Set up	Waveform with Parameters
<p>Test at A19R118 Press INSTR PRESET</p> <p>AMPTD        - 4 dBm Sweep Type    CW Freq            250 kHz</p> <p>Connect source to receiver under test</p>	<p>Spectrum Analyzer</p> <p>Start            100 kHz Stop            3.85 MHz Res BW         3 kHz VBW            3 kHz Ref Level      0 dBm dB/Div 1      0 dB</p>	<p>250 kHz Carrier, amplitude, intermodulation, noise</p> <p>REF 0.0 dBm    ATTN 10 dB</p>  <p>#4 (cont'd)</p>
<p>Test at A19TP4 Press INSTR PRESET</p> <p>AMPTD        - 4 dBm Sweep Type    CW Freq            50 kHz</p> <p>Connect source to receiver under test</p>	<p>Spectrum Analyzer</p> <p>Start            100 kHz Stop            3.85 MHz Res BW         3 kHz VBW            3 kHz Ref Level      0 dBm B/Div 1        0 dB</p>	<p>250 kHz Carrier, amplitude, intermodulation, noise</p> <p>REF 0.0 dBm    ATTN 10 dB</p>  <p>#5</p>
<p>Test at A19TP4 Press INSTR PRESET</p> <p>AMPTD        - 4 dBm Sweep Type    CW Freq            50 kHz</p> <p>Connect source to receiver under test</p>	<p>Spectrum Analyzer</p> <p>Start            100 kHz Stop            3.85 MHz Res BW         30 kHz VBW            1 kHz Ref Level      0 dBm dB/Div        10 dB</p>	<p>250 kHz Carrier, noise.</p> <p>REF 0.0 dBm    ATTN 10 dB</p>  <p>#5 (cont'd)</p>

Table 9-9. A71 Circuit Board, Troubleshooting Data Continued

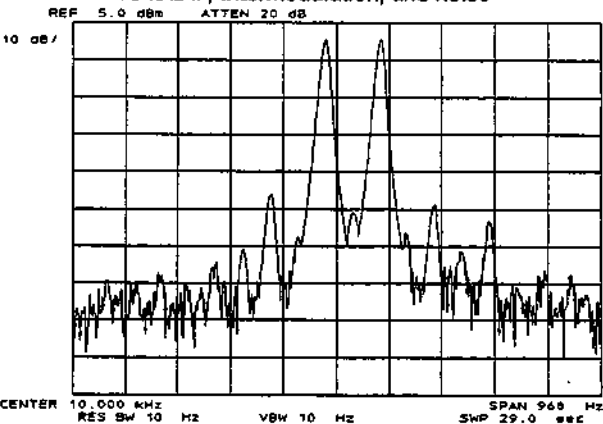
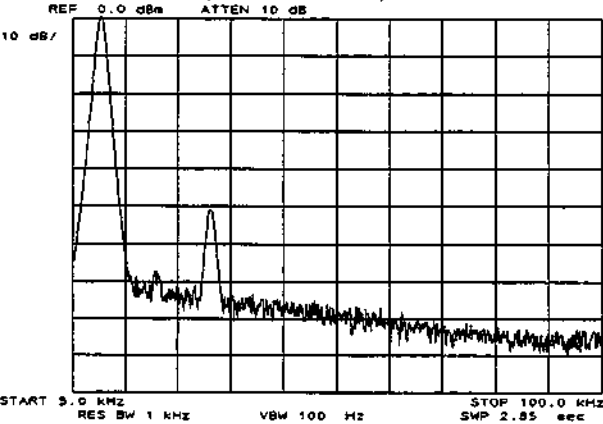
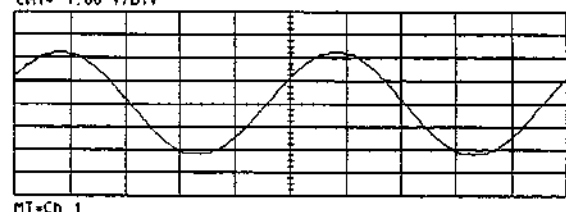
HP 3577B Set up	Measurement Set up	Waveform with Parameters
<p>Test at A19TP6 Press INSTR PRESET</p> <p>Sweep Type CW Freq 50 Hz Amptd -10 dBm</p> <p>Connect source to receiver under test</p>	<p>Spectrum Analyzer</p> <p>Center 10 kHz Span 968 Hz Res BW 10 Hz VBW 10 Hz Ref Level 5 dBm dB/Div 10 dB</p>	<p>10 kHz IF, intermodulation, and noise</p>  <p>REF 5.0 dBm ATTEN 20 dB</p> <p>CENTER 10.000 KHZ RES BW 10 HZ SPAN 968 HZ SWP 29.0 sec</p> <p>#6</p>
<p>Test at A19TP6 Press INSTR PRESET</p> <p>Sweep Type CW Freq 20 kHz Amptd -10 dBm</p> <p>Connect source to receiver under test</p>	<p>Spectrum Analyzer</p> <p>Start 5 kHz Stop 100 kHz Res BW 1 kHz VBW 100 Hz Ref Level 5 dBm dB/Div 10 dB</p>	<p>10 kHz IF, intermodulation, and noise</p>  <p>REF 0.0 dBm ATTEN 10 dB</p> <p>START 5.0 KHZ RES BW 1 KHZ STOP 100.0 KHZ SWP 2.85 sec</p> <p>#6 (cont'd)</p>
<p>Test at A19TP6 Press INSTR PRESET</p> <p>Sweep Type CW Freq 20 kHz AMPTD -10 dBm</p> <p>Connect source to receiver under test</p>	<p>Oscilloscope</p> <p>CH1 Coupling DC CH1 V/Div 1 V Time/Div 20 us Trigger CH1</p>	<p>Period, noise</p>  <p>CH1 CPLG=DC CH1= 1.00 V/Div</p> <p>MT=Ch 1 Main= 20.0 us/Div</p> <p>#6 (cont'd)</p>

Table 9-9. A71 Circuit Board, Troubleshooting Data Continued

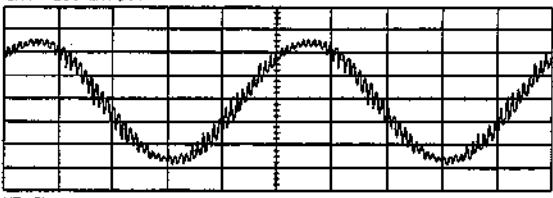
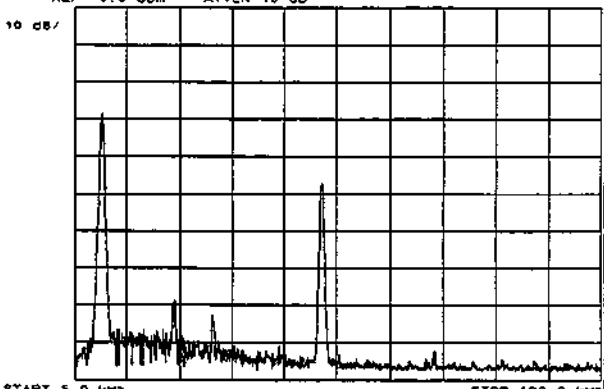
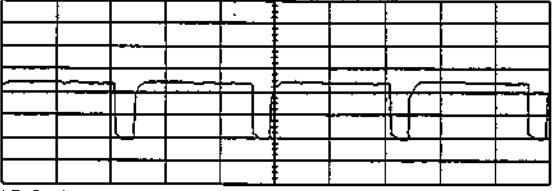
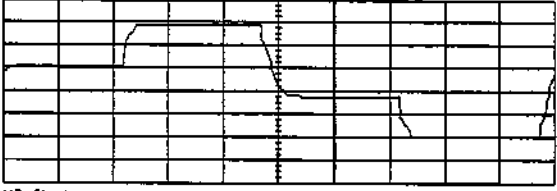
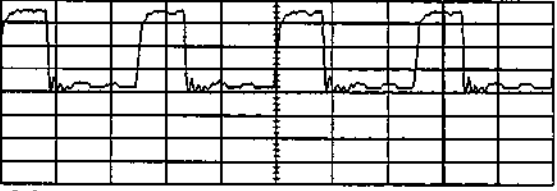

HP 3577B Set up	Measurement Set up	Waveform with Parameters
<p>Test at A19TP5 Press INSTR PRESET</p> <p>Sweep Type CW Freq 100 kHz AMPTD - 4 dBm</p> <p>Connect source to receiver under test</p>	<p>Oscilloscope</p> <p>CH1 Coupling DC CH1 V/Div 200 mV Time/Div 20 <math>\mu</math>s Trigger CH1</p>	<p>Period, noise</p>  <p>#7</p>
<p>Test at A19R13 Press INSTR PRESET</p> <p>Sweep Type CW Freq 20 kHz AMPTD - 4 dBm</p> <p>Connect source to receiver under test</p>	<p>Spectrum Analyzer</p> <p>Start 0 Hz Stop 100 kHz Res BW 300 Hz VBW 100 Hz Ref Level 0 dBm dB/Div 10 dB</p>	<p>10 kHz IF, intermodulation, and noise.</p>  <p>#8</p>
<p>Test at A19TP10 Press INSTR PRESET</p> <p>Connect source to receiver under test</p>	<p>Oscilloscope</p> <p>CH1 Coupling AC CH1 V/Div 100 mV Time/Div 50 <math>\mu</math>s Trigger CH1</p>	<p>Pulse Shape and noise</p>  <p>#9</p>

Table 9-9. A71 Circuit Board, Troubleshooting Data Continued

HP 3577B Set up	Measurement Set up	Waveform with Parameters
<p>Test at A19TP14 Press INSTR PRESET</p> <p>Sweep Type CW Freq 200 MHz Amptd -10 dBm</p> <p>Connect source to receiver under test</p>	<p>Oscilloscope</p> <p>CH1 Coupling DC CH1 V/Div 100 mV Time/Div 50 us Trigger CH1</p>	<p>Waveshape, noise</p>  <p>CH1 CPLG=AC CH1= 1.00 V/Div</p> <p>MT=Ch 1 Main= 50.0 us/Div</p>
<p>Test at TP7 Press INSTR PRESET</p> <p>Sweep Type CW Freq 200 MHz Amptd -10 dBm</p> <p>Connect source to receiver under test</p>	<p>Oscilloscope</p> <p>CH1 Coupling DC CH1 V/Div 200 mV Time/Div 50 us Trigger CH1</p>	<p>Waveshape, noise</p> <p>Note: This will shift in time due to trigger level</p>
<p>Test at A19 U28 Pin 12 Press INSTR PRESET</p> <p>Connect source to receiver under test</p>	<p>Oscilloscope</p> <p>CH1 Coupling DC CH1 V/Div 100 mV Time/Div 200 nS Trigger CH1</p>	<p>Waveshape, noise</p>  <p>CH1 CPLG=DC CH1= 1.00 V/Div</p> <p>MT=Ch 1 Main= 200 ns/Div</p> <p>#12</p>

**Table 9-9. A71 Circuit Board, Troubleshooting Data Continued**

HP 3577B Set up	Measurement Set up	Waveform with Parameters
<p>Test at TP11 Press INSTR PRESET</p> <p>Connect source to receiver under test</p>	<p>Oscilloscope</p> <p>CH1 Coupling DC CH1 V/Div 100 mV Time/Div 50 <math>\mu</math>S Trigger CH1</p>	<p>Waveshape, noise</p> <p>CH1 CPLG=DC CH1= 2.00 V/Div</p>  <p>MT=Ch 1 Main= 50.0 <math>\mu</math>s/Div</p> <p>#13</p>

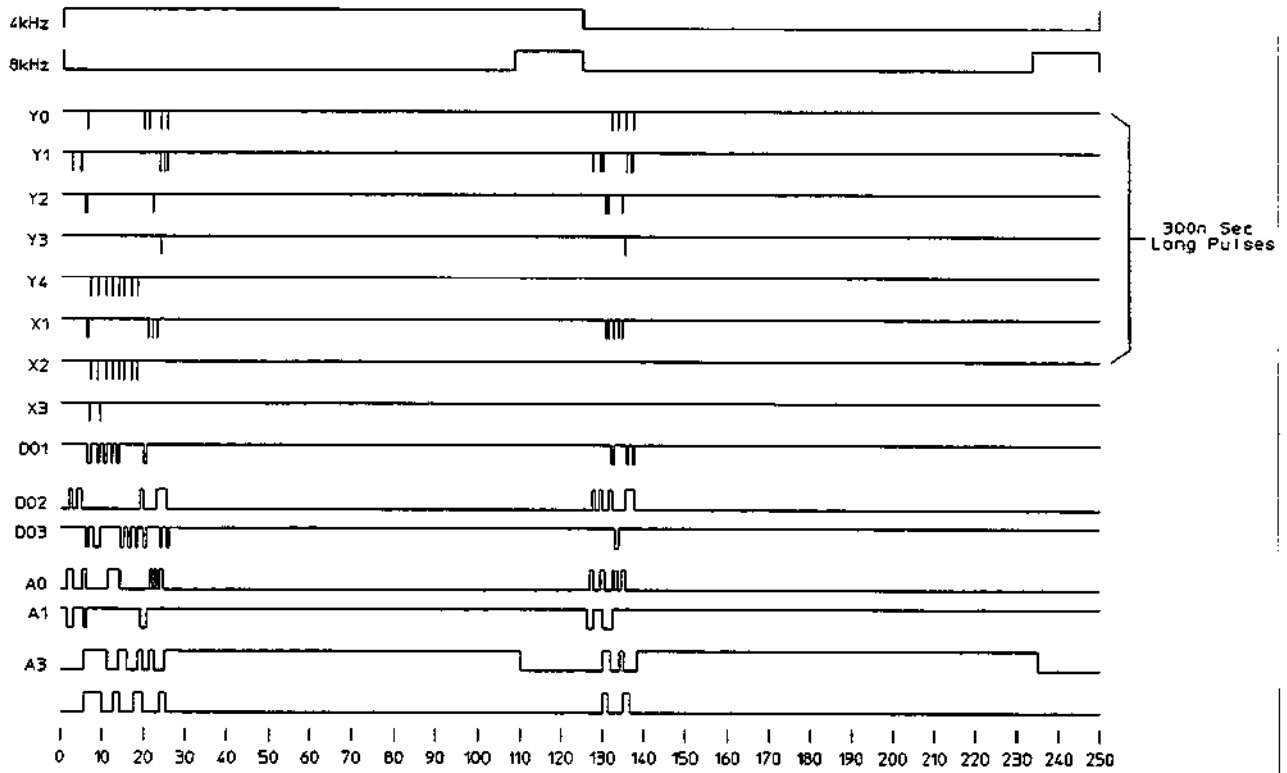


Figure 9-17. A19 Circuit Board Signature Analysis D



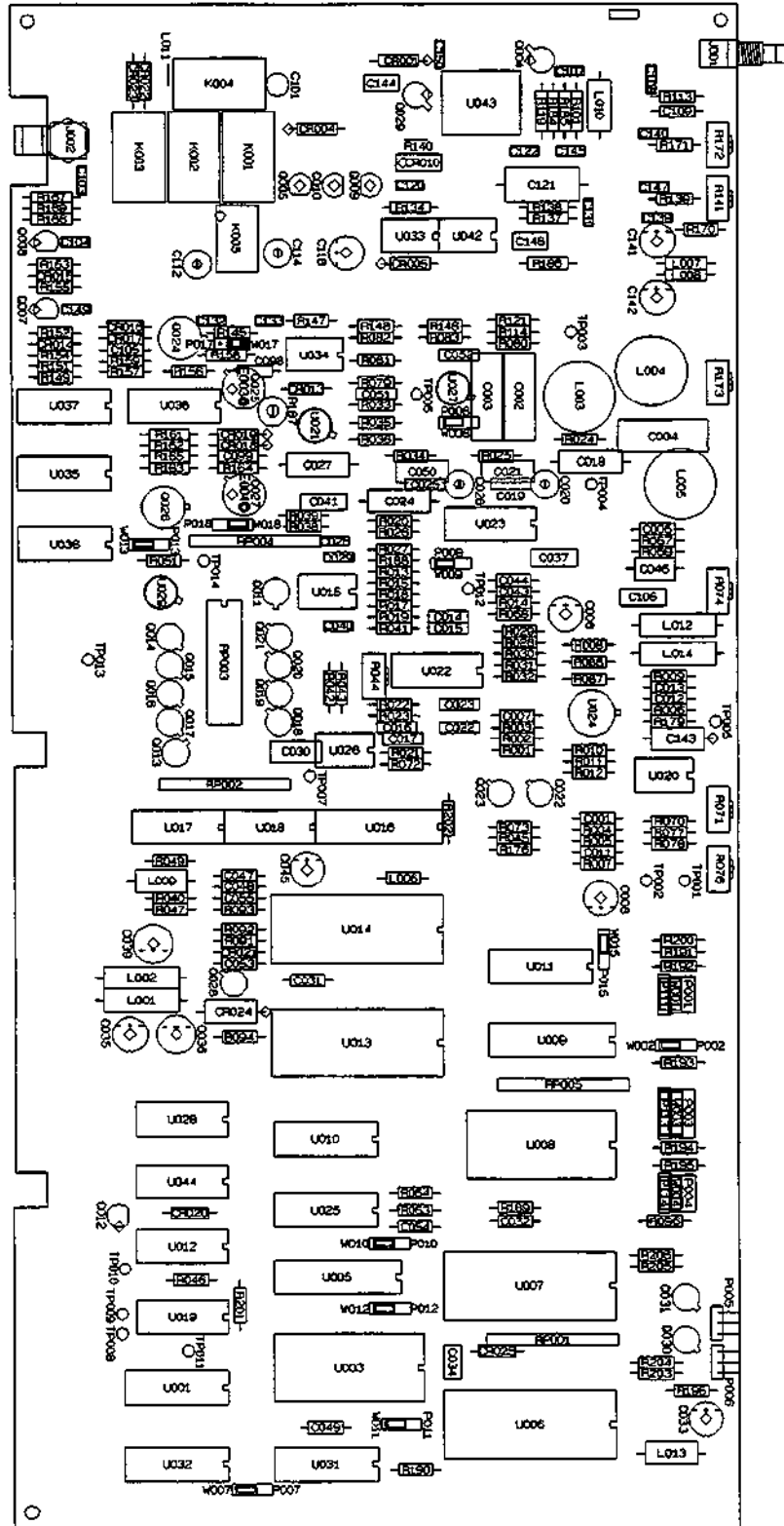


Figure 9-18. A19 Component Locator

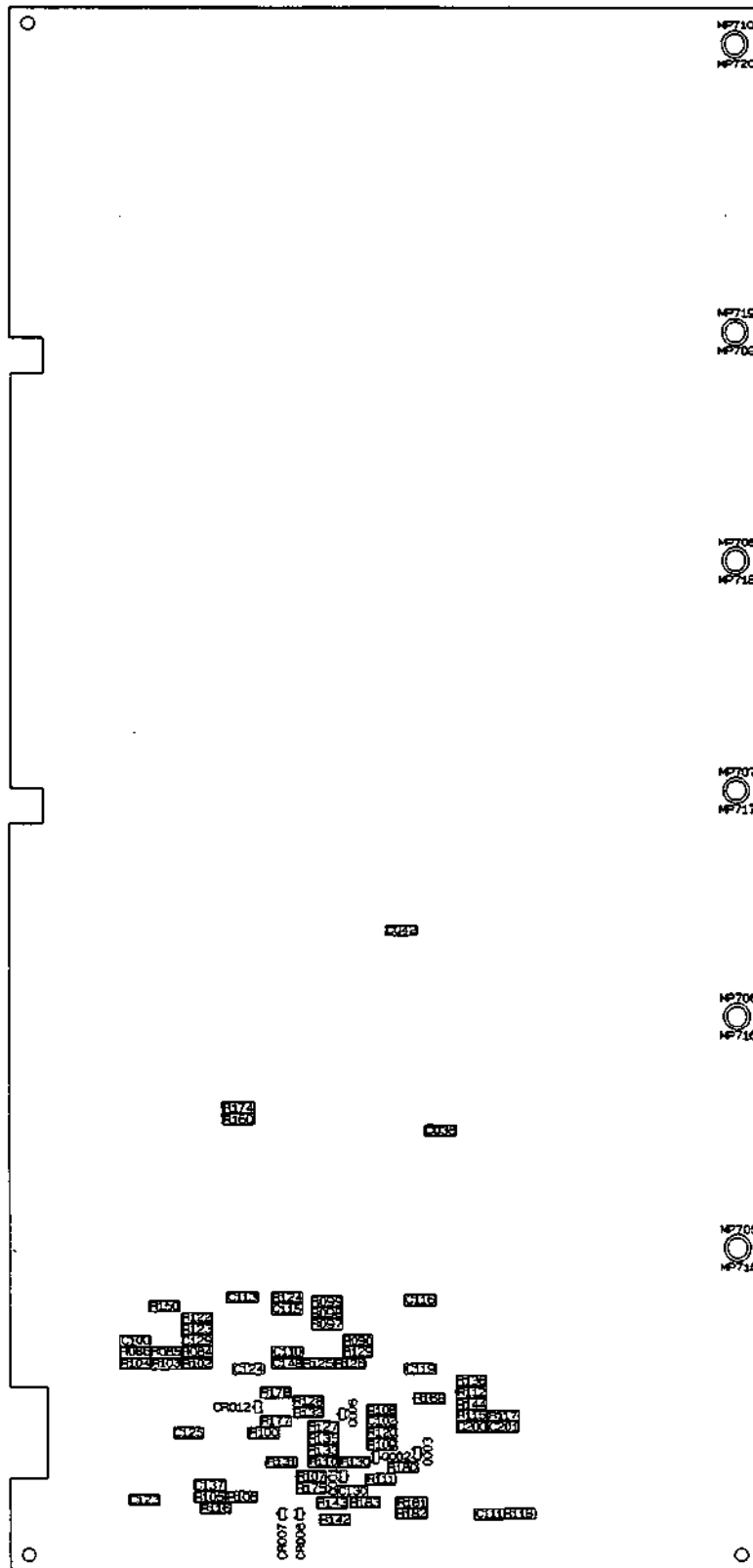
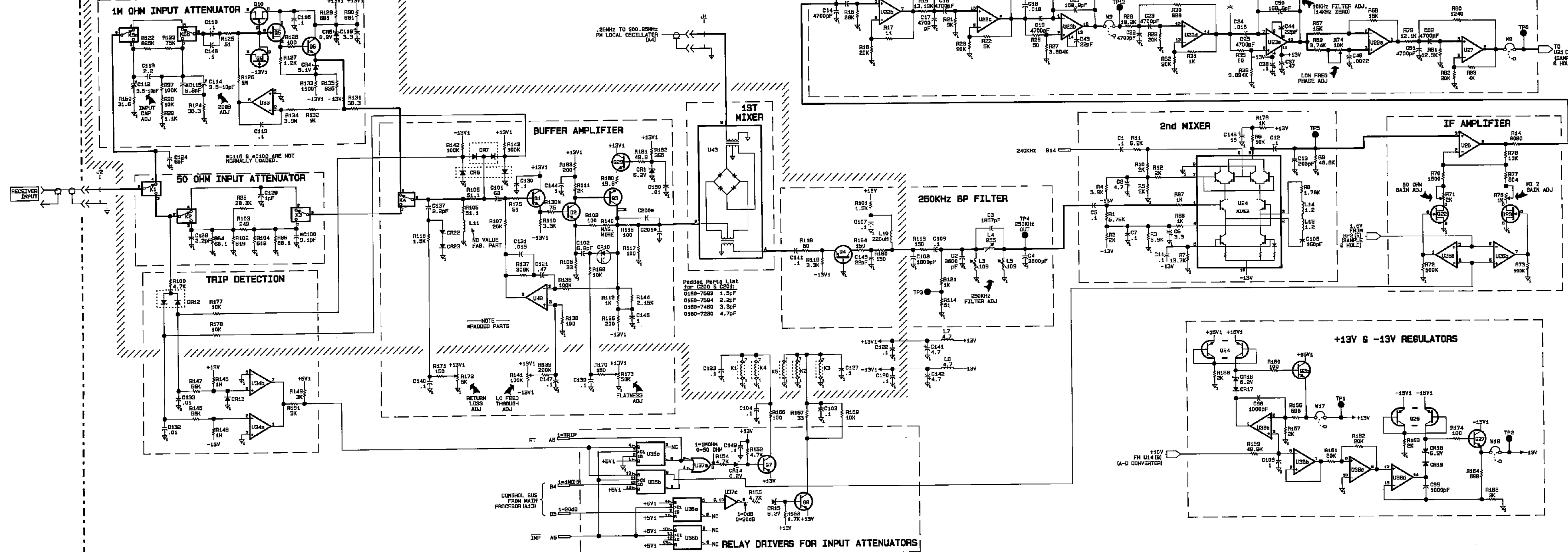


Figure 9-19. A19 Component Locator, Surface Mount Side

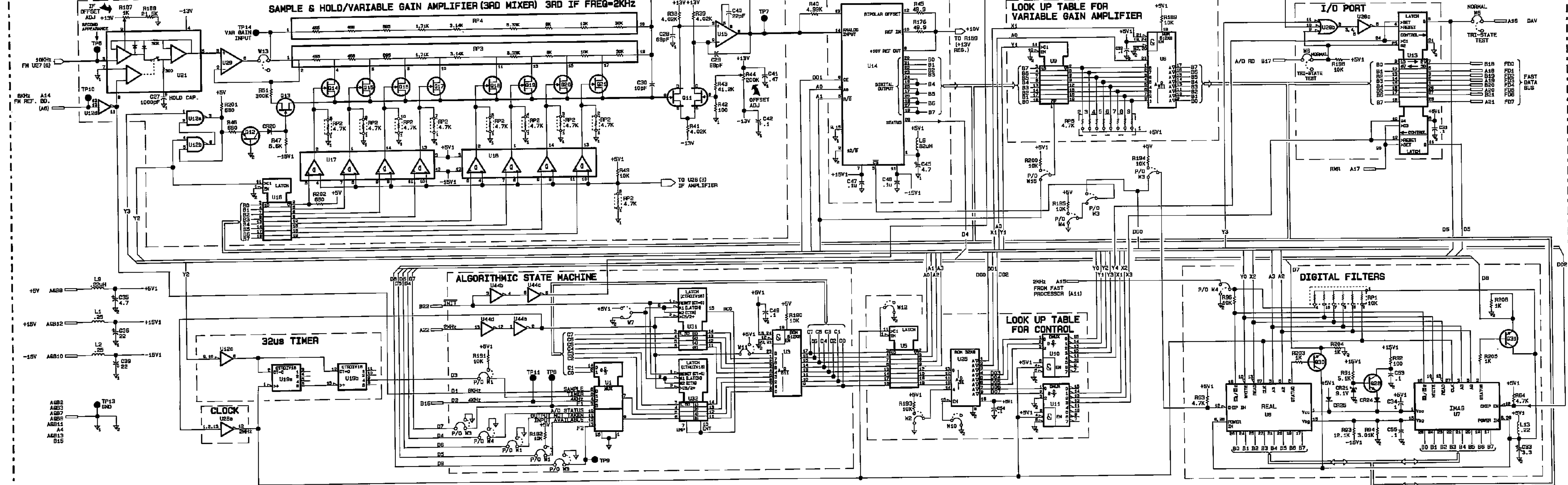
IC	Voltage &	Gnd 1	Gnd 2	Bypass Cap	
		Pin #		Desig.	Value
U1	+5V1,16		8		
U3	+5V1,24		12,20,21	C49	0.1
U5	+5V1,20		1,10		
U8	+5V1,24		12,20	C32	0.1
U9	+5V1,20		10		
U10	+5V1,16		5,8		
U11	+5V1,16		5,8		
U12	+5V1,14		7		
U13	+5V1,8		21	C31	0.1
			22,23		
U14	+15V1,7	9	2,15	C47	0.1
	-15V1,11			C48	0.1
U15	+13V,7			C41	0.1
	-13V,4			C42	0.1
U16	+5V1,20		1,10		
U17	+5V1,3				
	-15V1,12				
U18	+5V1,3				
	-15V1,12				
U19	+5V1,14		7		
U20	+13V,7				
	-13V,4				
U21	+13V,1				
	-13V,4				
U22	+13V,4				
	-13V,11				
U23	+13V,11			C37	0.47
	-13V,4			C38	0.1
U25	+5V1,16		8	C54	0.1
U26	+13V,8				
	-13V,4				
U27	+13V,7				
	-13V,4				
U28	+5V1,14		7		
U29	+13V,7				
	-13V,4				
U31	+5V1,16		8		
U32	+15V1,16		8		
U33	+13V1,7				
	-13V1,4				
U34	+15V1,8				
	-15V1,4				
U35	+5V1,14		7		
U36	+5V1,14		7		
U37	+5V1,14		7		
U38	+15V1,4				
	-15V1,11				
U42	+13V1,7				
	-13V1,4				
U44	+5V1,14				

Control Line	Control Function
A0	Selects upper or lower byte of ADC (U14) when A1 is high Selects 8 bit or 12 bit A/D conversion when A1 is low
A1	Selects upper or lower half of variable gain ROM (U8) Selects READ or CONVERT mode for ADC (U14) Enables output of variable gain ROM latch (U9)
A2 and A3	Control lines for digital filters (U6 and U7)
A4 to A17	Decoded into D00 through D07
D00	Chip enable for real digital filter (U6)
D01	Chip enable for ADC (U14)
D02	Chip enable for imaginary digital filter (U7)
D03 to D05	Decoded into Y0 to Y4
D06 and D07	Decoded into X1 to X3
Y0	Write control for digital filters (U6 and U7)
Y1	Strobe for variable gain lookup table latch (U9)
Y2	Resets gain = 1.1 latch (U12) Strobes gain latch (U16) Clears 32 $\mu$ s timer (U12c)
Y3	Sets gain = 1.1 latch (U12)
Y4	Strobes data into I/O PORT (U13)
X1	Output enable for variable gain lookup ROM (U8) Read control for digital filters (U6 and U7) Enables data read from I/O PORT and clears input available flag (U1a)



**A19 Input Board**  
**03577-66519**  
**Sheet 1 of 2**





A19 Input Board  
03577-66519  
Sheet 2 of 2



---

## 9-15 Service Group A20, Motherboard Assembly

The information in this section should be used to isolate faulty functional sub-blocks when servicing the HP 3577B. All procedures assume the Fault Isolation procedures of Section II have been used to determine which functional block has failed, and the Circuit Descriptions of Section VIII are understood.

---

### Warning



Service procedures described in this section are performed with the protective covers removed and power applied. Energy available at many points can, if contacted, result in personal injury.

---

### Caution



Do not insert or remove any circuit board in the HP 3577B with the line power turned on. Power transients caused by insertion or removal may damage the circuit boards.

---

### Note

This circuit board contains no active or signal conditioning components. All signal paths shown in A20 Motherboard table (P/N 03577-66520) can be checked for continuity using an ohmmeter.

---

### How to Use A20 Motherboard Table (P/N 03577-66520)

All signal names are listed vertically with each of the circuit boards listed horizontally. When a signal is connected to a circuit board, the edge connector pin number is entered in the table at the intersection point of the signal name and the circuit board in the matrix. All circuit board connections for a specific signal can be seen by looking left to right in the signal name row. All signals connected to a circuit board can be seen by looking up and down in the circuit board column.



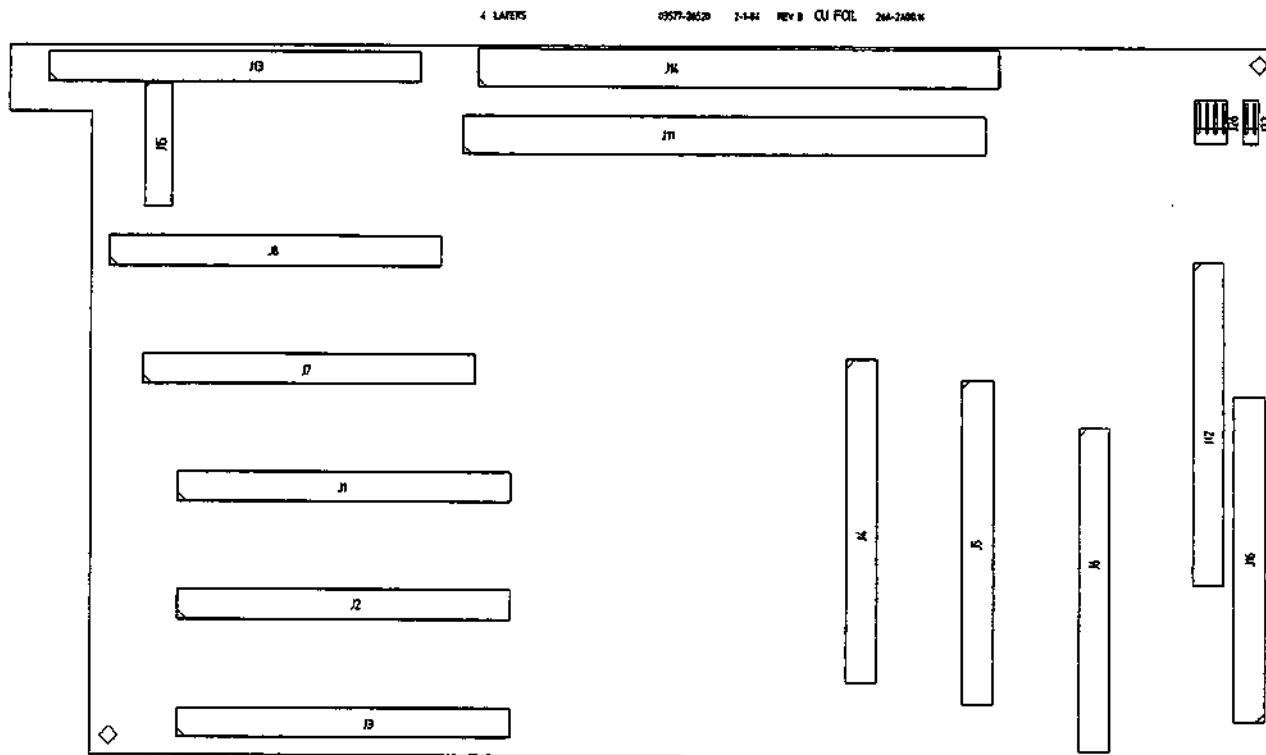


Figure 9-20. A20 Component Locator





---

## 9-16 Service Group A21, Main Power Supply Assembly

The information in this section should be used to isolate faulty functional sub-blocks when servicing the HP 3577B. All procedures assume the Fault Isolation procedures of Section II have been used to determine which functional block has failed, and the Circuit Descriptions of Section VIII are understood.

---

### Warning



Service procedures described in this section are performed with the protective covers removed and power applied. Energy available at many points can, if contacted, result in personal injury.

---

### Caution



Do not insert or remove any circuit board in the HP 3577B with the line power turned on. Power transients caused by insertion or removal may damage the circuit boards.

---

### Warning



230 Vdc is present in the Main Power Supply board (A21) even with the line switch in the off position and the power cord removed. Be extremely careful when working in the proximity of this area. This high voltage could cause serious personal injury if contacted. To remove this voltage, remove the main power cord from the rear panel and remove the bottom cover. Using insulated pliers, set the Main Power Supply board (A21) jumpers W1 and W2 into the TEST position. The capacitors (A21C2 and A21C3) holding this voltage will discharge to a relatively safe level after approximately two minutes.

---

**Note**



All power supplies in the HP 3577B are driven by the FET DRIVE circuit and transformer T1. The +5 volt supply is the reference for the PULSEWIDTH MODULATOR, and must be operating correctly for the other supplies to be in regulation.

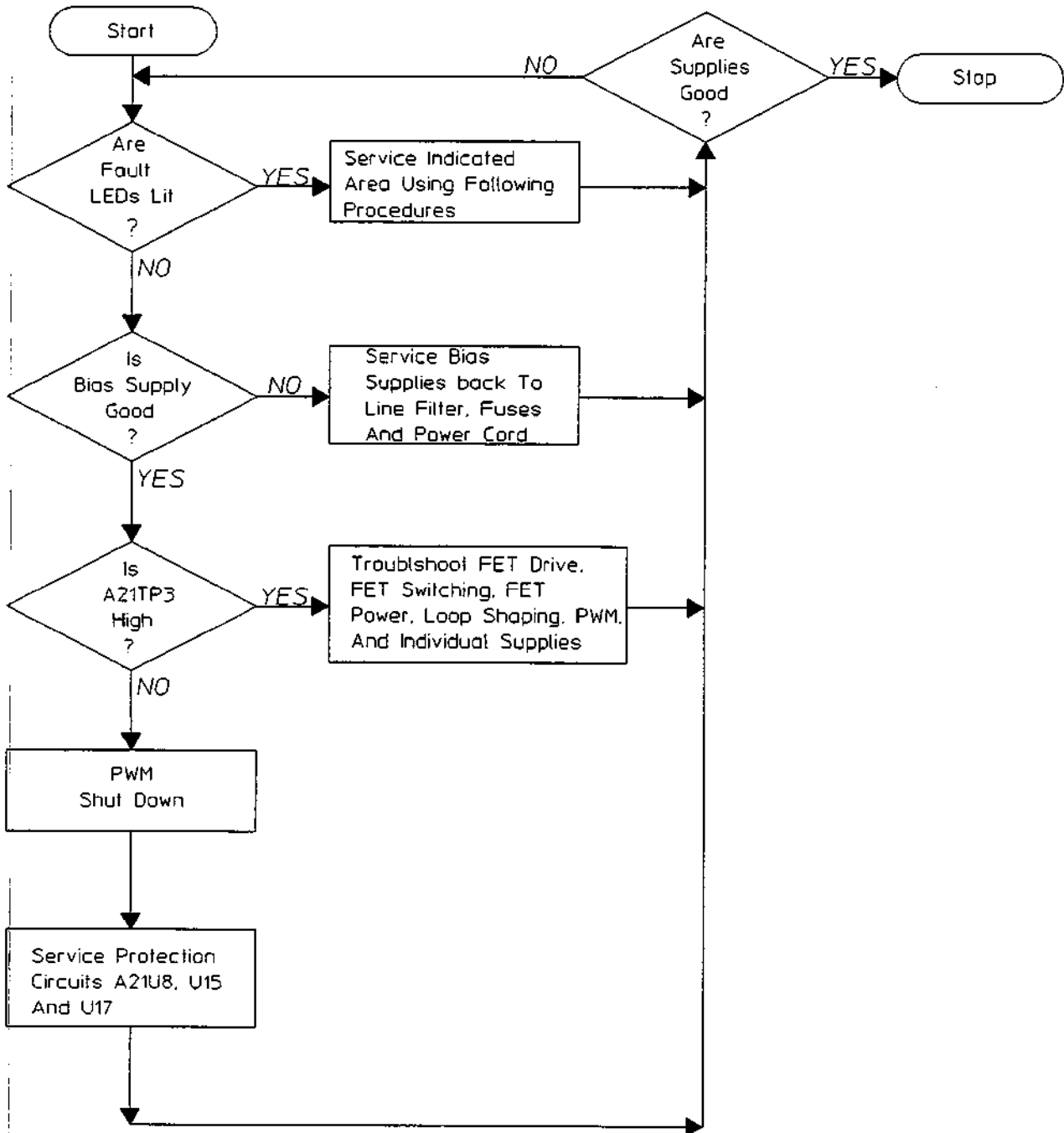
**Initial Conditions**

The following conditions apply to all procedures in this section:

- Turn OFF the instrument's power switch, and remove the power cord before removing the bottom cover.
- The +5 V supply must be loaded by at least the A61 Fast Processor and the A62/63 Main Processor boards. The voltage levels and circuit conditions in these procedures may not be correct if these boards are not inserted.
- The +15V and - 15 V supplies must have no load. Disconnect J1, J2, J3, J4, and J5.
- Unless otherwise noted, all jumpers, test pins, and components referred to in these procedures are located on the A21 Main Power Supply board.

**Troubleshooting Hints**

Symptom: The HP 3577B does not power up when the line switch is turned on.



Symptom: The +5 V supply cannot be adjusted to the correct value.

If the voltage is too high, troubleshoot the listed circuits in the following order:

- FET Drive
- Loop Shaping/Pulsewidth Modulator
- 5 V Control Loop

If the voltage is too low, troubleshoot the listed circuits in the following order:

- FET Drive
- FET Power
- Loop Shaping/Pulsewidth Modulator
- 5 V Control Loop

Symptom: A supply other than the +5 V is bad.

If the +5 V supply is properly loaded and adjusted to +5.10 0.02 V, troubleshoot from the secondary of T1 to the output. Remember that the output of T1 is a 40 kHz square wave (the reason for the large LC filters on the rectifier output).

## Protection Circuits

The A21 Main Power Supply protection mechanisms (except fuses) are as follows:

- Primary protection circuits
  - Turn On/Pop Circuits
  - Primary Current Limit
- Secondary protection circuits
  - +5V Current Limit
  - +15V Current Limit
  - -15 V Current Limit
  - +5 V Overvoltage
  - +15 V Overvoltage
  - -15 V Overvoltage
  - HI Temp

If TP3 is a TTL low, the pulsewidth modulator is shut down. The only protection circuit without a warning LED is the Turn On/Pop circuit. Check this circuit first if TP3 is a TTL low and there are no warning LEDs lit.

---

### Warning



Even with the power removed, there can be sufficient stored energy in some circuits to cause personal injury. These voltages will discharge to a relatively safe level after approximately two minutes, provided the jumpers are installed in the TEST position.

---

To distinguish between a real overvoltage or overcurrent situation and a protection circuit problem, turn OFF the instrument's power switch, and remove the power cord. Place W1 and W2 into the TEST position using insulated pliers. Connect the instrument to the power line and turn the POWER switch ON. If the fault indication persists, the problem is most likely in the protection circuit itself.



## Turn On/Pop Troubleshooting Procedure

- a. Turn OFF the instrument's power switch, and remove the power cord.

---

### Warning



Even with the power removed, there can be sufficient stored energy in some circuits to cause personal injury.

- 
- b. Connect the oscilloscope's channel A to TP25.
  - c. Connect the instrument to the power line, and turn the POWER switch ON.
  - d. The signal on the oscilloscope should stay low for approximately 2.4 seconds and then go high.
  - e. If this test failed, continue this procedure.
  - f. Connect the voltmeter positive terminal to TP24 and negative terminal to chassis ground. The voltage should read  $+27 \pm 3V$ .
  - g. If this test failed, troubleshoot from the diode bridge (CR110) back to the line filter.
  - h. If this test passed, troubleshoot the TURN ON/POP circuits.

## Primary Current Limit Troubleshooting Procedure

- a. Turn OFF the instrument's power switch, and remove the power cord.

---

### Warning



Even with the power removed, there can be sufficient stored energy in some circuits to cause personal injury. These voltages will discharge to a relatively safe level after approximately two minutes, provided the jumpers are installed in the TEST position.

- b. Using insulated needlenose pliers, move jumpers W1 and W2 into the TEST position. Short TP16 to TP15.
- c. Connect the instrument to the power line, and turn the POWER switch ON. The yellow primary current limit LED (CR22) should not be lit.
- d. Turn the POWER switch OFF. Remove the short between TP16 and TP15, and short TP16 to TP14.
- e. Turn the POWER switch ON. The yellow primary current limit LED (CR22) should be lit.
- f. If this test failed, troubleshoot the primary current limit circuit.
- g. If this test passed, continue this procedure.
- h. Turn OFF the instrument's power switch, and remove the power cord.
- i. Move W1 and W2 into the NORMAL position using insulated needlenose pliers. Turn the +15 V, -15 V, and +5 V adjustment pots fully counter clockwise. Verify that J1, J2, J3, J4, and J5 are not connected.
- j. Connect the instrument to the power line, and turn the POWER switch ON. The yellow primary current LED (CR22) should not be lit.
- k. If this test failed, the fault is most likely between T1 and the secondary current limit sense resistors.

---

### Note



Intermittent connections in the +5 V output area (L7, C71, and the +5 V connector) can cause a primary current limit.

- l. If the fault cannot be located with an ohmmeter, begin isolating portions of the secondary by lifting the diodes leading to the secondary outputs. **DO NOT REMOVE CR40. DAMAGE TO THE FETs MAY RESULT.**

**Note**



The primary current limit circuit is much faster than the secondary current limit circuits. Therefore it is possible for a secondary load following the current sense resistor to cause a primary current limit.

- m. If the primary current limit LED is not lit after lifting a diode, troubleshoot the components in the associated area.
- n. If the cause of the primary current limit does not appear to be in the secondary circuitry, first verify that the FET drive waveform is correct and then troubleshoot the primary circuits.

**Note**



Quite often, when one or both FETs are shorted, several other parts are damaged; notably those in the gate circuit. Occasionally, T1 itself has been known to cause a primary current limit. Also, the problem may be related to the primary current limit transformer T2 and diodes CR23 and CR24 which are not tested in steps a through e.

- o. If the above procedure fails to uncover the cause of the primary current limit, perform the +5 V Control Loop Troubleshooting Procedure.

**Note**



If the supply can be brought up slowly without causing a primary current limit, the problem may be associated with the soft start circuit (C59). The +5 V Control Loop Troubleshooting Procedure can be performed with or without a supply load. If the supply is loaded, a faulty soft start circuit may cause a primary current limit because of surge currents. The soft start circuit insures that the pulsewidth modulator starts out with a low duty cycle and then increases gradually (0.5 second) to the proper value.

**+ 5 V Current Limit Troubleshooting Procedure**

- a. Turn OFF the instrument's power switch, and remove the power cord.

**Warning**

Even with the power removed, there can be sufficient stored energy in some circuits to cause personal injury. These voltages will discharge to a relatively safe level after approximately two minutes, provided the jumpers are installed in the TEST position.

- b. Using insulated needlenose pliers, move jumpers W1 and W2 into the TEST position. Short TP33 to TP2 (+5 V REF).
- c. Connect the instrument to the power line, and turn the POWER switch ON. The yellow +5 current limit LED (CR14) should not be lit.
- d. Turn the POWER switch OFF. Remove the short connecting TP33 to TP2, and short TP32 to TP2.
- e. Turn the POWER switch ON. The yellow +5 current limit LED (CR14) should be lit.
- f. If this test failed, troubleshoot the +5 V current limit circuit.
- g. If this test passed, then the fault is most likely in the + 5 V output, +5 V loading, or current sensing circuits.

## + 15 V Current Limit Troubleshooting Procedure

- a. Turn OFF the instrument's power switch, and remove the power cord.

---

### Warning



Even with the power removed, there can be sufficient stored energy in some circuits to cause personal injury. These voltages will discharge to a relatively safe level after approximately two minutes, provided the jumpers are installed in the TEST position.

---

- b. Using insulated needlenose pliers, move jumpers W1 and W2 into the NORMAL position. Verify that J1, J3, J4, and J5 are not connected and that the +5 V supply is properly loaded.
- c. Connect the instrument to the power line, and turn the POWER switch ON. The yellow +15 V current limit LED (CR84) should not be lit.
- d. If this test failed, the fault is most likely the +15 V current limit, +15 V output, or the current sensing circuits.
- e. If this test passed, continue this procedure.
- f. Turn the POWER switch OFF. Short TP35 to TP36.
- g. Turn the POWER switch ON. The yellow +15 V current limit LED (CR84) should not be lit.
- h. Turn the POWER switch OFF. Remove the short connecting TP35 to TP36, and short TP34 to TP36.
- i. Turn the POWER switch ON. The yellow +15 V current limit LED (CR84) should be lit.
- j. If this test failed, troubleshoot the + 15 V current limit circuit.
- k. If this test passed, then the fault is most likely in the +15 V output, +15 V loading, or current sensing circuits.

**- 15 V Current Limit Troubleshooting Procedure**

- a. Turn OFF the instrument's power switch, and remove the power cord.

**Warning**

Even with the power removed, there can be sufficient stored energy in some circuits to cause personal injury. These voltages will discharge to a relatively safe level after approximately two minutes, provided the jumpers are installed in the TEST position.

- b. Using insulated needlenose pliers, move jumpers W1 and W2 into the NORMAL position. Verify that J1, J3, J4, and J5 are not connected and that the +5 V supply is properly loaded.
- c. Connect the instrument to the power line, and turn the POWER switch ON. The yellow - 15 V current limit LED (CR92) should not be lit.
- d. If this test failed, the fault is most likely the - 15 V current limit, - 15 V output, or the current sensing circuits.
- e. If this test passed, continue this procedure.
- f. Turn the POWER switch OFF. Short TP39 to TP37.
- g. Turn the POWER switch ON. The yellow +15 V current limit LED (CR84) should not be lit.
- h. Turn the POWER switch OFF. Remove the short connecting TP39 to TP37, and short TP37 to TP38.
- i. Turn the POWER switch ON. The yellow - 15 V current limit LED (CR92) should be lit.
- j. If this test failed, troubleshoot the - 15 V current limit circuit.
- k. If this test passed, then the fault is most likely in the - 15 V output, - 15 V loading, or current sensing circuit.

### + 5 V Overvoltage Troubleshooting Procedure

- a. Turn OFF the instrument's power switch, and remove the power cord.

---

#### Warning



Even with the power removed, there can be sufficient stored energy in some circuits to cause personal injury.

- 
- b. Using insulated needlenose pliers, move jumpers W1 and W2 into the NORMAL position. Disconnect the +5 V load (J8). Turn the +5 V adjust (R22) fully counter clockwise.
  - c. Connect the voltmeter positive terminal to TP26 and negative terminal to chassis ground.
  - d. Connect the instrument to the power line, and turn the POWER switch ON.
  - e. Adjust R22 slowly until the + 5 V overvoltage circuit trips and the red overvoltage LED (CR100) lights. The overvoltage trip point should be approximately 5.4 V.
  - f. If this test passed, then the fault is most likely in the +5 V output, loop shaping, or pulsewidth modulator circuits.
  - g. If this test failed, continue this procedure.

---

#### Note



A power supply that can drive 5.5 V into 10 $\Omega$  is needed for this procedure. The recommended power supply is an HP 6235A.

- h. Turn OFF the instrument's power switch, and remove the power cord. Move jumpers W1 and W2 into the TEST position using insulated needlenose pliers.
- i. Connect the voltmeter positive terminal to TP26 and negative terminal to chassis ground.
- j. Connect the variable dc power supply positive terminal to TP26 and negative terminal to chassis ground.
- k. Connect the instrument to the power line, and turn the POWER switch ON.
- l. Adjust the dc power supply voltage slowly until the +5 V overvoltage circuit trips and the red overvoltage LED (CR100) lights. The overvoltage trip point is approximately 5.4 V.
- m. If this test failed, troubleshoot the + 5 V overvoltage circuit.
- n. If this test passed, then the fault is most likely in the +5 V output, loop shaping, or pulsewidth modulator circuits.



## + 15 V Overvoltage Troubleshooting Procedure

- a. Turn OFF the instrument's power switch, and remove the power cord.

### Warning



Even with the power removed, there can be sufficient stored energy in some circuits to cause personal injury.

- b. Using insulated needlenose pliers, move jumpers W1 and W2 into the NORMAL position. Disconnect the +5V load (J8). Turn the +5V adjust (R22) fully counter clockwise.
- c. Connect the instrument to the power line, and turn the POWER switch ON.
- d. Adjust R122 (+15V adj) for +15.00 (+0.05, - 0.00) V.
- e. Turn the POWER switch OFF. Short TP6 to TP8.
- f. Turn the POWER switch ON. The red +15V overvoltage LED (CR95) should not be lit.
- g. Turn the POWER switch OFF. Remove the short connecting TP6 to TP8, and short TP7 to TP8.
- h. Turn the POWER switch ON. The red + 15V overvoltage LED (CR95) should be lit.
- i. If this test failed, troubleshoot the +15V overvoltage circuit.
- j. If this test passed, then the fault is most likely in the +15V output, +15V loading, or the voltage sensing circuits.

**- 15 V Overvoltage Troubleshooting Procedure.**

- a. Turn OFF the instrument's power switch, and remove the power cord.

**Warning**

**Even with the power removed, there can be sufficient stored energy in some circuits to cause personal injury.**

- b. Using insulated needlenose pliers, move jumpers W1 and W2 into the NORMAL position. Verify that J1, J3, J4, and J5 are not connected and that the +5V supply is properly loaded. Turn the - 15V adjust (R124) fully counter clockwise.
- c. Connect the instrument to the power line, and turn the POWER switch ON.
- d. Adjust R124 (- 15V adj) for - 15.00 0.05 .
- e. Turn the POWER switch OFF. Short TP4 to chassis ground.
- f. Turn the POWER switch ON. The red - 15V overvoltage LED (CR103) should not be lit.
- g. Turn the POWER switch OFF. Remove the short connecting TP4 to chassis ground, and short TP5 to chassis ground.
- h. Turn the POWER switch ON. The red - 15V overvoltage LED (CR103) should be lit.
- i. If this test failed, troubleshoot the - 15V overvoltage circuit.
- j. If this test passed, then the fault is most likely in the - 15V output, - 15V loading, or voltage sensing circuits.

## High Temp Troubleshooting Procedure

- a. Turn OFF the instrument's power switch, and remove the power cord. After removing the bottom cover, allow about 20 minutes for all components to cool off.

### Warning



Even with the power removed, there can be sufficient stored energy in some circuits to cause personal injury. These voltages will discharge to a relatively safe level after approximately two minutes, provided the jumpers are installed in the TEST position.

- b. Using insulated needlenose pliers, set jumpers W1 and W2 into the TEST position. Apply cool spray to S4 (mounted on CR40).
- c. Connect the instrument to the power line, and turn the POWER switch ON.
- d. The red HI Temp LED (CR106) should not be lit.
- e. If this test failed, troubleshoot the HI Temp circuit. (Check for loose hardware holding the temperature switch to the diodes.)
- f. If this test passed, then the fault is most likely in the +5V current limit or +5V output circuit. The high temp switch monitors CR40's case temperature, which increases with diode current. The high temperature trip point is approximately 105°C.

### Note



A dirty fan screen or improper fan operation may cause a HI Temp condition.

## Bias Supply Troubleshooting Procedure

- a. Connect the instrument to the power line, and turn the POWER switch ON.
- b. Connect the voltmeter negative terminal to chassis ground and positive terminal to TP23. The dc voltage should be  $+15 \pm 1V$ .
- c. Move the voltmeter positive terminal to TP22. The dc voltage should be  $-15 \pm 1V$ .
- d. If this test failed, troubleshoot the bias supplies back to the line filter.

## FET Drive Troubleshooting

- a. Turn OFF the instrument's power switch, and remove the power cord.

---

### Warning



Even with the power removed, there can be sufficient stored energy in some circuits to cause personal injury. These voltages will discharge to a relatively safe level after approximately two minutes, provided the jumpers are installed in the TEST position.

---

- b. Using insulated needlenose pliers, move jumpers W1 and W2 into the TEST position.
- c. Set the oscilloscope to chan1-chan2 mode and the trigger to external. Connect the external trigger to TP1 using a 1:1 probe. Connect channel 1 to TP17 and channel 2 to TP18 with properly compensated 10:1 probes. Connect the probe ground leads to the chassis.
- d. Connect the instrument to the power line, and turn the POWER switch ON.
- e. The waveform should appear as shown in table 9-8 step 1.
- f. If this test failed, then the fault is most likely the loop shaping circuit, pulsewidth modulator circuit, or shorted FETs. Check the voltage at TP29 with a dc voltmeter. It should be at approximately  $+6.0$  to  $+6.6 V$ . If the voltage is near zero, the loop shaping circuit is probably shutting down the pulsewidth modulator (U5).

**Note**



With W1 and W2 in the TEST position, the loop shaping circuit drives the FETs with a maximum duty cycle in an attempt to raise the output from zero to + 5V. This drives TP29 to about +6V. The FETs are not damaged since FET power is removed.

**Warning**



After replacing shorted FETs and BEFORE turning the HP 3577B on with the jumpers in the NORMAL position, perform the FET Switching Troubleshooting Procedure.

**FET Switching Troubleshooting Procedure**

- a. Turn OFF the instrument's power switch, and remove the power cord.

**Caution**



Even with the power removed, there can be sufficient stored energy in some circuits to cause personal injury. These voltages will discharge to a relatively safe level after approximately two minutes, provided the jumpers are installed in the TEST position.

- b. Using insulated needlenose pliers, move jumpers W1 and W2 into the TEST position.
- c. Set an external dc power supply to approximately 20V with the current limited to approximately 200 mA.
- d. Connect the power supply positive terminal to the junction of R9 and W1 and negative terminal to the junction of R10 and W2.
- e. Connect the instrument to the power line, and turn the POWER switch ON.
- f. The current meter on the external power supply should indicate 50 mA.

- g. A current significantly in excess of 50 mA indicates a shorted FET or improper FET drive. To determine if one or both sides of the FET drive circuit is shorted, repeat the remainder of this procedure for both sides of the FET drive (use the locations in parentheses for the other side of the FET drive).
- h. Set the oscilloscope to chan1-chan2 mode. Connect channel 1 to TP18 (TP20) and channel 2 to the junction of W1 and R9 (W2 and R10). A square wave with an approximate 50% duty cycle should be seen.
- i. If this test passed, return to step h and check the other side of the FET drive circuit using the locations in the parenthesis.
- j. If this test failed, continue this procedure to check the gate drive.

**Note**

A leaky/shorted CR7 or leaky/open C2 or C3 can cause the power FETs to be turned on at an improper time, thus causing the FETs to conduct current simultaneously and draw excessive, if not destructive, currents.

- k. Move channel 2 to TP17 (TP19) and leave channel 1 connected to TP18 (TP20). The oscilloscope should display a square wave with an approximate 50% duty cycle.
- l. If this test passed, the fault is probably a shorted FET.
- m. If this test failed, continue this procedure to determine if the input to the FET drive from the pulsewidth modulator is working properly.
- n. Set the oscilloscope to chan1-chan2 mode. Connect channel 1 to U3 pin 3 and channel 2 to U3 pin 12. The oscilloscope should display negative pulses 180 degrees out of phase.
- o. If this test passed, troubleshoot the FET drive.
- p. If this test failed, troubleshoot the pulsewidth modulator circuit.

## FET Power Troubleshooting Procedure

- a. Turn OFF the instrument's power switch, and remove the power cord.

---

### Caution



Perform the FET Switching Troubleshooting Procedure before doing this procedure.

---

### Warning



Even with the power removed, there can be sufficient stored energy in some circuits to cause personal injury.

- 
- b. Using insulated needlenose pliers, move jumpers W1 and W2 into the NORMAL position.
  - c. Connect the instrument to the power line, and turn the POWER switch ON.
  - d. Connect the voltmeter negative terminal to TP21 and positive terminal to the positive side of C2(+). The dc voltmeter should read  $+150 \pm \pm 15V$ .
  - e. Move the voltmeter positive terminal to the negative side of C3(-). The dc voltmeter should read  $-150 \pm \pm 15 V$ .
  - f. If this test failed, troubleshoot the FET power circuit back to the line filter.
  - g. If this test passed, continue this procedure.
  - h. Set the oscilloscope to chan1-chan2 mode. Connect channel 1 to the positive side of C10 and channel 2 to TP21 using properly compensated 10:1 probes. Connect the probe ground leads to chassis ground. The waveform should appear as shown in table 9-8 step 2.
  - i. If this test failed, the fault is most likely in the FET drive (including the FETs), pulsewidth modulator, +5 V output, or loop shaping circuits.

**+ 5 V Control Loop Troubleshooting Procedure**

- a. Turn OFF the instrument's power switch, and remove the power cord.

**Note**

Use this procedure if FET drive output is good with W1 and W2 in the test position, but the +5 V output cannot be adjusted to  $+5.10 \pm 0.02$  V.

**Caution**

When manually controlling the FET drive pulse width, it is very easy to damage (by overdriving) the power MOSFETs. This is especially true if any of the protection circuits have been disabled for troubleshooting purposes. Perform the +5 V Overvoltage Troubleshooting Procedure before continuing.

**Warning**

Even with the power removed, there can be sufficient stored energy in some circuits to cause personal injury.

- b. Using insulated needlenose pliers, place W1 and W2 into the NORMAL position.
- c. Set a positive referenced variable dc supply to 0 V output. Connect the positive terminal to TP28 and negative terminal to chassis ground. Turn the supply on.
- d. Place a short across R32.
- e. Connect the oscilloscope's channel 1 to the lead of C23 that is physically closest (and electrically connected) to L1 using a properly compensated 10:1 probe.
- f. Connect the dc voltmeter positive terminal to TP29 and negative terminal to chassis ground.



**Caution**



DO NOT apply power to the HP 3577B unless the external supply is connected, turned on, and set to zero volts output, otherwise damage to the circuit may occur.

- g. Connect the instrument to the power line, and turn the POWER switch ON. Nothing should happen on the secondary side of T1 because the pulsewidth modulator is shut down. The DC voltmeter should read approximately 0 V.
- h. SLOWLY increase the output of the variable dc supply watching the voltmeter and oscilloscope. As the voltage at (TP29) reaches about 0.8V narrow pulses should appear on the oscilloscope (C23). See table 9-20 Step 4.
- i. Move the voltmeter positive terminal to TP26 (+ 5 V Output).
- j. Continue increasing the output of the variable dc supply, watching the pulse width and the +5 V output (TP26) increase. When the +5 V output (TP26) is approximately +3.1V, the pulses on the oscilloscope (C23) should look like the waveform in table 9-8 Step 5.
- k. If this test failed, troubleshoot back to the pulsewidth modulator or loop shaping circuits.
- l. Reduce the dc supply to 0 volts output. Turn OFF the instrument's power switch, remove the power cord, and return the HP 3577B to its original state.

**+ 15 V Overvoltage Troubleshooting Procedure**

- a. Turn off the instrument's power switch and remove the power cord.
- 

**Warning**

Even with the power removed, there can be sufficient stored energy in some circuits to cause personal injury.

---

- b. Using insulated needlenose pliers, move jumpers W1 and W2 into the **NORMAL** position. Disconnect J1, J3, J4, and J5. Verify that J8 is connected and the +5 V supply is properly loaded.
- c. Connect the positive probe of the voltmeter to A1 TP8 and the negative probe to chassis.
- d. Turn R122 (+15 V adj) fully counterclockwise.
- e. Connect the instrument to the power line and turn the power switch on. The red +15 V overvoltage LED (CR95) should not be lit.
- f. Slowly turn R122 clockwise while observing the voltmeter. The overvoltage circuit should trip at approximately 16.5 V. The red +15V overvoltage LED (CR95) should be on after the circuit trips.
- g. If this test fails, troubleshoot the +15V overvoltage circuit.
- h. If this test passes, the fault is most likely in the +15V output, +15V loading, or the voltage sensing circuits.
- i. Before continuing with the troubleshooting, adjust R122 to give 15 (+0.05, - 0.00) V at TP8. See the Adjustments section for a detailed procedure.

## -15 V Overvoltage Troubleshooting Procedure

- a. Turn off the instrument's power switch and remove the power cord.

### Warning



Even with the power removed, there can be sufficient stored energy in some circuits to cause personal injury.

- b. Using insulated needlenose pliers, move jumpers W1 and W2 into the NORMAL position. Disconnect J1, J3, J4, and J5. Verify that J8 is connected and the +5V supply is properly loaded.
- c. Connect the positive probe of the voltmeter to A1 TP9 and the negative probe to chassis.
- d. Turn R122 (-15V adj) fully counterclockwise.
- e. Connect the instrument to the power line and turn the power switch on. The red -15 V overvoltage LED (CR103) should not be lit.
- f. Slowly turn R122 clockwise while observing the voltmeter. The overvoltage circuit should trip at approximately -16.5V. The red -15V overvoltage LED (CR103) should be on after the circuit trips.
- g. If this test fails, troubleshoot the -15V overvoltage circuit.
- h. If this test passes, the fault is most likely in the -15V output, -15V loading, or the voltage sensing circuits.
- i. Before continuing with the troubleshooting, adjust R122 to give -15 (+0.05, - 0.00) V at TP9. See the Adjustments section for a detailed procedure.

**Loop Shaping/Pulse Width Modulator Troubleshooting Procedure**

- a. Turn OFF the instrument's power switch, and remove the power cord.

**Warning**

Even with the power removed, there can be sufficient stored energy in some circuits to cause personal injury. These voltages will discharge to a relatively safe level after approximately two minutes, provided the jumpers are installed in the TEST position.

- b. Using insulated needlenose pliers, move jumpers W1 and W2 into the TEST position.
- c. Set an external variable DC power supply to 0 V output. Connect the negative terminal to chassis ground and positive terminal to TP28. Adjust the supply output to between 1 and 2V.
- d. Short TP27 to chassis ground.
- e. Connect the voltmeter positive terminal to TP29 and negative terminal to chassis ground.
- f. Connect the oscilloscope's channel A to the cathode of CR30 and channel B to the cathode of CR31 using properly compensated 10:1 probes. Connect the external trigger to TP1 using a 1:1 probe. Connect the probe ground leads to chassis ground.
- g. Connect power to the HP 3577B and turn it on.
- h. Setup oscilloscope and verify that the waveform is as shown in table 9-8 Step 3. The two waveforms should be exactly 180 degrees out of phase. This insures that only one of the power MOSFETs is ON at a time.
- i. Slowly decrease the output of the variable supply. When the voltage measured at TP29 reaches about 3V, the pulse width should start to narrow. When the voltage measured at TP29 reaches about 0.3V or close to 0V, the pulsewidth modulator should completely shut down. The external supply should have complete control over the duty cycle up to a maximum of near 50%.
- j. If this test passed, return to Troubleshooting Hints section.
- k. If this test failed, continue this procedure.
- l. Monitor TP29 with the voltmeter. It should vary from 0 to the +15V supply rail as the voltage on TP28 varies from 0 to 2V.
- m. Check TP29 with a oscilloscope for a clean waveform and a smooth response to the variable DC supply on TP28.

- n. If this test failed, troubleshoot the loop shaping circuit.
- o. If this test passed and the pulsewidth modulator is still shut down, continue this procedure.
- p. Drive TP29 to about 6V by adjusting the variable dc supply. This produces a 50% duty cycle in the pulsewidth modulator. Check for 6V on U5 pin 1.
- q. Measure the voltage at U5 pin 5. A logic low here represents a pulsewidth modulator shutdown. Troubleshoot the protection circuits. If the logic level at U5 pin 5 is high, verify the + 5V Ref (TP2) and +15V Bias (U5 pin 17).

---

**Note**



While troubleshooting the pulsewidth modulator, remember that Q35 and Q36 are capable of shutting down the pulsewidth modulator output if either one is turned on or shorted. R86 and C56 externally set the pulsewidth modulator frequency to  $40 \pm 4$  kHz.

---

**+ 15 V and - 15 V Output Regulator Troubleshooting Procedure**

- a. Turn OFF the instrument's power switch, and remove the power cord.

**Warning**

Even with the power removed, there can be sufficient stored energy in some circuits to cause personal injury.

- b. Using insulated needlenose pliers, move jumpers W1 and W2 into the NORMAL position. Verify that J1, J3, J4, and J5 are disconnected and that the + 5V supply is properly loaded.
- c. Connect the instrument to the power line, and turn the POWER switch ON.
- d. Connect the voltmeter positive terminal to TP26 and negative terminal to chassis ground. The dc voltmeter reading should be  $+5.10 \pm 0.02$  V.
- e. If this test failed, return to the Troubleshooting Hints section.
- f. If this test passed and a 15V supply cannot be adjusted to the correct value, troubleshoot the 15V regulator circuits. Trace the proper voltages back through the circuit to the main power transformer T1.

**Note**

The three pin voltage regulators usually require a 3V to 5V potential difference between the input and output for proper regulation.

**Final Power Supply Adjustments**

- g. Perform the adjustment in section 4-5, Power Supply Adjustments.

Table 9-10. A21 Circuit Board,, Troubleshooting Data

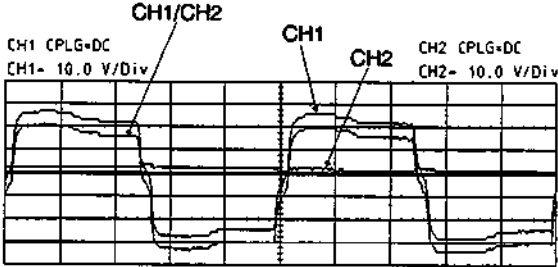
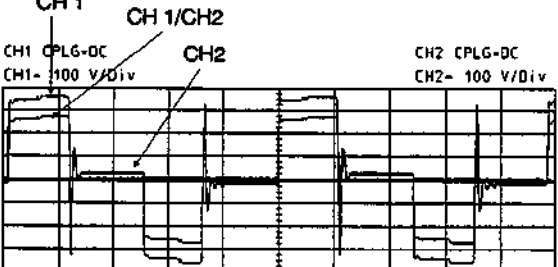
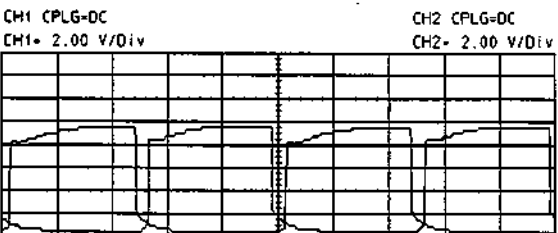
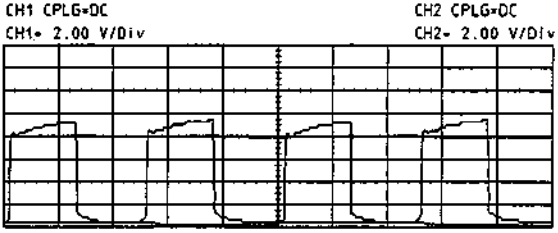
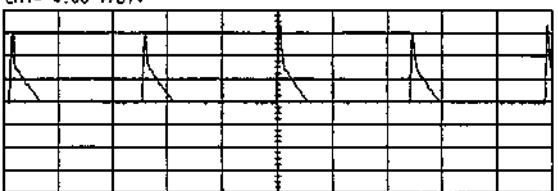

HP 3577B Set up	Measurement Set up	Waveform with Parameters
<p>Connect CH A to A21TP17 Connect CH B to A21TP18 Externally trigger on A21TP1 Set A21 W1 and W2 to TEST  Chan 1&amp;2 Probe10:1</p>	<p>Oscilloscope Mode 1-2 CH 1 V/Div 10 V CH 2 V/Div 10 V CH1-CH2 V/Div 20 V Time/Div 5us Trigger EXT, 2V CH 1 Coupling DC CH 2 Coupling DC</p>	<p>Pulse shape and duty cycle.</p>  <p>CH1 CPLG=DC CH1= 10.0 V/Div CH2 CPLG=DC CH2= 10.0 V/Div</p> <p>MT-EXT/1 DC CPLG A21TP1 Main= 5.00 us/Div</p> <p>#1</p>
<p>Connect CH A to A21C10 Connect CH B to A21TP21 Set A21 W1 and W2 to NORMAL  Chan 1&amp;2 Probe 10:1</p>	<p>Oscilloscope Mode 1-2 CH 1 V/Div 100 V CH 2 V/Div 100 V CH1-CH2 v/div 150V Time/Div 5 us Trigger INT CH1 Coupling DC CH2 Coupling DC</p>	<p>Pulse A-B V/Div shape and duty cycle</p>  <p>CH 1 CH 1/CH2 CH2 CH1 CPLG=DC CH1= 100 V/Div CH2 CPLG=DC CH2= 100 V/Div</p> <p>MT-EXT/1 DC CPLG A21TP1 Main= 5.00 us/Div</p> <p>#2</p>
<p>Connect CH A to A21CR30 Connect CH B to A21CR31 Externally trigger on A21TP1 Jumper TP27 to GND Set A21W1 and W2 to TEST Drive TP28 with external power supply to 1 V  Chan 1&amp;2 Probe 10:1</p>	<p>Oscilloscope CH 1V/Div 2V CH 2 V/Div 2 V Time/Div 5 us Trigger EXT, 2V CH1 Coupling DC CH 2 Coupling DC</p>	<p>Pulse shape, only one signal on at a time (no overlap)</p>  <p>CH1 CPLG=DC CH1= 2.00 V/Div CH2 CPLG=DC CH2= 2.00 V/Div</p> <p>MT-EXT/1 DC CPLG A21TP1 Main= 5.00 us/Div</p> <p>#3</p>

Table 9-10. A21 Circuit Board,, Troubleshooting Data Continued

HP 3577B Set up	Measurement Set up	Waveform with Parameters
<p>Connect CH A to A21CR30 Connect CH B to A21CR31 Externally trigger on A21TP1 Jumper TP27 to GND Set A21W1 and W2 to TEST Drive TP28 with external power supply to 0.5 V</p> <p>Chan 1&amp;2 Probe 10:1</p>	<p>Oscilloscope CH 1 V/Div 2 V CH2 V/Div 2 V Time/Div 5 us Trigger EXT, 2V CH 1 Coupling DC CH 2 Coupling DC</p>	<p>Pulse shape Only one signal on at a time (no overlap)</p>  <p>CH1 CPLG=DC CH1= 2.00 V/Div CH2 CPLG=DC CH2= 2.00 V/Div</p> <p>MT-EXT/1 DC CPLG A21TP1 Main= 5.00 us/Div</p> <p>#3 (cont)</p>
<p>Connect CH A to A21C23 Set A21 W1 and W2 to NORMAL Drive TP28 with external power supply to 0.8 V on TP29 Place a short across A21 R32</p> <p>Probe 10:1</p>	<p>Oscilloscope CH 1 V/Div 4 V Time/Div 5 us Trigger INT CH 1 Coupling DC</p>	<p>Peak-to-peak voltage</p>  <p>CH1 CPLG=DC CH1= 4.00 V/Div</p> <p>MT-Ch 1 Main= 5.00 us/Div</p> <p>#4</p>
<p>Connect CH A to A21C23 Set A21 W1 and W2 to NORMAL Drive TP28 with external power supply to 3.1 V on TP26 Place a short across A21R32</p> <p>Probe 10:1</p>	<p>Oscilloscope CH 1 V/Div 4 V Time/Div 5 us Trigger INT CH 1 Coupling DC</p>	<p>Peak-to-peak voltage, pulse shape, duty cycle, DC level</p>  <p>CH1 CPLG=DC CH1= 4.00 V/Div</p> <p>MT-Ch 1 Main= 5.00 us/Div</p>



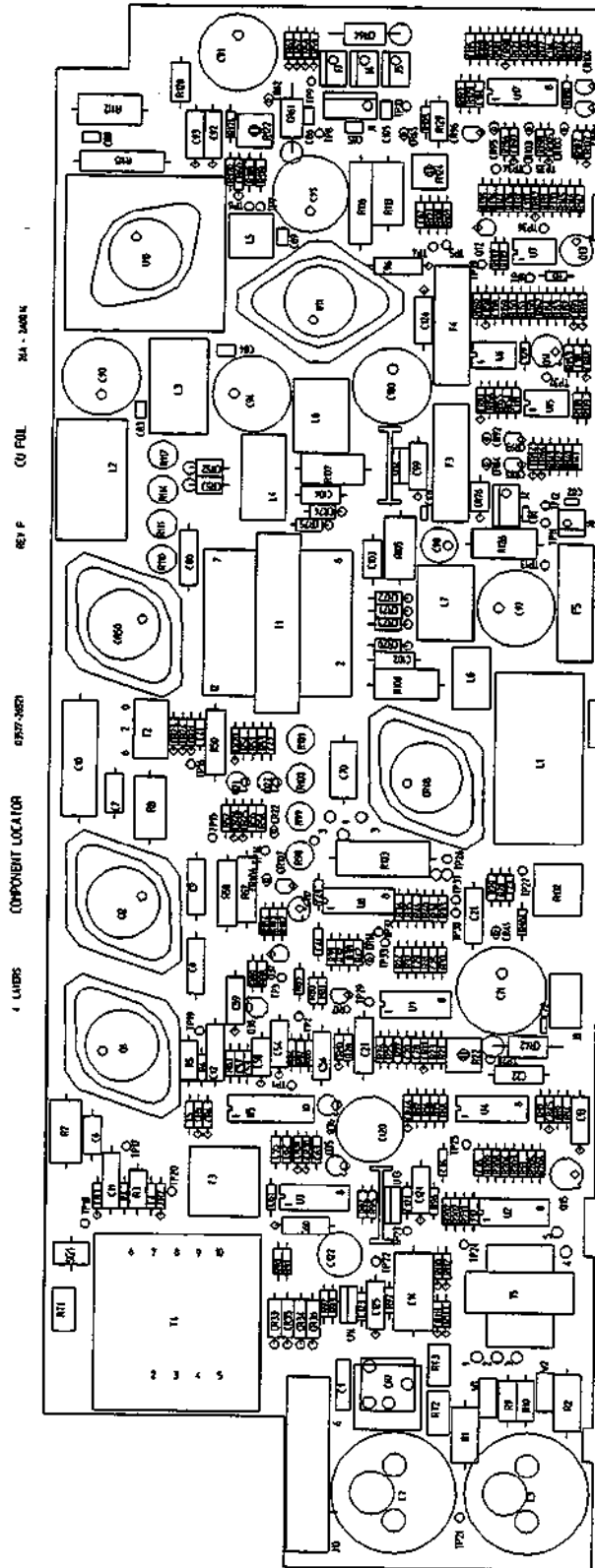
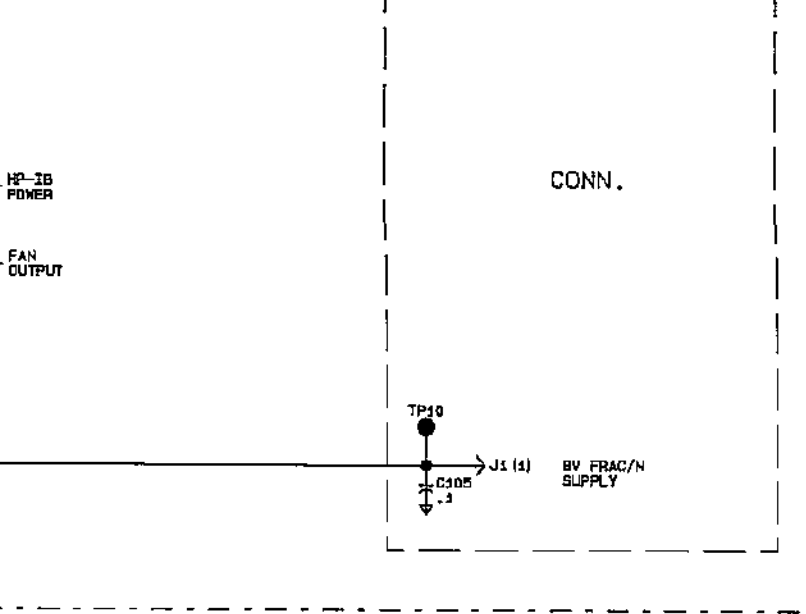
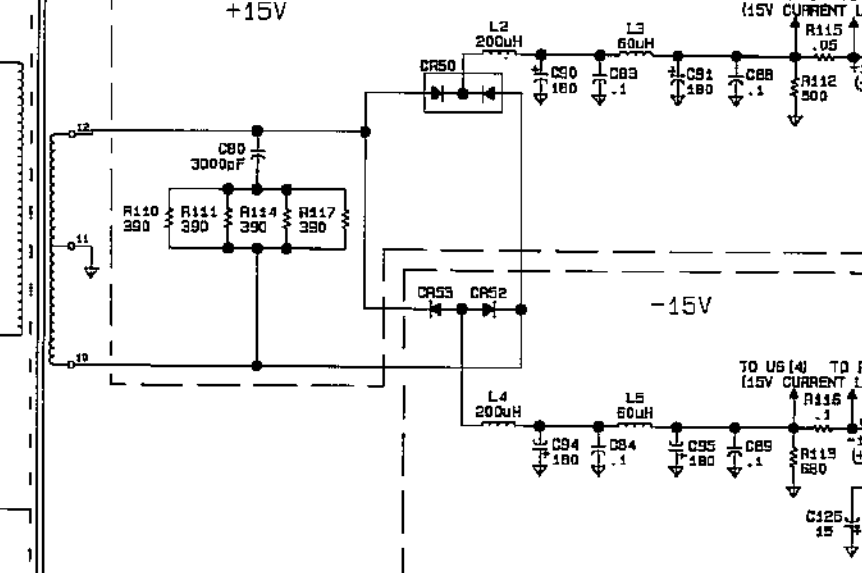
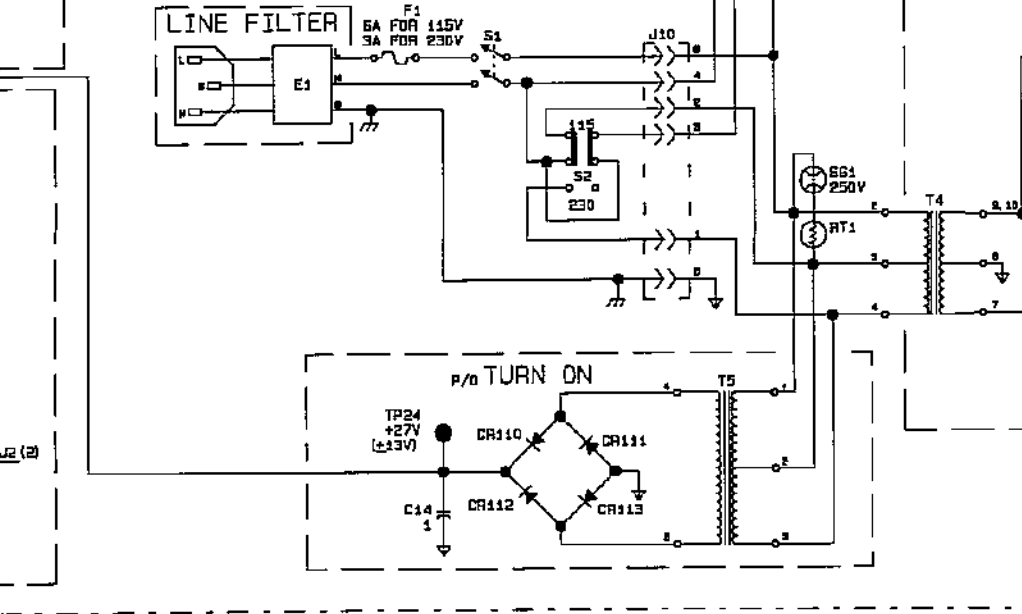
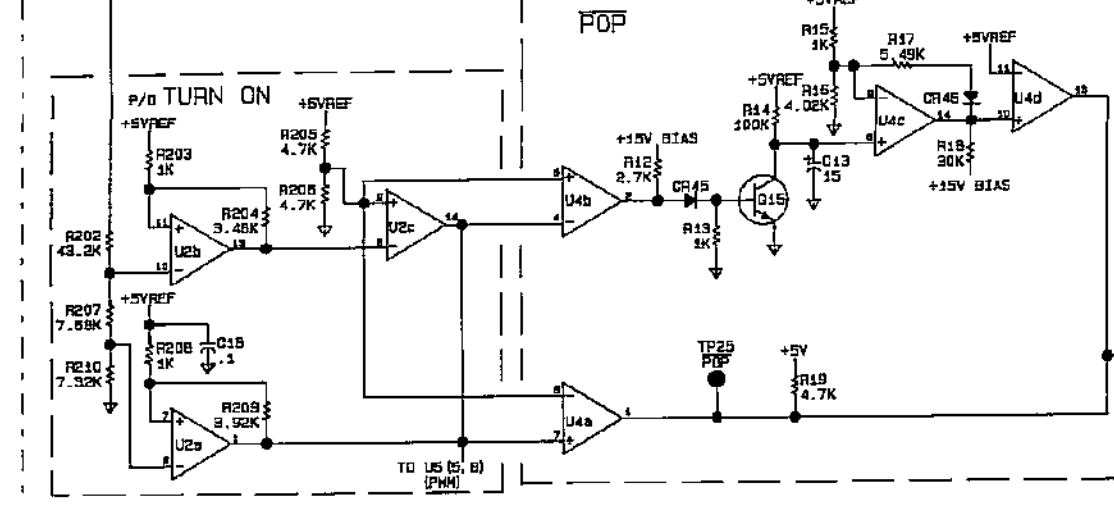
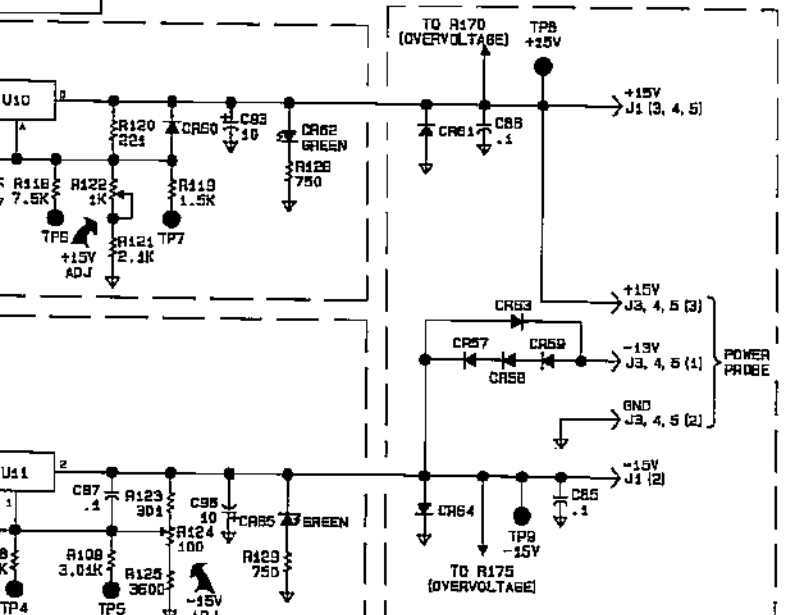
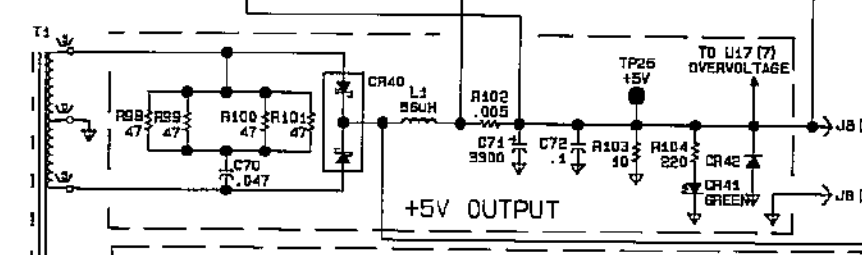
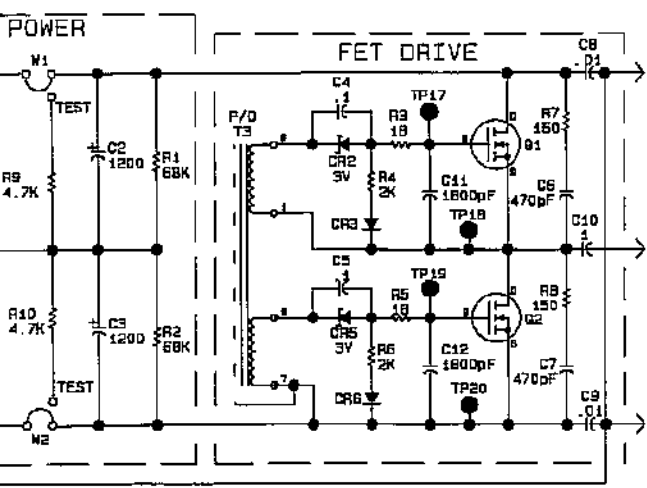
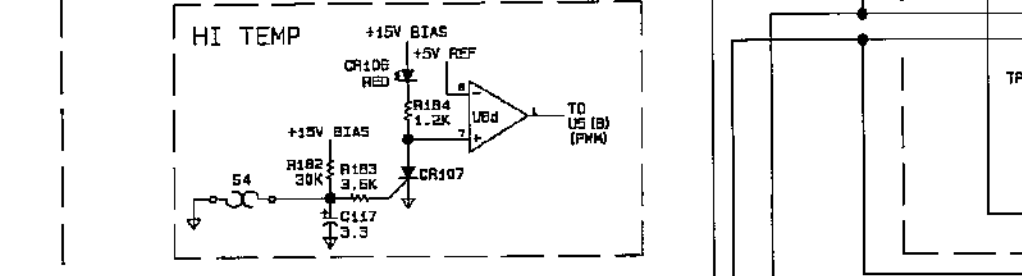
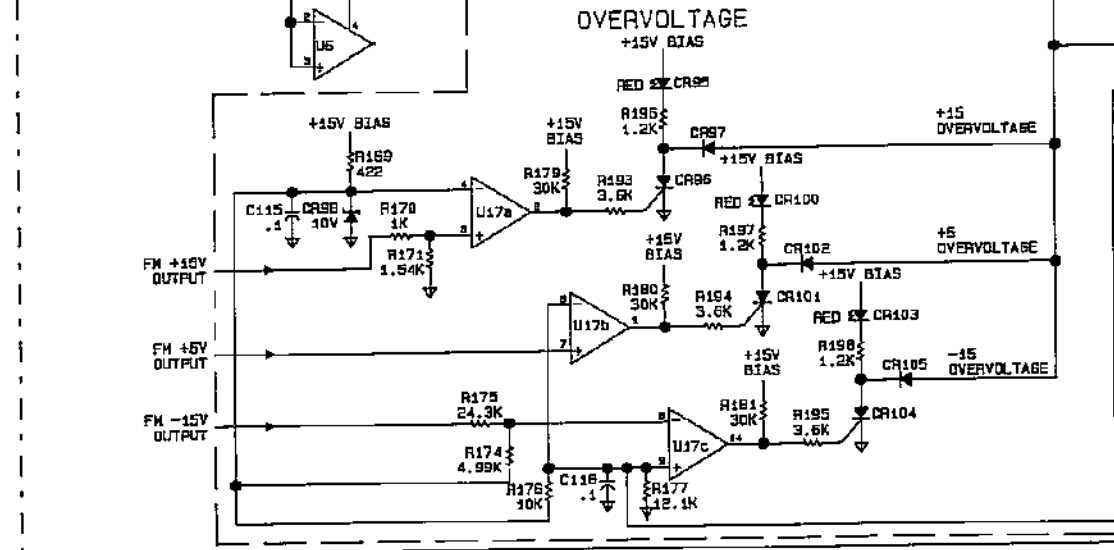
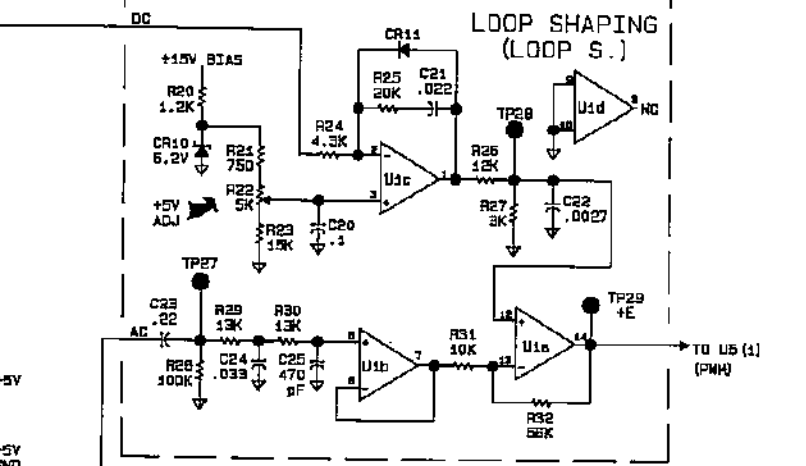
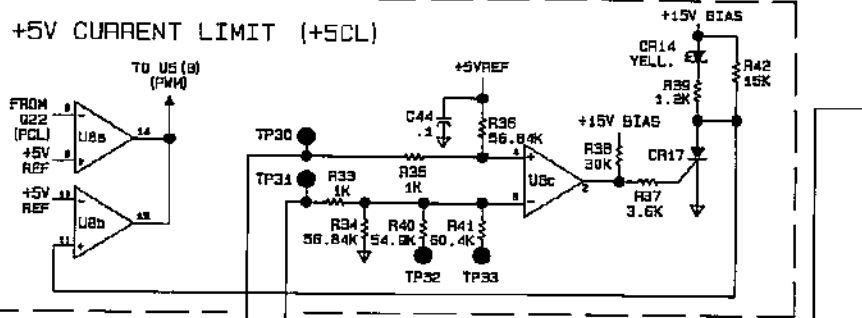
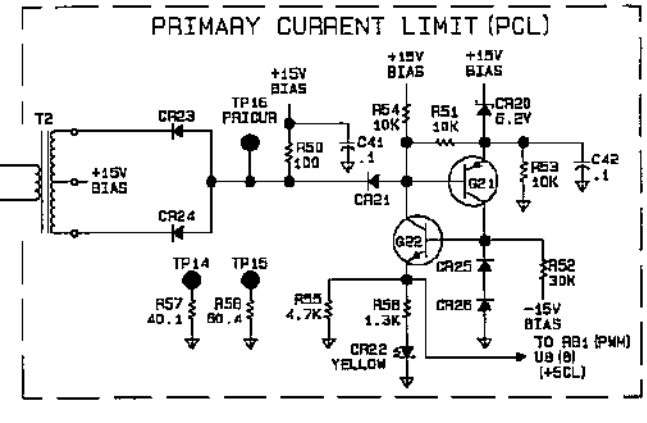
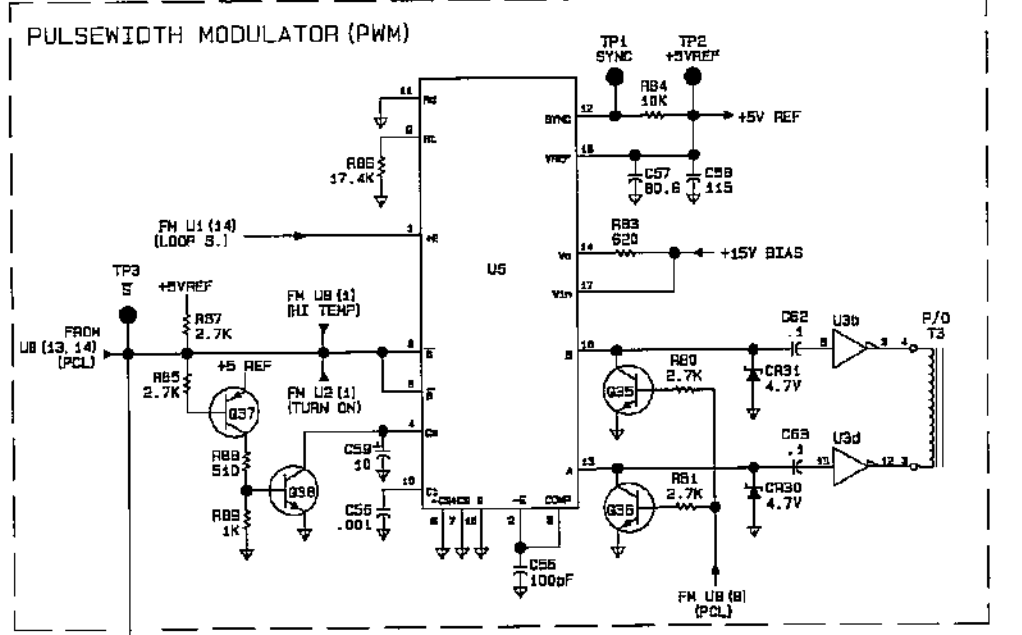
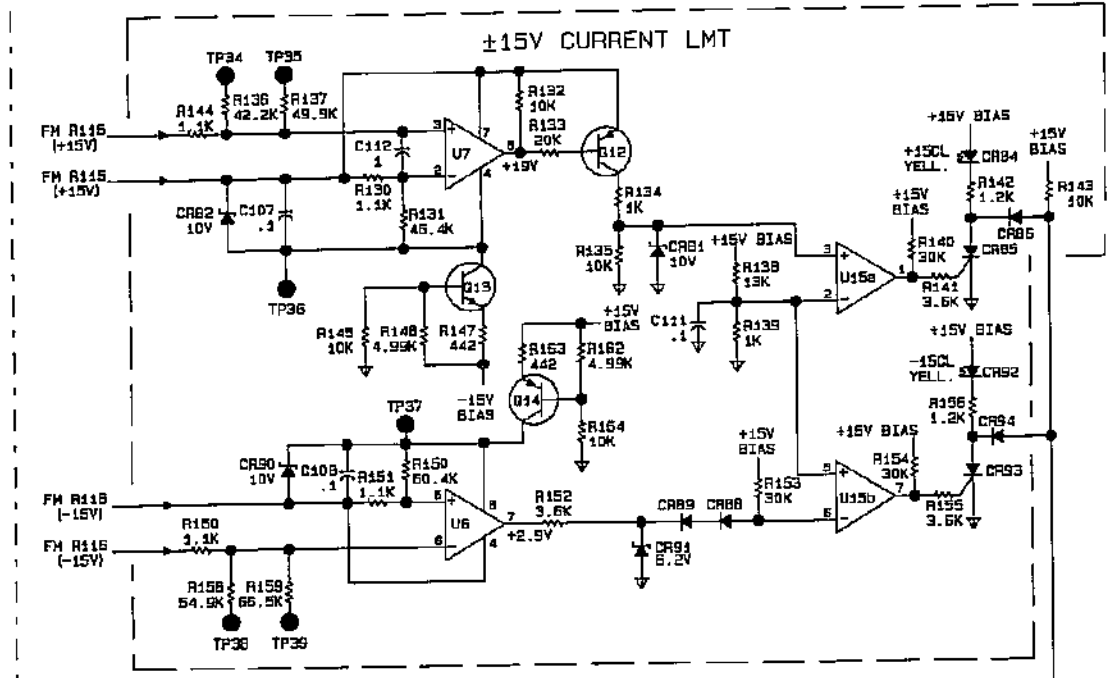


Figure 9-21. A21 Component Locator

IC	Bias Voltage	GND	Bypass Cap	
	Pin #		Desig.	Value
U1	+15V,4		C28	0.1
U1	-15V,11		C29	0.1
U2	+15V,3	12	C17	0.1
U3	+15V,14	7	C60	6.8
			C51	0.1
U4	+15V,3	12	C16	0.1
U5	+15V,17	15	C53	0.1
			C54	6.8
U8	+15V,3	12	C43	0.1
U10		1		
U11		1		
U13		3		
U14		1		
U15	+15V,8	4	C110	0.1
U17	+15V,3	12	C114	0.1







## 9-17 Service Group A31, Oven Assembly (Option 001 only)

The information in this section should be used to isolate faulty functional sub-blocks when servicing the HP 3577B. The Oven Assembly (A31) is present on the HP 3577B Option 001 only. It is not present on a standard instrument. All procedures assume the Fault Isolation procedures of Section II have been used to determine which functional block has failed, and the Circuit Descriptions of Section VIII are understood.

### Warning



Service procedures described in this section are performed with the protective covers removed and power applied. Energy available at many points can, if contacted, result in personal injury.

### Caution



Do not insert or remove any circuit board in the HP 3577B with the line power turned on. Power transients caused by insertion or removal may damage the circuit boards.

### Initial Conditions

Unless otherwise stated in the troubleshooting sections of the signal table, set the HP 3577B as described below, after power on:

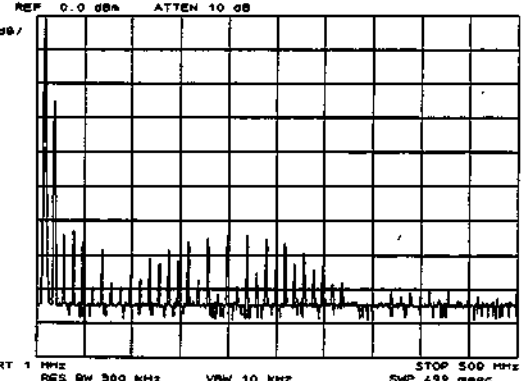
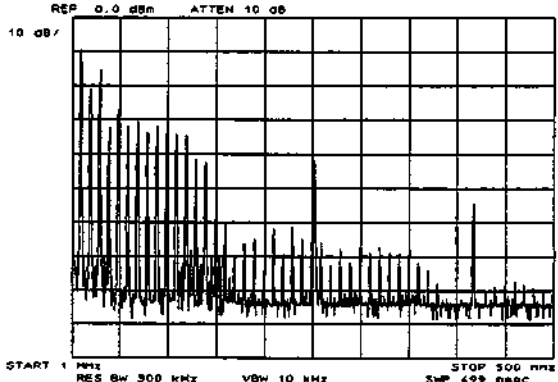
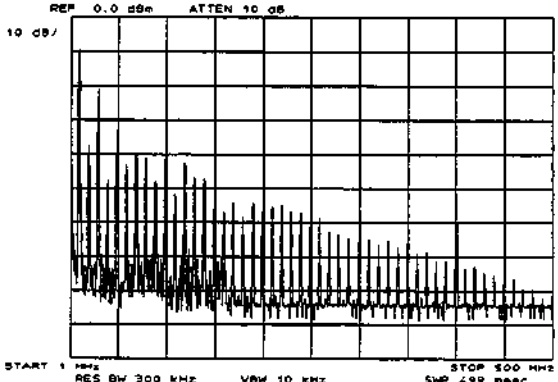
- Press INSTR PRESET
- Disconnect the EXT REF if connected

All Oscilloscope waveforms are taken using a 1:1 probe and a HP 1980B Oscilloscope. All Spectrum Analyzer waveforms connected to an SMB connector are taken through the 03577-84401 Service Kit BNC to SMB cable. All Spectrum Analyzer waveforms taken off component leads are taken through a 1:1 probe with 215Ω of series resistance.

### Troubleshooting Hints

1. Jumper A31 U2 pin 7 to ground. A31Q3 and A31Q4 should turn on and the oven signal should be on at A31J1 at approximately -1 dBm. If the signal is not present, suspect both A31Q3 and A31Q4 as being faulty.
2. Connect a jumper across A31 R17 shorting it. A31 Q3 and A31 Q4 should turn off and the oven signal should be < -100 dBm at A31 J1. If the signal is higher, suspect both A31Q3 and A31Q4 as being leaky.

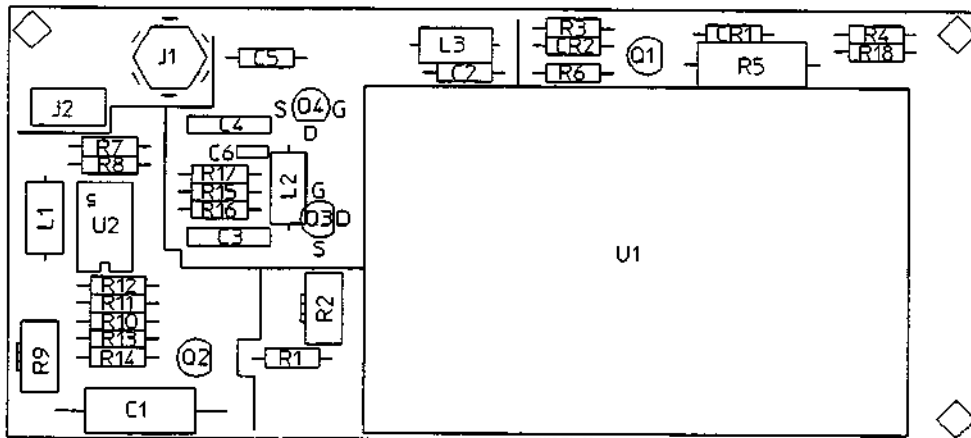
Table 9-11. A31 Circuit Board, Troubleshooting Data

HP 3577B Set up	Measurement Set up	Waveform with Parameters
Test at A31J1 Press INSTR PRESET	Spectrum Analyzer Start 10 MHz Stop 500 MHz Res BW 300 kHz VBW 10 kHz Ref Level 0 dBm dB/Div 10 dB	<p style="text-align: center;">10 MHz Amplitude, Harmonics.</p>  <p style="text-align: center;">#1</p>
Test at A31 U1 pin 4 Press INSTR PRESET	Spectrum Analyzer Start 10 MHz Stop 500 MHz Res BW 300 kHz VBW 10 kHz Ref Level 0 dBm dB/Div 10 dB	<p style="text-align: center;">10 MHz Amplitude, Harmonics.</p>  <p style="text-align: center;">#2</p>
Test at A31Q1 emitter Press INSTR PRESET	Spectrum Analyzer Start 10 MHz Stop 500 MHz Res BW 300 kHz VBW 10 kHz Ref Level 0 dBm dB/Div 10 dB	<p style="text-align: center;">10 MHz Amplitude, Harmonics.</p>  <p style="text-align: center;">#3</p>

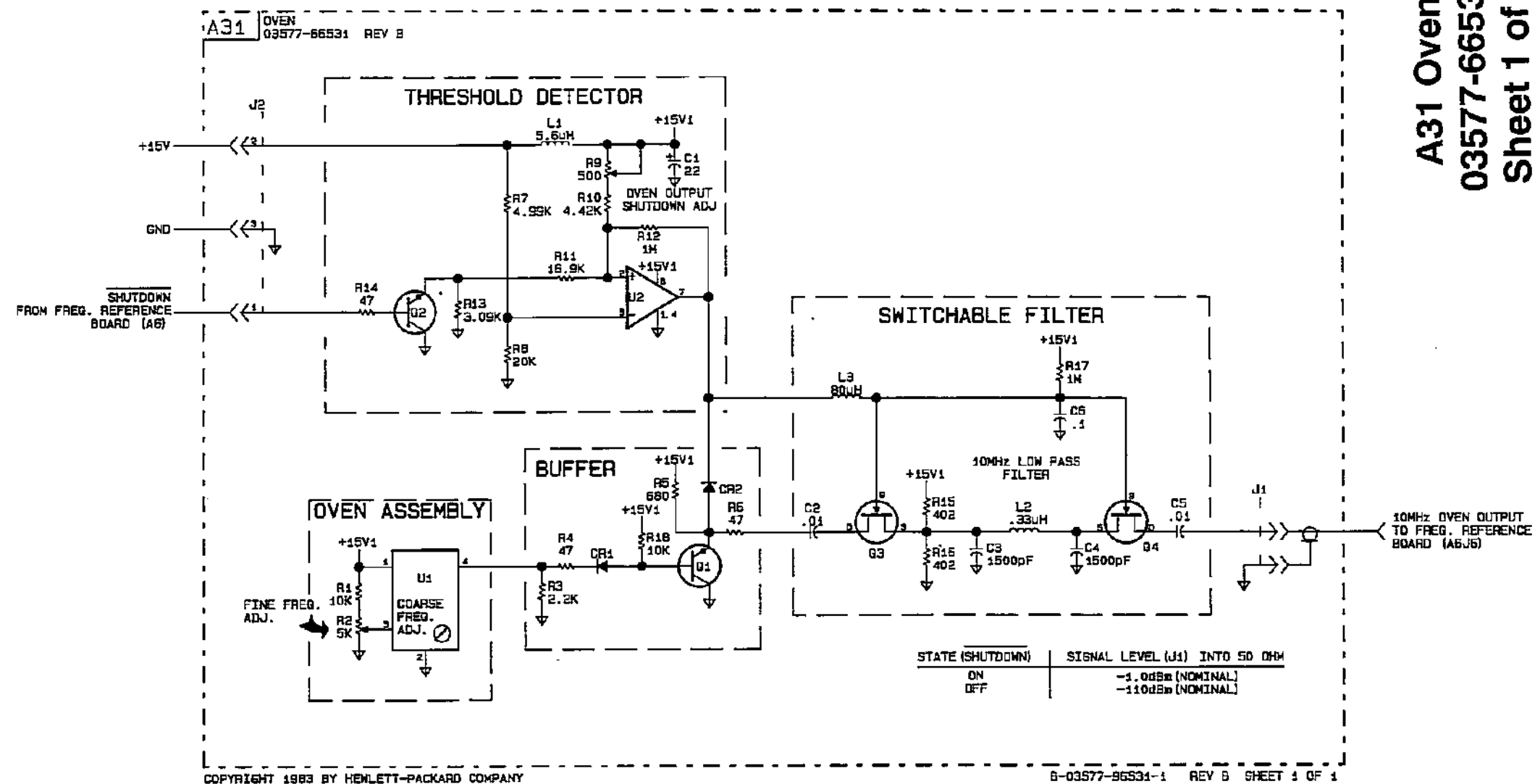


**Table 9-11. A31 Circuit Board, Troubleshooting Data Continued**

HP 3577B Set up	Measurement Set up	Waveform with Parameters
Test at A31 U2 pin 7	Oscilloscope Volts/Div 1 V Time/Div any Autotrigger	TTL State should TTL toggle when EXTREF is connected and disconnected



**Figure 9-22. A31 Component Locator**



A51/A61  
Fast Processor

---

## 9-18 Service Group A61, Fast Processor Assembly

The information in this section should be used to isolate faulty functional sub-blocks when servicing the HP 3577B. All procedures assume the Fault Isolation procedures of Section II have been used to determine which functional block has failed, and the Circuit Descriptions of Section VIII are understood.

---

### Warning



Service procedures described in this section are performed with the protective covers removed and power applied. Energy available at many points can, if contacted, result in personal injury.

---

### Caution



Do not insert or remove any circuit board in the HP 3577B with the line power turned on. Power transients caused by insertion or removal may damage the circuit boards.

---

### Initial Conditions

Unless otherwise stated in the troubleshooting sections of the signal table, set the HP 3577B as described below, after power on:

INSTR PRESET

All Oscilloscope waveforms are taken using a 10:1 probe and a HP 1980B Oscilloscope.  
All signatures are taken using a HP 5006A Signature Analyzer.

---

### Note



When running all signature analysis routines, keep the signature analyzer and the HP 3577B physically far from each other to prevent digital signal coupling.

---

## Troubleshooting Hints

### a. Self Tests and Diagnostics

Use the power on self tests and the service diagnostics described in Section II to isolate all problems. First verify that the problem encountered is on the A61 Fast Processor circuit board and not the A62/63 Main Processor-Controller board by running the power on self tests. Note which tests fail and troubleshoot the indicated circuit using the SA1 routine described below. The service diagnostics will test the Fast Processor and Main Processor-Controller communication, and will make the Fast Processor run a self test. Again, note the indicated circuit and test it using the SA1 routine.

All signatures for the A61 Fast Processor assembly are taken with the Main Processor-Controller (A62/63) board removed and all Receiver (A71) boards disconnected from the fast bus by placing A71W5 and A71W6 into the Tri-State position. These jumpers are available from the top of the instrument without removing the Receiver boards.

### b. SA1 Signature Analysis Routine

The SA1 signature Analysis routine is the general purpose signature analysis routine. Use SA1 to isolate the fault as narrowly as possible. After the HP 3577B is placed into SA1 mode (set W1 to the SA1 position) and power is applied, the fast processor must be reset by momentarily shorting INIT (A61TP6) to ground.

SA1 consists of ten different subtests. Due to the Fast Processor clock frequencies involved, different test configurations are required for stable, repeatable signatures. The test configuration for the first subtest is described below. At the beginning of each test, first set the signature analyzer as described below, then make any changes indicated by the subtest.

#### Signature Analysis SA1 Routine Test Set Up

Clock	A61J3 pin3
Qualify	No Connection
Start	A61J3 pin5
Stop	A61J3 pin4

#### Signature Analyzer Set Up

Clock	Rising pulse(1)
Qualify	N/A
Start	Rising pulse(1)
Stop	Rising pulse(1)

Reset the Fast Processor by momentarily shorting A61TP6 (INIT) to ground. Verify a good reset by watching for a toggle on the Signature Analyzer gate LED.

+5 V signature = 7A70

GND signature = 0000

**c. SA2 Signature Analysis Routine**

The SA2 Signature Analysis routine is to be used only after SA1 has been used to narrow down faults to the components covered in SA2. Move W1 to the SA2 position and set the Signature Analyzer as described below.

**Signature Analysis SA2 Routine Test Set Up**

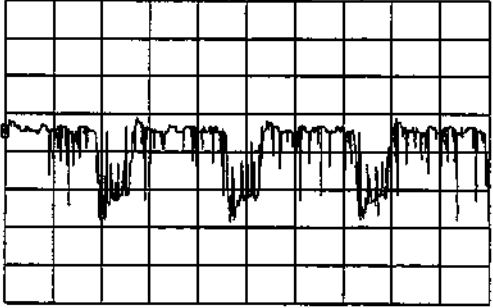
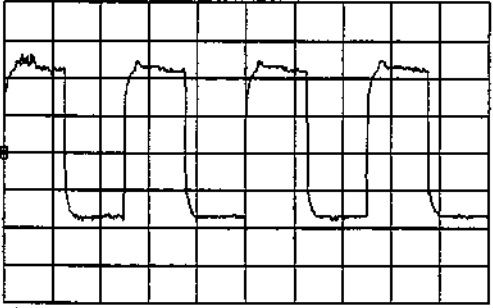
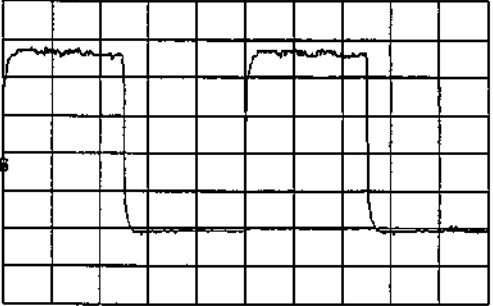
Clock	A61J3 pin3
Qualify	No Connection
Start	A61J3 pin5
Stop	A61J3 pin4

**Signature Analyzer Set Up**

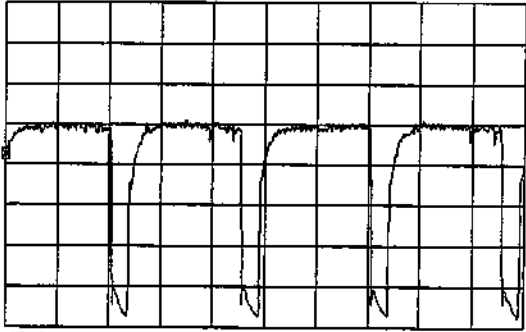
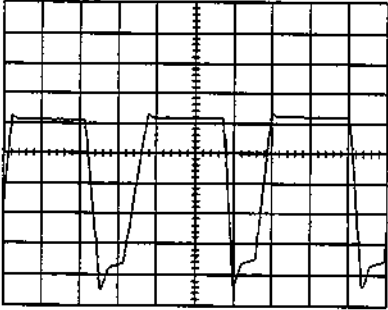
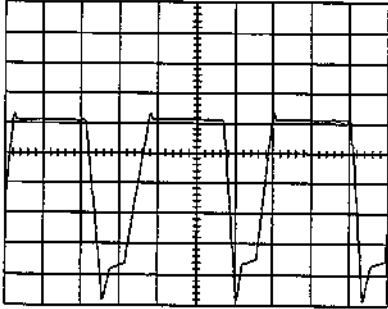
Clock	rising pulse
Qualify	N/A
Start	rising pulse
Stop	rising pulse
+ 5 V signature	= 9515
GND signature	= 0000

The SA2 mode is software driven, so the fast processor must be reset after moving the jumper to SA2 mode. To reset the fast processor, momentarily short INIT (A61 TP6) to ground. Verify a good reset by watching for a toggle on the Signature Analyzer gate LED.

**Table 9-12. A61 Circuit Board , Troubleshooting Data**

HP 3577B Set up	Measurement Set up	Parameters
Test at A61 P1 TP2 Press INSTR PRESET  Probe 10:1	Oscilloscope  CH1 Coupling AC CH1 V/Div 100V Time/Div 100 ns Trigger CH1	Risetime, Period, noise.  CH1 CPLG=AC CH1= 100 mV/Div    MT=Ch 1 Main= 100 ns/Div  #1
Test at A61P1 B3 Press INSTR PRESET  Probe 10:1	Oscilloscope  CH1 Coupling AC CH1 V/Div 1 V Time/Div 100 us Trigger CH1	Risetime, Period, noise.  CH1 CPLG=AC CH1= 1.00 V/Div    MT=Ch 1 Main= 100 us/Div  #2
Test at A61P1A7 Press INSTR PRESET  Probe 10:1	Oscilloscope  CH1 Coupling AC CH1 V/Div 1 V Time/Div 100 us Trigger CH1	Risetime, Period, noise.  CH1 CPLG=AC CH1= 1.00 V/Div    MT=Ch 1 Main= 100 us/Div  #3

**Table 9-12. A61 Circuit Board , Troubleshooting Data Continued**

HP 3577B Set up	Measurement Set up	Parameters
Test at A61TP4 Press INSTR PRESET  Probe 10:1	Oscilloscope  CH1 Coupling AC CH1 V/Div 1 V Time/Div 50 us Trigger CH1	Risetime, Period, noise.  CH1= 1.00 V/Div    MT=Ch 1 Main= 50.0 us/Div  #4
Test at A61J1B5 Press INSTR PRESET  Probe 10:1	Oscilloscope  CH1 Coupling AC CH1 V/Div 700 mV Time/Div 80 ns Trigger CH1	Risetime, Period, noise.  CH1 CPLG=AC CH1= 700 mV/Div    MT=Ch 1 Main= 80 ns/Div  #5
Test at A61TP2 Press INSTR PRESET  Probe 10:1	Oscilloscope  CH1 Coupling AC CH1 V/Div 700 mV Time/Div 80 ns Trigger CH1	Risetime, Period, noise  CH1 CPLG=AC CH1= 700 mV/Div    MT=Ch 1 Main= 80 ns/Div  #6



**Table 9-12. A61 Circuit Board , Troubleshooting Data Continued**

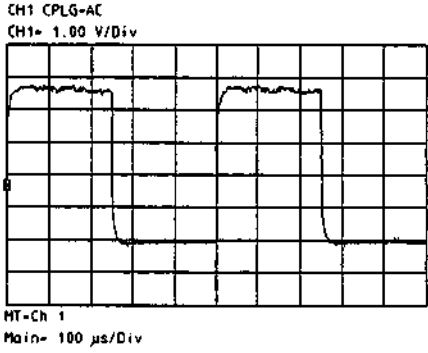
HP 3577B Set up	Measurement Set up	Parameters
Test at A61TP1 Press INSTR PRESET  Probe 10:1	Oscilloscope  CH1 Coupling AC CH1 V/Div 1 mV Time/Div 100 us Trigger CH1	Clean signal for TTL level transition   <p>CH1 CPLG-AC CH1= 1.00 V/Div</p> <p>HT-Ch 1 Main= 100 us/Div</p> <p>#7</p>
Digital Tests Press INSTR PRESET  Set A61W1 to SA1 A61W2 to mid A61W3 to mid	Oscilloscope  CH1 Coupling AC CH1 V/Div 1 V Time/Div 100 us Trigger CH1	Squarewave frequency.  A61U60 pin 5 12 kHz pin 9 12 kHz  A61U35 pin 14 12 kHz pin 13 6 kHz 12 kHz = 83.3us 6 kHz = 166.7us

Table 9-13a. A61 Circuit Board, Signature Analysis Data (SA1)

Component	Pin	Signature	Component	Pin	Signature		
U1 to U6	1	0772	U6	9	1PCC		
	2	4U2A		10	99P7		
	3	4442		11	26HU		
	4	P030		13	9HA3		
	5	H0AA		14	PFC6		
	6	HA07		15	FP94		
	7	C21A		16	5P4P		
	8	H62U		17	P8F6		
	18	7A70		U7	2	3PA4	
	21	U424			5	857H	
	22	1734			6	31PC	
	23	9635			9	08A0	
	U1	9			7H49	11	0000
		10			0AUC	12	8U70
11		05C1		15	3306		
13		06H0		16	A3C2		
14		P89H		19	4590		
15		PUH1	U8	2	5HFF		
16		63H6		5	FUA4		
17	4764	6		H138			
U2	9	CC99		9	5AP8		
	10	9U49		12	75F8		
	11	0C48	15	4HFH			
	13	PC90	16	7F2P			
	14	9C9C	19	85A4			
	15	C5H0	U9	2	0709		
	16	A270		5	6045		
17	U85H	6		6551			
U3	9	0P13		9	5HU9		
	10	F08C		11	0000		
	11	6F8F		12	3820		
	13	7041	15	9P95			
	14	C3CA	16	9682			
	15	3563	19	C646			
	16	FAA2	U10	2	A991		
17	A395	5		49H5			
U4	9	5323		6	661A		
	10	1H3C		9	A31F		
	11	C78U		12	72U8		
	13	6C61		15	19PF		
	14	33H9	16	47UF			
	15	4638	19	5CF7			
	16	FF34	U11	2	62H3		
17	99PP	5		81F3			
U5	9	4C37		6	P095		
	10	0387		9	F74A		
	11	47U8		12	A4C8		
	13	4971		15	PHAH		
	15	55FC	16	1C73			
	16	F12C	19	23UF			
17	36P7						

**Table 9-13a. A61 Circuit Board, Signature Analysis Data (SA1) Continued**

Component	Pin	Signature	Component	Pin	Signature	
U12	2	4815	U25	25	H97P	
	5	8CCC		29	F4A0	
	6	686U		36	9U8U	
	9	2002		37	A360	
	12	8999		38	99U8	
	15	U65C		39	PCAP	
	16	U463		U26	15	0000
	19	936U			25	FF67
	U13	7			7A70	29
14		7A70	36		868H	
U14	7	7A70	37		CCU5	
	14	7A70	38	AOPA		
U15	14	1983	39	3785		
	31	0000	U27	15	0000	
U16	3	27CF		23	P7UU	
	12	5HFF		29	AP09	
	13	444U		36	48A3	
U17	1	8UF0		37	360P	
	2	35F1		38	2PH6	
	3	4401		39	495A	
	15	59P3		U28	4	198H
U18	15	6U69			5	PCUA
	U21	1	U733		10	CA05
2		838U	U29	1	9682	
3		A2A6		2	9682	
4		3P80		3	PFU2	
9		UH1C		8	CA05	
11		F4A0		9	6045	
12		P46F		10	0709	
13		AP09		11	FF36	
14		A700		12	C646	
15		84HU		13	C646	
U23		3		HPH3	U30	5
		18	35F1	10		404U
		19	9AP0	12		1A3H
U24	15	0000	15	0000		
	22	4660	U31	2	P91U	
	23	60F1		3	7A70	
	29	UH1C		4	936U	
	31	8UF0		6	936U	
	33	35F1		9	3A3U	
	36	1323		10	FP6H	
	37	AFH1		11	7A70	
	38	59P3	U35	2	4U2A	
	39	8UF0		13	05HP	
				14	4858	
		U36	1	0496		
			5	HPH3		
		U43	7	7UAP		
			9	4858		

**Table 9-13a. A61 Circuit Board, Signature Analysis Data (SA1) Continued**

Component	Pin	Signature	Component	Pin	Signature
U44	1	0000	U48	3	0000
	2	0000		5	4815
	3	0000		6	3265
	4	0000		8	U1FC
	5	7A70		9	8CCC
U45	5	AP09	U49	8	F3AP
U46	15	60F1	U50	3	2HFP
	17	4660		8	C9HP
U47	3	FF67	U56	6	7A70
	5	P7UU	U57	6	7PP6
			U59	9	U424
			U60	3	7A70
				5	UAUU
				9	4858

**Table 9-13b. A61 Circuit Board, Signature Analysis Data (SA1)**

Move Signature Analyzer QUAL lead to A61U33 pin 11. Set QUAL mode to LOW.		
+5 V Signature = 001U Momentarily ground TP6		
Component	Pin	Signature
U33	1	0009
	4	001U
	5	0000
	9	0009
	10	0009
	11	0000
	13	001U
	14	001U
U34	15	0009
	1	0009
	4	001U
	9	0009
	10	0009
U41	13	001U
	15	0009
	1	0009
	4	001U
	9	0009
U42	10	0009
	13	001U
	15	0009
	1	0009
	9	0009

**Table 9-13c. A15 Circuit Board, Signature Analysis Data (SA1)**

Move Signature Analyzer QUAL lead to A61U12 pin 19. Set QUAL mode to LOW.		
+5 Signature = CH38		
Component	Pin	Signature
U37	4	0000
	5	0000
	7	U5C8
U38	1	066U
	2	2U11
	3	8630
	5	9333
	12	0AC5
	13	248H
	14	HCPP
U39	15	2663
	4	0000
	6	05AU
	7	F90P
	9	6A83
U40	11	5840
	1	9333
	3	2P0C
	5	CH38
	6	CH38
	8	C309
	11	CH38
12	0000	

**Table 9-13d. A61 Circuit Board, Signature Analysis Data (SA1)**

Move the Signature Analyzer QUAL lead to A61U12 pin 6. Set QUAL mode to LOW			
+5 Signature = 0877			
Component	Pin	Signature	
U51	1	0000	Note: These signatures are valid for both sides of A63RP3 and A63RP4
	2	P476	
	3	PF09	
	4	PF05	
	5	P4P2	
	6	P469	
	7	PFU7	
	8	PF05	
	9	P463	
	11	6034	
	12	P4F8	
	13	PFUC	
	14	PFU7	
	15	P4P8	
	16	P469	
	17	PFU7	
	18	PFU7	
	19	P4P8	
	U52	1	
2		U4UP	
3		PF05	
4		PFU7	
5		U4H4	
6		P4C7	
7		PF05	
8		PFU7	
9		7261	
11		6034	
12		770C	
13		PF35	
14		0A9U	
15		CA40	
16		3AAU	
17		PHU6	
18		PFU7	
19		UP81	

**Table 9-13e. A61 Circuit Board, Signature Analysis Data (SA1)**

Move Signature Analyzer QUAL lead to A61U19 pin 1. Set QUAL mode to LOW.			
+5 Signature = 4PC7			
Component	Pin	Signature	
U19	3	UH2F	Note: All buffer output signatures are the same as input signatures.
	5	7519	
	7	524A	
	9	72H0	
	12	9U96	
	14	FPFH	
	16	1A7C	
	18	H556	
U20	3	P5F0	
	5	95A4	
	7	F2C3	
	9	76UF	
	12	FU25	
	14	UFF0	
	16	F98U	
	18	F193	

**Table 9-13f. A61 Circuit Board Signature Analysis Data (SA1)**

Move the Signature Analyzer QUAL lead to A61U22 pin 1 Set QUAL mode to LOW.		
+5 Signature = 5CC7		
Component	Pin	Signature
U22	3	A0AC
	4	A0AC
	5	A0AC
	6	A0AC
	7	A0AC
	9	052A
	11	A0AC
	12	5F78
	13	3UUC



**Table 9-13g. A61 Circuit Board Signature Analysis Data (SA1)**

Move the Signature Analyzer QUAL lead to A61U24 pin 6. Set QUAL mode to HIGH.		
+5 Signature = H253		
Component	Pin	Signature
U24	8	A95A
	9	U268
U25	8	U268
	9	0CC6
U26	8	0CC6
	9	U9CH
U27	8	U9CH
	9	FH3A

**Table 9-13h. A61 Circuit Board Signature Analysis Data (SA1)**

Move the Signature Analyzer QUAL lead to A61U32 pin 1. Set QUAL mode to LOW.		
+5 Signature = CH38		
Component	Pin	Signature
U32	3	0000
	5	0000
	7	C309

**Table 9-13i. A61 Circuit Board Signature Analysis Data (SA1)**

Move the Signature Analyzer QUAL lead to A61U53 pin 1. Set QUAL mode to HIGH.		
+5 Signature = HFUJ		
Component	Pin	Signature
U53	2	2188
	3	HFUJ
	7	99AC
	9	A25F
	14	3C5C

**Table 9-13j. A61 Circuit Board Signature Analysis Data (SA1)**

Move the Signature Analyzer QUAL lead to A61U54 pin 1. Set QUAL mode to LOW.		
+5 Signature = CH38		
Component	Pin	Signature
U54	2	00A6
	3	3A79
	4	5A12
	5	8F65
	6	4P8A
	7	P009
	8	P520
	9	144U
	11	2P0C
	12	U21C
	13	8177
	14	0A1H
	15	U411
	U55	2
3		8FF8
4		F945
5		8630
6		066U
7		8F8C
8		56F9
9		2U11
11		2P0C
12		U81A
13		8H0A
14		2975
15		CF5A
16		9PUH
17	1HC1	
18	391F	
19	FP9A	

Table 9-14. A61 Circuit Board Signature Analysis Data (SA2)

+5 Signature = 9515						
Component	Pin	Signature	Component	Pin	Signature	
U19	3	AC37	U25	15	0000	
	5	56CA		36	876F	
	7	56CA		37	122F	
	9	AC37		38	8264	
	12	5HUF	39	10F8		
	14	AP3U	U26	15	0000	
	16	AP3U		36	876F	
	18	5HUF		37	122F	
U20	3	AP3U		38	8264	
	5	5HUF	39	10F8		
	7	AP3U	U27	15	0000	
	9	AC37		36	876F	
	12	56CA		37	122F	
	14	5HUF		38	8264	
16	56CA	39		10F8		
18	AC37	U45		2	5HHF	
U21	1		2PAF	3	9515	
	2		2U1A	5	0020	
	3		2PAF	10	0000	
	4		2U1A	11	0020	
	9		CCC9	U59 U24	9	AF44
	11		CCC9		1	A352
	12		CCC9		2	967C
	13		0020		3	FU97
	14		2PAF		4	50C8
	15		2U1A		5	H5C0
					6	0000
					7	U5P2
					11	01C6
					12	U76H
			13		7FU0	
		14	CF95			
		15	0000			
		17	A170			
		18	9U2U			
		19	2FU6			
		20	46A5			
		26	CA76			
		27	3U4A			
		28	F9AP			
		31	10F8			
		36	876F			
		37	122F			
		38	8264			
		39	10F8			

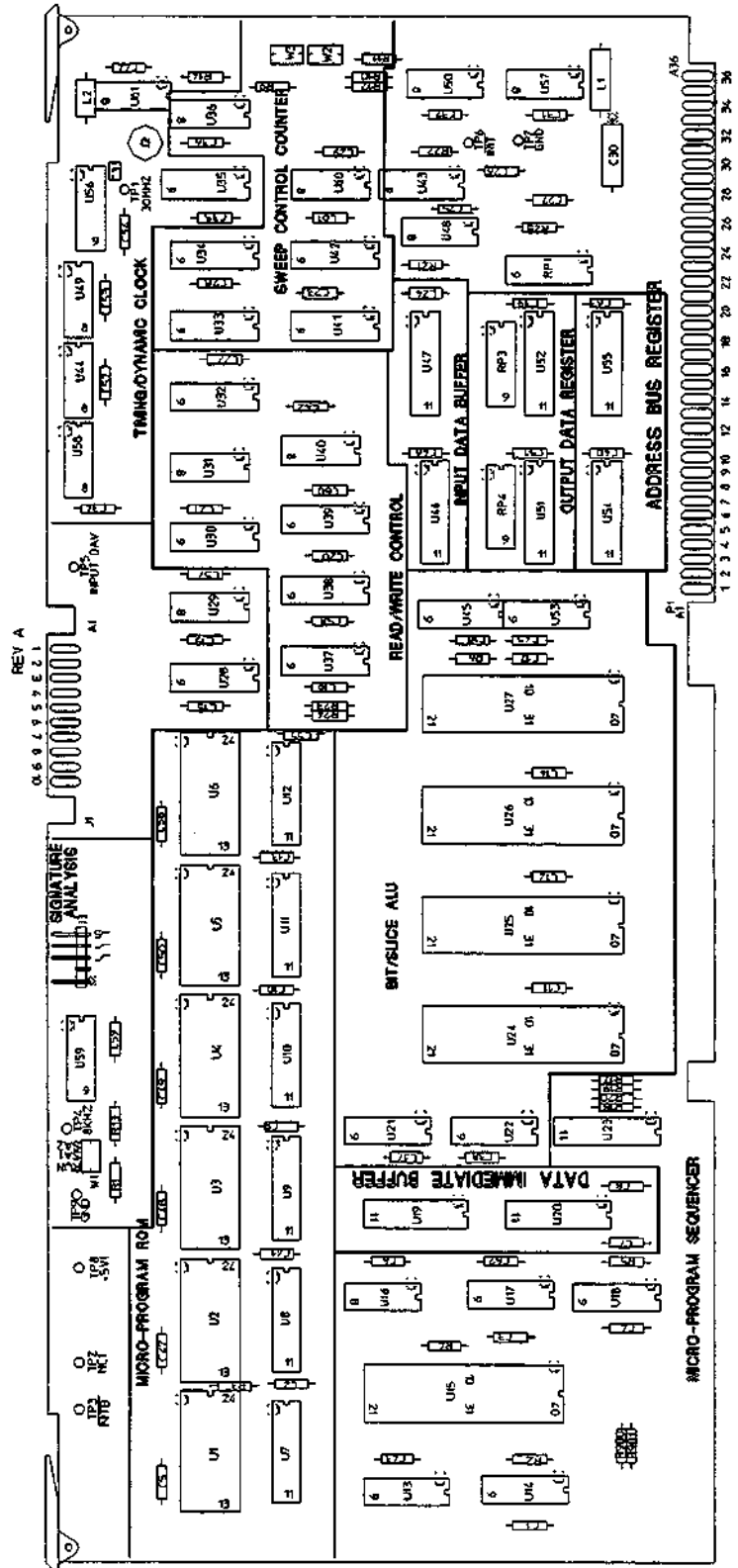
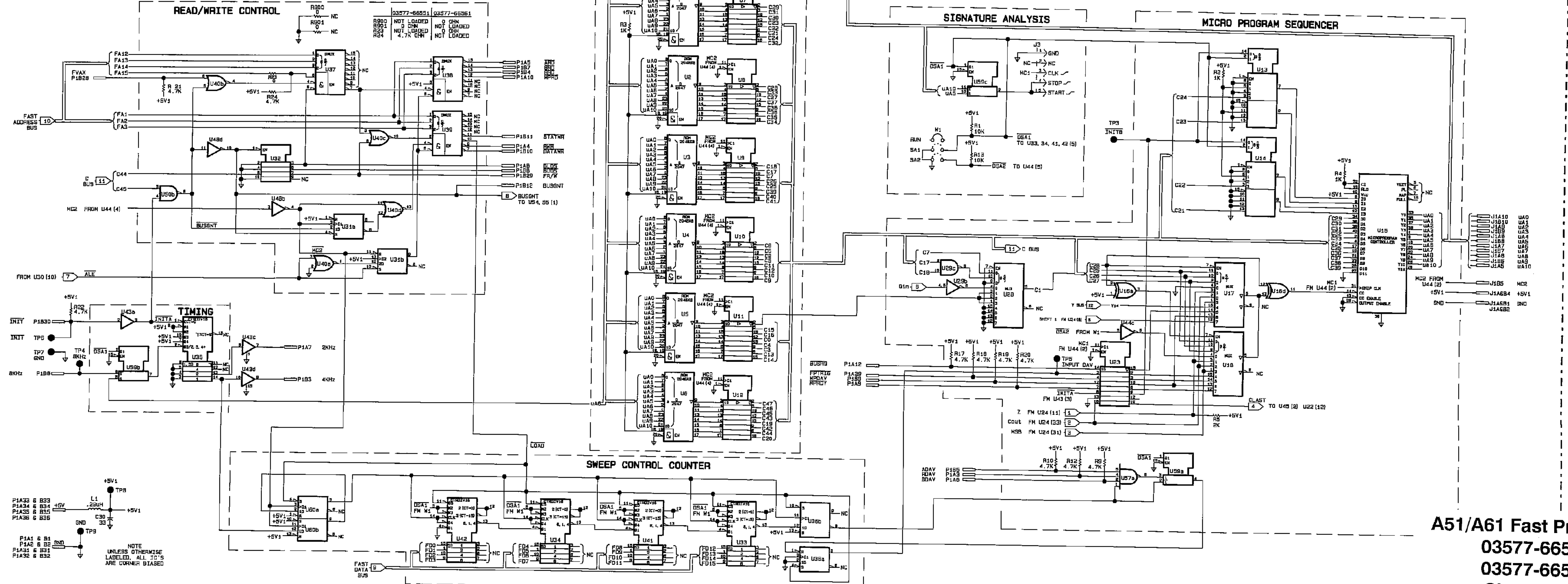


Figure 9-23. A61 Component Locator

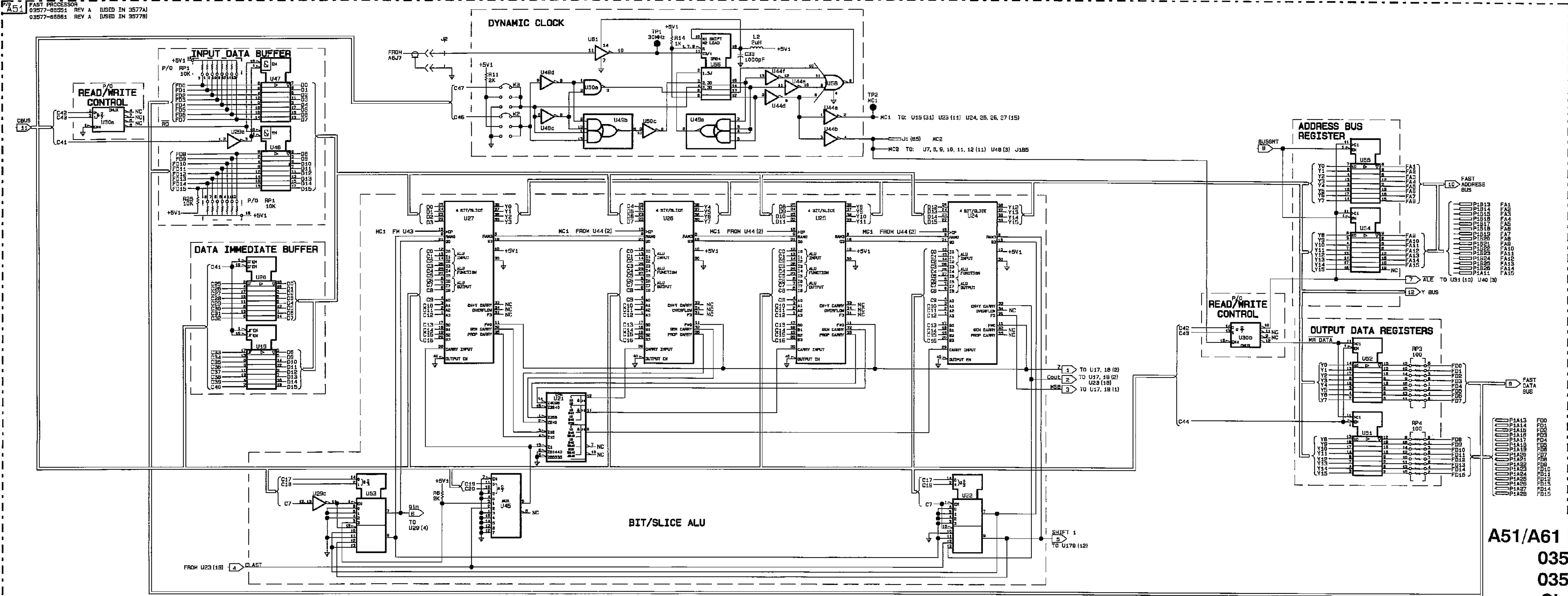
IC	+5V1	GND	Bypass Cap	
			Desig.	Value
U1	24	12,20		
U2	24	12,20	C5	0.1
U3	24	12,20	C9	0.1
U4	24	12,20	C10	0.1
U5	24	12,20	C13	0.1
U6	24	12,20	C15	0.1
U7	20	1,10	C2	0.1
U8	20	1,10	C41	0.1
U9	20	1,10		
U10	20	1,10		
U11	20	1,10		
U12	20	1,10	C16	0.1
U13	16	1,4,8,12,15	C43	0.1
U14	16	1,4,5,8 10,11,12	C1	0.1
U15	10	27,30	C3	0.1
U16	14	7	C6	0.1
U17	16	8		
U18	16	8	C4	0.1
U19	20	10	C38	0.1
U20	20	10	C7	0.1
U21	16	8	C37	0.1
U22	16	8		
U23	20	1,13,20	C8	0.1
U24	10	30,4,0	C11	0.1
U25	10	30,40	C12	0.1
U26	10	30,40	C14	0.1
U27	10	30,40	C17	0.1
U28	16	7,8,9 12,13,14,15		
U29	14	7	C19	0.1
U30	16	1,8		
U31	1,14	7	C21	0.1
U32	16	2,4,8	C42	0.1
U33	16	8	C22	0.1
U34	16	8	C23	0.1
U35	7,9,10,16	3,4,5,6,8	C28	0.1
U36	13,14	2,3,7		
U37	6,16	8		
U38				
U39	16	8	C20	0.1
U40	14	2,7		
U41	16	8		
U42	16	4,8	C25	0.1
U43	16	1,8,15		
U44	14	7		
U45	16	1,4,7,8,9 12,13,14,15	C18	0.1
U46	20	10		
U47	20	10	C24	0.1
U48	14	7	C27	0.1

IC	+5V1	GND	Bypass Cap	
			Desig.	Value
U49	14	7		
U50	14	7	C32	0.1
U51	20	10	C40	0.1
U52	20	10	C39	0.1
U53	16	4,5,6,8,11		
U54	20	10		
U55	20	10		
U56	16	8		
U57	14	7	C31	0.1
U58	14	4,7	C34	0.1
U59	16	8,15		
U60	1,10,14,13	7	C28	0.1









**A51/A61 Fast Processor**  
**03577-66551**  
**03577-66561**  
**Sheet 2 of 2**

A62/A63  
Main Processor

---

## 9-19 Service Group A62/63, Main Processor-Controller Assembly

The information in this section should be used to isolate faulty functional sub-blocks when servicing the HP 3577B. All procedures assume the Fault Isolation procedures of Section II have been used to determine which functional block has failed, and the Circuit Descriptions of Section VIII are understood.

The A62 is the Main Processor-Controller Assembly number for a standard HP 3577B. The A63 is the Main Processor-Controller Assembly number for an HP 3577B Option 1C2 (HP Instrument BASIC). These two assemblies differ only in the size and number of ROMs used. Therefore, they are treated as the same board except in the areas where they differ.

---

### Warning



Service procedures described in this section are performed with the protective covers removed and power applied. Energy available at many points can, if contacted, result in personal injury.

---

### Caution



Do not insert or remove any circuit board in the HP 3577B with the line power turned on. Power transients caused by insertion or removal may damage the circuit boards.

## Initial Conditions

Unless otherwise stated in the troubleshooting sections of the signal table, set the HP 3577B as described below, after power on:

### INSTR PRESET

All Oscilloscope waveforms are taken using a 10:1 probe but each oscilloscope display shows actual voltage. All signatures are taken using a HP 5006A Signature Analyzer.

## Note



When running all signature analysis routines, keep the signature analyzer and the HP 3577B physically far from each other to prevent digital signal coupling.

## Troubleshooting Hints

- a. This procedure assumes the initial Fault Isolation procedure listed in Section II has been followed and has indicated running these procedures. If the Fault Isolation Procedures have not been run, perform them now to make sure that the fault is resident on the Main Processor-Controller circuit board.
- b. Clock signal waveforms are shown in table 9-14. Check these waveforms as described in table 9-14.
- c. The following procedure is to be used as a general troubleshooting procedure when a fault exists on the A62/63 Main Processor-Controller board. Refer to the Digital Block Diagram in Section II when performing these tests as it shows the interaction of all the bus in the instrument.
  - Disconnect the mains power cord from the rear panel and remove the top cover. Reconnect the mains power cord and turn the instrument on.
  - Allow about 2 minutes for the display to warm up.
  - If the display does not operate, be sure that the display is not causing the problem by running the Fault Isolation procedures in Section II.
  - With the instrument properly warmed up, press the RESET pushbutton (A63S1) through the shield over the A62/63 board. Watch the ROM and RAM test LEDs.
  - If the ROM test LED extinguishes after approximately 5 seconds, then the ROM test has passed. This test verifies the ROM checksums and the first buffer on the main processor address and data bus.

- If the RAM test LED extinguishes after approximately 10 seconds, then the RAM test has passed. If a failure is detected, the testing will stop and either "RAM TEST FAILED: MSB", or "RAM TEST FAILED: LSB" will be displayed for about 5 seconds. If this occurs, note the memory block being tested and use the following tables to identify the IC being tested.

**If RAM ICs are 32K × 9-bit (256K bit):**

Block	Byte	IC Tested
0016K – 0064K	MSB	U033
0016K – 0064K	LSB	U034
0080K – 0128K	MSB	U133
0080K – 0128K	LSB	U134

**If RAM ICs are 128K × 8 bit (1M bit):**

Block	Byte	IC Tested
0016K – 0256K	MSB	U033
0016K – 0256K	LSB	U034
0272K – 0512K	MSB	U133
0272K – 0512K	LSB	U134
0528K – 0768K	MSB	U233
0528K – 0768K	LSB	U234

This test verifies the RAM with a marching ones test, and the second buffer on the main processor address and data bus. Note that all peripheral devices (fast processor, display, HP-IB, etc) are tied to this bus, so if any of these buffers are loading the bus, the RAM will not pass the self test. This self test verifies all RAM except that which have non-volatile requirements. The non-volatile memory stores the saved instrument states. If the instrument does not operate correctly when a saved state is recalled, then perform the total RAM test as described in the Power On Self Tests in Section II.

- Run the Service Diagnostics for the peripheral devices. To run these diagnostics, press the SPCL FCTN hardkey and select the SERVICE DIAG softkey. All service diagnostics to be run, and any special instructions for running them, are listed below.
  - TEST PATTERN: This test requires no external interaction with the user. The display test pattern is documented in the Section III Performance Tests under Digital Display Operation Verification. This will verify the display buffer and the display operation. To exit from this test mode, press the INSTR PRESET hardkey.
  - TRC MEM TEST: This test performs a marching ones test on the A62/63 Trace Memory circuitry. This test requires no external interaction with the user and is fully documented in Section II of this manual. If the fast processor does not operate correctly, it may cause the trace memory test to fail, even though the trace memory is good.
  - FASTPROC TEST: This test has the main processor command the fast processor to perform a self test, and send the results back to the main processor. This verifies the main processor, fast processor buffers and the fast processor logic.
  - FAST BUS INT TEST: This test has the main processor write to one of the fast processor buffers and then read the data. The test is then repeated by writing to the other buffer and reading from the first. The fast processor decoding logic must be operational for this test to pass.
  - DISP MEM TEST: This test verifies the memory board in the digital display module. The display buffer is also verified in this test. This is fully documented in Section II of this manual.
  - DISP HP-IB: This test makes the HP-IB circuit read the HP-IB control and data lines at the rear panel. Note that HP-IB protocol will not be followed in this test. To run this test, the operator should ground each of the HP-IB control and data lines to the connector shield. As the lines are grounded, a dot should appear in the slot for it drawn on the display. To exit from this test mode, press the INSTR PRESET hardkey.
- Run the confidence test for each of the inputs. The confidence test is run by pressing the SPCL FCTN hardkey and the CONF TEST softkey. The test requires a cable to connect the source to the channel under test. This test will verify that the instrument control bus is working properly, along with any hard analog failures.

- d. If the battery back-up is suspect, connect the oscilloscope to A62 TP8 (or A63 TP8). W30 must be in the normal battery backup position for this test. With power applied to the HP 3577B, the voltage should be approximately 5V. With the HP 3577B power turned off, the voltage should read approximately 2V. Repeat the above for A62/63 U37 pin 6. With power applied, the voltage should be approximately 0 V. With the power removed the voltage should be approximately 2V.
- e. Due to the interaction of the circuits on this board, it is impossible to have a troubleshooting tree which would catch all cases of error. If the procedure in step c does not lead you to the fault, then perform each of the signature analysis routines listed below. Run the SA1 routine first, as it is the most general test. SA2 is to be used when ambiguity remains after running SA1.

**SYMPTOM:** Unit fails ROM self test.

- Check the + 5V supply on the A62/63 board at A62TP2 or A63TP2. The reading should be  $5V \pm 0.2V$ . If the voltage is bad, replace the faulty components.
- Check for the clock signal at TP3 with the oscilloscope. The signal should look like the one in step 3 of table 9- 13. With the signal on the oscilloscope, cycle power by pressing LINE off and on. With the power on, the 8 MHz phase locked loop will free run. The frequency of the free run should be between 6 and 8 MHz. If the frequency is outside these limits, the microprocessor may not reset correctly, and will hang up. When the POP line goes high, then the signal should phase lock to the 1 MHz input signal from the A6 reference board. If either of these tests fail, then replace the faulty components.
- Run the SA1 a signature analysis routine.

**SYMPTOM:** Unit fails RAM self test.

- If only one RAM shows up as bad, then it is most likely a RAM chip failure. If half or all of RAM fails, then it is most likely a bus or an address decoder failure (A62U28 or A63U28). Replace all faulty components.
- Look at each data bus line with the oscilloscope while the RAM test is in progress. Each data line should toggle. If any data line does not toggle, then one of the buffers tied to this bus is most likely loading it down. Replace all faulty components.
- Run the SA2b signature analysis routine on the data bus buffers. If + 5V signature is bad, then look in the Address Decoding functional sub-block for failures. If the +5V signature is good, then check all the buffers tied to the RAM bus.



■ SA1 Signature Analysis Routine

This routine is the general signature analysis routine for the Main Processor-Controller board. Run this test first when led to the Main Processor-Controller from the Fault Isolation procedures. Remove the Fast Processor (A61) board. Disconnect all Receiver (A19) boards from the fast bus by placing A19W5 and A19W6 into the TriState position. The SA1 test set is described below. This test disables the ROM and forces an instruction on the data bus.

Signature Analysis SA1 Routine Test Set Up

Clock	A62 or A63 J2
Start	A62 or A63 J2
Stop	A62 or A63 J2
Qualify	No Connection

Signature Analyzer Set Up

Clock	Rising Pulse
Start	Rising Pulse
Stop	Rising Pulse
Qualify	N/A

+5 V signature = UP73

GND signature = 0000

Set the signature analysis jumper A63W1 to the TEST position and connect the Signature Analyzer to the SA test connectors. Press the RESET switch on the Main Processor to start the SA mode.



### ■ SA2 Signature Analysis Routine

This routine is used primarily to test the “kernel” and isolating functional sub-blocks from each other. This is done in the SA mode by setting all the tri-state buffers to read mode only. Run this after completing the Main Processor-Controller SA1 Signature Analysis Test and a functional sub-block is suspect. Remove the Fast Processor (A61) board. Disconnect all three Receiver (A19) boards from the fast bus by placing A19W5 and A19W6 into the Tri-State position. The SA2 test set up is described below.

#### Signature Analysis SA2 Routine Test Set Up

Clock	A62 or A63 J2
Start	A62 or A63 TP4
Stop	A62 or A63 TP4
Qualify	No Connection

#### Signature Analyzer Set Up

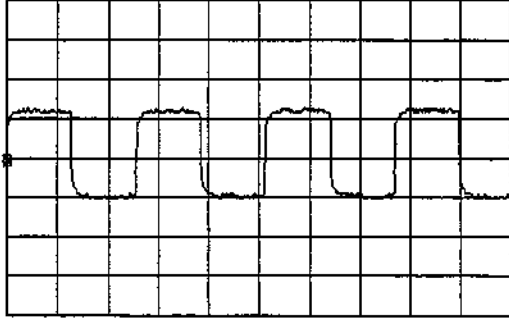
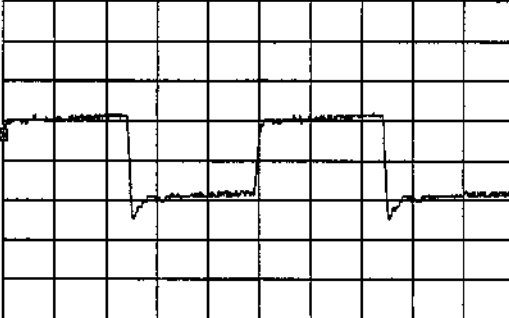
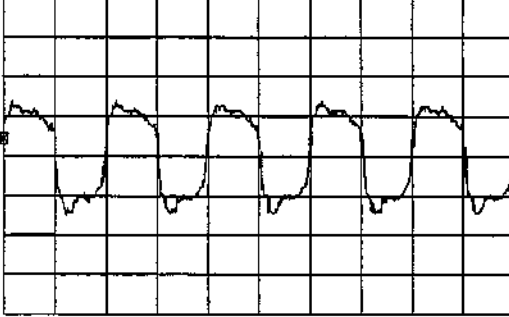
Clock	Rising Pulse (1)
Start	Rising Pulse (1)
Stop	Rising Pulse (1)
Qualify	N/A

+5 V signature = AU47

GND signature = 0000

Set the signature analysis jumper (A62J70 or A63J70) to the TEST position and connect the Signature Analyzer to the SA test connectors. Press the reset switch (A62S1 or A63S1) to start the SA mode.

**Table 9-15. A62/63 Circuit Board, Troubleshooting Data**

HP 3577B Set up	Measurement Set up	Waveform with Parameters
Test at A62/63 U65 Pin 8 Press INSTR PRESET	Oscilloscope CH1 Coupling AC CH1 V/Div 2 V Time/Div 100 ms Trigger CH1	<p style="text-align: center;">Risetime, Period</p> <p>CH1 CPLG=AC                      CH1= 2.00 V/Div</p>  <p>MT=Ch 1                      Main= 100 μs/Div</p> <p style="text-align: center;">#1</p>
Test at A62/63 P2 A30 Press INSTR PRESET	Oscilloscope CH1 Coupling AC CH1 V/Div 2 V Time/Div 200 ns Trigger CH1	<p style="text-align: center;">Risetime, Period</p> <p>CH1 CPLG=AC                      CH1= 2.00 V/Div</p>  <p>MT=Ch 1                      Main= 200 ns/Div</p> <p style="text-align: center;">#2</p>
Test at A62/63 TP3 Press INSTR PRESET	Oscilloscope CH1 Coupling AC CH1 V/Div 2 V Time/Div 50 ns Trigger CH1	<p style="text-align: center;">Risetime, Period</p> <p>CH1 CPLG=AC                      CH1= 100 mV/Div</p>  <p>MT=Ch 1                      Main= 100 ns/Div</p> <p style="text-align: center;">#3</p>

**Table 9-16a. A62/63 Circuit Board, Signature Analysis Data (SA1a)**

This signature analysis test is used to test the microprocessor and all functional sub-blocks. This test should be run first, after fault isolation to the A62/63 board is performed.			
+5V Signature = UP73			
Component	Pin	A62 Signature	A63 Signature
U1	1	UP73	UP73
	2	UP73	UP73
	3	UP73	UP73
	4	UP73	UP73
	5	0000	0000
	6	0000	0000
	7	0000	0000
	8	0000	0000
	9	UP73	UP73
	10	0000	0000
	11	UP73	UP73
	12	UP73	UP73
	13	UP73	UP73
	14	UP73	UP73
	15	0000	0000
	16	0000	0000
	17	UP73	UP73
	18	UP73	UP73
	19	UP73	UP73
	21	UP73	UP73
	22	UP73	UP73
	24	UP73	UP73
	25	UP73	UP73
	26	UP73	UP73
	27	UP73	UP73
	28	0000	0000
	29	55H1	55H1
	30	334U	334U
	31	0U16	0U16
	32	00UP	00UP
	33	UUUU	UUUU
	34	34P0	34P0
	35	0U52	0U52
	36	48C6	48C6
	37	HAP7	HAP7
	38	85U4	85U4
	39	FAF6	FAF6
	40	3HPH	3HPH
	41	U1U8	U1U8
	42	FA75	FA75
	43	C5F0	C5F0
	44	F3U8	F3U8
	45	55H1	55H1
	46	334U	334U
	47	0U16	0U16
	48	UP8H	UP8H

**Table 9-16a. A62/63 Circuit Board, Signature Analysis Data (SA1a)Continued**

This signature analysis test is used to test the microprocessor and all functional sub-blocks. This test should be run first, after fault isolation to the A62/63 board is performed.			
+5V Signature = UP73			
Component	Pin	A62 Signature	A63 Signature
U71	49	UP73	UP73
	50	UP8H	00UP
	53	0000	0000
	54	0000	0000
	55	UP73	UP73
	56	UP73	UP73
	57	UP73	UP73
	58	UP73	UP73
	59	UP73	UP73
	60	UP73	UP73
	61	0000	0000
	62	UP73	UP73
	63	UP73	UP73
	64	UP73	UP73
	1	0000	0000
	2	UP73	UP73
	3	UP73	UP73
	4	UP73	UP73
	5	0000	0000
	6	0000	0000
7	0000	0000	
8	UP73	UP73	
9	UP73	UP73	
10	0000	0000	
11	UP73	UP73	
12	UP73	UP73	
13	0000	0000	
14	0000	0000	
15	0000	0000	
16	UP73	UP73	
17	UP73	UP73	
18	UP73	UP73	
19	0000	0000	
20	UP73	UP73	
U14	1	0000	0000
	2	0000	0000
	3	0000	0000
	4	0000	0000
	5	UP73	UP73
	6	0000	0000
	7	0000	0000
	8	0000	0000
	9	0000	0000
	10	0000	0000
	11	0000	0000
	12	0000	0000
	13	0000	0000

**Table 9- 16a. A62/63 Circuit Board, Signature Analysis Data (SA1a) Continued**

This signature analysis test is used to test the microprocessor and all functional sub-blocks. This test should be run first, after fault isolation to the A62/63 board is performed.			
+5V Signature = UP73			
Component	Pin	A62 Signature	A63 Signature
U15	14	0000	0000
	15	UP73	UP73
	16	0000	0000
	17	0000	0000
	18	0000	0000
	19	0000	0000
	20	UP73	UP73
	1	0000	0000
	2	0000	0000
	3	55H1	55H1
	4	334U	334U
	5	0U16	0U16
	6	00UP	00UP
	7	UUUU	UUUU
	8	34P0	34P0
	9	0U52	0U52
	10	0000	0000
	11	0U52	0U52
	12	34P0	34P0
	13	UUUU	UUUU
U16	14	00UP	00UP
	15	0U16	0U16
	16	334U	334U
	17	55H1	55H1
	18	0000	0000
	19	0000	0000
	20	UP73	UP73
	1	0000	0000
	2	48C6	48C6
	3	HAP7	HAP7
	4	85U4	85U4
	5	FAF6	FAF6
	6	3HPH	3HPH
	7	U1U8	U1U8
	8	FA75	FA75
	9	C5F0	C5F0
	10	0000	0000
	11	C5F0	C5F0
	12	FA75	FA75
	13	U1U8	U1U8
14	3HPH	3HPH	
15	FAF6	FAF6	
16	85U4	85U4	
17	HAP7	HAP7	
18	48C6	48C6	
19	0000	0000	
20	UP73	UP73	

**Table 9-16a. A62/63 Circuit Board, Signature Analysis Data (SA1a) Continued**

This signature analysis test is used to test the microprocessor and all functional sub-blocks. This test should be run first, after fault isolation to the A62/63 board is performed. +5V Signature = UP73				
Component	Pin	A62 Signature	A63 Signature	
U17	1	0000	0000	
	2	F3U8	F3U8	
	3	55H1	55H1	
	4	334U	334U	
	5	0U16	0U16	
	6	UP8H	UP8H	
	7	00UP	00UP	
	10	0000	0000	
	13	00UP	00UP	
	14	UP8H	UP8H	
	15	0U16	0U16	
	16	334U	334U	
	17	55H1	55H1	
	18	F3U8	F3U8	
	19	0000	0000	
	20	UP73	UP73	
	U28	1	3HPH	3HPH
		2	U1U8	U1U8
		3	UP8H	UP8H
		4	00UP	00UP
5		0000	0000	
8		0000	0000	
12		UP73	UP73	
13		UP73	UP73	
14		UP73	UP73	
15		UP73	UP73	
U29	1	UP8H	UP8H	
	2	0000	0000	
	3	0000	0000	
	5	00UP	00UP	
	6	UP73	UP73	
	7	UP73	UP73	
	8	0000	0000	
	9	UP73	UP73	
	10	UP73	UP73	
	11	UP73	UP73	
	12	UP73	UP73	
	13	UP73	UP73	
	15	UP73	UP73	
	16	UP73	UP73	
U83	1	34P0	34P0	
	2	0U52	0U52	
	3	48C6	48C6	
	4	UP73	UP73	
	5	0000	0000	
	6	UP73	UP73	

**Table 9-16a. A62/63 Circuit Board, Signature Analysis Data (SA1a)Continued**

This signature analysis test is used to test the microprocessor and all functional sub-blocks. This test should be run first, after fault isolation to the A62/63 board is performed.			
+5V Signature = UP73			
Component	Pin	A62 Signature	A63 Signature
U86	7	UP73	UP73
	8	0000	0000
	9	UP73	UP73
	10	UP73	UP73
	11	UP73	UP73
	12	UP73	UP73
	13	UP73	UP73
	14	UP73	UP73
	15	UP73	UP73
	16	UP73	UP73
	1	34P0	34P0
	2	0U52	0U52
	3	48C6	48C6
	4	UP73	UP73
	5	0000	0000
	6	UP73	UP73
U82	7	UP73	UP73
	8	0000	0000
	9	UP73	UP73
	10	UP73	UP73
	11	UP73	UP73
	12	UP73	UP73
	13	UP73	UP73
	14	UP73	UP73
	15	UP73	UP73
	16	UP73	UP73
	1	34P0	34P0
	2	0U52	0U52
	3	48C6	48C6
	4	UP73	UP73
	5	0000	0000
	6	0000	0000
7	UP73	UP73	
8	0000	0000	
9	UP73	UP73	
10	UP73	UP73	
11	UP73	UP73	
12	UP73	UP73	
13	UP73	UP73	
14	UP73	UP73	
15	UP73	UP73	
16	UP73	UP73	
U85	1	34P0	34P0
	2	0U52	0U52
	3	48C6	48C6
	4	UP73	UP73
	5	0000	0000

**Table 9-16. A62/63 Circuit Board, Signature Analysis Data (SA1a)Continued**

This signature analysis test is used to test the microprocessor and all functional sub-blocks. This test should be run first, after fault isolation to the A62/63 board is performed.			
+5V Signature = UP73			
Component	Pin	A62 Signature	A63 Signature
U102	6	0000	0000
	8	0000	0000
	9	UP73	UP73
	10	UP73	UP73
	11	UP73	UP73
	12	UP73	UP73
	13	UP73	UP73
	14	UP73	UP73
	15	UP73	UP73
	16	UP73	UP73
	1	UP73	UP73
	2	UP73	UP73
	3	UP73	UP73
	4	UP73	UP73
	5	0000	0000
	6	UP73	UP73
U103	7	UP73	UP73
	8	UP73	UP73
	11	0000	0000
	12	UP73	UP73
	19	UP73	UP73
	20	UP73	UP73
	21	0000	0000
	22	0000	0000
	23	0000	0000
	24	UP73	UP73
	25	UP73	UP73
	26	UP73	UP73
	27	UP73	UP73
	28	UP73	UP73
	1	UP73	UP73
	2	UP73	UP73
	3	UP73	UP73
	4	UP73	UP73
	5	0000	0000
6	UP73	UP73	
7	UP73	UP73	
8	UP73	UP73	
11	0000	0000	
12	UP73	UP73	
19	UP73	UP73	
20	UP73	UP73	
21	0000	0000	
22	0000	0000	
23	0000	0000	
24	UP73	UP73	
25	UP73	UP73	



**Table 9-16a. A62/63 Circuit Board, Signature Analysis Data (SA1a) Continued**

This signature analysis test is used to test the microprocessor and all functional sub-blocks. This test should be run first, after fault isolation to the A62/63 board is performed. +5V Signature = UP73			
Component	Pin	A62 Signature	A63 Signature
U10	26	UP73	UP73
	27	UP73	UP73
	28	UP73	UP73
	1	UP73	UP73
	10	0000	0000
	11	UP73	UP73
	12	UP73	UP73
	13	UP73	UP73
	14	UP73	UP73
	15	UP73	UP73
U12	16	UP73	UP73
	17	UP73	UP73
	18	0000	0000
	19	UP73	UP73
	20	UP73	UP73
	1	UP73	UP73
	10	0000	0000
	11	0000	0000
	12	UP73	UP73
	13	UP73	UP73
U73	14	UP73	UP73
	15	UP73	UP73
	16	UP73	UP73
	17	UP73	UP73
	18	0000	0000
	19	UP73	UP73
	20	UP73	UP73
	1	UP73	UP73
	2	UP73	UP73
	3	UP73	UP73
U74	4	UP73	UP73
	7	0000	0000
	8	0000	0000
	9	UP73	UP73
	14	UP73	UP73
	1	UP73	UP73
	2	UP73	UP73
	3	UP73	UP73
	4	UP73	UP73
	5	UP73	UP73
6	0000	0000	
7	0000	0000	
8	0000	0000	
9	UP73	UP73	
12	UP73	UP73	
15	UP73	UP73	
16	UP73	UP73	

**Table 9-16a. A62/63 Circuit Board, Signature Analysis Data (SA1a) Continued**

This signature analysis test is used to test the microprocessor and all functional sub-blocks. This test should be run first, after fault isolation to the A62/63 board is performed.			
+5V Signature = UP73			
Component	Pin	A62 Signature	A63 Signature
U78	1	UP73	UP73
	2	0000	0000
	3	0000	0000
	4	0000	0000
	5	0000	0000
	6	0000	0000
	7	0000	0000
	8	0000	0000
	9	UP73	UP73
	10	0000	0000
	11	0000	0000
	12	0000	0000
	13	0000	0000
	14	UP73	UP73
U3	2	UP73	UP73
	3	UP73	UP73
	4	UP73	UP73
	5	0000	0000
	7	UP73	UP73
	8	0000	0000
	9	UP73	UP73
	10	UP73	UP73
	11	UP73	UP73
	12	UP73	UP73
U101	16	UP73	UP73
	1	UP73	UP73
	2	UP73	UP73
	3	UP73	UP73
	4	UP73	UP73
	5	0000	0000
	6	UP73	UP73
	7	0000	0000
	8	UP73	UP73
	9	0000	0000
	10	UP73	UP73
	11	UP73	UP73
	12	UP73	UP73
	13	UP73	UP73
U91	14	UP73	UP73
	1	UP73	UP73
	4	UP73	UP73
	6	0000	0000
	10	0000	0000
	13	0000	0000
	15	0000	0000
17	UP73	UP73	

**Table 9-16a. A62/63 Circuit Board, Signature Analysis Data (SA1a) Continued**

This signature analysis test is used to test the microprocessor and all functional sub-blocks. This test should be run first, after fault isolation to the A62/63 board is performed. +5V Signature = UP73				
Component	Pin	A62 Signature	A63 Signature	
U93	19	UP73	UP73	
	20	UP73	UP73	
	1	UP73	UP73	
	2	0000	UP73	
	4	UP73	UP73	
	6	0000	0000	
	8	0000	UP73	
	10	0000	0000	
	11	UP73	UP73	
	13	0000	0000	
	15	0000	UP73	
	17	UP73	UP73	
	19	UP73	UP73	
	20	UP73	UP73	
	U95	1	UP73	UP73
4		UP73	UP73	
6		UP73	0000	
7		UP73	UP73	
8		UP73	UP73	
9		UP73	0000	
10		0000	0000	
11		UP73	0000	
13		UP73	UP73	
19		0000	0000	
20		UP73	UP73	
U62		1	0000	0000
		2	0000	0000
		3	0000	0000
		4	UP73	UP73
	5	0000	0000	
	6	0000	0000	
	7	0000	0000	
	8	UP73	UP73	
	9	UP73	UP73	
	10	UP73	UP73	
	12	UP73	UP73	
	14	UP73	UP73	
	U100	1	UP73	UP73
		4	UP73	UP73
		5	UP73	UP73
6		UP73	UP73	
7		0000	0000	
11		UP73	UP73	
12		UP73	UP73	
13		UP73	UP73	
14		UP73	UP73	
U72		4	UP73	UP73

**Table 9-16a. A62/63 Circuit Board, Signature Analysis Data (SA1a) Continued**

This signature analysis test is used to test the microprocessor and all functional sub-blocks. This test should be run first, after fault isolation to the A62/63 board is performed.				
+5V Signature = UP73				
Component	Pin	A62 Signature	A63 Signature	
U81	6	UP73	UP73	
	7	0000	0000	
	11	UP73	UP73	
	12	UP73	UP73	
	14	UP73	UP73	
	1	UP73	UP73	
	2	UP73	UP73	
	3	UP73	UP73	
	4	UP73	UP73	
	5	0000	0000	
	6	UP73	UP73	
	7	0000	0000	
	12	0000	0000	
	13	UP73	UP73	
14	UP73	UP73		
U80	1	0000	0000	
	2	UP73	UP73	
	3	UP73	UP73	
	4	0000	0000	
	5	UP73	UP73	
	6	0000	0000	
	7	0000	0000	
	10	UP73	UP73	
	11	0000	0000	
	12	0000	0000	
	13	UP73	UP73	
	14	UP73	UP73	
	U75	1	UP73	UP73
		4	UP73	UP73
7		0000	0000	
9		UP73	UP73	
12		UP73	UP73	
14		UP73	UP73	
U37	1	0000	0000	
	2	UP73	UP73	
	3	0000	0000	
	4	UP73	UP73	
	5	UP73	UP73	
	6	0000	0000	
	7	0000	0000	
	8	UP73	UP73	
	9	0000	0000	
	10	UP73	UP73	
	11	0000	0000	
	12	UP73	UP73	
	13	0000	0000	
	14	UP73	UP73	

**Table 9-16a. A62/63 Circuit Board, Signature Analysis Data (SA1a) Contined**

This signature analysis test is used to test the microprocessor and all functional sub-blocks. This test should be run first, after fault isolation to the A62/63 board is performed. +5V Signature = UP73				
Component	Pin	A62 Signature	A63 Signature	
U70	1	0000	0000	
	2	0000	0000	
	3	0000	0000	
	4	0000	0000	
	5	0000	0000	
	6	0000	0000	
	7	0000	0000	
	8	UP73	UP73	
	9	0000	0000	
	10	UP73	UP73	
	12	UP8H	00UP	
	14	UP73	UP73	
	U76	1	UP73	UP73
		2	UP73	UP73
3		0000	0000	
4		0000	0000	
5		0000	0000	
6		UP73	UP73	
7		0000	0000	
8		UP73	UP73	
9		UP73	UP73	
10		0000	0000	
11		UP73	UP73	
12		0000	0000	
13		UP73	UP73	
14		UP73	UP73	
U63	1	UP73	UP73	
	2	0000	0000	
	3	0000	0000	
	4	UP73	UP73	
	5	0000	0000	
	6	UP73	UP73	
	7	0000	0000	
	10	UP73	UP73	
	12	UP73	UP73	
	14	UP73	UP73	
	U52	1	UP73	UP73
		2	UP73	UP73
		3	UP73	UP73
		4	0000	0000
5		UP73	UP73	
6		UP73	UP73	
7		0000	0000	
8		UP73	UP73	
9		UP73	UP73	
10		UP73	UP73	
11		UP73	UP73	

**Table 9-16a. A62/63 Circuit Board, Signature Analysis Data (SA1a) Continued**

This signature analysis test is used to test the microprocessor and all functional sub-blocks. This test should be run first, after fault isolation to the A62/63 board is performed.			
+5V Signature = UP73			
Component	Pin	A62 Signature	A63 Signature
U114	12	UP73	UP73
	13	UP73	UP73
	14	UP73	UP73
	1	0000	0000
	2	0000	0000
	3	0000	0000
	4	0000	0000
	5	0000	0000
	6	0000	0000
	7	0000	0000
	8	UP73	UP73
	9	0000	0000
	10	UP73	UP73
	12	0000	0000
14	UP73	UP73	

**Table 9-16b. A62/63 Circuit Board, Signature Analysis Data (SA1b)**

Move Signature Analyzer Start and Stop leads to A63TP6. Press A62SW1 or A63SW1 Reset switch. This signature analysis test checks the Bus Error Detection circuitry for faults.

+5V Signature = 6PCP

Component	Pin	A62 Signature	A63 Signature
U1	50	91FC	91FC
	51	3CPF	3CPF
	52	F9C2	F9C2
U111	1	A70F	A70F
	2	F9C2	F9C2
	3	0000	0000
U72	1	750C	750C
	2	750C	750C
	3	750C	750C
	4	6PCP	6PCP
	5	A70F	A70F
	6	6PCP	6PCP
	11	6PCP	6PCP
	12	6PCP	6PCP
U75	13	4455	4455
	8	A70F	A70F
	9	6PCP	6PCP
	10	F9C2	F9C2
	11	F9C2	F9C2
	12	6PCP	6PCP
	13	A70F	A70F

**Table 9-17a. A62/63 Circuit Board, Signature Analysis Data (SA2a)**

This signature analysis test is primarily used to test the "kernel" and to isolate functional subblocks from each other. This should be run after completing the A63 SA1 test.			
+5V Signature = AU47			
Component	Pin	A62 Signatere	A63 Signatere
U1	8	C471	C471
	9	P1H5	P1H5
	11	P1H5	P1H5
	12	C471	C471
U16	5	0000	0000
	15	0000	0000
U83	1	2U1C	2U1C
	2	2UF7	2UF7
	3	4HU2	4HU2
	4	55UF	55UF
	5	0000	0000
	6	AU47	AU47
	7	AU47	AU47
	8	0000	0000
	9	C471	C471
	10	AUF6	AUF6
	11	3580	3580
	12	2852	2852
	13	3775	3775
	14	4096	4096
	15	247A	247A
	16	AU47	AU47
U86	1	2U1C	2U1C
	2	2UF7	2UF7
	3	4HU2	4HU2
	4	011A	011A
	5	0000	0000
	6	AU47	AU47
	7	AU47	AU47
	8	0000	0000
	9	AU47	AU47
	10	AU47	AU47
	11	AU47	AU47
	12	AU47	AU47
	13	67HA	67HA
	14	9299	9299
	15	U459	U459
	16	AU47	AU47
U82	1	2U1C	2U1C
	2	2UF7	2UF7
	3	4HU2	4HU2
	4	0021	0021
	5	0000	0000
	6	4P92	4P92
	7	AU47	AU47
	8	0000	0000
	9	AU47	AU47



Table 9-17a. A62/63 Circuit Board, Signature Analysis Data (SA2a) Continued

This signature analysis test is primarily used to test the "kernel" and to isolate functional subblocks from each other. This should be run after completing the A63 SA1 test.			
+5V Signature = AU47			
Component	Pin	A62 Signature	A63 Signature
U85	10	9917	9917
	11	16F4	16F4
	12	1363	1363
	13	P5H1	P5H1
	14	8HP7	8HP7
	15	5CP0	5CP0
	16	AU47	AU47
	1	2U1C	2U1C
	2	2UF7	2UF7
	3	4HU2	4HU2
	4	2672	2672
	5	0000	0000
	6	4P92	4P92
	7	5F19	5F19
	8	0000	0000
	9	8CC0	8CC0
U102	10	0894	0894
	11	6668	6668
	12	10P0	10P0
	13	AU47	AU47
	14	9F7P	9F7P
	15	13C9	13C9
	16	AU47	AU47
	12	C295	C295
U103	19	C295	C295
	24	10P0	10P0
U35	24	10P0	10P0
	1	AP36	AP36
	2	A3CH	A3CH
	3	0000	0000
	4	0000	0000
	5	2768	2768
	6	54P6	54P6
	7	0000	0000
	8	0000	0000
	9	0000	0000
	11	0000	0000
	12	0000	0000
	13	0000	0000
	14	54P6	54P6
	15	CA67	CA67
	16	0000	0000
	17	0000	0000
	18	F931	F931
	U36	19	0000
1		AP36	AP36
2		467A	467A
4		6UA0	6UA0

**Table 9- 17a. A62/63 Circuit Board, Signature Analysis Data (SA2a) Continued**

This signature analysis test is primarily used to test the "kernel" and to isolate functional subblocks from each other. This should be run after completing the A63 SA1 test.			
+5V Signature = AU47			
Component	Pin	A62 Signature	A63 Signature
U112	6	6HA2	6HA2
	7	2U1C	2U1C
	8	2UF7	2UF7
	9	4HU2	4HU2
	11	CA71	CA71
	12	1357	1357
	13	4597	4597
	14	27HC	27HC
	16	PUA9	PUA9
	18	FUAA	FUAA
U95	19	0000	0000
	4	0894	0894
	9	8U38	8U38
U94	11	67HA	67HA
	7	97P2	97P2
	9	C1P6	C1P6
U73	11	C1P6	C1P6
	13	97P2	97P2
	1	AU47	AU47
	3	5F19	5F19
	4	AU47	AU47
	5	C1P6	C1P6
	9	97P2	97P2
	10	AU47	AU47
	11	8CC0	8CC0
	13	AU47	AU47
U74	1	AU47	AU47
	2	AU47	AU47
	3	AU47	AU47
	4	AU47	AU47
	6	26P8	26P8
	9	AU47	AU47
	10	26P8	26P8
	12	26P8	26P8
	13	26P8	26P8
	1	AU47	AU47
U110	6	0000	0000
	7	0000	0000
	9	AU47	AU47
	10	9299	9299
	11	C471	C471
	12	AU47	AU47
	13	26P8	26P8
	14	26P8	26P8
	1	AU47	AU47
	3	6668	6668
4	AU47	AU47	
5	U807	U807	

**Table 9-17a. A62/63 Circuit Board, Signature Analysis Data (SA2a) Continued**

This signature analysis test is primarily used to test the "kernel" and to isolate functional subblocks from each other. This should be run after completing the A63 SA1 test.			
+5V Signature = AU47			
Component	Pin	A62 Signature	A63 Signature
U111	9	F4U8	F4U8
	10	AU47	AU47
	11	6668	6668
	13	AU47	AU47
U62	8	0000	0000
	9	F4U8	F4U8
	10	6CCU	6CCU
U100	11	6CCU	6CCU
	8	9F7P	9F7P
	9	9F7P	9F7P
	10	AU47	AU47
U72	1	AU47	AU47
	2	C295	C295
	3	C295	C295
	8	C295	C295
	9	3580	3580
	10	2852	2852
U81	1	0021	0021
	2	0021	0021
	3	0021	0021
	4	0000	0000
	8	0021	0021
	9	0021	0021
	10	0021	0021
	1	AU47	AU47
	2	AU47	AU47
	3	AU47	AU47
U53	4	57P2	57P2
	5	U8A5	U8A5
	6	AU47	AU47
	8	UFHP	UFHP
	9	3775	3775
	10	4096	4096
	11	247A	247A
	12	4P92	4P92
	13	P1H5	P1H5
	1	9299	9299
	2	8U38	8U38
	3	9299	9299
	4	AU47	AU47
5	4679	4679	
6	AU47	AU47	
8	98UU	98UU	
9	4P92	4P92	
10	9299	9299	
11	98UU	98UU	
12	A7AF	A7AF	
13	98UU	98UU	

**Table 9-17a. A62/63 Circuit Board, Signature Analysis Data (SA2a) Continued**

This signature analysis test is primarily used to test the "kernel" and to isolate functional subblocks from each other. This should be run after completing the A63 SA1 test.				
+5V Signature = AU47				
Component	Pin	A62 Signature	A63 Signature	
U84	1	0000	0000	
	2	P1H5	P1H5	
	3	H2PF	H2PF	
	4	467A	467A	
	5	099A	099A	
	6	9940	9940	
	7	3111	3111	
	8	6UA0	6UA0	
	12	6UA0	6UA0	
	13	9U27	9U27	
	14	9940	9940	
	15	A7AF	A7AF	
	16	467A	467A	
	17	P1H5	P1H5	
	18	P1H5	P1H5	
	19	AP36	AP36	
	U80	1	AU47	AU47
		2	0000	0000
		3	AU47	AU47
4		0000	0000	
5		AU47	AU47	
6		0000	0000	
8		5399	5399	
9		UFHP	UFHP	
12		4P92	4P92	
13		P1H5	P1H5	
U75		4	AU47	AU47
		U70	1	0000
U76		2	0000	0000
	3	0000	0000	
	4	0000	0000	
	5	0000	0000	
	6	0000	0000	
	8	0000	0000	
	9	0000	0000	
	10	0000	0000	
	11	U6UP	U6UP	
	12	23P7	23P7	
	13	U6UP	U6UP	
	4	9U27	9U27	
	5	A7AF	A7AF	
6	AU47	AU47		
8	AP36	AP36		
9	AU47	AU47		
10	0171	0171		
11	AP36	AP36		
12	0171	0171		
13	AU47	AU47		

**Table 9-17a. A62/63 Circuit Board, Signature Analysis Data (SA2a)**

This signature analysis test is primarily used to test the "kernel" and to isolate functional subblocks from each other. This should be run after completing the A63 SA1 test.				
+5V Signature = AU47				
Component	Pin	A62 Signature	A63 Signature	
U2	1	AU47	AU47	
	2	1F50	1F50	
	3	08PC	08PC	
	4	AU47	AU47	
	6	3223	3223	
	8	3223	3223	
	10	AU47	AU47	
	11	08PC	08PC	
	12	3FF2	3FF2	
	13	AU47	AU47	
	U63	1	9F7P	9F7P
		2	0000	0000
		3	0000	0000
4		13C9	13C9	
5		0171	0171	
U54	1	9299	9299	
	2	26P8	26P8	
	3	AU47	AU47	
	4	4679	4679	
	5	26P8	26P8	
	6	CP37	CP37	
	8	26P8	26P8	
	9	0000	0000	
	10	26P8	26P8	
	11	4679	4679	
	12	P1H5	P1H5	
	13	A7AF	A7AF	
	U52	5	8U38	8U38
6		8U38	8U38	
U114	1	0000	0000	
	2	0000	0000	
	3	0000	0000	

**Table 9-17b. A62/63 Circuit Board, Signature Analysis Data (SA1b)**

Set Quality to failing pulse and connect Signature Analyzer lead to component pin as spec below. This signature analysis test check the buffers which connect the microprocessor to the rest of the digital portions of the instrument. Use this routine to troubleshoot the appropriate buffers.			
+5V Signature = 9515			
Component	Pin	A62 Signature	A63 Signature
Quality to U33 pin 19			
U33	1	5U9U	5U9U
	2	9A33	9A33
	3	3466	3466
	4	68FH	68FH
	5	H19A	H19A
	6	A334	A334
	7	4668	4668
	8	8FH1	8FH1
	9	19A3	19A3
	11	19A3	19A3
	12	8FH1	8FH1
	13	4668	4668
	14	A334	A334
	15	H19A	H19A
	16	68FH	68FH
	17	3466	3466
	18	9A33	9A33
	U34	1	5U9U
2		U39A	U39A
3		P734	P734
4		FP68	FP68
5		9FH1	9FH1
6		39A3	39A3
7		7346	7346
8		P68F	P68F
9		FH19	FH19
11		FH19	FH19
12		P68F	P68F
13		7346	7346
14		39A3	39A3
15		9FH1	9FH1
16		FP68	FP68
17		P734	P734
18		U39A	U39A
Quality to U50 pin 19			
+5V Signature = 9515			
U50	1	5U9U	5U9U
	2	9286	9286
	3	C913	C913
	4	2FH9	2FH9
	5	663F	663F
	6	F34P	F34P
	7	91U7	91U7
	8	C8AC	C8AC

**Table 9-17b. A62/63 Circuit Board, Signature Analysis Data (SA1b) Continued**

Set Quality to failing pulse and connect Signature Analyzer lead to component pin as spec below. This signature analysis test check the buffers which connect the microprocessor to the rest of the digital portions of the instrument. Use this routine to troubleshoot the appropriate buffers.			
+5V Signature = 9515			
Component	Pin	A62 Signature	A63 Signature
U51	9	AF05	AF05
	11	AF05	AF05
	12	C8AC	C8AC
	13	91U7	91U7
	14	F34P	F34P
	15	663F	663F
	16	2FH9	2FH9
	17	C913	C913
	18	9286	9286
	1	5U9U	5U9U
	2	463F	463F
	3	H34P	H34P
	4	19U7	19U7
	5	UFAC	UFAC
	6	8P05	8P05
	7	3752	3752
	8	6CU9	6CU9
	9	F5AF	F5AF
11	F5AF	F5AF	
12	6CU9	6CU9	
13	3752	3752	
14	8P05	8P05	
15	UFAC	UFAC	
16	19U7	19U7	
17	H34P	H34P	
18	463F	463F	
Quality to U92 pin 19 +5 V Signature = PCU5			
U92	1	0000	0000
	2	5FP9	5FP9
	3	AP74	AP74
	4	H73A	H73A
	5	6C9H	6C9H
	6	C5FP	C5FP
	7	5AP7	5AP7
	8	2H73	2H73
	9	96C9	96C9
	10	0000	0000
	11	96C9	96C9
	12	2H73	2H73
	13	5AP7	5AP7
	14	C5FP	C5FP
	15	6C9H	6C9H
	16	H73A	H73A
	17	AP74	AP74
	18	5FP9	5FP9

**Table 9-17b. A62/63 Circuit Board, Signature Analysis Data (SA1b) Continued**

Set Quality to failing pulse and connect Signature Analyzer lead to component pin as spec below. This signature analysis test check the buffers which connect the microprocessor to the rest of the digital portions of the instrument. Use this routine to troubleshoot the appropriate buffers.				
+5V Signature = 9515				
Component	Pin	A62 Signature	A63 Signature	
Qualify to U90 pin 19 +5V Signature = 4C63				
U90	1	PH5U	PH5U	
	2	F28U	F28U	
	3	UAC7	UAC7	
	4	66AC	66AC	
	5	A8A5	A8A5	
	6	4UA2	4UA2	
	7	3F21	3F21	
	9	60U5	60U5	
	11	60U5	60U5	
	12	05P0	05P0	
	13	3F21	3F21	
	14	4UA2	4UA2	
	15	A8A5	A8A5	
	16	66AC	66AC	
	17	UAC7	UAC7	
	18	F28U	F28U	
	Qualify to U96 pin 19 +5V Signature = P733			
	U96	1	14AA	14AA
2		U830	U830	
3		UF18	UF18	
4		UP0F	UP0F	
5		7U06	7U06	
6		3U83	3U83	
7		1UF1	1UF1	
8		0UP0	0UP0	
9		07U0	07U0	
11		07U0	07U0	
12		0UP0	0UP0	
13		1UF1	1UF1	
14		3U83	3U83	
15		7U06	7U06	
16		UP0F	UP0F	
17		UF18	UF18	
18		U830	U830	
Qualify to U93 pin 19 +5V Signature = 0001				
U93	1	0000	0000	
	3	0001	0001	
	5	0001	0001	
	7	0000	0000	
	9	0001	0001	
	12	0001	0001	
	16	0001	0001	



**Table 9-17b. A62/63 Circuit Board, Signature Analysis Data (SA1b) Continued**

Set Quality to failing pulse and connect Signature Analyzer lead to component pin as spec below. This signature analysis test check the buffers which connect the microprocessor to the rest of the digital portions of the instrument. Use this routine to troubleshoot the appropriate buffers.

+5V Signature = 9515

Component	Pin	A62 Signature	A63 Signature
U52	18	0001	0001
	2	0001	0001
	3	0001	0001
	4	0000	0000
	5	0000	0000
	6	0000	0000
	8	0001	0001
	9	0001	0001
	10	0000	0000
	11	0001	0001
	12	0001	0001
	13	0000	0000

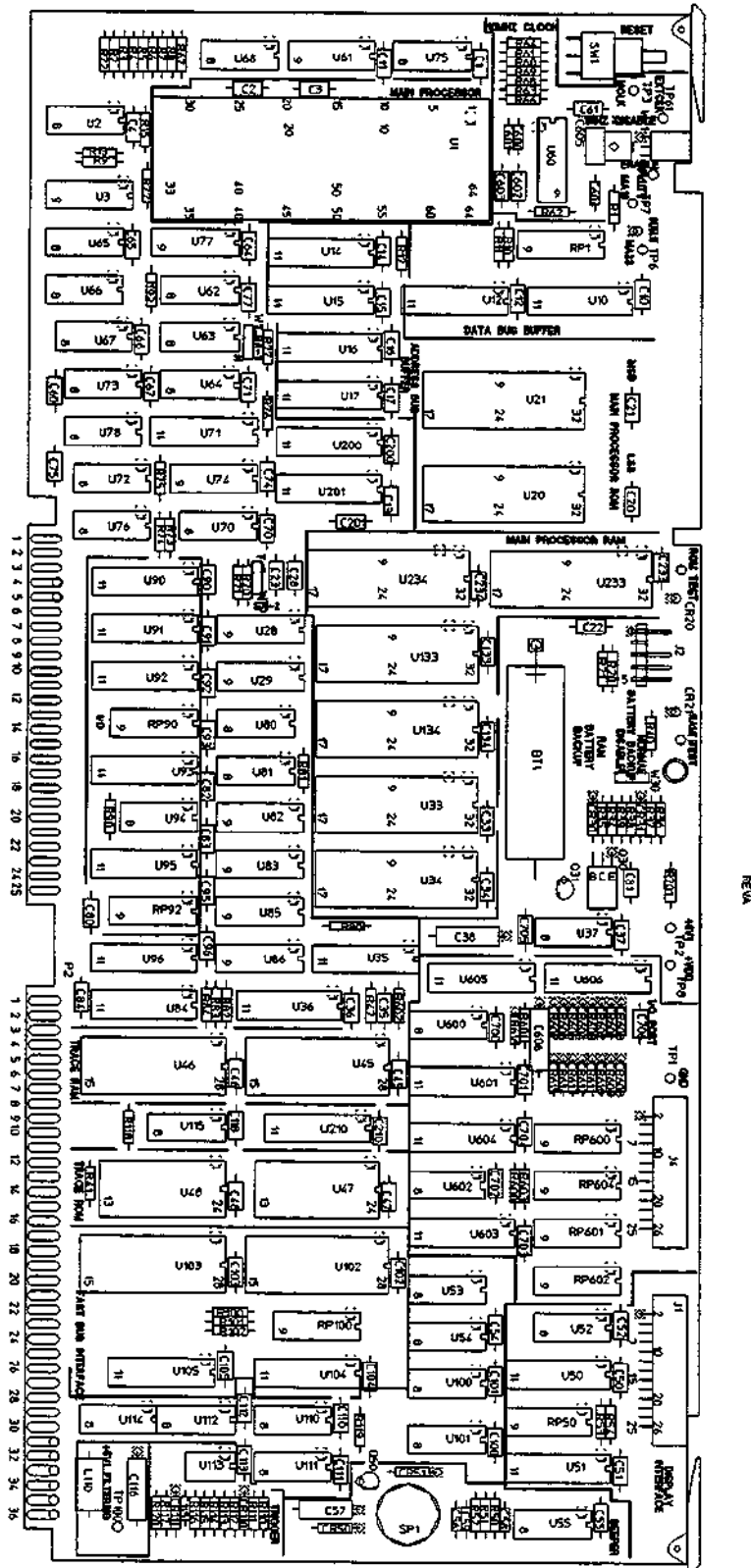
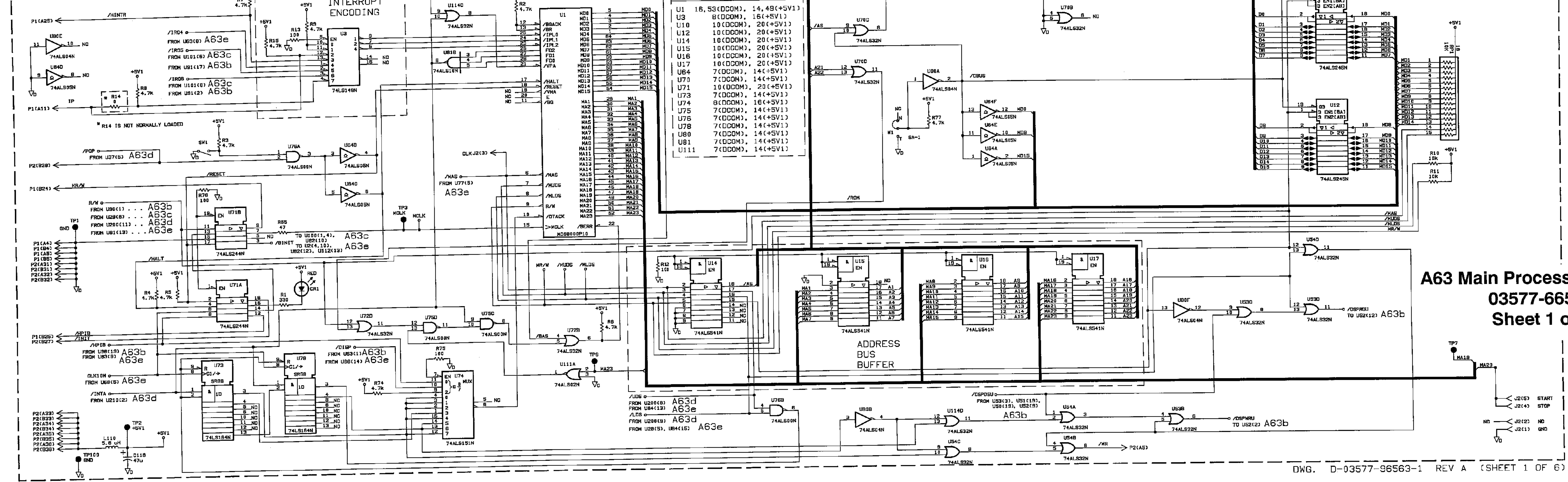


Figure 9-24. A62/63 Component Locator

IC	+5V1	+VDD	GND	Bypass Cap	
				Desig.	Value
U1	14,49		16,53	C14,15	0.1
U2	20		1,10,15,19	C31	0.1
U3	20		10	C20	0.1
U4	20		10	C21	0.1
U5	20		1,10,19	C22	0.1
U6	20		1,10,19	C27	0.1
U7	20		1,10,19	C30	0.1
U9	16		8	C61	0.1
U10	16		8		
U12	16		8		
U12	16		8		
U13	24		12	C48	0.1
U14	24		12		
U15		24	12	C59	0.1
U16		24	12	C60	0.1
U17		24	12	C62	0.1
U18		24	12	C63	0.1
U19	28		14	C32	0.1
U20	28		14	C33	0.1
U21	28		14	C36	0.1
U22	28		14	C37	0.1
U23	28		14	C39	0.1
U24	28		14	C42	0.1
U25	28		14	C41	0.1
U31	8		21,22, 23		
U32	8		21,22, 23		
U33	20		10	C72	0.1
U34	20		10	C73	0.1
U35	20		10	C66	0.1
U36	20		10,17	C69	0.1
U37	2,4,10, 12,24	7		C75	0.1
U38	1,10,14		2,7		
U39	20		10	C70	0.1
U40	20		10	C71	0.1
U41	20		10	C49	0.1
U42	20		10	C44	0.1
U43	20		10	C58	
U44	20		10	C45	0.1
U45	20		10	C52	0.1
U46	10,11,12 16		5,8	C16	0.1
U47	20		10,19	C55	0.1
U48	1,10		8	C17	0.1
U49	4,11,16		1,8,9 10,14,15	C18	0.1
U50	1,4,10 13,14		7		
U51	14		7		
U52	16		7,8	C38	0.1

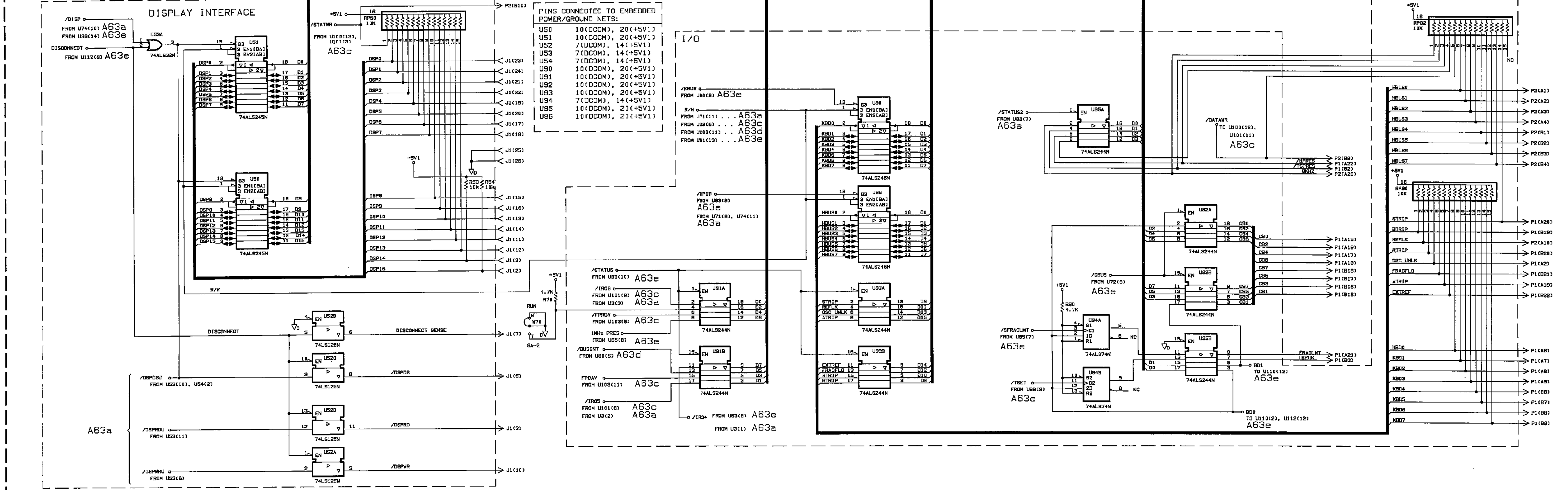
IC	+5V1	+VDD	GND	Bypass Cap	
				Desig.	Value
U53	1,4,13 10,14		7	C76	0.1
U54	8		4		
U55	14		7	C77	0.1
U56	4,14		7		
U57	14		7		
U58	14		7		
U59	14		7	C40	0.1
U60	14		2,7,12	C29	0.1
U61	14		7		
U62	20		1,10,11	C78	0.1
U63	14		7		
U64	14		7,11		
U65	14		7,9	C28	0.1
U66	2,14		7	C35	0.1
U67		14	1,3,7,9 11,13		
U68	14		7	C34	0.1
U69	10,14		7		
U70	1,13,14		7	C13	0.1
U71		24	12	C64	0.1
U72		24	12	C65	0.1
U77	14		2,7,12	C19	0.1
U78	14		2,7,12	C24	0.1
U79	10,12,14		2,3,7		
U80	14		7		
U81		24	12	C67	0.1
U82		24	12	C68	0.1
U83	20		10	C25	0.1
U84	20		10	C26	0.1
U85	14		4,7		
U86	1,4,14		7,9,10, 12,13		

P/0  
**A63**  
 MAIN PROCESSOR MEMORY  
 03577-66583 REV A  
 03577-66562 REV A



**A63 Main Processor Memory**  
 03577-66563  
 Sheet 1 of 6





PINS CONNECTED TO EMBEDDED POWER/GROUND NETS:

U50	10(DCCM), 20(+5V1)
U51	10(DCCM), 20(+5V1)
U52	7(DCCM), 14(+5V1)
U53	7(DCCM), 14(+5V1)
U54	7(DCCM), 14(+5V1)
U90	10(DCCM), 20(+5V1)
U91	10(DCCM), 20(+5V1)
U92	10(DCCM), 20(+5V1)
U93	10(DCCM), 20(+5V1)
U94	7(DCCM), 14(+5V1)
U95	10(DCCM), 20(+5V1)
U96	10(DCCM), 20(+5V1)

I/O

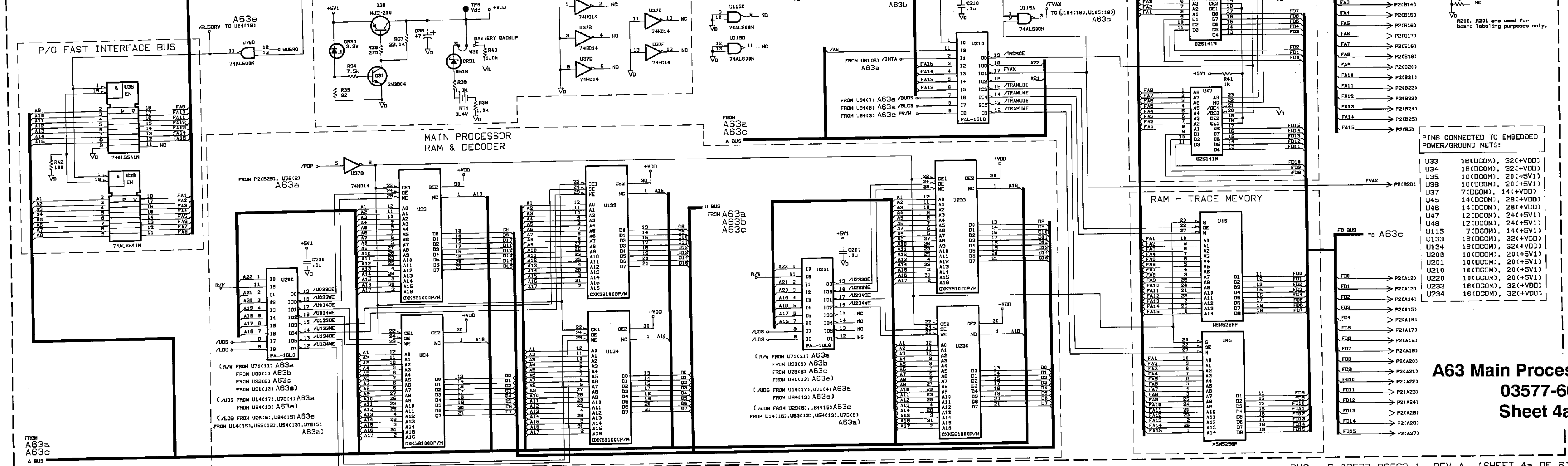
/BUS	FROM U80(8) A63e
R/W	FROM U71(11) ... A63a
	FROM U28(6) ... A63c
	FROM U20(11) ... A63d
	FROM U81(13) ... A63e
/NP18	FROM U93(9) A63e
	FROM U71(8), U74(11) A63a

/STATUS	FROM U3(10) A63e
/IRO8	FROM U101(8) A63c
	FROM U3(3) A63a
/FPROV	FROM U103(5) A63c
1MHz PRES	FROM U6(8) A63e
/BUSNT	FROM U80(8) A63c
FDAV	FROM U103(11) A63c
/IRO5	FROM U101(6) A63c
	FROM U3(2) A63a
/IRO4	FROM U6(8) A63e
	FROM U3(1) A63a

**A63**  
Main Processor  
Memory  
03577-66563  
Sheet 2 of 6



P/O MAIN PROCESSOR MEMORY  
**A63** 03577-66563 REV A  
 \* SCHEMATIC FOR 03577-66563 BOARD ONLY \*



PINS CONNECTED TO EMBEDDED POWER/GROUND NETS:

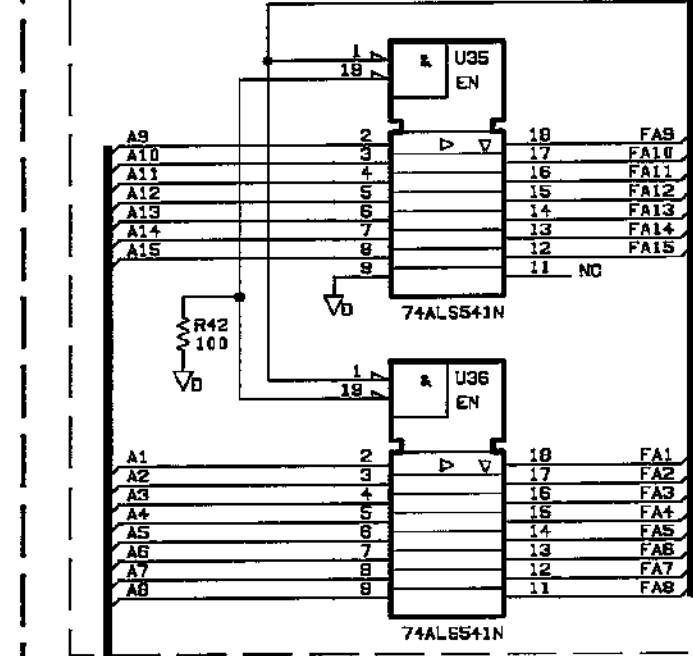
U33	16(DCOM), 32(+VDD)
U34	16(DCOM), 32(+VDD)
U35	10(DCOM), 20(+5V1)
U36	10(DCOM), 20(+5V1)
U37	7(DCOM), 14(+VDD)
U45	14(DCOM), 28(+VDD)
U46	14(DCOM), 28(+VDD)
U47	12(DCOM), 24(+5V1)
U48	12(DCOM), 24(+5V1)
U115	7(DCOM), 14(+5V1)
U133	16(DCOM), 32(+VDD)
U134	16(DCOM), 32(+VDD)
U200	10(DCOM), 20(+5V1)
U201	10(DCOM), 20(+5V1)
U210	10(DCOM), 20(+5V1)
U220	10(DCOM), 20(+5V1)
U233	16(DCOM), 32(+VDD)
U234	16(DCOM), 32(+VDD)

**A63 Main Processor Memory**  
 03577-66563  
 Sheet 4a of 6

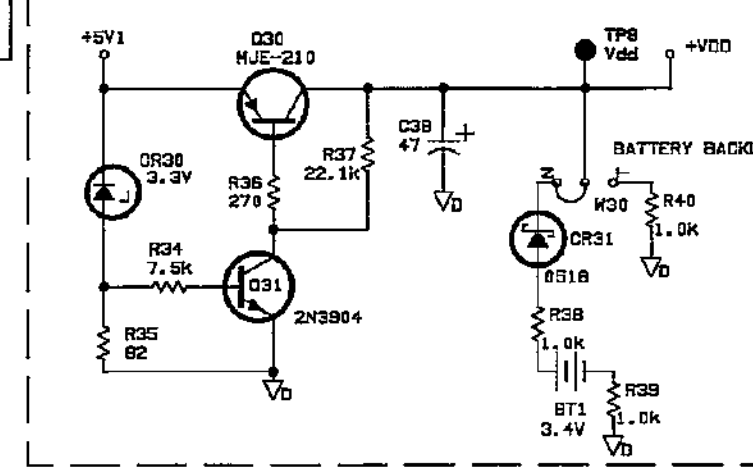


\* SCHEMATIC FOR 03577-66562 BOARD ONLY \*

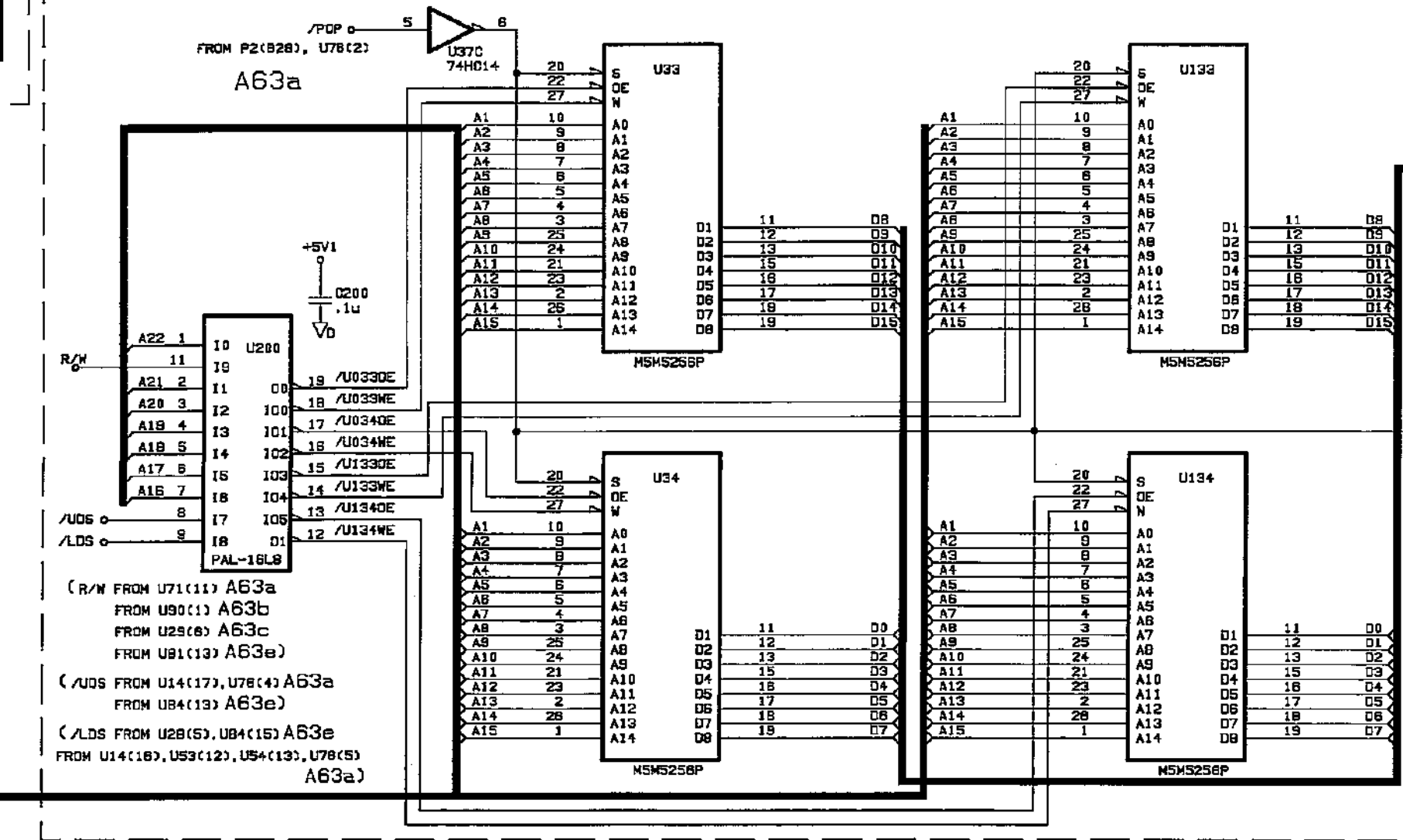
P/O FAST INTERFACE BUS



RAM BATTERY BACKUP



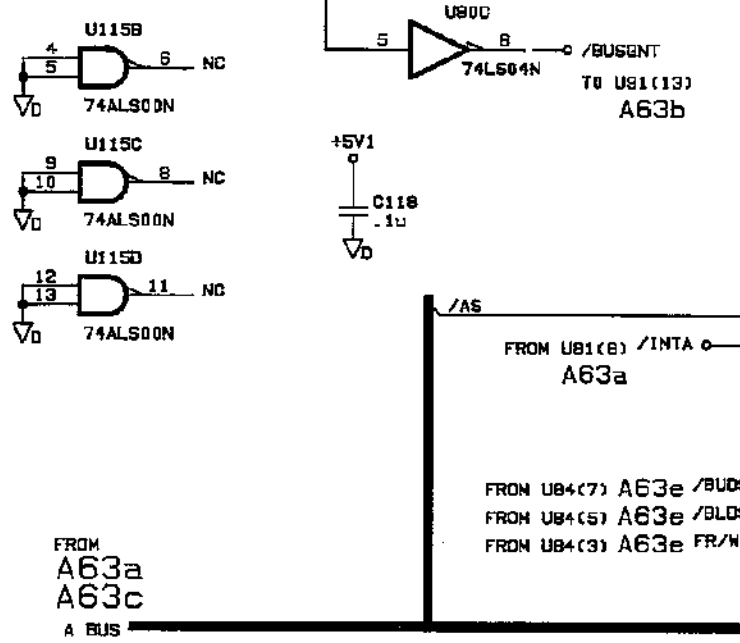
MAIN PROCESSOR RAM & DECODER



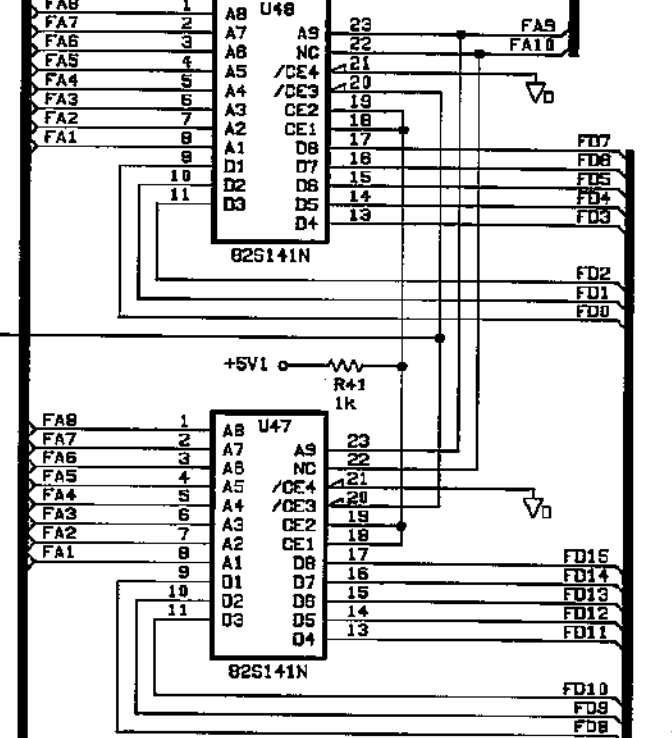
(R/W FROM U71(11) A63a  
FROM U90(1) A63b  
FROM U29(8) A63c  
FROM U91(13) A63e)

(A/D5 FROM U14(17), U78(4) A63a  
FROM U84(13) A63e)

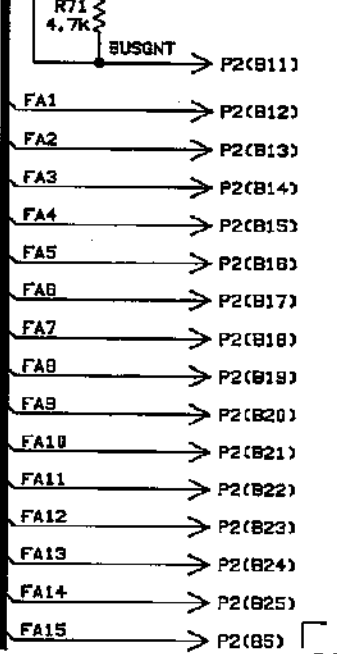
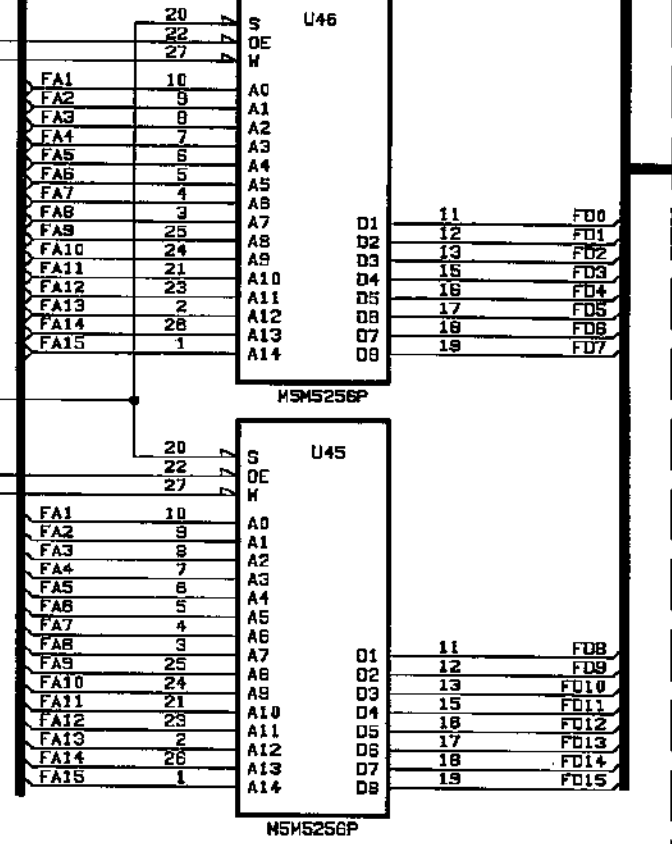
(A/D5 FROM U28(5), U84(15) A63e  
FROM U14(18), U33(12), U54(13), U78(5) A63a)



ROM - TRACE MEMORY



RAM - TRACE MEMORY



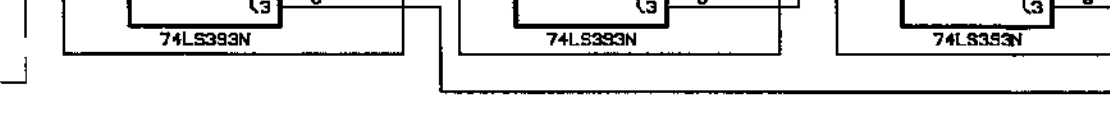
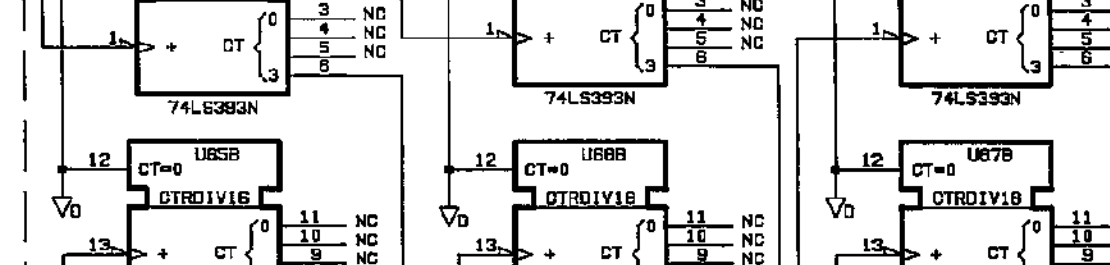
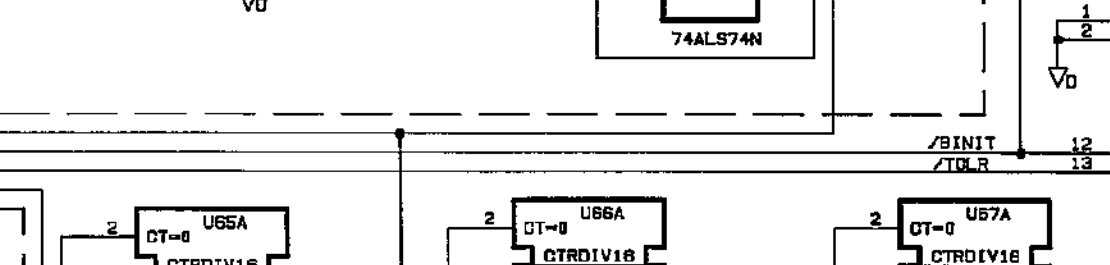
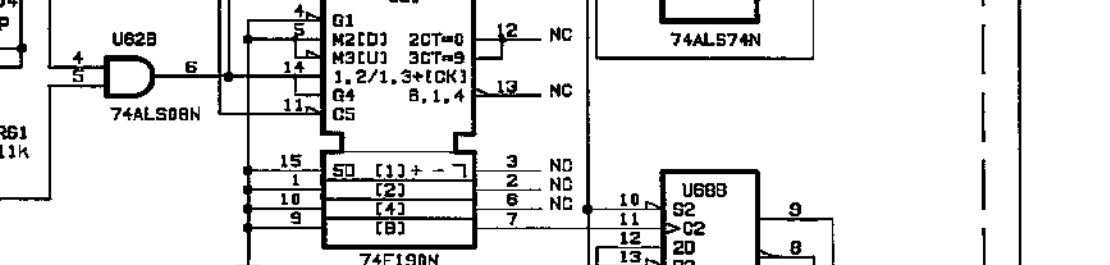
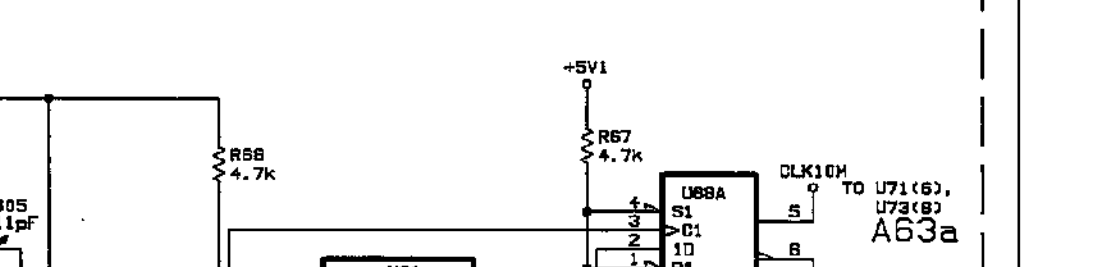
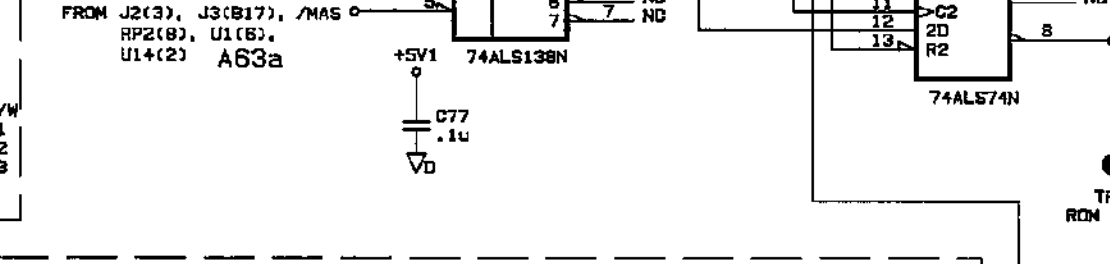
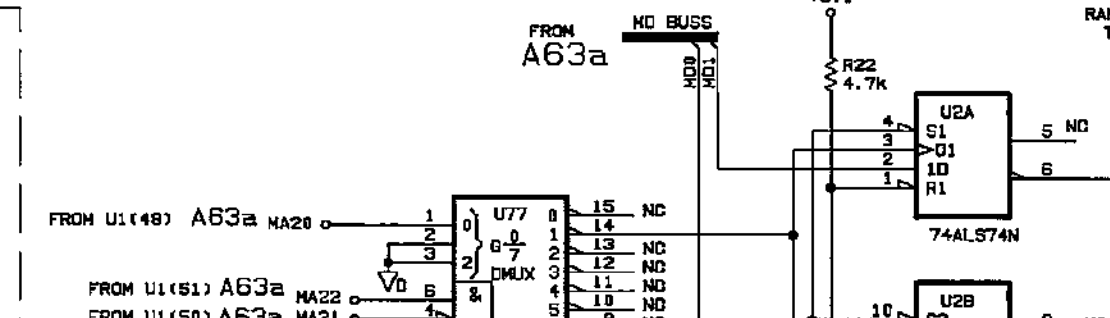
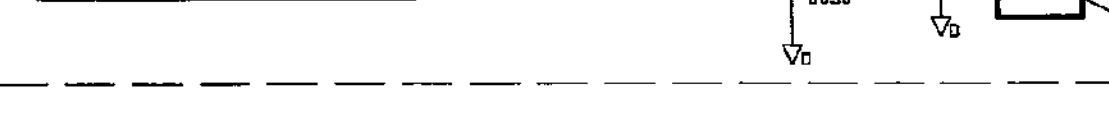
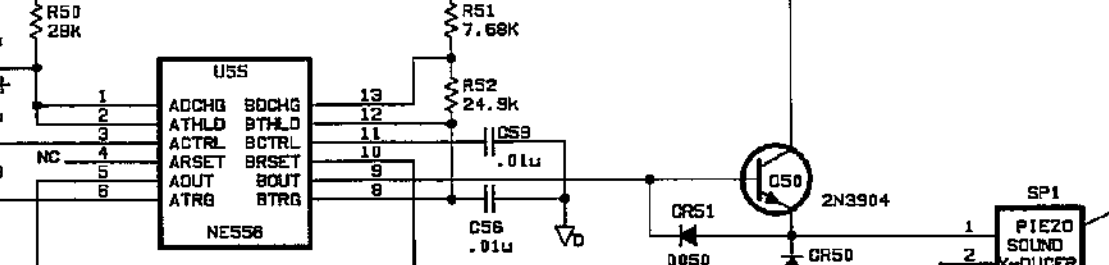
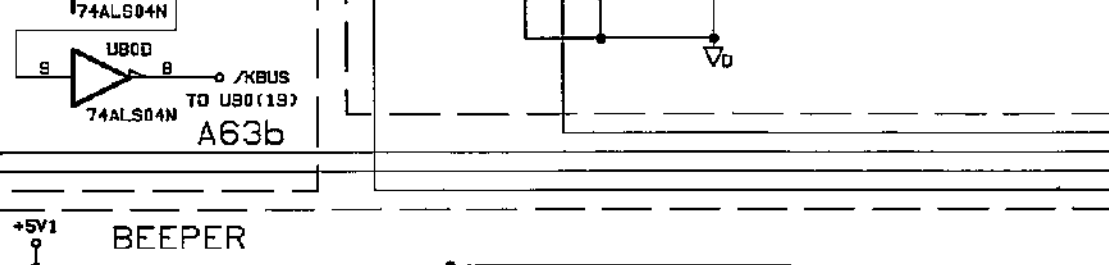
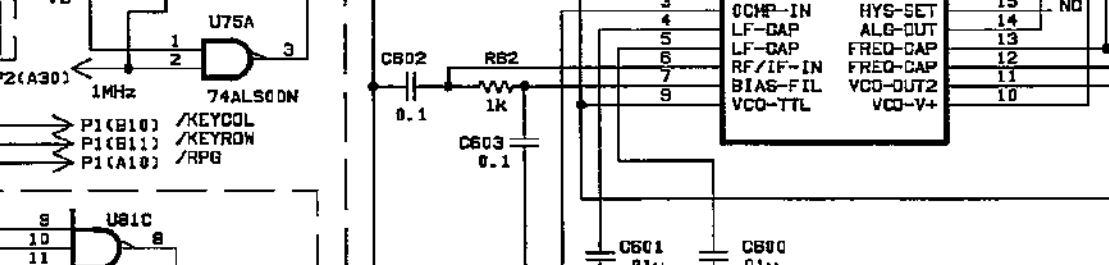
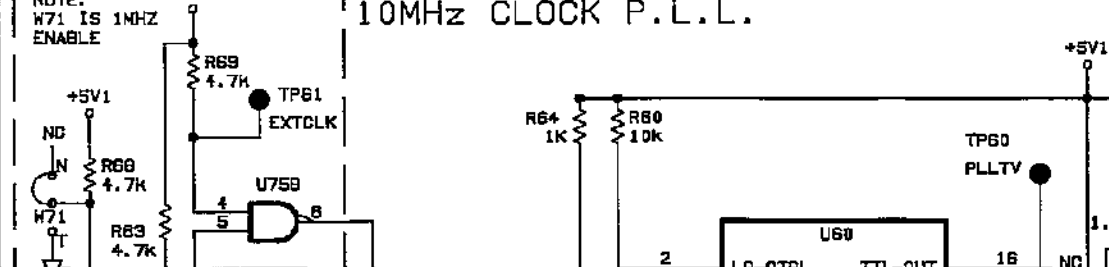
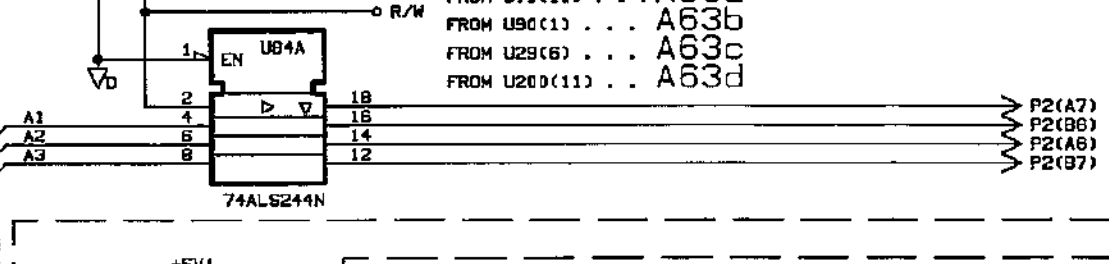
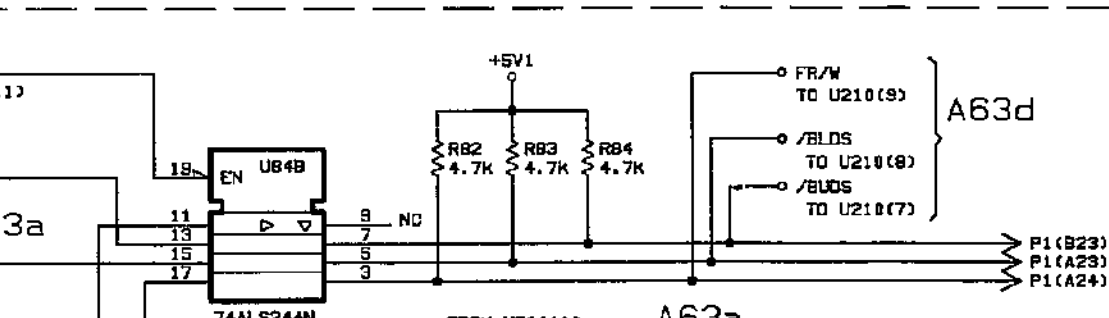
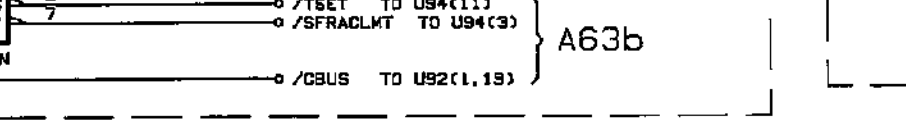
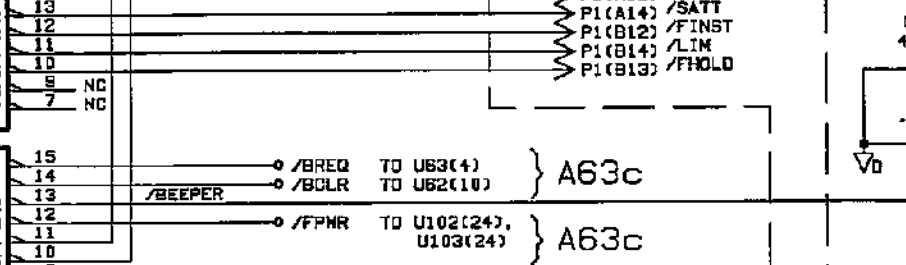
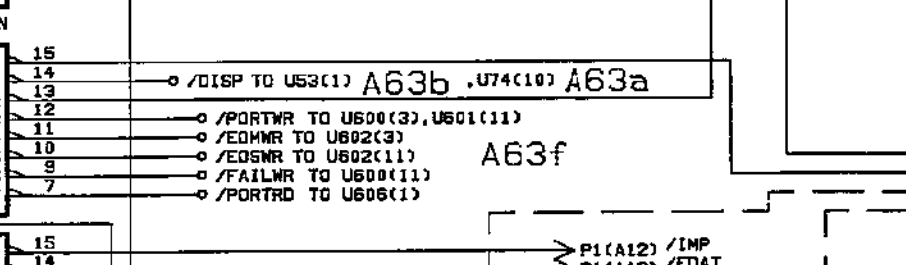
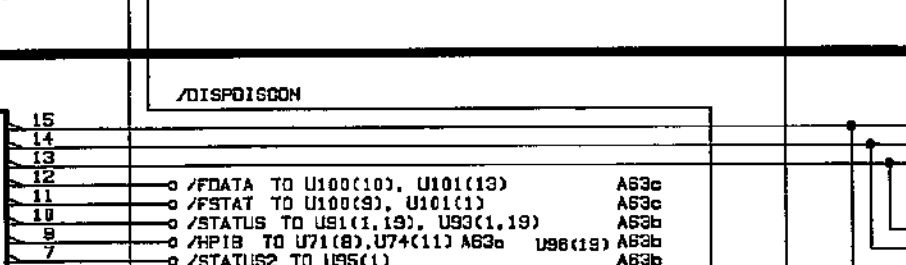
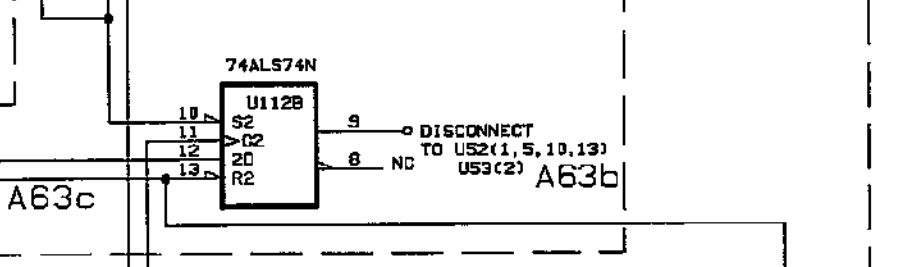
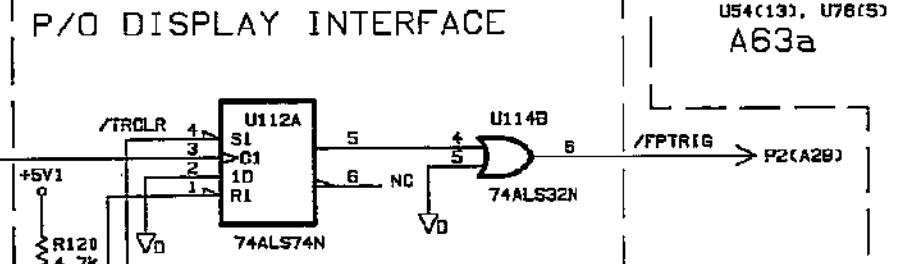
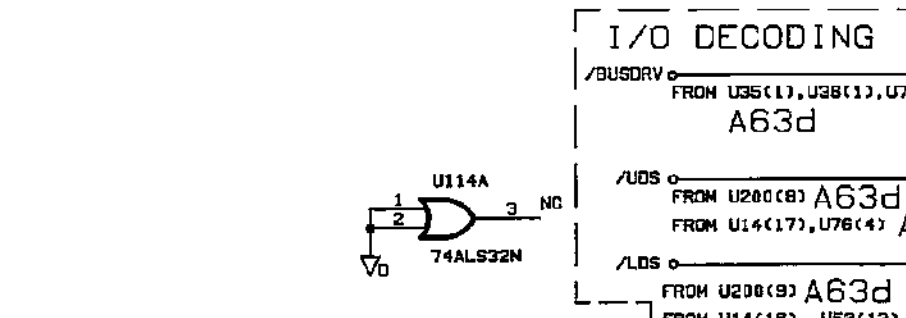
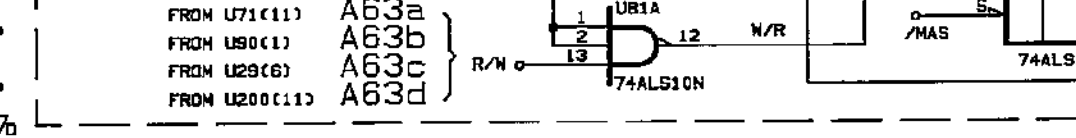
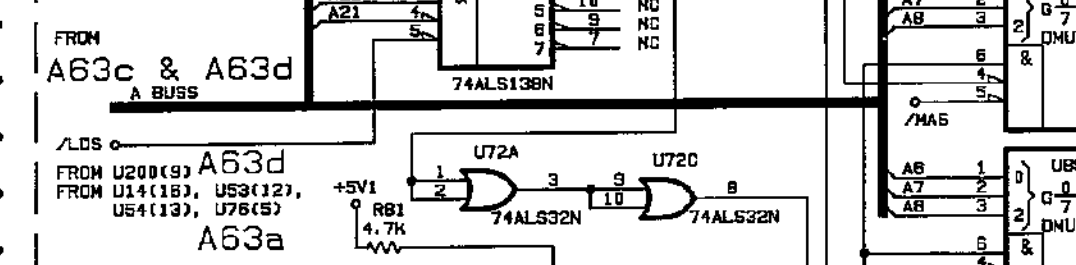
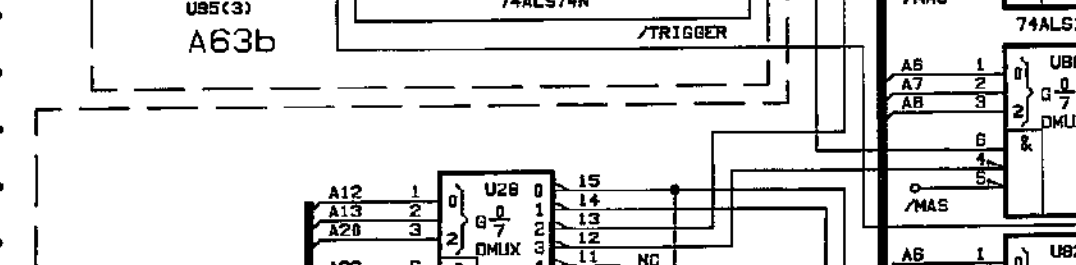
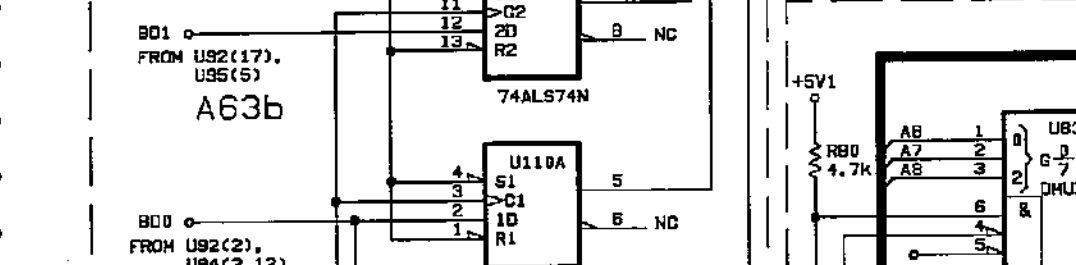
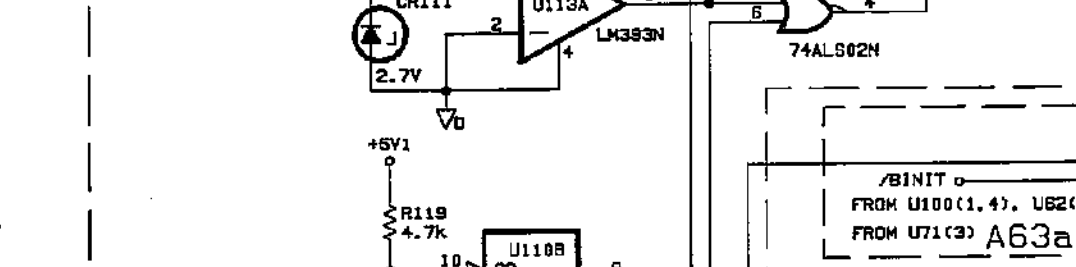
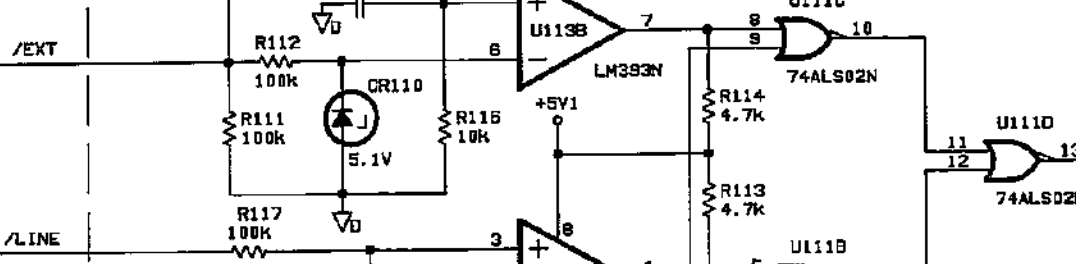
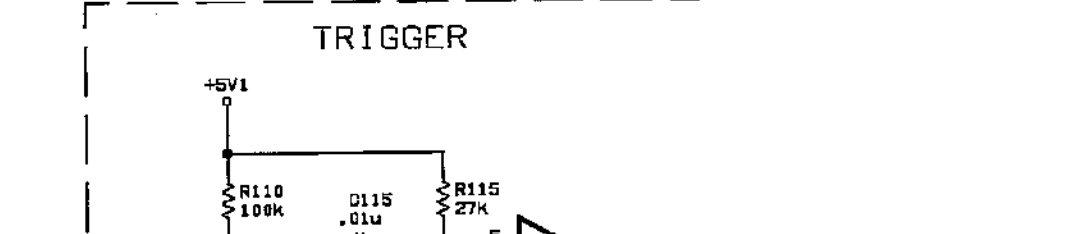
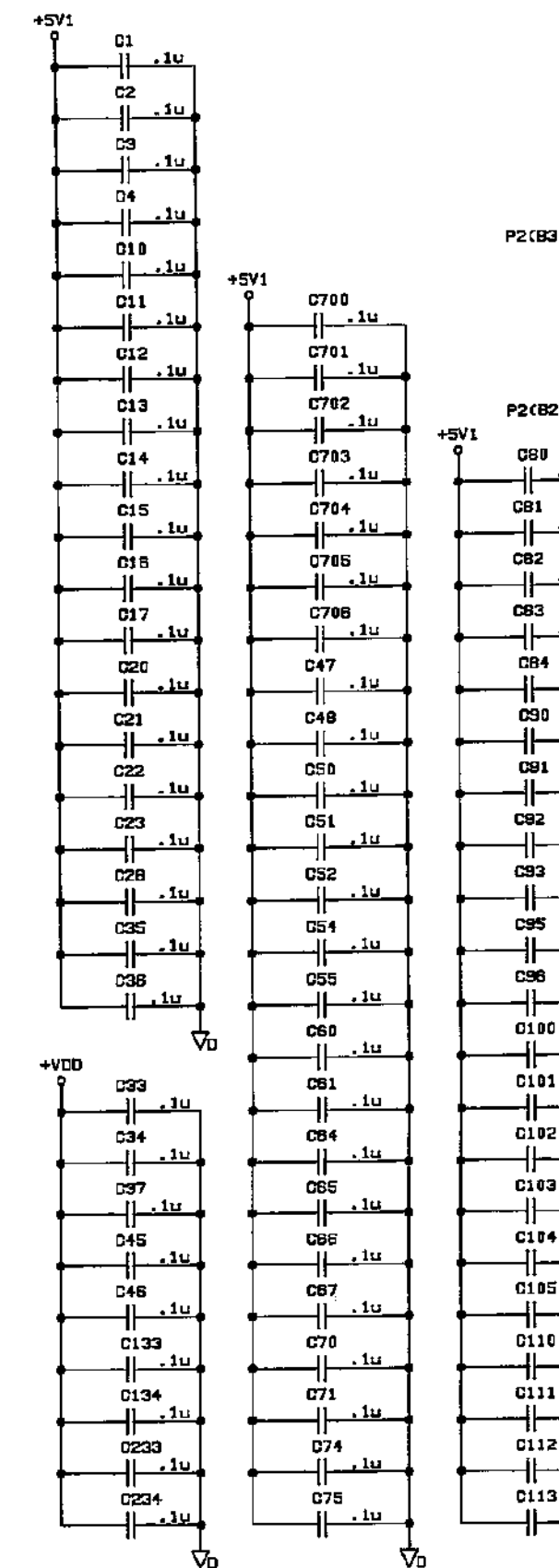
R200 and R201 are for board labeling purposes only.

PINS CONNECTED TO EMBEDDED POWER/GROUND NETS:

U33	16 (DCOM), 32 (+VDD)
U34	16 (DCOM), 32 (+VDD)
U35	10 (DCOM), 20 (+5V1)
U36	10 (DCOM), 20 (+5V1)
U37	7 (DCOM), 14 (+VDD)
U45	14 (DCOM), 28 (+VDD)
U46	14 (DCOM), 28 (+VDD)
U47	12 (DCOM), 24 (+5V1)
U48	12 (DCOM), 24 (+5V1)
U115	7 (DCOM), 14 (+5V1)
U133	16 (DCOM), 32 (+VDD)
U134	16 (DCOM), 32 (+VDD)
U200	10 (DCOM), 20 (+5V1)
U201	10 (DCOM), 20 (+5V1)
U210	10 (DCOM), 20 (+5V1)
U220	10 (DCOM), 20 (+5V1)
U233	16 (DCOM), 32 (+VDD)
U234	16 (DCOM), 32 (+VDD)

A63 Main Processor Memory  
03577-66562  
Sheet 4b of 6

**A63** MAIN PROCESSOR MEMORY  
03577-66563 REV A  
03577-66562 REV A

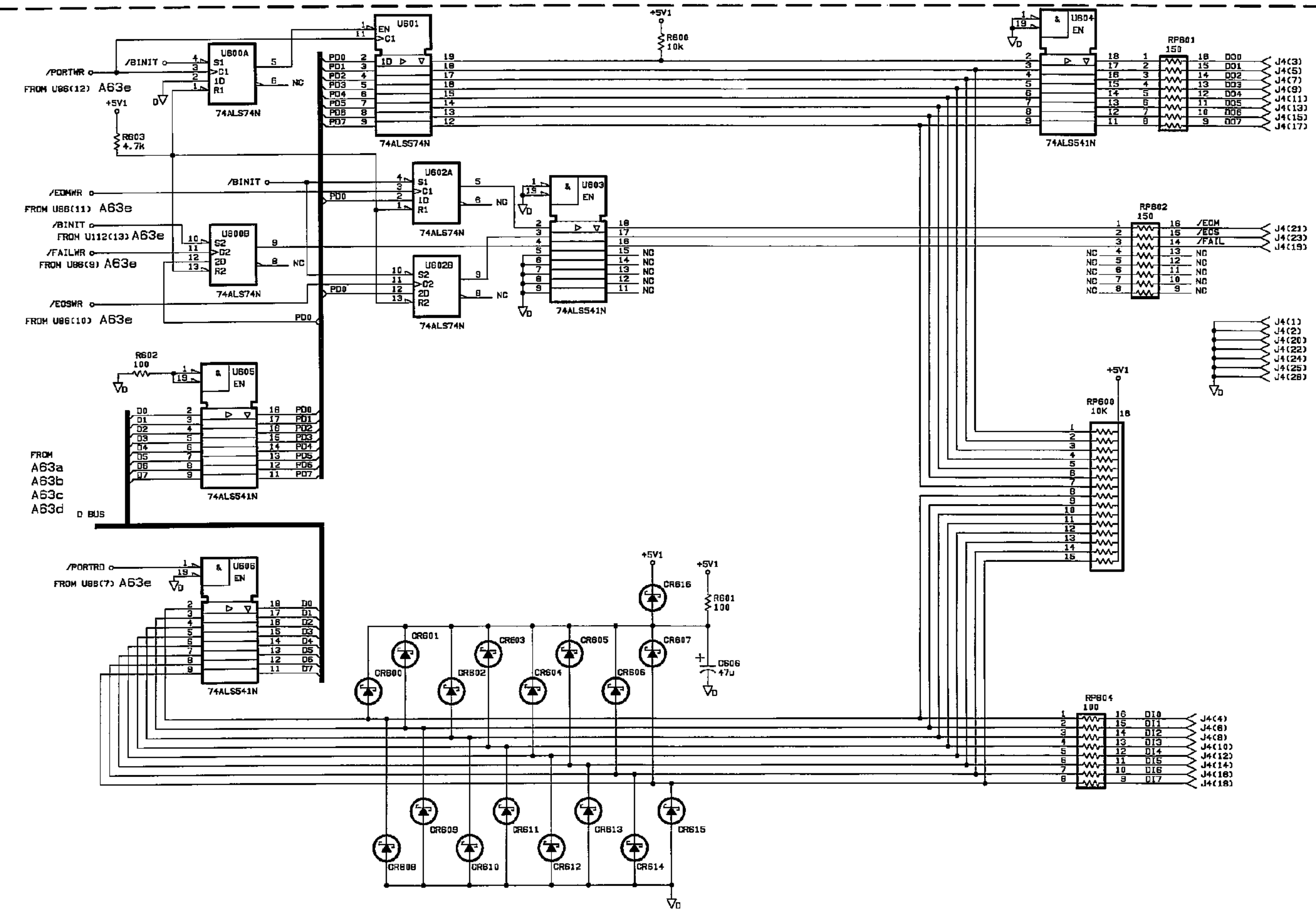


**PINS CONNECTED TO EMBEDDED POWER/GROUND NETS:**

U2	7(DCOM), 14(+5V1)
U28	8(DCOM), 16(+5V1)
U55	7(DCOM), 14(+5V1)
U60	8(DCOM), 1(+5V1)
U61	8(DCOM), 16(+5V1)
U62	7(DCOM), 14(+5V1)
U65	7(DCOM), 14(+5V1)
U66	7(DCOM), 14(+5V1)
U67	7(DCOM), 14(+5V1)
U68	7(DCOM), 14(+5V1)
U72	7(DCOM), 14(+5V1)
U75	7(DCOM), 14(+5V1)
U77	7(DCOM), 16(+5V1)
U82	8(DCOM), 16(+5V1)
U83	8(DCOM), 16(+5V1)
U84	10(DCOM), 20(+5V1)
U85	8(DCOM), 16(+5V1)
U86	8(DCOM), 16(+5V1)
U110	7(DCOM), 14(+5V1)
U112	7(DCOM), 14(+5V1)
U114	7(DCOM), 14(+5V1)

**A63 Main Processor Memory**  
03577-66563  
Sheet 5 of 6

P/0 A63 I/O PORT  
 03577-66563 REV A  
 03577-66562 REV A



PINS CONNECTED TO EMBEDDED POWER/GROUND NETS:	
U600	7 (DCOM), 14 (+5V1)
U601	10 (DCOM), 20 (+5V1)
U602	7 (DCOM), 14 (+5V1)
U603	10 (DCOM), 20 (+5V1)
U604	10 (DCOM), 20 (+5V1)
U605	10 (DCOM), 20 (+5V1)
U606	10 (DCOM), 20 (+5V1)

**A63 Main Processor Memory**  
 03577-66563  
 Sheet 6 of 6





---

## 9-20 HP Digital Display

### Introduction

This section contains instructions for troubleshooting and repairing the HP Digital Display. Use this section after performing the adjustment procedures in Section V. This section is used to isolate a failure to the subblock level. Each functional subblock consists of a small number of components, and the technician's expertise is relied upon to isolate the faulty component.

### Preventive Maintenance

Painted surfaces can be cleaned with a commercial, spray-type window cleaner or with a mild soap and water solution.

---

### Caution



Do not use chemical cleaning agents that might damage the plastics used in this instrument. Recommended cleaning agents are isopropyl alcohol, kelite (1 part kelite, 20 parts water), or a solution of 1% mild detergent and 99% water.

---

Corroded spots are best removed with soap and water. Stubborn residue can be removed with a fine abrasive. Protect such areas from further corrosion with an application of silicone resin such as GE DRIFILM 88.

## How to Use This Section

### Start

Perform the adjustment procedures listed in Section V of this manual. Some apparent malfunctions may be corrected by these adjustments, or failure to obtain a correct adjustment will often reveal the source of the trouble. The procedures are arranged in the recommended sequence of troubleshooting, not in the order of the circuit board assembly number.

### Reference

Use the component locators and schematics with each of the troubleshooting procedures.

For the location of cables and boards refer to figure 5-8 and 5-9 in Section V.

For the circuit block diagrams refer to Section VIII.

To understand the display's operation and signal mnemonics refer to Section VIII.

---

### Note



After completing a test or repair, check that all jumpers are in the **NORMAL** or **RUN** position and that all cables are connected.

---

### Digital Display Removal

The HP 3577B Digital Display is a stand alone digital display which is serviced separately using the HP 3577B Digital Display Service Manual included in this manual. To remove the display for servicing, the only screws requiring removal are those called out in figure 9-27. With the HP 3577B placed on its side, the internal cables used to connect to the display can be connected to the removed display. Perform the following steps to remove the display.

1. Disconnect the main power cord from the rear panel and remove the top cover.
2. Remove both internal shields covering the display unit.
3. Remove the screws holding the external adjustment pots to the rear panel.
4. Remove the trim strips from the top and left side of the front frame.
5. Remove the front frame and side panel screws as shown in figure 9-27.
6. Remove the screw which attaches the display to the instrument bottom deck and display bracket as shown in figure 9-27.
7. Pull the display out the front of the unit. Disconnect the display power cable and the display interface cable.

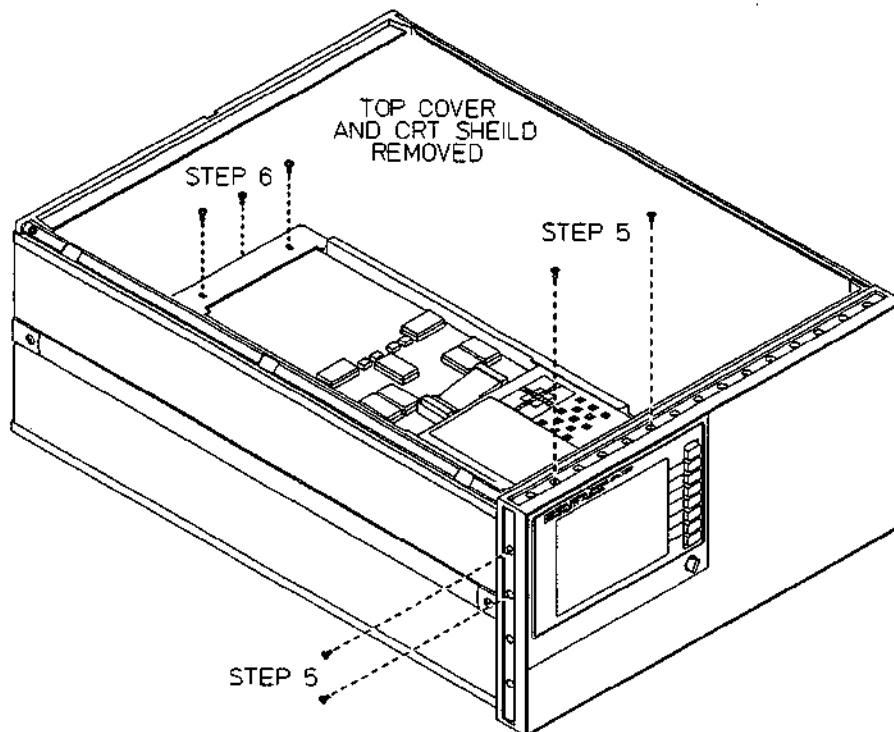
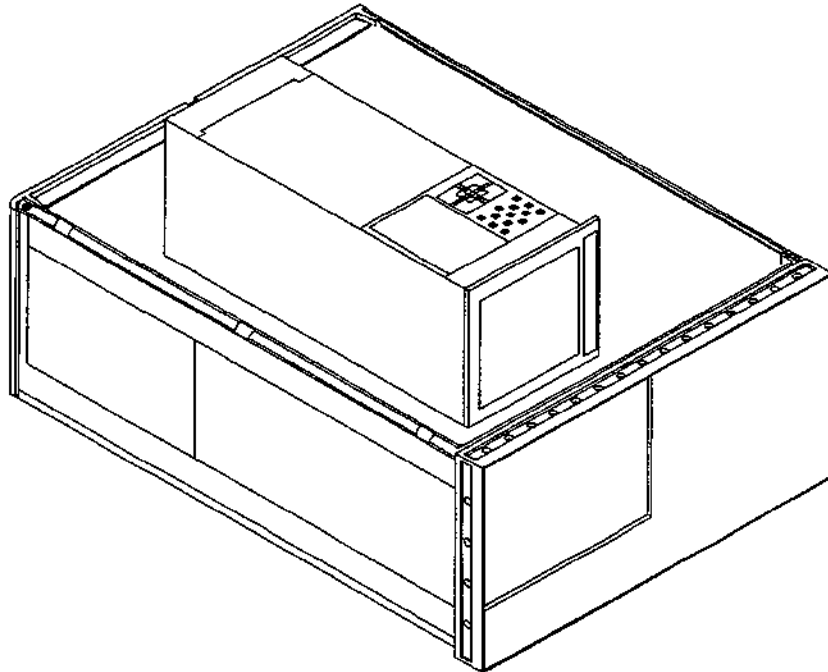


Figure 9-25. Digital Display Removal



**9-26. HP Digital Display Ready for Adjustment**

### **Logic Conventions**

Positive logic convention is used in this manual unless otherwise noted. Positive logic conventions define a logic "1" or "High" as more positive voltage and a logic "0" or "Low" as the more negative voltage.

### **Logic Symbols**

The logic symbols used in this manual is based on ANSI Y32.14-1973. The purpose of these symbols is to graphically represent device functions so that operation can be understood without having to "look up" how a device works. Basic logic symbols and examples of symbols are shown in figure 9-5. figure 9-3 provides an explanation of function labels used in the schematics.

### **Waveforms and dc Voltages**

Waveforms, dc voltages, and conditions for making these measurements are given on the test pattern illustrations. Since conditions for making measurements may differ from one circuit to another, always check the specific conditions listed for each schematic.

### **Recommended Test Equipment**

The recommended test equipment for troubleshooting is listed in table 1-2. Any item which meets or exceeds the critical requirements can be substituted for the model listed.



**Safety Considerations**

The HP 3577B is a Safety Class 1 instrument (provided with a protective earth terminal). The instrument and manuals should be reviewed for safety markings and instructions before operation. Refer to the safety symbol table in the preface of this manual.

**Warning**

Service procedures described in this section are performed with the protective covers removed and power applied. Hazardous voltage and energy available at many points can, if contacted, result in personal injury.

Order	Assembly	Name
1	—	Block Diagram
2	A82	Vector Processor Control
3	A81	X-Y-Z- Amplifier, Stroke Generator
4	A83	Low Voltage Power Supply
5	A80	High Voltage Power Supply
6	A84	Memory

**Note**

When the A84 Memory Option assembly is installed, jumper packs A82 U3 and A82 U4 must be removed.

## Description

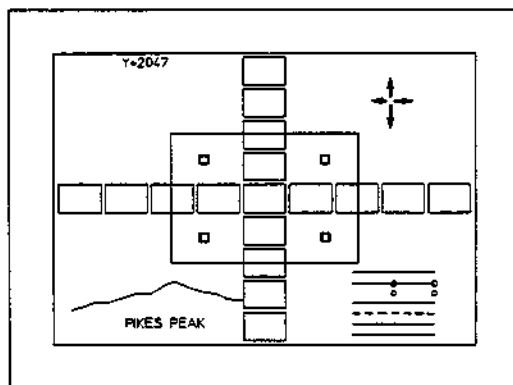
The Hewlett-Packard Digital Display is a 15.24 cm (6 in.) diagonal display component. It produces vector graphics on its display screen in response to digital commands from a user processor.

Because of its high resolution (2048 × 2048 addressable points), the HP Digital Display can draw both straight and curved lines (curvilinear vectors). The HP Digital Display draws all vectors in a picture by moving its display beam at the same speed. This constant writing rate ensures a picture of uniform brightness (short vectors do not become brighter than long vectors). At its faster drawing rate, and at 60 Hz refresh rate, the HP Digital Display can draw a picture that contains up to 3226 inches of vectors. If the refresh rate is slowed to 40 Hz (possible in some applications), then the picture can contain up to 4838 inches of vectors.

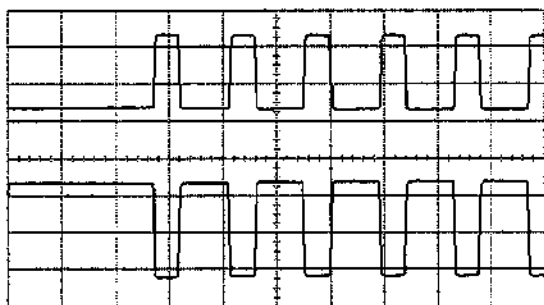
For labeling or identification of soft key functions, the HP Digital Display has a built in set of ASCII characters.

## Self Test

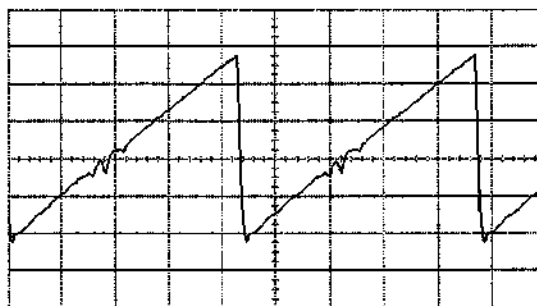
Self Test is invoked by disconnecting the I/O connector with power applied. The Test Pattern verifies that the HP Digital Display is fully operational and provides necessary stimulus for routine calibration. Alternate Test Pattern, invoked by internal jumper change, verifies performance specifications and allows calibration of focus and astigmatism adjustments.



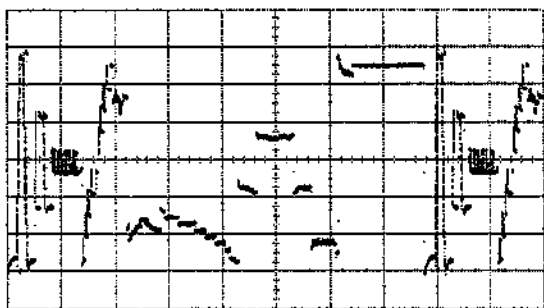
Obtain Primary Test Pattern As Shown Above



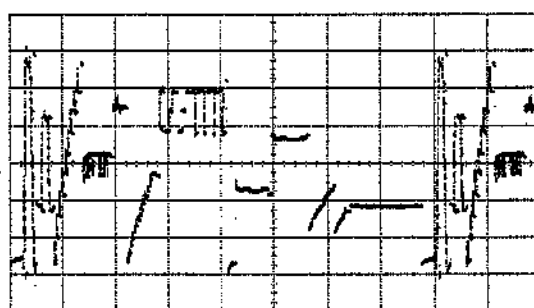
Top: LRFD A82, U17 Pin 3  
Bottom: LDAV A82, U17 Pin 2V/Div, 50  $\mu$ s/Div



Top: A84, Pin 7  
Bottom: A83, Q1 Collector .5 V/Div, 5  $\mu$ s /Div

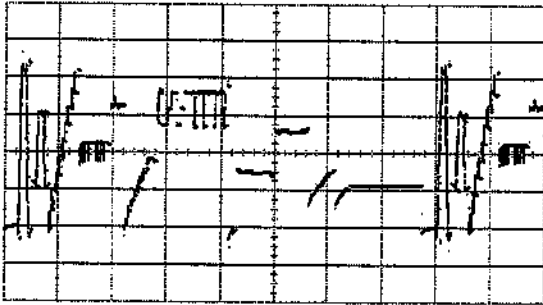


Y DAC Output 200 mV/Div, 2 ms/Div

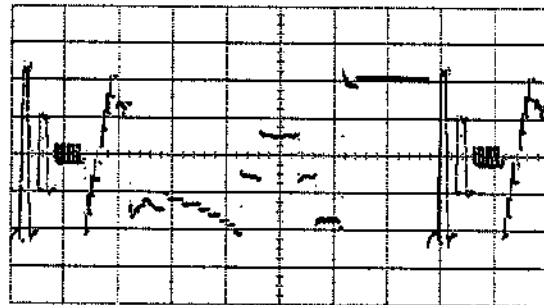


XDAC Output 200 mV/Div, 2 ms/Div

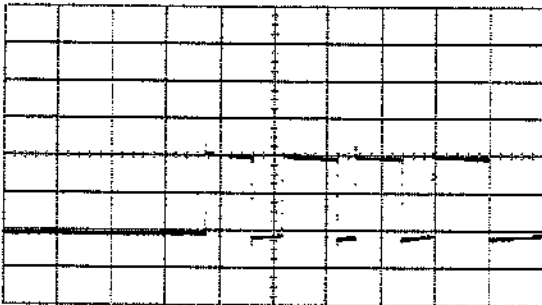
Figure 9-27. HP Digital Display Waveforms



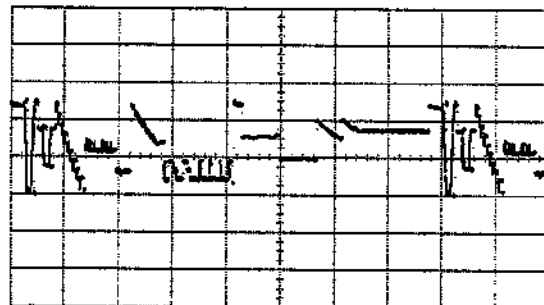
Auxiliary Output at A81 J5 .5 V/Div, 2 ms/Div



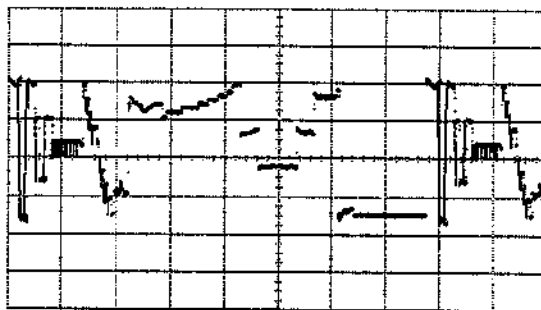
Auxiliary Y Output at A81 J4 .5 V/Div, 2 ms/Div



Auxiliary Z Output at A81 J3 .5 V/Div, 100  $\mu$ s/Div



X Output at A81 Q8 Collector  
(To Horizontal CRT Deflection Plates) 20 V/Div, 2 ms/Div



Y Output at A81 Q14 Collector  
(To Vertical CRT Deflection Plates) 20 V/Div, 2 ms/Div

9-27b. HP Digital Display Waveforms continued

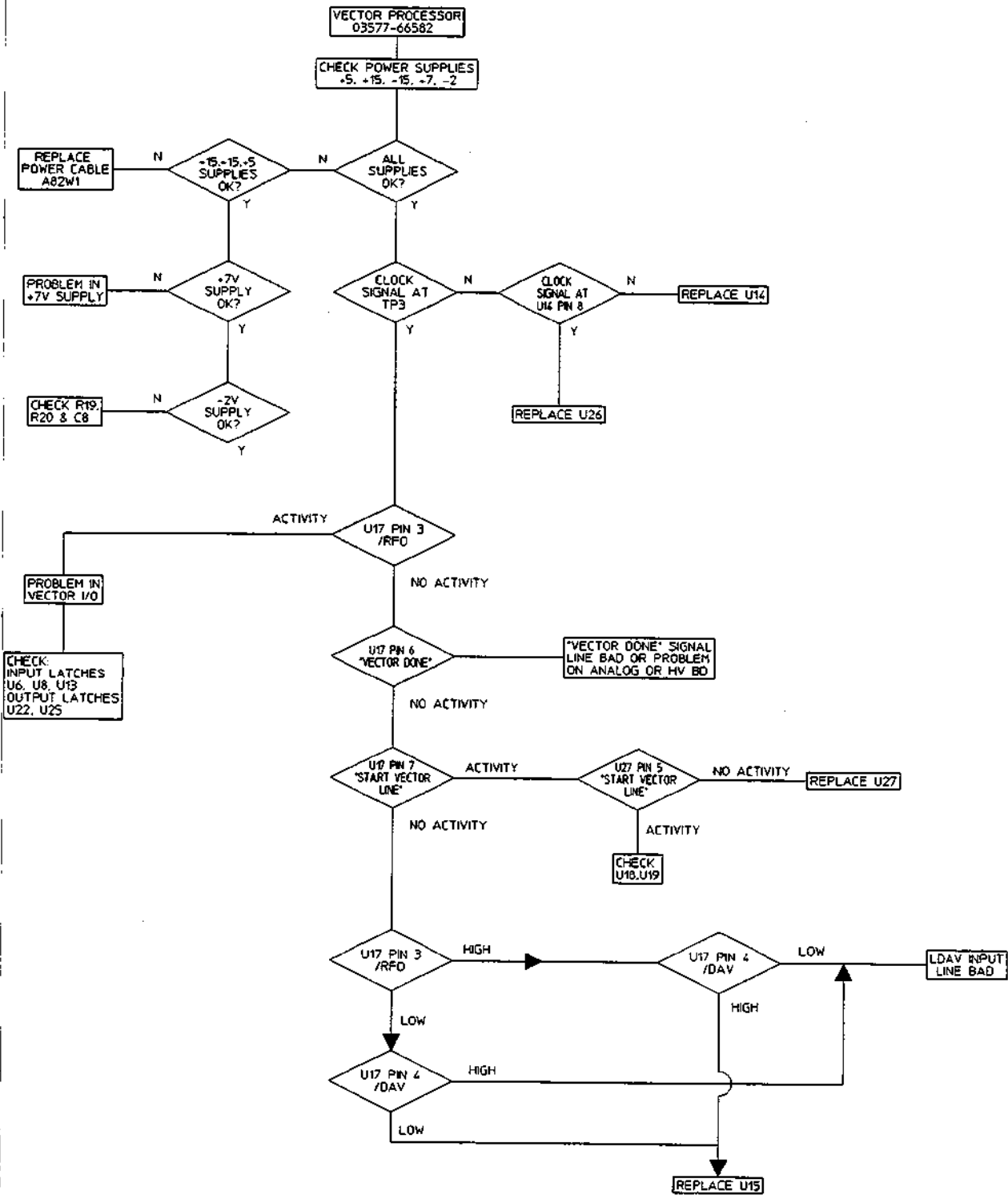


Figure 9-28. A82 Vector Processor  
Troubleshooting Procedure

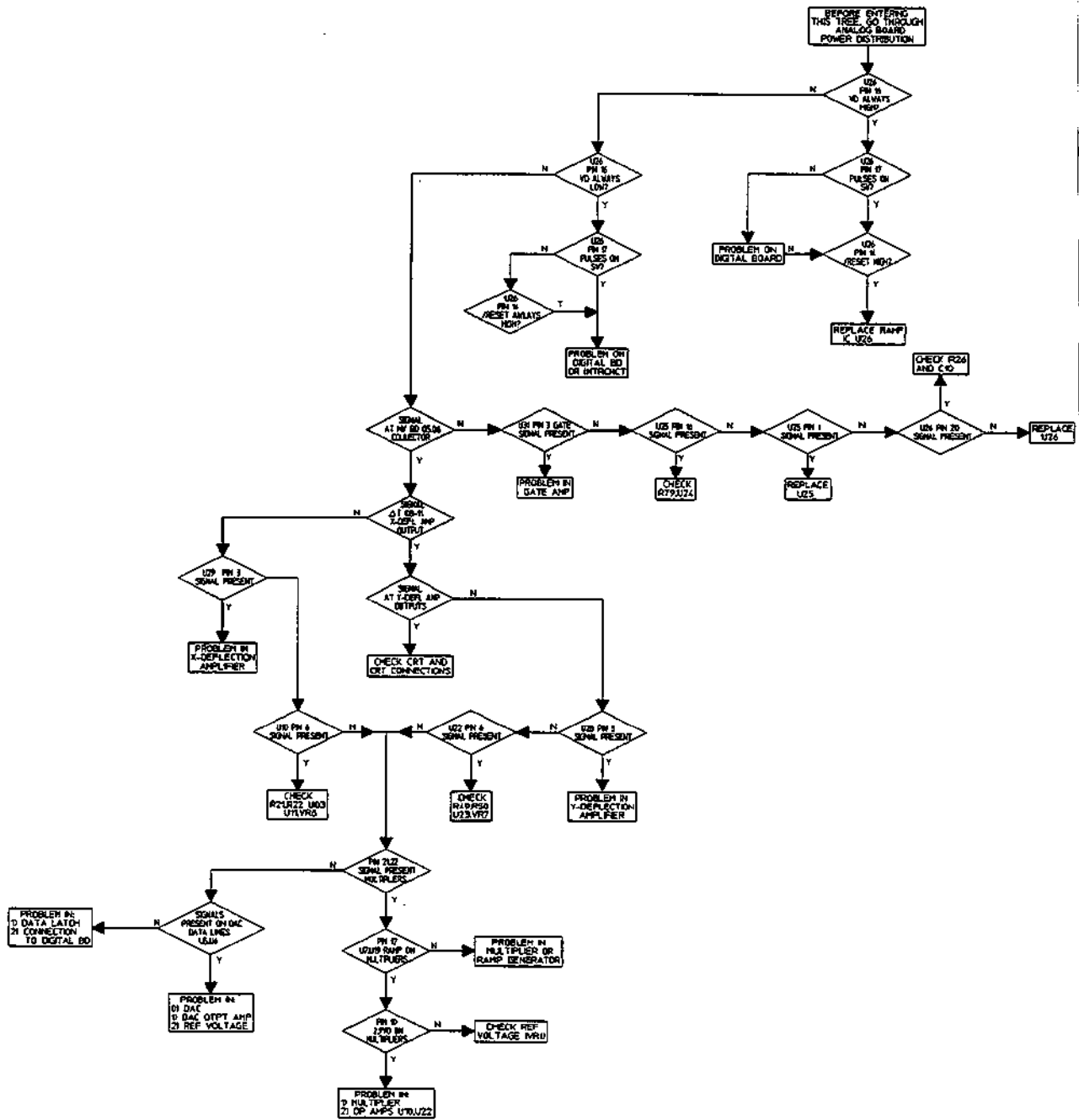
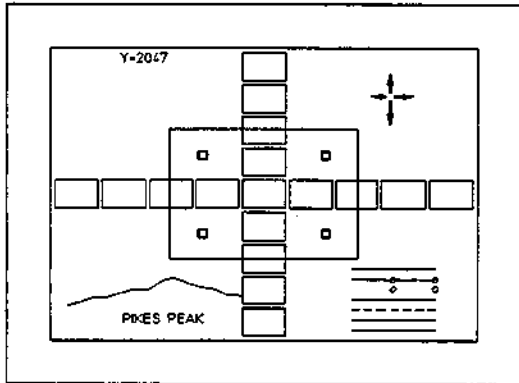
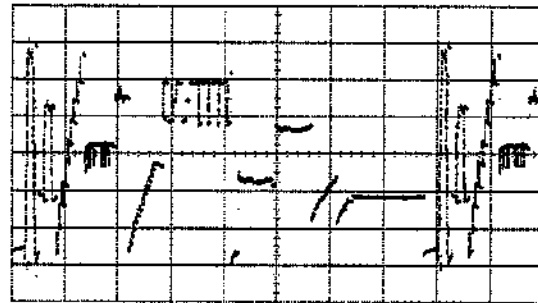


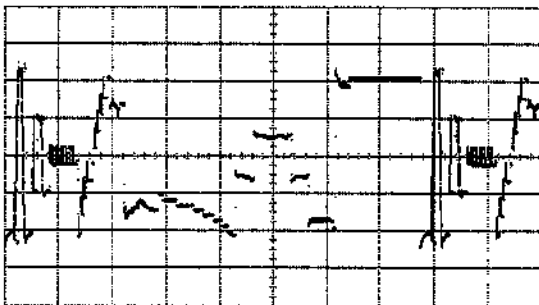
Figure 9-29. A81 X-Y-X Amplifier / Stroke Generator Troubleshooting Procedure



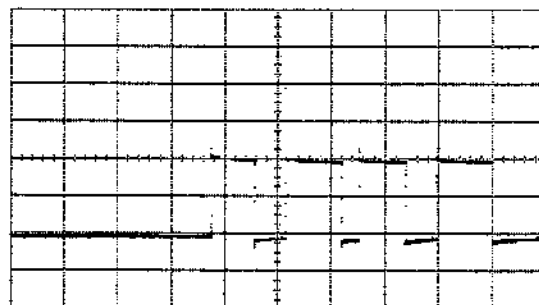
Obtain Primary Test Pattern As Shown Above



Auxiliary X Output at A81 J5 .2 V/Div, 2 ms/Div



Auxiliary Y Output at A81 J4 .5 V/Div, 2 ms/Div



Auxiliary Z Output at A81 J3 .5 V/Div 100 μs/Div

Figure 9-30. A81 X-Y-Z Amplifier / Stroke Generator Waveforms

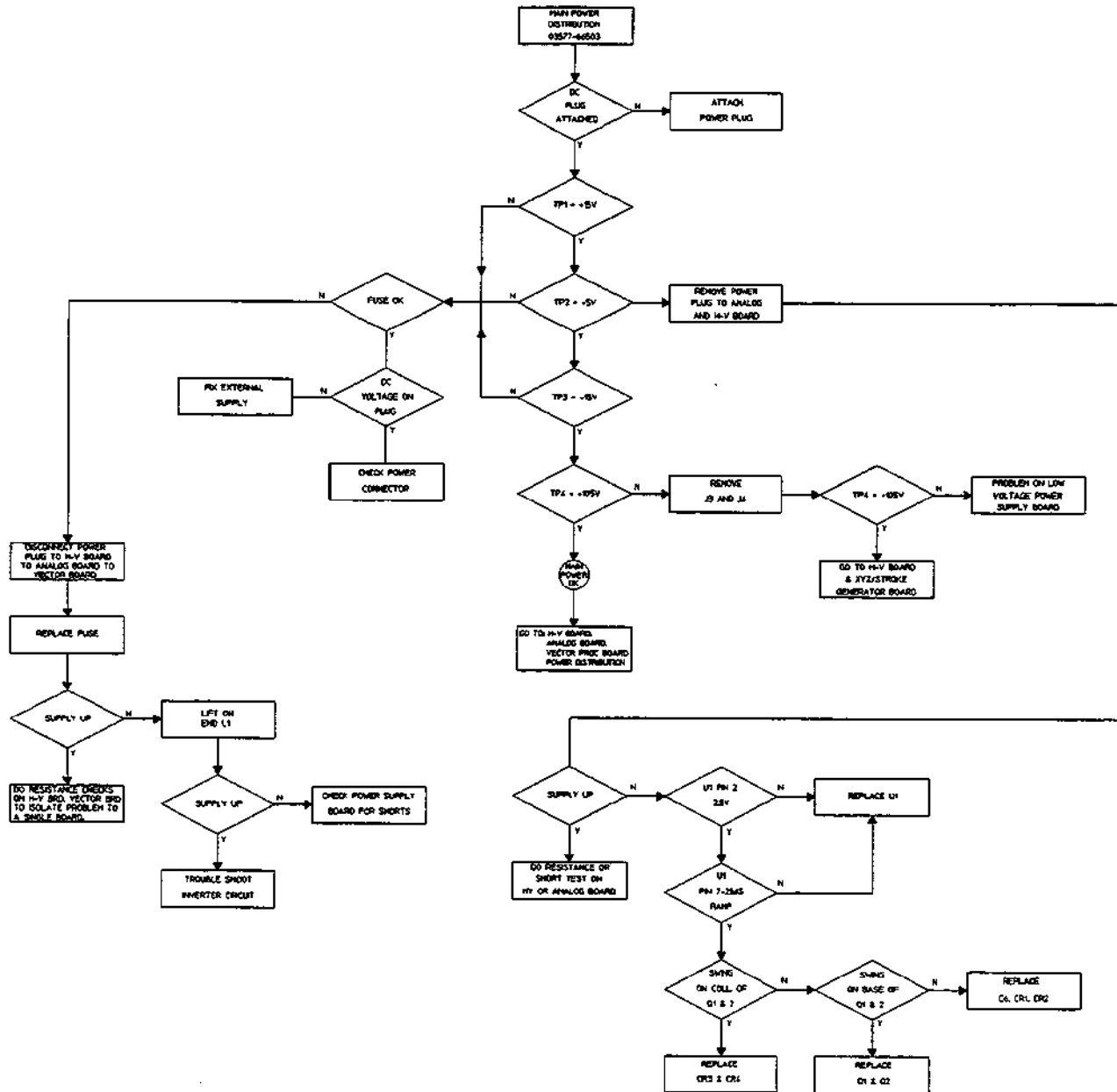


Figure 9-31. A83 Low Voltage Power Supply Troubleshooting Procedure



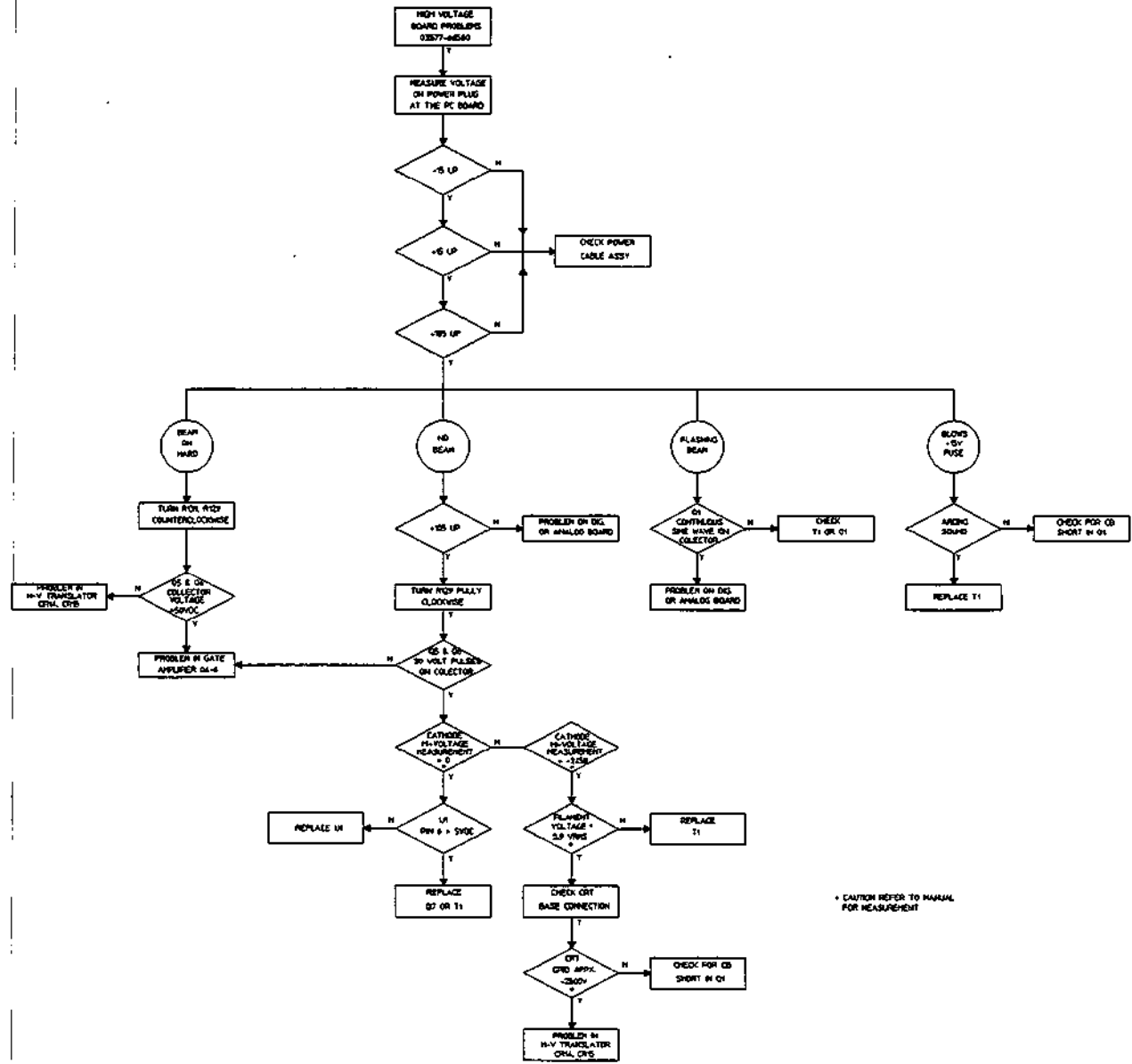


Figure 9-32. A80 High Voltage Power Supply Troubleshooting Procedure

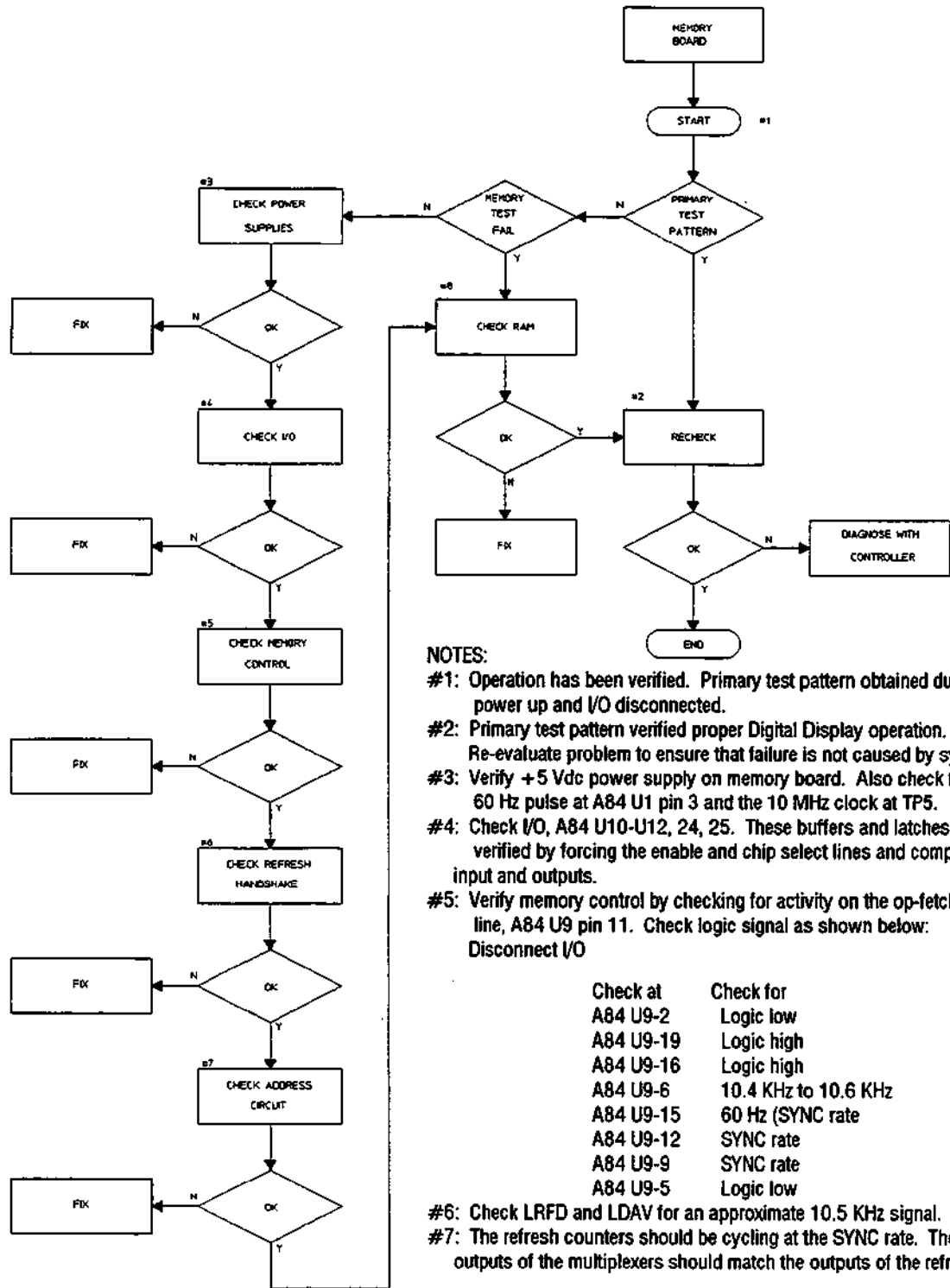
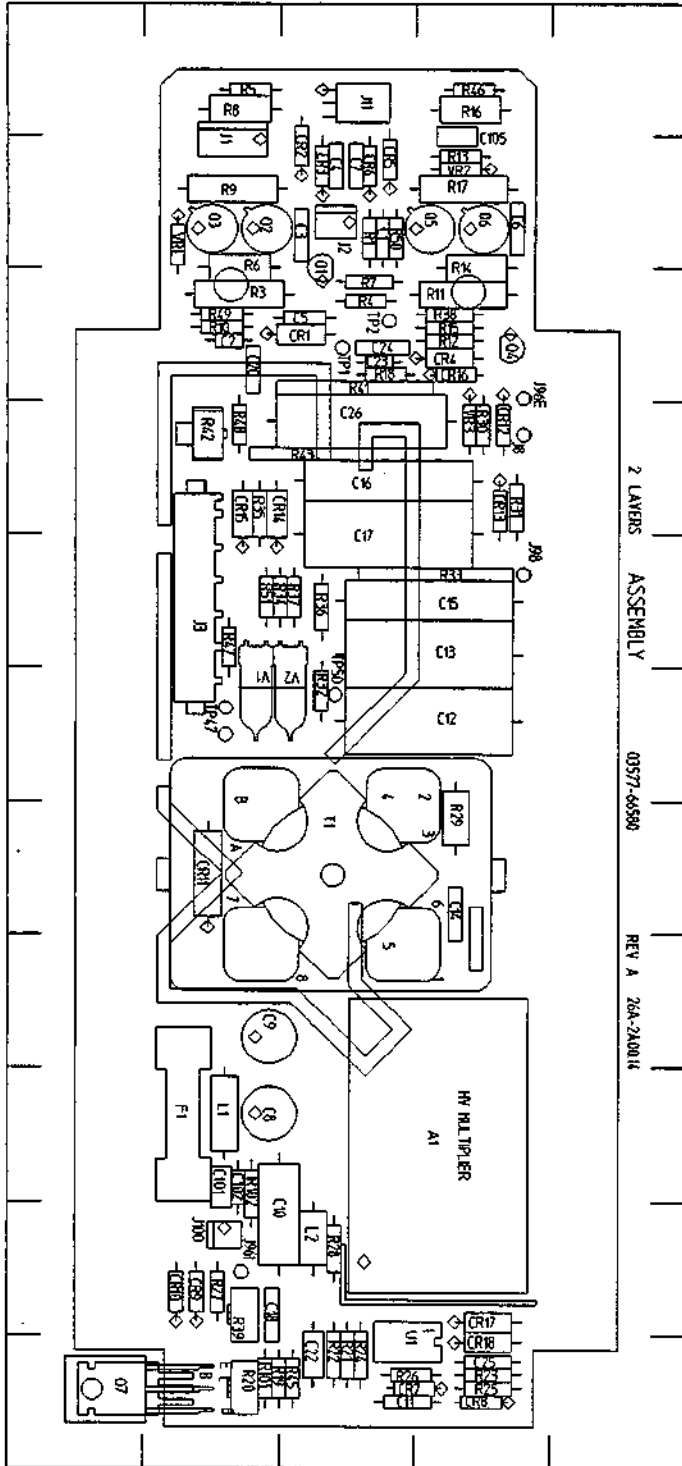


Figure 9-33. A84 Memory Circuit Troubleshooting Procedure



A  
B  
C  
D  
E  
F  
G  
H  
I  
J  
K

Ref Desig	Grid Loc	Ref Desig	Grid Loc
A1	J-3	R5	A-2
C1	B-3	R6	C-2
C2	C-2	R7	C-3
C3	B-3	R8	A-2
C4	B-3	R9	B-2
C5	C-3	R10	C-2
C6	B-4	R11	C-4
C7	B-3	R12	C-4
C8	I-2	R13	B-4
C9	H-2	R14	C-4
C10	I-2	R15	C-4
C11	K-3	R16	A-4
C12	F-4	R17	B-4
C13	E-4	R18	C-3
C14	G-4	R19	K-2
C15	E-4	R20	K-2
C16	D-3	R21	J-3
C17	E-4	R22	J-3
C18	J-2	R23	K-4
C19	J-2	R24	J-3
C20	C-2	R25	K-4
C21	C-2	R26	K-3
C22	J-3	R27	J-2
C23	C-4	R28	J-3
C24	C-3	R29	F-4
C25	K-4	R30	D-4
C26	D-4	R31	D-4
CR1	B-2	R32	F-2
CR2	B-3	R33	E-4
CR3	B-3	R34	E-2
CR4	B-4	R35	D-2
CR5	B-3	R36	E-2
CR6	B-3	R37	D-2
CR7	K-3	R38	C-4
CR8	K-4	R39	J-2
CR9	J-2	R40	J-2

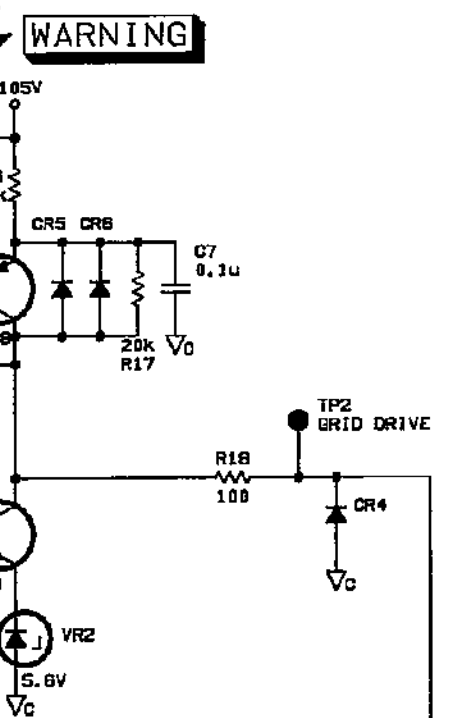
1 2 3 4 5

A80 High Voltage Power Supply Component Locator Rev A

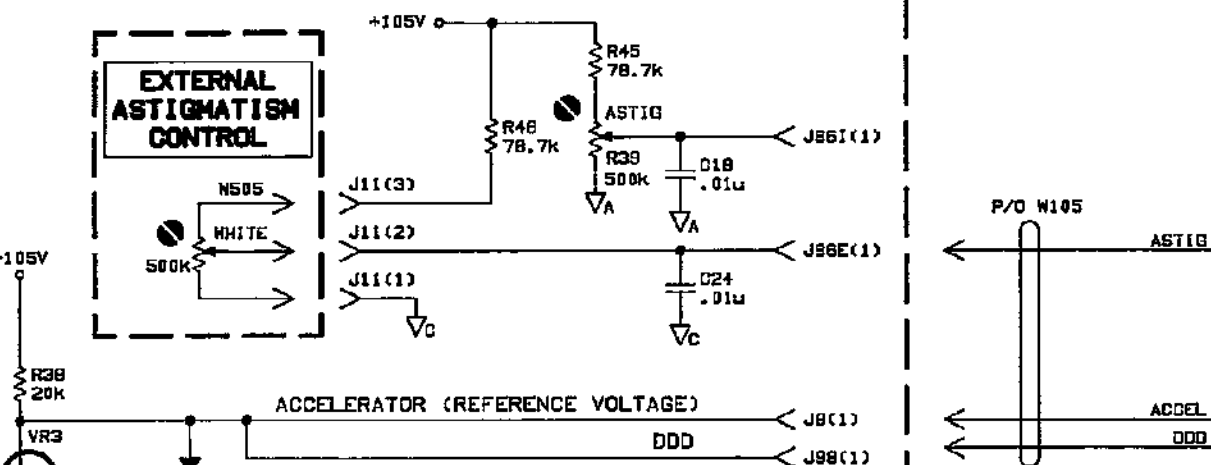
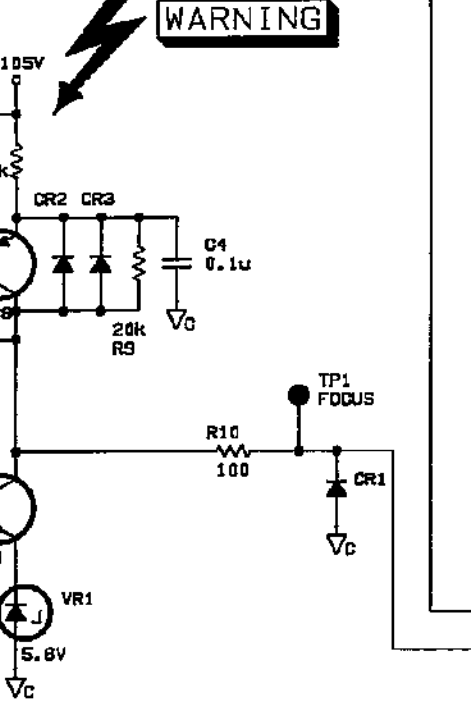
FROM LOW VOLTAGE  
POWER SUPPLY

(B) 3C

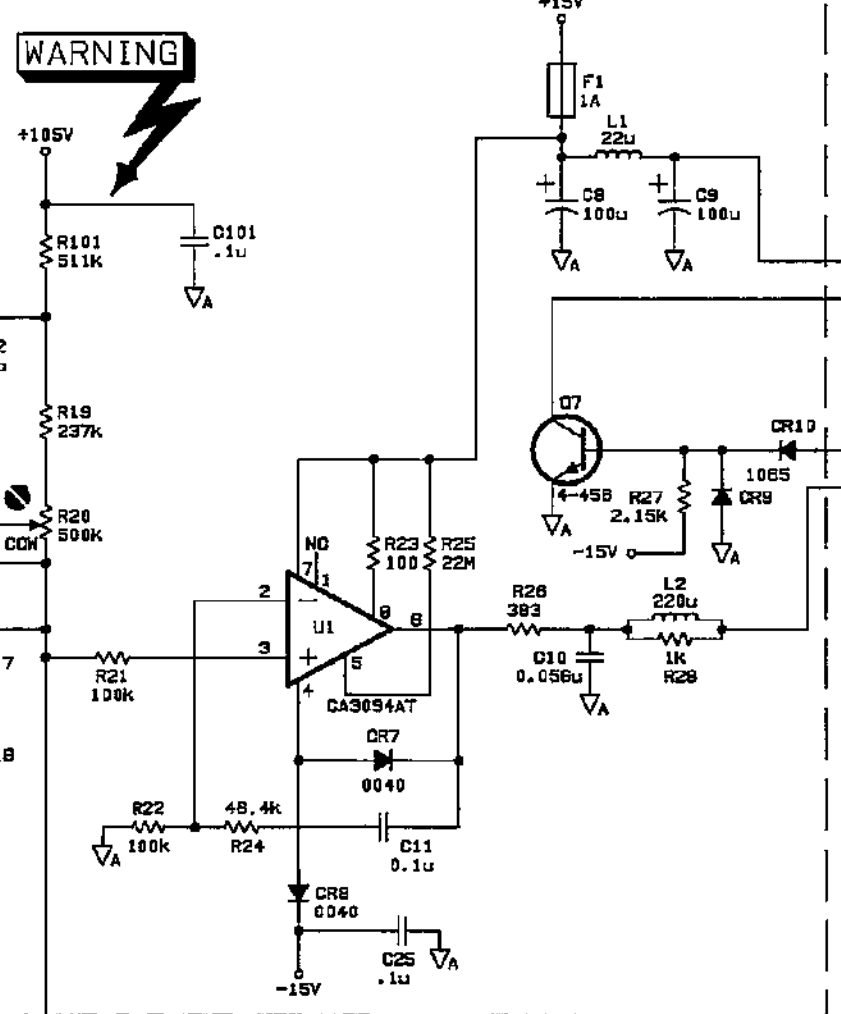
**INTENSITY AMPLIFIER**



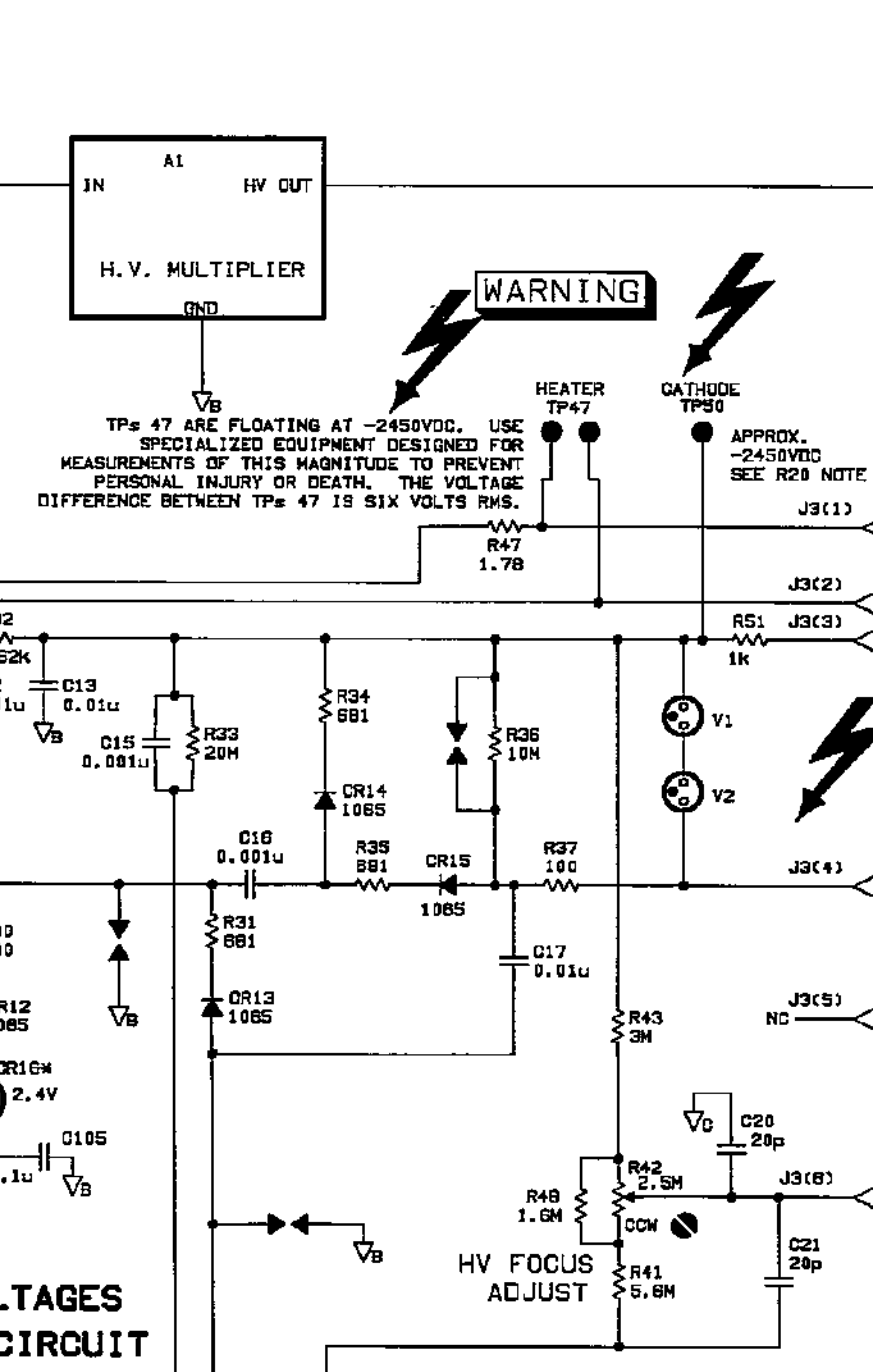
**FOCUS AMPLIFIER**



**HV OSCILLATOR**



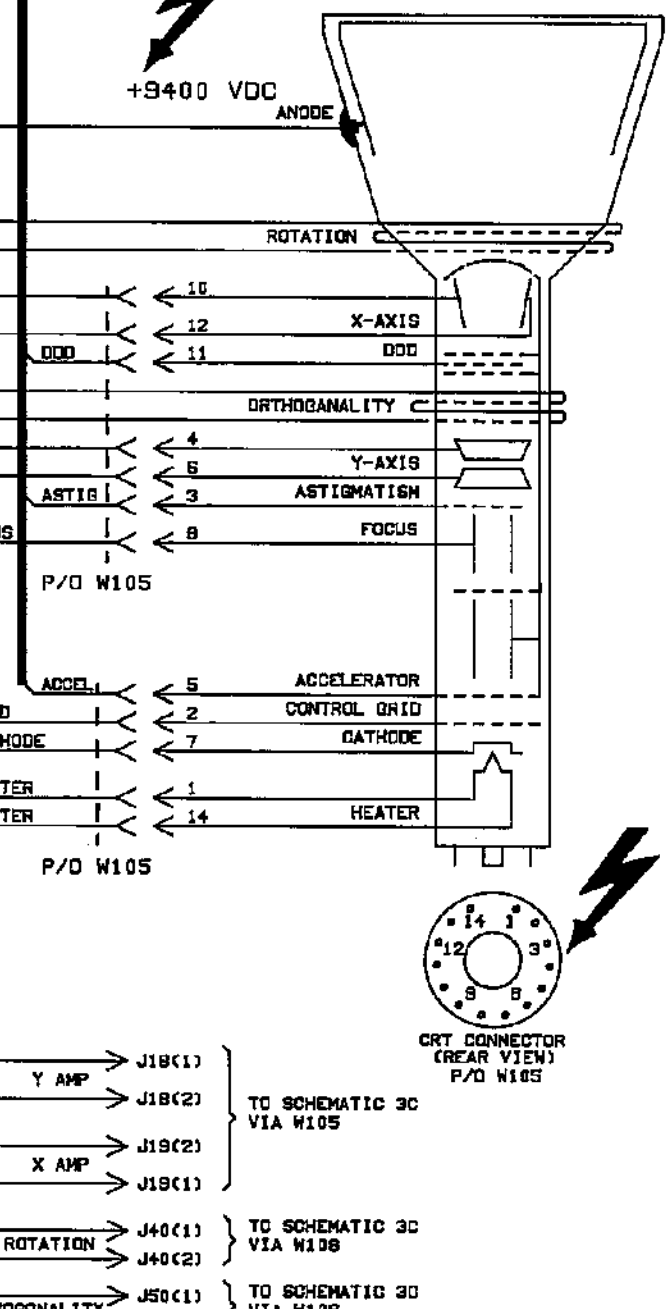
**HV POWER SUPPLY**



**DANGER! HIGH VOLTAGES  
PRESENT IN THIS CIRCUIT**

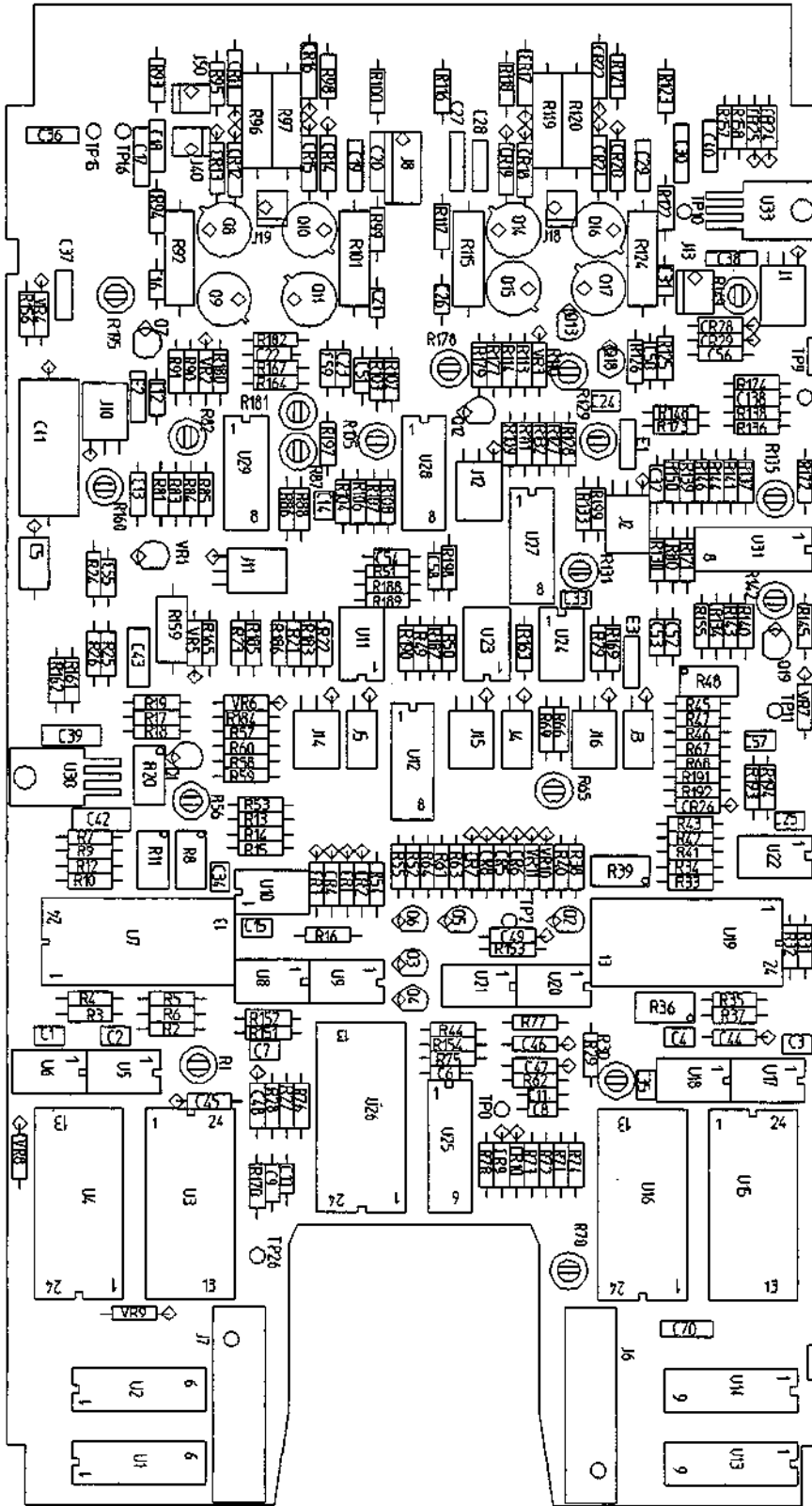
**WARNING HIGH VOLTAGE  
DISCONNECT CRT WITH CAUTION!  
DISCHARGE FIRST, BY SHORTING  
ANODE TO CHASSIS GROUND.**

**WARNING** THE CRT ANODE WILL  
RETAIN SOME CHARGE  
EVEN AFTER THE  
FIRST DISCHARGE.



**PARTS ON SCHEMATIC**

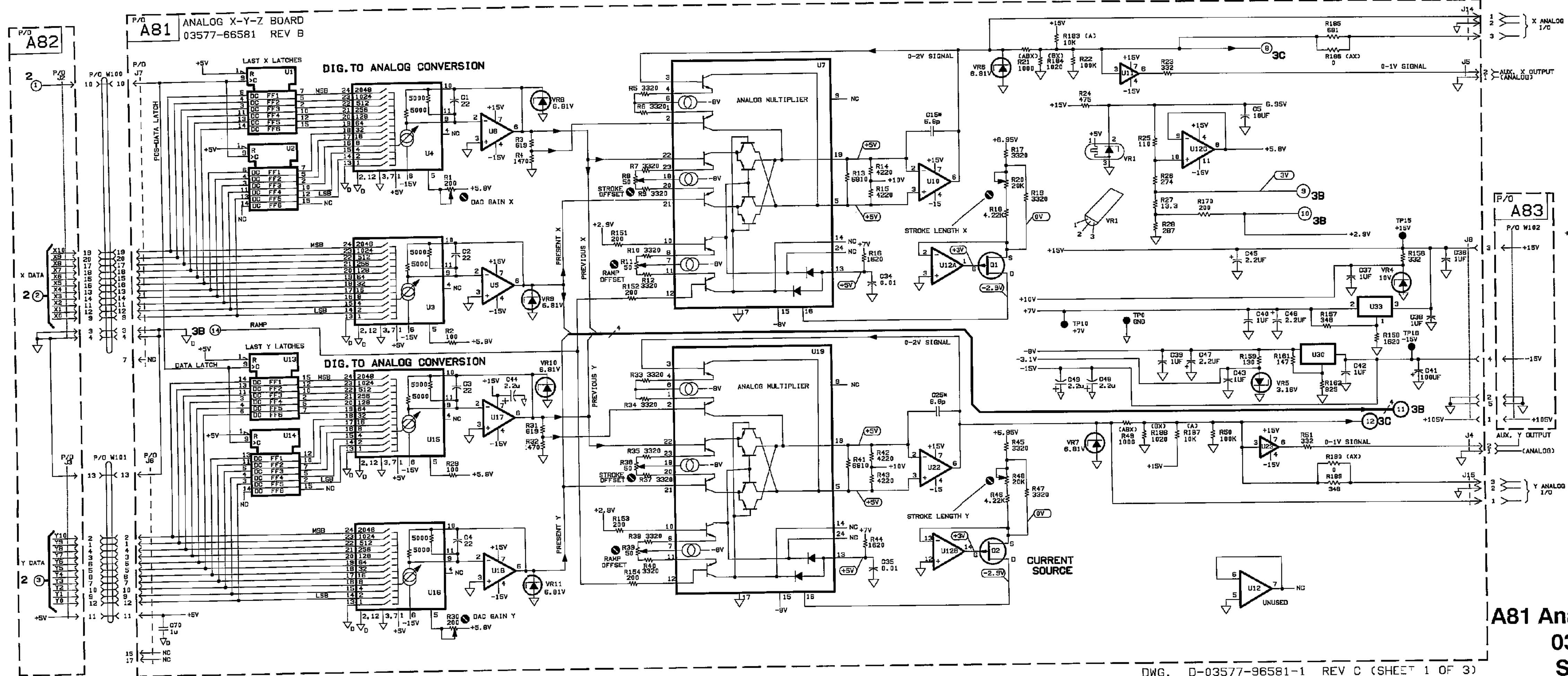
- A1
- C1-18, C26, C22-28, C161, C102, C105
- CR1-18
- F1
- J1-3, J100
- Q1-7
- R1, R3-38, R41-43, R45-51, R101, R102
- T1
- TP1, TP2, TP47, TP50, TP68
- U1
- V1, V2
- VR1-3



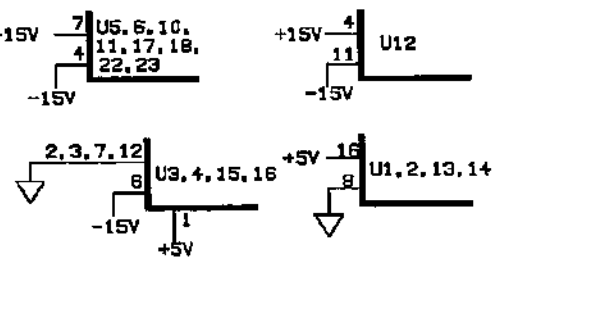
A81 X-Y-Z Amplifier/Stroke Generator Component Locator Rev B

Ref Desig	Grid Loc	Ref Desig	Grid Loc	Ref Desig	Grid Loc	Ref Desig	Grid Loc	Ref Desig	Grid Loc	Ref Desig	Grid Loc	Ref Desig	Grid Loc
C1	I-1	C55	E-2	J20	H-3	R31	G-6	R83	D-2	R137	D-6	R191	F-6
C2	J-2	C56	C-6	J21	I-3	R32	G-6	R84	D-2	R138	E-6	R192	F-6
C3	H-6	C57	F-6	J22	C-2	R33	G-6	R85	D-2	R139	D-6	R193	F-6
C4	H-6	C58	E-4	Q1	F-2	R34	G-6	R86	D-3	R140	E-6	R194	F-6
C5	E-1	C59	C-3	Q2	G-5	R35	H-6	R87	D-3	R141	D-6	R195	C-2
C6	H-4	CR1	G-3	Q3	G-4	R36	H-5	R88	D-3	R142	E-6	TP2	G-4
C7	H-3	CR2	G-3	Q4	H-4	R37	H-6	R90	C-2	R143	E-6	TP9	D-6
C8	I-4	CR3	G-3	Q5	G-4	R38	G-5	R91	C-2	R144	D-6	TP10	B-6
C9	I-3	CR4	G-3	Q6	G-4	R39	G-5	R92	B-2	R145	D-6	TP11	F-6
C10	I-3	CR5	G-4	Q7	C-2	R40	G-5	R93	A-2	R146	D-6	U1	K-1
C11	I-4	CR6	G-4	Q8	C-2	R41	G-6	R94	B-2	R147	D-6	U2	K-1
C12	D-2	CR7	G-4	Q9	C-3	R42	G-6	R95	A-2	R148	D-6	U3	I-2
C13	D-2	CR8	G-4	Q10	C-3	R43	G-6	R96	A-3	R149	C-6	U4	J-2
C14	D-3	CR9	I-4	Q11	C-3	R44	H-4	R97	A-3	R150	D-5	U5	H-2
C16	C-2	CR10	I-4	Q12	D-4	R45	F-6	R98	A-3	R151	H-3	U6	H-1
C17	B-2	CR11	B-2	Q13	C-5	R46	F-6	R99	B-3	R152	H-3	U7	H-1
C18	B-2	CR12	B-2	Q14	C-4	R47	F-6	R100	A-3	R153	G-5	U8	H-3
C19	B-3	CR13	B-2	Q15	C-4	R48	F-6	R101	B-3	R154	H-4	U9	H-3
C20	B-3	CR14	B-3	Q16	C-5	R49	E-4	R102	C-4	R155	E-6	U10	G-3
C21	C-3	CR15	B-3	Q17	C-5	R50	E-4	R103	C-3	R156	C-1	U11	F-3
C22	C-3	CR16	B-3	Q18	C-5	R51	E-4	R104	D-3	R157	B-6	U12	F-4
C23	C-3	CR17	B-4	Q19	F-6	R52	G-4	R105	D-3	R158	B-6	U13	K-6
C24	D-5	CR18	B-4	R1	H-2	R53	G-3	R106	D-3	R159	E-2	U14	J-6
C26	C-4	CR19	B-4	R2	H-2	R54	G-3	R107	D-3	R160	D-2	U15	I-6
C27	B-4	CR20	B-5	R3	H-1	R55	G-4	R108	D-4	R161	E-1	U16	J-6
C28	B-4	CR21	B-5	R4	G-1	R56	F-2	R109	D-4	R162	E-1	U17	H-6
C29	B-5	CR22	B-5	R5	H-2	R57	F-3	R110	D-5	R163	E-4	U18	H-6
C30	B-6	CR23	D-6	R6	H-2	R58	F-3	R111	D-4	R164	D-3	U19	G-6
C31	C-5	CR24	B-6	R7	G-2	R59	F-3	R113	C-4	R165	E-2	U20	H-5
C32	D-5	CR25	B-6	R8	G-2	R60	F-3	R114	C-4	R167	D-3	U21	H-4
C33	D-5	CR26	G-6	R9	G-2	R61	G-4	R115	B-4	R169	E-5	U22	G-6
C34	G-2	E1	D-5	R10	G-2	R62	H-5	R116	A-4	R170	I-3	U23	F-4
C35	H-5	E2	E-1	R11	G-1	R63	G-4	R117	B-4	R171	E-6	U24	E-5
C36	B-1	E3	E-5	R12	G-2	R64	G-4	R118	A-4	R172	D-6	U25	I-4
C37	C-1	J1	C-6	R13	G-3	R65	G-5	R119	A-5	R173	D-5	U26	I-4
C38	C-6	J2	D-5	R14	G-3	R66	F-5	R120	A-5	R174	D-5	U27	D-4
C39	F-1	J3	F-5	R15	G-3	R67	F-6	R121	A-5	R175	C-6	U28	D-4
C40	B-6	J4	F-4	R16	G-3	R68	F-6	R122	B-5	R176	C-6	U29	D-2
C41	D-1	J5	F-3	R17	F-2	R69	F-5	R123	A-5	R177	C-4	U30	F-2
C42	G-2	J6	K-5	R18	F-2	R70	J-5	R124	B-5	R178	D-4	U31	E-6
C43	E-2	J7	J-2	R19	F-2	R71	I-5	R125	C-5	R179	C-4	U33	C-6
C44	H-6	J8	B-4	R20	F-2	R72	I-5	R126	C-5	R180	C-2	VR1	E-2





**IC DEVICE POWER CONNECTIONS**

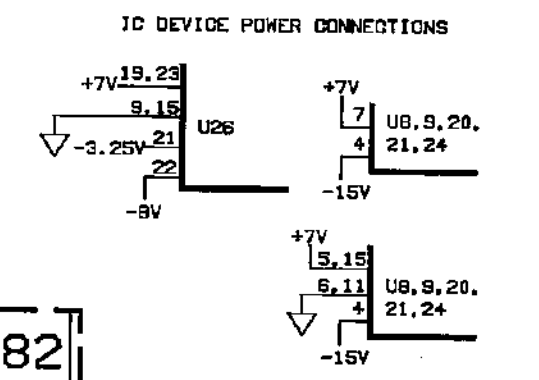
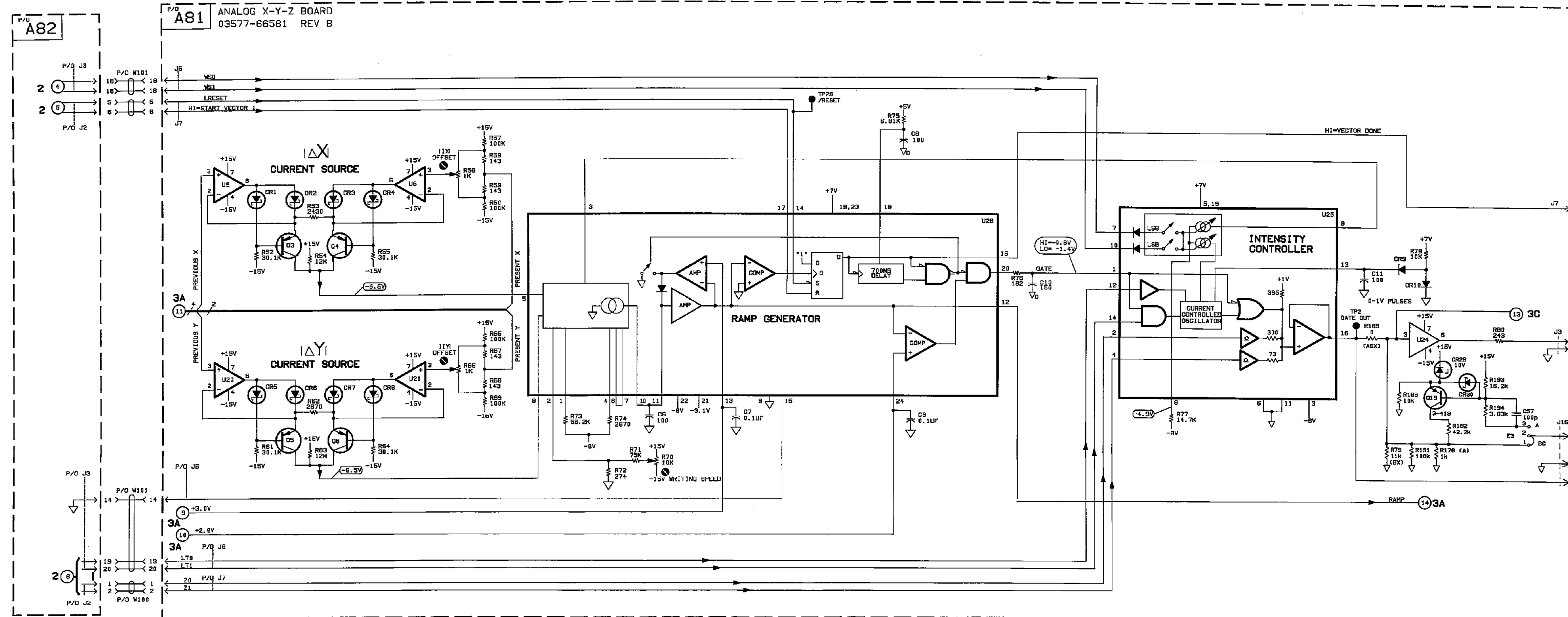


- NOTES:**
- GATES ARE SYMBOLIZED ACCORDING TO CIRCUIT FUNCTION.
  - UNLESS OTHERWISE NOTED: RESISTANCE IN OHMS; CAPACITANCE IN PICOFARADS; INDUCTANCE IN MICROHENRIES.
  - UNLESS OTHERWISE NOTED: LOGIC LEVELS ARE TTL; +2V TO +5V=LOGIC"1"=H; 0V TO +0.8V=LOGIC"0"=L.
  - PARTS LABELED AX, BX AND ABX ARE REMOVED ONLY FOR SPECIAL OPTIONS. R179, R183 & R187 LABELED (A) ARE REMOVED IN STANDARD DISPLAYS.

**PARTS ON THIS SCHEMATIC**

P/O A81	A82 CHASSIS	A83
C1-5, 15, 25, C34-43, 70	P/O J2	P/O W100
J4, 5, 8, 9, 14, 15	P/O J3	P/O W104
P/O J6, P/O J7		
U1, 2	A83	
U1-31, 151-154, 156-159, 181, 182, 170, 183-180	P/O W102	
U11-7, 10-19, 22, U23, 30, 33		
VR1, 4-11		

**A81 Analog X-Y-Z Board  
03577-66581  
Sheet 1 of 3**



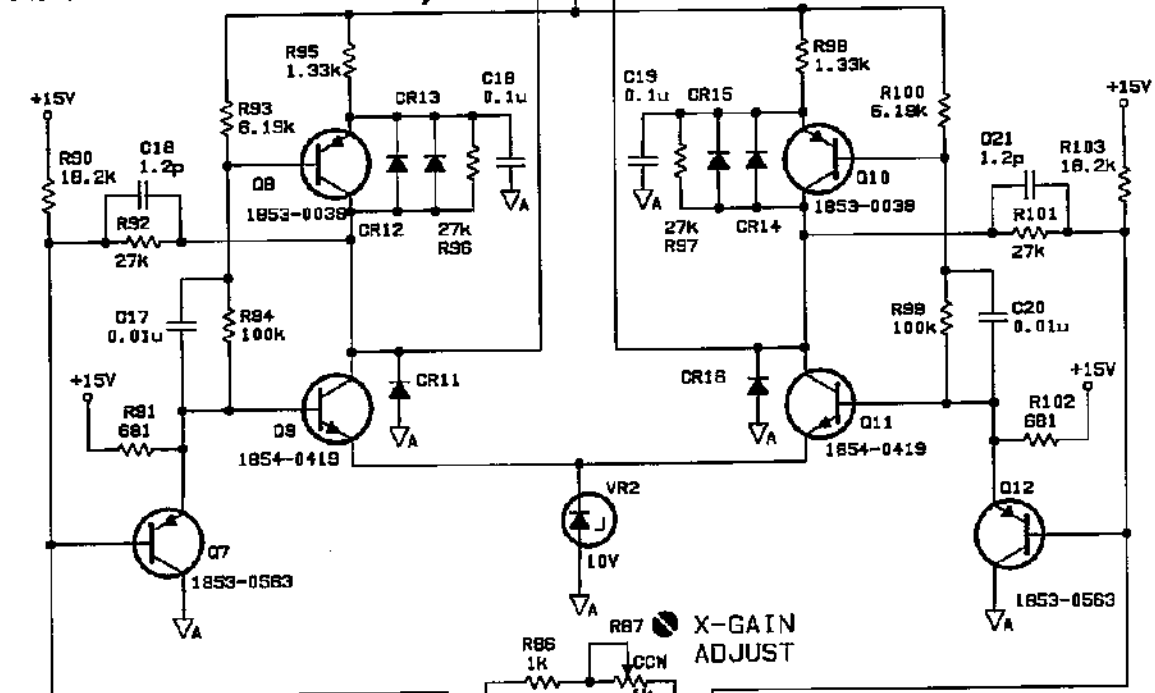
- NOTES:**
- GATES ARE SYMBOLIZED ACCORDING TO CIRCUIT FUNCTION.
  - UNLESS OTHERWISE NOTED: RESISTANCE IN OHMS CAPACITANCE IN PICOFARADS INDUCTANCE IN MICROHENRIES
  - UNLESS OTHERWISE NOTED: LOGIC LEVELS ARE TTL: +2V TO +5V=LOGIC"1" +0.8V TO +0.8V=LOGIC"0"=-L
  - PARTS LABELED AX, BX AND ABX ARE REMOVED ONLY FOR SPECIAL OPTIONS. R176, R183 & R187 LABELED (A) ARE REMOVED IN STANDARD DISPLAYS.

PARTS ON THIS SCHEMATIC	
P/D A81	CHASSIS
Q8-11, 57	P/D W100
DR1-11, 28	P/D W101
E3	
J3, 5, 7	
Q3-5, 19	
RS2-8U, 191-194	
U8, 9, 20, 21, 24-28	

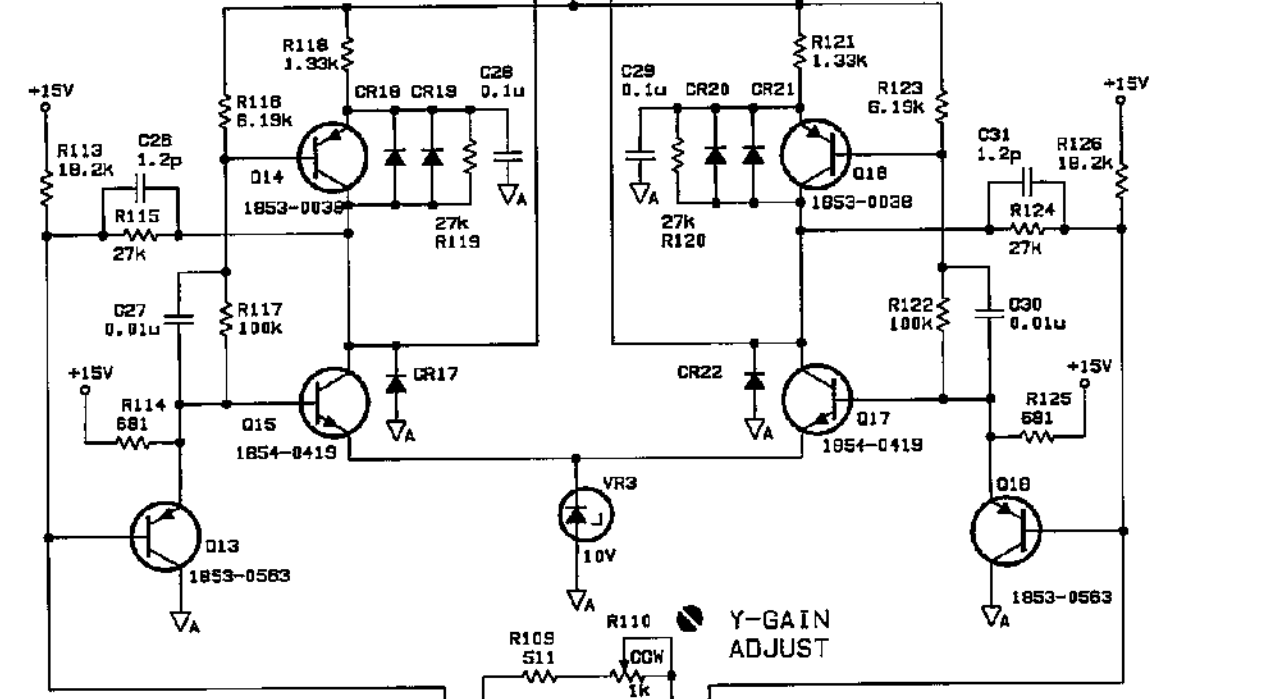
**A81 Analog X-Y-Z Board**  
**03577-66581**  
**Sheet 2 of 3**



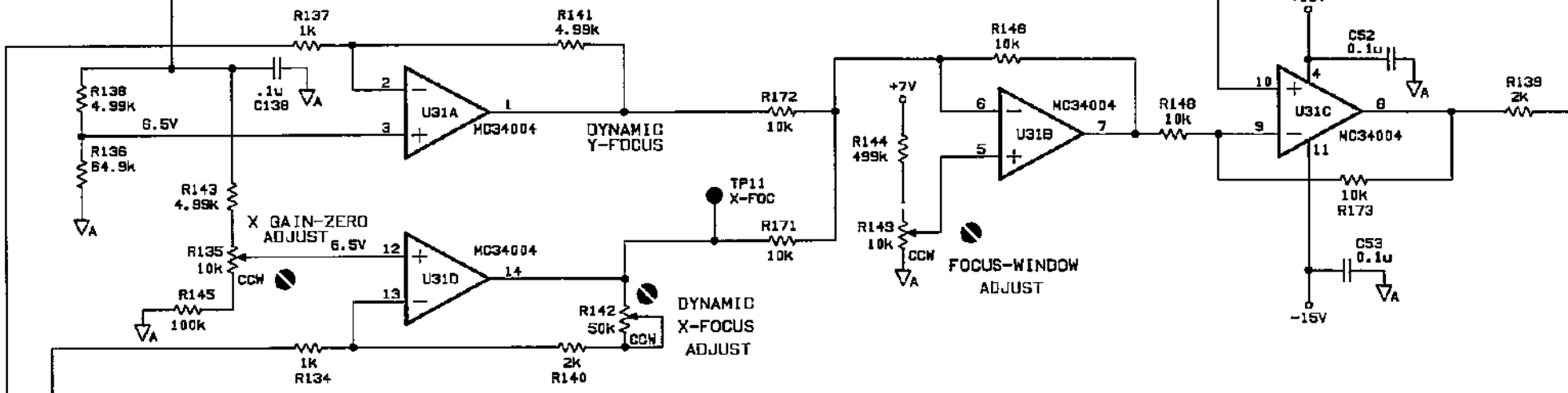
**X-AMPLIFIER**



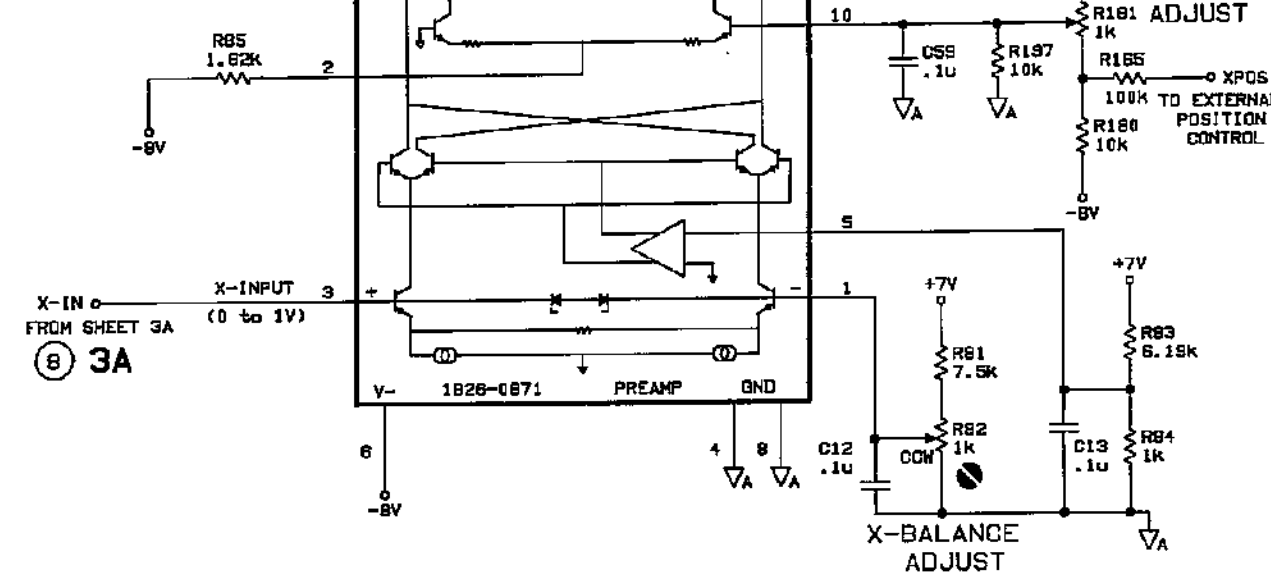
**Y-AMPLIFIER**



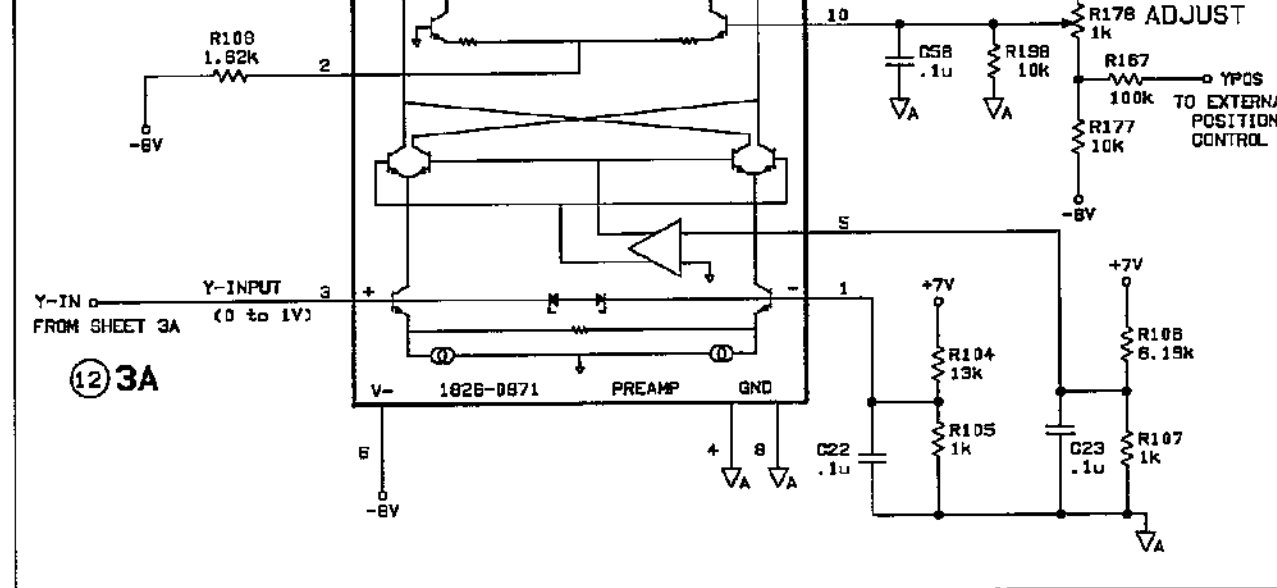
**DYNAMIC FOCUS**



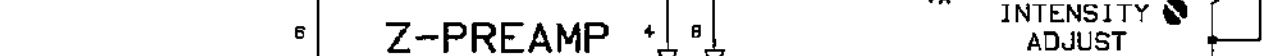
**X-PREAMP**



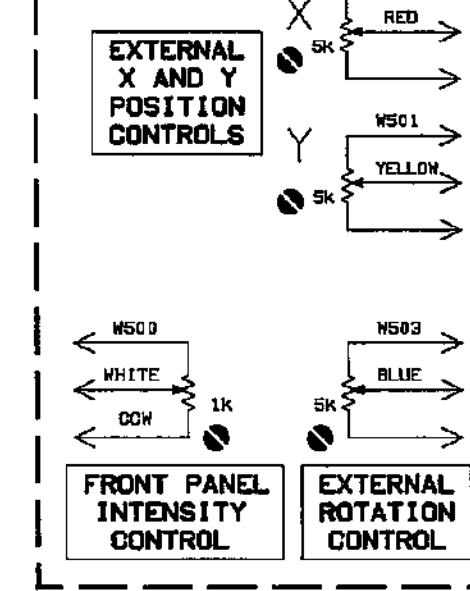
**Y-PREAMP**



**Z-PREAMP**



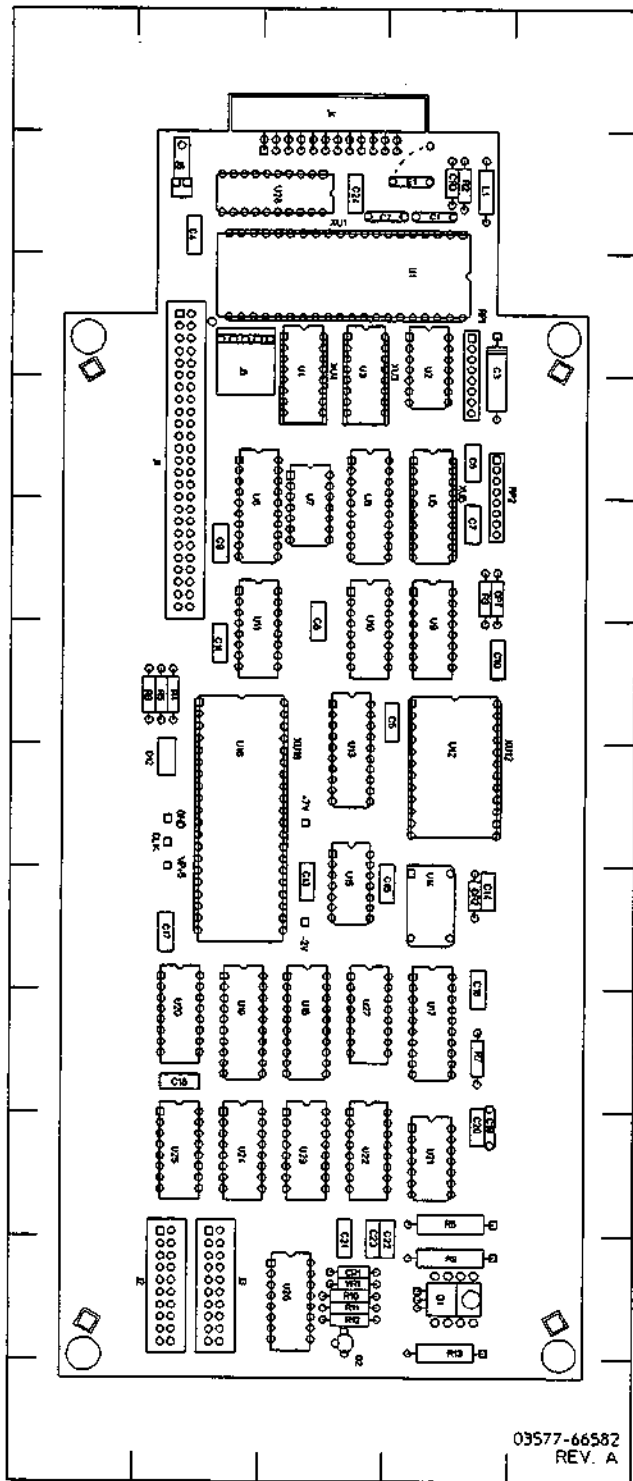
**EXTERNAL X AND Y POSITION CONTROLS**



**PARTS ON THIS SCHEMATIC**

P/O 81

C12-14, C18-24, C28-33, C52-56, C58, C59  
CR11-25, CR28, CR29  
E1, E2  
J1, J2, J10-13, J18-20  
Q7-17, Q121  
R20, R81-88, R90-111, R113-119, R121-148  
R171-174, R177-182, R185, R187-189  
TP8, TP11  
U27-25, U31  
VR2, VR3



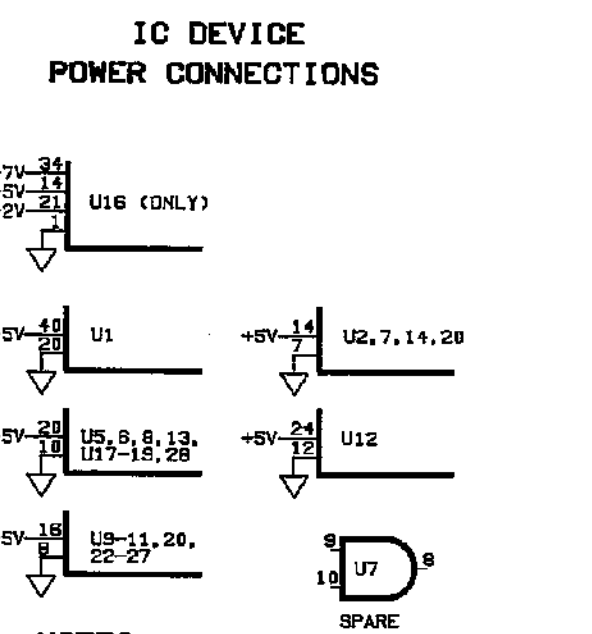
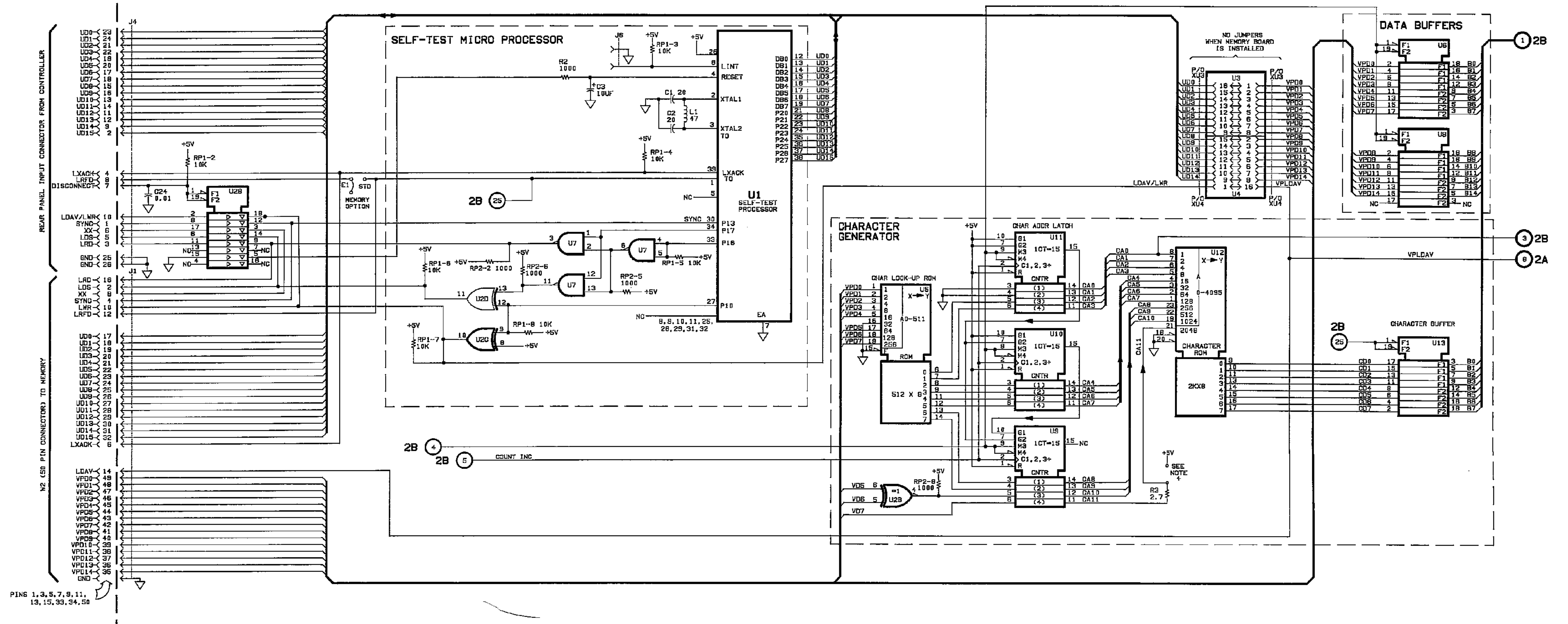
A  
B  
C  
D  
E  
F  
G  
H  
I  
J  
K  
L

Ref Desig	Grid Loc	Ref Desig	Grid Loc
C1	B-4	R8	J-4
C2	B-3	R9	K-4
C3	C-4	R10	K-3
C4	C-2	R11	K-3
C5	G-3	R12	K-3
C6	E-4	R13	K-4
C7	E-4	RP1	C-4
C8	F-3	RP2	D-4
C9	E-2	TP1	G-2
C10	F-4	TP2	G-2
C11	F-2	TP3	H-2
C12	G-2	TP4	G-3
C13	H-3	TP5	H-3
C14	H-4	U1	B-4
C15	H-3	U2	C-4
C16	I-4	U3	C-3
C17	H-2	U4	C-3
C18	I-2	U5	D-4
C19	J-4	U6	D-3
C20	J-4	U7	D-3
C21	K-3	U8	D-2
C22	K-3	U9	E-4
C23	K-3	U10	E-3
C24	B-3	U11	E-2
CR1	K-3	U12	F-4
CR2	H-4	U13	F-3
CR3	B-4	U14	H-4
E1	B-4	U15	H-3
J1	C-2	U16	F-2
J2	K-2	U17	I-4
J3	K-2	U18	I-3
J4	B-2	U19	I-2
J5	C-2	U20	I-2
J6	B-2	U21	J-4
L1	B-4	U22	J-3
Q1	K-4	U23	J-3

1 2 3 4 5

A82 Vector Processor Component Locator Rev A





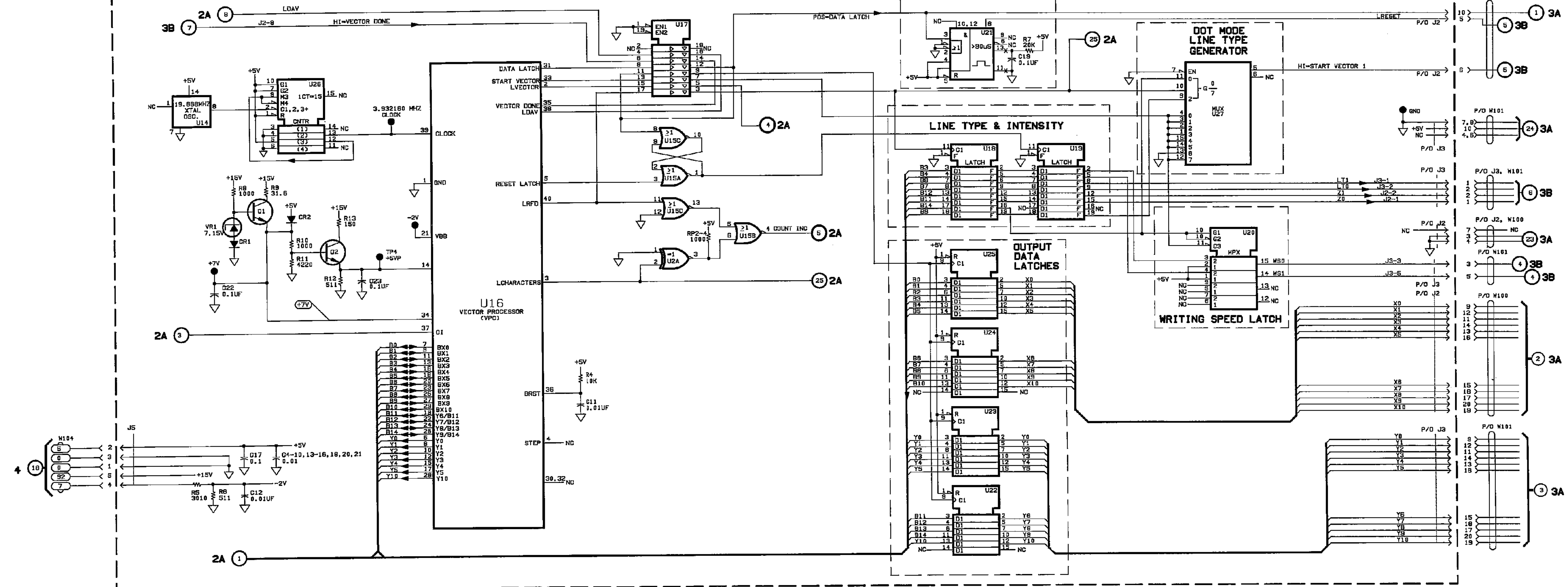
- NOTES:**
- GATES ARE SYMBOLIZED ACCORDING TO CIRCUIT FUNCTION.
  - UNLESS OTHERWISE NOTED: RESISTANCE IN OHMS, CAPACITANCE IN PICOFARADS, INDUCTANCE IN MICROHENRIES.
  - UNLESS OTHERWISE NOTED: LOGIC LEVELS ARE TTL: +2.0V TO +5.0V=LOGIC\*1\*H, 0V TO +0.6V=LOGIC\*0\*L.
  - R3 SHOWN IN POSITION FOR 32K ROM. USE ALTERNATE POSITION FOR 16K ROM.
  - WHEN MEMORY IS INSTALLED, JUMPERS U3 & U4 MUST BE REMOVED.
  - JUMPER E1 SHOWN "MEMORY INSTALLED". ALTERNATE POSITION IS FOR NO MEMORY.

**PARTS ON THIS SCHEMATIC**

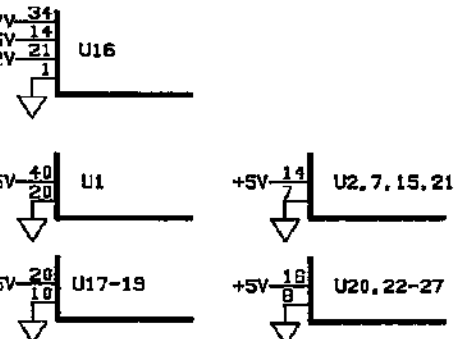
C1-3, 24
E1
J1, 4, 6
R2, 3
RP1, 2
U1-8, 10-13, 28

**A82 VPC Board**  
**03577-66582**  
**Sheet 1 of 2**



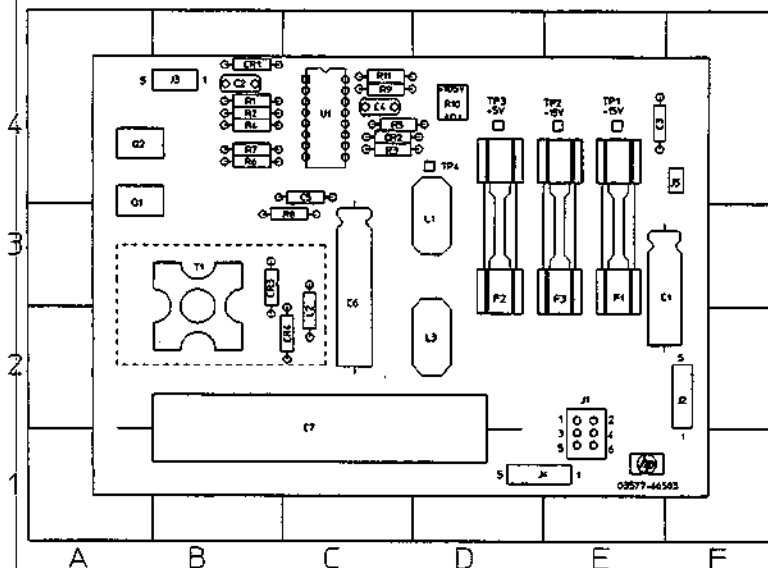


**IC DEVICE POWER CONNECTIONS**



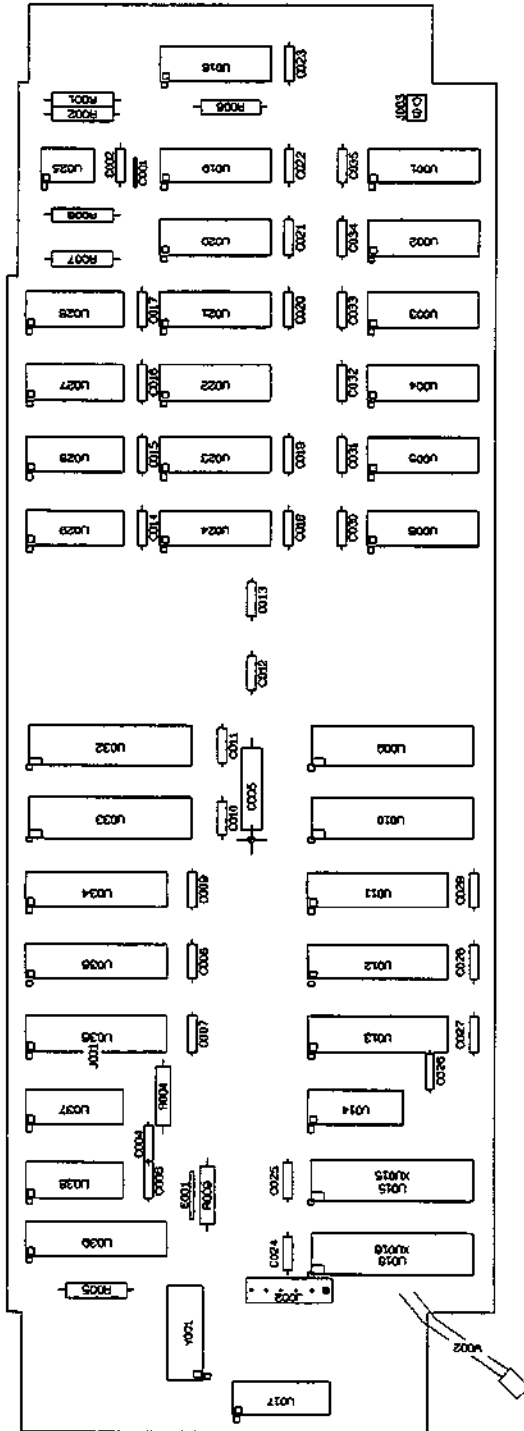
- NOTES:**
- GATES ARE SYMBOLIZED ACCORDING TO CIRCUIT FUNCTION.
  - UNLESS OTHERWISE NOTED: RESISTANCE IN OHMS, CAPACITANCE IN PICOFARADS, INDUCTANCE IN MICROHENRIES.
  - UNLESS OTHERWISE NOTED: LOGIC LEVELS ARE TTL: +2.0V TO +5.0V=LOGIC"1"=H, 0V TO +0.8V=LOGIC"0"=L

PARTS ON THIS SCHEMATIC	
A82	CHASSIS
04-23	W100
DR1, 2	W101
J2, 3, 5	W104
Q1, 2	
R4-13	
U14-27	
VR1	



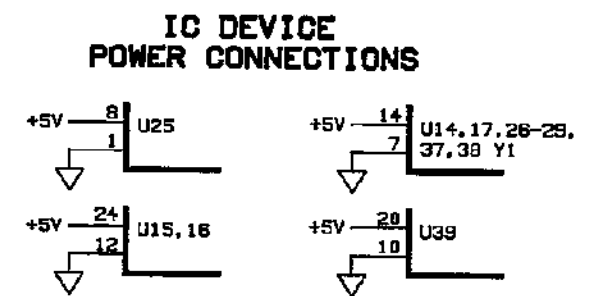
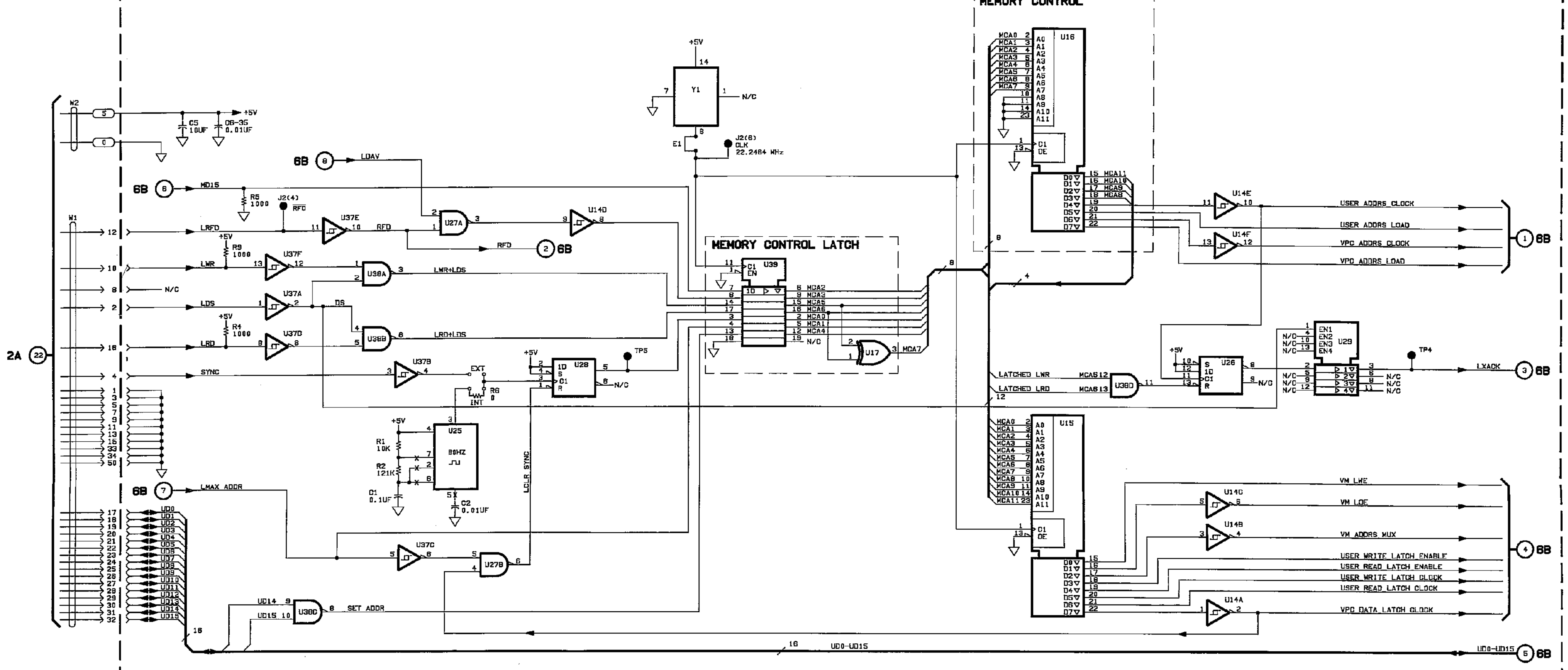
A83 Low Voltage Power Supply Component Locator Rev A

Ref Desig	Grid Loc	Ref Desig	Grid Loc
C1	E-3	L3	D-2
C2	B-4	Q1	A-3
C3	E-4	Q2	A-4
C4	C-4	R1	B-4
C5	C-3	R2	B-4
C6	C-3	R3	C-4
C7	C-2	R4	B-4
CR1	B-4	R5	C-4
CR2	C-4	R6	B-4
CR3	B-2	R7	B-4
CR4	B-2	R8	B-3
F1	E-2	R9	C-4
F2	D-2	R10	D-4
F3	E-2	R11	C-4
J1	E-2	T1	B-3
J2	E-2	TP1	E-4
J3	B-4	TP2	E-4
J4	D-1	TP3	D-4
J5	F-4	TP4	D-4
L1	D-3	U1	C-4
L2	C-3		

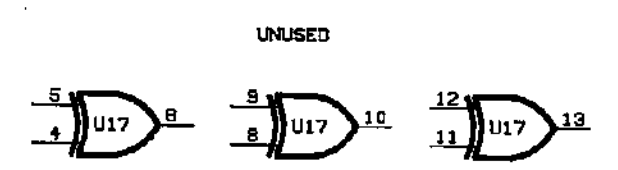


A84 Memory Circuit Component Locator Rev A

Ref Desig	Grid Loc	Ref Desig	Grid Loc
C1	I-3	R7	H-4
C2	I-3	R8	J-3
C4	C-3	R9	C-3
C5	E-2	U1	I-1
C6	C-3	U2	H-1
C7	D-3	U3	H-1
C8	D-3	U4	I-1
C9	E-3	U5	I-1
C10	E-3	U6	G-1
C11	F-3	U9	F-2
C12	F-2	U10	E-2
C13	G-2	U11	E-2
C14	G-3	U12	D-2
C15	H-3	U13	D-2
C16	H-3	U14	C-2
C17	H-3	U15	C-2
C18	G-2	U16	B-2
C19	H-2	U17	A-2
C20	H-2	U18	J-3
C21	I-2	U19	I-3
C22	I-2	U20	H-3
C23	J-2	U21	H-3
C24	B-2	U22	I-3
C25	C-2	U23	I-3
C26	D-1	U24	G-3
C27	D-1	U25	I-4
C28	D-1	U26	H-4
C29	E-1	U27	I-4
C30	G-2	U28	I-4
C31	H-2	U29	G-4
C32	H-2	U30	G-4
C33	H-2	U31	F-4
C34	I-2	U32	F-4
C35	I-2	U33	E-4
E1	C-3	U34	E-4
J1	B-2	U35	D-4



- NOTES:**
1. GATES ARE SYMBOLIZED ACCORDING TO CIRCUIT FUNCTION.
  2. UNLESS OTHERWISE NOTED: RESISTANCE IN OHMS CAPACITANCE IN PICOFARADS INDUCTANCE IN MICROHENRIES
  3. UNLESS OTHERWISE NOTED: LOGIC LEVELS ARE TTL: +2.0V TO +5.0V=LOGIC"1" +0.0V TO +0.8V=LOGIC"0"=L

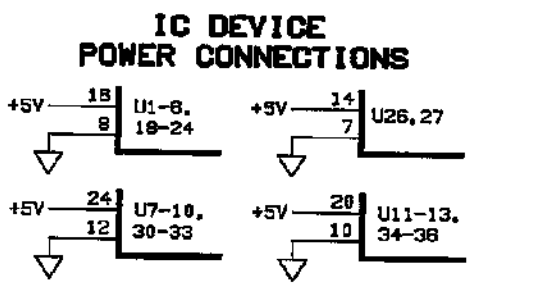
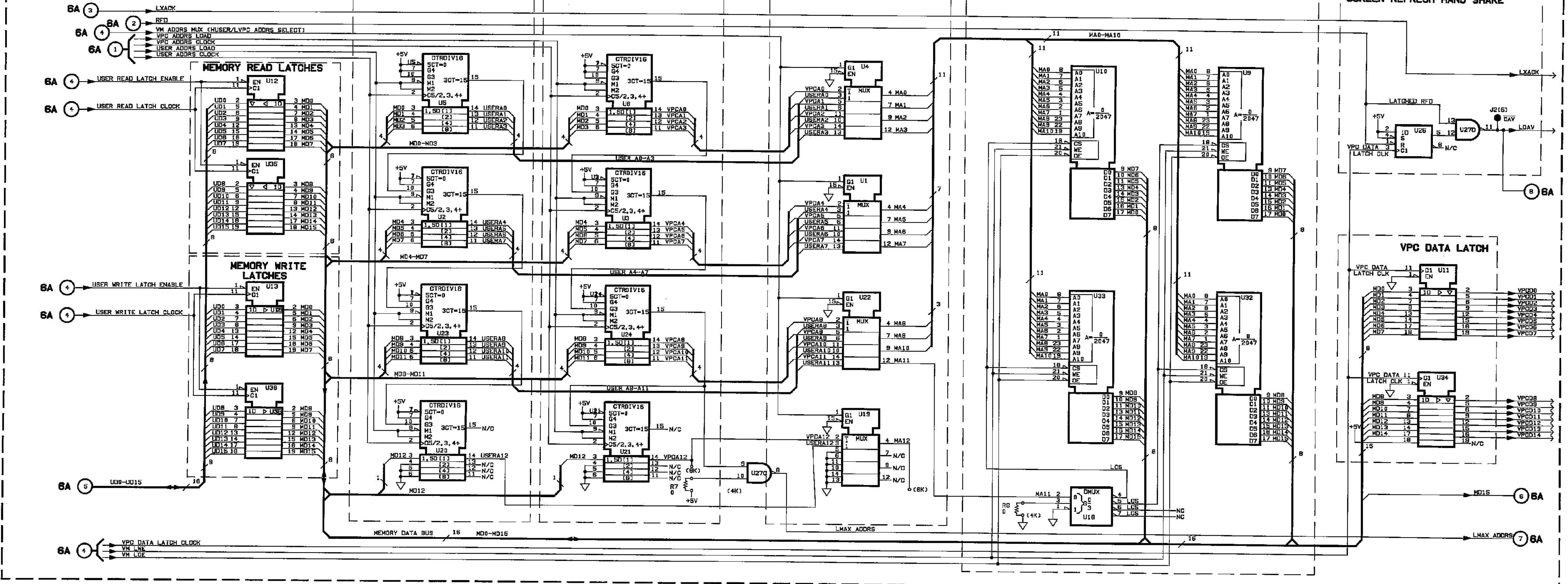


**PARTS ON THIS SCHEMATIC**

A84	CHASSIS
D1, C2, C5-35	W1
E1	W2
R1, 2, 4-8, 9	
U14-17, 25-29, 37-39	
W1, W2	
Y1	

**A84 Memory**  
**03577-66584**  
**Sheet 1 of 2**

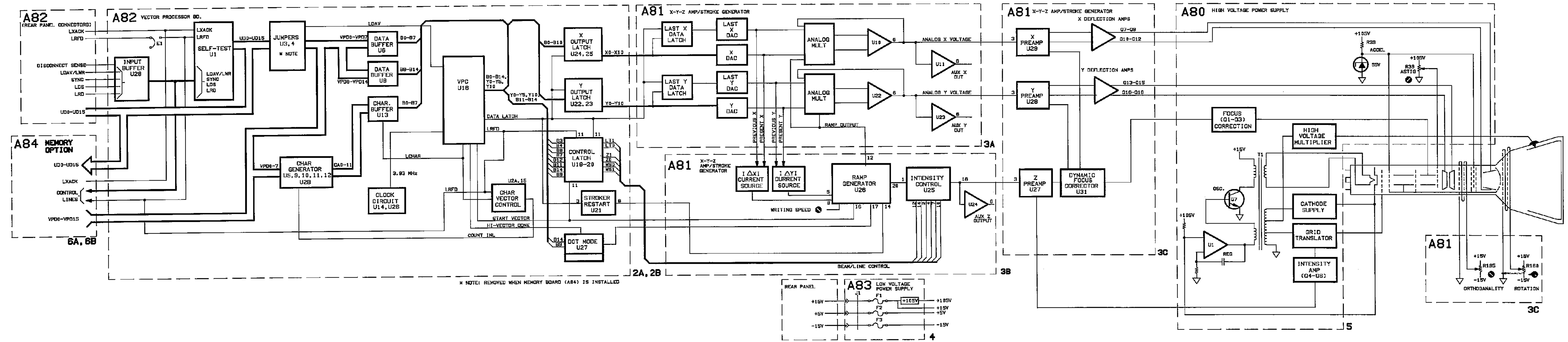




- NOTES:**
- GATES ARE SYMBOLIZED ACCORDING TO CIRCUIT FUNCTION.
  - UNLESS OTHERWISE NOTED: RESISTANCE IN OHMS CAPACITANCE IN PICOFARADS INDUCTANCE IN MICROHENRIES
  - UNLESS OTHERWISE NOTED: LOGIC LEVELS ARE TTL: +2.0V TO +5.0V=LOGIC"1" +0V TO +0.8V=LOGIC"0"-L

PARTS ON THIS SCHEMATIC	
A84	CHASSIS
R7, 8 U1-13, 18-24, 26, 27C, 27D, 30-38 27C, 27D, 30-38	W1

**A84 Memory**  
**03577-66584**  
**Sheet 2 of 2**



A80/A81/A82/A83/A84 Block Diagram