

Errata

Title & Document Type: 3310A/B Operating & Service Manual

Manual Part Number: 03310-90003

Revision Date: October 1973

HP References in this Manual

This manual may contain references to HP or Hewlett-Packard. Please note that Hewlett-Packard's former test and measurement, semiconductor products and chemical analysis businesses are now part of Agilent Technologies. We have made no changes to this manual copy. The HP XXXX referred to in this document is now the Agilent XXXX. For example, model number HP8648A is now model number Agilent 8648A.

About this Manual

We've added this manual to the Agilent website in an effort to help you support your product. This manual provides the best information we could find. It may be incomplete or contain dated information, and the scan quality may not be ideal. If we find a better copy in the future, we will add it to the Agilent website.

Support for Your Product

Agilent no longer sells or supports this product. You will find any other available product information on the Agilent Test & Measurement website:

www.tm.agilent.com

Search for the model number of this product, and the resulting product page will guide you to any available information. Our service centers may be able to perform calibration if no repair parts are needed, but no other support from Agilent is available.





OPERATING AND SERVICE MANUAL

-hp- Part No. 03310-90003
Microfiche Part No. 03310-90053

MODEL 3310A/3310B FUNCTION GENERATOR

3310A Serials Prefixed: 1151A
3310B Serials Prefixed: 1201A

Appendix C, Manual Backdating Changes, adapts this manual to lower serial numbers.

Copyright Hewlett-Packard Company 1969
P.O. Box 301, Loveland, Colorado 80537 U.S.A.

Printed: October 1973

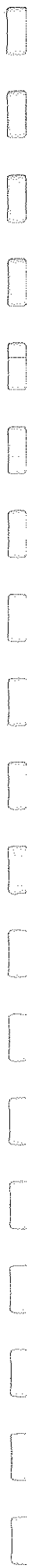

TABLE OF CONTENTS

<p>Section I GENERAL INFORMATION 1-1</p> <p>1-1. Introduction 1-1</p> <p>1-3. Specifications 1-1</p> <p>1-5. Description 1-1</p> <p>1-6. Model 3310A Function Generator . . . 1-1</p> <p>1-10. Model 3310B Function Generator . . . 1-1</p> <p>1-13. Instrument and Manual Identification . . 1-1</p> <p>Section II INSTALLATION 2-1</p> <p>2-1. Introduction 2-1</p> <p>2-3. Inspection 2-1</p> <p>2-5. Power Requirements 2-1</p> <p>2-7. Grounding Requirements 2-1</p> <p>2-10. Installation 2-1</p> <p>2-12. Rack/Bench Installation 2-1</p> <p>2-14. Repackaging for Shipment 2-1</p> <p>Section III OPERATING INSTRUCTIONS 3-1</p> <p>3-1. Introduction 3-1</p> <p>3-3. Panel Features 3-1</p> <p>3-5. General Operating Information 3-1</p> <p>3-6. 3310A/B 3-1</p> <p>3-18. 3310B 3-1</p> <p>3-22. Special Considerations 3-4</p> <p>3-23. Floating 3-4</p> <p>3-29. DC Offset 3-4</p> <p>3-31. Frequency Drift 3-4</p> <p>3-33. Amplitude Stability 3-4</p> <p>3-35. Changing the Duty Cycle (aspect ratio) of the 3310A/B Pulse and Ramp Waveforms 3-5</p> <p>3-37. Phase Locking the 3310A/B 3-5</p> <p>3-39. Useability of the 3310B Tone Burst Output Above 50 kHz 3-5</p> <p>3-41. Applications 3-6</p> <p>Section IV THEORY OF OPERATION 4-1</p> <p>4-1. Introduction 4-1</p> <p>4-3. Block Diagram Description (3310A) . . . 4-1</p> <p>4-16. Detailed Schematic Description (3310A) 4-1</p> <p>4-44. Block Diagram Description (3310B) . . . 4-3</p> <p>4-46. Detailed Schematic Description (3310B) 4-3</p> <p>Section V MAINTENANCE 5-1</p> <p>5-1. Introduction 5-1</p> <p>5-3. Test Equipment Required 5-1</p> <p>5-5. Performance Checks 5-1</p> <p>5-8. Frequency Range Check 5-1</p> <p>5-14. Sine Wave Frequency Response Check 5-1</p> <p>5-17. Triangle Symmetry Check 5-3</p> <p>5-20. Dial Accuracy Check 5-3</p> <p>5-49. SYNC OUTPUT Response Check . . . 5-6</p>	<p>5-53. Maximum HIGH Output (except pulses greater than 2 MHz) and OUTPUT LEVEL Range Check 5-6</p> <p>5-60. Maximum HIGH Output Check (pulses greater than 2 MHz) 5-6</p> <p>5-65. Minimum LOW Output Check 5-6</p> <p>5-70. SYNC OUTPUT Amplitude Check . . . 5-7</p> <p>5-76. Ext. Gate Sensitivity (3310B only) . . 5-7</p> <p>5-86. Ext. Trigger Check (3310B only) . . . 5-7</p> <p>5-93. Checks of General Operating Characteristics 5-8</p> <p>5-94. Low Output Check (30 dB Separation) 5-8</p> <p>5-100. Output Impedance Checks 5-8</p> <p>5-116. External Frequency Control Check . . 5-9</p> <p>5-119. Adjustment Procedure 5-9</p> <p>5-121. Cover Removal 5-9</p> <p>5-123. Power Supply Adjustment 5-9</p> <p>5-126. Triangle Amplifier Bias Adjustment . 5-10</p> <p>5-128. Symmetry Check 5-10</p> <p>5-134. Dial Calibration 5-10</p> <p>5-140. Frequency Calibration 5-10</p> <p>5-148. Distortion Adjustment 5-10</p> <p>5-150. D.C. Offset Adjustment (SINE function) 5-10</p> <p>5-154. Square Wave and Pulse Aberration Adjustment 5-10</p> <p>5-158. Frequency Response Adjustment . . 5-11</p> <p>5-160. START/STOP PHASE Limit Adjustment (3310B only) 5-11</p> <p>5-167. Troubleshooting 5-11</p> <p>5-169. General Troubleshooting Information . 5-11</p> <p>5-170. Front Panel Checks 5-11</p> <p>5-172. Specific Circuit Troubleshooting Aids and Maintenance Tips 5-14</p> <p>5-173. Circuit Troubleshooting 5-14</p> <p>5-182. Troubleshooting The 3310B 5-16</p> <p>5-184. Maintenance Tips 5-17</p> <p>5-185. A1 Board Removal 5-17</p> <p>5-186. Broken Trace Repair 5-17</p> <p>Section VI REPLACEABLE PARTS 6-1</p> <p>6-1. Introduction 6-1</p> <p>6-4. Ordering Information 6-1</p> <p>6-6. Non-Listed Parts 6-1</p> <p>Section VII CIRCUIT DIAGRAMS 7-1</p> <p>7-1. Introduction 7-1</p> <p>7-3. Functional Block Diagram 7-1</p> <p>7-5. Schematic Diagrams 7-1</p> <p>7-7. Component Location Diagrams 7-1</p> <p>APPENDICES</p> <p>A. CODE LIST OF MANUFACTURERS</p> <p>B. SALES AND SERVICE OFFICES</p> <p>C. MANUAL BACKDATING CHANGES</p>
---	---

LIST OF TABLES

Number	Page	Number	Page
1-1.	Specifications	1-2	
1-2.	General Information	1-3	
5-1.	Required Test Equipment	5-0	
5-2.	Dial Accuracy Check	5-3	
5-3.	(A and B) High Frequency Dial Check	5-4	
5-4.	Starred Value Component	5-12	
5-5.	Condensed Adjustment Procedure	5-13/5-14	
5-6.	D.C. Voltages on A1 Assembly With and Without Offset	5-16	
5-7.	D.C. Voltages for Tone Burst Circuit (A4 Assembly) With EXT. GATE Input	5-17	
5-8.	D.C. Voltages for Tone Burst Circuit (A4 Assembly) Without EXT. GATE Input	5-17	
6-1.	Replaceable Parts	6-2	

LIST OF ILLUSTRATIONS

Number	Page	Number	Page
3-1.	3310A/B Front and Rear Panel Features	3-2/3-3	
3-2.	Biasing a Transistor Using the Internal D.C. Offset of the Model 3310A	3-4	
3-3.	Floating the 3310A/B Output Using External Battery (Output Protection Circuit Installed)	3-5	
3-4.	Floating the 3310A/B Output Using Capacitance Coupling for Output Protection	3-5	
3-5.	Phase Locking the 3310A/B	3-5	
3-6.	Changing the Duty Cycle of the 3310A/B Pulse and Ramp Functions	3-6	
3-7.	Using the 3310A/B for Network Analysis	3-6	
3-8.	Using the 3310A/B as a Logic Interface	3-7	
3-9.	Using the 3310A/B as Clock Source for Logic Circuitry Troubleshooting	3-7	
3-10.	Checking the Dynamic Response of a Speaker	3-8	
3-11.	Using the 3310A/B to Show Basic Mathematical Concepts	3-9	
4-1.	Simplified Block Diagram	4-0	
5-1.	Frequency Response Check	5-1	
5-2.	Dial Accuracy/Triangle Symmetry Check	5-3	
5-3.	Distortion Check	5-4	
5-4.	5 MHz Distortion Check	5-5	
5-5.	Rise Time Check	5-5	
5-6.	Aberration Check	5-6	
5-7.	EXT. GATE Sensitivity Check	5-7	
5-8.	EXT. TRIGGER Check	5-8	
5-9.	External Frequency Control Check	5-9	
5-10.	Tunnel Diode Check	5-15	
5-11.	Troubleshooting Tree No. 1. No Output or Defective Output	5-19/5-20	
5-12.	Troubleshooting Tree No. 2. Output Not Obtainable on All Functions	5-19/5-20	
6-1.	3310A/B Mechanical Parts	6-13	
7-1.	Functional Block Diagram	7-3/7-4	
7-2.	Tuning and Inverting Amplifiers, Current Sources	7-5/7-6	
7-3.	Triangle and Feedback Amplifiers, Level Detectors	7-7/7-8	
7-4.	Sine Shaping and Output Circuits	7-9/7-10	
7-5.	Sine Shaping and Output Circuits (Backdating)	7-11/7-12	
7-6.	Power Supply (3310A only)	7-13/7-14	
7-7.	Power Supply and Tone Burst Generator (3310B only)	7-15/7-16	
7-8.	Wiring Diagram (3310A only)	7-17/7-18	

SECTION I

GENERAL INFORMATION

1-1. INTRODUCTION.

1-2. This section contains general information about the -hp- Model 3310A and the Model 3310B Function Generators. The description of these instruments, their specifications, and instrument identification information are included. Throughout this manual, the Model 3310A will be referred to as the 3310A. The Model 3310B will be referred to as the 3310B. If a statement refers to either/or both instruments they will be called the 3310A/B.

1-3. SPECIFICATIONS.

1-4. Table 1-1 contains specifications for the 3310A and the 3310B. Table 1-2 contains the general operating characteristics of these instruments. The information that Table 1-2 contains should not be considered specifications. Performance Checks have been provided in Section V. These checks can be used to compare the instruments with their published specifications. Checks of the more important general operating characteristics of the instruments, listed in Table 1-2, are also provided.

1-5. DESCRIPTION.

1-6. Model 3310A Function Generator.

1-7. The -hp- Model 3310A Function Generator is a versatile function generator having sine, triangle and square wave outputs, as well as positive-and negative-going pulses and positive-and negative-going ramps. All of these functions have a maximum output amplitude of 30V p-p. Any of these functions may be internally dc offset up to + or -10V. The sum of the dc component plus the peak value of the signal may not exceed 15V into open circuit. A LOW output connector provides a signal level 30dB below the HIGH output. With the 30dB variable attenuator, a total attenuation of greater than 60dB is available.

1-8. The frequency range of the 3310A is from .0005Hz to 5MHz, in 10 ranges. The frequency may be externally controlled, up to a 50:1 range, by an external voltage.

1-9. In addition to the HIGH and LOW outputs, a SYNC OUTPUT is available. This sync signal is a square wave in the Sine, Square, and Triangle functions, and is a pulse in the Ramp and Pulse functions.

1-10. Model 3310B Function Generator.

1-11. When the START/STOP PHASE control on the 3310B is set to FREE RUN the instrument functions as a Model 3310A Function Generator. If the START/STOP PHASE control is set to any other position, tone bursts of almost any length, adjustable in phase from +90° to -90°, are obtainable. The waveshape of the frequency within the burst is determined by the setting of the FUNCTION switch. Burst length is determined by the length of the positive portion of an external waveform applied to the EXT. GATE input at the rear of the instrument.

1-12. The frequency range of the 3310B is .0005 Hz to 5 MHz in "Free Run" mode. The triggering frequency range of the 3310B is .0005 Hz to 50 kHz although, for many applications the output is useable to 5 MHz.

1-13. INSTRUMENT AND MANUAL IDENTIFICATION.

1-14. Hewlett-Packard uses a two-section serial number. The first section (prefix) identifies a series of instruments. The last section (suffix) identifies a particular instrument within the series. If a letter is included with the serial number, it identifies the country in which the instrument was manufactured. If the serial prefix of your instrument differs from the one on the title page of this manual, a change sheet will be supplied to make this manual compatible with newer instruments or the backdating information in Appendix C will adapt this manual to earlier instruments. All correspondence with Hewlett-Packard should include the complete serial number.

Table 1-1. Specifications.

MODEL 3310A/B PERFORMANCE CHARACTERISTICS	3310B (only)
<p>Frequency range: 0.0005 Hz to 5 MHz in decade ranges.</p> <p>Sine wave frequency response: reference, 1 kHz at full output into 50 ohms. 0.0005 Hz to 50 kHz: $\pm 1\%$ 50 kHz to 5 MHz: $\pm 4\%$</p> <p>Dial accuracy: 0.0005 Hz to 500 kHz, all functions: $\pm(1\%$ of setting + 1% of full scale). 500 kHz to 5 MHz, sine, square, triangle: $\pm(3\%$ of setting + 3% of full scale). 500 kHz to 5 MHz, pulse and ramp: $\pm(10\%$ of setting + 1% of full scale).</p> <p>Sine wave distortion (below fundamental at full output): 10 Hz to 50 kHz (on 1 K range): greater than 46 dB (0.5%) 50 kHz to 500 kHz: greater than 40 dB (1%) 500 kHz to 5 MHz: greater than 30 dB (3%)</p> <p>Triangle symmetry: 0.0005 Hz to 20 Hz: less than 1% 20 Hz to 50 kHz: less than 0.5%</p> <p>Square wave and pulse response: less than 30 ns rise and fall times at full output. less than 35 ns rise and fall times at less than full output. less than 5% total aberration.</p> <p>Sync output response: less than 20 ns rise and fall times.</p> <p>External Frequency Control</p> <p>Input requirements: 0 to +10V ± 1 V for 50:1 increase. 0 to -10V ± 1 V for 50:1 decrease. An ac voltage will FM the frequency about a dial setting within the limits (1 > f < 50) X range knob setting.</p>	<p>The specifications for the 3310B are identical to those of the Model 3310A except as follows:</p> <p style="text-align: center;">NOTE</p> <p style="text-align: center;"><i>These specifications apply to the X.0001 through X 1 K ranges only.</i></p> <p>External Gate Sensitivity (DC coupled): Will cause the 3310B to free run when the gate input is held at between +1 V and +10 V, or will trigger a single cycle on a positive waveform ≥ 1 V but ≤ 10 V. To generate a single cycle the period of triggering waveform must be greater than the period of the 3310B output while the duty cycle is less than that of the 3310B output. When the gate signal goes to 0, the 3310A output will stop in the same phase it started.</p> <p>External Trigger Sensitivity (AC coupled): Requires a positive going square wave or pulse from 1.4 V p-p to 10 V p-p of lower frequency than that set on the 3310B. (The triggering signal can be dc offset, but its peak amplitude, including dc offset, must not exceed ± 10 V; i.e., [V ac peak + V dc] ≤ 10 V peak). Rise time of pulse: < 0.5 μs. Maximum gating rate: 50 kHz.</p> <p style="text-align: center;">OUTPUT CHARACTERISTICS</p> <p>Maximum HIGH outputs greater than 30 V p-p open circuit. greater than 15 V p-p into 50 ohms (except pulses greater than 2 MHz).</p> <p>Maximum HIGH output (pulses greater than 2 MHz): greater than 24 V p-p open circuit. greater than 12 V p-p into 50 ohms.</p> <p>Minimum LOW output: less than 30 mV p-p open circuit. less than 15 mV p-p into 50 ohms.</p> <p>OUTPUT LEVEL control: range greater than 30 dB. HIGH and LOW outputs overlap for a total range of greater than 60 dB; LOW output is 30 dB down from HIGH output.</p> <p>SYNC output amplitude: greater than 4 V p-p open circuit. greater than 2 V p-p into 50 ohms.</p>
<p style="text-align: center;">CAUTION</p> <p style="text-align: center;"><i>Do not apply greater than ± 10 V to either external gate or external trigger input.</i></p>	

Table 1-2. General Information (3310A/B).

<p>Frequency Range: 0005 Hz to 50 kHz (3310B only)</p> <p>LOW output: 30 dB below HIGH output for any amplitude setting, when LOW and HIGH are equally terminated.</p> <p>External Frequency Control</p> <p>Range: 50:1 on any range.</p> <p>Input requirement: with dial set to low end mark, 0 to +10 V \pm 1 V will linearly increase frequency 50:1. With dial set at 50, 0 to -10 V \pm 1 V will linearly decrease frequency 50:1. An ac voltage will FM the frequency about a dial setting within the limits $(1 < f < 50)$ x range setting.</p> <p>Sensitivity: 100 mV/minor division (of the frequency dial on any range).</p> <p>Linearity: ratio of output frequency to input voltage ($\Delta V/\Delta F$) will remain constant within 0.5%.</p> <p>Input impedance: 10 kΩ.</p> <p>Sine Wave Distortion (below fundamental): 0.0005 Hz to 10 Hz: greater than 40 dB (1%)</p> <p>Triangle and Ramp Linearity: 0.0005 Hz to 50 kHz: less than 1%.</p> <p>DC Offset</p> <p>Amplitude: \pm 10 V open circuit, \pm 5 V into 50 ohms, continuously adjustable.</p> <p>NOTE: maximum (V acp + V dc) is \pm 15 V open circuit, \pm 7.5 V into 50 ohms.</p> <p>Input impedance (3310B only): External Trigger: 390 pF in series with 500 ohms External Gate: 500 ohms</p>	<p>Modes of Operation (3310B only):</p> <p>Single Cycle: EXT TRIGGER (ac coupled) requires a positive-going square wave or pulse from 1 V p-p to 10 V p-p of lower frequency than that set on the 3310B; the triggering signal can be dc offset, but $(V_{ac\ peak} + V_{dc}) \leq \pm 10$ V. EXT GATE (dc coupled) will trigger a single cycle on any positive waveform ≥ 1 V but ≤ 10 V which has a period greater than the period of the 3310B output, and a duty cycle less than the period of the 3310B output. The gate signal cannot exceed 10 V. Applies to X.0001 thru X1K ranges only. NOTE: single negative pulses cannot be produced.</p> <p>Multiple cycle: MANUAL TRIGGER will cause the 3310B to free run when depressed. When the trigger button is released, the waveform will stop on the same phase as it started. EXT GATE will cause the 3310B to free run when the gate is held at between +1 and +10 V. When the gate signal goes to zero, the 3310B will stop on the same phase as it started. For accurate gating, a square wave or square pulse is recommended. Applies to X.0001 thru X1K ranges only.</p> <p>Start—stop phase: the start—stop phase can be adjusted over a range of approximately $\pm 90^\circ$ using the front panel control.</p> <p>Manual Trigger: Causes the 3310B to free run when depressed. When the trigger button is released, the waveform will stop in the same phase it started.</p> <p>Waveforms: sine, square, triangle, positive pulse, negative pulse, positive ramp, and negative ramp. Pulses and ramps have 15% or 85% duty cycle, SYNC waveform is a square wave for symmetrical functions, pulse for pulse and ramp functions.</p> <p>Power requirements: 115 V or 230 V \pm 10%, 48 Hz to 440 Hz, less than 20 VA.</p> <p>Operating temperature: 0 to 55$^\circ$ C.</p> <p>Accessories available: Combining case: -hp- 1051A Rack adapter: -hp- 5060-0797 Filler strip: -hp- 5060-0105</p>
---	--

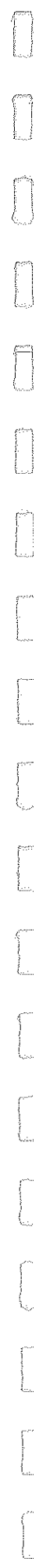

SECTION II

INSTALLATION

2-1. INTRODUCTION.

2-2. This section includes information and instructions necessary for the installation or shipment of this instrument. Included is information pertaining to initial inspection, installation, and repackaging for shipment.

2-3. INSPECTION.

2-4. This instrument was carefully inspected both mechanically and electrically before shipment. It should be physically free of marks or scratches and in perfect electrical order upon receipt. To confirm this, the instrument should be inspected for physical damage. Also, the electrical performance of the instrument should be tested using the procedure outlined in Section V of this manual. If there is damage or deficiency, see the warranty at the front of this manual.

2-5. POWER REQUIREMENTS.

2-6. This instrument will operate from either 115 or 230Vac, 48Hz to 440Hz. The instrument can easily be converted from 115 volt to 230 volt operation by changing the position of the slide switch located on the rear panel, so that the designation appearing on the switch matches the nominal voltage of the power source.

2-7. GROUNDING REQUIREMENTS.

2-8. To protect operating personnel, the National Electrical Manufacturers' Association (NEMA) recommends that the instrument panel and cabinet be grounded. Each Hewlett-Packard instrument is equipped with a three-conductor power cord which, when plugged into an appropriate receptacle grounds the instrument. The offset pin on the power cord three-prong connector is the ground wire.

2-9. To preserve the protection feature when operating the instrument from a two-contact outlet, use a three-prong to two-prong adapter and connect the green pigtail on the adapter to ground.

2-10. INSTALLATION.

2-11. This instrument is fully transistorized; therefore no special cooling is required. However, the instrument should

not be operated where the ambient temperature is outside the limits specified in Table 1-2.

2-12. Rack/Bench Installation.

2-13. This instrument is initially shipped as a bench-type instrument with plastic feet and tilt stand in place. This instrument can be rack mounted by using a rack mounting kit available at your nearest -hp- Sales and Service Office.

2-14. REPACKAGING FOR SHIPMENT.

2-15. The following is a general guide for repackaging for shipment. If you have any questions, contact your local -hp- Sales and Service Office. (See Appendix at the back of this manual for office location.)

NOTE

If the instrument is to be shipped to Hewlett-Packard for service or repair, attach a tag to the instrument identifying the owner and indicating the service or repair to be accomplished; include the model number and full serial number of the instrument. In any correspondence, identify the instrument by model number, serial number and serial number prefix.

2-16. Place the instrument in its original container if available. If the original container is not available, a suitable one can be purchased from your nearest -hp- Sales and Service Office.

2-17. If the original container is not used:

a. Wrap the instrument in heavy paper or plastic before placing in an inner container.

b. Use plenty of packing material around all sides of the instrument and protect panel faces with cardboard strips.

c. Place the instrument and inner container in a heavy carton or wooden box and seal with strong tape or metal bands.

d. Mark the shipping container with "DELICATE INSTRUMENT," "FRAGILE" etc.



SECTION III

OPERATING INSTRUCTIONS

3-1. INTRODUCTION.

3-2. This section contains information necessary for proper operation of the Model 3310A and Model 3310B Function Generators. Included in this section are identification of controls, indicators, and connectors (panel features), turn on procedures and general operating information. A special considerations and an applications section are also provided.

3-3. PANEL FEATURES.

3-4. The Model 3310A and Model 3310B panel features are described in Figure 3-1. Each operating control, indicator, and connector is identified by an associated number and described by a paragraph with the corresponding number.

3-5. GENERAL OPERATING INFORMATION.

3-6. 3310A/B.

NOTE

The circled numbers (X) refer to Figures 3-1 and 3-2. Paragraphs 3-6 through 3-17 apply to both the 3310A and 3310B. Paragraphs 3-18 through 3-21 apply to the 3310B only.

3-7. Before connecting the Model 3310A/B to primary power ensure that the proper fuse (14) for the line voltage selected is used. (See Table 6-1)

3-8. Set the line selector switch (15) to correspond to nominal line voltage being used.

3-9. Connect the A.C. power cord to the power receptacle (16).

3-10. Set the front panel switch (1) to "LINE". The indicator (2) should light.

3-11. RANGE (3). Set the 3310A/B to the desired frequency by selecting the desired RANGE and adjusting the frequency dial (13) and vernier (12) to the desired setting. The output frequency is equal to the RANGE setting times the frequency dial setting.

3-12. FUNCTION (4). Select the FUNCTION desired.

3-13. LOAD. Connect the desired load to the output to be used (HIGH (6) or LOW (7)). Connect an oscilloscope across the load.

3-14. OUTPUT LEVEL (5). Observe the oscilloscope and adjust the output amplitude to the desired level.

3-15. D.C. LEVEL (8). If D.C. OFFSET is required set the offset knob to the polarity desired and adjust the offset vernier (9) to obtain the desired amount of offset.

3-16. VCO INPUT (11). If it is desired to frequency modulate or sweep the 3310A/B output connect an external source to the VCO INPUT. The 3310A/B will sweep a 50:1 range upward when the dial is set to 1 and a 0 to +10 ramp voltage is applied. A 50:1 downward sweep can be obtained if the dial is set at 50 and a 0 to -10 V ramp voltage is applied. To sweep symmetrically around a particular frequency apply a ramp waveform which varies from + to - and is symmetrical about the 0 V level.

3-17. SYNC OUTPUT (10). An external oscillator can be synchronized with the 3310A/B by connecting the SYNC OUTPUT to the sync input of the external oscillator. The sync output a d.c. coupled square wave in SQ., SINE, and TRI functions. It is a pulse in the PULSE and RAMP functions. The sync signal is inverted with respect to the output signal.

3-18. 3310B.

NOTE

When the START/STOP PHASE control (18) of the 3310B is set to FREE RUN the 3310B operates as a Model 3310A Function Generator.

3-19. Manual Trigger (17). To use manual triggering, turn the START/STOP PHASE control to any setting other than FREE RUN. Set the controls (frequency, level, etc.) to obtain the desired output, and then depress the MANUAL TRIGGER button. The output will remain on as long as the button is held depressed, and will stop when the button is released. If a specific start and stop phase is desired, adjust the START/STOP PHASE control to obtain up to $\pm 90^\circ$ phase variation.

3-20. Ext. Trigger (19). Set the 3310B controls for the desired output, and turn the START/STOP PHASE control to any setting other than FREE RUN. Connect the triggering signal to the EXT. TRIGGER input terminal on the rear panel. The triggering signal must be a square wave or pulse between +1.4 V p-p and +10 V p-p; it can be dc offset, but ($V_{ac\ peak} + V_{dc}$) cannot be greater than ± 10 V. Single cycles of the 3310B output will be triggered at a repetition rate that is the same as the frequency of the triggering signal. The START/STOP PHASE control can be adjusted to vary the phase of the output approximately $\pm 90^\circ$.

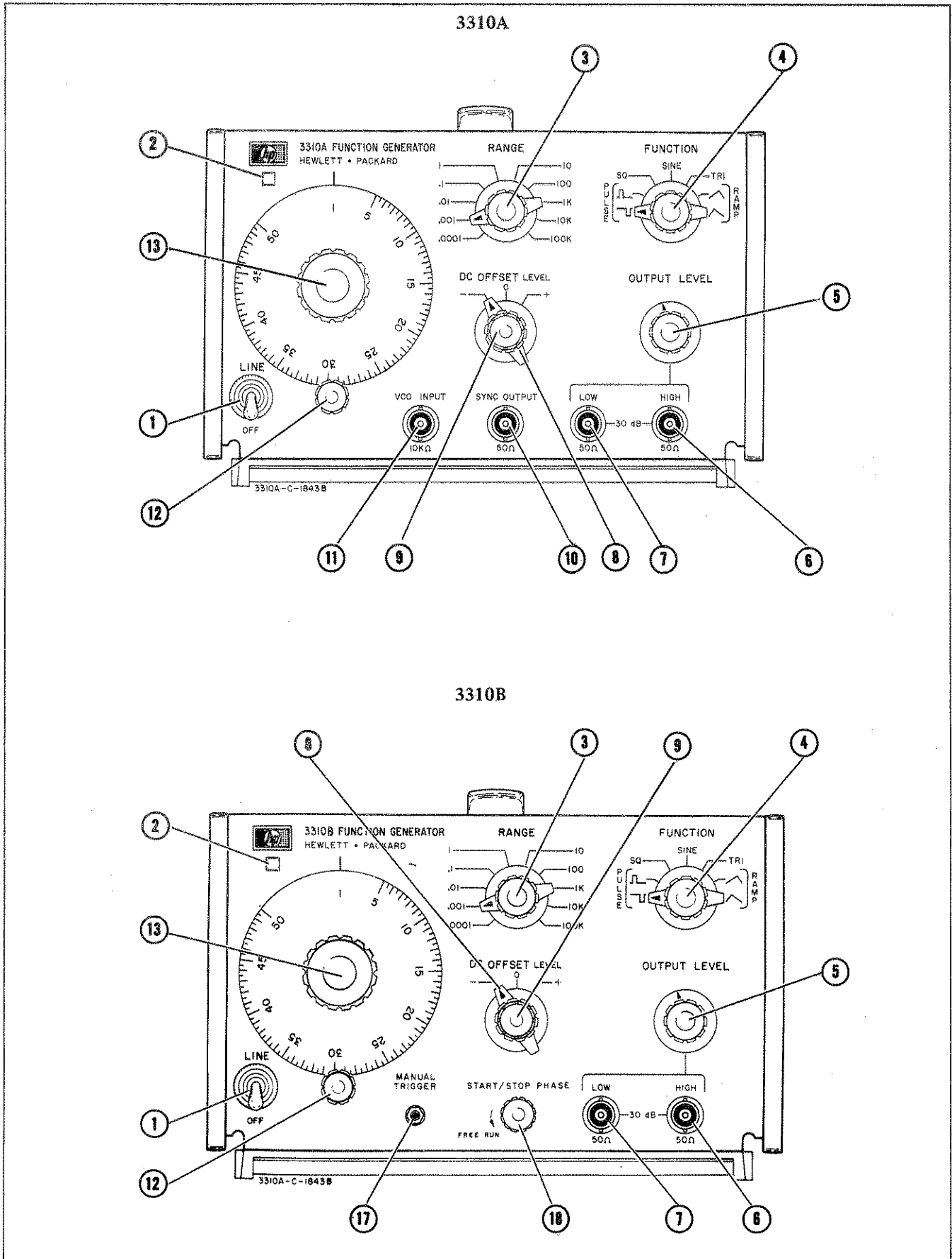

Figure 3-1. 3310A/B Front and Rear Panel Features.

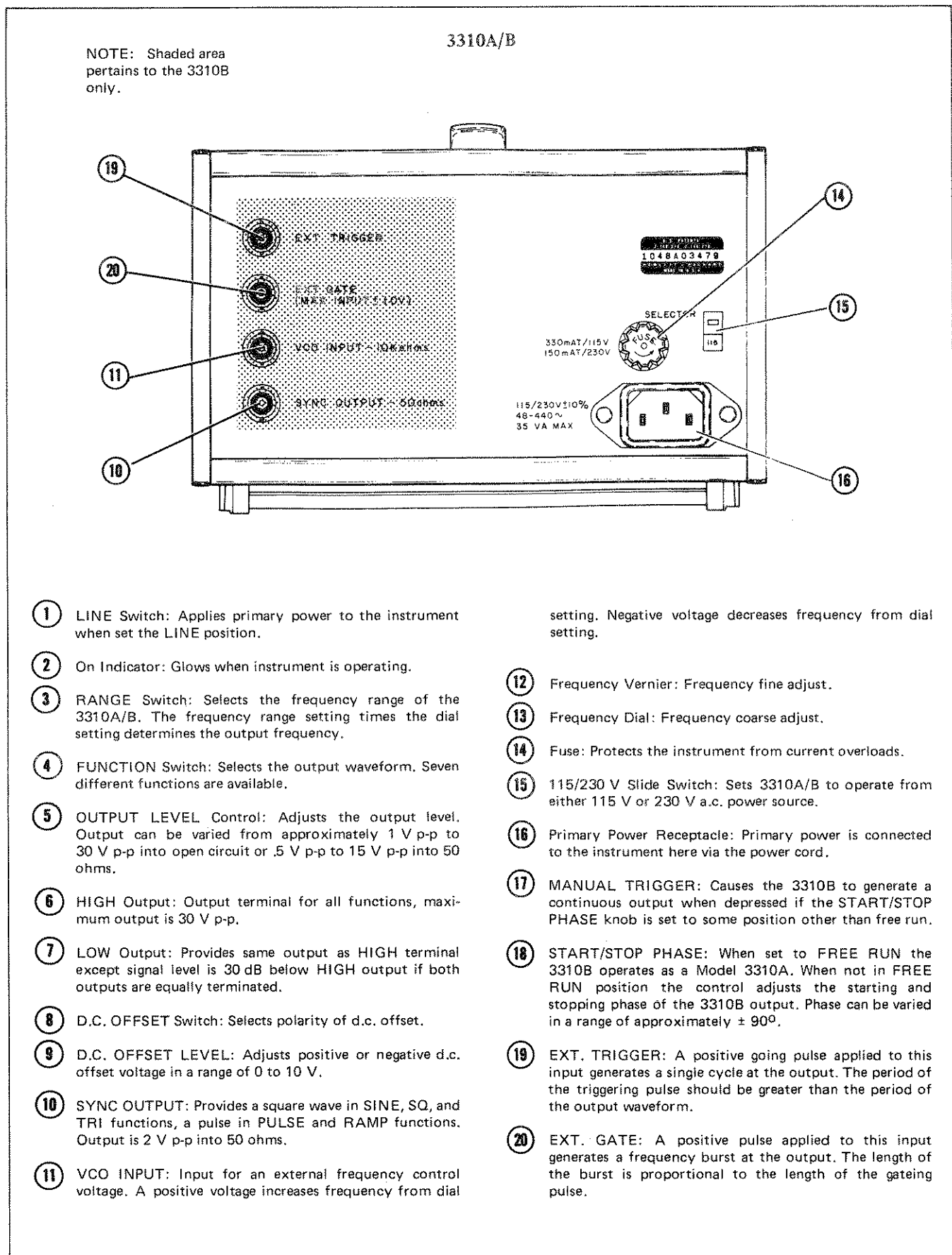

Figure 3-1. 3310A/B Front and Rear Panel Features (cont'd).

3-21. Ext. Gate (20). Set the 3310B controls for the desired output and turn the START/STOP PHASE control to any setting other than FREE RUN. Connect the gate signal to the EXT. GATE input terminal on the rear panel. The output will turn on at the application of +1 V to +10 V, and will remain on until the gate signal goes to zero. Adjust the START/STOP PHASE control to vary the phase of the output $\pm 90^\circ$. Single cycles can be triggered by applying any positive waveform between 1.4 V p-p and 10 V p-p which has a period greater than the period of the 3310B output and a duty cycle less than the period of the 3310B output. Multiple cycle bursts of any desired length can be obtained by setting the frequency of the gate input to a desired submultiple of the output frequency. The number of cycles per burst can be determined approximately by dividing the gate frequency into the output frequency. Exact determination of the number of cycles per burst must be made using an oscilloscope.

3-22. SPECIAL CONSIDERATIONS.

3-23. Floating.

3-24. Because the Model 3310A/B has a direct coupled output, caution must be observed when attempting to float either the 3310A/B output or an external load. It should be noted that the 3310A/B output ground is PERMANENTLY CONNECTED TO CHASSIS GROUND (). Therefore, any attempt to connect an external source, which has a ground common with chassis ground, to the 3310A/B output ground will short the external source. Likewise, if the external source is connected to the 3310A/B output it will drive current into the output. *THIS MAY DAMAGE TRANSISTORS IN THE OUTPUT CIRCUIT AND CAUSE THE POWER SUPPLIES TO MALFUNCTION* unless your instrument has been modified per Service Note 3310A-1A (Output Protection Circuit Kit No. 03310-69503). Instruments with serial nos. 1126A03651 and greater contain this modification.

3-25. In order to facilitate floating of the 3310A/B output, without the use of external sources, the \pm DC OFFSET has been provided. A maximum open circuit offset voltage of ± 10 V can be obtained. It should be noted, however, that the peak voltage of the signal plus the value of d.c. offset cannot exceed ± 15 V into open circuit. Voltages in excess of this will be clipped. When driving a 50Ω load the above mentioned levels are halved. Therefore the maximum offset into 50Ω is ± 5 V and the peak of the output ($V_{ac} + V_{dc}$) cannot exceed ± 7.5 V. An additional constraint is that the peak 3310A/B output current cannot exceed 150 mA. Figure 3-2 gives an example of how the internal d.c. offset can be used to bias a transistor.

3-26. If it is desired to float the 3310A/B using an external battery the method shown in Figure 3-3 should be used. *THIS METHOD IS RECOMMENDED ONLY IF THE MODIFICATION MENTIONED IN PARAGRAPH 3-24 HAS BEEN INSTALLED.....*

It should be remembered again that the maximum output current, including the current generated by the floating battery (V_f) cannot exceed 150 mA. In addition, the ratio

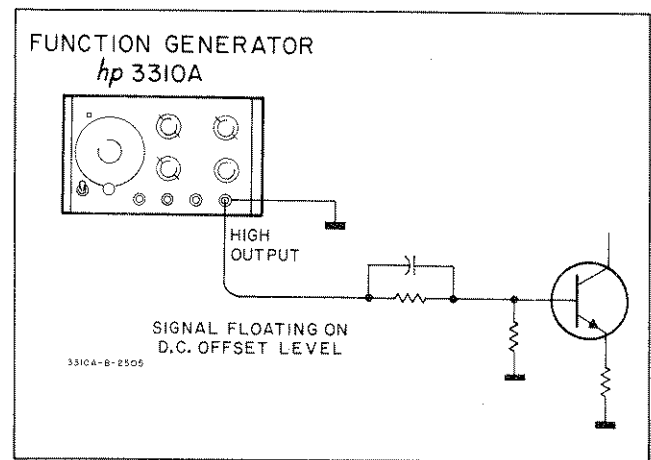

Figure 3-2. Biasing a Transistor Using the Internal D.C. Offset of the Model 3310A.

of R_L to the 3310A/B output impedance; i.e. 50Ω , should be large enough to permit no more than 15 V to be applied across the 3310A/B from the combined voltage of the 3310A/B output and the external source.

3-27. If so desired the 3310A/B output can be floated as shown in Figure 3-4. The CV product of the coupling capacitor C_c should always be small, however, in order to prevent surge currents from damaging the instrument when the floating battery is connected to the circuit. This method is, therefore, primarily for use at higher frequencies.

3-28. If the load is at some potential above chassis ground the 3310A/B output should be isolated from this potential for the reasons outlined in paragraph 3-24.



RESISTOR R7 IS A FUSING RESISTOR WHICH PROTECTS THE INSTRUMENT AGAINST LARGE, SUSTAINED OVERCURRENTS WHICH MAY BE APPLIED TO THE OUTPUT TERMINAL.

3-29. DC Offset.

3-30. A maximum d.c. offset of ± 10 V into open circuit or ± 5 V into 50Ω is obtainable. It should be noted, however, that the peak of the output signal cannot exceed ± 15 V peak to peak into open circuit or ± 7.5 V into 50Ω . THIS INCLUDES ANY DC OFFSET ASSOCIATED WITH THE SIGNAL.

3-31. Frequency Drift.

3-32. Under normal conditions of temperature and humidity the frequency drift of the Model 3310A/B is 0.1 % of setting for 10 minutes and .5 % of setting for 8 hours. The amount of drift varies from range to range and is affected by temperature and humidity.

3-33. Amplitude Stability.

NOTE

A 2 hour warmup period should be allowed for maximum frequency and amplitude stability.

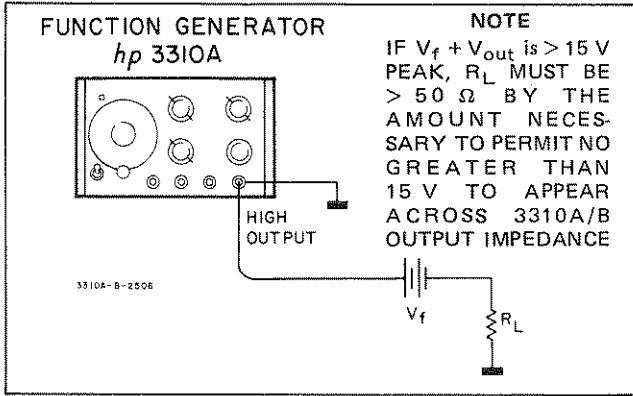

Figure 3-3. Floating the 3310A/B Output Using External Battery (Output Protection Circuit Installed).

3-34. Amplitude stability is affected by temperature and humidity. Under normal operating conditions the amplitude stability for a 10 minute period is .25 %. Over a period of 8 hours, it is slightly higher.

3-35. Changing The Duty Cycle (aspect ratio) of the 3310A/B Pulse and Ramp Waveforms.

3-36. The duty cycle of the 3310A/B output can be varied from a very small percentage of the output period to approximately 30 % by the method shown in Figure 3-6.

Both the 3310A/B frequency and the amplifier output amplitude potentiometer must be adjusted to obtain the desired frequency and duty cycle.

3-37. Phase Locking the 3310A/B.

3-38. To phase lock the 3310A/B to the fundamental or harmonics of another signal the circuit shown in Figure 3-5 should be used.

The 3N128 is a MOS-FET. It provides excellent isolation, therefore no distortion is introduced by the 3310A/B into the phase lock signal. The lock-in range depends on the

frequency and amplitude of the input and on the value of C. For an undistorted 3310A/B output, C should be large. For wide lock in range, C should be small. To make an initial selection of C, try $X_c = 50 \Omega$ at the desired frequency.

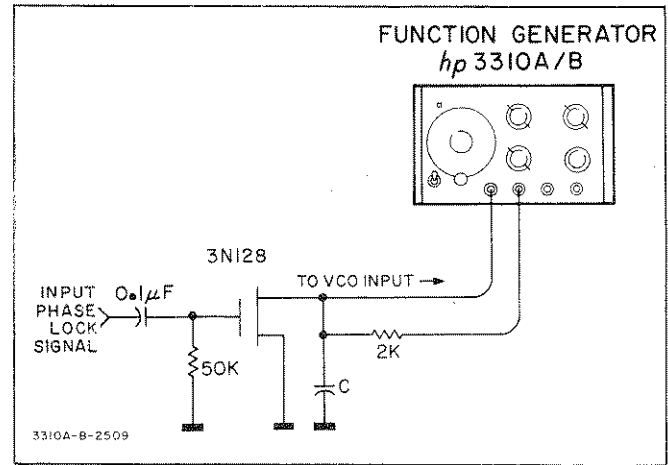

Figure 3-5. Phase Locking the 3310A/B.

3-39. Useability of the 3310B Tone Burst Output Above 50 kHz.

3-40. For many applications, the tone burst output of the Model 3310B is useful above 50 kHz. If the burst length of the 3310B output is large, i.e. long in respect to the period of one cycle of the output frequency, phase and amplitude fluctuations will be noted at the beginning of the burst. This phenomenon cannot be detected when using shorter burst lengths (5 to 10 cycles), however, because the phase and amplitude fluctuations which occur in the shorter time interval are very slight. As a result short bursts are useable in most applications. At higher frequencies (around 1 MHz) overshoot in the stop phase of the burst will be noted. This overshoot is typically less than 13 % of the peak to peak value of the output waveform.

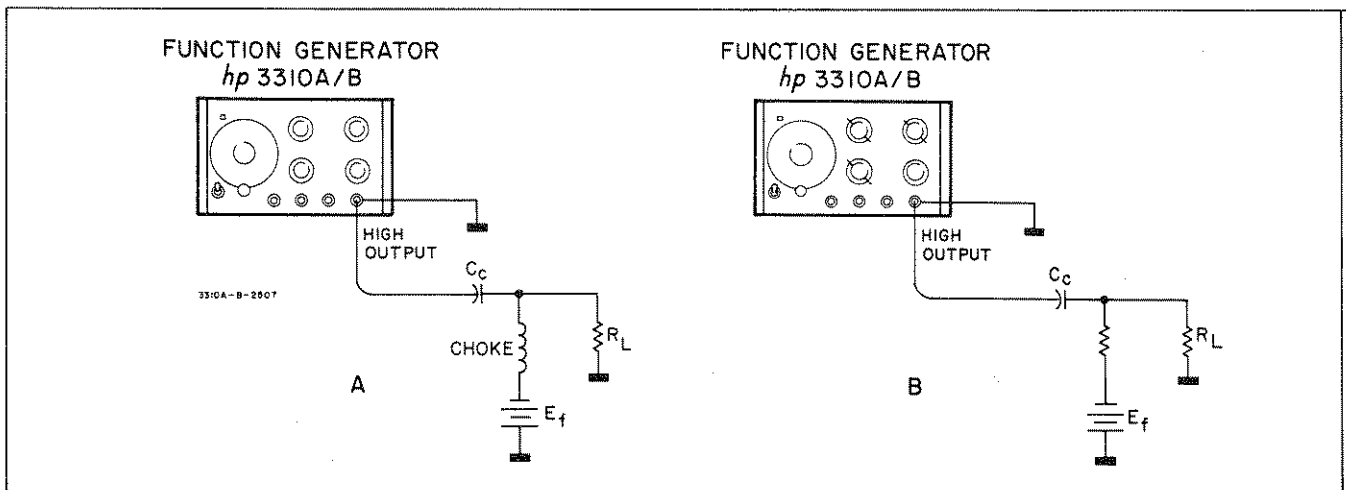

Figure 3-4. Floating the 3310A/B Output Using Capacitance Coupling for Output Protection.

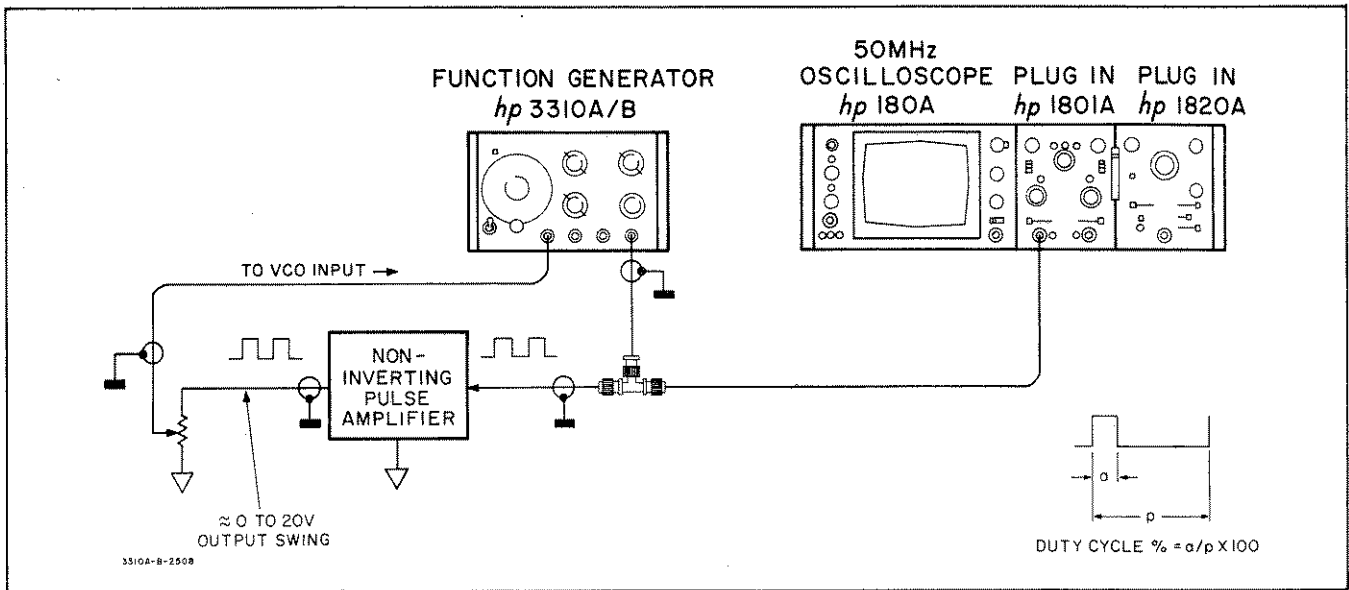
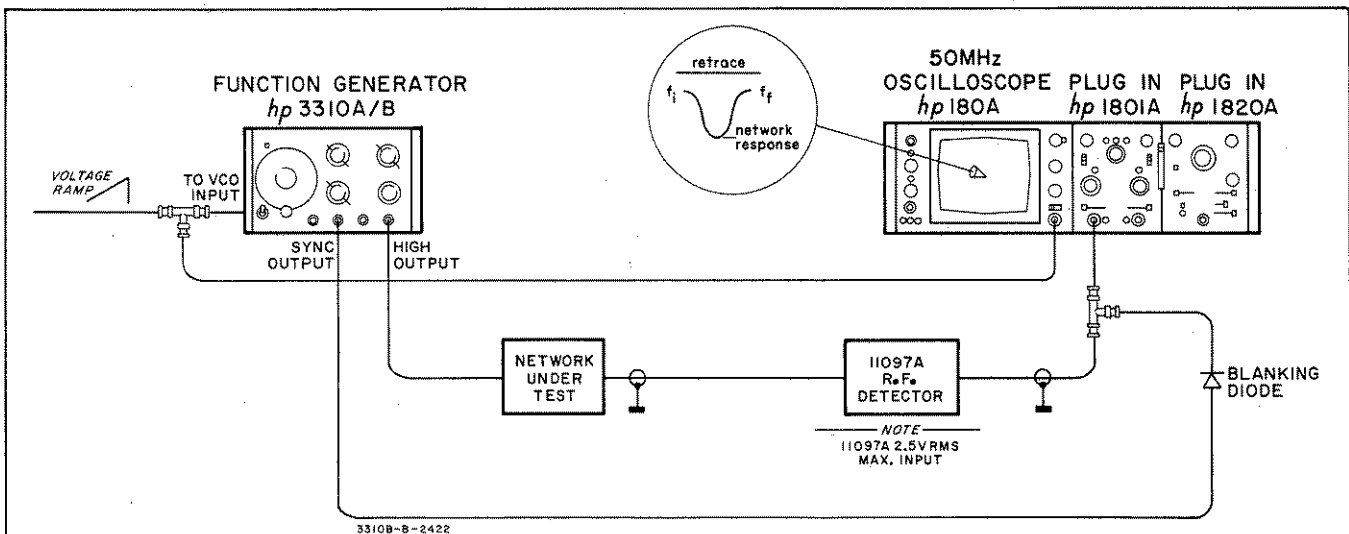

Figure 3-6. Changing the Duty Cycle of the 3310A/B Pulse and Ramp Functions.

3-41. APPLICATIONS.

to a wide range of applications. Frequency response matching, square wave circuit response testing, and time constant determination are but a few of the possible applications for the 3310A/B. Some specific applications are shown in Figures 3-7 through 3-11.

3-42. The Model 3310A and Model 3310B Function Generators, because of their great versatility, are adaptable



The 3310A/B can be used as sweeping signal generator for network analysis. To use the 3310A/B for this purpose the equipment should be connected as shown above.

To sweep the 3310A/B about a given frequency the ramp input to the VCO must vary from plus to minus. The amount of d.c. offset required for the ramp waveform will be determined by the dial setting of the 3310A/B. If the dial setting is 25 (middle of the dial) a ± 5 V triangle wave will sweep the 3310A/B through the full range of the dial symmetrically about 25. The values of f_i (initial frequency) and f_f (final frequency) can be determined by slowing the ramp speed sufficiently to permit measurement of these end point frequencies with an electronic counter. Since the sweep is linear the horizontal axis of the oscilloscope face can then be calibrated linearly in Hz/Cm. If it is desired to sweep upward only, through an entire frequency range (bottom to top of frequency dial), a 0 to +10 V ramp should be applied to the 3310A/B VCO input. A 0 to -10 V ramp will sweep the 3310A/B downward and entire frequency range. A major advantage of using 3310A/B as a sweeping signal generator is that the response of a network can be checked not only with a sine wave but also square waves and other functions.

Figure 3-7. Using the 3310A/B for Network Analysis.

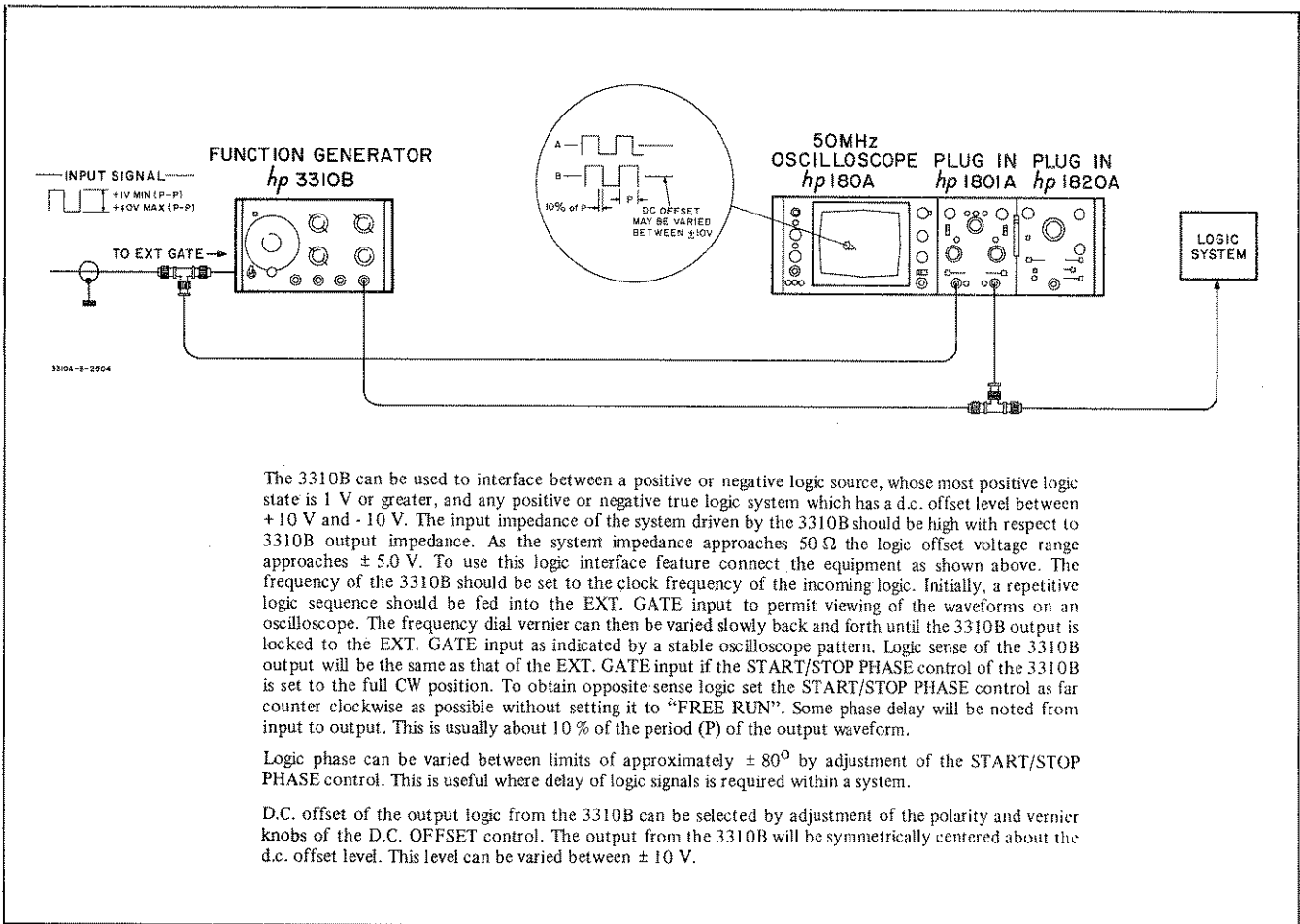

Figure 3-8. Using the 3310B as a Logic Interface.

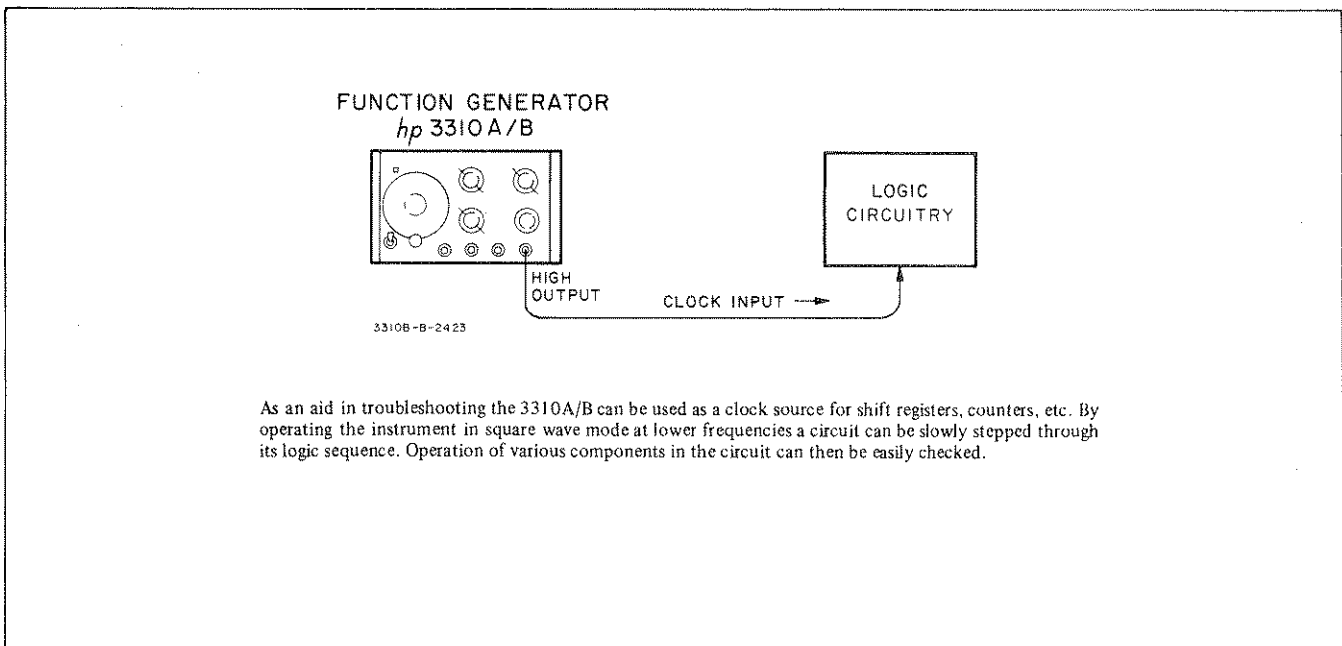

Figure 3-9. Using the 3310A/B as Clock Source for Logic Circuitry Troubleshooting.

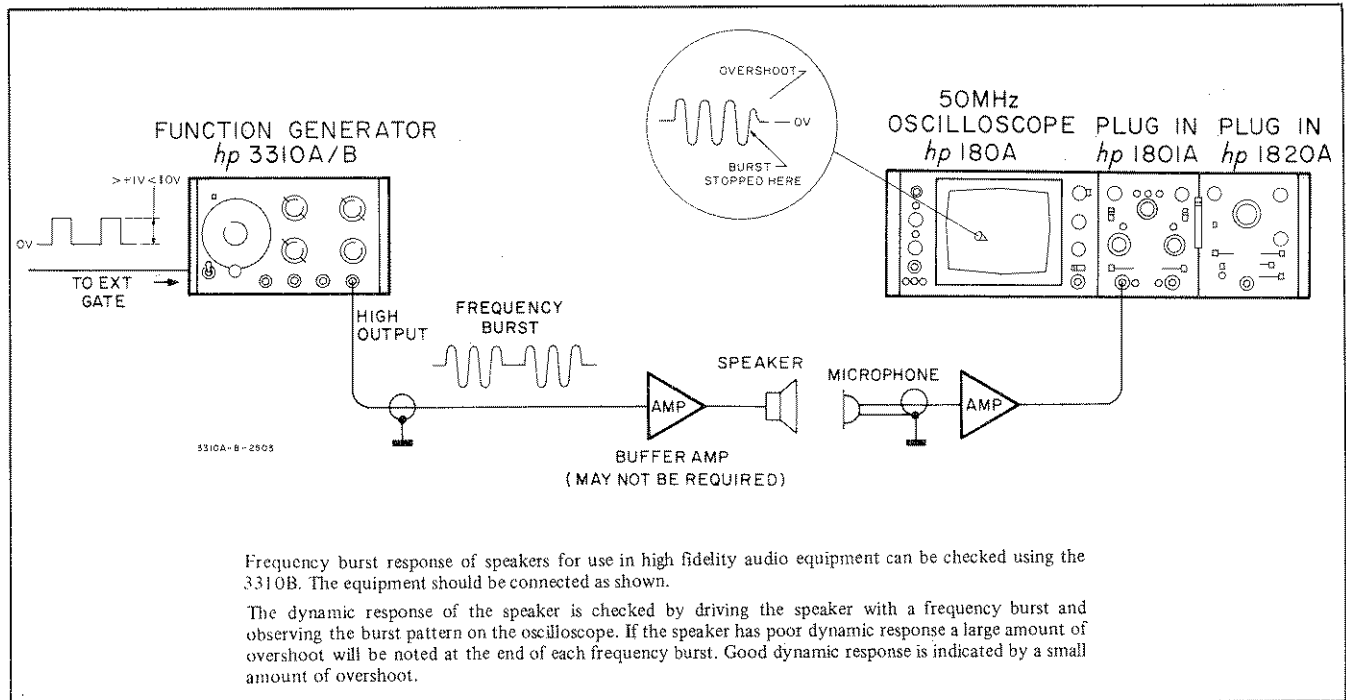

Figure 3-10. Checking the Dynamic Response of a Speaker.

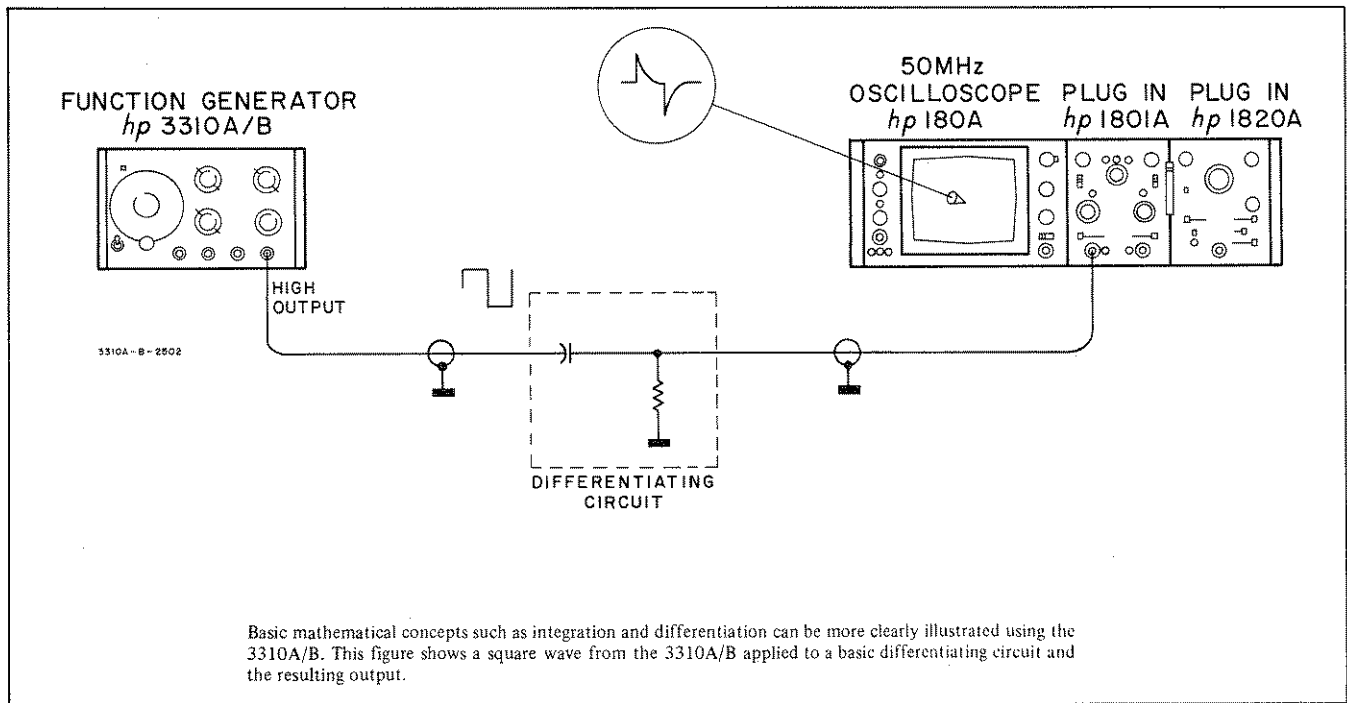

Figure 3-11. Using the 3310A/B to Show Basic Mathematical Concepts.

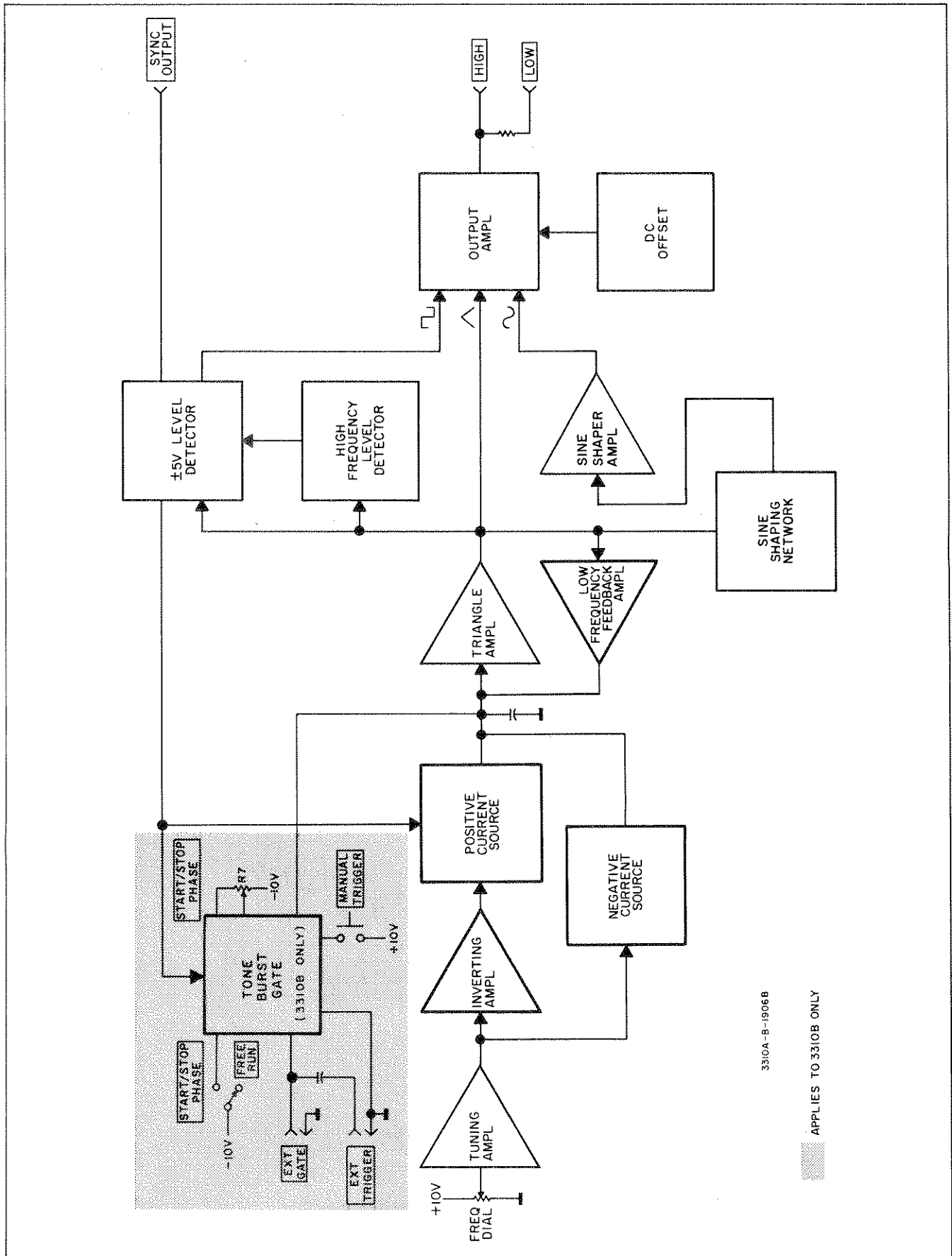

Figure 4-1. Simplified Block Diagram.

SECTION IV

THEORY OF OPERATION

4-1. INTRODUCTION.

4-2. This section contains a simplified block diagram of the 3310A/B, a discussion of the theory of operation relating to the simplified block diagram, and detailed schematic theory of operation referring to Figures 7-1 through 7-7

4-3. BLOCK DIAGRAM DESCRIPTION. (3310A)

4-4. This description refers to Figure 4-1, Simplified Block Diagram. A detailed Functional Block Diagram is found in Section VII of this manual.

4-5. This instrument incorporates a voltage to frequency conversion device. The Frequency Dial controls a potentiometer which supplies between 0 V and 9.0 V dc to the Tuning Amplifier. The Tuning Amplifier is an inverting amplifier with a gain of approximately two. The output of the tuning amplifier is coupled to a negative current source and to the Inverting Amplifier, which has a gain of one. The output of the Inverting Amplifier is coupled to a positive current source.

4-6. The input for the Triangle Amplifier is taken across an integrating capacitor. Current from a positive voltage source (positive current) first charges the capacitor. The capacitor is then discharged to a negative voltage source (negative current). In the symmetrical functions SQ, SINE, and TRI the positive current is equal to the negative current. In the asymmetrical RAMP and PULSE functions, the positive and negative currents are unequal. The currents are reversed when the output of the triangle amplifier reaches either + or - 5 V as detected by the ± 5 Volt Level Detector.

4-7. The positive current source linearly charges the integrating capacitance in a positive direction. This linearly changing voltage is the input of the Triangle Amplifier, causing the voltage output of the Triangle Amplifier to change linearly in a positive direction. When the output reaches + 5 volts, the ± 5 Volt Level Detector flips, and the negative current source begins to linearly discharge the integrating capacitance. As the integrating capacitance is discharged, the Triangle Amplifier output continues in a negative direction until it reaches - 5 volts. At - 5 volts the ± 5 Volt Level Detector flips, and one cycle of the triangle wave is complete.

4-8. The time required to charge and discharge the integrating capacitance determines the period of one cycle and therefore the frequency. The charge time may be changed by varying either the integrating current or the integrating capacitance.

4-9. On the X10 range and higher, the integrating capacitance value changes as the RANGE is switched. The Frequency Dial varies the integrating current at all frequencies. On the X.1 range and below, the Low Frequency Feedback Amplifier supplies an opposing integrating current. The amount supplied depends upon the RANGE position.

4-10. At frequencies above 50 kHz, the High Frequency Level Detector prevents overshoot in the ± 5 Volt Level Detector. To maintain high frequency accuracy it is necessary to flip the ± 5 Volt Level Detector before the 5 volt level is reached. The High Frequency Level Detector determines how early the flip must take place to correct for loop delay.

4-11. The output of the ± 5 Volt Level Detector is a square wave which, when amplified by the Output Amplifier, becomes the square wave output.

4-12. The output of the Triangle Amplifier is also coupled to the Sine Shaping Network and the Sine Shaper Amplifier. The triangle wave is synthesized into a sine wave by the Sine Shaping Network, and this sine wave is amplified by the Sine Shaper Amplifier. The output of the Sine Shaper Amplifier, when amplified by the Output Amplifier, becomes the sine wave output.

4-13. The outputs of the ± 5 Volt Level Detector, the Sine Shaper Amplifier, and the Triangle Amplifier are amplified by the Output Amplifier. A dc voltage may be summed with any of the inputs to the Output Amplifier to produce a dc offset output.

4-14. The output of the ± 5 Volt Level Detector provides the SYNC OUTPUT signal. This Sync Output signal is a square wave in SINE, SQ, and TRI. In the pulse and ramp functions it is a pulse.

4-15. The Output Amplifier supplies the chosen signal to the HIGH output connector. The same signal is attenuated 30 dB and is available at the LOW output connector.

4-16. DETAILED SCHEMATIC DESCRIPTION (3310A).

4-17. The following paragraphs refer to Figures 7-1 and 7-2.

4-18. The Tuning Amplifier consists of A1C1 and A1Q1. It is an operational amplifier, using feedback through A1R11. The input to the Tuning Amplifier is a summing junction which sums the voltage from the VCO INPUT with the voltage from the Frequency Dial potentiometer. R1.

Variable resistors A1R1 through A1R5 provide fine adjustment for each frequency range from X1 to X100 K. The output of the Tuning Amplifier is coupled to the input of the Inverting Amplifier and to the negative Current Source A1Q6.

4-19. The Inverting Amplifier consists of A1IC2 and A1Q2. It has a gain of one and inverts the voltage. The output of the Inverting Amplifier is coupled to the positive Current Source.

4-20. The inputs to both current sources are coupled through the FUNCTION switch A2S3. In sine, square, and triangle functions, the resistors A2R1 and A2R4 control the amount of current in the current sources. If the amount of current flowing in the negative current source A1Q6 is equal to i , then a current of $2i$ is flowing in the positive current source. The output of positive current source A1Q5 is gated on by the ± 5 Volt Level Detector during the positive portion of the Triangle Amplifier output.

4-21. Since A1Q5 is supplying current equal to $2i$, and A1Q6 is supplying a negative current equal to i , a positive current equal to i is coupled to the integrating capacitance at the Triangle Amplifier input. When the Triangle Amplifier output reaches +5 volts, the ± 5 Volt Level Detector changes state. A negative gate is coupled to A1CR4, terminating the positive $2i$ current from A1Q5. Since the negative current i is still flowing in A1Q6, this negative current i discharges the integrating capacitance. This condition exists until the output of the Triangle Amplifier reaches -5 volts, at which time the positive current $2i$ is gated on again. This completes one cycle of the oscillation.

4-22. In the pulse and ramp functions, asymmetrical values of positive and negative current flow. These different values of current determine an 85% or 15% duty cycle.

4-23. The feedback through A1R10 to the Tuning Amplifier input corrects for changes in characteristics in A1Q5 and A1Q6 and avoids frequency error.

4-24. The Bias Network consists of A1Q3 and A1Q4, and corrects for the individual differences between A1Q5 and A1Q6 and keeps their emitter voltages at the correct levels to avoid symmetry error.

4-25. The following paragraphs refer to Figures 7-1 and 7-3.

4-26. The value of integrating capacitance on the input of the Triangle Amplifier depends upon the position of the RANGE switch. Figure 7-3 shows this switch in the X.0001 position. If the RANGE switch were in the X10 position A1C13, A1C14, and A1C16 would be in parallel with A1C17 to form the total integrating capacitance.

4-27. As the frequency dial is varied, the currents in the current sources vary. The greater the current source outputs, the higher the rate of change seen at the integrating capacitance, and the shorter the period of each cycle of the Triangle Amplifier.

4-28. The input stage of the Triangle Amplifier is a field effect transistor, A1Q12. This FET has a very high input impedance. A1Q13 is a current source for the FET, and A1R56 is a bias adjustment. The output of the Triangle Amplifier is coupled to the ± 5 Volt Level Detector.

4-29. The output of the Triangle Amplifier is coupled to tunnel diodes A1CR21 and A1CR22. When the triangle output reaches +5 volts, A1CR21 conducts, causing the ± 5 Volt Level Detector to change states. When the triangle output reaches -5 volts, A1CR22 conducts, causing the level detector to flip back to its original state. Three parallel output stages furnish the square or rectangular wave outputs.

4-30. The triangle output is also coupled to the High Frequency Level Detector through A1CR13 and A1CR15. On the X10 K and X100 K ranges, the outputs of the A1Q22 and A1Q26 are coupled to the ± 5 Volt Level Detector.

4-31. As the frequency of the instrument increases above 50 kHz, the time required to gate the current source and reverse the triangle output becomes significant. Because of this loop delay, the triangle output begins to go slightly beyond ± 5 volts. This starts to increase the period of each cycle and introduces frequency error.

4-32. As the peak value of the triangle starts to increase, the charge on A1C22 and A1C26 increases. The outputs of A1Q22 and A1Q26 change and the result is a change of bias on the tunnel diodes, causing them to conduct at some level below ± 5 volts. This corrects the condition which would otherwise cause frequency error.

4-33. For ranges X.0001 through X10, the integration capacitance for the Triangle Amplifier remains the same because of physical size limitations. On these ranges the Low Frequency Feedback Amplifier becomes active. This amplifier, consisting of A1Q44 through A1Q51, supplies a negative feedback current to the integrating capacitance. When the current sources are supplying a positive current, the feedback amplifier is supplying a negative current. When the current sources are supplying a negative current, the feedback amplifier supplies a positive current. The integrating capacitance is then charged with a current equal to the source current minus the feedback current.

4-34. The feedback current changes by a factor of 10 with each change of range switch position. This is accomplished by switching in different values for the feedback resistor. The feedback current is constant for any one frequency.

4-35. The input stage of the feedback amplifier is a differential amplifier using a dual FET. This differential amplifier is referenced to the Triangle Amplifier input.

4-36. The following paragraphs refer to Figures 7-1 and 7-4.

4-37. At the input to the Sine Shaping Network, there is shown a feedback path going to the positive current source. The feedback capacitor A2C1 is selected to furnish a positive feedback current to the positive current source output that is equal to the amount of current lost through the capacitance of the positive current source transistor at higher frequencies.

4-38. The triangle wave is applied to the Sine Shaping Network through resistor A2R10. The even numbered diodes conduct in shaping of the negative half of the sine wave while the odd numbered diodes conduct in shaping the positive half of the sine wave. Transistors A3Q1 through A3Q6 are constant voltage supplies for the diode shaping network.

4-39. The signal at the input to the Sine Shaper Amplifier is a sine wave. The shaper amplifier is an inverting operational amplifier whose gain is approximately one, as controlled by the input resistor A2R11 and the feedback resistor A2R18.

4-40. The FUNCTION switch S3 is used to couple one of the waveforms to the OUTPUT LEVEL control A2R20. From the center arm of this potentiometer, the signal is coupled through A3R31 to a summing junction. At this summing junction, the signal is summed with the output of the DC OFFSET LEVEL control. Up to ± 10 V dc offset voltage may be coupled through A3R32 to the summing junction.

4-41. The lower frequencies are amplified by A3IC1 and coupled through A3CR28 and A3R36 to the collector of A3Q9. High frequencies are coupled through A3C5 and A3C6 to the bases of A3Q9 and A3Q12. At high frequencies A3C7 couples the signal from A3Q9 collector to A3Q11 emitter.

4-42. The final output transistors Q1 and Q2 complete the complementary symmetrical output stages. A3CR15 through A3CR20 are biasing diodes. A3R69 supplies negative feedback to the input of the amplifier to control the overall gain. Diodes CR1 and CR2 in conjunction with their associated circuitry provide voltage protection for the output circuit. Diodes A1CR30 and A1CR31 reduce the otherwise large junction capacity of the zener diodes CR1 and CR2.

4-43. A3R66 provides 50 ohms resistance for the amplifier HIGH output. R5 attenuates the signal 30 dB and R6 provides the 50 ohms resistance for the LOW output.

4-44. BLOCK DIAGRAM DESCRIPTION (3310B).

4-45. When the START/STOP PHASE control is set to FREE RUN the 3310B operates as a Model 3310A Function Generator. At any setting other than FREE RUN

the TONE BURST GATE is operable and can be controlled by the EXT. GATE, EXT. TRIGGER, or MANUAL TRIGGER inputs. Tone bursts of any length or duty cycle (within the triggering frequency range of the 3310B) can be generated. The START/STOP PHASE of the tone burst is determined by R7. The signal always stops in the same phase it started.

4-46. DETAILED SCHEMATIC DESCRIPTION (3310B).

4-47. The following paragraphs refer to Figure 7-7

4-48. The circuit for the TONE BURST GATE and the power supplies for the 3310B are mounted on the A5 assembly. This assembly occupies the same physical position as the A4 assembly in the 3310A.

4-49. When the START/STOP PHASE control is set to FREE RUN, relay K1 is open and the trigger and gate circuitry is deactivated. When the START/STOP PHASE control is at any setting other than FREE RUN, -10 V is applied to relay K1, closing it and connecting the output from the integrator to the limiter circuit. The limiter consists of A5Q1 through A5Q2 and associated circuitry.

4-50. The voltage set on the START/STOP PHASE control, R8, is applied to the base of A5Q2. When the voltage from the integrator equals that on the base of A5Q2, the limiter will clamp the integrator voltage to that level. With the integrator output held at this level, the ± 5 V detector will not switch the current sources, resulting in a dc level at the output which is proportional to the setting of R8. Thus R8 controls the stop phase of the output.

4-51. Potentiometer R8 also controls the start phase of the output. In order for the START/STOP PHASE control to have an effect on the output, A5Q7 must be on. If A5Q7 is off the voltage on the base of A5Q2 rises above the integrator voltage applied to the base of A5Q1. This allows the triangle wave from the integrator to continue from where it was limited, starting the output in the phase it was stopped.

4-52. The condition of A5Q7 is determined by the output of A5IC1. When an external gate signal is applied to the base of A5Q10, through J6, J7 or S6, A5Q10 conducts and shorts the square wave from the ± 5 V detector to ground. Transistor A5Q8 is also turned on at this time causing A5IC1 to shut off A5Q7. This, in turn, switches the limiter and allows the output to start as explained in paragraph 4-51. When the gate signal drops below approximately +1 V, A5Q8 and A5Q10 will stop conducting, and the next positive portion of the square wave from the detector will turn on A5Q9. This switches A5IC1 turning on A5Q7, allowing the limiter to clamp the triangle voltage from the integrator.

Table 5-1. Required Test Equipment

INSTRUMENT TYPE	REQUIRED SPECIFICATIONS	RECOMMENDED MODEL
Electronic Counter	0.0005 Hz to 5 MHz with time interval capability (5262A Plug-in)	-hp- Model 5245L/5262A
Oscilloscope	5 MHz Bandwidth	-hp- Model 180A/1801A/1820A
RMS Voltmeter	Accuracy: 2% dB Range: -60 dB to +10 dB	-hp- Model 3400A
Broadband Sampling Voltmeter	Frequency Range: 1 MHz to 50 MHz Voltage Range: 0.003 V to 3 V	-hp- Model 3406A
Digital Voltmeter	Ranges: 10 V dc to 30 V dc with 4 digit presentation	-hp- Model 3439A/3441A
AC/DC Voltmeter	Ranges: 1 V to 300 V Accuracy: 3%	-hp- Model 427A
DC Power Supply	Range: 0 V to 15 V continuously variable	-hp- Model 6215A
DC Null Voltmeter	Ranges: $\pm 3 \mu\text{V}$ to $\pm 30 \text{ mV}$	-hp- Model 419A
Thermal Converter	Input Impedance: 50 Ω Voltage Input: 3 V rms Frequency Range: 5 Hz to 5 MHz	-hp- Model 11049A
Feedthrough Terminating Resistance	Resistance: 50 Ω Frequency Range: dc to 5 MHz	-hp- Model 11048C
DC Reference Supply	(See Figure 5-1) Resistor: variable 50 Ω Resistor: variable 500 Ω Resistor: fixed 6.5 k Ω Battery: 1.3 V	-hp- Part No. 2100-1481 -hp- Part No. 2100-0324 -hp- Part No. 0811-0392 Mallory RM-42R
5 MHz High Pass Filter	(See Figure 5-4) C1, C: fxd 91 pF L1, L: var 10 - 20 μH	-hp- Part No. 0160-2203 -hp- Part No. 9140-0035
Pad: 50 Ω matching 5 dB attenuation	Resistor: fxd 14.7 Ω (2) Resistor: fxd 82.5 Ω	-hp- Part No. 0698-3428 -hp- Part No. 0757-0711
Oscillator	0 to $>200 \text{ kHz}$, $>1 \text{ Vrms}$ into 50 Ω	-hp- Model 204C
Power Supply	0 - 30 V, 100 mA, regulated	-hp- Model 721A
Square Wave Gen.	0 - 1 MHz, 30 V p-p output	-hp- Model 211B (or 3310A)
Strip Chart Recorder	10 inch chart width, 2 in/min chart speed	-hp- Model 7127A
Distortion Analyzer	Distortion measurement range: 5 Hz to 600 kHz $\pm 0.1\%$	-hp- Model 331A/332A

SECTION V MAINTENANCE

5-1. INTRODUCTION.

5-2. This section contains information necessary for proper maintenance and repair of the 3310A and 3310B Function Generators. Included are the Performance Checks, Adjustment and Calibration Procedures, Troubleshooting information, and Repair Procedures.

5-3. TEST EQUIPMENT REQUIRED.

5-4. Table 5-1 contains information about the test equipment necessary to perform the procedures given in this section. This table includes the types of instruments required, their critical specifications, and recommended models. If the recommended model is not available, any model which meets the same requirements may be substituted.

5-5. PERFORMANCE CHECKS.

5-6. The Performance Checks are designed to assist in comparing the 3310A/B with its published specifications. These checks may be used for incoming inspection, periodic maintenance, and after-repair checks. The Performance Checks should be done before any attempt is made to adjust or calibrate the instrument. The Performance Checks for the Model 3310A also apply to the Model 3310B when the 3310B START/STOP PHASE control is in the "FREE RUN" position. If the instrument does not meet the requirements outlined in the Performance Checks, refer to the Adjustment and Calibration procedure in this section.

5-7. A performance Check Test Card is provided at the end of this section for recording the performance of the 3310A/B during Performance Checks. The card may be removed from the manual and used as a permanent record if desired.

5-8. Frequency Range Check.

Specification

Frequency Range: 0.0005Hz to 5MHz in decade ranges

NOTE

This check requires 40 to 45 minutes to complete because of the time required to check the lowest output frequency. If desired the check may be omitted.

5-9. Terminate the HIGH output of the Model 3310A/B in 50 ohms and connect this output to the d.c. input of an electronic counter.

5-10. Set the Model 3310A/B Controls as follows:

- OUTPUT LEVEL Approximately 1/2 of maximum
- FUNCTION SQ (square wave)
- RANGE X.0001
- OFFSET LEVEL 0

5-11. Turn the frequency dial to the full clockwise position and measure the period of the 3310A/B output using the 5245L Electronic Counter. A period ≥ 2000 seconds should be observed.

5-12. Set the Model 3310A/B RANGE dial to X100K.

5-13. Turn the frequency dial to the full counterclockwise position and measure the frequency of the 3310A/B output using the 5245L Electronic Counter. A frequency ≥ 5 MHz should be observed.

5-14. Sine Wave Frequency Response Check.

Specification

Sine wave frequency response: reference, 1 kHz at full output into 50 ohms.

0.0005Hz to 50kHz: $\pm 1\%$

50kHz to 5MHz: $\pm 4\%$

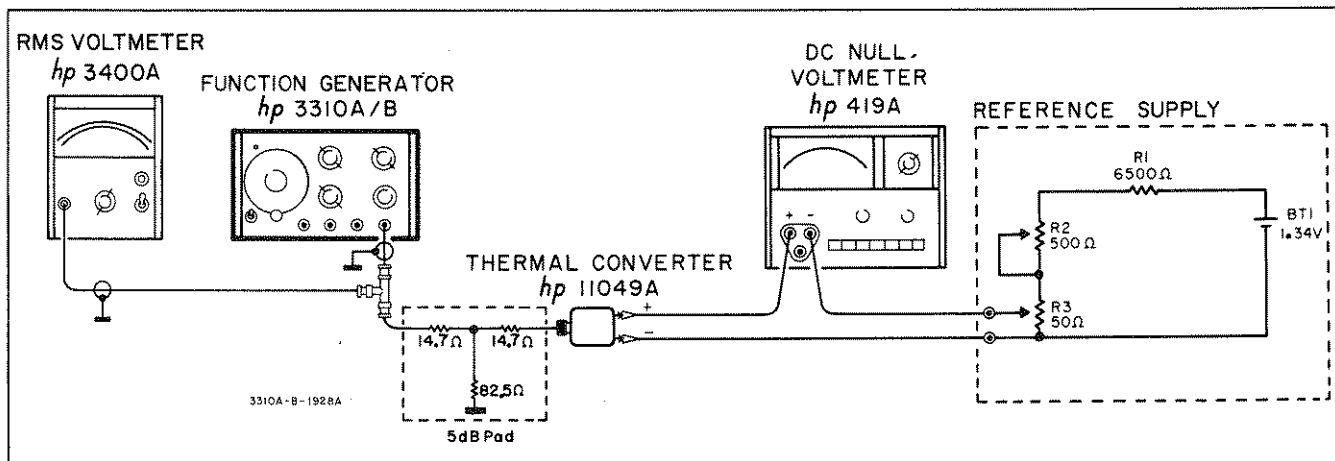

Figure 5-1. Frequency Response Check.

NOTE

An 11049A Thermal Converter will be required for this check. The thermal converter is theoretically a square-law device. The percent of change of output should, therefore, be 2 times the percent of change of the input. The actual factor is less than 2, typically 1.7. This is called the "converter multiplier" (k).

5-15. If the converter multiplier (k) of your device is not known, determine it in the following manner:



DO NOT EXCEED RATED INPUT OF THERMAL CONVERTER. ANY OVERLOAD OR HIGH VOLTAGE TRANSIENT MAY DESTROY THERMOELEMENT.

a. Connect equipment as shown in Figure 5-1 and set the coarse control (R3) to minimum resistance.

b. Set the RF output to 2.5 V rms.

c. Record reading of dc voltmeter (E_i).

d. Increase the RF output to 5 V rms.

e. Record reading of dc voltmeter (E_f).

f. The formula below may then be applied to determine (k):

$$k = E_f / 2E_i$$



THE MODEL 3310A OUTPUT LEVEL SHOULD BE REDUCED SUBSTANTIALLY BEFORE SWITCHING FREQUENCY RANGES; OTHERWISE, TRANSIENTS MAY DAMAGE THE THERMAL CONVERTER. THIS OPERATION SHOULD BE PERFORMED QUICKLY TO PREVENT THE NECESSITY OF ALLOWING TIME FOR THE THERMAL CONVERTER TO RESTABILIZE.

5-16. Disconnect the rms voltmeter and set the 3310A/B controls for a 1 kHz sine wave output. Proceed as follows:

a. Adjust the 3310A/B for a full output.

b. Set the null meter to voltmeter function.

c. Adjust the reference supply 50 ohm control for minimum resistance.

d. Record the null meter indication of the thermal converter output.

e. Adjust the reference supply 500 ohm and 50 ohm controls for the best null possible. Do not readjust these controls for the remainder of the check.

f. Allowing 5 seconds settling time before reading the null meter, check several frequencies between 5Hz and 50kHz. Maximum allowable null meter deviation may be determined by the formula:

$$\text{Max Deviation} = 0.01 * X \text{ therm. conv. output} * X \text{ therm. conv. multiplier}$$

Example:

$$\text{Max deviation} = \pm(0.01 * 7\text{mV} * 1.7) = \pm 0.119 \text{ mV}$$

g. Check several frequencies above 50kHz. Maximum allowable null meter reading may be determined by the formula:

$$\text{Max deviation} = 0.04 * X \text{ therm. conv. output} * X \text{ therm. conv. multiplier}$$

Example:

$$\text{Max deviation} = \pm(0.04 * 7 \text{ mV} * 1.7) = \pm 0.476 \text{ mV}$$

h. Remove the equipment connected to the thermal converter output.

i. Set the 3310A/B controls for a 1 kHz sine wave.

j. Connect an rms voltmeter across the thermal converter *input* terminals.

k. Observe the voltmeter and set the 3310A/B output voltage to .5 V rms. (Applied to the thermal converter input.)

l. Disconnect the rms voltmeter and connect a d.c. voltmeter across the thermal converter input terminals.

m. Set the 3310A/B output frequency to .005 Hz.

n. Measure the positive and negative peak of the 3310A/B output using the d.c. voltmeter. Record these values.

o. Calculate the rms voltage of the signal measured in step n by adding the two values together (disregarding sign) and dividing by 2.83.

p. Disconnect the d.c. voltmeter and connect the strip chart recorder (-hp- Model 7127A or equivalent) to the thermal converter input terminals. *For frequencies of .05 Hz and below the d.c. voltmeter can be used in place of the strip chart recorder. At very low frequencies (<.001 Hz), however, it is difficult to determine the exact peak of the waveform using a voltmeter. The process is also time consuming. A strip chart recorder is therefore recommended for these checks.*

q. Adjust the recorder sensitivity to display the peak to peak value of the 3310A/B output in 9 inches (9 divisions) of the strip chart paper. The peak to peak voltage of this waveform is the sum of the two values noted in step o of this procedure.

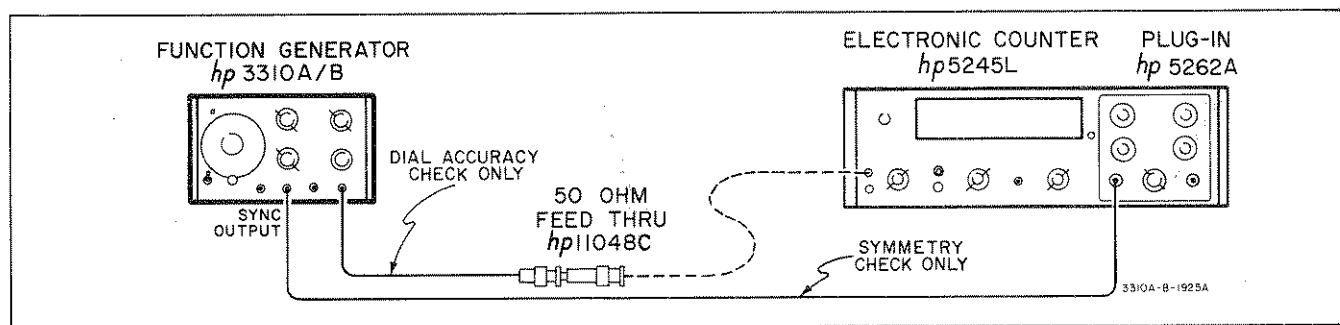

Figure 5-2. Dial Accuracy/Triangle Symmetry Check.

r. Record several frequencies below .005 Hz including .0005 Hz. Measure the peak to peak value, in volts, of the waveform at each frequency checked. Convert each value to rms volts by dividing by 2.83. All voltages measured should be 500 mV ± 5 mV.

s. Record several frequencies above .005 Hz including .5 Hz. Measure the peak to peak value, in volts, of the waveform at each frequency checked. Convert each value to rms volts by dividing by 2.83. All voltages measured should be 500 mV ± 5 mV.

5-20. Dial Accuracy Check.

Specification

Dial Accuracy:
 0.0005Hz to 500kHz, all functions: ±(1% of setting +1% of full scale).
 500kHz to 5MHz, sine, square, triangle: ±(3% of setting +3% of full scale).
 500kHz to 5MHz, pulse and ramp: ±(10% of setting +1% of full scale).

5-17. Triangle Symmetry Check.

Specification

Triangle symmetry:
 0.0005Hz to 20Hz: less than 1%
 20Hz to 50kHz: less than 0.5%

5-18. Set the 3310A/B FUNCTION switch to TRI. Connect the SYNC OUTPUT of the 3310A/B to the time interval input of an electronic counter as shown in Figure 5-2. Do not connect the 3310A/B output to the electronic counter signal input.

5-19. Symmetry error may be determined by the following formula:

$$E_s = \frac{T_1 - T_2}{T_1 + T_2}$$

where,

T₁ = period of positive transition of waveform

T₂ = period of negative transition of waveform

a. Check symmetry at several frequencies below 20Hz. This value should not exceed 1%.

b. Check symmetry at several frequencies between 20Hz and 50kHz. Symmetry error should not exceed 0.5%.

Table 5-2. Dial Accuracy Check.

Dial	Range	Counter Indication
5	.0001	1800 to 2240s
30	.0001	324 to 342s
50	.0001	196 to 204s
5	.001	180 to 224s
30	.001	32.4 to 34.2s
50	.001	19.6 to 20.4s
5	.01	18.0 to 22.4s
30	.01	3.24 to 3.42s
50	.01	1.96 to 2.04s
5	.1	1.80 to 2.24s
30	.1	324 to 342ms
50	.1	196 to 204ms
5	1	180 to 224ms
30	1	32.4 to 34.2ms
50	1	19.6 to 20.4ms
5	10	18.0 to 22.4ms
30	10	3.24 to 3.42ms
50	10	1.96 to 2.04ms
5	100	1.80 to 2.24ms
30	100	2920 to 3080Hz
50	100	4900 to 5100Hz
5	1K	4450 to 5550Hz
30	1K	29.20kHz to 30.80kHz
50	1K	49.00kHz to 51.00kHz
5	10K	44.50kHz to 55.50kHz
30	10K	292.0kHz to 308.0kHz
50	10K	490.0kHz to 510.0kHz

Table 5-3. (A and B) High Frequency Dial Accuracy.

A SYMMETRICAL FUNCTIONS			B PULSE and RAMP FUNCTIONS		
Dial	Range	Counter Indication	Dial	Range	Counter Indication
5	100K	345.0kHz to 655.0kHz	5	100K	400kHz to 600kHz
30	100K	2.760MHz to 3.240MHz	30	100K	2.65MHz to 3.35MHz
50	100K	4.700MHz to 5.300MHz	50	100K	4.45MHz to 5.55MHz

5-21. Connect the 3310A/B as shown in Figure 5-2 and set the OUTPUT LEVEL control to mid-range. Do not connect the SYNC output to the counter (symmetry check).

5-22. Set the FUNCTION switch to the full CCW position (negative pulse).

5-23. Measure the frequencies or periods shown in Table 5-2.

5-24. Repeat Paragraph 5-23 for each position of the 3310A/B FUNCTION switch.

5-25. Set the Model 3310A/B FUNCTION switch to SQ and measure the frequencies shown in Table 5-3A.

5-26. Repeat Paragraph 5-25 for the SINE and TRI functions.

5-27. Set the Model 3310A FUNCTION switch to the full CCW position (negative pulse) and measure the frequencies shown in Table 5-3B.

5-28. Repeat Paragraph 5-27 except check the positive pulse and the positive and negative ramps.

5-29. Sine Wave Distortion Check.

Specification

Sine wave distortion (below fundamental):
 10 Hz to 50 kHz: greater than 46 dB (0.5%)
 50 kHz to 500 kHz: greater than 40 dB (1%)
 500 kHz to 5 MHz: greater than 30 dB (3%)

5-30. Connect the 3310A/B as shown in Figure 5-3. Set the 3310A/B to SINE function at 10Hz. Distortion should be more than 46dB below the fundamental. Measure distortion at several frequencies between 10Hz and 50kHz. Distortion should be more than 46dB below the fundamental.

5-31. Measure distortion at several frequencies between 50kHz and 500kHz on the X10K range. Distortion should be more than 40dB below the fundamental.

5-32. Connect the equipment as shown in Figure 5-4.

5-33. Set the 3310A/B frequency dial to the full CW position.

5-34. Set the 3310A/B output so that the voltmeter moves to the nearest dB division. This is the reference level.

5-35. Readjust the 3310A/B frequency to 5 MHz.

5-36. Observe the voltmeter and adjust the coil in the 5 MHz filter for a null. This reading should be equal to or greater than 30 dB below the reference level noted in Paragraph 5-34.

5-37. Square Wave And Pulse Response Checks.

Specification

Square wave and pulse response:
 less than 30ns rise and fall times at full output.
 less than 35ns rise and fall times at less than full output.
 less than 5% total aberration.

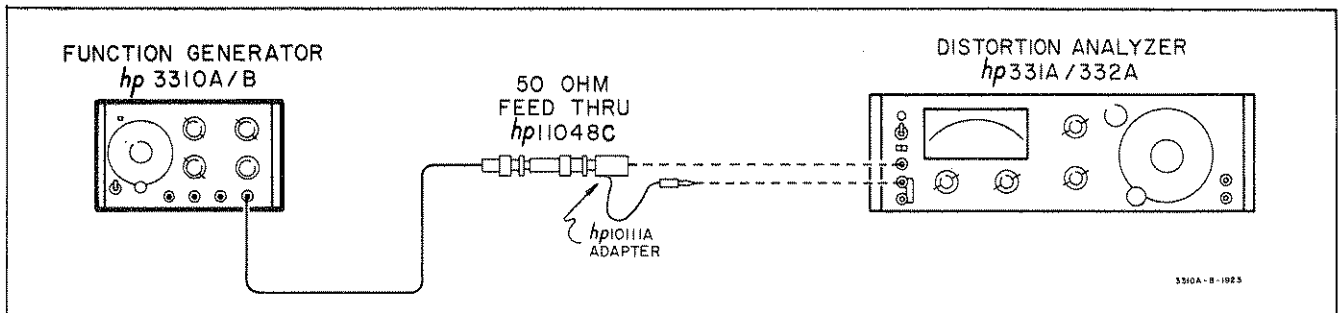

Figure 5-3. Distortion Check.

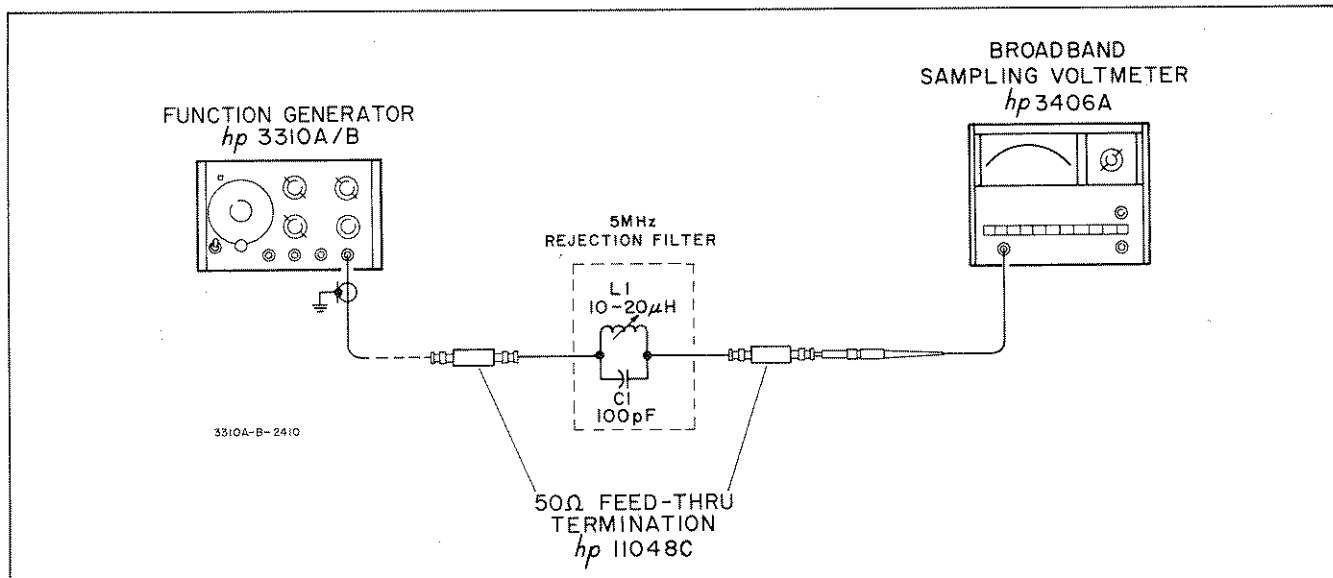

Figure 5-4. 5 MHz Distortion Check.

5-38. Connect the 3310A/B as shown in Figure 5-5 (Connect the HIGH output only). Set the OUTPUT LEVEL fully CW and the FUNCTION switch to SQ. Check the rise time and fall time at 1kHz. Time required for the transition between 10% and 90% of the square wave amplitude should be less than 30ns. Change the function switch to a pulse position. The rise and fall-times should still be less than 30ns.

5-39. Repeat the rise and fall time check for both square wave and pulse functions at several other frequencies to assure less than 30ns.

5-40. Reduce the OUTPUT LEVEL to center position. Measure rise and fall times for square waves and pulses at several different frequencies. These rise times should be less than 35ns.

5-41. Set the 3310A/B controls for a 5MHz square wave. Set the output to the full CW position.

5-42. Observe the oscilloscope and measure the voltage difference between the voltage points shown as V p-p in Figure 5-6. Record this value.

5-43. Again observe the oscilloscope and measure the voltage difference between the minimum and maximum voltage points at the top of the waveform (V_{ab}).

5-44. Using the following formula calculate percent of aberration.

$$\text{Aberration (\%)} = V_{ab}/V_{p-p} \times 100.$$

This value should not exceed 5%.

5-45. Repeat steps 5-42 thru 5-44 except measure the voltage points at the bottom of the waveform.

5-46. Set the 3310A/B for a positive pulse of .1 μsec . duration as observed on the oscilloscope.

5-47. Repeat steps 5-42 thru 5-45.

5-48. Set the 3310A/B for a negative pulse of .1 μsec . duration. Again repeat steps 5-42 thru 5-45.

NOTE

If the aberration specification cannot be met refer to A3C26* in Table 5-4 (Starred Value Components).

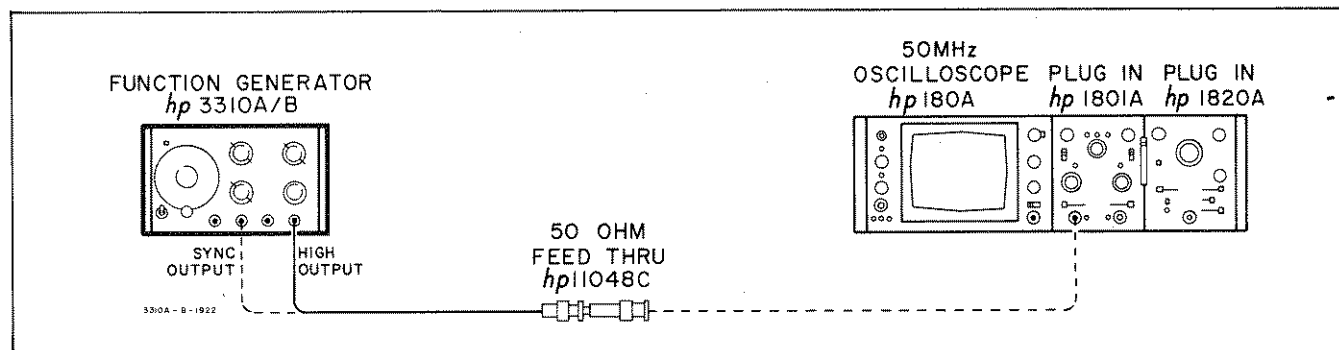

Figure 5-5. Rise Time Check.

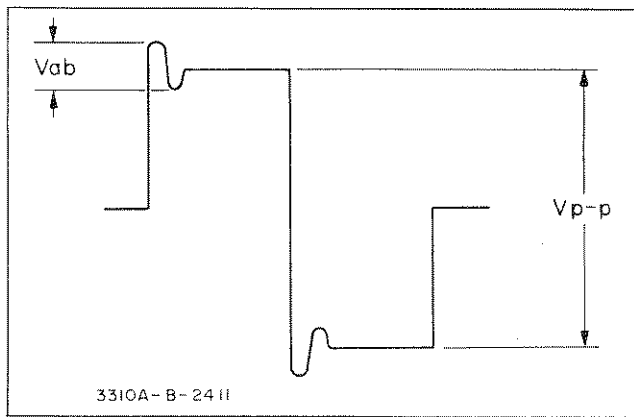

Figure 5-6. Aberration Check.

5-49. SYNC OUTPUT Response Check**Specification**

Sync output response:
less than 20ns rise and fall times.

5-50. Connect the equipment as shown in Figure 5-5. (Connect to the SYNC OUTPUT only.)

5-51. Set the Model 3310A/B controls for a 1kHz sine wave.

5-52. Check the rise and fall times of the SYNC OUTPUT pulse using the oscilloscope. The time required for the transition between 10% and 90% of the leading edge of the sync output pulse should be ≤ 20 ns. Time required for the transition between 90% and 10% of the trailing edge of the sync output pulse should also be ≤ 20 ns.

5-53. Maximum HIGH Output (except pulses greater than 2MHz), and OUTPUT LEVEL Range Check.**Specification**

Maximum HIGH output (except pulses greater than 2MHz):
greater than 15V p-p into 50 ohms (5.3V rms for sine function)
greater than 30V p-p open circuit. (10.6V rms for sine function)
OUTPUT LEVEL control: greater than 30dB range controlling HIGH and LOW outputs.

5-54. Terminate the HIGH output of the Model 3310A/B in 50 Ω and connect to an RMS voltmeter. Set the 3310A/B controls as follows:

OUTPUT LEVEL Full CW
FUNCTION SINE
RANGE X100K
frequency dial50
OFFSET LEVEL0

5-55. The voltmeter indication should be greater than 5.3V rms.

5-6

5-56. Remove the 50 Ω load and connect the Model 3310A/B output directly to the voltmeter. The voltmeter indication should now be greater than 10.6V rms. Record this indication in dB.

5-57. Turn the OUTPUT LEVEL control to the full CCW position and observe the meter. The meter indication should now be greater than 30dB below the indication recorded in step 5-56.

5-58. Set the 3310A/B controls for a 2 MHz pulse and turn OUTPUT LEVEL full CW. Connect the HIGH output (terminated in 50 Ω) to an oscilloscope. A pulse with a peak to peak amplitude of greater than 10 V should be noted.

5-59. Remove the 50 Ω termination and again observe the oscilloscope. A pulse with a peak to peak amplitude of 30 V should be noted.

5-60. Maximum HIGH Output Check (pulses greater than 2MHz.)**Specification**

Maximum HIGH output (pulses greater than 2MHz):
greater than 12V p-p into 50 ohms
greater than 24 V p-p open circuit.

5-61. Connect the HIGH output of the Model 3310A/B to a 50 Ω resistor (11048B) and connect this output to an oscilloscope.

5-62. Set the 3310A/B controls for a 5MHz pulse. (Ensure OUTPUT LEVEL is in full CW position.)

5-63. A pulse, with a peak to peak amplitude of greater than 12V, should be observed on the oscilloscope.

5-64. Remove the 50 Ω resistor and reconnect the 3310A/B HIGH output to the oscilloscope. A pulse, with a peak to peak amplitude of greater than 24V, should be observed.

5-65. Minimum LOW Output Check.**Specification**

Minimum LOW output:
less than 15mV p-p into 50 ohms.
less than 30mV p-p open circuit.

5-66. Terminate the LOW output of the Model 3310A/B in 50 Ω and connect this output to an RMS voltmeter (-hp-3400A).

5-67. Set the Model 3310A/B controls as indicated in Paragraph 5-54, except set OUTPUT LEVEL full CCW.

5-68. Observe the voltmeter, an indication of less than 5.3mV rms (15 mV p-p) should be noted.

5-69. Remove the 50Ω load and reconnect the 3310A/B to the RMS voltmeter. An output voltage of less than 10.6mV rms (30 mV p-p) should be observed.

5-70. SYNC OUTPUT Amplitude Check.

Specification

SYNC output amplitude:
greater than 2V p-p into 50 ohms.
greater than 4V p-p open circuit.

5-71. Terminate the SYNC OUTPUT of the Model 3310A/B in 50Ω and connect this output to an RMS voltmeter.

5-72. Set the Model 3310A/B controls as indicated in Paragraph 5-54.

5-73. Observe the voltmeter, an indication of greater than .707V rms (2 V p-p) should be noted.

5-74. Remove the 50Ω termination and reconnect the Model 3310A/B SYNC OUTPUT to the RMS voltmeter.

5-75. Observe the voltmeter, and indication of greater than 1.41 V rms (4 V p-p) should be noted.

5-76. Ext. Gate Sensitivity (3310B only).

Specification

Free running occurs with an input $\geq +1$ V but $\leq +10$ V. A maximum voltage of ± 10 V can be applied to the EXT. GATE input.

5-77. Connect the equipment as shown in Figure 5-7. (The positive output of the power supply goes to the center terminal of the EXT. GATE jack.)

5-78. Set the 3310B controls as follows:

RANGE X1K
frequency dial 50
FUNCTION SINE
DC OFFSET LEVEL 0
OUTPUT LEVEL MAX
START/STOP PHASE off of FREE RUN

5-79. Set the 721 A power supply output to approximately 10V as observed on the 427A. A sine wave should appear on the oscilloscope.

5-80. Turn the power supply output to minimum. The 3310B should stop free running (waveform will disappear from the oscilloscope).

5-81. Slowly increase the Model 721A output until the 3310B just begins to free run. Observe the dc voltmeter, a voltage ≤ 1 V should be observed. This verifies the minimum gate voltage specification of + 1 V.

5-82. Set the power supply output to 10 V.

5-83. Observe the oscilloscope. A sine wave should be noted indicating the 3310B is free running on the 10 V input.

5-84. Reverse the polarity of the power supply input. The 3310B should stop free running as indicated by the absence of the sine wave pattern on the oscilloscope.

5-85. Again reverse the power supply polarity. The 3310B should again generate a sine wave output indicating free running. This verifies the ± 10 V limits of the EXT. GATE input.

5-86. Ext. Trigger Check (3310B only).

Specification

Triggering occurs with input pulses ≥ 1.4 V (p-p) but ≤ 10 V (p-p).

5-87. Connect the equipment as shown in Figure 5-8. Set the 211B square wave generator output to minimum.

5-88. Set the 3310B controls as follows:

RANGE X1K
frequency dial 50
FUNCTION SINE
D.C. OFFSET LEVEL 0
START/STOP PHASE fully CW
OUTPUT LEVEL MAX

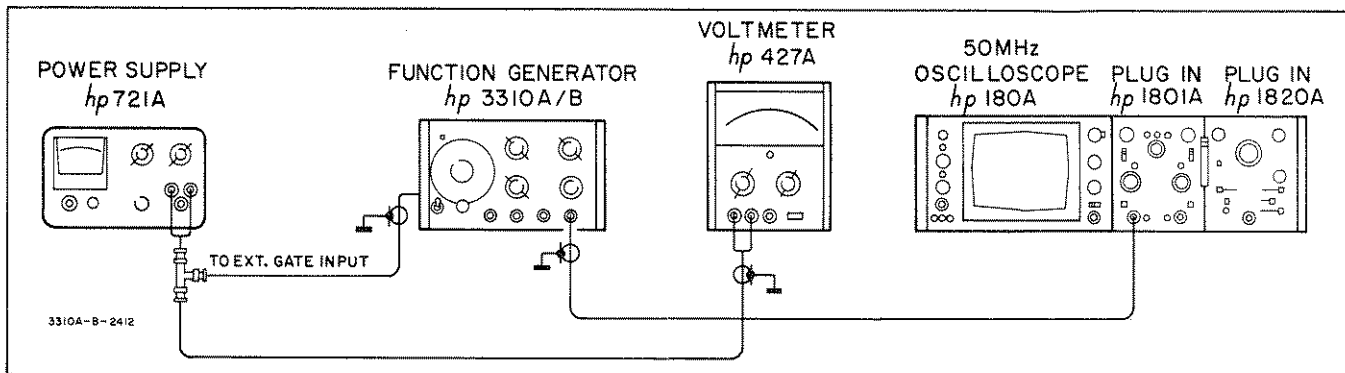

Figure 5-7. EXT. GATE Sensitivity Check.

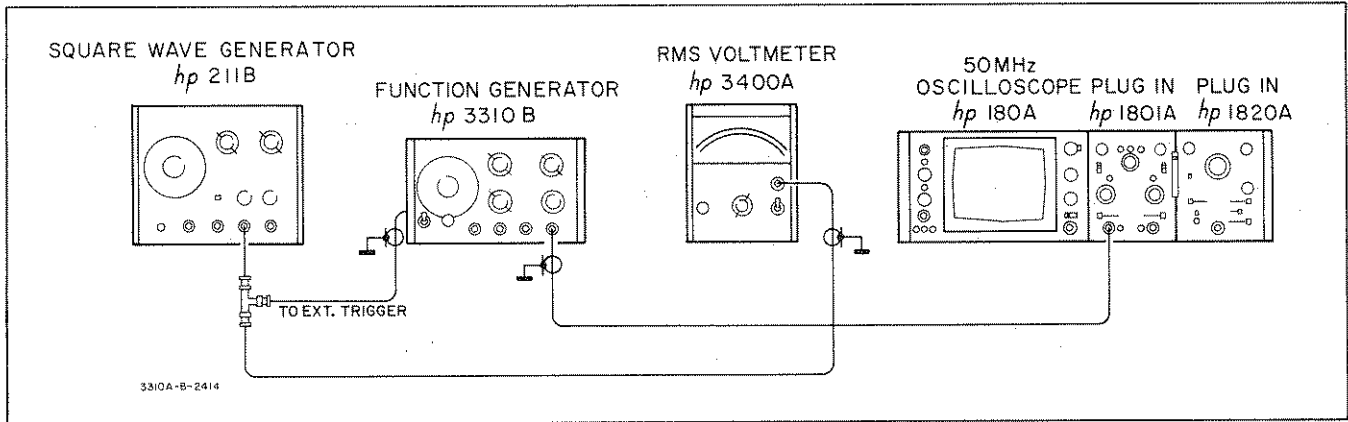

Figure 5-8. EXT. TRIGGER Check.

5-7

5-89. Adjust the output frequency of the square wave generator to 10 kHz and the output level to .7 V rms as observed on the RMS Voltmeter.

5-90. Observe the oscilloscope. Repetitive full cycles of a sine wave should be noted, indicating the 3310B is triggering on a 1.4 V p-p square wave.

5-91. Adjust the square wave generator to 5 V rms as observed on the RMS Voltmeter.

5-92. Again observe the oscilloscope. The oscilloscope pattern noted in Paragraph 5-90 should remain indicating the 3310B is triggering on a 10 V p-p square wave.

5-93. CHECKS OF GENERAL OPERATING CHARACTERISTICS.

NOTE

Paragraphs 5-94 thru 5-118 provide checks for some of the more important general operating characteristics of the Model 3310A/B. (Listed in Table 1-2.) These checks are not intended to be, nor should they be construed to be specification performance checks. These procedures will, however, provide useful information relating to the instrument.

5-94. Low Output Check (30 dB Separation).

5-95. Terminate the HIGH output of the Model 3310A/B in 50Ω. Connect this output to an A.C. Voltmeter.

5-96. Set the 3310A/B controls for a 1kHz sine wave and adjust the OUTPUT LEVEL to maximum. Note the voltmeter indication. 14.75

5-97. Disconnect the A.C. Voltmeter and the 50Ω termination from the HIGH output and connect to the LOW output.

5-98. Again note the A.C. Voltmeter indication. It should be approximately 30dB below the voltmeter indication noted in Paragraph 5-96. 15.15

5-8

5-99. Repeat Paragraphs 5-95 thru 5-98 for several other settings of the OUTPUT LEVEL control.

5-100. Output Impedance Checks.

5-101. Set the 3310A/B output frequency to 1kHz and adjust the OUTPUT LEVEL to approximately 1/2 of maximum. (Output should be unterminated.)

5-102. Connect an ac voltmeter to the HIGH output. Observe and record the voltmeter indication.

5-103. Remove the ac voltmeter and connect a 50Ω terminating resistor to the HIGH output.

5-104. Reconnect the ac voltmeter to the terminated output and record the voltmeter indication.

5-105. Calculate the output impedance according to the formula below:

$$Z_o = \frac{(V_{oc} - V_t)50}{V_t}$$

where:

V_{oc} = open circuit voltage (measured in Paragraph 5-102).

V_t = Voltage with 50Ω termination connected (measured in Paragraph 5-104).

5-106. Using the method outlined in Paragraphs 5-101 thru 5-105 check the output impedance of the LOW and SYNC outputs.

5-107. D.C. Offset Check.

5-108. Set the Model 3310A/B controls as follows:

- FUNCTION SQ (square wave)
- D.C. OFFSET LEVEL 0
- Frequency dial 10
- RANGE X100

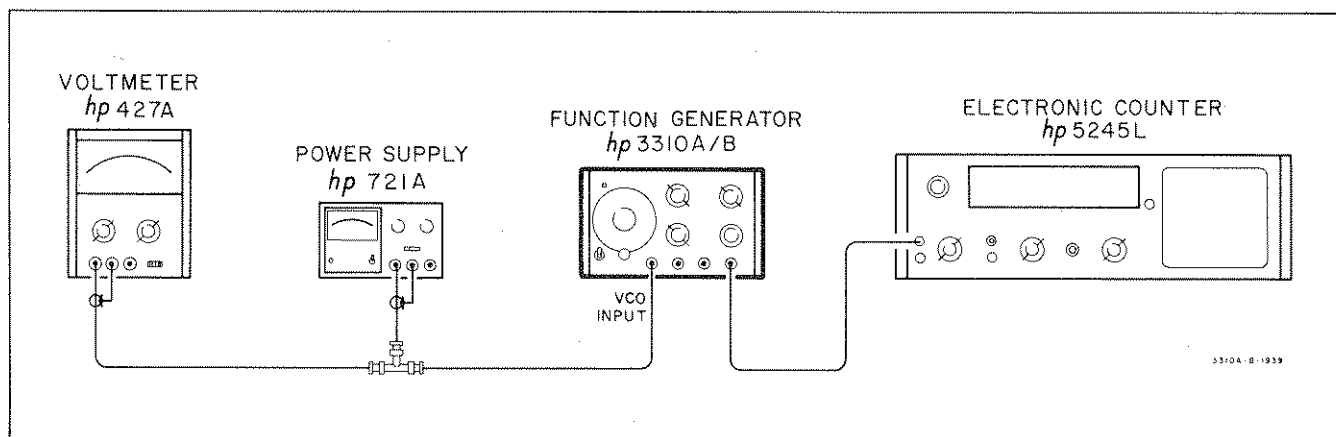

Figure 5-9. External Frequency Control Check.

5-109. Connect an oscilloscope directly to the HIGH output of the 3310A/B.

5-110. Observe the oscilloscope and adjust the 3310A/B output for approximately 3V p-p.

5-111. Set the bottom of the waveform on the horizontal center line of the oscilloscope.

5-112. Turn the D.C. OFFSET vernier to the full clockwise position and set the D.C. offset control to (+).

5-113. Again observe the oscilloscope. The bottom of the waveform should have shifted upward approximately 10V from its original position.

5-114. Set the D.C. OFFSET control to (-). The bottom of the waveform should now be approximately 10V below the horizontal center line of the oscilloscope.

5-115. Terminate the 3310A/B HIGH output in 50Ω and repeat steps 5-111 thru 5-114. The offsets noted in steps 5-113, and 5-114 should be approximately 5V with the 3310A/B terminated in 50 Ω.

5-116. External Frequency Control Check.

5-117. Connect the 3310A/B as shown in Figure 5-9. Set the 3310A/B to the X1K range and the OUTPUT LEVEL control to mid-position. Disconnect the VCO input and adjust the Frequency Dial until the counter indicates 50.0kHz. Reconnect the VCO input and adjust the power supply for a negative dc output. Increase the negative dc output until the counter indicates 1.0kHz. The dc voltage should be $-10V \pm 1.0V$.

5-118. With the VCO input disconnected, adjust the Frequency Dial for a counter indication of 1.0kHz. Apply a positive dc voltage until the counter reads 50.0kHz. The dc voltage should be $+10V \pm 1.0V$.

5-119. ADJUSTMENT PROCEDURE.

5-120. The following paragraphs contain a complete adjustment procedure for the Model 3310A/B Function Generators. This procedure should be performed only if it has been determined by the Performance Checks that the instrument is not operating within its published specifications. A condensed adjustment procedure (Table 5-5) is provided for persons who are already familiar with the instruments. The table provides brief information on the test point to be checked, the nominal value expected, and the adjustment involved. Voltage measurements are referenced to chassis ground ().

NOTE

Unless otherwise indicated the Model 3310B START/STOP PHASE control should be set to "FREE RUN" for these adjustments.

5-121. Cover Removal.

5-122. To remove the top or bottom cover, remove the screws, slide the cover to the rear, and lift off. A side cover may be removed by removing the screws and lifting the cover off.

5-123. Power Supply Adjustment.

5-124. Connect the 3310A/B to the power line and turn the instrument on. Connect the digital voltmeter to A3 Pin 3 and proceed with the following.

- a. Adjust A3R101 for $+10.00V \pm 10mV$.
- b. Measure A3 Pin 5 to confirm $-10.00V \pm 50mV$.
- c. Measure A3TP1 to confirm $+25.0V \pm 1.0V$.
- d. Measure A3TP3 to confirm $-25.0V \pm 1.0V$.

5-125. If any of the last three voltage measurements are out of tolerance, troubleshoot the power supply before trying to perform further adjustment and calibration.

5-126. Triangle Amplifier Bias Adjustment.

5-127. Set the 3310A/B controls to the X10 range and square wave function. Connect an oscilloscope to the A1TP11 and adjust A1R56 until the positive peak of the triangle is at $0\text{ V} \pm 0.1\text{ V}$.

5-128. Symmetry Adjustment.

5-129. Connect the SYNC output of the 3310A/B to the input of the time interval counter as shown in Figure 5-2. (Symmetry Check).

5-130. Set the 3310A/B RANGE to 100, the dial to 50, and the FUNCTION to SQ.

5-131. Measure the time interval of each half cycle. Adjust A1R24 until the time intervals for both half cycles are within $1.0\ \mu\text{s}$ of each other.

5-132. Set the 3310A/B dial to 5 and adjust A1R26 until the time intervals for both half cycles are within $10.0\ \mu\text{s}$ of each other.

NOTE

A1R24 and A1R26 interact. It may be necessary to repeat these adjustments to achieve symmetry at both ends of the dial.

5-133. Set the 3310A/B frequency dial to 5 and the RANGE to the X1 position. Adjust A1R162 for best symmetry. Set the dial to 50 and assure that the time intervals are within 20.0 ms of each other. If not, repeat all steps of this symmetry adjustment.

5-134. Dial Calibration.

5-135. Connect the digital voltmeter to the center terminal of the 3310A/B frequency dial tuning potentiometer (blue wire).

5-136. Set the frequency dial to 5, and confirm that the digital voltmeter reads between 850 mV and 950 mV. If not, the dial should be slipped by loosening its set screws until a reading of 850 mV to 950 mV is obtained at the 5 setting.

5-137. Set the frequency dial to the full CW position. A voltmeter reading between 100 and 170 mV should be noted.

5-138. With the frequency dial set to 5, measure and record the center terminal voltage reading. Subtract 900 mV from this reading and record the difference.

5-139. Adjust A1R17 for a reading of A1TP1 equal to the difference voltage above. For example if the center terminal voltage is 875 mV, A1R17 should be adjusted so that A1TP1 reads - 25 mV ($875\text{ mV} - 900\text{ mV}$).

5-10

5-140. Frequency Calibration.

5-141. Connect the SYNC output of the 3310A/B to counter. Set the 3310A/B dial to 50, the RANGE to X100K, and the FUNCTION switch to SINE. Adjust A1R6 for a $5.000\text{ MHz} \pm 20\text{ kHz}$ indication.

5-142. Change the 3310A/B RANGE to X10K. Adjust A1R5 for an indication of $500\text{ kHz} \pm 2\text{ kHz}$.

5-143. Change the 3310A RANGE to X1 K and adjust A1R4 for an indication of $50\text{ kHz} \pm 200\text{ Hz}$.

5-144. Turn the 3310A/B FUNCTION switch fully CW to the negative ramp position. Adjust A2R6 for a reading of $50\text{ kHz} \pm 200\text{ Hz}$.

5-145. Switch the 3310A/B FUNCTION back to sine wave and the RANGE to X100. Adjust A1R3 for an indication of $5000\text{ Hz} \pm 20\text{ Hz}$.

5-146. Change the 3310A/B RANGE to X10 and adjust A1R2 for an indication of $2000\ \mu\text{s} \pm 10\ \mu\text{s}$.

5-147. Change the 3310A/B RANGE to X1 and adjust A1R1 for an indication of $20,000\ \mu\text{s} \pm 100\ \mu\text{s}$.

5-148. Distortion Adjustment.

5-149. Set the 3310A/B RANGE to X100, the Dial to 50, OUTPUT LEVEL to approximately 1/2 of maximum, and the FUNCTION switch to SINE. Using a $50\ \Omega$ load, connect the HIGH output of the 3310A/B to the distortion analyzer. Adjust A3R4 and A3R27 for best distortion readings. The distortion measurement should be greater than 46 dB below the fundamental.

5-150. D.C. Offset Adjustment (SINE function).

5-151. Connect a digital voltmeter to the output of the Model 3310A/B and adjust the OUTPUT CONTROL for full output.

5-152. Set the 3310A/B for a 1 kHz Sine Wave output.

5-153. Set the D.C. OFFSET LEVEL control to 0 and adjust A2R23 for $0\text{ V} \pm 75\text{ MV}$ as observed on the voltmeter. The offset should be set as close to 0 V as possible.

5-154. Square Wave And Pulse Aberration Adjustment.

5-155. Set the 3310A/B for a 5 MHz square wave output, and set the OUTPUT LEVEL control to the full CW position.

5-156. Terminate the output in $50\ \Omega$ and connect an oscilloscope to the terminated output.

5-157. Check the aberration as described in Paragraphs 5-41 through 5-45. If it is out of specification, manually adjust the spacing between A3C26* and A3Q10 until the specification is met.

5-158. Frequency Response Adjustment.

5-159. Connect the 3310A/B as shown in Figure 5-1. Using the procedure in Paragraph 5-16, determine the maximum frequency response variation of the X100 K frequency range. Select A2C6* for best frequency response with maximum variation from the reference level being less than $\pm 3\%$. (See example Paragraph 5-16 g.)

5-160. START/STOP PHASE Limit Adjustment (3310B only).

5-161. Connect a signal source capable of providing a square wave that has a positive excursion of at least 1 volt across an impedance of $500\ \Omega$ to the 3310B EXT. GATE input.

5-162. Connect the 3310B output to an oscilloscope. Adjust the output frequency of the 3310B to 5X 1KHz sine wave. Adjust the external gating source so that the 3310B provides a single cycle output. Note: the external gating source should be slightly lower in frequency than the 3310B.

5-163. Turn the START/STOP PHASE control counterclockwise as far as possible without setting the instrument to FREE RUN.

5-164. Adjust A5R8 until the single cycle begins as near as possible to the bottom of the waveform. Now change the frequency of the 3310B to 5X 10KHz. Readjust A5R8 until the output tone burst is sinusoidal.

5-165. Now set the 3310B output frequency to 50X 1KHz positive going ramp. Also turn the START/STOP PHASE control fully clockwise.

5-166. Turn A5R4 clockwise until the 3310B begins to free run. Then turn A5R4 counterclockwise and slightly past the point where the 3310B stops free running and the tone burst begins as near as possible to the top of the waveform.

5-167. TROUBLESHOOTING.

5-168. This troubleshooting procedure is divided into two major sections; (1) General Troubleshooting Information, (2) Specific Troubleshooting Aids and Maintenance Tips. Section one contains Front Panel Checks. These checks will aid the troubleshooter in identifying and isolating a trouble to a major section of the instrument. The troubleshooting trees in section two provide a method of quick identification and isolation of most troubles encountered in the 3310A/B. Troubleshooting the 3310A/B will be much easier if you have obtained a good basic knowledge of the instrument. If information on the theory of operation of the Model 3310A/B is desired refer to Section IV of this manual. Figure 4-1 is the block diagram for the instrument. Schematic diagrams of the various circuits including waveforms and voltage levels, can be found in Section VII.

5-169. GENERAL TROUBLESHOOTING INFORMATION.

5-170. Front Panel Checks.

5-171. Front panel checks (below) are useful in isolating troubles of a recurrent or continuous nature. Using this type of procedure a trouble can often be isolated to a particular circuit within the instrument. The section on circuit troubleshooting (paragraph 5-178) can be referred to for specific helps. If the front panel troubleshooting procedure proves inadequate refer to Troubleshooting Tree Nos. 1 and 2 for more precise help.

a. Set the 3310A/B controls for a 100 Hz triangle wave output. Connect the HIGH output to an oscilloscope, and set the OUTPUT LEVEL fully CW. If a 100 Hz triangle wave is observed on the oscilloscope, go to step b. If not, go to step i.

b. Change the 3310A/B to SINE function. If a 100 Hz sine wave is observed, go to step c. If not, go to step h.

c. Change the 3310A/B RANGE to X100 and the FUNCTION to triangle wave output. If the triangle wave is normal, go to step d. If not, go to step i.

d. Change the 3310A/B RANGE to X1 K. If the triangle wave is normal, (not noticeably distorted), go to step e. If not, go to step i.

e. Check for proper triangle output on X10 K and X100 K ranges. If normal, go to step f. If not, go to step g.

f. Check for proper output on the X.1 range. If normal, check the X.01, X.001, and X.0001 ranges. If any of these ranges have problems, troubleshoot the Low Frequency Feedback Amplifier.

g. If only the X10 K and X100 K have abnormal operation, troubleshoot the High Frequency Level Detector.

h. If square and triangle outputs are normal and the sine wave is abnormal, troubleshoot the Sine Shaping Network and the Sine Shaper Amplifier.

i. If the triangle wave output is abnormal on the X10, X100, or X1 K range, a number of circuits could be responsible. Set the RANGE to X10, OUTPUT LEVEL fully CCW and switch in + DC OFFSET. While monitoring the HIGH output with a dc voltmeter, vary the dc offset from limit to limit. If a 0 to + 10 volt variation is observed, go to step j. If not, troubleshoot the Output Amplifier.

j. Set the Frequency Dial to 50, OUTPUT LEVEL fully CW and connect - 5 V dc to the VCO input. If the output is normal with the - 5 V input and there is no output when the VCO input is removed, troubleshoot the Frequency Dial potentiometer and Range switch. Otherwise troubleshoot the Tuning Amplifier, Current Sources, Triangle Amplifier, and ± 5 Volt Level Detector. Figures 7-2 through 7-7 show dc voltage levels to aid in troubleshooting.

NOTE

This table provides selection information for components whose optimum value is chosen at the factory. Due to changing parameters within an instrument or after a repair or calibration it may be necessary to change the value of one or more of these components. The component value should not, however, exceed limits indicated in the "nominal value" column.

Table 5-4. Starred Value Components.

Component	Purpose	Nominal Value
A1C17*	Frequency error on X100 k range. (Can also be caused by High Freq. Level Detector.) Feedback Capacitance on X100 k range must be 100 pF for proper frequency tracking. A1C17* adds to the junction capacitance of A1Q12, A1Q5 and A1Q6 to form a total of 100 pF.	68 pF \pm 10 pF
A1C20*	Prevents high freq, (\approx 40 MHz) oscillations in Triangle Amplifier. Increase value 1 or 2 pF if oscillations occur.	3.3 pF + 2 pF
A2C1*	Adjust for symmetry error on X100 k Range.	.68 pF \pm .3 pF
A2C2* and A2R9*	Triangle and Ramp Amplitude or flatness. A2R20 Amplitude Pot has some inherent capacitance. A2R20, A2C2* and A2R9* form a compensated attenuator for Triangle and Ramp functions.	A2C2* - 62 pF \pm 10 pF A2R9* - 464 Ω \pm 50 Ω
A2C6*	Frequency Response Adjustment at 5 MHz	4.7 pF to 10 pF
A2R18*	Sine Amplitude	1780 Ω \pm 100 Ω
A3R69*	Square Wave and Pulse Amplitude Control If A3R69* is changed, other functions' amplitudes are affected and may have to be corrected.	5.760 Ω \pm 200 Ω
A3C26*	Square and Pulse overshoot at full output, into 50 Ω . (Make sure DC offset is zero and that total amplitude is \leq 33 V p-p.) <i>NOTE: A3C26* was not usually installed prior to installation of output protection circuit. Value is not important, the amount of coupling with case of A3Q10 provides adjustment of C_{dist}</i>	10 pF*
A3R32*	Adjusts amount of DC OFFSET available with R2.	5.49 k Ω \pm 400 Ω

Table 5-5. Condensed Adjustment Procedure
NOTE: Follow in sequence for complete calibration.

STEP	CIRCUIT OR PURPOSE	TEST POINT (Use DCVM unless otherwise specified)	SPECIAL TEST CONDITIONS	NOMINAL VALUE	ADJUSTMENT
1	Power Supply	A3 Pin 3		+ 10 V \pm 10 mV	A3R101
2	Power Supply	A3 Pin 5		- 10 V \pm 50 mV	None: referenced to + 10 V supply
3	Power Supply	A3TP3		- 25 V \pm 1.0 V	None: referenced to + 10 V supply
4	Power Supply	A3TP1		+ 25 V \pm 1.0 V	None: referenced to - 10 V supply
5	Input Circuit	R1 Freq. Pot Center Terminal (Blue Wire)	3310A/B Freq. Dial at 5	900 mV \pm 50 mV (record for use in Step 7)	Rotate R1
6	Input Circuit	R1 Freq Pot Center Terminal	3310A/B Freq. Dial Max CW	135 mV \pm 35 mV	None
7	Tuning Amplifier	A1TP1	3310A Freq. Dial at 5	subtract 900 mV from reading in Step 5	A1R17
8	Triangle Amplifier	A3CR3 Cathode Use Oscilloscope	X10 Range: Square Wave	Positive peak of tri- angle at 0 V \pm 0.1 V	A1R56 (see note 1)
9	Upper Dial Symmetry	Sync Output Use Time Interval Recorder or Equiv	X100 Range: Square Wave Dial at 50	Both half cycle periods within 1 μ s of each other	A1R24 (see note 2)
10	Lower Dial Symmetry	Sync Output, Use Time Interval Re- corder or Equivalent	X100 Range: Square Wave Dial at 5	Half Cycle Periods within 10 μ s	A1R26
11	Low Freq. Symmetry	Sync Output Use Time Interval Recorder	X1 Range: Square Wave Dial at 5	Best Symmetry	A1R162
12	Low Freq. Symmetry	Sync Output Use Time Interval Recorder	X1 Range: Square Wave Dial at 50	Half Cycles within 200 ms	None - may have to repeat steps 9-12
13	Freq. Calib. 5 kHz	(Sync Output Use Counter)	X100 K Range, Sine Function Dial at 50	5.00 MHz \pm 20 kHz	A1R6
14	Freq. Calib. 500 kHz	(Sync Output Use Counter)	X10 K, Sine Function, Dial at 50.	500 kHz \pm 2 kHz	A1R5
15	Freq. Calib. 50 kHz	(Sync Output Use Counter)	X1 K, Sine Function, Dial at 50	50 kHz \pm 200 Hz	A1R4
16	Freq. Calib. 5 kHz	(Sync Output Use Counter)	X100, Sine Function Dial at 50	5 kHz \pm 20 Hz	A1R3

Table 5-5. Condensed Adjustment Procedures (cont'd).

STEP	CIRCUIT OR PURPOSE	TEST POINT (Use DCVM unless otherwise specified)	SPECIAL TEST CONDITIONS	NOMINAL VALUE	ADJUSTMENT
17	Freq. Calib. 500 Hz	(Sync Output Use Counter)	X10, Sine Function, Dial at 50	2000 μ s \pm 10 μ s	A1R2
18	Freq. Calib. 50 Hz	(Sync Output Use Counter)	X1, Sine Function, Dial at 50	20,000 μ s \pm 100 μ s	A1R1
19	Distortion	High Output Use 50 Ω Load and Distortion Analyzer.	X100 Range, Sine Function, Dial at 50	>46 dB down	A3R4 and A3R27
20	Freq; Response	Connect as shown in Figure 5-1	Use Procedure given in Para. 5-16; 5-158	\pm 3% on Top Ranges (1 kHz Reference)	A2C6
21	Square Wave and Pulse Abberation	HIGH output (use oscilloscope)	X100 RANGE Freq. Dial to 10	Aberration < 5 % of p-p value of waveform	spacing between A3C26* and Heat Sink of A3Q10.

NOTES

1. If triangle peak cannot be adjusted to 0 V \pm 0.1 V, two possible fixes are available:
 - A. Select FET for A1Q12 which can be adjusted. (IDSS of individual FETs causes this problem.)
 - B. In 3310A's S/N 920-00550 and below:
 - a. Change A1R55 to 270 Ω (-hp- Stock No. 0684-2771).
 - b. Change A1R54 to 4.7 k Ω (-hp- Stock No. 4721).
This change allows for a wider range on A1Q12 FET IDSS.
2. Steps 9 and 10 adjustments interact.

5-172. SPECIFIC CIRCUIT TROUBLESHOOTING AIDS AND MAINTENANCE TIPS.**5-173. Circuit Troubleshooting.**

5-174. Power Supply. The four supply voltages are ultimately referenced to the +10 V supply. Each supply is basically a series regulator; and, if any of the four supplies fail, all four voltages will be affected. If the supply voltages are out of specification, the following steps might be followed until the trouble is isolated:

- a. Ascertain that the \pm 25V power supplies are not in current limit due to a short in another part of the circuit. This can be accomplished by checking the base-emitter voltage on A3Q19 and A3Q23. A forward bias voltage of approximately .7 V would indicate that the power supplies are in current limit. The \pm 10 V power supplies can be checked in a similar manner by measuring the base-emitter

voltages of A3Q27 (-10 V supply) and A3Q32 (+10 V supply).

- b. Try adjusting A3R101 for proper voltages (see step 1 of condensed adjustment procedures).
- c. Check for proper input voltages shown on Figure 7-6.

NOTE

If the positive voltage at A3TP2 is high, check A3Q20, A3Q18. If the negative voltage at A3TP4 is high, check A3Q24, A3Q22.

- d. Lift negative side of A3R75 and apply -10 V to lifted lead. Turn 3310A/B on and +25 V supply should operate properly. If +25 V supply is good, go to step e after replacing R75 lead. If +25 V is bad, fix the supply, replace R75 lead and see if all four voltages are now good. If the voltages are still bad go to step e.

e. Lift positive side of R80 and apply + 10 V to lifted lead. - 25 V supply should now operate properly. If the - 25 V is working, replace R80 lead and go to step f.

f. If the ± 25 V supplies are good above, the trouble must be in ± 10 V supplies, Check the + 10 V supply by lifting one side of R91 and again lifting the negative side of R75 and applying - 10 V at that lifted lead. Turn the 3310A/B on and the + 10 V and ± 25 V supplies should operate. If they do, the trouble is in the - 10 V supply, If not, the + 10 V supply is bad.

NOTE

CR21 and CR23 in the + 25 V and - 25 V supplies are constant current devices.

5-175. Input Circuits. Check for proper output from frequency potentiometer (see Dial Calibration Procedure, Paragraph 5-134).

5-176. Tuning Amplifier and Inverting Amplifier. Voltage checks are best here. Pins 2 and 3 of IC1 should be at the same potential if the IC is good. The same is true of IC2.

Note that troubles in the current sources may be reflected back to these amplifiers and make it seem that the amplifiers are bad.

5-177. Current Sources, Triangle Amplifier, and Level Detector. If any one of these circuits fails, the output will be directly affected. The circuits are dependent on each other for operation and troubles may normally be isolated to one of the three circuits as follows:

- a. Disconnect cathode of A1CR4.
- b. Set the 3310A/B to a frequency of 1 kHz and a triangle output. From an external source apply to A1TP11 a 1 kHz 2 V p-p offset triangle wave, varying from 0 V to - 2 V. Check and make sure that the external signal is still varying from 0 V to - 2 V. If not, check A1Q12, Q5, Q6, and associated circuits.

c. Connect scope to A1TP4 and check for 10 V p-p triangle wave varying from - 5 V to + 5 V. If the waveform is missing or is not correct, try adjusting A1R56. If still not able to get the correct waveform, then the trouble is probably in the triangle amplifier.

When troubleshooting the triangle amplifier, first remove A1Q15, then connect scope to A1Q14 emitter and adjust A1R56. If you are not able to get a triangle waveform, then the problem exists in A1Q12 through A1Q14 circuits. If you are able to get a triangle waveform, then check A1Q16 through A1Q20 circuits. First, short emitter to base of A1Q16 and check to see if A1TP4 is ≤ - 5 V. Remove short from A1Q16 and then short emitter to base of A1Q17 and check to see if A1TP4 is ≥ + 5 V.

NOTE

Voltage checks should help isolate the problem in the triangle amplifier.

d. If a ± 5 V triangle appears at A1TP4, then monitor A1TP8 and A1TP9 with a scope. Now adjust A1R56 and source generator amplifier to get a waveform similar to what is indicated in Figure 7-3 for A1TP8 and A1TP9. If unable to get the correct waveforms, then check the tunnel diodes and their associated circuits.

1. Check A1CR21 and A1CR22 in circuit as follows: Turn off 3310A/B power and apply (+) lead from 412A ohmmeter (use 1 kΩ range) to anode of either tunnel diode FIRST. Apply (-) lead to cathode LAST.

Indications:

about 750 Ω	Diode is O.K.
about 1 kΩ	Diode is open
0 Ω	Diode is shorted or you applied ohmmeter leads in wrong order.

Another method of checking the tunnel diodes A1CR21 and A1CR22 is shown below. Figure 5-10.

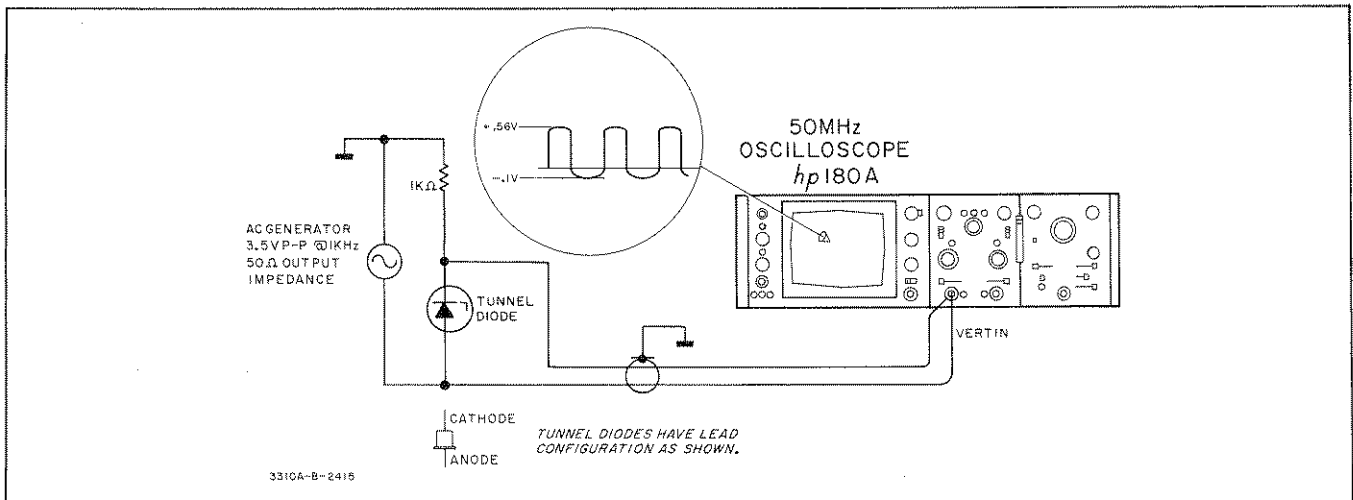

Figure 5-10. Tunnel Diode Check.

NOTE

The tunnel diodes must be removed from the instrument for this check. All grounds should be carefully checked to insure they are connected as shown. If the diode is functioning properly, the waveform shown should appear.

2. If both tunnel diodes check O.K. but it is suspected that one or both diodes are not firing when the 3310A/B is turned on, lift base lead of A1Q33 or A1Q36 (depending on which diode does not fire) and check for diode firing. If the diode(s) then fire, the remainder of the level detector may be checked by:
 - a. Driving transistors with proper waveforms shown on Figure 7-3 while checking for proper TP5 waveform.
 - b. Voltage checks.
 - e. If correct waveforms are present at A1TP8 and A1TP9, then check A1TP5 for a square wave varying from +1.2 V to -2.8 V. If the waveform is not present then the problem exists in the ± 5 V level detector.
 - f. If the square wave is not present at A1TP5, then check A1TP6 or A1TP7.
 1. If the square wave is present at one of these test points, then the problem exists in Q41 and/or Q42 circuitry.
 2. If the square wave is not present at either of the test points, then check the collectors of A1Q33 and A1Q36 with a scope. If either collector gives an amplified version of what is on TP8 or TP9, then check that side of the flip-flop for a defective component.

NOTE: Further voltage checks should isolate the problem in the ± 5 volt level detector.

g. If the correct square wave appears at A1TP5 then the problem exists in the current sources A1Q5 and/or A1Q6 circuit. Check the emitter and base of Q5 and Q6 for correct dc voltage. If the voltage is correct, then check A1CR3 and A1CR4.

5-178. Output Amplifier. Two methods for troubleshooting this circuit are:

- a. Apply proper 10 V p-p triangle at A1TP4; use triangle function and check waveforms in output amplifier, as shown on schematic (Figure 7-4).
- b. Using the DC offset function, check for the following approximate DC levels. (The A1 Board was removed when the levels were obtained using a scope with a X10 probe.)

5-179. Sine Shaping Network and Amplifier. Check for proper DC levels and AC waveforms shown on the schematic. A few waveforms are shown in the diode shaping network.

5-180. High Frequency Level Detector. Check AC waveforms and DC levels.

5-181. Low Frequency Level Detector. Check DC levels.

5-182. TROUBLESHOOTING THE 3310B.

5-183. Troubles occurring in the 3310B should be checked by first operating the instrument in "FREE RUN" mode. This will enable the troubleshooter to determine whether the problem is in the triggering mechanism of the 3310B or in the function generator portion of the instrument. If the trouble occurs with the instrument in FREE RUN mode the 3310B should be checked using the methods previously outlined for the 3310A/B (paragraphs 5-169 through 5-181). Failure of any transistor in the 3310B Tone Burst

Table 5-6. D.C. Voltages on A3 Assembly With and Without Offset.

	Maximum Negative DC Offset	Zero DC Offset	Maximum Positive DC Offset
A3Q9 Base	+ 20 V	+ 20 V	+ 20 V
A3Q10 Emmitter	+ 20 V	+ 20 V	+ 20 V
A3Q13 Base	- 8.5 V	+ 1.4 V	+ 11.5 V
Q1 Base	- 9.5 V	+ .7 V	+ 10.5 V
A3Q12 Base	- 20 V	- 20 V	- 20 V
A3Q11 Base	- 20 V	- 20 V	- 20 V
A3Q14 Base	- 8.5 V	- 1.4 V	+ 11.5 V
Q2 Base	- 9.5 V	- .7 V	+ 10.5 V

Table 5-7. D.C. Voltages for Tone Burst Circuit (A5 Assembly) With EXT. GATE Input.

	Q ₁	Q ₂	Q ₃	Q ₄	Q ₅	Q ₆	Q ₇	Q ₈	Q ₉	Q ₁₀	IC 1	
Emitter	-.1	.44	5.7	5.9	.9	.86	gnd	gnd	gnd	gnd	Pin 2	.09
Base	-1.1	1.1	5.0	5.2	1.6	.22	-.38	.7	.082	.67	Pin 13	1.6
Collector	10	5.2	.06	1.6	10	-10	4.7	.09	1.6	.082	Pin 8	.09

Table 5-8. D.C. Voltages for Tone Burst Circuit (A5 Assembly) Without EXT. GATE Input.

	Q ₁	Q ₂	Q ₃	Q ₄	Q ₅	Q ₆	Q ₇	Q ₈	Q ₉	Q ₁₀	IC 1	
Emitter	-2.6	-2.5	-5.7	7.1	-2.0	-2.0	N/A	N/A	N/A	N/A	Pin 2	1.6
Base	-2	-1.9	-5.0	6.4	-1.4	-2.7	.71	.12	.16	.12	Pin 13	1.7
Collector	10	6.4	-2.7	-1.4	10	-10	.07	1.6	1.7	.16	Pin 8	3.0 V

Gate will usually cause the 3310B to either free run or stop oscillating completely. The following method is useful in troubleshooting the 3310B TONE BURST GATE:

1. Set the 3310B controls for a 1 kHz sine wave.
2. Turn the START/STOP PHASE control just off "FREE RUN" position and connect an oscilloscope to the HIGH output.
3. Depress and hold the MANUAL TRIGGER button while observing the oscilloscope. A 1 kHz sine wave should appear.
4. Release the MANUAL TRIGGER control. The waveform should disappear.
5. If the proper indications, as outlined in paragraphs 5-183 (3) and (4), are not observed proceed as follows:
 - a. Connect any voltage between +1 V and +10 V to the EXT. GATE input.
 - b. Check the components listed in Table 5-7 for the approximate voltages indicated.
 - c. Remove the EXT. GATE voltage and recheck the components listed for the voltages indicated in Table 5-8.

5-184. MAINTENANCE TIPS.

5-185. A1 Board Removal.

NOTE

A1 Board removal gives easy access to the back of the A3 Board.

- a. Remove Range Switch knob and holding nut.
- b. Remove screw on rear corner of A1 Board.
- c. Work board out of connector then up and out of instrument. *AVOID UNDUE FLEXING OF BOARD AS THIS MAY CAUSE BROKEN INTERNAL TRACES.*

5-186. Broken Trace Repair.

5-187. If one or more internal traces are open or have high resistance, the connection should be hard wired on the back of the board whenever possible.



USE LOW WATTAGE SOLDERING IRONS WHEN REPLACING PARTS. THIS WILL HELP AVOID DAMAGE TO MULTILAYER BOARDS. HANDLE BOARDS CAREFULLY AND AVOID CONTAMINATION.



Output obtained incorrect.

Output incorrect or no output on some functions.

No output functions.

See Figure 5

Connect an Oscilloscope to HIGH Output.
Check all functions and frequencies.

No output on any function.

Set 3310A for 1kHz for -5V to +5V A1TP4.

W

F

W

not

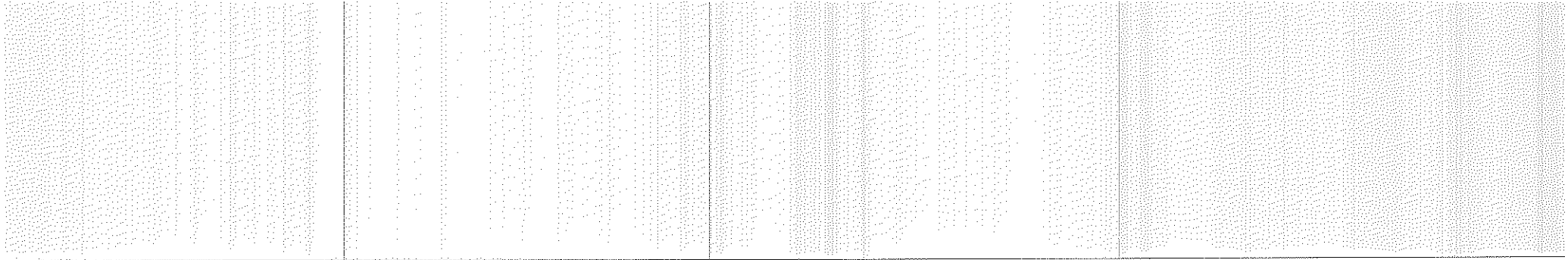

Recheck all adjustments in Adjustment Procedures. See Table 5-4 Starred Value Components.

Troubleshoot Output Amplifier. (Figure 7-4).

Waveform present

Connect an Oscilloscope to A3 connector pin 4. Set output level to maximum. A +2.7V to -2.7V triangle wave should be observed.

Waveform not present

Check OUTPUT LEVEL control (A2R20). Check A2R9*, A2C2*, A1R31 and all interconnecting wiring.

Troubleshoot Inverting Amplifier (Figure 7-2).

Waveform present

Triangle output. Check triangle waveform at

Waveform present

Connect a devm to A1TP2. Vary frequency dial slowly from end to end. A voltage variation of -4vdc to +22vdc should be observed.

Voltage correct

Connect a devm to A1TP1. A 0 to -2V triangle waveform should appear here.

Voltage correct

Voltage incorrect

Connect a devm to A1TP3. Vary frequency dial slowly from end to end. A voltage variation of ±4vdc to +22vdc should be observed.

Voltage correct

Troubleshoot current sources and ±5V level detector (Figures 7-2 and 7-3).

Troubleshoot the Triangle Amplifier (Figure 7-3).

Troubleshoot Tuning Amplifier and RANGE switch S20(R). Also check A1R1-R7 and

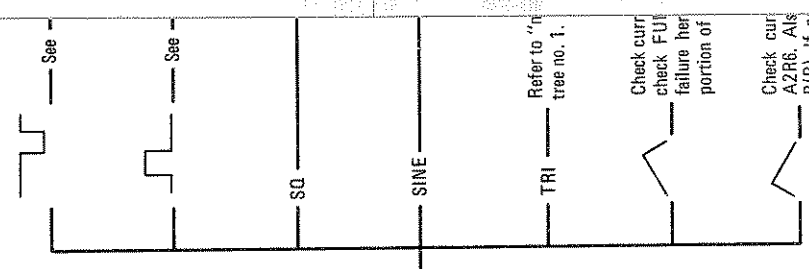

No output obtainable on one or more of the following functions (choose one).

TRI

Check current check failure here portion of

Check current A2R6. Also B(R). If not function'

See

See

SQ

SINE

Refer to tree no. 1.

Check current A2R6. Also B(R). If not function'

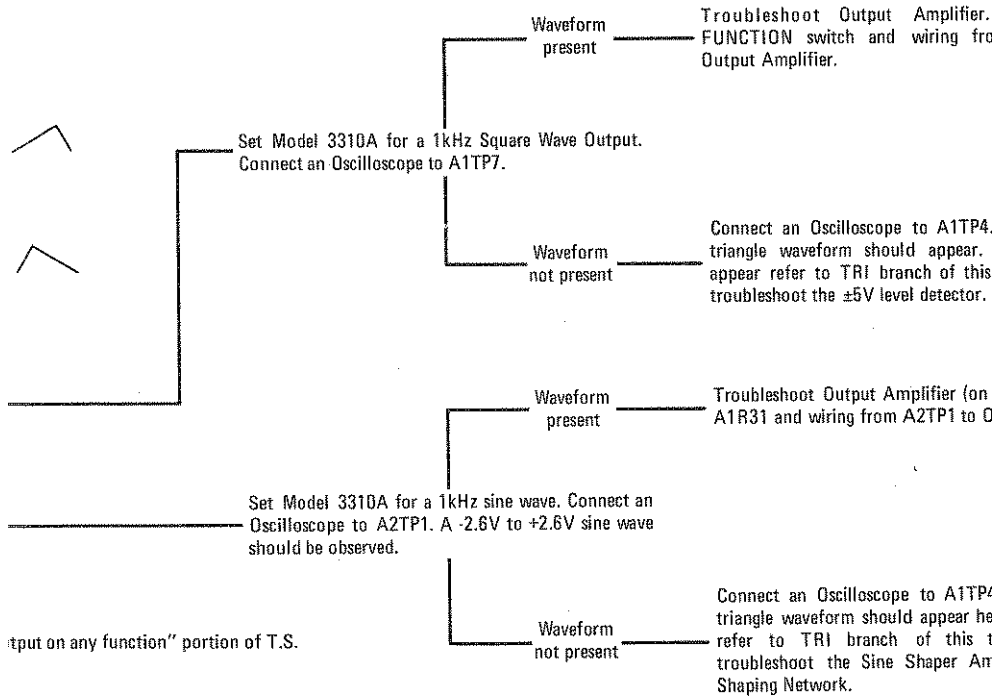

Output on any function" portion of T.S.

source resistors A2R2, and A2R3, Also FUNCTION switch A2S3A and B(R). If no refer to "no output for any function" tree no. 1.

source resistors A2R2, A2R5, and FUNCTION switch A2S3A and here refer to "no output on any

PERFORMANCE CHECK TEST CARD

Hewlett-Packard Model 3310 A and B
Function Generators
Serial No. _____

Test Performed By _____
Date _____

CHECK DESCRIPTION	SPECIFICATION	INDICATION																																																																																																																																														
FREQUENCY RANGE CHECK	Freq. (min) \leq .0005 Hz Freq. (max) \geq 5 MHz	_____ \geq 2000 μ s _____ \geq 5 MHz																																																																																																																																														
SINE WAVE FREQ. RESPONSE CHECK	5 Hz to 50 kHz: \pm 1 % 50 kHz to 5 MHz: \pm 4%	_____ \pm 1 % _____ \pm 4%																																																																																																																																														
TRIANGLE SYMMETRY CHECK	0.0005 Hz to 20 Hz: $<$ 1 % 20Hz to 50 kHz: $<$ 0.5 %	_____ $<$ 1 % _____ $<$ 0.5 %																																																																																																																																														
DIAL ACCURACY CHECK	<table border="0" style="width: 100%; border-collapse: collapse;"> <tr> <td style="width: 30%;"></td> <td style="text-align: center;">Dial</td> <td style="text-align: center;">Range</td> <td style="width: 40%;"></td> </tr> <tr> <td rowspan="18" style="vertical-align: middle; text-align: center;"> \pm (1 % of setting + 1 % of full scale) </td> <td style="text-align: center;">5</td> <td style="text-align: center;">.0001</td> <td>_____ 1800 to 2240s</td> </tr> <tr> <td style="text-align: center;">30</td> <td style="text-align: center;">.0001</td> <td>_____ 324 to 342s</td> </tr> <tr> <td style="text-align: center;">50</td> <td style="text-align: center;">.0001</td> <td>_____ 196 to 204s</td> </tr> <tr> <td style="text-align: center;">5</td> <td style="text-align: center;">.001</td> <td>_____ 180 to 224s</td> </tr> <tr> <td style="text-align: center;">30</td> <td style="text-align: center;">.001</td> <td>_____ 32.4 to 34.2s</td> </tr> <tr> <td style="text-align: center;">50</td> <td style="text-align: center;">.001</td> <td>_____ 19.6 to 20.4s</td> </tr> <tr> <td style="text-align: center;">5</td> <td style="text-align: center;">.01</td> <td>_____ 18.0 to 22.4s</td> </tr> <tr> <td style="text-align: center;">30</td> <td style="text-align: center;">.01</td> <td>_____ 3.24 to 3.42s</td> </tr> <tr> <td style="text-align: center;">50</td> <td style="text-align: center;">.01</td> <td>_____ 1.96 to 2.04s</td> </tr> <tr> <td style="text-align: center;">5</td> <td style="text-align: center;">.1</td> <td>_____ 1.80 to 2.24s</td> </tr> <tr> <td style="text-align: center;">30</td> <td style="text-align: center;">.1</td> <td>_____ 324 to 342ms</td> </tr> <tr> <td style="text-align: center;">50</td> <td style="text-align: center;">.1</td> <td>_____ 196 to 204ms</td> </tr> <tr> <td style="text-align: center;">5</td> <td style="text-align: center;">1</td> <td>_____ 180 to 224ms</td> </tr> <tr> <td style="text-align: center;">30</td> <td style="text-align: center;">1</td> <td>_____ 32.4 to 34.2ms</td> </tr> <tr> <td style="text-align: center;">50</td> <td style="text-align: center;">1</td> <td>_____ 19.6 to 20.4ms</td> </tr> <tr> <td style="text-align: center;">5</td> <td style="text-align: center;">10</td> <td>_____ 18.0 to 22.4ms</td> </tr> <tr> <td style="text-align: center;">30</td> <td style="text-align: center;">10</td> <td>_____ 3.24 to 3.42ms</td> </tr> <tr> <td style="text-align: center;">50</td> <td style="text-align: center;">10</td> <td>_____ 1.96 to 2.04ms</td> </tr> <tr> <td style="text-align: center;">5</td> <td style="text-align: center;">100</td> <td>_____ 1.80 to 2.24ms</td> </tr> <tr> <td style="text-align: center;">30</td> <td style="text-align: center;">100</td> <td>_____ 2920 to 3080 Hz</td> </tr> <tr> <td style="text-align: center;">50</td> <td style="text-align: center;">100</td> <td>_____ 4900 to 5100 Hz</td> </tr> <tr> <td style="text-align: center;">5</td> <td style="text-align: center;">1K</td> <td>_____ 4450 to 5550 Hz</td> </tr> <tr> <td style="text-align: center;">30</td> <td style="text-align: center;">1K</td> <td>_____ 29.20 Hz to 30.80 kHz</td> </tr> <tr> <td style="text-align: center;">50</td> <td style="text-align: center;">1K</td> <td>_____ 49.00 kHz to 51.00 kHz</td> </tr> <tr> <td style="text-align: center;">5</td> <td style="text-align: center;">10K</td> <td>_____ 44.50 kHz to 55.50 kHz</td> </tr> <tr> <td style="text-align: center;">30</td> <td style="text-align: center;">10K</td> <td>_____ 292.0 kHz to 308.9 kHz</td> </tr> <tr> <td style="text-align: center;">50</td> <td style="text-align: center;">10K</td> <td>_____ 490.0 kHz to 510.0 kHz</td> </tr> </table>		Dial	Range		\pm (1 % of setting + 1 % of full scale)	5	.0001	_____ 1800 to 2240s	30	.0001	_____ 324 to 342s	50	.0001	_____ 196 to 204s	5	.001	_____ 180 to 224s	30	.001	_____ 32.4 to 34.2s	50	.001	_____ 19.6 to 20.4s	5	.01	_____ 18.0 to 22.4s	30	.01	_____ 3.24 to 3.42s	50	.01	_____ 1.96 to 2.04s	5	.1	_____ 1.80 to 2.24s	30	.1	_____ 324 to 342ms	50	.1	_____ 196 to 204ms	5	1	_____ 180 to 224ms	30	1	_____ 32.4 to 34.2ms	50	1	_____ 19.6 to 20.4ms	5	10	_____ 18.0 to 22.4ms	30	10	_____ 3.24 to 3.42ms	50	10	_____ 1.96 to 2.04ms	5	100	_____ 1.80 to 2.24ms	30	100	_____ 2920 to 3080 Hz	50	100	_____ 4900 to 5100 Hz	5	1K	_____ 4450 to 5550 Hz	30	1K	_____ 29.20 Hz to 30.80 kHz	50	1K	_____ 49.00 kHz to 51.00 kHz	5	10K	_____ 44.50 kHz to 55.50 kHz	30	10K	_____ 292.0 kHz to 308.9 kHz	50	10K	_____ 490.0 kHz to 510.0 kHz	<table border="0" style="width: 100%; border-collapse: collapse;"> <tr> <td style="width: 30%;"></td> <td style="width: 40%;"></td> </tr> <tr> <td></td> <td>_____ 1800 to 2240s</td> </tr> <tr> <td></td> <td>_____ 324 to 342s</td> </tr> <tr> <td></td> <td>_____ 196 to 204s</td> </tr> <tr> <td></td> <td>_____ 180 to 224s</td> </tr> <tr> <td></td> <td>_____ 32.4 to 34.2s</td> </tr> <tr> <td></td> <td>_____ 19.6 to 20.4s</td> </tr> <tr> <td></td> <td>_____ 18.0 to 22.4s</td> </tr> <tr> <td></td> <td>_____ 3.24 to 3.42s</td> </tr> <tr> <td></td> <td>_____ 1.96 to 2.04s</td> </tr> <tr> <td></td> <td>_____ 1.80 to 2.24s</td> </tr> <tr> <td></td> <td>_____ 324 to 342ms</td> </tr> <tr> <td></td> <td>_____ 196 to 204ms</td> </tr> <tr> <td></td> <td>_____ 180 to 224ms</td> </tr> <tr> <td></td> <td>_____ 32.4 to 34.2ms</td> </tr> <tr> <td></td> <td>_____ 19.6 to 20.4ms</td> </tr> <tr> <td></td> <td>_____ 18.0 to 22.4ms</td> </tr> <tr> <td></td> <td>_____ 3.24 to 3.42ms</td> </tr> <tr> <td></td> <td>_____ 1.96 to 2.04ms</td> </tr> <tr> <td></td> <td>_____ 1.80 to 2.24ms</td> </tr> <tr> <td></td> <td>_____ 2920 to 3080 Hz</td> </tr> <tr> <td></td> <td>_____ 4900 to 5100 Hz</td> </tr> <tr> <td></td> <td>_____ 4450 to 5550 Hz</td> </tr> <tr> <td></td> <td>_____ 29.20 Hz to 30.80 kHz</td> </tr> <tr> <td></td> <td>_____ 49.00 kHz to 51.00 kHz</td> </tr> <tr> <td></td> <td>_____ 44.50 kHz to 55.50 kHz</td> </tr> <tr> <td></td> <td>_____ 292.0 kHz to 308.9 kHz</td> </tr> <tr> <td></td> <td>_____ 490.0 kHz to 510.0 kHz</td> </tr> </table>				_____ 1800 to 2240s		_____ 324 to 342s		_____ 196 to 204s		_____ 180 to 224s		_____ 32.4 to 34.2s		_____ 19.6 to 20.4s		_____ 18.0 to 22.4s		_____ 3.24 to 3.42s		_____ 1.96 to 2.04s		_____ 1.80 to 2.24s		_____ 324 to 342ms		_____ 196 to 204ms		_____ 180 to 224ms		_____ 32.4 to 34.2ms		_____ 19.6 to 20.4ms		_____ 18.0 to 22.4ms		_____ 3.24 to 3.42ms		_____ 1.96 to 2.04ms		_____ 1.80 to 2.24ms		_____ 2920 to 3080 Hz		_____ 4900 to 5100 Hz		_____ 4450 to 5550 Hz		_____ 29.20 Hz to 30.80 kHz		_____ 49.00 kHz to 51.00 kHz		_____ 44.50 kHz to 55.50 kHz		_____ 292.0 kHz to 308.9 kHz		_____ 490.0 kHz to 510.0 kHz
	Dial	Range																																																																																																																																														
\pm (1 % of setting + 1 % of full scale)	5	.0001	_____ 1800 to 2240s																																																																																																																																													
	30	.0001	_____ 324 to 342s																																																																																																																																													
	50	.0001	_____ 196 to 204s																																																																																																																																													
	5	.001	_____ 180 to 224s																																																																																																																																													
	30	.001	_____ 32.4 to 34.2s																																																																																																																																													
	50	.001	_____ 19.6 to 20.4s																																																																																																																																													
	5	.01	_____ 18.0 to 22.4s																																																																																																																																													
	30	.01	_____ 3.24 to 3.42s																																																																																																																																													
	50	.01	_____ 1.96 to 2.04s																																																																																																																																													
	5	.1	_____ 1.80 to 2.24s																																																																																																																																													
	30	.1	_____ 324 to 342ms																																																																																																																																													
	50	.1	_____ 196 to 204ms																																																																																																																																													
	5	1	_____ 180 to 224ms																																																																																																																																													
	30	1	_____ 32.4 to 34.2ms																																																																																																																																													
	50	1	_____ 19.6 to 20.4ms																																																																																																																																													
	5	10	_____ 18.0 to 22.4ms																																																																																																																																													
	30	10	_____ 3.24 to 3.42ms																																																																																																																																													
	50	10	_____ 1.96 to 2.04ms																																																																																																																																													
5	100	_____ 1.80 to 2.24ms																																																																																																																																														
30	100	_____ 2920 to 3080 Hz																																																																																																																																														
50	100	_____ 4900 to 5100 Hz																																																																																																																																														
5	1K	_____ 4450 to 5550 Hz																																																																																																																																														
30	1K	_____ 29.20 Hz to 30.80 kHz																																																																																																																																														
50	1K	_____ 49.00 kHz to 51.00 kHz																																																																																																																																														
5	10K	_____ 44.50 kHz to 55.50 kHz																																																																																																																																														
30	10K	_____ 292.0 kHz to 308.9 kHz																																																																																																																																														
50	10K	_____ 490.0 kHz to 510.0 kHz																																																																																																																																														
	_____ 1800 to 2240s																																																																																																																																															
	_____ 324 to 342s																																																																																																																																															
	_____ 196 to 204s																																																																																																																																															
	_____ 180 to 224s																																																																																																																																															
	_____ 32.4 to 34.2s																																																																																																																																															
	_____ 19.6 to 20.4s																																																																																																																																															
	_____ 18.0 to 22.4s																																																																																																																																															
	_____ 3.24 to 3.42s																																																																																																																																															
	_____ 1.96 to 2.04s																																																																																																																																															
	_____ 1.80 to 2.24s																																																																																																																																															
	_____ 324 to 342ms																																																																																																																																															
	_____ 196 to 204ms																																																																																																																																															
	_____ 180 to 224ms																																																																																																																																															
	_____ 32.4 to 34.2ms																																																																																																																																															
	_____ 19.6 to 20.4ms																																																																																																																																															
	_____ 18.0 to 22.4ms																																																																																																																																															
	_____ 3.24 to 3.42ms																																																																																																																																															
	_____ 1.96 to 2.04ms																																																																																																																																															
	_____ 1.80 to 2.24ms																																																																																																																																															
	_____ 2920 to 3080 Hz																																																																																																																																															
	_____ 4900 to 5100 Hz																																																																																																																																															
	_____ 4450 to 5550 Hz																																																																																																																																															
	_____ 29.20 Hz to 30.80 kHz																																																																																																																																															
	_____ 49.00 kHz to 51.00 kHz																																																																																																																																															
	_____ 44.50 kHz to 55.50 kHz																																																																																																																																															
	_____ 292.0 kHz to 308.9 kHz																																																																																																																																															
	_____ 490.0 kHz to 510.0 kHz																																																																																																																																															
SINE WAVE DISTORTION CHECK	10 Hz to 50 kHz: 0.1 % 50 kHz to 500 kHz: 1 % 5 MHz: 3 %	_____ $>$ 46 dB _____ $>$ 40 dB _____ $>$ 30 dB																																																																																																																																														
SQUARE WAVE AND PULSE RESPONSE CHECKS	$<$ 30ns rise and fall times at full output $<$ 35ns rise and fall times at $<$ full output $<$ 5 % total aberration	_____ $<$ 30ns (rise) _____ $<$ 30ns (fall) _____ $<$ 35ns (rise) _____ $<$ 35ns (fall) _____ $<$ 5 %																																																																																																																																														
SYNC OUTPUT RESPONSE CHECK	$<$ 20ns rise and fall times	_____ $<$ 20ns (rise) _____ $<$ 20ns (fall)																																																																																																																																														
MAXIMUM HIGH OUTPUT CHECK (except pulses $>$ 2 MHz). OUTPUT LEVEL RANGE	$>$ 15 V p-p into 50 Ω (5.3 Vrms, sine function) $>$ 30 V p-p open circuit (10.6 Vrms, sine function) $>$ 30 dB controlling HIGH and LOW output	_____ $>$ 5.3 Vrms _____ $>$ 10.6 Vrms _____ $>$ 30 dB																																																																																																																																														
MINIMUM LOW OUTPUT CHECK	$<$ 15 mV p-p into 50 Ω $<$ 30 mV p-p open circuit	_____ $<$ 15 mV p-p _____ $<$ 30 mV p-p																																																																																																																																														

PERFORMANCE CHECK TEST CARD (cont'd)

CHECK DESCRIPTION	SPECIFICATION	INDICATION
<p align="center">SYNC OUTPUT AMPLITUDE CHECK</p>	<p>> 2 V p-p into 50 Ω > 4 V p-p open circuit</p>	<p>_____ > 2 V p-p _____ > 4 V p-p</p>
<p align="center">EXT. GATE SENSITIVITY (3310B only)</p>	<p>Triggering occurs with an input $\geq +1$ V but $\leq +10$ V. A maximum voltage of ± 30 V can be applied to the EXT. GATE input.</p>	<p>_____ +1 V _____ +10 V Max. input voltage ± 10 V</p>
<p align="center">EXT TRIGGER CHECK (3310B only)</p>	<p>Triggering occurs with input pulses ≥ 1.4 V p-p but ≤ 10 V p-p.</p>	<p>_____ 1.4 V p-p _____ 10 V p-p</p>

SECTION VI REPLACEABLE PARTS

6-1. INTRODUCTION.

6-2. This section contains information for ordering replacement parts. Table 6-1 lists parts in alphameric order of their reference designators and indicates the description, -hp- part number of each part, together with any applicable notes, and provides the following:

- a. Total quantity used in the instrument (TQ column). The total quantity of a part is given the first time the part number appears.
- b. Description of the part. (See list of abbreviations below.)
- c. Typical manufacturer of the part in a five-digit code. (See Appendix A for list of manufacturers.)
- d. Manufacturer's part number.

6-3. Miscellaneous parts are listed at the end of Table 6-1.

6-4. ORDERING INFORMATION.

6-5. To obtain replacement parts, address order or inquiry to your local Hewlett-Packard Field Office. (See Appendix B for list of office locations.) Identify parts by their Hewlett-Packard part numbers.

6-6. NON-LISTED PARTS.

6-7. To obtain a part that is not listed, include:

- a. Instrument model number.
- b. Instrument serial number.
- c. Description of the part.
- d. Function and location of the part.

ABBREVIATIONS					
Ag silver Al aluminum A ampere(s) Au gold C capacitor cer ceramic coef coefficient com common comp composition conn connection dep deposited DPDT double-pole double-throw DPST double-pole single-throw elect electrolytic encap encapsulated F farad(s) FET field effect transistor fxd fixed GaAs gallium arsenide GHz gigahertz = 10 ⁹ hertz gd guard(led) Ge germanium gnd ground(led) H henry(ies) Hg mercury	Hz hertz (cycle(s) per second) ID inside diameter impg impregnated incd incandescent ins insulation(led) kΩ kilohm(s) = 10 ³ ohms kHz kilohertz = 10 ³ hertz L inductor lin linear taper log logarithmic taper mA milliampere(s) = 10 ⁻³ amperes MHz megahertz = 10 ⁶ hertz MΩ megohm(s) = 10 ⁶ ohms met film metal film mfr manufacturer ms millisecond mtg mounting mV millivolt(s) = 10 ⁻³ volts μF microfarad(s) μs microsecond(s) μV microvolt(s) = 10 ⁻⁶ volts mv Mylar® nA nanoampere(s) = 10 ⁻⁹ amperes NC normally closed Ne neon NO normally open	NPO negative positive zero (zero temperature coefficient) ns nanosecond(s) = 10 ⁻⁹ seconds nsr not separately replaceable Ω ohm(s) obd order by description OD outside diameter p peak pA picoampere(s) pc printed circuit pF picofarad(s) 10 ⁻¹² farads piv peak inverse voltage p/o part of pss position(s) poly polystyrene pot potentiometer p-p peak-to-peak ppm parts per million prec precision (temperature coefficient, long term stability and/or tolerance) R resistor Rh rhodium rms root-mean-square rot rotary Se selenium sect section(s) Si silicon	d slide SPDT single-pole double-throw SPST single-pole single-throw Ta tantalum TC temperature coefficient TiO ₂ titanium dioxide tog toggle tol tolerance trim trimmer TSTR transistor V volt(s) vacw alternating current working voltage var variable vdcw direct current working voltage W watt(s) w/ with wiv working inverse voltage w/o without ww wiraround * optimum value selected at factory, average value shown (part may be omitted) ** no standard type number assigned selected or special type Ⓡ Dupont de Nemours		
DECIMAL MULTIPLIERS					
Prefix	Symbols	Multiplier	Prefix	Symbols	Multiplier
	tera	T	centi	c	10 ⁻²
	giga	G	milli	m	10 ⁻³
	mega	M or Meg	micro	μ	10 ⁻⁶
	kilo	K or k	nano	n	10 ⁻⁹
	hecto	h	pico	p	10 ⁻¹²
	deka	da	femto	f	10 ⁻¹⁵
	deci	d	atto	a	10 ⁻¹⁸
DESIGNATORS					
A assembly B motor BT battery C capacitor CR diode DL delay line DS lamp E misc electronic part F fuse	FL filter HR heater IC integrated circuit J jack K relay L inductor M meter MP mechanical part P plug	Q transistor QCR transistor-diode R resistor RT thermistor S switch T transformer TB terminal board TC thermocouple TP test point	TS terminal strip U microcircuit V vacuum tube, neon bulb, photocell, etc. W cable X socket XDS lampholder XF fuseholder Y crystal Z network		

STD-B-2734

Table 6-1. Replaceable Parts

REFERENCE DESIGNATOR	-hp- PART NO.	TQ	DESCRIPTION	MFR.	MFR. PART NO.
A1	03310-66501	1	P.C. Board: Oscillator	-hp-	
C1	0180-0116	2	C: fxd 6.8 μ F 10 % 35 vdcw	56289	150D685X9035B2-DYS
C2, C3	0180-1719	2	C: fxd 22 μ F 10 % 25 vdcw	56289	109D226X9025C2
C4	0180-0116		C: fxd 6.8 μ F 10 % 35 vdcw	56289	150D685X9035B2-DYS
C5	0180-0100	2	C: fxd 4.7 μ F 10 % 35 vdcw	56289	150D475X9035B2-DYS
C6	0180-0161	2	C: fxd 3.3 μ F 20 % 35 vdcw	56289	150D335X0035B2-DYS
C7	0180-0100		C: fxd 4.7 μ F 10 % 35 vdcw	56289	150D475X9035B2-DYS
C8	0180-0161		C: fxd 3.3 μ F 20 % 35 vdcw	56289	150D335X0035B2-DYS
C9	0150-0093	7	C: fxd cer 0.01 μ F + 80 % - 20 % 100 vdcw	91418	TA obd
C10	0140-0199	1	C: fxd mica 240 pF 5 %	72136	obd
C11	0160-3077	1	C: fxd mylar 0.027 μ F 10 % 100 vdcw	56289	225R2739W31-PWM
C12	0160-0938	4	C: fxd mica 1000 pF 5 %	14655	obd
C13	0160-0945	1	C: fxd mica 910 pF 5 %	00853	obd
C14	0160-0457	1	C: fxd mica 10,000 pF 5%	-hp-	
C15	0160-3399	1	C: fxd 0.1 μ F 5 % 200 vdcw	84411	HEW 249 obd
C16	0160-3402	1	C: fxd 1.0 μ F 5 % 50 vdcw	84411	HEW 249 obd
C17*	0140-0192	1	C: fxd mica 68 pF 5 %	14655	obd
C18, C19			Not assigned		
C20*	0150-0022	1	C: fxd 3.3 pF 10 % 500 vdcw	78488	Type GA obd
C21	0160-0938		C: fxd mica 1000 pF 5 %	14655	obd
C22	0180-1743	6	C: fxd elect. 0.1 μ F 10% 35 vdcw	56289	150D104X9035A2-DYS
C23	0160-0170	2	C: fxd cer 0.22 μ F + 80 % - 20 % 25 vdcw	56289	5C93-CML
C24			Not assigned		
C25	0160-0938		C: fxd mica 1000 pF 5 %	14655	obd
C26	0180-1743		C: fxd elect. 0.1 μ F 10% 35 vdcw	56289	150D104X9035A2-DYS
C27	0160-0170		C: fxd cer 0.22 μ F + 80 % - 20 % 25 vdcw	56289	5C93-CML
C28 thru C31	0140-0202	5	C: fxd mica 15 pF 5 %	14655	obd
C32	0160-0763	1	C: fxd cer 5 pF + 80 % - 20 % 500 vdcw	56289	5C9B-CML
C33 thru C36	0150-0093		C: fxd cer 0.01 μ F + 80 % - 20 % 100 vdcw	91418	TA obd
C37, C38			Not assigned		
C39	0160-0938		C: fxd mica 1000 pF 5 %	14655	obd
C40	0140-0198	1	C: fxd mica 200 pF 5 %	72136	obd
C41	0160-3401	1	C: fxd 2.0 μ F 5 % 50 vdcw	84411	HEW-146 obd
CR1, CR2	1902-0049	2	Diode: breakdown 6.19 V 10 %	04713	SZ10939-139
CR3, CR4	1901-0518	5	Diode: hot carrier	-hp-	
CR5 thru CR8			Not assigned		
CR9 thru CR12	1901-0025	19	Diode: Si 100 wiv 12 pF 100 mA	07263	FD 2387
CR13 thru CR16	1901-0040	27	Diode: Si 30 wiv 12 pF, 100 mA	07263	FDG 1088
CR17, CR18			Not assigned		
CR19, CR20	1901-0040		Diode: Si 30 wiv 12 pF, 30 mA 2 ns	07263	FDG 1088
CR21, CR22	1912-0016	2	Diode: tunnel, germanium 1N3713	01002	obd
CR23 thru CR30	1901-0025		Diode: Si 100 wiv 12 pF 100 mA	07263	FD2387
IC1, IC2	1820-0203	3	Integrated Circuit MA741C Amp.	07263	SL8940
J1 thru J6	1251-2194	6	Connector: single contact	00779	3-331272-0
L1 thru L5			Not assigned		
L6	9140-0018	2	Coil-RF: choke	82142	10100-31
L7			Not assigned		
L8	9140-0018		Coil RF: choke	82142	10100-31
L9	9170-0016	1	Ferrite bead	02114	obd

Table 6-1. Replaceable Parts (Cont'd)

REFERENCE DESIGNATOR	-hp- PART NO.	TQ	DESCRIPTION	MFR.	MFR. PART NO.	
A1 (cont'd)						
Q1	1853-0086	2	TSTR: Si PNP	04713	SPS3322	
Q2	1854-0215	11	TSTR: Si NPN 2N3904	04713	SPS3611	
Q3	1854-0221	1	TSTR: Si NPN Dual	32293	ITS1015	obd
Q4	1854-0071	8	TSTR: Si NPN	01295	SKA1124	
Q5	1853-0086		TSTR: Si PNP	04713	SPS3322	
Q6	1854-0392	1	TSTR: Si NPN 2N5088	04713	obd	
Q7 thru Q11			Not assigned			
Q12	1855-0081	1	TSTR: Field Effect 2N5245	01295	obd	
Q13	1954-0071		TSTR: Si NPN	01295	SKA1124	
Q14	1854-0019	3	TSTR: Si NPN	04713	SS2188	
Q15	1854-0092	5	TSTR: Si NPN	04713	SPS3318	
Q16	1853-0034	5	TSTR: Si PNP 2N3634	04713	SM3197	
Q17, Q18	1854-0092		TSTR: Si NPN 2N3563	04713	SPS3318	
Q19	1854-0019		TSTR: Si NPN	04713	SS2188	
Q20	1853-0034		TSTR: Si PNP 2N3634	04713	SM3197	
Q21	1854-0215	16	TSTR: Si NPN 2N3904	04713	SPS3611	
Q22 thru Q25	1853-0036		TSTR: Si PNP 2N3906	04713	SPS3612	
Q26 thru Q28	1854-0215		TSTR: Si NPN 2N3904	04713	SPS3611	
Q29, Q30			Not assigned			
Q31	1854-0092		TSTR: Si NPN 2N3563	04713	SPS3318	
Q32	1854-0019		TSTR: Si NPN	04713	SS2188	
Q33	1854-0092		TSTR: Si NPN 2N3563	04713	SPS3318	
Q34	1854-0215		TSTR: Si NPN 2N3904	04713	SPS3611	
Q35	1853-0036		TSTR: Si PNP 2N3906	04713	SPS3612	
Q36	1853-0203	1	TSTR: Si PNP	07263	S24851	
Q37	1853-0036		TSTR: Si PNP 2N3906	04713	SPS3612	
Q38	1853-0034		TSTR: Si PNP 2N3634	04713	SM3197	
Q39	1854-0215		TSTR: Si NPN 2N3904	04713	SPS3611	
Q40	1853-0036		TSTR: Si PNP 2N3906	04713	SPS3612	
Q41	1854-0215		TSTR: Si NPN 2N3904	04713	SPS3611	
Q42	1853-0036		TSTR: Si PNP 2N3906	04713	SPS3612	
Q43			Not assigned			
Q44	1854-0087	3	TSTR: Si NPN	01002	X16N2989	
Q45	1853-0012	1	TSTR: Si PNP 2N2904A	04713	2N2904A	
Q46	1854-0087		TSTR: Si NPN	01002	X16N2989	
Q47, Q48	1854-0071		TSTR: Si NPN	01295	SKA1124	
Q49, Q50	1853-0036		TSTR: Si PNP 2N3904	04713	SPS3612	
Q51	1855-0308	1	TSTR: Field Effect - dual Si N channel	17856	DN324	obd
R1 thru R6	2100-1738	8	R: var 10 kΩ 10 % 1/2 W	73138	62-209-1	
R7	0698-6906	1	R: fxd flm 41.2 kΩ 0.5 % 1/8 W	75042	CEA T-2	obd
R8	0698-1235	1	R: fxd comp 12 kΩ 5 % 1/4 W	01121	CB1235	
R9	0757-0458	1	R: fxd flm 51.1 kΩ 1 % 1/8 W	14674	C4 T-0	obd
R10, R11	0698-7311	4	R: fxd met flm 85.6 kΩ .2 W	91637	KT-35	obd
R12	0698-3455	1	R: fxd flm 261 kΩ 1 % 1/8 W	14674	C4 T-0	obd
R13 thru R15			Not assigned			
R16	0757-0453	1	R: fxd met flm 30.1 kΩ 1 % 1/8 W	-hp- 73138	0757-0453	
R17	2100-1738		R: var 10 kΩ 10 % 1/2 W	73138	62-209-1	
R18	0757-0279	1	R: fxd flm 3.16 kΩ 1 % 1/8 W	14674	C4 T-0	obd
R19	0757-0407	2	R: fxd flm 200 Ω 1 % 1/8 W	14674	C4 T-0	obd
R20	0698-3245	1	R: fxd flm 20.5 kΩ 1 % 1/8 W	14674	C4 T-0	obd
R21	0683-1035	4	R: fxd comp 10 kΩ 5 % 1/4 W	01121	CB1035	
R22	0698-7312	2	R: fxd met flm 15 kΩ 0.1 % .2 W	91637	KT-35	obd
R23	0757-0398	1	R: fxd flm 75 Ω 1 % 1/8 W	14674	C5 T-0	obd
R24	2100-2061	1	R: var 200 Ω 10 % 1/2 W	73138	62-204-1	
R25	0698-7312		R: fxd met flm 15 kΩ 0.1 % .2 W	91637	KT-35	obd
R26	2100-1738		R: var 10 kΩ 10 % 1/2 W	73138	62-209-1	
R27	0757-0472	1	R: fxd flm 200 kΩ 1 % 1/8 W	14674	C4 T-0	obd
R28	0698-4123	2	R: fxd flm 499 Ω 1 % 1/8 W	14674	C4 T-0	obd

Table 6-1. Replaceable Parts (Cont'd)

REFERENCE DESIGNATOR	-hp- PART NO.	TQ	DESCRIPTION	MFR.	MFR. PART NO.	
A1 (cont'd)						
R29	0698-3518	1	R: fxd flm 7.32 kΩ 1 % 1/8 W	75042	CEA T-0	obd
R30	0683-1035		R: fxd comp 10 kΩ 5 % 1/4 W	01121	CB1035	
R31	0698-6918	1	R: fxd flm 64.9 kΩ 0.5 % 1/8 W	75042	CEA T-2	obd
R32, R33	0698-7311		R: fxd met flm 85.6 kΩ .2 W	91637	KT-35	obd
R34	0698-6933	1	R: fxd flm 130 kΩ 0.5 % 1/8 W	75042	CEA T-2	obd
R35	0698-3266	1	R: fxd flm 237 kΩ 1 % 1/8 W	14674	C4 T-0	obd
R36	0698-4541	1	R: fxd flm 442 kΩ 1 % 1/8 W	91637	MF-1/10-32 T-1	
R37	0757-0456	1	R: fxd flm 43.2 kΩ 1 % 1/8 W	91637	CMF-1/10-32 T-1	
R38	0683-3345	1	R: fxd comp 330 kΩ 5 % 1/4 W	01121	CB3345	
R39	0683-3335	2	R: fxd comp 33 kΩ 5 % 1/4 W	01121	CB3335	
R40	0698-0083	1	R: fxd flm 1.96 kΩ 1 % 1/8 W	14674	C4 T-0	obd
R41	0757-0280	7	R: fxd flm 1 kΩ 1 % 1/8 W	14674	C4 T-0	obd
R42, R43	0683-1005	11	R: fxd comp 10 Ω 5 % 1/4 W	01121	CB1005	
R44	0683-3305	9	R: fxd comp 33 Ω 5 % 1/4 W	01121	CB3305	
R45 thru R49			Not assigned			
R50	0683-0475	1	R: fxd comp 4.7 Ω 5 % 1/4 W	01121	CB47G5	
R51, R52	0683-0275	2	R: fxd comp 2.7 Ω 5 % 1/4 W	01121	CB27G5	
R53	0683-3325	1	R: fxd comp 3300 Ω 5 % 1/4 W	01121	CB3325	
R54	0684-4721	1	R: fxd comp 4700 Ω 10 % 1/4 W	01121	CB4721	
R55	0684-2711	1	R: fxd comp 270 Ω 10 % 1/4 W	01121	CB2711	
R56	2100-2497	1	R: var 2 kΩ 10 % 1/2 W	73138	62-207-1	
R57	0757-0422	1	R: fxd flm 909 Ω 1 % 1/8 W	14674	C4 T-0	obd
R58	0683-8205	3	R: fxd comp 82 Ω 5 % 1/4 W	01121	CB8205	
R59	0683-2015	4	R: fxd comp 200 Ω 5 % 1/4 W	01121	CB2015	
R60	0683-8215	2	R: fxd comp 820 Ω 5 % 1/4 W	01121	CB8215	
R61	0683-1625	1	R: fxd comp 1600 Ω 5 % 1/4 W	01121	CB1625	
R62 thru R64	0683-2015		R: fxd comp 200 Ω 5 % 1/4 W	01121	CB2015	
R65	0698-6860	1	R: fxd flm 98 Ω 0.25 % 1/8 W	75042	CEA T-2	obd
R66	0698-6697	1	R: fxd flm 402 Ω 0.25 % 1/8 W	75042	CEA T-2	obd
R67	0683-1015	2	R: fxd comp 100 Ω 5 % 1/4 W	01121	CB1015	
R68	0698-0058	1	R: fxd comp 4.02 kΩ 1 % 1/4 W	14674	C5 T-0	obd
R69, R70	0683-1005		R: fxd comp 10 Ω 5 % 1/4 W	01121	CB1005	
R71	0684-4741	4	R: fxd comp 470 kΩ 10% 1/4 W	01121	CB4741	
R72	0698-4519	2	R: fxd flm 140 kΩ 1 % 1/8 W	14674	C4 T-0	obd
R73	0698-4493	2	R: fxd flm 34 kΩ 1 % 1/8 W	14674	C4 T-0	obd
R74	0757-0281	2	R: fxd flm 2.74 kΩ 1 % 1/8 W	14674	C4 T-0	obd
R75	0698-3151	2	R: fxd flm 2.87 kΩ 1 % 1/8 W	91637	CMF-1/10-32 T-1	
R76	0757-0465	3	R: fxd flm 100 kΩ 1 % 1/8 W	14674	C4 T-0	obd
R77	0757-0739	2	R: fxd flm 2 kΩ 1 % 1/4 W	14674	C5 T-0	obd
R78	0683-1045		R: fxd comp 100 kΩ 5 % 1/4 W	01121	CB1045	
R79	0698-7322	2	R: fxd flm 4.25 kΩ 0.25 % 1/8 W	75042	CEA T-9	obd
R80	0698-7319	2	R: fxd flm 4.08 kΩ 0.25 % 1/8 W	75042	CEA T-9	obd
R81	0684-4741		R: fxd comp 470 kΩ 10% 1/4 W	01121	CB4741	
R82	0698-4519		R: fxd flm 140 kΩ 1 % 1/8 W	14674	C4 T-0	obd
R83	0698-4493		R: fxd flm 34 kΩ 1 % 1/8 W	14674	C4 T-0	obd
R84	0757-0281		R: fxd flm 2.74 kΩ 1 % 1/8 W	14674	C4 T-0	obd
R85	0698-3151		R: fxd flm 2.87 kΩ 1 % 1/8 W	91637	CMF-1/10-32 T-1	
R86	0757-0465		R: fxd flm 100 kΩ 1 % 1/8 W	14674	C4 T-0	obd
R87	0757-0739		R: fxd flm 2 kΩ 1 % 1/4 W	14674	C5 T-0	obd
R88	0683-1045		R: fxd comp 100 kΩ 5 % 1/4 W	01121	CB1045	
R89	0698-7322		R: fxd flm 4.25 kΩ 0.25 % 1/8 W	75042	CEA T-9	obd
R90	0698-7319		R: fxd flm 4.08 kΩ 0.25 % 1/8 W	75042	CEA T-9	obd
R91, R92			Not assigned			
R93, R94	0698-3240	2	R: fxd flm 500 Ω 1 % 1/8 W	91637	CMF-1/10-32 T-1	
R95	0698-6624	2	R: fxd flm 2 kΩ 0.1 % 1/8 W	75042	CEA-T-9	obd
R96	0698-7393	2	R: fxd flm 301 Ω 0.25 % 1/8 W	75042	CEA T-2	obd
R97, R98	0698-7394	2	R: fxd flm 698 Ω 0.1 % 1/8 W	75042	CEA T-9	obd
R99	0698-7393		R: fxd flm 301 Ω 0.25 % 1/8 W	75042	CEA T-2	obd
R100	0698-6624		R: fxd flm 2 kΩ 0.1 % 1/8 W	75042	CEA T-9	obd
R101	0698-4458	2	R: fxd flm 590 Ω 1 % 1/8 W	14674	C4 T-0	obd

Table 6-1. Replaceable Parts (Cont'd)

REFERENCE DESIGNATOR	-hp- PART NO.	TQ	DESCRIPTION	MFR.	MFR. PART NO.
A1 (cont'd)					
R102	0757-0290	2	R: fxd flm 6.19 kΩ 1 % 1/8 W	91637	CMF-1/10-32 T-1
R103	0757-0280		R: fxd flm 1 kΩ 1 % 1/8 W	14674	C4 T-0
R104	0757-0410	4	R: fxd flm 301 Ω 1 % 1/8 W	91637	MF-1/10-32 T-1
R105	0698-4409	2	R: fxd flm 127 Ω 1 % 1/8 W	14674	C4 T-0
R106	0757-0416	4	R: fxd flm 511 Ω 1 % 1/8 W	14674	C4 T-0
R107	0757-0410		R: fxd flm 301 Ω 1 % 1/8 W	91637	MF-1/10-32 T-1
R108	0698-4409		R: fxd flm 127 Ω 1 % 1/8 W	14674	C4 T-0
R109	0757-0416		R: fxd flm 511 Ω 1 % 1/8 W	14674	C4 T-0
R110	0757-0290		R: fxd flm 6.19 kΩ 1 % 1/8 W	91637	CMF-1/10-32 T-1
R111	0698-4458		R: fxd flm 590 Ω 1 % 1/8 W	14674	C4 T-0
R112	0757-0280		R: fxd flm 1 kΩ 1 % 1/8 W	14674	C4 T-0
R113	0757-0178	4	R: fxd flm 100 Ω 1 % 1/4 W	14674	C5 T-0
R114, R115	0683-1005		R: fxd comp 10 Ω 5 % 1/4 W	01121	CB1005
R116	0757-0178		R: fxd flm 100 Ω 1 % 1/4 W	14674	C5 T-0
R117, R118			Not assigned		
R119, R120	0757-0416		R: fxd flm 511 Ω 1 % 1/8 W	14674	C4 T-0
R121	0757-0178		R: fxd flm 100 Ω 1 % 1/4 W	14674	C5 T-0
R122, R123	0683-1005		R: fxd comp 10 Ω 5 % 1/4 W	01121	CB1005
R124	0757-0178		R: fxd flm 100 Ω 1 % 1/4 W	14674	C5 T-0
R125	0683-8215		R: fxd comp 820 Ω 5 % 1/4 W	01121	CB8215
R126	0683-1025	9	R: fxd comp 1000 Ω 5 % 1/4 W	01121	CB1025
R127	0683-3915	1	R: fxd comp 390 Ω 5 % 1/4 W	01121	CB3915
R128, R129	0683-1005		R: fxd comp 10 Ω 5 % 1/4 W	01121	CB1005
R130, R131			Not assigned		
R132	0698-7487	1	R: fxd flm 1.64 kΩ 0.5 % 1/4 W	91637	MFF-1/8-32 T-2
R133, R134	0683-4705	4	R: fxd comp 47 Ω 5 % 1/4 W	01121	CB4705
R135	0683-1535	1	R: fxd comp 15 kΩ 5 % 1/4 W	01121	CB1535
R136	0683-3315	2	R: fxd comp 330 Ω 5 % 1/4 W	01121	CB3315
R137	0683-5125	3	R: fxd comp 5100 Ω 5 % 1/4 W	01121	CB5125
R138	0683-1835	1	R: fxd comp 18 kΩ 5 % 1/4 W	01121	CB1835
R139	0683-2025	2	R: fxd comp 2000 Ω 5 % 1/4 W	01121	CB2025
R140	0698-3228	1	R: fxd flm 49.9 kΩ 1 % 1/8 W	14674	C4 T-0
R141, R142			Not assigned		
R143	0698-7316	1	R: fxd met flm 20 MΩ 0.5 % 1/2 W	91637	EMF-70-17
R144	0698-7317	1	R: fxd met flm 2 MΩ 0.5 % 1/2 W	00327	M12D
R145	0698-6090	1	R: fxd flm 199.8 kΩ 0.1 % 1/8 W	91637	MF-1/10-32 T-2
R146	0698-7313	1	R: fxd flm 19.8 kΩ 0.1 % 1/8 W	75042	CEA T-2
R147	0698-7486	1	R: fxd flm 1.78 kΩ .25 % 1/8 W	91637	MF-1/10-32 T-2
R148	0757-0462	2	R: fxd flm 75 kΩ 1 % 1/8 W	91637	CMF-1/10-32 T-1
R149	0683-1025		R: fxd comp 1000 Ω 5 % 1/4 W	01121	CB1025
R150	0757-0123	1	R: fxd flm 34.8 kΩ 1 % 1/8 W	91637	CMF-1/10-32 T-1
R151	0683-1025		R: fxd comp 1000 Ω 5 % 1/4 W	01121	CB1025
R152	0757-0462		R: fxd flm 75 kΩ 1 % 1/8 W	91637	CMF-1/10-32 T-1
R153	0683-1035		R: fxd comp 10 kΩ 5 % 1/4 W	01121	CB1035
R154	0757-0410		R: fxd flm 301 Ω 1 % 1/8 W	91637	MF-1/10-32 T-1
R155			Not assigned		
R156	0757-0410		R: fxd flm 301 Ω 1 % 1/8 W	91637	MF-1/10-32 T-1
R157	0683-6225	1	R: fxd comp 6200 Ω 5 % 1/4 W	01121	CB6225
R158 thru R161			Not assigned		
R162	2100-1984	1	R: var 100 Ω 10 % 1/2 W	73138	62-203-1
R163 thru R168	0684-0271	6	R: fxd comp 2.7 Ω 10 % 1/4 W	01121	CB27G1
	1205-0037	8	Heat dissipator	98978	TXBF-019-025B
	1205-0150		Heat sink	-hp-	1205-0150
S2	03310-61901	1	Switch assembly: range		
	3100-2701	1	Includes A1R43 thru A1R47 Switch: rotary	-hp- 81840	obd

Table 6-1. Replaceable Parts (Cont'd)

REFERENCE DESIGNATOR	-hp- PART NO.	TQ	DESCRIPTION	MFR.	MFR. PART NO.
A2	03310-66502	1	P.C. Board Ass'y: Control	-hp-	
C1*	0150-0046	1	C: fxd TiO ₂ .68 pF 5% 500 vdcw	78488	Type GA obd
C2*	0140-0205	1	C: fxd mica 62 pF 5%	72136	obd
C3	0150-0043	1	C: fxd Ti Dioxide 6.8 pF 5% 500 vdcw	78488	Type GA
C4	0150-0042	1	C: fxd TiO ₂ 4.7 pF 5% 500 vdcw	78488	Type GA obd
C5	0140-0202	1	C: fxd mica 15 pF 5%	14655	obd
C6*	0150-0044	1	C: fxd Ti 5.6 pF 5% 500 vdcw	78488	Type GA
	0150-0042	1	C: fxd Ti 4.7 pF 5% 500 vdcw	78488	Type GA
	0150-0043	1	C: fxd Ti Dioxide 6.8 pF 5% 500 vdcw	78488	Type GA
	0150-0045	1	C: fxd Ti 8.2 pF 5% 500 vdcw	78488	Type GA
	0150-0055	1	C: fxd Ti Dioxide 10 pF 5% 500 vdcw	78488	Type GA
C7, C8	0180-0058	2	C: fxd 50 μF + 75% - 10% 25 vdcw	56289	30D506G025CC2-DSM
C9, C10	0180-0197	2	C: fxd Solid Ta 2.2 μF 10% 20 vdcw	05397	T110A225K020AS
L1	9140-0179	1	Coil: molded choke 22 μF 10%	82142	15-4445-7J
Q1, Q2	1854-0071		TSTR: Si NPN (selected from SN3704)	-hp-	1854-0071
Q3	1853-0034		TSTR: Si PNP 2N3634	04713	SM3197
Q4	1854-0053	1	TSTR: Si NPN 2N2218	56289	2N2218
R1	1698-7315	1	R: fxd flm 4.25 kΩ .1% 1/4 W	91637	MFF-1/8-32 T-9
R2	0698-7326	1	R: fxd met flm 2.167 kΩ .1% 1/2 W	91637	MFF-1/2-15 T-9
R3	0698-7318	1	R: fxd flm 14.45 kΩ .25% 1/8 W	75042	CEA T-2
R4	0698-7314	1	R: fxd flm 8.5 kΩ .1% 1/4 W	91637	MFF-1/8-32 T-9
R5	0698-7325	1	R: fxd met flm 2.535 kΩ .25% 1/2 W	91637	MFF-1/2-15 T-9
R6	2100-2520	1	R: var cer flm 50 Ω 20%	73138	62-220-1
R7	0757-0283	1	R: fxd met flm 2.0 kΩ 1% 1/8 W	-hp-	
R8	0683-5105	3	R: fxd comp 51 Ω 5% 1/4 W	01121	CB5105
R9*	0698-0082	1	R: fxd flm 464 Ω 1% 1/8 W	14674	C4 T-0
R10	0757-0407	1	R: fxd flm 200 Ω 1% 1/8 W	14674	C4 T-0
R11	0757-0283	2	R: fxd flm 2 kΩ 1% 1/8 W	14674	C4 T-0
R12	0698-4426	2	R: fxd flm 1.58 kΩ 1% 1/8 W	14674	C4 T-0
R13	0698-3226	1	R: fxd flm 6.49 kΩ 1% 1/8 W	91637	CMF-1/10-32 T-1
R14	0757-0280	1	R: fxd flm 1 kΩ 1% 1/8 W	14674	C4 T-0
R15	0698-3153	2	R: fxd flm 3.83 kΩ 1% 1/8 W	14674	C4 T-0
R16	0757-0280	1	R: fxd flm 1 kΩ 1% 1/8 W	14674	C4 T-0
R17	0698-3207	1	R: fxd flm 499 Ω 1% 1/4 W	14674	C5 T-0
R18*	0757-0278	1	R: fxd flm 1.78 kΩ 1% 1/8 W	14674	C4 T-0
R19			Not assigned		
R20	2100-0024	1	R: var comp 1 kΩ 10% 2.25 W	12697	380
R21	0683-1205	1	R: fxd comp 12 Ω 5% 1/4 W	01121	CB1205
R22	0757-0465	1	R: fxd flm 100 kΩ 1% 1/8 W	14674	C4 T-0
R23	2100-2514	1	R: var cer flm 20 kΩ 10% 1/2 W	73138	62-288-1
S3	3100-2702	1	Switch: rotary	81840	obd
	03310-00602	1	Bracket: switch and level	-hp-	
	1251-0150		Heat Sink	-hp-	1251-0150
	1251-1633	1	Connector P.C.: 15 pin	71785	252-15-30-310
	1251-1634	1	Connector P.C.: 18 pin	71785	252-18-30-310
A3	03310-66513	1	P.C. Board Ass'y: Amplifier	-hp-	
C1, C2	0150-0121	2	C: fxd cer 0.1 μF + 80% - 20% 50 vdcw	56289	5C50B1 CM1
C3	0140-0195	1	C: fxd mica 130 pF 5% 300 vdcw	14655	DM15F131J-300V
C4			Not assigned		
C5, C6	0180-2050	2	C: fxd Ta 0.082 μF 10% 35 vdcw	56289	150C823X9035A2-DYS

Table 6-1. Replaceable Parts (Cont'd)

REFERENCE DESIGNATOR	-hp- PART NO.	TQ	DESCRIPTION	MFR.	MFR. PART NO.
A3 (cont'd)					
C7 thru C9 C10	0150-0093 0150-0069	2	C: fxd cer 0.01 μ F + 80 % - 20 % 100 vdcw C: fxd cer 0.001 μ F + 100 % - 20 % 500 vdcw	91418 72982	TA 801-010X5G0102Z obd
C11 C12 C13 C14 C15	0180-0376 0150-0069 0180-0376 0150-0093	2	C: fxd Ta 0.47 μ F 10 % 35 vdcw C: fxd cer 0.001 μ F + 100 % - 20 % 500 vdcw C: fxd Ta 0.47 μ F 10 % 35 vdcw Not assigned C: fxd cer 0.01 μ F + 80 % - 20 % 100 vdcw	56289 72982 56289 91418	150D474X9035A2-DYS 801-010X5G0102Z 150D474X9035A2-DYS TA obd
C16, C17 C18, C19 C20 C21 C22	0180-0291 0180-0049 0160-2197 0180-0049	2 3	Not assigned C: fxd Ta 1.0 μ F 10 % 35 vdcw C: fxd Al elect 20 μ F + 75 % - 20 % 50 vdcw C: fxd mica 10 pF 5 % C: fxd Al elect 20 μ F + 75 % - 20 % 50 vdcw	56289 56289 56289 56289	150D105X9035A2-DYS 30D206G050662-DSM 30D206G050CC2-DSM
C23 C24 C25 C26* C27, C28	0160-2197 0160-0159 0160-0301 0160-2197 0180-0291	1 1 1	C: fxd mica 10 pF 5 % C: fxd my 0.0068 μ F 10 % 200 vdcw C: fxd my 0.012 μ F 10 % 200 vdcw C: fxd mica 10 pF 5 % C: fxd Ta 1.0 μ F 10 % 35 vdcw	72136 56289 56289 72136 56289	obd 192P68292-PTS 192P12392-PTS obd 150D105X9035A2-DYS
CR1 thru CR14 CR15 thru CR20 CR21 CR22 CR23	1901-0040 1901-0025 1901-0527 1901-0527	2	Diode: Si 30 wiv 2 pF 50 mA 2 ns Diode: Si 100 wiv 12 pF 100 mA Diode: current regulator Not assigned Diode: current regulator	07263 07263 04713 04713	FDG1088 FD2387 SCL040 SCL040
CR24 CR25 CR26 CR27 CR28	1901-0025 1902-0786 1902-0681	1 1	Not assigned Diode: Si 100 wiv 12 pF 100 mA Diode: T.C. Reference 9 V 5 % 500 mW Not assigned Diode: breakdown 9.09 V 10 %	07263 04713 04713	FD2387 1N937 obd
CR29 thru CR31	1901-0050	3	Diode: Si 100 V 200 mA	07263	FDH6308
IC1	1820-0203		Integrated Circuit: MA741C Amp.	07263	SL8940
Q1 Q2 Q3 Q4 Q5	1854-0071 1853-0020 1854-0071 1853-0020 1854-0071	3	TSTR: Si NPN** TSTR: Si PNP** TSTR: Si NPN** TSTR: Si PNP** TSTR: Si NPN**	01295 01295 01295 01295 01295	SKA1124 SKA1123 SKA1124 SKA1123 SKA1124
Q6 Q7, Q8 Q9 Q10 Q11	1853-0020 1853-0015 1853-0007 1854-0351	1 1 1	TSTR: Si PNP** Not assigned TSTR: Si PNP 2N3640 TSTR: PNP JEDEC type 2N3251 TSTR: Si NPN**	01295 07263 04713 04713	SKA1123 S33030 obd SS2076
Q12 Q13 Q14 Q15, Q16 Q17	1854-0009 1854-0215 1853-0042 1854-0402	1 1 1 2	TSTR: Si NPN 2N709 TSTR: Si NPN TSTR: Si PNP** Not assigned TSTR: Si NPN TIP-29	07263 04713 04713 01295	obd SPS3611 SPS4653 SP-8438
Q18, Q19 Q20 Q21 Q22 thru Q24 Q25	1854-0215 1854-0087 1853-0233 1853-0036 1853-0233	2	TSTR: Si NPN 2N3904 TSTR: Si NPN** GE 2N3417 TSTR: Si PNP TIP-32 TSTR: Si PNP 2N3906 TSTR: Si PNP TIP-32	04713 56289 01295 04713 01295	SPS3611 TZ-1226 SP8442 SPS-3612 SP8442
Q26 thru Q28 Q29 Q30 Q31 thru Q35	1853-0036 1854-0475 1854-0402 1854-0215	1	TSTR: Si PNP 2N3906 TSTR: Si NPN dual** TSTR: Si NPN TIP-29 TSTR: Si NPN 2N3904	04713 32293 01295 04713	SPS3612 ITS 1068 SP-8438 SPS3611

Table 6-1. Replaceable Parts (Cont'd)

REFERENCE DESIGNATOR	-hp- PART NO.	TQ	DESCRIPTION	MFR.	MFR. PART NO.
A3 (cont'd)					
R1			Not assigned		
R2	0698-4470	2	R: fxd flm 6.98 k Ω 1 % 1/8 W	91637	CMF-1/10-32 T-1
R3	0698-3492	2	R: fxd flm 2.67 k Ω 1 % 1/8 W	75042	CEA T-0
R4	2100-1788	3	R: var 500 Ω 10 % 1/2 W	73138	62-205-1
R5	0683-5125		R: fxd comp 5100 Ω 5 % 1/4 W	01121	CB5125
R6	0683-1825	2	R: fxd comp 1800 Ω 5 % 1/4 W	01121	CB1825
R7	0683-5115	4	R: fxd comp 510 Ω 5 % 1/4 W	01121	CB-5115
R8	0683-3905	2	R: fxd comp 39 Ω 5 % 1/4 W	01121	CB3905
R9	0683-1215	1	R: fxd comp 120 Ω 5 % 1/4 W	01121	CB1215
R10	0683-3905		R: fxd comp 39 Ω 5 % 1/4 W	01121	CB3905
R11	0683-3005		R: fxd comp 30 Ω 5 % 1/4 W	01121	CB3005
R12	0683-3315		R: fxd comp 330 Ω 5 % 1/4 W	01121	CB3315
R13	0683-3005		R: fxd comp 30 Ω 5 % 1/4 W	01121	CB3005
R14	0683-4705		R: fxd comp 47 Ω 5 % 1/4 W	01121	CB4705
R15	0683-4715	2	R: fxd comp 470 Ω 5 % 1/4 W	01121	CB4715
R16	0683-4705		R: fxd comp 47 Ω 5 % 1/4 W	01121	CB4705
R17	0683-8205		R: fxd comp 82 Ω 5 % 1/4 W	01121	CB8205
R18	0683-1025		R: fxd comp 1000 Ω 5 % 1/4 W	01121	CB1025
R19	0683-8205		R: fxd comp 82 Ω 5 % 1/4 W	01121	CB8205
R20	0683-3305		R: fxd comp 33 Ω 5 % 1/4 W	01121	CB3305
R21	0683-2025		R: fxd comp 2000 Ω 5 % 1/4 W	01121	CB2025
R22	0683-3305		R: fxd comp 33 Ω 5 % 1/4 W	01121	CB3305
R23, R24	0683-1015		R: fxd comp 100 Ω 5 % 1/4 W	01121	CB1015
R25	0698-4470		R: fxd flm 6.98 k Ω 1 % 1/8 W	91637	CMF-1/10-32 T-1
R26	0698-3492		R: fxd flm 2.67 k Ω 1 % 1/8 W	75042	CEA T-0
R27	2100-1788		R: var 500 Ω 10 % 1/2 W Type H	73138	62-205-1
R28	0683-5125		R: fxd comp 5100 Ω 5 % 1/4 W	01121	CB5125
R29	0683-1825		R: fxd comp 1800 Ω 5 % 1/4 W	01121	CB1825
R30	0683-5115		R: fxd comp 510 Ω 5 % 1/4 W	01121	CB5115
R31	0757-0280		R: fxd flm 1000 Ω 1 % 1/8 W	75042	CEA T-0
R32*	0698-3382	1	R: fxd flm 5.49 k Ω 1 % 1/8 W	-hp-	0698-3382
R33	0683-1025		R: fxd comp 1000 Ω 5 % 1/4 W	01121	CB1025
R34, R35			Not assigned		
R36	0757-0427	1	R: fxd flm 1.5 k Ω 1 % 1/8 W	75042	CEA T-0
R37 thru R39			Not assigned		
R40	0683-9105	2	R: fxd comp 91 Ω 5 % 1/4 W	01121	CB9105
R41	0698-4469	2	R: fxd flm 1.15 k Ω 1 % 1/8 W	75042	CEA T-0
R42	0698-4307	1	R: fxd flm 14.3 k Ω 1 % 1/8 W	75042	CEA T-0
R43	0698-4421	2	R: fxd flm 249 Ω 1 % 1/8 W	75042	CEA T-0
R44	0683-5105		R: fxd comp 51 Ω 5 % 1/4 W	01121	CB5105
R45	0698-0063	2	R: fxd flm 5.23 k Ω 1 % 1/8 W	75042	CEA T-0
R46	0698-3499	1	R: fxd flm 40.2 k Ω 1 % 1/8 W	75042	CEA T-0
R47	0683-2005	2	R: fxd comp 20 Ω 5 % 1/4 W	01121	CB2005
R48	0698-0063		R: fxd flm 5.23 k Ω 1 % 1/8 W	75042	CEA T-0
R49	0683-2005		R: fxd comp 20 Ω 5 % 1/4 W	01121	CB2005
R50	0683-9105		R: fxd comp 91 Ω 5 % 1/4 W	01121	CB9105
R51	0698-4469		R: fxd flm 1.15 k Ω 1 % 1/8 W	91637	CMF-1/10-32 T-0
R52	0683-5105		R: fxd comp 51 Ω 5 % 1/4 W	01121	CB5105
R53	0757-0415	1	R: fxd flm 475 Ω 1 % 1/8 W	91637	CMF-1/10-32 T-1
R54 thru R59			Not assigned		
R60, R61	0683-3305		R: fxd comp 33 Ω 5 % 1/4 W	01121	CB3305
R62	0698-3613	3	R: fxd met oxide 39 Ω 5 % 2 W	14674	C42S
R63, R64	0698-4059	2	R: fxd comp 5.6 Ω 10 % 1/2 W	01121	EB56G1
R65	0698-3613		R: fxd met oxide 39 Ω 5 % 2 W	14674	C42S
R66	0698-3613		R: fxd met oxide 39 Ω 5 % 2 W	14674	C42S
R67, R68	0683-3305		R: fxd comp 33 Ω 5 % 1/4 W	01121	CB3305
R69*	0698-4445	1	R: fxd flm 5.76 k Ω 1 % 1/8 W	91637	CMF-1/10-32 T-1
R70			Not assigned		
R71	0686-0275	2	R: fxd comp 2.7 Ω 5 % 1/2 W	01121	EB27G5
R72	0683-6205	2	R: fxd comp 62 Ω 5 % 1/4 W	01121	CB6205

Table 6-1. Replaceable Parts (Cont'd)

REFERENCE DESIGNATOR	-hp- PART NO.	TQ	DESCRIPTION	MFR.	MFR. PART NO.
A3 (cont'd)					
R73	0683-2435	4	R: fxd comp 24 kΩ 5 % 1/4 W	01121	CB2435
R74	0698-4485	2	R: fxd flm 23.2 kΩ 1 % 1/8 W	91637	CMF-1/10-32 T-1
R75	0757-0442	2	R: fxd flm 10 kΩ 1 % 1/8 W	91637	CMF-1/10-32 T-1
R76	0686-0275		R: fxd comp 2.7 Ω 5 % 1/2 W	01121	EB27G5
R77	0683-6205		R: fxd comp 62 Ω 5 % 1/4 W	01121	CB6205
R78	0683-2435		R: fxd comp 24 kΩ 5 % 1/4 W	01121	CB2435
R79	0698-4485		R: fxd flm 23.2 kΩ 1 % 1/8 W	91637	CMF-1/10-32 T-1
R80	0757-0442		R: fxd flm 10 kΩ 1 % 1/8 W	91637	CMF-1/10-32 T-1
R81, R82	0683-0335	4	R: fxd comp 3.3 Ω 5 % 1/4 W	01121	CB33G5
R83	0683-5115		R: fxd comp 510 Ω 5 % 1/4 W	01121	CB5115
R84	0683-2435		R: fxd comp 24 kΩ 5 % 1/4 W	01121	CB2435
R85	0683-4735	2	R: fxd comp 47 kΩ 5 % 1/4 W	01121	CB4735
R86	0683-1225	2	R: fxd comp 1200 Ω 5 % 1/4 W	01121	CB1225
R87			Not assigned		
R88	0698-4502	1	R: fxd flm 64.9 kΩ 1 % 1/8 W	91637	CMF-1/10-32 T-1
R89	0698-4497	1	R: fxd flm 48.7 kΩ 1 % 1/8 W	91637	CMF-1/10-32 T-1
R90, R91	0698-6348	2	R: fxd flm 3 kΩ 0.1 % 1/8 W	91637	MF-1/10-32
R92, R93	0683-0335		R: fxd 3.3 Ω 5 % 1/4 W	01121	CB33G5
R94	0683-5115		R: fxd comp 510 Ω 5 % 1/4 W	01121	CB5115
R95	0683-2435		R: fxd comp 24 kΩ 5 % 1/4 W	01121	C42435
R96	0683-4735		R: fxd comp 47 kΩ 5 % 1/4 W	01121	CB4735
R97	0683-1225		R: fxd flm comp 1200 Ω 5 % 1/4 W	01121	CB1225
R98	0698-0084	2	R: fxd flm 2.15 kΩ 1 % 1/8 W	91637	CMF-1/10-32 T-1
R99	0698-4489	1	R: fxd flm 28.0 kΩ 1 % 1/8 W	91637	CMF-1/10-32 T-1
R100	0757-0454	1	R: fxd flm 33.2 kΩ 1 % 1/8 W	91637	CMF-1/10-32 T-1
R101	2100-1788		R: var 500 Ω 10 % 1/2 W Type H	73138	62-205-1
R102	0698-4420	1	R: fxd flm 226 Ω 1 % 1/8 W	91637	CMF-1/10-32 T-1
R103	0698-3153		R: fxd flm 3.83 kΩ 1 % 1/8 W	91637	CMF-1/10-32 T-1
R104, R105	0684-1031	2	R: fxd 10 kΩ 10 % 1/4 W	01121	CB1031
	1205-0037		Heat dissipator for semiconductor TO18	98978	TXBF-019-025B
	03310-21101	1	Heat dissipator	-hp-	
	1251-0150		Heat sink	-hp-	
	0340-0473	4	Insulator: transistor	13103	abd
A4 (3310A only)	03310-66504	1	P.C. Board Ass'y: Power Supply	-hp-	
C1, C2	0180-1956	4	C: fxd 500 μF + 75 % - 10 % 50 vdcw	56289	39D507G050GL4-DSB
C3, C4	0180-1985	4	C: fxd 500 μF + 70 % - 10 % 30 vdcw	56389	39D507G030FL4-DSB
CR1 thru CR8	1901-0158	16	Diode: Si 200 piv 0.75 A	-hp-	
	1251-1941	1	Connector P.C.: 6 pin	76531	252-06-30-310
	1205-0150		Heat sink	-hp-	

Table 6-1. Replaceable Parts (Cont'd)

REFERENCE DESIGNATOR	-hp- PART NO.	TQ	DESCRIPTION	MFR.	MFR. PART NO.
A5 (3310B only)	03310-66505	1	P.C. Ass'y: Tone Burst	-hp-	
C1, C2	0180-1956		C: fxd 500 μ F + 75 % - 10 % 50 vdcw	56289	39D507G050GL4-DSB
C3, C4	0180-1985		C: fxd 500 μ F + 75 % - 10 % 30 vdcw	56289	39D507G030FL4-DSB
C5			Not assigned		
C6	0160-2207	1	C: fxd mica 300 pF 5 %	14655	obd
C7	0150-0084	2	C: fxd .1 μ F + 80 % - 20 % 100 vdcw	72982	8131-100-651-104Z
C8*	0140-0202	1	C: fxd mica 15 pF 5 % 500 vdcw	-hp-	0140-0202
C9	0150-0084		C: fxd .1 μ F + 80 % - 20 % 100 vdcw	72982	8131-100-651-104Z
CR1 thru CR8	1901-0158		Diode: Si 200 piv	04713	SR1358-3
CR9 thru CR11	1901-0518		Diode: hot carrier	-hp-	
CR12 thru CR18	1901-0040		Diode: Si	07263	FDG1088
CR19	1902-0041	1	Diode: breakdown 5.11 V 5 %	04713	SZ10939-98
IC1	1820-0304	1	Integrated Circuit	01295	SN4464
K1	0490-0997	1	Reed relay RA 30191051	15636	obd
Q1, Q2	1854-0354	7	TSTR: Si NPN	04713	SS2077
Q3	1854-0071		TSTR: Si NPN	01295	SKA1124
Q4	1853-0018	1	TSTR: Si PNP	04713	SF5100
Q5	1854-0354		TSTR: Si NPN	04713	SS2077
Q6	1853-0034		TSTR: Si PNP	04713	SM3197
Q7 thru Q10	1854-0354		TSTR: Si NPN	04713	SS2077
R1	0683-1005		R: fxd comp 10 Ω 5 % 1/4 W	01121	CB1005
R2	0698-4456	1	R: fxd flm 549 Ω 1 % 1/8 W	91637	CMF-1/10-32 T-0
R3	0698-3495	2	R: fxd flm 866 Ω 1 % 1/8 W	91637	CMF-1/10-32 T-1
R4	2100-1986	1	R: var 1 k Ω 10 % 1/2 W	73138	62-206-1
R5	0698-4123		R: fxd flm 499 Ω 1 % 1/8 W	91637	CMF-1/10-32 T-1
R6	0757-0280		R: fxd flm 1 k Ω 1 % 1/8 W	91637	CMF-1/10-32 T-1
R7	0698-4435	2	R: fxd flm 2.49 k Ω 1 % 1/8 W	91637	obd
R8	2100-2216	1	R: var 5 k Ω 10 % 1/2 W	73138	62-208-1
R9	0698-4435		R: fxd flm 2.49 k Ω 1 % 1/8 W	91637	obd
R10	0698-3495		R: fxd flm 866 Ω 1 % 1/8 W	91637	CMF-1/10-32 T-1
R11	0757-0440	1	R: fxd flm 7.5 k Ω 1 % 1/8 W	91637	CMF-1/10-32 T-1
R12	0698-0084		R: fxd flm 2.15 k Ω 1 % 1/8 W	91637	CMF-1/10-32 T-1
R13, R14	0683-2205	2	R: fxd comp 22 Ω 5 % 1/4 W	01121	CB2205
R15	0757-0283		R: fxd flm 2 k Ω 1 % 1/8 W	91637	CMF-1/10-32 T-1
R16	0757-0273	1	R: fxd flm 3.01 k Ω 1 % 1/8 W	91637	CMF-1/10-32 T-1
R17	0683-1035		R: fxd comp 10 k Ω 5 % 1/4 W	01121	CB1035
R18	0683-4715		R: fxd comp 470 Ω 5 % 1/4 W	01121	CB4715
R19	0683-1025		R: fxd comp 1000 Ω 5 % 1/4 W	01121	CB1025
R20	0698-4421		R: fxd flm 249 Ω 1 % 1/8 W	91637	CMF-1/10-32 T-1
R21 thru R23	0683-1025		R: fxd comp 1000 Ω 5 % 1/4 W	01121	CB1025
	1251-1941		Connector: P.C. 6 pin	71785	252-06-30-310
A6	3100-2745	1	Switch Ass'y: D.C. Offset (consists of R2 and S4)	-hp-	
R2	2100-2840	1	R: var 1000 Ω 20 %	01121	Type JJS
S4	3100-2703	1	Switch: rotary	81840	obd

Table 6-1. Replaceable Parts (Cont'd)

REFERENCE DESIGNATOR	-hp- PART NO.	TQ	DESCRIPTION	MFR.	MFR. PART NO.
CHASSIS MOUNTED COMPONENTS					
C5	0160-0958	1	C: fxd 390 pF (3310B only)	14655	obd
CR1 CR2	1902-1219 1902-1200	2	Diode: zener 16 V ±5% Diode: zener 16 V	-hp- 04713	IN2980B
DS1	2140-0015	1	Lamp: neon	01002	Selected NE-2H
F1 F1	2110-0044 2110-0320	1 1	Fuse: .30 A s-b Fuse: .15 A s-b	71400 71400	MDL 3/10 MDL 15/100
J1, J2 J3 J4 J5 J6, J7	1250-0083 1250-0118 1250-0083 1251-2357 1250-0083	5 1 1 1 1	Connector R.F.: BNC Connector R.F.: BNC Connector R.F.: BNC Connector: AC power Connector: BNC (3310B only)	77068 77068 77068 82389 77068	30624-1 30384-1 30624-1 EAC-301 30624-1
Q1 Q2	03310-67903 03310-67904	1	TSTR: Si NPN TSTR: Si PNP	-hp- -hp-	
R1 R2, R3 R4 R5 R6	2100-2833 0683-3335 0698-4426 0757-0394	1 1	R: var lintaper, 1000 Ω 10 % 3/4 W Not assigned R: fxd comp 33 kΩ 5 % 1/4 W R: fxd flm 1.58 kΩ 1 % 1/8 W R: fxd met flm 51.1 Ω 1 % 1/8W	73138 01121 91637 -hp-	Type 3351 CB3335 CMF-1/10-32 T-1
R7 R8	0683-0825 2100-3129	1 1	R: fxd comp 8.2 Ω 5 % 1/4 W R: var, START/STOP PHASE 1 kΩ (3310B only)	01121 01121	CB82G5 obd
S1 S2 thru S4 S5 S6	3101-0036 3101-1234 3101-0063	1 1 1	Switch: toggle spst Not assigned Switch: DPST non-shorting Switch: push-button, normally open (3310B only)	88140 82389 81073	8928K61 11A-1242A 30-1
T1	9100-1459	1	Transformer: power	-hp-	
W1	8120-1348	1	Cord: power, black 7.5 ft long	70793	KHS-7041
MISCELLANEOUS					
	1400-0084 1500-0231 03310-80605 1410-0942 0590-0052	1 1 1 1 6	Holder: fuse Vernier drive Vernier drive plate ass'y Bushing: threaded vernier drive Nuts: sheet metal clip	75915 -hp- -hp- OOLAJ 78553	342014 obd C-8020-632-243
	7120-1254 03310-00203 03310-00208 1410-0943 03310-00604	1 1 1 1 1	Plate: identification Panel: rear (3310A only) Panel: front (3310B only) Bushing: threaded range switch Bracket: A1 assembly support	16758 -hp- -hp- OOLAJ -hp-	obd obd obd

Table 6-1. Replaceable Parts (Cont'd)

REFERENCE DESIGNATOR	-hp- PART NO.	TQ	DESCRIPTION	MFR.	MFR. PART NO.
MISCELLANEOUS (cont'd)					
	5020-0233	1	Collar: frequency dial stop	-hp-	
	5040-0234	1	Lampholder (for DS1)	-hp-	
	5040-0235	1	Base: lampholder (for DS1)	-hp-	
	03310-24701	1	Spacer: (P.C. board)	-hp-	
	03310-61601	1	Cable Assembly: SYNC (3310A only)	-hp-	
	7120-1364	1	Plate: serial	91345	obd
	03310-61602	1	Cable: ext gate	-hp-	
	03310-61603	1	Cable: power to tone burst (3310B only)	-hp-	
	03310-00603	1	Bracket: Attenuator (held in place by J3 hardware)	-hp-	
	0340-0038	1	Post: terminal (on attenuator bracket)	98291	X-L-041762-10
	1205-0205	1	Heat dissipator: semiconductor	13103	1116A-5
	0362-0227	1	Push on connector (for Q1 and Q2 leads)	27264	2125
MECHANICAL PARTS					
MP1	5060-5968	1	Cover ass'y: top	-hp-	
MP2	03310-60203	1	Panel ass'y: rear (3310A only; includes J5 and S5)	-hp-	
MP2	03310-60207	1	Panel ass'y: rear (3310B only; includes J5 and S5)	-hp-	
MP3	5060-0238	2	Frame ass'y: side	-hp-	
MP4	5000-8543	2	Cover: side	-hp-	
MP5	5060-0728	2	Foot ass'y: half mod	-hp-	
MP6	5000-8581	1	Cover: bottom	-hp-	
MP7	5040-0700	2	Hinge: tilt stand (locking)	-hp-	
MP8	1490-0032	1	Stand: half module tilt	91260	obd
MP9	0370-0133	1	Knob: 5/8 in. output level	-hp-	
MP10	0370-0077	2	Knob: 5/8 in. RANGE and FUNCTION	-hp-	
MP11	0370-0099	1	Knob: 5/8 in. bar D.C. OFFSET	-hp-	
MP12	0370-0151	2	Knob: 1/2 in. black D.C. OFFSET (vernier)	-hp-	
MP13	0370-0178	1	Knob: 1/2 in. frequency vernier	-hp-	
MP14	03310-64001	1	Dial ass'y: frequency (includes MP15)	-hp-	
MP15	0370-0030	1	Knob: frequency dial	-hp-	
MP16	03310-00204	1	Panel: front (3310A only)	-hp-	
MP17	5000-5838	2	Bracket: cover	-hp-	
MP18	03310-00611	2	Bar: heat sink (for zener diodes)	-hp-	
MP19	0370-0843	2	Knob: 1/2 gray, START/STOP PHASE (3310B only)	-hp-	
MP20	3101-0063	1	Switch: pushbutton MANUAL TRIGGER (3310B only)	-hp-	
MP21	3050-0014	1	Washer: flat (3310B only)	78471	obd
MP22	2950-0072	1	Nut: hexagonal (3310B only)	82389	obd

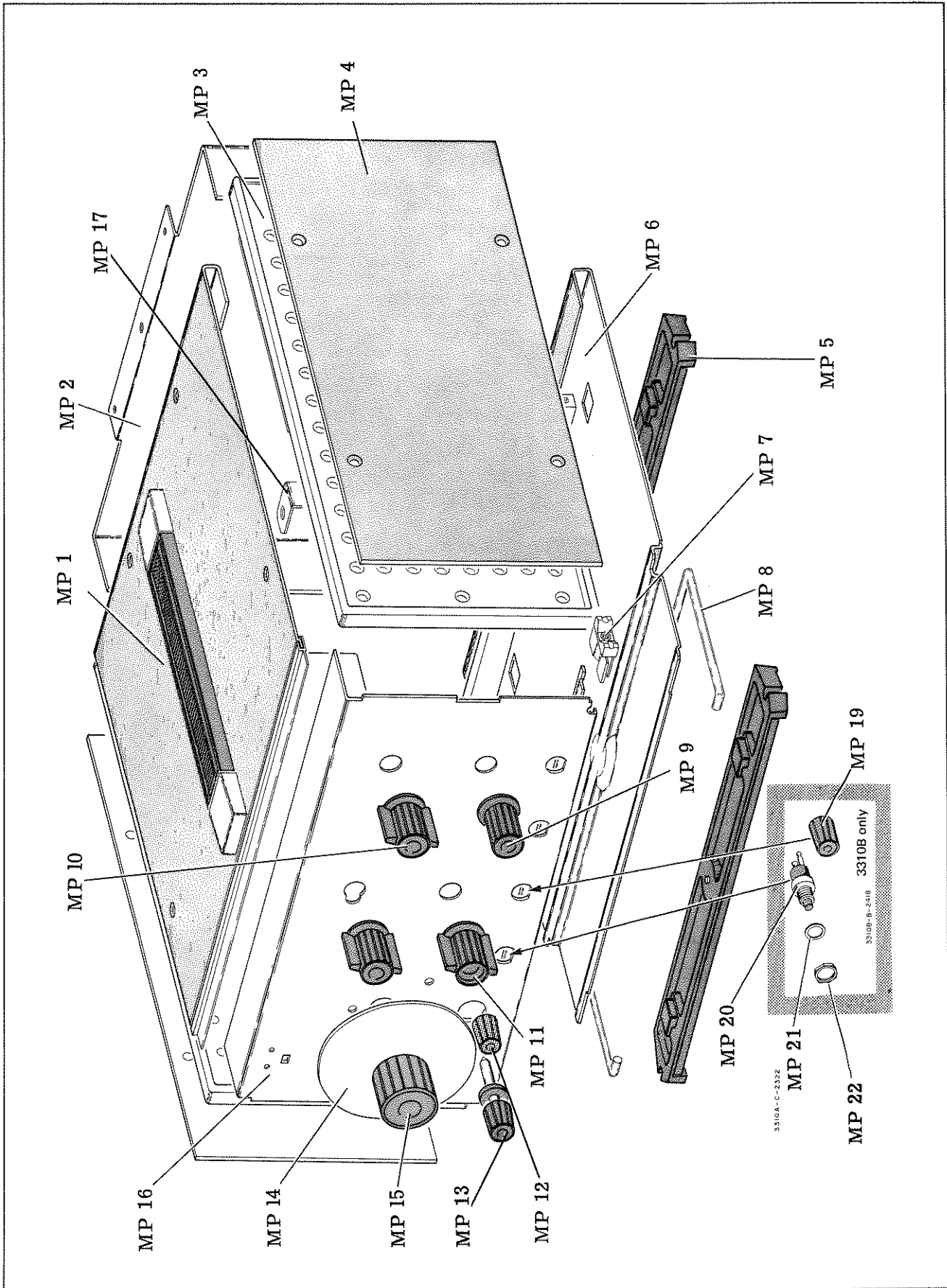

Figure 6-1. 3310A/B Mechanical Parts.



SECTION VII CIRCUIT DIAGRAMS

7-1. INTRODUCTION.

7-2. This section contains the Functional Block Diagram and the Detailed Schematic Diagrams for the Model 3310A/B.

7-3. FUNCTIONAL BLOCK DIAGRAM.

7-4. The Functional Block Diagram is a block diagram of the entire instrument, which also shows variable components used in the Adjustment and Calibration Procedure and important test points.

7-5. SCHEMATIC DIAGRAMS.

7-6. Figures 7-2 through 7-7 are detailed schematic diagrams of the circuits in the 3310A/B. The dc voltage levels or waveforms shown on the diagrams are subject to any conditions stated in the NOTES on that diagram. Figure 7-8 is a wiring diagram of the 3310A only.

7-7. COMPONENT LOCATION DIAGRAMS.

7-8. Included with each schematic diagram is a component location diagram to assist in the location of components on the assembly. Each component is identified by the reference designator used on the schematic diagram and in the replaceable parts list.

REFERENCE DESIGNATIONS

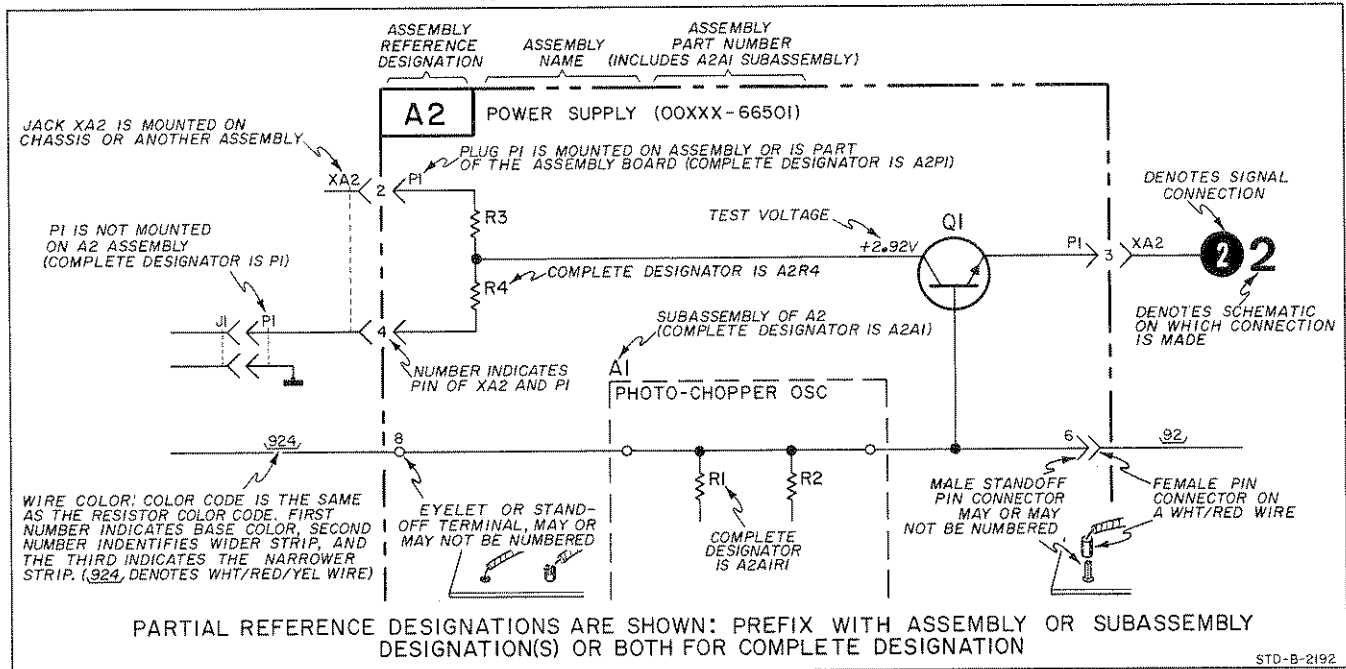













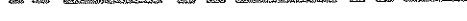

SCHEMATIC NOTES

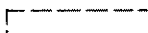
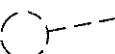
1. PARTIAL REFERENCE DESIGNATIONS ARE SHOWN. USE ASSEMBLY PREFIX DESIGNATION WITH REFERENCE DESIGNATION FOR COMPLETE REFERENCE DESIGNATION.

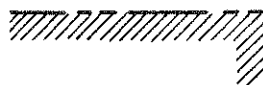
2. COMPONENT VALUES ARE SHOWN AS FOLLOWS UNLESS OTHERWISE NOTED:

RESISTANCE IN OHMS
CAPACITANCE IN MICROFARADS

3.  DENOTES POWER LINE GROUND.
4.  DENOTES CHASSIS GROUND.
5.  DENOTES ON BOARD GROUND.
6.  ANY NUMBER OR LETTER NEAR TRIANGLE IS A SPECIAL GROUND.
7.  DENOTES ASSEMBLY.
8.  DENOTES MAIN SIGNAL PATH.
9.  DENOTES FEEDBACK PATH.
10.  DENOTES FRONT PANEL MARKING.
11.  DENOTES REAR PANEL MARKING.
12.  DENOTES FRONT PANEL CONTROL.
13.  DENOTES ADJUSTMENT.
14.  DENOTES COMPONENTS NOT MOUNTED ON ASSEMBLY.
15. * OPTIMUM VALUE SELECTED AT FACTORY. COMPONENT MAY BE MISSING.
16. DC VOLTAGES AND WAVEFORMS ARE DEPENDENT ON CONDITIONS SET FORTH IN SCHEMATIC NOTES ASSOCIATED WITH EACH SCHEMATIC.
17.  DENOTES FIELD EFFECT TRANSISTOR WITH N MATERIAL CHANNEL.
18.  NUMBERS SHOWN INSIDE BOAT INDICATE WIRE COLOR CODE. COMPARES TO EIA COLOR CODE FOR RESISTORS, (e.g.  = WHITE, RED, YELLOW.)

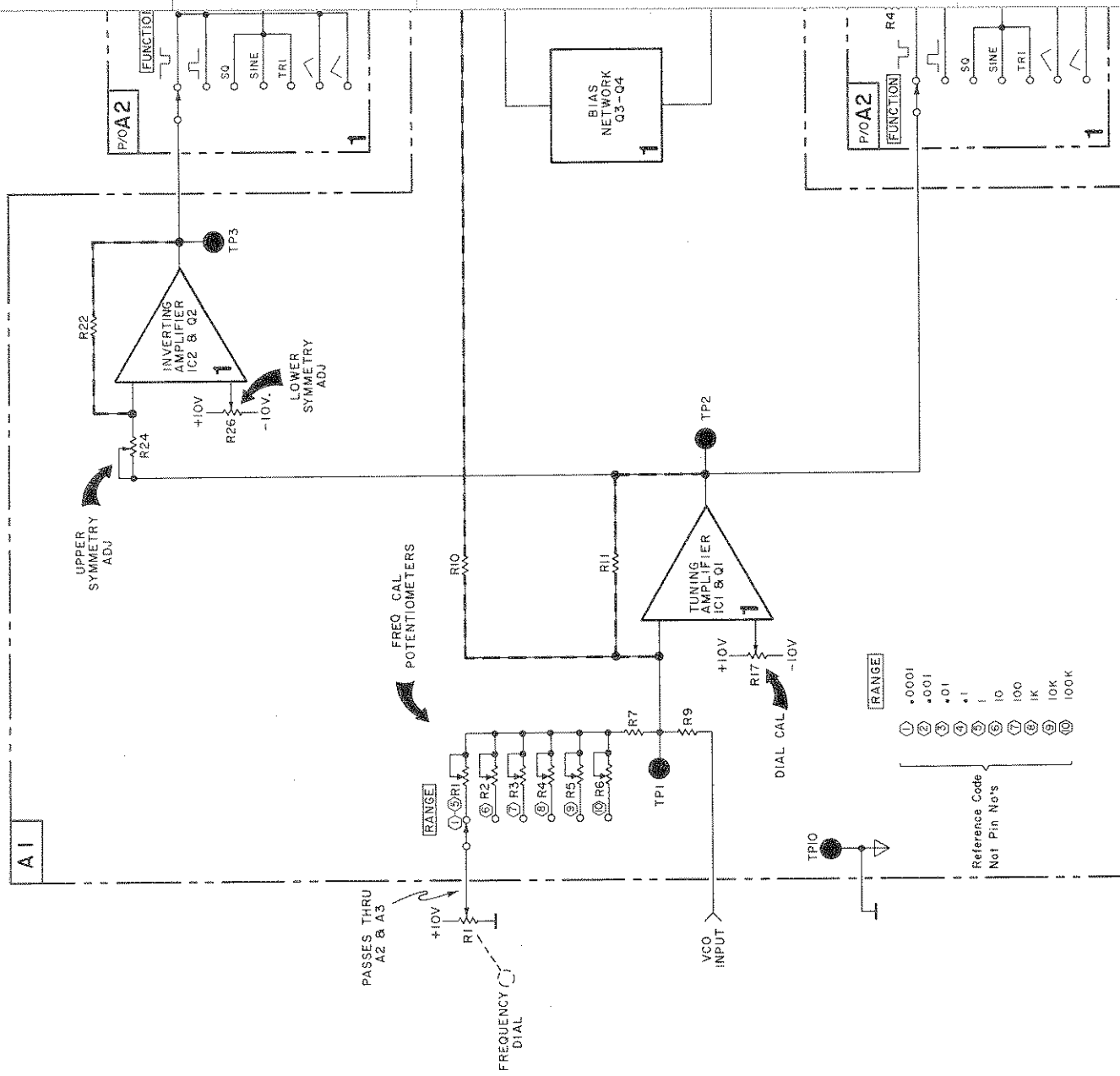

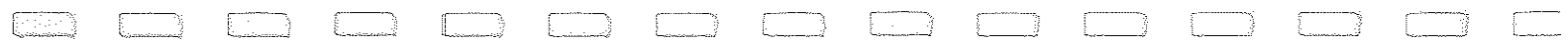

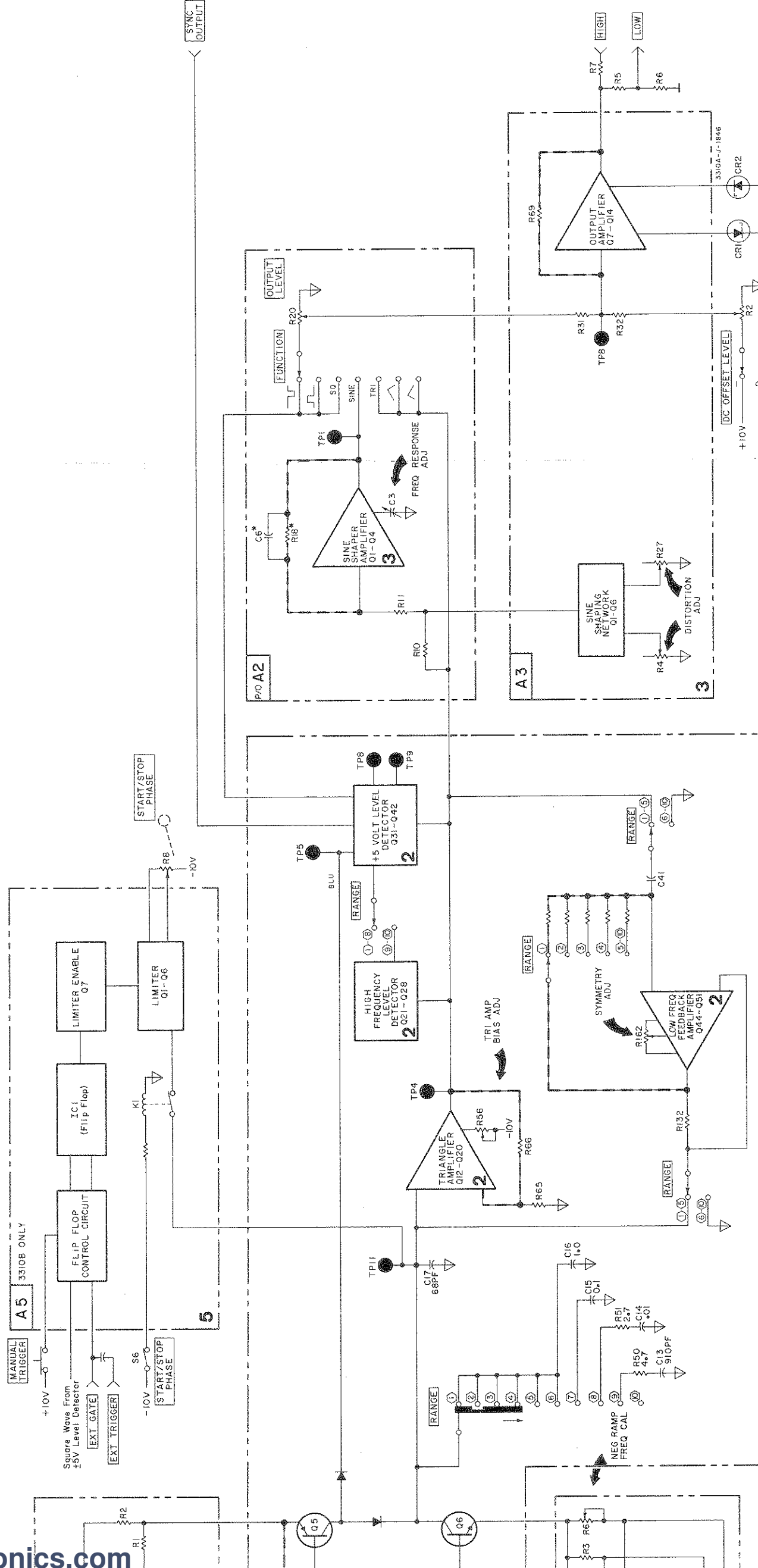

SYNC OUTPUT

3310A-J-1848

CR1

CR2

DC OFFSET LEVEL

+10V

R2

R4

R27

DISTORTION ADJ

3

SINE G SNAWORK Q1-Q6

OUTPUT AMPLIFIER Q7-Q14

3310A-J-1848

CR1

CR2

DC OFFSET LEVEL

+10V

R2

R4

R27

DISTORTION ADJ

3

SINE G SNAWORK Q1-Q6

OUTPUT AMPLIFIER Q7-Q14

3310A-J-1848

CR1

CR2

DC OFFSET LEVEL

+10V

A1 Board Component Location.

C	CR	R	Q	L	R	Q	R	R	R	R	TPI
1	C7	H6	G7		43	E6	85	C2	I27	B5	1
2	C6	H6	G7		44	D6	86	B2	I28	C5	2
3	C6	C5	D6		45		E2	A3	I29	C5	3
4	C7	C5	D6		46		E2	C1	I30		4
5	B7	C6	D5	D4	47		E2	B1	I31		5
6	D3	C6	D5		48		G2	B1	I32	D2	6
7	B7	F6			49		F2	D1	I33	D1	7
8	C3	E7		C4	50	F4	F2	D1	I34	D1	8
9	G7	E7			51	F4	F2	D1	I35	E1	9
10	E7	D5			52	F4		D1	I36	E1	10
11	D6	D2			53	D3		B4	I37	E1	11
12	D5	D2	E4		54	D3		C4	I38	E1	
13	F4	C1	E4		55	F2		C4	I39	E1	
14	E5	A1	E4		56	F3		C4	I40	G1	
15	E5	C1	E4		57	D4		C4	I41		
16	E5	C1	E3		58	D4		C4	I42		
17	E4	F7	E3		59	E2		A4	I43	F4	
18		F7	E3		60	F2		A4	I44	F4	
19		F7	D2		61	D4		A4	I45	F5	
20	E3	B4	D3		62	D5		A4	I46	F5	
21	B2	B4	B3		63	E2		A3	I47	F5	
22	B1	B4	A3		64	D4		A5	I48	G1	
23	A2	A5	B2		65	F3		A4	I49	F1	
24		A5	B2		66	F3		A3	I50	F1	
25	C3	C6	C2		67	E2		B5	I51	F1	
26	C1	C6	B3		68	D4		B4	I52	G1	
27	C2	C5	C1		69	D2		B4	I53	G2	
28	A4	C5	C2		70	D2		B4	I54	G2	
29	A4	E1	H7		71	B1		A7	I55		
30	B4	E1	E6		72	B2		A6	I56	G2	
31	B4	D7	A4		73	B3		A6	I57	F1	
32	A6	D7	A5		74	B3		A7	I58		
33	A6	D7	A4		75	B3		A7	I59		
34	A6	E7	A5		76	A3		B6	I60		
35	B6	D7	A5		77	A3		B6	I61		
36	B6	C7	B4		78	B1		B6	I62	G2	
37		D6	B4		79	A2		A7	I63	C7	
38		E6	B6		80	A2		A6	I64	D6	
39			B6		81	C1		B6	I65	C7	
40	G2	D6	B5		82	C3		A7	I66	B7	
41	G3	D6	B5		83	C3		B5	I67	B7	
42		E6	B5		84	C3		C6	I68	B7	

NOTES

1. d.c. voltage measurement conditions:

Freq. dist50
RANGE100
D.C. OFFSET LEVEL0
OUTPUT LEVELFull CW
FUNCTIONTRI
EXT. GATE drive1 to 30 V peak, 1 kHz, square wave (3310B Tone Burst operation only)

2. A Model 427A VM should be used for d.c. voltage measurement. Voltages < .1 V were considered 0 V.

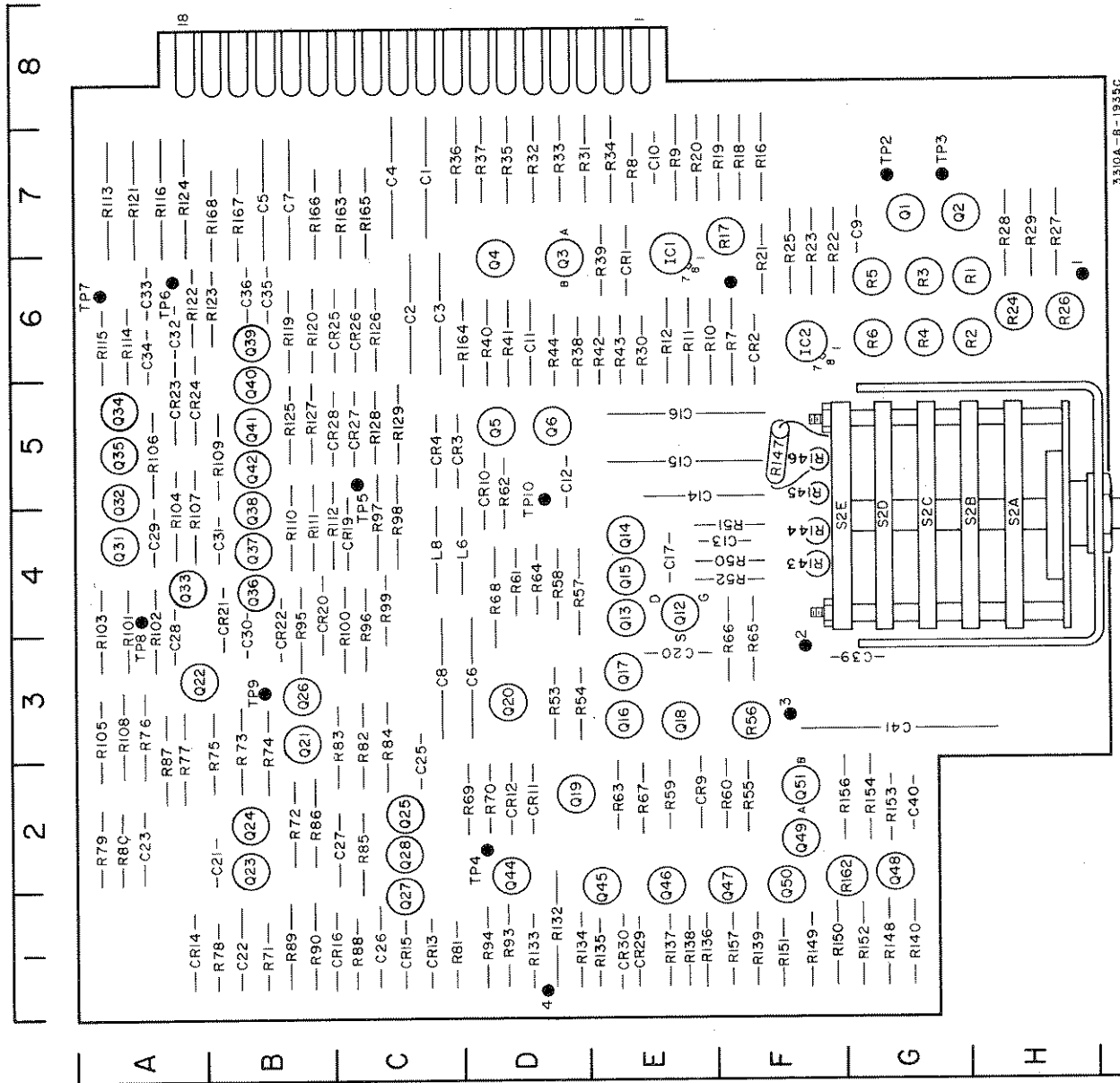

AI Board Component Location.

	C	CR	R	Q	L	R	Q	R	Q	R	R	R	IC	TPI	Pin
1	C7	E6	H6	G7		E6	D2	C2	85	C2	127	B5	1	E6	H6
2	C6	F6	H6	G7		E6	D6	B2	D2	B2	128	C5	2	F6	F3
3	C6	C5	G6	D6		C5	45	A3	E2	A3	129	C5	3	G7	F3
4	C7	C5	G6	D6		C5	46	C1	E2	C1	130		4	D2	D1
5	B7		G6	D5	D4		47	B1	F2	B1	131		5	C5	F6
6	D3		G6	D5			48	B1	G2	B1	132	D2	6	A6	
7	B7		F6				49		F2		133	D1	7	A6	
8	C3	E7	E7		C4		50	F4	F2		134	D1	8	A4	
9	G7	E2	E7				51	F4	F2	D1	135	E1	9	B3	
10	E7	D5	E6				52	F4	94	D1	136	E1	10	D5	
11	D6	D2	E6				53	D3	95	B4	137	E1	11	E5	
12	D5	D2	E6	E4			54	D3	96	C4	138	E1			
13	F4	C1		E4			55	F2	97	C4	139	E1			
14	E5	A1	E4	E4			56	F3	98	C4	140	G1			
15	E5	C1	E4	E4			57	D4	99	C4	141				
16	E5	C1	F7	E3			58	D4	100	C4	142				
17	E4		F7	E3			59	E2	101	A4	143	F4			
18			F7	E3			60	F2	102	A4	144	F4			
19		C4	F7	D2			61	D4	103	A4	145	F5			
20	E3	B4	E7	D3			62	D5	104	A4	146	F5			
21	B2	B4	F6	B3			63	E2	105	A3	147	F5			
22	B1	B4	F7	A3			64	D4	106	A5	148	G1			
23	A2	A5	F7	B2			65	F3	107	A4	149	E1			
24		A5	H6	B2			66	F3	108	A3	150	F1			
25	C3	C6	F7	C2			67	E2	109	B5	151	E1			
26	C1	C6	H6	B3			68	D4	110	B4	152	G1			
27	C2	C5	H7	C1			69	D2	111	B4	153	G2			
28	A4	C5	H7	C2			70	D2	112	B4	154	G2			
29	A4	E1	H7				71	B1	113	A7	155	G2			
30	B4	E1	E6				72	B2	114	A6	156	G2			
31	B4		D7	A4			73	B3	115	A6	157	F1			
32	A6		D7	A5			74	B3	116	A7	158				
33	A6		D7	A4			75	B3	117		159				
34	A6		E7	A5			76	A3	118		160				
35	B6		D7	A5			77	A3	119	B6	161				
36	B6		C7	B4			78	B1	120	B6	162	G2			
37			B4	B4			79	A2	121	A7	163	C7			
38			D6	B4			80	A2	122	A6	164	D6			
39	C3		E6	B6			81	C1	123	B6	165	C7			
40							82		124	A7	166				

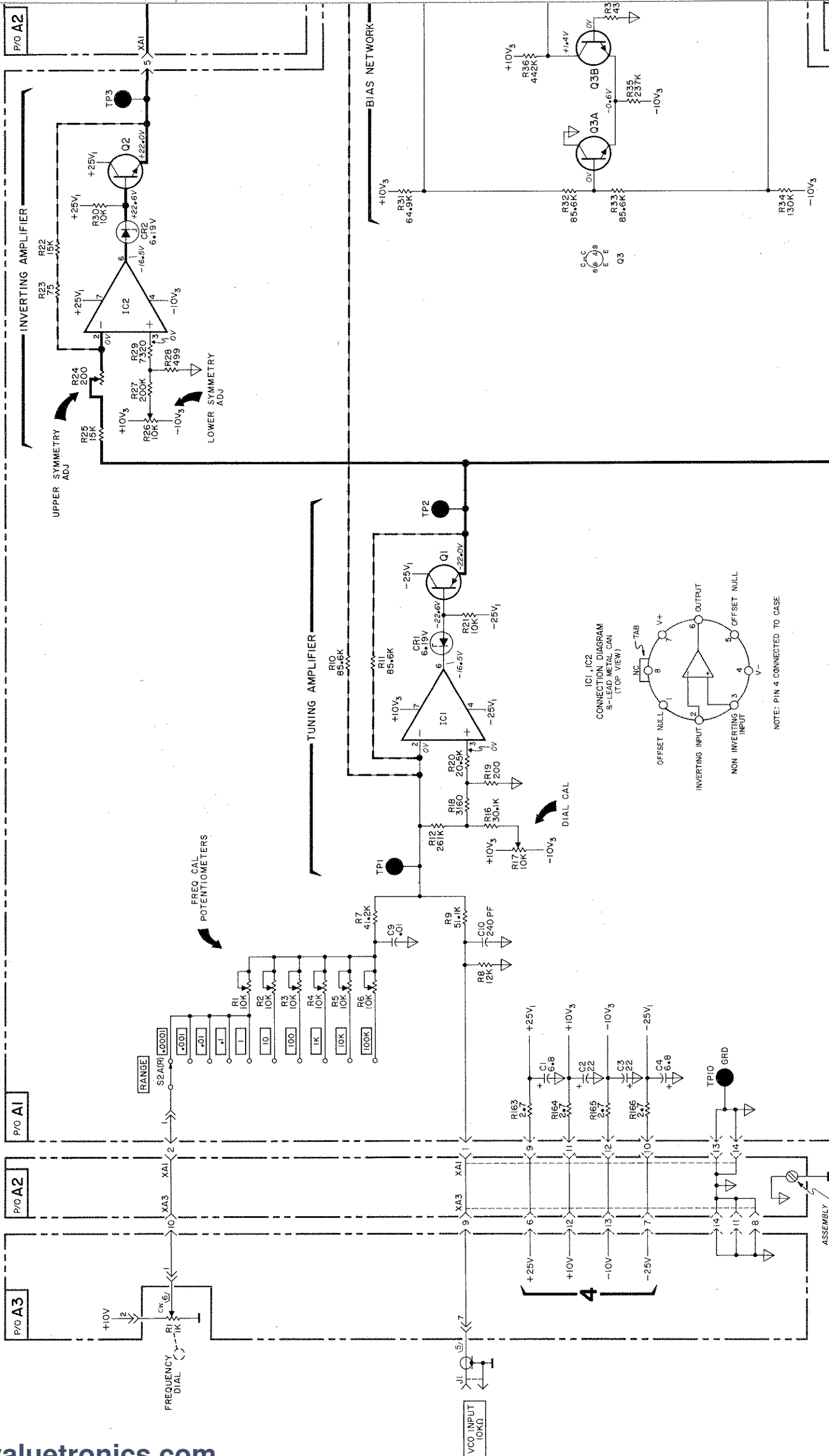

NOTE: PIN 4 CONNECTED TO CASE

FUNCTION

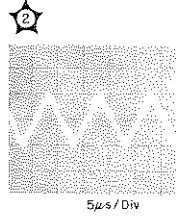
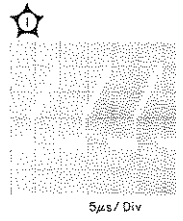
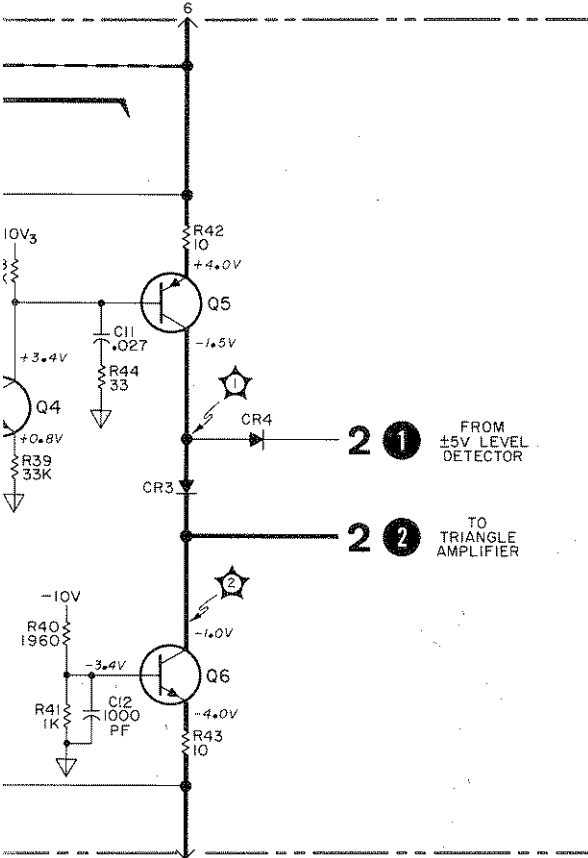
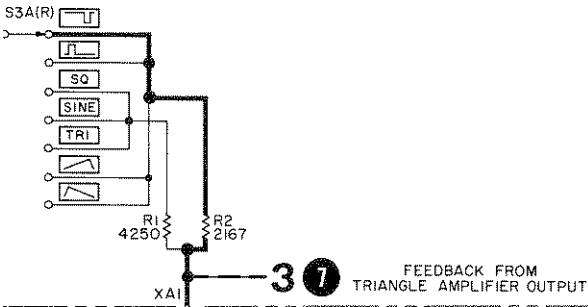

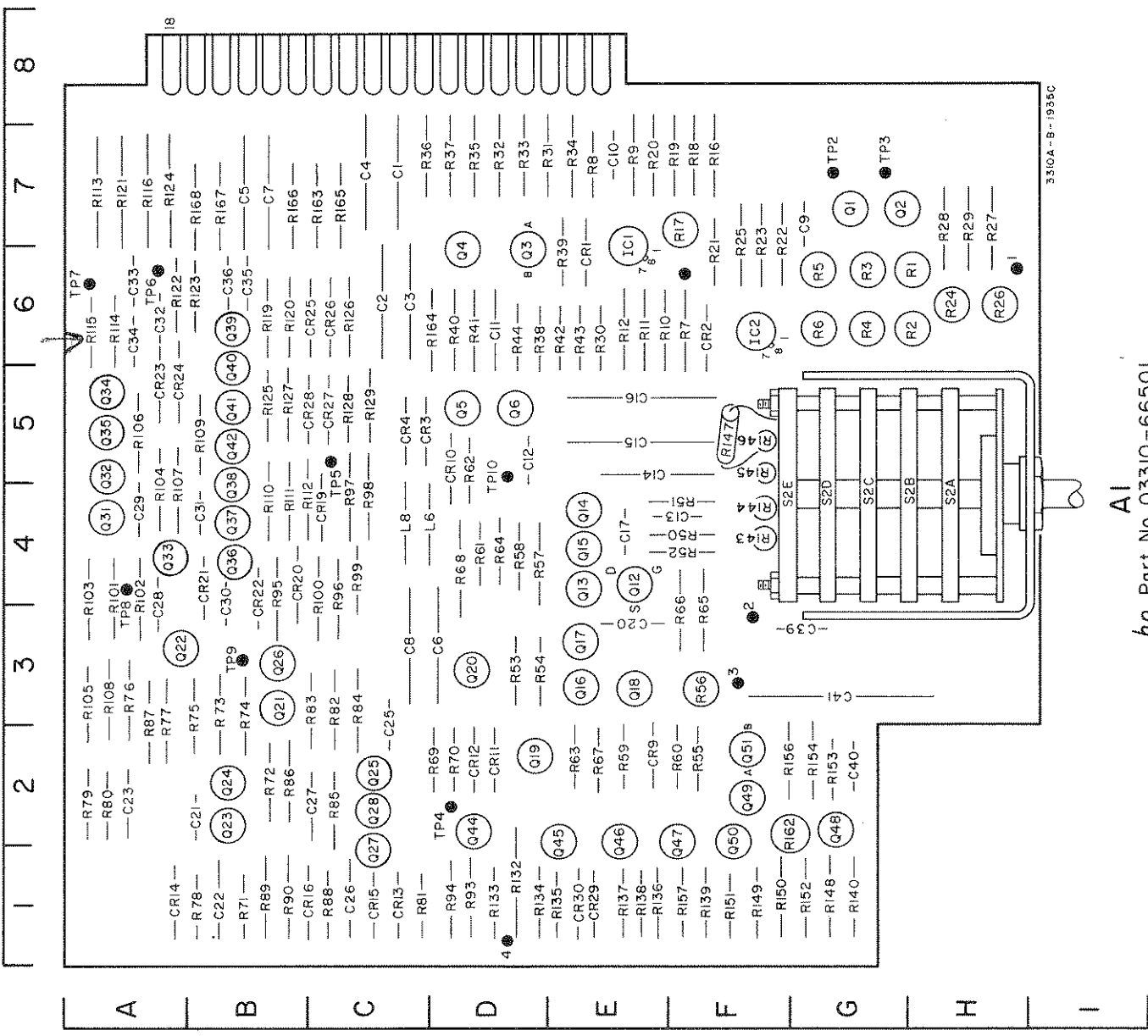

3310A-B-1955C

AI
hp Part No. 03310-66501

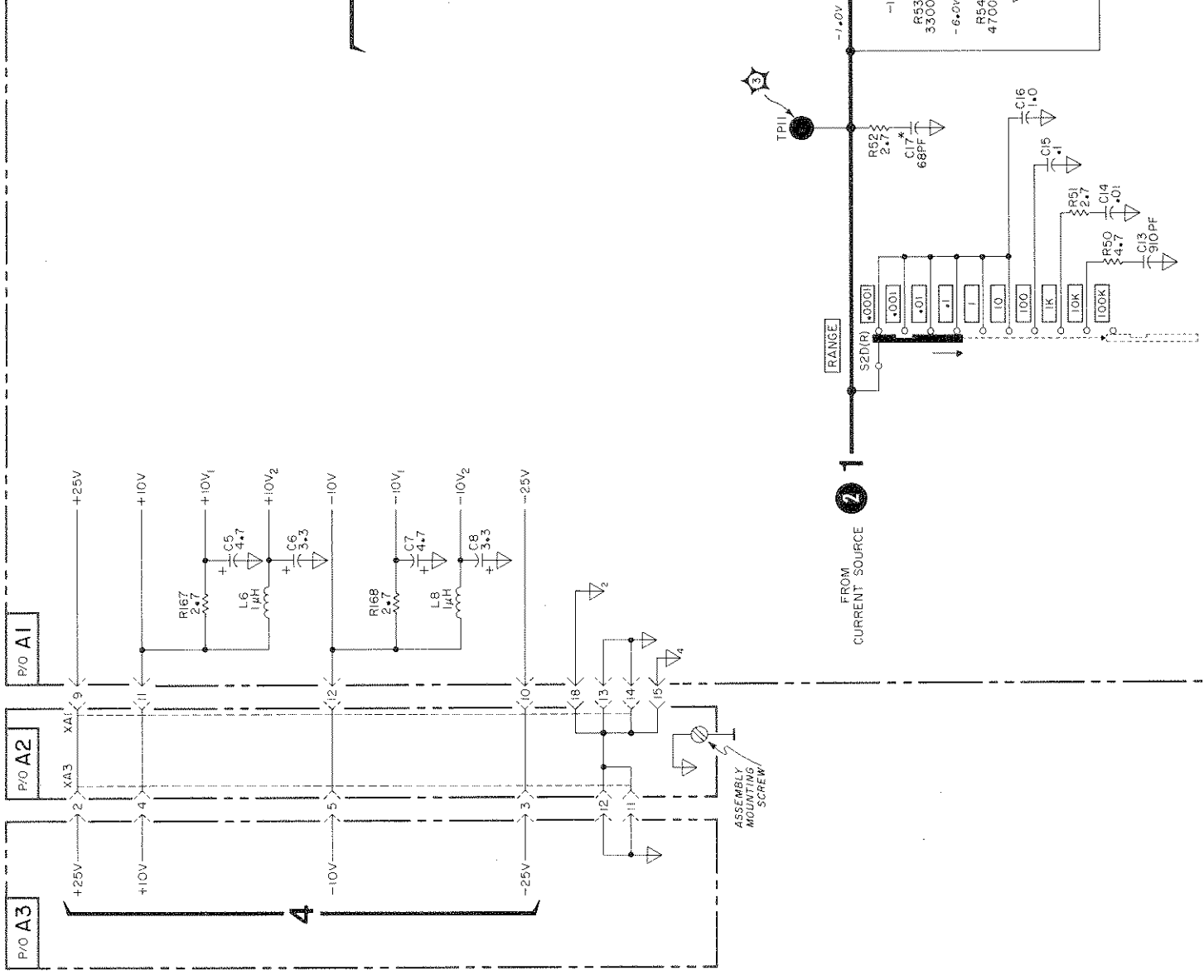

A3 Board Component Location.

	C	CR	Q	R	Q	R	Q	R	R	R	R	R	TP	Pin	IC
1	D5	C4	D4	D4	34	F2	67	E2	100	F2	1	G5	G1	D3	
2	B5	E5	D4	E4	35	G2	68	E2	101	F3	2	F6	G1		
3		E5	D4	D4	36		69	C2	102	F2	3	C4	F1		
4		D5	B4	D4	37		70		103	F2	4	F5	F1		
5	D2	D5	B4	C5	38		71	H5	104	B2	5	E6	F1		
6	D2	C5	B4	C4	39		72	G5	105	B2	6	A6	F1		
7	C2	C5		D5	40		73	G5			7	E4	F1		
8	C1	C5		D5	41		74	F5			8	D3	C1		
9	C1	C5	D2	D5	42		75	F5			9		A1		
10	E2	B5	C2	D5	43		76	H4			10		A1		
11	D1	B5	B2	D5	44		77	C4			11		A2		
12	E2	B5	D2	D5	45		78	C4			12		A2		
13	C1	B5	B3	D5	46		79	F4			13		B2		
14		B4	B3	C5	47		80	F4			14		B3		
15	B2	C3		C5	48		81	H3			15		A3		
16		C3		C5	49		82	H3			16		B3		
17		C3	16	C5	50		83	G3			17		B1		
18	B1	C3	C5	B5	51		84	G3			18		B1		
19	E1	A2	F5	B5	52		85	G3			19		B1		
20	E5	B2	F6	B5	53		86	G3			20		B3		
21	F5	G5	15	B5	54		87								
22	E5		G4	B5	55		88	F4							
23	F4	C4	F4	A5	56		89	F4							
24	F3		F5	A5	57		90	F4							
25	F3	F2	14	A4	58		91	F4							
26	D2	F2	H3	A4	59		92	H2							
27	B2		H3	B4	60		93	H2							
28	B3	D1	G3	C4	61		94	H2							
29		F2	G3	C4	62		95	H2							
30		B1	B3	C5	63		96	G2							
31		B1	H2	C3	64		97	G2							
32			H2	D3	65		98	G2							
33			G2	D3	66		99	G2							

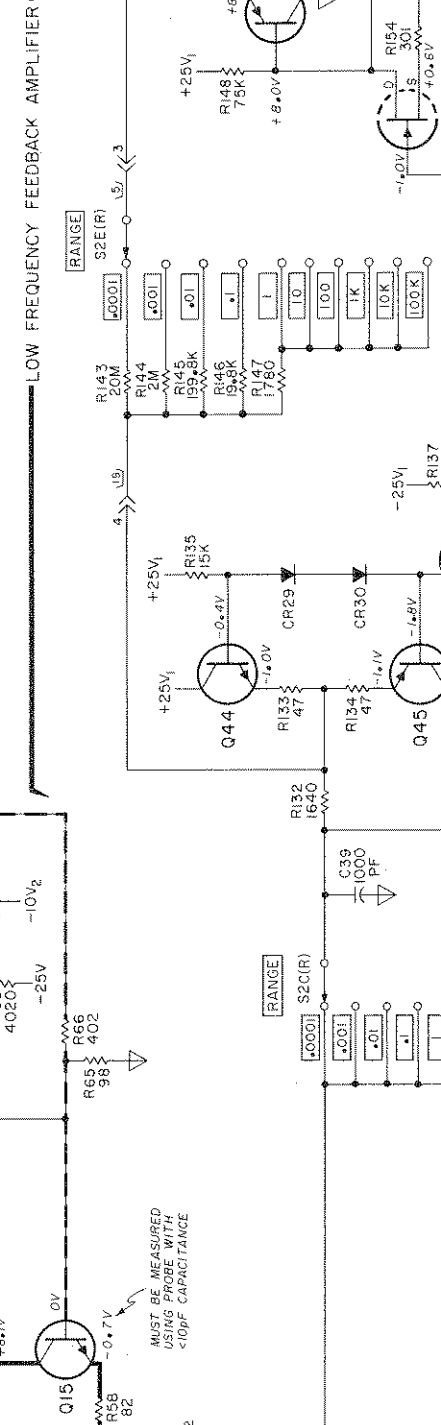
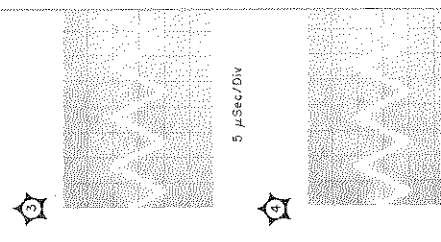
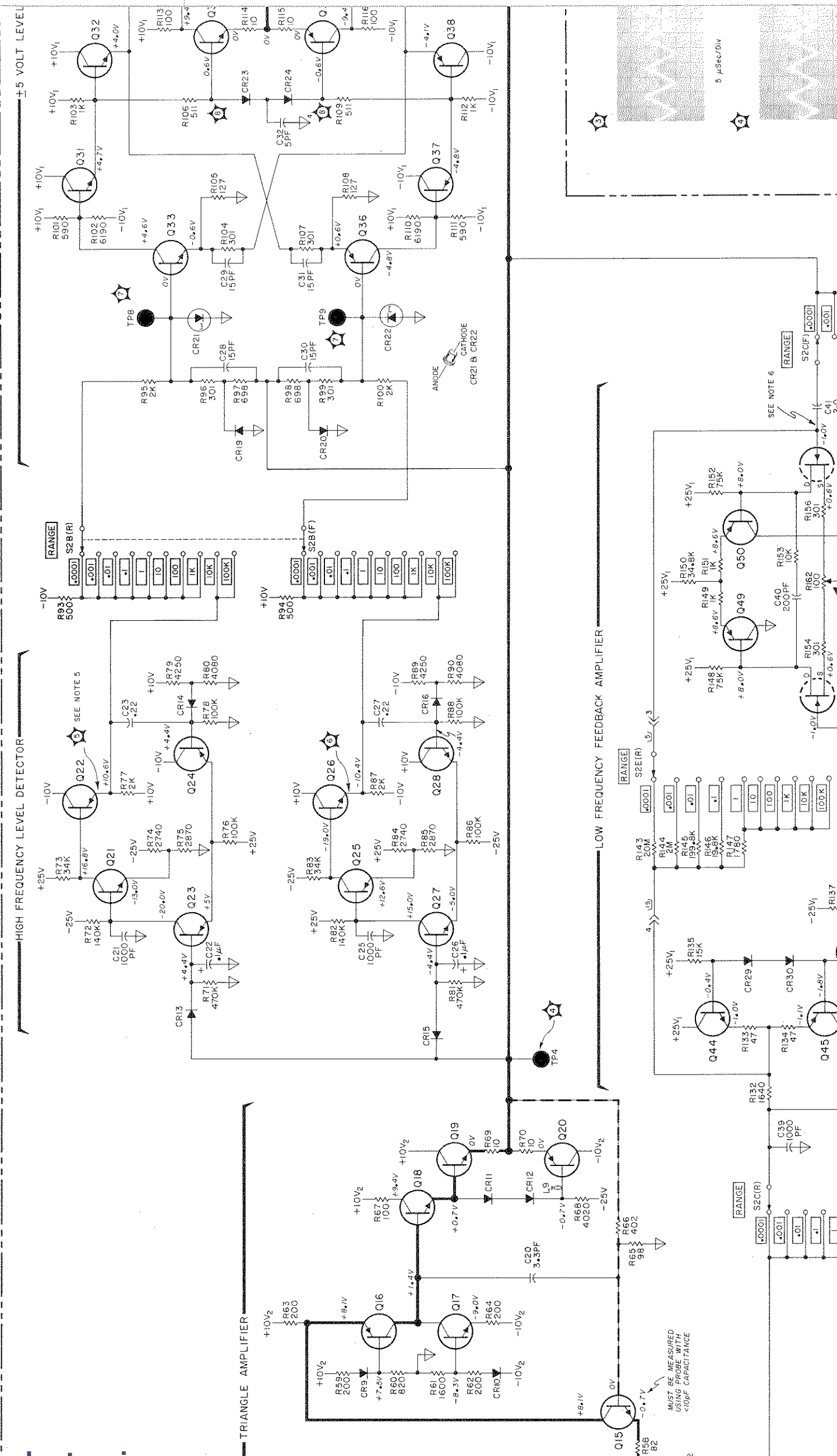

RECTOR

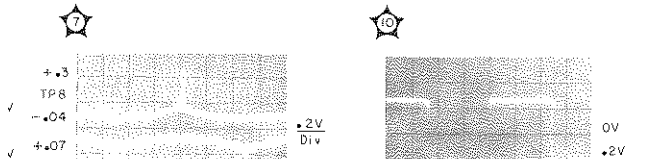
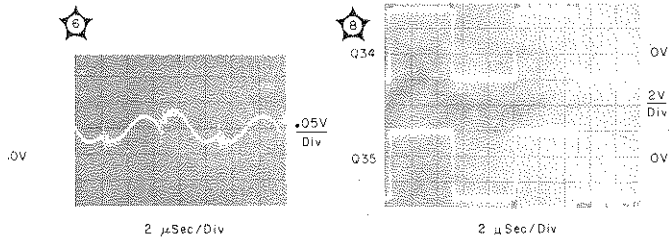
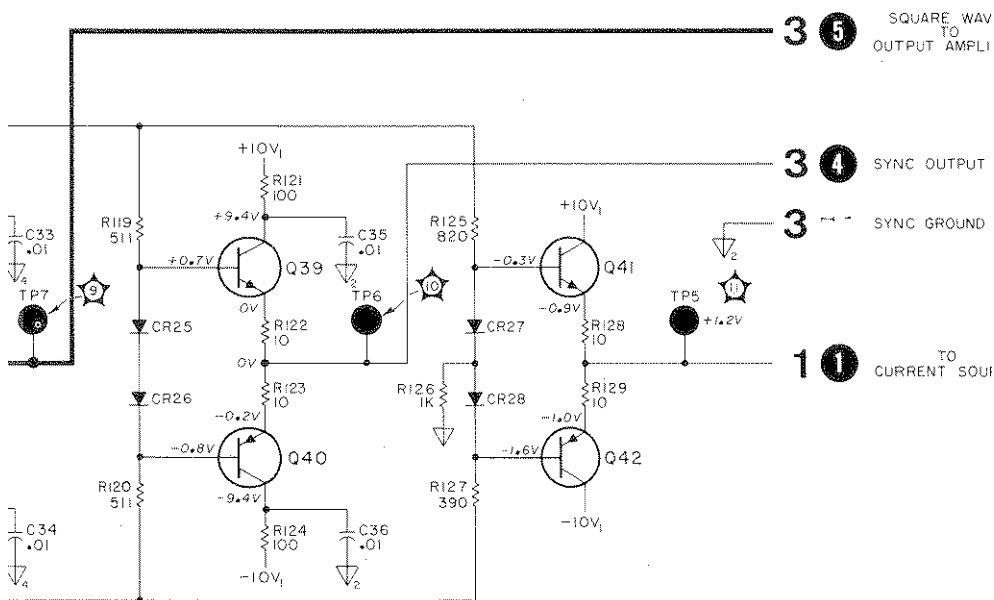

NOTES

- d.c. voltage measurement conditions:

Freq. dial
RANGE
D.C. OFFSET LEVEL
OUTPUT LEVEL
FUNCTION
EXT. GATE drive 1 to 30 V peak, square wave (3310B Tone Burst operatic
- A Model 427A VM should be used for d.c. vol voltages < .1 V were considered 0 V.
- Unless otherwise noted waveforms were che conditions:

Freq. dial
RANGE
Offset Level
FUNCTION
OUTPUT LEVEL 1/2
Load oper
START/STOP PHASE 1/2 (331C
EXT. GATE drive 2.5 V rms si (331C
- A Model 180A Oscilloscope with a 10:1 divid for waveform checks.

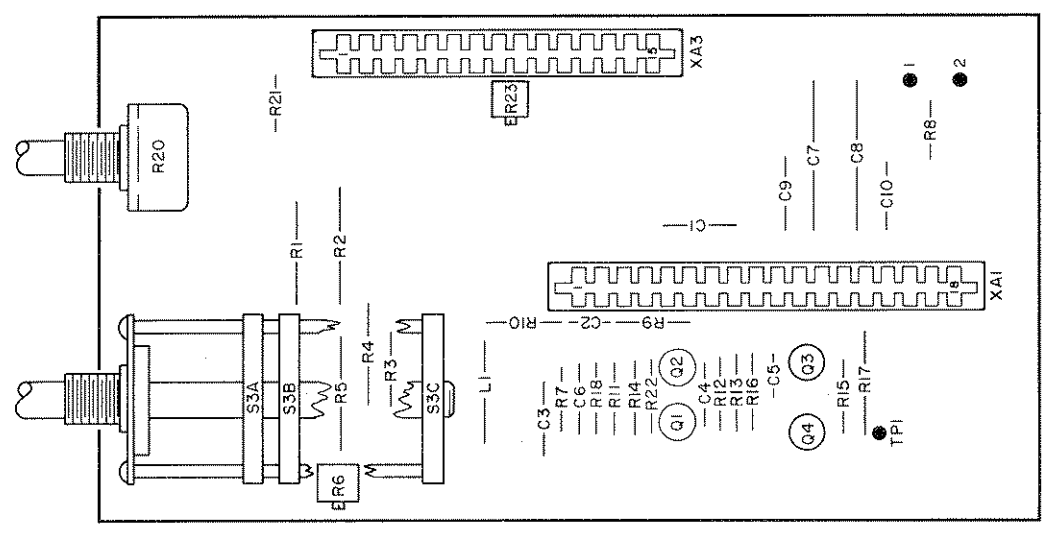

A2
hp Part No. 03310-66502
Rev B

3310A-B-1936A

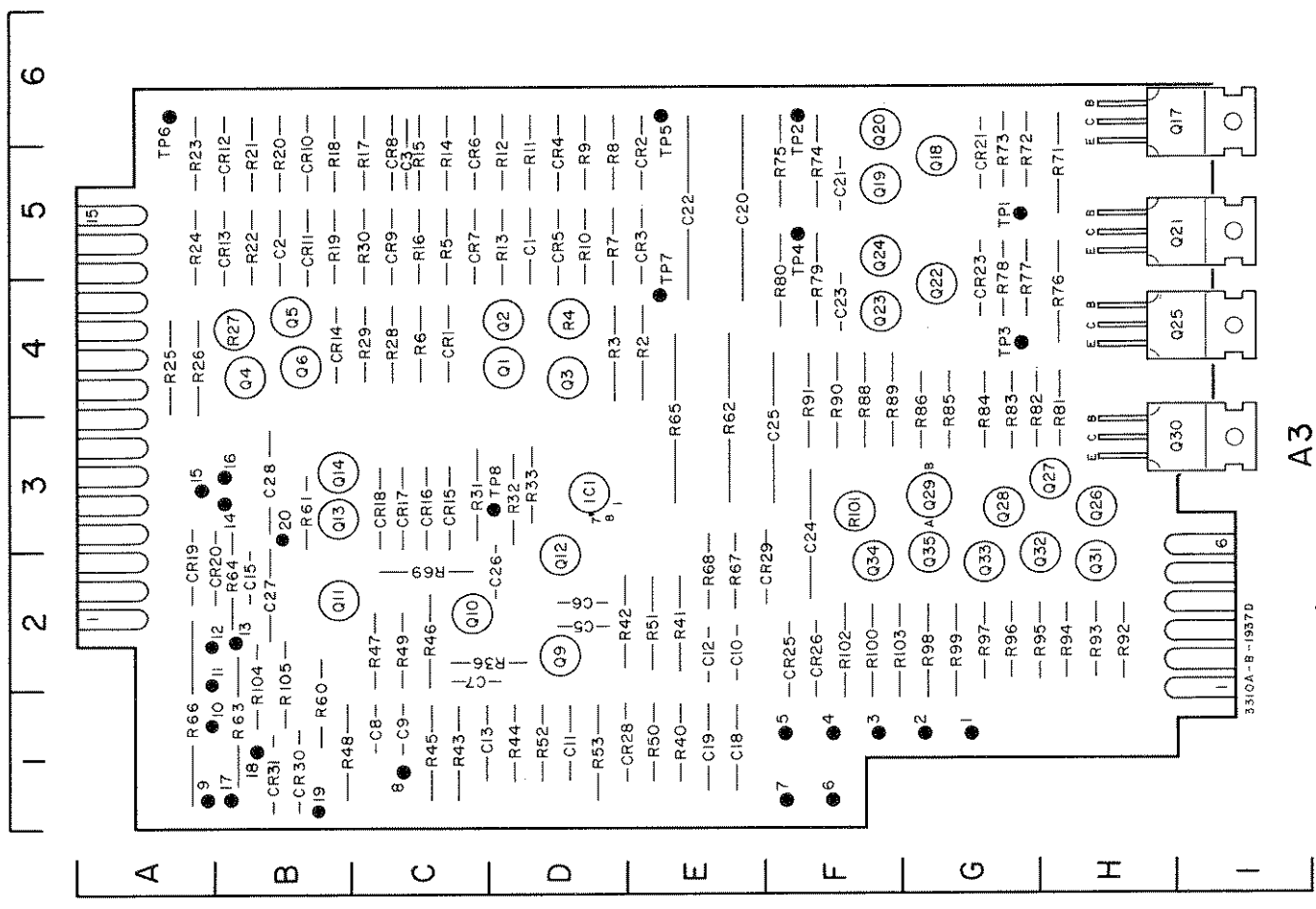

A3
hp Part No. 03310-66513

3310A-B-1937B

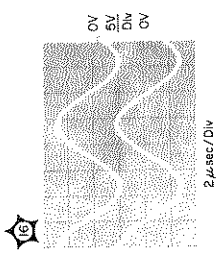
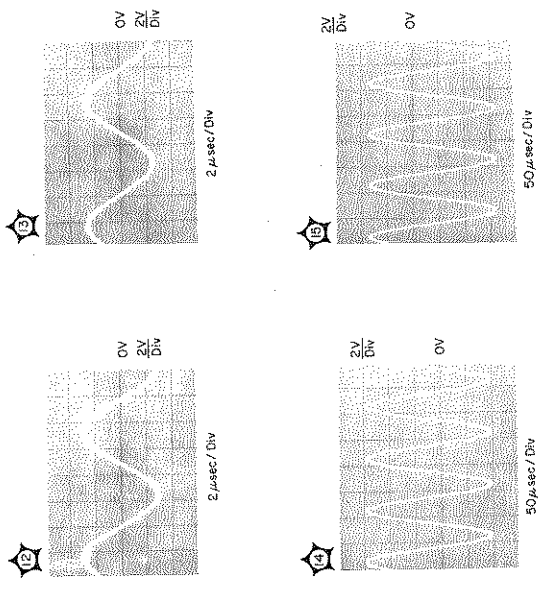

O1
O2

NOTES

- d.c. voltage measurement conditions:
 Freq. dial50
 RANGE100
 D.C. OFFSET LEVEL0
 OUTPUT LEVELfull CW
 FUNCTIONTRI
 EXT. GATE drive1 to 30 V peak, 1 kHz, square wave (3310B Tone Burst operation only)
- A Model 427A VM should be used for d.c. voltage measurement. Voltages < .1 V were considered 0 V.
- Unless otherwise noted waveforms were checked under these conditions:
 Freq. dial10
 RANGEX10K
 Offset Level0
 FUNCTIONSINE
 OUTPUT LEVEL1/2 of max.

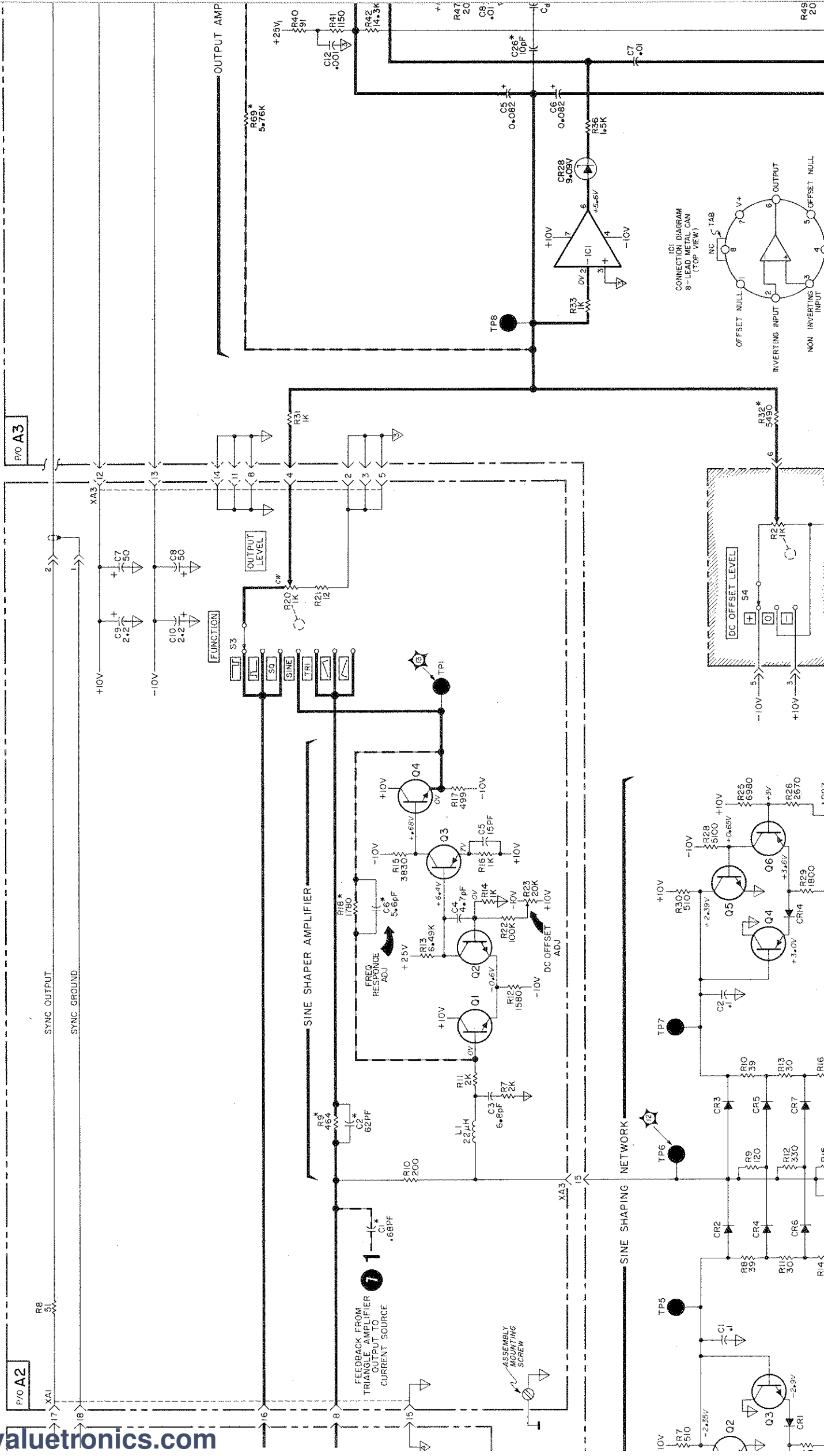

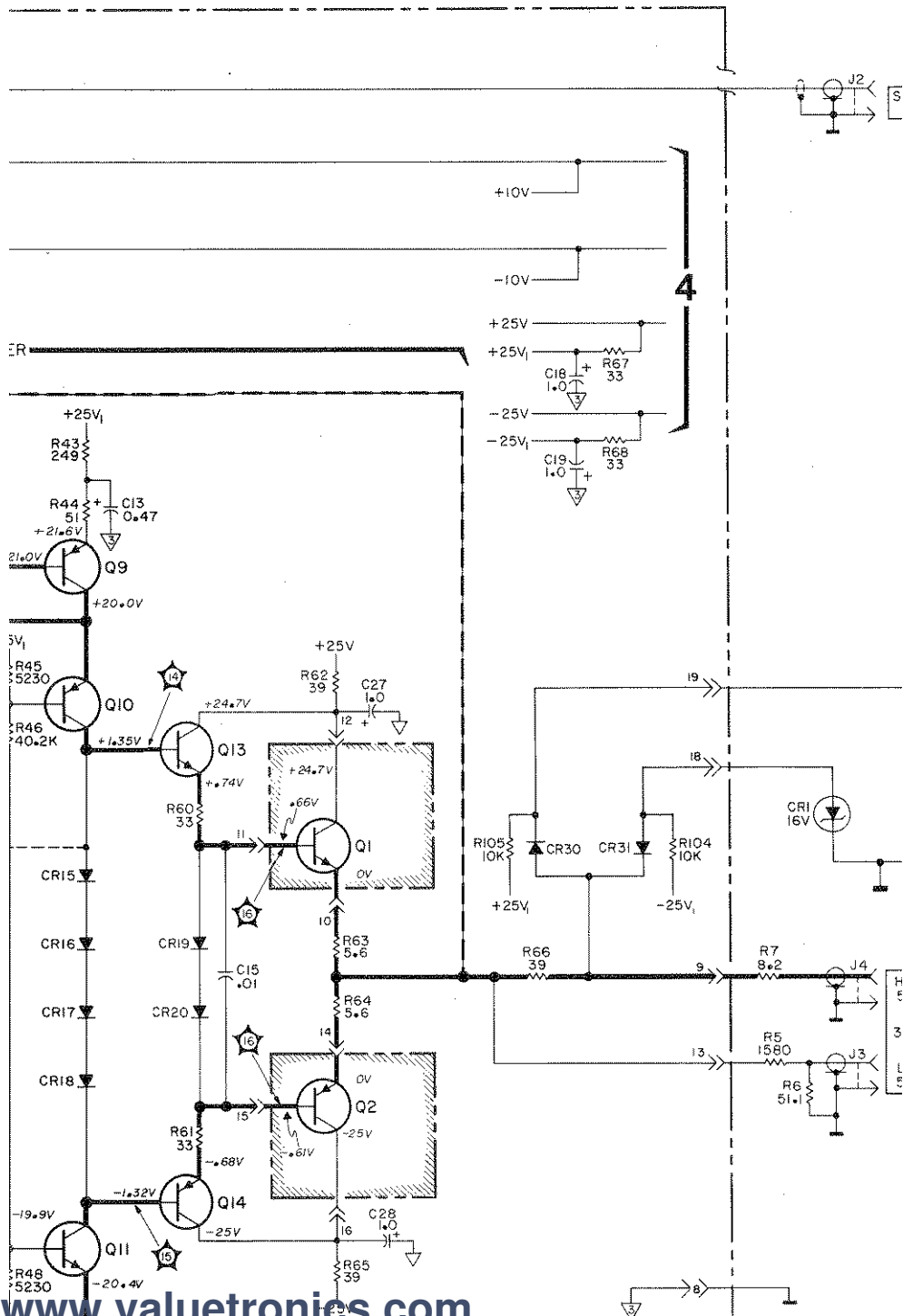

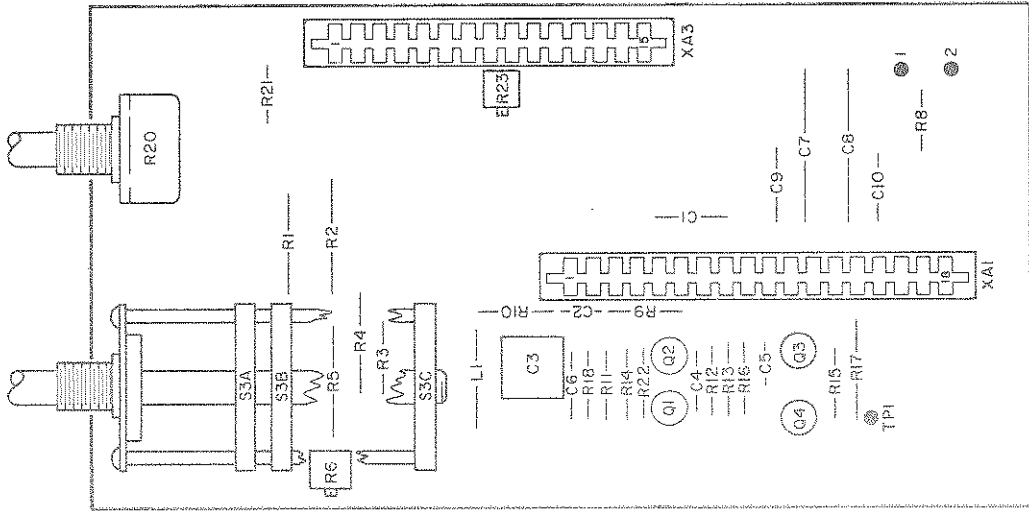

A2
hp Part No. 03310-66502
Rev B

- NOTES**
1. d.c. voltage measurement conditions:
 Freq. dial50
 RANGE 100
 D.C. OFFSET LEVEL 0
 OUTPUT LEVEL full CW
 FUNCTION TRI
 EXT. GATE drive 1 to 30 V peak, 1 kHz
 square wave (S310B Tone Burst operation only)
 2. A Model 427A VM should be used for d.c. voltage measurement.
 Voltages < .1 V were considered 0 V.
 3. Unless otherwise noted waveforms were checked under these conditions:

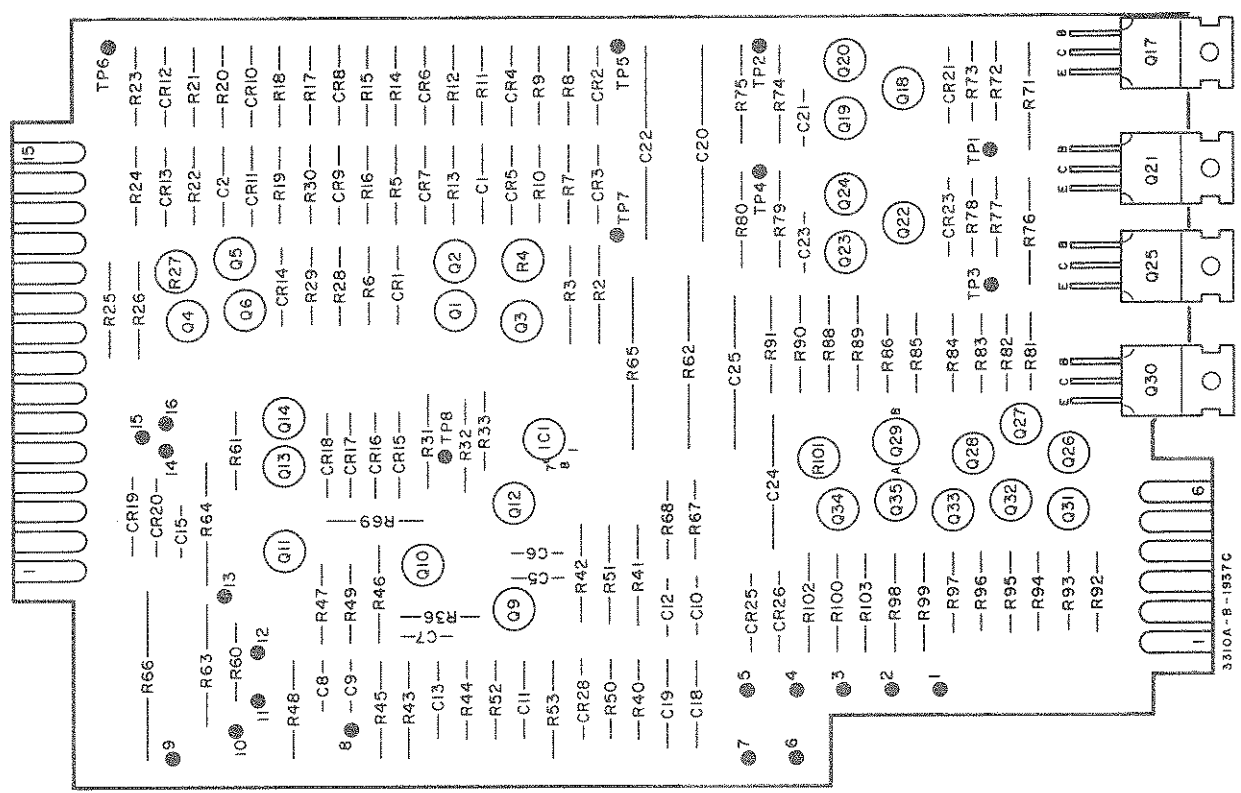

A3
hp Part No. 03310-66503
Rev C

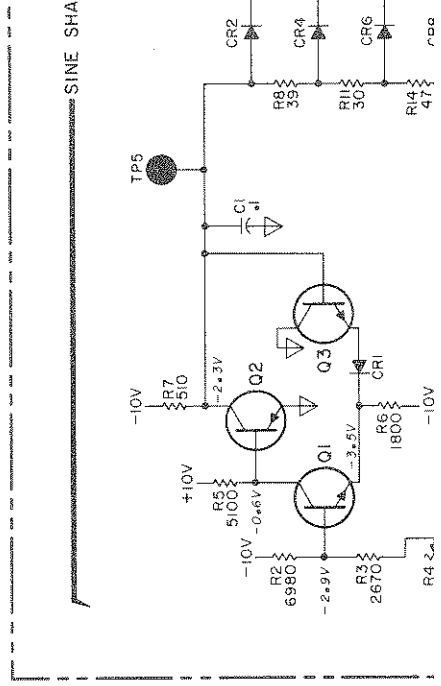
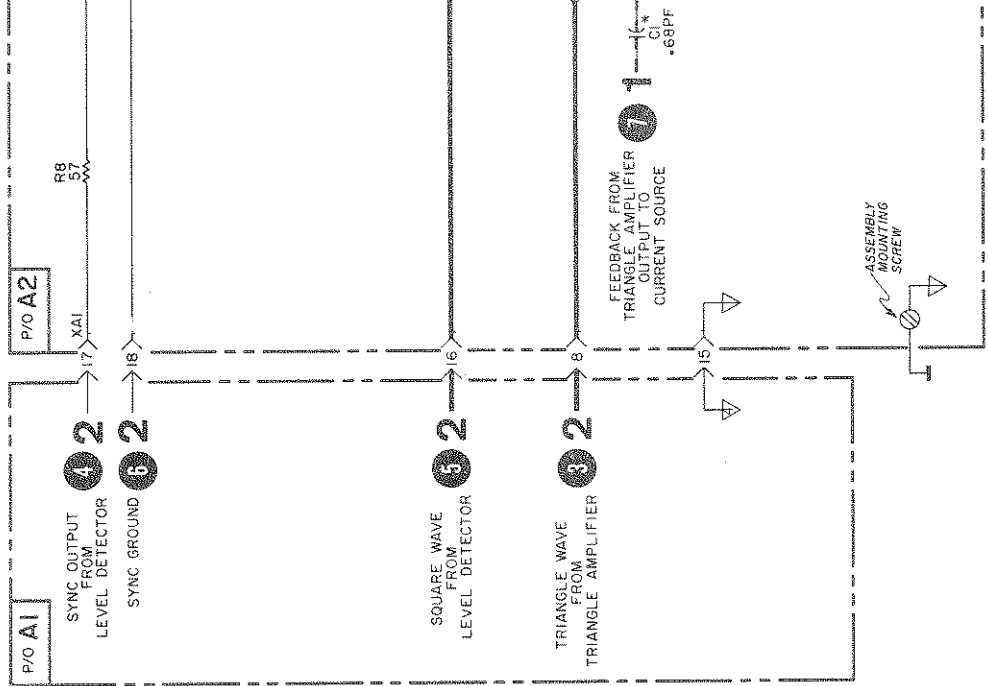

SINE SHAPE

A3 Board Component Location.

	C	CR	Q	R	R	Q	R	R	R	R	R	TP	Pin	IC
1	D5	C4	D4	D4	E2	F2	67	E2	100	F2	1	G5	G1	D3
2	B5	E5	D4	E4	E3	G2	68	E2	101	E3	2	F6	G1	
3		E5	D4	D4	C2		69	C2	102	F2	3	C4	F1	
4		D5	B4	D4			70		103	F2	4	F5	F1	
5	D2	D5	B4	C5			71	H5	104	B2	5	E6	F1	
6	D2	C5	B4	C4			72	G5	105	B2	6	A6	F1	
7	C2	C5		D5			73	G5			7	F4	F1	
8	C1	C5		D5	E1		74	F5			8	D3	C1	
9	C1	C5	D2	D5	D2		75	F5			9		A1	
10	E2	B5	C2	D5	C1		76	H4			10		A1	
11	D1	B5	B2	D5	D1		77	G4			11		A2	
12	E2	B5	D2	D5	C1		78	G4			12		A2	
13	C1	B5	B3	D5	C2		79	F4			13		B2	
14		B4	B3	C5	C2		80	F4			14		B3	
15	B2	C3		C5	B1		81	H5			15		A3	
16		C3		C5	C2		82	H3			16		B3	
17		C3	I6	C5	E1		83	G3			17		B1	
18	E1	C3	G5	B5	E2		84	G3			18		B1	
19	E1	A2	F5	B5	D1		85	G3			19		B1	
20	E5	B2	F6	B5	D1		86	G3			20		B3	
21	F5	G5	I5	B5			87							
22	E5		G4	B5			88	F4						
23	F4	G4	F4	A5			89	F4						
24	F3		F5	A5			90	F4						
25	F3	F2	I4	A4			91	F4						
26	D2	F2	H3	A4			92	H2						
27	B2		H3	B4			93	H2						
28	B3		D1	G3			94	H2						
29		F2	G3	C4			95	H2						
30		B1	I3	C5			96	G2						
31		B1	H2	C3			97	G2						
32			H2	D3			98	G2						
33			G2	D3			99	G2						

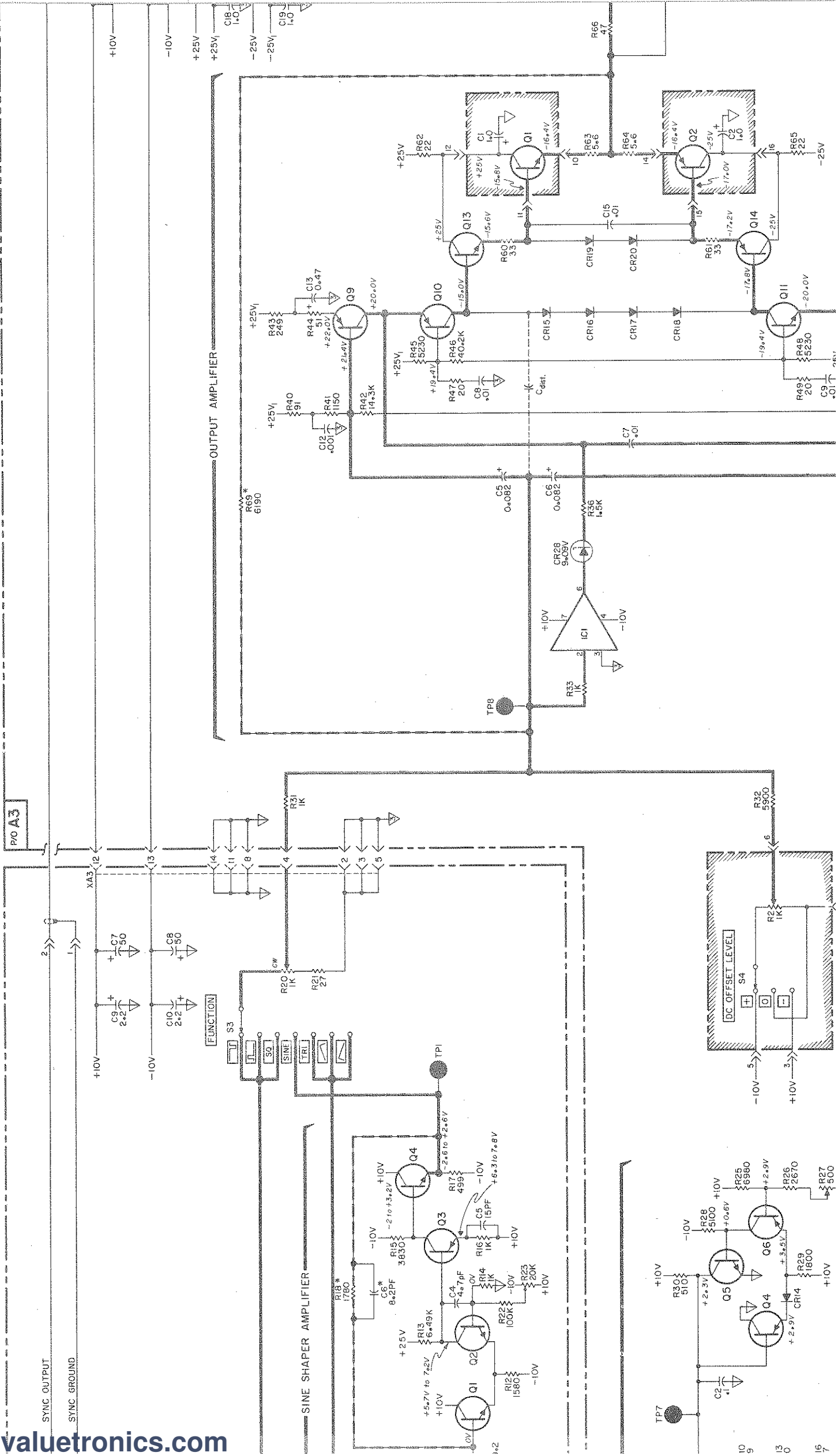

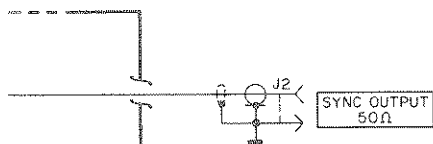

BACKDATING NOTES

(Serial No.'s 0947A02851 through 1048A03650)

1. Change value of A3R62, A3R65, and A3R66 to 39 ohms.
2. Change value of A3R72 and A3R77 to 62 ohms.
3. Change value of A3R32 and A3R69 to 5.49 kΩ and 5.76 kΩ, respectively.
4. On Schematic No. 4, add diode, A3CR29, between the

base and emitter of A3O35; cathode toward base.

5. Add the following part numbers.

Reference Designator	-hp- Part No.	Description
A3CR29	1901-0050	Diode
A7	03310-60610	Assy, Zener Diode
A7CR1, CR2	1901-0050	Diode
A7CR3, CR4	1902-1200	Diode, breakdown 16 V
A7R1	0683-0825	Resistor, 8.2 Ω
A7R2, R3	0684-1031	Resistor, 10 kΩ

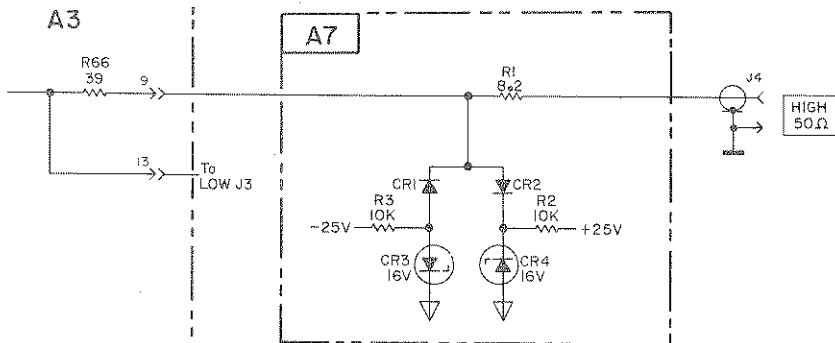
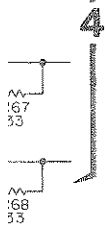

3310A-9-2409

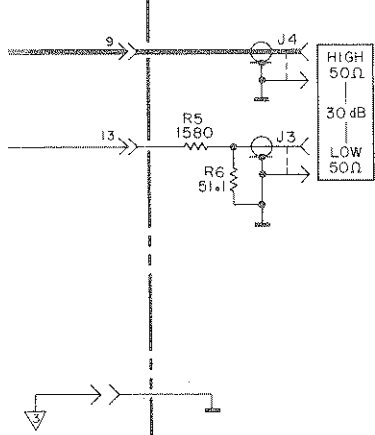

BACKDATING

3

Figure 7-5. Sine Shaping and Output Circuits (Backdating), A2, A3.

7-11/7-12

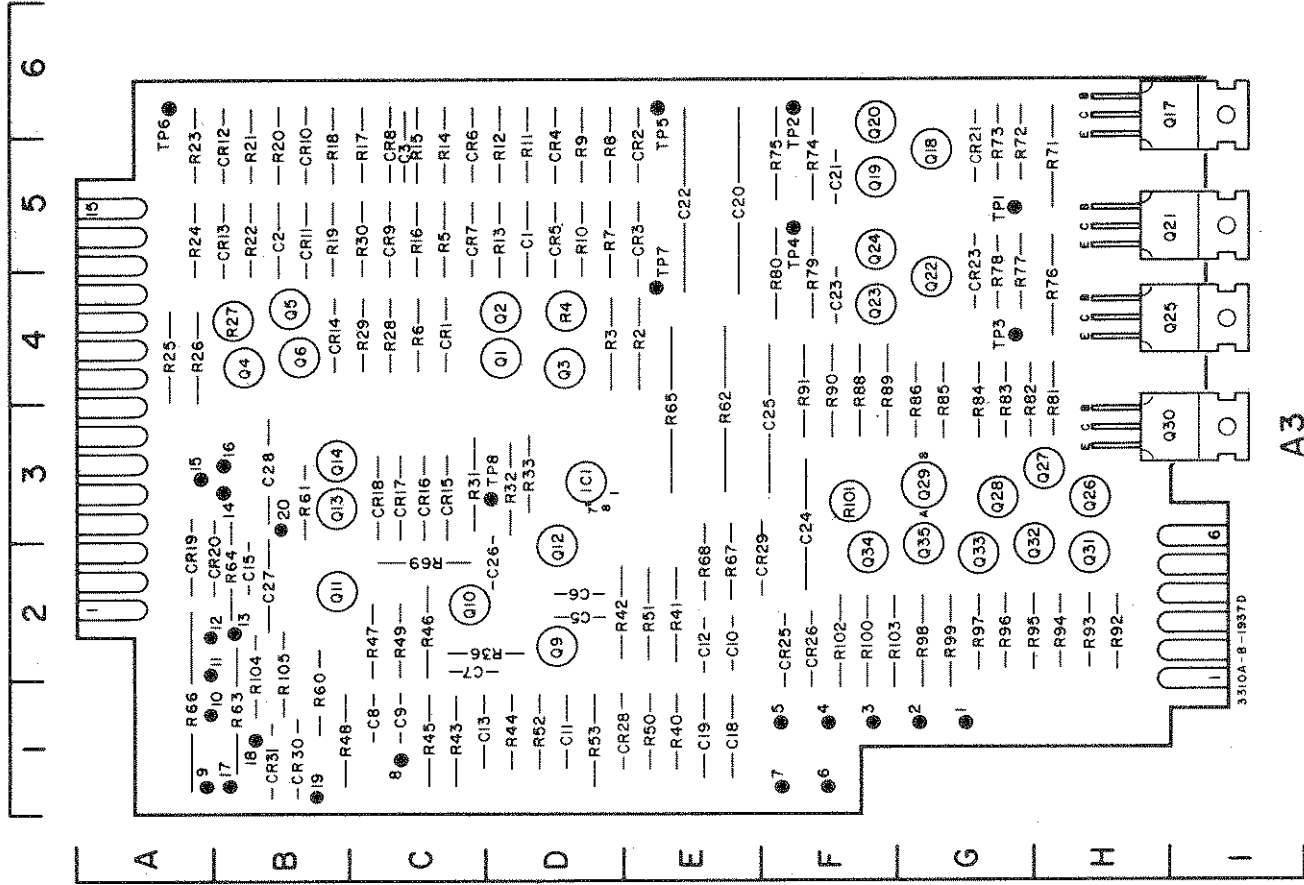

A3
hp Part No. 03310-66513
Rev B

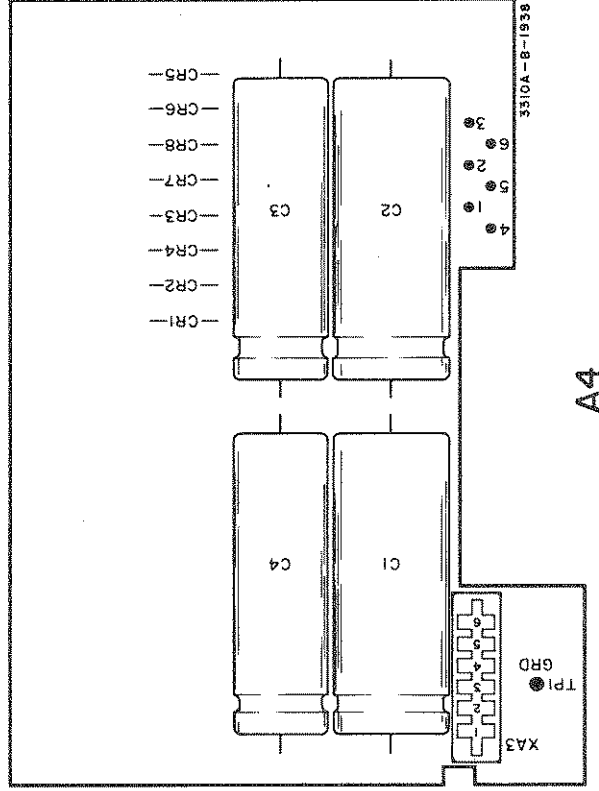

A4
hp Part No. 03310-66504

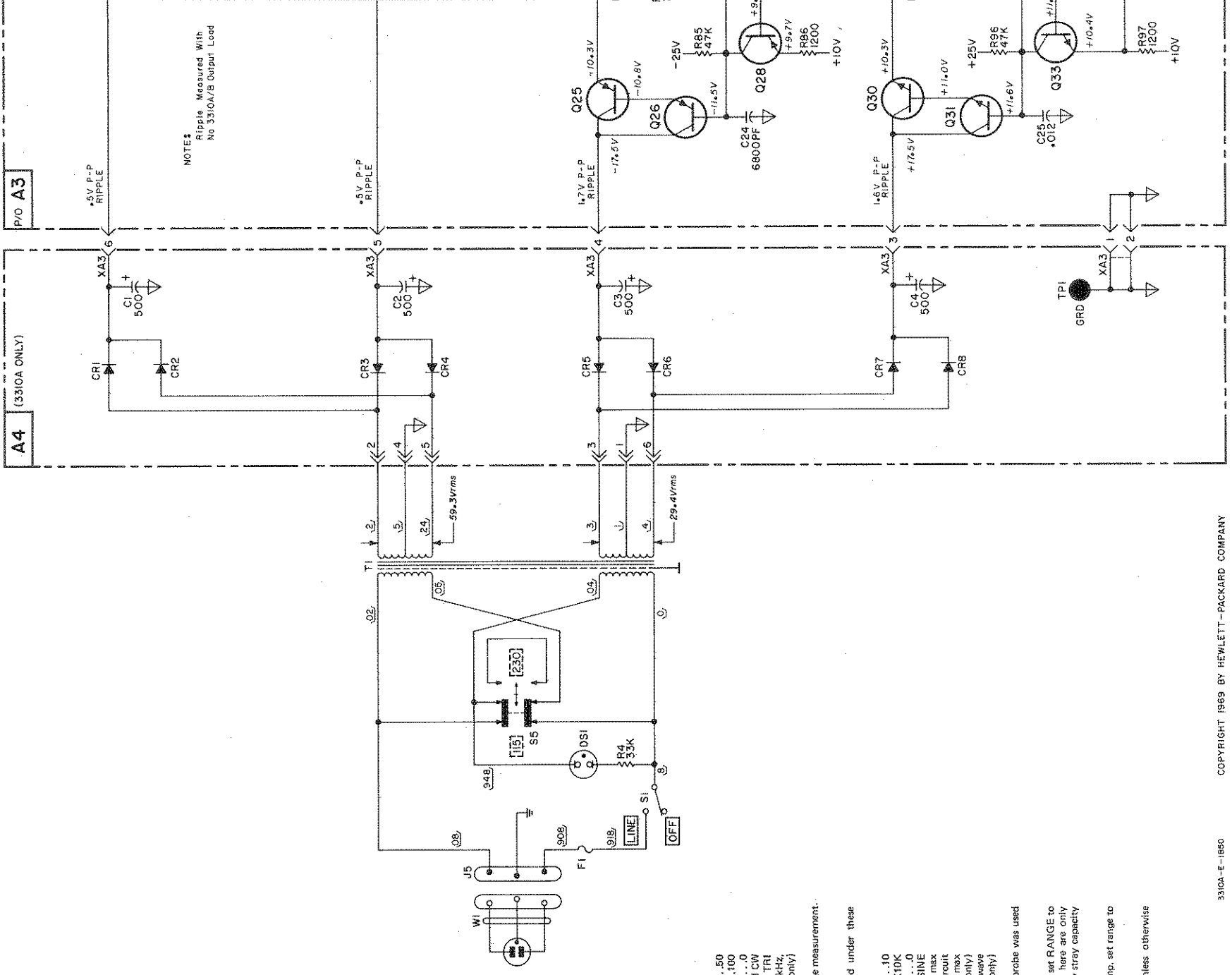

NOTE:
Ripple Measured With
No 3310A/B Output Load

NOTES

- d.c. voltage measurement conditions:

Freq. dial50
RANGE100
D.C. OFFSET LEVEL0
OUTPUT LEVELfull CW
FUNCTIONTRI
EXT. GATE drive1 to 30 V peak, 1 kHz, square wave (3310B Tone Burst operation only)
- A Model 427A VM should be used for d.c. voltage measurement. Voltages < .1 V were considered 0 V.
- Unless otherwise noted waveforms were checked under these conditions:

Freq. dial10
RANGEX10K
Offset Level0
FUNCTIONSINE
OUTPUT LEVEL1/2 of max
Loadopen circuit
START/STOP PHASE1/2 of max (3310B only)
EXT. GATE drive2.5 V rms sine wave (3310B only)
- A Model 180A Oscilloscope with a 10:1 divider probe was used for waveform checks.
- When checking waveforms on high freq. level det. set RANGE to X100K instead of X10K. The waveforms shown here are only approximate since they are somewhat affected by stray capacity (i.e. lead placement, etc.)
- When checking d.c. levels on low freq. feedback amp. set range to X1 instead of X100.
- All voltages given on schematic are ± 10 % unless otherwise noted.



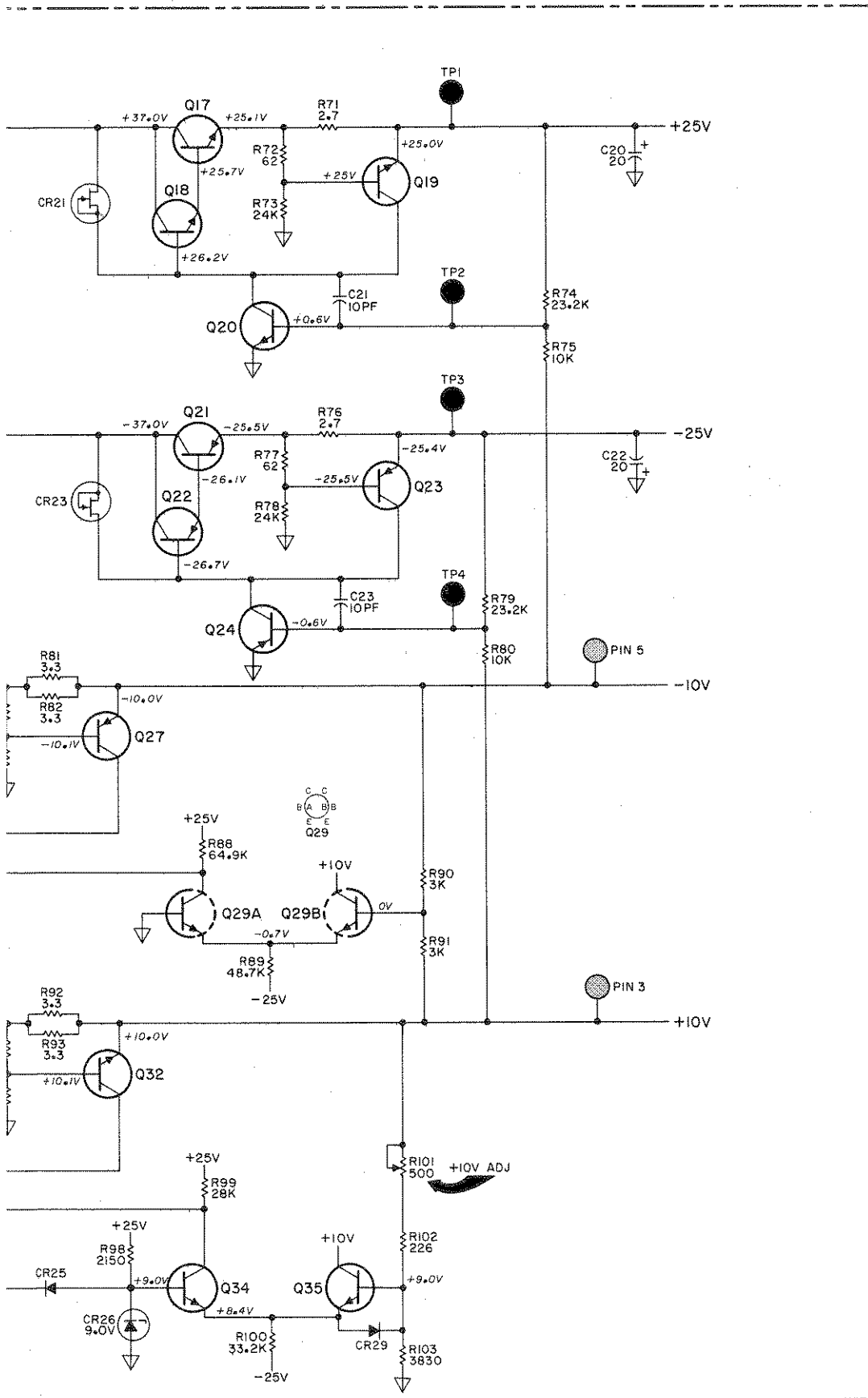

4

Figure 7-6. Power Supply (3310A only), A3, A4.

7-13/7-14

NOTE

FOR TROUBLESHOOTING INFORMATION AND PROPER TEST VOLTAGES REFER TO PARAGRAPH 5-182.

A5 Board Component Location.

	C	CR	K	Q	R	Pin
1	C2	B5	B4	A3	B5	D5
2	C5	B5	B4	A3	A3	D5
3	B5	B5	B4	B4	B2	D5
4	B2	B5	A4	A5	A5	D5
5	B6	B6	A5	A4	A4	D5
6	A2	B6	A5	B3	B3	D5
7	B3	B6	A3	B2	B2	A1
8	A3	A6	A1	A4	A2	A2
9	A6	B5	A2	B1	A1	A1
10	B4	B4	A1	B3	A2	A2
11	B4	B4	B4	A4	A2	A2
12	A4	A4	A4	A5	A2	A2
13	A4	A4	A5	A5	A2	A2
14	B3	B3	B3	A5	A3	A6
15	B3	B3	B3	B3	A6	A6
16	B1	B1	B1	B3	B3	B3
17	B1	B1	B1	A3	A3	A3
18	B1	B1	B1	A2	A2	A2
19	B2	B2	B2	A2	A2	A2
20				A3	A3	A3
21				A2	A2	A2
22				A2	A2	A2
23				A2	A2	A2

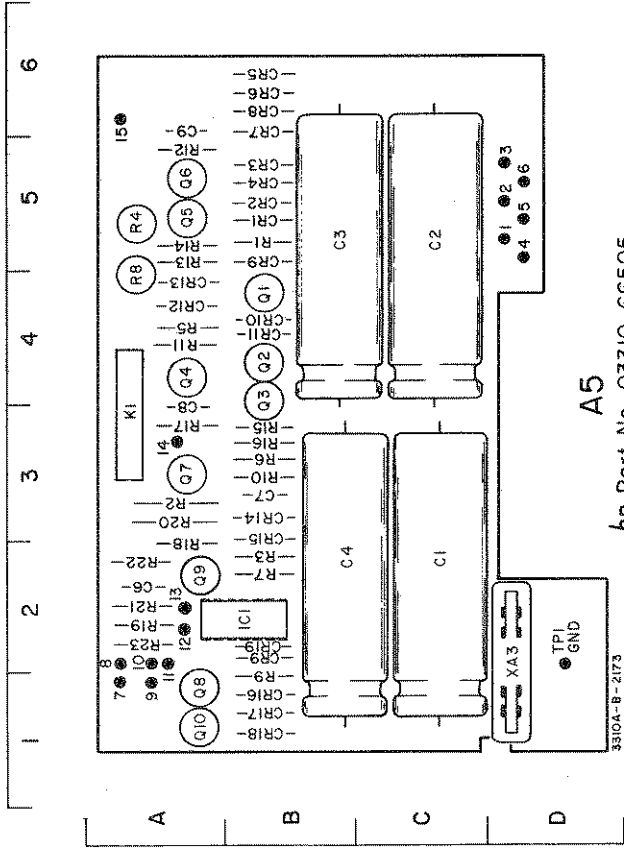

A5
hp Part No. 03310-66505

A51C1 PIN CONFIGURATION

AND-GATED J-K MASTER-SLAVE FLIP-FLOP WITH PRESET AND CLEAR

FUNCTION TABLE		OUTPUTS				
PRESET	CLEAR	CLOCK	J	K	Q	Q
L	H	X	X	X	H	L
H	L	X	X	X	L	H
L	L	X	X	X	H*	H*
H	H				L	Q ₀
H	H				L	H
H	H				L	L
H	H				L	H
H	H				H	L
H	H				H	H

positive logic: J = J1 · J2 · J3; K1 · K2 · K3

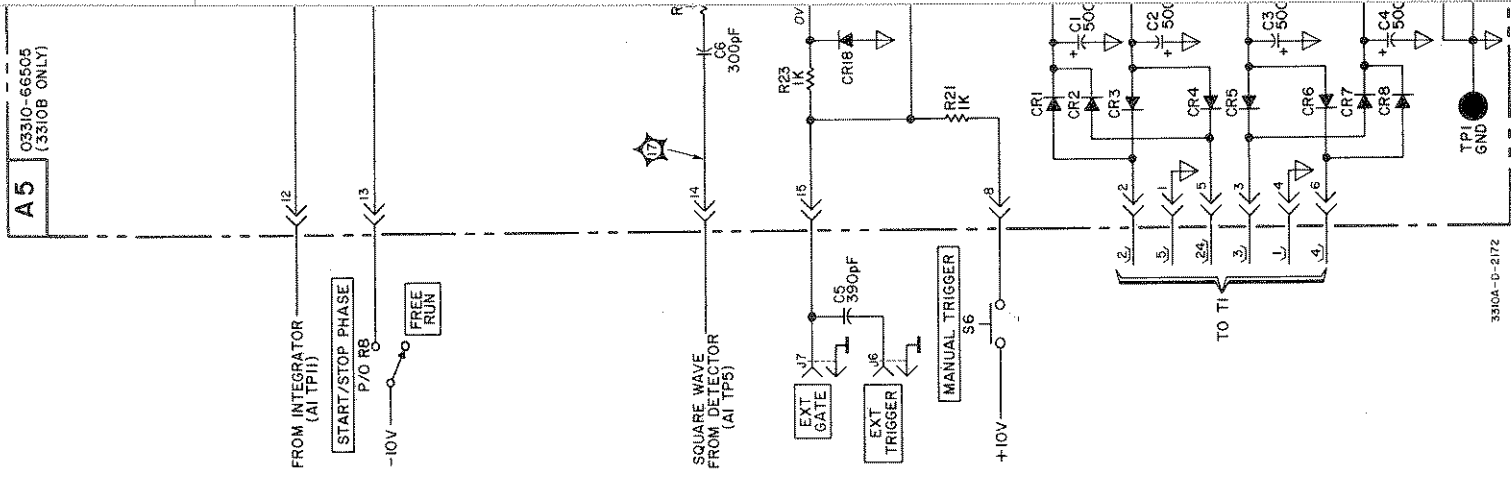
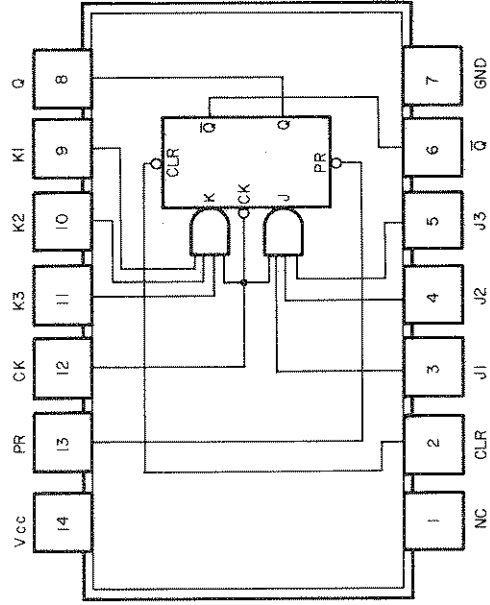

NOTES

- d.c. voltage measurement conditions:
 Freq. dial50
 RANGE100
 D.C. OFFSET LEVEL0
 OUTPUT LEVEL full CW
 FUNCTION TR1
 EXT. GATE drive 1 to 30 V peak, 1 kHz, square wave (3310B Tone Burst operation only)
 2. A Model 427A VM should be used for d.c. voltage measurement. Voltages < .1 V were considered 0 V.
 3. Unless otherwise noted waveforms were checked under these conditions:
 Freq. dial10
 RANGE X10K
 Offset Level 0
 FUNCTION SINE
 OUTPUT LEVEL 1/2 of max
 Load open circuit
 START/STOP PHASE 1/2 of max (3310B only)
 EXT. GATE drive 2.5 V rms sine wave (3310B only)
- A Model 180A Oscilloscope with a 10:1 divider probe was used for waveform checks.
- When checking waveforms on high freq. level det. set RANGE to X100K instead of X10K. The waveforms shown here are only approximate since they are somewhat affected by stray capacity (i.e. lead placement, etc.).
- When checking d.c. levels on low freq. feedback amp. set range to X1 instead of X100.
- All voltages given on schematic are ± 10 % unless otherwise noted.

3310A-D-2172

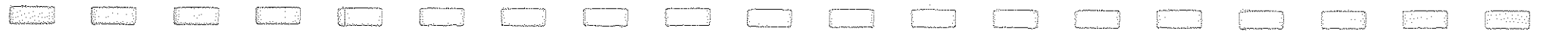
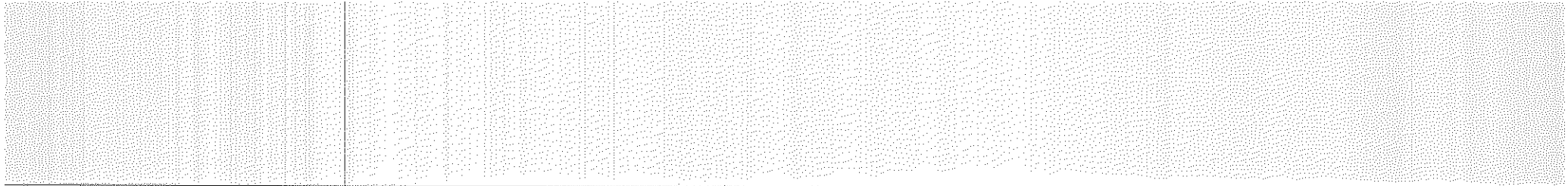

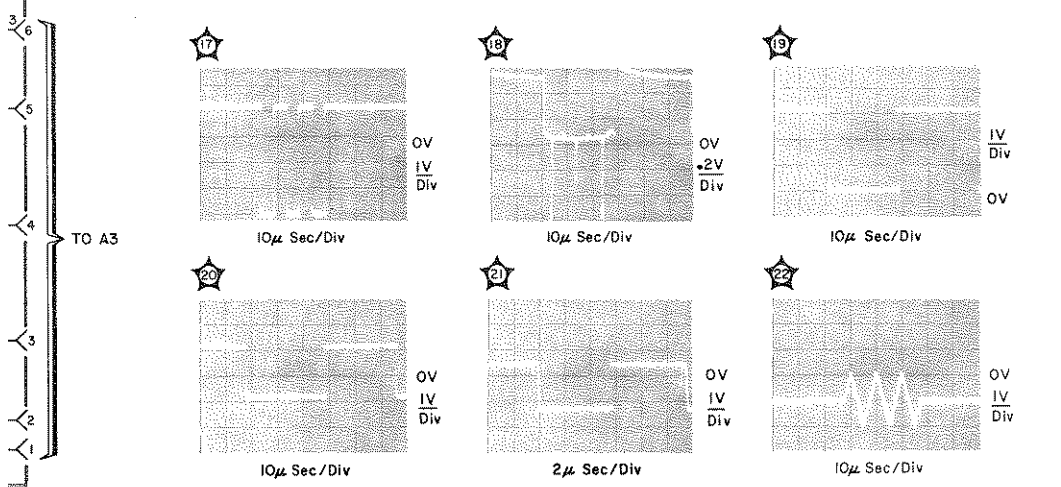
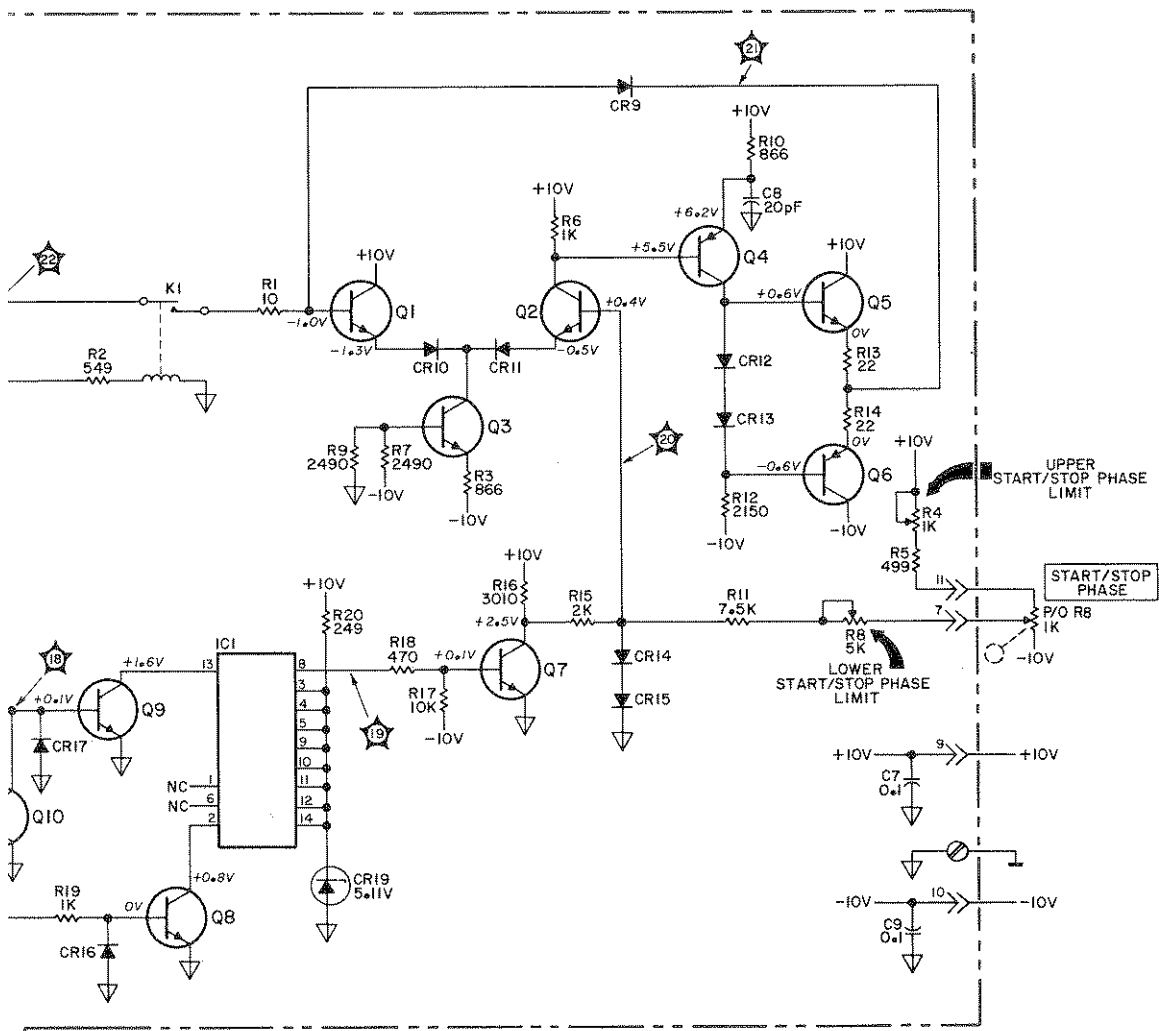

5

Figure 7-7. Power Supply and Tone Burst Generator (3310B only), A5.

7-15/7-16

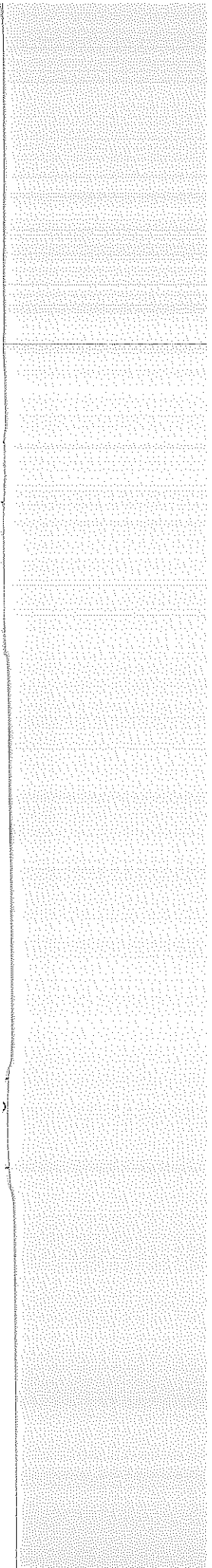

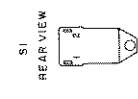
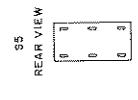
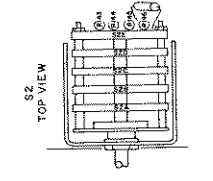
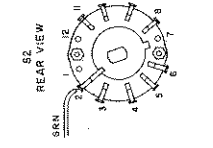
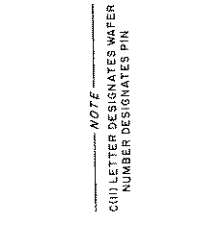
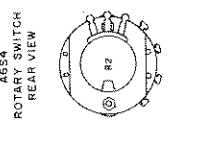
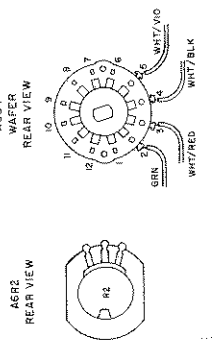
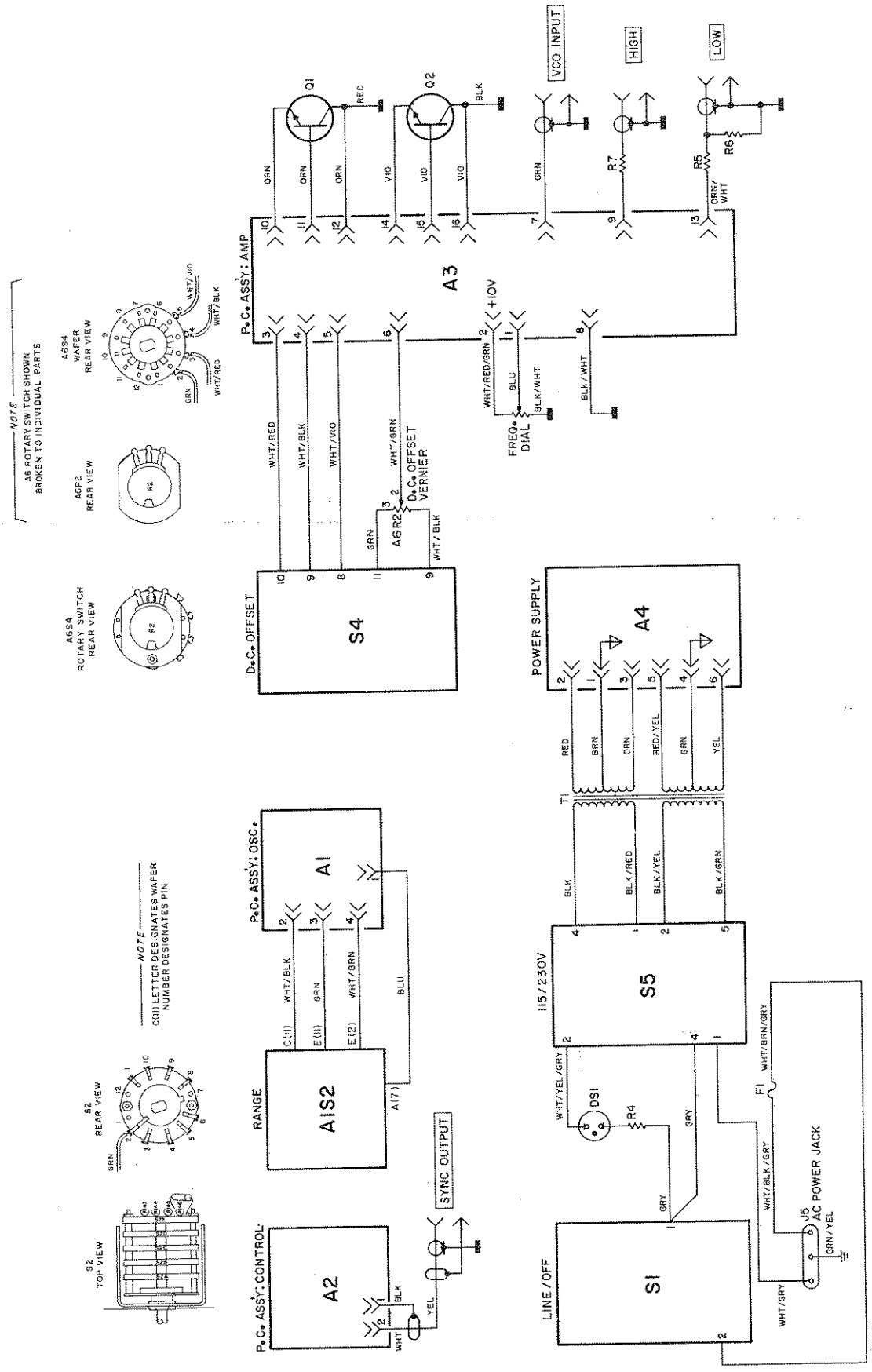

3310A-5-2-525

Figure 7-8. Wiring Diagram (3310A only).
7-17/7-18



CODE LIST OF MANUFACTURERS

The following code numbers are from the Federal Supply Code for Manufacturers Cataloging Handbooks H4-1 (Name to Code) and H4-2 (Code to Name) and their latest supplements. The date of revision and the date of the supplements used appear at the bottom of each page. Alphabetical codes have been arbitrarily assigned to suppliers not appearing in the H4 Handbooks.

Code No.	Manufacturer	Address	Code No.	Manufacturer	Address	Code No.	Manufacturer	Address
00000	U. S. A Common	Any supplier of U. S.	05347	Ultronix, Inc.	San Mateo, Cal.	11236	CTS of Berne, Inc.	Berne, Ind.
00136	McCoy Electronics	Mount Holly Springs, Pa.	05397	Union Carbine Corp., Elect.	New York, N. Y.	11237	Chicago Telephone of California, Inc.	So. Pasadena, Cal.
00213	Sage Electronics Corp.	Rochester, N. Y.	05574	Viking Ind. Inc.	Canoga Park, Cal.	11242	Bay State Electronics Corp.	Waltham, Mass
00287	Cemco, Inc.	Danielson, Conn.	05593	Icorte Electro-Plastics Inc.	Sunnyvale, Cal.	11312	Teledyne Inc., Microwave Div.	Palo Alto, Cal.
00334	Humidial	Colton, Calif.	05616	Cosmo Plastic (c/o Electrical Spec Co.)	Cleveland, Ohio	11314	National Seal	Downey, Cal.
00348	Micron, Co., Inc.	Valley Stream, N. Y.	05624	Barber Colman Co.	Rockford, Ill.	11453	Precision Connector Corp.	Jamaica, N. Y.
00373	Garlock Inc.	Cherry Hill, N. J.	05728	Tiffen Optical Co.	Roslyn Heights, Long Island, N. Y.	11534	Duncan Electronics Inc.	Costa Mesa, Cal.
00656	Aerovox Corp.	New Bedford, Mass.	05729	Metro-Tel Corp.	Westbury, N. Y.	11711	General Instrument Corp., Semiconductor Division Products Group	Newark, N. J.
00779	Amp. Inc.	Harrisburg, Pa.	05783	Stewart Engineering Co.	Santa Cruz, Cal.	11717	Imperial Electronic, Inc.	Buena Park, Cal.
00781	Aircraft Radio Corp.	Boonton, N. J.	05820	Wakefield Engineering Inc.	Wakefield, Mass.	11870	Melabs, Inc.	Palo Alto, Cal.
00809	Croven, Ltd.	Whitby, Ontario, Canada	06004	Bassick Co., Div. of Stewart Warner Corp.	Bridgeport, Conn.	12361	Grove Mfg. Co., Inc.	Shady Grove, Pa.
00815	Northern Engineering Laboratories, Inc.	Burlington, Wis.	06090	Raychem Corp.	Redwood City, Cal.	12574	Gulton Ind. Inc., Data System Div.	Albuquerque, N. M.
00853	Sangamo Electric Co., Pickens Div.	Pickens, S. C.	06402	E. T. A. Products Co. of America	Chicago, Ill.	12697	Ciarostat Mfg. Co.	Dover, N. H.
00866	Goe Engineering Co.	City of Industry, Cal.	06540	Amatom Electronic Hardware Co., Inc.	New Rochelle, N. Y.	12728	Elmar Filter Corp.	W. Haven, Conn.
00891	Carl E. Holmes Corp.	Los Angeles, Cal.	06555	Beebe Electrical Instrument Co., Inc.	Penacook, N. H.	12859	Nippon Electric Co., Ltd.	Tokyo, Japan
00929	Microlab Inc.	Livingstone, N. J.	06666	General Devices Co., Inc.	Indianapolis, Ind.	12881	Metex Electronics Corp.	Clark, N. J.
01002	General Electric Co., Capacitor Dept.	Hudson Falls, N. Y.	06751	Components Inc., Ariz. Div.	Phoenix, Arizona	12930	Delta Semiconductor Inc.	Newport Beach, Cal.
01009	Alden Products Co.	Brockton, Mass.	06812	Torrington Mfg. Co., West Div.	Van Nuys, Cal.	12954	Dickson Electronics Corp.	Scottsdale, Arizona
01121	Allen Bradley Co.	Milwaukee, Wis.	06980	Varian Assoc. Etmac Div.	San Carlos, Cal.	13019	Aircro Supply Co., Inc.	Wichita, Kansas
01255	Litton Industries, Inc.	Beverly Hills, Cal.	07088	Kelvin Electric Co.	Van Nuys, Cal.	13061	Wilco Products	Detroit, Mich.
01261	TRW Semiconductors, Inc.	Lawndale, Cal.	07126	Digitran Co.	Pasadena, Cal.	13103	Thermolloy	Dallas, Texas
01295	Texas Instruments, Inc., Transistor Products Div.	Dallas, Texas	07137	Transistor Electronics Corp.	Minneapolis, Minn.	13327	Solitron Devices Inc.	Tappan, N. Y.
01349	The Alliance Mfg. Co.	Alliance, Ohio	07138	Westinghouse Electric Corp., Electronic Tube Div.	Elmira, N. Y.	13396	Telefunken (GmbH)	Hanover, Germany
01538	Small Parts Inc.	Los Angeles, Cal.	07149	Filmohm Corp.	New York, N. Y.	13835	Midland-Wright Div. of Pacific Industries, Inc.	Kansas City, Kansas
01569	Pacific Relays, Inc.	Van Nuys, Cal.	07233	Cinch-Graphik Co.	City of Industry, Cal.	14099	Sem-Tech	Newbury Park, Cal.
01670	Gudebrod Bros. Silk Co.	New York, N. Y.	07256	Silicon Transistor Corp.	Carle Place, N. Y.	14193	Calif. Resistor Corp.	Santa Monica, Cal.
01930	Amerock Corp.	Rockford, Ill.	07261	Avnet Corp.	Culver City, Cal.	14298	American Components, Inc.	Conshohocken, Pa.
01960	Pulse Engineering Co.	Santa Clara, Cal.	07263	Fairchild Camera & Inst. Corp., Semiconductor Div.	Mountain View, Cal.	14433	ITT Semiconductor, a Div. of Int. Telephone and Telegraph Corporation	West Palm Beach, Fla.
02114	Ferroxcube Corp. of America	Saugerties, N. Y.	07322	Minnesota Rubber Co.	Minneapolis, Minn.	14493	Hewlett-Packard Company	Loveland, Colo.
02116	Wheelock Signals, Inc.	Long Branch, N. J.	07387	Birtcher Corp., The	Monterey Park, Cal.	14655	Cornell Dublier Electric Corp.	Newark, N. J.
02286	Cole Rubber and Plastics Inc.	Sunnyvale, Cal.	07397	Sylvania Elect. Prod. Inc., Mt. View Operations	Mountain View, Cal.	14674	Corning Glass Works	Corning, N. Y.
02660	Phenol-Borg Electronics Corp.	Broadview, Ill.	07700	Technical Wire Products Inc.	Cranford, N. J.	14752	Electro Cube Inc.	San Gabriel, Cal.
02735	Radio Corp. of America, Semiconductor and Materials Division	Somerville, N. J.	07829	Bodine Elect. Co.	Chicago, Ill.	14960	Williams Mfg. Co.	San Jose, Cal.
02771	Vocaline Co. of America, Inc.	Old Saybrook, Conn.	07910	Continental Device Corp.	Hawthorne, Cal.	15106	The Sphere Co., Inc.	Little Falls, N. J.
02777	Hopkins Engineering Co.	San Fernando, Cal.	07933	Raytheon Mfg. Co., Semiconductor Div.	Mountain View, Cal.	15203	Webster Electronics Co.	New York, N. Y.
02875	Hudson Tool & Die	Newark, N. J.	07980	Hewlett-Packard Co., New Jersey Division	Rockaway, N. J.	15287	Scionics Corp.	Northridge, Cal.
03296	Nylon Molding Corp.	Springfield, N. J.	08145	U. S. Engineering Co.	Los Angeles, Cal.	15291	Adjustable Bushing Co.	N. Hollywood, Cal.
03508	G. E. Semiconductor Prod. Dept.	Syracuse, N. Y.	08289	Bhim, Delbert Co.	Pomona, Cal.	15558	Micron Electronics	Garden City, Long Island, N. Y.
03705	Apex Machine & Tool Co.	Dayton, Ohio	08358	Burgess Battery Co.	Niagara Falls, Ontario, Canada	15566	Amprobe Inst. Corp.	Lynbrook, N. Y.
03797	Eldema Corp.	Compton, Calif.	08524	Deutsch Fastener Corp.	Los Angeles, Cal.	15631	Cabletronics	Costa Mesa, Cal.
03818	Parker Seal Co.	Los Angeles, Cal.	08664	Bristol Co., The	Waterbury, Conn.	15772	Twentieth Century Coil Spring Co.	Santa Clara, Cal.
03877	Transitron Electric Corp.	Wakefield, Mass.	08717	Sloan Company	Sun Valley, Cal.	15801	Fenwal Elect. Inc.	Framingham, Mass.
03888	Pyrofilm Resistor Co., Inc.	Cedar Knolls, N. J.	08718	ITT Cannon Electric Inc., Phoenix Div.	Phoenix, Arizona	15818	Amelco Inc.	Mountain View, Cal.
03954	Singer Co., Diehl Div., FINDER Plant	Sumerville, N. J.	08727	National Radio Lab. Inc.	Paramus, N. J.	16037	Spruce Pine Mica Co.	Spruce Pine, N. C.
04009	Arrow, Hart and Hegeman Elect. Co.	Hartford, Conn.	08792	CBS Electronics Semiconductor Operations, Div. of CBS Inc.	Lowell, Mass.	16179	Omni-Spectra Inc.	Detroit, Ill.
04013	Tarus Corp.	Lambertville, N. J.	08806	General Electric Co., Miniature Lamp Dept.	Cleveland, Ohio	16352	Computer Diode Corp.	Lodi, N. J.
04062	Arco Electronic Inc.	Great Neck, N. Y.	08984	Mel-Rain	Indianapolis, Ind.	16554	Electroid Co.	Union, N. J.
04217	Essex Wire	Los Angeles, Cal.	09026	Babcock Relays Div.	Costa Mesa, Cal.	16585	Boots Aircraft Nut Corp.	Pasadena, Cal.
04222	Hi-Q Division of Aerovox	Myrtle Beach, S. C.	09097	Electronic Enclosures Inc.	Los Angeles, Calif.	16688	Ideal Prec. Meter Co., Inc., De Jur Meter Div.	Brooklyn, N. Y.
04354	Precision Paper Tube Co.	Wheeling, Ill.	09134	Texas Capacitor Co.	Houston, Texas	16758	Delco Radio Div. of G. M. Corp.	Kokomo, Ind.
04404	Palo Alto Division of Hewlett-Packard Co.	Palo Alto, Cal.	09145	Tech. Ind. Inc. Atohm Elect.	Burbank, Cal.	17109	Thermonetics Inc.	Canoga Park, Cal.
04651	Sylvania Electric Products, Microwave Device Div.	Mountain View, Cal.	09250	Electro Assemblies, Inc.	Chicago, Ill.	17474	Tranex Company	Mountain View, Cal.
04673	Dakota Engr. Inc.	Culver City, Cal.	09353	C & K Components Inc.	Newton, Mass.	17675	Hamlin Metal Products Corp.	Akron, Ohio
04713	Motorola Inc. Semiconductor Prod. Div.	Phoenix, Arizona	09569	Mallory Battery Co. of Canada, Ltd.	Toronto, Ontario, Canada	17745	Angstrom Prec. Inc.	No. Hollywood, Cal.
04732	Filttron Co., Inc. Western Div.	Culver City, Cal.	09795	Pennsylvania Florocarbon	Clifton Heights, Penn.	17856	Siliconix Inc.	Sunnyvale, Cal.
04773	Automatic Electric Co.	Northlake, Ill.	09922	Burndy Corp.	Norwalk, Conn.	17870	McGraw-Edison Co.	Manchester, N. H.
04796	Sequia Wire Co.	Redwood City, Cal.	10214	General Transistor Western Corp.	Los Angeles, Cal.	18042	Power Design Pacific Inc.	Palo Alto, Cal.
04811	Precision Coil Spring Co.	El Monte, Cal.	10411	Ti-Tal, Inc.	Berkeley, Cal.	18083	Clevite Corp. Semiconductor Div.	Palo Alto, Cal.
04870	P. M. Motor Company	Westchester, Ill.	10648	Carborundum Co.	Niagara Falls, N. Y.	18324	Signetics Corp.	Sunnyvale, Cal.
04919	Component Mfg. Service Co.	W. Bridgewater, Mass.				18476	Ty-Car Mfg. Co., Inc.	Holliston, Mass.
05006	Twentieth Century Plastics, Inc.	Los Angeles, Cal.				18486	TRW Elect. Comp. Div.	Des Plaines, Ill.
05277	Westinghouse Electric Corp. Semiconductor Dept.	Youngwood, Pa.				18565	Chometrics	Plainville, Mass.
						18583	Curtis Instrument, Inc.	Mt. Kisco, N. Y.
						18612	Vislay Instruments Inc.	Malvern, Pa.
						18873	E. I. DuPont and Co., Inc.	Wilmington, Del.
						18911	Durant Mfg. Co.	Milwaukee, Wis.
						19315	The Bendix Corp., Navigation & Control Div.	Teterboro, N. J.
						19500	Thomas A. Edison Industries, Div. of McGraw-Edison	West Orange, N. J.
						19589	Concoa	Baldwin Park, Cal.



MANUAL BACKDATING CHANGES

Model Model 3310A/B

Name FUNCTION GENERATOR

Prefix _____

This manual backdating sheet makes this manual applicable to earlier instruments. Instrument-component values that differ from those in the manual, yet are not listed in the backdating sheet, should be replaced using the part number given in the manual. Accomplish the highest number change first, and work towards the lowest number.

Instrument Serial Prefix	Make Manual Changes	Instrument Serial Prefix	Make Manual Changes
920-00111 and below	11-1	947-01950 and below	11-7
920-0450 and below	11-2	0947A02850 and below	11-8
947-01200 and below	11-3	1048A03650 and below	11-9
947-01450 and below	11-4	3310A:1126A04250 & below 3310B: 1125A00175 & below	11, 10
947-1576 and below	11-5	3310A: 1151A05600 & below 3310B: 1201A00675 & below	11
947-01700 and below	11-6		

CHANGE NO. 1

Page 7-7/7-8, Figure 7-3

Delete Ferrite bead (L9) on the base of A1Q20.

Page 6-2, Table 6-1

Delete L9, Ferrite bead, Part No. 9170-0016.

CHANGE NO. 2

Page 6-4

Change A1R54 to R: fxd comp 1200 ohms 5% 1/4 W (0683-1225).

Change A1R55 to R: fxd comp 390 ohms 5% 1/4 W (0683-3915).

Page 6-10

Delete vernier drive plate assembly (03310-60605) and add spring: vernier (03310-09191).

Delete Assembly: heat sink spacer (03310-24701).

Page 7-7/7-8

Change A1R54 and A1R55 to 1200 ohms and 390 ohms, respectively.

CHANGE NO. 3

Table 6-1

Delete Panel: Rear (03310-00203). (Miscellaneous).

Add Panel: Rear (03310-00202). (Miscellaneous).

Delete J5, Connector: Power (1251-2357).

Add J5, Connector: Power (1251-0148).

Delete W1, Cord: Power (8120-1348).

Add W1, Cord: Power (8120-0078).

CHANGE NO. 4

Table 6-1

Delete A1R163 thru A1R168 and add A1L1 thru A1L5 and A1L7, Inductor: fxd 20uH 10% (9140-0047).

NOTE

It is recommended that inductors L1 thru L5 and L7 be replaced by the resistors R163 and R168 as indicated in the manual if replacement becomes necessary.

CHANGE NO. 5

Model 3310A's with Serial number 947-01575 and below have output transistors (Q1 and Q2) mounted on a metal bracket as shown below. To install replacement transistors, remove the bracket and connect the transistors' leads directly to the appropriate pins on the A3 assembly. Transistor assemblies A8 and A9 (mentioned in Change 9) should be used for this purpose. A heat sink spacer, -hp- part no. 03310-24702, will also be required.

NOTE

Instruments which have been modified per service note P-3310-69503 have assemblies A8 and A9 already installed.

CHANGE NO. 6

Table 6-1

Delete A3IC1 (1820-0203) and A3CR28 (1902-0681).
 Add A3Q7 and A3Q8 (1854-0215).
 Add A3R34, 7150 ohms fxd flm 1% 1/8 W (0698-4471).
 Delete A3R36, A3C5, and A3C6 and add A3R35 and A3R36, 2000 ohms fxd comp 5% 1/4 W (0683-2025).
 Add A3C4, A3C5, and A3C6, 0.001uF fxd cer 500 vdcw (0150-0069).

Figure 7-4

Delete A3R33, A3R36, A3IC1, A3CR28, A3C5 and A3C6.
 Replace with circuit below:

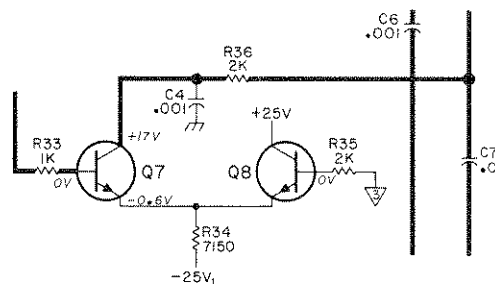

Change A3C13 and A3R43 near Q9 to .1uF and 357 ohms respectively.

Change C11 near Q12 to .1uF.

Delete the component location diagram for the A3 board as shown in Figures 7-4 and 7-5 and substitute the diagram shown below.

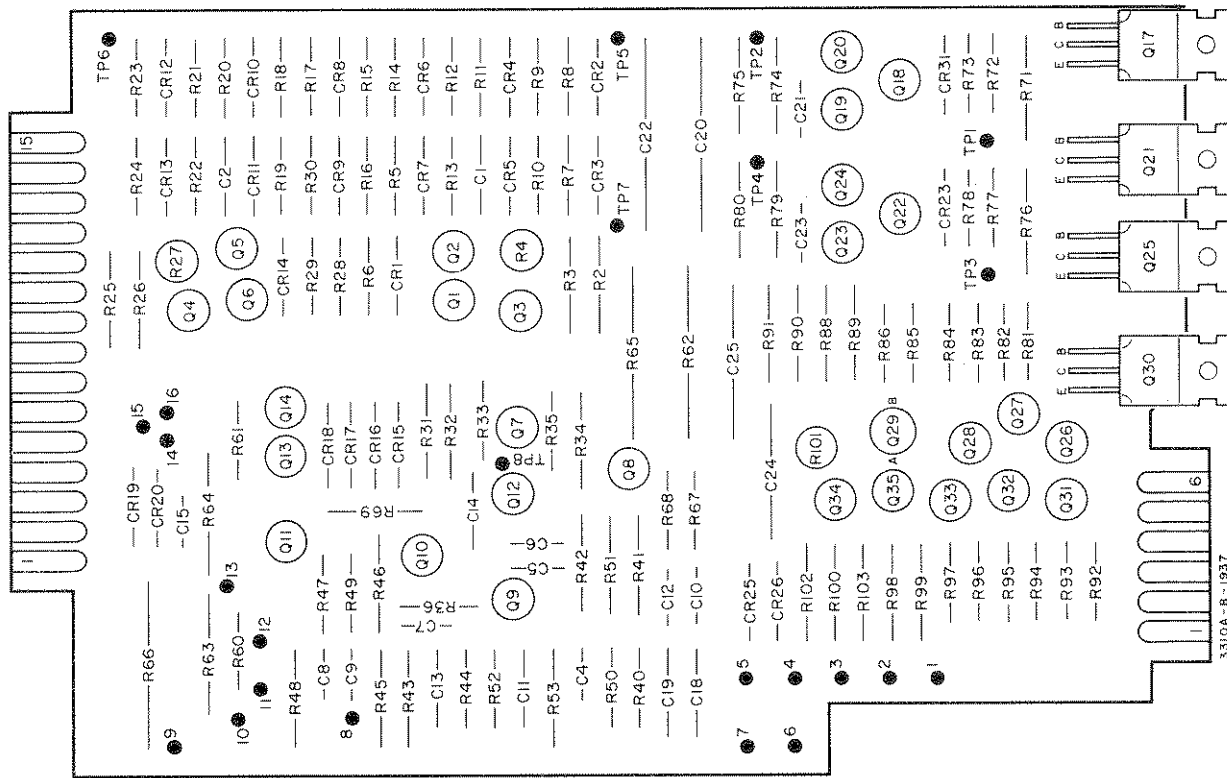

A3
hp Part No. 03310-66503

CHANGE NO. 7

Table 6-1

Delete A2R22 (0757-0465) and A2R23 (2100-2514).

Figure 7-4

Delete resistors A2R22 and A2R23 near A2Q2. Connect A2C4 from collector of A2Q2 to circuit ground.

Delete the component location diagram for the A2 board as shown in Figure 7-4 and substitute the diagram shown below.

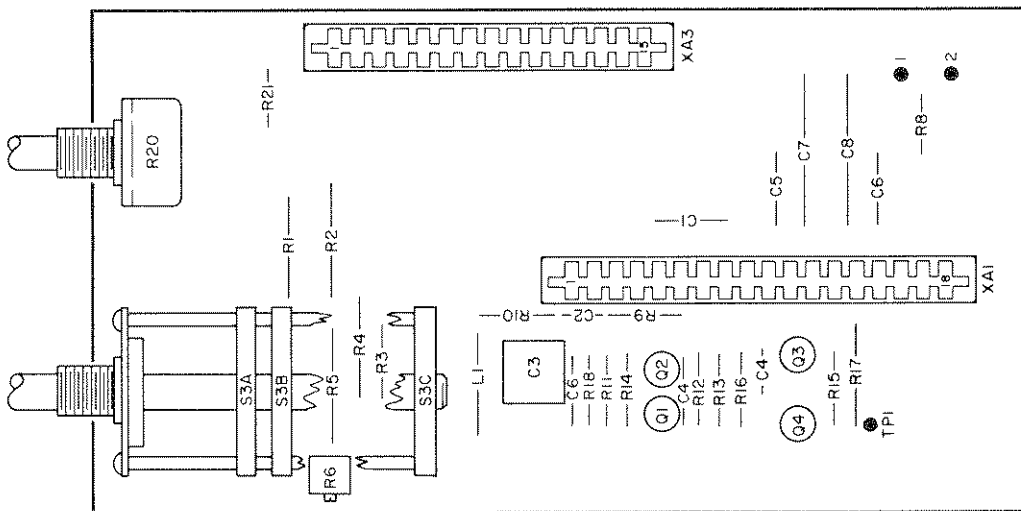

A2
hp Part No. 03310-66502

CHANGE NO. 8

Table 6-1:

Delete Panel Assembly: rear (Miscellaneous), -hp- part no. 03310-60201. (Includes J5 and S5).
 Change A2R21 to R: fxd, $27 \Omega \pm 5\%$ 1/4 W, -hp- part no. 0683-0465.
 Change the -hp- part no. of the A3 assembly to 03310-66503.
 Delete the following components:
 A3R26* and A3CR29
 Change A3R62 and A3R65 to R: fxd, $22 \Omega \pm 5\%$ 2 W, -hp- part no. 0698-3609.
 Change A3R66 to R: fxd, $47 \Omega \pm 5\%$ 2 W, -hp- part no. 0698-3615.
 Change A3R72 and A3R77 to R: fxd, $330 \Omega \pm 5\%$ 1/4 W, -hp- part no. 0683-3315.
 Change the -hp- part no. of J5 (a.c. power connector) to 1251-0148.
 Change the -hp- part no. of W1 (a.c. power cord) to 8120-0078.
 Add Panel: rear, -hp- part no. 03310-00202 (Miscellaneous).

CHANGE NO. 9

Table 6-1:

Delete Transistors: Output (Q1 and Q2), -hp- part nos. 1854-0254 and 1853-0012, respectively.
 Change the -hp- part no. of the A3 assembly to 03310-66503.
 Delete the following components:
 A3CR30, A3CR31, A3C27, A3C28, A3R104, and A3R105.
 Add to Chassis Mounted Components:
 Output transistor assembly (A8), -hp- part no. 03310-67901, includes:
 Transistor: Si NPN, -hp- part no. 1854-0254.
 C: fxd, $.47 \mu\text{F}$ 35 vdcw, -hp- part no. 0180-0291.
 Output transistor assembly (A9), -hp- part no. 03310-67902, includes:
 Transistor: Si PNP, -hp- part no. 0185-0012.
 C: fxd, $.47 \mu\text{F}$ 35 vdcw, -hp- part no. 0180-0291.
 Add Spacer: heat sink, -hp- part no. 03310-24702 1 ea. (Misc.).
 Also make the changes indicated on Figure 7-5 of this manual.
 Capacitor A3C26* should be shown in Figure 7-4. It is connected in the same manner as shown on the schematic for the latest instruments. (Figure 7-4).

All references to 3310B in the manual also apply to 3310A-H10.

Change A1R71 and A1R81 to R: fxd, $100 \text{ k}\Omega \pm 5\%$ 1/4W -hp- part no. 0683-1045.
 Change A1C22 and A1C26 to C: fxd, $1 \mu\text{F}$ 35 V, -hp- part no. 0180-0291.

CHANGE NO. 10

Table 6-1:

Change CR1 to 1902-1200
 Change Panel: front 3310A to 03310-00201
 Panel: front 3310B to 03310-00206
 Cover: side to 5000-0150
 Cover assy: top to 5060-5922
 Cover: bottom to 5000-0716

CHANGE NO. 11

Page 5-11, Paragraph 5-159, third sentence.

Change to read as follows: Adjust A2C3 for best frequency response . . .

Page 5-12, Table 5-4.

Under Purpose, opposite A2C6*, change to the following:

Pad for A2C3. Sine flatness at 5 MHz. Under Nominal Value, change to 10 pF \pm 2 pF.

Page 6-6.

Change A2C3 to 0121-0430 1.4 pF - 9.2 pF.

Change A2C6* to 0150-0055 5.6 pF

Add A3C3

Page 7-9.

Delete A2R7 and change C3 as follows:

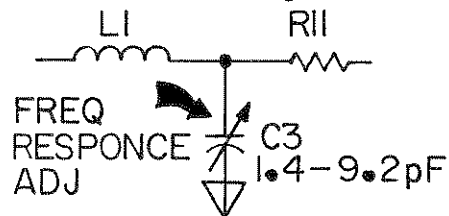

Change A2C6* to 10 pF.

Delete "FREQ RESPONSE ADJ" next to A2C6*.

Delete A3C3.