

Errata

Title & Document Type: 239A Oscillator Operating and Service Manual

Manual Part Number: 00239-90000

Revision Date: April 1978

About this Manual

We've added this manual to the Agilent website in an effort to help you support your product. This manual provides the best information we could find. It may be incomplete or contain dated information, and the scan quality may not be ideal. If we find a better copy in the future, we will add it to the Agilent website.

HP References in this Manual

This manual may contain references to HP or Hewlett-Packard. Please note that Hewlett-Packard's former test and measurement, life sciences, and chemical analysis businesses are now part of Agilent Technologies. The HP XXXX referred to in this document is now the Agilent XXXX. For example, model number HP8648A is now model number Agilent 8648A. We have made no changes to this manual copy.

Support for Your Product

Agilent no longer sells or supports this product. You will find any other available product information on the Agilent Test & Measurement website:

www.agilent.com

Search for the model number of this product, and the resulting product page will guide you to any available information. Our service centers may be able to perform calibration if no repair parts are needed, but no other support from Agilent is available.



Agilent Technologies

OPERATING AND SERVICE MANUAL

OSCILLATOR

239A



HEWLETT  PACKARD

4-239A



OPERATING AND SERVICE MANUAL

MODEL 239A OSCILLATOR

Serial Numbers: 1814A00101 and Greater

IMPORTANT NOTICE

This manual applies directly to instruments with the serial numbers shown on this page. If changes have been made in the instrument since this manual was printed, a "Manual Changes" supplement supplied with this manual will define these changes. Backdating information contained in Section VII adapts this manual to instruments having serial numbers lower than those shown on this page.

WARNING

To help minimize the possibility of electrical fire or shock hazards, do not expose this instrument to rain or excessive moisture.

Manual Part No. 00239-90000

Microfiche Part No. 00239-90050

Copyright Hewlett-Packard Company 1978
P.O. Box 301, Loveland, Colorado 80537 U.S.A.

Printed: April 1978

HEWLETT  PACKARD

CERTIFICATION

Hewlett-Packard Company certifies that this instrument met its published specifications at the time of shipment from the factory. Hewlett-Packard Company further certifies that its calibration measurements are traceable to the United States National Bureau of Standards, to the extent allowed by the Bureau's calibration facility, and to the calibration facilities of other International Standards Organization members.

WARRANTY AND ASSISTANCE

This Hewlett-Packard product is warranted against defects in materials and workmanship for a period of one year from the date of shipment, except that in the case of certain components, if any, listed in Section I of this operating manual, the warranty shall be for the specified period. Hewlett-Packard will, at its option, repair or replace products which prove to be defective during the warranty period provided they are returned to Hewlett-Packard, and provided the proper preventive maintenance procedures as listed in this manual are followed. Repairs necessitated by misuse of the product are not covered by this warranty. **NO OTHER WARRANTIES ARE EXPRESSED OR IMPLIED, INCLUDING BUT NOT LIMITED TO THE IMPLIED WARRANTIES OF MERCHANTABILITY AND FITNESS FOR A PARTICULAR PURPOSE. HEWLETT-PACKARD IS NOT LIABLE FOR CONSEQUENTIAL DAMAGES.**

If this product is sold as part of a Hewlett-Packard integrated instrument system, the above warranty shall not be applicable, and this product shall be covered only by the system warranty.

Service contracts or customer assistance agreements are available for Hewlett-Packard products.

For any assistance, contact your nearest Hewlett-Packard Sales and Service Office. Addresses are provided at the back of this manual.

TABLE OF CONTENTS

| Section | Page |
|--|---------|
| I. GENERAL INFORMATION | 1-1 |
| 1-1. Introduction..... | 1-1 |
| 1-4. Specifications..... | 1-1 |
| 1-6. Safety Considerations..... | 1-1 |
| 1-8. Instrument and Manual Identification..... | 1-1 |
| 1-12. Description..... | 1-2 |
| 1-15. Recommended Test Equipment..... | 1-2 |
| | |
| Section | Page |
| II. INSTALLATION | 2-1 |
| 2-1. Introduction..... | 2-1 |
| 2-3. Initial Inspection..... | 2-1 |
| 2-5. Preparation For Use..... | 2-1 |
| 2-6. Power Requirements..... | 2-1 |
| 2-8. Line Voltage Selection..... | 2-1 |
| 2-10. Power Cable..... | 2-2 |
| 2-12. Grounding Requirements..... | 2-3 |
| 2-14. Bench Use..... | 2-3 |
| 2-16. Rack Mounting..... | 2-3 |
| 2-18. Environmental Requirements..... | 2-3 |
| 2-19. Operating and Storage Temperature..... | 2-4 |
| 2-22. Humidity..... | 2-4 |
| 2-24. Altitude..... | 2-4 |
| 2-26. Repackaging For Shipment..... | 2-4 |
| | |
| Section | Page |
| III. OPERATION | 3-1 |
| 3-1. Introduction..... | 3-1 |
| 3-3. Operating Characteristics..... | 3-1 |
| 3-4. General..... | 3-1 |
| 3-7. Panel Features..... | 3-1 |
| 3-9. Operating Instructions..... | 3-1 |
| 3-10. Turn-On and Warm-Up..... | 3-1 |
| 3-12. Frequency Selection..... | 3-1 |
| 3-14. Output Level..... | 3-3/3-4 |
| 3-16. Ground Selection..... | 3-3/3-4 |
| 3-18. Operator's Maintenance..... | 3-3/3-4 |
| 3-19. Fuse Replacement..... | 3-3/3-4 |
| | |
| Section | Page |
| IV. PERFORMANCE TESTS | 4-1 |
| 4-1. Introduction..... | 4-1 |
| 4-3. Equipment Required..... | 4-1 |

| Section | Page |
|---|---------|
| IV. PERFORMANCE TESTS (Cont'd) | |
| 4-5. Test Record..... | 4-1 |
| 4-7. Calibration Cycle..... | 4-1 |
| 4-9. Performance Tests..... | 4-1 |
| 4-10. Output Impedance Test..... | 4-1 |
| 4-11. Output Level and Flatness Test..... | 4-2 |
| 4-12. Attenuator Accuracy Test..... | 4-2 |
| 4-15. Frequency Accuracy Test..... | 4-4 |
| 4-16. Total Harmonic Distortion Test..... | 4-4 |
| | |
| Section | Page |
| V. ADJUSTMENTS | 5-1 |
| 5-1. Introduction..... | 5-1 |
| 5-3. Equipment Required..... | 5-1 |
| 5-5. Adjustment Locations..... | 5-1 |
| 5-7. Factory Selected Components..... | 5-1 |
| 5-9. Adjustment Procedures..... | 5-1 |
| 5-10. Gain Adjustment..... | 5-1 |
| 5-11. Frequency Adjustment..... | 5-2 |
| 5-12. Output Adjustment..... | 5-2 |
| | |
| Section | Page |
| VI. REPLACEABLE PARTS | 6-1 |
| 6-1. Introduction..... | 6-1 |
| 6-4. Ordering Information..... | 6-1 |
| 6-6. Non-Listed Parts..... | 6-1 |
| 6-8. Parts Changes..... | 6-1 |
| 6-10. Proprietary Parts..... | 6-2 |
| | |
| Section | Page |
| VII. MANUAL CHANGES | 7-1/7-2 |
| 7-1. Introduction..... | 7-1/7-2 |
| | |
| Section | Page |
| VIII. SERVICE | 8-1 |
| 8-1. Introduction..... | 8-1 |
| 8-3. Safety Considerations..... | 8-1 |
| 8-8. Recommended Test Equipment..... | 8-1 |
| THEORY OF OPERATION | |
| 8-10. General Description..... | 8-2 |
| 8-15. Circuit Descriptions..... | 8-3 |
| 8-16. Frequency Generation..... | 8-3 |
| 8-18. Amplitude Control..... | 8-4 |
| 8-20. Output Buffer and Attenuator..... | 8-5/8-6 |

TABLE OF CONTENTS (Cont'd)

LIST OF TABLES

| Table | Page |
|--|---------|
| 1-1. Specifications | 1-2 |
| 1-2. Supplemental Characteristics..... | 1-3/1-4 |
| 1-3. Recommended Test Equipment..... | 1-3/1-4 |
| 4-1. Output Level Flatness Test..... | 4-2 |
| 4-2. Frequency Accuracy Test..... | 4-5 |
| 4-3. Oscillator Total Harmonic Distortion Test.... | 4-8 |
| 5-1. Factory Selected Components..... | 5-3/5-4 |
| 5-2. Adjustable Components..... | 5-3/5-4 |
| 6-1. Standard Abbreviations..... | 6-2 |
| 6-2. Code List of Manufacturers..... | 6-2 |
| 6-3. Replaceable Parts..... | 6-3 |

LIST OF ILLUSTRATIONS

| Figure | Page |
|---|-----------|
| 2-1. Line Voltage Selection..... | 2-2 |
| 2-2. Available Power Cables and Plug Configurations..... | 2-3 |
| 3-1. Control, Connector, and Indicator Descriptions..... | 3-2 |
| 4-1. Attenuator Accuracy Test..... | 4-3 |
| 4-2. Total Harmonic Distortion Test..... | 4-6 |
| 4-3. Logarithmic Addition of Harmonic Components..... | 4-7 |
| 5-1. Adjustment and Test Point Locations.... | 5-3/5-4 |
| 8-1. Model 239A Simplified Block Diagram..... | 8-2 |
| 8-2. Simplified Oscillator Circuitry..... | 8-3 |
| 8-3. Simplified Amplitude Control Circuit..... | 8-4 |
| 8-4. Oscillator and Amplitude Control Circuit..... | 8-9/8-10 |
| 8-5. Output and Power Supply Circuits..... | 8-11/8-12 |

SECTION I GENERAL INFORMATION

1-1. INTRODUCTION.

1-2. This Operating and Service Manual contains information necessary to install, operate, test, adjust, and service the Hewlett-Packard Model 239A Oscillator.

1-3. This section of the manual contains the performance specifications and general operating characteristics of the Model 239A. This section also lists available options and accessories and includes instrument and manual identification information.

1-4. SPECIFICATIONS.

1-5. Operating Specifications for the Model 239A are listed in Table 1-1. These specifications are the performance standards or limits against which the instrument is tested. Table 1-2 lists supplemental characteristics of the instrument. Supplemental characteristics are not specifications but are typical characteristics included as additional information for the user.

1-6. SAFETY CONSIDERATIONS.

1-7. This product is a Safety Class 1 instrument (provided with a protective earth terminal). The instrument and manual should be reviewed for safety markings and instructions before operation.

1-8. INSTRUMENT AND MANUAL IDENTIFICATION.

1-9. Instrument identification by serial number is located on a plate attached to the rear panel of the instrument. Hewlett-Packard uses a two-section serial number consisting of a four-digit prefix and a five-digit suffix separated by a letter designating the country in which the instrument was manufactured (A = U.S.A.; G = West Germany; J = Japan; U = United Kingdom). The prefix is the same for all identical instruments and changes only when a major instrument change is made. The suffix, however, is assigned sequentially and is unique to each instrument.

1-10. This manual applies to instruments with serial numbers indicated on the title page. If changes have been made in the instrument since the manual was printed, a yellow "Manual Changes" supplement supplied with the manual will define these changes and explain how to adapt the manual to the newer instruments. In addition, backdating information contained in Section VII adapts the manual to older instruments with serial numbers lower than those listed on the title page.

1-11. Part numbers for the manual and the microfiche copy of the manual are listed on the title page.

1-12. DESCRIPTION.

1-13. The Model 239A is an ultra-low distortion sinusoidal oscillator designed for application in the audio frequency range. Frequency range of the 239A extends from 10 Hz to 110 kHz in four overlapping decade ranges with two digit resolution. A frequency vernier provides continuous frequency coverage between settings of the second digit control.

1-14. Output level of the 239A is variable from less than 1 mV rms to 3.16 V rms when terminated with a 600 ohm load.

1-15. RECOMMENDED TEST EQUIPMENT.

1-16. Equipment required to maintain the Model 239A is listed in Table 1-3. Other equipment may be substituted if it meets the critical requirements listed in the table.

Table 1-1. Specifications.**Frequency Range:**

10 Hz to 110 kHz in 4 overlapping decade ranges with 2 digit resolution. Frequency vernier provides continuous frequency coverage between second digit switch settings.

Frequency Accuracy:

$\pm 2\%$ of selected frequency (with FREQUENCY VERNIER in CAL position).

Output Level:

Maximum Calibrated Output (1 kHz, 600 Ω load):
+ 10 dBV (3.16 Vrms) $\pm .2$ dB
Output variable from < 1 mV to 3.16 V rms into 600 ohms.

Output Attenuator:

Range: 60 dB in 10 dB steps
Accuracy: $\pm .25$ dB/10 dB step. Maximum Accumulative Error ± 1 dB
Output Vernier: > 10 dB range, continuously variable

Level Flatness:

20 Hz to 20 kHz: $\leq \pm 0.1$ dB
10 Hz to 110 kHz: $\leq \pm 0.2$ dB

Distortion ($\geq 600 \Omega$ Load, ≤ 3 V Output):

10 Hz to 20 kHz: < -95 dB (0.0018%) THD
20 kHz to 30 kHz: < -85 dB (0.0056%) THD
30 kHz to 50 kHz: < -80 dB (0.01%) THD
50 kHz to 110 kHz: < -70 dB (0.032%) THD

Output Impedance:

600 $\Omega \pm 5\%$

Table 1-2. Supplemental Characteristics.

| |
|---|
| <p>Operating Environment: Temperature: 0°C to 50°C (+ 32°F to + 122°F) Humidity Range: < 95%, 0°C to 40°C (+ 32°F to + 104°F)</p> <p>Storage Temperature: - 40°C to + 75°C (- 40°F to + 167°F)</p> <p>Power: 100/120/220/240 V, + 5%, - 10%, 48 to 66 Hz, 10 VA max.</p> <p>Weight: Net 2.5 kg (5.5 lbs.); Shipping 3.9 kg (8.5 lbs.)</p> <p>Dimension: 106 mm wide × 88 mm high × 269 mm deep (8.4" wide × 3.5" high × 10.6" deep)</p> |
|---|

Table 1-3. Recommended Test Equipment.

| Instrument | Critical Specification | Recommended Model | Use |
|----------------------|---|---|-----|
| Spectrum Analyzer | Frequency Range: 10 Hz-330 kHz Frequency Resolution: .1 Hz Input Amplitude: 1 V Dynamic Range: 50 dB Measurement Resolution: ± .1 dB Minimum Bandwidth: 3 Hz | -hp- Model 3044A Spectrum Analyzer | P |
| True RMS Voltmeter | Frequency Range: 10 Hz-110 kHz Voltage Range: 1 mV-10V rms Measurement Accuracy: ± .5% Measurement Resolution: .1% of full scale Crest Factor: ≥ 4 | -hp- Model 3403C True RMS Voltmeter | P |
| Tunable Notch Filter | Frequency Range: 10 Hz-110 kHz Notch Depth: ≥ - 80 dB Input Level: 3 V rms | -hp- Model 339A Distortion Measurement Set | P |
| Electronic Counter | Frequency Range: 10 Hz-110 kHz Measurement Resolution: .1% of reading | -hp- Model 5300A Counter Mainframe -hp- Model 5302A Counter Module | P |
| Attenuator | Attenuation: 0 to 60 dB Accuracy: ± 0.1 dB Input/Output Impedance: 600 Ω Frequency Range: 10Hz to 110kHz | -hp- Model 4437A Attenuator | P |
| DC Digital Voltmeter | Input Range: 15 V dc Measurement Accuracy: ± .1% Resolution: .01% of full scale | -hp- Model 3465A Digital Voltmeter | AT |
| Oscilloscope | Bandwidth: DC - 500 kHz Sweep Time: .1 μs - .5 sec/div. Sensitivity: .1 V/div. | -hp- Model 1221A Oscilloscope | T |
| Resistive Load | 600 Ω, ± .1% | -hp- Accessory No. 11095A | PA |

P = Performance Tests
 A = Adjustment Procedures
 T = Troubleshooting

SECTION II INSTALLATION

2-1. INTRODUCTION.

2-2. This section of the manual contains information and instructions necessary to install the Model 239A Oscillator. This section also includes initial inspection procedures, power and grounding requirements, environmental information, and packaging instructions.

2-3. INITIAL INSPECTION.

WARNING

To avoid hazardous electrical shock, do not perform electrical tests when there are signs of shipping damage to any portion of the outer enclosure (covers, panels, meters).

2-4. This instrument was carefully inspected, both mechanically and electrically, before shipment. It should be free of marks and scratches and in perfect electrical order. The instrument should be inspected upon receipt for damage that might have occurred in transit. If the shipping container or cushioning material is damaged, it should be kept until the contents of the shipment have been checked for completeness and the instrument has been mechanically and electrically inspected. Procedures for testing the electrical performance of the Model 239A are given in Section IV of this manual. If the contents are incomplete, if there is mechanical damage or defect, or if the instrument does not pass the Performance Tests, notify the nearest Hewlett-Packard Office. (A list of the -hp- Sales and Service Offices is presented at the back of this manual.) If the shipping container is damaged, or the cushioning material shows signs of stress, notify the carrier as well as the Hewlett-Packard Office. Save the shipping materials for the carrier's inspection.

2-5. PREPARATION FOR USE.

2-6. Power Requirements.

2-7. The Model 239A requires a power source of 100, 120, 220, or 240 V ac (+ 5%, - 10%), 48 Hz to 66 Hz single phase. Maximum power consumption is 10 VA.

2-8. Line Voltage Selection.

2-9. Before connecting ac power to the Model 239A make sure the rear panel line selector switches are set to correspond to the available power line voltage and that the proper fuse is installed (see Figure 2-1). The instrument is normally shipped from the factory with the line voltage and fuse selected for 120 V ac operation.

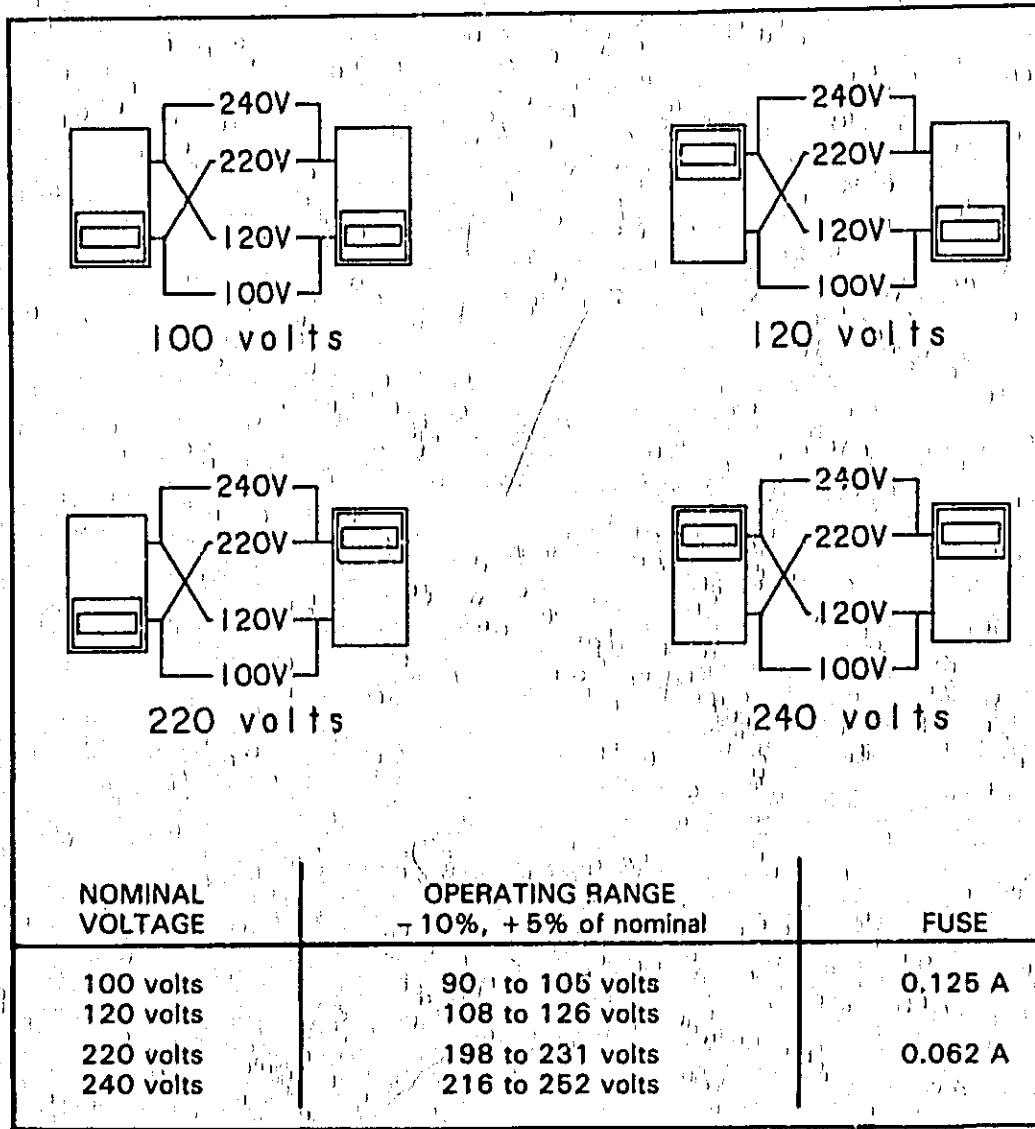

Figure 2-1. Line Voltage Selection.

2-10. Power Cable.

2-11. Figure 2-2 illustrates the standard configurations for -hp- power cables. The number directly below each drawing is the -hp- Part Number for a power cable equipped with a connector of that configuration. If the appropriate power cable is not included with the instrument, notify the nearest -hp- Sales and Service Office and the proper cable will be provided.

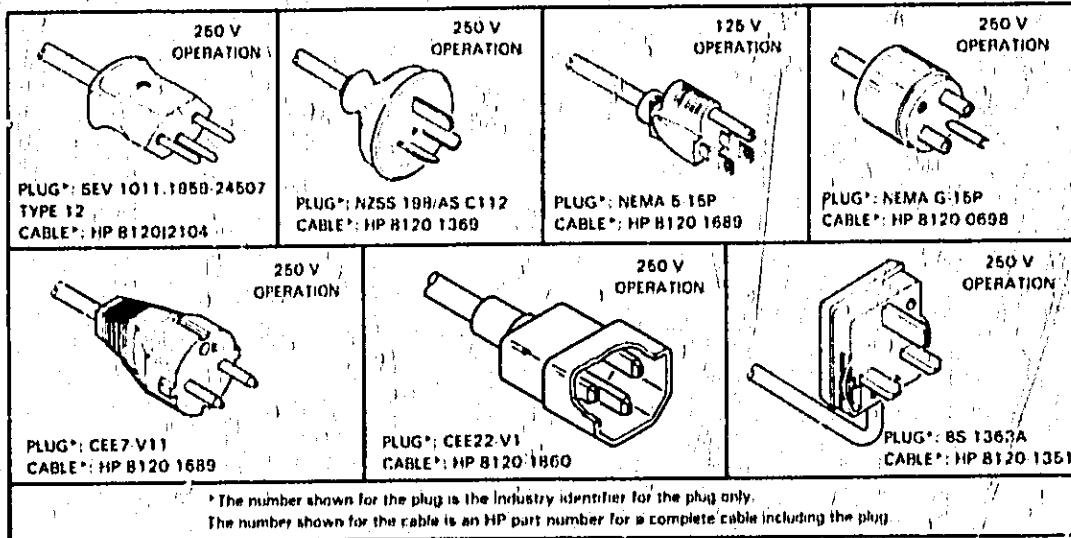

Figure 2-2. Available Power Cables and Plug Configurations.

2-12. Grounding Requirements.

2-13. To protect operating personnel, the National Electrical Manufacturer's Association (NEMA) recommends that the instrument cabinet and front panel be grounded. The Model 239A is equipped with a three-conductor power cable, which, when plugged into an appropriate receptacle, grounds the instrument.

2-14. Bench Use.

2-15. The Model 239A is shipped with plastic feet and tilt stands installed and is ready for use as a bench instrument. The plastic feet are shaped to permit "stacking" with other half-module Hewlett-Packard instruments. The tilt stand permits the operator to elevate the front of the instrument for operating and viewing convenience.

2-16. Rack Mounting.

2-17. The Model 239A may be rack mounted by adding rack mounting adapter kit -hp- Part Number 5061-0054. This kit contains all necessary hardware and instructions to permit the Model 239A to be mounted in a standard 19 inch rack.

2-18. ENVIRONMENTAL REQUIREMENTS.

WARNING

To prevent electrical shock or fire hazard, do not expose the instrument to rain or moisture.

2-19. Operating and Storage Temperature.

2-20. In order to meet the specifications listed in Table 1-1, the instrument should be operated within an ambient temperature range of 0°C to +50°C (+32°F to +122°F).

2-21. The instrument may be stored or shipped where the ambient temperature range does not exceed -40°C to +75°C (-40°F to +167°F). However, the instrument should not be stored or shipped where temperature fluctuations cause condensation within the instrument.

2-22. Humidity.

2-23. The instrument may be operated in environments with relative humidity of up to 95%. However, the instrument must be protected from temperature extremes which cause condensation within the instrument.

2-24. Altitude.

2-25. The instrument may be operated at altitudes up to 4572 meters (15,000 feet).

2-26. REPACKAGING FOR SHIPMENT.**NOTE**

If the instrument is to be shipped to Hewlett-Packard for service or repair, attach a tag to the instrument identifying the owner and indicating the service or repair to be accomplished. Include the model number and full serial number of the instrument. In any correspondence, identify the instrument by model number and full serial number. If you have any questions, contact your nearest -hp-Sales and Service Office.

2-27. The following is a general guide for repackaging the instrument for shipment. If the original container is available, place the instrument in the container with appropriate packing material and seal well with strong tape or metal bands. If the original container is not available, proceed as follows:

- a. Wrap the instrument in heavy paper or plastic before placing it in an inner container.
- b. Place packing around all sides of the instrument and protect the front panel with cardboard strips or plastic foam.
- c. Place the instrument and inner container in a heavy carton and seal with strong tape or metal bands.
- d. Mark the shipping container "DELICATE INSTRUMENT", "FRAGILE", etc.

SECTION III OPERATION

3-1. INTRODUCTION.

3-2. This section contains information and instructions necessary for operation of the Model 239A Oscillator. Included is a description of the operating characteristics and of the operating controls and connectors.

3-3. OPERATING CHARACTERISTICS.

3-4. General.

3-5. The Model 239A is an ultra-low distortion sinusoidal oscillator designed for use in the audio frequency range. Frequency range of 239A extends from 10 Hz to 110 kHz in four overlapping ranges with two digit resolution. A frequency vernier provides continuous frequency coverage between settings of the second digit control.

3-6. Output amplitude of the 239A is variable from 3.16 mV rms to 3.16 V rms in six 10 dB steps using the LEVEL control. A level vernier provides continuous level control between settings of the LEVEL control. Full output range of the 239A is less than 1 mV rms to 3.16 V rms when terminated by 600 ohms (< 2 mV rms to 6.32 V rms open circuit).

3-7. PANEL FEATURES.

3-8. Front and rear panel controls and connectors are described in Figure 3-1. The description of each control and connector is keyed to the number shown in the illustration.

3-9. OPERATING INSTRUCTIONS.

3-10. Turn-On and Warm-Up.

3-11. Before connecting ac power to the instrument, be certain the rear panel voltage selector switches are set to correspond to the voltage of the available power line and that the proper fuse is installed for the voltage selected. For rated accuracy, the 239A should be allowed to "warm up" for at least 15 minutes.

3-12. Frequency Selection.

3-13. The output frequency is determined by the setting of the FREQUENCY and FREQUENCY VERNIER controls. The units and tenths controls determine the first and second digits of the desired frequency. These numbers are then multiplied by the range selected. As an example—to select a frequency of 6.4 kHz, set the units control to 6, the tenths control to .4, and the multiplier to $\times 1k$. (The FREQUENCY VERNIER should be set to the CAL position.) The FREQUENCY VERNIER provides continuous frequency tuning between steps of the tenths control to permit continuous frequency selection from 10 Hz to 110 kHz.

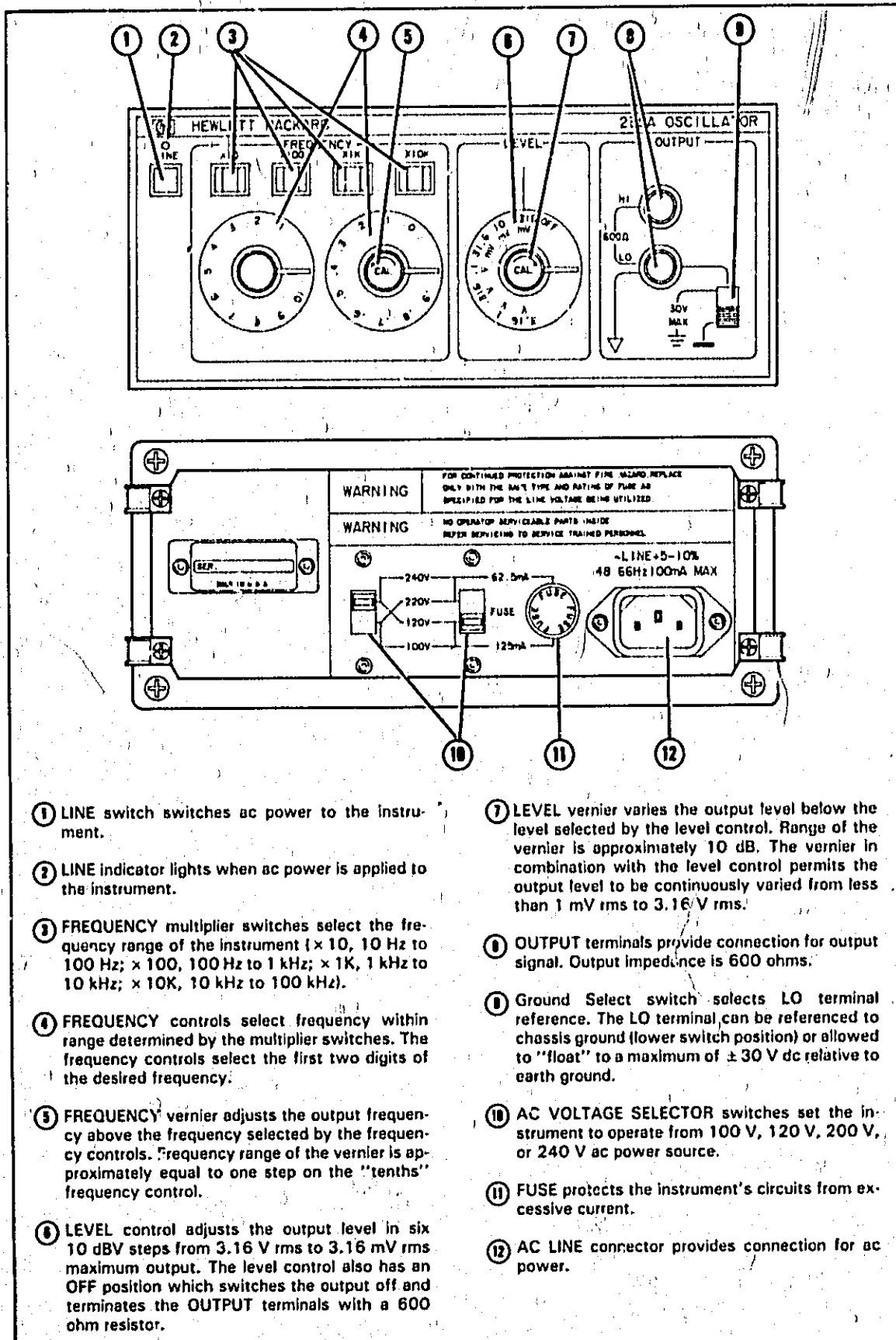

Figure 3-1. Control, Connector, and Indicator Descriptions.

3-14. Output Level.

3-15. The output amplitude is controlled by the LEVEL and LEVEL VERNIER controls. The LEVEL control selects output levels from 3.16 V rms full-scale to 3.16 mV rms full-scale in six 10 dBV steps (terminated with 600 ohms). The LEVEL VERNIER provides continuous level selection between settings of the LEVEL control to permit selection of output levels from less than 1 mV rms to 3.16 V rms into 600 ohms (< 2 mV rms to 6.32 V rms open circuit).

3-16. Ground Selection.

3-17. A front panel switch allows the user to reference the OUTPUT LO terminal to chassis ground (bottom position) or float the LO terminal to eliminate "ground loops". The 239A chassis ground is connected to safety or power line ground at the rear panel.

CAUTION

To prevent damage to the oscillator circuitry, do not float the LO OUTPUT terminal more than ± 30 V dc relative to earth ground.

3-18. OPERATOR'S MAINTENANCE.**3-19. Fuse Replacement.**

3-20. The ac line fuse is located on the rear panel of the instrument. Before checking or replacing the fuse, disconnect the ac line cord from the instrument. Refer to Figure 2-1 for the proper fuse value.

WARNING

For continued protection against fire hazard, replace only with the same type and rating of fuse as specified for the line voltage being used.

SECTION IV PERFORMANCE TESTS

4-1. INTRODUCTION.

4-2. This section contains performance test procedures which can be used to verify that the Model 239A Oscillator meets the specifications listed in Table I-1. All tests can be performed without access to the interior of the instrument.

4-3. EQUIPMENT REQUIRED.

4-4. The test equipment required for the performance tests is listed at the beginning of each procedure and in the Recommended Test Equipment Table in Section I. If the recommended equipment is not available, any equipment which meets the critical specifications given in the table may be substituted.

4-5. TEST RECORD.

4-6. A Performance Test Record is included at the end of this section for convenience in recording performance data. This record may be removed from the manual and used as a permanent record of the incoming inspection or of a routine performance test. The Performance Test Record may be reproduced without written permission of Hewlett-Packard.

4-7. CALIBRATION CYCLE.

4-8. The Model 239A requires periodic verification of performance. The performance should be tested as part of the incoming inspection and at 6 month or 1 year intervals depending upon the environmental conditions and the user's specific accuracy requirements.

4-9. PERFORMANCE TESTS.

4-10. Output Impedance Test.

Equipment Required:

- True RMS Voltmeter (-hp- Model 3403C)
- 600 ohm Resistive Load (-hp- 11095A)

- a. Set the 239A FREQUENCY controls for an output frequency of 1 kHz (1.0 × 1 k, frequency vernier to the CAL position) and the OUTPUT LEVEL control to the 3.16 V range.
- b. Set the RMS Voltmeter controls to measure ac volts.
- c. Connect a cable between the 239A OUTPUT terminals and the Voltmeter input connector.

- d. Adjust the 239A LEVEL VERNIER for a voltmeter reading of 6.00 V rms.
- e. Disconnect the cable from the voltmeter and insert the 600 ohm load. The voltmeter must indicate between 2.93 and 3.08 V rms.

4-11. Output Level and Flatness Test.

Equipment Required:

True RMS Voltmeter (-hp- Model 3403C)
600 ohm Resistive Load (-hp- Model 11095A)

- a. Set the 239A controls for an output frequency of 1 kHz (1.0×1 k, vernier to the CAL position) and an output level of 3.16 V (level control to the 3 V range, vernier to the CAL position).
- b. Set the True RMS Voltmeter controls to measure ac volts on the 10 volt range. Connect the 600 ohm load to the Voltmeter input.
- c. Connect the 239A output to the 600 ohm load. The voltmeter should indicate 3.16 V rms $\pm .07$ V rms.
- d. Adjust the 239A LEVEL controls for an output of 3.00 V rms.
- e. Set the 239A to each frequency listed in Table 4-1 and verify that the output level is within the limits specified.

Table 4-1. Output Level Flatness Test.

| Frequency | Test Limits |
|-----------|-------------------|
| 10 Hz | 2.93 - 3.07 V rms |
| 20 Hz | 2.97 - 3.03 V rms |
| 20 kHz | |
| 109 kHz | 2.93 - 3.07 V rms |

4-12. Attenuator Accuracy Test.

Equipment Required:

True RMS Voltmeter (-hp- Model 3403C)
Attenuator (-hp- Model 4437A)
600 ohm Resistive Load (-hp- Model 11095A)

4-13. Step Accuracy.

- a. Adjust the 239A controls for a frequency of 1 kHz.
- b. Connect the equipment as shown in Figure 4-1.
- c. Adjust the Attenuator controls for 60.0 dB of attenuation.
- d. Adjust the 239A LEVEL controls for a reading of 3.00 mV on the True RMS Voltmeter.
- e. Down-range the 239A LEVEL control to the next lower range.

NOTE

When changing the LEVEL control, care must be taken to not disturb the setting of the LEVEL Vernier control.

- f. Decrease the Attenuator setting by 10.0 dB.
- g. The True RMS Voltmeter must indicate between 2.91 and 3.09 mV.
- h. Repeat Steps d through g until each position of the 239A LEVEL control has been checked.
- i. Adjust the 239A controls for an output frequency of 100 kHz.
- j. Repeat Steps c through h.

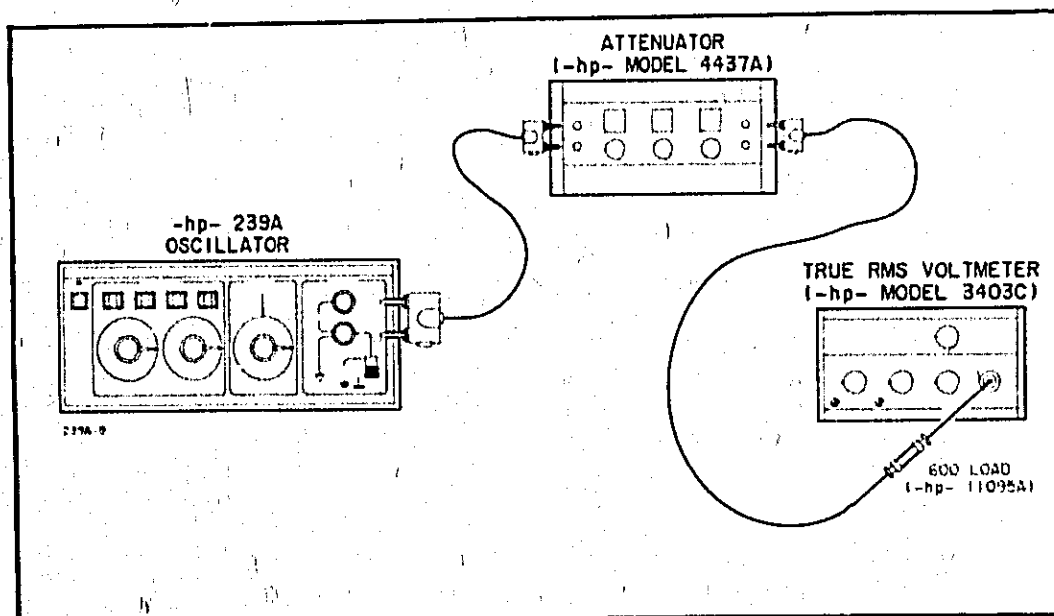

Figure 4-1. Attenuator Accuracy Test.

4-14. Accumulative Error Test.

- a. Adjust the 239A controls for an output frequency of 1 kHz.
- b. Set the Attenuator controls for 60.0 dB of attenuation.
- c. Connect the equipment as shown in Figure 4-1.
- d. Adjust the 239A controls for a 3.00 mV reading on the True RMS Voltmeter.
- e. Set the 239A LEVEL control to the 31.6 mV range.
- f. Adjust the Attenuator for 20 dB of attenuation. The True RMS Voltmeter reading must be between 2.67 and 3.37 mV.
- g. Set the 239A LEVEL control to the 10 mV range.
- h. Adjust the Attenuator for 10 dB of attenuation. The True RMS Voltmeter reading must be between 2.67 and 3.37 mV.
- i. Set the 239A LEVEL control to the 3.16 mV range.
- j. Adjust the Attenuator for 0 dB of attenuation. The True RMS Voltmeter reading must be between 2.67 and 3.37 mV.

4-15. Frequency Accuracy Test.**Equipment Required:**

Frequency Counter (-hp- Model 5300A Mainframe, -hp- Model 5302A Frequency Module)

- a. Set the 239A controls for an output frequency of 10 Hz (1.0×10 , frequency vernier to the CAL position) and an output LEVEL of 3 volts.
- b. Adjust the Frequency counter to measure period.
- c. Connect a cable between the 239A OUTPUT terminals and the Frequency counter input connector. The counter indication should be within the limits listed in Table 4-2 for a frequency of 10 Hz.
- d. Verify the 239A frequency accuracy for each frequency listed in Table 4-2.

4-16. Total Harmonic Distortion Test.**Equipment Required:**

Spectrum Analyzer (-hp- Model 3044A)
Tuneable Notch Filter (-hp- Model 339A)
600 ohm Resistive Load (-hp- 11095A)

Table 4-2. Frequency Accuracy Test.

| Frequency | 239A Frequency Range | Test Limits |
|--|----------------------------|--|
| 10 Hz | × 10 | 102.04 to 98.04 msec |
| 100 Hz | × 100 | 10.204 to 9.804 msec |
| 1 kHz 1.1 kHz 1.2 kHz 1.3 kHz 1.4 kHz 1.5 kHz 1.6 kHz 1.7 kHz 1.8 kHz 1.9 kHz 2.0 kHz 3.0 kHz 4.0 kHz 5.0 kHz 6.0 kHz 7.0 kHz 8.0 kHz 9.0 kHz 10.0 kHz | × 1K | 1020.4 to 980.4 μsec 927.64 to 891.27 μsec 850.34 to 816.99 μsec 784.93 to 754.15 μsec 728.86 to 700.28 μsec 680.27 to 653.59 μsec 637.76 to 612.75 μsec 600.24 to 576.70 μsec 566.89 to 544.66 μsec 537.06 to 516.00 μsec 510.20 to 490.20 μsec 340.14 to 326.80 μsec 255.10 to 245.10 μsec 204.08 to 196.08 μsec 170.07 to 163.40 μsec 145.77 to 140.06 μsec 127.55 to 122.55 μsec 113.38 to 108.93 μsec 102.04 to 98.039 μsec |
| 10 kHz 109 kHz | × 10K | 102.04 to 98.039 μsec 9.3615 to 8.9944 μsec |

NOTE

If it is only necessary to determine whether the Model 239A meets or exceeds the Total Harmonic Distortion specifications listed in Table 1-1, the measurement can often be made using the Distortion Analyzer alone. Keep in mind, however, the measurement includes noise as well as Harmonic distortion. If satisfactory measurements cannot be obtained with the Distortion Analyzer alone or if accurate measurement of the 239A total harmonic distortion is required, the following procedure should be used.

- a. Set the 239A controls for an output frequency of 10 Hz (1.0×10 , frequency vernier to the CAL position) at an output level of 3 volts.

- b. Connect the equipment as shown in Figure 4-2.
- c. Set the Spectrum Analyzer measurement reference to the level of the 239A fundamental frequency as follows:
 1. Set the Distortion Analyzer to the voltmeter function and adjust the input range control as necessary to obtain an on-scale meter reading as near full-scale as possible.
 2. Tune the Spectrum Analyzer to the exact frequency of the fundamental frequency (indicated by a maximum level reading on the Spectrum Analyzer).
 3. Use the level indicated as the measurement reference level.

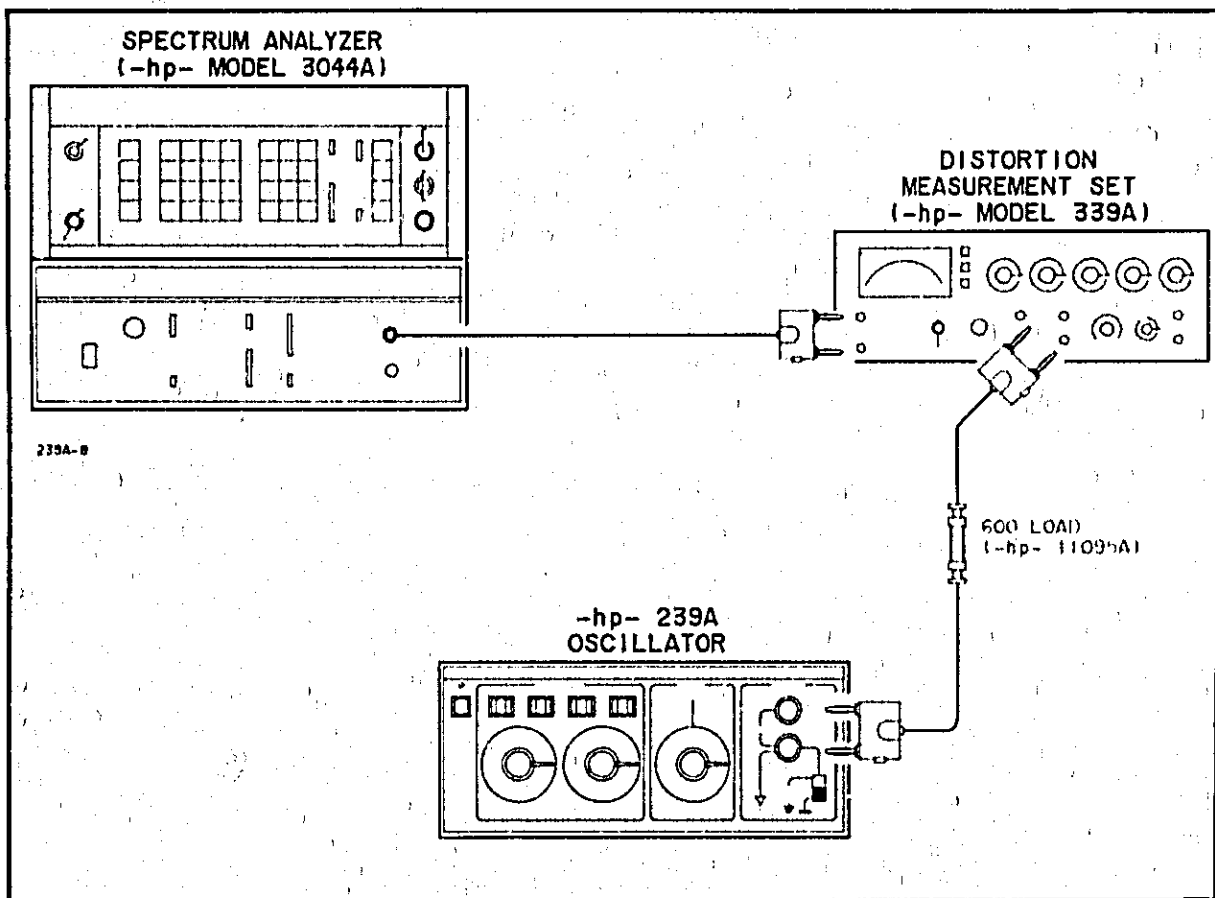

Figure 4-2. Total Harmonic Distortion Test.

d. Adjust the Distortion Analyzer controls as necessary to make a distortion measurement. (The purpose of this step is to null the fundamental frequency of the 239A output. This puts the distortion products within the dynamic range of the Spectrum Analyzer.)

e. Adjust the Spectrum Analyzer to measure the amplitude of the second harmonic frequency. The amplitude of the second harmonic, relative to the fundamental frequency, is determined by adding the Spectrum Analyzer reading and the distortion range setting of the Distortion Analyzer. (As an example-If the distortion range setting of the Distortion Analyzer is -80 dB and the Spectrum Analyzer indicates -23 dB the amplitude of the second harmonic is -103 dB, relative to the fundamental.) Record the amplitude reading of the second harmonic.

f. Adjust the Spectrum Analyzer controls to measure the amplitude of the third harmonic. Determine the relative amplitude of the third harmonic by adding the Spectrum Analyzer indication and the distortion range setting of the Distortion Analyzer. Record the amplitude reading of the third harmonic.

g. Calculate the Total Harmonic Distortion using the graph shown in Figure 4-3. As an example-If the amplitude of the second harmonic is -110 dB and the third harmonic amplitude is -114 dB the dB difference between the two is -4 dB. Locate this number on the horizontal axis of the graph. The -4 line intersects the curve at approximately the $+1.5$ level on the vertical axis. The total harmonic distortion is therefore the amplitude of the largest harmonic (second harmonic) plus the number determined on the vertical axis (-110 dB $+1.5$ dB = -108.5 dB).

h. The 239A should meet the 10 Hz THD specifications listed in Table 4-3.

i. Repeat Steps c through g for each frequency listed in Table 4-3.

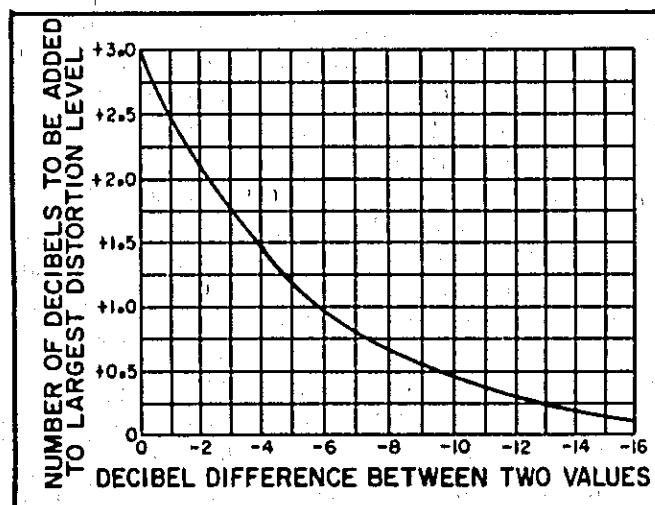

Figure 4-3. Logarithmic Addition of Harmonic Components.

Table 4-3: Oscillator Total Harmonic Distortion Test.

| 339A Frequency | THD Specification |
|-------------------|----------------------|
| 10 Hz | > -95 dB |
| 100 Hz | > -95 dB |
| 1 kHz | > -95 dB |
| 10 kHz | > -95 dB |
| 20 kHz | > -95 dB |
| 30 kHz | > -85 dB |
| 50 kHz | > -80 dB |
| 109 kHz | > -70 dB |

PERFORMANCE TEST RECORD

Hewlett-Packard Model 239A

Tests Performed By: _____

Oscillator

Date: _____

Serial No. _____

Output Impedance Test:

With an unloaded output level of 6.00 V rms, the output level into a 600 Ω load = _____

(Test limits, 2.93 to 3.08 V rms).

Output Level and Flatness Test:

Full output at 1 kHz into 600 Ω load = _____ (Test limits 3.09 to 3.23 V rms).

| Output Level at: (referenced to 3.00 V at 1 kHz) | |
|---|----------------------|
| 10 Hz = _____ | (2.93 to 3.07 V rms) |
| 20 Hz = _____ | (2.97 to 3.03 V rms) |
| 20 kHz = _____ | (2.97 to 3.03 V rms) |
| 109 kHz = _____ | (2.93 to 3.07 V rms) |

Attenuator Accuracy Test:

Step Accuracy

| 239A Output Level Setting | True RMS Meter Reading | Test Limits |
|------------------------------------|------------------------------|-----------------|
| 1 V | _____ | 2.91 to 3.09 mV |
| .316 V | _____ | |
| .1 V | _____ | |
| 3.16 mV | _____ | |
| 10 mV | _____ | |
| 3.16 mV | _____ | |

Accumulative Accuracy

| 239A Output Level Setting | True RMS Meter Reading | Test Limits |
|---------------------------|------------------------|-----------------|
| 10 mV | _____ | 2.67 to 3.37 mV |
| 3.16 mV | _____ | |

Frequency Accuracy Test:

| 239A Frequency | 239A Frequency Range | Frequency Counter Indication (Period) | Test Limits |
|----------------|----------------------|---------------------------------------|----------------------------|
| 10 Hz | x 10 | | 102.04 to 98.04 msec |
| 100 Hz | x 100 | | 10.204 to 9.804 msec |
| 1.0 kHz | x 1k | | 1020.4 to 980.4 μ sec |
| 1.1 kHz | | | 927.64 to 891.27 μ sec |
| 1.2 kHz | | | 850.34 to 816.99 μ sec |
| 1.3 kHz | | | 784.93 to 754.15 μ sec |
| 1.4 kHz | | | 728.86 to 700.28 μ sec |
| 1.5 kHz | | | 680.27 to 653.59 μ sec |
| 1.6 kHz | | | 637.76 to 612.75 μ sec |
| 1.7 kHz | | | 600.24 to 576.70 μ sec |
| 1.8 kHz | | | 566.89 to 544.66 μ sec |
| 1.9 kHz | | | 537.06 to 516.00 μ sec |
| 2.0 kHz | | | 510.20 to 490.20 μ sec |
| 3.0 kHz | | | 340.14 to 326.80 μ sec |
| 4.0 kHz | | | 255.10 to 245.10 μ sec |
| 5.0 kHz | | | 204.08 to 196.08 μ sec |
| 6.0 kHz | | 170.07 to 163.40 μ sec | |
| 7.0 kHz | | 145.77 to 140.06 μ sec | |
| 8.0 kHz | | 127.55 to 122.55 μ sec | |
| 9.0 kHz | | 113.38 to 108.93 μ sec | |
| 10.0 kHz | | 102.04 to 98.039 μ sec | |
| 10 kHz | x 10k | | 102.04 to 98.039 μ sec |
| 109 kHz | | | 9.3615 to 8.9944 μ sec |

Total Harmonic Distortion Test:

| 239A Output Frequency | Calculated THD | Test Limit |
|-----------------------------|-------------------|---------------|
| 10 Hz | | -95 dB |
| 100 Hz | | |
| 1 kHz | | |
| 10 kHz | | |
| 20 kHz | | |
| 30 kHz | | -85 dB |
| 50 kHz | | -80 dB |
| 109 kHz | | -70 dB |

WARNING

These servicing instructions are for use by trained service personnel only. To avoid electrical shock, do not perform any servicing other than that contained in the operating instructions unless you are qualified to do so.

SECTION V ADJUSTMENTS

5-1. INTRODUCTION.

5-2. This section contains complete adjustment procedures for the Model 239A Oscillator. After the instrument has been adjusted according to the procedures given in this section, it should meet the accuracy specified in Table 1-1.

5-3. EQUIPMENT REQUIRED.

5-4. The test equipment required to perform the adjustments is listed at the beginning of each adjustment procedure and in the Recommended Test Equipment Table in Section I. If the recommended equipment is not available, substitute equipment which meets the critical specifications listed in the table may be used.

5-5. ADJUSTMENT LOCATIONS.

5-6. The location of all adjustments is shown in Figure 5-1 at the back of this section. The function of each adjustment is listed in Table 5-2.

5-7. FACTORY SELECTED COMPONENTS.

5-8. Certain components in the Model 239A are individually selected to compensate for varying circuit parameters. These components are noted on the schematics and in the material list by an asterisk (*). The value listed in the material list and on the schematic is the typical value of the selected component. The function of the factory selected components and their value ranges are listed in Table 5-1.

5-9. ADJUSTMENT PROCEDURES.

5-10. Gain Adjustment.

Equipment Required: Digital Voltmeter (-hp- Model 3465A)

- a. Set the 239A controls for an output frequency of 100 Hz (1.0×100 , vernier in the CAL position).
- b. Set the DVM controls to measure DC volts (2 volt range). Connect the DVM's high input to TP5 and the low input to the GND test point.
- c. Adjust R56 (GAIN ADJUST) for a DVM reading of $-0.4 \text{ V dc} \pm 0.1 \text{ V dc}$.

- d. Set the 239A to the $\times 10$ range.
- e. The DVM reading should be more negative than -0.4 V dc; if not, readjust R56 for -0.4 V dc ± 0.1 V dc.

5-11. Frequency Adjustment.

Equipment Required: Electronic Counter (-hp- Model 5300A Mainframe, Model 5302A Universal Counter Module)

- a. Set the 239A controls for an output frequency of 10 kHz (1.0×10 k, vernier in the CAL position) and an output level of 3 volts.
- b. Connect the 239A output to the counter input.
- c. Adjust C5 (10 kHz FREQUENCY ADJUST) for a counter indication of 10 kHz ± 10 Hz.
- d. Adjust 239A FREQUENCY controls for a frequency of 100 kHz (10.0×10 k).
- e. Verify that the counter indicates 100 kHz ± 1 kHz. If not, readjust C5 until both the 10 kHz and 100 kHz readings are within the specified limits.

5-12. Output Adjustment.

Equipment Required: True RMS Voltmeter (-hp- Model 3403C)

- a. Set the 239A controls for an output frequency of 1 kHz (1.0×1 k, vernier in the CAL position) and an output level of 3.16 volts (LEVEL control to 3.16 V range and level vernier to the CAL position).
- b. Set the True RMS Voltmeter controls to measure ac volts. Connect the 239A output to the voltmeter input.
- c. Adjust R30 (OUTPUT LVL CAL) for a voltmeter indication of 3.16 volts rms.

Table 5-1. Factory Selected Components.

| Reference Designator | Range of Values | Description |
|----------------------|-----------------|--|
| C43 | 27 pF to 750 pF | Value selected for minimum second harmonic distortion at the output terminals for fundamental frequencies of 20 kHz and greater. |
| C45 | 0 to 22 pF | Used to adjust frequency at 100 kHz when the frequency adjustment (Paragraph 5-11) cannot be made. If C45 is necessary the frequency accuracy should be checked at 10 kHz intervals over the entire $\times 10$ k range. |

Table 5-2. Adjustable Components.

| Adjustment Name | Reference Designator | Adjustment Paragraph | Description |
|-------------------------|----------------------|----------------------|--|
| 10 kHz Frequency Adjust | C5 | 5-11 | Adjusts Oscillator frequency on the $\times 10$ K range. |
| Output Level Cal. | R30 | 5-12 | Adjust the maximum output level of the oscillator. |
| Gain Adjust | R56 | 5-10 | Adjusts the gain of the oscillator amplifier. |

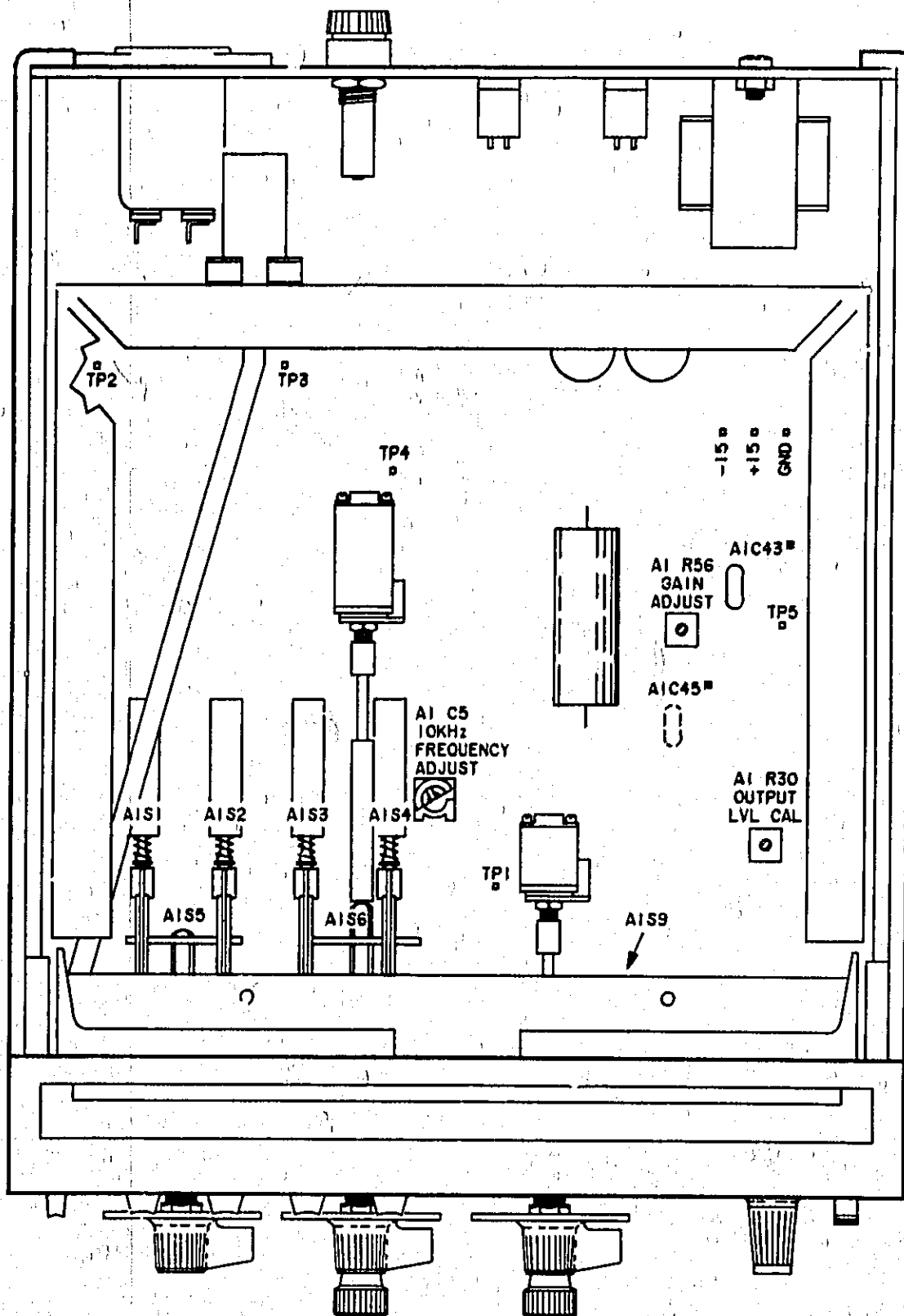

Figure 5-1. Adjustment and Test Point Locations.
5-3/5-4

SECTION VI REPLACEABLE PARTS

6-1. INTRODUCTION.

6-2. This section contains information for ordering replacement parts. Table 6-3 lists parts in alphabetic order of their reference designators and indicates the description, -hp- Part Number of each part, together with any applicable notes, and provides the following:

- a. Total quantity used in the instrument (Qty column). The total quantity of a part is given the first time the part number appears.
- b. Description of the part. (See abbreviations listed in Table 6-1.)
- c. Typical manufacturer of the part in a five-digit code. (See Table 6-2 for list of manufacturers.)
- d. Manufacturer's part number.

6-3. Miscellaneous parts are listed at the end of Table 6-3.

6-4. ORDERING INFORMATION.

6-5. To obtain replacement parts, address order or inquiry to your local Hewlett-Packard Field Office. (Field Office locations are listed at the back of the manual.) Identify parts by their Hewlett-Packard part numbers. Include instrument model and serial numbers.

6-6. NON-LISTED PARTS.

6-7. To obtain a part that is not listed, include:

- a. Instrument model number.
- b. Instrument serial number.
- c. Description of the part.
- d. Function and location of the part.

6-8. PARTS CHANGES.

6-9. Components which have been changed are so marked by one of three symbols; i.e., Δ , Δ with a letter subscript, e.g., Δa , or Δ with a number subscript, e.g., $\Delta 10$. A Δ with no subscript indicates the component listed is the preferred replacement for an earlier component. A Δ with a letter subscript indicates a change which is explained in a note at the bottom of the page. A Δ with a number subscript indicates the related change is discussed in backdating (Section VII). The number of the subscript indicates the number of the change in backdating which should be referred to.

Table 6-3. Replaceable Parts.

| Reference Designation | HP Part Number | Qty | Description | Mfr Code | Mfr Part Number |
|-----------------------|----------------|-----|---|----------|-----------------|
| A1 | 00230-00501 | 1 | PC ASSEMBLY, MOTHER | 22000 | 00230-00501 |
| | 00230-20501 | 1 | PC BOARD, PLANK | 22000 | 00230-20501 |
| A1C1 | 0100-0590 | 7 | CAPACITOR-FXD .050UF +-1% 200VDC | 22000 | 0100-0590 |
| A1C2 | 0100-0595 | 6 | CAPACITOR-FXD .500UF +-1% 200VDC | 22000 | 0100-0595 |
| A1C3 | 0100-0596 | 5 | CAPACITOR-FXD .000PF +-1% 200VDC | 22000 | 0100-0596 |
| A1C4 | 0100-0100 | 7 | CAPACITOR-FXD .000PF +-1% 200VDC MICA | 22000 | 0100-0100 |
| A1C5 | 0100-0107 | 6 | CAPACITOR-V T80-20% 2-10, 1PF 350V | 22000 | 0100-0107 |
| A1C6 | 0100-0001 | 5 | CAPACITOR-FXD .50UF +-1% 200VDC | 22000 | 0100-0001 |
| A1C7 | 0100-0000 | 6 | CAPACITOR-FXD .50UF +-1% 200VDC | 22000 | 0100-0000 |
| A1C8 | 0100-0590 | 7 | CAPACITOR-FXD .050UF +-1% 200VDC | 22000 | 0100-0590 |
| A1C9 | 0100-0595 | 6 | CAPACITOR-FXD .500UF +-1% 200VDC | 22000 | 0100-0595 |
| A1C10 | 0100-3022 | 8 | CAPACITOR-FXD .1UF +-20% 100VDC CER | 22000 | 0100-3022 |
| A1C11 | 0100-3022 | 8 | CAPACITOR-FXD .1UF +-20% 100VDC CER | 22000 | 0100-3022 |
| A1C12 | 0100-3022 | 8 | CAPACITOR-FXD .1UF +-20% 100VDC CER | 22000 | 0100-3022 |
| A1C13 | 0100-3022 | 8 | CAPACITOR-FXD .1UF +-20% 100VDC CER | 22000 | 0100-3022 |
| A1C14 | 0100-3022 | 8 | CAPACITOR-FXD .1UF +-20% 100VDC CER | 22000 | 0100-3022 |
| A1C15 | 0100-3022 | 8 | CAPACITOR-FXD .1UF +-20% 100VDC CER | 22000 | 0100-3022 |
| A1C16- | | | UNASSIGNED | | |
| A1C17 | 0100-2300 | 3 | CAPACITOR-FXD .27PF +-5% 300VDC MICA | 22000 | 0100-2300 |
| A1C18 | 0100-2200 | 2 | CAPACITOR-FXD .3PF +-25% 500VDC CER | 22000 | 0100-2200 |
| A1C19 | 0100-0302 | 7 | CAPACITOR-FXD .510PF +-5% 300VDC MICA | 22000 | 0100-0302 |
| A1C20- | | | UNASSIGNED | | |
| A1C21 | 0100-0303 | 8 | CAPACITOR-FXD .020PF +-5% 300VDC MICA | 22000 | 0100-0303 |
| A1C22- | | | UNASSIGNED | | |
| A1C23 | 0100-2300 | 3 | CAPACITOR-FXD .27PF +-5% 300VDC MICA | 22000 | 0100-2300 |
| A1C24 | 0100-2200 | 2 | CAPACITOR-FXD .3PF +-25% 500VDC CER | 22000 | 0100-2200 |
| A1C25 | 0100-2201 | 9 | CAPACITOR-FXD .15PF +-5% 500VDC CER | 22000 | 0100-2201 |
| A1C26 | 0100-0303 | 8 | CAPACITOR-FXD .020PF +-5% 300VDC MICA | 22000 | 0100-0303 |
| A1C27 | 0100-2201 | 7 | CAPACITOR-FXD .51PF +-5% 300VDC MICA | 22000 | 0100-2201 |
| A1C28- | | | UNASSIGNED | | |
| A1C29 | 0100-1720 | 2 | CAPACITOR-FXD .22UF+-10% 35VDC TA | 04200 | 1600274X0035A2 |
| A1C30 | 0100-0107 | 6 | CAPACITOR-FXD .22UF+-10% 20VDC TA | 50200 | 1500225002002 |
| A1C31 | 0100-2200 | 2 | CAPACITOR-FXD .220UF+-10% 17VDC TA | 50200 | 1500227001002 |
| A1C32 | 0100-2200 | 2 | CAPACITOR-FXD .100PF +-5% 300VDC MICA | 22000 | 0100-2200 |
| A1C33- | | | FACTORY SELECTED PART REFER TO TABLE 5-1. | | |
| A1C34 | 0100-0106 | 9 | CAPACITOR-FXD .001UF+-20% 50VDC TA | 50200 | 1500000000002 |
| A1C35- | | | NORMALLY NOT USED | | |
| A1C36 | 0100-3022 | 8 | CAPACITOR-FXD .1UF +-20% 100VDC CER | 22000 | 0100-3022 |
| A1C37 | | | UNASSIGNED | | |
| A1C38 | 0100-3022 | 8 | CAPACITOR-FXD .1UF +-20% 100VDC CER | 22000 | 0100-3022 |
| A1C39- | | | UNASSIGNED | | |
| A1C40 | 0100-3022 | 8 | CAPACITOR-FXD .1UF +-20% 100VDC CER | 22000 | 0100-3022 |
| A1C41 | 0100-2035 | 3 | CAPACITOR-FXD .0001UF+-10% 35VDC AL | 22000 | 0100-2035 |
| A1C42 | 0100-2035 | 3 | CAPACITOR-FXD .0001UF+-10% 35VDC AL | 22000 | 0100-2035 |
| A1C43 | 0100-3022 | 8 | CAPACITOR-FXD .1UF +-20% 100VDC CER | 22000 | 0100-3022 |
| A1C44 | 0100-3022 | 8 | CAPACITOR-FXD .1UF +-20% 100VDC CER | 22000 | 0100-3022 |
| A1C45- | | | UNASSIGNED | | |
| A1C46 | 0100-0201 | 3 | CAPACITOR-FXD .1UF+-10% 35VDC TA | 50200 | 1500103003502 |
| A1C47 | 0100-2200 | 2 | CAPACITOR-FXD .070UF+-10% 20VDC TA | 50200 | 1500070002002 |
| A1C48 | 0100-2200 | 2 | CAPACITOR-FXD .070UF+-10% 20VDC TA | 50200 | 1500070002002 |
| A1C49 | 0100-3022 | 8 | CAPACITOR-FXD .1UF +-20% 100VDC CER | 22000 | 0100-3022 |
| A1C50 | 0100-3022 | 8 | CAPACITOR-FXD .1UF +-20% 100VDC CER | 22000 | 0100-3022 |
| A1C51 | 0100-2070 | 2 | UNASSIGNED | | |
| A1C52 | 0100-2070 | 2 | CAPACITOR-FXD .030UF +-20% 50VDC CER | 22000 | 0100-2070 |
| A1C53 | 1901-0000 | 1 | DIODE-BATCHING 30V 50MA PWS 00-35 | 22000 | 1901-0000 |
| A1C54 | 1901-0000 | 1 | DIODE-BATCHING 30V 50MA PWS 00-35 | 22000 | 1901-0000 |
| A1C55 | 1901-0510 | 1 | DIODE-BATCHING 30V 50MA PWS 00-35 | 22000 | 1901-0510 |
| A1C56- | | | UNASSIGNED | | |
| A1C57 | 1901-0000 | 1 | DIODE-BATCHING 30V 50MA PWS 00-35 | 22000 | 1901-0000 |
| A1C58 | 1901-0000 | 1 | DIODE-BATCHING 30V 50MA PWS 00-35 | 22000 | 1901-0000 |
| A1C59- | | | UNASSIGNED | | |
| A1C60 | 1901-0025 | 2 | DIODE-GEN PWP 100V 201MA PWS | 22000 | 1901-0025 |
| A1C61 | 1902-0020 | 6 | DIODE-ZNR 12.1V 6% | 22000 | 1902-0020 |
| A1C62 | 1901-0025 | 2 | DIODE-GEN PWP 100V 201MA PWS | 22000 | 1901-0025 |
| A1C63 | 1902-0020 | 6 | DIODE-ZNR 12.1V 6% | 22000 | 1902-0020 |
| A1C64- | | | UNASSIGNED | | |

See Introduction to this section for ordering information

Table 6-3. Replaceable Parts (Cont'd).

| Reference Designation | HP Part Number | Qty | Description | Mfr Code | Mfr Part Number |
|-----------------------|----------------|-----|---|----------|-----------------|
| A1C300 | 1900-7090 | 7 | DICER-FR BRUG 2000 2A | 60713 | 404002 |
| A1C301 | UNASSIGNED | | | | |
| A1C30P | 1907-0933 | 3 | DICER-25P 145170B 44v 5k P305A 180500A | 60713 | 145170B |
| A1F1 | 2110-0304 | 0 | FUSE .0025 125V FAST-BLO .251A.093 | 20400 | 2110-0304 |
| A1J1 | 1251-3192 | 1 | CONNECTOR 3-PIN M POST TYPE | 20400 | 1251-3192 |
| A1J2 | 1251-3190 | 0 | CONNECTOR 2-PIN M POST TYPE | 20400 | 1251-3190 |
| A1J3 | 1251-3195 | 4 | CONNECTOR 4-PIN M POST TYPE | 20400 | 1251-3195 |
| A1J4 | 1251-0513 | 6 | CONNECTOR 3-PIN M POST TYPE | 20400 | 1251-0513 |
| A1J5 | UNASSIGNED | | | | |
| A1J6 | 1251-3192 | 1 | CONNECTOR 3-PIN M POST TYPE | 20400 | 1251-3192 |
| A1G1 | 1955-0265 | 3 | TRANSISTOR J-MET N-CMPL C-MODE TO-18 SI | 17950 | 17950 |
| A1H1 | 0699-0025 | 0 | RESISTOR 20.0K 1/2W .125 F TCM00-50 | 20400 | 0699-0025 |
| A1H2 | 0699-0025 | 0 | RESISTOR 20.0K 1/2W .125 F TCM00-50 | 20400 | 0699-0025 |
| A1H3 | 0699-0026 | 1 | RESISTOR 14.2K 1/2W .125 F TCM00-50 | 20400 | 0699-0026 |
| A1H4 | 0699-0026 | 1 | RESISTOR 14.2K 1/2W .125 F TCM00-50 | 20400 | 0699-0026 |
| A1H5 | 0699-0027 | 2 | RESISTOR 9.47K 1/2W .125 F TCM00-50 | 20400 | 0699-0027 |
| A1H6 | 0699-0027 | 2 | RESISTOR 9.47K 1/2W .125 F TCM00-50 | 20400 | 0699-0027 |
| A1H7 | 0699-0028 | 1 | RESISTOR 7.10K 1/2W .125 F TCM00-50 | 20400 | 0699-0028 |
| A1H8 | 0699-0028 | 1 | RESISTOR 7.10K 1/2W .125 F TCM00-50 | 20400 | 0699-0028 |
| A1H9 | 0699-0040 | 0 | RESISTOR 5.00K 1/2W .125 F TCM00-50 | 20400 | 0699-0040 |
| A1H10 | 0699-0040 | 0 | RESISTOR 5.00K 1/2W .125 F TCM00-50 | 20400 | 0699-0040 |
| A1H11 | 0699-0040 | 0 | RESISTOR 5.00K 1/2W .125 F TCM00-50 | 20400 | 0699-0040 |
| A1H12 | 0699-0040 | 0 | RESISTOR 5.00K 1/2W .125 F TCM00-50 | 20400 | 0699-0040 |
| A1H13 | 0699-0035 | 2 | RESISTOR 20.0K 1/2W .125 F TCM00-50 | 20400 | 0699-0035 |
| A1H14 | 0699-0035 | 2 | RESISTOR 20.0K 1/2W .125 F TCM00-50 | 20400 | 0699-0035 |
| A1H15 | 0699-0036 | 3 | RESISTOR 18.2K 1/2W .125 F TCM00-50 | 20400 | 0699-0036 |
| A1H16 | 0699-0036 | 3 | RESISTOR 18.2K 1/2W .125 F TCM00-50 | 20400 | 0699-0036 |
| A1H17 | 0699-0031 | 0 | RESISTOR 94.7K 1/2W .125 F TCM00-50 | 20400 | 0699-0031 |
| A1H18 | 0699-0031 | 0 | RESISTOR 94.7K 1/2W .125 F TCM00-50 | 20400 | 0699-0031 |
| A1H19 | 0699-0032 | 0 | RESISTOR 71.0K 1/2W .125 F TCM00-50 | 20400 | 0699-0032 |
| A1H20 | 0699-0032 | 0 | RESISTOR 71.0K 1/2W .125 F TCM00-50 | 20400 | 0699-0032 |
| A1H21 | 0699-0033 | 0 | RESISTOR 50.0K 1/2W .125 F TCM00-50 | 20400 | 0699-0033 |
| A1H22 | 0699-0033 | 0 | RESISTOR 50.0K 1/2W .125 F TCM00-50 | 20400 | 0699-0033 |
| A1H23 | 0699-0530 | 0 | RESISTOR 232K 1K .125 F TCM00-100 | 20400 | 0699-0530 |
| A1H24 | 0699-0530 | 0 | RESISTOR 232K 1K .125 F TCM00-100 | 20400 | 0699-0530 |
| A1H25 | UNASSIGNED | | | | |
| A1H26 | UNASSIGNED | | | | |
| A1H27 | 0699-3510 | 0 | RESISTOR 7.32K 1K .125 F TCM00-100 | 20400 | 0699-3510 |
| A1H28 | 0699-3492 | 0 | RESISTOR 24.0K 1K .125 F TCM00-100 | 20400 | 0699-3492 |
| A1H29 | 0757-0401 | 0 | RESISTOR 100 1K .125 F TCM00-100 | 20400 | 0757-0401 |
| A1H30 | 2100-0567 | 0 | RESISTOR-TM 2K 10K C TCM-ADJ 1-70A | 20400 | 2100-0567 |
| A1H31 | UNASSIGNED | | | | |
| A1H32 | 0757-0203 | 0 | RESISTOR 24 1K .125 F TCM00-100 | 20400 | 0757-0203 |
| A1H33 | 0699-3279 | 0 | RESISTOR 50.0K 1K .125 F TCM00-100 | 20400 | 0699-3279 |
| A1H34 | 0757-0401 | 0 | RESISTOR 100 1K .125 F TCM00-100 | 20400 | 0757-0401 |
| A1H35 | UNASSIGNED | | | | |
| A1H36 | UNASSIGNED | | | | |
| A1H37 | 0757-0401 | 0 | RESISTOR 100 1K .125 F TCM00-100 | 20400 | 0757-0401 |
| A1H38 | 0757-0402 | 0 | RESISTOR 10K 1K .125 F TCM00-100 | 20400 | 0757-0402 |
| A1H39 | 0757-0401 | 0 | RESISTOR 100 1K .125 F TCM00-100 | 20400 | 0757-0401 |
| A1H40 | 0757-0402 | 0 | RESISTOR 10K 1K .125 F TCM00-100 | 20400 | 0757-0402 |
| A1H41 | 0757-0401 | 0 | RESISTOR 100 1K .125 F TCM00-100 | 20400 | 0757-0401 |
| A1H42 | 0757-0402 | 0 | RESISTOR 10K 1K .125 F TCM00-100 | 20400 | 0757-0402 |
| A1H43 | 0699-3215 | 0 | RESISTOR 400K 1K .125 F TCM00-100 | 20400 | 0699-3215 |
| A1H44 | 0699-3215 | 0 | RESISTOR 400K 1K .125 F TCM00-100 | 20400 | 0699-3215 |
| A1H45 | 0757-0405 | 0 | RESISTOR 100K 1K .125 F TCM00-100 | 20400 | 0757-0405 |
| A1H46 | 0757-0402 | 0 | RESISTOR 10K 1K .125 F TCM00-100 | 20400 | 0757-0402 |
| A1H47 | 0757-0402 | 0 | RESISTOR 10K 1K .125 F TCM00-100 | 20400 | 0757-0402 |
| A1H48 | 0757-0200 | 0 | RESISTOR 1 K 1K .125 F TCM00-100 | 20400 | 0757-0200 |
| A1H49 | 0757-0203 | 3 | RESISTOR 2K 1K .125 F TCM00-100 | 20400 | 0757-0203 |
| A1H50 | 0757-0402 | 0 | RESISTOR 10K 1K .125 F TCM00-100 | 20400 | 0757-0402 |
| A1H51 | 0757-0200 | 3 | RESISTOR 1K 1K .125 F TCM00-100 | 20400 | 0757-0200 |
| A1H52 | 0757-0203 | 0 | RESISTOR 2K 1K .125 F TCM00-100 | 20400 | 0757-0203 |
| A1H53 | 0757-0203 | 0 | RESISTOR 2K 1K .125 F TCM00-100 | 20400 | 0757-0203 |
| A1H54 | 0757-0401 | 0 | RESISTOR 100 1K .125 F TCM00-100 | 20400 | 0757-0401 |
| A1H55 | 0757-0407 | 0 | RESISTOR 200 1K .125 F TCM00-100 | 20400 | 0757-0407 |
| A1H56 | 2100-0567 | 0 | RESISTOR-TM 2K 10K C TCM-ADJ 1-70A | 20400 | 2100-0567 |
| A1H57 | 0699-3490 | 5 | RESISTOR 3.0K 1K .125 F TCM00-100 | 20400 | 0699-3490 |
| A1H58 | UNASSIGNED | | | | |
| A1H59 | UNASSIGNED | | | | |
| A1H60 | 0699-4070 | 0 | RESISTOR 604 1K .5 F TCM00-100 | 20400 | 0699-4070 |
| A1H61 | 0699-4072 | 5 | RESISTOR 1.07K 1K .5 F TCM00-100 | 20400 | 0699-4072 |
| A1H62 | 0699-3406 | 5 | RESISTOR 1.33K 1K .5 F TCM00-100 | 20400 | 0699-3406 |
| A1H63 | 0699-3479 | 2 | RESISTOR 1.74K 1K .5 F TCM00-100 | 20400 | 0699-3479 |
| A1H64 | 0699-4080 | 0 | RESISTOR 1.18K 1K .5 F TCM00-100 | 20400 | 0699-4080 |

See Introduction to this section for ordering information

Table 6-3. Replaceable Parts (Cont'd).

| Reference Designation | HP Part Number | Qty | Description | Mfr Code | Mfr Part Number |
|-----------------------|----------------|-----|-------------------------------------|----------|----------------------|
| A1868 | 0698-3479 | 2 | RESISTOR 1.74K 1% .5W P TCR=100 | 28480 | 0698-3479 |
| A1869 | 0698-4488 | 9 | RESISTOR 1.12K 1% .5W P TCR=100 | 28480 | 0698-4488 |
| A1870 | 0698-3479 | 2 | RESISTOR 1.74K 1% .5W P TCR=100 | 28480 | 0698-3479 |
| A1871 | 0698-4488 | 9 | RESISTOR 1.12K 1% .5W P TCR=100 | 28480 | 0698-4488 |
| A1872 | 0698-3479 | 2 | RESISTOR 1.74K 1% .5W P TCR=100 | 28480 | 0698-3479 |
| A1873 | 0698-4488 | 9 | RESISTOR 1.12K 1% .5W P TCR=100 | 28480 | 0698-4488 |
| A1874 | 0698-3479 | 2 | RESISTOR 1.74K 1% .5W P TCR=100 | 28480 | 0698-3479 |
| A1875 | 0698-3479 | 1 | RESISTOR 800 1% .5W P TCR=100 | 28480 | 0698-3479 |
| A1876 | 0698-4488 | 9 | RESISTOR 600 1% .5W P TCR=100 | 28480 | 0698-4488 |
| A1877- | | | | | |
| A1899 | | | UNASSIGNED | | |
| A19100 | 0680-7025 | 7 | RESISTOR 20 5% .5W CC TCR=100 | 01121 | 0680-7025 |
| A19101- | | | | | |
| A19200 | | | UNASSIGNED | | |
| A19200 | 0683-0685 | 5 | RESISTOR 6.8 5% .25W PC TCR=100/100 | 01121 | 0683-0685 |
| A19301 | 0683-0685 | 5 | RESISTOR 6.8 5% .25W PC TCR=100/100 | 01121 | 0683-0685 |
| A19302 | 0757-0442 | 9 | RESISTOR 10K 1% .125W P TCR=100 | 24548 | 06170-1002-F |
| A19303 | 0757-0442 | 9 | RESISTOR 10K 1% .125W P TCR=100 | 24548 | 06170-1002-F |
| A191 | | | PART OF A18A1 | | |
| A192 | | | PART OF A18A1 | | |
| A193 | | | PART OF A18A1 | | |
| A194 | | | PART OF A18A1 | | |
| A195 | 3100-3422 | 3 | SWITCH=STRY, UNITS | 28480 | 3100-3422 |
| A196 | 3100-3422 | 3 | SWITCH=STRY, TENSIS | 28480 | 3100-3422 |
| A197 | | | UNASSIGNED | | |
| A198 | | | UNASSIGNED | | |
| A199 | 3130-0661 | 0 | SWITCH, ROTARY, LEVEL | 28480 | 3130-0661 |
| A101 | 1826-0487 | 0 | IC OP AMP TO-99 | 28480 | 1826-0487 |
| A102 | 1826-0139 | 9 | IC 1458 OP AMP R-DIP-8 | 01926 | 061458G |
| A103 | 1826-0487 | 0 | IC OP AMP TO-99 | 28480 | 1826-0487 |
| A104- | | | | | |
| A10299 | | | UNASSIGNED | | |
| A10300 | 1826-0487 | 0 | IC V REGTR TO-100 | 27014 | 18325H |
| | 1205-0050 | 7 | HEAT SINK TO-5/TO-39-PKG | 28480 | 1205-0050 |
| | | | AS MISCELLANEOUS | | |
| | 0380-0478 | 2 | SPACER, BUSHING | 28480 | 0380-0478 |
| | 00239-01201 | 8 | MOUNTING BRACKET, POTENTIOMETER | 28480 | 00239-01201 |
| | 0380-0113 | 2 | SCREW=MACH #12 .25-12xLG PANHD-PC21 | 00000 | ORDER BY DESCRIPTION |
| | 0380-0741 | 2 | STANDOFF | 00000 | ORDER BY DESCRIPTION |
| A18A1 | 3101-2321 | 1 | SWITCH ASSEMBLY, MULTIPLIER | 28480 | 3101-2321 |
| A15A2 | 3101-2178 | 4 | SWITCH, PUSHBUTTON | 28480 | 3101-2178 |

See Introduction to this section for ordering information

Table 6-3. Replaceable Parts (Cont'd).

| Reference Designation | HP Part Number | Qty | Description | Mfr Code | Mfr Part Number |
|-----------------------|----------------|-----|---|----------|----------------------|
| CABLE PARTS | | | | | |
| C301 | 0100-0345 | 2 | CAPACITOR-POLYRU 1000PF 50V 500V CEK | 01121 | F024-1022 |
| C302 | 0100-0345 | 2 | CAPACITOR-POLYRU 1000PF 50V 500V CEK | 01121 | F024-1022 |
| CR100 | 1990-0495 | 5 | 1PC-VISIBLE LUM-INTERRUPTOR (F0304)MKA | 28400 | 5022-4924 |
| F1-1 | 2110-0027 | 2 | FUSE 125A 250V NORM-BLD 1.25A,25 UL SEC (F0301)OPERATION | 28400 | 2110-0027 |
| F1 | 2110-0011 | 2 | FUSE 0.62A 250V NORM-BLD 1.25A,25 UL SEC (F0301)OPERATION | 28400 | 2110-0011 |
| J8A | 1510-0090 | 2 | BINDING POST BODY BGL BGL-TOP JCN | 28400 | 1510-0090 |
| J8B | 1510-0093 | 5 | BINDING POST BODY BGL BGL-TOP DBP BLD | 28400 | 1510-0093 |
| | 2950-0830 | 3 | MUT-HEX-DBL-CHAN 1/2-28-T-0 .075-14-T-00 | 00000 | ORDER BY DESCRIPTION |
| | 1050-0067 | 2 | HEAD-ER-PL MTLG 5/16 IN .375-IN-ID | 28400 | 1050-0067 |
| P1 | 1251-3071 | 3 | CONNECTOR 3-PIN F POST TYPE | 28400 | 1251-3071 |
| | 1251-3073 | 7 | CONTACT-CONN U/W-POST-TYPE FEM CRP | 28400 | 1251-3073 |
| P2 | 1251-3613 | 1 | CONNECTOR 2-PIN F POST TYPE | 28400 | 1251-3613 |
| | 1251-3073 | 7 | CONTACT-CONN U/W-POST-TYPE FEM CRP | 28400 | 1251-3073 |
| P3A | 1251-3013 | 1 | CONNECTOR 2-PIN F POST TYPE | 28400 | 1251-3013 |
| P3B | 1251-3013 | 1 | CONNECTOR 2-PIN F POST TYPE | 28400 | 1251-3013 |
| | 1251-3073 | 7 | CONTACT-CONN U/W-POST-TYPE FEM CAP | 28400 | 1251-3073 |
| P4 | | | PART OF CABLE ASSEMBLY, #1 | | |
| P5 | | | UNASSIGNED | | |
| P6 | 1251-3201 | 3 | CONNECTOR 3-PIN F POST TYPE | 28400 | 1251-3201 |
| | 1251-3073 | 7 | CONTACT-CONN U/W-POST-TYPE FEM CRP | 28400 | 1251-3073 |
| R25 | 2100-3730 | 4 | RESISTOR-VARIABLE TWOSECT 5W | 28400 | 2100-3730 |
| R31 | 2100-3736 | 3 | RESISTOR-VARIABLE 10K | 28400 | 2100-3736 |
| S7 | | 2 | PART OF R25 | | |
| S8 | | 2 | PART OF R31 | | |
| S10 | 3101-1235 | 2 | SWITCH-BL DPDT-NR BYD 1.5A 125VAC | 28400 | 3101-1235 |
| S11 | 3101-2216 | 3 | SWITCH-SP DPDT ALTAG 4A 250VAC | 28400 | 3101-2216 |
| S12 | 3101-2042 | 3 | SWITCH-BL DPDT-NR BYD 2A 250VAC 3LOC-LUG | 28400 | 3101-2042 |
| S13 | 3101-2042 | 3 | SWITCH-BL DPDT-NR BYD 2A 250VAC 3LOC-LUG | 28400 | 3101-2042 |
| T1 | 0100-4005 | 1 | TRANSFORMER, POWER | 28400 | 0100-4005 |
| W1 | 00230-01003 | 2 | CABLE ASSEMBLY, FREQUENCY VERNIER | 28400 | 00230-01003 |
| | 00140-04702 | 2 | INDICERS, PCAM | 28400 | 00140-04702 |
| W198A | 1251-0512 | 3 | CONNECTOR 3-PIN F POST TYPE | 28400 | 1251-0512 |
| W198B | 1251-3073 | 3 | CONTACT-CONN U/W-POST-TYPE FEM CRP | 28400 | 1251-3073 |
| XP1 | 2110-0070 | 5 | FUSEHOLDER BODY EXTR POST BAYONET TYP | 75915 | 105003-010 |
| | 2110-0065 | 2 | FUSEHOLDER CAP EXTR POST BAYONET TYP | 28400 | 2110-0065 |
| | 2950-0080 | 1 | MUT-HEX-DBL-CHAN 1/2-28-T-0 .125-14-T-00 | 00000 | ORDER BY DESCRIPTION |

See Introduction to this section for ordering information

Table 6-3. Replaceable Parts (Cont'd).

| Reference Designation | HP Part Number | Qty | Description | Mfr Code | Mfr Part Number |
|-----------------------|----------------|-----|--|----------|----------------------|
| | | | KNOB & MISCELLANEOUS PARTS | | |
| | 0370-0003 | 4 | KNOB, PUSHBUTTON, SQUARE (LINE) | 2840 | 0370-0003 |
| | 0370-0006 | 7 | KNOB, PZELL, SQUARE, PUSHBUTTON | 2840 | 0370-0006 |
| | 0001-0370 | 3 | EXTENDER, PUSHBUTTON SWITCH | 2840 | 0001-0370 |
| | 0370-2496 | 5 | KNOB, PUSHBUTTON | 2840 | 0370-2496 |
| | 0370-0016 | 0 | PZELL, PUSHBUTTON | 2840 | 0370-0016 |
| | 5041-1473 | 3 | EXTENDER PUSHBUTTON SWITCH | 2840 | 5041-1473 |
| | 00330-0400 | 6 | KNOB, FREQUENCY, UNIT | 2840 | 00330-0400 |
| | 3030-0090 | 2 | SCREEN-BET #40 .13-IN-LG SMALL CUP-PT | 0000 | ORDER BY DESCRIPTION |
| | 3130-0546 | 0 | DETENT - 10 POSITION | 2840 | 3130-0546 |
| | 2100-0016 | 3 | ASSEMBLY INFL T 3/8 IN .377-IN-ID | 2840 | 2100-0016 |
| | 2950-0043 | 3 | NUT-HEX-ORNL-CHAM 3/8-32-TWD .090-IN-THT | 0000 | ORDER BY DESCRIPTION |
| | 00330-0400 | 7 | KNOB, FREQUENCY, TENTHS | 2840 | 00330-0400 |
| | 3030-0090 | 2 | SCREEN-BET #40 .13-IN-LG SMALL CUP-PT | 0000 | ORDER BY DESCRIPTION |
| | 3130-0546 | 0 | DETENT - 10 POSITION | 2840 | 3130-0546 |
| | 2100-0016 | 3 | ASSEMBLY INFL T 3/8 IN .377-IN-ID | 2840 | 2100-0016 |
| | 2950-0043 | 4 | NUT-HEX-ORNL-CHAM 3/8-32-TWD .090-IN-THT | 0000 | ORDER BY DESCRIPTION |
| | 0370-1125 | 7 | KNOB, POINTER (VERNIER) | 2840 | 0370-1125 |
| | 3030-0090 | 2 | SCREEN-BET #40 .13-IN-LG SMALL CUP-PT | 0000 | ORDER BY DESCRIPTION |
| | 00230-0370 | 1 | SWIFT, FREQUENCY VERNIER | 2840 | 00230-0370 |
| | 1400-0001 | 7 | COUPLER-RGD .375-LG BR | 2840 | 1400-0001 |
| | 3030-0090 | 2 | SCREEN-BET #40 .13-IN-LG SMALL CUP-PT | 0000 | ORDER BY DESCRIPTION |
| | 00230-0370 | 1 | SWIFT, FREQUENCY VERNIER | 2840 | 00230-0370 |
| | 2100-0016 | 3 | ASSEMBLY INFL T 3/8 IN .377-IN-ID | 2840 | 2100-0016 |
| | 2950-0043 | 4 | NUT-HEX-ORNL-CHAM 3/8-32-TWD .090-IN-THT | 0000 | ORDER BY DESCRIPTION |
| | 0370-1125 | 7 | KNOB, POINTER (VERNIER) | 2840 | 0370-1125 |
| | 3030-0090 | 2 | SCREEN-BET #40 .13-IN-LG SMALL CUP-PT | 0000 | ORDER BY DESCRIPTION |
| | 7185-0011 | 2 | BRASS-RND 1/2 DIA 278 IN LRG | 2840 | 7185-0011 |
| | 1400-0001 | 7 | COUPLER-RGD .375-LG BR | 2840 | 1400-0001 |
| | 3030-0090 | 2 | SCREEN-BET #40 .13-IN-LG SMALL CUP-PT | 0000 | ORDER BY DESCRIPTION |
| | 1450-0406 | 4 | LENS CAP CLR-TL .125-DIA | 2840 | 1450-0406 |

See Introduction to this section for ordering information

Table 6-3. Replaceable Parts (Cont'd).

| Reference Designation | HP Part Number | Qty | Description | Mfr Code | Mfr Part Number |
|-----------------------|----------------|-----|--|----------|----------------------|
| MECHANICAL PARTS | | | | | |
| MP1 | 00239-00201 | 1 | FRONT PANEL | 28480 | 00239-00201 |
| MP2 | 00239-00202 | 1 | FRONT SUB-PANEL | 28480 | 00239-00202 |
| MP3 | 00239-00601 | 1 | FRONT SHIELD | 28480 | 00239-00601 |
| MP4 | 7300-0113 | 2 | SCREW-W/SCM #32 ,25-1/4-LG PAN-RO-PC21 | 00000 | CHECK BY DESCRIPTION |
| | 5020-0213 | 4 | FRONT FRAME | 28480 | 5020-0213 |
| | 7300-0190 | 5 | SCREW-W/SCM #32 ,100-1/4-LG 100 DEG | 00000 | CHECK BY DESCRIPTION |
| | 7300-0120 | 1 | SCREW-W/SCM 10-32 ,25-1/4-LG PAN-RO-PC21 | 00000 | CHECK BY DESCRIPTION |
| MP5 | 5000-7200 | 5 | COVER/TCR | 28480 | 5000-7200 |
| | 00239-00602 | 1 | TOP SHIELD | 28480 | 00239-00602 |
| MP6 | 7300-0190 | 5 | SCREW-W/SCM #32 ,100-1/4-LG 100 DEG | 00000 | CHECK BY DESCRIPTION |
| | 5000-7200 | 5 | COVER/TCR | 28480 | 5000-7200 |
| MP7 | 00239-00603 | 1 | NOTYCR SHIELD | 28480 | 00239-00603 |
| MP8 | 2300-0190 | 5 | SCREW-W/SCM #32 ,100-1/4-LG 100 DEG | 00000 | CHECK BY DESCRIPTION |
| | 5000-7210 | 1 | COVER, SIDE | 28480 | 5000-7210 |
| MP9 | 2300-0197 | 2 | SCREW-W/SCM #32 ,175-1/4-LG PAN-RO-PC21 | 00000 | CHECK BY DESCRIPTION |
| | 2510-0199 | 1 | SCREW-W/SCM #32 ,25-1/4-LG RO-RO-PC21 | 28480 | 2510-0199 |
| | 00239-00605 | 4 | SHIELD | 28480 | 00239-00605 |
| MP10 | 2300-0113 | 2 | SCREW-W/SCM #32 ,25-1/4-LG PAN-RO-PC21 | 00000 | CHECK BY DESCRIPTION |
| | 00239-00203 | 1 | REAR PANEL | 28480 | 00239-00203 |
| MP11 | 00239-00604 | 1 | REAR SHIELD | 28480 | 00239-00604 |
| MP12 | 7300-0113 | 2 | SCREW-W/SCM #32 ,25-1/4-LG PAN-RO-PC21 | 00000 | CHECK BY DESCRIPTION |
| | 5000-7201 | 4 | PCY(STANDARD) | 28480 | 5000-7201 |
| MP13 | 1400-1345 | 5 | TYLT STAND BRG | 28480 | 1400-1345 |
| MP14 | 5001-0038 | 7 | TRIM/SHIELD | 28480 | 5001-0038 |
| MP15 | 5000-7203 | 1 | TRIM/TCR 1/2 | 28480 | 5000-7203 |

See Introduction to this section for ordering information.

SECTION VII MANUAL CHANGES

7-1. INTRODUCTION.

7-2.^a This section of the manual normally contains backdating information necessary to adapt this manual to older instruments. Since no instrument modifications have been performed at the time this manual was printed, the manual applies directly to all instruments and no backdating material is required.

SECTION VIII SERVICE

8-1. INTRODUCTION.

8-2. This section contains theory of operation, troubleshooting information, safety considerations, and general service information for the Model 239A Oscillator.

8-3. SAFETY CONSIDERATIONS.

8-4. Although this instrument has been designed in accordance with international safety standards, this manual contains information, cautions, and warnings which must be followed to ensure safe operation and to maintain the instrument in safe operating condition. Service and adjustments should be performed by qualified service personnel only.

8-5. Any adjustment, maintenance, or repair of the opened instrument while any power or voltage is applied should be avoided as much as possible, and when inevitable, should be carried out only by a skilled person who is aware of the hazard involved.

WARNING

Any interruption of the protective grounding conductor (inside or outside the instrument) or disconnection of the protective earth terminal is likely to make the instrument dangerous. Intentional interruption of the protective grounding conductor is strictly prohibited.

8-6. It is possible for capacitors inside the instrument to still be charged even if the instrument has been disconnected from its power source.

8-7. Be certain that only fuses with the required current rating and of the specified type (normal blow, time delay, etc.) are used for replacement. The use of repaired fuses and the short-circuiting of fuse holders must be avoided.

WARNING

The service information presented in this manual is normally used with the protective covers removed and power applied to the instrument. Energy available at many points may, if contacted, result in personal injury.

8-8. RECOMMENDED TEST EQUIPMENT.

8-9. Test equipment required to maintain the Model 239A Oscillator is listed in Table 1-3. Equipment other than that listed may be used as long as the critical specifications are met.

THEORY OF OPERATION

8-10. GENERAL DESCRIPTION.

8-11. The Model 239A is an ultra-low distortion oscillator which provides a sinusoidal signal ranging from 10 Hz to 110 kHz at signal levels from less than 1 mV rms to 3.16 V rms into a 600 ohm impedance. Figure 8-1 shows a simplified block diagram of the Model 239A.

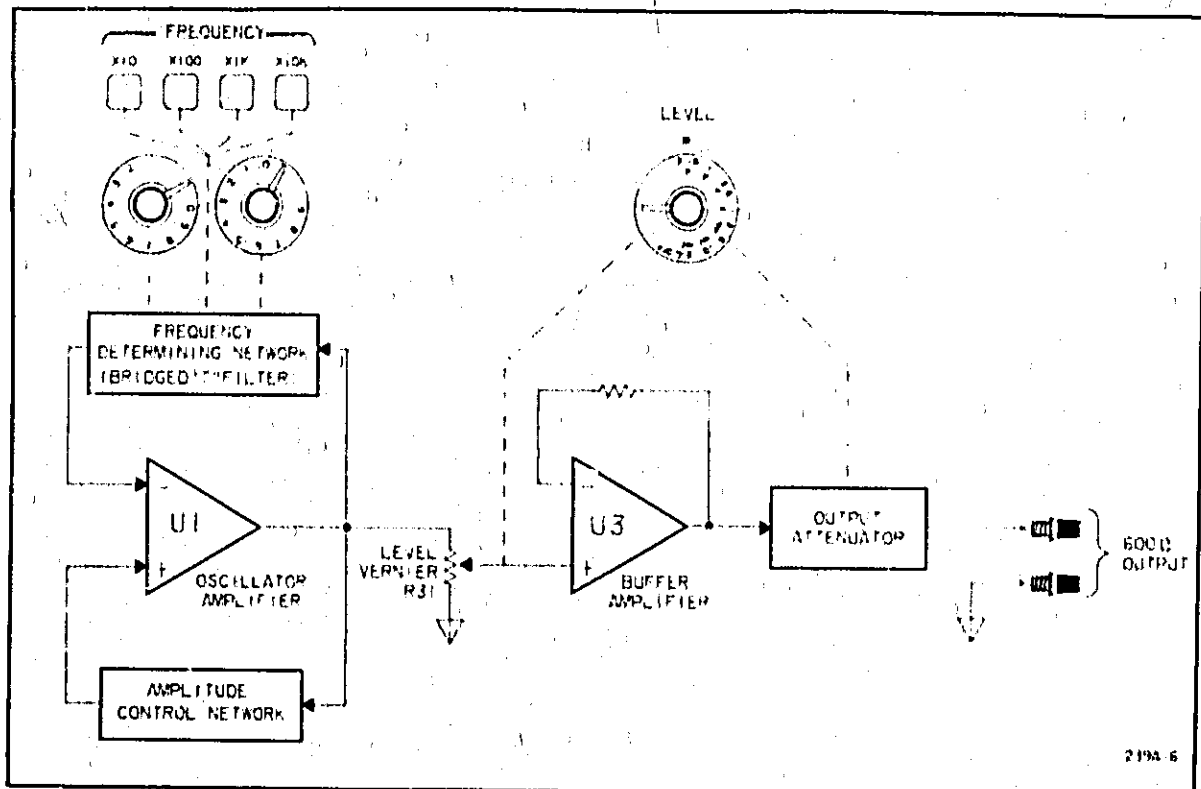

Figure 8-1. Model 239A Simplified Block Diagram.

8-12. Operating frequency of the oscillator is determined by a bridged "T" filter located in the negative feedback path of oscillator amplifier U1. Frequency is selected in four decade ranges with two digit resolution. A frequency vernier permits selection of frequencies between settings of the tenths frequency control for continuous frequency coverage from 10 Hz to 110 kHz.

8-13. Output level of the oscillator amplifier is maintained by an amplitude control circuit located in the positive feedback path of amplifier U1. The control circuit samples the positive peaks of the oscillator output and adjusts the gain of U1 as necessary to maintain a constant level.

8-14. Buffer amplifier U3 is a unity gain amplifier which isolates the oscillator circuitry from the output. The input level to U3 is varied from approximately 2 V rms to 6 V rms by LEVEL vernier R31. The output of U3 is applied to the output attenuator. The attenuator is a resistive divider which attenuates the output signal in 10 dBV steps. The maximum output level is 3.16 V rms into a 600 ohm load.

8-15. CIRCUIT DESCRIPTIONS.

8-16. Frequency Generation.

8-17. Figure 8-2 shows a simplified schematic diagram of the oscillator circuitry used in the Model 239A. The operating frequency of the oscillator is determined by the "bridge T" filter located in the negative feedback path of amplifier U1. At resonant frequency, the negative feedback signal at the inverting input of U1 is minimum and equal to $V_o/51$. The four decade frequency ranges ($\times 10$, $\times 100$, $\times 1k$, $\times 10k$) are determined by the values of C_A and C_B , while particular frequencies within each range are determined by the selection of resistors R_A and R_B .

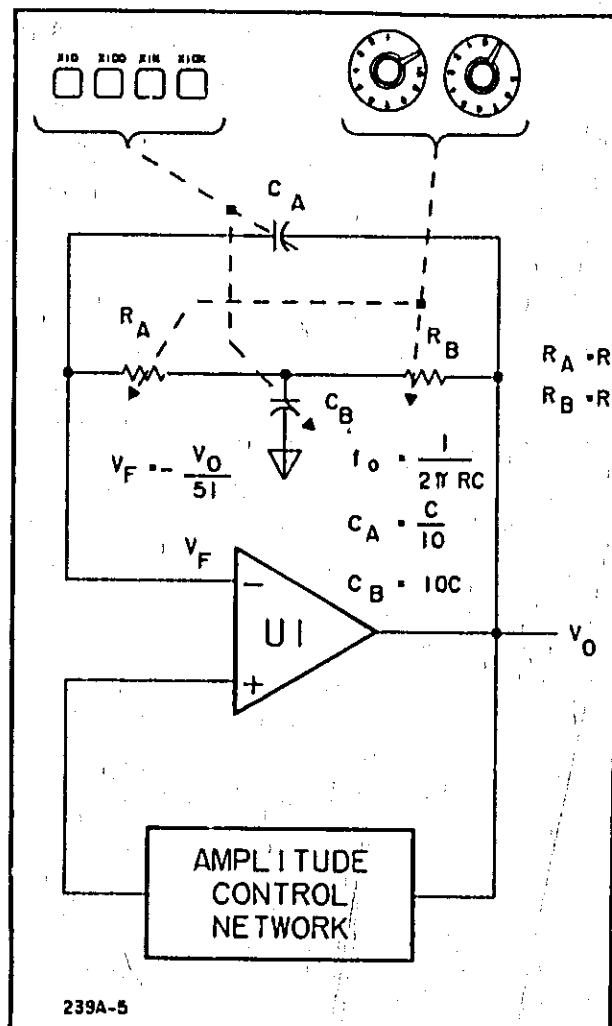

Figure 8-2. Simplified Oscillator Circuitry.

8-18. Amplitude Control.

8-19. The purpose of the amplitude control circuitry is to monitor the oscillator output level and derive an error signal to control the gain of amplifier U1. The basic oscillator amplitude is determined by resistors R55, R56 and R57 located in the positive feedback circuit of amplifier U1 and is regulated by the amplitude control circuit (see Figure 8-3).

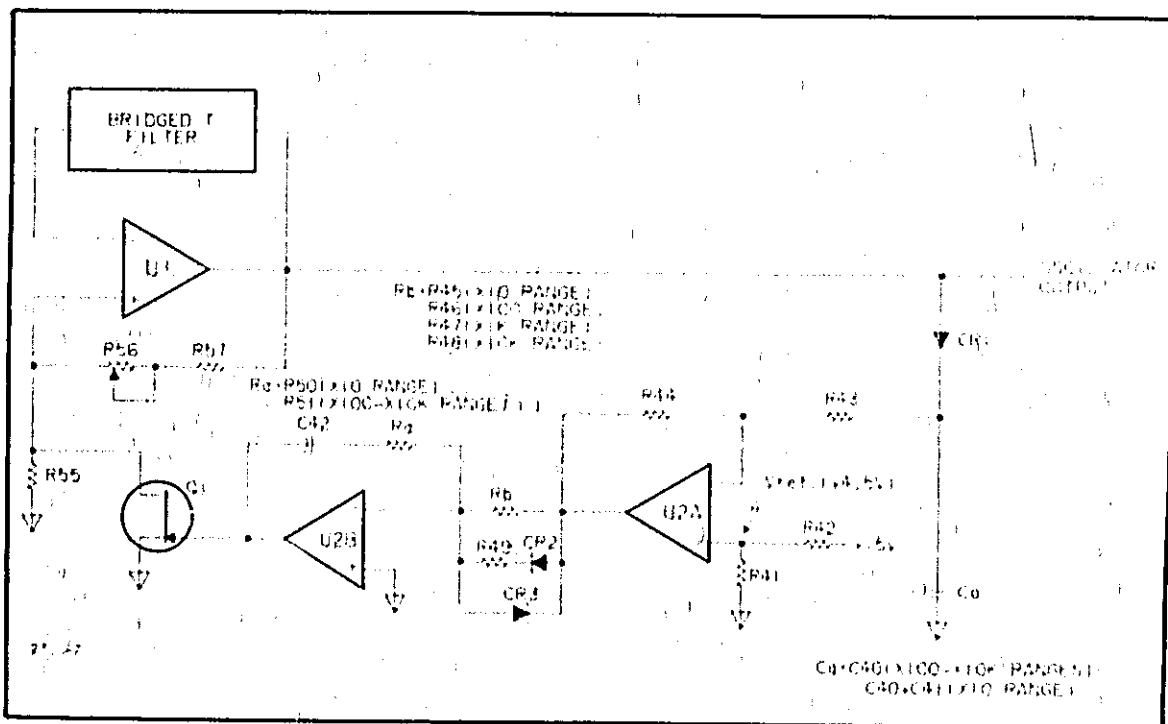

Figure 8-3. Simplified Amplitude Control Circuit.

The oscillator output is sampled during the positive peaks by the peak detector circuit consisting of CR1 and Cn. A dc level equal to the peak value of the oscillator signal is stored on capacitor Cn and is compared to a reference voltage by difference amplifier U2A. The output of U2A represents the amplitude error of the oscillator output. Under normal conditions, the error signal is small (less than 300 mV) and is applied to integrator U2B through resistor Rb. Integrator U2B acts as a low-pass filter to reduce ripple due to the peak detector circuit. Resistor Rb determines the integrator charge current and is unique to each frequency range selected. The integrator drives control FET Q1 which acts as a variable resistor in parallel with feedback resistor R55 to change the gain of oscillator amplifier U1. Diodes CR2 and CR3 provide a fast response path when large amplitude errors occur. In this case, the amplitude error causes the output of difference amplifier U2A to exceed the conduction voltage of CR2 (output too low) or CR3 (output too high) which increases the integrator charge current.

8-20. Output Buffer and Attenuator.















8-21. (Refer to Figure 8-5). The oscillator signal is applied to the output buffer amplifier (U3) through the LEVEL VERNIER control. The level vernier varies the output level of the buffer amplifier from approximately 2 V rms to 6 V rms. The buffer amplifier output is divided by the output attenuator in 10 dB V steps from 3.16 V rms to 3.16 mV rms maximum output into a 600 ohm load. The attenuator also includes an OFF position which disables the oscillator output and terminates the OUTPUT terminals with a 600 ohm resistive load. The combination of output attenuator and level vernier permits the selection of output levels from 1 mV rms to 3.16 V rms into 600 ohms (2 mV to 6.32 V open circuit).

8-22. A zener diode protection circuit (CR30-CR33) protects the oscillator circuitry from the accidental application of voltage to the oscillator OUTPUT terminals.

TROUBLESHOOTING

8-23. Troubleshooting information for the Model 239A consists of waveforms, voltage levels and notes included as part of the schematic diagrams. Due to the circuit simplicity of the 239A, no special troubleshooting procedures are included.

SCHEMATIC DIAGRAM NOTES

1. Partial component reference designations are shown. For complete reference designations, prefix with assembly designation. Example: R1 mounted on circuit assembly A1 becomes A1R1.
2. Unless otherwise noted, all resistance values are in ohms, all capacitance values are in microfarads.
3.  Denotes Earth Ground
4.  Denotes Chassis Ground
5.  Denotes Circuit Ground
6.  Denotes Assembly Borderline
7.  Denotes Main Signal Path
8.  Denotes Feedback Path
9.  Denotes Mechanical Connection
10.  Denotes Screwdriver Adjustment
11.  Denotes Troubleshooting Information
Located on apron page of respective schematic
12. * Denotes Factory Selected Component
Average Value shown on schematic
13.  Indicates wire colors. Color code same as resistors. For example, 947 indicates white base, yellow wide stripe, and violet narrow stripe
14.  Feedthrough capacitor
15.  Multi-section pushbutton or slide switch. Appropriate section shown for circuit illustration.
16.  N-Channel J-FET. Gate drawn to note Source Connection.
17.  Indicates numbered Test Point

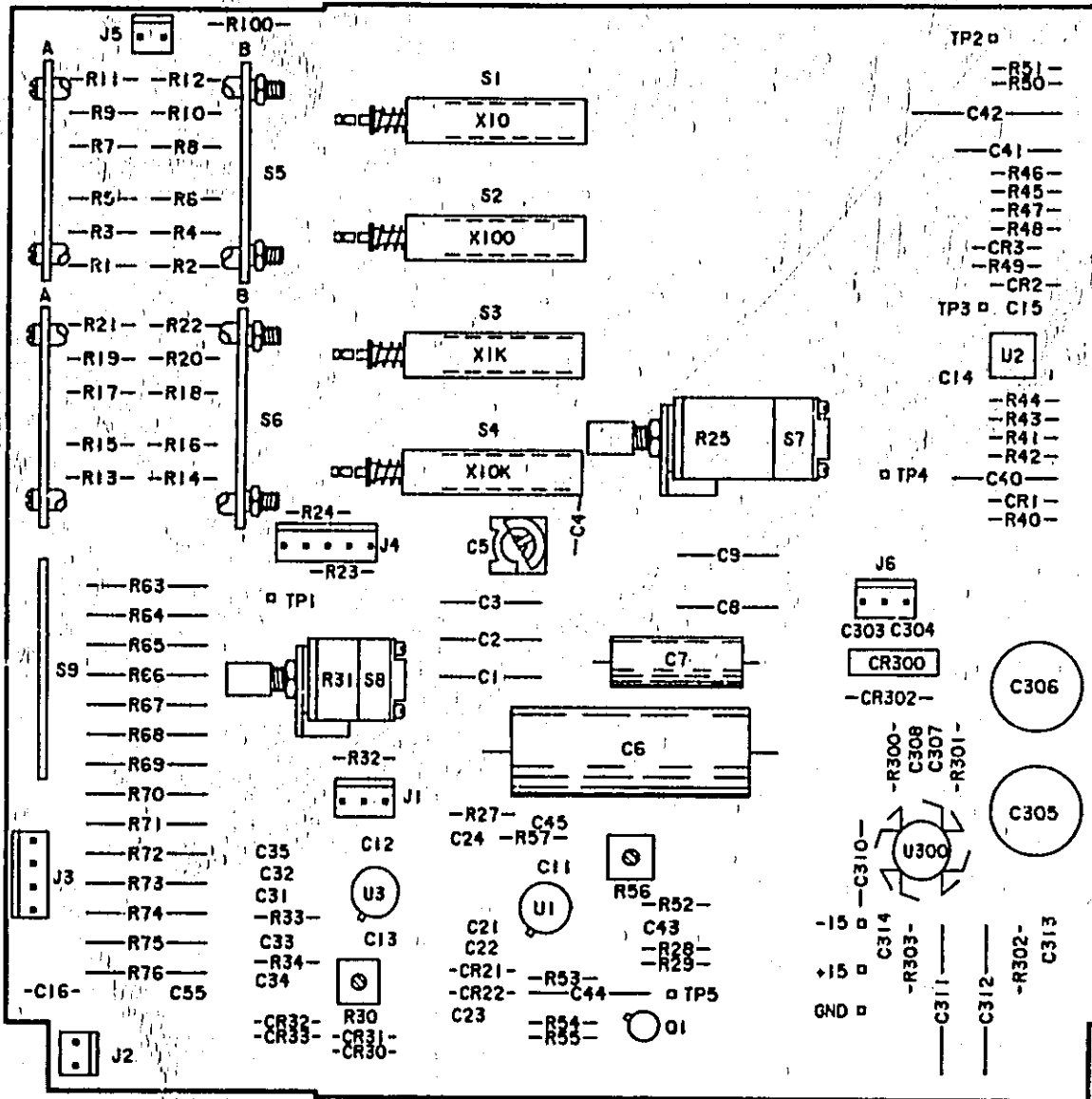

AI
00239-66501
REV. A

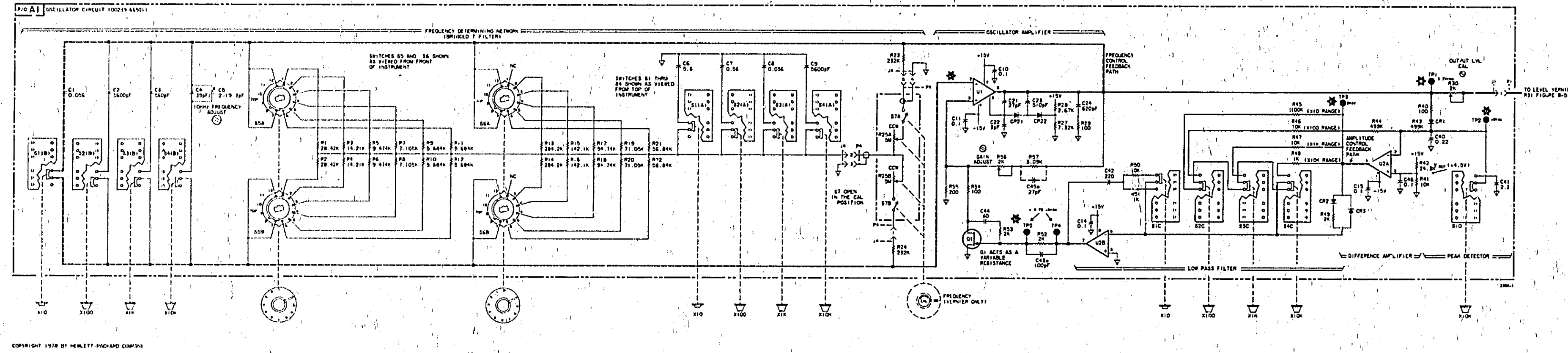
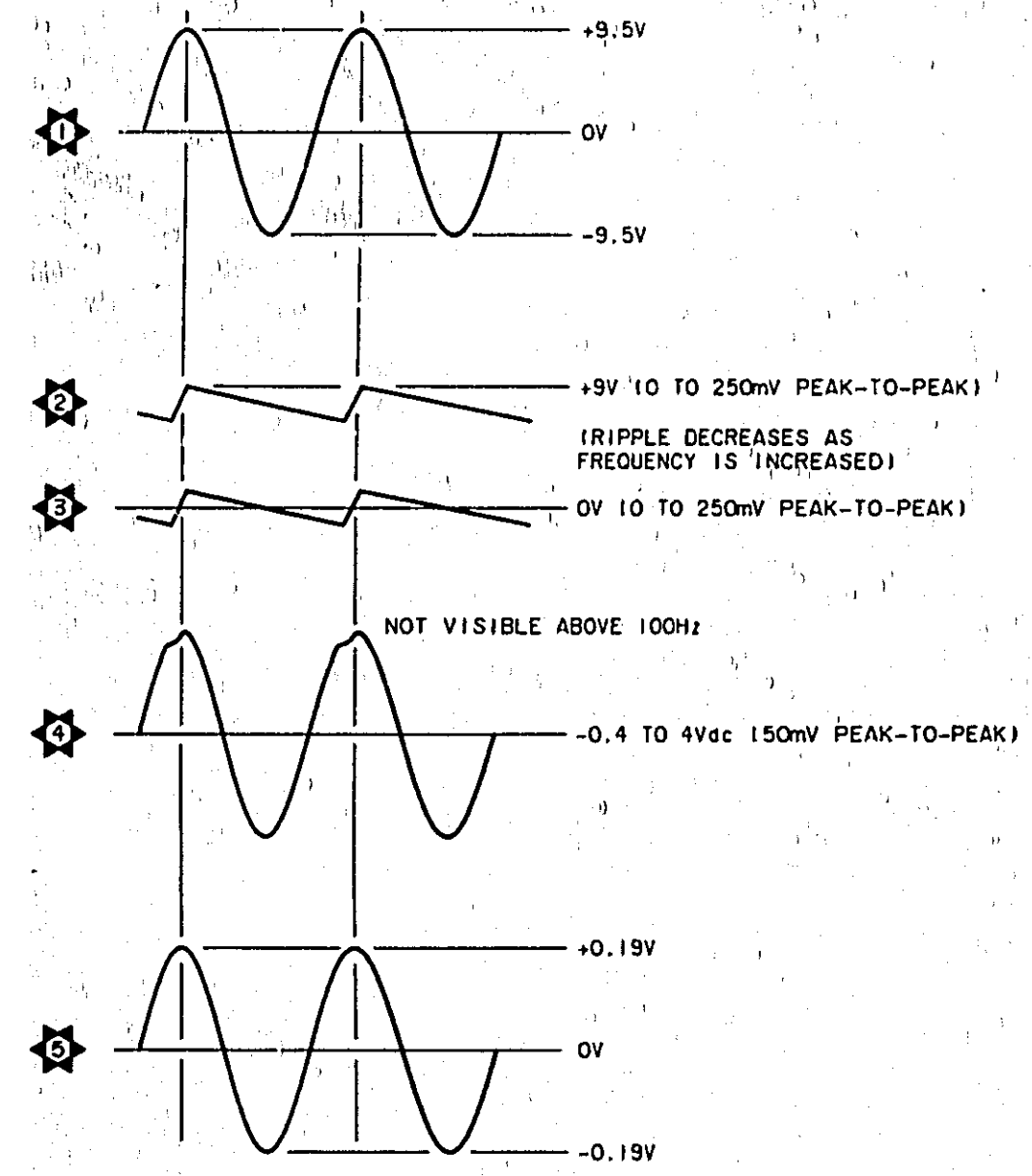
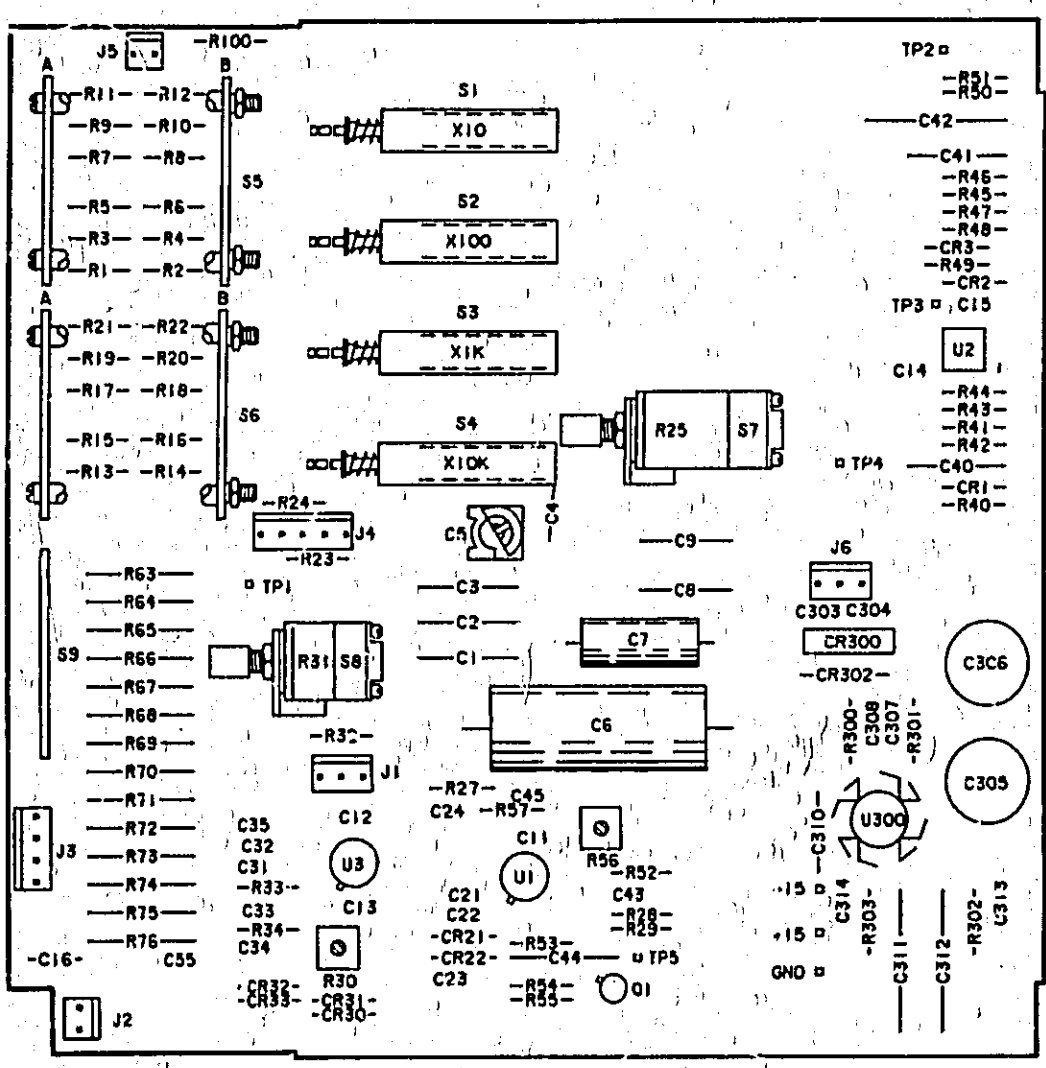

Figure 8-4. Oscillator and Amplitude Control Circuit. 8-9/8-10



AI
00239-66501
REV. A

COPYRIGHT 1978 BY HEWLETT-PACKARD COMPANY

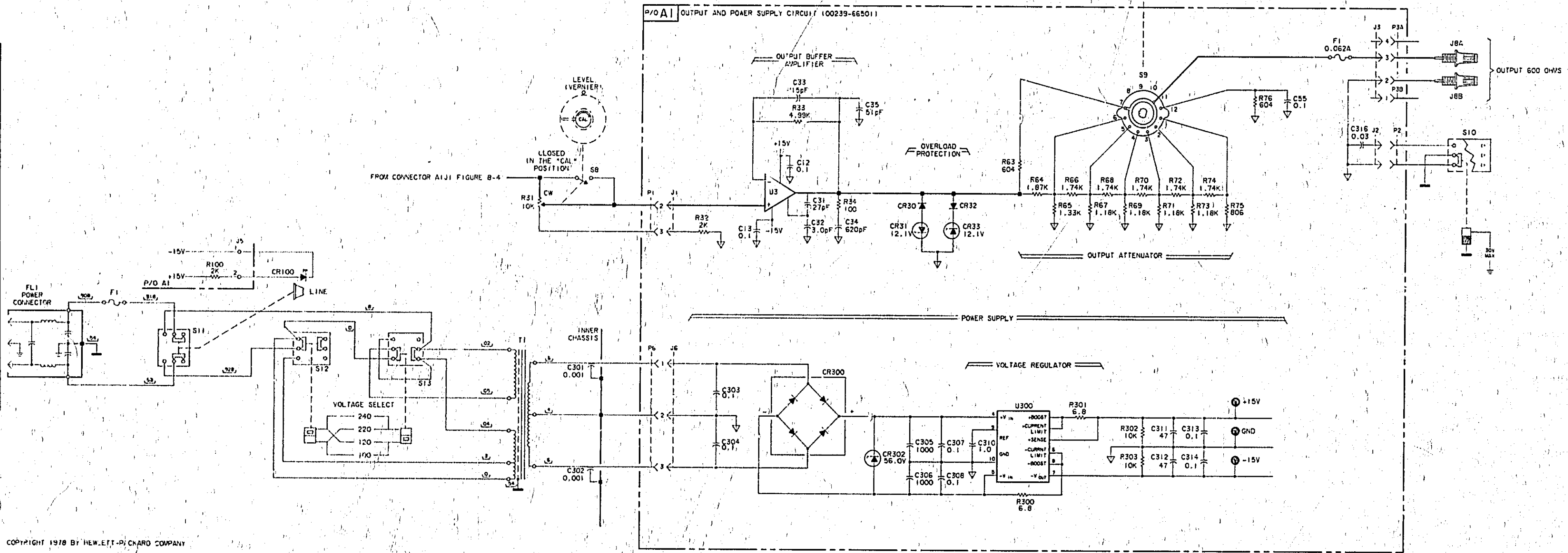

Figure 8-5. Output and Power Supply Circuits.
8-11/8-12