

Errata

Title & Document Type: 214B Pulse Generator Operating and Service Manual

Manual Part Number: 00214-90012

Revision Date: February 1981

HP References in this Manual

This manual may contain references to HP or Hewlett-Packard. Please note that Hewlett-Packard's former test and measurement, semiconductor products and chemical analysis businesses are now part of Agilent Technologies. We have made no changes to this manual copy. The HP XXXX referred to in this document is now the Agilent XXXX. For example, model number HP8648A is now model number Agilent 8648A.

About this Manual

We've added this manual to the Agilent website in an effort to help you support your product. This manual provides the best information we could find. It may be incomplete or contain dated information, and the scan quality may not be ideal. If we find a better copy in the future, we will add it to the Agilent website.

Support for Your Product

Agilent no longer sells or supports this product. You will find any other available product information on the Agilent Test & Measurement website:

www.tm.agilent.com

Search for the model number of this product, and the resulting product page will guide you to any available information. Our service centers may be able to perform calibration if no repair parts are needed, but no other support from Agilent is available.



214B PULSE GENERATOR

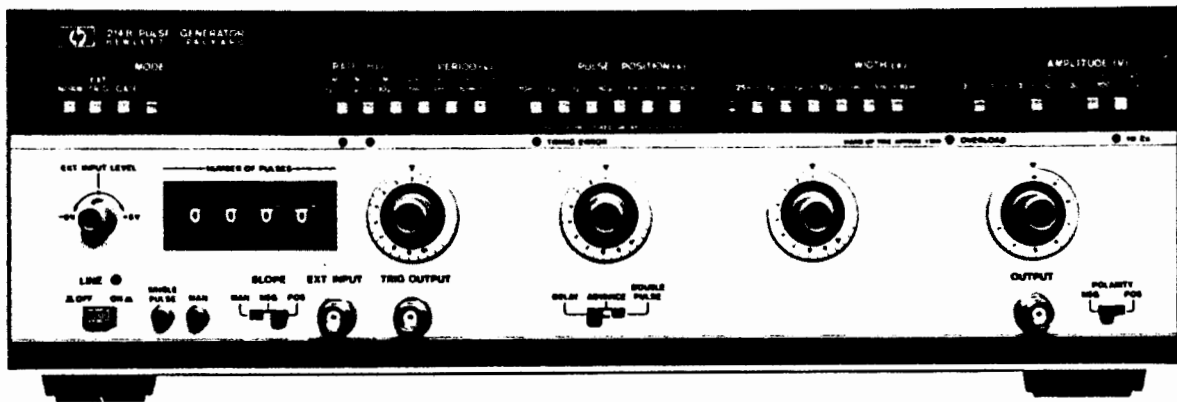

MANFRED BORMANN
 MANFRED BORMANN
 ALF DER ALLOGE 18
 D-4240 B A S 500 M
 TELEFON 0 42 41 55 16
 TELEFAX 0 42 41 55 16



**HEWLETT
PACKARD**

OPERATING AND SERVICE MANUAL

214B PULSE GENERATOR

(Including Options 001 and 907 to 910)

SERIAL NUMBERS

This manual applies directly to instruments with serial number 1846 G 00596 and higher. Any changes made in instruments having serial numbers higher than the above number will be found in a "Manual Changes" supplement supplied with this manual. Be sure to examine this supplement for any changes which apply to your instrument and record these changes in the manual. Any changes made in instruments having serial numbers lower than the above number can be found in the Backdating Section 7.

© HEWLETT-PACKARD GmbH 1980
D-7030 BÖBLINGEN, HERRENBERGER STR. 110
FEDERAL REPUBLIC OF GERMANY

MANUAL PART NO. 00214-90012
Microfiche Part No. 00214-95012

Printed: February 1981

List of Contents

CONTENTS		Page
Section 1 GENERAL INFORMATION		
1-1	Introduction	1-1
1-4	Specifications	1-1
1-6	Safety Considerations	1-1
1-9	Instruments Covered by Manual	1-1
1-11	Description	1-1
1-16	Options	1-1
Section 2 INSTALLATION		
2-1	Introduction	2-1
2-3	Initial Inspection	2-1
2-5	Preparation for Use	2-1
2-6	Power Requirements	2-1
2-10	Power Cable	2-1
2-13	Operating Environment	2-2
2-15	Front Handle/Rack Mounting	2-2
2-17	Claims and Repackaging	2-2
2-18	Claims for Damage	2-2
2-20	Storage and Shipment	2-2
Section 3 OPERATION		
3-1	Introduction	3-1
3-3	Special Operating Considerations	3-1
3-6	Operating Mode	3-1
3-9	Norm Mode	3-1
3-11	Ext. Trigger Mode	3-1
3-15	Gate Mode	3-2
3-19	Pulse Position	3-2
3-23	Duty Cycle	3-2
3-26	Constant Duty Cycle Mode	3-3
3-29	Amplitude	3-3
3-31	Polarity	3-3
Section 4 PERFORMANCE TESTS		
4-1	Introduction	4-1
4-3	Equipment Required	4-1
4-5	Test Record	4-1
4-7	Performance Tests	4-1
4-10	Repetition Rate; Vernier Accuracy	4-2
4-11	Pulse Position: Delay; Advance; Vernier Accuracy	4-4
4-12	Pulse Width; Vernier Accuracy; Max. Duty Cycle	4-7
4-13	Constant Duty Cycle; Vernier Accuracy	4-10
4-14	Pulse Amplitude; Vernier Accuracy; Source Impedance	4-13
4-15	Transition Times; Preshoot, Overshoot, Ringing; Pulse Polarity ..	4-15
4-16	Trigger Output; Double Pulse	4-17
4-17	External Modes; Trigger; Gate; Burst	4-19
4-18	Variable Trigger Level; Sensitivity	4-21

Section 5 ADJUSTMENTS

5-1	Introduction	5-1
5-3	Safety Considerations	5-1
5-9	Equipment Required	5-1
5-11	Power Supply	5-2
5-12	Period-Rate Adjust	5-3
5-13	Position Adjust	5-5
5-14	Constant Duty Cycle and Width	5-7
5-15	Pulse Amplitude	5-9
5-16	Minimum Width; Overshoot; Undershoot; Risetime; Int. Load ..	5-11
5-17	Trigger Level Sensitivity	5-13

Section 6 REPLACEABLE PARTS

6-1	Introduction	6-1
6-3	Abbreviations	6-1
6-5	Replaceable Parts	6-1
6-8	Ordering Information	6-1
6-11	Direct Mail Order System	6-1

Section 7 BACKDATING

7-1	Introduction	7-1
7-3	Change Sequence	7-1

Section 8 SERVICE

8-1	Introduction	8-1
8-4	Safety Considerations	8-1
8-6	After Service Safety Check	8-1
8-15	Service Blocks (Theory) / Troubleshooting	8-1
Appendix A	Option 001, Burst Capability	A1-1
A1-1	Introduction	A1-1
A2-1	Operating Instructions	A1-1
A3-1	Burst Performance Test	A1-2

List of Illustrations

ILLUSTRATIONS

Figure	Title	Page
1-1	214B and Supplied Accessories	1-0
1-2	Available Rack Mounting Accessories	1-0
1-3	Serial Number Plate	1-1
2-1	Switch Settings for the various Nominal Powerline Voltages	2-1
2-2	Power Cbles Available: Plug Identification	2-2
2-3	Removing Plastic Trim	2-2
3-1	Controls and Connectors	3-0
3-2	214B Outputs in Gate Mode	3-2
3-3	Timing Parameters in Double Pulse Mode	3-2

4-1	Test Setup – Rep. Rate	4-2
4-2	Test Setup – Pulse Position	4-4
4-3	Test Setup – Delay	4-5
4-4	Test Setup – Width	4-7
4-5	Test Setup – Width	4-8
4-6	Test Setup – Constant Duty Cycle	4-10
4-7	Test Setup – Constant Duty Cycle	4-11
4-8	Test Setup – Amplitude	4-13
4-9	Test Setup – Transition Times	4-15
4-10	Test Setup – Trigger Output	4-17
4-11	Test Setup – Double Pulse	4-18
4-12	Test Setup – External Modes	4-19
4-13	Test Setup – Variable Trigger Level	4-21
4-14	Waveform for +ve slope trigger	4-22
4-15	Waveform for –ve slope trigger	4-22
5-1	Setup for Period Adjust	5-3
5-2	Setup for Delay Adjust	5-5
5-3	Setup for Duty Cycle Adjust	5-7
5-4	Setup for Amplitude Adjust	5-9
5-5	Setup for Width Adjust	5-11
6-1	Parts Identification for Main Assembly	6-3
A3-1	Test Setup – Burst	A3-1

List of Tables

TABLES

Table	Title	Page
1-1	Recommended Test Equipment	1-2
1-2	Specifications	1-3
6-1	Abbreviations for Replaceable Parts	6-2
6-2	Manufacturers Code List	6-4
6-3	Replaceable Parts	6-7
8-1	Index to Assemblies	8-1
8-2	Index to Service Blocks	8-2
8-3	Schematic Diagram Notes	8-3

SCHEMATICS

Schematic	Title	Page
1	214B Block Diagram	8-7
2	Power Supply A4	8-13
3	P/O Timing Board A2	8-25
4	P/O Timing Board A2	8-27
5	Output Board A1	8-31
6	P/O Timing Board A2; Load Board A3	8-33
A1-1	P/O Timing Board A2 (Option)	A1-3
A1-2	P/O Timing Board A2 (Option)	A1-5
A1-3	P/O Timing Board A2 (Option)	A1-7

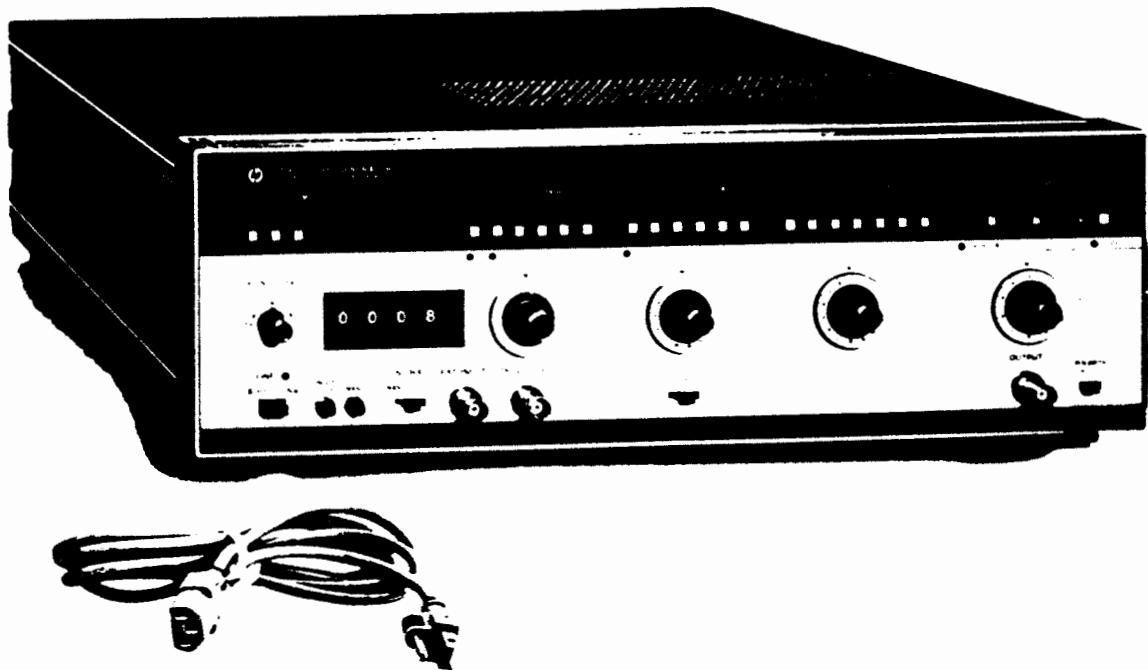
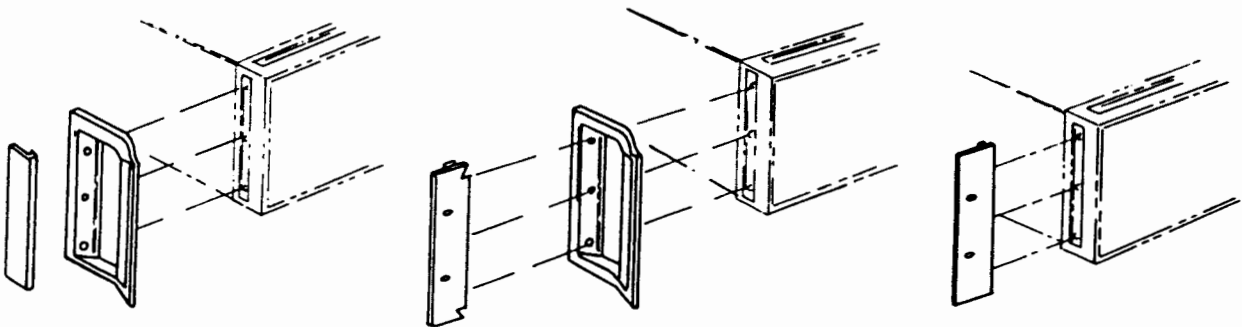

Figure 1-1. 214B and supplied Accessories (Option 001 fitted)



Front handle
Order Option 907
(H.P. Part No.
5061-0089)

Rack flange with front handle
Order Option 909
(H.P. Part No.
5061-0083)

Rack flange
Order Option 908
(H.P. Part No.
5061-0077)

Figure 1-2. Available Rack Mounting Accessories

SECTION I GENERAL INFORMATION

1-1 INTRODUCTION

1-2 This Operating and Service Manual contains information required to install, operate, test, adjust and service the Hewlett-Packard Model 214B. Figure 1-1 shows the main-frame and accessories supplied. This section covers instrument identification, description, accessories, specifications, and other basic information.

1-3 A microfiche version of this manual is available on 4 x 6 inch microfilm transparencies (order number on title page). Each microfilm contains up to 60 photo-duplicates of the manual pages. The microfiche package also includes the latest Manual Changes supplement as well as all pertinent Service Notes.

1-4 SPECIFICATIONS

1-5 Instrument specifications are listed in Table 1-2. These specifications are the performance standards or limits against which the instrument is tested.

1-6 SAFETY CONSIDERATIONS

1-7 The Model 214B is a Safety Class 1 instrument (it has an exposed metal chassis that is directly connected to earth via the power supply cable).

1-8 This operating and service manual contains information, cautions, and warnings which must be followed by the user to ensure safe operation and to maintain the instrument in a safe condition.

1-9 INSTRUMENTS COVERED BY MANUAL

1-10 Attached to the rear of this instrument is a serial number plate (Figure 1-3). The first four digits of the serial number only change when there is a significant change to the instrument. The last five digits are assigned to instruments sequentially. The contents of this manual apply directly to the instrument serial number quoted on the title page. For instruments with lower serial numbers, refer to the backdating information in Section 7 of this manual. For instruments with higher serial numbers, refer to the Manual Change sheets at the end of this manual. In addition to change information, the Manual Change sheets may contain information for correcting errors in the manual. To keep this manual as up-to-date and accurate

as possible, Hewlett-Packard recommends that you periodically request the latest Manual Change supplement. The supplement for this manual is identified with this manual's print date and part number, both of which appear on this manual's title page. Complimentary copies of the supplement are available from Hewlett-Packard.

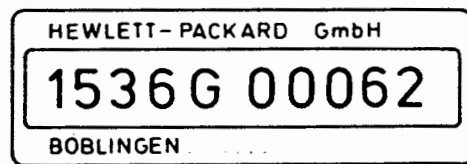

Figure 1-3. Serial Number Plate

1-11 DESCRIPTION

1-12 The Model 214B is a high power pulse generator delivering 200 watts pulse power at up to 4 MHz repetition rate and 15ns or less transition times. With reduced power, the repetition rate can be increased to 10 MHz.

1-13 Variable pulse parameters of the 214B include repetition rate, width, delay/advance, and duty cycle. In addition, the 214B constant Duty Cycle Mode ensures that duty cycle remains constant with a frequency range, thus maintaining a constant pulse energy at the output.

1-14 User orientated features of the 214B include push-button selection for parameter ranges, calibrated verniers for continuous setting within these ranges, and LED indications of timing error and output amplifier overload.

1-15 For a complete description of controls and modes of operation, refer to Section III.

1-16 OPTIONS

1-17 214B-Option 001: This allows a preselected number of pulses to be generated on receipt of a trigger signal. (Not retrofittable).

1-18 214B-Options 907, 908 and 909: Provides means of rack mounting the 214B. Further details are given in Figure 1-2.

Table 1-1. Recommended Test Equipment

QTY	INSTRUMENT TYPE	RECOMMENDED MODEL	REQUIRED CHARACTERISTICS	REQUIRED FOR		
					A	T
1	Digital Multimeter	3465A/B	10-1000VDC, AC; OHM Floating Input		A	T
1	Sampling Oscilloscope	180C Mainframe 1810A Sampling Plug In	1 GHz Bandwidth	P	A	T
1	Oscilloscope	1740A	100 MHz Bandwidth	P	A	T
1	Counter/Timer	5300B 5308A	50 MHz Start-Stop Mode	P	A	T
1	Test Oscillator	651 B	10 MHz Sinewave	P		T
1	20 dB Attenuator	8491A	20 dB Coax Attenuator	P	A	T
1	20 dB Attenuator 50 W	Narda 765-20	20 dB Coax Attenuator 50W	P	A	T
1	Pulse Generator	8012B	10 ns Pulse Width	P		T
1	Variac		Isolating Transformer		A	T

NOTE: P = Performance Check
 A = Adjustment
 T = Troubleshooting

Table 1-2. Specifications

OUTPUT CHARACTERISTICS

Pulse Amplitude

0.3V to 100V into 50 ohm. 5 ranges with calibrated vernier providing continuous adjustment within ranges.

Vernier Accuracy: $\pm 10\%$ of setting.

Source Impedance

Fixed 50 ohm nominal on ranges up to 10V. Selectable 50 ohm nominal or high impedance on 10-30V and 30-100V ranges. (Note: with 50 ohm source and load impedance, 10-30V and 30-100V ranges reduce to 5-15V and 15-50V respectively).

Polarity: Positive or negative, switch selectable.

Preshoot, Overshoot and Ringing: $\leq \pm 5\%$ of pulse amplitude.

Pulse Top Perturbations: $\leq \pm 5\%$ of pulse amplitude.

Transition Times: ≤ 15 ns for leading and trailing edges.

TIMING

Repetition Rate

10 Hz to 10 MHz in 6 decade ranges. In 30V-100V amplitude range, maximum repetition rate is 4 MHz. Calibrated vernier provides continuous adjustment within ranges.

Vernier Accuracy: $\pm (10\%$ of setting + 1% of full scale).

Period Jitter: $\leq 0.1\% + 300$ ps.

Pulse Position

Pulse Delay

Pulse can be delayed with respect to the Trigger Output from +10ns [+ fixed delay] to +10ms. [Fixed delay is 50 ns \pm 10ns].

Pulse Advance

Pulse can be delayed with respect to the Trigger Output from +10ns [- fixed delay] to +10ms. [Fixed delay is 50 ns \pm 10ns].

Controls

5 decade ranges with calibrated vernier providing continuous adjustment within ranges.

Vernier Accuracy: $\pm (10\%$ of setting + 1% of full scale) + fixed delay.

Maximum Pulse Position Duty Cycle: $\geq 50\%$.

Position Jitter: $\leq 0.1\% + 500$ ps.

Pulse Width

25ns to 10ms in 6 decade ranges. Calibrated vernier provides continuous adjustment within ranges.

Vernier Accuracy: $\pm (10\%$ of setting + 1% of full scale + 5ns).

Width Jitter: $\leq 0.1\% + 500$ ps.

Maximum Duty Cycle

$> 10\%$ for 30-100V amplitude range.

$> 50\%$ for all other ranges. (max. 10 ms width)

Constant Duty Cycle Mode (Disabled in External Trigger Mode)

Duty cycle of output pulse (hence output power) remains constant when the pulse period is changed. In this mode the duty cycle limits are:

Typically 8% fixed for 10M - 1 MHz frequency range (max. frequency 4 MHz without loss of amplitude)

2.5% to 10% for 1 M - .1 MHz frequency range

.25% to 10% for .1 MHz - 10 kHz frequency range

0.1% to 10% for all other frequency ranges

Calibrated vernier provides continuous adjustment within duty cycle ranges.

Vernier Accuracy: $\pm (15\%$ of setting + 1% of full scale).

Double Pulse

5 MHz maximum in all ranges except 30V-100V range. In 30V-100V range, the maximum frequency is 2 MHz. Minimum separation is 100ns.

Trigger Output

Amplitude: $\geq + 5$ V (from 50 ohm into open circuit).

Pulse Width: 10ns typical.

Source Impedance: 50 ohm nominal.

EXTERNALLY CONTROLLED OPERATION

External Trigger Mode : An output pulse is generated for each input pulse.

Gate Mode

Gating signal turns on repetition rate generator. First pulse occurs after start of gate signal, and last pulse is always completed even if gate ends during generation of last pulse.

Burst Mode (Optional)

Preselected number of pulses generated on receipt of trigger signal.

Number of Pulses: 1 to 9999.

Minimum Spacing between Bursts: 200ns.

External Input

Repetition Rate: DC to 10 MHz.

Sensitivity: 500mV peak to peak, dc coupled.

Slope: Positive or negative.

Trigger Level: Continuously adjustable from -5V to +5V.

Maximum Input Level: ± 100 V.

Trigger Pulse Width: > 10 ns.

Input Impedance: 10k ohm nominal.

Manual

Pushbutton can be used for:

- triggering single pulses (EXT TRIGGER Mode)
- generating gate signals (GATE Mode)
- triggering pulse bursts (BURST Mode)

GENERAL

Environmental : Instrument operates within 0°C to 55°C.

Power Requirements

100V, 120V, 220V or 240V, +5%, -10%. 48 Hz to 66 Hz, 360VA max.

Weight : Net 13.6 kg (30.1 lb), shipping 15.6 kg (34.3 lb).

Dimensions

133mm high, 426mm wide, 422mm deep (5.2 x 16.8 x 16.6 inches).

NOTES

1. Dimensions are for general information only. If dimensions are required for building special enclosures, contact your HP field engineer.

2. Dimensions are in millimetres and (inches).

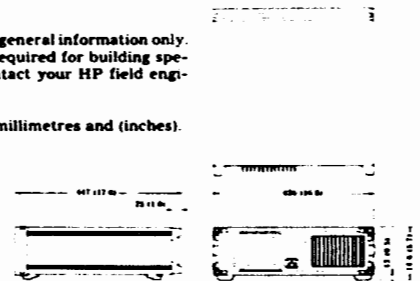

OPTIONS

Option 001

Burst. Preselected number of pulses generated on receipt of trigger signal. Number of Pulses: 1 to 9999.

Option 907

Front Handle Kit, part number 5061-0089.

Option 908

Rack Mounting Kit, part number 5061-0079

Option 909

Combined Front Handle and Rack Mounting Kit, part number 5061-0083.

Option 910

Additional Operating and Service Manual

Data subject to change

SECTION II INSTALLATION

2-1 INTRODUCTION

2-2 This section provides installation instructions for the instrument and its accessories. It also includes information about initial inspection and damage claims, preparation for use, and packaging, storage and shipment.

2-3 INITIAL INSPECTION

2-4 Inspect the shipping container for damage. If the container or cushioning material is damaged, it should be kept until the contents of the shipment have been checked for completeness and the instrument has been checked mechanically and electrically. The contents of the shipment should be as shown in Figure 1-1 plus any accessories that were ordered with the instrument. Procedures for checking the electrical operation are given in Section 4. If the contents are incomplete, if there is mechanical damage or defect, or if the instrument does not pass the operator's checks, notify the nearest Hewlett-Packard office. Keep the shipping materials for carrier's inspection. The HP office will arrange for repair or replacement without waiting for settlement.

2-5 PREPARATION FOR USE

2-6 Power Requirements

2-7 The instrument requires a power source of 100V, 120V, 220V or 240V (+5%, -10%) at a frequency of 48 to 66 Hz single phase. The maximum power consumption is 380V A.

2-8 Line Voltage Selection

CAUTION

BEFORE SWITCHING ON THIS INSTRUMENT make sure that the instrument is set to the local line voltage.

2-9 Figure 2-1 provides information for line voltage and fuse selection:

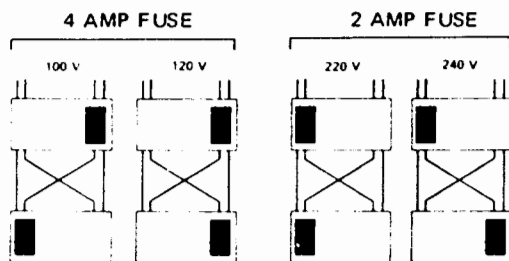

Figure 2-1. Switch Settings for the various Nominal Power-line Voltages

2-10 Power Cable

WARNING

To avoid the possibility of injury or death, the following precautions must be followed before the instrument is switched on:

- a. If this instrument is to be energized via an autotransformer for voltage reduction, make sure that the common terminal is connected to the grounded pole of the power source.*
- b. The power cable plug shall only be inserted into a socket outlet provided with a protective ground contact. The protective action must not be negated by the use of an extension cord without a protective conductor.*
- c. Before switching on the instrument, the protective ground terminal of the instrument must be connected to a protective conductor of the power cable. This is verified by checking that the resistance between the instrument chassis and the front panels of all modules in the instrument and the ground pin of the power cable plug is zero ohms.*

2-11 In accordance with international safety standards, this instrument is equipped with a three-wire power cable. When connected to an appropriate ac power receptacle, this cable grounds the instrument cabinet. The type of power cable shipped with each instrument depends on the country of destination. Refer to Figure 2-2 for the part number of the power cords available.

2-12 If the plug on the cable supplied does not fit your power outlet, then cut the cable at the plug end and connect a suitable plug. The plug should meet local safety requirements and include the following features:

- Minimum current rating of 4A
- Ground connection
- Cable clamp.

The colour coding used in the cable will depend on the cable supplied (see Figure 2-2).

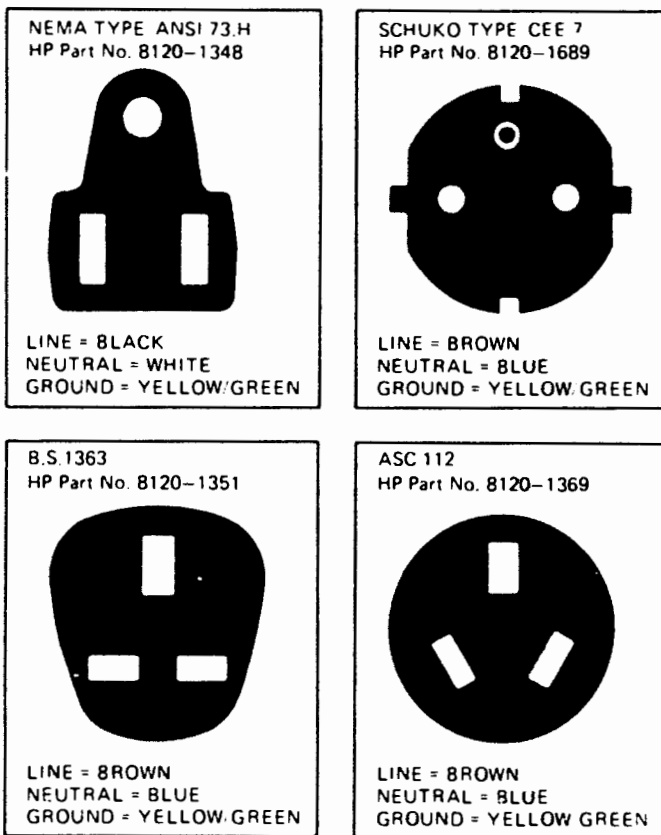

Figure 2-2. Power Cables Available: Plug Identification

2-13 Operating Environment

2-14 The instrument will operate within specifications when the ambient temperature is between 0°C and 55°C.

2-15 FRONT HANDLE/RACK MOUNTING

2-16 Figure 1-2 shows the possible handle/rack-mounting configurations. If handles are fitted and subsequently need to be removed, the plastic trim must first be taken off as shown in Figure 2-3.

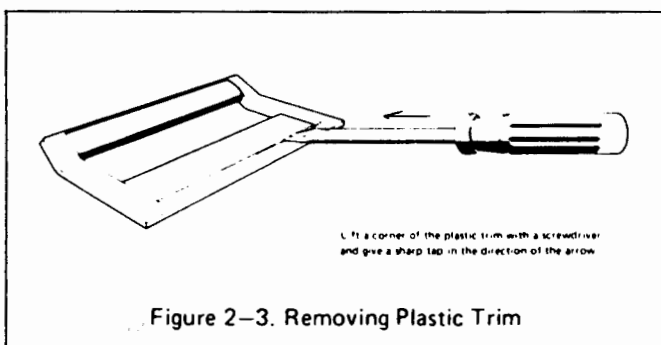

Figure 2-3. Removing Plastic Trim

2-17 CLAIMS AND REPACKAGING

2-18 Claims for Damage

2-19 If physical damage is evident or if the instrument does not meet specification when received, notify the carrier and the nearest Hewlett-Packard Sales/Service Office. The Sales/Service Office will arrange for repair or replacement of the unit without waiting for settlement of the claim against the carrier.

2-20 STORAGE AND SHIPMENT

2-21 The instrument can be stored or shipped at temperatures between -40°C and 75°C. The instrument should be protected from temperature extremes which cause condensation within the instrument.

2-22 If the instrument is to be shipped to a Hewlett-Packard Sales/Service Office, attach a tag showing owner, return address, model number and full serial number and the type of service required. The original shipping carton and packaging material may be re-usable but the Hewlett-Packard Sales/Service office will also provide information and recommendations on materials to be used if the original packing is not available or re-usable. General instructions for re-packing are as follows:

1. Wrap instrument in heavy paper or plastic.
2. Use strong shipping container. A double wall carton made of 350-pound test material is adequate.
3. Use enough shock-absorbing material (3 to 4-inch layer) around all sides of instrument to provide firm cushion and prevent movement inside container. Protect control panel with cardboard.
4. Seal shipping container securely.
5. Mark shipping container FRAGILE to encourage careful handling.
6. In any correspondence, refer to instrument by model number and serial number.

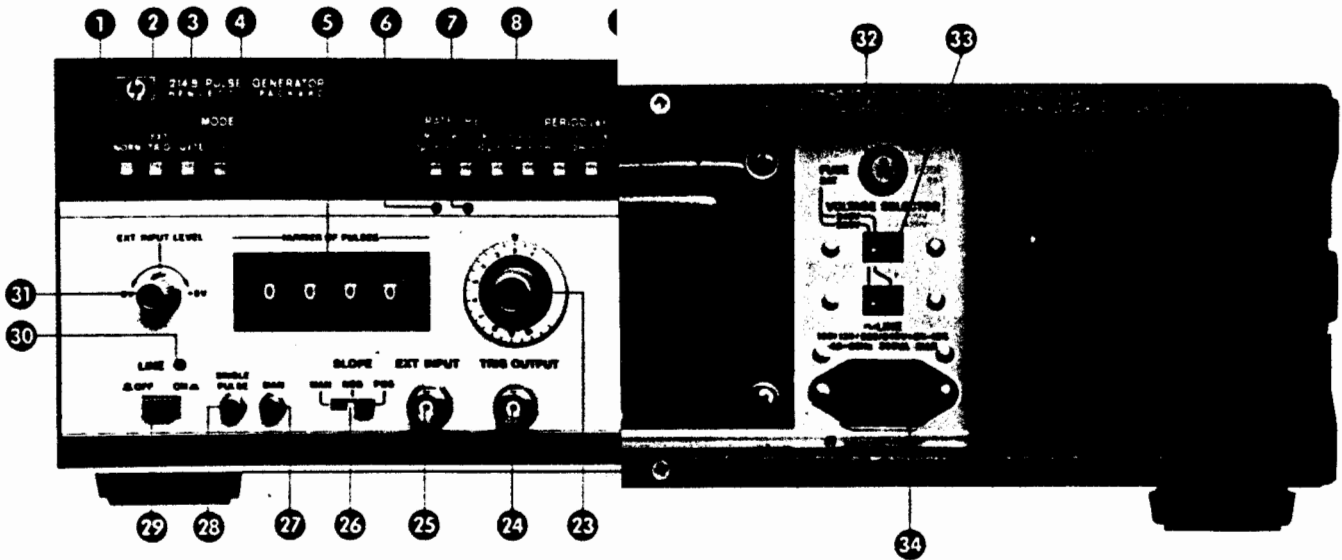

- 1 NORM. Pushbutton for selecting internal repetition rate.
- 2 EXT TRIG. Pushbutton for selecting external trigger source. In this mode an output pulse is generated for every transition (slope selectable at 26) at the EXT INPUT connector, or for each momentary operation of the MAN pushbutton 27
- 3 GATE. Pushbutton for selecting gating mode of operation. In this mode, output pulses are generated for the duration of a signal applied to the EXT INPUT connector, or for as long as the MAN pushbutton 27 remains pressed.
- 4 BURST. (Option 001). Pushbutton for selecting burst mode of operation. In this mode a preselected number of pulses are output on receipt of a signal at the EXT INPUT connector, or by momentary operation of MAN pushbutton 27
- 5 NUMBER OF PULSES (Option 001). Thumb-wheel switch for presetting the number of output pulses in burst mode.
- 6 8 % FXD LED. Provides visual indication that duty cycle is fixed at 8 % and will remain constant should frequency vernier 23 be adjusted. Width pushbuttons 12 and vernier 20 are disabled when this LED is illuminated.
- 7 2.5-10 % LED. Provides visual indication that duty cycle can be varied within the limits 2.5-10 %, and that once set, will remain constant should frequency vernier 23 be adjusted.
- 26 SLOPE. Slide switch for selecting trigger slope of external signal or for selecting manual command operation.
- 27 MAN. Pushbutton for providing a manual trigger in EXT TRIG mode, or gate signal in GATE mode. When Option 001 is fitted, this switch also provides a trigger signal for a pulse output burst.
- 28 SINGLE PULSE (Option 001). Pushbutton for providing a single pulse output in BURST mode.
- 29 LINE OFF/ON. Switch for applying primary ac power to the instrument.
- 30 LINE LED. Indicates when primary ac power is applied to the instrument.
- 31 EXT INPUT LEVEL. Control for adjusting trigger level of external input signal.
- 32 FUSE. Accepts standard fuses to provide instrument protection in case of current overload. A 2A slow-blow fuse must be used when operating from 240V/220V power source. A 4A fuse is used when operating from 100V/120V power source.
- 33 VOLTAGE SELECTOR. These switches connect the internal power transformer to accept the primary power source voltage. BOTH SWITCHES must be set to the position marked for the power source being used.
- 34 LINE. A three-pronged receptacle to provide chassis ground through the power cable for operator protection.

SECTION III OPERATION

3-1 INTRODUCTION

3-2 This operating section explains the functions of the controls and indicators of the Model 214B Pulse Generator. Front and rear panel controls and connectors are identified and briefly described in Figure 3-1. A more detailed description of the control and connector functions is given in the following paragraphs.

3-3 SPECIAL OPERATING CONSIDERATIONS

3-4 Prior to operating the Model 214B, the operator should familiarise himself with the controls and connectors by reading this section in its entirety.



When operating in the 30-100V amplitude range, the output voltage is dangerous to life. Care should therefore be taken when connecting the 214B to external instruments.

3-5 The following steps should be taken before applying power to the 214B.

- a) Read the safety summary at the front of this manual.
- b) Be sure the power selector switches are set properly for the power source being used to avoid instrument damage.

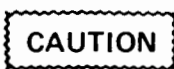

Do not change the LINE SELECTOR switch setting with the instrument on or with power connected to the rear panel.

- c) When connecting the 214B to an external device, ensure that the device cannot be overloaded by the 214B output.

3-6 OPERATING MODE

3-7 The 214B operating mode is selected by pressing one of three pushbuttons.

- NORM when rate is determined by the internal generator.
- EXT TRIG when an external trigger source is connected.
- GATE when the internal repetition rate generator needs to be switched on only for the duration of an external gating signal.

3-8 A more complete description of these three operating modes is given in the following paragraphs.

3-9 NORM MODE

3-10 With this mode selected, the frequency is set via the RATE pushbutton row and the calibrated RATE vernier. For each pushbutton selection of rate range, a corresponding period range is shown to simplify adjustment of pulse position and pulse width, i.e. correct timing is assured when the pulse position and pulse width settings are less than the selected period.

3-11 EXT TRIGGER MODE

3-12 With external trigger mode selected, a 214B output pulse is generated either by applying an external trigger signal to the EXT INPUT connector or by operation of the MAN pushbutton.

3-13 When operating from an external trigger source, the trigger signal can be from dc to 10MHz, with minimum amplitude 0.5V centred on the trigger level, and minimum pulse width 10ns. The trigger slope is then selectable via the SLOPE slide switch, and trigger level adjustable between -5V and +5V via the EXT INPUT LEVEL control.

NOTE:

To avoid incompatible timing settings, the pulse position and pulse width settings should each be less than the period of the external trigger signal.

3-14 When using the MAN pushbutton to generate an output pulse, the SLOPE slide switch must be set to MAN, and then a single pulse is generated every time the MAN pushbutton is pressed. Other front panel controls are set to obtain the desired pulse characteristics e.g. pulse position, pulse width, amplitude.

3-15 GATE MODE

3-16 With gate mode selected, the internal repetition rate generator is turned on either by applying an external signal to the EXT INPUT connector or by operation of the MAN pushbutton.

3-17 If an external signal is applied, then pulses occur at the 214B output when:

- a) with positive slope selected, the external signal is more positive than the selected trigger level (selected by EXT INPUT LEVEL control). See figure 3-2.
- b) with negative slope selected, the external signal is more negative than the selected trigger level. See figure 3-2.

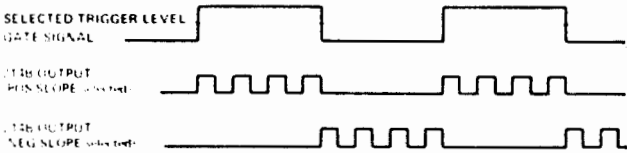

Figure 3-2 214B Outputs in Gate Mode

In either case, the effective period of the gate signal should be greater than the period selected at the RATE/PERIOD controls. Also, as in NORM trigger mode, pulse position and pulse width settings should be less than PERIOD setting to avoid timing errors.

3-18 When using the MAN pushbutton to generate output pulses, the SLOPE slide switch must be set to MAN, then 214B output pulses occur for as long as the MAN pushbutton remains pressed. Other front panel controls are set to obtain the desired pulse characteristics e.g. frequency, delay, width etc.

3-19 PULSE POSITION

3-20 The output pulse of the 214B can be delayed or advanced with respect to the trigger output, according to the setting of DELAY/ADVANCE slide switch. In either case, the range is selected via the PULSE POSITION pushbutton row, and exact setting accomplished via the PULSE POSITION calibrated vernier.

3-21 In the event of the selected delay/advance being greater than the selected period, the TIMING ERROR LED will be illuminated and remain illuminated as long as this error relationship exists. (Note: the TIMING ERROR LED functions only in NORM mode).

3-22 For DOUBLE PULSE operation, the PULSE POSITION controls are used to set the delay between the start of

the first pulse and start of the second pulse. In this mode, the following timing conditions should be observed for a true output:

- a) the pulse position setting less than the selected period. (Note: in this mode, range 10n-1u is not specified)
- b) the minimum separation between the first and second pulse (see figure 3-3) is the minimum setting of the selected pulse position range e.g. in 1m-10m pulse position range, minimum separation is 1ms.

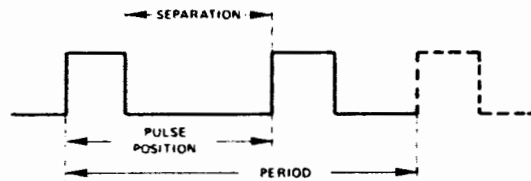

Figure 3-3. Timing parameters in Double Pulse Mode.

3-23 DUTY CYCLE

3-24 Duty cycle is defined as the percentage ratio of pulse width to pulse period. With the 214B, a DUTY CYCLE pushbutton is provided, whereby:

- if released, the WIDTH pushbutton row is operational, and the vernier provides continuous width adjustment within the selected range. In this case, the width remains constant when the period is changed, hence duty cycle varies with frequency.
- if pressed, then only the DUTY CYCLE range pushbuttons are operational, and the vernier provides continuous adjustment of duty cycle within the selected range. Once set, the duty cycle remains constant in the event of a frequency change. This feature is referred to as Constant Duty Cycle Mode of operation.

3-25 When the DUTY CYCLE pushbutton is released, the pulse width is set via the WIDTH pushbutton row and related vernier, the duty cycle then being operator - calculated by relating this time to the output pulse period. The maximum duty cycle in this case (whether internal or external trigger) is:

- at least 10 % for the 30-100 V amplitude range
- at least 50 % for all other amplitude ranges (up to a max. pulse width 10 ms)

If the maximum allowed duty cycle is exceeded, the 214B output will be automatically disabled and thus safeguarded from overload.

The disabled condition is generally indicated by the OVERLOAD LED. At rates above 4 MHz, however, the

LED may not operate. Consequently, the user should verify width/period settings and not rely on the LED when operating at higher rates.

The output is automatically re-enabled when the width/period relationship is adjusted for a duty cycle at or below the allowed maximum.

3-26 CONSTANT DUTY CYCLE MODE

3-27 The constant duty cycle mode is selected by pressing the DUTY CYCLE pushbutton, and only functions when the internal trigger is in operation i.e. NORM mode, GATE mode, and BURST mode if option 001 is fitted.

3-28 When operating in constant duty cycle mode, different duty cycle limits exist according to the rate setting. These are:

- typically 8 % fixed in the 1MHz-10MHz rate range
- 2.5-10 % in the .1MHz-1MHz rate range.
- .25-10 % in the 10 kHz - .1 MHz rate range.
- 0.1-10 % for all other frequency ranges.

For the two highest rate ranges, the duty cycle limits are indicated by an illuminated LED. In those rate ranges where the constant duty cycle can be adjusted (1MHz and lower), the duty cycle is set via the DUTY CYCLE range push-buttons and duty cycle vernier.

Whereas the settings on this vernier correspond to width times, when the DUTY CYCLE pushbutton is released, they are now used to set percentage duty cycle.

3-29 AMPLITUDE

3-30 The Model 214B output amplitude is determined primarily by the AMPLITUDE pushbutton row and

AMPLITUDE vernier. Also affecting the output amplitude are the 214B source impedance and the load impedance. In the .3-1-3-10V amplitude ranges, the source impedance is a fixed 50 ohm, and the amplitude indicated by the pushbutton range and vernier setting is true when operating with a 50 ohm load.

With a high load impedance in these ranges, the front panel amplitude indication is one-half of the actual amplitude.

On the 10-30-100V amplitude ranges, the source impedance is selectable via the INT LOAD pushbutton. When this pushbutton is in the released position, a high source impedance exists, and when depressed, a 50 ohm source impedance is switched in. The lower amplitude scale (10-30-100) applies when either the load or the source impedance is high (NOTE: one 50 ohm termination must remain). The upper scale (5-15-50) applies when both source and load impedances are 50 ohm. When the source impedance is high, the HIZs LED is illuminated.

3-31 POLARITY

3-32 The polarity slide switch is used to set the polarity of the selected amplitude with respect to 0V. e.g. with amplitude set to 36V and polarity set to NEG, then the output pulse transitions between 0V and -36V.

SECTION IV PERFORMANCE TESTS

4-1 INTRODUCTION

4-2 The procedures in this section test the electrical performance of the pulse generator using the specifications of Table 1-2 as performance standards. All tests can be performed without access to the interior of the instrument.

4-3 EQUIPMENT REQUIRED

4-4 Equipment required for the performance tests is listed in Table 1-1, Recommended Test Equipment. Any equipment that satisfies the critical specifications given in the table may be substituted for the recommended model(s).

4-5 TEST RECORD

4-6 Results of the performance tests may be tabulated on the Test Record at the end of the test procedures. The Test Record lists all of the tested specifications and their acceptable limits. Test results recorded at incoming inspection can be used for comparison in periodic maintenance, troubleshooting, and after repairs or adjustments.

4-7 PERFORMANCE TESTS

4-8 The performance tests given in this section are suitable for incoming inspection, troubleshooting, or preventive maintenance. During any performance test, all shields and connecting hardware must be in place. The tests are designed to verify the published instrument specifications, perform the tests in the order given and record the data on the test card and/or in the data spaces provided at the end of each procedure.

4-9 Each test is arranged so that the specification is written as it appears in Table 1-2. Next, a description of the test and any special instructions or problem areas are included. Each test that requires test equipment has a setup drawing and a list of the required equipment. The initial steps of each procedure give control settings required for that particular test.

PERFORMANCE TESTS

4-10 REPETITION RATE; VERNIER ACCURACY

SPECIFICATION:

Repetition Rate 10 Hz to 10 MHz in six decade ranges.
 In 30V – 100V amplitude range, maximum repetition rate is 4 MHz.
 Calibrated vernier provides continuous adjustment within ranges.
 Vernier Accuracy: \pm (10% of setting + 1% of full scale).

EQUIPMENT:

Counter/Timer
 50 Ω Feedthrough

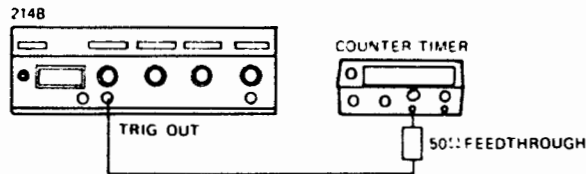

Figure 4-1.

1. Connect equipment as shown in Figure 4-1 and set 214B controls as follows:

MODE	NORM
PERIOD Range1 μ – 1 μ
PERIOD Vernier	10
POSITION Range	10n – .1 μ
POSITION Vernier	1
DUTY CYCLE %	*
DUTY CYCLE Range	*
DUTY CYCLE Vernier	*
WIDTH RANGE	*
AMPLITUDE Range	3-10
AMPLITUDE Vernier	3
INT LOAD	*
SLOPE	*
DEL/ADV/D.P.	*
POLARITY	*

* = don't care

2. Set counter to Period or Period AVG to get the best resolution.

PERFORMANCE TESTS

3. Set PERIOD VERNIER exactly to 10.
Switch from range to range and check that Counter/Timer reading is within the listed results.

PERIOD RANGE	VERNIER SETTING	RESULT
.1 μ - 1 μ	10	890ns - 1110ns
1 μ - 10 μ	10	8900ns - 11100ns
10 μ - .1m	10	89 μ s - 111 μ s
.1m - 1m	10	890 μ s - 1110 μ s
1m - 10m	10	8900 μ s - 11100 μ s
10m - .1	10	89ms - 111ms

4. Set PERIOD VERNIER exactly to 1.
Switch from range to range and check that Counter/Timer reading is within the listed results.

PERIOD RANGE	VERNIER SETTING	RESULT
10m - .1	1	8000 μ s - 12000 μ s
1m - 10m	1	800 μ s - 1200 μ s
.1m - 1m	1	80 μ s - 120 μ s
10 μ - .1m	1	8000ns - 12000ns
1 μ - 10 μ	1	800ns - 1200ns
.1 μ - 1 μ	1	80ns - 120ns

5. For checking dial tracking set PERIOD VERNIER exactly to the listed settings and check results.

PERIOD RANGE	VERNIER SETTING	RESULT
.1 μ - 1 μ	2	170ns - 230ns
.1 μ - 1 μ	3	260ns - 340ns
.1 μ - 1 μ	4	350ns - 450ns
.1 μ - 1 μ	5	440ns - 560ns
.1 μ - 1 μ	6	530ns - 670ns
.1 μ - 1 μ	7	620ns - 780ns
.1 μ - 1 μ	8	710ns - 890ns
.1 μ - 1 μ	9	800ns - 1000ns

PERFORMANCE TESTS

4-11 PULSE POSITION: DELAY; ADVANCE; VERNIER ACCURACY

SPECIFICATION:

- DELAY: Pulse can be delayed with respect to the Trigger Output from +10ns (+ fxd delay) to +10ms in 5 decade ranges. [Fixed delay is 50 ns ± 10 ns]
- ADVANCE: Pulse can be advanced with respect to the Trigger Output from +10 ns (-fxd delay) to +10 ms in 5 decade ranges. [Fixed delay is 50 ns ± 10 ns]
- VERNIER: Accuracy ± (10% of setting + 1% of full scale) + fixed delay . Fixed delay is 50 ns ± 10 ns.

EQUIPMENT:

- Sampling Oscilloscope
- 2 x 20dB Coax Attenuator
- 2 x 50 Ω Feedthrough
- Counter / Timer

CAUTION: Do not overload Attenuators and Oscilloscope Inputs.

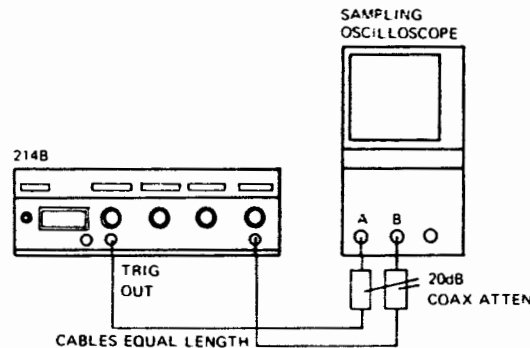

Figure 4-2.

1. Connect equipment as shown in Figure 4-2 and set 214B controls as follows:

MODE	NORM
PERIOD Range1μ - 1μ
PERIOD Vernier	10
POSITION Range	10n - .1μ
POSITION Vernier	10
DUTY CYCLE %	Depressed
DUTY CYCLE Range	*
DUTY CYCLE Vernier	*
AMPLITUDE Range	1-3
AMPLITUDE Vernier	as required
INT LOAD	*
SLOPE	*
DEL/ADV /D.P.	DELAY
OUTPUT POLARITY	POS

* = don't care

PERFORMANCE TESTS

2. Trigger Sampling Oscilloscope to Channel A and set Timebase to 20ns/DIV.
3. Ensure that POSITION VERNIER is set exactly to 10, and measure time between TRIG OUTPUT and OUTPUT signal. RESULT: 129 ns – 171 ns.
4. Set VERNIER exactly to 1 and check that delay is 48 ns – 72 ns.
5. Switch 214B to ADVANCED and with VERNIER set to 1 delay should be 28 ns – 52 ns.
6. Set Vernier exactly to 10 and measure time between OUTPUT and TRIG OUTPUT signal. RESULT: 29 ns to 71 ns.
8. Change test setup to that shown in Figure 4-3 to check DELAY RANGES. .1μ – 1μ to 1m – 10m.

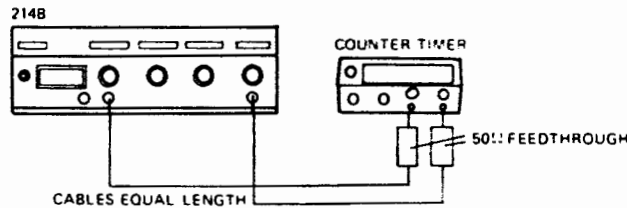

Figure 4-3.

9. Set 214B controls as follows:

MODE	NORM
PERIOD Range	10m – .1
PERIOD Vernier	10
POSITION Range1μ – 1μ
POSITION Vernier	10
DUTY CYCLE	Depressed
DUTY CYCLE Range	*
DUTY CYCLE Vernier	*
AMPLITUDE Range	1-3
AMPLITUDE Vernier	as required
INT LOAD	*
SLOPE	*
DEL/ADV/D.P.	DEL
OUTPUT POLARITY	POS

* = don't care

10. Measure time between positive going edge of Trigger and positive going edge of Output signal for specifications. First with POSITION VERNIER set exactly to 10 and then with POSITION VERNIER exactly set to 1.

POSITION RANGE	VERNIER SETTING	RESULT	VERNIER SETTING	RESULT
.1 μ – 1 μ	10	.93 μ s – 1.170 μ s	1	120 ns – 180 ns
1 μ – 10 μ	10	8.94 μ s – 11.16 μ s	1	.840 μ s – 1.26 μ s
10 μ – .1m	10	89.04 μ s – 111.06 μ s	1	8.04 μ s – 12.06 μ s
.1m – 1m	10	890 μ s – 1110 μ s	1	80 μ s – 120 μ s
1m – 10m	10	8900 μ s – 11100 μ s	1	800 μ s – 1200 μ s

11. For checking dial tracking set POSITION VERNIER exactly to the listed settings and check results.

POSITION RANGE	VERNIER SETTING	RESULT
1 m – 10 m	2	1700 μ s – 2300 μ s
	3	2600 μ s – 3400 μ s
	4	3500 μ s – 4500 μ s
	5	4400 μ s – 5600 μ s
	6	5300 μ s – 6700 μ s
	7	6200 μ s – 7800 μ s
	8	7100 μ s – 8900 μ s
	9	8000 μ s – 10000 μ s

PERFORMANCE TESTS

4-12 PULSE WIDTH; VERNIER ACCURACY; MAX. DUTY CYCLE

SPECIFICATION:

WIDTH 25ns to 10ms in 6 decade ranges continuously adjustable by vernier.

VERNIER ACCURACY - (10% of setting + 1% of full scale)
 + (10% of setting + 1% of full scale + 5ns).

DUTY CYCLE \geq 10% for 30-100V amplitude range
 \geq 50% for all other ranges

EQUIPMENT:

- Sampling Oscilloscope
- 20dB Attenuator
- 20dB Attenuator 50W
- Tee

CAUTION: Do not overload Attenuators and Oscilloscopes Inputs.

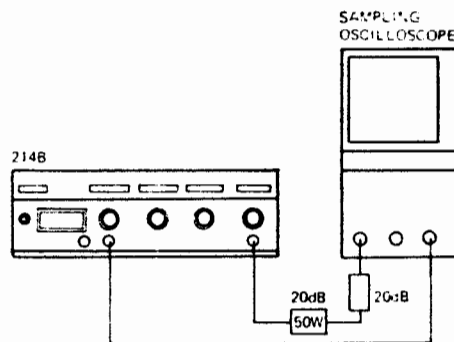

Figure 4-4.

1. Connect equipment as shown in Figure 4-4 and set 214B controls as follows:

MODE	NORM
PERIOD Range	1 μ - 10 μ
PERIOD Vernier	10
POSITION Range	10n - .1 μ
POSITION Vernier	10
DUTY CYCLE %	Released
WIDTH Range	25n - .1 μ
WIDTH Vernier	2.5
AMPLITUDE Range	10-30
AMPLITUDE Vernier	3 (30V)
INT LOAD	Depressed
SLOPE	*
DEL/ADV/D.P.	DEL
OUTPUT POLARITY	PCS

* = don't care

2. Measure pulse width at 50% of amplitude with WIDTH VERNIER set exactly to 2.5.
 RESULT: 21.5 - 33.5ns.

PERFORMANCE TEST

3. Set WIDTH VERNIER exactly to 10. Pulse Width should be 89 – 116ns.
4. Select $.1\mu - 1\mu$ WIDTH range and check pulse width with WIDTH VERNIER set to 10;
RESULT: $.890\mu - 1.115\mu$.
With VERNIER set to 1; RESULT: 80 ns – 125 ns.
5. Select $.1\mu - 1\mu$ PERIOD range and set PERIOD vernier to 3 and adjust the Sampling Oscilloscope so that one period is displayed.
6. Increase WIDTH (duty cycle). RESULT: Maximum Duty Cycle must be $\geq 50\%$ before signal disappears and 214B OVERLOAD LED is illuminated.
7. Select 25 n – $.1\mu$ WIDTH range and set OUTPUT AMPLITUDE to 100V (50V).
8. Increase WIDTH and check that Duty Cycle is $\geq 10\%$ before 214B OUTPUT is switched off and OVERLOAD LED is on. Switch 214B to 1–3 V AMPLITUDE range.

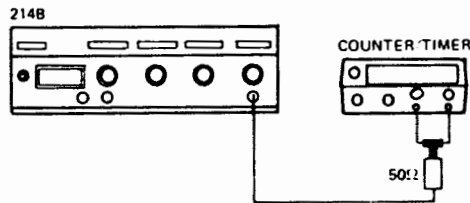



Figure 4-5.

9. Change Test setup as shown in Figure 4-5 to measure Pulse Width in the 4 highest ranges. Set 214B controls as follows:

MODE	NORM
PERIOD Range	10m – .1
PERIOD Vernier	3
POSITION Range	*
POSITION Vernier	*
DUTY CYCLE %	Released
WIDTH Range	$1\mu - 10\mu$
WIDTH Vernier	1
AMPLITUDE Range	1–3
AMPLITUDE Vernier	3 (3V)
INT LOAD	*
SLOPE	*
DEL/ADV/D.P.	DEL
OUTPUT POLARITY	POS

* = don't care

PERFORMANCE TESTS

10. Trigger Counter/Timer Channel A to  and Channel B to  and check Pulse Width for specifications.
11. Check Vernier Accuracy for specifications as listed.

WIDTH RANGE	VERNIER SETTING	RESULT	VERNIER SETTING	RESULT
1μ – 10μ	1	.8 μs – 1.205 μs	10	8.90 μs – 11.10 μs
10μ – .1m	1	8.00 μs – 12.00 μs	10	89.0 μs – 111.0 μs
.1m – 1m	1	80 μs – 120 μs	10	890 μs – 1110 μs
1m – 10m	1	800 μs – 1200 μs	10	8900 μs – 11100 μs

WIDTH RANGE	VERNIER SETTING	RESULT
1m – 10m	9	8000 μs – 10 000 μs
1m – 10m	8	7100 μs – 8900 μs
1m – 10m	7	6200 μs – 7800 μs
1m – 10m	6	5300 μs – 6700 μs
1m – 10m	5	4400 μs – 5600 μs
1m – 10m	4	3500 μs – 4500 μs
1m – 10m	3	2600 μs – 3400 μs
1m – 10m	2	1700 μs – 2300 μs

PERFORMANCE TESTS

4-13 CONSTANT DUTY CYCLE; VERNIER ACCURACY

SPECIFICATION :

- Duty cycle of output pulse remains constant when pulse period is changed.
- Typically 8% fixed for 10-1 MHz frequency range
- 2.5% to 10% for 1 - .1 MHz frequency range
- .25% to 10% for .1 MHz - 10 KHz
- .1% to 10% for all other frequency ranges
- Vernier Accuracy \pm (15% of setting + 1% of full scale)

EQUIPMENT:

- Sampling Oscilloscope
- Counter/Timer
- 50Ω Feedthrough
- Tee
- 20dB Attenuator

CAUTION: Do not overload Attenuators and Inputs

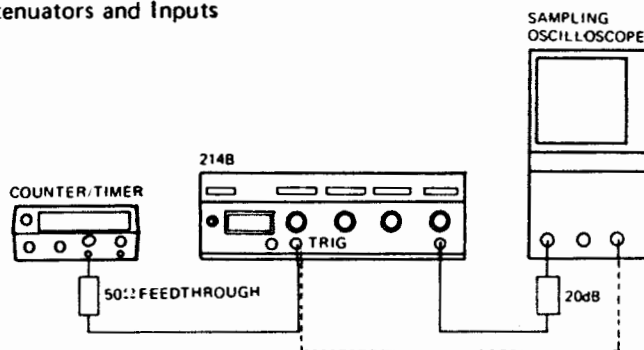

Figure 4-6

1. Connect equipment as shown in Figure 4-6 and set 214B controls as follows:

MODE	NORM
PERIOD Range1μ - 1μ
PERIOD Vernier	10
POSITION Range	10n - .1μ
POSITION Vernier	1
DUTY CYCLE %	Depressed
DUTY CYCLE Vernier	*
DUTY CYCLE Range	*
AMPLITUDE Range	1-3
AMPLITUDE Vernier	3 (3V)
INT LOAD	*
SLOPE	*
DEL/ADV/D.P.	DEL
OUTPUT POLARITY	POS

* = don't care

PERFORMANCE TESTS

2. Adjust 214B PERIOD VERNIER for exactly 1000ns reading on counter and measure output pulse width. RESULT: typically 80ns. (8%). Fixed duty cycle is indicated by LED.
3. Select 1 μ s – 10 μ s PERIOD range and adjust PERIOD for 10 000ns. (2.5–10% duty cycle range is indicated by LED).
4. Set DUTY CYCLE VERNIER (WIDTH VERNIER) to 2.5 and measure pulse width. RESULT: 202.5 – 297.5ns.
5. With VERNIER set to 10 width should be 840 – 1160ns.

NOTE: Trigger Sampling Oscilloscope EXT after adjusting PERIOD with Counter/Timer.

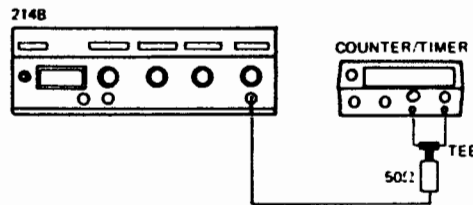

Figure 4-7

6. Change Test Setup as shown in Figure 4-7 and set 214B controls as follows:

MODE	NORM
PERIOD Range	10m – .1
PERIOD Vernier	10
POSITION Range	10n – .1 μ
POSITION Vernier	10
DUTY CYCLE %	Depressed
DUTY CYCLE Range1 – 1
DUTY CYCLE Vernier	1
AMPLITUDE Range	1–3
AMPLITUDE Vernier	3 (3V)
INT LOAD	*
SLOPE	*
DEL/ADV/D.P.	DEL
OUTPUT POLARITY	POS

* = don't care

7. Trigger Counter/Timer channel A to \int and channel B to \int . Switch to PERIOD and adjust 214B PERIOD for exactly 100.0ms.
8. Set 214B DUTY CYCLE VERNIER exactly to 1 (.1%) and switch Counter/Timer to Time Interv. A to B . RESULT: 75 – 125 μ s.
9. Set DUTY CYCLE VERNIER exactly to 10 (1%) and measure pulse width . RESULT: 840 – 1160 μ s.

PERFORMANCE TESTS

10. Select 1 – 10% DUTY CYCLE range on the 214B and check DUTY CYCLE vernier accuracy with PERIOD set exactly to 100.0ms.

PERIOD	VERNIER SETTING	
100.0ms	10	8.4ms – 11.6ms
100.0ms	9	7.55ms – 10.45ms
100.0ms	8	6.70ms – 9.30ms
100.0ms	7	5.85ms – 8.15ms
100.0ms	6	5.00ms – 7.00ms
100.0ms	5	4.15ms – 5.85ms
100.0ms	4	3.30ms – 4.70ms
100.0ms	3	2.45ms – 3.55ms
100.0ms	2	1.60ms – 2.40ms
100.0ms	1	.75ms – 1.25ms

11. Adjust PERIOD to exactly 10ms and check that with DUTY CYCLE vernier set to 1 width is 75µs – 125µs.

PERFORMANCE TESTS

4-14 PULSE AMPLITUDE; VERNIER ACCURACY; SOURCE IMPEDANCE

SPECIFICATION:

0.3V to 100V into 50 Ω . 5 Ranges with calibrated vernier providing continuous adjustment within ranges.
 Vernier Accuracy: ± 10% of setting.

EQUIPMENT:

- Sampling Oscilloscope
- 20dB Attenuator
- 20dB Attenuator 50W

CAUTION: Do not overload Attenuators and Inputs.

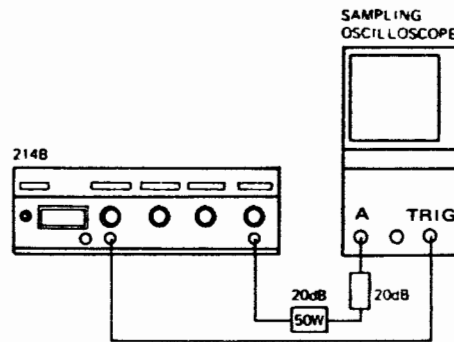

Figure 4-8

1. Connect equipment as shown in Figure 4-8 and set 214B controls as follows:

MODE	NORM
PERIOD Range	10 μ - .1m
PERIOD Vernier	1
POSITION Range1 μ - 1 μ
POSITION Vernier	as required
DUTY CYCLE %	Released
WIDTH Range	25 - .1μ
WIDTH Vernier	10
AMPLITUDE Range	30-100
AMPLITUDE Vernier	3 (30V)
INT LOAD	Released
SLOPE	*
DEL/ADV/D.P.	DEL
OUTPUT POLARITY	POS

* = don't care

PERFORMANCE TESTS

2. Measure pulse amplitude with INT. LOAD pushbutton released and then depressed in 30–100 and 10–30V AMPLITUDE ranges for specifications listed below.

NOTE: High source impedance is indicated by LED.

AMPLITUDE RANGE	VERNIER SETTING	RESULT INT. LOAD OFF	RESULT INT. LOAD ON	
30–100	3 10	27V – 33V 90V – 110V	13.5V – 16.5V 45V – 55V	
10–30	3 1	27V – 33V 9V – 11V	13.5V – 16.5V 4.5V – 5.5V	DARK SCALE

3. Switch 214B AMPLITUDE range to .3 – 1 and remove one 20dB attenuator.
4. Check AMPLITUDE ranges with VERNIER settings as listed.

AMPLITUDE RANGE	VERNIER SETTING	RESULT	
.3V – 1	3	.27V – .33V	
.3V – 1	10	.9V – 1.1V	
1V – 3	3	2.7V – 3.3V	DARK SCALE
1V – 3	1	.9V – 1.1V	DARK SCALE

5. Select 3–10V AMPLITUDE range and measure Vernier Accuracy.

AMPLITUDE RANGE	VERNIER SETTING	RESULT
3–10	3	2.7V – 3.3V
3–10	4	3.6V – 4.4V
3–10	5	4.5V – 5.5V
3–10	6	5.4V – 6.6V
3–10	7	6.3V – 7.7V
3–10	8	7.2V – 8.8V
3–10	9	8.1V – 9.9V
3–10	10	9V – 11V

PERFORMANCE TESTS

4-15 TRANSITION TIMES; PRESHOOT; OVERSHOOT; RINGING; PULSE POLARITY

SPECIFICATION:

Transition times $\leq 15\text{ns}$ for leading and trailing edges. Preshoot, overshoot and Ringing $\leq \pm 5\%$ of pulse amplitude. Polarity: Positive or negative, switch selectable.

EQUIPMENT:

- Sampling Oscilloscope
- 20dB Attenuator
- 20dB Attenuator 50W

CAUTION: Do not overload Attenuators and Inputs

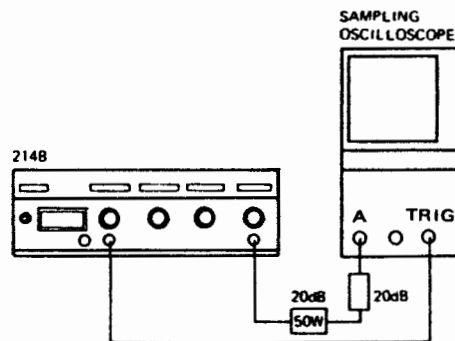

Figure 4-9

1. Connect equipment as shown in Figure 4-9 and set 214B controls as follows:

MODE	NORM
PERIOD Range	10 μ - .1m
PERIOD Vernier	1
POSITION Range1 μ - 1 μ
POSITION Vernier	as required
DUTY CYCLE %	Released
WIDTH Range	25n - .1 μ
WIDTH Vernier	10
AMPLITUDE Range	10 - 30
AMPLITUDE Vernier	1 (10V)
INT LOAD	Released
SLOPE	*
DEL/ADV/D.P.	DEL
OUTPUT POLARITY	as required

* = don't care

PERFORMANCE TESTS

2. Measure transition time of leading and trailing edge from 10% to 90% of pulse amplitude for positive and negative going pulse.

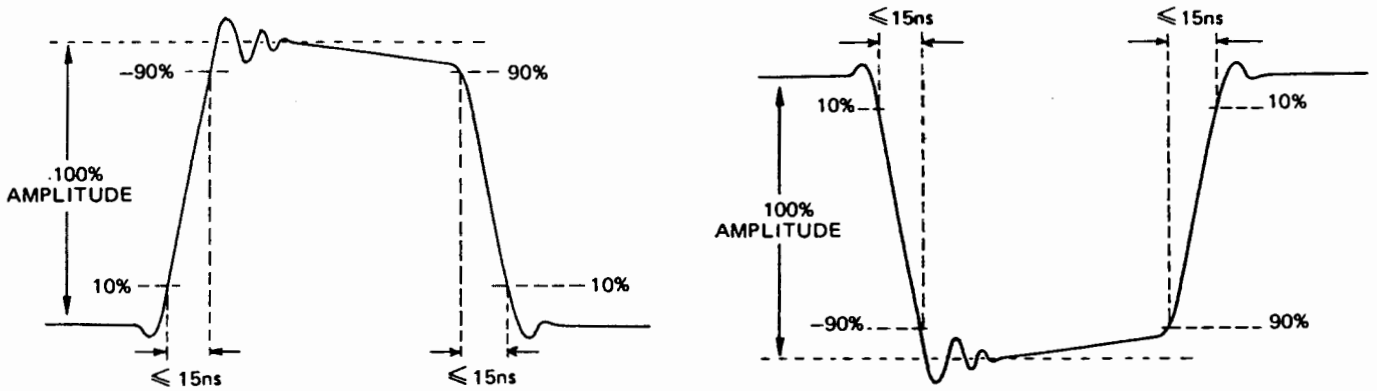

3. Measure Preshoot, Overshoot and Ringing of Positive and Negative pulse.

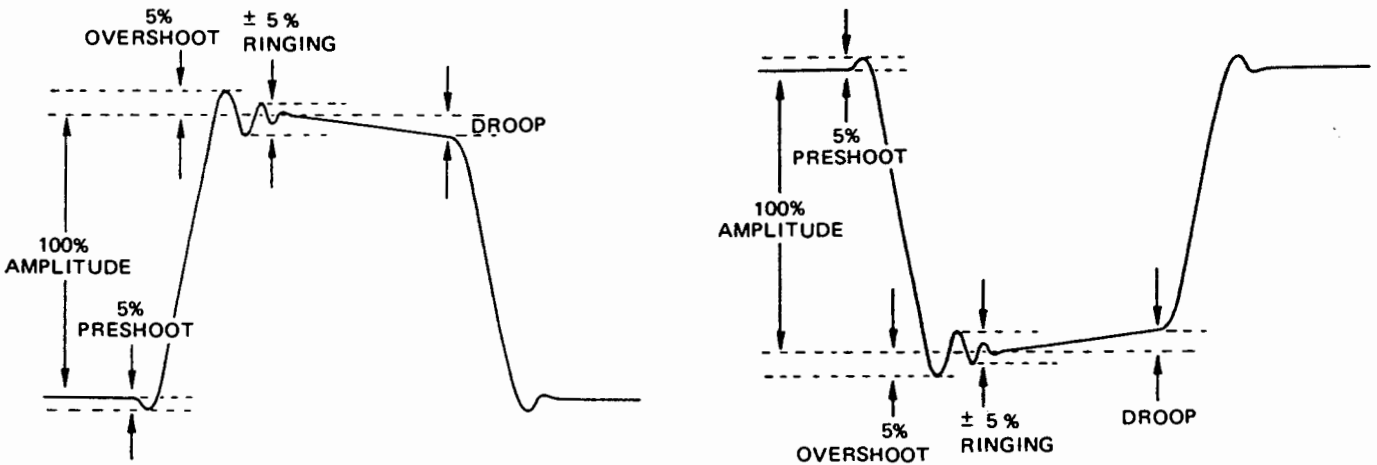

PERFORMANCE TESTS

4-16 TRIGGER OUTPUT; DOUBLE PULSE

SPECIFICATION:

Trigger Output: Minimum Amplitude +5V
(from 50 ohm into open circuit). Pulse Width: 10ns typical.

Double Pulse: 5 MHz in all ranges except 30V – 100V range.
In 30V–100V range, the maximum frequency is 2 MHz. Minimum separation between double pulse is 100ns.

EQUIPMENT:

- Sampling Oscilloscope
- 20dB Attenuator
- 20dB Attenuator 50W

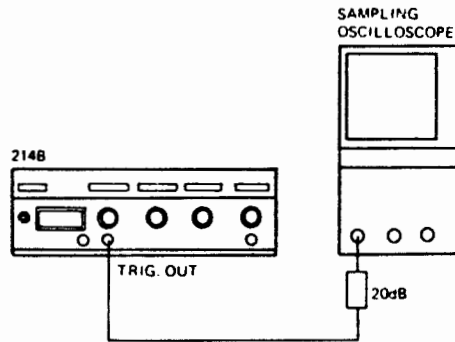

Figure 4-10.

1. Connect equipment as shown in Figure 4-10 and set 214B controls as follows:

MODE	NORM
PERIOD Range1μ – 1 μ
PERIOD Vernier2
POSITION Range	10n – .1μ
POSITION Vernier	1
DUTY CYCLE %	*
DUTY CYCLE / WIDTH Range	*
AMPLITUDE Range	3–10
AMPLITUDE Vernier	3 (3V)
INT LOAD	*
SLOPE	*
DEL/ADV/D.P.	*
OUTPUT POLARITY	*

* = don't care

2. Measure amplitude and width of trigger signal.
RESULT: Amplitude ≥ 2.5V (from 50Ω into 50Ω)
Width 10ns typical.

PERFORMANCE TESTS

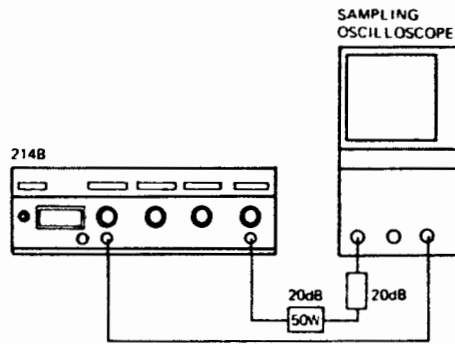

Figure 4-11

3. Change Test Setup as shown in Figure 4-11 to check Double Pulse Mode. Set 214B controls as follows:

CAUTION: Do not overload Attenuators and Inputs.

MODE	NORM
PERIOD Range1 μ - 1 μ
PERIOD Vernier	5 (2 MHz)
POSITION Range1 μ - 1 μ
POSITION Vernier	2
DUTY CYCLE %	Released
WIDTH Range	25ns - .1 μ
WIDTH Vernier	2
AMPLITUDE Range	30-100
AMPLITUDE Vernier	5 (50V)
INT LOAD	Released
SLOPE	*
DEL/ADV/D.P.	DOUBLE PULSE
OUTPUT POLARITY	POS

* = don't care

4. Adjust Sampling Oscilloscope so that both pulses are displayed.
5. Turn POSITION Vernier slowly CCW and check that both pulses are still displayed when minimum separation (100ns) is reached.
6. Set 214B PERIOD Vernier to 2 (5 MHz) and switch to 10-30 V AMPLITUDE range.
7. Check that DOUBLE PULSE mode is operating at .2 μ s PERIOD setting.

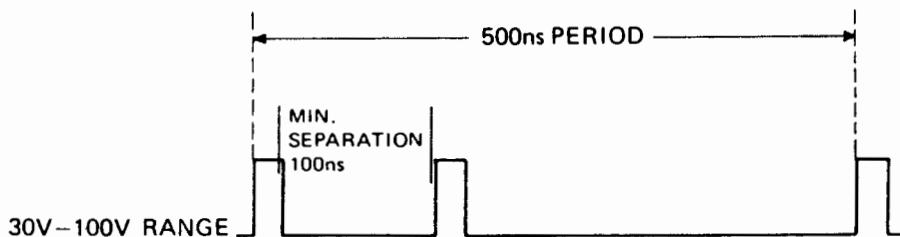

PERFORMANCE TESTS

4-17 EXTERNAL MODES; TRIGGER; GATE; BURST

SPECIFICATION:

Ext. Trigger Mode. An output pulse is generated for each input pulse.
Gate Mode. Gating signal turns on repetition rate generator. First pulse occurs after start of gate signal, and last pulse is always completed even if gate ends during generation of last pulse.
Burst Mode. Preselected number of pulses generated on receipt of trigger signal.
 Number of pulses: 1 to 9999. Minimum Spacing between Bursts: 200ns.

EQUIPMENT:

- Pulse Generator
- Oscilloscope
- 2 x 50 Ω Feedthrough
- Tee

CAUTION: Do not overload Attenuators and Inputs.

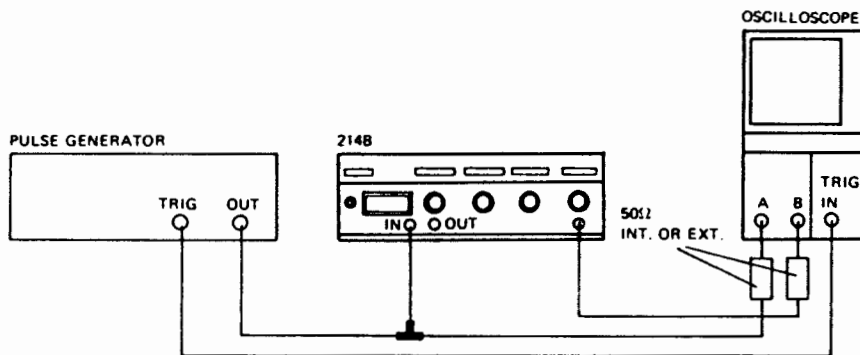

Figure 4-12

1. Connect equipment as shown in Figure 4-12 and set 214B controls as follows:

MODE	EXT TRIG
PERIOD Range1 μ - 1 μ
PERIOD Vernier	1
POSITION Range	10n - .1 μ
POSITION Vernier	1
DUTY CYCLE %	Released
WIDTH Range	25n - .1 μ
WIDTH Vernier	3
AMPLITUDE Range	1-3
AMPLITUDE Vernier	as required
INT. LOAD	*
SLOPE	as required
DEL. ADV. D.P.	DEL
OUTPUT POLARITY	POS

* = don't care

PERFORMANCE TESTS

2. Set Pulse Generator to 10ns pulse width, amplitude to 0.5V peak to peak min. and adjust PERIOD for 100ns.
3. Trigger 214B with EXT INPUT LEVEL Control and check that for each ext. trigger pulse one 214B output pulse is generated with SLOPE set to NEG and then one pulse with SLOPE set to POS.

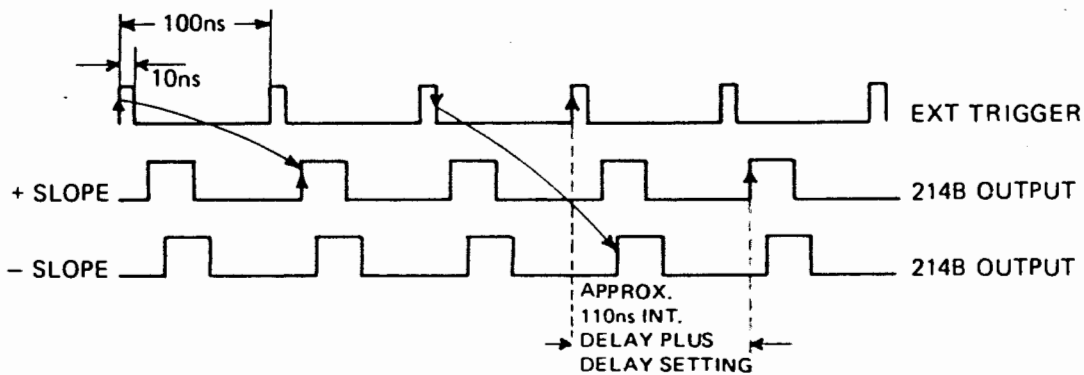

NOTE: It might be necessary to readjust INPUT LEVEL Control when changing SLOPE.

4. Select BURST MODE and set Pulse Generator to the next PERIOD range down the scale.
5. Set NUMBER OF PULSES from 0001 up to 0009 and check that the selected number of pulses corresponds to the displayed signal.
6. Switch 214B to GATE MODE and increase external pulse width (GATE SIGNAL).
7. When increasing GATE SIGNAL number of pulses should increase step by step.
8. Check GATE MODE with SLOPE set to - .

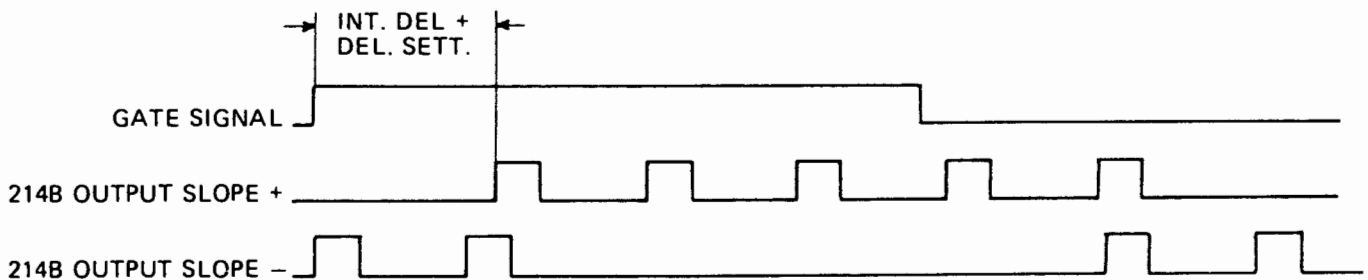

PERFORMANCE TESTS

4-18 VARIABLE TRIGGER LEVEL; SENSITIVITY

SPECIFICATION:

Trigger Level: Continuously variable from -5V to +5V.
Sensitivity: 500mV peak to peak.

EQUIPMENT:

- Oscilloscope
- Sinewave Generator
- Tee

CAUTION: Do not overload Oscilloscope Inputs.

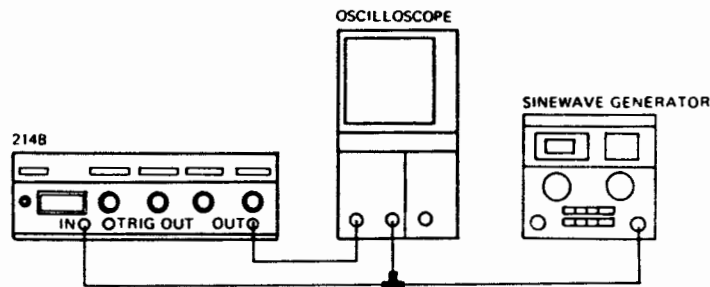

Figure 4-13

1. Connect equipment as shown in Figure 4-13 and set 214B controls as follows:

MODE	EXT TRIG
PERIOD Range	*
PERIOD Vernier	*
POSITION Range	10n - .1μ
POSITION Vernier	1
DUTY CYCLE %	Released
WIDTH Range1μ - 1μ
WIDTH Vernier	10
AMPLITUDE Range	3-10V
AMPLITUDE Vernier	as required
INT LOAD	*
SLOPE	*
DEL/ADV/D.P.	DEL
OUTPUT POLARITY	POS
EXT INPUT LEVEL	as required

2. Set Sinewave Generator to 100 KHz and 11V amplitude peak to peak.

PERFORMANCE TESTS

3. Set Oscilloscope controls to get a display as shown in Figure 4-14.
4. Vary EXT. INPUT LEVEL control from CCW to CW and check that trigger level is adjustable within +5V and -5V (Figure 4-14).
5. Repeat step 4 with SLOPE set to - and check trigger level variation as shown in Figure 4-15.

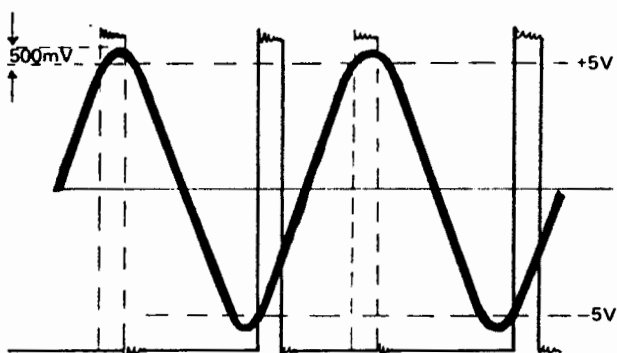

Figure 4-14

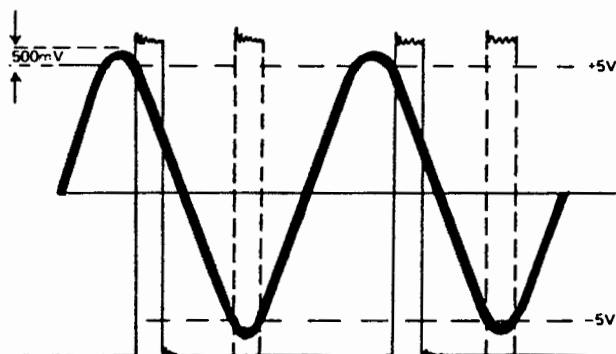

Figure 4-15

PERFORMANCE TESTS

Table 4-1. Performance Test Record

Hewlett-Packard Company Model 214B/214B Option 001 Pulse Generator Serial No.		Tested By _____ Date _____			
Para. No.	Test Description	Result			
		Min.	Max.	Actual	
4-10	REPETITION RATE; VERNIER ACCURACY				
	PERIOD RANGE	VERNIER SETTING			
	.1 μ - 1 μ	10	890 ns	1110 ns	_____
	1 μ - 10 μ	10	8900 ns	11100 ns	_____
	10 μ - .1 m	10	89 μ s	111 μ s	_____
	.1 m - 1 m	10	890 μ s	1110 μ s	_____
	1 m - 10 m	10	8900 μ s	11100 μ s	_____
	10 m - .1	10	89 ms	111 ms	_____
	10 m - .1	1	8000 μ s	12000 μ s	_____
	1 m - 10 m	1	800 μ s	1200 μ s	_____
	.1 m - 1 m	1	80 μ s	120 μ s	_____
	10 μ - .1 m	1	8000 ns	12000 ns	_____
	1 μ - 10 μ	1	800 ns	1200 ns	_____
	.1 μ - 1 μ	1	80 ns	120 ns	_____
	.1 μ - 1 μ	2	170 ns	230 ns	_____
		3	260 ns	340 ns	_____
		4	350 ns	450 ns	_____
		5	440 ns	560 ns	_____
		6	530 ns	670 ns	_____
		7	620 ns	780 ns	_____
	8	710 ns	890 ns	_____	
	9	800 ns	1000 ns	_____	

PERFORMANCE TESTS

Para No.	Test Description	Result			
		Min.	Max.	Actual.	
4-11	PULSE POSITION: DELAY; ADVANCE; VERNIER ACCURACY				
	Time between TRIGGER OUTPUT and OUTPUT				
	DELAY: with VERNIER set to 10	129 ns	171 ns	_____	
	DELAY: with VERNIER set to 1	48 ns	72 ns	_____	
	ADVANCE: with POSITION VERNIER set to 1	28 ns	52 ns	_____	
	Time between OUTPUT and TRIGGER OUTPUT				
	ADVANCED: with POSITION VERNIER set to 10	29 ns	71 ns	_____	
	DELAY RANGE	VERNIER SETTING			
	.1 μ - 1 μ	10	.930 μ s	1.170 μ s	_____
	1 μ - 10 μ	10	8.94 μ s	11.16 μ s	_____
	10 μ - .1 m	10	89.04 μ s	111.06 μ s	_____
	.1 m - 1 m	10	890 μ s	1110 μ s	_____
	1 m - 10 m	10	8900 μ s	11100 μ s	_____
	.1 μ - 1 μ	1	120 ns	180 ns	_____
	1 μ - 10 μ	1	.840 μ s	1.26 μ s	_____
	10 μ - .1 m	1	8.04 μ s	12.06 μ s	_____
	.1 m - 1 m	1	80 μ s	120 μ s	_____
	1 m - 10 m	1	800 μ s	1200 μ s	_____
	1 m - 10 m	2	1700 μ s	2300 μ s	_____
	1 m - 10 m	3	2600 μ s	3400 μ s	_____
1 m - 10 m	4	3500 μ s	4500 μ s	_____	
1 m - 10 m	5	4400 μ s	5600 μ s	_____	
1 m - 10 m	6	5300 μ s	6700 μ s	_____	
1 m - 10 m	7	6200 μ s	7800 μ s	_____	
1 m - 10 m	8	7100 μ s	8900 μ s	_____	
1 m - 10 m	9	8000 μ s	10000 μ s	_____	

PERFORMANCE TESTS

Para. No.	Test Description	Result		
		Min.	Max.	Actual
	<p>AMPLITUDE RANGE VERNIER SETTING</p> <p>.3 V - 1 3</p> <p>.3 V - 1 10</p> <p>1 V - 3 3 DARK</p> <p>1 V - 3 1 SCALE</p> <p>3 V - 10 V 3</p> <p>3 V - 10 V 4</p> <p>3 V - 10 V 5</p> <p>3 V - 10 V 6</p> <p>3 V - 10 V 7</p> <p>3 V - 10 V 8</p> <p>3 V - 10 V 9</p> <p>3 V - 10 V 10</p>	.27 V .9 V	.33 V 1.1 V	_____
		2.7 V .9 V	3.3 V 1.1 V	_____
		2.7 V 3.6 V	3.3 V 4.4 V	_____
		4.5 V 5.4 V	5.5 V 6.6 V	_____
		6.3 V 7.2 V	7.7 V 8.8 V	_____
		8.1 V 9 V	9.9 V 11 V	_____
4-15	<p>TRANSITION TIMES; PRESHOOT; OVERSHOOT; RINGING; PULSE POLARITY</p> <p>Positive Pulse</p> <p>Transition Time Leading edge</p> <p>Transition Time Trailing edge</p> <p>Overshoot</p> <p>Ringling</p> <p>Preshoot</p> <p>Negative Pulse</p> <p>Transition Time Leading edge</p> <p>Transition Time Trailing edge</p> <p>Overshoot</p> <p>Ringling</p> <p>Preshoot</p>		<p>≤ 15 ns</p> <p>≤ 15 ns</p> <p>≤ ± 5 %</p> <p>≤ ± 5 %</p> <p>≤ ± 5 %</p> <p>≤ 15 ns</p> <p>≤ 15 ns</p> <p>≤ ± 5 %</p> <p>≤ ± 5 %</p> <p>≤ ± 5 %</p>	_____
4-16	<p>TRIGGER OUTPUT; DOUBLE PULSE</p> <p>Trigger Amplitude (from 50 Ω into 50 Ω)</p> <p>Width</p> <p>Minimum Separation</p> <p>DOUBLE PULSE 5 MHz 10-30 V Range</p>	<p>≥ 2.5 V</p> <p>10 ns typ.</p>	<p>≤ 100 ns</p>	_____

PERFORMANCE TESTS

Para. No.	Test Description	Result		
		Min.	Max.	Actual
4-17	<p>EXTERNAL MODES; TRIGGER; GATE; BURST</p> <p>Trigger Output for each Pulse positive Slope negative Slope</p> <p>Number of Bursts</p> <p>Increasing number pulses in GATE MODE</p>			<p>_____</p> <p>_____</p> <p>_____</p> <p>_____</p>
4-18	<p>VARIABLE TRIGGER LEVEL; SENSIVITY</p> <p>Trigger Level positive slope Trigger Level negative slope</p> <p>Trigger Sensivity</p>	<p>-5 V to +5 V -5 V to +5 V</p>	<p>≤ 500 mVpp</p>	<p>_____</p> <p>_____</p> <p>_____</p>

SECTION V ADJUSTMENTS

5-1 INTRODUCTION

5-2 This section describes the adjustments which will return the instrument to peak operating condition after repairs are completed.

5-3 SAFETY CONSIDERATIONS

5-4 Although this instrument has been designed in accordance with international safety standards, this manual contains information, cautions, and warnings which must be followed to ensure safe operation and to retain the instrument in safe condition (see Sections II and III). Service and adjustments should be performed only by qualified service personnel.

WARNING

Any interruption of the protective (grounding) conductor (inside or outside the instrument or disconnection of the protective earth terminal is likely to make the instrument dangerous. Intentional interruption is prohibited.

5-5 Any adjustment, maintenance, and repair of the opened instrument with voltage applied should be avoided as much as possible and, when inevitable, should be carried out only by a skilled person who is aware of the hazard involved.

5-6 Capacitors inside the instrument may still be charged even if the instrument has been disconnected from its source of supply.

5-7 Make sure that only fuses with the required rated current and of the specified type (normal blow, time delay, etc.) are used for replacement. The use of repaired fuses and the shortcircuiting of fuseholders must be avoided.

5-8 Whenever it is likely that the protection offered by fuses has been impaired, the instrument must be made inoperative and secured against any unintended operation.



Adjustments described herein are performed with power supplied to the instrument while protective covers are removed. Energy available at many points may, if contacted, result in personal injury or death.

5-9 EQUIPMENT REQUIRED

5-10 The test equipment required for the adjustment procedures is listed in Table 1-1, Recommended Test Equipment. The critical specifications of substitute test instruments must meet or exceed the standards listed in the table if the instrument is to meet the standards set forth in Table 1-2, Specifications.

ADJUSTMENTS

5-11 POWER SUPPLY

EQUIPMENT:

Digital Multimeter 10-1000 V DC

WARNING

High Voltage dangerous to life.

PROCEDURE:

Set 214B controls as follows:

MODE	EXT
PERIOD Range	*
PERIOD Vernier	*
POSITION Range	*
POSITION Vernier	*
DUTY CYCLE %	released
DUTY CYCLE Range	*
DUTY CYCLE Vernier	*
WIDTH RANGE	*
AMPLITUDE Range	3-10 V
AMPLITUDE Vernier	*
INT LOAD	*
SLOPE	*
DEL/ADV/D.P.	DEL
POLARITY	NEG

* = don't care

NOTE: All voltages are measured with reference ground (TP7 $\frac{1}{\infty}$).

1. Measure voltage on TP1 (approx. 155 V) and TP5 (approx. 133 V) and adjust A4R604 so that the voltage difference between TP1 and TP5 is $22 \text{ V} \pm 220 \text{ mV}$.
2. Switch to 30-100 V AMPLITUDE Range and check that voltages increase to approx. 263 V (TP1) and 241 V (TP5). $\Delta \text{V} = 22 \text{ V}$.
3. Check that power supply voltages are within limits as listed:

VOLTAGE	TEST POINT	RESULT
-5.2	MARKED ON PC-BOARD	4.94 V - 5.46 V
+15	MARKED ON PC-BOARD	14.25 V - 15.75 V
-15	MARKED ON PC-BOARD	14.25 V - 15.75 V
+5	MARKED ON PC-BOARD	4.75 V - 5.25 V

4. Check that the Q602 collector voltage is approximately half the Q601 collector voltage.

ADJUSTMENTS

5-12 PERIOD ADJUST

EQUIPMENT:

Counter/Timer
50 Ω Feedthrough

Note: If potentiometer R107 has been replaced, set the new potentiometer so that its resistance is 200 Ω. Next, fit the dial so that the '1' on the light grey scale is exactly beneath the arrow. (It may be necessary to slightly readjust the dial when specifications cannot be reached).

WARNING

High voltage dangerous to life.

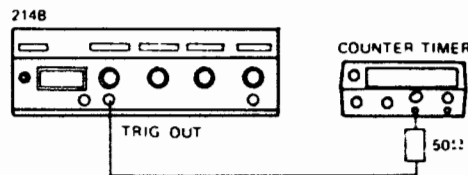

Figure 5-1

PROCEDURE:

1. Connect equipment as shown in Figure 5-1 and set 214B controls as follows:

- MODE NORM
- PERIOD Range 1m – 1μ
- PERIOD Vernier 10
- POSITION Range 1μ – 10μ
- POSITION Vernier 1
- DUTY CYCLE % released
- WIDTH Vernier 1
- WIDTH Range 1μ – 10μ
- AMPLITUDE Range 3–10
- AMPLITUDE Vernier *
- INT LOAD *
- SLOPE *
- DEL/ADV/D.P. DEL
- OUTPUT POLARITY *

* = don't care

2. Ensure that Period Vernier is exactly set to 10 (1 ms) and if necessary adjust A1R69 (on Output Amplifier Board) for a counter reading of 1000 μ.

Note: Due to the influence of A1R69 on the width circuit, width and duty cycle must be readjusted by any adjustment of A1R69.

- 3. Set 214B Period Vernier exactly to 1 (.1 ms) and adjust A2R46 for 100 μs. (≤ 1 %).
- 4. Repeat step 2 and step 3 and readjust if necessary.

ADJUSTMENTS

5. Check Vernier tracking for specifications as listed below.

PERIOD RANGE	VERNIER SETTING	RESULT
.1m – 1m	1	80 μ s – 120 μ s
.1m – 1m	2	170 μ s – 230 μ s
.1m – 1m	3	260 μ s – 340 μ s
.1m – 1m	4	350 μ s – 450 μ s
.1m – 1m	5	440 μ s – 560 μ s
.1m – 1m	6	530 μ s – 670 μ s
.1m – 1m	7	620 μ s – 780 μ s
.1m – 1m	8	710 μ s – 890 μ s
.1m – 1m	9	800 μ s – 1000 μ s
.1m – 1m	10	890 μ s – 1110 μ s

6. Set Pulse Position to 10 ns and press Duty Cycle pushbutton. Select .1 μ – 1 μ Period Range and turn Period Vernier fully ccw.
7. Using the counter, adjust A2R126 for 12.5 MHz. Check that the frequency is in specification with dial set to 1 (8.9 MHz – 11.1 MHz) and dial set to 10 (0.8 MHz – 1.2 MHz).
8. Re-adjust A2R126 if specifications cannot be reached.

ADJUSTMENTS

5-13 POSITION ADJUST

EQUIPMENT: Counter/Timer
2 x 50 Ω Feedthrough

WARNING

High voltage dangerous to life.

CAUTION

Do not overload feedthroughs and inputs.

Note: If position potentiometer R158 has been replaced, set the new potentiometer so that its resistance is 300 Ω. Next, fit the dial so that the '1' on the light grey scale is exactly beneath the arrow. (It may be necessary to slightly readjust if specifications cannot be reached).

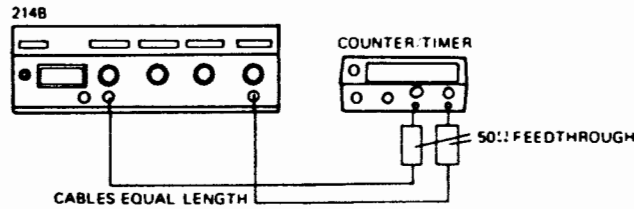

Figure 5-2

PROCEDURE:

1. Connect equipment as shown in Figure 5-2 and set 214B controls as follows:

MODE	NORM
PERIOD Range	1m - 10m
PERIOD Vernier	10
POSITION Range1m - 1m
POSITION Vernier	10
DUTY CYCLE %	released
WIDTH Vernier	10
WIDTH Range	1μ - 10μ
AMPLITUDE Range	3-10
AMPLITUDE Vernier	as required
INT LOAD	*
SLOPE	*
DEL/ADV/D.P.	DEL
OUTPUT POLARITY	POS

* = don't care

2. Set Counter/Timer to TIME INTERV. A to B, trigger both channels to slope and measure time between trigger and output signal.
3. Adjust A2R45 for 1000μs delay ± 10μs. (POSITION Vernier exactly set to 10).
4. Set Position Vernier exactly to 1 and adjust A2R119 for 100μs ± 1μs.

ADJUSTMENTS

5. Repeat step 3 and step 4 and readjust if necessary.
6. Check Vernier Accuracy for specifications as listed below.

POSITION RANGE	VERNIER SETTING	RESULT
.1m – 1m	2	170 μ s – 230 μ s
.1m – 1m	3	260 μ s – 340 μ s
.1m – 1m	4	350 μ s – 450 μ s
.1m – 1m	5	440 μ s – 560 μ s
.1m – 1m	6	530 μ s – 670 μ s
.1m – 1m	7	620 μ s – 780 μ s
.1m – 1m	8	710 μ s – 890 μ s
.1m – 1m	9	800 μ s – 1000 μ s

ADJUSTMENTS

5-14 CONSTANT DUTY CYCLE AND WIDTH

EQUIPMENT: Counter/Timer
50 Ω Feedthrough

WARNING

High voltage dangerous to life.

CAUTION

Do not overload feedthrough or counter inputs.

Note: If width potentiometer R222 has been replaced, set the new potentiometer so that its resistance is 200 Ω. Next, fit the dial so that the '1' on the light grey scale is exactly beneath the arrow. (It may be necessary to slightly readjust if specifications cannot be reached).

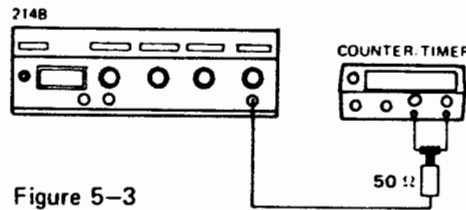

Figure 5-3

PROCEDURE:

1. Connect equipment as shown in Figure 5-3 and set 214B controls as follows:

MODE	NORM
PERIOD Range	1ms – 10ms
PERIOD Vernier	10
POSITION Range	0.1μ – 1μ
POSITION Vernier	1
DUTY CYCLE %	depressed
DUTY CYCLE Range	1% – 10%
DUTY CYCLE Vernier	10
WIDTH RANGE	—
AMPLITUDE Range	1-3 V
AMPLITUDE Vernier	as required
INT LOAD	*
SLOPE	*
DEL/ADV/D.P.	DEL
POLARITY	POS

* = don't care

NOTE: Period settings must be done by using the counter.

2. Set 214B period to 10 000μs.
3. Measure time between positive and negative transition of 214B output pulse and adjust A2R51 for 1000μs. (10% duty cycle).

ADJUSTMENTS

4. Set 214B period to 1000 μ s (without changing the range) and measure time between positive and negative transition. Adjust A2R217 for 100 μ s.
5. Set 214B period to 10 000 μ s and release DUTY CYCLE pushbutton.
6. Select .1m – 1m WIDTH Range, set Width Vernier exactly to 10 and adjust A2R216 for 1000 μ s width.
7. Set Width Vernier exactly to 1 and adjust A2R128 for 100 μ s width.
8. Repeat steps 1 to 7 and readjust if necessary.
9. Check Vernier Accuracy for 1–10% DUTY CYCLE range and .1m – 1m WIDTH Range.

DUTY CYCLE RANGE	VERNIER SETTING	RESULT
1–10% Period 10 000 μ s	1	75 μ s – 125 μ s
	2	160 μ s – 240 μ s
	3	245 μ s – 355 μ s
	4	330 μ s – 470 μ s
	5	415 μ s – 585 μ s
	6	500 μ s – 700 μ s
	7	585 μ s – 815 μ s
	8	670 μ s – 930 μ s
	9	755 μ s – 1045 μ s
	10	840 μ s – 1160 μ s

WIDTH RANGE	VERNIER SETTING	RESULT
.1m – 1m PERIOD 10 000 μ s	1	80 μ s – 120 μ s
	2	170 μ s – 230 μ s
	3	260 μ s – 340 μ s
	4	350 μ s – 450 μ s
	5	440 μ s – 560 μ s
	6	530 μ s – 670 μ s
	7	620 μ s – 780 μ s
	8	710 μ s – 890 μ s
	9	800 μ s – 1000 μ s
	10	890 μ s – 1110 μ s

ADJUSTMENTS

5-15 PULSE AMPLITUDE

EQUIPMENT: Oscilloscope
 20dB Attenuator
 20dB Attenuator 50W

WARNING

High voltage dangerous to life.

CAUTION

Do not overload Attenuator or Oscilloscope inputs.

Note: If the amplitude potentiometer R460 has been replaced, set the new potentiometer so that the resistance between the white/red/grey wire and the white/violet wire is 70 Ω. Next, fit the dial so that the '3' on the light grey scale is exactly beneath the arrow. (It may be necessary to slightly readjust the dial when specifications cannot be reached).

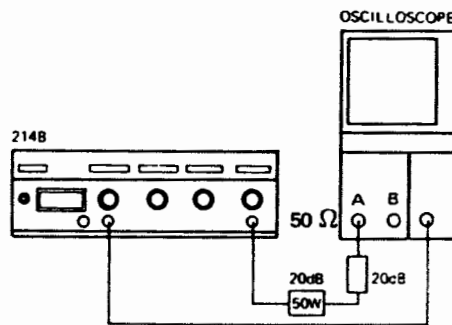

Figure 5-4

PROCEDURE:

1. Connect equipment as shown in Figure 5-4 and set 214B controls as follows:

MODE	NORM
PERIOD Range	10m - .1
PERIOD Vernier	10
POSITION Range	10n - .1μ
POSITION Vernier	1
DUTY CYCLE %	depressed
DUTY CYCLE Range	1-10%
DUTY CYCLE Vernier	5
AMPLITUDE Range	30-100V
AMPLITUDE Vernier	3
INT LOAD	OFF
SLOPE	*
DEL/ADV/D.P.	DEL
OUTPUT POLARITY	POS

* = don't care

2. Set oscilloscope so that one pulse with approx. 5 DIV. width is displayed on screen.
3. Turn A1R462 CW and adjust A1R457 for 29 V output amplitude.

ADJUSTMENTS

4. Set Amplitude Vernier exactly to 10 and adjust A1R462 for 105 V amplitude.
5. Recheck 29 V and 105 V adjustment and readjust if necessary.
6. Select the 10 V – 30 V range, set vernier to 1 and check that 10 V setting is within $\pm 10\%$. With vernier fully CCW the amplitude must be ≤ 10 V. Readjust R457 if necessary.
7. Select 3 V – 10 V range and check that the amplitude is > 10 V with vernier set to CW. Readjust R462 if necessary.
8. Check Amplitude vernier accuracy in the 30 – 100 V and 10 – 30 V ranges as listed below.

AMPLITUDE RANGE	VERNIER SETTING	RESULT
30V–100V	10	90V–110V
30V–100V	9	81V– 99V
30V–100V	8	72V– 88V
30V–100V	7	63V– 77V
30V–100V	6	54V– 66V
30V–100V	5	45V– 55V
30V–100V	4	36V– 44V
30V–100V	3	27V– 33V

AMPLITUDE RANGE	VERNIER SETTING (DARK SCALE)	RESULT
10–30V	1	9 V – 11 V
10–30V	2	18 V – 22 V
10–30V	3	27 V – 33 V

ADJUSTMENTS

5-16 MINIMUM WIDTH; OVERSHOOT; RISE TIME; INT. LOAD; FIXED DUTY CYCLE

EQUIPMENT: Sampling Oscilloscope
 20dB Attenuator
 20dB Attenuator 50W

WARNING

High voltage dangerous to life.

CAUTION

Do not overload Attenuators or Oscilloscope inputs.

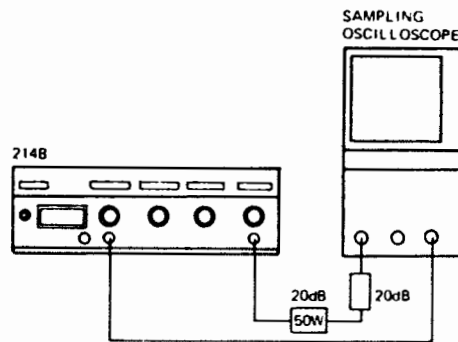

Figure 5-5

PROCEDURE:

1. Connect equipment as shown in Figure 5-5 and set 214B controls as follows:

MODE	NORM
PERIOD Range	1μ - 10μ
PERIOD Vernier	10
POSITION Range	10n - .1μ
POSITION Vernier	1
DUTY CYCLE %	released
WIDTH Range	25n - .1μ
WIDTH Vernier	2.5
AMPLITUDE Range	10-30V
AMPLITUDE Vernier	3 (DARK SCALE)
INT LOAD	OFF
SLOPE	*
DEL/ADV/D.P.	DEL
OUTPUT POLARITY	POS

* = don't care

2. Adjust A1R480 (MIN. PULSE WIDTH) for 25ns WIDTH.

ADJUSTMENTS

3. Select $.1 \mu - 1 \mu$ WIDTH range and set vernier to 2 (200 ns). Set Amplitude to 100 V with internal load switched off.
4. Adjust A1R436 and A1R408 for fastest risetime.
5. Adjust A1R419 for minimum overshoot before amplitude decreases.
6. Check that risetime is < 15 ns and overshoot and ringing is $< 5\%$. If necessary readjust A1R419, A1R436 and A1R408.
7. Select 10 – 30 V amplitude range, switch internal load on, and set amplitude to 30 V.
8. Adjust A1C501 for overshoot = ringing.
9. Adjust A1R487 and A1R421 for flat pulse top.
10. Adjust R506 for minimum ringing.
11. Adjust A1C504 for overshoot \approx ringing.
12. Check risetime, overshoot and ringing for specifications and, if necessary, optimize pulse via C501, C504, R421 and R487.
13. Switch internal load off, check pulse specifications, and optimize adjustment if necessary.
14. Recheck risetime, overshoot and ringing at 100 V amplitude with and without internal load.
15. Select $.3 - 1$ V amplitude range, set amplitude for 1 V and adjust A2C514 for minimum ringing.
16. Select the $.1 \mu - 1 \mu$ period range and press DUTY CYCLE pushbutton.
17. Set the Sampling Oscilloscope so that exactly one period is displayed.
18. Adjust A2R197 for 8 % duty cycle at 50 % of amplitude.

ADJUSTMENTS

5-17 TRIGGER LEVEL SENSITIVITY

EQUIPMENT:

- Oscilloscope
- Sinewave Generator
- Tee

CAUTION: Do not overload Oscilloscope Inputs.

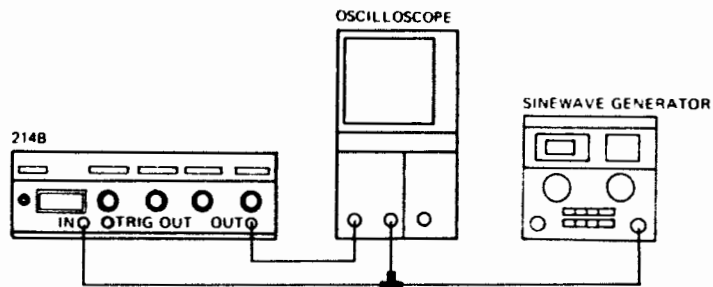

Figure 5-6

1. Connect equipment as shown in Figure 5-6 and set 214B controls as follows:

MODE	EXT TRIG
PERIOD Range	*
PERIOD Vernier	*
POSITION Range	10n - .1μ
POSITION Vernier	1
DUTY CYCLE %	Released
WIDTH Range1μ - 1μ
WIDTH Vernier	10
AMPLITUDE Range	3-10V
AMPLITUDE Vernier	as required
INT LOAD	*
SLOPE	*
DEL/ADV/D.P.	DEL
OUTPUT POLARITY	POS
EXT INPUT LEVEL	as required

2. Set Sinewave Generator to 100 KHz and 300 mV amplitude peak to peak.

ADJUSTMENTS

3. Set EXT. INPUT LEVEL vernier to mid-range.
4. Adjust A2R19 so that output pulses appear.
5. Switch to NEG. SLOPE and readjust A2R19 to obtain output pulses.
6. Optimize adjustment with A2R19 until output pulses appear with SLOPE switch set to NEG or to POS.

Note: It might be necessary to set the LEVEL vernier slightly off center position to get triggering on NEG and POS SLOPE. The arrow of the knob should stay within ± 1 mm of center position.

7. When R15 has been replaced, proceed as follows: Measure the voltage at the junction of A2R14 and R15 (wht/brn/org wire) and set LEVEL vernier R15 for 0 V. Then perform adjustment as described above and tighten the knob until the arrow points to mid-range.

ADJUSTMENTS

Para No.	ADJUSTMENT	adjust		RANGE
5-11	POWER SUPPLY	A4R604	$\Delta V = 22 V \pm 220 \text{ mV}$ (TP1/TP5)	3 V – 10 V
5-12	PERIOD	A1R69 A2R46 A2R126	1000 $\mu\text{s} \pm 1\%$ 99 $\mu\text{s} \pm 1\%$ $\approx 12.5 \text{ MHz}$ with VERNIER CCW	.1 m – 1 m .1 m – 1 m .1 μ – 1 μ
5-13	POSITION	A2R45 A2R119	1000 $\mu\text{s} \pm 1\%$ 100 $\mu\text{s} \pm 1\%$.1 m – 1 m .1 m – 1 m
5-14	C. DUTY CYCLE	A2R51 A2R217	1000 $\mu\text{s} \pm 1\%$ 100 $\mu\text{s} \pm 1\%$	1% – 10% 1% – 10%
5-14	WIDTH	A2R216 A2R128	1000 $\mu\text{s} \pm 1\%$ 100 $\mu\text{s} \pm 1\%$.1 m – 1 m .1 m – 1 m
5-15	AMPLITUDE	A1R457 A1R462	29 V 105 V	30 V – 100 V 30 V – 100 V
5-16	MIN. WIDTH	A1R480	25 ns	25 n – .1 μs
5-16	PULSE PARAMETERS	A1R436 A1R408 A1R419 A3C501 A1R487 A1R421 A2R506 A3C504 A2C514	max. risetime max. risetime max. amplitude; min. overshoot overshoot = ringing flat pulse top flat pulse top min. ringing opt. risetime and ringing min. ringing	30 V – 100 V 30 V – 100 V 30 V – 100 V 10 V – 30 V 10 V – 30 V 10 V – 30 V 10 V – 30 V 10 V – 30 V .3 V – 1 V
5-16	FIXED D.C.	A2R197	8% duty cycle	.1 μ – 1 μ Period
5-17	SLOPE	A2R19	output with NEG/POS SLOPE	

SECTION VII BACKDATING

7-1 INTRODUCTION

7-2 This section contains backdating information which adapts this manual to instrument with serial numbers lower than that shown on the title page.

7-3 CHANGE SEQUENCE

7-4 Changes are listed in the serial number order that they occurred in the manufacture of the instrument. However, in adapting this manual to an instrument with a particular serial number, apply the changes in reverse order. That is, begin with the latest change and progress to the earliest change that applies to the serial number in question. Table 7-1 lists the serial numbers to which each change applies.

Table 7-1. Manual Backdating Changes

Instrument Serial Number	Make Manual Changes
1718G00120 and lower	1 to 9
1718G00190 and lower	2 to 9
1846G00230 and lower	3 to 9
1846G00320 and lower	4 to 9
1846G00345 and lower	5 to 9
1846G00420 and lower	6 to 9
1846G00495 and lower	7 to 9
1846G00545 and lower	8, 9
1846G00595 and lower	9

CHANGE 1 (for serial numbers 1718G00120 and lower)

Delete A3C504 from parts list, component layout and schematic 5.

CHANGE 2 (for serial numbers 1718G00190 and lower)

See Service Note 214B-1.

Also, delete diode AJCR428 (connected between U401b/pin 7 and R458).

CHANGE 3 (for serial numbers 1846G00230 and lower)

Change A2Q41, Q57, Q76 part no. to 1854-0215

Change A1Q426 part no. to 1854-0215

CHANGE 4 (for serial numbers 1846G00320 and lower)

Change A4DS600 part no. to 1970-0044

On Component Layout 2, locate DS600 alongside CR604.

CHANGE 5 (for serial numbers 1846G00345 and lower)

Delete R1 (0757-0384) from Main Assembly parts list.

CHANGE 6 (for serial numbers 1846G00420 and lower)

Change the Assembly A2 (standard and option 001) parts list to read:

R128	2100-0554	R-F 500
R159	0757-0405	R-F 162
R221	0698-4453	R-F 402
R212	0698-4431	R-F 2.05 K
R51	2100-3212	R-F 200

Also, add the following parts to Assembly A2 (standard and option 001) parts list:

R47	0757-0424	R-F 1.1 K
R50	2100-3212	R-VAR 200

On Schematic 3 and A1-1:

connect R47 between Q43 collector and -5.2 V.

connect R50 between R212 and +15 V.

Change the Assembly A3 parts list to read:

C504	0140-0202	C-F 15 pF
------	-----------	-----------

Change the Assembly A4 parts list to read:

C601	0180-2352	C-F 6000 μ F
------	-----------	------------------

CHANGE 7 (for serial numbers 1846G00495 and lower)

Change Assembly A2 (standard and option 001) parts list to read:

R34	0698-3444	R-F 316
-----	-----------	---------

CHANGE 8 (for serial numbers 1846G00545 and lower)

Delete VR430 from Assembly A1 parts list.

On Service Sheet 5, delete VR430 (located between CR432 anode and -155 V).

CHANGE 9 (for serial numbers 1846G00595 and lower)

Change Main Assembly parts list to read:

Q601	1854-0624	XSTR 2N6308
Q602	1854-0624	XSTR 2N6308



MANUAL CHANGES

Manual for Model Number	214B
Manual printed on	February, 1981
Manual Part Number	00214-90012

Make all ERRATA corrections.

Check the following table for your instrument serial prefix/serial number and make the listed changes to your manual.

▶ New Item

Serial Prefix or Serial Number	Manual Changes	Serial Prefix or Serial Number	Manual Changes
--------------------------------	----------------	--------------------------------	----------------

ERRATA

1846G00846	and above	1	
1846G00871	and above	1-2	
1846G00946	and above	1-3	
1846G01021	and above	1-4	
2030G01171	and above	1-5	
2118G01496	and above	1-6	
2118G01521	and above	1-7	
2118G01546	and above	1-8	
2118G01596	and above	1-9	
2118G01671	and above	1-10	
2118G01696	and above	1-11	
2118G01946	and above	1-12	

MODEL 214B INDEX OF MANUAL CHANGES

MANUAL CHANGE	FRAME	A1	A2	A3	A4	MISCELL.
ERRATA	FL601 S602, 603	HPA04 7401				Page 8-25 Page 8-28
1	HP61, 62		D179-100 C244-248 R29, 108			Page 8-14 Page 8-25 Page 8-27
2	HP90, 91, 92	CA12				
3	R68					
4	MP55					
5	A3 MP73, 74					
6	A3					
7	HP87					
8	B1					
9	S601					
10	MP3, L509 L510*, 511*		L509, 510			Page 6-5 Page 8-33
11		CR433 R419, 487	R19*, 20* R177*			Page 8-14 Page 8-25
12		CA12				Page 8-28

MANUAL CHANGE	FRAME	A2	A5	A6	MISCELL.
ERRATA		R328		M301	Page A1-5 Page A1-8
1	MP30	U175-183 C244-248 R29-108	M301		Page A1-4 Page A1-5 Page A1-7
4				R310	
11		C19-20*			Page A1-5

ERRATA :

On Page 6-11, Table 6-3, change the Table of Replaceable Parts to read :

A17401 Instead of A171

Delete : A1MP404

A2R328 (only Opt.00), Page 6-27 and diagram A1-2)

A6M301

On Page 8-25 and A1-5, change the following values :

A2R132 to 68.1 OHM

A2R169 to 301 OHM

A2R255 to 162 OHM

On Page A1-8, change the Component Layout to read :

A 6 BURST BOARD

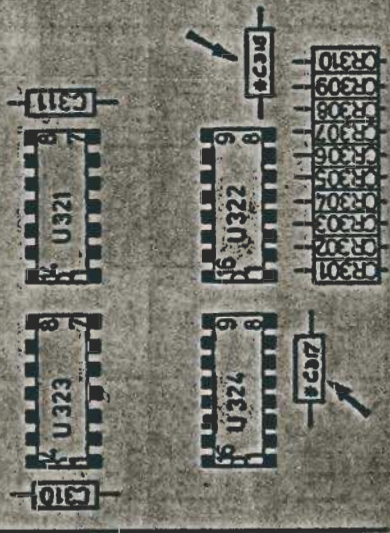

On Page 6-7 and 6-8, Table 6-3, Replaceable Parts :

Add : FL601

S602,603

FILTER LINE SWITCH-SETDE

On Page 8-28, change the Component Layout to read :

J401 Instead of J1.

MANUAL CHANGE 1

On Table 6-3, change the Table of Replaceable Parts to read:

Alt. 1402	5040-9316	LOCK CLIP 16 PDL
A2R103	0757-0416	R-FXD 51 15 125H
MP61	3050-0019	WASHER BRS 2 10
MP62	3050-0376	WASHER NYL 250 1D
MP30	0370-0571	M308 P-PTN BLUE (Opt. 001 only)
A2E179-183	0160-0576	C-FXD 1UF 20% 50V
A2224-248	0160-0576	C-FXD 1UF 20% 50V
A2R29	0698-4418	R-FXD 205 15 125H
A5V301	5081-1963	CBL R8 16C 254 MM (Opt. 001 only)

On Page 8-25 and on Page A1-5, change the diagram to read:

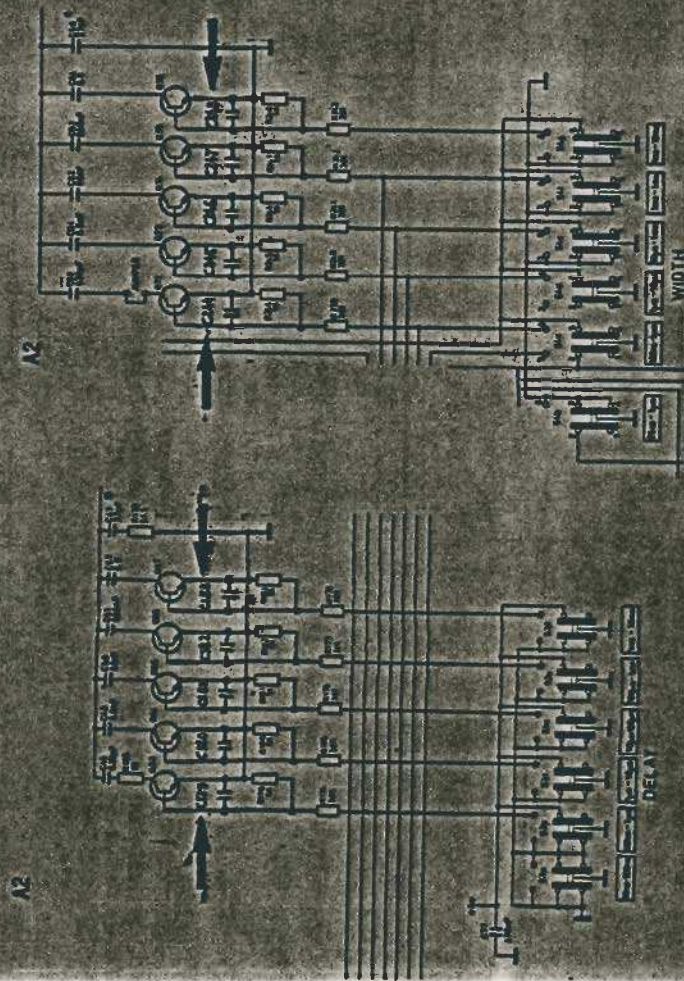

MANUAL CHANGE 1 (Cont.)

On Page 8-14 and A1-4, change the component layout to read:

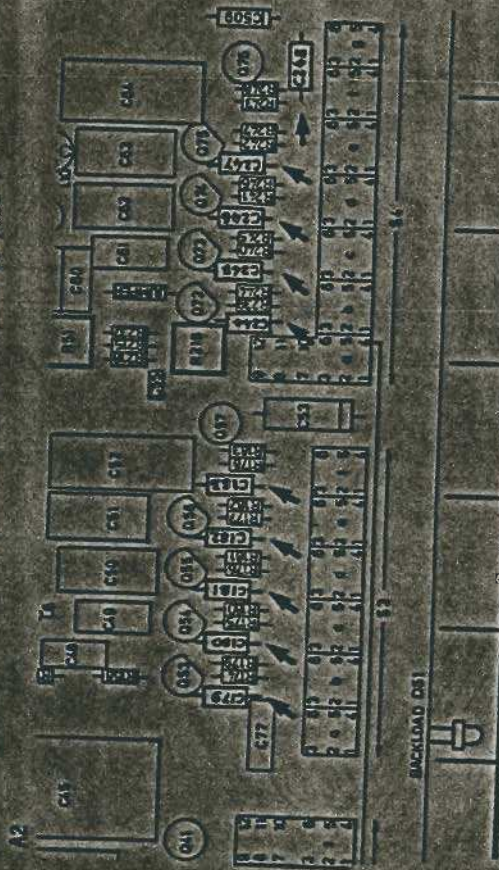

On Page 8-27 and A1-7, change the diagram to read:

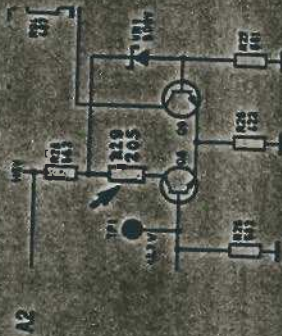

On Page 8-14 and A1-4, change the component layout to read: R29 instead of R328

MANUAL CHANGE 2

On Table 6-3, change the Table of Replaceable Parts to read :

ALC412	0160-2387	G-FXD 1001 UF 500V
NP90	00214-00256	PANEL SHIELD
NP91	2350-0113	SCREW-MCH 6-32
NP92	3050-0010	WASHER BRG 147

mounted on A2 80 AY-TIMING

MANUAL CHANGE 3

On Table 6-3, change the Table of Replaceable Parts to read :

A1R68	0698-3152	R-FXD 3.48 1% .125M
-------	-----------	---------------------

MANUAL CHANGE 4

On Table 6-3, change the Table of Replaceable Parts to read :

A6R310	0757-0717	R-FXD 182 1% .26V
NP55	5024-8779	NUT HEX

MANUAL CHANGE 5

On Table 6-3, change the Table of Replaceable Parts to read :

A3	00214-56563	80 ASSY LOAD
NP73	00214-04157	COVER SAFETY
NP74	00214-01256	BRACKET POWER

MANUAL CHANGE 6

On Table 6-3, change the Table of Replaceable Parts to read :

A3	00214-66553	80 ASSY LOAD
----	-------------	--------------

MANUAL CHANGE 7

On Table 6-3, Replaceable Parts :

Delete : NP87

MANUAL CHANGE 8

On Table 6-3, change the Table of Replaceable Parts to read :

81	3160-0379	FAN TUBE AXIAL
----	-----------	----------------

MANUAL CHANGE 9

On Table 6-3, change the Table of Replaceable Parts to read :

S601	3101-2216	SWITCH PBTN
------	-----------	-------------

MANUAL CHANGE 10

On Table 6-3, Replaceable Parts :

Add :	MP93	00214-01262	BRACKET GUIDE
	L509	1970-1034	CORE TORO10
	L510*, L511*		

Delete : A2L509, 510

On Page 6-6, Figure 6-1, change the diagram to read :

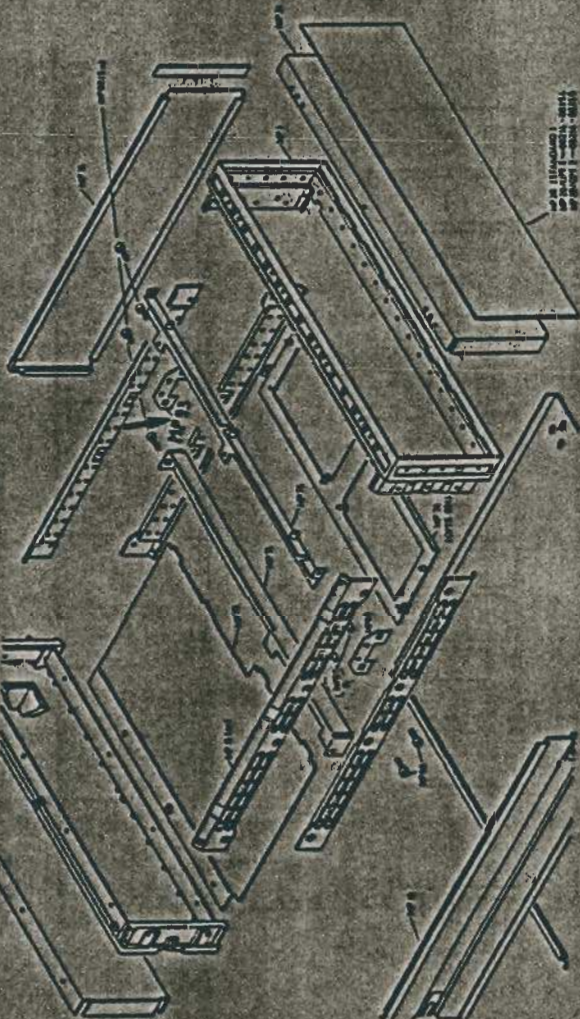

On Page 8-33, change the diagram to read :
The L511* is located between A1 and A2 wire 8.

MANUAL CHANGE 11

On Table 6-3, change the Table of Replaceable Parts to read :

AICR433	1901-0620	DIODE 5V S1 60V
AIR419	2100-2512	R-VAR 20G 10%
AIR487	2100-2426	R-VAR 20 10%
AZR17*	0757-0280	R-FXD 1K 1% .125M
Addr: AZR19*, 20*	0160-2454	C-FXD 620PF 300V

On Page 8-14, change the Component Layout of A2 to read :

C19* is located parallel to R63
 C20* is located parallel to R64

On Page 8-25 and A1-5, change the diagram to read :

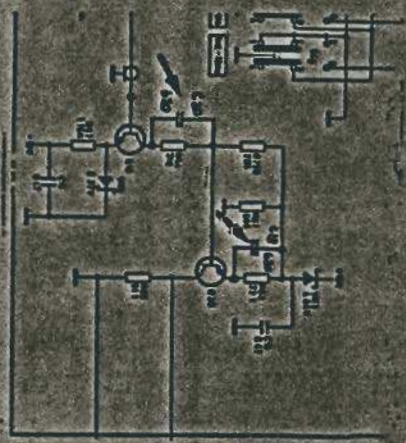

MANUAL CHANGE 12

On Table 6-3, change the Table of Replaceable Parts to read :

A1C412	0160-5466	C-FXD 1000PF 6%
--------	-----------	-----------------

On Page 8-28, change the Component Layout to read :



SECTION VIII SERVICE

8-1 INTRODUCTION

8-2 This section contains the information to service the HP Model 214B. The information includes theory of operation, troubleshooting, schematics, component layouts and block diagram.

8-3 The schematics and component layouts are organized as 'Service Sheets' which are identified by a large number within a square in the lower corners. A table relating these Service Sheets to board assemblies is given in Table 8-1. Schematic diagram symbols are given in Table 8-3.

Table 8-1. Index to Assemblies

Assembly	Service Sheet
A1 Output Board	5
A2 Timing Board (Standard)	3, 4
A2 Timing Board (Option)	A1-1, A1-2
A3 Load Board	6
A4 Power Supply Board	2
A6 Burst Board (Option)	A1-3

8-4 SAFETY CONSIDERATIONS

8-5 This section contains warnings and cautions that must be followed for your protection and to avoid damage to the equipment:

WARNING

Dangerous voltages, capable of causing death are present in this instrument. HV-power supply and output amplifier excepted, all other servicing can be accomplished without the need for a high voltage supply. Before carrying out such servicing, therefore, avoid danger to life and possible instrument damage by disconnecting the white-red-violet wire (with power cord removed) from the A4 power supply board. Isolate the crimp connector on the disconnected wire. When servicing is complete, the After Service Safety Check must be performed.

8-6 AFTER SERVICE SAFETY CHECK

8-7 Execute the following checks when servicing is completed.

8-8 Disconnect power cord from line. Visually inspect interior of instrument for any sign of abnormal internally generated heat, such as discolored printed circuit boards or components, damaged insulation, or evidence of arcing. Determine cause and remedy.

8-9 Check cabinet/ground pin continuity in accordance with IEC/VDE. Flex the power cord while making the measurement to detect any intermittent discontinuity. Check internal ground connections on boards and frame. Also check resistance of any front or rear panel ground terminals marked \perp .

8-10 Check cabinet/line isolation in accordance with IEC/VDE. Replace any component which results in a failure or refer to production Memo or Service Note issued by product division for alternate action.

8-11 Check line fuse to verify that the proper value is installed.

8-12 Check that safety covers are installed.

8-13 Check that all coaxial and flat cables inside are properly connected. Check that all boards and the heatsink on the chassis are properly connected. Verify that the board clamp is fitted.

8-14 Inform Hewlett-Packard (internally, the responsible product division) of any repeated failures in the above tests or any other safety features.

8-15 SERVICE BLOCKS (THEORY/TROUBLESHOOTING)

8-16 The theory of operation and troubleshooting is divided into Service Blocks, each Service Block corresponding to a complete function within the 214B. Service Block 1 deals with overall instrument troubleshooting, including a detailed block diagram of all HP 214B functions. The purpose of the general instrument troubleshooting is to provide a fast means of isolating a fault down to a function. The Serviceman should then proceed to the Service Block providing detailed theory of operation and troubleshooting hints for that function. A table relating function to Service Block is given in Table 8-2.

Table 8-2. Index to Service Blocks

Service Block	Function
1	Troubleshooting Tree
2	Power Supply
3	Timing
4	Output
A1-1	Burst

8-17 Tables and Figures within each Service Block are given three-digit codes e.g. Figure 8-3-1. The first digit refers to the Manual Section (8), the second digit to the Service Block and the third to the Figure number, e.g. Figure 8-3-1 means Section 8, Service Block 3, Figure 1.

Table 8-3. Schematic Diagram Notes (1 of 2)

The following symbols conform, as far as possible, with ANSI Y 32.2, IEEE No. 315 and ANSI Y32.14 (for the logic symbols). These standards should be consulted when further informations is required.













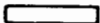















General		Components	
Units	Resistance values are in ohms, capacitance values in microfarads and inductance values in microhenries unless otherwise noted !		Normally open toggle switch. Circles (O) are used for the contacts to indicate a locking type switch.
P/O	Part of		Spring return, 2-position transfer switch. Triangle (▲) are used for the contacts to indicate a non-locking type switch.
*	Asterisk denotes a factory selected value. The value shown is the nominal value.		2-position, 2-pole slide switch.
	Encloses front panel nomenclature.		Air cored inductor.
	Encloses rear panel nomenclature.		Air cored transformer. The dot (●) is used, when necessary, to indicate instantaneous polarity.
	Heavy line indicates signal path.		Iron core
	Heavy dashed line indicates primary feedback path.		Ferrite core
<u>947</u>	Wire colour code. Same as resistor colour code. First number is wire body colour.		Ferrite bead
	Wire or plug used as link.		Varactor diode
	Test point in a circuit. Point may/may not be identified on P.C. board.		Multi-junction diode
	Used with trimmer potentiometers or capacitors to indicate screwdriver adjustment.		Diode
	Direct connection to earth.		Zener diode
	Ground connection to instrument chassis or frame.		Schottky diode
	Used when a number of common-return connections are at the same potential. If there is more than one such system in the same circuit, numbers are written in the triangles so that all connections with the same potential have the same number.		Light Emitting Diode (LED)
	Specific potential difference with respect to a potential reference level, eg. +10 V		Photodiode
Schematic Referencing			Fuse
			Neon
<p>These references on a signal leaving a schematic diagram indicate the signal destination. The circle contains the signal number and the square contains the number of the schematic to which that signal goes.</p>			Filament lamp
<p>These references on a signal entering a schematic diagram indicate the signal origin. The circle contains the signal number and the square contains the number of the schematic to which that signal originates.</p>			

Table 8-3. Schematic Diagram Notes (2 of 2)

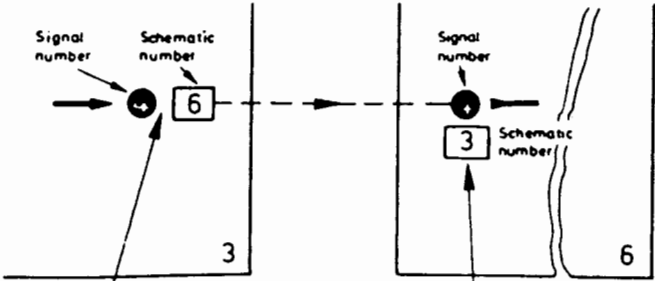

SERVICE BLOCK 1 TROUBLESHOOTING TREE

The purpose of the following troubleshooting tree is to provide a fast means of isolating a fault down to a function. For detailed theory of operation on a specific function, the serviceman should proceed to the associated Service Block e.g. Service Block 3 for Timing.

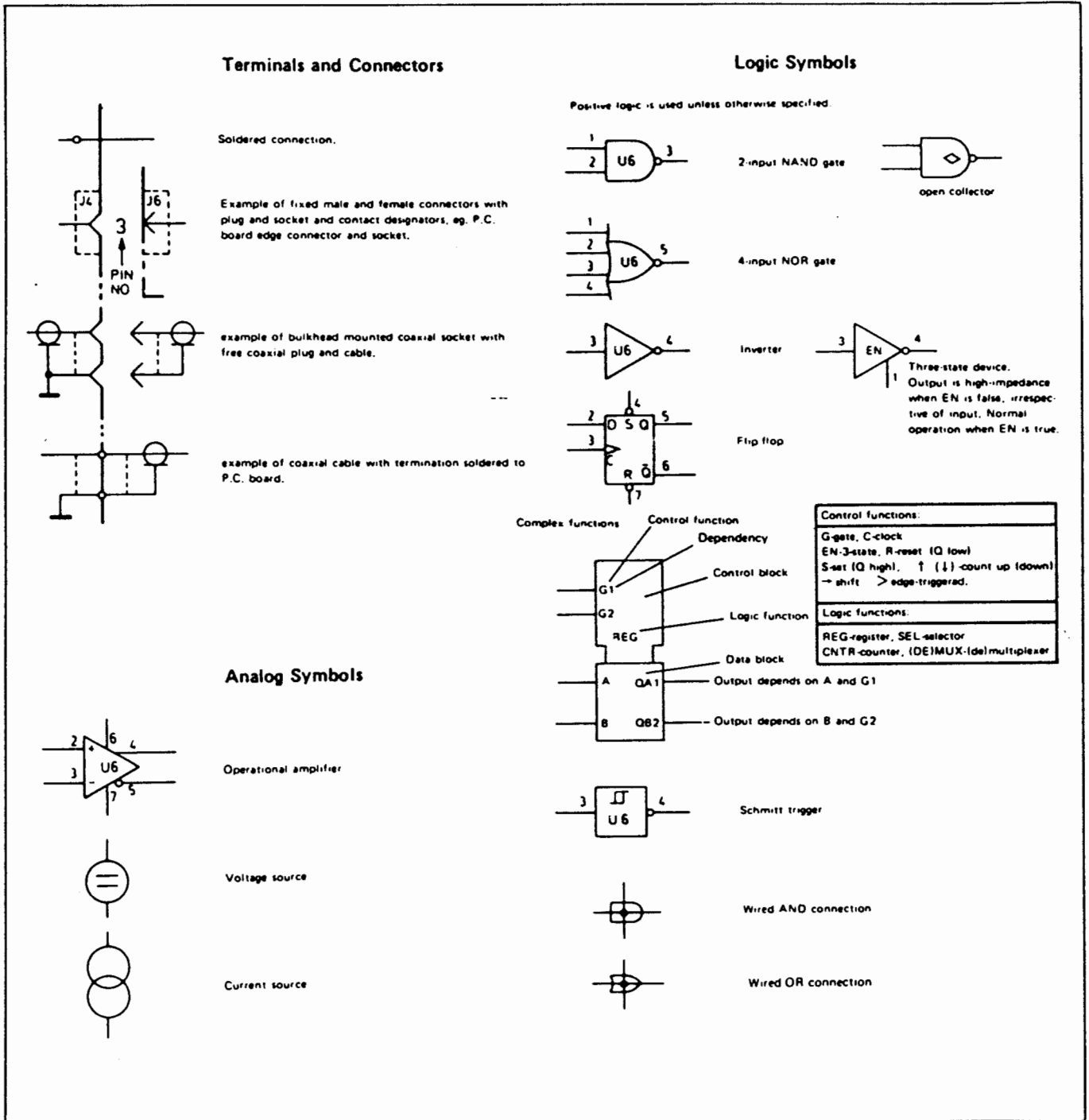
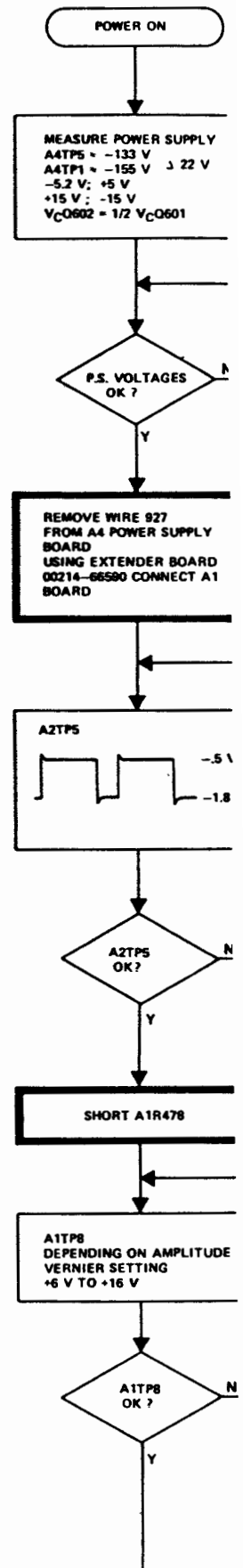

SERVICE BLOCK 4 OUTPUT BOARD A1

THEORY OF OPERATION

The output board A1 can be divided into 4 main functional blocks:

- input Schmitt trigger
- duty cycle detect/overload detect
- amplitude vernier and overload switch
- output amplifier

Each of these blocks is described in the following paragraphs.

Input Schmitt Trigger

The input Schmitt trigger comprises:

- transformer T401, which isolates potentials of the output amplifier from the timing board, and also differentiates the timing circuit output pulse.
- emitter follower Q400, which isolates the transformer T401 from the following Schmitt trigger.
- Schmitt trigger Q401/Q402.

A positive pulse at the base of Q401 causes Q401 to cut off, and Q402 conducts. This stable conditions exists until the next negative pulse arrives from Q400 which switches Q401 on and Q402 off.

The duty cycle detect signal is derived from the Q401 collector and routed to the overload detection circuit. To ensure that integrator charge-up (in the overload detect circuit) is determined only by the duty cycle of the detect signal (and not amplitude), the amplitude is clamped to approx. 3.5 V by CR400 and VR400.

Overload Detection/Overload Switch/Amplitude Vernier

The duty cycle detect signal derived from Q401 collector is inverted by Q421 and limited by CR424. Pulses at the collector of Q421 are then integrated by R447 and C416. With increasing duty cycle at the base of Q421, the voltage across C416 decreases (switching Q421 on causes C416 to discharge). Should the C416 voltage decrease to a point where it is lower than the reference voltage at U401a/pin 2, the output voltage of comparator U401a is switched to a minimum. (The threshold voltage at comparator U401 changes according to amplitude range due to the varying duty cycle limits i.e. 10% in 30–100 V range: 50% in all other ranges. In the 30–100 V amplitude range, K403 switches the Q425 base to –155 V, thus turning Q425 off. U401a threshold is then determined by R448/R449. In all other amplitude ranges, Q425 is turned on, resistors R450/R451 then being connected in parallel with R449, thus lowering the U401a threshold).

With U401a output switched to minimum, C419 is discharged via CR427, which in turn switches U401b/pin 7 to maximum output (OVERLOAD LED on). Q426 switches on (via CR428, R464) and transistors Q427/Q428 switch off, causing approximately –155 V to be applied to the grids of tubes V401, V402. This negative voltage at Q428 collector is also applied to the bases of Q406/Q407 (Q416/Q417) via R413/R414 (R428/R427). Transistor Q407 (Q417) turns off and Q406 (Q416) turns on, switching –155 V to the gates of FET's Q408/Q418. With negative voltages at the tube grids and FET gates, the output amplifier is disabled (i.e. no output current).

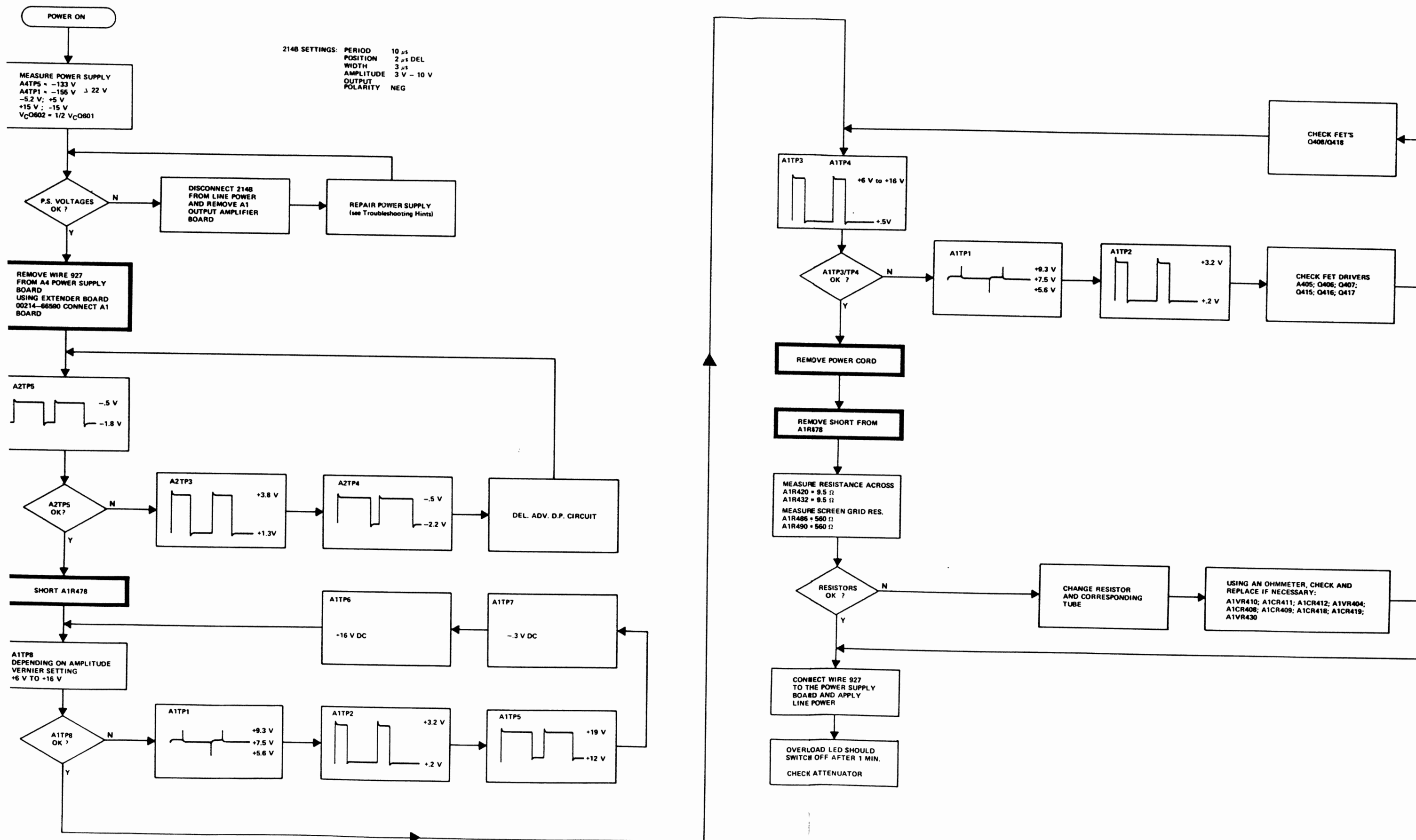

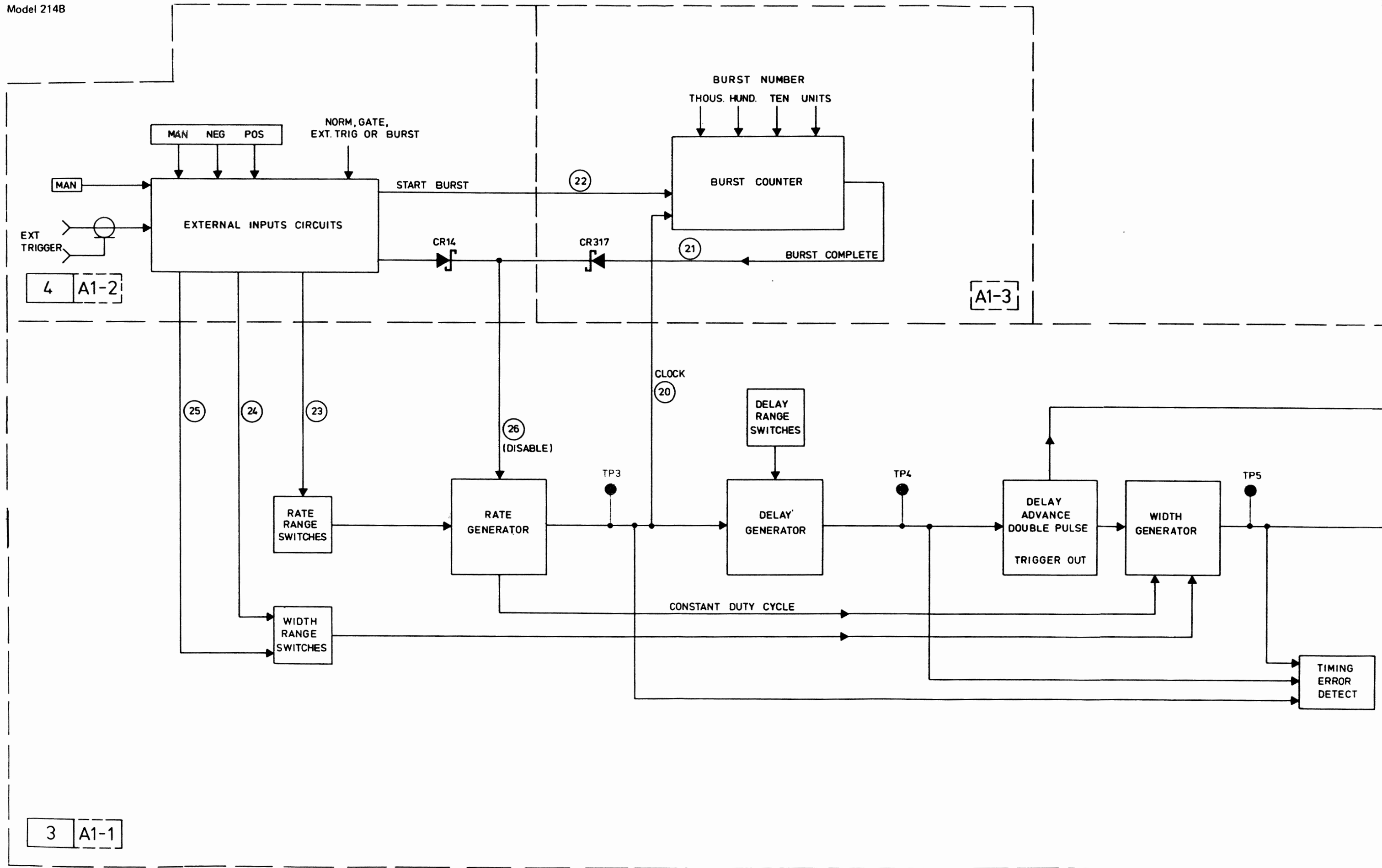

4 A1-2

A1-3

3 A1-1

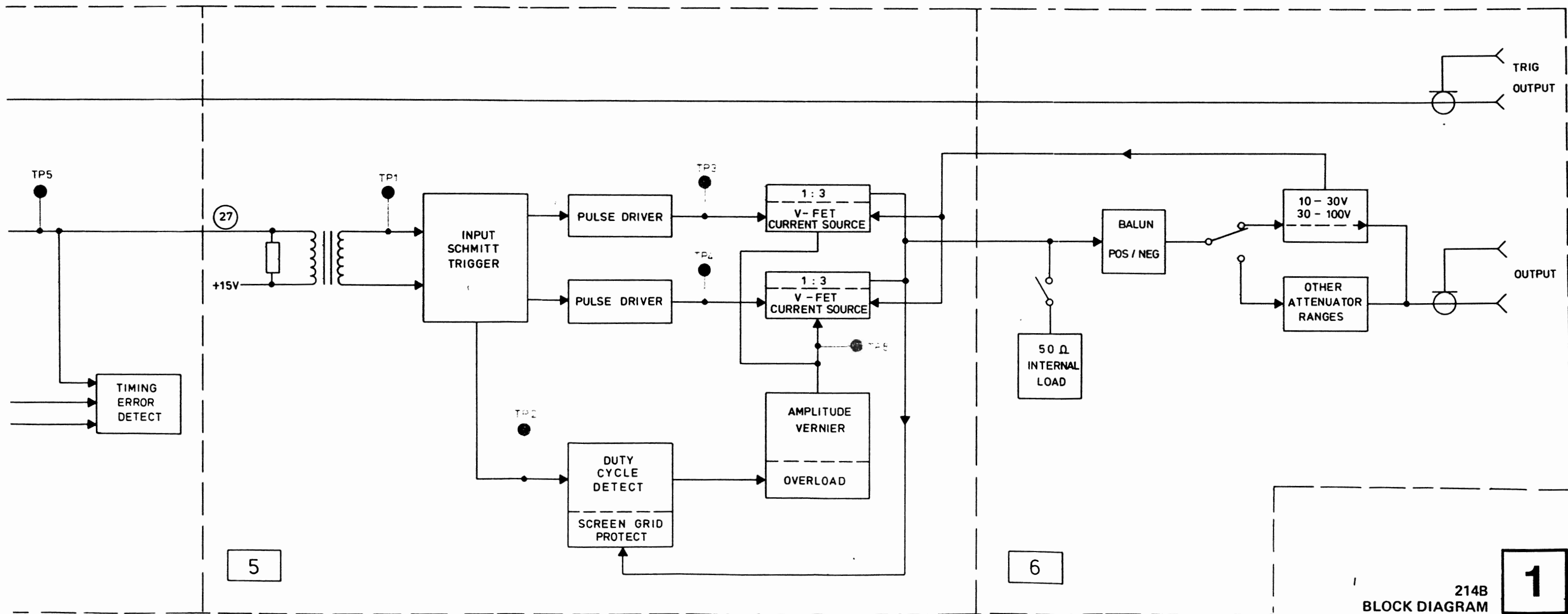

214B
BLOCK DIAGRAM

1

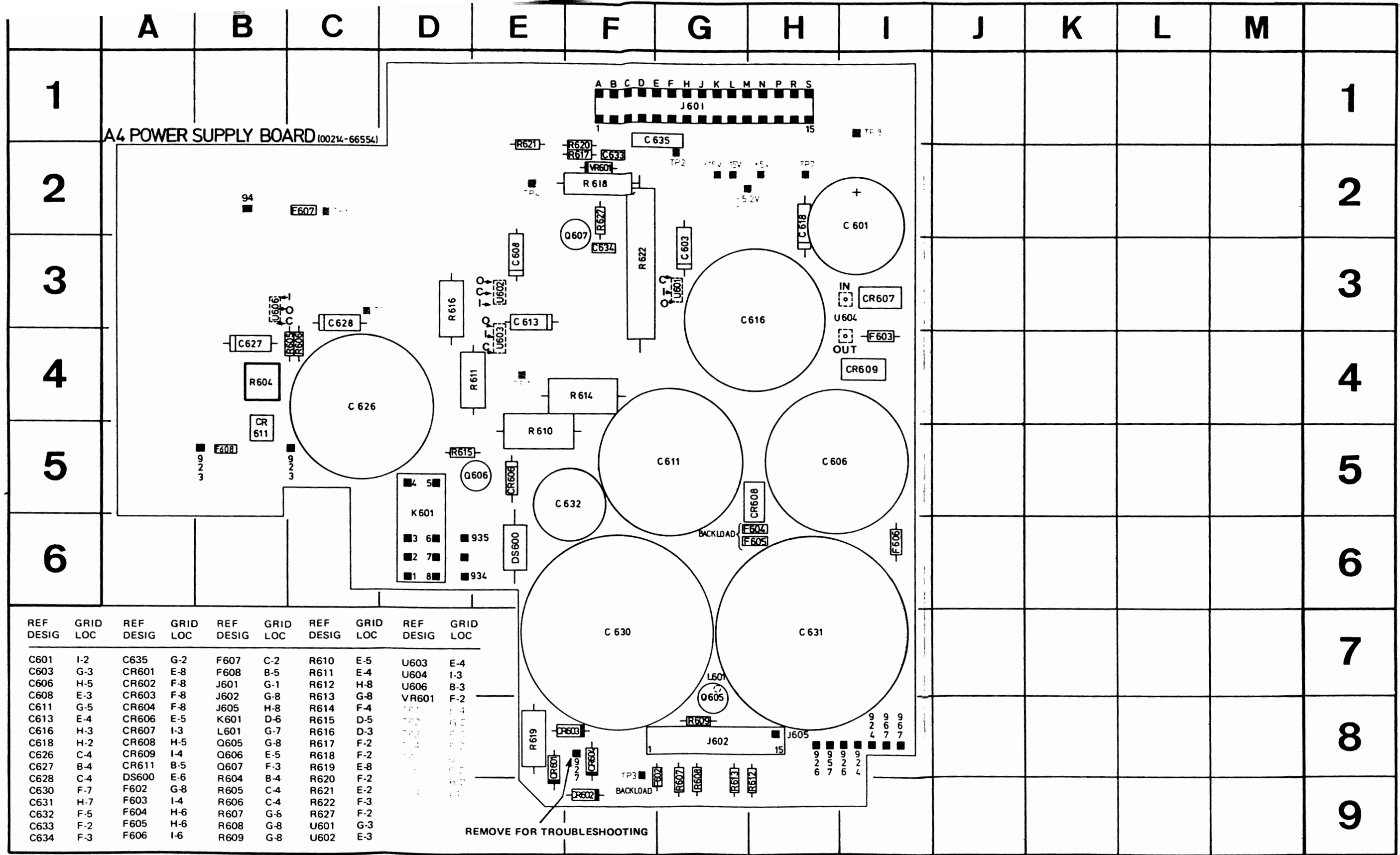

2

SERVICE BLOCK 2

HIGH VOLTAGE SUPPLY A4 2

THEORY OF OPERATION

General

The 214B high voltage supply comprises a regulated -155 V supply, which in turn is used as reference potential for a $+22\text{ V}$ supply. A functional diagram of these two supplies is given in Figure 8-2-1.

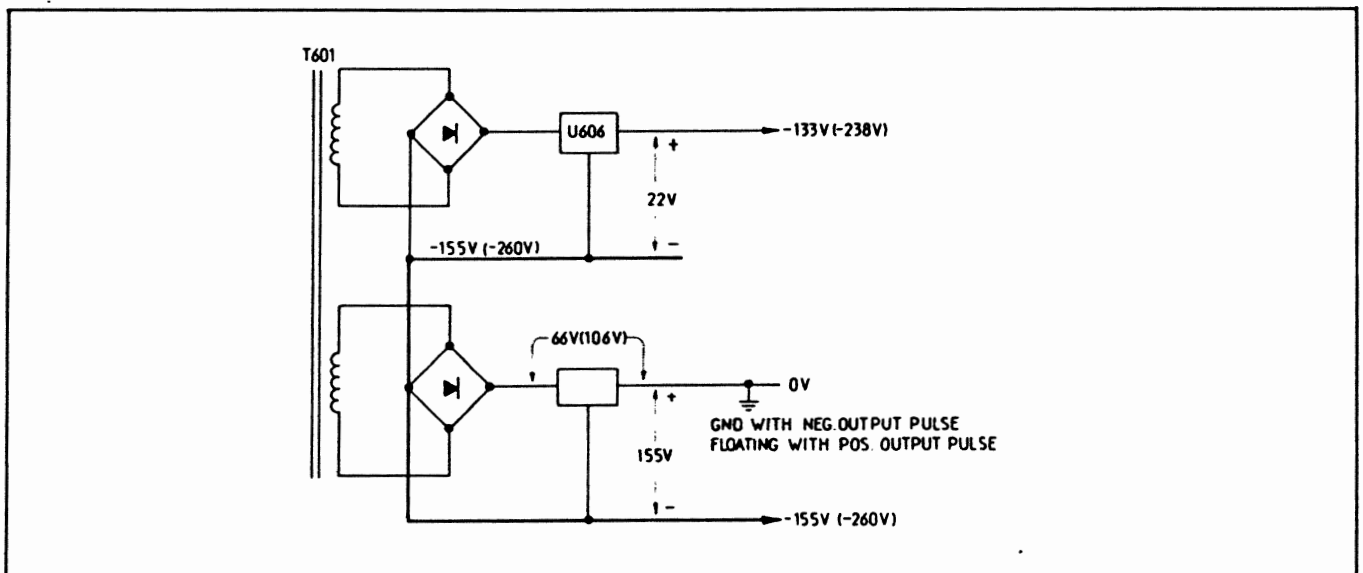

Figure 8-2-1. Functional diagram of high voltage supply.

In Figure 8-2-1, the voltages indicated in brackets, i.e. -260 V , -238 V are generated when $30\text{ V} - 100\text{ V}$ amplitude is selected. When negative output pulse is selected, the $-155\text{ V} (-260\text{ V})$ and $-133\text{ V} (-238\text{ V})$ are referenced to chassis ground. With positive output selected, this ground becomes floating.

22 V Supply

The $+22\text{ V}$ supply is referenced to the $-155\text{ V} (-260\text{ V})$ supply, and is the power source on the output amplifier board for the input Schmitt trigger, overload detection circuit, amplitude vernier and the FET drive circuits. This supply must be adjusted to 22 volt, although the absolute value of the reference potential ($-155\text{ V}/-260\text{ V}$), may vary slightly.

Adjustment is achieved via the adjustable voltage divider R604, R605 and R606, which sets the reference voltage for the 3-terminal positive voltage regulator U606.

Two other points for mention in the $+22\text{ V}$ regulator circuit are C627 used to bypass the input, and C628 which improves transient response.

High Voltage Supply (-155 V/-260 V)

A functional diagram of the high voltage supply circuit is given in Figure 8-2-2. Basically, this circuit comprises two cascaded series regulators (Q601 and Q602) and a sense amplifier Q607. Series regulator Q601 in conjunction with Q603, Q605 forms a Darlington amplifier; similarly regulator Q602 together with Q604 and Q606.

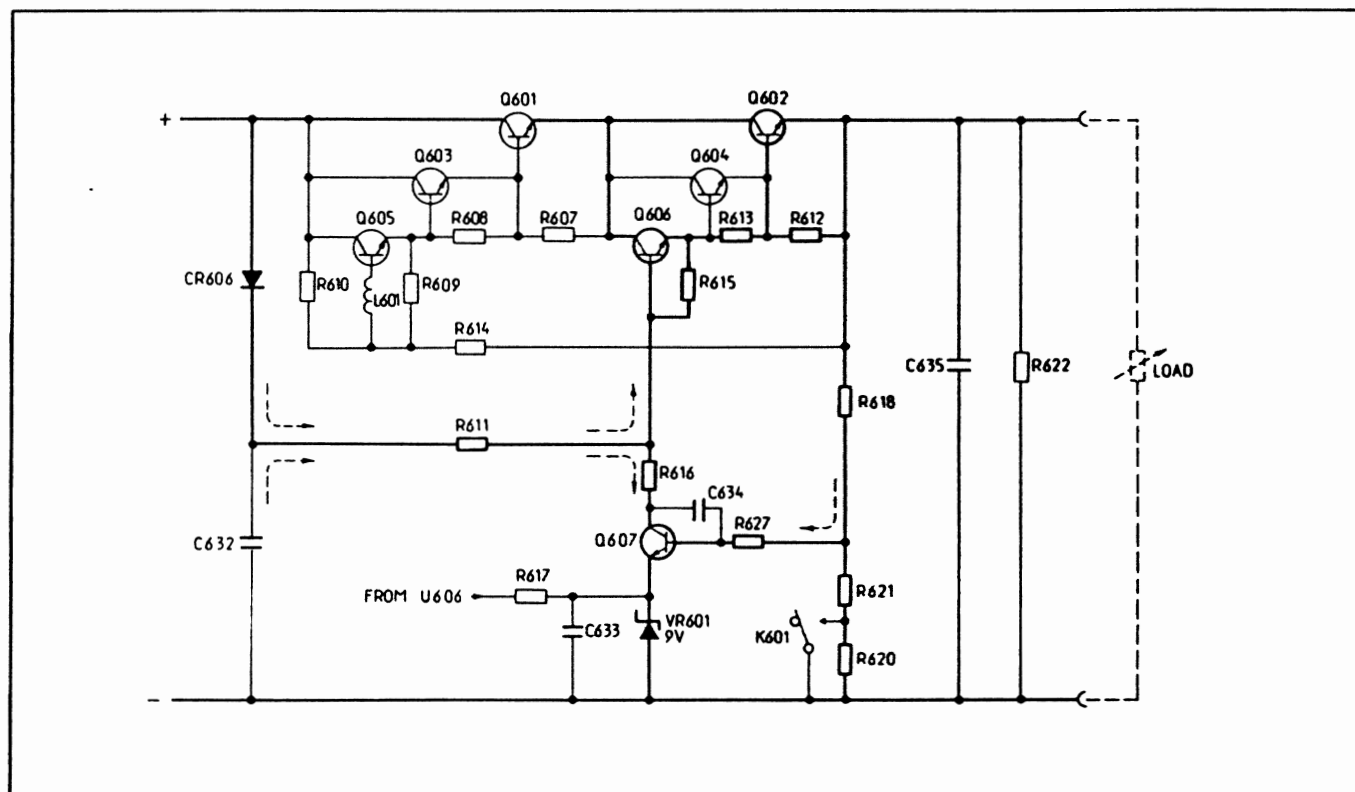

Figure 8-2-2.

To ensure that secondary breakdown of the series regulators does not occur, the collector/emitter voltage drop across Q601 and Q602 is equalized via voltage divider R610/R614.

CR606, R611 and C632 form a current source. (C632 is charged to the positive potential; should this potential then drop, CR606 becomes reversed biased and C632 is discharged via R611). Part of this current is routed to the base of Q606 thus switching regulator Q602 on; the rest of the current is routed via R616, Q607 and VR601 to the negative potential. If the load at the Q602 emitter increases, the voltage at the junction R618/R621 decreases, which in turn is sensed by Q607. The current flowing to the negative potential is thus reduced, and more current fed to the Q606 base. This causes the series regulators to conduct more, thus regulating the output voltage.

Due to the large load changes which occur, for example, by 100 V output amplitude, the bias current for VR601 is supplied by U606, thus making the zener voltage independent of load.

R622 ensures correct operation of the regulator circuit when no load exists, while L601 and C634 are used to damp oscillations.

When 30-100 V amplitude range is selected, the regulator output voltage is increased from -155 V to approximately -260 V. This is achieved via relay K601 which switches the secondary voltage of T601, and changes the potential at the voltage tap-off from divider R618, R621, R620 by shorting R620.

TROUBLESHOOTING HINTS A4 POWER SUPPLY BOARD

1. Voltages at U601; U602; U603; U604; U606 and TP6 must be measured with wire 927 removed (no high voltage).
 Note: Voltage Regulators have internal current limiting.

2. T601 secondary voltages measured without load.

WIRE	VOLT RMS
967 to 967	9.9 V
926 to 926	39.4 V
924 to 924	9.9 V
94 to 94	6.9 V
923 to 923	26.2 V
934 to 935	115.0 V
935 to 927	173.0 V

3. For troubleshooting the High Voltage Power Supply remove the A1 Output Amplifier Board and W602. (214B input current is approx. 200 mA at 220 V AC (400 mA at 110 V AC)).
 Check voltages as shown below with DVM Common connected to TP1.

PIN	1	2	3	4	5	6	7	8	9	10	11	12	13	14	15
J602	+230			+192	+191	+191	+190	+190		+157	+155	+155	+155		

Q607 Collector +109 V
 VR601 Cathode +9 V
 TP4 +9.5 V
 CR606 Cathode +228 V
 TP2 +155 V

Note: Voltages may vary slightly

Check Q601; Q602; Q603 and Q604 for short or open (Heatsink).

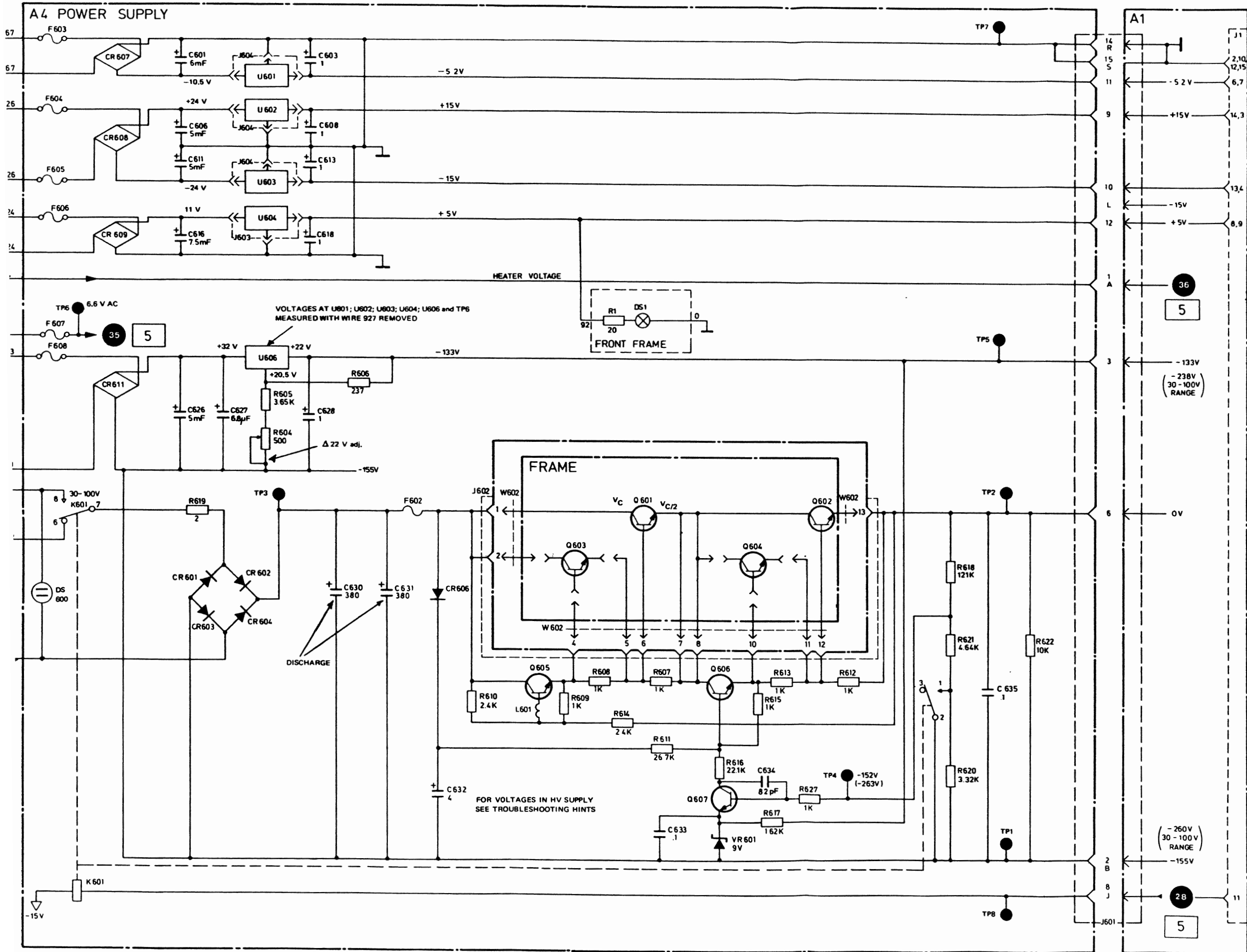

POWER SUPPLY BOARD A4



P/O FRAME

A4 POWER SU

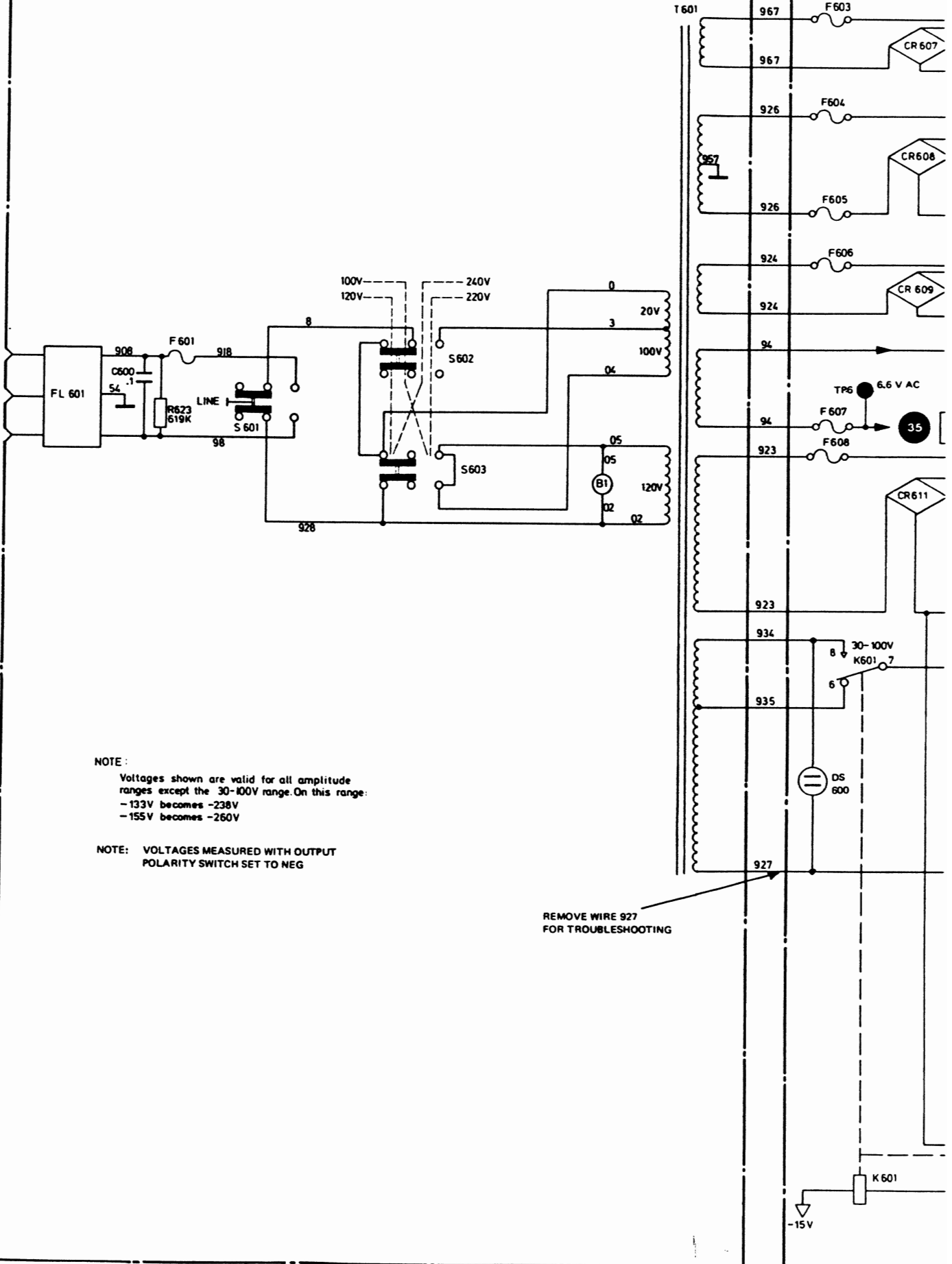

NOTE:
 Voltages shown are valid for all amplitude ranges except the 30-100V range. On this range:
 -133V becomes -238V
 -155V becomes -260V

NOTE: VOLTAGES MEASURED WITH OUTPUT POLARITY SWITCH SET TO NEG

REMOVE WIRE 927 FOR TROUBLESHOOTING

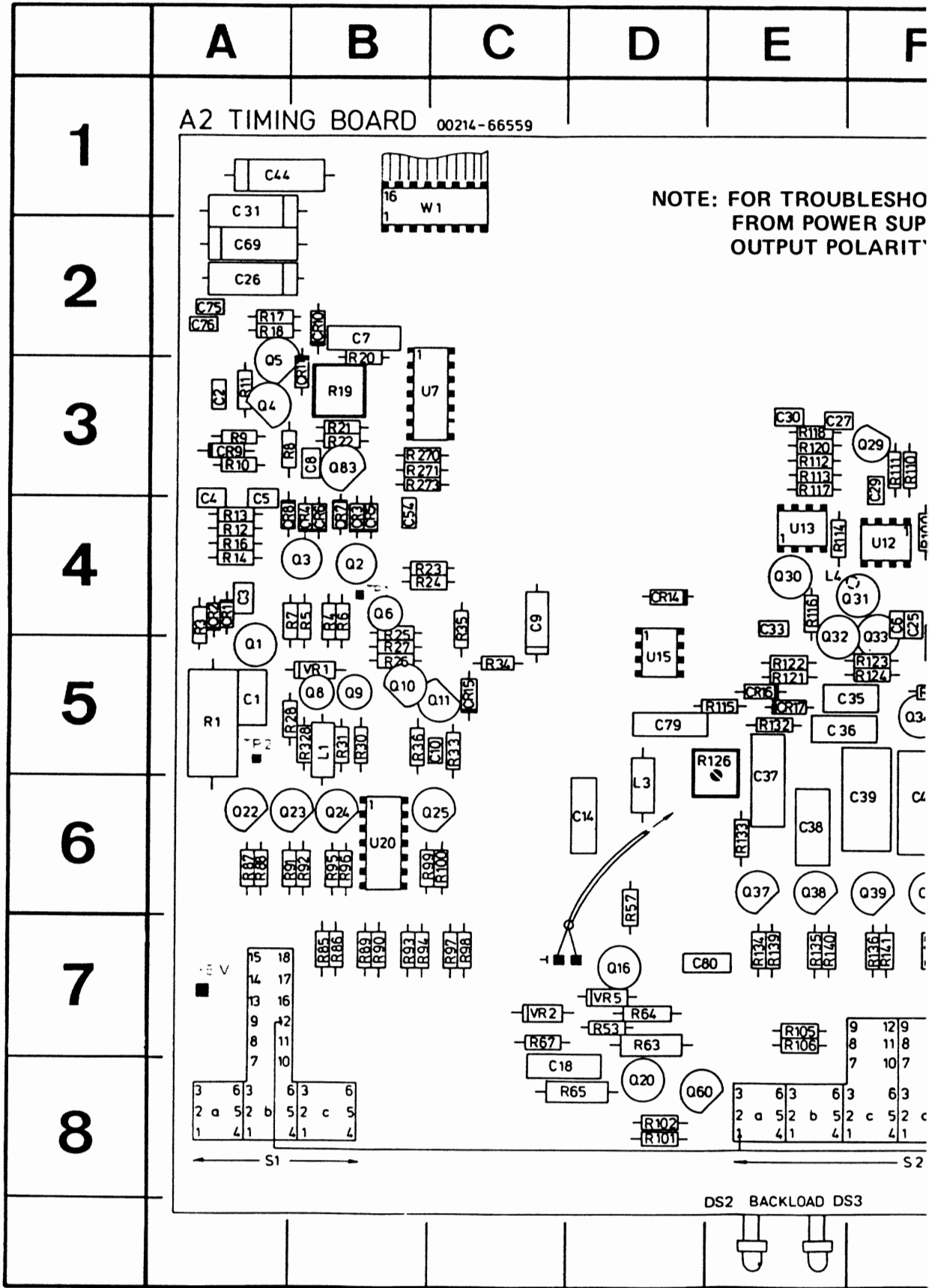

3

D	E	F	G	H	I	J	K	L	M	N	O	P	Q	R	
---	---	---	---	---	---	---	---	---	---	---	---	---	---	---	--

NOTE: FOR TROUBLESHOOTING REMOVE WIRE 927 FROM POWER SUPPLY BOARD AND SWITCH OUTPUT POLARITY TO NEG

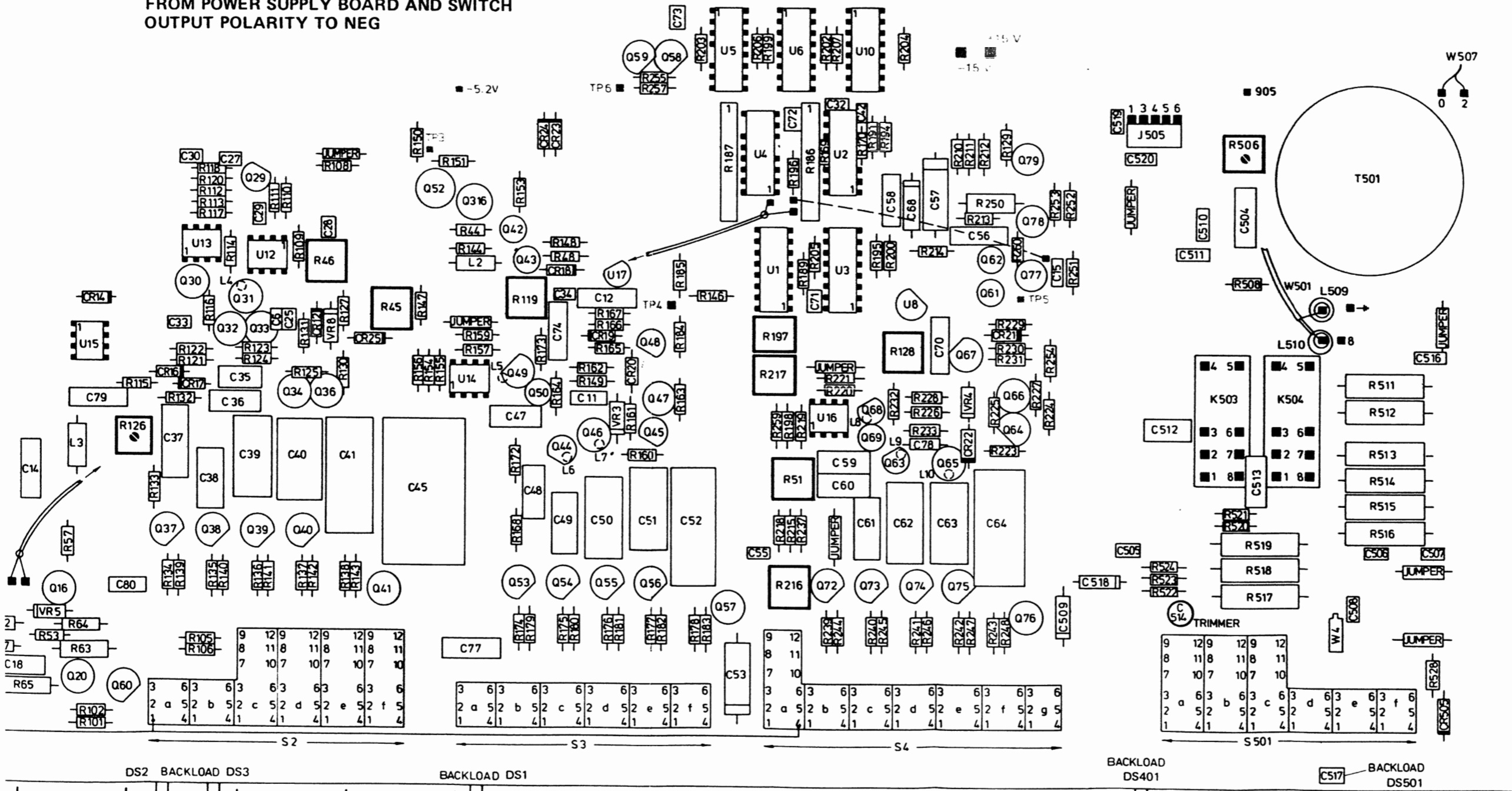

- 1
- 2
- 3
- 4
- 5
- 6
- 7
- 8

REF DESIG	GRID LOC	REF DESIG	GRID LOC	REF DESIG	GRID LOC	REF DESIG	GRID LOC	REF DESIG	GRID LOC	REF DESIG	GRID LOC
C1	A-5	C512	O-6	Q38	E-6	R46	F-4	R155	G-5	R243	L-7
C2	A-3	C514	N-7	Q39	F-6	R48	H-4	R156	G-5	R244	K-7
C3	A-4	C516	P-5	Q40	F-6	R51	J-6	R157	H-5	R245	K-7
C4	A-3	C517	O-8	Q41	G-7	R53	D-7	R159	H-5	R246	L-7
C5	A-3	C518	M-7	Q42	H-4	R57	D-6	R160	I-6	R247	L-7
C6	F-4	C519	M-3	Q43	H-4	R63	D-7	R161	I-5	R248	L-7
C7	B-2	C520	N-3	Q44	H-6	R64	D-7	R162	I-5	R250	L-3
C8	B-3	CR1	A-4	Q45	I-5	R65	C-8	R163	I-5	R251	M-4
C9	C-4	CR2	A-4	Q46	I-5	R67	C-7	R164	H-5	R252	M-3
C10	B-5	CR3	B-4	Q47	I-5	R85	B-7	R165	I-5	R253	M-3
C11	I-5	CR4	B-4	Q48	I-5	R86	B-7	R166	I-4	R254	M-5
C12	I-4	CR5	B-4	Q49	H-5	R87	A-6	R167	I-4	R255	I-2
C14	D-6	CR6	B-4	Q50	H-5	R88	A-6	R168	H-6	R257	I-2
C15	M-4	CR7	B-4	Q52	G-3	R89	B-7	R169	K-3	R259	J-5
C18	C-8	CR8	A-4	Q53	H-7	R90	B-7	R170	K-3	R260	L-4
C25	F-4	CR9	A-3	Q54	H-7	R91	A-6	R172	H-6	R270	B-3
C26	A-2	CR10	B-2	Q55	I-7	R92	B-6	R173	H-5	R271	B-3
C27	E-3	CR11	B-3	Q56	I-7	R93	B-7	R174	H-7	R273	B-3
C28	F-4	CR12	F-4	Q57	J-7	R94	B-7	R175	H-7	R506	O-3
C29	F-3	CR14	D-4	Q58	I-2	R95	B-6	R176	I-7	R508	O-4
C30	E-3	CR15	C-5	Q59	I-2	R96	B-6	R177	I-7	R511	P-5
C31	A-1	CR16	E-5	Q60	D-8	R97	C-7	R178	J-7	R512	P-5
C32	K-2	CR17	E-5	Q61	L-4	R98	C-7	R179	H-7	R513	P-6
C33	E-4	CR18	H-4	Q62	L-4	R99	B-6	R180	H-7	R514	P-6
C34	H-4	CR19	I-5	Q63	K-6	R100	C-6	R181	I-7	R515	P-6
C35	E-5	CR20	I-5	Q64	L-5	R101	D-8	R182	I-7	R516	P-6
C36	E-5	CR21	L-4	Q65	L-6	R102	D-8	R183	J-7	R517	O-7
C37	E-5	CR22	L-5	Q66	L-5	R105	E-7	R184	I-5	R518	O-7
C38	E-6	CR23	H-3	Q67	L-5	R106	E-7	R185	I-4	R519	O-6
C39	F-6	CR24	H-3	Q68	K-5	R108	F-3	R186	K-3	R520	O-6
C40	F-6	CR25	G-5	Q69	K-5	R109	F-4	R187	J-3	R521	O-6
C41	F-6	CR505	P-8	Q72	K-7	R110	F-3	R189	K-4	R522	N-7
C42	K-2	DS1	H-8	Q73	K-7	R111	F-3	R191	K-3	R523	N-7
C44	A-1	DS2	E-8	Q74	L-7	R112	E-3	R194	K-3	R524	N-7
C45	G-6	DS3	E-8	Q75	L-7	R113	E-3	R195	K-4	R528	P-7
C47	H-5	DS401	N-8	Q76	M-7	R114	E-4	R196	J-3	S1	A-8
C48	H-6	DS501	P-8	Q77	M-4	R115	F-5	R197	J-4	S2	F-8
C49	H-6	J505	N-3	Q78	M-3	R116	E-4	R198	J-5	S3	I-8
C50	I-6	K503	N-5	Q79	M-3	R117	E-3	R199	J-2	S4	K-8
C51	I-6	K504	O-5	Q83	B-3	R118	E-3	R200	K-4	S501	O-8
C52	J-6	L1	B-5	R1	A-5	R119	H-4	R202	K-2	T501	P-3
C53	J-8	L2	H-4	R3	A-4	R120	E-3	R203	J-2	U1	J-4
C54	B-4	L3	D-5	R4	B-4	R121	E-5	R204	K-2	U2	K-3
C55	J-6	L4	E-4	R5	B-4	R122	E-5	R205	K-4	U3	K-4
C56	L-4	L5	H-5	R6	B-4	R123	F-5	R206	J-2	U4	J-3
C57	L-3	L6	H-6	R7	A-4	R124	F-5	R207	K-2	U5	J-2
C58	K-3	L7	I-6	R8	A-3	R125	F-5	R210	L-3	U6	K-2
C59	K-6	L8	K-5	R9	A-3	R126	D-5	R211	L-3	U7	B-3
C60	K-6	L9	K-6	R10	A-3	R127	F-4	R212	L-3	U8	L-4
C61	K-6	L10	L-6	R11	A-3	R128	K-5	R213	L-3	U10	K-2
C62	K-6	Q1	A-4	R12	A-4	R129	L-3	R214	L-4	U12	F-4
C63	L-6	Q2	B-4	R13	A-4	R130	F-5	R215	J-6	U13	E-4
C64	L-6	Q3	B-4	R14	A-4	R131	F-4	R216	J-7	U14	H-5
C68	L-3	Q4	A-3	R16	A-4	R132	E-5	R217	J-5	U15	D-5
C69	A-2	Q5	A-2	R17	A-2	R133	E-6	R218	J-6	U16	K-5
C70	L-5	Q6	B-4	R18	A-2	R134	E-7	R219	K-5	U17	I-4
C71	K-4	Q8	B-5	R19	B-3	R135	E-7	R220	K-5	U20	B-6
C72	J-3	Q9	B-5	R20	B-2	R136	F-7	R221	K-5	VR1	B-5
C73	I-2	Q10	B-5	R21	B-3	R137	F-7	R223	L-6	VR2	C-7
C74	H-4	Q11	B-5	R22	B-3	R138	F-7	R224	M-5	VR3	I-5
C75	A-2	Q16	D-7	R23	B-4	R139	E-7	R225	L-5	VR4	L-5
C76	A-2	Q20	D-8	R24	B-4	R140	E-7	R226	L-5	VR5	D-7
C77	H-7	Q22	A-6	R25	B-4	R141	F-7	R227	M-5	VR8	F-4
C78	L-5	Q23	A-6	R26	B-5	R142	F-7	R228	L-5	W1	B/C-1
C79	D-5	Q24	B-6	R27	B-5	R143	F-7	R229	L-4	W4	O-7
C80	D-7	Q25	B-6	R28	A-5	R144	H-4	R230	L-5	W501	O-4
C504	O-3	Q29	F-3	R30	B-5	R146	J-4	R231	L-5		
C505	N-6	Q30	E-4	R31	B-5	R147	G-4	R232	K-5		
C506	P-6	Q31	E-4	R33	C-5	R148	H-4	R233	L-5		
C507	P-6	Q32	E-4	R34	C-5	R149	I-5	R237	K-6		
C508	P-7	Q33	F-4	R35	C-4	R150	G-3	R239	K-7		
C509	M-7	Q34	F-5	R36	B-5	R151	G-3	R240	K-7		
C510	N-3	Q36	F-5	R44	H-4	R153	H-3	R241	L-7		
C511	N-4	Q37	E-6	R45	G-4	R154	G-5	R242	L-7		

SERVICE BLOCK 3 TIMING BOARD A2

THEORY OF OPERATION

Rate Generator

As can be seen from Figure 8-3-1, the rate generator is essentially a voltage-controlled oscillator, comprising the following functional blocks:

- adjustable constant voltage source U12a
- constant current source U12b/Q29
- constant current sources U13a/Q30 (negative) and U13b/Q31 (positive)
- ramp capacitors C36/C37/C38/C39/C40/C41/C45
- transistor switch Q32/Q33
- Schmitt trigger Q34/Q36

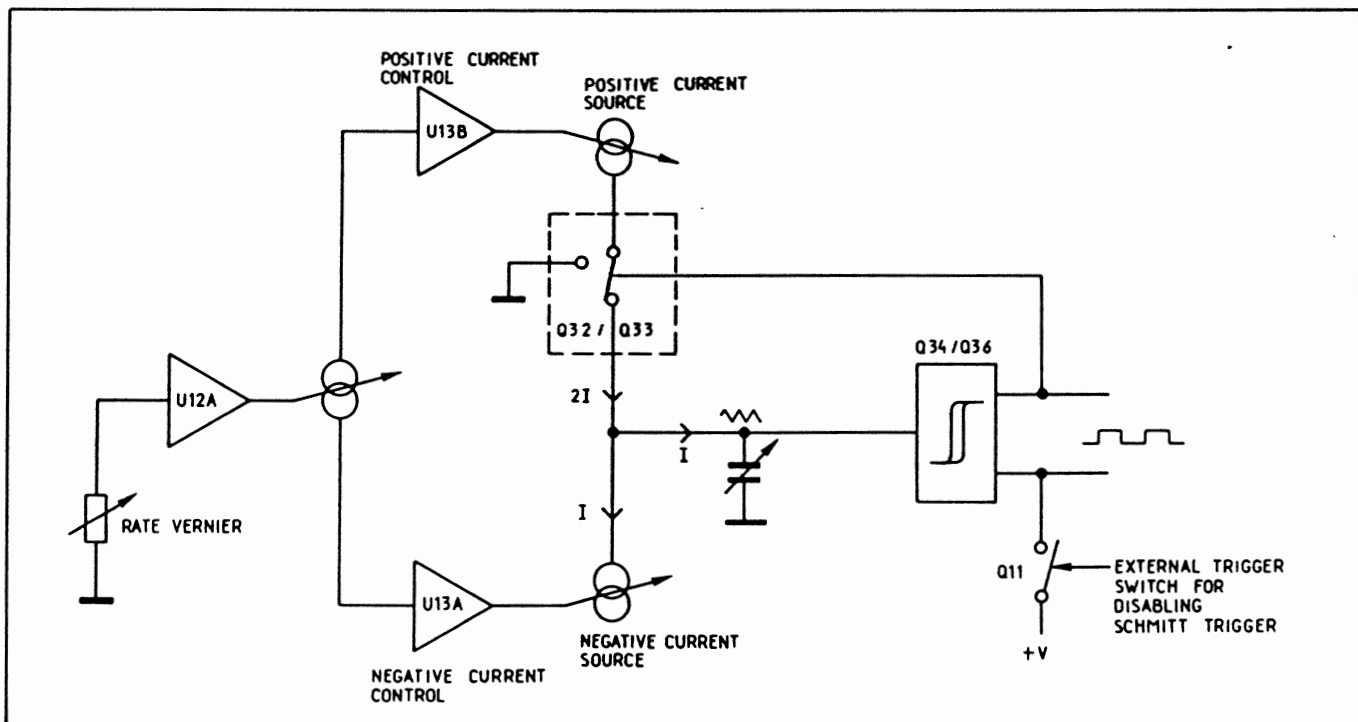

Figure 8-3-1. Functional diagram of rate generator

Voltage control is achieved via RATE VERNIER R107 which adjusts the constant voltage source U12a. In accordance with the output voltage at U12a/pin 7, the current through Q29 is varied and generates changing voltages across resistors R118/R113 (Note: an equal voltage drop across each resistor). These voltages then control current sources U13a/Q30 and U13b/Q31.

The positive current source is switched on and off the ramp node (Q34 base) via Q32/Q33 wired as a current switch. With the positive source delivering a current $2I$, a current I charges the ramp capacitors (switched in by pushbutton selection at S2a) and a current I flows into the negative source. (The 2:1 ratio of positive to negative current is determined by resistors R120 and R117). When the voltage at the ramp node reaches the Schmitt trigger threshold voltage, the Schmitt trigger changes state and switches

the current switch (Q32/Q33) off. (Q34 is now conducting which turns Q33 on and routes the positive current to ground). The ramp capacitors now discharge into the negative current source with a current I. When the ramp capacitor voltage drops to the lower Schmitt trigger threshold, the Schmitt trigger changes state again and switches the current switch on, thus repeating the whole cycle.

In External Trigger, Gate or Burst modes, the VCO is disabled during rest periods by raising the Schmitt trigger threshold – at the same time clamping the ramp side of the Schmitt trigger to 0 V via diode CR17. The Schmitt trigger threshold is raised via the action of transistor switch Q10/Q11, which switches approximately +4 V through to the VR8/CR12 junction and thereby raises the Q36 base potential to +0.7 V.

A 214B output pulse in External Trigger mode occurs for each pulse at the EXT TRIG input. This is achieved by momentarily switching Q11 off, which allows the Schmitt trigger to toggle once (the ramp capacitors therefore have no influence on the output frequency).

In Gate mode, the internal VCO runs for the duration of the gate signal at the EXT input. This signal switches Q11 off, thus lowering the Schmitt trigger threshold and allowing it to toggle in response to the ramp capacitor charge/discharge process.

In Burst mode, the Schmitt trigger is enabled for the duration of the preselected number of pulses, a 'BURST COMPLETE' signal disabling the Schmitt trigger upon completion of the last pulse.

Delay Generator

The delay generator comprises the following functional blocks:

- adjustable constant voltage source U14a/R45
- adjustable constant current source U14b/Q49/vernier R158
- ramp capacitors C47–C52
- current switch Q50
- pre-amplifier/Schmitt trigger Q44, Q45/Q46, Q47

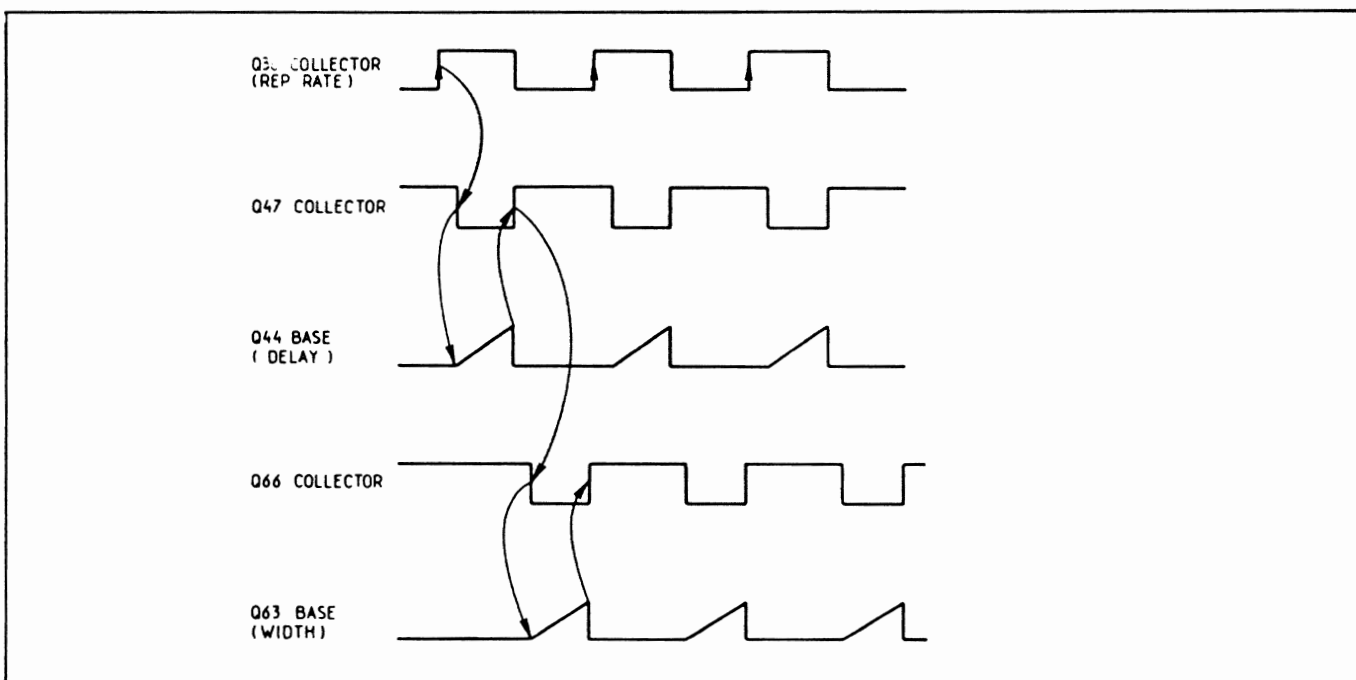

Figure 8-3-2. Timing diagram

As can be seen from the timing diagram, Figure 8-3-2, the delay generator is similar in function to the rep. rate generator, the delay being determined by the time taken to charge the ramp capacitors to the Schmitt trigger threshold. The capacitors are charged via adjustable current source Q49/Vernier R158, and discharged via current switch Q50, which switches on at the end of the selected delay time. The delay generation cycle begins on the positive edge of the signal at Q36 collector (rep. rate Schmitt trigger). Transistors Q52/Q43 turn on, the resulting positive-going voltage at Q45 base switching Q45/Q47 on and Q44/Q46 off. (The negative edge on the Q47 collector signal is now used to generate the TRIGGER OUT – see later description for 'Pulse Position').

This positive-going voltage at the Q45 base is also routed to transistor switch Q50, which turns off, and allows the ramp capacitors (selected via DELAY pushbutton row) to charge from adjustable current source Q49/vernier R158. By adjusting R158, the charging current, and hence time to reach the Schmitt trigger threshold, can be varied.

Upon reaching the threshold, Q46 turns on, Q47 turns off, and the voltage drop at the Q45 base switches on Q50 to cause a fast discharge of the ramp capacitors. The delay generation cycle is now complete, the positive edge now on the Q47 collector being the start signal for the width generator.

Width Generator

The width generator comprises the following functional blocks:

- adjustable constant voltage source U16a
- adjustable constant current source U16b/Q68/vernier R222
- ramp capacitors C59–C64
- current switch Q69
- pre-amplifier/Schmitt trigger Q63, Q64/Q65, Q66

The width generator is identical in function to the delay generator, the width being determined by the time taken to charge the ramp capacitors to the Schmitt trigger threshold. The capacitors are charged via adjustable current source Q68/vernier R222, and discharged via current switch Q69 which switches on at the end of the selected width time.

The width generation cycle begins on the positive edge of the signal at Q47 collector (delay Schmitt trigger). Via U1B, U2A and U3A, Q61 turns on, the resulting positive-going voltage at Q64 base switching Q64/Q66 on and Q63/Q65 off. This positive transition at Q64 base is also routed to transistor switch Q69, which turns off, and allows the ramp capacitors (selected via WIDTH pushbutton row) to charge from adjustable current source Q68/vernier R222. By adjusting R222, the charging current and hence time to reach the Schmitt trigger threshold, can be varied.

Upon reaching the threshold, Q65 turns on, Q66 turns off, and the voltage drop at the Q64 base switches on Q69 to cause a fast discharge of the ramp capacitors.

Pulse Position

There are 3 settings of the Pulse Position switch, the effect of each setting on the associated logic circuits being described in the following paragraphs. A simplified functional diagram of these logic circuits is given in Figure 8-3-3.

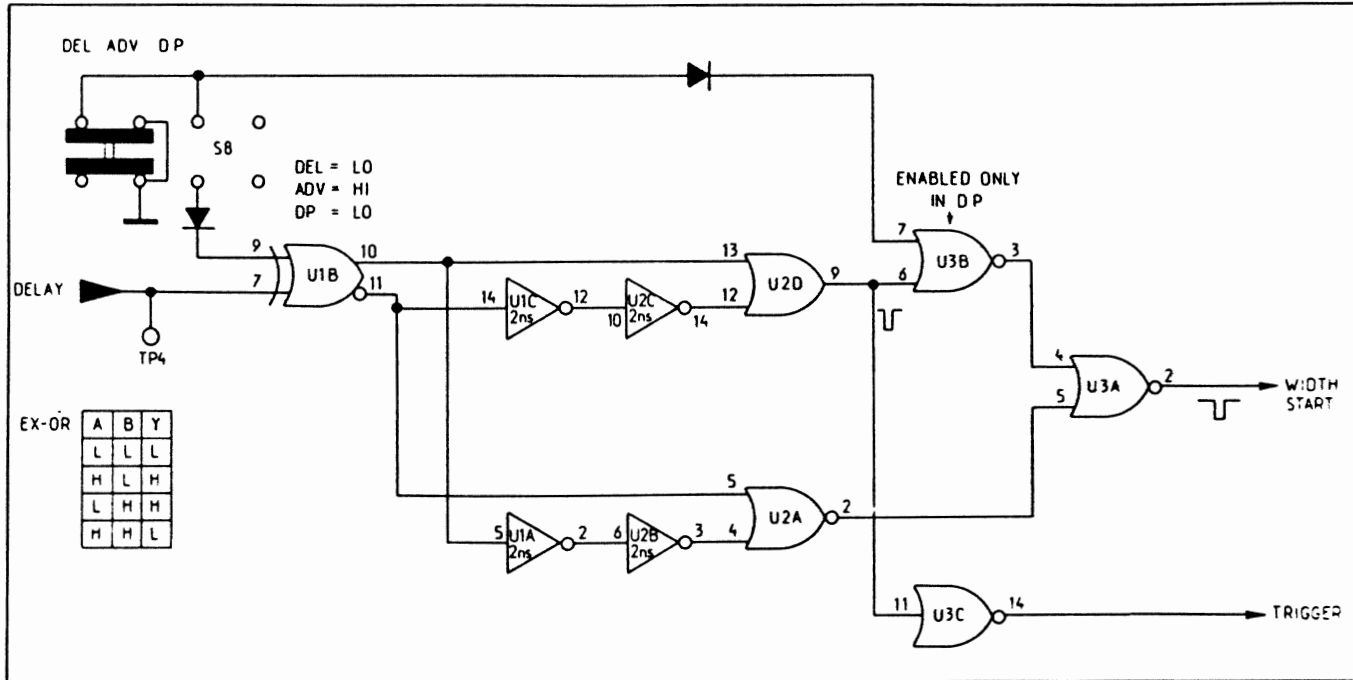

Figure 8-3-3. Simplified functional diagram of pulse position logic

Delay

With delay selected, the TRIGGER OUT is generated by the negative edge on the signal at Q47 collector (TP4). The prevailing conditions in this setting are:

- a high on U3B/pin 7 thus disabling gate 3B.
- a low on U3B/pin 9 (due to internal pull-down resistor)

A negative-going edge at U1B/pin 7 therefore causes U1B/pin 10 to go low and U1B/pin 11 to go high. While the U1B/pin 10 output is routed directly to OR-gate U2D, the U1B/pin 11 output is delayed via U1C and U2C, thus generating a 4 ns output pulse at U2D/pin 9. This pulse is inverted by U3C before amplification by trigger amplifier Q16/Q20.

Double Pulse

With double pulse selected, the width generation circuit is triggered on both the negative and positive edge of the signal at TP4 — thus generating two width cycles per clock period. The prevailing conditions in this setting are:

- a low on U3B/pin 7 (due to internal pull-down resistor) thus enabling gate U3B
- a low on U1B/pin 9 (due to internal pull-down resistor)

As in the delay setting, a 4 ns pulse is generated at U2D/pin 9 due to the negative edge on the TP4 signal, this now being routed via gates U3B and U3A to trigger the width generator. On the positive edge of the signal at TP4, a 4 ns output pulse is generated at U2A/pin 2 (the 4 ns being determined by the delay action of gates U1A and U2B), this being routed via U3A to trigger the width generator for the second time within one clock period. A timing diagram illustrating the double pulse logic sequence is given in Figure 8-3-4.

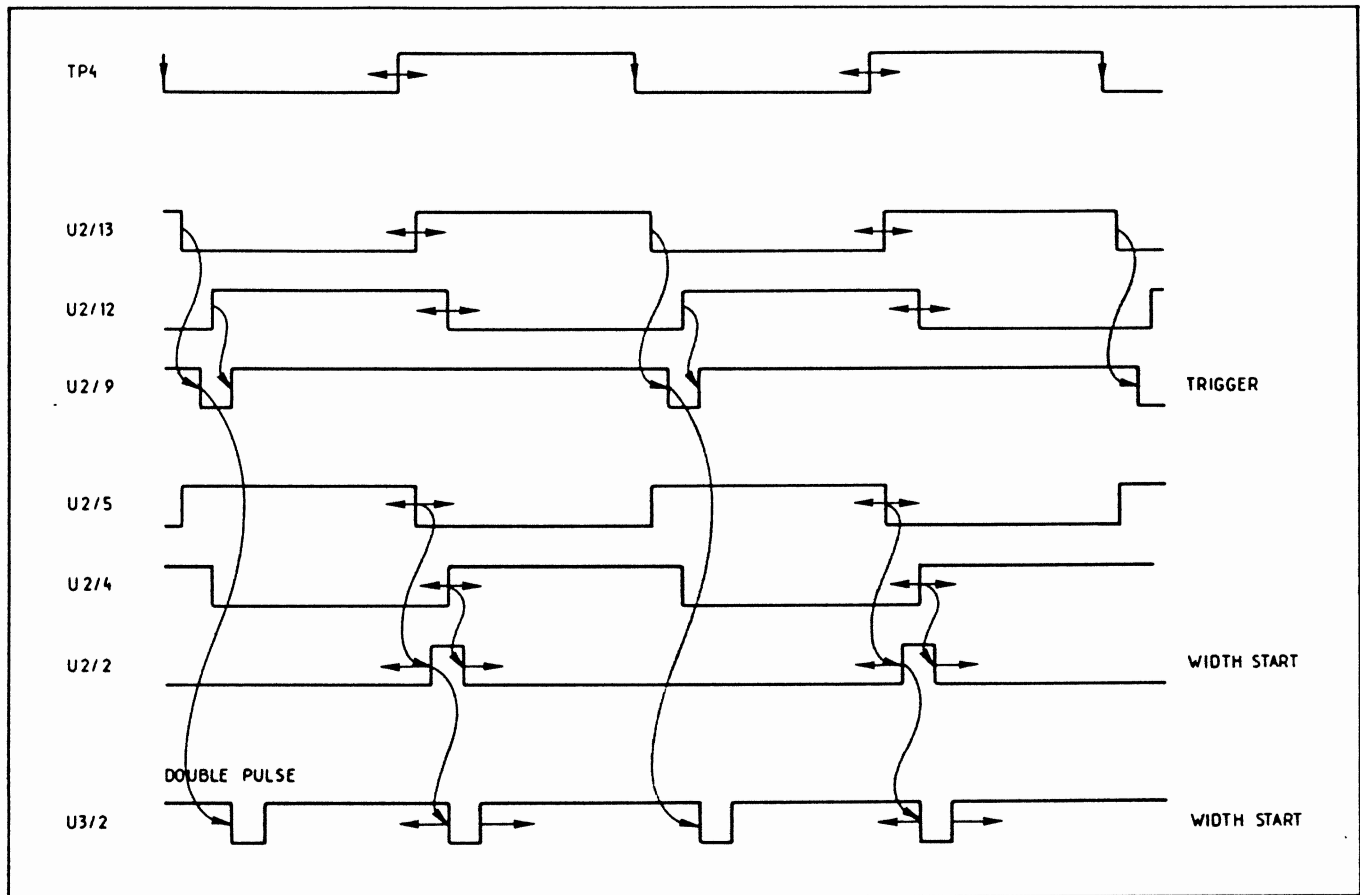

Figure 8-3-4. Timing diagram in double pulse mode

Advanced

With advance selected, the TRIGGER OUT signal is generated by the positive edge on the signal at TP4, the width 'start' signal then being generated by the negative edge. The prevailing conditions in this setting are:

- a high on U1B/pin 9
- a high on U3B/pin 7 thus disabling gate U3B.

Because U1B/pin 9 is high, the output stages of U1B are reverse of those in DELAY mode for the same TP4 signal. As a result, the negative-going edge on the TP4 signal generates the 4 ns width 'start' pulse (the 4 ns being determined by the delay action of U1A and U2B). After a time determined by the DELAY setting, the TP4 signal goes positive, causing the TRIGGER OUT pulse to be generated via U1C, U2C, U3C and trigger amplifier Q16/Q20. A timing diagram indicating the logic sequence in advance mode is given in Figure 8-3-5.

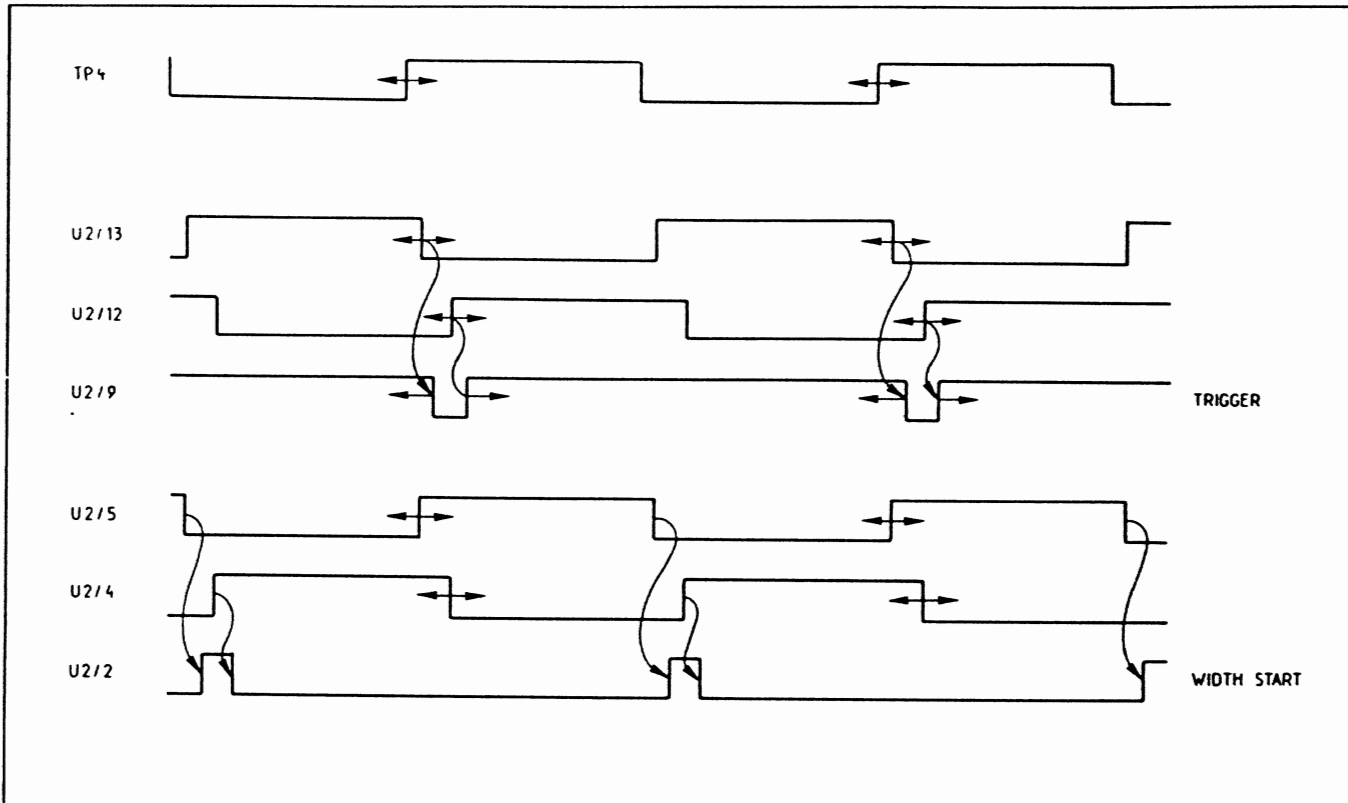

Figure 8-3-5. Timing diagram in advance mode

Constant Duty Cycle Mode

When Constant Duty Cycle Mode is selected, the control voltage for the rep. rate generator's negative current source (U13a/Q30) is also routed to the width generator — thus changing the pulse width in proportion to any frequency change. This is achieved by tapping the junction voltage at R112/R113 and routing it via U15, S4a/pins 8, 9, R215 and R51 to U16a/pin 2, which drives the positive current source U16b/Q68 of the width generator.

The duty cycle limits vary according to which frequency range is selected, an individual description for each range being given in the following.

In the 10 MHz — 1 MHz frequency range, the duty cycle is fixed at approximately 8%. This is achieved by re-routing the supply voltage (from S2a/pin 3) via R198/R197 to the width current source — instead of via the width vernier R222. The width range switches are disabled and the width is solely dependent on the frequency setting.

In the 1 MHz — .1 MHz frequency range, the duty cycle can be selected from 2.5% to 10%. The supply voltage for the width current source is routed via S2a/pins 1, 2 to the width vernier R222. All width range switches are disabled, and the width (duty cycle) is determined by a combination of the fixed width ramp capacitor C59, the width vernier setting and the voltage derived from U15/pin 6.

In the frequency ranges .1 MHz to 10 kHz, 10 kHz to 1 kHz, and 1 kHz to 10 Hz, only the width range switches S4b and S4c are enabled. Transistors Q72 to Q75 and the associated ramp capacitors C60 to C64 are switched in by the rate range switches S2c/d/e/f.

Double Pulse Timing Error

With Double Pulse Mode selected, the width generator is started twice within a single clock period. The first 'start' pulse occurs after the negative-going edge on the TP4 signal (i.e. delay generator start), and the second start pulse after the positive-going edge (i.e. at the end of the selected delay period). As both pulses must be generated within one period, the following formula determines valid operation of the 214B:

$$\text{delay} + (2 \times \text{width}) + \text{pulse separation} \leq \text{pulse period}$$

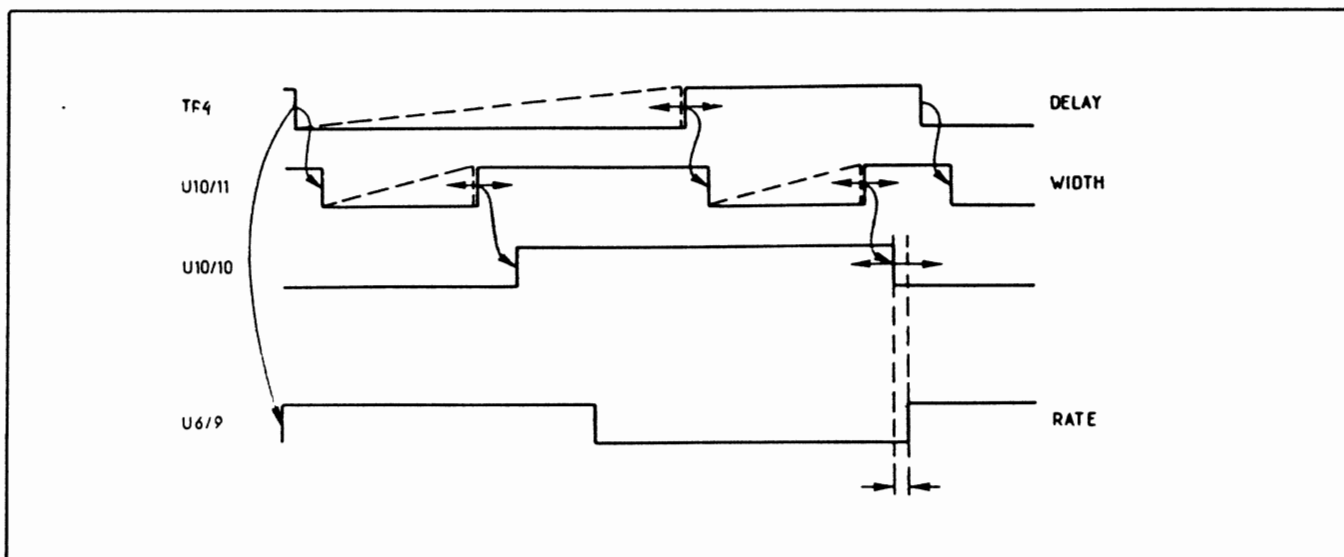

Figure 8-3-6. Timing diagram for error detect in double pulse mode

Figure 8-3-6 provides a timing diagram for the error detect circuits in double pulse. The negative-going edge on the TP4 signal generates a negative spike at U3/pin 2 to start the width generator. The TP5 signal, then goes low, and returns high after a time determined by the width-setting. This low-high transition clocks U10b via U3D and U4C, causing the \bar{Q} output to go high. At the end of the second width cycle a low-high transition at TP5 again clocks U10b (via U3/U4) and the \bar{Q} output returns low. With this condition (low) now prevailing at the D-input of U6b, there is no change at the U6b output on the next clock pulse from the rate generator – hence no timing error is indicated.

Should the U6b clock pulse from the rate generator arrive while the U10b/ \bar{Q} output is still high, the U6b/ \bar{Q} goes low and switches Q58 on (via U5). DSI then illuminates to indicate timing error.

Delay Error

Delay timing error is indicated when the pulse delay is equal to or greater than the pulse period. An erroneous delay setting is detected by U6a which compares the 'period' signal from U4/pin 2 with the 'delay signal from U4/pin 6. With an incorrect delay setting, the delay ramp capacitors are still being charged when the delay 'start' signal arrives from the rep. rate Schmitt trigger (Q34/Q36). The TP4 signal is therefore still low, which in turn puts a high on the D-input of U6a. This high is clocked through by the 'period' signal from U4/pin 2 and the timing error LED DSI is illuminated. A simplified diagram of the timing error logic circuit for detecting incompatible delay settings is given in Figure 8-3-7.

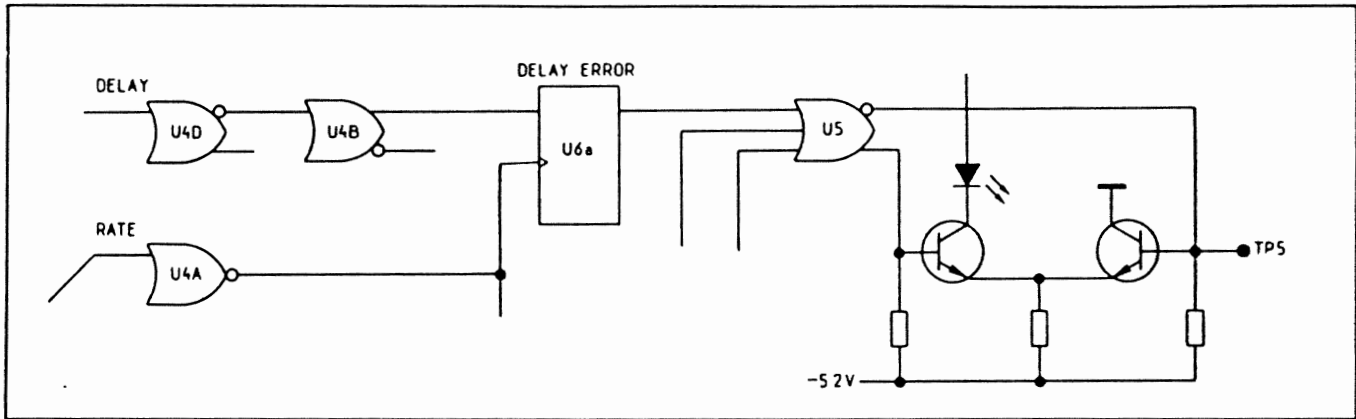

Figure 8-3-7. Functional diagram for error detect

Width Error

Width timing error is indicated when the pulse width is greater than or equal to the pulse period. An erroneous width setting is detected by U10a which compares the width 'start' signal from U2/pin 2 with the width 'duty cycle' signal from TP5. With an incorrect width setting, the width ramp capacitors are still being charged when the width 'start' signal arrives from the delay Schmitt trigger. The TP5 signal is therefore still low, which in turn puts a high on the D-input of U10a. This high is clocked through by the width 'start' signal from U2/pin 2, and the timing error LED DSI is illuminated. A simplified diagram of the timing error logic circuit for detecting incompatible width settings is given in Figure 8-3-8.

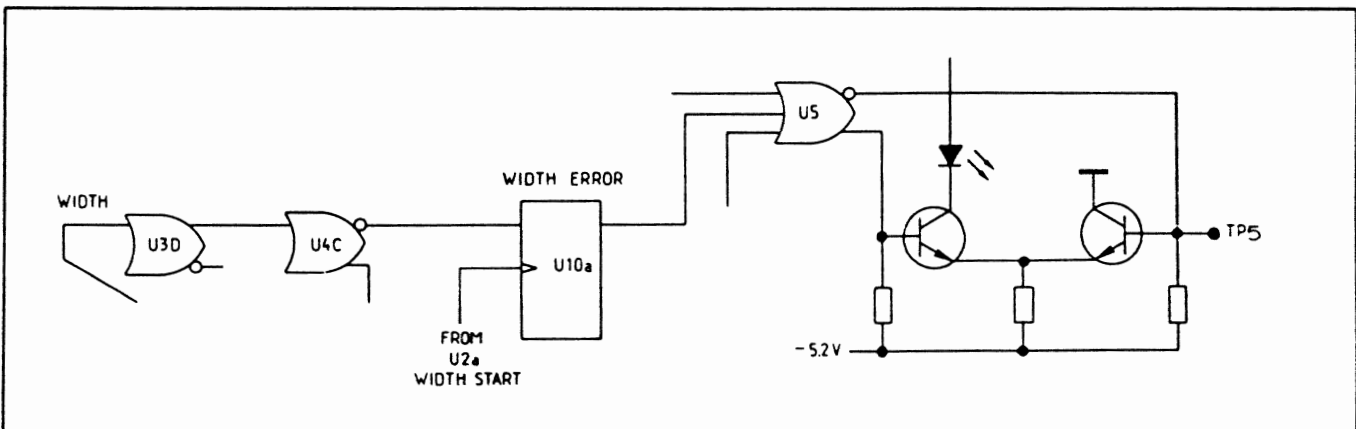

Figure 8-3-8. Functional diagram for error detect in width settings

EXTERNAL INPUT CIRCUITS

Transistors Q2/Q3 and constant current sources Q4/Q5 form a differential amplifier with a current mode at the CR5/CR6 anode junction. By switching current on and off this node, Schmitt trigger Q8/Q9 can be switched via base-stage Q6. FET Q1b is used to set the offset level which is adjustable via R15 (TRIGGER LEVEL), and Q1a ensures a high input impedance for the external trigger and gate signals. The external signal applied to the Q1a gate is clamped to +5.7 V and -5.9 V.

The action of the MAN/NEG/POS switch can best be explained by considering the current node at CR5/CR6 anode. With NEG selected, diodes CR4 and CR5 are reverse biased and the following equations relate the different transistor currents:

$$(i) \quad I_4 = I_2 + I_3 \quad (\text{where } I_4 = Q4 \text{ current; } I_2 = Q2 \text{ current; } I_3 = Q3 \text{ current})$$

$$(ii) \quad I_5 = I_6 + I_3 \quad (\text{where } I_5 = Q5 \text{ current; } I_6 = Q6 \text{ current; } I_3 = Q3 \text{ current})$$

Substituting (i) in (ii) the following equation results:

$$(iii) \quad I_5 = I_6 + I_4 - I_2$$

Since I_5 and I_4 are constant currents then:

$$(iv) \quad dI_6 = dI_2$$

So any change in the transistor Q2 current causes a corresponding change in the Q6 current. As a result, when Q1a gate voltage is high, TP1 is also high (Q2 and Q6 are conducting maximum current), therefore the rate Schmitt trigger is disabled by the CR14 cathode voltage (Q9 is switched off; Q10 switched off; and Q11 is switched on). When the signal applied to the Q1a gate goes negative, a negative-going edge is generated at TP1, which removes the disable voltage at CR14 cathode (Q9 is switched on; Q10 is switched on; and Q11 is switched off) and allows the rate Schmitt trigger to switch. With POS selected at the MAN/NEG/POS switch, CR3 and CR6 are reverse biased, and the following equations relate the different transistor currents:

$$(v) \quad I_4 = I_2 + I_3 \quad (\text{where } I_4 = Q4 \text{ current; } I_2 = Q2 \text{ current; } I_3 = Q3 \text{ current})$$

$$(vi) \quad I_5 = I_2 + I_6 \quad (\text{where } I_5 = Q5 \text{ current; } I_2 = Q2 \text{ current; } I_6 = Q6 \text{ current})$$

From equation (vi), it can be deduced that ...

$$dI_2 = -dI_6$$

... because I_5 is constant. An increase, therefore, in Q2 current is followed by a decrease in Q6 current. In voltage terms, a positive-going voltage at Q1a gate generates a negative-going edge at TP1, which in turn removes the rate Schmitt trigger disable voltage at CR14 cathode.

Normal Mode

In NORMAL mode, the timing error circuit is enabled via U20E and Q60. In addition, current source Q22 is enabled (via U20A) which in turn cuts off Q10. With Q10 disabled, any external trigger signal is prevented from reaching the internal rate circuit. Current source Q25 is also disabled and CR14 reverse biased.

External Trigger Mode

With EXT TRIG mode selected:

- current sources Q22 and Q24 are disabled
- current source Q25 is switched on
- rate Schmitt trigger Q34/Q36 is disabled via Q11 and CR14 (approx. +4 V at CR14 cathode)
- current source Q23 is switched on, L1 acting as an inductive load for Q9.

When Schmitt trigger Q8/Q9 is switched by an external trigger signal, positive and negative spikes are generated by L1, the negative spike switching Q10 on. Transistor Q11 cuts off and the rate Schmitt trigger (Q34/Q36) toggles once, the disable voltage at CR14 cathode being removed for the duration of the spike.

Also in EXT TRIG mode, the rate selector switches S2D to S2f are disabled by removing +5 V at S1b/pin 17 (signal 23).

Gate Mode

With GATE mode selected:

- current sources Q22 and Q23 are disabled
- current source Q25 is switched on
- rate Schmitt trigger Q34/Q36 is disabled via Q11 and CR14
- current source Q24 is switched on.

When the gate signal is present at the EXT TRIG connector, the TP1 signal goes low. Q10 collector follows with a low and switches Q10 on. The disable signal at CR14 cathode for the rate Schmitt trigger is removed and pulses are generated for the duration of the gate signal (because Q9 collector remains low during this time).

Manual Trigger

When MAN is selected at the MAN/NEG/POS switch, CR11 is forward biased with the effect that increased current is delivered from Q5 to current node CR7/CR8. The TP1 signal is therefore held at a high level, turning Q8 and Q11 on and disabling the rate Schmitt trigger Q34/Q36 via the voltage at CR14 cathode.

Pressing the MAN pushbutton then generates a single pulse at U7/pin 7 (the duration of which depends on how long the pushbutton is pressed) which turns Q83 on and reverse biases CR11. With less current now being delivered to the CR5/CR6 node, the voltage at TP1 drops, turning Q8 off and Q9 on. Depending on whether GATE mode or EXT TRIG mode is selected, determines whether a negative-going spike or a negative-going pulse (of the same duration as the MAN pushbutton is pressed) is generated. If GATE is selected, a negative pulse is generated which functions as a gate signal for the rate Schmitt trigger i.e. the disable voltage at CR14 cathode is removed for the duration of this pulse. If EXT TRIG is selected, a negative spike causes the disable signal to be removed momentarily allowing the rate Schmitt trigger to switch once.

Burst Mode (Schematic A1–2)

With BURST mode selected, only current source Q24 is switched on. The rate Schmitt trigger is disabled by a high level derived from A6Q304, which is turned on by flip-flop A6U319 (cleared when burst counters have count down).

The burst can be started either by pressing the MAN pushbutton (with MAN selected at the MAN/NEG/POS switch) or by applying the appropriate signal to the EXT TRIG connector. In either case, a negative-going edge is generated at TP1 which causes the A2Q8 collector to go high. This resets A6U319 via A6Q305 causing A6Q304 to be switched off. The disable signal is thus removed from the rate Schmitt trigger which now switches continuously until the 'end of burst' has been detected. Flip-flop A6U319 is then cleared again and the rate Schmitt trigger disabled.

FOR TROUBLESHOOTING REMOVE WIRE 927 FROM POWER SUPPLY BOARD AND SWITCH OUTPUT POLARITY TO NEG

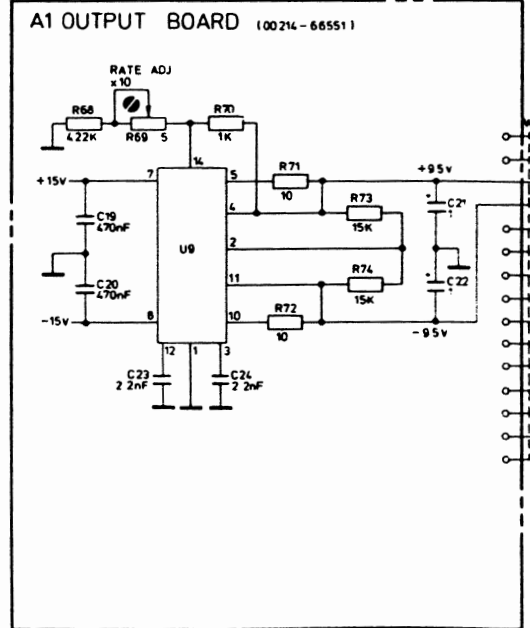
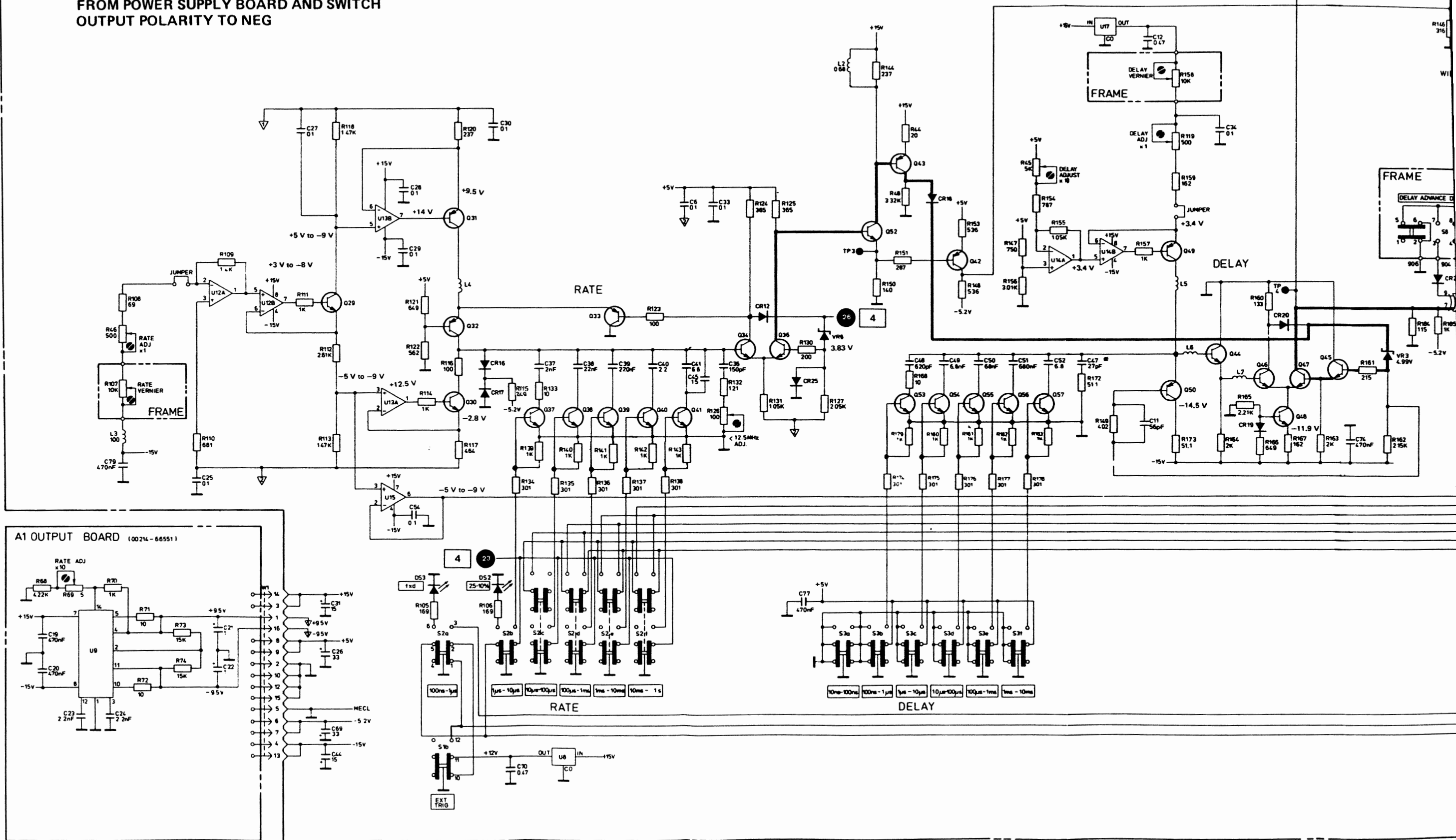

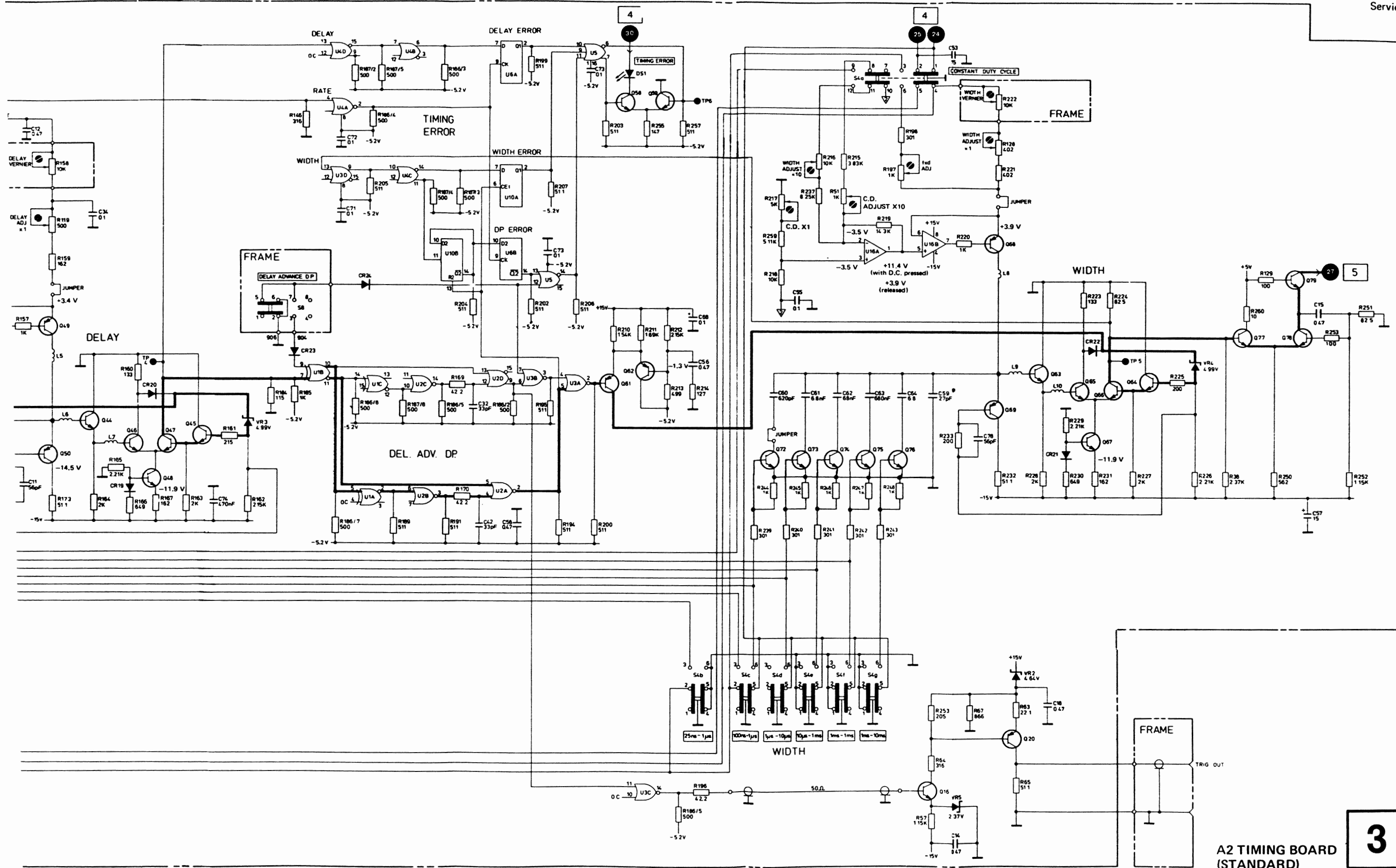

A2 TIMING BOARD (STANDARD)

3

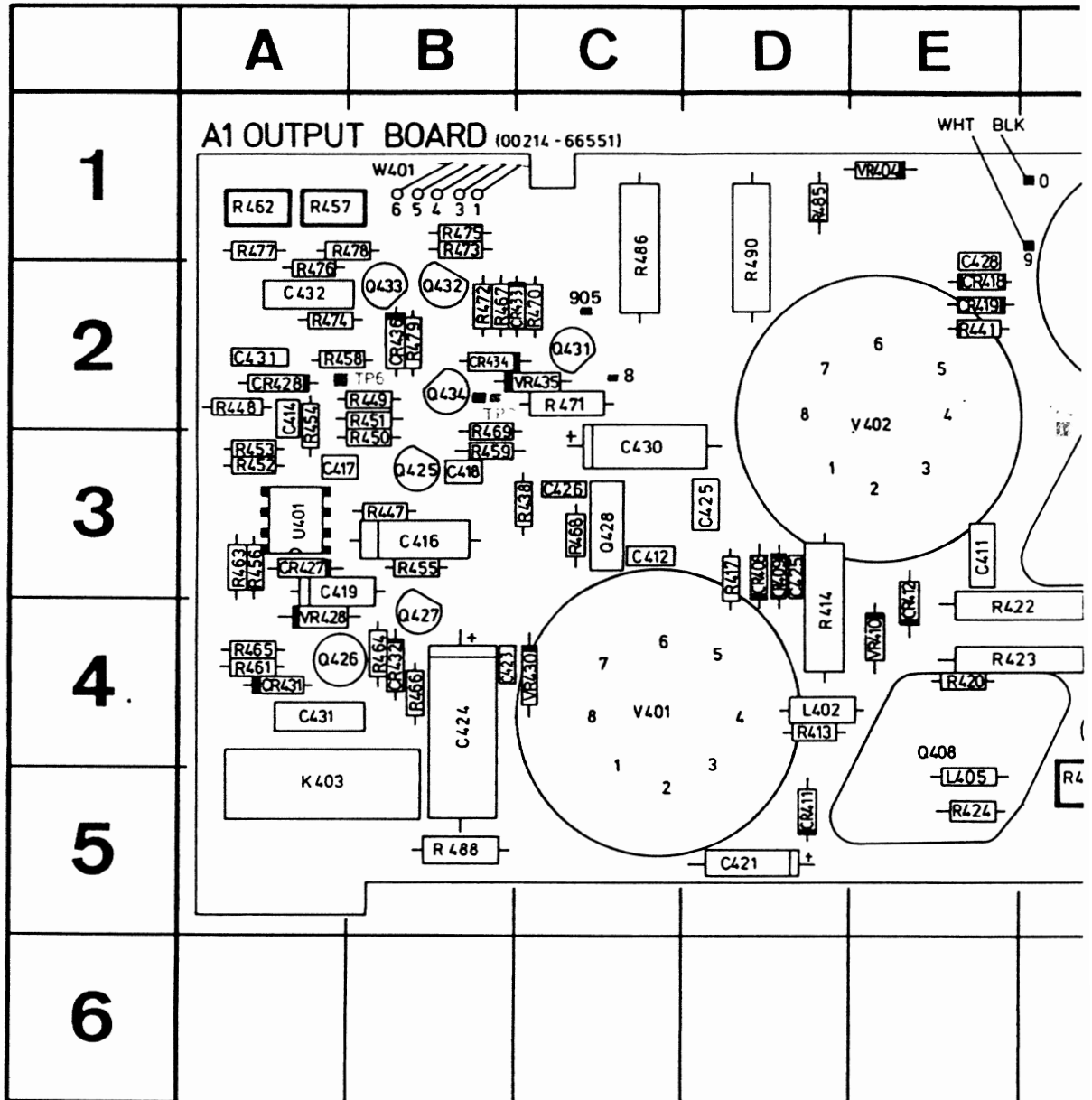

REF DESIG	GRID LOC	REF DESIG	GRID LOC	REF DESIG	GRID LOC	REF DESIG	GRID LOC	REF DESIG	GRID LOC	REF DESIG	GRID LOC	REF DESIG	GRID LOC
C19	P-2	C410	I-3	C427	J-2	CR427	A-3	L409	H-3	Q418	F-3	R7	
C20	P-2	C411	E-3	C428	E-1	CR428	A-2	L410	H-3	Q421	I-2	R2	
C21	O-1	C412	C-3	C429	A-2	CR431	A-4	Q400	I-5	Q425	B-3	R2	
C22	O-3	C413	H-2	C430	C-3	CR432	B-4	Q401	I-4	Q426	A-4	R4	
C23	P-2	C414	A-2	C431	A-2	CR433	B-2	Q402	I-4	Q427	B-4	R4	
C24	O-2	C415	I-3	C432	A-2	CR434	B-2	Q403	H-5	Q428	C-3	R4	
C400	J-4	C416	B-3	CR400	I-4	CR436	B-2	Q404	H-4	Q431	C-2	R4	
C401	J-3	C417	A-3	CR404	F-4	F607	D-5	Q405	F-5	Q432	B-2	R4	
C402	H-4	C418	B-3	CR408	D-3	J1	N-2	Q406	F-5	Q433	B-2	R4	
C403	G-5	C419	A-3	CR409	D-3	J601	N-4	Q407	F-4	Q434	B-2	R4	
C404	H-2	C420	I-4	CR411	D-5	K401	G-4	Q408	E-4	R68	P-1	R4	
C405	F-2	C421	D-5	CR412	E-4	K403	A-5	Q413	H-4	R69	P-1	R4	
C406	G-4	C423	B-4	CR414	H-2	L402	D-4	Q414	H-4	R70	P-2	R4	
C407	G-3	C424	B-4	CR418	E-2	L403	G-4	Q415	H-3	R71	O-2	R4	
C408	H-4	C425	D-3	CR419	E-2	L404	H-2	Q416	G-3	R72	O-2	R4	
C409	L-3	C426	C-3	CR424	I-3	L405	E-5	Q417	G-2	R73	O-2	R4	

5

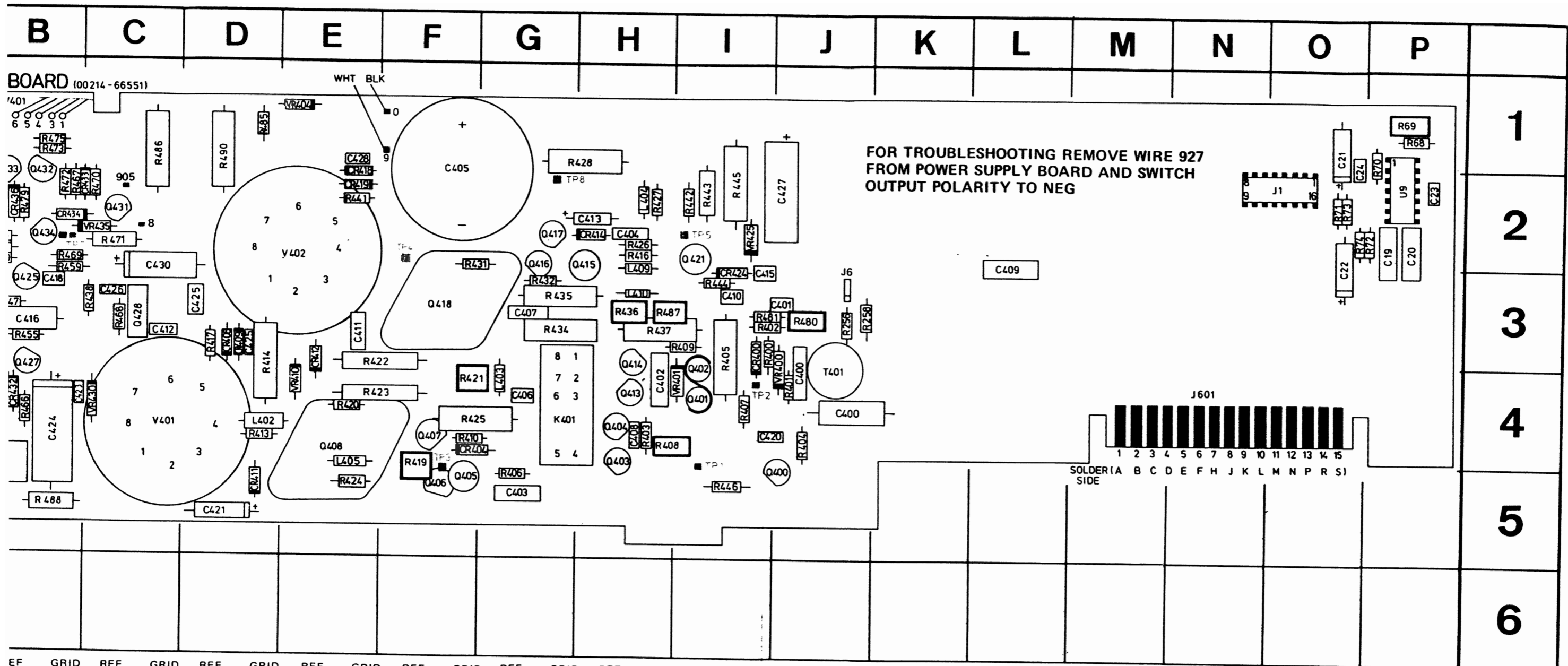

EF	GRID	REF	GRID	REF	GRID	REF	GRID	REF	GRID	REF	GRID	REF	GRID	REF	GRID	REF	GRID	REF	GRID	REF	GRID
ESIG	LOC	DESIG	LOC	DESIG	LOC	DESIG	LOC	DESIG	LOC	DESIG	LOC	DESIG	LOC	DESIG	LOC	DESIG	LOC	DESIG	LOC	DESIG	LOC
427	J-2	CR427	A-3	L409	H-3	Q418	F-3	R74	O-2	R416	H-2	R436	H-3	R453	A-3	R470	C-2	R490	D-1	TP6	A-2
428	E-1	CR428	A-2	L410	H-3	Q421	I-2	R256	J-3	R417	D-3	R437	H-3	R454	A-2	R471	C-2	R492	E-4	TP7	B-2
429	A-2	CR431	A-4	Q400	I-5	Q425	B-3	R258	J-3	R419	F-5	R438	C-3	R455	B-3	R472	B-2	V401	C-4	TP8	G-2
430	C-3	CR432	B-4	Q401	I-4	Q426	A-4	R400	I-3	R420	E-4	R440	E-2	R456	A-3	R473	B-1	V402	E-2	T401	J-4
431	A-2	CR433	B-2	Q402	I-4	Q427	B-4	R401	J-4	R421	F-4	R441	E-2	R457	A-1	R474	A-2	VR400	I-4	U9	P-2
432	A-2	CR434	B-2	Q403	H-5	Q428	C-3	R402	I-3	R422	E-4	R442	I-2	R458	A-2	R475	B-1	VR401	H-4	U401	A-3
4400	I-4	CR436	B-2	Q404	H-4	Q431	C-2	R403	H-4	R423	E-4	R443	I-2	R459	B-3	R476	A-2	VR404	E-1		
4408	D-3	J1	N-2	Q406	F-5	Q433	B-2	R404	J-4	R424	E-5	R444	I-3	R461	A-4	R477	A-1	VR410	E-4		
4409	D-3	J601	N-4	Q407	F-4	Q434	B-2	R405	I-3	R425	F-4	R445	I-2	R462	A-1	R478	B-1	VR425	I-2		
4411	D-5	K401	G-4	Q408	E-4	R68	P-1	R406	G-5	R426	A-2	R446	I-5	R463	A-3	R479	B-2	VR428	A-4		
4412	E-4	K403	A-5	Q413	H-4	R69	P-1	R407	I-4	R427	H-2	R447	B-3	R464	B-4	R480	J-3	VR435	C-2		
4414	H-2	L402	D-4	Q414	H-4	R70	P-2	R408	H-4	R428	H-2	R448	A-2	R465	A-4	R481	I-3	TP1	I-4		
4418	E-2	L403	G-4	Q415	H-3	R71	P-2	R409	I-3	R431	F-3	R449	B-2	R466	B-4	R485	D-1	TP2	I-4		
4419	E-2	L404	H-2	Q416	G-3	R72	O-2	R410	F-4	R432	G-3	R450	B-3	R467	B-2	R486	C-1	TP3	I-4		
4424	I-3	L405	E-5	Q417	G-2	R73	O-2	R413	D-4	R434	G-3	R451	B-2	R468	C-3	R487	H-3	TP4	I-4		
								R414	D-4	R435	G-3	R452	A-3	R469	B-2	R488	B-5	TP5	I-4		

P/O A2 TIMING BOARD (00 214-66559)
EXT. INPUT CIRCUITS

FOR TROUBLESHOOTING REMOVE WIRE 927
FROM POWER SUPPLY BOARD AND SWITCH
OUTPUT POLARITY TO NEG

FRAME

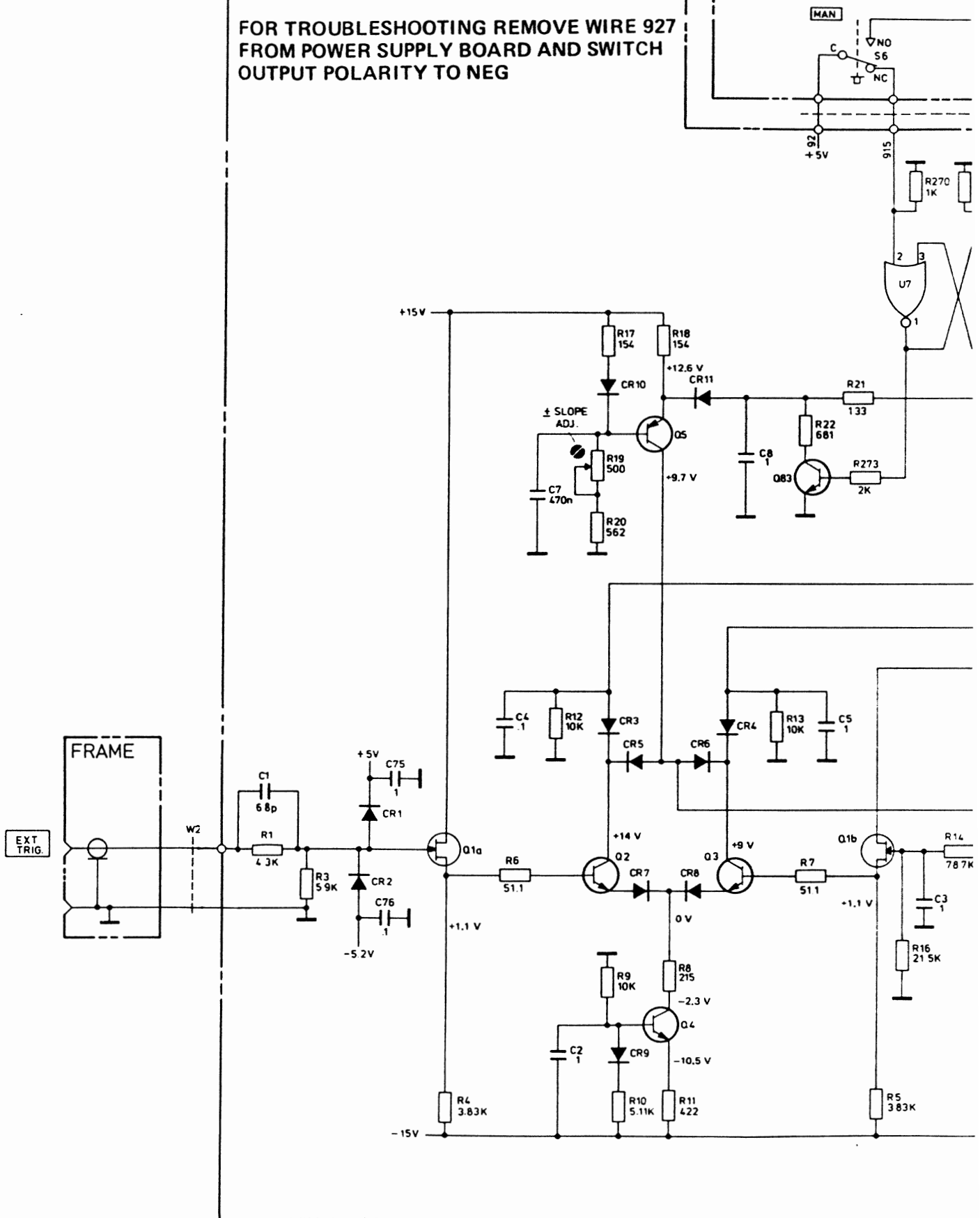

IG BOARD (00214-66559)
INPUT CIRCUITS

LESHOOTING REMOVE WIRE 927
R SUPPLY BOARD AND SWITCH
ARITY TO NEG

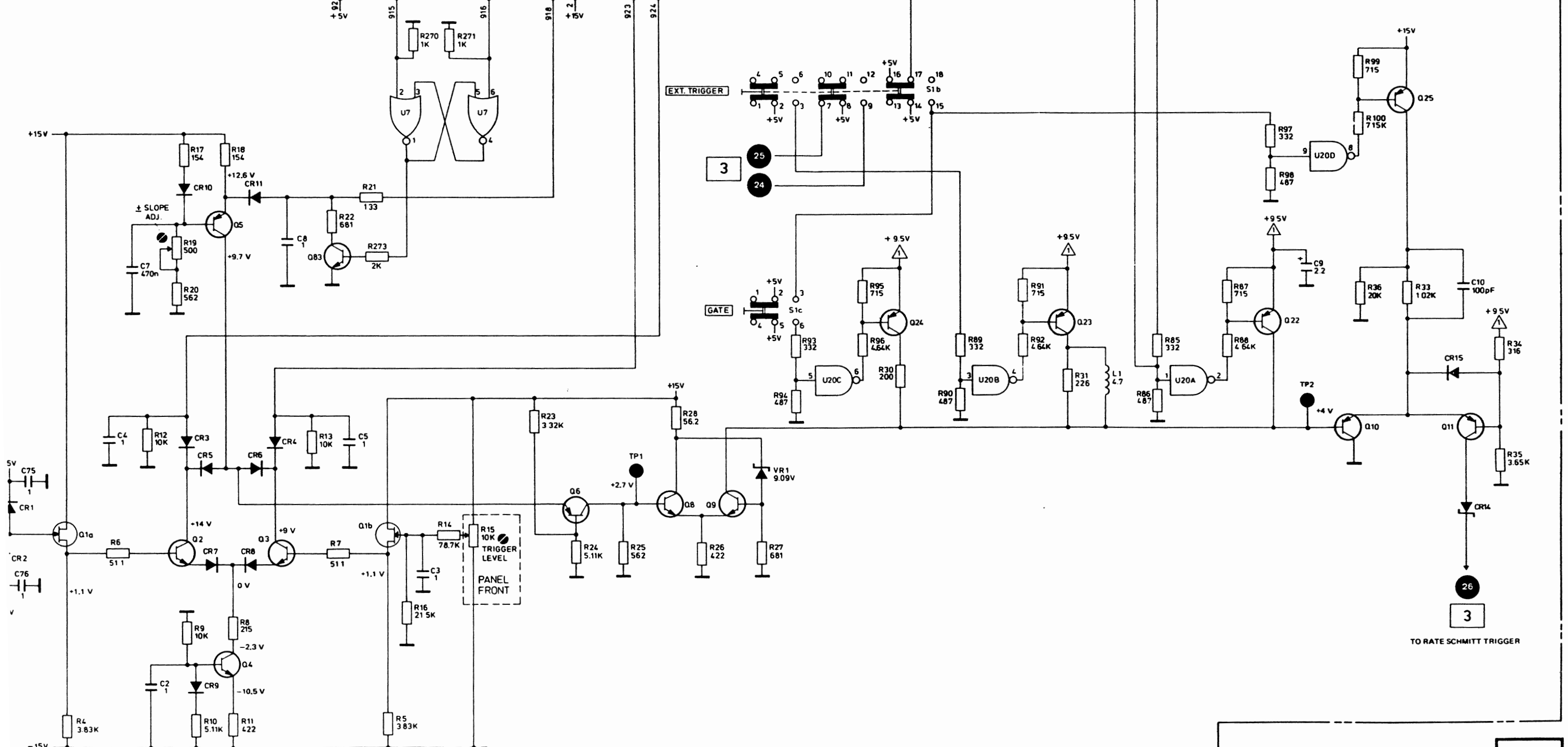
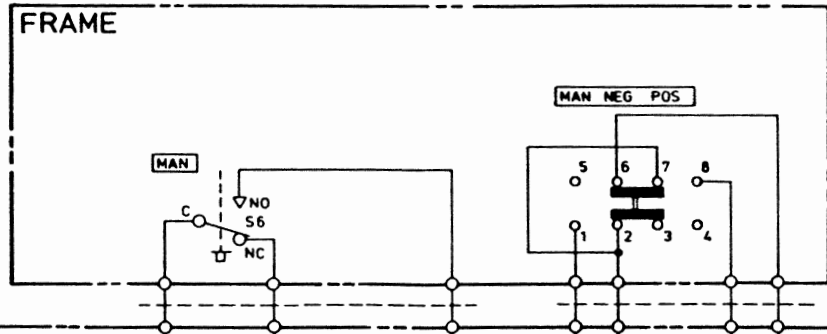

P/O TIMING BOARD A2

4

Service

SERVICE BLOCK 4 OUTPUT BOARD A1

THEORY OF OPERATION

The output board A1 can be divided into 4 main functional blocks:

- input Schmitt trigger
- duty cycle detect/overload detect
- amplitude vernier and overload switch
- output amplifier

Each of these blocks is described in the following paragraphs.

Input Schmitt Trigger

The input Schmitt trigger comprises:

- transformer T401, which isolates potentials of the output amplifier from the timing board, and also differentiates the timing circuit output pulse.
- emitter follower Q400, which isolates the transformer T401 from the following Schmitt trigger.
- Schmitt trigger Q401/Q402.

A positive pulse at the base of Q401 causes Q401 to cut off, and Q402 conducts. This stable conditions exists until the next negative pulse arrives from Q400 which switches Q401 on and Q402 off.

The duty cycle detect signal is derived from the Q401 collector and routed to the overload detection circuit. To ensure that integrator charge-up (in the overload detect circuit) is determined only by the duty cycle of the detect signal (and not amplitude), the amplitude is clamped to approx. 3.5 V by CR400 and VR400.

Overload Detection/Overload Switch/Amplitude Vernier

The duty cycle detect signal derived from Q401 collector is inverted by Q421 and limited by CR424. Pulses at the collector of Q421 are then integrated by R447 and C416. With increasing duty cycle at the base of Q421, the voltage across C416 decreases (switching Q421 on causes C416 to discharge). Should the C416 voltage decrease to a point where it is lower than the reference voltage at U401a/pin 2, the output voltage of comparator U401a is switched to a minimum. (The threshold voltage at comparator U401 changes according to amplitude range due to the varying duty cycle limits i.e. 10 % in 30–100 V range; 50 % in all other ranges. In the 30–100 V amplitude range, K403 switches the Q425 base to –155 V, thus turning Q425 off. U401a threshold is then determined by R448/R449. In all other amplitude ranges, Q425 is turned on, resistors R450/R451 then being connected in parallel with R449, thus lowering the U401a threshold).

With U401a output switched to minimum, C419 is discharged via CR427, which in turn switches U401b/pin 7 to maximum output (OVERLOAD LED on). Q426 switches on (via CR428, R464) and transistors Q427/Q428 switch off, causing approximately –155 V to be applied to the grids of tubes V401, V402. This negative voltage at Q428 collector is also applied to the bases of Q406/Q407 (Q416/Q417) via R413/R414 (R428/R427). Transistor Q407 (Q417) turns off and Q406 (Q416) turns on, switching –155 V to the gates of FET's Q408/Q418. With negative voltages at the tube grids and FET gates, the output amplifier is disabled (i.e. no output current).

In normal operation (OVERLOAD LED off), the voltage at C416 is higher than the reference voltage at U401a/pin 2 (duty cycle at the base of Q421 is now lower, thus C416 cannot sufficiently discharge). The output of U401a goes to maximum and cuts off CR427, allowing C419 to be charged via R452 to the Zener voltage of VR428. If the C419 voltage is greater than the reference voltage at U401b/pin 5, the output at pin 7 is switched to minimum which turns Q426 off. The voltage at TP8 is then adjustable between ~ 8 V and ~ 20 V via the AMPLITUDE VERNIER R460.

Screen grid protection

A second function of the overload detect circuit is to provide screen grid protection. Should tubes V401/V402 be operated without load, the entire cathode current would flow into the screen grid (G2) and cause damage. To avoid this, the anode voltage is sensed. With no load, the anode voltage drops to approximately -155 V, this voltage drop being routed to monostable Q432/Q433/C432/R473/R478 causing it to change state. Transistor Q433 conducts and the voltage drop across R475 turns Q434 on. The threshold of U401a is thus shifted to approximately -133 V, and the comparator switches off the output stage (as already described).

Note: the monostable is employed as pulse-stretcher to ensure a pulse width adequate for the U401a response time, and thus secure switch-off of the output stage.

Output Amplifier

The output amplifier comprises two identical stages working in parallel (anodes of tubes V401/V402 are connected together). For this reason, only one stage need be described in detail.

The signal from the timing board is routed via the input Schmitt trigger and push-pull stage Q403/Q404 to the base of Q405. Transistor Q405 then functions in a saturated Schottky configuration, whereby diode CR404 is used to reduce the storage time of the saturated Q405.

With Q405 turned on, Q407 is switched off and Q406 is conducting. A potential -155 V is then applied to the gate of FET Q408, which cuts off Q408 and interrupts the current through tube V401.

With Q405 turned off, the voltage at the gate of Q408 is approximately equal to that applied to the collector of Q428. (Note: this voltage depends on the R460 AMPLITUDE VERNIER setting). The amplifier output current is then determined by the difference between the gate and gate-source voltages of Q408 together with the Q408 source resistors $I_{OUT} = \frac{V_G - V_{GS}}{R_S}$.

In the 30–100 V amplitude range K401 shorts R425, thus changing the output current by a factor 1:3. Additionally supply voltages -155 V and -133 V are changed to -260 V and -238 V respectively, via relay K501.

Power-on Circuit

The output tubes require about 30 seconds warm-up time after power switch-on. During this time, no current flows. At power-on, Q431 is turned on and holds the Q432 base at approximately -155 V. The monostable Q402/Q403 is then in the unstable state (as when the output amplifier is operated without load). Approximately -155 V is then applied to the grids at V401/V402, and to the gates of FETs Q408/Q418, thus switching off the amplifier. After 1 minute, capacitor C430 is charged via R467 such that Q431 turns off. The monostable Q432/Q433 is released and returns to the stable state, thus enabling the output amplifier.

FOR TROUBLESHOOTING
REMOVE WIRE 927 FROM
POWER SUPPLY BOARD AND
SWITCH OUTPUT POLARITY
TO NEG

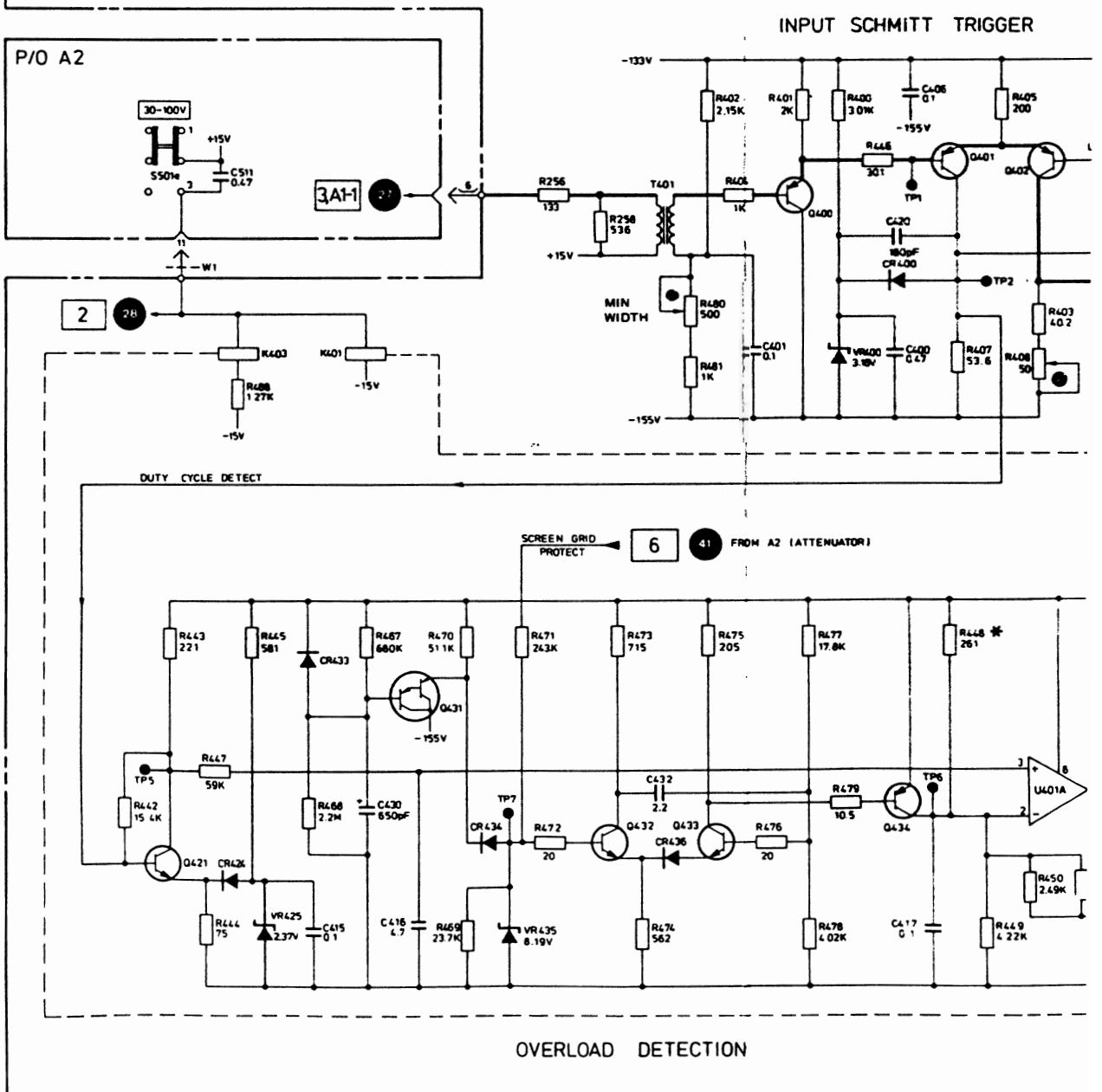
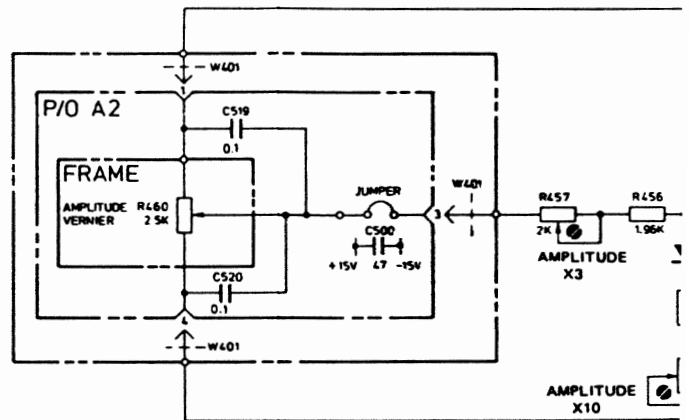

AMPLITUDE VERNIER AND OVERLOAD SWITCH

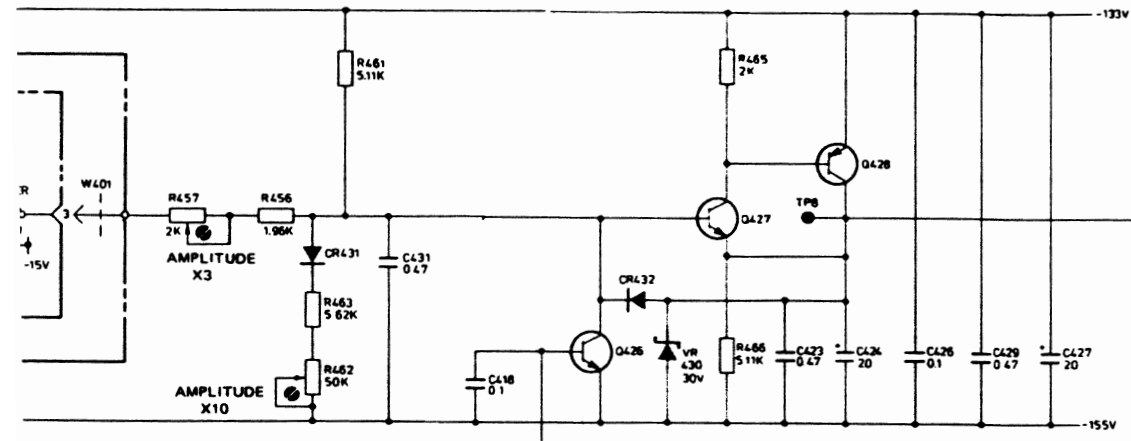

OUTPUT AMPLIFIER

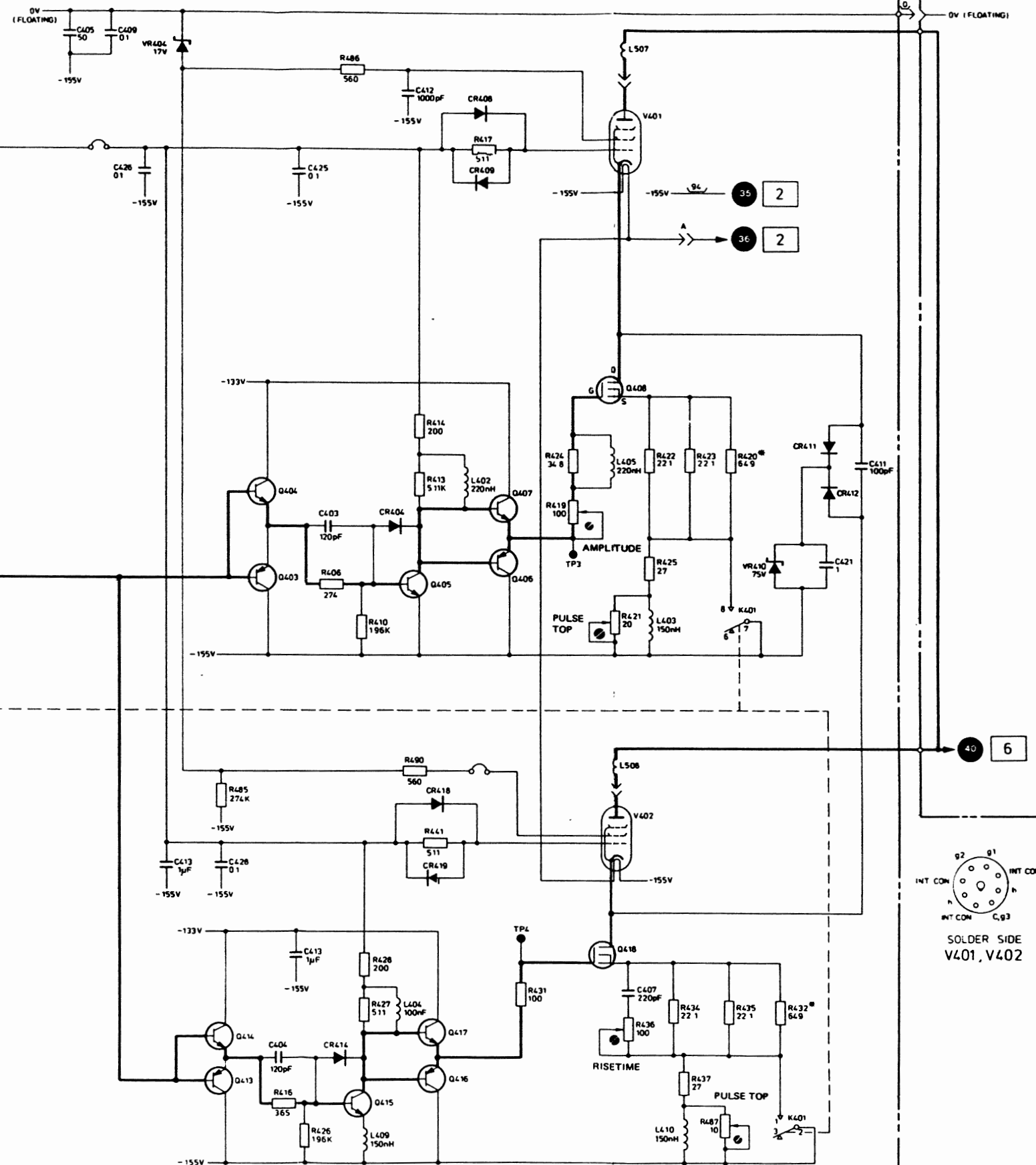

SCHMITT TRIGGER

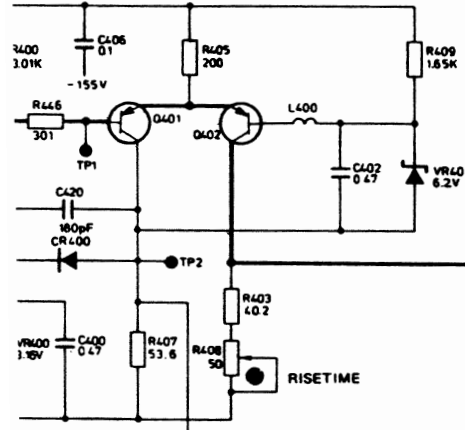

R1

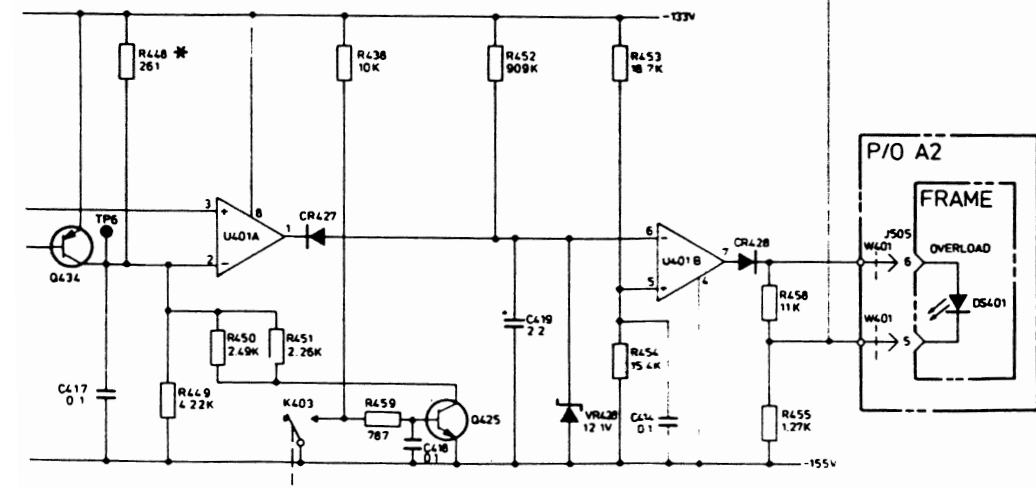

P/O A3 LOAD BOARD

0V (FLOATING)

35 2

36 2

40 6

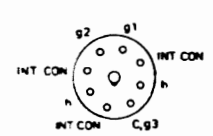

SOLDER SIDE V401, V402

OUTPUT BOARD A1
P/O TIMING BOARD A2

5

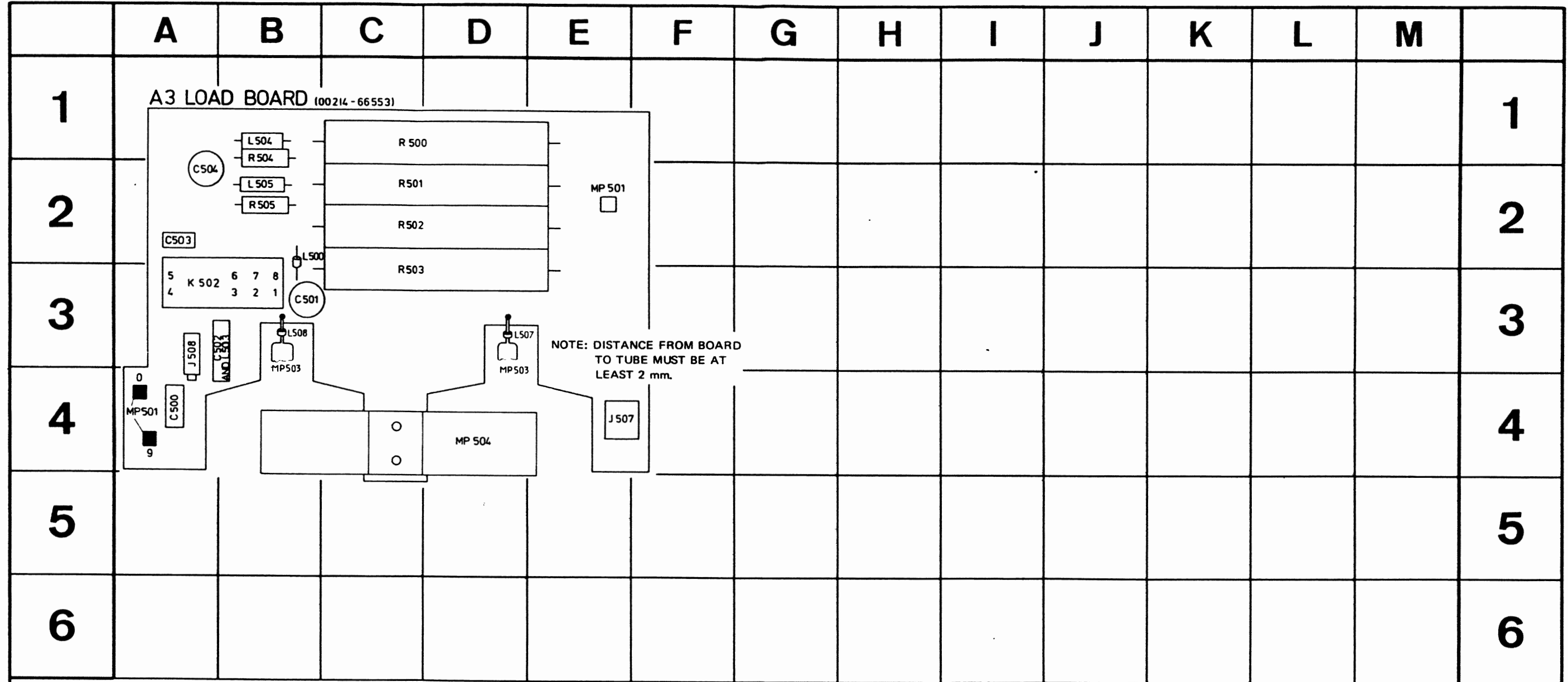

REF DESIG	GRID LOC	REF DESIG	GRID LOC
C500	A-4	MP504	D-4
C501	B-3	R500	C-1
C502	B-3	R501	C-2
C503	A-2	R502	C-2
C504	A-2	R503	C-3
J507	E-4	R504	B-1
J508	A-3	R505	B-2
K501	A-3		
L500	B-2		
L503	B-3		
L504	B-1		
L505	B-2		
L507	D-3		
L508	B-3		
MP501	A-4/E-2		
MP503	B-3/D-3		

6

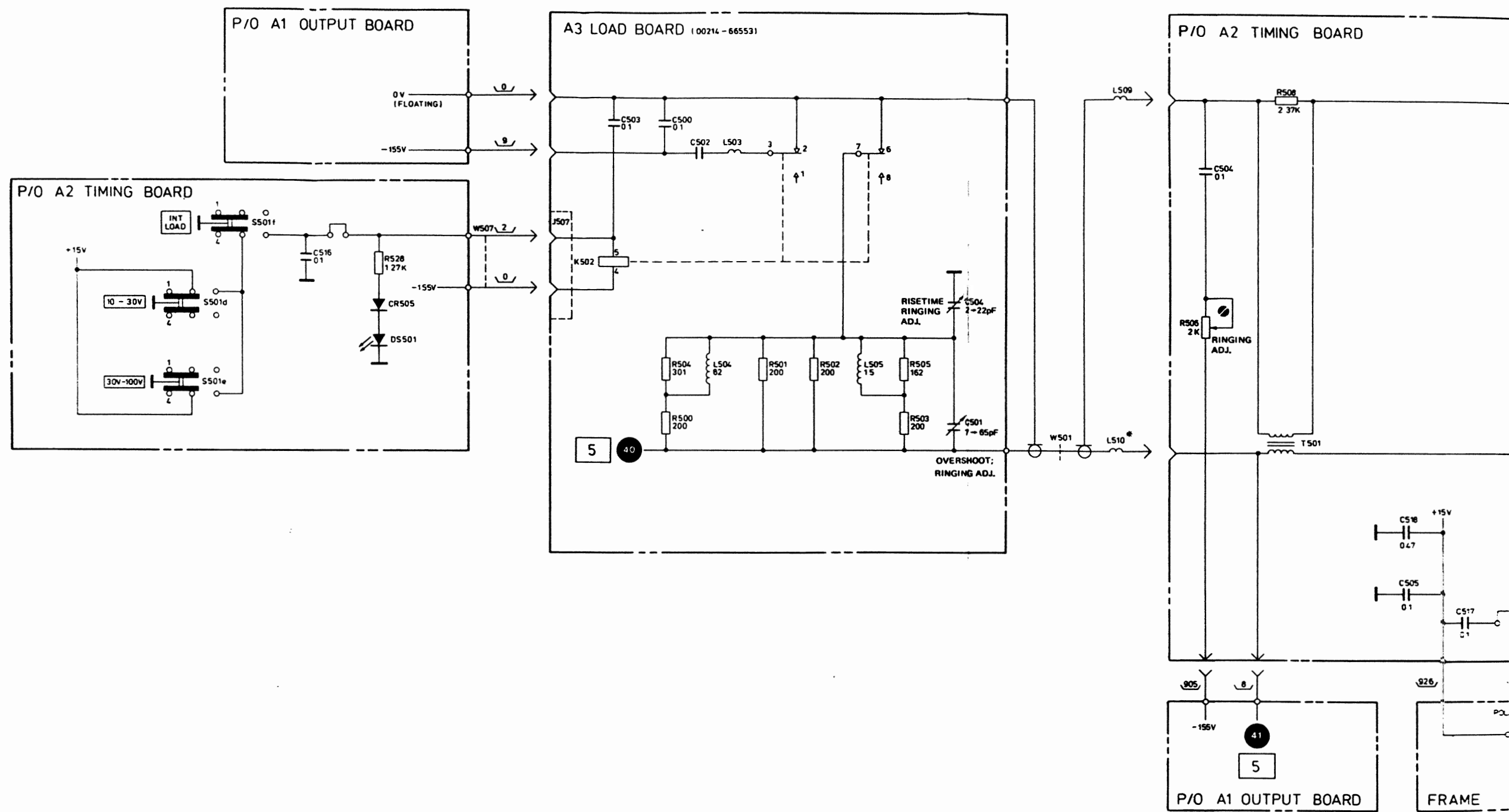

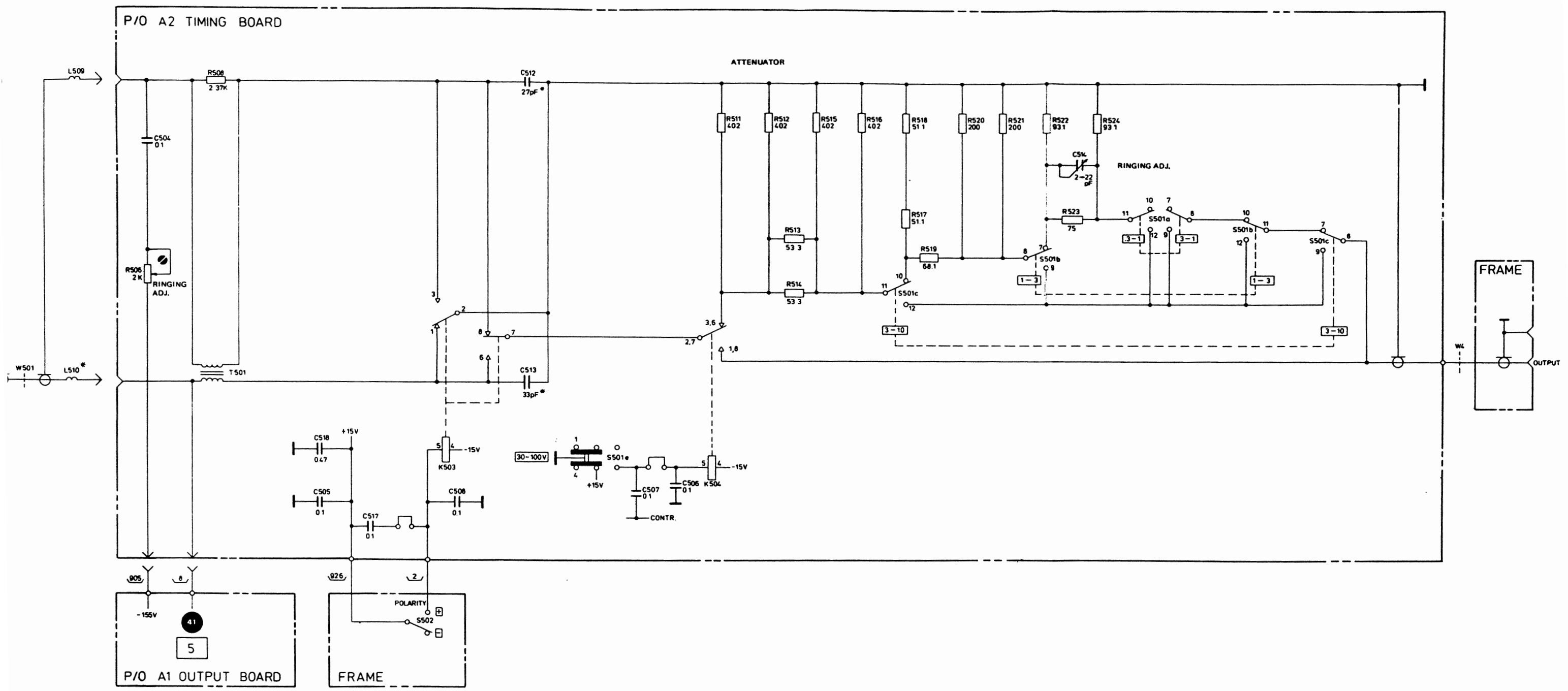

LOAD BOARD A3
TIMING BOARD A2

6

APPENDIX OPTION 001, BURST CAPABILITY

A1-1 INTRODUCTION

A1-2 This appendix contains the extra operating and service information required when the Model 214B is equipped with option 001. Figure 3-1 indicates which controls are additional should option 001 be fitted.

A1-3 The 214B Option 001 enables the instrument to generate a preselected number of pulses on receipt of a trigger pulse or manual trigger. The number of pulses (between 1 and 9999) is set on a 4-digit thumbwheel switch on the front panel. An additional single pulse can be generated manually. Specifications are identical to the standard version except:

Burst Mode — preselected number of pulses (1 to 9999) generated on receipt of a trigger signal.

Trigger Source — external signal applied to EXT INPUT connector or manual trigger (see External Input specifications in Table 1-2 for complete specifications of external signal).

Minimum Burst Recycle Time — 200ns.

Single Pulse — single pulse generated on manual command irrespective of selected number of pulses.

A2-1 OPERATING INSTRUCTIONS

A2-2 The BURST mode is similar to the NORM mode in that the pulse parameters (rate, width, etc.) are set on the front panel controls, however, the required NUMBER OF PULSES is set on the front panel thumbwheel switch. The burst is then started by either applying a signal to the EXT INPUT connector or pressing the MAN pushbutton.

At the end of the burst, pulses can be added individually by pressing the SINGLE PULSE pushbutton.

A2-3 BURST can be selected in conjunction with DOUBLE PULSE, in which case, twice the preset number of pulses will be generated.

A3-1 BURST PERFORMANCE TEST

SPECIFICATION:

Preselected number of pulses is generated on receipt of trigger signal.
 Number of pulses: 1 to 9999.
 Minimum spacing between bursts: 200ns.

EQUIPMENT:

Counter/Timer
 50Ω Feedthrough

CAUTION: Do not overload Feedthrough.

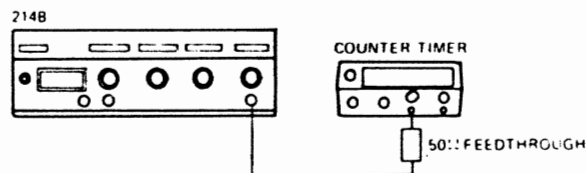
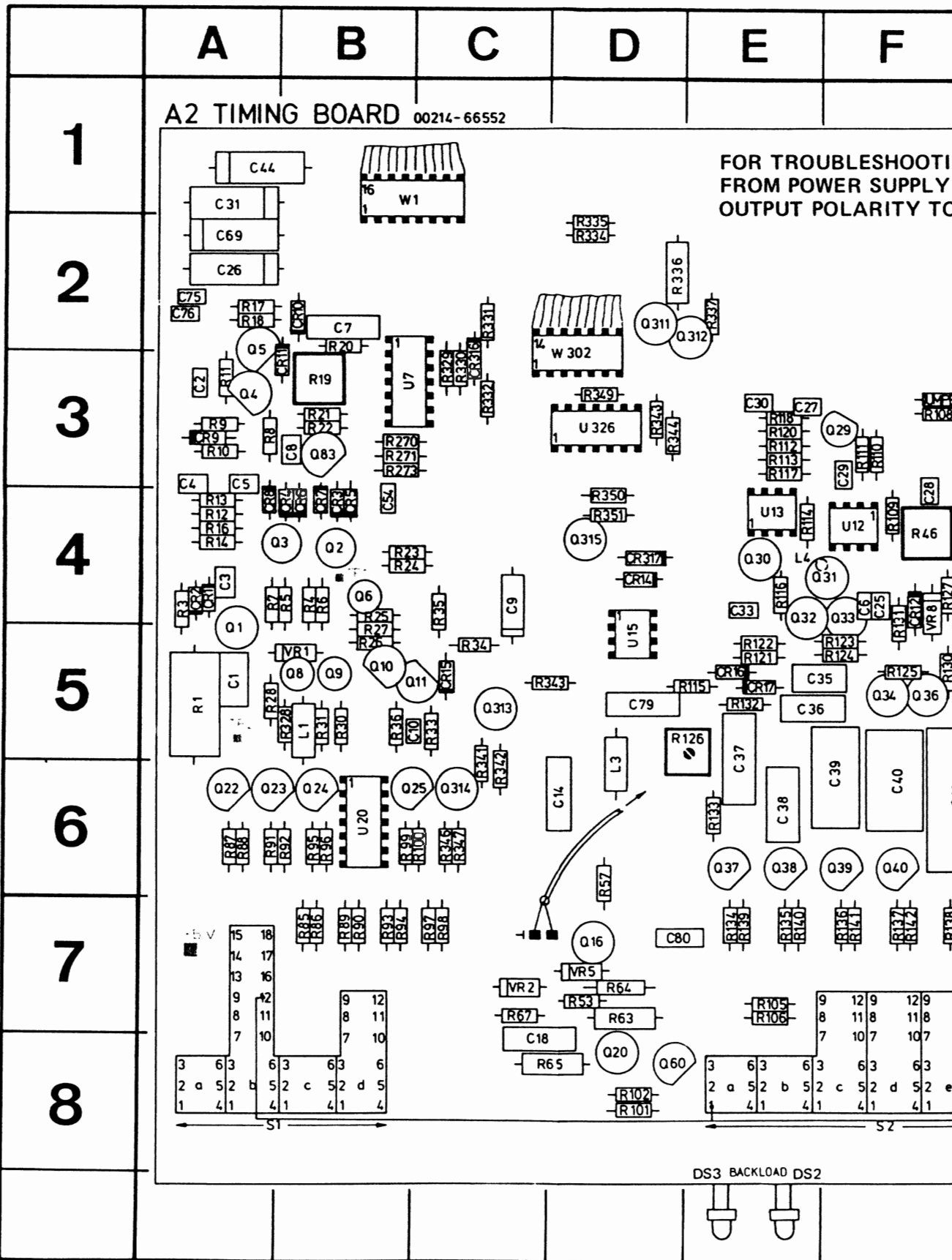

Figure A3-1

1. Connect equipment as shown in Figure A3-1 and set 214B controls as follows:

MODE	BURST
PERIOD Range	.1μ - 1μ
PERIOD Vernier	1
DELAY Range	10n - .1μ
DELAY Vernier	1
DUTY CYCLE %	Released
WIDTH Range	15n - .1μ
WIDTH Vernier	2
AMPLITUDE Range	1-3
AMPLITUDE Vernier	3 (3V)
INT LOAD	*
SLOPE	MAN
DEL/ADV/D.P.	DEL
OUTPUT POLARITY	POS
NUMBER OF PULSES	0001

2. Set Counter/Timer to START, TIME BASE to .1μs and press RESET pushbutton.
3. Press MAN pushbutton on the 214B. Counter should display 1.
4. Reset Counter. Set NUMBER OF PULSES to 0002 and start BURST by pressing MAN pushbutton. RESULT: Counter should display 2.
5. Repeat step 4 up to setting 0009 then reset to 0000.
6. Repeat step 4 for settings 0010 through 0090. (i.e. the 9 settings of the 10¹ switch) checking each time that the counter display corresponds to the NUMBER OF PULSES setting.
7. Check thumbwheel switch settings from 1 to 9 for each of the 10² and 10³ decade switches, checking each time that the counter display corresponds to the NUMBER OF PULSES setting.



A1-1

	D	E	F	G	H	I	J	K	L	M	N	O	P	Q	R	
--	---	---	---	---	---	---	---	---	---	---	---	---	---	---	---	--

52

FOR TROUBLESHOOTING REMOVE WIRE 927 FROM POWER SUPPLY BOARD AND SWITCH OUTPUT POLARITY TO NEG

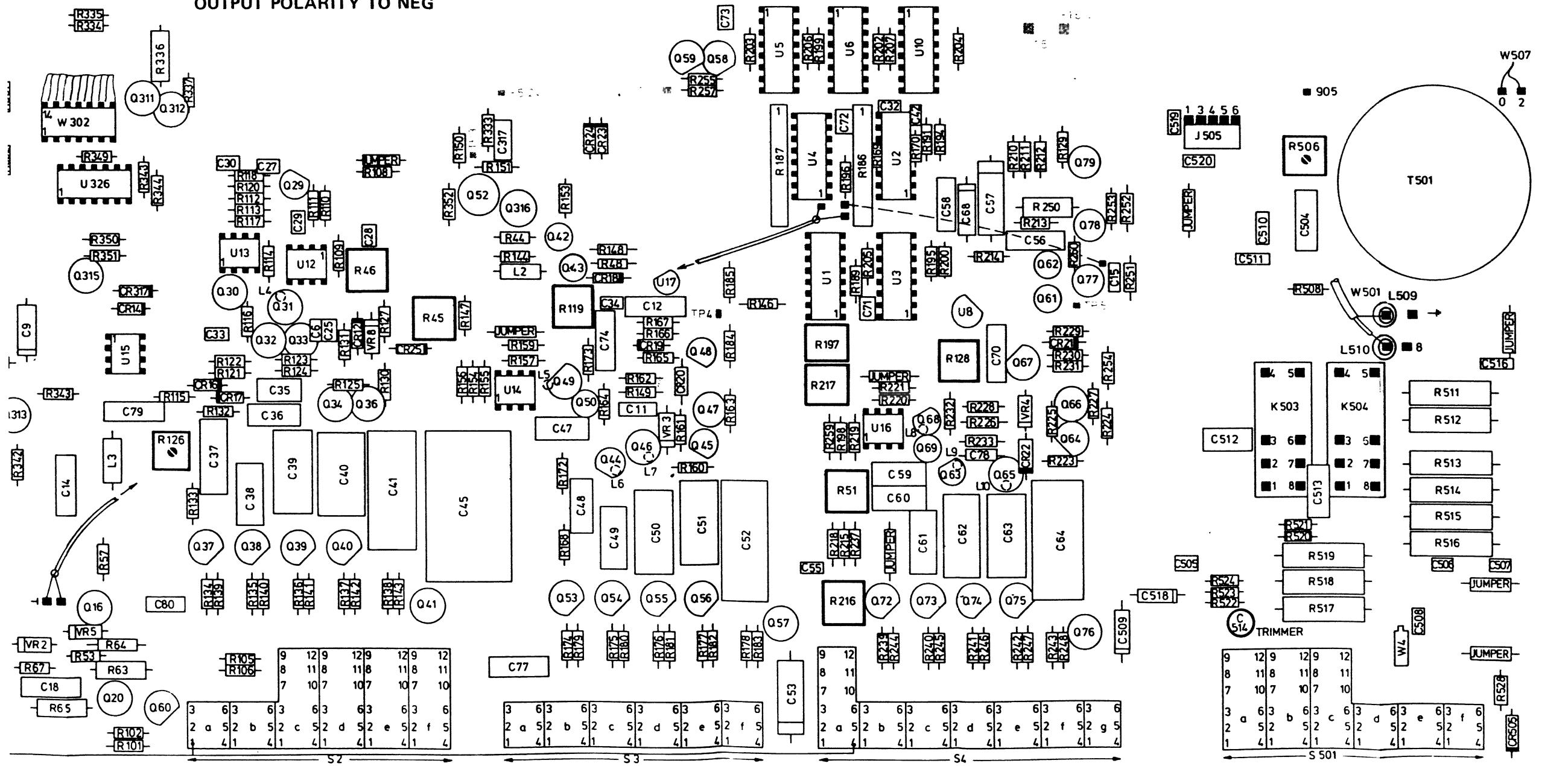

	1
	2
	3
	4
	5
	6
	7
	8

FOR TROUBLESHOOTING REMOVE WIRE 927 FROM POWER SUPPLY BOARD AND SWITCH OUTPUT POLARITY TO NEG

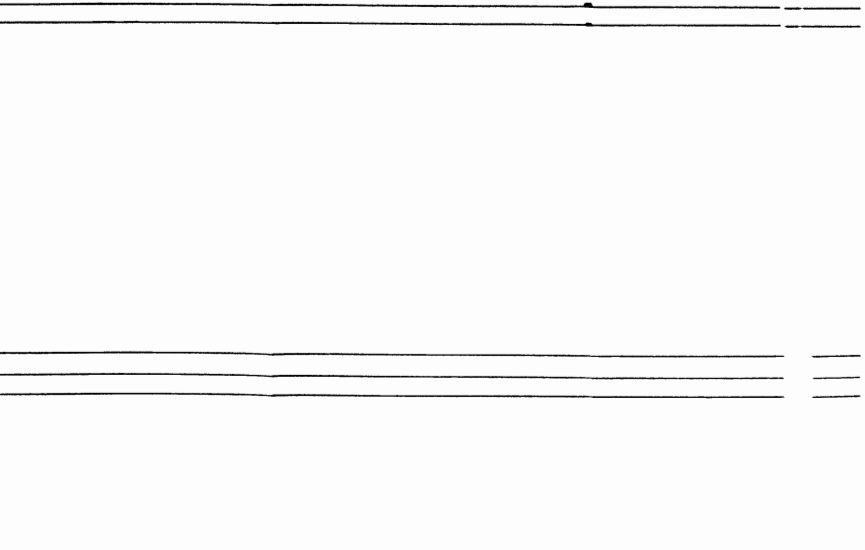
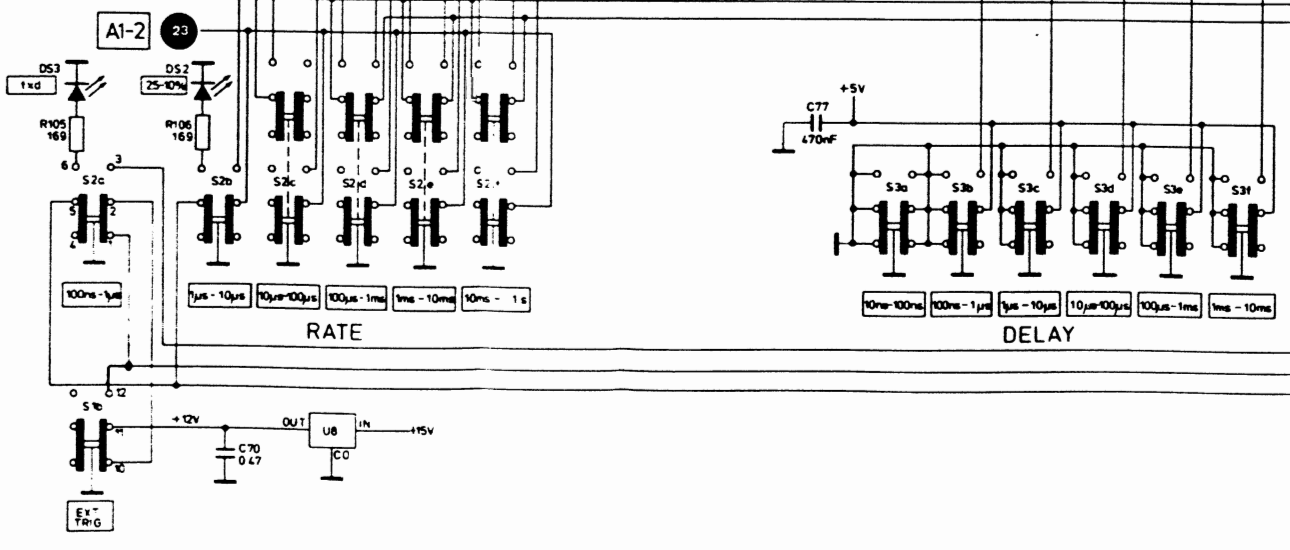
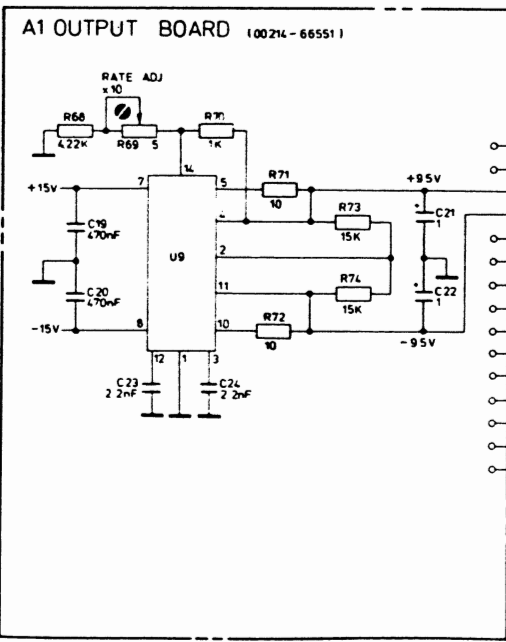
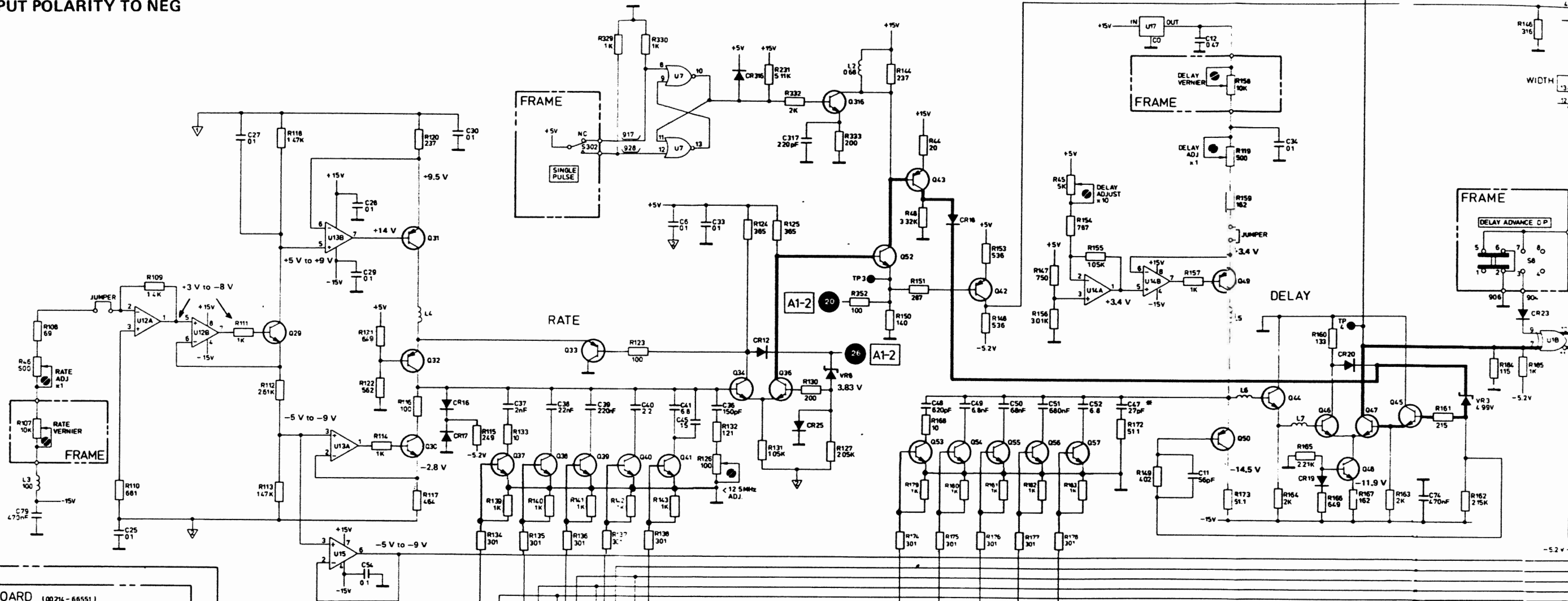

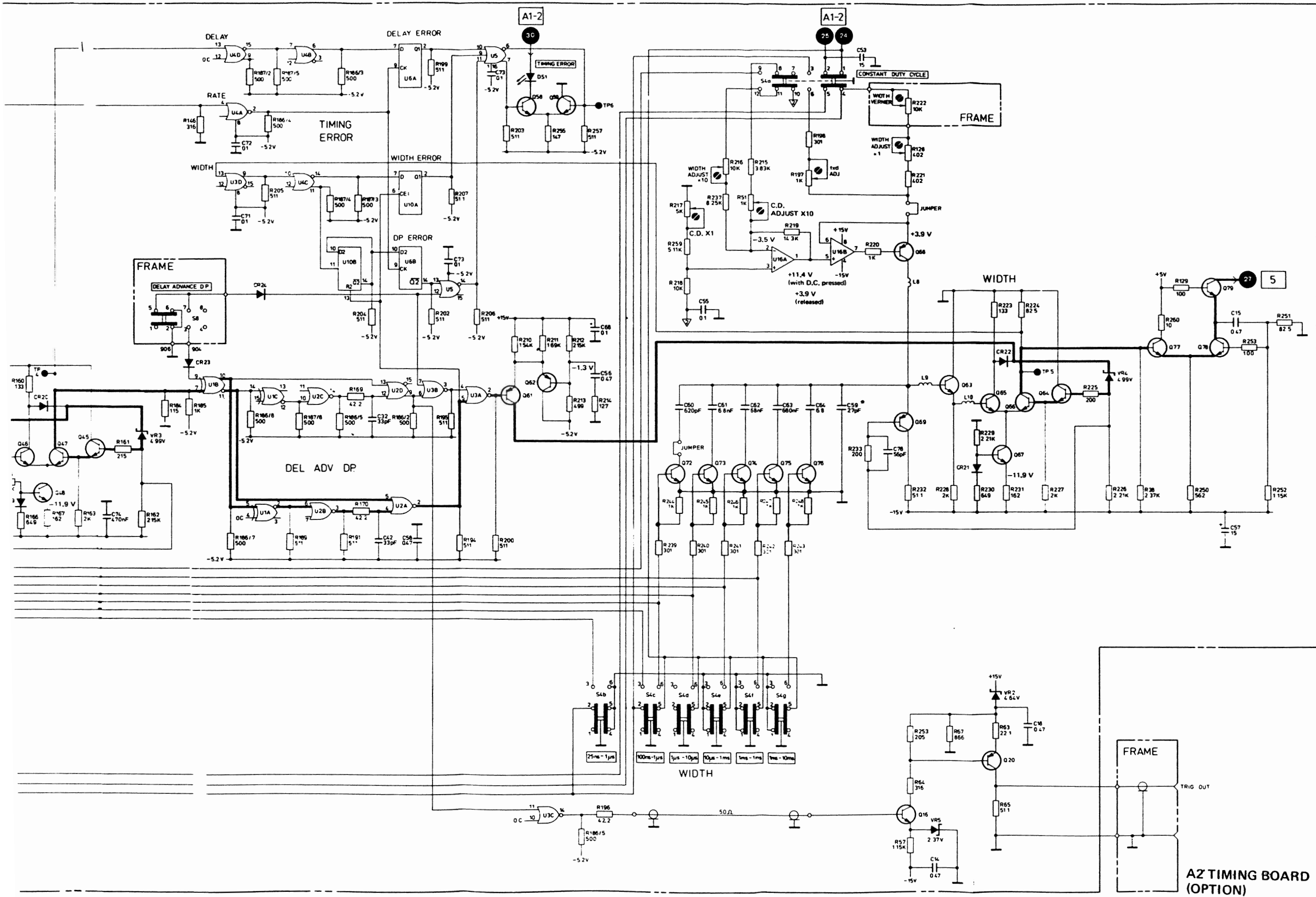

A1-1

AZ TIMING BOARD (OPTION)

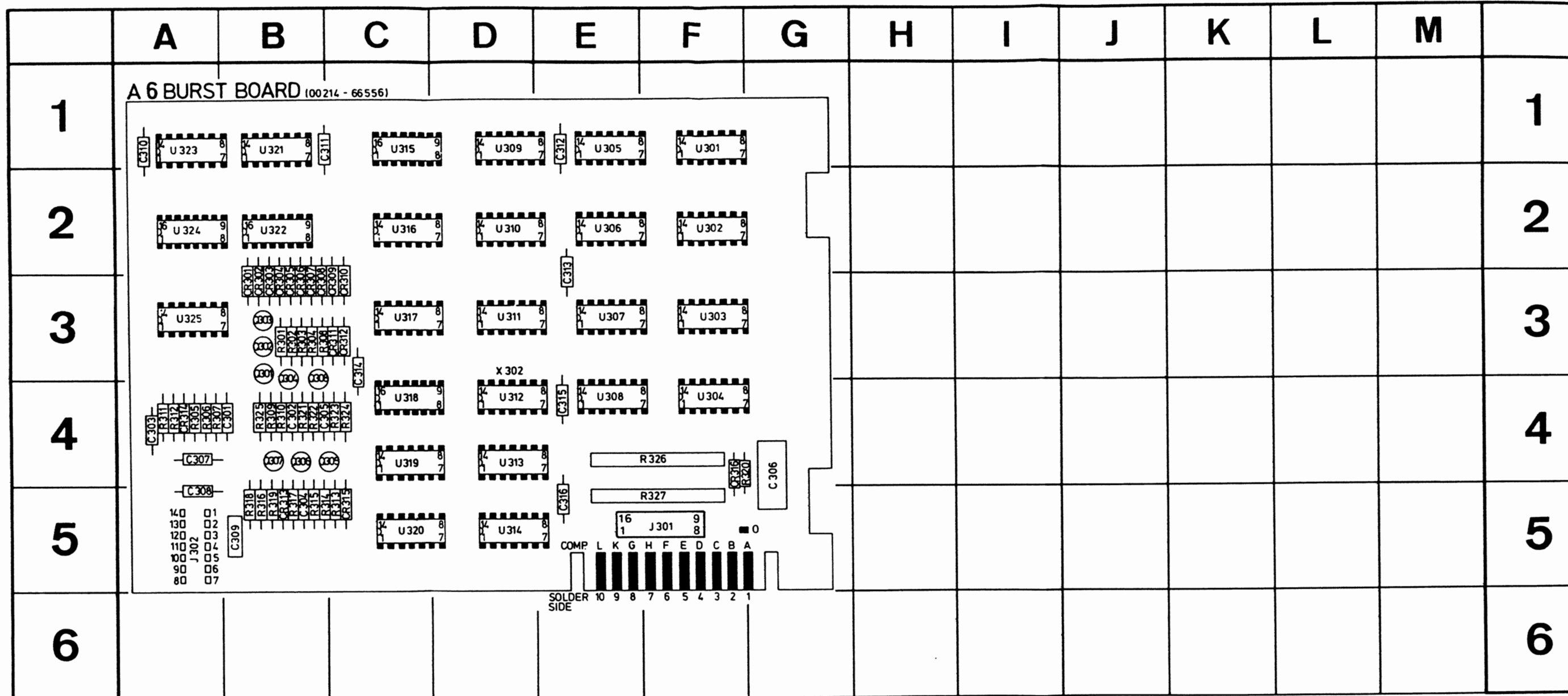

REF DESIG	GRID LOC	REF DESIG	GRID LOC	REF DESIG	GRID LOC	REF DESIG	GRID LOC	REF DESIG	GRID LOC	REF DESIG	GRID LOC
C301	B-4	CR301	B-2	J301	F-5	R307	A-4	R323	C-4	U312	D-4
C302	B-4	CR302	B-2	J302	A-5	R308	B-3	R324	C-4	U313	D-4
C303	A-4	CR303	B-2	Q301	B-3	R309	B-4	R325	B-4	U314	D-5
C304	B-5	CR304	B-2	Q302	B-3	R310	B-4	R326	F-4	U315	C-1
C305	B-4	CR305	B-2	Q303	B-3	R311	A-4	R327	F-5	U316	C-2
C306	G-4	CR306	B-2	Q304	B-3	R312	A-4	U301	F-1	U317	C-3
C307	A-4	CR307	B-2	Q305	B-4	R313	C-5	U302	F-2	U318	C-4
C308	A-4	CR308	B-2	Q306	B-4	R314	B-5	U303	F-3	U319	C-4
C309	B-5	CR309	C-2	Q307	B-4	R315	B-5	U304	F-4	U320	C-5
C310	A-1	CR310	C-2	Q308	B-3	R316	B-5	U305	E-1	U321	B-1
C311	B-1	CR311	C-3	R301	B-3	R317	B-5	U306	E-2	U322	B-2
C312	E-1	CR312	C-3	R302	B-3	R318	B-5	U307	E-3	U323	A-1
C313	E-2	CR313	B-5	R303	B-3	R319	B-5	U308	E-4	U324	A-2
C314	C-3	CR314	A-4	R304	B-3	R320	F-4	U309	D-1	U325	A-3
C315	E-4	CR315	C-5	R305	A-4	R321	B-4	U310	D-2		
C316	E-5	CR316	F-4	R306	A-4	R322	B-4	U311	D-3		

A1-3

REF DESIG	GRID LOC	REF DESIG	GRID LOC	REF DESIG	GRID LOC	REF DESIG	GRID LOC	REF DESIG	GRID LOC	REF DESIG	GRID LOC	REF DESIG	GRID LOC
C1	A-5	C511	N-4	Q33	F-4	R27	B-5	R143	F-7	R229	L-4	U3	K-4
C2	A-3	C512	N-5	Q34	F-5	R28	A-5	R144	H-4	R230	L-5	U4	J-3
C3	A-4	C513	O-6	Q36	F-5	R30	B-5	R146	J-4	R231	L-5	U5	J-2
C4	A-3	C514	N-7	Q37	E-6	R31	B-5	R147	G-4	R232	K-5	U6	K-2
C5	A-3	C516	P-5	Q38	E-6	R33	C-5	R148	H-4	R233	L-5	U7	B-3
C6	F-4	C517	O-8	Q39	F-6	R34	C-5	R149	I-5	R237	K-6	U8	L-4
C7	B-2	C518	M-7	Q40	F-6	R35	C-4	R150	G-3	R239	K-7	U10	K-2
C8	B-3	C519	M-3	Q41	G-7	R36	B-5	R151	G-3	R240	K-7	U12	F-4
C9	C-4	C520	N-3	Q42	H-4	R44	H-4	R153	H-3	R241	L-7	U13	E-4
C10	B-5	CR1	A-4	Q43	H-4	R45	G-4	R154	G-5	R242	L-7	U14	H-5
C11	I-5	CR2	A-4	Q44	H-6	R46	F-4	R155	G-5	R243	L-7	U15	D-5
C12	I-4	CR3	B-4	Q45	I-5	R48	H-4	R156	G-5	R244	K-7	U16	K-5
C14	D-6	CR4	B-4	Q46	I-5	R51	J-6	R157	H-5	R245	K-7	U17	I-4
C15	M-4	CR5	B-4	Q47	I-5	R53	D-7	R159	H-5	R246	L-7	U20	B-6
C18	C-8	CR6	B-4	Q48	I-5	R57	D-6	R160	I-6	R247	L-7	U326	D-3
C25	F-4	CR7	B-4	Q49	H-5	R63	D-7	R161	I-5	R248	L-7	VR1	B-5
C26	A-2	CR8	A-4	Q50	H-5	R64	D-7	R162	I-5	R250	L-3	VR2	C-7
C27	E-3	CR9	A-3	Q52	G-3	R65	C-8	R163	I-5	R251	M-4	VR3	I-5
C28	F-4	CR10	B-2	Q53	H-7	R67	C-7	R164	H-5	R252	M-3	VR4	L-5
C29	F-3	CR11	B-3	Q54	H-7	R85	B-7	R165	I-5	R253	M-3	VR5	D-7
C30	E-3	CR12	F-4	Q55	I-7	R86	B-7	R166	I-4	R254	M-5	VR8	F-4
C31	A-1	CR14	D-4	Q56	I-7	R87	A-6	R167	I-4	R255	I-2	W1	B/C-1
C32	K-2	CR15	C-5	Q57	J-7	R88	A-6	R168	H-6	R257	I-2	W4	O-7
C33	E-4	CR16	E-5	Q58	I-2	R89	B-7	R169	K-3	R259	J-5	W501	O-4
C34	H-4	CR17	E-5	Q59	I-2	R90	B-7	R170	K-3	R260	L-4	W302	D-3
C35	E-5	CR18	H-4	Q60	D-8	R91	A-6	R172	H-6	R270	B-3		
C36	E-5	CR19	I-5	Q61	L-4	R92	B-6	R173	H-5	R271	B-3		
C37	E-5	CR20	I-5	Q62	L-4	R93	B-7	R174	H-7	R273	B-3		
C38	E-6	CR21	L-4	Q63	K-6	R94	B-7	R175	H-7	R328	B-5		
C39	F-6	CR22	L-5	Q64	L-5	R95	B-6	R176	I-7	R329	C-3		
C40	F-6	CR23	H-3	Q65	L-6	R96	B-6	R177	I-7	R330	C-3		
C41	F-6	CR24	H-3	Q66	L-5	R97	C-7	R178	J-7	R331	C-2		
C42	K-2	CR25	G-5	Q67	L-5	R98	C-7	R179	H-7	R332	C-3		
C44	A-1	CR316	C-3	Q68	K-5	R99	B-6	R180	H-7	R333	G-3		
C45	G-6	CR317	D-4	Q69	K-5	R100	C-6	R181	I-7	R334	D-2		
C47	H-5	CR505	P-8	Q72	K-7	R101	D-8	R182	I-7	R335	D-2		
C48	H-6	DS1	H-8	Q73	K-7	R102	D-8	R183	J-7	R336	D-3		
C49	H-6	DS2	E-8	Q74	L-7	R105	E-7	R184	I-5	R337	E-2		
C50	I-6	DS3	E-8	Q75	L-7	R106	E-7	R185	I-4	R341	C-5		
C51	I-6	DS401	N-8	Q76	M-7	R108	F-3	R186	K-3	R342	C-6		
C52	J-6	DS501	P-8	Q77	M-4	R109	F-4	R187	J-3	R343	C-5		
C53	J-8	J505	N-3	Q78	M-3	R110	F-3	R189	K-4	R344	D-3		
C54	B-4	K503	N-5	Q79	M-3	R111	F-3	R191	K-3	R346	C-6		
C55	J-6	K504	O-5	Q83	B-3	R112	E-3	R194	K-3	R347	C-6		
C56	L-4	L1	B-5	Q311	D-2	R113	E-3	R195	K-4	R348	D-3		
C57	L-3	L2	H-4	Q312	E-2	R114	E-4	R196	J-3	R349	D-3		
C58	K-3	L3	D-5	Q313	C-5	R115	F-5	R197	J-4	R350	D-4		
C59	K-6	L4	E-4	Q314	C-6	R116	E-4	R198	J-5	R351	D-4		
C60	K-6	L5	H-5	Q315	D-4	R117	E-3	R199	J-2	R352	G-3		
C61	K-6	L6	H-6	Q316	H-3	R118	E-3	R200	K-4	R506	O-3		
C62	K-6	L7	I-6	R1	A-5	R119	H-4	R202	K-2	R508	O-4		
C63	L-6	L8	K-5	R3	A-4	R120	E-3	R203	J-2	R511	P-5		
C64	L-6	L9	K-6	R4	B-4	R121	E-5	R204	K-2	R512	P-5		
C68	L-3	L10	L-6	R5	B-4	R122	E-5	R205	K-4	R513	P-6		
C69	A-2	Q1	A-4	R6	B-4	R123	F-5	R206	J-2	R514	P-6		
C70	L-5	Q2	B-4	R7	A-4	R124	F-5	R207	K-2	R515	P-6		
C71	K-4	Q3	B-4	R8	A-3	R125	F-5	R210	L-3	R516	P-6		
C72	J-3	Q4	A-3	R9	A-3	R126	D-5	R211	L-3	R517	O-7		
C73	I-2	Q5	A-2	R10	A-3	R127	F-4	R212	L-3	R518	O-7		
C74	H-4	Q6	B-4	R11	A-3	R128	K-5	R213	L-3	R519	O-6		
C75	A-2	Q8	B-5	R12	A-4	R129	L-3	R214	L-4	R520	O-6		
C76	A-2	Q9	B-5	R13	A-4	R130	F-5	R215	J-6	R521	O-6		
C77	H-7	Q10	B-5	R14	A-4	R131	F-5	R216	J-7	R522	N-7		
C78	L-5	Q11	B-5	R16	A-4	R132	E-5	R217	J-5	R523	N-7		
C79	D-5	Q16	D-7	R17	A-2	R133	E-6	R218	J-5	R524	N-7		
C80	D-7	Q20	D-8	R18	A-2	R134	E-7	R219	K-5	R528	P-7		
C317	G-3	Q22	A-6	R19	B-3	R135	E-7	R220	L-5	S1	A-8		
C504	O-3	Q23	A-6	R20	B-2	R136	F-7	K221	K-5	S2	F-8		
C505	N-6	Q24	B-6	R21	B-3	R137	F-7	R223	L-6	S3	I-8		
C506	P-6	Q25	B-6	R22	B-3	R138	F-7	R224	L-5	S4	K-8		
C507	P-6	Q29	F-3	R23	B-4	R139	E-7	R225	L-5	S501	O-8		
C508	P-7	Q30	E-4	R24	B-4	R140	E-7	R226	L-5	T501	P-3		
C509	M-7	Q31	E-4	R25	B-4	R141	F-7	R227	M-5	U1	J-4		
C510	N-3	Q32	E-4	R26	B-5	R142	F-7	R228	L-5	U2	K-3		

P/O A2 TIMING BOARD (00214-66552)
OPT. 001 EXT. INPUT CIRCUITS

FRAME

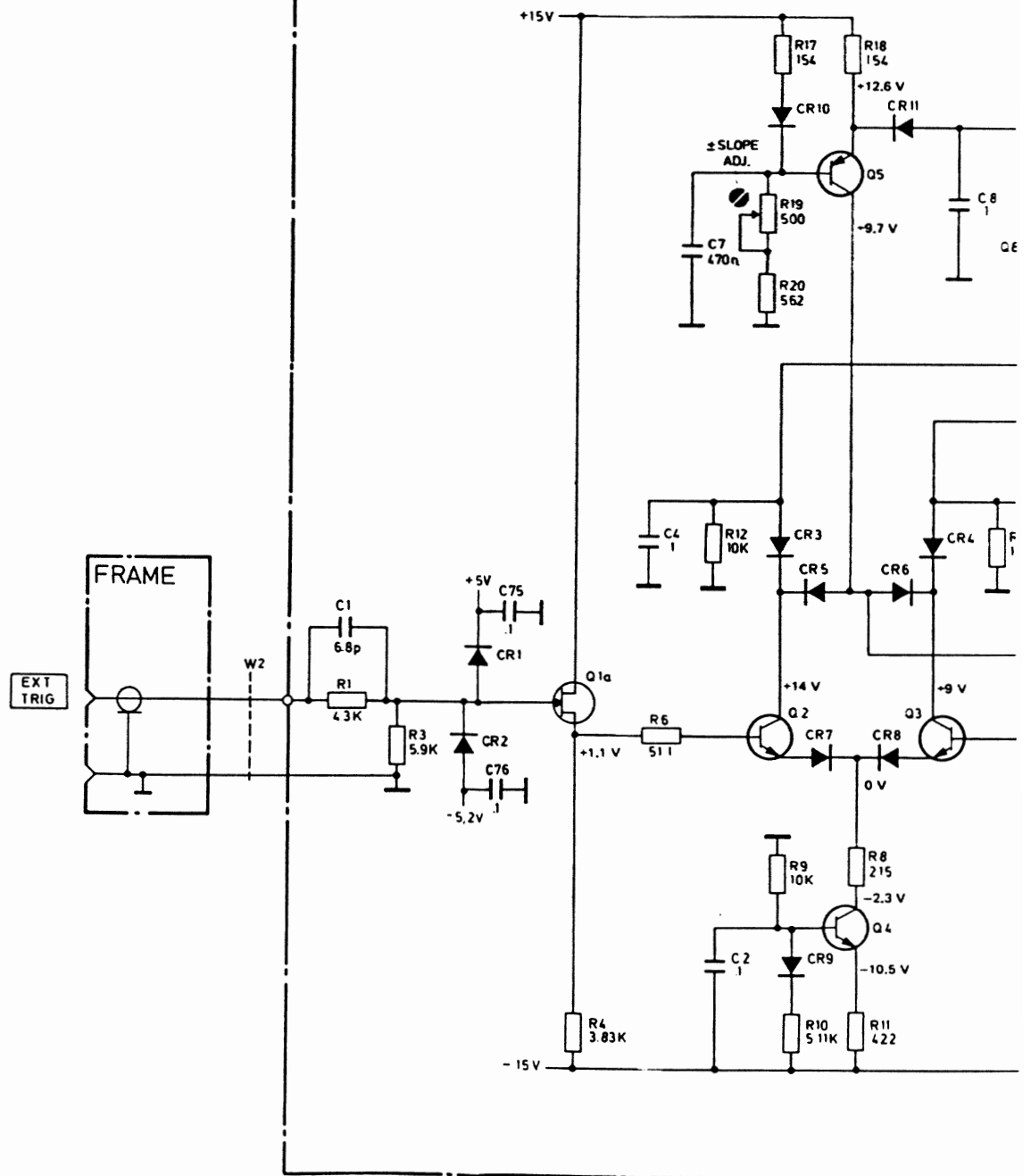

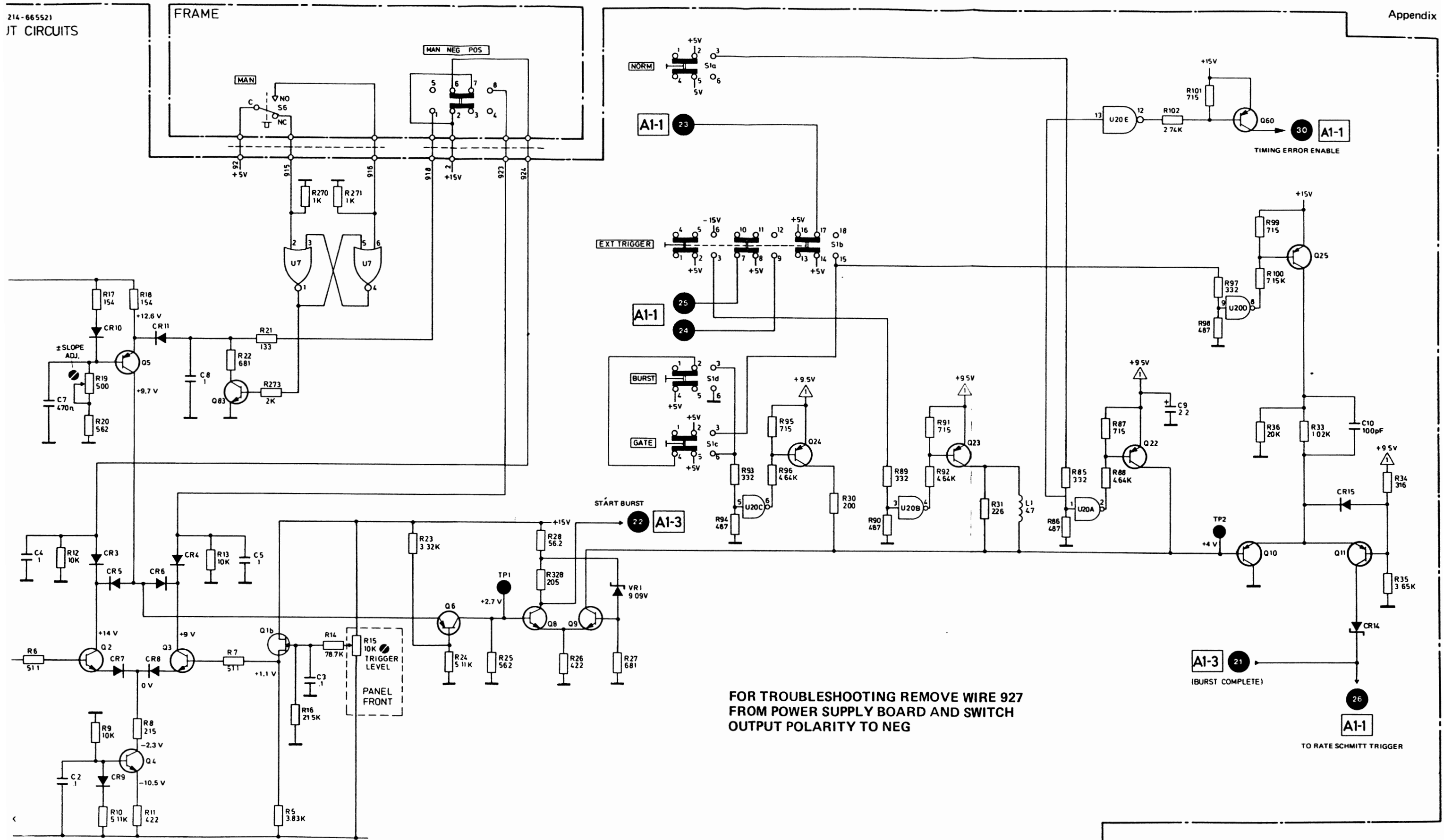

FOR TROUBLESHOOTING REMOVE WIRE 927
FROM POWER SUPPLY BOARD AND SWITCH
OUTPUT POLARITY TO NEG

P/O TIMING BOARD A2 (OPTION) **A1-2**

SERVICE BLOCK A1-1

BURST BOARD A6

THEORY OF OPERATION

The Burst Control essentially consists of a counter which is loaded with numbers from front panel thumbwheel switches. When a burst is started, pulses from the rate generator decrement the counter until it is empty. This condition (all zeroes) is detected and generates a BURST COMPLETE signal which disables the rate generator.

The following description divides the burst operation into four successive stages:

1. Loading the Burst Counter
2. Start Burst
3. Zero Detection
4. Burst Complete

Loading the Burst Counter

When BURST mode is selected, the BURST ENABLE line goes high (0 V) and 'clears' U319 (via Q307, C306, U313, U312), setting the Q output low. A low on this output then enables data to be loaded from the thumbwheel switches into the counter.

As data is being loaded, a comparator (U301, U302, U307, U308) checks for equivalence between the counter inputs and outputs. When equivalence is detected, input pin 11 of U312d goes high, and the LOAD line (from output pin 13 of U312d) goes low thus preventing further loading of the counter.

Throughout this load process, the high on the \bar{Q} output of U319 disables the repetition rate generator (via AND gate CR311, CR312 and OR gate Q302, Q303) and therefore prevents the counter from counting.

Start Burst

When the START BURST signal is received, U319 is 'preset' (via NAND gate Q305, Q306) causing the Q and \bar{Q} outputs to change state. The low on the \bar{Q} output starts the repetition rate generator, and the counter begins to count down from the preset number. The high on the Q output of U319 ensures that the LOAD line remains disabled, thus preventing a re-load of the counter (e.g. by thumbwheel switch change) before the end of the burst.

Zero Detection

Throughout the count-down process, all outputs of the counter are monitored by two 'zero detect' configurations, one consisting of U309 and U311, and the other consisting of U309 and CR302 → CR310. The significance of the two configurations is explained in the following Burst Complete description.

Burst Complete

When the counter reaches the 'all zero' condition, the fast 'zero detect' circuit (U309, CR302 → CR310) generates a BURST COMPLETE signal, which disables the repetition rate generator via OR gate Q302, Q303. This fast zero detection is achieved by using a 'hot carrier' diode for CR310, which monitors the final zero state, C301, of the counter. Fast detection then ensures that the repetition rate generator is switched off after the correct number of pulses have been output.

The other 'zero detect' circuit (U309, U311) clears U319, setting the Q output low again, and thus allowing the counter to be loaded once more from the thumbwheel switches.

TROUBLESHOOTING

1. With oscilloscope set to 1 μ s/division, set the 214B to exactly 1 MHz.
2. Set 214B to Burst Mode.
3. Connect the 214B TRIGGER OUTPUT to the 214B TRIGGER INPUT.
4. Disconnect the base connection of transistor A6Q304 and leave as 'open base'.
5. Disconnect pin 13 of A6U312 from socket X302 and leave as 'open circuit'.
6. Wire-connect the open track (from which A6U312 pin 13 is disconnected) to ground.
7. Set Scope to internal trigger.
8. Check the waveforms detailed in the following list:

214B BOARD A6	Oscilloscope Screen	OSCILLOSCOPE	
		Time Div	Trigger Slope
U318 Pin 1		1 μ s	⊖
U315 Pin 4		1 μ s	⊖
U322 Pin 4		10 μ s	⊖
U324 Pin 4		0.1ms	⊖
U324 Pin 7		1ms	⊖
U302 Pin 8		10 μ s	⊖
U301 Pin 8		1ms	⊖
U312 Pin 10		1ms	⊕
U311 Pin 8		10 μ s	⊖
U309 Pin 8		1ms	⊖
U319 Pin 2		1ms	⊖
Q303 emitter		1ms	⊕
U319 Pin 13		1 μ s	⊖
U319 Pin 6		1ms	⊕
Q303 collector		1ms	⊕
U319 Pin 8		1ms	⊖

NOTES: 1. To get the signals at U319 adjust EXT INPUT LEVEL Vernier.
 2. Some duty cycles are difficult to see on oscilloscope screen.

P/O A2 TIMING BOARD
OPTION 001

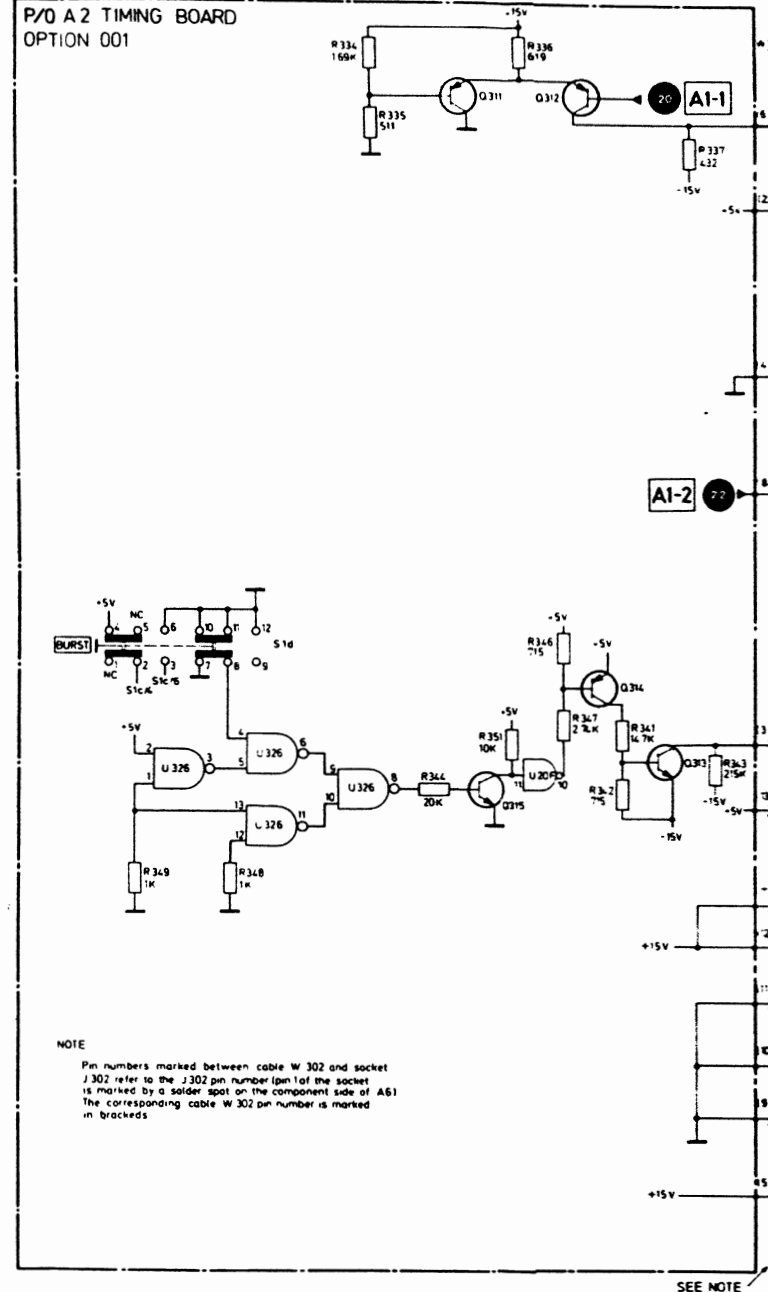

NOTE
Pin numbers marked between cable W 302 and socket J 302 refer to the J 302 pin number (pin 1 of the socket is marked by a solder spot on the component side of A61). The corresponding cable W 302 pin number is marked in brackets.

SEE NOTE

A6

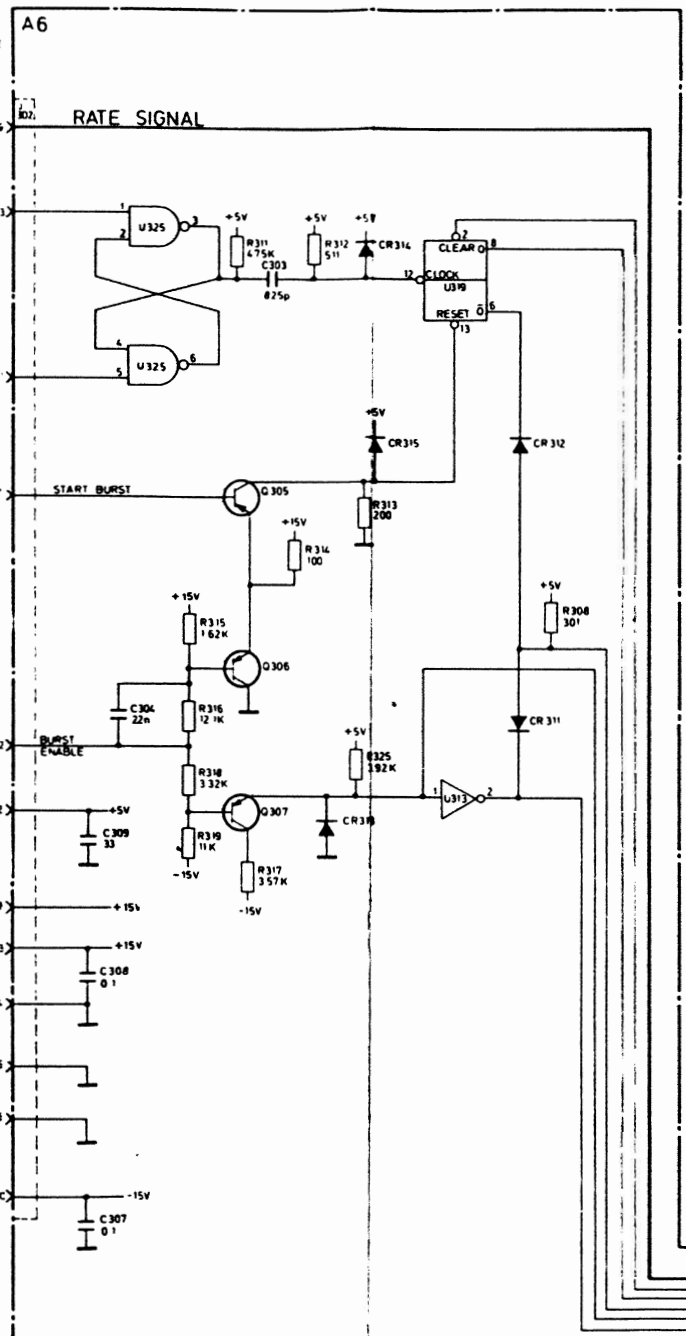

A6 BURST BOARD

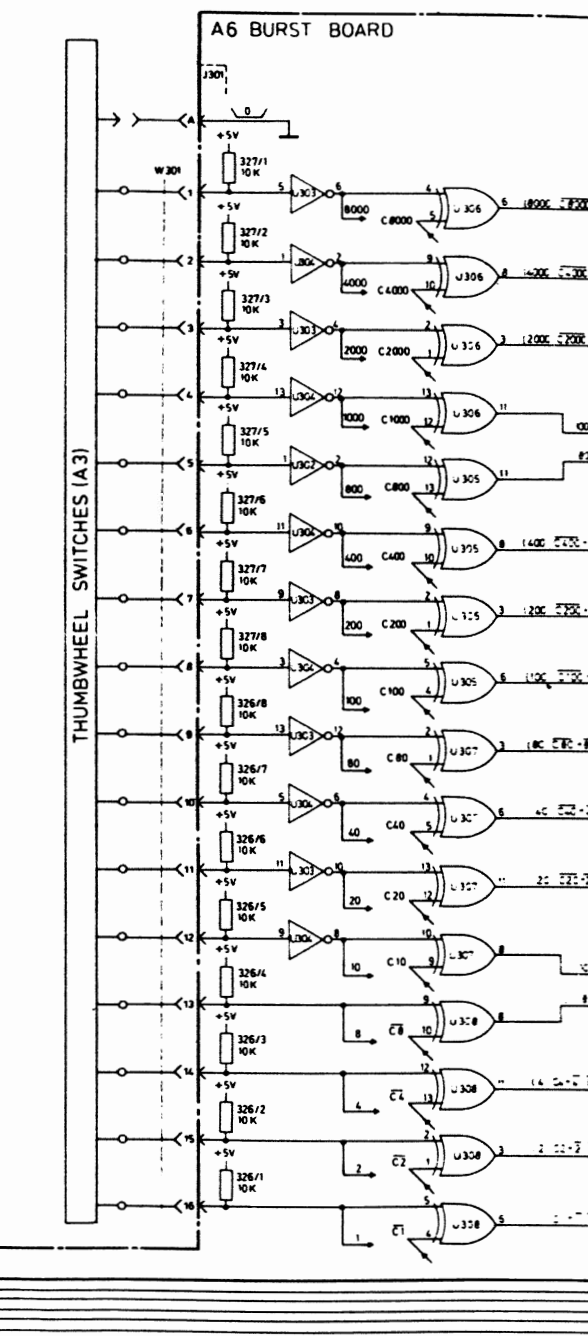

THUMBWHEEL SWITCHES (A3)

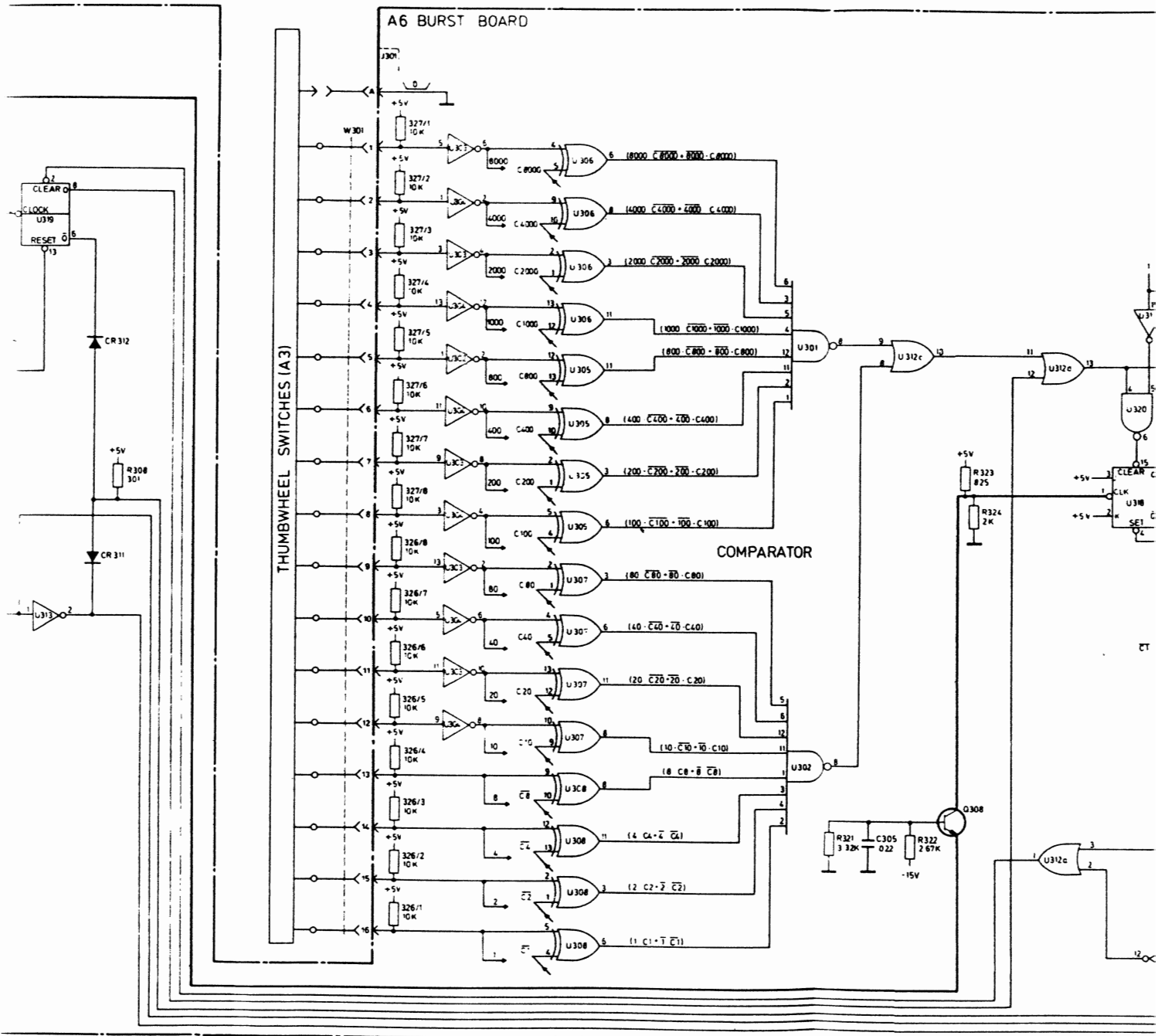

NOTE
ALL SWITCHES ARE SHOWN
IN THE "OUT" POSITION

PUSH IN TO SELECT MODE OR RANGE

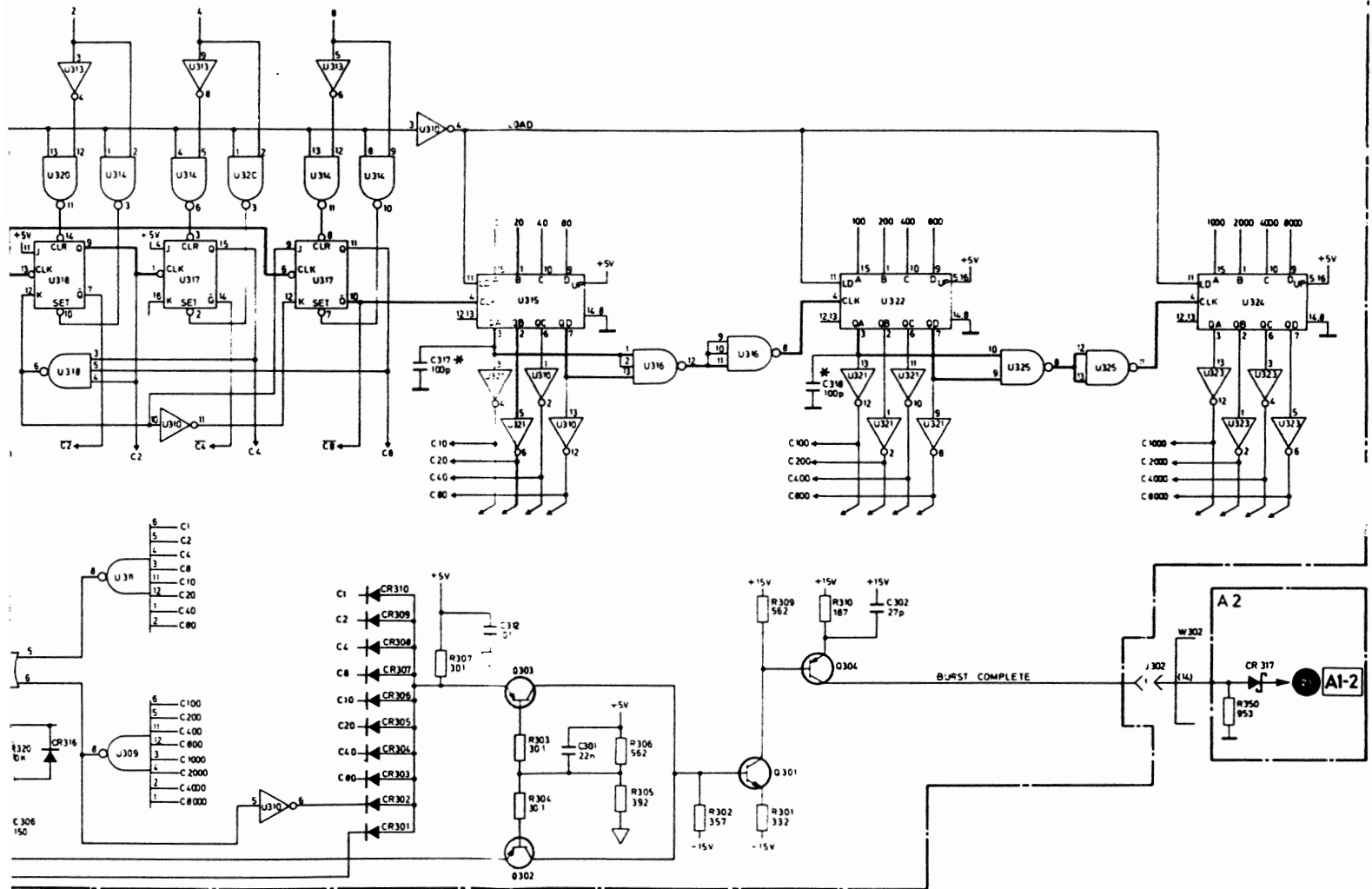

OUTPUT BOARD A1
P/O TIMINGBOARD A2

A1-3