

## Errata

**Title & Document Type:** 1630A/D Logic Analyzer Operating Manual

**Manual Part Number:** 01630-90901

**Revision Date:** February 1983

---

### HP References in this Manual

This manual may contain references to HP or Hewlett-Packard. Please note that Hewlett-Packard's former test and measurement, semiconductor products and chemical analysis businesses are now part of Agilent Technologies. We have made no changes to this manual copy. The HP XXXX referred to in this document is now the Agilent XXXX. For example, model number HP8648A is now model number Agilent 8648A.

### About this Manual

We've added this manual to the Agilent website in an effort to help you support your product. This manual provides the best information we could find. It may be incomplete or contain dated information, and the scan quality may not be ideal. If we find a better copy in the future, we will add it to the Agilent website.

### Support for Your Product

Agilent no longer sells or supports this product. You will find any other available product information on the Agilent Test & Measurement website:

[www.tm.agilent.com](http://www.tm.agilent.com)

Search for the model number of this product, and the resulting product page will guide you to any available information. Our service centers may be able to perform calibration if no repair parts are needed, but no other support from Agilent is available.





**OPERATING MANUAL**

**LOGIC ANALYZER  
1630A/D**

© COPYRIGHT HEWLETT-PACKARD COMPANY/LOGIC SYSTEMS DIVISION 1982  
1900 GARDEN OF THE GODS ROAD, COLORADO SPRINGS, COLORADO, U.S.A.

ALL RIGHTS RESERVED

## SAFETY SUMMARY

*The following general safety precautions must be observed during all phases of operation, service, and repair of this instrument. Failure to comply with these precautions or with specific warnings elsewhere in this manual violates safety standards of design, manufacture, and intended use of the instrument. Hewlett-Packard Company assumes no liability for the customer's failure to comply with these requirements.*

### GROUND THE INSTRUMENT

To minimize shock hazard, the instrument chassis and cabinet must be connected to an electrical ground. The instrument is equipped with a three-conductor AC power cable. The power cable must either be plugged into an approved three-contact electrical outlet or used with a three-contact to two-contact adapter with the grounding wire (green tint), connected to an electrical ground (metal ground) at the power outlet. The power jack and mating plug of the power cable meet International Electrotechnical Commission (IEC) safety standards.

### DO NOT OPERATE IN AN EXPLOSIVE ATMOSPHERE.

Do not operate the instrument in the presence of flammable gases or fumes. Operation of any electrical instrument in such an environment constitutes a definite safety hazard.

### KEEP AWAY FROM LIVE CIRCUITS.

Operating personnel must not remove instrument covers. Component replacement and internal adjustments must be made by qualified maintenance personnel. Do not replace components with power cable connected. Under certain conditions, dangerous voltages may exist even with the power cable removed. To avoid injuries, always disconnect power and discharge circuits before touching them.

### DO NOT SERVICE OR ADJUST ALONE

Do not attempt internal service or adjustment, unless another person, capable of rendering first aid and resuscitation, is present.

### USE CAUTION WHEN EXPOSING OR HANDLING THE CRT

Breakage of the Cathode Rays Tube (CRT) causes a high-velocity scattering of glass fragments (shrapnel). To prevent CRT implosion, avoid rough handling or jarring of the instrument. Handling of the CRT shall be done only by qualified maintenance personnel using approved safety mask and gloves.

### DO NOT SUBSTITUTE PARTS OR MODIFY INSTRUMENT.

Because of the danger of introducing additional hazards, do not install substitute parts or perform any unauthorized modification of the instrument. Return the instrument to a Hewlett-Packard Sales and Service Office for service and repair to ensure that safety features are maintained.

### DANGEROUS PROCEDURE WARNINGS.

Warnings such as the example below precede potentially dangerous procedures throughout this manual. Intention contained in the warnings must be followed.

**WARNING**

**Dangerous voltages, capable of causing death, are present in this instrument.  
Use extreme caution when handling, testing, and adjusting.**

89-1175

## Table of Contents

### Chapter 1: General Information

Introduction .....	1-1
Manual Contents .....	1-1
Analyzer Description .....	1-2
Physical Configurations .....	1-2
Analyzer Memory .....	1-3
The System Specification .....	1-3
The Format Specification .....	1-3
The Trace Specification .....	1-3
List Displays .....	1-3
Waveform Displays .....	1-4
Chart Displays .....	1-4
Performance Verification .....	1-5

### Chapter 2: Installation

Introduction .....	2-1
Site Selection .....	2-1
Rear-Panel Address Switches .....	2-1
Rear-Panel Output BNC Connectors .....	2-2
Connecting Analyzer To System Under Test .....	2-2
Connecting Analyzer Through Probe Interface .....	2-2
Connecting Probes Directly To System Under Test .....	2-2
Connecting Operating Power .....	2-3

### Chapter 3: Getting Started

Introduction .....	3-1
Setup and Connections .....	3-1
Making Simple State Measurements .....	3-4
Capturing Activity From The System Under Test .....	3-4
Creating Meaningful Labels .....	3-6
Triggering A Trace On A Unique Occurrence .....	3-10
Controlling The State Display .....	3-13
Simple Timing Measurements .....	3-15
Activating The Timing Analyzer .....	3-15
Controlling The Timing Display .....	3-16
Selecting Trace Positions On The Display .....	3-19
Triggering On A Timing Event .....	3-20
Using The Relocation Feature .....	3-22
Setup For Relocation Use .....	3-24
Running A Trace With Relocation Addresses .....	3-28

## Table of Contents (Cont'd)

Using The User Base Feature .....	3-31
Setup For User Base Usage .....	3-31
Obtaining Displays In User Base .....	3-33
Making Coordinated State And Timing Measurements .....	3-34
Setup For State And Timing Measurements .....	3-34
Executing Coordinated Measurements .....	3-36
Using The Tape Memory Accessory .....	3-41
<b>Chapter 4: The Menu Map</b>	
<b>Chapter 5 Using The SYSTEM Menus</b>	
Introduction .....	5-1
[Configuration] System Specification .....	5-1
[Peripherals] System Specification .....	5-1
<b>Chapter 6: State Measurements</b>	
<b>Chapter 6A: State Analyzer FORMAT Specification</b>	
Introduction .....	6A-1
[Assignment] State Format Specification .....	6A-1
Label Assignments .....	6A-2
Clock Assignments .....	6A-2
Pod Threshold Assignments .....	6A-2
[Relocation] State Format Specification .....	6A-3
[User Base] State Format Specification .....	6A-4
<b>Chapter 6B: The State TRACE Specification</b>	
Introduction .....	6B-1
[Single] State Trace Specification .....	6B-1
[Continuous] State Trace Specification .....	6B-5
[Compare] State Trace Specification .....	6B-5
How To Make A Compare List .....	6B-7
[Overview] State Trace Specification .....	6B-8
<b>Chapter 6C: The State Display</b>	
Introduction .....	6C-1
List Displays .....	6C-1
[Single] List Displays .....	6C-1
[Continuous] List Displays .....	6C-3
[Compare] List Displays .....	6C-3
[Overview] List Displays .....	6C-4

## Table of Contents (Cont'd)

Waveform Displays .....	6C-4
XY Charts Of Label Activity .....	6C-6
Obtaining Inverse-Assembled Object Code In Analyzer List Displays .....	6C-7
<b>Chapter 7: Performance Analysis Measurements</b>	
Introduction .....	7-1
Performance Analysis By Overview Of A State Label .....	7-2
State Label Overview FORMAT Specification .....	7-2
State Label Overview TRACE Specification .....	7-2
State Label Overview Histogram Chart .....	7-2
Performance Analysis By Overview Of A Time Interval .....	7-5
Time Interval Overview FORMAT Specification .....	7-5
Time Interval Overview TRACE Specification .....	7-5
Time Interval Overview Histogram Chart .....	7-5
<b>Chapter 8: Timing Measurements</b>	
<b>Chapter 8A: The Timing FORMAT Specification</b>	
Introduction .....	8A-1
Timing Format Specification [Assignment] .....	8A-1
Timing Format Specification [User Base] .....	8A-1
<b>Chapter 8B: The Timing TRACE Specification</b>	
Introduction .....	8B-1
[Single] Timing Trace Specification .....	8B-1
[Continuous] Timing Trace Specification .....	8B-1
<b>Chapter 8C: The Timing Display</b>	
Introduction .....	8C-1
Waveform Displays .....	8C-1
List Displays .....	8C-3
Chart Displays .....	8C-6
<b>Chapter 9: Combined State/Timing Measurements</b>	
Introduction .....	9-1
The FORMAT Specification .....	9-1
The TRACE Specification .....	9-1
Interactive State/Timing Displays .....	9-2
<b>Appendix A: Using The Tape Memory Accessory</b>	
Introduction .....	A-1

## Table of Contents (Cont'd)

How To Create A New File .....	A-4
How To Read A File .....	A-4
How To Copy An Existing File From One Tape To Another .....	A-5
How To Copy An HP Write-Protected Inverse-Assembler File Into A User File .....	A-5

### Appendix B: Using A Printer

Introduction .....	B-1
Obtaining Hard Copy From A Printer .....	B-1
Using A Controller To Operate The Analyzer And Printer .....	B-3

### Appendix C: Using The HP-IB or HP-IL Interface

Introduction .....	C-1
HP-IB And HP-IL Interface Capabilities .....	C-1
HP-IB And HP-IL Interface Limitations .....	C-2
Keyboard Mnemonics .....	C-2
Non-keyboard Mnemonics .....	C-3
Learn String Commands .....	C-7
Format For Data Acquired .....	C-9
State Overview Data File (Data Type 1) .....	C-10
Time Interval Overview Data File (Data Type 2) .....	C-10
Data Transfer Termination .....	C-11

### Appendix D: Display Messages

#### Index

## List of Illustrations

3-1	Front Panel Controls .....	3-2
3-2	Default System Configuration For 1630D .....	3-5
3-3	Default Trace List .....	3-6
3-4	Default Format Specification .....	3-7
3-5	Labeling Address Bits In Trace List .....	3-8
3-6	Labeling Address, Data, and Control Bits In Trace List .....	3-10
3-7	Specifying A Trigger State .....	3-11
3-8	Trace List With Trigger At Start .....	3-12
3-9	Trace List With Trigger At Center .....	3-13
3-10	Trace List With [Show] Selected .....	3-14

### List of Illustrations (Cont'd)

3-11	Selecting The Timing Analyzer Configuration In 1630D	3-15
3-12	Default Timing Measurement For 1630D	3-16
3-13	Magnification Around "x"	3-17
3-14	Selecting Waveform Positions On Display	3-19
3-15	Triggering On A Pattern And Edge Transition	3-21
3-16	Triggering On A Timing Event	3-22
3-17	Address Map For Relocation Example	3-23
3-18	State Analyzer System Configuration	3-24
3-19	State Assignment Format Specification For 1630D	3-25
3-20	Relocation Menu Assignments	3-28
3-21	Trace List Using Values From Relocation Menu	3-29
3-22	State Assignment Format Specification With Two Labels For The Address Bits	3-30
3-23	Trace List Using Values From Relocation Menu And Corresponding Absolute Values	3-30
3-24	State Assignment Format Specification With Labels Added For WR-RD And MEMIO	3-31
3-25	State User Base Menu Setup	3-33
3-26	Trace List Using Values From Relocation And User Base Menus Together	3-34
3-27	Combined State/Timing Analyzer System Configuration	3-35
3-28	State Assignment Format Specification	3-35
3-29	State Trace Specification In State/Timing Measurements	3-36
3-30	State Trace Specification With Trigger In Row "b"	3-37
3-31	Timing Trace Specification For Combined State/Timing Measurements	3-38
3-32	Timing Waveform Display	3-39
3-33	Timing Trace Specification With Master [Timing]	3-40
3-34	Timing Listing Display	3-41
3-35	Tape Operations Menu	3-42
5-1	Configuration System Specification	5-2
5-2	Peripherals System Specification	5-3
6A-1	State Assignment Format Specification	6A-1
6A-2	State Relocation Format Specification	6A-3
6A-3	State User Base Format Specification	6A-4



### List of Illustrations (Cont'd)

6B-1.	State Single Trace Specification .....	6B-2
6B-2.	Sequence/Trigger Flow Chart .....	6B-3
6B-3.	Storage Example .....	6B-4
6B-4.	State Continuous Trace Specification .....	6B-5
6B-5.	State Compare Trace Specification .....	6B-6
6C-1.	Typical List Display In Single Trace Mode .....	6C-2
6C-2.	Typical List Display In Compare Trace Mode .....	6C-4
6C-3.	Typical State Waveform Display .....	6C-5
6C-4.	Typical State XY Chart Of A Label .....	6C-6
6C-5.	Example Display Showing HP Inverse-Assembled Data List .....	6C-9
7-1.	State Label Overview Trace Specification .....	7-3
7-2.	State Label Overview Histogram Chart .....	7-4
7-3.	State Time-Interval Overview Trace Specification .....	7-6
7-4.	Time Interval Histogram Chart .....	7-7
8A-1.	Timing Assignment Format Specification .....	8A-2
8A-2.	Timing User Base Format Specification .....	8A-4
8B-1.	Timing Trace Specification .....	8B-2
8C-1.	Typical Timing Waveform Display .....	8C-2
8C-2.	Typical List Display Of Timing Activity .....	8C-4
8C-3.	Typical Timing XY Chart Of A Label .....	8C-6
A-1.	Tape Operations System Menu .....	A-2
C-1.	Data Format For State Acquisition Learn String Sent On HP-IB .....	C-10

### List of Tables

1-1.	Specifications .....	1-6
1-2.	Operating Characteristics .....	1-8
C-1.	HP-IB/HP-IL keyboard Mnemonics .....	C-3



## Chapter 1 General Information

### Introduction

This manual describes how to operate the Hewlett-Packard Model 1630A and 1630D Logic Analyzer. This chapter describes the physical and electrical characteristics of the analyzer. At the end of this chapter are two tables: one lists the analyzer specifications guaranteed by HP, and the other lists the analyzer operating characteristics. The last paragraph in this chapter describes how to initiate the analyzer performance verification.

### Manual Contents

This manual contains instructions and information to help you install and operate the analyzer. It shows how to assign labels in the format specification to identify signals from the input probes, and shows how to assign symbols to represent values found on those labeled inputs.

Chapter 3 of this manual is called Getting Started. As soon as you can, you should perform the procedures in chapter 3. These will help you become familiar with the analyzer.

Chapter 4 is a map of the menus in the analyzer. It will help you understand the organization of the analyzer.

Chapter 5 discusses the System menus which you will use to set up the basic analyzer configuration for the type of measurements you will make.

Chapters 6 through 9 describe how to use the analyzer to perform state measurements, timing measurements, performance analysis measurements, and combined state/timing measurements, respectively. Each of these chapters discusses how to set up the menus and read the displays for the corresponding measurements.

Appendices in this manual show how to use the accessory digital cassette drive for a tape memory, how to obtain hard copy on an accessory printer, and how to control the analyzer through the HP-IB and/or HP-IL interfaces. The last appendix lists all of the error and status messages displayed by the analyzer.

## Analyzer Description

The analyzer performs trace measurements. It can trace the flow of synchronous states in a microprogrammed state machine. It can also trace electrical activity at several points during a period of system operating time. The analyzer can perform both state and timing measurements together, and interactively control the capture of information in each of these two functions.

The analyzer can perform overview measurements which allow you to analyze the performance of code modules in software-intensive systems. The analyzer can perform all of its measurements as a stand-alone instrument, or as part of a system controlled through a standard HP-IB or HP-IL interface bus.

### Physical Configurations

The following is a list of the analyzer configurations, components, and optional accessories:

1. HP Model Number 1630A Logic Analyzer. Offers 35 channels for state, timing, and combined state/timing measurements.
2. HP Model Number 1630D Logic Analyzer. Same as 1630A, except offers 8 additional channels for state and timing measurements.
3. HP Part Number 10271A General Purpose State Probe. Nine channels for collecting state activity plus an input clock channel. Used to supply state activity only.
4. HP Part Number 10272A General Purpose State/Timing Probe. Eight channels for collecting state activity or timing activity. No input clock channel.
5. HP Model Number 82161A Digital Cassette Drive. HP Option used to store instrument setups and captured data in tape memory.
6. HP Model Number 10269A Probe Interface with HP preprocessor option. HP option used to make all connections to interface the analyzer to a specific microprocessor.

### **Analyzer Memory**

The trace memory of the analyzer is 1024 states deep. It stores each qualified state captured by the input probes. The trace memory also stores measurements of time for the timing listing so you can analyze periods between occurrences of interest.

The compare memory in the analyzer is 16 states deep. It can store up to sixteen lines for comparison with the corresponding lines in the trace memory. You can set the analyzer to save any trace in which the lines of the trace memory are identical to the lines of the compare memory, or where the lines of the trace memory are not identical to the lines of the compare memory. Each state in the compare memory can be edited to specify polarity and set "don't care" comparisons.

### **The System Specification**

Use the menus in this specification to identify how the analyzer will be used: whether as a state analyzer, a timing analyzer (with or without glitch capture), or a combined state and timing analyzer. In this menu, you also identify the way the analyzer will operate when used as part of a system, or when using capabilities offered by accessories.

### **The Format Specification**

Use the menus in this specification to set up the way the analyzer formulates displays from its captured information. You can label individual bits or sets of bits, and assign names to identify address ranges and/or specific values found in those labeled sets. The analyzer will compose displays using your labels and names, if desired.

### **The Trace Specification**

Use the menus in this specification to enter parameters for making your measurements. You can set up the analyzer to trace state flow and/or record electrical activity at nodes in a system under test. The analyzer can also perform overview measurements to gauge the efficiency of selected software routines.

### **List Displays**

The analyzer composes lists of information captured from labeled sets of bits. These lists show a series of software executions, and/or a sequence of electrical activities at nodes in a system under test. Values shown in these lists can be expressed using names of your choice, as well as using numbers in the binary, octal, decimal, and hexadecimal number bases. Values can also be expressed as ASCII codes for labels having from 6 to 16 bits.

### **Waveform Displays**

The waveform display shows up to 16 individual traces of electrical activity on selected bits. Each trace is shown as a continuous line of high and low states. The waveform shows how the states changed with time at each monitored point. You can also see points on the traces where glitches were detected during the measurement, if desired. Glitch detection is accomplished by combining two timing probes to make a single channel, and using one of the probes as a glitch detector.

### **Chart Displays**

The analyzer can format two types of chart displays: XY charts, and histograms. XY charts show a plot of the flow of values on a labeled set of bits. You can control the horizontal and vertical scales of the chart to examine the details around areas of interest on the XY chart.

Histogram charts are bar graphs used to measure the performance of software modules in a system under test. The analyzer can show two types of histograms: state label histograms, and time interval histograms. A state label histogram shows the relative number of executions within each range of states you define. Up to eight ranges of states can be defined for a label histogram. Time interval histograms show eight time ranges; you can define the period of each range. You can set up the analyzer to make time interval measurements each time the software executes from one selected point to another in the system under test. The time interval histogram shows how often execution of the selected software module was completed within each of the time ranges you defined.



## Performance Verification

The performance verification is a self-test routine contained in the analyzer ROM. It checks for proper functioning of the measurement channels within the analyzer, and provides an indication on the display if the analyzer functions are normal. It also provides troubleshooting information in case an analyzer function is not normal.

To initiate the analyzer self-test, proceed as follows:

1. In the rear-panel set of address switches, set switch 6 to "1" (switch lever up).
2. Turn off the LINE power and then turn it back on. During power up, the analyzer will execute the self-test routine. When it has completed the self-test, the display will show "PV Tests Pass". Any other message (or a blank screen) is indicative of a problem.

### Possible Messages

PV Tests Pass  
Error in RAM  
Error in ROM #n Expected XX was YY  
Acq error  
nn nn nn nn nn nn nn

To return to the normal logic analysis mode after the test, set switch 6 to "0" (switch lever down). It is not necessary to cycle the LINE power switch at this time.

If your instrument does not pass the self-test, and you want to return it to Hewlett-Packard for service, fill out one of the tags at the back of this manual and attach it to your instrument. Be sure to note the failure message from the CRT on the tag.

**Table 1-1. Specifications**

Measurement Configurations

	STATE	TIMING
1630A	35	0
	0	8
	27	8
1630D	43	0
	0	16
	35	8
	27	16

Note: Number of timing channels halved in Glitch mode

Measurement Functions

Memory

Data Acquisition	1024 words
Compare	16 words.
Search	Memory may be searched for any pattern defined within a label set. All pattern matches in memory may be marked or separately displayed.

Input Specifications

Clock repetition rate	25 MHz with single clock and single edge specified.
Single Phase	20 MHz with any ORed combination of clocks and edges
Multiplexed	Master/Slave clock timing. Master clock must follow slave clock by at least 10 ns and precede next slave clock by 50 ns or more.
Clock Pulse Width	$\geq 10$ ns at threshold.
RC	100 kilohms $\pm 2\%$ shunted by approx 5 pF at probe body
Setup time	time data must be present prior to clock transition, $\geq 20$ ns.
Hold time	time data must be present after clock transition, 0 ns
Minimum swing	600 mV p-p.
Minimum input overdrive	250 mV or 30% of input amplitude, whichever is greater

**Table 1-1. Specifications (Cont'd)**

Maximum voltage:	+40 volts, peak
Threshold Range:	-9.9 volts to +9.9 volts in 0.1-volt increments. Accuracy 2.5% $\pm$ 120 mV
Dynamic Range:	$\pm$ 10 volts about threshold.
Glitch:	With glitch detection on, number of timing channels are halved. Minimum detectable glitch: 5 nsec width at threshold.
Operating environment	
Temperature:	0 to 55 degrees C (32 to 131 degrees F), 20 to 30 degrees C recommended.
Humidity:	up to 95% relative humidity at +40 degrees C, 40% to 80% relative humidity recommended.
Altitude:	to 4600 m (15,000 ft)
Vibration:	vibrated in three planes for 15 min. each with 0.3 mm excursions, 5 to 55 Hz.
Dimensions:	

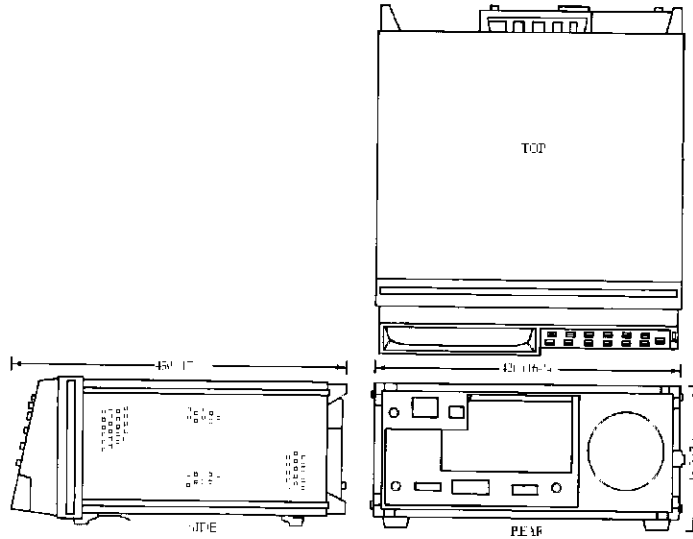



**Table 1-2. Operating Characteristics**

State Mode	
Clocks	three ORed clocks operate in single-phase or two-phase demultiplexing mode. Clock edge is selectable as positive, negative, or both edges for each clock. Different edge selections may be made on the same clock if used in each phase of the multiplexed mode.
Data Indexing	
Resources:	four terms including the Boolean NOT of each term, ALL patterns, or NO pattern. (A term is the AND combination of bit patterns in each label.) Terms may be used as often as desired.
Trigger:	up to four resource terms may be used in sequence to establish the trace parameter. The last term in the sequence may use up to four resource terms in an ORed format.
Restart:	one to four resource terms may be used in an ORed condition for a sequence-restart condition.
Store qualifiers:	one to four resource terms may be used in an ORed format. Store qualification may be separately defined for each term in the trigger sequence.
Occurrence	occurrence of the last event in the sequence may be specified up to $n = 59999$ .
Compare	trace until compare "equal to" or "not equal to" is provided. The compare file is the width of the analyzer, with a depth up to 16 words. Each word in the compare buffer can have "don't cares" and can be compared anywhere in the 1024 deep memory.
Arming:	the state analyzer can be armed by the full Data Indexing capability of the Timing Analyzer.

**Table 1-2. Operating Characteristics (Cont'd)**

Overview	
XY Chart:	a chart of any user-defined label can be shown. The user can change the upper and lower bounds of the chart, and all 1024 states of the memory can be simultaneously displayed
Time measurement:	a timer can be started on completion of a sequence of up to three resource terms with restart and occurrence capability like state data indexing. The timer can be stopped and/or restarted on OR'd combinations of one to four resource terms. A histogram of the start/stop time measurement is displayed. The user can specify up to eight time ranges. Minimum time, maximum time, average time, last time, total time, and total samples are also displayed. Resolution - displayed statistics 250 ns or 0.1% of reading, whichever is greater. 4-digit display. - Histogram ranges 1 microsecond
State histogram	a histogram of any user-defined label can be shown. The user can specify up to eight labels and ranges. Maximum Count - 263-1. Resolution - actual count is rounded to 0.1% (4-digit display).
Timing mode	
Clock	
Ranges	10 ns to 500 ms in 1, 2, 5 sequence
Accuracy:	+/-0.01%
Data Indexing	
Asynchronous pattern:	20 ns to 1 ms in 1, 2, 5 sequence with an accuracy of +/- 20% or 15 ns, whichever is greater.
Glitch or edge on any channels AND'd with asynchronous pattern	
Maximum time delay.	approx 2 <sup>18</sup> times the sample period to a maximum of 9999 sec.

**Table 1-2. Operating Characteristics (Cont'd)**

Arming:	the timing analyzer may be armed by the full data indexing capability of the state analyzer
Markers	time between dual markers (x and o) is displayed to accuracy of one sample period.
Expansion	X1 to X40 in 1, 2, 4 sequence. Display is a compressed representation of the 1K memory in X1 magnification. In X2 magnification, each displayed sample represents a single sample in memory.
Overview	a chart of any user-defined label can be shown. The user can change the upper and lower bounds of the chart, and all 1024 states of the memory can be simultaneously displayed.
General Characteristics	
Labels	
Input channel labels	up to 8 state, 16 timing, user-defined, 5-character labels may be assigned bit patterns in any configuration. Bits may be used in more than one label and need not be contiguous. Primary use is for identifying bits assigned to bus structures such as Address, Data, and Status.
User field:	all labels with 4 bits or less allow mnemonics to be assigned to specific patterns. Primary use is to identify such functions as Read, Write, Op Code, etc.
Relocatable field:	any single state label may be defined to have relocatable properties to facilitate viewing software modules in the format they were written. Up to 16 module starting locations may be specified, allowing trigger parameters to be based on module names, plus an offset value. An onboard calculator that operates in hex, octal, binary, or decimal facilitates general offset calculations.
Time-of-day-clock:	24-hour clock prints out time of data collection on all stored records.

**Table 1-2. Operating Characteristics (Cont'd)**

Activity Markers	provided in format display for quick identification of active inputs.
Outputs	
HP-IB.	<p>HP-IB connector with 8-position HP-IB switch located on rear panel. Five positions on switch are used to determine address. 2 positions used to determine TALK ONLY mode for hardcopy, or system controller</p> <p>HP-IB can be used in following environments</p> <ol style="list-style-type: none"> <li>1. Logic analyzer being controlled from a controller, such as HP 9826A Maximum bus transfer rate is approximately 4K bytes per second</li> <li>2. Stand-alone hard copy on a graphics printer, such as HP 2671G</li> </ol>
HP-IL	<p>HP-IL connector located on rear panel for HP-IL control, or for interfacing to HP 82161A, low-cost mini-cassette drive. Not required to use analyzer, but enhances analyzer operation as follows:</p> <ol style="list-style-type: none"> <li>1. Storage of user setups and measurement results, 10 different files can be stored on one cassette</li> <li>2. When coupled with an appropriate pre-processor, allows analyzer to assume a processor-specific personality to present data in mnemonic format.</li> </ol>
Rear-panel BNCs	<p>one output BNC labeled PORT, located on rear panel, with a TTL output level, high <math>\geq 2V</math> into 50 ohms; low <math>\leq 0.4V</math> into 50 ohms</p> <p>The BNC can be programmed from the keyboard to provide the following signals</p> <ol style="list-style-type: none"> <li>1. Pulse on State Trace Point</li> <li>2. High until State Trace Point</li> <li>3. Low until State Trace Point</li> <li>4. High on last Sequence.</li> <li>5. High on Timing Pattern</li> <li>6. Constant High</li> <li>7. Constant Low</li> </ol>

**Table 1-2. Operating Characteristics (Cont'd)**

	one BNC labeled ACCESSORY POWER supplies +5V for preprocessor or logic probes
Weight	1630A: 12.6 kg (28 lb) net, 17 kg (38 lb) shipping 1630D: 13.2 kg (29 lb) net, 17.7 kg (39 lb) shipping
Power requirement	115/230 Vac, -22% to +10%; 275W max, 48 to 66 Hz.
Accessories supplied	three 10-bit 10271A state probes and one 10272A state and timing probe with 1630A (two 10272A with 1630D), one 2.3 m (7.5 ft) power cord, one Operating Manual
Service And Calibration Support	The 1630A/D contains all necessary interfaces to allow high-speed troubleshooting and calibration with automatic equipment. Guided probe techniques, utilizing signature analysis under computer control, coupled with special test instruments and fixtures allow most failures to be isolated to the component level in a minimum amount of time. After repair, full and complete calibration can be accomplished in minutes, using the same equipment. Since this integrated design can only be serviced efficiently and economically with this automated system, all major HP service facilities have installed this special equipment. This HP investment will provide you with the fastest, most complete and lowest cost repairs and calibrations. For those companies where economies of scale make in-house repair and calibration cost-effective, an option is available that provides the special hardware, software and related documentation and training to allow 1630A/D repair. Additional test equipment is required. Contact your local HP sales representative for further information.

## Chapter 2 Installation

### Introduction

The purpose of this section is to show you how to set up the analyzer and connect the probe cables to make measurements in a system under test.

### Site Selection

Place the logic analyzer on a clean workspace which has adequate ventilation.

### Rear-Panel Address Switches

The address switches are a set of eight switches on the mainframe rear panel. These configure the analyzer to operate on the HP-IB and/or HP-IL interface buses, and to execute the performance verification self-test. Refer to the label located below the address switches to set the switches for desired operation.

- a. If you are operating the analyzer as part of a system, set switches one through five to select the system address for your analyzer. Set switches seven and eight to select the desired system controller.
- b. If you are operating the analyzer in a stand-alone configuration, with or without an external printer, set switches seven and eight to select the TALK ONLY mode (both switches to "0").
- c. Set switch six to "0". Switch six is only set to "1" during the performance verification self-test.

#### NOTE

---

A switch is set to "1" when its toggle lever is up, and set to "0" when its toggle lever is down.

---

### **Rear-Panel Output BNC Connectors**

The rear-panel BNC labeled ACCESSORY POWER provides 5 volts for operating an external HP preprocessor or logic probes.

The rear-panel BNC labeled PORT provides a TTL control signal whose characteristics are selectable in the SYSTEM [Peripherals] menu for control of external measurement instruments and equipment.

### **Connecting Analyzer To System Under Test**

The analyzer can gather information through either the Model 10269A Probe Interface or through direct connections from the general purpose probes. The procedures to be followed when making connections differ. Refer to the procedure that describes how to make connections using your interface.

#### **Connecting Analyzer Through Probe Interface**

1. Connect the probe pods from the analyzer to the appropriate pod sockets on the probe interface. Refer to the manual for the general purpose preprocessor.
2. Connect the ribbon cable from the probe interface (with preprocessor interface module installed) to the microprocessor in the target system.
3. Connect a BNC cable from the ACCESSORY POWER BNC on the analyzer rear panel to the ACCESSORY POWER (+5v) BNC connector on the probe interface.

#### **Connecting Probes Directly To System Under Test**

1. Snap on the adapters for each of the general purpose probe pods.
2. Connect the line for each probe bit to monitor a node in the system under test. Leave extra lines unconnected. Do not connect signals with different threshold levels (some TTL and some ECL, for example) in the same probe pod.
3. Connect the ground probe from each pod to a ground point in the system under test.





### Connecting Operating Power

Before connecting operating power, set the associated power selector switch to identify the kind of power in use either 115V or 230V. Then connect the line power cord from the analyzer to a source of operating power.



## Chapter 3 Getting Started

### Introduction

The purpose of this chapter is to help you become familiar with the Model 1630A/D Logic Analyzer. This chapter shows you how to use the analyzer by leading you through a series of steps in which you gather information about the software in your system. First, you will use the analyzer to make state measurements. Next, you will make timing measurements. Then you will make a series of measurements using some of the special features of the analyzer. Finally, you will make coordinated state and timing measurements together.

The keyboard of the 1630A/D Logic Analyzer is simple to use, after a short familiarization, but it is not a key-per-function keyboard. Functions are layered on the keys via the instrument menus. The functions of each of the keyboard keys is discussed in figure 3-1.

### Setup And Connections

The demonstration procedures in this chapter can be performed using any 8-bit or 16-bit microprocessor system as a source. If you are going to make measurements on a system which has an Intel 8085, these connections will apply directly to you. If you are going to use a system which has any other microprocessor, this procedure will describe the modifications you need to make to obtain proper operation.

1. Set the rear-panel power-selector switch to identify the operating power in use (either 115V or 230V).
2. Connect the power cord to a source of operating power.
3. Refer to chapter 2 of this manual and follow all of the procedures, as applicable.
4. If you are using a preprocessor interface with a personality module to connect to the microprocessor in your system, the interface will make all of the clock and probe channel connections. You can skip the remainder of this procedure and begin with Making Simple State Measurements.

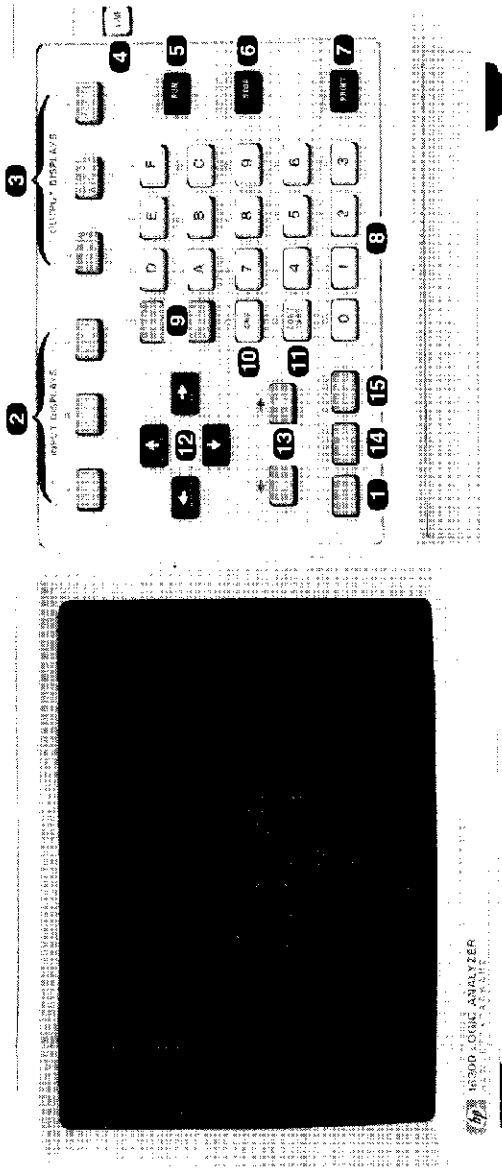

- 1** blue key: This key activates the blue SHIFT function assigned to each keyboard key. A momentary press activates the SHIFT function for the next keystroke. The SHIFT function will continue as long as you keep the blue key pressed.
- 2** INPUT DISPLAYS: Three keys that select sets of 1630A/D menus. SYSTEM calls up menus that define the instrument configuration, set up secondary configurations and outputs for peripherals, and control tape operations (when the 82161A drive is connected and active). FORMAT has three menus that determine how data is collected and interpreted on the display. TRACE has a series of menus that specify the measurement mode and parameters for collecting data.
- 3** OUTPUT DISPLAYS, three keys that select a state display (LIST), timing display (WFORM), or performance overview chart (CHART).
- 4** LINE. Turns on operating power.

- 5** RUN initiates a new measurement; RESUME continues an incomplete measurement that was halted by pressing the STOP key.
- 6** STOP. Terminates a measurement; RETURN TO LOCAL overrides an HP-IB or HP-IL controller to return control of the analyzer to the keyboard.
- 7** PRINT commands the current display content to be printed on an HP-IB graphics printer; PRINT ALL prints the entire content of the displayed menu or list, including all on-screen and off-screen information.
- 8** Hex keyboard for data entry.
- 9** NEXT and PREV keys cycle through all the menu selections available for fields enclosed in brackets, [ ].

Figure 3-1. Front Panel Controls

- 
- 10 CHS. Used to change +/- signs when specifying memory locations in either direction from the trigger event, and when specifying polarities. This key will also print a dash when used in a text field
  - 11 DON'T CARE enters an "X" in lieu of a number, to indicate "any value will serve"
  - 12 CURSOR. These keys move the cursor from field to field in the menus. The blue SHIFT function allows these keys to rearrange the order of labels in the menus, and to move the cursor from pod to pod in the label lines of the FORMAT [Assignment] menu. The CURSOR keys can also move the configuration bar in the SYSTEM [Configuration] menu, and the "x" and "o" markers on the waveform and chart displays.
  - 13 ROLL keys move timing displays left or right, state lists up or down, and the configuration bar in the SYSTEM [Configuration] menu
  - 14 INSERT/DELETE are used to add or delete fields and labels
  - 15 CLEAR ENTRY. This is the field eraser key, DEFAULT returns all fields in the displayed menu to their power-up conditions

Figure 3-1. Front Panel Controls (Cont'd)

5. If you are using the general purpose adapters to connect analyzer probe channels to pins of the microprocessor in your system, make the connections as follows:
  - a. Connect the channels of pod 2 to the lower nine bits of the address bus (channel 0 to the LSB, channel 1 to the next bit, etc).
  - b. Connect the channels of pod 3 to the next higher seven bits of the address bus. (Leave channels 7 and 8 open on pod 3.)
  - c. Connect the channels of pod 1 to the least significant eight bits of the data bus (channel 0 to the LSB, channel 1 to the next higher bit, etc).
  - d. Connect the channels of pod 4 to the control lines in your system under test to obtain status information.
  - e. Connect the clock line of pod 2 (the L clock) to the address clock. Connect the clock line of pod 4 (the J clock) to the data clock.

**NOTE**

---

If you are making connections to a system that uses a single clock, connect it to the L clock line of pod 2.

---

6. Leave all remaining channels of the probe pods unconnected. This completes the connections required to use the analyzer in the procedures described in this chapter.

**Making Simple State Measurements**

The following procedure will show you how to capture state flow using the analyzer. It will show you how to arrange the state activity into labeled fields, how to trigger a trace during particular occurrences in state flow; and how to get a desired portion of the captured information on the display.

**Capturing Activity From The System Under Test**

1. Turn on operating power in the system you are going to use as a signal source for making these tests.

2. Turn on the LINE pushbutton power switch on the front panel of the analyzer. The analyzer will execute its boot-up routines and configure itself to make a simple state measurement (all channels will be dedicated to making state measurements, and none to making timing measurements). This configuration is shown by the position of the bright bar on the system specification (figure 3-2).
3. Press the RUN key on the front panel. The analyzer will execute a single trace, capture data, and present a list on screen. The list will be one column of information. The column will include all of the activity captured from all of the analyzer channels. An unconnected probe bit will show up as 0 on the trace list. The list may not make much sense right now, but its presence ensures that the analyzer is connected to the system under test, and it can gather data. See figure 3-3.



**Figure 3-2. Default System Configuration For 1630D  
(1630A has 8 less channels)**

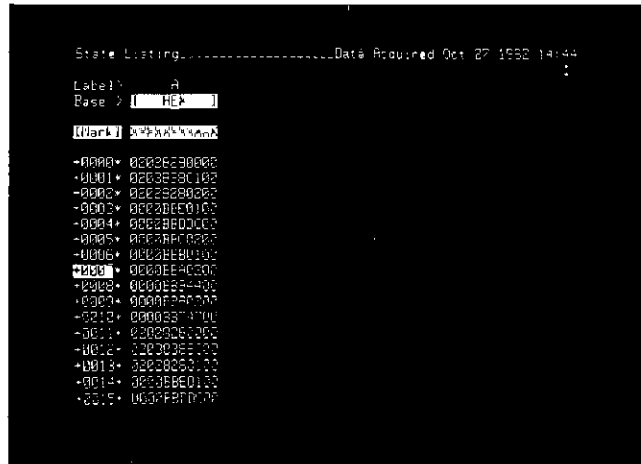
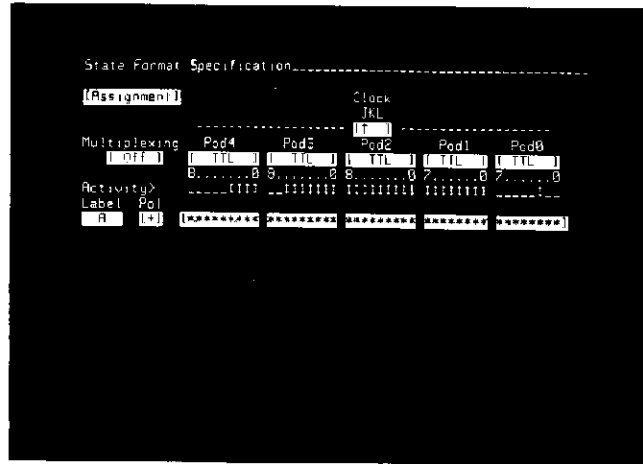

Figure 3-3. Default Trace List

#### Creating Meaningful Labels

- 1 Press the FORMAT key. This selects the Format Specification menu. In this menu, you select the arrangement for presenting captured data so that the information will be easy to read and interpret. See figure 3-4
- 2 The cursor selects the field of the menu to be edited by the keyboard keys. Use the CURSOR keys to move the cursor from field to field on the State Format Specification menu. Notice that the cursor will advance left-to-right and right-to-left if you hold down the corresponding CURSOR arrow key, and it will stop at the end of the row. By a series of presses of the same CURSOR arrow key, the cursor will travel across each row and it will advance from row to row on the menu.
- 3 Notice that the format specification was automatically loaded with label "A", and that label A includes all of the bits of information from all of the probe lines in the analyzer. (Each asterisk indicates the corresponding probe line is included in the label.)



**Figure 3-4. Default Format Specification**

4. Press the CURSOR-down-arrow key three times. This places the cursor in the name assignment field of label A.
5. Notice the message at the top of the screen. This tells you that the analyzer is ready to create new labels, if desired.
6. Press the INSERT key. This creates a new label field in the format specification. It has no name, and no bits are assigned to it.
7. From the keyboard, type in ADDR5 under label in the new field. (Press the blue SHIFT key to obtain keyboard blue functions, press and hold the blue shift key to type a series of SHIFT functions.)
8. Press and hold the CURSOR-right-arrow key to move the cursor down the label line until it is in bit 6 of pod 3.
9. Press the NEXT key sixteen times or hold it down. The asterisks that appear in the entries under Pod3 and Pod2 assign the corresponding probe bits to the label named ADDR5.

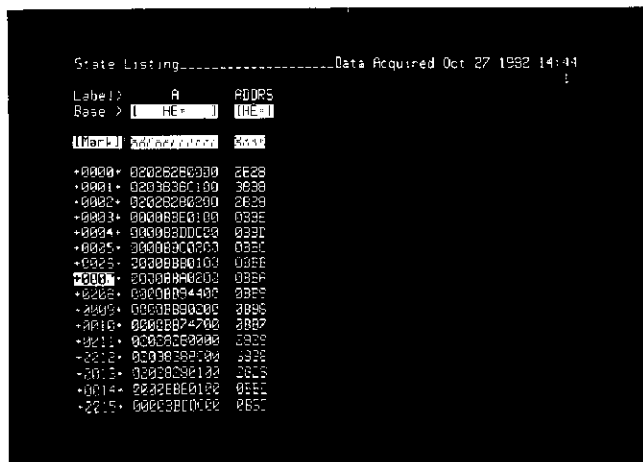

**Figure 3-5. Labeling Address Bits In Trace List**

10. Press the LIST key. See figure 3-5. The information collected from the sixteen channels of pod 3 and pod 2 (connected to the address bus in your system) is shown under a separate label called ADDR. Is this the address space you expected to see executed by the system under test? If not, check your probe connections and check the clock polarity in the format specification.
11. Press the FORMAT key. Now you can create new labels for the information collected from the data bus and the control bus.
12. Press the INSERT key. This opens a blank field for a new label on screen.
13. Type in DATA from the keyboard, and then press the CURSOR-right-arrow key and hold it until the cursor steps down the label field to bit 7 of pod 1.



14. Press the NEXT[] key eight times. This gathers all of the information obtained by the eight probe channels of pod 1 under the label called DATA. These are the channels you connected to the data bus in your system under test.
15. Press the INSERT key again.
16. Type in CNTRL, and use the CURSOR keys to move the cursor into the probe field under pod 4 where you connected the probe channels to control lines in your system under test.
17. Press the NEXT[] key, as required, to assign (with asterisks) the bits of pod 4 that are connected to control lines in the system under test.

#### NOTE

---

The bits included in a label do not need to be physically adjacent. Channel 2 in pod 1 can be combined with channel 5 in pod 3 to make a single label consisting of two probe bits.

---

18. Press the LIST key. Now your list display will show the original label A, along with separate columns of information collected from the address lines, the data lines, and the control lines. (See figure 3-6.)
19. Use the CURSOR-right-arrow key to move the cursor to the [HEX] field under the CNTRL label.
20. Press the NEXT[] key two times to select binary as the numerical base for display of control information. Now you can see the conditions of each of the control lines as the measurement was made.
21. Press the FORMAT key.
22. With the CURSOR-up-arrow key, move the cursor up into the row of label A.
23. Press the blue SHIFT key and DELETE key to remove label A from your analyzer.

State Listing.....Data Acquired Oct 27 1982 14:44

Label	A	ADDRS	DATA	CTRL
Base	(Hex)	(Hex)	(Hex)	(Bin)
[Blank]	XXXXXXXX	XXXX	XX	XXXX
+0000-	2232220000	2826	30	1001
+0001-	2232220100	2826	30	1001
+0002-	0000220000	0326	30	0001
+0003-	0000220000	0326	31	0001
+0004-	0000220100	0326	30	0001
+0005-	0000220000	0326	30	0001
+0006-	0000220000	0326	30	0001
+0007-	0000220200	0326	30	0001
+0008-	0000220400	0326	31	0001
+0009-	0000220200	0326	30	0001
+0010-	0000220400	0326	31	0001
+0011-	2232220000	2826	30	1001
+0012-	2232220100	2826	30	1001
+0013-	2232220000	2826	30	1001
+0014-	0000220000	0326	30	0001
+0015-	0000220000	0326	30	0001

Figure 3-6. Labeling Address, Data, and Control Bits In Trace List

- 24 Press the LIST key. See that only your own labels are present on the list display.

**Triggering A Trace On A Unique Occurrence**

1. Select one of the addresses from the ADDRS column on the list display, and write it down.
2. Press the TRACE key. This brings the trace specification to the display. In this specification, you can set up the conditions that will define the trigger point and the kind of activity to be captured in the trace memory.
3. Press the CURSOR-down-arrow key to place the cursor in the [any state] field. This is where trigger selections can be specified.
4. Press the NEXT[] key two times. This selects trace triggering to occur when the analyzer finds the state defined in row "a" on the display.

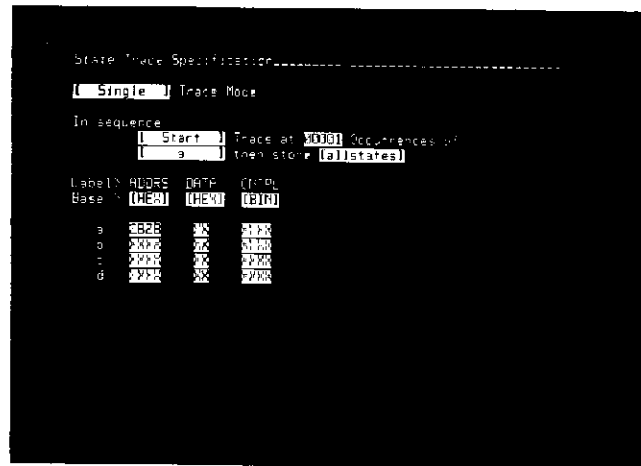

Figure 3-7. Specifying A Trigger State

5. Press the CURSOR-down-arrow key to place the cursor in row "a"
6. Using keyboard keys, type in the address you wrote down in step 1 above. This sets up the state measurement function to trigger when it finds your selected state on the address lines. The X's under DATA and CNTRL indicate that any states on those lines will satisfy the row "a" specification. See figure 3-7.
7. Press the RUN key. The analyzer will monitor activity from the system under test until it finds the state you specified on the address lines. Then it will capture that state into memory and store each state that it finds after that until its memory is filled one time. Then it will stop storing states and place the message "Trace Complete" at the top of the screen. See figure 3-8.

```

State Listing-----Data Acquired Oct 27 1992 14:44
Label: > ADDR_ DATA_ CTRL_
Base: > [HEX] [HEX] [HEX]
[Start] [ ] [ ] [ ]
-0000+ 2828 00 1000
-0001+ 3828 01 1000
-0002+ 2828 02 1000
+0003+ 0828 01 0000
+0004+ 0828 02 0000
+0005+ 0828 03 0000
+0006+ 0828 04 0000
+0007+ 0828 05 0000
+0008+ 0828 06 0000
+0009+ 0828 07 0000
+0010+ 0828 08 0000
+0011+ 0828 09 1000
+0012+ 0828 0A 1000
+0013+ 0828 0B 1000
+0014+ 0828 0C 0000
+0015+ 0828 0D 0000

```

**Figure 3-8. Trace List With Trigger At Start**

8. Note that the state you specified as trigger is the first state on your display (line number 0000). Trigger was specified to be the start of the trace.
9. Press the TRACE key
10. Press the CURSOR-up-arrow key to place the cursor in the [Start] trigger position field.
11. Press the NEXT[ ] key to select center of memory for your trigger position
12. Press the RUN key. The analyzer will begin storing states into memory. When it finds the state you specified as trigger, it will capture that state and then store an additional number of states equal to one-half of the memory. The states that were captured before trigger will be identified on the list with line numbers preceded by minus signs. The states captured after the trigger state will be identified by line numbers preceded by plus signs. See figure 3-9.

State Listing-----Data Acquired Oct 27 1992 15:05

Label	ADDRS	DATA	CNTN
Base	[HEX]	[HEX]	[HEX]
[MARK]			
-0007*	03B1	17	0110
-0006*	03B0	FF	0110
-0005*	03AF	54	0110
-0004*	03AE	0A	0110
-0003*	03AD	F0	0110
-0002*	03AC	06	0110
-0001*	03AB	06	0110
*0000*	2828	00	1110
+0001*	3030	E3	1110
+0002*	2828	20	1110
+0003*	0EAA	01	0110
+0004*	0EAS	0C	0110
+0005*	0EAE	2E	0110
+0006*	0EAF	0E	0110
+0007*	0EAB	20	0110
+000E*	0EAS	44	0110

Figure 3-9. Trace List With Trigger At Center

**NOTE**

If the trigger state is found before the first half of memory is completely filled with states, the portion of unfilled memory will not be available for display in the list.

**Controlling The State Display**

1. Press the CURSOR-down-arrow key to place the cursor in the ADDRS field beside the [MARK] indicator.
2. Type in the state you selected for a trigger state. The analyzer will place an asterisk on screen to mark each line that has your selected state. You can use the ROLL-up-arrow and ROLL-down-arrow keys to scroll through memory and see the states with asterisks beside them.
3. Press the CURSOR-left-arrow key to bring the cursor into the [MARK] field

```

State Listing-----Data Acquired Oct 27 1992 15:06
Label: ADDR5  DATA  CTRL
Base > [HEX] [HEX] [BIT]
[Show] 2020  00  2055

-0203> 2020  00  11:0
-0202 2020  20  11:2
+0011 2020  00  11:0
+0010 2020  10  11:0
+0022 2020  05  11:0
+0024 2020  00  11:0
+0033 2020  00  11:0
+0035 2020  24  11:0
-0244 2020  00  11:0

```

**Figure 3-10. Trace List With [Show] Selected**

4. Now press the NEXT[ ] key. The field will change to [SHOW], and the display will show only those lines from memory that have the address state you selected. See figure 3-10.
5. If the display shows many lines, alternately press the ROLL-up-arrow and ROLL-down-arrow keys. The display will scroll through memory and show you all of the memory locations that meet the specification of the [SHOW] line above.
6. Notice the ">" symbol beside one of the line numbers on screen. This identifies which line in memory will be shown on screen. If you select a [MARK] display (which includes all lines of memory).
7. Press the NEXT[ ] key to select a [Mark] display. The line that had the ">" symbol beside it is centered on screen. Its line number is shown in inverse video.
8. Press the CURSOR-down-arrow key to move the cursor into the inverse-video line number field.

9. Use the CURSOR-right-arrow key to move the cursor two locations to the right. Now type in a different line number. See that the display window is repositioned to the location in memory which includes the line number you just typed in.

### Simple Timing Measurements

The following procedure shows you how to make measurements of time-related activity in logic systems. You will see how to trigger traces of electrical activity and how to compose desired displays and measure activity on the displays.

#### Activating The Timing Analyzer

1. Press the SYSTEM key.
2. Press the ROLL-down-arrow one time or CURSOR-down-arrow two times. This moves the bright bar to the second analyzer configuration. All channels which can collect timing information are activated for timing measurements. No channels are active for state measurements. See figure 3-11.

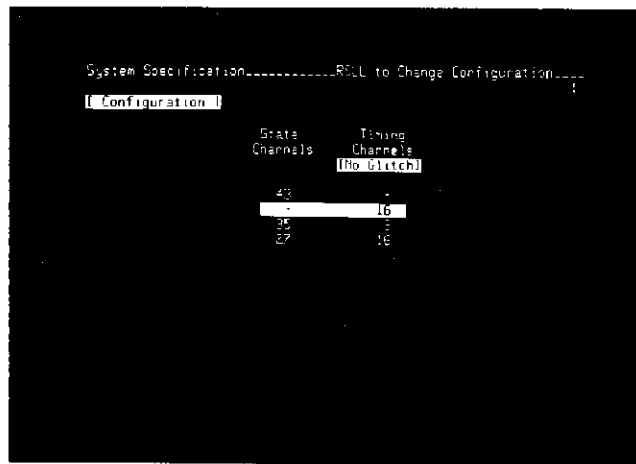
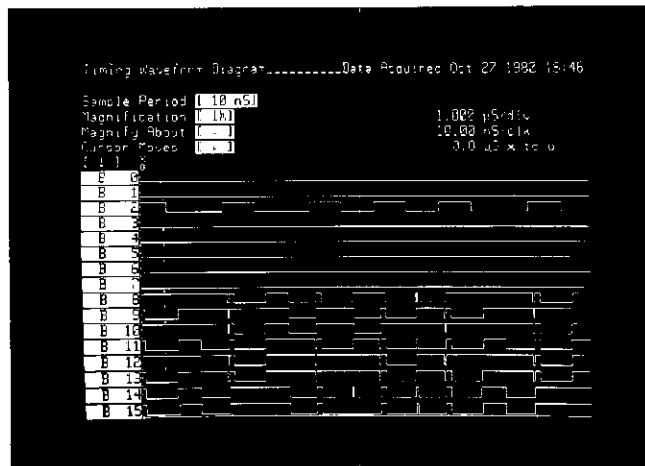

Figure 3-11. Selecting The Timing Analyzer Configuration In 1630D (1630A has 8 less channels)



**Figure 3-12. Default Timing Measurement For 1630D  
(1630A has 8 less channels)**

- 3 Press the RUN key. The analyzer will execute a measurement at the default specification (trigger on anything), and present a waveform display on screen. This display is at X1 magnification. It shows the entire 1K memory content on screen. Unconnected timing bits are constant lows. See figure 3-12.

#### Controlling The Timing Display

- 1 Press the CURSOR-down-arrow to select the Magnification field.
- 2 Press the NEXT[] key to obtain 4X magnification. This shows a window in the timing memory. One-fourth of the memory is on screen.
- 3 Press the ROLL-down-arrow to see the window move through the timing memory (display moves across the screen).
- 4 Press the NEXT[] key several times to see the magnifications available. Select a magnification factor that leaves several waveform transitions on screen.



5. Press and hold the CURSOR-right-arrow key until the "x" marker moves out onto the display area. Place the "x" marker on one of the waveform transitions on the display. The first line above the waveforms on the right-hand side of the screen shows the measurement of time between the start of the memory and the position where you placed the "x" (o to x).
6. Press the NEXT[ ] key several times to see that magnification of the display occurs around the area in memory you selected by the position of "x". See figure 3-13.
7. Press the CURSOR-down-arrow to select the Magnify About field.
8. Press the NEXT[ ] key to change "x" to "o".
9. Move the cursor up into the "Magnification" field.
10. Press the NEXT[ ] key several times. Notice that display magnification now occurs around the position of "o" (at the start of the timing memory).
11. Select a magnification that leaves the "x" marker on screen.

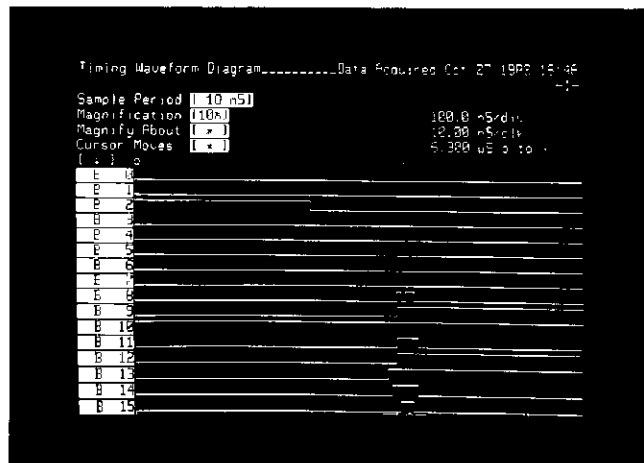

Figure 3-13. Magnification Around "x"

12. Press the CURSOR-down-arrow key to select the "Cursor Moves" field
13. Press the NEXT[] key to change "x" to "o".
14. Press the CURSOR-right-arrow key and hold it to move the "o" out on the display. Notice the time measurement indication change as the "o" moves closer to the "x"
15. Place the "o" marker on another waveform transition on the display.
16. The time measurement indication on the display will show you the measure of time between the two waveform transitions you selected using the "x" and "o" markers.
17. With the cursor in the "Cursor Moves" field, press the NEXT[] key to obtain the [x&o] indication. With this selection, the "x" and "o" markers will move together and maintain a constant interval between them. You can use these two markers together to compare intervals between any two points of interest on the display.
18. Move the cursor into the "Magnification" field and use the NEXT[] key to obtain a X1 display
19. Use the CURSOR-right-arrow and CURSOR-left-arrow keys to move the "o" and "x" markers together to another set of waveform transitions on the display
20. Place the "x" marker on one of the waveform transitions
21. Move the cursor down into the "Cursor Moves" field and press the PREV[] key to select "Cursor Moves [o]".
22. If the events are not the same distance apart as the first set, use the CURSOR keys to move the "o" marker alone. You can measure the dimension between the two new waveform transitions
23. Press the CURSOR-left-arrow and CURSOR-right-arrow keys. Notice that the "o" marker can cross the "x" marker, and the measurement indication above the traces will correct itself (show "x to o" or "o to x")

### Selecting Trace Positions On The Display

1. Press the CURSOR-down-arrow key to move the cursor into the B5 field.
2. Press the PREV[ ] key several times. You can place any of the bits from the timing memory at any location on the display. You can also turn off a display channel, if desired.
3. Press the DELETE key several times. You can eliminate channels from the display, if desired. Note that the vertical display is magnified when eight or less channels are on screen.
4. Press the INSERT key several times. You can add channels to the display, up to a maximum of 16 channels in non-glitch mode and 8 in glitch mode. See figure 3-14.
5. Press the blue SHIFT key and DEFAULT. This restores all channels in the display to their original positions.

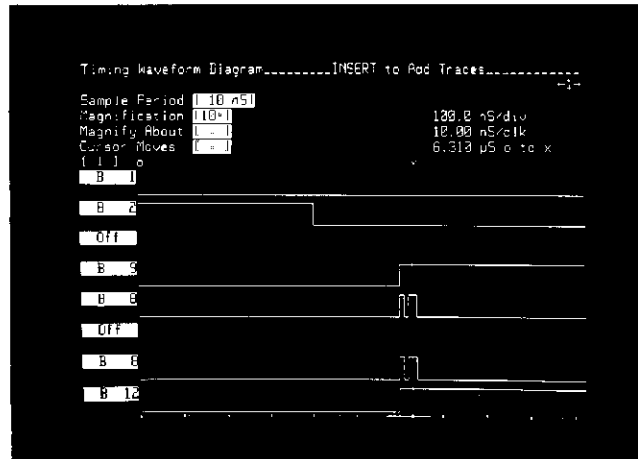
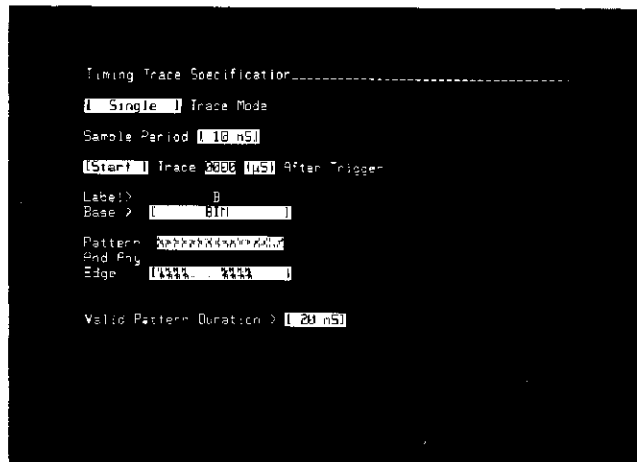

Figure 3-14. Selecting Waveform Positions On Display

### Triggering On A Timing Event

- 1 Find a point on the waveform display where two of the channels are high at the same time that one of the other channels has a transition from low to high (change display magnification, if necessary) Write down these three channel numbers and their conditions
- 2 Press the TRACE key
- 3 Use the CURSOR keys to place the cursor in the row of X's in the Pattern field This is an AND field Its default state is all don't cares All "1" or "0" specifications that you enter in this field must be met during the same clock period in order for the timing analyzer to recognize its trigger
- 4 Use the CURSOR keys to place the cursor at the points in the "Pattern" field which correspond to the bits that you noted as having high states Enter a "1" from the keyboard in each of these two bits (B0 is the first bit on the right-hand side of the field)
- 5 Use the CURSOR keys to place the cursor in the "Edge" field The "Edge" field is an OR field You can specify recognition of low-to-high transitions, high-to-low transitions, or both transitions in any of the bits where such selections are available If any of the selected transitions occurs in any bit during a clock period, the entire field is satisfied.
- 6 Use the CURSOR keys to position the cursor on the point in this field corresponding to the bit you noted as having a low-to-high transition (B0 is on the right-hand side).
- 7 If there is a dot in the field where you positioned the cursor, press the NEXT[] key one time to obtain the rising-edge arrow. If there is an N/A (not available) notation in this field, you will have to return to the WFORM display and select new channels, a different one with a low-to-high transition and two other channels that are high, if required. Edge recognition is not available for all of the timing bits. See figure 3-15.



**Figure 3-15. Triggering On A Pattern And Edge Transition**

- 8 Press the RUN key. The analyzer will search the incoming activity until it finds a clock period in which both of the high channels you specified are high and a low-to-high transition occurs in the channel you selected. Then the analyzer will trigger a trace and fill its memory.
- 9 See figure 3-16. Note the vertical, dashed line on the display. This line identifies the trigger point.
10. Move the cursor up into the "Sample Period" field and press the NEXT[] key several times.
- 11 Press the RUN key to take a measurement using the new sample period.

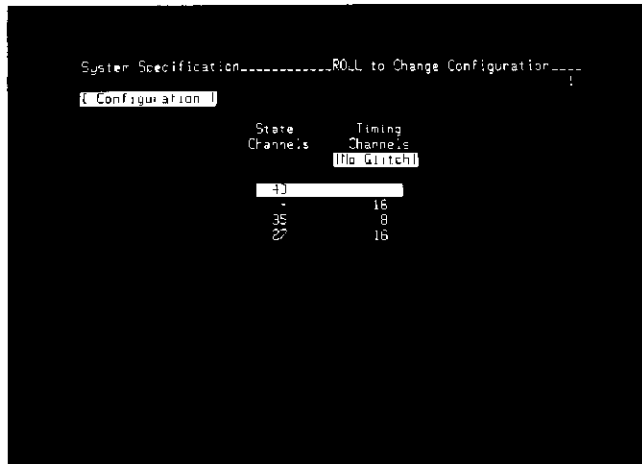

Figure 3-18. State Analyzer System Configuration

#### Setup For Relocation Use

1. Press the SYSTEM key.
2. Press the ROLL-up-arrow one time to select use of the analyzer as a state measurement instrument. See figure 3-18.
3. Press the FORMAT key.
4. Set up the [Assignment] menu of the State Format Specification as in figure 3-19. Move the cursor into the appropriate fields and use the NEXT[] or PREV[] keys and the keyboard keys, as required.

#### NOTE

---

This is the correct assignment setup for a system using an Intel 8085 microprocessor. You may need to change clock assignments if your system uses a different microprocessor.

---



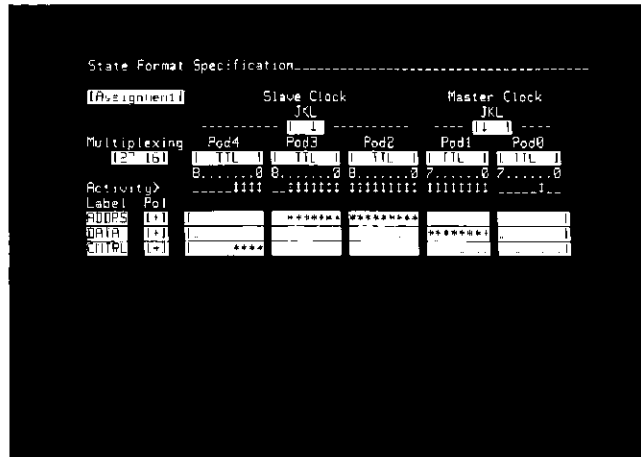

**Figure 3-19. State Assignment Format Specification For 1630D (1630A does not have POD0)**

5. Move the cursor into the [Assignment] field
6. Press the NEXT[] key to get [Relocation] on screen.
7. Press the CURSOR-right-arrow one time. You should have "For Label [ADDRS]" on screen. If not, press the NEXT[] key or PREV[] key until you have [ADDRS].
8. Use the CURSOR-down-arrow to place the cursor in the abs0000 field. The code starting at this address is not named in the example listing of figure 3-17. This code can be shown in absolute values.
9. Press the INSERT key. This brings up a new field for entry of the next starting address. The cursor will be in the first position for entry of the new module name.
10. Type in KEYBD from the analyzer keyboard
11. Move the cursor into the Starting Value area and type in 01D0 from the analyzer keyboard

12. Press the INSERT key. The number of addresses used by KEYBD is 0012H. The next module (TIME) does not start right after KEYBD. There is unnamed code in the address space between the end of the KEYBD routine and the start of TIME. Determine the starting address value of this unknown code, as follows:
  - a. Move the cursor into the upper field of the Calculator, and type in 01D0 (the starting address of KEYBD)
  - b. Move the cursor into the middle field of the Calculator, and type in 0012 (the number of addresses used by the KEYBD routine).
  - c. The bottom field of the Calculator shows 01E2 (the first address after the end of the KEYBD routine). This is the starting address of the undefined code. Assign name A to this undefined code space.
13. Move the cursor to the bottom [abs] field under Module Name and type in A.
14. Place the cursor in the Starting Value area for the block of absolute code labeled A. Then type in 01E2 from the keyboard.
15. Press the INSERT key.
16. Type in TIME from the analyzer keyboard.
17. Place the cursor in the "Starting Value" field, and type in 0429.
18. Press the INSERT key. Again, there is unknown code between the end of the present routine and the start of the next routine. You can use the calculator to determine the address where unknown code begins by placing the address of the start of the last known routine on the top line (0429) and the number of steps in that routine on the second line (001E). Label the unknown code B, and enter its starting value (4047).
19. Press the INSERT key.
20. Type in STACK from the analyzer keyboard.
21. Move the cursor into the Starting Value field, and type in 0BB0.





- 22 Press the INSERT key. Again, there is unknown code between the end of the present routine and the start of the next routine. Use the calculator to determine the address where unknown code begins by placing the address of the start of the last known routine on the top line (0BB0) and the number of steps in that routine on the second line (0050). Beside the bottom "abs" module name, enter its starting value (0C00).
- 23 Press the INSERT key.
- 24 Type in SCAN from the keyboard.
- 25 Move the cursor into the Starting Value column, and type in 2828 from the keyboard (the address of an I/O single value).
- 26 Press the INSERT key.
- 27 Move the cursor into the new field and type in 2829 in the Starting Value column (the first absolute address after the end of the I/O address).
- 28 Press the INSERT key.
- 29 Type in DSPLY from the analyzer keyboard.
- 30 Move the cursor into the Starting Value column, and type in 3838, the address of another IO location.
- 31 Press the INSERT key.
- 32 Move the cursor into the Starting Value field and type in 3839 beside the bottom "abs" entry. Your display should be the same as in figure 3-20.

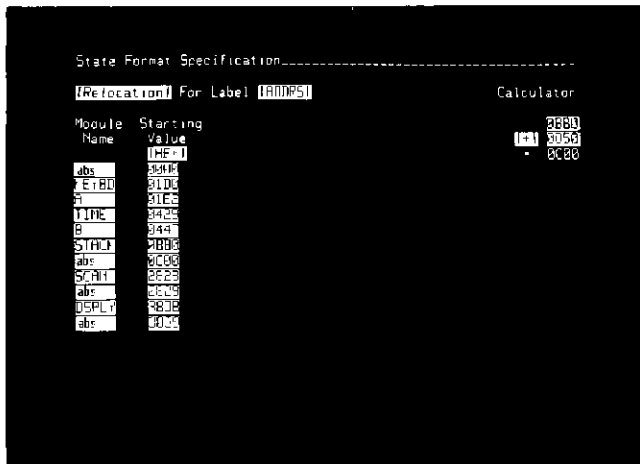

Figure 3-20. Relocation Menu Assignments

#### Running A Trace With Relocation Addresses

- 1 Press the RUN key. The analyzer will run a trace of the system activity and show a list of the information captured from the address, data, and control buses.
- 2 Move the cursor into the [HEX] field under the ADDR5 label, if not already there, and press the NEXT[] key two times. The field will change to [REL+HEX], and the column of information will show module names with offset values. The module names will correspond to the addresses you set up before the trace. The offsets will show how far each measured transaction was into the particular object code module. See figure 3-21

```

State Listing-----Data Acquired Oct 27 1982 15:06
Label>  ADDR5  DATA  CNTRL
Base>  [RELOCATED]  (HEX)  (OCT)
[Mark]  [Label]  [ADDR]  [ ]  [ ]
-0007  STACK +0001  17  0110
-0006  STACK +0000  FF  0110
-0005  B      +0763  54  0110
-0004  B      +0767  00  0110
-0003  B      +0766  F0  0110
-0002  B      +0765  06  0110
-0001  B      +0764  06  0110
+0000* SCAN +0000  00  1110
+0001  JSELY +0000  E3  1110
+0002* SCAN +0000  20  1110
+0003  B      +0763  01  0110
+0004  B      +0762  0C  0110
+0005  B      +0761  20  0110
+0006  B      +0760  06  0110
+0007  B      +075F  20  0110
+0008  B      +075E  44  0110

```

Figure 3-21. Trace List Using Values From Relocation Menu

- 3 Press the FORMAT key twice to obtain the [Assignment] display.
- 4 Move the cursor down into the ADDR5 label line, and press the INSERT key.
- 5 In the label line just created, type in ADDR1, and enter asterisks to activate each probe line that is active for the ADDR5 label. This creates a label called ADDR1 that is identical to the ADDR5 label. See figure 3-22.
- 6 Press the LIST key. The list display will show all of your labels on screen. There will be two columns of address information one will have the relocatable object code modules, each with its own count of address space, and the other will have the absolute, hexadecimal values captured from the system under test. See figure 3-23.

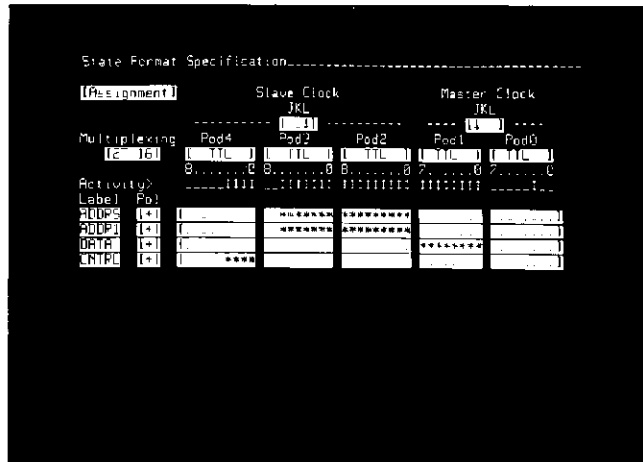

Figure 3-22. State Assignment Format Specification With Two Labels For The Address Bits

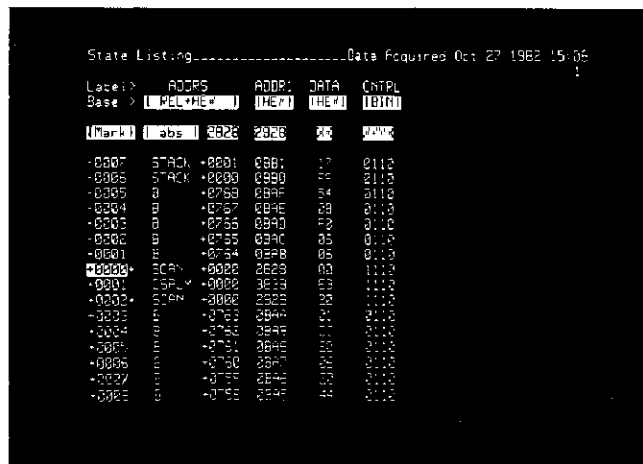

Figure 3-23. Trace List Using Values From Relocation Menu And Corresponding Absolute Values

## Using The User Base Feature

The analyzer can present list displays which give you written descriptions of conditions found on the control bus lines instead of just the hexadecimal values. The following procedure will show you how to create two labels and assign descriptive notations to values found on the labeled lines. Then you will see how to show these notations on the analyzer display in place of numerical values.

### Setup For User Base Usage

1. Press the FORMAT key. The State Format Specification for [Assignment] should be on screen. If not, place the cursor into the upper, left-hand field and press the NEXT[] key to obtain the [Assignment] display. See figure 3-24.
2. Move the cursor to the bottom label line on the display (CNTRL).
3. Press the INSERT key.
4. Type in the label WR-RD. Use the CHS key to obtain the "-"

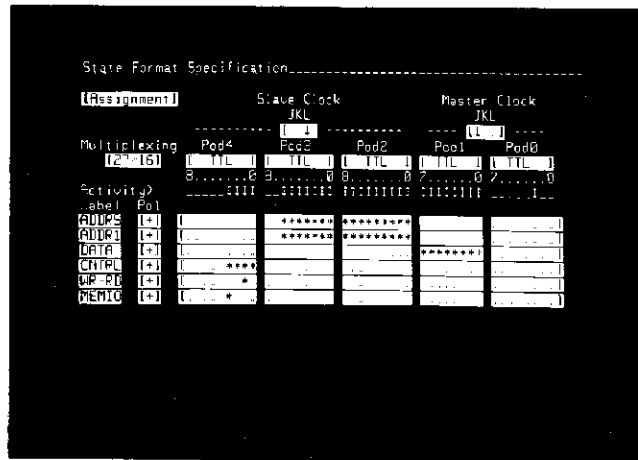

Figure 3-24. State Assignment Format Specification With Labels Added For WR-RD And MEMIO

- 5 Move the cursor across the label line to the probe bit connected to the READ/WRITE line in your system under test, if known. Otherwise, position the cursor at any one of the probe bits included in the control bus (CNTRL label).
- 6 Press the NEXT[ ] key to assign this bit to the write-read (WR-RD) label.
- 7 Press the INSERT key.
- 8 Type in MEMIO (memory IO) from the analyzer keyboard.
- 9 If your system has a memory IO select line in the control bus, move the cursor over and activate that bit for the MEMIO label. If not, move the cursor over and activate any other bit from the CNTRL label, except the one used in step 6 above.
- 10 Move the cursor up into the [Assignment] field.
- 11 Press the NEXT[ ] key twice to obtain the [User Base] display. (See figure 3-25.) This display will show every label that is composed of four or less bits. Under each label will be bright fields, one bright field for each value which can be found on the label. You can define a descriptive word to be shown in place of each of the values by typing that name into the associated bright field.
- 12 Move the cursor into the first bright field under the WR-RD label, and type in the word WRITE. This assigns the word WRITE to the value 0, if found on the WR-RD label.
- 13 Move the cursor into the second bright field under the WR-RD label, and type in the word READ. This assigns the word READ to the value 1, if found on the WR-RD label.
- 14 Move the cursor into the first bright field under the MEMIO label and type in the word MEMRY from the analyzer keyboard.
- 15 Move the cursor into the second bright field under the MEMIO label and type in the word IN-OT.

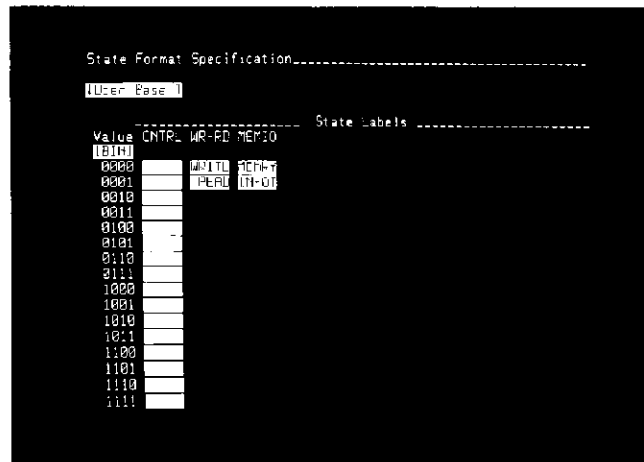

Figure 3-25. State User Base Menu Setup

#### Obtaining Displays In User Base

1. Press the LIST key. Your newly created labels will be on screen. The information under these labels will be shown as hexadecimal values.
2. Move the cursor over into the [HEX] field under WR-RD.
3. Press the NEXT[] key to change the field to [USR] which shows the user-defined notations.
4. Move the cursor into the [HEX] field under MEMIO, and press the NEXT[] key to change it to user-defined notations. [USR]
5. See figure 3-26. By using this procedure, you can specify user names to identify values on any of the labels consisting of four or less bits.

State Listing-----Data Acquired On: 27 1988 15:06  
1-

Lab#( )	ADDRS	ADDR:	DATA	CTRL	AR-RE	MEMIO	
Base >	PEL+HEX	(HEX)	(HEX)	(BIT)	(USR)	(USR)	
(Mark)	abs	2000	2000	2K	2000	(Mark)	(Mark)
-0007	STACK	+0001	0001	17	0110	READ	MEMORY
-0006	STACK	+0000	0000	FF	0110	READ	MEMORY
-0005		+2768	2B9F	54	0110	READ	MEMORY
-0004		+2767	2B9E	02	0110	READ	MEMORY
-0003		+2766	2EAD	F2	0110	READ	MEMORY
-0002		+2765	2EAC	06	0110	READ	MEMORY
-0001		+2764	0B98	06	0110	READ	MEMORY
0000	CALL	+0022	23E7	20	1110	READ	IN-OT
-0001	JMP.Y	+0000	30E7	03	1110	READ	IN-OT
-0002	CALL	+0000	09E7	03	1110	READ	IN-OT
-0003		+2767	2B9A	21	0110	READ	MEMORY
-0004		+2766	2B99	1C	0110	READ	MEMORY
-0005		+2765	0B98	06	0110	READ	MEMORY
-0006		+2764	2EAD	06	0110	READ	MEMORY
-0007		+2763	4E95	18	0110	READ	MEMORY
-0008		+2762	2EAD	44	0110	READ	MEMORY

Figure 3-26. Trace List Using Values From Relocation And User Base Menus Together

### Making Coordinated State And Timing Measurements

The following procedure shows how the state and timing measurement functions can perform independent measurements using separate trigger events at the same time. This procedure also demonstrates the ability of one of the measurement functions (state or timing) to arm the other function to perform its trigger recognition

#### Setup For State And Timing Measurements

1. Press the SYSTEM key
2. Press the ROLL-down-arrow key to select the combined state and timing system specification shown in figure 3-27
3. Press the FORMAT key. Make sure the [Assignment] menu is set up as shown in figure 3-28
4. Press the TRACE key. The state trace specification will be on screen (See figure 3-29.) The analyzer should still be set up to trigger when it finds the first occurrence of a state that matches the specification in row "a". If not, move the cursor into the trigger field and press NEXT[], as required, to obtain [a].



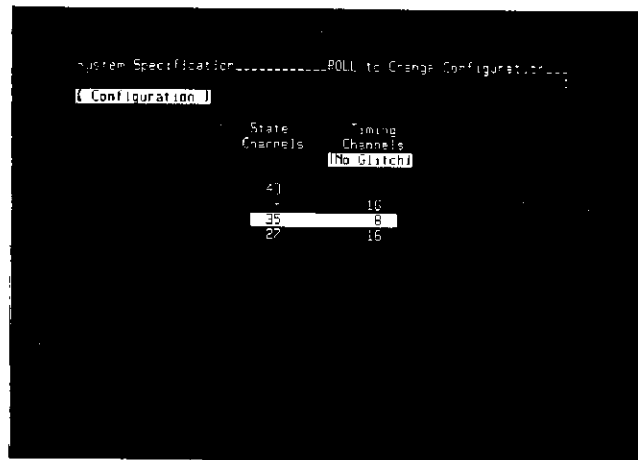

Figure 3-27. Combined State/Timing Analyzer System Configuration

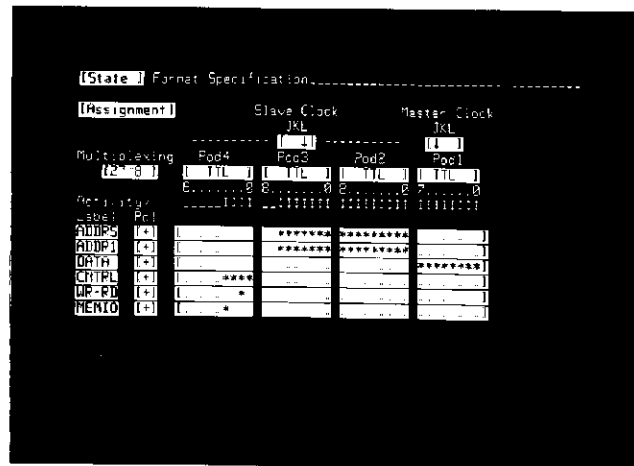
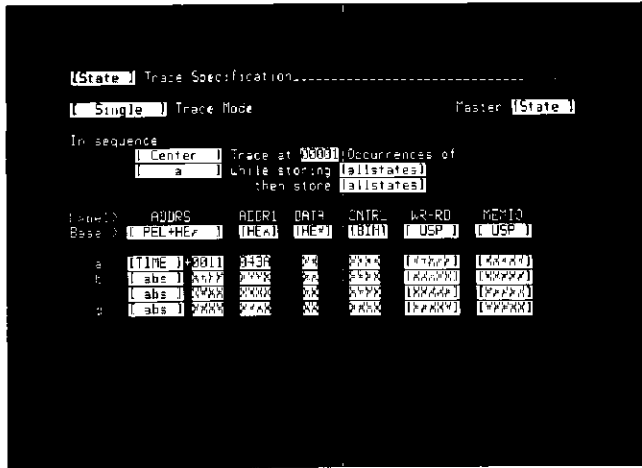

Figure 3-28. State Assignment Format Specification



**Figure 3-29. State Trace Specification  
In State/Timing Measurements**

- 5 Move the cursor down into the ADDR5 field in row "a" and enter [TIME]+0011. Use the NEXT[] key to obtain [TIME] and the numeric keys to obtain +0011. See figure 3-29.

**Executing Coordinated Measurements**

- 1 Press the RUN key. The analyzer will find the state you specified as its trigger, and complete a state trace. If the analyzer does not find its state trigger (TIME+0011 on the 16 address lines of the address bus), the message "Waiting for State Trigger" will be on screen. In this case, press the STOP key. The message "Trace Aborted" will be on screen, along with a listing of the last eight transactions before you pressed the STOP key.
- 2 Write down one of the executions shown on the display under the ADDR5 label (such as TIME+001A).
- 3 Press the TRACE key.
- 4 Move the cursor down into the row "b" line.

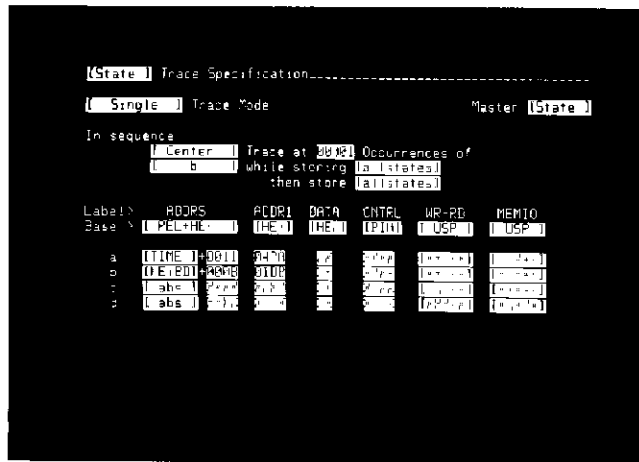
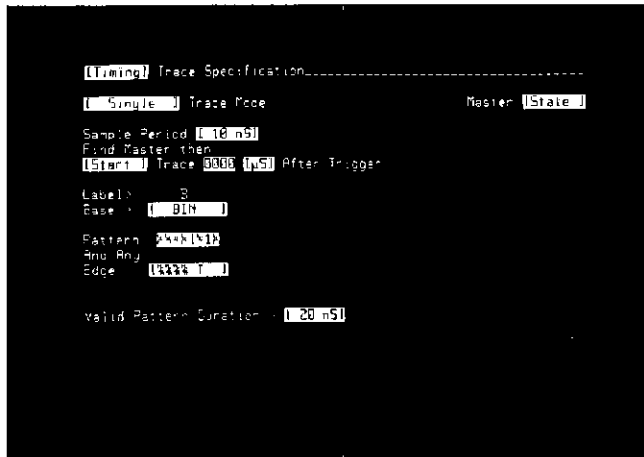

Figure 3-30. State Trace Specification With Trigger In Row "b"

5. Enter the module name and offset value you copied from the screen (use keyboard NEXT[]) and hexadecimal keys). See figure 3-30.
6. Move the cursor up into the trigger field and press the NEXT[] key to change [ a ] to [ b ]. This sets the analyzer to trigger when it finds the state in row "b" (the state you copied from the display)
7. Press the RUN key. The analyzer will find the state you specified as its trigger, and complete a state trace. It will show the message "Trace Complete" at the top of the display. The state you selected as the trigger will be on line 0000.
8. Press the LIST key several times. Notice that pressing any of the INPUT DISPLAYS and OUTPUT DISPLAYS keys can switch between the state analyzer and timing analyzer.
9. Press the FORMAT key. Press it a second time, if necessary, to place the [Timing] format specification on screen.



**Figure 3-31. Timing Trace Specification For Combined State/Timing Measurements**

10. Check the display of the Activity line. If bit 2 in the timing pod shows no activity, connect bit 2 (the third line) from the timing probe to any active node in your system under test.
11. Press the TRACE key. See figure 3-31.
12. Move the cursor into the Pattern field and enter a pattern of XXXX1X1X (with a binary display base).
13. Move the cursor down into the Edge field and use the NEXT[] key to enter a positive-going transition requirement (up arrow) for channel B2 (third from right-hand side) of the timing pod.
14. Press the RUN key. The state measurement in the analyzer will be completed as before. After the state trigger has been found, the timing function will search for the timing trigger. If it finds the timing trigger, it will complete its trace and show a waveform display. If it does not find its trigger, the analyzer will show the message "Waiting for Timing Trigger" on screen. In this case, press the STOP key. The message on screen will show "Trace Aborted". There will be waveforms displayed.

15. Press the LIST key two times. You will see the trace list that was completed by the state measurement function. It will show your state trigger on screen, along with other states it captured.
16. Press the TRACE key two times. This will place the trace specification for the timing function on screen.
17. Move the cursor down into the Pattern field and press and hold the DON'T CARE key until the field is all "X's". This can also be done by pressing CLEAR ENTRY. Now the timing analyzer trigger will be satisfied when the first low-to-high edge is found on channel 2 in pod 0.
18. Press the RUN key. The analyzer will search through the incoming states until it finds the state trigger. When it finds the state trigger, it will begin capturing states into memory, and at the same time, it will arm the timing analyzer to search for its trigger. The timing analyzer will monitor the incoming activity until it finds a rising edge on bit B2. Then it will store a series of samples of activity to complete its timing measurement. It will show "Trace Complete" on the top of the screen, and waveforms of timing information across the display. See figure 3-32.

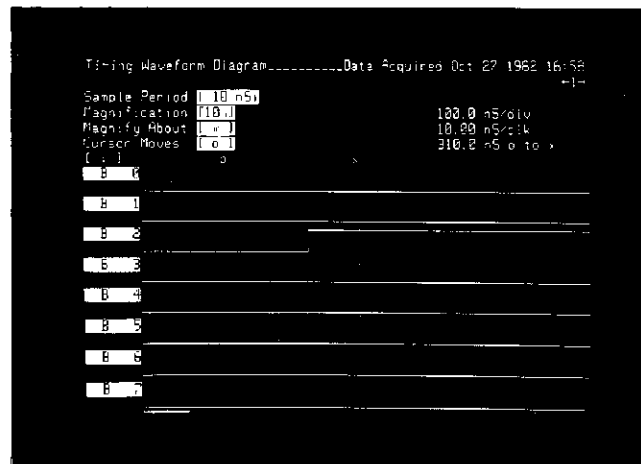
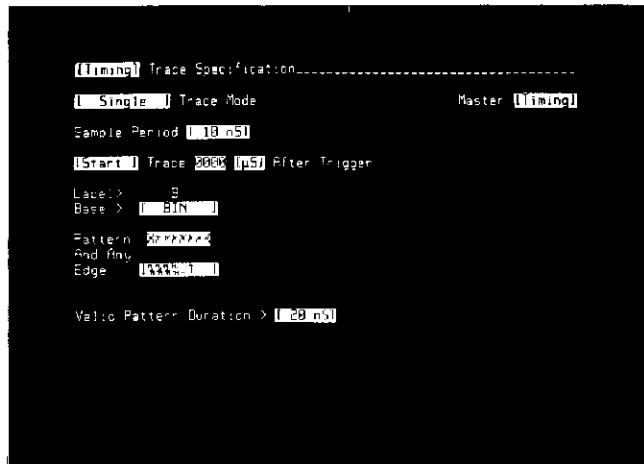

Figure 3-32. Timing Waveform Display



**Figure 3-33. Timing Trace Specification With Master [Timing]**

- 19 Press the TRACE key. See figure 3-33
- 20 Move the cursor into the "Master" field and press the NEXT[] key to change [State] to [Timing]. This makes the analyzer recognize its timing trigger before it can arm the state function to recognize the state trigger.
- 21 Press the RUN key. The analyzer will begin its measurement by looking for the condition that satisfies its timing trigger. When it finds this condition (rising edge on B2), it starts collecting timing information, and arms the state measurement function to look for its trigger. The timing analyzer displays its waveform information on screen while the state function completes its measurement.

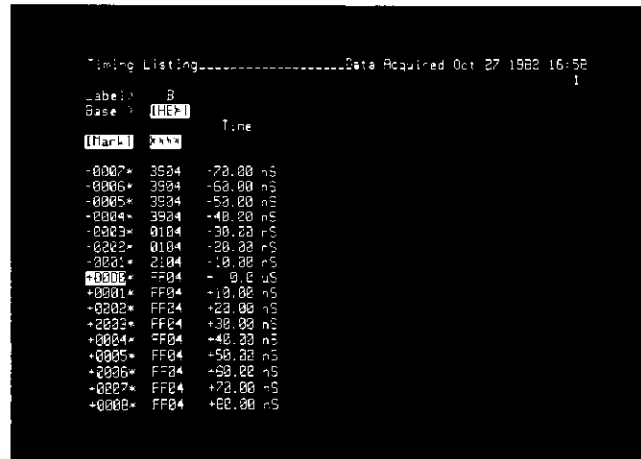

Figure 3-34. Timing Listing Display

22. Press the LIST key. The display will show a listing of the timing activity. See figure 3-34.
23. Press the LIST key, again. The display will change to a listing of the information from the state analysis function.

### Using The Tape Memory Accessory

The following procedure will help you become familiar with how to use the tape memory accessory, if you have the HP 82161A Digital Cassette Drive accessory for your analyzer.

1. Connect the operating power cord to the digital cassette drive and to a source of operating power.
2. Connect the two HP-IL interface cables to the analyzer rear panel and to the digital cassette drive. Note the different shapes of the two HP-IL connectors.

3. Turn on operating power on the panel of the digital cassette drive. Select the STANDBY position of the power switch to conserve the battery in the digital cassette drive. In STANDBY, power is only turned on in the digital cassette drive when the analyzer is using it.
4. Press the OPEN button on the digital cassette drive, install a blank tape cassette, and close the cassette door.
5. Press the SYSTEM key on the analyzer keyboard.
6. Press the NEXT[ ] key to obtain the [Tape Operations] menu. The analyzer will only display this menu when it has the tape memory accessory connected. See figure 3-35.

**NOTE**

Figure 3-35 shows all of the possible entries for the [Tape Operations] menu. File 1 is an HP-supplied inverse-assembler file. File 2 is a user-generated file with the date and time of its creation. File 10 is a copyfile; it allows copying of write protected files from one tape to another. The remaining files have no data stored.

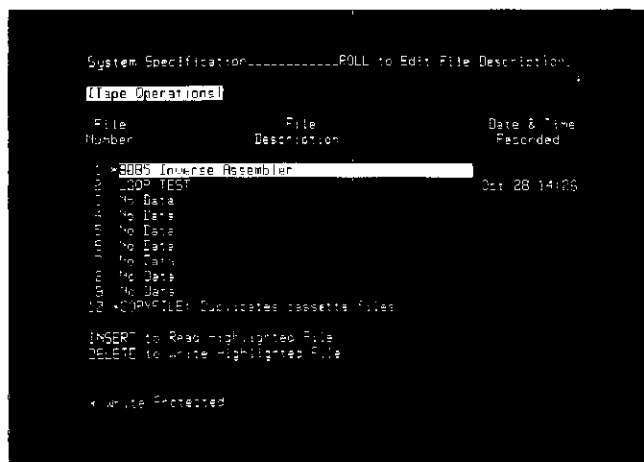

**Figure 3-35. Tape Operations Menu**



- 7 Move the cursor down into the Erase & Format Cassette field and change it to [Yes]. This will immediately cause the analyzer to erase everything on the tape and format ten blank files. This operation takes approximately 5 minutes. All other functions of the analyzer can be used while it is formatting the tape.

**NOTE**

---

You cannot erase and format a tape that has any write-protected files.

---

- 8 When tape formatting is complete, the display will show No Data for each file. Move the cursor into the bright bar in the File Description column, and Type in the letter A. This assigns file name A to the associated file space. Now you can save the setups of the FORMAT and TRACE menus, and the content of the trace memory on tape in file A.
- 9 The analyzer would identify the date and time that it saved your setup and data, and make this information available to you if you had set the analyzer clock, but it is not set.
- 10 Try going to the [Peripherals] menu to set the clock. The ERROR message indicates that you cannot leave this file until you store information in it. Since you don't want to store the instrument setup until you can identify the date and time of storage, press the blue SHIFT key and press DEFAULT. This returns the file to the undefined state.
11. Move the cursor up into the [Tape Operations] field and change it to [Peripherals].
- 12 Move the cursor down into the "Clock Set:" field and enter the month, day, year, and time (hour:minute:second).
13. Press the TRACE key, and change the trace mode field to read [Continuous].
14. Press the RUN key and then the STOP key. This obtains data in memory.
15. Press the SYSTEM key and obtain the [Tape Operations] menu.

- 16 Move the cursor into the bright bar in the File Description column and type in the letter A. This assigns file A to store the instrument setup and acquired data at the indicated location on the tape
17. Press the blue SHIFT key and DELETE to write your present instrument setup on the tape. The message WAIT Writing Cassette File will be on screen while the analyzer is writing the setup and data
- 18 After tape storage is complete and the tape has been rewound, cycle the LINE power switch off and back on. The System Specification [Configuration] menu will be on screen. The analyzer will loose its clock set
19. Press the TRACE key. See that the [Single] trace mode is in effect. This is the default mode set up during power-up
- 20 Press the LIST key. See that the trace list memory is blank.
21. Press the SYSTEM key and change [Configuration] to [Tape Operations]. See that your file A is identified on screen, along with the date and time it was stored. The bright bar in the File Description column should be on your file A. Use ROLL keys to move bright bar, if necessary.
22. Press the INSERT key. The message WAIT Reading Cassette File will be on the display. Allow several seconds for the analyzer to read the file and set up the menus. When the reading of the file is complete, the SYSTEM [Configuration] menu will be on screen.
- 23 Press the TRACE key. See that the trace specification is set up to perform in the [Continuous] trace mode. This is the measurement mode you recorded on tape
- 24 Press the LIST key. See that the trace memory is loaded with activity. This is the activity that was in the trace memory when you recorded the setup.

This completes the introduction to operation of the analyzer. Complete details of how to use the features of the analyzer are given in other chapters of this manual.

## Chapter 4 The Menu Map

This chapter contains a set of maps which show all of the menus available in the analyzer. Each menu is shown below the front panel key that calls it to the screen. The left-hand menus are available for use when the analyzer is making State measurements, and the right-hand menus are available when the analyzer is making Timing measurements. Use the NEXT and PREV keys to select between menus within a set.

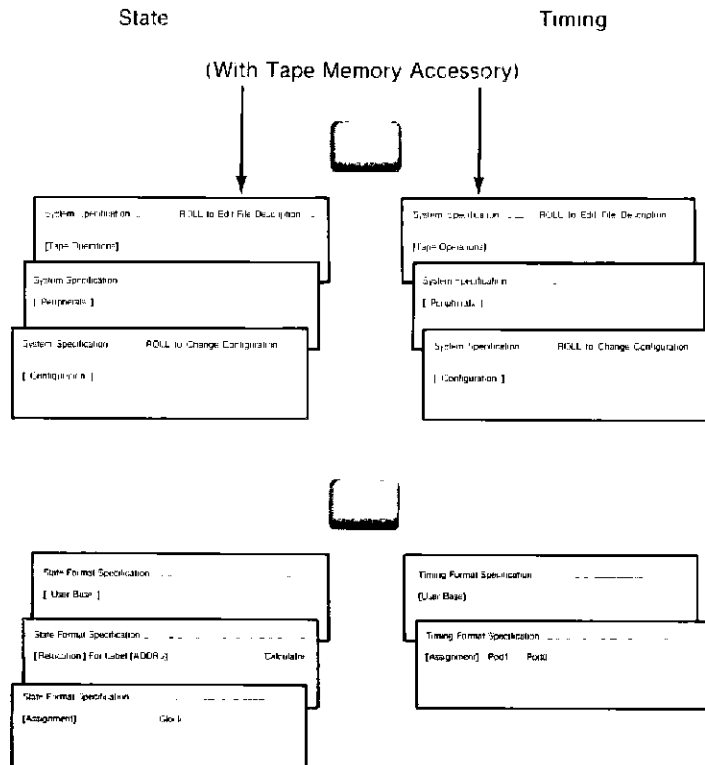

**State**  
In State-only configuration

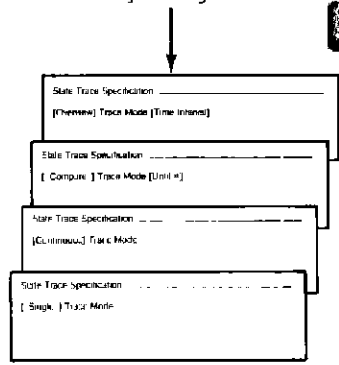

**Timing**

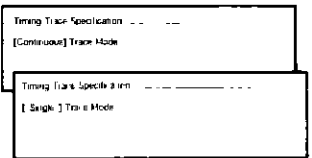

In Compare mode

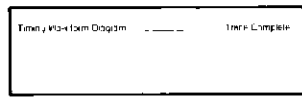
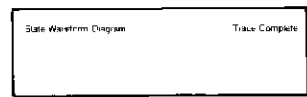
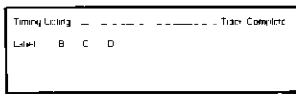
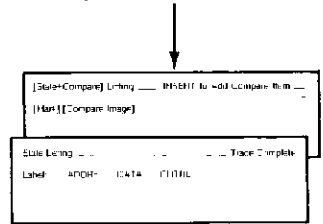

In Overview TRACE mode

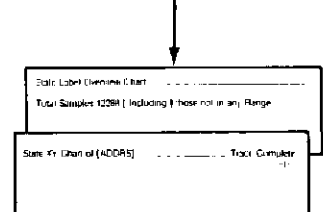

## Using The SYSTEM Menus

### Introduction

The system specification is made up of three menus: [Configuration], [Peripherals], and [Tape Operations]. The [Configuration] and [Peripherals] menus are used to determine whether the instrument will make state measurements, timing measurements, or interactive measurements, and how the analyzer will interact with peripherals. Both of these menus are discussed in this chapter. The [Tape Operations] menu is only available to instruments using the tape memory accessory. It is discussed in Appendix A of this manual.

### [Configuration] System Specification

The analyzer can be configured to make measurements as a state analyzer, as a timing analyzer, or as an interactive analyzer combining both state and timing analysis and interactive triggering. Use the ROLL keys to place the bright bar on a line that assigns the desired number of probe channels to serve each analysis function. For example, by placing the bright bar on the top line, you assign all probe channels to serve state analysis and none to serve timing analysis (selecting the state-only configuration of the analyzer).

### [Peripherals] System Configuration

In this menu, you can set up the way the analyzer will interact with peripherals through its interface connectors. You can also set up the instrument clock and determine whether or not the instrument will beep at predetermined points in its operation and when error conditions are detected.

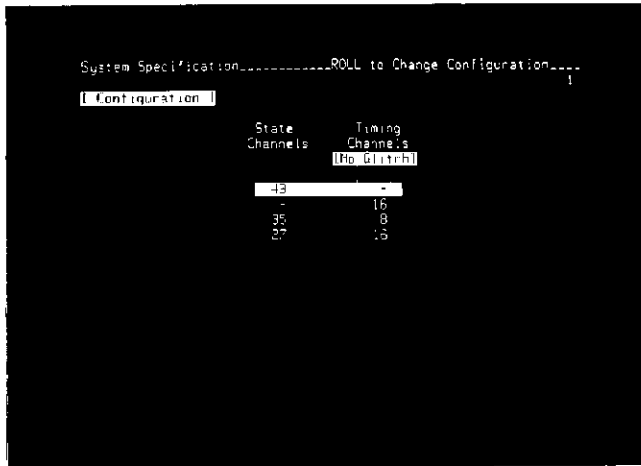

**Figure 5-1. 1630D Configuration System Specification**

- State Channels:** The number of probes serving information to state analysis measurement channels is listed
- Timing Channels:** The number of probes serving information to timing analysis measurement channels is listed
- [No Glitch]** - no glitch detection is available in the analyzer.
- [Glitch]** - glitch detection is available. Only half as many channels are available for timing analysis because two probes are internally combined for each channel in this mode one to detect timing activity, and the other to detect glitch activity

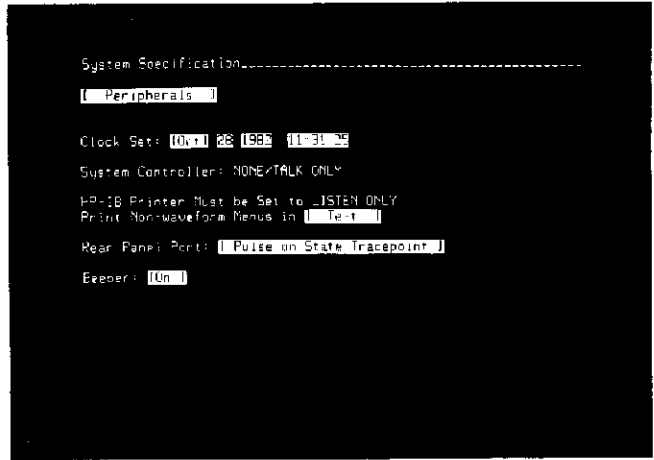

**Figure 5-2. Peripherals System Specification**

- Clock Set:** Field used by analyzer to identify when information was captured into memory. Enter [month] day year hour minute:second. Once set, this clock will continue to keep time as long as analyzer power is on
- Print Non-waveform Menus:** Selects code for information transfer to external printer.  
 [Text] selects information transfer using ASCII codes  
 [Graphics] selects information transfer using HP-GRAPHICS codes
- Rear Panel Port** Selects control signal to be supplied through the rear panel BNC output PORT to an external device, as follows  
 [Pulse on State Tracepoint] - analyzer outputs 15-nsec TTL positive pulse when it finds state tracepoint.  
 [High til State Tracepoint] - after run start, analyzer outputs TTL high until it finds state tracepoint. Then it switches TTL low.  
 [Low til State Tracepoint] - after run start, analyzer outputs TTL low until it finds state tracepoint. Then it switches TTL high.

Beeper.

**[High on Last Sequence]** - analyzer outputs TTL high when it is searching for the last term in a trigger sequence.

**[High on Timing Pattern]** - analyzer outputs TTL high as long as the timing trigger pattern occurs for longer than the specified valid pattern duration

**[Constant High]** - analyzer outputs TTL high.

**[Constant Low]** - analyzer outputs TTL low when **[On]**, the analyzer will beep whenever it completes a measurement, and whenever it flashes an error or warning message on screen. When **[Off]**, the analyzer will not beep at any time





## Chapter 6 State Measurements

All of the state measurements that the analyzer can perform are discussed in Chapter 6. Chapter 6 is divided into four sections, this chapter, plus Chapters 6A, 6B, and 6C. Chapter 6A discusses how to set up the FORMAT specification. Chapter 6B discusses the use of the TRACE specification. Chapter 6C discusses the LIST, WFORM, and CHART displays that can be obtained by the analyzer when it is performing state-only measurements.

## State Analyzer FORMAT Specification

### Introduction

This chapter describes how to use the FORMAT Specification when operating the analyzer as a state measurement instrument. The State FORMAT Specification is divided into three menus: [Assignment], [Relocation], and [User Base]. Each of these three menus is described separately in this chapter.

### [Assignment] State Format Specification

The [Assignment] menu allows you to set up the analyzer to present information in a format that will be useful. In the [Assignment] menu, you perform three setup assignments: label assignments, clock assignments, and threshold assignments. These three assignments are described in the following paragraphs.

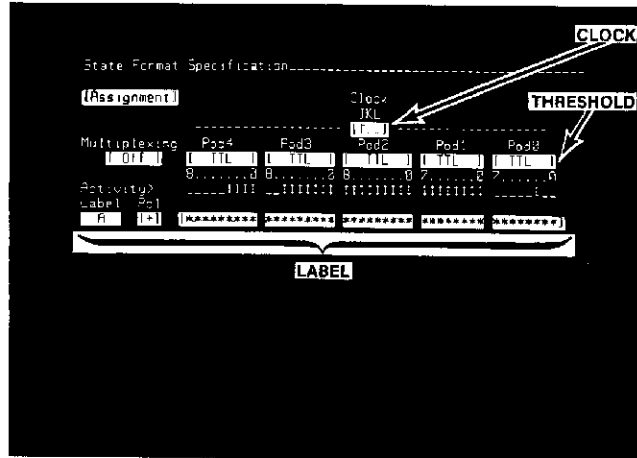
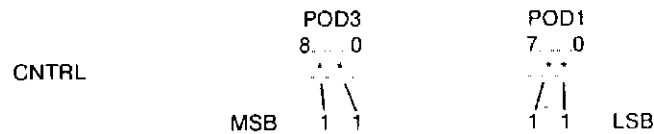

Figure 6A-1. State Assignment Format Specification

### Label Assignments

Maximum no. of labels 8  
Label size: 1 to 5 alphanumeric characters.  
Label content: 1 to all bits. Same bit can be included in all labels.  
Label polarity: [+] = positive-true; [-] = negative-true.  
Label bit arrangement: (Example of 4-bit label)



When the analyzer makes a measurement, it collects the states from all input bits (whether part of a label or not). When you assign labels, you identify which bits are to be grouped together in each column of information. By labeling sets of bits, you gather all of the information from the lines connected to a particular activity, such as the address bus, and show that information as a single variable. You can do the same with data bus information, control bus information, etc.

### Clock Assignments

Clock Multiplexing [Off]  
Clock function: strobe all bits into analyzer  
Clock field: OR'd. Each line can be positive-true, negative-true, both edges true, or deactivated

Clock Multiplexing Modes  
Slave clock function: loads associated bits into intermediate latch  
Master clock function: strobes associated bits plus intermediate latch into analyzer.

### Pod Threshold Assignments

Pod assignments: Each pod defined separately.  
Thresholds available: TTL, ECL, selectable from -9.9V to +9.9V, in 0.1V increments

## [Relocation] State Format Specification

The [Relocation] feature is intended for use when analyzing relocatable object code modules in absolute address space. It can be used for mapping any label defined in the [Assignment] menu. You can create a set of module names to identify object code modules, and assign a range to each module. The analyzer uses this map to identify each value captured by its appropriate module name plus offset value.

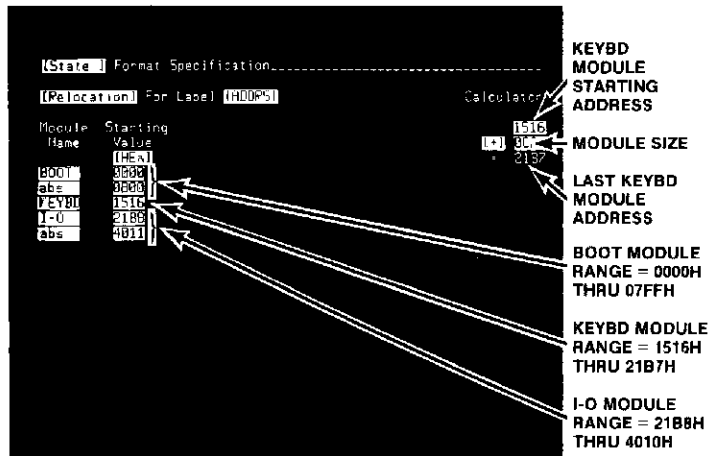

Figure 6A-2 State Relocation Format Specification

Example of LIST display from [Relocation]

ADDRS	ADDRS
[REL+HEX]	[HEX]
KEYBD+0CA0	21B6
KEYBD+0CA1	21B7
I-O +0000	21B8

Labels

No. of labels that can be mapped: 1 from [Assignment] menu

No. of bits in mapped label: 1 to all

**Modules**

Module names in map: 1 to 16. Composed of 1 to 5 alphanumeric characters each

Module starting values: any value in range of label.

Identification of values outside of all modules: abs.

**Calculator**

Functions: add [+] and subtract [-]

Base: defined in "Starting Value" column.

**[User Base] State Format Specification**

The [User Base] menu allows you to assign names to be displayed in place of status values. You can choose different names to identify each of the states, such as "READ" and "WRITE" to identify the two states found on the WR-RD bit.

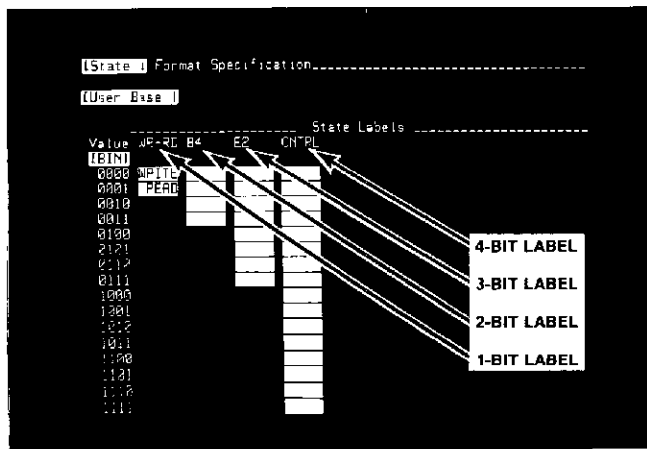

**Figure 6A-3. State User Base Format Specification**

User Base Labels: all [Assignment] labels with 4 bits or less.

Max labels on menu: 8

Status names: one name for each possible value (16 names on a 4-bit label), 1 to 5 alphanumeric characters.

## The State TRACE Specification

### Introduction

This chapter describes how to use the State TRACE Specification when operating the analyzer as a state analyzer. The TRACE Specification sets parameters to be followed when the analyzer captures a series of states from a system under test.

There are four trace modes offered by the analyzer for state analysis: **[Single]**, **[Continuous]**, **[Compare]**, and **[Overview]**. Three of these trace modes are discussed in this chapter. The **[Overview]** trace mode is discussed in performance analysis chapter 7.

### **[Single] State Trace Specification**

The **[Single]** trace mode is used to capture a series of states in program flow. In this trace mode, the analyzer will satisfy its trigger and storage requirements one time. The trigger is required to complete a trace. The storage requirements must be met in order to save states in memory (other than the state trace point).

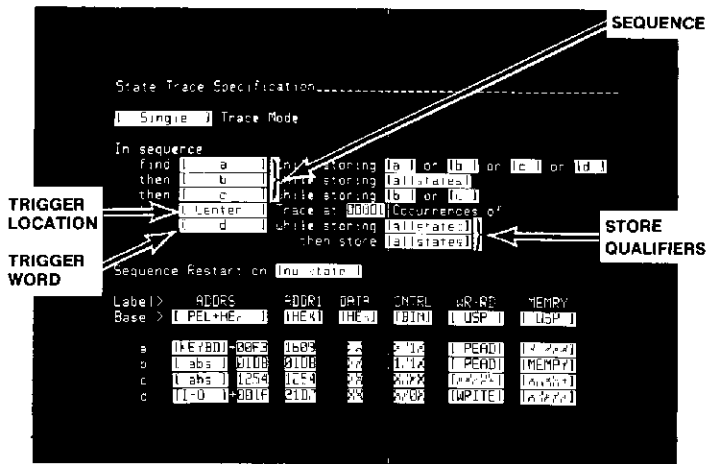

Figure 6B-1. State Single Trace Specification

Term Specifications

The analyzer can recognize terms specified in any of the following value bases

1. Binary, Octal, Decimal, and Hexadecimal.
2. Address offsets within selected object code modules
3. User-specified notations describing activity found on selected labels.

Trigger (Figure 6B-2)

Location: [Start], [Center], or [End] of trace memory (determines amount of pretrigger and post-trigger activity in memory)

Terms: [any state], [no state], [a, b, c, d], and [=a, b, c, d].

Max OR'd terms 4

Occurrence Count: 59,999 occurrences max

Sequence with restart (Figure 6B-2)

Sequence Terms: 3 consecutive terms plus trigger, max

Restart Terms: 1 pattern composed of up to 4 OR'd terms.

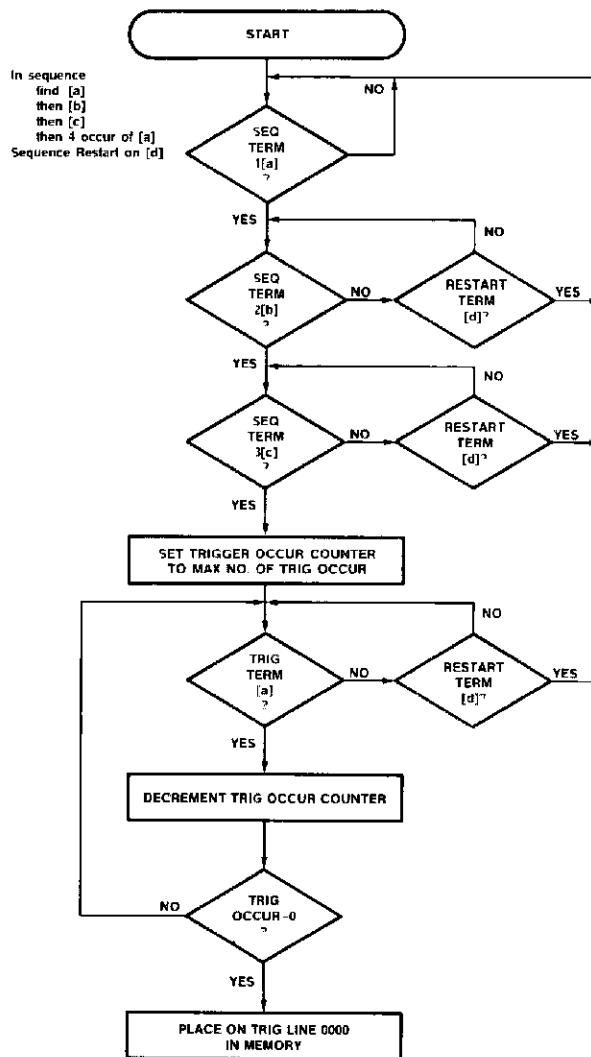

Figure 6B-2. Sequence/Trigger Flow Chart



Terms: a, b, c, d; Boolean not of a, b, c, d; all states; and no states.  
 Max OR'd terms 4 in each trigger sequence.

In sequence  
 find [a] while storing [d]  
 then [Center] Trace at 00002 Occurrences of [d] while  
 storing [allstates]  
 then store [b] or [c]

	State Flow	Trace Memory	
	b		During search for sequence term, only "d" was store-qualified. The sequence term was not store-qualified
	c		
	d	-0007 d	
SEQUENCE TERM →	a		During search for Trace point (trigger * occur count), all states were store-qualified. Trace point is always store-qualified
	b	-0006 b	
	c	-0005 c	
	d	-0004 d	
	a	-0003 a	
	b	-0002 b	
	c	-0001 c	
TRACE POINT →	d	+0000 d	After trace point, only "b" and "c" were store-qualified
	a		
	b	+0001 b	
	c	+0002 c	
	d		
	a		
	b	+0003 b	
	c	+0004 c	
	d		

**NOTE**

Terms "a", through "d" represent complex terms which you define in the TRACE specification

**Figure 6B-3. Storage Example**

### [Continuous] State Trace Specification

In the [Continuous] mode of state measurement, the analyzer performs a series of [Single] trace measurements. At the completion of each measurement, the analyzer updates its display and starts a new measurement. This continues until you press the STOP key.

#### NOTE

If you press the STOP key one time, the analyzer will complete its present measurement. If you press STOP a second time, it will abort the measurement.

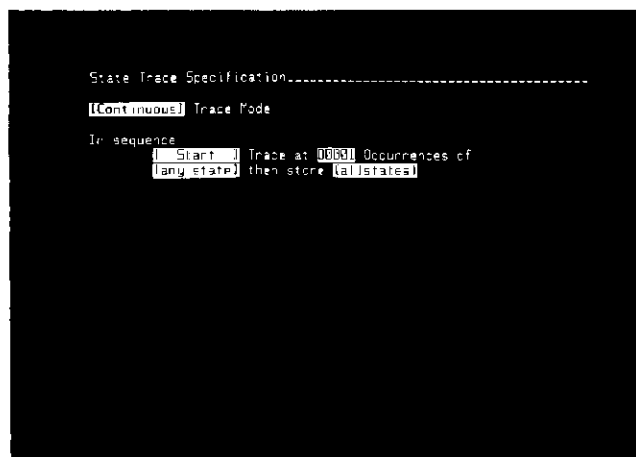
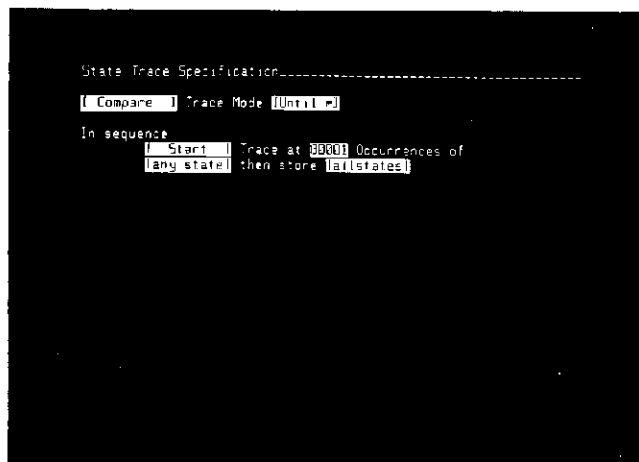

Figure 6B-4. State Continuous Trace Specification

### [Compare] State Trace Specification

The [Compare] trace mode is used to capture information about a system when it executes any of a complex set of activities. In the [Compare] mode, you define a specific trigger point to be found in state flow, and a Compare List of activities to be checked at selected points with reference to the location of the trigger. For example, your Compare List might specify that the value FFFF (hex) should be found in the fifth transaction (line +0005 in the trace memory) after the trigger.

The analyzer executes a compare measurement by performing a [Single] trace measurement. When the trace is complete, the analyzer compares its trace memory against the "Compare List" (sees if line +0005 has FFFF on its address bus, in the example). If the trace memory is the same as the Compare List and you selected [Until ≠], the analyzer will update its display with the trace information, and start a new [Single] measurement. This continues until either you press STOP or the analyzer finds a trace which has a value different from the Compare List (other than FFFF on the address bus in line +0005).



**Figure 6B-5. State Compare Trace Specification**

- Compare List Content 16 non-contiguous lines max.  
Each with a different line no  
Each may have don't care values (X's).
- No. of Compare Items/Line:  
1 per line no.
- [State & Compare] fields
  - [Compare Image]. [Mark] shows both trace memory and compare memory together on screen and places asterisk (\*) beside each compare memory line. [Show] shows only compare memory lines on screen

[Differences]: [Mark] shows both trace memory and compare memory on screen, and places an asterisk beside each compare memory line that is different from corresponding line in trace memory. [Show] shows the lines from Compare Memory that are different from the present trace memory lines.

Modes of operation

[Until ≠] and [Until =] defines the comparison result that halts the measurements.

### How To Make A Compare List

- 1 Select the [Compare] Trace Mode in the state trace specification. Select [Until ≠] if you want the analyzer to save the first trace memory that is different from your compare list. Select [Until =] if you want the analyzer to save the first trace memory that is the same as your compare list.
- 2 Enter trigger (and sequence) information required to define the reference point in state flow.
- 3 Press the RUN key. The analyzer will be performing continuous traces if using [Until ≠] trace mode.
- 4 Press the STOP key. The analyzer will complete the single trace in process and show a trace list on screen.
- 5 Move the cursor up into the [State] field at the top of the screen and change it to [State+Compare]. Select the [Mark] display.
- 6 Select a line of the trace list that you want to copy to the compare list, and roll its line number to the inverse-video block in the center of the trace list display.
- 7 Press the INSERT key. This places a copy of the selected line in the compare list. You can have only one copy for each line in the compare list (only one copy of line +0054 can be in the compare list at a time).
- 8 Move the cursor into the inverse-video line of values (the compare list line) and specify the values you want in that line of your compare list.

Label	ADDR	ADDR1	DATA	CONTR	WR-RD	MEMORY
Base	REL+HEX	HEX	ASCII	BIN	USER	USER
[Mark]	abs	0000	XXXX	FFFF	XXXX	XXXX
+0000	BOOT	+0433	0433	<STX>	0111	READ IN-OT
+0001	BOOT	+0433	0433	0	0111	READ IN-OT
+0002	BOOT	+0100	0100	0	0100	WRITE IN-OT
+0003	BOOT	+0100	0100	0	0100	WRITE IN-OT
+0004	BOOT	+0100	0100	6	0100	WRITE IN-OT
+0005	BOOT	+0100	0100	6	0100	WRITE IN-OT
+0006	BOOT	+0100	0100	<SO>	0100	WRITE IN-OT
+0007	BOOT	+0100	0100	0	0100	WRITE IN-OT
+0008	BOOT	+0429	0429	0	0111	READ IN-OT
+0009	BOOT	+0429	0429	<DCI>	0111	READ IN-OT
+0010	BOOT	+0431	0431	2	0111	READ IN-OT
+0011	BOOT	+0431	0431	0	0111	READ IN-OT
+0012	BOOT	+0433	0433	<STX>	0111	READ IN-OT
+0013	BOOT	+0433	0433	w	0111	READ IN-OT
+0014	BOOT	+0102	0102	0	0101	WRITE IN-OT
+0015	BOOT	+0105	0105	<SS>	0101	WRITE IN-OT
+0016	BOOT	+0108	0108	0	0101	WRITE IN-OT

Figure 6C-1. Typical List Display In Single Trace Mode

Display Control Fields

Base

hexadecimal, decimal, octal, binary, ASCII (for labels from 6 to 16 bits), user (values assigned in [User Base] menu), and REL+HEX (values assigned in [Relocation] menu).

[Mark]:

places asterisk beside each line number that has values specified in [Mark] line.

[Show]:

shows only those lines on screen that have values specified in [Show] line.

Line no :

inverse-video field can be changed to any line number in memory. Display window will shift to area in memory which includes selected line.

Display Information

Blanked while analyzer gathers states. If states are captured at a slow rate, top line will show count of states still to be captured. After trace complete, up to 16 lines of state memory will be on screen.

Every label defined in Format Specification will be on screen (subject to max screen width). Labels can be reordered by placing cursor in the base field under a label and

Roll Indicator

pressing blue SHIFT key plus LABEL right-arrow or left-arrow key. arrow(s) in upper, right-hand corner. Indicate whether display window can be positioned up, down, left, or right by ROLL keys

**[Continuous] List Displays**

The list in the continuous trace mode is like the list in the single trace mode, except that "Continuous Trace in Process" appears at the top. In this mode, the analyzer makes a continuous series of single traces, updating the display each time it completes a trace. The content of the list will change as each new trace is completed if the display is updated with different information. To stop a continuous trace, press the STOP key. This causes the analyzer to complete its trace in progress and not start a new trace.

**[Compare] List Displays**

Figure 6C-2 shows a typical display that can be obtained in the [Compare] trace mode. On the top line, you can select either the display of [State] or [State+Compare]. If you select [State], the display will show only the content of the trace memory, just as you would see in the [Single] trace mode. The [State+Compare] display is unique to the [Compare] trace mode.

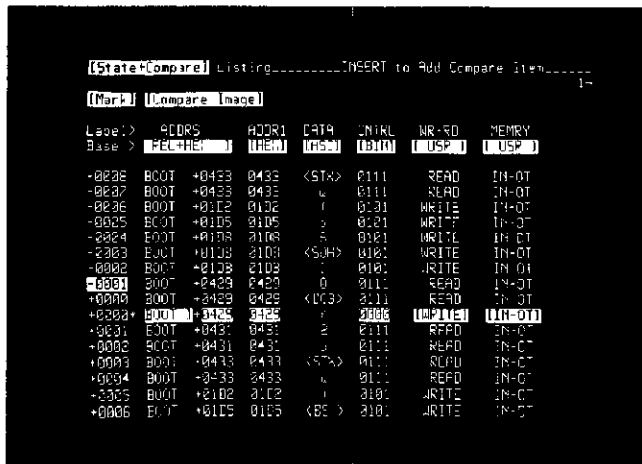

Figure 6C-2. Typical List Display In Compare Trace Mode

Display Control Fields

- [Mark]** places integrated display of trace list and Compare list on screen.
- [Show]:** places only lines of Compare List on screen in [Show] mode or marks lines of Compare List in [Mark] mode.
- [Compare Image]:** all lines of Compare List can be on screen.
- [Differences]** only lines of Compare List that are different from corresponding lines in trace list can be on screen in [Show] mode or marked in [Mark] mode.

**[Overview] List Displays**

You cannot obtain a list or waveform display when the analyzer is making an overview measurement.

**Waveform Displays**

Figure 6C-3 shows a typical state waveform display. It represents the states on eight channels. You can obtain waveform displays in any of the state trace modes, except overview. The information on the display is the same, regardless of the trace mode where it was obtained.

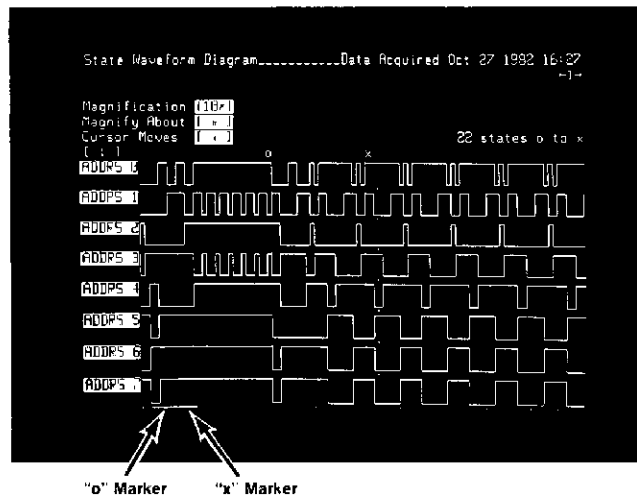

**Figure 6C-3. Typical State Waveform Display**

Display Content	1 to 16 channels (X2 vertical magnification with 8 or less channels)
Channels on Display:	Any bit in any position, identified by label name and bit number (if in multi-bit label) on left-hand side
Display control fields	
Magnification	selects from 1X to 40X Bright bar in dotted line at bottom shows position of display window in memory.
Magnify About	Moves magnified display window to area around "x" or "o" markers
Cursor Moves:	Selects "x", "o", or "x&o" markers to be moved by CURSOR keys. Scale at top shows number of states between "o" and "x" on display
Bit Labels:	Press NEXT[ ] key to bring any bit to any point Press INSERT and DELETE to add or remove channels. Press CLEAR ENTRY to turn off a channel Press LABEL up-arrow or down-arrow to move a channel up or down on the display



Roll Indicator: arrows in upper, right-hand corner indicate whether display window can be positioned left or right by ROLL keys

### XY Charts Of Label Activity

The analyzer can format XY charts of the activity collected from any labeled set of bits. These charts can show patterns of activity. Figure 6C-4 shows a typical XY chart of a label.

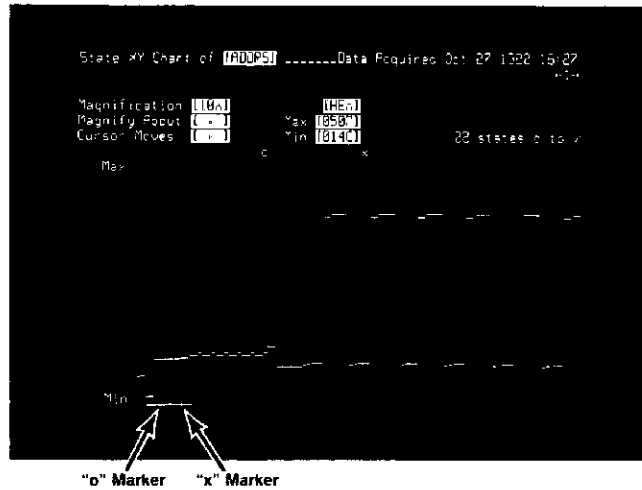

Figure 6C-4. Typical State XY Chart Of A Label

Display Control Fields	
Magnification	selects from 1X to 40X. Bright bar on dotted line at bottom shows position of display window in memory.
Magnify About	Moves magnified display window to area around "x" or "o" markers
Cursor Moves:	selects "x", "o", or "x&o" markers to be moved by CURSOR keys. Scale at top shows number of states between "x" and "o" on the display
Max and Min:	selects vertical display scale.

## Obtaining Inverse-Assembled Object Code In Analyzer List Displays

The logic analyzer can present list displays in which the data is inverse-assembled and presented in the mnemonics of the microprocessor system you are testing. To obtain this special display capability, you will need the optional HP digital cassette drive and a cassette tape with the HP inverse-assembler routine for the microprocessor you are testing.

The inverse-assembler tape file also automatically sets up the [Assignment] and for some microprocessors, the [User Base] menus in the Format Specification. These menu setups select clock multiplexing, if required; define the interpretation of each bit captured by the analyzer; and assign mnemonic definitions to the values of the status bits. These assignments correspond to the interconnections from the HP Model 10269A Probe Interface with the applicable HP preprocessor option.

Cassette tapes have a finite life. You should make a copy of the HP inverse-assembler file on a different cassette for performing your tests, and then save the original write-protected cassette for making future user cassettes. Refer to Appendix A for details of how to make user tape files, if necessary.

Use the following procedure to obtain displays of inverse-assembled object code:

1. Select the [Tape Operations] menu of the System Specification. Refer to Appendix A, if necessary.
2. Read an inverse-assembler routine into the analyzer. It contains the following information:
  - a. Complete inverse-assembler routine for selected microprocessor.
  - b. FORMAT Specification setups for [Assignment] and for some microprocessors, the [User Base] menus.
3. Set up the [Relocation] menu of the Format Specification with the address map of the system you are testing, if desired. Refer to the information in Chapter 6A.

## Obtaining Inverse-Assembled Object Code In Analyzer List Displays

The logic analyzer can present list displays in which the data is inverse-assembled and presented in the mnemonics of the microprocessor system you are testing. To obtain this special display capability, you will need the optional HP digital cassette drive and a cassette tape with the HP inverse-assembler routine for the microprocessor you are testing.

The inverse-assembler tape file also automatically sets up the [Assignment] and for some microprocessors, the [User Base] menus in the Format Specification. These menu setups select clock multiplexing, if required; define the interpretation of each bit captured by the analyzer; and assign mnemonic definitions to the values of the status bits. These assignments correspond to the interconnections from the HP Model 10269A Probe Interface with the applicable HP preprocessor option.

Cassette tapes have a finite life. You should make a copy of the HP inverse-assembler file on a different cassette for performing your tests, and then save the original write-protected cassette for making future user cassettes. Refer to Appendix A for details of how to make user tape files, if necessary.

Use the following procedure to obtain displays of inverse-assembled object code:

1. Select the [Tape Operations] menu of the System Specification. Refer to Appendix A, if necessary.
2. Read an inverse-assembler routine into the analyzer. It contains the following information:
  - a. Complete inverse-assembler routine for selected microprocessor.
  - b. FORMAT Specification setups for [Assignment] and for some microprocessors, the [User Base] menus.
3. Set up the [Relocation] menu of the Format Specification with the address map of the system you are testing, if desired. Refer to the information in Chapter 6A.

4. Set up the Trace Specification menu according to the test you want to perform. Refer to the information in Chapter 6B, if desired.
5. Write this setup to a tape file of your choice if you want to repeat this measurement later. The tape file will store all of the menu setups together. To repeat the measurement later, load the tape file that contains the inverse-assembler routine, and then load the file just stored. The second file will rewrite all of the menus to correspond with the test you want to perform.
6. Press the RUN key and perform the measurement. In the list display, select the ASM display base for your data column to obtain the inverse-assembled object code for your microprocessor.

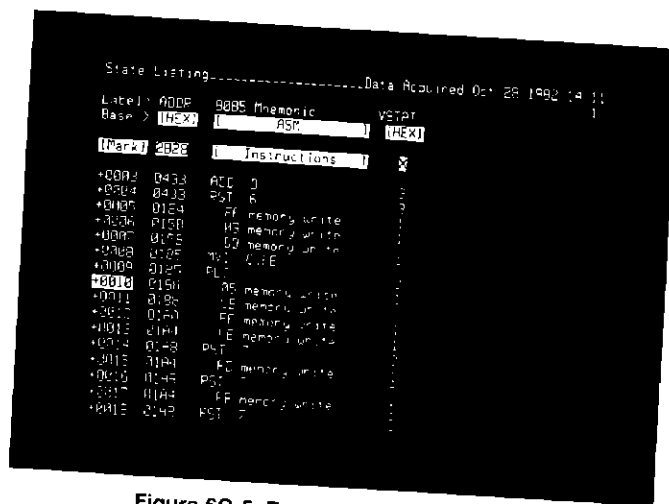

Figure 6C-5. Example Display Showing HP Inverse-Assembled Data List

Display Control Fields

Base:

hexadecimal, decimal, octal, binary, ASCII, user (values assigned in [User Base] menu), REL+HEX (values assigned in [Relocation] menu), and ASM (inverse-assembled data listing in mnemonics of microprocessor system under test).

[Mark]:

places asterisk beside each line number that has values specified in [Mark] line.

[Show]:

shows only those lines on screen that have values specified in [Show] line.

[All Cycles]:

shows all lines of memory. Each line that contains an instruction will have the complete instruction plus corresponding data. Each line that contains data will identify that data.

[Instructions]:

shows only those lines of memory that contain an instruction. Each line will have the complete instruction with corresponding operands.

Line no	inverse-video field can be changed to any line number in memory. Display window will shift to area in memory which includes selected line.
Display Information	Blanked while analyzer gathers states. If states are captured at a slow rate, top line will show count of states collected. After trace complete, up to 16 lines of state memory will be on screen. Every label defined in Format Specification will be on screen (subject to max screen width)
Roll Indicator	arrow(s) in upper, right-hand corner. Indicate whether display window can be positioned up, down, left, or right by ROLL keys



## Performance Analysis Measurements

### Introduction

Overview measurements (available in state-only configuration) are used for measuring software performance. They provide a higher level of viewing software than is available by capturing the details of state transactions. You can use overview measurements to compare relative performance of software routines. You can use these measurements to characterize process flows and execution times. You can also measure the usage of resources in a system under test.

The displays obtained from overview measurements are bar graphs (called histograms) which are selected by the CHART key. The analyzer can show two types of histograms: state label histograms, and time interval histograms. A state label histogram shows the relative number of executions within each range of states you define. Up to eight ranges of states can be defined for a label. Time interval histograms show eight time ranges; you can define the period of each range. You can set up the analyzer to make time interval measurements each time the software executes from one selected point to another in the system under test. The time interval histogram shows how often execution of the selected software module was completed within each of the time ranges you defined.

The analyzer runs overview measurements in the "continuous" mode. You must press the STOP key to end an overview measurement when you have obtained the information you need.

## Performance Analysis By Overview Of A State Label

In this measurement, you select a label to be monitored by the analyzer, and you assign names to ranges of states that will be found on that label (such as selecting the label assigned to the bits from the address bus, and assigning the name KEYBD to identify the range of addresses involved in the keyboard service routine). During this measurement, the analyzer captures states into its trace memory, and compares those states with the named ranges you defined. Each time a state falls within any of the named ranges, the analyzer increments a counter associated with that range. Ranges may overlap so a state may be counted as a member of several ranges. As the measurement progresses, a histogram will be on screen, showing the relative number of occurrences that met the specifications defined for each of the named ranges.

The measurement is made in the continuous mode. As each trace is completed, the data is sorted and the histogram updated. Because the analyzer sorts the information before it begins another trace, the data should be thought of as statistically sampled.

### State Label Overview FORMAT Specification

Set up the menus of the FORMAT specification just as you would for any state analysis measurement (refer to chapter 6A). Use all three of the menus in the FORMAT specification, if desired.

### State Label Overview TRACE Specification

Set up the menu of the TRACE specification for the Overview trace mode and select the state label you want to overview. Set up the trigger and sequence area of this menu as you would for any state trace measurement (refer to chapter 6B). Enter names for each of the ranges that you want to include in your overview measurement, and assign the ranges that correspond to each name. Figure 7-1 shows a typical setup for the TRACE specification menu.

### State Label Overview Histogram Chart

The histogram chart shows an overview of values occurring on a state label. Label histogram charts are often used to compare the number of executions of different address ranges on the address label (measuring the use of system resources by each of several software routines). Figure 7-2 shows a typical label histogram chart.



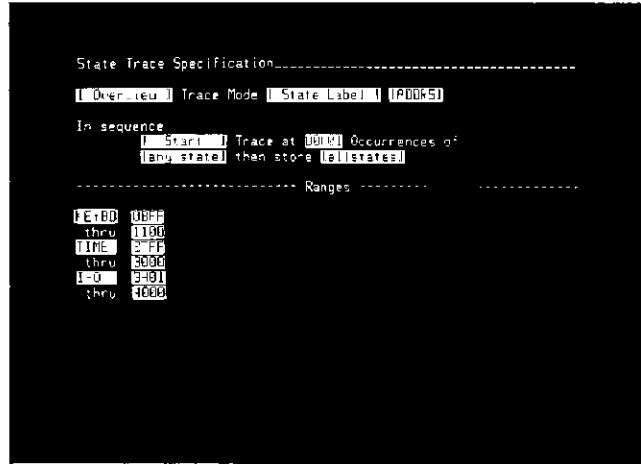

**Figure 7-1. State Label Overview Trace Specification**

**Labels Available For Overview**

Any label defined in state Format Specification.

**Label Ranges**

8 max. Definable from single value to entire width of label. Numerical base same as on LIST display in [Single] trace mode. Overlapping ranges allowed.

**Label Range Names**

1 to 5 alphanumeric characters. Used to identify corresponding ranges on histogram chart

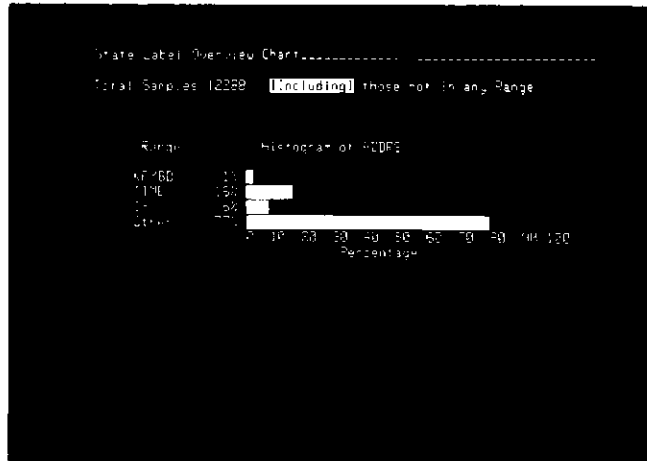

**Figure 7-2. State Label Overview Histogram Chart**

- Ranges shown:** all ranges specified for the label in the trace specification, plus an optional "other" range.
- Display Control Fields**
- Excluding:** Only transactions which fall within one of the defined fields are represented on the display.
  - Including:** All transactions are represented on the display. Those which did not meet any of the defined fields are shown as "other".
  - Percentage:** percent of states that fell within each range.

## Performance Analysis By Overview Of A Time Interval

The time interval overview is a measurement that gathers statistics about how long it takes a system to transition from one point in software to another. The use of this trace mode is to gather statistics about how long it takes a system under test to execute particular software, such as how long it typically takes to process an interrupt routine after the system under test has acknowledged the interrupt.

### Time Interval Overview FORMAT Specification

Set up the [Assignment] menu of the FORMAT specification as you would for any state analysis measurement (refer to chapter 6A).

### Time Interval Overview TRACE Specification

In the TRACE specification for the Overview trace mode, select [Time Interval]. Then enter the software occurrences where you want your time-interval measurements to start and end (such as the entry to the interrupt processor routine, and the return to normal program execution). Now specify the time ranges to be identified on the histogram chart. Figure 7-3 shows a typical setup for the TRACE specification menu.

### Time Interval Overview Histogram Chart

The time interval histogram chart shows an overview of time intervals measured between the states specified in the Trace Specification. Time interval histogram charts are used to compare how often a routine can be executed in particular time periods (indicating consistency of the execution). No states are captured in this mode so the histogram chart is the only display available when overviewing time intervals.

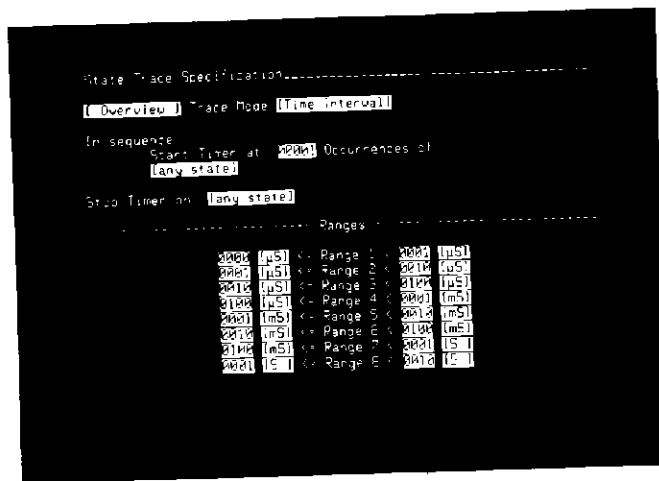

**Figure 7-3. State Time-Interval Overview Trace Specification**

- Start Timer Point:** As simple as [any state]. As complex as 4 OR'd states preceded by a 2-level sequence and trigger occurrence count.
- Stop Timer Point:** As simple as [any state]. As complex as 4 OR'd states.
- Sequence Restart:** As simple as [any state]. As complex as 4 OR'd states. To restart sequence containing more than one term or more than one occurrence.
- Readout available:** Histogram Chart only.
- Time Ranges:** 8 ranges, fixed. Any range can be as narrow as a single value or as wide as from 0.0 usec to 9999 sec. Overlapping ranges allowed.



**Figure 7-4. Time Interval Histogram Chart**

Percentages	percent of time interval measurements that fell within each range.
Time Ranges:	all eight ranges specified in Trace Specification.
Total Samples:	number of time interval measurements represented on screen.
Total Time:	accumulated time of all time intervals represented on screen.
Minimum	shortest time interval measured.
Maximum:	longest time interval measured.
Average:	average duration of time intervals measured.
Last:	duration of the last time interval measured.

Chapter **8**

**Timing Measurements**

All of the timing measurements that the analyzer can perform are discussed in Chapter 8. Chapter 8 is divided into four sections, this chapter, plus Chapters 8A, 8B, and 8C. Chapter 8A discusses how to set up the FORMAT specification. Chapter 8B discusses the use of the TRACE specification. Chapter 8C discusses the LIST, WFORM, and CHART displays that can be obtained by the analyzer when it is performing timing-only measurements.

Chapter **8A**  
**The Timing FORMAT  
Specification**

**Introduction**

This chapter describes how to use the FORMAT Specification when operating the analyzer as a timing measurement instrument. The Timing FORMAT Specification is divided into two menus: [Assignment] and [User Base]. Both of these menus are described in this chapter.

**Timing Format Specification [Assignment]**

The [Assignment] menu allows you to set up the analyzer to present information in a format that will be useful. In the [Assignment] menu, you perform two setup assignments: label assignments and threshold assignments.

**Timing Format Specification [User Base]**

The [User Base] menu allows you to assign names to be displayed in place of numbers when identifying states found on labeled bits. You can choose different names to identify each of the states, such as "ACTIV" and "INACT" to identify the two states found on the interrupt bit.

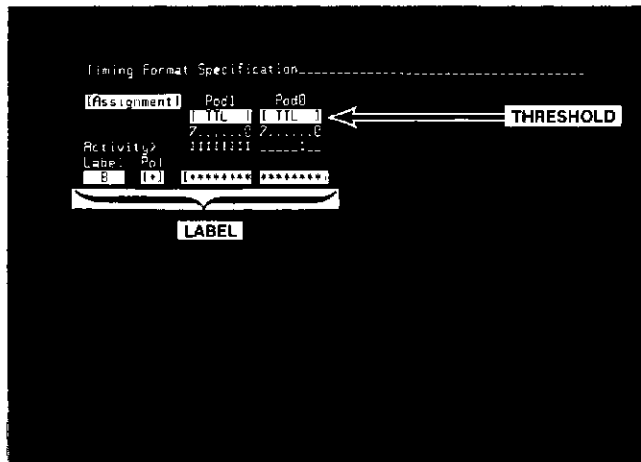

Figure 8A-1. Timing Assignment Format Specification

#### Label Assignments

When the analyzer makes a measurement, it collects the states from all input bits (whether part of a label or not). When you assign a label to a bit, you make that bit available to the display. The analyzer cannot place the activity from a bit on the display unless that bit has a label assigned to it.

A benefit of labeling sets of bits during a timing analysis is that you can easily identify an abnormal occurrence, such as two handshake lines high during the same instant of time.

The label capabilities and limitations are as follows:

- Maximum no. of labels: 16
- Label size: 1 to 5 alphanumeric characters.
- Label content: 1 to all bits. Same bit can be included in all labels.
- Label polarity: [+] = positive-true, [-] = negative-true (only affects LIST displays and TRACE specification)



Label bit arrangement (Example of 4-bit label)

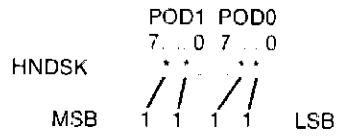

**Pod Threshold Assignments**

The pod threshold capabilities and limitations are as follows

Pod assignments: Each pod defined separately

Thresholds available: TTL, ECL, selectable from -9.9V to +9.9V, in 0.1V increments

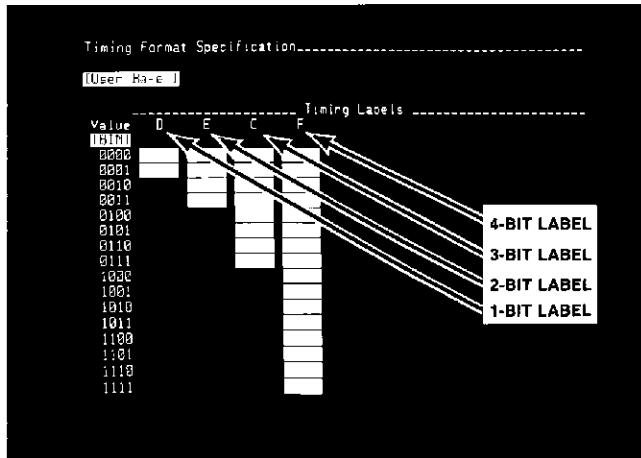

**Figure 8A-2. Timing User Base Format Specification**

- The [User Base] capabilities and limitations are as follows.
- Max labels on menu: 8.
  - Label size: 1 to 4 bits.
  - Max names/label: One name for each possible value (16 names on a 4-bit label)
  - Name Composition: 1 to 5 alphanumeric characters

## The Timing TRACE Specification

### Introduction

This chapter describes how to use the timing TRACE Specification when operating the analyzer as a timing analyzer. The TRACE Specification is the specification which establishes the type of parameters to be recognized when the analyzer captures timing information from a system under test.

There are two timing trace modes offered by the analyzer [Single], and [Continuous]. These two trace modes are discussed separately in the following paragraphs.

### [Single] Timing Trace Specification

The [Single] trace mode is used to capture a single trace of timing activity for each bit in the timing probe pods. This menu allows you to select the sample period, trigger location, trigger activity, and trigger duration.

### [Continuous] Timing Trace Specification

In the [Continuous] mode of timing measurement, the analyzer performs a measurement just like in [Single]. As soon as the measurement is complete and the display is updated, the analyzer begins another measurement. This will continue until you press STOP.

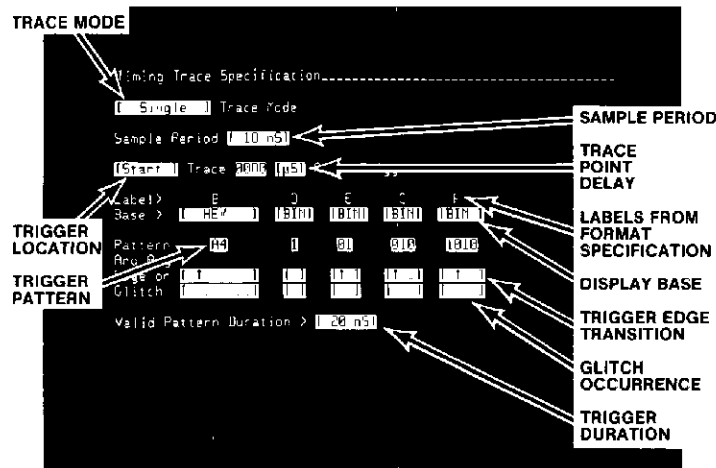

**Figure 8B-1. Timing Trace Specification (with [Glitch] Selected)**

Sample Period:	from one sample every 10 ns to one sample every 500 ms (24 sample period selections) in 1, 2, 5 sequence
Trigger Location	[Start], [Center], or [End] (determines amount of pretrigger and posttrigger time in memory).
Trigger Pattern	combination of pattern and edge. "AND" field composed of 1, 0, or X logic levels on all bits in all labels.
Edge:	"OR" field composed of positive-going, negative-going, either-edge, or off [ ] for each capable bit. Bits not capable of edge recognition are identified by N/A.
Duration:	from 20 ns to 1 ms (period that pattern must remain stable to be recognized as trigger) in 1, 2, 5 sequence
Trace Point Delay	from 0000 ns to 9999 sec after trigger recognition. Max delay depends on Sample Period selected. Note the analyzer rounds off the delay entry to the nearest multiple of four times the selected sample period.



## Chapter 8C The Timing Display

### Introduction

This chapter discusses how to read the displays which can be obtained when using the analyzer for timing measurements. The analyzer can present three kinds of displays: waveforms, lists, and XY charts. These displays are discussed in this chapter.

### Waveform Displays

Figure 8C-1 shows a typical timing waveform display. It shows the states of six channels during a measurement. The probe channels shown on the waveform display are identified on the left-hand side of the display by their label names and numbers which identify bit positions within the label.

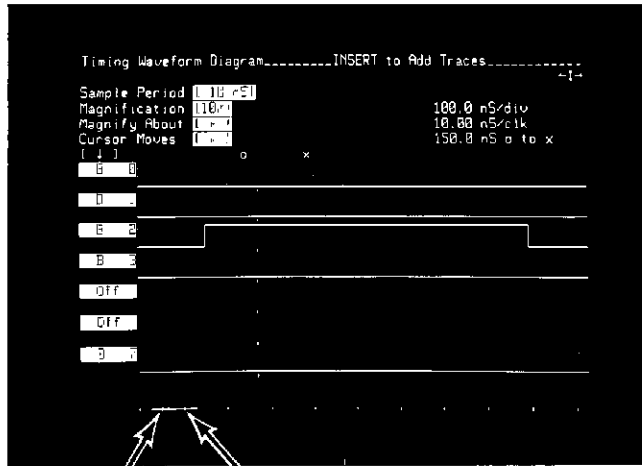

"o" Marker "x" Marker

**Figure 8C-1. Typical Timing Waveform Display**

Display Content:	1 to 16 channels (X2 vertical magnification with 8 or less channels).
Channels on Display	Any bit in any position, identified by label name and bit number (if in multi-bit label) on left-hand side.
Display control fields	
Sample Period	10 ns to 500 ms. You can change sample period and run new traces when in this menu
Magnification:	selects from 1X to 40X Bright bar in dotted line at bottom shows position of display window in memory
Magnify About	Moves magnified display window to area around "x" or "o" markers.
Cursor Moves:	Selects "x", "o", or "x&o" markers to be moved by CURSOR keys. Scale at top shows time period between "o" and "x" on display.
Bit Labels:	Press NEXT[] key to bring any bit to any point Press INSERT and DELETE to add or remove channels. Press CLEAR ENTRY to

Roll indicator:

turn off a display channel. Press LABEL up-arrow or down-arrow to move a channel up or down on the display. Arrows in upper, right-hand corner indicate whether display window can be positioned left or right by ROLL keys.

### List Displays

List displays can be obtained when you are performing timing measurements. Figure 8C-2 shows a typical list of timing information captured from a logic software system. The time column shows the absolute time interval between each line of information and the trigger line.

The message "Continuous Trace in Process" appears at the top of the display when in the [Continuous] trace mode. In this mode, the analyzer makes a continuous series of single traces, updating the display after it completes each trace. The content of the list will change after each new trace is completed if the display is updated with new information. To stop a continuous trace, press the STOP key. This causes the analyzer to complete the trace it has in progress and not to start a new trace.

```

Timing Listing-----Data Acquired Oct 27 1992 16:58
Label>      B      C      D
Base > [HEX] [BIN] [OCT]
[Mark] [Show] [Line]
+0205* FF04 111 1 +50.00 nS
+0206* FF04 111 1 +60.00 nS
+0207* FF04 111 1 +70.00 nS
+0208* FF04 111 1 +80.00 nS
+0209* FF04 111 1 +90.00 nS
+0210* FF04 111 1 +100.00 nS
+0211* 0004 110 1 +110.00 nS
+0212* 3404 100 1 +120.00 nS
+0213* 3404 100 1 +130.00 nS
+0214* 2404 100 1 +140.00 nS
+0215* 2404 100 1 +150.00 nS
+0216* 0404 100 1 +160.00 nS
+0217* 0404 100 1 +170.00 nS
+0218* 0404 100 1 +180.00 nS
+0219* 0404 100 1 +190.00 nS
+0220* 2404 100 1 +200.00 nS

```

Figure 8C-2. Typical List Display Of Timing Activity

Display Control Fields

**Base:** hexadecimal, decimal, octal, binary, ASCII (for labels from 6 to 16 bits), and user (values assigned in [User Base] menu). User values not specified are shown in hexadecimal numbers.

**[Mark]** places asterisk beside each line number that has values specified in [Mark] line.

**[Show]:** shows only those lines on screen that have values specified in [Show] line.

**Line no.:** inverse-video field can be changed to any line number in memory. Display window will shift to area in memory which includes selected line.

**Display Information:** Blanked while analyzer gathers activity. If timing activity is captured at a slow rate, top line will show amount of memory still to be filled. After trace complete, up to 16 lines of activity from memory will be on screen. Every label defined in Format Specification will be on screen (subject to max screen width). Labels can be reordered by placing cursor in the base field under a label and





Roll Indicator:

Time column

pressing the blue SHIFT key plus LABEL right-arrow or left-arrow key arrow(s) in upper, right-hand corner. Indicate whether display window can be positioned up, down, left, or right by ROLL keys shows absolute time between each sample and trigger line

## Chart Displays

The analyzer can format XY charts of the activity collected from any labeled set of bits. You can use these charts to see patterns of activity. Figure 8C-3 shows a typical XY chart for label A (a label composed of four bits).

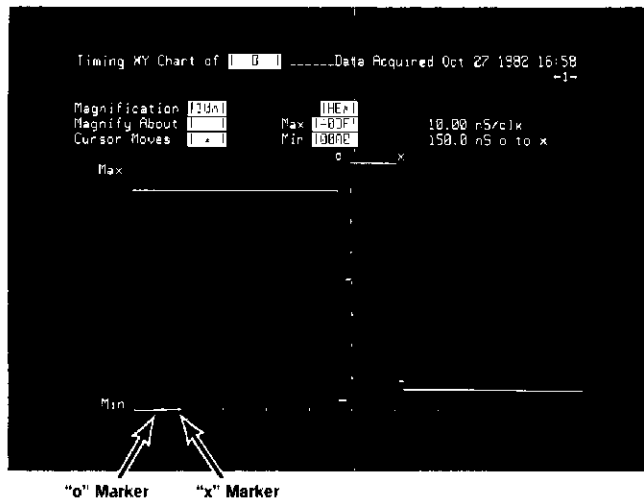

Figure 8C-3. Typical Timing XY Chart Of A Label

### Display Control Fields

- |                |  |
|----------------|--|
| Magnification: | selects from 1X to 40X. Bright bar on dotted line at bottom shows position of display window in memory.                              |
| Magnify About: | Moves magnified display window to area around "x" or "o" markers.  |
| Cursor Moves:  | selects "x", "o", or "x&o" markers to be moved by CURSOR keys. Scale at top shows period of time between "x" and "o" on the display. |
| Max and Min:   | selects vertical display scale.  |

## Combined State/Timing Measurements

### Introduction

The analyzer can perform simultaneous state and timing measurements (as described in Chapters 6 and 8) with nearly the same capabilities as when performing dedicated state or timing measurements alone.

This chapter describes the menus of the analyzer that are used to do simultaneous state and timing measurements. To select between state and timing versions of a given menu, simply press the key again for the menu you have on screen.

### The FORMAT Specification

The Format Specification menus for [State] and [Timing] will show only those probes assigned to each analysis function. The capabilities and limitations of the Format Specification menus are the same as when performing State-only or Timing-only measurements.

### The TRACE Specification

The trace specification for [State] and [Timing] is the same as described in Chapters 6 and 8 for state-only or timing-only measurements, except for operating modes and the "Master" field.

Operating Modes	[Single], [Continuous], or [Compare]. Both state and timing operate in the same mode [Overview] not available.
Master:	Selects one analysis function to look for its trigger before the other one can look for its trigger.

### Interactive State/Timing Displays

The information available in LIST and WFORM displays is the same as in the dedicated [State] and [Timing] modes. The XY CHART displays are the same as in the dedicated [State] and [Timing] modes. The Overview histogram display is not available when the analyzer is used for interactive [State] and [Timing] measurements.



## Using The Tape Memory Accessory

### Introduction

This appendix describes how to use the HP 82161A Digital Cassette Drive as an accessory to store and load test setups and captured data for the analyzer. It also describes how to copy files from one tape cassette to another.

When the digital cassette drive is connected to the analyzer, you can obtain the [Tape Operations] menu shown in figure A-1 (part of the set of SYSTEM menus).

The digital cassette drive obtains its operating power from its internal battery pack (charged from its power connector). When operating the digital cassette drive with a connection to 110V, use the ON position of the power switch. Use the STANDBY position when operating the digital cassette drive from its internal battery pack without a connection to 110V. The 110V connection provides maximum charge to the battery pack when the power switch is OFF.

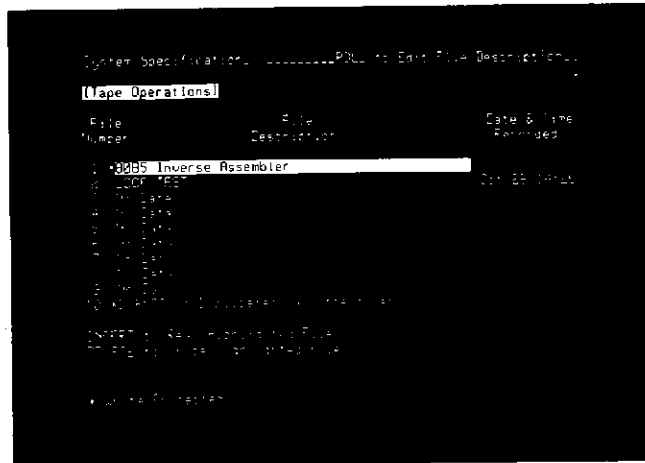
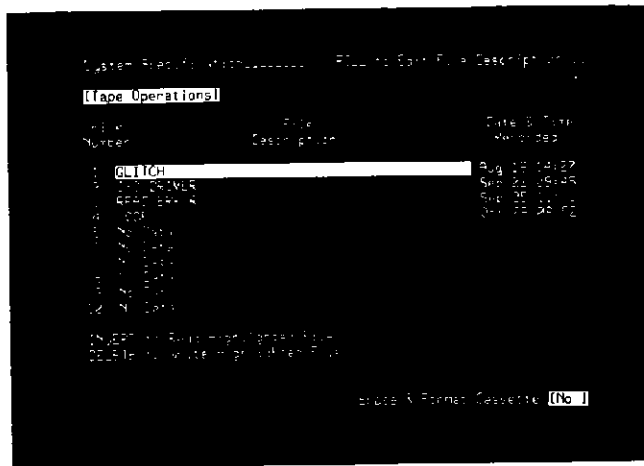

Figure A-1. Tape Operations System Menu



User File Names      all upper-case letters  
HP-supplied file names      file description preceded by asterisk. Write-protected (tapes with these files cannot be reformatted).

Display Control Fields  
File Description:      bright bar identifies file that will be written to if you press DELETE, or read if you press INSERT

Erase & Format Cassette  
change [No] to [Yes]. The analyzer will automatically erase the entire tape (all ten files), and reformat the tape with ten blank files. This field is not available for cassettes with one or more "write-protected" files. The formatting process takes approximately 5 minutes

Tape Files      10 files, fixed Selected using ROLL keys.  
Information stored in file:  
System, Format, and Trace specification menu setups, and content of trace memory for List, Waveform, XY Chart, and Histogram Chart displays, and date and time of data collection if clock was set

### How To Create A New File

1. Place the cursor in the bright bar under File Description.
2. Use the ROLL keys to move the bright bar to the desired location for the new file.
3. On the keyboard, type in a file name using any of the alpha-numeric characters. After the name of a file has been typed, you cannot access any other part of the analyzer until you store an instrument setup plus data in that file. If you have to leave that file location before storing the setup and data, press the blue SHIFT key and DEFAULT.
4. Press the blue SHIFT key and DELETE to write the analyzer setup and data to the selected tape file. This takes from 30 to 70 seconds, approximately.

#### NOTE

---

For ease of creating a file description similar to one already on screen, move the bright bar into the present file name and type just the first letter of that name. Then ROLL the bright bar to the location where you want to create the new name. A copy of the entire line will follow the bright bar. You can edit the copy to obtain the File Description you want.

---

### How To Read A File

1. Use the ROLL keys to move the bright bar to the location of the file you want to read.
2. Press the INSERT key. The message WAIT Reading Cassette File will appear on screen. The read takes from 20 to 60 seconds, approximately. When the read is complete, the [Configuration] System Specification will appear on screen.



### **How To Copy An Existing File From One Tape To Another**

You can make as many copies of your user files as desired by following the procedures described in this appendix. First load your file into the analyzer as described in "How To Read A File". Then write the analyzer setup to as many other cassettes as desired, as described in "How To Create A New File."

### **How To Copy An HP Write-Protected Inverse-Assembler File Into A User File**

All tape cassettes have a finite life. You should make user copies of your cassettes that have HP-supplied inverse-assembler files. Then store the original tapes; use them only when making new user copies. The following procedure will help you create user copies of HP-supplied inverse-assembler files.

1. Install the tape cassette that has the HP write-protected inverse-assembler file into the digital cassette drive.
2. Obtain the [Tape Operations] menu. Each cassette with an HP-supplied inverse-assembler file will have an additional file labeled, "COPYFILE: Duplicates cassette files". This contains the routines that read an HP-supplied inverse-assembler, and copy it to other cassettes.
3. Move the highlighted bar to the "COPYFILE" line.
4. Press the INSERT key. This causes the analyzer to read the COPYFILE program. When finished, the analyzer will place the following messages on screen: "COPYFILE: Press INSERT to copy highlighted file" at the bottom of the menu, and "Press STOP to exit COPYFILE" at the top of the menu.
5. Move the highlighted bar to the write-protected inverse-assembler file you want to copy.
6. Press the INSERT key. This reads the inverse-assembler file into the analyzer along with the copyfile program. When finished, the message at the bottom of the menu will change to "COPYFILE: Press DELETE to store copy in highlighted file."

7. Now open the digital cassette drive, remove the tape cassette, and install the new cassette that you want to contain your user file. The analyzer will display the directory of the new tape.
8. Move the highlighted bar to the location where you want to store the inverse-assembler routine.
9. Press the DELETE key. The analyzer will write the inverse-assembler routine to the tape at the location you selected. All attributes of the source file will be transferred. Because the source file was write-protected, your user file will also be write-protected.
10. You can now repeat steps 7 through 9 to create as many cassettes with inverse-assembler routines as desired.
11. Press the STOP key. This exits the COPYFILE program and returns the analyzer to normal program execution.

## Appendix **B** Using A Printer

### Introduction

The analyzer can be connected through an HP-IB interface cable to a graphics printer that understands the HP-IB command set, and the analyzer can control the printer to obtain hard copies of any of its displays, as well as hard copies of the entire content of its list memory. This appendix lists the steps required to connect a printer to the analyzer and obtain hard copy.

The speed with which you can obtain a copy of a display depends upon which printer you are using, the complexity of the display you want to copy, and whether you are using HP-text or HP-graphics (selected in [Peripherals] SYSTEM menu) to transfer information. Use the following information as a guide to estimating the printer speed of your system.

Max. Data Transfer Rate: 4K bytes/sec approximately  
Example times for making copies on HP 2671G printer using [Text] language ([Text] is approximately twice as fast as [Graphics]):  
Copy small menu: 7 seconds approximately  
Copy large menu: 20 seconds approximately  
Copy complete timing diagram: 30 seconds approximately  
Copy Max width list (8 labels): 85 words/min approximately. Full 1K list can be copied in approximately 12 minutes

### Obtaining Hard Copy From A Printer

The following procedure is written to help you hook up a printer through an HP-IB interface cable, and obtain hard copies of displays.

1. Connect an HP-IB interface cable between the analyzer rear panel and the printer.
2. Set the address switches on the analyzer rear panel to the TALK ONLY position (address switches 7 and 8 to 00)

- 3 Set the printer to the "listen only" mode
- 4 Turn on operating power at the printer
- 5 Turn analyzer LINE power off and then on again. When the analyzer executes its power-up routine, it will read the position of the address switches. To check this, select the [Peripherals] menu in the SYSTEM menu set, and see that the display says, "System Controller: NONE/TALK ONLY"
- 6 Set up a display on the analyzer that you would like to copy and press the analyzer PRINT key. The analyzer will send the commands required to obtain a complete copy of the display. If you copied a list display, note that the line number which was in inverse video is underlined in the print using HP-text and in inverse-video using HP-graphics.
- 7 You can obtain a copy of the trace memory beyond the portion shown on the display, if desired. To do this, place the list display on screen. Then use the ROLL keys to get the first line of the desired copy on screen (if you want to start your copy at line +0100, roll the display to the point where line +0100 is the top line on screen)
- 8 Press the blue shift key and PRINT ALL key. The analyzer will activate the printer and start printing with the top line on screen. It will continue to send print information to the printer until the entire content of the trace memory has been printed. It will resend the heading information each time it starts a new page.
- 9 You can stop the print before the entire 1K memory has been printed, if desired. To do this, press the analyzer STOP key. When you press the STOP key, the analyzer will stop sending new information to the printer buffer. The information for the lines on screen will already be in the printer buffer. The print will continue until the last line of the present display is printed. Then it will halt.



### **Using A Controller To Operate The Analyzer And Printer**

Reset the analyzer address switches to the HP-IB CONTROLLED or HP-IL CONTROLLED positions, as applicable, and cycle the analyzer LINE power. Check to see that the SYSTEM [Peripherals] menu shows that the analyzer is controlled and that it lists the desired address. Refer to appendix C for the complete list of device-dependent commands for controlling operation of the analyzer.

In the controlled mode, the PRINT key can still be used to obtain hard copy from a printer. If you press the PRINT key (or "PR" sent from controller), the analyzer must be addressed to talk and the printer addressed to listen before the print will occur.

## Using The HP-IB Or HP-IL Interface

### Introduction

This appendix will help you program the operation of the analyzer using the HP-IB or HP-IL interfaces. The HP-IB and HP-IL interface capabilities and device-dependent commands are identical. All operations that can be obtained by pressing a front-panel key can also be obtained by using the analyzer device-dependent commands when they are sent over an HP-IB or HP-IL interface from a controller. This appendix provides detailed information about each of the device-dependent commands and how these commands affect the analyzer.

### HP-IB And HP-IL Interface Capabilities

The following HP-IB and HP-IL interface functions are implemented in the analyzer

**SERVICE REQUEST** - Programmable service request (SRQ). Reset when status byte read by SERIAL POLL or via SB command

**SERIAL POLLING** - Preferred method of checking machine status because serial polling will not cause the analyzer to abort any currently pending output. The "SB" command does cause such aborts.

**PARALLEL POLLING** - Complete parallel polling capability. Sense bit of ENABLE message is used to determine whether a service request is indicated by a 1 or 0 on the specified bit. Request is cleared by a serial poll or by sending SB1.

**GROUP EXECUTE TRIGGER** - Executes a measurement.

**REMOTE/LOCAL/LOCAL LOCKOUT** - Complete capability.

**INTERFACE CLEAR** - Aborts any input or output transmission pending

**DEVICE CLEAR** - Resets instrument to "power up" state.

### HP-IB And HP-IL Interface Limitations

The analyzer will abort any pending output if it receives a new command from the controller before it has been addressed to send its output. For example, if the controller tells the analyzer to send its status byte, and then the controller commands a menu change in the analyzer before it addresses the analyzer to talk, the analyzer will abort its status byte message.

### Keyboard Mnemonics

The device-dependent commands for keyboard functions are implemented in a mnemonic-per-keystroke format. Table C-1 lists the HP-IB and HP-IL command mnemonic for each key. Any mnemonic can be followed by an ASCII number that indicates how many times to repeat that key. For example "CD 5" will cause the "Cursor Down" command to be executed five times. Sending the command "NX 10" is the same as pressing the NEXT key ten times.

To send data keys (i.e. numeric 0123456789ABCD or alphabetic values) enclose the ASCII representations of those keys in field delimiters. For example, if a pattern is to be sent after positioning the cursor to a particular field, send the pattern in field delimiters, i.e., OUTPUT 700; "A01XX1533A". Four different field delimiters are allowed: ", ' ( ), and ^". Use the same delimiter at the start and end of a field. Mnemonics can be sent using either upper case or lower case letters. Use the semicolon ";" for delimiting multiple mnemonic commands, i.e., "NX;CL;RD".

**Table C-1. HP-IB/HP-IL Keyboard Mnemonics**

KEY	MNEMONIC	KEY	MNEMONIC
SYSTEM menu	SM	INSERT	IN
FORMAT menu	FM	DELETE	DE
TRACE menu	TM		
LIST menu	LM	CLEAR ENTRY	CE
WFORM menu	WM	DEFAULT	DM
CHART menu	CM		
		NEXT[]	NX
CURSOR left	CL	PREV[]	PV
CURSOR right	CR	CHS	CS
CURSOR up	CU	DON'T CARE	DC
CURSOR down	CD		
LABEL left	LL	RUN	RN
LABEL right	LR	RESUME	RE
LABEL up	LU	STOP	ST
LABEL down	LD	PRINT	PR
		PRINT ALL	PA
ROLL down	RD		
ROLL up	RU		
ROLL left	RL		
ROLL right	RR		

### Non-Keyboard Mnemonics

The following HP-IB and HP-IL mnemonics command the analyzer to take actions that are not possible from the keyboard.

BP - Beep. Sounds analyzer beeper.

SYNTAX: BP;

CH - Cursor Home. Moves cursor to known location at upper leftmost field of analyzer display.

SYNTAX: CH;



DB - Display Blank. Clears analyzer display. For proper operation, the SYSTEM [Configuration] menu should be on the display when you issue the "DB" command. The word "REMOTE" will not disappear from the display. If a trace is in process, the message area of the screen may be asynchronously updated.

SYNTAX: DB;

DR - Display Read. Command causes analyzer to read from display memory, starting from specified row and column, specified number of characters for transfer to HP-IB/HP-IL interface

SYNTAX: DR <ROW> <COL> <BYTE\_COUNT>;

where BYTE\_COUNT has maximum integer value of 1472 (23 rows X 64 columns)

ROW is integer value with range of 1 to 23

COL is integer value with range of 1 to 64

DW - Display Write. Writes ASCII string of 80 or less characters to analyzer display, beginning at position specified by row and column

SYNTAX DW [I] <ROW> <COL> "STRING",

where I is optional parameter specifying that string be displayed in inverse video.

Legal delimiters for STRING are ", ', (), or ^.^.

ID - Send Identification code. Causes analyzer to send identification code indicating instrument configuration.

SYNTAX ID;

where returned value is a string containing the instrument model number ("HP1630A" or "HP1630D").

HP1630A - (35-channel state, 8 timing)

HP1630D - (43-channel state, 16 timing)

KE - Send buffered Key Causes analyzer to send key mnemonic (refer to table C-1) for any key that has been pressed while in remote mode. Buffer saves up to last 15 key presses. If no keys have been pressed, the analyzer returns double question marks (??).

SYNTAX: KE;

MB - Set service request mask. Enables service request modes specified in argument. Mask byte is set to 0 at power-on, disabling any service requests.

SYNTAX: MB <mask\_value>;

where mask\_value is an ASCII integer (i.e., 0 to 255) in decimal format. A service request (SRQ) will be generated if the mask bit for a condition is set to one and that condition occurs. The mask bit positions are:

- Bit 0 (01H) = Print Complete
- Bit 1 (02H) = Measurement Complete
- Bit 2 (04H) = Slow Clock
- Bit 3 (08H) = Key Pressed (Front Panel Request)
- Bit 4 (10H) = Not Busy
- Bit 5 (20H) = Error in Last Command
- Bit 6 (40H) = Reserved for indicating Service Request

PU - Power up Defaults all instrument menus

SYNTAX: PU;

SB - Status Byte. Returns analyzer status byte to controller on next read. One of four status bytes may be requested. Serial polling returns status byte 1. Sending the SB command causes the analyzer to abort the current operation being executed. Serial polling does not abort the current operation.

SYNTAX: SB <N>;

where N is integer value from 1 to 4. If argument N is omitted, the default condition is status byte 1. Requesting status byte 1 or executing a serial poll resets SRQ

Status byte 1 - Machine status (of bits currently enabled by Service Request Mask)

- Bit 0 (01H) = Print Complete
- Bit 1 (02H) = Measurement Complete
- Bit 2 (04H) = Slow Clock
- Bit 3 (08H) = Key Pressed (Front Panel Request)
- Bit 4 (10H) = Not Busy
- Bit 5 (20H) = Error in Last Command
- Bit 6 (40H) = Reserved for indicating Service Request

Status byte 2 - Machine status (all bits)

Same as status byte 1.

Status byte 3 - Trace status consisting of two 4-bit quantities Q2Q1 packed in a single byte.

- Q2 = 0 - No Trace Taken
- 1 - Trace in Progress
- 2 - Measurement Complete
- 3 - Measurement Aborted
  
- Q1 = 0 - Not Active (no measurement in progress)
- 1 - Waiting for State Trigger Term
- 2 - Waiting for Sequence Term #1
- 3 - Waiting for Sequence Term #2
- 4 - Waiting for Sequence Term #3
- 5 - Waiting for Overview Start Term
- 6 - Waiting for Overview End Term
- 7 - Slow Clock
- 8 - Waiting for Timing Trigger
- 9 - Delaying Timing Trace
- 10 - Timing Trace in Progress

Status byte 4 - Controller error codes indicating error condition or action required from controller.

Error code =

- 4 - Illegal Value
- 8 - Use NEXT[] PREV[] Keys
- 9 - Numeric Entry Required
- 10 - Use Hex Keys
- 11 - Use Alphanumeric Keys
- 13 - Fix Problem First
- 15 - DON'T CARE not legal here
- 16 - Use 0 or 1
- 17 - Use 0, 1, or DON'T CARE
- 18 - Use 0 thru 7
- 19 - Use 0 thru 7 or DON'T CARE
- 20 - Use 0 thru 3
- 21 - Use 0 thru 3 or DON'T CARE
- 22 - Value is Too Large
- 24 - Use CHS Key
- 30 - Maximum INSERT's used
- 40 - Cassette Contains Non HP1630 Data
- 41 - Checksum Does Not Match
- 46 - No Cassette in Drive
- 47 - Requires File Description
- 50 - Tape Operation ABORTED
- 58 - Unrecognized Command

### Learn String Commands

The following learn string commands instruct the analyzer to transmit its internal configuration, state measurement file, and/or timing measurement file to the controller. Learn string commands provide a means of saving configurations and measurement data for later use and analysis. Measurement configurations can be stored and reloaded to repeat complex measurements. Likewise, measurement data can be returned to the analyzer for analysis at a more convenient time. You need only dump the learn string back to the analyzer to restore a configuration or measurement data. The learn string contains the correct information for the receive learn string command. Each learn string contains the proper mnemonic header (RC, RS, or RT), a binary byte-count word, the binary data, and two CRC check bytes. The binary byte-count word gives the number of bytes contained in the binary data file, including the two CRC bytes.

TC - Transmit Configuration Learn String. This learn string command causes the analyzer to transmit a string containing its configuration data plus two CRC check bytes.

SYNTAX: TC

Learn String Format:

Starting Byte Position In String	Number Of Bytes	Contents
1	2	RC (Receive Configuration Command)
3	2	Binary byte count
5	N	Configuration data (<5K bytes in 1630 internal format)
N+5	2	CRC Check Bytes

TS - Transmit State Acquisition Learn String. This learn string command causes the analyzer to transmit a string containing its state measurement data.

SYNTAX: TS

Learn String Format:

Starting Byte Position In String	Number Of Bytes	Contents
1	2	RS (Receive State Command)
3	2	Binary byte count
5	1	Month
6	1	Day
7	1	Hours
8	1	Minutes
9	1	Seconds
10	2	Year
12	1	Type of Data 0 = State trace data 1 = State overview 2 = Time interval overview
13	N	Data file
N+13	2	CRC check bytes

State Trace Data file (Data type 0)

No. of Bytes	Contents
1	Number of state channels
2	Number of valid states captured
2	State Trace Point
N	Data Acquired (N = (No. of Valid States)*(M))

M = 0 if no state channels

M = 4 if 27 state channels

M = 5 if 35 state channels.

M = 6 if 43 state channels.

### Format For Data Acquired

The format for transmitting data over HP-IB in the state acquisition learn string is shown in figure C-1. Data is transmitted in byte-serial format. To transmit each valid state requires 4, 5, or 6 bytes, depending upon the state analyzer configuration. The five MSB of the first byte for each state are "don't care" bits; they are set to zero (0) by the analyzer. The data bits (B) begin with bit 2 of the first byte. The data is binary, each bit represents one channel in a probe pod. The polarity of the data corresponds with the physical value at the probe tip (0 = more negative voltage, 1 = more positive voltage).

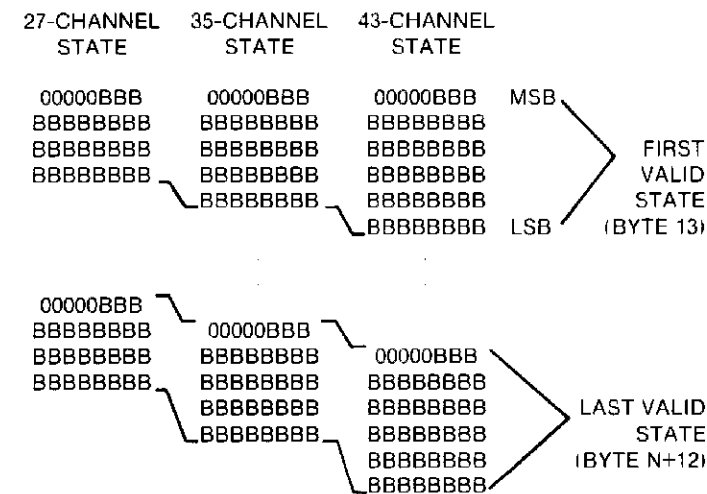

**Figure C-1. Data Format For State Acquisition  
Learn String Sent On HP-IB**

**State Overview Data File (Data Type 1)**

No. of Bytes	Contents
211	State overview data (data in 1630 internal format)

**Time Interval Overview Data File (Data Type 2)**

No. of Bytes	Contents
120	Time Interval overview data (data in 1630 internal format)

TT - Transmit Timing Acquisition Learn String. This learn string command causes the analyzer to transmit a string containing its Timing measurement data

SYNTAX: TT

Learn String Format

Starting Position In String	Number Of Bytes	Contents
1	2	RT (Receive Timing Command)
3	2	Binary byte count
5	1	Number of timing channels
6	2	Number of valid states captured
8	2	Trace point
10	1	Glitch data taken (Boolean)
11	2	Sample period
12	1	Month
13	1	Day
14	1	Hours
15	1	Minutes
16	1	Seconds
17	2	Year
19	N	Data acquisition file (N = (No. valid states)*(No. channels/8))
N+19	2	CRC check bytes

TE - Transmit Everything This learn string command instructs the analyzer to transmit the following data in the listed sequence: (1) Configuration learn string, (2) State data acquisition learn string, and (3). Timing data acquisition learn string. Refer to the TC, TS, and TT command descriptions for learn string formats

### Data Transfer Termination

Binary transfers of data are terminated by setting EOI true with the last byte transferred. Non-binary transfers are terminated by sending CR LF with EOI true



## Appendix D

# Display Messages

This appendix lists and defines each of the status, error, and prompt messages that the analyzer presents on screen.

**All Names Must Be Unique** - This message is displayed when you create a name that is identical to one of the other names already in use on that menu.

**At Least 1 Clock Edge Required** - This message is displayed when you set up the CLOCK field in the state FORMAT specification so that no clock line is active.

**Continuous Trace in Process** - This message is displayed when the analyzer has a continuous trace in process, such as during the execution of an overview measurement.

**Delay Too Big for Sample Period** - This message is displayed when you select a trigger delay in the timing TRACE specification that is too long for the analyzer to measure using its present sample period selection.

**DELETE to Remove Field** - This message is displayed on menus which have all available fields assigned, such as when the state [Assignment] menu of the FORMAT specification has 8 labels assigned. This message tells you how to delete fields from a full menu.

**DELETE (Write) / DEFAULT Required** - This message is displayed when an entry has been made in the highlighted file description line. You must either press the DELETE key to write the instrument configuration to that tape file, or press the DEFAULT key to return the edited line to its previous unedited condition.

**Each Label Must Have a Name** - This message is displayed when you press INSERT to create a new label, before you have made any entry into the field for naming that new label.

**ERROR Cassette Contains Non HP1630 Data** - This message is displayed when the analyzer reads directory information that is not as written by the analyzer. You can erase and reformat the tape if you still intend to use it with the analyzer.

**ERROR CRC Does Not Match** - This message is displayed when the CRC value read in from a tape file or a learn string did not match the CRC value calculated by the analyzer when it received the data.

**ERROR DONT CARE Not Allowed** - This message is displayed when you press the DONT CARE key and the cursor is in a field where "don't care" entries can not be accepted.

**ERROR In Controller Command** - This message is displayed when the analyzer received a command from the controller (HP-IB or HP-IL) and did not recognize the command. A second line shows <...>?? with the first character of the unrecognized command in inverse video.

**ERROR Invalid in this Trace Mode** - This message is displayed when you try to obtain a display that is not available in the selected trace mode, such as a trace list when the analyzer is performing an overview measurement.

**ERROR Maximum INSERT's Used** - This message is displayed when you press the INSERT key to insert an additional field, such as another label in the [Assignment] menu of the FORMAT specification, and the menu already has as many entries of that type as it can accept.

**ERROR No Cassette in Drive** - This message is displayed when the door on the cassette is open or no tape is currently in the drive when a read or write operation is attempted.

**ERROR Numeric Entry Required** - This message is displayed when you press a non-numeric key, such as NEXT[], and the cursor is in a field that accepts only numeric entries.

**ERROR Only Bits 0-3 Edge Trigger** - This message is displayed when you try to assign edge triggering to one of the timing bits that does not have edge-trigger capability.

ERROR Requires Correction First - This message is displayed when you have entered a partial specification, and before completing it, you try to switch to another analyzer menu, such as when you have entered the name of a label in the FORMAT specification, and you try to change to the TRACE specification before you assign a bit for that label.

ERROR Requires File Description - This message is displayed when an attempt has been made to write a tape file without creating a file description.

ERROR RESUME Not Allowed - This message is displayed when you press the RESUME key in an operation that the analyzer has completed and it cannot resume.

ERROR Tape Operation Aborted - This message is displayed when the STOP key has been pressed during a tape read or write operation, or when a data error has been detected by the analyzer.

ERROR Use Alphanumeric Keys - This message is displayed when you press the NEXT[] or PREV[] keys while the cursor is in a field which accepts only alphanumeric entries, such as a module name field in the [User Base] menu of the FORMAT specification.

ERROR Use CHS Key - This message is displayed when the cursor is on a mathematical sign, and you try to change the sign with any key other than the CHS (change sign) key.

ERROR Use Hex Keys - This message is displayed when you press a non-hex key when the cursor is in a field that accepts only hexadecimal entries.

ERROR Use NEXT[] PREV[] Keys - This message is displayed when you press a keyboard letter or number key in a field where selections must be made with the NEXT[] or PREV[] keys.

ERROR Use 0 or 1 - This message is displayed when you try to enter a non-binary character in a specification that is set to accept only binary entries.

ERROR Use 0, 1, or DON'T CARE - This message is displayed when you try to enter a non-binary character in a specification field that is set up to accept only binary or "don't care" entries.

ERROR Use 0 thru 3 - This message is displayed when you try to enter too large a value into a field made up of only two bits, and set to accept a number base other than binary

ERROR Use 0 thru 3 or DON'T CARE - This message is displayed when you try to enter too large a value into a field made up of only two bits, and set to accept either a DON'T CARE, or a number with a non-binary base.

ERROR Use 0 thru 7 - This message is displayed when you press an "8" or "9" key for an entry in a field that accepts only numbers in the octal number base or is made up of only 3 bits.

ERROR Use 0 thru 7 or DON'T CARE - This message is displayed when you try to enter a non-octal character in a specification field that is set up to accept only octal or "don't care" entries, or is made up of only 3 bits.

ERROR Value is Too Large - This message is displayed when you press a numeric key in a numeric field, but the number is too large for the cursor position in the numeric field

ERROR Write Protected File - This message is displayed when the highlighted bar is on a file that is write protection enabled and a write operation is attempted.

INSERT to Add Compare Item - This message is displayed in the state and compare list display. It indicates that you can add a duplicate of the line shown in inverse video to the compare list by pressing the INSERT key

INSERT to Add New Label - This message is displayed when the cursor is in the label field of the format [Assignment] menu. It describes what you must do to create a new label in this menu.

INSERT to Add New Module - This message is displayed when you are creating code modules on the [Relocation] menu of the FORMAT specification. It describes what you must do to create an additional code module in the map.

INSERT to Add New Range - This message is displayed when you have the cursor in the range field of a menu, and the analyzer has space available in that field for creating additional ranges

INSERT to Add OR'd Pattern - This message is displayed when the cursor is in the proper position to allow entry of an additional term to be OR'd with the present term in the specification. It describes what you must do to create this additional term.

INSERT to Add Sequence Term - This message is displayed when the cursor is in the proper position to allow entry of a sequence term. It describes what you must do to create a new sequence term in this menu.

INSERT to Add Traces - This message is displayed in the waveform display when you have the cursor in the proper area where you can add more waveform channels to the display. The message indicates how you can add channels to the display.

Invalid Clock Setting - This message is displayed when the analyzer clock in the SYSTEM [Peripherals] menu has not been set to a correct date. The clock date must be greater than December, 1981.

NOTE: Compare List is Empty - This message is displayed when you select the state Compare trace mode and the list in the compare memory has no entries.

One "" Required For Each Label - This message is displayed when you have created a name for a new label, before you have assigned the first bit to be identified by that label.

Power-Up Complete - This message is displayed after the analyzer has successfully completed its power-up test routine.

ROLL to Change Configuration - This message is displayed when in the SYSTEM [Configuration] menu. It tells you to use the ROLL keys to change the distribution of input bits between the state and timing measurement channels.

ROLL to Edit File Description - This message is displayed when in the [Tape Operations] menu. It indicates that the ROLL keys will move the highlighted bar to the file description you intend to edit.

Single Trace in Process - This message is displayed when operating in a continuous measurement mode, after you press the STOP key, while the analyzer is completing the trace in process.

Trace Aborted - This message is displayed when you have pressed the STOP key during a single trace execution before that trace has been completed

Trace Complete - This message is displayed when the analyzer completes a single trace

WAIT PRINT in Progress - This message is displayed when the printer starts sending codes to obtain a copy of the display on an external printer

WAIT Reading Cassette File - This message is displayed when the INSERT key has been pressed in the [Tape Operations] menu. The machine configuration plus data are read from the tape file that is highlighted by the inverse-video bar

WAIT Writing Cassette File - This message is displayed when the DELETE key has been pressed in the [Tape Operations] menu. The machine configuration plus data are written to the tape file that is highlighted by the inverse-video bar

WARNING Awaiting HP-IB Transfer - This message is displayed when the analyzer has been commanded to send data but the HP-IB controller is not accepting transmissions from the analyzer. This message will disappear when data transfer begins.

WARNING Awaiting HP-IL Transfer - This message is displayed when the analyzer has been commanded to send data but the HP-IL controller is not accepting transmissions from the analyzer. The message will disappear when data transfer begins.

WARNING Command Ignored - This message is displayed when you try to execute a command that is invalid for the field that is identified by the position of the cursor, such as trying to INSERT a label in the [Assignment] FORMAT specification when the cursor is in the [Assignment] field

WARNING New Tape Inserted - The analyzer rereads the tape directory each time it enters the [Tape Operations] menu. This message is displayed when the directory read does not match the current memory of the [Tape Operations] menu.



WARNING [NEXT/PREV] Erases Tape - This message appears when the cursor is moved into the Erase & Format Cassette field. If you press the NEXT[] or PREV[] key, the analyzer will automatically erase and reformat the entire tape.

WARNING Press STOP Key First - This message appears when you have tried to change a trace parameter during a measurement. The analyzer can not change trace parameters while a measurement is in process.

WARNING Printer Down - This message is displayed when the analyzer tries to send data to print a copy of its display on an external printer and the data transfer is not taking place or has been suspended for approximately 1 second.

WARNING Slow Clock - This message is displayed when the repetition rate of the incoming state clock is slower than the minimum rate. It usually means that the analyzer is not receiving any clock activity on the line(s) you have designated as the incoming clock lines.

WARNING Value Not Allowed - This message is displayed when you try to enter a value that is too big for the selected decimal field.

## Index

Accessories .....	1-2, 1-12
ACCESSORY POWER .....	2-2
Address Switches .....	1-5, 2-1
[Assignment] menu .....	8A-2
Beeper .....	5-4
Capturing State Flow .....	3-4
Clock assignments .....	6A-2
Clock set .....	5-3
[Compare] trace .....	6B-5 thru 6B-8
Configurations .....	1-2
[Configuration] menu .....	5-2
[Continuous] trace .....	6B-5
Getting Started Procedure .....	3-1
Glitch selection .....	5-2
Histograms .....	7-1, 7-4, 7-7
HP-IB .....	C-1
HP-IL .....	C-1
Interface specifications .....	C-1
Inverse-Assembled Object Code .....	6C-7
Label assignments .....	6A-2, 8A-2
Labels, Creating .....	3-6
Learn Strings .....	C-7
List displays .....	6C-1 thru 6C-4, 6C-7 thru 6C-10, 8C-3
[Master] field .....	9-1
Memory description .....	1-3
Menu Map .....	4-1
Messages displayed .....	D-1
Mnemonics, device-dependent .....	C-2 thru C-6
Operating Characteristics .....	1-8
[Overview] .....	7-1
Performance Analysis .....	7-1
Performance Verification .....	1-5
[Peripherals] menu .....	5-3, B-1



Pod Threshold assignments .....	8A-3
Pod thresholds .....	6A-2
PORT .....	5-3
Print specifications .....	B-1
Probe Interface .....	2-2
[Relocation] menu .....	3-22 thru 3-30, 6A-3
Sample period .....	8B-2
Sequence .....	6B-2 thru 6B-4
Service and calibration policy .....	1-12
[Single] trace .....	6B-1, 8B-1
Specifications .....	1-6
State [Assignment] menu .....	6A-1
State Label Overviews .....	7-2 thru 7-4
State/Timing Combined .....	3-34 thru 3-41
State/Timing Interactive .....	9-1
Storing .....	6B-4
TALK ONLY mode .....	2-1, B-2
Tape files .....	A-4, A-5
Tape Memory .....	3-44, A-1
[Tape Operations] menu .....	3-42, A-2, A-5
Time Interval Overviews .....	7-5 thru 7-7
Timing .....	8-1
Trigger edge .....	8B-2
trigger pattern .....	8B-2
Triggering .....	3-10, 3-20, 6B-2 thru 6B-4
[User Base] menu .....	3-31 thru 3-34, 6A-4, 8A-4
Waveform displays .....	6C-4 thru 6C-6, 8C-1
XY Chart displays .....	6C-6, 8C-6



Should one of your HP instruments need repair, the HP service organization is ready to serve you. However, you can help us serve you more effectively. When sending an instrument to HP for repair, please fill out this card and attach it to the product. Increased repair efficiency and reduced turn-around time should result.

COMPANY \_\_\_\_\_

ADDRESS \_\_\_\_\_

TECHNICAL CONTACT PERSON \_\_\_\_\_

PHONE NO. EXT. \_\_\_\_\_

MODEL NO. SERIAL NO. \_\_\_\_\_

P.O. NO. DATE \_\_\_\_\_

Accessories returned with unit \_\_\_\_\_

DIPHONE DPROBES) \_\_\_\_\_

DPOWER CABLE DADAPTERS) \_\_\_\_\_

OTHER \_\_\_\_\_ over



Should one of your HP instruments need repair, the HP service organization is ready to serve you. However, you can help us serve you more effectively. When sending an instrument to HP for repair, please fill out this card and attach it to the product. Increased repair efficiency and reduced turn-around time should result.

COMPANY \_\_\_\_\_

ADDRESS \_\_\_\_\_

TECHNICAL CONTACT PERSON \_\_\_\_\_

PHONE NO. EXT. \_\_\_\_\_

MODEL NO. SERIAL NO. \_\_\_\_\_

P.O. NO. DATE \_\_\_\_\_

Accessories returned with unit \_\_\_\_\_

DIPHONE DPROBES) \_\_\_\_\_

DPOWER CABLE DADAPTERS) \_\_\_\_\_

OTHER \_\_\_\_\_ over



Should one of your HP instruments need repair, the HP service organization is ready to serve you. However, you can help us serve you more effectively. When sending an instrument to HP for repair, please fill out this card and attach it to the product. Increased repair efficiency and reduced turn-around time should result.

COMPANY \_\_\_\_\_

ADDRESS \_\_\_\_\_

TECHNICAL CONTACT PERSON \_\_\_\_\_

PHONE NO. EXT. \_\_\_\_\_

MODEL NO. SERIAL NO. \_\_\_\_\_

P.O. NO. DATE \_\_\_\_\_

Accessories returned with unit \_\_\_\_\_

DIPHONE DPROBES) \_\_\_\_\_

DPOWER CABLE DADAPTERS) \_\_\_\_\_

OTHER \_\_\_\_\_ over



Service needed  
 CALIBRATION ONLY  
 REPAIR  REPAIR & CAL  
 OTHER \_\_\_\_\_

Service needed  
 CALIBRATION ONLY  
 REPAIR  REPAIR & CAL  
 OTHER \_\_\_\_\_

Service needed  
 CALIBRATION ONLY  
 REPAIR  REPAIR & CAL  
 OTHER \_\_\_\_\_

Observed symptoms/problems  
 FAILURE MODE IS  
 CONSTANT  INTERMITTENT  
 SENSITIVE TO  
 COLD  HEAT  VIBRATION  
 FAILURE SYMPTOMS/SPECIAL  
 CONTROL SETTINGS \_\_\_\_\_

Observed symptoms/problems  
 FAILURE MODE IS  
 CONSTANT  INTERMITTENT  
 SENSITIVE TO  
 COLD  HEAT  VIBRATION  
 FAILURE SYMPTOMS/SPECIAL  
 CONTROL SETTINGS \_\_\_\_\_

Observed symptoms/problems  
 FAILURE MODE IS  
 CONSTANT  INTERMITTENT  
 SENSITIVE TO  
 COLD  HEAT  VIBRATION  
 FAILURE SYMPTOMS/SPECIAL  
 CONTROL SETTINGS \_\_\_\_\_

SELF-TEST  
 FAILURE MESSAGE \_\_\_\_\_

SELF-TEST  
 FAILURE MESSAGE \_\_\_\_\_

SELF-TEST  
 FAILURE MESSAGE \_\_\_\_\_

If unit is part of system list model number(s) or other  
 interconnected instruments \_\_\_\_\_

If unit is part of system list model number(s) or other  
 interconnected instruments \_\_\_\_\_

If unit is part of system list model number(s) or other  
 interconnected instruments \_\_\_\_\_

9530-3866 Printed in U.S.A.

9530-3866 Printed in U.S.A.

9530-3866 Printed in U.S.A.





01630-90901, FEBRUARY 1983  
Replaces 01630-90901, November 1982

PRINTED IN U.S.A.

