

Agilent 11960A EMC Preselector

Product Overview

Agilent 8590EM EMC Analyzers
Agilent 8590E Spectrum Analyzers

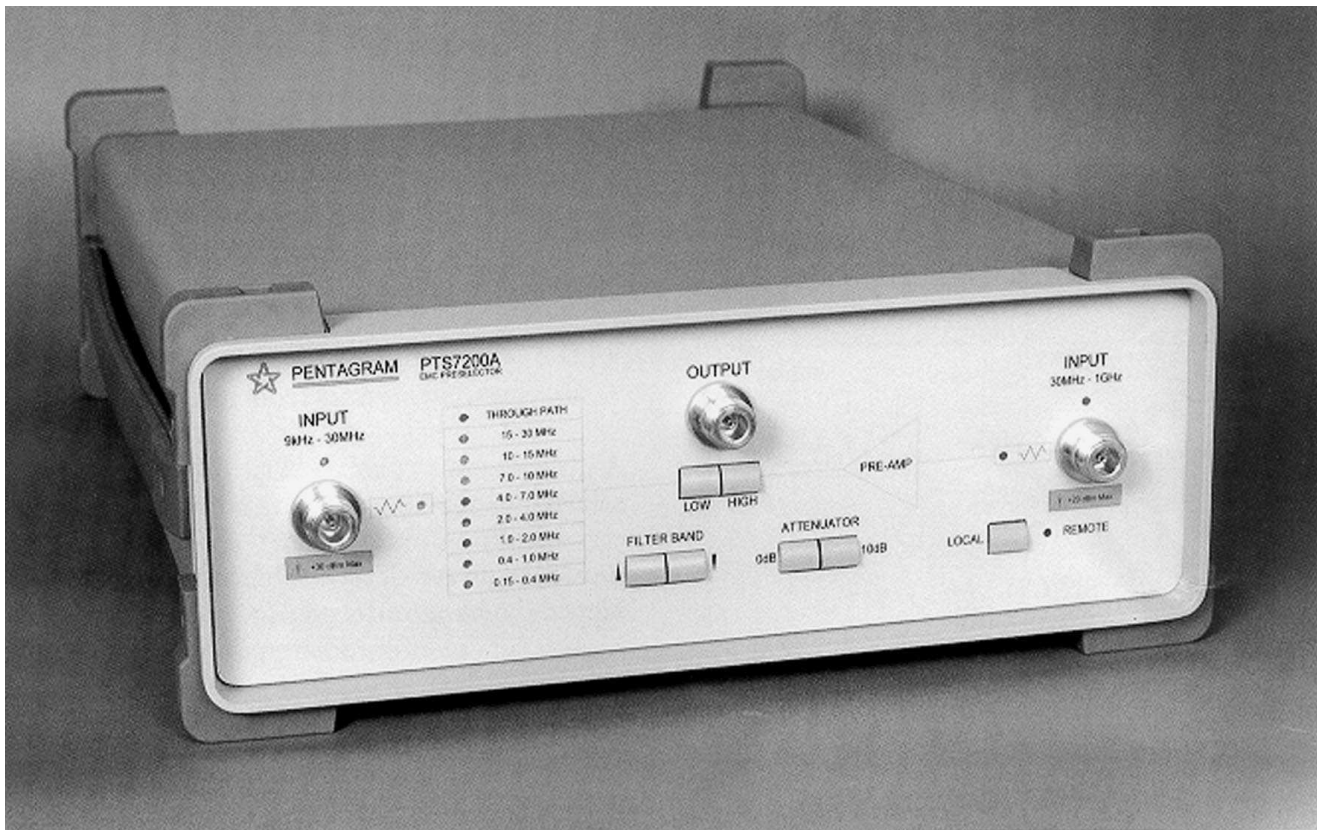

Reduce RF overload from broadband and out-of-band signals



Agilent Technologies
Innovating the HP Way

Reduce RF Overloading and Its Effects

Performing conducted emissions measurements on today's products usually involves testing switching-mode power supplies. Even though switchers are lightweight and economical to use, they do produce broadband noise which can couple onto power lines. This broadband noise can cause overloading of the receiver's or analyzer's first mixer producing measurement errors.

With the use of a preselector, the bandwidth of the energy presented to the first mixer is reduced, thereby reducing mixer overload and measurement errors. See Figure 1.

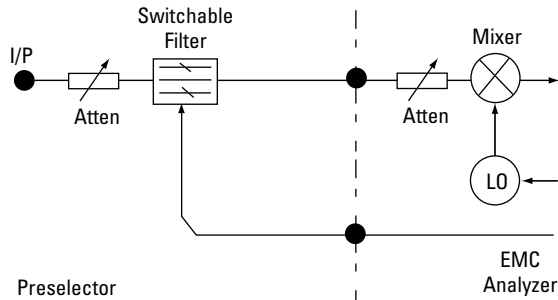

The Agilent Technologies 11960A EMC preselector is a series of switched band pass filters designed to reduce the bandwidth of the energy present at the first mixer of the EMC analyzer.

You will be able to perform near compliance CISPR 16 conducted emissions measurements from 150 kHz to 30 MHz when the preselector is used with the Agilent 8590EM series EMC analyzer.

Improve Radiated Emissions Measurement Sensitivity

The 11960A preselector has a built-in preamplifier to improve the sensitivity of radiated emissions measurements above 30 MHz. The amplifier has a 30 dB gain and an 8 dB noise figure. With the amplifier the system sensitivity improves by 20 dB. The improved sensitivity gives you a greater margin between the test limit and the noise floor. See Figures 1a and b.

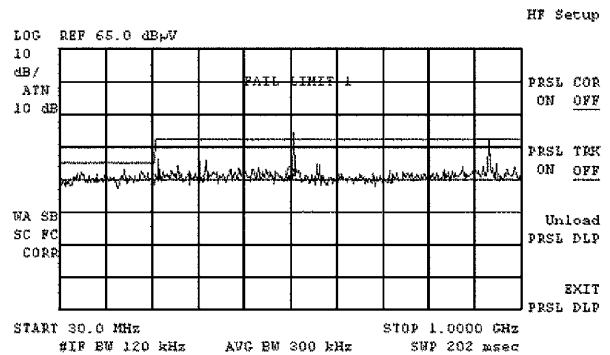

Figure 1a. Without preamplifier

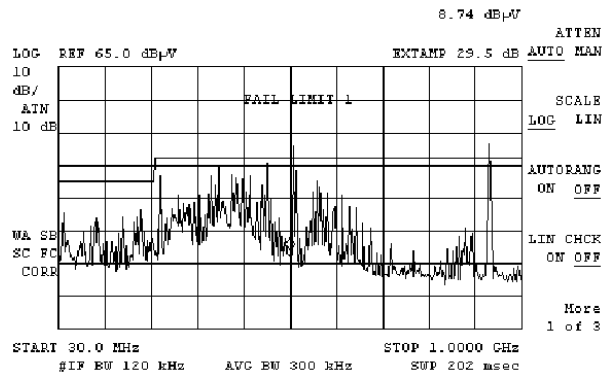

Figure 1b. With built-in preamplifier

Fully Automated Conducted Emissions Measurement

The Agilent 11961A EMI measurement software performs fully automated EMI measurements. The software controls both the EMC analyzer and the preselector to insure the correct bandwidths, frequency bands, and preselector filters are chosen. In addition, the software measures all signals above a margin or limit line. The measured signals are stored in a list for further analysis and the test results are integrated into a formal report.

The preselector's losses and gain are corrected for by the software to insure the best possible measurement accuracy.

The software also corrects radiated emissions measurements for antenna factors, cable losses, and the gain of the preselector amplifier.

Overlay up to three measurements to see the effects of changes made to the design, or compare the ambient signal environment to measurements made with the equipment under test switched on.

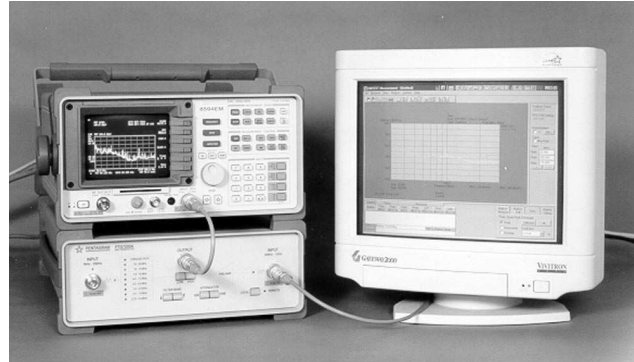

Measurement Configuration

The configuration shown in the block diagram block includes a limiter (Agilent 11947A) used to protect the system from large inductive spikes caused by rapid changes in current. The line impedance stabilization network has very large inductors which can produce large voltage spikes if the main power is removed during the maximum current cycle.

The antenna is connected to the righthand port (30 MHz to 1 GHz) and the built-in amplifier is connected to the port to give improved sensitivity.

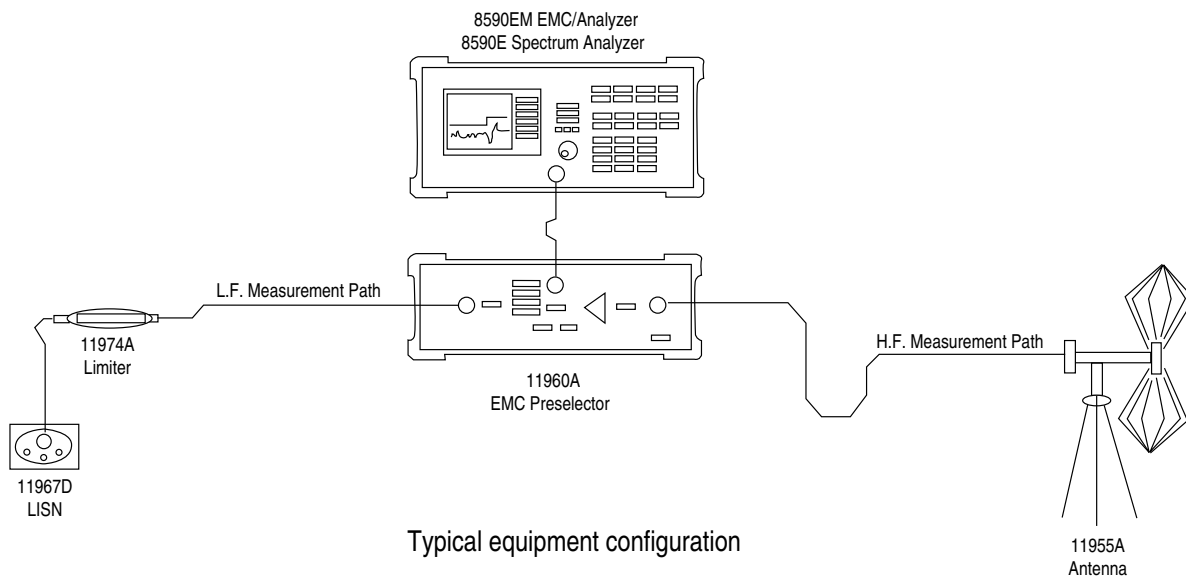

Specification Summary

Input/output impedance	50 Ω (VSWR <2:1 Type-N connector)
Maximum input signal	30 dBm low band, 20 dBm high band
Maximum input/output DC voltage	50V DC
Passband flatness	± 1 dB
Stopband rejection	>40 dB
Input attenuator (switched)	10 dB
LF filter bands (nominal loss 4 dB)	
0.15 MHz to 0.4 MHz	
0.4 MHz to 1.0 MHz	
1.0 MHz to 2.0 MHz	
2.0 MHz to 4.0 MHz	
4.0 MHz to 7.0 MHz	
7.0 MHz to 10.0 MHz	
10.0 MHz to 15.0 MHz	
15.0 MHz to 30.0 MHz	
LF through path	
Frequency range	9 kHz to 30 MHz
Loss	4 dB nominal
HF Path (amplified)	
Frequency range	30 MHz to 1000 MHz
Gain	30 dB nominal
Noise figure	8.0 dB nominal
Attenuator (switched)	10 dB
Power requirements	
115V/230V AC (50/60 Hz)	25W

Ordering Information

11960A	EMC preselector
11947A	RF limiter
11955A	Biconical antenna
11956A	Log periodic antenna
11968C	Tripod
11967D	LISN (NEMA connector)
Option 001	SCHUKO connector
Option 002	British connector

Agilent Technologies' Test and Measurement Support, Services, and Assistance

Agilent Technologies aims to maximize the value you receive, while minimizing your risk and problems. We strive to ensure that you get the test and measurement capabilities you paid for and obtain the support you need. Our extensive support resources and services can help you choose the right Agilent products for your applications and apply them successfully. Every instrument and system we sell has a global warranty. Support is available for at least five years beyond the production life of the product. Two concepts underlie Agilent's overall support policy: "Our Promise" and "Your Advantage."

Our Promise

"Our Promise" means your Agilent test and measurement equipment will meet its advertised performance and functionality. When you are choosing new equipment, we will help you with product information, including realistic performance specifications and practical recommendations from experienced test engineers. When you use Agilent equipment, we can verify that it works properly, help with product operation, and provide basic measurement assistance for the use of specified capabilities, at no extra cost upon request. Many self-help tools are available.

Your Advantage

"Your Advantage" means that Agilent offers a wide range of additional expert test and measurement services, which you can purchase according to your unique technical and business needs. Solve problems efficiently and gain a competitive edge by contracting with us for calibration, extra-cost upgrades, out-of-warranty repairs, and on-site education and training, as well as design, system integration, project management, and other professional services. Experienced Agilent engineers and technicians worldwide can help you maximize your productivity, optimize the return on investment of your Agilent instruments and systems, and obtain dependable measurement accuracy for the life of those products.

Get assistance with all your test and measurement needs at:
www.agilent.com/find/assist

Product specifications and descriptions in this document subject to change without notice.

Copyright © 1997, 2000 Agilent Technologies
Printed in U.S.A. 7/00
5966-0438E



Agilent Technologies

Innovating the HP Way