

Service Guide

ESA Spectrum Analyzers

This manual provides documentation for the following instruments:

E4401B (9 kHz - 1.5 GHz)
E4402B (9 kHz - 3.0 GHz)
E4404B (9 kHz - 6.7 GHz)
E4405B (9 kHz - 13.2 GHz)
E4407B (9 kHz - 26.5 GHz)

and

E4411B (9 kHz - 1.5 GHz)
E4403B (9 kHz - 3.0 GHz)
E4408B (9 kHz - 26.5 GHz)



Manufacturing Part Number: E4401-90474

Printed in USA

February 2014

Supersedes: April 2013

© Copyright 2000 - 2014 Agilent Technologies, Inc.

The information contained in this document is subject to change without notice.

Agilent Technologies makes no warranty of any kind with regard to this material, including but not limited to, the implied warranties of merchantability and fitness for a particular purpose. Agilent Technologies shall not be liable for errors contained herein or for incidental or consequential damages in connection with the furnishing, performance, or use of this material.

Safety Notes

This product has been designed and tested in accordance with IEC Publication 1010, Safety Requirements for Electronic Measuring Apparatus, and has been supplied in a safe condition. The instruction documentation contains information and warnings which must be followed by the user to ensure safe operation and to maintain the product in a safe condition.

The following examples illustrate warning and caution statements that are used throughout this manual.

WARNING

Warning denotes a hazard. It calls attention to a procedure which, if not correctly performed or adhered to, could result in injury or loss of life. Do not proceed beyond a warning note until the indicated conditions are fully understood and met.

CAUTION

Caution denotes a hazard. It calls attention to a procedure that, if not correctly performed or adhered to, could result in damage to or destruction of the instrument. Do not proceed beyond a caution sign until the indicated conditions are fully understood and met.

The following safety notes are used throughout this manual. Familiarize yourself with each of the notes and its meaning before operating this instrument.

WARNING

This is a Safety Class 1 Product (provided with a protective earth ground incorporated in the power cord). The mains plug shall only be inserted in a socket outlet provided with a protective earth contact. Any interruption of the protective conductor inside or outside of the product is likely to make the product dangerous. Intentional interruption is prohibited.

WARNING **These servicing instructions are for use by qualified personnel only. To avoid electrical shock, do not perform any servicing unless you are qualified to do so.**

WARNING **If this product is not used as specified, the protection provided by the equipment could be impaired. This product must be used in a normal condition (in which all means for protection are intact) only.**

CAUTION This product is designed for use in Installation Category II and Pollution Degree 2 per IEC 101 and 664 respectively.

Warranty

This Agilent Technologies instrument product is warranted against defects in material and workmanship for a period of one year from date of shipment. During the warranty period, Agilent Technologies will, at its option, either repair or replace products which prove to be defective.

For warranty service or repair, this product must be returned to a service facility designated by Agilent Technologies. Buyer shall prepay shipping charges to Agilent Technologies and Agilent Technologies shall pay shipping charges to return the product to Buyer. However, Buyer shall pay all shipping charges, duties, and taxes for products returned to Agilent Technologies from another country.

Agilent Technologies warrants that its software and firmware designated by Agilent Technologies for use with an instrument will execute its programming instructions when properly installed on that instrument. Agilent Technologies does not warrant that the operation of the instrument, or software, or firmware will be uninterrupted or error-free.

LIMITATION OF WARRANTY

The foregoing warranty shall not apply to defects resulting from improper or inadequate maintenance by Buyer, Buyer-supplied software or interfacing, unauthorized modification or misuse, operation outside of the environmental specifications for the product, or improper site preparation or maintenance.

NO OTHER WARRANTY IS EXPRESSED OR IMPLIED. AGILENT TECHNOLOGIES SPECIFICALLY DISCLAIMS THE IMPLIED WARRANTIES OF MERCHANTABILITY AND FITNESS FOR A PARTICULAR PURPOSE.

EXCLUSIVE REMEDIES

THE REMEDIES PROVIDED HEREIN ARE BUYER'S SOLE AND EXCLUSIVE REMEDIES. AGILENT TECHNOLOGIES SHALL NOT BE LIABLE FOR ANY DIRECT, INDIRECT, SPECIAL, INCIDENTAL, OR CONSEQUENTIAL DAMAGES, WHETHER BASED ON CONTRACT, TORT, OR ANY OTHER LEGAL THEORY.

Lithium Battery Disposal

When the battery on the A4 processor assembly (3 volt lithium battery, part number 1420-0556) is exhausted and/or ready for disposal, dispose of it according to your country's requirements. You can the battery to your nearest Agilent Technologies Sales and Service office for disposal, if required. Refer to ["Parts List" in Chapter 5](#).

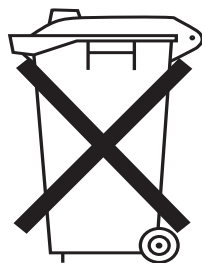

**DO NOT THROW BATTERIES AWAY BUT
COLLECT AS SMALL CHEMICAL WASTE.**

sk780a

1. Troubleshooting the Analyzer

What You Will Find in This Chapter	12
Before You Start	13
Replacement Assemblies	15
After an Analyzer Repair	15
ESD Information	15
Check the Basics	19
Problems at Instrument Power-Up	20
Troubleshooting an Inoperative Analyzer	21
Check the Analyzer Setup	21
If the Line Fuse Has Blown	22
If the Fan is Not Operating	22
Checking the Power Supplies	23
Troubleshooting the LCD Display	25
Viewing Angle	25
Isolating an LO, IF, or Video Problem	27
Checking Detector Modes	27
Checking Corrected versus Uncorrected Performance Using Video Shift On/Off	27
Verifying the A3 IF Assembly Performance	28
Checking a Horizontal Trace With No Signal or Noise Floor Present	29
Checking an Analyzer That Displays a Low Signal Level	29
Checking an Analyzer That Displays a High Noise Floor	30
Checking an Analyzer Signal Amplitude That Appears Too High	30
Checking an Analyzer Signal That Is Distorted	30
Checking an Analyzer Signal That Is Off Frequency	31
Checking the 21.4 MHz Alignment Signal	31
Using the Internal Service-Diagnostic Routines	32
Timebase (in Alignments Menu)	32
Timebase (in Service Menu)	33
Video Shift On/Off	33
Align Now	34
Visible Align	35
Noise Source	35
Load Defaults	35
Restoring System Defaults	35
Troubleshooting the A4 Processor Assembly	37
Initial Checks	37
Bootrom Self-Test Check	38
Clearing Dynamic RAM	39
Clearing Flash EPROM	39
Troubleshooting the A2 1.5 GHz Tracking Generator (E4401B and E4411B) (Option 1DN/1DQ)	40
If Output is Unleveled (TG Unleveled message displayed)	40
If the TG LO is Unlocked (TG LO Unlocked message displayed)	41
If the Tracking Generator Is Not Properly Recognized by the Firmware	41
If Flatness is Out of Tolerance	42
If Vernier Accuracy is Out of Tolerance	42
If Harmonics and Spurious Outputs are Too High	42
If Power Sweep is Not Functioning Properly	44
If There is No Output Power	44
Troubleshooting the A2 3.0 GHz Tracking Generator (E4402B, E4403B, E4404B, E4405B, E4407B, and E4408B) (Option 1DN)	45
Troubleshooting the Digital Demod Hardware (E4402B, E4404B, E4405B, and E4407B) (Option B7D and B7E)	47
Troubleshooting Analyzer Mode Errors Caused By the DDRF or DSP Boards	47

Contents

Troubleshooting the Digital Demodulation Hardware When Running the cdmaOne or GSM Personalities	48
Troubleshooting the A7A13 Noise Source Driver Assembly	54
2. Troubleshooting the RF Section	
What You Will Find in This Chapter	58
Verifying the RF Section Performance (E4401B and E4411B)	59
RF Performance Check	59
Verifying the RF Section Performance (E4402B and E4403B)	61
Quick Check RF Procedure	61
Detailed RF Troubleshooting	63
Verifying the RF Section Performance (E4404B, E4405B, E4407B, and E4408B)	71
“Quick Check” RF Procedure in Low Band (Non-Preselected)	71
Detailed RF Troubleshooting for Low Band	73
Quick Check RF Procedure for High Bands (Preselected)	81
Detailed RF Troubleshooting for High Bands (Preselected)	83
3. Block Diagrams	
What You Will Find in This Chapter	92
A8 1.5 GHz RF Assembly	93
Input Connector	93
Input Protection	93
Attenuator	94
Low-Pass Filter	94
First Mixer	94
First IF Amplifier/Filter/Attenuator	94
Second Mixer	94
21.4 MHz Amplifier	95
Frequency Reference	95
LO	95
Interconnections to Other Assemblies	96
A8 RF Assembly	97
A8J10 Input Connector	98
A8A1 3.0 GHz RF Assembly	98
A8A1A1 Reference/Third Converter	99
A8A1A2 Front End/LO	99
A8A2 Second Converter	100
A8A3 dc Block	100
A8A4 LO Amplifier/IF Switch (LOIS)	100
A8A5 Input Attenuator	101
A8A6 YIG-Tuned Filter/Mixer (RYTHM)	101
A8FL1 3.1 GHz Low-Pass Filter (LPF)	101
A7A4 Frequency Extension	101
A3 IF Assembly	102
Cal Attenuator	102
21.4 MHz Bandpass Filters	102
Log Detector	102
Linear Detector	102
Interconnections to Other Assemblies	103
Downconverter	103
A4 Processor Assembly	104

Analog Section	104
Analyzer Battery Information	105
Interconnections to Other Assemblies	106
A4A1 Flash SIMM	107
A4A2 DRAM SIMM	107
A5 Power Supply Assembly	108
Interconnections to Other Assemblies	108
A7 Motherboard	109
Miscellaneous	110
A1 Display/Front Panel	110
Motherboard Mnemonics and Connectors	111
Tracking Generator Block Diagrams	139
Digital Demod DSP/Fast ADC Block Diagram	141
Digital Demod RF Block Diagram	142
4. Options and Accessories	
Options	147
How to Order Options	148
12 Vdc Power Cable (Option A5D)	148
3 Year Calibration Contract (Option W32)	148
3 Year Service Support (Option W30)	148
5 Year Calibration Contract (Option W52)	148
5 Year Service Support (Option W50)	148
50 Ω to 75 Ω Matching Pad (Option 1D7)	148
50 Ohm Tracking Generator (Option 1DN)	148
75 Ohm Input Impedance (Option 1DP)	149
75 Ohm Tracking Generator (Option 1DQ)	149
8566 Series Programming Code Compatibility (Option 266)	149
ACPR Dynamic Range Extension (Option 120)	149
Additional Manual Set (Option 0B1)	149
APC 3.5 Input Connector (Option BAB)	149
Backpack Operating and Carrying Cases (Option 042/044)	150
Benchlink Spectrum Analyzer (Option B70)	150
Benchlink Web Remote Control Software (Option 230)	150
Bluetooth FM Demodulation (Option 106)	150
Bluetooth General Purpose Bundle (Option 303)	151
Bluetooth Measurement Personality (Option 228)	151
Bluetooth Premium Bundle (Option 304)	151
Cable TV Measurement Personality (Option 227)	151
cdmaOne Measurement Personality (Option BAC)	151
Color Display (Option 049)	152
Commercial Calibration with Test Data (Option UK6)	152
Component Level Service Documentation (Option 0BV)	152
Delete Manual Set (Option 0B0)	152
Digital Signal Processing and Fast ADC (Option B7D)	153
Distance to Fault Accessory Kit (Option B7K)	153
Distance to Fault Measurement Personality (Option 225)	153
Enhanced Memory Upgrade (Option B72)	153
External Mixing (Option AYZ)	153

Contents

Fast Digitized Time Domain Sweeps (Option AYY)	154
Firmware Upgrade Kit (Option UE2)	154
FM Demodulation (Option BAA)	154
Front Panel Protective Cover (Option UK9)	155
GPIO and Parallel Interface (Option A4H)	155
GSM Measurement Personality (Option BAH)	155
Hard Transit Case (Option AXT)	155
High Stability Frequency Reference (Option ID5)	155
IF, Sweep and Video Ports (Option A4J)	155
Low Emission (Option 060)	156
Low Frequency Extension (Option UKB)	156
Narrow Resolution Bandwidth (Option IDR)	156
Noise Figure Measurement Personality and Hardware (Option 219)	156
Operating and Carrying Cases (Option AYT/AYU)	156
Performance Bundle (Option B75)	157
Phase Noise Measurement Personality (Option 226)	157
Pre-amplifier (Option IDS)	157
Rack Mount Kit With Handles (Option ICP)	157
RF and Digital Communications Hardware (Option B74)	157
RF Communications Hardware (Option B7E)	157
RS-232 and Parallel Interface (Option 1AX)	157
Service Documentation (Option 0BW)	158
Time-Gated Spectrum Analysis (Option ID6)	158
TV Trigger and Picture on Screen (Option B7B)	158
Accessories	159
50 Ω /75 Ω Minimum Loss Pad	159
75 Ω Matching Transformer	159
AC Probe	159
Broadband Preamplifiers and Power Amplifiers	159
Carrying Strap (Part Number E4401-60028)	160
External Keyboard	160
GPIO Cable	160
Agilent 11970 Series Harmonic Mixers	160
Agilent 11974 Series Preselected Millimeter Mixers	160
Agilent E1779BA Battery Pack	161
Parallel Interface Cable	161
Printer	161
RF and Transient Limiters	161
RF Bridges	162
RS-232 Cable	162
5. Parts List	
What You Will Find in This Chapter	164
How to Order Parts	165
Direct Mail-Order System	165
Direct Phone-Order System	166
Replaceable Parts	172
Component-Level Information Packets	238
Ordering CLIPs	238

Contacting Agilent Technologies	241
How to Return Your Analyzer for Service	242
Service Tag	242
Original Packaging	242
Other Packaging	244
6. Replacing Assemblies	
What You Will Find in This Chapter	246
Before You Start	247
Service tools you will need	247
After a spectrum analyzer repair	248
Removal and Replacement Procedures in This Chapter	249
Instrument Outer Case	250
Removal	251
Replacement	251
Chassis Cover	252
Removal	252
Replacement	253
A1 Front Frame Assembly	254
Extension	254
Removal	255
Replacement	256
Nameplate	257
Removal and Replacement	257
Connector Label	258
Removal	258
Installation	260
Replacement	261
Front Frame Subassemblies	262
A1A2 Display	262
A1A1 Front Panel Interface Board	265
Front Panel RPG	266
Keypad/Flex Circuit	267
Lens/Keypad Assembly	268
Display Backlight	269
Vibration Support Bar	271
Removal	271
Replacing the Vibration Support Bar	271
A2 1.5 GHz Tracking Generator Assembly	274
Removal	274
Replacement	274
Tracking Generator Boards	275
Tracking Generator RF Board Removal	276
Tracking Generator Control Board Removal	276
Tracking Generator Output Board Removal	277
1.5 GHz Tracking Generator RF Output Connector	278
A2 3.0 GHz Tracking Generator Assembly	279
Removal	279
Replacement	280
A3 IF Assembly	281
Removal	281
Replacement	282
A4 Processor Assembly	283

Contents

Removal	283
Replacement	284
A4A1 and A4A2 Flash and DRAM SIMM	285
Removal and Replacement	285
A4MAU58 Battery	286
Removal and Replacement	286
A5 Power Supply	287
Removal	287
Replacement	288
A5B1 Fan	289
Removal	289
Replacement	290
A6 Floppy Drive and Speaker Assembly	291
Removal	291
Replacement	292
A7 Motherboard Assembly	293
Removal	293
Replacement	294
Card Cage Assemblies	296
FM Demod, SIO, GPIB, RS-232, Noise Source Driver	296
Digital Demod Assemblies Replacement	298
A8 1.5 GHz RF Assembly	304
Removal	304
Replacement	305
A8 3.0 GHz RF Assembly	307
Removal	307
Replacement	309
RF Subassemblies	311
A8A1 OCXO Precision Frequency Reference	311
A8A4 LO Amp/IF Switch Assembly	312
A8A5 Input Attenuator	313
A8A6 YIG-Tuned Filter/Mixer	315
A8A2 Second Converter	317
RF Input Connector	319
1.5 GHz RF Input Connector	321
7. Post-Repair Procedures	
What You Will Find in This Chapter	324
Safety	325
Before You Start	326
Finding abnormal indications during adjustments	326
Periodically verifying calibration	326
Replacing or repairing an assembly	326
List of Tests and Adjustments for Calibration	327
List of Tests and Adjustments for Post-Repair	330
8. Performance Verification and Adjustment Software	
What You Will Find in This Chapter	334
Introduction	335
Instruments with Option 266 or Option 290	335
N7800A Calibration and Adjustment Software	335
ESA Field Test Software	335

1 Troubleshooting the Analyzer

What You Will Find in This Chapter

This chapter provides information that is useful when starting to troubleshoot an analyzer failure. It provides procedures for troubleshooting common failures and isolating problems in the analyzer. Assembly descriptions are located in [Chapter 3](#), "Block Diagrams."

Component level information containing material lists, schematics, and component location diagrams, is available separately.

Before You Start

There are four things you should do before starting to troubleshoot a failure:

- o Check that you are familiar with the safety symbols marked on the instrument, and read the general safety considerations and the safety note definitions given in the front of this guide.
- o The analyzer contains static sensitive components. Read the section entitled “ESD Information” on page 1-15 in this chapter.
- o Become familiar with the organization of the troubleshooting information in this chapter.
- o Read the rest of this section.

WARNING These servicing instructions are for use by qualified personnel only. To avoid electrical shock, do not perform any servicing unless you are qualified to do so.

WARNING The opening of covers or removal of parts is likely to expose dangerous voltages. Disconnect the product from all voltage sources while it is being opened.

WARNING The detachable power cord is the instrument disconnecting device. It disconnects the mains circuits from the mains supply before other parts of the instrument. The front panel switch is only a standby switch and is not a LINE switch (disconnecting device).

CAUTION Always position the instrument for easy access to the disconnecting device (detachable power cord).

WARNING To prevent electrical shock, disconnect the analyzer from mains before cleaning. Use a dry cloth or one slightly dampened with water to clean the external case parts. Do not attempt to clean internally.

WARNING For continued protection against fire hazard, replace fuses, and or circuit breakers only with same type and ratings. The use of other fuses, circuit breakers or materials is prohibited.

WARNING This is a Safety Class 1 Product (provided with a protective earth ground incorporated in the power cord). The mains plug shall only be inserted in a socket outlet provided with a protective earth contact. Any interruption of the protective conductor inside or outside of the product is likely to make the product dangerous. Intentional interruption is prohibited.

CAUTION Always use the three-prong ac power cord supplied with this product. Failure to ensure adequate earth grounding by not using this cord may cause product damage.

CAUTION Before switching on this instrument, make sure of the following:

- the correct fuse is installed
- the supply voltage is in the specified range

CAUTION This instrument has auto-ranging line voltage input, be sure the supply voltage is within the specified range and voltage fluctuations do not to exceed 10 percent of the nominal supply voltage.

WARNING The Agilent Technologies E4402B, E4403B, E4404B, E4405B, E4407B, E4408B, E4411B, E7402A, E7405A may be used with an E1779B Rechargeable Battery Pack which contains a Ni-Cd battery. The battery must be recycled or disposed of properly.

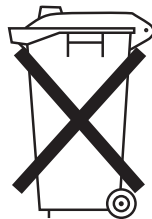

DO NOT THROW BATTERIES AWAY BUT
COLLECT AS SMALL CHEMICAL WASTE.

sk780a

Replacement Assemblies

The analyzer assemblies are not repairable to the component level. The following assemblies must be replaced as an assembly.

- RF assembly (E4401B, E4411B)
- RF assembly and associated microcircuits (E4402B, E4403B, E4404B, E4405B, E4407B, E4408B)
- Frequency extension assembly (E4404B, E4405B, E4407B, E4408B)
- IF assembly
- Power supply assembly
- Processor assembly
- Motherboard
- Speaker/floppy assembly
- Display
- Display interface board
- Option boards:
 - Fast ADC assembly (Option AYZ)
 - FM Demod assembly (Option BAA)
 - IF, Sweep, and Video Ports assembly (Option A4J)
 - ACPR dynamic range enhancement assembly (Option 120)
 - Bluetooth FM Demod assembly (Option 106)
 - Noise Source Drive assembly (part of Option 219)
 - Digital Demod DSP assembly (Option B7D)
 - Digital Demod RF assembly (Option B7E)

The tracking generator assembly (Option 1DN or 1DP) consists of three subassemblies and is repairable to the subassembly level.

After an Analyzer Repair

If one or more analyzer assemblies have been repaired or replaced, perform the related adjustments and performance verification tests. Refer to [Table 7-2 in Chapter 7](#) for the related adjustments and performance verification tests required for each assembly.

ESD Information

Protection from Electrostatic Discharge

Electrostatic discharge (ESD) can damage or destroy electronic components. All work on electronic assemblies should be performed at a static-safe workstation. [Figure 1-1](#) shows an example of a static-safe workstation using two types of ESD protection:

- o Conductive table-mat and wrist-strap combination.
- o Conductive floor-mat and heel-strap combination.

Troubleshooting the Analyzer
Before You Start

Both types, when used together, provide a significant level of ESD protection. Of the two, only the table-mat and wrist-strap combination provides adequate ESD protection when used alone. To ensure user safety, the static-safe accessories must provide at least 1 megohm of isolation from ground. Refer to [Table 1-1 on page 16](#) for information on ordering static-safe accessories.

WARNING **These techniques for a static-safe workstation should not be used when working on circuitry with a voltage potential greater than 500 volts.**

Figure 1-1 **Example of a Static-Safe Workstation**

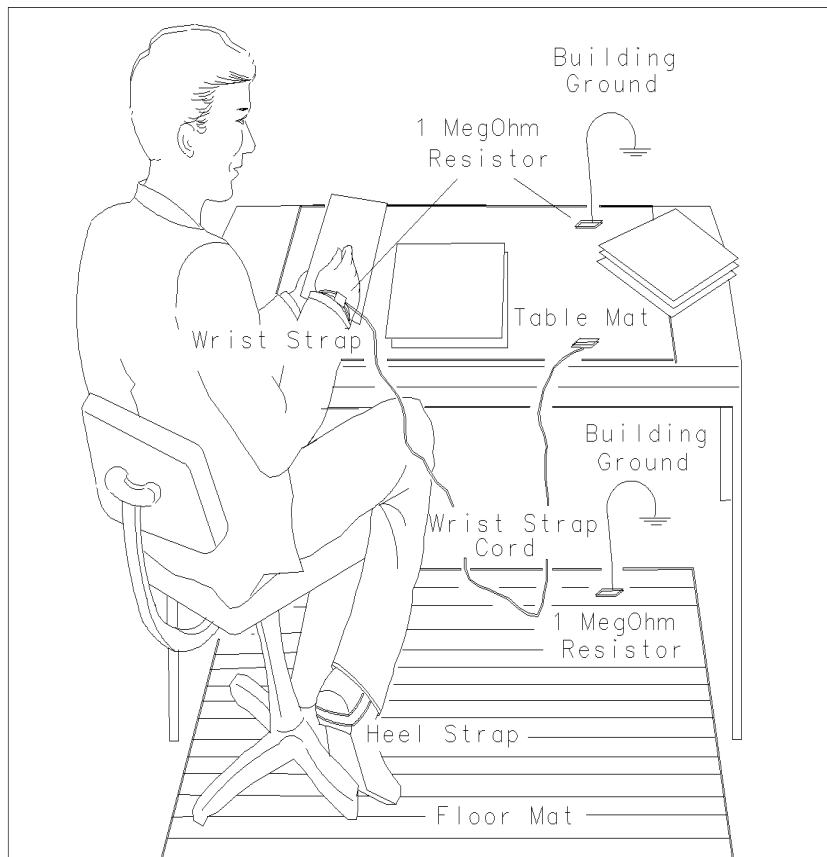

FORMAT46

Table 1-1 **Static Safe Accessories**

Part Number	Description
85043-80013	Set includes: 3M static control mat 0.4 m × 0.6 m (16 inches × 23 inches) and 4.6 cm (15 ft) ground wire, wrist strap, and wrist-strap cord.
9300-0980	Wrist-strap cord 1.5 m (5 ft)

Table 1-1 **Static Safe Accessories**

Part Number	Description
9300-1367	Wrist-strap, color black, stainless steel, without cord, has four adjustable links and a 7 mm post-type connection.
9300-1308	ESD heel-strap (reusable 6 to 12 months)

Handling of Electronic Components and ESD

The possibility of unseen damage caused by ESD is present whenever components are transported, stored, or used. The risk of ESD damage can be greatly reduced by close attention to how all components are handled.

- o Perform work on all components at a static-safe workstation.
- o Keep static-generating materials at least one meter away from all components.
- o Store or transport components in static-shielding containers.

CAUTION

Always handle printed circuit board assemblies by the edges. This will reduce the possibility of ESD damage to components and prevent contamination of exposed plating.

Test Equipment Usage and ESD

- o Before connecting any coaxial cable to an analyzer connector, momentarily short the center and outer conductors of the cable together.
- o Personnel should be grounded with a 1 megohm resistor-isolated wrist-strap before touching the center pin of any connector and before removing any assembly from the analyzer.
- o Be sure that all analyzers are properly earth-grounded to prevent build-up of static charge.

For Additional Information about ESD

For more information about preventing ESD damage, contact the Electrical Over Stress/Electrostatic Discharge (EOS/ESD) Association, Inc. The ESD standards developed by this agency are sanctioned by the American National Standards Institute (ANSI).

Check the Basics

A problem can often be resolved by repeating the procedure you were following when the problem occurred. Before calling Agilent Technologies or returning the analyzer for service, please make the following checks:

- o Check the line fuse.
- o Is there power at the receptacle?
- o Is the analyzer turned on? Make sure the fan is running, which indicates that the power supply is on.
- o If the display is dark or dim, press the upper **Viewing Angle** key in the upper-left corner of the front panel. If the display is too bright, adjust the lower **Viewing Angle** key in the upper-left corner of the front panel.
- o If other equipment, cables, and connectors are being used with your analyzer, make sure they are connected properly and operating correctly.
- o Review the procedure for the measurement being performed when the problem appeared. Are all the settings correct?
- o If the analyzer is not functioning as expected, return the analyzer to a known state by pressing the **Preset** key and **Factory Preset** (if present).

Some analyzer settings are not affected by a Preset. Refer to the “Front-Panel Key Reference” chapter of the user’s guide for information on settings affected by a Preset.

- o Is the measurement being performed, and the results that are expected, within the specifications and capabilities of the analyzer? Refer to the appropriate “Specifications and Characteristics” chapters in the specifications guide for more details.
- o In order to meet specifications, the analyzer must be aligned. Either Auto Align All must be selected (press **System, Alignments, Auto Align, All**), or the analyzer must be manually aligned at least once per hour, or whenever the temperature changes more than 3° C. When **Auto Align, All** is selected, AA appears on the left edge of the display. Refer to the appropriate “Specifications and Characteristics” chapters in the specifications guide for more details.
- o Is the analyzer displaying an error message? If so, refer to the instrument messages/functional tests guide.
- o If the necessary test equipment is available, perform the performance verification tests in the calibration guide or use the performance verification software. Record all results on a Performance Verification Test Record form which follows the tests.
- o If the equipment to perform the performance verification tests is not available, you may still be able to perform the functional checks in the user’s guide.

Problems at Instrument Power-Up

This section describes symptoms that can occur when the analyzer is first powered on.

CAUTION

Immediately unplug the analyzer from the ac power line if the unit shows any of the following symptoms:

- Smoke, arcing, or unusual noise from inside the unit, except as noted below.
- No response of any kind when unit is plugged into ac power mains and turned on.
- The analyzer ac power fuse blows.
- A circuit breaker or fuse on the main ac power line opens.

These potentially serious faults must be corrected before proceeding. Refer to [“Troubleshooting an Inoperative Analyzer” on page 21](#).

Note that these analyzers are equipped with a speaker and normally emit noise from the speaker at power-up. This is not a problem; adjust the volume control as desired.

The analyzer will also occasionally emit “clicking” noises. These are normal and are related to the analyzer self alignment routines.

If the analyzer always turns on when power is applied, check the rear of the analyzer. There is an “always on” power mode switch that can be changed. Refer to the rear panel features section of the user’s guide for information on this switch.

Troubleshooting an Inoperative Analyzer

When an analyzer appears to be dead (no display or inoperative fan) there is often little evidence that points directly to the cause. This section provides steps and solutions to typical failure modes relating to an inoperative analyzer.

Before troubleshooting an analyzer, ensure that it has been set up correctly.

Check the Analyzer Setup

Perform the steps in the section titled “Check the Basics” earlier in this chapter.

Initial Checks

Perform the following initial checks when first troubleshooting an inoperative analyzer.

1. Is the fan running?
 - a. If the fan is not running, refer to the section [“If the Fan is Not Operating” on page 22](#).
 - b. If the fan is running, this indicates the power supply is functioning at least partially.
2. Is the display on?
 - a. If the display is blank, refer to the section [“Checking the Power Supplies” on page 23](#). Also verify that the firmware is good by performing the [“Bootrom Self-Test Check” on page 38](#).
 - b. If the display is on and the fan is running, suspect one or more power supplies is being pulled down, or a defective processor assembly. In either case, the analyzer outer case and inner shield must be removed. Refer to [Chapter 6](#) for removal procedures.
3. Check the power supplies.
 - a. To check the power supply voltages, refer to the section [“Checking the Power Supplies” on page 23](#).
 - b. If the supplies all measure good, suspect a defective processor, or a defective LCD or interface board.

Troubleshooting the Analyzer

Troubleshooting an Inoperative Analyzer

4. Perform the following checks for the processor assembly.
 - a. Is the analyzer “clicking?” The analyzer should occasionally emit “clicking” noises. These are related to the analyzer automatic self alignment routines, and indicate the processor is basically functioning. When the analyzer is cold, there will be more self alignment activity (more clicking) than when it is warm.

If you do not hear any clicks after a few minutes, suspect a defective processor assembly. Refer to the section “[Troubleshooting the A4 Processor Assembly](#)” on page 37.
 - b. Are the processor assembly LEDs all out? There are LEDs along the top edge of the processor assembly. These should all be off. To check their functionality, cycle the analyzer power. The processor LEDs should all go on for a few seconds, then go off. If one or more LEDs remains on, suspect the processor assembly is defective. Refer to the section “[Bootrom Self-Test Check](#)” on page 38.
 - c. If the analyzer is clicking, and all of the processor LEDs are out, suspect a defective LCD or a defective front panel interface board. Refer to the section “[Troubleshooting the LCD Display](#)” on page 25.

If the Line Fuse Has Blown

If the line fuse has blown, perhaps a nonstandard fuse with too low a current rating was installed. If the line fuse still blows, suspect that the power supply assembly is defective.

WARNING

For continued protection against fire hazard, replace fuses, and or circuit breakers only with same type and ratings. The use of other fuses, circuit breakers or materials is prohibited.

If the Fan is Not Operating

CAUTION

The power supply may be hot if the instrument has been operating without the fan running. Allow the instrument to cool down before troubleshooting.

1. If there is no display:
 - a. Unplug the line-power cord.
 - b. Change the switch at the rear of the analyzer so the power is always on. Refer to the rear panel features section of the user’s guide for information on this switch. This will bypass the front panel power switch.

- c. If the fan still does not turn on, suspect a defective power supply assembly. Refer to the section “[Checking the Power Supplies](#)” on page 23, to check individual supply voltages.
 - d. If the fan starts, this indicates a problem with the front panel switch or the circuitry to the front panel switch.
2. If there is a display:
- a. Remove the analyzer outer case. Refer to [Chapter 6](#) for removal details.
 - b. Measure the fan voltage.
 - c. The fan voltage can be checked directly at the center of the fan where the wires connect. The fan normally operates on a voltage ranging from -5 to -16 Vdc depending on the temperature of the analyzer. As analyzer temperature increases, fan voltage should become more negative, increasing the speed of the fan.

If the correct voltage is present, suspect a defective fan.

If the voltage is not present, check the plug where the fan wires attach to the power supply board. If this looks good, suspect a defective power supply. Refer to [Chapter 6](#) for information on how to remove the power supply.

Checking the Power Supplies

The power supply test board is no longer supplied. If the power supply is suspect, change the power supply. All ESA models use the same power supply, so substitution is possible to determine if the power supply is defective.

WARNING

The analyzer contains potentially hazardous voltages. Refer to the safety symbols provided on the analyzer, and in the general safety instructions in this guide, before operating the unit with the cover removed. Ensure that safety instructions are strictly followed. Failure to do so can result in severe or fatal injury.

The $+15$ V and -12.6 V supplies can be measured directly on the probe power connector located on the front of the instrument. See [Figure 1-2](#) for these test points. If -12.6 V is within limits, it is a reasonably good indicator that -15 V is within specifications.

Figure 1-2 Probe Power Connector Voltages

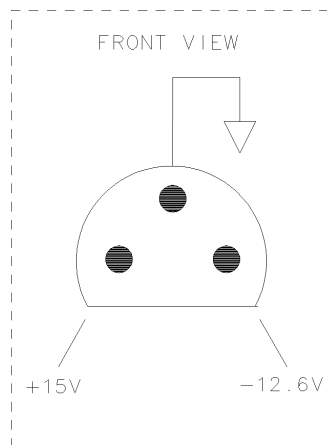

SK1122

If All Low Voltage Supplies are At or Near Zero Volts

If all the power supplies are dead, suspect a defective A5 power supply assembly. Refer to [Chapter 6](#) for removal instructions.

If Some Low Voltage Supplies are At or Near Zero Volts

If some supplies are functioning while others are dead or low, it is possible that one of the assemblies in the analyzer is loading down the power supply.

In this case it is necessary to sequentially remove the assemblies, taking care to disconnect the line-power cord before removing any assembly. A logical first step would be to unplug the RF assembly ribbon cable from the motherboard at the rear of the instrument. This disconnects the complete RF section without having to remove it from the chassis. Refer to [Chapter 6](#) for any other assembly removal procedures.

After an assembly is disconnected or removed, plug the line-power cord back into the analyzer and remeasure the supply that was down. If it is still down, continue with the assembly removal. If the supply is now up, suspect the last assembly removed as being defective.

Troubleshooting the LCD Display

The only adjustment that can be made to the LCD display is the viewing angle. This is found on the front panel of the analyzer in the upper left corner.

Viewing Angle

1. Verify that the analyzer has gone through a full power-on sequence. Refer to the section [“Troubleshooting an Inoperative Analyzer”](#) on page 21.
2. If the display is dark (not visible), connect an external VGA monitor to the rear panel VGA output connector on the analyzer. It is possible that some multisync monitors may not be able to lock to a 60 Hz sync pulse. If the video information is not present on the external VGA monitor, the most probable cause is the A4 processor assembly.
3. If the external VGA monitor is functioning, verify that the ribbon cables going to and from the A1A1 front panel interface assembly are aligned properly and securely plugged into the connectors.
4. To determine whether the A1A2 LCD display or the A1A1 front panel interface assembly is defective, remove the front frame assembly. See [Chapter 6, “Replacing Assemblies.”](#)

WARNING

The inverter board contains high voltage for the backlights. Carefully remove the inverter board by taking out the two screws securing it to the front frame, then turn it over to access the CN1 connector.

Refer to [Table 1-2 on page 25](#) and carefully measure the voltage coming into the inverter board at CN1 pins 1-6 with a digital voltmeter.

Table 1-2

Measurement Locations and Expected Voltages

Measurement Location	Expected Voltage from A1A1 Front Panel Interface
CN1 Pin 1	0 Vdc
CN1 Pin 2	0 Vdc
CN1 Pin 3	5 Vdc
CN1 Pin 4	5 Vdc
CN1 Pin 5	30 mV
CN1 Pin 6	2.5 Vdc

The display is not field-repairable, and must be replaced as an assembly. Refer to [Chapter 5](#) for part-number information.

Figure 1-3 LCD Troubleshooting Measurement Locations

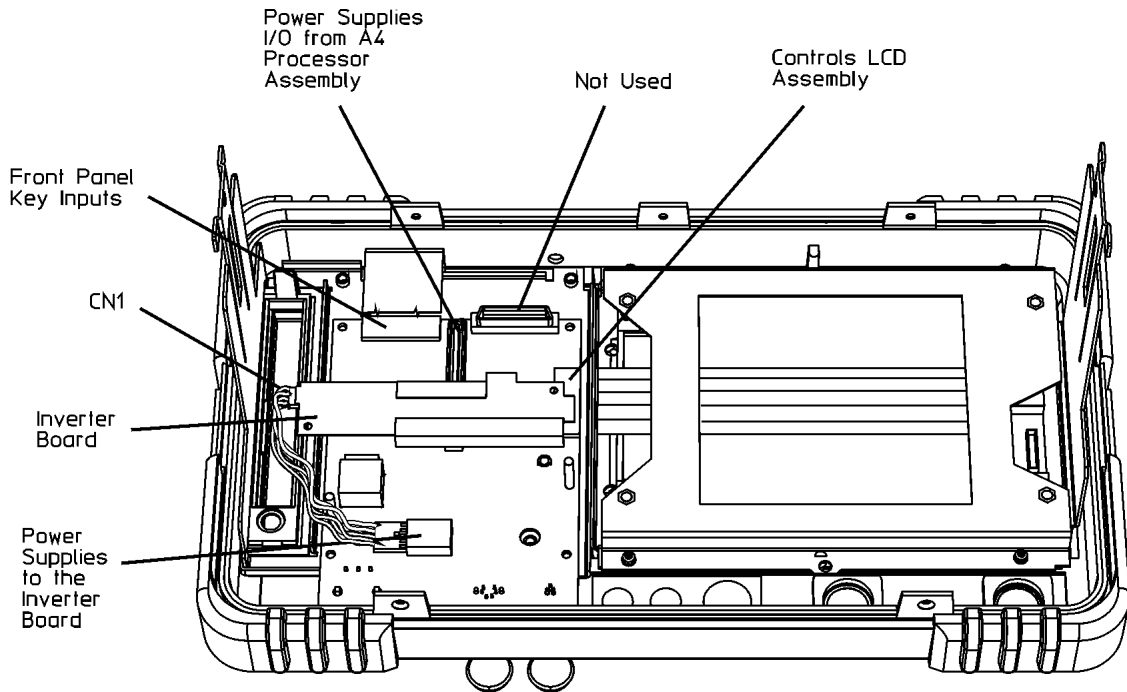

sl725b

If the voltages are correct, the most probable cause of failure is the A1A2 LCD assembly.

NOTE

The LCD has two backlights to illuminate the LCD. If both backlights are defective, the screen will be dark. The backlights can be replaced individually, however, it is improbable that both backlights are defective simultaneously. If one backlight is defective, the LCD will illuminate but the dimness will be noticeable, and you will need to replace A1A2DS1 or A1A2DS2. It is recommended that both backlights be replaced at the same time if it is likely that one simply wore out.

Isolating an LO, IF, or Video Problem

This section provides techniques for isolating amplitude failures along the signal path.

Checking Detector Modes

The instrument has three detector modes known as peak, negative peak, and sample. All of these detectors are located on the A4 processor board. Normal instrument power up routes the detected video signal through the positive peak detector only. If there are no graticules, signal information, or screen annotations, refer to the section [“Troubleshooting the LCD Display” on page 25](#). The assumption from this point on is that the graticules and annotations have come up on the screen, but the noise floor and signal information is not present.

1. If no video is present on the analyzer screen switch to Sample or Negative Peak detector mode by pressing **Det/Demod, Detector**, and the proper softkey.
2. If the video signal appears in one of these two modes, the most probable cause is the A4 processor board itself.
3. If there is no video information present in any detector mode, inject a signal into the IF assembly as per [“Verifying the A3 IF Assembly Performance” on page 28](#). This step will produce 2 Vdc (IF_VIDEO) at the output of the IF assembly. The 2 Vdc can be measured on the motherboard at A7J13 pin 24 if the analyzer is an E4403B, E4408B, or E4411B. If you do not measure a dc level at approximately 2 Vdc, the IF assembly is the most probable cause. Refer to [Figure 1-2](#).
4. If you measure 2 Vdc on the output of the IF assembly but do not see a flat line at the top of the graticule, there may be a problem between the output of the IF assembly and the input to the A4 processor board. Check for an open trace or a bent pin on the A7 motherboard.
5. If you measure 2 Vdc right up to the IF_VIDEO input on the A4 processor board and still don't have a flat line near the top of the screen, the A4 processor board is the most probable cause.

Checking Corrected versus Uncorrected Performance Using Video Shift On/Off

If you have a frequency response failure such as a power hole or power spike, you should turn the video shift off to see if the digital correction values are having an adverse effect on the analyzer performance.

1. Turn the video shift off by pressing **System, Service**, (Password = -2010), **Enter, Service, Video Shift On Off (Off)**.
2. If the power hole or spike goes away, perform the *Frequency Response*

Troubleshooting the Analyzer

Isolating an LO, IF, or Video Problem

Adjustments using the *Adjustment Software*. Refer to section “Using the Internal Service-Diagnostic Routines” on page 32 for more information about the video shift function.

3. If the power hole or power spike does not go away after re-adjusting the frequency response (flatness), the RF assembly is the most probable cause.

Verifying the A3 IF Assembly Performance

NOTE

At frequencies >50 MHz in zero span, the gain of the A3 IF assembly will increase, necessitating the input level to be decreased for top of screen response. If the analyzer is in full span and the 21.4 MHz input frequency has a power level of -20 dBm, the displayed response will be the inverse of the RF assembly flatness. Setting the Video Shift Off as stated in “Checking Corrected versus Uncorrected Performance Using Video Shift On/Off” on page 27 will result in a flat line. In narrow spans, the flatness correction will be done by changing the A3 IF assembly gain. In large spans, when it is not practical to change the A3 IF assembly gain as the analyzer sweeps, video shift is used for flatness correction. Some video shift will be used for flatness correction even when A3 IF assembly gains are also used, but the maximum video shift will be less than 1 dB, unless there is insufficient A3 IF assembly gain available.

-
1. Turn the Auto Align off by pressing **System, Alignments, Auto Align, Off**.
 2. Perform an Align Now All by pressing **System, Alignments, Align Now, All**.
 3. Verify that the initial failure viewed on the analyzer screen is acceptable.
 - a. If the signal on screen appears to be correct, turn the Auto Align back on by pressing **System, Alignments, Auto Align, All** and make sure the signal remains correct.
 - b. If the signal is not correct press **System, Alignments, Load Defaults, Load Defaults**. (Press this key twice for the defaults to load.)

NOTE

When the defaults are loaded, the IF filter response of some resolution bandwidth settings may appear distorted and the amplitude response may vary significantly as the resolution bandwidth is changed.

- c. If the signal is not correct with the defaults loaded proceed to the next step. Otherwise:
 1. Perform Align Now All by pressing **System, Alignments, Align Now, All** and wait for the alignment to complete. Three complete alignment sequences will be performed.
 2. Turn Auto Align back on by pressing **System, Alignments, Auto Align, All**.
 3. Verify the analyzer performance now that the A3 IF assembly has had the defaults loaded and the auto align has been turned back on.

4. If the signal on screen is still not correct perform “[Checking Detector Modes](#)” on [page 27](#). Now inject a 21.4 MHz signal at –10 dBm from a synthesizer into the A3 IF assembly. With the reference level at 0 dBm, the input attenuator set to 0 dB, and center frequency at 50 MHz in zero span, a flat line should appear at the top graticule.
5. If the signal is not at the top graticule, measure A7J13 pin 24 on the motherboard with a voltmeter and verify 2 Vdc. Refer to [Figure 1-1](#).
6. If 2 Vdc is not present the most probable cause would be the A3 IF assembly, but first check for a bent pin on the A7J2 motherboard connector pin 16 (IF_VIDEO). Refer to [Figure 1-2](#).
7. If 2 Vdc is present the most probable cause is either an A7 motherboard trace problem to the A4 processor board, a bent pin on A7J7 motherboard connector, or the A4 processor board itself.

Checking a Horizontal Trace With No Signal or Noise Floor Present

1. For E4402B, E4404B, E4405B, and E4407B connect the Amptd Ref out to the Input.

Check the ADC circuitry on the A4 processor board by pressing **Preset, FREQUENCY 50 MHz, SPAN, Zero Span, Input/Output, Amptd Ref Out (On), AMPLITUDE, –27 dBm** for 50 Ω , or **+24.75 dBmV** for 75 Ω input (for E4401B or E4411B). For any other ESA, press **Preset, FREQUENCY, 50 MHz, SPAN, Zero Span, Input/Output, Amptd Ref Out (On), AMPLITUDE, –20 dBm** (–27 dBm for E4401B or E4411B). This should provide a 2 Vdc output from the A3 IF assembly.

2. Connect a voltmeter to A7J13 pin 24 on the A7 motherboard to probe the output of the A3 IF assembly. If the IF assembly is working properly the voltmeter will read approximately 2 Vdc. Refer to [Figure 1-2](#).

If you measure 2 Vdc at this point, the most probable cause is the A4 processor board.

If you DO NOT measure 2 Vdc at this point, check the integrity of the A3 IF assembly as stated in “[Verifying the A3 IF Assembly Performance](#)” on [page 28](#).

NOTE

It is possible that there is a bent pin (IF_VIDEO) on the A7 motherboard connectors or an open trace on the A7 motherboard itself. Follow the 2 Vdc from the output of the A3 IF assembly to the input of the A4 processor board.

Checking an Analyzer That Displays a Low Signal Level

A low signal level can be caused by a number of assemblies inside the analyzer.

1. Verify that this problem is not related to the detectors by performing the procedure as stated in “[Checking Detector Modes](#)” on [page 27](#).

Troubleshooting the Analyzer

Isolating an LO, IF, or Video Problem

2. The two most common assemblies for a low signal level would be the RF assembly and the A3 IF assembly respectively. To verify the RF assembly performance see [Chapter 2, “Troubleshooting the RF Section,” on page 57](#)
3. If step 2 measures properly, refer to [“Verifying the A3 IF Assembly Performance” on page 28.](#)

Checking an Analyzer That Displays a High Noise Floor

A high noise floor is often caused by a low gain situation. When the analyzer adjusts for excessive low gain, the displayed noise level will rise too high.

1. Verify the ADC performance per the procedure in [“Checking an Analyzer That Displays a Low Signal Level” on page 29](#) before taking any measurements.
2. The RF assembly is the most probable cause due to an over-correction during the frequency response adjustment. To verify the RF assembly performance see [Chapter 2, “Troubleshooting the RF Section,” on page 57.](#)

If the 21.4 MHz IF alignment signal from the RF assembly was not getting to the A3 IF assembly the noise floor may rise. Verify the 21.4 MHz alignment signal is getting switched to the A3 IF assembly as per [“Checking the 21.4 MHz Alignment Signal” on page 31.](#)

3. Verify the A3 IF assembly performance per the procedure stated in [“Verifying the A3 IF Assembly Performance” on page 28](#) if the RF assembly appears to be O.K.

Checking an Analyzer Signal Amplitude That Appears Too High

1. Verify the A3 IF assembly performance per the procedure stated in [“Verifying the A3 IF Assembly Performance” on page 28.](#)
2. Verify the RF assembly performance as per [Chapter 2, “Troubleshooting the RF Section,” on page 57](#)
3. Verify the A4 processor board performance per the procedure stated in [“Checking a Horizontal Trace With No Signal or Noise Floor Present” on page 29.](#)

Checking an Analyzer Signal That Is Distorted

1. Verify the A3 IF assembly performance per the procedure stated in [“Verifying the A3 IF Assembly Performance” on page 28.](#)
2. Verify the RF assembly performance as per [Chapter 2, “Troubleshooting the RF Section.”](#)

Checking an Analyzer Signal That Is Off Frequency

1. Verify the 10 MHz reference is adjusted properly as per the *Reference Frequency Adjustment* using the *Adjustment Software*.
2. If the 10 MHz reference cannot be adjusted within specifications, the RF assembly is the most probable cause.

Checking the 21.4 MHz Alignment Signal

This alignment signal is generated on the RF assembly and is switched in during various background alignment sequences to align the A3 IF assembly. If this signal is not present during the alignments there will be problems with analyzer gains and possibly noise floor issues as well.

1. Verify this signal by turning the analyzer on and pressing **Preset**.
2. Turn Auto Align to off by pressing **System, Alignments, Auto Align, Off**.
3. Disconnect the flexible gray cable at the input of the A3 IF assembly (A3J2).
4. Connect the female end of an SMB tee to the A3 IF assembly, one end to a calibrated spectrum analyzer using an SMB cable, and the other end to the flexible gray cable that was previously connected.
5. Press **System, Alignments, Align Now, All**. During the Align IF you will see the 21.4 MHz alignment signal on your spectrum analyzer during most of this alignment. The power level should be approximately -55 dBm. If this signal is significantly lower, the RF assembly is the most probable cause.
6. Reconnect the flexible gray cable to the input of the A3 IF assembly (A3J2).
7. After measuring the 21.4 MHz alignment signal, turn the Auto Align back on by pressing **System, Alignments, Auto Align, All**.

Using the Internal Service-Diagnostic Routines

The analyzer has several routines which are helpful in diagnosing faults:

- Timebase (in Alignments menu)
- Timebase (in Service Menu, password-protected)
- Video Shift On Off (in Service Menu, password-protected)
- Align Now
- Visible Align
- Noise Source
- Load Defaults
- Restore System Defaults
- Front Panel Test (in Diagnostic menu)

The service menu is password protected. To access this menu, press **System, Service**. At the password prompt, enter –2010 and press **Enter**.

Timebase (in Alignments Menu)

This function allows adjustment of the coarse and fine digital to analog converters (DACs) controlling the voltage-controlled crystal oscillator (VCXO) timebase (OCXO, if Option 1D5 is installed). The primary use for this function is verifying the timebase setability specification of the VCXO. Refer to the 10 MHz reference performance test in the user's guide. However, it can also be used to verify proper operation of the phase locked loops (PLLs).

The coarse DAC has a resolution of approximately 9 Hz per DAC count (for the VCXO). The fine DAC has a resolution of approximately 1.2 Hz per DAC count (for the VCXO). Any changes made to these DACs will remain in effect until the power is cycled or the analyzer is Preset. To change the timebase DAC values stored in EEROM, it is necessary to use the Timebase function in the Service menu.

To check proper operation of the PLLs:

1. Connect a frequency counter to the 10 MHz REF OUT of the analyzer. Set the counter for 1 Hz frequency resolution.
2. Connect a 1 GHz, –10 dBm signal to the analyzer INPUT 50 Ω .
3. On the analyzer, press **Preset, FREQUENCY**, 1 GHz, **SPAN** 100 kHz. If necessary, adjust the center frequency to place the 1 GHz signal at the center frequency.

4. On the analyzer, press **System, Alignments, Timebase, Coarse**. Note the frequency displayed on the frequency counter and the position of the signal on screen. Use the knob to change the coarse timebase such that the signal displayed on the analyzer moves by 1 division (10 kHz). The coarse DAC value should require a change of approximately 11 counts (for the VCXO). If the signal does not move as the coarse DAC value is changed, the PLLs are not functioning properly.
5. Note the frequency displayed on the frequency counter. If the PLLs are operating properly, the difference between this new frequency and the frequency noted in step 4 should be approximately 100 Hz (for the VCXO). If this frequency difference is significantly greater or less than 100 Hz, the PLL is not functioning properly.

Timebase (in Service Menu)

The Timebase function in the Service menu functions the same way as the Timebase function in the Alignments menu. However, with the Timebase function in the Service menu, the coarse and fine DAC values can be stored in EEROM by pressing **Save**. This function is used primarily to adjust the 10 MHz reference, but can also be used to check the PLLs as mentioned above. (A password is required to access the Service menu. See [step 2 on page 34](#) below.)

Video Shift On/Off

Amplitude errors in the analyzer are compensated for by adding IF gain on the A3 IF assembly, by “shifting” the digitized video signal, or by a combination of both IF gain and video shift. By turning video shift on or off, it is possible to isolate problems in analog hardware from problems caused by faults in the auto alignment routines or adjustment procedures.

IF gain is used only to compensate for frequency response (“flatness”) errors when in relatively narrow spans. In the narrow spans, a single IF gain setting can compensate for the majority of the flatness error. In wider spans, however, a single IF gain setting would not yield acceptable flatness. Therefore, in the wider spans, video shift is used to compensate for flatness errors.

When both IF gain and video shift are used, the amount of video shift is typically less than 1 dB; most of the amplitude correction is done with IF gain.

Video shift is also used to correct for log amplifier errors, especially errors more than 50 dB below the reference level. Therefore, when observing a signal in a narrow span, with the noise level more than 70 dB below the reference level, it is typical to see the signal peak change by only a few dB while the noise changes by approximately 25 dB as video shift is turned on and off.

To determine whether an anomaly (such as a glitch or spurious response on the trace) is caused by the analog hardware (“raw performance”) or caused by incorrect video shift being applied, proceed as follows:

1. Set up the analyzer so that the anomaly appears on the displayed trace.

Troubleshooting the Analyzer

Using the Internal Service-Diagnostic Routines

2. Press **System, Service**. When prompted for the password, enter –2010 and press **Enter**.
3. Press **Video Shift** (Off).
4. If the anomaly disappears, it was caused by an unusually high amount of video shift being applied. This could be the result of an amplitude glitch during execution of an auto alignment routine or an adjustment procedure. Perform an **Align Now, All**. Then, set **Video Shift** (On) and check whether or not the anomaly is still present. If so, it is necessary to perform the *Frequency Response Adjustment* using the *Adjustment Software*.
5. If the anomaly does not disappear when Video Shift is set to Off, the hardware is at fault. The RF assembly is the most likely cause.

Align Now

During normal analyzer operation, a small portion of the analog circuitry is being realigned between each sweep. In this mode (“**Auto Align On**”), a complete realignment occurs approximately every 10 minutes to 1 hour. Realignments are done more frequently when the analyzer is first turned on (when it is cold) and then less frequently as the analyzer warms up. Normal analyzer operation is not interrupted in this “background” mode.

Align Now halts normal analyzer operation and forces a complete realignment of the entire system (**Align Now, All**) or of a piece of the system (**Align Now, RF**, for example).

If any amplitude errors, bandwidth symmetry errors, or log fidelity errors occur, perform an **Align Now, All**. This will take approximately 60 seconds, depending upon installed options. Most of this time is spent aligning the IF subsystem. In some cases, it may be necessary to perform **Align Now, All** two or three times to correct serious errors.

If performing **Align Now, All** does not fix the problem, it may be necessary to first **Load Defaults** (see below), and then perform **Align Now, All**. The analyzer will execute three complete alignment sequences.

When performing **Align Now, All** or **Align Now, RF**, the presence of an external 50 MHz signal is checked. If an external 50 MHz signal > -25 dBm is detected, the RF alignment will be skipped and the message “Align RF skipped 50 MHz detected” will be displayed. If this occurs, remove the 50 MHz signal from the analyzer input and perform **Align Now, All** or **Align Now, RF** again.

Visible Align

The visible align function is turned off in normal operation. This function can be turned on so the user can view which hardware is being adjusted during the background alignment or during the auto alignment process.

To turn Visible Align on, press: **System, Service, -2010, Enter, Service, Align, Visible Align (On)**.

If a failure occurs during the alignment process, a fail message will appear on the screen. This message can aid in determining which assembly is causing the failure. Visible align will remain on until it is turned off, instrument preset is pressed, or the instrument power is cycled. About 95% of the auto alignment process is adjusting IF-section related circuitry.

Noise Source

If the A7A13 Noise Source Driver Assembly is installed, and the firmware revision is A.12.00 or later, this function allows you to turn the noise source connected to the +28V PULSED or the SNS SERIES NOISE SOURCE connector output on and off. This can be used as part of a functional check of A7A13.

Load Defaults

If a problem occurs during an auto alignment routine (due to an intermittent hardware problem for example) the correction constants calculated by the auto alignment routine will be incorrect. Performing **Align Now, All** will not always allow recovery from such a failure.

Pressing **Load Defaults** loads default values for the alignment system, turns on the frequency corrections, and resets the timebase to the factory values. Once the default values for the alignment system are loaded, **Align Now, All** should be able to correctly align the analyzer.

Load Defaults can also be used with **Auto Align Off** to set the analyzer hardware to a consistent, nominal condition for future troubleshooting.

Restoring System Defaults

Restore Sys Defaults resets the analyzer to the original factory-set user configuration. It also performs an instrument preset. The following table shows the default user-configuration settings which result from pressing **Restore Sys Defaults**. To access this function, press **System, Restore Sys Defaults**.

Troubleshooting the Analyzer
Using the Internal Service-Diagnostic Routines

Table 1-3

Configuration	Default Value
Amplitude units	dBm
Power-on	IP (Preset)
Analyzer address (Option A4H)	18
Baud rate (Option 1AX)	9600
DTR Control (Option 1AX)	Hardware pacing on
RTS Control (Option 1AX)	Hardware pacing, input buffer full
Receive pacing (Option 1AX)	None
Transmit pacing (Option 1AX)	None
Color palette	Default
Date mode	Month-day-year format
Print mode	Print screen
Printer	Auto
Print orientation	Portrait
Print Language	PCL3
Color-capable	No
Prints per page	1
Time/Date display	On
Viewing angle	4
Volume	0

Use **Restore Sys Defaults** to return the analyzer to a known “safe” state.

Troubleshooting the A4 Processor Assembly

After you have determined that the problem is caused by the A4 processor assembly, use the following procedures to determine if A4 must be replaced or if it can be restored to normal operation. The *ESA Spectrum Analyzer & EMC Analyzer Component-Level Information* is required to assist with some of these procedures. Refer to [Chapter 5](#) for a list of available component-level service information.

Initial Checks

The troubleshooting steps immediately following will help you determine whether or not the A4 processor assembly should be replaced or if it can be restored to normal operation. Some steps reference other troubleshooting procedures which appear later in this section.

1. If **ADC-2V fail**, **ADC-Gnd fail**, or **ADC-time fail** error messages are displayed, check for a 10 MHz signal at A7J15 pin 52. Refer to [Figure 1-2 on page 24](#) for information on probing A7J15 (the connector is not loaded). The 10 MHz signal is required to clock the ADC. If this 10 MHz signal is not present, suspect the RF assembly.
2. Verify the analyzer product number, serial number, and firmware revision. Press **System, Show System**. The display should be similar to the following:

Figure 1-4

Example Show System Display



If the information is not correct, perform the Processor Initialization procedure in the adjustment software.

3. Turn the analyzer power Off and reseal A4. Referring to [Figure 6-15 on page](#)

271, remove the vibration support. Referring to [Figure 6-23 on page 283](#), remove the single screw (4) which secures the processor assembly (8) to the chassis. Carefully lift the processor assembly until the assembly disengages from the two motherboard connectors. Carefully plug the processor assembly into the motherboard. Replace the single screw (4) to secure the processor assembly to the chassis. Turn the analyzer power On. If normal operation is not restored, continue with step 4.

4. Perform the “[Bootrom Self-Test Check](#)” as described in the following text.
5. If proper operation has not been restored by following the preceding steps, replace A4.

Bootrom Self-Test Check

When the analyzer is powered-on, the bootrom performs several self-tests. Before each test, the LEDs along the top edge of the A4 processor assembly will light in a pattern which indicates the test to be performed. As tests succeed, the pattern will change. If a test fails, the LED pattern will remain in a state which corresponds to the test that failed. If the display is not functioning, observing the LED pattern will provide information on the status of the self tests performed.

1. Power up the analyzer. Verify that LED DS1 is flashing approximately every one second. If DS1 is continuously on or off, replace the basic or enhanced memory A4 processor assembly.

The following table lists the LED patterns and their associated tests:

Table 1-4

Self-Tests versus LED Pattern

Self-Test Performed	LED Pattern							
	D	D	D	D	D	D	D	D
	S	S	S	S	S	S	S	S
	1	7	13	11	9	12	10	8
Start of Test	1	1	1	1	1	1	1	1
Bootrom Flash EPROM Checksum	1	1	1	1	1	1	1	0
RAM used by Bootrom (destructive)	1	1	1	1	1	1	0	0
Remainder of RAM (non-destructive)	1	1	1	1	1	0	0	0
Main Firmware Checksum	1	1	1	0	0	0	0	0
All Tests Completed Successfully	0	0	0	0	0	0	0	0

2. Cycle the analyzer power and observe the LEDs. If all the LEDs do not light at the start of the test, the bootrom self-tests did not run. Turn the analyzer power Off and reseal the bootrom, A4U77. Turn the analyzer power On. If the LEDs still do not light, replace the basic or enhanced memory A4 processor assembly.
3. If the self-test indicates a RAM failure, perform the “[Clearing Dynamic RAM](#)” procedure below.

4. If all tests completed successfully, continue with [step 5 on page 38](#) of the initial checks for A4 troubleshooting.

Observing the LEDs as described above is useful if the LCD display is not functioning.

Clearing Dynamic RAM

The RAM in the analyzer can be cleared by setting switch 2 on A4S1 to the on position (toward the rear of the analyzer). Alternatively, the RAM can be cleared by the following procedure:

1. Turn the analyzer power Off.
2. Press and hold the **Esc** and **Return** keys simultaneously.
3. Turn the analyzer power On and wait 5 seconds while continuing to hold the **Esc** and **Return** keys.
4. Release the **Esc** and **Return** keys.
5. Cycle the analyzer power. The entire RAM has been set to 0.

Clearing Flash EPROM

Flash EPROM can be cleared by setting switch 3 on A4S1 to the on position (toward the rear of the analyzer). Wait approximately 10 minutes to ensure the flash EPROM is erased. This should only be performed when all contents of flash EPROM need to be erased. Alternatively, flash EPROM may be cleared by the following procedure:

1. Turn the analyzer power Off.
2. Press and hold the **Esc** and **View/Trace** keys simultaneously.
3. Turn the analyzer power On and wait 5 seconds while continuing to hold the **Esc** and **View/Trace** keys.
4. Release the **Esc** and **View/Trace** keys.
5. Wait approximately 10 minutes to ensure flash EPROM is fully erased.
6. Cycle the analyzer power. The entire Flash EPROM has been set to 0.

Troubleshooting the A2 1.5 GHz Tracking Generator (E4401B and E4411B) (Option 1DN/1DQ)

The A2 tracking generator (TG) assembly (Option 1DN/1DQ), is comprised of three board assemblies: the A2A1 tracking generator control board, the A2A2 tracking generator RF board, the A2A3 tracking generator output board. The troubleshooting procedures which follow will help to isolate a failure to one of these three board assemblies.

If Output is Unleveled (TG Unleveled message displayed)

A window comparator on the A2A2 tracking generator RF board is used to monitor the ALC lines. If an unleveled condition occurs, L_UNLEVELED will be set true (low). The unleveled indicator is checked at the end of each sweep. For this reason, it is possible that the output could be unleveled during a portion of a sweep, and although the output returns to a leveled condition by the end of the sweep, TG Unleveled will be displayed at the end of the sweep.

If TG Unleveled is displayed, proceed as follows:

1. Verify that the tracking generator frequency is between 9 kHz and 1.5 GHz for 50 Ω tracking generators between 1 MHz and 1.5 GHz for 75 Ω tracking generators. Also verify that the source amplitude setting is between 0 dBm and -70 dBm for 50 Ω and between +42.75 dBmV and -27.25 dBmV for 75 Ω .
2. Check at which frequencies the output is unleveled. Set the analyzer to zero span and step the center frequency in 50 MHz increments. Note at which frequencies the output is unleveled.
3. Check at which power levels the output is unleveled. With the analyzer in zero span, set the center frequency to 50 MHz or one of the frequencies noted in [step 2 on page 40](#). Lock the source attenuation to 0 dB by pressing **Source, Attenuation, Auto Man** (Man). Press **Amptd, Step, Auto Man** (Man), **Amplitude On Off** (On), **0 dBm** and step the Source Amptd setting in 1 dB increments from 0 dBm to -15 dBm for 50 Ω input. Step the Source Amptd setting in 1 dB increments from 42.75 dBmV to 27.75 dBmV for 75 Ω input. Note at which power levels the output is unleveled. The output may be unleveled when the power level is greater than +1 dBm for 50 Ω or 43.75 dBmV for 75 Ω .
4. Perform the *Tracking Generator ALC* and the *Tracking Generator Frequency Slope* adjustments using the *Adjustment Software*.
5. Check the presence of the 10 MHz reference. Temporarily remove the A2 tracking generator assembly. Refer to [Chapter 6](#) for removal instructions. If a 10 MHz signal is not present on A7J10 pin 52, suspect the RF assembly. Refer to [Figure 1-2 on page 24](#). Reinstall A2.
6. Check that the TG LO signal is present.

Troubleshooting the A2 1.5 GHz Tracking Generator (E4401B and E4411B) (Option 1DN/1DQ)

- a. Set the analyzer to a center frequency of 50 MHz and zero span.
- b. Use an active probe, such as the HP/Agilent 85024A, and a microwave spectrum analyzer to probe A2A1J4. J4 is not loaded, but the holes for the jack are present; probe the center hole. One of the other four holes may be used for a ground connection.
- c. Set the microwave spectrum analyzer to a center frequency of 2.5 GHz and a span of 1 GHz.
- d. An LO signal of 2.45 GHz at approximately -20 dBm should be present.
- e. If the LO signal is not present, or is significantly off frequency, suspect the A2A1 tracking generator control board.
- f. If the LO signal is OK, suspect the A2A2 tracking generator RF board.

If the TG LO is Unlocked (TG LO Unlocked message displayed)

The TG LO is referenced to the 10 MHz reference generated on the RF assembly. The TG LO resides on the A2A1 tracking generator control board.

1. Check the presence of the 10 MHz reference. Temporarily remove the A2 tracking generator assembly. Refer to [Chapter 6](#) for removal instructions. If a 10 MHz signal is not present on A7J10 pin 52, suspect the RF assembly. Refer to [Figure 1-2](#). Reinstall A2.
2. Check that the TG LO signal is present.
 - a. Set the analyzer to a center frequency of 50 MHz and zero span.
 - b. Use an active probe, such as the HP/Agilent 85024A, and a microwave spectrum analyzer to probe A2A1J4. J4 is not loaded, but the holes for the jack are present; probe the center hole. One of the other four holes may be used for a ground connection.
 - c. Set the microwave spectrum analyzer to a center frequency of 2.5 GHz and a span of 1 GHz.
 - d. An LO signal of 2.45 GHz at approximately -20 dBm should be present.
 - e. If the LO signal is not present, or is significantly off frequency, suspect the A2A1 tracking generator control board.
 - f. If the LO signal is OK, suspect the A2A1 tracking generator control board (the lock-detect circuitry is also on A2A1).

If the Tracking Generator Is Not Properly Recognized by the Firmware

When the analyzer is powered-up, the firmware queries each board assembly for its identification information. If a board does not respond to a query, it is assumed to not be present. If the A2 tracking generator assembly does not respond to the firmware's query, the functions under the **Source** menu will not be available.

Troubleshooting the Analyzer

Troubleshooting the A2 1.5 GHz Tracking Generator (E4401B and E4411B) (Option 1DN/1DQ)

1. Check the **Show System** screen. Press **System, Show System**. Verify that “1DN: 1.5 GHz TG, 50 Ω ” or “1DQ: 1.5 GHz TG, 75 Ω ” is displayed.
2. If the information in the **Show System** screen does not identify a tracking generator, try reseating A2 in its motherboard connector. If **Show System** still does not identify a tracking generator, suspect the A2A1 tracking generator control board.
3. If the information in the **Show System** screen identified a 75 Ω tracking generator (Option 1DQ), but the tracking generator is actually a 50 Ω tracking generator (Option 1DN). The A2A3 tracking generator output board might not be properly connected to A2A2J4. A2A2J4 pin 2 is normally grounded by the A2A3 tracking generator output board to identify the A2 assembly as a 50 ohm tracking generator. If A2A2J4 pin 2 is not connected, this line will be pulled high, causing the A2 assembly to be identified as a 75 Ω tracking generator.

If Flatness is Out of Tolerance

1. Check the output connector for damage. Replace the connector if it is damaged.
2. Perform the *Tracking Generator ALC* and *Tracking Generator Frequency Slope* adjustments using the *Adjustment Software*.
3. If the adjustments did not bring flatness within tolerance, suspect the A2A2 tracking generator RF board or the A2A3 tracking generator output board.

If Vernier Accuracy is Out of Tolerance

1. Perform the Tracking Generator ALC Adjustment using the Adjustment Software.
2. If the adjustment did not bring vernier accuracy within tolerance, suspect the A2A2 tracking generator RF board.

If Harmonics and Spurious Outputs are Too High

High harmonic output levels will generally be caused by problems on the A2A2 tracking generator RF board. However, some non-harmonic spurious output levels may be caused by the TG LO on the A2A1 tracking generator control board.

1. If harmonic output levels are out of tolerance, suspect the A2A2 tracking generator RF board.
2. If non-harmonic output levels are out of tolerance, note the frequency difference between the fundamental output frequency and the spurious output. Check the LO to see it also displays a spurious output with the same frequency difference:
 - a. Set the analyzer to the center frequency used to determine the out-of-tolerance condition and zero span.
 - b. Use an active probe, such as the HP/Agilent 85024A, and a microwave spectrum analyzer to probe A2A1J4. J4 is not loaded, but the holes for the

**Troubleshooting the A2 1.5 GHz Tracking Generator (E4401B and E4411B)
(Option 1DN/1DQ)**

jack are present; probe the center hole. One of the other four holes may be used for a ground connection.

- c. Set the microwave spectrum analyzer to a center frequency of 2.4 GHz higher than the analyzer center frequency. Set the span to at least twice the frequency difference between the non-harmonic spurious output and the fundamental output.
- d. An LO signal at approximately -20 dBm should be present.
- e. If the LO shows a spurious response at an offset equal to the difference between the tracking generator's fundamental output and the non-harmonic spurious output, suspect the A2A1 tracking generator control board.
- f. If the LO does not show a spurious response as described above, suspect the A2A2 tracking generator RF board.

If Power Sweep is Not Functioning Properly

The power sweep function is implemented on the A2A2 tracking generator RF board, but is controlled via digital signals from the A2A1 tracking generator control assembly.

1. Perform the Absolute Amplitude and Vernier Accuracy performance test in the calibration guide.
2. If the performance test passes, suspect the A2A2 tracking generator RF board.
3. If the performance test fails, perform the *Tracking Generator ALC Adjustment* using the *Performance Verification and Adjustment Software*. Rerun the performance test.
4. If the performance test fails again, suspect the A2A1 tracking generator control board (digital control signals might be corrupted) or the A2A2 tracking generator RF board (the power level control DACs might not be responding properly).

If There is No Output Power

No output power can be caused not only by a failure in the mixer, output amplifier, or output attenuators, but also by one of the two synthesizers being extremely off-frequency.

1. Check the presence of the 10 MHz reference. Temporarily remove the A2 tracking generator assembly. Refer to [Chapter 6](#) for removal instructions. If a 10 MHz signal is not present on A7J10 pin 52, suspect the RF assembly. Refer to [Figure 1-2 on page 24](#). Reinstall A2.
2. Check that the TG LO signal is present.
 - a. Set the analyzer to a center frequency of 50 MHz and zero span.
 - b. Use an active probe, such as the HP/Agilent 85024A, and a microwave spectrum analyzer to probe A2A1J4. J4 is not loaded, but the holes for the jack are present; probe the center hole. One of the other four holes may be used for a ground connection.
 - c. Set the microwave spectrum analyzer to a center frequency of 2.5 GHz and a span of 1 GHz.
 - d. An LO signal of 2.45 GHz at approximately -20 dBm should be present.
 - e. If the LO signal is not present, or is significantly off frequency, suspect the A2A1 tracking generator control board.
 - f. If the LO signal is OK, suspect the A2A2 tracking generator RF board or the A2A3 tracking generator output board.

Troubleshooting the A2 3.0 GHz Tracking Generator (E4402B, E4403B, E4404B, E4405B, E4407B, and E4408B) (Option 1DN)

The tracking generator (TG) assembly (Option 1DN) is comprised of three major assemblies: the A2A1 tracking generator control board, the A2A2 tracking generator assembly, and the A2A3 output attenuator.

The A2A1 tracking generator control board plugs directly into the motherboard where it receives the I/O inputs and power supplies. The A2A1 tracking generator control board performs three main functions:

- provides the power supplies and modulator drive voltages to the A2A2 tracking generator
- provides an amplitude-compensated leveled 1st LO output to the A2A2 tracking generator
- provides the correct switching logic for the A2A3 output attenuator

The A2A3 output attenuator is a 56 dB step attenuator (in 8 dB steps) that simply controls the RF output level to the front panel RF output connector. This attenuator is automatically coupled to the desired output source power.

The A2A2 tracking generator receives all the correct switching logic and input frequencies to yield the desired tracking generator output. It is a self-contained non-serviceable assembly and must be replaced if proven defective.

To help isolate a TG-related failure, verify the TG performance by pressing the following analyzer keys, make the measurements listed in [Table 1-5 on page 46](#), and compare the results with the levels indicated in that table:

Preset
FREQUENCY 50 MHz
SPAN, Zero Span
Source
AMPLITUDE (On)

Measure locations A-D with a calibrated spectrum analyzer.

With the settings stated above, the tracking generator source power should be -10 dBm and the tracking output attenuator (A2A3) will be set to 8 dB.

Table 1-5 3.0 GHz Tracking Generator Troubleshooting

Signal Description	Measurement Location	Expected Frequency	Expected Amplitude	Notes
1st LO Input	A	3971.4 MHz	0 dBm	LO Input from A8A1A2 LO board on E4402B and E4403B. LO Input from A8A4 LO Amp/IF Switch on the E4404B, E4405B, E4407B and E4408B. Measured at the cable end.
1st LO Output	B	3971.4 MHz	+13 dBm	LO Output from A2A1 TG controlboard to A2A2J4 TG Input. Measured on the output of the TG control board.
RF Output	C	50 MHz	-2 dBm	RF Output from A2A2J2 TG. Measured at J2
600 MHz	D	600 MHz	-7 dBm	600 MHz from A8A1A1J2 reference/3rd converter to A2A2J5. Measured at the cable end.

Figure 1-5 3.0 GHz Tracking Generator Measurement Locations

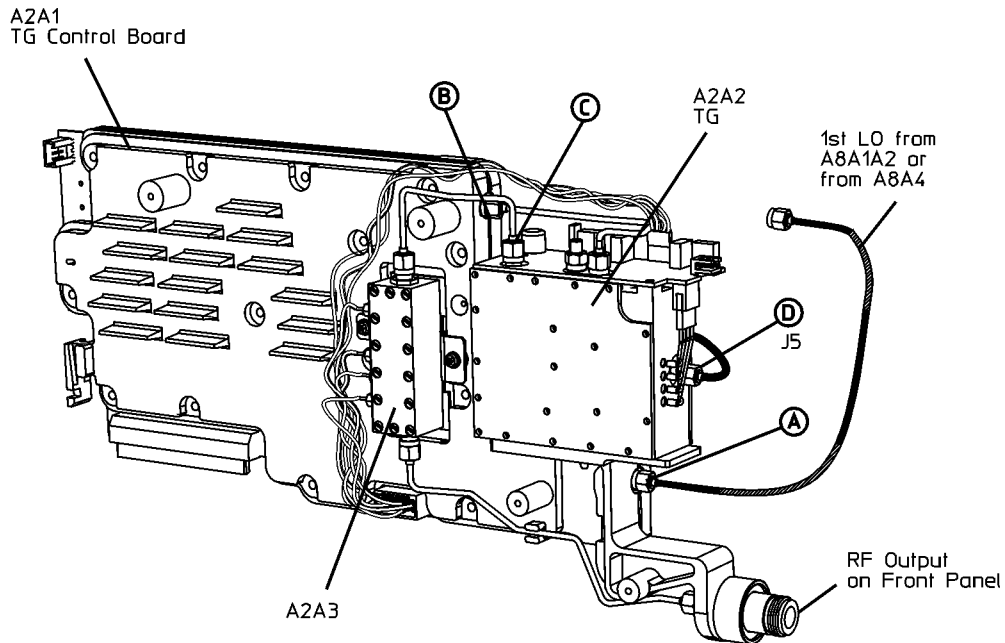

sl724b

Troubleshooting the Digital Demod Hardware (E4402B, E4404B, E4405B, and E4407B) (Option B7D and B7E)

The ESA Spectrum Analyzer base unit may effect any of the measurements performed with Options B7D and B7E. Verify that the base instrument functions correctly prior to troubleshooting the digital demod options.

The Digital Demod RF (DDRF) board, Option B7E, downconverts the 21.4 MHz IF to the various intermediate frequencies (IF) required for the Digital Signal Processing (DSP) board, Option B7D. The DDRF board also provides the sample rate oscillator for the DSP board. The DDRF board allows the user to input a reference frequency from 1 MHz to 30 MHz. The DDRF board divides the signal appropriately to produce a 10 MHz reference signal. This signal can then be routed to the 10 MHz reference on the ESA spectrum analyzer. The DDRF board provides no additional functionality without a measurement personality loaded.

The DSP board, Option B7D, performs the digital demodulation of the signal. The option is used when performing phase and frequency measurements with the GSM personality, Option BAH and modulation accuracy measurement with the cdmaOne personality, Option BAC. Fast time domain sweeps from the DSP FADC is the only functionality available without a personality.

Troubleshooting Analyzer Mode Errors Caused By the DDRF or DSP Boards

If the analyzer will not power-up or powers off prior to completing the initial alignment, remove the DDRF and DSP boards. If this corrects the problem, insert the boards in sequence to determine which of the two boards is causing the problem. Replace the defective board. Refer to [“Digital Demod Assemblies Replacement” on page 298](#).

If the problem observed is specific to running the BAC or BAH measurement personalities, refer to [“Troubleshooting the Digital Demodulation Hardware When Running the cdmaOne or GSM Personalities” on page 48](#). If option B7D or B7E are suspected of causing amplitude or frequency errors in the spectrum analyzer (SA) mode this could be caused by the routing of the IF signal through the DDRF board. The IF signal is input to the DDRF board at connector J11. The IF signal is switched out through connector J10 when the instrument is in the SA mode. To verify that the DDRF IF OUT A7A8J10 signal is correct perform the following procedure:

Troubleshooting the Analyzer

Troubleshooting the Digital Demod Hardware (E4402B, E4404B, E4405B, and E4407B) (Option B7D and B7E)

1. Connect the AMPTD REF OUT signal to the input of the ESA spectrum analyzer.
2. Power on the spectrum analyzer.
3. Set the Center Frequency of the spectrum analyzer to 50 MHz.
4. Set the SPAN to Zero Span.
5. Turn Auto Align to Off.
6. Set the internal Attenuation to 0 dB.
7. Turn the 50 MHz AMPTD REF ON by pressing **INPUT** and **Amptd Ref On**.
8. A flat trace should be displayed at -20 dBm.
 - If this trace is present, it is probable that the DDRF IF circuitry is functioning correctly.
 - If this trace is not present, refer to [Chapter 2, “Troubleshooting the RF Section,” on page 57](#).
 - If the 21.4 MHz IF output from A8A1A1 is correct, continue to the next step.
9. Verify that the Signal present at the DDRF connector J10 is approximately -20 dBm with an 8560 E-Series spectrum analyzer or equivalent. See [Figure 1-7](#).
10. If this signal is not present or the amplitude difference is significant:
 - Verify that the input attenuation is 0 dB
 - Verify that Cable W29 DDRF IF IN cable is not faulty.
 - Replace the DDRF board.

Troubleshooting the Digital Demodulation Hardware When Running the cdmaOne or GSM Personalities

The functional check of the option boards will require signal generator E4433B with Options UN5, UND, and 1E5 for cdmaOne or Options UN8 and 1E5 for GSM.

Verify that the GSM or cdmaOne measurement personality is installed in the spectrum analyzer by pressing the **MODE** key on the ESA. A softkey menu should be displayed with cdmaOne or GSM selection available. If neither of these personalities exist, go to the following URL to download a copy to install:

www.agilent.com/find/esa

The installation instructions are available on this site. Verify that the personalities have been licensed by pressing **System, Personalities, GSM** or **cdmaOne**. GSM or cdmaOne should be listed as being licensed. If no license information is present, verify, with the customer, that option BAH or BAC has been installed and licensed.

Verifying the Operation with the cdmaOne Option BAC Personality

Step 1: Functional Check

1. Connect the signal generator RF out to the input of the ESA spectrum analyzer and the 10 MHz OUT of the spectrum analyzer to the 10 MHz reference IN on the signal generator.
2. Configure the signal generator by pressing the following keys:

Mode
Arb Waveform Generator
CDMA
Formats
IS-95A
CDMA Off/On (ON)
Setup Select
Pilot
Frequency, 870.03, and MHz
Amplitude, -10, and dBm
RF On/Off (ON)

3. Configure the spectrum analyzer by pressing the following keys:

Mode
cdmaOne
FREQUENCY (Verify that the RF channel selected is 1 and the frequency is
870.03 MHz)
MEASURE
Modulation Accuracy (Rho)

The spectrum analyzer display should be very similar to [Figure 1-6](#).

Verify that the EVM, Mag Error, Phase Error, and Rho are close to the values shown in [Figure 1-6](#). If the results are similar to the ones listed above, the digital demodulation hardware is functioning correctly. You can verify the performance using the Performance Verification Test procedure in the calibration guide.

Figure 1-6 Modulation Accuracy (Rho) Display

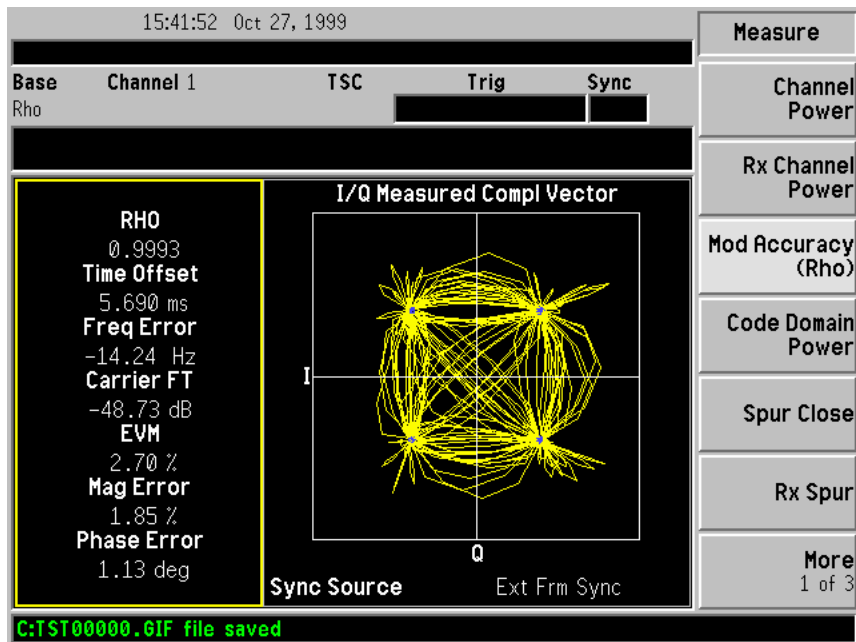

- If a “DSP Failure” error message is displayed or if any LED (DS1 through DS8) on the DSP board are ON, replace the digital demod DSP board.
- If the EVM or Magnitude Errors are very large, this could be indicative of spectrum analyzer phase noise or 321.4 MHz amplitude flatness problems with the second IF.
- If the measurement does not start or the message “Signal could not be Correlated” is displayed, verify that the spectrum analyzer functions correctly in the SA mode then proceed to [“Step 2: Verify that the DSP IF OUT is functioning correctly.”](#)
- If the results are not close to the values listed in [Figure 1-6](#), verify that the spectrum analyzer functions correctly in the SA mode then proceed to [“Step 2: Verify that the DSP IF OUT is functioning correctly.”](#)

Step 2: Verify that the DSP IF OUT is functioning correctly.

1. Set the ESA Spectrum Analyzer and signal generator to the settings in STEP 1.
2. Observe the DSP IF OUT at connector J5 of the DDRF board with an 8560E series spectrum analyzer or equivalent spectrum analyzer with a Center Frequency of 3.7 MHz and a SPAN of 5 MHz. The output should be similar to Figure 1-7.

Figure 1-7 8560E Series Spectrum Analyzer Display

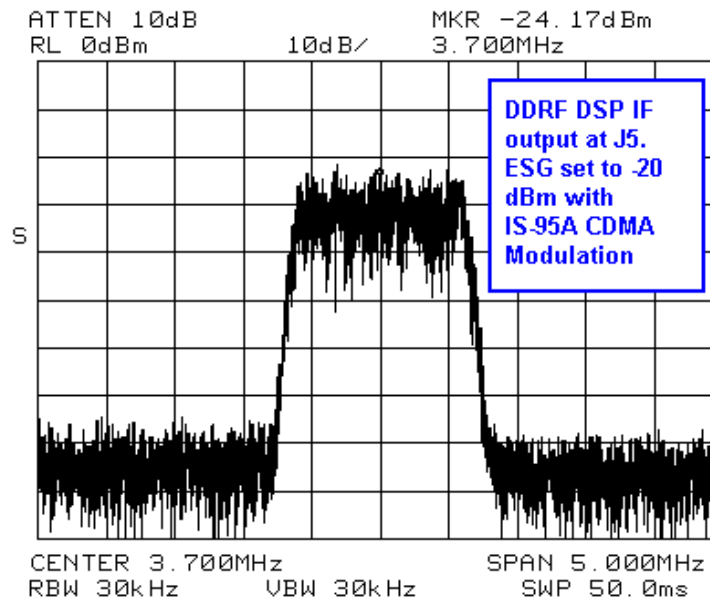

This signal will periodically be displayed on the 8560E series spectrum analyzer when the signal is periodically routed to the DSP board through the DDRF connector J5.

- If this signal is not periodically displayed on the 8560E series spectrum analyzer replace the DDRF board.
- If the signal is periodically present proceed to “[Step 3: Verify the Sample Rate Clock](#)”.

Step 3: Verify the Sample Rate Clock

Verify a Clock signal is present at connector J12 of the DDRF board.

- If this signal is not present, replace the DDRF board.
- If both the Sample Rate Clock and DSP IF out signals are present and correct on the DDRF board, replace the DSP board.

Verifying Operation With the GSM Option BAH Personality

Step 1. Functional Check

1. Connect the signal generator RF out to the input of the ESA Spectrum Analyzer and the 10 MHz OUT of the spectrum analyzer to the 10 MHz reference IN on the signal generator.
2. Configure the signal generator by pressing the following keys:

MODE
Real Time I/Q BaseBand
TDMA
GSM
GSM Off/On ON
Data Format to Framed
Frequency, 935.2, and MHz
Amplitude, -20, and dBm
RF On/Off On

3. Configure the spectrum analyzer by pressing the following keys:

MODE
GSM
Frequency Verify that the ARFCN channel selected is 1 and the Frequency is 935.2 MHz.
MEASURE
Phase and Frequency
Meas Setup
Trigger Source
RF Burst (Wideband).

The ESA display should be very similar to [Figure 1-8](#).

Figure 1-8

Phase and Frequency Error Display

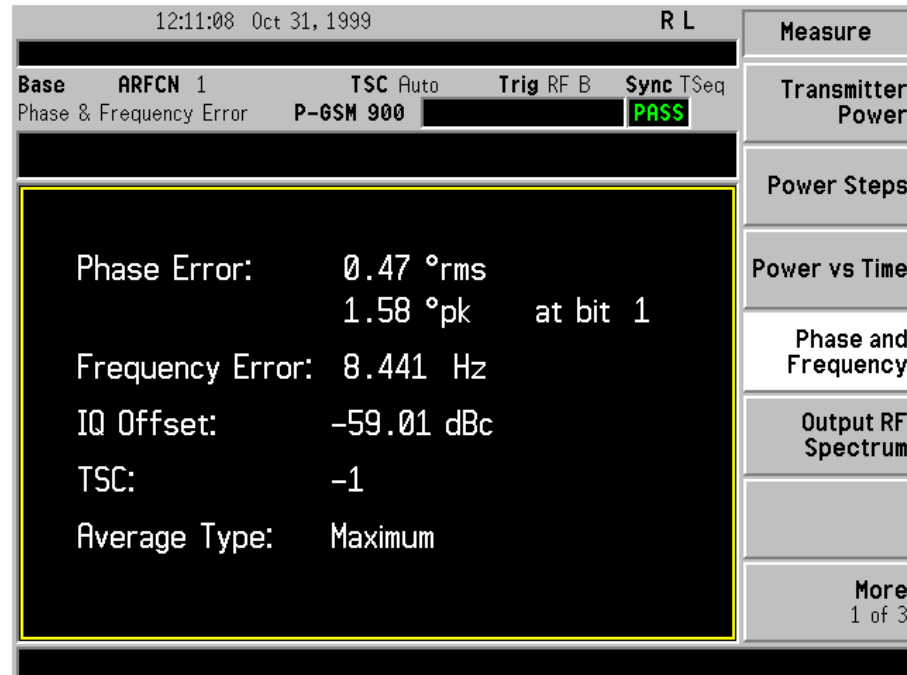

Verify that the Phase Error and Frequency are close to the values displayed in [Figure 1-8](#). If the results are similar to the ones listed above, the digital demodulation hardware is functioning correctly. You can verify the performance using the Performance Verification Test procedure in the calibration guide.

- If a “DSP Failure” error message is displayed or if any LED (DS1 through DS8) on the DSP board are ON replace the digital demod DSP board.
- If the Phase and Frequency Errors are very large this could be indicative of a spectrum analyzer phase noise problem.
- If the measurement does not start or the message “Valid GSM Burst not Found” is displayed, verify that the spectrum analyzer functions correctly in the SA mode.

If SA mode function is correct, replace the DDRF board and repeat “[Step 1. Functional Check](#)”.

- If the results are not close to the values listed in [Figure 1-8](#), verify that the spectrum analyzer functions correctly in the SA mode.

If SA mode function is correct, replace the DDRF board and repeat “[Step 1. Functional Check](#)”.

- If the results are still incorrect, replace the DSP board and repeat “[Step 1. Functional Check](#)”.

Troubleshooting the A7A13 Noise Source Driver Assembly

The A7A13 Noise Source Driver assembly contains the circuitry to control either an SNS Series Noise Source (SNS) or a 346 Series (Norm) Noise Source. This assembly is used exclusively by the Noise Figure Measurement Personality, Option 219. In addition to switching the noise source on and off via a signal which toggles between 0 V (Off) and 28 V (On), it provides the interface to download the ENR data from the SNS Series noise sources.

Verify +28V PULSED Output Operation

1. Connect a voltmeter to the +28V PULSED output on the analyzer rear panel using a BNC cable and a BNC to dual banana plug adapter.
2. Set the voltmeter to read dc voltages between 0 and 30V.
3. On the analyzer, press **System, More, More, Service**.
4. Press **-2010, Enter**.
5. Press **Service, More, Noise Source (On)**.
6. Verify that the voltmeter reads $+28V \pm 0.1 V$.
7. Press **Noise Source (Off)**.
8. Verify that the voltmeter reads less than +1 V.
9. If the voltages measured are not as described above, the A7A13 Noise Source Driver assembly is defective.

Verify SNS Digital Interface Operation

To properly verify the digital interface capability of A7A13, it is necessary to have the Noise Figure Measurement Personality installed and licensed. Also, a known good SNS Series Noise Source (model N4000A, N4001A, or N4002A) and a noise source cable (11730A or 8120-8319) will be needed.

1. Connect the SNS Series Noise Source to the SNS SERIES NOISE SOURCE connector on the rear panel.
2. Enter the Noise Figure Measurement Personality by pressing **MODE, Noise Figure**. It will take several seconds for the analyzer to switch to the Noise Figure mode.
3. Press **Meas Setup, ENR, Common Table (On)**.
4. Press **SNS Setup**. Set **Preference** to SNS.
5. Press **Meas Setup, ENR, Meas & Cal Table**. Press the right Tab key until the yellow highlight appears in the Frequency column.
6. Press **More, Delete All**. Press **Delete All** again to confirm the delete process.
7. Verify that the ENR table is empty and the error message “No entries in ENR table” appears in the status line.

8. Press **Fill Table From SNS**.
9. After a few seconds, the ENR table should be filled with the data downloaded from the noise source. Verify that the serial number and model number shown on the screen agree with the serial number and model number of the noise source.
10. If the ENR data is not downloaded, the noise source driver assembly is defective.

Troubleshooting the Analyzer

Troubleshooting the Digital Demod Hardware (E4402B, E4404B, E4405B, and E4407B) (Option B7D and B7E)

2 Troubleshooting the RF Section

What You Will Find in This Chapter

This chapter provides information that is useful when starting to troubleshoot the RF section of the analyzer. It explains how to isolate RF problems and provides procedures for troubleshooting common failures.

Component level information containing material lists, schematics, and component location diagrams, is available separately.

Verifying the RF Section Performance (E4401B and E4411B)

(9 kHz - 1.5 GHz)

This section provides techniques for isolating amplitude failures along the signal path.

The RF section downconverts the analyzer input signal to the final IF of 21.4 MHz. You can troubleshoot the RF section by injecting a 50 MHz CW signal at -20 dBm to the RF input of the analyzer. The 21.4 MHz downconverted IF signal will be the input level minus the input attenuation. The RF section's frequency response will roll off by about 8 dB at 1.5 GHz. The analyzer first upconverts to a 2.4214 GHz 1st IF and then downconverts to a 21.4 MHz IF. Refer to Figure 2-1 for two examples of downconversion, one with an input frequency of 1 GHz, and one with an input frequency of 50 MHz.

Figure 2-1

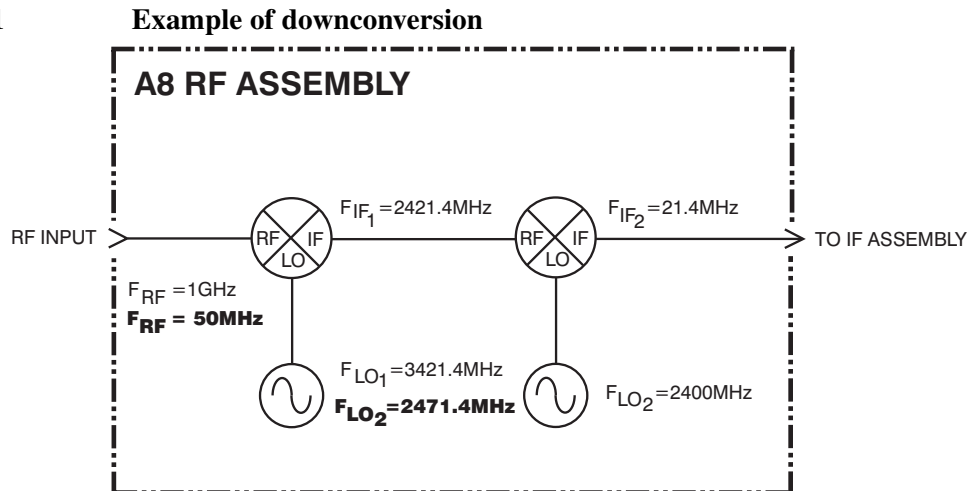

sl759a

RF Performance Check

1. Inject a CW signal at 50 MHz at -20 dBm for a 50 Ω analyzer and at $+28.76$ dBmV for a 75 Ω analyzer (Option 1DP) into the RF input of the analyzer.
2. Tune the analyzer to 50 MHz, zero span, with input attenuation set to 0 dB by pressing **FREQUENCY, Center Freq, 50 MHz, SPAN, Zero Span, Attenuation Auto Man (Man), 0, dB**.
3. Turn Auto Align On/Off to Off by pressing **System, Alignments, Auto Align, Off**.

4. Disconnect the flexible gray cable (W2) going into the A3 IF assembly at A3J2.
5. Connect a calibrated spectrum analyzer to this flexible gray cable (W2) and measure the 21.4 MHz output from the RF section.

If the RF section is operating properly, you should measure 21.4 MHz out of the RF section at -20 dBm for a $50\ \Omega$ analyzer and $+28.76$ dBmV for a $75\ \Omega$ analyzer on the calibrated spectrum analyzer. See [Figure 2-2](#).

NOTE

If your signal amplitude is too high or too low, vary the input attenuation from 0 to 60 dB and note that for every 5 dB of attenuator change, the 21.4 MHz IF output signal from the RF section should change 5 dB as well. The signal amplitude problem may be the result of a defective attenuator/switch on the RF section itself.

Figure 2-2 21.4 MHz Output – A8A1A1

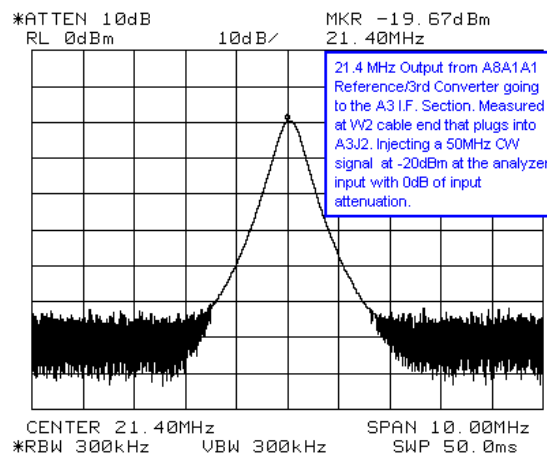

- If you notice a frequency response problem, visually inspect the RF input connector for mechanical integrity.
- If the analyzer has a frequency response problem, you can inject the frequency of interest, tune the analyzer to that frequency in zero span, and monitor the 21.4 MHz IF signal level for abnormalities on your calibrated spectrum analyzer.
- If you have excessive loss through the RF section, replace the RF section.

You can also use the internal 50 MHz calibrator signal for troubleshooting by pressing **Input, Amptd Ref On Off (On)**. This is a 50 MHz signal at approximately -27 dBm for $50\ \Omega$ analyzers or $+21.75$ dBmV for $75\ \Omega$ analyzers that originates from the RF section.

Verifying the RF Section Performance (E4402B and E4403B)

(9 kHz - 3 GHz)

This section provides techniques for isolating amplitude failures along the signal path.

The RF section downconverts the analyzer input signal to the final IF of 21.4 MHz. You can troubleshoot the RF section by injecting a 50 MHz CW signal at -20 dBm to the RF input of the analyzer. The 21.4 MHz downconverted IF signal will be the input level minus the input attenuation. There are three conversions made in these analyzers. Refer to Figure 2-3 for two examples of downconversion: one with an input frequency of 1 GHz, and one with an input frequency of 50 MHz.

Figure 2-3 RF Section

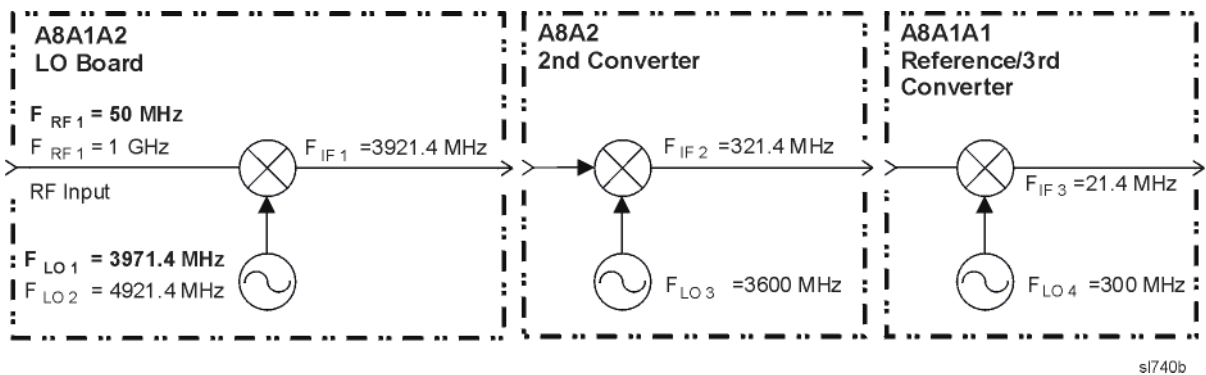

Quick Check RF Procedure

1. Inject a 50 MHz CW signal at -20 dBm into the RF input of the analyzer.
2. Tune the analyzer to 50 MHz, zero span, with input attenuation set to 0 dB by pressing **FREQUENCY, Center Freq, 50, MHz, SPAN, Zero Span, Attenuation Auto Man (Man), 0, dB**.
3. Turn Auto Align On/Off to Off by pressing **System, Alignments, Auto Align, Off**.
4. Disconnect the flexible gray cable (W2) going into the A3 IF assembly at A3J2.

Troubleshooting the RF Section

Verifying the RF Section Performance (E4402B and E4403B)

5. Connect a calibrated spectrum analyzer to this flexible gray cable (W2) and measure the 21.4 MHz output from the RF section.

If the RF section is operating properly, you should measure 21.4 MHz out of the RF section at -20 dBm on the calibrated spectrum analyzer. See [Figure 2-4](#).

Figure 2-4 21.4 MHz RF

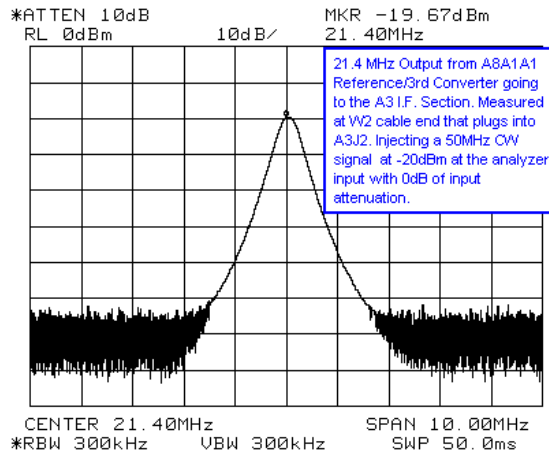

NOTE

If your signal amplitude is too high or too low, vary the input attenuation from 0 to 65 dB and note that for every 5 dB of attenuator change, the 21.4 MHz IF output signal from the RF section should change 5 dB as well. The signal amplitude problem may be the result of a defective A8A5 input attenuator or the attenuator logic from A8A1A1 Reference/Third Converter.

Detailed RF Troubleshooting

To isolate the failing assembly, use the analyzer settings as stated in “[Quick Check RF Procedure](#)” on page 61, then refer to [Table 2-1](#) on page 63, [Figure 2-5](#), and [Figure 2-6](#) to measure the troubleshooting points throughout the RF section. The Measurement Location column of the table corresponds to the locations called out on the drawing and the block diagram. The Expected Measured Signal column references figures that illustrate the signal expected at that measurement point.

Table 2-1 **RF Section Troubleshooting Points**

Signal Description	Measurement Location ^a	Expected Frequency	Expected Level	Expected Measured Signal ^b	Notes
1st IF Output	A	3921.4 MHz	-23.2 dBm	Figure 2-7	A8A1A2 has ~3.2 dB of loss.
2nd IF Output	B	321.4 MHz	-27.5 dBm	Figure 2-8	A8A2 has ~4.5 dB of loss.
RF Input	C	50 MHz	-20.5 dBm	Figure 2-9	
1st LO Output	D	3971.4 MHz	-1 dBm	Figure 2-10	Out of A8A1A2
2nd LO Input	E	600 MHz	-3 to +6 dBm	Figure 2-11	Out of A8A1A1 (through A7A9 with Option 120)
2nd LO Multiplied	F Block Diagram only	3600 MHz	-13.5 dBm	Figure 2-12	Out of A8A2J5 LO Test Port
600 MHz TG	G	600 MHz	-7 dBm	Figure 2-13	Out of A8A1A1
10 MHz Reference	H	10 MHz	+5 dBm	Figure 2-14	Rear Panel 10 MHz Ref. Out
50 MHz Amplitude Reference	I	50 MHz	-20 dBm	Figure 2-15	Out of A8A1A1

- a. To locate the measurement points, refer to [Figure 2-5](#) and [Figure 2-6](#).
- b. To see the signal expected at each measurement location, reference the figures in this column.

Figure 2-5 RF Section Troubleshooting Points

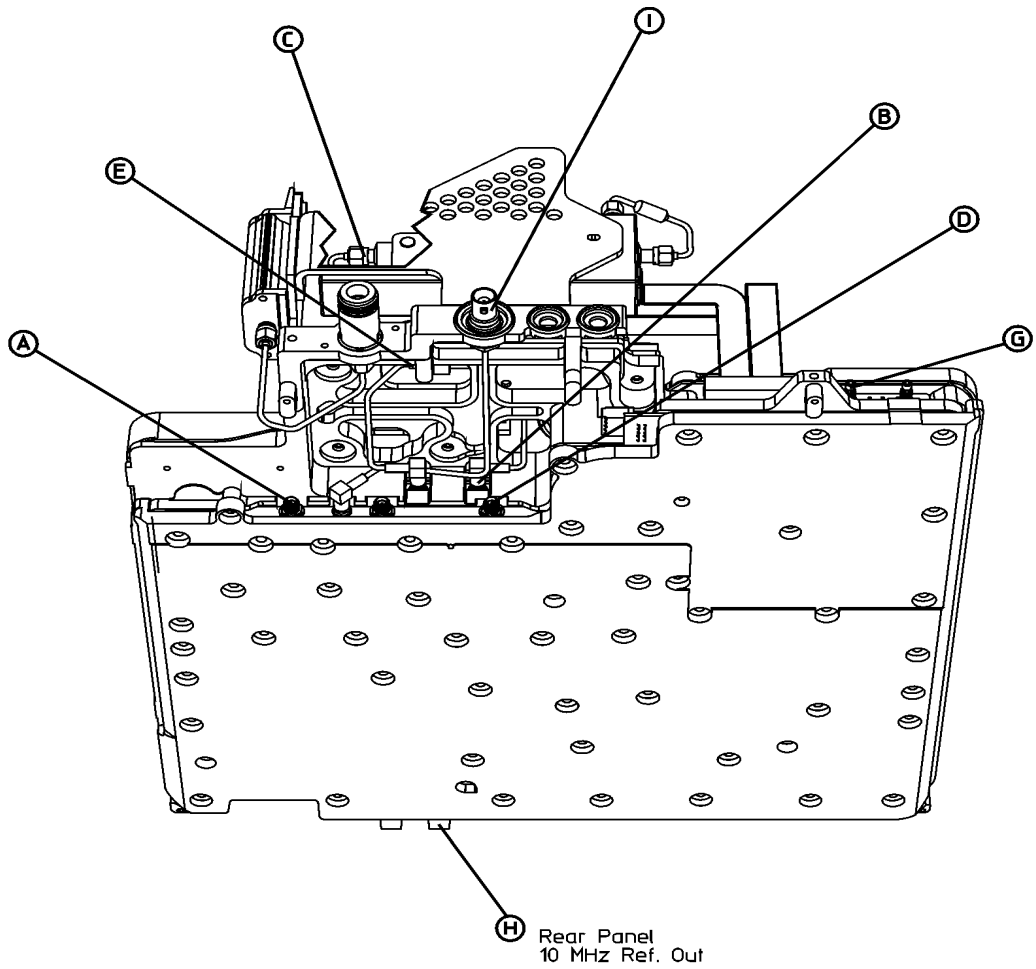

sl722b

Figure 2-6 RF Section Block Diagram (E4402B and E4403B)

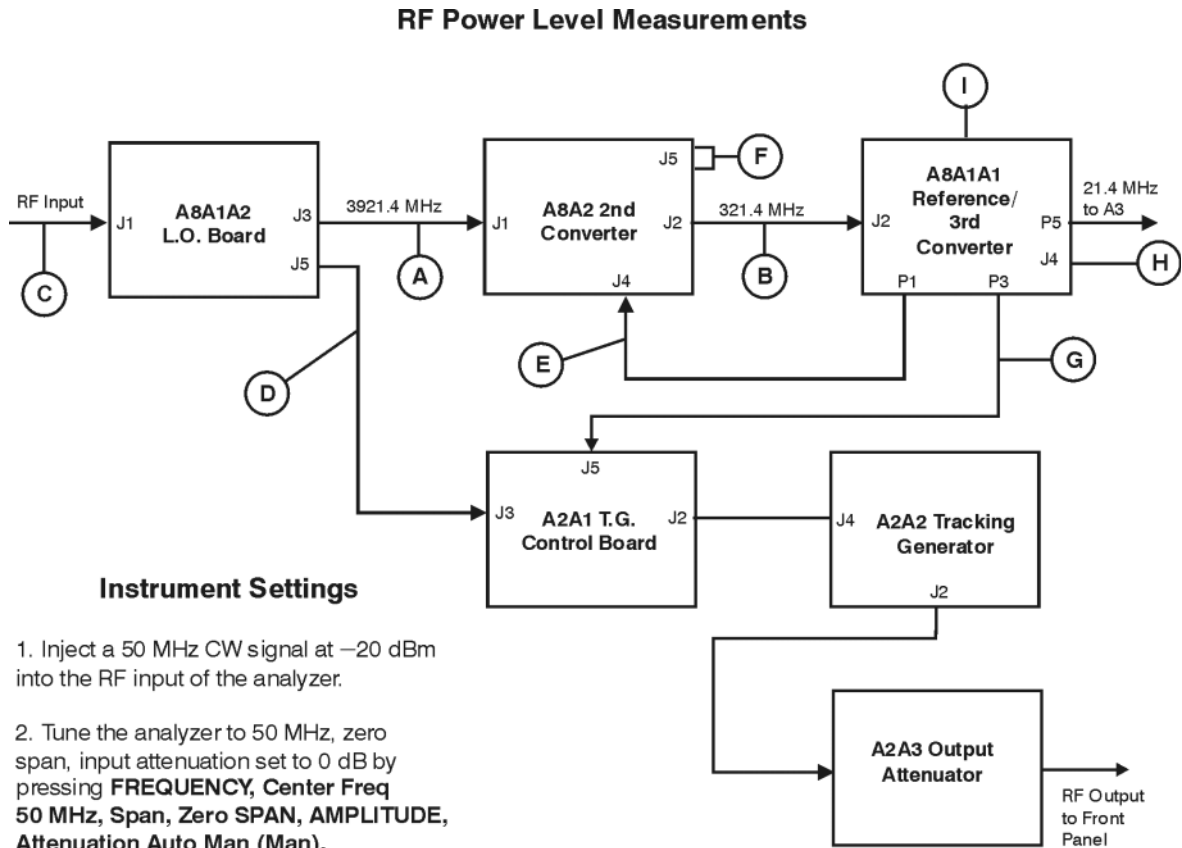

s731b

Figure 2-7 1st IF Output – A8A1A2J3

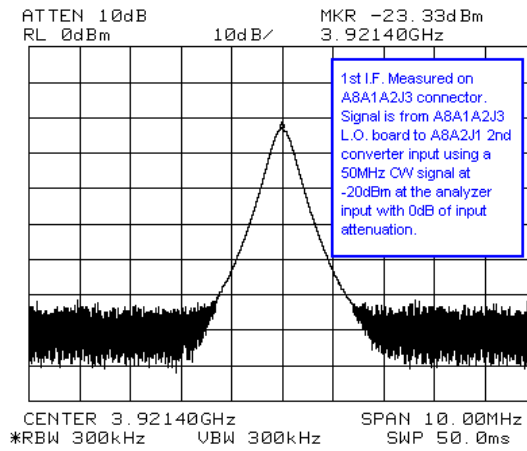

Figure 2-8 2nd IF Output – A8A2

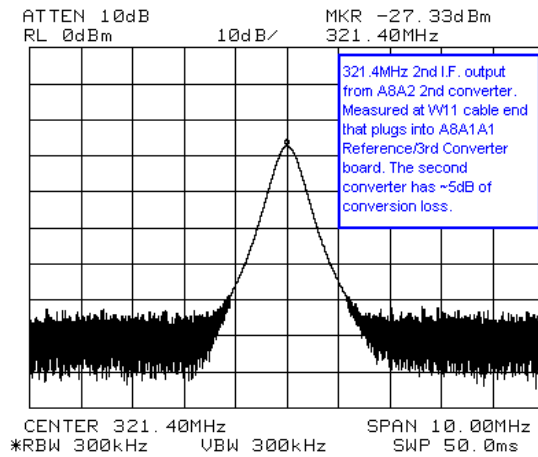

Figure 2-9 RF Input Measured from A8A3

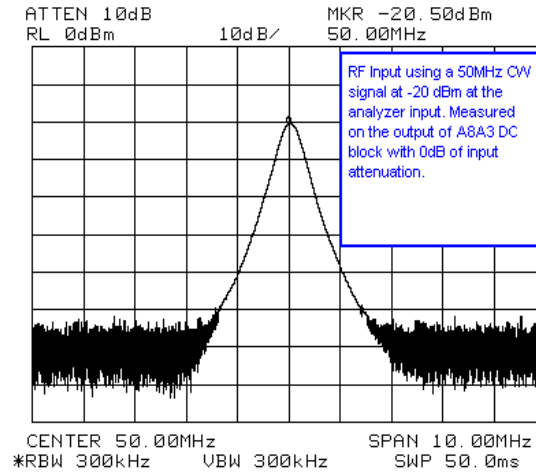

Figure 2-10 1st LO Output – A8A1A2J5

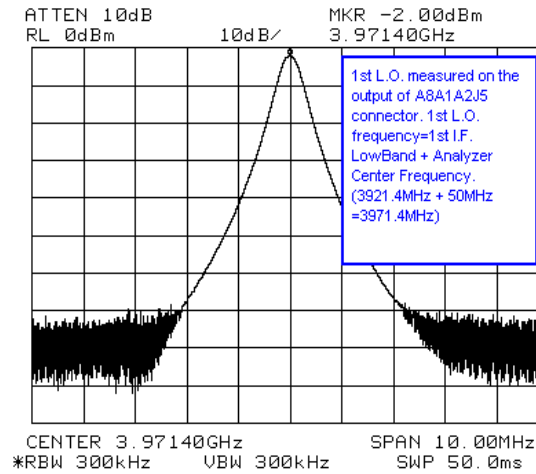

Figure 2-11 600 MHz 2nd LO – A8A1A1P1

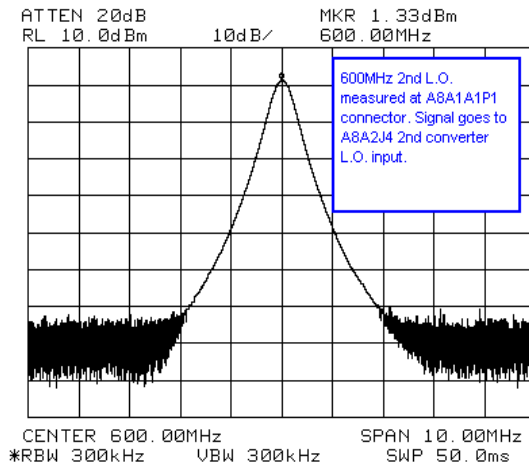

Figure 2-12 2nd LO Test Port – A8A2J5

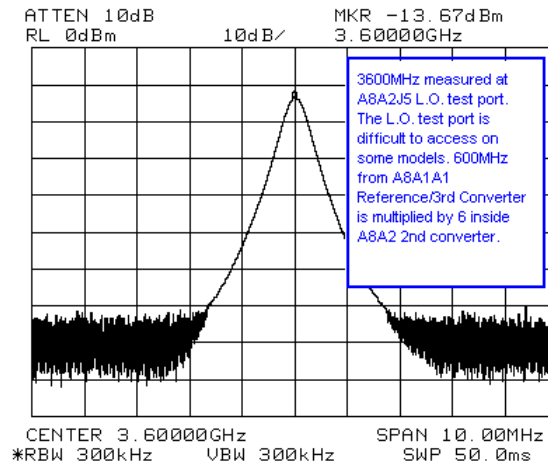

Figure 2-13 600 MHz BITG Drive – A8A1A1P3

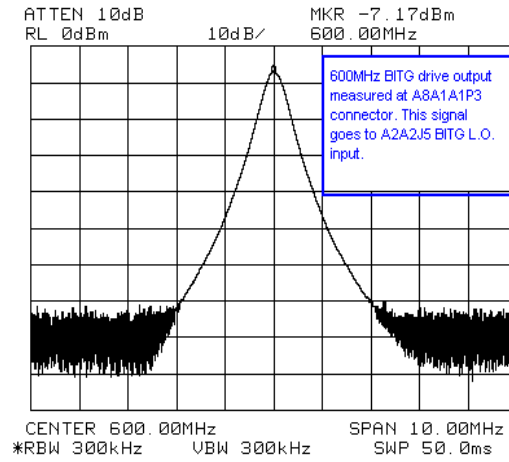

Figure 2-14 10 MHz Reference Output

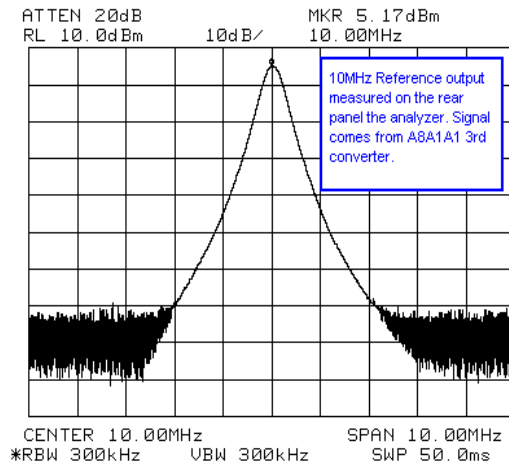
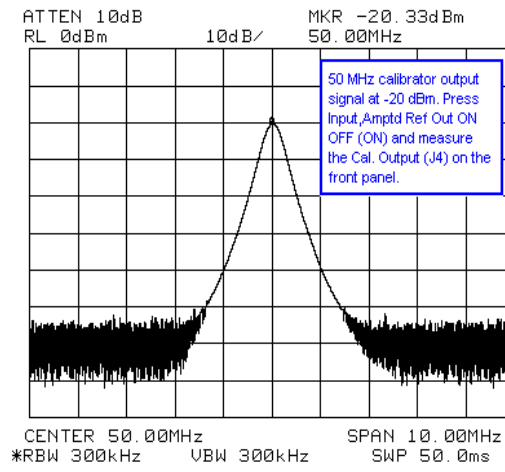

Figure 2-15

50 MHz Cal Out Signal



Verifying the RF Section Performance (E4404B, E4405B, E4407B, and E4408B)

(9 kHz - 6.7 GHz, 13.2 GHz or 26.5 GHz)

The RF section downconverts the analyzer input signal to the final IF of 21.4 MHz. You can troubleshoot the RF section by injecting a 50 MHz CW signal at -20 dBm to the RF input of the analyzer. The 21.4 MHz downconverted IF signal will be the input level minus the input attenuation. There are three conversions made in these analyzers.

“Quick Check” RF Procedure in Low Band (Non-Preselected)

1. Inject a 50 MHz CW signal at -20 dBm into the RF input of the analyzer.
2. Tune the analyzer to 50 MHz, zero span, with input attenuation set to 0 dB by pressing **FREQUENCY, Center Freq, 50 MHz, SPAN, Zero Span, Attenuation Auto Man (Man), 0 dB**.
3. Turn Auto Align On/Off to Off by pressing **System, Alignments, Auto Align, Off**.
4. Disconnect the flexible gray cable (W2) going into the A3 IF assembly at A3J2.
5. Connect a calibrated spectrum analyzer to this flexible gray cable (W2) and measure the 21.4 MHz output from the RF section.

If the RF section is operating properly, you should measure 21.4 MHz out of the RF section at -20 dBm. See [Figure 2-1 on page 59](#).

Figure 2-16

21.4 MHz Third IF

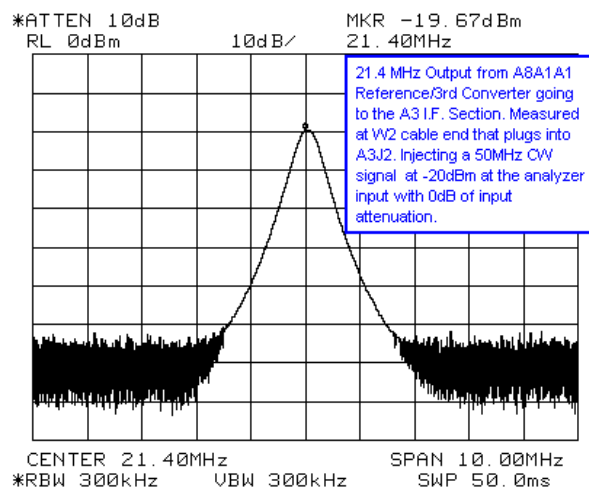

NOTE

If your signal amplitude is too high or too low, vary the input attenuation from 0 to 65 dB and note that for every 5 dB of attenuator change, the 21.4 MHz IF output signal from the RF section should change 5 dB as well. The signal amplitude problem may be the result of a defective A8A5 input attenuator or the attenuator logic from A8A1A1 Reference/Third Converter.

- If you notice a frequency response problem, visually inspect the RF input connector for mechanical integrity.
- If the analyzer has a frequency response problem you can inject the frequency of interest, tune the analyzer to that frequency in zero span, and monitor the 21.4 MHz IF signal level for abnormalities on your calibrated spectrum analyzer.
- If you have excessive loss through the RF section, see “[Detailed RF Troubleshooting for Low Band](#)” on page 73 to isolate the defective assembly.

Detailed RF Troubleshooting for Low Band

1. Inject a 50 MHz CW signal at -20 dBm into the RF input of the analyzer.
2. Tune the analyzer to 50 MHz, zero span, with input attenuation set to 0 dB by pressing **FREQUENCY, Center Freq, 50 MHz, SPAN, Zero Span, Attenuation Auto Man (Man), 0 dB**.
3. Turn Auto Align On/Off to Off by pressing **System, Alignments, Auto Align, Off**.

NOTE

With an input frequency of 50 MHz, the A8A6 YTF/Mixer (RYTHM) assembly is internally bypassed using switching PIN diodes. The switching logic for the PIN diodes comes from the A7A4 Frequency Extension assembly. The 1st LO from the A8A4 LO Amp/IF Switch assembly is turned off, since the mixer portion of A8A6 is not used in low band (frequencies < 3.0 GHz).

With the analyzer settings stated above, use a calibrated spectrum analyzer to measure the following signals in [Table 2-2](#).

To isolate the failing assembly, refer to [Table 2-2](#) and [Figure 2-17](#) and [Figure 2-18](#) to measure the troubleshooting points throughout the RF section. The Measurement Location column of the table corresponds to the locations called out on the drawing and the block diagram. The Expected Measured Signal column references figures that illustrate the signal expected at that measurement point.

Table 2-2 RF Section Low Band Troubleshooting Points

Signal Description	Measurement Location ^a	Expected Frequency	Expected Level	Expected Measured Signal ^b	Notes
1st IF Output	A	3921.4 MHz	-23.2 dBm	Figure 2-19	A8A1A2 has ~3.2 dB of loss.
2nd IF Output	B	321.4 MHz	-27.5 dBm	Figure 2-20	A8A2 has ~4.5 dB of loss.
RF Input	C	50 MHz	-20.5 dBm	Figure 2-21	Out of A8A3
1st LO Output	D	3971.4 MHz	-1 dBm	Figure 2-22	Out of A8A1A2
2nd LO Input	E	600 MHz	-3 to +6 dBm	Figure 2-23	Out of A8A1A1 (through A7A9 with Option 120)
2nd LO Multiplied	F Block Diagram only	3600 MHz	-13.5 dBm	Figure 2-24	Out of A8A2J5 LO Test Port
600 MHz TG	G	600 MHz	-7 dBm	Figure 2-25	Out of A8A1A1
10 MHz Reference	H	10 MHz	+5 dBm	Figure 2-26	Rear Panel 10 MHz Ref. Out
50 MHz Calibrator	I	50 MHz	-20 dBm	Figure 2-27	Out of A8A1A1

a. To locate the measurement points, refer to [Figure 2-17](#) and [Figure 2-18](#).

b. To see the signal expected at each measurement location, reference the figures in this column.

Figure 2-17 RF Section Low Band Troubleshooting Points

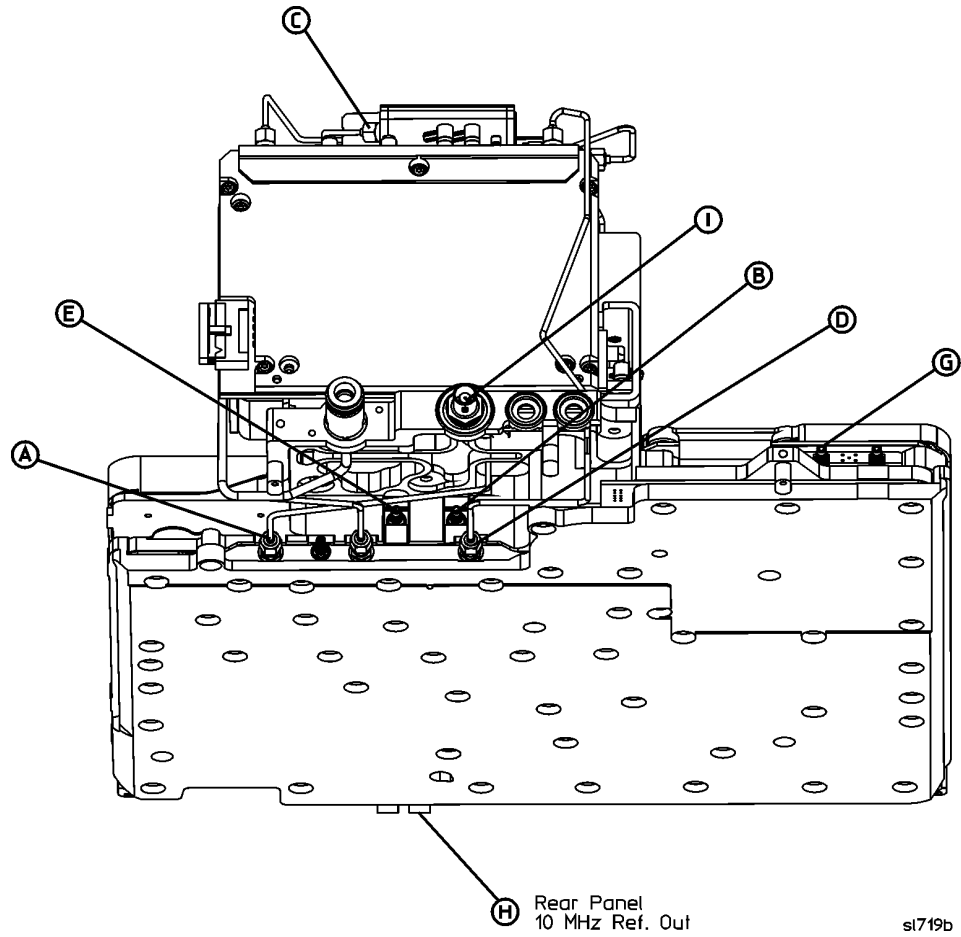
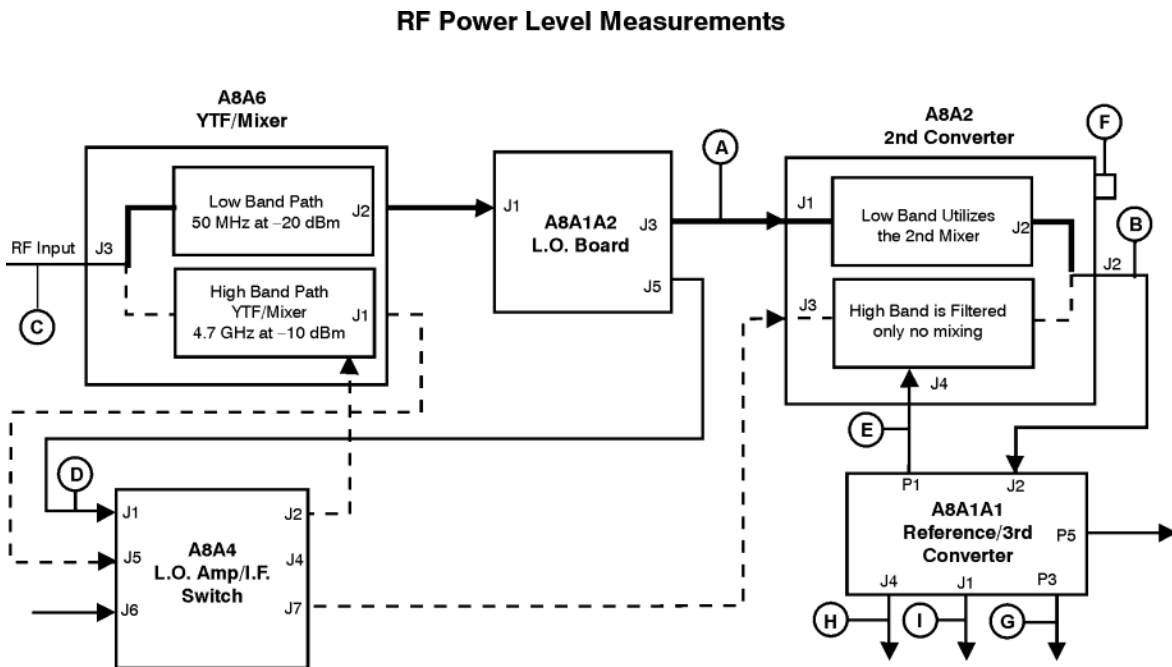

Figure 2-18 RF Section Low Band Block Diagram E4404B, E4405B, E4407B, and E4408B



Instrument Settings

Low Band

1. Inject a 50 MHz CW signal at -20 dBm into the RF input of the analyzer.
2. Tune the analyzer to 50 MHz, zero span, input attenuation set to 0 dB by pressing **FREQUENCY**, **Center Freq 50 MHz**, **SPAN**, **Zero Span**, **AMPLITUDE**, **Attenuation Auto Man (Man)**, **0 dB**.
3. Turn Auto Align On/Off to Off by pressing **System**, **Alignments**, **Auto Align**, **Off**.

High Band

1. Inject a 4.7 GHz CW signal at -10 dBm into the RF Input of the analyzer.
2. Tune the analyzer to 4.7 GHz zero span, input attenuation set to 0 dB by pressing **FREQUENCY**, **Center Freq 4.7 GHz**, **SPAN**, **Zero Span**, **AMPLITUDE**, **Attenuation Auto Man (Man)**, **0 dB**.
3. Turn Auto Align On/Off to Off by pressing **System**, **Alignments**, **Auto Align**, **Off**.

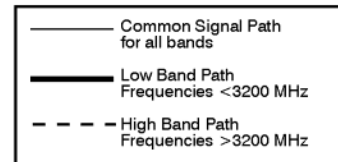

sl732b

Figure 2-19 1st IF Output – A8A1A2J3

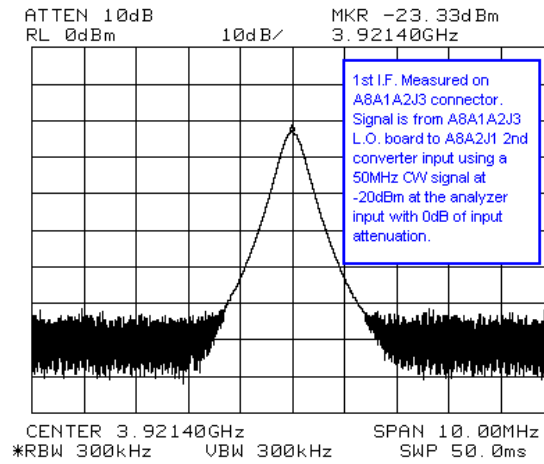

Figure 2-20 321.4 MHz 2nd IF Output – A8A2

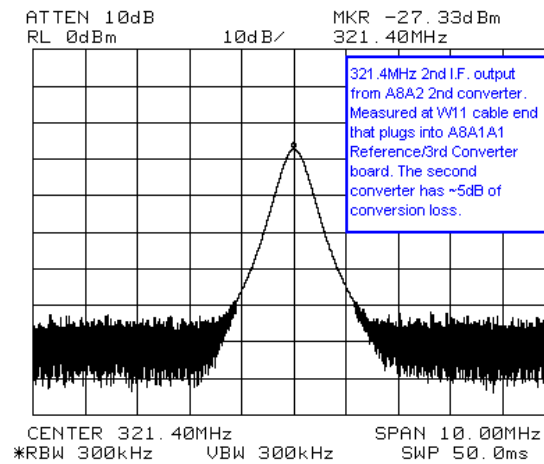

Figure 2-21

RF Input

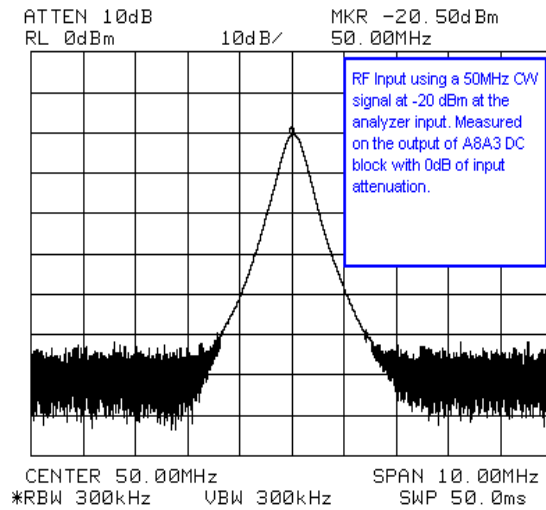

Figure 2-22

1st LO Output – A8A1A2J5

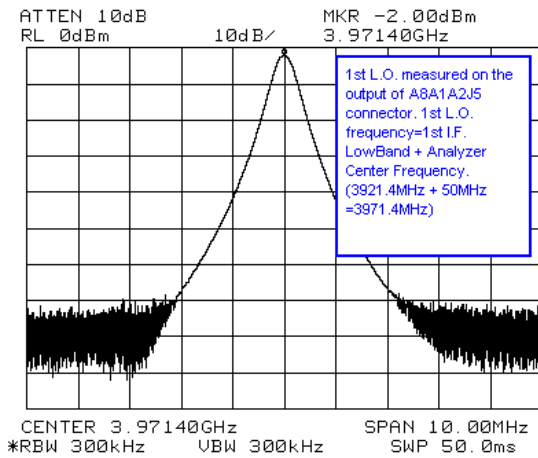

Figure 2-23 600 MHz 2nd LO – A8A1A1P1

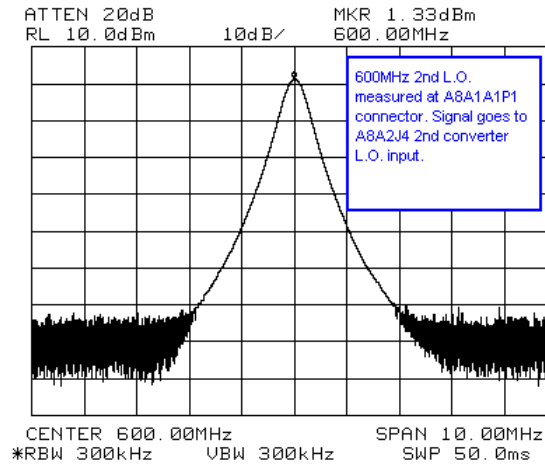

Figure 2-24 3600 MHz A8A2J5 LO Test Port

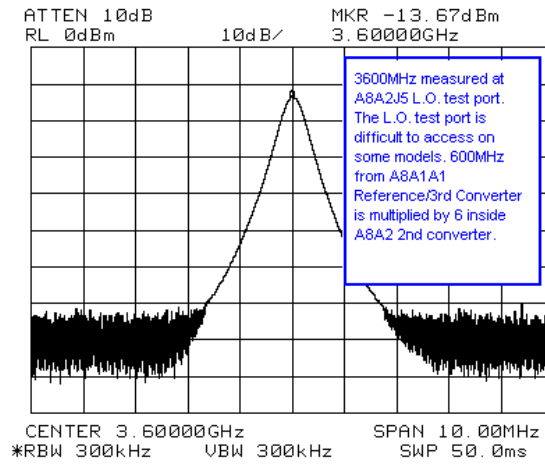

Figure 2-25

600 MHz BITG Output – A8A1A1P3

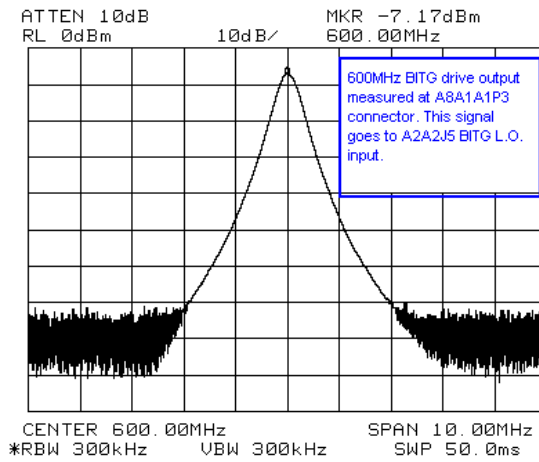

Figure 2-26

10 MHz Reference Output – A8A1A1

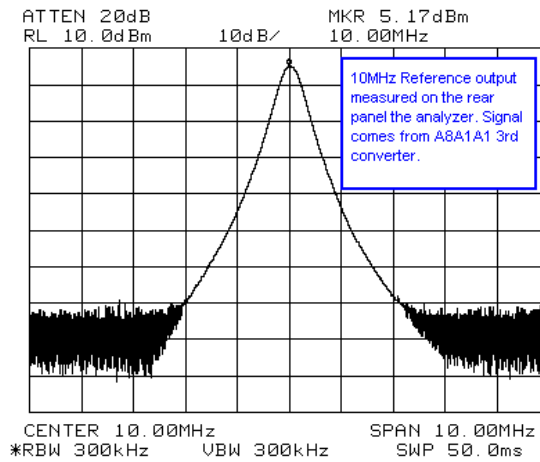
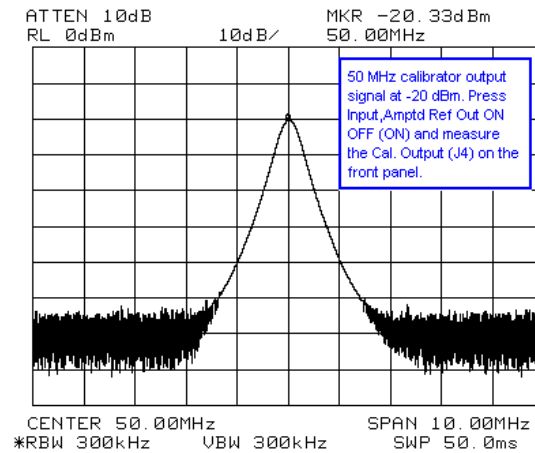

Figure 2-27 50 MHz Cal Out Signal



Quick Check RF Procedure for High Bands (Preselected)

1. Inject a 4.7 GHz CW signal at -10 dBm into the RF input of the analyzer.
2. Tune the analyzer to 4.7 GHz, zero span, input attenuation set to 0 dB by pressing **FREQUENCY, Center Freq, 4.7 GHz, SPAN, Zero Span, Attenuation Auto Man (Man), 0 dB**.
3. Turn Auto Align On/Off to Off by pressing **System, Alignments, Auto Align, Off**.
4. Disconnect the flexible gray cable (W2) going into the A3 IF assembly at A3J2.
5. Connect a calibrated spectrum analyzer to this flexible gray cable (W2) and measure the 21.4 MHz output from the RF section.
6. If the RF section is operating properly, you should measure 21.4 MHz out of the RF section at -10 dBm. See [Figure 2-28](#).

Figure 2-28

21.4 MHz Output - From A8A1A1 to A3

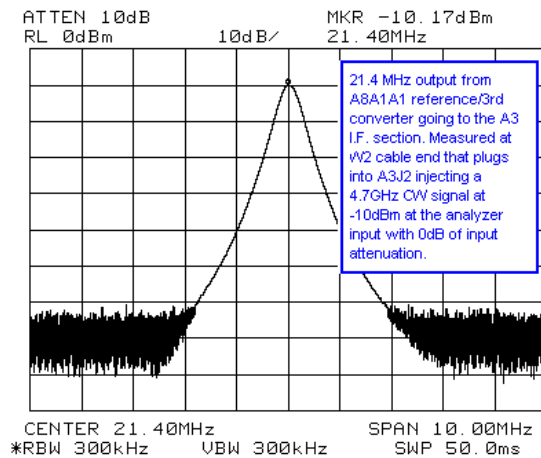

NOTE

If your signal amplitude is too high or too low, vary the input attenuation from 0 to 65 dB and note that for every 5 dB of attenuator change, the 21.4 MHz IF output signal from the RF section should change 5 dB as well. The signal amplitude problem may be the result of a defective A8A5 input attenuator or the attenuator logic from A8A1A1 Reference/Third Converter.

- If you notice a frequency response problem, visually inspect the RF input connector for mechanical integrity.
- If the analyzer has a frequency response problem you can inject the frequency of interest, tune the analyzer to that frequency in zero span, and monitor the 21.4 MHz IF signal level for abnormalities on your calibrated spectrum analyzer.
- If you have excessive loss through the RF section, see [“Detailed RF Troubleshooting for Low Band”](#) on page 73 to isolate the defective assembly.

Detailed RF Troubleshooting for High Bands (Preselected)

To isolate the failing assembly, refer to [Table 2-4](#) and [Figure 2-29](#) and [Figure 2-30](#) to measure the troubleshooting points throughout the RF section. The Measurement Location column of the table corresponds to the locations called out on the drawing and the block diagram. The Expected Measured Signal column references figures that illustrate the signal expected at that measurement point.

1. Inject a 4.7 GHz CW signal at -10 dBm into the RF input of the analyzer.
2. Tune the analyzer to 4.7 GHz, zero span, input attenuation set to 0 dB by pressing **FREQUENCY, Center Freq, 4.7 GHz, SPAN, Zero Span, Attenuation Auto Man (Man), 0 dB**.
3. Turn Auto Align On/Off to Off by pressing **System, Alignments, Auto Align, Off**.

With the analyzer settings stated in the above steps, use a calibrated spectrum analyzer to measure the signals in [Table 2-4](#).

NOTE

The 1st LO originating from the A8A1A2 LO board is heavily attenuated in the A8A4 LO Amp/ IF switch assembly when the analyzer is tuned to frequencies below ~3200 MHz. During this time the A8A6 YTF/Mixer assembly is internally and electronically bypassed.

However, when the analyzer is tuned higher than ~3200 MHz, the A8A6 YTF/Mixer assembly is used for down conversion and therefore, high LO power is supplied to the A8A6 YTF/Mixer for conversion efficiency. During this time the A8A4 LO Amp/IF switch is amplifying the 1st LO.

The 1st LO modulator drive voltage originates on the A7A4 Frequency Extension board. Before changing the A8A6 YTF/Mixer assembly or the A8A4 LO Amp/IF switch, first verify the switching logic as per [Table 2-3](#).

Table 2-3

A8A6 YTF/Mixer Switching Logic

Measurement Location	Frequencies < 3200 MHz	Frequencies > 3200 MHz
A7A4J2 pin 9	0 V	5 V
A7A4J2 pin 20	5 V	0 V
A7A4J2 pin 21	0 V	0 V

Table 2-4 RF Section High Band Troubleshooting Points

Signal Description	Measurement Location ^a	Expected Frequency	Expected Level	Expected Measured Signal ^b	Notes
1st IF Output	A	321.4 MHz	-22.5 dBm	Figure 2-31	A8A6 has ~12 dB of loss.
1st IF Output	B	321.4 MHz	-16 dBm	Figure 2-32	A8A4 amplifies the 321.4 MHz IF by ~6.5 dB.
1st LO Output	Refer to Figure 2-17 location D	3971.4 MHz	-2 dBm	Figure 2-33	Out of A8A1A2
1st LO Output	D	3521.4 MHz	+14 dBm	Figure 2-34	Out of A8A4 in high bands ONLY. LOIS amplifies the input by ~16 dB
TG LO Output	E	3971.4 MHz	-2 dBm	Figure 2-36	Misc. Signal out of A8A4 used for option 1DN.
External 1st LO Output	F	3971.4 MHz	+12.5 dBm	Figure 2-36	Output of A8A4. Used for external mixing.

a. To locate the measurement points, refer to [Figure 2-29](#) and [Figure 2-30](#).

b. To see the signal expected at each measurement location, reference the figures in this column.

Figure 2-29 RF Section High Band Troubleshooting Points

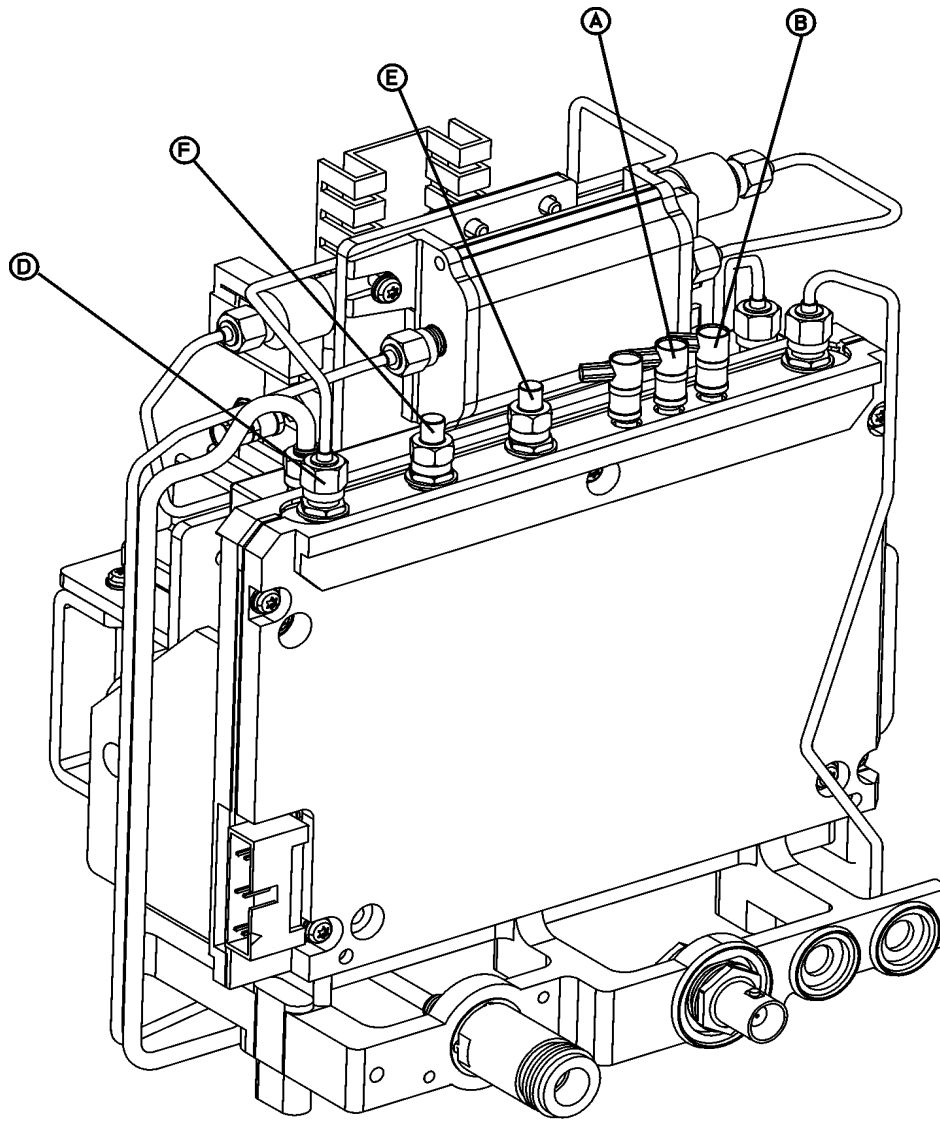

sl726b

Figure 2-30 RF Section High Band Block Diagram E4404B, E4405B, E4407B, and E4408B
RF Power Level Measurements

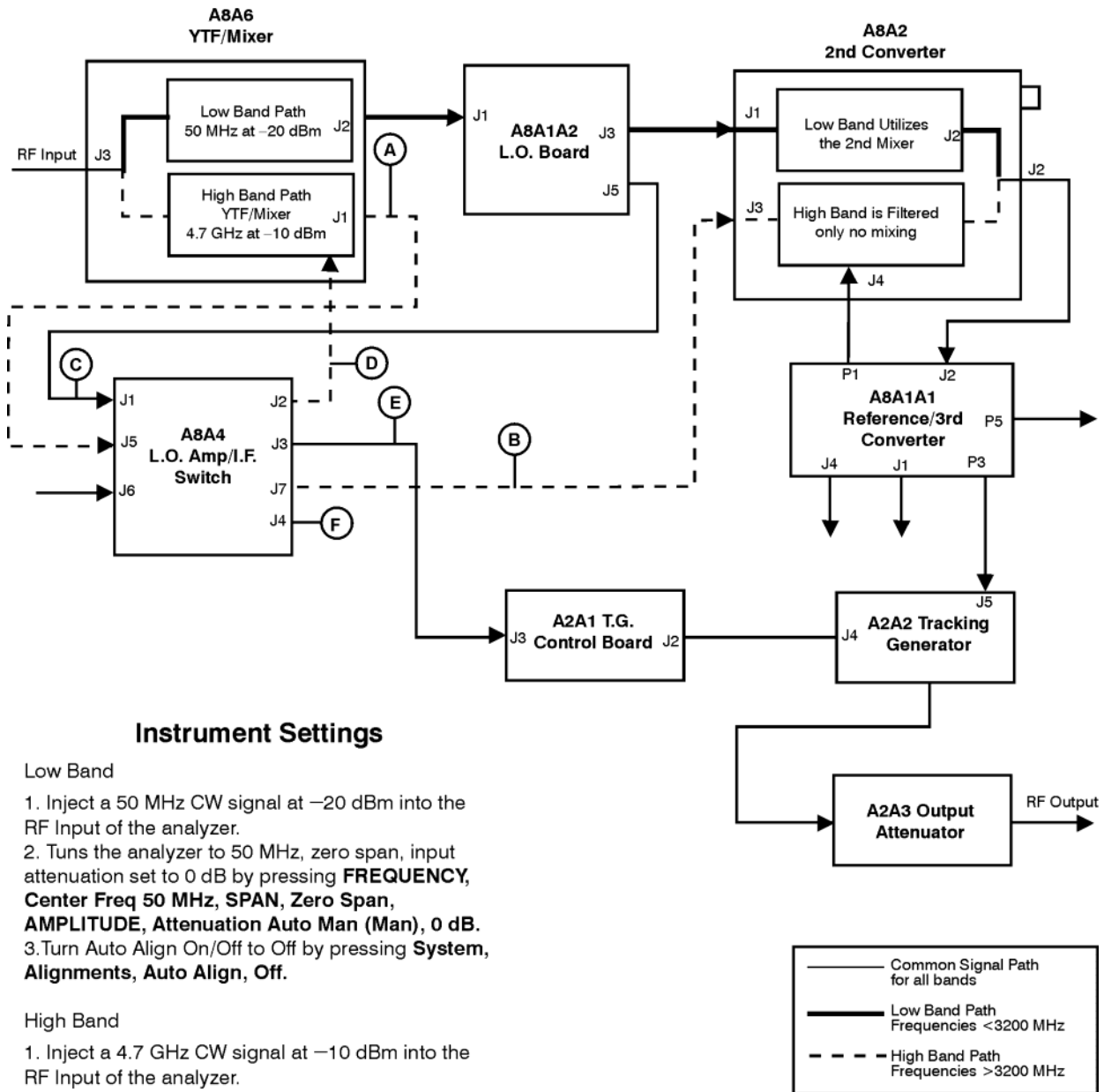

Instrument Settings

Low Band

1. Inject a 50 MHz CW signal at -20 dBm into the RF Input of the analyzer.
2. Tunes the analyzer to 50 MHz, zero span, input attenuation set to 0 dB by pressing **FREQUENCY**, **Center Freq 50 MHz**, **SPAN**, **Zero Span**, **AMPLITUDE**, **Attenuation Auto Man (Man)**, **0 dB**.
3. Turn Auto Align On/Off to Off by pressing **System**, **Alignments**, **Auto Align**, **Off**.

High Band

1. Inject a 4.7 GHz CW signal at -10 dBm into the RF Input of the analyzer.
2. Tune the analyzer to 4.7 GHz zero span, input attenuation set to 0 dB by pressing **FREQUENCY**, **Center Freq 4.7 GHz**, **SPAN**, **Zero Span**, **AMPLITUDE**, **Attenuation Auto Man (Man)**, **0 dB**.
3. Turn Auto Align On/Off to Off by pressing **System**, **Alignments**, **Auto Align**, **Off**.

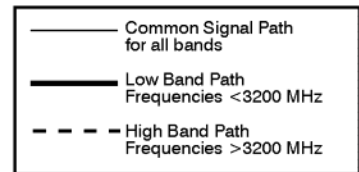

sl733b

Figure 2-31 321.4 MHz IF High Band – A8A6J1

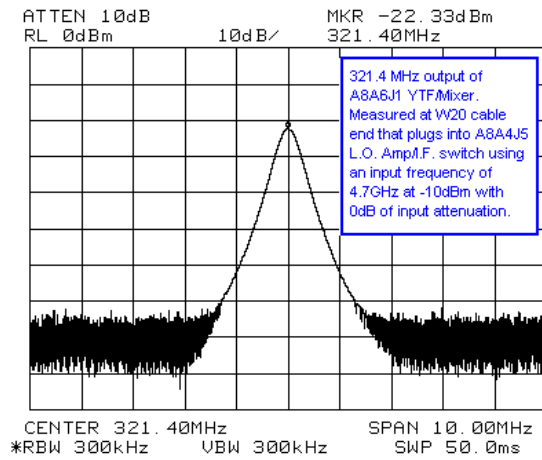
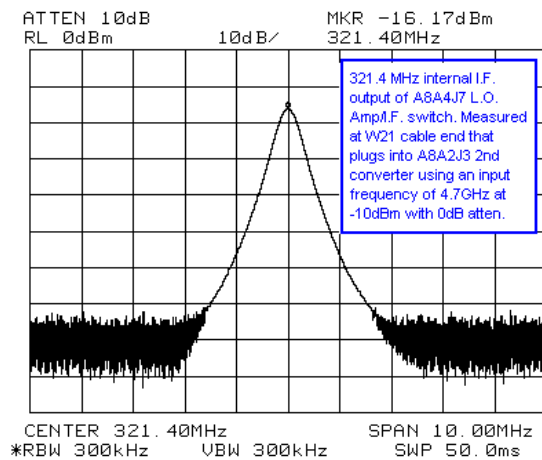

Figure 2-32 321.4 MHz Internal IF – A8A4J7



Troubleshooting the RF Section

Verifying the RF Section Performance (E4404B, E4405B, E4407B, and E4408B)

Figure 2-33

1st LO – A8A1A2J5

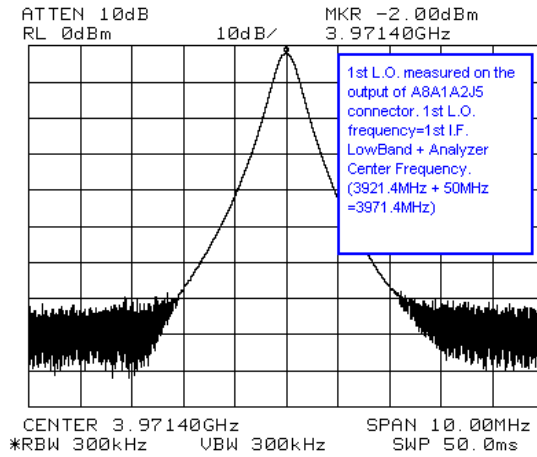

Figure 2-34

High Band LO - A8A4J2

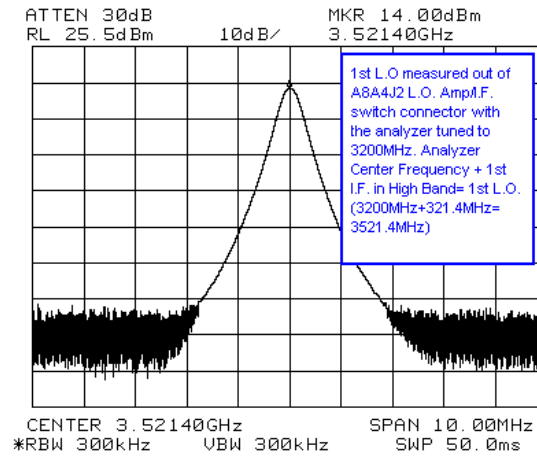

Figure 2-35 Tracking Generator 1st LO - A8A4J4

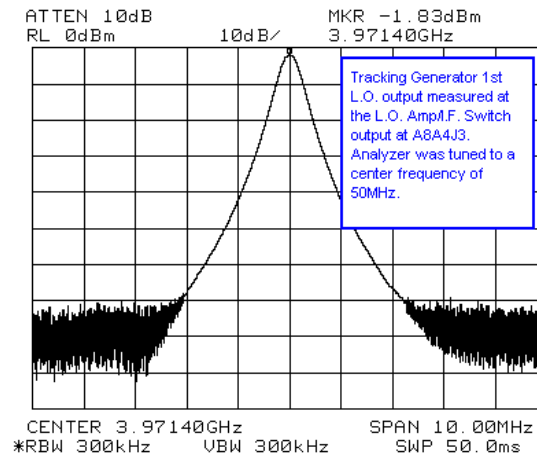
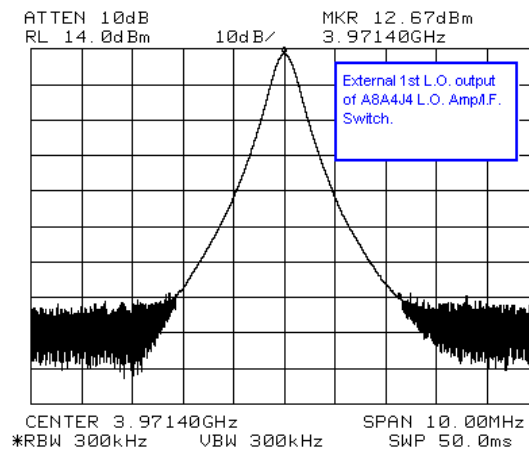

Figure 2-36 External 1st LO Output - A8A4



Troubleshooting the RF Section

Verifying the RF Section Performance (E4404B, E4405B, E4407B, and E4408B)

3 **Block Diagrams**

What You Will Find in This Chapter

This chapter provides information about the operation of the analyzer that is useful when first troubleshooting a failure. Refer to the appropriate overall block diagram at the end of this chapter when reading the assembly descriptions that follow. These figures show all major assemblies in the analyzer.

The ESA series spectrum analyzers are microprocessor-controlled swept receivers with frequency ranges from 9 kHz to 1.5 GHz, 3.0 GHz, 6.5 GHz, 13.2 GHz, or 26.5 GHz, depending on the model number. This chapter briefly describes each of the following analyzer assemblies:

- “A8 1.5 GHz RF Assembly” on page 93
- “A8 RF Assembly” on page 97 which includes:
 - “A8J10 Input Connector” on page 98
 - “A8A1 3.0 GHz RF Assembly” on page 98
 - “A8A1A1 Reference/Third Converter” on page 99
 - “A8A1A2 Front End/LO” on page 99
 - “A8A2 Second Converter” on page 100
 - “A8A3 dc Block” on page 100
 - “A8A4 LO Amplifier/IF Switch (LOIS)” on page 100
 - “A8A5 Input Attenuator” on page 101
 - “A8A6 YIG-Tuned Filter/Mixer (RYTHM)” on page 101
 - “A8FL1 3.1 GHz Low-Pass Filter (LPF)” on page 101
 - “A7A4 Frequency Extension” on page 101
- “A3 IF Assembly” on page 102
- “A4 Processor Assembly” on page 104
- “A5 Power Supply Assembly” on page 108
- “A1 Display/Front Panel” on page 110

All of the board assemblies listed above are connected to the serial digital interface through the motherboard connection. All data and control information and all power supplies, are distributed through these connections. Each of these board assemblies has its own individual EEPROM with stored serial numbers and alignment data for the board.

The assemblies listed below do not have individual EEPROMs and are not connected to the serial digital interface.

- “A7 Motherboard” on page 109
- “A6 Speaker/Floppy Board Assembly” on page 110

A8 1.5 GHz RF Assembly

(E4401B and E4411B)

The A8 RF assembly performs the following major functions:

- Provides input protection
- Provides input attenuation
- Converts RF input signals to the 21.4 MHz IF
- Generates first and second local oscillator (LO) signals for down-conversion
- Uses a fractional-N phase-locked loop for first LO stability
- Generates a 10 MHz reference signal
- Generates an internal 50 MHz amplitude reference signal and a 21.4 MHz IF alignment signal

The RF section uses a two-stage frequency conversion to convert RF signals to the 21.4 MHz final IF.

Input Connector

The input connector is mounted directly on the RF assembly. This connector can be easily replaced without disassembling the RF section. Refer to [Chapter 6](#) for the removal procedure.

Input Protection

CAUTION

Exposing the analyzer to high levels of input power over a prolonged time period can damage the circuitry.

The analyzer input circuitry can be damaged by power levels that exceed the maximum safe input level specifications. Refer to the analyzer specifications for the exact values.

Some input protection is provided by a dc-blocking capacitor after the input connector. The input relay that switches between input signals and an internal 50 MHz alignment signal also functions as an overload protection switch. The relay is driven by an overload detector that has two power trip points. When the input attenuation is less than 15 dB, the trip point is approximately +13 dBm (68 dBmV with Option 1DP) to protect the mixer. When the input attenuation is 15 dB or greater, the trip point is set to approximately +33 dBm (76 dBmV with Option 1DP) to protect the attenuator.

During an overload condition, the input signal will still be displayed, but at a lower amplitude. This condition is accompanied by a message displayed on screen informing the operator of the overload. Refer to the user's guide for your analyzer for information on how to clear the overload condition.

Attenuator

The input attenuator provides 0 to 60 dB of attenuation in 5 dB steps. To select 10 dB attenuation, press **Preset**.

Low-Pass Filter

The input signal passes through a 1.5 GHz low-pass filter (LPF) to eliminate unwanted signals above 1.5 GHz.

First Mixer

The first mixer converts incoming signals to a 2.4214 GHz first IF by mixing the input signal with a 2.4214 to 3.9214 GHz first local oscillator (LO). This LO is derived by tripling the output from an 800 to 1308 MHz fractional-N phase-locked loop (PLL) synthesizer.

First IF Amplifier/Filter/Attenuator

The overall gain of the front end is set by the digital-to-analog converter (DAC)-controlled RF variable gain amplifier. The variable gain amplifier has an input LPF, input attenuator, amplifier, output attenuator, and an output LPF. The LPFs provide rejection of harmonics of the LO in order to attenuate unwanted spurious signals. The two attenuators control the approximately 30 dB of available gain. This range is used to provide an overall gain of 0 dB from the RF input to the 21.4 MHz output to the IF assembly.

Second Mixer

The second mixer converts the 2.4214 GHz first IF to a 21.4 MHz second and final IF, by mixing it with a 2.4 GHz second LO. The second LO is derived by tripling the frequency of an 800 MHz voltage-controlled oscillator (VCO).

21.4 MHz Amplifier

The 21.4 MHz amplifier has 3 functions:

- A bandpass filter (BPF) at the input, to reject signals at 10.7 MHz
- An amplifier, with a typical gain of 12 dB
- A PIN switch circuit, to switch between the IF and the 21.4 MHz IF alignment signal that is generated by the first LO

Frequency Reference

The 10 MHz voltage-controlled crystal oscillator (VCXO) frequency reference is used to phase-lock the 800 to 1308 MHz PLL first LO, and the 800 MHz PLL second LO. It is also used for synchronization with the processor assembly for the analog-to-digital converter (ADC).

An optional oven-controlled crystal oscillator (OCXO) is also available on the E4401B as option 1D5. Option 1D5 adds a small board, A8A1 OCXO, to the basic A8 RF assembly. Cables interconnect A8A1 to A8.

LO

First LO

The 2.4214 to 3.9214 GHz first LO signal is derived from an 800 to 1308 MHz PLL synthesized signal that is tripled by a diode tripler/filter.

This first LO multiplier consists of three tripler/filter paths that are selected by PIN diode switches. Each path contains its own tripler/filter and the appropriate signal path is switched-in based on the desired LO frequency. The three paths are identical except for the range of their bandpass filters.

The output of the tripler is bandpass-filtered to remove the harmonics, and then sent to the output switch. It is then amplified with a limiting amplifier, before going to the first LO amplifier to drive the input mixer.

For frequency sweeps that cross over more than one path range, the two adjacent paths are enabled simultaneously during band crossings to produce a “make-before-break” type of switching action. This action is controlled by the system processor to avoid first LO power drop outs.

The first LO generates the 21.4 MHz IF alignment signal by dividing the PLL output by 40 and bandpass filtering the divided-down signal.

Second LO

The 2.4 GHz second LO signal and the 50 MHz alignment signal are both synthesized from the 800 MHz VCO that is phase-locked to the 10 MHz reference. The 2.4 GHz signal is derived by multiplying the 800 MHz signal with the use of a tripler/filter path similar to the one used to generate the first LO signal. The 50 MHz amplitude reference signal is derived by dividing the 800 MHz signal by 16.

A8A1 OCXO (Option 1D5)

The A8A1 OCXO (oven-controlled crystal oscillator) provides improved frequency accuracy and stability. A8A1 receives power and control via A8J2. The OCXO output is fed back to A8 via A8J4.

Interconnections to Other Assemblies

The A8 RF assembly has three external connectors, (two at the rear of the analyzer and one at the front). It also has seven internal connectors, (four on the top of the board, two on the bottom, and one on the bandpass filter (BPF) cavity).

A8J10	RF Input (front external port)
A8J12	EXT REF IN - accepts an external frequency source to provide the 10 MHz, -15 to +10 dBm frequency reference used by the analyzer. (rear external port)
A8J3	21.4 MHz IF output to the A3 IF Assembly (internal)
A8J11	EXT REF OUT - provides a 10 MHz, 0 dBm minimum, time-based reference signal. (rear external port)
A8J5	First LO VCO test port (internal)
A8J6	Second LO VCO test port (internal)
A8J13	BPF alignment port (internal)
A8J4	OCXO 10 MHz REF INPUT from A8A1
A8J2	OCXO (A8A1) power and control (Option 1D5)

Unused

A8J7 (internal)

A8 RF Assembly

(E4402B, E4403B, E4404B, E4405B, E4407B, and E4408B)

The A8 RF assembly performs the following major functions:

- Provides input attenuation
- Provides tracking preselection when tuned above 2.85 GHz
- Converts RF input signals to the 21.4 MHz IF
- Generates first, second and third local oscillator (LO) signals for up-conversion and down-conversion
- Uses a fractional-N phase-locked loop for first LO stability
- Generates a 10 MHz reference signal
- Generates a 50 MHz amplitude reference signal, and an internal 21.4 MHz IF alignment signal
- Provides an auxiliary first LO output and a 600 MHz signal to drive the optional 3.0 GHz tracking generator

When tuned below 3.0 GHz, the RF section up-converts the signal to a 3.9214 GHz first IF, and then down-converts it to a 321.4 MHz second IF, and finally to a 21.4 MHz third IF. When tuned above 3.0 GHz, the RF section down-converts the signal directly to the 321.4 MHz second IF and then to the 21.4 MHz third IF.

The RF Section consists of four board assemblies, and three microcircuits. Two of the board assemblies (A8A1A1 and A8A1A2) comprise the A8A1 3.0 GHz RF Assembly. Not all microcircuits and board assemblies are used in every model. Refer to the following table.

Block Diagrams
A8 RF Assembly

Description	E4402B and E4403B	E4404B and E4405B	E4407B and E4408B
A8A1 3.0 GHz RF Assembly (includes A8A1A1 and A8A1A2)	X	X	X
A8A1A1 Reference/Third Converter (part of A8A1 3.0 GHz RF Assembly)	X	X	X
A8A1A2 Front End/LO (part of A8A1 3.0 GHz RF Assembly)	X	X	X
A8A2 Second Converter	X	X	X
A8A3 DC Block	X	X	X
A8A4 LO Amplifier/IF Switch (LOIS)		X	X
A8A5 Input Attenuator	X		X
A8A5 Input Attenuator with Switchable dc Block	(Option UKB) only	X	(Option UKB) only
A8A6 YIG-Tuned Filter/Mixer (RYTHM)		X	X
A8FL1 3.1 GHz Low-Pass Filter (LPF)	X	X	X
A7A4 Frequency Extension		X	X

A8J10 Input Connector

The input connector is mounted to the middle shield of the 3.0 GHz RF assembly. This connector can be easily replaced without disassembling the RF section. Refer to [Chapter 6](#) for the removal procedure.

A8A1 3.0 GHz RF Assembly

The A8A1 3.0 GHz RF Assembly is comprised of two boards, the A8A1A1 Reference/Third Converter and the A8A1A2 Front End/LO, in the same shield set. The A8J10 input connector and the Amptd Ref Out connector (part of the A8A1W4 50 MHz Amptd Ref Signal), also mount to A8A1. Refer to the following descriptions for “[A8A1A1 Reference/Third Converter](#)” and “[A8A1A2 Front End/LO.](#)”

A8A1A1 Reference/Third Converter

(Part of the A8A1 3.0 GHz RF Assembly)

The standard frequency reference is a 10 MHz VCXO. Option 1D5 adds an oven-controlled crystal oscillator (OCXO). The frequency reference is used to phase-lock a 100 MHz VCXO. This 100 MHz signal is divided by two to yield the 50 MHz amplitude reference signal, and is tripled to provide the 300 MHz third LO.

The 300 MHz third LO is then doubled to yield a 600 MHz signal which is the reference for the first LO and will be used by the A8A2 Second Converter to generate the 3.6 GHz second LO.

The second IF amplifiers provide approximately 24 dB of gain. There is also a 400 MHz low-pass filter and a 321.4 MHz bandpass filter before the third mixer. The third mixer is an active mixer, which includes an IF amplifier. The third mixer down-converts from 321.4 MHz to 21.4 MHz. A variable gain stage, controlled by a DAC, follows the third mixer. The gain is set to provide -10 dBm output at A8A1A1P5 when a -10 dBm signal is applied to the analyzer input with 0 dB input attenuation.

The third IF amplifier is followed by a switch to allow the 21.4 MHz alignment signal from A8A1A2 to be routed to the A3 IF Assembly for performing automatic IF alignments between sweeps. Either the output of the third amplifier or the 21.4 MHz alignment signal is routed to the A3 IF Assembly.

A8A1A1 also provides power and control signals for the A8A5 Input Attenuator and the A8A2 Second Converter.

A8A1A2 Front End/LO

(Part of the A8A1 3.0 GHz RF Assembly)

A limiter at the A8A1A2 input protects the first mixer from excessive RF signals. A switch following the limiter allows the 50 MHz amplitude reference signal to be switched-in to perform automatic RF alignments. A preamplifier (available as Option 1DS on E4401B, E4402B, E4404B, E4405B, and E4407B analyzers) can be switched-in just before the first mixer. The first mixer is an active mixer with LO and IF amplifiers. A 700 MHz wide bandpass filter follows the first mixer. The variable gain first IF amplifier corrects for conversion losses in the front end.

The first LO uses a YIG-tuned oscillator in a fractional-N phase-locked loop (PLL). The 600 MHz reference from A8A1A1 is divided by 128 or 129 dual-modulus prescaler and the resulting ~4.66 MHz signal is used as the reference for the fractional-N PLL. The 21.4 MHz alignment signal is generated by dividing the first LO signal by 64 and then limiting the divided signal. The first LO signal drives a series of three directional couplers. The first directional coupler is used to drive an ALC loop to level the first LO signal. The second directional coupler provides feedback for the fractional-N PLL. The last directional coupler provides an auxiliary first LO output for driving either the optional 3.0 GHz tracking generator or the A8A4 LO Amplifier/IF Switch (LOIS), which then provides a first LO signal for the A8A6 YIG-Tuned Filter/Mixer (RYTHM).

A8A2 Second Converter

The A8A2 Second Converter down-converts the 3.9214 GHz first IF to a 321.4 MHz second IF. In high band, it passes the 321.4 MHz first IF from A8A4 (E4404B, E4405B, E4407B, and E4408B) to the A8A1A1 Reference/Third Converter. The converter generates a 3.6 GHz second LO by multiplying a 600 MHz reference. Bandpass filters remove unwanted harmonics of the 600 MHz driving signal. First IF and second LO signals are filtered by cavity filters, which are not user adjustable.

A8A3 dc Block

The dc block protects the input circuitry. It begins to roll off below 9 kHz, the low frequency limit of the analyzers. A8A3 is not present in analyzers with Option UKB.

A8A4 LO Amplifier/IF Switch (LOIS)

(E4404B, E4405B, E4407B, and E4408B)

The A8A4 LO Amplifier/IF Switch (LOIS) amplifies the auxiliary LO output from A8A1A2 and levels the output, as necessary, to provide the optimum first LO amplitudes to the A8A6 YIG-Tuned Filter/Mixer (RYTHM). An output is also provided to drive the A2 3.0 GHz tracking generator (Option 1DN). An additional levelled output is available for External Mixing (Option AYZ).

The IF switch routes the 321.4 MHz IF signal from A8A6 and amplifies it before passing it along to the A8A7 Second Converter. The IF switch also allows for an external 321.4 MHz IF input. A dc bias can be applied to the external IF input signal.

The A8A4 LO Amplifier/IF Switch is controlled by the A7A4 Frequency Extension assembly.

A8A5 Input Attenuator

The input attenuator provides 0 to 65 dB of attenuation in 5 dB steps. The attenuator in the E4402B, E4404B, E4405B, and E4407B with Option UKB also includes a dc block which can be switched out. With the dc block switched in, the analyzer can make measurements as low as 100 kHz (10 MHz for E4407B with Option UKB). With the dc block switched out, the analyzer can make measurements as low as 9 kHz (100 Hz for Option UKB). Pressing **Preset** selects 10 dB attenuation and, for analyzers with a switchable dc block, switches in the dc block.

A8A6 YIG-Tuned Filter/Mixer (RYTHM)

(E4404B, E4405B, E4407B, and E4408B)

The A8A6 RYTHM (Routing YIG-Tuned Harmonic Mixer) is a microcircuit which combines an RF switch, a tracking preselector, and a high-band mixer. The PIN diode switch directs the RF input to the appropriate mixer in the A8A6 or the A8A1 3.0 GHz RF assembly.

The tracking preselector is a YIG-tuned filter. It functions as a tunable bandpass filter for high-band signals (2.85 GHz to either 6.5, 13.2, or 26.5 GHz). The preselector's tuned frequency is controlled by DACs on the A7A4 Frequency Extension assembly.

The high-band mixer is ac coupled. It uses the first, second, and fourth harmonics of the first LO to mix with the incoming signals to cover the frequency range.

A8FL1 3.1 GHz Low-Pass Filter (LPF)

The A8FL1 3.1 GHz LPF precedes the 3.0 GHz RF assembly to eliminate image and out-of-band responses when in low-band. When in low-band, only signals greater than 3.1 GHz can generate image and out-of-band responses. By filtering out these signals, image and out-of-band responses are virtually eliminated.

A7A4 Frequency Extension

(E4404B, E4405B, E4407B, and E4408B)

The A7A4 Frequency Extension provides power and control signals to the A8A4 LO Amplifier/IF Switch (LOIS) and the A8A6 YIG-Tuned Filter/Mixer (RYTHM). A DAC on A7A4 is used to control the amplitude of LO outputs on the A8A4. A variable-rate generator and sweep clock drive DACs, which control the tuning of the preselector and the A8A6. Several drivers are provided to control the PIN diode switches on A8A4 and A8A6. A DAC also provides bias to the high-band mixer in A8A6.

The flatness correction data for high-band is stored on A7A4.

A3 IF Assembly

The A3 IF assembly uses combined crystal and LC filters to process 21.4 MHz input signals and create a video output signal.

The IF assembly provides the following main functions:

- Resolution bandwidth filtering
- Step gain amplification
- Log amplification
- Linear detection
- Frequency counter prescaling
- Down-conversion to 8.5 kHz for narrow bandwidths (Option 1DR).

Cal Attenuator

The Cal Attenuator has 0 to 49 dB of attenuation (in 7 dB steps) to provide gain range for the log amplifier alignment. The attenuator is switched on only as part of IF alignment, not during any normal analyzer sweeps.

21.4 MHz Bandpass Filters

The 21.4 MHz IF filters are a series of four pole, synchronously-tuned combined crystal and LC filters with adjustable gain and bypass switches.

Nine IF bandwidths, from 1 kHz to 5 MHz, can be selected in a 1, 3, 10 sequence. There are also 9 kHz and 120 kHz 6 dB bandwidths for EMC measurements.

The resolution bandwidths are normally coupled to the center frequency of the analyzer. Sweep time is also coupled to both resolution bandwidth and span for optimum amplitude response. The resolution bandwidth, sweep time, and span can be set independently.

Log Detector

The log detector displays the input signal logarithmically due to the successive detection log amplifier that has an overall range of 85 dB.

In log mode, the default vertical amplitude unit is dBm, (dB relative to a milliwatt) rather than volts. (The default vertical amplitude unit is dBmV with Option 1DP.)

Linear Detector

The input signal can be displayed in linear mode, so that the vertical deflection on the screen is directly proportional to the voltage of the input signal.

Interconnections to Other Assemblies

A3J2 Unfiltered 21.4 MHz input on SMB cable from the A8 RF assembly at -10 dBm nominal level corresponding to a full scale (top of screen) output video level of 2 V

- Filtered 21.4 MHz output to A7A1 (option A4J) at $+10$ dBm nominal level corresponding to a full scale (top of screen) input of -10 dBm
- Video output, nominally 0 V at bottom of screen and 2 V at top of screen
- Frequency counter output, differential output 100 mV at 10.7 MHz

Downconverter

The narrow bandwidths ($\text{Res BW} \leq 300$ Hz) are implemented digitally using digital signal processing performed by the CPU. The narrow bandwidths are only available in ESA models with Option 1DR.

The downconverter mixes the 21.4 MHz IF signal with the 21.4 MHz (approximately) VCXO signal to yield an 8.5 kHz IF. This 8.5 kHz signal is bandpass-filtered. The 8.5 kHz video signal is digitized by the ADC on the A4 processor assembly.

A4 Processor Assembly

The A4 processor assembly provides the following main functions:

- Main CPU processing
- Memory, including boot memory and firmware
- Video filtering
- Peak detection
- Analog-to-digital conversion of the video output from A3
- Real-time clock
- IF counters
- Communicates with I/O assemblies
- Front panel interface
- LCD interface
- Digital signal processing for digitally-implemented narrow resolution bandwidths (Option 1DR).

Analog Section

The analog section of the processor assembly controls all video processing. The analog section includes the input mux, video filter, peak detector, and analog-to-digital conversion circuitry.

Input Multiplexers

There are two input multiplexers on the processor assembly. MUX A selects which signal passes through the video filters to the peak detectors. MUX B selects which signal is digitized by the analog-to-digital converter.

Video Filters

There are 10 video filter bandwidths in the video section of the processor assembly. They are simple low-pass RC filters created by switching one of five different capacitors and one of two different resistors into the system. The video filters range from 1 MHz to 30 Hz in a 1, 3, 10 sequence in 10 steps.

Peak Detectors

There are two peak detectors on the processor assembly. The positive peak detector saves the maximum value reached between measurement buckets. The negative peak detector saves the minimum value reached between measurement buckets.

Analog-to-Digital Converter (ADC)

The analog-to-digital converter on the processor assembly has a 0 to +2 V range and uses a 12 bit conversion for normal measurements. This results in a vertical resolution of approximately 0.05 dB in log mode and 0.05% of reference level in linear mode.

Temperature Sensor

The processor assembly has an on-board temperature sensor to give the firmware the ability to determine when the analyzer should be realigned due to temperature changes.

Audio

There is an audio line on the motherboard that goes to the speaker assembly installed in the analyzer. A signal is sent to the audio line in order for it to be heard through the speaker or headphone jack. The processor has the ability to put two different signals onto the AUDIO line. The first is the AUX_VIDEO line; this is the signal going through the video filters. The second is the CPU_SOUND line, which is currently unused.

Real-Time Clock

The real-time clock uses a 32 kHz crystal to keep track of the time and date. It has battery backup from the same battery and controller as the SRAM. The real-time clock and the display controller each have their own separate timers.

IF Count

The processor counts the IF divided by two (10.7 MHz) to determine precisely where the analyzer is tuned. This is used for the frequency counter function.

Analyzer Battery Information

The analyzers use a single 3 V lithium battery to enable the internal memory to retain data. The date that the battery was installed is displayed on a label on the rear panel of the analyzer. See [Figure 3-1](#).

The minimum life expectancy of the battery is seven years at 25 °C. If you experience problems with the battery, or the recommended time period for battery replacement has elapsed see, “[Contacting Agilent Technologies](#)” on [page 241](#).

If you wish to replace the battery yourself, refer to the “A4MAU58 Battery” on page 286 replacement procedure in [Chapter 6](#). The battery is mounted onto the analyzer processor board. If the battery fails or the battery connection is broken, the real-time clock stops and all data stored in RAM is lost. This data will need to be restored after the battery is replaced. The following are examples of the data types that will need to be restored:

- GPIB address (Option A4H) or RS-232 baud rate (Option 1AX)
- Current correction factors (factory correction factors are stored on each assembly)
- Any current limit lines, and correction tables
- Any customized analyzer settings like display contrast, etc.

After replacing the analyzer battery, write the date of battery replacement on the rear panel label.

Figure 3-1 Rear Panel Battery Information Label

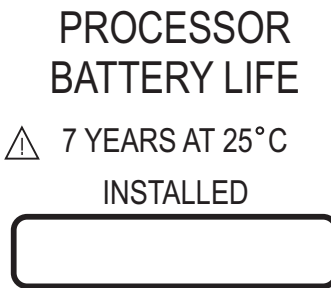

sl79b

Interconnections to Other Assemblies

There are four connectors to the rear panel:

A4J7	VGA OUTPUT - drives an external VGA-compatible monitor with a signal that has 31.5 kHz horizontal, 60 Hz vertical synchronizing rate, non-interlaced.
A4J1	(service connector for factory use only)
A4J8	GATE TRIG/EXT TRIG IN (TTL) - accepts the positive edge of an external voltage input that triggers the analyzer internal sweep source.
A4J9	GATE/HI SWP OUT (TTL) - indicates when the analyzer is sweeping.

The following front panel interface connector contains the signals and voltages for all front panel circuitry:

- Power supplies.
- Rotary pulse generator (RPG) interface. There are two RPGs; one for the active function and one for volume.
- Front panel keyboard interface.
- AT keyboard interface. An AT-style PC keyboard can be plugged into the front panel.
- LCD digital interface. The display controller for the processor assembly can drive an LCD (internal) and a VGA (external) CRT simultaneously.
- Front panel serial interface. This is used to communicate with the front panel of the analyzer.
- Probe power unfiltered supply (+15 V and –15 V supplies). The –15 V supply is converted to –12.6 V on the front panel interface board for the probe power connector.

A4A1 Flash SIMM

The A4A1 Flash SIMM provides additional memory for firmware enhancements such as downloadable programs. A 4 Mbyte Flash SIMM is standard. Option B72 replaces the 4 Mbyte Flash SIMM with a 32 Mbyte Flash SIMM.

A4A2 DRAM SIMM

The A4A2 DRAM SIMM provides additional memory for storing traces, states, limitlines, and amplitude correction (“ampcor”) sets. A 16 Mbyte DRAM is standard. Option B72 replaces the 16 Mbyte DRAM with a 32 Mbyte DRAM.

A5 Power Supply Assembly

The A5 power supply assembly can be powered by a 90 to 140 volt or 200 to 264 volt ac supply, or an external 12 to 22 Vdc supply. It supplies the analyzer with all of the supply voltages listed below. The line module, line fuse, and the dc power connector and dc fuse are all part of the power supply assembly. Refer to the parts list in [Chapter 5](#) for the fuse types.

If the analyzer loses power for more than 30 seconds, the controller may not retain the power-on state (On or Off) selected by the operator. When power is restored, the analyzer will normally be Off. To set the analyzer to automatically turn On when power is applied, set the switch at the rear of the analyzer. This feature is especially useful under the following conditions:

- If the analyzer is in a rack with other analyzers, the entire rack can be turned on with a single switch.
- If the analyzer is operating unattended, you may want to have measurements continue after power is restored.

The fan is mounted directly to the power supply assembly. The fan speed varies with internal analyzer temperature; as the internal temperature increases, the fan speed also increases.

NOTE

Because of safety concerns, the power supply is not repairable.

Interconnections to Other Assemblies

The following power supply connections can be made to other assemblies:

- +5 V, +15 V, +28 V, -5 V, and -15 V supplies to the power supply bus
- Voltage for the fan control
- Connector at the rear panel for a dc supply input

A7 Motherboard

The A7 motherboard provides the power supply and digital bus interconnections between assemblies in the analyzer. Refer to [Table 3-1](#) through [Table 3-10](#) in this chapter for details on the motherboard connectors and mnemonics used.

Miscellaneous

A1 Display/Front Panel

Display

The display is an LCD color flat screen with 640×480 VGA resolution. A connector for an external VGA display is available at the rear panel.

A1A1 Front Panel Interface Board

The A1A1 front panel interface board provides the interface between the display generation circuitry on the processor assembly and the display. It also interfaces the front panel keyboard to the processor assembly. Any display-specific voltages (other than 5 V digital) are created on this board. The front panel interface board also includes the following:

- Main RPG
- Volume RPG
- Plug for external AT style PC keyboard
- Probe power (-12.6 Vdc, $+15$ Vdc, and ground)
- Circuits to digitally adjust the display

A1A2A2 Backlight Inverter Board

The backlight supply provides the high voltage to the two backlights in the LCD display.

A6 Speaker/Floppy Board Assembly

The speaker/floppy board assembly has an internal speaker and a front panel earphone jack which provides the capability to listen to a demodulated signal. The 3.5" floppy drive (A:) and the earphone jack can be accessed by opening the media door. The volume knob on the front panel controls the volume.

Motherboard Mnemonics and Connectors

Table 3-1 **Motherboard Mnemonics**

Mnemonic	Description
10 MHZ_AC	This is the 10 MHz reference from the RF section to the A7A1 and processor. It is terminated in 50 Ω by the processor board. Signal: AC coupled 0.5 V peak to peak Line Impedance: 50 Ω
10 MHZ_TG	This is the 10 MHz reference from the RF section to the tracking generator. It is terminated in 50 Ω by the tracking generator board. Signal: AC coupled 0.5 V peak to peak Line Impedance: 50 Ω
ACOM	Analog Common
AC_IF	Analog Card IF. An uncorrected, buffered IF signal from the output of the IF assembly. Frequency: 21.4 MHz Line Impedance: 50 Ω
AC_TRIG	Analog Card Trigger, provides trigger to system for option cards (E4401B, E4402B, E4404B, E4405B, and E4407).
ADC_SYNC	A positive-going signal that indicates when the main ADC on the video/processor assembly has started an A/D conversion.
ANA_TST	An analog signal from the RF section, tracking generator, or the analog card cage to the ADC of the video processor. When it is selected, the signal bypasses the video filter and peak detector sections. Line Impedance: 50 Ω
AUDIO	AUDIO line to internal speaker Line Impedance: 50 Ω
AUX_VIDEO	Auxiliary video: A detected video signal (0–2 V) that has passed through the video filters. Line Impedance: 50 Ω
CRD_ANLG1	Card Analog 1 provides input to CPU for option cards (E4401B, E4402B, E4404B, E4405B, and E4407B).
CRD_ANLG2	Card Analog 2 provides input to CPU for option cards (E4401B, E4402B, E4404B, E4405B, and E4407B).
CRD_ANLG3/7	Provides option card interconnection (E4401B, E4402B, E4404B, E4405B, and E4407B).

Table 3-1 Motherboard Mnemonics (Continued)

Mnemonic	Description
DCOM	A common ground for all digital circuitry.
DI_FREQ_CNT	Differential Inverted Frequency Count: 10.7 MHz signal from IF to processor to be counted for marker count function
DN_FREQ_CNT	Differential Non-Inverted Frequency Count: 10.7 MHz signal from IF to processor to be counted for marker count function
HPUP_AC	High = Processor Up Analog Card: This line will go high when power is applied and will go low before the supplies fully shut down.
HPUP_SYNC	(not used)
HPUP_PS	High = Processor Up Power Supply: This line will go high when power is applied and will go low before the supplies fully shut down.
HSWP_AC	High = Sweeping for analog card. A high indicates the analyzer is sweeping. (HC)
HSWP_CNTRL	High = Sweep Control: This signal provides control for the analyzer display sweep and retrace.
HWR_END_IO	High = Write_End. A signal that indicates the end of cycle for I/O card. (TTL)
H_SWEEP	High = Sweep for RF and TG. A high indicates the analyzer is sweeping. (HC)
IF_VIDEO	The detected 21.4 MHz IF signal from the detector on the IF assembly to the input multiplexer of the video processor. Line Impedance: 50 Ω
IO_A(16/0)	I/O Address Lines
IO_D(15/0)	I/O Data Lines
LADDR	Low = Address, serial bus strobe for address information
LAS_IO	Low = Address strobe for I/O card. A TTL low indicates address valid
LCNTRL	Low = Control, serial bus strobe for control information
LCS_HIGH_IO	Low = Chip select for High I/O
LCS_IO	Low = Chip select for I/O card (TTL)
LDATA	Low = Data, serial bus strobe for sending data
LDS_IO	Low = Data strobe for I/O card (TTL)
LDTACK_IO	Low = Data acknowledge for I/O card
LINE_TRIG	TTL signal synchronous with AC line

Table 3-1 Motherboard Mnemonics (Continued)

Mnemonic	Description
LI_IO0/4	Four Dedicated interrupt lines for I/O boards: LI_IO0 is for the Speaker board (J20) LI_IO1 is for Card Slot 1 (J21) LI_IO2 is for Card Slot 2 (J22) LI_IO3 is for Card Slot 3 (J23) LI_IO4 is for Card Slot 3 (J24)
LI_IO_SLOW	I/O Card Slow Interrupt
LLW_IO	Low = Lower write, strobe for lower 8 bits
LOE_IO	Low = output enable, strobe for reading data
LRESET_IO	Low = reset IO card (TTL)
LSRQ	Low Service Request
LUW_IO	Low = Upper write, strobe for upper 8 bits
LWAIT_IO	Low = wait_IO card, low extends bus cycle
MB_ID3/0	(not used)
MISO	Master In Slave Out serial data
MOSI	Master Out Slave In serial data
N15	-15 volts
N5	-5 volts
P15	+15 volts
P28	+28 volts
P5	+5 volts
P5C	+5 volts Constant
P5D	+5 volts for Digital
PS_COM	see PS_ON
PS_OFF	(not used)
PS_ON	PS_ON line, when connected to PS_COM the analyzer will turn on
PS_ID0	Power supply ID bit
SCK	Serial clock
WLR_IO	Write Low Read
X1	(not used)
X2	(not used)

Table 3-2 Mnemonic Pin Locations

Mnemonic	A7 Motherboard Connector							
	J1	J2	J4	J6	J7	J10 through J16 ^a	J20	J21 through J24 ^b
10MHZ_AC			40		56	52 (J11 to J16)		
10MHZ_TG			18			52 (J10 only)		
ACOM	25-36,7 5-86	6-10, 12-15, 17-19,3 2-39	7, 9, 11, 13-17,1 9,20, 33-35,3 7-39		1, 3-7, 9-11,13-15, 17-19,21-23 , 25-29,31,33, 35,37, 39-42,50,51, 53-55,57-67 , 69-71,73-77 , 90-92, 100	1-3, 5-7, 9-11,13-15, 17-19,21-232 5-27,29,3133 , 40, 48, 51, 53-55, 57-59,61-636 5-67,69-7173 -75,77-7990, 98	42, 43, 48-50, 92, 93, 98, 100	1, 2, 7, 8, 51, 52, 57, 58
AC_IF		34				76		
ADC_SYNC					32	32		
ANA_TST			36		12	56		
AUDIO					8	4		
AUX_VIDEO					72	72		
DCOM	8-12, 58-62			3, 5, 7, 9, 11, 13, 15, 17,19-21, 23, 25, 27, 29, 31, 33, 35, 37, 39, 41, 43, 68, 69, 81, 93		49, 99	1, 5, 7, 9, 11, 13, 15, 17, 19, 21, 23, 25, 27, 29, 31, 33, 35, 37, 39-41, 66, 78	9, 11, 13, 15, 17, 19, 21-23, 25, 27, 29, 31, 33, 35, 37, 39, 41, 43, 45, 46, 50, 72, 73, 85
DI_FREQ_CNT		20			52			
DN_FREQ_CNT		40			2			
HPUP_AC		11			36	34		
HPUP_PS	2			49				
HSWP_AC					81	81 (J11 to J16)		
HSWP_CNTRL					80	80		
HWR_END_IO				8			38	10
H_SWEEP			8		79	81 (J10 only)		

Table 3-2 Mnemonic Pin Locations (Continued)

Mnemonic	A7 Motherboard Connector							
	J1	J2	J4	J6	J7	J10 through J16 ^a	J20	J21 through J24 ^b
IF_VIDEO		16			24	24		
IO_A(0)				32			16	34
IO_A(1)				80			67	84
IO_A(2)				30			18	32
IO_A(3)				79			68	83
IO_A(4)				78			69	82
IO_A(5)				28			20	30
IO_A(6)				77			70	81
IO_A(7)				76			71	80
IO_A(8)				26			22	28
IO_A(9)				75			72	79
IO_A(10)				74			73	78
IO_A(11)				24			24	26
IO_A(12)				73			74	77
IO_A(13)				72			75	76
IO_A(14)				22			26	24
IO_A(15)				71			76	75
IO_A(16)				70			77	74
IO_D(0)				92			55	96
IO_D(1)				91			56	95
IO_D(2)				42			6	44
IO_D(3)				90			57	94
IO_D(4)				89			58	93
IO_D(5)				40			8	42
IO_D(6)				88			59	92
IO_D(7)				87			60	91
IO_D(8)				38			10	40
IO_D(9)				86			61	90
IO_D(10)				85			62	89

Table 3-2 Mnemonic Pin Locations (Continued)

Mnemonic	A7 Motherboard Connector							
	J1	J2	J4	J6	J7	J10 through J16 ^a	J20	J21 through J24 ^b
IO_D(11)				36			12	38
IO_D(12)				84			63	88
IO_D(13)				83			64	87
IO_D(14)				34			14	36
IO_D(15)				82			65	86
LADDR	95	26	27		89	89		
LAS_IO				14			32	16
LCNTRL	99	30	31		85	85		
LCS_IO				10			36	12
LDATA	97	28	29		87	87		
LDS_IO				62			84	66
LDTACK_IO							87	63
LINE_TRIG	50				38			
LI_IO0				6			91	
LI_IO1				55				59 (J21 only)
LI_IO2				54				59 (J22 only)
LI_IO3				4				59 (J23 only)
LI_IO4				53				59 (J24 only)
LI_IO_SLOW				56			90	60
LLW_IO				63			83	67
LOE_IO				60			86	64
LRESET_IO				61			85	65
LSRQ	49		12		82	82		
LUW_IO				64			82	68
LWAIT_IO				58			88	62
MISO	100	31	32		84	84		
MOSI	98	29	30		86	86		

Table 3-2 Mnemonic Pin Locations (Continued)

Mnemonic	A7 Motherboard Connector							
	J1	J2	J4	J6	J7	J10 through J16 ^a	J20	J21 through J24 ^b
N15	39-44 89-94	5, 25	6, 26		43, 44 93, 94	41, 91	47, 97	3, 53
N5	37-38 87-88	4, 24	5, 25		45, 95	42, 92	46, 96	4, 54
P15	17-22 67-72	2, 22	2, 22		47, 48 97, 98	45, 46 95, 96	44, 94	6, 56
P28	23, 24 73, 74		1, 21		49, 99	47, 97		
P5	13-16 63-66	3, 23	3, 23		46, 96	43, 44 93, 94	45, 95	5, 55
P5C		1, 21	4, 24					
P5D	3-7 53-57			44-48 94-98		50, 100	3, 4 53, 54	47, 48 97, 98
PS_COM	52			99				
PS_ON	1			50				
PS_ID0	45							
SCK	96	27	28		88	88		
WLR_IO				12			34	14

- a. J13, J14, and J15 are not loaded on ESA-L Series motherboards.
- b. J23, J24, J25, and J26 are not loaded on ESA-L Series motherboards.

Table 3-3 A7J1 Power Supply Connector

Pin	Signal	Pin	Signal
1	PS_ON	51	PS_OFF
2	HPUP_PS	52	PS_COM
3	P5D	53	P5D
4	P5D	54	P5D
5	P5D	55	P5D
6	P5D	56	P5D
7	P5D	57	P5D
8	DCOM	58	DCOM
9	DCOM	59	DCOM
10	DCOM	60	DCOM
11	DCOM	61	DCOM
12	DCOM	62	DCOM
13	P5	63	P5
14	P5	64	P5
15	P5	65	P5
16	P5	66	P5
17	P15	67	P15
18	P15	68	P15
19	P15	69	P15
20	P15	70	P15
21	P15	71	P15
22	P15	72	P15
23	P28	73	P28
24	P28	74	P28
25	ACOM	75	ACOM
26	ACOM	76	ACOM
27	ACOM	77	ACOM
28	ACOM	78	ACOM
29	ACOM	79	ACOM

Table 3-3 A7J1 Power Supply Connector

Pin	Signal	Pin	Signal
30	ACOM	80	ACOM
31	ACOM	81	ACOM
32	ACOM	82	ACOM
33	ACOM	83	ACOM
34	ACOM	84	ACOM
35	ACOM	85	ACOM
36	ACOM	86	ACOM
37	N5	87	N5
38	N5	88	N5
39	N15	89	N15
40	N15	90	N15
41	N15	91	N15
42	N15	92	N15
43	N15	93	N15
44	N15	94	N15
45	PS_ID0	95	LADDR
46		96	SCK
47	FAN	97	LDATA
48	FAN_RTN	98	MOSI
49	LSRQ	99	LCNTRL
50	LINE_TRIG	100	MISO

Table 3-4 A7J2 IF Assembly Connector

Pin	Signal	Pin	Signal
1	P5C	21	P5C
2	P15	22	P15
3	P5	23	P5
4	N5	24	N5
5	N15	25	N15
6	ACOM	26	LADDR

Table 3-4

A7J2 IF Assembly Connector

Pin	Signal	Pin	Signal
7	ACOM	27	SCK
8	ACOM	28	LDATA
9	ACOM	29	MOSI
10	ACOM	30	LCNTRL
11	HPUP_AC	31	MISO
12	ACOM	32	ACOM
13	ACOM	33	ACOM
14	ACOM	34	AC_IF
15	ACOM	35	ACOM
16	IF_VIDEO	36	ACOM
17	ACOM	37	ACOM
18	ACOM	38	ACOM
19	ACOM	39	ACOM
20	DI_FREQ_CNT	40	DN_FREQ_CNT

Table 3-5

A7J4 RF Connector

Pin	Signal	Pin	Signal
1	P28	21	P28
2	P15	22	P15
3	P5	23	P5
4	P5C	24	P5C
5	N5	25	N5
6	N15	26	N15
7	ACOM	27	LADDR
8	H_SWEEP	28	SCK
9	ACOM	29	LDATA
10	HPUP_SYNC	30	MOSI
11	ACOM	31	LCNTRL
12	LSRQ	32	MISO
13	ACOM	33	ACOM

Table 3-5

A7J4 RF Connector

Pin	Signal	Pin	Signal
14	ACOM	34	ACOM
15	ACOM	35	ACOM
16	ACOM	36	ANA_TST
17	ACOM	37	ACOM
18	10MHZ_TG	38	ACOM
19	ACOM	39	ACOM
20	ACOM	40	10MHZ_AC

Table 3-6 A7J6 Processor Digital Connector

Pin	Signal	Pin	Signal
1	MB_ID0	51	MB_ID1
2	MB_ID2	52	MB_ID3
3	DCOM	53	LI_IO4
4	LI_IO3	54	LI_IO2
5	DCOM	55	LI_IO1
6	LI_IO0	56	LI_IO_SLOW
7	DCOM	57	LCS_HIGH_IO
8	HWR_END_IO	58	LWAIT_IO
9	DCOM	59	LDTACK
10	LCS_IO	60	LOE_IO
11	DCOM	61	LRESET_IO
12	WLR_IO	62	LDS_IO
13	DCOM	63	LLW_IO
14	LAS_IO	64	LUW_IO
15	DCOM	65	SIZ0_IO
16	LEN_DTACK_IO	66	SIZ1_IO
17	DCOM	67	X2
18	X1	68	DCOM
19	DCOM	69	DCOM
20	DCOM	70	IO_A(16)
21	DCOM	71	IO_A(15)
22	IO_A(14)	72	IO_A(13)
23	DCOM	73	IO_A(12)
24	IO_A(11)	74	IO_A(10)
25	DCOM	75	IO_A(9)
26	IO_A(8)	76	IO_A(7)
27	DCOM	77	IO_A(6)
28	IO_A(5)	78	IO_A(4)
29	DCOM	79	IO_A(3)

Table 3-6 A7J6 Processor Digital Connector

Pin	Signal	Pin	Signal
30	IO_A(2)	80	IO_A(1)
31	DCOM	81	DCOM
32	IO_A(0)	82	IO_D(15)
33	DCOM	83	IO_D(13)
34	IO_D(14)	84	IO_D(12)
35	DCOM	85	IO_D(10)
36	IO_D(11)	86	IO_D(9)
37	DCOM	87	IO_D(7)
38	IO_D(8)	88	IO_D(6)
39	DCOM	89	IO_D(4)
40	IO_D(5)	90	IO_D(3)
41	DCOM	91	IO_D(1)
42	IO_D(2)	92	IO_D(0)
43	DCOM	93	DCOM
44	P5D	94	P5D
45	P5D	95	P5D
46	P5D	96	P5D
47	P5D	97	P5D
48	P5D	98	P5D
49	HPUP_PS	99	PS_COM
50	PS_ON	100	PS_OFF

Table 3-7

A7J7 Processor Analog Connector

Pin	Signal	Pin	Signal
1	ACOM	51	ACOM
2	DN_FREQ_CNT	52	DI_FREQ_CNT
3	ACOM	53	ACOM
4	ACOM	54	ACOM
5	ACOM	55	ACOM
6	ACOM	56	10MHZ_AC
7	ACOM	57	ACOM
8	AUDIO	58	ACOM
9	ACOM	59	ACOM
10	ACOM	60	ACOM
11	ACOM	61	ACOM
12	ANA_TST	62	ACOM
13	ACOM	63	ACOM
14	ACOM	64	ACOM
15	ACOM	65	ACOM
16	AUDIO_OUT	66	ACOM
17	ACOM	67	ACOM
18	ACOM	68	CRD_ANLG2
19	ACOM	69	ACOM
20	CRD_ANLG1	70	ACOM
21	ACOM	71	ACOM
22	ACOM	72	AUX_VIDEO
23	ACOM	73	ACOM
24	IF_VIDEO	74	ACOM
25	ACOM	75	ACOM
26	ACOM	76	ACOM
27	ACOM	77	ACOM
28	ACOM	78	GATE_AC
29	ACOM	79	H_SWEEP

Table 3-7 A7J7 Processor Analog Connector

Pin	Signal	Pin	Signal
30	AC_TRIG	80	HSWP_CNTRL
31	ACOM	81	HSWP_AC
32	ADC_SYNC	82	LSRQ
33	ACOM	83	NC
34	HPUP_SYNC	84	MISO
35	ACOM	85	LCNTRL
36	HPUP_AC	86	MOSI
37	ACOM	87	LDATA
38	LINE_TRIG	88	SCK
39	ACOM	89	LADDR
40	ACOM	90	ACOM
41	ACOM	91	ACOM
42	ACOM	92	ACOM
43	N15	93	N15
44	N15	94	N15
45	N5	95	N5
46	P5	96	P5
47	P15	97	P15
48	P15	98	P15
49	P28	99	P28
50	ACOM	100	ACOM

Table 3-8

A7J10 through A7J16 Analog Card/ J10 Tracking Generator Connector

Pin	Signal	Pin	Signal
1	ACOM	51	ACOM
2	ACOM	52	10MHz_AC/10MHz_T G
3	ACOM	53	ACOM
4	AUDIO	54	ACOM
5	ACOM	55	ACOM
6	ACOM	56	ANA_TST
7	ACOM	57	ACOM
8	CRD_ANLG7	58	ACOM
9	ACOM	59	ACOM
10	ACOM	60	CRD_ANLG6
11	ACOM	61	ACOM
12	CRD_ANLG5	62	ACOM
13	ACOM	63	ACOM
14	ACOM	64	CRD_ANLG4
15	ACOM	65	ACOM
16	CRD_ANLG3	66	ACOM
17	ACOM	67	ACOM
18	ACOM	68	CRD_ANLG2
19	ACOM	69	ACOM
20	CRD_ANLG1	70	ACOM
21	ACOM	71	ACOM
22	ACOM	72	AUX_VIDEO
23	ACOM	73	ACOM
24	IF_VIDEO	74	ACOM
25	ACOM	75	ACOM
26	ACOM	76	AC_IF
27	ACOM	77	ACOM
28	GATE_AC	78	ACOM
29	ACOM	79	ACOM

Table 3-8 A7J10 through A7J16 Analog Card/ J10 Tracking Generator Connector

Pin	Signal	Pin	Signal
30	AC_TRIG	80	HSWP_CNTRL
31	ACOM	81	HSWP_AC/H_SWEEP
32	ADC_SYNC	82	LSRQ
33	ACOM	83	HPUP_SYNC
34	HPUP_AC	84	MISO
35	AC_ID0	85	LCNTRL
36	AC_ID1	86	MOSI
37	AC_ID2	87	LDATA
38	AC_ID3	88	SCK
39	AC_ID4	89	LADDR
40	ACOM	90	ACOM
41	N15	91	N15
42	N5	92	N5
43	P5	93	P5
44	P5	94	P5
45	P15	95	P15
46	P15	96	P15
47	P28	97	P28
48	ACOM	98	ACOM
49	DCOM	99	DCOM
50	P5D	100	P5D

Table 3-9 A7J20 Speaker Board Connector

Pin	Signal	Pin	Signal
1	DCOM	51	IO_ID0
2	IO_ID1	52	IO_ID2
3	P5D	53	P5D
4	P5D	54	P5D
5	DCOM	55	IO_D(0)
6	IO_D(2)	56	IO_D(1)
7	DCOM	57	IO_D(3)
8	IO_D(5)	58	IO_D(4)
9	DCOM	59	IO_D(6)
10	IO_D(8)	60	IO_D(7)
11	DCOM	61	IO_D(9)
12	IO_D(11)	62	IO_D(10)
13	DCOM	63	IO_D(12)
14	IO_D(14)	64	IO_D(13)
15	DCOM	65	IO_D(15)
16	IO_A(0)	66	DCOM
17	DCOM	67	IO_A(1)
18	IO_A(2)	68	IO_A(3)
19	DCOM	69	IO_A(4)
20	IO_A(5)	70	IO_A(6)
21	DCOM	71	IO_A(7)
22	IO_A(8)	72	IO_A(9)
23	DCOM	73	IO_A(10)
24	IO_A(11)	74	IO_A(12)
25	DCOM	75	IO_A(13)
26	IO_A(14)	76	IO_A(15)
27	DCOM	77	IO_A(16)
28	X1	78	DCOM
29	DCOM	79	X2

Table 3-9 A7J20 Speaker Board Connector

Pin	Signal	Pin	Signal
30	LEN_DTACK_IO	80	SIZ1_IO
31	DCOM	81	SIZ0_IO
32	LAS_IO	82	LUW_IO
33	DCOM	83	LLW_IO
34	WLR_IO	84	LDS_IO
35	DCOM	85	LRESET_IO
36	LCS_IO	86	LOE_IO
37	DCOM	87	LDTACK_IO
38	HWR_END_IO	88	LWAIT_IO
39	DCOM	89	LCS_HIGH_IO
40	DCOM	90	LI_IO_SLOW
41	DCOM	91	LI_IO0
42	ACOM	92	ACOM
43	ACOM	93	ACOM
44	P15	94	P15
45	P5	95	P5
46	N5	96	N5
47	N15	97	N15
48	ACOM	98	ACOM
49	ACOM	99	AUDIO_OUT
50	ACOM	100	ACOM

Table 3-10 A7J21 and A7J24 I/O Assembly Connector

Pin	Signal	Pin	Signal
1	ACOM	51	ACOM
2	ACOM	52	ACOM
3	N15	53	N15
4	N5	54	N5
5	P5	55	P5
6	P15	56	P15
7	ACOM	57	ACOM
8	ACOM	58	ACOM
9	DCOM	59	LI_IO1/2/3/4
10	HWR_END_IO	60	LI_IO_SLOW
11	DCOM	61	LCS_HIGH_IO
12	LCS_IO	62	LWAIT_IO
13	DCOM	63	LDTACK_IO
14	WLR_IO	64	LOE_IO
15	DCOM	65	LRESET_IO
16	LAS_IO	66	LDS_IO
17	DCOM	67	LLW_IO
18	LEN_DTACK_IO	68	LUW_IO
19	DCOM	69	SIZ0_IO
20	X1	70	SIZ1_IO
21	DCOM	71	X2
22	DCOM	72	DCOM
23	DCOM	73	DCOM
24	IO_A(14)	74	IO_A(16)
25	DCOM	75	IO_A(15)
26	IO_A(11)	76	IO_A(13)
27	DCOM	77	IO_A(12)
28	IO_A(8)	78	IO_A(10)
29	DCOM	79	IO_A(9)

Table 3-10 **A7J21 and A7J24 I/O Assembly Connector**

Pin	Signal	Pin	Signal
30	IO_A(5)	80	IO_A(7)
31	DCOM	81	IO_A(6)
32	IO_A(2)	82	IO_A(4)
33	DCOM	83	IO_A(3)
34	IO_A(0)	84	IO_A(1)
35	DCOM	85	DCOM
36	IO_D(14)	86	IO_D(15)
37	DCOM	87	IO_D(13)
38	IO_D(11)	88	IO_D(12)
39	DCOM	89	IO_D(10)
40	IO_D(8)	90	IO_D(9)
41	DCOM	91	IO_D(7)
42	IO_D(5)	92	IO_D(6)
43	DCOM	93	IO_D(4)
44	IO_D(2)	94	IO_D(3)
45	DCOM	95	IO_D(1)
46	DCOM	96	IO_D(0)
47	P5D	97	P5D
48	P5D	98	P5D
49	IO_ID1	99	IO_ID2
50	DCOM	100	IO_ID0

Graphic Symbols Used On Block Diagrams

	Bus Line		Op Amplifier		Band Pass Filter
	Indicates a plug-in connection (F) to (M)		Summer		High Pass Filter
	Connection symbol indicating plug (movable)		Phase Frequency Detector		Low Pass Filter
	Connection symbol indicating jack (movable)		Mixer		Band Reject Filter
	Heavy line indicates path and direction of main signal		Oscillator or Generator		Common Return
	Color code for cable		Capacitor		Numbered Test Point. Measurement aid provided.
	Variable Gain Amplifier		Resistor		Lettered Test Point. No Measurement aid provided.
	Amplifier Buffer		Variable Resistor		Slide, Toggle, or Rocker, Switch
	Inverter Buffer		Switch Open		Diode
	Limiter		Analog Digital Converter		Grounded Coaxial Sheilding
	Variable Integrator		Digital Analog Converter		Directional Coupler

formt123

ESA-E SERIES BLOCK DIAGRAM

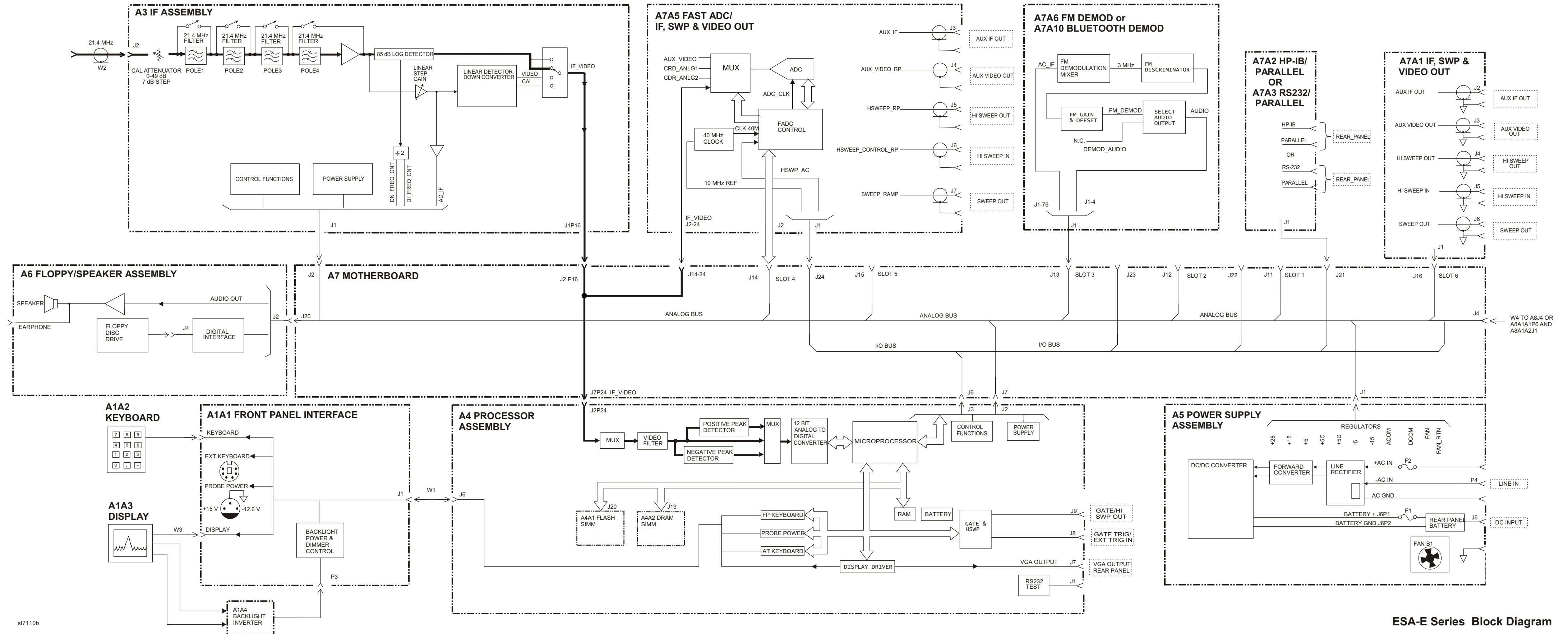

ESA-E Series Block Diagram

sl7110b

E4402B/E4403B RF SECTION BLOCK DIAGRAM

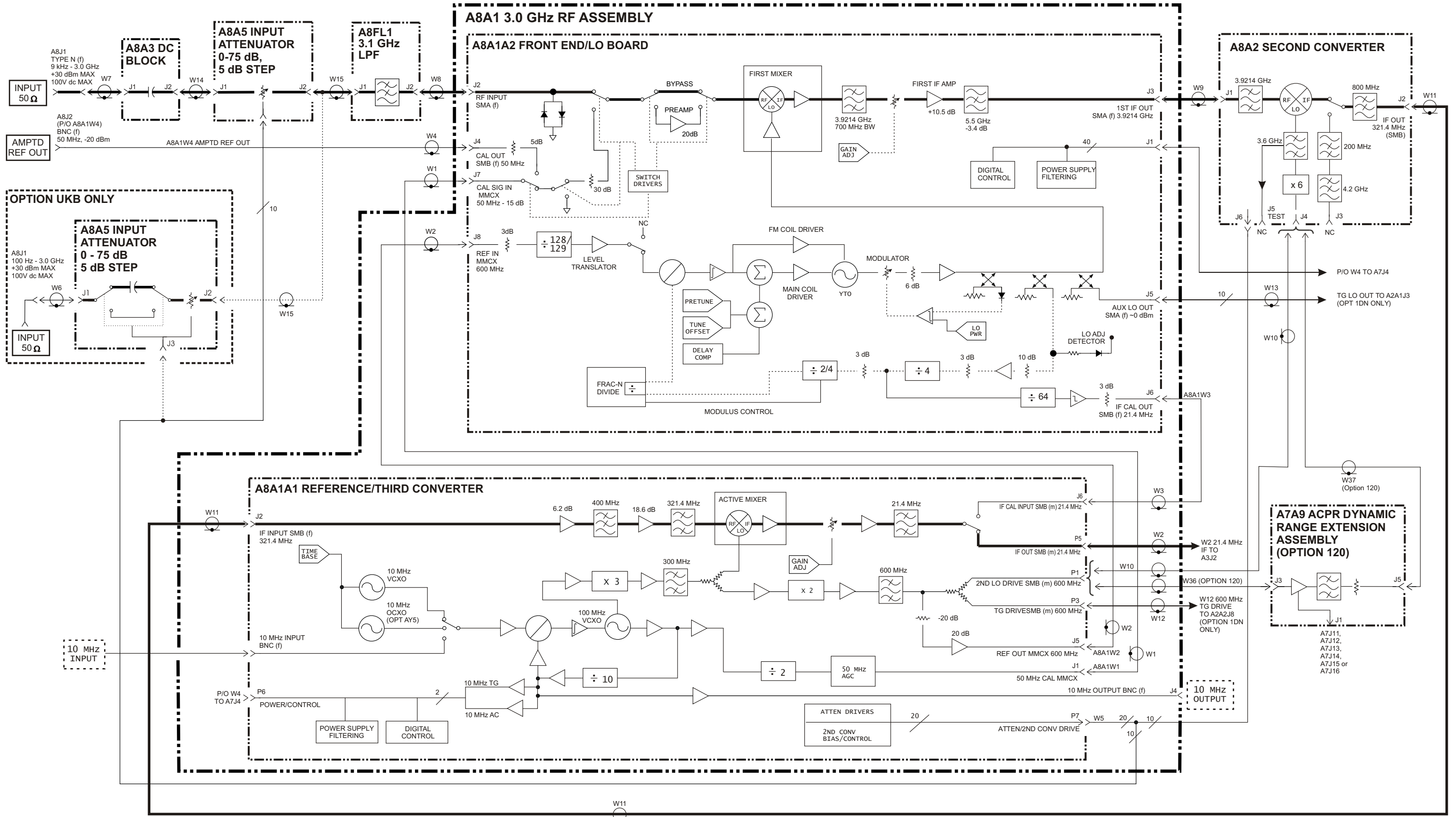

sl7101b

E4402B/E4403B RF SECTION BLOCK DIAGRAM

E4404B, E4405B, E4407B, AND E4408B RF SECTION BLOCK DIAGRAM

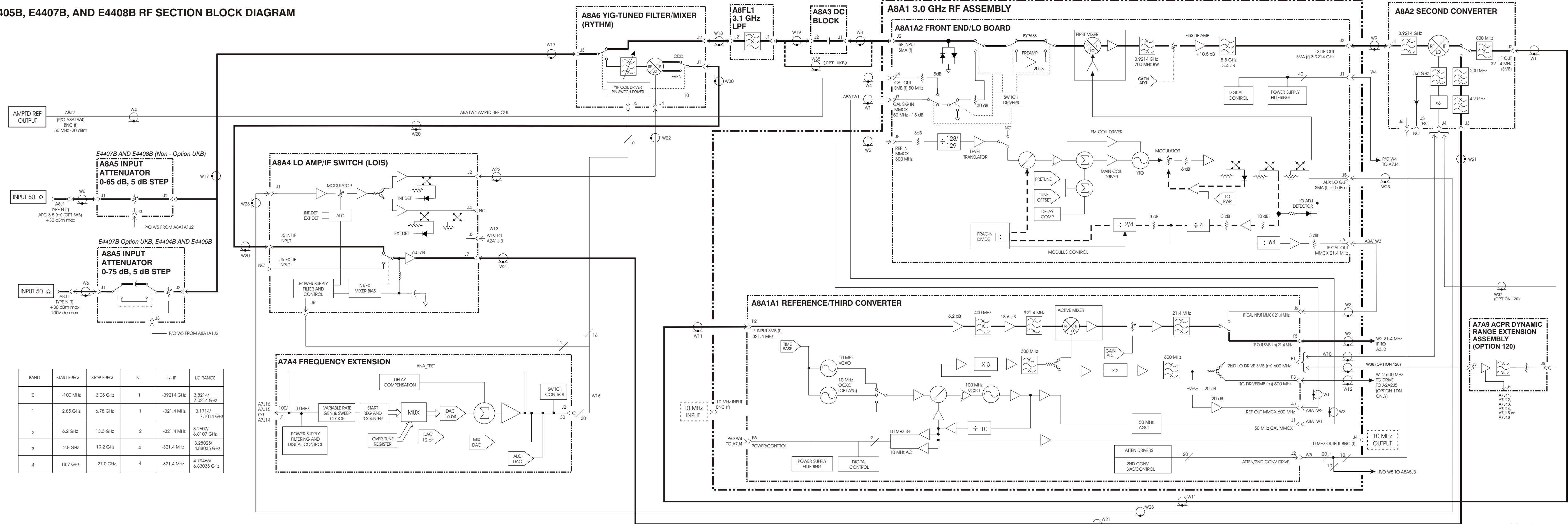

BAND	START FREQ	STOP FREQ	N	+/- IF	LO RANGE
0	-100 MHz	3.05 GHz	1	-3921.4 MHz	3.8214/7.0214 GHz
1	2.85 GHz	6.78 GHz	1	-321.4 MHz	3.1714/7.1014 GHz
2	6.2 GHz	13.3 GHz	2	-321.4 MHz	3.2607/6.8107 GHz
3	12.8 GHz	19.2 GHz	4	-321.4 MHz	3.28025/4.88035 GHz
4	18.7 GHz	27.0 GHz	4	-321.4 MHz	4.79465/6.83035 GHz

E4404B, E4405B, E4407B, AND E4408B RF SECTION BLOCK DIAGRAM

Tracking Generator Block Diagrams

Figure 3-2 A2 1.5 GHz Tracking Generator Block Diagram, E4401B and E4411B

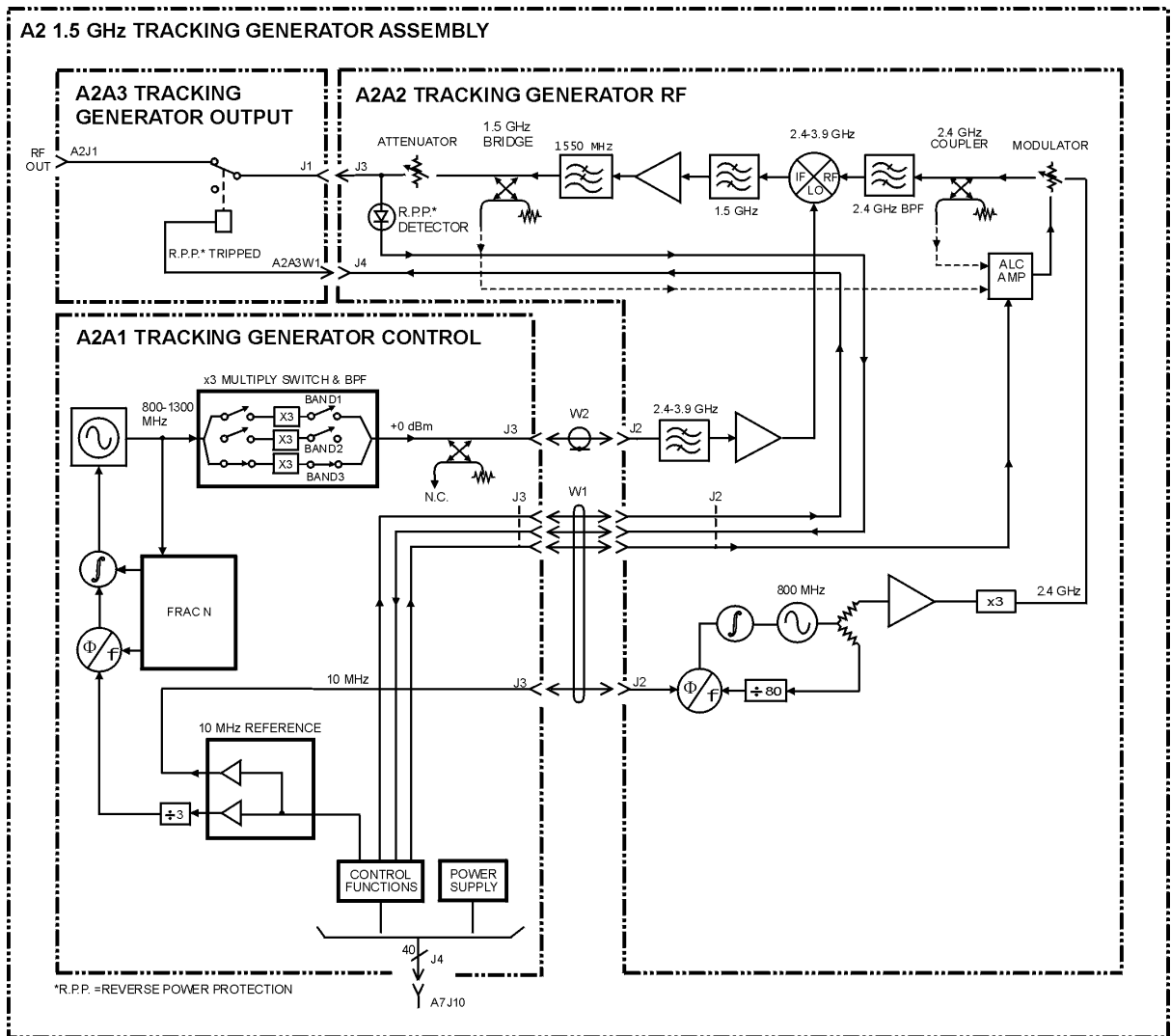
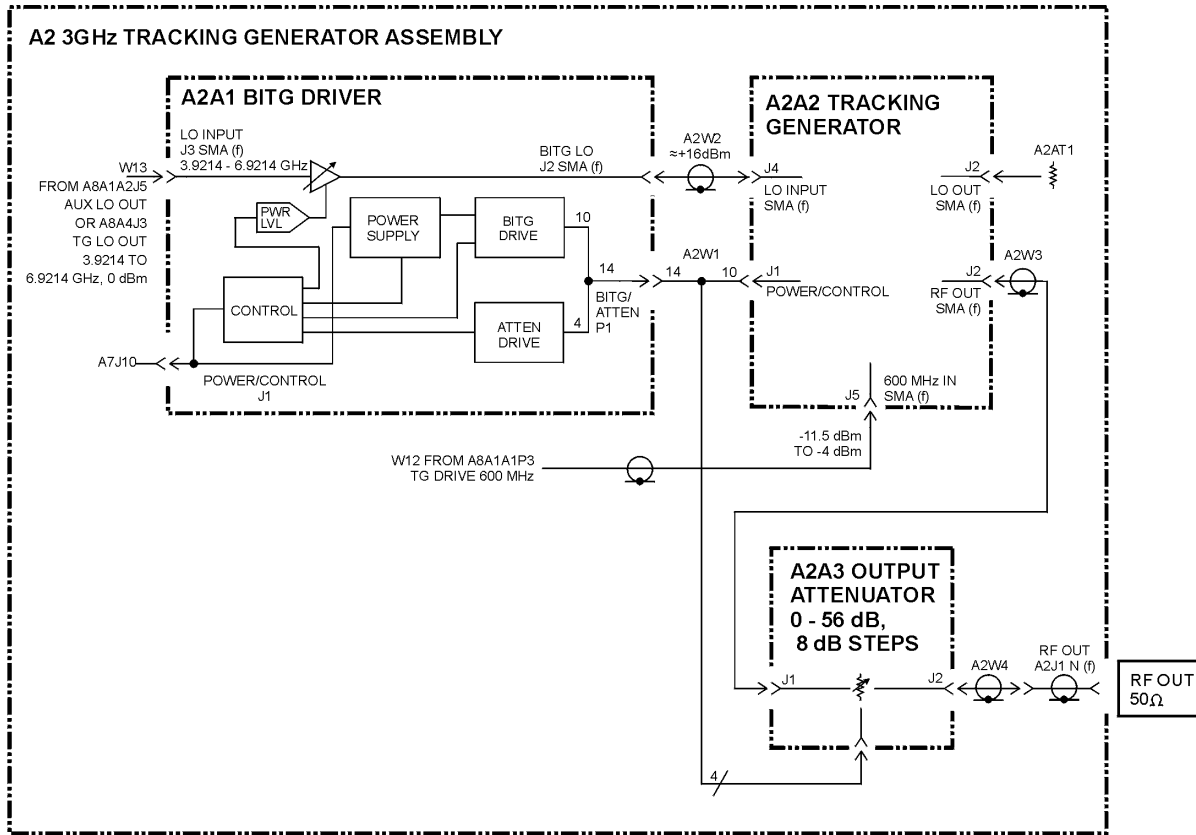

Figure 3-3 A2 3.0 GHz Tracking Generator Block Diagram, E4402B, E4403B, E4404B, E4405B, E4407B, and E4408B



sl74b

Digital Demod DSP/Fast ADC Block Diagram

Figure 3-4 A7A7 DSP Block Diagram, E4402B, E4404B, E4405B, and E4407B

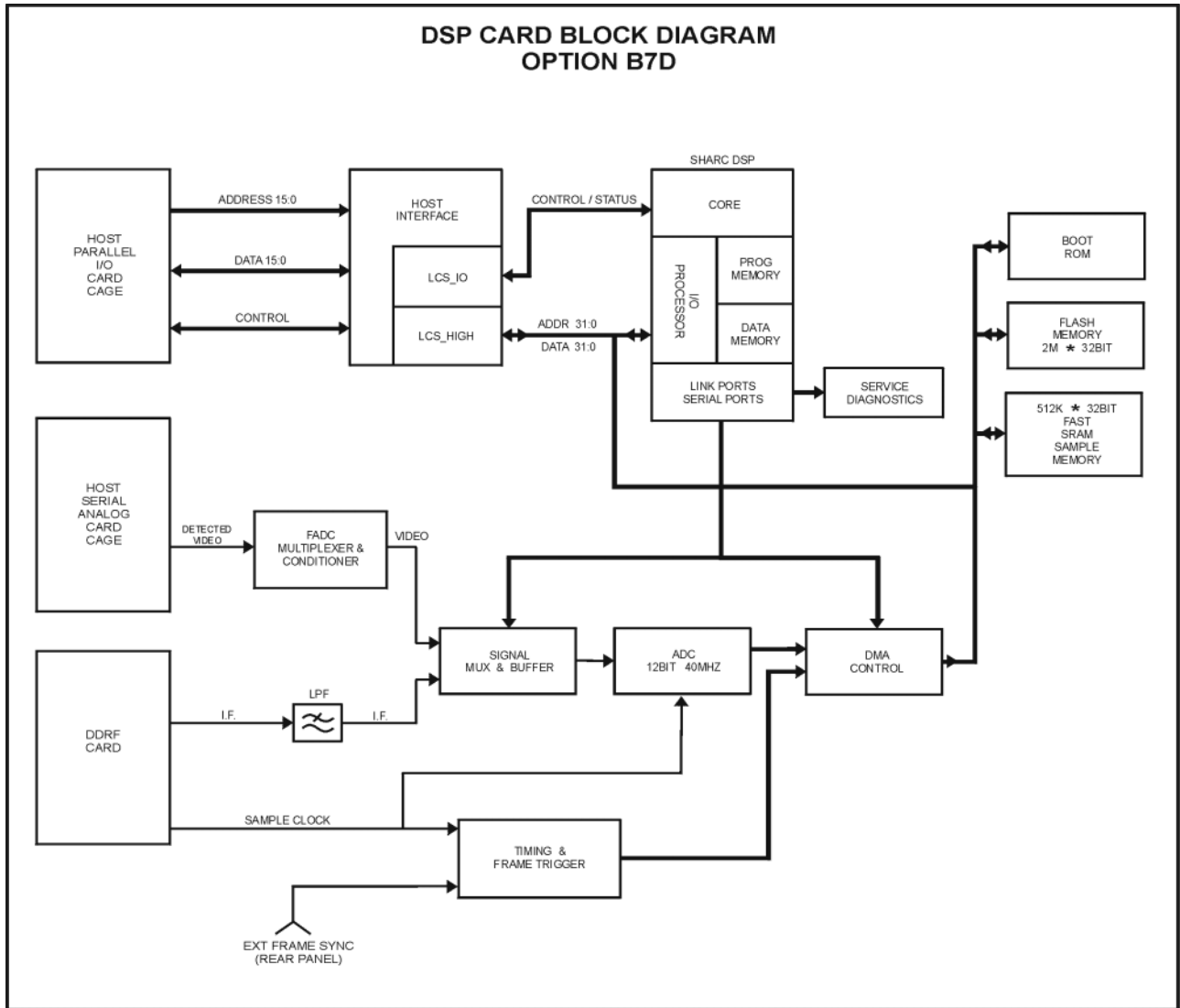

sl78c

Digital Demod RF Block Diagram

Figure 3-5 A7A8 DD RF Block Diagram, E4402B, E4404B, E4405B, and E4407B

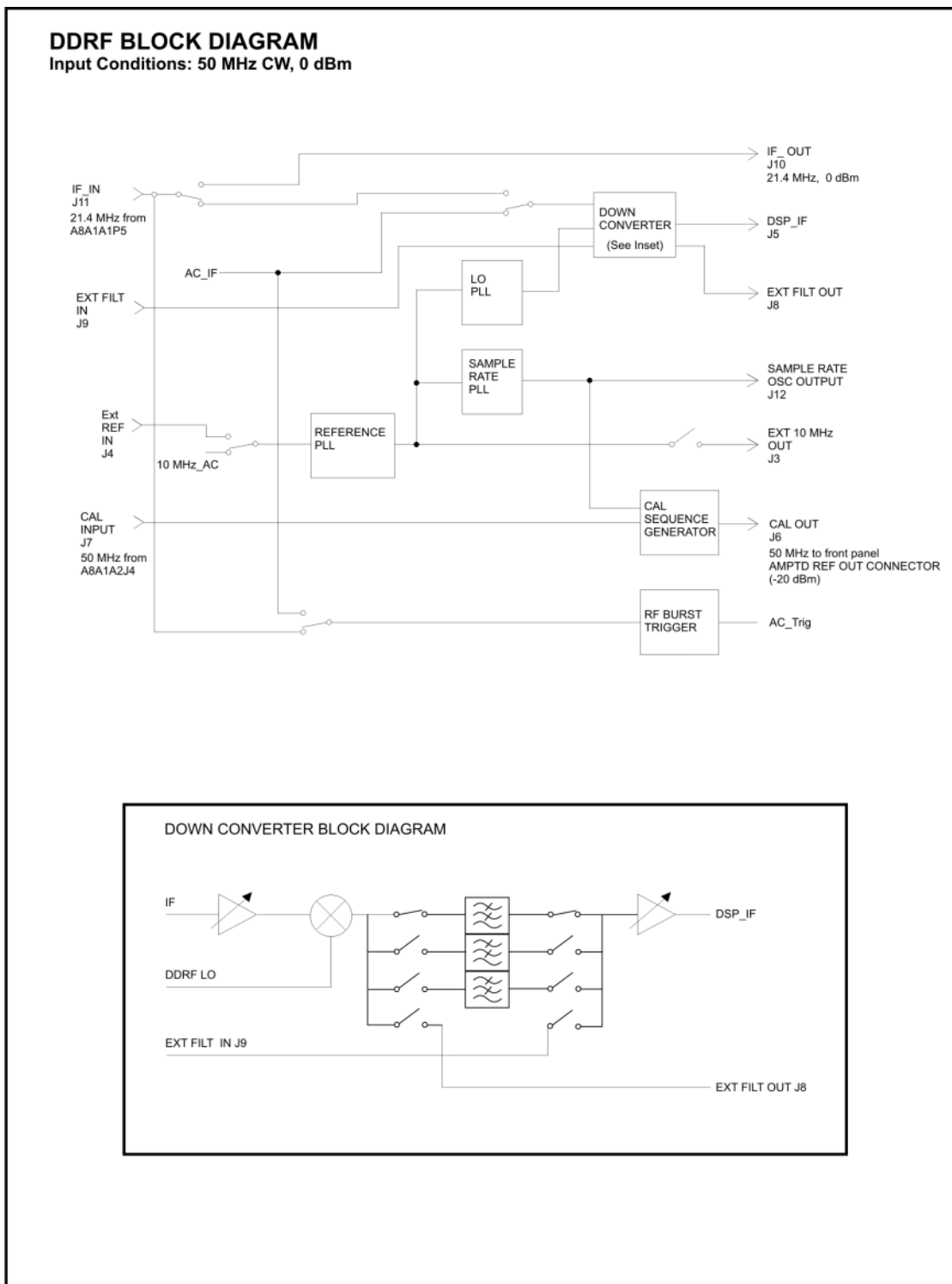

sl77c

4 Options and Accessories

This chapter lists the options and accessories that can be ordered along with your analyzer. The Option Table on the following page shows which options are available for your particular product.

Table 4-1 Option Table

Option		E4411B	E4401B	E4402B	E4403B	E4404B	E4405B	E4407B	E4408B
042	Gray Backpack carrying case	•	•	•	•	•	•	•	•
044	Yellow Backpack carrying case	•	•	•	•	•	•	•	•
049	Color Display ¹	•			•				•
060	Low Emission ^{2,3}		•	•		•	•	•	
106	Bluetooth FM Demodulation ⁴			•		•	•	•	
120	ACPR Dynamic Range Extension			•		•	•	•	
219	Noise Figure Measurement Personality and Hardware		•	•		•	•	•	
225	Distance to Fault Measurement Personality		•	•		•	•	•	
226	Phase Noise Measurement Personality		•	•		•	•	•	
227	Cable TV Measurement Personality		•	•		•	•	•	
228	Bluetooth Measurement Personality			•		•	•	•	
230	Benchlink Web Remote Control Software ⁵	•	•	•	•	•	•	•	•
266	8566 Series Programming Code Compatibility	•	•	•	•	•	•	•	•
303	Bluetooth General Purpose Bundle			•		•	•	•	
304	Bluetooth Premium Bundle			•		•	•	•	
0B0	Delete Manual Set	•	•	•	•	•	•	•	•
0B1	Add Manual Set	•	•	•	•	•	•	•	•
0BV	Service Documentation, Component Level	•	•	•	•	•	•	•	•
0BW	Service Documentation, Assembly Level	•	•	•	•	•	•	•	•
1AX	RS-232 and Parallel Interface ⁶	•	•	•	•	•	•	•	•
1CP	Rack Mount with Handles	•	•	•	•	•	•	•	•
1D5	High Stability Frequency Reference		•	•		•	•	•	
1D6	Time-Gated Spectrum Analysis		•	•		•	•	•	
1D7	50 to 75 Ohm Matching Pad	•	•	•	•	•	•	•	•
1DN	50 Ohm Tracking Generator	•	•	•	•	•	•	•	•
1DP	75 Ohm input ⁷	•	•						
1DR	Narrow Resolution Bandwidths	•	•	•	•	•	•	•	•

Table 4-1 Option Table (Continued)

Option		E4411B	E4401B	E4402B	E4403B	E4404B	E4405B	E4407B	E4408B
1DQ	75 Ohm Tracking Generator ⁸	•	•						
1DS	RF Preamplifier		•	•		•	•	•	
A4H	GPIB and Parallel Interface ⁹	•	•	•	•	•	•	•	•
A4J	IF, Video and Sweep Ports	•	•	•	•	•	•	•	•
A5D	DC Power Cable	•	•	•	•	•	•	•	•
AXT	Transit Case	•	•	•	•	•	•	•	•
AYT	Gray Soft Carrying/Operating Case	•	•	•	•	•	•	•	•
AYU	Yellow Carrying/Operating Case	•	•	•	•	•	•	•	•
AYX	Fast Time Domain Sweeps		•	•		•	•	•	
AYZ	External Mixing							•	
B70	Benchlink Spectrum Analyzer	•	•	•	•	•	•	•	•
B72	Enhanced Memory Upgrade		•	•		•	•	•	
B74	RF and Digital Communications Hardware			•		•	•	•	
B75	Performance Bundle ⁷		•	•		•	•	•	
B7B	TV Trigger and Picture on Screen ¹⁰		•	•		•	•	•	
B7D	Digital Signal Processing and Fast ADC			•		•	•	•	
B7E	RF Communications Hardware			•		•	•	•	
B7K	Distance to Fault Accessory Kit			•		•	•	•	
BAA	FM Demodulation ¹¹		•	•		•	•	•	
BAB	APC 3.5 Input Connector							•	•
BAC	cdmaOne Measurement Personality			•		•	•	•	
BAH	GSM Measurement Personality			•		•	•	•	
UE2	Firmware Upgrade Kit	•	•	•	•	•	•	•	•
UKB	Low Frequency Extension ¹²			•		•	•	•	
UK6	Commercial Calibration ⁷	•	•	•	•	•	•	•	•
UK9	Front Panel Cover	•	•	•	•	•	•	•	•
W30	3 Year Service Support	•	•	•	•	•	•	•	•

Table 4-1 Option Table (Continued)

Option		E4411B	E4401B	E4402B	E4403B	E4404B	E4405B	E4407B	E4408B
W32	3 Year Calibration Contract	•	•	•	•	•	•	•	•
W50	5 Year Service Support	•	•	•	•	•	•	•	•
W52	5 Year Calibration Contract	•	•	•	•	•	•	•	•

1. Option 049 is standard on newer ESA-L Series analyzers.
2. This option is incompatible with Option B7B.
3. This option operates only with ac input power. Battery or dc power will not enable this option on the analyzer.
4. Option 106 is incompatible with Option BAA.
5. This option requires Option A4H or 1AX.
6. Option 1AX is incompatible with Option A4H.
7. This option is only available at time of purchase.
8. This option has a 75 Ohm output impedance, and is only available with Option 1DP.
9. Option A4H is incompatible with Option 1AX.
10. Option B7B requires Option BAA.
11. Option BAA is incompatible with Option 106
12. Option UKB requires Option 1DR.

Options

Options can be ordered by option number when you order your analyzer. Some of the options are also available as kits that can be ordered and installed after you have received your spectrum analyzer. Refer to [Table 4-1 on page 144](#) to determine which options are available for your particular product.

How to Order Options

At the time of instrument purchase, options can be ordered using your product number and the number of the option you are ordering. For example, if you are ordering Option 1D6 for an Agilent E4401B, you would order E4401B 1D6.

If you are ordering an option after the purchase of your analyzer, you will need to add a U (for upgrade) to the product number and then specify which option you are ordering.

The options are listed in alphabetical order by name below for your review. If you know the option you wish to order, refer to [Table 4-1 on page 144](#) which is in ascending order by option number.

12 Vdc Power Cable (Option A5D)

Option A5D provides a 12 Vdc power cable that allows your analyzer to be powered from 12 V automotive or truck batteries.

3 Year Calibration Contract (Option W32)

Option W32 provides your analyzer with a 3 year instrument calibration contract.

3 Year Service Support (Option W30)

Option W30 provides your analyzer with a total of 3 years of service support. This adds a 2 year service contract to the analyzer's base 1 year warranty.

5 Year Calibration Contract (Option W52)

Option W52 provides your analyzer with a 5 year instrument calibration contract.

5 Year Service Support (Option W50)

Option W50 provides your analyzer with a total of 5 years of service support. This adds a 4 year service contract to the analyzer's base 1 year warranty.

50 Ω to 75 Ω Matching Pad (Option 1D7)

This option provides a 50 Ω to 75 Ω matching pad with dc block to be used on the analyzer input. The pad has a frequency range of 9 MHz to 2 GHz. It adapts your standard 50 Ω analyzer to be compatible with a 75 Ω system under test. Connector types are 50 Ω Type-N (m) to 75 Ω BNC (f).

50 Ohm Tracking Generator (Option 1DN)

Option 1DN provides a 9 kHz to 1.5 GHz built-in tracking generator for the Agilent E4401B and the Agilent E4411B. Option 1DN provides a 9 kHz to 3 GHz

built-in tracking generator for the Agilent E4402B, E4403B, E4404B, E4405B, E4407B and E4408B. This source creates a source-receiver combination that allows insertion-loss, frequency response, and return-loss measurements. The tracking generator has a wide distortion-free dynamic range, plus good sensitivity and selectivity.

75 Ohm Input Impedance (Option 1DP)

This option provides a 75 Ω input impedance instead of the standard 50 Ω impedance. Analyzers with this option use cables, circuit boards, and front panels that are different from the standard units. Option 1DP is only available on the Agilent E4401B and E4411B.

Option 1DP is not available after the purchase of your analyzer.

75 Ohm Tracking Generator (Option 1DQ)

Option 1DQ provides a 1 MHz to 1.5 GHz built-in tracking generator for the Agilent E4401B and the Agilent E4411B. Option 1DQ provides a 1 MHz to 3 GHz built-in tracking generator for the Agilent E4402B, E4403B, E4404B, E4405B, and E4407B. This source creates a source-receiver combination that allows insertion-loss, frequency response, and return-loss measurements. The tracking generator has a wide distortion-free dynamic range, plus good sensitivity and selectivity.

Option 1DQ has a 75 Ω output impedance, and is only available with Option 1DP.

8566 Series Programming Code Compatibility (Option 266)

Option 266 allows use of a limited set of 8566 Series programming commands to control the ESA Series analyzers. When this option is enabled, SCPI commands are disabled if the remote language selected is not SCPI.

ACPR Dynamic Range Extension (Option 120)

Option 120 provides extended dynamic range for ACPR measurements by improving phase noise at offsets 800 kHz to 8 MHz.

Additional Manual Set (Option 0B1)

Option 0B1 provides an additional copy of the *Agilent ESA Spectrum Analyzers User's Guide*, *Agilent ESA Spectrum Analyzers Calibration Guide*, *Agilent ESA Spectrum Analyzers Specifications Guide - E Series* or *Agilent ESA Spectrum Analyzers Specifications Guide - L Series*, and the *Agilent ESA Spectrum Analyzers Reference Guide*.

APC 3.5 Input Connector (Option BAB)

The type-N female connector is replaced with an APC 3.5 mm male connector. An

APC 3.5 (f) to APC 3.5 (f), and BNC (f) to SMA (m) adapters are included for alignment purposes.

Backpack Operating and Carrying Cases (Option 042/044)

Options 042 and 044 are protective soft operating and backpack carrying cases. Option 042 is made of gray rip-stop nylon and Option 044 is made of yellow rip-stop nylon. An outside pocket holds manuals or other accessories. Reinforced adjustable padded shoulder straps provides ergonomic distribution between your shoulder. The front and rear panel soft covers adjust to be compatible with the front panel protective hard cover (Option UK9) and snap on battery pack (Agilent E1779BA). Side ventilation allows for operation without removal, but the maximum operating temperature is reduced to 45 °C.

Benchlink Spectrum Analyzer (Option B70)

Option B70 provides the Benchlink Spectrum Analyzer software which can be used to capture screen images and trace data using a personal computer (PC). The captured information can then be used in other PC applications, including word processing and spread sheets.

Benchlink Web Remote Control Software (Option 230)

Option 230 provides software which can be used to control the analyzer remotely over the web. When the analyzer is connected via GP-IB to one personal computer (PC), access to the analyzer is available through any internet connection by specifying the IP address of the physically connected PC. The following analyzer functions are available through remote web access:

- front panel control
- capture screen images
- capture trace data
- remote programming commands (SCPI)

Bluetooth FM Demodulation (Option 106)

Option 106 is required to perform FM demodulation on signals measured with the Bluetooth Measurement Personality (Option 228).

Option 106 allows you to demodulate, display and measure deviation on Bluetooth FM modulated signals. You can listen to audio signals on a built-in speaker or with an earphone.

Option 106 provides the following additional port:

EXT VIDEO OUT - provides a detected video output (before the analog-to-digital conversion) proportional to the vertical deflection of the trace (75 Ω).

Bluetooth General Purpose Bundle (Option 303)

Option 303 provides

- Bluetooth FM Demodulation (Option 106)
- Bluetooth Measurement Personality (Option 228)
- Fast Digitized Time Domain Sweeps (Option AYY)
- Enhanced Memory Upgrade (Option B72)

Bluetooth Measurement Personality (Option 228)

Option 228 provides transmitter and receiver measurements required to test Bluetooth devices. The set of Bluetooth measurements includes:

- Modulation Overview
- Output Power
- Carrier Frequency Drift
- Monitor Band/Channel
- Initial Carrier Frequency Tolerance
- Modulation Characteristics

Option 228 includes: Bluetooth user's guide, Bluetooth quick reference card, Bluetooth measurement guide, and Bluetooth programming commands manual.

Bluetooth FM Demodulation (Option 106) is required for full functionality of this personality.

Bluetooth Premium Bundle (Option 304)

Option 304 provides the following:

- Bluetooth demodulator board (Option 106)
- Bluetooth measurement personality (Option 228)
- high stability frequency reference (Option 1D5)
- digital signal processing and fast ADC (Option B7D)
- RF communications hardware (Option B7E)
- enhanced memory upgrade (Option B72)
- RF preamplifier (Option 1DS)

Cable TV Measurement Personality (Option 227)

Option 227 provides measurement capabilities necessary for installation and service of cable TV.

cdmaOne Measurement Personality (Option BAC)

Option BAC provides transmitter and receiver measurements that comply with various international digital communications standards, including TIA/EIA/IS-95-A, TIA/EIA-95-B, TIA/EIA/IS-97-A, TIA/EIA-97-B, TIA/EIA/IS-98-A, TIA/EIA-98-B, J-STD-008, J-STD-018, J-STD-019, ARIB STD-T53, CKOR, and PKOR. The set of cdmaOne measurements includes:

Options and Accessories

How to Order Options

- channel power
- receiver channel power
- modulation accuracy (RHO)
- code domain power
- receiver spurious
- out-of-band spurious
- harmonics
- occupied bandwidth
- monitor channel/band
- close-in spur

Option BAC includes a cdmaOne user's guide, cdmaOne quick reference card, cdmaOne measurement guide and cdmaOne programming commands manual.

NOTE

For optimum performance of this personality, installation of “RF and Digital Communications Hardware (Option B74)” is recommended.

Color Display (Option 049)

Option 049 provides a color display on ESA-L Series analyzers (E4403B, E4408B, and E4411B). Option 049 is standard on all newer ESA-L Series analyzers and may be retrofitted into older analyzers.

Commercial Calibration with Test Data (Option UK6)

Option UK6 provides the factory calibration test data and the standard commercial calibration certificate on the initial analyzer shipment.

Option UK6 is only available at time of purchase.

Component Level Service Documentation (Option 0BV)

Option 0BV provides a copy of the *Agilent ESA Spectrum Analyzers Component-Level Information*. The component-level information includes parts lists, component-location diagrams, and schematic diagrams for selected repairable assemblies.

Delete Manual Set (Option 0B0)

Option 0B0 deletes copies of the *Agilent ESA Spectrum Analyzers User's Guide*, *Agilent ESA Spectrum Analyzers Calibration Guide*, *Agilent ESA Spectrum Analyzers Specifications Guide - E Series* or *Agilent ESA Spectrum Analyzers Specifications Guide - L Series*, and the *Agilent ESA Spectrum Analyzers Reference Guide*.

Digital Signal Processing and Fast ADC (Option B7D)

Option B7D provides digital signal processing and fast ADC. This option is required for many of the mobile communication measurements in the GSM and cdmaOne measurement personalities. Option B7D must be ordered with Option B7E (RF communications hardware) and Option 1D5 (high stability frequency reference).

For A.07.00 firmware revisions and later, either this option or Option AYZ (Fast Digitized Time Domain Sweeps) is required to perform the PowerStat Complementary Cumulative Distribution Function (PowerStat CCDF) for all radio standards. It is also required to perform the ACP measurement when the NADC radio standard is selected.

Distance to Fault Accessory Kit (Option B7K)

Option B7K includes the 86205A (RF bridge), 11636A (power divider), 909A (coax termination), 11512A (coax short), 8120-8687 (coax cable), and 9211-0050 (padded case).

Distance to Fault Measurement Personality (Option 225)

Option 225 performs a Fast Fourier Transform to calculate the distance to a cable fault. This option must be ordered with 50 Ω Tracking Generator (Option 1DN). This measurement includes on-screen instructional dialog to guide set up and calibration. Velocity factor and cable loss can be user-defined or selected from several different pre-defined cable types.

Enhanced Memory Upgrade (Option B72)

Option B72 provides 2 SIMMS which increases the analyzer's RAM to 32 MBytes and its flash or data storage memory to 16 MBytes (10 MBytes of which are available to the user for data storage).

External Mixing (Option AYZ)

Option AYZ allows the use of Agilent 11970 Series, and Agilent 11974 external mixers with the Agilent E4407B analyzer to extend the frequency range to 110 GHz. Operation to 325 GHz is also possible with non-Agilent mixers.

Fast Digitized Time Domain Sweeps (Option AYX)

Option AYX allows fast digitized sweep times as fast as 20 μ sec in spans of 0 Hz. This option is required to perform the Complementary Cumulative Distribution Function (CCDF) available in A.07.00 firmware revisions and later. Refer to the **Sweep** key description in the user's guide for information about possible sweep times. It also provides the following additional inputs and outputs:

Option AYX - provides the analyzer with additional inputs and outputs. They are as follows: SWP OUT, HI SWP OUT (TTL), HI SWP IN (TTL), AUX VIDEO OUT, and AUX IF OUT.

SWP OUT - sweep ramp output, provides a voltage ramp proportional to the sweep of the analyzer (0 V to 10 V).

HI SWP OUT (TTL) - provides the HI SWP TTL signal as an output (TTL high during a sweep, TTL low during a retrace). It indicates when the analyzer is sweeping

HI SWP IN (TTL) - allows external sweep control. It can be grounded to stop and reset the sweep.

AUX VIDEO OUT - provides detected video output (before the analog-to-digital conversion) proportional to vertical deflection of the trace.

AUX IF OUT - provides a 50 Ω , 21.4 MHz IF output that is the down-converted signal of the RF input of the analyzer.

For A.07.00 firmware revisions and later, either this option or Option B7D (Digital Signal Processing and Fast ADC) is required to perform the PowerStat Complementary Cumulative Distribution Function (PowerStat CCDF) for all radio standards. It is also required to perform the ACP measurement when the NADC radio standard is selected.

Firmware Upgrade Kit (Option UE2)

Option UE2 provides the most current ESA spectrum analyzer firmware on 3-1/2 inch floppy disks.

FM Demodulation (Option BAA)

Option BAA allows you to demodulate, display and measure deviation on FM modulated signals. You can listen to audio signals on a built-in speaker or with an earphone.

Option BAA provides the following additional port:

EXT VIDEO OUT - provides a detected video output (before the analog-to-digital conversion) proportional to the vertical deflection of the trace (75 Ω).

Front Panel Protective Cover (Option UK9)

The cover assembly snaps onto the front of your analyzer to protect the front panel during travel and when the unit is not in use. The front panel protective cover includes a storage compartment to house small accessories or cables.

GPIB and Parallel Interface (Option A4H)

Option A4H allows you to control your analyzer from a computer that uses a general purpose interface bus (GPIB). Option A4H includes an GPIB connector, a parallel interface connector for printers, a CD-ROM containing IntuiLink Toolbar software¹, and the *Agilent ESA Spectrum Analyzers Programmer's Guide*.

Option A4H allows the analyzer to copy its display to a printer.

GSM Measurement Personality (Option BAH)

Option BAH provides transmitter and receiver measurements that comply with various international digital communications standards, including ETS 300 607-1, ETS 300 609-1, ETS 300 910, and J-STD-007. The set of GSM measurements includes, transmit power, power steps, power versus time, spurious emissions suite, intermodulation attenuation suite, phase and frequency error, cable fault location suite, slow frequency hopping cycle verification, monitor suite, and output RF spectrum suite. Option BAH includes a GSM user's guide, GSM quick reference card, GSM measurement guide, and programming commands manual.

Hard Transit Case (Option AXT)

Option AXT provides a hard transit case. The hard transit case will survive commercial transportation. This rugged case has two wheels and an extendible handle for easy transport. The case can also accommodate two battery packs and ac adapters.

High Stability Frequency Reference (Option 1D5)

Option 1D5 improves the frequency reference accuracy. The analyzer's synthesizer is phase locked to an oven controlled crystal oscillator (OCXO), instead of the standard VCXO.

IF, Sweep and Video Ports (Option A4J)

Option A4J provides the analyzer with additional inputs and outputs. They are as follows: SWP OUT, HI SWP OUT (TTL), HI SWP IN (TTL), AUX VIDEO OUT, and AUX IF OUT.

SWP OUT - sweep ramp output, provides a voltage ramp proportional to the sweep

1. This program allows you to download spectrum analyzer display or data files to a personal computer using Microsoft® Word or Microsoft® Excel. Benchlink installation instructions are included with the CD-ROM.

Options and Accessories

How to Order Options

of the analyzer (0 V to 10 V).

HI SWP OUT (TTL) - provides the HI SWP TTL signal as an output (TTL high during a sweep, TTL low during a retrace). It indicates when the analyzer is sweeping.

HI SWP IN (TTL) - allows external sweep control. It can be grounded to stop sweeping.

AUX VIDEO OUT - provides detected video output (before the analog-to-digital conversion) proportional to vertical deflection of the trace.

AUX IF OUT - provides a 50 Ω , 21.4 MHz IF output that is the down-converted signal of the RF input of the analyzer.

Low Emission (Option 060)

Option 060 provides reduced radiated and conducted emissions to comply with EN55011 Class B requirements. This option applies during ac operation only.

Option 060 is incompatible with TV Trigger (Option B7B).

Low Frequency Extension (Option UKB)

Option UKB extends the frequency range of the analyzer on the low end to 100 Hz when DC coupling is selected. This option requires installation of “[Narrow Resolution Bandwidth \(Option 1DR\)](#)” on ESA models E4402B, E4404B, E4405B, and E4407B.

Narrow Resolution Bandwidth (Option 1DR)

This option provides additional narrow resolution bandwidths of 10 Hz, 30 Hz, 100 Hz, and 300 Hz and 200 Hz EMI. These bandwidths improve the analyzer sensitivity and allow you to resolve closely spaced signals.

Noise Figure Measurement Personality and Hardware (Option 219)

This option provides noise figure and gain measurement capability on the ESA-E Series spectrum analyzers. Support for Agilent Technologies SNS Series Noise Sources, and for normal noise sources, such as the HP/Agilent 346-Series noise sources, is provided.

Operating and Carrying Cases (Option AYT/AYU)

Options AYT and AYU are protective soft operating and carrying cases. Option AYT is made of gray rip-stop nylon and Option ATU is made of yellow rip-stop nylon. An outside pocket holds manuals or other accessories. A reinforced adjustable padded shoulder strap provides ergonomic distribution between your hand and shoulder. The front and rear panel soft covers adjust to be compatible with the front panel protective hard cover (Option UK9) and snap on battery pack

(Agilent E1779B). Side ventilation allows for operation without removal, but the maximum operating temperature is reduced to 45 °C.

Performance Bundle (Option B75)

Option B75 provides the pre-amplifier, narrow resolution bandwidths, and high stability frequency reference. Refer to Options 1DS, 1DR, and 1D5 for details.

This option is only available at time of purchase.

Phase Noise Measurement Personality (Option 226)

Option 226 provides an automatic log plot display of phase noise (dBc/Hz) vs. log offset frequency. It includes spot frequency and RMS noise. High Stability Frequency Reference (*Option 1D5*) is recommended.

Pre-amplifier (Option 1DS)

The pre-amplifier improves the analyzer's sensitivity (lowers the noise floor) by approximately 16 dB.

Rack Mount Kit With Handles (Option 1CP)

Option 1CP provides the parts necessary to mount the analyzer in an Agilent System II cabinet or in a standard 19 inch (482.6 mm) equipment rack. It includes front handles and rack slides for added convenience.

RF and Digital Communications Hardware (Option B74)

Option B74 includes the RF Communications Hardware (*Option B7E*), Digital Signal Processing and Fast ADC (*Option B7D*), Time-Gated Spectrum Analysis (*Option 1D6*), Memory Extension (*Option B72*), High Stability Frequency Reference (*Option 1D5*), Preamplifier (*Option 1DS*), and Narrow Resolution Bandwidth (*Option 1DR*) assemblies. These assemblies are required for optimum performance of the cdmaOne (*Option BAC*) or GSM measurement personality (*Option BAH*).

RF Communications Hardware (Option B7E)

Option B7E provides the communications hardware required for many digital communication measurements. Option B7E must be ordered with Option B7D (digital signal processing and fast ADC) and Option 1D5 (high stability frequency reference).

RS-232 and Parallel Interface (Option 1AX)

Option 1AX allows you to control your analyzer from a computer that uses an RS-232 interface. It includes a 2.5 meter 9-pin (f) to 9-pin (f) connector RS-232

cable (Agilent 5182-4794), a parallel interface connector for printers, a CD-ROM containing IntuiLink Toolbar software¹, and the *Agilent ESA Spectrum Analyzers Programmer's Guide*.

Option 1AX allows the analyzer to copy its display to a printer.

Service Documentation (Option 0BW)

Option 0BW provides a paper copy and PDF on CDROM version of the *Agilent ESA Spectrum Analyzers Service Guide*. Also included is the ESA Specifications Guide, Calibration Guide, and Instrument Messages and Functional Tests, and the ESA Documentation Set on CDROM.

Time-Gated Spectrum Analysis (Option 1D6)

Option 1D6 allows you to selectively measure the spectrum of signals that may overlap in the frequency domain, but are separated in the time domain. By adjusting a time gate based on a user-supplied trigger signal, you can significantly increase the diagnostic capability of your spectrum analyzer for time-interleaved signals.

TV Trigger and Picture on Screen (Option B7B)

Option B7B requires Option BAA.

Option B7B allows you to trigger the analyzer sweep on a TV line of a demodulated TV waveform and view TV images in NTSC, PAL and SECAM standards on the analyzer display.

Option B7B provides the following additional ports:

EXT VIDEO IN/TV TRIG OUT - provides a shared baseband video input and a TTL output for the TV trigger (output through 75 Ω source impedance).

EXT VIDEO OUT - provides a detected video output (before the analog-to-digital conversion) proportional to the vertical deflection of the trace (similar to Option BAA alone), and provides passthrough of the signal at EXT VIDEO IN/TV TRIG OUT, if selected (75 Ω).

1. This program allows you to download spectrum analyzer display or data files to a personal computer using Microsoft® Word or Microsoft® Excel. Benchlink installation instructions are included with the CD-ROM.

Accessories

A number of accessories are available from Agilent Technologies to help you configure your analyzer for your specific applications. They can be ordered through your local Agilent Sales and Service Office and are listed below in alphabetical order by name.

50 Ω /75 Ω Minimum Loss Pad

The Agilent 11852B is a low VSWR minimum loss pad that allows you to make measurements on 75 Ω devices using an analyzer with a 50 Ω input. It is effective over a frequency range of dc to 2 GHz.

75 Ω Matching Transformer

The Agilent 11694A allows you to make measurements in 75 Ω systems using an analyzer with a 50 Ω input. It is effective over a frequency range of 3 to 500 MHz.

AC Probe

The Agilent 85024A high frequency probe performs in-circuit measurements without adversely loading the circuit under test. The probe has an input capacitance of 0.7 pF shunted by 1 M Ω of resistance and operates over a frequency range of 300 kHz to 3 GHz. High probe sensitivity and low distortion levels allow measurements to be made while taking advantage of the full dynamic range of the spectrum analyzer.

The Agilent 41800A low frequency probe has a low input capacitance and a frequency range of 5 Hz to 500 MHz.

Broadband Preamplifiers and Power Amplifiers

Preamplifiers and power amplifiers can be used with your spectrum analyzer to enhance measurements of very low-level signals.

The Agilent 8447D preamplifier provides a minimum of 25 dB gain from 100 kHz to 1.3 GHz.

The Agilent 87405A preamplifier provides a minimum of 22 dB gain from 10 MHz to 3 GHz. (Power is supplied by the probe power output of the analyzer.)

The Agilent 85905A CATV 75 ohm preamplifier provides a minimum of 18 dB gain from 45 MHz to 1 GHz. (Power is supplied by the probe power output of the analyzer.)

The 11909A low noise preamplifier provides a minimum of 32 dB gain from 9 kHz to 1 GHz and a typical noise figure of 1.8 dB.

Carrying Strap (Part Number E4401-60028)

This carrying strap comes with Options AYT and AYU. It can also be ordered separately and used with Agilent ESA spectrum analyzers.

External Keyboard

The HP C1405B keyboard is an IBM AT compatible keyboard that can be connected to the external keyboard connector on the front panel of the analyzer. You may use any IBM AT compatible keyboard with a mini DIN connector. Screen titles and filenames can be entered with the external keyboard.

GPIB Cable

For use with Option A4H. The Agilent 10833 Series GPIB cables interconnect GPIB devices and are available in four different lengths. GPIB cables are used to connect controllers to a spectrum analyzer.

Agilent 11970 Series Harmonic Mixers

The 11970 Series harmonic mixers are available to extend the frequency range of analyzers with Option AYZ (external mixing) up to 110 GHz. The following six models are available:

Table 4-2

Agilent Model Number	Frequency Range
11970K	18.0 to 26.5 GHz
11970A	26.5 to 40.0 GHz
11970Q	33.0 to 50.0 GHz
11970U	40.0 to 60.0 GHz
11970V	50.0 to 75.0 GHz
11970W	75.0 to 110 GHz

Agilent 11974 Series Preselected Millimeter Mixers

11974 Series preselected millimeter mixers are available to extend the frequency range of analyzers with Option AYZ (external mixing) up to 75 GHz. Preselection reduces mixer overload from broadband signals, reduces radiation of local oscillator harmonics back to the device under test, and reduces the level of image

and multiple responses displayed. The following four models are available:

Table 4-3

Agilent Model Number	Frequency Range
11974A	26.5 to 40.0 GHz
11974Q	33.0 to 50.0 GHz
11974U	40.0 to 60.0 GHz
11974V	50.0 to 75.0 GHz

Agilent E1779BA Battery Pack

The E1779BA is a battery pack that will power an Agilent ESA spectrum analyzer for 80 to 114 minutes, depending on the options installed in the analyzer. Refer to the *E1779BA Battery Pack User's Guide* for more information.

Parallel Interface Cable

For use with Option A4H and 1AX. The Agilent C2950A parallel interface cable is a 36-pin to 25-pin male-to-male 2 meter cable used to connect supported printers to a spectrum analyzer. This cable is IEEE-1284 compliant.

Printer

For use with Option A4H or 1AX. The DeskJet personal printers provide black and white or color printing for another form of permanent records of your test results. The HP LaserJet series printers are also compatible. The printers connect to the parallel interface installed on the spectrum analyzer with either Option A4H or 1AX.

RF and Transient Limiters

The Agilent 11867A and 11693A RF Limiters protect the spectrum analyzer input circuits from damage due to high power levels. The 11867A operates over a frequency range of dc to 1800 MHz and begins reflecting signal levels over 1 mW up to 10 W average power and 100 watts peak power. The 11693A microwave limiter (0.1 to 12.4 GHz, usable to 18 GHz) guards against input signals over 1 milliwatt up to 1 watt average power and 10 watts peak power.

The 11947A Transient Limiter protects the spectrum analyzer input circuits from damage due to signal transients. It specifically is needed for use with a line impedance stabilization network (LISN). It operates over a frequency range of 9 kHz to 200 MHz, with 10 dB of insertion loss.

RF Bridges

The Agilent 86205A 50 Ω RF bridge and 86207A 75 Ω RF bridge can be used to make reflection measurements using an analyzer with tracking generator Option 1DN or 1DQ or with an external signal generator. These external directional bridges offer high directivity and excellent port match. The 86205A operates over a frequency range of 300 kHz to 6 GHz. The 86207A operates over a frequency range of 300 kHz to 3 GHz.

RS-232 Cable

For use with Option 1AX. The HP 24542G is a 3 meter 9-pin (f) to 25-pin (m) RS-232 cable. The HP 24542U is a 3 meter 9-pin (f) to 9-pin (f) RS-232 cable for serial 9-pin PC connection to an analyzer. The modem cable required is HP 24542M 9-pin (f) to 25-pin (m), and the PC cable is HP 24542U. The Agilent 5182-4794 is a 2.5 meter 9-pin (f) to 9-pin (f) RS-232 cable for serial 9-pin PC connection to an analyzer (included with Option 1AX).

5 **Parts List**

What You Will Find in This Chapter

This chapter contains information for identifying and ordering replacement assemblies.

Major assembly location information is provided in [Chapter 6](#).

Component level information containing material lists, schematics, and component location diagrams, is available separately.

The following tables are included in this chapter:

- [Table 5-1](#) lists reference designator descriptions.
- [Table 5-2](#) lists abbreviations used in the parts list.
- [Table 5-3](#) lists value multipliers.
- [Table 5-4](#) lists replacement parts.

How to Order Parts

To order an assembly or mechanical part listed in this chapter, quote the Agilent Technologies, Inc. part number and indicate the quantity required.

To order a part that is *not* listed, include the following information with the order:

- o Analyzer model number.
- o Analyzer serial number.
- o Description of where the part is located, what it looks like, and its function (if known).
- o Quantity needed

Parts can be ordered by addressing the order to the nearest Agilent Technologies, Inc. office. Customers within the USA can also use either the direct mail-order system, or the direct phone-order system described below. The direct phone-order system has a toll-free phone number available.

Direct Mail-Order System

Within the USA, Agilent Technologies, Inc. can supply parts through a direct mail-order system. Advantages of using the system are as follows:

- o Direct ordering and shipment from Agilent Technologies, Inc.
- o No maximum or minimum on any mail order. (There is a minimum order amount for parts ordered through a local Agilent Technologies, Inc. office when the orders require billing and invoicing.)
- o Prepaid transportation. (There is a small handling charge for each order.)
- o No invoices.

To provide these advantages, a check or money order must accompany each order. Mail-order forms and specific ordering information are available through your local Agilent Technologies, Inc. office.

Direct Phone-Order System

Within the USA, a phone order system is available for regular and hotline replacement parts service. A toll-free phone number is available, and Mastercard and Visa are accepted. Outside the USA, get in touch with your local sales and service office. Refer to [“Contacting Agilent Technologies”](#) on page 241.

General Information

Table 5-1 Reference Designations

REFERENCE DESIGNATIONS					
A	Assembly	F	Fuse	T	Transformer
AT	Attenuator, Isolator, Limiter, Termination	FL	Filter	TB	Terminal Board
B	Fan, Motor	HY	Circulator	TC	Thermocouple
BT	Battery	J	Electrical Connector (Stationary Portion), Jack	TP	Test Point
C	Capacitor	K	Relay	U	Integrated Circuit, Microcircuit
CP	Coupler	L	Coil, Inductor	V	Electron Tube
CR	Diode, Diode Thyristor, Step Recovery Diode, Varactor	M	Meter	VR	Breakdown Diode (Zener), Voltage Regulator
DC	Directional Coupler	MP	Miscellaneous Mechanical Part	W	Cable, Wire, Jumper
DL	Delay Line	P	Electrical Connector (Movable Portion), Plug	X	Socket
DS	Annunciator, Lamp, Light Emitting Diode (LED), Signaling Device (Visible)	Q	Silicon Controlled Rectifier (SCR), Transistor, Triode Thyristor	Y	Crystal Unit (Piezoelectric, Quartz)
E	Miscellaneous Electrical Part	R	Resistor	Z	Tuned Cavity, Tuned Circuit
		RT	Thermistor		
		S	Switch		

Table 5-2 Abbreviations

A	
A	Across Flats, Acrylic, Air (Dry Method), Ampere
ADJ	Adjust, Adjustment
ANSI	American National Standards Institute (formerly USASI-ASA)
ASSY	Assembly
AWG	American Wire Gage
B	
BCD	Binary Coded Decimal
BD	Board, Bundle
BE-CU	Beryllium Copper
BNC	Type of Connector
BRG	Bearing, Boring
BRS	Brass
BSC	Basic
BTN	Button
C	
C	Capacitance, Capacitor, Center Tapped, Cermet, Cold, Compression
CCP	Carbon Composition Plastic
CD	Cadmium, Card, Cord
CER	Ceramic
CHAM	Chamfer
CHAR	Character, Characteristic, Charcoal
CMOS	Complementary Metal Oxide Semiconductor
CNDCT	Conducting, Conductive, Conductivity, Conductor
CONT	Contact, Continuous Control, Controller

Table 5-2 Abbreviations (Continued)

CONV	Converter
CPRSN	Compression
CUP-PT	Cup Point
CW	Clockwise, Continuous Wave
D	
D	Deep, Depletion, Depth, Diameter, Direct Current
DA	Darlington
DAP-GL	Diallyl Phthalate Glass
DBL	Double
DCDR	Decoder
DEG	Degree
D-HOLE	D-Shaped Hole
DIA	Diameter
DIP	Dual In-Line Package
DIP-SLDR	Dip Solder
D-MODE	Depletion Mode
DO	Package Type Designation
DP	Deep, Depth, Diametric Pitch, Dip
DP3T	Double Pole Three Throw
DPDT	Double Pole Double Throw
DWL	Dowell
E	
E-R	E-Ring
EXT	Extended, Extension, External, Extinguish
F	
F	Fahrenheit, Farad, Female, Film (Resistor), Fixed, Flange, Frequency

Table 5-2 Abbreviations (Continued)

FC	Carbon Film/Composition, Edge of Cutoff Frequency, Face
FDTHRU	Feedthrough
FEM	Female
FIL-HD	Fillister Head
FL	Flash, Flat, Fluid
FLAT-PT	Flat Point
FR	Front
FREQ	Frequency
FT	Current Gain Bandwidth Product (Transition Frequency), Feet, Foot
FXD	Fixed
G	
GEN	General, Generator
GND	Ground
GP	General Purpose, Group
H	
H	Henry, High
HDW	Hardware
HEX	Hexadecimal, Hexagon, Hexagonal
HLCL	Helical
HP	Hewlett-Packard Company, High Pass
I	
IC	Collector Current, Integrated Circuit
ID	Identification, Inside Diameter
IF	Forward Current, Intermediate Frequency
IN	Inch
INCL	Including

Table 5-2 Abbreviations (Continued)

INT	Integral, Intensity, Internal
J	
J-FET	Junction Field Effect Transistor
JFET	Junction Field Effect Transistor
K	
K	Kelvin, Key, Kilo, Potassium
KNRLD	Knurled
KVDC	Kilovolts Direct Current
L	
LED	Light Emitting Diode
LG	Length, Long
LIN	Linear, Linearity
LK	Link, Lock
LKG	Leakage, Locking
LUM	Luminous
M	
M	Male, Maximum, Mega, Mil, Milli, Mode
MA	Milliampere
MACH	Machined
MAX	Maximum
MC	Molded Carbon Composition
MET	Metal, Metallized
MHz	Megahertz
MINTR	Miniature
MIT	Miter
MLD	Mold, Molded
MM	Magnetized Material, Millimeter
MOM	Momentary
MTG	Mounting

Table 5-2 Abbreviations (Continued)

MTLC	Metallic
MW	Milliwatt
N	
N	Nano, None
N-CHAN	N-Channel
NH	Nanohenry
NM	Nanometer, Nonmetallic
NO	Normally Open, Number
NOM	Nominal
NPN	Negative Positive Negative (Transistor)
NS	Nanosecond, Non-Shorting, Nose
NUM	Numeric
NYL	Nylon (Polyamide)
O	
OA	Over-All
OD	Outside Diameter
OP AMP	Operational Amplifier
OPT	Optical, Option, Optional
P	
PA	Picoampere, Power Amplifier
PAN-HD	Pan Head
PAR	Parallel, Parity
PB	Lead (Metal), Pushbutton
PC	Printed Circuit
PCB	Printed Circuit Board
P-CHAN	P-Channel
PD	Pad, Power Dissipation
PF	Picofarad, Power Factor
PKG	Package

Table 5-2 Abbreviations (Continued)

PLSTC	Plastic
PNL	Panel
PNP	Positive Negative Positive (Transistor)
POLYC	Polycarbonate
POLYE	Polyester
POT	Potentiometer
POZI	Pozidrive Recess
PREC	Precision
PRP	Purple, Purpose
PSTN	Piston
PT	Part, Point Pulse Time
PW	Pulse Width
Q	
Q	Figure of Merit
R	
R	Range, Red, Resistance, Resistor, Right, Ring
REF	Reference
RES	Resistance, Resistor
RF	Radio Frequency
RGD	Rigid
RND	Round
RR	Rear
RVT	Rivet, Riveted
S	
SAWR	Surface Acoustic Wave Resonator
SEG	Segment
SGL	Single
SI	Silicon, Square Inch
SL	Slide, Slow

Table 5-2 Abbreviations (Continued)

SLT	Slot, Slotted
SMA	Subminiature, A Type (Threaded Connector)
SMB	Subminiature, B Type (Slip-on Connector)
SMC	Subminiature, C-Type (Threaded Connector)
SPCG	Spacing
SPDT	Single Pole Double Throw
SPST	Single Pole Single Throw
SQ	Square
SST	Stainless Steel
STL	Steel
SUBMIN	Subminiature
SZ	Size
T	
T	Teeth, Temperature, Thickness, Time, Timed, Tooth, Typical
TA	Ambient Temperature, Tantalum
TC	Temperature Coefficient
THD	Thread, Threaded
THK	Thick
TO	Package Type Designation
TPG	Tapping
TR-HD	Truss Head
TRMR	Trimmer
TRN	Turn, Turns
TRSN	Torsion
U	
UCD	Microcandela
UF	Microfarad

Table 5-2 Abbreviations (Continued)

UH	Microhenry
UL	Microliter, Underwriters' Laboratories, Inc.
UNHDND	Unhardened
V	
V	Variable, Violet, Volt, Voltage
VAC	Vacuum, Volts—Alternating Current
VAR	Variable
VDC	Volts— Direct Current
W	
W	Watt, Wattage, White, Wide, Width
W/SW	With Switch
WW	Wire Wound
X	
X	By (Used with Dimensions), Reactance
Y	
YIG	Yttrium-Iron-Garnet
Z	
ZNR	Zener

Table 5-3 Multipliers

MULTIPLIERS					
Abbreviation	Prefix	Multiple	Abbreviation	Prefix	Multiple
T	tera	10^{12}	m	milli	10^{-3}
G	giga	10^9	μ	micro	10^{-6}
M	mega	10^6	n	nano	10^{-9}
k	kilo	10^3	p	pico	10^{-12}
da	deka	10	f	femto	10^{-15}
d	deci	10^{-1}	a	atto	10^{-18}
c	centi	10^{-2}			

Replaceable Parts

Table 5-4 Assembly Level Replaceable Parts

Reference Designator	Description	Agilent Part Number	E4401B/ E4411B	E4402B/ E4403B	E4404B	E4405B	E4407B/ E4408B
A1A1	Front Panel Interface Board Kit	E4401-60241	X	X	X	X	X
A1A1A1	Rotary Pulse Generator	1990-1865	X	X	X	X	X
A1A1MP1	Backlight Inverter Shield	E4401-00046	X	X	X	X	X
A1A1W1	Backlight Inverter Cable	8120-8482	X	X	X	X	X
A1A1A2	Volume Rotary Pulse Generator	0960-0892	X	X	X	X	X
A1A2	Liquid Crystal Display Assembly Kit (Serial Prefix \geq US4119)	E4401-60242	X	X	X	X	X
	Liquid Crystal Display Assembly Kits (one each required) (Serial Prefix $<$ US4119)	E4401-60241	X	X	X	X	X
		E4401-60242	X	X	X	X	X
A1A2A2	Backlight Inverter Board	0950-3644	X	X	X	X	X
A1A2DS1	Display Backlight, Upper	E4401-60241 & E4401-60242	X	X	X	X	X
	<ul style="list-style-type: none"> LCD with white backing on rear of LCD. 	2090-0380					
A1A2DS2	Display Backlight, Lower	E4401-60241 & E4401-60242	X	X	X	X	X
		2090-0380					
A1A2MP1	LCD Bracket	E4401-00034	X	X	X	X	X
A1A3	Front Frame Assembly (except Option 060) (includes A1A3MP9)	E4401-60257	X	X	X	X	X
	Front Frame Assembly (50 Ω) (Option 060) (includes A1A3MP9)	E4401-60259	X	X	X	X	X
A1A3MP9	Lens/Keypad Assembly (except Option 060)	E4401-60127	X	X	X	X	X
	Lens/Keypad Assembly (Option 060)	E4401-60256	X	X	X	X	X
A1A4	Rear Frame Assembly	E4401-60160	X	X	X	X	X
A1A5	Shock Spreader Assembly	E4403-60032		X	X	X	X

Table 5-4 Assembly Level Replaceable Parts

Reference Designator	Description	Agilent Part Number	E4401B/ E4411B	E4402B/ E4403B	E4404B	E4405B	E4407B/ E4408B
A1MP3	Subpanel Kit	E4401-60104	X	X	X	X	X
A1MP4	Flex Circuit, Main	E4401-60198	X	X	X	X	X
A1MP5	Main Keypad	E4401-40002	X	X	X	X	X
A1MP7	RPG Knob	0370-3229	X	X	X	X	X
A1MP8	Volume Knob	0370-3230	X	X	X	X	X
A1MP10	Front Panel Connector Cover	E4401-40006	X	X	X	X	X
A1MP12	Media Bezel with Gasket	E4401-60197	X	X	X	X	X
A1MP13	Volume Knob Gasket	E4401-20044	X	X	X	X	X
A1MP14	Media Door	E4401-40004	X	X	X	X	X
A1MP15	Tracking Generator I/O Hole Plug	E4401-40020	X	X	X	X	X

Parts List
Replaceable Parts

Table 5-4 Assembly Level Replaceable Parts

Reference Designator	Description	Agilent Part Number	E4401B/ E4411B	E4402B/ E4403B	E4404B	E4405B	E4407B/ E4408B
A1MP16	Model ID Nameplate, 1.5 GHz (50 Ω) (E4411B)	E4411-80012	X				
	Model ID Nameplate, 1.5 GHz (75 Ω) (E4411B) (Option 1DP)	E4411-80013	X				
	Model ID Nameplate, 1.5 GHz (75 Ω) (E4411B) (Option HD _x)	E4411-80014	X				
	Model ID Nameplate, 1.5 GHz (50 Ω) (E4401B)	E4401-80027	X				
	Model ID Nameplate, 1.5 GHz (75 Ω) Option 1DP (E4401B)	E4401-80028	X				
	Model ID Nameplate, 3.0 GHz (50 Ω) (E4402B)	E4402-80002		X			
	Model ID Nameplate, 3.0 GHz (50 Ω) (E4402B) (Option UKB)	E4403-80016		X			
	Model ID Nameplate, 3.0 GHz (50 Ω) (E4403B)	E4403-80008		X			
	Model ID Nameplate, 6.7 GHz (50 Ω) (E4404B)	E4404-80004			X		
	Model ID Nameplate, 6.7 GHz (50 Ω) (E4404B) (Option UKB)	E4404-80008			X		
	Model ID Nameplate, 13.2 GHz (50 Ω) (E4405B)	E4405-80003				X	
	Model ID Nameplate, 13.2 GHz (50 Ω) (E4405B) (Option UKB)	E4405-80006				X	
	Model ID Nameplate, 26.5 GHz (50 Ω) (E4407B)	E4407-80003					X
	Model ID Nameplate, 26.5 GHz (50 Ω) (E4407B) (Option UKB)	E4407-80006					X
	Model ID Nameplate, 26.5 GHz (50 Ω) (E4408B)	E4408-80003					X
A1MP17	Front Frame Grounding Clip Kit (5 pieces)	E4401-00054	X	X	X	X	X
A1MP18	RF Input Connector Gasket (50 Ω)	E4403-20046	X	X	X	X	X
A1MP19	TG Output Connector Gasket (50 Ω) (Option 1DN)	E4403-20046	X	X	X	X	X
A1MP20	Amptd Ref Out/Ext Mixer Gasket	E4401-20089	X	X	X	X	X

Table 5-4 Assembly Level Replaceable Parts

Reference Designator	Description	Agilent Part Number	E4401B/ E4411B	E4402B/ E4403B	E4404B	E4405B	E4407B/ E4408B
A1MP21	Connector Label, (50 Ω)	E4401-80003	X				
	Connector Label, (75 Ω)	E4401-80002	X				
	Connector Label, 3 GHz (except Option UKB)	E4403-80002		X			
	Connector Label, 3 GHz (Option UKB) (E4402B)	E4403-80015		X			
	Connector Label, 6.7GHz (except Option UKB)	E4404-80001			X		
	Connector Label, 6.7GHz (Option UKB)	E4404-80007			X		
	Connector Label, 13.2 GHz (except Option UKB)	E4405-80001				X	
	Connector Label, 13.2 GHz (Option UKB)	E4405-80005				X	
	Connector Label, 26.5GHz	E4407-80001					X
	Connector Label, External Mixing Connector (E4407B) (Option AYZ)	E4407-80005					X
	Connector Label, 26.5GHz (E4407B) (Option UKB)	E4407-80007					X
	Connector Label, 26.5GHz (E4407B) (Options UKB and AYZ)	E4407-80008					X
	A2	1.5 GHz Tracking Generator Assembly (50 Ω) (Option 1DN)	E4401-60128	X			
1.5 GHz Tracking Generator Assembly (75 Ω) (Option 1DQ)		E4401-60129	X				
A2A1	1.5 GHz Tracking Generator Control Board Kit, (Option 1DN/1DQ)	E4401-60131	X				
	3.0 GHz Tracking Generator Driver Board Assy with shields, (Option 1DN)	E4403-60043		X	X	X	X
	3.0 GHz Tracking Generator Driver Board Assy with shields, (Option 1DN) exchange	E4403-69043		X	X	X	X

Parts List
Replaceable Parts

Table 5-4 Assembly Level Replaceable Parts

Reference Designator	Description	Agilent Part Number	E4401B/ E4411B	E4402B/ E4403B	E4404B	E4405B	E4407B/ E4408B
A2A2	1.5 GHz Tracking Generator RF Board Kit (50 Ω) (<i>Option 1DN</i>)	E4401-60133	X				
	1.5 GHz Tracking Generator RF Board Kit (75 Ω) (<i>Option 1DQ</i>)	E4401-60134	X				
	3.0 GHz BITG Microcircuit Assembly, (<i>Option 1DN and not HSB</i>)	E4403-60089		X	X	X	X
	3.0 GHz BITG Microcircuit, (<i>Option HSB</i>)	5087-7705		X	X	X	X
A2A3	1.5 GHz TG Output Board (50 Ω) (<i>Option 1DN</i>)	E4401-60135	X				
	1.5 GHz TG Output Board (75 Ω) (<i>Option 1DQ</i>)	E4401-60136	X				
	3.0 GHz TG Output Attenuator (without Bracket A2MP5), (<i>Option 1DN</i>)	0955-0679		X	X	X	X
A2J1	Type-N Connector, 1.5 GHz TG RF Output (50 Ω) (<i>Option 1DN</i>)	1250-2514	X				
	BNC Connector, 1.5 GHz TG RF Output (75 Ω) (<i>Option 1DQ</i>)	1250-2792	X				
	Type-N Connector Kit, 3.0 GHz TG RF Output, (<i>Option 1DN</i>)	E4403-60015		X	X	X	X
A2MP1	Gasket–BNC, 1.5 GHz TG RF Output Connector (75 Ω) (<i>Option 1DN/1DQ</i>)	E4401-20024	X				
A2MP2	3.0 GHz TG Support Shield, (<i>Option 1DN</i>)	E4403-60007		X	X	X	X
A2MP3	3.0 GHz TG Cover Shield, (<i>Option 1DN</i>)	E4403-60006		X	X	X	X
A2MP4	1.5 GHz TG Center Shield, (<i>Options 1DN/1DQ</i>)	E4401-60052	X				
A2MP5	3.0 GHz Attenuator Bracket (<i>Option 1DN</i>)	E4403-00004		X	X	X	X
A2MP7	1.5 GHz TG Control Shield, (<i>Options 1DN/1DQ</i>)	E4401-60051	X				
A2MP9	1.5 GHz TG RF Shield, (<i>Options 1DN/1DQ</i>)	E4401-60050	X				

Table 5-4 Assembly Level Replaceable Parts

Reference Designator	Description	Agilent Part Number	E4401B/ E4411B	E4402B/ E4403B	E4404B	E4405B	E4407B/ E4408B
A2W1	Cable Assembly, 1.5 GHz TG (Internal Ribbon) (<i>Options 1DN/1DQ</i>)	8120-6944	X				
	Cable Assembly, 3.0 GHz TG Power and Control (Wire Harness) (<i>Option 1DN</i>)	E4403-60025		X	X	X	X
A2W2	Cable Assembly, 1.5 GHz TG (Internal Coaxial) (<i>Options 1DN/1DQ</i>)	8120-6384	X				
	Cable Assembly, 3.0 GHz TG LO Drive (Semi-rigid) (<i>Option 1DN</i>)	E4403-20072 E4403-20083		X	X	X	X
A2W3	Cable Assembly, 3.0 GHz TG RF Output (Semi-rigid) (<i>Option 1DN</i>)	E4403-20073		X	X	X	X
A2W4	Cable Assembly, 3.0 GHz TG Attenuator RF Output (Semi-rigid) (<i>Option 1DN</i>)	E4403-20022		X	X	X	X
A3	IF Assembly with Shields	E4401-60401	X	X	X	X	X
A4	Processor Assembly, Enhanced Memory (<i>Option B72</i>)	E4401-60233	X	X	X	X	X
A4A1	12 MB Flash SIMM, (<i>Option B72</i>)	E4401-60081	X	X	X	X	X
	4 MB Flash SIMM	E4401-60105	X	X	X	X	X
A4A2	32 MB DRAM SIMM, (<i>Option B72</i>)	1818-6431	X	X	X	X	X
	16 MB DRAM SIMM	1818-6430C	X	X	X	X	X
A4MAU58	3 V Lithium Battery	1420-0556	X	X	X	X	X
A5	Power Supply Assembly	E4401-60222	X	X	X	X	X
A5B1	Fan	3160-0866	X	X	X	X	X
A5F1	Fuse (dc) 20 A, 32 V	2110-1317	X	X	X	X	X
	DC Fuse kit w/label	E4401-60286	X	X	X	X	X
A5F2	Fuse (Line) 5 A, 250 V	2110-0709	X	X	X	X	X
A5MP1-4	Plastic Rivet	0361-1814	X	X	X	X	X
A6	Speaker/Floppy Assembly	E4401-60368	X	X	X	X	X
A6MP1	Transportation Disk	1150-1806	X	X	X	X	X
A7	Motherboard (ESA E-Series)	E4401-60107	X	X	X	X	X
	Motherboard (ESA L-Series)	E4411-60013	X	X			X
A7A1	IF Video Sweep Ports, (<i>Option A4J</i>)	E4401-60096	X	X	X	X	X

Parts List
Replaceable Parts

Table 5-4 Assembly Level Replaceable Parts

Reference Designator	Description	Agilent Part Number	E4401B/ E4411B	E4402B/ E4403B	E4404B	E4405B	E4407B/ E4408B
A7A2	GPIB Assembly, (Option A4H)	E4401-60367	X	X	X	X	X
A7A3	RS-232 Assembly, (Option IAX)	E4401-60366	X	X	X	X	X
A7A4	Frequency Extension Assembly	E4404-60001			X	X	X
A7A5	Fast ADC Assembly, (Option AYX) ^a	E4401-60083	X	X	X	X	X
A7A6	FM Demod Assembly, (Option BAA) ^a	E4401-60343 ^b	X	X	X	X	X
A7A7	Digital Demod DSP Assembly, (Option B7D) ^c	E4401-60088		X	X	X	X
A7A8	Digital Demod RF Assembly, (Option B7E) ^d	E4401-60295		X	X	X	X
A7A9	ACPR Dynamic Range Extension Assembly, (Option I20)	E4403-60065		X	X	X	X
A7A10	Bluetooth FM Demodulator	E4401-60223		X	X	X	X
A7A11	Quasi Peak Detector Assembly, (Option HYQ)	E7401-60003	X	X	X	X	X
A7A12	IF Out Assembly (Option H55)	E4403-60076	X	X	X	X	X
	IF Out Assembly (Option H70)	E4404-60034	X	X	X	X	X
A7A13	Noise Source Driver, (part of Option 219)	E4401-60123	X	X	X	X	X
A8	1.5 GHz RF Assembly (50 Ω)	E4401-60402	X				
	1.5 GHz RF Exchange Assembly (50 Ω)	E4401-69294	X				
	1.5 GHz RF Assembly (75 Ω) (Option IDP)	E4401-60100	X				
A8A1	Precision Frequency Reference, (Option ID5) ^e	E4401-60036	X				
	3 GHz RF Complete Assy with Precision Frequency Reference	E4403-60087		X	X	X	X
A8A1W1	Cable Assy, 50 MHz Amptd Reference Signal (Braided Coax)	E4403-60020		X	X	X	X
A8A1W2	Cable Assy, 600 MHz Reference Signal (Braided Coax)	E4403-60020		X	X	X	X
A8A1W3	Cable Assy, 21.4 MHz Cal Signal (Braided Coax)	E4403-60020		X	X	X	X

Table 5-4 Assembly Level Replaceable Parts

Reference Designator	Description	Agilent Part Number	E4401B/ E4411B	E4402B/ E4403B	E4404B	E4405B	E4407B/ E4408B
A8A1W4	Cable/Connector Assy, 50 MHz External Amptd Ref Out Signal	5062-0721		X	X	X	X
A8A2	Second Converter	5086-7958		X	X	X	X
A8A3	dc Block (<i>except Option UKB</i>)	E4403-60026		X	X	X	X
A8A4	LO Amplifier/IF Switch (LOIS)	E4404-60030			X	X	X
	LO Amplifier/IF Switch (LOIS)	E4404-69030			X	X	X
A8A5	3 GHz Input Attenuator (<i>except Option UKB</i>)	33321-60051		X			
	3 GHz Input Attenuator (<i>Option UKB</i>)	33321-60052		X			
	6.7/13.2 GHz Input Attenuator	33321-60052			X	X	
	26.5 GHz Input Attenuator (<i>except Option UKB</i>)	33321-60057					X
	26.5 GHz Input Attenuator (<i>Option UKB</i>)	33321-60061					X
A8A6	6.7/13.2 GHz YIG-Tuned Harmonic Mixer (RYTHM)	5087-7034			X	X	
	6.7/13.2 GHz YIG-Tuned Harmonic Mixer (RYTHM) Exchange	5087-6034			X	X	
	26.5 GHz YIG-Tuned Harmonic Mixer (RYTHM)	5087-7031					X
	26.5 GHz YIG-Tuned Harmonic Mixer (RYTHM) Exchange	5087-6031					X
A8FL1	3.1 GHz Low Pass Filter (LPF)	0955-0988		X	X	X	X
A8J1	RF Input Type-N Connector Kit (50 Ω) (<i>except Option 060</i>)	E4403-60015		X	X	X	X
	RF Input Type-N Connector (50 Ω) (<i>Option 060</i>)	86290-60005		X	X	X	X
	RF Input APC-3.5 Connector Kit, (<i>Option BAB</i>)	E4407-60002					X
A8J10	Type-N Connector, RF Input (50 Ω)	1250-2514	X				
	BNC Connector, RF Input (75 Ω)	1250-2792	X				
A8MP1	Micro Bracket	E4404-00001			X	X	X
	Micro Bracket (<i>Option UKB</i>)	E4404-00001		X			

Parts List
Replaceable Parts

Table 5-4 Assembly Level Replaceable Parts

Reference Designator	Description	Agilent Part Number	E4401B/ E4411B	E4402B/ E4403B	E4404B	E4405B	E4407B/ E4408B
A8MP2	Sub Bracket	E4404-00003			X	X	X
	Sub Bracket (<i>Option UKB</i>)	E4404-00003		X			
A8MP3	Filter Clamp	5022-3619			X	X	X
	Filter Clamp (<i>Option UKB</i>)	5022-3619		X			
A8MP4	Attenuator Bracket (<i>except Option UKB</i>)	E4403-00001		X			
A8MP5	Filter Bracket (<i>except Option UKB</i>)	E4403-00007		X			
A8MP15	Connector Cover, 1.5 GHz RF Input	E4401-00021	X				
A8MP24	Type-N Connector Gasket, RF Input (50 Ω)	E4403-20046	X				
	BNC Connector Gasket, RF Input (75 Ω)	E4401-20024	X				
MP1	Chassis Cover, Inner Shield (Serial ≥US/MY41060000)	E4401-00067	X	X	X	X	X
	Chassis & Dress Cover Kit, (Serial <US41060000)	E4401-60265	X	X	X	X	X
MP4	Dress Cover Kit (Serial ≥US41060000)	E4401-60266	X	X	X	X	X
MP5	Ergonomic Handle Including Dress Cover Hardware Kit to mount handle.	E4401-60246	X	X	X	X	X
MP6	Chassis	E4401-00045	X	X	X	X	X
MP7	Vibration Support	E4401-40026	X	X	X	X	X
MP8	Rear Blank Panel	E4401-00059	X	X	X	X	X
MP9	Handle Assembly, Ergonomic Design	E4401-60246	X	X	X	X	X
MP10	Dress Cover Hardware (For mounting ergonomic handle)	E4401-60409	X	X	X	X	X
W1	Cable Assembly, Processor to Front Panel Interface (Ribbon Cable)	8120-6919	X	X	X	X	X
W2	Cable Assembly, 21.4 MHz IF, RF to IF (Flexible Coaxial)	8120-6153	X				
	Cable Assembly, 21.4 MHz IF, RF to IF (Flexible Coaxial)	E4402-60020		X	X	X	X

Table 5-4 Assembly Level Replaceable Parts

Reference Designator	Description	Agilent Part Number	E4401B/ E4411B	E4402B/ E4403B	E4404B	E4405B	E4407B/ E4408B
W3 ^f	Cable Assembly, Front Panel Interface to Display (Ribbon Cable) (Serial < US41190000)	E4401-60198	X	X	X	X	X
	Cable Assembly, Front Panel Interface to Display (Ribbon Cable) (Serial ≥ US41190000)	E4401-60243	X	X	X	X	X
W4	Cable Assembly, RF Power and Control (Ribbon Cable)	8120-6943	X				
	Cable Assembly, RF Power and Control (Ribbon Cable)	E4403-60018		X	X	X	X
W5	Cable Assembly, Attenuator and 2nd Converter Power and Control (Ribbon Cable)	E4403-60019		X			X
	Cable Assembly, Attenuator and 2nd Converter Power and Control (Ribbon Cable) (E4407B Option UKB)	E4404-60004		X			
	Cable Assembly, Attenuator and 2nd Converter Power and Control (Ribbon Cable)	E4404-60004			X	X	
W6	Cable Assembly, RF Input (Semi-rigid Coaxial)	E4404-20009			X	X	
	Cable Assembly, RF Input (Semi-rigid Coaxial) (Option UKB)	E4404-20009		X			X
	Cable Assembly, RF Input (Semi-rigid Coaxial)	E4404-20022					X
	Cable Assembly, RF Input (Semi-rigid Coaxial) (Option BAB)	E4404-20017					X
W7	Cable Assembly, RF Input (Semi-rigid Coaxial) (except Option UKB)	E4403-20026		X			
W8	Cable Assembly, Filtered Low Band RF Input (Semi-rigid Coaxial) (except Option UKB)	E4403-20028		X			
	Cable Assembly, Filtered Low Band RF Input (Semi-rigid Coaxial) (Option UKB)	E4403-20058		X			
	Cable Assembly, Filtered Low Band RF Input (Semi-rigid Coaxial) (except Option UKB)	E4404-20015			X	X	X

Parts List
Replaceable Parts

Table 5-4 Assembly Level Replaceable Parts

Reference Designator	Description	Agilent Part Number	E4401B/ E4411B	E4402B/ E4403B	E4404B	E4405B	E4407B/ E4408B
W9	Cable Assembly, 3.9107 GHz IF (Semi-rigid Coaxial)	E4403-20029		X	X	X	X
W10	Cable Assembly, 600 MHz 2nd LO Drive (Flexible Coaxial)	8120-8674		X	X	X	X
W11	Cable Assembly, 2nd Converter 321.4 MHz IF Output (Flexible Coaxial)	8120-8674		X	X	X	X
W12	Cable Assembly, 600 MHz TG Drive (Flexible Coaxial) (<i>Option 1DN</i>)	E4402-60022		X	X	X	X
W13	Cable Assembly, 3.0 GHz TG 1st LO Drive (Braided Coaxial), (<i>Option 1DN</i>)	E4403-20023		X	X	X	X
W14	Cable Assembly, DC Blocked RF Input (Semi-rigid Coaxial) (<i>except Option UKB</i>)	E4403-20030		X			
W15	Cable Assembly, RF Attenuator Output (Semi-rigid Coaxial) (<i>except Option UKB</i>)	E4403-20027		X			
	Cable Assembly, RF Attenuator Output (Semi-rigid Coaxial) (<i>Option UKB</i>)	E4403-20059		X			
W16	Cable Assembly, RYTHM/LOIS Power and Control	E4404-60003			X	X	X
W17	Cable Assembly, RF Attenuator Output (Semi-rigid Coaxial) (<i>E4407B Option UKB</i>)	E4404-20014			X	X	X
	Cable Assembly, RF Attenuator Output (Semi-rigid Coaxial) (<i>except Option UKB</i>)	E4404-20018					X
W18	Cable Assembly, RYTHM Low Band Output (Semi-rigid Coaxial)	E4404-20003			X	X	X
W19	Cable Assembly, DC Blocked RF Input (Semi-rigid Coaxial) (<i>except Option UKB</i>)	E4404-20004			X	X	X
W20	Cable Assembly, RYTHM 321.4 MHz IF Output (Flexible Coaxial)	8120-8674			X	X	X
W21	LOIS 321.4 MHz IF Output (Flexible Coaxial)	E4404-60008			X	X	X
W22	Cable Assembly, RYTHM LO (Semi-rigid Coaxial)	E4404-20005			X	X	X

Table 5-4 Assembly Level Replaceable Parts

Reference Designator	Description	Agilent Part Number	E4401B/ E4411B	E4402B/ E4403B	E4404B	E4405B	E4407B/ E4408B
W23	Cable Assembly, Auxiliary LO Output (Semi-rigid Coaxial)	E4404-20008			X	X	X
W25	Cable Assembly, OCXO (Power and Control) (<i>Option 1D5</i>)	E4401-60043	X				
W26	Cable Assembly, OCXO (Flexible Coaxial) (<i>Option 1D5</i>)	8120-5024	X				
W29	Digital Demod RF Input (Flexible Coaxial) (<i>Option B7E</i>)	E4402-60024		X	X	X	X
W30	50 MHz External Amptd Ref Out Kit Signal (Flexible Coaxial) (<i>Option B7E</i>)	E4402-60023		X	X	X	X
W31	Digital Demod IF Input (Flexible Coaxial) (<i>Option B7E</i>)	E4402-60021		X	X	X	X
W32	Digital Demod IF Output (Flexible Coaxial) (<i>Option B7E</i>)	8120-8866		X	X	X	X
W33	Digital Demod DSP Sample Rate (Flexible Coaxial) (<i>Option B7D</i>)	8120-8867		X	X	X	X
W34	Digital Demod DSP IF (Flexible Cable) (<i>Option B7D</i>)	E4402-60027		X	X	X	X
W35	Cable Assembly, Filtered Low Band RF Input (semi-rigid coaxial) (<i>Option UKB</i>)	E4403-20058		X			
	Cable Assembly, Filtered Low Band RF Input (semi-rigid coaxial) (<i>Option UKB</i>)	E4404-20026			X	X	X
W36	Cable Assembly, Filtered 600 MHz 2nd LO Drive (flexible cable) (<i>Option 120</i>)	E4402-60026 [§]		X	X	X	X
W37	Cable Assembly, 600 MHz 2nd LO Drive (flexible cable) (<i>Option 120</i>)	E4402-60025 [§]		X	X	X	X
W38	Cable Assembly, Ext Mixer LO OUT (<i>Option AYZ</i>)	E4404-20006					X
W39	Cable Assembly, Ext Mixer IF INPUT (<i>Option AYZ</i>)	8120-5141					X
W40	Cable Assembly, 2nd Converter Out (<i>Option H55, H70</i>)	E4440-60411	X	X	X	X	X
W41	Cable Assembly, A7A12 321.4 MHz Out (<i>Option H55, H70</i>)	E4440-60411	X	X	X	X	X

Parts List
Replaceable Parts

Table 5-4 Assembly Level Replaceable Parts

Reference Designator	Description	Agilent Part Number	E4401B/ E4411B	E4402B/ E4403B	E4404B	E4405B	E4407B/ E4408B
W42	Cable Assembly, Downconverted IF Out (<i>Option H55, H70</i>)	E4440-60413	X	X	X	X	X

- a. ESA-E Series (E4401B, E4402B, E4404B, E4405B, and E4407B only).
- b. E4401-60343 includes E4401-60338 BAA ROM kit.
- c. Requires Option B7E, (E4402B, E4404B, E4405B, and E4407B only).
- d. Requires Option B7D, (E4402B, E4404B, E4405B, and E4407B only).
- e. Serial prefix \geq MY5014 & SG5014 added diode batches and epoxy to the driver board to reduce EMF spikes. The attenuator part number did not change.
- f. Place adhesive on each end of cable connector and LCD connector to eliminate the risk of the cable unplugging.
- g. ESA-E Series part (E4402B, E4404B, E4405B, and E4407B only)

Figure 5-1 Front Frame with Hardware, E4411B, and E4401B

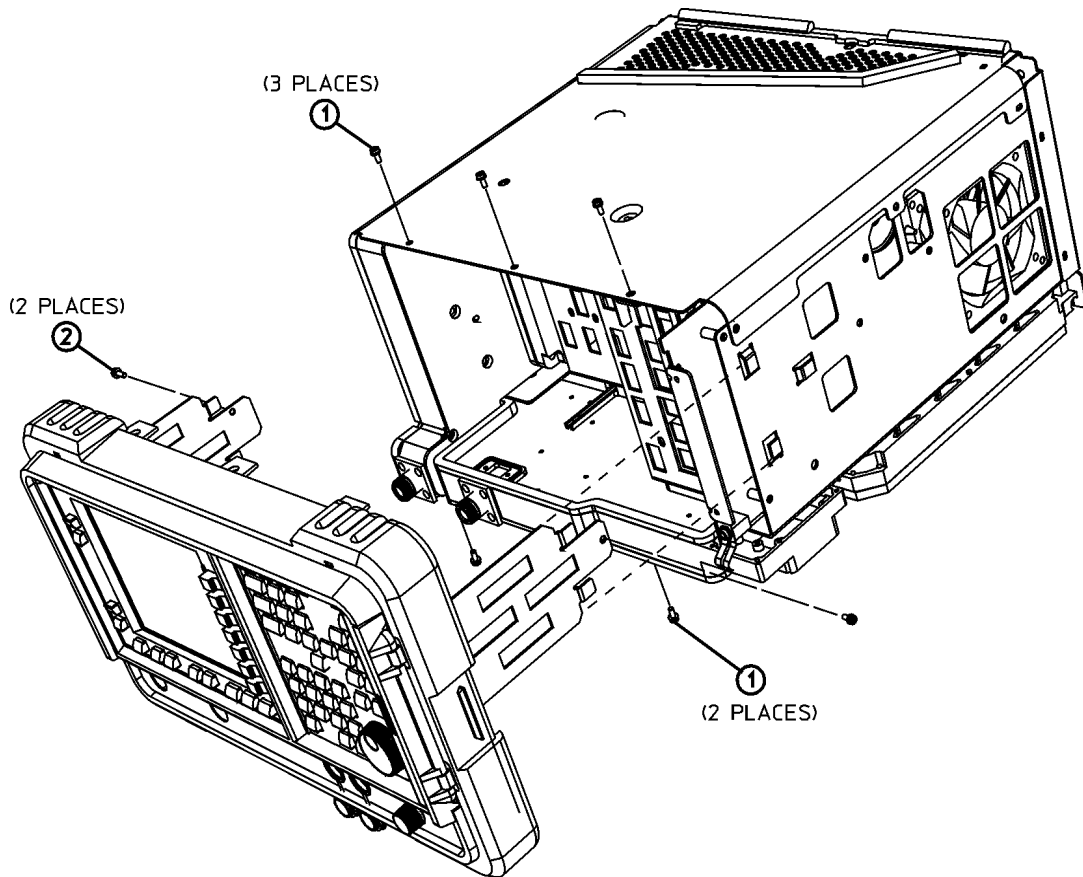

sl710a

Table 5-5 provides a schematic reference designation, a description, and a part number for the items called out in Figure 5-1.

Table 5-5

Item	Description	Part Number
1	Screw - M3 X 10 mm (TORX Flat Head)	0515-2600
2	Screw - M3 X 8 mm (TORX Pan Head with Crest Washer)	0515-0372

Figure 5-2 Front Frame with Hardware, E4402B, E4403B, E4404B, E4405B, E4407B, and E4408B

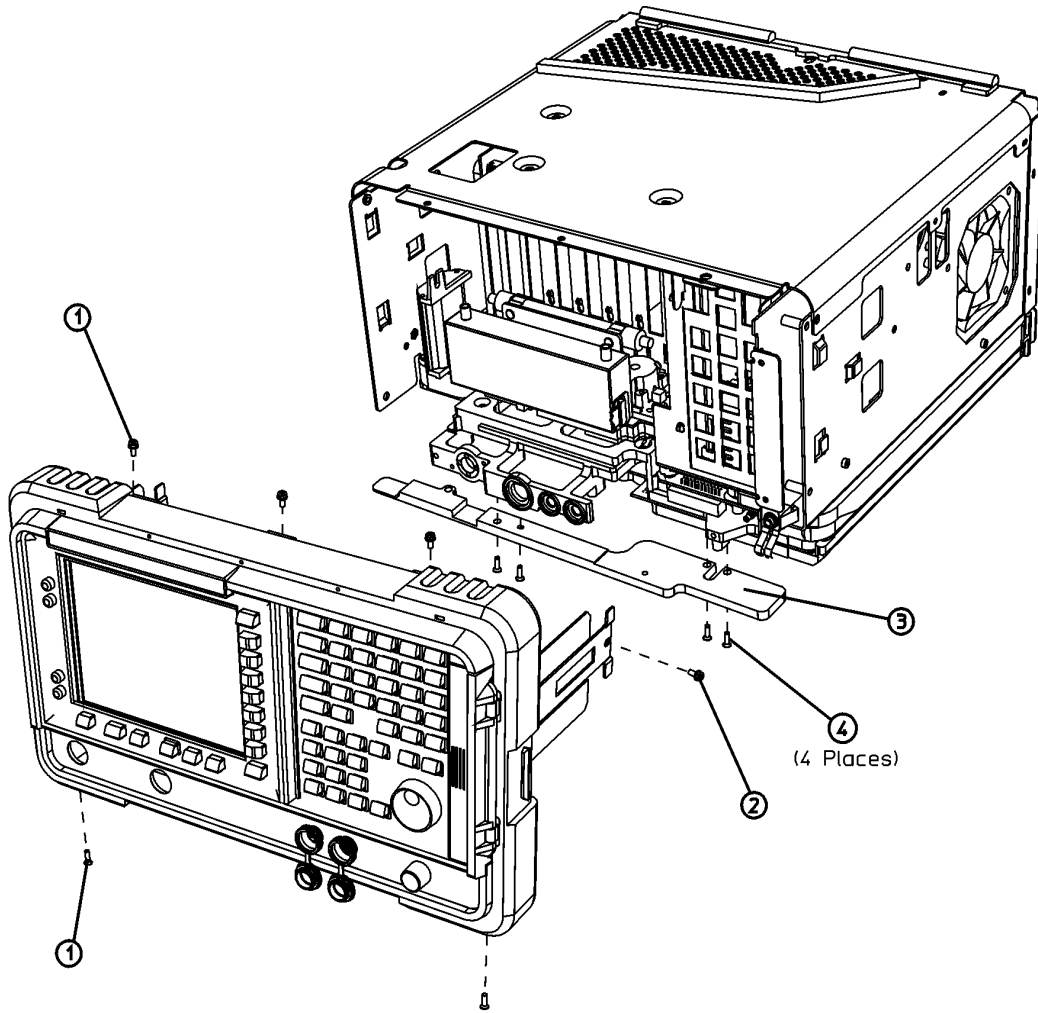

sl738b

Table 5-6 provides a schematic reference designation, a description, and a part number for the items called out in Figure 5-2.

Table 5-6

Item	Reference Designator	Description	Part Number
1		Screw - M3 X 10 mm (TORX Flat Head)	0515-2600
2		Screw - M3 X 8 mm (TORX Pan Head with Crest Washer)	0515-0372
3	A1A5	Shock Spreader Assembly	E4403-60032
4		Screw - M4 X 12 mm	0515-0943

Figure 5-3 Front Panel Parts

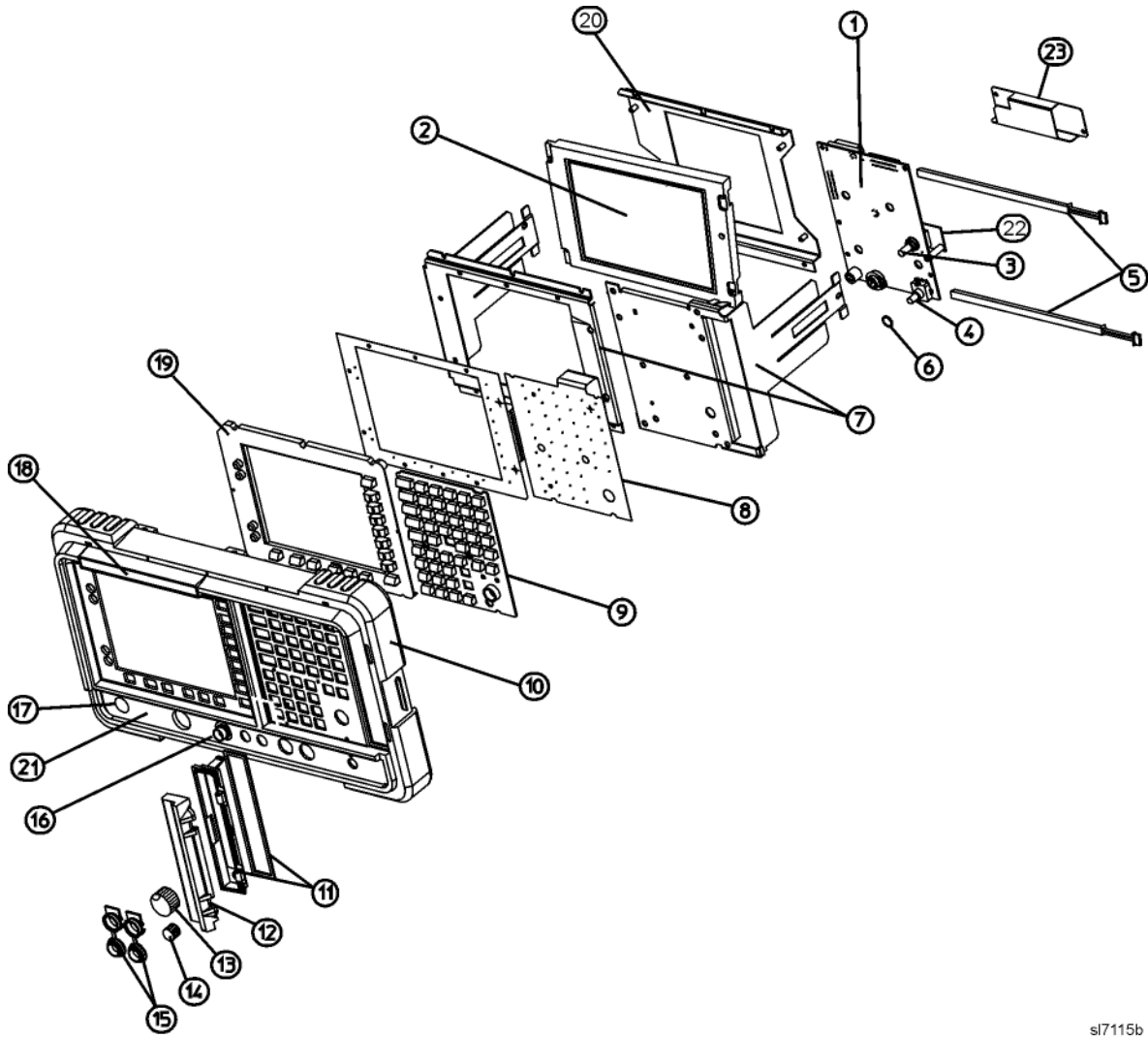

sl7115b

Table 5-7 provides a schematic reference designation, a description, and a part number for the items called out in Figure 5-3.

Parts List
Replaceable Parts

Table 5-7

Item	Reference Designator	Description	Part Number
1	A1A1	Front Panel Interface Assembly	E4401-60241
2	A1A2	Liquid Crystal Display Assembly Kit (Serial Prefix ≥US4119) (includes Backlights and Inverter Board)	E4401-60242
		Liquid Crystal Display Assembly Kits (one each required) (Serial Prefix <US4119) (includes Backlights and Inverter Board)	E4401-60241, and E4401-60242
3	A1A1A1	Rotary Pulse Generator	1990-1865
4	A1A1A2	Volume Rotary Pulse Generator	0960-0892
5	A1A2DS1 and A1A2DS2	Display Backlights	E4401-60241 & E4401-60242 2090-0380
6	A1MP13	Gasket–Volume RPG	E4401-20044
7	A1MP3	Sub Panel (2 pieces) Front Panel Interface Board Subpanel and LCD Subpanel	E4401-60104
8	A1MP4	Flex Circuit, Main	E4401-60198
9	A1MP5	Main Keypad	E4401-40002
10	A1A3 ^a	Front Frame Assembly (<i>except Option 060</i>)	E4401-60257
		Front Frame Assembly (<i>Option 060</i>)	E4401-60259
11	A1MP12	Media Bezel with Gasket	E4401-60197
12	A1MP14	Media Door	E4401-40004
13	A1MP7	RPG Knob	0370-3229
14	A1MP8	Volume Knob	0370-3230
15	A1MP10	Front Panel Connector Cover	E4401-40006
16	A8A1W4	Amptd Ref Out Connector	5062-0721
17	A1MP15	Tracking Generator I/O Hole Plug	E4401-40020

Table 5-7 (Continued)

Item	Reference Designator	Description	Part Number
18	A1MP16	Nameplate 1.5 GHz (50 Ω)(E4401B)	E4401-80027
		Nameplate 1.5 GHz (75 Ω) (E4401B)	E4401-80028
		Nameplate 3.0 GHz (E4402B) (except Option UKB)	E4402-80002
		Nameplate 3.0 GHz (E4402B) (Option UKB)	E4403-80016
		Nameplate 3.0 GHz (E4403B)	E4403-80008
		Nameplate 6.7 GHz (E4404B) (except Option UKB)	E4404-80004
		Nameplate 6.7 GHz (E4404B) (Option UKB)	E4404-80008
		Nameplate 13.2 GHz (E4405B) (except Option UKB)	E4405-80003
		Nameplate 13.2 GHz (E4405B) (Option UKB)	E4405-80006
		Nameplate 26.5 GHz (E4407B) (except Option UKB)	E4407-80003
		Nameplate 26.5 GHz (E4407B) (Option UKB)	E4407-80006
		Nameplate 26.5 GHz (E4408B)	E4408-80003
		Nameplate 1.5 GHz (E4411B) (50 Ω)	E4411-80012
		Nameplate 1.5 GHz (E4411B) (75 Ω)	E4411-80013
19	A1A3MP9	Lens/Keypad Assembly (50 Ω)	E4401-60127
		Lens/Keypad Assembly (50 Ω) (Option 060)	E4401-60256
20	A1A2MP1	LCD Bracket	E4401-00034

Parts List
Replaceable Parts

Table 5-7 (Continued)

Item	Reference Designator	Description	Part Number
21	A1A2MP21	Connector Label, 1.5 GHz (50 Ω) (E4401B, E4411B)	E4401-80003
		Connector Label, 1.5 GHz (75 Ω) (E4401B, E4411B)	E4401-80002
		Connector Label, 3 GHz (except Option UKB) (E4402B, E4403B)	E4403-80002
		Connector Label, 3 GHz (Option UKB) (E4402B)	E4403-80015
		Connector Label, 6.7 GHz (except Option UKB) (E4404B)	E4404-80001
		Connector Label, 6.7 GHz (Option UKB) (E4404B)	E4404-80007
		Connector Label, 13.2 GHz (except Option UKB) (E4405B)	E4405-80001
		Connector Label, 13.2 GHz (Option UKB) (E4405B)	E4405-80005
		Connector Label, 26.5 GHz (E4407B, E4408B)	E4407-80001
		Connector Label, 26.5 GHz (Option AYZ) (E4407B)	E4407-80005
		Connector Label, 26.5 GHz (Option UKB) (E4407B)	E4407-80007
		Connector Label, 26.5 GHz (Option UKB and AYZ) (E4407B)	E4407-80008
22	A1A2A2	Backlight Inverter Board	0950-3644
23	A1A1MP1	Backlight Inverter Board Shield	E4401-00046

a. Front Frame Assembly also includes the following:

- Front Frame
- Main Keypad Label (the piece around the outside of the keys)
- Media Bezel with Gasket (see A1MP12)
- Media Door (see A1MP14)
- Front Panel Connector Cover (see A1MP10)
- Tracking Generator I/O Hole Plug (see A1MP15)
- RF Input Connector Gasket (see A1MP18)
- Tracking Generator Output Connector Gasket (see A1MP19)
- Amptd Ref Out/Ext Mixer Gasket (E4402B, E4403B, E4404B, E4405B, E4407B, E4408B) (see A1MP20)
- Lens/keypad assembly (see A1A3MP9)
- Grounding Clip (see A1MP17)

Figure 5-4 Rear Frame with Hardware

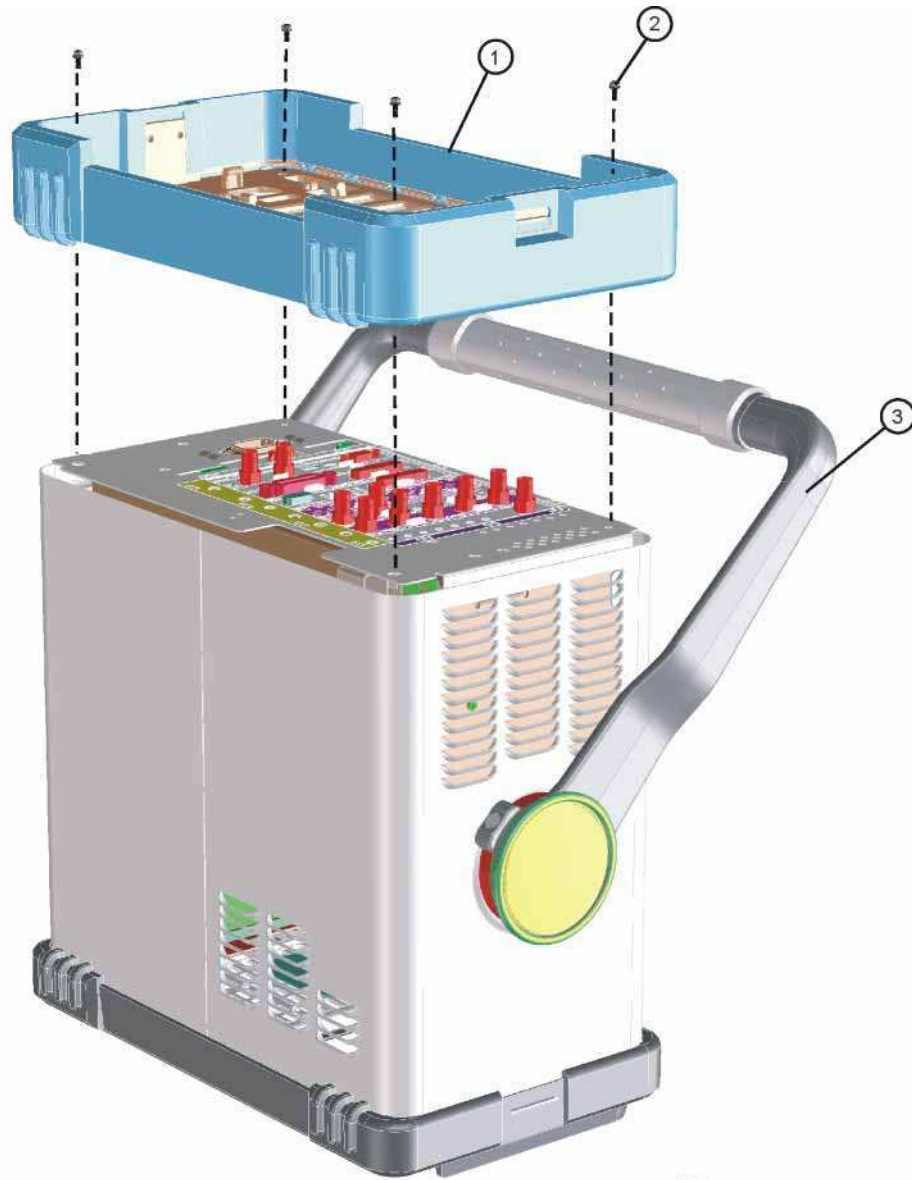

sb99a

Parts List
Replaceable Parts

Table 5-8 provides a schematic reference designation, a description, and a part number for the items called out in Figure 5-4.

Table 5-8

Item	Reference Designator	Description	Part Number
1	A1A4	Rear Frame Assy	E4401-60160
2		Screw-M4 X 12 mm (<i>4 required</i>) (TORX Pan Head with Crest Washer)	0515-0382
3		Handle assembly	E4401-60246

Figure 5-5 Front Panel with Hardware

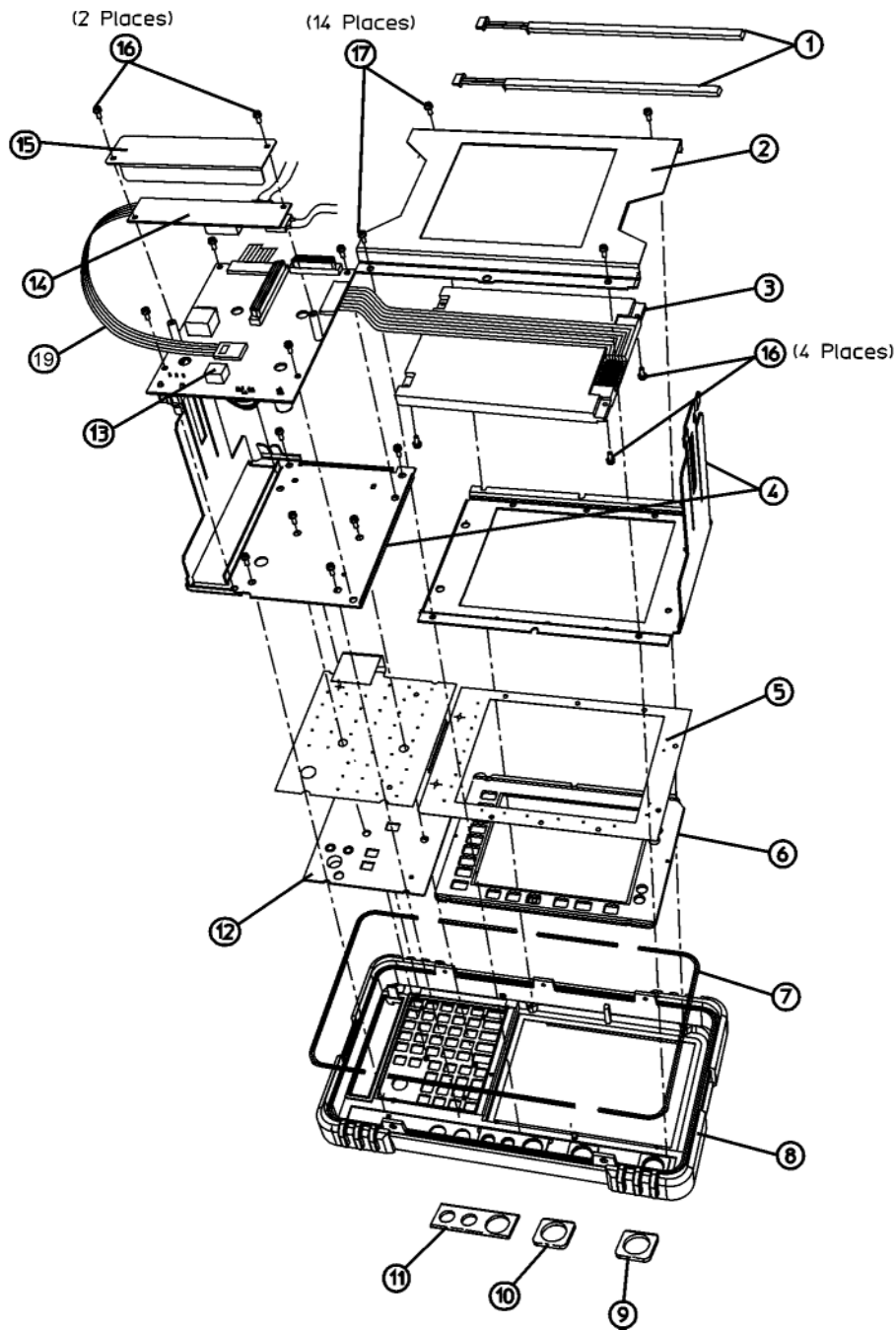

sl782b

Table 5-9 provides a schematic reference designation, a description, and a part number for the items called out in Figure 5-5.

Parts List
Replaceable Parts

Table 5-9

Item	Reference Designator	Description	Part Number
1	A1A2DS1 and A1A2DS2	Display Backlights	E4401-60241 & E4401-60242 2090-0380
2	A1A2MP1	LCD Bracket	E4401-00034
3	A1A2	Liquid Crystal Display Assembly Kit (Serial Prefix ≥US4119) (includes Backlights and Inverter Board)	E4401-60242
		Liquid Crystal Display Assembly Kits (one each required) (Serial Prefix <US4119) (includes Backlights and Inverter Board)	E4401-60241 (A1A1), and E4401-60242
4	A1MP3	Sub Panel (2 pieces) Front Panel Interface Board Subpanel and LCD Subpanel	E4401-60104
5	A1MP4	Flex Circuit, Main	E4401-60198
6	A1A3MP9	Lens/Keypad Assembly (<i>except Option 060</i>)	E4401-60127
		Lens/Keypad Assembly, (<i>Option 060</i>)	E4401-60256
7	A1MP17	Grounding Clip Kit (5 pieces)	E4401-00054
8	A1A3	Front Frame Assembly (<i>except Option 060</i>)	E4401-60257
		Front Frame Assembly (<i>Option 060</i>)	E4401-60259
9	A1MP18	RF Input Connector Gasket	E4403-20046
10	A1MP19	TG Output Connector Gasket	E4403-20046
11	A1MP20	Amptd Ref Out/Ext Mixer Gasket	E4401-20089
12	A1MP5	Main Keypad	E4401-40002
13	A1A1	Front Panel Interface Board Assy	E4401-60241
14	A1A2A2	Backlight Inverter Board for 2090-0379	0950-3644
15	A1A1MP1	Backlight Inverter Board Shield	E4401-00046
16		Screws - M2.5 X 6 (<i>6 required</i>) (TORX Pan Head)	0515-0366
17		Screws - M3 X 8 mm (<i>14 required</i>) (TORX Pan Head with Crest Washer)	0515-0372
18	A1MP13	Gasket - Volume RPG	E4401-20044
19	A1A1W1	Cable, Backlight Inverter Board to Front Panel Interface Board	8120-8482

Figure 5-6 Inner Shield with Hardware

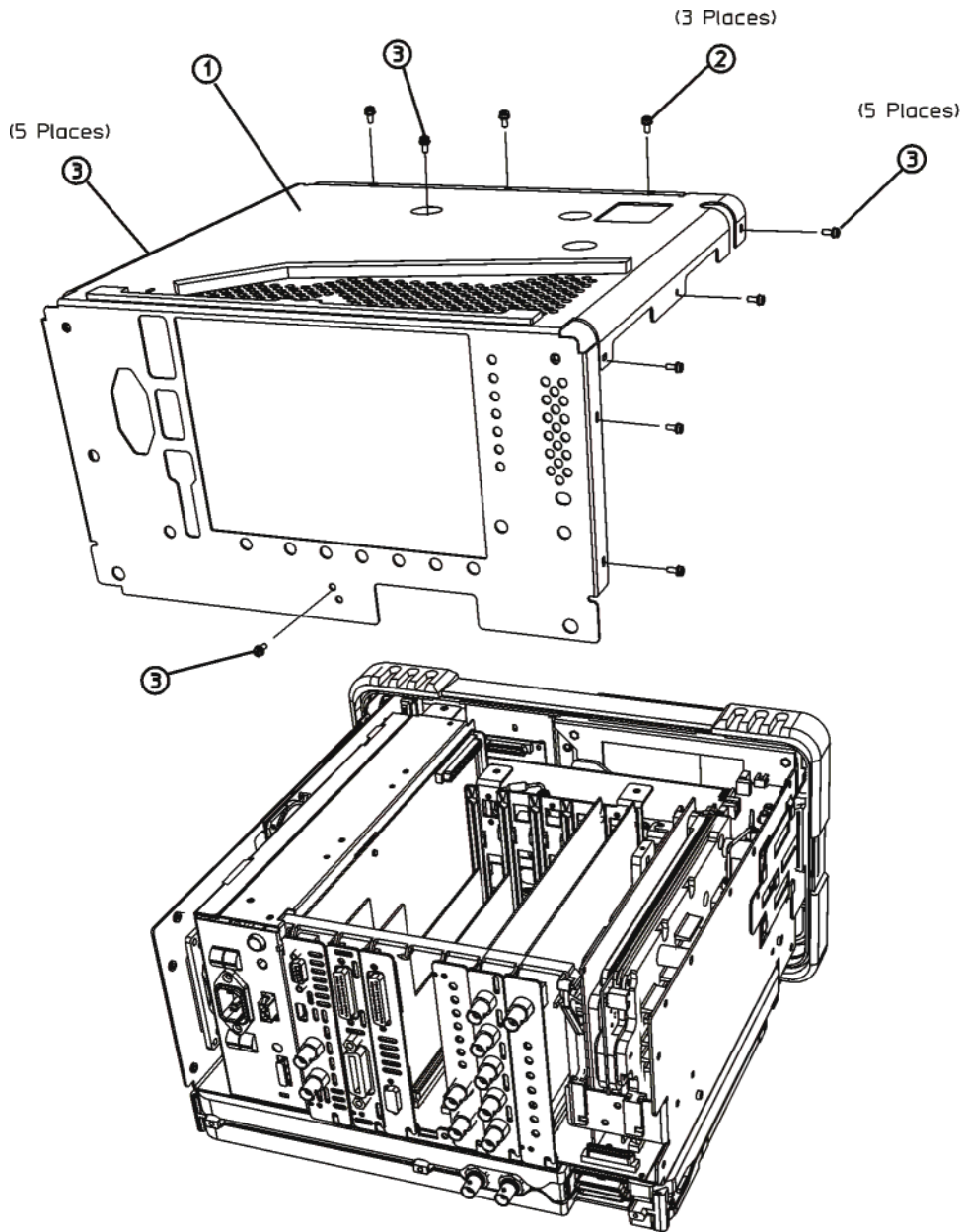

sl729b

Table 5-10 provides a schematic reference designation, a description, and a part number for the items called out in Figure 5-6.

Parts List
Replaceable Parts

Table 5-10

Item	Reference Designator	Description	Part Number
1	MP1	Chassis Cover (Inner Shield)	E4401-00067
2		Screw - M3 X 10 mm (<i>3 required</i>) (TORX Flat Head)	0515-2600
3		Screw - M3 X 8 mm (<i>12 required</i>) (TORX Pan Head with Crest Washer)	0515-0372

Figure 5-7 Motherboard Hardware

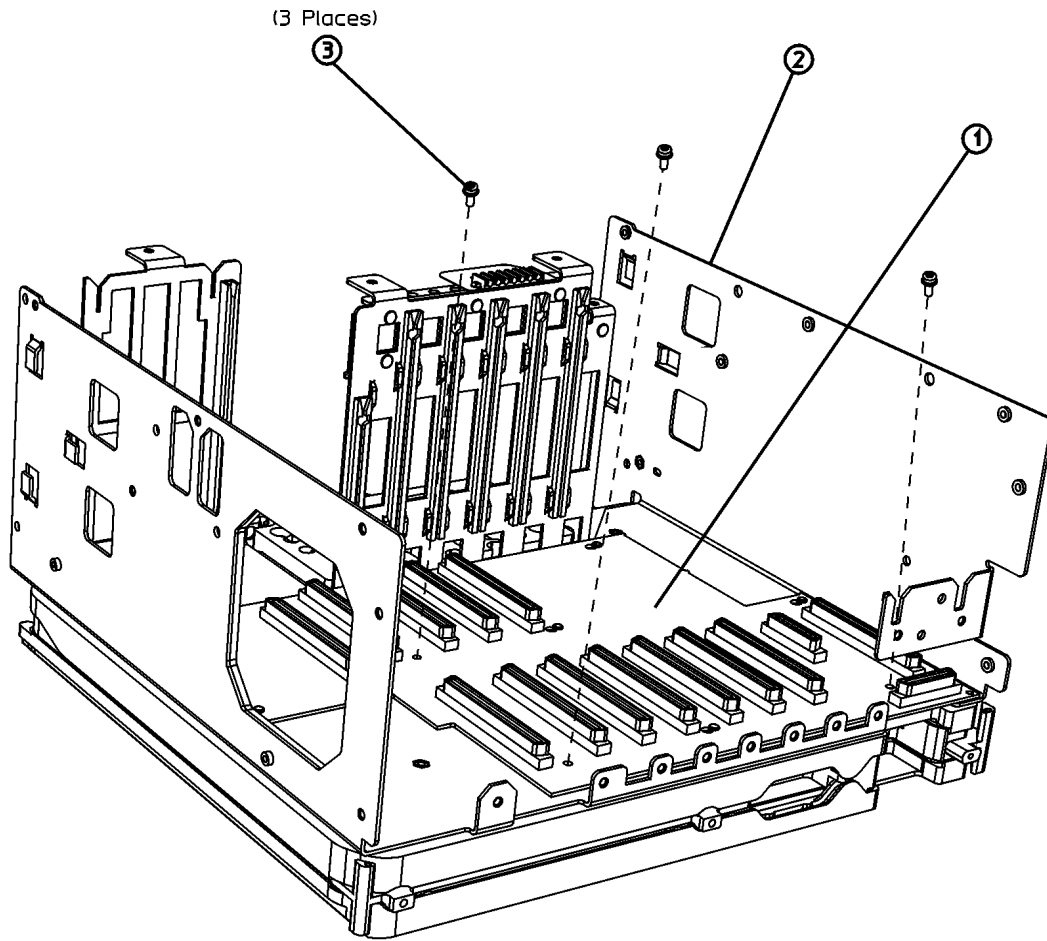

st737b

Table 5-11 provides a schematic reference designation, a description, and a part number for the items called out in Figure 5-7.

Parts List
Replaceable Parts

Table 5-11

Item	Reference Designator	Description	Part Number
1	A7	Motherboard, ESA-E Series (shown here)	E4401-60107
		Motherboard, ESA-L Series	E4411-60013
2	MP6	Chassis	E4401-00045
3		Screw - M3 X 8 mm (TORX Pan Head with Crest Washer)	0515-0372

Figure 5-8 Rear Panel with Hardware

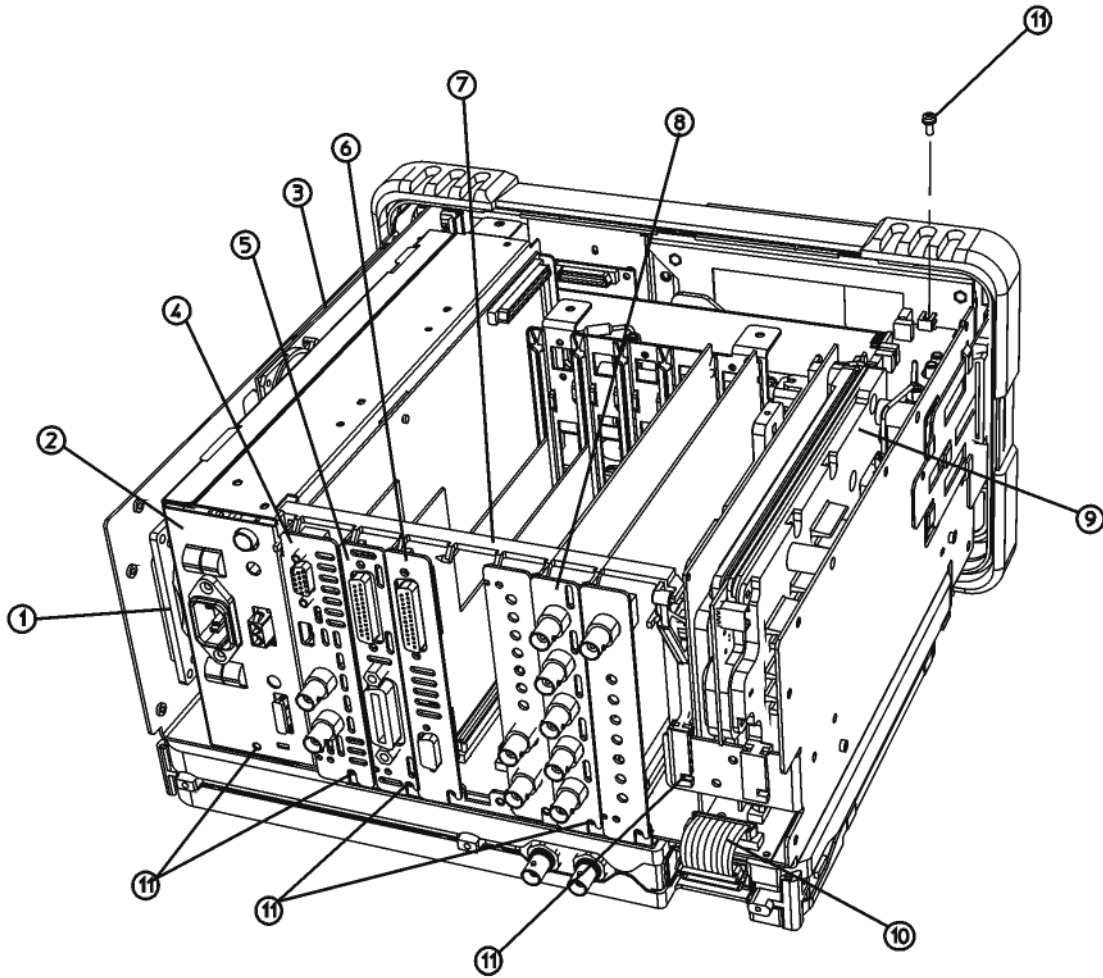

sl730b

Table 5-12 provides a schematic reference designation, a description, and a part number for the items called out in Figure 5-8.

Parts List
Replaceable Parts

Table 5-12

Item	Reference Designator	Description	Part Number
1	A5B1	Fan	3160-0866
2	A5	Power Supply Assy	E4401-60222
3	A6	Speaker/Floppy Assembly	E4401-60008
4	A4	Main Processor Board	E4401-60233
		Main Processor Board with Enhanced Memory	E4401-60233
5	A7A2	GPIB Board Assembly, (<i>Option A4H</i>)	E4401-60367
6	A7A3	RS 232 Assembly, (<i>Option 1AX</i>)	E4401-60366
Not shown	MP8	Rear Blank Panels	E4401-00059
7	MP7	Vibration Support Bar	E4401-40026
8	A7A1	IF Video Sweep Ports, (<i>Option A4J</i>)	E4401-60096
9	A2	Tracking Generator Assembly 1.5 GHz 50 Ω , (<i>Option 1DN</i>)	E4401-60128
		Tracking Generator Assembly 1.5 GHz 75 Ω , (<i>Option 1DQ</i>)	E4401-60129
10	W4	RF Power and Control Ribbon Cable, A7J4 to A8A1A1P6 & A8A1A2J1 (E4402B, E4403B, E4404B, E4405B, E4407B, E4408B)	E4403-60018
		RF Power and Control Ribbon Cable, A7J4 to A8J4 (E4401B and E4411B)	8120-6943
11		Screw - M3 X 8 mm (<i>10 required</i>) (TORX Pan Head with Crest Washer)	0515-0372

Figure 5-9 Speaker/Floppy Board with Hardware

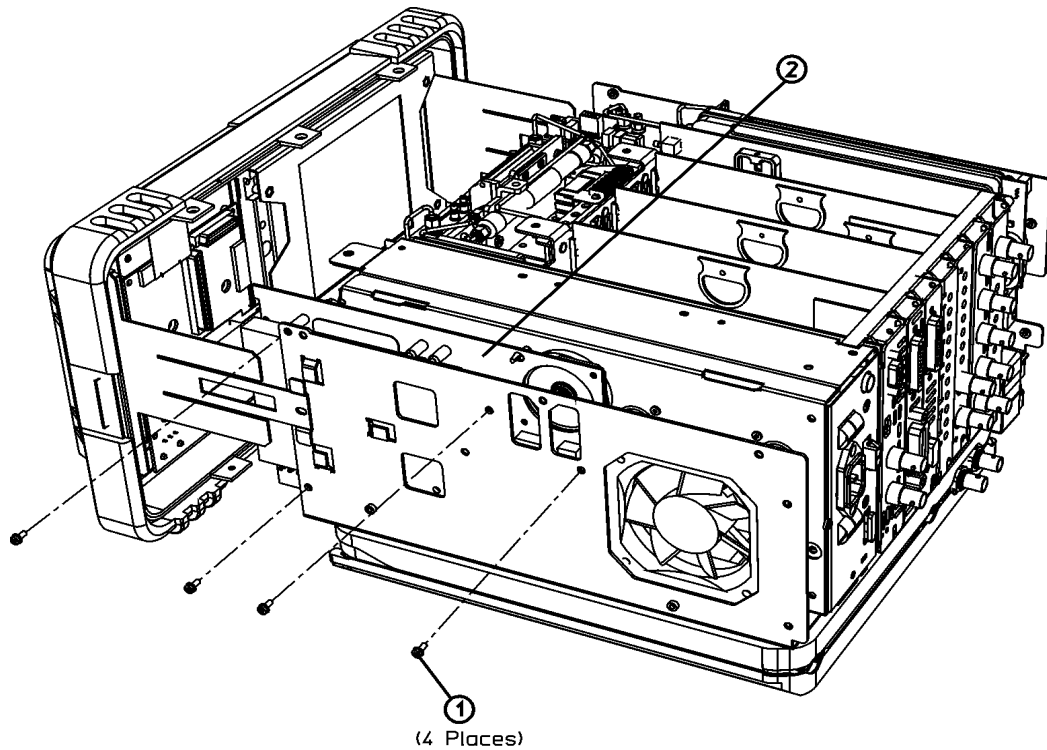

sl756b

Table 5-13 provides a schematic reference designation, a description, and a part number for the items called out in Figure 5-9.

Table 5-13

Item	Reference Designator	Description	Part Number
1		Screw - M3 X 8 mm (4 required) (TORX Pan Head with Crest Washer)	0515-0372
2	A6	Speaker/Floppy Assembly	E4401-60368

Figure 5-10

RF Assembly with Hardware, E4401B and E4411B

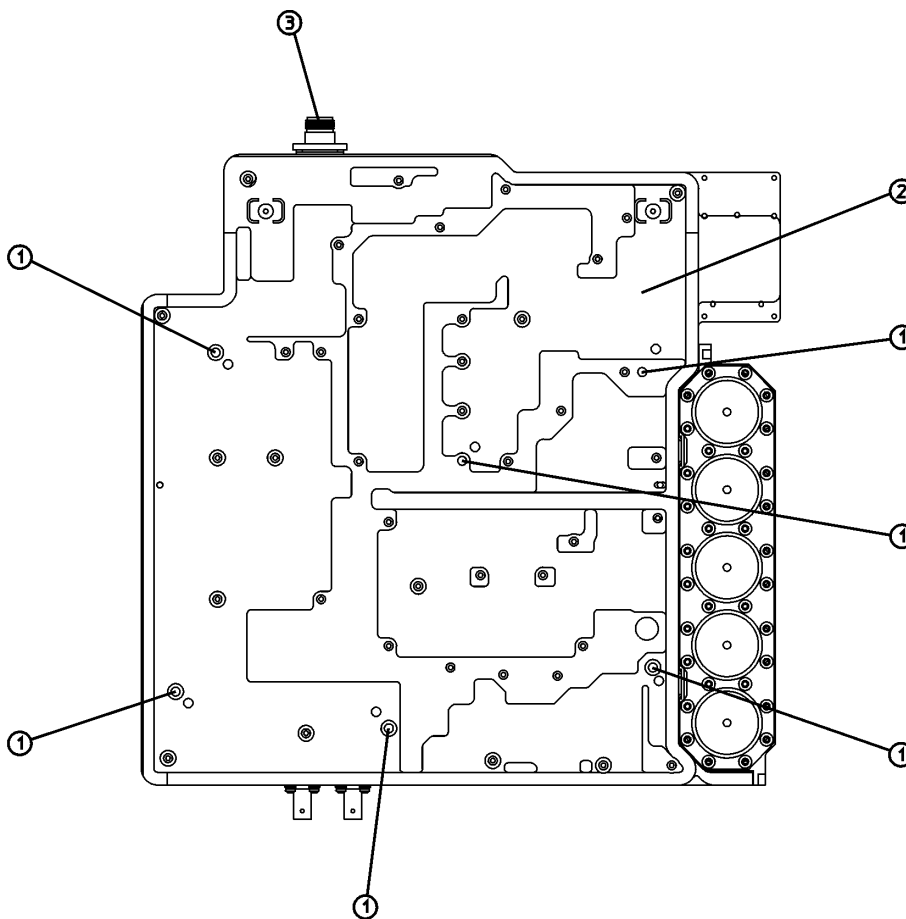

sl735b

Table 5-14 provides a schematic reference designation, a description, and a part number for the items called out in Figure 5-10.

Table 5-14

Item	Reference Designator	Description	Part Number
1		Screw - M3 X 25 mm (6 required) (TORX Pan Head with Crest Washer)	0515-0667
2	A8	1.5 GHz RF Assembly, 50 Ω	E4401-60402
		1.5 GHz RF Exchange Assembly, 50 Ω	E4401-69294
		1.5 GHz RF Assembly, 75 Ω, (Option 1DP)	E4401-60100
3	A8J10	RF Input Type-N Connector, 50 Ω	1250-2514
		RF Input BNC Connector, 75 Ω	1250-2792

Figure 5-11 RF Input Connector Hardware (E4401B and E4411B)
and Precision Frequency Reference, Option 1D5 (E4401B)

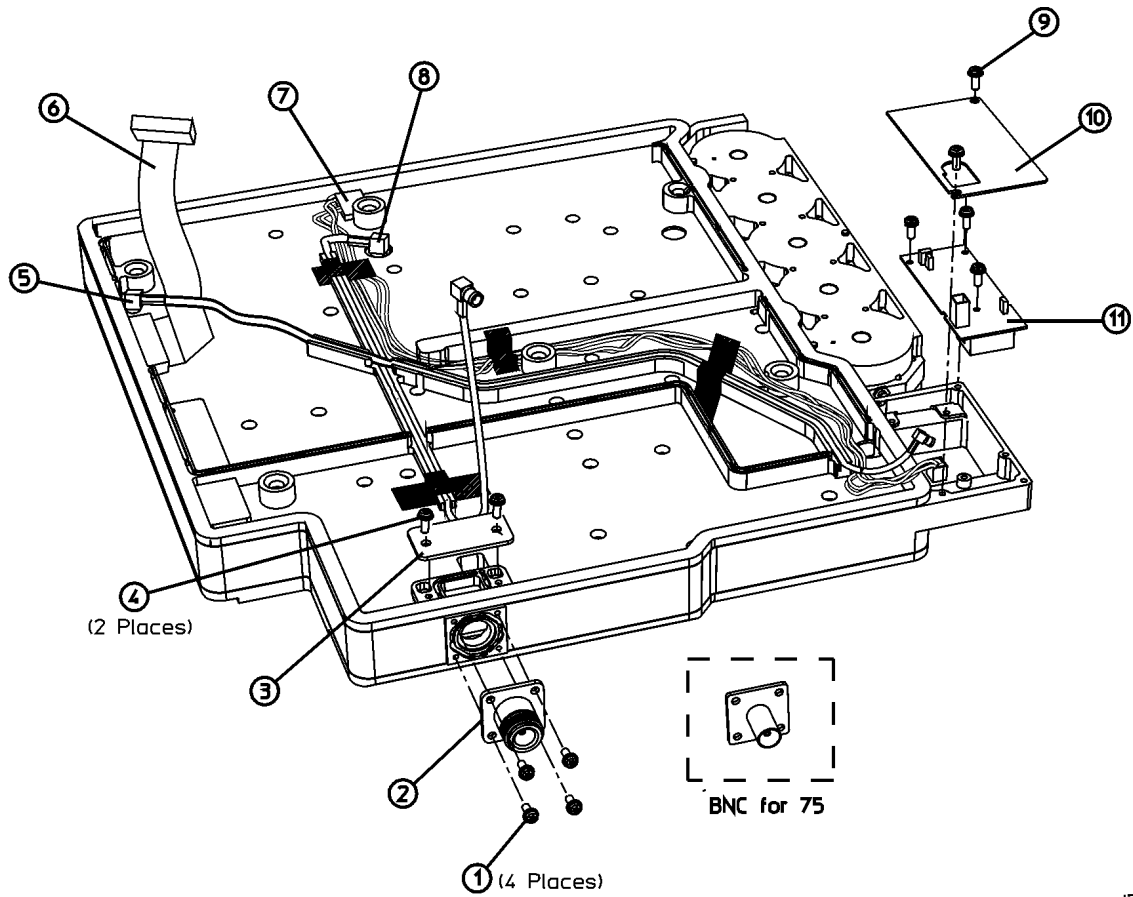

sl795b

Table 5-15 provides a schematic reference designation, a description, and a part number for the items called out in Figure 5-11.

Parts List
Replaceable Parts

Table 5-15

Item	Reference Designator	Description	Part Number
1		Screw - M2.5 X 8 mm (TORX Flat Head) <i>(4 required)</i>	0515-2487
2	A8J10	Connector, Type-N (50 Ω)	1250-2514
		Connector, BNC (75 Ω)	1250-2792
3	A8MP15	1.5 GHz RF Input Connector Cover	E4401-00021
4		Screw - M3 X 8 mm (TORX Pan Head with Crest Washer) <i>(2 required)</i>	0515-0372
5	W26	Precision Frequency Reference Cable, Flexible Coax, A8A1 to A8 <i>(E4401B)</i>	8120-5024
6	W4	Cable Assembly, RF Power and Control, Ribbon Cable <i>(E4401B)</i>	8120-6943
7	W25	Precision Frequency Reference Power Harness, A8A1 to A8 <i>(E4401B)</i>	E4401-60043
8	W2	21.4 MHz IF Input Coax A8J3 to A3J2	8120-6153
9		Screws, M3 X 8 mm <i>(5 required)</i>	0515-0372
10		Precision Frequency Reference Cover Shield <i>(E4401B)</i>	E4401-00055
11	A8A1	A8A1.5 GHz Precision Frequency Reference Assembly, <i>(Option 1D5) (E4401B)</i>	E4401-60036

Figure 5-12 3 GHz RF Assembly with Hardware, E4402B, E4403B, E4404B, E4405B, E4407B, and E4408B

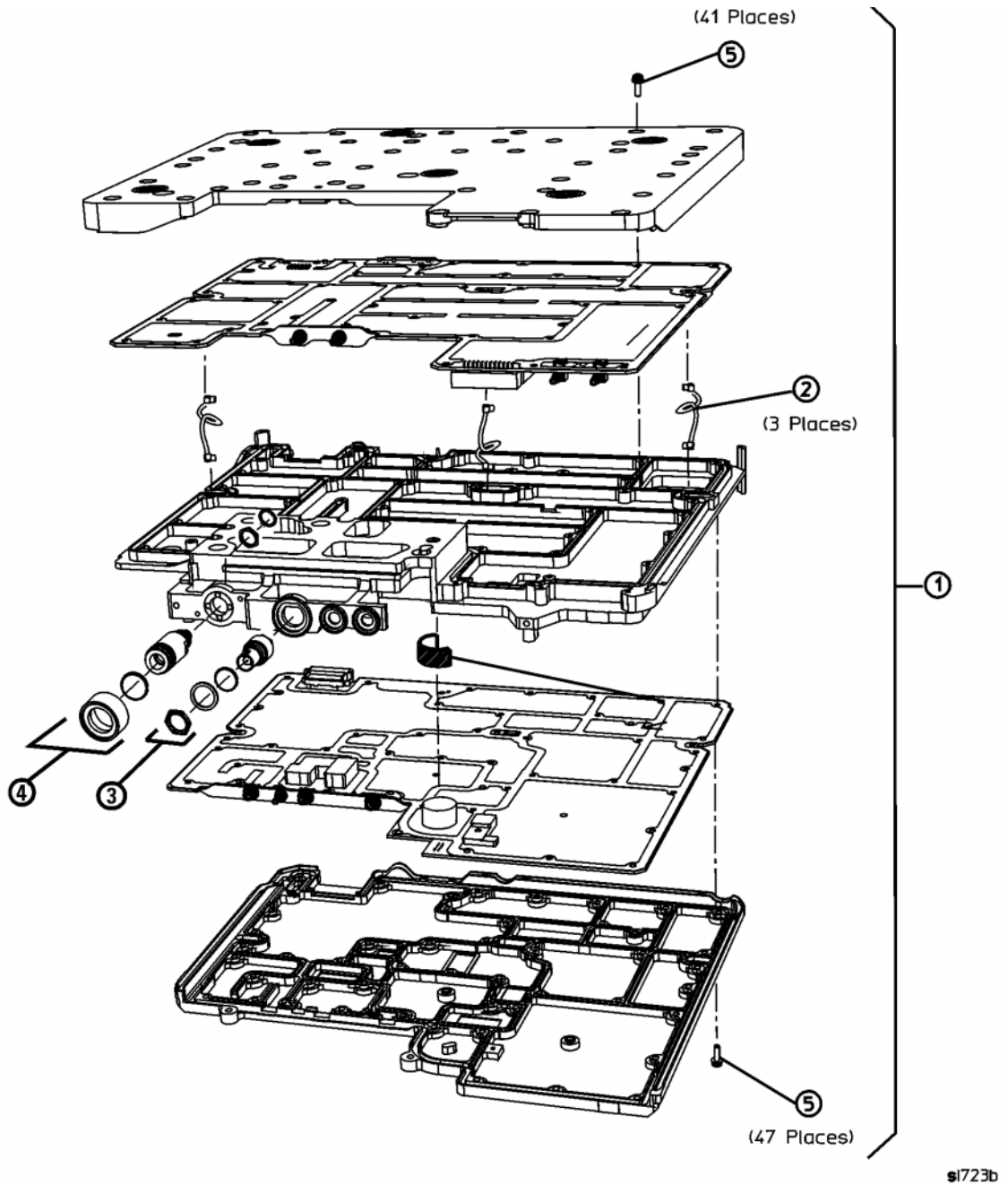

Table 5-16 provides a schematic reference designation, a description, and a part number for the items called out in Figure 5-12.

Parts List
Replaceable Parts

Table 5-16

Item	Reference Designator	Description	Part Number
1	A8A1	3 GHz RF Complete Assy with Precision Frequency Reference	E4403-60087
2	A8A1W1	50 MHz Cal Signal Cable, Braided Coax <i>A8A1A2J7 to A8A1A1J1</i>	E4403-60020
	A8A1W2	600 MHz Reference Cable, Braided Coax <i>A8A1A1J5 to A8A1A2J8</i>	
	A8A1W3	21.4 MHz Cal Signal Cable, Braided Coax <i>A8A1A2J6 to A8A1A1J6</i>	
3	A8A1W4	50 MHz External Amptd Ref Out Signal Cable Connector <i>A8A1A2J4 to A8J2</i>	5062-0721
		SMB/BNC Amptd Ref Cable	5062-0721
		O-Ring	0900-0016
		Flat Washer	2190-0119
		Hex Nut	2950-0035

Table 5-16 (Continued)

Item	Reference Designator	Description	Part Number	
4	A8J1 shown here	Type-N RF Input Connector Kit (50 Ω) <i>(except Option 060)</i>	E4403-60015	
		Type-N Connector		
		Lock Washer		
		Hex Nut		
		Sleeve		
		EMI O-Ring		
	A8J1	Type-N RF Input Connector <i>(Option 060)</i>		
		Type-N Connector	86290-60005	
		Lock Washer	2190-0104	
		Hex Nut	2950-0132	
		Wavy Washer	3050-2127	
		Type-N Spacer	5022-6164	
		Conductive Washer	E4402-20010	
	A8J1	RF Input APC-3.5 Connector Kit, <i>(Option BAB) (E4407B, E4408B)</i>		E4407-60002
		Connector		
		Block		
		Nut		
		M3 X 18 Flathead Torque Screw <i>(2 required)</i>		
	5		SMM3 X 14 mm Screws <i>(88 required)</i>	0515-2994

Parts List
Replaceable Parts

Figure 5-13 RF Major Assemblies and Cables, Rear View, E4402B and E4403B

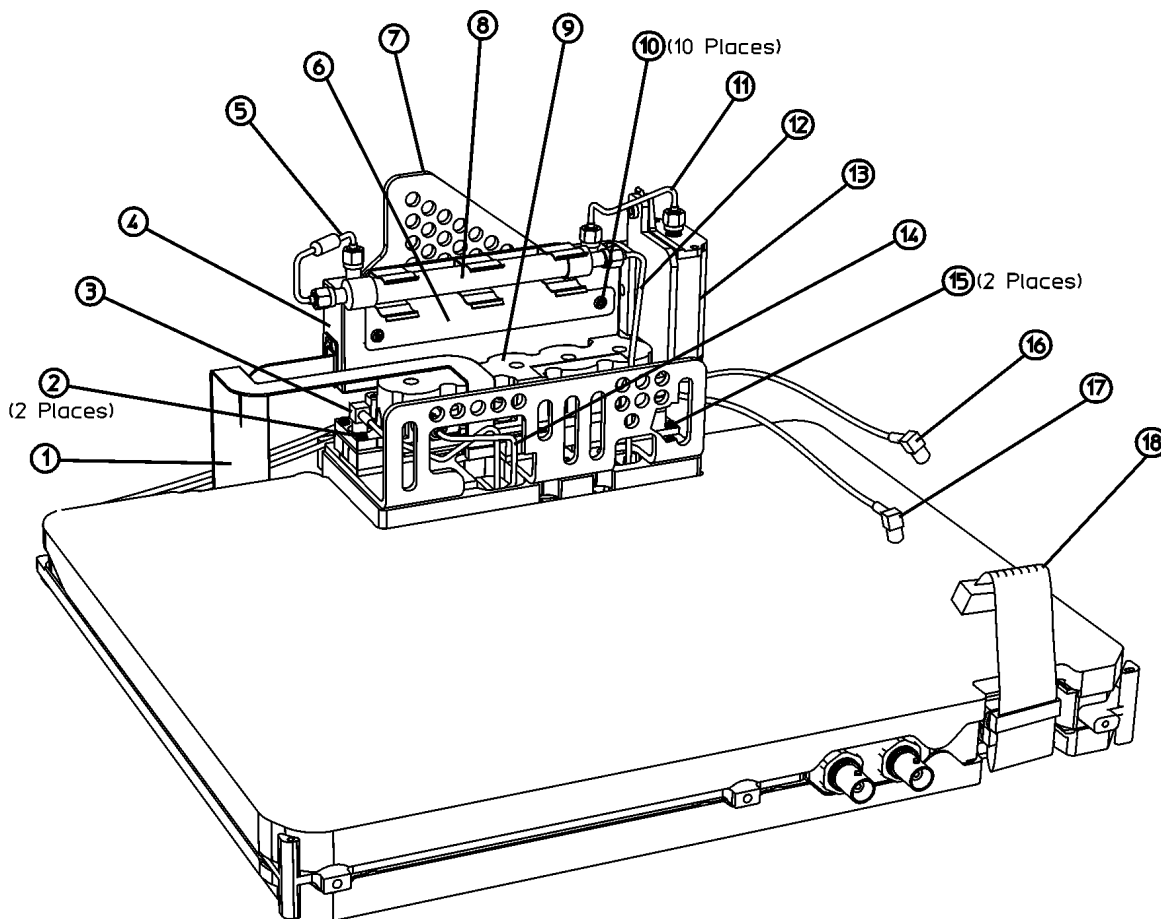

sl720b

Table 5-17 provides a schematic reference designation, a description, and a part number for the items called out in Figure 5-13.

Table 5-17

Item	Reference Designator	Description	Cable Runs		Part Number
			From	To	
1	W5	Attenuator and 2 nd Converter Power and Control, Ribbon Cable	A8A1A1J2	A8A5J3 and A8A2J6	E4403-60019
2		Screws - M3 X 22 mm (2 required) (TORX Pan Head with Crest Washer)			0515-2693
3	W11	2 nd Converter 321.4 MHz IF Output Cable, Flexible Coax	A8A2J2	A8A1A1P2	8120-8674

Table 5-17 (Continued)

Item	Reference Designator	Description	Cable Runs		Part Number
			From	To	
4	A8A5	3 GHz Input Attenuator			33321-60051
5	W15	RF Attenuator Output, Semi-rigid Coax	A8A5J2	A8FL1J2	E4403-20027
6	A8MP5	Filter Bracket			E4403-00007
7	A8MP4	Attenuator Bracket			E4403-00001
8	A8FL1	3.1 GHz Low Pass Filter			0955-0988
9	A8A2	Second Converter			5086-7958
10		Screws - M3 X 10 mm (<i>10 required</i>) (TORX Pan Head with Crest Washer)			0515-0372
11	W14	DC Blocked RF Input Cable, Semi-rigid Coax	A8A3J2	A8A5J1	E4403-20030
12	W8	Filtered Low Band RF Input Cable, Semi-rigid Coax	A8FL1J1	A8A1A2J2	E4403-20028
13	A8A3	dc Filter Block			E4403-20026
14	W9	3.9 GHz IF Cable, Semi-rigid Coax	A8A1A2J3	A8A2J1	E4403-20029
15		Screws - M3 X 10 mm (<i>2 required</i>) (TORX Pan Head with Crest Washer)			0515-2134
16	W2	21.4 MHz IF, RF to IF Cable, Flexible Coax	A8A1A1P5	A3J2	8120-6153
17	W12	600 MHz Tracking Generator Drive Cable, Flexible Coax, (<i>Option 1DN</i>)	A8A1A1P3	A2A2J5	E4402-60022
18	W4	RF Power & Control Cable, 40-pin Ribbon Cable	A7J4	A8A1A1P6 and A8A1A2J1	E4403-60018

Figure 5-14 Microwave RF Major Assemblies, E4404B, E4405B, E4407B and E4408B

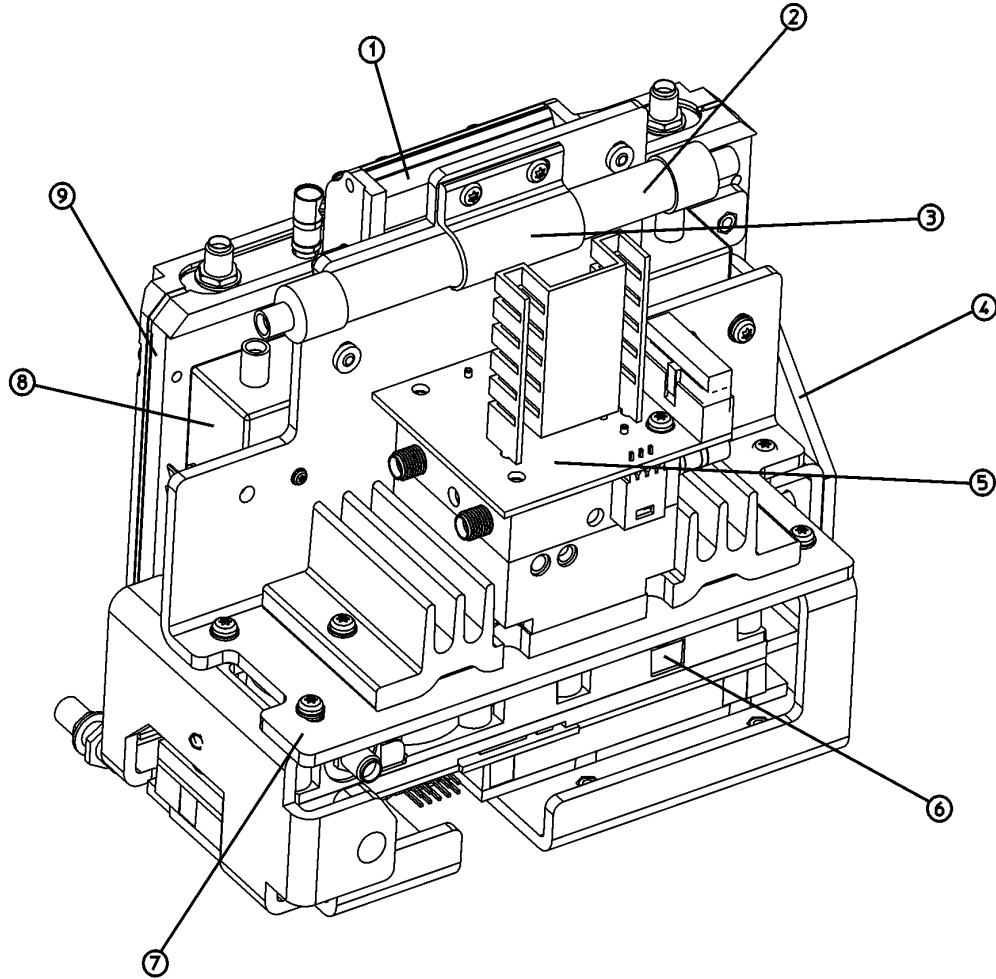

sl721b

Table 5-18 provides a schematic reference designation, a description, and a part number for the items called out in Figure 5-14.

Table 5-18

Item	Reference Designator	Description	Part Number
1	A8A3	dc Block (except Option UKB)	E4403-60026
2	A8FL1	3.1 GHz Low Pass Filter	0955-0988
3	A8MP3	Filter Clamp	5022-3619
4	A8MP1	Micro Bracket	E4404-00001

Table 5-18 (Continued)

Item	Reference Designator	Description	Part Number
5	A8A6	6.7/13.2 GHz Routing YIG-Tuned Harmonic Mixer (RYTHM) (E4404B, E4405B)	5087-7034
		6.7/13.2 GHz Routing YIG-Tuned Harmonic Mixer (RYTHM) Exchange Part (E4404B, E4405B)	5087-6034
		26.5 GHz Routing YIG-Tuned Harmonic Mixer (RYTHM) (E4407B, E4408B)	5087-7031
		26.5 GHz Routing YIG-Tuned Harmonic Mixer Exchange Part (RYTHM) (E4407B, E4408B)	5087-6031
6	A8A2	Second Converter	5086-7958
7	A8MP2	Sub-bracket	E4404-00003
8	A8A5	6.7/13.2 GHz Input Attenuator (E4404B, E4405B)	33321-60052
		26.5 GHz Input Attenuator (except Option UKB) (E4407B, E4408B)	33321-60057
		26.5 GHz Input Attenuator (Option UKB) (E4407B)	33321-60061
9	A8A4	LO Amp/IF Switch	E4404-60030

Parts List
 Replaceable Parts

Figure 5-15 Microwave RF Assembly Bottom View, Semi-rigid Cables E4402B and E4403B

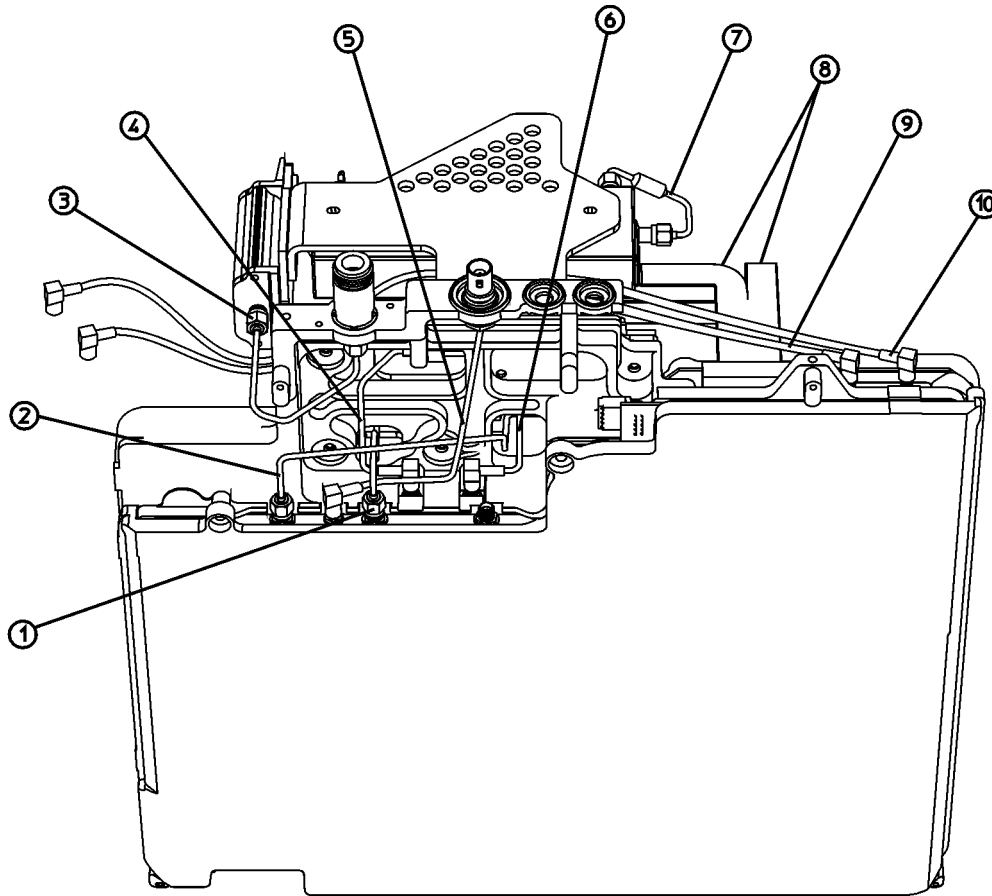

sl714b

Table 5-19 provides a schematic reference designation, a description, and a part number for the items called out in Figure 5-15.

Table 5-19

Item	Reference Designator	Description	Cable Runs		Part Number
			From	To	
1	W8	Filtered Low Band RF Input Cable, Semi-rigid Coax	A8FL1J1	A8A1A2J2	E4403-20028
2	W9	3.9 GHz IF Cable, Semi-rigid Coax	A8A1A2J3	A8A2J1	E4403-20029
3	W7	RF Input Cable, Semi-rigid Coax	A8J1	A8A3J1	E4403-20026
4	W10	600 MHz 2 nd LO Drive Cable, Flexible Coax	A8A1A1P1	A8A2J4	8120-8674

Table 5-19 (Continued)

Item	Reference Designator	Description	Cable Runs		Part Number
			From	To	
5	A8A1W4	50 MHz External Amptd Ref Out Signal Cable/Connector, Flexible Coax	A8A1A2J4	A8J2	5062-0721
6	W11	2 nd Converter 321.4 MHz IF Output Cable, Flexible Coax	A8A2J2	A8A1A1P2	8120-8674
7	W15	RF Attenuator Output, Semi-rigid Coax	A8A5J2	A8FL1J2	E4403-20027
8	W5	Attenuator and 2 nd Converter Power and Control, Ribbon Cable	A8A1A1J2	A8A5J3 and A8A2J6	E4403-60019
9	W12	600 MHz Tracking Generator Drive Cable, Flexible Coax, Option 1DN	A8A1A1P3	A2A2J5	E4402-60022
10	W2	21.4 MHz IF, RF to IF Cable, Flexible Coax	A8A1A1P5	A3J2	8120-6153

Figure 5-16

Microwave RF Assembly Front View, Semi-rigid Cables
E4404B, E4405B, E4407B and E4408B

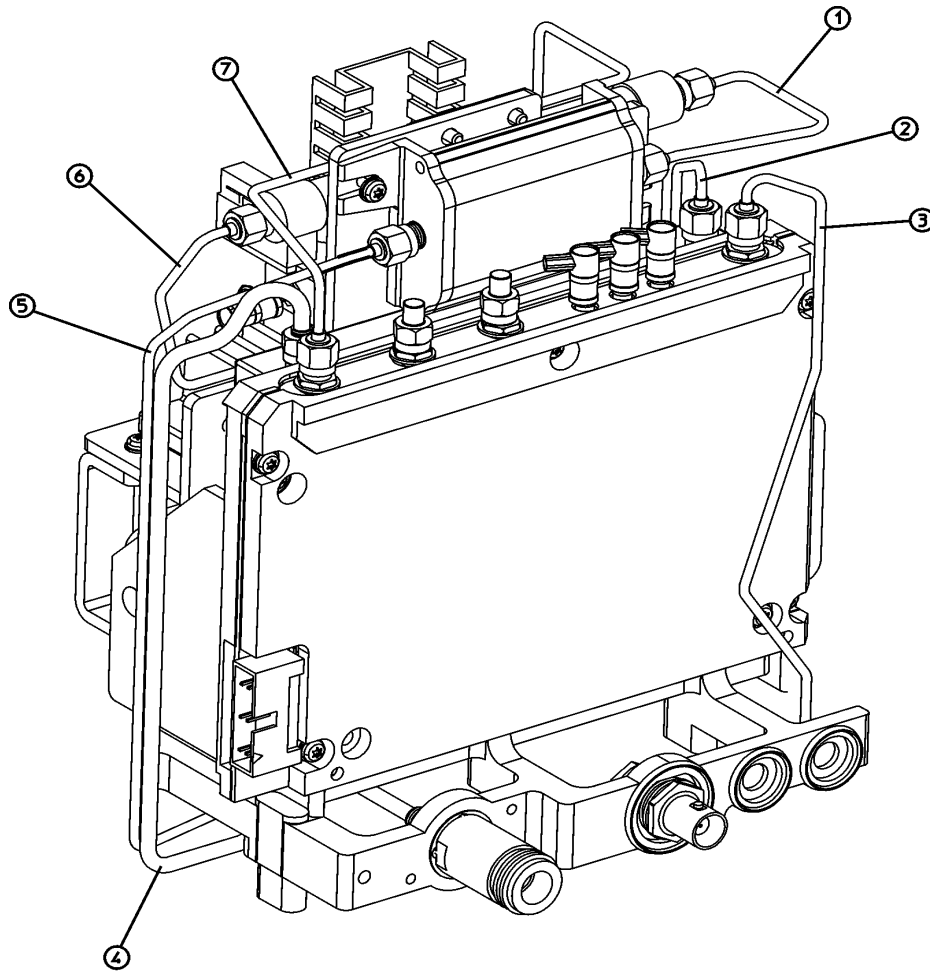

sl71fb

Table 5-20 provides a schematic reference designation, a description, and a part number for the items called out in Figure 5-16.

Table 5-20

Item	Reference Designator	Description	From	To	Part Number
1	W19	dc Blocked RF Input Cable, Semi-rigid Coax	A8FL1J2	A8A3J2	E4404-20004
2	W17	RF Attenuator Output Cable, Semi-rigid Coax (<i>E4404B, E4405B</i>)	A8A6J3	A8A5J2	E4404-20014
		RF Attenuator Output Cable, Semi-rigid Coax (<i>E4407B, E4408B</i>)	A8A6J3	A8A5J2	E4404-20018
3	W23	Aux LO Output Cable, Semi-rigid Coax	A8A4J1	A8A1A2J5	E4404-20008
4	W6	RF Input Cable, Semi-rigid Coax (<i>E4404B, E4405B</i>)	A8A5J1	A8J1	E4404-20009
		RF Input Cable, Semi-rigid Coax (<i>E4407B, E4408B</i>)	A8A5J1	A8J1	E4404-20022
		RF Input Cable, Semi-rigid Coax, (<i>Option BAB</i>) (<i>E4407B, E4408B</i>)	A8A5J1	A8J1	E4404-20017
5	W8	Filtered Low Band RF Input Cable, Semi-rigid Coax	A8A1A2J2	A8A3J1	E4404-20015
6	W18	RYTHM Low Band Output Cable, Semi-rigid Coax	A8FL1J1	A8A6J2	E4404-20003
7	W24	RYTHM LO Cable, Semi-rigid Coax	A8A6J4	A8A4J2	E4404-20005

Figure 5-17 Microwave RF Assembly Front View, Semi-rigid Cables
 Option UKB E4402B

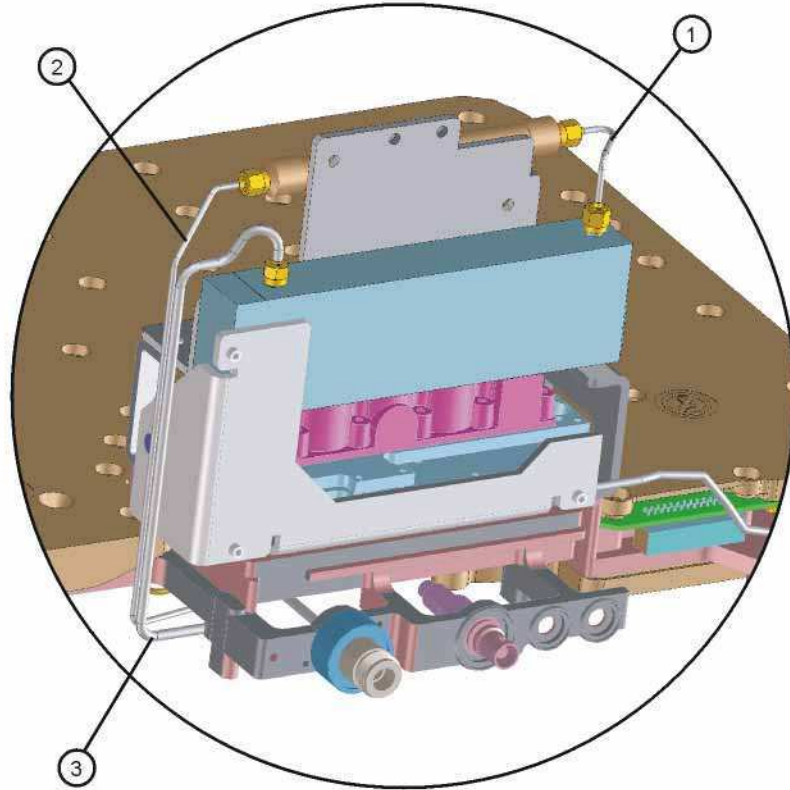
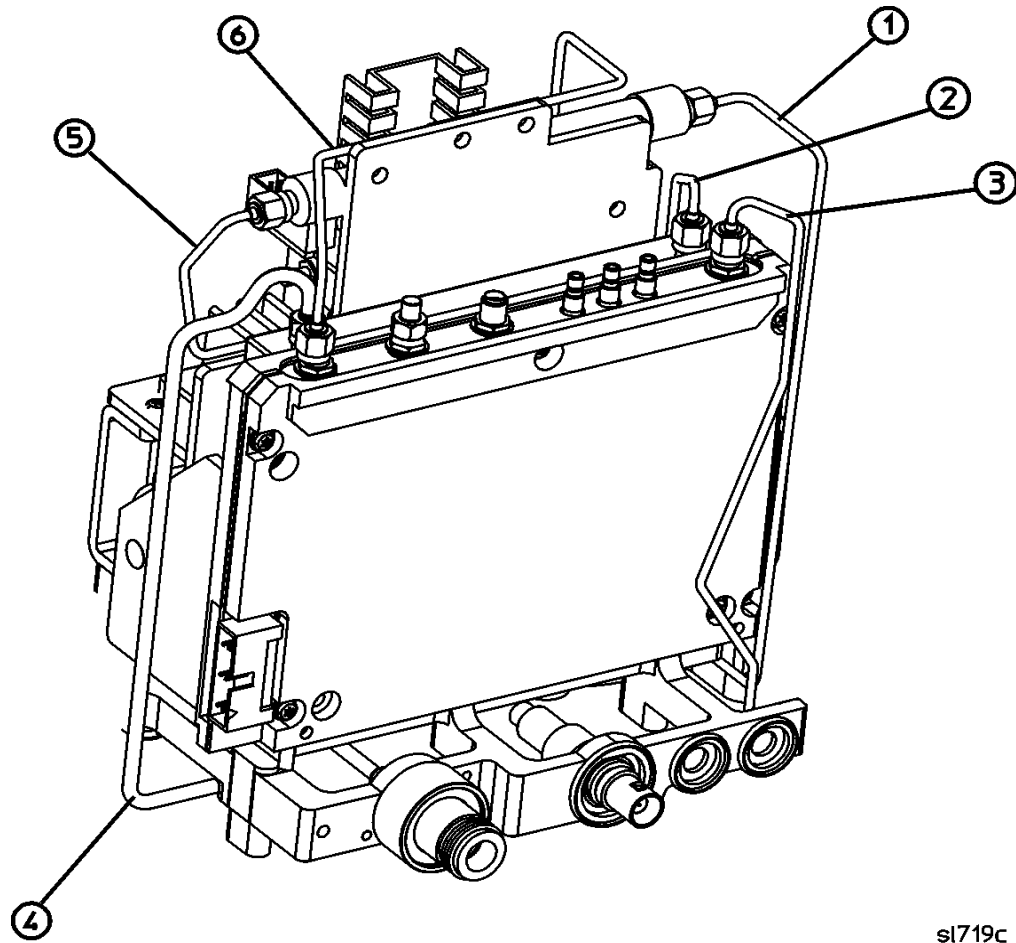

Table 5-21 provides a schematic reference designation, a description, and a part number for the items called out in Figure 5-17.

Table 5-21

Item	Reference Designator	Description	From	To	Part Number
1	W15	RF Attenuator Output Cable, Semi-rigid Coax	A8A5J2	A8FL1J1	E4403-20059
2	W8	Filtered Lowband Cable, Semi-rigid Coax	A8FL1J2	A8A1A2J2	E4403-20058
3	W6	RF Input Cable, Semi-rigid Coax	A8A5J1	A8J1	E4404-20009

Figure 5-18 **Microwave RF Assembly Front View, Semi-rigid Cables**
Option UKB E4404B, E4405B, and E4407B



sl719c

Table 5-22 provides a schematic reference designation, a description, and a part number for the items called out in Figure 5-18.

Parts List
Replaceable Parts

Table 5-22

Item	Reference Designator	Description	From	To	Part Number
1	W35	Filtered Low Band RF Input Cable, Semi-rigid Coax	A8FL1J2	A8A1A2J2	E4404-20026
2	W17	RF Attenuator Output Cable, Semi-rigid Coax (<i>E4404B, E4405B</i>)	A8A6J3	A8A5J2	E4404-20014
		RF Attenuator Output Cable, Semi-rigid Coax (<i>E4407B</i>)	A8A6J3	A8A5J2	E4404-20018
3	W23	Aux LO Output Cable, Semi-rigid Coax	A8A4J1	A8A1A2J5	E4404-20008
4	W6	RF Input Cable, Semi-rigid Coax (<i>E4404B, E4405B</i>)	A8A5J1	A8J1	E4404-20009
5	W18	RYTHM Low Band Output Cable, Semi-rigid Coax	A8FL1J1	A8A6J2	E4404-20003
6	W22	RYTHM LO Cable, Semi-rigid Coax	A8A6J4	A8A4J2	E4404-20005

Figure 5-19

Microwave RF Assembly Rear View, Semi-rigid Cables
E4404B, E4405B, E4407B and E4408B

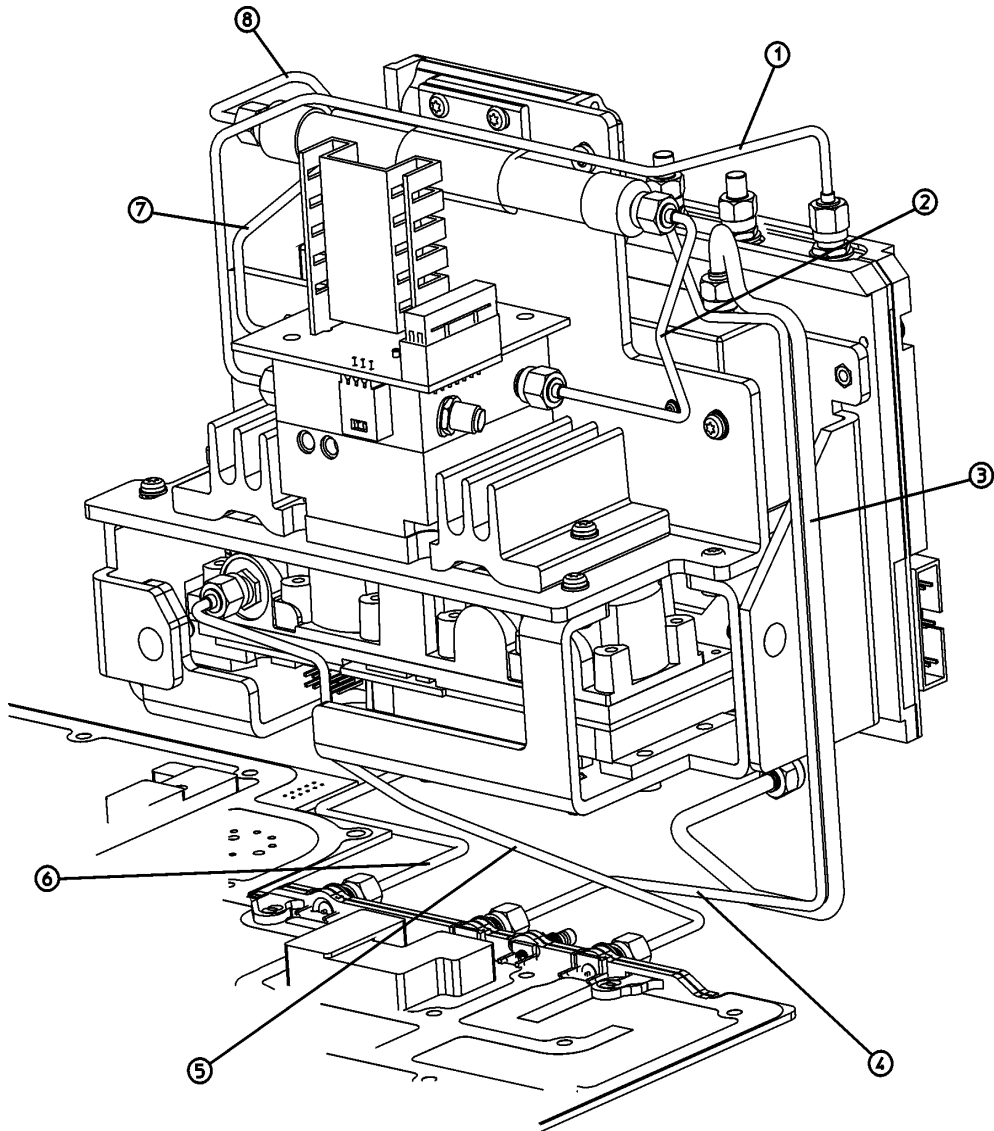

sl710b

Table 5-23 provides a schematic reference designation, a description, and a part number for the items called out in Figure 5-19.

Parts List
Replaceable Parts

Table 5-23

Item	Reference Designator	Description	From	To	Part Number
1	W22	RYTHM LO Cable, Semi-rigid Coax	A8A4J2	A8A6J4	E4404-20005
2	W18	RYTHM Low Band Output Cable, Semi-rigid Coax	A8A6J2	A8FL1J1	E4404-20003
3	W6	RF Input Cable, Semi-rigid Coax (<i>E4404B, E4405B</i>)	A8J1	A8A5J1	E4404-20009
		RF Input Cable, Semi-rigid Coax (<i>E4407B, E4408B</i>)	A8J1	A8A5J1	E4404-20022
		RF Input Cable, Semi-rigid Coax, (<i>Option BAB</i>) (<i>E4407B, E4408B</i>)	A8J1	A8A5J1	E4404-20017
4	W8	Filtered Low Band RF Input Cable, Semi-rigid Coax	A8A3J1	A8A1A2J2	E4404-20015
5	W9	3.9 GHz IF Cable, Semi-rigid Coax	A8A1A2J3	A8A2J1	E4403-20029
6	W23	Aux LO Output Cable, Semi-rigid Coax	A8A1A2J5	A8A4J1	E4404-20008
7	W17	RF Attenuator Output Cable, Semi-rigid Coax (<i>E4404B, E4405B</i>)	A8A5J2	A8A6J3	E4404-20014
		RF Attenuator Output Cable, Semi-rigid Coax (<i>E4407B, E4408B</i>)	A8A5J2	A8A6J3	E4404-20018
8	W19	dc Blocked RF Input Cable, Semi-rigid Coax	A8A3J2	A8FL1J2	E4404-20004

Figure 5-20 **Microwave RF Assembly Front View, Flexible Coaxial Cables**
E4404B, E4405B, E4407B and E4408B

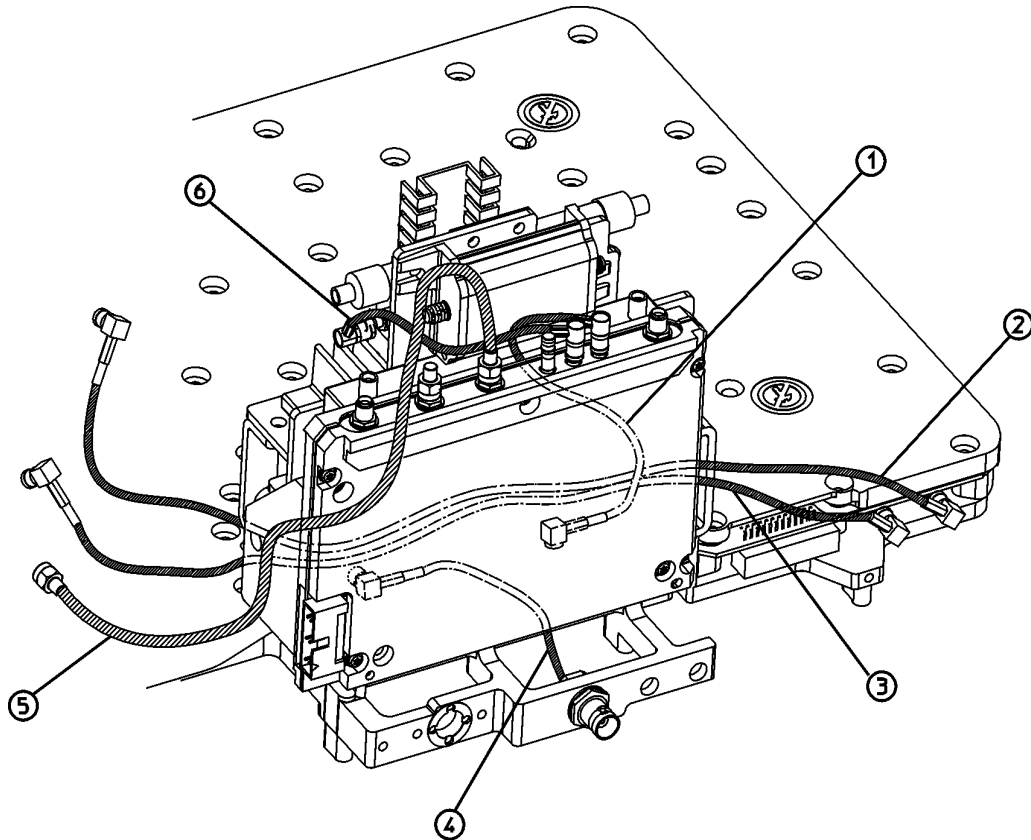

sl715b

Table 5-24 provides a schematic reference designation, a description, and a part number for the items called out in Figure 5-20.

Parts List
 Replaceable Parts

Table 5-24

Item	Reference Designator	Description	From	To	Part Number
1	W21	LOIS 321.4 MHz IF Output Cable, Flexible Coax	A8A4J7	A8A2J3	E4404-60008
2	W2	21.4 MHz IF, RF to IF Cable, Flexible Coax	A8A1A1P5	A3J2	E4402-60020
3	W12	600 MHz Tracking Generator Drive Cable, Flexible Coax, (<i>Option 1DN</i>)	A8A1A1P3	A2A2J5	E4402-60022
4	A8A1W4	50 MHz External Amptd Ref Out Kit Signal Cable/Connector, Flexible Coax	A8A1A2J4	A8J2	5062-0721
5	W13	3.0 GHz Tracking Generator 1 st LO Drive Cable, Braided Coax, (<i>Option 1DN</i>)	A8A4J3	A2A1J3	E4403-20023
6	W20	RYTHM 321.4 MHz IF Output Cable, Flexible Coax	A8A6J1	A8A4J5	8120-8674

Figure 5-21 Microwave Option B74 RF Assembly Front View, Flexible Coaxial Cables E4402B, E4404B, E4405B and E4407B

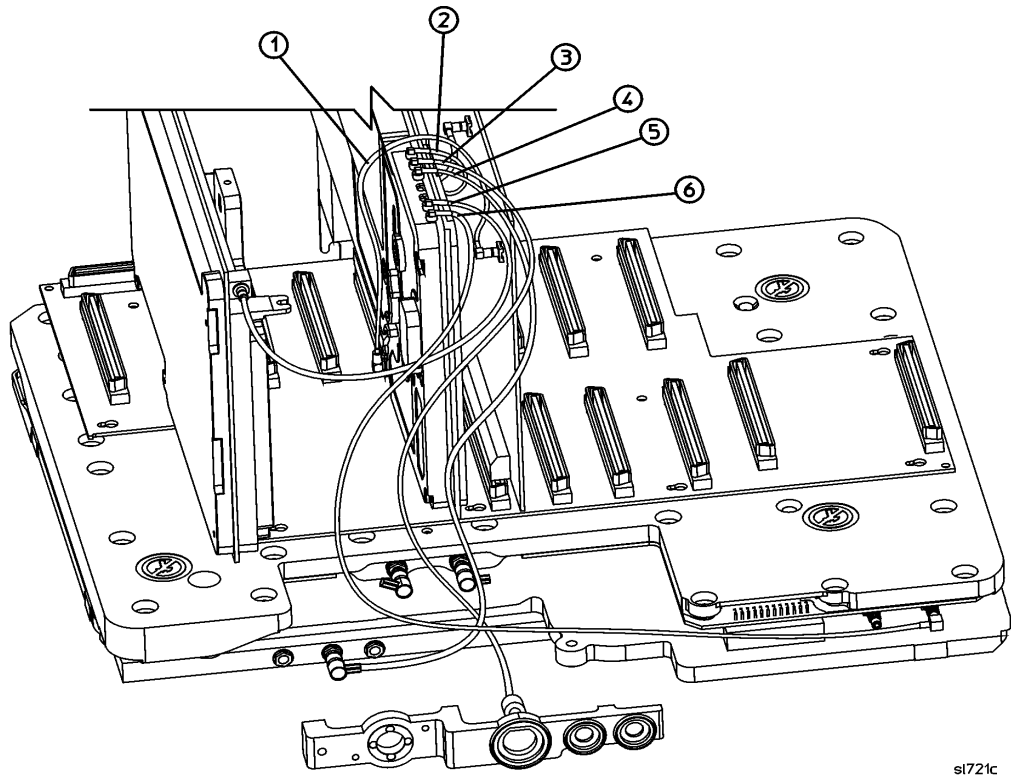

sl721c

Table 5-24 provides a schematic reference designation, a description, and a part number for the items called out in Figure 5-20.

Parts List
Replaceable Parts

Table 5-25

Item	Reference Designator	Description	From	To	Part Number
1	W33	Digital Demod DSP Sample Rate (Flexible Coaxial) (<i>Option B7D</i>)	A7A7P4	A7A8J12	8120-8867
2	W34	Digital Demod DSP IF (Flexible Cable) (<i>Option B7D</i>)	A7A7P5	A7A8J5	E4402-60027
3	W30	50 MHz External Amptd Ref Out Kit Signal (Flexible Coaxial) (<i>Option B7E</i>)	A8A1A2J4	A7A8J6	E4402-60023
4	W29	Digital Demod RF Input (Flexible Coaxial) (<i>Option B7E</i>)	A8A8A2J4	A7A8J7	E4402-60024
5	W32	Digital Demod IF Output (Flexible Coaxial) (<i>Option B7E</i>)	A3J2	A7A8J10	8120-8866
6	W31	21.4 MHz IF, RF to IF In Cable, (Flexible Coaxial)	A8A1A1P5	A7A8J11	E4402-60021

Figure 5-22 Microwave RF Assembly Rear View, Flexible Coaxial Cables E4404B, E4405B, E4407B and E4408B

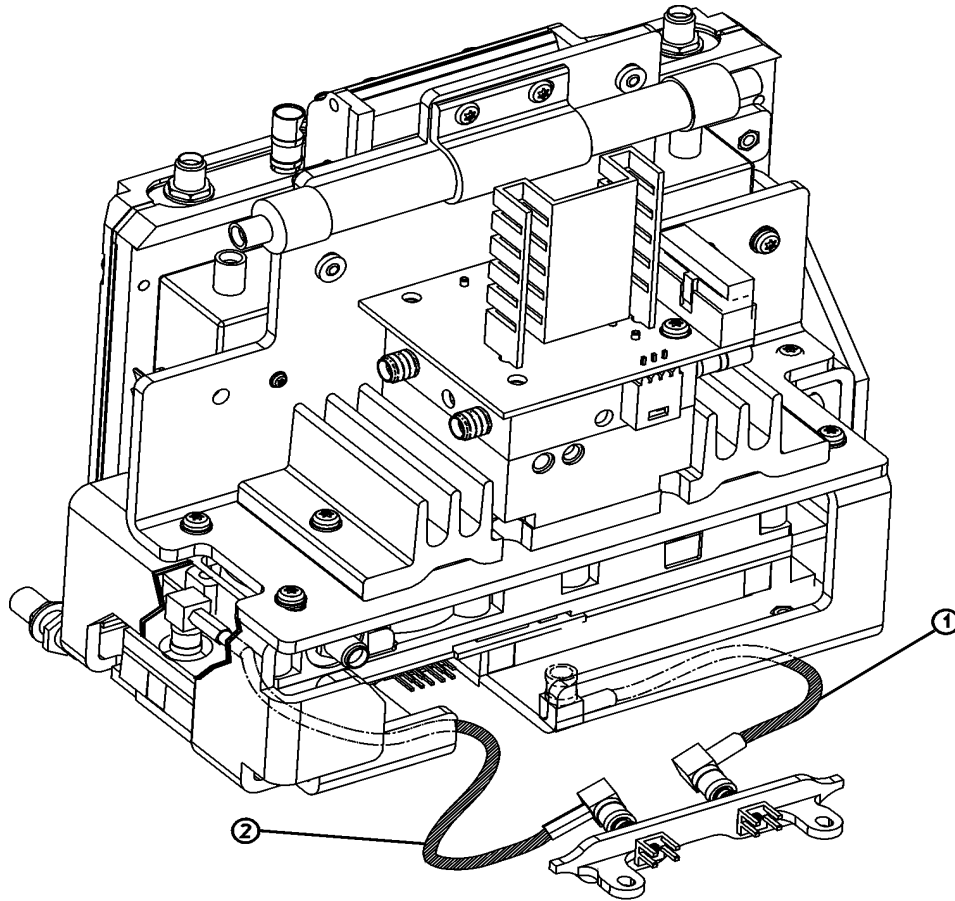

sl713b

Table 5-26 provides a schematic reference designation, a description, and a part number for the items called out in Figure 5-22.

Parts List
Replaceable Parts

Table 5-26

Item	Reference Designator	Description	From	To	Part Number
1	W10	600 MHz 2 nd LO Drive Cable, Flexible Coax	A8A1A1P1	A8A2J4	8120-8674
2	W11	2 nd Converter 321.4 MHz IF Output Cable, Flexible Coax	A8A2J2	AiA1A1P2	8120-8674

Figure 5-23 **Microwave RF Assembly Ribbon Cables**
E4404B, E4405B, E4407B and E4408B

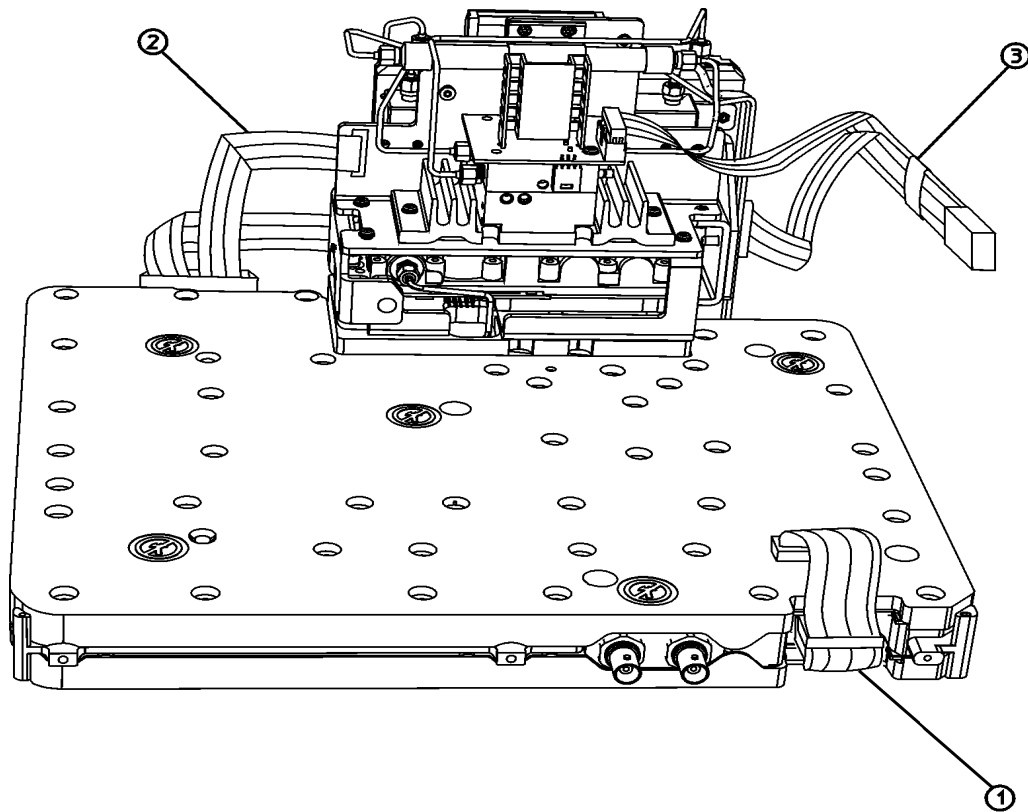

sl712b

Table 5-27 provides a schematic reference designation, a description, and a part number for the items called out in Figure 5-23.

Parts List
Replaceable Parts

Table 5-27

Item	Reference Designator	Description	From	To	Part Number
1	W4	RF Power and Control Cable, Ribbon	A7J4	A8A1A1P6 and A8A1A2J1	E4403-60018
2	W5	Attenuator and 2 nd Converter Power and Control Cable, Ribbon (<i>E4407B, E4408B - except Option UKB</i>)	A8A1A1J2	A8A5J3 and A8A2J6	E4403-60019
		Attenuator and 2 nd Converter Power and Control Cable, Ribbon (<i>E4404B, E4405B, and E4407B Option UKB</i>)	A8A1A1J2	A8A5J3 and A8A2J6	E4404-60004
3	W16	RYTHM/LOIS Power and Control Cable, Ribbon	A7A4J2	A8A4J8 and A8A6J5	E4404-60003

Figure 5-24 Power Supply Hardware

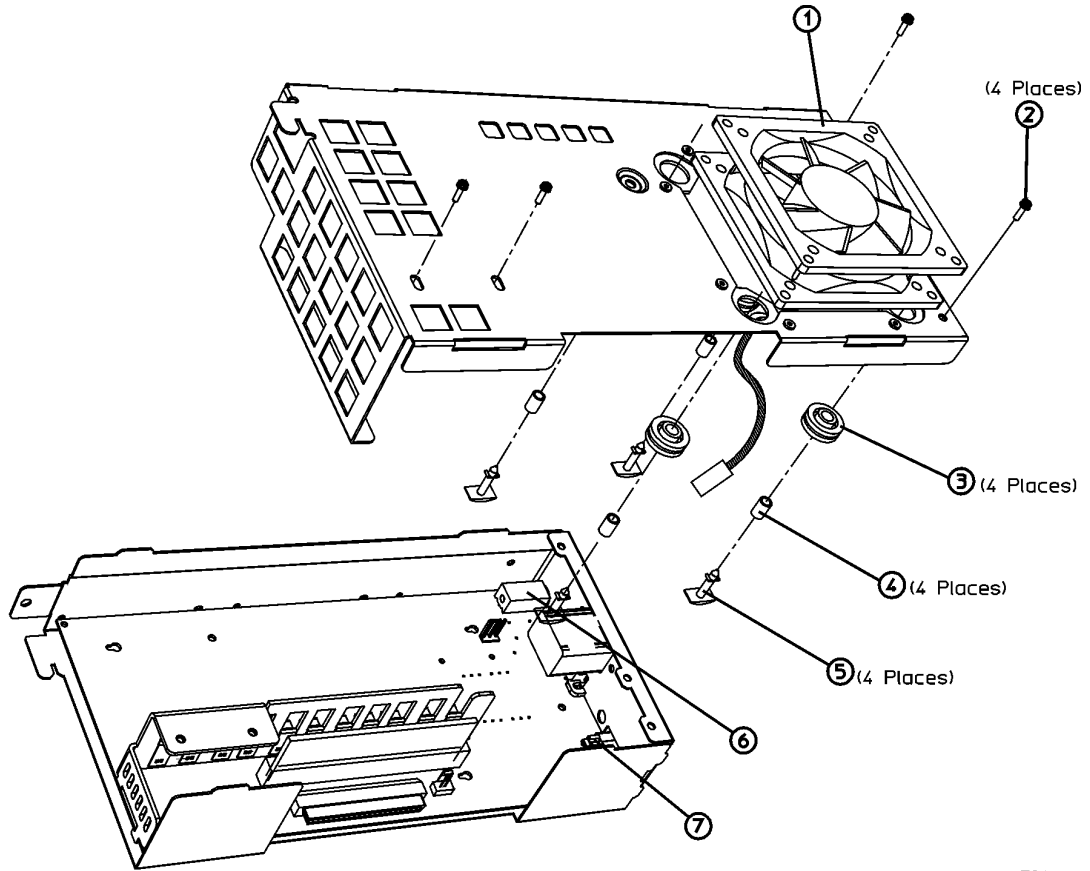

sl794b

Table 5-28 provides a schematic reference designation, a description, and a part number for the items called out in Figure 5-24.

Parts List
Replaceable Parts

Table 5-28

Item	Reference Designator	Description	Part Number
1	A5B1	Fan	3160-0866
2		Screw - M3 X 8 mm (TORX Pan Head with Crest Washer)	0515-0372
3		Rubber grommet	0400-0713
4		Metal bushing	0380-0006
5	A5MP1-4	Plastic rivet	0361-1814
6	A5F1	Fuse (dc) 20 A, 32 V	2110-1317
7	A5F2	Fuse (dc Line) 5 A, 250 V	2110-0709

Figure 5-25 1.5 GHz Tracking Generator Hardware

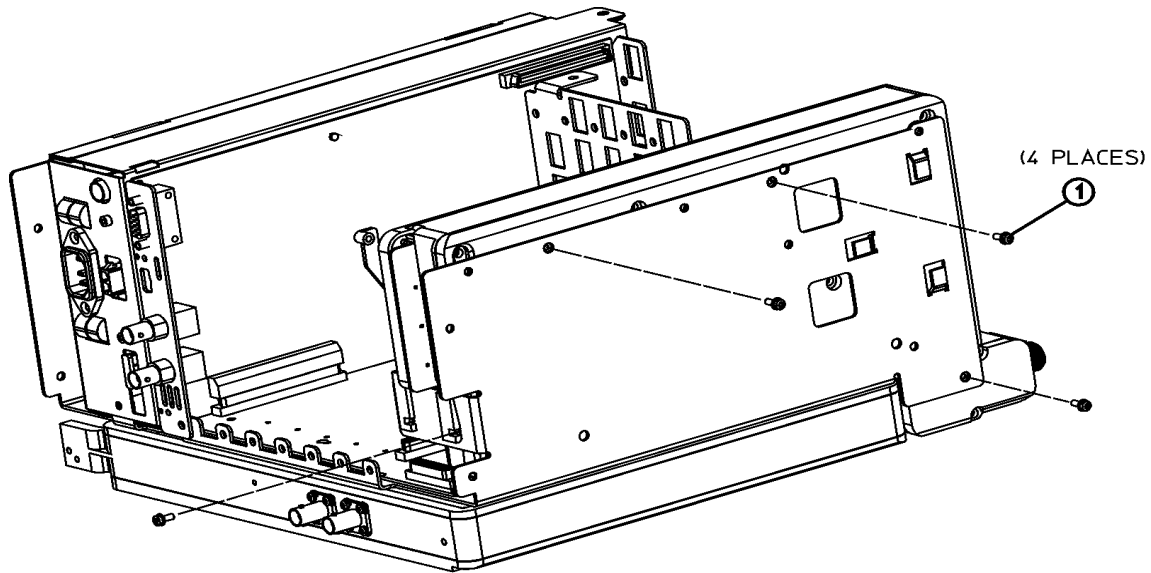

sl715a

Table 5-29 provides a description, and a part number for the items called out in Figure 5-25.

Table 5-29

Item	Description	Part Number
1	Screw - M3 X 8 mm (TORX Pan Head with Crest Washer)	0515-0372

Figure 5-26 3.0 GHz Tracking Generator Hardware

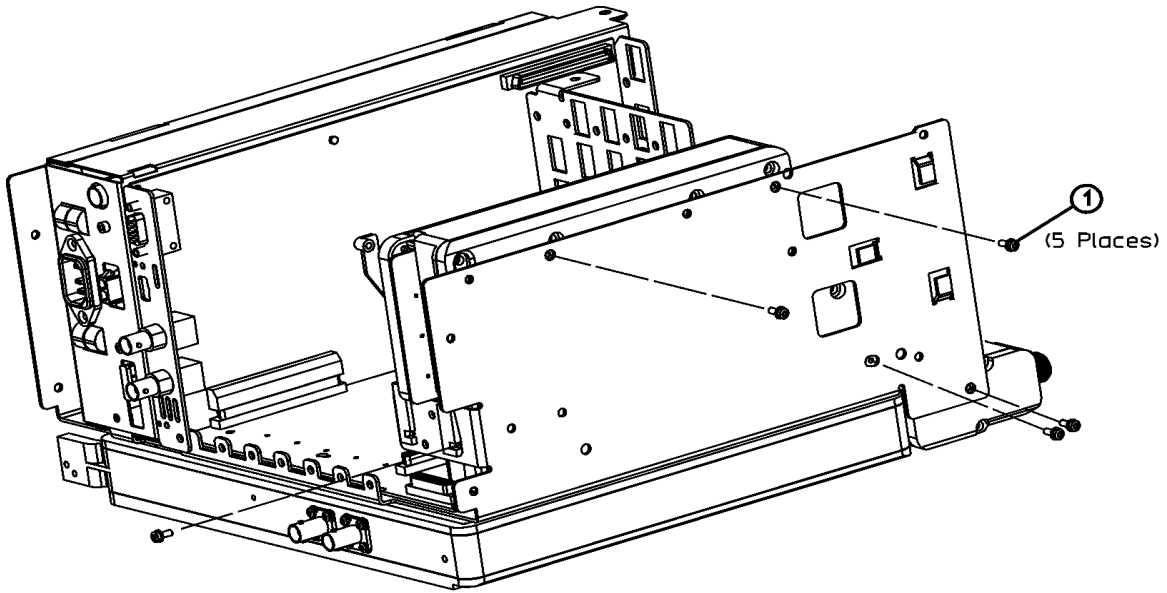

sl79c

Table 5-30 provides a description, and a part number for the items called out in Figure 5-26.

Table 5-30

Item	Description	Part Number
1	Screw - M3 X 8 mm (TORX Pan Head with Crest Washer)	0515-0372

Figure 5-27 1.5 GHz Tracking Generator Assembly with Hardware

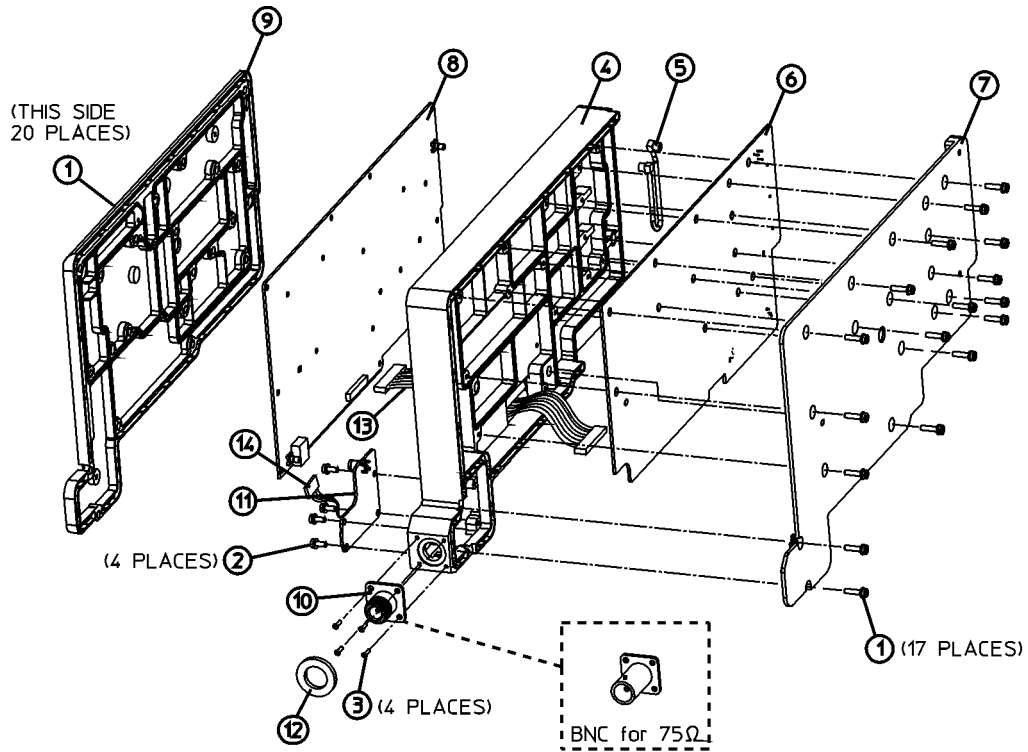

sn75a

Table 5-31 provides a schematic reference designation, a description, and a part number for the items called out in Figure 5-27.

Parts List
Replaceable Parts

Table 5-31

Item	Reference Designator	Description	Part Number
1		Screw - M3 X 12 mm, waxed (TORX Pan Head with Crest Washer)	0515-2993
2		Screw - M3 X 8 mm (TORX Pan Head with Crest Washer)	0515-0372
3		Screw - M2.5 X 8 mm (TORX Flat Head)	0515-2487
4	A2MP4	1.5 GHz TG Center Shield, <i>(Option 1DN/1DQ)</i>	E4401-60052
5	A2W2	1.5 GHz TG Cable Assembly (internal Coaxial) <i>(Option 1DN/1DQ)</i> (from A2A1J3 to A2A2J2)	8120-6384
6	A2A1	1.5 GHz TG Control Board Kit, <i>(Option 1DN/1DQ)</i>	E4401-60131
7	A2MP7	1.5 GHz TG Control Shield, <i>(Option 1DN/1DQ)</i>	E4401-60051
8	A2A2	1.5 GHz TG RF Board (50 Ω) Kit, <i>(Option 1DN)</i>	E4401-60133
		1.5 GHz TG RF Board (75 Ω) Kit, <i>(Option 1DQ)</i>	E4401-60134
9	A2MP9	1.5 GHz TG RF Shield, <i>(Option 1DN)</i>	E4401-60050
10	A2J1	1.5 GHz TG RF Output Type-N Connector Kit, (50 Ω) <i>(Option 1DN)</i>	1250-2514
		1.5 GHz TG RF Output BNC Connector Kit, (75 Ω) <i>(Option 1DQ)</i>	1250-2792
11	A2A3	1.5 GHz TG Output Board (50 Ω) Kit, <i>(Option 1DN)</i>	E4401-60135
		1.5 GHz TG Output Board (75 Ω) Kit, <i>(Option 1DQ)</i>	E4401-60136
12	A2MP1	1.5 GHz TG RF Output Gasket (50 Ω) <i>(Option 1DQ)</i>	E4401-20024
		1.5 GHz TG RF Output Gasket (75 Ω) <i>(Option 1DQ)</i>	E4401-20024
13	A2W1	1.5 GHz TG Cable Assembly (internal Ribbon) <i>(Option 1DN/1DQ)</i> (from A2A1J2 to A2A2J1)	8120-6944

Figure 5-28 3.0 GHz Tracking Generator Assembly with Hardware

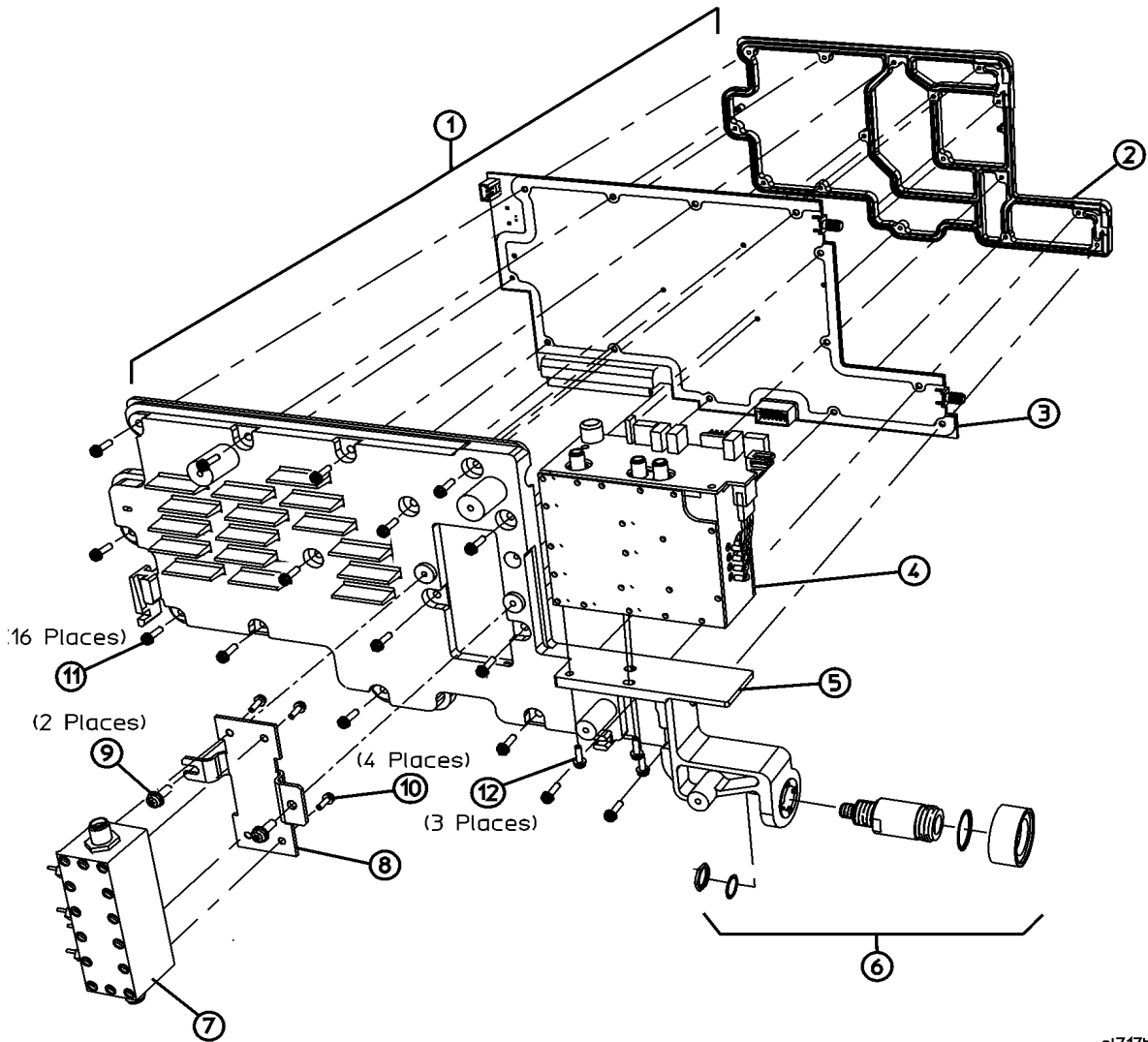

sl717b

Table 5-32 provides a schematic reference designation, a description, and a part number for the items called out in Figure 5-28.

Parts List
Replaceable Parts

Table 5-32

Item	Reference Designator	Description	Part Number
1	A2A1	3.0 GHz TG Driver Board Assembly with shields, (<i>Option 1DN</i>)	E4401-60131
		Item 3 - 3.0 GHz TG Driver Board, (<i>Option 1DN</i>)	
	A2MP3	Item 2 - 3.0 GHz TG Cover Shield, (<i>Option 1DN</i>)	E4403-60006
	A2MP2	Item 5 - 3.0 GHz TG Support Shield, (<i>Option 1DN</i>)	E4403-60007
4	A2A2	3.0 GHz BITG Microcircuit Assembly, (<i>Option 1DN</i>)	E4403-60089
6	A2J1	3.0 GHz TG RF Output Type-N Connector Kit (<i>Option 1DN</i>)	E4403-60015
		Connector	
		O-Ring	
		Sleeve	
		Washer	
		Nut	
7	A2A3	3.0 GHz TG Output Attenuator, (<i>Option 1DN</i>)	0955-0679
8	A2MP5	TG Attenuator Bracket, (<i>Option 1DN</i>)	E4403-00004
9		Screw - M3 X 8 mm (TORX Pan Head with Crest Washer) (2 required)	0515-0372
10		Screw - M2-56 X 0.188 (TORX Flat Head) (4 required)	0520-0314
11		Screw - M3 X 14 mm (TORX Pan Head with Crest Washer) (16 required)	0515-2994
12		Screw - M3 X 10 mm (TORX Pan Head with Crest Washer) (3 required)	0515-2134

Figure 5-29 3.0 GHz Tracking Generator Assembly with Cables

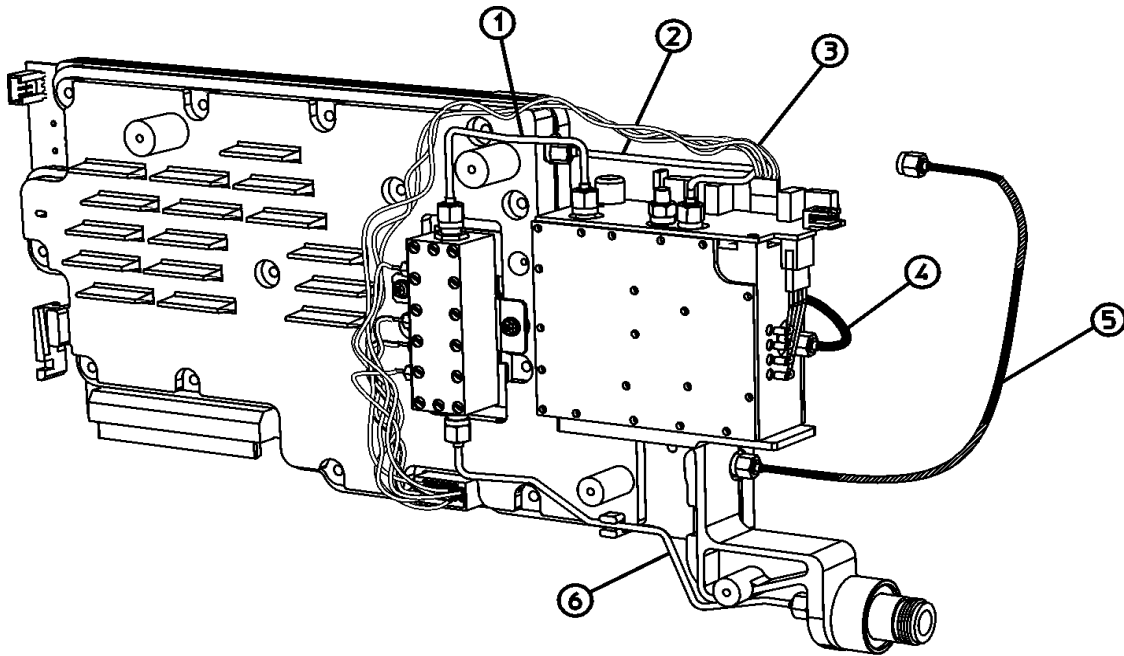

sl716b

Table 5-33 provides a schematic reference designation, a description, and a part number for the items called out in Figure 5-29.

Table 5-33

Item	Reference Designator	Description	From	To	Part Number
1	A2W3	3.0 GHz TG RF Output Semi-rigid Cable, (Option 1DN)	A2A2J2	A2A3J1	E4403-20073
2	A2W2	3.0 GHz TG LO Drive Semi-rigid Cable, (Option 1DN)	A2A1J2	A2A2J4	E4403-20072 E4403-20083
3	A2W1	3.0 GHz TG Power & Control Wire Harness, (Option 1DN)	A2A1P1	A2A2J1	E4403-60025
4	W12	600 MHz TG Drive Flexible Coax, (Option 1DN)	A8A1A1P3	A2A2J5	E4402-60022
5	W13	3.0 GHz TG 1 st LO Drive Braided Coax Cable, (Option 1DN) (E4402B, E4403B)	A8A1A2J5	A2A1J3	E4403-20023
		3.0 GHz TG 1 st LO Drive Braided Coax Cable, (Option 1DN) (E4404B, E4405B, E4407B, E4408B)	A8A4J3	A2A1J3	E4403-20023
6	A2W4	3.0 GHz TG Attenuator RF Output Semi-rigid Cable, (Option 1DN)	A2A3J2	A2J1	E4403-20022

Component-Level Information Packets

Component-level information is available for selected instrument assemblies. The information for each repairable assembly is provided in the form of a Component-Level Information Packets (CLIPs).

A CLIP consists of a parts list, component-location diagram, and schematic diagram relating to a unique instrument assembly. An Agilent part number is assigned to each CLIP. When an assembly number changes, a new CLIP is generated.

Ordering CLIPs

For ordering convenience, current CLIPs for a specific instrument are combined into component-level information binders. The current set of CLIPs contains information supporting the instrument assemblies manufactured at the time the manuals was printed, plus a packet containing general CLIP information.

A complete set of CLIPs can be ordered by ordering the CLIP set Option 0BV part number: E4401-90310.

Updated or replacement CLIPs may be ordered through your local Agilent Technologies Sales or Service office using the CLIP part number provided in [Table 5-34 on page 239](#).

Table 5-34 ESA Series Spectrum Analyzer Board Assembly, Serial Number, and CLIP Number Cross-Reference

Reference Designator	Assembly Description	Board Assembly Part Number	Serial Number	CLIP Part Number
A1A1	Front panel interface	E4401-60234		E4401-90163
A2A1	1.5 GHz Tracking Generator Control <i>(Option IDN)</i>	E4401-60095		E4401-90120
	3.0 GHz Tracking Generator Control <i>(Option IDN)</i>	E4403-60004		E4403-90003
A2A2	1.5 GHz Tracking Generator RF (50 Ohm) <i>(Option IDN)</i>	E4401-60004		E4401-90031
	1.5 GHz Tracking Generator RF (75 Ohm) <i>(Option IDN)</i>	E4402-60004		E4402-90003
A2A3	1.5 GHz Tracking Generator Output (50 Ohm) <i>(Option IDN)</i>	E4401-60005		E4401-90033
	1.5 GHz Tracking Generator Output (75 Ohm) <i>(Option IDN)</i>	E4402-60005		E4402-90001
A3	21.4 MHz IF with shields	E4401-60183		E4401-90164
A4	Processor	E4401-60059		E4401-90122
A6	Speaker/Floppy	E4401-60008		E4401-90021
A7	Motherboard (ESA-L Series)	E4411-60013		E4411-90057
	Motherboard (ESA-E Series)	E4401-60107		E4401-90119
A7A1	IF Video Sweep Ports, <i>(Option A4J)</i>	E4401-60096		E4401-90125
A7A2	GPIB <i>(Option A4H)</i>	E4401-60013		E4401-90025
A7A3	Serial/Parallel I/O <i>(Option IAX)</i>	E4401-60014		E4401-90026
A7A4	Frequency Extension	E4404-60001		E4401-90001
A7A5	Fast ADC <i>(Option AYZ)</i>	E4401-60083		E4401-90123
A7A6	FM Demod <i>(Option BAA)</i>	E4401-60082		E4401-90124
A8	1.5 GHz RF (50 ohm)	E4401-60203		E4401-90216
	1.5 GHz RF (75 ohm)	E4401-60100 ^a		E4401-90127
A8A1A1	3.0 GHz Reference/ Third Converter (50 ohm) (Top Board)	E4403-60001		E4403-90004
	3.0 GHz Reference/ Third Converter with precision frequency reference (50 ohm) (Top Board)	E4403-60053 ^a		E4403-90006

Table 5-34 **ESA Series Spectrum Analyzer Board Assembly, Serial Number, and CLIP Number Cross-Reference (Continued)**

Reference Designator	Assembly Description	Board Assembly Part Number	Serial Number	CLIP Part Number
A8A1A2	3.0 GHz Front End/LO (Bottom Board)	E4403-60033		E4403-90008
A7A7	Digital Demod DSP Assembly, <i>(Option B7D)</i>	E4401-60088		E4401-90213
A7A8	Digital Demod RF Assembly, <i>(Option B7E)</i>	E4402-60087		E4401-90214

a. Denotes refurbished board assemblies are available. Refurbished board assembly part numbers have 9 as the second digit of the suffix. For example, E4401-69119 is the refurbished part number for board assembly E4401-60119.

Contacting Agilent Technologies

For assistance, contact your nearest Agilent Technologies Sales and Service Office. To find your local Agilent office access the following URL, or if in the United States, call the following telephone number:

<http://www.agilent.com/find/assist>

1-800-829-4444 (8 am - 8 pm ET, Monday - Friday)

In any correspondence or telephone conversations, refer to your analyzer by its product number, full serial number, and firmware revision.

How to Return Your Analyzer for Service

Service Tag

If you are returning your analyzer to Agilent Technologies, Inc. for servicing, fill in and attach a blue service tag. Several service tags are supplied at the rear of this chapter. Please be as specific as possible about the nature of the problem. If you have recorded any error messages that appeared on the display, or have completed a Performance Test Record, or have any other specific data on the performance of your analyzer, please send a copy of this information with your analyzer.

Original Packaging

Before shipping, pack the unit in the original factory packaging materials if they are available. If the original materials were not retained, see [“Other Packaging” on page 244](#).

NOTE Ensure that the instrument handle is in the rear-facing position in order to reduce the possibility of damage during shipping. Refer to the following illustration.

NOTE Install the transportation disk into the floppy drive to reduce the possibility of damage during shipping. If the original transportation disk is not available, a blank floppy may be substituted.

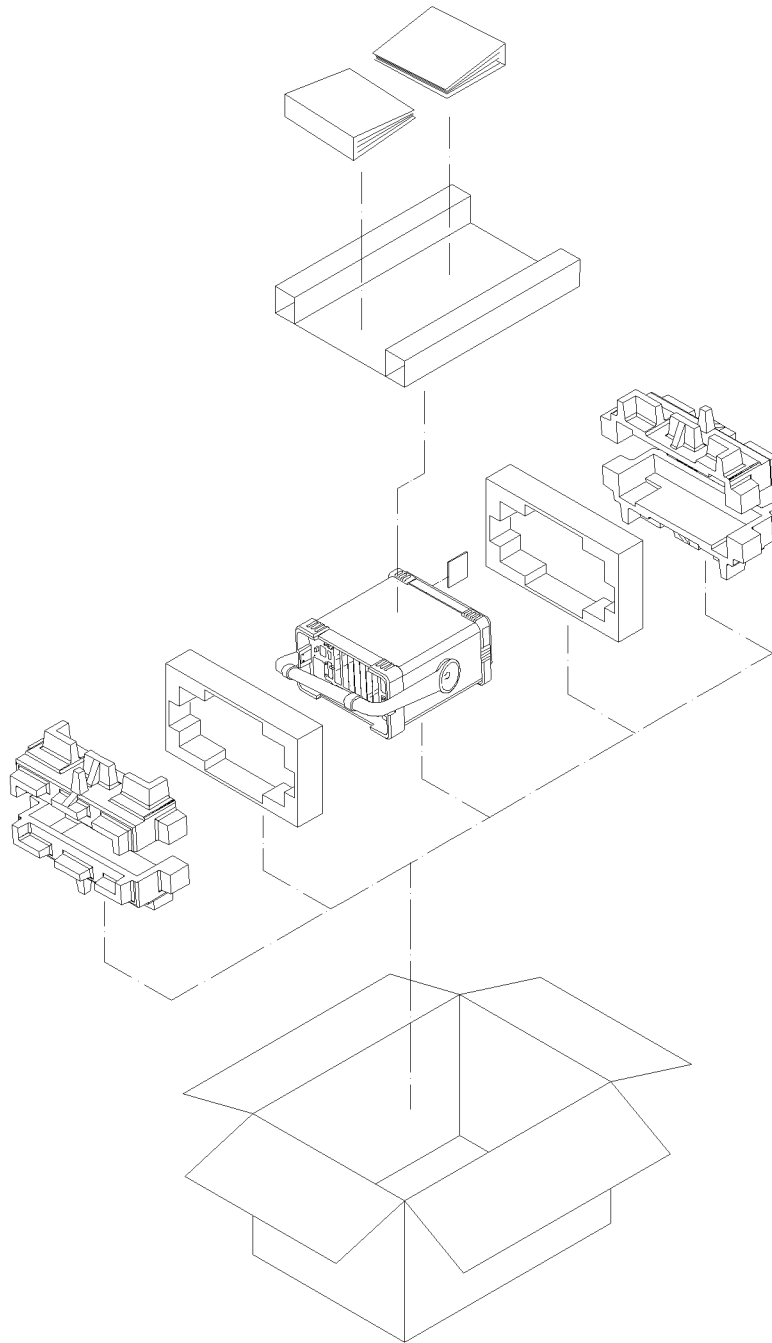

orm122

Other Packaging

CAUTION

Analyzer damage can result from using packaging materials other than those specified. Never use styrene pellets in any shape as packaging materials. They do not adequately cushion the equipment or prevent it from shifting in the carton. They cause equipment damage by generating static electricity and by lodging in the analyzer louvers, blocking airflow.

You can repackage the instrument with commercially available materials, as follows:

1. Attach a completed service tag to the instrument.
2. Install the transportation disk or a blank floppy disk into the disk drive.
3. If you have a front-panel cover, install it on the instrument. If you do not have a front panel cover, make sure the instrument handle is in the forward-facing position to protect the control panel.
4. Wrap the instrument in antistatic plastic to reduce the possibility of damage caused by electrostatic discharge.
5. Use a strong shipping container. A double-walled, corrugated cardboard carton with 159 kg (350 lb) bursting strength is adequate. The carton must be both large enough and strong enough to accommodate the analyzer. Allow at least 3 to 4 inches on all sides of the analyzer for packing material.
6. Surround the equipment with three to four inches of packing material to prevent the equipment from moving in the carton. If packing foam is not available, the best alternative is S.D.-240 Air Cap™ from Sealed Air Corporation (Hayward, California, 94545). Air Cap looks like a plastic sheet filled with 1-1/4 inch air bubbles. Use the pink-colored Air Cap to reduce static electricity. Wrapping the equipment several times in this material should both protect the equipment and prevent it from moving in the carton.
7. Seal the shipping container securely with strong nylon adhesive tape.
8. Mark the shipping container “FRAGILE, HANDLE WITH CARE” to assure careful handling.
9. Retain copies of all shipping papers.

6 **Replacing Assemblies**

What You Will Find in This Chapter

The procedures in this chapter describe the location, removal and replacement of major assemblies in the spectrum analyzer. Refer to [Chapter 5, “Parts List,”](#) for part numbers, assembly descriptions, and ordering information.

Numbers in parentheses, for example **(1)**, indicate numerical callouts on the figures.

Before You Start

Before starting to disassemble the analyzer:

- o Check that you are familiar with the safety symbols marked on the analyzer, and read the general safety considerations and the safety note definitions given in the front of this guide.
- o The spectrum analyzer contains static sensitive components. Read the section entitled “ESD Information” in Chapter 1.

WARNING

The opening of covers or removal of parts is likely to expose dangerous voltages. Disconnect the product from all voltage sources while it is being opened.

WARNING

The spectrum analyzer contains potentially hazardous voltages. Refer to the safety symbols on the spectrum analyzer and the general safety considerations at the beginning of this service guide before operating the unit with the cover removed. Failure to heed the safety precautions can result in severe or fatal injury.

Service tools you will need

Figure 6-1

TORX Tool

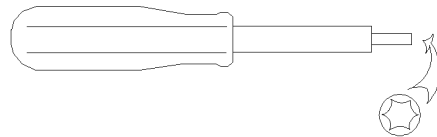

s1736a

Table 6-1

Description	Agilent Part Number
TORX Hand Driver - Size T8	8710-1614
TORX Hand Driver - Size T10	8710-1623
TORX Hand Driver - Size T15	8710-1622

After a spectrum analyzer repair

If one or more analyzer assemblies have been repaired or replaced, perform the related adjustments and performance verification tests. Refer to [Table 7-2 on page 330](#) for the related adjustments and performance verification tests required for each assembly.

The adjustments and performance verification tests are done using the *Performance Verification and Adjustment Software*. The software can be purchased through your local Agilent Technologies sales and service office. (Refer to Chapter 8, “Performance Verification and Adjustment Software,” on page 333.)

Removal and Replacement Procedures in This Chapter

This chapter describes the removal and replacement procedures for the following Agilent ESA series spectrum analyzer major assemblies:

- “Instrument Outer Case” on page 250
- “Chassis Cover” on page 252
- “A1 Front Frame Assembly” on page 254
- “Nameplate” on page 257
- “Connector Label” on page 258
- “Front Frame Subassemblies” on page 262, which includes:
 - “A1A2 Display” on page 262
 - “A1A1 Front Panel Interface Board” on page 265
 - “Front Panel RPG” on page 266
 - “Keypad/Flex Circuit” on page 267
 - “Lens/Keypad Assembly” on page 268
 - “Display Backlight” on page 269
 - “Media Door/Bezel” on page 270
- “A2 1.5 GHz Tracking Generator Assembly” on page 274, which includes:
 - “Tracking Generator Boards” on page 275
 - “1.5 GHz Tracking Generator RF Output Connector” on page 278
- “A2 3.0 GHz Tracking Generator Assembly” on page 279
- “A3 IF Assembly” on page 281
- “A4 Processor Assembly” on page 283
- “A4A1 and A4A2 Flash and DRAM SIMM” on page 285
- “A4MAU58 Battery” on page 286
- “A5 Power Supply” on page 287
- “A5B1 Fan” on page 289
- “A6 Floppy Drive and Speaker Assembly” on page 291
- “A7 Motherboard Assembly” on page 293
- “Card Cage Assemblies” on page 296, which includes:
 - “FM Demod, SIO, GPIB, RS-232, Noise Source Driver” on page 296
 - “Digital Demod Assemblies Replacement” on page 298
- “A8 1.5 GHz RF Assembly” on page 304
- “A8 3.0 GHz RF Assembly” on page 307
- “RF Subassemblies” on page 311, which includes:
 - “A8A1 OCXO Precision Frequency Reference” on page 311
 - “A8A4 LO Amp/IF Switch Assembly” on page 312
 - “A8A5 Input Attenuator” on page 313
 - “A8A6 YIG-Tuned Filter/Mixer” on page 315
 - “A8A2 Second Converter” on page 317
 - “RF Input Connector” on page 319
 - “1.5 GHz RF Input Connector” on page 321

Instrument Outer Case

Figure 6-2 Outer Case, Rear Frame Removal

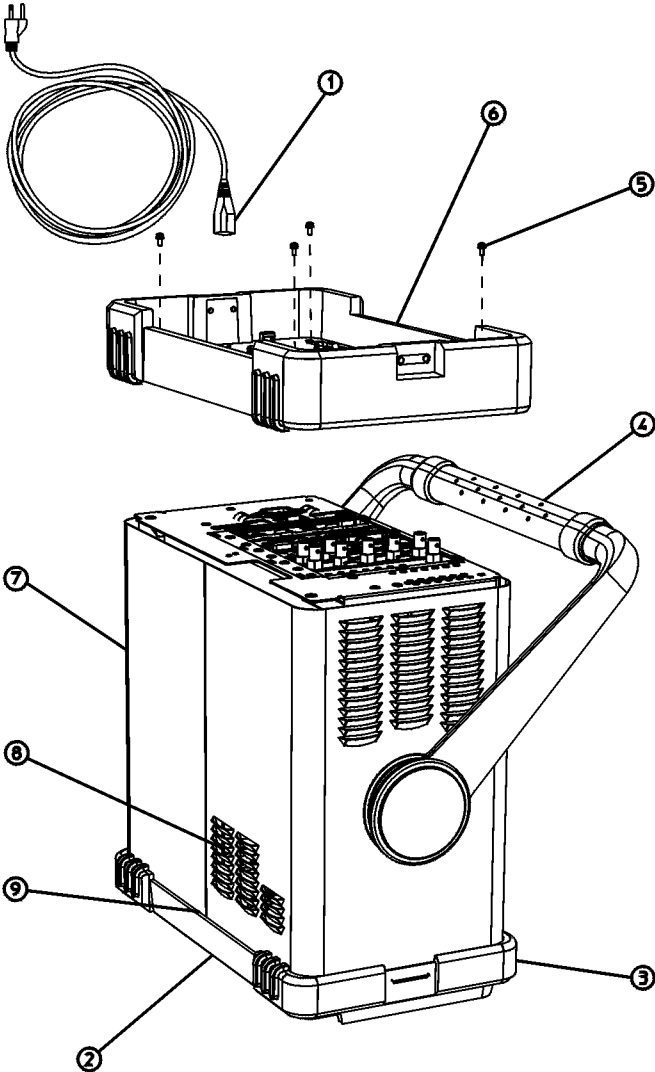

sl745b

Removal

1. Referring to [Figure 6-2](#) disconnect the spectrum analyzer from ac power **(1)**.
2. Remove any adapters or cables **(2)** connected to the front frame.
3. Carefully place the analyzer on the work surface with the front frame **(3)** facing down.
4. Position the handle **(4)** as shown.
5. Remove the four screws **(5)** that hold the rear frame and outer case in place.
6. Remove the rear frame **(6)**.
7. Pull the outer cover off towards the rear of the analyzer.

Replacement

1. Referring to [Figure 6-2](#), disconnect the spectrum analyzer from ac power **(1)**.
2. Remove any adapters or cables **(2)** connected to the front frame.
3. Carefully place the spectrum analyzer on the work surface with the front frame **(3)** facing down.
4. Replace the analyzer outer case, matching the grill **(8)** on the bottom of the case to the bottom of the analyzer.
5. Fit the leading edge of the case completely into the slot **(9)** on the back of the front frame assembly.
6. Replace the rear frame assembly **(6)** using the four screws **(5)** to fasten the rear frame to the analyzer. Tighten them to 21 inch-pounds.

Chassis Cover

Figure 6-3 Chassis Cover Removal

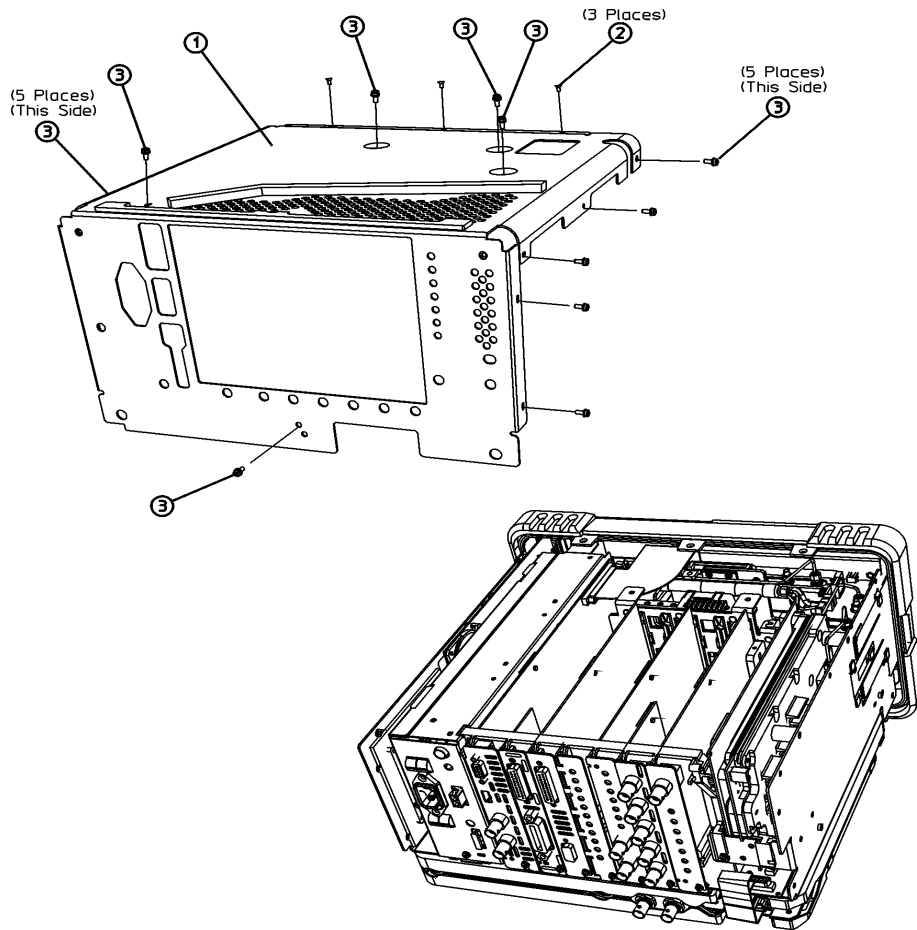

sl746b

Removal

1. If you haven't already done so, remove the instrument outer case. Refer to the removal procedure "[Instrument Outer Case](#)" on page 250.
2. Lay the analyzer flat as shown in [Figure 6-3](#).
3. Remove the 17 screws (2) and (3) attaching the chassis cover (1) to the chassis. Note that the number of screws attaching the chassis cover may vary with option mixes.
4. The chassis cover can now be removed from the chassis.

Replacement

1. Position the chassis cover **(1)** over the analyzer as shown in [Figure 6-3](#), then lower onto the analyzer.
2. Replace the 17 screws **(2)** as **(3)** shown and tighten them to 9 inch-pounds.
3. Replace the outer case. Refer to the replacement procedure “[Instrument Outer Case](#)” on page 250.

A1 Front Frame Assembly

CAUTION Use ESD precautions when performing this replacement procedure.

Extension

The A1 front frame assembly can be extended from the analyzer without detaching any connections.

Figure 6-4 A1 Front Frame Assembly Removal

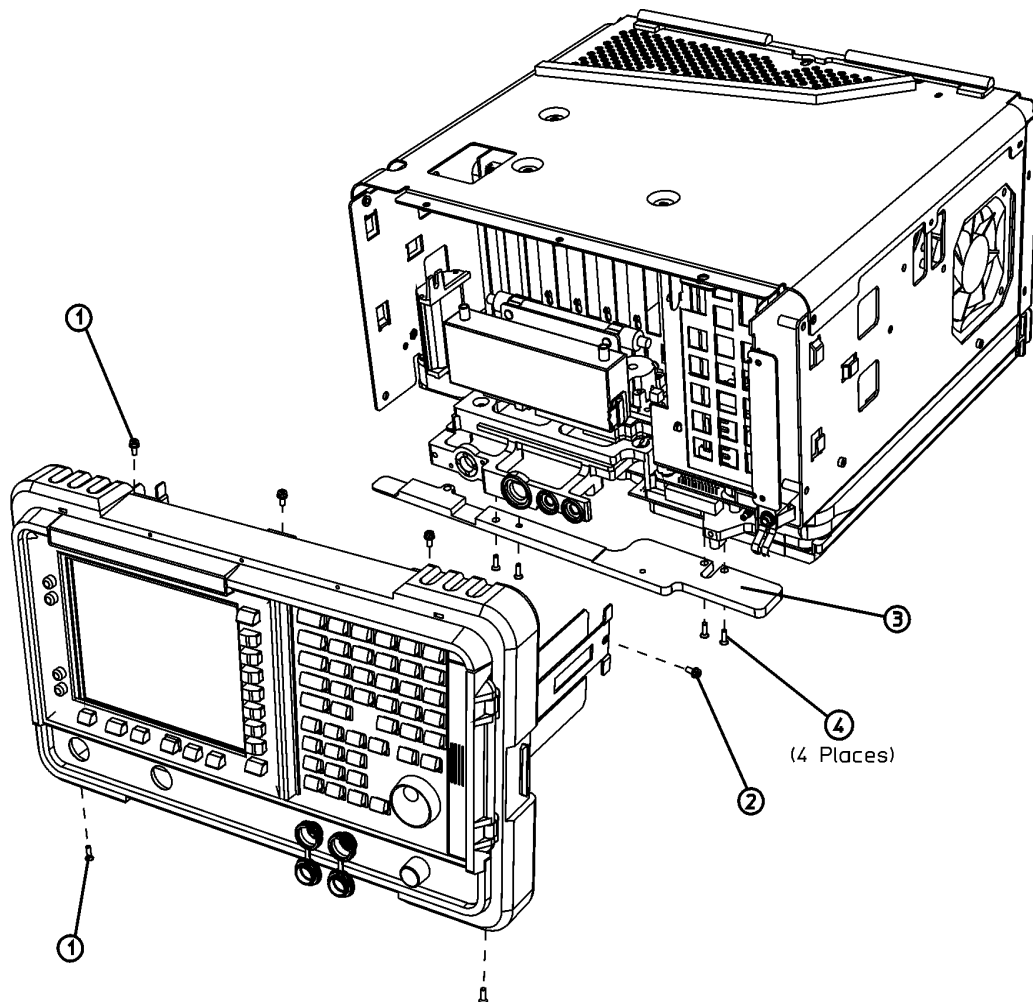

sl738b

1. Remove the instrument outer case. Refer to the removal procedure “[Instrument Outer Case](#)” on page 250.
2. Refer to [Figure 6-4](#). With the analyzer still on its face, remove the five screws (1), two on the bottom side and three on the top of the analyzer, that secure the

front frame to the RF assembly and chassis cover.

3. Place the analyzer with the top side facing up and remove the remaining two screws **(2)** that secure the front frame subpanel to the chassis.
4. Slide the front frame forward until it catches on the tabs on the sides of the chassis.

Removal

Refer to [Figure 6-4](#). To completely remove the A1 front frame assembly, complete the “[Extension](#)” procedure, then continue with the following steps:

Figure 6-5

Front Frame Ribbon Cable

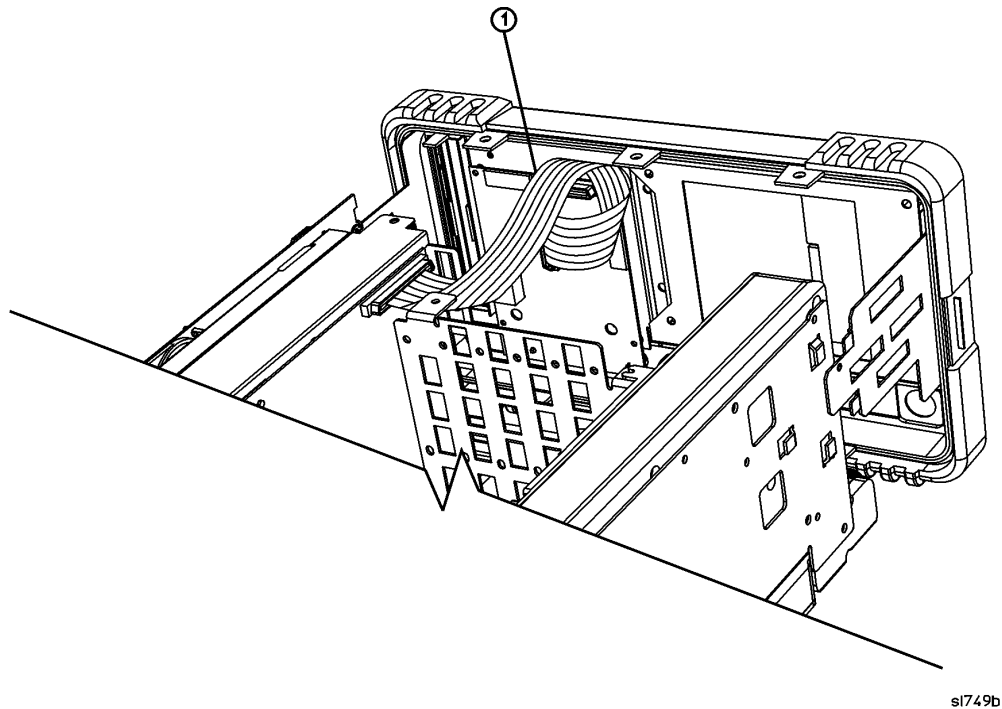

1. Refer to [Figure 6-5](#). Disconnect the ribbon cable **(1)** from the A1A1 front panel interface board.
2. Carefully pull the sides of the front frame subpanel away from the chassis and over the tabs on the chassis.
3. Slide the front frame forward to disengage from the chassis assembly.

Replacement

1. Align the A1 front frame subpanel rails with the chassis as shown in [Figure 6-4](#).
2. Refer to [Figure 6-5](#). Connect the ribbon cable **(1)** to the front frame assembly.
3. Carefully slide the front frame toward the chassis, assuring the ribbon cable is not pinched between assemblies, and the RF input connector lines up correctly with the opening in the front frame.

NOTE

Make sure the water seal is still in place around the input connector (and around the A2 tracking generator connector if the analyzer is an Option 1DN or 1DQ) before reinstalling the front frame assembly.

4. Refer to [Figure 6-4](#). Replace the screws **(1)** that secure the front frame to the chassis. Tighten them to 9 inch-pounds.
5. Replace the outer case. Refer to the replacement procedure for the “[Instrument Outer Case](#)” on page 250.
6. Refer to [Table 7-2 on page 330](#) for the related adjustments and performance verification tests required for each assembly.

Nameplate

Removal and Replacement

1. Remove the existing nameplate (1) as shown in Figure 6-6.
2. Clean the surface (2) of any adhesive residue.
3. Peel the backing (3) off the new nameplate.
4. Place the new nameplate (4) as shown.

Figure 6-6 Nameplate Replacement

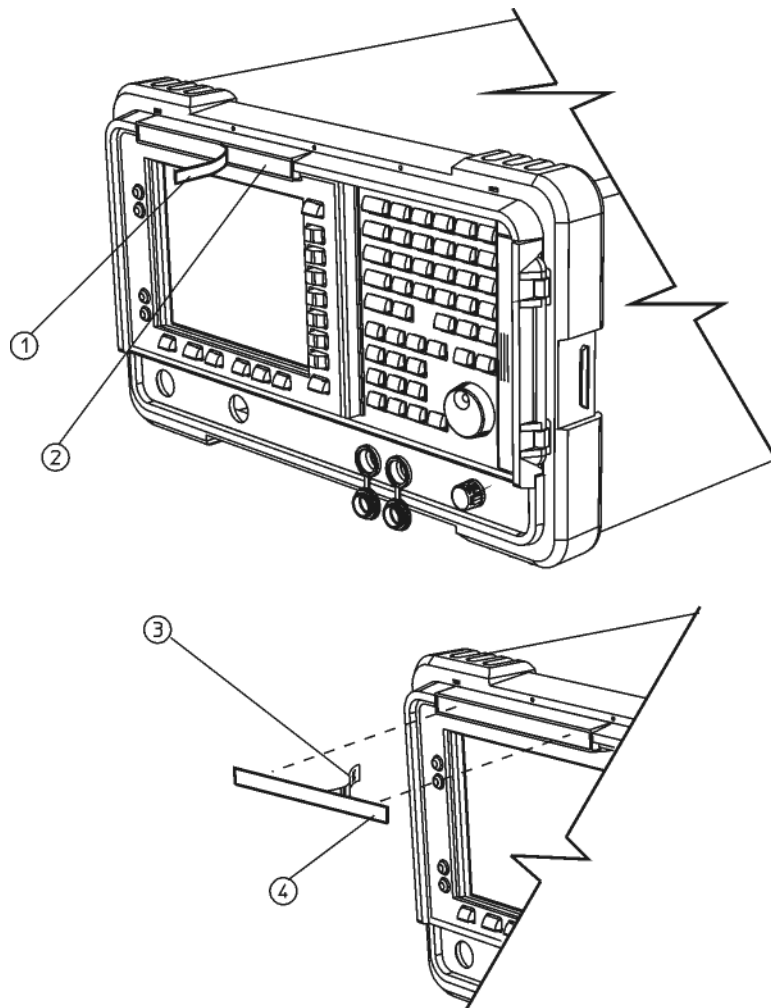

sl714b

Connector Label

CAUTION Use ESD precautions when performing this replacement procedure.

Removal

1. Remove the instrument outer case. Refer to the removal procedure “[Instrument Outer Case](#)” on page 250.
2. Remove the front frame assembly. Refer to the removal procedure “[A1 Front Frame Assembly](#)” on page 254.
3. Remove the volume and RPG knobs. Refer to the removal procedure “[A1A1 Front Panel Interface Board](#)” on page 265.

TIP It is possible to perform this procedure without completely removing the front panel interface board. You can remove the knobs (1), the two lower screws (2), and loosen the two top screws (3) 2 turns, just so the knob shafts clear the front panel as shown in [Figure 6-7](#).

4. If the analyzer does not have a tracking generator, remove the hole plug for the RF OUT connector.
5. Remove the two connector covers from the front panel by pinching them from the sides (4) and removing them through the front of the front frame assembly. See [Figure 6-7](#).
6. Peel off the old connector label (1) loosening any residual adhesive with a sharp knife or razor blade as you go. See [Figure 6-8](#).

Figure 6-7 Connector Covers

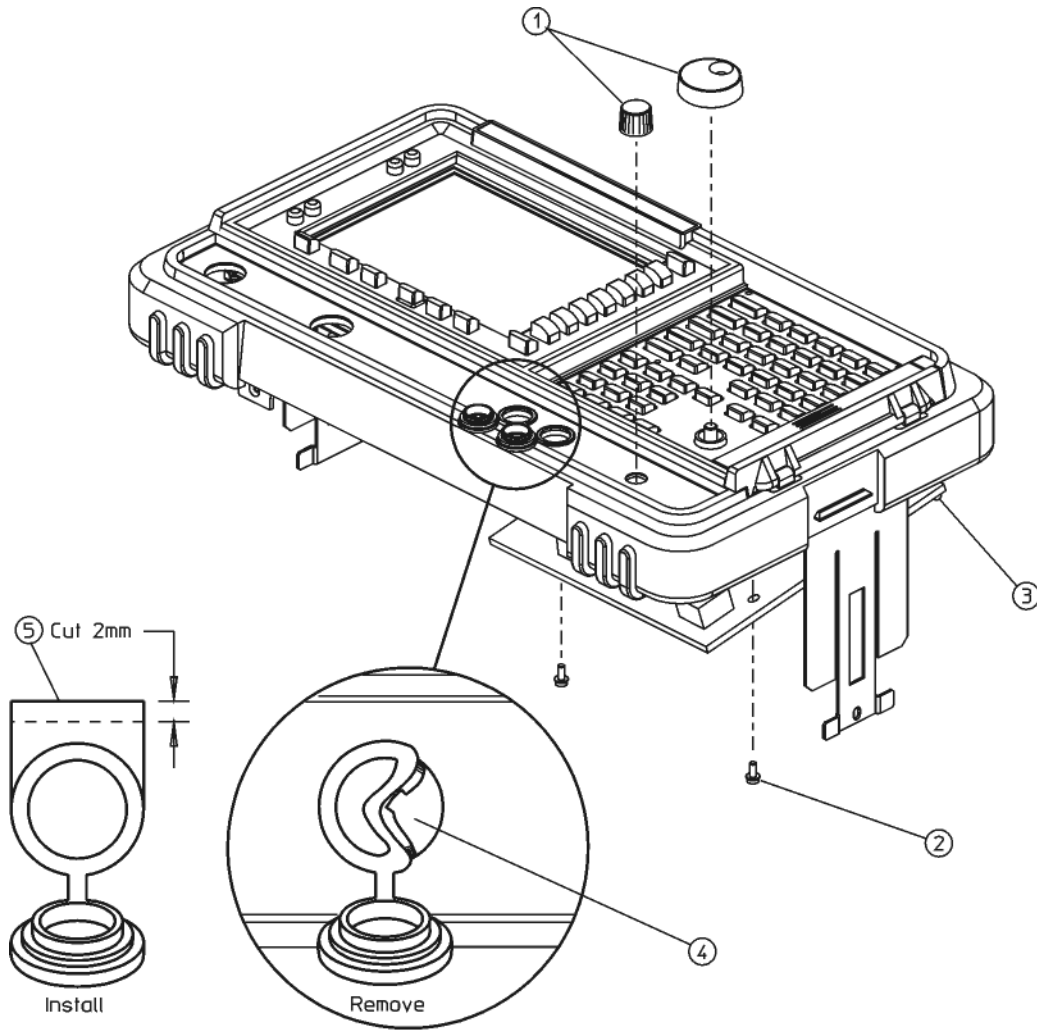

sl7111b

Installation

Before installing the new connector label, make sure the surface is free from any adhesive residue left over from the old label. Failure to do so may result in an uneven (lumpy) appearance of the new label.

1. Peel the backing (2) off the new label as show in [Figure 6-8](#).
2. Align and install the label by placing a finger in the RF OUT and VOLUME holes. Observe the alignment of the INPUT and PROBE POWER holes (3).

Figure 6-8 Connector Label Removal and Installation

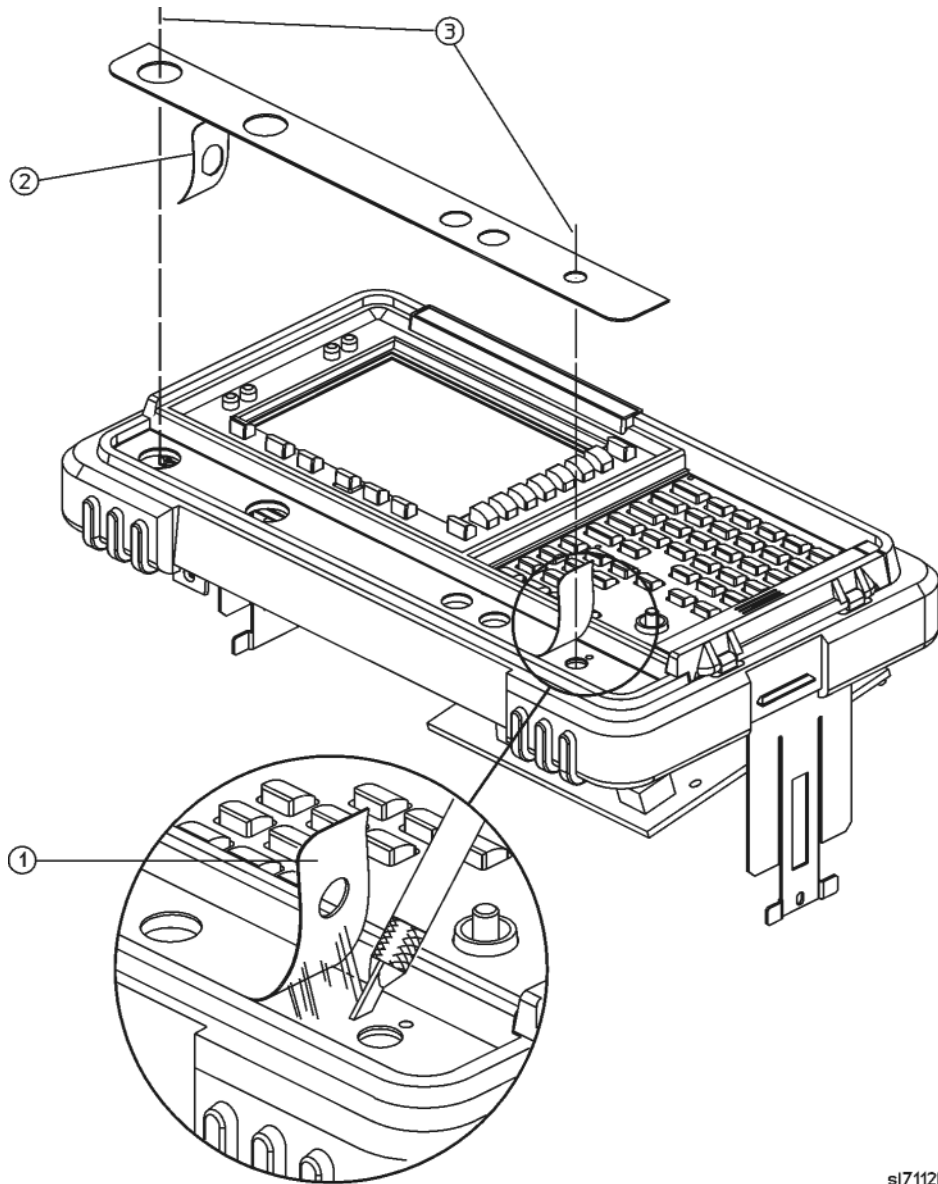

sl7112b

TIP

It may be helpful to trim off about 2 mm of the tabs (5) on the connector covers prior to reinstalling them. This will help in aligning the covers. See [Figure 6-7](#).

3. Reinstall the two connector covers from the front panel by pinching them from the sides (4) and installing them through the front of the assembly. See [Figure 6-7](#).
4. Align the connector covers so they open downward as shown.

Replacement

1. Re-install or re-attach the front panel interface board. Refer to the replacement procedure [“A1A1 Front Panel Interface Board” on page 265](#).
2. Inspect the ribbon cables to the front panel interface board to ensure they have not come loose.
3. Replace the RPG and volume knobs. It may be helpful to add a drop of isopropyl alcohol or water to the RPG to make it easier to press on the shaft.
4. Re-install the front frame assembly. Refer to the replacement procedure [“A1 Front Frame Assembly” on page 254](#).
5. Re-install the instrument outer case. Refer to the replacement procedure [“Instrument Outer Case” on page 250](#).

Front Frame Subassemblies

In order to remove any of the following subassemblies, it is necessary to remove the A1 front frame assembly from the main chassis. Refer to the removal procedure “A1 Front Frame Assembly” on page 254.

After the subassembly is replaced, reconnect the front frame to the chassis. Refer to the replacement procedure for the “A1 Front Frame Assembly” on page 254.

Refer to [Table 7-2 in Chapter 7](#) for the related adjustments and performance verification tests required for each assembly.

CAUTION

Use ESD precautions when performing the following replacement procedures.

A1A2 Display

Figure 6-9

A1A2 Display Replacement

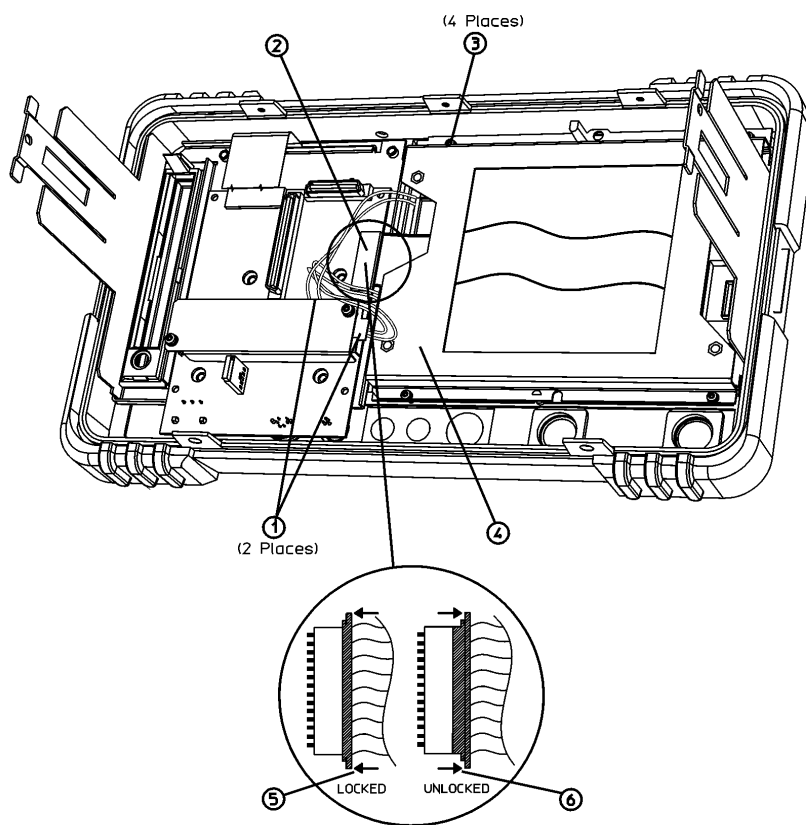

sl748b

Removal

Refer to [Figure 6-9](#) for the following procedure.

1. Place the front frame assembly face down on the work surface.
2. Disconnect the two 2-wire backlight cables **(1)** from the front panel interface inverter board.
3. Disconnect W3 ribbon cable **(2)** from the front panel interface board.

CAUTION

The W3 display ribbon cable connector **(2)** is delicate. With a small screwdriver or similar tool, gently push the lock tabs out from the back of the connector. Excessive force on the locking tab can break the retaining clips, and if broken, board replacement will be necessary.

4. Remove the four screws **(3)** securing the display (in a bracket) **(4)** to the front frame.
5. Carefully lift the display out of the front frame assembly.

Replacement

CAUTION

The display monitor comes with a protective plastic sheet over the glass. Remove this plastic very slowly to avoid damage due to ESD.

CAUTION

The surface of the display is very easily scratched. Avoid touching it with your bare hands or other objects. Use a blower to remove any dust from the display surface.

1. Clean the inside of the lens that is attached to the front frame.
2. Refer to [Figure 6-10](#). Place the display **(3)** into the front frame assembly. Make sure that the cables are not pinched between the display and the front frame, and the W3 ribbon cable is not folded.
3. Replace the four screws **(17)** that secure the display bracket to the front frame. Tighten them to 9 inch-pounds.
4. Connect the W3 display ribbon cable **(2)** to the front panel interface board.

Replacing Assemblies Front Frame Subassemblies

TIP

An easy way to insert this delicate cable into the connector is to place your finger on the cable, in the center of the LCD display, and gently slide the cable toward the connector until they align. Then, providing guidance with the other hand as necessary, slide the cable until the end slips into the connector.

Ensure the cable end is seated completely and is aligned straight within the connector body.

Continue to hold the cable in place with your finger, and with the other hand gently press the locking tabs **(5)** into place. See [Figure 6-9](#).

NOTE

If you experience display problems, check this connection.

5. Connect the two backlight cables **(1)** to the front panel interface inverter board.

Figure 6-10 Front Frame Assembly Parts

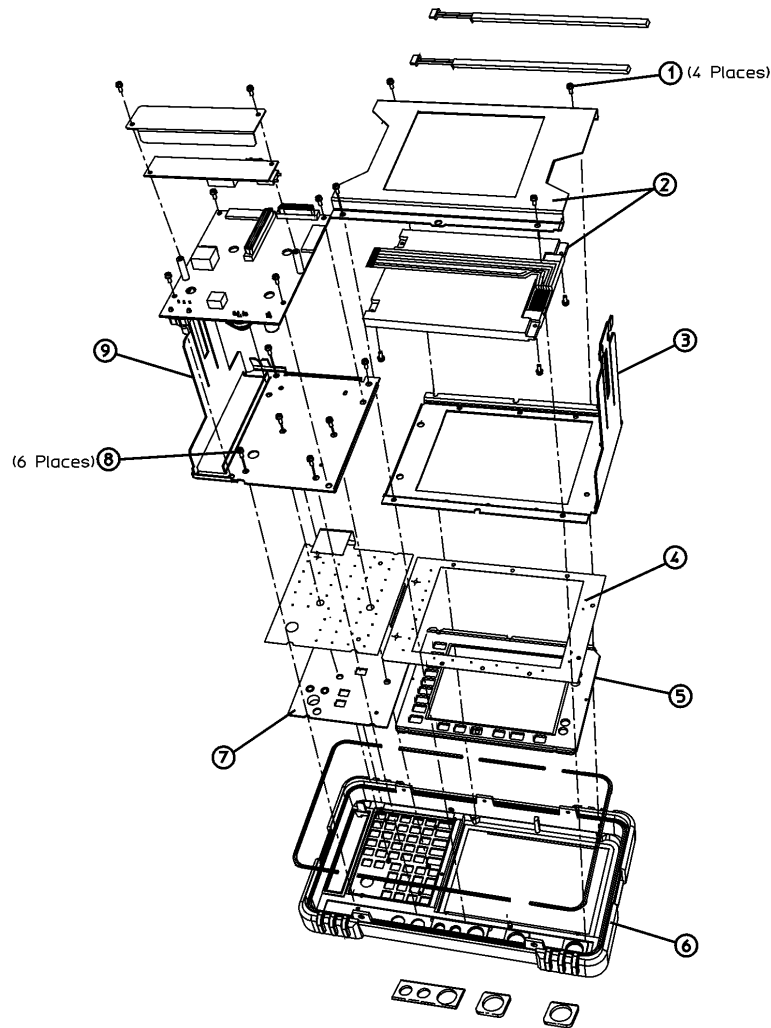

st7104b

A1A1 Front Panel Interface Board

Removal

1. Refer to [Figure 6-11](#). Remove the media door (1) from the front panel.
2. Insert a flat-blade screwdriver under the RPG knob (2) as shown in [Figure 6-11](#), and twist it to remove the knob.

Figure 6-11

Removing the Knobs

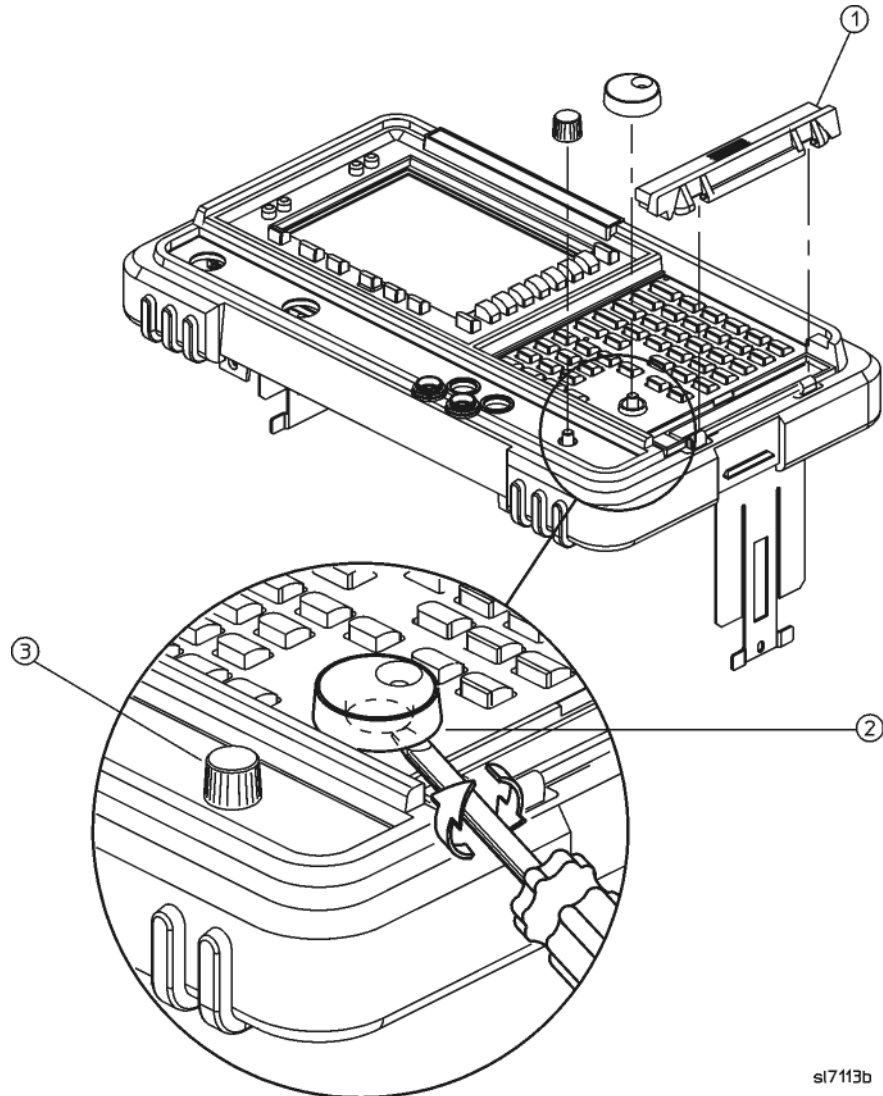

sl7113b

3. Grasp the volume knob (3) and pull it off.
4. Refer to [Figure 6-9](#). Disconnect the two 2-wire backlight cables (1) from the inverter board.
5. Disconnect the display ribbon cable (2) and the keypad ribbon cable from the front panel interface board.

CAUTION

The display ribbon cable connector **(2)** is delicate. Refer to [Figure 6-9](#). With a small screwdriver or similar tool, gently push the lock tabs **(6)** out from the back of the connector. Excessive force on the locking tab will break the retaining clips, and if broken, board replacement will be necessary.

6. Refer to [Figure 6-10](#). Remove the four screws that secure the A1A1 front panel interface board **(13)** to the front frame.
7. Remove the front panel interface board from the front frame assembly.

NOTE

There is a water-seal gasket placed around the volume control shaft that will need to be repositioned during the replacement procedure.

Replacement

1. Place the front panel interface board **(13)** in the correct position in the front frame assembly. Make sure the water seal is in place around the volume shaft.
2. Replace the four screws that secure the board to the front frame. Tighten them to 9 inch-pounds.
3. Connect the W3 display ribbon cable **(2)** to the front panel interface board.

TIP

An easy way to insert this delicate cable into the connector is to place your finger on the cable, in the center of the LCD display, and gently slide the cable toward the connector until they align. Then, providing guidance with the other hand as necessary, slide the cable until the end slips into the connector.

Ensure the cable end is seated completely and is aligned straight within the connector body.

Continue to hold the cable in place with your finger, and with the other hand gently press the locking tabs **(5)** into place.

See [Figure 6-9](#).

NOTE

If you experience display problems, check this connection.

4. Reconnect the two 2-wire backlight cables **(1)** to the inverter board, making sure that the cables are dressed away from the openings for the control knobs.
5. Press the volume and RPG knobs onto their control shafts.

Front Panel RPG

Removal/Replacement

1. Remove the front panel interface board. Refer to the removal procedure “[A1A1 Front Panel Interface Board](#)” on page 265.
2. Unsolder the appropriate RPG and remove it from the front panel interface board.

3. Place the new RPG in the correct position and resolder the leads.
4. Replace the front panel interface board. Refer to the replacement procedure “A1A1 Front Panel Interface Board” on page 265.

Keypad/Flex Circuit

Removal

1. Remove the RPG knobs.

TIP

To facilitate knob removal, slide any flat flexible material (such as a folded business card) under the knob and pry upward.

2. Remove the front panel interface board. Refer to the removal procedure “A1A1 Front Panel Interface Board” on page 265.
3. Refer to [Figure 6-10](#). Remove the four screws **(1)** that secure the display to the front frame.
4. Remove the display assembly **(2)** then the support bracket **(3)**.
5. Remove the 6 screws **(8)** securing the subpanel assembly (9) to the front frame **(6)**.
6. Remove the subpanel assembly **(9)**.
7. Lift out the keypad/flex circuit **(4)** and the main keypad **(7)**. Be careful to avoid touching the keypad contacts with your fingers.

Replacement

1. Refer to [Figure 6-10](#). Place the main keypad **(7)** so it lays flat in the front frame **(6)**. Be careful to avoid touching the keypad contacts with your fingers.
2. Lay in the flex circuit **(4)** so it aligns with the pegs on the front frame and lays flat. A small amount of circuit ripple will be unavoidable.
3. Replace the subpanel **(9)**, and secure with the six screws **(8)**. Tighten them to 9 inch-pounds.

NOTE

If you are putting in a new flex circuit, it will need to be preformed in order to fit properly in the front frame. Slightly bend the circuit along the slits in two places between the main key section and the display section to conform to the contours of the front frame. Be careful to not bend the circuit too much (no more than a 90° angle), and do not crease it. This can damage the traces in the flex circuit.

4. Replace the support bracket **(3)**, along with the display **(2)** and secure with the four screws **(1)**. Tighten them to 9 inch-pounds.
5. Replace the front panel interface board. Refer to the replacement procedure “A1A1 Front Panel Interface Board” on page 265.
6. Replace the RPG knobs.

Lens/Keypad Assembly

Removal

NOTE

The lens/keypad assembly is pressed into place, using a strong adhesive instead of hardware. It is made of a plastic material and will bend but not break.

1. Remove the keypad/flex circuit. Refer to the removal procedure “Keypad/Flex Circuit” on page 267.
2. To remove the lens/keypad from the front frame, apply pressure from the front side. Using both thumbs, press in the corner of the lens as shown in Figure 6-12 until it pops out.

Figure 6-12

Lens Removal

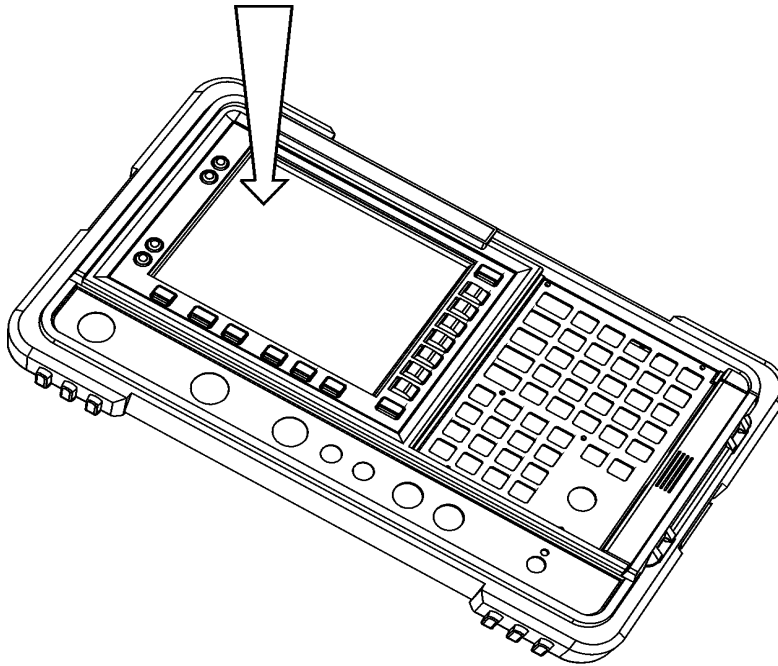

sl784b

Replacement

1. Remove the paper covering the adhesive on the lens/keypad assembly.
2. Carefully fit the new lens/keypad assembly into place in the front frame. Press along the edges of the lens from the inside to adhere it to the front frame.
3. Make sure the inside of the lens is clean from contaminants such as lint and fingerprints before proceeding.
4. Replace the main keypad, flex circuit, and subpanel assembly (with the display

and front panel interface board attached). Refer to the replacement procedure “Keypad/Flex Circuit” on page 267.

5. Replace the front panel interface board. Refer to the replacement procedure “A1A1 Front Panel Interface Board” on page 265.
6. After the front frame is reattached to the chassis, remove the protective plastic covering from the lens.

Display Backlight

Removal

1. Remove the display. Refer to the removal procedure “A1A2 Display” on page 262.
2. Refer to [Figure 6-13](#). Locate the two 2-wire connectors on the display. These are the backlight assemblies (1). Carefully press on the opposite end from the wires to slide a backlight assembly partially out of the display (2). Once the end of a backlight casing is exposed, you can pull it straight out from the display.

Figure 6-13

Display Backlight Replacement

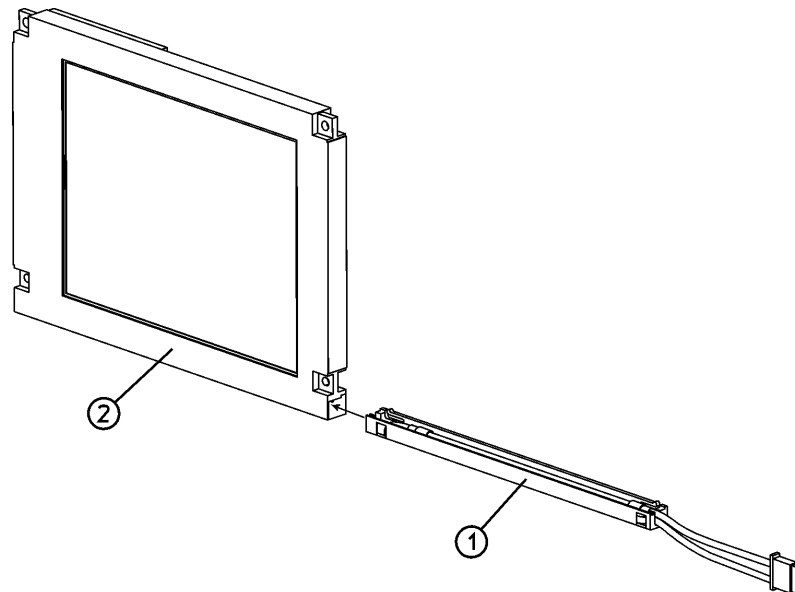

sl735a

Replacement

NOTE

Do not touch the bulb encased in the plastic backlight assembly.

1. Insert the new backlight assembly (1) by sliding it into the display, non-wired end first, taking care not to force it. It is keyed so it will only fit properly one way. Slide it all the way in to the end of the casing.

NOTE

It is recommended that both backlights be replaced at the same time, even though only one has failed. The remaining (functioning) backlight will likely fail shortly after the first backlight fails.

2. Replace the display. Refer to the replacement procedure “A1A2 Display” on page 262.

Media Door/Bezel

1. The media door snaps on and off of the media bezel.
2. Refer to [Figure 6-14](#). To remove the media bezel (1), it is necessary to remove the front frame. Refer to the removal procedure “A1 Front Frame Assembly” on page 254.
3. The bezel also snaps into place. It can be removed by pressing the tabs together from the inside and pushing the bezel out of the front frame.

Figure 6-14

Media Door/Bezel

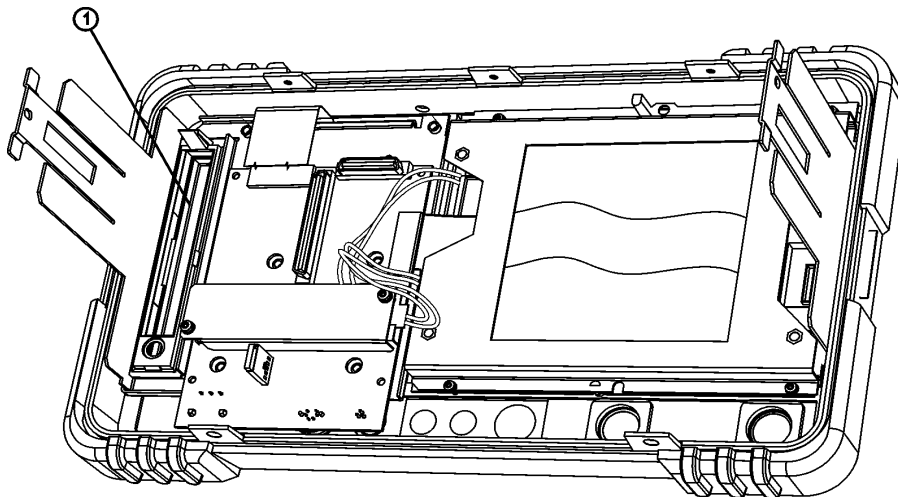

sl7102b

Vibration Support Bar

Removal

1. Referring to [Figure 6-15](#), loosen, but do not remove, all nine of the screws **(1)** securing the boards and blank panels at the rear of the chassis.

CAUTION

The vibration support bar is fragile. Use caution to avoid breakage when removing it.

2. On the vibration support bar, press in the locking tabs **(2)** and rotate the bar **(3)** upward. Remove the bar by sliding it out of the holes in each of the assemblies and lifting it up.

Figure 6-15 Removing the Vibration Support Bar

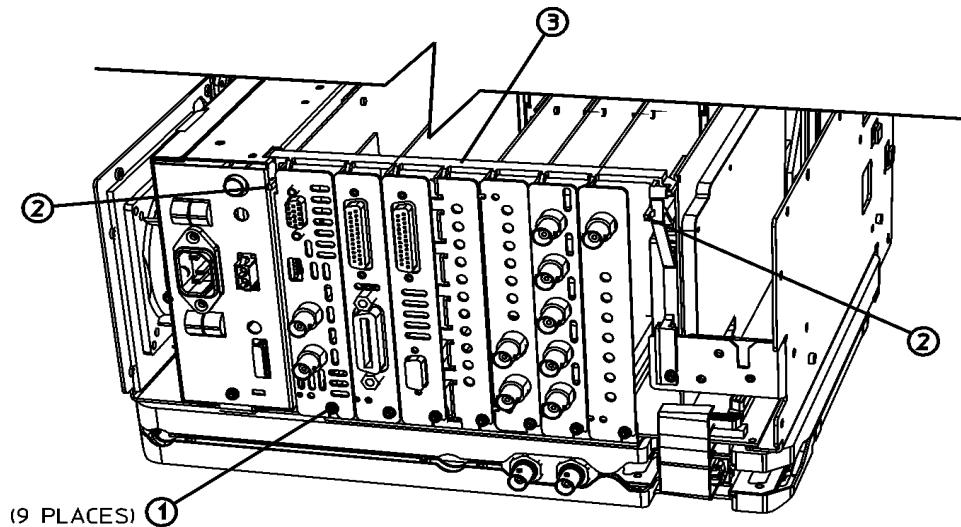

sl754b

Replacing the Vibration Support Bar

1. Referring to [Figure 6-16](#), replace the vibration support bar **(1)** as follows:
 - a. Position the vibration support bar **(1)** as shown and insert the hook **(2)** into the A3 IF assembly's support arm.
 - b. Engage each hook **(3)** of the other assemblies or blank panels.
 - c. After you position each of the assemblies or blank panels, rotate **(4)** the support bar to lock them in place.
 - d. Referring to [Figure 6-17](#), make sure that the tab **(1)** is positioned in the slot of the power supply chassis and the vibration bar is fully seated and locked **(2)** into position.

Replacing Assemblies
Vibration Support Bar

CAUTION The vibration support bar can easily be broken if it is forced. Install it with care.

2. Refer to [Figure 6-15](#). Tighten all the screws that were loosened in the removal procedure to 9 inch-pounds.

Figure 6-16 Installing the Vibration Support Bar

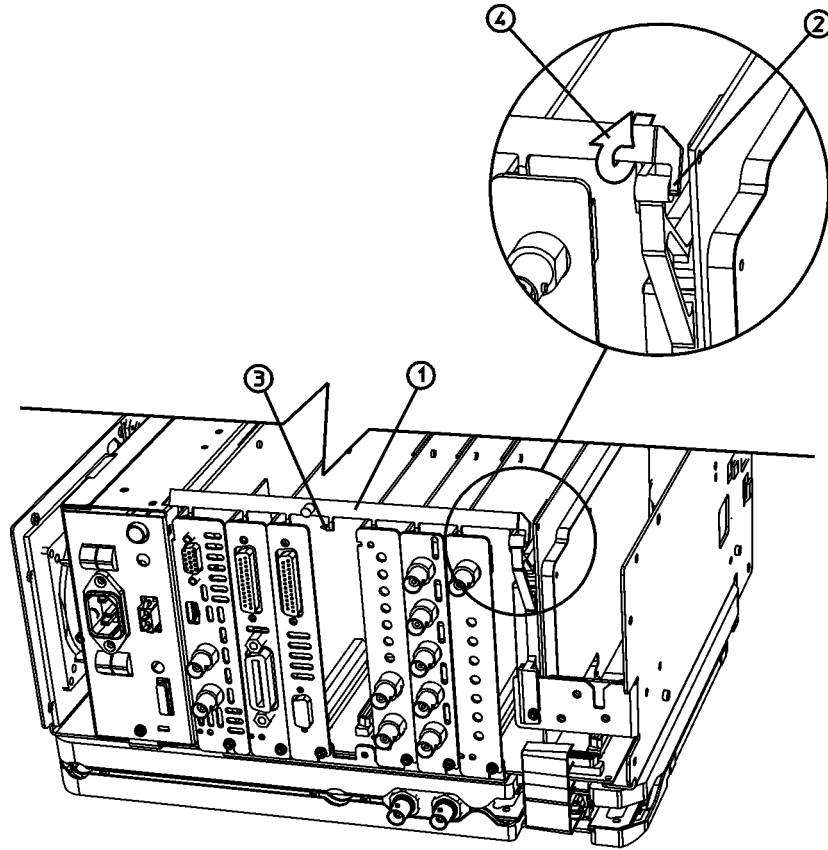

sl753b

Figure 6-17 Seating the Vibration Support Bar

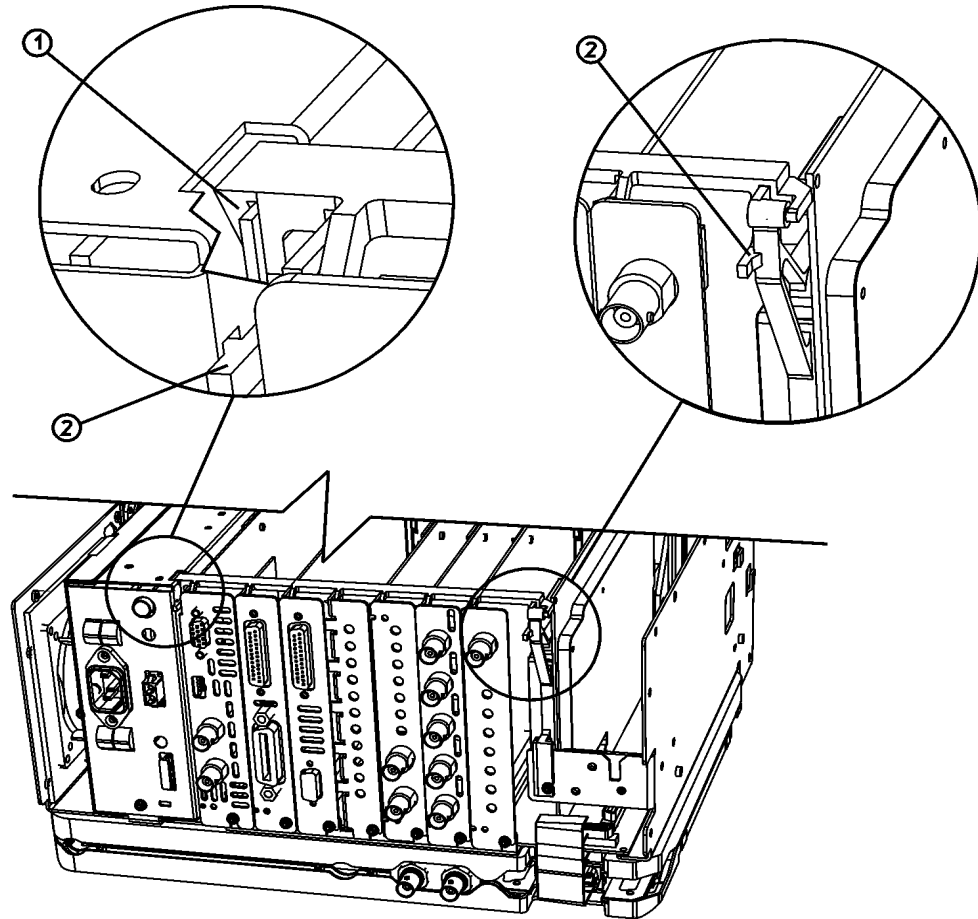

sl755b

A2 1.5 GHz Tracking Generator Assembly

(E4401B and E4411B)

CAUTION Use ESD precautions when performing this replacement procedure.

Removal

1. Remove the analyzer chassis cover. Refer to the removal procedure “Chassis Cover” on page 252.
2. Extend the A1 front frame assembly. Refer to the extension procedure “A1 Front Frame Assembly” on page 254.
3. Remove the water seal from around the front of the tracking generator connector.
4. Refer to [Figure 6-18](#). Remove the four screws (1), (three from the side and one from the back), securing the tracking generator assembly to the chassis.
5. Carefully pull up on the tracking generator assembly to remove it from the motherboard connector.

Figure 6-18

A2 1.5 GHz Tracking Generator Hardware

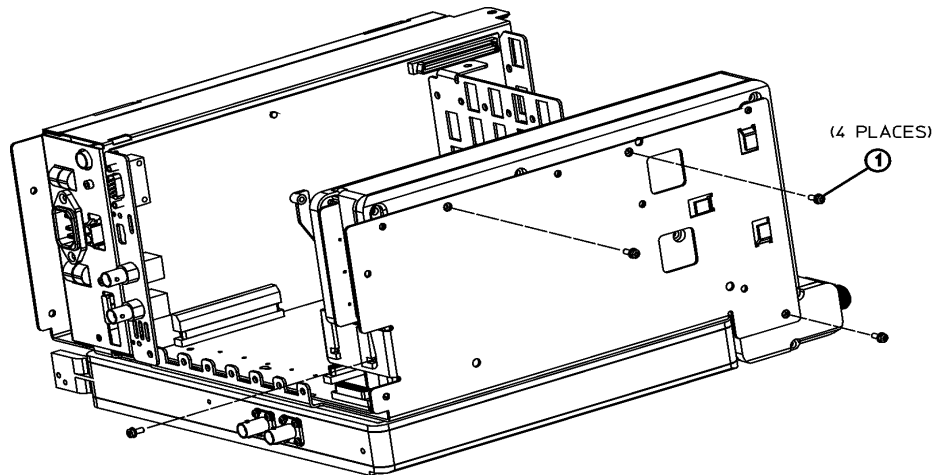

sl715a

Replacement

1. Carefully plug the tracking generator assembly into the motherboard.

2. Refer to [Figure 6-18](#). Replace the four screws **(1)** that secure the tracking generator to the chassis. Tighten them to 9 inch-pounds.
3. Replace the water seal around the front of the tracking generator connector.
4. Reconnect the A1 front frame to the chassis. Refer to the replacement procedure “[A1 Front Frame Assembly](#)” on page 254.
5. Replace the chassis cover. Refer to the replacement procedure “[Chassis Cover](#)” on page 252.
6. Replace the outer case. Refer to the replacement procedure “[Instrument Outer Case](#)” on page 250.
7. Refer to [Table 7-2 in Chapter 7](#) for the related adjustments and performance verification tests required for each assembly.

Tracking Generator Boards

The removal and replacement of any of the three boards (RF board, control board, and output board) that make up the 1.5 GHz tracking generator assembly (T.G.) requires that the T.G. first be removed from the analyzer. Refer to the removal and replacement procedures “[A2 1.5 GHz Tracking Generator Assembly](#)” on page 274. After any board removal, refer to [Table 7-2 in Chapter 7](#) for the related adjustments and performance verification tests required. For the following procedures, refer to [Figure 6-19](#).

CAUTION

Use ESD precautions when performing the following replacement procedures.

Figure 6-19 Tracking Generator Board Replacement

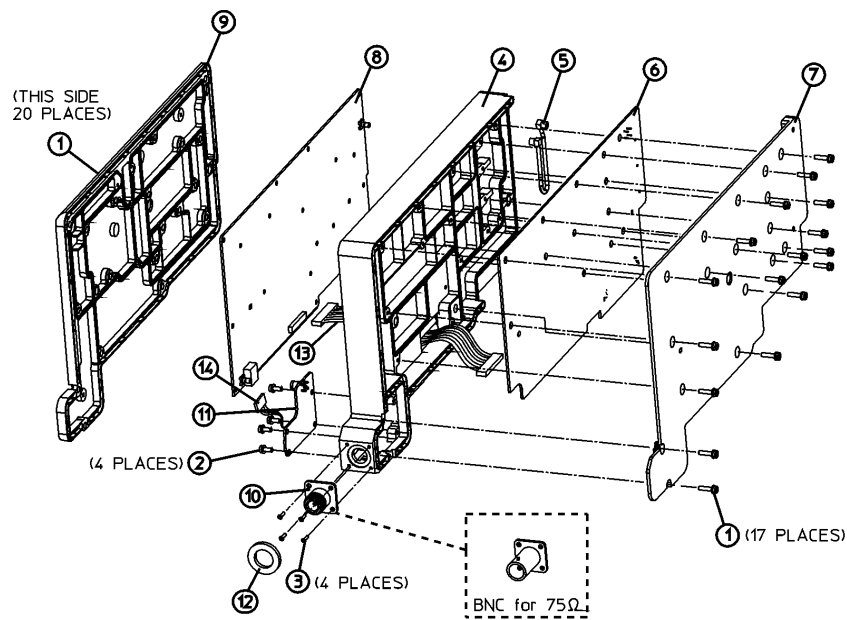

sn75a

Tracking Generator RF Board Removal

Removal

1. Remove the 20 screws **(1)** that secure the RF shield **(9)** to the center shield **(4)**.
2. Unplug the output board wire harness **(14)** from the RF board **(8)**.
3. Carefully lift the RF board **(8)** straight away from the center shield to disconnect the connector on the output board **(11)**.
4. Disconnect the ribbon cable **(13)** from the RF board.
5. Disconnect the coaxial cable **(5)** from the RF board.

Replacement

1. Plug in the ribbon cable **(13)** and the coaxial cable **(5)** into the RF board **(8)**.
2. Carefully position the RF board onto the center shield, ensuring no cables will be pinched between the shields. Press down to engage the connectors at the output board.
3. Plug the output board wire harness **(14)** into the RF board.
4. Replace the RF shield **(9)** with the 20 screws removed earlier. Tighten them to 13.5 inch-pounds.

Tracking Generator Control Board Removal

Removal

1. Remove the 17 screws **(1)** that secure the control shield **(7)** to the center shield **(4)**.
2. Unplug the ribbon cable **(13)** from the control board **(6)**.
3. Unplug the coaxial cable **(5)** from the control board.

Replacement

1. Plug in the ribbon **(13)** and the coaxial cable **(5)** into the control board **(6)**.
2. Position the control board onto the center shield **(4)**, ensuring no cables will be pinched between the shields.
3. Replace the control shield **(7)** with the 17 screws removed earlier. Tighten them to 13.5 inch-pounds.

Tracking Generator Output Board Removal

Removal

1. Remove the 20 screws **(1)** that secure the RF shield **(9)** to the center shield **(4)**.
2. Remove the 17 screws **(1)** that secure the control shield **(7)** to the center shield **(4)**.
3. Unsolder the RF output connector **(10)**.
4. Unplug the wire harness **(14)** from the RF board **(8)**.
5. Carefully lift the RF board **(8)** straight away from the center shield to disconnect the connector on the output board **(11)**.
6. Remove the 4 screws **(2)** that secure the output board **(11)** to the center shield **(4)**.
7. Lift the output board from the center shield.

Replacement

1. Place the output board **(11)** into the center shield **(4)**.
2. Carefully position the RF board **(8)** onto the center shield, ensuring no cables will be pinched between the shields. Press down to engage the connectors at the output board.
3. Replace the 4 screws securing the output board that were removed earlier. Tighten them to 9 inch-pounds.
4. Plug the wire harness **(14)** into the RF board.
5. Resolder the RF output connector **(10)** to the output board.
6. Replace the RF and control shields. Tighten all of the screws to 13.5 inch-pounds.

1.5 GHz Tracking Generator RF Output Connector

Removal

1. Remove the 17 screws **(1)** that secure the control shield to the center shield.
2. Remove the water seal **(12)** from around the RF output connector **(10)**.
3. Remove the 4 screws **(3)** securing the connector to the center shield **(4)**.
4. Heat the connector center contact on the output board and pull the connector out gently.

Replacement

1. Remove excess solder from the output board pad.
2. Fasten the new input connector to the center shield with the four screws **(3)** tightened to 9 inch-pounds.
3. Resolder the center conductor to the output board.
4. Replace the water seal **(12)** around the RF output connector.
5. Replace the 17 screws that secure the control shield to the center shield. Tighten them to 13.5 inch-pounds.

A2 3.0 GHz Tracking Generator Assembly

(E4404B, E4405B, E4407B, and E4408B)

CAUTION

Use ESD precautions when performing this replacement procedure.

Removal

1. Remove the analyzer chassis cover. Refer to the removal procedure “Chassis Cover” on page 252.
2. Extend the A1 front frame assembly. Refer to the extension procedure “A1 Front Frame Assembly” on page 254.
3. Refer to [Figure 6-20](#). Disconnect the SMB cable (1) and the SMA cable (2) from the tracking generator assembly.
4. Refer to [Figure 6-21](#). Remove the five screws (1), (four from the side and one from the back), securing the A2 tracking generator assembly (2) to the chassis.
5. Carefully pull up on the tracking generator assembly to remove it from the motherboard connector.

Figure 6-20

A2 Tracking Generator Cables (E4404B, E4405B, E4407, and E4408B)

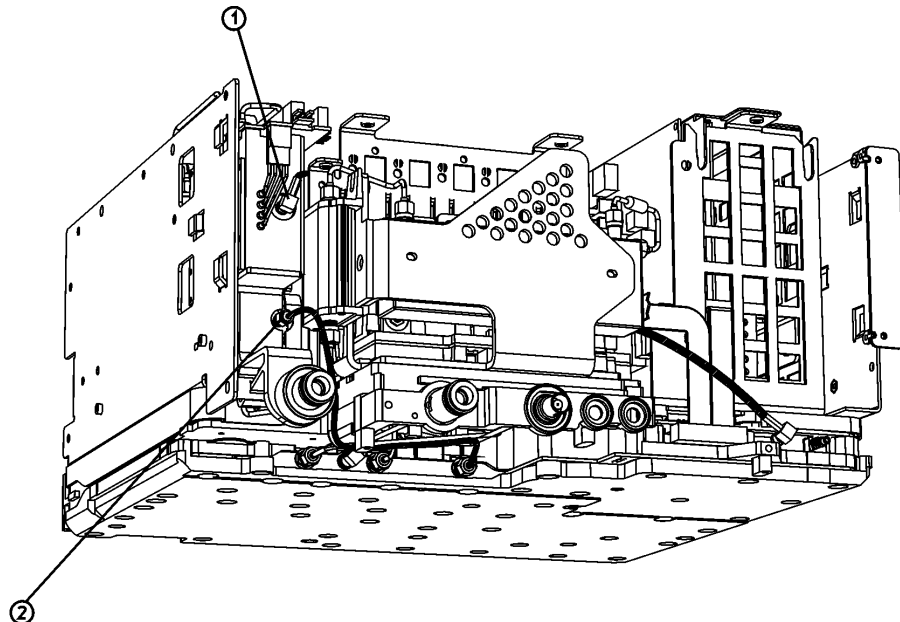

sl789b

Figure 6-21

A2 3.0 GHz Tracking Generator Hardware

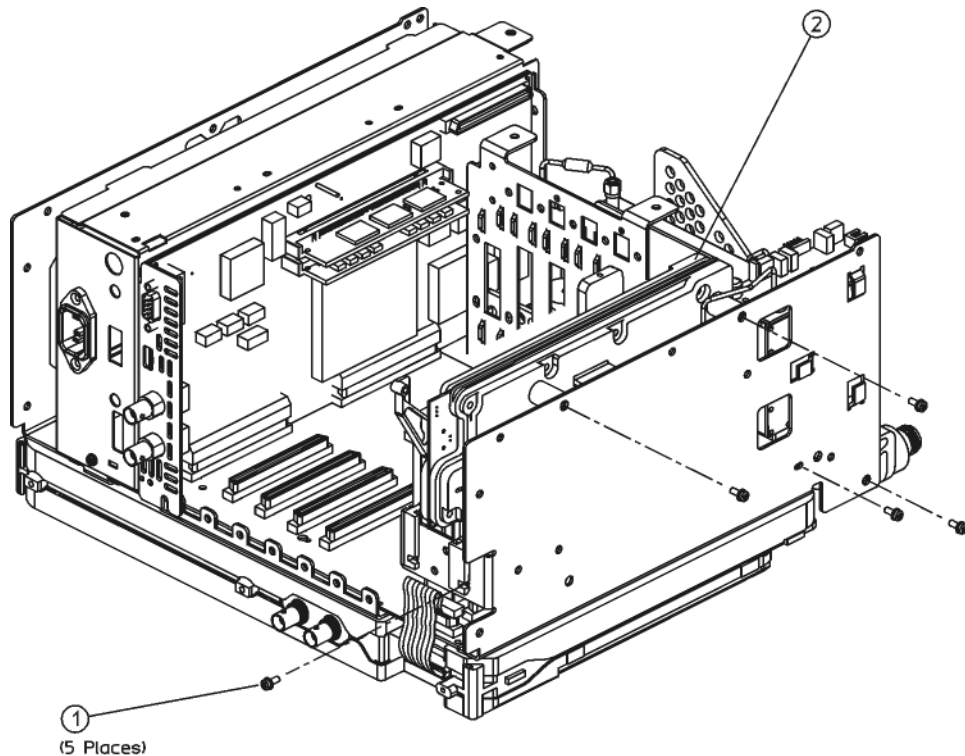

sl7116b

Replacement

1. Refer to [Figure 6-21](#). Carefully plug the tracking generator assembly **(2)** into the motherboard.
2. Refer to [Figure 6-21](#). Replace the five screws **(1)** that secure the tracking generator to the chassis. Tighten them to 9 inch-pounds.
3. Refer to [Figure 6-20](#). Reconnect the SMB cable **(1)** and the SMA cable **(2)** to the tracking generator assembly. Tighten the SMA connector to 10 inch-pounds.
4. Replace the water seal around the front of the tracking generator connector.
5. Reconnect the A1 front frame to the chassis. Refer to the replacement procedure “[A1 Front Frame Assembly](#)” on page 254.
6. Replace the chassis cover. Refer to the replacement procedure “[Chassis Cover](#)” on page 252.
7. Replace the outer case. Refer to the replacement procedure “[Instrument Outer Case](#)” on page 250.
8. Refer to [Table 7-2 in Chapter 7](#) for the related adjustments and performance verification tests required for each assembly.

A3 IF Assembly

CAUTION

Use ESD precautions when performing this replacement procedure.

Removal

1. Remove the analyzer chassis cover. Refer to the removal procedure “[Chassis Cover](#)” on page 252.
2. Remove the vibration support bar. Refer to the removal procedure “[Vibration Support Bar](#)” on page 271.
3. Refer to [Figure 6-22](#). Remove the two screws **(1)** securing the A3 IF assembly to the chassis.
4. Disconnect the W2 **(2)** coaxial cable from the IF assembly.
5. Carefully lift the IF assembly to remove it from the motherboard connector.

Figure 6-22

A3 IF Assembly

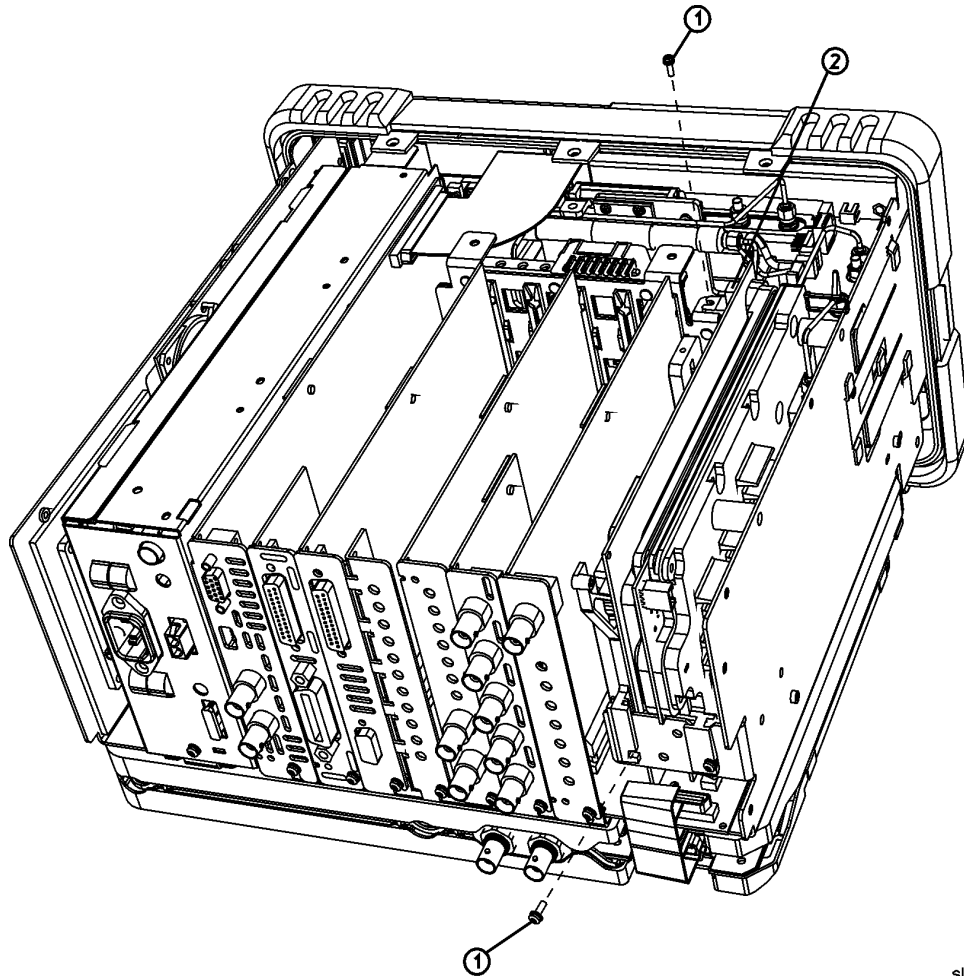

sl767b

Replacement

1. Carefully plug the IF assembly into the motherboard.
2. Refer to [Figure 6-22](#). Replace the two screws **(1)** that secure the IF assembly to the chassis. Tighten them to 9 inch-pounds.
3. Connect the W2 **(2)** coaxial cable to the IF assembly.
4. Replace the vibration support bar. Refer to the replacement procedure “[Vibration Support Bar](#)” on page 271.
5. Replace the chassis cover. Refer to the replacement procedure “[Chassis Cover](#)” on page 252.
6. Replace the outer case. Refer to the replacement procedure “[Instrument Outer Case](#)” on page 250.
7. Refer to [Table 7-2 on page 330](#) for the related adjustments and performance verification tests required for each assembly.

A4 Processor Assembly

CAUTION

Use ESD precautions when performing this replacement procedure.

Removal

1. Remove the analyzer chassis cover. Refer to the removal procedure “Chassis Cover” on page 252.
2. Remove the vibration support bar. Refer to the removal procedure “Vibration Support Bar” on page 271.
3. Refer to Figure 6-23. Remove the single screw (1) securing the A4 processor assembly to the chassis.
4. Disconnect the front panel ribbon cable (2) from the processor assembly.
5. Carefully lift the processor assembly to remove it from the motherboard connector.

Figure 6-23 A4 Processor Assembly

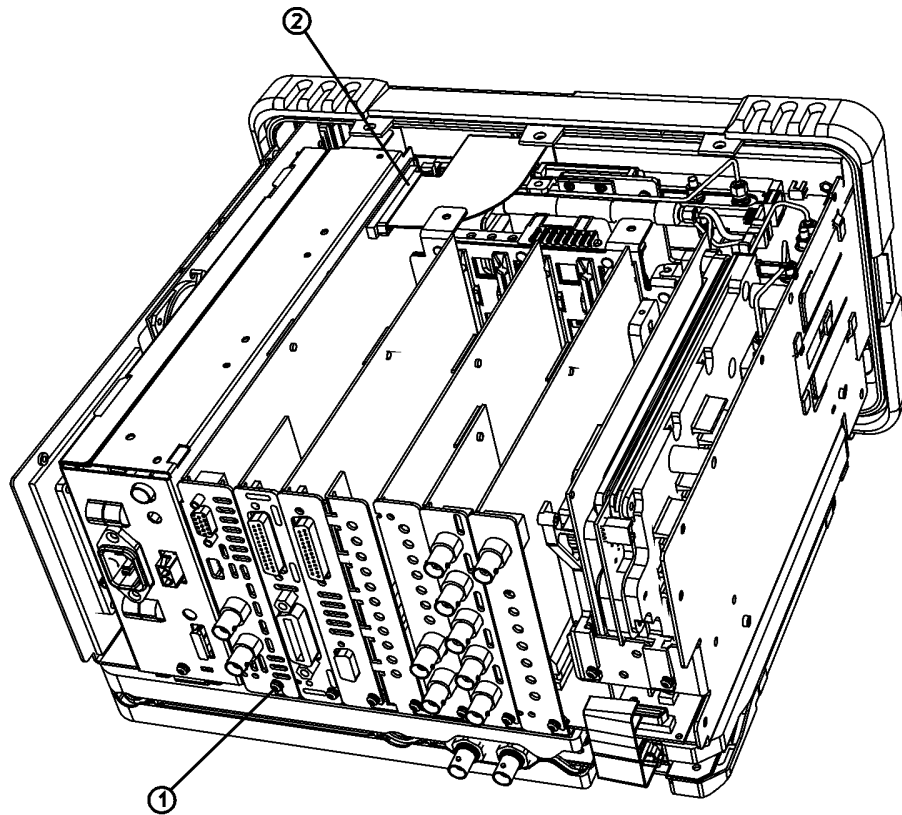

sl785b

Replacement

1. Carefully plug the processor assembly into the motherboard.
2. Refer to [Figure 6-23](#). Replace the single screw **(1)** that secures the processor assembly to the chassis, but do not tighten it yet.
3. Reconnect the front panel ribbon cable **(2)** to the processor assembly.
4. Replace the vibration support bar. Refer to the replacement procedure [“Vibration Support Bar” on page 271](#).
5. Replace the chassis cover. Refer to the replacement procedure [“Chassis Cover” on page 252](#).
6. Replace the outer case. Refer to the replacement procedure [“Instrument Outer Case” on page 250](#).
7. Refer to [Table 7-2 on page 330](#) for the related adjustments and performance verification tests required for each assembly.

A4A1 and A4A2 Flash and DRAM SIMM

CAUTION Use ESD precautions when performing this replacement procedure.

Removal and Replacement

1. Remove the A4 processor assembly. Refer to the removal procedure “A4 Processor Assembly” on page 283.
2. Refer to Figure 6-24. Carefully remove the flash SIMM (1) or the DRAM SIMM (2).
3. Replace the flash SIMM (1) or the DRAM SIMM (2).
4. Replace the A4 processor assembly. Refer to the replacement procedure “A4 Processor Assembly” on page 283.
5. Refer to Table 7-2 on page 330 for the related adjustments and performance verification tests required for each assembly.

Figure 6-24 Flash SIMM and DRAM SIMM

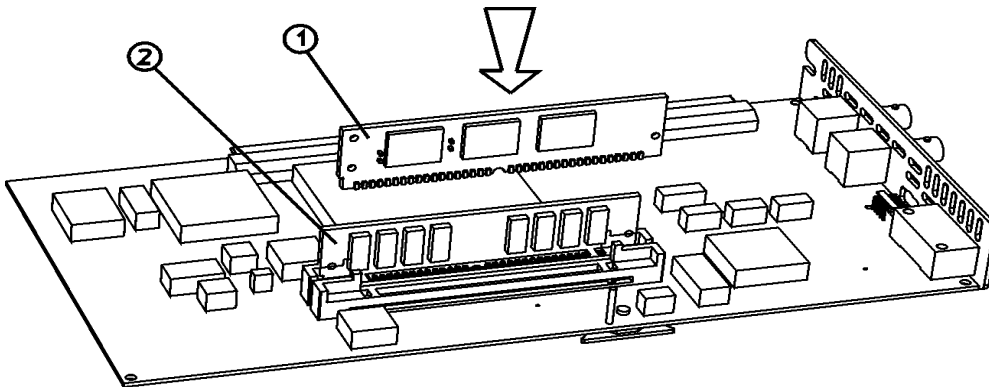

sl786b

A4MAU58 Battery

CAUTION Use ESD precautions when performing this replacement procedure.

WARNING There is a danger of explosion if the battery is incorrectly replaced. Replace only with the same or equivalent type recommended. Discard used batteries according to manufacturer's instruction.



DO NOT THROW BATTERIES AWAY BUT
COLLECT AS SMALL CHEMICAL WASTE.

sk780a

Removal and Replacement

1. Remove the A4 processor assembly from the analyzer. Refer to the removal procedure “A4 Processor Assembly” on page 283.
2. Refer to [Figure 6-25](#). Gently pry the A4MAU58 lithium battery from the processor board.
3. Insert the new battery, ensuring proper polarity as indicated on the socket.
4. Replace the processor assembly in the analyzer. Refer to the replacement procedure “A4 Processor Assembly” on page 283.
5. Refer to [Table 7-2 on page 330](#) for the related adjustments and performance verification tests required for each assembly.

Figure 6-25

Processor Battery Location

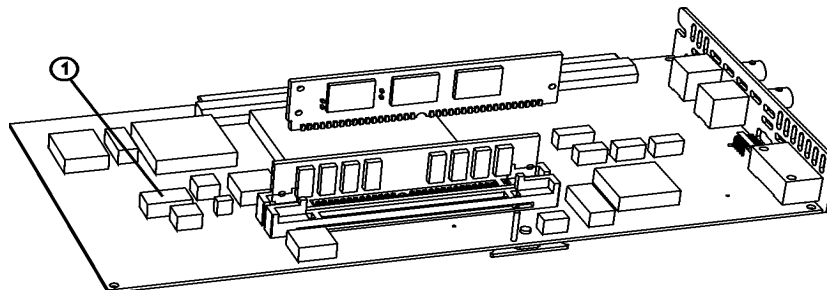

si759b

A5 Power Supply

CAUTION

Use ESD precautions when performing this replacement procedure.

Removal

1. Remove the analyzer chassis cover. Refer to the removal procedure “Chassis Cover” on page 252.
2. Remove the vibration support bar. Refer to the removal procedure “Vibration Support Bar” on page 271.
3. Extend the A1 front frame assembly. Refer to the extension procedure “A1 Front Frame Assembly” on page 254.
4. Refer to [Figure 6-26](#). Remove the single screw (4) securing the A5 power supply assembly (5) to the chassis at the rear of the analyzer.
5. Carefully pull up on the power supply assembly to remove it from motherboard connector.

Figure 6-26 A5 Power Supply

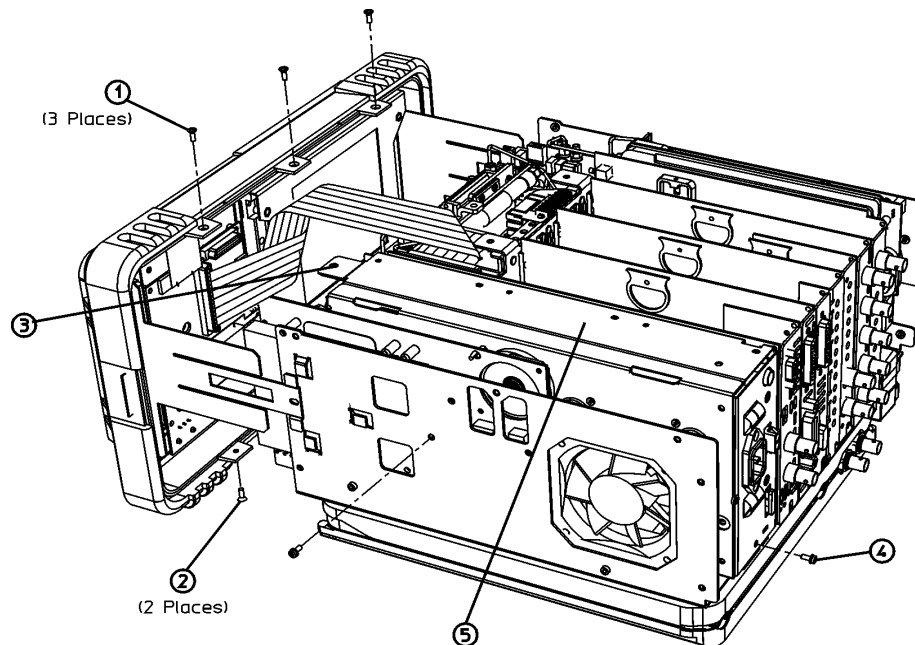

sl750b

Replacement

1. Carefully plug the A5 power supply assembly into the motherboard.
2. Refer to [Figure 6-26](#). Replace the single screw **(4)** that secures the power supply **(5)** to the chassis, but do not tighten it yet.
3. Reconnect the front frame assembly to the chassis. Refer to the replacement procedure [“A1 Front Frame Assembly” on page 254](#).
4. Replace the vibration support bar. Refer to the replacement procedure [“Vibration Support Bar” on page 271](#).
5. Replace the chassis cover. Refer to the replacement procedure [“Chassis Cover” on page 252](#).
6. Replace the outer case. Refer to the replacement procedure [“Instrument Outer Case” on page 250](#).
7. Refer to [Table 7-2 on page 330](#) for the related adjustments and performance verification tests required for each assembly.

A5B1 Fan

CAUTION

Use ESD precautions when performing this replacement procedure.

Removal

1. Remove the power supply assembly. Refer to the removal procedure “A5 Power Supply” on page 287.
2. Unplug the fan wires (2) from the power supply board connector (3) inside the assembly. Refer to [Figure 6-27](#)
3. Refer to [Figure 6-27](#). Remove the four screws (1) securing the top cover to the power supply assembly.

Figure 6-27 Power Supply Cover Removal

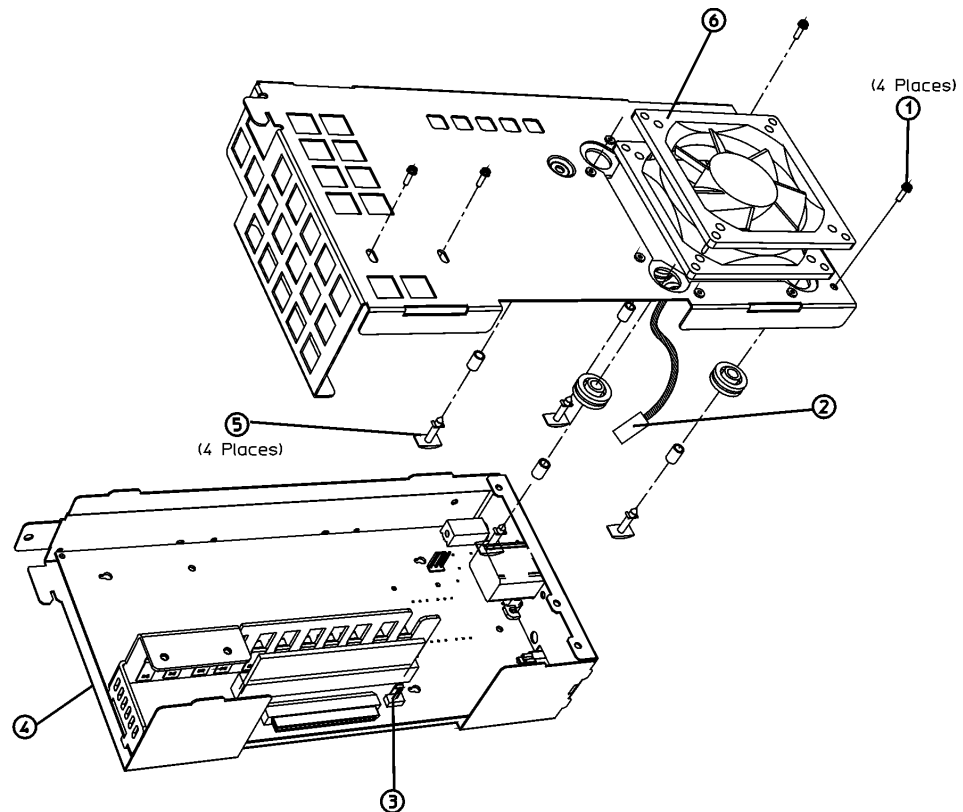

sl752b

Replacing Assemblies

A5B1 Fan

4. Remove the top cover.
5. Locate the four plastic rivets **(5)** that secure the fan **(6)** to the cover.
6. The rivets are not reusable and need to be cut off in order to change the fan.
7. The fan can be removed after the four rivets are cut out.

Replacement

1. Position the fan on the outside of the power supply cover so that the fan wires go through the opening of the cover and are aligned with the notch. Be careful to install the fan so that the arrow indicating the direction of the air flow, (on the body of the fan), is pointing away from the cover. This will ensure the proper air flow through the analyzer and exiting through the side panel. Be careful not to pinch the fan wires against the cover.
2. Refer to [Figure 6-27](#). Assemble the bushing, grommet, and rivet as shown in four places.
3. Replace the power supply cover, with fan, on the power supply assembly. Make sure the lip on the top cover catches underneath **(4)** the bottom cover.
4. Replace the four screws **(1)** that secure the top cover to the power supply assembly. Tighten them to 9 inch-pounds.
5. Plug the fan connector into the power supply board.
6. Replace the power supply assembly. Refer to the replacement procedure “[A5 Power Supply](#)” on page 287.
7. Refer to [Table 7-2 on page 330](#) for the related adjustments and performance verification tests required for each assembly.

A6 Floppy Drive and Speaker Assembly

CAUTION

Use ESD precautions when performing this replacement procedure.

Removal

1. Remove the analyzer chassis cover. Refer to the removal procedure “Chassis Cover” on page 252.
2. Extend the A1 front frame. Refer to the extension procedure “A1 Front Frame Assembly” on page 254.
3. Refer to Figure 6-28. Remove the four screws (1) securing the A6 floppy/speaker assembly (2) to the side frame.
4. Carefully pull up on the floppy/speaker assembly to remove it from the motherboard connector.

Figure 6-28

A6 Speaker Assembly Removal

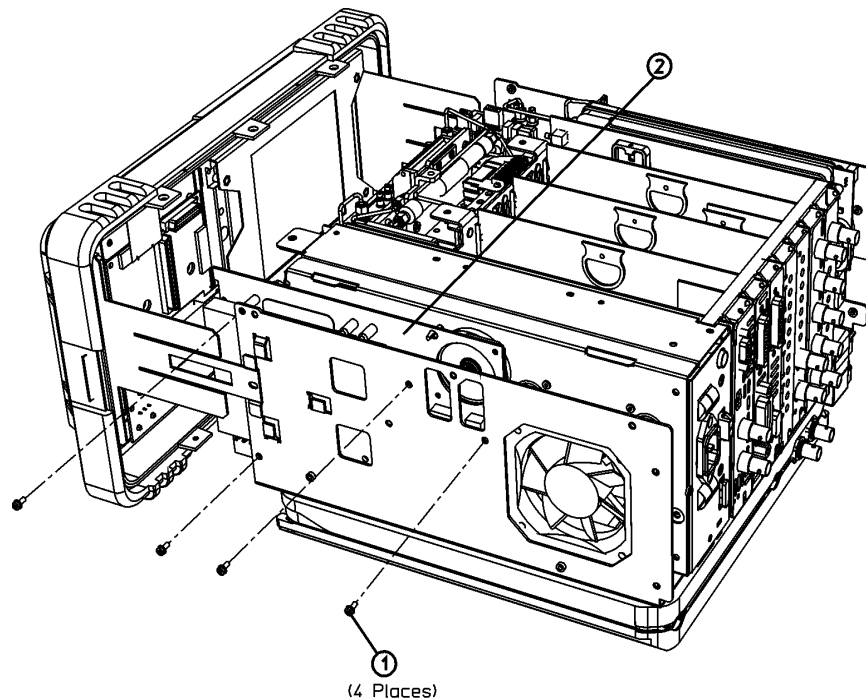

sl756b

Replacement

1. Carefully plug the A6 floppy/speaker assembly into the motherboard.
2. Refer to [Figure 6-28](#). Replace the four screws **(1)** that secure the floppy/speaker assembly **(2)** to the side chassis. Tighten them to 9 inch-pounds.
3. Reconnect the A1 Front Frame to the chassis. Refer to the replacement procedure [“A1 Front Frame Assembly” on page 254](#).
4. Replace the chassis cover. Refer to the replacement procedure [“Chassis Cover” on page 252](#).
5. Replace the outer case. Refer to the replacement procedure [“Instrument Outer Case” on page 250](#).
6. Refer to [Table 7-2 on page 330](#) for the related adjustments and performance verification tests required for each assembly.

A7 Motherboard Assembly

CAUTION

Use ESD precautions when performing this replacement procedure.

Removal

1. Remove the instrument outer case. Refer to the removal procedure “[Instrument Outer Case](#)” on page 250.
2. Remove the analyzer chassis cover. Refer to the removal procedure “[Chassis Cover](#)” on page 252.
3. Extend the A1 front frame. Refer to the extension procedure “[A1 Front Frame Assembly](#)” on page 254.
4. Remove the vibration support bar. Refer to the removal procedure “[Vibration Support Bar](#)” on page 271.
5. Remove the A6 floppy/speaker assembly. Refer to the removal procedure “[A6 Floppy Drive and Speaker Assembly](#)” on page 291.
6. If the analyzer is an Option 1DN or Option 1DQ, remove the A2 tracking generator. Refer to the removal procedure “[A2 1.5 GHz Tracking Generator Assembly](#)” on page 274 or “[A2 3.0 GHz Tracking Generator Assembly](#)” on page 279.
7. Remove the A3 IF assembly. Refer to the removal procedure “[A3 IF Assembly](#)” on page 281.
8. Remove the A4 processor assembly. Refer to the removal procedure “[A4 Processor Assembly](#)” on page 283.
9. Remove the A5 power supply assembly. Refer to the removal procedure “[A5 Power Supply](#)” on page 287.
10. Remove all installed input/output or optional assemblies from the motherboard. Refer to the removal procedure “[FM Demod, SIO, GPIB, RS-232, Noise Source Driver](#)” on page 296.

Figure 6-29 A7 Motherboard Removal

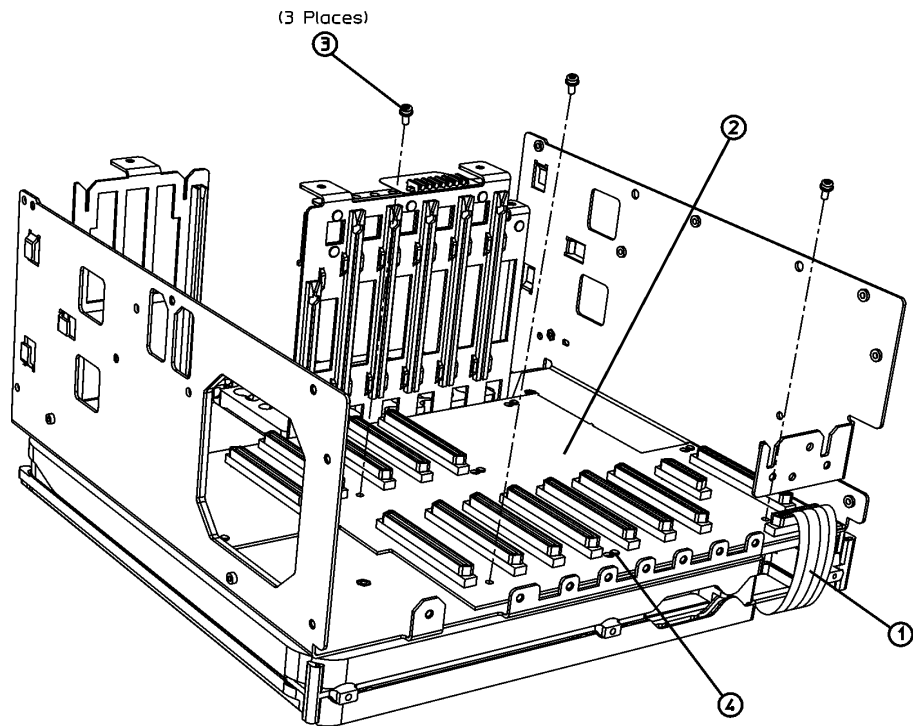

11. Refer to [Figure 6-29](#). Disconnect the RF ribbon cable **(1)** from the motherboard **(2)**.
12. Remove the three screws **(3)** as indicated in [Figure 6-29](#).
13. Slide the motherboard sideways to disengage the shoulder lock standoffs **(4)**, and lift the motherboard out of the chassis.

Replacement

1. Refer to [Figure 6-29](#). Carefully place the motherboard **(2)** into the chassis.
2. Slide the motherboard sideways to engage the shoulder locks **(4)** on the chassis.
3. Replace the three screws **(3)** that secure the motherboard to the chassis. Tighten them to 9 inch-pounds.
4. Refer to [Figure 6-29](#). Connect the RF ribbon cable **(1)** to the motherboard.
5. Replace the A5 power supply assembly. Refer to the replacement procedure “A5 Power Supply” on page 287.
6. Replace the A4 processor assembly. Refer to the replacement procedure “A4 Processor Assembly” on page 283.
7. Replace the A3 IF assembly. Refer to the replacement procedure “A3 IF

Assembly” on page 281.

8. Replace the A2 tracking generator assembly (Option 1DN) if applicable. Refer to the replacement procedure “[A2 1.5 GHz Tracking Generator Assembly](#)” on page 274 or “[A2 3.0 GHz Tracking Generator Assembly](#)” on page 279.
9. Replace the A6 speaker assembly. Refer to the replacement procedure “[A6 Floppy Drive and Speaker Assembly](#)” on page 291.
10. Replace the I/O assemblies. Refer to the replacement procedure “[FM Demod, SIO, GPIB, RS-232, Noise Source Driver](#)” on page 296.
11. Reconnect the A1 front frame to the chassis. Refer to the replacement procedure “[A1 Front Frame Assembly](#)” on page 254.
12. Replace the vibration support bar. Refer to the replacement procedure “[Vibration Support Bar](#)” on page 271.
13. Replace the chassis cover. Refer to the replacement procedure “[Chassis Cover](#)” on page 252.
14. Replace the outer case. Refer to the replacement procedure “[Instrument Outer Case](#)” on page 250.
15. Refer to [Table 7-2 on page 330](#) for the related adjustments and performance verification tests required for each assembly.

Card Cage Assemblies

FM Demod, SIO, GPIB, RS-232, Noise Source Driver

CAUTION

Use ESD precautions when performing this replacement procedure.

The following procedure can be used for all of the Card Cage assemblies:

- A7A1 Spectrum Analyzer Input/Output Assembly (Option A4J)
- A7A2 GPIB/Parallel Assembly (Option A4H)
- A7A3 RS-232/Parallel Assembly (Option 1AX)
- A7A4 Frequency Extension Assembly (E4404B, E4405B, E4407B, E4408B)
- A7A5 Fast ADC Assembly (Option AYX – available on all Agilent ESA-E Series spectrum analyzers: E4401B, E4402B, E4404B, E4405B, and E4407B)
- A7A6 FM Demod Assembly (Option BAA - available on all Agilent ESA-E series spectrum analyzers: E4401B, E4402B, E4404B, E4405B, and E4407B)
- A7A10 Bluetooth Demodulator Assembly (Option 106 - available on E4402B, E4404B, E4405B, and E4407B)
- A7A13 Noise Source Driver Assembly (part of Option 219 - available on all ESA-E Series spectrum analyzers; E4401B, E4402B, E4404B, E4405B, and E4407B)

Removal

1. Remove the analyzer chassis cover. Refer to the removal procedure “[Chassis Cover](#)” on page 252.
2. Remove the vibration support bar. Refer to the removal procedure “[Vibration Support Bar](#)” on page 271.
3. Locate the assembly to be removed.

Figure 6-30 Card Cage Hardware

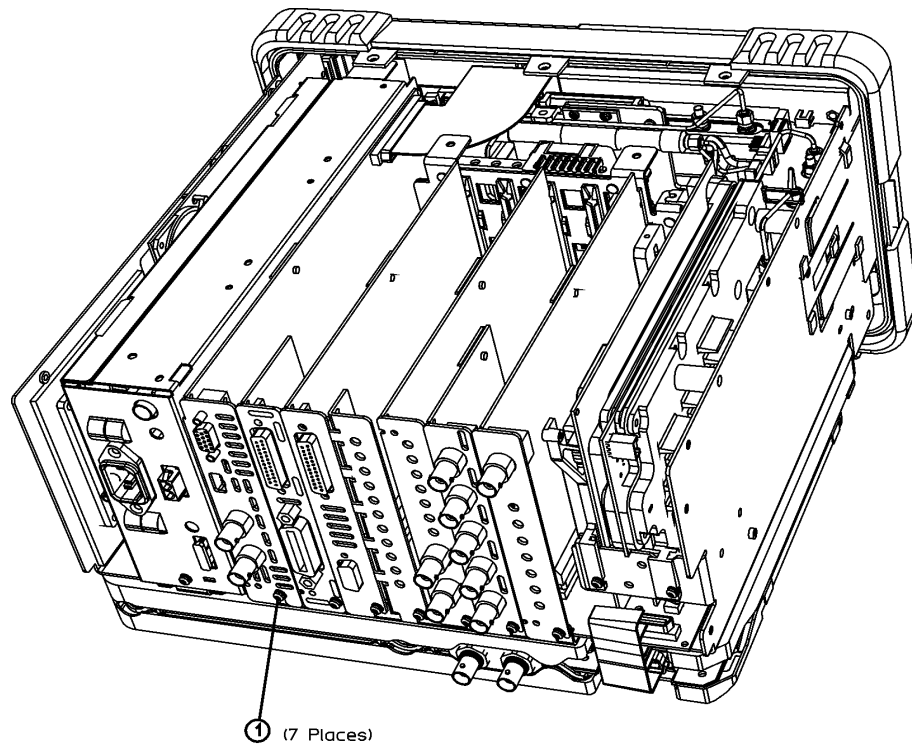

sl715c

4. Refer to [Figure 6-30](#). Loosen, the single screw **(1)** securing the card cage assembly to the chassis.
5. Carefully pull up on the assembly to remove it from the motherboard connector.

Replacement

1. Carefully plug the assembly into the motherboard.
2. Refer to [Figure 6-30](#). Replace the single screw **(1)** that secures the card cage assembly to the chassis, but do not tighten it yet.
3. Replace the vibration support bar. Refer to the replacement procedure [“Vibration Support Bar”](#) on page 271.
4. Refer to [Figure 6-30](#). Tighten the single screw **(1)** that secures the card cage assembly to the chassis to 9 inch-pounds.
5. Replace the chassis cover. Refer to the replacement procedure [“Chassis Cover”](#) on page 252.
6. Replace the outer case. Refer to the replacement procedure [“Instrument Outer Case”](#) on page 250.
7. Refer to [Table 7-2](#) on page 330 for the related adjustments and performance verification tests required for each assembly.

Digital Demod Assemblies Replacement

Digital Signal Processor Board Removal

CAUTION

Use ESD precautions when performing this replacement procedure.

1. Remove the analyzer chassis cover. Refer to the removal procedure “[Chassis Cover](#)” on page 252.
2. Remove the vibration support bar. Refer to the removal procedure “[Vibration Support Bar](#)” on page 271.
3. Refer to [Figure 6-31](#). Loosen, the single screw **(1)** securing the digital signal processor (DSP) assembly to the chassis.
4. Carefully pull up on the DSP assembly to remove it from the motherboard connector.
5. Unplug the sample rate cable **(2)** and the DSP out cable **(3)** from the DSP assembly.
6. Remove the DSP assembly.

Figure 6-31 **Digital Signal Processor Board**

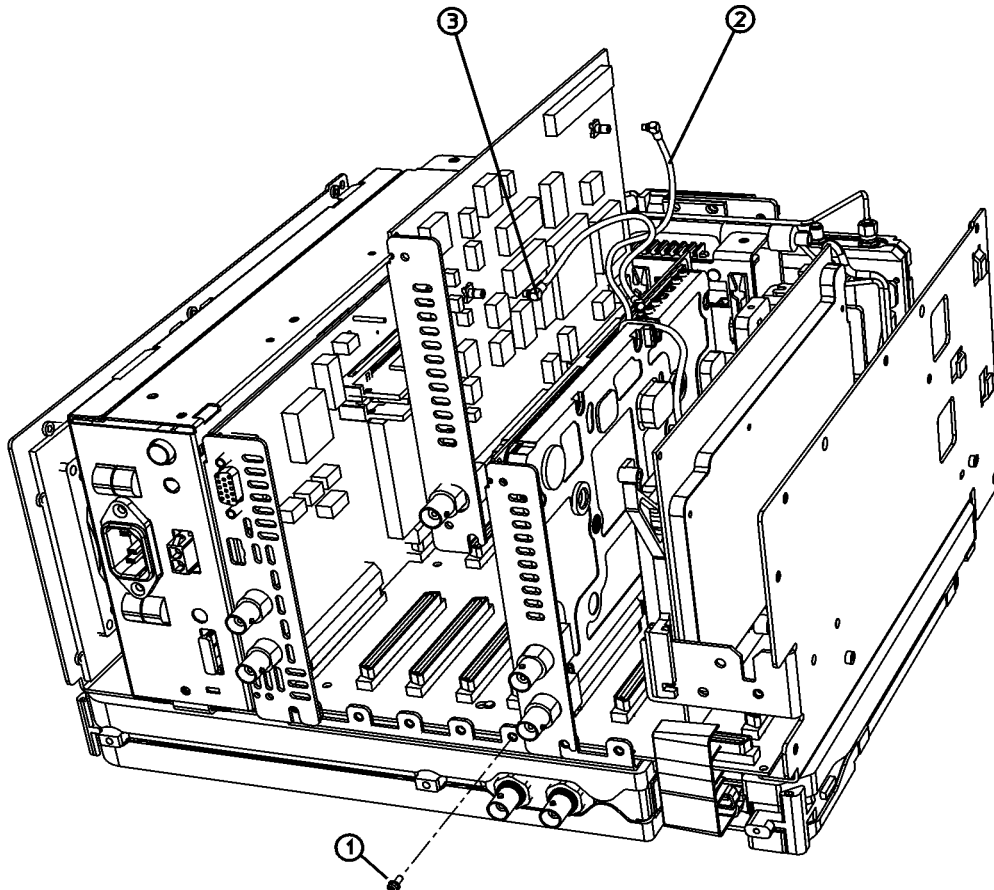

st73c

Digital Signal Processor Board Replacement

CAUTION

Use ESD precautions when performing this replacement procedure.

1. Refer to [Figure 6-31](#). Position the digital signal processor (DSP) assembly to be able to connect the cables as shown.
2. Connect the sample rate cable **(2)** and the DSP out cable **(3)** to the DSP assembly.
3. Lower the assembly into the card cage being careful not to pinch the cables, and plug it into the motherboard.
4. Replace the single screw **(1)** securing the DSP assembly to the chassis.
5. Replace the vibration support bar. Refer to the replacement procedure [“Vibration Support Bar” on page 271](#).
6. Replace the analyzer chassis cover. Refer to the replacement procedure [“Chassis Cover” on page 252](#).

Digital Demod RF Board Removal

CAUTION

Use ESD precautions when performing this replacement procedure.

1. Remove the DSP board. Refer to the procedure [“Digital Signal Processor Board Removal” on page 298](#).
2. Refer to [Figure 6-30](#). Loosen, the single screw **(1)** securing the Digital Demod RF (DDRF) assembly to the chassis.
3. Refer to [Figure 6-32](#). Unplug the MMCX cable connectors **(2)** through **(6)** from the DDRF board.

Figure 6-32 Digital Demod RF Board Cables

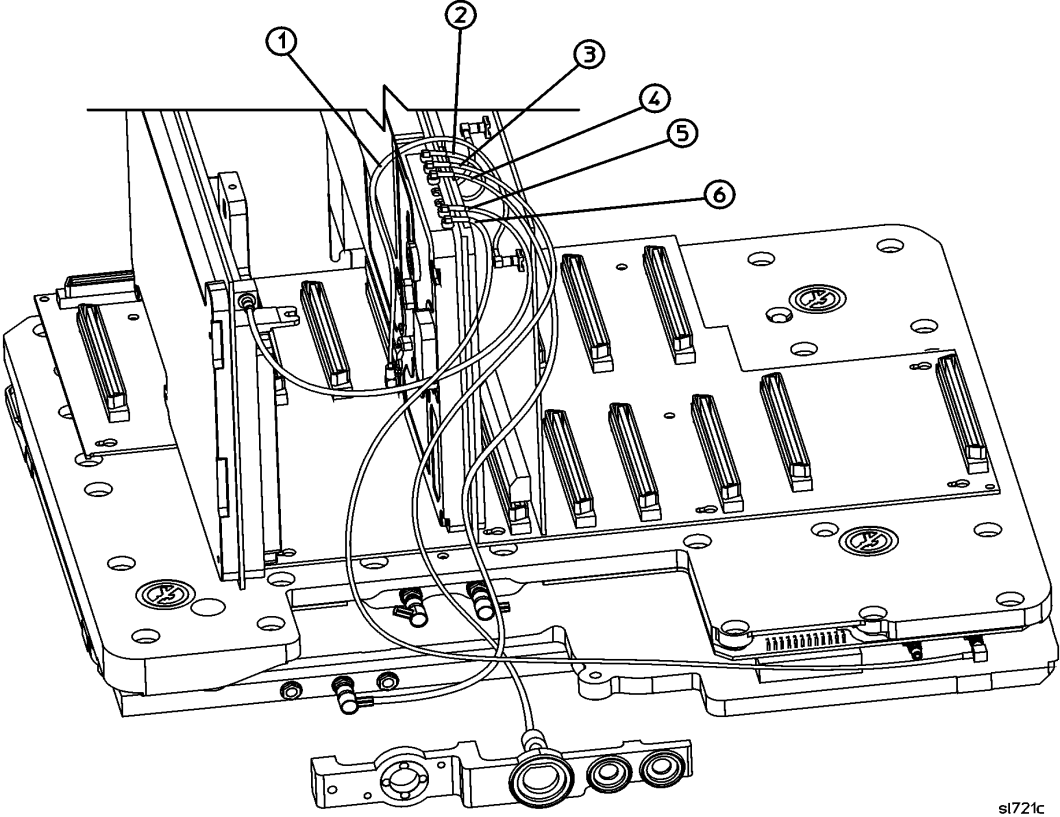

sl721c

Figure 6-33 Digital Demod RF Board Cable Clip

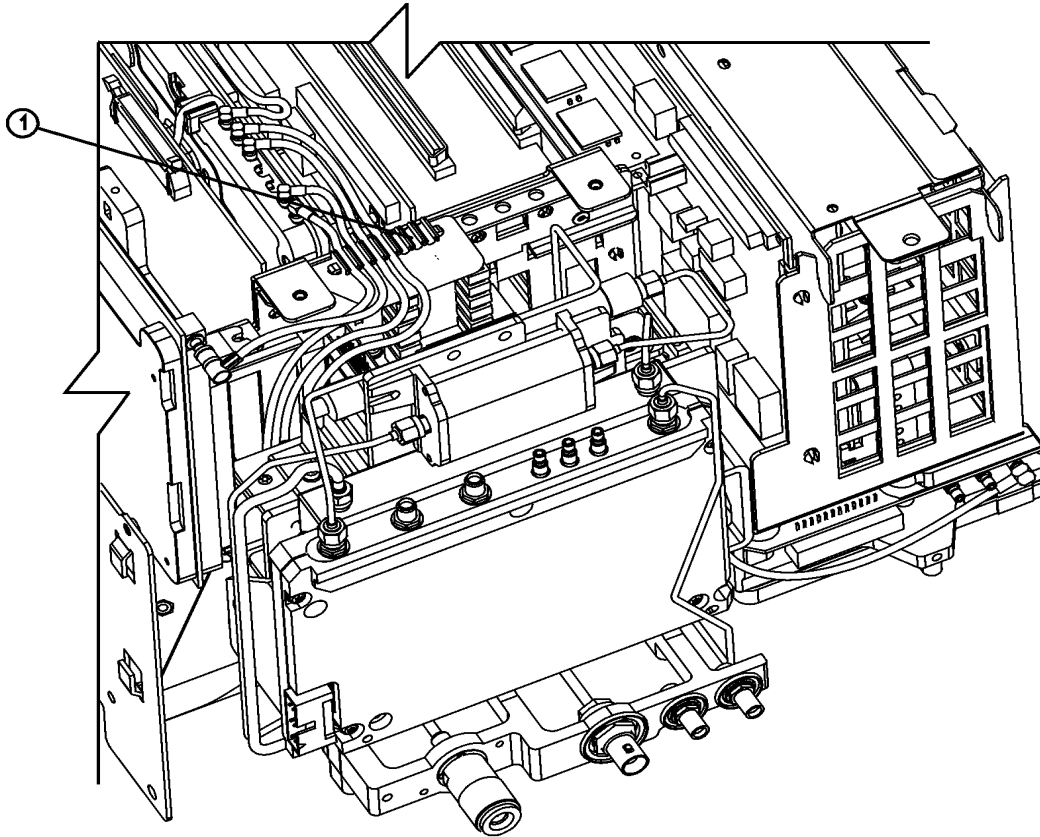

sl75c

4. Refer to [Figure 6-33](#). Remove the cables from the cable clip **(1)**.
5. Carefully pull up on the DDRF assembly, to unplug it from the motherboard, remove the DDRF assembly.
6. Refer to [Figure 6-34](#). If necessary, unplug the sample rate cable **(1)** from the DDRF board and remove the cable from the groves on the shield and the cable clip **(2)**.

Digital Demod RF Board Replacement

CAUTION Use ESD precautions when performing this replacement procedure.

Figure 6-34 Digital Demod RF Board Sample Rate Cable Routing

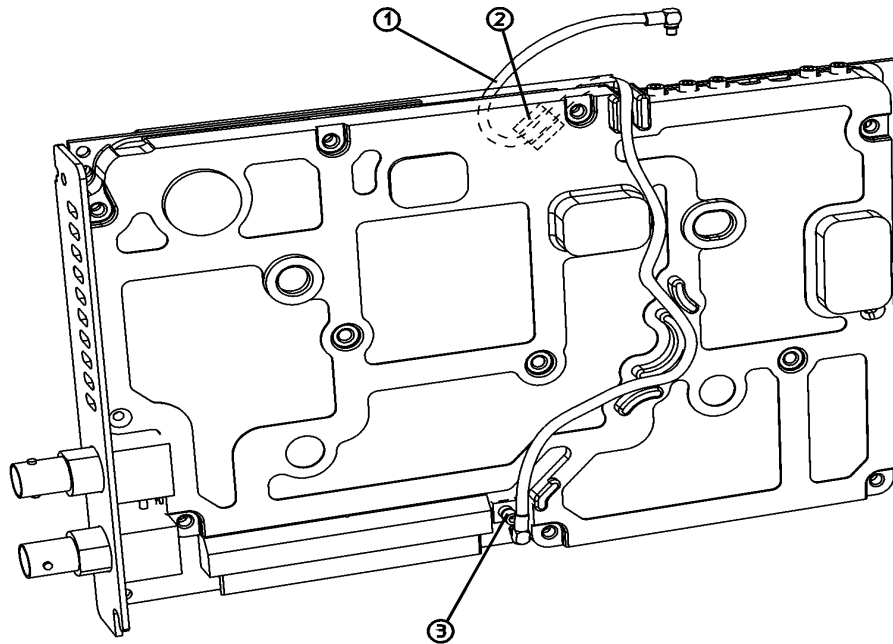

sl720c

1. Refer to [Figure 6-33](#). Ensure that the DDRF cables have been removed from the cable clip **(1)**.
2. Refer to [Figure 6-34](#). Connect sample rate cable **(3)** to the DDRF board at J12.
3. Dress the cable into the grooves on the shield, over the top of the board, and secure it in the cable clip **(2)** as shown.

Figure 6-35 Digital Demod RF Board Option Slot

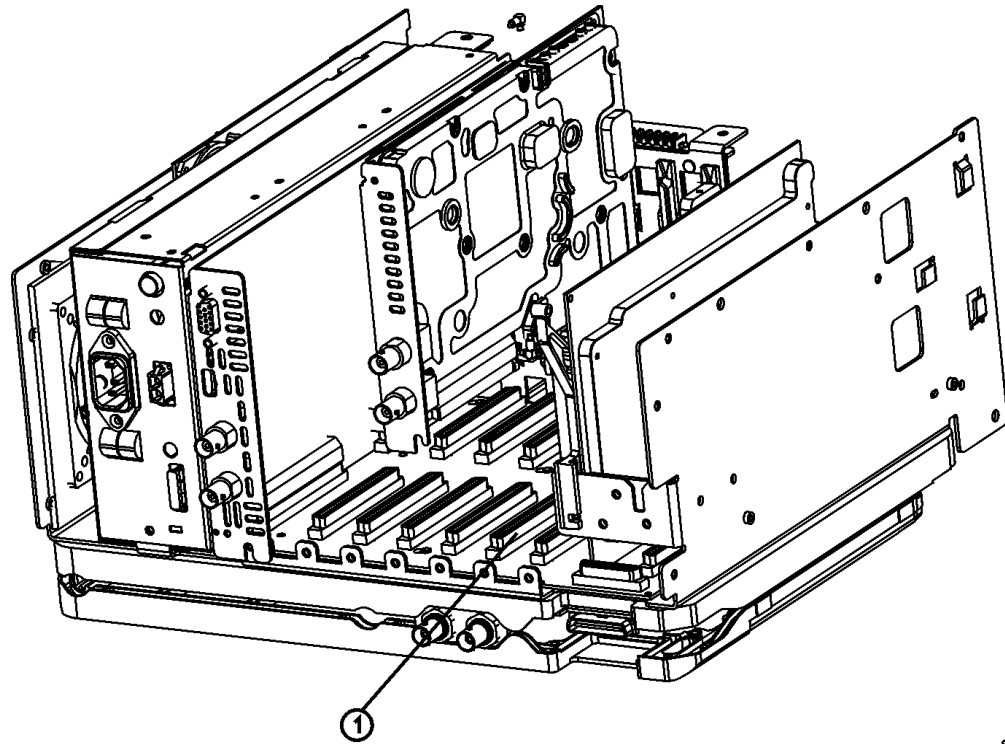

sl72c

4. Refer to [Figure 6-35](#). Lower the assembly into the card cage being careful not to pinch the cables and plug it into Option Slot 5 **(1)** on the motherboard.
5. Refer to [Figure 6-32](#). Connect the MMCX cable connectors to the DDRF board as shown in the illustration.
6. Refer to [Figure 6-33](#). Secure the MMCX cables in the cable clip **(1)**.
7. Refer to [Figure 6-30](#). Replace the single screw **(1)** securing the DDRF assembly to the chassis.
8. Connect the sample rate cable to the DSP board and replace the DSP board into Option Slot 4. Refer to the procedure “[Digital Signal Processor Board Replacement](#)” on page 299.

A8 1.5 GHz RF Assembly

(E4401B and E4411B)

CAUTION Use ESD precautions when performing this replacement procedure.

NOTE The RF assembly is not field serviceable. Please do not remove the shields (other than the input connector cover).

Removal

1. Remove the instrument outer case. Refer to the removal procedure “[Instrument Outer Case](#)” on page 250.
2. Remove chassis cover. Refer to the removal procedure “[Chassis Cover](#)” on page 252.
3. Remove the A1 Front Frame assembly. Refer to the removal procedure “[A1 Front Frame Assembly](#)” on page 254.

Figure 6-36 A8 1.5 GHz RF Assembly Cables

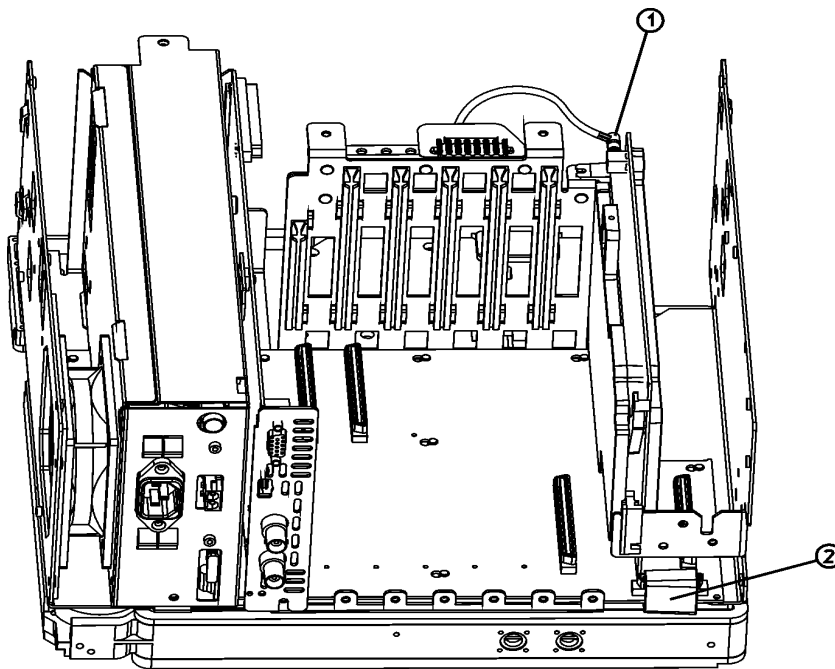

sl771b

4. Refer to [Figure 6-36](#). Disconnect the W2 coaxial cable (1) from the A3 IF assembly.
5. Disconnect the RF ribbon cable (2) from the motherboard at the rear of the analyzer.

Figure 6-37 A8 1.5 GHz RF Assembly Removal

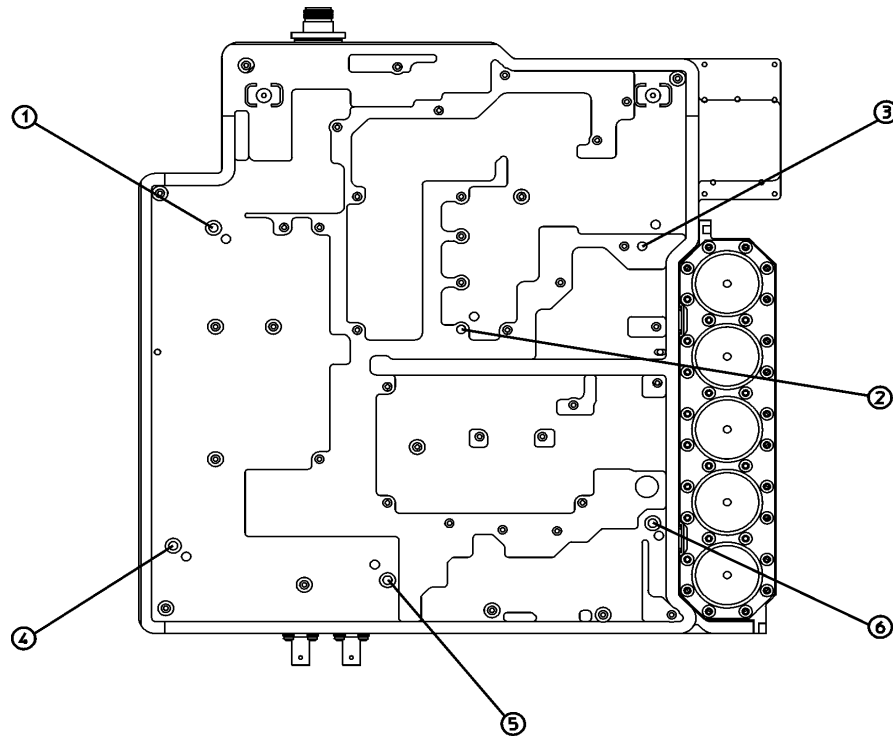

st712a

6. Refer to [Figure 6-37](#). Turn the analyzer upside down and remove the six screws labeled (1 - 6) that hold the RF assembly to the chassis.
7. Lift the RF assembly from the spectrum analyzer.

Replacement

1. Place the analyzer chassis upside down on the work surface.
2. Position the RF assembly on the chassis, taking care not to pinch any of the cables.
3. Refer to [Figure 6-37](#). Replace the six screws labeled (1 - 6) that secure the RF assembly to the chassis. The correct screw holes are marked 1 through 6 on the assembly. Tighten them to 9 inch-pounds.
4. Refer to [Figure 6-36](#). Connect the ribbon cable (1) to the RF assembly and W2 coaxial cable (2) to the A3 IF assembly.
5. Replace the chassis cover. Refer to the replacement procedure “[Chassis Cover](#)” on page 252.

Replacing Assemblies
A8 1.5 GHz RF Assembly

6. Make sure the water seal is in place on the input connector.
7. Reconnect the A1 front frame to the chassis. Refer to the replacement procedure “[A1 Front Frame Assembly](#)” on page 254.
8. Replace the outer case. Refer to the replacement procedure “[Instrument Outer Case](#)” on page 250.
9. Refer to [Table 7-2 on page 330](#) for the related adjustments and performance verification tests required for each assembly.

A8 3.0 GHz RF Assembly

(E4402B, E4404B, E4405B, E4407B, and E4408B)

CAUTION

Use ESD precautions when performing this replacement procedure.

Removal

1. Remove the analyzer chassis cover. Refer to the removal procedure “Chassis Cover” on page 252.
2. Remove the A1 front frame assembly. Refer to the removal procedure “A1 Front Frame Assembly” on page 254.

Figure 6-38 3.0 GHz RF Assembly Ribbon Cable

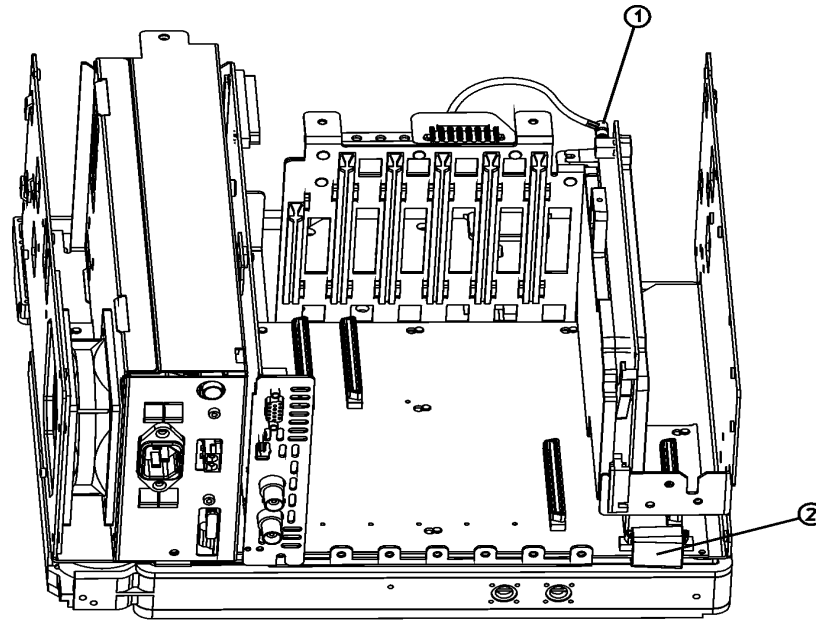

sl771b

3. Referring to Figure 6-38, disconnect the SMB cable (1) from the IF assembly.
4. Disconnect the RF assembly ribbon cable (2).

Figure 6-39 3.0 GHz RF Assembly Cables

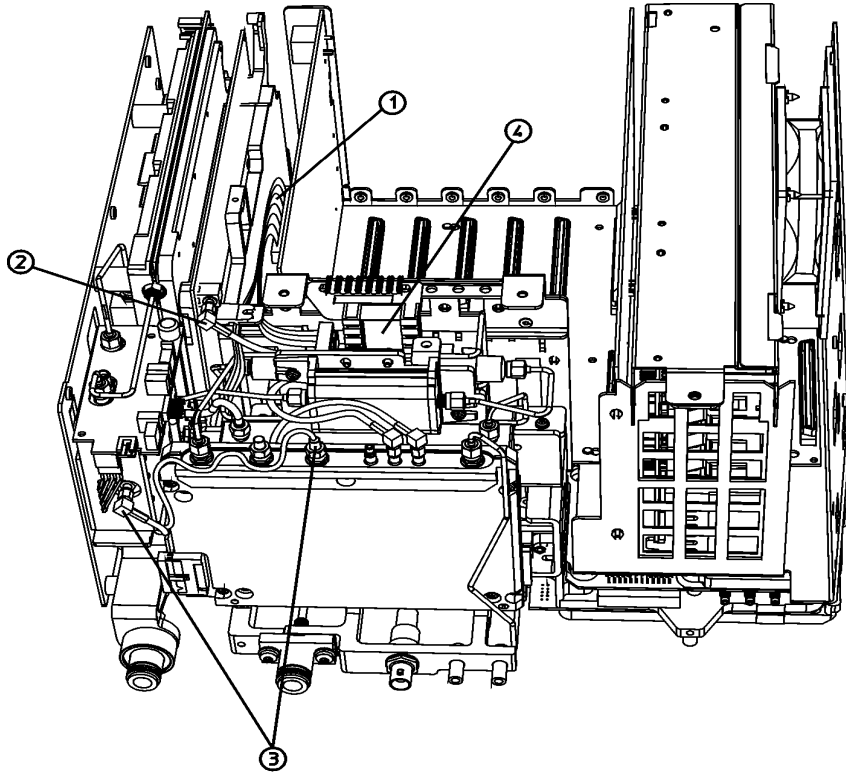

sl773b

5. Referring to [Figure 6-39](#), disconnect the frequency extension ribbon cable **(1)**. (E4404B, E4405B, E4407B, and E4408B only)
6. Gently tuck these two cables away behind the microcircuits **(4)** of the RF assembly.
7. If the analyzer has a tracking generator, disconnect the cable **(3)** from the tracking generator connector. Tuck the cable end with the yellow tag away with the other cables as described in the previous step.

Figure 6-40 RF Deck Screws

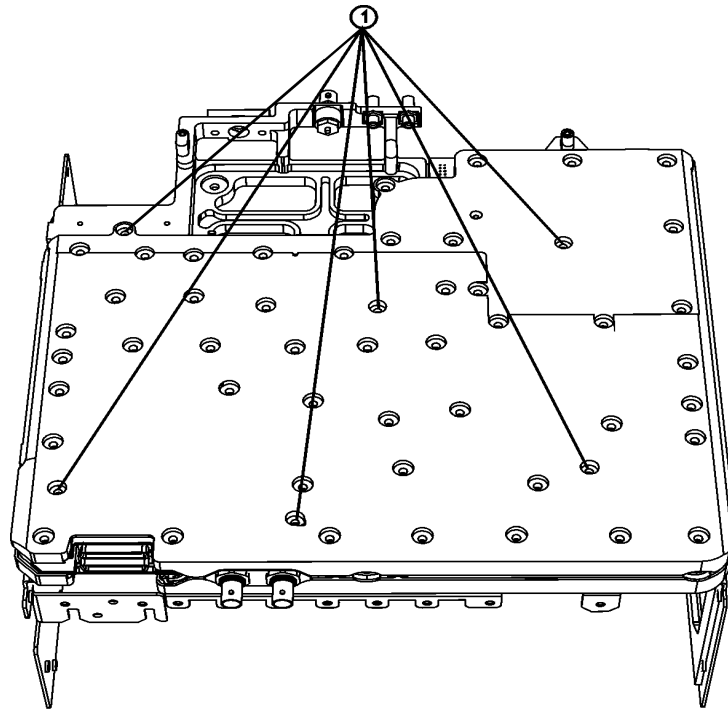

sl779b

8. Referring to [Figure 6-40](#), position the analyzer upside down and remove the six screws **(1)** marked “RF Deck” securing the RF assembly to the chassis.
9. Carefully lift the RF assembly from the chassis.

CAUTION

The cables and assemblies are easily damaged. Once removed, it is best to lay the RF assembly flat on a work surface. Do not rest it against any of the microcircuits or cables.

Replacement

1. Position the analyzer upside down on the work surface.
2. Referring to [Figure 6-39](#), tuck the cables away behind the microcircuits **(4)**.
3. Lower the RF assembly onto the chassis taking care not to pinch any cables.
4. Referring to [Figure 6-40](#), replace the six screws **(1)** securing the RF assembly to the chassis, and tighten them to 9 inch-pounds.
5. Referring to [Figure 6-39](#), connect the ribbon cable **(1)** to the frequency extension assembly. (E4404B, E4405B, E4407B, and E4408B only)
6. Connect the SMB cable **(2)** to the IF assembly.
7. If the analyzer has a tracking generator, reconnect the cables **(3)** to it, and tighten the SMA connector to 10 inch-pounds.

Replacing Assemblies

A8 3.0 GHz RF Assembly

8. Connect the RF assembly ribbon cable **(2)** as shown in [Figure 6-38](#).
9. Replace the A1 front frame assembly. Refer to the replacement procedure “[A1 Front Frame Assembly](#)” on page 254.
10. Replace the analyzer chassis cover. Refer to the replacement procedure “[Chassis Cover](#)” on page 252.

RF Subassemblies

CAUTION Use ESD precautions when performing this replacement procedure.

A8A1 OCXO Precision Frequency Reference

(Option 1D5 - E4401B only)

CAUTION Use ESD precautions when performing this replacement procedure.

Removal

1. Remove the A8 1.5 GHz RF Assembly. Refer to the removal procedure “A8 1.5 GHz RF Assembly” on page 304.

Figure 6-41 Precision Frequency Reference

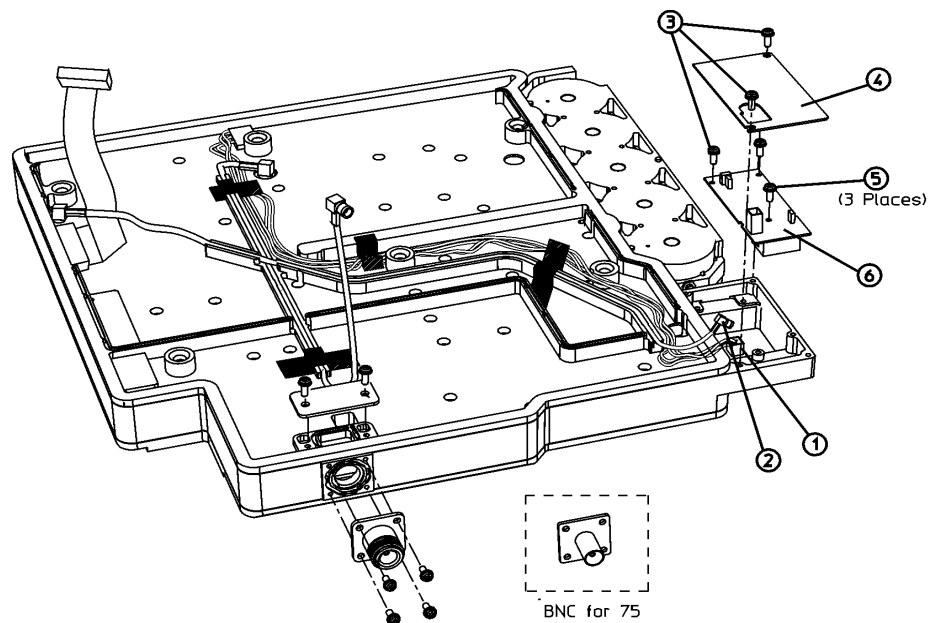

st791b

2. Referring to [Figure 6-41](#), disconnect the control cable (1) and the SMB cable (2) from the precision frequency assembly.
3. Remove the screws (3) and cover (4).
4. Remove the screws (5) and the assembly (6).

Replacement

1. Referring to [Figure 6-41](#), replace the assembly (6) and secure with the screws (5).

Replacing Assemblies RF Subassemblies

2. Replace the cover **(4)** and screws **(3)**.
3. Reconnect the control cable **(1)** and the SMB cable **(2)** to the precision frequency assembly.
4. Dress the cables to avoid pinching during reassembly.

A8A4 LO Amp/IF Switch Assembly

(E4404B, E4405B, E4407B, and E4408B)

CAUTION

Use ESD precautions when performing this replacement procedure.

NOTE

The LO amplifier and IF switch (LOIS) assembly can be removed without removing the RF assembly.

Removal

1. Remove the analyzer chassis cover. Refer to the removal procedure “[Chassis Cover](#)” on page 252.
2. Remove the A1 front frame assembly. Refer to the removal procedure “[A1 Front Frame Assembly](#)” on page 254.
3. Referring to [Figure 6-42](#), disconnect any cables and loads **(1)** from the LOIS assembly.
4. Remove the three screws **(2)** and remove the LOIS assembly.

Figure 6-42 Removing the LO Amplifier/IF Switch Assembly

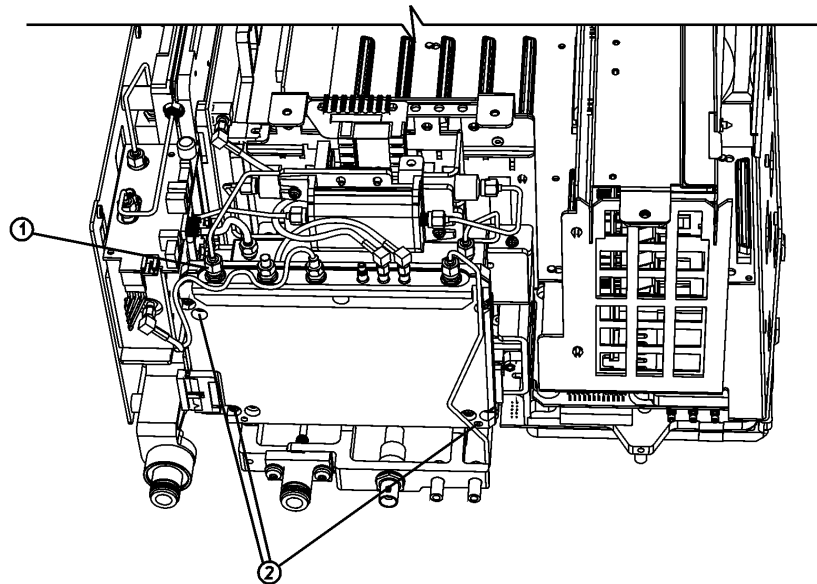

sl775b

Replacement

CAUTION

Use care not to pinch any cables during reassembly.

1. Referring to [Figure 6-42](#), replace the assembly and secure in place with the three screws **(2)**. Tighten them to 9 inch-pounds.
2. Reconnect the previously removed cables and loads **(1)**. Tighten the SMA connectors to 10 inch-pounds.
3. Replace the A1 front frame assembly. Refer to the replacement procedure “[A1 Front Frame Assembly](#)” on page 254.
4. Replace the analyzer chassis cover. Refer to the replacement procedure “[Chassis Cover](#)” on page 252.

A8A5 Input Attenuator

(E4402 (Option UKB), E4404B, E4405B, E4407B, and E4408B)

CAUTION

Use ESD precautions when performing this replacement procedure.

Removal

1. Remove the A8 RF Assembly. Refer to the removal procedure “[A8 3.0 GHz RF Assembly](#)” on page 307.

Figure 6-43 Input Attenuator Hardware

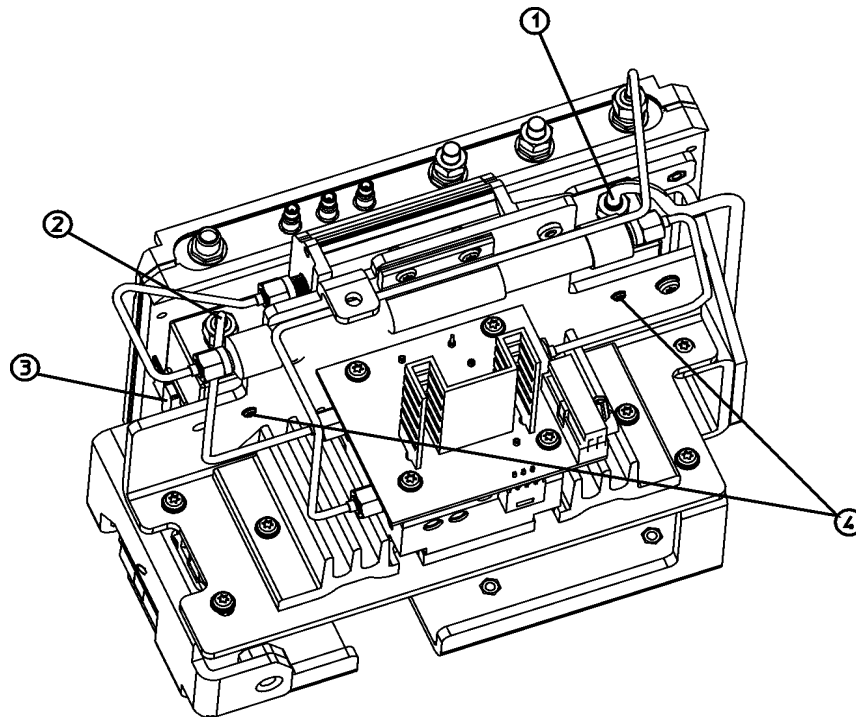

sl793b

Replacing Assemblies RF Subassemblies

2. Refer to [Figure 6-43](#). Disconnect the input semi-rigid cable **(1)** from the attenuator.
3. Remove the semi-rigid cable **(2)** from the attenuator.
4. Disconnect the ribbon cable **(3)** from the attenuator.
5. Remove the screws **(4)**.
6. Remove the attenuator from the left side as shown in [Figure 6-44](#).

Replacement

CAUTION

Use care not to pinch any cables during reassembly.

Figure 6-44

Input Attenuator Remove and Replace

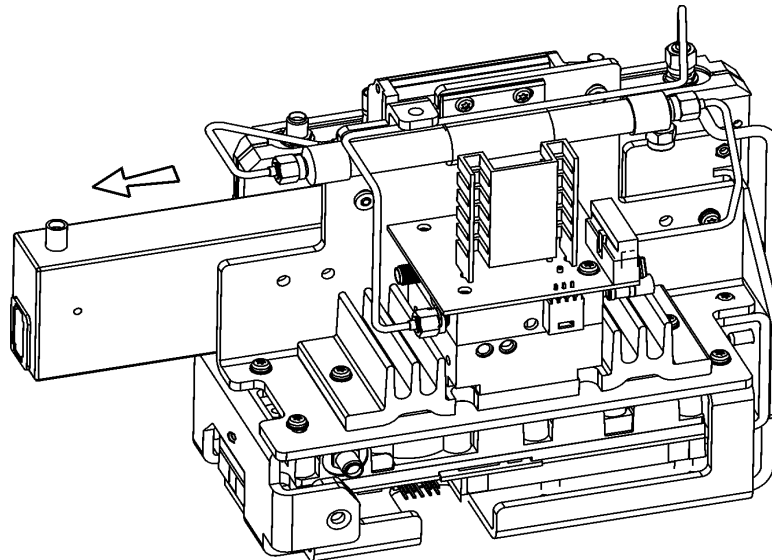

sl792b

1. Refer to [Figure 6-44](#). Install the attenuator from the left side and secure in place with the two screws **(4)**. Tighten them to 9 inch-pounds.
2. Refer to [Figure 6-43](#). Reconnect the ribbon cable **(3)** to the attenuator.
3. Reconnect the semi-rigid cables **(1)** and **(2)** to the attenuator. Tighten them to 10 inch-pounds.

A8A6 YIG-Tuned Filter/Mixer

(E4404B, E4405B, E4407B, and E4408B)

CAUTION

Use ESD precautions when performing this replacement procedure.

Removal

1. Remove the A8 RF assembly. Refer to the removal procedure “A8 3.0 GHz RF Assembly” on page 307.
2. Position the A8 RF assembly right side up on the work bench.

Figure 6-45 YIG-Tuned Mixer/Filter

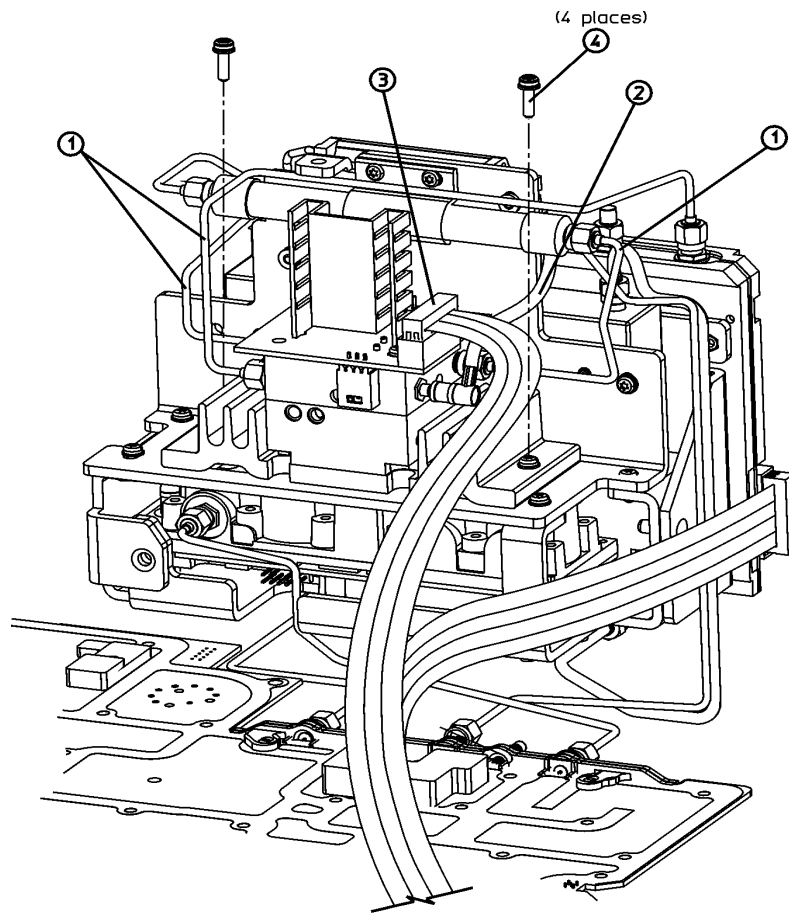

sl774b

3. Refer to [Figure 6-45](#). Remove the three semi-rigid cables **(1)** from the assembly.
4. Disconnect the SMB coax cable **(2)** from the YTF assembly.

Replacing Assemblies

RF Subassemblies

5. Disconnect the frequency extension ribbon cable **(3)**.

Use a T10 TORX driver to remove the two screws **(4)** from the assembly bracket.

6. Lift out the assembly.

Replacement

CAUTION

Use great care not to overtighten the SMA connections to the YIG-tuned filter/mixer assembly. If the connectors are broken loose, the assembly will have to be returned to the factory for repair.

1. Refer to [Figure 6-45](#). Replace the A8A6 YIG-tuned filter/mixer assembly onto the A8 RF assembly.
2. Replace the two screws, **(4)** and tighten them to 9 inch-pounds.
3. Replace the three semi-rigid cables **(1)** to the assembly and tighten them to 10 inch-pounds with a 5/16" wrench.
4. Reconnect the SMB coax cable **(2)**.
5. Reconnect the frequency extension ribbon cable **(3)**.
6. Replace the A8 RF Assembly. Refer to the replacement procedure "[A8 3.0 GHz RF Assembly](#)" on page 307.

A8A2 Second Converter

(E4404B, E4405B, E4407B, and E4408B)

CAUTION

Use ESD precautions when performing this replacement procedure.

Removal

1. Remove the RF Assembly. Refer to the removal procedure “A8 3.0 GHz RF Assembly” on page 307.

Figure 6-46 YTM Deck Cables

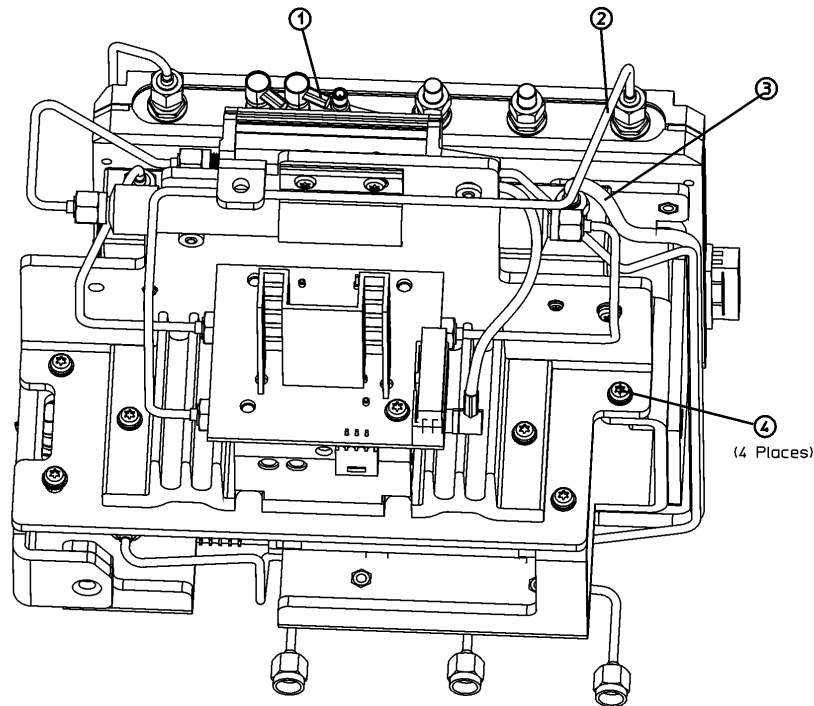

sl777b

2. Refer to [Figure 6-46](#), and position the A8 RF Assembly upright on the work bench.
3. Disconnect the SMB cables **(1)** from LOIS.
4. Disconnect the SMA semi-rigid cable **(2)** from LOIS.
5. Disconnect the SMA semi-rigid cable **(3)** to the input attenuator.
6. Disconnect the SMA semi-rigid cable **(4)** to the dc block assembly.
7. Disconnect the ribbon cable **(5)** from the YTM-mixer/filter assembly.
8. Remove the four screws **(6)**, then remove the sub-bracket from the microcircuit bracket.

Figure 6-47 Second Converter, Bottom View

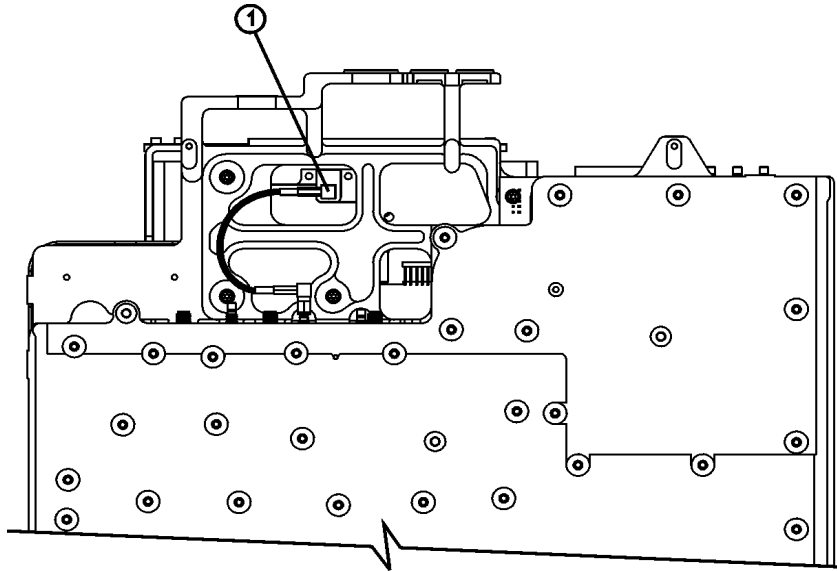

sl776b

Figure 6-48 Second Converter Hardware

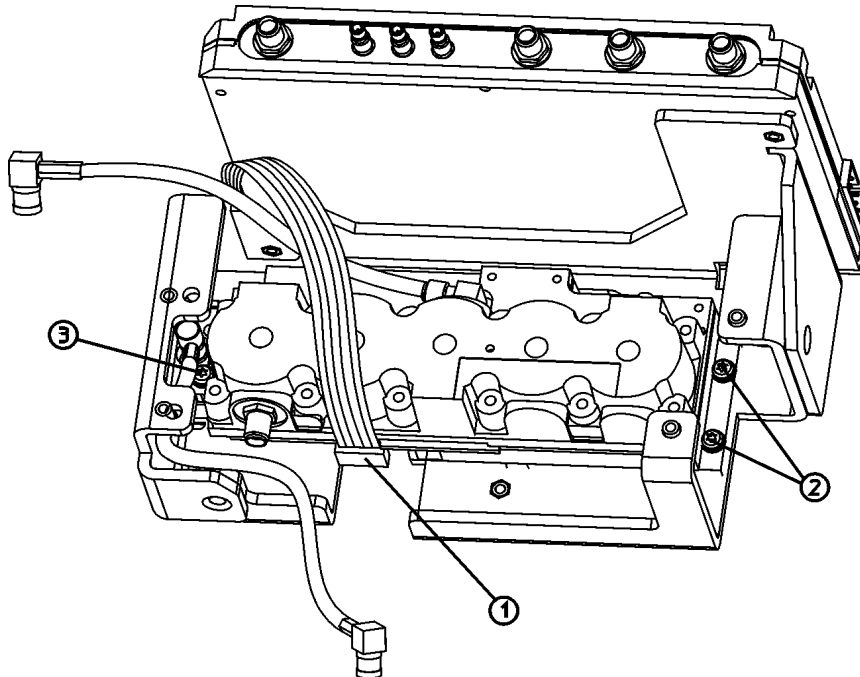

sl778b

9. Refer to [Figure 6-47](#). Disconnect the SMB cable **(1)** from the bottom side of the second converter.
10. Refer to [Figure 6-48](#). Disconnect the ribbon cable **(1)**.
11. Remove the two screws **(2)** and then the single screw **(3)**.
12. Remove the second converter assembly.
13. Remove any of the remaining cables and transfer them to the new second converter. Tighten the SMA cables to 10 inch-pounds.

Replacement

1. Refer to [Figure 6-48](#). Install the second converter assembly with the single screw **(3)**, but don't tighten it yet.

NOTE

The screws that secure the second converter in place are slightly longer than the other assembly screws.

2. Install the other two screws **(2)**, and tighten all three screws to 9 inch-pounds.
3. Connect the ribbon cable **(1)** and place it as shown in [Figure 6-48](#).
4. Refer to [Figure 6-46](#). Replace the sub-bracket to the microcircuit bracket and replace the four screws **(4)**. Tighten them to 9 inch-pounds.
5. Reconnect the SMB cable **(1)** to LOIS.
6. Reconnect the SMA semi-rigid cable **(2)** from LOIS.
7. Reconnect the SMA semi-rigid cable **(3)** to the input attenuator.
8. Reconnect the SMA semi-rigid cable **(4)** to the dc block assembly.
9. Reconnect the ribbon cable **(5)** to the YTM-mixer/filter assembly.
10. Replace the RF Assembly. Refer to the replacement procedure "[A8 3.0 GHz RF Assembly](#)" on page 307.

RF Input Connector

(E4402B, E4403B, E4404B, E4405B, E4407B, and E4408B)

CAUTION

Use ESD precautions when performing this replacement procedure.

Removal

1. Remove the analyzer chassis cover. Refer to the removal procedure "[Chassis Cover](#)" on page 252.
2. Remove the A1 front frame assembly. Refer to the removal procedure "[A1 Front Frame Assembly](#)" on page 254.
3. Remove the RF connector. For a Type-N connector, refer to the removal procedure "[Type-N Connector](#)" on page 320. For a APC 3.5, refer to the

removal procedure “APC 3.5 Connector” on page 320.

Figure 6-49 RF Connector, Type-N and APC 3.5

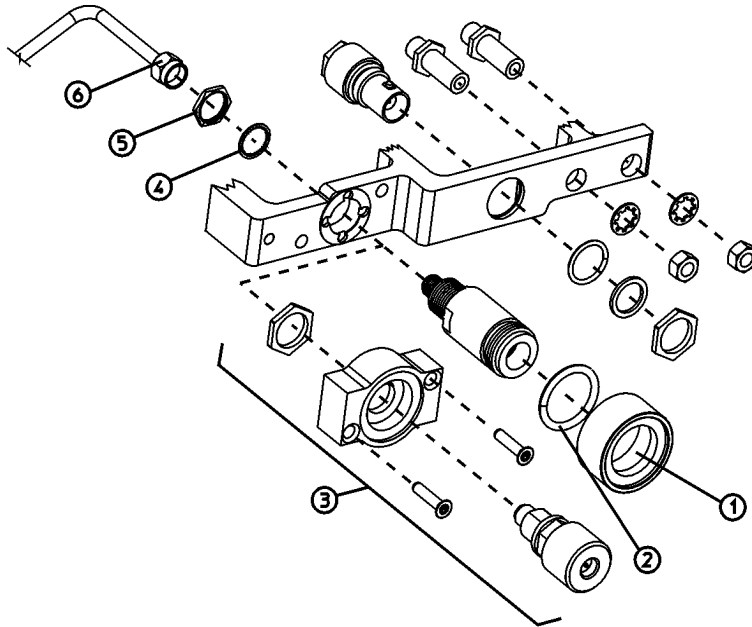

sl797b

Type-N Connector

- a. Refer to [Figure 6-49](#). Gently twist the water seal (1) and remove it from around the input connector. Make sure the O-ring (2) is retained within the water seal.
- b. Use a 5/16” wrench to remove the semi-rigid (6) cable from the input connector.
- c. Loosen the nut (5) from the back side of the input connector with a 9/16” wrench, and gently remove the connector, retaining the washer (4) and nut.

APC 3.5 Connector

- a. Refer to [Figure 6-49](#). Use a 5/16” wrench to remove the semi-rigid (6) cable from the input connector.
- b. Remove the two screws that fasten the APC 3.5 connector assembly (3) to the frame.
- c. Remove the connector assembly.

Replacement

1. Install the RF connector. For a Type-N connector, refer to the replacement procedure “[Type-N Connector](#)” on page 320. For a APC 3.5, refer to the replacement procedure “[APC 3.5 Connector](#)” on page 320.

Type-N Connector

- a. Refer to [Figure 6-49](#). Reattach the input connector and secure with the washer (5), and nut (4). Tighten the nut to 21 inch-pounds.
- b. Reattach the semi-rigid cable (6) to the input connector with a 5/16” wrench. Tighten it to 10 inch-pounds.
- c. Make sure the O-ring (2) is still inside the water seal (1), then gently twist and push the water seal onto the input connector.
- d. Continue with [step 2](#) below.

APC 3.5 Connector

- a. Refer to [Figure 6-49](#). Reattach the APC 3.5 input connector assembly (2) and secure with the two screws. Tighten them to 9 inch-pounds.
 - b. Reattach the semi-rigid cable (6) to the input connector with a 5/16” wrench. Tighten it to 10 inch-pounds.
 - c. Continue with [step 2](#) below.
2. Reconnect the A1 front frame to the chassis. Refer to the replacement procedure “[A1 Front Frame Assembly](#)” on page 254.
 3. Replace the chassis cover. Refer to the replacement procedure “[Chassis Cover](#)” on page 252.
 4. Replace the outer case. Refer to the replacement procedure “[Instrument Outer Case](#)” on page 250.
 5. Refer to [Table 7-2 on page 330](#) for the related adjustments and performance verification tests required for each assembly.

1.5 GHz RF Input Connector

CAUTION

Use ESD precautions when performing this replacement procedure.

Removal

1. Remove the analyzer chassis cover. Refer to the removal procedure “[Chassis Cover](#)” on page 252.
2. Remove the A1 front frame assembly. Refer to the removal procedure “[A1 Front Frame Assembly](#)” on page 254.
3. Remove the RF assembly. Refer to the removal procedure “[A8 1.5 GHz RF Assembly](#)” on page 304.

Figure 6-50 A8J10 RF Input Connector

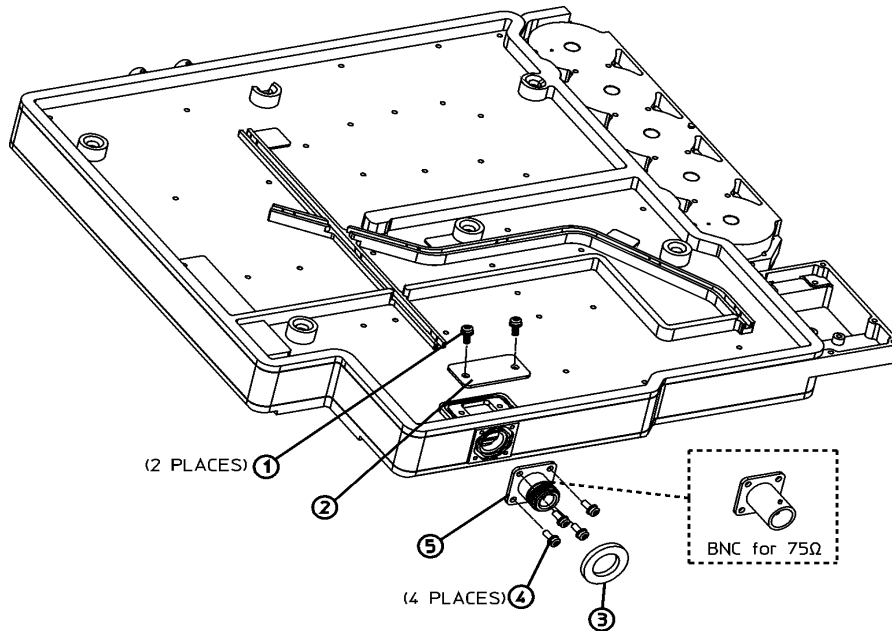

sn74a

4. Refer to [Figure 6-50](#). Remove the two screws **(1)** that secure the input connector cover **(2)**, and remove the cover.
5. Remove the water seal **(3)** from around the input connector.
6. Remove the four screws **(4)** that secure the input connector.
7. Apply heat to the center conductor with a soldering iron, and gently pull out the input connector.

Replacement

1. Remove excess solder from the RF board pad.
2. Refer to [Figure 6-50](#). Insert the RF connector and fasten in place with the four screws **(4)**. Tighten them to 9 inch-pounds.
3. Replace the water seal **(3)** around the input connector.
4. Resolder the center conductor to the RF board.
5. Replace the input connector cover **(2)**, and secure it with the two screws **(1)**. Tighten them to 9 inch-pounds.
6. Replace the RF assembly. Refer to the replacement procedure “[A8 1.5 GHz RF Assembly](#)” on page 304.
7. Replace the A1 front frame assembly. Refer to the replacement procedure “[A1 Front Frame Assembly](#)” on page 254.

7 **Post-Repair Procedures**

What You Will Find in This Chapter

The tables in this chapter list the adjustments that should be performed if there is a performance test failure or an assembly has been repaired or replaced. Automated software is required to provide most of the analyzer adjustments. Never perform adjustments as routine maintenance. Adjustments should be performed after a repair or a performance test failure. For information on installing and using the adjustment software, refer to [Chapter 8, “Performance Verification and Adjustment Software”](#).

Safety

Familiarize yourself with the safety symbols marked on the analyzer and read the general safety considerations and the safety note definitions in the front of this guide, *before* you begin the procedures in this chapter.

Before You Start

There are three things you should do before starting an adjustment procedure:

- o Check that you are familiar with the safety symbols marked on the analyzer and read the general safety considerations and the symbol definitions given in the front of this service guide.
- o Check that the analyzer has been turned on and allowed to warm up for at least 30 minutes at room temperature before making any adjustments. The analyzer *must* be allowed to stand at room temperature at least 2 hours prior to the 30 minute warm-up.
- o Read the rest of this section.

Finding abnormal indications during adjustments

If the indications received during an adjustment do not agree with the normal conditions given in the adjustment procedures, a fault exists in your analyzer. The fault should be repaired *before* proceeding with any further adjustments. Refer to the troubleshooting and repair information in [Chapter 1](#) of this guide.

Periodically verifying calibration

The analyzer requires periodic verification of operation. Under most conditions of use, you should test the analyzer at least once a year with the complete set of performance verification tests located in the calibration guide for your analyzer or using the performance verification and adjustment software.

When test results show proper operation and calibration, no adjustments are necessary. However, if test results indicate that the instrument does not meet specifications, the cause should be determined and rectified. Refer to the troubleshooting information in [Chapter 1](#) before attempting to recalibrate.

Replacing or repairing an assembly

If one or more analyzer assemblies has been replaced or repaired, related adjustment procedures should be done prior to verifying operation. Refer to [Table 7-2](#) to determine which adjustment to perform after replacing or repairing an assembly. Find the assembly that has been repaired or replaced in the left-hand column. Then perform the adjustments marked across the adjustment column for that assembly. It is important that adjustments are performed in the order indicated to ensure that the instrument meets all of its specifications.

List of Tests and Adjustments for Calibration

To perform calibration:

1. Run ALL applicable performance verification tests listed in Column 1 of [Table 7-1](#).
2. If any of the performance verification tests fail, perform the appropriate calibration adjustments listed in Column 2 of [Table 7-1](#) which corresponds to the failure.
3. Repeat ALL of the performance verification tests listed in Column 1 of [Table 7-1](#) if any calibration adjustments were made in [step 2](#). This will confirm that there is no interaction between adjustments which could negatively impact performance.

NOTE

If performance verifications fail and there are no corresponding calibration adjustments to be performed, or if failures continue to occur after calibration adjustments have been performed, this indicates a hardware problem. Review the troubleshooting tips in Column 3 of [Table 7-1](#) for possible defective assemblies.

Table 7-1 Calibration Requirements

Test Number	Column 1 Performance Verification Tests	Column 2 Calibration Adjustments	Column 3 Troubleshooting Tips
1	10 MHz Reference Output Accuracy	10 MHz Reference Adjustment	RF
2	10 MHz Precision Frequency Reference Output Accuracy	10 MHz Reference Adjustment	RF
3, 4	Frequency Readout and Marker Frequency Accuracy	None	IF/Processor/RF
5, 6	Frequency Span Readout Accuracy	None	RF
7	Noise Sidebands	IF Amplitude	RF/IF
8	System Related Sidebands	IF Amplitude	RF
9	Residual FM	None	RF
10	Sweep Time Accuracy	None	RF
11	Display Scale Fidelity	IF Amplitude Align Now, All	RF IF
12	Input Attenuation Switching Uncertainty	50 MHz Amplitude Reference	RF
13, 14	Reference Level Accuracy	IF Amplitude Align Now, All	RF IF

Post-Repair Procedures
List of Tests and Adjustments for Calibration

Table 7-1 Calibration Requirements

Test Number	Column 1 Performance Verification Tests	Column 2 Calibration Adjustments	Column 3 Troubleshooting Tips
15	Resolution Bandwidth Switching Uncertainty	IF Amplitude	IF
16, 17	Absolute Amplitude Accuracy (Reference Settings)	50 MHz Amplitude Reference IF Amplitude	RF IF
18, 19	Overall Absolute Amplitude Accuracy	None	RF
20	Resolution Bandwidth Accuracy	IF Amplitude	RF/IF
21, 22, 23	Frequency Response	Frequency Response	RF
24, 25, 26	Frequency Response (Preamp On)	Frequency Response	RF
27, 28	Other Input-Related Spurious Responses	None	RF
29, 30, 31	Spurious Responses	None	RF
32, 33	Gain Compression	None	RF, IF
34, 35 36, 37	Displayed Average Noise Level	Frequency Response	RF, IF
38	Residual Responses	None	RF, IF
39.	Fast Time Domain Amplitude Accuracy	None	Option AYX
40, 41	Tracking Generator Absolute Amplitude and Vernier Accuracy	Tracking Generator ALC and Tracking Generator Frequency Slope	TG
42, 43	Tracking Generator Level Flatness	Tracking Generator ALC and Tracking Generator Frequency Slope	TG
44, 45	Tracking Generator Harmonic Spurious Outputs	None	TG
46, 47	Tracking Generator Non-Harmonic Spurious Outputs	None	TG
48	Tracking Generator LO Feedthrough Amplitude	LO Power (TG)	TG
49	Gate Delay Accuracy and Gate Length Accuracy	None	
50	Gate Mode Amplitude Error	None	
51	First LO Output Amplitude Accuracy	LO Power	
52	IF Input Accuracy	IF Input Correction	

Table 7-1 Calibration Requirements

Test Number	Column 1 Performance Verification Tests	Column 2 Calibration Adjustments	Column 3 Troubleshooting Tips
53	Comms Frequency Response	Frequency Response	
58	GSM — Phase and Frequency	Align Now, All	
59	Comms Absolute Amplitude Accuracy	50 MHz Amplitude Reference, IF Amplitude, Align Now, All	

List of Tests and Adjustments for Post-Repair

Table 7-2 lists the adjustments and performance tests needed after an assembly repair or replacement. Performance tests are located in the *ESA Spectrum Analyzers Calibration Guide*.

Table 7-2 Adjustments and Tests for Replaced or Repaired Assemblies

Assembly changed or repaired	Perform the following adjustments in the order listed	Perform the following performance tests after the adjustments are completed
A1 Front Frame Assembly	Front Panel Internal Test	Displayed Average Noise Level Residual Responses
A2 1.5 GHz Tracking Generator Assembly	Tracking Generator ALC ^a Tracking Generator Frequency Slope ^a Align Now, All	Absolute Amplitude and Vernier Sweep Accuracy Tracking Generator Level Flatness Harmonic Spurious Outputs Non-Harmonic Spurious Outputs
A2A2 BITG Microcircuit Assembly	Align Now, TG L. O. Power Adjustment BITG only ^a	Absolute Amplitude and Vernier Sweep Accuracy Tracking Generator Level Flatness Harmonic Spurious Outputs Non-Harmonic Spurious Outputs
A3 IF Assembly	Align Now, All	Reference Level Accuracy Display Scale Fidelity Overall Amplitude Accuracy Resolution Bandwidth Switching Uncertainty
A4 Processor Assembly	Processor Initialization	Reference Level Accuracy Scale Fidelity Absolute Amplitude Accuracy Displayed Average Noise Level
A4MAU58 Processor Battery	Processor Initialization	None
A5 Power Supply Assembly	None	Noise Sidebands System-Related Sidebands Displayed Average Noise Level Residual FM
A6 Speaker /Floppy Assembly	None	None
A7 Motherboard	Align Now, All	None
A7A4 Frequency Extension Assembly	YTF Adjust LO Power Frequency Response	System Related Sidebands Frequency Response Displayed Average Noise Level
A7A5 Fast ADC Assembly	None	None

Table 7-2 Adjustments and Tests for Replaced or Repaired Assemblies

Assembly changed or repaired	Perform the following adjustments in the order listed	Perform the following performance tests after the adjustments are completed
A7A6 FM Demod Assembly	None	None
A7A7 Digital Demod DSP Assembly	None	Sweep time accuracy GSM Phase/Frequency ^b Fast Time Domain Accuracy
A7A8 Digital Demod RF Assembly	50 MHz Amplitude Reference IF Amplitude Align Now, All	Comms Frequency Response Absolute Amplitude Accuracy Display Scale Fidelity Reference Level Accuracy Comms Absolute Power Accuracy GSM Phase/Frequency ^b
A7A9 Enhanced ACPR Dynamic Range Assembly	Align Now, All	Displayed Average Noise Level Residual Responses Noise Sidebands Noise Sidebands, Wide Offsets
A7A10 Bluetooth FM Demod Assembly	None	None
A7A13 Noise Source Driver Assembly	None	Displayed Average Noise Level Residual Responses
A8 RF Assembly	10 MHz Reference ^a IF Amplitude ^a 50 MHz Amplitude Reference ^a Frequency Response ^a	10 MHz Reference Accuracy Noise Sidebands System-Related Sidebands Residual FM Frequency Span Readout Accuracy Frequency Readout and Marker Count Accuracy Absolute Amplitude Accuracy Frequency Response Spurious Responses Gain Compression Other Input Related Spurious Responses Displayed Average Noise Level Residual Responses
A8A1 Precision Frequency Reference	10 MHz Reference	10 MHz Reference Out Accuracy Residual FM

Post-Repair Procedures
List of Tests and Adjustments for Post-Repair

Table 7-2 Adjustments and Tests for Replaced or Repaired Assemblies

Assembly changed or repaired	Perform the following adjustments in the order listed	Perform the following performance tests after the adjustments are completed
A8A1 3.0 GHz RF Assembly	10 MHz Reference ^a IF Amplitude ^a 50 MHz Amplitude Reference ^a Frequency Response IF Input Correction (Option AYZ only)	10 MHz Reference Accuracy Noise Sidebands System-Related Sidebands Residual FM Frequency Span Readout Accuracy Frequency Readout and Marker Count Accuracy Absolute Amplitude Accuracy Frequency Response Spurious Responses Gain Compression Other Input Related Spurious Responses Displayed Average Noise Level Residual Responses
A8A2 Second Converter	IF Input Correction (Option AYZ only)	Displayed Average Noise Level Frequency Response Residual FM IF Input Accuracy (Option AYZ only)
A8A4 LOIS LO Amp/IF Switch	LO Power IF Input Correction (Option AYZ only)	System Related Sidebands Frequency Response IF Input Accuracy (Option AYZ only)
A8A5 Input Attenuator	Frequency Response	Input Attenuator Switching Uncertainty Frequency Response
A8A6 RYTHM	YTF Adjust Frequency Response	Gain Compression Frequency Response

- a. Only necessary after a repair to the assembly
- b. Only with Option BAH

What You Will Find in This Chapter

Information about instruments with Option 226 or Option 290. ESA specific field test software information. A link to the Field Calibration Software webpage.

Introduction

Instruments with Option 266 or Option 290

Instruments with Option 266, 8566 Series Programming Code Compatibility, installed and with the language set to something other than SCPI will not be able to execute or process SCPI commands. The software will notify you and set the language to SCPI prior to running the performance verification software.

Instruments with Option 290, 8590 Series Programming Code Compatibility, installed will not be able to execute or process SCPI commands. Therefore, Option 290 will need to be uninstalled prior to running the performance verification software. To uninstall or reinstall Option 290, refer to “Uninstalling/Installing Option 290” in the 8590 Series Programming Compatibility Guide.

You can find a free download for Option 290 at:

<http://www.home.agilent.com/agilent/software.jsp?cc=US&lc=eng&ckey=1000000936:epsg:sud&nid=-536902958.536881907.02&id=1000000936:epsg:sud>

N7800A Calibration and Adjustment Software

<http://www.agilent.com/find/calibrationsoftware> provides detailed information about the field test software.

ESA Field Test Software

Go to <http://calsw.tm.agilent.com>. Scroll down to the table and locate the ESA platform. Select the “Help” link. This page has links to:

- Getting Started
- Required Equipment
- Performance Tests
- Adjustments
- ESA utilities

Numerics

- 1.5 GHz tracking generator assembly troubleshooting, 40
- 3.0 GHz RF assembly, 332
- 3.0 GHz tracking generator, 45
- 50 ohm RF bridge, 162
- 50 ohm/75 ohm minimum loss pad, 159
- 75 ohm matching transformer, 159, 161
- 75 ohm RF bridge, 162
- 8566 Series Programming Code Compatibility, 149

A

- A1 display/front panel, 110
 - A1A1 front panel interface board, 110
 - A1A4 backlight supply, 110
 - A6 speaker board, 110 display, 110
- A2 1.5 GHz tracking generator assembly troubleshooting, 40
- A2 3.0 GHz tracking generator assembly troubleshooting, 45
- A3 IF assembly, 102
 - 21.4 MHz bandpass filters, 102
 - cal attenuator, 102
 - downconverter, 103
 - interconnections to other assemblies, 103
 - linear detector, 102
 - log detector, 102
- A4 processor assembly, 104
 - A4A1 flash SIMM, 107
 - A4A2 DRAM SIMM, 107
 - analog section, 104
 - analyzer battery information, 105
 - interconnections to other assemblies, 106
- A4 processor assembly troubleshooting, 37
- A5 power supply assembly, 108
 - interconnections to other assemblies, 108
- A7 motherboard, 109
 - A7A4 frequency extension, 101
 - A7J1 power supply connector, 118
 - A7J10 through A7J16 analog card/J10 tracking generator connector, 126
 - A7J2 IF assembly connector, 119
 - A7J20 speaker board connector, 128
 - A7J21 and A7J26 I/O assembly connector, 130
 - A7J4 RF connector, 120
 - A7J6 processor digital connector, 122
 - A7J7 processor analog connector, 124

- A8 RF assembly, 93, 97
 - E4401B and E4411B, 96
 - A8A1 3.0 GHz RF assembly, 98
 - A8A1A1 reference/third converter, 99
 - A8A1A2 front end/LO, 99
 - A8A2 second converter, 100
 - A8A3 dc block, 100
 - A8A4 amplifier/IF switch (LOIS), 100
 - A8A5 input connector, 101
 - A8A6 YIG-tuned filter/mixer (RYTHM), 101
 - A8FL1 3.1 GHz low-pass filter (LPF), 101
 - A8J10 input connector, 98
 - abbreviations, 167
 - ac probe, 159
 - accessories, 159
 - 50 ohm/75 ohm minimum loss pad, 159
 - 75 ohm matching transformer, 159
 - ac probe, 159
 - battery pack, 161
 - broadband preamplifiers, 159
 - carrying strap, 160
 - external keyboard, 160
 - GPIB cable, 160
 - harmonic mixers, 160
 - Parallel Interface Cable, 161
 - preselected millimeter mixers, 160
 - printer, 161
 - RF bridge, 162
 - RF limiters, 161
 - RS-232 cable, 162
 - transient limiters, 161
- ACPR Dynamic Range Extension, 149
- acronyms, 167
- adjusting the analog converters, 32
- adjustment software, 15
- Agilent Technologies, contacting, 241
- align now, 34
- alignment signal, 31
- amplifier 21.4 MHz, 95
- amplifiers, 159
- analyzer battery, 105
- APC 3.5 input connector, 320
- assembly
 - 1.5 GHz RF, 304
 - 3.0 GHz RF, 307
 - attenuator, 313
 - front frame, 254, 258
 - IF, 102, 281
 - LOIS, 312
 - motherboard, 293
 - power supply, 108
 - processor, 283, 285
 - second converter, 317
 - speaker, 291

- tracking generator, 274
 - tracking generator, 3.0 GHz, 279
 - YTM, 315
- auto align now, 34
- auto align off, 28

B

- B7D and B7E digital demod assemblies troubleshooting
 - digital demod RF, DDRF, 47
 - digital signal processing, DSP, 47
- backlight, 269
- backlight supply, 110
- backpack, 150
- basic checks, 23
- battery, 330
- battery pack, 161
- Benchlink, 150
- Benchlink Web Remote Control Software, 150
- BITG microcircuit assembly, 330
- block diagrams, 133–138
- blown fuse, 22
- Bluetooth
 - FM Demodulation, 150
 - General Purpose Bundle, 150
 - Measurement Personality, 150
 - Premium Bundle, 150
- bootrom self-test, 38
- broadband preamplifiers, 159

C

- cable
 - GPIB, 160
 - parallel interface, 161
 - RS-232, 162
- Cable TV Measurement Personality, 151
- calibration
 - verifying, 326
- calibration requirements, 327
- carrying case, 150
- carrying strap, 160
- cdmaOne operation, 49
- chassis cover, 252
- checking power supply, 23
- checking the basics, 19
- clearing EPROM, 39
- clearing RAM, 39
- connector
 - A7J1 power supply, 118
 - A7J10 through A7J16 analog card/J10 tracking generator, 126
 - A7J2 IF assembly, 119
 - A7J20 speaker board, 128
 - A7J21 and A7J26 I/O assembly, 130
 - A7J4 RF, 120

A7J6 processor, digital, 122
A7J7 processor, analog, 124
connector, type-N, 320
cooling fan, 22
corrected performance, 27
cover, 250
 chassis, 252
 inner, 252

D

DAC
 controlling, 32
 tuning, 32
dc probes
 use of, 159
dead instrument, 21
demodulation
 Bluetooth FM, 150
detector modes, 27
diagnostic routines, 32
display, 110
display backlight, 269
display/front panel, 110
 A1A1 front panel interface board, 110
 A1A4 backlight supply, 110
 A6 speaker board, 110
displays, external, 25
Distance to Fault Measurement
 Personality, 153
distorted signal, 30
downconversion, 61, 71
downconverting, 59

E

electrostatic discharge, 15
EMI
 Low Emission (Option 060), 156
EPROM, 39
EPROM, clearing, 39
ESD Information, 15
excessive loss, 60
external keyboard, 160

F

fan, 22, 289
fast ADC assembly, 330
firmware queries, 41
flash EPROM, 39
flatness tolerance, 42
floppy speaker assembly, 291
FM demod assembly, 331
frequency extension assembly, 330
frequency response, 59
front frame assembly, 254, 258, 330
front panel interface board, 110

front panel rpg, 266
fuse, 22

G

GPIB, 155
GPIB cable, 160
GSM Measurement Personality, 155

H

harmonic output levels, 42
high band block diagram, 86
high band quick check, 81
high band troubleshooting points, 84
high noise floor, 30
high signal amplitude, 60, 82
horizontal trace, checking, 29
how to return your analyzer for service, 242

I

IF assembly, 102, 281, 330
 21.4 MHz bandpass filters, 102
 cal attenuator, 102
 downconverter, 103
 interconnections to other assemblies, 103
 linear detector, 102
 log detector, 102
IF assembly connector, 119
IF gain, 33
IF problem, 27
IF problem isolation, 27
initial checks of processor, 37
inner cover, 252
inner shield, 252
inoperative analyzer, 21
inoperative analyzer troubleshooting, 21
input attenuator, 313, 332
input connector, 319
 1.5 GHz RF, 321
 connector, 319
input connector, APC 3.5, 320
instrument outer case, 250
interface bus
 GPIB, 155
 RS-232, 157
internal diagnostic routines, 32
introduction
 performance verification, 335
 performance verification tests, 335
isolating amplitude failures, 61

K

keypad/flex circuit, 267

L

LCD display, 25
LCD display troubleshooting, 25
LED patterns, 38
lens/keypad assembly, 268
limiters
 RF and transient, 161
line fuse, 22
LO, 312
LO amp/IF switch asse, 312
LO amp/IF switch assembly, 312
LO problem, 27
LO problem isolation, 27
load default, 35
log amplifier errors, 33
LOIS, 100
LOIS LO amp/IF switch, 332
low band troubleshooting points, 74, 75
low signal amplitude, 82
low signal level, 29

M

media door/bezel, 270
mixers
 External Mixing (Option AYZ), 153
 harmonic, 160
 preselected millimeter, 160
mnemonics, 111
mnemonics pin locations, 114
motherboard, 109, 330
motherboard assembly, 293
motherboard mnemonics, 111
motherboard mnemonics and connectors, 111–132
multipliers, 171

N

N2714A test and adj. software, 15
non-harmonic output levels, 42

O

OCCO, 96
OCCO precision frequency reference, 311
Option 106, 150
Option 1AX, 158
Option 226, 157
Option B70, 150
Option B7B (TV trigger and picture on screen), 158
Options, 147
 RS-232 and parallel interface, 150, 158
ordering options, 148
outer case, 250

output power, TG, 44

P

packaging, 242

packaging materials, 242, 244

Parallel Interface Cable, 161

parts

assembly level, 172

how to order, 165

reference designators, 166

replaceable, 172, 238

password, 34

performance test software, 15

performance verification

introduction, 335

software, 334

performance verification tests

introduction, 335

software, 334

Personality

Bluetooth, 151

Cable TV, 151

Distance to Fault, 153

GSM, 155

Phase Noise Measurement Personality, 157

phase noise personality, 157

PLL operation, 32

post-repair adjustments, 330

power amplifiers, 159

power supply, 23, 287

power supply assembly, 108, 330

interconnections to other assemblies, 108

power supply connector, 118

power sweep, 44

power-up problems, 20

preamplifiers, 159

precision frequency, 311

precision frequency reference, 331

printer, 161

printer connector

parallel, 155, 157

probe power connector voltages, 23

probes

ac and dc, 159

problems at power-up, 20

processor assembly, 104, 283, 285, 330

A4A1 flash SIMM, 107

A4A2 DRAM SIMM, 107

analog section, 104

analyzer battery information, 105

interconnections to other assemblies, 106

processor assembly troubleshooting, 37

processor, analog connector, 124

processor, digital connector, 122

R

RAM, clearing, 39

rear-panel battery information label, 106

reference, 311

reference designators, 166

remote control

8566 Series Programming Code
Compatibility, 149

Benchlink Web Remote Control
Software, 150

replaceable parts, 172, 238

restore system defaults, 35

returning your analyzer, 242

returning your analyzer for service, 242

RF, 64

RF assembly, 93, 97, 331

21.4 MHz amplifier, 95

A7A4 frequency extension, 101

A8A1 3.0 GHz RF assembly, 98

A8A1A1 reference/third converter, 99

A8A1A2 front end/LO, 99

A8A2 second converter, 100

A8A3 dc block, 100

A8A4 amplifier/IF switch(LOIS), 100

A8A5 input connector, 101

A8A6 YIG-tuned filter/mixer
(RHYTHM), 101

A8FL1 3.1 GHz low-pass filter
(LPF), 101

A8J10 input connector, 98

attenuator, 94

first IF amplifier/filter/attenuator, 94

first mixer, 94

frequency reference, 95

input connector, 93

input protection, 93

LO, 95

LO, A8A1 OCXO, 96

LO, first LO, 95

LO, second LO, 96

low-pass filter, 94

second mixer, 94

RF assembly, 1.5 GHz, 304

RF assembly, 3.0 GHz, 307

RF bridge, 162

RF connector, 120

RF input connector, 319

RF input connector, 1.5 GHz, 321

RF limiters, 161

RF performance check, 59

RF problem, 27

RF quick check, 61

RF section block diagram, 64

RF section high band block diagram, 86

RF section performance, 61

RF section, low band block diagram, 76

RF section, verifying performance, 71

RF subassemblies, 311

RF troubleshooting points, 64, 73

RF troubleshooting, detailed, 63

RF troubleshooting, detailed, high
band, 83

rpg replacement, 266

RS-232, 157

RS-232 Cable, 162

RS-232 cable, 162

RHYTHM, 101, 315, 332

S

second converter, 317, 332

service menu password, 34

service tag, 242

shipping container, 244

software

performance verification, 334

performance verification tests, 334

speaker assembly, 291

speaker board, 110

speaker/floppy assembly, 330

spurious output, 43

system defaults, restoring, 35

T

test software, 15

TG LO unlock, 41

timebase function, 33

tracking generator, 40

tracking generator ALC adjustment, 42

tracking generator assembly, 330

tracking generator assembly, 3.0 GHz, 279

tracking generator assembly, 3.0 GHz
troubleshooting, 45

tracking generator boards, 275

tracking generator output power, 44

tracking generator power sweep, 44

tracking generator, 1.5 GHz, 274

tracking generator, 3.0 GHz, 45

transient limiter, 161

troubleshoot the RF section, 59

troubleshooting

LO, IF, video problems, 27

troubleshooting A2 1.5 GHz tracking
generator assembly, 40

troubleshooting A2 3.0 GHz tracking generator assembly, [45](#)
troubleshooting A4 processor assembly, [37](#)
troubleshooting B7D and B7E digital demod assemblies
 digital demod RF, DDRF, [47](#)
 digital signal processing, DSP, [47](#)
troubleshooting inoperative analyzer, [21](#)
troubleshooting LCD display, [25](#)
troubleshooting the processor, [37](#)
TV Trigger and Picture on Screen, [158](#)
type-N connector, [320](#)

U

uncorrected performance, [27](#)
unleveled TG output, [40](#)

V

verifying calibration, [326](#)
verifying cdmaOne operation, [49](#)
verifying the A3 IF assembly performance, [28](#)
vernier accuracy tolerance, [42](#)
VGA monitor, [25](#)
vibration support bar, [272](#)
video problem, [27](#)
video problem isolation, [27](#)
video shift, [33](#)
visible align, [35](#)

Y

YIG-tuned filter/mixer, [315](#)
YTM, [315](#)