

# Specifications Guide

## Agilent Technologies ESA-E Series Spectrum Analyzers

This manual provides documentation for the following instruments:

**E4402B (9 kHz – 3.0 GHz)**

**E4404B (9 kHz – 6.7 GHz)**

**E4405B (9 kHz – 13.2 GHz)**

**E4407B (9 kHz – 26.5 GHz)**

**Manufacturing Part Number: E4401-90490**

**Printed in USA**

**January 2011**

**Supersedes: March 2005**

© Copyright 2000 - 2011 Agilent Technologies

The information contained in this document is subject to change without notice.

Agilent Technologies makes no warranty of any kind with regard to this material, including but not limited to, the implied warranties of merchantability and fitness for a particular purpose. Agilent Technologies shall not be liable for errors contained herein or for incidental or consequential damages in connection with the furnishing, performance, or use of this material.

The following safety symbols are used throughout this manual. Familiarize yourself with the symbols and their meaning before operating this instrument.

**WARNING**      ***Warning* denotes a hazard. It calls attention to a procedure which, if not correctly performed or adhered to, could result in injury or loss of life. Do not proceed beyond a warning note until the indicated conditions are fully understood and met.**

**WARNING**      **This is a Safety Class 1 Product (provided with a protective earthing ground incorporated in the power cord). The mains plug shall only be inserted in a socket outlet provided with a protected earth contact. Any interruption of the protective conductor inside or outside of the product is likely to make the product dangerous. Intentional interruption is prohibited.**

**WARNING**      **If this product is not used as specified, the protection provided by the equipment could be impaired. This product must be used in a normal condition (in which all means for protection are intact) only.**

**CAUTION**      *Caution* denotes a hazard. It calls attention to a procedure that, if not correctly performed or adhered to, could result in damage to or destruction of the instrument. Do not proceed beyond a caution sign until the indicated conditions are fully understood and met.

**CAUTION**      Always use the three-prong ac power cord supplied with this product. Failure to ensure adequate earth grounding by not using this cord may cause product damage.

**CAUTION**      This instrument has autoranging line voltage input, be sure the supply voltage is within the specified range.

## **Warranty**

This Agilent Technologies instrument product is warranted against defects in material and workmanship for a period of one year from date of shipment. During the warranty period, Agilent Technologies Company will, at its option, either repair or replace products which prove to be defective.

For warranty service or repair, this product must be returned to a service facility designated by Agilent Technologies. Buyer shall prepay shipping charges to Agilent Technologies and Agilent Technologies shall pay shipping charges to return the product to Buyer. However, Buyer shall pay all shipping charges, duties, and taxes for products returned to Agilent Technologies from another country.

Agilent Technologies warrants that its software and firmware designated by Agilent Technologies for use with an instrument will execute its programming instructions when properly installed on that instrument. Agilent Technologies does not warrant that the operation of the instrument, or software, or firmware will be uninterrupted or error-free.

## **LIMITATION OF WARRANTY**

The foregoing warranty shall not apply to defects resulting from improper or inadequate maintenance by Buyer, Buyer-supplied software or interfacing, unauthorized modification or misuse, operation outside of the environmental specifications for the product, or improper site preparation or maintenance.

**NO OTHER WARRANTY IS EXPRESSED OR IMPLIED. AGILENT TECHNOLOGIES SPECIFICALLY DISCLAIMS THE IMPLIED WARRANTIES OF MERCHANTABILITY AND FITNESS FOR A PARTICULAR PURPOSE.**

## **EXCLUSIVE REMEDIES**

**THE REMEDIES PROVIDED HEREIN ARE BUYER'S SOLE AND EXCLUSIVE REMEDIES. AGILENT TECHNOLOGIES SHALL NOT BE LIABLE FOR ANY DIRECT, INDIRECT, SPECIAL, INCIDENTAL, OR CONSEQUENTIAL DAMAGES, WHETHER BASED ON CONTRACT, TORT, OR ANY OTHER LEGAL THEORY.**

## **Where to Find the Latest Information**

Documentation is updated periodically. For the latest information about Agilent Spectrum Analyzers, including firmware upgrades and application information, please visit the following Internet URL:

<http://www.agilent.com/find/esa>

<b>1. Agilent E4402B Specifications and Characteristics</b>	
About This Chapter	8
Frequency	10
Amplitude	19
Options	32
Time Gated Spectrum Analysis (Option 1D6)	32
Tracking Generator (Option 1DN)	33
Phase Noise (Option 226)	37
FM Demodulation and Quasi Peak Detector (Option AYQ)	40
Bluetooth FM Demodulation (Option 106)	42
Bluetooth Measurements Personality (Option 228)	43
FM Demodulation (Option BAA)	46
TV Trigger and Picture On Screen (Option B7B)	47
cdmaOne Measurement Personality (Option BAC)	48
GSM with EDGE Measurement Personality (Option BAH, 252)	56
Noise Figure Measurement Personality and Hardware (Option 219) Specifications	65
General	73
Inputs and Outputs	79
Front Panel	79
Rear Panel	81
Regulatory Information	87
Declaration of Conformity	87
Declaration of Compliance	87
<b>2. Agilent E4404B Specifications and Characteristics</b>	
About This Chapter	90
Frequency	92
Amplitude	101
Options	116
Time Gated Spectrum Analysis (Option 1D6)	116
Tracking Generator (Option 1DN)	117
Phase Noise (Option 226)	121
FM Demodulation and Quasi Peak Detector (Option AYQ)	124
Bluetooth FM Demodulation (Option 106)	126
Bluetooth Measurements Personality (Option 228)	127
FM Demodulation (Option BAA)	130
TV Trigger and Picture On Screen (Option B7B)	131
cdmaOne Measurement Personality (Option BAC)	132
GSM with EDGE Measurement Personality (Option BAH, 252)	141
Noise Figure Measurement Personality and Hardware (Option 219) Specifications	150
General	158
Inputs and Outputs	164
Front Panel	164
Rear Panel	166
Regulatory Information	172
Declaration of Conformity	172
Declaration of Compliance	172
<b>3. Agilent E4405B Specifications and Characteristics</b>	
About This Chapter	174
Frequency	176
Amplitude	185

---

## Contents

Options .....	200
Time Gated Spectrum Analysis (Option 1D6) .....	200
Tracking Generator (Option 1DN) .....	201
Phase Noise (Option 226) .....	205
FM Demodulation and Quasi Peak Detector (Option AYQ) .....	208
Bluetooth FM Demodulation (Option 106) .....	210
Bluetooth Measurements Personality (Option 228) .....	211
FM Demodulation (Option BAA) .....	214
TV Trigger and Picture On Screen (Option B7B) .....	215
cdmaOne Measurement Personality (Option BAC) .....	216
GSM with EDGE Measurement Personality (Option BAH, 252) .....	225
Noise Figure Measurement Personality and Hardware (Option 219) Specifications .....	234
General .....	242
Inputs and Outputs .....	248
Front Panel .....	248
Rear Panel .....	250
Regulatory Information .....	256
Declaration of Conformity .....	256
Declaration of Compliance .....	256
<b>4. Agilent E4407B Specifications and Characteristics</b>	
About This Chapter .....	258
Frequency .....	260
Amplitude .....	269
Options .....	286
Time Gated Spectrum Analysis (Option 1D6) .....	286
Tracking Generator (Option 1DN) .....	287
Phase Noise (Option 226) .....	291
FM Demodulation and Quasi Peak Detector (Option AYQ) .....	294
External Mixing (Option AYZ) .....	296
Bluetooth FM Demodulation (Option 106) .....	298
Bluetooth Measurements Personality (Option 228) .....	299
FM Demodulation (Option BAA) .....	302
TV Trigger and Picture On Screen (Option B7B) .....	303
cdmaOne Measurement Personality (Option BAC) .....	304
GSM with EDGE Measurement Personality (Option BAH, 252) .....	312
Noise Figure Measurement Personality and Hardware (Option 219) Specifications .....	321
General .....	329
Inputs and Outputs .....	334
Front Panel .....	334
Rear Panel .....	336
Regulatory Information .....	342
Declaration of Conformity .....	342
Declaration of Compliance .....	342

---

**1**      **Agilent E4402B Specifications and  
Characteristics**

## About This Chapter

This chapter contains specifications and characteristics for the Agilent E4402B spectrum analyzer. The distinction between specifications and characteristics is described as follows.

- Specifications describe the performance of parameters covered by the product warranty. (The temperature range is 0 °C to 55 °C, unless otherwise noted.)
- Characteristics describe product performance that is useful in the application of the product, but is not covered by the product warranty.
- Typical performance describes additional product performance information that is not covered by the product warranty. It is performance beyond specification that 80% of the units exhibit with a 95% confidence level over the temperature range 20 to 30 °C. Typical performance does not include measurement uncertainty.
- Nominal values indicate the expected performance, or describe product performance that is useful in the application of the product, but is not covered by the product warranty.

The following conditions must be met for the analyzer to meet its specifications.

- o The analyzer is within the one year calibration cycle.
- o If **Auto Align All** is selected:
  - After 2 hours of storage within the operating temperature range.
  - 5 minutes after the analyzer is turned on with sweep times less than 4 seconds.
  - After the front-panel amplitude reference is connected to the INPUT, and **Align Now RF** has been run, after the analyzer is turned on. And, once every 24 hours, or if ambient temperature changes more than 30 °C<sup>1</sup>.
- o If **Auto Align Off** is selected:
  - When the analyzer is at a constant temperature, within the operating temperature range, for a minimum of 90 minutes.
  - After the analyzer is turned on for a minimum of 90 minutes, the front panel amplitude reference has been connected to the INPUT, and **Align Now All** has been run.
  - When **Align Now All** is run:
    - Every hour
    - If the ambient temperature changes more than 3 °C

1. 10 °C if Preamp (Option 1DS) is active.



- If the 10 MHz reference changes
- When **Align Now RF** is run (with the front-panel amplitude reference connected to the INPUT):
  - Every 24 hours
  - If the ambient temperature changes more than 30 °C<sup>1</sup>
- o If **Auto Align All but RF** is selected:
  - When the analyzer is at a constant temperature, within the operating temperature range, for a minimum of 90 minutes.
  - After the analyzer is turned on for a minimum of 90 minutes, the front panel amplitude reference has been connected to the INPUT, and **Align Now RF** has been run.
  - When **Align Now RF** is run (with the front-panel amplitude reference connected to the INPUT):
    - Every hour
    - If the ambient temperature changes more than 3 °C

---

1. 10 °C if Preamp (Option 1DS) is active.

## Frequency

	Specifications	Supplemental Information
<b>Frequency Range</b>	9 kHz to 3.0 GHz	
<i>(Option UKB)</i>		
dc Coupled	100 Hz to 3.0 GHz	30 Hz to 3.0 GHz, characteristic
ac Coupled	100 kHz to 3.0 GHz	
Preamp On <i>(Option IDS)</i>	1 MHz to 3.0 GHz	

	Specifications	Supplemental Information
<b>Frequency Reference</b>		
Aging Rate	$\pm 2 \times 10^{-6}$ /year	$\pm 1.0 \times 10^{-7}$ /day, characteristic
Settability	$\pm 5 \times 10^{-7}$	
Temperature Stability	$\pm 5 \times 10^{-6}$	

	Specifications	Supplemental Information
<b>High Stability Frequency Reference (Option 1D5)</b>		
Aging Rate	$\pm 1 \times 10^{-7}/\text{year}$	$\pm 5 \times 10^{-10}/\text{day}$ , 7-day average after being powered on for 7 days, characteristic
Settability	$\pm 1 \times 10^{-8}$	
Temperature Stability		
20 to 30 °C	$\pm 1 \times 10^{-8}$	
0 to 55 °C	$\pm 5 \times 10^{-8}$	
Warm-up (Internal frequency reference selected)		
After 5 minutes		$< \pm 1 \times 10^{-7}$ of final frequency, <sup>a</sup> characteristic
After 15 minutes		$< \pm 1 \times 10^{-8}$ of final frequency, <sup>a</sup> characteristic

a. Final frequency is defined as frequency 60 minutes after power-on with analyzer set to internal frequency reference.

	Specifications	Supplemental Information
<b>Frequency Readout Accuracy</b>		
(Start, Stop, Center, Marker)	$\pm((\text{frequency indication} \times \text{frequency reference error}^{\text{a}})$ $+ 0.5\% \text{ of span}$ $+ \frac{\text{span}}{\text{sweep points} - 1}$ $+ 15\% \text{ of RBW}$ $+ 10 \text{ Hz})$	

a. Frequency reference error = (aging rate  $\times$  period of time since adjustment + settability + temperature stability).

	Specifications	Supplemental Information
<b>Marker Frequency Counter</b>		
Resolution	Selectable from 1 Hz to 100 kHz	
Accuracy <sup>a</sup>	$\pm(\text{marker frequency} \times \text{frequency reference error}^b + \text{counter resolution})$	For RBW $\geq$ 1 kHz

- a. Marker level to displayed noise level > 25 dB, RBW/ Span  $\geq$  0.002, frequency offset = 0 Hz.  
 b. Frequency reference error = (aging rate  $\times$  period of time since adjustment + settability + temperature stability).

	Specifications	Supplemental Information
<b>Frequency Span</b>		
Range	0 Hz (zero span), 100 Hz to 3 GHz	
Resolution	2 Hz	
Accuracy <sup>a</sup>		
Sweep type Lin	$\pm(0.5\% \text{ of span} + 2 \times \frac{\text{span}}{\text{sweep points} - 1})$	
Sweep type Log		$\pm 2.0\%$ of span, nominal

- a. Applies to each sweep segment.

	Specifications	Supplemental Information
<b>Sweep Time</b>		
Range		
Span > 0 Hz	1 ms to 4000 s <sup>a,b,c</sup>	$\frac{\text{sweep points} - 1}{100 \text{ kHz}}$ to 4000 s
Span = 0 Hz	10 $\mu$ s to 4000 s <sup>a</sup>	
Tracking Generator On (Option 1DN)		50 ms is the minimum sweep time
Fast Time-domain Sweep (Option AYZ) (For Span = 0 Hz, RBW $\geq$ 1 kHz)	50 ns to 4000 s <sup>d,e</sup>	$\frac{\text{sweep points} - 1}{20 \text{ MHz}}$ to 4000 s
DSP and fast ADC (Option B7D) (For Span = 0 Hz, RBW $\geq$ 1 kHz)	25 ns to 4000 s <sup>f</sup>	$\frac{\text{sweep points} - 1}{40 \text{ MHz}}$ to 4000 s
Accuracy (Span = 0 Hz)		

	Specifications	Supplemental Information
10 $\mu$ s to 4000 s <sup>a,c</sup>	$\pm 1\%$	
(Option AYX) 50 ns to 4000 s <sup>d,g</sup>	$\pm 1\%$	
(Option B7D) 25 ns to 4000 s <sup>f</sup>	$\pm 1\%$	
Sweep Trigger <sup>g,h</sup>	Free Run, Single, Line, Video <sup>i</sup> , External, Delayed, Offset <sup>j</sup>	
(Option 1D6)	Add Gate	
(Option B7B)	Add TV	
(Option B7E)	Add RF Burst Trigger	
Delayed Trigger <sup>h,k</sup>		
Range	1 $\mu$ s to 400 s	
Resolution	$\frac{\text{delay in seconds}}{65000}$ rounded up to nearest $\mu$ s	
Accuracy	$\pm(500 \text{ ns} + (0.01\% \text{ of delay}))$	
RF burst trigger (Option B7E)		
Relative level trigger mode		
Peak carrier power range <sup>lm</sup>		30 to -25 dBm, nominal
Preamp On (Option 1DS)		30 to -45 dBm, nominal
Trigger level range	0 to -25 dB relative to signal peak	
Absolute level trigger mode		
Peak carrier power range <sup>n,o</sup>		30 to -35 dBm, nominal
Preamp On (Option 1DS)		30 to -55 dBm, nominal
Offset Trigger <sup>j</sup>		
Resolution	$\frac{\text{sweep time}}{\text{sweep points} - 1}$	
Range	$\pm 327 \text{ ms}$ to $\pm 12.3 \text{ ks}$	Where ST = sweep time and SP = sweep points $\frac{-32766 \times \text{ST}}{\text{SP} - 1}$ to $\frac{(32766 - \text{SP}) \times \text{ST}}{\text{SP} - 1}$

	Specifications	Supplemental Information
Fast Time-domain sweep <i>(Option AYZ)</i> (For sweep times $\frac{\text{sweep points} - 1}{20 \text{ MHz}}$ to $\frac{\text{sweep points} - 1}{100 \text{ kHz}}$ )	±1.23 ms to ±245 ms	$\frac{-32766 \times ST}{SP - 1}$ to $\frac{(32766 - SP) \times ST}{SP - 1}$
DSP and fast ADC <i>(Option B7D)</i> (For sweep times $\frac{\text{sweep points} - 1}{40 \text{ MHz}}$ to $\frac{\text{sweep points} - 1}{100 \text{ kHz}}$ )	± 13 ms to ±5.15 s	$\frac{-524031 \times ST}{SP - 1}$ to $\frac{(524031 - SP) \times ST}{SP - 1}$

- a. For firmware revisions prior to A.04.00, 5 ms to 2000 s.
- b. For spans ≥ 10 MHz and ≤ 600 MHz, and stop frequency ≤ 3 GHz.
- c. For firmware revisions prior to A.05.00, 1 ms to 4000 s.
- d. For firmware revisions prior to A.04.00, 20 μs to 2000 s.
- e. For firmware revisions prior to A.05.00, 5 μs to 4000 s.
- f. For firmware revisions prior to A.05.00, 2.5 μs to 4000 s.
- g. Gate cannot be used simultaneously with delayed or TV trigger (Option B7B).
- h. Auto align is suspended in video, external, gate, and delayed trigger modes while waiting for a trigger event to occur.
- i. Unavailable when RBW ≤ 300 Hz (Option 1DR).
- j. For firmware revision A.04.00 or later.
- k. Delayed trigger is available with line, external trigger, and TV trigger (Option B7B).
- l. With trigger level set to -6 dB.
- m. For GSM-type signals (burst length 570 μs, burst period 4.63 ms, constant envelope). Ranges with other types of signals may differ.
- n. Nominal values apply for Bluetooth-type signals (burst length 625 μs, burst period 50 ms). Ranges with other types of signals may differ.
- o. With trigger level set 5 dB below peak signal level.

	Specifications	Supplemental Information
<b>Sweep (trace) Points</b>		
Range		
Span > 0 Hz	101 to 8192 <sup>a</sup>	
Span = 0 Hz	2 to 8192 <sup>a,b</sup>	

- a. For firmware revisions prior to A.04.00, 401 points.  
b. For firmware revisions prior to A.05.00, 101 to 8192 points.

	Specifications	Supplemental Information
<b>Resolution Bandwidth (RBW)</b>		
Range		
-3 dB bandwidth	1 kHz to 3 MHz, in 1-3-10 sequence, 5 MHz <sup>a</sup>	
<i>(Option 1DR)</i>	Adds 10, 30, 100, 300 Hz <sup>a,b</sup>	
<i>(Option 1DR and 1D5)</i>	Adds 1, 3 Hz <sup>a,b</sup>	
-6 dB bandwidth (EMI)	9 kHz and 120 kHz	
<i>(Option 1DR)</i>	Add 200 Hz <sup>a,b</sup>	
Accuracy		
1 Hz to 3 Hz (-3 dB) RBW <sup>c</sup> <i>(Option 1DR and 1D5)</i>	±10%	
10 Hz to 300 Hz (-3 dB) RBW <i>(Option 1DR)</i>	±10%	
1 kHz to 3 MHz (-3 dB) RBW	±15%	
5 MHz (-3 dB) RBW	±30%	
9 kHz, 120 kHz (-6 dB) RBW (EMI)	±20%	
200 Hz (-6 dB) RBW (EMI) <i>(Option 1DR)</i>	±10%	
Shape		
1 Hz to 3 Hz RBW <sup>c</sup> <i>(Option 1DR and 1D5)</i>		Digital, approximately Gaussian shape
10 Hz to 300 Hz RBW <i>(Option 1DR)</i>		Digital, approximately Gaussian shape
1 kHz to 5 MHz RBW		Synchronously tuned four poles, approximately Gaussian shape

Agilent E4402B Specifications and Characteristics  
**Frequency**

	Specifications	Supplemental Information
Selectivity (60 dB/3 dB bandwidth ratio)		
1 Hz to 3 Hz RBW <sup>c</sup> (Option 1DR and 1D5)		<5:1, nominal
10 Hz to 300 Hz RBW (Option 1DR)		<5:1, nominal
1 kHz to 5 MHz RBW		<15:1, nominal

- a. The Average detector is not compatible with the 5 MHz resolution bandwidths, nor with resolution bandwidths <1 kHz.
- b. Only available in spans ≤5 MHz, sweep times ≥ (sweep points – 1)/100 kHz and not usable with tracking generator on (Option 1DN).
- c. Firmware revision A.08.00 and later.

	Specifications	Supplemental Information
<b>Video Bandwidth (VBW) (-3 dB)</b>		
Range  (Option 1DR)	30 Hz to 1 MHz in 1-3-10 sequence  Adds 1, 3, 10 Hz for RBW's <1 kHz	3 MHz, characteristic
Accuracy		±30%, characteristic
Shape		Post detection, single pole low-pass filter used to average displayed noise  Video bandwidths below 30 Hz are digital bandwidths with anti-aliasing filtering.

	Specifications	Supplemental Information
<b>Stability</b>		
Noise Sidebands (Offset from CW signal with 1 kHz RBW, 30 Hz VBW and sample detector)		
<b>Serial prefixes ≥ MY4510, SG4510, US4510</b>		
≥1 kHz (Option 1DR, 1D5)		≤ -78 dBc/Hz, typical
≥10 kHz (Option 1DR)	≤ -98 dBc/Hz	≤ -101 dBc/Hz, typical
≥10 kHz	≤ -90 dBc/Hz	≤ -94 dBc/Hz, typical



	Specifications	Supplemental Information
≥20 kHz	≤ -104 dBc/Hz	≤ -107 dBc/Hz, typical
≥30 kHz	≤ -110 dBc/Hz	≤ -113 dBc/Hz, typical
≥100 kHz	≤ -118 dBc/Hz	≤ -122 dBc/Hz, typical
≥1 MHz	≤ -125 dBc/Hz	≤ -127 dBc/Hz, typical
≥5 MHz	≤ -127 dBc/Hz	≤ -129 dBc/Hz, typical
≥10 MHz	≤ -131 dBc/Hz	≤ -136 dBc/Hz, typical
<b>Serial prefixes &lt; MY4510, SG4510, US4510</b>		
≥1 kHz ( <i>Option IDR, ID5</i> )		≤ -78 dBc/Hz, typical
≥10 kHz	≤ -90 dBc/Hz	≤ -94 dBc/Hz, typical
≥20 kHz	≤ -100 dBc/Hz	≤ -105 dBc/Hz, typical
≥30 kHz	≤ -106 dBc/Hz	≤ -112 dBc/Hz, typical
≥100 kHz	≤ -118 dBc/Hz	≤ -122 dBc/Hz, typical
≥1 MHz	≤ -125 dBc/Hz	≤ -127 dBc/Hz, typical
≥5 MHz	≤ -127 dBc/Hz	≤ -129 dBc/Hz, typical
≥10 MHz	≤ -131 dBc/Hz	≤ -136 dBc/Hz, typical
<i>(Option 120)</i>		
≥1 MHz	≤ -133 dBc/Hz	≤ -136 dBc/Hz, typical
≥5 MHz	≤ -135 dBc/Hz	≤ -139 dBc/Hz, typical
≥10 MHz	≤ -137 dBc/Hz	≤ -141 dBc/Hz, typical
<b>Residual FM</b>		
1 kHz RBW, 1 kHz VBW	≤150 Hz p-p in 100 ms	
<i>(Option ID5)</i>	≤100 Hz p-p in 100 ms	
10 Hz RBW, 10 Hz VBW	≤2 Hz p-p in 20 ms	
<i>(Option IDR and ID5)</i>		
10 Hz RBW, 10 Hz VBW		≤10 Hz p-p in 20 ms, characteristic
<i>(Option IDR)</i>		
<b>System-Related Sidebands, offset from CW signal</b>		
≥30 kHz	≤ -65 dBc	
<b>Line-Related Sidebands, offset from CW signal (<i>Option IDR</i>)</b>		
<300 Hz		≤ -50 dBc, characteristic

	Specifications	Supplemental Information
>300 Hz to 30 kHz		$\leq -55$ dBc, characteristic

Noise Sidebands Normalized to 1 Hz Versus Offset from Carrier

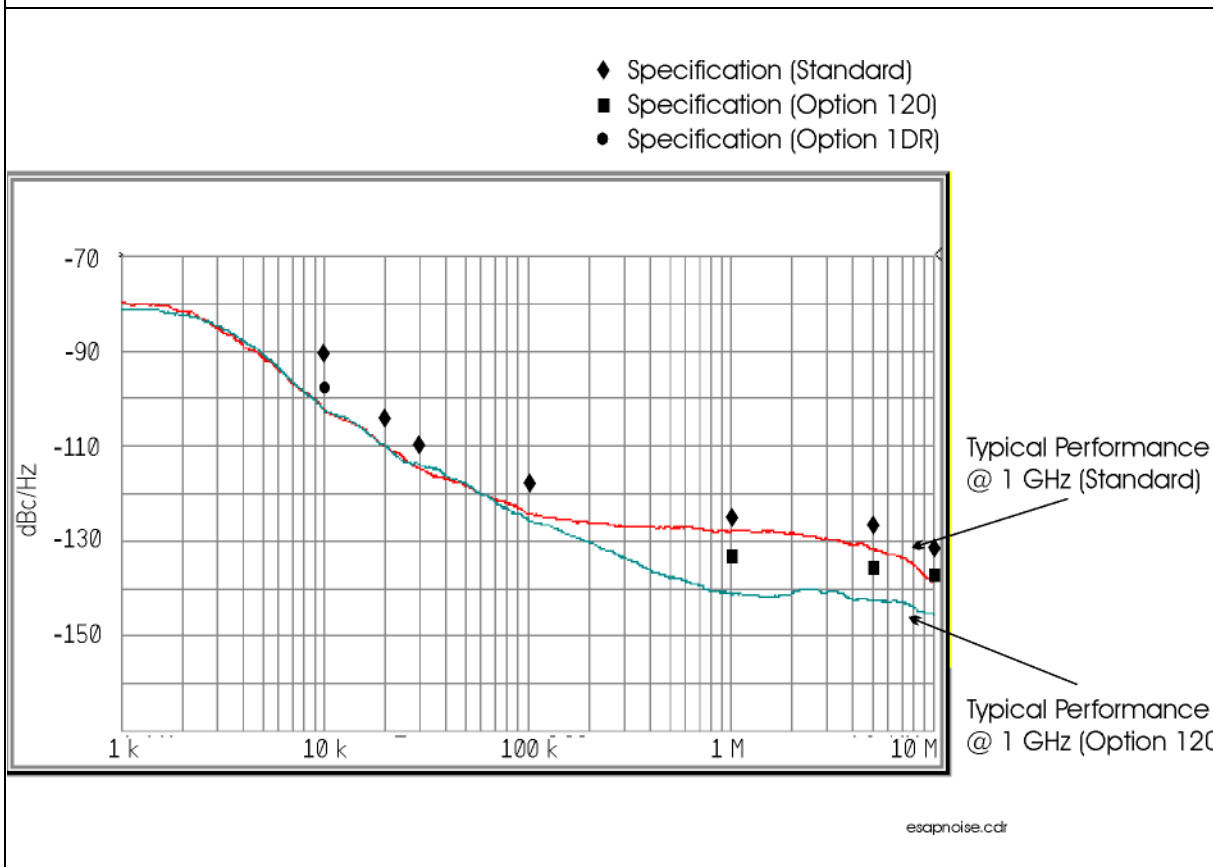

Agilent E4402B Specifications and Characteristics

## Amplitude

Amplitude specifications do not apply for the negative peak detector mode.

	Specifications	Supplemental Information
<b>Measurement Range</b>	Displayed Average Noise Level to Maximum Safe Input Level	
Input Attenuator Range	0 to 65 dB, in 5 dB steps	0 to 75 dB, in 5 dB steps, characteristic

	Specifications	Supplemental Information
<b>Maximum Safe Input Level</b>		
Average Continuous Power (Input attenuator setting $\geq 5$ dB)	+30 dBm (1 W)	
Peak Pulse Power (for $<10$ $\mu$ sec pulse width, $<1\%$ duty cycle, and input attenuation $\geq 30$ dB)	+50 dBm (100 W)	
dc (Option UKB)	100 Vdc	
dc coupled	0 Vdc	
ac coupled	50 Vdc	

	Specifications	Supplemental Information
<b>1 dB Gain Compression</b>		
Total power at input mixer <sup>a,b</sup> 50 MHz to 3.0 GHz	0 dBm	
Preamp On ( <i>Option IDS</i> ) Total power at the preamp <sup>c</sup>		-20 dBm, characteristic

- a. Mixer power level (dBm) = input power (dBm) – input attenuation (dB).
- b. For resolution bandwidths 1 kHz to 30 kHz, the maximum input signal amplitude must be  $\leq$  reference level +10 dB.
- c. Total power at the preamp (dBm) = total power at the input (dBm) – input attenuation (dB).

	Specifications		Supplemental Information		
<b>Displayed Average Noise Level</b> (Input terminated, 0 dB attenuation, sample detector, Reference Level = -70 dBm)					
	1 kHz RBW 30 Hz VBW	10 Hz RBW 1 Hz VBW (Option 1DR)	1 kHz RBW 30 Hz VBW (typical)	10 Hz RBW 1 Hz VBW (Option 1DR) (typical)	1 Hz RBW 1 Hz VBW (Option 1DR and 1D5) <sup>a</sup> (typical)
30 Hz to 9 kHz (Option UKB)				≤ -93 dBm	≤ -103 dBm
9 kHz to 100 kHz				≤ -109 dBm	≤ -119 dBm
100 kHz to 1 MHz				≤ -135 dBm	≤ -145 dBm
1 MHz to 10 MHz			≤ -117 dBm	≤ -136 dBm	≤ -146 dBm
1 MHz to 10 MHz (Option 120)			≤ -120 dBm	≤ -139 dBm	≤ -149 dBm
10 MHz to 1.0 GHz	≤ -117 dBm	≤ -136 dBm	≤ -120 dBm	≤ -140 dBm	≤ -150 dBm
1.0 GHz to 2.0 GHz	≤ -116 dBm	≤ -135 dBm	≤ -120 dBm	≤ -140 dBm	≤ -150 dBm
2.0 GHz to 3.0 GHz	≤ -114 dBm	≤ -133 dBm	≤ -120 dBm	≤ -140 dBm	≤ -150 dBm
Preamp On (Option 1DS)	1 kHz RBW 30 Hz VBW	10 Hz RBW 1 Hz VBW (Option 1DR)	1 kHz RBW 30 Hz VBW (typical)	10 Hz RBW 1 Hz VBW (Option 1DR) (typical)	1 Hz RBW 1 Hz VBW (Option 1DR and 1D5) <sup>a</sup> (typical)
0 to 55 °C					
10 MHz to 1.0 GHz	≤ -132 dBm	≤ -151 dBm			
1.0 GHz to 2.0 GHz	≤ -132 dBm	≤ -151 dBm			
2.0 GHz to 3.0 GHz	≤ -129 dBm	≤ -148 dBm			
20 to 30 °C					
1 MHz to 10 MHz			≤ -134 dBm	≤ -152 dBm	≤ -162 dBm
10 MHz to 1.0 GHz	≤ -133 dBm	≤ -152 dBm	≤ -136 dBm	≤ -156 dBm	≤ -166 dBm
1.0 GHz to 2.0 GHz	≤ -134 dBm	≤ -153 dBm	≤ -136 dBm	≤ -156 dBm	≤ -166 dBm
2.0 GHz to 3.0 GHz	≤ -132 dBm	≤ -151 dBm	≤ -134 dBm	≤ -154 dBm	≤ -164 dBm

a. Only available with firmware revision A.08.00 or later

	Specifications	Supplemental Information
<b>Display Range</b>		
Log Scale	Ten divisions displayed; 0.1, 0.2, 0.5 dB/division and 1 to 20 dB/division in 1 dB steps	
RBW $\geq$ 1 kHz	Calibrated 0 to -85 dB from Reference Level	
RBW $\leq$ 300 Hz ( <i>Option 1DR</i> )	Calibrated 0 to -120 dB <sup>a</sup> from Reference Level	
Linear Scale	Ten divisions	
Scale Units	dBm, dBmV, dB $\mu$ V, dB $\mu$ A, A, V, and W	
( <i>Option BAA, 106</i> )	Add Hz	

- a. 0 to -70 dB range when span = 0 Hz, or when IF Gain is fixed:  
(:DISPlay:WINDow:TRACe:Y[:SCALe]:LOG:RANGe:AUTO OFF).

	Specifications	Supplemental Information
<b>Marker Readout Resolution</b>		
Log scale		
RBW $\geq$ 1 kHz		
0 to -85 dB from ref level	0.04 dB	
RBW $\leq$ 300 Hz ( <i>Option 1DR</i> )		
0 to -120 dB from ref level	0.04 dB	
Linear scale	0.01% of Reference Level	
Fast Sweep Times for Zero Span		
( <i>Option AYX</i> )		
For sweep times		
$\frac{\text{sweep points} - 1}{20 \text{ MHz}}$ to		
$\frac{\text{sweep points} - 1}{100 \text{ kHz}}$		
Log		
0 to -85 dB from ref level	0.3 dB	
Linear	0.3% of Reference Level for linear scale	

	Specifications	Supplemental Information
<p><i>(Option B7D)</i>                      For sweep times  <math>\frac{\text{sweep points} - 1}{40 \text{ MHz}}</math>  <math>\frac{\text{sweep points} - 1}{100 \text{ kHz}}</math></p> <p>For:  <math>\frac{\text{sweep points} - 1}{\text{sweep time}} &lt; 40 \text{ MHz}</math></p> <p>Log                      0 to -85 dB from ref level</p> <p>Linear</p> <p>For:  <math>\frac{\text{sweep points} - 1}{\text{sweep time}} \geq 40 \text{ MHz}</math></p> <p>Log                      0 to -85 dB from ref level</p> <p>Linear</p>	<p>0.2 dB</p> <p>0.2% of Reference Level</p> <p>0.3 dB</p> <p>0.3% of Reference Level</p>	

	Specifications	Supplemental Information
<p><b>Frequency Response<sup>a</sup></b></p> <p>10 dB attenuation</p> <p>9 kHz to 3.0 GHz</p> <p>20 to 30 °C</p> <p>0 to 55 °C</p> <p>800 MHz to 1.0 GHz<sup>b</sup></p> <p>20 to 30 °C</p> <p>0 to 55 °C</p> <p>1.7 GHz to 2.0 GHz<sup>b</sup></p> <p>20 to 30 °C</p> <p>0 to 55 °C</p> <p><i>(Option UKB)</i></p> <p>100 Hz to 3.0 GHz                      (dc coupled)</p> <p>20 to 30 °C</p> <p>0 to 55 °C</p>	<p>±0.46 dB</p> <p>±0.76 dB</p> <p>±0.46 dB</p> <p>±0.76 dB</p> <p>±0.46 dB</p> <p>±0.76 dB</p> <p>±0.5 dB</p> <p>±1.0 dB</p>	<p>±0.12 dB, typical</p> <p>±0.04 dB, typical</p> <p>±0.04 dB, typical</p>

	Specifications	Supplemental Information
30 Hz to 3.0 GHz (dc coupled)		
20 to 30 °C		±0.5 dB, characteristic
0 to 55 °C		±1.0 dB, characteristic
100 kHz to 3.0 GHz (ac coupled)		
20 to 30 °C	±0.5 dB	
0 to 55 °C	±1.0 dB	
800 MHz to 1.0 GHz (ac coupled)		
20 to 30 °C	±0.5 dB	
0 to 55 °C	±1.0 dB	
1.7 GHz to 2.0 GHz (ac coupled)		
20 to 30 °C	±0.5 dB	
0 to 55 °C	±1.0 dB	
Preamp On ( <i>Option IDS</i> )		
0 dB attenuation		
1 MHz to 3.0 GHz		
20 to 30 °C	±1.5 dB	
0 to 55 °C	±2.0 dB	
800 MHz to 1.0 GHz		
20 to 30 °C	±1.5 dB	±0.22 dB, typical
0 to 55 °C	±2.0 dB	
1.7 GHz to 2.0 GHz		
20 to 30 °C	±1.5 dB	±0.16 dB, typical
0 to 55 °C	±2.0 dB	

- a. Frequency response values are referenced to the amplitude at 50 MHz.
- b. This specification applies only to analyzers with serial numbers ≥ US39441006.

	Specifications	Supplemental Information
<b>Input Attenuation Switching Uncertainty at 50 MHz</b>		
Attenuator Setting		

Agilent E4402B Specifications and Characteristics  
**Amplitude**

	Specifications	Supplemental Information
0 dB to 5 dB	±0.3 dB	
10 dB	Reference	
15 dB	±0.3 dB	
20 to 65 dB attenuation	±(0.1 dB + 0.01 × Attenuator Setting)	

Attenuation Accuracy Relative to the 10 dB Attenuator Setting, Characteristic		
	Frequency Range	
Attenuation	dc–3.0 GHz	
0 dB	±0.3 dB	
5 dB	±0.3 dB	
10 dB	Reference	
15 dB	±0.4 dB	
20 dB	±0.4 dB	
25 dB	±0.5 dB	
30 dB	±0.5 dB	
35 dB	±0.6 dB	
40 dB	±0.6 dB	
45 dB	±0.7 dB	
50 dB	±0.7 dB	
55 dB	±0.9 dB	
60 dB	±0.9 dB	
65 dB	±1.0 dB	



	Specifications	Supplemental Information
<b>Preamp (Option 1DS)</b>		Refer also to Displayed Average Noise Level specification
Gain		+20 dB, nominal <sup>a</sup>
Noise figure		5 dB, characteristic

a. Amplifier is between the input attenuator and the input mixer.

	Specifications	Supplemental Information
<b>Absolute Amplitude Accuracy</b>		
At reference settings <sup>a</sup>	±0.34 dB	±0.13 dB, typical
Preamp On <sup>b</sup> (Option 1DS)	±0.37 dB	±0.14 dB, typical
95 % Confidence Absolute <sup>c</sup> Amplitude Accuracy Input Frequency ≤ 3 GHz –50 dBm ≤ Input Power ≤ 0dBm –50 dBm ≤ Ref Level ≤ 0 dBm –20 dBm ≤ (Input Power – Ref Level) ≤ 0dBm Input Attenuation = 10 dBm 10 Hz ≤ RBW ≤ 1 MHz 20 to 30 °C		±0.4 dB
<b>Overall Amplitude Accuracy<sup>d</sup></b>		
20 to 30 °C	± (0.54 dB + Absolute Frequency Response)	

- Settings are: reference level –20 dBm; input attenuation 10 dB; dc coupled (Option UKB); center frequency 50 MHz; RBW 1 kHz; VBW 1 kHz; amplitude scale linear or log; span 2 kHz; frequency scale linear; sweep time coupled, sample detector, signal at reference level.
- Settings are: reference level –30 dBm; input attenuation 0 dB; dc coupled (Option UKB); center frequency 50 MHz; RBW 1 kHz; VBW 1 kHz; amplitude scale linear or log; span 2 kHz; frequency scale linear; sweep time coupled, signal at reference level.
- Absolute Amplitude Accuracy applies over the wide range of signal conditions and analyzer settings listed with 95 % confidence. The value given is computed from the observation of a statistically significant number of instruments. The computation includes the root-sum-squaring of these terms: the absolute amplitude accuracy of the internal 50 MHz amplitude reference; the relative amplitude accuracy observed at 50 MHz at 26 quasi-random combinations of input power level, reference level and position on the log curve; the frequency response relative to 50 MHz at 59 test frequencies, located between the frequency response correction frequencies; the resolution bandwidth switching uncertainty relative to the reference bandwidth of 1 kHz; and the uncertainties of tracing the measurements involved in these observations to the National Institute of Standards and Technology. To this root-sum-squared result is added the environmental effects of 20 to 30 °C variation. The 95th percentiles are determined with 95 % confidence. Note that the observations of the 50 MHz amplitude accuracy are performed immediately after invoking RF and IF alignments to minimize the effects of alignment drifts.

Agilent E4402B Specifications and Characteristics  
**Amplitude**

- d. For reference level 0 to -50 dBm; input attenuation 10 dB; dc coupled (Option UKB); RBW 1 kHz; VBW 1 kHz; amplitude scale log, log range 0 to -50 dB from reference level; frequency scale linear; sweep time coupled; signal input 0 to -50 dBm; span  $\leq 20$  kHz.

	Specifications	Supplemental Information	
<b>RF Input VSWR</b> (at tuned frequency)			
Attenuator setting 0 dB		characteristic	
100 kHz to 3 GHz		$\leq 3.0:1$	
Attenuator setting 5 dB			
100 kHz to 3 GHz		$\leq 1.6:1$	
Attenuator setting 10 to 65 dB			
9 kHz to 100 kHz		$\leq 2.0:1$	
100 kHz to 3 GHz		$\leq 1.4:1$	
<i>(Option UKB)</i>		characteristic	characteristic
Attenuator setting 0 dB		(dc coupled)	(ac coupled)
100 Hz to 100 kHz		$\leq 1.1:1$	
100 kHz to 3 GHz		$\leq 3.0:1$	$\leq 3.0:1$
Attenuator setting 5 dB		(dc coupled)	(ac coupled)
100 Hz to 100 kHz		$\leq 1.1:1$	
100 kHz to 300 kHz		$\leq 1.1:1$	$\leq 2.3:1$
300 kHz to 1.0 MHz		$\leq 1.1:1$	$\leq 1.6:1$
1.0 MHz to 3.0 GHz		$\leq 1.4:1$	$\leq 1.4:1$
Attenuator setting 10 to 65 dB		(dc coupled)	(ac coupled)
100 Hz to 100 kHz		$\leq 1.1:1$	
100 kHz to 300 kHz		$\leq 1.1:1$	$\leq 2.1:1$
300 kHz to 1.0 MHz		$\leq 1.1:1$	$\leq 1.5:1$
1.0 MHz to 3.0 GHz		$\leq 1.2:1$	$\leq 1.2:1$

	Specifications	Supplemental Information
<b>Auto Alignment<sup>a</sup></b>		
Sweep-to-sweep variation		$\pm 0.1$ dB, characteristic

- a. Set **Auto Align** to **Off** and use **Align Now, All** to eliminate this variation.

	Specifications	Supplemental Information
<b>Resolution Bandwidth Switching Uncertainty</b> (at Reference Level)		
1 kHz RBW	Reference	
3 kHz to 3 MHz RBW	$\pm 0.3$ dB	
5 MHz RBW	$\pm 0.6$ dB	
10 Hz to 300 Hz RBW ( <i>Option 1DR</i> )	$\pm 0.3$ dB	
1 Hz to 3 Hz RBW ( <i>Option 1DR and 1D5</i> ) <sup>a</sup>	$\pm 0.3$ dB	

a. Firmware revision A.08.00 or later.

	Specifications	Supplemental Information
<b>Reference Level</b>		
Range	-149.9 dBm to maximum mixer level + attenuator setting	
Resolution		
Log Scale	$\pm 0.1$ dB	
Linear Scale	$\pm 0.12\%$ of Reference Level	
Accuracy (at a fixed frequency, a fixed attenuator, and referenced to -30 dBm (-10 dBm, Preamp On ( <i>Option 1DS</i> )))		
Reference Level (dBm) – input attenuator setting (dB) + preamp gain (dB)		
-10 dBm to > -60 dBm	$\pm 0.3$ dB	
-60 dBm to > -85 dBm	$\pm 0.5$ dB	
-85 dBm to -90 dBm	$\pm 0.7$ dB	

	Specifications	Supplemental Information
<b>Display Scale Switching Uncertainty</b>		
Switching between Linear and Log	$\pm 0.15$ dB at reference level	
Log Scale Switching	No error	

	Specifications	Supplemental Information
<b>Display Scale Fidelity</b>		
Log Maximum Cumulative		
RBW $\geq$ 1 kHz		
dB Below Reference Level		
0 dB Reference	0 dB	
> 0 to 10 dB	$\pm 0.3$ dB	$\pm 0.08$ dB, typical
> 10 to 20 dB	$\pm 0.4$ dB	$\pm 0.09$ dB, typical
> 20 to 30 dB	$\pm 0.5$ dB	$\pm 0.10$ dB, typical
> 30 to 40 dB	$\pm 0.6$ dB	$\pm 0.23$ dB, typical
> 40 to 50 dB	$\pm 0.7$ dB	$\pm 0.35$ dB, typical
> 50 to 60 dB	$\pm 0.7$ dB	$\pm 0.35$ dB, typical
> 60 to 70 dB	$\pm 0.8$ dB	$\pm 0.39$ dB, typical
> 70 to 80 dB	$\pm 0.8$ dB	$\pm 0.46$ dB, typical
> 80 to 85 dB	$\pm 1.15$ dB	$\pm 0.79$ dB, typical
RBW $\leq$ 300 Hz ( <i>Option 1DR</i> )		
Span > 0 Hz		
Auto range On		
0 to 98 dB <sup>a</sup> below reference level	$\pm(0.3 \text{ dB} + 0.01 \times \text{dB from reference level})$	
> 98 to 120 dB below reference level		$\pm 2.0$ dB, characteristic
Auto range Off <sup>b</sup>		
0 to 60 dB <sup>a</sup> below reference level	$\pm(0.3 \text{ dB} + 0.015 \times \text{dB from reference level})$	
> 60 to 70 dB below reference level	$\pm 1.5$ dB	
Span = 0 Hz		
0 to 60 dB <sup>a</sup> below reference level	$\pm(0.3 \text{ dB} + 0.015 \times \text{dB from reference level})$	
> 60 to 70 dB below reference level	$\pm 1.5$ dB	
Log Incremental Accuracy		

	Specifications	Supplemental Information
0 to 80 dB <sup>a,c</sup> below reference level	±0.4 dB/4 dB	
Linear Accuracy	±2% of Reference Level	

- a. 0 to 30 dB for RBW = 200 Hz
- b. The SCPI command for auto range off is:  
(:DISPlay:WINDow:TRACe:Y[:SCALe]:LOG:RANGe:AUTO OFF)
- c. 0 to 50 dB for RBWs ≤ 300 Hz and span = 0 Hz, or when auto ranging is off.

	Specifications	Supplemental Information
<b>Spurious Responses</b>		
Second Harmonic Distortion		
Input Signal		
10 MHz to 500 MHz	< -65 dBc for -30 dBm signal at input mixer <sup>a</sup>	+35 dBm SHI (second harmonic intercept)
500 MHz to 1.5 GHz	< -75 dBc for -30 dBm signal at input mixer <sup>a</sup>	+45 dBm SHI
Preamp On ( <i>Option IDS</i> ) 10 MHz to 1.5 GHz		-5 dBm SHI, characteristic
Third Order Intermodulation Distortion		
10 MHz to 100 MHz		+7 dBm TOI (third order intercept), characteristic
100 MHz to 3 GHz	< -85 dBc for two -30 dBm signals at input mixer <sup>a</sup> and >50 kHz separation	+12.5 dBm TOI +16 dBm TOI, typical
Preamp On ( <i>Option IDS</i> ) 10 MHz to 3 GHz		-16 dBm TOI, characteristic
Other Input Related Spurious		
>30 kHz offset	< -65 dBc for -20 dBm signal at input mixer <sup>a</sup>	

- a. Mixer power level (dBm) = input power (dBm) – input attenuation (dB).

	Specifications	Supplemental Information
<b>W-CDMA Adjacent Channel Power Ratio<sup>a</sup></b>		
Dynamic range <sup>b</sup>		

	Specifications	Supplemental Information
Offset frequency		
5 MHz		-60.0 dBc, characteristic
10 MHz		-64.5 dBc, characteristic
<i>(Option 120)</i>		
5 MHz		-65.0 dBc, characteristic
10 MHz		-65.5 dBc, characteristic
<i>(Option 120) With noise correction On<sup>c</sup></i>		
5 MHz		-66.5 dBc, characteristic
10 MHz		-67.0 dBc, characteristic

- a. Firmware revision A.07.00 or higher
- b. Measured by selecting “Measure, ACP”, 20 to 30 °C, 3GPP (3.1 Dec 1999) W-CDMA signal with 1 DPCH, channel power -9 dBm/3.84 MHz, integration bandwidth 3.84 MHz, carrier frequency 2 GHz, reference level -16 dBm, input attenuation 0 dB, RBW 30 kHz.
- c. Noise correction can be turned On by selecting **Meas Setup, More, Noise Corr On**

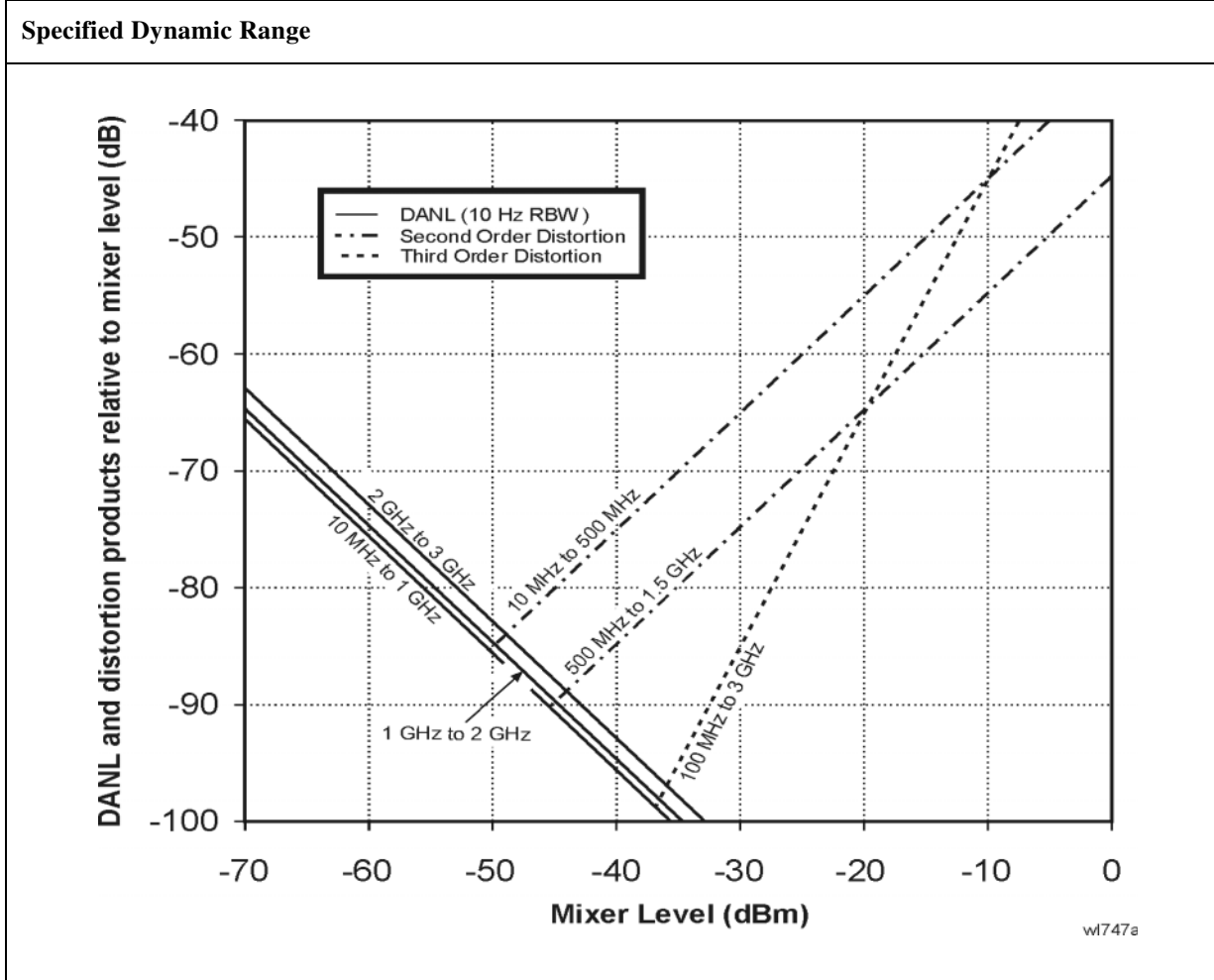

Agilent E4402B Specifications and Characteristics

	Specifications	Supplemental Information
<b>Residual Responses</b> (Input terminated and 0 dB attenuation)  150 kHz to 3 GHz	< -90 dBm	

## Options

## Time Gated Spectrum Analysis (Option 1D6)

	Specifications	Supplemental Information
<b>Gate Delay</b>		
Range	1 $\mu$ s to 400 s	
Accuracy	$\pm(500 \text{ ns} + (0.01\% \times (\text{maximum of gate delay or length})))$	From gate trigger input to positive edge of gate output
<b>Gate Length</b>		
Range	1 $\mu$ s to 400 s	
Accuracy	$\pm(500 \text{ ns} + (0.01\% \times (\text{maximum of gate delay or length})))$	From positive edge to negative edge of gate output
<b>Resolution</b>	$((\text{maximum of gate delay or length in seconds})/65000)$ rounded up to nearest $\mu$ s	Dependent on the greater of gate delay or gate length
<b>Additional Amplitude Error<sup>a</sup></b>		
Log Scale	$\pm 0.2$ dB	
Linear Scale	$\pm 0.1\%$ of reference level	

a. While in gate mode.



### Tracking Generator (Option 1DN)

The spectrum analyzer/tracking generator combination will meet its specification after a cable (8120-5148) and adapter are connected between RF OUT and INPUT and **Align Now, TG** has been run.

	Specifications	Supplemental Information
<b>Warm-up</b>	5 minutes	

	Specifications	Supplemental Information
<b>Output Frequency Range</b>	9 kHz to 3.0 GHz	

	Specifications	Supplemental Information
<b>Minimum Resolution BW</b>	1 kHz	Not usable with resolution bandwidths $\leq 300$ Hz ( <i>Option 1DR</i> )

	Specifications	Supplemental Information
<b>Output Power Level</b>		
Range	-2 to -66 dBm	
Resolution	0.1 dB	
Absolute Accuracy (at 50 MHz with coupled source attenuator, referenced to -20 dBm)	$\pm 0.75$ dB	
Vernier		
Range	8 dB	
Accuracy (with coupled source attenuator, 50 MHz, -20 dBm)		
Incremental	$\pm 0.2$ dB/dB	
Cumulative	$\pm 0.5$ dB, total	
Output Attenuator Range	0 to 56 dB in 8 dB steps	

	Specifications	Supplemental Information
<b>Maximum Safe Reverse Level</b>		+30 dBm (1 W), 50 Vdc, characteristic

Agilent E4402B Specifications and Characteristics  
Options

	Specifications	Supplemental Information
<b>Output Power Sweep</b>		
Range	(-10 to -2 dBm) – (Source Attenuator Setting)	
Resolution	0.1 dB	
Accuracy (zero span)	<1 dB peak-to-peak	

	Specifications	Supplemental Information
<b>Output Flatness</b>		
Referenced to 50 MHz, -20 dBm		
9 kHz to 10 MHz	±3 dB	
10 MHz to 3 GHz	±2 dB	

	Specifications	Supplemental Information
<b>Spurious Outputs</b>		
(-2 dBm output)		
Harmonic Spurs		
TG Output 9 kHz to 20 kHz	≤ -15 dBc	
TG Output 20 kHz to 3 GHz	≤ -25 dBc	
Non-harmonic Spurs		
TG Output 9 kHz to 2 GHz	≤ -27 dBc	
TG Output 2 GHz to 3 GHz	≤ -23 dBc	
LO Feedthrough		
LO Frequency 3.921409 GHz to 6.9214 GHz	≤ -16 dBm	

	Specifications	Supplemental Information
<b>Dynamic Range</b>	Maximum Output Power Level – Displayed Average Noise Level	

	Specifications	Supplemental Information
<b>Output Tracking</b>		
Drift		1.5 kHz/5 minute, characteristic

	Specifications	Supplemental Information
Swept Tracking Error		Usable in 1 kHz RBW after 5 minutes of warm-up

	Specifications	Supplemental Information
<b>RF Power-Off Residuals</b> 9 kHz to 3 GHz		< -120 dBm, characteristic

	Specifications	Supplemental Information
<b>Output Attenuator Repeatability</b> 9 kHz to 300 MHz 300 MHz to 2 GHz 2 GHz to 3 GHz		±0.1 dB, characteristic ±0.2 dB, characteristic ±0.3 dB, characteristic

	Specifications	Supplemental Information
<b>Output VSWR</b> 0 dB attenuation ≥ 8 dB attenuation		<2.0:1, characteristic <1.5:1, characteristic

	Specifications	Supplemental Information
<b>Output Attenuator Accuracy</b> 0 dB 8 dB 16 dB 24 dB 32 dB 40 dB 48 dB 56 dB	Reference	±0.5 dB, characteristic ±0.5 dB, characteristic ±0.5 dB, characteristic ±0.6 dB, characteristic ±0.8 dB, characteristic ±1.0 dB, characteristic ±1.1 dB, characteristic

<b>Tracking Generator Output Accuracy</b>	
Relative Accuracy (Referred to -20 dBm) = Output Attenuator Accuracy + Vernier Accuracy + Output Flatness	

<b>Tracking Generator Output Accuracy</b>
---

Absolute Accuracy = Relative Accuracy (Referred to -20 dBm) + Absolute Accuracy at 50 MHz
--

### Phase Noise (Option 226)

Carrier Frequency Range	Specifications	Supplemental Information
E4402B	1 MHz to 3.0 GHz	
E4404B	1 MHz to 6.7 GHz	
E4405B	1 MHz to 13.2 GHz	
E4407B	1 MHz to 26.5 GHz	

Measurement Characteristics	Specifications	Supplemental Information
Measurements	Log plot Spot frequency RMS noise RMS jitter Residual FM	
Maximum number of decades	7 (whole decades only)	
Filtering (ratio of video bandwidth to resolution bandwidth)	None (VBW/RBW = 1.0) Little (VBW/RBW = 0.3) Medium (VBW/RBW = 0.1) Maximum (VBW/RBW = 0.03)	

Offset Frequency	Specifications	Supplemental Information
Range	10 kHz to 100 MHz	The minimum offset is limited to 10 times the narrowest RBW of the analyzer
<i>(Option1DR)</i>	100 Hz to 100 MHz	
<i>(Option1DR and 1D5)</i>	10 Hz to 100 MHz	

Measurement Accuracy	Specifications	Supplemental Information
<b>Amplitude Accuracy<sup>a</sup></b> (carrier frequency 1 MHz to 3.0 GHz)		±1.52 dB <sup>b</sup>

- Amplitude accuracy is derived from analyzer specification and characteristics. It is based on a 1 GHz signal at 0 dBm while running the log plot measurement with all other measurement and analyzer settings at their factory defaults.
- This does not include the effect of system noise floor. This error is a function of the signal (phase noise) to noise (analyzer noise floor) ratio, SN, in decibels. The function is  $\text{Error} = 10 \times \log(1 + 10^{-\text{SN}/10})$ . For example, if the phase noise being measured is 10 dB above the measurement floor, the error due to adding the analyzer's noise to the UUT is 0.41 dB.

	Specifications	Supplemental Information			
<b>Amplitude Repeatability</b>		<b>Standard Deviation<sup>a,b</sup></b>			
		<b>No Filtering</b>	<b>Little Filtering</b>	<b>Medium Filtering</b>	<b>Maximum Filtering</b>
	No Smoothing				
	Offset				
	100 Hz <sup>d</sup>	5.9 dB	4.9 dB	4.0 dB	3.9 dB
	1 kHz <sup>d</sup>	5.8 dB	4.7 dB	3.7 dB	3.5 dB
	10 kHz	4.4 dB	2.4 dB	2.4 dB	1.7 dB
	100 kHz	3.9 dB	2.3 dB	1.7 dB	1.6 dB
	1 MHz	3.2 dB	2.2 dB	1.4 dB	0.95 dB
	4% Smoothing <sup>c</sup>				
	Offset				
	100 Hz <sup>d</sup>	1.8 dB	1.5 dB	1.2 dB	1.1 dB
	1 kHz <sup>d</sup>	1.0 dB	0.58 dB	0.57 dB	0.49 dB
	10 kHz	0.83 dB	0.54 dB	0.41 dB	0.29 dB
	100 kHz	0.78 dB	0.51 dB	0.36 dB	0.20 dB
	1 MHz	0.67 dB	0.23 dB	0.23 dB	0.20 dB

- a. Amplitude repeatability is the nominal standard deviation of the measured phase noise. This table comes from an observation of 30 log plot measurements using a 1 GHz, 0 dBm signal with the filtering and smoothing settings shown. All other analyzer and measurement settings are set to their factory defaults.
- b. The standard deviation can be further reduced by applying averaging. The standard deviation will improve by a factor of the square root of the number of averages. For example, 10 averages will improve the standard deviation by a factor of 3.162.
- c. Smoothing can cause additional amplitude errors near rapid transitions of the data, such as with discrete spurious signals and impulsive noise. The effect is more pronounced as the number of points smoothed increases.
- d. These offsets are available only when Option 1DR is installed.

	Specifications	Supplemental Information
Frequency Offset Accuracy <sup>a</sup>	± 3.7%	0.053 octave

a. The frequency offset error in octaves causes an additional amplitude accuracy error proportional to the product of the frequency error and slope of the phase noise. For example, a 0.01 octave frequency error combined with an 18 dB/octave slope gives 0.18 dB additional amplitude error.

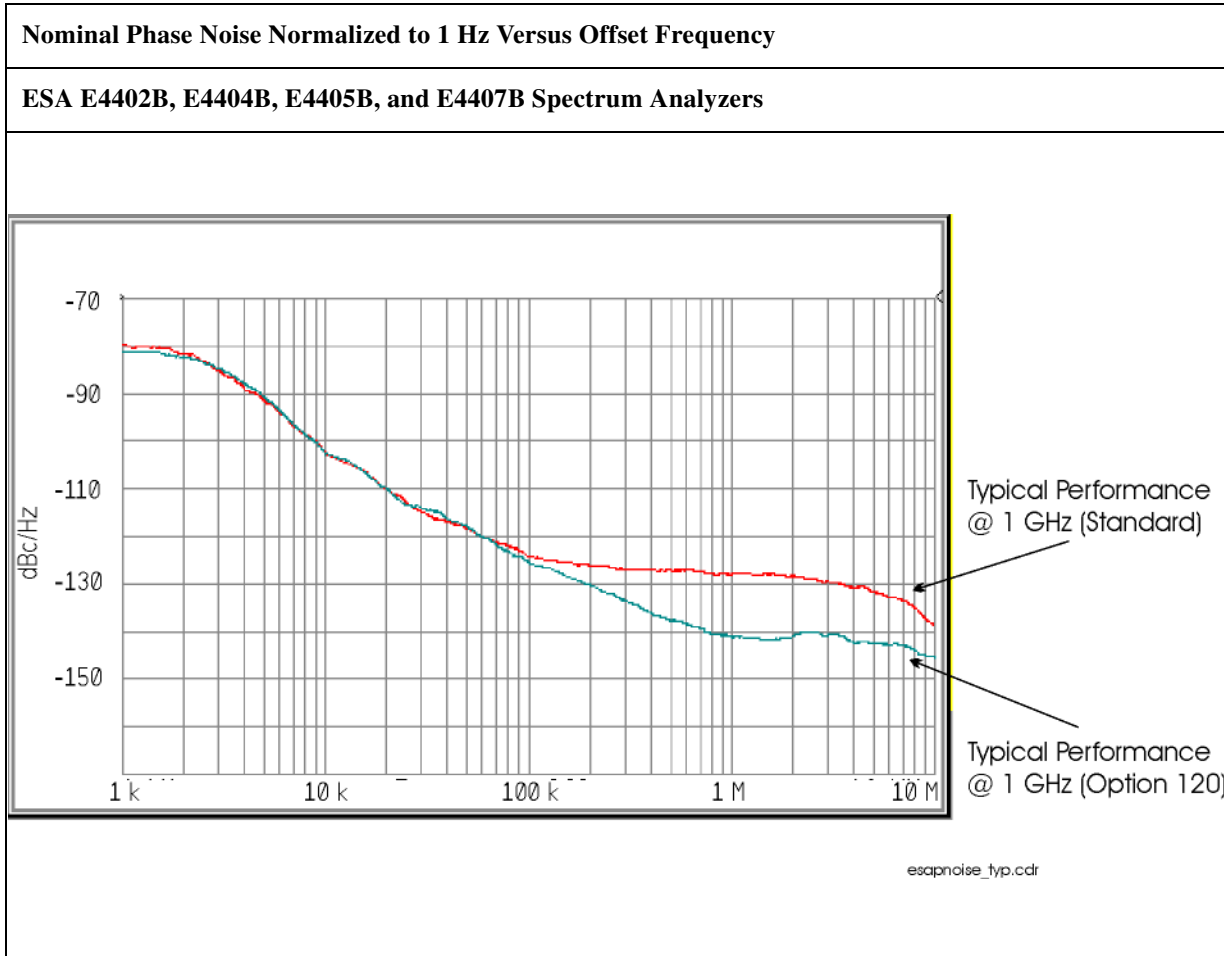

Agilent E4402B Specifications and Characteristics

### FM Demodulation and Quasi Peak Detector (Option AYQ)

The FM demodulation characteristics will apply after an **Align Now, FM Demod** has been run.

	Specifications	Supplemental Information
<b>Optimum Input Level</b>		$\geq (-60 \text{ dBm} + \text{attenuator setting} - \text{preamp gain})$ and within 30 dB of the reference level
<b>FM Deviation</b>		
Range		10 kHz to 1 MHz
Resolution		300Hz, characteristic
Accuracy <sup>a</sup>		$< (2\% \text{ of FM deviation range} + 2 \times \text{Resolution})$ , characteristic
FM Rate $< \text{FM BW}/100$ , VBW $\geq (30 \times \text{FM Rate})$ , RBW $>$ the maximum of ( $30 \times \text{FM deviation}$ ) or ( $30 \times \text{FM Rate}$ )		
Offset Error <sup>a</sup>		5% of FM Deviation Range + 300 Hz, characteristic
<b>FM Bandwidth</b> (-3 dB)		
FM Deviation Range		
10 kHz to 40 kHz		$0.5 \times \text{FM deviation range}$ , characteristic
>40 kHz to 200 kHz		$0.5 \times \text{FM deviation range}$ , characteristic
>200 kHz to 1 MHz		$0.4 \times \text{FM deviation range}$ , characteristic

a. In time domain sweeps (span = 0 Hz)



	Specifications	Supplemental Information
<b>Quasi-Peak Detector</b>	<p>The quasi-peak detector provides the quasi-peak amplitude of pulsed radio frequency (RF) or continuous wave (CW) signals.</p> <p>The amplitude response conforms to Publication 16 of CISPR Section 1, Clause 2, except as indicated in the Relative Quasi-Peak Response Table.</p>	

Relative Quasi-Peak Response to a CISPR Pulse (dB)			
Frequency Band			
Pulse Repetition Frequency	120 kHz EMI BW 0.03 to 1 GHz	9 kHz EMI BW 0.15 to 30 MHz	200 Hz EMI BW 9 to 150 kHz
1000 Hz	+8.0 ± 1.0	+4.5 ± 1.0	N/A
100 Hz	0 dB reference <sup>a</sup>	0 dB reference <sup>a</sup>	+4.0 ± 1.0
60 Hz	N/A	N/A	+3.0 ± 1.0
25 Hz	N/A	N/A	0 dB reference <sup>a</sup>
20 Hz	-9.0 ± 1.0	-6.5 ± 1.0	N/A
10 Hz	-14.0 ± 1.5	-10.0 ± 1.5	-4.0 ± 1.0
5 Hz	N/A	N/A	-7.5 ± 1.5
2 Hz	-26.0 ± 2.0	-20.5 ± 2.0	-13.0 ± 2.0
1 Hz		-22.5 ± 2.0	-17.0 ± 2.0
Isolated Pulse		-23.5 ± 2.0	-19.0 ± 2.0

- a. Reference pulse amplitude accuracy relative to a 66 dBμV CW signal is <1.5 dB as specified in CISPR Publication 16. CISPR reference pulse: 0.044 μVs for 30 MHz to 1.0 GHz, 0.316 μVs for 15 kHz to 30 MHz, and 13.5 μVs for 9 to 150 kHz.

### Bluetooth FM Demodulation (Option 106)

The FM demodulation characteristics will apply after an **Align Now, FM Demod** has been run.

	Specifications	Supplemental Information
<b>Optimum Input Level</b>		$\geq (-40 \text{ dBm} + \text{attenuator setting} - \text{preamp gain})$ and within 10 dB of the reference level
<b>FM Deviation</b>		
Range		$\pm 200 \text{ kHz}$ , nominal
Resolution		Provides 400 Hz display annotation resolution, nominal
Accuracy <sup>a</sup>		$\pm 10 \text{ kHz}$ , typical
Input level = -30 dBm		$\pm 4 \text{ kHz}$ with video averaging On and averages $\geq 25$
Reference level = -30 dBm		
FM Rate = 500 kHz sine		
VBW = 3 MHz,		
RBW = 5 MHz,		
FM Deviation = 140 kHz		
Offset Error <sup>a</sup>		$\pm 1 \text{ kHz}$ , typical
<b>FM Bandwidth</b> (-3 dB)		1.2 MHz, nominal

a. In time domain sweeps (span = 0 Hz).

### Bluetooth Measurements Personality (Option 228)

The demodulation related nominal values will apply after an **Align Now**, **FM Demod** has been run.

	Specifications	Supplemental Information
<b>In-Band Frequency Range</b>		
Bluetooth (ISM) Band	2400 to 2483.5 MHz	

	Specifications	Supplemental Information
<b>Output Power</b> (Option AYX or B7D)		
Range at RF Input	30 to -40 dBm	
(Option 1DS)	30 to -60 dBm	
Absolute Amplitude Accuracy		See “Absolute Amplitude Accuracy” on page 55.
Average type	Video, Power	
Average mode	Exponential, Repeat	
Trigger source	Video, RF burst <sup>a</sup> , External, Free Run	
Burst synch	RF Amplitude, Preamble <sup>b</sup> , None	

a. Requires Option B7E

b. Requires Option 106 Bluetooth FM demodulation.

	Specifications	Supplemental Information
<b>Modulation Characteristics<sup>a</sup></b> (Option 106 and AYX or B7D)		
Range at RF Input	30 to -40 dBm	
(Option 1DS)	30 to -60 dBm	
FM Deviation		
Range		±200 kHz, nominal
Accuracy		±4 kHz, nominal (25 measurement averages, signal level > -30 dBm)
Payload data	11110000, 10101010, auto-detect	
Average mode	Exponential, Repeat	

	Specifications	Supplemental Information
Trigger source	Video, RF burst <sup>b</sup> , External, Free Run	
Burst synch	RF Amplitude, Preamble <sup>c</sup> , None	
Limits	$\Delta f_2/\Delta f_1$ lower, $\Delta f_1$ max lower/upper $\Delta f_2$	

- a. The DUT must have frequency hopping disabled.
- b. Requires Option B7E
- c. Requires Option 106 Bluetooth FM demodulation.

	Specifications	Supplemental Information
<b>Carrier Frequency Drift</b> <sup>a</sup> (Option 106 and AYX or B7D)		
Range at RF Input	30 to -40 dBm	
(Option 1DS)	30 to -60 dBm	
Measurement range		±100 kHz, nominal
Measurement accuracy		±4 kHz, nominal (25 measurement averages, signal level > -30 dBm)
Average mode	Exponential, Repeat	
Trigger source	Video, RF burst <sup>b</sup> , External, Free Run	
Burst synch	Preamble <sup>c</sup> , None	

- a. The DUT must have frequency hopping disabled.
- b. Requires Option B7E
- c. Requires Option 106 Bluetooth FM demodulation.

	Specifications	Supplemental Information
<b>Initial Carrier Frequency Tolerance (ICFT)</b> <sup>a</sup> (Option 106 and AYX or B7D)		
Range at RF Input (Option 1DS)	30 to -40 dBm 30 to -60 dBm	
Measurement range		±100 kHz, nominal
Measurement accuracy		±4 kHz, nominal (25 measurement averages, signal level > -30 dBm)
Average mode	Exponential, Repeat	
Trigger source	Video, RF burst <sup>b</sup> , External, Free Run	
Burst synch	RF Amplitude, Preamble <sup>c</sup> , None	
Limits	ICFT upper/lower	

- a. The DUT must have frequency hopping disabled.
- b. Requires Option B7E
- c. Requires Option 106 Bluetooth FM demodulation.

### FM Demodulation (Option BAA)

The FM demodulation characteristics will apply after an **Align Now, FM Demod** has been run.

	Specifications	Supplemental Information
<b>Optimum Input Level</b>		$\geq (-60 \text{ dBm} + \text{attenuator setting} - \text{preamp gain})$ and within 30 dB of the reference level
<b>FM Deviation</b>		
Range		10 kHz to 1 MHz
Resolution		Provides 1 Hz display annotation resolution
FM Deviation Range		
10 kHz to 40 kHz		12 Hz, characteristic
>40 kHz to 200 kHz		60 Hz, characteristic
>200 kHz to 1 MHz		300 Hz, characteristic
Accuracy <sup>a</sup>		
FM Rate < FM BW/100, VBW $\geq (30 \times \text{FM Rate})$ , RBW > the maximum of (30 $\times$ FM deviation) or (30 $\times$ FM Rate)		< (2% of FM deviation range + 2 $\times$ Resolution), characteristic
Offset Error <sup>a</sup>		5% of FM Deviation Range + 300 Hz, characteristic
<b>FM Bandwidth</b> (-3 dB)		
FM Deviation Range		
10 kHz to 40 kHz		7.5 $\times$ FM deviation range, characteristic
>40 kHz to 200 kHz		1.3 $\times$ FM deviation range, characteristic
>200 kHz to 1 MHz		0.3 $\times$ FM deviation range, characteristic

a. In time domain sweeps (span = 0 Hz).

### TV Trigger and Picture On Screen (Option B7B)

Option BAA is required.

	Specifications	Supplemental Information
<b>TV Trigger and Picture On Screen</b>		TV Trigger initiates a sweep of the analyzer after the sync pulse of a selected line of a TV video field. Picture On Screen displays the TV picture on the analyzer display.
Amplitude Requirements TV Source: SA		Top 50% of linear display, characteristic
TV Source: EXT VIDEO IN		500 mVp-p to 2 Vp-p, characteristic
Compatible Standards	NTSC-M, NTSC-Japan, PAL-M, PAL-B,D,G,H,I, PAL-N, PAL-N Combination, SECAM-L	
Field Selection	Entire frame, even, odd	
Sync Polarity	Positive or negative	
<b>TV Trigger</b>		
Line Selection	1 to 525, or 1 to 625, standard dependent	

### cdmaOne Measurement Personality (Option BAC)

Unless otherwise noted, all specifications are with RF input range auto, default cdmaOne measurement settings, and in the in-band frequency range. Option B72 is required.

	Specifications	Supplemental Information
<b>In-Band Frequency Range</b>		
Cellular bands	824 to 870 MHz 869 to 925 MHz	
PCS bands	1715 to 1780 MHz 1805 to 1870 MHz 1850 to 1910 MHz 1930 to 1990 MHz	

	Specifications	Supplemental Information
<b>Adjacent Channel Power Ratio<sup>a</sup></b>		
Carrier power range at RF Input	30 to -20 dBm	
Dynamic range <sup>b</sup>		Referenced to average power of carrier in 1.23 MHz BW
Offset Frequency	Integration BW	
750 kHz	30 kHz	-70.0 dBc, characteristic
885 kHz	30 kHz	-73.5 dBc, characteristic
1.25625 MHz	12.5 kHz	-78.0 dBc, characteristic
1.98 MHz	30 kHz	-75.5 dBc, characteristic
2.75 MHz	1 MHz	-60.5 dBc, characteristic
Relative accuracy <sup>c</sup>	See Display Scale Fidelity	
Resolution	0.01 dB	

- This measurement is available with personality revisions of A.02.00 or later.
- IS-97A nominal base station test model levels (fraction of carrier power); Pilot: 0.20 (-7.0 dBc), Sync: 0.0471 (-13.3 dBc), Paging: 0.1882 (-7.3 dBc), 6 Traffic channels: 0.09412 (-10.3 dBc)
- Does not include uncertainty due to noise.



	Specifications	Supplemental Information
<b>Channel Power (1.23 MHz Integration BW)</b>		Integration BW range 1 kHz to 10 MHz
Range at RF Input	30 to -70 dBm	
Absolute power accuracy for in-band signal (Mean channel power at RF Input, plus any external attenuation, excluding mismatch error)		
Cellular Bands		
30 to -5 dBm 20 to 30 °C	±0.90 dB	±0.39 dB, typical
0 to 55 °C	±1.23 dB	
-5 to -25 dBm 20 to 30 °C	±0.86 dB	±0.37 dB, typical
0 to 55 °C	±1.13 dB	
-25 to -45 dBm 20 to 30 °C	±0.70 dB	±0.21 dB, typical
0 to 55 °C	±0.96 dB	
-45 to -55 dBm 20 to 30 °C	±0.78 dB	±0.28 dB, typical
0 to 55 °C	±0.98 dB	
-55 to -70 dBm 20 to 30 °C	±0.90 dB	±0.38 dB, typical
0 to 55 °C	±1.23 dB	
PCS Bands		
30 to -5 dBm 20 to 30 °C	±0.74 dB <sup>a</sup>	±0.26 dB <sup>a</sup> , typical
0 to 55 °C	±1.15 dB <sup>a</sup>	
-5 to -25 dBm 20 to 30 °C	±0.69 dB <sup>a</sup>	±0.23 dB <sup>a</sup> , typical
0 to 55 °C	±1.03 dB <sup>a</sup>	
-25 to -45 dBm 20 to 30 °C	±0.70 dB <sup>a</sup>	±0.26 dB <sup>a</sup> , typical
0 to 55 °C	±1.00 dB <sup>a</sup>	
-45 to -55 dBm 20 to 30 °C	±0.78 dB <sup>a</sup>	±0.33 dB <sup>a</sup> , typical

	Specifications	Supplemental Information
0 to 55 °C	$\pm 1.02$ dB <sup>a</sup>	$\pm 0.43$ dB <sup>a</sup> , typical
-55 to -70 dBm 20 to 30 °C	$\pm 0.90$ dB <sup>a</sup>	
0 to 55 °C	$\pm 1.27$ dB <sup>a</sup>	

a. For Option UKB, add 0.10 dB.

	Specifications	Supplemental Information
Channel power relative power accuracy (same channel, different Tx power, input attenuator fixed, RF input range manual).	See Display Scale Fidelity	

	Specifications	Supplemental Information
<b>Receive Channel Power</b>		
Absolute Power Accuracy		
Cellular bands		
30 to 0 dBm	$\pm 1.09$ dB	$\pm 0.58$ dB, typical
0 to -85 dBm	$\pm 1.58$ dB	$\pm 0.63$ dB, typical
PCS bands		
30 to 0 dBm	$\pm 1.01$ dB <sup>a</sup>	$\pm 0.53$ dB <sup>a</sup> , typical
0 to -85 dBm	$\pm 1.52$ dB <sup>a</sup>	$\pm 0.58$ dB <sup>a</sup> , typical
Preamp ( <i>Option IDS</i> )		
Cellular bands		
30 to -80 dBm	$\pm 1.77$ dB	$\pm 1.20$ dB, typical
-80 to -100 dBm	$\pm 3.00$ dB	$\pm 2.15$ dB, typical
PCS bands		
30 to -80 dBm	$\pm 1.86$ dB	$\pm 0.90$ dB, typical
-80 to -100 dBm	$\pm 3.09$ dB	$\pm 1.85$ dB, typical

a. For Option UKB, add 0.10 dB.

	Specifications	Supplemental Information
<b>Occupied Bandwidth</b>		
Carrier power range	30 to -45 dBm	
Frequency resolution of occupied BW	1.88 kHz	
Frequency accuracy of occupied BW (1.23 MHz channel BW)		±15 kHz, characteristic
Frequency resolution of delta frequency	3.75 kHz	
Frequency accuracy of delta frequency		± (35 kHz + frequency reference error × carrier frequency), characteristic

	Specifications	Supplemental Information
<b>Code Domain Power</b> (Requires <i>Options 1D5, B7D, and B7E</i> . Measurement interval ≥1.25 ms unless otherwise noted.)		
Carrier power range at RF Input (Pilot channel power > -11 dBc)	30 to -13 dBm	30 to -65 dBm <sup>a</sup> , characteristic
Preamp ( <i>Option 1DS</i> )	30 to -30 dBm	30 to -82 dBm <sup>a</sup> , characteristic
Measurement interval range	0.5 ms to 26.67 ms	
Code domain power		
Display dynamic range	50 dB	
Accuracy (Walsh channel power within 20 dB of total power)		±0.2 dB, typical
Displayed resolution	0.01 dB	
Other reported power parameters (dB referenced to total power)		Average active traffic, maximum inactive traffic, average inactive traffic, pilot, paging, sync channels
Carrier frequency error (Measurement interval ≥2.5 ms)		Excludes frequency reference error.
Input frequency error range	±100 kHz	±200 kHz, typical
Accuracy	±10 Hz	±7 Hz, typical
Displayed resolution	Four digits	
Estimated Rho		

	Specifications	Supplemental Information
Range	0.9 to 1.0	0.5 to 1.0 <sup>b</sup>
Accuracy (With 9 channels active over the specified range) <sup>c</sup>		±0.02, characteristic
Displayed resolution	0.0001	
Pilot time offset		From even second signal to start of PN sequence
Range	–13.33 ms to +13.33 ms	
Accuracy	±150 ns	
Displayed resolution	Four digits	
Code domain timing		Pilot to code channel time tolerance
Range	±200 ns	
Accuracy (IS-97A nominal power levels) <sup>d</sup>		±7 ns, typical
Code domain phase		Pilot to code channel phase tolerance
Range	±200 mrad	
Accuracy (IS-97A nominal power levels) <sup>d</sup>		±10 mrad, typical
Displays		Power Graph and Metrics, or Power, Timing, and Phase Graphs

- Performance may degrade outside of the specified carrier power range at RF input listed in the specifications column.
- Performance may degrade outside of the estimated rho range listed in the specifications column.
- The Active Set Threshold is less than all active channels, but greater than –20 dBc.
- IS-97A nominal base station test model levels (fraction of carrier power); Pilot: 0.20 (–7.0 dBc), Sync: 0.0471 (–13.3 dBc), Paging: 0.1882 (–7.3 dBc), 6 Traffic channels: 0.09412 (–10.3 dBc)

	Specifications	Supplemental Information
<b>Modulation Accuracy (Rho)</b> (Requires Options 1D5, B7D, and B7E. Measurement interval ≥1.25 ms unless otherwise noted.)		
Carrier power range at RF Input	30 to –28 dBm	30 to –70 dBm <sup>a</sup> , characteristic
Preamp ( <i>Option 1DS</i> )	30 to –45 dBm	30 to –87 dBm <sup>a</sup> , characteristic
Measurement interval range	0.15 ms to 26.67 ms	
Rho (waveform quality)		

	Specifications	Supplemental Information
Range	0.9 to 1.0	0.5 to 1.0 <sup>b</sup> , characteristic
Accuracy		±0.0016, typical
Displayed resolution	0.0001	
Carrier frequency error (Measurement interval ≥2.5 ms)		Excludes frequency reference error
Input frequency error range	±100 kHz	±200 kHz, typical
Accuracy	±10 Hz	±7 Hz, typical
Displayed resolution	Four digits	
Pilot time offset		From even second signal to start of PN sequence
Range	-13.33 ms to +13.33 ms	
Accuracy	±150 ns	
Displayed resolution	Four digits	
EVM		
Floor		3.8%, typical
Accuracy <sup>c</sup>		±1.1%, typical
Displayed Resolution	0.01%	
Carrier feedthrough		
Floor		-51 dBc, typical
Accuracy (Carrier feedthrough ≥ -43 dBc)		±2.3 dB, typical
Displayed resolution	0.01 dB	
Magnitude error		
Floor		3.8%, typical
Accuracy <sup>c</sup>		±1.1%, typical
Displayed resolution	0.01%	
Phase error		
Accuracy <sup>c</sup>		±0.65 degrees, typical
Displayed resolution	0.01 degrees	
Displays		Numeric results or Numeric results and IQ graph

- a. Performance may degrade outside of the specified carrier power range at RF input listed in the specifications column.
- b. Performance may degrade outside of the rho range listed in the specifications column.

- c. Accuracy does not include the effects of the EVM floor. The measurement variance increases as the result approaches the EVM floor.

	Specifications	Supplemental Information
<b>Spur Close (In Band)</b>		
Carrier power range at RF Input	30 to -12 dBm	
Dynamic range		
Input power		
30 to 25 dBm	55 dB	
25 to 20 dBm	50 dB	
20 to -12 dBm	46 dB	
Relative accuracy	$\pm(2.7 \text{ dB} + 0.01 \times (\text{dB from reference level}))$	$\pm(0.3 \text{ dB} + 0.01 \times (\text{dB from reference level}))$ , typical
Displayed resolution	0.01 dB	

	Specifications	Supplemental Information
<b>Out-of-Band Spurious<sup>a</sup></b>		Refer to the Amplitude specifications section in this guide.

- a. The out-of-band measurement is made with the user-defined tables with 20 frequency ranges each (up to the top 10 spurs per range, 100 spurs maximum). Table parameters include frequency range, RBW, video BW, detector type, and amplitude test limits.

	Specifications	Supplemental Information
<b>Receiver Spurious Emissions</b>		
Spurious emission power range	-20 to -83 dBm	
Preamp On ( <i>Option IDS</i> )	-40 to -101 dBm	
Absolute spurious emission power accuracy		
-20 to -60 dBm	$\pm 2.2 \text{ dB}^a$	$\pm 1.1 \text{ dB}^a$ , typical
-60 to -83 dBm	$\pm 3.9 \text{ dB}^a$	$\pm 2.7 \text{ dB}^a$ , typical
Preamp On ( <i>Option IDS</i> )		
-40 to -70 dBm	$\pm 2.6 \text{ dB}$	$\pm 1.4 \text{ dB}$ , typical
-70 to -101 dBm	$\pm 4.1 \text{ dB}$	$\pm 2.8 \text{ dB}$ , typical

- a. For Option UKB, add 0.10 dB.

	Specifications	Supplemental Information
<b>External Correction</b> External attenuation, external gain Range Resolution	-90 to 90 dB  0.01 dB	

	Specifications	Supplemental Information
<b>Trigger</b> Trigger source (Actual available choices dependent on measurement)  (Option B7D and B7E) Delay trigger Range Resolution RF burst trigger level (Option B7E) Trigger slope (External and RF burst) Frame timing period Frame synchronizing source Frame synchronizing slope	Free run, external  Add RF Burst, frame  0 to 500 ms 300 ns 0 to -25 dBc  Positive/Negative  50 ns to 13.6533 s External frame sync  Positive/Negative	       Rear panel connector labelled EXT FRAME SYNC (Option B7D)

	Specifications	Supplemental Information
<b>Demod Trigger Source</b> Even second input (Frame trigger only, Option B7D and B7E) PN offset range	  0 to 511 x 64 [chips]	Rear panel connector labelled EXT FRAME SYNC

## Options

**GSM with EDGE Measurement Personality (Option BAH, 252)**

Unless otherwise noted, all specifications are with RF input range auto, default GSM measurement settings, and in the in-band frequency range. Option 1D6 and Option B72 are required.

	Specifications	Supplemental Information
<b>In-Band Frequency Ranges<sup>a</sup></b>		
GSM 900, P-GSM bands	890 to 915 MHz 935 to 960 MHz	
GSM 900, E-GSM bands	880 to 915 MHz 925 to 960 MHz	
GSM 900, R-GSM bands	876 to 915 MHz 921 to 960 MHz	
DCS 1800 bands	1710 to 1785 MHz 1805 to 1880 MHz	
PCS 1900 bands	1850 to 1910 MHz 1930 to 1990 MHz	
<b>Alternative Frequency Ranges<sup>b</sup></b>		
GSM 450 bands	450.4 to 457.6 MHz 460.4 to 467.6 MHz	
GSM 480 bands	478.8 to 486 MHz 488.8 to 496 MHz	
GSM 850 bands	824 to 849 MHz 869 to 894 MHz	

a. Frequency ranges over which all specifications apply.

b. Frequency ranges with tuning plans.

	Specifications	Supplemental Information
<b>Transmitter Power</b> (Requires <i>Option B7D</i> or <i>AYX</i> )		
Range at RF Input	30 to -60 dBm	
Absolute power accuracy for in-band signal (Mean channel power at RF Input, plus any external attenuation, excluding mismatch error)		



	Specifications	Supplemental Information
P-GSM, E-GSM, and R-GSM Bands		
30 to -20 dBm 20 to 30 °C	±0.99 dB	±0.44 dB, typical
0 to 55 °C	±1.49 dB	
-20 to -30 dBm 20 to 30 °C	±0.92 dB	±0.38 dB, typical
0 to 55 °C	±1.23 dB	
-30 to -40 dBm 20 to 30 °C	±0.97 dB	±0.39 dB, typical
0 to 55 °C	±1.22 dB	
-40 to -50 dBm 20 to 30 °C	±1.16 dB	±0.57 dB, typical
0 to 55 °C	±1.35 dB	
-50 to -60 dBm 20 to 30 °C	±1.29 dB	±0.70 dB, typical
0 to 55 °C	±1.46 dB	
DCS 1800 and PCS 1900 Bands		
30 to -20 dBm 20 to 30 °C	±0.83 dB <sup>a</sup>	±0.31 dB <sup>a</sup> , typical
0 to 55 °C	±1.41 dB <sup>a</sup>	
-20 to -30 dBm 20 to 30 °C	±0.75 dB <sup>a</sup>	±0.28 dB <sup>a</sup> , typical
0 to 55 °C	±1.08 dB <sup>a</sup>	
-30 to -40 dBm 20 to 30 °C	±0.80 dB <sup>a</sup>	±0.29 dB <sup>a</sup> , typical
0 to 55 °C	±1.07 dB <sup>a</sup>	
-40 to -50 dBm 20 to 30 °C	±0.99 dB <sup>a</sup>	±0.47 dB <sup>a</sup> , typical
0 to 55 °C	±1.20 dB <sup>a</sup>	
-50 to -60 dBm 20 to 30 °C	±1.12 dB <sup>a</sup>	±0.60 dB <sup>a</sup> , typical
0 to 55 °C	±1.31 dB <sup>a</sup>	

a. For Option UKB, add 0.10 dB.

	Specifications	Supplemental Information
<b>Transmitter Power Relative Power Accuracy</b> (same channel, different Tx power, input attenuator fixed, RF input range manual).	See Display Scale Fidelity	

	Specifications	Supplemental Information
<b>GMSK Power versus Time and EDGE Power versus Time</b> (Requires <i>Option B7D</i> or <i>AYX</i> )		
Carrier power range at RF Input	30 to -23 dBm	30 to -55 dBm <sup>a</sup> , nominal
Preamplifier On ( <i>Option 1DS</i> )	30 to -40 dBm	30 to -72 dBm <sup>a</sup> , nominal
Time resolution accuracy		±1% of sweep time, nominal
Maximum record length	8 time slots	
Burst to mask uncertainty (Requires <i>Option B7D</i> and <i>B7E</i> )	$\pm \left[ 0.1 + \frac{ST / (TP - 1)}{T_{sym}} \right]$ symbol	Where ST = sweep time <sup>b</sup> TP = trace points and T <sub>sym</sub> = 3.69 μs  Examples: Meas Time=1 and TP=1601, gives 0.22 symbol  Meas Time=8 and TP=6401, gives 0.30 symbol

- a. Performance may degrade outside of the specified carrier power range at RF input listed in the specifications column.
- b. Sweep Time value can be found on the key label in the **Advanced** settings menu, with GSM w/EDGE personality software versions C.01.00 and later.

	Specifications	Supplemental Information
<b>GMSK Output RF Spectrum and EDGE Output RF Spectrum</b>		
Carrier power range at RF Input	+30 to -4 dBm	
Reference power accuracy	Transmitter Power Accuracy ±0.13 dB	
Relative accuracy <sup>a</sup>		
Due to modulation		
Offsets ≤1200 kHz	±0.83 dB	
Offsets ≥1800 kHz	±0.96 dB	
Due to switching	±1.63 dB	

	Specifications		Supplemental Information
Spectrum due to modulation displayed dynamic range <sup>b,c</sup>	<b>Non-Option 120</b>	<b>Option 120</b>	67 dB, nominal <sup>e</sup>
100 kHz offset <sup>d</sup>	67.5 dB	67.5 dB	
200 kHz offset <sup>d</sup>	69.5 dB	71.9 dB	
250 kHz offset <sup>d</sup>	70.2 dB	73.3 dB	
400 kHz offset GSM <sup>d</sup> EDGE	71.7 dB	76.3 dB	
600 kHz to 1200 kHz offset	72.8 dB	78.8 dB	
1.8 MHz offset	69.9 dB	76.3 dB	
6 MHz offset	70.1 dB	77.1 dB	
Spectrum due to switching transients displayed dynamic range <sup>b,c</sup>	<b>Non-Option 120</b>	<b>Option 120</b>	
400 kHz offset	62.5 dB	67.1 dB	
600 kHz offset	63.6 dB	69.6 dB	
1200 kHz offset	65.1 dB	72.5 dB	
1800 kHz offset	65.4 dB	72.7 dB	

- a. Does not include uncertainty due to noise.
- b. Previously available GSM measurements options for ESA specified dynamic range for CW signals only. These specifications apply for GSM and EDGE signals.
- c. Using default settings, the RBW filter has a corrected noise BW and impulse BW equivalent to five-pole synchronously tuned filter.
- d. The dynamic range for offsets under 400 kHz is not directly observable because the signal spectrum obscures the result. These dynamic range specifications are derived from phase noise specifications.
- e. The analyzer performance can be dominated by third-order distortion products. These products depend on the mixer level. Their relative level will vary by 10 dB as the mixer level (input RF power minus attenuation) varies over a 5 dB range. When the Input Attenuator is auto coupled, the resolution of the attenuator keeps the mixer level in a 5 dB range. The indicated nominal performance was observed at the worst-case mixer level. Increasing the input attenuation by 10 dB from the auto coupled setting will improve the dynamic range for EDGE signals to very close to that for GSM signals at the 400 kHz offset. The optimum mixer level for dynamic range is approximately -15 dBm for EDGE at 400 kHz offset; the auto coupled setting is controlled to be in the -4 to -9 dBm range to optimize the trade off between compression errors and noise for wider offsets.

	Specifications	Supplemental Information
<b>Phase and Frequency Error</b> (Requires <i>Option 1D5, B7D, and B7E</i> )		

	Specifications	Supplemental Information
Carrier power range at RF Input	30 to -23 dBm	30 to -55 dBm <sup>a</sup> , nominal
Preamp On (Option 1DS)	30 to -40 dBm	30 to -72 dBm <sup>a</sup> , nominal
Phase error		
Range	0 to 180°	
Displayed resolution	0.01°	
Accuracy (Averages ≥10)		
Peak	±2.1°	±1.5°, typical
RMS	±1.1°	±0.6°, typical
Frequency error		Excludes frequency reference error
Initial frequency error range	±100 kHz	
Accuracy (Avg. Type = Mean, Averages ≥10)	±10 Hz	±5 Hz, typical
I/Q offset range	-10 to -46 dBc	
Burst sync time uncertainty	±0.1 bit	
Displays		Numeric summary

- a. Performance may degrade outside of the specified carrier power range at RF input listed in the specifications column.

	Specifications	Supplemental Information
<b>Transmit Band Spurious</b>		
Carrier power range at RF Input		30 to -12 dBm, typical
Dynamic range		
Upper and lower adjacent segments		55 dB, nominal
Upper and lower segments		44 dB, nominal
Relative accuracy		$\pm(0.3 \text{ dB} + 0.01 \times (\text{dB from reference level}))$ , nominal
Displayed resolution	0.01 dB	

	Specifications	Supplemental Information
<b>Out-of-Band Spurious<sup>a</sup></b>		
Absolute Spurious Power Accuracy		Refer to the Amplitude specifications section in this guide.
Sensitivity <sup>b</sup>		
RBW		
1 kHz		-95 dBm, nominal
3 kHz		-90 dBm, nominal
10 kHz		-85 dBm, nominal
30 kHz		-78 dBm, nominal
100 kHz		-71 dBm, nominal
300 kHz		-64 dBm, nominal
1 MHz		-57 dBm, nominal
3 MHz		-50 dBm, nominal

- a. The out-of-band spurious measurement is made in accordance with the tables defined in the appropriate 3GPP specification document. The measurement is made over several frequency ranges (up to 10 spurs per range, 100 spurs maximum).
- b. With input attenuation of 5 dB. For all other attenuation settings, add (input attenuation - 5) dB.

	Specifications	Supplemental Information
<b>Receive Band Spurious</b>		
Spurious emission power range <sup>a</sup>		-20 to -73 dBm, nominal
Preamp On ( <i>Option IDS</i> )		-40 to -91 dBm, nominal
Absolute spurious emission power accuracy		
-20 to -60 dBm		±1.5 dB <sup>b</sup> , nominal
-60 to -73 dBm		±2.1 dB <sup>b</sup> , nominal
Preamp on ( <i>Option IDS</i> )		
-40 to -70 dBm		±1.9 dB, nominal
-70 to -91 dBm		±3.1 dB, nominal

- a. Requires bandpass filter centered on receive band, peak detector mode, 0 dB attenuation, 100 kHz RBW. Does not include insertion loss of bandpass filter.
- b. For Option UKB, add 0.10 dB.

	Specifications	Supplemental Information
<b>EDGE Error Vector Magnitude (EVM)</b> (Requires <i>Option IDS, B7D</i> and <i>B7E</i> )		3 $\pi$ /8 shifted 8PSK modulation Specifications based on 200 bursts
Carrier power range at RF Input	30 to -23 dBm	30 to -55 dBm <sup>a</sup> , nominal
Preamp On ( <i>Option IDS</i> )	30 to -40 dBm	30 to -72 dBm <sup>a</sup> , nominal
EVM		
Operating range		0 to 25 % (nominal)
Floor (RMS)		0.8 % (nominal)
Accuracy <sup>b</sup> (RMS)		$\pm$ 0.75 % (nominal)
EVM range 1 % to 10 %		
Input power +24 to -12 dBm		
Frequency Error		Excludes frequency reference error
Accuracy		$\pm$ 5 Hz, nominal
IQ Origin Offset		
DUT maximum offset	-20 dBc	
Maximum analyzer noise floor	-45 dBc	

- a. Performance may degrade outside of the specified carrier power range at RF input listed in the specifications column.
- b. The accuracy specification applies when the Burst Sync is set to the Training Sequence. The definition of accuracy for the purposes of this specification is how closely the result meets the expected results. The expected result is 0.975 of the actual RMS EVM of the signal (per 3GPP TS 5.05, annex G).

	Specifications	Supplemental Information
<b>Amplitude Range Control</b>		RF Input Autorange, Manually set <b>Max Total Pwr</b> Manually set <b>Input Atten</b>

	Specifications	Supplemental Information
<b>External Gain/Attenuation Correction</b>		
Base gain, base attenuation, mobile gain, mobile attenuation		
Range	0 to 81.9 dB	
Resolution	0.01 dB	

	Specifications	Supplemental Information
<b>Trigger</b>		
Trigger source (Actual available choices dependent on measurement)	Free run, external	

	Specifications	Supplemental Information
<i>(Option B7D and B7E)</i>	Add RF burst and frame	
RF burst trigger <i>(Option B7E)</i>		
Peak carrier power range <sup>a</sup>	30 to -25 dBm	30 to -30 dBm, typical
Preamp On <i>(Option IDS)</i>	30 to -45 dBm	30 to -50 dBm, typical
Trigger level range	0 to -25 dB relative to signal peak	

a. With trigger level set to -6 dB.

	Specifications	Supplemental Information
<b>Burst Sync</b> <i>(Requires Option AXX or B7D)</i>		
Source <i>(Actual available choices dependent on measurement)</i>	RF amplitude, none	
<i>(Option B7D and B7E)</i>	Add training sequence	
Training sequence code		GSM defined 0 to 7 Auto (search) or Manual
Burst type		Normal (TCH and CCH) Sync (SCH) Access (RACH)



**Noise Figure Measurement Personality and Hardware  
(Option 219) Specifications.**

	Specifications	Supplemental Information
<b>+28 V PULSED</b>		Noise source drive Used by option 219
Connector type	50 Ω BNC(f)	
Output voltage		
On	28.0 V ±0.1 V	60mA peak
Off	<1V	
<b>SNS SERIES NOISE SOURCE</b>		For use with Agilent Technologies SNS Series noise sources

	Specifications	Supplemental Information
<b>Noise Figure</b>		Uncertainty Calculator <sup>a</sup>
10 MHz to 3 GHz		Using internal preamp (Option 1DS), and RBW=1 MHz
Noise Source ENR	Measurement Range	Instrument Uncertainty <sup>b</sup>
4.5 to 6.5 dB	0 to 20 dB	±0.24 dB
12 to 17 dB	0 to 30 dB	±0.41 dB
20 to 22 dB	0 to 35 dB	±0.46 dB
3 to 26.5 GHz <sup>c</sup>		No internal preamp
Instrument Uncertainty		Nominally the same as for the 10 MHz to 3 GHz range; External preamp caution <sup>d</sup>
3 to 10 GHz		Well-controlled preselector <sup>e</sup>
10 to 20 GHz		Good preselector stability <sup>f</sup>
20 to 26.5 GHz		Preselector Drift Effects <sup>g</sup>

a. The figures given in the table are for the uncertainty added by the ESA instrument only. To compute the total uncertainty for your noise figure measurement, you need to take into account other factors including: DUT NF, Gain and Match; Instrument NF, Gain Uncertainty and Match; Noise source ENR uncertainty and Match. The computations can be performed with the uncertainty calculator included with the Noise Figure Measurement Personality. Go to **Mode Setup** then select **Uncertainty Calculator**. Similar calculators are also available on the Agilent web site; go to [www.agilent.com/find/nfu](http://www.agilent.com/find/nfu).

- b. "Instrument Uncertainty" is defined for noise figure analysis as uncertainty due to relative amplitude uncertainties encountered in the analyzer when making the measurements required for a noise figure or gain computation. The relative amplitude uncertainty is given by the relative display scale fidelity, also known as incremental log fidelity. The uncertainty of the analyzer is multiplied within the computation by an amount that depends on the Y factor to give the total uncertainty of the noise figure or gain measurement.

See Agilent App Note 57-2, literature number 5952-3706E for details on the use of this specification. Jitter (amplitude variations) will also affect the accuracy of results. The standard deviation of the measured result decreases by a factor of the square root of the Resolution Bandwidth used and by the square root of the number of averages. ESA uses the 1 MHz resolution Bandwidth as default since this is the widest bandwidth with uncompromised accuracy.

- c. For this frequency range, the Instrument Noise Figure Uncertainty is still well controlled, but other accuracy issues become critical. Because there is no internal preamplifier in this range, the Instrument Noise Figure is much higher than in the range below 3 GHz. This causes the effect on total measurement Noise Figure Uncertainty of the Instrument Gain Uncertainty to be much higher, and that Instrument Gain Uncertainty is in turn much higher than in the range below 3 GHz because of the effects of the preselector, explained in subsequent footnotes. As a result, when the DUT has high gain, the total measurement Noise Figure Uncertainty computed with the Uncertainty Calculator can still be excellent, but modest and low gain devices can have very high uncertainties of noise figure. Graphs that follow demonstrate. The first graph shows the computed measurement NF uncertainty with no preamp, and shows how much gain is required to achieve good accuracy. The second graph shows computed measurement NF uncertainty when using an external preamp with 23 dB gain and 6 dB NF. Both graphs were plotted using the uncertainty calculator with the assumptions shown.
- d. An external preamp can reduce the total NF measurement uncertainty substantially because it will reduce the effective noise figure of the measurement system, and thus it will reduce the sensitivity of the total NF uncertainty to the Instrument Gain Uncertainty. But if the signal levels into such an external preamp are large enough, that external preamp may experience some compression. The compression differences between the noise-source-on and noise-source-off states causes an error that must be added to Instrument Noise Figure Uncertainty for use in the Noise Figure Uncertainty Calculator. Such signal levels are quite likely for the case where the DUT has some combination of high gain, high noise figure and wide bandwidth.

As an example, we will use the Agilent 83006A as the external preamplifier. The measurement will be made at 18 GHz. The typical gain is 25 dB and the noise figure is 7 dB. We will assume the DUT has 20 dB gain, a 10 dB NF, and a passband from 5 to 30 GHz. We will use a noise source with 17 dB ENR. When the noise source is on, the DUT output can be computed by starting with  $kT$  ( $-174$  dBm/Hz) and adding  $10 \cdot \log(30 \text{ GHz to } 5 \text{ GHz})$  or 104 dB, giving  $-70$  dBm for the thermal noise. Add to this the ENR of the noise source (17 dB) combined with the NF of the DUT (10 dB) to give an equivalent input ENR of 18 dB, thus  $-52$  dBm input noise power. Add the gain of the DUT (20 dB) to find the DUT output power to be  $-32$  dBm. The noise figure of the external preamp may be neglected. The external preamplifier gain of 25 dB adds, giving a preamplifier output power of  $-7$  dBm. The typical 1 dB compression point of this amplifier is +19 dBm. Therefore, the output noise is 26 dB below the 1 dB compression point. This amplifier will have negligible compression.

As an approximation, the compression of a noise signal is under 0.1 dB if the average noise power is kept 7 dB below the 1 dB CW compression point. The compression in decibels will usually double for every 3 dB increase in noise power. Use cases with higher gain DUTs or preamplifiers with lower output power capability could be compressed, leading to additional errors.

- e. In this frequency range, the preselector is well-controlled and there should be no need for special measurement techniques.
- f. In this frequency range, the preselector usually requires no special measurement techniques in a lab environment. But if the temperature changes by a few degrees, or the analyzer frequency is swept or changed across many gigahertz, Agilent recommends centering the preselector at one user determined critical frequency before a measurement. To adjust the preselector, follow the instructions in the *Noise Figure Measurement Personality Guide*.

- g. In this frequency range, the preselector may sometimes require special measurement techniques, even in a lab environment. Agilent recommends centering the preselector at one user determined critical frequency before a measurement. To adjust the preselector, follow the instructions in the *Noise Figure Measurement Personality Guide*.

**Noise Figure Error Range vs. DUT Gain, Non-warranted Frequency Range (>3 GHz)**

**Computed Measurement NF Uncertainty vs. DUT Gain, Non-warranted Frequency Range**

Assumptions: Measurement Frequency 12 GHz, Instrument NF = 28.7 dB, Instrument VSWR = 1.58, Instrument Gain Uncertainty = 2.7 dB, Instrument NF Uncertainty = 0.41 dB, Agilent 346B Source with Uncertainty = 0.2 dB, Source VSWR = 1.25, DUT input/output VSWR = 1.5.

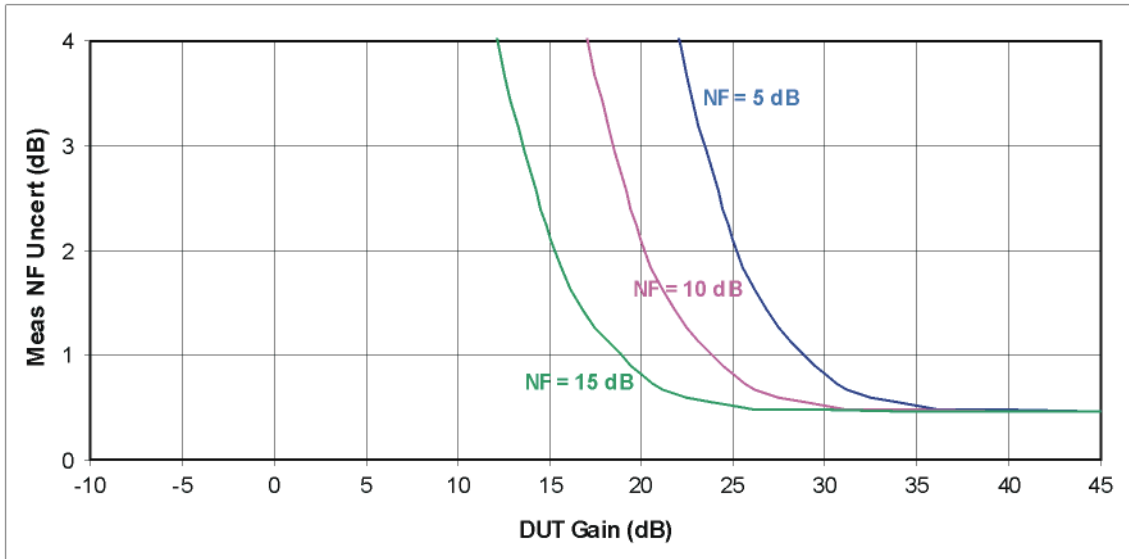

**Computed Measurement NF Uncertainty vs. DUT Gain, Non-warranted Frequency Range**

Assumptions: Same as above, with the addition of an external preamp that has a gain of 23 dB and a NF of 6 dB (for example, 83006A). Also, the Agilent 346A Source is used. The 346A changes the instrument noise figure uncertainty to 0.24 dB. With the external preamp, the preamp/analyzer combination NF is 8.86 dB. Instrument VSWR now moves to the external preamp with VSWR = 2.6

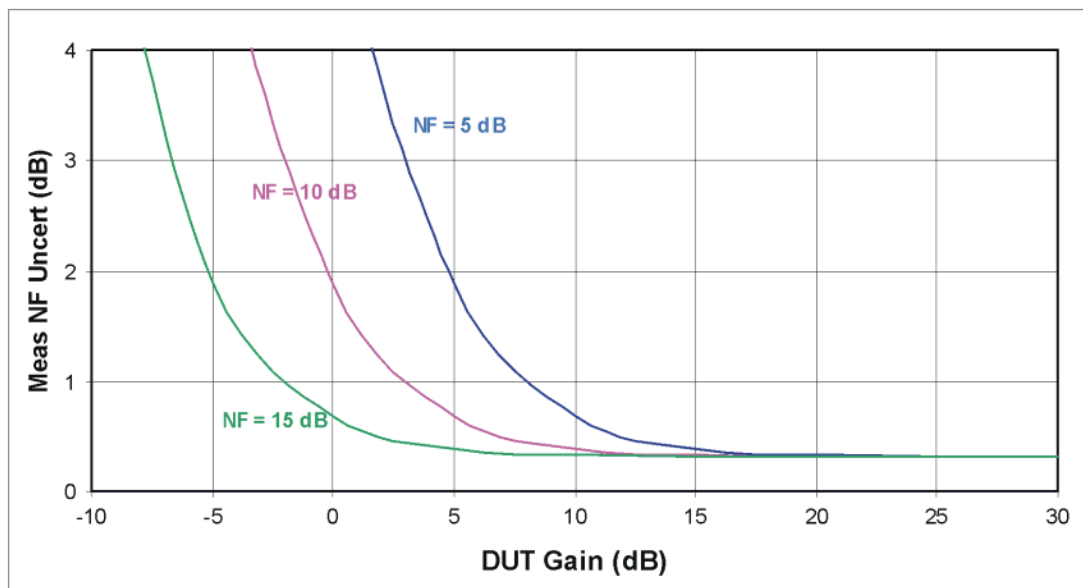

	Specifications		Supplemental Information
<b>Gain</b>			
10 MHz to 3 GHz			
Noise Source ENR	Measurement Range	Instrument Uncertainty <sup>a</sup>	
4.5 to 6.5 dB	-20 to 40 dB	±0.83 dB	
12 to 17 dB	-20 to 40 dB	±0.83 dB	
20 to 22 dB	-20 to 40 dB	±0.83 dB	
3 to 26.5 GHz <sup>b</sup>			
Instrument Uncertainty			±2.7 dB (nominal) <sup>c</sup> for Measurement Range -20 to 40 dB

- a. See the “Instrument Uncertainty” footnote [b](#) on page 66.
- b. See footnotes [d](#), [e](#), [f](#), and [g](#) for this frequency range in the Noise Figure section.
- c. The performance shown would apply when there is a long time between the calibration step and the DUT-measurement step in a NF or Gain measurement. Under special circumstances of small changes in frequency (such as spot frequency measurements) and short time periods between the calibration time and the measurement time, this error source becomes much smaller, approaching the Instrument Uncertainty shown for the 10 MHz to 3 GHz frequency range. These special circumstances would be frequency span ranges of under 1 GHz, with that frequency range unchanged for 30 minutes, and the time between the calibration step and the DUT measurement step held to less than 10 minutes.

	Specifications	Supplemental Information
<b>Noise Figure Uncertainty Calculator<sup>a</sup></b>		
Instrument Noise Figure Uncertainty	See Noise Figure	
Instrument Gain Uncertainty	See Gain	
Instrument Noise Figure		See graphs, Nominal Noise Figure DANL +145.87 dB (nominal) <sup>b</sup>
Instrument Input Match		See graphs, Nominal VSWR

- a. The Noise Figure Uncertainty Calculator requires the parameters shown in order to calculate the total uncertainty of a Noise Figure measurement.
- b. Nominally, the noise figure of the spectrum analyzer is given by
 
$$NF = D - (K - L + N + B)$$
 where D is the DANL (displayed average noise level) specification,  
 K is kTB (-173.88 dB in a 1 Hz bandwidth at 25 °C)  
 L is 2.51 dB (the effect of log averaging used in DANL verifications)  
 N is 0.52 dB (the ratio of the noise bandwidth of the RBW filter with which DANL is specified to an ideal noise bandwidth)  
 B is ten times the base-10 logarithm of the RBW (in hertz) in which the DANL is specified. B is 30 dB for the 1 kHz RBW. The actual NF will vary from the nominal due to frequency response errors.

Nominal Instrument Noise Figure

Nominal Instrument Noise Figure 10 MHz to 3 GHz Preamplifier On

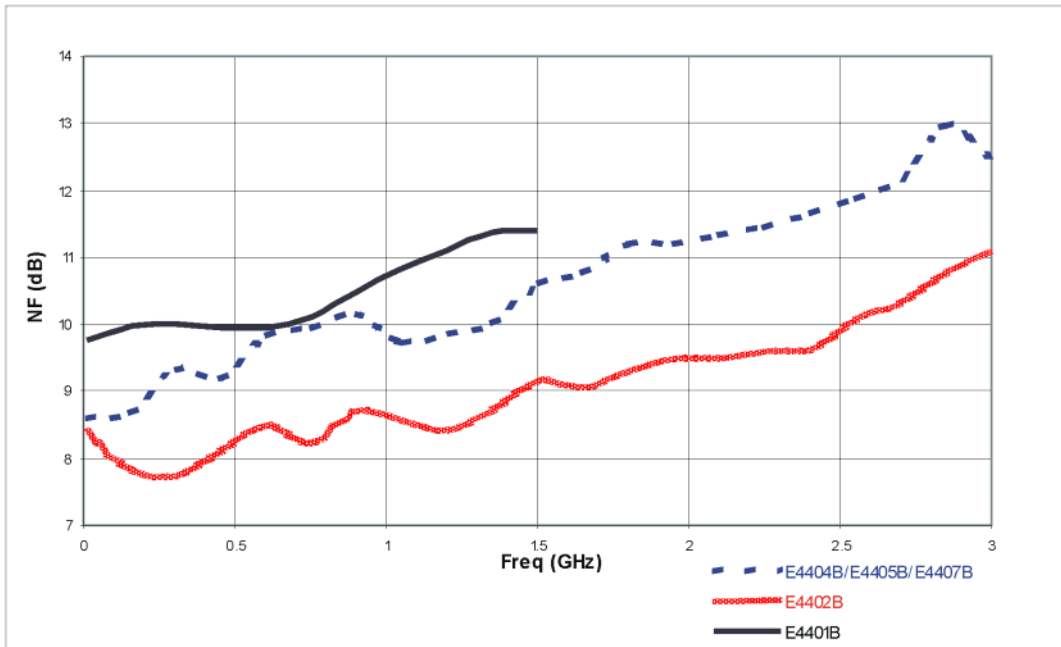

Nominal Instrument Noise Figure 3 to 26.5 GHz  
No Preamplifier; two example units

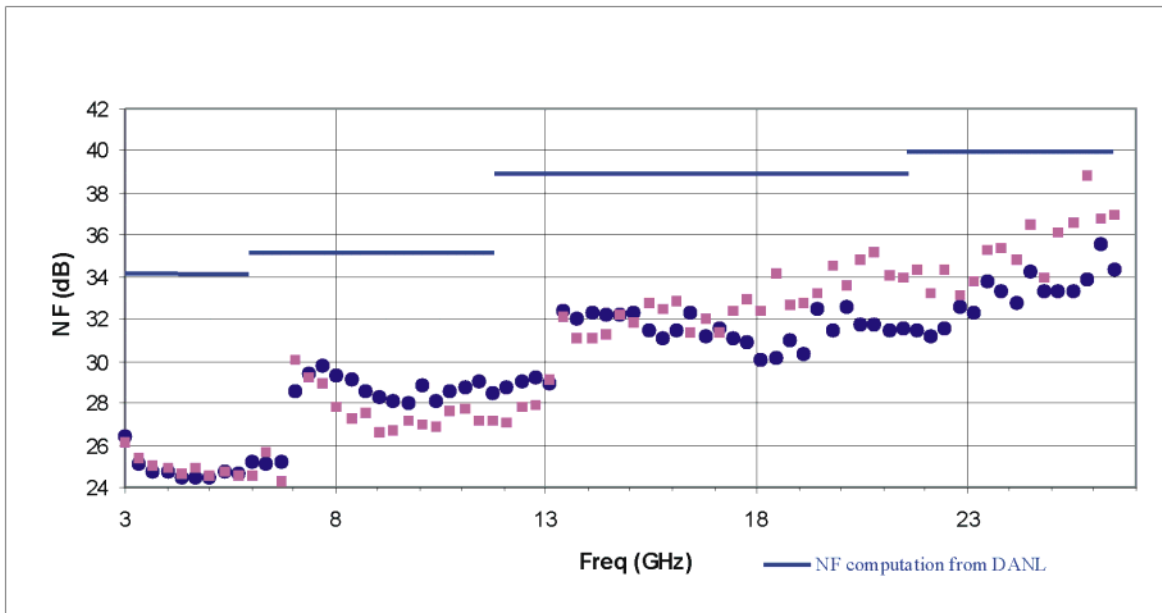

Agilent E4402B Specifications and Characteristics

### Nominal Instrument Input VSWR

#### Nominal Instrument Input VSWR 10 MHz to 3 GHz; Preamp On, Attenuation = 0 dB

VSWR of four instruments shown. Nine graphs are representative of different input coupling configurations of E4401/2/5/7B models.

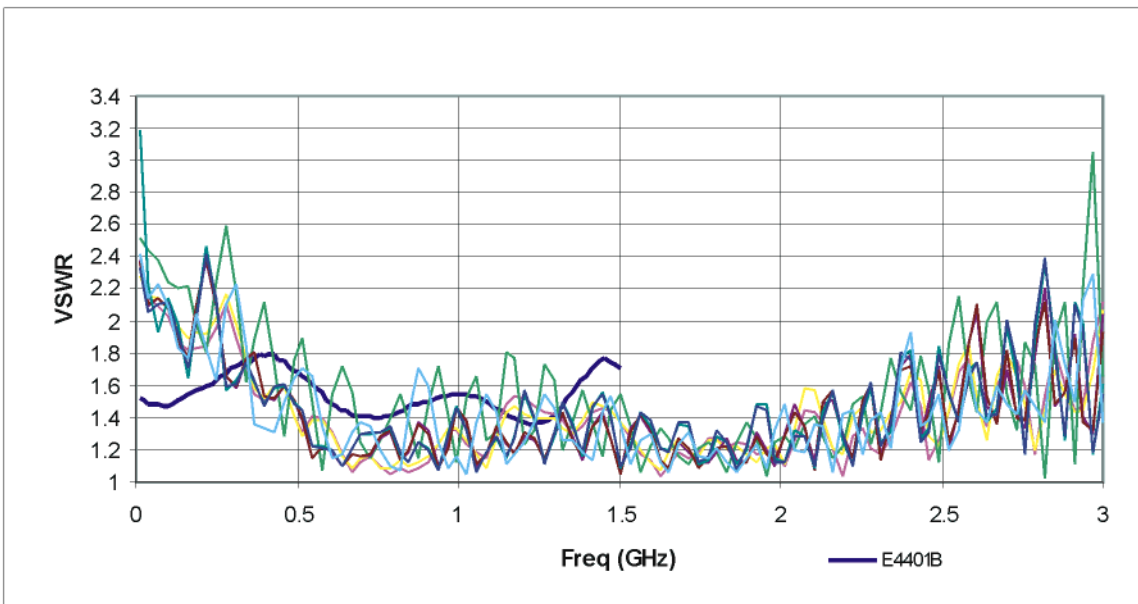

#### Nominal Instrument Input VSWR 3 to 26.5 GHz; No Preamp, Attenuation = 0 dB

VSWR of three instruments shown. Three graphs are representative of different input coupling configurations of E4407B models

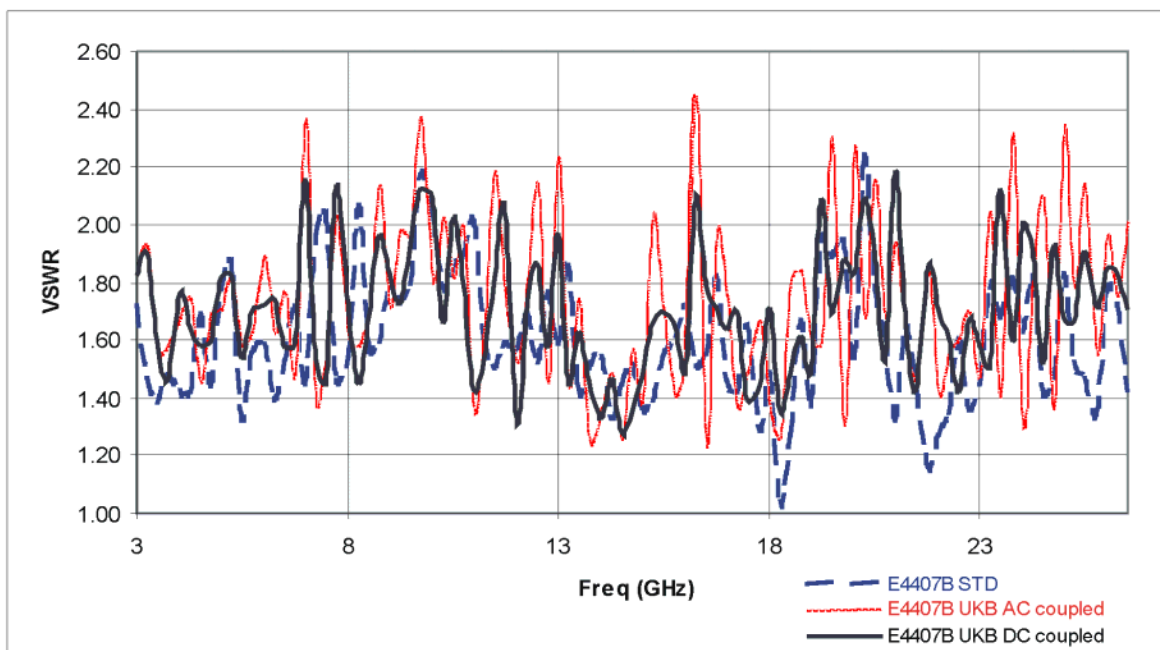



## General

	Specifications	Supplemental Information
<b>Temperature Range</b>		
Operating	0 to 55 °C	Floppy disk 10 to 40 °C
Storage	-40 to 75 °C	

	Specifications	Supplemental Information
<b>Altitude Range</b>		
Operating	Up to 4600 meters	

	Specifications	Supplemental Information
<b>Humidity Range</b>		
Operating	maximum relative humidity 80% for temperatures up to 31°C decreasing linearly to 50% relative humidity at 40°C	

	Specifications	Supplemental Information
<b>Audible Noise (ISO 7779)</b>		
Sound Pressure at 25 °C		<40 dBa, (<4.6 Bels power)

	Specifications	Supplemental Information
<b>Military Specification</b>	Has been type tested to the environmental specifications of MIL-PRF-28800F class 3.	

	Specifications	Supplemental Information
<b>EMI Compatibility</b>	Conducted and radiated emission is in compliance with CISPR Pub. 11/1990 Group 1 Class A.	
(Option 060) <sup>a</sup>	Conducted and radiated emission is in compliance with CISPR Pub. 11/1990 Group 1 Class B <sup>b</sup> .	

a. Option 060 is not compatible with Option B7B nor Option 1DP.

b. Meets Class A performance during dc operation.

	Specifications	Supplemental Information
<b>Immunity Testing</b> Radiated Immunity  Electrostatic Discharge		Testing was done at 3 V/m according to IEC 801-3/1984. When the analyzer tuned frequency is identical to the immunity test signal frequency, there may be signals of up to -60 dBm displayed on the screen.  Air discharges of up to 8 kV were applied according to IEC 801-2/1991. Discharges to center pins of any of the connectors may cause damage to the associated circuitry.

	Specifications	Supplemental Information
<b>Acoustic Noise Emission/Geraeuschemission</b> LpA <70 dB Operator position Normal position Per ISO 7779	LpA <70 dB Am Arbeitsplatz Normaler Betrieb Nach DIN 45635 t.19	

	Specifications	Supplemental Information
<b>Power Requirements</b> ac Operation Voltage, frequency Power Consumption, On Power Consumption, Standby dc Operation Voltage Power Consumption Power Consumption, Standby	90 to 132 Vrms, 47 to 440 Hz 195 to 250 Vrms, 47 to 66 Hz <300 W <5 W 12 to 20 Vdc <200 W <100 mW	

	Specifications	Supplemental Information
<b>Measurement Speed</b>		

	Specifications	Supplemental Information
Local Measurement and Display Update rate <sup>a</sup>		
Sweep points = 101		≥ 45/s, characteristic
Sweep points = 401		≥ 30/s, characteristic
Remote Measurement and GPIB Transfer Rate <sup>b c</sup>		
(Option A4H)		
Sweep points = 101		≥ 45/s, characteristic
Sweep points =401		≥ 30/s, characteristic
RF Center Frequency Tune, Measure, and GPIB Transfer Time <sup>b d</sup>		
(Option A4H)		
Sweep points = 101		≤ 75 ms, characteristic
Sweep points = 401		≤ 90 ms, characteristic

- a. Factory preset, auto align Off, segmented sweep Off, fixed center frequency, RBW = 1 MHz, frequency scale linear, and spans >10 MHz and ≤600 MHz.
- b. Display Off (:DISPlay:ENABle OFF), and 32-bit integer data format (:FORMat:DATA INT,32), if Option AXX or A4J is installed, disable sweep ramp, (:SYSTem: PORTs:IFVSweep: ENABle OFF), markers Off, single sweep, measured with IBM compatible PC with 550 MHz Pentium® III running Windows® NT 4.0, one meter GPIB cable, National Instruments PCI-GPIB card and NI-488.2 DLL.
- c. Factory preset, auto align Off, segmented sweep Off, RBW = 1 MHz, frequency scale linear, span= 20 MHz, fixed center frequency, average of 100 measurements.
- d. Factory preset, auto align Off, segmented sweep Off, RBW = 1 MHz, frequency scale linear, span= 20 MHz, and center frequency tune step size = 50 MHz.

	Specifications	Supplemental Information
<b>Data Storage</b>		
Internal <sup>a</sup>		8.0 MB, nominal
External (10 to 40 °C)		3.5" 1.44 MB, MS-DOS® compatible floppy disk

- a. For serial numbers prior to US41440000 or MY41440000, 1 MB without Option B72, 8 MB with Option B72.

	Specifications	Supplemental Information
<b>Memory Usage</b>		
State		20 kB <sup>a</sup> , nominal

	Specifications	Supplemental Information
State plus 401-point trace		21 kB <sup>a</sup> , nominal
Applications memory usage <sup>b</sup>		
Distance to Fault ( <i>Option 225</i> )		0.6 MB, nominal
Phase noise ( <i>Option 226</i> )		1.1 MB, nominal
Cable TV ( <i>Option 227</i> )		1 MB, nominal
Bluetooth ( <i>Option 228</i> )		1.32 MB, nominal
Modulation Analysis ( <i>Option 229</i> )		1.7 MB, nominal
HP 8566/68B Compatibility ( <i>Option 266</i> )		0.24 MB, nominal
8590 Compatibility ( <i>Option 290</i> )		0.7 MB, nominal
GSM ( <i>Option BAH</i> )		3.2 MB, nominal
CDMA One ( <i>Option BAC</i> )		2.8 MB, nominal
Noise Figure ( <i>Option 219</i> )		1.6 MB, nominal

- a. The size of state will increase depending on installed applications.  
b. Some applications may share files which may reduce total memory usage.

	Specifications	Supplemental Information
<b>Demod Tune and Listen</b>		Internal speaker, front-panel earphone jack and front-panel volume control.
Demod ( <i>Option BAA</i> )  ( <i>Option A4J or AYY</i> )	AM  Add FM	An uncalibrated demodulated signal is available on the AUX VIDEO OUT connector at the rear panel.
( <i>Option 106 or BAA</i> )		An uncalibrated demodulated signal is available on the EXT VIDEO OUT connector at the rear panel.

	Specifications	Supplemental Information
<b>Weight</b> (without options)		
Net		15.5 kg (34.2 lb), characteristic

	<b>Specifications</b>	<b>Supplemental Information</b>
Shipping		27.4 kg (60.4 lb), characteristic

	Specifications	Supplemental Information
<b>Display<sup>a</sup></b>		
Resolution	640 × 480	

- a. The LCD display is manufactured using high precision technology. However, there may be up to six bright points (white, blue, red or green in color) that constantly appear on the LCD screen. These points are normal in the manufacturing process and do not affect the measurement integrity of the product in any way.

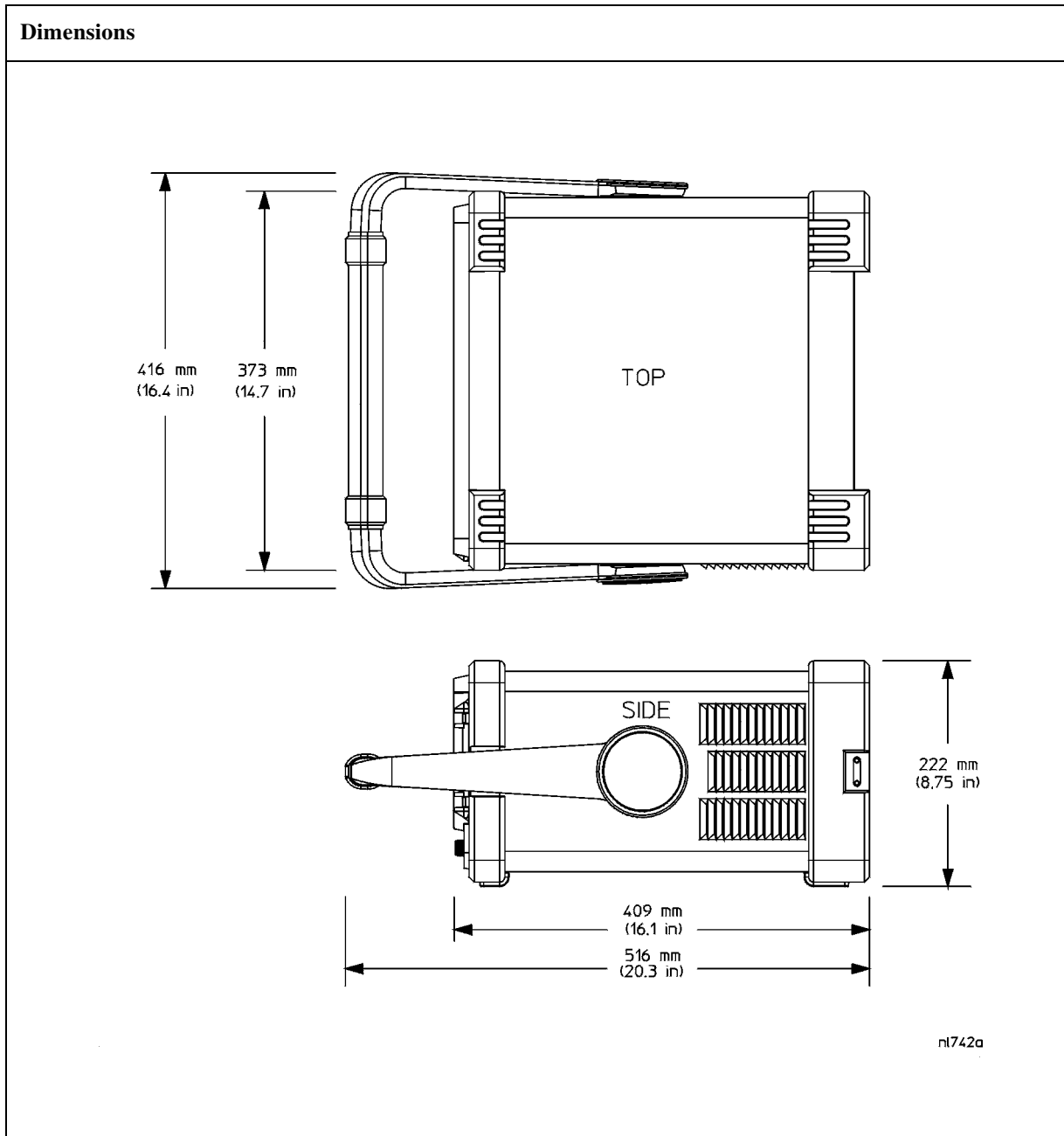

## Inputs and Outputs

### Front Panel

	Specifications	Supplemental Information
<b>INPUT 50 Ω</b>		
Connector	Type-N female	
Impedance		50 Ω, nominal
LO Emissions		< -70 dBm, characteristic. Average level of 1st LO, 3.9214 to 6.9214 GHz, present at INPUT 50 Ω connector.

	Specifications	Supplemental Information
<b>RF OUT 50 Ω, (Option 1DN)</b>		
Connector	Type-N female	
Impedance		50 Ω, nominal

	Specifications	Supplemental Information
<b>AMPTD REF OUT<sup>a</sup></b>		Amplitude Reference
Connector	BNC female	
Impedance		50 Ω, nominal
Frequency		50 MHz
Frequency Accuracy		Frequency reference error <sup>b</sup>
50 Ω Amplitude <sup>c</sup>		-20 dBm, nominal

- a. Turn the amplitude reference on/off by pressing the keys: **Input/Output, Amptd Ref Out.**
- b. Frequency reference error = (aging rate × period of time since adjustment + settability + temperature stability).
- c. The internal amplitude reference actual power is stored internally.

Agilent E4402B Specifications and Characteristics  
**Inputs and Outputs**

	Specifications	Supplemental Information
<b>PROBE POWER</b> Voltage/Current		+15 Vdc, $\pm 7\%$ at 150 mA max., characteristic  -12.6 Vdc $\pm 10\%$ at 150 mA max., characteristic

	Specifications	Supplemental Information
<b>EXT KEYBOARD<sup>a</sup></b>  Connector	  6-pin mini-DIN	Used for entering screen titles and filenames only. Interface compatible with most IBM-compatible PC keyboards.

a. The feature is not implemented in firmware revisions prior to A.04.00.

	Specifications	Supplemental Information
<b>Speaker</b>		Front panel knob controls volume

	Specifications	Supplemental Information
<b>Headphone</b> Connector  Power Output	  3.5 mm (1/8 inch) miniature audio jack	Front panel knob controls volume  0.2 W into 4 $\Omega$ , characteristic



**Rear Panel**

	Specifications	Supplemental Information
<b>10 MHz REF OUT</b>		
Connector	BNC female	
Impedance		50 $\Omega$ , nominal
Output Amplitude		>0 dBm, characteristic

	Specifications	Supplemental Information
<b>10 MHz REF IN</b>		
Connector	BNC female	Note: Analyzer noise sidebands and spurious response performance may be affected by the quality of the external reference used.
Impedance		50 $\Omega$ , nominal
Input Amplitude Range		-15 to +10 dBm, characteristic
Frequency		10 MHz, nominal

	Specifications	Supplemental Information
<b>EXT REF IN</b> (Option B7E)		
Connector	BNC, female	
Impedance		50 $\Omega$ , nominal
Input amplitude range	-5 to 10 dBm	
Frequency	1 to 30 MHz, selectable	
Frequency lock range	$\pm 5 \times 10^{-6}$ of specified external reference input frequency	

Agilent E4402B Specifications and Characteristics

Agilent E4402B Specifications and Characteristics  
**Inputs and Outputs**

Agilent E4402B Specifications and Characteristics

	Specifications	Supplemental Information
<b>10 MHz OUT</b> (Option B7E)		
Connector	BNC, female	
Impedance		50 $\Omega$ , nominal
Frequency		10 MHz, nominal
Level		0 dBm when Option 10 MHz Out is On

	Specifications	Supplemental Information
<b>GATE TRIG/EXT TRIG IN</b>		
Connector	BNC female	
External Trigger Input		
Trigger Level		Selectable positive or negative edge initiates sweep in EXT TRIG mode (5 V TTL)
Gate Trigger Input ( <i>Option 1D6</i> )		
Minimum Pulse Width		>30 ns (5 V TTL)

	Specifications	Supplemental Information
<b>GATE/HI SWP OUT</b>		
Connector	BNC female	
High Sweep Output		
Level		High = sweep <sup>a</sup> ; Low = retrace (5 V TTL)
Gate Output ( <i>Option 1D6</i> )		
Level		High = gate on; Low = gate off (5 V TTL)

a. High sweep may be high longer than the indicated sweep times.

	Specifications	Supplemental Information
<b>VGA OUTPUT</b>		
Connector	VGA compatible, 15-pin mini D-SUB	
Format		VGA (31.5 kHz horizontal, 60 Hz vertical sync rates, non-interlaced) Analog RGB
Resolution	640 × 480	

	Specifications	Supplemental Information
<b>AUX IF OUT</b> <i>(Option A4J or AYY)</i>		RBW ≥ 1 kHz
Connector	BNC female	
Frequency		21.4 MHz, nominal
Amplitude (for signal at reference level and for reference levels – input attenuation + preamp gain of –10 to –70 dBm)		–10 dBm (uncorrected), characteristic
Impedance		50 Ω, nominal

	Specifications	Supplemental Information
<b>AUX VIDEO OUT</b> <i>(Option A4J or AYY)</i>		RBW ≥ 1 kHz
Connector	BNC female	
Amplitude Range (into >10 kΩ)		0 to 1 V (uncorrected), characteristic

	Specifications	Supplemental Information
<b>HI SWP IN</b> <i>(Option A4J or AYY)</i>		
Connector	BNC female	
Input		Open collector, low resets and holds the sweep (5 V TTL)

	Specifications	Supplemental Information
<b>HI SWP OUT</b> <i>(Option A4J or AYY)</i>		
Connector	BNC female	

Agilent E4402B Specifications and Characteristics  
**Inputs and Outputs**

	Specifications	Supplemental Information
Output		High = sweep <sup>a</sup> , Low = retrace (5 V TTL)

a. High sweep may be high longer than the indicated sweep times.

	Specifications	Supplemental Information
<b>SWP OUT</b> (Option A4J or AYX)		
Connector	BNC female	
Amplitude		0 to +10 V ramp, characteristic

	Specifications	Supplemental Information
<b>GPIB Interface</b> (Option A4H)		
Connector	IEEE-488 bus connector	
GPIB Codes		SH1, AH1, T6, SR1, RL1, PP0, DC1, C1, C2, C3 and C28

	Specifications	Supplemental Information
<b>Serial Interface</b> (Option IAX)		
Connector	9-pin D-SUB male	RS-232

	Specifications	Supplemental Information
<b>Parallel Interface</b> (Option A4H or IAX)		Printer port only
Connector	25-pin D-SUB female	

	Specifications	Supplemental Information
<b>EXT VIDEO IN/TV TRIG OUT<sup>a</sup></b> (Option B7B or BAA)		EXT VIDEO IN is the Baseband composite video input for TV trigger and picture on screen. TV TRIG OUT is the TV trigger output.
Connector	BNC Female (75 Ω)	
Impedance		75 Ω, nominal
(Option BAA without Option B7B)		Feature not implemented

	Specifications	Supplemental Information
(Option BAA with Option B7B) External Video Input Video Amplitude  TV Trigger Output  Amplitude		1 V <sub>p-p</sub> , nominal, characteristic  Positive edge indicates start of selected TV line after sync. pulse  TTL (0 V and 3.4 V with 75 Ω series resistance), characteristic

- a. This connector is labelled EXT VIDEO IN on older spectrum analyzers and EXT VIDEO IN/TV TRIG OUT on newer spectrum analyzers.



## Regulatory Information

### CAUTION

This product is designed for use in Installation Category II and Pollution Degree 2 per IEC 1010 and 664 respectively.

### NOTE

This product has been designed and tested in accordance with accepted industry standards, and has been supplied in a safe condition. The documentation contains information and warnings that must be followed by the user to ensure safe operation and to maintain the product in a safe condition.



The CE mark is a registered trademark of the European Community.



The C-Tick mark is a registered trademark of the Australian Spectrum Management Agency.



This ISM device complies with Canadian ICES-001. Cet appareil ISM est conforme à la norme NMB du Canada.

This is also a symbol of an Industrial Scientific and Medical Group 1 Class A product (CISPR 11, Clause 4).



The CSA mark is a registered trademark of the CSA International.



This symbol indicates separate collection for electrical and electronic equipment mandated under EU law as of August 13, 2005. All electric and electronic equipment are required to be separated from normal waste for disposal (Reference WEEE Directive 2002/96/EC).



Indicates the time period during which no hazardous or toxic substance elements are expected to leak or deteriorate during normal use. Forty years is the expected useful life of the product.



This symbol on all primary and secondary packaging indicates compliance to China standard GB 18455-2001.

### Declaration of Conformity

A copy of the Manufacturer's European Declaration of Conformity for this instrument can be obtained by contacting your local Agilent Technologies sales representative.

### Declaration of Compliance

This instrument has been designed and tested in accordance with CAN/CSA 22.2 No. 61010-1-04 & UL Std. No. 61010-1 (2<sup>nd</sup> Edition).





---

**2**

## **Agilent E4404B Specifications and Characteristics**

## About This Chapter

This chapter contains specifications and characteristics for the Agilent E4404B spectrum analyzer. The distinction between specifications and characteristics is described as follows.

- Specifications describe the performance of parameters covered by the product warranty. (The temperature range is 0 °C to 55 °C, unless otherwise noted.)
- Characteristics describe product performance that is useful in the application of the product, but is not covered by the product warranty.
- Typical performance describes additional product performance information that is not covered by the product warranty. It is performance beyond specification that 80% of the units exhibit with a 95% confidence level over the temperature range 20 to 30 °C. Typical performance does not include measurement uncertainty.
- Nominal values indicate the expected performance, or describe product performance that is useful in the application of the product, but is not covered by the product warranty.

The following conditions must be met for the analyzer to meet its specifications.

- o The analyzer is within the one year calibration cycle.
- o If **Auto Align All** is selected:
  - After 2 hours of storage within the operating temperature range.
  - 5 minutes after the analyzer is turned on with sweep times less than 4 seconds.
  - After the front-panel amplitude reference is connected to the INPUT, and **Align Now RF** has been run, after the analyzer is turned on. And, once every 24 hours, or if ambient temperature changes more than 30 °C<sup>1</sup>.
- o If **Auto Align Off** is selected:
  - When the analyzer is at a constant temperature, within the operating temperature range, for a minimum of 90 minutes.
  - After the analyzer is turned on for a minimum of 90 minutes, the front panel amplitude reference has been connected to the INPUT, and **Align Now All** has been run.

1. 10 °C if Preamp (Option 1DS) is active.

- When **Align Now All** is run:
  - Every hour
  - If the ambient temperature changes more than 3 °C
  - If the 10 MHz reference changes
- When **Align Now RF** is run (with the front-panel amplitude reference connected to the INPUT):
  - Every 24 hours
  - If the ambient temperature changes more than 30 °C<sup>1</sup>
- o If **Auto Align All but RF** is selected:
  - When the analyzer is at a constant temperature, within the operating temperature range, for a minimum of 90 minutes.
  - After the analyzer is turned on for a minimum of 90 minutes, the front panel amplitude reference has been connected to the INPUT, and **Align Now RF** has been run.
  - When **Align Now RF** is run (with the front-panel amplitude reference connected to the INPUT):
    - Every hour
    - If the ambient temperature changes more than 3 °C

---

1. 10 °C if Preamp (Option 1DS) is active.

## Frequency

	Specifications	Supplemental Information
<b>Frequency Range</b>		
dc Coupled	9 kHz to 6.7 GHz	30 Hz to 6.7 GHz, characteristic
<i>(Option UKB)</i>	100 Hz to 6.7 GHz	
ac Coupled	100 kHz to 6.7 GHz	
Preamp On <i>(Option 1DS)</i>	1 MHz to 3.0 GHz	

	Specifications	Supplemental Information
<b>Frequency Reference</b>		
Aging Rate	$\pm 2 \times 10^{-6}$ /year	$\pm 1.0 \times 10^{-7}$ /day, characteristic
Settability	$\pm 5 \times 10^{-7}$	
Temperature Stability	$\pm 5 \times 10^{-6}$	

	Specifications	Supplemental Information
<b>High Stability Frequency Reference</b> <i>(Option 1DS)</i>		
Aging Rate	$\pm 1 \times 10^{-7}$ /year	$\pm 5 \times 10^{-10}$ /day, 7-day average after being powered on for 7 days, characteristic
Settability	$\pm 1 \times 10^{-8}$	
Temperature Stability		
20 to 30 °C	$\pm 1 \times 10^{-8}$	
0 to 55 °C	$\pm 5 \times 10^{-8}$	
Warm-up (Internal frequency reference selected)		
After 5 minutes		$< \pm 1 \times 10^{-7}$ of final frequency, <sup>a</sup> characteristic
After 15 minutes		$< \pm 1 \times 10^{-8}$ of final frequency, <sup>a</sup> characteristic

a. Final frequency is defined as frequency 60 minutes after power-on with analyzer set to internal frequency reference.

	Specifications	Supplemental Information
<b>Frequency Readout Accuracy</b> (Start, Stop, Center, Marker)	$\pm((\text{frequency indication} \times \text{frequency reference error}^{\text{a}}) + 0.5\% \text{ of span} + \frac{\text{span}}{\text{sweep points} - 1} + 15\% \text{ of RBW} + 10 \text{ Hz})$	

a. Frequency reference error = (aging rate × period of time since adjustment + settability + temperature stability).

	Specifications	Supplemental Information
<b>Marker Frequency Counter</b>		
Resolution	Selectable from 1 Hz to 100 kHz	
Accuracy <sup>a</sup>	$\pm(\text{marker frequency} \times \text{frequency reference error}^{\text{b}} + \text{counter resolution})$	For RBW ≥ 1 kHz

a. Marker level to displayed noise level > 25 dB, RBW/ Span ≥ 0.002, frequency offset = 0 Hz.  
 b. Frequency reference error = (aging rate × period of time since adjustment + settability + temperature stability).

	Specifications	Supplemental Information
<b>Frequency Span</b>		
Range	0 Hz (zero span), 100 Hz to 6.7 GHz	
Resolution	2 Hz	
Accuracy <sup>a</sup>		
Sweep type Lin	$\pm(0.5\% \text{ of span} + 2 \times \frac{\text{span}}{\text{sweep points} - 1})$	
Sweep type Log		±2.0% of span, nominal

a. Applies to each sweep segment.

	Specifications	Supplemental Information
<b>Sweep Time</b>		
Range		

	Specifications	Supplemental Information
Span > 0 Hz	1 ms to 4000 s <sup>a,b,c</sup>	$\frac{\text{sweep points} - 1}{100 \text{ kHz}}$ to 4000 s
Span = 0 Hz	10 $\mu$ s to 4000 s <sup>a</sup>	
Tracking Generator On (Option 1DN)		50 ms is the minimum sweep time
Fast Time-domain Sweep (Option AYZ) (For Span = 0 Hz, RBW $\geq$ 1 kHz)	50 ns to 4000 s <sup>d,e</sup>	$\frac{\text{sweep points} - 1}{20 \text{ MHz}}$ to 4000 s
DSP and fast ADC (Option B7D) (For Span = 0 Hz, RBW $\geq$ 1 kHz)	25 ns to 4000 s <sup>f</sup>	$\frac{\text{sweep points} - 1}{40 \text{ MHz}}$ to 4000 s
Accuracy (Span = 0 Hz)		
10 $\mu$ s to 4000 s <sup>a,c</sup> (Option AYZ)	$\pm 1\%$	
50 ns to 4000 s <sup>d,e</sup> (Option B7D)	$\pm 1\%$	
25 ns to 4000 s <sup>f</sup>	$\pm 1\%$	
Sweep Trigger <sup>g,h</sup>	Free Run, Single, Line, Video <sup>i</sup> , External, Delayed, Offset <sup>j</sup>	
(Option 1D6)	Add Gate	
(Option B7B)	Add TV	
(Option B7E)	Add RF Burst Trigger	
Delayed Trigger <sup>h,k</sup>		
Range	1 $\mu$ s to 400 s	
Resolution	$\frac{\text{delay in seconds}}{65000}$ rounded up to nearest $\mu$ s	
Accuracy	$\pm(500 \text{ ns} + (0.01\% \text{ of delay}))$	
RF burst trigger (Option B7E)		
Relative level trigger mode		
Peak carrier power range <sup>lm</sup>		30 to -25 dBm, nominal
Preamp On (Option 1DS)		30 to -45 dBm, nominal

	Specifications	Supplemental Information
Trigger level range	0 to -25 dB relative to signal peak	
Absolute level trigger mode		
Peak carrier power range <sup>n,o</sup>		30 to -35 dBm, nominal
Preamp On ( <i>Option IDS</i> )		30 to -55 dBm, nominal
Offset Trigger <sup>i</sup>		
Resolution	$\frac{\text{sweep time}}{\text{sweep points} - 1}$	
Range	±327 ms to ±12.3 ks	Where ST = sweep time and SP = sweep points $\frac{-32766 \times ST}{SP - 1}$ to $\frac{(32766 - SP) \times ST}{SP - 1}$
Fast Time-domain sweep ( <i>Option AYX</i> ) (For sweep times $\frac{\text{sweep points} - 1}{20 \text{ MHz}}$ to $\frac{\text{sweep points} - 1}{100 \text{ kHz}}$ )	±1.23 ms to ±245 ms	$\frac{-32766 \times ST}{SP - 1}$ to $\frac{(32766 - SP) \times ST}{SP - 1}$
DSP and fast ADC ( <i>Option B7D</i> ) (For sweep times $\frac{\text{sweep points} - 1}{40 \text{ MHz}}$ to $\frac{\text{sweep points} - 1}{100 \text{ kHz}}$ )	±13 ms to ±5.15 s	$\frac{-524031 \times ST}{SP - 1}$ to $\frac{(524031 - SP) \times ST}{SP - 1}$

- a. For firmware revisions prior to A.04.00, 5 ms to 2000 s.
- b. For spans ≥ 10 MHz and ≤ 600 MHz, and stop frequency ≤ 3 GHz.
- c. For firmware revisions prior to A.05.00, 1 ms to 4000 s.
- d. For firmware revisions prior to A.04.00, 20 μs to 2000 s.
- e. For firmware revisions prior to A.05.00, 5 μs to 4000 s.
- f. For firmware revisions prior to A.05.00, 2.5 μs to 4000 s.
- g. Gate cannot be used simultaneously with delayed or TV trigger (*Option B7B*).
- h. Auto align is suspended in video, external, gate, and delayed trigger modes while waiting for a trigger event to occur.
- i. Unavailable when RBW ≤ 300 Hz (*Option 1DR*).
- j. For firmware revision A.04.00 or later.
- k. Delayed trigger is available with line, external trigger, and TV trigger (*Option B7B*).
- l. With trigger level set to -6 dB.
- m. For GSM-type signals (burst length 570 μs, burst period 4.63 ms, constant envelope). Ranges with other types of signals may differ.
- n. Nominal values apply for Bluetooth-type signals (burst length 625 μs, burst period 50 ms). Ranges with other types of signals may differ.
- o. With trigger level set 5 dB below peak signal level.

	Specifications	Supplemental Information
<b>Sweep (trace) Points</b>		
Range		
Span > 0 Hz	101 to 8192 <sup>a</sup>	
Span = 0 Hz	2 to 8192 <sup>a,b</sup>	

- a. For firmware revisions prior to A.04.00, 401 points.  
b. For firmware revisions prior to A.05.00, 101 to 8192 points.

	Specifications	Supplemental Information
<b>Resolution Bandwidth (RBW)</b>		
Range		
-3 dB bandwidth	1 kHz to 3 MHz, in 1-3-10 sequence, 5 MHz <sup>a</sup>	
(Option IDR)	Adds 10, 30, 100, 300 Hz <sup>a,b</sup>	
(Option IDR and 1D5)	Adds 1, 3 Hz <sup>a,b</sup>	
-6 dB bandwidth (EMI)	9 kHz and 120 kHz	
(Option IDR)	Add 200 Hz <sup>a,b</sup>	
Accuracy		
1 Hz to 3 Hz (-3 dB) RBW <sup>c</sup> (Option IDR and 1D5)	±10%	
10 Hz to 300 Hz (-3 dB) RBW (Option IDR)	±10%	
1 kHz to 3 MHz (-3 dB) RBW	±15%	
5 MHz (-3 dB) RBW	±30%	
9 kHz, 120 kHz (-6 dB) RBW (EMI)	±20%	
200 Hz (-6 dB) RBW (EMI) (Option IDR)	±10%	
Shape		
1 Hz to 3 Hz RBW <sup>c</sup> (Option IDR and 1D5)		Digital, approximately Gaussian shape
10 Hz to 300 Hz RBW (Option IDR)		Digital, approximately Gaussian shape
1 kHz to 5 MHz RBW		Synchronously tuned four poles, approximately Gaussian shape



	Specifications	Supplemental Information
Selectivity (60 dB/3 dB bandwidth ratio)		
1 Hz to 3 Hz RBW <sup>c</sup> (Option 1DR and 1D5)		<5:1, nominal
10 Hz to 300 Hz RBW (Option 1DR)		<5:1, nominal
1 kHz to 5 MHz RBW		<15:1, nominal

- a. The Average detector is not compatible with the 5 MHz resolution bandwidths, nor with resolution bandwidths <1 kHz.
- b. Only available in spans ≤5 MHz, sweep times ≥ (sweep points – 1)/100 kHz and not usable with tracking generator on (Option 1DN).
- c. Firmware revision A.08.00 and later.

Agilent E4404B Specifications and Characteristics  
**Frequency**

	Specifications	Supplemental Information
<b>Video Bandwidth (VBW) (-3 dB)</b>		
Range	30 Hz to 1 MHz in 1-3-10 sequence	3 MHz, characteristic
(Option IDR)	Adds 1, 3, 10 Hz for RBW's <1 kHz	
Accuracy		±30%, characteristic
Shape		Post detection, single pole low-pass filter used to average displayed noise  Video bandwidths below 30 Hz are digital bandwidths with anti-aliasing filtering.

	Specifications	Supplemental Information
<b>Stability</b>		
Noise Sidebands (Offset from CW signal with 1 kHz RBW, 30 Hz VBW and sample detector)		
<b>Serial prefixes ≥ MY4510, SG4510, US4510</b>		
≥1 kHz (Option IDR, ID5)		≤ -78 dBc/Hz, typical
≥10 kHz (Option IDR)	≤ -98 dBc/Hz	≤ -101 dBc/Hz, typical
≥10 kHz	≤ -90 dBc/Hz	≤ -94 dBc/Hz, typical
≥20 kHz	≤ -104 dBc/Hz	≤ -107 dBc/Hz, typical
≥30 kHz	≤ -110 dBc/Hz	≤ -113 dBc/Hz, typical
≥100 kHz	≤ -118 dBc/Hz	≤ -122 dBc/Hz, typical
≥1 MHz	≤ -125 dBc/Hz	≤ -127 dBc/Hz, typical
≥5 MHz	≤ -127 dBc/Hz	≤ -129 dBc/Hz, typical
≥10 MHz	≤ -131 dBc/Hz	≤ -136 dBc/Hz, typical
<b>Serial prefixes &lt; MY4510, SG4510, US4510</b>		
≥1 kHz (Option IDR, ID5)		≤ -78 dBc/Hz, typical
≥10 kHz	≤ -90 dBc/Hz	≤ -94 dBc/Hz, typical
≥20 kHz	≤ -100 dBc/Hz	≤ -105 dBc/Hz, typical
≥30 kHz	≤ -106 dBc/Hz	≤ -112 dBc/Hz, typical

	Specifications	Supplemental Information
≥100 kHz	≤ -118 dBc/Hz	≤ -122 dBc/Hz, typical
≥1 MHz	≤ -125 dBc/Hz	≤ -127 dBc/Hz, typical
≥5 MHz	≤ -127 dBc/Hz	≤ -129 dBc/Hz, typical
≥10 MHz	≤ -131 dBc/Hz	≤ -136 dBc/Hz, typical
<i>(Option 120)</i>		
≥1 MHz	≤ -133 dBc/Hz	≤ -136 dBc/Hz, typical
≥5 MHz	≤ -135 dBc/Hz	≤ -139 dBc/Hz, typical
≥10 MHz	≤ -137 dBc/Hz	≤ -141 dBc/Hz, typical
Residual FM		
1 kHz RBW, 1 kHz VBW	≤150 Hz p-p in 100 ms	
<i>(Option 1D5)</i>	≤100 Hz p-p in 100 ms	
10 Hz RBW, 10 Hz VBW	≤2 Hz p-p in 20 ms	
<i>(Option 1DR and 1D5)</i>		
10 Hz RBW, 10 Hz VBW		≤10 Hz p-p in 20 ms, characteristic
<i>(Option 1DR)</i>		
System-Related Sidebands, offset from CW signal		
≥30 kHz	≤ -65 dBc	
Line-Related Sidebands, offset from CW signal <i>(Option 1DR)</i>		
<300 Hz		≤ -50 dBc, characteristic
>300 Hz to 30 kHz		≤ -55 dBc, characteristic

Noise Sidebands Normalized to 1 Hz Versus Offset from Carrier

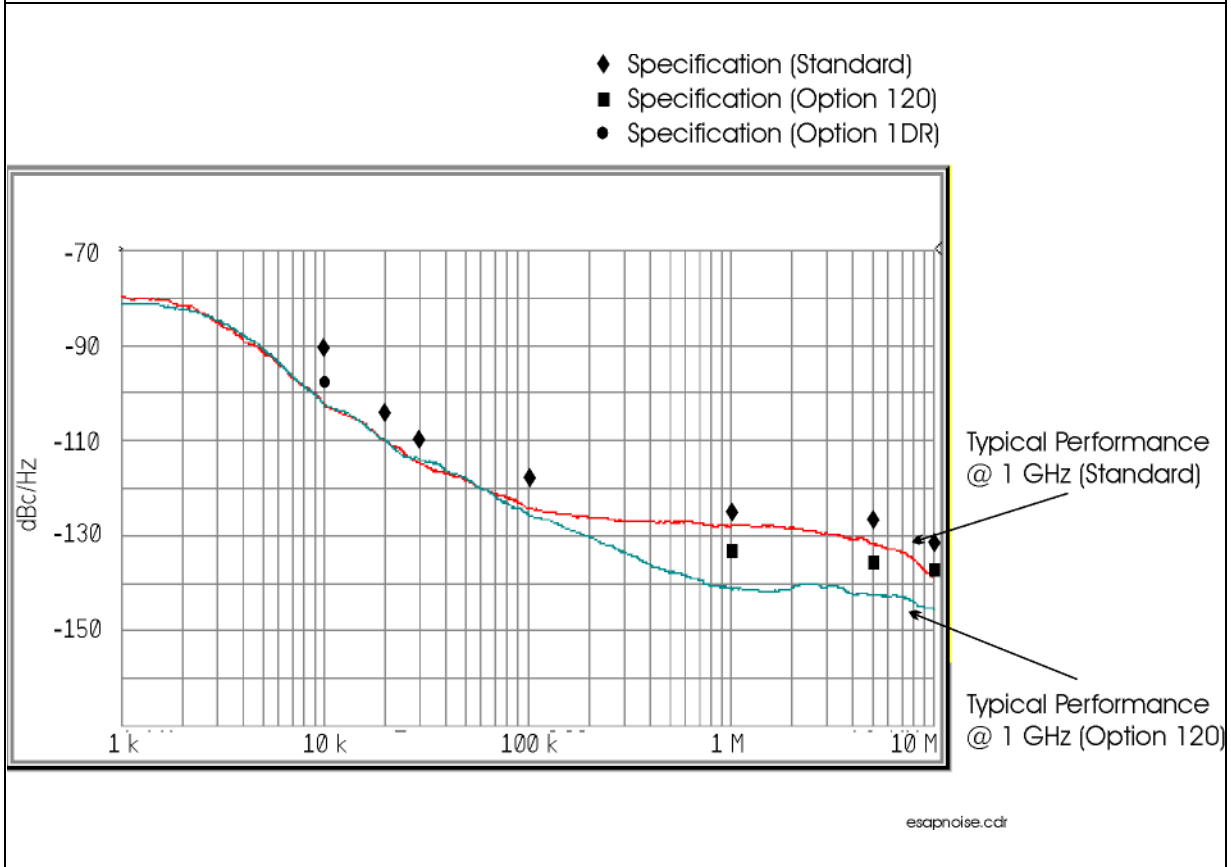

## Amplitude

Amplitude specifications do not apply for the negative peak detector mode.

	Specifications	Supplemental Information
<b>Measurement Range</b>	Displayed Average Noise Level to Maximum Safe Input Level	
Input Attenuator Range	0 to 65 dB, in 5 dB steps	0 to 75 dB, in 5 dB steps, characteristic

	Specifications	Supplemental Information
<b>Maximum Safe Input Level</b>		
Average Continuous Power (Input attenuator setting $\geq 5$ dB)	+30 dBm (1 W)	
Peak Pulse Power (for $<10$ $\mu$ sec pulse width, $<1\%$ duty cycle, and input attenuation $\geq 30$ dB)	+50 dBm (100 W)	
dc		
dc Coupled	0 Vdc	
ac Coupled	50 Vdc	

	Specifications	Supplemental Information
<b>1 dB Gain Compression</b>		
Total power at input mixer <sup>a,b</sup>		
50 MHz to 3.0 GHz	0 dBm	
3.0 GHz to 6.7 GHz	0 dBm	
Preamp On ( <i>Option IDS</i> )		
Total power at the preamp <sup>c</sup>		-20 dBm, characteristic

- a. Mixer power level (dBm) = input power (dBm) – input attenuation (dB).
- b. For resolution bandwidths 1 kHz to 30 kHz, the maximum input signal amplitude must be  $\leq$  reference level +10 dB.
- c. Total power at the preamp (dBm) = total power at the input (dBm) – input attenuation (dB).

	Specifications	Supplemental Information
<b>Displayed Average Noise Level</b>		

Agilent E4404B Specifications and Characteristics  
Amplitude

	Specifications		Supplemental Information		
(Input terminated, 0 dB attenuation, sample detector, Reference Level = -70 dBm)					
	1 kHz RBW 30 Hz VBW	10 Hz RBW 1 Hz VBW (Option 1DR)	1 kHz RBW 30 Hz VBW (typical)	10 Hz RBW 1 Hz VBW (Option 1DR) (typical)	1 Hz RBW 1 Hz VBW (Option 1DR and 1D5) <sup>a</sup> (typical)
30 Hz to 9 kHz (Option UKB)				≤ -93 dBm	≤ -103 dBm
9 kHz to 100 kHz				≤ -109 dBm	≤ -119 dBm
100 kHz to 1 MHz				≤ -135 dBm	≤ -145 dBm
1 MHz to 10 MHz			≤ -117 dBm	≤ -137 dBm	≤ -147 dBm
1 MHz to 10 MHz (Option 120)			≤ -120 dBm	≤ -139 dBm	≤ -149 dBm
10 MHz to 1.0 GHz	≤ -116 dBm	≤ -135 dBm	≤ -119 dBm	≤ -139 dBm	≤ -149 dBm
1.0 GHz to 2.0 GHz	≤ -116 dBm	≤ -135 dBm	≤ -120 dBm	≤ -140 dBm	≤ -150 dBm
2.0 GHz to 3.0 GHz	≤ -112 dBm	≤ -131 dBm	≤ -118 dBm	≤ -138 dBm	≤ -148 dBm
3.0 GHz to 6.0 GHz	≤ -112 dBm	≤ -131 dBm	≤ -118 dBm	≤ -138 dBm	≤ -148 dBm
6.0 GHz to 6.7 GHz	≤ -111 dBm	≤ -130 dBm	≤ -117 dBm	≤ -137 dBm	≤ -147 dBm
Preamp On (Option 1DS)	1 kHz RBW 30 Hz VBW	10 Hz RBW 1 Hz VBW (Option 1DR)	1 kHz RBW 30 Hz VBW (typical)	10 kHz RBW 1 Hz VBW (Option 1DR) (typical)	1 Hz RBW 1 Hz VBW (Option 1DR and 1D5) <sup>a</sup> (typical)
0 to 55 °C					
10 MHz to 1.0 GHz	≤ -131 dBm	≤ -150 dBm			
1.0 GHz to 2.0 GHz	≤ -131 dBm	≤ -150 dBm			
2.0 GHz to 3.0 GHz	≤ -127 dBm	≤ -146 dBm			
20 to 30 °C					
1 MHz to 10 MHz			≤ -135 dBm	≤ -155 dBm	≤ -165 dBm
10 MHz to 1.0 GHz	≤ -132 dBm	≤ -151 dBm	≤ -137 dBm	≤ -157 dBm	≤ -167 dBm
1.0 GHz to 2.0 GHz	≤ -132 dBm	≤ -151 dBm	≤ -135 dBm	≤ -155 dBm	≤ -165 dBm
2.0 GHz to 3.0 GHz	≤ -130 dBm	≤ -149 dBm	≤ -132 dBm	≤ -152 dBm	≤ -162 dBm

a. Only available with firmware revision A.08.00 or later

	Specifications	Supplemental Information
<b>Display Range</b>		
Log Scale	Ten divisions displayed; 0.1, 0.2, 0.5 dB/division and 1 to 20 dB/division in 1 dB steps	
RBW $\geq$ 1 kHz	Calibrated 0 to -85 dB from Reference Level	
RBW $\leq$ 300 Hz ( <i>Option 1DR</i> )	Calibrated 0 to -120 dB <sup>a</sup> from Reference Level	
Linear Scale	Ten divisions	
Scale Units	dBm, dBmV, dB $\mu$ V, dB $\mu$ A, A, V, and W	
( <i>Option BAA, 106</i> )	Add Hz	

a. 0 to -70 dB range when span = 0 Hz, or when IF Gain is fixed:  
(:DISPlay:WINDow:TRACe:Y[:SCALE]:LOG:RANGE:AUTO OFF).

	Specifications	Supplemental Information
<b>Marker Readout Resolution</b>		
Log scale		
RBW $\geq$ 1 kHz	0 to -85 dB from ref level	0.04 dB
RBW $\leq$ 300 Hz ( <i>Option 1DR</i> )	0 to -120 dB from ref level	0.04 dB
Linear scale		0.01% of Reference Level
Fast Sweep Times for Zero Span ( <i>Option AYX</i> )		
For sweep times		
$\frac{\text{sweep points} - 1}{20 \text{ MHz}}$ to		
$\frac{\text{sweep points} - 1}{100 \text{ kHz}}$		
Log		
0 to -85 dB from ref level		0.3 dB
Linear		0.3% of Reference Level for linear scale

**Amplitude**

	Specifications	Supplemental Information
<p><i>(Option B7D)</i>                      For sweep times  <math>\frac{\text{sweep points} - 1}{40 \text{ MHz}}</math>  <math>\frac{\text{sweep points} - 1}{100 \text{ kHz}}</math></p> <p>For:  <math>\frac{\text{sweep points} - 1}{\text{sweep time}} &lt; 40 \text{ MHz}</math></p> <p>Log                      0 to -85 dB from ref level</p> <p>Linear</p> <p>For:  <math>\frac{\text{sweep points} - 1}{\text{sweep time}} \geq 40 \text{ MHz}</math></p> <p>Log                      0 to -85 dB from ref level</p> <p>Linear</p>	<p>0.2 dB</p> <p>0.2% of Reference Level</p> <p>0.3 dB</p> <p>0.3% of Reference Level</p>	

Agilent E4404B Specifications and Characteristics

	Specifications	Supplemental Information
<p><b>Frequency Response</b></p> <p>50 Ω, Absolute<sup>a</sup>/Relative</p> <p>10 dB attenuation (dc coupled)</p> <p>9 kHz to 3.0 GHz</p> <p>20 to 30 °C</p> <p>0 to 55 °C</p> <p>(ac coupled)</p> <p>100 kHz to 3.0 GHz</p> <p>20 to 30 °C</p> <p>0 to 55 °C</p> <p>800 MHz to 1.0 GHz</p> <p>20 to 30 °C</p> <p>0 to 55 °C</p> <p>1.7 GHz to 2.0 GHz</p> <p>20 to 30 °C</p>	<p>±0.46 dB</p> <p>±0.76 dB</p> <p>±0.50 dB</p> <p>±1.0 dB</p> <p>±0.50 dB</p> <p>±1.0 dB</p> <p>±0.50 dB</p>	<p>±0.14 dB, typical</p> <p>±0.10 dB, typical</p> <p>±0.08 dB, typical</p>



	Specifications	Supplemental Information
0 to 55 °C (Option UKB)	±1.0 dB	
100 Hz to 3.0 GHz (dc coupled)		
20 to 30 °C	±0.50 dB	
0 to 55 °C	±1.00 dB	
30 Hz to 3.0 GHz (dc coupled)		
20 to 30 °C		±0.5 dB, characteristic
0 to 55 °C		±1.0 dB, characteristic
Absolute <sup>a</sup> /Relative, Preamp On (Option IDS)		
0 dB attenuation		
1 MHz to 3.0 GHz		
20 to 30 °C	±1.5 dB	
0 to 55 °C	±2.0 dB	
800 MHz to 1.0 GHz		
20 to 30 °C	±1.5 dB	±0.35 dB, typical
0 to 55 °C	±2.0 dB	
1.7 GHz to 2.0 GHz		
20 to 30 °C	±1.5 dB	±0.26 dB, typical
0 to 55 °C	±2.0 dB	
Preselector centered for frequency >3.0 GHz		
10 dB attenuation		
3.0 GHz to 6.7 GHz (ac or dc coupled)		
Absolute <sup>a</sup>		
20 to 30 °C	±1.5 dB	
0 to 55 °C	±2.5 dB	
Relative		
20 to 30 °C	±1.3 dB	
0 to 55 °C	±1.5 dB	

Agilent E4404B Specifications and Characteristics  
**Amplitude**

a. Absolute frequency response values are referenced to the amplitude at 50 MHz.

	Specifications	Supplemental Information
<b>Input Attenuation Switching Uncertainty at 50 MHz</b>		
Attenuator Setting		
0 dB to 5 dB	±0.3 dB	
10 dB	Reference	
15 dB	±0.3 dB	
20 to 65 dB attenuation	±(0.1 dB + 0.01 × Attenuator Setting)	

Attenuation Accuracy Relative to the 10 dB Attenuator Setting, Characteristic		
	Frequency Range	
Attenuation	dc–3.0 GHz	3.0–6.7 GHz
0 dB	±0.3 dB	±0.5 dB
5 dB	±0.3 dB	±0.5
10 dB	Reference	Reference
15 dB	±0.4 dB	±0.5 dB
20 dB	±0.4 dB	±0.5 dB
25 dB	±0.5 dB	±0.6 dB
30 dB	±0.5 dB	±0.6 dB
35 dB	±0.6 dB	±0.7 dB
40 dB	±0.6 dB	±0.7 dB
45 dB	±0.7 dB	±1.0 dB
50 dB	±0.7 dB	±1.0 dB
55 dB	±0.9 dB	±1.1 dB
60 dB	±0.9 dB	±1.1 dB
65 dB	±1.0 dB	±1.6 dB

	Specifications	Supplemental Information
<b>Preamp (Option 1DS)</b>		Refer also to Displayed Average Noise Level specification
Gain		+20 dB, nominal <sup>a</sup>

	<b>Specifications</b>	<b>Supplemental Information</b>
Noise figure		5 dB, characteristic

- a. Amplifier is between the input attenuator and the input mixer.

	Specifications	Supplemental Information
<b>Absolute Amplitude Accuracy</b>		
At reference settings <sup>a</sup>	±0.34 dB	±0.13 dB, typical
Preamp On <sup>b</sup> ( <i>Option IDS</i> )	±0.37 dB	±0.14 dB, typical
95 % Confidence Absolute Amplitude Accuracy Input Frequency ≤ 3 GHz –50 dBm ≤ Input Power ≤ 0dBm –50 dBm ≤ Ref Level ≤ 0 dBm –20 dBm ≤ (Input Power – Ref Level) ≤ 0dBm Input Attenuation = 10 dBm 10 Hz ≤ RBW ≤ 1 MHz 20 to 30 °C		±0.4 dB
<b>Overall Amplitude Accuracy<sup>c</sup></b>		
20 to 30 °C	± (0.54 dB + Absolute Frequency Response)	

- Settings are: reference level –20 dBm; input attenuation 10 dB; dc coupled; center frequency 50 MHz; RBW 1 kHz; VBW 1 kHz; amplitude scale linear or log; span 2 kHz; frequency scale linear; sweep time coupled, sample detector, signal at reference level.
- Settings are: reference level –30 dBm; input attenuation 0 dB; dc coupled; center frequency 50 MHz; RBW 1 kHz; VBW 1 kHz; amplitude scale linear or log; span 2 kHz; frequency scale linear; sweep time coupled, signal at reference level.
- For reference level 0 to –50 dBm; input attenuation 10 dB; dc coupled; RBW 1 kHz; VBW 1 kHz; amplitude scale log, log range 0 to –50 dB from reference level; frequency scale linear; sweep time coupled; signal input 0 to –50 dBm; span ≤20 kHz.

	Specifications	Supplemental Information	
<b>RF Input VSWR</b> (at tuned frequency)		characteristic	characteristic
Attenuator setting 0 dB		(dc coupled)	(ac coupled)
9 kHz to 100 kHz		≤3.0:1	
100 kHz to 6.7 GHz		≤3.0:1	≤3.0:1
100 Hz to 100 kHz ( <i>Option UKB</i> )		≤1.1:1	
Attenuator setting 5 dB		(dc coupled)	(ac coupled)
9 kHz to 100 kHz		≤2.0:1	
100 kHz to 300 kHz		≤1.4:1	≤2.3:1
300 kHz to 1.0 MHz		≤1.4:1	≤1.6:1

	Specifications	Supplemental Information	
1.0 MHz to 3.0 GHz		≤1.4:1	≤1.4:1
3.0 GHz to 6.7 GHz		≤1.4:1	≤1.7:1
100 Hz to 100 kHz (Option UKB)		≤1.1:1	
Attenuator setting 10 to 65 dB		(dc coupled)	(ac coupled)
9 kHz to 100 kHz		≤2.0:1	
100 kHz to 300 kHz		≤1.3:1	≤2.1:1
300 kHz to 1.0 MHz		≤1.3:1	≤1.5:1
1.0 MHz to 3.0 GHz		≤1.3:1	≤1.3:1
3.0 GHz to 6.7 GHz		≤1.3:1	≤1.5:1
100 Hz to 100 kHz (Option UKB)		≤1.1:1	

	Specifications	Supplemental Information	
<b>Auto Alignment<sup>a</sup></b>			
Sweep-to-sweep variation		±0.1 dB, characteristic	

a. Set **Auto Align** to **Off** and use **Align Now, All** to eliminate this variation.

	Specifications	Supplemental Information
<b>Resolution Bandwidth Switching Uncertainty (at Reference Level)</b>		
1 kHz RBW	Reference	
3 kHz to 3 MHz RBW	±0.3 dB	
5 MHz RBW	±0.6 dB	
10 Hz to 300 Hz RBW (Option 1DR)	±0.3 dB	
1 Hz to 3 Hz RBW (Option 1DR and 1D5) <sup>a</sup>	±0.3 dB	

a. Firmware revision A.08.00 or later.

	Specifications	Supplemental Information
<b>Reference Level</b>		
Range	-149.9 dBm to maximum mixer level + attenuator setting	
Resolution		
Log Scale	±0.1 dB	
Linear Scale	±0.12% of Reference Level	
Accuracy (at a fixed frequency, a fixed attenuator, and referenced to -30 dBm (-10 dBm, Preamp On (Option 1DS)))		
Reference Level (dBm) – input attenuator setting (dB) + preamp gain (dB)		
-10 dBm to > -60 dBm	±0.3 dB	
-60 dBm to > -85 dBm	±0.5 dB	
-85 dBm to -90 dBm	±0.7 dB	

	Specifications	Supplemental Information
<b>Display Scale Switching Uncertainty</b>		
Switching between Linear and Log	$\pm 0.15$ dB at reference level	
Log Scale Switching	No error	

	Specifications	Supplemental Information
<b>Display Scale Fidelity</b>		
Log Maximum Cumulative		
RBW $\geq 1$ kHz		
dB Below Reference Level		
0 dB Reference	0 dB	
> 0 to 10 dB	$\pm 0.3$ dB	$\pm 0.08$ dB, typical
> 10 to 20 dB	$\pm 0.4$ dB	$\pm 0.09$ dB, typical
> 20 to 30 dB	$\pm 0.5$ dB	$\pm 0.10$ dB, typical
> 30 to 40 dB	$\pm 0.6$ dB	$\pm 0.23$ dB, typical
> 40 to 50 dB	$\pm 0.7$ dB	$\pm 0.35$ dB, typical
> 50 to 60 dB	$\pm 0.7$ dB	$\pm 0.35$ dB, typical
> 60 to 70 dB	$\pm 0.8$ dB	$\pm 0.39$ dB, typical
> 70 to 80 dB	$\pm 0.8$ dB	$\pm 0.46$ dB, typical
> 80 to 85 dB	$\pm 1.15$ dB	$\pm 0.79$ dB, typical
RBW $\leq 300$ Hz ( <i>Option 1DR</i> )		
Span > 0 Hz		
Auto range On		
0 to 98 dB <sup>a</sup> below reference level	$\pm(0.3 \text{ dB} + 0.01 \times \text{dB from reference level})$	
> 98 to 120 dB below reference level		$\pm 2.0$ dB, characteristic
Auto range Off <sup>b</sup>		
0 to 60 dB <sup>a</sup> below reference level	$\pm(0.3 \text{ dB} + 0.015 \times \text{dB from reference level})$	
> 60 to 70 dB below reference level	$\pm 1.5$ dB	

	Specifications	Supplemental Information
Span = 0 Hz		
0 to 60 dB <sup>a</sup> below reference level	$\pm(0.3 \text{ dB} + 0.015 \times \text{dB from reference level})$	
> 60 to 70 dB below reference level	$\pm 1.5 \text{ dB}$	
Log Incremental Accuracy		
0 to 80 dB <sup>a,c</sup> below reference level	$\pm 0.4 \text{ dB}/4 \text{ dB}$	
Linear Accuracy	$\pm 2\%$ of Reference Level	

- a. 0 to 30 dB for RBW = 200 Hz
- b. The SCPI command for auto range off is:  
(:DISPlay:WINDow:TRACe:Y[:SCALE]:LOG:RANGE:AUTO OFF)
- c. 0 to 50 dB for RBWs  $\leq$  300 Hz and span = 0 Hz, or when auto ranging is off.

	Specifications	Supplemental Information
<b>Spurious Responses</b>		
Second Harmonic Distortion		
Input Signal		
10 MHz to 500 MHz	$< -65 \text{ dBc}$ for $-30 \text{ dBm}$ signal at input mixer <sup>a</sup>	+35 dBm SHI (second harmonic intercept)
500 MHz to 1.5 GHz	$< -75 \text{ dBc}$ for $-30 \text{ dBm}$ signal at input mixer <sup>a</sup>	+45 dBm SHI
1.5 GHz to 2.0 GHz	$< -85 \text{ dBc}$ for $-10 \text{ dBm}$ signal at input mixer <sup>a</sup>	+75 dBm SHI
2.0 GHz to 3.35 GHz	$< -100 \text{ dBc}^b$ for $-10 \text{ dBm}$ signal at input mixer <sup>a</sup>	+90 dBm SHI
Preamp On ( <i>Option 1DS</i> ) 10 MHz to 1.5 GHz		-5 dBm SHI, characteristic
Third Order Intermodulation Distortion		
10 MHz to 100 MHz		+7 dBm TOI (third order intercept), characteristic
100 MHz to 3 GHz	$< -85 \text{ dBc}$ for two $-30 \text{ dBm}$ signals at input mixer <sup>a</sup> and $> 50 \text{ kHz}$ separation	+12.5 dBm TOI +16 dBm TOI, typical



	Specifications	Supplemental Information
3.0 GHz to 6.7 GHz	< -82 dBc for two -30 dBm signals at input mixer <sup>a</sup> and >50 kHz separation	+11 dBm TOI +18 dBm TOI, typical
Preamp On ( <i>Option 1DS</i> ) 10 MHz to 3 GHz		-16 dBm TOI, characteristic
Other Input Related Spurious		
Inband Responses		
>30 kHz offset	< -65 dBc for -20 dBm signal at input mixer <sup>a</sup>	
Out-of-band Responses	< -80 dBc for -10 dBm signal at input mixer <sup>a</sup>	

a. Mixer power level (dBm) = input power (dBm) – input attenuation (dB).

b. For signal below displayed average noise level.

	Specifications	Supplemental Information
<b>W-CDMA Adjacent Channel Power Ratio<sup>a</sup></b>		
Dynamic range <sup>b</sup>		
Offset frequency		
5 MHz		-60.0 dBc, characteristic
10 MHz		-64.5 dBc, characteristic
( <i>Option 120</i> )		
5 MHz		-65.0 dBc, characteristic
10 MHz		-65.5 dBc, characteristic
( <i>Option 120</i> ) With noise correction On <sup>c</sup>		
5 MHz		-66.5 dBc, characteristic
10 MHz		-67.0 dBc, characteristic

- a. Firmware revision A.07.00 or higher
- b. Measured by selecting “Measure, ACP”, 20 to 30 °C, 3GPP (3.1 Dec 1999) W-CDMA signal with 1 DPCH, channel power -9 dBm/3.84 MHz, integration bandwidth 3.84 MHz, carrier frequency 2 GHz, reference level -16 dBm, input attenuation 0 dB, RBW 30 kHz.
- c. Noise correction can be turned On by selecting **Meas Setup, More, Noise Corr On**

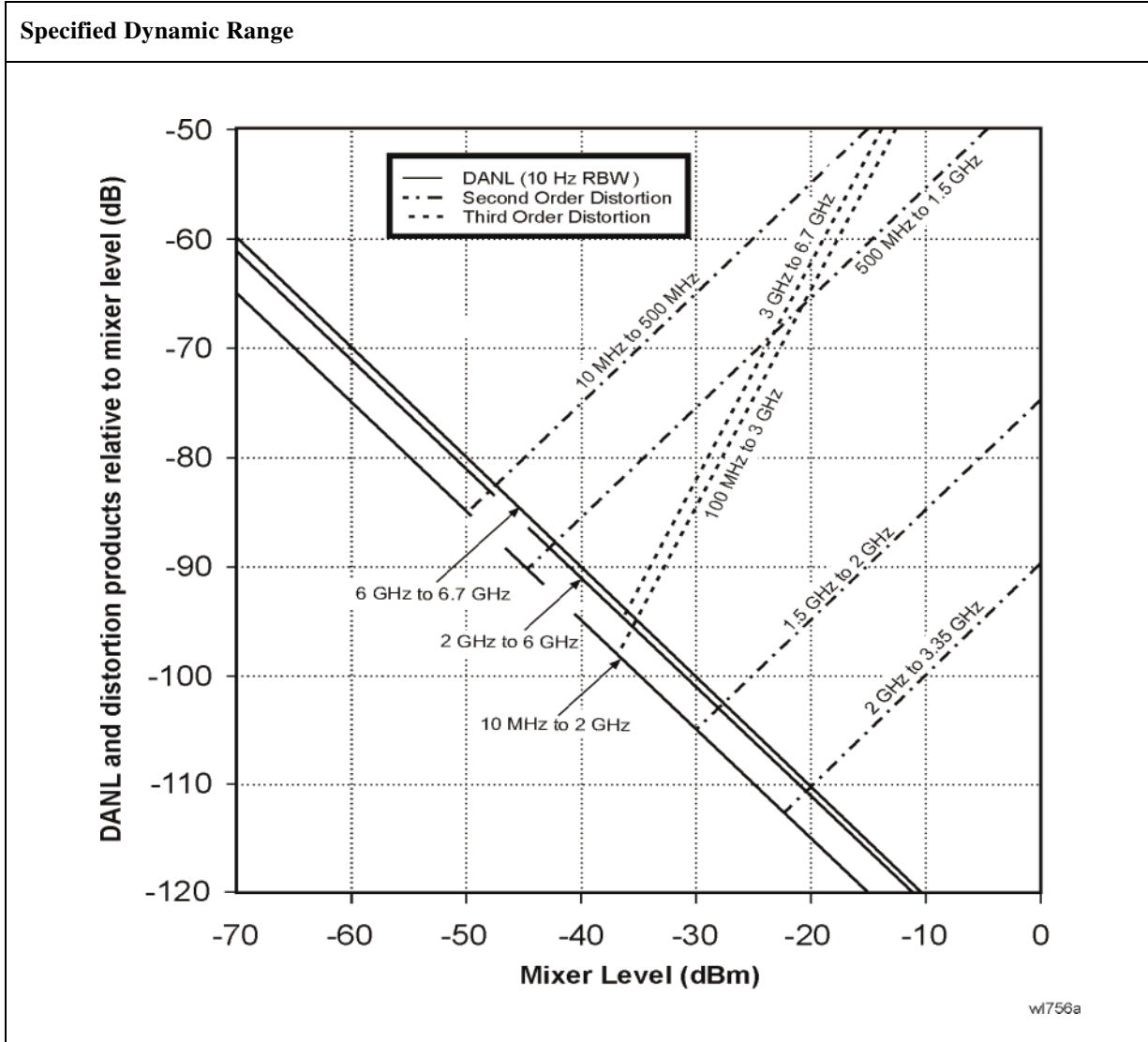

	Specifications	Supplemental Information
<b>Residual Responses</b> (Input terminated and 0 dB attenuation) 150 kHz to 6.7 GHz	< -90 dBm	

Agilent E4404B Specifications and Characteristics

## Options

### Time Gated Spectrum Analysis (Option 1D6)

	Specifications	Supplemental Information
<b>Gate Delay</b>		
Range	1 $\mu$ s to 400 s	
Accuracy	$\pm(500 \text{ ns} + (0.01\% \times (\text{maximum of gate delay or length})))$	From gate trigger input to positive edge of gate output
<b>Gate Length</b>		
Range	1 $\mu$ s to 400 s	
Accuracy	$\pm(500 \text{ ns} + (0.01\% \times (\text{maximum of gate delay or length})))$	From positive edge to negative edge of gate output
<b>Resolution</b>	$((\text{maximum of gate delay or length in seconds})/65000)$ rounded up to nearest $\mu$ s	Dependent on the greater of gate delay or gate length
<b>Additional Amplitude Error<sup>a</sup></b>		
Log Scale	$\pm 0.2 \text{ dB}$	
Linear Scale	$\pm 0.1\%$ of reference level	

a. While in gate mode.

### Tracking Generator (Option 1DN)

The spectrum analyzer/tracking generator combination will meet its specification after a cable (8120-5148) and adapter are connected between RF OUT and INPUT and **Align Now, TG** has been run.

	Specifications	Supplemental Information
<b>Warm-up</b>	5 minutes	

	Specifications	Supplemental Information
<b>Output Frequency Range</b>	9 kHz to 3.0 GHz	

	Specifications	Supplemental Information
<b>Minimum Resolution BW</b>	1 kHz	Not usable with resolution bandwidths $\leq 300$ Hz ( <i>Option 1DR</i> )

	Specifications	Supplemental Information
<b>Output Power Level</b>		
Range	-2 to -66 dBm	
Resolution	0.1 dB	
Absolute Accuracy (at 50 MHz with coupled source attenuator, referenced to -20 dBm)	$\pm 0.75$ dB	
Vernier		
Range	8 dB	
Accuracy (with coupled source attenuator, 50 MHz, -20 dBm)		
Incremental	$\pm 0.2$ dB/dB	
Cumulative	$\pm 0.5$ dB, total	
Output Attenuator Range	0 to 56 dB in 8 dB steps	

	Specifications	Supplemental Information
<b>Maximum Safe Reverse Level</b>		+30 dBm (1 W), 50 Vdc, characteristic

Agilent E4404B Specifications and Characteristics  
Options

	Specifications	Supplemental Information
<b>Output Power Sweep</b>		
Range	(-10 to -2 dBm) – (Source Attenuator Setting)	
Resolution	0.1 dB	
Accuracy (zero span)	<1 dB peak-to-peak	

	Specifications	Supplemental Information
<b>Output Flatness</b>		
Referenced to 50 MHz, -20 dBm		
9 kHz to 10 MHz	±3 dB	
10 MHz to 3 GHz	±2 dB	

	Specifications	Supplemental Information
<b>Spurious Outputs</b>		
(-2 dBm output)		
Harmonic Spurs		
TG Output 9 kHz to 20 kHz	≤ -15 dBc	
TG Output 20 kHz to 3 GHz	≤ -25 dBc	
Non-harmonic Spurs		
TG Output 9 kHz to 2 GHz	≤ -27 dBc	
TG Output 2 GHz to 3 GHz	≤ -23 dBc	
LO Feedthrough		
LO Frequency 3.921409 GHz to 6.9214 GHz	≤ -16 dBm	

	Specifications	Supplemental Information
<b>Dynamic Range</b>	Maximum Output Power Level – Displayed Average Noise Level	

	Specifications	Supplemental Information
<b>Output Tracking</b>		
Drift		1.5 kHz/5 minute, characteristic

	Specifications	Supplemental Information
Swept Tracking Error		Usable in 1 kHz RBW after 5 minutes of warm-up

	Specifications	Supplemental Information
<b>RF Power-Off Residuals</b> 9 kHz to 3 GHz		< -120 dBm, characteristic

	Specifications	Supplemental Information
<b>Output Attenuator Repeatability</b> 9 kHz to 300 MHz 300 MHz to 2 GHz 2 GHz to 3 GHz		±0.1 dB, characteristic ±0.2 dB, characteristic ±0.3 dB, characteristic

	Specifications	Supplemental Information
<b>Output VSWR</b> 0 dB attenuation ≥ 8 dB attenuation		<2.0:1, characteristic <1.5:1, characteristic

	Specifications	Supplemental Information
<b>Output Attenuator Accuracy</b> 0 dB 8 dB 16 dB 24 dB 32 dB 40 dB 48 dB 56 dB	Reference	±0.5 dB, characteristic ±0.5 dB, characteristic ±0.5 dB, characteristic ±0.6 dB, characteristic ±0.8 dB, characteristic ±1.0 dB, characteristic ±1.1 dB, characteristic

<b>Tracking Generator Output Accuracy</b>
Relative Accuracy (Referred to -20 dBm) = Output Attenuator Accuracy + Vernier Accuracy + Output Flatness

Agilent E4404B Specifications and Characteristics

<b>Tracking Generator Output Accuracy</b>
---

Absolute Accuracy = Relative Accuracy (Referred to -20 dBm) + Absolute Accuracy at 50 MHz
--



### Phase Noise (Option 226)

Carrier Frequency Range	Specifications	Supplemental Information
E4402B	1 MHz to 3.0 GHz	
E4404B	1 MHz to 6.7 GHz	
E4405B	1 MHz to 13.2 GHz	
E4407B	1 MHz to 26.5 GHz	

Measurement Characteristics	Specifications	Supplemental Information
Measurements	Log plot Spot frequency RMS noise RMS jitter Residual FM	
Maximum number of decades	7 (whole decades only)	
Filtering (ratio of video bandwidth to resolution bandwidth)	None (VBW/RBW = 1.0) Little (VBW/RBW = 0.3) Medium (VBW/RBW = 0.1) Maximum (VBW/RBW = 0.03)	

Offset Frequency	Specifications	Supplemental Information
Range	10 kHz to 100 MHz	The minimum offset is limited to 10 times the narrowest RBW of the analyzer
<i>(Option1DR)</i>	100 Hz to 100 MHz	
<i>(Option1DR and 1D5)</i>	10 Hz to 100 MHz	

Measurement Accuracy	Specifications	Supplemental Information
<b>Amplitude Accuracy<sup>a</sup></b> (carrier frequency 1 MHz to 3.0 GHz)		±1.52 dB <sup>b</sup>

- a. Amplitude accuracy is derived from analyzer specification and characteristics. It is based on a 1 GHz signal at 0 dBm while running the log plot measurement with all other measurement and analyzer settings at their factory defaults.
- b. This does not include the effect of system noise floor. This error is a function of the signal (phase noise) to noise (analyzer noise floor) ratio, SN, in decibels. The function is  $\text{Error} = 10 \times \log(1 + 10^{-\text{SN}/10})$ . For example, if the phase noise being measured is 10 dB above the measurement floor, the error due to adding the analyzer's noise to the UUT is 0.41 dB.

Amplitude Repeatability	Specifications	Supplemental Information			
		<b>Standard Deviation<sup>a,b</sup></b>			
		<b>No Filtering</b>	<b>Little Filtering</b>	<b>Medium Filtering</b>	<b>Maximum Filtering</b>
No Smoothing					
Offset					
100 Hz <sup>c</sup>		5.9 dB	4.9 dB	4.0 dB	3.9 dB
1 kHz <sup>c</sup>		5.8 dB	4.7 dB	3.7 dB	3.5 dB
10 kHz		4.4 dB	2.4 dB	2.4 dB	1.7 dB
100 kHz		3.9 dB	2.3 dB	1.7 dB	1.6 dB
1 MHz		3.2 dB	2.2 dB	1.4 dB	0.95 dB
4% Smoothing <sup>d</sup>					
Offset					
100 Hz <sup>c</sup>		1.8 dB	1.5 dB	1.2 dB	1.1 dB
1 kHz <sup>c</sup>		1.0 dB	0.58 dB	0.57 dB	0.49 dB
10 kHz		0.83 dB	0.54 dB	0.41 dB	0.29 dB
100 kHz		0.78 dB	0.51 dB	0.36 dB	0.20 dB
1 MHz		0.67 dB	0.23 dB	0.23 dB	0.20 dB

- a. Amplitude repeatability is the nominal standard deviation of the measured phase noise. This table comes from an observation of 30 log plot measurements using a 1 GHz, 0 dBm signal with the filtering and smoothing settings shown. All other analyzer and measurement settings are set to their factory defaults.
- b. The standard deviation can be further reduced by applying averaging. The standard deviation will improve by a factor of the square root of the number of averages. For example, 10 averages will improve the standard deviation by a factor of 3.162.
- c. These offsets are available only when Option 1DR is installed.
- d. Smoothing can cause additional amplitude errors near rapid transitions of the data, such as with discrete spurious signals and impulsive noise. The effect is more pronounced as the number of points smoothed increases.

	Specifications	Supplemental Information
Frequency Offset Accuracy <sup>a</sup>	± 3.7%	0.053 octave

a. The frequency offset error in octaves causes an additional amplitude accuracy error proportional to the product of the frequency error and slope of the phase noise. For example, a 0.01 octave frequency error combined with an 18 dB/octave slope gives 0.18 dB additional amplitude error.

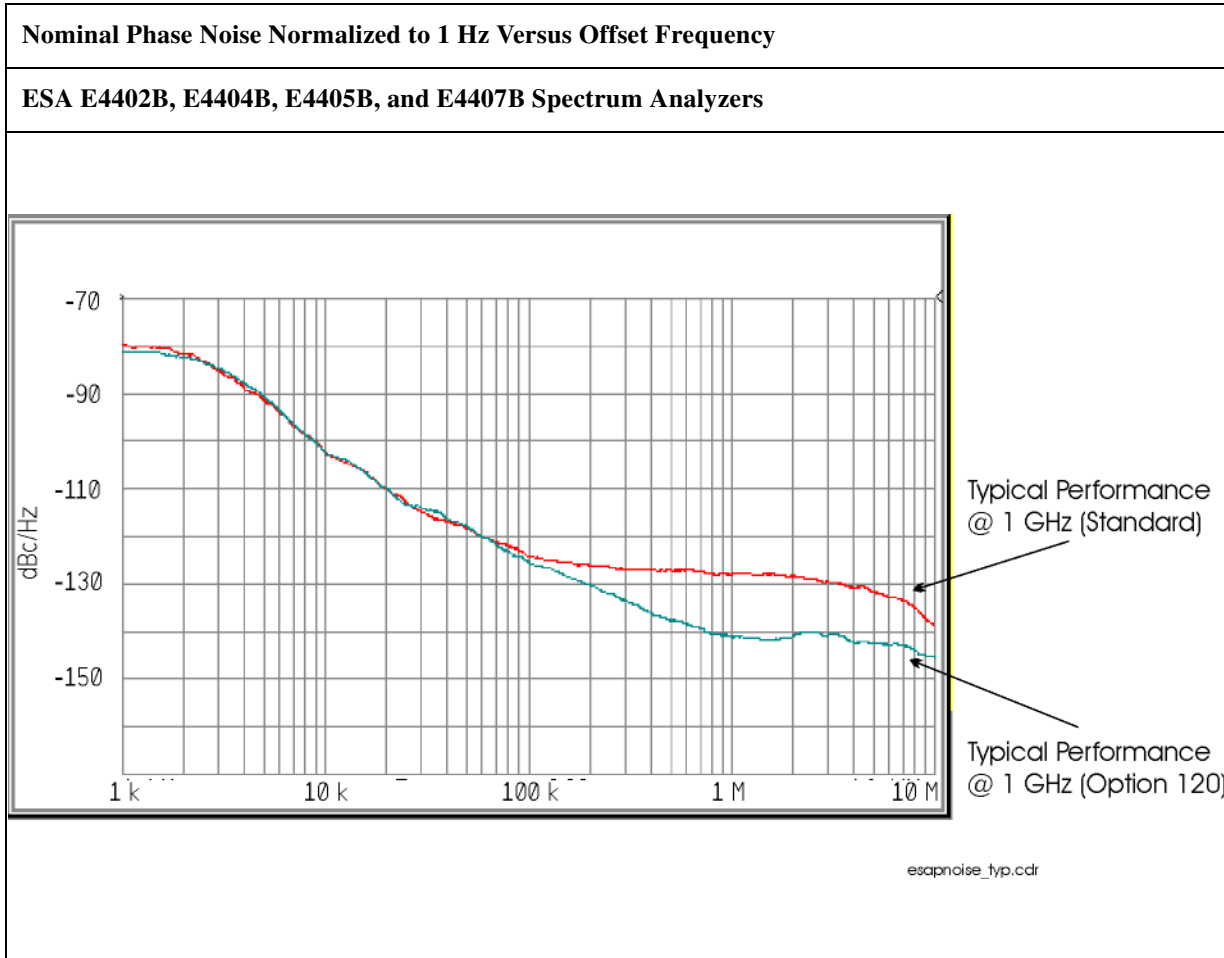

Agilent E4404B Specifications and Characteristics

### FM Demodulation and Quasi Peak Detector (Option AYQ)

The FM demodulation characteristics will apply after an **Align Now, FM Demod** has been run.

	Specifications	Supplemental Information
<b>Optimum Input Level</b>		$\geq (-60 \text{ dBm} + \text{attenuator setting} - \text{preamp gain})$ and within 30 dB of the reference level
<b>FM Deviation</b>		
Range		10 kHz to 1 MHz
Resolution		300Hz, characteristic
Accuracy <sup>a</sup>		$< (2\% \text{ of FM deviation range} + 2 \times \text{Resolution})$ , characteristic
FM Rate $< \text{FM BW}/100$ , VBW $\geq (30 \times \text{FM Rate})$ , RBW $>$ the maximum of ( $30 \times \text{FM deviation}$ ) or ( $30 \times \text{FM Rate}$ )		
Offset Error <sup>a</sup>		5% of FM Deviation Range + 300 Hz, characteristic
<b>FM Bandwidth</b> (-3 dB)		
FM Deviation Range		
10 kHz to 40 kHz		$0.5 \times \text{FM deviation range}$ , characteristic
$>40 \text{ kHz}$ to 200 kHz		$0.5 \times \text{FM deviation range}$ , characteristic
$>200 \text{ kHz}$ to 1 MHz		$0.4 \times \text{FM deviation range}$ , characteristic

a. In time domain sweeps (span = 0 Hz)

	Specifications	Supplemental Information
<b>Quasi-Peak Detector</b>	<p>The quasi-peak detector provides the quasi-peak amplitude of pulsed radio frequency (RF) or continuous wave (CW) signals.</p> <p>The amplitude response conforms to Publication 16 of CISPR Section 1, Clause 2, except as indicated in the Relative Quasi-Peak Response Table.</p>	

Relative Quasi-Peak Response to a CISPR Pulse (dB)			
Frequency Band			
Pulse Repetition Frequency	120 kHz EMI BW 0.03 to 1 GHz	9 kHz EMI BW 0.15 to 30 MHz	200 Hz EMI BW 9 to 150 kHz
1000 Hz	+8.0 ± 1.0	+4.5 ± 1.0	N/A
100 Hz	0 dB reference <sup>a</sup>	0 dB reference <sup>a</sup>	+4.0 ± 1.0
60 Hz	N/A	N/A	+3.0 ± 1.0
25 Hz	N/A	N/A	0 dB reference <sup>a</sup>
20 Hz	-9.0 ± 1.0	-6.5 ± 1.0	N/A
10 Hz	-14.0 ± 1.5	-10.0 ± 1.5	-4.0 ± 1.0
5 Hz	N/A	N/A	-7.5 ± 1.5
2 Hz	-26.0 ± 2.0	-20.5 ± 2.0	-13.0 ± 2.0
1 Hz		-22.5 ± 2.0	-17.0 ± 2.0
Isolated Pulse		-23.5 ± 2.0	-19.0 ± 2.0

- a. Reference pulse amplitude accuracy relative to a 66 dBμV CW signal is <1.5 dB as specified in CISPR Publication 16. CISPR reference pulse: 0.044 μVs for 30 MHz to 1.0 GHz, 0.316 μVs for 15 kHz to 30 MHz, and 13.5 μVs for 9 to 150 kHz.

### Bluetooth FM Demodulation (Option 106)

The FM demodulation characteristics will apply after an **Align Now, FM Demod** has been run.

	Specifications	Supplemental Information
<b>Optimum Input Level</b>		$\geq (-40 \text{ dBm} + \text{attenuator setting} - \text{preamp gain})$ and within 10 dB of the reference level
<b>FM Deviation</b>		
Range		$\pm 200 \text{ kHz}$ , nominal
Resolution		Provides 400 Hz display annotation resolution, nominal
Accuracy <sup>a</sup>		$\pm 10 \text{ kHz}$ , typical
Input level = -30 dBm		$\pm 4 \text{ kHz}$ with video averaging On and averages $\geq 25$
Reference level = -30 dBm		
FM Rate = 500 kHz sine		
VBW = 3 MHz,		
RBW = 5 MHz,		
FM Deviation = 140 kHz		
Offset Errora		$\pm 1 \text{ kHz}$ , typical
<b>FM Bandwidth</b> (-3 dB)		1.2 MHz, nominal

a. In time domain sweeps (span = 0 Hz).

### Bluetooth Measurements Personality (Option 228)

The demodulation related nominal values will apply after an **Align Now**, **FM Demod** has been run.

	Specifications	Supplemental Information
<b>In-Band Frequency Range</b>		
Bluetooth (ISM) Band	2400 to 2483.5 MHz	

	Specifications	Supplemental Information
<b>Output Power</b> (Option AYX or B7D)		
Range at RF Input	30 to -40 dBm	
(Option 1DS)	30 to -60 dBm	
Absolute Amplitude Accuracy		See “Absolute Amplitude Accuracy” on page 55.
Average type	Video, Power	
Average mode	Exponential, Repeat	
Trigger source	Video, RF burst <sup>a</sup> , External, Free Run	
Burst synch	RF Amplitude, Preamble <sup>b</sup> , None	

a. Requires Option B7E

b. Requires Option 106 Bluetooth FM demodulation.

	Specifications	Supplemental Information
<b>Modulation Characteristics<sup>a</sup></b> (Option 106 and AYX or B7D)		
Range at RF Input	30 to -40 dBm	
(Option 1DS)	30 to -60 dBm	
FM Deviation		
Range		±200 kHz, nominal
Accuracy		±4 kHz, nominal (25 measurement averages, signal level > -30 dBm)
Payload data	11110000, 10101010, auto-detect	
Average mode	Exponential, Repeat	

Agilent E4404B Specifications and Characteristics  
Options

	Specifications	Supplemental Information
Trigger source	Video, RF burst <sup>b</sup> , External, Free Run	
Burst synch	RF Amplitude, Preamble <sup>c</sup> , None	
Limits	$\Delta f_2/\Delta f_1$ lower, $\Delta f_1$ max lower/upper $\Delta f_2$	

- a. The DUT must have frequency hopping disabled.
- b. Requires Option B7E
- c. Requires Option 106 Bluetooth FM demodulation.

	Specifications	Supplemental Information
<b>Carrier Frequency Drift</b> <sup>a</sup> (Option 106 and AYX or B7D)		
Range at RF Input	30 to -40 dBm	
(Option 1DS)	30 to -60 dBm	
Measurement range		$\pm 100$ kHz, nominal
Measurement accuracy		$\pm 4$ kHz, nominal (25 measurement averages, signal level > -30 dBm)
Average mode	Exponential, Repeat	
Trigger source	Video, RF burst <sup>b</sup> , External, Free Run	
Burst synch	Preamble <sup>c</sup> , None	

- a. The DUT must have frequency hopping disabled.
- b. Requires Option B7E
- c. Requires Option 106 Bluetooth FM demodulation.



	Specifications	Supplemental Information
<b>Initial Carrier Frequency Tolerance (ICFT)</b> <sup>a</sup> (Option 106 and AYX or B7D)		
Range at RF Input (Option 1DS)	30 to -40 dBm 30 to -60 dBm	
Measurement range		±100 kHz, nominal
Measurement accuracy		±4 kHz, nominal (25 measurement averages, signal level > -30 dBm)
Average mode	Exponential, Repeat	
Trigger source	Video, RF burst <sup>b</sup> , External, Free Run	
Burst synch	RF Amplitude, Preamble <sup>c</sup> , None	
Limits	ICFT upper/lower	

- a. The DUT must have frequency hopping disabled.
- b. Requires Option B7E
- c. Requires Option 106 Bluetooth FM demodulation.

### FM Demodulation (Option BAA)

The FM demodulation characteristics will apply after an **Align Now, FM Demod** has been run.

	Specifications	Supplemental Information
<b>Optimum Input Level</b>		$\geq (-60 \text{ dBm} + \text{attenuator setting} - \text{preamp gain})$ and within 30 dB of the reference level
<b>FM Deviation</b>		
Range		10 kHz to 1 MHz
Resolution		Provides 1 Hz display annotation resolution
FM Deviation Range		
10 kHz to 40 kHz		12 Hz, characteristic
>40 kHz to 200 kHz		60 Hz, characteristic
>200 kHz to 1 MHz		300 Hz, characteristic
Accuracy <sup>a</sup>		
FM Rate < FM BW/100, VBW $\geq (30 \times \text{FM Rate})$ , RBW > the maximum of (30 $\times$ FM deviation) or (30 $\times$ FM Rate)		< (2% of FM deviation range + 2 $\times$ Resolution), characteristic
Offset Error <sup>a</sup>		5% of FM Deviation Range + 300 Hz, characteristic
<b>FM Bandwidth</b> (-3 dB)		
FM Deviation Range		
10 kHz to 40 kHz		7.5 $\times$ FM deviation range, characteristic
>40 kHz to 200 kHz		1.3 $\times$ FM deviation range, characteristic
>200 kHz to 1 MHz		0.3 $\times$ FM deviation range, characteristic

a. In time domain sweeps (span = 0 Hz).

## TV Trigger and Picture On Screen (Option B7B)

Option BAA is required.

	Specifications	Supplemental Information
<b>TV Trigger and Picture On Screen</b>		TV Trigger initiates a sweep of the analyzer after the sync pulse of a selected line of a TV video field. Picture On Screen displays the TV picture on the analyzer display.
Amplitude Requirements TV Source: SA		Top 50% of linear display, characteristic
TV Source: EXT VIDEO IN		500 mVp-p to 2 Vp-p, characteristic
Compatible Standards	NTSC-M, NTSC-Japan, PAL-M, PAL-B,D,G,H,I, PAL-N, PAL-N Combination, SECAM-L	
Field Selection	Entire frame, even, odd	
Sync Polarity	Positive or negative	
<b>TV Trigger</b>		
Line Selection	1 to 525, or 1 to 625, standard dependent	

### cdmaOne Measurement Personality (Option BAC)

Unless otherwise noted, all specifications are with RF input range auto, default cdmaOne measurement settings, and in the in-band frequency range. Option B72 is required.

	Specifications	Supplemental Information
<b>In-Band Frequency Range</b>		
Cellular bands	824 to 870 MHz 869 to 925 MHz	
PCS bands	1715 to 1780 MHz 1805 to 1870 MHz 1850 to 1910 MHz 1930 to 1990 MHz	

	Specifications	Supplemental Information
<b>Adjacent Channel Power Ratio<sup>a</sup></b>		
Carrier power range at RF Input	30 to -20 dBm	
Dynamic range <sup>b</sup>		Referenced to average power of carrier in 1.23 MHz BW
Offset Frequency	Integration BW	
750 kHz	30 kHz	-70.0 dBc, characteristic
885 kHz	30 kHz	-73.5 dBc, characteristic
1.25625 MHz	12.5 kHz	-78.0 dBc, characteristic
1.98 MHz	30 kHz	-75.5 dBc, characteristic
2.75 MHz	1 MHz	-60.5 dBc, characteristic
Relative accuracy <sup>c</sup>	See Display Scale Fidelity	
Resolution	0.01 dB	

- This measurement is available with personality revisions of A.02.00 or later.
- IS-97A nominal base station test model levels (fraction of carrier power); Pilot: 0.20 (-7.0 dBc), Sync: 0.0471 (-13.3 dBc), Paging: 0.1882 (-7.3 dBc), 6 Traffic channels: 0.09412 (-10.3 dBc)
- Does not include uncertainty due to noise.

	Specifications	Supplemental Information
<b>Channel Power (1.23 MHz Integration BW)</b>		Integration BW range 1 kHz to 10 MHz
Range at RF Input	30 to $\angle 70$ dBm	
Absolute power accuracy for in-band signal (Mean channel power at RF Input, plus any external attenuation, excluding mismatch error)		
Cellular Bands		
30 to -5 dBm 20 to 30 °C	$\pm 0.82$ dB	$\pm 0.39$ dB, typical
0 to 55 °C	$\pm 1.09$ dB	
-5 to -25 dBm 20 to 30 °C	$\pm 0.78$ dB	$\pm 0.37$ dB, typical
0 to 55 °C	$\pm 1.05$ dB	
-25 to -45 dBm 20 to 30 °C	$\pm 0.69$ dB	$\pm 0.21$ dB, typical
0 to 55 °C	$\pm 0.94$ dB	
-45 to -55 dBm 20 to 30 °C	$\pm 0.77$ dB	$\pm 0.28$ dB, typical
0 to 55 °C	$\pm 0.96$ dB	
-55 to -70 dBm 20 to 30 °C	$\pm 0.89$ dB	$\pm 0.38$ dB, typical
0 to 55 °C	$\pm 1.21$ dB	
PCS Bands		
30 to -5 dBm 20 to 30 °C	$\pm 0.78$ dB	$\pm 0.26$ dB, typical
0 to 55 °C	$\pm 1.11$ dB	
-5 to -25 dBm 20 to 30 °C	$\pm 0.74$ dB	$\pm 0.23$ dB, typical
0 to 55 °C	$\pm 1.02$ dB	
-25 to -45 dBm 20 to 30 °C	$\pm 0.71$ dB	$\pm 0.26$ dB, typical
0 to 55 °C	$\pm 0.99$ dB	
-45 to -55 dBm 20 to 30 °C	$\pm 0.79$ dB	$\pm 0.33$ dB, typical

Agilent E4404B Specifications and Characteristics  
Options

	Specifications	Supplemental Information
0 to 55 °C	±1.01 dB	±0.43 dB, typical
-55 to -70 dBm 20 to 30 °C	±0.91 dB	
0 to 55 °C	±1.26 dB	

	Specifications	Supplemental Information
Channel power relative power accuracy (same channel, different Tx power, input attenuator fixed, RF input range manual).	See Display Scale Fidelity	

	Specifications	Supplemental Information
<b>Receive Channel Power</b>		
Absolute Power Accuracy		
Cellular bands		
30 to 0 dBm	±0.95 dB	±0.53 dB, typical
0 to -85 dBm	±1.46 dB	±0.63 dB, typical
PCS bands		
30 to 0 dBm	±0.97 dB	±0.52 dB, typical
0 to -85 dBm	±1.35 dB	±0.59 dB, typical
Preamp ( <i>Option 1DS</i> )		
Cellular and PCS bands		
30 to -80 dBm	±1.88 dB	±1.15 dB, typical
-80 to -100 dBm	±2.95 dB	±1.93 dB, typical

	Specifications	Supplemental Information
<b>Occupied Bandwidth</b>		
Carrier power range	30 to -45 dBm	
Frequency resolution of occupied BW	1.88 kHz	
Frequency accuracy of occupied BW (1.23 MHz channel BW)		±15 kHz, characteristic
Frequency resolution of delta frequency	3.75 kHz	
Frequency accuracy of delta frequency		± (35 kHz + frequency reference error × carrier frequency), characteristic

	Specifications	Supplemental Information
<b>Code Domain Power</b> (Requires <i>Options 1D5, B7D, and B7E</i> . Measurement interval ≥1.25 ms unless otherwise noted.)		
Carrier power range at RF Input (Pilot channel power > -11 dBc)	30 to -13 dBm	30 to -65 dBm <sup>a</sup> , characteristic
Preamp ( <i>Option 1D5</i> )	30 to -30 dBm	30 to -82 dBm <sup>a</sup> , characteristic
Measurement interval range	0.5 ms to 26.67 ms	
Code domain power		
Display dynamic range	50 dB	
Accuracy (Walsh channel power within 20 dB of total power)		±0.2 dB, typical
Displayed resolution	0.01 dB	
Other reported power parameters (dB referenced to total power)		Average active traffic, maximum inactive traffic, average inactive traffic, pilot, paging, sync channels
Carrier frequency error (Measurement interval ≥2.5 ms)		Excludes frequency reference error.
Input frequency error range	±100 kHz	±200 kHz, typical
Accuracy	±10 Hz	±7 Hz, typical
Displayed resolution	Four digits	
Estimated Rho		

	Specifications	Supplemental Information
Range	0.9 to 1.0	0.5 to 1.0 <sup>b</sup>
Accuracy (With 9 channels active over the specified range) <sup>c</sup>		±0.02, characteristic
Displayed resolution	0.0001	
Pilot time offset		From even second signal to start of PN sequence
Range	–13.33 ms to +13.33 ms	
Accuracy	±150 ns	
Displayed resolution	Four digits	
Code domain timing		Pilot to code channel time tolerance
Range	±200 ns	
Accuracy (IS-97A nominal power levels) <sup>d</sup>		±7 ns, typical
Code domain phase		Pilot to code channel phase tolerance
Range	±200 mrad	
Accuracy (IS-97A nominal power levels) <sup>d</sup>		±10 mrad, typical
Displays		Power Graph and Metrics, or Power, Timing, and Phase Graphs

- Performance may degrade outside of the specified carrier power range at RF input listed in the specifications column.
- Performance may degrade outside of the estimated rho range listed in the specifications column.
- The Active Set Threshold is less than all active channels, but greater than –20 dBc.
- IS-97A nominal base station test model levels (fraction of carrier power); Pilot: 0.20 (–7.0 dBc), Sync: 0.0471 (–13.3 dBc), Paging: 0.1882 (–7.3 dBc), 6 Traffic channels: 0.09412 (–10.3 dBc)

	Specifications	Supplemental Information
<b>Modulation Accuracy (Rho)</b> (Requires Options 1D5, B7D, and B7E. Measurement interval ≥1.25 ms unless otherwise noted.)		
Carrier power range at RF Input	30 to –28 dBm	30 to –70 dBm <sup>a</sup> , characteristic
Preamplifier (Option 1DS)	30 to –45 dBm	30 to –87 dBm <sup>a</sup> , characteristic
Measurement interval range	0.15 ms to 26.67 ms	
Rho (waveform quality)		



	Specifications	Supplemental Information
Range	0.9 to 1.0	0.5 to 1.0 <sup>b</sup> , characteristic
Accuracy		±0.0016, typical
Displayed resolution	0.0001	
Carrier frequency error (Measurement interval ≥2.5 ms)		Excludes frequency reference error
Input frequency error range	±100 kHz	±200 kHz, typical
Accuracy	±10 Hz	±7 Hz, typical
Displayed resolution	Four digits	
Pilot time offset		From even second signal to start of PN sequence
Range	-13.33 ms to +13.33 ms	
Accuracy	±150 ns	
Displayed resolution	Four digits	
EVM		
Floor		3.8%, typical
Accuracy <sup>c</sup>		±1.1%, typical
Displayed Resolution	0.01%	
Carrier feedthrough		
Floor		-51 dBc, typical
Accuracy (Carrier feedthrough ≥ -43 dBc)		±2.3 dB, typical
Displayed resolution	0.01 dB	
Magnitude error		
Floor		3.8%, typical
Accuracy <sup>c</sup>		±1.1%, typical
Displayed resolution	0.01%	
Phase error		
Accuracy <sup>c</sup>		±0.65 degrees, typical
Displayed resolution	0.01 degrees	
Displays		Numeric results or Numeric results and IQ graph

- a. Performance may degrade outside of the specified carrier power range at RF input listed in the specifications column.
- b. Performance may degrade outside of the rho range listed in the specifications column.

- c. Accuracy does not include the effects of the EVM floor. The measurement variance increases as the result approaches the EVM floor.

	Specifications	Supplemental Information
<b>Spur Close (In Band)</b>		
Carrier power range at RF Input	30 to -12 dBm	
Dynamic range		
Input power		
30 to 25 dBm	55 dB	
25 to 20 dBm	50 dB	
20 to -12 dBm	46 dB	
Relative accuracy	$\pm(2.7 \text{ dB} + 0.01 \times (\text{dB from reference level}))$	$\pm(0.3 \text{ dB} + 0.01 \times (\text{dB from reference level}))$ , typical
Displayed resolution	0.01 dB	

	Specifications	Supplemental Information
<b>Out-of-Band Spurious<sup>a</sup></b>		Refer to the Amplitude specifications section in this guide.

- a. The out-of-band measurement is made with the user-defined tables with 20 frequency ranges each (up to the top 10 spurs per range, 100 spurs maximum). Table parameters include frequency range, RBW, video BW, detector type, and amplitude test limits.

	Specifications	Supplemental Information
<b>Receiver Spurious Emissions</b>		
Spurious emission power range	-20 to -83 dBm	
Preamp On ( <i>Option IDS</i> )	-40 to -101 dBm	
Absolute spurious emission power accuracy		
-20 to -60 dBm	$\pm 2.0 \text{ dB}$	$\pm 1.1 \text{ dB}$ , typical
-60 to -83 dBm	$\pm 3.8 \text{ dB}$	$\pm 2.7 \text{ dB}$ , typical
Preamp On ( <i>Option IDS</i> )		
-40 to -70 dBm	$\pm 2.5 \text{ dB}$	$\pm 1.3 \text{ dB}$ , typical
-70 to -101 dBm	$\pm 4.0 \text{ dB}$	$\pm 2.6 \text{ dB}$ , typical

	Specifications	Supplemental Information
<b>External Correction</b> External attenuation, external gain Range Resolution	-90 to 90 dB 0.01 dB	

	Specifications	Supplemental Information
<b>Trigger</b>		
Trigger source (Actual available choices dependent on measurement)  (Option B7D and B7E)	Free run, external  Add RF Burst, frame	
Delay trigger Range	0 to 500 ms	
Resolution	300 ns	
RF burst trigger level (Option B7E)	0 to -25 dBc	
Trigger slope (External and RF burst)	Positive/Negative	
Frame timing period	50 ns to 13.6533 s	
Frame synchronizing source	External frame sync	Rear panel connector labelled EXT FRAME SYNC (Option B7D)
Frame synchronizing slope	Positive/Negative	

	Specifications	Supplemental Information
<b>Demod Trigger Source</b>		
Even second input (Frame trigger only, Option B7D and B7E)		Rear panel connector labelled EXT FRAME SYNC
PN offset range	0 to 511 x 64 [chips]	

### GSM with EDGE Measurement Personality (Option BAH, 252)

Unless otherwise noted, all specifications are with RF input range auto, default GSM measurement settings, and in the in-band frequency range. Option 1D6 and Option B72 are required.

	Specifications	Supplemental Information
<b>In-Band Frequency Ranges<sup>a</sup></b>		
GSM 900, P-GSM bands	890 to 915 MHz	
	935 to 960 MHz	
GSM 900, E-GSM bands	880 to 915 MHz	
	925 to 960 MHz	
GSM 900, R-GSM bands	876 to 915 MHz	
	921 to 960 MHz	
DCS 1800 bands	1710 to 1785 MHz	
	1805 to 1880 MHz	
PCS 1900 bands	1850 to 1910 MHz	
	1930 to 1990 MHz	
<b>Alternative Frequency Ranges<sup>b</sup></b>		
GSM 450 bands	450.4 to 457.6 MHz	
	460.4 to 467.6 MHz	
GSM 480 bands	478.8 to 486 MHz	
	488.8 to 496 MHz	
GSM 850 bands	824 to 849 MHz	
	869 to 894 MHz	

a. Frequency ranges over which all specifications apply.

b. Frequency ranges with tuning plans.

## Options

	Specifications	Supplemental Information
<b>Transmitter Power</b> (Requires <i>Option B7D</i> or <i>AYX</i> )		
Range at RF Input	30 to -60 dBm	
Absolute power accuracy for in-band signal (Mean channel power at RF Input, plus any external attenuation, excluding mismatch error)		
P-GSM, E-GSM, and R-GSM Bands		
30 to -20 dBm 20 to 30 °C	±0.81 dB	±0.34 dB, typical
0 to 55 °C	±1.25 dB	
-20 to -30 dBm 20 to 30 °C	±0.74 dB	±0.31 dB, typical
0 to 55 °C	±1.06 dB	
-30 to -40 dBm 20 to 30 °C	±0.79 dB	±0.31 dB, typical
0 to 55 °C	±1.05 dB	
-40 to -50 dBm 20 to 30 °C	±0.95 dB	±0.47 dB, typical
0 to 55 °C	±1.15 dB	
-50 to -60 dBm 20 to 30 °C	±1.09 dB	±0.60 dB, typical
0 to 55 °C	±1.27 dB	
DCS 1800 and PCS 1900 Bands		
30 to -20 dBm 20 to 30 °C	±0.77 dB	±0.29 dB, typical
0 to 55 °C	±1.27 dB	
-20 to -30 dBm 20 to 30 °C	±0.70 dB	±0.28 dB, typical
0 to 55 °C	±1.05 dB	
-30 to -40 dBm 20 to 30 °C	±0.75 dB	±0.28 dB, typical
0 to 55 °C	±1.04 dB	
-40 to -50 dBm 20 to 30 °C	±0.91 dB	±0.44 dB, typical

	Specifications	Supplemental Information
0 to 55 °C	±1.14 dB	±0.57 dB, typical
-50 to -60 dBm 20 to 30 °C	±1.05 dB	
0 to 55 °C	±1.26 dB	

	Specifications	Supplemental Information
<b>Transmitter Power Relative Power Accuracy</b> (same channel, different Tx power, input attenuator fixed, RF input range manual).	See Display Scale Fidelity	

	Specifications	Supplemental Information
<b>GMSK Power versus Time and EDGE Power versus Time</b> (Requires <i>Option B7D</i> or <i>AYX</i> )		
Carrier power range at RF Input	30 to -23 dBm	30 to -55 dBm <sup>a</sup> , nominal
Preamp On ( <i>Option IDS</i> )	30 to -40 dBm	30 to -72 dBm <sup>a</sup> , nominal
Time resolution accuracy		±1% of sweep time, nominal
Maximum record length	8 time slots	
Burst to mask uncertainty (Requires <i>Option B7D</i> and <i>B7E</i> )	$\pm \left[ 0.1 + \frac{ST / (TP - 1)}{T_{sym}} \right]$ symbol	Where ST = sweep time <sup>b</sup> TP = trace points and T <sub>sym</sub> = 3.69 μs  Examples: Meas Time=1 and TP=1601, gives 0.22 symbol  Meas Time=8 and TP=6401, gives 0.30 symbol

- a. Performance may degrade outside of the specified carrier power range at RF input listed in the specifications column.
- b. Sweep Time value can be found on the key label in the **Advanced** settings menu, with GSM w/EDGE personality software versions C.01.00 and later.

	Specifications	Supplemental Information
<b>GMSK Output RF Spectrum and EDGE Output RF Spectrum</b>		
Carrier power range at RF Input	+30 to -4 dBm	
Reference power accuracy	Transmitter Power Accuracy ±0.13 dB	

Agilent E4404B Specifications and Characteristics

	Specifications		Supplemental Information
Relative accuracy <sup>a</sup>			
Due to modulation			
Offsets $\leq 1200$ kHz	$\pm 0.83$ dB		
Offsets $\geq 1800$ kHz	$\pm 0.96$ dB		
Due to switching	$\pm 1.63$ dB		
Spectrum due to modulation displayed dynamic range <sup>b,c</sup>	<b>Non-Option 120</b>	<b>Option 120</b>	
100 kHz offset <sup>d</sup>	67.5 dB	67.5 dB	
200 kHz offset <sup>d</sup>	69.5 dB	71.9 dB	
250 kHz offset <sup>d</sup>	70.2 dB	73.3 dB	
400 kHz offset			
GSM <sup>d</sup>	71.7 dB	76.3 dB	
EDGE			67 dB, nominal <sup>e</sup>
600 kHz to 1200 kHz offset	72.8 dB	78.8 dB	
1.8 MHz offset	69.9 dB	76.3 dB	
6 MHz offset	70.1 dB	77.1 dB	
Spectrum due to switching transients displayed dynamic range <sup>b,c</sup>	<b>Non-Option 120</b>	<b>Option 120</b>	
400 kHz offset	62.5 dB	67.1 dB	
600 kHz offset	63.6 dB	69.6 dB	
1200 kHz offset	65.1 dB	72.5 dB	
1800 kHz offset	65.4 dB	72.7 dB	

- Does not include uncertainty due to noise.
- Previously available GSM measurements options for ESA specified dynamic range for CW signals only. These specifications apply for GSM and EDGE signals.
- Using default settings, the RBW filter has a corrected noise BW and impulse BW equivalent to five-pole synchronously tuned filter.
- The dynamic range for offsets under 400 kHz is not directly observable because the signal spectrum obscures the result. These dynamic range specifications are derived from phase noise specifications.

	Specifications	Supplemental Information
<b>Phase and Frequency Error</b> (Requires <i>Option 1D5</i> , <i>B7D</i> , and <i>B7E</i> )		
Carrier power range at RF Input	30 to $-23$ dBm	30 to $-55$ dBm <sup>a</sup> , nominal



- e. The analyzer performance can be dominated by third-order distortion products. These products depend on the mixer level. Their relative level will vary by 10 dB as the mixer level (input RF power minus attenuation) varies over a 5 dB range. When the Input Attenuator is auto coupled, the resolution of the attenuator keeps the mixer level in a 5 dB range. The indicated nominal performance was observed at the worst-case mixer level. Increasing the input attenuation by 10 dB from the auto coupled setting will improve the dynamic range for EDGE signals to very close to that for GSM signals at the 400 kHz offset. The optimum mixer level for dynamic range is approximately -15 dBm for EDGE at 400 kHz offset; the auto coupled setting is controlled to be in the -4 to -9 dBm range to optimize the trade off between compression errors and noise for wider offsets.

	Specifications	Supplemental Information
Preamp On (Option 1DS)	30 to -40 dBm	30 to -72 dBm <sup>a</sup> , nominal
Phase error		
Range	0 to 180°	
Displayed resolution	0.01°	
Accuracy (Averages ≥10)		
Peak	±2.1°	±1.5°, typical
RMS	±1.1°	±0.6°, typical
Frequency error		Excludes frequency reference error
Initial frequency error range	±100 kHz	
Accuracy (Avg. Type = Mean, Averages ≥10)	±10 Hz	±5 Hz, typical
I/Q offset range	-10 to -46 dBc	
Burst sync time uncertainty	±0.1 bit	
Displays		Numeric summary

- a. Performance may degrade outside of the specified carrier power range at RF input listed in the specifications column.

	Specifications	Supplemental Information
<b>Transmit Band Spurious</b>		
Carrier power range at RF Input		30 to -12 dBm, typical
Dynamic range		
Upper and lower adjacent segments		55 dB, nominal
Upper and lower segments		44 dB, nominal
Relative accuracy		$\pm(0.3 \text{ dB} + 0.01 \times (\text{dB from reference level}))$ , nominal
Displayed resolution	0.01 dB	

	Specifications	Supplemental Information
<b>Out-of-Band Spurious<sup>a</sup></b>		
Absolute Spurious Power Accuracy		Refer to the Amplitude specifications section in this guide.
Sensitivity <sup>b</sup>		
RBW		
1 kHz		-95 dBm, nominal
3 kHz		-90 dBm, nominal
10 kHz		-85 dBm, nominal
30 kHz		-78 dBm, nominal
100 kHz		-71 dBm, nominal
300 kHz		-64 dBm, nominal
1 MHz		-57 dBm, nominal
3 MHz		-50 dBm, nominal

- a. The out-of-band spurious measurement is made in accordance with the tables defined in the appropriate 3GPP specification document. The measurement is made over several frequency ranges (up to 10 spurs per range, 100 spurs maximum).
- b. With input attenuation of 5 dB. For all other attenuation settings, add (input attenuation - 5) dB.

	Specifications	Supplemental Information
<b>Receive Band Spurious</b>		
Spurious emission power range <sup>a</sup>		-20 to -73 dBm, nominal
Preamp On ( <i>Option IDS</i> )		-40 to -91 dBm, nominal
Absolute spurious emission power accuracy		
-20 to -60 dBm		±1.4 dB, nominal
-60 to -73 dBm		±2.0 dB, nominal
Preamp on ( <i>Option IDS</i> )		
-40 to -70 dBm		±1.8 dB, nominal
-70 to -91 dBm		±3.0 dB, nominal

a. Requires bandpass filter centered on receive band, peak detector mode, 0 dB attenuation, 100 kHz RBW. Does not include insertion loss of bandpass filter.

	Specifications	Supplemental Information
<b>EDGE Error Vector Magnitude (EVM)</b> (Requires <i>Option IDS</i> , <i>B7D</i> and <i>B7E</i> )		3 $\pi$ /8 shifted 8PSK modulation Specifications based on 200 bursts
Carrier power range at RF Input	30 to -23 dBm	30 to -55 dBm <sup>a</sup> , nominal
Preamplifier On ( <i>Option IDS</i> )	30 to -40 dBm	30 to -72 dBm <sup>a</sup> , nominal
EVM		
Operating range		0 to 25 % (nominal)
Floor (RMS)		0.8 % (nominal)
Accuracy <sup>b</sup> (RMS)		$\pm$ 0.75 % (nominal)
EVM range 1 % to 10 %		
Input power +24 to -12 dBm		
Frequency Error		Excludes frequency reference error
Accuracy		$\pm$ 5 Hz, nominal
IQ Origin Offset		
DUT maximum offset	-20 dBc	
Maximum analyzer noise floor	-45 dBc	

- Performance may degrade outside of the specified carrier power range at RF input listed in the specifications column.
- The accuracy specification applies when the Burst Sync is set to the Training Sequence. The definition of accuracy for the purposes of this specification is how closely the result meets the expected results. The expected result is 0.975 of the actual RMS EVM of the signal (per 3GPP TS 5.05, annex G).

	Specifications	Supplemental Information
<b>Amplitude Range Control</b>		RF Input Autorange, Manually set <b>Max Total Pwr</b> Manually set <b>Input Atten</b>

	Specifications	Supplemental Information
<b>External Gain/Attenuation Correction</b>		
Base gain, base attenuation, mobile gain, mobile attenuation		
Range	0 to 81.9 dB	
Resolution	0.01 dB	

	Specifications	Supplemental Information
<b>Trigger</b>		
Trigger source (Actual available choices dependent on measurement)	Free run, external	

	Specifications	Supplemental Information
<i>(Option B7D and B7E)</i>	Add RF burst and frame	
RF burst trigger <i>(Option B7E)</i>		
Peak carrier power range <sup>a</sup>	30 to -25 dBm	30 to -30 dBm, typical
Preamp On <i>(Option 1DS)</i>	30 to -45 dBm	30 to -50 dBm, typical
Trigger level range	0 to -25 dB relative to signal peak	

a. With trigger level set to -6 dB.

	Specifications	Supplemental Information
<b>Burst Sync</b> <i>(Requires Option AYX or B7D)</i>		
Source <i>(Actual available choices dependent on measurement)</i>	RF amplitude, none	
<i>(Option B7D and B7E)</i>	Add training sequence	
Training sequence code		GSM defined 0 to 7 Auto (search) or Manual
Burst type		Normal (TCH and CCH) Sync (SCH) Access (RACH)

**Noise Figure Measurement Personality and Hardware  
(Option 219) Specifications.**

	Specifications	Supplemental Information
<b>+28 V PULSED</b>		Noise source drive Used by option 219
Connector type	50 Ω BNC(f)	
Output voltage		
On	28.0 V ±0.1 V	60mA peak
Off	<1V	
<b>SNS SERIES NOISE SOURCE</b>		For use with Agilent Technologies SNS Series noise sources

	Specifications	Supplemental Information
<b>Noise Figure</b>		Uncertainty Calculator <sup>a</sup>
10 MHz to 3 GHz		Using internal preamp (Option 1DS), and RBW=1 MHz
Noise Source ENR	Measurement Range	Instrument Uncertainty <sup>b</sup>
4.5 to 6.5 dB	0 to 20 dB	±0.24 dB
12 to 17 dB	0 to 30 dB	±0.41 dB
20 to 22 dB	0 to 35 dB	±0.46 dB
3 to 26.5 GHz <sup>c</sup>		No internal preamp
Instrument Uncertainty		Nominally the same as for the 10 MHz to 3 GHz range; External preamp caution <sup>d</sup>
3 to 10 GHz		Well-controlled preselector <sup>e</sup>
10 to 20 GHz		Good preselector stability <sup>f</sup>
20 to 26.5 GHz		Preselector Drift Effects <sup>g</sup>

a. The figures given in the table are for the uncertainty added by the ESA instrument only. To compute the total uncertainty for your noise figure measurement, you need to take into account other factors including: DUT NF, Gain and Match; Instrument NF, Gain Uncertainty and Match; Noise source ENR uncertainty and Match. The computations can be performed with the uncertainty calculator included with the Noise Figure Measurement Personality. Go to **Mode Setup** then select **Uncertainty Calculator**. Similar calculators are also available on the Agilent web site; go to [www.agilent.com/find/nfu](http://www.agilent.com/find/nfu).

- b. "Instrument Uncertainty" is defined for noise figure analysis as uncertainty due to relative amplitude uncertainties encountered in the analyzer when making the measurements required for a noise figure or gain computation. The relative amplitude uncertainty is given by the relative display scale fidelity, also known as incremental log fidelity. The uncertainty of the analyzer is multiplied within the computation by an amount that depends on the Y factor to give the total uncertainty of the noise figure or gain measurement.

See Agilent App Note 57-2, literature number 5952-3706E for details on the use of this specification. Jitter (amplitude variations) will also affect the accuracy of results. The standard deviation of the measured result decreases by a factor of the square root of the Resolution Bandwidth used and by the square root of the number of averages. ESA uses the 1 MHz resolution Bandwidth as default since this is the widest bandwidth with uncompromised accuracy.

- c. For this frequency range, the Instrument Noise Figure Uncertainty is still well controlled, but other accuracy issues become critical. Because there is no internal preamplifier in this range, the Instrument Noise Figure is much higher than in the range below 3 GHz. This causes the effect on total measurement Noise Figure Uncertainty of the Instrument Gain Uncertainty to be much higher, and that Instrument Gain Uncertainty is in turn much higher than in the range below 3 GHz because of the effects of the preselector, explained in subsequent footnotes. As a result, when the DUT has high gain, the total measurement Noise Figure Uncertainty computed with the Uncertainty Calculator can still be excellent, but modest and low gain devices can have very high uncertainties of noise figure. Graphs that follow demonstrate. The first graph shows the computed measurement NF uncertainty with no preamp, and shows how much gain is required to achieve good accuracy. The second graph shows computed measurement NF uncertainty when using an external preamp with 23 dB gain and 6 dB NF. Both graphs were plotted using the uncertainty calculator with the assumptions shown.
- d. An external preamp can reduce the total NF measurement uncertainty substantially because it will reduce the effective noise figure of the measurement system, and thus it will reduce the sensitivity of the total NF uncertainty to the Instrument Gain Uncertainty. But if the signal levels into such an external preamp are large enough, that external preamp may experience some compression. The compression differences between the noise-source-on and noise-source-off states causes an error that must be added to Instrument Noise Figure Uncertainty for use in the Noise Figure Uncertainty Calculator. Such signal levels are quite likely for the case where the DUT has some combination of high gain, high noise figure and wide bandwidth.

As an example, we will use the Agilent 83006A as the external preamplifier. The measurement will be made at 18 GHz. The typical gain is 25 dB and the noise figure is 7 dB. We will assume the DUT has 20 dB gain, a 10 dB NF, and a passband from 5 to 30 GHz. We will use a noise source with 17 dB ENR. When the noise source is on, the DUT output can be computed by starting with  $kT$  ( $-174$  dBm/Hz) and adding  $10 \cdot \log(30 \text{ GHz} / 5 \text{ GHz})$  or 104 dB, giving  $-70$  dBm for the thermal noise. Add to this the ENR of the noise source (17 dB) combined with the NF of the DUT (10 dB) to give an equivalent input ENR of 18 dB, thus  $-52$  dBm input noise power. Add the gain of the DUT (20 dB) to find the DUT output power to be  $-32$  dBm. The noise figure of the external preamp may be neglected. The external preamplifier gain of 25 dB adds, giving a preamplifier output power of  $-7$  dBm. The typical 1 dB compression point of this amplifier is  $+19$  dBm. Therefore, the output noise is 26 dB below the 1 dB compression point. This amplifier will have negligible compression.

As an approximation, the compression of a noise signal is under 0.1 dB if the average noise power is kept 7 dB below the 1 dB CW compression point. The compression in decibels will usually double for every 3 dB increase in noise power. Use cases with higher gain DUTs or preamplifiers with lower output power capability could be compressed, leading to additional errors.

- e. In this frequency range, the preselector is well-controlled and there should be no need for special measurement techniques.
- f. In this frequency range, the preselector usually requires no special measurement techniques in a lab environment. But if the temperature changes by a few degrees, or the analyzer frequency is swept or changed across many gigahertz, Agilent recommends centering the preselector at one user determined critical frequency before a measurement. To adjust the preselector, follow the instructions in the *Noise Figure Measurement Personality Guide*.

- g. In this frequency range, the preselector may sometimes require special measurement techniques, even in a lab environment. Agilent recommends centering the preselector at one user determined critical frequency before a measurement. To adjust the preselector, follow the instructions in the *Noise Figure Measurement Personality Guide*.



**Noise Figure Error Range vs. DUT Gain, Non-warranted Frequency Range (>3 GHz)**

**Computed Measurement NF Uncertainty vs. DUT Gain, Non-warranted Frequency Range**

Assumptions: Measurement Frequency 12 GHz, Instrument NF = 28.7 dB, Instrument VSWR = 1.58, Instrument Gain Uncertainty = 2.7 dB, Instrument NF Uncertainty = 0.41 dB, Agilent 346B Source with Uncertainty = 0.2 dB, Source VSWR = 1.25, DUT input/output VSWR = 1.5.

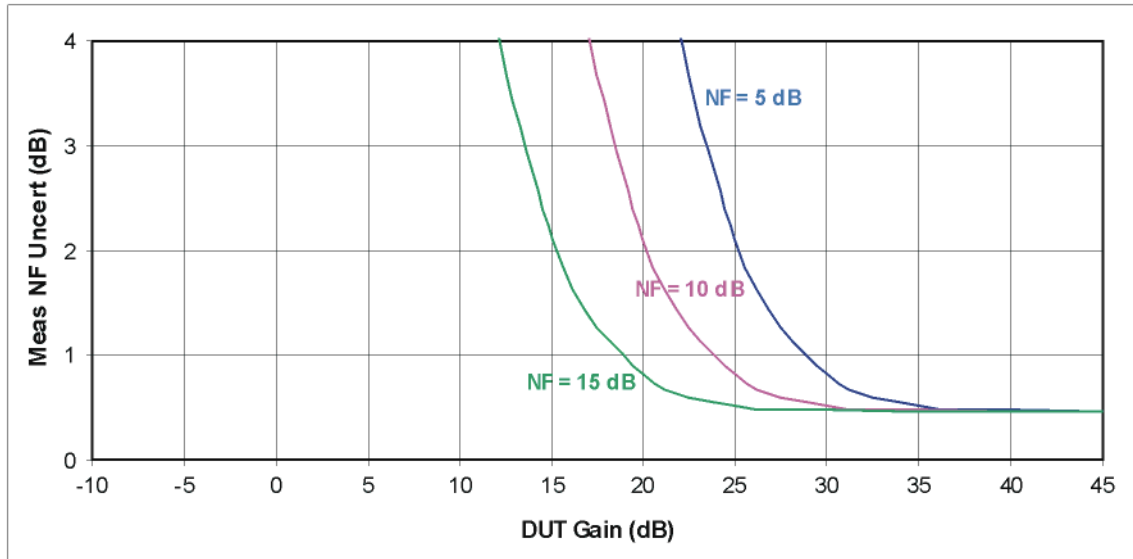

**Computed Measurement NF Uncertainty vs. DUT Gain, Non-warranted Frequency Range**

Assumptions: Same as above, with the addition of an external preamp that has a gain of 23 dB and a NF of 6 dB (for example, 83006A). Also, the Agilent 346A Source is used. The 346A changes the instrument noise figure uncertainty to 0.24 dB. With the external preamp, the preamp/analyzer combination NF is 8.86 dB. Instrument VSWR now moves to the external preamp with VSWR = 2.6

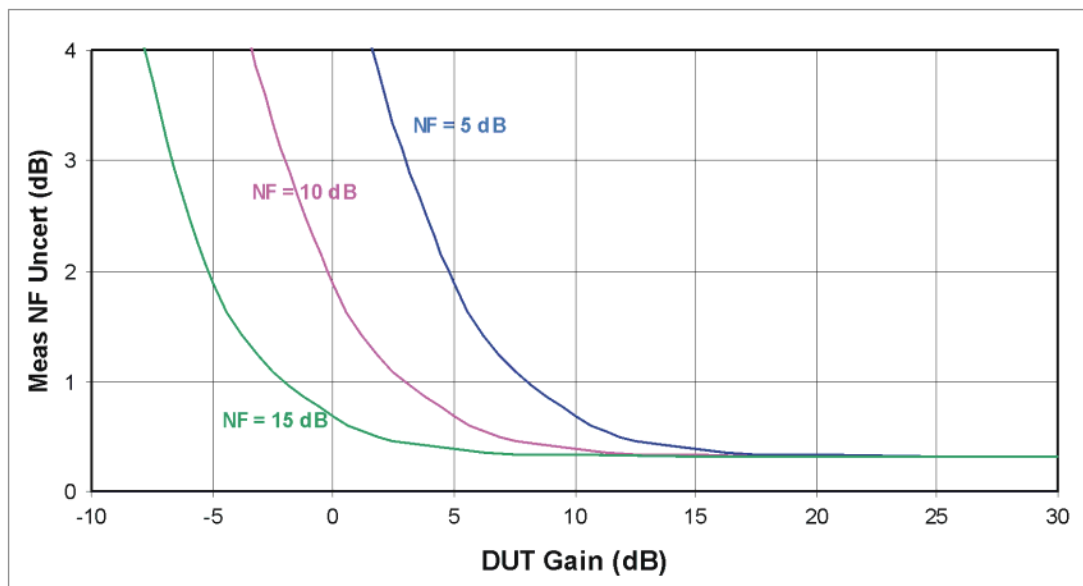

	Specifications		Supplemental Information
<b>Gain</b>			
10 MHz to 3 GHz			
Noise Source ENR	Measurement Range	Instrument Uncertainty <sup>a</sup>	
4.5 to 6.5 dB	-20 to 40 dB	±0.83 dB	
12 to 17 dB	-20 to 40 dB	±0.83 dB	
20 to 22 dB	-20 to 40 dB	±0.83 dB	
3 to 26.5 GHz <sup>b</sup>			
Instrument Uncertainty			±2.7 dB (nominal) <sup>c</sup> for Measurement Range -20 to 40 dB

- a. See the “Instrument Uncertainty” footnote [b](#) on page 151.
- b. See footnotes [d](#), [e](#), [f](#), and [g](#) for this frequency range in the [Noise Figure](#) section.
- c. The performance shown would apply when there is a long time between the calibration step and the DUT-measurement step in a NF or Gain measurement. Under special circumstances of small changes in frequency (such as spot frequency measurements) and short time periods between the calibration time and the measurement time, this error source becomes much smaller, approaching the Instrument Uncertainty shown for the 10 MHz to 3 GHz frequency range. These special circumstances would be frequency span ranges of under 1 GHz, with that frequency range unchanged for 30 minutes, and the time between the calibration step and the DUT measurement step held to less than 10 minutes.

	Specifications	Supplemental Information
<b>Noise Figure Uncertainty Calculator<sup>a</sup></b>		
Instrument Noise Figure Uncertainty	See <a href="#">Noise Figure</a>	
Instrument Gain Uncertainty	See <a href="#">Gain</a>	
Instrument Noise Figure		See graphs, Nominal Noise Figure DANL +145.87 dB (nominal) <sup>b</sup>
Instrument Input Match		See graphs, Nominal VSWR

a. The Noise Figure Uncertainty Calculator requires the parameters shown in order to calculate the total uncertainty of a Noise Figure measurement.

b. Nominally, the noise figure of the spectrum analyzer is given by

$$NF = D - (K - L + N + B)$$

where D is the DANL (displayed average noise level) specification,

K is kTB (-173.88 dB in a 1 Hz bandwidth at 25 °C)

L is 2.51 dB (the effect of log averaging used in DANL verifications)

N is 0.52 dB (the ratio of the noise bandwidth of the RBW filter with which DANL is specified to an ideal noise bandwidth)

B is ten times the base-10 logarithm of the RBW (in hertz) in which the DANL is specified. B is 30 dB for the 1 kHz RBW. The actual NF will vary from the nominal due to frequency response errors.

Nominal Instrument Noise Figure

Nominal Instrument Noise Figure 10 MHz to 3 GHz Preamplifier On

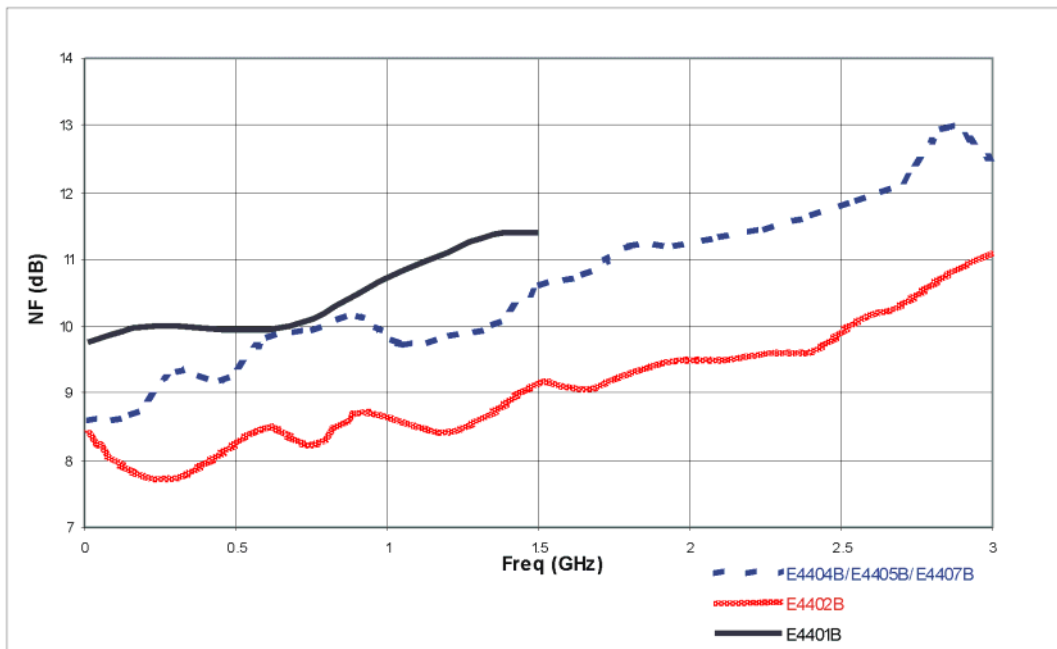

Nominal Instrument Noise Figure 3 to 26.5 GHz  
No Preamplifier; two example units

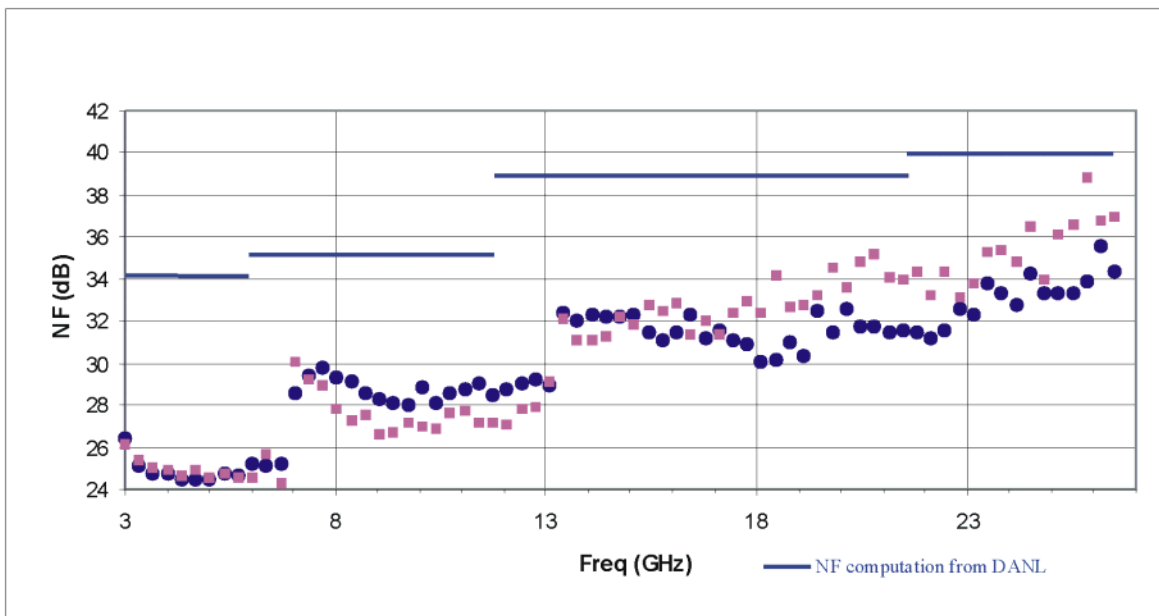

### Nominal Instrument Input VSWR

#### Nominal Instrument Input VSWR 10 MHz to 3 GHz; Preamp On, Attenuation = 0 dB

VSWR of four instruments shown. Nine graphs are representative of different input coupling configurations of E4401/2/5/7B models.

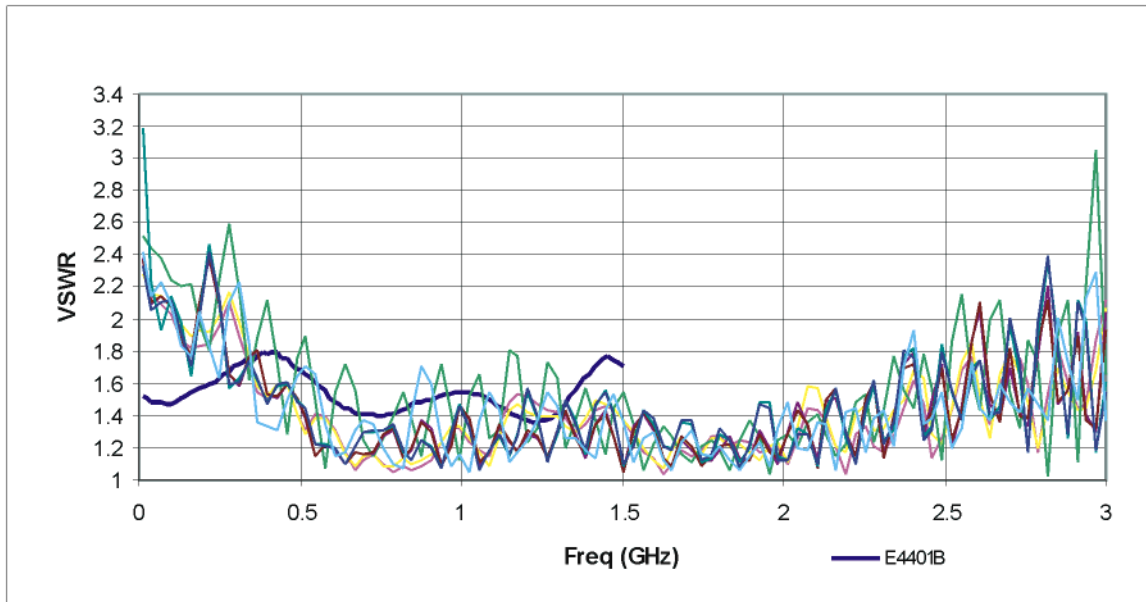

#### Nominal Instrument Input VSWR 3 to 26.5 GHz; No Preamp, Attenuation = 0 dB

VSWR of three instruments shown. Three graphs are representative of different input coupling configurations of E4407B models

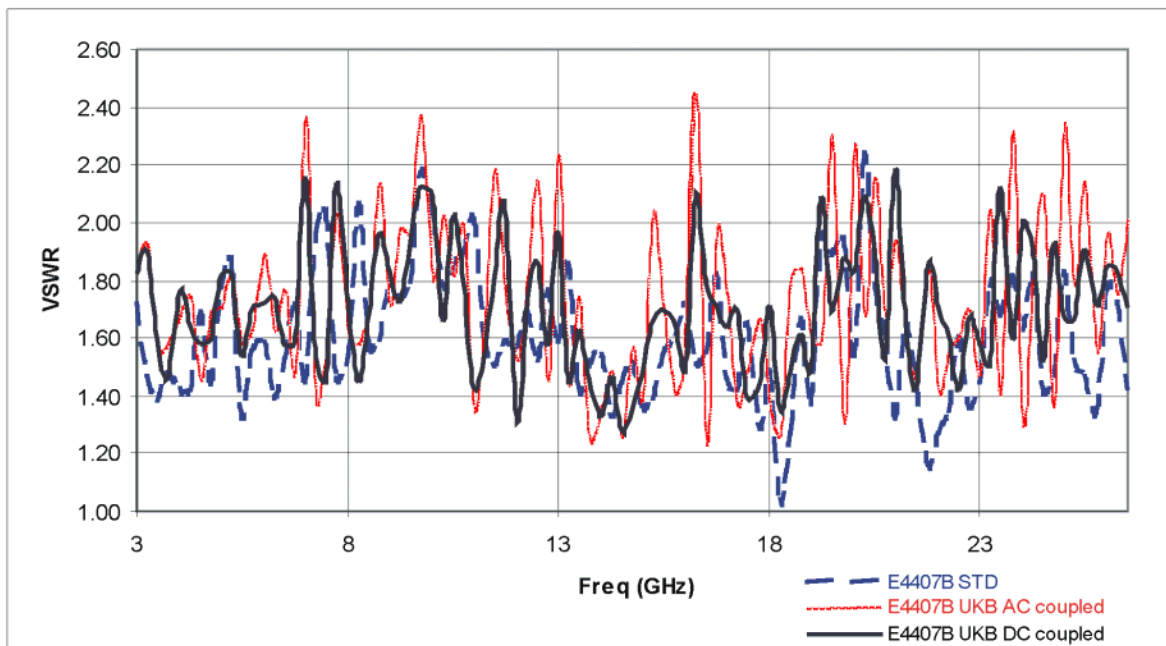

## General

	Specifications	Supplemental Information
<b>Temperature Range</b>		
Operating	0 to 55 °C	Floppy disk 10 to 40 °C
Storage	-40 to 75 °C	

	Specifications	Supplemental Information
<b>Altitude Range</b>		
Operating	Up to 4600 meters	

	Specifications	Supplemental Information
<b>Humidity Range</b>		
Operating	maximum relative humidity 80% for temperatures up to 31°C decreasing linearly to 50% relative humidity at 40°C	

	Specifications	Supplemental Information
<b>Audible Noise (ISO 7779)</b>		
Sound Pressure at 25 °C		<40 dBa, (<4.6 Bels power)

	Specifications	Supplemental Information
<b>Military Specification</b>	Has been type tested to the environmental specifications of MIL-PRF-28800F class 3.	

	Specifications	Supplemental Information
<b>EMI Compatibility</b>	Conducted and radiated emission is in compliance with CISPR Pub. 11/1990 Group 1 Class A.	
(Option 060) <sup>a</sup>	Conducted and radiated emission is in compliance with CISPR Pub. 11/1990 Group 1 Class B <sup>b</sup> .	

a. Option 060 is not compatible with Option B7B nor Option 1DP.

b. Meets Class A performance during dc operation.

	Specifications	Supplemental Information
<b>Immunity Testing</b>  Radiated Immunity        Electrostatic Discharge		Testing was done at 3 V/m according to IEC 801-3/1984. When the analyzer tuned frequency is identical to the immunity test signal frequency, there may be signals of up to -60 dBm displayed on the screen.  Air discharges of up to 8 kV were applied according to IEC 801-2/1991. Discharges to center pins of any of the connectors may cause damage to the associated circuitry.

	Specifications	Supplemental Information
<b>Acoustic Noise Emission/Geraeuschemission</b>  LpA <70 dB Operator position Normal position Per ISO 7779	LpA <70 dB Am Arbeitsplatz Normaler Betrieb Nach DIN 45635 t.19	

	Specifications	Supplemental Information
<b>Power Requirements</b>  ac Operation Voltage, frequency  Power Consumption, On Power Consumption, Standby  dc Operation Voltage Power Consumption Power Consumption, Standby	  90 to 132 Vrms, 47 to 440 Hz 195 to 250 Vrms, 47 to 66 Hz  <300 W <5 W  12 to 20 Vdc <200 W <100 mW	

	Specifications	Supplemental Information
<b>Measurement Speed</b>		

Agilent E4404B Specifications and Characteristics

	Specifications	Supplemental Information
Local Measurement and Display Update rate <sup>a</sup>		
Sweep points = 101		≥ 40/s, characteristic
Sweep points = 401		≥ 28/s, characteristic
Remote Measurement and GPIB Transfer Rate <sup>b,c</sup>		
(Option A4H)		
Sweep points = 101		≥ 40/s, characteristic
Sweep points = 401		≥ 28/s, characteristic
RF Center Frequency Tune, Measure, and GPIB Transfer Time <sup>b,d</sup>		
(Option A4H)		
Sweep points = 101		≤ 75 ms, characteristic
Sweep points = 401		≤ 90 ms, characteristic

- Factory preset, auto align Off, segmented sweep Off, fixed center frequency, RBW = 1 MHz, frequency scale linear, spans >10 MHz and ≤600 MHz, and stop frequency ≤3 GHz.
- Display Off (:DISPlay:ENABle OFF), and 32-bit integer data format (:FORMat:DATA INT,32), if Option AXX or A4J is installed, disable sweep ramp, (:SYSTem:PORTs: IFVSweep:ENABle OFF), markers Off, single sweep, measured with IBM compatible PC with 550 MHz Pentium® III running Windows® NT 4.0, one meter GPIB cable, National Instruments PCI-GPIB card and NI-488.2 DLL.
- Factory preset, auto align Off, fixed center frequency, RBW = 1 MHz, frequency scale linear, and span = 20 MHz, fixed center frequency, stop frequency ≤3 GHz, average of 100 measurements.
- Factory preset, auto align Off, segmented sweep Off, RBW = 1 MHz, frequency scale linear, span = 20 MHz, stop frequency ≤3 GHz, center frequency tune step size = 50 MHz.

	Specifications	Supplemental Information
<b>Data Storage</b>		
Internal <sup>a</sup>		8.0 MB, nominal
External (10 to 40 °C)		3.5" 1.44 MB, MS-DOS® compatible floppy disk

- For serial numbers prior to US41440000 or MY41440000, 1 MB without Option B72, 8 MB with Option B72.

	Specifications	Supplemental Information
Memory Usage State		20 kB <sup>a</sup> , nominal



	Specifications	Supplemental Information
State plus 401-point trace		21 kB <sup>a</sup> , nominal
Applications memory usage <sup>b</sup>		
Distance to Fault ( <i>Option 225</i> )		0.6 MB, nominal
Phase noise ( <i>Option 226</i> )		1.1 MB, nominal
Cable TV ( <i>Option 227</i> )		1 MB, nominal
Bluetooth ( <i>Option 228</i> )		1.32 MB, nominal
Modulation Analysis ( <i>Option 229</i> )		1.7 MB, nominal
HP 8566/68B Compatibility ( <i>Option 266</i> )		0.24 MB, nominal
8590 Compatibility ( <i>Option 290</i> )		0.7 MB, nominal
GSM ( <i>Option BAH</i> )		3.2 MB, nominal
CDMA One ( <i>Option BAC</i> )		2.8 MB, nominal
Noise Figure ( <i>Option 219</i> )		1.6 MB, nominal

- a. The size of state will increase depending on installed applications.
- b. Some applications may share files which may reduce total memory usage.

	Specifications	Supplemental Information
<b>Demod Tune and Listen</b>		Internal speaker, front-panel earphone jack and front-panel volume control.
Demod (Option BAA)	AM	
(Option A4J or AYX)	Add FM	An uncalibrated demodulated signal is available on the AUX VIDEO OUT connector at the rear panel.
(Option 106 or BAA)		An uncalibrated demodulated signal is available on the EXT VIDEO OUT connector at the rear panel.

	Specifications	Supplemental Information
<b>Weight</b> (without options)		
Net		17.1 kg (37.7 lb), characteristic

Agilent E4404B Specifications and Characteristics

**General**

	<b>Specifications</b>	<b>Supplemental Information</b>
Shipping		31.9 kg (70.3 lb), characteristic

	Specifications	Supplemental Information
<b>Display<sup>a</sup></b>		
Resolution	640 × 480	

- a. The LCD display is manufactured using high precision technology. However, there may be up to six bright points (white, blue, red or green in color) that constantly appear on the LCD screen. These points are normal in the manufacturing process and do not affect the measurement integrity of the product in any way.

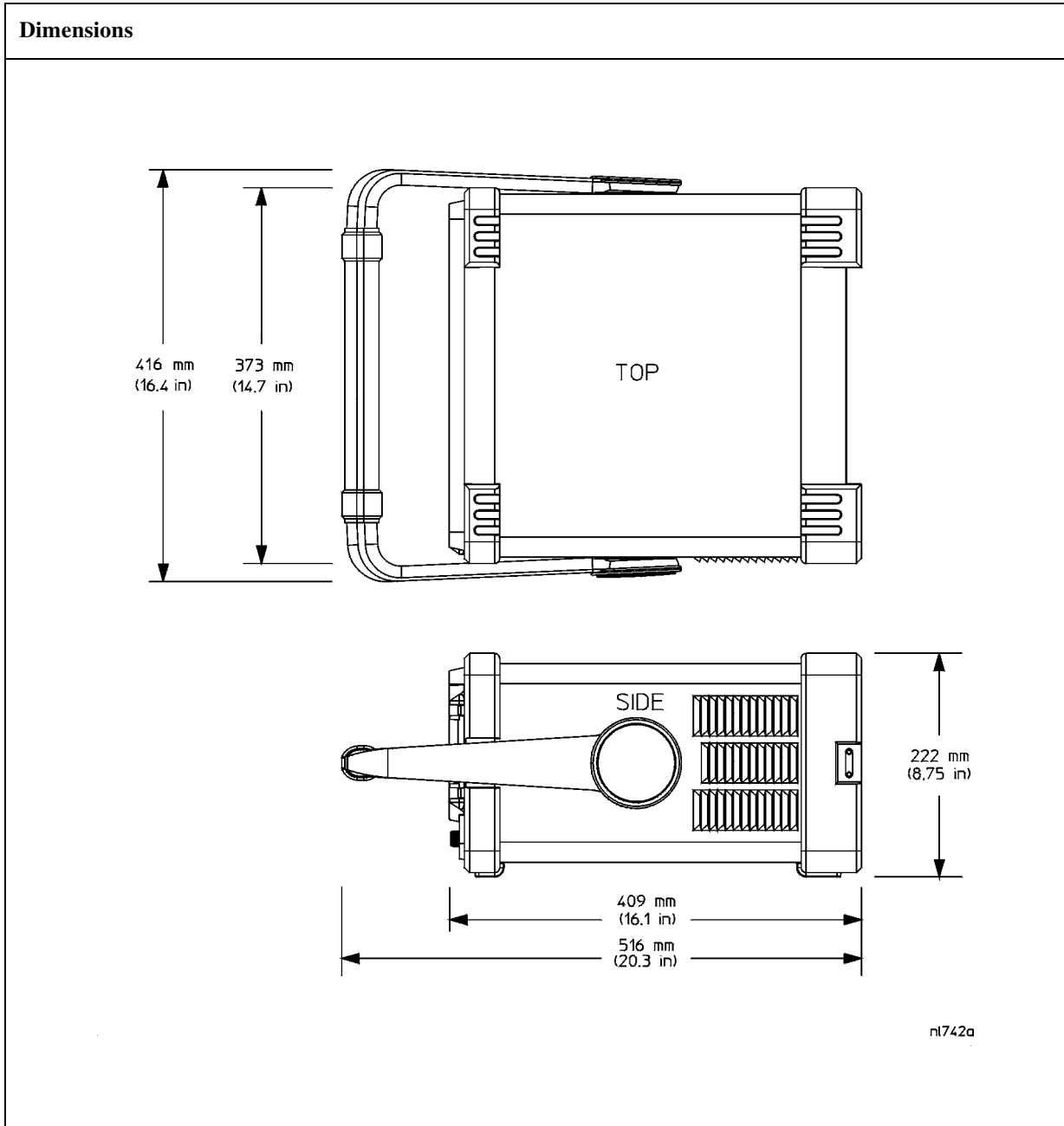

Agilent E4404B Specifications and Characteristics

## Inputs and Outputs

### Front Panel

	Specifications	Supplemental Information
<b>INPUT 50 Ω</b>		
Connector	Type-N female	
Impedance		50 Ω, nominal

	Specifications	Supplemental Information
<b>RF OUT 50 Ω, (Option 1DN)</b>		
Connector	Type-N female	
Impedance		50 Ω, nominal

	Specifications	Supplemental Information
<b>AMPTD REF OUT<sup>a</sup></b>		Amplitude Reference
Connector	BNC female	
Impedance		50 Ω, nominal
Frequency		50 MHz
Frequency Accuracy		Frequency reference error <sup>b</sup>
50 Ω Amplitude <sup>c</sup>		-20 dBm, nominal

- a. Turn the amplitude reference on/off by pressing the keys: **Input/Output, Amptd Ref Out**.
- b. Frequency reference error = (aging rate × period of time since adjustment + settability + temperature stability).
- c. The internal amplitude reference actual power is stored internally.

	Specifications	Supplemental Information
<b>PROBE POWER</b> Voltage/Current		+15 Vdc, $\pm 7\%$ at 150 mA max., characteristic  -12.6 Vdc $\pm 10\%$ at 150 mA max., characteristic

	Specifications	Supplemental Information
<b>EXT KEYBOARD<sup>a</sup></b> Connector	6-pin mini-DIN	Used for entering screen titles and filenames only. Interface compatible with most IBM-compatible PC keyboards.

a. The feature is not implemented in firmware revisions prior to A.04.00.

	Specifications	Supplemental Information
<b>Speaker</b>		Front panel knob controls volume

	Specifications	Supplemental Information
<b>Headphone</b> Connector Power Output	3.5 mm (1/8 inch) miniature audio jack	Front panel knob controls volume  0.2 W into 4 $\Omega$ , characteristic

**Rear Panel**

	Specifications	Supplemental Information
<b>10 MHz REF OUT</b>		
Connector	BNC female	
Impedance		50 $\Omega$ , nominal
Output Amplitude		>0 dBm, characteristic

	Specifications	Supplemental Information
<b>10 MHz REF IN</b>		
Connector	BNC female	Note: Analyzer noise sidebands and spurious response performance may be affected by the quality of the external reference used.
Impedance		50 $\Omega$ , nominal
Input Amplitude Range		-15 to +10 dBm, characteristic
Frequency		10 MHz, nominal

	Specifications	Supplemental Information
<b>EXT REF IN</b> (Option B7E)		
Connector	BNC, female	
Impedance		50 $\Omega$ , nominal
Input amplitude range	-5 to 10 dBm	
Frequency	1 to 30 MHz, selectable	
Frequency lock range	$\pm 5 \times 10^{-6}$ of specified external reference input frequency	

	Specifications	Supplemental Information
<b>10 MHz OUT</b> (Option B7E)		
Connector	BNC, female	
Impedance		50 $\Omega$ , nominal
Frequency		10 MHz, nominal
Level		0 dBm when Option 10 MHz Out is On

	Specifications	Supplemental Information
<b>GATE TRIG/EXT TRIG IN</b>		
Connector	BNC female	
External Trigger Input		
Trigger Level		Selectable positive or negative edge initiates sweep in EXT TRIG mode (5 V TTL)
Gate Trigger Input ( <i>Option 1D6</i> )		
Minimum Pulse Width		>30 ns (5 V TTL)

	Specifications	Supplemental Information
<b>GATE/HI SWP OUT</b>		
Connector	BNC female	
High Sweep Output		
Level		High = sweep <sup>a</sup> ; Low = retrace (5 V TTL)
Gate Output ( <i>Option 1D6</i> )		
Level		High = gate on; Low = gate off (5 V TTL)

a. High sweep may be high longer than the indicated sweep times.

Agilent E4404B Specifications and Characteristics  
**Inputs and Outputs**

	Specifications	Supplemental Information
<b>VGA OUTPUT</b>		
Connector	VGA compatible, 15-pin mini D-SUB	VGA (31.5 kHz horizontal, 60 Hz vertical sync rates, non-interlaced) Analog RGB
Format		
Resolution	640 × 480	

	Specifications	Supplemental Information
<b>AUX IF OUT</b> <i>(Option A4J or AYX)</i>		RBW ≥ 1 kHz
Connector	BNC female	21.4 MHz, nominal  –10 dBm (uncorrected), characteristic  50 Ω, nominal
Frequency		
Amplitude (for signal at reference level and for reference levels – input attenuation + preamp gain of –10 to –70 dBm)		
Impedance		

	Specifications	Supplemental Information
<b>AUX VIDEO OUT</b> <i>(Option A4J or AYX)</i>		RBW ≥ 1 kHz
Connector	BNC female	0 to 1 V (uncorrected), characteristic
Amplitude Range (into >10 kΩ)		

	Specifications	Supplemental Information
<b>HI SWP IN</b> <i>(Option A4J or AYX)</i>		
Connector	BNC female	Open collector, low resets and holds the sweep (5 V TTL)
Input		

	Specifications	Supplemental Information
<b>HI SWP OUT</b> <i>(Option A4J or AYX)</i>		
Connector	BNC female	



	Specifications	Supplemental Information
Output		High = sweep <sup>a</sup> , Low = retrace (5 V TTL)

a. High sweep may be high longer than the indicated sweep times.

	Specifications	Supplemental Information
<b>SWP OUT</b> (Option A4J or AYW)		
Connector	BNC female	
Amplitude		0 to +10 V ramp, characteristic

	Specifications	Supplemental Information
<b>PRESEL TUNE OUTPUT</b>		
Connector	BNC female	
Load Impedance (dc coupled)		> 10 k $\Omega$ , nominal
Range		0 to +10 V, characteristic
Sensitivity		0.33 V/GHz of tuned frequency > 3 GHz, characteristic

	Specifications	Supplemental Information
<b> GPIB Interface (Option A4H)</b>		
Connector	IEEE-488 bus connector	
GPIB Codes		SH1, AH1, T6, SR1, RL1, PP0, DC1, C1, C2, C3 and C28

	Specifications	Supplemental Information
<b>Serial Interface (Option IAX)</b>		
Connector	9-pin D-SUB male	RS-232

	Specifications	Supplemental Information
<b>Parallel Interface</b> (Option A4H or IAX)		Printer port only
Connector	25-pin D-SUB female	

Agilent E4404B Specifications and Characteristics

Agilent E4404B Specifications and Characteristics  
**Inputs and Outputs**

	Specifications	Supplemental Information
<p><b>EXT VIDEO IN/TV TRIG OUT<sup>a</sup></b> (<i>Option B7B or BAA</i>)</p> <p>Connector</p> <p>Impedance</p> <p>(<i>Option BAA without Option B7B</i>)</p> <p>(<i>Option BAA with Option B7B</i>)</p> <p>External Video Input Video Amplitude</p> <p>TV Trigger Output</p> <p>Amplitude</p>	<p>BNC Female (75 <math>\Omega</math>)</p>	<p>EXT VIDEO IN is the Baseband composite video input for TV trigger and picture on screen. TV TRIG OUT is the TV trigger output.</p> <p>75 <math>\Omega</math>, nominal</p> <p>Feature not implemented</p> <p>1 V<sub>p-p</sub>, nominal, characteristic</p> <p>Positive edge indicates start of selected TV line after sync. pulse</p> <p>TTL (0 V and 3.4 V with 75 <math>\Omega</math> series resistance), characteristic</p>

- a. This connector is labelled EXT VIDEO IN on older spectrum analyzers and EXT VIDEO IN/TV TRIG OUT on newer spectrum analyzers.

	Specifications	Supplemental Information
<b>EXT VIDEO OUT</b> <i>(Option B7B or BAA)</i> Connector Impedance <i>(Option BAA without Option B7B)</i> Amplitude <i>(Option BAA with Option B7B)</i> Amplitude TV Source: SA TV Source and EXT VIDEO IN <i>(Option 106)</i> Connector Impedance Amplitude	  BNC female (75 Ω)          BNC female (75 Ω)	Baseband video output RBW ≥ 1 kHz  75 Ω, nominal  0 to 1 V (uncorrected), characteristic  0 to 1 V (uncorrected), characteristic  Same as level at EXT VIDEO IN/TV TRIG OUT, characteristic  75 Ω, nominal  0 to 1 V (uncorrected), characteristic

	Specifications	Supplemental Information
<b>EXT FRAME SYNC</b> <i>(Option B7D)</i> Connector Level	  BNC, female	  5 V TTL

---

## Regulatory Information

---

**CAUTION** This product is designed for use in Installation Category II and Pollution Degree 2 per IEC 1010 and 664 respectively.

---

**NOTE** This product has been designed and tested in accordance with accepted industry standards, and has been supplied in a safe condition. The documentation contains information and warnings that must be followed by the user to ensure safe operation and to maintain the product in a safe condition.

---



The CE mark is a registered trademark of the European Community.



The C-Tick mark is a registered trademark of the Australian Spectrum Management Agency.

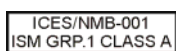

This ISM device complies with Canadian ICES-001. Cet appareil ISM est conforme a la norme NMB du Canada.

This is also a symbol of an Industrial Scientific and Medical Group 1 Class A product (CISPR 11, Clause 4).



The CSA mark is a registered trademark of the CSA International.



This symbol indicates separate collection for electrical and electronic equipment mandated under EU law as of August 13, 2005. All electric and electronic equipment are required to be separated from normal waste for disposal (Reference WEEE Directive 2002/96/EC).



Indicates the time period during which no hazardous or toxic substance elements are expected to leak or deteriorate during normal use. Forty years is the expected useful life of the product.



This symbol on all primary and secondary packaging indicates compliance to China standard GB 18455-2001.

### Declaration of Conformity

A copy of the Manufacturer's European Declaration of Conformity for this instrument can be obtained by contacting your local Agilent Technologies sales representative.

### Declaration of Compliance

This instrument has been designed and tested in accordance with CAN/CSA 22.2 No. 61010-1-04 & UL Std. No. 61010-1 (2<sup>nd</sup> Edition).

---

**3**

**Agilent E4405B Specifications and Characteristics**

---

## About This Chapter

This chapter contains specifications and characteristics for the Agilent E4405B spectrum analyzer. The distinction between specifications and characteristics is described as follows.

- Specifications describe the performance of parameters covered by the product warranty. (The temperature range is 0 °C to 55 °C, unless otherwise noted.)
- Characteristics describe product performance that is useful in the application of the product, but is not covered by the product warranty.
- Typical performance describes additional product performance information that is not covered by the product warranty. It is performance beyond specification that 80% of the units exhibit with a 95% confidence level over the temperature range 20 to 30 °C. Typical performance does not include measurement uncertainty.
- Nominal values indicate the expected performance, or describe product performance that is useful in the application of the product, but is not covered by the product warranty.

The following conditions must be met for the analyzer to meet its specifications.

- o The analyzer is within the one year calibration cycle.
- o If **Auto Align All** is selected:
  - After 2 hours of storage within the operating temperature range.
  - 5 minutes after the analyzer is turned on with sweep times less than 4 seconds.
  - After the front-panel amplitude reference is connected to the INPUT, and **Align Now RF** has been run, after the analyzer is turned on. And, once every 24 hours, or if ambient temperature changes more than 30 °C<sup>1</sup>.
- o If **Auto Align Off** is selected:
  - When the analyzer is at a constant temperature, within the operating temperature range, for a minimum of 90 minutes.
  - After the analyzer is turned on for a minimum of 90 minutes, the front panel amplitude reference has been connected to the INPUT, and **Align Now All** has been run.

---

1. 10 °C if Preamp (Option 1DS) is active.

- When **Align Now All** is run:
  - Every hour
  - If the ambient temperature changes more than 3 °C
  - If the 10 MHz reference changes
- When **Align Now RF** is run (with the front-panel amplitude reference connected to the INPUT):
  - Every 24 hours
  - If the ambient temperature changes more than 30 °C<sup>1</sup>
- o If **Auto Align All but RF** is selected:
  - When the analyzer is at a constant temperature, within the operating temperature range, for a minimum of 90 minutes.
  - After the analyzer is turned on for a minimum of 90 minutes, the front panel amplitude reference has been connected to the INPUT, and **Align Now RF** has been run.
  - When **Align Now RF** is run (with the front-panel amplitude reference connected to the INPUT):
    - Every hour
    - If the ambient temperature changes more than 3 °C

---

1. 10 °C if Preamp (Option 1DS) is active.

## Frequency

	Specifications	Supplemental Information
<b>Frequency Range</b>		
dc Coupled	9 kHz to 13.2 GHz	30 Hz to 13.2 GHz, characteristic
<i>(Option UKB)</i>	100 Hz to 13.2 GHz	
ac Coupled	100 kHz to 13.2 GHz	
<b>Band</b>		Harmonic Mixing Mode (N <sup>a</sup> )
0 (0 Hz to 3.0 GHz)		1–
1 (2.85 GHz to 6.7 GHz)		1–
2 (6.2 GHz to 13.2 GHz)		2–
Preamp On <i>(Option IDS)</i>	1 MHz to 3.0 GHz	

- a. N is the harmonic mixing mode. For negative mixing modes (as indicated by the “–”), the desired 1st LO harmonic is higher than the tuned frequency by the 1st IF (3.9214 for the 9 kHz to 3 GHz band, 321.4 MHz for all other bands).

	Specifications	Supplemental Information
<b>Frequency Reference</b>		
Aging Rate	$\pm 2 \times 10^{-6}$ /year	$\pm 1.0 \times 10^{-7}$ /day, characteristic
Settability	$\pm 5 \times 10^{-7}$	
Temperature Stability	$\pm 5 \times 10^{-6}$	

	Specifications	Supplemental Information
<b>High Stability Frequency Reference</b> <i>(Option ID5)</i>		
Aging Rate	$\pm 1 \times 10^{-7}$ /year	$\pm 5 \times 10^{-10}$ /day, 7-day average after being powered on for 7 days, characteristic
Settability	$\pm 1 \times 10^{-8}$	
Temperature Stability		
20 to 30 °C	$\pm 1 \times 10^{-8}$	
0 to 55 °C	$\pm 5 \times 10^{-8}$	



	Specifications	Supplemental Information
Warm-up (Internal frequency reference selected)		
After 5 minutes		$< \pm 1 \times 10^{-7}$ of final frequency, <sup>a</sup> characteristic
After 15 minutes		$< \pm 1 \times 10^{-8}$ of final frequency, <sup>a</sup> characteristic

a. Final frequency is defined as frequency 60 minutes after power-on with analyzer set to internal frequency reference.

	Specifications	Supplemental Information
<b>Frequency Readout Accuracy</b> (Start, Stop, Center, Marker)	$\pm((\text{frequency indication} \times \text{frequency reference error}^{\text{a}})$ $+ 0.5\% \text{ of span}$ $+ \frac{\text{span}}{\text{sweep points} - 1}$ $+ 15\% \text{ of RBW}$ $+ 10 \text{ Hz} + 1 \text{ Hz} \times N^{\text{b}})$	

a. Frequency reference error = (aging rate  $\times$  period of time since adjustment + settability + temperature stability).  
 b. N is the harmonic mixing mode.

	Specifications	Supplemental Information
<b>Marker Frequency Counter</b>		
Resolution	Selectable from 1 Hz to 100 kHz	
Accuracy <sup>a</sup>	$\pm(\text{marker frequency} \times \text{frequency reference error}^{\text{b}} + \text{counter resolution})^{\text{c}}$	For RBW $\geq 1$ kHz

a. Marker level to displayed noise level  $> 25$  dB, RBW/ Span  $\geq 0.002$ , frequency offset = 0 Hz.  
 b. Frequency reference error = (aging rate  $\times$  period of time since adjustment + settability + temperature stability).  
 c. For firmware revisions prior to A.03.00, add 1 Hz  $\times$  N, where N is the harmonic mixing mode.

	Specifications	Supplemental Information
<b>Frequency Span</b>		
Range	0 Hz (zero span), 100 Hz to 13.2 GHz	
Resolution	2 Hz $\times N^{\text{a}}$	
Accuracy <sup>b</sup>		

	Specifications	Supplemental Information
Sweep type Lin	$\pm(0.5\% \text{ of span} + 2 \times \frac{\text{span}}{\text{sweep points} - 1})$	
Sweep type Log		$\pm 2.0\%$ of span, nominal

- a. N is the harmonic mixing mode.
- b. Applies to each sweep segment.

	Specifications	Supplemental Information
<b>Sweep Time</b>		
Range		
Span > 0 Hz	1 ms to 4000 s <sup>a,b,c</sup>	$\frac{\text{sweep points} - 1}{100 \text{ kHz}}$ to 4000 s
Span = 0 Hz	10 $\mu$ s to 4000 s <sup>a</sup>	
Tracking Generator On (Option 1D6)		50 ms is the minimum sweep time
Fast Time-domain Sweep (Option AYX) (For Span = 0 Hz, RBW $\geq$ 1 kHz)	50 ns to 4000 s <sup>d,e</sup>	$\frac{\text{sweep points} - 1}{20 \text{ MHz}}$ to 4000 s
DSP and fast ADC (Option B7D) (For Span = 0 Hz, RBW $\geq$ 1 kHz)	25 ns to 4000 s <sup>f</sup>	$\frac{\text{sweep points} - 1}{40 \text{ MHz}}$ to 4000 s
Accuracy (Span = 0 Hz)		
10 $\mu$ s to 4000 s <sup>a,c</sup>	$\pm 1\%$	
(Option AYX) 50 ns to 4000 s <sup>d,e</sup>	$\pm 1\%$	
(Option B7D) 25 ns to 4000 s <sup>f</sup>	$\pm 1\%$	
Sweep Trigger <sup>g,h</sup>	Free Run, Single, Line, Video <sup>i</sup> , External, Delayed, Offset <sup>j</sup>	
(Option 1D6)	Add Gate	
(Option B7B)	Add TV	
(Option B7E)	Add RF Burst Trigger	
Delayed Trigger <sup>h,k</sup>		
Range	1 $\mu$ s to 400 s	

	Specifications	Supplemental Information
Resolution	$\frac{\text{delay in seconds}}{65000}$ rounded up to nearest $\mu\text{s}$	
Accuracy	$\pm(500 \text{ ns} + (0.01\% \text{ of delay}))$	
RF burst trigger (Option B7E)		
Relative level trigger mode		
Peak carrier power range <sup>lm</sup>		30 to -25 dBm, nominal
Preamp On (Option 1DS)		30 to -45 dBm, nominal
Trigger level range	0 to -25 dB relative to signal peak	
Absolute level trigger mode		
Peak carrier power range <sup>n,o</sup>		30 to -35 dBm, nominal
Preamp On (Option 1DS)		30 to -55 dBm, nominal
Offset Trigger <sup>j</sup>		
Resolution	$\frac{\text{sweep time}}{\text{sweep points} - 1}$	
Range	$\pm 327 \text{ ms}$ to $\pm 12.3 \text{ ks}$	Where ST = sweep time and SP = sweep points $\frac{-32766 \times \text{ST}}{\text{SP} - 1}$ to $\frac{(32766 - \text{SP}) \times \text{ST}}{\text{SP} - 1}$
Fast Time-domain sweep (Option AYX) (For sweep times $\frac{\text{sweep points} - 1}{20 \text{ MHz}}$ to $\frac{\text{sweep points} - 1}{100 \text{ kHz}}$ )	$\pm 1.23 \text{ ms}$ to $\pm 245 \text{ ms}$	$\frac{-32766 \times \text{ST}}{\text{SP} - 1}$ to $\frac{(32766 - \text{SP}) \times \text{ST}}{\text{SP} - 1}$
DSP and fast ADC (Option B7D) (For sweep times $\frac{\text{sweep points} - 1}{40 \text{ MHz}}$ to $\frac{\text{sweep points} - 1}{100 \text{ kHz}}$ )	$\pm 13 \text{ ms}$ to $\pm 5.15 \text{ s}$	$\frac{-524031 \times \text{ST}}{\text{SP} - 1}$ to $\frac{(524031 - \text{SP}) \times \text{ST}}{\text{SP} - 1}$

- a. For firmware revisions prior to A.04.00, 5 ms to 2000 s.
- b. For spans  $\geq 10 \text{ MHz}$  and  $\leq 600 \text{ MHz}$ , and stop frequency  $\leq 3 \text{ GHz}$ .
- c. For firmware revisions prior to A.05.00, 1 ms to 4000 s.
- d. For firmware revisions prior to A.04.00, 20  $\mu\text{s}$  to 2000 s.
- e. For firmware revisions prior to A.05.00, 5  $\mu\text{s}$  to 4000 s.

Agilent E4405B Specifications and Characteristics  
**Frequency**

- f. For firmware revisions prior to A.05.00, 2.5  $\mu$ s to 4000 s.
- g. Gate cannot be used simultaneously with delayed or TV trigger (Option B7B).
- h. Auto align is suspended in video, external, gate, and delayed trigger modes while waiting for a trigger event to occur.
- i. Unavailable when  $RBW \leq 300$  Hz (Option 1DR).
- j. For firmware revision A.04.00 or later.
- k. Delayed trigger is available with line, external trigger, and TV trigger (Option B7B).
- l. With trigger level set to  $-6$  dB.
- m. For GSM-type signals (burst length 570  $\mu$ s, burst period 4.63 ms, constant envelope). Ranges with other types of signals may differ.
- n. Nominal values apply for Bluetooth-type signals (burst length 625  $\mu$ s, burst period 50 ms). Ranges with other types of signals may differ.
- o. With trigger level set 5 dB below peak signal level.

	Specifications	Supplemental Information
<b>Sweep (trace) Points</b>		
Range		
Span > 0 Hz	101 to 8192 <sup>a</sup>	
Span = 0 Hz	2 to 8192 <sup>a,b</sup>	

- a. For firmware revisions prior to A.04.00, 401 points.
- b. For firmware revisions prior to A.05.00, 101 to 8192 points.

	Specifications	Supplemental Information
<b>Resolution Bandwidth (RBW)</b>		
Range		
-3 dB bandwidth	1 kHz to 3 MHz, in 1-3-10 sequence, 5 MHz <sup>a</sup>	
(Option 1DR)	Adds 10, 30, 100, 300 Hz <sup>a,b</sup>	
(Option 1DR and 1D5)	Adds 1, 3 Hz <sup>a,b</sup>	
-6 dB bandwidth (EMI)	9 kHz and 120 kHz	
(Option 1DR)	Add 200 Hz <sup>a,b</sup>	
Accuracy		
1 Hz to 3 Hz (-3 dB) RBW <sup>c</sup> (Option 1DR and 1D5)	$\pm 10\%$	
10 Hz to 300 Hz (-3 dB) RBW (Option 1DR)	$\pm 10\%$	
1 kHz to 3 MHz (-3 dB) RBW	$\pm 15\%$	
5 MHz (-3 dB) RBW	$\pm 30\%$	

	Specifications	Supplemental Information
9 kHz, 120 kHz (–6 dB) RBW (EMI)	±20%	
200 Hz (–6 dB) RBW (EMI) (Option 1DR)	±10%	
Shape		
1 Hz to 3 Hz RBW <sup>c</sup> (Option 1DR and 1D5)		Digital, approximately Gaussian shape
10 Hz to 300 Hz RBW (Option 1DR)		Digital, approximately Gaussian shape
1 kHz to 5 MHz RBW		Synchronously tuned four poles, approximately Gaussian shape
Selectivity (60 dB/3 dB bandwidth ratio)		
1 Hz to 3 Hz RBW <sup>c</sup> (Option 1DR and 1D5)		<5:1, nominal
10 Hz to 300 Hz RBW (Option 1DR)		<5:1, nominal
1 kHz to 5 MHz RBW		<15:1, nominal

- The Average detector is not compatible with the 5 MHz resolution bandwidths, nor with resolution bandwidths <1 kHz.
- Only available in spans ≤5 MHz, sweep times ≥ (sweep points – 1)/100 kHz and not usable with tracking generator on (Option 1DN).
- Firmware revision A.08.00 and later.

	Specifications	Supplemental Information
<b>Video Bandwidth (VBW) (–3 dB)</b>		
Range	30 Hz to 1 MHz in 1-3-10 sequence	3 MHz, characteristic
(Option 1DR)	Adds 1, 3, 10 Hz for RBW's <1 kHz	
Accuracy		±30%, characteristic
Shape		Post detection, single pole low-pass filter used to average displayed noise  Video bandwidths below 30 Hz are digital bandwidths with anti-aliasing filtering.

	Specifications	Supplemental Information
<b>Stability</b>		
Noise Sidebands (Offset from CW signal with 1 kHz RBW, 30 Hz VBW and sample detector)		
<b>Serial prefixes ≥ MY4510, SG4510, US4510</b>		
≥1 kHz ( <i>Option IDR, ID5</i> )		≤ -78 dBc/Hz <sup>a</sup> , typical
≥10 kHz ( <i>Option IDR</i> )	≤ -98 dBc/Hz <sup>a</sup>	≤ -101 dBc/Hz <sup>a</sup> , typical
≥10 kHz	≤ -90 dBc/Hz <sup>a</sup>	≤ -94 dBc/Hz <sup>a</sup> , typical
≥20 kHz	≤ -104 dBc/Hz <sup>a</sup>	≤ -107 dBc/Hz <sup>a</sup> , typical
≥30 kHz	≤ -110 dBc/Hz <sup>a</sup>	≤ -113 dBc/Hz <sup>a</sup> , typical
≥100 kHz	≤ -118 dBc/Hz <sup>a</sup>	≤ -122 dBc/Hz <sup>a</sup> , typical
≥1 MHz	≤ -125 dBc/Hz <sup>a</sup>	≤ -127 dBc/Hz <sup>a</sup> , typical
≥5 MHz	≤ -127 dBc/Hz <sup>a</sup>	≤ -129 dBc/Hz <sup>a</sup> , typical
≥10 MHz	≤ -131 dBc/Hz <sup>a</sup>	≤ -136 dBc/Hz <sup>a</sup> , typical
<b>Serial prefixes &lt; MY4510, SG4510, US4510</b>		
≥1 kHz ( <i>Option IDR, ID5</i> )		≤ -78 dBc/Hz <sup>a</sup> , typical
≥10 kHz	≤ -90 dBc/Hz <sup>a</sup>	≤ -94 dBc/Hz <sup>a</sup> , typical
≥20 kHz	≤ -100 dBc/Hz <sup>a</sup>	≤ -105 dBc/Hz <sup>a</sup> , typical
≥30 kHz	≤ -106 dBc/Hz <sup>a</sup>	≤ -112 dBc/Hz <sup>a</sup> , typical
≥100 kHz	≤ -118 dBc/Hz <sup>a</sup>	≤ -122 dBc/Hz <sup>a</sup> , typical
≥1 MHz	≤ -125 dBc/Hz <sup>a</sup>	≤ -127 dBc/Hz <sup>a</sup> , typical
≥5 MHz	≤ -127 dBc/Hz <sup>a</sup>	≤ -129 dBc/Hz <sup>a</sup> , typical
≥10 MHz	≤ -131 dBc/Hz <sup>a</sup>	≤ -136 dBc/Hz <sup>a</sup> , typical
<i>(Option 120)</i>		
≥1 MHz	≤ -133 dBc/Hz <sup>b</sup>	≤ -136 dBc/Hz, typical
≥5 MHz	≤ -135 dBc/Hz <sup>b</sup>	≤ -139 dBc/Hz, typical
≥10 MHz	≤ -137 dBc/Hz <sup>b</sup>	≤ -141 dBc/Hz, typical

	Specifications	Supplemental Information
Residual FM		
1 kHz RBW, 1 kHz VBW <i>(Option 1D5)</i>	$\leq 150 \text{ Hz} \times N \text{ p-p in } 100 \text{ ms}$	
10 Hz RBW, 10 Hz VBW <i>(Option 1DR and 1D5)</i>	$\leq 100 \text{ Hz} \times N \text{ p-p in } 100 \text{ ms}$	
10 Hz RBW, 10 Hz VBW <i>(Option 1DR)</i>	$\leq 2 \text{ Hz} \times N \text{ p-p in } 20 \text{ ms}$	$\leq 10 \text{ Hz} \times N \text{ p-p in } 20 \text{ ms}$ , characteristic
System-Related Sidebands, offset from CW signal		
$\geq 30 \text{ kHz}$	$\leq -65 \text{ dBc}^a$	
Line-Related Sidebands, offset from CW signal <i>(Option 1DR)</i>		
$< 300 \text{ Hz}$		$\leq -50 \text{ dBc}^a$ , characteristic
$> 300 \text{ Hz to } 30 \text{ kHz}$		$\leq -55 \text{ dBc}^a$ , characteristic

- a. Add  $20 \text{ Log}(N)$  for frequencies  $> 6.7 \text{ GHz}$ .
- b. Applies only to frequencies  $\leq 3 \text{ GHz}$

Noise Sidebands Normalized to 1 Hz Versus Offset from Carrier

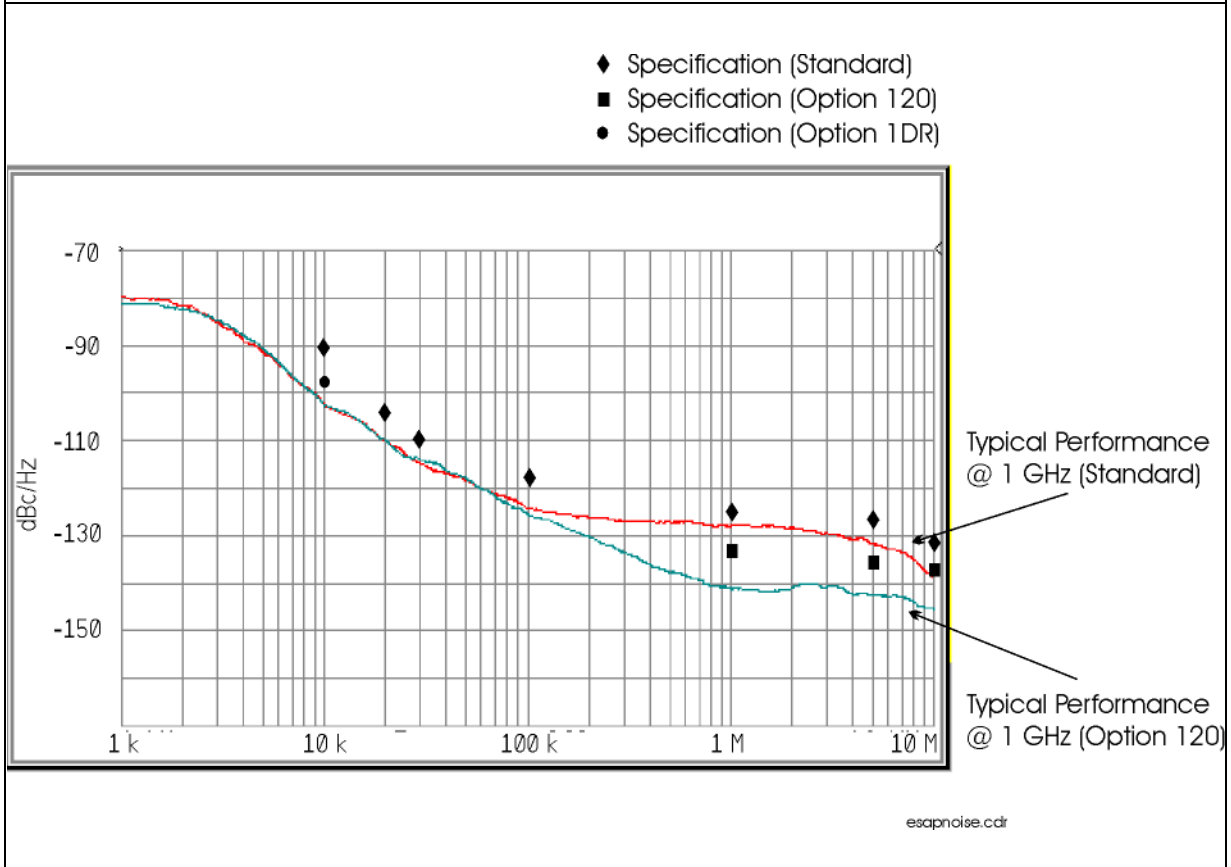



## Amplitude

Amplitude specifications do not apply for the negative peak detector mode.

	Specifications	Supplemental Information
<b>Measurement Range</b>	Displayed Average Noise Level to Maximum Safe Input Level	
Input Attenuator Range	0 to 65 dB, in 5 dB steps	0 to 75 dB, in 5 dB steps, characteristic

	Specifications	Supplemental Information
<b>Maximum Safe Input Level</b>		
Average Continuous Power (Input attenuator setting $\geq 5$ dB)	+30 dBm (1 W)	
Peak Pulse Power (for $< 10 \mu\text{sec}$ pulse width, $< 1\%$ duty cycle, and input attenuation $\geq 30$ dB)	+50 dBm (100 W)	
dc		
dc Coupled	0 Vdc	
ac Coupled	50 Vdc	

	Specifications	Supplemental Information
<b>1 dB Gain Compression</b>		
Total power at input mixer <sup>a,b</sup>		
50 MHz to 3.0 GHz	0 dBm	
3.0 GHz to 6.7 GHz	0 dBm	
6.7 GHz to 13.2 GHz	-3 dBm	
Preamp On ( <i>Option 1DS</i> )		
Total power at the preamp <sup>c</sup>		-20 dBm, characteristic

- a. Mixer power level (dBm) = input power (dBm) – input attenuation (dB).  
b. For resolution bandwidths 1 kHz to 30 kHz, the maximum input signal amplitude must be ≤ reference level +10 dB.  
c. Total power at the preamp (dBm) = total power at the input (dBm) – input attenuation (dB).

	Specifications		Supplemental Information		
<b>Displayed Average Noise Level</b>					
(Input terminated, 0 dB attenuation, sample detector, Reference Level = -70 dBm)					
	1 kHz RBW 30 Hz VBW	10 Hz RBW 1 Hz VBW ( <i>Option 1DR</i> )	1 kHz RBW 30 Hz VBW (typical)	10 Hz RBW 1 Hz VBW ( <i>Option 1DR</i> ) (typical)	1 Hz RBW 1 Hz VBW ( <i>Option 1DR and 1D5</i> ) <sup>a</sup> (typical)
30 Hz to 9 kHz ( <i>Option UKB</i> )				≤ -93 dBm	≤ -103 dBm
9 kHz to 100 kHz				≤ -109 dBm	≤ -119 dBm
100 kHz to 1 MHz				≤ -135 dBm	≤ -145 dBm
1 MHz to 10 MHz			≤ -117 dBm	≤ -137 dBm	≤ -147 dBm
1 MHz to 10 MHz ( <i>Option 120</i> )			≤ -120 dBm	≤ -139 dBm	≤ -149 dBm
10 MHz to 1.0 GHz	≤ -116 dBm	≤ -135 dBm	≤ -119 dBm	≤ -139 dBm	≤ -149 dBm
1.0 GHz to 2.0 GHz	≤ -116 dBm	≤ -135 dBm	≤ -120 dBm	≤ -140 dBm	≤ -150 dBm
2.0 GHz to 3.0 GHz	≤ -112 dBm	≤ -131 dBm	≤ -118 dBm	≤ -138 dBm	≤ -148 dBm
3.0 GHz to 6.0 GHz	≤ -112 dBm	≤ -131 dBm	≤ -118 dBm	≤ -138 dBm	≤ -148 dBm
6.0 GHz to 12 GHz	≤ -111 dBm	≤ -130 dBm	≤ -117 dBm	≤ -137 dBm	≤ -147 dBm
12 GHz to 13.2 GHz	≤ -107 dBm	≤ -126 dBm	≤ -114 dBm	≤ -134 dBm	≤ -144 dBm

	Specifications		Supplemental Information		
Preamp On ( <i>Option IDS</i> )	1 kHz RBW 30 Hz VBW	10 Hz RBW 1 Hz VBW ( <i>Option IDR</i> )	1 kHz RBW 30 Hz VBW (typical)	10 kHz RBW 1 Hz VBW ( <i>Option IDR</i> ) (typical)	1 Hz RBW 1 Hz VBW ( <i>Option IDR</i> and <i>ID5</i> <sup>f</sup> ) (typical)
0 to 55 °C					
10 MHz to 1.0 GHz	≤ -131 dBm	≤ -150 dBm			
1.0 GHz to 2.0 GHz	≤ -131 dBm	≤ -150 dBm			
2.0 GHz to 3.0 GHz	≤ -127 dBm	≤ -146 dBm			
20 to 30 °C					
1 MHz to 10 MHz			≤ -135 dBm	≤ -155 dBm	≤ -165 dBm
10 MHz to 1.0 GHz	≤ -132 dBm	≤ -151 dBm	≤ -137 dBm	≤ -157 dBm	≤ -167 dBm
1.0 GHz to 2.0 GHz	≤ -132 dBm	≤ -151 dBm	≤ -135 dBm	≤ -155 dBm	≤ -165 dBm
2.0 GHz to 3.0 GHz	≤ -130 dBm	≤ -149 dBm	≤ -132 dBm	≤ -152 dBm	≤ -162 dBm

a. Only available with firmware revision A.08.00 or later

	Specifications	Supplemental Information
<b>Display Range</b>		
Log Scale	Ten divisions displayed; 0.1, 0.2, 0.5 dB/division and 1 to 20 dB/division in 1 dB steps	
RBW ≥ 1 kHz	Calibrated 0 to -85 dB from Reference Level	
RBW ≤ 300 Hz ( <i>Option IDR</i> )	Calibrated 0 to -120 dB <sup>a</sup> from Reference Level	
Linear Scale	Ten divisions	
Scale Units	dBm, dBmV, dBμV, dBμA, A, V, and W	
( <i>Option BAA, 106</i> )	Add Hz	

a. 0 to -70 dB range when span = 0 Hz, or when IF Gain is fixed:  
(:DISPlay:WINDow:TRACe:Y[:SCALE]:LOG:RANGe:AUTO OFF).

	Specifications	Supplemental Information
<b>Marker Readout Resolution</b>		
Log scale		

	Specifications	Supplemental Information
RBW $\geq$ 1 kHz 0 to -85 dB from ref level RBW $\leq$ 300 Hz (Option 1DR) 0 to -120 dB from ref level Linear scale Fast Sweep Times for Zero Span (Option AYZ) For sweep times $\frac{\text{sweep points} - 1}{20 \text{ MHz}}$ to $\frac{\text{sweep points} - 1}{100 \text{ kHz}}$ Log 0 to -85 dB from ref level Linear (Option B7D) For sweep times $\frac{\text{sweep points} - 1}{40 \text{ MHz}}$ to $\frac{\text{sweep points} - 1}{100 \text{ kHz}}$ For: $\frac{\text{sweep points} - 1}{\text{sweep time}} < 40 \text{ MHz}$ Log 0 to -85 dB from ref level Linear For: $\frac{\text{sweep points} - 1}{\text{sweep time}} \geq 40 \text{ MHz}$ Log 0 to -85 dB from ref level Linear	0.04 dB 0.04 dB 0.01% of Reference Level 0.3 dB 0.3% of Reference Level for linear scale 0.2 dB 0.2% of Reference Level 0.3 dB 0.3% of Reference Level	

	Specifications	Supplemental Information
<b>Frequency Response</b> 50 $\Omega$ , Absolute <sup>a</sup> /Relative		

	Specifications	Supplemental Information
10 dB attenuation (dc coupled)		
9 kHz to 3.0 GHz		
20 to 30 °C	±0.46 dB	±0.14 dB, typical
0 to 55 °C	±0.76 dB	
(ac coupled)		
100 kHz to 3.0 GHz		
20 to 30 °C	±0.50 dB	
0 to 55 °C	±1.0 dB	
800 MHz to 1.0 GHz		
20 to 30 °C	±0.50 dB	±0.10 dB, typical
0 to 55 °C	±1.0 dB	
1.7 GHz to 2.0 GHz		
20 to 30 °C	±0.50 dB	±0.08 dB, typical
0 to 55 °C	±1.0 dB	
(Option UKB)		
100 Hz to 3.0 GHz (dc coupled)		
20 to 30 °C	±0.50 dB	
0 to 55 °C	±1.00 dB	
30 Hz to 3.0 GHz (dc coupled)		
20 to 30 °C		±0.5 dB, characteristic
0 to 55 °C		±1.0 dB, characteristic
Absolute <sup>a</sup> /Relative, Preamp On (Option IDS)		
0 dB attenuation		
1 MHz to 3.0 GHz		
20 to 30 °C	±1.5 dB	
0 to 55 °C	±2.0 dB	
800 MHz to 1.0 GHz		
20 to 30 °C	±1.5 dB	±0.35 dB, typical
0 to 55 °C	±2.0 dB	

Agilent E4405B Specifications and Characteristics  
**Amplitude**

	Specifications	Supplemental Information
1.7 GHz to 2.0 GHz		
20 to 30 °C	±1.5 dB	±0.26 dB, typical
0 to 55 °C	±2.0 dB	
Preselector centered for frequency >3.0 GHz		
10 dB attenuation		
3.0 GHz to 6.7 GHz (ac or dc coupled)		
Absolute <sup>a</sup>		
20 to 30 °C	±1.5 dB	
0 to 55 °C	±2.5 dB	
Relative		
20 to 30 °C	±1.3 dB	
0 to 55 °C	±1.5 dB	
6.7 GHz to 13.2 GHz (ac or dc coupled)		
Absolute <sup>a</sup>		
20 to 30 °C	±2.0 dB	
0 to 55 °C	±3.0 dB	
Relative		
20 to 30 °C	±1.8 dB	
0 to 55 °C	±2.0 dB	

a. Absolute frequency response values are referenced to the amplitude at 50 MHz.

	Specifications	Supplemental Information
<b>Input Attenuation Switching Uncertainty at 50 MHz</b>		
Attenuator Setting		
0 dB to 5 dB	±0.3 dB	
10 dB	Reference	
15 dB	±0.3 dB	
20 to 65 dB attenuation	±(0.1 dB + 0.01 × Attenuator Setting)	

<b>Attenuation Accuracy Relative to the 10 dB Attenuator Setting, Characteristic</b>		
	<b>Frequency Range</b>	
<b>Attenuation</b>	<b>dc–3.0 GHz</b>	<b>3.0–13.2 GHz</b>
0 dB	±0.3 dB	±0.5 dB
5 dB	±0.3 dB	±0.5
10 dB	Reference	Reference
15 dB	±0.4 dB	±0.5 dB
20 dB	±0.4 dB	±0.5 dB
25 dB	±0.5 dB	±0.6 dB
30 dB	±0.5 dB	±0.6 dB
35 dB	±0.6 dB	±0.7 dB
40 dB	±0.6 dB	±0.7 dB
45 dB	±0.7 dB	±1.0 dB
50 dB	±0.7 dB	±1.0 dB
55 dB	±0.9 dB	±1.1 dB
60 dB	±0.9 dB	±1.1 dB
65 dB	±1.0 dB	±1.6 dB

	Specifications	Supplemental Information
<b>Preamp (Option 1DS)</b>		Refer also to Displayed Average Noise Level specification
Gain		+20 dB, nominal <sup>a</sup>
Noise figure		5 dB, characteristic

a. Amplifier is between the input attenuator and the input mixer.

	Specifications	Supplemental Information
<b>Absolute Amplitude Accuracy</b>		
At reference settings <sup>a</sup>	±0.34 dB	±0.13 dB, typical
Preamp On <sup>b</sup> ( <i>Option 1DS</i> )	±0.37 dB	±0.14 dB, typical
95 % Confidence Absolute Amplitude Accuracy Input Frequency ≤ 3 GHz –50 dBm ≤ Input Power ≤ 0dBm –50 dBm ≤ Ref Level ≤ 0 dBm –20 dBm ≤ (Input Power – Ref Level) ≤ 0dBm Input Attenuation = 10 dBm 10 Hz ≤ RBW ≤ 1 MHz 20 to 30 °C		±0.4 dB
<b>Overall Amplitude Accuracy<sup>c</sup></b>		
20 to 30 °C	± (0.54 dB + Absolute Frequency Response)	

a. Settings are: reference level –20 dBm; input attenuation 10 dB; dc coupled; center frequency 50 MHz; RBW 1 kHz; VBW 1 kHz; amplitude scale linear or log; span 2 kHz; frequency scale linear; sweep time coupled, sample detector, signal at reference level.

b. Settings are: reference level –30 dBm; input attenuation 0 dB; dc coupled; center frequency 50 MHz; RBW 1 kHz; VBW 1 kHz; amplitude scale linear or log; span 2 kHz; frequency scale linear; sweep time coupled, signal at reference level.

c. For reference level 0 to –50 dBm; input attenuation 10 dB; dc coupled; RBW 1 kHz; VBW 1 kHz; amplitude scale log, log range 0 to –50 dB from reference level; frequency scale linear; sweep time coupled; signal input 0 to –50 dBm; span ≤20 kHz.

	Specifications	Supplemental Information	
<b>RF Input VSWR</b> (at tuned frequency)		characteristic	characteristic
Attenuator setting 0 dB		(dc coupled)	(ac coupled)
9 kHz to 100 kHz		≤3.0:1	



	Specifications	Supplemental Information	
100 kHz to 13.2 GHz		≤3.0:1	≤3.0:1
100 Hz to 100 kHz (Option UKB)		≤1.1:1	
Attenuator setting 5 dB		(dc coupled)	(ac coupled)
9 kHz to 100 kHz		≤2.0:1	
100 kHz to 300 kHz		≤1.4:1	≤2.3:1
300 kHz to 1.0 MHz		≤1.4:1	≤1.6:1
1.0 MHz to 3.0 GHz		≤1.4:1	≤1.4:1
3.0 GHz to 6.7 GHz		≤1.4:1	≤1.7:1
6.7 GHz to 13.2 GHz		≤1.7:1	≤1.9:1
100 Hz to 100 kHz (Option UKB)		≤1.1:1	
Attenuator setting 10 to 65 dB		(dc coupled)	(ac coupled)
9 kHz to 100 kHz		≤2.0:1	
100 kHz to 300 kHz		≤1.3:1	≤2.1:1
300 kHz to 1.0 MHz		≤1.3:1	≤1.5:1
1.0 MHz to 3.0 GHz		≤1.3:1	≤1.3:1
3.0 GHz to 6.7 GHz		≤1.3:1	≤1.5:1
6.7 GHz to 13.2 GHz		≤1.5:1	≤1.7:1
100 Hz to 100 kHz (Option UKB)		≤1.1:1	

	Specifications	Supplemental Information
<b>Auto Alignment<sup>a</sup></b>		
Sweep-to-sweep variation		±0.1 dB, characteristic

a. Set **Auto Align** to **Off** and use **Align Now, All** to eliminate this variation.

	Specifications	Supplemental Information
<b>Resolution Bandwidth Switching Uncertainty</b> (at Reference Level)		
1 kHz RBW	Reference	
3 kHz to 3 MHz RBW	±0.3 dB	
5 MHz RBW	±0.6 dB	

Agilent E4405B Specifications and Characteristics  
**Amplitude**

	Specifications	Supplemental Information
10 Hz to 300 Hz RBW ( <i>Option IDR</i> )	±0.3 dB	
1 Hz to 3 Hz RBW ( <i>Option IDR and ID5</i> ) <sup>a</sup>	±0.3 dB	

a. Firmware revision A.08.00 or later.

	Specifications	Supplemental Information
<b>Reference Level</b>		
Range	-149.9 dBm to maximum mixer level + attenuator setting	
Resolution		
Log Scale	±0.1 dB	
Linear Scale	±0.12% of Reference Level	
Accuracy (at a fixed frequency, a fixed attenuator, and referenced to -30 dBm (-10 dBm, Preamp On ( <i>Option IDS</i> )))		
Reference Level (dBm) – input attenuator setting (dB) + preamp gain (dB)		
-10 dBm to > -60 dBm	±0.3 dB	
-60 dBm to > -85 dBm	±0.5 dB	
-85 dBm to -90 dBm	±0.7 dB	

	Specifications	Supplemental Information
<b>Display Scale Switching Uncertainty</b>		
Switching between Linear and Log	$\pm 0.15$ dB at reference level	
Log Scale Switching	No error	

	Specifications	Supplemental Information
<b>Display Scale Fidelity</b>		
Log Maximum Cumulative		
RBW $\geq 1$ kHz		
dB Below Reference Level		
0 dB Reference	0 dB	
> 0 to 10 dB	$\pm 0.3$ dB	$\pm 0.08$ dB, typical
> 10 to 20 dB	$\pm 0.4$ dB	$\pm 0.09$ dB, typical
> 20 to 30 dB	$\pm 0.5$ dB	$\pm 0.10$ dB, typical
> 30 to 40 dB	$\pm 0.6$ dB	$\pm 0.23$ dB, typical
> 40 to 50 dB	$\pm 0.7$ dB	$\pm 0.35$ dB, typical
> 50 to 60 dB	$\pm 0.7$ dB	$\pm 0.35$ dB, typical
> 60 to 70 dB	$\pm 0.8$ dB	$\pm 0.39$ dB, typical
> 70 to 80 dB	$\pm 0.8$ dB	$\pm 0.46$ dB, typical
> 80 to 85 dB	$\pm 1.15$ dB	$\pm 0.79$ dB, typical
RBW $\leq 300$ Hz ( <i>Option 1DR</i> )		
Span > 0 Hz		
Auto range On		
0 to 98 dB <sup>a</sup> below reference level	$\pm(0.3 \text{ dB} + 0.01 \times \text{dB from reference level})$	
> 98 to 120 dB below reference level		$\pm 2.0$ dB, characteristic
Auto range Off <sup>b</sup>		
0 to 60 dB <sup>a</sup> below reference level	$\pm(0.3 \text{ dB} + 0.015 \times \text{dB from reference level})$	
> 60 to 70 dB below reference level	$\pm 1.5$ dB	

Agilent E4405B Specifications and Characteristics  
**Amplitude**

	Specifications	Supplemental Information
Span = 0 Hz		
0 to 60 dB <sup>a</sup> below reference level	$\pm(0.3 \text{ dB} + 0.015 \times \text{dB from reference level})$	
> 60 to 70 dB below reference level	$\pm 1.5 \text{ dB}$	
Log Incremental Accuracy		
0 to 80 dB <sup>a,c</sup> below reference level	$\pm 0.4 \text{ dB}/4 \text{ dB}$	
Linear Accuracy	$\pm 2\%$ of Reference Level	

- a. 0 to 30 dB for RBW = 200 Hz
- b. The SCPI command for auto range off is:  
(:DISPlay:WINDow:TRACe:Y[:SCALE]:LOG:RANGE:AUTO OFF)
- c. 0 to 50 dB for RBWs  $\leq$  300 Hz and span = 0 Hz, or when auto ranging is off.

	Specifications	Supplemental Information
<b>Spurious Responses</b>		
Second Harmonic Distortion		
Input Signal		
10 MHz to 500 MHz	$< -65 \text{ dBc}$ for $-30 \text{ dBm}$ signal at input mixer <sup>a</sup>	+35 dBm SHI (second harmonic intercept)
500 MHz to 1.5 GHz	$< -75 \text{ dBc}$ for $-30 \text{ dBm}$ signal at input mixer <sup>a</sup>	+45 dBm SHI
1.5 GHz to 2.0 GHz	$< -85 \text{ dBc}$ for $-10 \text{ dBm}$ signal at input mixer <sup>a</sup>	+75 dBm SHI
2.0 GHz to 3.35 GHz	$< -100 \text{ dBc}^b$ for $-10 \text{ dBm}$ signal at input mixer <sup>a</sup>	+90 dBm SHI
3.35 GHz to 6.6 GHz	$< -100 \text{ dBc}^a$ for $-10 \text{ dBm}$ signal at input mixer <sup>a</sup>	+90 dBm SHI
Preamp On ( <i>Option 1DS</i> ) 10 MHz to 1.5 GHz		-5 dBm SHI, characteristic
Third Order Intermodulation Distortion		
10 MHz to 100 MHz		+7 dBm TOI (third order intercept), characteristic

	Specifications	Supplemental Information
100 MHz to 3 GHz	< -85 dBc for two -30 dBm signals at input mixer <sup>a</sup> and >50 kHz separation	+12.5 dBm TOI +16 dBm TOI, typical
3.0 GHz to 6.7 GHz	< -82 dBc for two -30 dBm signals at input mixer <sup>a</sup> and >50 kHz separation	+11 dBm TOI +18 dBm TOI, typical
6.7 GHz to 13.2 GHz	< -75 dBc for two -30 dBm signals at input mixer <sup>a</sup> and >50 kHz separation	+7.5 dBm TOI +12 dBm TOI, typical
Preamp On ( <i>Option 1DS</i> ) 10 MHz to 3 GHz		-16 dBm TOI, characteristic
Other Input Related Spurious		
Inband Responses		
>30 kHz offset	< -65 dBc for -20 dBm signal at input mixer <sup>a</sup>	
Out-of-band Responses	< -80 dBc for -10 dBm signal at input mixer <sup>a</sup>	

a. Mixer power level (dBm) = input power (dBm) – input attenuation (dB).

b. For signal below displayed average noise level.

	Specifications	Supplemental Information
<b>W-CDMA Adjacent Channel Power Ratio<sup>a</sup></b>		
Dynamic range <sup>b</sup>		
Offset frequency		
5 MHz		-60.0 dBc, characteristic
10 MHz		-64.5 dBc, characteristic
( <i>Option 120</i> )		
5 MHz		-65.0 dBc, characteristic
10 MHz		-65.5 dBc, characteristic
( <i>Option 120</i> ) With noise correction On <sup>c</sup>		
5 MHz		-66.5 dBc, characteristic
10 MHz		-67.0 dBc, characteristic

- a. Firmware revision A.07.00 or higher
- b. Measured by selecting “Measure, ACP”, 20 to 30 °C, 3GPP (3.1 Dec 1999) W-CDMA signal with 1 DPCH, channel power -9 dBm/3.84 MHz, integration bandwidth 3.84 MHz, carrier frequency 2 GHz, reference level -16 dBm, input attenuation 0 dB, RBW 30 kHz.
- c. Noise correction can be turned On by selecting **Meas Setup, More, Noise Corr On**

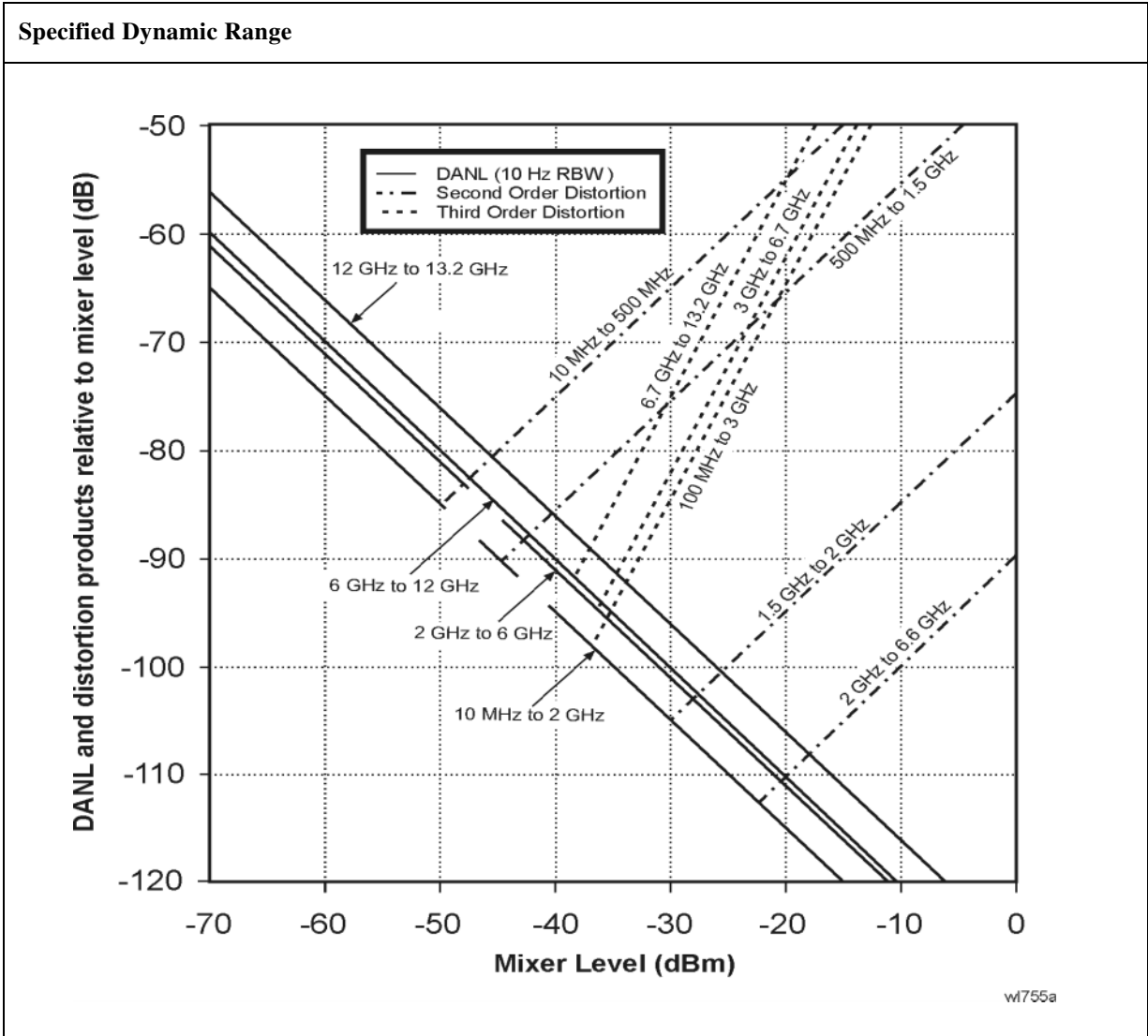

	Specifications	Supplemental Information
<b>Residual Responses</b> (Input terminated and 0 dB attenuation)  150 kHz to 6.7 GHz	< -90 dBm	

## Options

### Time Gated Spectrum Analysis (Option 1D6)

	Specifications	Supplemental Information
<b>Gate Delay</b>		
Range	1 $\mu$ s to 400 s	
Accuracy	$\pm(500 \text{ ns} + (0.01\% \times (\text{maximum of gate delay or length})))$	From gate trigger input to positive edge of gate output
<b>Gate Length</b>		
Range	1 $\mu$ s to 400 s	
Accuracy	$\pm(500 \text{ ns} + (0.01\% \times (\text{maximum of gate delay or length})))$	From positive edge to negative edge of gate output
<b>Resolution</b>	$((\text{maximum of gate delay or length in seconds})/65000)$ rounded up to nearest $\mu$ s	Dependent on the greater of gate delay or gate length
<b>Additional Amplitude Error<sup>a</sup></b>		
Log Scale	$\pm 0.2 \text{ dB}$	
Linear Scale	$\pm 0.1\%$ of reference level	

a. While in gate mode.



### Tracking Generator (Option 1DN)

The spectrum analyzer/tracking generator combination will meet its specification after a cable (8120-5148) and adapter are connected between RF OUT and INPUT and **Align Now, TG** has been run.

	Specifications	Supplemental Information
<b>Warm-up</b>	5 minutes	

	Specifications	Supplemental Information
<b>Output Frequency Range</b>	9 kHz to 3.0 GHz	

	Specifications	Supplemental Information
<b>Minimum Resolution BW</b>	1 kHz	Not usable with resolution bandwidths $\leq 300$ Hz ( <i>Option 1DR</i> )

	Specifications	Supplemental Information
<b>Output Power Level</b>		
Range	-2 to -66 dBm	
Resolution	0.1 dB	
Absolute Accuracy (at 50 MHz with coupled source attenuator, referenced to -20 dBm)	$\pm 0.75$ dB	
Vernier		
Range	8 dB	
Accuracy (with coupled source attenuator, 50 MHz, -20 dBm)		
Incremental	$\pm 0.2$ dB/dB	
Cumulative	$\pm 0.5$ dB, total	
Output Attenuator Range	0 to 56 dB in 8 dB steps	

	Specifications	Supplemental Information
<b>Maximum Safe Reverse Level</b>		+30 dBm (1 W), 50 Vdc, characteristic

Agilent E4405B Specifications and Characteristics  
Options

	Specifications	Supplemental Information
<b>Output Power Sweep</b>		
Range	(-10 to -2 dBm) – (Source Attenuator Setting)	
Resolution	0.1 dB	
Accuracy (zero span)	<1 dB peak-to-peak	

	Specifications	Supplemental Information
<b>Output Flatness</b>		
Referenced to 50 MHz, -20 dBm		
9 kHz to 10 MHz	±3 dB	
10 MHz to 3 GHz	±2 dB	

	Specifications	Supplemental Information
<b>Spurious Outputs</b>		
(-2 dBm output)		
Harmonic Spurs		
TG Output 9 kHz to 20 kHz	≤ -15 dBc	
TG Output 20 kHz to 3 GHz	≤ -25 dBc	
Non-harmonic Spurs		
TG Output 9 kHz to 2 GHz	≤ -27 dBc	
TG Output 2 GHz to 3 GHz	≤ -23 dBc	
LO Feedthrough		
LO Frequency 3.921409 GHz to 6.9214 GHz	≤ -16 dBm	

	Specifications	Supplemental Information
<b>Dynamic Range</b>	Maximum Output Power Level – Displayed Average Noise Level	

	Specifications	Supplemental Information
<b>Output Tracking</b>		
Drift		1.5 kHz/5 minute, characteristic

	Specifications	Supplemental Information
Swept Tracking Error		Usable in 1 kHz RBW after 5 minutes of warm-up

	Specifications	Supplemental Information
<b>RF Power-Off Residuals</b> 9 kHz to 3 GHz		< -120 dBm, characteristic

	Specifications	Supplemental Information
<b>Output Attenuator Repeatability</b> 9 kHz to 300 MHz 300 MHz to 2 GHz 2 GHz to 3 GHz		±0.1 dB, characteristic ±0.2 dB, characteristic ±0.3 dB, characteristic

	Specifications	Supplemental Information
<b>Output VSWR</b> 0 dB attenuation ≥ 8 dB attenuation		<2.0:1, characteristic <1.5:1, characteristic

	Specifications	Supplemental Information
<b>Output Attenuator Accuracy</b> 0 dB 8 dB 16 dB 24 dB 32 dB 40 dB 48 dB 56 dB	Reference	±0.5 dB, characteristic ±0.5 dB, characteristic ±0.5 dB, characteristic ±0.6 dB, characteristic ±0.8 dB, characteristic ±1.0 dB, characteristic ±1.1 dB, characteristic

<b>Tracking Generator Output Accuracy</b>
Relative Accuracy (Referred to -20 dBm) = Output Attenuator Accuracy + Vernier Accuracy + Output Flatness

<b>Tracking Generator Output Accuracy</b>
---

Absolute Accuracy = Relative Accuracy (Referred to -20 dBm) + Absolute Accuracy at 50 MHz
--

### Phase Noise (Option 226)

Carrier Frequency Range	Specifications	Supplemental Information
E4402B	1 MHz to 3.0 GHz	
E4404B	1 MHz to 6.7 GHz	
E4405B	1 MHz to 13.2 GHz	
E4407B	1 MHz to 26.5 GHz	

Measurement Characteristics	Specifications	Supplemental Information
Measurements	Log plot Spot frequency RMS noise RMS jitter Residual FM	
Maximum number of decades	7 (whole decades only)	
Filtering (ratio of video bandwidth to resolution bandwidth)	None (VBW/RBW = 1.0) Little (VBW/RBW = 0.3) Medium (VBW/RBW = 0.1) Maximum (VBW/RBW = 0.03)	

Offset Frequency	Specifications	Supplemental Information
Range	10 kHz to 100 MHz	The minimum offset is limited to 10 times the narrowest RBW of the analyzer
<i>(Option1DR)</i>	100 Hz to 100 MHz	
<i>(Option1DR and 1D5)</i>	10 Hz to 100 MHz	

Measurement Accuracy	Specifications	Supplemental Information
<b>Amplitude Accuracy<sup>a</sup></b> (carrier frequency 1 MHz to 3.0 GHz)		±1.52 dB <sup>b</sup>

- Amplitude accuracy is derived from analyzer specification and characteristics. It is based on a 1 GHz signal at 0 dBm while running the log plot measurement with all other measurement and analyzer settings at their factory defaults.
- This does not include the effect of system noise floor. This error is a function of the signal (phase noise) to noise (analyzer noise floor) ratio, SN, in decibels. The function is  $\text{Error} = 10 \times \log(1 + 10^{-\text{SN}/10})$ . For example, if the phase noise being measured is 10 dB above the measurement floor, the error due to adding the analyzer's noise to the UUT is 0.41 dB.

Agilent E4405B Specifications and Characteristics  
Options

	Specifications	Supplemental Information			
<b>Amplitude Repeatability</b>		<b>Standard Deviation<sup>a,b</sup></b>			
		<b>No Filtering</b>	<b>Little Filtering</b>	<b>Medium Filtering</b>	<b>Maximum Filtering</b>
	No Smoothing				
	Offset				
	100 Hz <sup>c</sup>	5.9 dB	4.9 dB	4.0 dB	3.9 dB
	1 kHz <sup>c</sup>	5.8 dB	4.7 dB	3.7 dB	3.5 dB
	10 kHz	4.4 dB	2.4 dB	2.4 dB	1.7 dB
	100 kHz	3.9 dB	2.3 dB	1.7 dB	1.6 dB
	1 MHz	3.2 dB	2.2 dB	1.4 dB	0.95 dB
	4% Smoothing <sup>d</sup>				
	Offset				
	100 Hz <sup>c</sup>	1.8 dB	1.5 dB	1.2 dB	1.1 dB
	1 kHz <sup>c</sup>	1.0 dB	0.58 dB	0.57 dB	0.49 dB
	10 kHz	0.83 dB	0.54 dB	0.41 dB	0.29 dB
100 kHz	0.78 dB	0.51 dB	0.36 dB	0.20 dB	
1 MHz	0.67 dB	0.23 dB	0.23 dB	0.20 dB	

- a. Amplitude repeatability is the nominal standard deviation of the measured phase noise. This table comes from an observation of 30 log plot measurements using a 1 GHz, 0 dBm signal with the filtering and smoothing settings shown. All other analyzer and measurement settings are set to their factory defaults.
- b. The standard deviation can be further reduced by applying averaging. The standard deviation will improve by a factor of the square root of the number of averages. For example, 10 averages will improve the standard deviation by a factor of 3.162.
- c. These offsets are available only when Option 1DR is installed.
- d. Smoothing can cause additional amplitude errors near rapid transitions of the data, such as with discrete spurious signals and impulsive noise. The effect is more pronounced as the number of points smoothed increases.

	Specifications	Supplemental Information
Frequency Offset Accuracy <sup>a</sup>	± 3.7%	0.053 octave

a. The frequency offset error in octaves causes an additional amplitude accuracy error proportional to the product of the frequency error and slope of the phase noise. For example, a 0.01 octave frequency error combined with an 18 dB/octave slope gives 0.18 dB additional amplitude error.

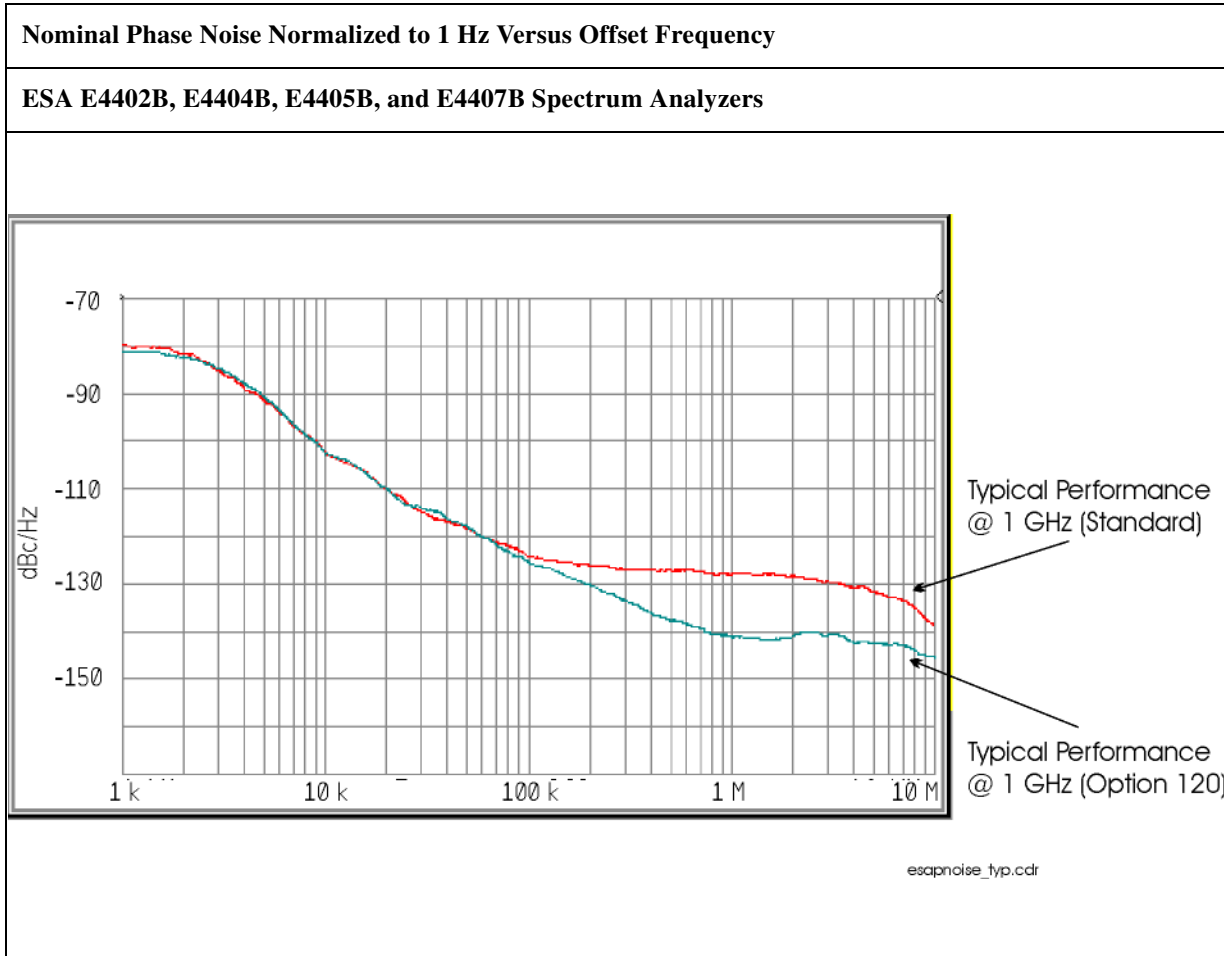

### FM Demodulation and Quasi Peak Detector (Option AYQ)

The FM demodulation characteristics will apply after an **Align Now, FM Demod** has been run.

	Specifications	Supplemental Information
<b>Optimum Input Level</b>		$\geq (-60 \text{ dBm} + \text{attenuator setting} - \text{preamp gain})$ and within 30 dB of the reference level
<b>FM Deviation</b>		
Range		10 kHz to 1 MHz
Resolution		300Hz, characteristic
Accuracy <sup>a</sup>		$< (2\% \text{ of FM deviation range} + 2 \times \text{Resolution})$ , characteristic
FM Rate $< \text{FM BW}/100$ , VBW $\geq (30 \times \text{FM Rate})$ , RBW $>$ the maximum of ( $30 \times \text{FM deviation}$ ) or ( $30 \times \text{FM Rate}$ )		
Offset Error <sup>a</sup>		5% of FM Deviation Range + 300 Hz, characteristic
<b>FM Bandwidth</b> (-3 dB)		
FM Deviation Range		
10 kHz to 40 kHz		$0.5 \times \text{FM deviation range}$ , characteristic
$>40 \text{ kHz}$ to 200 kHz		$0.5 \times \text{FM deviation range}$ , characteristic
$>200 \text{ kHz}$ to 1 MHz		$0.4 \times \text{FM deviation range}$ , characteristic

a. In time domain sweeps (span = 0 Hz)



	Specifications	Supplemental Information
<b>Quasi-Peak Detector</b>	<p>The quasi-peak detector provides the quasi-peak amplitude of pulsed radio frequency (RF) or continuous wave (CW) signals.</p> <p>The amplitude response conforms to Publication 16 of CISPR Section 1, Clause 2, except as indicated in the Relative Quasi-Peak Response Table.</p>	

<b>Relative Quasi-Peak Response to a CISPR Pulse (dB)</b>			
<b>Frequency Band</b>			
<b>Pulse Repetition Frequency</b>	<b>120 kHz EMI BW 0.03 to 1 GHz</b>	<b>9 kHz EMI BW 0.15 to 30 MHz</b>	<b>200 Hz EMI BW 9 to 150 kHz</b>
1000 Hz	+8.0 ± 1.0	+4.5 ± 1.0	N/A
100 Hz	0 dB reference <sup>a</sup>	0 dB reference <sup>a</sup>	+4.0 ± 1.0
60 Hz	N/A	N/A	+3.0 ± 1.0
25 Hz	N/A	N/A	0 dB reference <sup>a</sup>
20 Hz	-9.0 ± 1.0	-6.5 ± 1.0	N/A
10 Hz	-14.0 ± 1.5	-10.0 ± 1.5	-4.0 ± 1.0
5 Hz	N/A	N/A	-7.5 ± 1.5
2 Hz	-26.0 ± 2.0	-20.5 ± 2.0	-13.0 ± 2.0
1 Hz		-22.5 ± 2.0	-17.0 ± 2.0
Isolated Pulse		-23.5 ± 2.0	-19.0 ± 2.0

- a. Reference pulse amplitude accuracy relative to a 66 dBμV CW signal is <1.5 dB as specified in CISPR Publication 16. CISPR reference pulse: 0.044 μVs for 30 MHz to 1.0 GHz, 0.316 μVs for 15 kHz to 30 MHz, and 13.5 μVs for 9 to 150 kHz.

### Bluetooth FM Demodulation (Option 106)

The FM demodulation characteristics will apply after an **Align Now, FM Demod** has been run.

	Specifications	Supplemental Information
<b>Optimum Input Level</b>		$\geq (-40 \text{ dBm} + \text{attenuator setting} - \text{preamp gain})$ and within 10 dB of the reference level
<b>FM Deviation</b>		
Range		$\pm 200 \text{ kHz}$ , nominal
Resolution		Provides 400 Hz display annotation resolution, nominal
Accuracy <sup>a</sup>		$\pm 10 \text{ kHz}$ , typical
Input level = -30 dBm		$\pm 4 \text{ kHz}$ with video averaging On and averages $\geq 25$
Reference level = -30 dBm		
FM Rate = 500 kHz sine		
VBW = 3 MHz,		
RBW = 5 MHz,		
FM Deviation = 140 kHz		
Offset Error <sup>a</sup>		$\pm 1 \text{ kHz}$ , typical
<b>FM Bandwidth</b> (-3 dB)		1.2 MHz, nominal

a. In time domain sweeps (span = 0 Hz).

### Bluetooth Measurements Personality (Option 228)

The demodulation related nominal values will apply after an **Align Now, FM Demod** has been run.

	Specifications	Supplemental Information
<b>In-Band Frequency Range</b>		
Bluetooth (ISM) Band	2400 to 2483.5 MHz	

	Specifications	Supplemental Information
<b>Output Power</b> (Option AYX or B7D)		
Range at RF Input	30 to -40 dBm	
(Option 1DS)	30 to -60 dBm	
Absolute Amplitude Accuracy		See “Absolute Amplitude Accuracy” on page 55.
Average type	Video, Power	
Average mode	Exponential, Repeat	
Trigger source	Video, RF burst <sup>a</sup> , External, Free Run	
Burst synch	RF Amplitude, Preamble <sup>b</sup> , None	

a. Requires Option B7E

b. Requires Option 106 Bluetooth FM demodulation.

	Specifications	Supplemental Information
<b>Modulation Characteristics<sup>a</sup></b> (Option 106 and AYX or B7D)		
Range at RF Input	30 to -40 dBm	
(Option 1DS)	30 to -60 dBm	
FM Deviation		
Range		±200 kHz, nominal
Accuracy		±4 kHz, nominal (25 measurement averages, signal level > -30 dBm)
Payload data	11110000, 10101010, auto-detect	
Average mode	Exponential, Repeat	

Agilent E4405B Specifications and Characteristics  
Options

	Specifications	Supplemental Information
Trigger source	Video, RF burst <sup>b</sup> , External, Free Run	
Burst synch	RF Amplitude, Preamble <sup>c</sup> , None	
Limits	$\Delta f_2/\Delta f_1$ lower, $\Delta f_1$ max lower/upper $\Delta f_2$	

- a. The DUT must have frequency hopping disabled.
- b. Requires Option B7E
- c. Requires Option 106 Bluetooth FM demodulation.

	Specifications	Supplemental Information
<b>Carrier Frequency Drift</b> <sup>a</sup> (Option 106 and AYX or B7D)		
Range at RF Input	30 to -40 dBm	
(Option 1DS)	30 to -60 dBm	
Measurement range		±100 kHz, nominal
Measurement accuracy		±4 kHz, nominal (25 measurement averages, signal level > -30 dBm)
Average mode	Exponential, Repeat	
Trigger source	Video, RF burst <sup>b</sup> , External, Free Run	
Burst synch	Preamble <sup>c</sup> , None	

- a. The DUT must have frequency hopping disabled.
- b. Requires Option B7E
- c. Requires Option 106 Bluetooth FM demodulation.

	Specifications	Supplemental Information
<b>Initial Carrier Frequency Tolerance (ICFT)</b> <sup>a</sup> (Option 106 and AYX or B7D)		
Range at RF Input (Option 1DS)	30 to -40 dBm 30 to -60 dBm	
Measurement range		±100 kHz, nominal
Measurement accuracy		±4 kHz, nominal (25 measurement averages, signal level > -30 dBm)
Average mode	Exponential, Repeat	
Trigger source	Video, RF burst <sup>b</sup> , External, Free Run	
Burst synch	RF Amplitude, Preamble <sup>c</sup> , None	
Limits	ICFT upper/lower	

- a. The DUT must have frequency hopping disabled.
- b. Requires Option B7E
- c. Requires Option 106 Bluetooth FM demodulation.

### FM Demodulation (Option BAA)

The FM demodulation characteristics will apply after an **Align Now, FM Demod** has been run.

	Specifications	Supplemental Information
<b>Optimum Input Level</b>		$\geq (-60 \text{ dBm} + \text{attenuator setting} - \text{preamp gain})$ and within 30 dB of the reference level
<b>FM Deviation</b>		
Range		10 kHz to 1 MHz
Resolution		Provides 1 Hz display annotation resolution
FM Deviation Range		
10 kHz to 40 kHz		12 Hz, characteristic
>40 kHz to 200 kHz		60 Hz, characteristic
>200 kHz to 1 MHz		300 Hz, characteristic
Accuracy <sup>a</sup>		
FM Rate < FM BW/100, VBW $\geq (30 \times \text{FM Rate})$ , RBW > the maximum of (30 $\times$ FM deviation) or (30 $\times$ FM Rate)		< (2% of FM deviation range + 2 $\times$ Resolution), characteristic
Offset Error <sup>a</sup>		5% of FM Deviation Range + 300 Hz, characteristic
<b>FM Bandwidth</b> (-3 dB)		
FM Deviation Range		
10 kHz to 40 kHz		7.5 $\times$ FM deviation range, characteristic
>40 kHz to 200 kHz		1.3 $\times$ FM deviation range, characteristic
>200 kHz to 1 MHz		0.3 $\times$ FM deviation range, characteristic

a. In time domain sweeps (span = 0 Hz).

### TV Trigger and Picture On Screen (Option B7B)

Option BAA is required.

	Specifications	Supplemental Information
<b>TV Trigger and Picture On Screen</b>		TV Trigger initiates a sweep of the analyzer after the sync pulse of a selected line of a TV video field. Picture On Screen displays the TV picture on the analyzer display.
Amplitude Requirements TV Source: SA		Top 50% of linear display, characteristic
TV Source: EXT VIDEO IN		500 mVp-p to 2 Vp-p, characteristic
Compatible Standards	NTSC-M, NTSC-Japan, PAL-M, PAL-B,D,G,H,I, PAL-N, PAL-N Combination, SECAM-L	
Field Selection	Entire frame, even, odd	
Sync Polarity	Positive or negative	
<b>TV Trigger</b>		
Line Selection	1 to 525, or 1 to 625, standard dependent	

### cdmaOne Measurement Personality (Option BAC)

Unless otherwise noted, all specifications are with RF input range auto, default cdmaOne measurement settings, and in the in-band frequency range. Option B72 is required.

	Specifications	Supplemental Information
<b>In-Band Frequency Range</b>		
Cellular bands	824 to 870 MHz 869 to 925 MHz	
PCS bands	1715 to 1780 MHz 1805 to 1870 MHz 1850 to 1910 MHz 1930 to 1990 MHz	

	Specifications	Supplemental Information
<b>Adjacent Channel Power Ratio<sup>a</sup></b>		
Carrier power range at RF Input	30 to -20 dBm	
Dynamic range <sup>b</sup>		Referenced to average power of carrier in 1.23 MHz BW
Offset Frequency	Integration BW	
750 kHz	30 kHz	-70.0 dBc, characteristic
885 kHz	30 kHz	-73.5 dBc, characteristic
1.25625 MHz	12.5 kHz	-78.0 dBc, characteristic
1.98 MHz	30 kHz	-75.5 dBc, characteristic
2.75 MHz	1 MHz	-60.5 dBc, characteristic
Relative accuracy <sup>c</sup>	See Display Scale Fidelity	
Resolution	0.01 dB	

- This measurement is available with personality revisions of A.02.00 or later.
- IS-97A nominal base station test model levels (fraction of carrier power); Pilot: 0.20 (-7.0 dBc), Sync: 0.0471 (-13.3 dBc), Paging: 0.1882 (-7.3 dBc), 6 Traffic channels: 0.09412 (-10.3 dBc)
- Does not include uncertainty due to noise.



	Specifications	Supplemental Information
<b>Channel Power (1.23 MHz Integration BW)</b>		Integration BW range 1 kHz to 10 MHz
Range at RF Input	30 to $\angle 70$ dBm	
Absolute power accuracy for in-band signal (Mean channel power at RF Input, plus any external attenuation, excluding mismatch error)		
Cellular Bands		
30 to -5 dBm 20 to 30 °C	$\pm 0.82$ dB	$\pm 0.39$ dB, typical
0 to 55 °C	$\pm 1.09$ dB	
-5 to -25 dBm 20 to 30 °C	$\pm 0.78$ dB	$\pm 0.37$ dB, typical
0 to 55 °C	$\pm 1.05$ dB	
-25 to -45 dBm 20 to 30 °C	$\pm 0.69$ dB	$\pm 0.21$ dB, typical
0 to 55 °C	$\pm 0.94$ dB	
-45 to -55 dBm 20 to 30 °C	$\pm 0.77$ dB	$\pm 0.28$ dB, typical
0 to 55 °C	$\pm 0.96$ dB	
-55 to -70 dBm 20 to 30 °C	$\pm 0.89$ dB	$\pm 0.38$ dB, typical
0 to 55 °C	$\pm 1.21$ dB	
PCS Bands		
30 to -5 dBm 20 to 30 °C	$\pm 0.78$ dB	$\pm 0.26$ dB, typical
0 to 55 °C	$\pm 1.11$ dB	
-5 to -25 dBm 20 to 30 °C	$\pm 0.74$ dB	$\pm 0.23$ dB, typical
0 to 55 °C	$\pm 1.02$ dB	
-25 to -45 dBm 20 to 30 °C	$\pm 0.71$ dB	$\pm 0.26$ dB, typical
0 to 55 °C	$\pm 0.99$ dB	
-45 to -55 dBm 20 to 30 °C	$\pm 0.79$ dB	$\pm 0.33$ dB, typical

## Options

	Specifications	Supplemental Information
0 to 55 °C	±1.01 dB	±0.43 dB, typical
-55 to -70 dBm 20 to 30 °C	±0.91 dB	
0 to 55 °C	±1.26 dB	

	Specifications	Supplemental Information
Channel power relative power accuracy (same channel, different Tx power, input attenuator fixed, RF input range manual).	See Display Scale Fidelity	

	Specifications	Supplemental Information
<b>Receive Channel Power</b>		
Absolute Power Accuracy		
Cellular bands		
30 to 0 dBm	±0.95 dB	±0.53 dB, typical
0 to -85 dBm	±1.46 dB	±0.63 dB, typical
PCS bands		
30 to 0 dBm	±0.97 dB	±0.52 dB, typical
0 to -85 dBm	±1.35 dB	±0.59 dB, typical
Preamp ( <i>Option IDS</i> )		
Cellular and PCS bands		
30 to -80 dBm	±1.88 dB	±1.15 dB, typical
-80 to -100 dBm	±2.95 dB	±1.93 dB, typical

	Specifications	Supplemental Information
<b>Occupied Bandwidth</b>		
Carrier power range	30 to -45 dBm	
Frequency resolution of occupied BW	1.88 kHz	
Frequency accuracy of occupied BW (1.23 MHz channel BW)		±15 kHz, characteristic
Frequency resolution of delta frequency	3.75 kHz	
Frequency accuracy of delta frequency		± (35 kHz + frequency reference error × carrier frequency), characteristic

	Specifications	Supplemental Information
<b>Code Domain Power</b> (Requires <i>Options 1D5, B7D, and B7E</i> . Measurement interval $\geq 1.25$ ms unless otherwise noted.)		
Carrier power range at RF Input (Pilot channel power $> -11$ dBc)	30 to $-13$ dBm	30 to $-65$ dBm <sup>a</sup> , characteristic
Preamplifier ( <i>Option 1D5</i> )	30 to $-30$ dBm	30 to $-82$ dBm <sup>a</sup> , characteristic
Measurement interval range	0.5 ms to 26.67 ms	
Code domain power		
Display dynamic range	50 dB	
Accuracy (Walsh channel power within 20 dB of total power)		$\pm 0.2$ dB, typical
Displayed resolution	0.01 dB	
Other reported power parameters (dB referenced to total power)		Average active traffic, maximum inactive traffic, average inactive traffic, pilot, paging, sync channels
Carrier frequency error (Measurement interval $\geq 2.5$ ms)		Excludes frequency reference error.
Input frequency error range	$\pm 100$ kHz	$\pm 200$ kHz, typical
Accuracy	$\pm 10$ Hz	$\pm 7$ Hz, typical
Displayed resolution	Four digits	
Estimated Rho		
Range	0.9 to 1.0	0.5 to 1.0 <sup>b</sup>
Accuracy (With 9 channels active over the specified range) <sup>c</sup>		$\pm 0.02$ , characteristic
Displayed resolution	0.0001	
Pilot time offset		From even second signal to start of PN sequence
Range	$-13.33$ ms to $+13.33$ ms	
Accuracy	$\pm 150$ ns	
Displayed resolution	Four digits	
Code domain timing		Pilot to code channel time tolerance
Range	$\pm 200$ ns	

	Specifications	Supplemental Information
Accuracy (IS-97A nominal power levels) <sup>d</sup>		±7 ns, typical
Code domain phase		Pilot to code channel phase tolerance
Range	±200 mrad	
Accuracy (IS-97A nominal power levels) <sup>d</sup>		±10 mrad, typical
Displays		Power Graph and Metrics, or Power, Timing, and Phase Graphs

- a. Performance may degrade outside of the specified carrier power range at RF input listed in the specifications column.
- b. Performance may degrade outside of the estimated rho range listed in the specifications column.
- c. The Active Set Threshold is less than all active channels, but greater than -20 dBc.
- d. IS-97A nominal base station test model levels (fraction of carrier power); Pilot: 0.20 (-7.0 dBc), Sync: 0.0471 (-13.3 dBc), Paging: 0.1882 (-7.3 dBc), 6 Traffic channels: 0.09412 (-10.3 dBc)

	Specifications	Supplemental Information
<b>Modulation Accuracy (Rho)</b> (Requires Options 1D5, B7D, and B7E. Measurement interval $\geq 1.25$ ms unless otherwise noted.)		
Carrier power range at RF Input	30 to $-28$ dBm	30 to $-70$ dBm <sup>a</sup> , characteristic
Preamp ( <i>Option 1DS</i> )	30 to $-45$ dBm	30 to $-87$ dBm <sup>a</sup> , characteristic
Measurement interval range	0.15 ms to 26.67 ms	
Rho (waveform quality)		
Range	0.9 to 1.0	0.5 to 1.0 <sup>b</sup> , characteristic
Accuracy		$\pm 0.0016$ , typical
Displayed resolution	0.0001	
Carrier frequency error (Measurement interval $\geq 2.5$ ms)		
Input frequency error range	$\pm 100$ kHz	$\pm 200$ kHz, typical
Accuracy	$\pm 10$ Hz	$\pm 7$ Hz, typical
Displayed resolution	Four digits	
Pilot time offset		
Range	$-13.33$ ms to $+13.33$ ms	From even second signal to start of PN sequence
Accuracy	$\pm 150$ ns	
Displayed resolution	Four digits	
EVM		
Floor		3.8%, typical
Accuracy <sup>c</sup>		$\pm 1.1\%$ , typical
Displayed Resolution	0.01%	
Carrier feedthrough		
Floor		$-51$ dBc, typical
Accuracy (Carrier feedthrough $\geq -43$ dBc)		$\pm 2.3$ dB, typical
Displayed resolution	0.01 dB	
Magnitude error		
Floor		3.8%, typical
Accuracy <sup>c</sup>		$\pm 1.1\%$ , typical

	Specifications	Supplemental Information
Displayed resolution	0.01%	±0.65 degrees, typical  Numeric results or Numeric results and IQ graph
Phase error		
Accuracy <sup>c</sup>		
Displayed resolution	0.01 degrees	
Displays		

- Performance may degrade outside of the specified carrier power range at RF input listed in the specifications column.
- Performance may degrade outside of the rho range listed in the specifications column.
- Accuracy does not include the effects of the EVM floor. The measurement variance increases as the result approaches the EVM floor.

	Specifications	Supplemental Information
<b>Spur Close (In Band)</b>		
Carrier power range at RF Input	30 to -12 dBm	±(0.3 dB + 0.01 × (dB from reference level)), typical
Dynamic range		
Input power		
30 to 25 dBm	55 dB	
25 to 20 dBm	50 dB	
20 to -12 dBm	46 dB	
Relative accuracy	±(2.7 dB + 0.01 × (dB from reference level))	
Displayed resolution	0.01 dB	

	Specifications	Supplemental Information
<b>Out-of-Band Spurious<sup>a</sup></b>		Refer to the Amplitude specifications section in this guide.

- The out-of-band measurement is made with the user-defined tables with 20 frequency ranges each (up to the top 10 spurs per range, 100 spurs maximum). Table parameters include frequency range, RBW, video BW, detector type, and amplitude test limits.

	Specifications	Supplemental Information
<b>Receiver Spurious Emissions</b>		
Spurious emission power range	-20 to -83 dBm	
Preamp On ( <i>Option IDS</i> )	-40 to -101 dBm	

	Specifications	Supplemental Information
Absolute spurious emission power accuracy		
-20 to -60 dBm	±2.0 dB	±1.1 dB, typical
-60 to -83 dBm	±3.8 dB	±2.7 dB, typical
Preamp On ( <i>Option IDS</i> )		
-40 to -70 dBm	±2.5 dB	±1.3 dB, typical
-70 to -101 dBm	±4.0 dB	±2.6 dB, typical

	Specifications	Supplemental Information
<b>External Correction</b>		
External attenuation, external gain		
Range	-90 to 90 dB	
Resolution	0.01 dB	

Agilent E4405B Specifications and Characteristics  
Options

	Specifications	Supplemental Information
<b>Trigger</b>		
Trigger source (Actual available choices dependent on measurement)  (Option B7D and B7E)	Free run, external  Add RF Burst, frame	
Delay trigger Range	0 to 500 ms	
Resolution	300 ns	
RF burst trigger level (Option B7E)	0 to -25 dBc	
Trigger slope (External and RF burst)	Positive/Negative	
Frame timing period	50 ns to 13.6533 s	
Frame synchronizing source	External frame sync	Rear panel connector labelled EXT FRAME SYNC (Option B7D)
Frame synchronizing slope	Positive/Negative	

	Specifications	Supplemental Information
<b>Demod Trigger Source</b>		
Even second input (Frame trigger only, Option B7D and B7E)		Rear panel connector labelled EXT FRAME SYNC
PN offset range	0 to 511 x 64 [chips]	



### GSM with EDGE Measurement Personality (Option BAH, 252)

Unless otherwise noted, all specifications are with RF input range auto, default GSM measurement settings, and in the in-band frequency range. Option 1D6 and Option B72 are required.

	Specifications	Supplemental Information
<b>In-Band Frequency Ranges <sup>a</sup></b>		
GSM 900, P-GSM bands	890 to 915 MHz	
	935 to 960 MHz	
GSM 900, E-GSM bands	880 to 915 MHz	
	925 to 960 MHz	
GSM 900, R-GSM bands	876 to 915 MHz	
	921 to 960 MHz	
DCS 1800 bands	1710 to 1785 MHz	
	1805 to 1880 MHz	
PCS 1900 bands	1850 to 1910 MHz	
	1930 to 1990 MHz	
<b>Alternative Frequency Ranges <sup>b</sup></b>		
GSM 450 bands	450.4 to 457.6 MHz	
	460.4 to 467.6 MHz	
GSM 480 bands	478.8 to 486 MHz	
	488.8 to 496 MHz	
GSM 850 bands	824 to 849 MHz	
	869 to 894 MHz	

a. Frequency ranges over which all specifications apply.

b. Frequency ranges with tuning plans.

## Options

	Specifications	Supplemental Information
<b>Transmitter Power</b> (Requires <i>Option B7D</i> or <i>AYX</i> )		
Range at RF Input	30 to -60 dBm	
Absolute power accuracy for in-band signal (Mean channel power at RF Input, plus any external attenuation, excluding mismatch error)		
P-GSM, E-GSM, and R-GSM Bands		
30 to -20 dBm 20 to 30 °C	±0.81 dB	±0.34 dB, typical
0 to 55 °C	±1.25 dB	
-20 to -30 dBm 20 to 30 °C	±0.74 dB	±0.31 dB, typical
0 to 55 °C	±1.06 dB	
-30 to -40 dBm 20 to 30 °C	±0.79 dB	±0.31 dB, typical
0 to 55 °C	±1.05 dB	
-40 to -50 dBm 20 to 30 °C	±0.95 dB	±0.47 dB, typical
0 to 55 °C	±1.15 dB	
-50 to -60 dBm 20 to 30 °C	±1.09 dB	±0.60 dB, typical
0 to 55 °C	±1.27 dB	
DCS 1800 and PCS 1900 Bands		
30 to -20 dBm 20 to 30 °C	±0.77 dB	±0.29 dB, typical
0 to 55 °C	±1.27 dB	
-20 to -30 dBm 20 to 30 °C	±0.70 dB	±0.28 dB, typical
0 to 55 °C	±1.05 dB	
-30 to -40 dBm 20 to 30 °C	±0.75 dB	±0.28 dB, typical
0 to 55 °C	±1.04 dB	
-40 to -50 dBm 20 to 30 °C	±0.91 dB	±0.44 dB, typical

	Specifications	Supplemental Information
0 to 55 °C	±1.14 dB	±0.57 dB, typical
-50 to -60 dBm 20 to 30 °C	±1.05 dB	
0 to 55 °C	±1.26 dB	

	Specifications	Supplemental Information
<b>Transmitter Power Relative Power Accuracy</b> (same channel, different Tx power, input attenuator fixed, RF input range manual).	See Display Scale Fidelity	

	Specifications	Supplemental Information
<b>GMSK Power versus Time and EDGE Power versus Time</b> (Requires <i>Option B7D</i> or <i>AYX</i> )		
Carrier power range at RF Input	30 to -23 dBm	30 to -55 dBm <sup>a</sup> , nominal
Preamp On ( <i>Option IDS</i> )	30 to -40 dBm	30 to -72 dBm <sup>a</sup> , nominal
Time resolution accuracy		±1% of sweep time, nominal
Maximum record length	8 time slots	
Burst to mask uncertainty (Requires <i>Option B7D</i> and <i>B7E</i> )	$\pm \left[ 0.1 + \frac{ST / (TP - 1)}{T_{sym}} \right]$ symbol	Where ST = sweep time <sup>b</sup> TP = trace points and T <sub>sym</sub> = 3.69 μs  Examples: Meas Time=1 and TP=1601, gives 0.22 symbol  Meas Time=8 and TP=6401, gives 0.30 symbol

- a. Performance may degrade outside of the specified carrier power range at RF input listed in the specifications column.
- b. Sweep Time value can be found on the key label in the **Advanced** settings menu, with GSM w/EDGE personality software versions C.01.00 and later.

	Specifications	Supplemental Information
<b>GMSK Output RF Spectrum and EDGE Output RF Spectrum</b>		
Carrier power range at RF Input	+30 to -4 dBm	
Reference power accuracy	Transmitter Power Accuracy ±0.13 dB	

	Specifications		Supplemental Information
Relative accuracy <sup>a</sup>			
Due to modulation			
Offsets ≤1200 kHz	±0.83 dB		
Offsets ≥1800 kHz	±0.96 dB		
Due to switching	±1.63 dB		
Spectrum due to modulation displayed dynamic range <sup>b,c</sup>	<b>Non-Option 120</b>	<b>Option 120</b>	
100 kHz offset <sup>d</sup>	67.5 dB	67.5 dB	
200 kHz offset <sup>d</sup>	69.5 dB	71.9 dB	
250 kHz offset <sup>d</sup>	70.2 dB	73.3 dB	
400 kHz offset			
GSM <sup>d</sup>	71.7 dB	76.3 dB	
EDGE			67 dB, nominal <sup>e</sup>
600 kHz to 1200 kHz offset	72.8 dB	78.8 dB	
1.8 MHz offset	69.9 dB	76.3 dB	
6 MHz offset	70.1 dB	77.1 dB	
Spectrum due to switching transients displayed dynamic range <sup>b,c</sup>	<b>Non-Option 120</b>	<b>Option 120</b>	
400 kHz offset	62.5 dB	67.1 dB	
600 kHz offset	63.6 dB	69.6 dB	
1200 kHz offset	65.1 dB	72.5 dB	
1800 kHz offset	65.4 dB	72.7 dB	

- a. Does not include uncertainty due to noise.
- b. Previously available GSM measurements options for ESA specified dynamic range for CW signals only. These specifications apply for GSM and EDGE signals.
- c. Using default settings, the RBW filter has a corrected noise BW and impulse BW equivalent to five-pole synchronously tuned filter.
- d. The dynamic range for offsets under 400 kHz is not directly observable because the signal spectrum obscures the result. These dynamic range specifications are derived from phase noise specifications.

	Specifications	Supplemental Information
<b>Phase and Frequency Error</b> (Requires <i>Option 1D5, B7D, and B7E</i> )		
Carrier power range at RF Input	30 to -23 dBm	30 to -55 dBm <sup>a</sup> , nominal

- e. The analyzer performance can be dominated by third-order distortion products. These products depend on the mixer level. Their relative level will vary by 10 dB as the mixer level (input RF power minus attenuation) varies over a 5 dB range. When the Input Attenuator is auto coupled, the resolution of the attenuator keeps the mixer level in a 5 dB range. The indicated nominal performance was observed at the worst-case mixer level. Increasing the input attenuation by 10 dB from the auto coupled setting will improve the dynamic range for EDGE signals to very close to that for GSM signals at the 400 kHz offset. The optimum mixer level for dynamic range is approximately -15 dBm for EDGE at 400 kHz offset; the auto coupled setting is controlled to be in the -4 to -9 dBm range to optimize the trade off between compression errors and noise for wider offsets.

	Specifications	Supplemental Information
Preamp On (Option 1DS)	30 to -40 dBm	30 to -72 dBm <sup>a</sup> , nominal
Phase error		
Range	0 to 180°	
Displayed resolution	0.01°	
Accuracy (Averages ≥10)		
Peak	±2.1°	±1.5°, typical
RMS	±1.1°	±0.6°, typical
Frequency error		Excludes frequency reference error
Initial frequency error range	±100 kHz	
Accuracy (Avg. Type = Mean, Averages ≥10)	±10 Hz	±5 Hz, typical
I/Q offset range	-10 to -46 dBc	
Burst sync time uncertainty	±0.1 bit	
Displays		Numeric summary

- a. Performance may degrade outside of the specified carrier power range at RF input listed in the specifications column.

	Specifications	Supplemental Information
<b>Transmit Band Spurious</b>		
Carrier power range at RF Input		30 to -12 dBm, typical
Dynamic range		
Upper and lower adjacent segments		55 dB, nominal
Upper and lower segments		44 dB, nominal
Relative accuracy		$\pm(0.3 \text{ dB} + 0.01 \times (\text{dB from reference level}))$ , nominal
Displayed resolution	0.01 dB	

	Specifications	Supplemental Information
<b>Out-of-Band Spurious<sup>a</sup></b>		
Absolute Spurious Power Accuracy		Refer to the Amplitude specifications section in this guide.
Sensitivity <sup>b</sup>		
RBW		
1 kHz		-95 dBm, nominal
3 kHz		-90 dBm, nominal
10 kHz		-85 dBm, nominal
30 kHz		-78 dBm, nominal
100 kHz		-71 dBm, nominal
300 kHz		-64 dBm, nominal
1 MHz		-57 dBm, nominal
3 MHz		-50 dBm, nominal

- a. The out-of-band spurious measurement is made in accordance with the tables defined in the appropriate 3GPP specification document. The measurement is made over several frequency ranges (up to 10 spurs per range, 100 spurs maximum).
- b. With input attenuation of 5 dB. For all other attenuation settings, add (input attenuation - 5) dB.

	Specifications	Supplemental Information
<b>Receive Band Spurious</b>		
Spurious emission power range <sup>a</sup>		-20 to -73 dBm, nominal
Preamp On ( <i>Option IDS</i> )		-40 to -91 dBm, nominal
Absolute spurious emission power accuracy		
-20 to -60 dBm		±1.4 dB, nominal
-60 to -73 dBm		±2.0 dB, nominal
Preamp on ( <i>Option IDS</i> )		
-40 to -70 dBm		±1.8 dB, nominal
-70 to -91 dBm		±3.0 dB, nominal

a. Requires bandpass filter centered on receive band, peak detector mode, 0 dB attenuation, 100 kHz RBW. Does not include insertion loss of bandpass filter.

	Specifications	Supplemental Information
<b>EDGE Error Vector Magnitude (EVM)</b> (Requires <i>Option IDS</i> , <i>B7D</i> and <i>B7E</i> )		3 $\pi$ /8 shifted 8PSK modulation Specifications based on 200 bursts
Carrier power range at RF Input	30 to -23 dBm	30 to -55 dBm <sup>a</sup> , nominal
Preamp On ( <i>Option IDS</i> )	30 to -40 dBm	30 to -72 dBm <sup>a</sup> , nominal
EVM		
Operating range		0 to 25 % (nominal)
Floor (RMS)		0.8 % (nominal)
Accuracy <sup>b</sup> (RMS)		$\pm$ 0.75 % (nominal)
EVM range 1 % to 10 %		
Input power +24 to -12 dBm		
Frequency Error		Excludes frequency reference error
Accuracy		$\pm$ 5 Hz, nominal
IQ Origin Offset		
DUT maximum offset	-20 dBc	
Maximum analyzer noise floor	-45 dBc	

- Performance may degrade outside of the specified carrier power range at RF input listed in the specifications column.
- The accuracy specification applies when the Burst Sync is set to the Training Sequence. The definition of accuracy for the purposes of this specification is how closely the result meets the expected results. The expected result is 0.975 of the actual RMS EVM of the signal (per 3GPP TS 5.05, annex G).

	Specifications	Supplemental Information
<b>Amplitude Range Control</b>		RF Input Autorange, Manually set <b>Max Total Pwr</b> Manually set <b>Input Atten</b>

	Specifications	Supplemental Information
<b>External Gain/Attenuation Correction</b>		
Base gain, base attenuation, mobile gain, mobile attenuation		
Range	0 to 81.9 dB	
Resolution	0.01 dB	

	Specifications	Supplemental Information
<b>Trigger</b>		
Trigger source (Actual available choices dependent on measurement)	Free run, external	



	Specifications	Supplemental Information
<i>(Option B7D and B7E)</i>	Add RF burst and frame	
RF burst trigger <i>(Option B7E)</i>		
Peak carrier power range <sup>a</sup>	30 to -25 dBm	30 to -30 dBm, typical
Preamp On <i>(Option 1DS)</i>	30 to -45 dBm	30 to -50 dBm, typical
Trigger level range	0 to -25 dB relative to signal peak	

a. With trigger level set to -6 dB.

	Specifications	Supplemental Information
<b>Burst Sync</b> <i>(Requires Option AYX or B7D)</i>		
Source <i>(Actual available choices dependent on measurement)</i>	RF amplitude, none	
<i>(Option B7D and B7E)</i>	Add training sequence	
Training sequence code		GSM defined 0 to 7 Auto (search) or Manual
Burst type		Normal (TCH and CCH) Sync (SCH) Access (RACH)

**Noise Figure Measurement Personality and Hardware  
(Option 219) Specifications.**

	Specifications	Supplemental Information
<b>+28 V PULSED</b>		Noise source drive Used by option 219
Connector type	50 $\Omega$ BNC(f)	
Output voltage		
On	28.0 V $\pm$ 0.1 V	60mA peak
Off	<1V	
<b>SNS SERIES NOISE SOURCE</b>		For use with Agilent Technologies SNS Series noise sources

	Specifications	Supplemental Information
<b>Noise Figure</b>		Uncertainty Calculator <sup>a</sup>
10 MHz to 3 GHz		Using internal preamp (Option 1DS), and RBW=1 MHz
Noise Source ENR	Measurement Range	Instrument Uncertainty <sup>b</sup>
4.5 to 6.5 dB	0 to 20 dB	$\pm$ 0.24 dB
12 to 17 dB	0 to 30 dB	$\pm$ 0.41 dB
20 to 22 dB	0 to 35 dB	$\pm$ 0.46 dB
3 to 26.5 GHz <sup>c</sup>		No internal preamp
Instrument Uncertainty		Nominally the same as for the 10 MHz to 3 GHz range; External preamp caution <sup>d</sup>
3 to 10 GHz		Well-controlled preselector <sup>e</sup>
10 to 20 GHz		Good preselector stability <sup>f</sup>
20 to 26.5 GHz		Preselector Drift Effects <sup>g</sup>

a. The figures given in the table are for the uncertainty added by the ESA instrument only. To compute the total uncertainty for your noise figure measurement, you need to take into account other factors including: DUT NF, Gain and Match; Instrument NF, Gain Uncertainty and Match; Noise source ENR uncertainty and Match. The computations can be performed with the uncertainty calculator included with the Noise Figure Measurement Personality. Go to **Mode Setup** then select **Uncertainty Calculator**. Similar calculators are also available on the Agilent web site; go to [www.agilent.com/find/nfu](http://www.agilent.com/find/nfu).

- b. "Instrument Uncertainty" is defined for noise figure analysis as uncertainty due to relative amplitude uncertainties encountered in the analyzer when making the measurements required for a noise figure or gain computation. The relative amplitude uncertainty is given by the relative display scale fidelity, also known as incremental log fidelity. The uncertainty of the analyzer is multiplied within the computation by an amount that depends on the Y factor to give the total uncertainty of the noise figure or gain measurement.

See Agilent App Note 57-2, literature number 5952-3706E for details on the use of this specification. Jitter (amplitude variations) will also affect the accuracy of results. The standard deviation of the measured result decreases by a factor of the square root of the Resolution Bandwidth used and by the square root of the number of averages. ESA uses the 1 MHz resolution Bandwidth as default since this is the widest bandwidth with uncompromised accuracy.

- c. For this frequency range, the Instrument Noise Figure Uncertainty is still well controlled, but other accuracy issues become critical. Because there is no internal preamplifier in this range, the Instrument Noise Figure is much higher than in the range below 3 GHz. This causes the effect on total measurement Noise Figure Uncertainty of the Instrument Gain Uncertainty to be much higher, and that Instrument Gain Uncertainty is in turn much higher than in the range below 3 GHz because of the effects of the preselector, explained in subsequent footnotes. As a result, when the DUT has high gain, the total measurement Noise Figure Uncertainty computed with the Uncertainty Calculator can still be excellent, but modest and low gain devices can have very high uncertainties of noise figure. Graphs that follow demonstrate. The first graph shows the computed measurement NF uncertainty with no preamp, and shows how much gain is required to achieve good accuracy. The second graph shows computed measurement NF uncertainty when using an external preamp with 23 dB gain and 6 dB NF. Both graphs were plotted using the uncertainty calculator with the assumptions shown.
- d. An external preamp can reduce the total NF measurement uncertainty substantially because it will reduce the effective noise figure of the measurement system, and thus it will reduce the sensitivity of the total NF uncertainty to the Instrument Gain Uncertainty. But if the signal levels into such an external preamp are large enough, that external preamp may experience some compression. The compression differences between the noise-source-on and noise-source-off states causes an error that must be added to Instrument Noise Figure Uncertainty for use in the Noise Figure Uncertainty Calculator. Such signal levels are quite likely for the case where the DUT has some combination of high gain, high noise figure and wide bandwidth.

As an example, we will use the Agilent 83006A as the external preamplifier. The measurement will be made at 18 GHz. The typical gain is 25 dB and the noise figure is 7 dB. We will assume the DUT has 20 dB gain, a 10 dB NF, and a passband from 5 to 30 GHz. We will use a noise source with 17 dB ENR. When the noise source is on, the DUT output can be computed by starting with  $kT$  ( $-174$  dBm/Hz) and adding  $10 \cdot \log(30 \text{ GHz} / 5 \text{ GHz})$  or 104 dB, giving  $-70$  dBm for the thermal noise. Add to this the ENR of the noise source (17 dB) combined with the NF of the DUT (10 dB) to give an equivalent input ENR of 18 dB, thus  $-52$  dBm input noise power. Add the gain of the DUT (20 dB) to find the DUT output power to be  $-32$  dBm. The noise figure of the external preamp may be neglected. The external preamplifier gain of 25 dB adds, giving a preamplifier output power of  $-7$  dBm. The typical 1 dB compression point of this amplifier is  $+19$  dBm. Therefore, the output noise is 26 dB below the 1 dB compression point. This amplifier will have negligible compression.

As an approximation, the compression of a noise signal is under 0.1 dB if the average noise power is kept 7 dB below the 1 dB CW compression point. The compression in decibels will usually double for every 3 dB increase in noise power. Use cases with higher gain DUTs or preamplifiers with lower output power capability could be compressed, leading to additional errors.

- e. In this frequency range, the preselector is well-controlled and there should be no need for special measurement techniques.
- f. In this frequency range, the preselector usually requires no special measurement techniques in a lab environment. But if the temperature changes by a few degrees, or the analyzer frequency is swept or changed across many gigahertz, Agilent recommends centering the preselector at one user determined critical frequency before a measurement. To adjust the preselector, follow the instructions in the *Noise Figure Measurement Personality Guide*.

- g. In this frequency range, the preselector may sometimes require special measurement techniques, even in a lab environment. Agilent recommends centering the preselector at one user determined critical frequency before a measurement. To adjust the preselector, follow the instructions in the *Noise Figure Measurement Personality Guide*.

**Noise Figure Error Range vs. DUT Gain, Non-warranted Frequency Range (>3 GHz)**

**Computed Measurement NF Uncertainty vs. DUT Gain, Non-warranted Frequency Range**

Assumptions: Measurement Frequency 12 GHz, Instrument NF = 28.7 dB, Instrument VSWR = 1.58, Instrument Gain Uncertainty = 2.7 dB, Instrument NF Uncertainty = 0.41 dB, Agilent 346B Source with Uncertainty = 0.2 dB, Source VSWR = 1.25, DUT input/output VSWR = 1.5.

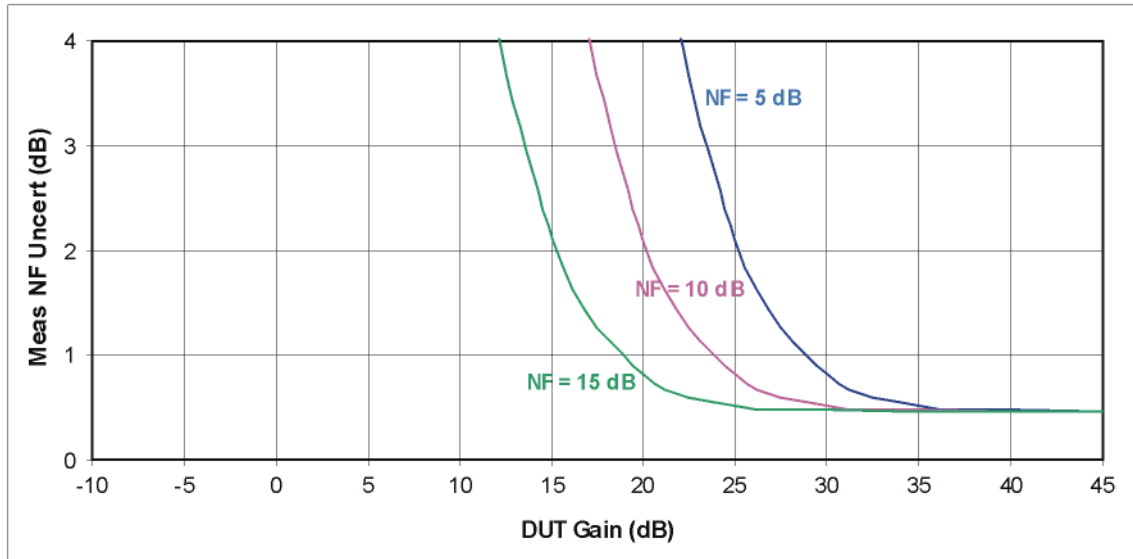

**Computed Measurement NF Uncertainty vs. DUT Gain, Non-warranted Frequency Range**

Assumptions: Same as above, with the addition of an external preamp that has a gain of 23 dB and a NF of 6 dB (for example, 83006A). Also, the Agilent 346A Source is used. The 346A changes the instrument noise figure uncertainty to 0.24 dB. With the external preamp, the preamp/analyzer combination NF is 8.86 dB. Instrument VSWR now moves to the external preamp with VSWR = 2.6

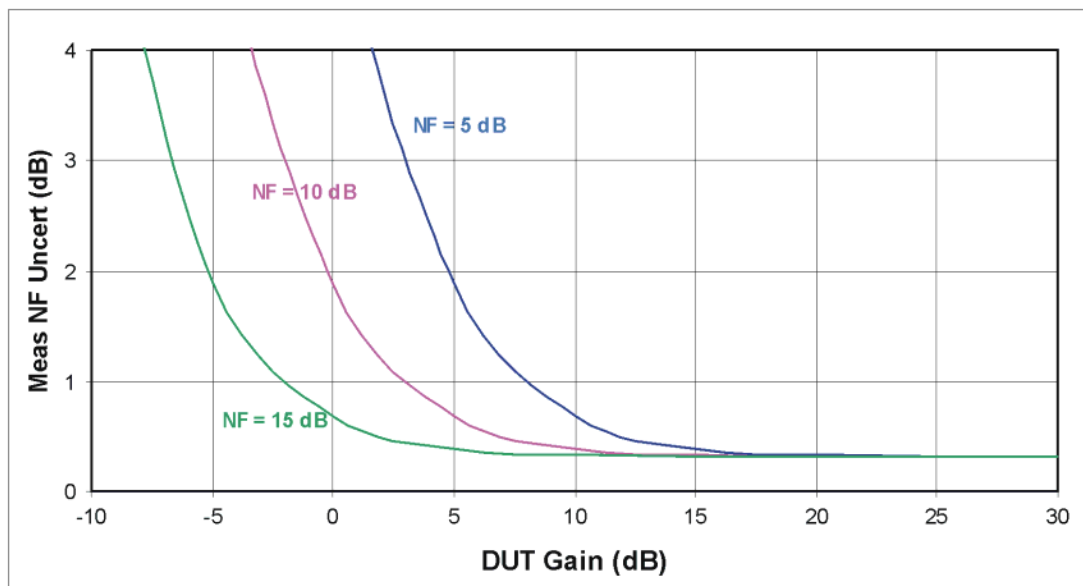

	Specifications		Supplemental Information
<b>Gain</b>			
10 MHz to 3 GHz			
Noise Source ENR	Measurement Range	Instrument Uncertainty <sup>a</sup>	
4.5 to 6.5 dB	-20 to 40 dB	±0.83 dB	
12 to 17 dB	-20 to 40 dB	±0.83 dB	
20 to 22 dB	-20 to 40 dB	±0.83 dB	
3 to 26.5 GHz <sup>b</sup>			
Instrument Uncertainty			±2.7 dB (nominal) <sup>c</sup> for Measurement Range -20 to 40 dB

- a. See the “Instrument Uncertainty” footnote [b](#) on page 235.
- b. See footnotes [d](#), [e](#), [f](#), and [g](#) for this frequency range in the [Noise Figure](#) section.
- c. The performance shown would apply when there is a long time between the calibration step and the DUT-measurement step in a NF or Gain measurement. Under special circumstances of small changes in frequency (such as spot frequency measurements) and short time periods between the calibration time and the measurement time, this error source becomes much smaller, approaching the Instrument Uncertainty shown for the 10 MHz to 3 GHz frequency range. These special circumstances would be frequency span ranges of under 1 GHz, with that frequency range unchanged for 30 minutes, and the time between the calibration step and the DUT measurement step held to less than 10 minutes.

	Specifications	Supplemental Information
<b>Noise Figure Uncertainty Calculator<sup>a</sup></b>		
Instrument Noise Figure Uncertainty	See <a href="#">Noise Figure</a>	
Instrument Gain Uncertainty	See <a href="#">Gain</a>	
Instrument Noise Figure		See graphs, Nominal Noise Figure DANL +145.87 dB (nominal) <sup>b</sup>
Instrument Input Match		See graphs, Nominal VSWR

a. The Noise Figure Uncertainty Calculator requires the parameters shown in order to calculate the total uncertainty of a Noise Figure measurement.

b. Nominally, the noise figure of the spectrum analyzer is given by

$$NF = D - (K - L + N + B)$$

where D is the DANL (displayed average noise level) specification,

K is kTB (-173.88 dB in a 1 Hz bandwidth at 25 °C)

L is 2.51 dB (the effect of log averaging used in DANL verifications)

N is 0.52 dB (the ratio of the noise bandwidth of the RBW filter with which DANL is specified to an ideal noise bandwidth)

B is ten times the base-10 logarithm of the RBW (in hertz) in which the DANL is specified. B is 30 dB for the 1 kHz RBW. The actual NF will vary from the nominal due to frequency response errors.

Nominal Instrument Noise Figure

Nominal Instrument Noise Figure 10 MHz to 3 GHz Preamplifier On

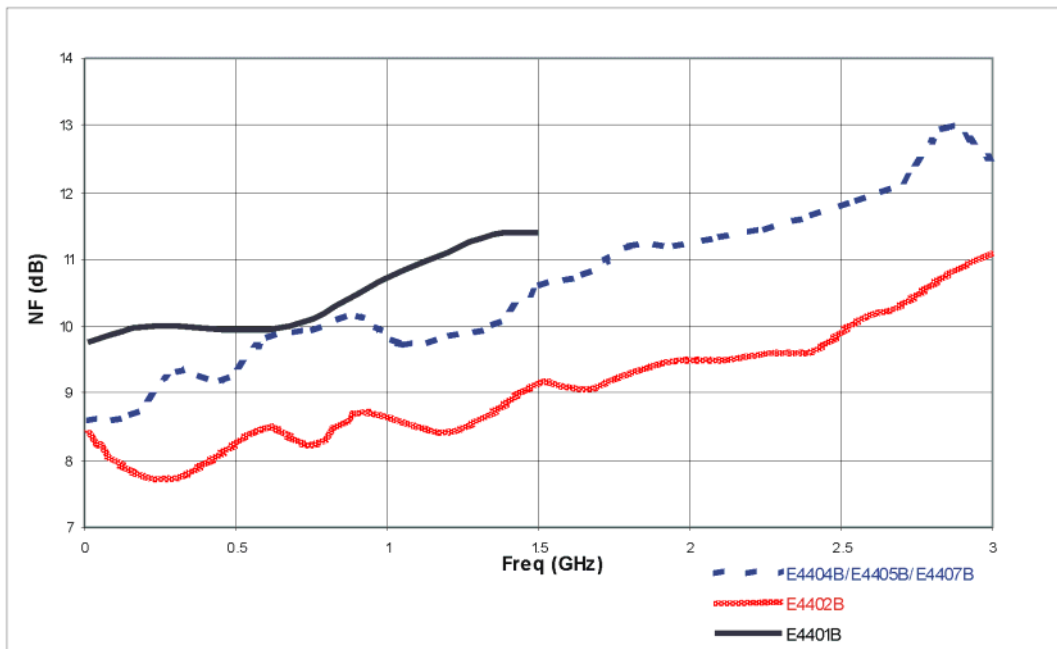

Nominal Instrument Noise Figure 3 to 26.5 GHz  
No Preamplifier; two example units

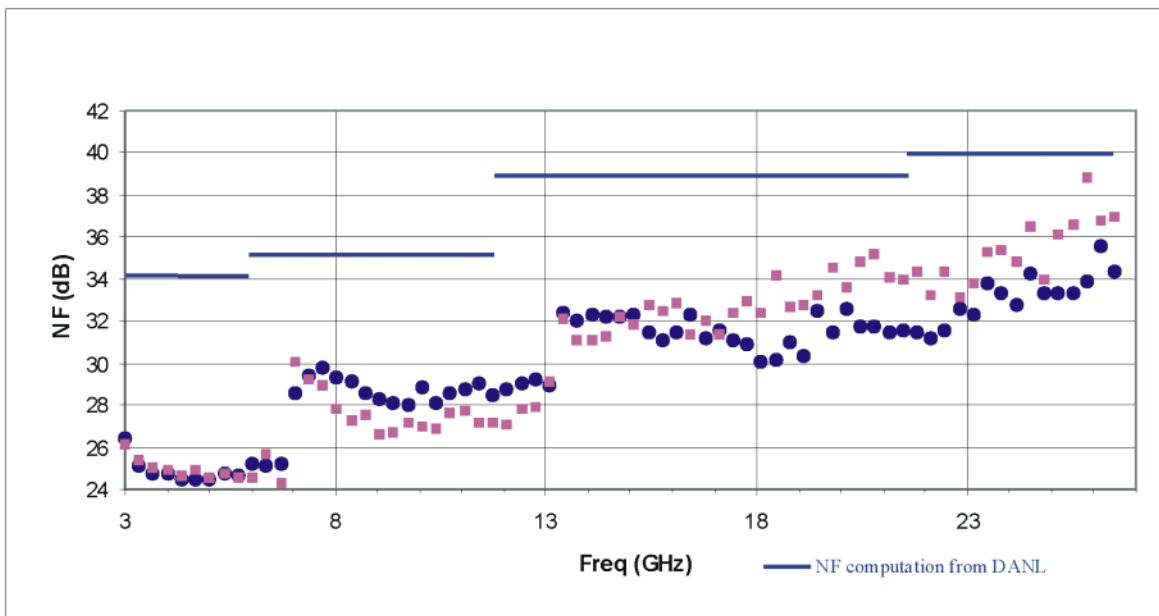



**Nominal Instrument Input VSWR**

**Nominal Instrument Input VSWR 10 MHz to 3 GHz; Preamp On, Attenuation = 0 dB**

VSWR of four instruments shown. Nine graphs are representative of different input coupling configurations of E4401/2/5/7B models.

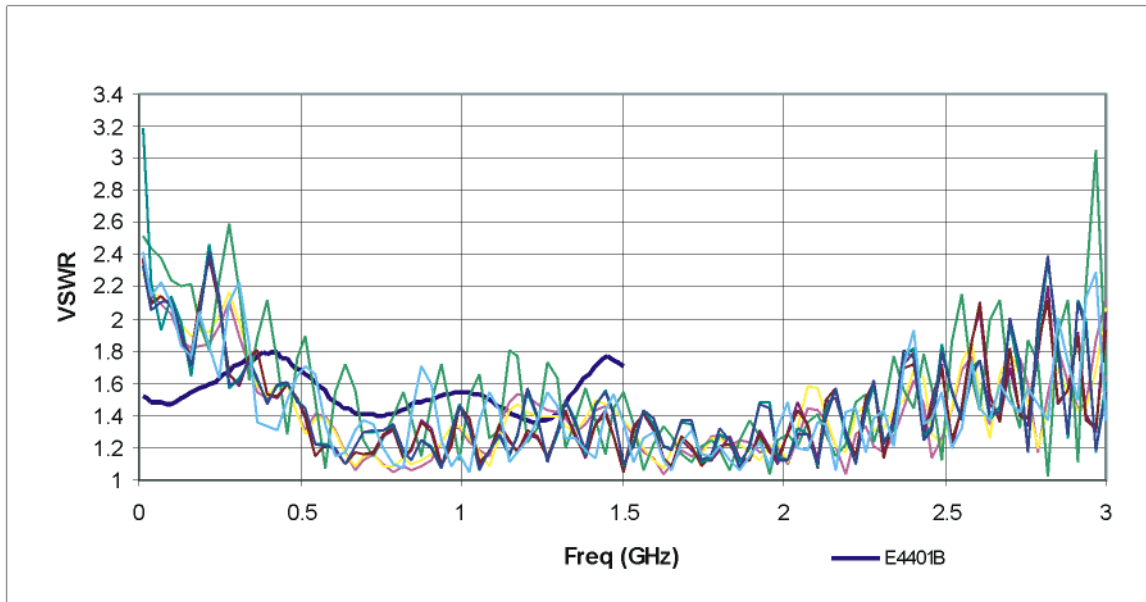

**Nominal Instrument Input VSWR 3 to 26.5 GHz; No Preamp, Attenuation = 0 dB**

VSWR of three instruments shown. Three graphs are representative of different input coupling configurations of E4407B models

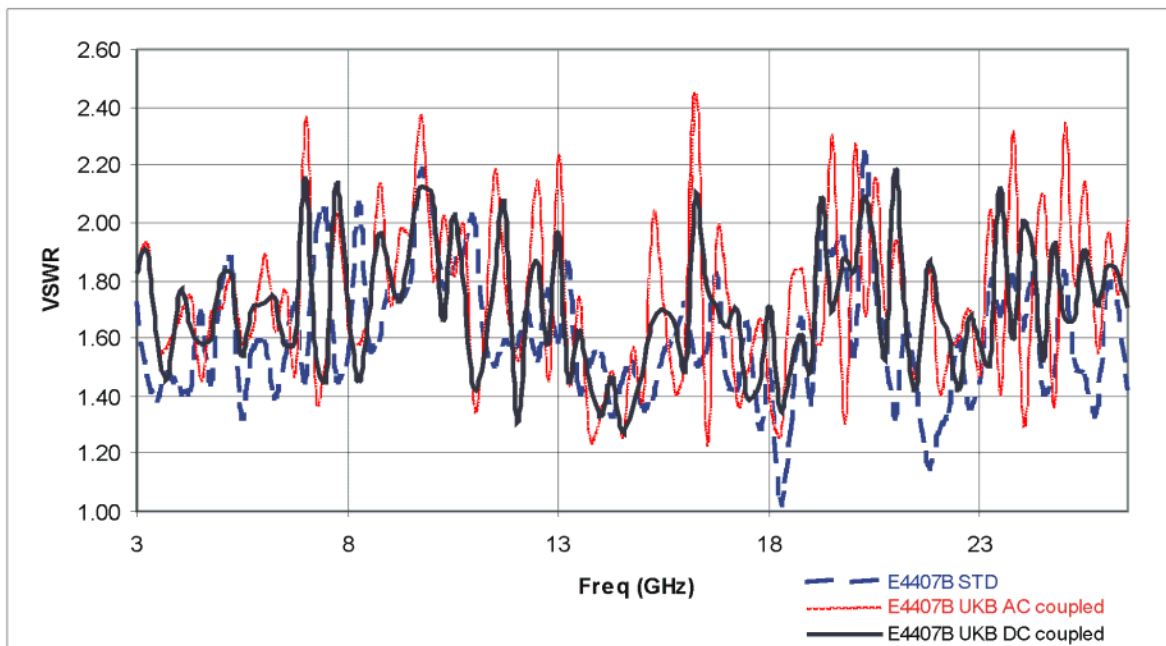

## General

	Specifications	Supplemental Information
<b>Temperature Range</b>		
Operating	0 to 55 °C	Floppy disk 10 to 40 °C
Storage	-40 to 75 °C	

	Specifications	Supplemental Information
<b>Altitude Range</b>		
Operating	Up to 4600 meters	

	Specifications	Supplemental Information
<b>Humidity Range</b>		
Operating	maximum relative humidity 80% for temperatures up to 31°C decreasing linearly to 50% relative humidity at 40°C	

	Specifications	Supplemental Information
<b>Audible Noise (ISO 7779)</b>		
Sound Pressure at 25 °C		<40 dBa, (<4.6 Bels power)

	Specifications	Supplemental Information
<b>Military Specification</b>	Has been type tested to the environmental specifications of MIL-PRF-28800F class 3.	

	Specifications	Supplemental Information
<b>EMI Compatibility</b>	Conducted and radiated emission is in compliance with CISPR Pub. 11/1990 Group 1 Class A.	
(Option 060) <sup>a</sup>	Conducted and radiated emission is in compliance with CISPR Pub. 11/1990 Group 1 Class B <sup>b</sup> .	

a. Option 060 is not compatible with Option B7B nor Option 1DP.

b. Meets Class A performance during dc operation.

	Specifications	Supplemental Information
<b>Immunity Testing</b>  Radiated Immunity        Electrostatic Discharge		Testing was done at 3 V/m according to IEC 801-3/1984. When the analyzer tuned frequency is identical to the immunity test signal frequency, there may be signals of up to -60 dBm displayed on the screen.  Air discharges of up to 8 kV were applied according to IEC 801-2/1991. Discharges to center pins of any of the connectors may cause damage to the associated circuitry.

	Specifications	Supplemental Information
<b>Acoustic Noise Emission/Geraeuschemission</b>  LpA <70 dB Operator position Normal position Per ISO 7779	LpA <70 dB Am Arbeitsplatz Normaler Betrieb Nach DIN 45635 t.19	

	Specifications	Supplemental Information
<b>Power Requirements</b>  ac Operation Voltage, frequency  Power Consumption, On Power Consumption, Standby  dc Operation Voltage Power Consumption Power Consumption, Standby	  90 to 132 Vrms, 47 to 440 Hz 195 to 250 Vrms, 47 to 66 Hz  <300 W <5 W  12 to 20 Vdc <200 W <100 mW	

	Specifications	Supplemental Information
<b>Measurement Speed</b>		

	Specifications	Supplemental Information
Local Measurement and Display Update rate <sup>a</sup>		
Sweep points = 101		≥ 40/s, characteristic
Sweep points = 401		≥ 28/s, characteristic
Remote Measurement and GPIB Transfer Rate <sup>b,c</sup>		
(Option A4H)		
Sweep points = 101		≥ 40/s, characteristic
Sweep points = 401		≥ 28/s, characteristic
RF Center Frequency Tune, Measure, and GPIB Transfer Time <sup>c,d</sup>		
(Option A4H)		
Sweep points = 101		≤ 75 ms, characteristic
Sweep points = 401		≤ 90 ms, characteristic

- Factory preset, auto align Off, segmented sweep Off, fixed center frequency, RBW = 1 MHz, frequency scale linear, spans >10 MHz and ≤600 MHz, and stop frequency ≤3 GHz.
- Display Off (:DISPlay:ENABle OFF), and 32-bit integer data format (:FORMat:DATA INT,32), if Option AXX or A4J is installed, disable sweep ramp, (:SYSTem:PORTs: IFVSweep:ENABle OFF), markers Off, single sweep, measured with IBM compatible PC with 550 MHz Pentium® III running Windows® NT 4.0, one meter GPIB cable, National Instruments PCI-GPIB card and NI-488.2 DLL.
- Factory preset, auto align Off, fixed center frequency, RBW = 1 MHz, frequency scale linear, and span = 20 MHz, fixed center frequency, stop frequency ≤3 GHz, average of 100 measurements.
- Factory preset, auto align Off, segmented sweep Off, RBW = 1 MHz, frequency scale linear, span = 20 MHz, stop frequency ≤3 GHz, center frequency tune step size = 50 MHz.

	Specifications	Supplemental Information
<b>Data Storage</b>		
Internal <sup>a</sup>		8.0 MB, nominal
External (10 to 40 °C)		3.5" 1.44 MB, MS-DOS® compatible floppy disk

- For serial numbers prior to US41440000 or MY41440000, 1 MB without Option B72, 8 MB with Option B72.

	Specifications	Supplemental Information
Memory Usage State		20 kB <sup>a</sup> , nominal

	Specifications	Supplemental Information
State plus 401-point trace		21 kB <sup>a</sup> , nominal
Applications memory usage <sup>b</sup>		
Distance to Fault ( <i>Option 225</i> )		0.6 MB, nominal
Phase noise ( <i>Option 226</i> )		1.1 MB, nominal
Cable TV ( <i>Option 227</i> )		1 MB, nominal
Bluetooth ( <i>Option 228</i> )		1.32 MB, nominal
Modulation Analysis ( <i>Option 229</i> )		1.7 MB, nominal
HP 8566/68B Compatibility ( <i>Option 266</i> )		0.24 MB, nominal
8590 Compatibility ( <i>Option 290</i> )		0.7 MB, nominal
GSM ( <i>Option BAH</i> )		3.2 MB, nominal
CDMA One ( <i>Option BAC</i> )		2.8 MB, nominal
Noise Figure ( <i>Option 219</i> )		1.6 MB, nominal

- a. The size of state will increase depending on installed applications.
- b. Some applications may share files which may reduce total memory usage.

	Specifications	Supplemental Information
<b>Demod Tune and Listen</b>		Internal speaker, front-panel earphone jack and front-panel volume control.
Demod (Option BAA)	AM	
(Option A4J or AYX)	Add FM	An uncalibrated demodulated signal is available on the AUX VIDEO OUT connector at the rear panel.
(Option 106 or BAA)		An uncalibrated demodulated signal is available on the EXT VIDEO OUT connector at the rear panel.

	Specifications	Supplemental Information
<b>Weight</b> (without options)		
Net		17.1 kg (37.7 lb), characteristic

**General**

	<b>Specifications</b>	<b>Supplemental Information</b>
Shipping		31.9 kg (70.3 lb), characteristic

	Specifications	Supplemental Information
<b>Display<sup>a</sup></b>		
Resolution	640 × 480	

- a. The LCD display is manufactured using high precision technology. However, there may be up to six bright points (white, blue, red or green in color) that constantly appear on the LCD screen. These points are normal in the manufacturing process and do not affect the measurement integrity of the product in any way.

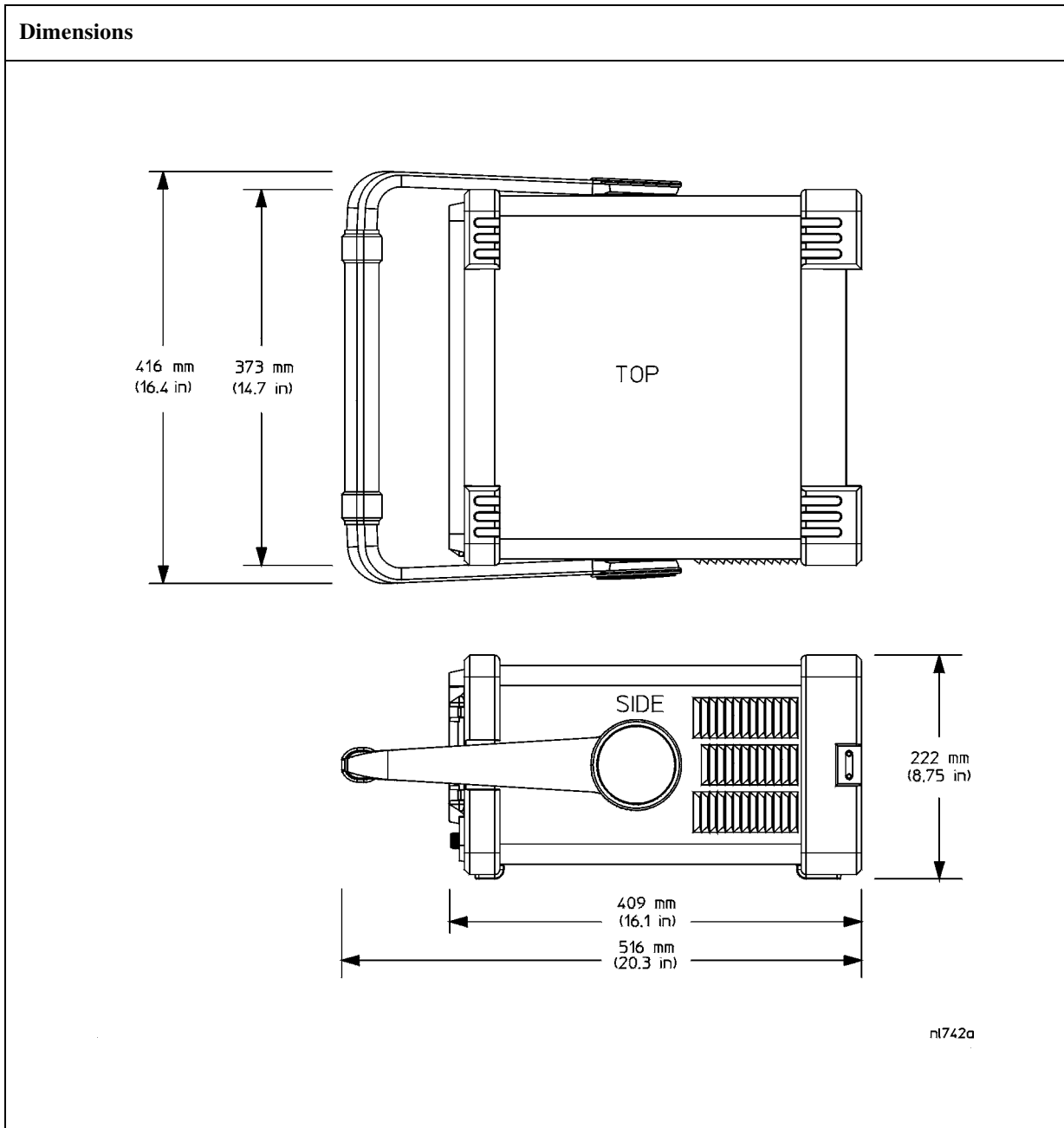

## Inputs and Outputs

### Front Panel

	Specifications	Supplemental Information
<b>INPUT 50 Ω</b>		
Connector	Type-N female	
Impedance		50 Ω, nominal

	Specifications	Supplemental Information
<b>RF OUT 50 Ω, (Option 1DN)</b>		
Connector	Type-N female	
Impedance		50 Ω, nominal

	Specifications	Supplemental Information
<b>AMPTD REF OUT<sup>a</sup></b>		Amplitude Reference
Connector	BNC female	
Impedance		50 Ω, nominal
Frequency		50 MHz
Frequency Accuracy		Frequency reference error <sup>b</sup>
50 Ω Amplitude <sup>c</sup>		-20 dBm, nominal

- a. Turn the amplitude reference on/off by pressing the keys: **Input/Output, Amptd Ref Out**.
- b. Frequency reference error = (aging rate × period of time since adjustment + settability + temperature stability).
- c. The internal amplitude reference actual power is stored internally.



	Specifications	Supplemental Information
<b>PROBE POWER</b> Voltage/Current		+15 Vdc, $\pm 7\%$ at 150 mA max., characteristic  -12.6 Vdc $\pm 10\%$ at 150 mA max., characteristic

	Specifications	Supplemental Information
<b>EXT KEYBOARD<sup>a</sup></b>  Connector	  6-pin mini-DIN	Used for entering screen titles and filenames only. Interface compatible with most IBM-compatible PC keyboards.

a. The feature is not implemented in firmware revisions prior to A.04.00.

	Specifications	Supplemental Information
<b>Speaker</b>		Front panel knob controls volume

	Specifications	Supplemental Information
<b>Headphone</b> Connector  Power Output	  3.5 mm (1/8 inch) miniature audio jack	Front panel knob controls volume  0.2 W into 4 $\Omega$ , characteristic

**Rear Panel**

	Specifications	Supplemental Information
<b>10 MHz REF OUT</b>		
Connector	BNC female	
Impedance		50 $\Omega$ , nominal
Output Amplitude		>0 dBm, characteristic

	Specifications	Supplemental Information
<b>10 MHz REF IN</b>		
Connector	BNC female	Note: Analyzer noise sidebands and spurious response performance may be affected by the quality of the external reference used.
Impedance		50 $\Omega$ , nominal
Input Amplitude Range		-15 to +10 dBm, characteristic
Frequency		10 MHz, nominal

	Specifications	Supplemental Information
<b>EXT REF IN</b> (Option B7E)		
Connector	BNC, female	
Impedance		50 $\Omega$ , nominal
Input amplitude range	-5 to 10 dBm	
Frequency	1 to 30 MHz, selectable	
Frequency lock range	$\pm 5 \times 10^{-6}$ of specified external reference input frequency	

	Specifications	Supplemental Information
<b>10 MHz OUT</b> (Option B7E)		
Connector	BNC, female	
Impedance		50 $\Omega$ , nominal
Frequency		10 MHz, nominal
Level		0 dBm when Option 10 MHz Out is On

	Specifications	Supplemental Information
<b>GATE TRIG/EXT TRIG IN</b>		
Connector	BNC female	
External Trigger Input		
Trigger Level		Selectable positive or negative edge initiates sweep in EXT TRIG mode (5 V TTL)
Gate Trigger Input ( <i>Option 1D6</i> )		
Minimum Pulse Width		>30 ns (5 V TTL)

	Specifications	Supplemental Information
<b>GATE/HI SWP OUT</b>		
Connector	BNC female	
High Sweep Output		
Level		High = sweep <sup>a</sup> ; Low = retrace (5 V TTL)
Gate Output ( <i>Option 1D6</i> )		
Level		High = gate on; Low = gate off (5 V TTL)

a. High sweep may be high longer than the indicated sweep times.

Agilent E4405B Specifications and Characteristics  
**Inputs and Outputs**

	Specifications	Supplemental Information
<b>VGA OUTPUT</b>		
Connector	VGA compatible, 15-pin mini D-SUB	VGA (31.5 kHz horizontal, 60 Hz vertical sync rates, non-interlaced) Analog RGB
Format		
Resolution	640 × 480	

	Specifications	Supplemental Information
<b>AUX IF OUT</b> <i>(Option A4J or AYX)</i>		RBW ≥ 1 kHz
Connector	BNC female	21.4 MHz, nominal  –10 dBm (uncorrected), characteristic  50 Ω, nominal
Frequency		
Amplitude (for signal at reference level and for reference levels – input attenuation + preamp gain of –10 to –70 dBm)		
Impedance		

	Specifications	Supplemental Information
<b>AUX VIDEO OUT</b> <i>(Option A4J or AYX)</i>		RBW ≥ 1 kHz
Connector	BNC female	0 to 1 V (uncorrected), characteristic
Amplitude Range (into >10 kΩ)		

	Specifications	Supplemental Information
<b>HI SWP IN</b> <i>(Option A4J or AYX)</i>		
Connector	BNC female	Open collector, low resets and holds the sweep (5 V TTL)
Input		

	Specifications	Supplemental Information
<b>HI SWP OUT</b> <i>(Option A4J or AYX)</i>		
Connector	BNC female	

	Specifications	Supplemental Information
Output		High = sweep <sup>a</sup> , Low = retrace (5 V TTL)

a. High sweep may be high longer than the indicated sweep times.

	Specifications	Supplemental Information
<b>SWP OUT</b> (Option A4J or AYY)		
Connector	BNC female	
Amplitude		0 to +10 V ramp, characteristic

	Specifications	Supplemental Information
<b>PRESEL TUNE OUTPUT</b>		
Connector	BNC female	
Load Impedance (dc coupled)		> 10 k $\Omega$ , nominal
Range		0 to +10 V, characteristic
Sensitivity		0.33 V/GHz of tuned frequency > 3 GHz, characteristic

	Specifications	Supplemental Information
<b> GPIB Interface (Option A4H)</b>		
Connector	IEEE-488 bus connector	
GPIB Codes		SH1, AH1, T6, SR1, RL1, PP0, DC1, C1, C2, C3 and C28

	Specifications	Supplemental Information
<b>Serial Interface (Option IAX)</b>		
Connector	9-pin D-SUB male	RS-232

	Specifications	Supplemental Information
<b>Parallel Interface</b> (Option A4H or IAX)		Printer port only
Connector	25-pin D-SUB female	

Agilent E4405B Specifications and Characteristics  
**Inputs and Outputs**

	Specifications	Supplemental Information
<b>EXT VIDEO IN/TV TRIG            OUT<sup>a</sup> (Option B7B or BAA)</b>  Connector  Impedance  (Option BAA without Option B7B)  (Option BAA with Option B7B) External Video Input Video Amplitude  TV Trigger Output  Amplitude	BNC Female (75 Ω)	EXT VIDEO IN is the Baseband composite video input for TV trigger and picture on screen. TV TRIG OUT is the TV trigger output.  75 Ω, nominal  Feature not implemented  1 V <sub>p-p</sub> , nominal, characteristic  Positive edge indicates start of selected TV line after sync. pulse  TTL (0 V and 3.4 V with 75 Ω series resistance), characteristic

- a. This connector is labelled EXT VIDEO IN on older spectrum analyzers and EXT VIDEO IN/TV TRIG OUT on newer spectrum analyzers.

	Specifications	Supplemental Information
<b>EXT VIDEO OUT</b> <i>(Option B7B or BAA)</i> Connector Impedance <i>(Option BAA without Option B7B)</i> Amplitude <i>(Option BAA with Option B7B)</i> Amplitude TV Source: SA TV Source and EXT VIDEO IN <i>(Option 106)</i> Connector Impedance Amplitude	  BNC female (75 Ω)         BNC female (75 Ω)	Baseband video output RBW ≥ 1 kHz  75 Ω, nominal  0 to 1 V (uncorrected), characteristic  0 to 1 V (uncorrected), characteristic  Same as level at EXT VIDEO IN/TV TRIG OUT, characteristic  75 Ω, nominal  0 to 1 V (uncorrected), characteristic

	Specifications	Supplemental Information
<b>EXT FRAME SYNC</b> <i>(Option B7D)</i> Connector Level	  BNC, female	  5 V TTL

---

## Regulatory Information

---

**CAUTION** This product is designed for use in Installation Category II and Pollution Degree 2 per IEC 1010 and 664 respectively.

---

**NOTE** This product has been designed and tested in accordance with accepted industry standards, and has been supplied in a safe condition. The documentation contains information and warnings that must be followed by the user to ensure safe operation and to maintain the product in a safe condition.

---



The CE mark is a registered trademark of the European Community.



The C-Tick mark is a registered trademark of the Australian Spectrum Management Agency.

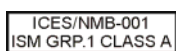

This ISM device complies with Canadian ICES-001. Cet appareil ISM est conforme a la norme NMB du Canada.

This is also a symbol of an Industrial Scientific and Medical Group 1 Class A product (CISPR 11, Clause 4).



The CSA mark is a registered trademark of the CSA International.



This symbol indicates separate collection for electrical and electronic equipment mandated under EU law as of August 13, 2005. All electric and electronic equipment are required to be separated from normal waste for disposal (Reference WEEE Directive 2002/96/EC).



Indicates the time period during which no hazardous or toxic substance elements are expected to leak or deteriorate during normal use. Forty years is the expected useful life of the product.



This symbol on all primary and secondary packaging indicates compliance to China standard GB 18455-2001.

### Declaration of Conformity

A copy of the Manufacturer's European Declaration of Conformity for this instrument can be obtained by contacting your local Agilent Technologies sales representative.

### Declaration of Compliance

This instrument has been designed and tested in accordance with CAN/CSA 22.2 No. 61010-1-04 & UL Std. No. 61010-1 (2<sup>nd</sup> Edition).



---

## **4 Agilent E4407B Specifications and Characteristics**

---

## About This Chapter

This chapter contains specifications and characteristics for the Agilent E4407B spectrum analyzer. The distinction between specifications and characteristics is described as follows.

- Specifications describe the performance of parameters covered by the product warranty. (The temperature range is 0 °C to 55 °C, unless otherwise noted.)
- Characteristics describe product performance that is useful in the application of the product, but is not covered by the product warranty.
- Typical performance describes additional product performance information that is not covered by the product warranty. It is performance beyond specification that 80% of the units exhibit with a 95% confidence level over the temperature range 20 to 30 °C. Typical performance does not include measurement uncertainty.
- Nominal values indicate the expected performance, or describe product performance that is useful in the application of the product, but is not covered by the product warranty.

The following conditions must be met for the analyzer to meet its specifications.

- o The analyzer is within the one year calibration cycle.
- o If **Auto Align All** is selected:
  - After 2 hours of storage within the operating temperature range.
  - 5 minutes after the analyzer is turned on with sweep times less than 4 seconds.
  - After the front-panel amplitude reference is connected to the INPUT, and **Align Now RF** has been run, after the analyzer is turned on. And, once every 24 hours, or if ambient temperature changes more than 30 °C<sup>1</sup>.
- o If **Auto Align Off** is selected:
  - When the analyzer is at a constant temperature, within the operating temperature range, for a minimum of 90 minutes.
  - After the analyzer is turned on for a minimum of 90 minutes, the front panel amplitude reference has been connected to the INPUT, and **Align Now All** has been run.

---

1. 10 °C if Preamp (Option 1DS) is active.

- When **Align Now All** is run:
  - Every hour
  - If the ambient temperature changes more than 3 °C
  - If the 10 MHz reference changes
- When **Align Now RF** is run (with the front-panel amplitude reference connected to the INPUT):
  - Every 24 hours
  - If the ambient temperature changes more than 30 °C<sup>1</sup>
- o If **Auto Align All but RF** is selected:
  - When the analyzer is at a constant temperature, within the operating temperature range, for a minimum of 90 minutes.
  - After the analyzer is turned on for a minimum of 90 minutes, the front panel amplitude reference has been connected to the INPUT, and **Align Now RF** has been run.
  - When **Align Now RF** is run (with the front-panel amplitude reference connected to the INPUT):
    - Every hour
    - If the ambient temperature changes more than 3 °C

---

1. 10 °C if Preamp (Option 1DS) is active.

## Frequency

	Specifications	Supplemental Information	
<b>Frequency Range</b>	9 kHz to 26.5 GHz		
<i>(Option UKB)</i>			
dc coupled	100 Hz to 26.5 GHz	30 Hz to 26.5 GHz, characteristic	
ac coupled	10 MHz to 26.5 GHz		
<b>Band</b>		Harmonic Mixing Mode (N <sup>3</sup> )	
0 (0 Hz to 3.0 GHz)		1-	
1 (2.85 GHz to 6.7 GHz)		1-	
2 (6.2 GHz to 13.2 GHz)		2-	
3 (12.8 GHz to 19.2 GHz)		4-	
4 (18.7 GHz to 26.5 GHz)		4-	
<b>Preamp On</b> <i>(Option IDS)</i>	1 MHz to 3.0 GHz		
<i>(Option UKB)</i>			
dc coupled	1 MHz to 3.0 GHz		
ac coupled	10 MHz to 3.0 GHz		
<b>External Mixing</b> <i>(Option AYZ)</i>	18 GHz to 325 GHz		
		Harmonic Mixing Mode (N <sup>3</sup> )	
<b>Band</b>		Preselected	Unpreselected
K (18.0 GHz to 26.5 GHz)		n/a	6-
A (26.5 GHz to 40.0 GHz)		8+	8-
Q (33.0 GHz to 50.0 GHz)		10+	10-
U (40.0 GHz to 60.0 GHz)		10+	10-
V (50.0 GHz to 75.0 GHz)		14+	14-
E (60.0 GHz to 90.0 GHz)		n/a	16-
W (75.0 GHz to 110.0 GHz)		n/a	18-
F (90.0 GHz to 140.0 GHz)		n/a	20-
D (110.0 GHz to 170.0 GHz)		n/a	24-
G (140.0 GHz to 220.0 GHz)		n/a	32-
Y (170.0 GHz to 260.0 GHz)		n/a	38-

	Specifications	Supplemental Information	
J (220.0 GHz to 325.0 GHz)		n/a	46–

- a. N is the harmonic mixing mode. For negative mixing modes (as indicated by the “–”), the desired 1st LO harmonic is higher than the tuned frequency by the 1st IF (3.9214 for the 9 kHz to 3 GHz band, 321.4 MHz for all other bands) For positive mixing modes, the desired 1st LO harmonic is lower than the tuned frequency by 321.4 MHz.

	Specifications	Supplemental Information
<b>Frequency Reference</b>		
Aging Rate	$\pm 2 \times 10^{-6}$ /year	$\pm 1.0 \times 10^{-7}$ /day, characteristic
Settability	$\pm 5 \times 10^{-7}$	
Temperature Stability	$\pm 5 \times 10^{-6}$	

	Specifications	Supplemental Information
<b>High Stability Frequency Reference (Option 1D5)</b>		
Aging Rate	$\pm 1 \times 10^{-7}$ /year	$\pm 5 \times 10^{-10}$ /day, 7-day average after being powered on for 7 days, characteristic
Settability	$\pm 1 \times 10^{-8}$	
Temperature Stability		
20 to 30 °C	$\pm 1 \times 10^{-8}$	
0 to 55 °C	$\pm 5 \times 10^{-8}$	
Warm-up (Internal frequency reference selected)		
After 5 minutes		$< \pm 1 \times 10^{-7}$ of final frequency, <sup>a</sup> characteristic
After 15 minutes		$< \pm 1 \times 10^{-8}$ of final frequency, <sup>a</sup> characteristic

- a. Final frequency is defined as frequency 60 minutes after power-on with analyzer set to internal frequency reference.

Agilent E4407B Specifications and Characteristics  
Frequency

	Specifications	Supplemental Information
<b>Frequency Readout Accuracy</b> (Start, Stop, Center, Marker)	$\pm((\text{frequency indication} \times \text{frequency reference error}^a) + 0.5\% \text{ of span} + \frac{\text{span}}{\text{sweep points} - 1} + 15\% \text{ of RBW} + 10 \text{ Hz} + 1 \text{ Hz} \times N^b)$	

- a. Frequency reference error = (aging rate × period of time since adjustment + settability + temperature stability).
- b. N is the harmonic mixing mode.

	Specifications	Supplemental Information
<b>Marker Frequency Counter</b> Resolution Accuracy <sup>a</sup>	Selectable from 1 Hz to 100 kHz  $\pm(\text{marker frequency} \times \text{frequency reference error}^b + \text{counter resolution})^c$	For RBW ≥ 1 kHz

- a. Marker level to displayed noise level > 25 dB, RBW/ Span ≥ 0.002, frequency offset = 0 Hz.
- b. Frequency reference error = (aging rate × period of time since adjustment + settability + temperature stability).
- c. For firmware revisions prior to A.03.00, add 1 Hz x N, where N is the harmonic mixing mode.

	Specifications	Supplemental Information
<b>Frequency Span</b> Range Internal Mixing External Mixing (Option AYZ) Resolution Accuracy <sup>b</sup> Sweep type Lin Sweep type Log	0 Hz (zero span), 100 Hz to 26.5 GHz  0 Hz (zero span), Minimum span = 100 Hz  $2 \text{ Hz} \times N^a$  $\pm(0.5\% \text{ of span} + 2 \times \frac{\text{span}}{\text{sweep points} - 1})$	$\pm 2.0\% \text{ of span, nominal}$

- a. N is the harmonic mixing mode.
- b. Applies to each sweep segment.

	Specifications	Supplemental Information
<b>Sweep Time</b>		
Range		
Span > 0 Hz	1 ms to 4000 s <sup>a,b,c</sup>	$\frac{\text{sweep points} - 1}{100 \text{ kHz}}$ to 4000 s
Span = 0 Hz	10 μs to 4000 s <sup>a</sup>	
Tracking Generator On (Option 1DN)		50 ms is the minimum sweep time
Fast Time-domain Sweep (Option AYX) (For Span = 0 Hz, RBW ≥ 1 kHz)	50 ns to 4000 s <sup>d e</sup>	$\frac{\text{sweep points} - 1}{20 \text{ MHz}}$ to 4000 s
DSP and fast ADC (Option B7D) (For Span = 0 Hz, RBW ≥ 1 kHz)	25 ns to 4000 s <sup>f</sup>	$\frac{\text{sweep points} - 1}{40 \text{ MHz}}$ to 4000 s
Accuracy (Span = 0 Hz)		
10 μs to 4000 s <sup>a c</sup> (Option AYX)	±1%	
50 ns to 4000 s <sup>d,e</sup> (Option B7D)	±1%	
25 ns to 4000 s <sup>f</sup>	±1%	
Sweep Trigger <sup>g h</sup>	Free Run, Single, Line, Video <sup>i</sup> , External, Delayed, Offset <sup>j</sup>	
(Option 1D6)	Add Gate	
(Option B7B)	Add TV	
(Option B7E)	Add RF Burst Trigger	
Delayed Trigger <sup>h k</sup>		
Range	1 μs to 400 s	
Resolution	$\frac{\text{delay in seconds}}{65000}$ rounded up to nearest μs	
Accuracy	±(500 ns + (0.01% of delay))	
RF burst trigger (Option B7E)		
Relative level trigger mode		

Agilent E4407B Specifications and Characteristics  
Frequency

	Specifications	Supplemental Information
Peak carrier power range <sup>lm</sup>		30 to -25 dBm, nominal
Preamp On ( <i>Option 1DS</i> )		30 to -45 dBm, nominal
Trigger level range	0 to -25 dB relative to signal peak	
Absolute level trigger mode		
Peak carrier power range <sup>n,o</sup>		30 to -35 dBm, nominal
Preamp On ( <i>Option 1DS</i> )		30 to -55 dBm, nominal
Offset Trigger <sup>j</sup>		
Resolution	$\frac{\text{sweep time}}{\text{sweep points} - 1}$	
Range	$\pm 327 \text{ ms to } \pm 12.3 \text{ ks}$	Where ST = sweep time and SP = sweep points $\frac{-32766 \times \text{ST}}{\text{SP} - 1}$ to $\frac{(32766 - \text{SP}) \times \text{ST}}{\text{SP} - 1}$
Fast Time-domain sweep ( <i>Option AYX</i> ) (For sweep times $\frac{\text{sweep points} - 1}{20 \text{ MHz}}$ to $\frac{\text{sweep points} - 1}{100 \text{ kHz}}$ )	$\pm 1.23 \text{ ms to } \pm 245 \text{ ms}$	$\frac{-32766 \times \text{ST}}{\text{SP} - 1}$ to $\frac{(32766 - \text{SP}) \times \text{ST}}{\text{SP} - 1}$
DSP and fast ADC ( <i>Option B7D</i> ) (For sweep times $\frac{\text{sweep points} - 1}{40 \text{ MHz}}$ to $\frac{\text{sweep points} - 1}{100 \text{ kHz}}$ )	$\pm 13 \text{ ms to } \pm 5.15 \text{ s}$	$\frac{-524031 \times \text{ST}}{\text{SP} - 1}$ to $\frac{(524031 - \text{SP}) \times \text{ST}}{\text{SP} - 1}$

- a. For firmware revisions prior to A.04.00, 5 ms to 2000 s.
- b. For spans  $\geq 10 \text{ MHz}$  and  $\leq 600 \text{ MHz}$ , and stop frequency  $\leq 3 \text{ GHz}$ .
- c. For firmware revisions prior to A.05.00, 1 ms to 4000 s.
- d. For firmware revisions prior to A.04.00, 20  $\mu\text{s}$  to 2000 s.
- e. For firmware revisions prior to A.05.00, 5  $\mu\text{s}$  to 4000 s.
- f. For firmware revisions prior to A.05.00, 2.5  $\mu\text{s}$  to 4000 s.
- g. Gate cannot be used simultaneously with delayed or TV trigger (*Option B7B*).
- h. Auto align is suspended in video, external, gate, and delayed trigger modes while waiting for a trigger event to occur.
- i. Unavailable when  $\text{RBW} \leq 300 \text{ Hz}$  (*Option 1DR*).
- j. For firmware revision A.04.00 or later.
- k. Delayed trigger is available with line, external trigger, and TV trigger (*Option B7B*).
- l. With trigger level set to -6 dB.
- m. For GSM-type signals (burst length 570  $\mu\text{s}$ , burst period 4.63 ms, constant envelope). Ranges with other types of signals may differ.



- n. Nominal values apply for Bluetooth-type signals (burst length 625  $\mu$ s, burst period 50 ms). Ranges with other types of signals may differ.
- o. With trigger level set 5 dB below peak signal level.

	Specifications	Supplemental Information
<b>Sweep (trace) Points</b>		
Range		
Span > 0 Hz	101 to 8192 <sup>a</sup>	
Span = 0 Hz	2 to 8192 <sup>a,b</sup>	

- a. For firmware revisions prior to A.04.00, 401 points.
- b. For firmware revisions prior to A.05.00, 101 to 8192 points.

	Specifications	Supplemental Information
<b>Resolution Bandwidth (RBW)</b>		
Range		
-3 dB bandwidth	1 kHz to 3 MHz, in 1-3-10 sequence, 5 MHz <sup>a</sup>	
<i>(Option 1DR)</i>	Adds 10, 30, 100, 300 Hz <sup>a,b</sup>	
<i>(Option 1DR and 1D5)</i>	Adds 1, 3 Hz <sup>a,b</sup>	
-6 dB bandwidth (EMI)	9 kHz and 120 kHz	
<i>(Option 1DR)</i>	Add 200 Hz <sup>a,b</sup>	
Accuracy		
1 Hz to 3 Hz (-3 dB) RBW <sup>c</sup> <i>(Option 1DR and 1D5)</i>	$\pm 10\%$	
10 Hz to 300 Hz (-3 dB) RBW <i>(Option 1DR)</i>	$\pm 10\%$	
1 kHz to 3 MHz (-3 dB) RBW	$\pm 15\%$	
5 MHz (-3 dB) RBW	$\pm 30\%$	
9 kHz, 120 kHz (-6 dB) RBW (EMI)	$\pm 20\%$	
200 Hz (-6 dB) RBW (EMI) <i>(Option 1DR)</i>	$\pm 10\%$	
Shape		
1 Hz to 3 Hz RBW <sup>c</sup> <i>(Option 1DR and 1D5)</i>		Digital, approximately Gaussian shape

Agilent E4407B Specifications and Characteristics  
**Frequency**

	Specifications	Supplemental Information
10 Hz to 300 Hz RBW <i>(Option IDR)</i>		Digital, approximately Gaussian shape
1 kHz to 5 MHz RBW		Synchronously tuned four poles, approximately Gaussian shape
Selectivity (60 dB/3 dB bandwidth ratio)		
1 Hz to 3 Hz RBW <sup>c</sup> <i>(Option IDR and 1D5)</i>		<5:1, nominal
10 Hz to 300 Hz RBW <i>(Option IDR)</i>		<5:1, nominal
1 kHz to 5 MHz RBW		<15:1, nominal

- a. The Average detector is not compatible with the 5 MHz resolution bandwidths, nor with resolution bandwidths <1 kHz.
- b. Only available in spans ≤5 MHz, sweep times ≥ (sweep points – 1)/100 kHz and not usable with tracking generator on (Option 1DN).
- c. Firmware revision A.08.00 and later.

	Specifications	Supplemental Information
<b>Video Bandwidth (VBW) (-3 dB)</b>		
Range <i>(Option IDR)</i>	30 Hz to 1 MHz in 1-3-10 sequence  Adds 1, 3, 10 Hz for RBW's <1 kHz	3 MHz, characteristic
Accuracy		±30%, characteristic
Shape		Post detection, single pole low-pass filter used to average displayed noise  Video bandwidths below 30 Hz are digital bandwidths with anti-aliasing filtering.

	Specifications	Supplemental Information
<b>Stability</b>		
Noise Sidebands (Offset from CW signal with 1 kHz RBW, 30 Hz VBW and sample detector)		
<b>Serial prefixes ≥ MY4510, SG4510, US4510</b>		

	Specifications	Supplemental Information
≥1 kHz ( <i>Option IDR, ID5</i> )		≤ -78 dBc/Hz <sup>a</sup> , typical
≥10 kHz ( <i>Option IDR</i> )	≤ -98 dBc/Hz <sup>a</sup>	≤ -101 dBc/Hz <sup>a</sup> , typical
≥10 kHz	≤ -90 dBc/Hz <sup>a</sup>	≤ -94 dBc/Hz <sup>a</sup> , typical
≥20 kHz	≤ -104 dBc/Hz <sup>a</sup>	≤ -107 dBc/Hz <sup>a</sup> , typical
≥30 kHz	≤ -110 dBc/Hz <sup>a</sup>	≤ -113 dBc/Hz <sup>a</sup> , typical
≥100 kHz	≤ -118 dBc/Hz <sup>a</sup>	≤ -122 dBc/Hz <sup>a</sup> , typical
≥1 MHz	≤ -125 dBc/Hz <sup>a</sup>	≤ -127 dBc/Hz <sup>a</sup> , typical
≥5 MHz	≤ -127 dBc/Hz <sup>a</sup>	≤ -129 dBc/Hz <sup>a</sup> , typical
≥10 MHz	≤ -131 dBc/Hz <sup>a</sup>	≤ -136 dBc/Hz <sup>a</sup> , typical
<b>Serial prefixes &lt; MY4510, SG4510, US4510</b>		
≥1 kHz ( <i>Option IDR, ID5</i> )		≤ -78 dBc/Hz <sup>a</sup> , typical
≥10 kHz	≤ -90 dBc/Hz <sup>a</sup>	≤ -94 dBc/Hz <sup>a</sup> , typical
≥20 kHz	≤ -100 dBc/Hz <sup>a</sup>	≤ -105 dBc/Hz <sup>a</sup> , typical
≥30 kHz	≤ -106 dBc/Hz <sup>a</sup>	≤ -112 dBc/Hz <sup>a</sup> , typical
≥100 kHz	≤ -118 dBc/Hz <sup>a</sup>	≤ -122 dBc/Hz <sup>a</sup> , typical
≥1 MHz	≤ -125 dBc/Hz <sup>a</sup>	≤ -127 dBc/Hz <sup>a</sup> , typical
≥5 MHz	≤ -127 dBc/Hz <sup>a</sup>	≤ -129 dBc/Hz <sup>a</sup> , typical
≥10 MHz	≤ -131 dBc/Hz <sup>a</sup>	≤ -136 dBc/Hz <sup>a</sup> , typical
<i>(Option 120)</i>		
≥1 MHz	≤ -133 dBc/Hz <sup>b</sup>	≤ -136 dBc/Hz, typical
≥5 MHz	≤ -135 dBc/Hz <sup>b</sup>	≤ -139 dBc/Hz, typical
≥10 MHz	≤ -137 dBc/Hz <sup>b</sup>	≤ -141 dBc/Hz, typical
Residual FM		
1 kHz RBW, 1 kHz VBW <i>(Option ID5)</i>	≤150 Hz × N p-p in 100 ms ≤100 Hz × N p-p in 100 ms	
10 Hz RBW, 10 Hz VBW <i>(Option IDR and ID5)</i>	≤2 Hz × N p-p in 20 ms	
10 Hz RBW, 10 Hz VBW <i>(Option IDR)</i>		≤10 Hz × N p-p in 20 ms, characteristic

## Agilent E4407B Specifications and Characteristics Frequency

	Specifications	Supplemental Information
System-Related Sidebands, offset from CW signal  ≥30 kHz	$\leq -65 \text{ dBc}^a$	
Line-Related Sidebands, offset from CW signal ( <i>Option 1DR</i> )  <300 Hz		$\leq -50 \text{ dBc}^a$ , characteristic
>300 Hz to 30 kHz		$\leq -55 \text{ dBc}^a$ , characteristic

a. Add  $20 \text{ Log}(N)$  for frequencies  $> 6.7 \text{ GHz}$ .

b. Applies only to frequencies  $\leq 3 \text{ GHz}$

**Noise Sidebands Normalized to 1 Hz Versus Offset from Carrier**

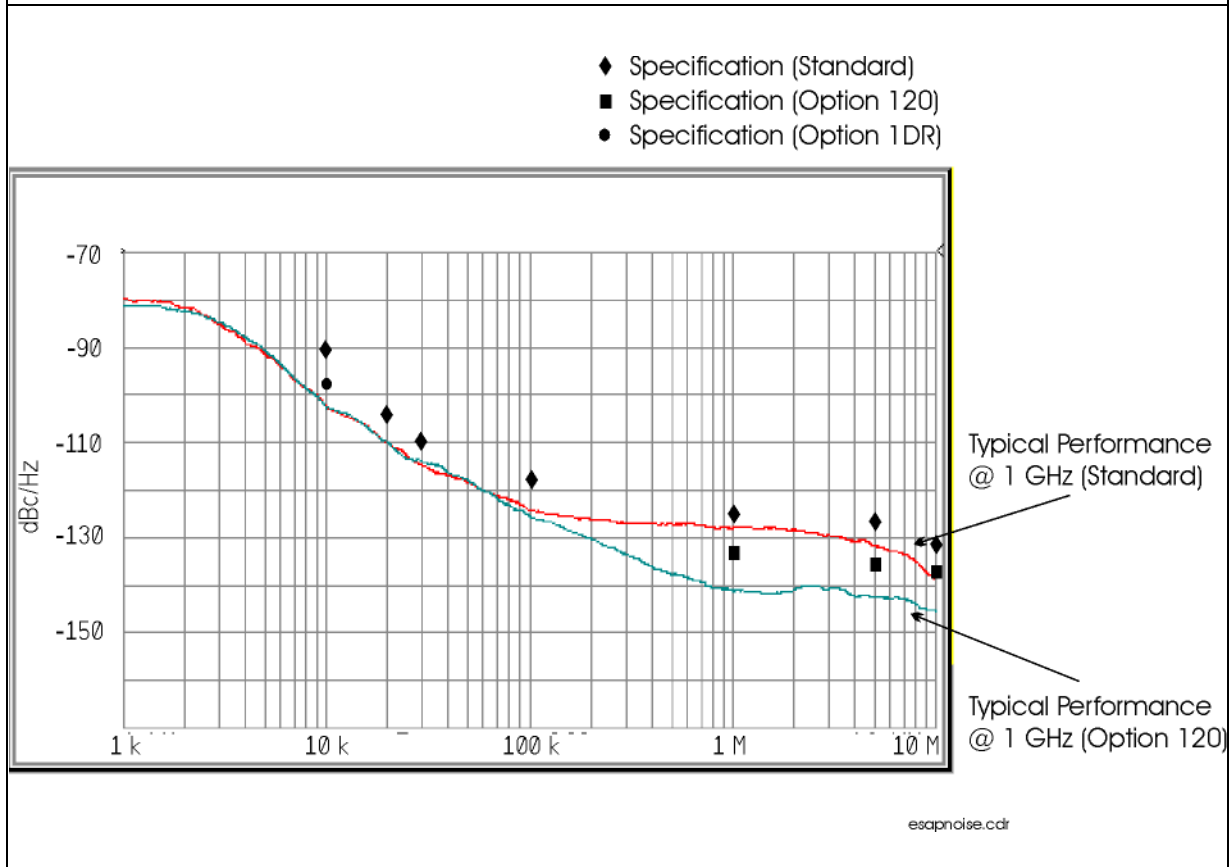

## Amplitude

Amplitude specifications do not apply for the negative peak detector mode.

	Specifications	Supplemental Information
<b>Measurement Range</b>	Displayed Average Noise Level to Maximum Safe Input Level	
Input Attenuator Range	0 to 65 dB, in 5 dB steps	

	Specifications	Supplemental Information
<b>Maximum Safe Input Level</b>		
Average Continuous Power (Input attenuator setting $\geq 5$ dB)	+30 dBm (1 W)	
Peak Pulse Power (for $< 10 \mu\text{sec}$ pulse width, $< 1\%$ duty cycle, and input attenuation $\geq 30$ dB)	+50 dBm (100 W)	
dc (Option UKB)	0 Vdc	
dc coupled	0 Vdc	
ac coupled	50 Vdc	

Agilent E4407B Specifications and Characteristics  
**Amplitude**

	Specifications	Supplemental Information
<b>1 dB Gain Compression</b>		
Total power at input mixer <sup>a,b</sup>		
50 MHz to 3.0 GHz	0 dBm	
3.0 GHz to 6.7 GHz	0 dBm	
6.7 GHz to 13.2 GHz	-3 dBm	
13.2 GHz to 26.5 GHz	-5 dBm	
Preamp On ( <i>Option 1DS</i> )		
Total power at the preamp <sup>c</sup>		-20 dBm, characteristic

- a. Mixer power level (dBm) = input power (dBm) – input attenuation (dB).
- b. For resolution bandwidths 1 kHz to 30 kHz, the maximum input signal amplitude must be ≤ reference level +10 dB.
- c. Total power at the preamp (dBm) = total power at the input (dBm) – input attenuation (dB).

	Specifications		Supplemental Information		
<b>Displayed Average Noise Level</b>					
(Input terminated, 0 dB attenuation, sample detector, Reference Level = -70 dBm)					
	1 kHz RBW 30 Hz VBW	10 Hz RBW 1 Hz VBW ( <i>Option 1DR</i> )	1 kHz RBW 30 Hz VBW (typical)	10 Hz RBW 1 Hz VBW ( <i>Option 1DR</i> ) (typical)	1 Hz RBW 1 Hz VBW ( <i>Option 1DR and 1D5</i> ) <sup>a</sup> (typical)
30 Hz to 9 kHz ( <i>Option UKB</i> )				≤ -93 dBm	≤ -103 dBm
9 kHz to 100 kHz				≤ -109 dBm	≤ -119 dBm
100 kHz to 1 MHz				≤ -135 dBm	≤ -145 dBm
1 MHz to 10 MHz			≤ -117 dBm	≤ -137 dBm	≤ -147 dBm
1 MHz to 10 MHz ( <i>Option 120</i> )			≤ -120 dBm	≤ -139 dBm	≤ -149 dBm
10 MHz to 1.0 GHz	≤ -116 dBm	≤ -135 dBm	≤ -119 dBm	≤ -139 dBm	≤ -149 dBm
1.0 GHz to 2.0 GHz	≤ -116 dBm	≤ -135 dBm	≤ -120 dBm	≤ -140 dBm	≤ -150 dBm
2.0 GHz to 3.0 GHz	≤ -112 dBm	≤ -131 dBm	≤ -118 dBm	≤ -138 dBm	≤ -148 dBm
3.0 GHz to 6.0 GHz	≤ -112 dBm	≤ -131 dBm	≤ -118 dBm	≤ -138 dBm	≤ -148 dBm
6.0 GHz to 12 GHz	≤ -111 dBm	≤ -130 dBm	≤ -117 dBm	≤ -137 dBm	≤ -147 dBm

	Specifications		Supplemental Information		
12 GHz to 22 GHz	≤ -107 dBm	≤ -126 dBm	≤ -114 dBm	≤ -134 dBm	≤ -144 dBm
22 GHz to 26.5 GHz	≤ -106 dBm	≤ -125 dBm	≤ -112 dBm	≤ -132 dBm	≤ -142 dBm
Preamp On ( <i>Option IDS</i> )	1 kHz RBW 30 Hz VBW	10 Hz RBW 1 Hz VBW ( <i>Option IDR</i> )	1 kHz RBW 30 Hz VBW (typical)	10 kHz RBW 1 Hz VBW ( <i>Option IDR</i> ) (typical)	1 Hz RBW 1 Hz VBW ( <i>Option IDR</i> and <i>ID5</i> <sup>a</sup> ) (typical)
0 to 55 °C					
10 MHz to 1.0 GHz	≤ -131 dBm	≤ -150 dBm			
1.0 GHz to 2.0 GHz	≤ -131 dBm	≤ -150 dBm			
2.0 GHz to 3.0 GHz	≤ -127 dBm	≤ -146 dBm			
20 to 30 °C					
1 MHz to 10 MHz ( <i>Option UKB</i> ) (dc coupled)			≤ -135 dBm	≤ -155 dBm	≤ -165 dBm
10 MHz to 1.0 GHz	≤ -132 dBm	≤ -151 dBm	≤ -137 dBm	≤ -157 dBm	≤ -167 dBm
1.0 GHz to 2.0 GHz	≤ -132 dBm	≤ -151 dBm	≤ -135 dBm	≤ -155 dBm	≤ -165 dBm
2.0 GHz to 3.0 GHz	≤ -130 dBm	≤ -149 dBm	≤ -132 dBm	≤ -152 dBm	≤ -162 dBm
External Mixing ( <i>Option AYZ</i> )			1 kHz RBW 30 Hz VBW ≤ -134 dBm + external mixer conversion loss, characteristic	10 Hz RBW 1 Hz VBW ( <i>Option IDR</i> ) ≤ -153 dBm + external mixer conversion loss, characteristic	

a. Only available with firmware revision A.08.00 or later

Agilent E4407B Specifications and Characteristics  
**Amplitude**

	Specifications	Supplemental Information
<b>Display Range</b>		
Log Scale	Ten divisions displayed; 0.1, 0.2, 0.5 dB/division and 1 to 20 dB/division in 1 dB steps	
RBW $\geq$ 1 kHz	Calibrated 0 to $-85$ dB from Reference Level	
RBW $\leq$ 300 Hz ( <i>Option 1DR</i> )	Calibrated 0 to $-120$ dB <sup>a</sup> from Reference Level	
Linear Scale	Ten divisions	
Scale Units	dBm, dBmV, dB $\mu$ V, dB $\mu$ A, A, V, and W	
( <i>Option BAA, 106</i> )	Add Hz	

- a. 0 to  $-70$  dB range when span = 0 Hz, or when IF Gain is fixed:  
(:DISPlay:WINDow:TRACe:Y[:SCALE]:LOG:RANGE:AUTO OFF).

	Specifications	Supplemental Information
<b>Marker Readout Resolution</b>		
Log scale		
RBW $\geq$ 1 kHz		
0 to $-85$ dB from ref level	0.04 dB	
RBW $\leq$ 300 Hz ( <i>Option 1DR</i> )		
0 to $-120$ dB from ref level	0.04 dB	
Linear scale	0.01% of Reference Level	
Fast Sweep Times for Zero Span		
( <i>Option AXX</i> )		
For sweep times		
$\frac{\text{sweep points} - 1}{20 \text{ MHz}}$ to		
$\frac{\text{sweep points} - 1}{100 \text{ kHz}}$		
Log		
0 to $-85$ dB from ref level	0.3 dB	
Linear	0.3% of Reference Level for linear scale	



	Specifications	Supplemental Information
<p><i>(Option B7D)</i>  <i>For sweep times</i>  <math>\frac{\text{sweep points} - 1}{40 \text{ MHz}}</math>  <math>\frac{\text{sweep points} - 1}{100 \text{ kHz}}</math></p> <p><i>For:</i>  <math>\frac{\text{sweep points} - 1}{\text{sweep time}} &lt; 40 \text{ MHz}</math></p> <p>Log                      0 to -85 dB from ref level</p> <p>Linear</p> <p><i>For:</i>  <math>\frac{\text{sweep points} - 1}{\text{sweep time}} \geq 40 \text{ MHz}</math></p> <p>Log                      0 to -85 dB from ref level</p> <p>Linear</p>	<p>0.2 dB</p> <p>0.2% of Reference Level</p> <p>0.3 dB</p> <p>0.3% of Reference Level</p>	

	Specifications	Supplemental Information
<p><b>Frequency Response</b></p> <p>Absolute<sup>3</sup>/Relative</p> <p>10 dB attenuation</p> <p>9 kHz to 3.0 GHz</p> <p>20 to 30 °C</p> <p>0 to 55 °C</p> <p>800 MHz to 1.0 GHz</p> <p>20 to 30 °C</p> <p>0 to 55 °C</p> <p>1.7 GHz to 2.0 GHz</p> <p>20 to 30 °C</p> <p>0 to 55 °C</p> <p>(Option UKB)                      (dc coupled)</p> <p>100 Hz to 3.0 GHz</p> <p>20 to 30 °C</p>	<p>±0.46 dB</p> <p>±0.76 dB</p> <p>±0.46 dB</p> <p>±0.76 dB</p> <p>±0.46 dB</p> <p>±0.76 dB</p> <p>±0.5 dB</p>	<p>±0.14 dB, typical</p> <p>±0.10 dB, typical</p> <p>±0.08 dB, typical</p>

Agilent E4407B Specifications and Characteristics  
**Amplitude**

	Specifications	Supplemental Information
0 to 55 °C	±1.0 dB	
30 Hz to 3.0 GHz		
20 to 30 °C		±0.5 dB, characteristic
0 to 55 °C		±1.0 dB, characteristic
(ac coupled)		
10 MHz to 3.0 GHz		
20 to 30 °C	±0.5 dB	
0 to 55 °C	±1.0 dB	
800 MHz to 1.0 GHz		
20 to 30 °C	±0.5 dB	
0 to 55 °C	±1.0 dB	
1.7 GHz to 2.0 GHz		
20 to 30 °C	±0.5 dB	
0 to 55 °C	±1.0 dB	
Absolute <sup>a</sup> /Relative Preamp On		
(Option IDS)		
0 dB attenuation		
1 MHz to 3.0 GHz		
20 to 30 °C	±1.5 dB	±0.47 dB, typical
0 to 55 °C	±2.0 dB	
800 MHz to 1.0 GHz		
20 to 30 °C	±1.5 dB	±0.35 dB, typical
0 to 55 °C	±2.0 dB	
1.7 GHz to 2.0 GHz		
20 to 30 °C	±1.5 dB	±0.26 dB, typical
0 to 55 °C	±2.0 dB	
(Option UKB)		
(dc coupled)		
1 MHz to 3.0 GHz		
20 to 30 °C	±1.5 dB	±0.47 dB, typical
0 to 55 °C	±2.0 dB	

	Specifications	Supplemental Information
(ac coupled)		
10 MHz to 3.0 GHz		
20 to 30 °C	±1.5 dB	
0 to 55 °C	±2.0 dB	
800 MHz to 1.0 GHz		
20 to 30 °C	±1.5 dB	±0.35 dB, typical
0 to 55 °C	±2.0 dB	
1.7 GHz to 2.0 GHz		
20 to 30 °C	±1.5 dB	±0.26 dB, typical
0 to 55 °C	±2.0 dB	
Preselector centered for frequency >3.0 GHz (Option UKB) (ac or dc coupled)		
10 dB attenuation		
3.0 GHz to 6.7 GHz		
Absolute <sup>a</sup>		
20 to 30 °C	±1.5 dB	±0.38 dB, typical
0 to 55 °C	±2.5 dB	
Relative		
20 to 30 °C	±1.3 dB	
0 to 55 °C	±1.5 dB	
6.7 GHz to 13.2 GHz		
Absolute <sup>a</sup>		
20 to 30 °C	±2.0 dB	±0.68 dB, typical
0 to 55 °C	±3.0 dB	
Relative		
20 to 30 °C	±1.8 dB	
0 to 55 °C	±2.0 dB	
13.2 GHz to 26.5 GHz		
Absolute <sup>a</sup>		
20 to 30 °C	±2.0 dB	±0.86 dB, typical
0 to 55 °C	±3.0 dB	

Agilent E4407B Specifications and Characteristics  
**Amplitude**

	Specifications	Supplemental Information
Relative		
20 to 30 °C	±1.8 dB	
0 to 55 °C	±2.0 dB	

a. Absolute frequency response values are referenced to the amplitude at 50 MHz.

	Specifications	Supplemental Information
<b>Input Attenuation Switching Uncertainty at 50 MHz</b>		
Attenuator Setting		
0 dB to 5 dB	±0.3 dB	
10 dB	Reference	
15 dB	±0.3 dB	
20 to 65 dB attenuation	±(0.1 dB + 0.01 × Attenuator Setting)	

Attenuation Accuracy Relative to the 10 dB Attenuator Setting, Characteristic					
	Frequency Range				
Attenuation	dc–3 GHz	3.0–13.2 GHz	13.2–19 GHz	19–22 GHz	22–26.5 GHz
0 dB	±0.3 dB	±0.5 dB	±0.8 dB	±0.9 dB	±1.0 dB
5 dB	±0.3 dB	±0.5 dB	±0.8 dB	±0.9 dB	±1.0 dB
10 dB	Reference	Reference	Reference	Reference	Reference
15 dB	±0.4 dB	±0.5 dB	±0.8 dB	±1.0 dB	±1.5 dB
20 dB	±0.4 dB	±0.5 dB	±0.8 dB	±1.0 dB	±1.5 dB
25 dB	±0.5 dB	±0.6 dB	±0.8 dB	±1.2 dB	±2.0 dB
30 dB	±0.5 dB	±0.6 dB	±0.8 dB	±1.2 dB	±2.0 dB
35 dB	±0.6 dB	±0.7 dB	±1.0 dB	±1.8 dB	±3.0 dB
40 dB	±0.6 dB	±0.7 dB	±1.0 dB	±1.8 dB	±3.0 dB
45 dB	±0.7 dB	±1.0 dB	±1.3 dB	±2.2 dB	±3.4 dB
50 dB	±0.7 dB	±1.0 dB	±1.3 dB	±2.2 dB	±3.4 dB
55 dB	±0.9 dB	±1.1 dB	±1.6 dB	±2.7 dB	±3.5 dB
60 dB	±0.9 dB	±1.1 dB	±1.6 dB	±2.7 dB	±3.5 dB
65 dB	±1.0 dB	±1.6 dB	±2.0 dB	±3.2 dB	±3.8 dB

	Specifications	Supplemental Information
<b>Preamp (Option 1DS)</b>		Refer also to Displayed Average Noise Level specification
Gain		+20 dB, nominal <sup>a</sup>
Noise figure		5 dB, characteristic

a. Amplifier is between the input attenuator and the input mixer.

	Specifications	Supplemental Information
<b>Absolute Amplitude Accuracy</b>		
At reference settings <sup>a</sup>	±0.34 dB	±0.13 dB, typical
Preamp On <sup>b</sup> ( <i>Option 1DS</i> )	±0.37 dB	±0.14 dB, typical
External Mixing ( <i>Option AYZ</i> )	IF INPUT absolute amplitude accuracy + external mixer conversion loss accuracy <sup>c</sup>	
95 % Confidence Absolute Amplitude Accuracy Input Frequency ≤ 3 GHz –50 dBm ≤ Input Power ≤ 0dBm –50 dBm ≤ Ref Level ≤ 0 dBm –20 dBm ≤ (Input Power – Ref Level) ≤ 0dBm Input Attenuation = 10 dBm 10 Hz ≤ RBW ≤ 1 MHz 20 to 30 °C		±0.4 dB
<b>Overall Amplitude Accuracy<sup>d</sup></b>		
20 to 30 °C	± (0.54 dB + Absolute Frequency Response)	

- Settings are: reference level –20 dBm; input attenuation 10 dB; dc coupled (Option UKB); center frequency 50 MHz; RBW 1 kHz; VBW 1 kHz; amplitude scale linear or log; span 2 kHz; frequency scale linear; sweep time coupled, sample detector, signal at reference level.
- Settings are: reference level –30 dBm; input attenuation 0 dB; dc coupled (Option UKB); center frequency 50 MHz; RBW 1 kHz; VBW 1 kHz; amplitude scale linear or log; span 2 kHz; frequency scale linear; sweep time coupled, signal at reference level.
- Preselector centered with HP/Agilent 11974-Series mixers.
- For reference level 0 to –50 dBm; input attenuation 10 dB; dc coupled (Option UKB); RBW 1 kHz; VBW 1 kHz; amplitude scale log, log range 0 to –50 dB from reference level; frequency scale linear; sweep time coupled; signal input 0 to –50 dBm; span ≤20 kHz; internal mixing.

Agilent E4407B Specifications and Characteristics  
**Amplitude**

	Specifications	Supplemental Information	
<b>RF Input VSWR</b> (at tuned frequency)			
Attenuator setting 0 dB			
9 kHz to 26.5 GHz		≤3.0:1, characteristic	
Attenuator setting 5 dB			
9 kHz to 100 kHz		≤2.0:1, characteristic	
100 kHz to 6.7 GHz		≤1.4:1, characteristic	
6.7 GHz to 13.2 GHz		≤1.7:1, characteristic	
13.2 GHz to 22.0 GHz		≤2.3:1, characteristic	
22.0 GHz to 26.5 GHz		≤2.6:1, characteristic	
Attenuator setting 10 to 65 dB			
9 kHz to 6.7 GHz		≤1.3:1, characteristic	
6.7 GHz to 13.2 GHz		≤1.5:1, characteristic	
13.2 GHz to 22.0 GHz		≤2.0:1, characteristic	
22.0 GHz to 26.5 GHz		≤2.2:1, characteristic	
(Option UKB)		characteristic	characteristic
Attenuator setting 0 dB		(dc coupled)	(ac coupled)
100 Hz to 100 kHz		≤1.1:1	
100 kHz to 3 GHz		≤3.0:1	≤3.0:1
100 kHz to 6.7 GHz		≤1.4:1, characteristic	
6.7 GHz to 13.2 GHz		≤1.7:1, characteristic	
13.2 GHz to 22.0 GHz		≤2.3:1, characteristic	
22.0 GHz to 26.5 GHz		≤2.6:1, characteristic	

	Specifications	Supplemental Information	
Attenuator setting 5 dB	100 Hz to 100 kHz	(dc coupled) ≤1.1:1	(ac coupled)
	100 kHz to 300 kHz	≤1.1:1	≤2.3:1
	300 kHz to 1.0 MHz	≤1.1:1	≤1.6:1
	1.0 MHz to 3.0 GHz	≤1.4:1	≤1.4:1
	100 kHz to 6.7 GHz	≤1.4:1, characteristic	
	6.7 GHz to 13.2 GHz	≤1.7:1, characteristic	
	13.2 GHz to 22.0 GHz	≤2.3:1, characteristic	
	22.0 GHz to 26.5 GHz	≤2.6:1, characteristic	
	Attenuator setting 10 to 65 dB	100 Hz to 100 kHz	(dc coupled) ≤1.1:1
100 kHz to 300 kHz		≤1.1:1	≤2.1:1
300 kHz to 1.0 MHz		≤1.1:1	≤1.5:1
1.0 MHz to 3.0 GHz		≤1.2:1	≤1.2:1
100 kHz to 6.7 GHz		≤1.4:1, characteristic	
6.7 GHz to 13.2 GHz		≤1.7:1, characteristic	
13.2 GHz to 22.0 GHz		≤2.3:1, characteristic	
22.0 GHz to 26.5 GHz		≤2.6:1, characteristic	

	Specifications	Supplemental Information
<b>Auto Alignment<sup>a</sup></b>		
Sweep-to-sweep variation		±0.1 dB, characteristic

a. Set **Auto Align** to **Off** and use **Align Now, All** to eliminate this variation.

Agilent E4407B Specifications and Characteristics  
**Amplitude**

	Specifications	Supplemental Information
<b>Resolution Bandwidth Switching Uncertainty (at Reference Level)</b>		
1 kHz RBW	Reference	
3 kHz to 3 MHz RBW	±0.3 dB	
5 MHz RBW	±0.6 dB	
10 Hz to 300 Hz RBW ( <i>Option 1DR</i> )	±0.3 dB	
1 Hz to 3 Hz RBW ( <i>Option 1DR and 1D5</i> ) <sup>a</sup>	±0.3 dB	

a. Firmware revision A.08.00 or later.

	Specifications	Supplemental Information
<b>Reference Level</b>		
Range	-149.9 dBm to maximum mixer level + attenuator setting	
Resolution		
Log Scale	±0.1 dB	
Linear Scale	±0.12% of Reference Level	
Accuracy (at a fixed frequency, a fixed attenuator, and referenced to -30 dBm (-10 dBm, Preamp On ( <i>Option 1DS</i> )))		
Reference Level (dBm) – input attenuator setting (dB) + preamp gain (dB)		
-10 dBm to > -60 dBm	±0.3 dB	
-60 dBm to > -85 dBm	±0.5 dB	
-85 dBm to -90 dBm	±0.7 dB	



	Specifications	Supplemental Information
<b>Display Scale Switching Uncertainty</b>		
Switching between Linear and Log	$\pm 0.15$ dB at reference level	
Log Scale Switching	No error	

	Specifications	Supplemental Information
<b>Display Scale Fidelity</b>		
Log Maximum Cumulative		
RBW $\geq 1$ kHz		
dB Below Reference Level		
0 dB Reference	0 dB	
> 0 to 10 dB	$\pm 0.3$ dB	$\pm 0.08$ dB, typical
> 10 to 20 dB	$\pm 0.4$ dB	$\pm 0.09$ dB, typical
> 20 to 30 dB	$\pm 0.5$ dB	$\pm 0.10$ dB, typical
> 30 to 40 dB	$\pm 0.6$ dB	$\pm 0.23$ dB, typical
> 40 to 50 dB	$\pm 0.7$ dB	$\pm 0.35$ dB, typical
> 50 to 60 dB	$\pm 0.7$ dB	$\pm 0.35$ dB, typical
> 60 to 70 dB	$\pm 0.8$ dB	$\pm 0.39$ dB, typical
> 70 to 80 dB	$\pm 0.8$ dB	$\pm 0.46$ dB, typical
> 80 to 85 dB	$\pm 1.15$ dB	$\pm 0.79$ dB, typical
RBW $\leq 300$ Hz ( <i>Option 1DR</i> )		
Span > 0 Hz		
Auto range On		
0 to 98 dB <sup>a</sup> below reference level	$\pm(0.3 \text{ dB} + 0.01 \times \text{dB from reference level})$	
> 98 to 120 dB below reference level		$\pm 2.0$ dB, characteristic
Auto range Off <sup>b</sup>		
0 to 60 dB <sup>a</sup> below reference level	$\pm(0.3 \text{ dB} + 0.015 \times \text{dB from reference level})$	
> 60 to 70 dB below reference level	$\pm 1.5$ dB	

Agilent E4407B Specifications and Characteristics  
**Amplitude**

	Specifications	Supplemental Information
Span = 0 Hz		
0 to 60 dB <sup>a</sup> below reference level	$\pm(0.3 \text{ dB} + 0.015 \times \text{dB from reference level})$	
> 60 to 70 dB below reference level	$\pm 1.5 \text{ dB}$	
Log Incremental Accuracy		
0 to 80 dB <sup>a,c</sup> below reference level	$\pm 0.4 \text{ dB}/4 \text{ dB}$	
Linear Accuracy	$\pm 2\%$ of Reference Level	

- a. 0 to 30 dB for RBW = 200 Hz
- b. The SCPI command for auto range off is:  
(:DISPlay:WINDow:TRACe:Y[:SCALE]:LOG:RANGE:AUTO OFF)
- c. 0 to 50 dB for RBWs  $\leq$  300 Hz and span = 0 Hz, or when auto ranging is off.

	Specifications	Supplemental Information
<b>Spurious Responses</b>		
Second Harmonic Distortion		
Input Signal		
10 MHz to 500 MHz	$< -65 \text{ dBc}$ for $-30 \text{ dBm}$ signal at input mixer <sup>a</sup>	+35 dBm SHI (second harmonic intercept)
500 MHz to 1.5 GHz	$< -75 \text{ dBc}$ for $-30 \text{ dBm}$ signal at input mixer <sup>a</sup>	+45 dBm SHI
1.5 GHz to 2.0 GHz	$< -85 \text{ dBc}$ for $-10 \text{ dBm}$ signal at input mixer <sup>a</sup>	+75 dBm SHI
2.0 GHz to 3.35 GHz	$< -100 \text{ dBc}^b$ for $-10 \text{ dBm}$ signal at input mixer <sup>a</sup>	+90 dBm SHI
3.35 GHz to 6.6 GHz	$< -100 \text{ dBc}^b$ for $-10 \text{ dBm}$ signal at input mixer <sup>a</sup>	+90 dBm SHI
6.6 GHz to 13.25 GHz	$< -100 \text{ dBc}^b$ for $-10 \text{ dBm}$ signal at input mixer <sup>a</sup>	+90 dBm SHI
Preamp On ( <i>Option IDS</i> ) 10 MHz to 1.5 GHz		-5 dBm SHI, characteristic
Third Order Intermodulation Distortion		
10 MHz to 100 MHz		+7 dBm TOI (third order intercept), characteristic

	Specifications	Supplemental Information
100 MHz to 3 GHz	< -85 dBc for two -30 dBm signals at input mixer <sup>a</sup> and >50 kHz separation	+12.5 dBm TOI +16 dBm TOI, typical
3.0 GHz to 6.7 GHz	< -82 dBc for two -30 dBm signals at input mixer <sup>a</sup> and >50 kHz separation	+11 dBm TOI +18 dBm TOI, typical
6.7 GHz to 13.2 GHz	< -75 dBc for two -30 dBm signals at input mixer <sup>a</sup> and >50 kHz separation	+7.5 dBm TOI +12 dBm TOI, typical
13.2 GHz to 26.5 GHz	< -75 dBc for two -30 dBm signals at input mixer <sup>a</sup> and >50 kHz separation	+7.5 dBm TOI +11 dBm TOI, typical
Preamp On ( <i>Option 1DS</i> ) 10 MHz to 3 GHz		-16 dBm TOI, characteristic
Other Input Related Spurious		
Inband Responses		
>30 kHz offset	< -65 dBc for -20 dBm signal at input mixer <sup>a</sup>	
Out-of-band Responses	< -80 dBc for -10 dBm signal at input mixer <sup>a</sup>	

- a. Mixer power level (dBm) = input power (dBm) – input attenuation (dB).  
b. or signal below displayed average noise level.

Agilent E4407B Specifications and Characteristics  
**Amplitude**

	Specifications	Supplemental Information
<b>W-CDMA Adjacent Channel Power Ratio<sup>a</sup></b>		
Dynamic range <sup>b</sup>		
Offset frequency		
5 MHz		-60.0 dBc, characteristic
10 MHz		-64.5 dBc, characteristic
( <i>Option 120</i> )		
5 MHz		-65.0 dBc, characteristic
10 MHz		-65.5 dBc, characteristic
( <i>Option 120</i> ) With noise correction On <sup>c</sup>		
5 MHz		-66.5 dBc, characteristic
10 MHz		-67.0 dBc, characteristic

- a. Firmware revision A.07.00 or higher
- b. Measured by selecting “Measure, ACP”, 20 to 30 °C, 3GPP (3.1 Dec 1999) W-CDMA signal with 1 DPCH, channel power -9 dBm/3.84 MHz, integration bandwidth 3.84 MHz, carrier frequency 2 GHz, reference level -16 dBm, input attenuation 0 dB, RBW 30 kHz.
- c. Noise correction can be turned On by selecting **Meas Setup, More, Noise Corr On**

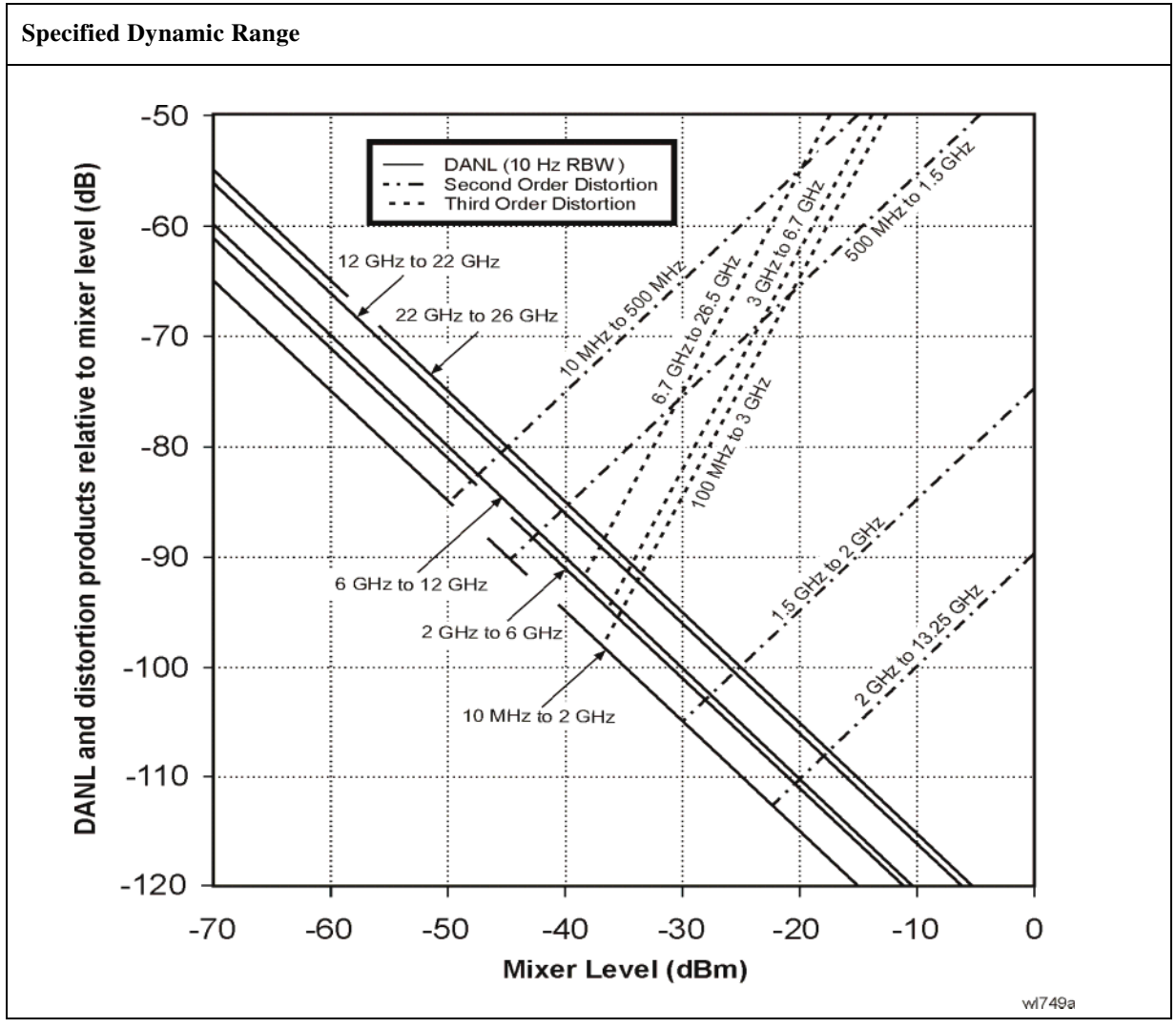

	Specifications	Supplemental Information
<b>Residual Responses</b> (Input terminated and 0 dB attenuation)  150 kHz to 6.7 GHz	< -90 dBm	

## Options

### Time Gated Spectrum Analysis (Option 1D6)

	Specifications	Supplemental Information
<b>Gate Delay</b>		
Range	1 $\mu$ s to 400 s	
Accuracy	$\pm(500 \text{ ns} + (0.01\% \times (\text{maximum of gate delay or length})))$	From gate trigger input to positive edge of gate output
<b>Gate Length</b>		
Range	1 $\mu$ s to 400 s	
Accuracy	$\pm(500 \text{ ns} + (0.01\% \times (\text{maximum of gate delay or length})))$	From positive edge to negative edge of gate output
<b>Resolution</b>	$((\text{maximum of gate delay or length in seconds})/65000)$ rounded up to nearest $\mu$ s	Dependent on the greater of gate delay or gate length
<b>Additional Amplitude Error<sup>a</sup></b>		
Log Scale	$\pm 0.2 \text{ dB}$	
Linear Scale	$\pm 0.1\%$ of reference level	

a. While in gate mode.

### Tracking Generator (Option 1DN)

The spectrum analyzer/tracking generator combination will meet its specification after a cable (8120-5148) and adapter are connected between RF OUT and INPUT and **Align Now, TG** has been run.

	Specifications	Supplemental Information
<b>Warm-up</b>	5 minutes	

	Specifications	Supplemental Information
<b>Output Frequency Range</b>	9 kHz to 3.0 GHz	

	Specifications	Supplemental Information
<b>Minimum Resolution BW</b>	1 kHz	Not usable with resolution bandwidths $\leq 300$ Hz ( <i>Option 1DR</i> )

	Specifications	Supplemental Information
<b>Output Power Level</b>		
Range	-2 to -66 dBm	
Resolution	0.1 dB	
Absolute Accuracy (at 50 MHz with coupled source attenuator, referenced to -20 dBm)	$\pm 0.75$ dB	
Vernier		
Range	8 dB	
Accuracy (with coupled source attenuator, 50 MHz, -20 dBm)		
Incremental	$\pm 0.2$ dB/dB	
Cumulative	$\pm 0.5$ dB, total	
Output Attenuator Range	0 to 56 dB in 8 dB steps	

	Specifications	Supplemental Information
<b>Maximum Safe Reverse Level</b>		+30 dBm (1 W), 50 Vdc, characteristic

Agilent E4407B Specifications and Characteristics  
Options

	Specifications	Supplemental Information
<b>Output Power Sweep</b>		
Range	(-10 to -2 dBm) – (Source Attenuator Setting)	
Resolution	0.1 dB	
Accuracy (zero span)	<1 dB peak-to-peak	

	Specifications	Supplemental Information
<b>Output Flatness</b>		
Referenced to 50 MHz, -20 dBm		
9 kHz to 10 MHz	±3 dB	
10 MHz to 3 GHz	±2 dB	

	Specifications	Supplemental Information
<b>Spurious Outputs</b>		
(-2 dBm output)		
Harmonic Spurs		
TG Output 9 kHz to 20 kHz	≤ -15 dBc	
TG Output 20 kHz to 3 GHz	≤ -25 dBc	
Non-harmonic Spurs		
TG Output 9 kHz to 2 GHz	≤ -27 dBc	
TG Output 2 GHz to 3 GHz	≤ -23 dBc	
LO Feedthrough		
LO Frequency 3.921409 GHz to 6.9214 GHz	≤ -16 dBm	

	Specifications	Supplemental Information
<b>Dynamic Range</b>	Maximum Output Power Level – Displayed Average Noise Level	

	Specifications	Supplemental Information
<b>Output Tracking</b>		
Drift		1.5 kHz/5 minute, characteristic



	Specifications	Supplemental Information
Swept Tracking Error		Usable in 1 kHz RBW after 5 minutes of warm-up

	Specifications	Supplemental Information
<b>RF Power-Off Residuals</b> 9 kHz to 3 GHz		< -120 dBm, characteristic

	Specifications	Supplemental Information
<b>Output Attenuator Repeatability</b> 9 kHz to 300 MHz 300 MHz to 2 GHz 2 GHz to 3 GHz		±0.1 dB, characteristic ±0.2 dB, characteristic ±0.3 dB, characteristic

	Specifications	Supplemental Information
<b>Output VSWR</b> 0 dB attenuation ≥ 8 dB attenuation		<2.0:1, characteristic <1.5:1, characteristic

	Specifications	Supplemental Information
<b>Output Attenuator Accuracy</b> 0 dB 8 dB 16 dB 24 dB 32 dB 40 dB 48 dB 56 dB	Reference	±0.5 dB, characteristic ±0.5 dB, characteristic ±0.5 dB, characteristic ±0.6 dB, characteristic ±0.8 dB, characteristic ±1.0 dB, characteristic ±1.1 dB, characteristic

<b>Tracking Generator Output Accuracy</b>
Relative Accuracy (Referred to -20 dBm) = Output Attenuator Accuracy + Vernier Accuracy + Output Flatness

Agilent E4407B Specifications and Characteristics  
**Options**

<b>Tracking Generator Output Accuracy</b>
---

Absolute Accuracy = Relative Accuracy (Referred to -20 dBm) + Absolute Accuracy at 50 MHz
--

### Phase Noise (Option 226)

Carrier Frequency Range	Specifications	Supplemental Information
E4402B	1 MHz to 3.0 GHz	
E4404B	1 MHz to 6.7 GHz	
E4405B	1 MHz to 13.2 GHz	
E4407B	1 MHz to 26.5 GHz	

Measurement Characteristics	Specifications	Supplemental Information
Measurements	Log plot Spot frequency RMS noise RMS jitter Residual FM	
Maximum number of decades	7 (whole decades only)	
Filtering (ratio of video bandwidth to resolution bandwidth)	None (VBW/RBW = 1.0) Little (VBW/RBW = 0.3) Medium (VBW/RBW = 0.1) Maximum (VBW/RBW = 0.03)	

Offset Frequency	Specifications	Supplemental Information
Range	10 kHz to 100 MHz	The minimum offset is limited to 10 times the narrowest RBW of the analyzer
<i>(Option1DR)</i>	100 Hz to 100 MHz	
<i>(Option1DR and 1D5)</i>	10 Hz to 100 MHz	

Measurement Accuracy	Specifications	Supplemental Information
<b>Amplitude Accuracy<sup>a</sup></b> (carrier frequency 1 MHz to 3.0 GHz)		±1.52 dB <sup>b</sup>

- a. Amplitude accuracy is derived from analyzer specification and characteristics. It is based on a 1 GHz signal at 0 dBm while running the log plot measurement with all other measurement and analyzer settings at their factory defaults.
- b. This does not include the effect of system noise floor. This error is a function of the signal (phase noise) to noise (analyzer noise floor) ratio, SN, in decibels. The function is  $\text{Error} = 10 \times \log(1 + 10^{-\text{SN}/10})$ . For example, if the phase noise being measured is 10 dB above the measurement floor, the error due to adding the analyzer's noise to the UUT is 0.41 dB.

## Agilent E4407B Specifications and Characteristics Options

Amplitude Repeatability	Specifications	Supplemental Information			
		<b>Standard Deviation<sup>a,b</sup></b>			
		<b>No Filtering</b>	<b>Little Filtering</b>	<b>Medium Filtering</b>	<b>Maximum Filtering</b>
No Smoothing					
Offset					
100 Hz <sup>d</sup>		5.9 dB	4.9 dB	4.0 dB	3.9 dB
1 kHz <sup>d</sup>		5.8 dB	4.7 dB	3.7 dB	3.5 dB
10 kHz		4.4 dB	2.4 dB	2.4 dB	1.7 dB
100 kHz		3.9 dB	2.3 dB	1.7 dB	1.6 dB
1 MHz		3.2 dB	2.2 dB	1.4 dB	0.95 dB
4% Smoothing <sup>c</sup>					
Offset					
100 Hz <sup>d</sup>		1.8 dB	1.5 dB	1.2 dB	1.1 dB
1 kHz <sup>d</sup>		1.0 dB	0.58 dB	0.57 dB	0.49 dB
10 kHz		0.83 dB	0.54 dB	0.41 dB	0.29 dB
100 kHz		0.78 dB	0.51 dB	0.36 dB	0.20 dB
1 MHz		0.67 dB	0.23 dB	0.23 dB	0.20 dB

- a. Amplitude repeatability is the nominal standard deviation of the measured phase noise. This table comes from an observation of 30 log plot measurements using a 1 GHz, 0 dBm signal with the filtering and smoothing settings shown. All other analyzer and measurement settings are set to their factory defaults.
- b. The standard deviation can be further reduced by applying averaging. The standard deviation will improve by a factor of the square root of the number of averages. For example, 10 averages will improve the standard deviation by a factor of 3.162.
- c. Smoothing can cause additional amplitude errors near rapid transitions of the data, such as with discrete spurious signals and impulsive noise. The effect is more pronounced as the number of points smoothed increases.
- d. These offsets are available only when Option 1DR is installed.

	Specifications	Supplemental Information
Frequency Offset Accuracy <sup>a</sup>	± 3.7%	0.053 octave

a. The frequency offset error in octaves causes an additional amplitude accuracy error proportional to the product of the frequency error and slope of the phase noise. For example, a 0.01 octave frequency error combined with an 18 dB/octave slope gives 0.18 dB additional amplitude error.

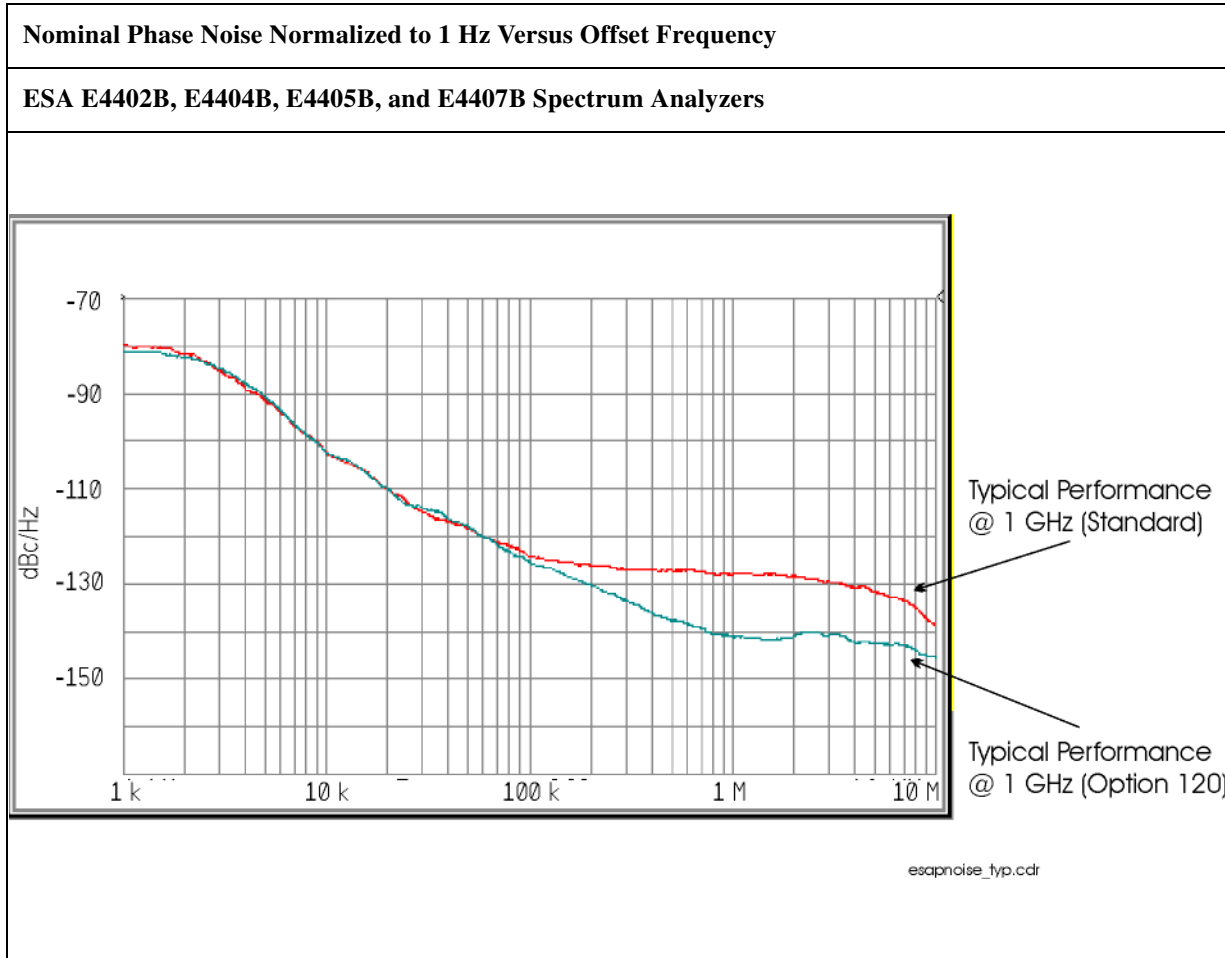

**Options**

**FM Demodulation and Quasi Peak Detector (Option AYQ)**

The FM demodulation characteristics will apply after an **Align Now, FM Demod** has been run.

	Specifications	Supplemental Information
<b>Optimum Input Level</b>		$\geq (-60 \text{ dBm} + \text{attenuator setting} - \text{preamp gain})$ and within 30 dB of the reference level
<b>FM Deviation</b>		
Range		10 kHz to 1 MHz
Resolution		300Hz, characteristic
Accuracy <sup>a</sup>		$< (2\% \text{ of FM deviation range} + 2 \times \text{Resolution})$ , characteristic
FM Rate $< \text{FM BW}/100$ , VBW $\geq (30 \times \text{FM Rate})$ , RBW $>$ the maximum of $(30 \times \text{FM deviation})$ or $(30 \times \text{FM Rate})$		
Offset Error <sup>a</sup>		5% of FM Deviation Range + 300 Hz, characteristic
<b>FM Bandwidth (-3 dB)</b>		
FM Deviation Range		
10 kHz to 40 kHz		$0.5 \times \text{FM deviation range}$ , characteristic
>40 kHz to 200 kHz		$0.5 \times \text{FM deviation range}$ , characteristic
>200 kHz to 1 MHz		$0.4 \times \text{FM deviation range}$ , characteristic

a. In time domain sweeps (span = 0 Hz)

	Specifications	Supplemental Information
<b>Quasi-Peak Detector</b>	<p>The quasi-peak detector provides the quasi-peak amplitude of pulsed radio frequency (RF) or continuous wave (CW) signals.</p> <p>The amplitude response conforms to Publication 16 of CISPR Section 1, Clause 2, except as indicated in the Relative Quasi-Peak Response Table.</p>	

<b>Relative Quasi-Peak Response to a CISPR Pulse (dB)</b>			
<b>Frequency Band</b>			
<b>Pulse Repetition Frequency</b>	<b>120 kHz EMI BW 0.03 to 1 GHz</b>	<b>9 kHz EMI BW 0.15 to 30 MHz</b>	<b>200 Hz EMI BW 9 to 150 kHz</b>
1000 Hz	+8.0 ± 1.0	+4.5 ± 1.0	N/A
100 Hz	0 dB reference <sup>a</sup>	0 dB reference <sup>a</sup>	+4.0 ± 1.0
60 Hz	N/A	N/A	+3.0 ± 1.0
25 Hz	N/A	N/A	0 dB reference <sup>a</sup>
20 Hz	-9.0 ± 1.0	-6.5 ± 1.0	N/A
10 Hz	-14.0 ± 1.5	-10.0 ± 1.5	-4.0 ± 1.0
5 Hz	N/A	N/A	-7.5 ± 1.5
2 Hz	-26.0 ± 2.0	-20.5 ± 2.0	-13.0 ± 2.0
1 Hz		-22.5 ± 2.0	-17.0 ± 2.0
Isolated Pulse		-23.5 ± 2.0	-19.0 ± 2.0

- a. Reference pulse amplitude accuracy relative to a 66 dBμV CW signal is <1.5 dB as specified in CISPR Publication 16. CISPR reference pulse: 0.044 μVs for 30 MHz to 1.0 GHz, 0.316 μVs for 15 kHz to 30 MHz, and 13.5 μVs for 9 to 150 kHz.

**External Mixing (Option AYZ)**

	Specifications		Supplemental Information
<b>LO OUTPUT</b>			
Frequency Range	2.9 to 7.1 GHz		
Power			When connected to external mixers with an HP/Agilent 5061-5458 cable, provides 14.5 to 16 dBm at the mixer, characteristic.
2.9 to 6.1 GHz 20 to 30°C	15.5 to 17 dBm		
0 to 55°C	15 to 17.5 dBm		
2.9 to 7.1 GHz	13 to 17.5 dBm		
VSWR			<1.9:1, characteristic
<b>IF INPUT</b>			
Frequency Range			321.4 MHz ±5 MHz, characteristic
Maximum Safe Input Level			
ac			10 dBm, characteristic
dc			±10 V, characteristic
VSWR			<1.9:1, characteristic
Absolute Amplitude Accuracy <sup>a</sup>			
For Reference Levels from -10 to -60 dBm			
Amplitude Corrections	20 to 30°C	0 to 55°C	
15 to 30 dB	±1.0 dB	±1.5 dB	
>30 to 50 dB	±1.2 dB	±1.7 dB	
>50 to 60 dB	±1.4 dB	±1.9 dB	
1 dB Gain Compression Level <sup>b</sup>			-20 dBm, characteristic with -10 dBm reference level
<b>Mixer Bias (IF INPUT)</b>			
<b>Voltage</b>			
Maximum Range			±3.3 V, characteristic
Linear Compliant Range			±2 V, characteristic
<b>Current (0 Ω load)</b>			
Range	±10 mA		
Resolution			< 20 μA, characteristic
Accuracy	±10 mA		±(3% + Resolution), characteristic



	Specifications		Supplemental Information
Output Impedance			490 $\Omega$ , nominal

- a. Settings are: RBW 1 kHz; VBW 1 kHz; scale linear or log; span 2 kHz; sweep time coupled, sample detector, signal at reference level.
- b. With amplitude corrections 0 dB.

### Bluetooth FM Demodulation (Option 106)

The FM demodulation characteristics will apply after an **Align Now, FM Demod** has been run.

	Specifications	Supplemental Information
<b>Optimum Input Level</b>		$\geq (-40 \text{ dBm} + \text{attenuator setting} - \text{preamp gain})$ and within 10 dB of the reference level
<b>FM Deviation</b>		
Range		$\pm 200 \text{ kHz}$ , nominal
Resolution		Provides 400 Hz display annotation resolution, nominal
Accuracy <sup>a</sup>		$\pm 10 \text{ kHz}$ , typical
Input level = -30 dBm		$\pm 4 \text{ kHz}$ with video averaging On
Reference level = -30 dBm		and averages $\geq 25$
FM Rate = 500 kHz sine		
VBW = 3 MHz,		
RBW = 5 MHz,		
FM Deviation = 140 kHz		
Offset Error		$\pm 1 \text{ kHz}$ , typical
<b>FM Bandwidth</b> (-3 dB)		1.2 MHz, nominal

a. In time domain sweeps (span = 0 Hz).

### Bluetooth Measurements Personality (Option 228)

The demodulation related nominal values will apply after an **Align Now, FM Demod** has been run.

	Specifications	Supplemental Information
<b>In-Band Frequency Range</b>		
Bluetooth (ISM) Band	2400 to 2483.5 MHz	

	Specifications	Supplemental Information
<b>Output Power</b> (Option AYX or B7D)		
Range at RF Input	30 to -40 dBm	
(Option 1DS)	30 to -60 dBm	
Absolute Amplitude Accuracy		See “Absolute Amplitude Accuracy” on page 55.
Average type	Video, Power	
Average mode	Exponential, Repeat	
Trigger source	Video, RF burst <sup>a</sup> , External, Free Run	
Burst synch	RF Amplitude, Preamble <sup>b</sup> , None	

- a. Requires Option B7E
- b. Requires Option 106 Bluetooth FM demodulation.

	Specifications	Supplemental Information
<b>Modulation Characteristics<sup>a</sup></b> (Option 106 and AYX or B7D)		
Range at RF Input	30 to -40 dBm	
(Option 1DS)	30 to -60 dBm	
FM Deviation		
Range		±200 kHz, nominal
Accuracy		±4 kHz, nominal (25 measurement averages, signal level > -30 dBm)
Payload data	11110000, 10101010, auto-detect	
Average mode	Exponential, Repeat	

Agilent E4407B Specifications and Characteristics  
Options

	Specifications	Supplemental Information
Trigger source	Video, RF burst <sup>b</sup> , External, Free Run	
Burst synch	RF Amplitude, Preamble <sup>c</sup> , None	
Limits	$\Delta f_2/\Delta f_1$ lower, $\Delta f_1$ max lower/upper $\Delta f_2$	

- a. The DUT must have frequency hopping disabled.
- b. Requires Option B7E
- c. Requires Option 106 Bluetooth FM demodulation.

	Specifications	Supplemental Information
<b>Carrier Frequency Drift</b> <sup>a</sup> (Option 106 and AYX or B7D)		
Range at RF Input	30 to -40 dBm	
(Option 1DS)	30 to -60 dBm	
Measurement range		±100 kHz, nominal
Measurement accuracy		±4 kHz, nominal (25 measurement averages, signal level > -30 dBm)
Average mode	Exponential, Repeat	
Trigger source	Video, RF burst <sup>b</sup> , External, Free Run	
Burst synch	Preamble <sup>c</sup> , None	

- a. The DUT must have frequency hopping disabled.
- b. Requires Option B7E
- c. Requires Option 106 Bluetooth FM demodulation.

	Specifications	Supplemental Information
<b>Initial Carrier Frequency Tolerance (ICFT)<sup>a</sup></b> (Option 106 and AYX or B7D)		
Range at RF Input (Option 1DS)	30 to -40 dBm 30 to -60 dBm	
Measurement range		±100 kHz, nominal
Measurement accuracy		±4 kHz, nominal (25 measurement averages, signal level > -30 dBm)
Average mode	Exponential, Repeat	
Trigger source	Video, RF burst <sup>b</sup> , External, Free Run	
Burst synch	RF Amplitude, Preamble <sup>c</sup> , None	
Limits	ICFT upper/lower	

- a. The DUT must have frequency hopping disabled.
- b. Requires Option B7E
- c. Requires Option 106 Bluetooth FM demodulation.

### FM Demodulation (Option BAA)

The FM demodulation characteristics will apply after an **Align Now, FM Demod** has been run.

	Specifications	Supplemental Information
<b>Optimum Input Level</b>		$\geq (-60 \text{ dBm} + \text{attenuator setting} - \text{preamp gain})$ and within 30 dB of the reference level
<b>FM Deviation</b>		
Range		10 kHz to 1 MHz
Resolution		Provides 1 Hz display annotation resolution
FM Deviation Range		
10 kHz to 40 kHz		12 Hz, characteristic
>40 kHz to 200 kHz		60 Hz, characteristic
>200 kHz to 1 MHz		300 Hz, characteristic
Accuracy <sup>a</sup>		
FM Rate < FM BW/100, VBW $\geq (30 \times \text{FM Rate})$ , RBW > the maximum of (30 $\times$ FM deviation) or (30 $\times$ FM Rate)		< (2% of FM deviation range + 2 $\times$ Resolution), characteristic
Offset Error <sup>a</sup>		5% of FM Deviation Range + 300 Hz, characteristic
<b>FM Bandwidth</b> (-3 dB)		
FM Deviation Range		
10 kHz to 40 kHz		7.5 $\times$ FM deviation range, characteristic
>40 kHz to 200 kHz		1.3 $\times$ FM deviation range, characteristic
>200 kHz to 1 MHz		0.3 $\times$ FM deviation range, characteristic

a. In time domain sweeps (span = 0 Hz).

### TV Trigger and Picture On Screen (Option B7B)

Option BAA is required.

	Specifications	Supplemental Information
<b>TV Trigger and Picture On Screen</b>		TV Trigger initiates a sweep of the analyzer after the sync pulse of a selected line of a TV video field. Picture On Screen displays the TV picture on the analyzer display.
Amplitude Requirements TV Source: SA		Top 50% of linear display, characteristic
TV Source: EXT VIDEO IN		500 mVp-p to 2 Vp-p, characteristic
Compatible Standards	NTSC-M, NTSC-Japan, PAL-M, PAL-B,D,G,H,I, PAL-N, PAL-N Combination, SECAM-L	
Field Selection	Entire frame, even, odd	
Sync Polarity	Positive or negative	
<b>TV Trigger</b>		
Line Selection	1 to 525, or 1 to 625, standard dependent	

### cdmaOne Measurement Personality (Option BAC)

Unless otherwise noted, all specifications are with RF input range auto, default cdmaOne measurement settings, and in the in-band frequency range. Option B72 is required.

	Specifications	Supplemental Information
<b>In-Band Frequency Range</b>		
Cellular bands	824 to 870 MHz 869 to 925 MHz	
PCS bands	1715 to 1780 MHz 1805 to 1870 MHz 1850 to 1910 MHz 1930 to 1990 MHz	

	Specifications	Supplemental Information
<b>Adjacent Channel Power Ratio<sup>a</sup></b>		
Carrier power range at RF Input	30 to -20 dBm	
Dynamic range <sup>b</sup>		Referenced to average power of carrier in 1.23 MHz BW
Offset Frequency	Integration BW	
750 kHz	30 kHz	-70.0 dBc, characteristic
885 kHz	30 kHz	-73.5 dBc, characteristic
1.25625 MHz	12.5 kHz	-78.0 dBc, characteristic
1.98 MHz	30 kHz	-75.5 dBc, characteristic
2.75 MHz	1 MHz	-60.5 dBc, characteristic
Relative accuracy <sup>c</sup>	See Display Scale Fidelity	
Resolution	0.01 dB	

- a. This measurement is available with personality revisions of A.02.00 or later.
- b. IS-97A nominal base station test model levels (fraction of carrier power); Pilot: 0.20 (-7.0 dBc), Sync: 0.0471 (-13.3 dBc), Paging: 0.1882 (-7.3 dBc), 6 Traffic channels: 0.09412 (-10.3 dBc)
- c. Does not include uncertainty due to noise.



	Specifications	Supplemental Information
<b>Channel Power (1.23 MHz Integration BW)</b>		Integration BW range 1 kHz to 10 MHz
Range at RF Input	30 to -70 dBm	
Absolute power accuracy for in-band signal (Mean channel power at RF Input, plus any external attenuation, excluding mismatch error)		
Cellular Bands		
30 to -5 dBm 20 to 30 °C	±0.95 dB	±0.33 dB, typical
0 to 55 °C	±1.27 dB	
-5 to -25 dBm 20 to 30 °C	±0.84 dB	±0.28 dB, typical
0 to 55 °C	±1.11 dB	
-25 to -45 dBm 20 to 30 °C	±0.87 dB	±0.29 dB, typical
0 to 55 °C	±1.12 dB	
-45 to -55 dBm 20 to 30 °C	±0.95 dB	±0.36 dB, typical
0 to 55 °C	±1.14 dB	
-55 to -70 dBm 20 to 30 °C	±1.07 dB	±0.46 dB, typical
0 to 55 °C	±1.39 dB	
PCS Bands		
30 to -5 dBm 20 to 30 °C	±0.93 dB	±0.25 dB, typical
0 to 55 °C	±1.32 dB	
-5 to -25 dBm 20 to 30 °C	±0.78 dB	±0.23 dB, typical
0 to 55 °C	±1.06 dB	
-25 to -45 dBm 20 to 30 °C	±0.77 dB	±0.25 dB, typical
0 to 55 °C	±1.05 dB	
-45 to -55 dBm 20 to 30 °C	±0.85 dB	±0.32 dB, typical

Agilent E4407B Specifications and Characteristics  
Options

	Specifications	Supplemental Information
0 to 55 °C	±1.07 dB	±0.42 dB, typical
-55 to -70 dBm 20 to 30 °C	±0.97 dB	
0 to 55 °C	±1.32 dB	

	Specifications	Supplemental Information
Channel power relative power accuracy (same channel, different Tx power, input attenuator fixed, RF input range manual).	See Display Scale Fidelity	

	Specifications	Supplemental Information
<b>Receive Channel Power</b>		
Absolute Power Accuracy		
Cellular bands		
30 to 0 dBm	±1.13 dB	±0.53 dB, typical
0 to -85 dBm	±1.56 dB	±0.67 dB, typical
PCS bands		
30 to 0 dBm	±1.18 dB	±0.52 dB, typical
0 to -85 dBm	±1.45 dB	±0.59 dB, typical
Preamp ( <i>Option IDS</i> )		
Cellular and PCS bands		
30 to -80 dBm	±2.15 dB	±1.26 dB, typical
-80 to -100 dBm	±2.95 dB	±1.92 dB, typical

	Specifications	Supplemental Information
<b>Occupied Bandwidth</b>		
Carrier power range	30 to -45 dBm	
Frequency resolution of occupied BW	1.88 kHz	
Frequency accuracy of occupied BW (1.23 MHz channel BW)		±15 kHz, characteristic
Frequency resolution of delta frequency	3.75 kHz	
Frequency accuracy of delta frequency		± (35 kHz + frequency reference error × carrier frequency), characteristic

	Specifications	Supplemental Information
<b>Code Domain Power</b> (Requires <i>Options 1D5, B7D, and B7E</i> . Measurement interval $\geq 1.25$ ms unless otherwise noted.)		
Carrier power range at RF Input (Pilot channel power $> -11$ dBc)	30 to $-13$ dBm	30 to $-65$ dBm <sup>a</sup> , characteristic
Preamplifier ( <i>Option 1DS</i> )	30 to $-30$ dBm	30 to $-82$ dBm <sup>a</sup> , characteristic
Measurement interval range	0.5 ms to 26.67 ms	
Code domain power		
Display dynamic range	50 dB	
Accuracy (Walsh channel power within 20 dB of total power)		$\pm 0.2$ dB, typical
Displayed resolution	0.01 dB	
Other reported power parameters (dB referenced to total power)		Average active traffic, maximum inactive traffic, average inactive traffic, pilot, paging, sync channels
Carrier frequency error (Measurement interval $\geq 2.5$ ms)		Excludes frequency reference error.
Input frequency error range	$\pm 100$ kHz	$\pm 200$ kHz, typical
Accuracy	$\pm 10$ Hz	$\pm 7$ Hz, typical
Displayed resolution	Four digits	
Estimated Rho		
Range	0.9 to 1.0	0.5 to 1.0 <sup>b</sup>
Accuracy (With 9 channels active over the specified range) <sup>c</sup>		$\pm 0.02$ , characteristic
Displayed resolution	0.0001	
Pilot time offset		From even second signal to start of PN sequence
Range	$-13.33$ ms to $+13.33$ ms	
Accuracy	$\pm 150$ ns	
Displayed resolution	Four digits	
Code domain timing		Pilot to code channel time tolerance
Range	$\pm 200$ ns	

Agilent E4407B Specifications and Characteristics  
Options

	Specifications	Supplemental Information
Accuracy (IS-97A nominal power levels) <sup>d</sup>		±7 ns, typical
Code domain phase		Pilot to code channel phase tolerance
Range	±200 mrad	
Accuracy (IS-97A nominal power levels) <sup>d</sup>		±10 mrad, typical
Displays		Power Graph and Metrics, or Power, Timing, and Phase Graphs

- a. Performance may degrade outside of the specified carrier power range at RF input listed in the specifications column.
- b. Performance may degrade outside of the estimated rho range listed in the specifications column.
- c. The Active Set Threshold is less than all active channels, but greater than -20 dBc.
- d. IS-97A nominal base station test model levels (fraction of carrier power); Pilot: 0.20 (-7.0 dBc), Sync: 0.0471 (-13.3 dBc), Paging: 0.1882 (-7.3 dBc), 6 Traffic channels: 0.09412 (-10.3 dBc)

	Specifications	Supplemental Information
<b>Modulation Accuracy (Rho)</b> (Requires Options 1D5, B7D, and B7E. Measurement interval ≥1.25 ms unless otherwise noted.)		
Carrier power range at RF Input	30 to -28 dBm	30 to -70 dBm <sup>a</sup> , characteristic
Preamp ( <i>Option 1DS</i> )	30 to -45 dBm	30 to -87 dBm <sup>a</sup> , characteristic
Measurement interval range	0.15 ms to 26.67 ms	
Rho (waveform quality)		
Range	0.9 to 1.0	0.5 to 1.0 <sup>b</sup> , characteristic
Accuracy		±0.0016, typical
Displayed resolution	0.0001	
Carrier frequency error (Measurement interval ≥2.5 ms)		Excludes frequency reference error
Input frequency error range	±100 kHz	±200 kHz, typical
Accuracy	±10 Hz	±7 Hz, typical
Displayed resolution	Four digits	
Pilot time offset		From even second signal to start of PN sequence
Range	-13.33 ms to +13.33 ms	
Accuracy	±150 ns	

	Specifications	Supplemental Information
Displayed resolution	Four digits	
EVM		
Floor		3.8%, typical
Accuracy <sup>c</sup>		±1.1%, typical
Displayed Resolution	0.01%	
Carrier feedthrough		
Floor		-51 dBc, typical
Accuracy (Carrier feedthrough ≥ -43 dBc)		±2.3 dB, typical
Displayed resolution	0.01 dB	
Magnitude error		
Floor		3.8%, typical
Accuracy <sup>c</sup>		±1.1%, typical
Displayed resolution	0.01%	
Phase error		
Accuracy <sup>c</sup>		±0.65 degrees, typical
Displayed resolution	0.01 degrees	
Displays		Numeric results or Numeric results and IQ graph

- a. Performance may degrade outside of the specified carrier power range at RF input listed in the specifications column.
- b. Performance may degrade outside of the rho range listed in the specifications column.
- c. Accuracy does not include the effects of the EVM floor. The measurement variance increases as the result approaches the EVM floor.

	Specifications	Supplemental Information
<b>Spur Close (In Band)</b>		
Carrier power range at RF Input	30 to -12 dBm	
Dynamic range		
Input power		
30 to 25 dBm	55 dB	
25 to 20 dBm	50 dB	
20 to -12 dBm	46 dB	

Agilent E4407B Specifications and Characteristics  
Options

	Specifications	Supplemental Information
Relative accuracy	$\pm(2.7 \text{ dB} + 0.01 \times (\text{dB from reference level}))$	$\pm(0.3 \text{ dB} + 0.01 \times (\text{dB from reference level}))$ , typical
Displayed resolution	0.01 dB	

	Specifications	Supplemental Information
<b>Out-of-Band Spurious<sup>a</sup></b>		Refer to the Amplitude specifications section in this guide.

a. The out-of-band measurement is made with the user-defined tables with 20 frequency ranges each (up to the top 10 spurs per range, 100 spurs maximum). Table parameters include frequency range, RBW, video BW, detector type, and amplitude test limits.

	Specifications	Supplemental Information
<b>Receiver Spurious Emissions</b>		
Spurious emission power range	-20 to -83 dBm	
Preamp On ( <i>Option 1DS</i> )	-40 to -101 dBm	
Absolute spurious emission power accuracy		
-20 to -60 dBm	$\pm 2.1 \text{ dB}$	$\pm 1.1 \text{ dB}$ , typical
-60 to -83 dBm	$\pm 3.9 \text{ dB}$	$\pm 2.7 \text{ dB}$ , typical
Preamp On ( <i>Option 1DS</i> )		
-40 to -70 dBm	$\pm 2.5 \text{ dB}$	$\pm 1.3 \text{ dB}$ , typical
-70 to -101 dBm	$\pm 4.0 \text{ dB}$	$\pm 2.6 \text{ dB}$ , typical

	Specifications	Supplemental Information
<b>External Correction</b>		
External attenuation, external gain		
Range	-90 to 90 dB	
Resolution	0.01 dB	

	Specifications	Supplemental Information
<b>Trigger</b>		
Trigger source (Actual available choices dependent on measurement)  (Option B7D and B7E)	Free run, external  Add RF Burst, frame	
Delay trigger Range	0 to 500 ms	
Resolution	300 ns	
RF burst trigger level (Option B7E)	0 to -25 dBc	
Trigger slope (External and RF burst)	Positive/Negative	
Frame timing period	50 ns to 13.6533 s	
Frame synchronizing source	External frame sync	Rear panel connector labelled EXT FRAME SYNC (Option B7D)
Frame synchronizing slope	Positive/Negative	

	Specifications	Supplemental Information
<b>Demod Trigger Source</b>		
Even second input (Frame trigger only, Option B7D and B7E)		Rear panel connector labelled EXT FRAME SYNC
PN offset range	0 to 511 x 64 [chips]	

### GSM with EDGE Measurement Personality (Option BAH, 252)

Unless otherwise noted, all specifications are with RF input range auto, default GSM measurement settings, and in the in-band frequency range. Option 1D6 and Option B72 are required.

	Specifications	Supplemental Information
<b>In-Band Frequency Ranges<sup>a</sup></b>		
GSM 900, P-GSM bands	890 to 915 MHz 935 to 960 MHz	
GSM 900, E-GSM bands	880 to 915 MHz 925 to 960 MHz	
GSM 900, R-GSM bands	876 to 915 MHz 921 to 960 MHz	
DCS 1800 bands	1710 to 1785 MHz 1805 to 1880 MHz	
PCS 1900 bands	1850 to 1910 MHz 1930 to 1990 MHz	
<b>Alternative Frequency Ranges<sup>b</sup></b>		
GSM 450 bands	450.4 to 457.6 MHz 460.4 to 467.6 MHz	
GSM 480 bands	478.8 to 486 MHz 488.8 to 496 MHz	
GSM 850 bands	824 to 849 MHz 869 to 894 MHz	

a. Frequency ranges over which all specifications apply.

b. Frequency ranges with tuning plans.



	Specifications	Supplemental Information
<b>Transmitter Power</b> (Requires <i>Option B7D</i> or <i>AYX</i> )		
Range at RF Input	30 to -60 dBm	
Absolute power accuracy for in-band signal (Mean channel power at RF Input, plus any external attenuation, excluding mismatch error)		
P-GSM, E-GSM, and R-GSM Bands		
30 to -20 dBm 20 to 30 °C	±0.94 dB	±0.34 dB, typical
0 to 55 °C	±1.43 dB	
-20 to -30 dBm 20 to 30 °C	±0.80 dB	±0.28 dB, typical
0 to 55 °C	±1.10 dB	
-30 to -40 dBm 20 to 30 °C	±0.83 dB	±0.28 dB, typical
0 to 55 °C	±1.09 dB	
-40 to -50 dBm 20 to 30 °C	±0.99 dB	±0.44 dB, typical
0 to 55 °C	±1.19 dB	
-50 to -60 dBm 20 to 30 °C	±1.13 dB	±0.57 dB, typical
0 to 55 °C	±1.31 dB	
DCS 1800 and PCS 1900 Bands		
30 to -20 dBm 20 to 30 °C	±0.92 dB	±0.27 dB, typical
0 to 55 °C	±1.48 dB	
-20 to -30 dBm 20 to 30 °C	±0.74 dB	±0.26 dB, typical
0 to 55 °C	±1.09 dB	
-30 to -40 dBm 20 to 30 °C	±0.79 dB	±0.26 dB, typical
0 to 55 °C	±1.08 dB	
-40 to -50 dBm 20 to 30 °C	±0.95 dB	±0.42 dB, typical

Agilent E4407B Specifications and Characteristics  
**Options**

	Specifications	Supplemental Information
0 to 55 °C	±1.18 dB	±0.55 dB, typical
-50 to -60 dBm 20 to 30 °C	±1.09 dB	
0 to 55 °C	±1.30 dB	

	Specifications	Supplemental Information
<b>Transmitter Power Relative Power Accuracy</b> (same channel, different Tx power, input attenuator fixed, RF input range manual).	See Display Scale Fidelity	

	Specifications	Supplemental Information
<b>GMSK Power versus Time and EDGE Power versus Time</b> (Requires <i>Option B7D</i> or <i>AYX</i> )		
Carrier power range at RF Input	30 to -23 dBm	30 to -55 dBm <sup>a</sup> , nominal
Preamp On ( <i>Option IDS</i> )	30 to -40 dBm	30 to -72 dBm <sup>a</sup> , nominal
Time resolution accuracy		±1% of sweep time, nominal
Maximum record length	8 time slots	
Burst to mask uncertainty (Requires <i>Option B7D</i> and <i>B7E</i> )	$\pm \left[ 0.1 + \frac{ST}{T_{sym}(TP - 1)} \right]$ symbol	Where ST = sweep time <sup>b</sup> TP = trace points and T <sub>sym</sub> = 3.69 μs  Examples: Meas Time=1 and TP=1601, gives 0.22 symbol  Meas Time=8 and TP=6401, gives 0.30 symbol

- a. Performance may degrade outside of the specified carrier power range at RF input listed in the specifications column.
- b. Sweep Time value can be found on the key label in the **Advanced** settings menu, with GSM w/EDGE personality software versions C.01.00 and later.

	Specifications	Supplemental Information
<b>GMSK Output RF Spectrum and EDGE Output RF Spectrum</b>		
Carrier power range at RF Input	+30 to -4 dBm	
Reference power accuracy	Transmitter Power Accuracy ±0.13 dB	

	Specifications		Supplemental Information
Relative accuracy <sup>a</sup>			
Due to modulation			
Offsets ≤1200 kHz	±0.83 dB		
Offsets ≥1800 kHz	±0.96 dB		
Due to switching	±1.63 dB		
Spectrum due to modulation displayed dynamic range <sup>b,c</sup>	<b>Non- Option 120</b>	<b>Option 120</b>	67 dB, nominal <sup>e</sup>
100 kHz offset <sup>d</sup>	67.5 dB	67.5 dB	
200 kHz offset <sup>d</sup>	69.5 dB	71.9 dB	
250 kHz offset <sup>d</sup>	70.2 dB	73.3 dB	
400 kHz offset GSM <sup>d</sup> EDGE	71.7 dB	76.3 dB	
600 kHz to 1200 kHz offset	72.8 dB	78.8 dB	
1.8 MHz offset	69.9 dB	76.3 dB	
6 MHz offset	70.1 dB	77.1 dB	
Spectrum due to switching transients displayed dynamic range <sup>b,c</sup>	<b>Non-Option 120</b>	<b>Option 120</b>	
400 kHz offset	62.5 dB	67.1 dB	
600 kHz offset	63.6 dB	69.6 dB	
1200 kHz offset	65.1 dB	72.5 dB	
1800 kHz offset	65.4 dB	72.7 dB	

- a. Does not include uncertainty due to noise.
- b. Previously available GSM measurements options for ESA specified dynamic range for CW signals only. These specifications apply for GSM and EDGE signals.
- c. Using default settings, the RBW filter has a corrected noise BW and impulse BW equivalent to five-pole synchronously tuned filter.
- d. The dynamic range for offsets under 400 kHz is not directly observable because the signal spectrum obscures the result. These dynamic range specifications are derived from phase noise specifications.

	Specifications	Supplemental Information
<b>Phase and Frequency Error</b> (Requires <i>Option 1D5, B7D, and B7E</i> )		
Carrier power range at RF Input	30 to -23 dBm	30 to -55 dBm <sup>a</sup> , nominal

## Agilent E4407B Specifications and Characteristics

### Options

- e. The analyzer performance can be dominated by third-order distortion products. These products depend on the mixer level. Their relative level will vary by 10 dB as the mixer level (input RF power minus attenuation) varies over a 5 dB range. When the Input Attenuator is auto coupled, the resolution of the attenuator keeps the mixer level in a 5 dB range. The indicated nominal performance was observed at the worst-case mixer level. Increasing the input attenuation by 10 dB from the auto coupled setting will improve the dynamic range for EDGE signals to very close to that for GSM signals at the 400 kHz offset. The optimum mixer level for dynamic range is approximately -15 dBm for EDGE at 400 kHz offset; the auto coupled setting is controlled to be in the -4 to -9 dBm range to optimize the trade off between compression errors and noise for wider offsets.

	Specifications	Supplemental Information
Preamp On (Option 1DS)	30 to -40 dBm	30 to -72 dBm <sup>a</sup> , nominal
Phase error		
Range	0 to 180°	
Displayed resolution	0.01°	
Accuracy (Averages ≥10)		
Peak	±2.1°	±1.5°, typical
RMS	±1.1°	±0.6°, typical
Frequency error		Excludes frequency reference error
Initial frequency error range	±100 kHz	
Accuracy (Avg. Type = Mean, Averages ≥10)	±10 Hz	±5 Hz, typical
I/Q offset range	-10 to -46 dBc	
Burst sync time uncertainty	±0.1 bit	
Displays		Numeric summary

- a. Performance may degrade outside of the specified carrier power range at RF input listed in the specifications column.

	Specifications	Supplemental Information
<b>Transmit Band Spurious</b>		
Carrier power range at RF Input		30 to -12 dBm, typical
Dynamic range		
Upper and lower adjacent segments		55 dB, nominal
Upper and lower segments		44 dB, nominal
Relative accuracy		$\pm(0.3 \text{ dB} + 0.01 \times (\text{dB from reference level}))$ , nominal
Displayed resolution	0.01 dB	

	Specifications	Supplemental Information
<b>Out-of-Band Spurious<sup>a</sup></b>		
Absolute Spurious Power Accuracy		Refer to the Amplitude specifications section in this guide.
Sensitivity <sup>b</sup>		
RBW		
1 kHz		-95 dBm, nominal
3 kHz		-90 dBm, nominal
10 kHz		-85 dBm, nominal
30 kHz		-78 dBm, nominal
100 kHz		-71 dBm, nominal
300 kHz		-64 dBm, nominal
1 MHz		-57 dBm, nominal
3 MHz		-50 dBm, nominal

- a. The out-of-band spurious measurement is made in accordance with the tables defined in the appropriate 3GPP specification document. The measurement is made over several frequency ranges (up to 10 spurs per range, 100 spurs maximum).
- b. With input attenuation of 5 dB. For all other attenuation settings, add (input attenuation - 5) dB.

Agilent E4407B Specifications and Characteristics  
Options

	Specifications	Supplemental Information
<b>Receive Band Spurious</b>		
Spurious emission power range <sup>a</sup>		
Preamp On ( <i>Option IDS</i> )		–20 to –73 dBm, nominal
Preamp Off		–40 to –91 dBm, nominal
Absolute spurious emission power accuracy		
–20 to –60 dBm		±1.5 dB, nominal
–60 to –73 dBm		±2.1 dB, nominal
Preamp on ( <i>Option IDS</i> )		
–40 to –70 dBm		±1.8 dB, nominal
–70 to –91 dBm		±3.0 dB, nominal

a. Requires bandpass filter centered on receive band, peak detector mode, 0 dB attenuation, 100 kHz RBW. Does not include insertion loss of bandpass filter.

	Specifications	Supplemental Information
<b>EDGE Error Vector Magnitude (EVM)</b> (Requires <i>Option IDS, B7D</i> and <i>B7E</i> )		3 $\pi$ /8 shifted 8PSK modulation Specifications based on 200 bursts
Carrier power range at RF Input	30 to -23 dBm	30 to -55 dBm <sup>a</sup> , nominal
Preamp On ( <i>Option IDS</i> )	30 to -40 dBm	30 to -72 dBm <sup>a</sup> , nominal
EVM		
Operating range		0 to 25 % (nominal)
Floor (RMS)		0.8 % (nominal)
Accuracy <sup>b</sup> (RMS)		$\pm$ 0.75 % (nominal)
EVM range 1 % to 10 %		
Input power +24 to -12 dBm		
Frequency Error		Excludes frequency reference error
Accuracy		$\pm$ 5 Hz, nominal
IQ Origin Offset		
DUT maximum offset	-20 dBc	
Maximum analyzer noise floor	-45 dBc	

- a. Performance may degrade outside of the specified carrier power range at RF input listed in the specifications column.
- b. The accuracy specification applies when the Burst Sync is set to the Training Sequence. The definition of accuracy for the purposes of this specification is how closely the result meets the expected results. The expected result is 0.975 of the actual RMS EVM of the signal (per 3GPP TS 5.05, annex G).

	Specifications	Supplemental Information
<b>Amplitude Range Control</b>		RF Input Autorange, Manually set <b>Max Total Pwr</b> Manually set <b>Input Atten</b>

	Specifications	Supplemental Information
<b>External Gain/Attenuation Correction</b>		
Base gain, base attenuation, mobile gain, mobile attenuation		
Range	0 to 81.9 dB	
Resolution	0.01 dB	

	Specifications	Supplemental Information
<b>Trigger</b>		
Trigger source (Actual available choices dependent on measurement)	Free run, external	

Agilent E4407B Specifications and Characteristics  
Options

	Specifications	Supplemental Information
<i>(Option B7D and B7E)</i>	Add RF burst and frame	
RF burst trigger <i>(Option B7E)</i>		
Peak carrier power range <sup>a</sup>	30 to -25 dBm	30 to -30 dBm, typical
Preamp On <i>(Option IDS)</i>	30 to -45 dBm	30 to -50 dBm, typical
Trigger level range	0 to -25 dB relative to signal peak	

a. With trigger level set to -6 dB.

	Specifications	Supplemental Information
<b>Burst Sync</b> <i>(Requires Option AXX or B7D)</i>		
Source <i>(Actual available choices dependent on measurement)</i>	RF amplitude, none	
<i>(Option B7D and B7E)</i>	Add training sequence	
Training sequence code		GSM defined 0 to 7 Auto (search) or Manual
Burst type		Normal (TCH and CCH) Sync (SCH) Access (RACH)



### Noise Figure Measurement Personality and Hardware (Option 219) Specifications.

	Specifications	Supplemental Information
<b>+28 V PULSED</b>		Noise source drive Used by option 219
Connector type	50 Ω BNC(f)	
Output voltage		
On	28.0 V ±0.1 V	60mA peak
Off	<1V	
<b>SNS SERIES NOISE SOURCE</b>		For use with Agilent Technologies SNS Series noise sources

	Specifications	Supplemental Information
<b>Noise Figure</b>		Uncertainty Calculator <sup>a</sup>
10 MHz to 3 GHz		Using internal preamp (Option 1DS), and RBW=1 MHz
Noise Source ENR	Measurement Range	Instrument Uncertainty <sup>b</sup>
4.5 to 6.5 dB	0 to 20 dB	±0.24 dB
12 to 17 dB	0 to 30 dB	±0.41 dB
20 to 22 dB	0 to 35 dB	±0.46 dB
3 to 26.5 GHz <sup>c</sup>		No internal preamp
Instrument Uncertainty		Nominally the same as for the 10 MHz to 3 GHz range; External preamp caution <sup>d</sup>
3 to 10 GHz		Well-controlled preselector <sup>e</sup>
10 to 20 GHz		Good preselector stability <sup>f</sup>
20 to 26.5 GHz		Preselector Drift Effects <sup>g</sup>

a. The figures given in the table are for the uncertainty added by the ESA instrument only. To compute the total uncertainty for your noise figure measurement, you need to take into account other factors including: DUT NF, Gain and Match; Instrument NF, Gain Uncertainty and Match; Noise source ENR uncertainty and Match. The computations can be performed with the uncertainty calculator included with the Noise Figure Measurement Personality. Go to **Mode Setup** then select **Uncertainty Calculator**. Similar calculators are also available on the Agilent web site; go to [www.agilent.com/find/nfu](http://www.agilent.com/find/nfu).

## Agilent E4407B Specifications and Characteristics

### Options

- b. "Instrument Uncertainty" is defined for noise figure analysis as uncertainty due to relative amplitude uncertainties encountered in the analyzer when making the measurements required for a noise figure or gain computation. The relative amplitude uncertainty is given by the relative display scale fidelity, also known as incremental log fidelity. The uncertainty of the analyzer is multiplied within the computation by an amount that depends on the Y factor to give the total uncertainty of the noise figure or gain measurement.

See Agilent App Note 57-2, literature number 5952-3706E for details on the use of this specification. Jitter (amplitude variations) will also affect the accuracy of results. The standard deviation of the measured result decreases by a factor of the square root of the Resolution Bandwidth used and by the square root of the number of averages. ESA uses the 1 MHz resolution Bandwidth as default since this is the widest bandwidth with uncompromised accuracy.

- c. For this frequency range, the Instrument Noise Figure Uncertainty is still well controlled, but other accuracy issues become critical. Because there is no internal preamplifier in this range, the Instrument Noise Figure is much higher than in the range below 3 GHz. This causes the effect on total measurement Noise Figure Uncertainty of the Instrument Gain Uncertainty to be much higher, and that Instrument Gain Uncertainty is in turn much higher than in the range below 3 GHz because of the effects of the preselector, explained in subsequent footnotes. As a result, when the DUT has high gain, the total measurement Noise Figure Uncertainty computed with the Uncertainty Calculator can still be excellent, but modest and low gain devices can have very high uncertainties of noise figure. Graphs that follow demonstrate. The first graph shows the computed measurement NF uncertainty with no preamp, and shows how much gain is required to achieve good accuracy. The second graph shows computed measurement NF uncertainty when using an external preamp with 23 dB gain and 6 dB NF. Both graphs were plotted using the uncertainty calculator with the assumptions shown.
- d. An external preamp can reduce the total NF measurement uncertainty substantially because it will reduce the effective noise figure of the measurement system, and thus it will reduce the sensitivity of the total NF uncertainty to the Instrument Gain Uncertainty. But if the signal levels into such an external preamp are large enough, that external preamp may experience some compression. The compression differences between the noise-source-on and noise-source-off states causes an error that must be added to Instrument Noise Figure Uncertainty for use in the Noise Figure Uncertainty Calculator. Such signal levels are quite likely for the case where the DUT has some combination of high gain, high noise figure and wide bandwidth.

As an example, we will use the Agilent 83006A as the external preamplifier. The measurement will be made at 18 GHz. The typical gain is 25 dB and the noise figure is 7 dB. We will assume the DUT has 20 dB gain, a 10 dB NF, and a passband from 5 to 30 GHz. We will use a noise source with 17 dB ENR. When the noise source is on, the DUT output can be computed by starting with  $kT$  ( $-174$  dBm/Hz) and adding  $10 \cdot \log(30 \text{ GHz to } 5 \text{ GHz})$  or 104 dB, giving  $-70$  dBm for the thermal noise. Add to this the ENR of the noise source (17 dB) combined with the NF of the DUT (10 dB) to give an equivalent input ENR of 18 dB, thus  $-52$  dBm input noise power. Add the gain of the DUT (20 dB) to find the DUT output power to be  $-32$  dBm. The noise figure of the external preamp may be neglected. The external preamplifier gain of 25 dB adds, giving a preamplifier output power of  $-7$  dBm. The typical 1 dB compression point of this amplifier is +19 dBm. Therefore, the output noise is 26 dB below the 1 dB compression point. This amplifier will have negligible compression.

As an approximation, the compression of a noise signal is under 0.1 dB if the average noise power is kept 7 dB below the 1 dB CW compression point. The compression in decibels will usually double for every 3 dB increase in noise power. Use cases with higher gain DUTs or preamplifiers with lower output power capability could be compressed, leading to additional errors.

- e. In this frequency range, the preselector is well-controlled and there should be no need for special measurement techniques.
- f. In this frequency range, the preselector usually requires no special measurement techniques in a lab environment. But if the temperature changes by a few degrees, or the analyzer frequency is swept or changed across many gigahertz, Agilent recommends centering the preselector at one user determined critical frequency before a measurement. To adjust the preselector, follow the instructions in the *Noise Figure Measurement Personality Guide*.

- g. In this frequency range, the preselector may sometimes require special measurement techniques, even in a lab environment. Agilent recommends centering the preselector at one user determined critical frequency before a measurement. To adjust the preselector, follow the instructions in the *Noise Figure Measurement Personality Guide*.

**Noise Figure Error Range vs. DUT Gain, Non-warranted Frequency Range (>3 GHz)**

**Computed Measurement NF Uncertainty vs. DUT Gain, Non-warranted Frequency Range**

Assumptions: Measurement Frequency 12 GHz, Instrument NF = 28.7 dB, Instrument VSWR = 1.58, Instrument Gain Uncertainty = 2.7 dB, Instrument NF Uncertainty = 0.41 dB, Agilent 346B Source with Uncertainty = 0.2 dB, Source VSWR = 1.25, DUT input/output VSWR = 1.5.

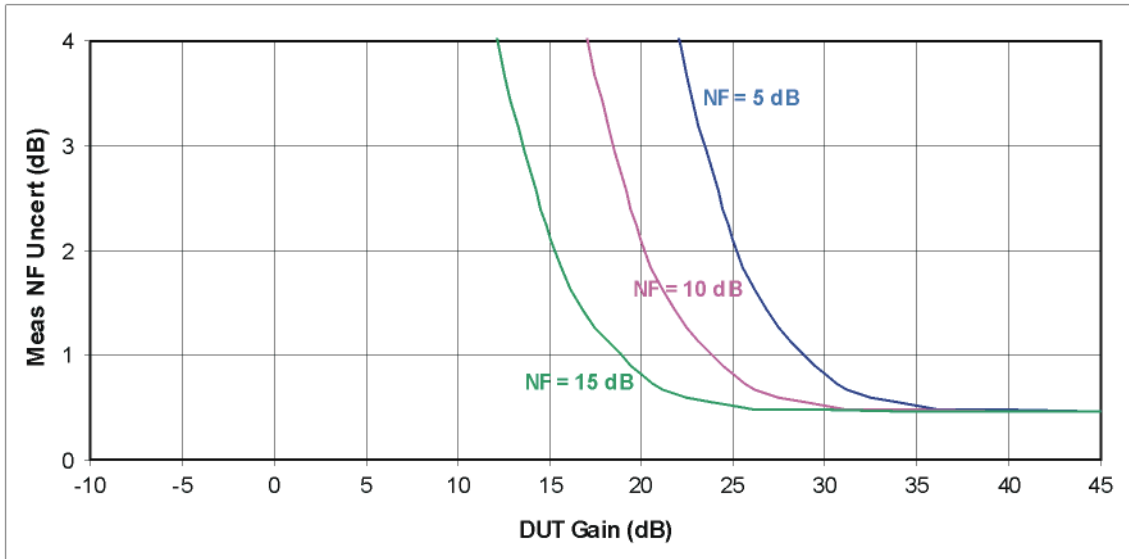

**Computed Measurement NF Uncertainty vs. DUT Gain, Non-warranted Frequency Range**

Assumptions: Same as above, with the addition of an external preamp that has a gain of 23 dB and a NF of 6 dB (for example, 83006A). Also, the Agilent 346A Source is used. The 346A changes the instrument noise figure uncertainty to 0.24 dB. With the external preamp, the preamp/analyzer combination NF is 8.86 dB. Instrument VSWR now moves to the external preamp with VSWR = 2.6

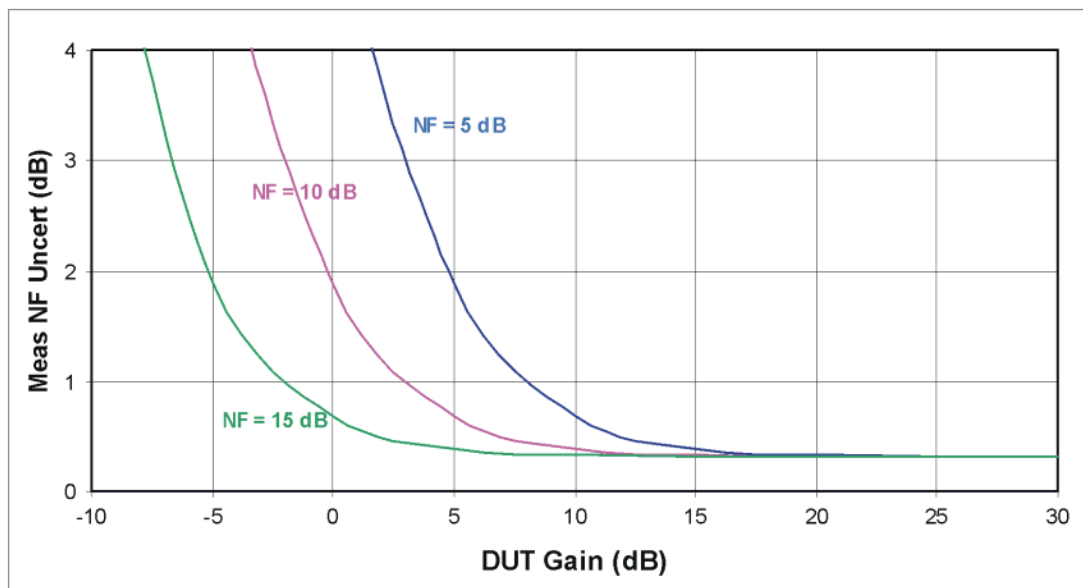

	Specifications		Supplemental Information
<b>Gain</b>			
10 MHz to 3 GHz			
Noise Source ENR	Measurement Range	Instrument Uncertainty <sup>a</sup>	
4.5 to 6.5 dB	-20 to 40 dB	±0.83 dB	
12 to 17 dB	-20 to 40 dB	±0.83 dB	
20 to 22 dB	-20 to 40 dB	±0.83 dB	
3 to 26.5 GHz <sup>b</sup>			
Instrument Uncertainty			±2.7 dB (nominal) <sup>c</sup> for Measurement Range -20 to 40 dB

- a. See the “Instrument Uncertainty” footnote [b on page 322](#).
- b. See footnotes [d](#), [e](#), [f](#), and [g](#) for this frequency range in the Noise Figure section.
- c. The performance shown would apply when there is a long time between the calibration step and the DUT-measurement step in a NF or Gain measurement. Under special circumstances of small changes in frequency (such as spot frequency measurements) and short time periods between the calibration time and the measurement time, this error source becomes much smaller, approaching the Instrument Uncertainty shown for the 10 MHz to 3 GHz frequency range. These special circumstances would be frequency span ranges of under 1 GHz, with that frequency range unchanged for 30 minutes, and the time between the calibration step and the DUT measurement step held to less than 10 minutes.

Agilent E4407B Specifications and Characteristics  
Options

	Specifications	Supplemental Information
<b>Noise Figure Uncertainty Calculator<sup>a</sup></b>		
Instrument Noise Figure Uncertainty	See Noise Figure	
Instrument Gain Uncertainty	See Gain	
Instrument Noise Figure		See graphs, Nominal Noise Figure DANL +145.87 dB (nominal) <sup>b</sup>
Instrument Input Match		See graphs, Nominal VSWR

- a. The Noise Figure Uncertainty Calculator requires the parameters shown in order to calculate the total uncertainty of a Noise Figure measurement.
- b. Nominally, the noise figure of the spectrum analyzer is given by
 
$$NF = D - (K - L + N + B)$$
 where D is the DANL (displayed average noise level) specification,  
 K is kTB (-173.88 dB in a 1 Hz bandwidth at 25 °C)  
 L is 2.51 dB (the effect of log averaging used in DANL verifications)  
 N is 0.52 dB (the ratio of the noise bandwidth of the RBW filter with which DANL is specified to an ideal noise bandwidth)  
 B is ten times the base-10 logarithm of the RBW (in hertz) in which the DANL is specified. B is 30 dB for the 1 kHz RBW. The actual NF will vary from the nominal due to frequency response errors.

**Nominal Instrument Noise Figure**

**Nominal Instrument Noise Figure 10 MHz to 3 GHz Preamplifier On**

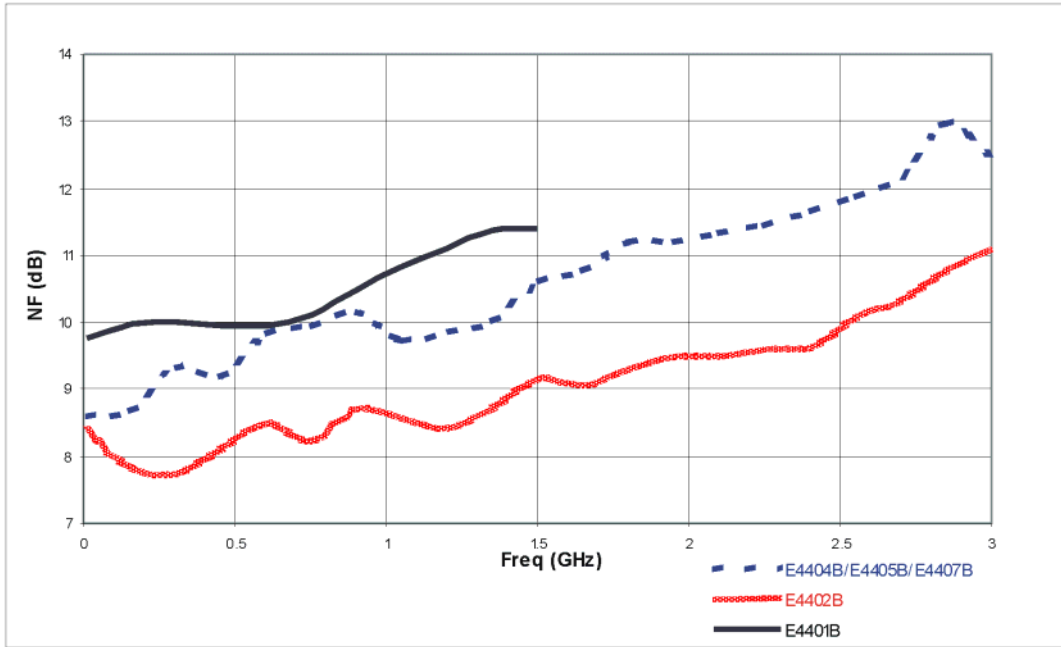

**Nominal Instrument Noise Figure 3 to 26.5 GHz  
No Preamplifier; two example units**

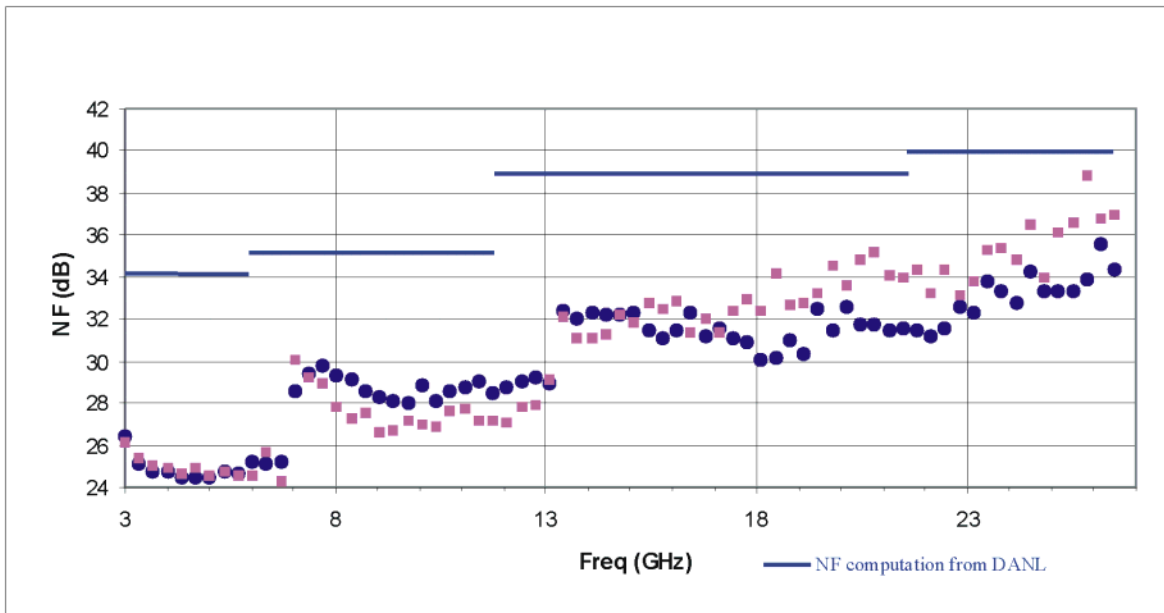

**Nominal Instrument Input VSWR**

**Nominal Instrument Input VSWR 10 MHz to 3 GHz; Preamp On, Attenuation = 0 dB**

VSWR of four instruments shown. Nine graphs are representative of different input coupling configurations of E4401/2/5/7B models.

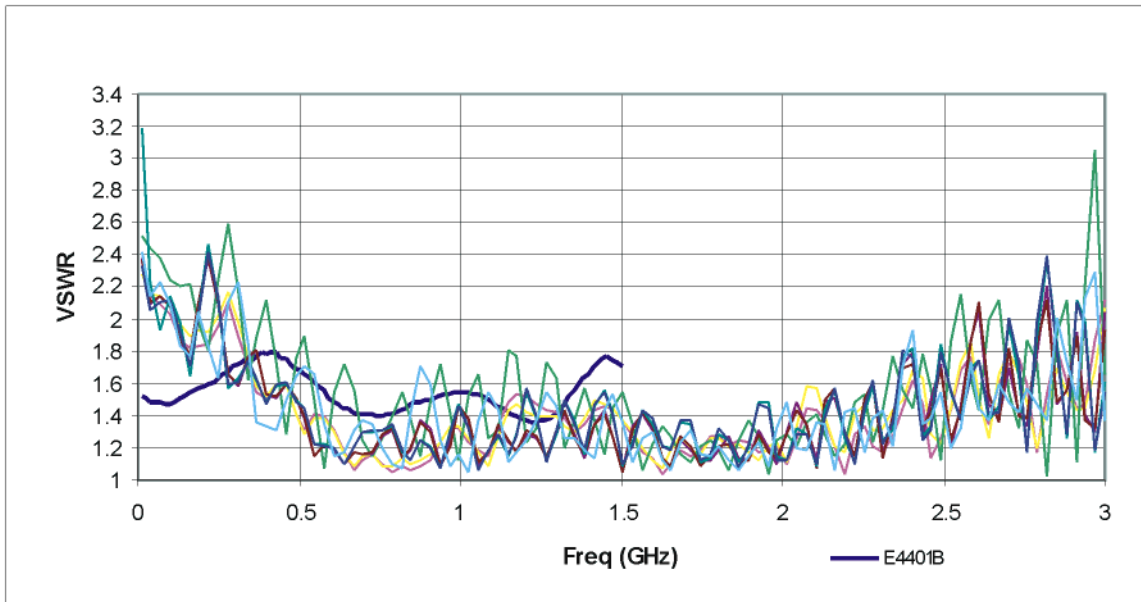

**Nominal Instrument Input VSWR 3 to 26.5 GHz; No Preamp, Attenuation = 0 dB**

VSWR of three instruments shown. Three graphs are representative of different input coupling configurations of E4407B models

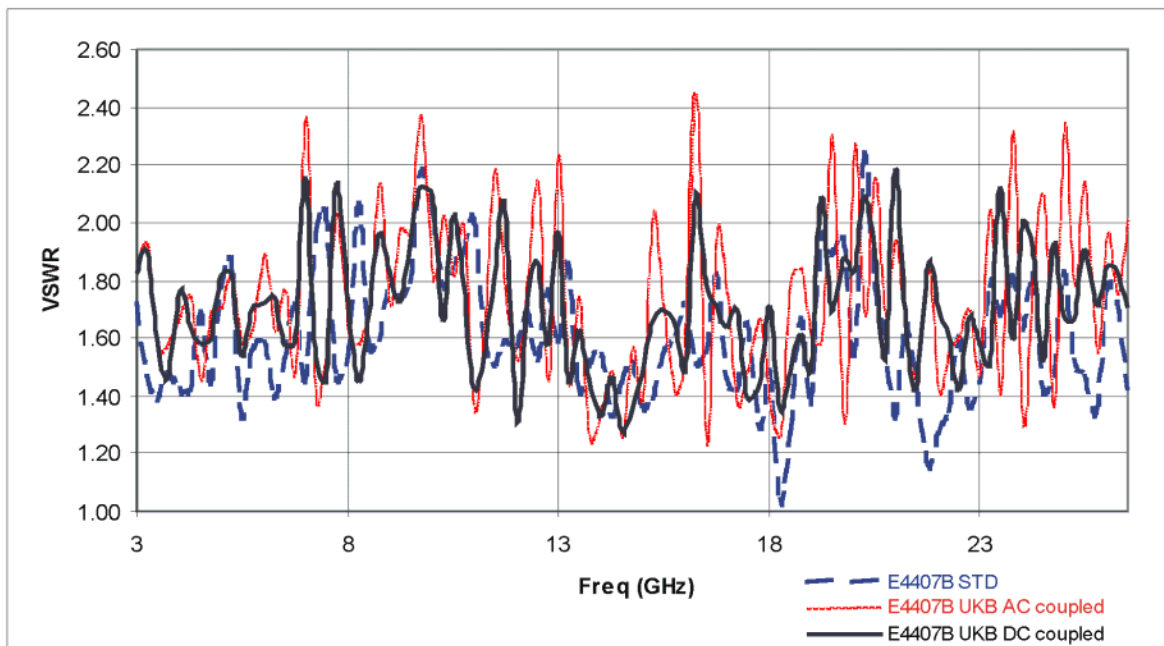



## General

	Specifications	Supplemental Information
<b>Temperature Range</b>		
Operating	0 to 55 °C	Floppy disk 10 to 40 °C
Storage	-40 to 75 °C	

	Specifications	Supplemental Information
<b>Audible Noise (ISO 7779)</b>		
Sound Pressure at 25 °C		<40 dBa, (<4.6 Bels power)

	Specifications	Supplemental Information
<b>Altitude Range</b>		
Operating	Up to 4600 meters	

	Specifications	Supplemental Information
<b>Humidity Range</b>		
Operating	maximum relative humidity 80% for temperatures up to 31°C decreasing linearly to 50% relative humidity at 40°C	

	Specifications	Supplemental Information
<b>Military Specification</b>	Has been type tested to the environmental specifications of MIL-PRF-28800F class 3.	

	Specifications	Supplemental Information
<b>EMI Compatibility</b>	Conducted and radiated emission is in compliance with CISPR Pub. 11/1990 Group 1 Class A.	
(Option 060) <sup>a</sup>	Conducted and radiated emission is in compliance with CISPR Pub. 11/1990 Group 1 Class B <sup>b</sup> .	

a. Option 060 is not compatible with Option B7B nor Option 1DP.

b. Meets Class A performance during dc operation.

Agilent E4407B Specifications and Characteristics  
**General**

	Specifications	Supplemental Information
<b>Immunity Testing</b>  Radiated Immunity        Electrostatic Discharge		Testing was done at 3 V/m according to IEC 801-3/1984. When the analyzer tuned frequency is identical to the immunity test signal frequency, there may be signals of up to -60 dBm displayed on the screen.  Air discharges of up to 8 kV were applied according to IEC 801-2/1991. Discharges to center pins of any of the connectors may cause damage to the associated circuitry.

	Specifications	Supplemental Information
<b>Acoustic Noise Emission/Geraeuschemission</b>  LpA <70 dB Operator position Normal position Per ISO 7779	LpA <70 dB Am Arbeitsplatz Normaler Betrieb Nach DIN 45635 t.19	

	Specifications	Supplemental Information
<b>Power Requirements</b>  ac Operation Voltage, frequency Power Consumption, On Power Consumption, Standby dc Operation Voltage Power Consumption Power Consumption, Standby	90 to 132 Vrms, 47 to 440 Hz 195 to 250 Vrms, 47 to 66 Hz <300 W <5 W 12 to 20 Vdc <200 W <100 mW	

	Specifications	Supplemental Information
<b>Measurement Speed</b>		

	Specifications	Supplemental Information
Local Measurement and Display Update rate		
Sweep points = 101		≥ 40/s, characteristic
Sweep points = 401		≥ 28/s, characteristic
Remote Measurement and GPIB Transfer Rate <sup>a,b</sup>		
(Option A4H)		
Sweep points = 101		≥ 40/s, characteristic
Sweep points = 401		≥ 28/s, characteristic
RF Center Frequency Tune, Measure, and GPIB Transfer Time <sup>a,c</sup>		
(Option A4H)		
Sweep points = 101		≤ 75 ms, characteristic
Sweep points = 401		≤ 90 ms, characteristic

- a. Display Off (:DISPlay:ENABle OFF), and 32-bit integer data format (:FORMat:DATA INT,32), if Option AXX or A4J is installed, disable sweep ramp, (:SYSTem:PORTs: IFVSweep:ENABle OFF), markers Off, single sweep, measured with IBM compatible PC with 550 MHz Pentium® III running Windows® NT 4.0, one meter GPIB cable, National Instruments PCI-GPIB card and NI-488.2 DLL.
- b. Factory preset, auto align Off, fixed center frequency, RBW = 1 MHz, frequency scale linear, and span = 20 MHz, fixed center frequency, stop frequency ≤ 3 GHz, average of 100 measurements.
- c. Factory preset, auto align Off, segmented sweep Off, RBW = 1 MHz, frequency scale linear, span = 20 MHz, stop frequency ≤ 3 GHz, center frequency tune step size = 50 MHz.

	Specifications	Supplemental Information
<b>Data Storage</b>		
Internal <sup>a</sup>		8.0 MB, nominal
External (10 to 40 °C)		3.5" 1.44 MB, MS-DOS® compatible floppy disk

- a. For serial numbers prior to US41440000 or MY41440000, 1 MB without Option B72, 8 MB with Option B72.

	Specifications	Supplemental Information
Memory Usage		
State		20 kB <sup>a</sup> , nominal
State plus 401-point trace		21 kB <sup>a</sup> , nominal

Agilent E4407B Specifications and Characteristics  
**General**

	Specifications	Supplemental Information
Applications memory usage <sup>b</sup>		
Distance to Fault ( <i>Option 225</i> )		0.6 MB, nominal
Phase noise ( <i>Option 226</i> )		1.1 MB, nominal
Cable TV ( <i>Option 227</i> )		1 MB, nominal
Bluetooth ( <i>Option 228</i> )		1.32 MB, nominal
Modulation Analysis ( <i>Option 229</i> )		1.7 MB, nominal
HP 8566/68B Compatibility ( <i>Option 266</i> )		0.24 MB, nominal
8590 Compatibility ( <i>Option 290</i> )		0.7 MB, nominal
GSM ( <i>Option BAH</i> )		3.2 MB, nominal
CDMA One ( <i>Option BAC</i> )		2.8 MB, nominal
Noise Figure ( <i>Option 219</i> )		1.6 MB, nominal

- a. The size of state will increase depending on installed applications.
- b. Some applications may share files which may reduce total memory usage.

	Specifications	Supplemental Information
<b>Demod Tune and Listen</b>		Internal speaker, front-panel earphone jack and front-panel volume control.
Demod ( <i>Option BAA</i> ) ( <i>Option A4J or AYY</i> )	AM  Add FM	An uncalibrated demodulated signal is available on the AUX VIDEO OUT connector at the rear panel.
( <i>Option 106 or BAA</i> )		An uncalibrated demodulated signal is available on the EXT VIDEO OUT connector at the rear panel.

	Specifications	Supplemental Information
<b>Weight</b> (without options)		
Net		17.1 kg (37.7 lb), characteristic
Shipping		31.9 kg (70.3 lb), characteristic

	Specifications	Supplemental Information
<b>Display<sup>a</sup></b>		
Resolution	640 × 480	

- a. The LCD display is manufactured using high precision technology. However, there may be up to six bright points (white, blue, red or green in color) that constantly appear on the LCD screen. These points are normal in the manufacturing process and do not affect the measurement integrity of the product in any way.

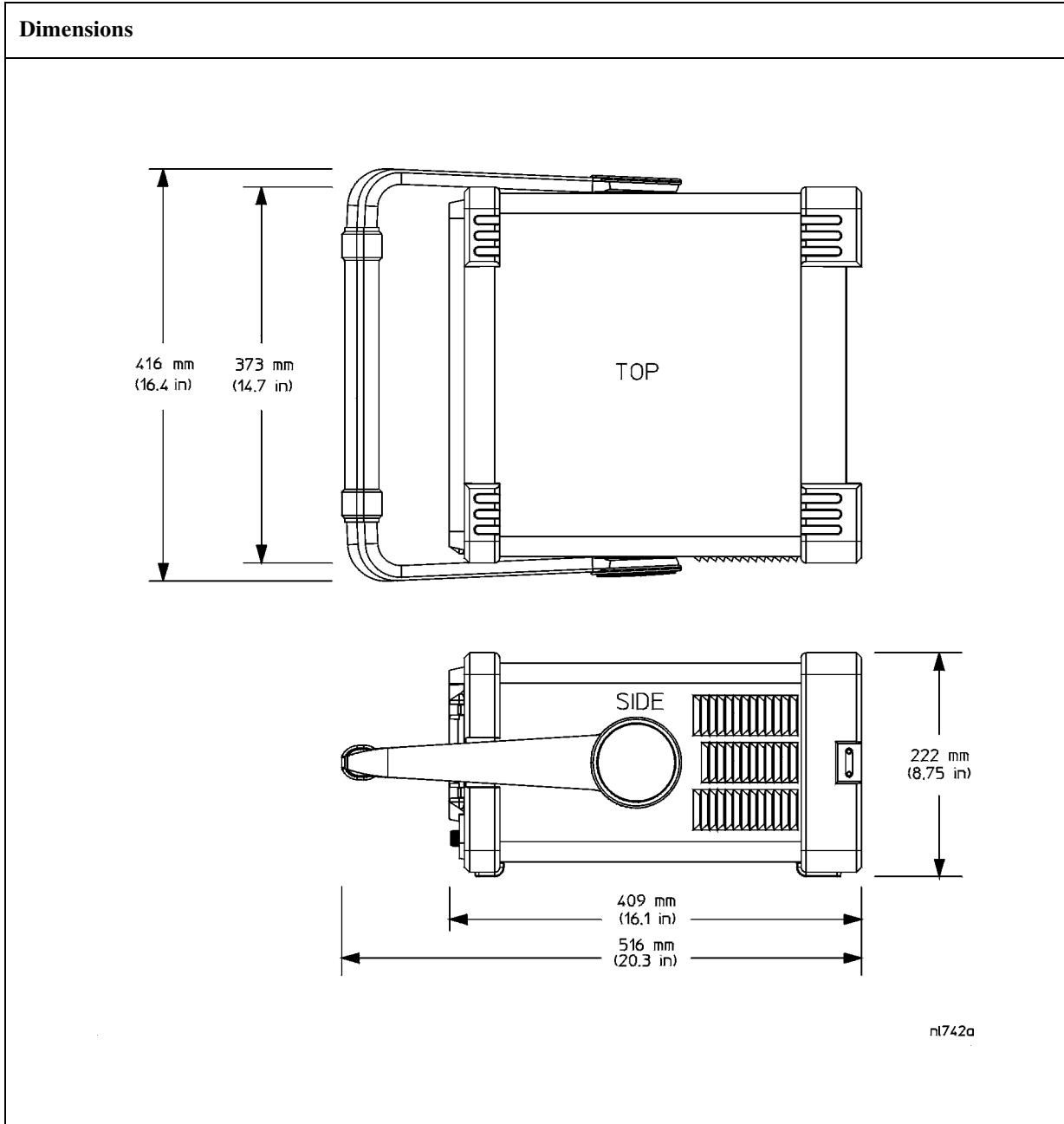

## Inputs and Outputs

### Front Panel

	Specifications	Supplemental Information
<b>INPUT 50 Ω</b>		
Connector	Type-N female	
(Option BAB)	APC 3.5 male	
Impedance		50 Ω, nominal

	Specifications	Supplemental Information
<b>RF OUT 50 Ω, (Option 1DN)</b>		
Connector	Type-N female	
Impedance		50 Ω, nominal

	Specifications	Supplemental Information
<b>AMPTD REF OUT<sup>a</sup></b>		Amplitude Reference
Connector	BNC female	
Impedance		50 Ω, nominal
Frequency		50 MHz
Frequency Accuracy		Frequency reference error <sup>b</sup>
50 Ω Amplitude <sup>c</sup>		-20 dBm, nominal

- a. Turn the amplitude reference on/off by pressing the keys: **Input/Output, Amptd Ref Out**.
- b. Frequency reference error = (aging rate × period of time since adjustment + settability + temperature stability).
- c. The internal amplitude reference actual power is stored internally.

	Specifications	Supplemental Information
<b>PROBE POWER</b>		
Voltage/Current		+15 Vdc, ±7% at 150 mA max., characteristic -12.6 Vdc ±10% at 150 mA max., characteristic

	Specifications	Supplemental Information
<b>EXT KEYBOARD<sup>a</sup></b>		Used for entering screen titles and filenames only. Interface compatible with most IBM-compatible PC keyboards.
Connector	6-pin mini-DIN	

a. The feature is not implemented in firmware revisions prior to A.04.00.

	Specifications	Supplemental Information
<b>Speaker</b>		Front panel knob controls volume

	Specifications	Supplemental Information
<b>Headphone</b>		Front panel knob controls volume
Connector	3.5 mm (1/8 inch) miniature audio jack	
Power Output		0.2 W into 4 $\Omega$ , characteristic

	Specifications	Supplemental Information
<b>IF INPUT (Option AYZ)</b>		
Connector	SMA female	
Impedance		50 $\Omega$ , nominal
Frequency		321.4 MHz, characteristic

	Specifications	Supplemental Information
<b>LO OUTPUT (Option AYZ)</b>		
Connector	SMA female	
Impedance		50 $\Omega$ , nominal, must be terminated with 50 $\Omega$

**Rear Panel**

	Specifications	Supplemental Information
<b>10 MHz REF OUT</b>		
Connector	BNC female	
Impedance		50 Ω, nominal
Output Amplitude		>0 dBm, characteristic

	Specifications	Supplemental Information
<b>10 MHz REF IN</b>		
Connector	BNC female	Note: Analyzer noise sidebands and spurious response performance may be affected by the quality of the external reference used.
Impedance		50 Ω, nominal
Input Amplitude Range		-15 to +10 dBm, characteristic
Frequency		10 MHz, nominal

	Specifications	Supplemental Information
<b>EXT REF IN</b> (Option B7E)		
Connector	BNC, female	
Impedance		50 Ω, nominal
Input amplitude range	-5 to 10 dBm	
Frequency	1 to 30 MHz, selectable	
Frequency lock range	$\pm 5 \times 10^{-6}$ of specified external reference input frequency	



	Specifications	Supplemental Information
<b>10 MHz OUT</b> (Option B7E)		
Connector	BNC, female	
Impedance		50 $\Omega$ , nominal
Frequency		10 MHz, nominal
Level		0 dBm when Option 10 MHz Out is On

	Specifications	Supplemental Information
<b>GATE TRIG/EXT TRIG IN</b>		
Connector	BNC female	
External Trigger Input		
Trigger Level		Selectable positive or negative edge initiates sweep in EXT TRIG mode (5 V TTL)
Gate Trigger Input ( <i>Option 1D6</i> )		
Minimum Pulse Width		>30 ns (5 V TTL)

	Specifications	Supplemental Information
<b>GATE/HI SWP OUT</b>		
Connector	BNC female	
High Sweep Output		
Level		High = sweep <sup>a</sup> ; Low = retrace (5 V TTL)
Gate Output ( <i>Option 1D6</i> )		
Level		High = gate on; Low = gate off (5 V TTL)

a. High sweep may be high longer than the indicated sweep times.

Agilent E4407B Specifications and Characteristics  
Inputs and Outputs

	Specifications	Supplemental Information
<b>VGA OUTPUT</b>		
Connector	VGA compatible, 15-pin mini D-SUB	VGA (31.5 kHz horizontal, 60 Hz vertical sync rates, non-interlaced) Analog RGB
Format		
Resolution	640 × 480	

	Specifications	Supplemental Information
<b>AUX IF OUT</b> <i>(Option A4J or AYX)</i>		RBW ≥ 1 kHz
Connector	BNC female	21.4 MHz, nominal  –10 dBm (uncorrected), characteristic  50 Ω, nominal
Frequency		
Amplitude (for signal at reference level and for reference levels – input attenuation + preamp gain of –10 to –70 dBm)		
Impedance		

	Specifications	Supplemental Information
<b>AUX VIDEO OUT</b> <i>(Option A4J or AYX)</i>		RBW ≥ 1 kHz
Connector	BNC female	0 to 1 V (uncorrected), characteristic
Amplitude Range (into >10 kΩ)		

	Specifications	Supplemental Information
<b>HI SWP IN</b> <i>(Option A4J or AYX)</i>		
Connector	BNC female	Open collector, low resets and holds the sweep (5 V TTL)
Input		

	Specifications	Supplemental Information
<b>HI SWP OUT</b> <i>(Option A4J or AYX)</i>		
Connector	BNC female	

	Specifications	Supplemental Information
Output		High = sweep <sup>a</sup> , Low = retrace (5 V TTL)

a. High sweep may be high longer than the indicated sweep times.

	Specifications	Supplemental Information
<b>SWP OUT</b> (Option A4J or AYZ)		
Connector	BNC female	
Amplitude		0 to +10 V ramp, characteristic

	Specifications	Supplemental Information
<b>PRESEL TUNE OUTPUT</b>		
Connector	BNC female	
Load Impedance (dc coupled)		> 10 k $\Omega$ , nominal
Range		0 to +10 V, characteristic
Sensitivity		
Internal Mixing		0.33 V/GHz of tuned frequency > 3 GHz, characteristic
External Mixing (Option AYZ)		1.5 V/GHz of tuned L.O. frequency, characteristic

	Specifications	Supplemental Information
<b>GPIB Interface (Option A4H)</b>		
Connector	IEEE-488 bus connector	
GPIB Codes		SH1, AH1, T6, SR1, RL1, PP0, DC1, C1, C2, C3 and C28

Agilent E4407B Specifications and Characteristics  
**Inputs and Outputs**

	Specifications	Supplemental Information
<b>Serial Interface</b> ( <i>Option IAX</i> )		
Connector	9-pin D-SUB male	RS-232

	Specifications	Supplemental Information
<b>Parallel Interface</b> ( <i>Option A4H or IAX</i> )		
Connector	25-pin D-SUB female	Printer port only

	Specifications	Supplemental Information
<b>EXT VIDEO IN/TV TRIG OUT<sup>a</sup></b> ( <i>Option B7B or BAA</i> )		
Connector	BNC Female (75 Ω)	EXT VIDEO IN is the Baseband composite video input for TV trigger and picture on screen. TV TRIG OUT is the TV trigger output.
Impedance		75 Ω, nominal
( <i>Option BAA without Option B7B</i> )		Feature not implemented
( <i>Option BAA with Option B7B</i> )		
External Video Input Video Amplitude		1 V <sub>p-p</sub> , nominal, characteristic
TV Trigger Output		Positive edge indicates start of selected TV line after sync. pulse
Amplitude		TTL (0 V and 3.4 V with 75 Ω series resistance), characteristic

- a. This connector is labelled EXT VIDEO IN on older spectrum analyzers and EXT VIDEO IN/TV TRIG OUT on newer spectrum analyzers.



---

## Regulatory Information

---

**CAUTION**

This product is designed for use in Installation Category II and Pollution Degree 2 per IEC 1010 and 664 respectively.

---

**NOTE**

This product has been designed and tested in accordance with accepted industry standards, and has been supplied in a safe condition. The documentation contains information and warnings that must be followed by the user to ensure safe operation and to maintain the product in a safe condition.

---



The CE mark is a registered trademark of the European Community.



The C-Tick mark is a registered trademark of the Australian Spectrum Management Agency.



This ISM device complies with Canadian ICES-001. Cet appareil ISM est conforme a la norme NMB du Canada.

This is also a symbol of an Industrial Scientific and Medical Group 1 Class A product (CISPR 11, Clause 4).



The CSA mark is a registered trademark of the CSA International.



This symbol indicates separate collection for electrical and electronic equipment mandated under EU law as of August 13, 2005. All electric and electronic equipment are required to be separated from normal waste for disposal (Reference WEEE Directive 2002/96/EC).



Indicates the time period during which no hazardous or toxic substance elements are expected to leak or deteriorate during normal use. Forty years is the expected useful life of the product.



This symbol on all primary and secondary packaging indicates compliance to China standard GB 18455-2001.

### Declaration of Conformity

A copy of the Manufacturer's European Declaration of Conformity for this instrument can be obtained by contacting your local Agilent Technologies sales representative.

### Declaration of Compliance

This instrument has been designed and tested in accordance with CAN/CSA 22.2 No. 61010-1-04 & UL Std. No. 61010-1 (2<sup>nd</sup> Edition).