

# **Service Guide**

## **E8356A, E8357A, and E8358A** **Agilent Technologies** **PNA Series** **RF Network Analyzers**



**Agilent Technologies**

**Part Number E8356-90002**

**Printed in USA**  
**June 2004**

Supersedes: March 2004

© Agilent Technologies, Inc. 2000-2001, 2004

---

## **WARRANTY STATEMENT**

THE MATERIAL CONTAINED IN THIS DOCUMENT IS PROVIDED “AS IS,” AND IS SUBJECT TO BEING CHANGED, WITHOUT NOTICE, IN FUTURE EDITIONS. FURTHER, TO THE MAXIMUM EXTENT PERMITTED BY APPLICABLE LAW, AGILENT DISCLAIMS ALL WARRANTIES, EITHER EXPRESS OR IMPLIED WITH REGARD TO THIS MANUAL AND ANY INFORMATION CONTAINED HEREIN, INCLUDING BUT NOT LIMITED TO THE IMPLIED WARRANTIES OF MERCHANTABILITY AND FITNESS FOR A PARTICULAR PURPOSE. AGILENT SHALL NOT BE LIABLE FOR ERRORS OR FOR INCIDENTAL OR CONSEQUENTIAL DAMAGES IN CONNECTION WITH THE FURNISHING, USE, OR PERFORMANCE OF THIS DOCUMENT OR ANY INFORMATION CONTAINED HEREIN. SHOULD AGILENT AND THE USER HAVE A SEPARATE WRITTEN AGREEMENT WITH WARRANTY TERMS COVERING THE MATERIAL IN THIS DOCUMENT THAT CONFLICT WITH THESE TERMS, THE WARRANTY TERMS IN THE SEPARATE AGREEMENT WILL CONTROL.

---

## **DFARS/Restricted Rights Notice**

If software is for use in the performance of a U.S. Government prime contract or subcontract, Software is delivered and licensed as “Commercial computer software” as defined in DFAR 252.227-7014 (June 1995), or as a “commercial item” as defined in FAR 2.101(a) or as “Restricted computer software” as defined in FAR 52.227-19 (June 1987) or any equivalent agency regulation or contract clause. Use, duplication or disclosure of Software is subject to Agilent Technologies’ standard commercial license terms, and non-DOD Departments and Agencies of the U.S. Government will receive no greater than Restricted Rights as defined in FAR 52.227-19(c)(1-2) (June 1987). U.S. Government users will receive no greater than Limited Rights as defined in FAR 52.227-14 (June 1987) or DFAR 252.227-7015 (b)(2) (November 1995), as applicable in any technical data.

---

## **Certification**

Agilent Technologies, Inc. certifies that this product met its published specifications at the time of shipment from the factory. Agilent Technologies, Inc. further certifies that its calibration measurements are traceable to the United States National Institute of Standards and Technology, to the extent allowed by the Institute's calibration facility, and to the calibration facilities of other International Standards Organization members.

---

## Assistance

Product maintenance agreements and other customer assistance agreements are available for Agilent Technologies, Inc. products. For information about these agreements and for other assistance, contact Agilent. Refer to [“Contacting Agilent” on page 2-9](#).

---

## Safety and Regulatory and Information

The safety and regulatory information pertaining to this product is located in [Chapter 1, “Safety and Regulatory Information.”](#)

---

## Safety Notes

The following safety notes are used throughout this manual. Familiarize yourself with each of the notes and its meaning before operating this instrument. All pertinent safety notes for using this product are located in [Chapter 1, “Safety and Regulatory Information.”](#)

---

<b>WARNING</b>	<b>Warning denotes a hazard. It calls attention to a procedure which, if not correctly performed or adhered to, could result in injury or loss of life. Do not proceed beyond a warning note until the indicated conditions are fully understood and met.</b>
----------------	---

---

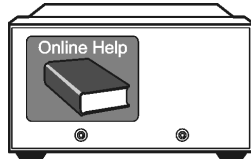
---

<b>CAUTION</b>	Caution denotes a hazard. It calls attention to a procedure that, if not correctly performed or adhered to, could result in damage to or destruction of the instrument. Do not proceed beyond a caution sign until the indicated conditions are fully understood and met.
----------------	---

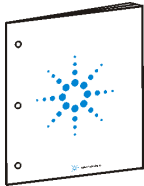
---

---

## Documentation Map



The online Help files are embedded in the analyzer, offering quick reference to programming and user documentation. From the Help drop-down menu, you can access the Help system in five different languages. Also, you can view the Analyzer Product Overview multimedia presentation and access the analyzer's Web page.



The *Installation and Quick Start Guide* helps you to quickly familiarize yourself with the analyzer. Procedures are provided for installing, configuring, and verifying the operation of the analyzer.



The **CD-ROM** provides the following:

- *Installation and Quick Start Guide* (PDF)
- *Service Guide* (PDF)
- Help system
- Network Analyzer Product Overview multimedia presentation

---

## Printing Copies of Documentation on the Web

To print copies of documentation from the Web, download the PDF file from the Agilent web site:

- Go to <http://www.agilent.com>.
- Enter the document's part number (located on the title page) in the **Quick Search** box.
- Click **GO**.

---

# Contents

## 1 Safety and Regulatory Information

Information in This Chapter	1-2
Chapter One at-a-Glance	1-2
Safety Symbols	1-3
General Safety Considerations	1-3
Safety Earth Ground	1-3
Before Applying Power	1-3
Servicing	1-4
Electrostatic Discharge Protection	1-5
Regulatory Information	1-6
Instrument Markings	1-6
Lithium Battery Disposal	1-6
Compliance with Canadian EMC Requirements	1-7
Compliance with German FTZ Emissions Requirements	1-7
Compliance with German Noise Requirements	1-7

## 2 General Product Information

Information in This Chapter	2-2
Chapter Two at-a-Glance	2-2
Maintenance	2-3
Physical Maintenance	2-3
Electrical Maintenance	2-3
Analyzer Options, Upgrades, and Accessories	2-3
Option 006, Extended Frequency Range to 6 GHz	2-3
Option 009, Extended Frequency Range to 9 GHz	2-3
Option 010, Time Domain	2-3
Option 015, Configurable Test Set	2-4
Option 098, Upgraded CPU Board	2-4
Option 099, Firmware Upgrade	2-4
CD-RW Drive	2-4
USB Hub	2-4
Option UK6, Calibration Certificate and Data	2-5
Option 1CM, Rack Mount Flange Kit for Instruments without Handles	2-5
Option 1CP, Rack Mount Flange Kit for Instruments with Handles	2-5
Required Service Test Equipment	2-6
Agilent Support, Services, and Assistance	2-8
Service and Support Options	2-8
Calibration Options	2-8
Contacting Agilent	2-9
Shipping Your Analyzer to Agilent for Service or Repair	2-10

## 3 Tests and Adjustments

Information in This Chapter . . . . .	3-2
Chapter Three at-a-Glance . . . . .	3-2
Before You Begin . . . . .	3-4
Verify the Operating Environment . . . . .	3-4
Protect Against Electrostatic Discharge (ESD) . . . . .	3-4
Allow the Analyzer to Warm Up . . . . .	3-4
Review the Principles of Connector Care . . . . .	3-5
About System Verification and Performance Tests . . . . .	3-6
System Specifications . . . . .	3-6
Instrument Specifications . . . . .	3-6
System Verification Procedure . . . . .	3-7
Performance Tests . . . . .	3-7
Certificate of Calibration . . . . .	3-7
ANSI/NCSL Z540–1–1994 Verification . . . . .	3-8
Non-ANSI/NCSL Z540–1–1994 Verification . . . . .	3-9
Preliminary Checks . . . . .	3-10
The Operator’s Check . . . . .	3-10
The Test Port Cable Checks . . . . .	3-13
System Verification . . . . .	3-20
What the System Verification Verifies . . . . .	3-20
Measurement Uncertainty . . . . .	3-21
Measurement Traceability . . . . .	3-22
Performing System Verification . . . . .	3-23
Performance Tests (Agilent N2721A Software Package) . . . . .	3-30
Source Power Accuracy Test . . . . .	3-30
Source Power Linearity Test . . . . .	3-31
Frequency Accuracy Test . . . . .	3-31
Trace Noise Test . . . . .	3-32
Receiver Compression Test . . . . .	3-32
Noise Floor Test . . . . .	3-33
Calibration Coefficient Test . . . . .	3-34
System Crosstalk Test . . . . .	3-35
Dynamic Accuracy Test . . . . .	3-35
Power Meter Accuracy Test . . . . .	3-37
Adjustments . . . . .	3-42
Source Calibration Adjustment . . . . .	3-43
Receiver Calibration Adjustment . . . . .	3-44
LO Power Adjustment . . . . .	3-46
10 MHz Frequency Reference Adjustment . . . . .	3-47
3.8 GHz PMYO Frequency Adjustment . . . . .	3-48

## 4 Troubleshooting

Information in This Chapter . . . . .	4-2
Chapter Four at-a-Glance . . . . .	4-2
Protect Against Electrostatic Discharge (ESD) . . . . .	4-3
Assembly Replacement Sequence . . . . .	4-3
Getting Started With Troubleshooting . . . . .	4-4
Check the Basics . . . . .	4-4

Troubleshooting Organization . . . . .	4-5
Power Up Troubleshooting. . . . .	4-6
Power Supply Check . . . . .	4-7
If the Fans Are Not Operating . . . . .	4-12
Troubleshooting LCD Display Problems . . . . .	4-13
Creating the Test Setup . . . . .	4-13
Verifying the Inverter Board . . . . .	4-14
Verifying the A3 Front Panel Interface Board Assembly . . . . .	4-16
Front Panel Troubleshooting . . . . .	4-17
A1 Front Panel Keypad and RPG Test. . . . .	4-17
A2 Display Test . . . . .	4-19
A3 Front Panel Interface Board Assembly . . . . .	4-20
Rear Panel Troubleshooting . . . . .	4-21
Checking the USB Port. . . . .	4-21
Checking the SERIAL (RS-232), PARALLEL (1284-C) or VGA Port. . . . .	4-21
Checking the GPIB Port . . . . .	4-22
LAN Troubleshooting . . . . .	4-23
Measurement System Troubleshooting. . . . .	4-27
Verifying the A, B, R1, and R2 Traces . . . . .	4-27
Where to Begin Troubleshooting . . . . .	4-28
Checking the Source Assembly Group. . . . .	4-31
Checking the Signal Separation Group. . . . .	4-41
Checking the Receiver Assembly Group . . . . .	4-45
Instrument Block Diagrams Sheet 1. . . . .	4-49
PNA Series RF Network Analyzers E8356A,E8357A,E8358A. . . . .	4-49
Instrument Block Diagrams Sheet 2. . . . .	4-51
Option 015 E8356A,E8357A,E8358A. . . . .	4-51

## 5 Theory of Operation

Information in This Chapter . . . . .	5-2
Chapter Five at-a-Glance . . . . .	5-2
Network Analyzer System Operation . . . . .	5-3
Functional Groups of the Network Analyzer. . . . .	5-3
Source Group Operation . . . . .	5-5
Band Modes . . . . .	5-5
A8 Fractional-N Synthesizer Board Assembly and A17 LODA . . . . .	5-8
A10 Frequency Reference Board Assembly . . . . .	5-8
A11 Phase Lock Board Assembly . . . . .	5-8
A12 Source Assembly . . . . .	5-9
Rear Panel Interconnects . . . . .	5-9
Signal Separation Group Operation . . . . .	5-10
A22 Switch Splitter. . . . .	5-10
A23 and A24 Test Port Couplers . . . . .	5-10
A25 and A26 70 dB Step Attenuators . . . . .	5-11
Option 015 Configurable Test Set . . . . .	5-12
Receiver Group Operation . . . . .	5-15
A18, A19, A20, and A21 Receiver Modules . . . . .	5-15
A16 Test Set Motherboard Assembly. . . . .	5-15
A6 SPAM Board Assembly (Analog Description) . . . . .	5-21

---

# Contents

Digital Processing and Digital Control Group Operation . . . . .	5-22
Front Panel Subgroup . . . . .	5-22
Data Acquisition and Processing Subgroup . . . . .	5-24
Power Supply Group Operation . . . . .	5-26
<b>6 Replaceable Parts</b>	
Information in This Chapter . . . . .	6-2
Chapter Six at-a-Glance . . . . .	6-2
Ordering Information . . . . .	6-3
Assembly Replacement Sequence . . . . .	6-4
Rebuilt-Exchange Assemblies . . . . .	6-5
Replaceable Parts Listings . . . . .	6-6
Front Panel Assembly . . . . .	6-8
Top Assemblies and Hardware . . . . .	6-10
Bottom Assemblies and Hardware, Standard . . . . .	6-12
Bottom Assemblies and Hardware, Option 015 . . . . .	6-14
Top Cables . . . . .	6-16
Bottom Cables, Standard . . . . .	6-18
Bottom Cables, Option 015 . . . . .	6-20
Internal Hardware and Parts . . . . .	6-22
Hard Disk Drive Assembly . . . . .	6-24
Rear Panel Assembly . . . . .	6-25
External Parts . . . . .	6-26
Miscellaneous Part Numbers . . . . .	6-28
<b>7 Repair and Replacement Procedures</b>	
Information in This Chapter . . . . .	7-2
Chapter Seven at-a-Glance . . . . .	7-2
Assembly Replacement Sequence . . . . .	7-2
Personal Safety Warnings . . . . .	7-3
Electrostatic Discharge (ESD) Protection . . . . .	7-3
Removal and Replacement Procedures . . . . .	7-4
Removing the Covers . . . . .	7-6
Removing and Replacing the Front Panel Assembly . . . . .	7-8
Removing and Replacing Front Panel Subassemblies . . . . .	7-10
Removing and Replacing the Display Inverter Board and the Display Lamp . . . . .	7-12
Removing and Replacing the A4 Power Supply Assembly . . . . .	7-14
Removing and Replacing the A6, A8, and A10 Board Assemblies . . . . .	7-16
Removing and Replacing the A11 Phase Lock Board Assembly . . . . .	7-18
Removing and Replacing the A12 Source Assembly . . . . .	7-20
Removing and Replacing the A14 Motherboard Assembly . . . . .	7-22
Removing and Replacing the A15 CPU Board Assembly . . . . .	7-24
Removing and Replacing the A16 Test Set Motherboard Assembly . . . . .	7-26
Removing and Replacing the A17 Local Oscillator Distribution Assembly (LODA) . . . . .	7-28
Removing and Replacing the A18, A19, A20, and A21 Receiver Module Assemblies . . . . .	7-30
Removing and Replacing the A22 Switch Splitter Assembly . . . . .	7-32
Removing and Replacing the A23 and A24 Test Port Couplers . . . . .	7-34
Removing and Replacing the A25 and A26 70 dB Step Attenuators . . . . .	7-36



---

# Contents

Option 015, Removing and Replacing the A27 and A28 35 dB Step Attenuators . . . . .	7-38
Removing and Replacing the A30 Floppy Disk Drive . . . . .	7-40
Removing and Replacing the A31 Hard Disk Drive Assembly (HDDA) . . . . .	7-42
Copy Unique Files from the Hard Disk . . . . .	7-42
Set Up the Agilent Administrator Password . . . . .	7-46
Install Backup Files onto the New Hard Disk Drive . . . . .	7-47
Post-Repair Procedures. . . . .	7-48
Removing and Replacing the Midweb and the B1 Fan . . . . .	7-49
Reconfiguring the Pinout of the Handler I/O Port . . . . .	7-52
Post-Repair Procedures . . . . .	7-53
<b>A Error Terms</b>	
Information in This Appendix . . . . .	A-2
Appendix A at-a-Glance . . . . .	A-2
Using Error Terms as a Diagnostic Tool . . . . .	A-3
Preventive Maintenance . . . . .	A-3
Troubleshooting. . . . .	A-3
Performing Measurement Calibration . . . . .	A-4
Using Flowgraphs to Identify Error Terms . . . . .	A-4
Accessing Error Terms . . . . .	A-6
Manual Access to Error Terms . . . . .	A-6
Programmatic Access to Error Terms . . . . .	A-7
Typical Error Term Data . . . . .	A-8
If Error Terms Seem Worse than Typical Values . . . . .	A-8
Directivity (EDF and EDR) . . . . .	A-9
Source Match (ESF and ESR) . . . . .	A-10
Load Match (ELF and ELR) . . . . .	A-11
Reflection Tracking (ERF and ERR) . . . . .	A-12
Transmission Tracking (ETF and ETR) . . . . .	A-13
Isolation (EXF and EXR) . . . . .	A-14
<b>B Option Enable Utility</b>	
Information in This Appendix . . . . .	B-2
Appendix B at-a-Glance . . . . .	B-2
Accessing the Option Enable Utility . . . . .	B-3
Enabling or Removing Options . . . . .	B-4
Repairing and Recovering Option Data . . . . .	B-5
Recovery of Data After Repair . . . . .	B-5
Recovery of Data if Option or Model Numbers are Incorrect . . . . .	B-5
Installing or Changing a Serial Number . . . . .	B-6
<b>C Firmware Upgrades</b>	
Information in This Appendix . . . . .	C-2
Appendix C at-a-Glance . . . . .	C-2
Downloading from the Internet . . . . .	C-2
Downloading Using Option 099, Firmware Upgrade . . . . .	C-3
Installation Requirements . . . . .	C-3
Downloading from a USB CD Drive Connected to the Analyzer . . . . .	C-3

---

# Contents

Downloading from a Shared CD Drive Over the LAN .....	C-3
Downloading Over the LAN .....	C-4

## **D Operating System Recovery**

Information in This Appendix .....	D-2
Appendix D at-a-Glance .....	D-2
Overview .....	D-3
System Recovery Procedure .....	D-4
If the Operating System Does Not Boot from the Hard Disk Drive .....	D-5
If the Operating System Does Not Boot from the Floppy Disk Drive .....	D-6

---

# 1 Safety and Regulatory Information

---

## Information in This Chapter

This chapter provides safety information that will help protect you and your network analyzer. It also contains information that is required by various government regulatory agencies.

### Chapter One at-a-Glance

Section Title	Summary of Content	Start Page
<a href="#">Safety Symbols</a>	Descriptions of <b>CAUTION</b> and <b>WARNING</b> symbols used throughout this manual.	<a href="#">Page 1-3</a>
<a href="#">General Safety Considerations</a>	A list of safety points to consider when servicing your network analyzer.	<a href="#">Page 1-3</a>
<a href="#">Electrostatic Discharge Protection</a>	A discussion of electrostatic discharge (ESD) and related recommendations and requirements for ESD protection.	<a href="#">Page 1-5</a>
<a href="#">Regulatory Information</a>	Definitions of instrument markings. Instructions for disposing of the analyzer's lithium battery. Information on compliance with Canadian EMC requirements. Information on compliance with German FTZ emissions requirements. Information on compliance with German noise requirements.	<a href="#">Page 1-6</a>

---

## Safety Symbols

The following safety symbols are used throughout this manual. Familiarize yourself with each of the symbols and its meaning before operating this instrument.

---

**CAUTION** Caution denotes a hazard. It calls attention to a procedure that, if not correctly performed or adhered to, could result in damage to or destruction of the instrument. Do not proceed beyond a caution note until the indicated conditions are fully understood and met.

---

---

**WARNING** Warning denotes a hazard. It calls attention to a procedure which, if not correctly performed or adhered to, could result in injury or loss of life. Do not proceed beyond a warning note until the indicated conditions are fully understood and met.

---

---

## General Safety Considerations

### Safety Earth Ground

---

**WARNING** This is a Safety Class I product (provided with a protective earthing ground incorporated in the power cord). The mains plug shall only be inserted in a socket outlet provided with a protective earth contact. Any interruption of the protective conductor, inside or outside of the instrument, will make the instrument dangerous. Intentional interruption is prohibited.

---

### Before Applying Power

---

**CAUTION** This product is designed for use in Installation Category II and Pollution Degree 2 per IEC 1010 and 664 respectively.

---

---

**CAUTION** Make sure that the analyzer line voltage selector switch is set to the voltage of the power supply and the correct fuse is installed.

---

---

**CAUTION** Always use the three-prong AC power cord supplied with this product. Failure to ensure adequate grounding by not using this cord may cause product damage.

---

---

**CAUTION** If this product is to be energized via an autotransformer make sure the common terminal is connected to the neutral (grounded side of the mains supply).

---

## Servicing

---

**WARNING**     **These servicing instructions are for use by qualified personnel only. To avoid electrical shock, do not perform any servicing unless you are qualified to do so.**

---

**WARNING**     **The opening of covers or removal of parts may expose dangerous voltages. Disconnect the instrument from all voltage sources while it is opened.**

---

**WARNING**     **Danger of explosion if battery is incorrectly replaced. Replace only with the same or equivalent type recommended. Discard used batteries according to manufacturer's instructions.**

---

**WARNING**     **Procedures described in this document may be performed with power supplied to the product while protective covers are removed. Energy available at many points may, if contacted, result in personal injury.**

---

**WARNING**     **The power cord is connected to internal capacitors that may remain live for 5 seconds after disconnecting the plug from its power supply.**

---

**WARNING**     **For continued protection against fire hazard, replace line fuse only with same type and rating. The use of other fuses or material is prohibited.**

---

**WARNING**     **The detachable power cord is the instrument disconnecting device. It disconnects the mains circuits from the mains supply before other parts of the instrument. The front panel switch is only a standby switch and is not a LINE switch (disconnecting device).**

---

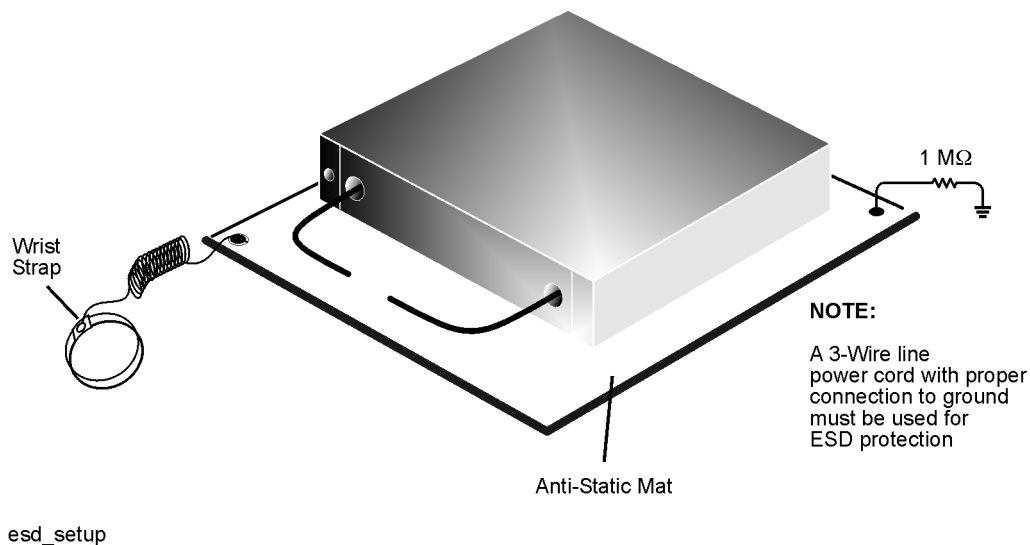
## Electrostatic Discharge Protection

Protection against electrostatic discharge (ESD) is essential while removing assemblies from or connecting cables to the network analyzer. Static electricity can build up on your body and can easily damage sensitive internal circuit elements when discharged. Static discharges too small to be felt can cause permanent damage. To prevent damage to the instrument:

- *always* have a grounded, conductive table mat in front of your test equipment.
- *always* wear a grounded wrist strap, connected to a grounded conductive table mat, having a 1 M $\Omega$  resistor in series with it, when handling components and assemblies or when making connections.
- *always* wear a heel strap when working in an area with a conductive floor. If you are uncertain about the conductivity of your floor, wear a heel strap.
- *always* ground yourself before you clean, inspect, or make a connection to a static-sensitive device or test port. You can, for example, grasp the grounded outer shell of the test port or cable connector briefly.
- *always* ground the center conductor of a test cable before making a connection to the analyzer test port or other static-sensitive device. This can be done as follows:
  1. Connect a short (from your calibration kit) to one end of the cable to short the center conductor to the outer conductor.
  2. While wearing a grounded wrist strap, grasp the outer shell of the cable connector.
  3. Connect the other end of the cable to the test port and remove the short from the cable.

Figure 1-1 shows a typical ESD protection setup using a grounded mat and wrist strap. Refer to “ESD Supplies” on page 6-45 for part numbers.

**Figure 1-1 ESD Protection Setup**



---

## Regulatory Information

This section contains information that is required by various government regulatory agencies.

### Instrument Markings



The instruction documentation symbol. The product is marked with this symbol when it is necessary for the user to refer to the instructions in the documentation.



The CE mark is a registered trademark of the European Community. (If accompanied by a year, it is when the design was proven.)



The CSA mark is a registered trademark of the Canadian Standards Association.

ICES/NMB-001

This is a marking to indicate product compliance with the Canadian Interference-Causing Equipment Standard (ICES-001).

ISM1-A

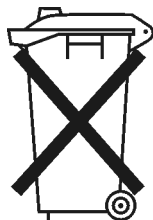
This is a symbol of an Industrial Scientific and Medical Group 1 Class A product.



This is a required mark signifying compliance with an EMC requirement. The C-Tick mark is a registered trademark of the Australian Spectrum Management Agency.

### Lithium Battery Disposal

If the battery on the A15 CPU board assembly needs to be disposed of, dispose of it in accordance with your country's requirements. If required, you may return the battery to Agilent Technologies for disposal. Refer to [“Contacting Agilent” on page 2-9](#) for assistance.



DO NOT THROW BATTERIES AWAY BUT  
COLLECT AS SMALL CHEMICAL WASTE.



## Compliance with Canadian EMC Requirements

This ISM device complies with Canadian ICES-001.  
Cet appareil ISM est conforme a la norme NMB du Canada.

## Compliance with German FTZ Emissions Requirements

This network analyzer complies with German FTZ 526/527 Radiated Emissions and Conducted Emission requirements.

## Compliance with German Noise Requirements

This is to declare that this instrument is in conformance with the German Regulation on Noise Declaration for Machines (Laermangabe nach der Maschinenlaermrerordnung-3. GSGV Deutschland).

Acoustic Noise Emission/Geraeuschemission	
LpA<70 dB	Lpa<70 dB
Operator Position	am Arbeitsplatz
Normal Operation	normaler Betrieb
per ISO 7779	nach DIN 45635 t. 19



---

## **2 General Product Information**

---

## Information in This Chapter

### Chapter Two at-a-Glance

Section Title	Summary of Content	Start Page
<a href="#">Maintenance</a>	Cleaning instructions for the external surfaces of your analyzer. Information about electrical maintenance of your analyzer.	<a href="#">Page 2-3</a>
<a href="#">Analyzer Options, Upgrades, and Accessories</a>	A list of the options and upgrades available for the E8356A, E8357A, and the E8358A network analyzers.	<a href="#">Page 2-3</a>
<a href="#">Required Service Test Equipment</a>	A list of service equipment that is required to perform system verification, performance tests, adjustments, and troubleshooting.	<a href="#">Page 2-6</a>
<a href="#">Agilent Support, Services, and Assistance</a>	The Internet address (URL) for online assistance. Telephone and fax numbers for contacting Agilent for assistance. Service and support options available. Important information about shipping your analyzer to Agilent for service or repair.	<a href="#">Page 2-8</a>

---

## Maintenance

---

**WARNING** To prevent electrical shock, disconnect the analyzer from the mains source before cleaning. Use a dry cloth or one slightly dampened with water to clean the external case parts. Do not attempt to clean internally.

---

### Physical Maintenance

Clean the cabinet, including the front panel, using a dry or slightly damp cloth only.

### Electrical Maintenance

Refer to [“Contacting Agilent” on page 2-9](#) and to [Chapter 3, “Tests and Adjustments.”](#)

---

## Analyzer Options, Upgrades, and Accessories

### Option 006, Extended Frequency Range to 6 GHz

This option extends the high-end frequency of the E8356A network analyzer from 3 GHz to 6 GHz.

This option is also available as an upgrade kit, part number: E8356-60104.

### Option 009, Extended Frequency Range to 9 GHz

This option extends the high-end frequency of the E8356A network analyzer from 3 GHz to 9 GHz or the high-end frequency of the E8357A network analyzer from 6 GHz to 9 GHz.

This option is also available as an upgrade kit, part number: E8356-60105 for the E8356A or E8357-60101 for the E8357A.

### Option 010, Time Domain

An Option 010 analyzer can display the time domain response of a network or test device by calculating the inverse Fourier transform of the frequency domain response. This calculation allows the Option 010 analyzer to show the response of a test device as a function of time or distance. In time domain, the magnitude and location of a discontinuity and the characteristics of individual transmission paths of a network or test device can be determined. Time domain operation retains all accuracy inherent with the active error correction.

This option is also available as an upgrade kit: E8356-60101.

## Option 015, Configurable Test Set

An Option 015 analyzer can be configured to measure high-power devices and devices for high dynamic range.

For a high-power measurement, external amplifiers and high power attenuators or isolators can be added to complete the test setup. In this configuration, test port output power up to 1 Watt (+30 dBm) can be applied to the device under test (DUT). Additionally, there is an external reference input that allows the external amplifier's frequency response and drift to be ratioed out. There are also internal step attenuators between the coupler and the receivers to prevent receiver overload.

For high dynamic range measurements, front panel jumpers are moved to reverse the signal path through one of the couplers. This allows for a 15 dB improvement in transmitted signal sensitivity in one direction only. These jumpers are installed on both ports allowing the user to choose a high dynamic range measurement in either the forward or reverse direction.

This option is also available as an upgrade kit: E8356-60102.

## Option 098, Upgraded CPU Board

This option replaces the standard 266 MHz CPU board with a new 500 MHz CPU board.

This option is also available as an upgrade kit: E8356-60106.

## Option 099, Firmware Upgrade

This upgrade provides the latest revision of firmware for the PNA series RF network analyzers on CD-ROM. This firmware is user installable. The installation requires a USB CD-ROM drive (see “CD-RW Drive” below) or an external computer connected to a Local Area Network (LAN).

This firmware is also available on the Internet at the Agilent website: <http://www.agilent.com/find/pna>. (Select your analyzer's model number in this website to view available upgrades.)

This option is available as an upgrade only: E8356-60103.

## CD-RW Drive

This accessory is an external read/write CD drive with a USB cable.

This accessory can be ordered as model number N4688A.

## USB Hub

This accessory is a 4-port USB hub for connecting additional USB peripheral devices.

This accessory can be ordered as model number N4689A.

## **Option UK6, Calibration Certificate and Data**

This option adds a certificate of calibration and the corresponding calibration data on a 3.5-in floppy disk.

This option is not available as an upgrade. To obtain this data for your analyzer, contact Agilent. Refer to [“Agilent Support, Services, and Assistance”](#) on page 2-8.

## **Option 1CM, Rack Mount Flange Kit for Instruments without Handles**

Option 1CM is a rack mount kit that contains a pair of flanges, rack mount rails, and the necessary hardware to mount the analyzer in an equipment rack with 482.6 mm (19 inches) horizontal spacing. Refer to [Chapter 6, “Replaceable Parts,”](#) for replacement part numbers of individual items.

## **Option 1CP, Rack Mount Flange Kit for Instruments with Handles**

Option 1CP is a rack mount kit that contains a pair of flanges (cut to adapt to handles), rack mount rails, and the necessary hardware to mount the analyzer in an equipment rack with 482.6 mm (19 inches) horizontal spacing. Refer to [Chapter 6, “Replaceable Parts,”](#) for replacement part numbers of individual items.

## Required Service Test Equipment

Equipment	Critical Specifications	Recommended Model or Part Number	Alternate Model Number	Use <sup>a</sup>
<b>Test Instruments and Software</b>				
Frequency counter	Freq: 300 kHz to 9.0 GHz Accuracy : ±0.5 ppm	53131A/32A Opt 010,124	53181A Opt 010,124	P,A,T
Spectrum analyzer	Max Freq: >4 GHz RBW: 300 Hz	8561E	856xE Max freq: >4 GHz	A,T
Power meter	Accuracy: ±0.0068 dB	E4418B/19B <sup>b</sup> Opt G12 or H12 <sup>c</sup>	E4418A/19A <sup>d</sup>	P,A,T
Power sensor	Freq: 300 kHz to 3.0 GHz Range: -30 to +20 dBm	8482A	None	P,A,T
Power sensor	Freq: 3.0 to 9.0 GHz Range: -30 to +20 dBm	E4412A <sup>b</sup>	None	P,A,T
Power sensor cable (2 required)	Compatible with power meter and power sensors.	11730A	None	P,A,T
Dynamic accuracy test set	None	Z5623A Opt H01	None	P
Digital voltmeter	Resolution: 10 mV	Any	Any	T
Oscilloscope	Bandwidth: 100 MHz	Any	Any	T
Printer	N/A	Any printer with Microsoft® Windows® 2000 driver		P
Range calibrator	N/A	11683A	None	P <sup>c</sup>
Test software	N/A	N2721A	None	P

- a. P = Performance tests, A = Adjustments, T = Troubleshooting, V = System Verification
- b. When testing the E8356A, the E4418B power meter can be used and the E4412A power sensor is not needed.
- c. The accuracy of a standard E4418B or E4419B of ±0.02 dB is adequate for all tests except “Dynamic Accuracy Test.” This test requires a power meter with Option G12 or H12 that has been certified to a higher accuracy specification. If an Option G12 or H12 power meter is not available, a test is provided on [page 3-37](#) to verify the accuracy of a standard power meter.
- d. If an accurate measurement of the dynamic accuracy specification is not required, the E4419A (or E4418A for testing the E8356A) can be used.

Microsoft® and Windows® are U.S. registered trademarks of Microsoft Corporation.



Equipment	Critical Specifications	Recommended Model or Part Number	Alternate Model Number	Use <sup>a</sup>
<b>Calibration and Verification Kits</b>				
Type-N calibration kit	Refer to kit specifications	85032F	85033E <sup>b</sup>	P,T,V
Type-N ECal module	Refer to kit specifications	85092B	85093B <sup>b</sup>	T,V
Type-N verification kit	Refer to kit specifications	85055A	85053B <sup>b</sup>	V
<b>Cables</b>				
BNC cable (2 required)	50Ω, 24 inch	8120-1839	None	A
Type-N RF cable (2 required)	50Ω, 24 inch	N6314A	None	P,A,V
GPIB cable	N/A	10833A/B/C/D	None	P,A
<b>Adapters and Accessories<sup>c</sup></b>				
Type-N (male to male)	N/A	1250-0778	None	P
Type-N (female to female)	N/A	1250-0777	None	P,A
BNC (male) to Type-N (female)	N/A	1250-1477	None	P,A
Type-N (female) to 3.5 mm (male)	N/A	1250-1750	None	A,V
<b>Tools and Static Safety Parts</b>				
Extender board	N/A	E8356-60021	None	T
T-10 TORX driver	4, 7, 9 in-lb torque settings	N/A	N/A	T,R
T-20 TORX driver	21 in-lb torque setting	N/A	N/A	T,R
5/16 in open-end wrench	10, 21 in-lb torque settings	N/A	N/A	T,R
Adjustable antistatic wrist strap	N/A	9300-1367	None	P,A,T
Antistatic wrist strap grounding cord (5 foot)	N/A	9300-0980	None	P,A,T
Static control table mat and earth ground wire	N/A	9300-0797	None	P,A,T
Floppy disks	3.5 inch	Any	None	A

- a. P = Performance tests, A = Adjustments, T = Troubleshooting, R = Repair, V = System Verification
- b. The Type-N calibration kit and verification kit are required for performance tests. These 3.5 mm kits can be used for system verification and analyzing the error terms.
- c. Use of some adapters may be necessary if using the alternate 3.5 mm calibration or verification kits.

---

## Agilent Support, Services, and Assistance

Information on the following topics is included in this section.

- [“Service and Support Options”](#)
- [“Calibration Options”](#)
- [“Contacting Agilent”](#)
- [“Shipping Your Analyzer to Agilent for Service or Repair”](#)

### Service and Support Options

The analyzer’s standard warranty is a *one-year return to Agilent Technologies* service warranty.

---

**NOTE** There are many other repair and calibration options available from the Agilent Technologies support organization. These options cover a range of service agreements with varying response times. Contact Agilent for additional information on available service agreements for this product. Refer to [“Contacting Agilent” on page 2-9](#).

---

### Calibration Options

#### Option R-50C-001, Commercial Calibration with Data

This option adds a calibration label, a calibration certificate, and the corresponding calibration data on a 3.5-in floppy disk. This calibration conforms to ISO 9001.

This certificate and data can be obtained by sending your analyzer to Agilent for calibration along with an order for R-50C-001. Refer to [“Shipping Your Analyzer to Agilent for Service or Repair”](#).

#### Option R-50C-002, Standards Compliant Calibration

This option adds calibration label, a calibration certificate, and the corresponding calibration data, measurement uncertainties, and guardbands on all customer specifications on a CD-ROM. This calibration conforms to ISO 17025 and ISO 9001.

This certificate and data can be obtained by sending your analyzer to Agilent for calibration along with an order for R-50C-002. Refer to [“Shipping Your Analyzer to Agilent for Service or Repair”](#).

## Contacting Agilent

By internet, phone, or fax, get assistance with all your test and measurement needs.

<b>Online assistance:</b> <a href="http://www.agilent.com/find/assist">www.agilent.com/find/assist</a>			
<b>Americas</b>			
<b>Brazil</b> <i>(tel)</i> (+55) 11 4197 3700 <i>(fax)</i> (+55) 11 4197 3800	<b>Canada</b> <i>(tel)</i> 888 447 7378 <i>(fax)</i> 905 282 6495	<b>Mexico</b> <i>(tel)</i> 1 800 734 7703 <i>(fax)</i> 1 800 734 7704	<b>United States</b> <i>(tel)</i> 800 829 4444 <i>(alt)</i> (+1) 303 662 3998 <i>(fax)</i> 800 829 4433
<b>Asia Pacific and Japan</b>			
<b>Australia</b> <i>(tel)</i> 1 800 225 574 <i>(alt)</i> 1 800 893 449 <i>(fax)</i> 1 800 681 776 <i>(fax)</i> 1 800 225 539	<b>China</b> <i>(tel)</i> 800 810 0508 <i>(alt)</i> 800 810 0510 <i>(fax)</i> 800 810 0507 <i>(fax)</i> 800 810 0362	<b>Hong Kong</b> <i>(tel)</i> 800 933 229 <i>(fax)</i> 800 900 701	<b>India</b> <i>(tel)</i> 1600 112 929 <i>(alt)</i> 1600 112 626 <i>(fax)</i> 1600 112 727 <i>(fax)</i> 1600 113 040
<b>Japan (Bench)</b> <i>(tel)</i> 0120 32 0119 <i>(alt)</i> (+81) 426 56 7799 <i>(fax)</i> 0120 01 2144	<b>Japan (On-Site)</b> <i>(tel)</i> 0120 802 363 <i>(alt)</i> (+81) 426 56 7498 <i>(fax)</i> (+81) 426 60 8953	<b>Singapore</b> <i>(tel)</i> 1 800 275 0880 <i>(fax)</i> (+65) 6836 0240 <i>(fax)</i> (+65) 6755 1235 <i>(fax)</i> (+65) 6755 1214	<b>South Korea</b> <i>(tel)</i> 080 770 7774 <i>(tel)</i> 080 778 0011 <i>(tel)</i> 080 778 0012 <i>(alt)</i> +65 270 1207 <i>(fax)</i> 080 778 0013 <i>(fax)</i> +82 080 778-0014 <i>(fax)</i> 080 770 7778
<b>Taiwan</b> <i>(tel)</i> 0800 047 661 <i>(tel)</i> 0800 047 669 <i>(fax)</i> 0800 047 667	<b>Thailand</b> <i>(tel)</i> 1 800 2758 5822 <i>(alt)</i> (+66) 259 3442 <i>(fax)</i> 1 800 656 336	<b>Malaysia</b> <i>(tel)</i> 1800 880 399 <i>(fax)</i> 1800 801 054	
<b>Europe</b>			
<b>Austria</b> <i>(tel)</i> 0820 87 44 11* <i>(fax)</i> 0820 87 44 22	<b>Belgium</b> <i>(tel)</i> (+32) (0)2 404 9340 <i>(alt)</i> (+32) (0)2 404 9000 <i>(fax)</i> (+32) (0)2 404 9395	<b>Denmark</b> <i>(tel)</i> (+45) 7013 1515 <i>(alt)</i> (+45) 7013 7313 <i>(fax)</i> (+45) 7013 1555	<b>Finland</b> <i>(tel)</i> (+358) 10 855 2100 <i>(fax)</i> (+358) (0) 10 855 2923
<b>France</b> <i>(tel)</i> 0825 010 700* <i>(alt)</i> (+33) (0)1 6453 5623 <i>(fax)</i> 0825 010 701*	<b>Germany</b> <i>(tel)</i> 01805 24 6333* <i>(alt)</i> 01805 24 6330* <i>(fax)</i> 01805 24 6336*	<b>Ireland</b> <i>(tel)</i> (+353) (0)1 890 924 204 <i>(alt)</i> (+353) (0)1 890 924 206 <i>(fax)</i> (+353) (0)1 890 924 024	<b>Israel</b> <i>(tel)</i> (+972) 3 9288 500 <i>(fax)</i> (+972) 3 9288 501
<b>Italy</b> <i>(tel)</i> (+39) (0)2 9260 8484 <i>(fax)</i> (+39) (0)2 9544 1175	<b>Luxemburg</b> <i>(tel)</i> (+32) (0)2 404 9340 <i>(alt)</i> (+32) (0)2 404 9000 <i>(fax)</i> (+32) (0)2 404 9395	<b>Netherlands</b> <i>(tel)</i> (+31) (0)20 547 2111 <i>(alt)</i> (+31) (0)20 547 2000 <i>(fax)</i> (+31) (0)20 547 2190	<b>Russia</b> <i>(tel)</i> (+7) 095 797 3963 <i>(alt)</i> (+7) 095 797 3900 <i>(fax)</i> (+7) 095 797 3901
<b>Spain</b> <i>(tel)</i> (+34) 91 631 3300 <i>(alt)</i> (+34) 91 631 3000 <i>(fax)</i> (+34) 91 631 3301	<b>Sweden</b> <i>(tel)</i> 0200 88 22 55* <i>(alt)</i> (+46) (0)8 5064 8686 <i>(fax)</i> 020 120 2266*	<b>Switzerland (French)</b> <i>(tel)</i> 0800 80 5353 opt. 2* <i>(alt)</i> (+33) (0)1 6453 5623 <i>(fax)</i> (+41) (0)22 567 5313	<b>Switzerland (German)</b> <i>(tel)</i> 0800 80 5353 opt. 1* <i>(alt)</i> (+49) (0)7031 464 6333 <i>(fax)</i> (+41) (0)1 272 7373
<b>Switzerland (Italian)</b> <i>(tel)</i> 0800 80 5353 opt. 3* <i>(alt)</i> (+39) (0)2 9260 8484 <i>(fax)</i> (+41) (0)22 567 5314	<b>United Kingdom</b> <i>(tel)</i> (+44) (0)7004 666666 <i>(alt)</i> (+44) (0)7004 123123 <i>(fax)</i> (+44) (0)7004 444555		
<i>(tel)</i> = primary telephone number; <i>(alt)</i> = alternate telephone number; <i>(fax)</i> = FAX number; * = in country number			

## Shipping Your Analyzer to Agilent for Service or Repair

---

**IMPORTANT** Agilent Technologies reserves the right to reformat or replace the internal hard disk drive in your analyzer as part of its repair. This will erase all user information stored on the hard disk. It is imperative, therefore, that you make a backup copy of your critical test data located on the analyzer's hard disk before shipping it to Agilent for repair.

---

If you wish to send your network analyzer to Agilent Technologies for service or repair:

- Include a complete description of the service requested or of the failure and a description of any failed test and any error message.
- Ship the analyzer using the original or comparable antistatic packaging materials.
- Contact Agilent for instructions on where to ship your analyzer. Refer to [“Contacting Agilent”](#) on page 2-9.

---

## **3 Tests and Adjustments**

---

## Information in This Chapter

This chapter contains procedures to help you check, verify, and adjust your PNA series RF network analyzer.

- The checks verify the operation of the assemblies in your analyzer.
- The verification compares the operation of your analyzer to a gold standard.
- The adjustments allow you to tune your analyzer for maximum response.

---

**NOTE** A description of the performance tests in the Agilent N2721A software package is included in this chapter. The Agilent N2721A software package must be purchased separately.

---

## Chapter Three at-a-Glance

Section Title	Summary of Content	Start Page
<a href="#">Before You Begin</a>	Items to consider or procedures to perform before testing is begun: <ul style="list-style-type: none"><li>• <a href="#">Verify the Operating Environment</a></li><li>• <a href="#">Protect Against Electrostatic Discharge (ESD)</a></li><li>• <a href="#">Allow the Analyzer to Warm Up</a></li><li>• <a href="#">Review the Principles of Connector Care</a></li></ul>	<a href="#">Page 3-4</a>
<a href="#">About System Verification and Performance Tests</a>	Descriptions of: <ul style="list-style-type: none"><li>• <a href="#">System Specifications</a></li><li>• <a href="#">Instrument Specifications</a></li><li>• <a href="#">System Verification Procedure</a></li><li>• <a href="#">Performance Tests</a></li><li>• <a href="#">Certificate of Calibration</a></li></ul>	<a href="#">Page 3-6</a>
<a href="#">ANSI/NCSL Z540-1-1994 Verification</a>	The ANSI/NCSL Z540-1-1994 process of verifying your analyzer.	<a href="#">Page 3-8</a>
<a href="#">Non-ANSI/NCSL Z540-1-1994 Verification</a>	The non-ANSI/NCSL Z540-1-1994 process of verifying your analyzer.	<a href="#">Page 3-9</a>

Section Title	Summary of Content	Start Page
Preliminary Checks	Performing the operator's check. Checking your test cables. <i>Perform these checks before performing system verification.</i>	Page 3-10
System Verification	What the system verification does. How to perform the verification test. How to interpret the results.	Page 3-20
Performance Tests (Agilent N2721A Software Package) <sup>1</sup>	A brief summary of each performance test in the Agilent N2721A software package: <ul style="list-style-type: none"> <li>• Source Power Accuracy Test</li> <li>• Source Power Linearity Test</li> <li>• Frequency Accuracy Test</li> <li>• Trace Noise Test</li> <li>• Receiver Compression Test</li> <li>• Noise Floor Test</li> <li>• Calibration Coefficient Test</li> <li>• System Crosstalk Test</li> <li>• Dynamic Accuracy Test</li> </ul>	Page 3-30
Adjustments	Setups and procedures for adjusting your analyzer: <ul style="list-style-type: none"> <li>• Source Calibration Adjustment</li> <li>• Receiver Calibration Adjustment</li> <li>• LO Power Adjustment</li> <li>• 10 MHz Frequency Reference Adjustment</li> <li>• 3.8 GHz PMYO Frequency Adjustment</li> </ul>	Page 3-42

1. The Agilent N2721A software package must be purchased separately.

---

## Before You Begin

Before checking, verifying, or adjusting the analyzer, refer to the following paragraphs to:

- make sure the operating environment is within its requirements
- make sure that proper electrostatic discharge (ESD) protection is provided
- make sure the analyzer has warmed up properly to achieve system stability
- review the principles of connector care

## Verify the Operating Environment

Due to their operating specifications, the verification and calibration kit devices determine your operating environment conditions. Open the calibration and verification kits and place all the devices on top of the foam inserts so they will reach room temperature. As the device dimensions change with temperature, their electrical characteristics change as well. It is necessary to keep the environmental levels within the following limits:

- Temperature:  $+25\text{ }^{\circ}\text{C} \pm 5\text{ }^{\circ}\text{C}$

Once the measurement calibration has been done, the ambient temperature must be maintained to within  $\pm 1\text{ }^{\circ}\text{C}$  of the calibration temperature.

- Humidity: 0 to 80% at 26 °C maximum

## Protect Against Electrostatic Discharge (ESD)

This is important. If not properly protected against, electrostatic discharge can seriously damage your analyzer, resulting in costly repair.

---

**CAUTION** To reduce the chance of electrostatic discharge, follow all of the recommendations outlined in [“Electrostatic Discharge Protection”](#) on page 1-5, for all of the procedures in this chapter.

---

## Allow the Analyzer to Warm Up

---

**NOTE** To achieve the maximum system stability, allow the analyzer to warm up for at least 90 minutes.

---



## Review the Principles of Connector Care

Proper connector care and connection technique are critical for accurate and repeatable measurements. Refer to [Table 3-1](#) for tips on connector care.

Prior to making connections to your analyzer, carefully review the information about inspecting, cleaning, and gaging connectors. Refer to the calibration kit documentation for detailed connector care information.

For course numbers about additional connector care instruction, contact Agilent Technologies. Refer to [“Contacting Agilent” on page 2-9](#).

**Table 3-1 Connector Care Quick Reference Guide**

Handling and Storage	
<b>Do</b> <ul style="list-style-type: none"> <li>• Keep connectors clean</li> <li>• Extend sleeve or connector nut</li> <li>• Use plastic end-caps during storage</li> </ul>	<b>Do Not</b> <ul style="list-style-type: none"> <li>• Touch mating-plane surfaces</li> <li>• Set connectors contact-end down</li> </ul>
Visual Inspection	
<b>Do</b> <ul style="list-style-type: none"> <li>• Inspect all connectors carefully</li> <li>• Look for metal particles, scratches, and dents</li> </ul>	<b>Do Not</b> <ul style="list-style-type: none"> <li>• Use a damaged connector - ever</li> </ul>
Connector Cleaning	
<b>Do</b> <ul style="list-style-type: none"> <li>• Try compressed air first</li> <li>• Use isopropyl alcohol</li> <li>• Clean connector threads</li> </ul>	<b>Do Not</b> <ul style="list-style-type: none"> <li>• Use any abrasives</li> <li>• Get liquid into plastic support beads</li> </ul>
Gaging Connectors	
<b>Do</b> <ul style="list-style-type: none"> <li>• Clean and zero the gage before use</li> <li>• Use the correct gage type</li> <li>• Use correct end of calibration block</li> <li>• Gage all connectors before first use</li> </ul>	<b>Do Not</b> <ul style="list-style-type: none"> <li>• Use an out-of-specification connector</li> </ul>
Making Connections	
<b>Do</b> <ul style="list-style-type: none"> <li>• Align connectors carefully</li> <li>• Make preliminary connection contact lightly</li> <li>• Turn only the connector nut</li> <li>• Use a torque wrench for final connection</li> </ul>	<b>Do Not</b> <ul style="list-style-type: none"> <li>• Apply bending force to connection</li> <li>• Over tighten preliminary connection</li> <li>• Twist or screw any connection</li> <li>• Tighten past torque wrench “break” point</li> </ul>

---

## About System Verification and Performance Tests

The performance of the network analyzer is specified in two ways: system specifications, and instrument specifications. Respectively, the analyzer's conformance to these specifications is verified in two ways: system verification, and performance tests.

### System Specifications

System specifications specify warranted performance of the measurement system when making error-corrected measurements. The measurement system includes the analyzer, test cables, and calibration kit.

The analyzer's system specifications are described in the *Agilent PNA Series Network Analyzer Data Sheet* and also in the analyzer's on-line help system.

System specifications are included in section titled "Corrected System Performance."

System specifications are expressed in two ways:

- residual errors of the measurement system
- graphs of measurement uncertainty versus reflection and transmission coefficients

System specifications are applicable when the measurement system is used to make error-corrected measurements.

System specifications are verified in one of the following ways:

- Complete the system verification procedure using a certified verification kit, or
- Complete all of the performance tests and certify (or recertify) the calibration kit that will be used for future measurements. This alternative verifies both the system specifications and the instrument specifications for the analyzer.

### Instrument Specifications

Instrument specifications specify the network analyzer's uncorrected measurement port characteristics and its output and input behavior.

The analyzer's instrument specifications are described in the *Agilent PNA Series Network Analyzer Data Sheet* and also in the analyzer's on-line help system. The sections that describe instrument specifications are titled:

- "Uncorrected System Performance"
- "Test Port Output"
- "Test Port Input"

These specifications apply when the analyzer is used to make measurements other than error-corrected measurements. An example would be the measurement of amplifier gain compression.

Performance tests are used to confirm that the analyzer meets the instrument specifications.

## System Verification Procedure

The system verification procedure tests the network analyzer measurement system, as defined previously, against the system specifications. If confirmation is successful, the measurement system is capable of making measurements to the accuracy specified by the graphs of measurement uncertainty.

An illustrated outline of the system verification procedure:

- for ANSI/NCSL Z540-1-1994 verification, is shown in [Figure 3-1 on page 3-8](#).
- for non-ANSI/NCSL Z540-1-1994 verification, is shown in [Figure 3-2 on page 3-9](#).

---

**NOTE** Calibration kits are different from verification kits. Calibration kits are used to determine the systematic errors of a network analyzer measurement system. Verification kits are used to confirm system specifications and are not used to generate error correction.

---

## Performance Tests

Performance tests are used to confirm analyzer performance against the instrument specifications. If confirmation is successful, the analyzer meets the instrument specifications.

If the calibration kit to be used for measurements is also certified, successful completion of the performance tests also ensures that the network analyzer measurement system meets the system specifications.

## Certificate of Calibration

Agilent Technologies will issue a certificate of calibration for the product upon successful completion of system verification or completion of the performance tests. The certificate of calibration will include a “System Attachment” if the system verification procedure is used to confirm the system specifications. If the performance tests are used to confirm instrument specifications, the certificate of calibration will not include a system attachment. The equipment and measurement standards used for the tests must be certified and must be traceable to recognized standards.

---

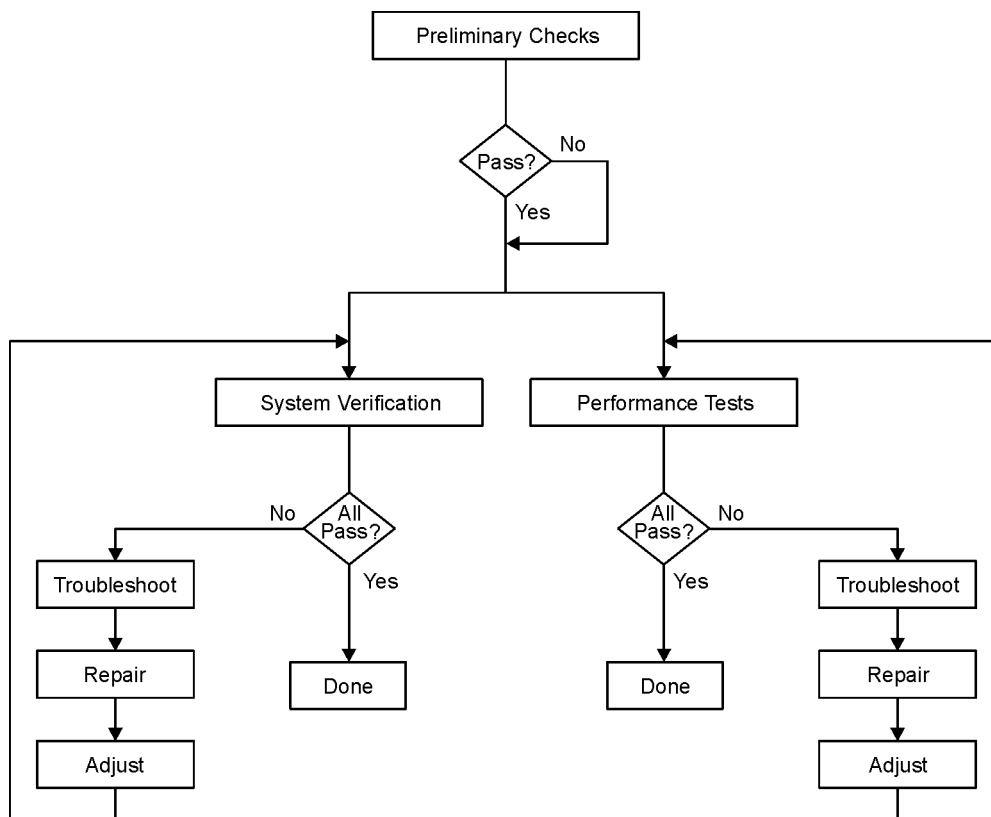
**NOTE** If you have a measurement application that does not use all of the measurement capabilities of the analyzer, you may ask your local Agilent Technologies service office to verify only a subset of the specifications. However, this creates the possibility of making inaccurate measurements if you then use the analyzer in an application requiring additional capabilities.

---

## ANSI/NCSL Z540-1-1994 Verification

To meet the criteria for ANSI/NCSL Z540-1-1994, perform the preliminary checks and either system verification or performance tests *without stopping to repair or adjust*<sup>1</sup>. Refer to [Figure 3-1](#) for test flow. Print data at the completion of all the tests, even if you are aware that the analyzer did not pass. If there is a failure, complete the verification before you troubleshoot, repair, and adjust. After the failure has been corrected, repeat the entire system verification or performance tests and generate a new set of data.

**Figure 3-1** ANSI/NCSL Z540-1-1994 Test Path Verification Flowchart



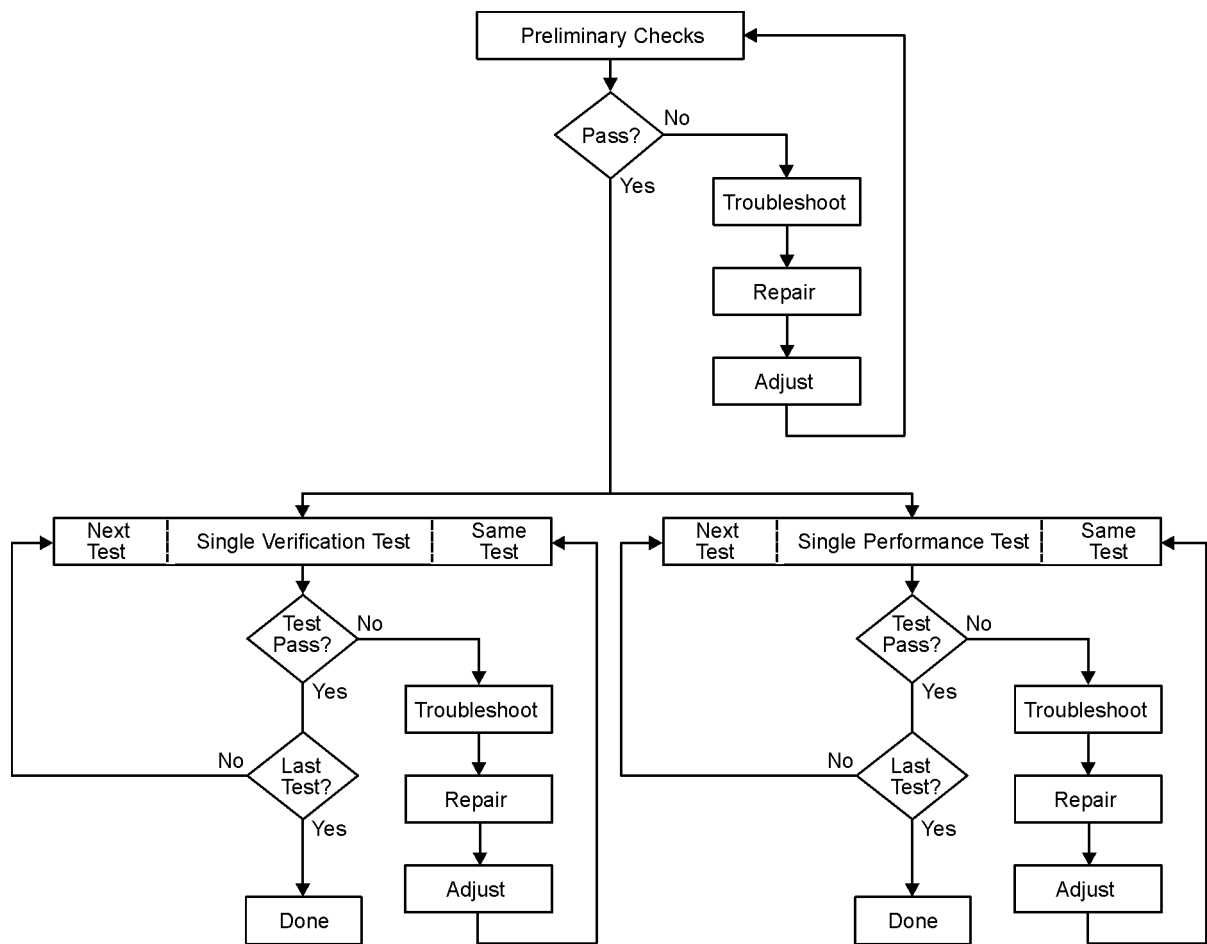
sc870a

1. Stop only in case of a catastrophic failure or cable connector damage

## Non-ANSI/NCSL Z540-1-1994 Verification

For non-ANSI/NCSL Z540-1-1994, perform the preliminary checks and either the system verification or performance tests while *stopping to troubleshoot*. Refer to [Figure 3-2](#) for test flow. Troubleshoot and repair the first problem encountered without continuing to other tests. After you troubleshoot, repair, and adjust, repeat the *last failed* portion and generate a new set of data. Print out the system verification results or complete the performance test record as the analyzer passes each test.

**Figure 3-2 Non-ANSI/NCSL Z540-1-1994 Test Path Verification Flowchart**



sc869a

---

## Preliminary Checks

Preliminary checks include the following:

- “The Operator’s Check” on page 3-10  
The operator’s check tests the network analyzer’s basic functionality of the source, switch, step attenuators, and receivers.
- “The Test Port Cable Checks” on page 3-13  
The test port cable checks are not required, but are recommended to verify the performance of the test port cables before performing the verification test.

### The Operator’s Check

---

**NOTE** To achieve the maximum system stability, allow the analyzer to warm up for at least 90 minutes before performing the Operator’s Check.

---

The operator’s check is a software driven test that checks the basic operation of the assemblies in the Port 1 and Port 2 paths. By performing the operator’s check, the following is determined:

- operation of the transfer switch (switch repeatability check)
- phase-lock capability across the entire frequency band (switch repeatability check)
- function of the four receivers (switch repeatability check)
- operation of the step attenuators (attenuator range check)
- receivers’ linearity (attenuator range check)

### Switch Repeatability Check

The check performs a reflection measurement of a short and stores the resulting trace in memory. The transfer switch is toggled to the opposite port and back, and then another reflection measurement is made. The difference between the stored trace and the return trace is the switch repeatability. This test also checks the phase lock across the entire frequency band and operation of all four receivers.

### Attenuator Range Check

This check performs a reflection measurement of a short and stores the resulting trace in memory. As the internal attenuator is switched in 10 dB steps over its 70 dB range, reflection measurements are made and compared with the stored trace. The resulting measurements must fall within a limit testing window to pass the test. The window size is based on source and receiver specifications. By performing the Port 1 and Port 2 tests, rough checks of the linearity for all four receivers (from 0 dB to 70 dB) are verified and operation of the attenuator is verified.

### Accessories Used in the Operator's Check

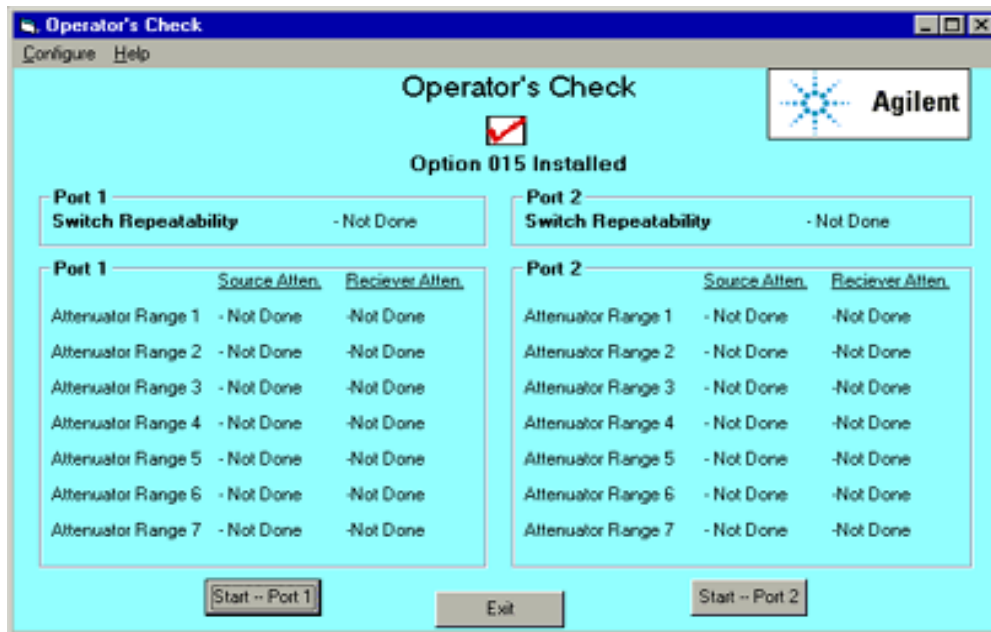
Equipment Type	Part Number
Male short, type-N <sup>1</sup>	85032-60016 (from the 85032F calibration kit)

1. Alternate choice: 3.5 mm short from 3.5 mm 85033E calibration kit and type-N to 3.5 mm adapter.

### Performing the Operator's Check

1. From the **System** menu, point to **Service**, and then click **Operator's Check**.
2. In the **Operator's Check** dialog box (refer to [Figure 3-3](#)), click **Configure**, and then select either **Automatic**, to run through the test without stopping, or **Prompted**, to pause at each step in the test process.
3. To check Port 1, click **Start--Port 1** or to check Port 2, click **Start--Port 2**.
4. The test will prompt you to connect the short.
5. The result of the operator's check will be shown as a PASS or FAIL next to the test.

**Figure 3-3 Operator's Check Dialog Box**



### If the Operator's Check Fails

1. Clean the test ports, shorts, and adapters. Torque to specification. Repeat the check.
2. If the check still fails, suspect a faulty component:
  - A repeated failure in the switch repeatability for both the Port 1 and Port 2 checks indicates a faulty A22 RF switch splitter. Refer to [“Removing and Replacing the A22 Switch Splitter Assembly”](#) on page 7-32.

- A repeated failure in *any* of the ranges of the attenuator check indicates a faulty step attenuator.
  - If the Port 1 check fails, the A25 step attenuator may be faulty.
  - If the Port 2 check fails, the A26 step attenuator may be faulty.Refer to [“Removing and Replacing the A25 and A26 70 dB Step Attenuators”](#) on page 7-36.
- If *all* ranges of the attenuator check fail, suspect a loose connection on the step attenuator control cable.
  - If the Port 1 check fails, check the A25 step attenuator cable.
  - If the Port 2 check fails, check the A26 step attenuator cable.



## The Test Port Cable Checks

A faulty test port cable can cause a failure in the verification test. The following checks are not required, but are recommended to verify the performance of the test port cable.

- “Cable Return Loss Check” on page 3-14
- “Cable Insertion Loss Check” on page 3-15
- “Cable Magnitude and Phase Stability Check” on page 3-16
- “Cable Connector Repeatability Check” on page 3-18

### Accessories Used in the Test Port Cable Checks

Equipment Type	Part Number	Alternate Part Number
RF cable, type-N	N6314A	See “Cable Substitution” on page 3-23.
Calibration kit	85032F (type-N)	85033E (3.5 mm) <sup>1</sup>

1. Use of this alternate will require the use of adapters.

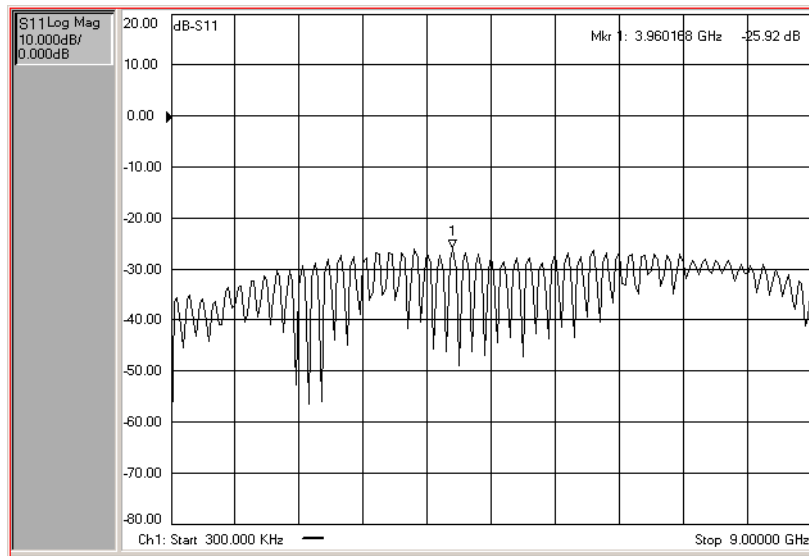
### Cable Return Loss Check

1. Press **Preset**.
2. Perform a one-port calibration on Port 1, **1-Port Reflection**. Refer to the embedded help in the analyzer if necessary.
3. Connect the test port cable to Port 1. Connect a broadband load to the other end of the cable. Tighten to the specified torque for the connector type.

The analyzer now displays the return loss of the cable.

4. From the **Marker** menu, click **Marker Search**. In the **Marker Search** dialog box, in the **Search Type** box, make sure **Maximum** is selected. Click **Execute**, and then click **OK**.
5. The marker annotation on the screen indicates the worst case return loss. Refer to the cable manual to see if it meets the return loss specification. For an example of a typical return loss measurement, see [Figure 3-4](#).

**Figure 3-4 Typical Cable Return Loss Response**



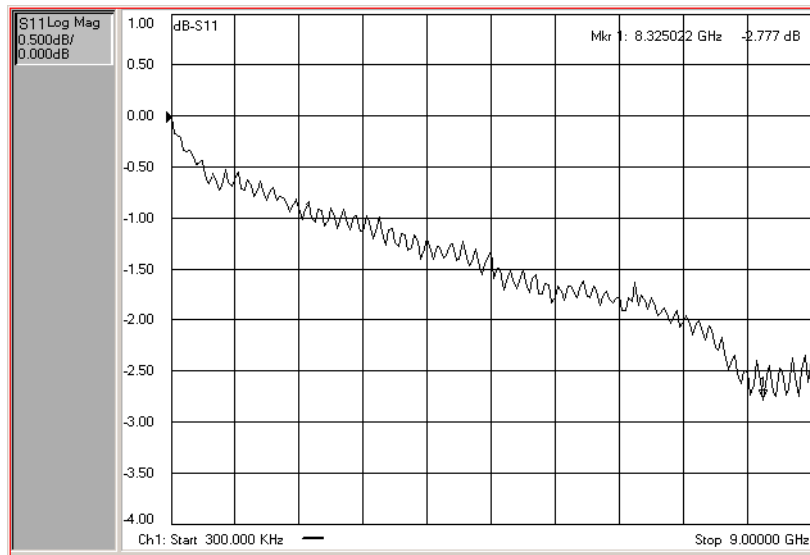
### If the Cable Return Loss Check Fails

1. Clean the cable and devices and torque to specification. Repeat the check.
2. If the check still fails, the cable should be repaired or replaced.

### Cable Insertion Loss Check

1. Keep the test port cable connected to Port 1.
2. Connect a short to the end of the cable.
3. From the **Marker** menu, click **Marker Search**. In the **Marker Search** dialog box, in the **Search Type** box, select **Minimum**. Click **Execute**, and then click **OK**.
4. The displayed response is twice the actual loss. To get the actual worst case insertion loss, divide the value at the marker annotation by two. Refer to the cable manual to see if it meets the insertion loss specification. For an example of a typical insertion loss measurement, see [Figure 3-5](#).

**Figure 3-5 Typical Cable Insertion Loss Response**



### If the Cable Insertion Loss Check Fails

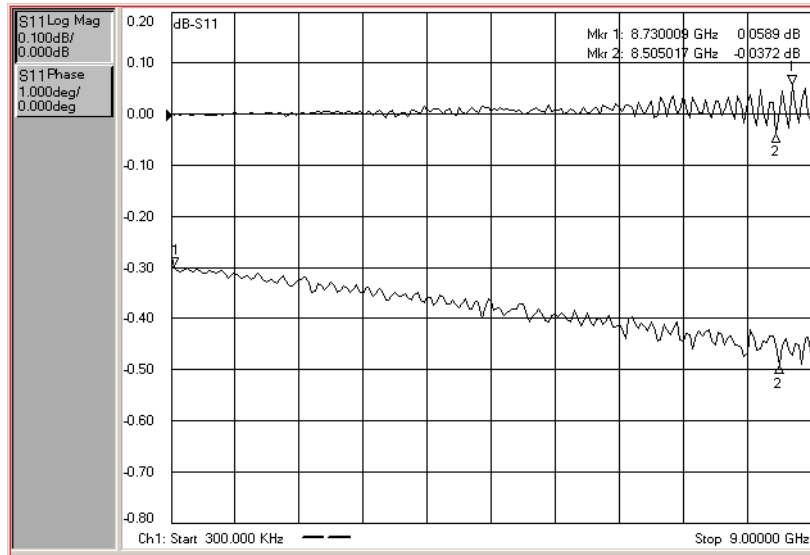
1. Clean the cable and devices and torque to specification. Repeat the check.
2. If the check still fails, the cable should be repaired or replaced.

### Cable Magnitude and Phase Stability Check

1. Keep the cable connected to Port 1, then connect a short to the end of the cable.
2. Press **Preset**.
3. On the **Trace** menu, click **New Trace**. In the **New Trace** dialog box, click the **S11** box, and then click **OK**.
4. On the **Trace** menu, click **Format**. In the **Format** dialog box, click **Phase**, and then click **OK**.
5. On the **Channel** menu, click **Average**. In the **Average** dialog box, click the **Average ON** check box. In the **Average Factor** box, type 50 or click the arrows to select 50, and then click **OK**.
6. To provide a good reference, hold the test cable in a straight line perpendicular to the front panel of the network analyzer.
7. On the **Channel** menu, click **Restart Avg**.
8. Wait for the analyzer to average the measurement 50 times (approximately two seconds).
9. To normalize the data trace:
  - a. On the **Trace** menu, click **Math/Memory**.
  - b. In the **Math/Memory** dialog box, click the **Data->Memory** button.
  - c. In the **Data Math** list, select **Data/Memory**.
  - d. Under **Trace View Options**, make sure **Data Trace** is selected.
  - e. Click **OK**
10. Slowly make a 180 degree bend in the middle of the cable and hold it in that position.
11. For each trace: On the **Scale** menu, set the **Scale Per Division** for optimum viewing as shown in [Figure 3-6](#).
12. Place a marker on the largest deflection that goes above the reference line and is within the cable's specified frequency range. For a typical response of cable magnitude and phase stability, see [Figure 3-6](#).
13. Place a marker on the largest deflection that goes below the reference line and is within the cable's specified frequency range.

In this  $S_{11}$  measurement, the displayed trace results from energy being propagated down the cable and reflected back from the short. Therefore, the measured deflection value must be divided in half to reach the correct value.

**Figure 3-6 Typical Cable Magnitude and Phase Stability Response**



**If the Cable Magnitude and Phase Stability Check Fails**

1. Clean the cable and devices and torque to specification. Repeat the check.
2. If the check still fails, the cable should be repaired or replaced.

## Cable Connector Repeatability Check

---

**NOTE** The connector repeatability measurement should be done at the test port as well as at the end of the test port cable.

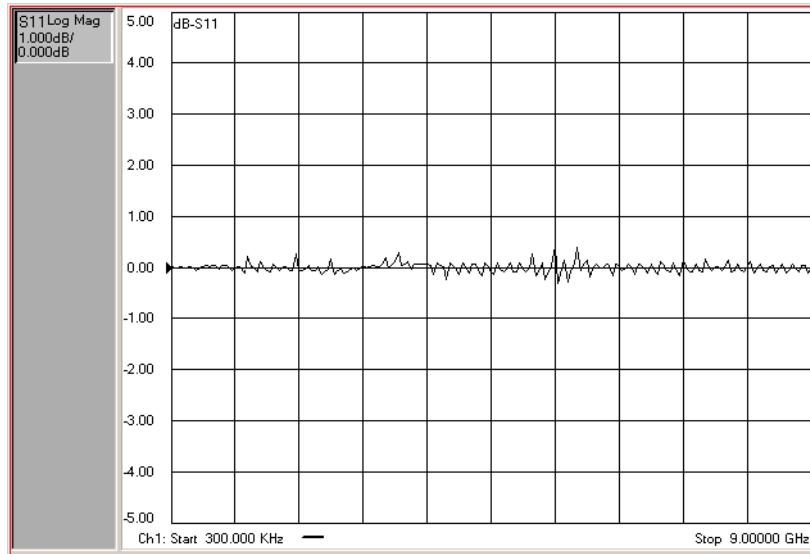
---

1. With the test port cable still connected to Port 1, connect a broadband load to the other end of the cable.
2. Press **Preset**.
3. On the **Channel** menu, click **Average**. In the **Average** dialog box, click the **Average ON** check box. In the **Average Factor** box, type 100 or click the arrows to select 100. Click **OK**.
4. Wait for the analyzer to average the measurement 100 times (approximately five seconds).
5. To normalize the data trace:
  - a. On the **Trace** menu, click **Math/Memory**.
  - b. In the **Math/Memory** dialog box, click the **Data->Memory** button.
  - c. In the **Data Math** list, select **Data/Memory**.
  - d. Under **Trace View Options**, make sure **Data Trace** is selected.
  - e. Click **OK**
6. To adjust the display scale:
  - a. On the **Scale** menu, click **Scale**.
  - b. In the **Scale Per Division** box, click the arrow to select **0.5 dB**.
  - c. In the **Level** box under **Reference** click the arrow to select **0 dB**.
  - d. Click **OK**.
7. Disconnect and then reconnect the cable to the test port. Tighten the connection to the specified torque for the connector type.
8. On the **Channel** menu, click **Restart Avg**.
9. Look at the trace for spikes or modes.
10. To re-normalize the data trace of the reconnected cable:
  - a. On the **Trace** menu, click **Math/Memory**.
  - b. In the **Math/Memory** dialog box, click the **Data->Memory** button.
  - c. Click **OK**.
11. Repeat steps 7 through 9 at least three times to look for modes. (Modes appear when a harmonic of the source fundamental frequency is able to propagate through the cable or connector). It is helpful to print a plot of the trace each time to compare several connections. If any mode appears each time the cable is connected and reconnected, measurement integrity will be affected.

For a typical response of cable connector repeatability, see [Figure 3-7](#).

12. For the Port 2 Check, connect the cable to Port 2 and repeat steps 2 through 11.

**Figure 3-7 Typical Cable Connector Repeatability Response**



**If the Cable Connector Repeatability Check Fails**

1. Clean the cable and devices, and torque to specification. Repeat the check.
2. If the check still fails, the cable should be repaired or replaced.

---

## System Verification

System verification is used to verify system-level, error-corrected uncertainty limits for network analyzer measurements. The verification procedure is automated and is contained in the firmware of the analyzer.

The device data provided with the verification kit has a traceable path to a national standard. The difference between the supplied traceable data and the measured data must fall within the total uncertainty limits at all frequencies for the system verification to pass.

The total measurement uncertainty limits for the system verification are the sum of the factory measurement uncertainties for the verification devices and the uncertainties associated with the system being verified. You can determine your system measurement uncertainty limits by referring to the analyzer embedded on-line help.

---

**IMPORTANT** Passing this system verification does not guarantee that the analyzer meets all of its performance specifications. However, it does show that the network analyzer being verified measures the same devices with the same results as a factory system which has had all of its specifications verified and its total measurement uncertainty minimized.

---

### What the System Verification Verifies

The system verification procedure verifies proper operation of the:

- network analyzer
- calibration kit
- test port cables

---

**NOTE** Additional equipment or accessories used with the above system are not verified by system verification.

---



## Measurement Uncertainty

Measurement uncertainty is defined as the sum of:

- the residual systematic (repeatable) errors, and
- the random (non-repeatable) errors

in the measurement system after calibration.

The systematic errors are:

- directivity,
- source match,
- load match,
- reflection and transmission frequency tracking, and
- isolation (crosstalk).

The random errors include:

- noise,
- drift,
- connector repeatability, and
- test cable stability.

A complete description of system errors and how they affect measurements is provided in the analyzer's on-line embedded help.

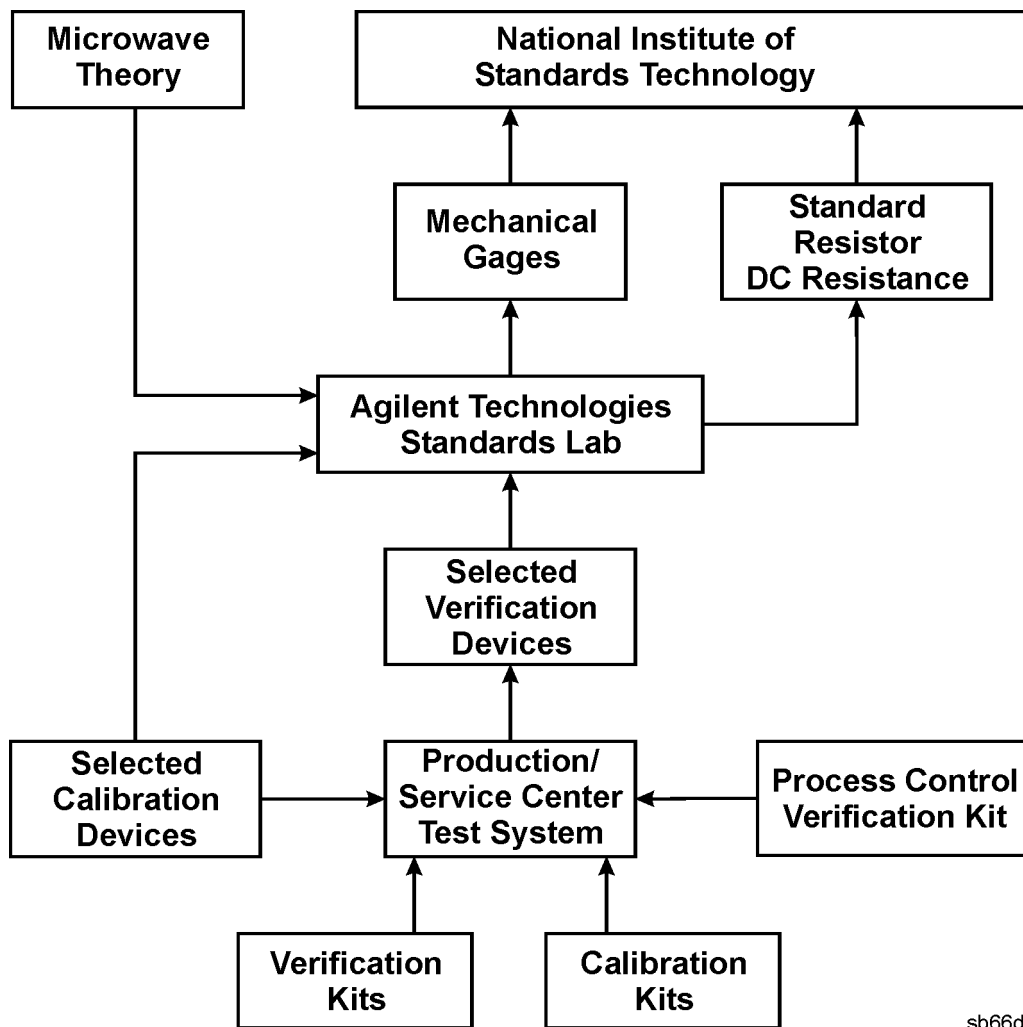
Any measurement result is the vector sum of the actual test device response plus all error terms. The precise effect of each error term depends on its magnitude and phase relationship to the actual test device response. When the phase of an error response is not known, phase is assumed to be worst-case ( $-180^\circ$  to  $+180^\circ$ ). Random errors such as noise and connector repeatability are generally combined in a root-sum-of-the-squares (RSS) manner.

## Measurement Traceability

To establish a measurement traceability path to a national standard for a network analyzer system, the overall system performance is verified through the measurement of devices that have a traceable path. This is accomplished by measuring the devices in an Agilent verification kit.

The measurement of the devices in the verification kit has a traceable path because the factory system that measured the devices is calibrated and verified by measuring standards that have a traceable path to the National Institute of Standards and Technology (NIST) (see [Figure 3-8](#)). This chain of measurements defines how the verification process brings traceability to the network analyzer system.

**Figure 3-8 NIST Traceability Path for Calibration and Verification Standard**



sb66d

## Performing System Verification

The following verification procedure is automated by the analyzer firmware. For each verification device, the analyzer reads a file from the verification disk and sequentially measures the magnitude and phase for all four S-parameters.

---

**NOTE** Although the performance for all four S-parameters are measured, the  $S_{11}$  and  $S_{22}$  phase uncertainties for the attenuators and airlines are less important for verifying system performance. Therefore, the limit lines will not appear on the printout.

---

### Equipment Used in the System Verification Procedure

Equipment Type	Part Number	Alternate Part Number <sup>1</sup>
Calibration kit <i>or</i>	85032F (type-N)	85033E (3.5 mm)
ECal module	85092B (type-N)	85093B (3.5 mm)
Verification kit	85055A (type-N)	85053B (3.5 mm)
RF cable	N6314A (type-N)	See “Cable Substitution” below.

1. Use of these alternates may require the use of adapters.

### Cable Substitution

The test port cables specified for the network analyzer system have been characterized for connector repeatability, magnitude and phase stability with flexing, return loss, insertion loss, and aging rate. Since test port cable performance is a significant contributor to the system performance, cables of lower performance will increase the uncertainty of your measurement. Refer to the plots in the cable tests (earlier in this chapter) that show the performance of good cables. It is highly recommended that the test port cables to be regularly tested.

If the system verification is performed with a non-Agilent cable, ensure that the cable meets or exceeds the specifications for the N6314A type-N cable. Refer to the N6314A user’s guide for specifications.

### Calibration Kit Substitution

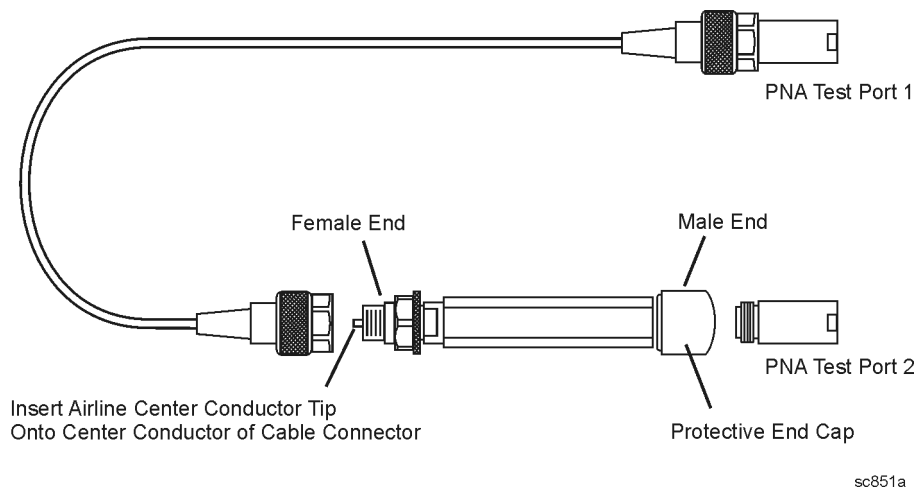
Non-Agilent calibration kits are not recommended nor supported.

### Precautions for Handling Airlines

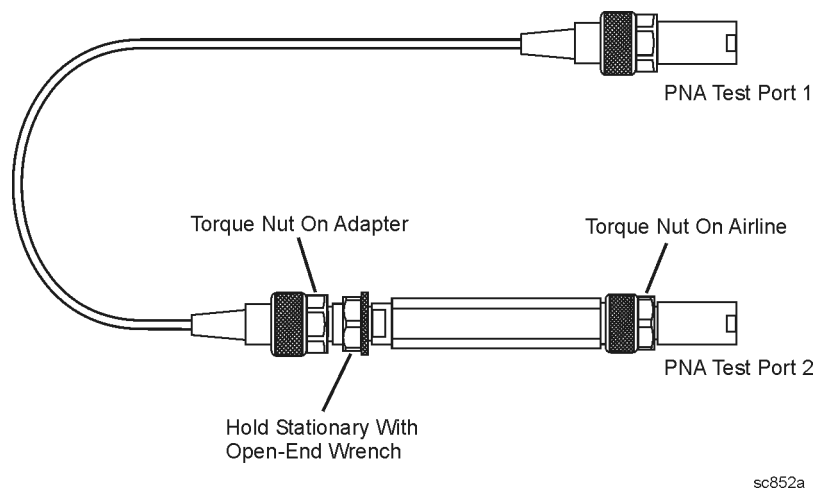
The verification kit includes airlines. Follow the steps below to ensure good measurement techniques.

- Be very careful not to drop the airline's center or outer conductor. Irreparable damage will result if these devices are dropped.
- During this procedure, you will be touching the exposed center conductor of the test port and the center conductor of the airline.
  - Observe proper ESD procedures.
  - Clean your hands or wear gloves; skin oils will cause a change in electrical performance.
- Refer to [Figure 3-9](#) and [Figure 3-10](#) for connection procedures.

**Figure 3-9** Aligning the Center Conductor



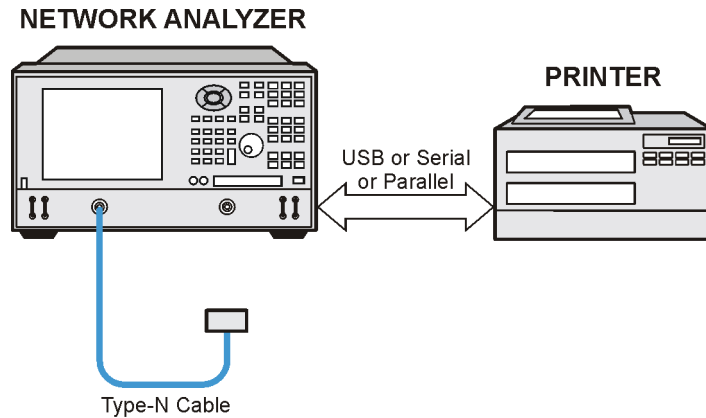
**Figure 3-10** Torquing the Connection



### System Verification Procedure

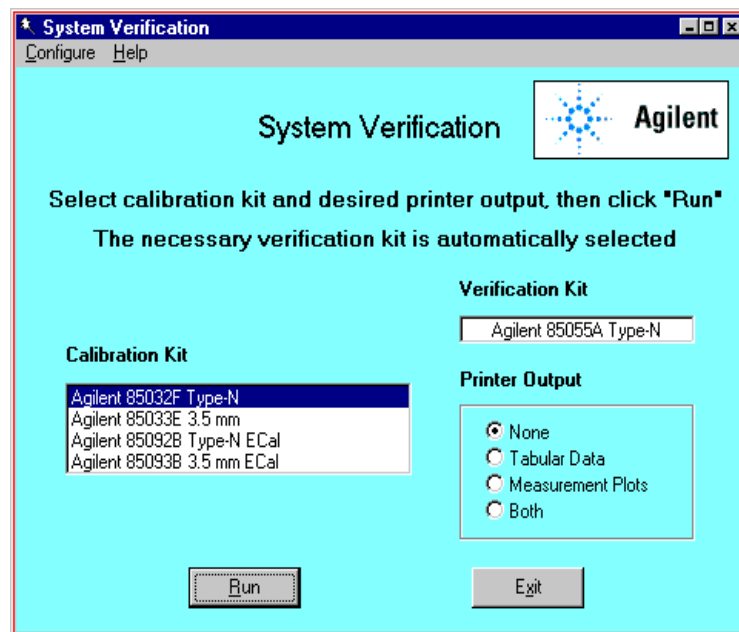
1. Connect a cable to Port 1 on the analyzer as shown in [Figure 3-11](#). If you desire printed test outputs, connect a printer to the analyzer. For the printer, ensure that the correct driver is loaded and the printer is defined as the default printer. Refer to the embedded help in the analyzer for printer setup. Let the analyzer warm up for at least 90 minutes.

**Figure 3-11 System Verification Test Setup**



2. Insert the verification kit disk into the analyzer disk drive.
3. On the **System** menu, point to **Service**, and then click **System Verification**. The **System Verification** dialog box is displayed; refer to [Figure 3-12](#).

**Figure 3-12 System Verification Dialog Box**



4. In the **Calibration Kit** box, select the calibration kit that is being used by clicking on it. The corresponding verification kit to use is selected for you and displayed in the **Verification Kit** box. Refer to [Figure 3-12](#).
5. Under **Printer Output**, click one of the following options. Refer to [Figure 3-12](#).
  - **None**: No printout of results.
  - **Tabular Data**: Prints the verification data in tabular form which includes measured data and uncertainty limits. For an example, refer to [Figure 3-15 on page 3-28](#).
  - **Measurement Plots**: Prints the verification data in graphical form. The graphical form includes the measured data trace, factory supplied data trace, and uncertainty limits. For an example, refer to [Figure 3-16 on page 3-29](#).
  - **Both**: Prints the verification data in both formats.

---

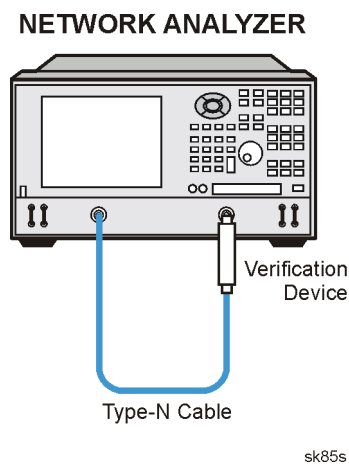
**NOTE** For printed output, it is assumed that the printer has been tested and the Windows 2000 driver is installed for the printer that is being used. The system verification test prints to the printer that has been designated as the default printer. (On the Windows Desktop display, click on **My Computer**, **Control Panel**, and then **Printers** to verify the printer setup.)

---

6. Click **Run**.
7. Follow the instructions on the analyzer for performing a full 2-port calibration.
8. After completion of the full 2-port calibration, follow the instructions on the analyzer for performing the system verification.

For the system verification, insert the devices as shown in [Figure 3-13](#).

**Figure 3-13 System Verification Device Connections**

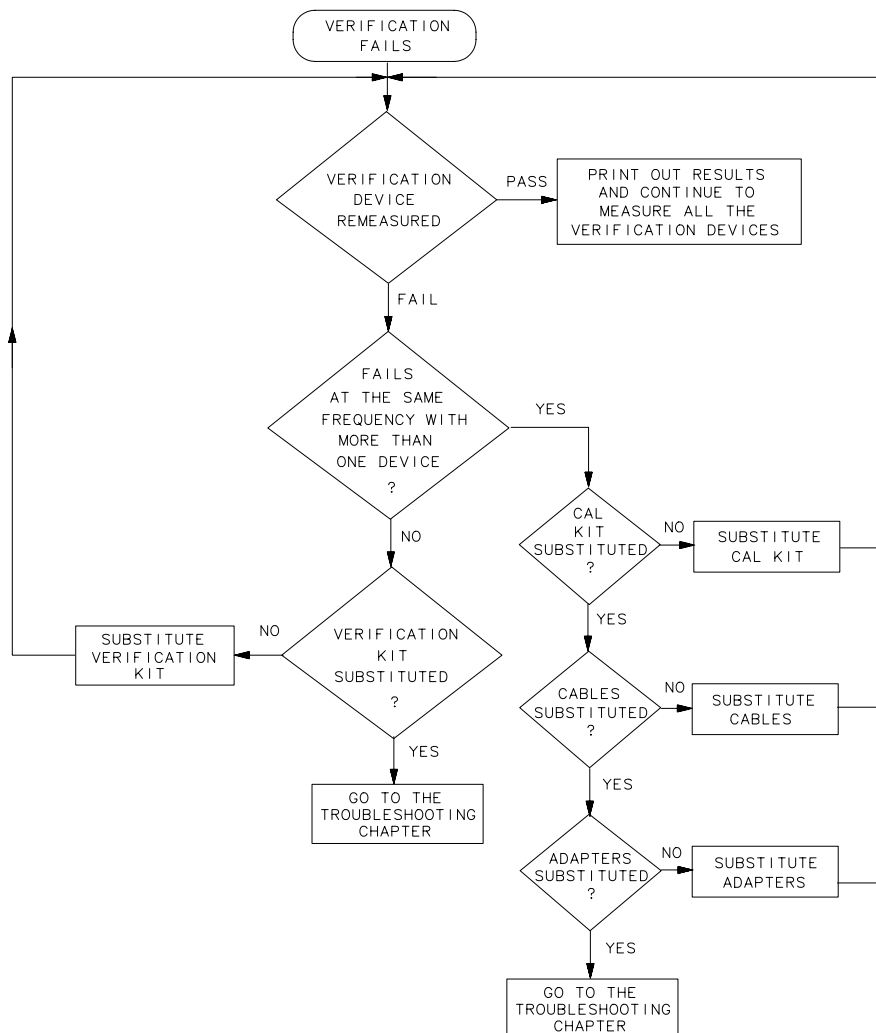


### If the System Fails the Verification Test

**IMPORTANT** Inspect all connections. *Do not* remove the cable from the analyzer test port. This *will invalidate* the calibration that you performed earlier.

1. Disconnect and clean the device that failed the verification test.
2. Reconnect the device making sure that all connections are torqued to the proper specifications.
3. Measure the device again.
4. If the analyzer still fails the test, check the measurement calibration by viewing the error terms as described in “[Accessing Error Terms](#)” on page A-6.
5. Refer to [Figure 3-14](#) for additional troubleshooting steps.

**Figure 3-14 System Verification Failure Flowchart**



sb69d

## Interpreting the Verification Results

Figure 3-15 shows an example of typical verification results with **Tabular Data** selected in the **Printer Output** area of the **System Verification** dialog box.

At the top of the printed output is the name of the device, the serial number of the device, and the date tested.

Each S-parameter measurement result is printed with frequency tested, lower and upper limit lines, the measured data, and the result of the test.

### Figure 3-15 Example of Printed Tabular Verification Results

```

Sys Ver -- 20 dB attenuator magnitude results, Serial #00810 -- 6 Sep 2000

S11 Results
Frequency      Lower Limit      Measured Data      Upper Limit      Result
0.3 MHz        0.0048 Units    0.0090 Units       0.0139 Units    PASS
100            0.0046           0.0091             0.0137          PASS
200            0.0042           0.0092             0.0134          PASS
300            0.0040           0.0091             0.0133          PASS
400            0.0038           0.0089             0.0131          PASS
500            0.0036           0.0087             0.0129          PASS
600            0.0034           0.0085             0.0127          PASS
700            0.0031           0.0082             0.0125          PASS
800            0.0029           0.0080             0.0122          PASS
900            0.0026           0.0079             0.0119          PASS
1000           0.0023           0.0075             0.0117          PASS
1100           0.0020           0.0072             0.0114          PASS
1200           0.0017           0.0068             0.0111          PASS
1300           0.0013           0.0064             0.0107          PASS
1400           -0.0006          0.0059             0.0118          PASS
1500           -0.0011          0.0052             0.0113          PASS
1600           -0.0015          0.0044             0.0108          PASS
1700           -0.0020          0.0038             0.0103          PASS
1800           -0.0026          0.0032             0.0097          PASS
1900           -0.0031          0.0024             0.0091          PASS
2000           -0.0036          0.0019             0.0085          PASS
2100           -0.0045          0.0016             0.0082          PASS
2200           -0.0050          0.0018             0.0077          PASS
2300           -0.0054          0.0023             0.0073          PASS
2400           -0.0052          0.0031             0.0075          PASS
2500           -0.0048          0.0039             0.0080          PASS
2600           -0.0040          0.0050             0.0087          PASS
2700           -0.0032          0.0060             0.0094          PASS
2800           -0.0024          0.0071             0.0103          PASS
2900           -0.0014          0.0082             0.0113          PASS
3000           -0.0004          0.0095             0.0124          PASS

```

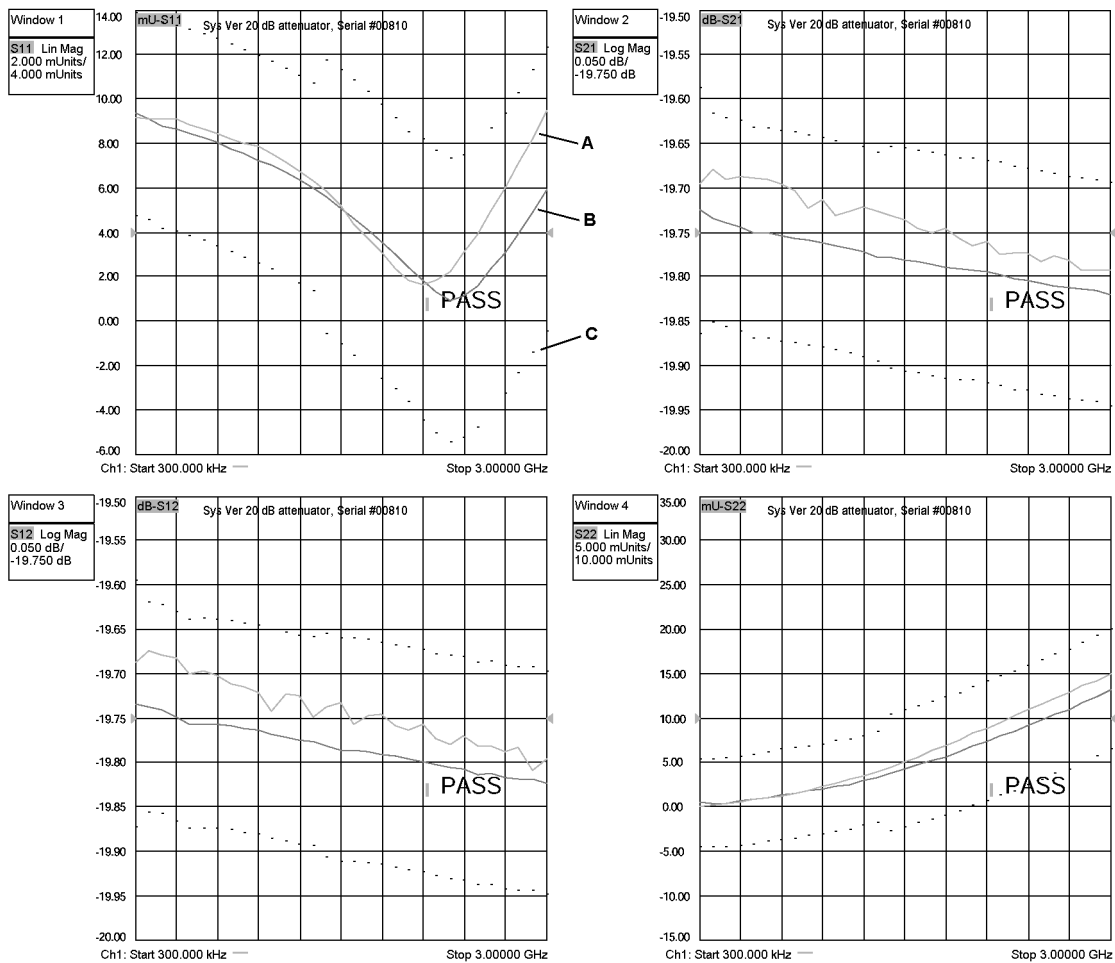
Overall PASS/FAIL result for entire frequency range = PASS



Figure 3-16 shows an example of typical verification results with **Measurement Plots** selected in the **Printer Output** area of the **System Verification** windows. The printed graphical results show the following:

- the name of the device measured
- the serial number of the device
- the parameters measured
- Results of the measurements. Labeled as A in Figure 3-16.
- Data measured at the factory from the verification kit. Labeled as B in Figure 3-16.
- Upper and lower limit points as defined by the total system uncertainty system. Labeled as C in Figure 3-16.

**Figure 3-16 Example of Printed Graphical Verification Results**



---

## Performance Tests (Agilent N2721A Software Package)

The Agilent N2721A software package verifies the electrical performance of your network analyzer. The software automatically configures your analyzer to execute the performance tests. The N2721A software package is not included with the analyzer; it must be ordered separately. The model numbers of the equipment used are specified under “[Required Service Test Equipment](#)” on page 2-6.

There are nine tests in the software package:

- [Source Power Accuracy Test](#)
- [Source Power Linearity Test](#)
- [Frequency Accuracy Test](#)
- [Trace Noise Test](#)
- [Receiver Compression Test](#)
- [Noise Floor Test](#)
- [Calibration Coefficient Test](#)
- [System Crosstalk Test](#)
- [Dynamic Accuracy Test](#)

### Source Power Accuracy Test

**Function of the Test:** To confirm the accuracy of the source output power of your network analyzer over its full frequency range.

**Specification Tested:** Test Port Output–Power Level Accuracy

**Equipment Used:** A power meter, power sensors, and adapters.

#### Description of the Test:

1. The analyzer’s output power level is set to 0 dBm.
2. A power sensor is connected to Port 1.
3. The output power is measured at hundreds of CW frequencies across the analyzer’s frequency range and the values compared to the setting of 0 dBm.

#### If the Analyzer Fails this Test:

- Perform the “[Source Calibration Adjustment](#)” on page 3-43 and repeat this test.
- If the analyzer still fails this test, replace the source assembly and repeat this test. Refer to “[Removing and Replacing the A12 Source Assembly](#)” on page 7-20.

## Source Power Linearity Test

**Function of the Test:** To verify that the power level is linear over the analyzer's frequency range and to check the linearity of the automatic leveling control (ALC).

**Specification Tested:** Power Sweep Range and Power Level Linearity

**Equipment Used:** A test cable. (And a 20 dB pad if the analyzer does not have an internal step attenuator.)

### Description of the Test:

1. The Port 2 receiver is used to test Port 1. The receiver linearity is the standard against which the source linearity is checked.
2. A test cable is connected between Port 1 and Port 2 with 20 dB of attenuation in series with the cable. This can be done with an internal step attenuator or an external 20 dB pad. This attenuation ensures that the receiver remains in its linear range.
3. The analyzer is set to 25 different points across its frequency range.
4. At each frequency point, the output power level on Port 2 is set to 0.000 dBm and the power is measured to establish a reference,  $P_{\text{reference}}$ .
5. The source setting is then stepped from  $-15$  to  $+10$  dBm in 1 dB steps and the power is measured,  $P_{\text{measured}}$ , at each setting.
6. The non-linearity in dB at each frequency point is calculated as:  
 $(P_{\text{measured}} - P_{\text{reference}}) - (\text{source setting})$

### If the Analyzer Fails this Test:

- Perform the [“Source Calibration Adjustment” on page 3-43](#) and repeat this test.
- If the analyzer still fails this test, replace the source assembly and repeat this test. Refer to [“Removing and Replacing the A12 Source Assembly” on page 7-20](#).

## Frequency Accuracy Test

**Function of the Test:** To verify the frequency accuracy and range of the analyzer's source output.

**Specification Tested:** Test Port Output–CW Accuracy

**Equipment Used:** A frequency counter, a test cable, and adapters.

### Description of the Test:

1. Port 1 is connected to a frequency counter.
2. A series of frequencies across the band are checked.

### If the Analyzer Fails this Test:

- Verify the accuracy of the 10 MHz OCXO by connecting a frequency counter to the rear-panel 10 MHz REF OUT.
- If the 10 MHz reference is off by more than 10 Hz, perform the [“10 MHz Frequency Reference Adjustment” on page 3-47](#) and also the [“3.8 GHz PMYO Frequency Adjustment” on page 3-48](#) and repeat this test.

## Trace Noise Test

**Function of the Test:** To measure the stability of a signal in the internal source and receiver system of your analyzer.

**Specification Tested:** Test Port Input–Trace Noise Magnitude and Trace Noise Phase

**Equipment Used:** A test cable.

### Description of the Test:

1. Port 1 and Port 2 are connected with a test cable.
2. The analyzer is set to a series of CW frequencies across its frequency range.
3. Magnitude and phase are measured at each frequency at both 1 kHz and 10 kHz IF bandwidths, in both directions.
4. All measurements are made at a nominal power level of 0 dBm and with 201 points per sweep.

### If the Analyzer Fails this Test:

- Repeat this test. It is unlikely for the analyzer to fail this test without a complete failure of the network analyzer system.
- If the analyzer still fails this test, perform the [“Receiver Calibration Adjustment”](#) on page 3-44 and repeat this test.

## Receiver Compression Test

**Function of the Test:** To measure the compression at the analyzer’s specified maximum power level for the receivers.

**Specification Tested:** Test Port Input–Maximum Test Port Input Level

**Equipment Used:** The compression test set (Z5623A Option K01), a power meter, power sensors, two test cables, and a calibration kit. (And 10-dB and 20-dB pads if the analyzer does not have an internal step attenuator.)

### Description of the Test:

1. All measurements are made with a 50 kHz IF bandwidth and 201 points per sweep.
2. The measurements are made separately on each port.
3. The analyzer is set to various CW frequencies across the range of the analyzer.
4. A power sensor is connected to the “signal source point” to be used to test the port. The “signal source point” may be either the port connector itself, when a short is used, or the end of the test cable, when the compression test set is used to source the test signal.
5. The analyzer source output level is adjusted to create the maximum power level specified for the receiver.
6. The power sensor is disconnected and the “signal source point” is connected to the port to be tested.
7. The absolute log magnitude value (dBm) for the reference channel on the source port is read.

8. The log magnitude ratioed measurement using the receiver under test is read: ( $P_a$ ).
9. The source output level is adjusted to decrease the output by 15 dB.
10. The log magnitude ratioed measurement using the receiver under test is read: ( $P_b$ ).
11. Attenuation of 20 dB is introduced between the source and receiver. This can be done with an internal step attenuator, an external 10 dB pad (if a short is being used to reflect the signal back into the port), or an external 20 dB pad (if the signal source is the compression test set).
12. The log magnitude ratioed measurement using the receiver under test is read: ( $P_c$ ).
13. The source output level is adjusted to produce a reading of Pref (within  $\pm 0.03$  dBm) for the reference channel on the source port.
14. The log magnitude ratioed measurement using the receiver under test is read: ( $P_d$ ).
15. The compression in dB =  $(P_a - P_b) - (P_d - P_c)$ .

**If the Analyzer Fails this Test:**

- Repeat this test. There are no adjustments that can be made.
- Since all four receivers are identical, the suspect failed receiver can be swapped with one of the other receivers to verify that it is faulty. Swap the suspect receiver and repeat this test. Refer to [“Removing and Replacing the A18, A19, A20, and A21 Receiver Module Assemblies”](#) on page 7-30.
- If the faulty channel “follows” the receiver, replace the receiver. If the same channel (now with a different receiver) is still faulty, suspect the associated cabling.

## Noise Floor Test

**Function of the Test:** To measure the absolute power level of the noise floor for the analyzer’s receivers.

**Specification Tested:** Test Port Input–Test Port Noise Floor

**Equipment Used:** A power meter, power sensor, a calibration kit, and a test cable.

**Description of the Test:**

1. The analyzer is set to various CW frequencies across its frequency range at an IF bandwidth of 1 kHz and 801 points per sweep.
2. A test cable is connected to the driving port for the measurement and a power sensor is connected to the other end of the cable.
3. The power level at the end of the cable is set to  $-5.00$  dBm.
4. The power sensor is disconnected and the cable is connected to the port to be tested.
5. The absolute power level in dBm (log magnitude) is read: ( $P_{log}$ ).
6. The test cable is removed and loads are connected to both ports.
7. The analyzer’s trace is set to represent the absolute power level (linear magnitude) for the receiver under test and a sweep is taken.

8. The mean of the points on the trace, in watts, is read: ( $P_{lin}$ ).
9. Average power in dBm is calculated:  $P_{dBm}=10*\text{Log}10(P_{lin}*1000)$ .
10. Corrected noise floor in dBm for a 10 Hz IF bandwidth =  $P_{dBm}-19.96 \text{ dB}-(5.00-P_{log})$ .

**If the Analyzer Fails this Test:**

- A failure of this test indicates a failure of one or more of the following assemblies.
  - A18 channel A receiver
  - A21 channel B receiver
  - A6 SPAM board
- Since all four receivers are identical, the channel A and channel B receivers can be swapped with the channel R1 and channel R2 receivers to determine if they are the cause of the failure. Refer to [“Removing and Replacing the A18, A19, A20, and A21 Receiver Module Assemblies” on page 7-30](#). After swapping the receivers, repeat this test.
- If the analyzer still fails this test, replace the A6 SPAM board and repeat this test. Refer to [“Removing and Replacing the A6, A8, and A10 Board Assemblies” on page 7-16](#).

**Calibration Coefficient Test**

**Function of the Test:** To verify the uncorrected calibration coefficients of your analyzer. The calibration coefficients are measured in forward and reverse direction. Refer to [Appendix A, “Error Terms,”](#) for error term information relating to the calibration coefficients measured.

**Specification Tested:** Uncorrected System Performance

**Equipment Used:** A calibration kit and a test cable.

**Description of the Test:**

1. A series of 2-port calibrations are performed. Two full SOLT 2-port calibrations are performed on each port. Isolation is turned off during each 2-port calibration.
2. A test cable is attached to the first port, and a calibration is performed at the end of the cable and at the second port. The cable is moved to the second port and another calibration is performed. Using two calibrations helps to eliminate the unknown characteristics of the through cable.
3. Each calibration produces 12 error terms.
4. The error terms are used to determine the following characteristics: directivity, source match, load match, reflection tracking, and transmission tracking.

**If the Analyzer Fails this Test:**

- If the analyzer fails tracking error terms only, perform [“Receiver Calibration Adjustment” on page 3-44](#) and repeat this test.
- Failure of any other error terms indicate a hardware failure. Refer to the appropriate error term discussion in [Appendix A, “Error Terms,”](#) for a typical cause of failure. Refer to [Chapter 7, “Repair and Replacement Procedures,”](#) for instructions on replacing the suspected faulty component or assembly.

## System Crosstalk Test

**Function of the Test:** To measure the level of signal leakage between the analyzer's test ports.

**Specification Tested:** Test Port Input–Crosstalk

**Equipment Used:** A calibration kit and a test cable.

### Description of the Test:

1. The analyzer is tested in both directions at various frequency segments.
2. The analyzer sweep is set for the desired frequency and number of points at a 10 Hz IF bandwidth. The power level is set to the lesser of either the maximum specified power level for the driving port or the maximum input power level for the receiving port.
3. A test cable is connected between the driving and receiving ports.
4. The analyzer is set for a ratioed through measurement (S21 for example) with log magnitude display and a sweep is taken and stored to memory (MEM).
5. The trace is set to data divided by memory (DATA/MEM).
6. The test cable is removed and shorts are placed on both ports.
7. The average of 16 sweeps is taken.
8. The resultant log magnitude trace represents the system crosstalk in dB for the frequency range or segment tested.

### If the Analyzer Fails this Test:

- A failure of this test usually indicates one of the following:
  - a loose cable connection
  - degradation of signal isolation in the receivers
  - degradation of signal isolation on the A16 test set motherboard
- Remove the covers from the analyzer and tighten all RF cable connections and tighten all screws on the receivers and repeat this test. Refer to [“Removing and Replacing the A18, A19, A20, and A21 Receiver Module Assemblies”](#) on page 7-30 for instructions on how to remove the covers and for illustrations of the cable and screw locations.
- If the analyzer still fails this test, replace the receiver associated with the port that is failing and repeat this test. Refer to [“Removing and Replacing the A18, A19, A20, and A21 Receiver Module Assemblies”](#) on page 7-30.
- If the analyzer still fails this test, replace the A16 test set motherboard and repeat this test. Refer to [“Removing and Replacing the A16 Test Set Motherboard Assembly”](#) on page 7-26.

## Dynamic Accuracy Test

**Function of the Test:** To measure the relative power linearity of the analyzer's receivers.

**Specification Tested:** Test Port Input–Dynamic Accuracy

**Equipment Used:** The dynamic accuracy test set (Z5623A Option H01), a power meter (E4418B or E4419B Option G12 or Option H12)<sup>1</sup>, power sensors, and two test cables.

**Description of the Test:**

1. The analyzer's test ports are tested separately at a specific CW frequency and a reference power level of  $-20$  dBm.
2. The analyzer's driving port is connected to the dynamic accuracy test set's source port and the analyzer's receiving port is connected to the dynamic accuracy test set's receiver port. A power sensor is connected to the dynamic accuracy test set's power meter port.
3. The dynamic accuracy test set is used to input a signal from the driving port on the analyzer. The input signal is routed through step attenuators to both the analyzer and a power sensor.
4. The analyzer source and the dynamic accuracy test set create power levels that are "deltas" from the reference power level of  $-20$  dBm. Each delta is measured two ways: by the power sensor and by the analyzer's receiver under test.
5. The analyzer's power level into the port under test is set to the  $-20$  dBm reference level.
6. The power level is measured with the power sensor: ( $P_{mr}$ ).
7. The power level is measured using the analyzer's receiver under test: ( $P_{pr}$ ).
8. The power level into the analyzer's port under test is stepped, in 5 dB steps, over the range of 0 to  $-120$  dBm. Each power level represents a "delta" from the reference power level.
9. At each step, the power level is measured using the power meter: ( $P_{md}$ ).
10. At each step, the power level is measured using the receiver under test: ( $P_{pd}$ ).
11. The power error in dB =  $(P_{mr}-P_{md})-(P_{pr}-P_{pd})$ .

**If the Analyzer Fails this Test:**

- A failure of this test indicates a failure of one or more of the following assemblies.
  - A18 channel A receiver
  - A21 channel B receiver
  - A6 SPAM board
- Since all four receivers are identical, the channel A and channel B receivers can be swapped with the channel R1 and channel R2 receivers to determine if they are the cause of the failure. Refer to ["Removing and Replacing the A18, A19, A20, and A21 Receiver Module Assemblies"](#) on page 7-30. After swapping the receivers, repeat this test.
- If the analyzer still fails this test, replace the A6 SPAM board and repeat this test. Refer to ["Removing and Replacing the A6, A8, and A10 Board Assemblies"](#) on page 7-16.

---

1. This test requires a higher accuracy power meter than standard. Refer to ["Required Service Test Equipment"](#) on page 2-6 for specifications. If an Option G12 or H12 power meter is not available, refer to the ["Power Meter Accuracy Test"](#) on page 3-37 to verify the accuracy of a standard power meter.



## Power Meter Accuracy Test

This test is intended for power meters used in testing the PNA series network analyzers. The “[Dynamic Accuracy Test](#)” requires the use of a power meter that has been calibrated to a higher accuracy than the standard power meter.

Power meters with options G12 and H12 specify an improved instrumentation accuracy over a limited power range. (These power meters do not contain unique hardware.) A power meter may be returned to the factory to have one of these options added to an existing power meter or to renew the calibration for one of these options.

This test procedure is an alternative to returning the power meter to the factory. When a power meter passes this test, it is considered to be *calibrated* for the G12 or H12 option even though it has not been returned to the factory.

This test procedure is available on the Internet as a separate document, Agilent Part Number E8356-90051. The on-line document may have a more recent print date. Refer to “[Contacting Agilent](#)” on [page 2-9](#) for the Internet address (URL).

### EPM Series Power Meters That Can Be Tested Using This Procedure

This procedure assumes that the recommended model number power meter is being tested. The alternate model numbers can be tested but the necessary procedural steps may differ.

Recommended Model Number	Alternate Model Numbers
E4419B	E4418A/B, E4419A, EPM-441A, EPM-442A

**NOTE** It is recommended that the revision number for the power meter “Main Firmware” be Ax.03.00 or higher. This applies to all power meter model numbers listed above (both recommended and alternate).

### Equipment Used for the Power Meter Accuracy Test

Equipment Type	Recommended Model or Part Number	Alternate Model or Part Number
Range calibrator	11683A	None
Precision digital voltmeter	3458A	Any with the required accuracy and resolution <sup>1</sup>
Power sensor cable	8120-8319, 11730A	Any equivalent
Cable, BNC, 50Ω	Any	Any
Adapter for connecting BNC cable to DVM inputs	Any	Any

1. Required accuracy and resolution at the following voltage levels:

14 mV input:	0.0100% accuracy	10 nV resolution
0.140 V input:	0.0050% accuracy	100 nV resolution
0.450 V input:	0.003% accuracy	100 nV resolution

## Description of the Test

The power meter accuracy is verified for various power inputs and the actual readings are recorded in a test record. A range calibrator is used to provide the reference inputs.

---

**NOTE** It is recommended that a copy of the test record on [page 3-41](#) be made, and the values be recorded on the copy, thus preserving the original for future use.

---

## Test Procedure

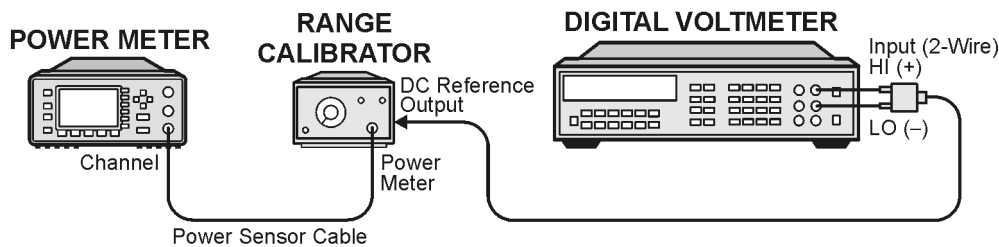
---

**NOTE** This procedure assumes the use of the recommended equipment model numbers. The actual steps required, therefore, may differ for other model numbers of equipment used.

---

1. Setup the equipment as shown in [Figure 3-17](#):
  - a. Connect the DC REFERENCE OUTPUT connector on the rear panel of the range calibrator to the DVM voltage input.
  - b. Connect the POWER METER output of the range calibrator to the input of the power meter being tested.
  - c. Switch on the power to the power meter, the range calibrator, and the digital voltmeter.

**Figure 3-17 Setup for the Power Meter Accuracy Test**



st410a

2. Preset the power meter: Press [**Preset/Local**], then **Confirm**.
3. Perform the following steps for each channel on the power meter:
  - a. Set to read in dBm: Press [**dBm/W**], then **dBm**.
  - b. Set the ref cal factor to 100%: Press [**Zero/Cal**], **Cal**, **A/B Ref CF**, then set to **100.0**, if necessary.
  - c. Set the cal factor to 100%: Press [**Frequency/Cal Fac**], **A/B Cal Fac**, then set to **100.0**, if necessary.
  - d. Set readout to 0.001 dBm: Press [**Meas Setup**], then **Resolution 1 2 3 4**, to highlight **4**.
  - e. Set filter step detect on and filter length to 512: Press [**System/Inputs**], channel **A** or **B Input Settings**, [**More**], **Ch A/B Filter**, **Step Det On**, **Filter On**, **Mode MAN**, **Length**, then set the filter length to **512**.

4. Setup the digital voltmeter (DVM) as follows:
  - a. Reset the DVM: Press the **blue key** followed by **Reset**.
  - b. Set the sample period to a value greater than one second: Press **NPLC, 5, 0**, then **Enter**.
5. Set the range calibrator controls as follows:

POLARITY . . . . . NORMAL  
RANGE . . . . . 1 mW  
FUNCTION . . . . . CALIBRATE
6. Allow the equipment to warm up for approximately 30 minutes. Do not change any connections or control settings during this time.
7. Zero and calibrate the power meter channel to which the range calibrator is connected:
  - a. The range calibrator's RANGE switch should be set to 1 mW.
  - b. Set the range calibrator's FUNCTION switch to STANDBY.
  - c. Press **[Zero/Cal]**, then **Zero A** or **Zero B** (as appropriate). Wait for the operation to complete.
  - d. Set the range calibrator's FUNCTION switch to CALIBRATE.
  - e. Press **[Zero/Cal]**, **Cal**, then **Cal A** or **Cal B** (as appropriate). Wait for the operation to complete.
8. Monitor the drift rate of the power meter reading: Five minutes following calibration, the meter must read 0.001, 0.000, or -0.001 dBm. If the power meter reading is not one of these values, allow additional warm up time, then check the drift rate again. The range calibrator must remain connected to the power meter during this warm up time.
9. Zero and calibrate the power meter channel to which the range calibrator is connected:

---

**NOTE** After a channel on the power meter is calibrated, do not allow more than 5 minutes to elapse before completing the remaining measurement steps for that channel.

---

- a. The range calibrator's RANGE switch should be set to 1 mW.
  - b. Set the range calibrator's FUNCTION switch to STANDBY.
  - c. Press **[Zero/Cal]**, then **Zero A** or **Zero B** (as appropriate). Wait for the operation to complete.
  - d. Set the range calibrator's FUNCTION switch to CALIBRATE.
  - e. Press **[Zero/Cal]**, **Cal**, then **Cal A** or **Cal B** (as appropriate). Wait for the operation to complete.
10. Record the DVM voltage reading as value A in the test record on [page 3-41](#).

---

**NOTE** All DVM readings in this procedure should be recorded showing five significant digits.

---

11. The reading on the power meter should be 0.000 ±0.001 dBm.

12. Switch the range calibrator RANGE to 300  $\mu$ W.
13. Record the DVM voltage reading as value B in the test record.
14. Wait for the power meter reading to settle (no settling drift within 20 seconds).
15. Record the power meter reading as value C in the test record.
16. Switch the range calibrator RANGE to 100  $\mu$ W.
17. Record the DVM voltage reading as value D in the test record.
18. Wait for the power meter reading to settle (no settling drift within 20 seconds).
19. Record the power meter reading as value E in the test record.
20. If testing a dual-channel power meter, perform steps 7 through 19 for the other channel.
21. Perform the pass/fail calculations indicated on the test record.

---

**NOTE**      If a channel of the power meter does not pass this test, the power meter cannot be used in applications that require Option G12 or H12. There are no adjustments that can be performed to improve the performance of the power meter. Typically, replacing the A6 measurement assembly associated with the failed channel will correct the problem.

---

<b>TEST RECORD FOR POWER METER ACCURACY TEST</b>							
<b>Power Meter Tested:</b> Model No.: _____ Serial No.: _____							
<b>Date:</b> _____ <b>Tested by:</b> _____							
Test Equipment Used							
<b>Range Calibrator:</b> Model No.: <u>11683A</u> Serial No.: _____							
<b>Digital Voltmeter:</b> Model No.: _____ Serial No.: _____							
Test Results							
Range Calibrator Setting	Channel A		Channel B				
	DVM Reading (Vdc)	Power Meter Reading (dBm)	DVM Reading (Vdc)	Power Meter Reading (dBm)			
1 mW	A = _____	0.000 ±0.001	A = _____	0.000 ±0.001			
300 μW	B = _____	C = _____	B = _____	C = _____			
100 μW	D = _____	E = _____	D = _____	E = _____			
Pass/Fail Calculations							
300 μW	R = B/A = _____		R = B/A = _____				
	$S = 10^{(C/10)} =$ _____		$S = 10^{(C/10)} =$ _____				
	% ERROR = $((R-S)/R) \times 100 =$ _____ %		% ERROR = $((R-S)/R) \times 100 =$ _____ %				
	Limits: ±0.13%		Limits: ±0.13%				
Pass <input type="checkbox"/>		Fail <input type="checkbox"/>		Pass <input type="checkbox"/>		Fail <input type="checkbox"/>	
100 μW	T = D/A = _____		T = D/A = _____				
	$U = 10^{(E/10)} =$ _____		$U = 10^{(E/10)} =$ _____				
	% ERROR = $((T-U)/T) \times 100 =$ _____ %		% ERROR = $((T-U)/T) \times 100 =$ _____ %				
	Limits: ±0.10%		Limits: ±0.10%				
Pass <input type="checkbox"/>		Fail <input type="checkbox"/>		Pass <input type="checkbox"/>		Fail <input type="checkbox"/>	

---

## **Adjustments**

These adjustments are firmware-driven tests that are used to fine-tune your analyzer for optimum response. The tests are as follows:

- “Source Calibration Adjustment” on page 3-43
- “Receiver Calibration Adjustment” on page 3-44
- “LO Power Adjustment” on page 3-46
- “10 MHz Frequency Reference Adjustment” on page 3-47
- “3.8 GHz PMYO Frequency Adjustment” on page 3-48

## Source Calibration Adjustment

The source calibration is used to adjust your network analyzer for a flat source power across its full frequency range. The differences between Port 1 and Port 2 are negligible; therefore, a Port 2 adjustment is not required.

### Equipment Used for the Source Calibration Adjustment

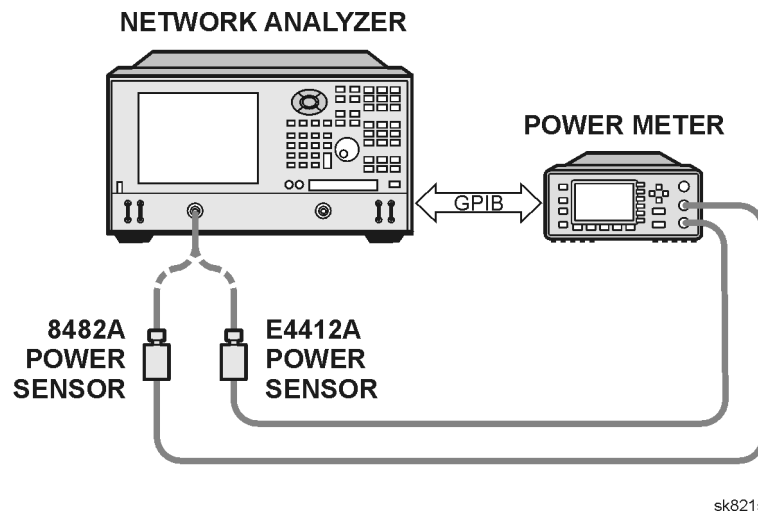
Equipment Type	Part Number
Power meter	E4419B
Power sensor	8482A (100 kHz–4.2 GHz)
Power sensor	E4412A <sup>1</sup> (10 MHz–18 GHz)
RF Cable, type-N	N6314A

1. The E4412A is not needed with the E8356A.

### Procedure

1. Connect the equipment as shown in [Figure 3-18](#). Connect a GPIB cable between the network analyzer and the power meter.

**Figure 3-18 Setup for the Source Calibration Adjustment**



2. On the **System** menu, point to **Service, Adjustments**, and then click **Source Calibration**.
3. Ensure the GPIB settings are correct.
4. Click **Calibrate**, and then follow the instructions as they are displayed.

## Receiver Calibration Adjustment

The receiver calibration is used to adjust the network analyzer receivers for a flat response across its full frequency range. A power meter is connected to Port 1, as shown in [Figure 3-19](#), to establish a reference for flatness. A signal from Port 1, as shown in [Figure 3-20](#), is used to adjust the “B” receiver at Port 2. The adjustment is repeated using a signal from Port 2 to adjust the “A” receiver at Port 1.

### Equipment Used for the Receiver Calibration Adjustment

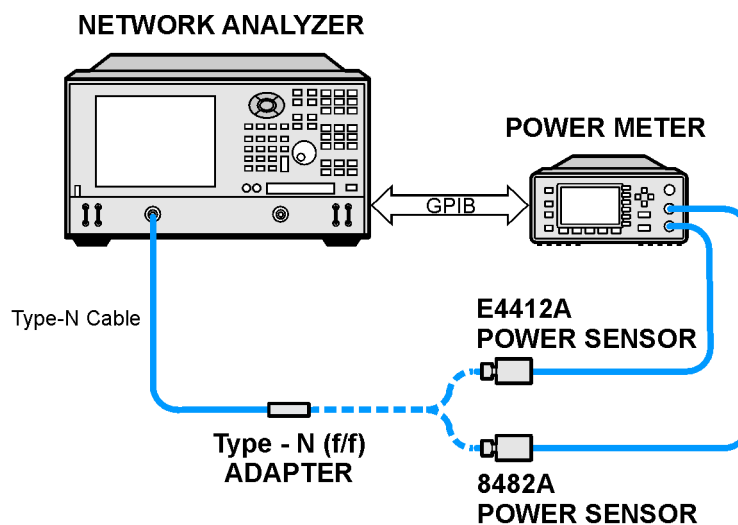
Equipment Type	Part Number
Power meter	E4419B
Power sensor	8482A (100 kHz–4.2 GHz)
Power sensor	E4412A <sup>1</sup> (10 MHz–18 GHz)
Adapter, type-N (female to female)	1250-0777
RF Cable, type-N	N6314A

1. The E4412A is not needed with the E8356A.

### Procedure

1. Connect the equipment as shown in [Figure 3-19](#). Connect a GPIB cable between the network analyzer and the power meter.

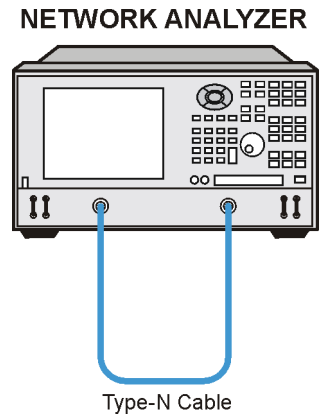
**Figure 3-19 Setup for the Receiver Calibration Adjustment**



sk84s



**Figure 3-20 Setup for the Receiver Calibration Adjustment of Port 2**



sk820s

2. On the **System** menu, point to **Service, Adjustments**, and then click **Receiver Calibration**.
3. Ensure the GPIB settings are correct.
4. Click **Calibrate**, and then follow the instructions as they are displayed.

## LO Power Adjustment

The LO power adjustment is used to adjust the power level of the LO signals from the A17 LO distribution assembly. This adjustment is done for only one LO output. The differences between each LO output is negligible; therefore, separate adjustments are not required.

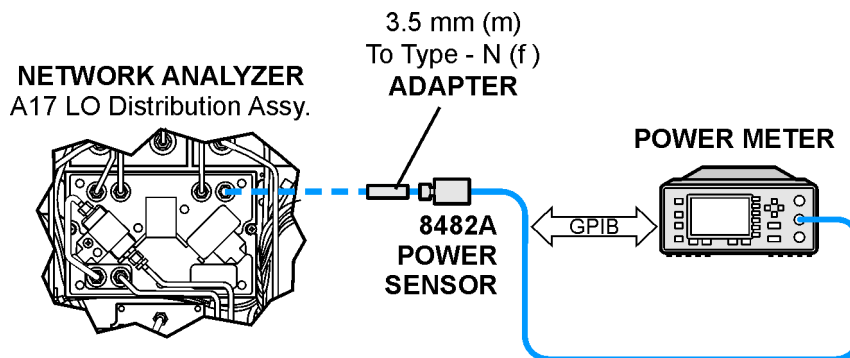
### Equipment used for the LO Power Adjustment

Equipment Type	Part Number
Power meter	E4419B
Power sensor	8482A
Adapter, type-N (female) to 3.5 mm (male)	1250-1750

### Procedure

1. Turn off the network analyzer and remove the power cable and other external cables from the rear panel.
2. Remove the outer cover. Refer to “[Removing the Covers](#)” on page 7-6.
3. Place the analyzer on its side to allow access to the bottom of the analyzer.
4. Connect the equipment as shown in [Figure 3-21](#), making sure to support the power sensor to prevent excess pressure on the SMA connector. Connect a GPIB cable between the network analyzer and the power meter.

**Figure 3-21 Setup for the LO Power Adjustment**



sk83s

5. Reconnect the power and USB cables. Turn on the analyzer.
6. On the **System** menu, point to **Service, Adjustments**, and then click **LO Power Adjust**.
7. Ensure the GPIB settings are correct.
8. Click **Begin Adj**, and then follow the instructions as they are displayed.
9. Turn off the analyzer, disconnect the power cable, and replace the covers.

## 10 MHz Frequency Reference Adjustment

The 10 MHz frequency adjustment is used to adjust the frequency accuracy of the network analyzer's 10 MHz frequency reference on the A10 frequency reference board assembly. For Option 1D5, this is an oven-controlled crystal oscillator (OCXO).

### Equipment Used for the Frequency Adjustment at 10 MHz

Equipment Type	Part Number
RF cable, BNC, 50Ω, 24 inch	8120-1839
Frequency counter	53131A/32A Opt 010,124 <sup>1</sup>

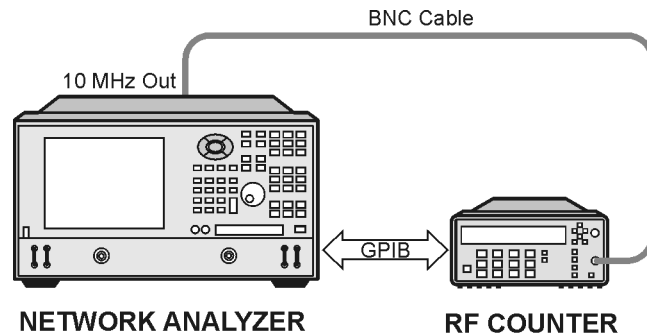
1. Alternate choice: 53181A (Opt 010,124)

### Procedure

**NOTE** The specification of frequency accuracy is  $\pm 1$  ppm. However, this test typically adjusts to  $\pm 0.01$  ppm.

1. Connect the equipment as shown in [Figure 3-22](#). Connect a GPIB cable between the network analyzer and the frequency counter.

**Figure 3-22 Setup for the Frequency Adjustment at 10 MHz**



sk81s

2. On the **System** menu, point to **Service, Adjustments**, and then click **10 MHz Freq Adjust**.
3. Ensure the GPIB settings are correct.
4. Click **Begin Adj**, and then follow the instructions as they are displayed.

### 3.8 GHz PMYO Frequency Adjustment

The 3.8 GHz adjustment is used to adjust the frequency accuracy of the network analyzer's 3.8 GHz permanent-magnet YIG oscillator (PMYO) on the A12 source assembly.

#### Equipment used for the Frequency Adjustment at 3.8 GHz

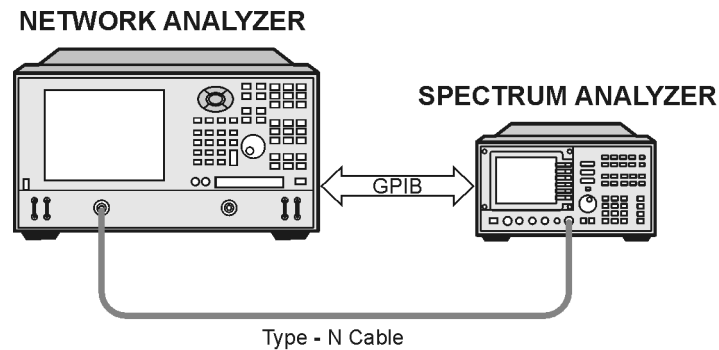
Equipment Type	Part Number
Spectrum analyzer	8561E <sup>1</sup>

1. or as alternate 856xE

#### Procedure

1. Connect the equipment as shown in [Figure 3-23](#). Connect a GPIB cable between the network analyzer and the spectrum analyzer.

**Figure 3-23 Setup for the Frequency Adjustment at 3.8 GHz**



sk82s

2. On the **System** menu, point to **Service, Adjustments**, and then click **3.8 GHz Freq Adjust**.
3. Ensure the GPIB settings are correct.
4. Click **Begin Adj**, and then follow the instructions as they are displayed.

---

## 4 Troubleshooting

## Information in This Chapter

The information in this chapter helps you:

- identify the portion of the analyzer at fault.
- locate the specific troubleshooting procedure to identify the assembly or peripheral at fault.

The sections in this chapter are arranged in a logical troubleshooting order. The following table lists the sections and a brief summary of what to look for in that section.

### Chapter Four at-a-Glance

Section Title	Summary of Content	Start Page
<a href="#">Getting Started With Troubleshooting</a>	A starting point to begin troubleshooting.	<a href="#">Page 4-2</a>
<a href="#">Power Up Troubleshooting</a>	Power-up problems: <ul style="list-style-type: none"> <li>• Power supply problems</li> <li>• LCD problems</li> <li>• Bootup for the network analyzer interface</li> </ul>	<a href="#">Page 4-6</a>
<a href="#">Front Panel Troubleshooting</a>	Problems occurring after the network analyzer interface is loaded: <ul style="list-style-type: none"> <li>• Does the display color appear correct?</li> <li>• Do the front panel keys function properly?</li> <li>• Does the front panel USB connector function properly?</li> </ul>	<a href="#">Page 4-17</a>
<a href="#">Rear Panel Troubleshooting</a>	Problems associated with the rear panel interconnects. <i>The data found at these rear panel interconnects can be used to troubleshoot the CPU board.</i>	<a href="#">Page 4-21</a>
<a href="#">Measurement System Troubleshooting</a>	Problems associated with the measurement portion of the analyzer. <ul style="list-style-type: none"> <li>• Checking the A, B, R1, and R2 signals.</li> <li>• Checking the source assembly group.</li> <li>• Checking the receiver assembly group.</li> <li>• Checking the signal separation group.</li> </ul>	<a href="#">Page 4-27</a>
<a href="#">Instrument Block Diagrams</a>	Block diagrams for both a standard analyzer and an Option 015 analyzer.	<a href="#">Page 4-49</a>

---

## Protect Against Electrostatic Discharge (ESD)

This is important. If not properly protected against, electrostatic discharge can seriously damage your analyzer, resulting in costly repair.

---

**CAUTION** To reduce the chance of electrostatic discharge, follow all of the recommendations outlined in [“Electrostatic Discharge Protection”](#) on page 1-5, for all of the procedures in this chapter.

---

---

## Assembly Replacement Sequence

After identifying the problem requiring an assembly to be replaced, follow these steps:

- Step 1.** Order a replacement assembly. Refer to [Chapter 6, “Replaceable Parts.”](#)
- Step 2.** Replace the faulty assembly and determine what adjustments are necessary. Refer to [Chapter 7, “Repair and Replacement Procedures.”](#)
- Step 3.** Perform the necessary adjustments. Refer to [Chapter 3, “Tests and Adjustments.”](#)
- Step 4.** Perform the necessary performance tests. Refer to [Chapter 3, “Tests and Adjustments.”](#)

---

## Getting Started With Troubleshooting

Where you begin troubleshooting depends upon the symptoms of the failure. Start by checking the basics as outlined in the following section. Also review the flowchart in [Figure 4-1 on page 4-5](#). You should then be able to determine where in the troubleshooting procedure to begin, to locate the failed assembly.

### Check the Basics

A problem can often be solved by repeating the procedure you were following when the problem occurred. Before calling Agilent Technologies or returning the instrument for service, please perform the following checks:

1. Is there power at the mains receptacle? If not, correct this situation and proceed.
2. Is the instrument turned on? Check to see if the front panel line switch and any of the LED rings around the ports glow. This indicates the power supply is on. If the front panel line switch is on but the power supply does not appear to be on, go to [“Power Up Troubleshooting” on page 4-6](#).
3. Is the Windows® operating system running? If not, refer to [Appendix D, “Operating System Recovery,”](#) for instructions.
4. If other equipment, cables, and connectors are being used with the instrument, make sure they are connected properly and operating correctly.
5. Review the procedure for the measurement being performed when the problem appeared. Are all the settings correct? If not, correct them.
6. If the instrument is not functioning as expected, return the unit to a known state by pressing the **Preset** key.
7. Is the measurement being performed, and the results that are expected, within the specifications and capabilities of the instrument? Refer to the embedded help in the analyzer for instrument specifications.
8. If the problem is thought to be due to firmware, check to see if the instrument has the latest firmware before starting the troubleshooting procedure. Refer to [Appendix C, “Firmware Upgrades,”](#) for instructions.
9. If the necessary test equipment is available, perform the operator’s check and system verification in [Chapter 3, “Tests and Adjustments.”](#)

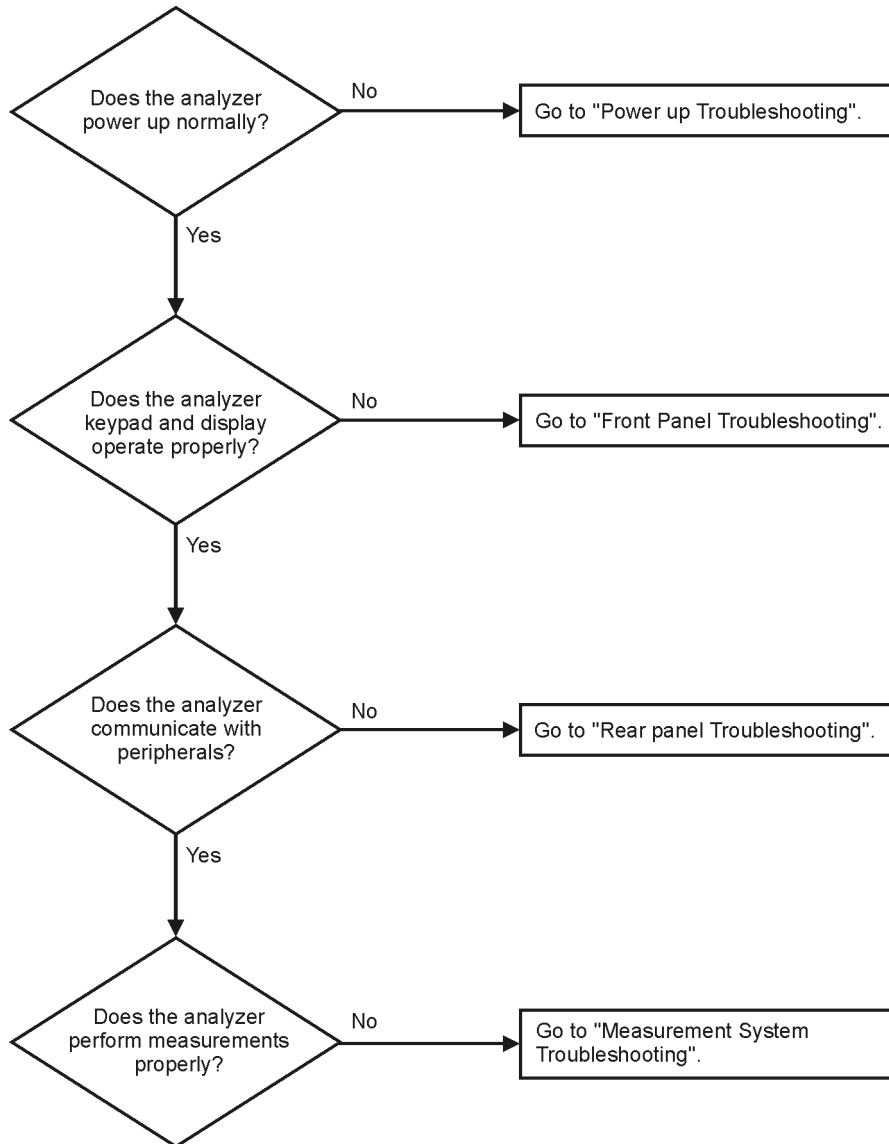
Windows® is a U.S. registered trademark of Microsoft Corporation.



## Troubleshooting Organization

Follow the flowgraph in [Figure 4-1](#) to help direct you to the correct section for troubleshooting the analyzer.

**Figure 4-1 Troubleshooting Organization Flowchart**



sc867a

---

## Power Up Troubleshooting

---

**WARNING** Immediately unplug the instrument from the ac power line if the unit shows any of the following symptoms:

- Smoke, arcing, or unusual noise from inside the analyzer.
  - A circuit breaker or fuse on the main ac power line opens.
- 

Check your network analyzer for evidence that it is powering up correctly. Perform the following steps and make sure that the analyzer is displaying correct behavior as noted in the following steps.

**Step 1.** Disconnect all peripherals and plug in the network analyzer. Before the analyzer is powered on, the line switch should glow yellow and no other lights should be on.

**Step 2.** Turn on the network analyzer.

- The line switch and the LED rings around each port should glow.
- The fans should be audible.
- The display should flash and then show the hardware boot-up sequence. This process checks the RAM and communication with the hard disk drive assembly. These checks return an error message if a problem is detected.
- The Windows 2000 operating system should start.
- The network analyzer measurement interface should open with an S<sub>11</sub> measurement displayed. The Port 1 LED ring should glow green and the Port 2 LED ring should be off.

**Step 3.** If the analyzer powers up correctly, continue troubleshooting with [“Front Panel Troubleshooting”](#) on page 4-17.

**Step 4.** If the analyzer does not power up correctly, follow these troubleshooting steps:

- If the line switch and the LED rings around each port do not glow green or the fans are not operating (audible), go to [“Power Supply Check”](#) on page 4-7.
- If you cannot hear the fans operating, go to [“If the Fans Are Not Operating”](#) on page 4-12.
- If the line switch and the LED rings around each port glow green and the fans are operating (audible), but the display remains dark, go to [“Troubleshooting LCD Display Problems”](#) on page 4-13.
- If the instrument appears to abort the network analyzer measurement interface process, contact Agilent. Refer to [Table , “Contacting Agilent”](#), on page 2-9.

## Power Supply Check

---

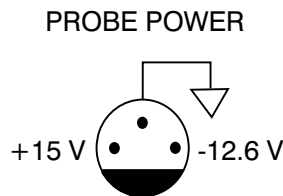
**NOTE** There are no fuses to replace within the power supply. If you determine that the power supply is the failed assembly, replace the power supply.

---

A catastrophic failure in the power supply assembly can be determined by observing the line switch and the LED rings around each port, and by measuring the probe power at the front-panel Probe Power connectors:

1. Ensure that the instrument is plugged in with the power switch in the standby position (power not switched on). Verify that the line switch glows yellow. A line switch that glows yellow indicates that the +15 VDC line (P15 STB) is providing enough voltage to light the LED. (The actual voltage may not be +15 VDC.)
2. Turn on the instrument power and verify that the line switch glows bright green and the LED rings around each port glow a light green. When the line switch and the LED rings around each port glow, it is an indication that the power supply has received an “ON” command and that the +5.2 VDC supply can supply enough current to light, at least, these lamps.
3. The front-panel probe power-connector can be used to check the +15 VDC and –12.5 VDC (–15 VDC) supplies. The –12.5 VDC is produced by post regulating the –15 VDC supply. Refer to [Figure 4-2](#) for a diagram of the probe power connector.

**Figure 4-2 Probe Power Connector**



sa869a

If all of these supply voltages are missing, it is likely that the problem is either a defective A4 power supply assembly, or another assembly is loading down the A4 power supply assembly. Continue with [“If All Supply Voltages are Missing” on page 4-10](#), to determine the cause of the problem.

If the line switch and the LED rings around each port are lit correctly, and the probe power voltages measure within the specifications listed in [Table 4-1, “Extender Board Measurement Points”, on page 4-9](#), the power supply has not suffered a catastrophic failure; however, the power supply could still be at fault. Continue with the next section to measure the individual voltage supplies.

---

## Measure the Individual Voltage Supplies

---

**WARNING**    **The instrument contains potentially hazardous voltages. Refer to the safety symbols provided on the instrument and in “General Safety Considerations” on page 1-3 before operating the unit with the cover removed. Make sure that the safety instructions are strictly followed. Failure to do so can result in personal injury or loss of life.**

---

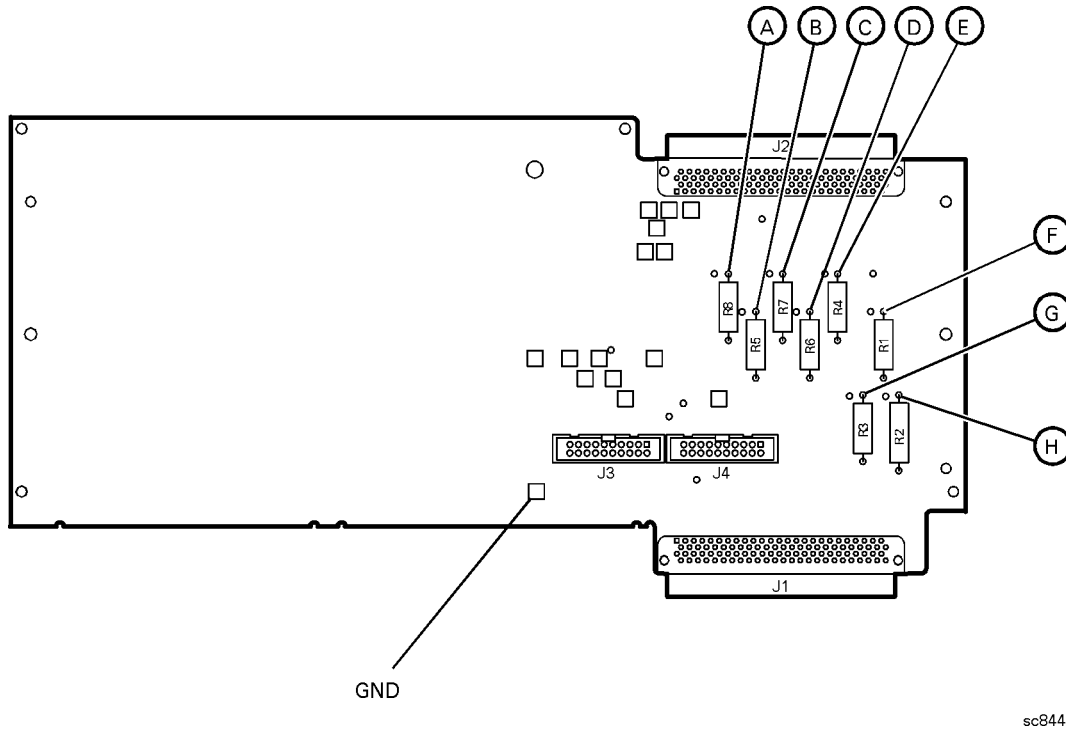
To measure the power supply voltages, it is necessary to remove the instrument’s outer and inner covers. Refer to “Removing the Covers” on page 7-6 for removal procedures. Use the E8356-60021 extender board to measure the individual power supply voltages. Insert the extender board into an empty slot next to the A6 signal processing ADC module (SPAM) Board.

**NOTE**        If any one individual voltage supply from the A4 power supply assembly develops an over-voltage or over-current problem, all supplies are affected. The supply goes into a “burp” mode characterized by the supplies cycling on and off at a low voltage level. The cause of the over-voltage or over-current condition can be the A4 power supply assembly itself, or any assembly to which the A4 power supply assembly provides voltage. To isolate the cause of “burp” mode, continue to the assembly removal process as described in the section titled “If All Supply Voltages are Missing” on page 4-10.

---

On the extender board, measure the power supply voltages using a digital voltmeter. Refer to Figure 4-3 for the power supply test points on the extender board. Use the point marked as “GND” for the ground connection. Refer to Table 4-1, “Extender Board Measurement Points”, on page 4-9 for the correct voltages and tolerances.

**Figure 4-3 E8356-60021 Synthesizer/Reference Extender Measurement Points**



sc844a

**Table 4-1 Extender Board Measurement Points**

Measurement Location	Signal Description	Test Equipment Used	Expected Level (Vdc)
A	power supply	DVM	+5.0
B	power supply	DVM	-15.0
C	power supply	DVM	-5.0
D	power supply	DVM	+9
E	power supply	DVM	+15
F	power supply	DVM	+15
G	power supply	DVM	+22
H	power supply	DVM	+32

**If All Supply Voltages are Present**

If all of the supplies have measured within tolerances, and the instrument still is not functioning properly, refer to “Rear Panel Troubleshooting” on page 4-21.

## If All Supply Voltages are Missing

---

**WARNING**     **Disconnect the line-power cord before removing any assembly.**  
**Procedures described in this document may be performed with power supplied to the product while protective covers are removed. Energy available at many points may, if contacted, result in personal injury or loss of life.**

---

It is necessary to sequentially remove all of the assemblies, taking care to disconnect the line-power cord before each removal, and then to measure the supply voltages after each removal.

If the missing supply voltages return to a “power on” condition after removal of an assembly, suspect that assembly as being defective.

Remove the network analyzer assemblies in the order specified in the following steps (refer to [Chapter 7](#) for removal instructions).

1. Unplug the test set motherboard assembly cable from the A16 test set motherboard assembly.
2. Unplug the front panel interface cable from the A3 front panel interface board.
3. Remove the A6 SPAM board assembly.
4. Remove the A8 fractional-N synthesizer board assembly.
5. Remove the A10 frequency reference board assembly.
6. Remove the A11 phase lock board assembly.
7. Unplug the A30 floppy disk drive from the A14 motherboard assembly.
8. Unplug the A31 hard disk drive assembly from the A15 CPU board assembly.

The minimum required assemblies to power up the analyzer are:

- A4 power supply assembly
- A14 motherboard assembly
- A15 CPU board assembly

To further isolate the failure in the three remaining assemblies, measure the resistance on the extender board (with the power turned off) from the power supply test points to “GND”. Refer to [Figure 4-3 on page 4-9](#). The voltages should be as shown in [Table 4-2](#).

---

**NOTE**     Make sure that the only assemblies plugged in are the three minimum required assemblies listed above.

---

Check for shorts (zero  $\Omega$ ) or very low resistance (approximately 1  $\Omega$ ). If a short or low resistance is measured, isolate each of the remaining three boards in the following order, and recheck the shorted test point after each board is removed. Note that the resistance may be different from that listed in the table, but you should be able to determine if the shorted condition has changed.

Isolate the remaining three assemblies:

- remove the A15 CPU board assembly
- remove the A4 power supply assembly

This leaves only the A14 motherboard assembly installed. If the measurements are still incorrect, this is the suspected faulty assembly.

**Table 4-2 Power Supply Voltages and Resistances**

Measurement Location	Supply (Vdc)	Approximate Resistance ( $\Omega$ )
A	+5.0	285
B	-15.0	12.7 k
C	-5.0	7.2 k
D	+9	4.0 k
E	+15	3.0 k
F	+22	2.8 k
G	+22	890
H	+32	2.6 k

## If the Fans Are Not Operating

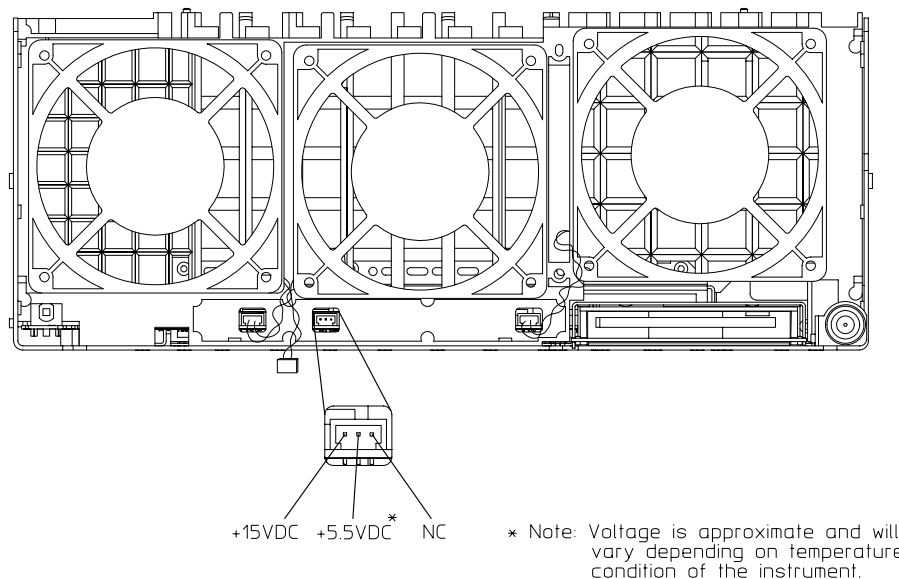
**CAUTION** The power supply may be in thermal shutdown if the instrument has been operating without the fans running. Allow the instrument to cool down before troubleshooting.

If all three fans are not operating, suspect a power supply problem or a defective A14 motherboard assembly. Refer to [“Power Supply Check” on page 4-7](#) to check the individual supplies. If the supplies are within specifications, the most probable cause is a defective A14 motherboard assembly. Refer to [“Removing and Replacing the A14 Motherboard Assembly” on page 7-22](#).

If only one or two fans are not functioning, and the power supplies are within specifications, suspect the A14 motherboard assembly or a defective fan. Perform the following procedure.

1. Remove the front panel assembly from the instrument. Refer to [“Removing and Replacing the Front Panel Assembly” on page 7-8](#).
2. Refer to [Figure 4-4](#). Measure the fan voltages at J1, J3, and J4 on the A14 motherboard assembly.

**Figure 4-4 Fan Voltages**



sa867a

3. If the correct voltage is present and the fan connector is in good mechanical condition, suspect a defective fan. Refer to [“Removing and Replacing the Midweb and the B1 Fan” on page 7-50](#).
4. If the voltage is not present, suspect a defective A14 motherboard. Refer to [“Removing and Replacing the A14 Motherboard Assembly” on page 7-22](#).



## Troubleshooting LCD Display Problems

This procedure is intended to isolate the faulty assembly when the display is dark. If the display is lit, but the color mix is faulty, refer to [“A2 Display Test” on page 4-19](#).

---

**NOTE**            There are no front panel adjustments for intensity and contrast of the LCD.

---

1. If the display is dim, the backlight assembly is defective. Refer to [“Removing and Replacing the Front Panel Assembly” on page 7-8](#).
2. If the display is dark (not visible), connect an external VGA monitor to the rear panel VGA output connector on the instrument. Be aware that some multisync monitors might not be able to lock to a 60 Hz sync pulse. If the video information is not present on the external VGA monitor, the most probable cause is the A15 CPU board assembly. Refer to [“Removing and Replacing the A15 CPU Board Assembly” on page 7-24](#).
3. If the external VGA monitor is functioning, verify that the front panel interface ribbon cable is properly plugged into the motherboard connector.
4. If the front panel interface ribbon cable is properly connected, suspect that one or more of the following is defective:
  - inverter board (mounted on the display assembly)
  - display lamp assembly
  - A3 front panel interface board
  - A2 display assembly

Refer to the following paragraphs to determine which of the above listed assemblies is defective.

### Creating the Test Setup

For easy access to measure the voltages on the inverter board and on the A3 front panel interface board, it is best to disassemble the front panel and remove these two boards to set in front of you for testing. Use the ribbon cables that come with the boards and the analyzer as the supply source. Follow this procedure:

1. Turn off the analyzer.
2. Remove the front panel. Refer to [“Removing and Replacing the Front Panel Assembly” on page 7-8](#).
3. After the front panel is removed from the analyzer, isolate the inverter board by first removing the display assembly. Refer to [“Removing the A2 Display Assembly” on page 7-10](#). Put the A2 assembly and its ribbon cables aside.
4. Remove the A3 board by referring to [“Removing the A3 Front Panel Interface Board Assembly” on page 7-10](#). Put the A3 board aside.
5. Duplicate the board connections on your ESD safe test desk top by laying the A2 and A3 in front of the open-faced analyzer. Lay the A2 and A3 boards component-side down, the A2 to the left of the A3, with the top of the boards towards you.

6. Connect the display ribbon cable and display lamp cable from A2 to A3. Connect the front panel interface ribbon cable coming from the analyzer to the A3 board.
7. Turn the analyzer on and refer to “Verifying the Inverter Board” on page 4-14 and “Verifying the A3 Front Panel Interface Board Assembly” on page 4-16 to test and troubleshoot the boards.

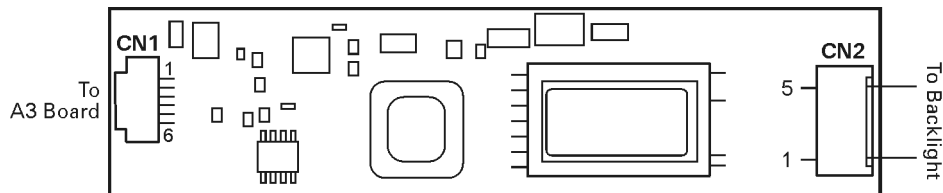
## Verifying the Inverter Board

**WARNING** High voltage is present on the inverter board and the A3 front panel interface board. Be careful when measuring signals and voltages on these boards.

**NOTE** To access the front panel boards for measurements, it is necessary to remove the front panel assembly. Refer to “Removing and Replacing the Front Panel Assembly” on page 7-8.

Using Figure 4-5 as a reference, measure the signals and voltages indicated in Table 4-3, “Inverter Board, Voltages and Signals”, on page 4-14. If the signals and voltages measure good, the inverter board is functioning correctly.

**Figure 4-5 Inverter Board Test Point Locations**



sc846a

**Table 4-3 Inverter Board, Voltages and Signals**

Test Point	Signal or Voltage	Test Point	Signal or Voltage
CN1 pin 1	+5.1 Vdc	CN1 pin 5	0 V (ground)
CN1 pin 2	+5.1 Vdc	CN1 pin 6	+2.54 V
CN1 pin 3	39 mV	CN2 pin 1	+400 V peak sinewave @ 38 kHz
CN1 pin 4	0 V (ground)	CN2 pin 5	ac neutral (referenced to pin 1)

After measuring the points CN1 and CN2, match the results and perform the rework as indicated in the action column in Table 4-4.

**Table 4-4 Inverter Board Troubleshooting Steps**

<b>Input (CN1)</b>	<b>Output (CN2)</b>	<b>Action</b>
Good	Good	Replace the display lamp. Refer to “ <a href="#">Removing and Replacing the Display Inverter Board and the Display Lamp</a> ” on page 7-12.
Good	<b>Bad</b>	Replace the inverter. Refer to “ <a href="#">Removing and Replacing the Display Inverter Board and the Display Lamp</a> ” on page 7-12.
<b>Bad</b>	<b>Bad</b>	Refer to “ <a href="#">Verifying the A3 Front Panel Interface Board Assembly</a> ” on page 4-16.

## Verifying the A3 Front Panel Interface Board Assembly

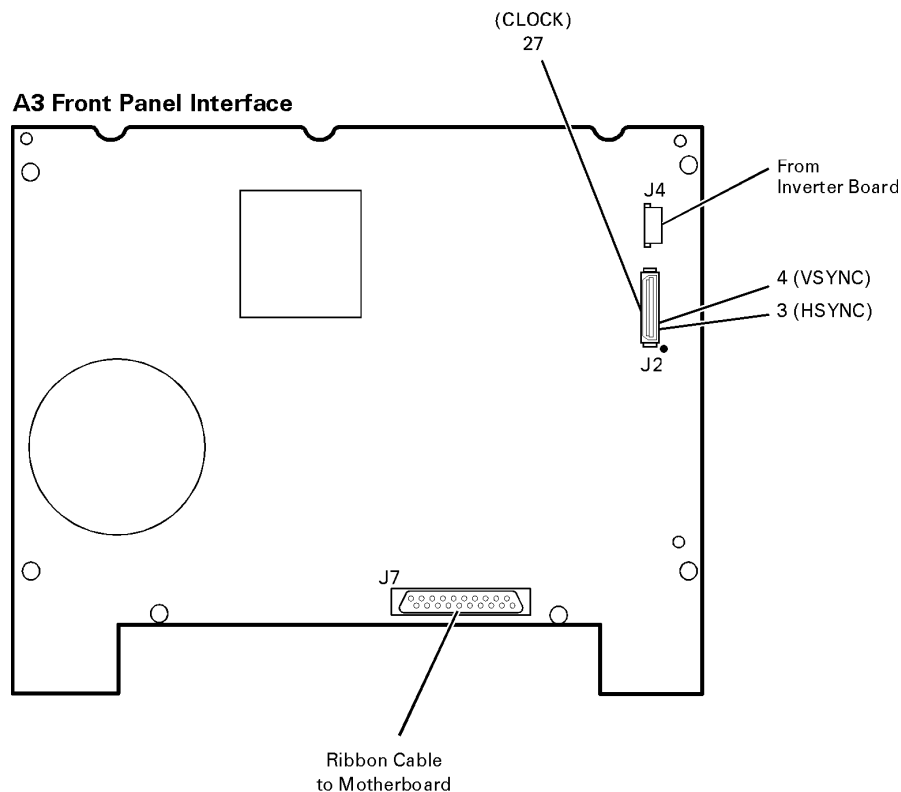
To verify that the HSYNC (horizontal sync), VSYNC (vertical sync), and LCD clock are functioning correctly, measure the following signals as indicated in [Figure 4-6](#). If all of these signals measure correctly, suspect a defective backlight or LCD. The backlight is the most probable cause.

**CAUTION** Be careful not to short connector pins together when measuring these signals.

**Table 4-5 A3 Front Panel Interface Board Assembly, Voltages and Signals**

Signal Type	Test Point	Voltage	Signal
HSYNC	J2 pin 3	0 to +3 V	30.8 kHz square wave
VSYNC	J2 pin 4	0 to +3 V	60 Hz square wave
CLOCK	J2 pin 27	0 to +3.4 V pk to pk	25 MHz sine wave

**Figure 4-6. Verifying HSYNC, VSYNC, and LCD Clock**



sc845a

If any of the three signal types is incorrect, replace the A3 front panel interface board assembly. Refer to [“Removing the A3 Front Panel Interface Board Assembly”](#) on page 7-10.

If all of the signal types are correct, replace the A2 display assembly. Refer to [“Removing the A2 Display Assembly”](#) on page 7-10.

---

## Front Panel Troubleshooting

The front panel assembly consists of the A1 keypad, A2 display, and the A3 front panel interface. The following tests verify the operation of the front panel assembly when the analyzer is in the measurement mode. If the instrument fails to power up correctly, or it is difficult to verify due to a faulty display, refer to “Power Up Troubleshooting” on page 4-6.

Refer to the following sections to verify the operation of the noted assemblies.

- “A1 Front Panel Keypad and RPG Test” below
- “A2 Display Test” on page 4-19
- “A3 Front Panel Interface Board Assembly” on page 4-20
  - USB
  - Speaker
  - Probe Power

If all assemblies are working correctly, continue troubleshooting with “Rear Panel Troubleshooting” on page 4-21.

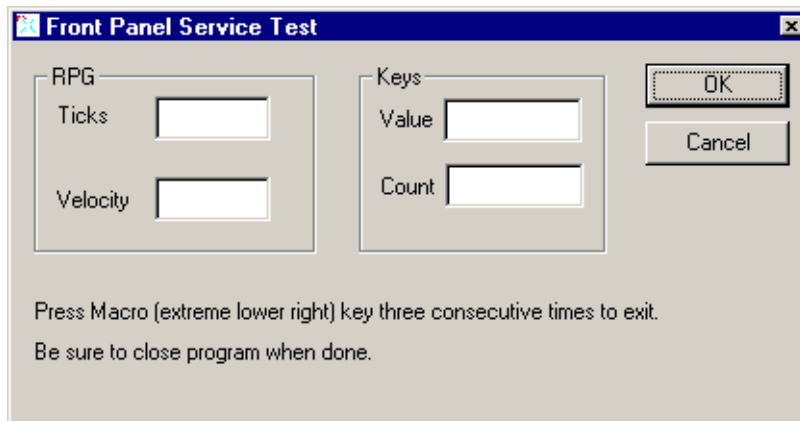
### A1 Front Panel Keypad and RPG Test

Test the front panel keypad by running the front panel test. To run the front panel test, perform the following:

On the **System** menu, point to **Service** and click **Front Panel Test**.

A **Front Panel Test** dialog box will be displayed, as shown in Figure 4-7.

**Figure 4-7 Front Panel Service Test Dialog Box**



### Checking the Front Panel Keys

To check the front panel keys, push each key and compare the decimal value in the Value box under Keys to the key values in [Table 4-6](#).

- If all the key values are correct, then the A1 front panel keypad is working. If some of the keys are not working, suspect a faulty A1 keypad assembly. To replace the A1 keypad assembly, refer to [“Removing the A1 Keypad Assembly”](#) on page 7-10.
- If none of the keys are working correctly, suspect a faulty A3 front panel interface board assembly. To replace the A3 front panel interface board assembly, refer to [“Removing the A3 Front Panel Interface Board Assembly”](#) on page 7-10.

**Table 4-6 Keyboard Key Numbers**

Key Value	Front Panel Key	Key Value	Front Panel Key	Key Value	Front Panel Key	Key Value	Front Panel Key
50	Tab ←	66	Measure Setups	82	7	98	1
51	Up ↑	67	F2	83	8	99	2
52	Tab →	68	F3	84	6	100	+/- ←
53	Window	69	F4	85	M/u	101	Not Applicable
54	OK	70	Help	86	Cancel	102	Not Applicable
55	Start/ Center	71	Trigger	87	Marker	103	Save
56	Stop/ Span	72	Average	88	Marker Table	104	Maximum Window Icon
57	Power	73	Calibrate	89	Limit Table	105	Preset
58	Down ↓	74	F1	90	4	106	0
59	Click	75	Not Applicable	91	5	107	.
60	Trace	76	9	92	3	108	Not Applicable
61	Display Configure Icon	77	G/n	93	Enter	109	Not Applicable
62	Not Applicable	78	Menu Dialog	94	Not Applicable	110	Not Applicable
63	Sweep Setup	79	Measure	95	Marker Search	111	Recall
64	Channel	80	Format	96	Marker Function	112	Print Icon
65	Sweep Type	81	Scale	97	Math/ Memory	113	Macro

## Checking the RPG (Front Panel Knob)

To check the RPG knob, rotate the knob and check for a fluid movement of numbers in the **Velocity** box.

- If the movement of numbers in the **Velocity** box is not smooth or no numbers appear at all, suspect a faulty A3 front panel interface board assembly. To replace the A3 front panel interface board assembly, refer to [“Removing the A3 Front Panel Interface Board Assembly” on page 7-10](#).

## A2 Display Test

The display should be bright with all annotations and text readable. The display test allows you to check for non-functioning pixels and other problems.

---

**NOTE** If the display is dim or dark, refer to [“Troubleshooting LCD Display Problems” on page 4-13](#).

---

### What is a Damaged Pixel?

A pixel is a picture element that combines to create the image on the display. They are about the size of a small pin point. Damaged pixels can be either “stuck on” or “dark.”

- A “stuck on” pixel is red, green, or blue and is always displayed regardless of the display setting. It will be visible on a dark background.
- A “dark” pixel is always dark and will be displayed against a background of its own color.

### How to Run the Display Test

To run the display test, perform the following:

On the **System** menu, point to **Service**, and then click **Display Test**.

A multi-color screen is displayed. Be prepared to look for the symptoms described in [“How to Identify a Faulty Display”](#), and then click the **Start Test** button. To continue to the next test, click the moving **Next Test** button. The button moves to allow you to see all of the display. After the test is completed, the display defaults to the network analyzer screen.

### How to Identify a Faulty Display

One or more of the following symptoms indicate a faulty A2 display assembly:

- a complete row or column of “stuck on” or “dark” pixels
- more than six “stuck on” pixels (but not more than three green)
- more than twelve “dark” pixels (but not more than seven of the same color)
- two or more consecutive “stuck on” pixels or three or more consecutive “dark” pixels (but no more than one set of two consecutive dark pixels)
- “stuck on” or “dark” pixels less than 6.5 mm apart (excluding consecutive pixels)

If any of these symptoms occur, replace the A2 display assembly. Refer to [“Removing the A2 Display Assembly” on page 7-10](#).

## A3 Front Panel Interface Board Assembly

This assembly performs the following functions:

- It routes USB signals between the front-panel USB connector and the A15 CPU board assembly.
- The speaker produces the audio output from signals supplied by the A15 CPU board assembly.
- It supplies power to the two front-panel probe power connectors.
- It routes key pad commands from the A1 keypad assembly to the A15 CPU board assembly.
- It routes display signals from the A15 CPU board assembly to the A2 display assembly.

### Checking the USB Port

To verify proper operation of the USB port:

- Connect a known good USB device, such as a USB mouse.
- Wait 15 seconds for the analyzer to verify the device connection, and then check the operation of the USB device.
- If the device performs correctly, the USB port is functioning properly.
- If the device does not perform correctly, the USB port is faulty. Refer to [“Removing the A3 Front Panel Interface Board Assembly”](#) on page 7-10.

### Checking the Speaker

If no audio is heard:

- Verify that the volume is set correctly and the proper sound driver is loaded; do the following:
  - On the **System** menu, point to **Configure**, and then click **Control Panel**.
- Click the **Sounds and Multimedia** icon. Follow the normal Windows procedure to check the sound drivers and volume. If the audio is still not heard, suspect a faulty speaker. Refer to [“Removing the A3 Front Panel Interface Board Assembly”](#) on page 7-10.

### Checking the Probe Power Connectors

To verify the probe power operation, refer to [“Power Supply Check”](#) on page 4-7.

### Checking the Operation of the Key Pad Commands

To verify the key pad functionality, refer to [“A1 Front Panel Keypad and RPG Test”](#) on page 4-17.

### Checking the Display

To verify the display functionality, refer to [“A2 Display Test”](#) on page 4-19.



---

## Rear Panel Troubleshooting

Each rear panel connector is associated with a hardware group in the analyzer. You can use the data at these rear panel connectors to help troubleshoot these hardware groups in addition to testing the connectors.

The connectors discussed in this section are:

- USB
- SERIAL (RS-232)
- PARALLEL (1284-C)
- VGA
- GPIB
- LAN

### Checking the USB Port

To verify proper operation of the USB port:

- Connect a known good USB device, such as a USB mouse.
- Wait 15 seconds for the analyzer to verify the device connection, and then check the operation of the USB device.
- If the device performs correctly, the USB port is functioning properly.
- If the device does not perform correctly, the A15 CPU board assembly is faulty. Refer to [“Removing and Replacing the A15 CPU Board Assembly” on page 7-24](#).

### Checking the SERIAL (RS-232), PARALLEL (1284-C) or VGA Port

To verify the proper operation of the SERIAL, PARALLEL, or VGA port:

- connect a known good serial, parallel, or VGA peripheral device.
- Wait 15 seconds for the analyzer to verify the device connection, and then check the operation of the peripheral device.
- If the peripheral device performs correctly, the port is functioning properly.
- If the peripheral device does not function properly, the A15 CPU board assembly is faulty. Refer to [“Removing and Replacing the A15 CPU Board Assembly” on page 7-24](#).

## Checking the GPIB Port

The network analyzer uses a National Instruments 488.2 GPIB controller and associated driver software. This software includes a test utility which scans the GPIB bus and returns the status of all the connected peripherals.

To run the test utility software and check the GPIB status:

1. Connect a known good peripheral to the analyzer using a known good GPIB cable.
2. On the **System** menu, point to **Configure**, and click **SCPI/GPIB**. A **SCPI/GPIB** dialog box is displayed.
3. In the **GPIB** block, menu, click **System Controller**. Wait for the instrument to configure, and then click **OK**.
4. On the **System** menu, click **Windows Taskbar** to open the **Start Menu** window.
5. On the **Start Menu** window, point to **Programs, National Instruments NI-488.2**, and then click **Explore GPIB** to open the **Measurement & Automation** window.
6. On the left side of the **Measurement & Automation** window under folders:
  - a. Click the plus sign to expand the **Measurement & Automation** folder.
  - b. Click the plus sign to expand the **Devices and Interfaces** folder.
  - c. Right click **GPIB0 (AT-GPIB/TNT)** to open a submenu.
7. On the submenu, click **Scan for Instruments** to run the test.
8. The state of all the peripherals found on the bus is returned.
9. If problems are detected, check the connections of all GPIB cables, and check all the GPIB addresses of the instruments on the bus.

---

### NOTE

#### Address Information

- Each device must have its own unique address.
- The network analyzer's default GPIB address in the controller mode is 21.
- The address set on each device must match the one recognized by the analyzer (and displayed).

Refer to the manual of the peripheral to read or change its address.

---

## Troubleshooting Systems with Controllers

Passing the preceding test indicates that the analyzer's peripheral functions are operating normally. Therefore, if the analyzer has not been operating properly with an external controller, check the following:

- The GPIB interface hardware is incorrectly installed or not operational. (Refer to the embedded help in your analyzer.)
- The programming syntax is incorrect. (Refer to the embedded help in your analyzer.)

## LAN Troubleshooting

Problems with the Local Area Network (LAN) can be difficult to solve. Software and protocol problems can make it difficult to determine whether the analyzer's hardware is working properly, or if there is a problem with the LAN or cabling.

The purpose of this section is to determine if the analyzer's hardware is functioning properly. While the turn-on self-test verifies some LAN hardware functionality, it is limited to internal testing only. Incorrect IP addresses will prevent proper operation. Improper subnet masks may allow only one-way communication, while improper gateway addresses may exclude outside LAN access.

### Ping Command

The analyzer has the built-in capability of performing a “ping” operation. Ping will request the analyzer to send a few bytes of information to a specific LAN device. That device will then signal the analyzer that it has received the information. The analyzer computes the approximate round trip time of the communication cycle and displays it. For a full test of two-way communications, a ping test should be performed in two directions.

- **First:** you should ping from the analyzer to the local area network.
- **Second:** you should ping from the local area network to the analyzer.

---

**NOTE** In the second case, any other network device capable of sending a ping command could be used, assuming it is connected to the same network. This could be a computer or even another analyzer.

---

### How to Ping from the Analyzer to the Local Area Network (LAN)

Follow the steps below to verify proper LAN operation (assuming you have a functioning LAN). If no network LAN is available, see “[Testing Between Two Analyzers](#)” on page 4-25.

1. Make sure the IP address on the analyzer is set properly and that it is unique. If unsure how to check the IP address, refer to the embedded help in the analyzer.
2. Make sure the subnet mask is 0.0.0.0. If not, note the current setting (to allow setting it back later) and then set it to 0.0.0.0.
3. Find and note the IP address of another working LAN device on the same network. Make sure this device is turned on, connected, and is functioning properly.
4. To ping the network device:
  - a. On the **System** menu, click **Windows Taskbar**.
  - b. On the **Windows Taskbar** menu, point to **Programs, Accessories**, and then click **Command Prompt**.
  - c. The command prompt window is displayed.
  - d. At the prompt, type `ping xxx.xxx.xxx.xxx1` and press **Enter** on the front panel or keyboard. Refer to Step 5 for the results of a successful ping.

---

1. The letters x represent the IP address of the other device on the network.

5. The analyzer attempts four cycles of communications with the indicated LAN device.
  - It displays the time it took to complete each cycle.
  - Each cycle times-out after one second if no communication is established and the message, Request timed out, is displayed.
  - It is common for the first of the four cycles to time-out even though subsequent cycles pass.
  - See below for an example output of a successful ping.

```
C:>ping 141.121.69.162

Pinging 141.121.69.162 with 32 bytes of data:

Reply from 141.121.69.162: bytes=32 time<10ms TTL=127
Reply from 141.121.69.162: bytes=32 time<10ms TTL=127
Reply from 141.121.69.162: bytes=32 time<10ms TTL=127
Reply from 141.121.69.162: bytes=32 time<10ms TTL=127

Ping statistics for 141.121.69.162:

    Packets: Sent = 4, Received = 4, lost = 0 <0% loss>.
Approximate round trip times in milli-seconds:
    Minimum = 0ms, Maximum = 0ms, Average = 0ms
```

6. The above message verifies that one way communication from the analyzer to the network has been established
7. If the subnet mask was changed in step 2, set it back at this time.

### How to Ping from the Local Area Network (LAN) to the Analyzer

Reverse communication should also be verified. Determining this, though, is dependent upon your network setup and software. Generally, you need to issue a ping command using the IP address of the analyzer to be tested. For example, using Windows 95, 98, 2000 and while at a DOS prompt, type in `ping xxx.xxx.xxx.xxx`<sup>1</sup>. Then press **Enter** on the front panel or keyboard. If full communication can be established, then the computer display shows the cycle time for each of four cycle attempts (similar to that in step 5). Other software may behave somewhat differently, but basically the same.

If the analyzer can talk to the network, but the network can not talk to the analyzer, then the computer or device used from the network may have a subnet mask that excludes communication with the IP address chosen for the analyzer. Any subnet mask other than 0.0.0.0 will exclude operation from some addresses. Changing the subnet mask of a computer or other device should only be attempted by a qualified network administrator. Failure to communicate due to a subnet mask incompatibility does not indicate any failure of the analyzer.

If the analyzer fails to ping in either direction, and assuming the subnet masks are set properly, then the fault must be isolated to the analyzer or to the network. Contact a qualified network administrator.

---

1. The letters x represent the IP address of the analyzer.

## Testing Between Two Analyzers

The ability of the analyzer's LAN to function can be easily tested by connecting two analyzers together using a “crossover cable” (a short length of cable with an RJ-45 connector on each end).

Some network hubs have the capability to make a crossover connection using two normal, or straight-through, cables. If this capability is not available and a crossover cable is not available, a crossover cable can be made by following the directions in “[Constructing a Crossover Cable](#)” on page 4-25.

Set the IP addresses on two analyzers. The addresses can be set to anything, but they must be different. Make sure the subnet mask and gateway addresses are set to 0.0.0.0 and that the LAN is active on both analyzers. Connect the two analyzers together using either a crossover cable or a crossover hub.

Now follow the steps in “[How to Ping from the Analyzer to the Local Area Network \(LAN\)](#)” on page 4-23 to have the first analyzer ping the second analyzer. When done, repeat the procedure having the second analyzer ping the first. If both procedures function properly, the LAN circuitry on both analyzers is verified.

If neither function properly:

- One or both IP addresses could be wrong.
- One or both LAN states could be set to off.
- The crossover cable could be miswired.
- One or both analyzers could be defective.

If possible, eliminate the possibility of a defective analyzer by substitution of a known working unit. Once the analyzer has been proven to be working properly, concentration can be placed on the network itself to determine the cause of the failure.

## Constructing a Crossover Cable

A crossover cable can be made from a standard LAN cable by connecting pin 1 from each connector to pin 3 of the other connector, and pin 2 from each connector to pin 6 of the other connector.

1. Strip away a few inches of the outside jacket insulation from the middle of a standard LAN cable that has an RJ-45 connector on each end.

---

**NOTE** Pins 1, 2, 3, and 6 of the connectors must be located to determine which wires to cut in the following steps. Most, but not all, LAN cables use the color coding listed in [Table 4-7](#). If your cable does not use this color scheme, you will have to determine the locations of the appropriate wires before proceeding with this procedure.

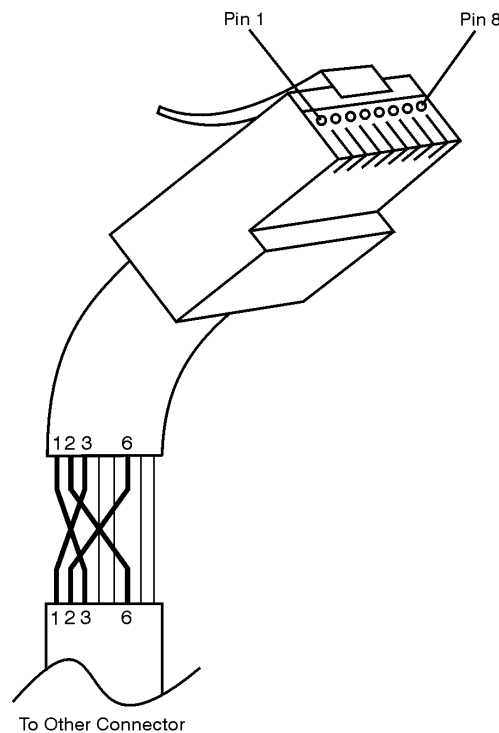
---

**Table 4-7 LAN Pin Definitions and Wire Color Codes**

Pin Number	Color	Pin Number	Color
1 (transmit +)	White/orange	5	White/blue
2 (transmit -)	Orange	6 (receive -)	Green
3 (receive +)	White/green	7	White/brown
4	Blue	8	Brown

2. Cut the wires going to pins 1, 2, 3, and 6. Strip away a small amount of insulation from each of the eight cut ends.
  - a. Connect the wire from pin 1 on one end of the cable to the wire from pin 3 on the other end of the cable.
  - b. Connect the wire from pin 3 on one end of the cable to the wire from pin 1 on the other end of the cable.
  - c. Connect the wire from pin 2 on one end of the cable to the wire from pin 6 on the other end of the cable.
  - d. Connect the wire from pin 6 on one end of the cable to the wire from pin 2 on the other end of the cable.
3. Insulate all exposed wires so that they cannot short together.
4. Label this as a crossover cable so that it cannot be confused with a standard cable.

**Figure 4-8 Construction of a Crossover Cable**



sd623c

## Measurement System Troubleshooting

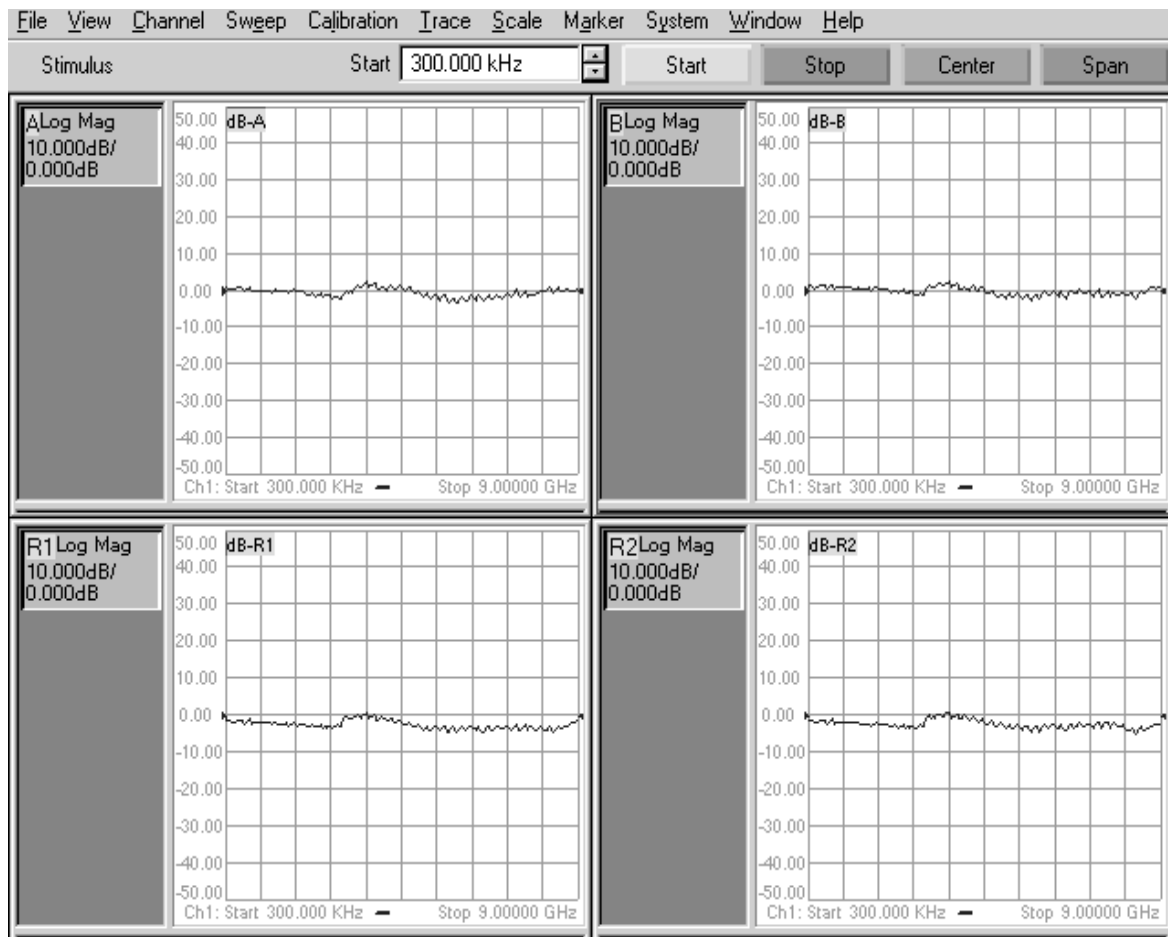
This section provides troubleshooting procedures for the measurement portion of the PNA series RF network analyzer. In this section, the analyzer is used as a tool to help isolate the suspected faulty functional group. Once the faulty functional group is determined, troubleshooting steps are provided to help you isolate the faulty assembly or part.

### Verifying the A, B, R1, and R2 Traces

The first step is to verify that the A, B, R1, and R2 traces are present and that they are approximately level:

- On the **System** menu, point to **Service, Utilities**, and then click **Receiver Display**.
- Traces A, B, R1, and R2 are displayed in four separate data windows as shown in [Figure 4-9](#). Identifying discrepancies of the traces in these windows can help you to isolate the faulty assembly.

**Figure 4-9 Typical Receiver Display**



- If all traces are present and are similar to the traces in [Figure 4-9](#), then there are no major problems with the analyzer's measurement system. There may, however, be a minor failure in the analyzer.

To test further:

- Go to [Chapter 3, "Tests and Adjustments,"](#) and perform all the tests in that section.
- If a problem still exists, contact Agilent. Refer to [Table , "Contacting Agilent,"](#) on [page 2-9](#).
- If any of the traces are not present, are noisy or distorted, or are at an incorrect level, then there is a problem with the analyzer's measurement system. Proceed to ["Where to Begin Troubleshooting."](#)

## Where to Begin Troubleshooting

For the purposes of troubleshooting, the analyzer block diagram is divided into the following functional groups:

- **the source assembly group**
  - A8 fractional-N synthesizer
  - A10 frequency reference
  - A11 phase lock
  - A12 source
  - A16 test set motherboard (circuitry pertaining to the 2nd LO and the phase-lock signal multiplexer (MUX))
- **the signal separation group**
  - A22 switch splitter
  - A25 and A26 70 dB step attenuators
  - A27 and A28 35 dB step attenuators (Option 015 only)
  - A23 and A24 test port couplers
  - Port 1, Port 2, A, B, R1, and R2 ports
- **the receiver assembly group**
  - A17 local oscillator distribution assembly (LODA)
  - A16 test set motherboard
  - A18 receiver A
  - A19 receiver R1
  - A20 receiver R2
  - A21 receiver B
  - A6 signal processing ADC module (SPAM)

Use the list on the following pages to help you determine in which analyzer functional group to begin troubleshooting.



This is by no means an exhaustive list of possible symptoms nor possible failures. It is recommended that you view the system block diagram, located at the end of this chapter, as you review the entries in this list and while performing any of the troubleshooting procedures listed.

Good judgement and established logical troubleshooting techniques must be used to complement the procedures contained in this section.

Refer to [Table 5-2, “Subsweep Frequencies”](#), on [page 5-5](#) for a list of the frequencies associated with each of the network analyzer’s seven bands (bands 0–6).

## All Traces

- *If all traces are missing in all bands*, the problem is most likely in the source assembly group or the reference (R channel) phase lock signal. This condition will be characterized by a “PHASE LOCK LOST” error message on the display.

However, a missing or disabled DSP driver may exhibit the same or similar symptoms. To verify that this DSP driver is present and enabled:

1. Click My Computer, **Properties**, **Hardware** tab, **Device Manager**. Expand **Network Adapters**. The following entry should be listed: **Agilent Technologies DSP Driver #2** and should be enabled.
  2. If the icon to the left of the name is a yellow box containing an exclamation mark (!), use Windows Explorer to verify the presence of the following file:  
C:\WINNT\system32/drivers\spampnp.sys.
  3. If you have verified that the DSP driver is present and enabled, but all traces are still missing in all bands, go to [“Checking the Source Assembly Group”](#) on [page 4-31](#).
- *If the trace faults are band-related*, the problem is in either the source assembly group or the A17 LODA. Go to [“Checking the Source Assembly Group”](#) on [page 4-31](#) and check the A8 fractional-N synthesizer board assembly outputs and the A10 frequency reference board assembly outputs. If these are OK, go to [“Checking the A17 LODA and Receiver Outputs in Bands 1 through 6”](#) on [page 4-45](#).

## R1 and A Traces

If both traces are affected, the problem is in the R1 phase lock loop.

- *If both traces are missing in all bands*, the problem is in the A16 test set motherboard assembly, the A19 channel R1 receiver module assembly, or the A22 switch splitter assembly. To determine which is at fault:
  1. Bypass the A22 switch splitter assembly using a flexible RF cable connected between the input cable W1 and the R1 output cable W6.
  2. If the R1 trace is now present, replace the A22 switch splitter assembly. If the R1 trace is still missing, reconnect the cables to the A22 switch splitter assembly.
  3. Swap the A19 channel R1 receiver module assembly with the A20 channel R2 receiver module assembly. (Each of the four receivers is identical.)
  4. If the missing trace is now R2 (still associated with the same A19 channel R1 receiver), replace the A19 channel R1 receiver module assembly. If the R1 trace is

still missing, replace the A16 test set motherboard assembly.

- ***If both traces are missing in bands 1 through 6***, (but present in band 0), the problem is with the channel R1 1st LO output of the A17 LODA. Go to [“Checking the A17 LODA and Receiver Outputs in Bands 1 through 6”](#) on page 4-45.

## R2 and B Traces

If both traces are affected, the problem is in the R2 phase lock loop.

- ***If both traces are missing in all bands***, the problem is in the A16 test set motherboard assembly, the A20 channel R2 receiver module assembly, or the A22 switch splitter assembly. To determine which is at fault:
  1. Bypass the A22 switch splitter assembly using a flexible RF cable connected between the input cable W1 and the R2 output cable W7.
  2. If the R2 trace is now present, replace the A22 switch splitter assembly. If the R2 trace is still missing, reconnect the cables to the A22 switch splitter assembly.
  3. Swap the A19 channel R1 receiver module assembly with the A20 channel R2 receiver module assembly. (Each of the four receivers is identical.)
  4. If the missing trace is now R1 (still associated with the same A20 channel R2 receiver), replace the A20 channel R2 receiver module assembly. If the R2 trace is still missing, replace the A16 test set motherboard assembly.
- ***If both traces are missing in bands 1 through 6***, (but present in band 0), the problem is with the channel R2 1st LO output of the A17 LODA. Go to [“Checking the A17 LODA and Receiver Outputs in Bands 1 through 6”](#) on page 4-45.

## R1 Trace Only

***A problem that affects only the R1 trace*** is isolated to the A19 channel R1 receiver module assembly or the A6 SPAM board assembly. Go to [“Checking the Receiver Assembly Group”](#) on page 4-45.

## R2 Trace Only

***A problem that affects only the R2 trace*** is isolated to the A20 channel R2 receiver module assembly or the A6 SPAM board assembly. Go to [“Checking the Receiver Assembly Group”](#) on page 4-45.

## A or B Trace Only

- ***If the trace is missing in all bands***, go to [“Checking the Signal Separation Group”](#) on page 4-41.
- ***If the trace is missing in bands 1 through 6***, the problem is with the channel 1st LO output of the A17 LODA. Go to [“Checking the A17 LODA and Receiver Outputs in Bands 1 through 6”](#) on page 4-45.

## Checking the Source Assembly Group

### Serial Bus Test

Before performing tests on specific assemblies in the source assembly group, it is recommended that you perform the serial bus test. This may help to isolate the failure to a specific assembly.

Through the front panel, the serial bus test allows you to check signal and voltage levels at 32 points (nodes) distributed across four of the printed circuit board assemblies in the analyzer. With this test you can isolate problem board assemblies in the analyzer. The board assemblies tested and their associated node numbers are as follows:

---

**NOTE** This test is written for a PNA series RF network analyzer as it was originally shipped from the factory. Due to changes in board production, this test may not show accurate pass/fail results if the A8, A10, A11, or A12 board assemblies have been replaced with newer board assemblies.

---

Board Assembly	Node Numbers
A12 Source Assembly	111 to 118
A10 Frequency Reference	211 to 218
A11 Phase Lock	311 to 318
A8 Fractional-N Synthesizer	411 to 418

Descriptions of each board assembly and node are included in this section. Location of the nodes is indicated with a ♦ symbol on the block diagrams located at the end of this chapter.

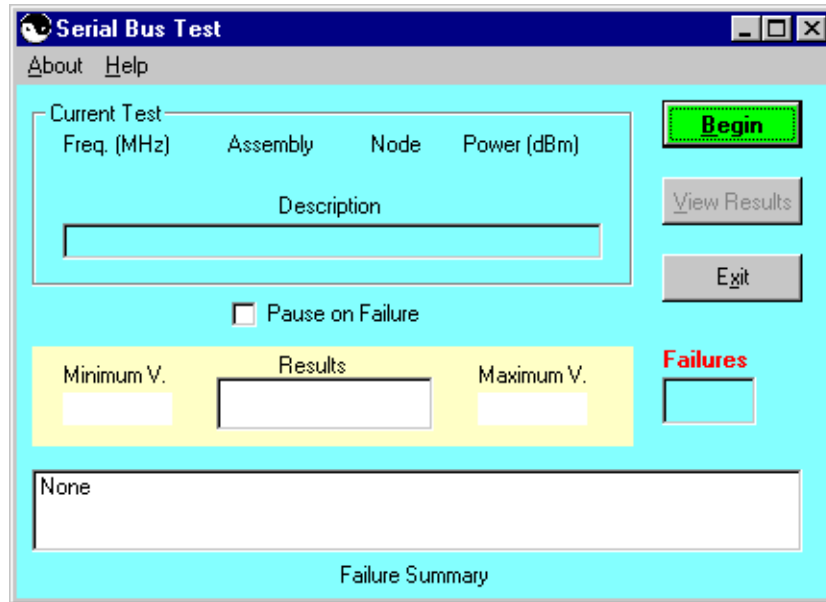
### Performing the Serial Bus Test

First, this test sequentially checks all 32 nodes at 300 kHz. Next, the test checks all nodes that change values with frequency, at eleven different frequency points. For each node, measured values are copied to an ASCII text file in the service directory on the hard disk drive. Any measured values that exceed the tolerances are highlighted in the application and the data file.

To run the serial bus test:

- On the **System** menu, point to **Service**, and then click **Serial Bus Test**.
- The dialog box in [Figure 4-10 on page 4-32](#) is displayed. Click **Begin** to start the test.

Figure 4-10 Serial Bus Test Dialog Box



### Node Descriptions, A12 Source Assembly

- Node 111**     ***ALC integrator*** Node 111 senses the output of the ALC integrator. The output of the ALC integrator is the combined voltage output of all compensation circuits in the ALC. The voltage level varies with frequency and output power.
- Node 112**     ***Level Output*** Node 112 senses the output of the detector log amp in the ALC.
- Node 113**     ***Detector Level*** Node 113 senses the power level of the internal detector signal from the A22 switch splitter or the power level from the external detector from the rear panel.
- Node 114**     ***-1V/GHz Compensation*** Node 114 senses the inverse of the -1V/GHz signal that comes from the A11 phase lock board. The -1V/GHz compensates for first-order power changes of the YIG oscillator with respect to frequency.
- Node 115**     ***Temperature Compensation*** Node 115 senses the output of thermistor circuitry that compensates for changes in operating temperature of the YIG oscillator.
- Node 116**     ***Power DAC*** Node 116 senses the output voltage of the power DAC. This output is summed with other compensation signals to control the source output level. The power DAC has the most influence of the compensation signals.
- Node 117**     ***Power Amplifier Compensation*** Node 117 senses the voltage compensation for the source output power amplifiers. This compensation is set for each source band.

**Node 118**     ***Permanent Magnet YIG Oscillator (PMYO) DAC*** Node 118 senses the output voltage of the DAC that sets the frequency of the 3.8 GHz PMYO.

#### **Node Descriptions, A10 Frequency Reference Board Assembly**

**Node 211**     ***100 MHz Tune*** Node 211 senses the tune voltage that phase locks the 100 MHz VCO. The tune voltage is set by referencing the 100 MHz VCO to the internal 10 MHz OCXO or to the 10 MHz EXT REF.

**Node 212**     ***100 MHz Level*** Node 212 senses the average voltage output level of the 100 MHz VCO phase locked reference signal.

**Node 213**     ***100.167 MHz Tune*** Node 213 senses the tune voltage that phase locks the 100.167 MHz VCO. The tune voltage is set by referencing the 100 MHz VCO.

**Node 214**     ***100.167 MHz level*** Node 214 senses the average voltage output level of the 100.167 MHz reference VCO.

**Node 215**     ***External Reference Detect*** Node 215 senses a TTL signal which is used to set the reference frequency switch. The node registers a low TTL voltage when the internal 10 MHz OCXO signal is used or a high TTL voltage when the external 10 MHz EXT REF is used.

**Node 216**     ***4 MHz 2nd LO Average Voltage*** Node 216 senses the average voltage of the 4 MHz 2nd LO signal that is routed to the A16 test set motherboard assembly. This voltage is constant through bands 1 and 6. There is no voltage present in band 0.

**Node 217**     ***Phase Lock Average Voltage*** Node 217 senses the average voltage of the phase lock reference signal that is routed to the A11 phase lock board assembly. This voltage is constant through bands 1 and 6. There is no voltage present in band 0.

**Node 218**     ***1 MHz Average Voltage*** Node 218 senses the average voltage of the 1 MHz reference signal for the 100.167 MHz reference signal. This voltage is constant in all bands.

#### **Node Descriptions, A11 Phase Lock Board Assembly**

**Node 311**     ***30 kHz Phase Detector*** Node 311 senses the average voltage of the band 0 phase comparator at the output of a 30 kHz low pass filter. This signal path is not used in Bands 1 through 6.

**Node 312**     ***100 kHz Phase Detector*** Node 312 senses the average voltage of the Bands 1 through 6 phase comparator at the output of a 100 kHz low pass filter. This signal path is not used in Band 0.

**Node 313**     ***30 kHz Phase Detector Integrator*** Node 313 senses the tune voltage that phase locks the source in band 0. The integrator that supplies this signal receives its input from the 30 kHz phase detector (Node 311).

- Node 314**     ***100 kHz Phase Detector Integrator*** Node 314 senses the tune voltage that phase locks the source in Bands 1 through 6. The integrator that supplies this signal receives its input from the 100 kHz phase detector (Node 312).
- Node 315**     ***1V/GHz YTO Drive Voltage*** Node 315 senses the YIG tuned oscillator drive voltage which sweeps at 1V/GHz.
- Node 316**     ***YTO Drive Current*** Node 316 senses the YIG-tuned oscillator drive current.
- Node 317**     ***YTO Tune Compensation*** Node 317 senses the voltage output of the YTO tune compensation summation node.
- Node 318**     ***Ground*** Node 318 is connected to digital ground to serve as a measurement reference.

#### **Node Descriptions, A8 Fractional-N Synthesizer Board Assembly**

- Node 411**     ***+ 5 Vdc Supply Voltage*** Node 411 senses the 5 Vdc supply voltage which serves as a measurement reference.
- Node 412**     ***1.5 to 3.0 GHz VCO Compensation*** Node 412 senses the average voltage output level of the 1.5 to 3.0 GHz VCO.
- Node 413**     ***1.5 to 3.0 GHz VCO Tune Voltage*** Node 413 senses the average voltage input level of the 1.5 to 3.0 GHz VCO.
- Node 414**     ***Heterodyne Band ALC Level*** Node 414 senses the ALC output voltage which is used to level the heterodyne circuit output for band 1.
- Node 415**     ***2.250 GHz VCO Tune Voltage*** Node 415 senses the average voltage input level of the 2.250 GHz VCO.
- Node 416**     ***Fundamental and Divide-by-2 Band ALC Level*** Node 416 senses the ALC output voltage which is used to level the heterodyne circuit output for bands 2-6.
- Node 417**     ***2.250 GHz VCO Compensation*** Node 417 senses the average voltage output level of the 2.250 GHz VCO.
- Node 418**     ***ALC Level Adjust*** Node 418 senses the voltage which is used to set the offset on the heterodyne band ALC.

## Source Assembly Tests

---

**NOTE** A defective A22 switch splitter assembly can exhibit the same symptom as a faulty source. Therefore, if it is determined that the source is functioning properly in [“Checking the Source Assembly Group” on page 4-31](#), you are directed to [“Checking the Signal Separation Group” on page 4-41](#).

---

### Equipment Used for These Tests

Use a spectrum analyzer to check the signals of the source assembly group.

Equipment Type	Part Number
Spectrum analyzer <sup>1</sup>	8561E
Power Meter	E4418B or E4419B
Power Sensor	E4412A
RF Cable, SMA	Any
Adapter, type-N to SMA female	Any
Adapter, SMB female to SMA female	Any

1. Alternate: any 856xE spectrum analyzer.

### Getting Ready to Test

Before checking the assemblies, you must open the analyzer.

---

**CAUTION** Use an antistatic work surface and wrist strap to reduce the chance of electrostatic discharge for all of the procedures in this chapter.

---

1. Turn off the analyzer power.
2. Unplug the power to the analyzer and disconnect all rear panel connections.
3. Remove the covers from the analyzer. Refer to [“Removing the Covers” on page 7-6](#).
4. With the covers off, plug in the analyzer and turn on the power.

### Single vs. Broadband Failure

There are two main types of failures that are related to the source group. The failures are classified as:

- single band
- broadband

Single band failures are indicated by all four channel traces having partial dropouts across the frequency range or intermittent phase lock problems. Troubleshooting information is provided in the paragraph titled “If the trace faults are band-related” under [“All Traces” on page 4-29](#).

Broadband failures are indicated by all four channel traces being in the noise floor. Most often this is due to problems in the phase lock signal path and will be characterized by a “PHASE LOCK LOST” error message on the display.

A phase lock problem is due to either:

- bad frequency accuracy (caused by the A8, A10, or A11 assembly), or
- bad power level (caused by the A12 assembly)

To isolate a broadband failure to either the A8 or A10 board assembly, refer to the data obtained from the “[Serial Bus Test](#)” on page 4-31.

- If the data obtained for the A10 frequency reference board assembly is out of tolerance, replace the A10 board assembly.
- If the data obtained for the A10 frequency reference board assembly is correct but the data for the A8 fractional-N synthesizer board assembly is out of tolerance, replace the A8 board assembly.

To isolate a broadband failure to either the A11 or A12 board assembly:

- Connect a power meter and power sensor to Port 1 of the analyzer.
- On the analyzer, press **Preset**, set the **Center Frequency** to **2 GHz**, and the **Frequency Span** to **0 Hz**.

In the unlocked state, the analyzer will “search” for the reference signal. The output power, as indicated on the power meter, will vary  $\pm\pm 5$  dBm.

- If the output power is approximately  $\pm 5$  dBm, the problem is frequency related, replace the A11 phase lock board assembly.
- If the output power is at or below the minimum power level for the power sensor, the problem is power related, replace the A12 source assembly.



### Checking the A10 5 MHz Reference Output

1. Refer to the block diagram at the end of this chapter and to [“Top Cables” on page 6-16](#). Locate flexible cable W41, at the A10 frequency reference board assembly.
2. Disconnect W41 from A10J10.
3. Connect the spectrum analyzer to A10J10.
4. The spectrum analyzer should measure a signal at 5 MHz.
5. If no 5 MHz signal is present, replace the A10 frequency reference board assembly. Refer to [“Removing and Replacing the A6, A8, and A10 Board Assemblies” on page 7-16](#).
6. If the 5 MHz signal is present, reconnect cable W41, then continue with [“Checking the A10 Phase Lock Reference Output” on page 4-37](#).

### Checking the A10 Phase Lock Reference Output

1. Refer to the block diagram at the end of this chapter and [“Top Cables” on page 6-16](#). Locate flexible cable W39 at the A10 frequency reference board assembly.
2. Disconnect W39 from A10J5.
3. Connect the spectrum analyzer to A10J5.
4. Verify the phase lock reference output for band 0 and bands 1 through 6. For each network analyzer CW setting in [Table 4-8](#), verify the spectrum analyzer measurement result at A10J5.

**Table 4-8 Network Analyzer Settings and Measurement Results**

Band Number	Network Analyzer Setting (CW Frequency)	Spectrum Analyzer Measurement Result
Band 0	9.9 MHz	9.9 MHz
Band 1 through 6	1 GHz	1.04166 MHz

---

**NOTE** In band 0, the network analyzer attempts to lock to a higher band. Therefore, the spectrum analyzer shows a multitude of signals while it attempts to lock. The 9.9 MHz signal shows up as a strong signal for a short time before attempting to lock.

---

5. If the signals are not present for either band condition, replace the A10 frequency reference board assembly. Refer to [“Removing and Replacing the A6, A8, and A10 Board Assemblies” on page 7-16](#).
6. If the signals are present, reconnect cable W39, then continue with [“Checking the 2nd LO at the A10 Frequency Reference for Band 0” on page 4-38](#).

### Checking the 2nd LO at the A10 Frequency Reference for Band 0

Perform this procedure if the problem is in one of the receiver channels and appears to be a band related problem.

1. Refer to the block diagram at the end of this chapter and to [“Top Cables” on page 6-16](#). Locate the flexible cable W36 at the A10 frequency reference board assembly.
2. Disconnect the flexible cable W36 at A10J7.
3. Connect the spectrum analyzer to A10J7.
4. Set the network analyzer to measure a CW signal at 5 MHz and the spectrum analyzer to measure a signal at 20.167 MHz.
5. If the 20.167 MHz signal is not present, replace the A10 frequency reference board assembly. Refer to [“Removing and Replacing the A6, A8, and A10 Board Assemblies” on page 7-16](#).
6. If the signal is present, reconnect cable W36, then go to [“Checking the Receiver Outputs and Option 015 Attenuators in Band 0” on page 4-46](#).

### Checking the 2nd LO at the A10 Frequency Reference for Bands 1 through 6

Perform this procedure if a problem is in one of the receiver channels and appears to be a band related problem.

1. Refer to the block diagram at the end of this chapter and to [“Top Cables” on page 6-16](#). Locate the flexible cable W35 at the A10 frequency reference board assembly.
2. Disconnect the flexible cable W35 at A10J4.
3. Connect the spectrum analyzer to A10J4.
4. Set the network analyzer to measure a 1 GHz CW signal and the spectrum analyzer to measure a 4 MHz signal.
5. If the signal is not present, replace the A10 frequency reference board assembly. Refer to [“Removing and Replacing the A6, A8, and A10 Board Assemblies” on page 7-16](#).
6. If the signal is present, reconnect cable W35, then go to [“Checking the Receiver Outputs and Option 015 Attenuators in Band 0” on page 4-46](#).

### Checking the A8 Fractional-N Synthesizer Band 0 Output

1. Refer to the block diagram at the end of this chapter and to [“Top Cables” on page 6-16](#). Locate the flexible cable W37, at the A8 fractional-N synthesizer board assembly.
2. Disconnect W37 from A8J102.
3. Connect the spectrum analyzer to A8J102.
4. Set the network analyzer to measure a CW signal at 5 MHz CW and the spectrum analyzer to measure a signal at 120.16 MHz.
5. If the 120.16 MHz signal is not present and the 5 MHz reference signal is present from [“Checking the A10 5 MHz Reference Output,”](#) replace the A8 fractional-N synthesizer board assembly. Refer to [“Removing and Replacing the A6, A8, and A10 Board Assemblies” on page 7-16](#).

- If the 120.16 MHz signal is present, reconnect cable W37, then continue with “[Checking the A8 Fractional-N Synthesizer Band 1 Output](#)” on page 4-39.

### Checking the A8 Fractional-N Synthesizer Band 1 Output

Perform this procedure if you observe a problem in band 1 in all receivers.

- Refer to the block diagram at the back of this chapter and to “[Top Cables](#)” on page 6-16. Locate semirigid cable W20, at the A8 fractional-N synthesizer board assembly.

---

**CAUTION** Be careful not to damage the center pins of the semirigid cable. Some flexing of the cables is necessary to measure the output.

---

- Using a 5/16-inch torque wrench, disconnect W20 at A8J101.
- Connect the spectrum analyzer to A8J101.
- Set the network analyzer to measure a CW signal at 500 MHz and the spectrum analyzer to measure a signal at 501.04 MHz.
- If this signal is not present, replace the A8 fractional-N synthesizer board assembly. Refer to “[Removing and Replacing the A6, A8, and A10 Board Assemblies](#)” on page 7-16.
- If the signal is present, reconnect cable W20, then continue with “[Checking the A8 Fractional-N Synthesizer Bands 2 through 6 Output](#)” on page 4-39.

### Checking the A8 Fractional-N Synthesizer Bands 2 through 6 Output

Perform this procedure if you observe a problem in bands 2 through 6 in all receivers.

- Refer to the block diagram at the end of this chapter and to “[Top Cables](#)” on page 6-16. Locate semirigid cable W19, at the A8 fractional-N synthesizer board assembly.

---

**CAUTION** Be careful not to damage the center pins of the semirigid cable. Some flexing of the cables is necessary to measure the output.

---

- Using a 5/16-inch torque wrench, disconnect W19 at A8J106.
- Connect the spectrum analyzer to A8J106.
- For each network analyzer CW setting listed in [Table 4-9](#), verify the spectrum analyzer measurement result at A8J106.

**Table 4-9 Network Analyzer Settings and Measurement Results**

Band Number	Network Analyzer Setting (CW Frequency)	Spectrum Analyzer Measurement Result
Band 2	1 GHz	1001.04 MHz
Band 3	2 GHz	2001.04 MHz
Band 4	4 GHz	1333.68 MHz
Band 5	6 GHz	2000.35 MHz
Band 6	8 GHz	2667.01 MHz

5. If the signals are not present, replace the A8 fractional-N synthesizer board assembly. Refer to [“Removing and Replacing the A6, A8, and A10 Board Assemblies”](#) on page 7-16.
6. If the signals are present, reconnect cable W19, then continue with [“Checking the A11 Phase Lock YTO Tune Output”](#) on page 4-40.

### **Checking the A11 Phase Lock YTO Tune Output**

1. Perform the Serial Bus Test. Refer to [“Serial Bus Test”](#) on page 4-31.
2. Examine the “Phase Lock, Node 315” entry in the test results.
3. If the result at Node 315 passes the test, the A12 source assembly is faulty; replace it. Refer to [“Removing and Replacing the A12 Source Assembly”](#) on page 7-20.
4. If the result at Node 315 fails the test, the A11 phase lock board assembly is faulty; replace it. Refer to [“Removing and Replacing the A11 Phase Lock Board Assembly”](#) on page 7-18.

## Checking the Signal Separation Group

Before checking the signal separation group, perform the following procedures:

- [“Getting Ready to Test” on page 4-35](#)

### Checking the Output Power of the A and B Signals

Using a power meter, you can measure the outputs of the A and B signals from the front panel. The measurement results will help you isolate a faulty assembly. The outputs of the R1 and R2 channels cannot be measured because it would necessitate breaking the phase lock loop, causing all of the signals to be lost.

### Equipment Used for These Tests

Equipment Type	Part Number
Power meter	E4418B or E4419B
Power sensor	E4412A

### Equipment Setup

1. Before starting these checks, zero and calibrate the power meter. (See the power meter user’s guide for instructions on setting the calibration factor.)
2. If the **Receiver Display** ([Figure 4-9](#)) is not on the analyzer screen, perform the following: On the **System** Menu, point to **Service, Utilities**, and then click **Receiver Display**.
3. Set the sweep speed for a 10 second sweep: On the **Sweep** menu, click **Sweep Time** and set the time to 10.000 seconds in the **Sweep Time** box.

### Checking Port 1 Power (A Signal)

The object of this check is to verify the power of the A signal across the entire frequency range. Perform this test if there is an observed problem only with the channel A trace. The ten second sweep is slow enough to allow you to observe the output power on the power meter as the sweep occurs.

1. Connect the power sensor to Port 1.
2. Set the network analyzer controls to perform an  $S_{11}$  measurement.
3. Observe the power reading on the power meter as the sweep occurs on the analyzer.
4. The measured output power on the power meter should be within  $\pm 1.0$  dBm over the entire frequency range.
  - If the measured power is correct, go to [“Checking the Receiver Assembly Group” on page 4-45](#).
  - If the measured power is not correct, go to [“Checking the Signal through the Signal Separation Path” on page 4-43](#).

### Checking Port 2 Power (B Signal)

The object of this check is to verify the power of the B signal across the entire frequency range. Perform this test if there is an observed problem only with the channel B trace. The ten second sweep is slow enough to allow you to observe the output power on the power meter as the sweep occurs.

1. Connect the power sensor to Port 2.
2. Set the network analyzer controls to perform an  $S_{22}$  measurement.
3. Observe the power reading on the power meter as the sweep occurs on the analyzer.
4. The measured output power on the power meter should be within  $\pm 1.0$  dBm over the entire frequency range.

## Checking the Signal through the Signal Separation Path

Refer to the block diagram at the end of this chapter and to “[Bottom Assemblies and Hardware, Standard](#)” on page 6-12 for these checks.

Port 1 trace loss in the signal separation group is due to one or more of the following assemblies being defective:

- A22 switch splitter assembly
- A25 70 dB step attenuator
- A23 test port 1 coupler

Port 2 trace loss in the signal separation group is due to one or more of the following assemblies being defective:

- A22 switch splitter assembly
- A26 70 dB step attenuator
- A24 test port 2 coupler

## Equipment Used for These Tests

Use a spectrum analyzer to check the signals of the signal separation group.

Equipment Type	Part Number
Spectrum analyzer <sup>1</sup>	8561E
RF cable, SMA	Any
Adapter, type-N male to SMA female	Any

1. Alternate: any 856xE spectrum analyzer.

To determine which assembly is defective, check the signal at each available measurement point in the signal path from the A22 switch splitter assembly to the test port coupler.

For Port 1 measurements, set the network analyzer for an  $S_{11}$  measurement with a CW frequency of 1GHz.

For Port 2 measurements, set the network analyzer for an  $S_{22}$  measurement with a CW frequency of 1 GHz.

Perform “[Checking the A22 Switch Splitter Assembly](#)” and “[Checking the Step Attenuators and Test Port Couplers](#)” in the order presented.

### Checking the A22 Switch Splitter Assembly

1. Locate the semirigid cable (W2 for Port 1 or W3 for Port 2) at the A22 switch splitter assembly.
2. Using a 5/16-inch torque wrench, disconnect the semirigid cable at the A22 switch splitter assembly.
3. Connect the spectrum analyzer to the connector. Set the spectrum analyzer to measure a signal at 1GHz.
4. If the 1 GHz signal is not present, replace the A22 switch splitter assembly. Refer to [“Removing and Replacing the A22 Switch Splitter Assembly”](#) on page 7-32.
5. If the 1 GHz signal is present, reconnect the cable disconnected in step 2, then continue with [“Checking the Step Attenuators and Test Port Couplers”](#) on page 4-44.

### Checking the Step Attenuators and Test Port Couplers

1. Refer to the block diagram at the end of this chapter and to [“Bottom Assemblies and Hardware, Standard”](#) on page 6-12.

For Port 1 checks, locate the semirigid cable W4, at the A25 70 dB step attenuator.

For Port 2 checks, locate the semirigid cable W5, at the A26 70 dB step attenuator.

2. Using a 5/16-inch torque wrench, disconnect the semirigid cable at the step attenuator.
3. Connect the spectrum analyzer to the step attenuator connector. Set the spectrum analyzer to measure a signal at 1 GHz.
4. If the 1 GHz signal is not present, replace the appropriate 70 dB step attenuator. Refer to [“Removing and Replacing the A25 and A26 70 dB Step Attenuators”](#) on page 7-36.
5. If the 1 GHz signal is present, replace the appropriate test port coupler. Refer to [“Removing and Replacing the A23 and A24 Test Port Couplers”](#) on page 7-34.



## Checking the Receiver Assembly Group

### Equipment Used for These Tests

Use a spectrum analyzer to check the receiver assembly group.

Equipment Type	Part Number
Spectrum analyzer <sup>1</sup>	8561E
RF cable, SMA	Any
Adapter, type-N male to SMA female	Any

1. Alternate: any 856xE spectrum analyzer.

### Getting Ready to Test

Before checking the assemblies, you must open the analyzer.

---

**CAUTION** Use an antistatic work surface and wrist strap to reduce the chance of electrostatic discharge for all of the procedures in this chapter.

---

1. Turn off the analyzer power.
2. Unplug the power to the analyzer and disconnect all rear panel connections.
3. Remove the covers from the analyzer. Refer to [“Removing the Covers” on page 7-6](#).
4. With the covers off, plug in the analyzer and turn on the power.

### Checking the A17 LODA and Receiver Outputs in Bands 1 through 6

Perform this procedure if you observe a problem in bands 1 through 6 but not band 0.

1. Refer to the block diagram at the end of this chapter and to [“Bottom Cables, Standard” on page 6-18](#). Locate the semirigid cables W15, W16, W17, and W18 at the A17 local oscillator distribution assembly (LODA).

---

**CAUTION** Be careful not to damage the center pins of the semirigid cable. Some flexing of the cables is necessary to measure the output.

---

2. Using a 5/16-inch torque wrench, disconnect the semirigid cable associated with the faulty channel, from the A17 LODA.
3. Connect the spectrum analyzer to the connector to which this cable was connected.
4. For each network analyzer CW setting listed in [Table 4-10](#), verify the spectrum analyzer measurement result at the A17 LODA.
5. If the signals are not present, replace the A17 LODA. Refer to [“Removing and Replacing the A17 Local Oscillator Distribution Assembly \(LODA\)” on page 7-28](#).
6. If the signals are present, reconnect the cable disconnected in step 2, then verify that the 2nd LO signal is present. Refer to [“Checking the 2nd LO at the A10 Frequency Reference for Bands 1 through 6” on page 4-38](#)

7. If the 1st LO signal from the A17 LODA is present and the 2nd LO signal from the A10 frequency reference board assembly is present, then the problem must be either the A16 test set motherboard assembly or a receiver. To determine which is at fault:
  - a. Replace the suspect receiver with a known good receiver. You can use a known good receiver from the same analyzer because they are all identical. Refer to [“Removing and Replacing the A18, A19, A20, and A21 Receiver Module Assemblies”](#) on page 7-30.
  - b. If the error still occurs, replace the A16 test set motherboard assembly. Refer to [“Removing and Replacing the A16 Test Set Motherboard Assembly”](#) on page 7-26.
  - c. If the replacement receiver functions properly, replace the faulty receiver.

**Table 4-10 Network Analyzer Settings and Measurement Results**

Band Number	Network Analyzer Setting (CW Frequency)	Spectrum Analyzer Measurement Result
Band 1	500MHz	501.04 MHz
Band 2	1 GHz	1001.04 MHz
Band 3	2 GHz	2001.04 MHz
Band 4	4 GHz	1333.68 MHz
Band 5	6 GHz	2000.35 MHz
Band 6	8 GHz	2667.01 MHz

### Checking the Receiver Outputs and Option 015 Attenuators in Band 0

Perform this procedure if a problem appears to be in one of the receiver channels.

1. Set the network analyzer to measure a signal at 5 MHz (Band 0).
2. Refer to the block diagram at the end of this chapter and to [“Bottom Cables, Standard”](#) on page 6-18. Locate the flexible cable at each receiver IF output (W31, W32, W33 and W34).
3. Disconnect the flexible cable at the suspect receiver.
4. Connect the spectrum analyzer to the suspect receiver connector.
5. The measured signal on the spectrum analyzer should be at 41.667 kHz.
6. If the measured signal is present, replace the A6 SPAM board assembly. Refer to [“Removing and Replacing the A6, A8, and A10 Board Assemblies”](#) on page 7-16.
7. If the measured signal is not present, verify the receiver operation:
  - a. Replace the suspect receiver with a known good receiver. You can use a known good receiver from the same analyzer as they are all identical. Refer to [“Removing and Replacing the A18, A19, A20, and A21 Receiver Module Assemblies”](#) on page 7-30.
  - b. If the signal is present after replacing the receiver, replace the suspect receiver.

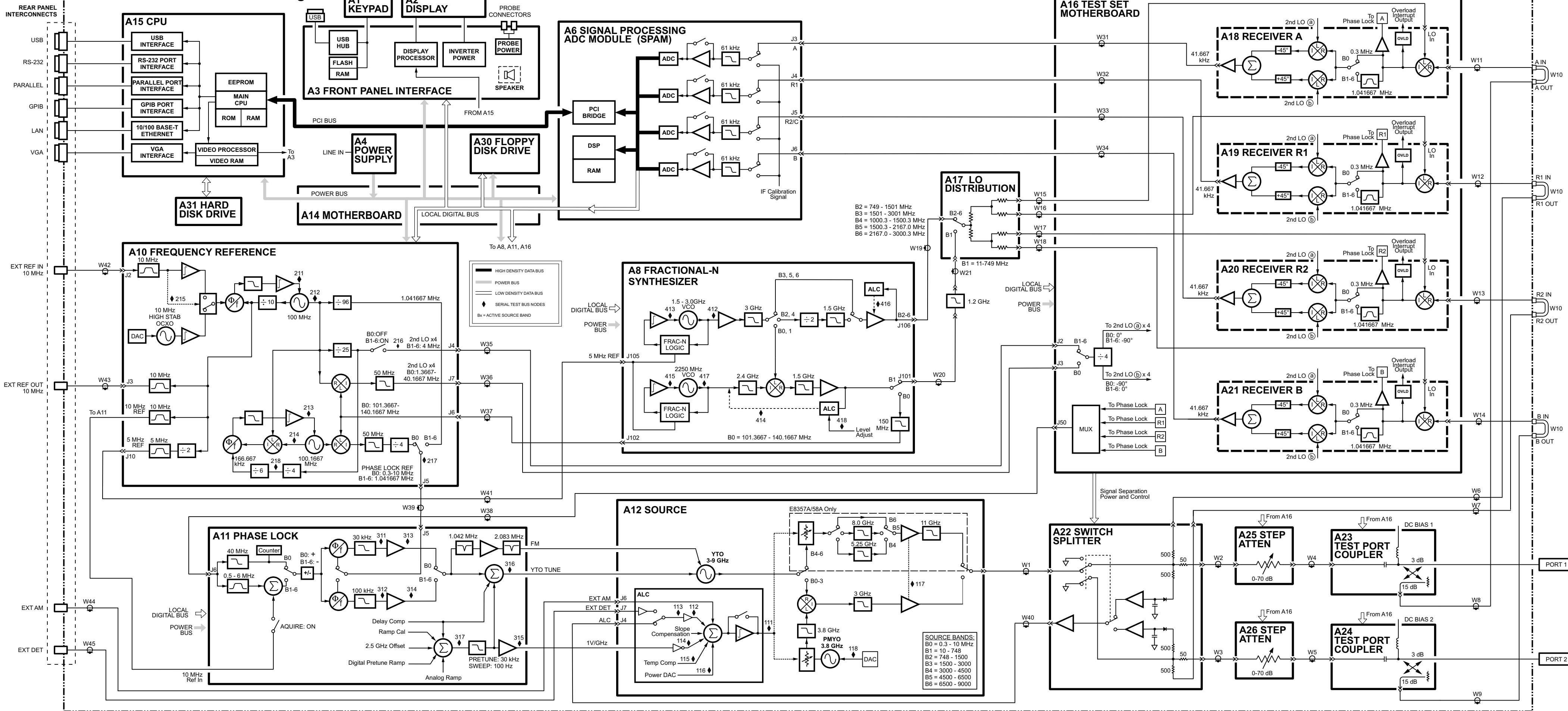
8. If the measured signal is still not present, and Option 015 IS NOT installed or the suspected faulty channel IS NOT channel A or channel B, replace the A16 test set motherboard assembly. Refer to [“Removing and Replacing the A16 Test Set Motherboard Assembly”](#) on page 7-26.

If the measured signal is still not present, and Option 015 IS installed, and the suspected faulty channel IS channel A or channel B, verify the step attenuator operation:

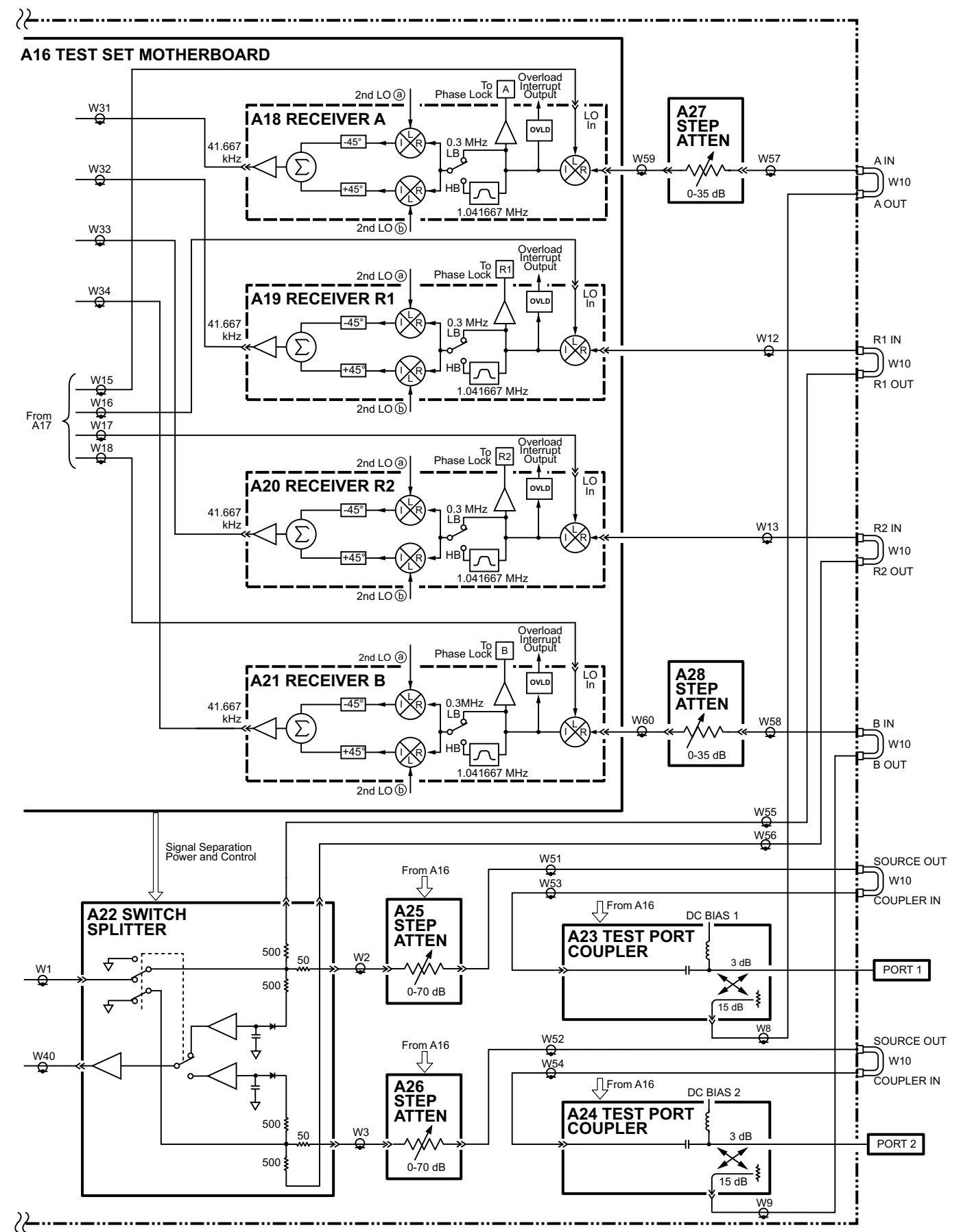
- a. Replace the step attenuator with a known good attenuator. You can use the other receiver step attenuator (if that channel is functioning properly), as they are identical. Refer to [“Option 015, Removing and Replacing the A27 and A28 35 dB Step Attenuators”](#) on page 7-38.
  - b. If the signal is present after the attenuator is replaced, replace the suspect step attenuator.
9. If the signal is still not present after the attenuator is replaced, replace the A16 test set motherboard assembly. Refer to [“Removing and Replacing the A16 Test Set Motherboard Assembly”](#) on page 7-26.



# E8356A/57A/58A Overall Block Diagram







sc855a  
23 March 2004



E8356A/57A/58A Partial Block Diagram - Opt. 015  
Service Guide E8356-90002





---

## **5 Theory of Operation**

---

## Information in This Chapter

This chapter provides a general description of the operating theory of the PNA series RF network analyzers (E8356A, E8357A, and E8358A). Theory of operation is explained to the assembly level only; component-level circuit theory is not provided. Simplified block diagrams are included for each functional group. More detailed block diagrams are located at the end of [Chapter 4, “Troubleshooting.”](#)

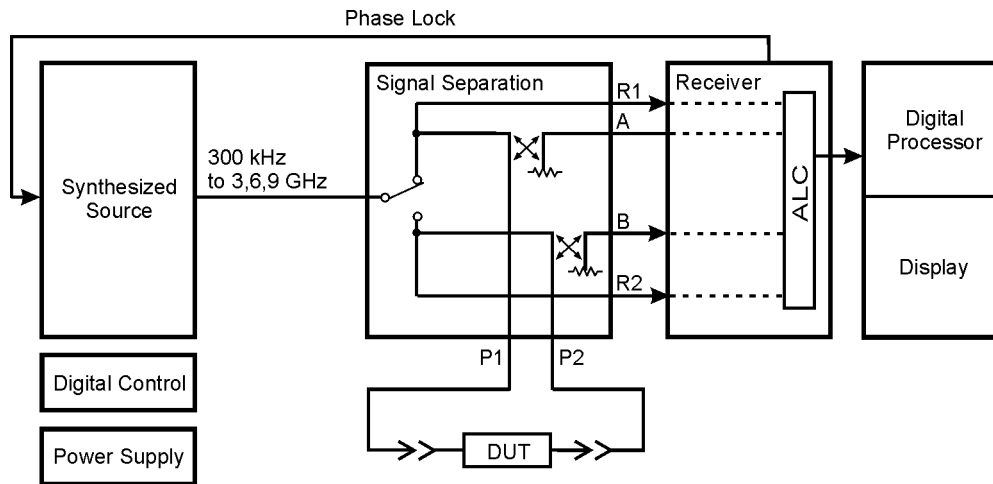
### Chapter Five at-a-Glance

Section Title	Summary of Content	Start Page
<a href="#">Network Analyzer System Operation</a>	A summary of the theory of operation for the analyzer.  A summary of the operation of the five functional groups of the analyzer.	<a href="#">Page 5-3</a>
<a href="#">Source Group Operation</a>	Operation of the assemblies associated with the source group.	<a href="#">Page 5-5</a>
<a href="#">Signal Separation Group Operation</a>	Operation of the assemblies associated with signal separation, including the operation of Option 015.	<a href="#">Page 5-10</a>
<a href="#">Receiver Group Operation</a>	Operation of the assemblies associated with the receiver group.	<a href="#">Page 5-15</a>
<a href="#">Digital Processing and Digital Control Group Operation</a>	Operation of the assemblies associated with digital processing and control.	<a href="#">Page 5-22</a>
<a href="#">Power Supply Group Operation</a>	Operation of the power supply assembly group.	<a href="#">Page 5-26</a>

## Network Analyzer System Operation

The PNA series network analyzer generates a phase-locked incident signal from the internal synthesized source. By means of signal separation, the incident signal is divided into a reference signal and a test signal. The reference signal is applied to the receiver group, while the test signal is applied to the device under test (DUT) and then to the receiver group. The signals are downconverted and are next sampled and digitally processed. Figure 5-1 is a simplified block diagram of the network analyzer system.

Figure 5-1 System Simplified Block Diagram



sc858a

## Functional Groups of the Network Analyzer

The operation of the network analyzer can be separated into five functional groups. Each group consists of several major assemblies that perform a distinct function in the instrument. Some of the assemblies are related to more than one group, and all the groups, to some extent, are interrelated and affect each other's performance. The five major functional groups are:

- synthesized source group
- signal separation group
- receiver group
- digital processor and digital control group
- power supply group

## Synthesized Source Group

The built-in synthesized source generates a swept, stepped, or continuous wave (CW) signal in the frequency ranges as listed in Table 5-1. The source output power is leveled by an internal automatic leveling control (ALC) circuit. A portion of the source signal is routed to one of the reference receivers (R1 or R2), and fed back to the source for phase lock. The maximum output power level of the network analyzer at the test ports is shown in Table 5-1. The operation of the source functional group is described in [“Source Group Operation” on page 5-5](#).

**Table 5-1 Frequency Range and Maximum Output Power Level**

Parameter	E8356A	E8357A	E8358A	
Frequency Range	300 kHz to 3.0 GHz	300 kHz to 6.0 GHz	300 kHz to 6.0 GHz	6.0 GHz to 9.0 GHz
Maximum Output Power	+10 dBm	+10 dBm	+10 dBm	+5 dBm

## Signal Separation Group

The source signal is separated into a reference path and a test path. The reference signal is transmitted to the receiver group. The test signal is transmitted through—and reflected from—the DUT and then is transmitted to the receiver group. The signal separation group also provides attenuation for the test signals, RF path switching to allow forward and reverse measurements, and external connections for the DUT. The operation of the signal separation functional group is described in [“Signal Separation Group Operation” on page 5-10](#).

## Receiver Group

The receiver converts the test signal to a 41 kHz intermediate frequency (IF) for signal processing, retaining both magnitude and phase characteristics. The IF is converted to digital signals by the digital processing group. The operation of the receiver functional group is described in [“Receiver Group Operation” on page 5-15](#).

## Digital Processor and Digital Control Group

The digital processor and digital control group are divided into a front panel group and a data acquisition and processing group. The front panel group provides communication to the network analyzer. The data acquisition and processing group provides signal processing and analyzer control, and output to the display. The operation of the digital processing and control functional group is described in [“Digital Processing and Digital Control Group Operation” on page 5-22](#).

## Power Supply Group

The power supply functional group provides power for the other assemblies in the instrument. The operation of this functional group and its assemblies is described in [“Power Supply Group Operation” on page 5-26](#).

## Source Group Operation

The source group produces a stable output signal by phase locking a yttrium-iron-garnet (YIG) oscillator to a synthesized voltage-controlled oscillator (VCO). Refer to [Table 5-2 on page 5-5](#) for the full frequency range of the source. The outputs at the front panel test ports are swept, stepped or CW signals. Maximum leveled output powers are listed in [Table 5-1 on page 5-4](#). For a simple block diagram of the source group, refer to [Figure 5-2](#).

In this section the following characteristics and assemblies of the source group are described:

- [Band Modes](#)
- [A8 Fractional-N Synthesizer Board Assembly and A17 LODA](#)
- [A10 Frequency Reference Board Assembly](#)
- [A11 Phase Lock Board Assembly](#)
- [A12 Source Assembly](#)
- [Rear Panel Interconnects](#)

### Band Modes

The source group operates in one of two different configurations during normal operation. These configurations are:

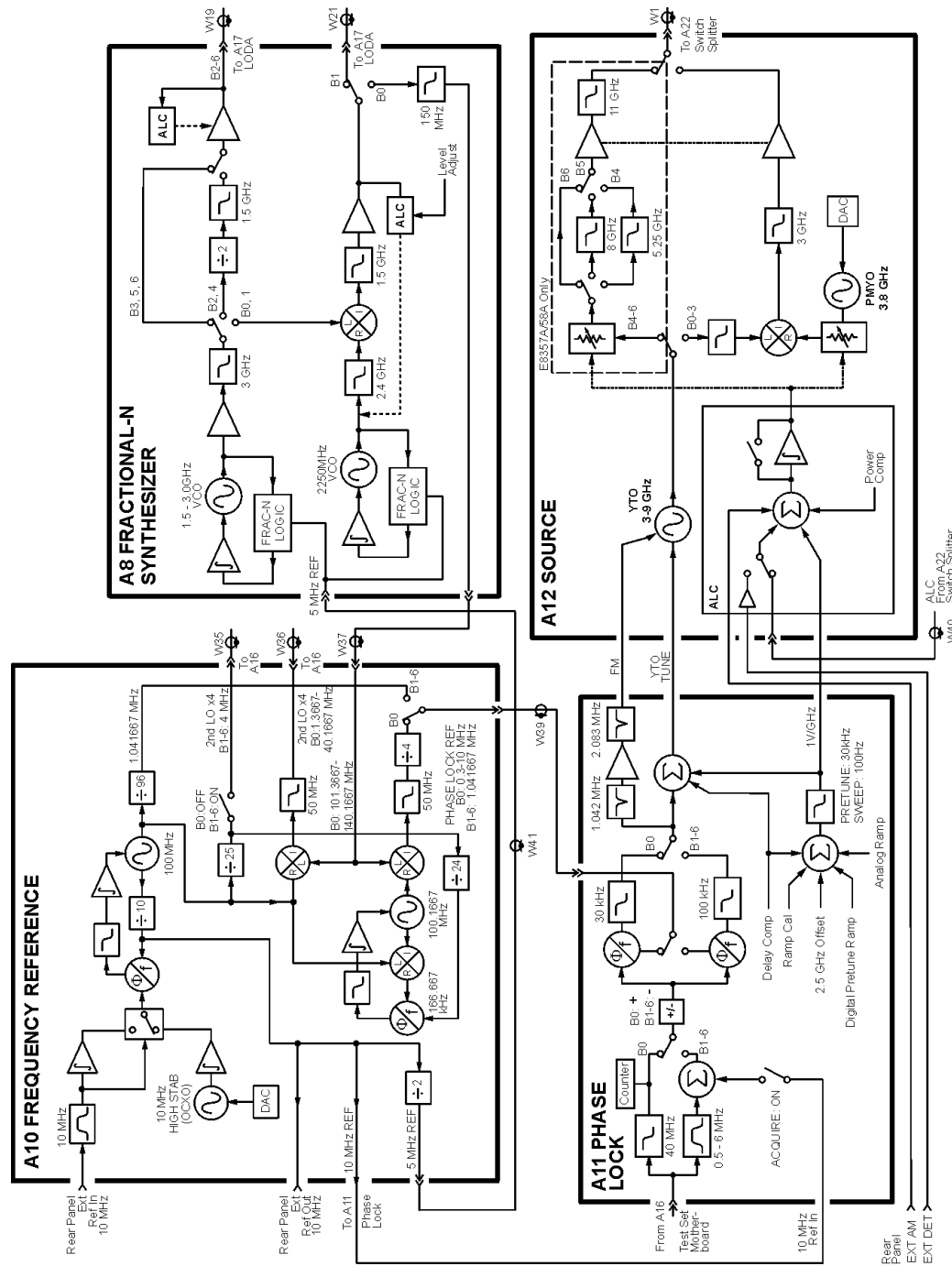
- [Band 0](#)
- [Bands 1 through 6](#)

Table 5-2 lists the synthesizer frequencies, harmonic number, and resulting source frequency. This table is referred to throughout this chapter.

**Table 5-2 Subsweep Frequencies**

Band	Synthesizer Frequency (MHz)	Harmonic Number (N)	Source Frequency (MHz)
0	101.3667 to 140.1667	1	0.3 to 10.0
1	11 to 749	1	10 to 748
2	749 to 1501	1	748 to 1500
3	1501 to 3001	1	1500 to 3000
4	1000.3 to 1500.3	3	3000 to 4500
5	1500.3 to 2167.0	3	4500 to 6500
6	2167.0 to 3000.3	3	6500 to 9000

Figure 5-2 Source Group



sc860a

## Band 0

In Band 0, the output of the A8 fractional-N synthesizer board assembly is sent to the A10 frequency reference board assembly to generate the phase lock reference and 2nd local oscillator (LO) signals.

The A8 fractional-N synthesizer board assembly generates a signal sweep from 101.3667 MHz to 140.1667 MHz. This signal is switched into the A10 frequency reference board assembly where it is divided into two paths:

In the first path:

1. The synthesizer signal is mixed with the 100.1667 MHz reference signal and the resulting signal is divided by four to produce a swept phase lock reference signal from 0.3 MHz to 10.0 MHz.
2. The phase lock reference signal is routed to the A11 phase lock board assembly where it is used to tune the A12 source assembly for the same frequency range.
3. This 0.3 MHz to 10.0 MHz output signal from the A12 source assembly is sent to the active test and reference channels and then to the active receiver modules. There is no 1st LO to the receiver modules in band 0, so this signal passes through the first converter into the 1st IF path unchanged. A portion of this signal is then passed through the phase lock multiplexer back to the A11 phase lock board assembly to complete the phase lock loop. In the receiver module, this 1st IF signal is mixed with the 2nd LO to produce a constant 2nd IF signal at 41.667 kHz.

In the second path:

1. The synthesizer signal is mixed with a 100 MHz reference signal to produce a swept signal from 1.366668 MHz to 40.166668 MHz.
2. This resultant swept signal is passed to the A16 test set motherboard assembly where the frequency is divided by four to produce a swept 2nd LO signal from 0.341667 MHz to 10.041667 MHz.
3. This 2nd LO signal is then divided into two signals, the 2nd LO (a) and the 2nd LO (b). The 2nd LO (b) signal is phase shifted  $-90^\circ$  relative to 2nd LO (a). Both of these signals are then distributed to each of the four receiver modules.

## Bands 1 through 6

In bands 1 through 6 the A10 frequency reference board assembly produces a constant phase locked reference signal of 1.041667 MHz which is sent to the A11 phase lock board assembly.

The A8 fractional-N synthesizer board assembly produces an LO signal which is sent through the A17 LO distribution assembly (LODA) to the 1st converter for each of the four receiver modules. The frequency is synthesized such that the mixing product of this LO signal with the main source output is a constant 1.041667 MHz. A portion of this 1st IF signal is passed through the phase lock multiplexer on the A16 test set motherboard back to the A11 phase lock board to complete the phase lock loop. In the 2nd converter of the receiver module, this 1st IF signal is mixed with the 2nd LO signals to produce a constant 2nd IF signal at 41.667 kHz.

The A10 frequency reference board assembly also produces a constant 4 MHz signal which is passed to the A16 test set motherboard assembly where the frequency is divided by four to produce a constant 2nd LO signal of 1 MHz. It is then divided into two signals, the 2nd LO (a) and the 2nd LO (b). The 2nd LO (b) signal is phase shifted  $-90^\circ$  relative to 2nd LO (a). Both of these signals are then distributed to each of the four receiver modules.

## **A8 Fractional-N Synthesizer Board Assembly and A17 LODA**

The A8 fractional-N synthesizer board assembly uses the 5 MHz reference signal from the A10 frequency reference board assembly to tune two VCO circuits: one that sweeps from 1500 to 3000 MHz and one that is set to a CW frequency of 2250 MHz. In bands 0 and 1, these two signals are heterodyned to produce the output frequencies listed in [Table 5-2 on page 5-5](#). In bands 2 and 4, the output of the swept VCO is passed through a divide-by-2 circuit to produce the output frequencies listed in Table 5-2. In bands 3, 5, and 6, the swept VCO signal is sent directly to the synthesizer output.

An ALC circuit maintains the power level at a constant  $-3$  dBm. In band 0, a switch at the output passes the signal to the A10 frequency reference board assembly to produce the 2nd LO and phase lock reference signals. In band 1, the output is sent through a 1.2 GHz low pass filter to the A17 LO distribution assembly (LODA). In bands 2 through 6, the output is sent to the A17 LODA and then on to the four receivers as the 1st LO signal.

## **A10 Frequency Reference Board Assembly**

This assembly provides stable reference frequencies to the rest of the instrument. A high stability 10 MHz oven-controlled crystal oscillator (OCXO) normally provides the frequency standard. However, if a 10 MHz external reference signal is detected at the 10 MHz EXT REF IN port on the rear panel, it is used as the frequency reference instead.

The 10 MHz reference signal is used to phase lock a 100 MHz VCO. This VCO is then used to phase lock a second VCO at 100.1667 MHz. It is also used to provide the 10 MHz EXT REF OUT rear panel signal, reference for the A11 phase lock board assembly, and a 5 MHz reference for the A6 signal processing ADC module (SPAM) board assembly and the A8 fractional-N synthesizer board assembly.

In band 0, the swept signal from the A8 fractional-N synthesizer board assembly is mixed with the 100 MHz VCO signal to produce the fourth multiple of the 2nd LO signal which is sent to the A16 test set motherboard. It is also mixed with the 100.1667 MHz VCO signal to produce the fourth multiple of the phase lock reference signal which is sent to the A11 phase lock board assembly.

In bands 1 through 6, the 100 MHz reference signal is sent through a divide-by-25 circuit to produce the fourth multiple of the 1 MHz 2nd LO signal which is sent to the A16 test set motherboard. The 100 MHz reference signal is also sent through a divide-by-96 circuit to produce the 1.041667 phase lock reference signal which is sent to the A11 phase lock board assembly.

## **A11 Phase Lock Board Assembly**

The A11 phase lock board assembly compares the phase lock IF signal from the A16 test set motherboard with the phase lock reference signal from the A10 frequency reference



board assembly to generate the tuning voltage for the A12 source assembly YIG-tuned oscillator (YTO). In addition, various digital-to-analog converters (DACs) on this assembly are set by the A6 SPAM board assembly to inject offset and delay voltages for the various source bands and measurement sweep rates.

## A12 Source Assembly

The A12 source assembly contains a 3–9 GHz YIG-tuned oscillator (YTO) and a fixed frequency 3.8 GHz permanent-magnet YIG oscillator (PMYO). The YTO has a main coil and an FM coil. These are analogous to the woofer and the tweeter in a stereo speaker: the woofer reproduces low frequencies and the tweeter reproduces high frequencies. Similarly in the YTO, the main coil allows large, slow changes in frequency but cannot respond to high frequency deviations, which are sent to the faster-acting FM coil.

The tune current from the A11 phase lock board assembly splits into two paths. One path is lowpass filtered, removing high frequency components, and goes to the YTO main coil; the other path is highpass filtered, removing low frequency components, and goes to the YTO FM coil. The filters are matched in stop-band response, such that one picks up where the other leaves off.

The frequency of the PMYO is set by a voltage received from a DAC set by the A6 SPAM board assembly. In bands 0 through 3, the 3.8003 to 6.8 GHz output of the YTO and the 3.8 GHz output of the PMYO are mixed to produce the required output frequency. In bands 4 through 6, the output of the YTO is filtered and sent directly to the source output.

A portion of this output signal is split off in the A22 switch splitter assembly and returned to the A12 source assembly. This signal is combined with other inputs in the automatic level control (ALC) circuitry to set the output power level. The other inputs include the temperature and slope compensation circuits, the power level DAC, and the rear panel EXTERNAL AM input.

## Rear Panel Interconnects

<b>10 MHz REF. INPUT</b>	A BNC connector that allows an external frequency reference signal to be used to phase lock the analyzer for increased frequency accuracy.  The analyzer automatically enables the external frequency reference feature when a signal is connected to this input. When the signal is removed, the analyzer automatically switches back to its internal frequency reference.
<b>10 MHz REF. OUTPUT</b>	A BNC connector that allows a 10 MHz reference signal, produced by the A10 frequency reference board assembly, to be output for use in phase locking external test equipment.
<b>EXT. AM INPUT</b>	A BNC connector that allows an external, analog input signal to be applied to the ALC circuitry of the analyzer's source. This analog input signal amplitude modulates the RF output signal.
<b>EXT. DETECTOR INPUT</b>	A BNC connector that allows a DC voltage from an external detector to be applied to the ALC circuitry of the analyzer's source. This DC voltage controls the power level of the RF output signal.

---

## Signal Separation Group Operation

The signal separation group divides the source signal into a reference path and a test path. The reference signal is transmitted to the receiver group. The test signal is transmitted through—and reflected from—the device under test (DUT) and then is transmitted to the receiver group. Control lines to this group are routed from the A16 test set motherboard.

In this section, the following assemblies are described:

- [A22 Switch Splitter](#)
- [A23 and A24 Test Port Couplers](#)
- [A25 and A26 70 dB Step Attenuators](#)
- [A27 and A28 35 dB Step Attenuators \(Option 015 Configurable Test Set\)](#)

### A22 Switch Splitter

The output of the A12 source assembly is routed to the A22 switch splitter assembly. This is a solid-state switch. It switches between the Port 1 and Port 2 measurement paths, automatically enabling alternate forward and reverse measurements. The A22 switch splitter assembly provides an internal termination for the measurement port that is inactive.

Both measurement paths in the A22 switch splitter assembly include a three-way splitter. The signal is split into the test port signal, the receiver signal, and the ALC signal.

The test port signal is routed through the step attenuator (A25 or A26), through the test port coupler (A23 or A24) and out through either PORT 1 or PORT 2 to the DUT.

The reference signal is routed through the front-panel channel R jumper to the appropriate R channel receiver module (A19 or A20).

The ALC signal is routed, through a log amplifier circuit, to the ALC circuitry in the A12 source assembly for source leveling.

### A23 and A24 Test Port Couplers

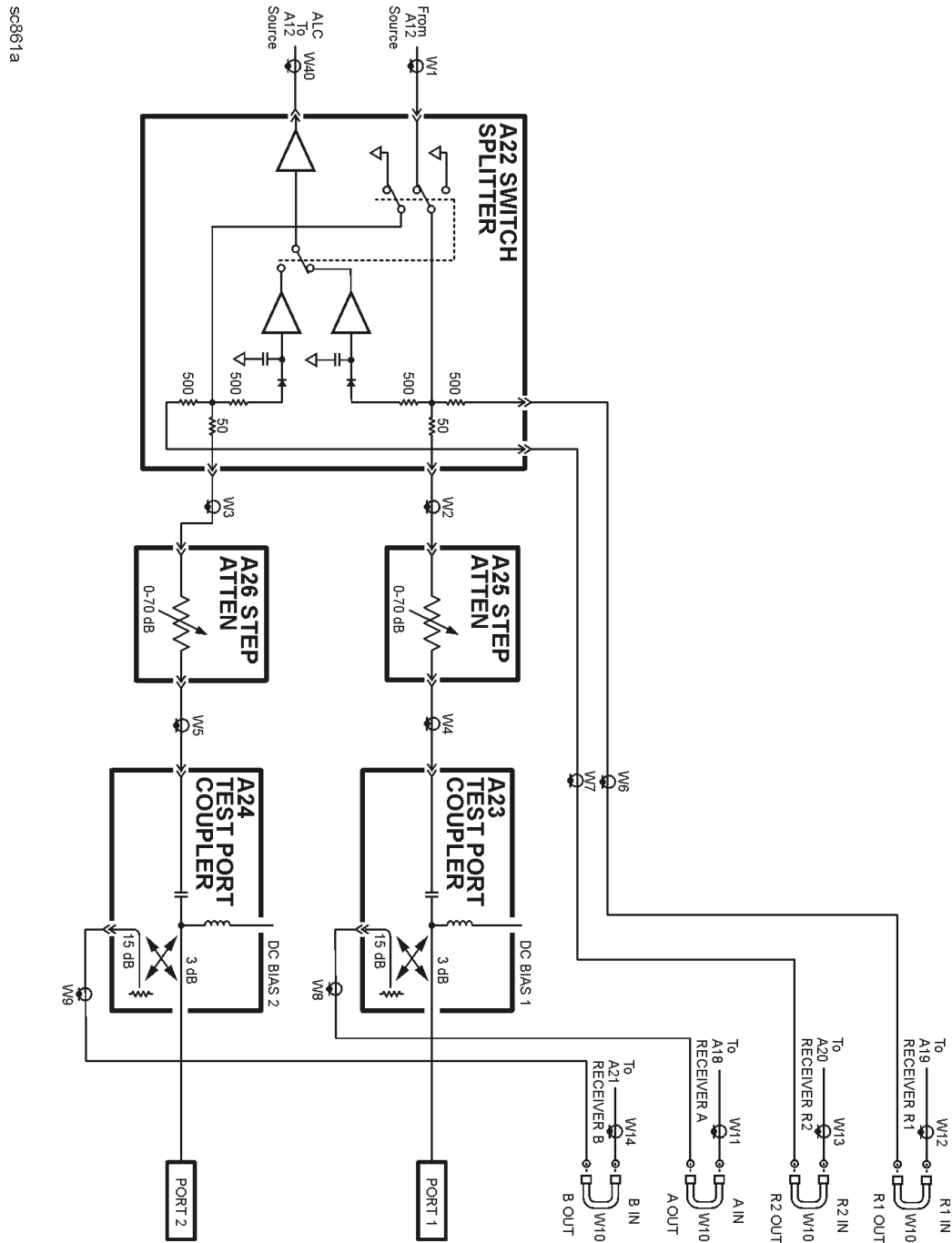
The test port signal goes into the through-line arm of the couplers, and from there to the test ports and the DUT. The coupled arm of the couplers carries the signal reflected from or transmitted through the DUT to the receiver through a front panel jumper for measurement. The coupling coefficient of the directional couplers is nominally 15 dB over the full frequency range.

Each coupler includes a dc bias circuit which provides a means of biasing active devices with an external dc voltage connected to the rear panel DC BIAS CONNECT ports. The dc voltage is applied directly to the center conductor of the test port connectors. A blocking capacitor ensures that the bias current goes only to the DUT, and not back into the source. Likewise, an inductor in the bias path prevents RF from being imposed on the external dc supply.

### A25 and A26 70 dB Step Attenuators

The 70 dB step attenuators provide coarse power control for the test port signals. They are electro-mechanical step attenuators, controlled by the A15 CPU board assembly, that provide 0 to 70 dB of attenuation in 10 dB steps. They adjust the power level to the DUT without changing the level of the incident power in the reference path.

Figure 5-3 Signal Separation Group, Standard Analyzer



## Option 015 Configurable Test Set

The Option 015 analyzer allows you to measure devices with higher power and higher dynamic range limits than the standard analyzer. The theory of operation is the same as for the standard analyzer except that there are two additional front panel SMA jumpers and two 35 dB step attenuators (A27 and A28).

As shown in [Figure 5-4](#), the additional jumpers allow access to the test port signals between:

- the A25 70 db step attenuator and the A23 test port coupler
- the A26 70 db step attenuator and the A24 test port coupler

The A27 and A28 35 dB step attenuators protect the A18 and A21 test receivers from amplified input signals.

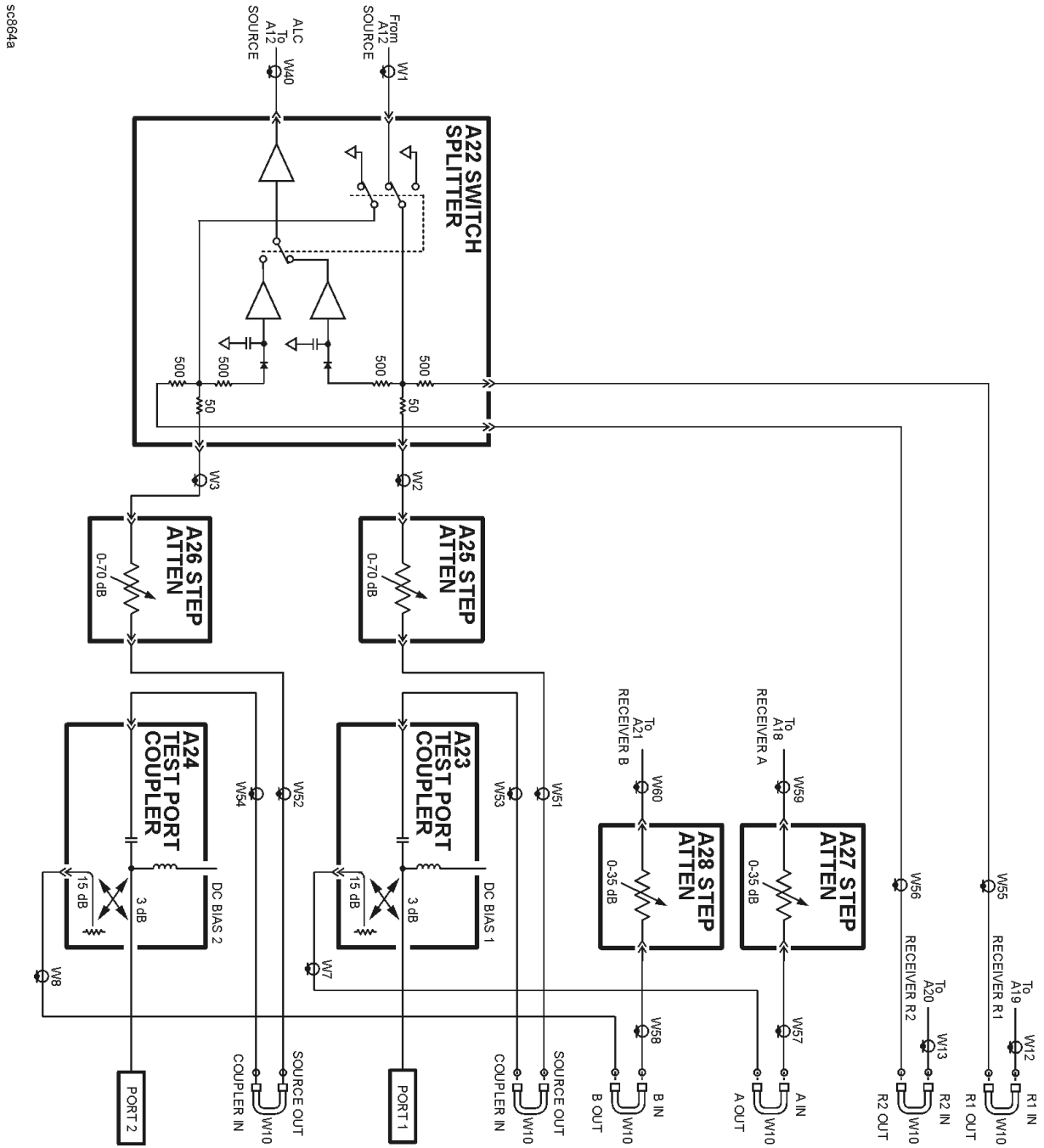
### A27 and A28 35 dB Step Attenuators

The 35 dB step attenuators provide coarse power control for amplified input. They are electro-mechanical step attenuators, controlled by the A15 CPU board assembly, that provide 0 to 35 dB of attenuation in 5 dB steps.

### Normal Option 015 Configuration

The normal configuration for the Option 015 is shown in [Figure 5-4](#). With this configuration and inclusion of an external amplifier and accessories, you can calibrate the analyzer and test devices at power levels up to +30 dBm. You can make measurements in the forward, reverse or both directions and still achieve these high power levels. For more information on higher power measurements, search for “Option 015” in the embedded help index in the analyzer.

Figure 5-4 Signal Separation Group, Option 015 Analyzer



sc9864a

### High Dynamic Range Configuration

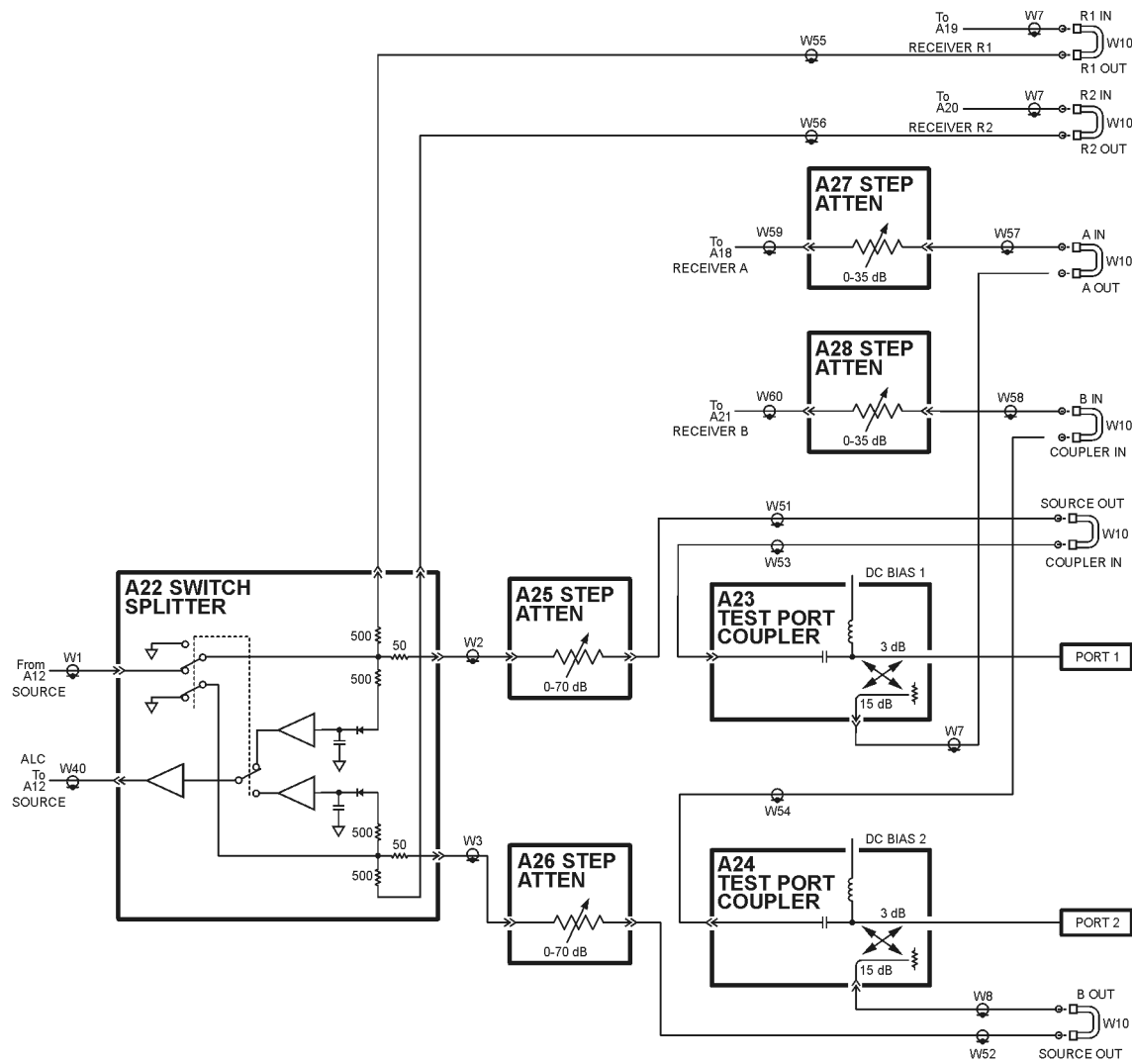
With a few jumper changes, you can configure the Option 015 for higher dynamic range measurements. By swapping the front panel jumpers for one port, signal flow through the corresponding coupler is reversed, increasing the test signal sensitivity by 15 dB.

In the forward direction, as shown in [Figure 5-5](#), the signal flow through the test port coupler (A24) is reversed by arranging the front panel jumpers such that B IN connects to COUPLER IN and B OUT connects to SOURCE OUT.

In the reverse direction, not shown, the signal flow through the test port coupler (A23) is reversed by arranging the front panel jumpers such that A IN connects to COUPLER IN and A OUT connects to SOURCE OUT.

For more information on high dynamic range measurements and configurations, search for “Option 015” in the embedded help index in the analyzer.

**Figure 5-5 High Dynamic Range Configuration in the Forward Direction**



sc865a

---

## Receiver Group Operation

The receiver group measures and processes the input signals into digital information for processing and eventual display. [Figure 5-6](#) is a simplified block diagram of the receiver functional group.

In this section the following assemblies are described:

- [A18, A19, A20, and A21 Receiver Modules](#)
- [A16 Test Set Motherboard Assembly](#)
- [A6 SPAM Board Assembly \(Analog Description\)](#)

### A18, A19, A20, and A21 Receiver Modules

The four receiver modules function identically and are completely interchangeable. Each of these receiver modules consists of two converter stages.

The 1st converter receives the RF reference or test signal and mixes it with the 1st LO signal from the A17 LO distribution assembly (LODA) (except in band 0 where the 1st LO is not used) to create the 1st IF signal at a constant 1.041667 MHz. The 1st IF signal is sensed by an overload circuit that shuts off the source if excessive power is encountered. A portion of the 1st IF signal is sent to a multiplexer on the A16 test set motherboard assembly, the output of which is routed to the A11 phase lock board assembly to complete the phase lock loop. The 1.041667 MHz 1st IF signal is also filtered (bands 1-6) and routed to the 2nd converter.

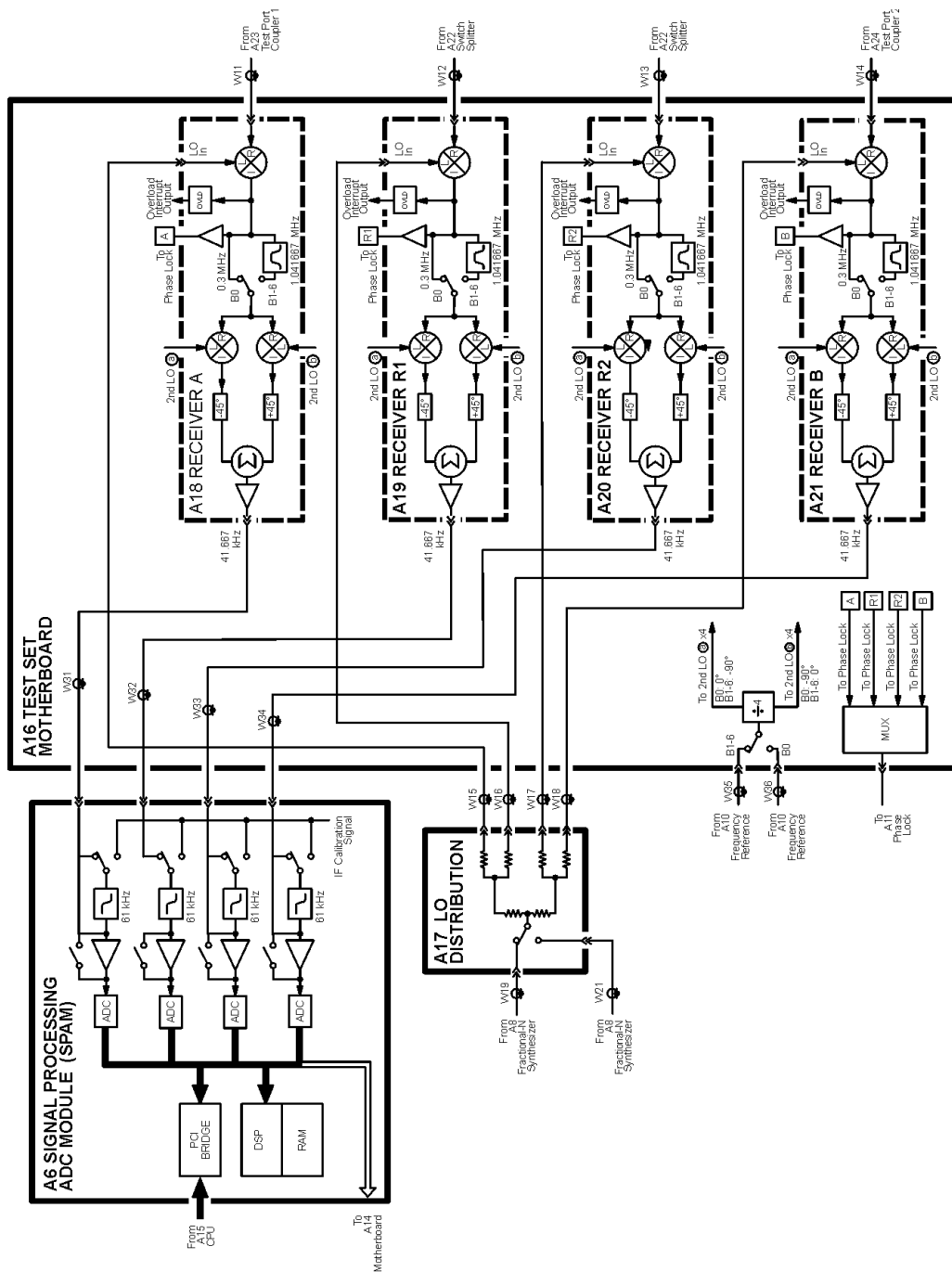
The 2nd converter divides the 1.041667 MHz signal into two paths and mixes each with a separate LO signal, designated 2nd LO (a) and 2nd LO (b). Both of these 2nd LO signals are 1.000 MHz. In band 0, the 2nd LO (b) signal is phase shifted  $-90^\circ$  relative to the 2nd LO (a) signal. In bands 1 through 6, the 2nd LO (b) signal is phase shifted  $+90^\circ$  relative to the 2nd LO (a) signal. These two generated 2nd IF signals are a constant 41.667 kHz. These 2nd IF (a) and 2nd IF (b) signals are phase shifted  $-45$  degrees and  $+45$  degrees, respectively. These signals are summed together and routed to the A6 signal processing and ADC module (SPAM) board assembly.

### A16 Test Set Motherboard Assembly

The A16 test set motherboard assembly serves three functions:

- to act as a controller for the four receiver modules and as a passage for the 2nd LO and phase lock signals.
- to act as an interface between the A15 CPU board assembly and the auxiliary rear panel interconnects.
- to route control signals to the signal separation group. Refer to [“Signal Separation Group Operation” on page 5-10](#) for more information.

Figure 5-6 Receiver Group



sc862a



## Receiver Control

The A16 test set motherboard assembly supplies power and signal leveling control to the A18, A19, A20, and A21 receiver modules. It also receives the two 2nd LO signals from the A10 frequency reference board assembly.

- The first signal is used for Band 0 operation and ranges from 1.3667 MHz to 40.1667 MHz. The appropriate signal is selected, its frequency is divided by four, and it is divided into two paths, designated 2nd LO (a) and 2nd LO (b). In Band 0, the 2nd LO (b) signal is phase shifted  $-90^\circ$  relative to the 2nd LO (a) signal.
- The second signal is used for Bands 1 to 6 and is a constant 4 MHz. In Bands 1 through 6, the 2nd LO (b) signal is phase shifted  $+90^\circ$  relative to the 2nd LO (a) signal. Both of these signals are distributed to each of the receiver modules.

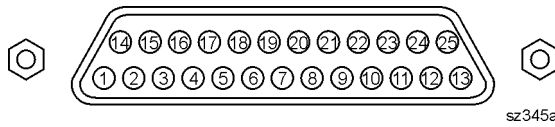
A portion of the 1.041667 MHz 1st IF signal from each of the receiver modules is routed through the A16 test set motherboard assembly to a multiplexing circuit. With control from the A15 CPU board assembly, one of these four signals is selected for routing to the A11 phase lock board assembly to complete the phase lock loop.

## Rear Panel Interconnects

The A16 test set motherboard assembly includes the following rear panel interconnects.

<b>TEST SET I/O</b>	<p>A DB-25 female connector that is used to control external test sets. The external test set bus consists of 13 multiplexed address and data lines, three control lines, and an open-collector interrupt line. Pin assignments are listed in <a href="#">Table 5-3 on page 5-18</a>.</p> <p>Up to 16 test sets may be “daisy-chained” on the bus at one time.</p> <p>The Test Set I/O is not compatible with 8753 network analyzer test sets.</p>
<b>HANDLER I/O</b>	<p>A rectangular 36-pin, female connector providing four independent parallel input/output ports, nine control signal lines, one ground, and a power supply line. Pin assignments are listed in <a href="#">Table on page 5-19</a>.</p> <p>All signals are TTL-compatible. Data input/output ports consist of two 8-bit output ports (Port A and Port B) and two 4-bit bidirectional ports (Port C and Port D).</p> <p>Connector settings can be changed using SCPI and COM commands. The settings are not accessible from the front panel.</p> <p>Inside the analyzer, the rear panel connector is connected, via a ribbon cable, to one of two headers on the A16 test set motherboard. Changing this internal connection allows selection between Type 1 and Type 2 output pin assignments. Refer to <a href="#">“Reconfiguring the Pinout of the Handler I/O Port” on page 7-53</a>.</p>
<b>AUX I/O</b>	<p>A DB-25 male connector that provides a variety of both analog and digital input and output signals as described in <a href="#">Table 5-5 on page 5-20</a>.</p>

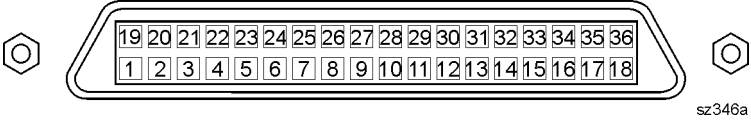
**Table 5-3 TEST SET I/O Connector Pin Assignments**



**DB-25 Female Connector**

Pin Numbers	Name	Function
1	SEL0	TTL out, test set select bit 0, tied to 0 V
2	Sweep Holdoff In	TTL in, low level holds off sweep
3–6	AD12–AD8	TTL I/O, address and latched data
7	GND	0 V, ground reference
8	LAS	TTL out, active low address strobe (1 $\mu$ s min)
9–11	AD4–AD2	TTL I/O, address and latched data
12	GND	0 V, ground reference
13	Interrupt In	TTL in, low level (10 $\mu$ s min) aborts sweep
14	+22 V	+22 Vdc, 100 mA max.
15–16	SEL1–2	TTL out, test set select bits 1-2, tied to 0 V
17	AD11	TTL I/O, address and latched data
18	SEL3	TTL out, test set select bit 3, tied to 0 V
19–21	AD7–5	TTL I/O, address and latched data
22–23	AD0–1	TTL I/O, address and latched data
24	LDS	TTL out, active low data strobe (1 $\mu$ s min)
25	RLW	TTL out, high = read, low = write

**Table 5-4 HANDLER I/O Connector Key Pin Assignments**



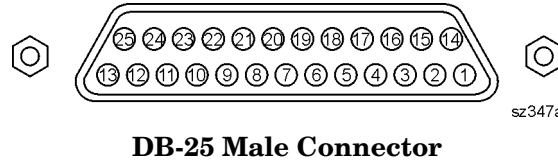
**Rectangular 36-Pin Female Connector**

Pin Numbers		Name	Function
Type 1 <sup>1</sup>	Type 2 <sup>1</sup>		
1	1	GND	0 V, ground reference
2	2	INPUT1	TTL in, negative pulse (1 $\mu$ s min) latches OUTPUT1-2
3-4	3-4	OUTPUT1-2	TTL out, latched
5-12	5-12	Port A0-7 Out	TTL out, latched
13-17, 19-21	13-20	Port B0-7 Out	TTL out, latched
22-25	21-24	Port C I/O	TTL I/O, latched
26-29	25-28	Port D I/O	TTL I/O, latched
30	29	Port C Status	TTL out, low = input mode, high = output mode
31	30	Port D Status	TTL out, low = input mode, high = output mode
32	31	Output Strobe Write Strobe	TTL out, active low data write strobe (1 $\mu$ s min)
18	32	No connect	Not used
33	33	Pass Fail	TTL out, latched, indicates pass fail (programmable polarity)
35	34	+5 V	+5 Vdc, 100 mA max.
34	35	Sweep End	TTL out, active low (10 $\mu$ s min) indicates sweep done
36	36	Pass/Fail Write Strobe	TTL out, active low pass/fail write strobe (1 $\mu$ s min)

1. Refer to [HANDLER I/O](#) under “Rear Panel Interconnects” on page 5-17.

**Table 5-5 AUX I/O Connector Pin Assignments**

Pin Numbers	Name	Function
1	ACOM	0 V, ground reference for analog signals
2–3	Analog Out 2–1	–10 to +10 Vdc output, 10 mA max, $R_o = 100 \Omega$
4	No connect	For future enhancements
5	DCOM	0 V, ground reference for digital signals
6–8	Pulse Out 3–1	TTL out, programmable pulse (for future use)
9	+5V	+5 Vdc output, 100 mA max.
10	Pass/Fail Write Strobe	TTL out, active low (1 $\mu$ s min) indicates pass/fail line is valid
11	Sweep End	TTL out, active low (10 $\mu$ s min) indicates sweep is done
12	Pass/Fail	TTL out, latched, indicates pass or fail (programmable polarity)
13	Output Port Write Strobe	TTL out, active low (10 $\mu$ s min) writes I/O port data
14	Analog In	–10 to +10 Vdc input, $R_i = 100k \Omega$
15	ACOM	0 V, ground reference for analog signals
16	Power Button In	Open-collector input, active low replicates a power button press
17	DCOM	0 V, ground reference for digital signals
18	Ready for Trigger	TTL out, low indicates ready for external trigger
19	External Trigger In	TTL in, level trigger (width >1 $\mu$ s), programmable polarity
20	Footswitch In	TTL in, active low (width >1 $\mu$ s), triggers a programmable event
21	+22V	+22 Vdc output, 100 mA max.
22–25	In/Out Port C0–3	TTL I/O, general purpose



## A6 SPAM Board Assembly (Analog Description)

The A6 signal processing and ADC module (SPAM) board assembly contains digital and analog circuitry. For digital descriptions, refer to [“A6 SPAM Board Assembly \(Digital Description\)”](#) on page 5-24.

In this assembly, the 2nd IF signals from the A, B, R1, and R2 second converters go through a gain stage where signals less than  $-40$  dBm are amplified by 34 dB to ensure that they can be detected by the analog-to-digital converter (ADC).

All four signals are sampled simultaneously by the ADCs, where they are converted to digital form. The ADC conversions are triggered by timing signals from the digital signal processor (DSP) in response to commands from the central processing unit (CPU). The digitized data is processed into magnitude and phase data by the DSP and sent to the CPU random access memory (RAM) by way of the peripheral component interconnect (PCI) bus.

The processed and formatted data is finally routed to the display, and to the general-purpose interface bus (GPIB) for remote operation. Refer to [“Digital Processing and Digital Control Group Operation”](#) on page 5-22 for more information on signal processing.

---

## Digital Processing and Digital Control Group Operation

The digital processor and control group provides digital control for the entire analyzer. It provides:

- front panel operation,
- output to the display,
- math processing functions, and
- communications between the analyzer and an external controller or peripherals.

A block diagram of the digital control functional group is shown in [Figure 5-7](#).

The digital control functional group consists of two subgroups:

- [Front Panel Subgroup](#)
- [Data Acquisition and Processing Subgroup](#)

### Front Panel Subgroup

The front panel subgroup contains the following assemblies:

- [A1 Keypad Assembly](#)
- [A2 Display Assembly](#)
- [A3 Front Panel Interface Board Assembly](#)

#### A1 Keypad Assembly

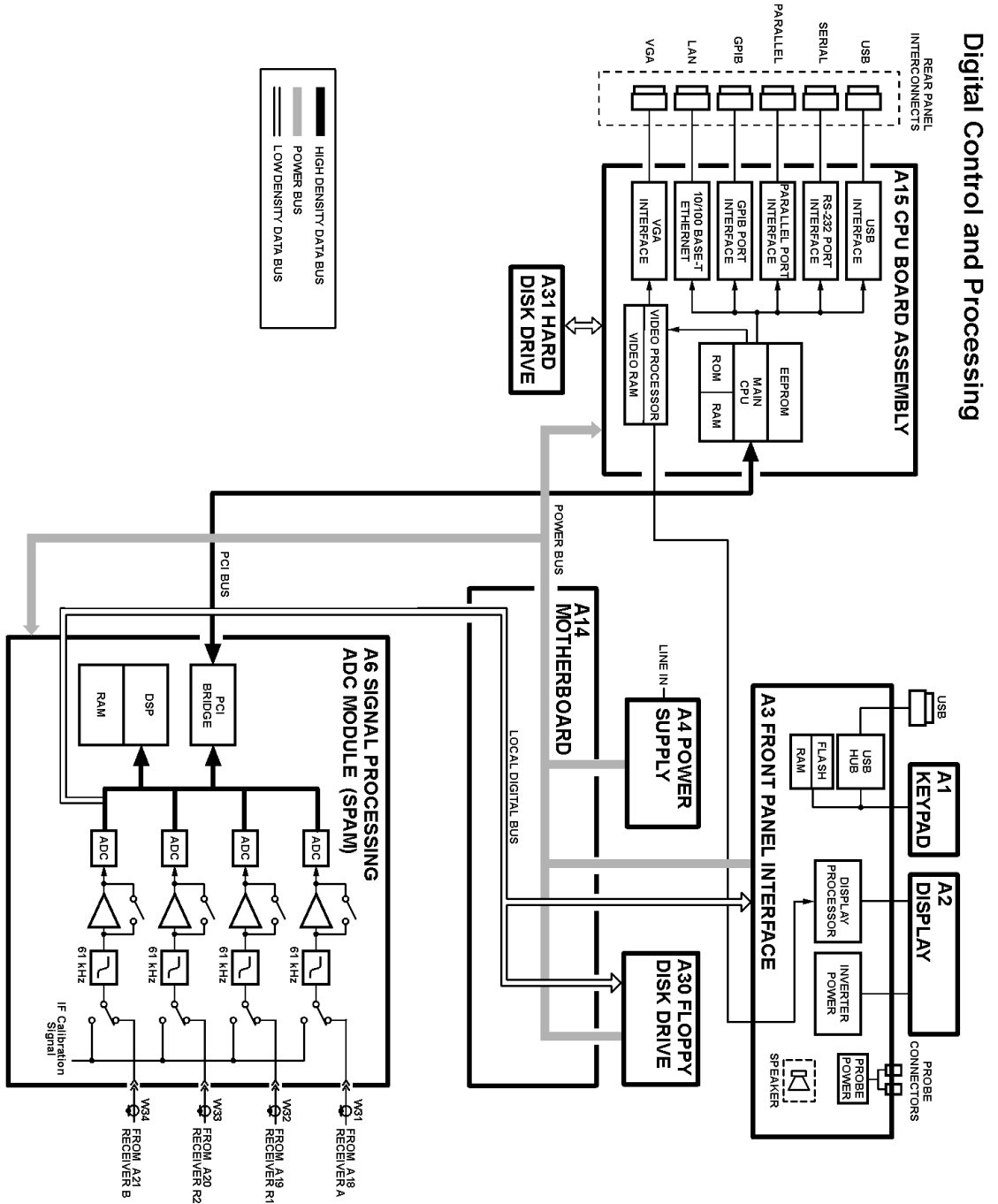
The A1 keypad assembly provides user interface to the analyzer. The front panel rotary pulse generator (RPG) knob is not electrically connected to the keypad, but rather provides user inputs directly to the front panel processor.

#### A2 Display Assembly

The A2 display assembly contains an 8.4-inch LCD with associated drive circuitry and backlight inverter. Two cables between the A2 display assembly and the A3 front panel interface board assembly provide all necessary power and data for normal operation. The two cables are:

1. A cable to the inverter that supplies buffered power.
2. A cable to the display circuitry that supplies decoded data from the video processor on the A15 CPU board assembly and the necessary drive circuit power. The video data received from the A15 CPU board assembly includes the following:
  - digital TTL horizontal sync
  - digital TTL vertical sync
  - digital TTL red video
  - digital TTL green video
  - digital TTL blue video
  - blanking
  - data clock

Figure 5-7 Digital Processing and Digital Control Group



SC859a

### A3 Front Panel Interface Board Assembly

The A3 front panel interface board assembly detects and decodes user inputs from the A1 keypad assembly and front panel knob, and transmits them to the A15 CPU board assembly by way of the A14 motherboard assembly. It also decodes video data from the video processor on the A15 CPU board assembly and supplies this to the A2 display assembly. Power from the power bus on the A14 motherboard assembly is buffered and routed to the A1 keypad assembly and the A2 display assembly. All data and power signals are routed through a single cable connector to the A14 motherboard assembly.

The A3 front panel interface board assembly also includes the following items:

<b>USB</b>	A universal serial bus (USB) jack (an industry standard 4-pin connector).
<b>Probe Power</b>	Two identical connectors (fused inside the instrument) that supply power to an active probe for in-circuit measurements of ac circuits.
<b>Speaker</b>	A speaker that emits the audio signals received from the A15 CPU board assembly.

### Data Acquisition and Processing Subgroup

The data acquisition and processing subgroup contain the following assemblies. See [Figure 5-7 on page 5-23](#).

- [A6 SPAM Board Assembly \(Digital Description\)](#)
- [A15 CPU Board Assembly](#)
- [A30 Floppy Disk Drive](#)
- [A31 Hard Disk Drive Assembly](#)

#### A6 SPAM Board Assembly (Digital Description)

The A6 SPAM board assembly contains digital and analog circuitry. For analog descriptions, refer to [“A6 SPAM Board Assembly \(Analog Description\)” on page 5-21](#).

The digital signal processor (DSP) receives digitized data from the digital circuitry of the A6 SPAM board assembly. It computes discrete Fourier transforms to extract the complex phase and magnitude data from the 41.667 kHz IF signal. The resulting raw data is written into the main random access memory (RAM). The data taking sequence is triggered either externally from the rear panel or by firmware on the A15 CPU board assembly.

#### A15 CPU Board Assembly

The A15 CPU board assembly contains the circuitry to control the operation of the analyzer. Some of the components include the central processing unit (CPU), memory (EEPROM, ROM, RAM), bus lines to other board assemblies, and connections to the rear panel. Some of the main components are described next:

- [CPU](#)
- [Main RAM](#)
- [Rear Panel Interconnects](#)



**CPU** The central processing unit (CPU) is a microprocessor that maintains digital control over the entire instrument through the instrument bus. The CPU receives external control information from the keypad, any USB device, LAN or GPIB, and performs processing and formatting operations on the raw data in the main RAM. It controls the DSP, the video processor, and the interconnect port interfaces. In addition, when the analyzer is in the system controller mode, the CPU controls peripheral devices through the peripheral port interfaces.

Front panel settings are stored in SRAM, with a battery providing at least five years of backup storage when external power is off.

**Main RAM** The main random access memory (RAM) is shared memory for the CPU and the DSP. It stores the raw data received from the DSP while additional calculations are performed on it by the CPU. The CPU reads the resulting formatted data from the main RAM, converts it to a user-definable display format, and writes this to the video processor for display.

**Rear Panel Interconnects** The rear panel includes the following interfaces:

<b>USB</b>	A universal serial bus (USB) jack (an industry standard 4-pin connector).
<b>GPIB</b>	A 24-pin, female, type D-24 connector that meets IEEE-488 standards.
<b>Serial</b>	A 9-pin, male, RS-232 compatible, D-sub connector.
<b>Parallel</b>	A 36-pin, mini-D, 1284-C connector that provides connection to printers or any other parallel port peripheral.
<b>LAN</b>	A standard 8-pin, 10/100BaseT, Ethernet connection. It auto selects between the two data rates.
<b>Display (VGA)</b>	A 15-pin, female, D-sub connector that provides a video output of the analyzer display that can be viewed on an external VGA monitor.

### A30 Floppy Disk Drive

The A30 floppy disk drive allows you to store and recall instrument states and measurement results on a 3.5 inch, 1.44 MB floppy disk. This assembly is connected directly to the A14 motherboard assembly.

### A31 Hard Disk Drive Assembly

The A31 hard disk drive assembly (HDDA) is an integrated development environment (IDE) data storage device which is connected directly to the A15 CPU board assembly. The full operating system and firmware for the network analyzer is stored on this hard disk drive.

---

## Power Supply Group Operation

The A4 power supply assembly is a switching power supply operating at 103 kHz switching frequency. The input power ranges for the power supply are 90 to 132 Vac or 195 to 250 Vac. The power supply automatically senses the input voltage and switches between these two ranges.

The dc output voltages are:

- +5.2 V
- -5.2 V
- +9 V
- +15 V
- +15 V standby (always on)
- -15 V
- +22 V
- VCC (5.2 V for the A15 CPU board assembly)
- VDL (3.3 V to the A15 CPU board assembly)

The +15 V standby line remains on continuously whenever the power supply is plugged in. This line is used to provide power to front panel LEDs and CPU components when the analyzer is turned off.

An additional +32 V supply line is generated on the A14 motherboard from the +22 V supply line.

---

<b>NOTE</b>	If the power supply senses an over-voltage or over-current condition on any of the supply lines, the power supply will cycle on and off at a low voltage level (burp mode).
-------------	---

---

---

## **6 Replaceable Parts**

---

## Information in This Chapter

This chapter:

- identifies the replaceable parts for the Agilent PNA series RF network analyzers (E8536A, E8537A, E8538A).
- includes several tables and illustrations to assist you in identifying the correct part for your analyzer.
- contains ordering information for new assemblies and rebuilt-exchange assemblies.

### Chapter Six at-a-Glance

Section Title	Summary of Content	Start Page
<a href="#">Ordering Information</a>	How to order a replaceable part from Agilent Technologies.	<a href="#">Page 6-3</a>
<a href="#">Assembly Replacement Sequence</a>	The correct sequence for replacing a defective assembly.	<a href="#">Page 6-4</a>
<a href="#">Rebuilt-Exchange Assemblies</a>	The definition of a rebuilt-exchange assembly. The procedure for replacing and returning a defective assembly to Agilent Technologies.	<a href="#">Page 6-5</a>
<a href="#">Replaceable Parts Listings</a>	A table that lists the assemblies by reference designator. Lists and illustrated locations of the replaceable parts in your analyzer: <ul style="list-style-type: none"><li>• Assemblies (front panel, top, and bottom)</li><li>• Cables (top and bottom)</li><li>• Hardware (internal, hard disk drive, rear panel, and external)</li><li>• Miscellaneous replaceable parts</li></ul>	<a href="#">Page 6-6</a>

---

## Ordering Information

To order a part listed in the replaceable parts lists:

- include the part number
- indicate the quantity required
- Contact Agilent Technologies for instructions on where to send the order. Refer to [“Contacting Agilent” on page 2-9](#).

To order a part that is not listed in the replaceable parts lists:

- include the instrument model number and complete instrument serial number
- include the description and function of the part
- indicate the quantity required
- Contact Agilent Technologies for instructions on where to send the order. Refer to [“Contacting Agilent” on page 2-9](#).

---

## Assembly Replacement Sequence

The following steps outline the sequence to be performed to replace an assembly in the network analyzer.

- Step 1.** Identify the faulty group. Begin with [Chapter 4, “Troubleshooting.”](#) Follow up with the appropriate troubleshooting chapter that identifies the faulty assembly.
- Step 2.** Order a replacement assembly. Refer to this chapter.
- Step 3.** Replace the faulty assembly and determine what adjustments are necessary. Refer to [Chapter 7, “Repair and Replacement Procedures.”](#)
- Step 4.** Perform the necessary adjustments. Refer to [Chapter 3, “Tests and Adjustments.”](#)
- Step 5.** Perform the necessary performance tests. Refer to [Chapter 3, “Tests and Adjustments.”](#)

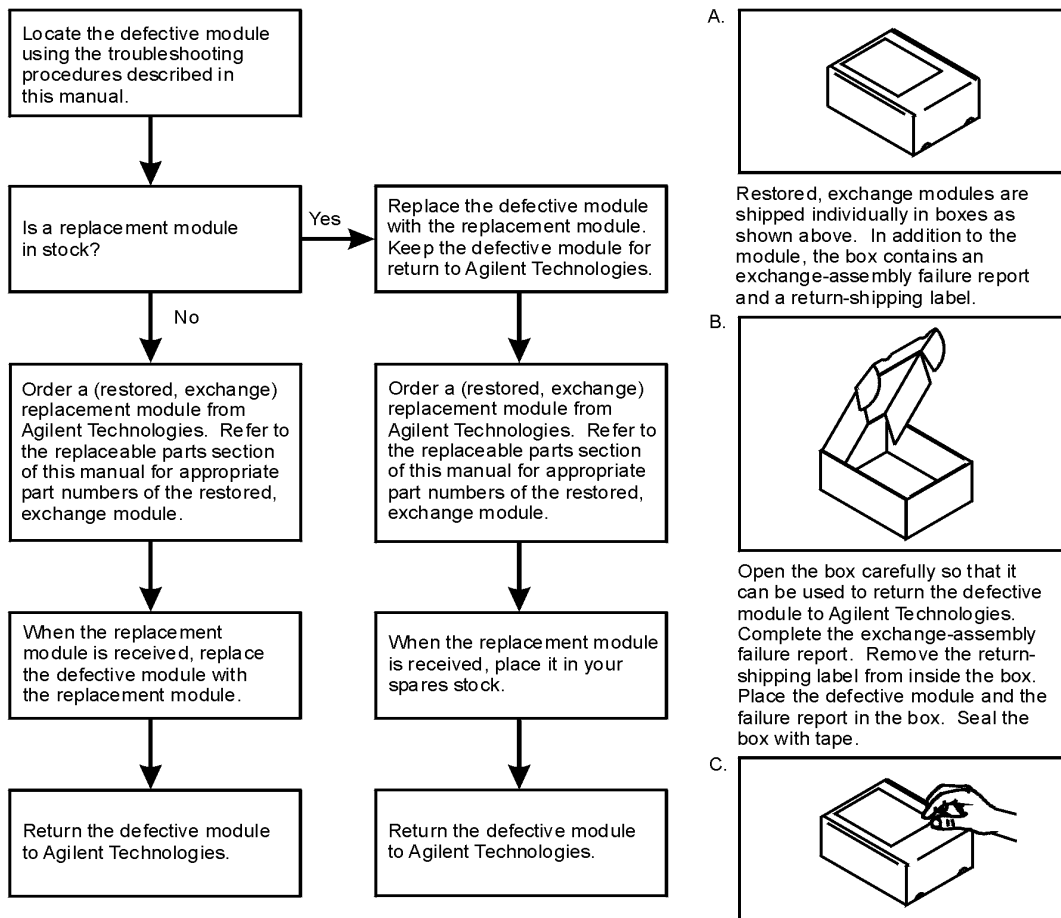
## Rebuilt-Exchange Assemblies

Under the rebuilt-exchange assembly program, certain factory-repaired and tested modules (assemblies) are available on a trade-in basis. These assemblies are offered for lower cost than a new assembly, but meet all factory specifications required of a new assembly.

The defective assembly must be returned for credit under the terms of the rebuilt-exchange assembly program. Any spare assembly stock desired should be ordered using the new assembly part number. [Figure 6-1](#) illustrates the module exchange procedure.

**Figure 6-1 Module Exchange Procedure**

The module exchange program described here is a fast, efficient, economical method of keeping your instrument in service.



formt120

For shipping within the USA, affix the return-shipping label over the existing label. Mail the box to Agilent Technologies. (Postage is paid by Agilent Technologies on boxes mailed within the USA.) Outside the USA, address and mail the box to the nearest Agilent Technologies office. Do not use the return-shipping label.

## Replaceable Parts Listings

This section contains the replacement part numbers and their descriptions for your Agilent PNA series network analyzer (E8356A, E8357A, and E8358A). You can find the replaceable parts in this section:

- by reference designator in [Table 6-1](#), or
- by the type of part in [Table 6-2](#).

**Table 6-1 Location by Reference Designator**

Reference Designator	Description	Location
A1	Keypad assembly	
A2	Display assembly	“Front Panel Assembly” on page 6-8
A3	Front panel interface board assembly	
A4	Power supply assembly	
A6	Signal processing ADC module (SPAM) board assembly	“Top Assemblies and Hardware” on page 6-10
A8	Fractional-N synthesizer board assembly	
A10	Frequency reference board assembly	
A11	Phase lock board assembly	
A12	Source assembly	
A14	Motherboard assembly	
A15	CPU board assembly	
A16	Test set motherboard assembly	
A17	Local oscillator (LO) distribution assembly	“Bottom Assemblies and Hardware, Standard” on page 6-12
A18	Channel A receiver module assembly	
A19	Channel R1 receiver module assembly	
A20	Channel R2 receiver module assembly	
A21	Channel B receiver module assembly	
A22	Switch splitter assembly	
A23	Test port 1 coupler	
A24	Test port 2 coupler	
A25	70 dB step attenuator	
A26	70 dB step attenuator	
A27	35 dB step attenuator (Option 015 only)	“Bottom Assemblies and Hardware, Option 015” on page 6-14
A28	35 dB step attenuator (Option 015 only)	
A30	Floppy disk drive	“Internal Hardware and Parts” on page 6-22
A31	Hard disk drive assembly	“Hard Disk Drive Assembly” on page 6-24



**Table 6-2 Part Number Location by Type of Part**

Type of Part	Location
<b>Assemblies</b>	<ul style="list-style-type: none"> <li>• “Front Panel Assembly” on page 6-8</li> <li>• “Top Assemblies and Hardware” on page 6-10</li> <li>• “Bottom Assemblies and Hardware, Standard” on page 6-12</li> <li>• “Bottom Assemblies and Hardware, Option 015” on page 6-14</li> </ul>
<b>Cables</b>	<ul style="list-style-type: none"> <li>• “Top Cables” on page 6-16</li> <li>• “Bottom Cables, Standard” on page 6-18</li> <li>• “Bottom Cables, Option 015” on page 6-20</li> </ul>
<b>Hardware</b>	<ul style="list-style-type: none"> <li>• “Internal Hardware and Parts” on page 6-22</li> <li>• “Rear Panel Assembly” on page 6-25</li> <li>• “Hard Disk Drive Assembly” on page 6-24</li> <li>• “External Parts” on page 6-26</li> </ul>
<b>Miscellaneous</b>	<ul style="list-style-type: none"> <li>• “Miscellaneous Part Numbers” on page 6-28               <ul style="list-style-type: none"> <li>— Service Tools</li> <li>— Fuses</li> <li>— Documentation</li> <li>— Upgrade Kits</li> <li>— Protective Caps for Connectors</li> <li>— GPIB Cables/Adapter</li> <li>— Touch-up Paint</li> <li>— ESD Supplies</li> <li>— USB Accessories</li> <li>— Rack Mount Kits and Handle Kits</li> </ul> </li> </ul>

## Front Panel Assembly

Reference Designator	Model	Part Number	Qty	Description
A1	All	E8356-60001	1	Keypad assembly
A2 <sup>a</sup>	All	E8356-60002	1	Display assembly
		0950-3379	1	Inverter board (included in A2 <sup>b</sup> )
		2090-0386	1	Display lamp for LCD (included in A2 <sup>b</sup> )
		1000-1161	1	Display glass (included in A2 <sup>b</sup> )
A3	All	E8361-60061	1	Front panel interface board assembly
RPG	All	E8356-40006	1	Front knob
①	All	5041-9182	2	With handles—front handle side trim
	All	5041-9173	2	Without handles—trim strip, filler
② <sup>c</sup>	All	5063-9204	2	Front handle
③	All	E8356-80002	1	Front panel overlay, Standard
	All	E8356-80003		Front panel overlay, Option 015
④	All	E8356-00025	1	Trim strip, filler
⑤	All	0515-1227	2	Machine screw, M3.0 x 6 FL-TX (to attach item ④)
⑥	E8356A	E8356-80005	1	Nameplate
	E8357A	E8357-80001		
	E8358A	E8358-80001		
⑦ <sup>d</sup>	All	E8356-60074	1	Front frame assembly
⑧	All	0515-0375	4	Machine screw, M3.0 x 14 CW-PN-TX
⑨	All	0515-0372	8	Machine screw, M3.0 x 08 CW-PN-TX

- a. When ordering a replacement A2 display assembly, you must also order item ⑥.
- b. Although included in the A2 display assembly, each of these parts is also available separately. If one of these parts should have to be replaced, it is not necessary to replace the entire A2 display assembly. For any other parts failure within the display, replace the entire A2 display assembly.
- c. For part numbers of complete rack mount kits and handle kits, refer to [“Rack Mount Kits and Handle Kits” on page 6-29](#).
- d. When ordering a replacement front frame assembly, you must also order item ③.

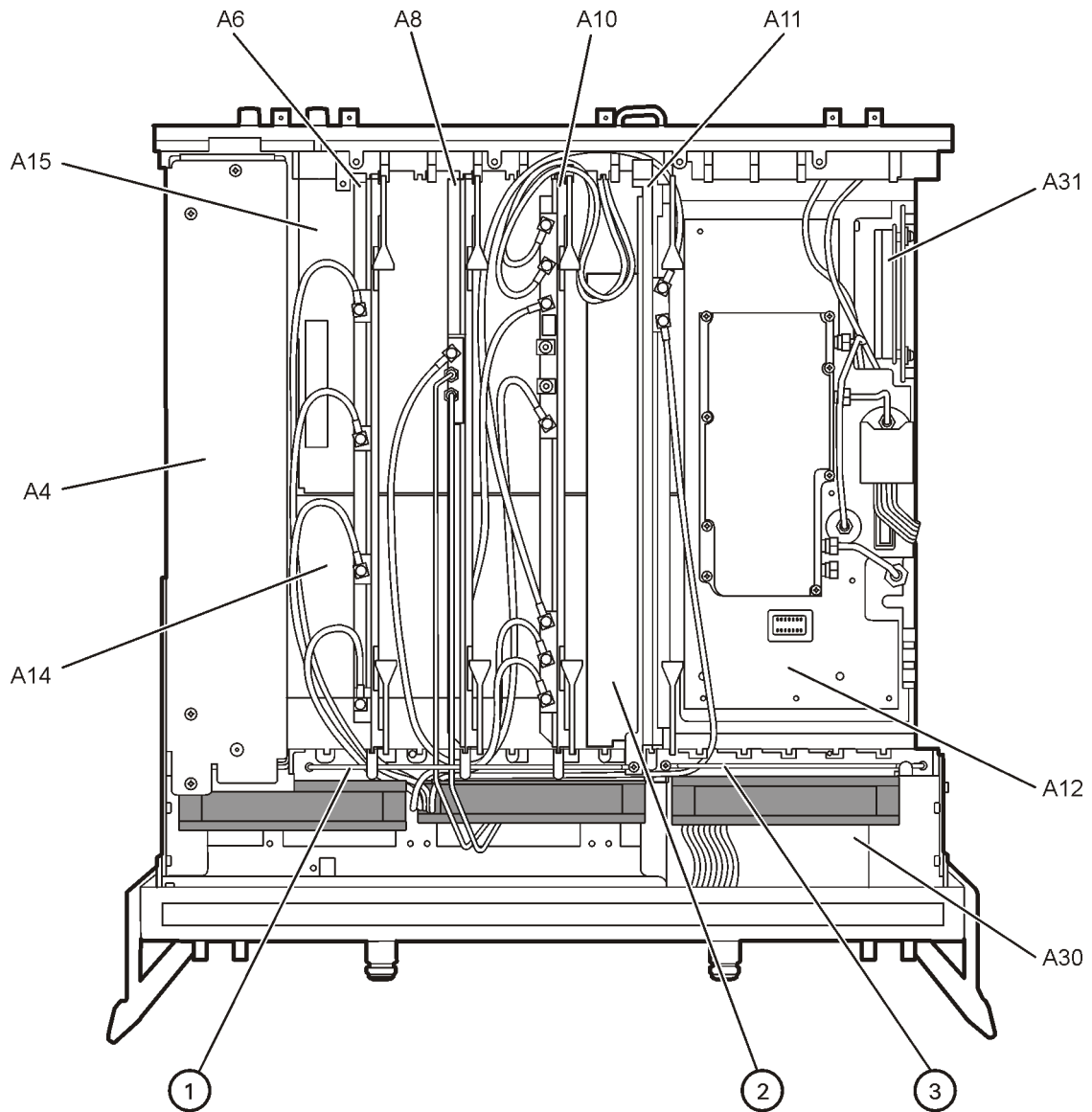


## Top Assemblies and Hardware

Reference Designator	Model/Option	Part Number	Qty	Description
A4	All	0950-3384	1	Power supply assembly
A6	All	E8356-60006	1	Signal processing ADC module (SPAM) board assembly
A8	All	E8356-60008	1	Fractional-N synthesizer board assembly
A10	All	E8356-60010	1	Frequency reference board assembly
A11	All	E8356-60011	1	Phase lock board assembly
A12	E8356A	E8356-60031	1	Source assembly
	E8356A	E8356-69031	1	Source assembly (rebuilt-exchange)
	E8357A E8358A	E8356-60012	1	Source assembly
	E8357A E8358A	E8356-69012	1	Source assembly (rebuilt-exchange)
A14	All	E8356-60014	1	Motherboard assembly
A15	All <sup>a</sup>	E8364-60025	1	CPU board; 500MHz, 512MB RAM
A30	Refer to <a href="#">“Internal Hardware and Parts” on page 6-22.</a>			Floppy disk drive assembly
A31	Refer to <a href="#">“Hard Disk Drive Assembly” on page 6-24.</a>			Hard disk drive assembly (HDDA)
①	All	5022-6134	1	Cable hold down
②	All	E8356-40001	1	Air flow plenum
③	All	5022-6135	1	Cable hold down

- a. The following analyzers were originally equipped with a 266 MHz CPU board: E8356A with serial numbers prefixed US4146 and below; E8357A with serial numbers prefixed US4147 and below; E8358A with serial numbers prefixed US4148 and below. When this 266 MHz CPU board is replaced with the newer 500 MHz CPU board, you must also replace the A31 hard disk drive with a new hard disk drive, part number E8801-60063.

**Figure 6-3 Illustration of Top Assemblies**



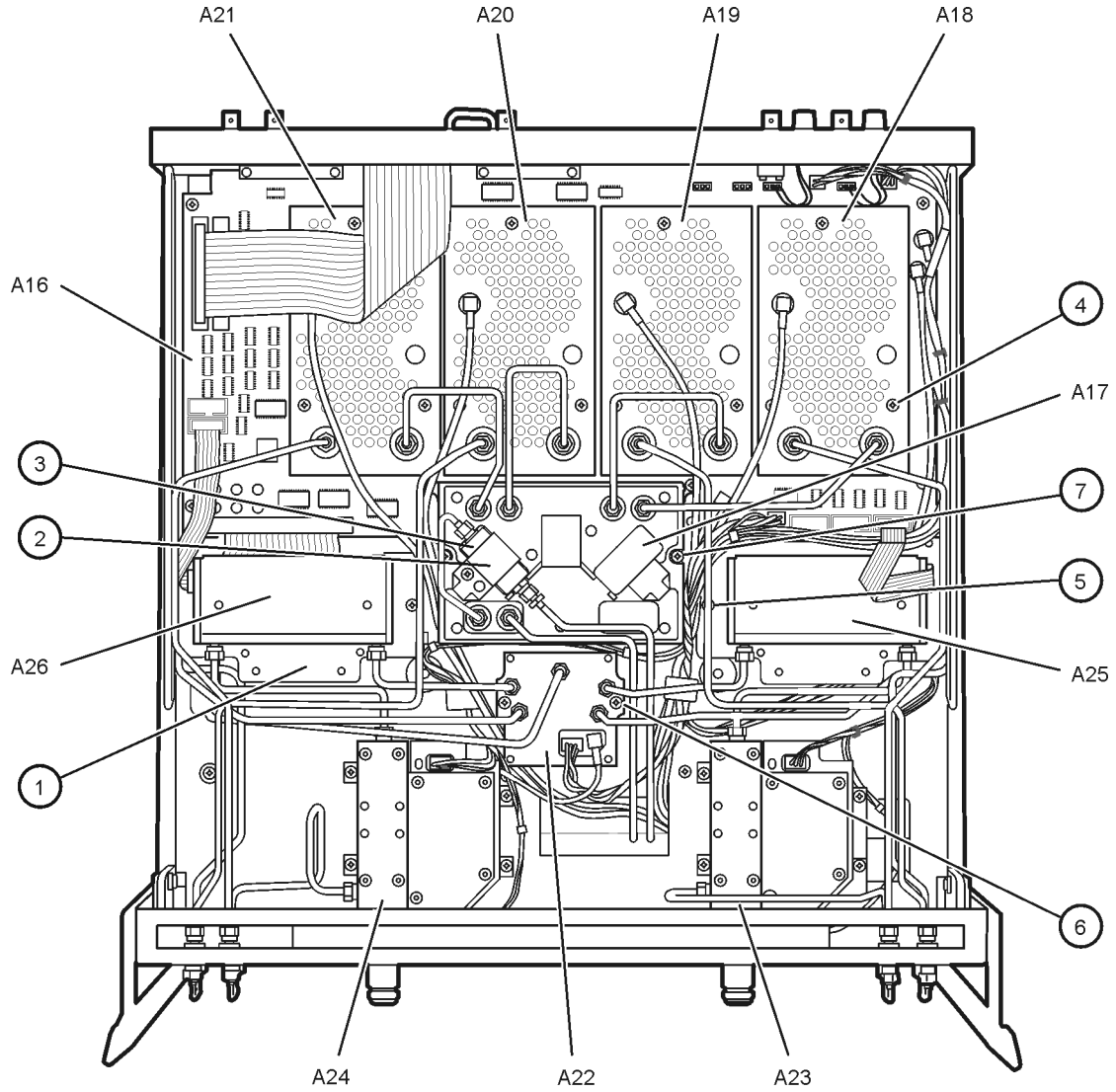
sc847a

## Bottom Assemblies and Hardware, Standard

Reference Designator	Part Number	Qty	Description
A16	E8356-60049	1	Test set motherboard assembly
A17	E8356-60017	1	Local oscillator distribution assembly (LODA)
A18	E8356-60018 <sup>a</sup>	4	Channel A receiver module assembly
A19			Channel R1 receiver module assembly
A20			Channel R2 receiver module assembly
A21			Channel B receiver module assembly
A18	E8356-69018 <sup>a</sup>	4	Channel A receiver module assembly (rebuilt-exchange)
A19			Channel R1 receiver module assembly (rebuilt-exchange)
A20			Channel R2 receiver module assembly (rebuilt-exchange)
A21			Channel B receiver module assembly (rebuilt-exchange)
A22	5087-7019	1	Switch splitter assembly
A22	5087-6019	1	Switch splitter assembly (rebuilt-exchange)
A23	5087-7020	2	Test port 1 coupler
A24			Test port 2 coupler
A23	5087-6020	2	Test port 1 coupler (rebuilt-exchange)
A24			Test port 2 coupler (rebuilt-exchange)
A25	33321-60056	2	70 dB step attenuator
A26			70 dB step attenuator
①	N3381-00001	2	Attenuator bracket
②	E8356-00021	1	Cable / filter clamp
③	9135-5305	1	1.2 GHz lowpass filter
④	0515-1349	12	Machine screw M3.0 x 30 CW-PN-TX
⑤	0515-0372	39	Machine screw M3.0 x 8 CW-PN-TX
⑥	0515-0375	2	Machine screw M3.0 x 16 CW-PN-TX
⑦	0515-0374	4	Machine screw M3.0 x 10 CW-PN-TX
⑧	N3381-20032	4	Receiver gasket

a. When ordering a replacement receiver module, you must order item ⑧ also.

**Figure 6-4 Illustration of Bottom Assemblies and Hardware, Standard**



sc88a

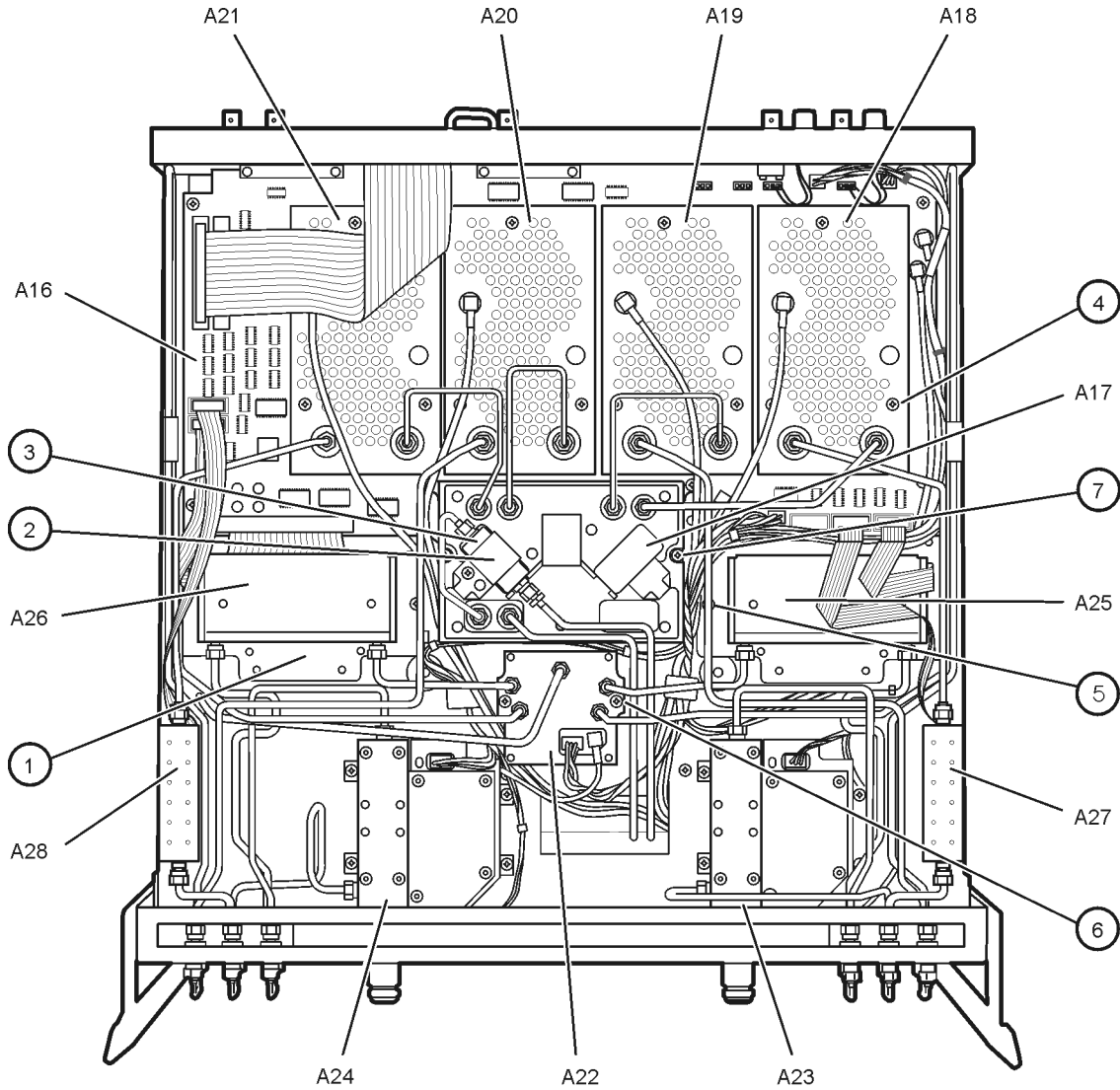
## Bottom Assemblies and Hardware, Option 015

Reference Designator	Part Number	Qty	Description
A16	E8356-60049	1	Test set motherboard assembly
A17	E8356-60017	1	Local oscillator distribution assembly (LODA)
A18	E8356-60018 <sup>a</sup>	4	Channel A receiver module assembly
A19			Channel R1 receiver module assembly
A20			Channel R2 receiver module assembly
A21			Channel B receiver module assembly
A18	E8356-69018 <sup>a</sup>	4	Channel A receiver module assembly (rebuilt-exchange)
A19			Channel R1 receiver module assembly (rebuilt-exchange)
A20			Channel R2 receiver module assembly (rebuilt-exchange)
A21			Channel B receiver module assembly (rebuilt-exchange)
A22	5087-7019	1	Switch splitter assembly
A22	5087-6019	1	Switch splitter assembly (rebuilt-exchange)
A23	5087-7020	2	Test port 1 coupler
A24			Test port 2 coupler
A23	5087-6020	2	Test port 1 coupler (rebuilt-exchange)
A24			Test port 2 coupler (rebuilt-exchange)
A25	33321-60056	2	70 dB step attenuator
A26			70 dB step attenuator
A27	33325-60008	2	35 dB step attenuator
A28			35 dB step attenuator
①	N3381-00001	2	Attenuator bracket
②	E8356-00021	3	Cable / filter clamp
③	9135-5305	1	1.2 GHz low pass filter
④	0515-1349	12	Machine screw M3.0 x 30 CW-PN-TX
⑤	0515-0372	39	Machine screw M3.0 x 8 CW-PN-TX
⑥	0515-0375	2	Machine screw M3.0 x 16 CW-PN-TX
⑦	0515-0374	4	Machine screw M3.0 x 10 CW-PN-TX
⑧	N3381-20032	4	Receiver gasket

a. When ordering a replacement receiver module, you must order item ⑧ also.



**Figure 6-5 Illustration of Bottom Assemblies and Hardware, Option 015**



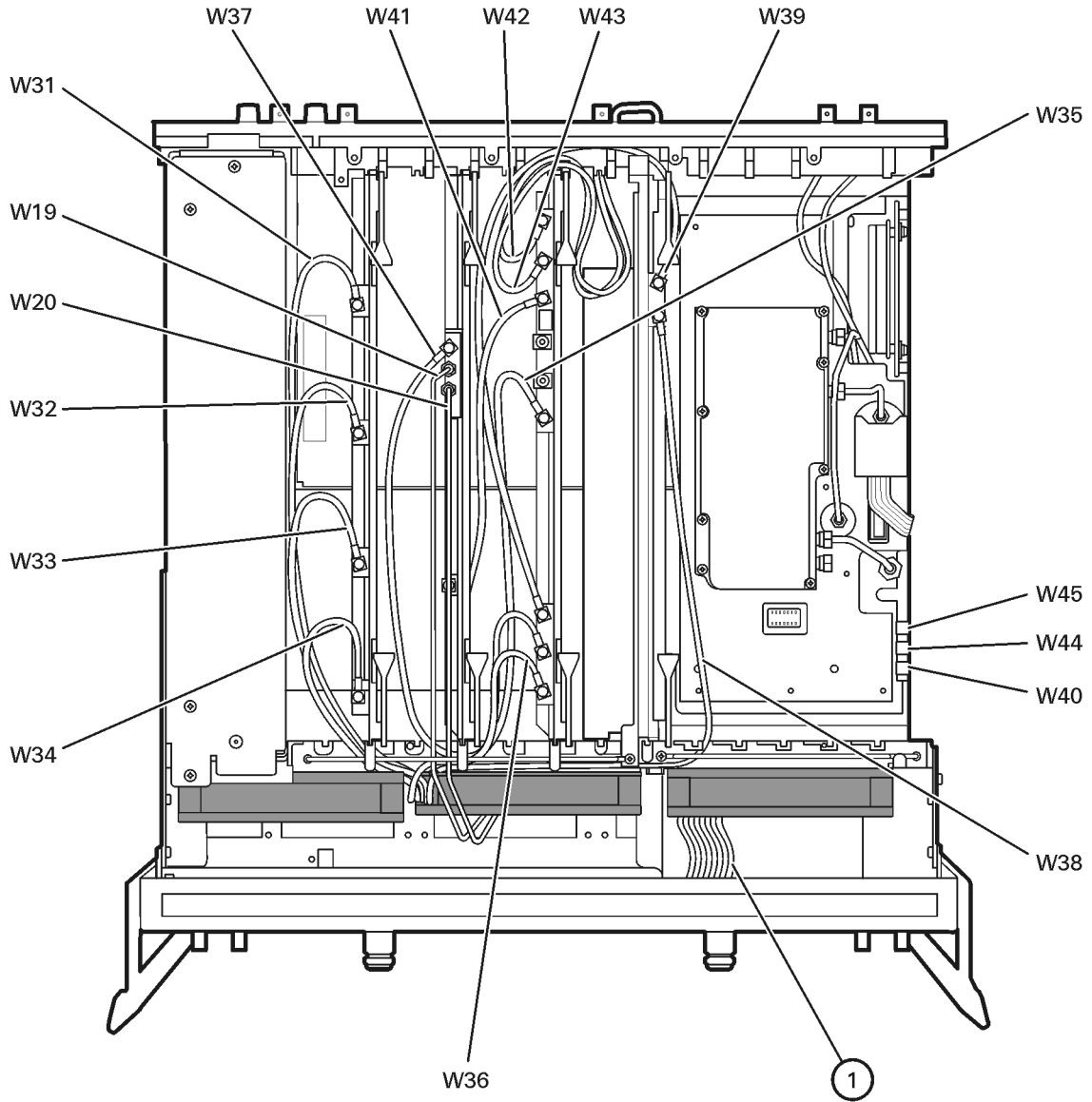
sc824a

## Top Cables

Reference Designator	Type <sup>a</sup>	Part Number	Qty	Description
W19	SR	E8356-20053	1	A8 fractional -N synthesizer board assembly(A8J106) to A17 LODA (A17J101)
W20	SR	E8356-20091	1	A8 fractional-N synthesizer board assembly (A8J101) to filter
W31	F	E8356-60037	1	A18 channel A receiver module assembly (A18J400) to A6 SPAM board assembly (A6J3)
W32	F	E8356-60038	1	A19 channel R1 receiver module assembly (A19J400) to A6 SPAM board assembly (A6J4)
W33	F	E8356-60039	1	A20 channel R2 receiver module assembly (A20J400) to A6 SPAM board assembly (A6J5)
W34	F	E8356-60040	1	A21 channel B receiver module assembly (A21J400) to A6 SPAM board assembly (A6J6)
W35	F	E8356-60042	1	A10 frequency reference board assembly (A10J4) to A16 test set motherboard assembly (A16J2)
W36	F	E8356-60044	1	A10 frequency reference board assembly (A10J7) to A16 test set motherboard assembly (A16J3)
W37	F	E8356-60041	1	A8 fractional-N synthesizer board assembly (A8J102) to A10 frequency reference board assembly (A10J6)
W38	F	E8356-60045	1	A11 phase lock board assembly (A11J6) to A16 test set motherboard assembly(A16J50)
W39	F	E8356-60043	1	A10 frequency reference board assembly (A10J5) to A11 phase lock board assembly (A11J5)
W40	F	E8356-60046	1	A22 switch splitter (A22J1) to A12 source assembly(A12J4)
W41	F	E8356-60052	1	A8 fractional-N synthesizer board assembly (A8J105) to A10 frequency reference board assembly (A10J10)
W42	F	8120-5055	4	A10 frequency reference board assembly to rear-panel 10 MHz REF. IN (A10J2)
W43				A10 frequency reference board assembly to rear-panel 10 MHz REF. OUT (A10J3)
W44				Rear-panel EXT. AM INPUT to A12 source assembly (A12J6)
W45				Rear-panel EXT. DETECTOR INPUT to A12 source assembly (A12J7)
①	40R	8121-0116	1	A3 front panel interface board assembly to A14 motherboard assembly

a. F = flexible coaxial cable; SR = semirigid coaxial cable; nR = n wires in a ribbon (flat) cable

**Figure 6-6 Illustration of Top Cables**



sc823a.cdr

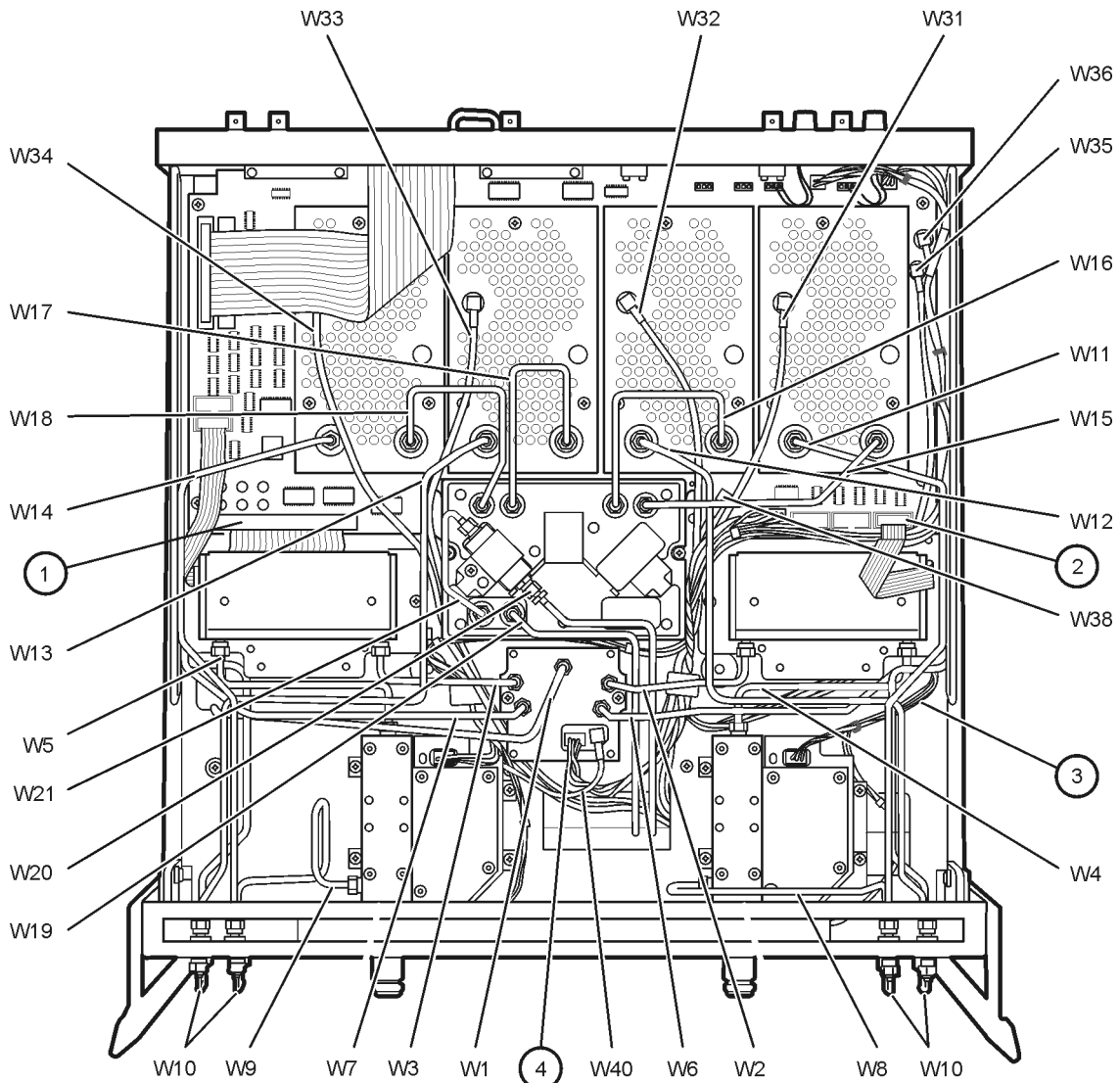
## Bottom Cables, Standard

Reference Designator	Type <sup>a</sup>	Part Number	Qty	Description
W1	SR	E8356-20058	1	A12 source assembly (A12J6) to A22 switch splitter assembly (A22J1)
W2	SR	E8356-20056	1	A22 switch splitter assembly to A25 70 dB step attenuator
W3	SR	E8356-20057	1	A22 switch splitter assembly to A26 70 dB step attenuator
W4 W5	SR	E8356-20054	2	A25 70 dB step attenuator to A23 test port coupler A26 70 dB step attenuator to A24 test port coupler
W6	SR	E8356-20050	1	A22 switch splitter assembly to front panel R1 OUT
W7	SR	E8356-20052	1	A22 switch splitter assembly to front panel R2 OUT
W8	SR	E8356-20048	1	A23 test port 1 coupler to front panel A OUT
W9	SR	E8356-20055	1	A24 test port 2 coupler to front panel B OUT
W10	SR	E8356-20072	4	Front-panel jumper
W11	SR	E8356-20066	1	Front-panel A IN to A18 channel A receiver module assembly
W12	SR	E8356-20051	1	Front-panel R1 IN to A19 channel R1 receiver module assembly
W13	SR	E8356-20073	1	Front-panel R2 IN to A20 channel R2 receiver module assembly
W14	SR	E8356-20049	1	Front-panel B IN to A21 channel B receive module assembly
W15	SR	E8356-20082	1	A17 LODA (A17J70) to A18 channel A receiver module assembly
W16	SR	E8356-20085	1	A17 LODA (A17J80) to A19 channel R1 receiver module assembly
W17	SR	E8356-20086	1	A17 LODA (A17J50) to A20 channel R2 receiver module assembly
W18	SR	E8356-20084	1	A17 LODA (A17J60) to A20 channel B receiver module assembly
W19, W20	SR	See <a href="#">page 6-16</a>	2	Semirigid cables routed from the top of the analyzer and listed under “ <a href="#">Top Cables</a> ” on <a href="#">page 6-16</a> .
W21	SR	E8356-20092	1	Filter to A17 LODA
W31 to W36, and W38	F	See <a href="#">page 6-16</a>	7	Flexible cables routed from the top of the analyzer and listed under “ <a href="#">Top Cables</a> ” on <a href="#">page 6-16</a> .
①	100R	8121-0118	1	A14 motherboard assembly to A16 test set motherboard assembly

Reference Designator	Type <sup>a</sup>	Part Number	Qty	Description
②	10W	8120-5537	2	Attenuator control cable
③	6W	8121-0122	2	A16 test set motherboard assembly to A23 or A24 test port coupler
④	6W	83437-60013	1	A22 switch splitter assembly to A16 test set motherboard assembly

a. F = flexible coaxial cable; SR = semirigid coaxial cable; nW = n wires in a wrapped cable; nR = n wires in a ribbon (flat) cable

**Figure 6-7 Illustration of Bottom Cables, Standard**



sc810a

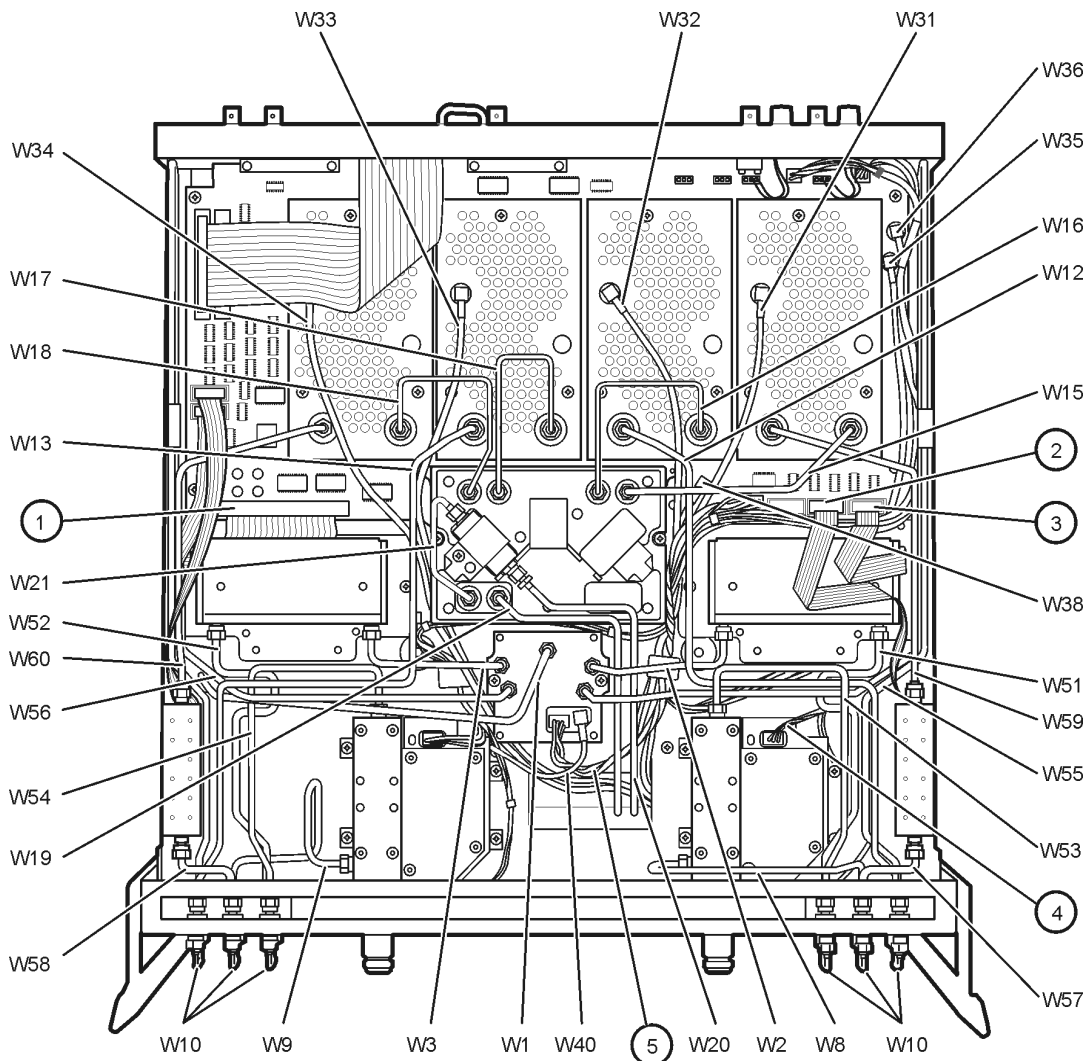
## Bottom Cables, Option 015

Reference Designator	Type <sup>a</sup>	Part Number	Qty	Description
W1	SR	E8356-20058	1	A12 source assembly (A12J6) to A22 switch splitter assembly (A22J1)
W2	SR	E8356-20056	1	A22 switch splitter assembly to A25 70 dB step attenuator
W3	SR	E8356-20057	1	A22 switch splitter assembly to A26 70 dB step attenuator
W8	SR	E8356-20048	1	A23 test port 1 coupler to front-panel A OUT
W9	SR	E8356-20055	1	A24 test port 2 coupler to front-panel B OUT
W10	SR	E8356-20072	6	Front-panel jumper
W12	SR	E8356-20051	1	Front-panel R1 IN to A19 channel R1 receiver module assembly
W13	SR	E8356-20073	1	Front-panel R2 IN to A20 R2 receiver module assembly
W15	SR	E8356-20082	1	A17 LODA to A18 channel A receiver module assembly
W16	SR	E8356-20085	1	A17 LODA to A19 channel R1 receiver module assembly
W17	SR	E8356-20086	1	A17 LODA to A20 channel R2 receiver module assembly
W18	SR	E8356-20084	1	A17 LODA to A20 channel R2 receiver module assembly
W19, W20	SR	See <a href="#">page 6-16</a>	2	Semirigid cables routed from the top of the analyzer and listed under “Top Cables” on <a href="#">page 6-16</a> .
W21	SR	E8356-20092	1	Filter to A17 LODA
W31 to W36, and W38	F	See <a href="#">page 6-16</a>	7	Flexible cables routed from the top of the analyzer and listed under “Top Cables” on <a href="#">page 6-16</a> .
W51	SR	E8356-20067	1	A25 70 dB step attenuator to front-panel SOURCE OUT
W52	SR	E8356-20068	1	A26 70 dB step attenuator to front-panel SOURCE OUT
W53	SR	E8356-20069	1	Front-panel COUPLER IN to A23 test port 1 coupler
W54	SR	E8356-20070	1	Front-panel COUPLER IN to A24 test port 2 coupler
W55	SR	E8356-20094	1	A22 switch splitter assembly to front-panel R1 OUT
W56	SR	E8356-20095	1	A22 switch splitter assembly to front panel R2 OUT
W57	SR	E8356-20078	1	Front-panel A IN to A27 35 dB step attenuator
W58	SR	E8356-20076	1	Front-panel B IN to A28 35 dB step attenuator
W59	SR	E8356-20077	1	A27 35 dB step attenuator to A18 channel A receiver module assembly
W60	SR	E8356-20075	1	A28 35 dB step attenuator to A21 channel B receiver module assembly
①	100R	8121-0118	1	A14 motherboard assembly to A16 test set motherboard assembly

Reference Designator	Type <sup>a</sup>	Part Number	Qty	Description
②	10R	8121-0119	2	35 dB step attenuator control cable
③	10R	8120-5537	2	Attenuator control cable
④	6W	8121-0122	2	A16 test set motherboard assembly to A23 or A24 test port coupler
⑤	6W	83437-60013	1	A22 switch splitter assembly to A16 test set motherboard assembly

a. F = flexible coaxial cable; SR = semirigid coaxial cable; nW = n wires in a wrapped cable; nR = n wires in a ribbon (flat) cable

**Figure 6-8 Illustration of Bottom Cables, Option 015**



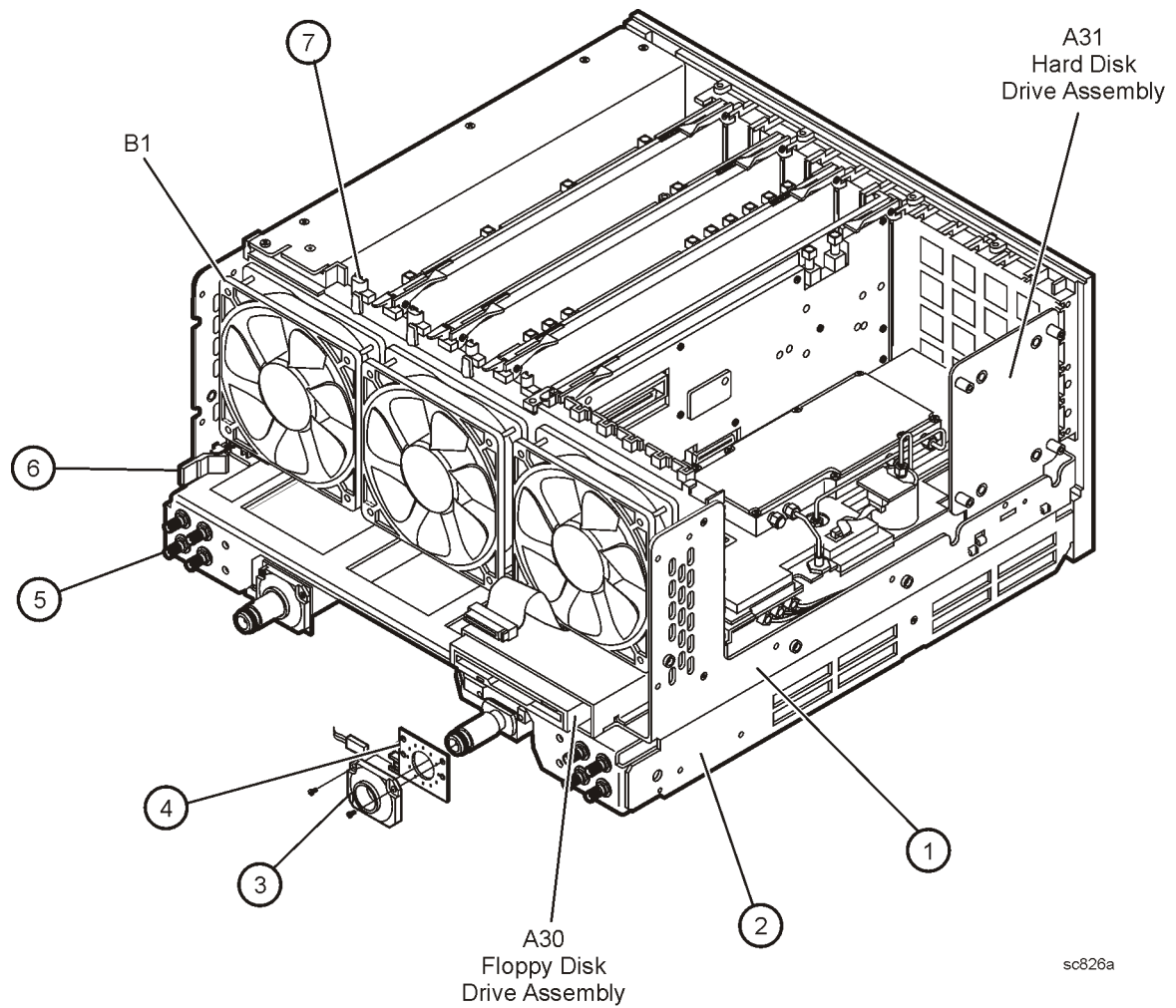
sc825a

## Internal Hardware and Parts

Reference Designator	Model/Option	Part Number	Qty	Description
A30	All	0950-2782	1	Floppy disk drive
	All	8121-0120	1	Cable
	All	E4406-60014	1	Floppy disk drive board
	All	E4406-40006	1	Floppy disk drive mount
	All	E8356-00007	1	Floppy disk drive enclosure
A31	Refer to “ <a href="#">Hard Disk Drive Assembly</a> ” on page 6-24.			Hard disk drive assembly (HDDA)
B1	All	3160-1085	3	Fan
①	All	E8356-00027	1	Chassis assembly
②	All	E8356-00008	1	Test set deck
③	All	5041-9626	2	Coupler LED ring
④	All	5064-3959	2	Coupler LED board
⑤	All except Option 015	1250-1251	8	SMA (f) to SMA (f), bulkhead connector
⑤	Option 015	1250-1251	12	SMA (f) to SMA (f), bulkhead connector
⑥	All	E8356-40004	1	Line switch button
	All	1460-2632	1	Line switch spring
ý⑦	All	E4406-60109	1	Midweb assembly (includes three fans)



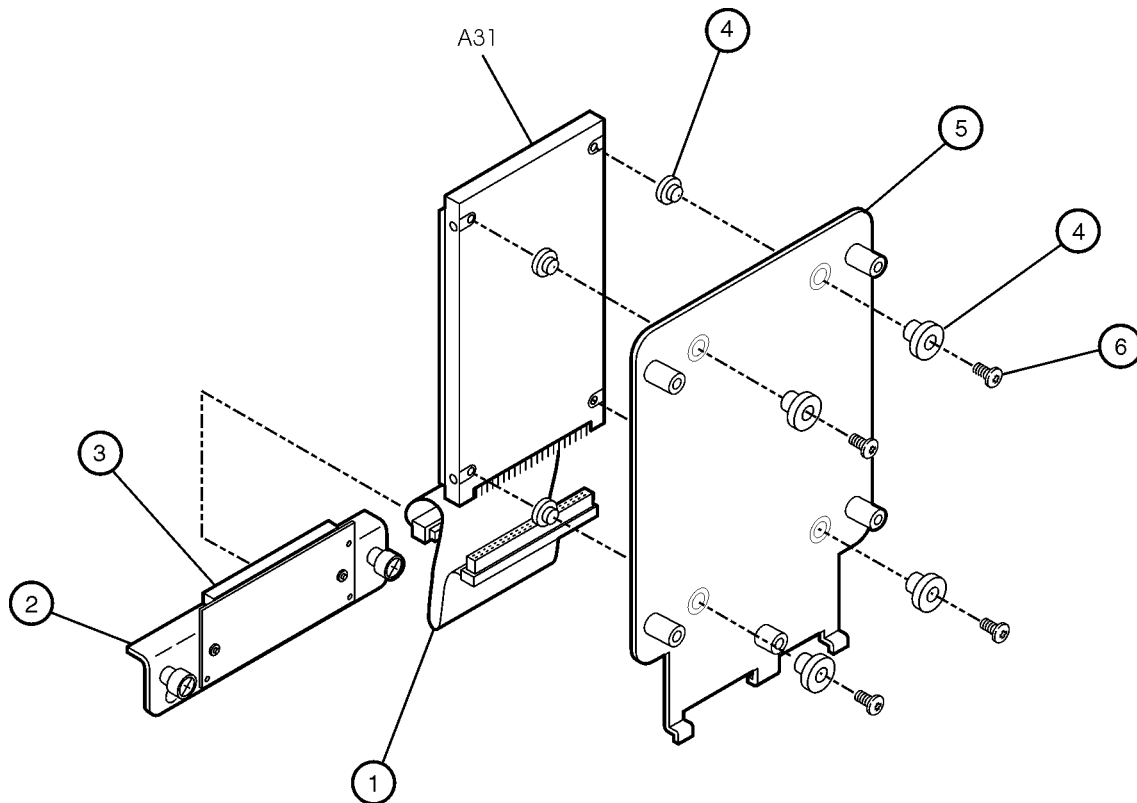
**Figure 6-9 Illustration of Internal Hardware and Parts**



## Hard Disk Drive Assembly

Reference Designator	Part Number	Qty	Description
A31	E8356-60076	1	Programmed hard disk drive for 266 MHz CPU board
	E8801-60063	1	Programmed hard disk drive for 500 MHz CPU board
①	8121-0114	1	Interface cable
②	E8356-00014	1	Hard disk drive interface board bracket
③	E8356-60024	1	Hard disk drive interface board assembly
④	0340-1525	8	Bushing
⑤	E8356-00010	1	Hard disk drive mounting plate
⑥	0515-0664	4	Machine screw, M3.0 x 12 CW-PN-TX

**Figure 6-10 Illustration of the Hard Disk Drive Assembly**



sc83a

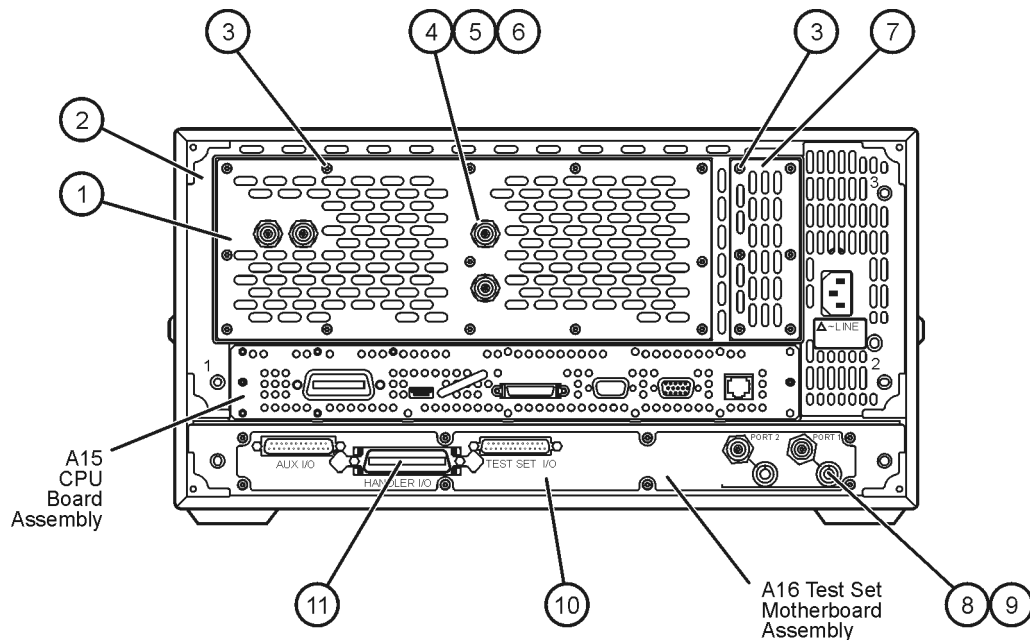
### Rear Panel Assembly

Item Number	Part Number	Qty	Description
①	E8356-00023	1	Cover plate, large
②	E8356-60055	1	Rear frame assembly (includes items ① through ⑥)
③	0515-0372	19	Machine screw, M3.0 x 8, CW-PN-TX
④	8120-5055	4	BNC cable assembly
⑤	2950-0035	4	Hex nut for BNC connector
⑥	2190-0102	4	Lock washer for BNC connector
⑦	E8356-00022	1	Cover plate, digital section
⑧	85047-60005	2	Fuse holder (includes wire harness, nut, and washer) <sup>a</sup>
⑨	1400-0112	2	Fuse holder cap
⑩ <sup>b</sup>	E8356-00017	1	Test set motherboard rear panel
⑪ <sup>b</sup>	8121-0763	1	Cable assembly, Handler I/O (includes connector)

a. See [page 6-29](#) for fuse part numbers.

b. For the following serial numbers, items ⑩ and ⑪ must be replaced together as a set:  
E8356A—serial numbers prefixed US4106 and below; E8357A—serial numbers prefixed US4107 and below; E8358A—serial numbers prefixed US4108 and below.

**Figure 6-11 Illustration of the Rear Panel Assembly**

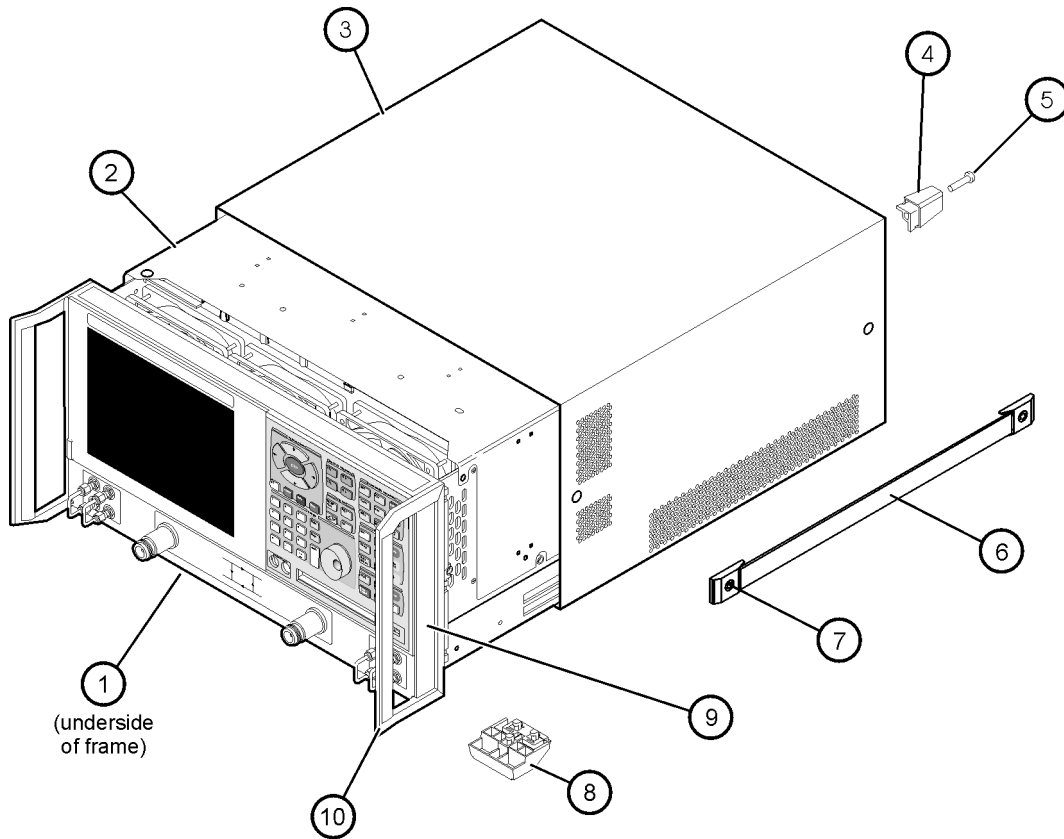


sc872a

## External Parts

Reference Designator	Part Number	Qty	Description
①	E8356-00025	1	Trim strip, filler
②	E8356-00011	1	Inner cover
③	E8356-00009	1	Outer cover
④	5041-9611	4	Rear feet
⑤	0515-1619	4	Machine screw M4.0 25 PNTX
⑥	E4400-60026	2	Strap handle assembly (includes item ⑦)
⑦	0515-0710	4	Machine screw M5.0 x 18 FLTX
⑧	5041-9167	4	Bottom feet
⑨	5041-9182	2	With handles—front handle side trim
	5041-9173	2	Without handles—trim strip, filler
⑩	5063-9204	2	Front handle

**Figure 6-12 Illustration of External Parts**



sc828a

## Miscellaneous Part Numbers

Description	Model or Part Number
<b>Service Tools</b>	
Extender board, synthesizer/reference	E8356-60021
T-10 TORX driver (set to 4, 7, and 9 in-lb)	N/A
T-20 TORX driver (set to 21 in-lb)	N/A
5/16 in open-end torque wrench (set to 10 in-lb)	N/A
<b>Documentation</b>	
Installation and Quick Start Guide	E8356-90001
Service Guide (Not available in printed form. Refer to <a href="#">“Printing Copies of Documentation on the Web”</a> on page iv.)	E8356-90002
CD-ROM Includes: <i>Installation and Quick Start Guide in PDF format</i> <i>Service Guide in PDF format</i> <i>Embedded Help program to run on a PC</i>	E8356-10001
<b>Upgrade Kits</b>	
Extended frequency; 3 GHz to 6 GHz for E8356A (Option 006)	E8356-60104
Extended frequency; 3 GHz to 9 GHz for E8356A (Option 009)	E8356-60105
Extended frequency; 6 GHz to 9 GHz for E8357A (Option 009)	E8357-60101
Time domain (Option 010)	E8356-60101
Configurable test set (Option 015)	E8356-60102
CPU board; replace 266 MHz with 500 MHz (Option 098)	E8356-60106
Firmware upgrade on CD-ROM (Option 099)	E8356-60103
<b>USB Accessories</b>	
Mouse	1150-7799
Keyboard	1150-7896j
Read/write CD-ROM	N4688A
Hub	N4689A
<b>ESD Supplies</b>	
Adjustable antistatic wrist strap	9300-1367
Antistatic wrist strap grounding cord (5 foot length)	9300-0980
Static control table mat and earth ground wire	9300-0797

Description	Model or Part Number
<b>Fuses</b>	
Rear Panel Bias Input Fuse for Port 1 and Port 2 (1 A, 125 V)	2110-0047
<b>Protective Caps for Connectors</b>	
Female GPIB connector	1252-5007
Female parallel port	1252-0387
RS-232 connector	1252-4697
Type-N connector	1401-0247
<b>GPIB Cables/Adapter</b>	
GPIB cable, 1M (3.3 feet)	10833A
GPIB cable, 2M (6.6 feet)	10833B
GPIB cable, 4M (13.2 feet)	10833C
GPIB cable, 0.5M (1.6 feet)	10833D
Adapter, GPIB cable to GPIB cable	10834A
<b>Touch-up Paint</b>	
Dove gray <i>(for use on frame around front panel and painted portion of handles)</i>	6010-1146
French gray <i>(for use on cover)</i>	6010-1147
Parchment white <i>(for use on rack mount flanges, rack support flanges, and front panels)</i>	6010-1148
<b>Rack Mount Kits and Handle Kits</b>	
Rack mount kit for instruments with handles (Option 1CP)	5063-9236
Rack mount kit for instruments without handles (Option 1CM)	5063-9216
Rack mount flange (two included in 5063-9236)	5063-2808
Rack mount flange (two included in 5063-9216)	5063-2801
Rack mount rail set (one set included in 5063-9236 and 5063-9216)	E3663AC
Front handle kit (two handles and hardware)	5063-9229
Front handle (two included in 5063-9229)	5063-9204





---

# **7 Repair and Replacement Procedures**

---

## Information in This Chapter

This chapter contains procedures for removing and replacing the major assemblies of your Agilent Technologies PNA series RF network analyzers (E8356A, E8357A, E8358A).

### Chapter Seven at-a-Glance

Section Title	Summary of Content	Start Page
<a href="#">Assembly Replacement Sequence</a>	The proper assembly replacement sequence for your analyzer.	<a href="#">Page 7-2</a>
<a href="#">Personal Safety Warnings</a>	Warnings and cautions pertaining to personal safety and ESD protection.	<a href="#">Page 7-3</a>
<a href="#">Electrostatic Discharge (ESD) Protection</a>	Information pertaining to ESD protection.	<a href="#">Page 7-3</a>
<a href="#">Removal and Replacement Procedures</a>	A table of removal and replacement procedures and the corresponding page number.	<a href="#">Page 7-4</a>
Removal and Replacement Procedures	The procedures for removing and replacing the major assemblies in your analyzer. <i>The procedures occur in reference designator numerical order.</i>	See <a href="#">Table 7-1 on page 7-4</a> for specific procedures.
<a href="#">Post-Repair Procedures</a>	A table for the proper tests, verifications, and adjustments to perform on your analyzer after repair.	<a href="#">Page 7-54</a>

---

## Assembly Replacement Sequence

The following steps show the sequence that you should follow to replace an assembly in the network analyzer.

- Step 1.** Identify the faulty group. Begin with [Chapter 4, “Troubleshooting.”](#)
- Step 2.** Order a replacement assembly. Refer to [Chapter 6, “Replaceable Parts.”](#)
- Step 3.** Replace the faulty assembly and determine what adjustments are necessary. Refer to this chapter.
- Step 4.** Perform the necessary adjustments. Refer to [Chapter 3, “Tests and Adjustments.”](#)
- Step 5.** Perform the necessary performance tests. Refer to [Chapter 3, “Tests and Adjustments.”](#)

---

## Personal Safety Warnings

---

**WARNING** These servicing instructions are for use by qualified personnel only. To avoid electrical shock, do not perform any servicing unless you are qualified to do so.

---

**WARNING** The opening of covers or removal of parts is likely to expose dangerous voltages. Disconnect the analyzer from all voltage sources while it is being opened.

---

**WARNING** The detachable power cord is the instrument disconnecting device. It disconnects the mains circuits from the mains supply before other parts of the instrument. The front panel switch is only a standby switch and is not a LINE switch (disconnecting device).

---

**WARNING** The power cord is connected to internal capacitors that may remain live for 10 seconds after disconnecting the plug from its power supply assembly. Wait at least 10 seconds, after disconnecting the plug, before removing the covers.

---

---

## Electrostatic Discharge (ESD) Protection

---

**CAUTION** Many of the assemblies in this instrument are very susceptible to damage from electrostatic discharge (ESD). Perform the following procedures only at a static-safe workstation and wear a grounded wrist strap.

This is important. If not properly protected against, electrostatic discharge can seriously damage your analyzer, resulting in costly repair.

To reduce the chance of electrostatic discharge, follow all of the recommendations outlined in [“Electrostatic Discharge Protection”](#) on page 1-5, for each of the procedures in this chapter.

---

## Removal and Replacement Procedures

**Table 7-1 List of Procedures**

<b>Reference Designator</b>	<b>Assembly Type</b>	<b>Location</b>
N/A	Covers, outer and inner	Page 7-6
N/A	Midweb and fans	Page 7-50
N/A	Front panel assembly	Page 7-8
A1	Keypad assembly	Page 7-10
A2	Display assembly	
A3	Front panel interface board assembly	
A4	Power supply assembly	Page 7-14
A6	Signal processing ADC module (SPAM) board assembly	Page 7-16
A8	Fractional-N synthesizer board assembly	
A10	Frequency reference board assembly	
A11	Phase lock board assembly	Page 7-18
A12	Source assembly	Page 7-20
A14	Motherboard assembly	Page 7-22
A15	CPU board assembly	Page 7-24
A16	Test set motherboard assembly	Page 7-26
A17	Local oscillator distribution assembly (LODA)	Page 7-28
A18	Channel A receiver module assembly	Page 7-30
A19	Channel R1 receiver module assembly	
A20	Channel R2 receiver module assembly	
A21	Channel B receiver module assembly	
A22	Switch splitter assembly	Page 7-32

**Table 7-1 List of Procedures**

<b>Reference Designator</b>	<b>Assembly Type</b>	<b>Location</b>
A23	Test port 1 coupler	<a href="#">Page 7-34</a>
A24	Test port 2 coupler	
A25	70 dB step attenuator	<a href="#">Page 7-36</a>
A26	70 dB step attenuator	
A27	35 dB step attenuator (Option 015 only)	<a href="#">Page 7-38</a>
A28	35 dB step attenuator (Option 015 only)	
A30	Floppy disk drive	<a href="#">Page 7-40</a>
A31	Hard disk drive assembly (HDDA)	<a href="#">Page 7-42</a>

**Table 7-2 Other Procedures**

<b>Procedure</b>	<b>Location</b>
Reconfiguring the Pinout of the Handler I/O Port	<a href="#">Page 7-53</a>

---

## Removing the Covers

### Tools Required

- T-10 TORX driver (set to 9 in-lb)
- T-20 TORX driver (set to 21 in-lb)

### Removal Procedure

---

**CAUTION** This procedure is best performed with the analyzer resting on its front handles in the vertical position. *Do not place the analyzer on its front panel without the handles.* This will damage the front panel assemblies.

---

#### Removing the Outer Cover

Refer to [Figure 7-1](#) for this procedure.

1. Disconnect the power cord.
2. With a T-20 TORX driver, remove the strap handles (item ①) by loosening the screws (item ②) on both ends until the handle is free of the analyzer.
3. With a T-20 TORX driver, remove the four rear panel feet (item ③) by removing the center screws (item ④).
4. Slide the four bottom feet (item ⑤) off the cover.
5. Slide the cover off of the frame.

#### Removing the Inner Cover

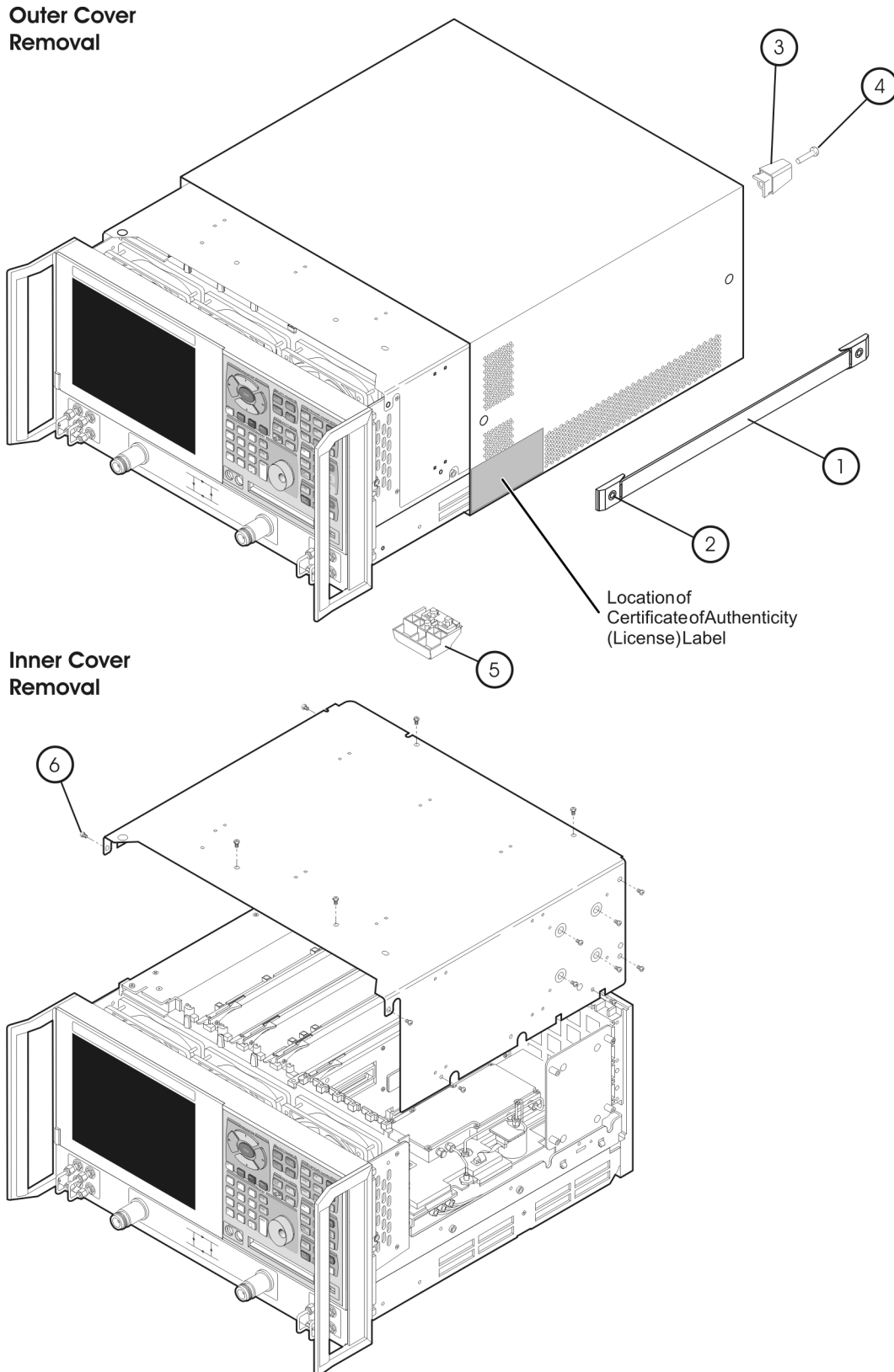
Refer to [Figure 7-1](#) for this procedure.

1. With a T-10 TORX driver, remove the 15 screws (item ⑥).
2. Lift off the cover.

### Replacement Procedure

Reverse the order of the removal procedures.

**Figure 7-1 Outer and Inner Cover Removal**



---

## Removing and Replacing the Front Panel Assembly

### Tools Required

- T-10 TORX driver (set to 9 in-lb)
- T-20 TORX driver (set to 21 in-lb)
- 5/16-inch open-end torque wrench (set to 10 in-lb)
- ESD grounding wrist strap

### Removal Procedure

Refer to [Figure 7-2](#) for this procedure.

1. Disconnect the power cord.
2. Remove the outer cover. Refer to “[Removing the Covers](#)” on page 7-6.
3. With a 5/16-in torque wrench, remove all the semirigid jumpers (item ①) from the front panel.
4. With a T-10 TORX driver, remove the six screws (item ②) from the sides of the frame.

---

**CAUTION** Before removing the front panel from the analyzer, lift and support the front of the analyzer frame.

---

5. Slide the front panel over the test port connectors.
6. Disconnect the front panel interface ribbon cable (item ③).

The front panel is now free from the analyzer.

### Replacement Procedure

---

**CAUTION** When replacing the front panel, align the power switch and the floppy disk drive to their corresponding front panel cutouts.

---

---

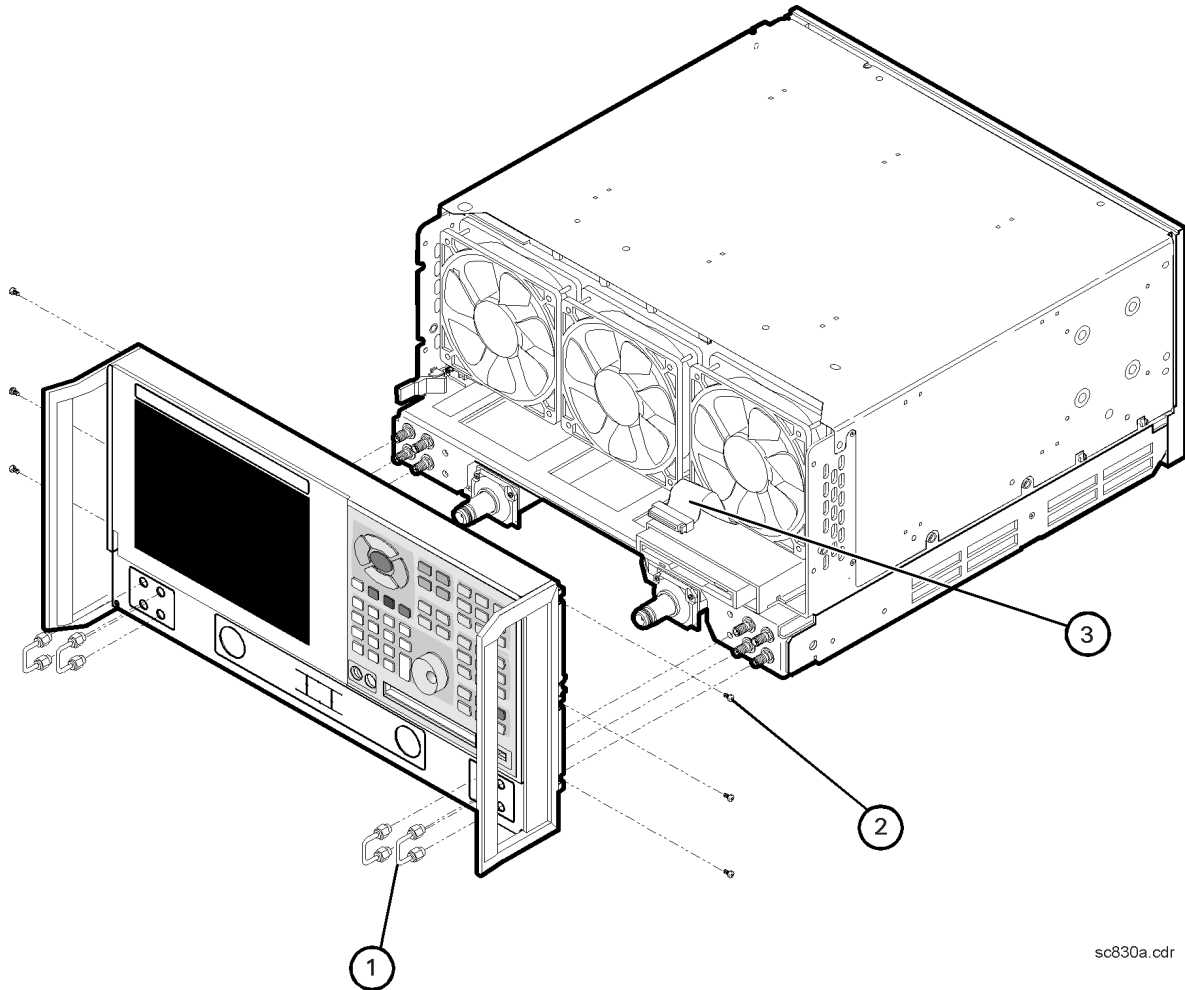
**IMPORTANT** When reconnecting semirigid cables, torque the cable connectors to 10 in-lb.

---

1. Reverse the order of the removal procedure.
2. Perform the post-repair adjustments, verifications, and performance tests that pertain to this removal procedure. Refer to [Table 7-3 on page 7-54](#).



**Figure 7-2 Front Panel Assembly Removal**



sc830a.cdr

---

## Removing and Replacing Front Panel Subassemblies

### Tools Required

- T-10 TORX driver (set to 9 in-lb)
- T-20 TORX driver (set to 21 in-lb)
- 5/16-inch open-end torque wrench (set to 10 in-lb)
- ESD grounding wrist strap

### Removal Procedure

Refer to [Figure 7-3](#) for this procedure.

1. Disconnect the power cord.
2. Remove the front panel assembly. Refer to [“Removing and Replacing the Front Panel Assembly” on page 7-8](#).
3. Disconnect the display ribbon cable (item ①) and the display lamp cable (item ②) from the A3 front panel interface board assembly.

### Removing the A2 Display Assembly

1. With a T-10 TORX driver, remove the four retaining screws (item ③) from the display assembly.
2. Remove the display assembly from the front panel.

### Removing the A3 Front Panel Interface Board Assembly

1. Remove the round knob (RPG) from the front panel by gently pulling the knob forward.
2. With a T-10 TORX driver, remove the seven screws (item ④) from the front panel interface board.
3. From the bottom of the frame, lift the A3 front panel interface board assembly up at an angle until the board clears the frame. Disconnect the keypad ribbon cable (item ⑤) from the A3 front panel interface board assembly and lift out the board.

### Removing the A1 Keypad Assembly

1. Remove the A3 front panel interface board assembly as instructed above.
2. From the rear of the front panel assembly, remove the center retaining screw (item ⑥). Bend the bottom keypad assembly tabs away from the frame and push the A1 keypad assembly out of the frame.

## Replacement Procedure

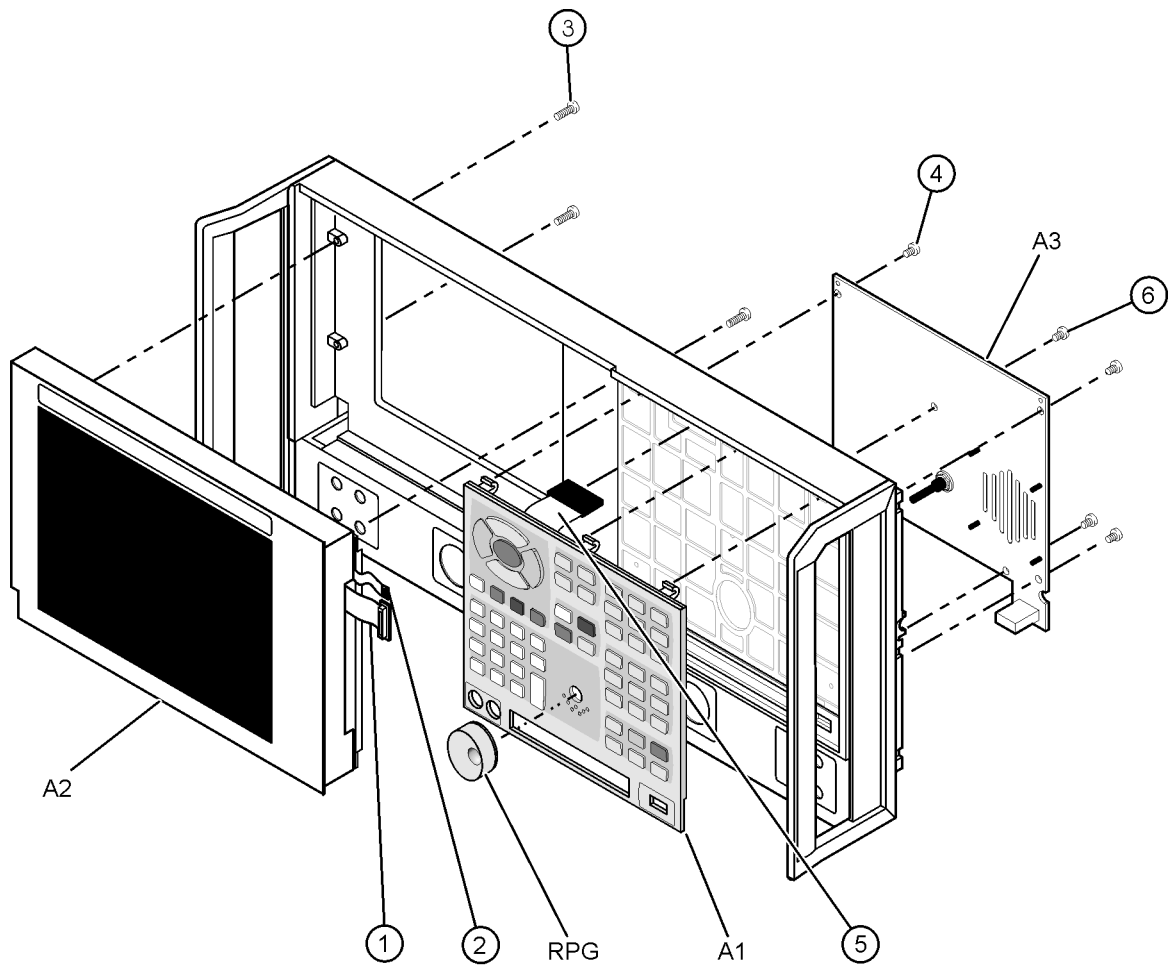
---

**NOTE** When replacing the assemblies, ensure that the ribbon cables are not under the assemblies.

---

1. Reverse the order of the removal procedure.
2. Perform the post-repair adjustments, verifications, and performance tests that pertain to this removal procedure. Refer to [Table 7-3 on page 7-54](#).

**Figure 7-3 Front Panel Subassemblies Removal**



sc84a

---

## Removing and Replacing the Display Inverter Board and the Display Lamp

### Tools Required

- T-10 TORX driver (set to 9 in-lb)
- T-20 TORX driver (set to 21 in-lb)
- Small jeweler's screwdriver
- 5/16-inch open-end torque wrench (set to 10 in-lb)
- ESD grounding wrist strap

### Removal Procedure

Refer to [Figure 7-4](#) for this procedure.

1. Disconnect the power cord.
2. Remove the front panel assembly. Refer to [“Removing and Replacing the Front Panel Assembly” on page 7-8](#).
3. Remove the display assembly. Refer to [“Removing the A2 Display Assembly” on page 7-10](#).

### Removing the Display Inverter Board

1. Disconnect the ribbon cable (item ①) and the display lamp cable (item ②) from the display inverter board.
2. Lift the inverter retention tabs (item ③) with slight pressure and rotate the display inverter board (item ④).
3. Lift the display inverter board (item ④) out of the slot.

---

**NOTE** Stop now if you are only removing the display inverter board. Replace the board and reverse the removal procedure.

---

### Removing the Display Lamp

1. Remove the display lamp cable (item ②) from the display inverter board (item ④).
2. With a T-10 TORX driver, remove the four screws (item ⑤) on the display back panel and then lift the panel off.
3. Remove the four display bumpers (item ⑥).
4. To gain access to the display lamp, rotate the top of the display slightly out of the display frame.

---

**NOTE** To avoid dust or dirt particles from getting in between the display glass and the display, do not completely take out the display.

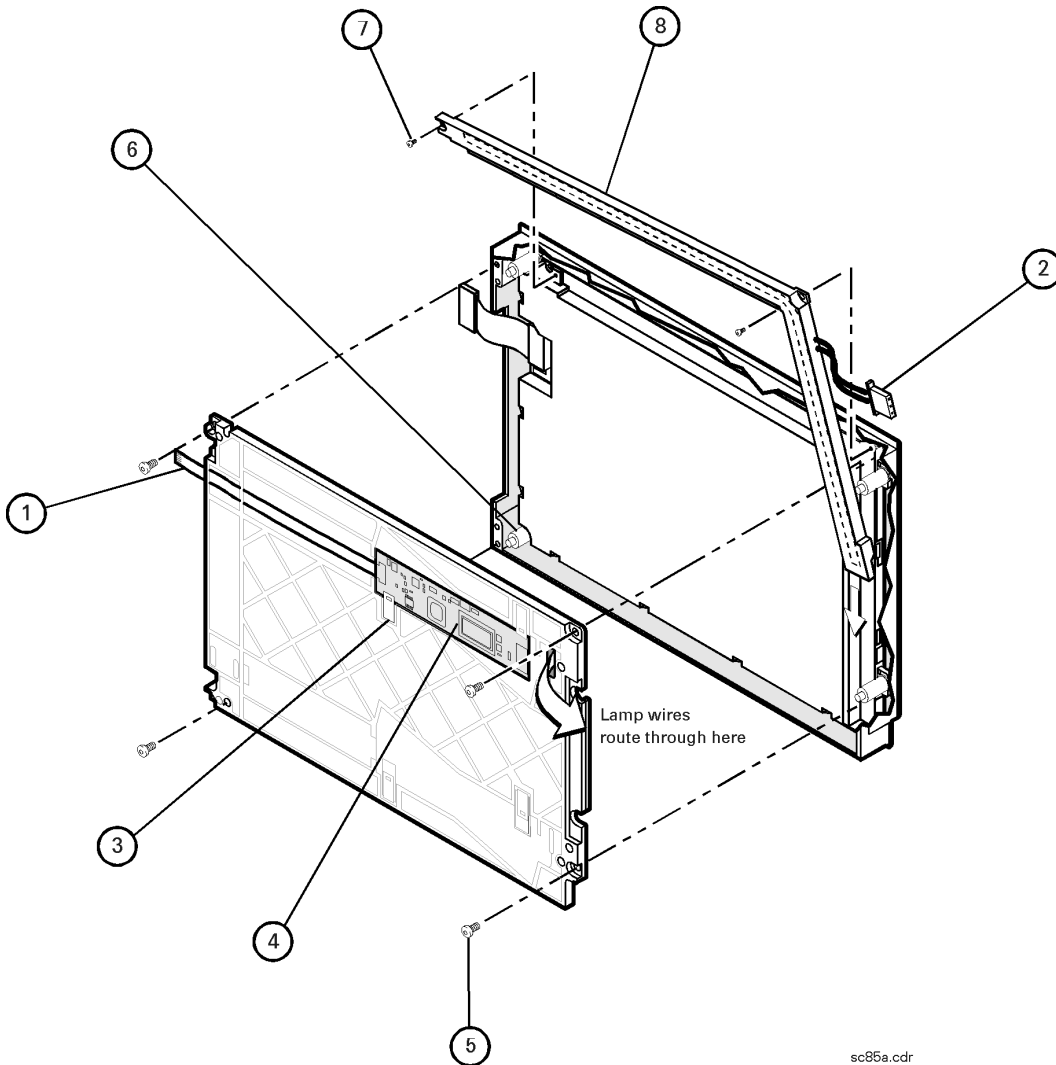
---

5. Remove the two screws (item ⑦) from the display with the jeweler's screwdriver. Slide the lamp enclosure up to remove it.
6. Remove the display lamp (item ⑧).

## Replacement Procedure

1. Reverse the order of the removal procedure.
2. Perform the post-repair adjustments, verifications, and performance tests that pertain to this removal procedure. Refer to [Table 7-3 on page 7-54](#).

**Figure 7-4 Display Inverter Board and Display Lamp Removal**



---

## Removing and Replacing the A4 Power Supply Assembly

### Tools Required

- T-10 TORX driver (set to 9 in-lb)
- T-20 TORX driver (set to 21 in-lb)
- ESD grounding wrist strap

### Removal Procedure

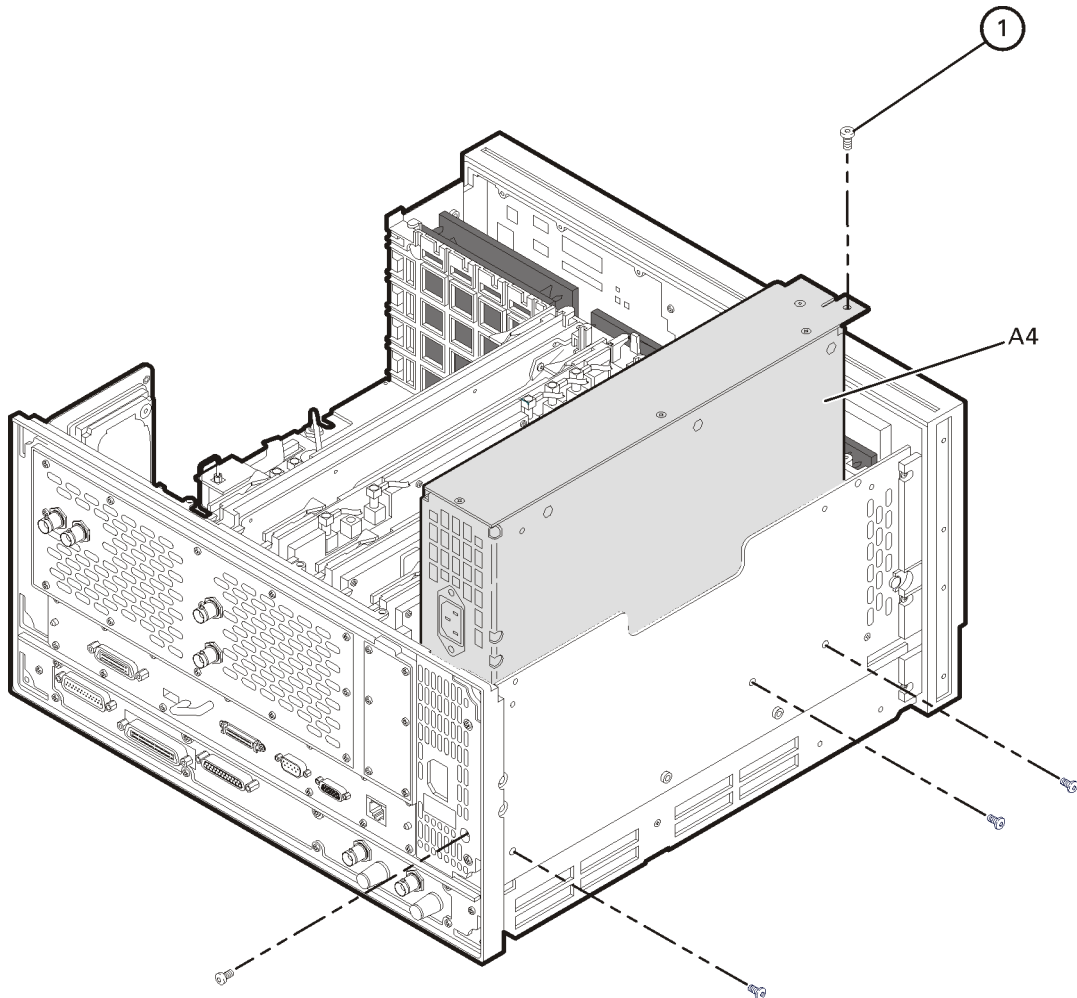
Refer to [Figure 7-5](#) for this procedure.

1. Disconnect the power cord.
2. Remove the outer and inner covers. Refer to [“Removing the Covers” on page 7-6](#).
3. With a T-10 TORX driver, remove the five screws (item ①) from the power supply assembly.
4. Lift out the A4 power supply assembly.

### Replacement Procedure

1. Reverse the order of the removal procedure.
2. Perform the post-repair adjustments, verifications, and performance tests that pertain to this removal procedure. Refer to [Table 7-3 on page 7-54](#).

**Figure 7-5 A4 Power Supply Assembly Removal**



sc831a

---

## Removing and Replacing the A6, A8, and A10 Board Assemblies

### Tools Required

- T-10 TORX driver (set to 9 in-lb)
- T-20 TORX driver (set to 21 in-lb)
- ESD grounding wrist strap

### Removal Procedure

Refer to [Figure 7-6](#) for this procedure.

1. Disconnect the power cord.
2. Remove the outer and inner covers. Refer to [“Removing the Covers” on page 7-6](#).
3. With a T-10 TORX driver, remove the two brackets that secure cables to the top of the midweb.
4. Identify the board you want to remove and disconnect any cables that are attached to it.
5. Lift the two extractors (item ①), located at each end of the board.

---

**NOTE** Before removing the board, check the bottom of the boards for any attached cables.

---

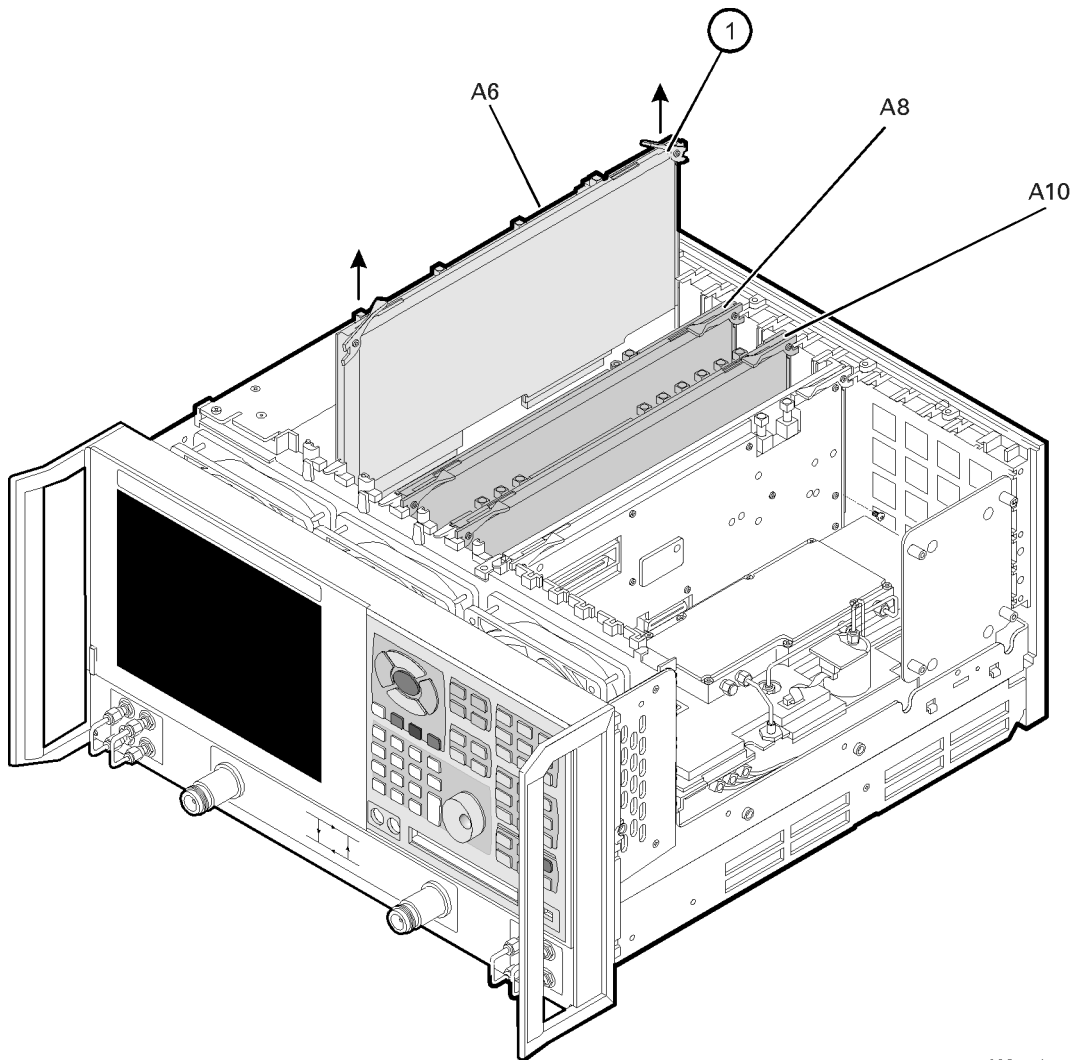
6. While holding on to the extractors, slide the board out of the slot and remove from the analyzer.

### Replacement Procedure

1. Reverse the order of the removal procedure.
2. Perform the post-repair adjustments, verifications, and performance tests that pertain to this removal procedure. Refer to [Table 7-3 on page 7-54](#).



**Figure 7-6 A6, A8, and A10 Board Assemblies Removal**



sc832a.cdr

---

## Removing and Replacing the A11 Phase Lock Board Assembly

### Tools Required

- T-10 TORX driver (set to 9 in-lb)
- T-20 TORX driver (set to 21 in-lb)
- ESD grounding wrist strap

### Removal Procedure

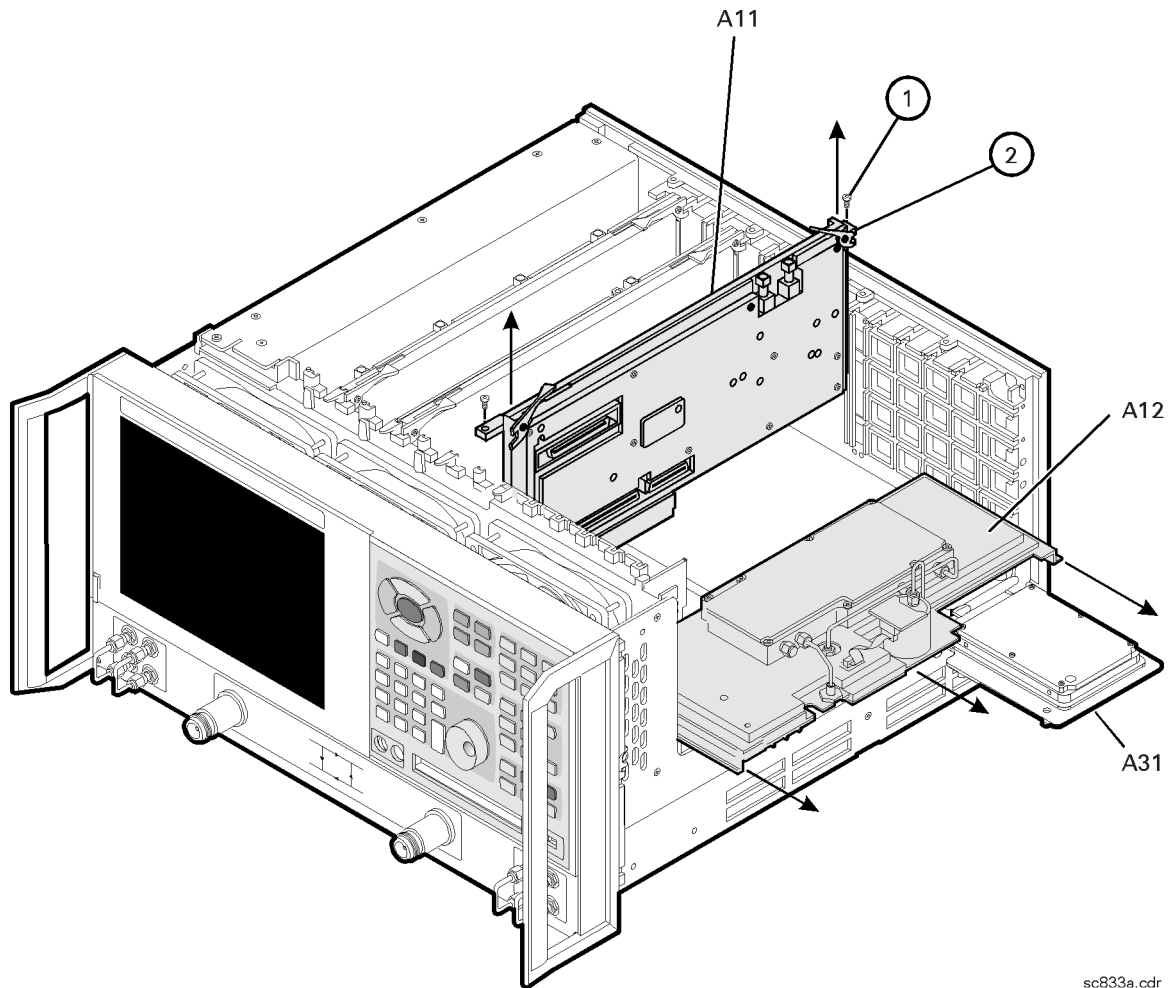
Refer to [Figure 7-7](#) for this procedure.

1. Disconnect the power cord.
2. Remove the outer and inner covers. Refer to [“Removing the Covers”](#) on page 7-6.
3. With a T-10 TORX driver, remove the two brackets that secure cables to the top of the midweb.
4. Place the A31 hard disk drive assembly into the service position. Refer to [“Placing the HDDA in the Service Position”](#) on page 7-43.
5. With a T-10 TORX driver, remove the two screws (item ①) from the top of the A11 phase lock board assembly.
6. Disengage the A12 source assembly from the A11 connector and slide the A12 partially out of the analyzer. Refer to [“Removing and Replacing the A12 Source Assembly”](#) on page 7-20.
7. Disconnect any flexible cables that are attached to the A11 phase lock board assembly.
8. Lift the two extractors (item ②) located at each end of the board.
9. While holding on to the extractors, lift the A11 phase lock board assembly out of the analyzer.

### Replacement Procedure

1. Reverse the order of the removal procedure.
2. Perform the post-repair adjustments, verifications, and performance tests that pertain to this removal procedure. Refer to [Table 7-3](#) on page 7-54.

**Figure 7-7 A11 Phase Lock Board Assembly Removal**



sc833a.cdr

---

## Removing and Replacing the A12 Source Assembly

### Tools Required

- T-10 TORX driver (set to 9 in-lb)
- T-20 TORX driver (set to 21 in-lb)
- 5/16-inch open-end torque wrench (set to 10 in-lb)
- ESD grounding wrist strap

### Removal Procedure

Refer to [Figure 7-8](#) for this procedure.

1. Disconnect the power cord.
2. Remove the outer and inner covers. Refer to [“Removing the Covers”](#) on page 7-6.
3. Place the A31 hard disk drive assembly into the service position. Refer to [“Placing the HDDA in the Service Position”](#) on page 7-43.
4. Disconnect the three flexible cables (item ①) from the A12 source assembly.

---

**CAUTION** Be careful not to damage the center pins of the semirigid cables. Some flexing of the cables is necessary to remove the assembly. Do not over-bend the semirigid cables.

---

5. With a 5/16-in torque wrench, disconnect the semirigid cable (item ②) from the bottom of the A12 source assembly.

---

**CAUTION** To avoid damage to the semirigid cable (item ②), pull down on the cable from the bottom of the analyzer to move it away while sliding out the A12 source assembly. The cable has some spring to it and the RF pin could be damaged by the A12 source assembly.

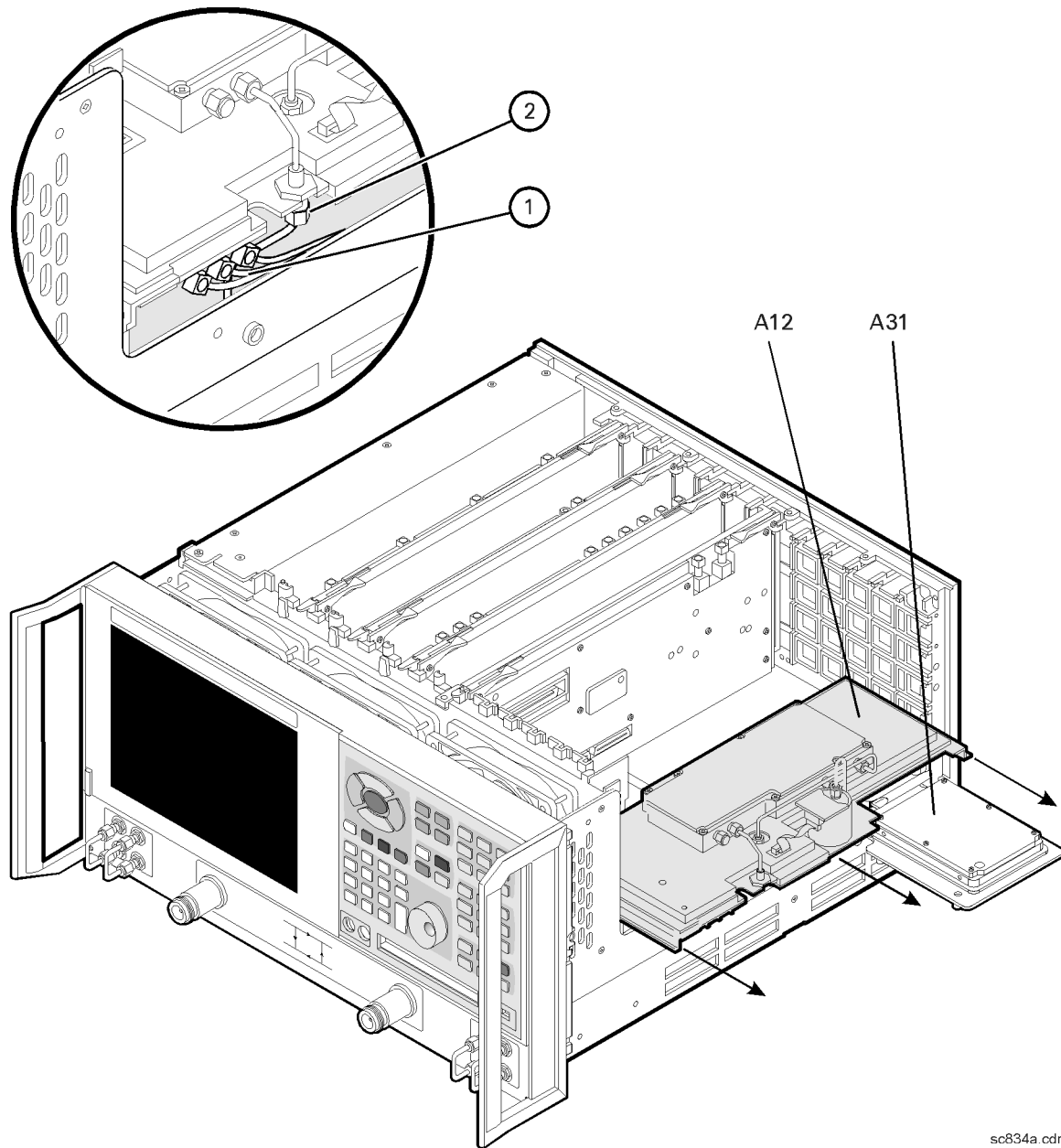
---

6. Slide the A12 source assembly out of the analyzer.

### Replacement Procedure

1. Reverse the order of the removal procedure.
2. Perform the post-repair adjustments, verifications, and performance tests that pertain to this removal procedure. Refer to [Table 7-3](#) on page 7-54.

Figure 7-8 A12 Source Assembly Removal



sc834a.cdr

---

## Removing and Replacing the A14 Motherboard Assembly

### Tools Required

- T-10 TORX driver (set to 9 in-lb)
- T-20 TORX driver (set to 21 in-lb)
- 5/16-inch open-end torque wrench (set to 10 in-lb)
- ESD grounding wrist strap

### Removal Procedure

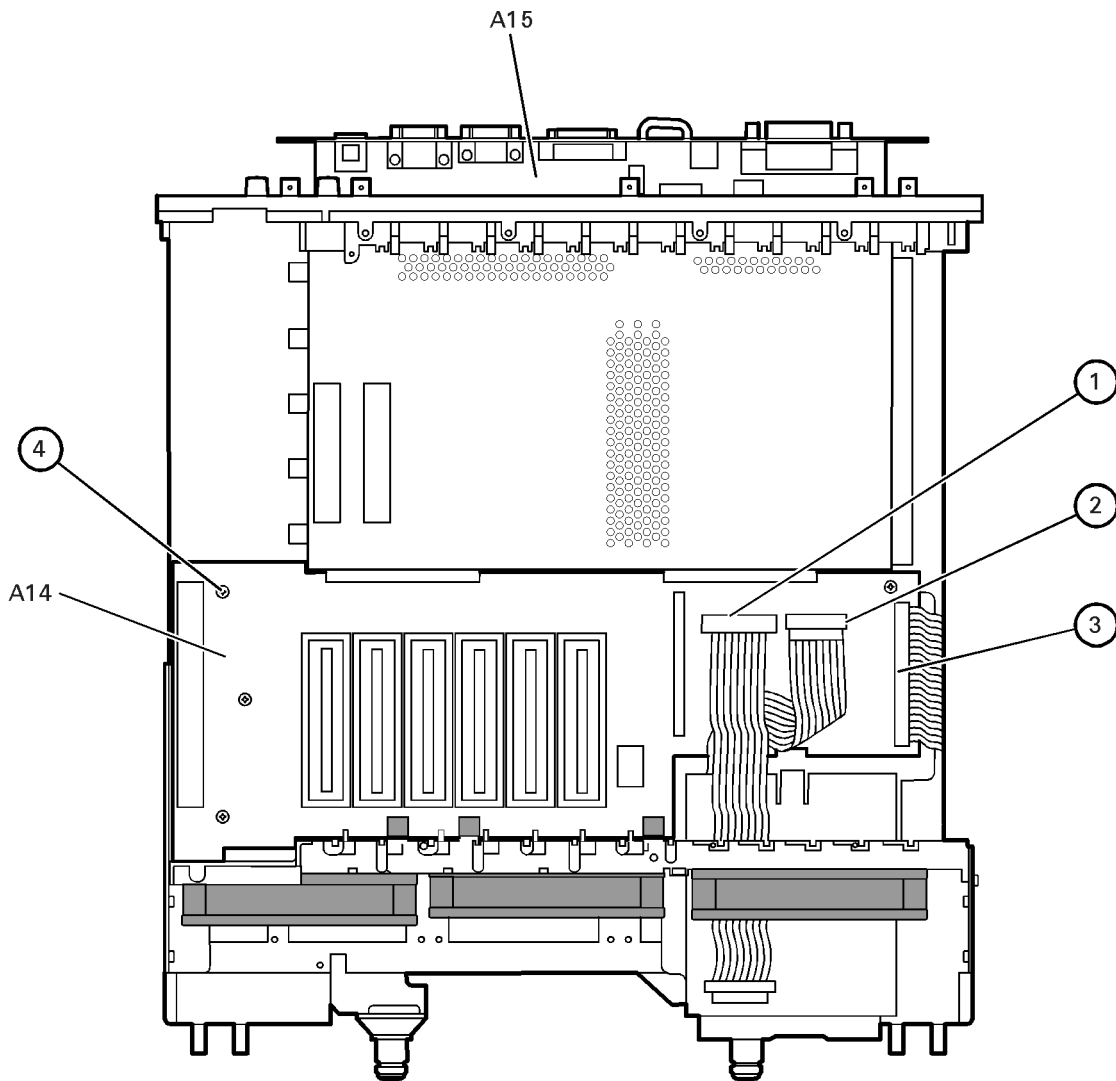
Refer to [Figure 7-9](#) for this procedure.

1. Disconnect the power cord.
2. Remove the outer and inner covers. Refer to [“Removing the Covers”](#) on page 7-6.
3. Remove the front panel assembly. Refer to [“Removing and Replacing the Front Panel Assembly”](#) on page 7-8.
4. Remove the A31 hard disk drive assembly. Refer to [“Removing the HDDA”](#) on page 7-44.
5. Remove the A12 source assembly. Refer to [“Removing and Replacing the A12 Source Assembly”](#) on page 7-20.
6. Remove the A11 phase lock board assembly. Refer to [“Removing and Replacing the A11 Phase Lock Board Assembly”](#) on page 7-18.
7. Remove the A4 power supply assembly. Refer to [“Removing and Replacing the A4 Power Supply Assembly”](#) on page 7-14.
8. Remove the card cage boards (A6, A8, and A10). Refer to [“Removing and Replacing the A6, A8, and A10 Board Assemblies”](#) on page 7-16.
9. Remove the A15 CPU board assembly. Refer to [“Removing and Replacing the A15 CPU Board Assembly”](#) on page 7-24.
10. Remove the Midweb. Refer to [“Removing and Replacing the Midweb and the B1 Fan”](#) on page 7-50.
11. Disconnect the A1 front panel ribbon cable (item ①), the A30 floppy disk drive ribbon cable (item ②), and the A16 test set motherboard assembly ribbon cable (item ③) from the A14 motherboard assembly.
12. Lift the tab at the rear of the A30 floppy disk drive enclosure and remove the rear enclosure cover.
13. Remove the four screws (item ④) that secure the A14 motherboard assembly.
14. Lift the A14 motherboard assembly out of the analyzer.

## Replacement Procedure

1. Reverse the order of the removal procedure.
2. Perform the post-repair adjustments, verifications, and performance tests that pertain to this removal procedure. Refer to [Table 7-3 on page 7-54](#).

**Figure 7-9 A14 Motherboard Assembly Removal**



sc835a.cdr

---

## Removing and Replacing the A15 CPU Board Assembly

### Tools Required

- T-10 TORX driver (set to 9 in-lb)
- T-20 TORX driver (set to 21 in-lb)
- ESD grounding wrist strap

### Removal Procedure

Refer to [Figure 7-10](#) for this procedure.

1. Disconnect the power cord.
2. Remove the outer and inner covers. Refer to “[Removing the Covers](#)” on page 7-6.
3. Remove the A31 hard disk drive assembly. Refer to “[Removing and Replacing the A31 Hard Disk Drive Assembly \(HDDA\)](#)” on page 7-42.
4. Disengage the A6 SPAM board assembly from the A15 CPU board assembly by performing the following steps.
  - a. Lift the two extractors located at each end of the board.
  - b. While holding onto the extractors, lift the board halfway out of the slot.
  - c. Let the extractors drop to their normal position.
  - d. Lower the board into the slot.

The board should now rest above its normal seated position.

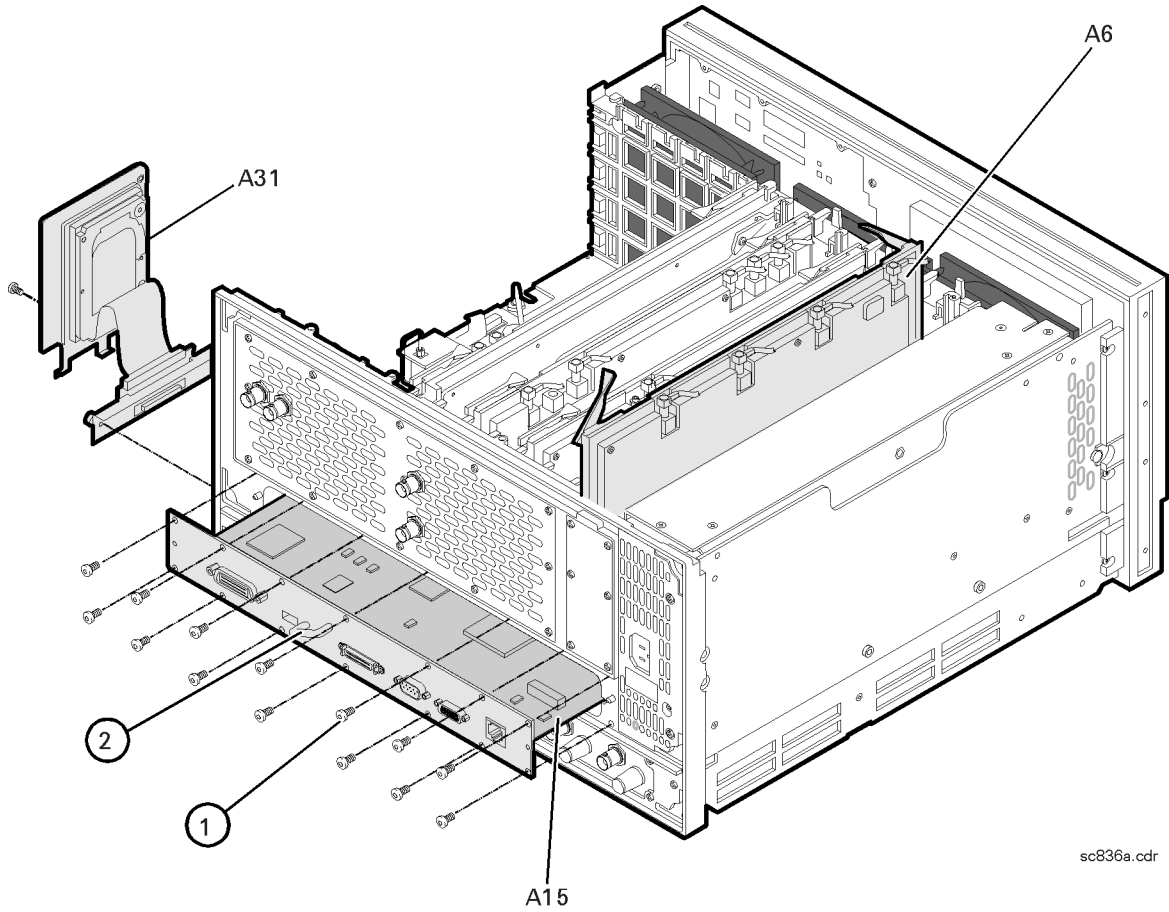
5. With a T-10 TORX driver, remove the 14 screws (item ①) from the rear panel of the A15 CPU board assembly.
6. Gently pull on the finger grip (item ②) to disengage the A15 CPU board assembly from the analyzer.
7. Slide the A15 CPU board assembly out of the analyzer.

### Replacement Procedure

1. Reverse the order of the removal procedure.
2. If a new Certificate of Authenticity (license) label is provided with your new A15 CPU board, adhere it to the outer cover in the location specified in [Figure 7-1](#) on page 7-7.
3. Perform the post-repair adjustments, verifications, and performance tests that pertain to this removal procedure. Refer to [Table 7-3](#) on page 7-54.



Figure 7-10 A15 CPU Board Assembly Removal



sc836a.cdr

---

## Removing and Replacing the A16 Test Set Motherboard Assembly

### Tools Required

- T-10 TORX driver (set to 9 in-lb)
- T-20 TORX driver (set to 21 in-lb)
- 5/16-inch open-end torque wrench (set to 10 in-lb)
- ESD grounding wrist strap

### Removal Procedure

Refer to [Figure 7-11](#) for this procedure.

1. Disconnect the power cord.
2. Remove the outer cover. Refer to [“Removing the Covers” on page 7-6](#).
3. Remove the A17 local oscillator (LO) distribution assembly (LODA). Refer to [“Removing and Replacing the A17 Local Oscillator Distribution Assembly \(LODA\)” on page 7-28](#).
4. Disconnect the step attenuator ribbon cables (item ①) from the A16 test set motherboard assembly.
5. Disconnect the coupler stranded power cables (item ②).
6. Disconnect the stranded switch control cable (item ③).
7. Disconnect the A14 motherboard ribbon cable (item ④).
8. Disconnect seven flexible cables (item ⑤): one each from the A18, A19, A20, and A21 receiver module assemblies and three from the A16 test set motherboard assembly. Move the flexible cables out of the way.

---

**CAUTION** Be careful not to damage the center pins of the semirigid cables. Some flexing of the cables is necessary to remove the assembly. Do not over-bend the semirigid cables.

---

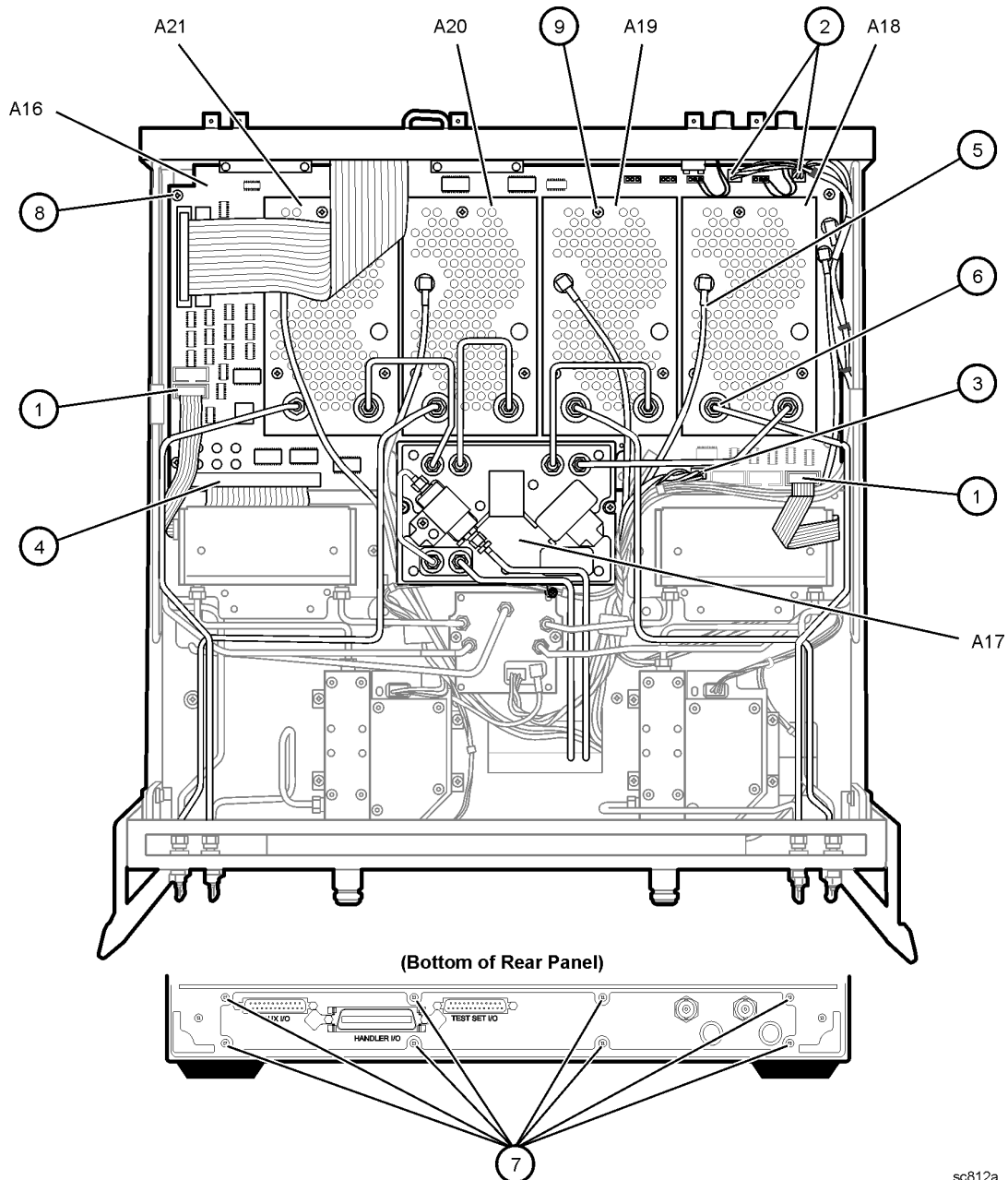
9. With a 5/16-in torque wrench, disconnect all the semirigid cables from the A18, A19, A20, and A21 receiver module assemblies (item ⑥).
10. With a T-10 TORX driver, remove the eight screws (item ⑦) from the rear panel and the six screws (item ⑧) from the edges of the A16 test set motherboard assembly.
11. Remove the A16 test set motherboard assembly, taking care not to bend or damage the semirigid cables.

12. With the A16 test set motherboard assembly out of the analyzer, remove the four receiver module assemblies (A18, A19, A20, and A21) by removing the screws (item 9) and lifting them off of the board.

## Replacement Procedure

1. Reverse the order of the removal procedure.
2. Perform the post-repair adjustments, verifications, and performance tests that pertain to this removal procedure. Refer to [Table 7-3 on page 7-54](#).

**Figure 7-11 A16 Test Set Motherboard Assembly Removal**



sc812a

---

## Removing and Replacing the A17 Local Oscillator Distribution Assembly (LODA)

### Tools Required

- T-10 TORX driver (set to 9 in-lb)
- T-20 TORX driver (set to 21 in-lb)
- 5/16-inch open-end torque wrench (set to 10 in-lb)
- ESD grounding wrist strap

### Removal Procedure

Refer to [Figure 7-12](#) for this procedure.

1. Disconnect the power cord.
2. Remove the outer cover. Refer to [“Removing the Covers” on page 7-6](#).

---

**CAUTION** Be careful not to damage the center pins of the semirigid cables. Some flexing of the cables is necessary to remove the assembly. Do not over-bend the semirigid cables.

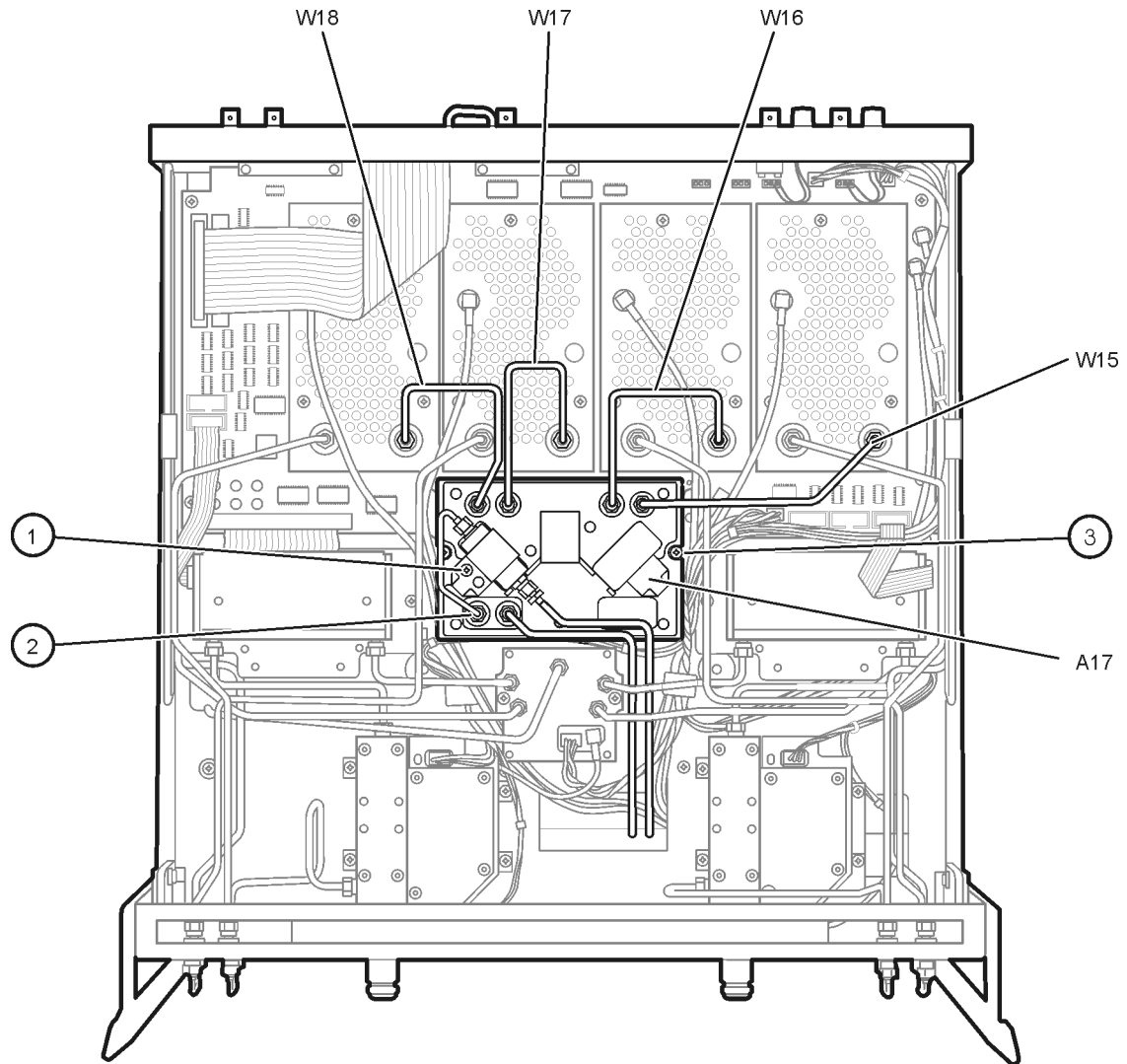
---

3. Remove W15, W16, W17, and W18 semirigid cables from the analyzer.
4. Remove the filter retaining bracket by removing the screw (item ①).
5. With a 5/16-inch torque wrench, disconnect two semirigid cables (item ②) from the A17 LO distribution assembly (LODA).
6. With a T-10 TORX driver, remove the four mounting screws (item ③).
7. Support the filter and semirigid cables and remove the A17 LO distribution assembly (LODA).

### Replacement Procedure

1. Reverse the order of the removal procedure.
2. Perform the post-repair adjustments, verifications, and performance tests that pertain to this removal procedure. Refer to [Table 7-3 on page 7-54](#).

**Figure 7-12 A17 LO Distribution Assembly Removal**



sc813a

---

## Removing and Replacing the A18, A19, A20, and A21 Receiver Module Assemblies

### Tools Required

- T-10 TORX driver (set to 9 in-lb)
- T-20 TORX driver (set to 21 in-lb)
- 5/16-inch open-end torque wrench (set to 10 in-lb)
- ESD grounding wrist strap

### Removal Procedure

Refer to [Figure 7-13](#) for this procedure.

1. Disconnect the power cord.
2. Remove the outer cover. Refer to [“Removing the Covers” on page 7-6](#).

---

**CAUTION** Be careful not to damage the center pins of the semirigid cables. Some flexing of the cables is necessary to remove the assembly. Do not over-bend the semirigid cables.

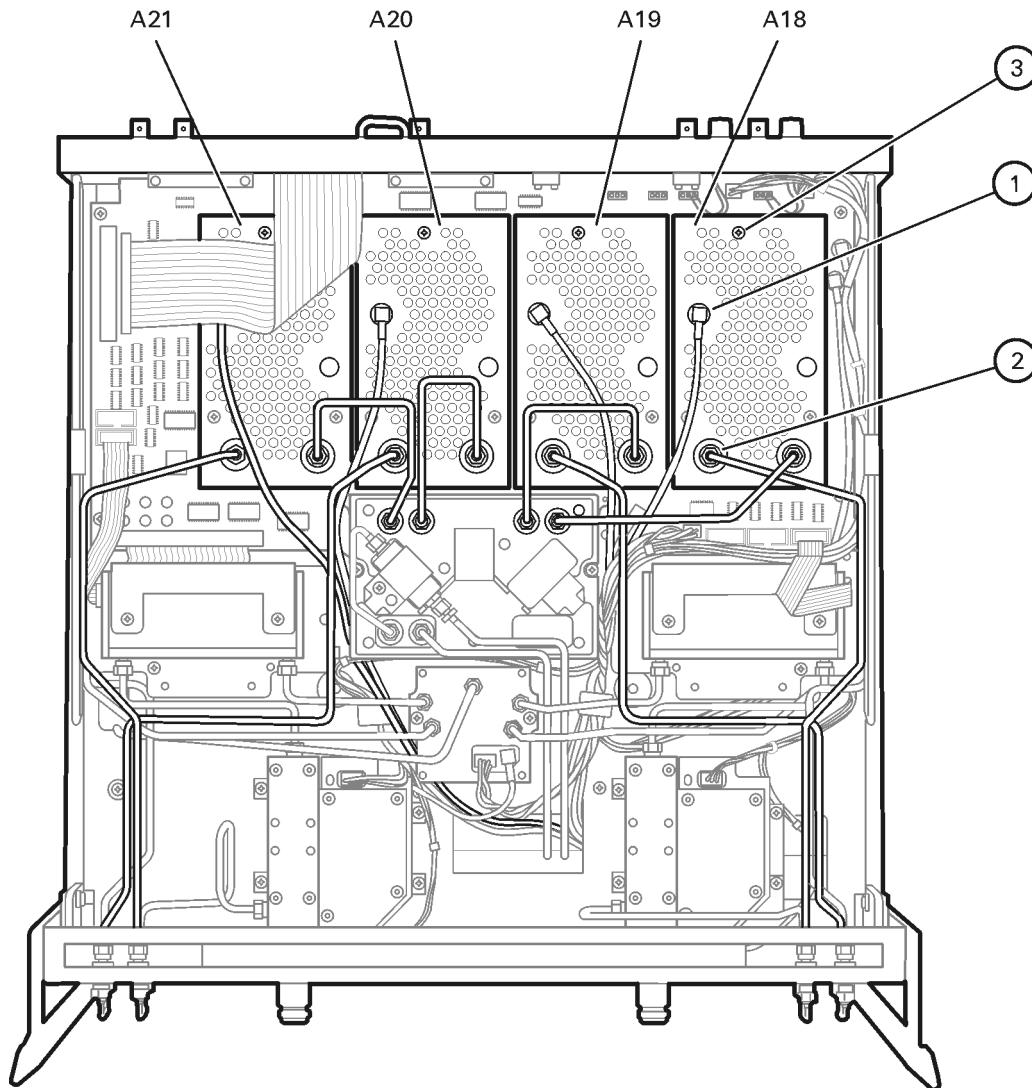
---

3. Identify the receiver module to be removed.
4. Disconnect the appropriate flexible cable (item ①) and, with a 5/16-in torque wrench, disconnect the semirigid cables (item ②) from the appropriate receiver module assembly.
5. With a T-10 TORX driver, remove the three mounting screws (item ③) from the appropriate receiver module assembly.
6. Remove the receiver module assembly.

### Replacement Procedure

1. Reverse the order of the removal procedure.
2. Perform the post-repair adjustments, verifications, and performance tests that pertain to this removal procedure. Refer to [Table 7-3 on page 7-54](#).

**Figure 7-13 A18, A19, A20, and A21 Receiver Assemblies Removal**



sc814a.cdr

---

## Removing and Replacing the A22 Switch Splitter Assembly

### Tools Required

- T-10 TORX driver (set to 9 in-lb)
- T-20 TORX driver (set to 21 in-lb)
- 5/16-inch open-end torque wrench (set to 10 in-lb)
- ESD grounding wrist strap

### Removal Procedure

Refer to [Figure 7-14](#) for this procedure.

1. Disconnect the power cord.
2. Remove the outer cover. Refer to [“Removing the Covers” on page 7-6](#).

---

**CAUTION** Be careful not to damage the center pins of the semirigid cables. Some flexing of the cables is necessary to remove the assembly. Do not over-bend the semirigid cables.

---

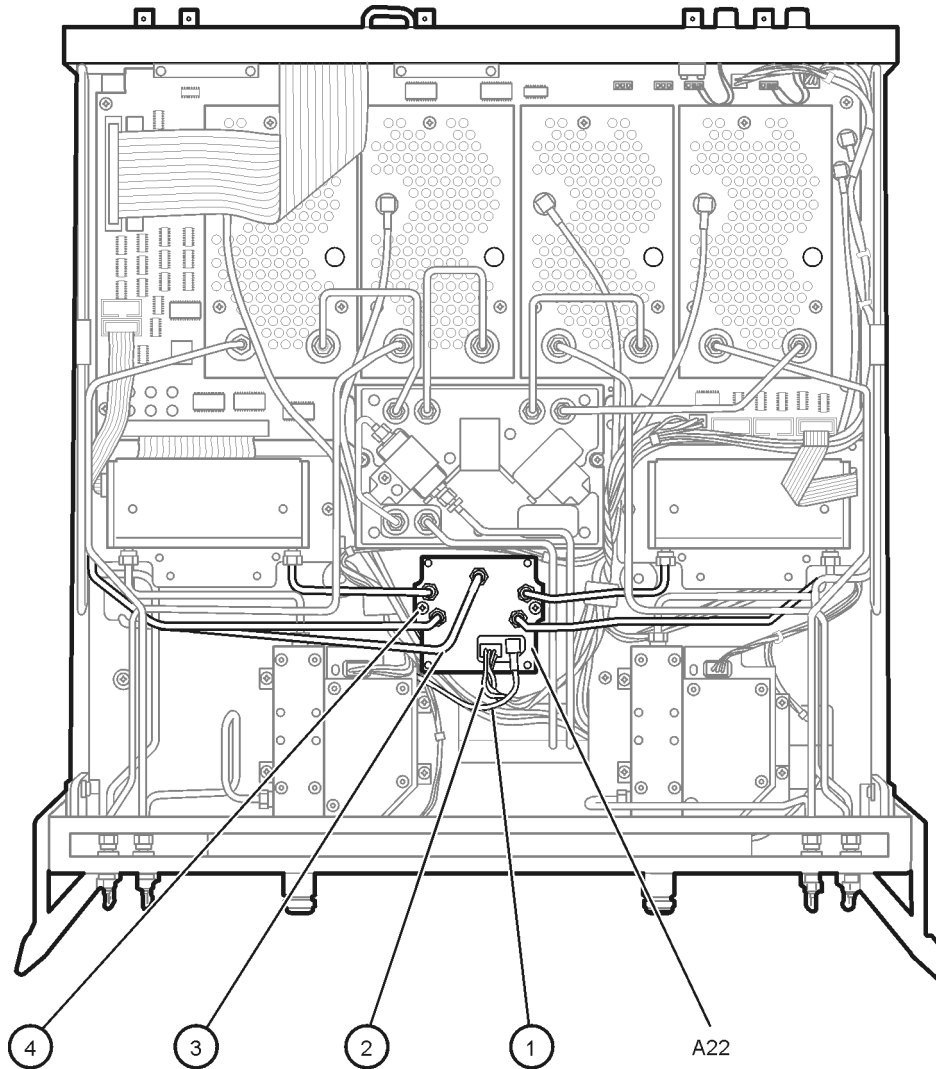
3. Disconnect the flexible cable (item ①) and the stranded switch control cable (item ②) from the A22 switch splitter assembly.
4. With a 5/16-in torque wrench, disconnect the semirigid cables (item ③).
5. With a T-10 TORX driver, remove the two mounting screws (item ④).
6. Remove the A22 switch splitter assembly.

### Replacement Procedure

1. Reverse the order of the removal procedure.
2. Perform the post-repair adjustments, verifications, and performance tests that pertain to this removal procedure. Refer to [Table 7-3 on page 7-54](#).



**Figure 7-14 A22 Switch Splitter Assembly Removal**



sc815a

---

## Removing and Replacing the A23 and A24 Test Port Couplers

### Tools Required

- T-10 TORX driver (set to 9 in-lb)
- T-20 TORX driver (set to 21 in-lb)
- 5/16-inch open-end torque wrench (set to 10 in-lb)
- ESD grounding wrist strap

### Removal Procedure

Refer to [Figure 7-15](#) for this procedure.

1. Disconnect the power cord.
2. Remove the outer cover. Refer to [“Removing the Covers” on page 7-6](#).

---

**CAUTION** Be careful not to damage the center pins of the semirigid cables. Some flexing of the cables is necessary to remove the assembly. Do not over-bend the semirigid cables.

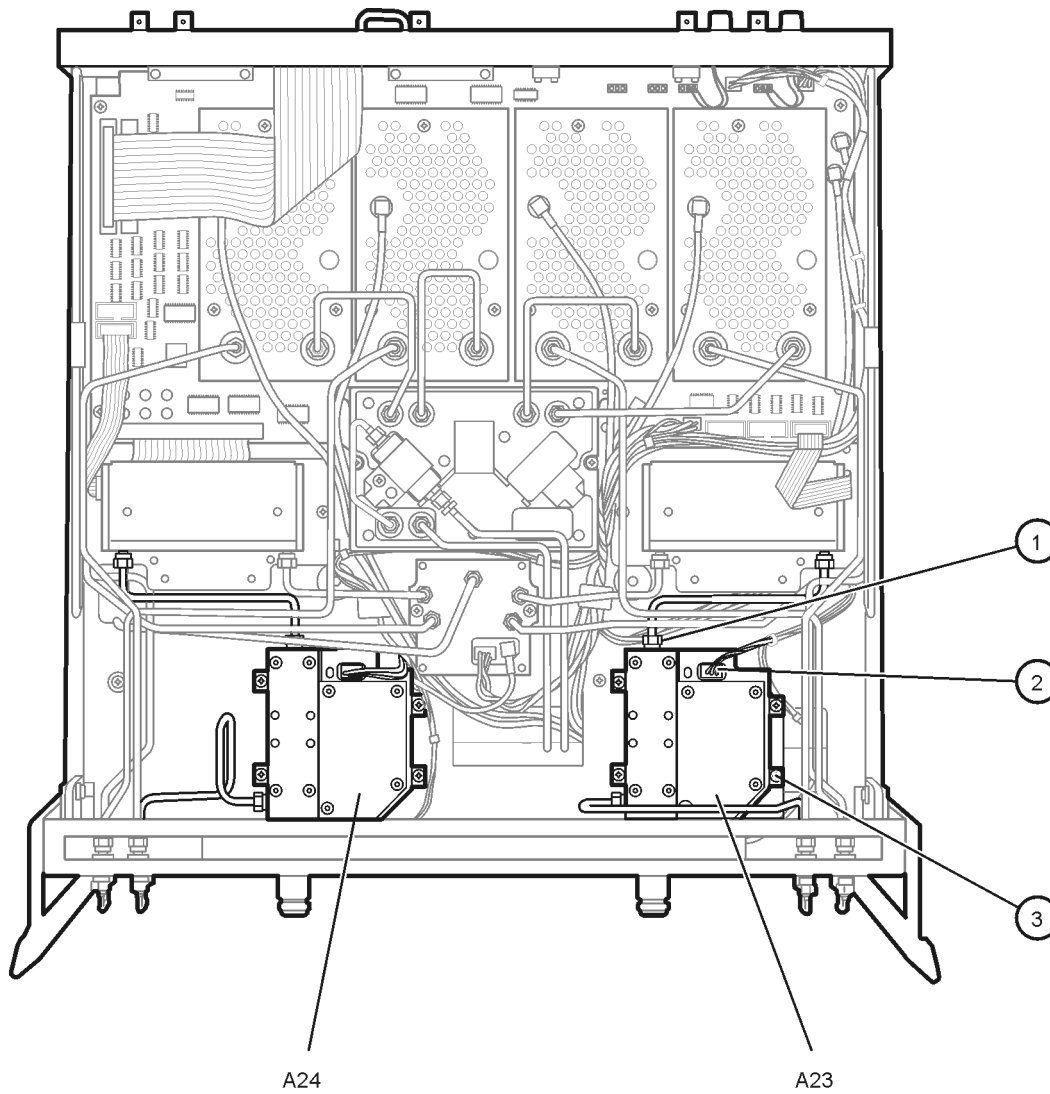
---

3. Identify the test port coupler to be removed.
4. With a 5/16-in torque wrench, disconnect the two semirigid cables (item ①) and the stranded wire assembly (item ②) from the appropriate test port coupler.
5. With a T-10 TORX driver, remove the four mounting screws (item ③).
6. Remove the test port coupler.

### Replacement Procedure

1. Reverse the order of the removal procedure.
2. Perform the post-repair adjustments, verifications, and performance tests that pertain to this removal procedure. Refer to [Table 7-3 on page 7-54](#).

**Figure 7-15 A23 and A24 Test Port Couplers Removal**



sc816a

---

## Removing and Replacing the A25 and A26 70 dB Step Attenuators

### Tools Required

- T-10 TORX driver (set to 9 in-lb)
- T-20 TORX driver (set to 21 in-lb)
- 5/16-inch open-end torque wrench (set to 10 in-lb)
- ESD grounding wrist strap

### Removal Procedure

Refer to [Figure 7-16](#) for this procedure.

1. Disconnect the power cord.
2. Remove the outer cover. Refer to [“Removing the Covers” on page 7-6](#).

---

**CAUTION** Be careful not to damage the center pins of the semirigid cables. Some flexing of the cables is necessary to remove the assembly. Do not over-bend the semirigid cables.

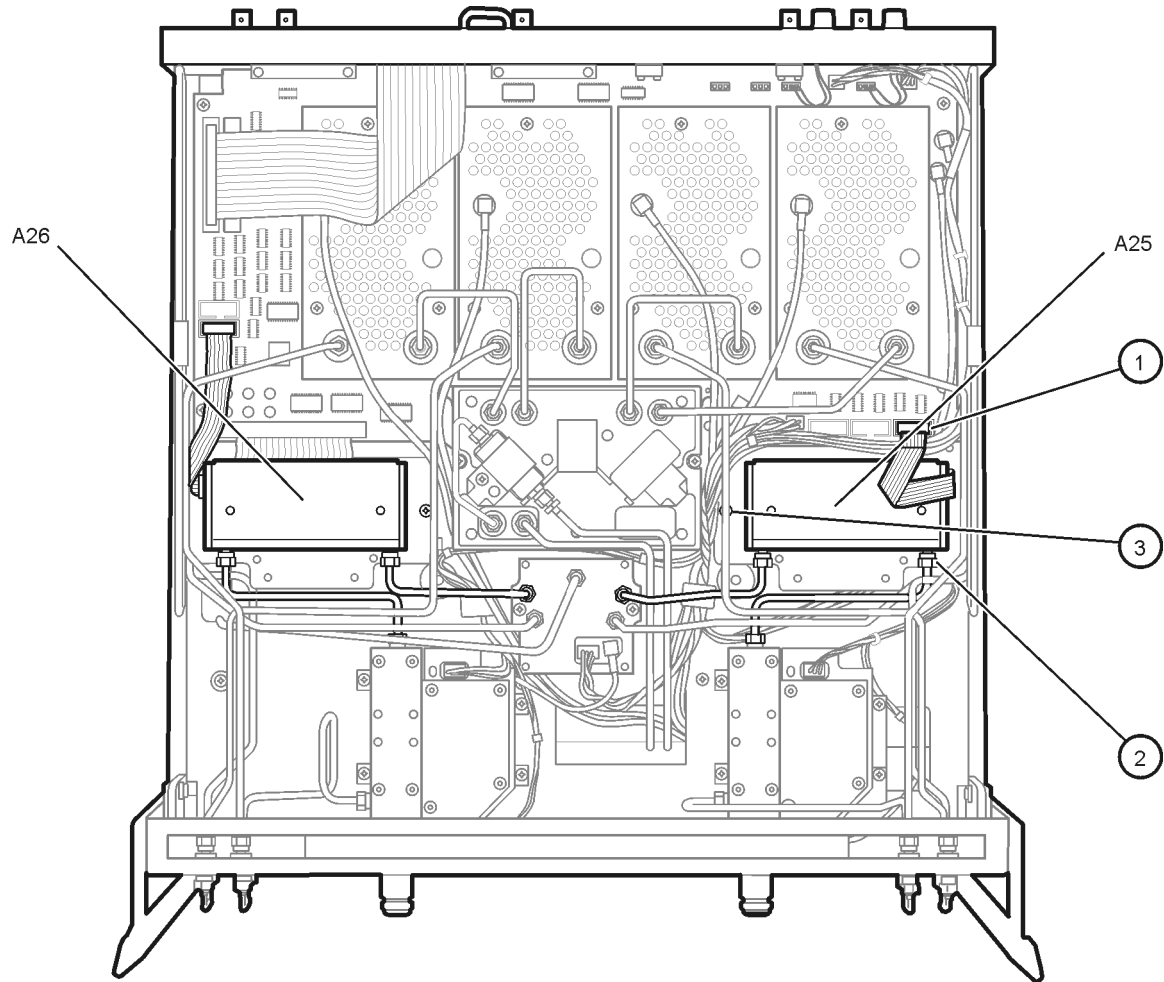
---

3. Identify the step attenuator to be removed.
4. Disconnect the appropriate ribbon cable (item ①) from the A16 test set motherboard assembly.
5. With a 5/16-in torque wrench, disconnect the two semirigid cables (item ②) from the appropriate step attenuator.
6. With a T-10 TORX driver, remove the attenuator mounting bracket screw (item ③).
7. Remove the step attenuator with the bracket attached.
8. Remove the step attenuator from the mounting bracket by removing the two mounting screws on the underside of the bracket.

### Replacement Procedure

1. Attach the new step attenuator to the mounting bracket by installing the two mounting screws on the underside of the bracket.
2. Install the new step attenuator and bracket into the analyzer by reversing the order of the removal procedure.
3. Perform the post-repair adjustments, verifications, and performance tests that pertain to this removal procedure. Refer to [Table 7-3 on page 7-54](#).

**Figure 7-16 A25 and A26 70 dB Step Attenuators Removal**



sc817a

---

## Option 015, Removing and Replacing the A27 and A28 35 dB Step Attenuators

### Tools Required

- T-10 TORX driver (set to 9 in-lb)
- T-20 TORX driver (set to 21 in-lb)
- 5/16-inch open-end torque wrench (set to 10 in-lb)
- ESD grounding wrist strap

### Removal Procedure

Refer to [Figure 7-17](#) for this procedure.

1. Disconnect the power cord.
2. Remove the outer cover. Refer to [“Removing the Covers” on page 7-6](#).

---

**CAUTION** Be careful not to damage the center pins of the semirigid cables. Some flexing of the cables is necessary to remove the assembly. Do not over-bend the semirigid cables.

---

3. Identify the step attenuator to be removed.
4. Disconnect the appropriate ribbon cable (item ①) from the A16 test set motherboard assembly.
5. With a 5/16-in torque wrench, disconnect the appropriate semirigid cable (item ②) at the step attenuator end of the cable.

---

**CAUTION** The semirigid cable (item ③) can break easily at the cable bends. Use extreme caution when disconnecting this cable.

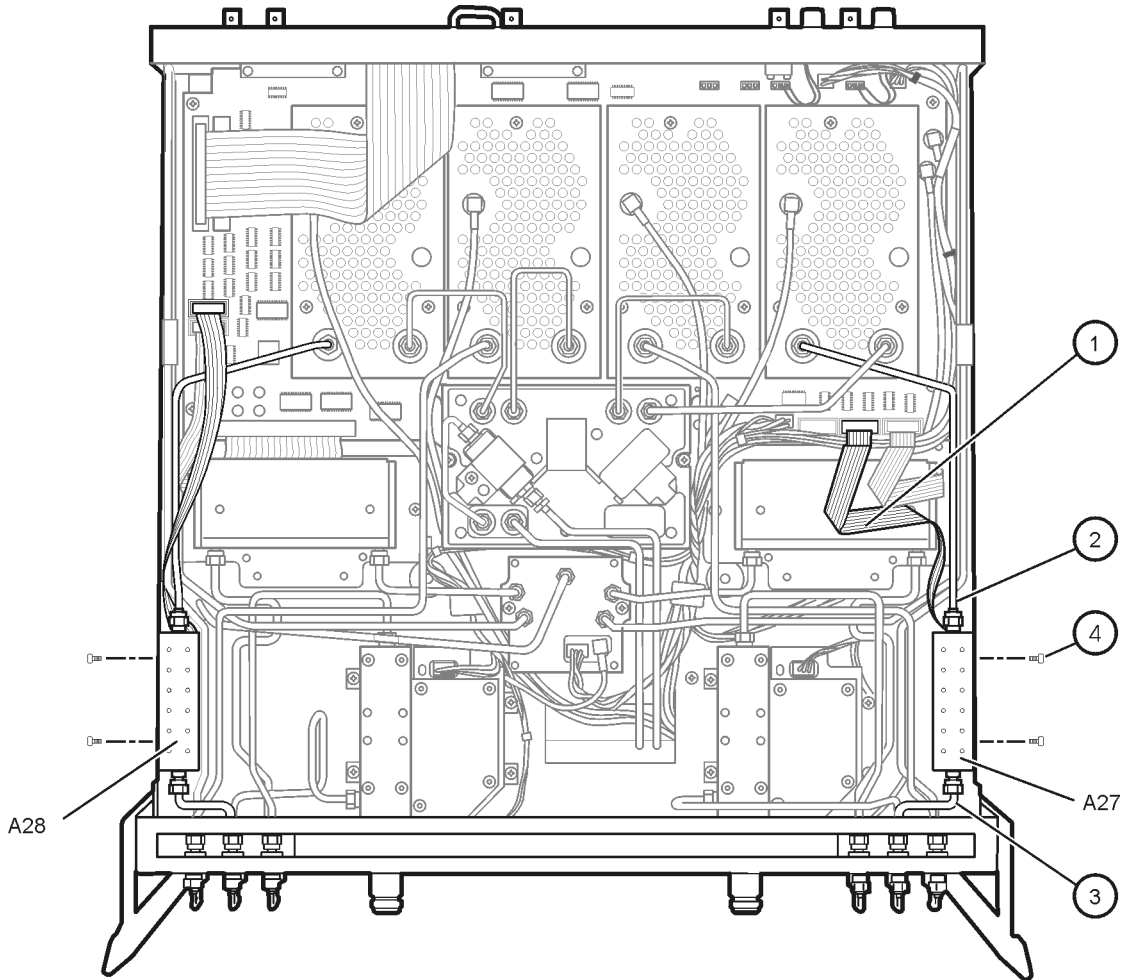
---

6. With a 5/16-in torque wrench, disconnect the appropriate semirigid cable (item ③) at the step attenuator end of the cable.
7. With a T-10 TORX driver, remove the two mounting screws (item ④).
8. Remove the step attenuator.

### Replacement Procedure

1. Reverse the order of the removal procedure.
2. Perform the post-repair adjustments, verifications, and performance tests that pertain to this removal procedure. Refer to [Table 7-3 on page 7-54](#).

**Figure 7-17 Option 015, A27 and A28 35 dB Step Attenuators Removal**



sc837a

---

## Removing and Replacing the A30 Floppy Disk Drive

### Tools Required

- T-10 TORX driver (set to 9 in-lb)
- T-20 TORX driver (set to 21 in-lb)
- 5/16-inch open-end torque wrench (set to 10 in-lb)
- ESD grounding wrist strap

### Removal Procedure

Refer to [Figure 7-18](#) and [Figure 7-19](#) for this procedure.

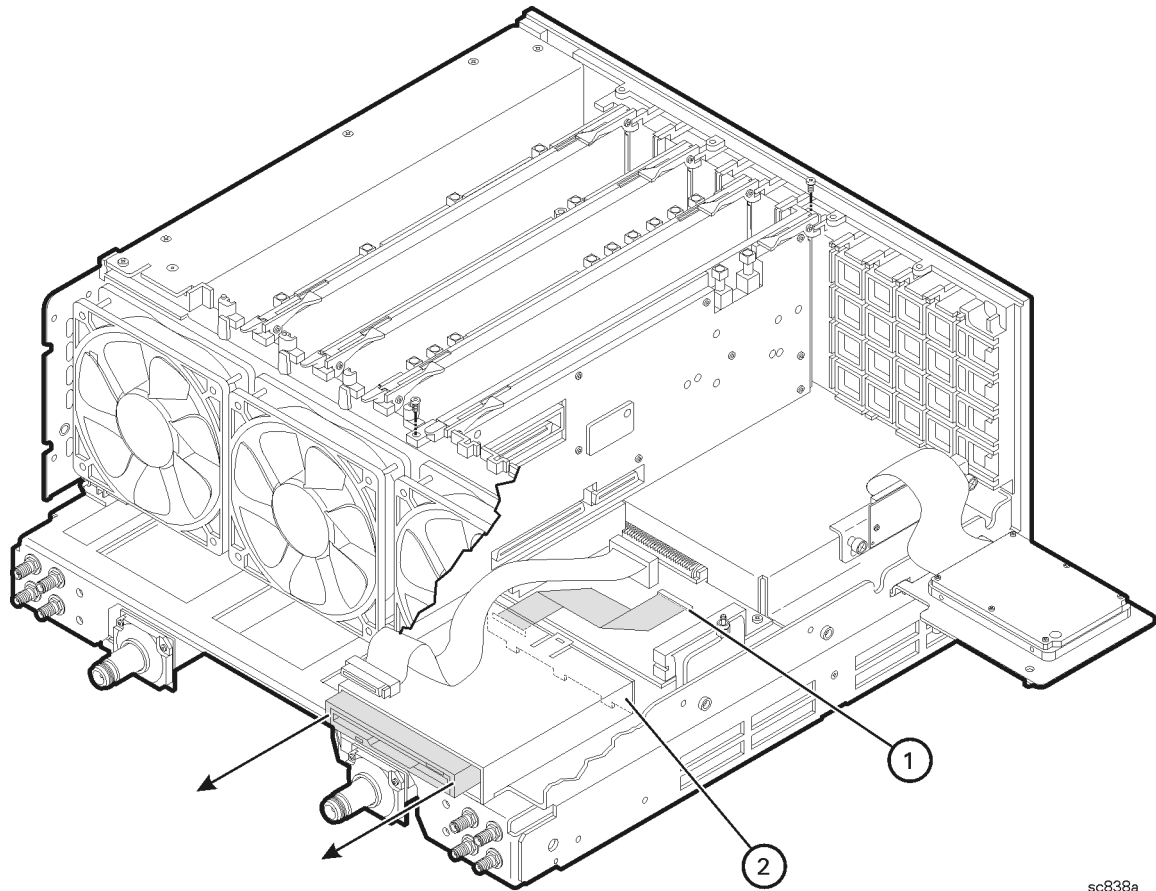
1. Disconnect the power cord.
2. Remove the outer and inner covers. Refer to [“Removing the Covers”](#) on page 7-6.
3. Remove the front panel assembly. Refer to [“Removing and Replacing the Front Panel Assembly”](#) on page 7-8.
4. Place the A31 hard disk drive assembly into the service position. Refer to [“Placing the HDDA in the Service Position”](#) on page 7-43.
5. Remove the A12 source assembly. Refer to [“Removing and Replacing the A12 Source Assembly”](#) on page 7-20.
6. Disconnect the ribbon cable (item ①) from the A14 motherboard assembly.
7. Lift the tab at the rear of the A30 floppy disk drive enclosure and remove the rear enclosure cover (item ②).
8. Slide the A30 floppy disk drive out of the front of the enclosure. The A30 floppy disk drive fits snugly. You may have to push the drive from the back to remove it from the analyzer.

### Replacement Procedure

1. Reverse the order of the removal procedure.
2. Perform the post-repair adjustments, verifications, and performance tests that pertain to this removal procedure. Refer to [Table 7-3](#) on page 7-54.

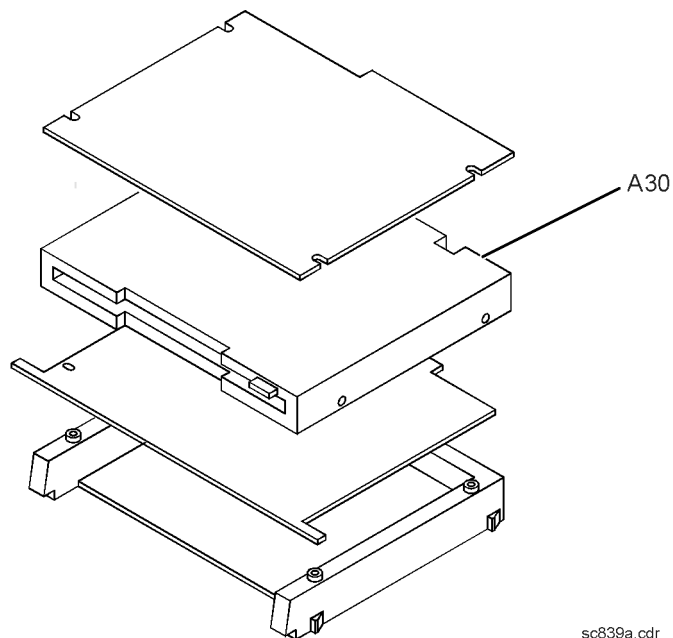


**Figure 7-18 A30 Floppy Disk Drive Removal**



sc838a

**Figure 7-19 A30 Floppy Disk Drive (Exploded View)**



sc839a.cdr

---

## Removing and Replacing the A31 Hard Disk Drive Assembly (HDDA)

Certain unique files exist on the hard disk drive that are necessary for proper operation of your analyzer. These files must be copied to another location to allow them to be installed onto the new hard disk drive after it has been installed. If you are replacing the hard disk, not just placing the HDDA in the service position, this procedure must be performed first.

If you are not replacing the actual hard disk, proceed to [“Tools Required” on page 7-43](#).

### Copy Unique Files from the Hard Disk

The files to be copied include:

- license file (gen.lic)
- mixer calibration files (mxcalfile\_)
- user calibration kit file (user\_calkitfile)
- any user data files or program files that need to be preserved

The network analyzer must be powered up and operating for this procedure.

**An abbreviated procedure is provided in *italic* typeface.** If you need more detailed instructions, they are provided in each step following the italicized instruction.

1. *Insert a writable floppy disk into the floppy disk drive.*

2. *Open two copies of **Windows Explorer**:*

Detailed instructions:

- a. Click on **START**. (It may be necessary to exit the **Network Analyzer** application.)
- b. Point to **Programs, Accessories**, and then click on **Windows Explorer**.
- c. Adjust the horizontal width of the **Windows Explorer** window to approximately one-half the width of the display and position it to either the left or right side of the display.
- d. Repeat steps a–c to create another copy of the **Windows Explorer** window and position it to the opposite side of the display so that the two copies are displayed side-by-side.

3. *Set one copy of **Windows Explorer** to the **A:** drive and the other to the **C:** drive:*

Detailed instructions:

- a. In one copy of **Windows Explorer**, double-click on **My Computer**, and then double-click on **3 1/2 Floppy (A:)**. A listing of the files on the floppy disk will appear in the right-hand side of the window.
- b. In the other copy of **Windows Explorer**, double-click on **My Computer**, and then double-click on **Hard Disk (C:)**.
- c. Navigate to C:\Program Files\Agilent\Network Analyzer by double-clicking on each of the names in this path name, in turn. A listing of the files in this directory on the hard disk will appear in the right-hand side of the window.

4. Copy each of the following files from the hard disk drive to the floppy disk drive:

Detailed instructions:

a. Files to copy:

gen.lic user\_calckitfile any files beginning with mxcalfile\_

Any personal user files that you wish to preserve.

b. Click and drag each of the files on the **C:** drive from the C:\Program Files\Agilent\Network Analyzer directory by clicking and holding on the file name in the directory and, while holding the mouse button down, drag the file name to the **A:** drive. If you need help with this “dragging” process, refer to Windows Help.

5. After all files have been copied, remove the floppy disk from the analyzer’s disk drive and exit both copies of **Windows Explorer**.

## Tools Required

- T-10 TORX driver (set to 4 in-lb; for hard disk drive replacement)
- T-10 TORX driver (set to 7 in-lb; for hard disk drive replacement)
- T-10 TORX driver (set to 9 in-lb; for all other T-10 applications)
- T-20 TORX driver (set to 21 in-lb)
- ESD grounding wrist strap

## Three Levels of Procedures

There are three procedures related to removing and replacing the A31 hard disk drive assembly (HDDA):

### Placing the HDDA in the Service Position

Place the HDDA in the service position where the hard disk drive is still electrically connected, but is mounted on the outer frame so that the following assemblies may be serviced.

- A11 phase lock board assembly
- A12 source assembly
- A30 floppy disk drive

### Removing the HDDA

Disconnect and remove the HDDA from the analyzer so that the following assemblies may be serviced.

- A14 motherboard assembly
- A15 CPU board assembly
- A31 hard disk drive assembly

### Disassembling the HDDA

This procedure outlines how to disassemble the HDDA once it has been removed from the analyzer. This is necessary to replace the actual hard disk drive.

## Removal Procedure

1. Exit all applications, set the power switch to standby, and disconnect the power cord.
2. Remove the outer and inner covers. Refer to “Removing the Covers” on page 7-6.

## Placing the HDDA in the Service Position

Refer to [Figure 7-20](#).

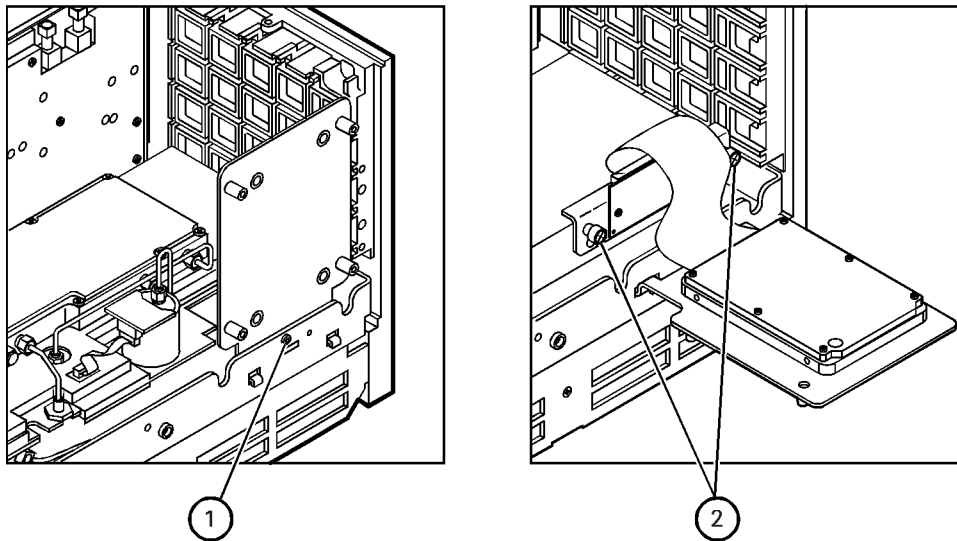
1. With a T-10 TORX driver, remove the mounting screw (item ①).
2. Move the HDDA to the outside of the analyzer and slide the HDDA bracket feet into the slots on the frame to the horizontal position. This is the service position.

## Removing the HDDA

Refer to [Figure 7-20](#).

1. Put the HDDA in the service position. Refer to “Placing the HDDA in the Service Position” on page 7-44.
2. With a T-10 TORX driver, loosen the mounting screws (item ②) and disconnect the interface board from the A15 CPU board assembly.
3. Remove the A31 hard disk drive assembly from the analyzer.

**Figure 7-20 A31 Hard Disk Drive Assembly Removal and Service Position**



sc840a.cdr

## Disassembling the HDDA

---

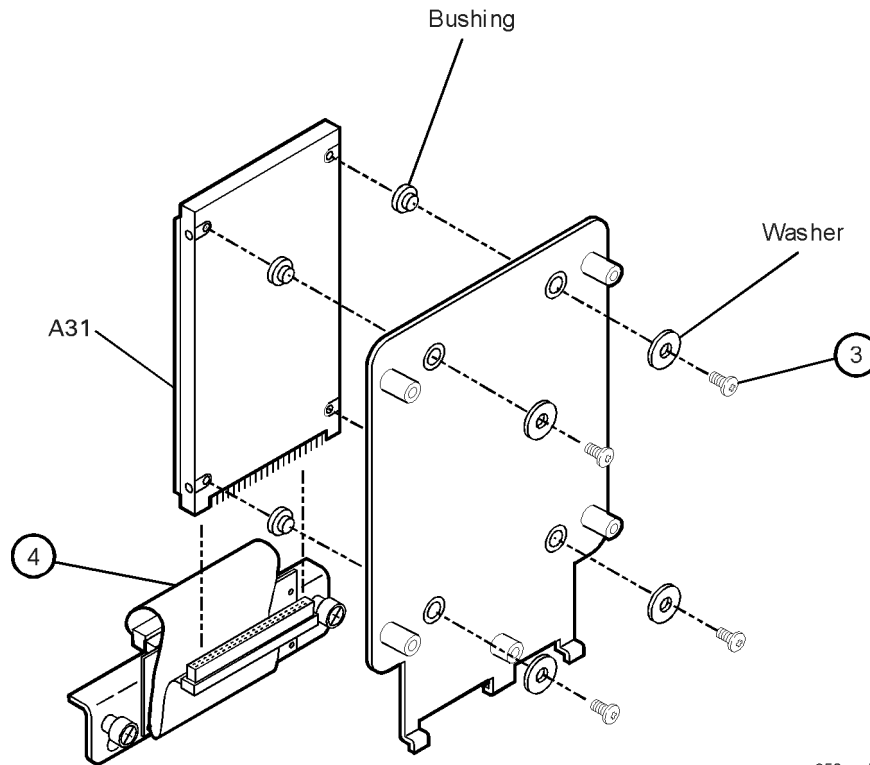
**IMPORTANT** When replacing the HDDA, first torque all four screws (item ③) to 4 in-lb with a T-10 TORX driver. Then secure each screw to 7 in-lb with a T-10 TORX driver.

---

Refer to [Figure 7-21](#).

1. Remove the A31 hard disk drive assembly from the analyzer. Refer to “[Removing the HDDA](#)” on page 7-43.
2. With a T-10 TORX driver, remove the four screws (item ③), flat washers, and bushings that mount the hard disk drive assembly to the bracket.
3. Disconnect the ribbon cable (item ④) from the hard disk drive. Discard the hard disk drive if it is being replaced.

**Figure 7-21 A31 Hard Disk Drive Assembly (Exploded View)**



## Replacement Procedure

---

**WARNING** When connecting the ribbon cable (item ④ in [Figure 7-21](#)) to the hard disk drive, take special care to align the connector pins. Applying power to a misaligned connection can permanently damage the hard disk drive.

---

**IMPORTANT** When installing the hard disk drive, first torque all four screws (item ③) to 4 in-lb with a T-10 TORX driver. Then secure each screw to 7 in-lb with a T-10 TORX driver.

---

### Installing the New Hard Disk Drive

Refer to [Figure 7-21](#).

1. Connect the ribbon cable (item ④) to the new hard disk drive. Refer to **WARNING** above.
2. With a T-10 TORX driver, install the four screws (item ③), flat washers, and bushings that mount the hard disk drive to the bracket. Refer to **IMPORTANT** note above.

### Reinstalling the A31 Hard Disk Drive Assembly (HDDA)

1. **If you're replacing a hard disk drive in an analyzer that has a Windows 2000 operating system:**
  - a. Do not reinstall the hard disk drive assembly (HDDA) at this time. Proceed to ["Update the Bios" on page 7-47](#).
2. **If you're replacing a hard disk drive in an analyzer that has a Windows XP operating system:**
  - a. Reinstall the hard disk drive assembly (HDDA) into the analyzer (refer to [Figure 7-20 on page 7-44](#)):
    1. Place the HDDA in the service position by inserting the bracket feet into the slots in the frame.
    2. Place the interface board into position and, with a T-10 TORX driver, tighten the mounting screws (item ②).
    3. Remove the HDDA from the service position and place it into its permanent location.
    4. With a T-10 TORX driver, install the mounting screw (item ①).
    5. Replace the inner and outer covers. Refer to ["Removing the Covers" on page 7-6](#).
  - b. Proceed to ["Initialize the New Windows XP Operating System" on page 7-47](#).

## Update the Bios

---

**IMPORTANT** Perform this procedure only if replacing a hard disk drive in an analyzer that has a Windows 2000 operating system.

---

### Using the BIOS Update Disk

1. Insert the BIOS Update Disk, that has been provided, into the floppy disk drive.
2. With the hard disk drive removed, turn on power to the analyzer.
3. Since there is no hard disk installed, the analyzer will automatically boot from the BIOS Update Disk located in the floppy disk drive. The BIOS update process will run automatically. The entire process takes approximately one minute. Make sure that power to the analyzer is not interrupted during this process.
4. When the BIOS update process has completed, press and hold the analyzer's power button until the analyzer turns off (approximately five seconds).
5. Remove the BIOS Update Disk from the floppy disk drive.

### Reinstalling the HDDA

1. Reinstall the hard disk drive assembly (HDDA) into the analyzer (refer to [Figure 7-20 on page 7-44](#)):
  - a. Place the HDDA in the service position by inserting the bracket feet into the slots in the frame.
  - b. Place the interface board into position and, with a T-10 TORX driver, tighten the mounting screws (item ②).
  - c. Remove the HDDA from the service position and place it into its permanent location.
  - d. With a T-10 TORX driver, install the mounting screw (item ①).
  - e. Replace the inner and outer covers. Refer to [“Removing the Covers” on page 7-6](#).

### Initialize the New Windows XP Operating System

1. Connect a mouse and keyboard to the analyzer.
2. Turn on power to the analyzer.
3. The operating system initialization process will run automatically. Part way through the process, you will be prompted to accept the Windows XP licensing agreement. The entire process takes approximately six minutes.
4. When the initialization process is complete, the analyzer will reboot automatically. After the PNA application screen is displayed, there may be a display to remind you to upgrade the firmware. If so, click **OK** to continue.

## Set Up the Agilent Administrator Password

If the hard disk has been replaced, it is necessary to setup the Agilent administrator password for the analyzer. This requires obtaining a password from Agilent:

### Obtaining a Password

- If this procedure is being performed by Agilent personnel, go to the following Internet site and follow the instructions under “Agilent Administrator Password”.

<http://mktwww.soco.agilent.com/field/service/network/pna/support.htm>

- If this procedure is being performed by non-Agilent personnel, contact Agilent for a password before beginning this procedure. Refer to “Contacting Agilent” on page 2-9.

### Entering Your Agilent Administrator Password

The network analyzer must be powered up and operating for this procedure.

1. On the **Windows Desktop**, right-click on **My Computer**, and then click **Manage**.
2. In the **Computer Management** window, navigate to **System Tools, Local Users and Groups, Users**.
3. Right-click on **Agilent**, and then click on **Set Password**.
  - a. Type the password obtained from Agilent as the **Password**. Refer to “Obtaining a Password” on page 7-48 for information if you have not yet obtained this password.
  - b. Type the password again in the **Confirm password** block.
  - c. Click **OK**.
4. Right-click on **Agilent**, and then click on **Properties**.
  - a. Unselect **User must change password at next logon** (if not already unselected).
  - b. Unselect **User cannot change password** (if not already unselected).
  - c. Select **Password never expires** (if not already selected).
  - d. Click **OK**.
5. Close the **Computer Management** window.

## Install Backup Files onto the New Hard Disk Drive

The files that were previously saved onto a floppy disk must now be installed onto the new hard disk drive. The network analyzer must be powered up and operating.

**An abbreviated procedure is provided in *italic* typeface.** If you need more detailed instructions, they are provided in each step following the italicized instruction.

1. *Insert the floppy disk containing the backup files into the floppy disk drive.*
2. *Open two copies of **Windows Explorer**:*

Detailed instructions:

- a. Click on **START**. (It may be necessary to exit the **Network Analyzer** application.)



- b. Point to **Programs, Accessories**, and then click on **Windows Explorer**.
  - c. Adjust the horizontal width of the **Windows Explorer** window to approximately one-half the width of the display and position it to either the left or right side of the display.
  - d. Repeat steps a–c to create another copy of the **Windows Explorer** window and position it to the opposite side of the display so that the two copies are displayed side-by-side.
3. *Set one copy of **Windows Explorer** to the **A:** drive and the other to the **C:** drive:*

Detailed instructions:

- a. In one copy of **Windows Explorer**, double-click on **My Computer**, and then double-click on **3 1/2 Floppy (A:)**. A listing of the files on the floppy disk will appear in the right-hand side of the window.
  - b. In the other copy of **Windows Explorer**, double-click on **My Computer**, and then double-click on **Hard Disk (C:)**.
  - c. Navigate to C:\Program Files\Agilent\Network Analyzer by double-clicking on each of the names in this path name, in turn. A listing of the files in this directory on the hard disk will appear in the right-hand side of the window.
4. *Copy each of the backup files from the floppy disk to the hard disk drive:*

Detailed instructions:

- a. Click and drag each of the files from the **A:** drive to the C:\Program Files\Agilent\Network Analyzer directory by clicking and holding on the file name in the **A:** directory and, while holding the mouse button down, drag the file name to the Network Analyzer directory on the **C:** drive. If you need help with this “dragging” process, refer to Windows Help.
5. *Repeat steps 3 and 4 using the **A:** and **D:** drives. After all files have been copied, remove the floppy disk from the analyzer’s disk drive and exit both copies of **Windows Explorer***

## Post-Repair Procedures

1. If a new Certificate of Authenticity (license) label is supplied with your new hard disk drive, adhere it to the outer cover in the location specified in [Figure 7-1 on page 7-7](#).
2. Perform the post-repair adjustments, verifications, and performance tests that pertain to this removal procedure. Refer to [Table 7-3 on page 7-54](#).

---

## Removing and Replacing the Midweb and the B1 Fan

### Tools Required

- T-10 TORX driver (set to 9 in-lb)
- T-20 TORX driver (set to 21 in-lb)
- Pozidriv screw driver
- 5/16-inch open-end torque wrench (set to 10 in-lb)
- ESD grounding wrist strap

### Removal Procedure

1. Disconnect the power cord.
2. Remove the outer and inner covers. Refer to [“Removing the Covers” on page 7-6](#).
3. Put the A31 hard disk drive assembly in the service position. Refer to [“Placing the HDDA in the Service Position” on page 7-44](#).
4. Remove the A12 source assembly. Refer to [“Removing and Replacing the A12 Source Assembly” on page 7-20](#).
5. Remove the A11 phase lock board assembly. Refer to [“Removing and Replacing the A11 Phase Lock Board Assembly” on page 7-18](#).
6. Remove the A4 power supply assembly. Refer to [“Removing and Replacing the A4 Power Supply Assembly” on page 7-14](#).
7. Remove the card cage boards (A6, A8, and A10). Refer to [“Removing and Replacing the A6, A8, and A10 Board Assemblies” on page 7-16](#).

---

**NOTE** This procedure has two parts: removing the midweb and removing the fan from the midweb. You must remove the midweb before removing the fan.

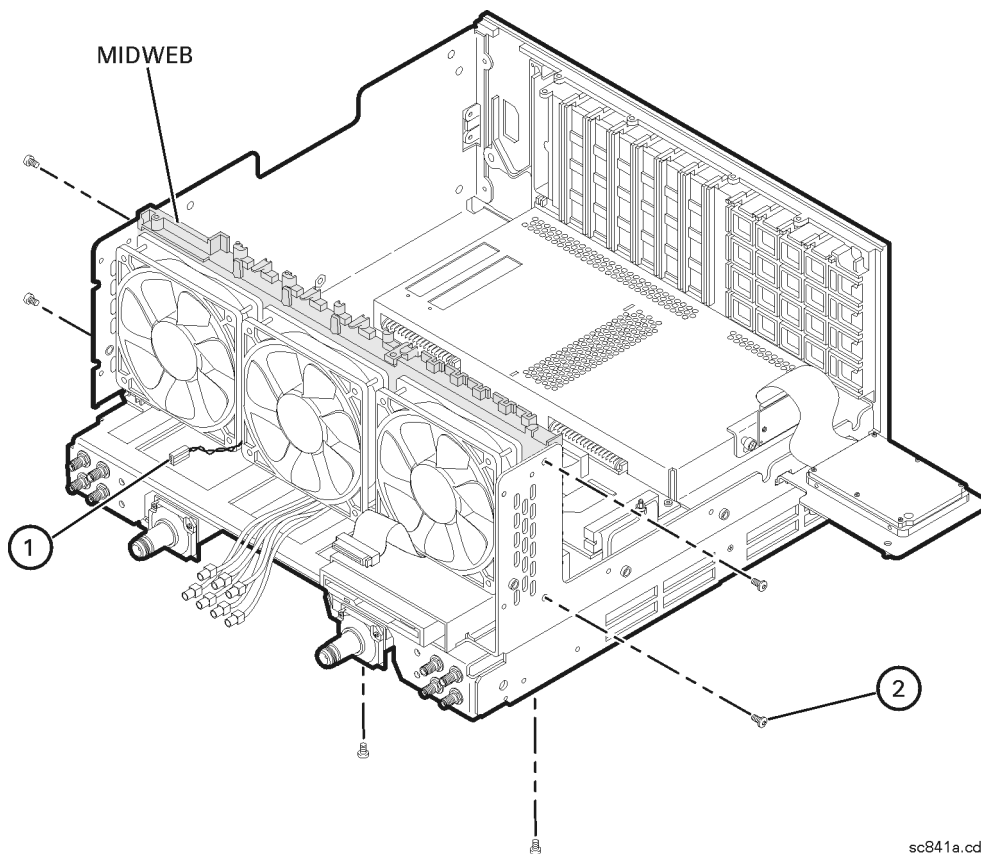
---

## Removing the Midweb

Refer to [Figure 7-22](#).

1. Disconnect the power cable (item ①) for the three fans from the A14 motherboard assembly.
2. With a T-10 TORX driver, remove the six midweb mounting screws (item ②). Lift out the midweb.

**Figure 7-22 Midweb Removal**

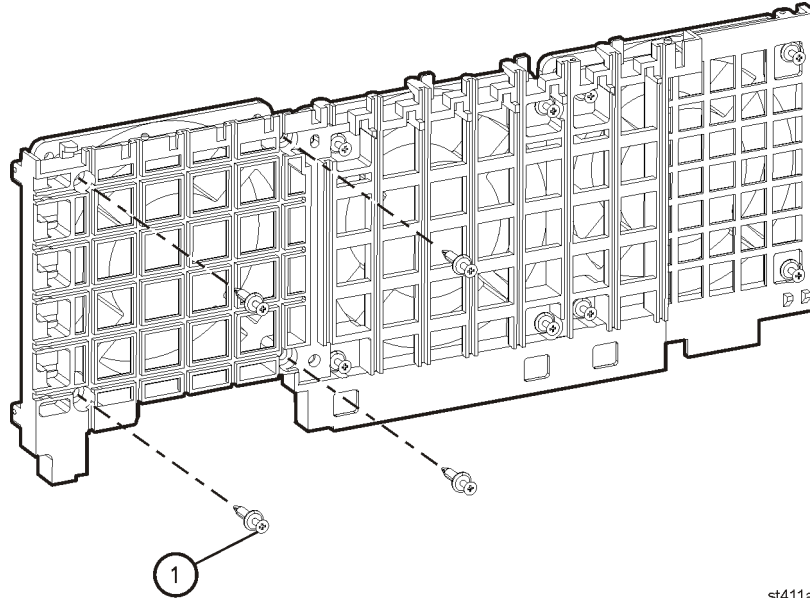


## Removing the Fan

Refer to [Figure 7-23](#).

1. To remove the fan, it is necessary to remove the four nylon rivets that attach it to the midweb. To do this, use the Pozidriv screwdriver on the nylon screw (item ①) and a small blade screwdriver to stabilize the rivet. Turn and push the rivet out of the rivet hole. Once the four rivets are out, remove the fan.

**Figure 7-23 B1 Fan Removal**



st411a

## Replacement Procedure

1. Reverse the order of the removal procedure.
2. Perform the post-repair adjustments, verifications, and performance tests that pertain to this removal procedure. Refer to [Table 7-3 on page 7-54](#).

---

## Reconfiguring the Pinout of the Handler I/O Port

### Tools Required

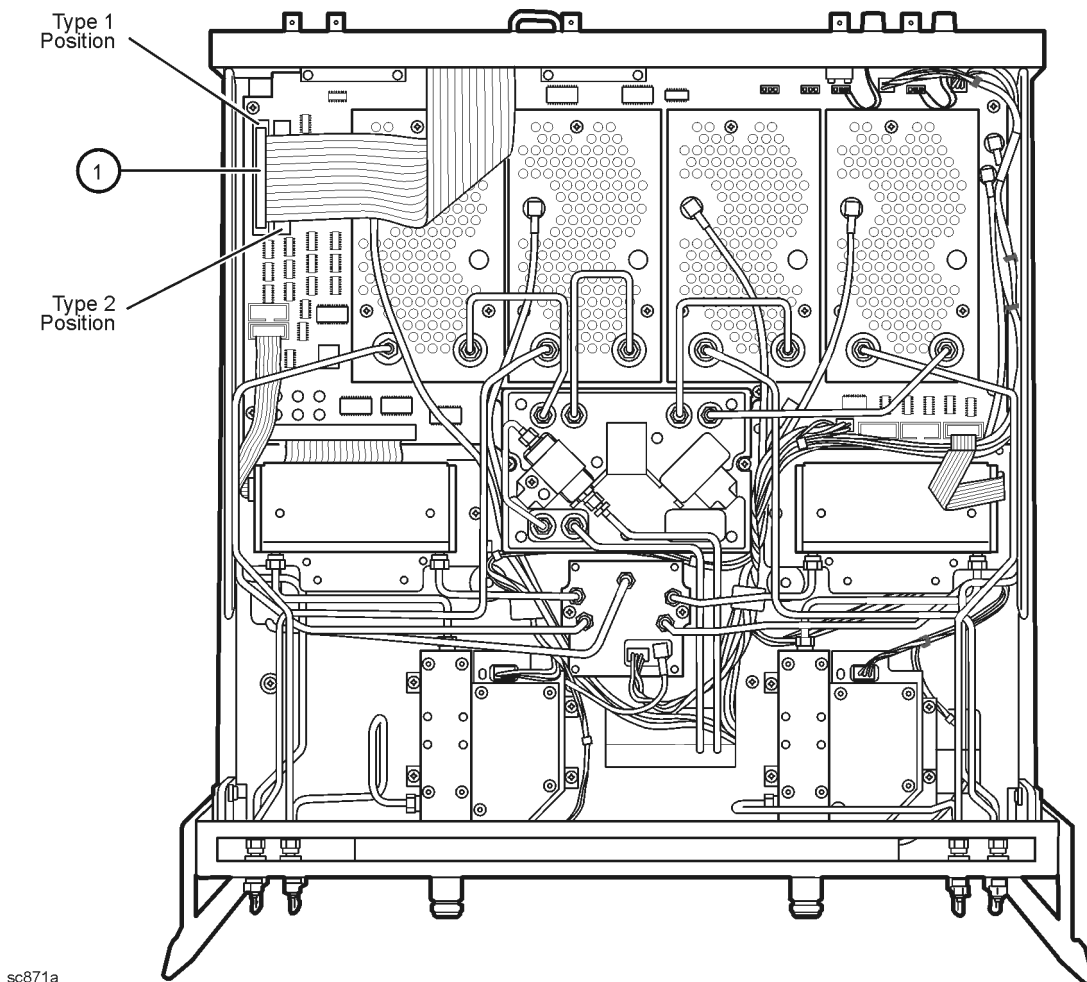
- T-20 TORX driver (set to 21 in-lb)

### Procedure

Refer to [Figure 7-24](#) for this procedure.

1. Disconnect the power cord.
2. Remove the outer cover. Refer to “[Removing the Covers](#)” on page 7-6.
3. Move the connector (item ①) from its present position to the other position.
4. Replace the outer cover.

**Figure 7-24 Handler I/O Port, Cable Connector Relocation**



## Post-Repair Procedures

After the replacement of an assembly, you must perform the service procedures in the order listed in [Table 7-3](#). Procedures referenced in this table are located in [Chapter 3](#), “[Tests and Adjustments](#)”, unless specified otherwise.

**Table 7-3 Related Service Procedures**

Replaced Assembly	Adjustments and Other Procedures	Verification, Performance, and Other Tests and Procedures
A1 keypad assembly	No adjustment needed	<a href="#">A1 Front Panel Keypad and RPG Test</a> in <a href="#">Chapter 4</a>
A2 display assembly	No adjustment needed	<a href="#">A2 Display Test</a> in <a href="#">Chapter 4</a>
A3 front panel interface board assembly	No adjustment needed	<a href="#">A1 Front Panel Keypad and RPG Test</a> and <a href="#">A2 Display Test</a> in <a href="#">Chapter 4</a>
A4 power supply assembly	No adjustment needed	None needed
A6 SPAM board assembly	No adjustment needed	<a href="#">Trace Noise Test</a> <a href="#">Noise Floor Test</a> <a href="#">System Crosstalk Test</a>
A8 fractional-N synthesizer board assembly	<a href="#">LO Power Adjustment</a>	<a href="#">Frequency Accuracy Test</a> <a href="#">The Operator’s Check</a>
A10 frequency reference board assembly	<a href="#">10 MHz Frequency Reference Adjustment</a> <a href="#">Repairing and Recovering Option Data</a> in <a href="#">Appendix B</a>	<a href="#">Frequency Accuracy Test</a>
A11 phase lock board assembly	No adjustment needed	<a href="#">Frequency Accuracy Test</a>
A12 source assembly	<a href="#">3.8 GHz PMYO Frequency Adjustment</a> <a href="#">Source Calibration Adjustment</a>	<a href="#">Source Power Accuracy Test</a> <a href="#">Source Power Linearity Test</a> <a href="#">Frequency Accuracy Test</a>
A14 motherboard assembly	No adjustment needed	<a href="#">A1 Front Panel Keypad and RPG Test</a> and <a href="#">A2 Display Test</a> in <a href="#">Chapter 4</a> <a href="#">The Operator’s Check</a>
A15 CPU board assembly	No adjustment needed	<a href="#">The Operator’s Check</a>
A16 test set motherboard assembly	Reinstall the serial number. Refer to “ <a href="#">Installing or Changing a Serial Number</a> ” in <a href="#">Appendix B</a> . Re-enable all hardware options. Refer to “ <a href="#">Enabling or Removing Options</a> ” in <a href="#">Appendix B</a> .	<a href="#">The Operator’s Check</a> <a href="#">System Crosstalk Test</a>

**Table 7-3 Related Service Procedures**

Replaced Assembly	Adjustments and Other Procedures	Verification, Performance, and Other Tests and Procedures
A17 LO distribution assembly (LODA)	LO Power Adjustment	The Operator's Check
A18, A19, A20, and A21 receiver module assemblies	Receiver Calibration Adjustment	Receiver Compression Test Noise Floor Test Calibration Coefficient Test System Crosstalk Test Dynamic Accuracy Test
A22 switch splitter assembly	Source Calibration Adjustment	Source Power Accuracy Test Source Power Linearity Test Receiver Compression Test Calibration Coefficient Test
A23 and A24 test port couplers	Source Calibration Adjustment	Source Power Accuracy Test Source Power Linearity Test Receiver Compression Test Calibration Coefficient Test
A25 and A26 70 dB step attenuators	Source Calibration Adjustment	Source Power Accuracy Test Source Power Linearity Test Receiver Compression Test Calibration Coefficient Test
A27 and A28 35 dB step attenuators (Option 015 only)	Receiver Calibration Adjustment	Receiver Compression Test Calibration Coefficient Test Dynamic Accuracy Test
A30 floppy disk drive	No adjustment needed	Write to and read from the drive.
A31 hard disk drive assembly (HDDA)	Restore previously saved receiver calibration data <sup>1</sup> (or perform Receiver Calibration Adjustment).  Load the latest firmware in Appendix C, "Firmware Upgrades."	Write to and read from the drive.
B1 fan	No adjustment needed	Check for fan operation.

1. If a backup copy of receiver calibration data from the faulty disk drive is available, it can be copied to the new disk drive. If not, new data must be generated by performing the "Receiver Calibration Adjustment".





---

# **A Error Terms**

---

## Information in This Appendix

Your PNA series RF network analyzer calculates error terms by measuring well-defined calibration devices over the frequency range of interest and comparing the measured data with an ideal model for the devices. The differences of the compared data represent systematic (repeatable) errors of the analyzer system. The analyzer calculates and stores these differences as error terms. These error terms are then removed from subsequent measurements when error correction is on.

---

**NOTE** For details on the various levels and theory of error-correction, refer to the embedded help in the analyzer.

---

## Appendix A at-a-Glance

Section Title	Summary of Content	Start Page
<a href="#">Using Error Terms as a Diagnostic Tool</a>	How to use error terms as a preventive maintenance and troubleshooting tool.	<a href="#">Page A-3</a>
<a href="#">Performing Measurement Calibration</a>	Procedure for measurement calibration. <i>Measurement calibration must be performed before you can use error terms as a tool.</i>	<a href="#">Page A-4</a>
<a href="#">Using Flowgraphs to Identify Error Terms</a>	Flowgraphs of the error terms for 1 port and 2 port calibrations.	<a href="#">Page A-4</a>
<a href="#">Accessing Error Terms</a>	How to access error terms either manually or programmatically using the analyzer front panel or SCPI and COM/DCOM commands.	<a href="#">Page A-6</a>
<a href="#">Typical Error Term Data</a>	Typical values of the error terms of your analyzer. Included are: <ul style="list-style-type: none"><li>• a table of typical values</li><li>• typical response plots</li><li>• typical assembly failures</li></ul>	<a href="#">Page A-8</a>

---

## Using Error Terms as a Diagnostic Tool

By examining error terms, you can monitor system performance for preventive maintenance and troubleshooting purposes.

The magnitude and shape of the error terms are affected by:

- calibration kit devices
- cables
- adapters and accessories
- the assemblies from the signal separation group of the analyzer

Calibration kit devices, cables, and adapters and accessories are the most common cause of error term anomalies. Make sure of the following:

- Connectors must be clean, gaged, and within specification.
- Use proper connection technique during measurement and calibration. For information on connection technique and on cleaning and gaging connectors, refer to [“Review the Principles of Connector Care” on page 3-5](#) or to the calibration kit’s user’s and service guide.

### Preventive Maintenance

If you print or plot the error terms at set intervals (weekly, monthly and so forth), you can compare current error terms to these records. A stable system should generate repeatable error terms over long intervals, (for example, six months). Look for the following:

- A long-term trend often reflects drift, connector and cable wear, or gradual degradation, indicating the need for further investigation and preventive maintenance. Yet, the system may still conform to specifications. The cure is often as simple as cleaning and gaging connectors and cables.
- A sudden shift in error terms may indicate the need for troubleshooting.

### Troubleshooting

You can use the error terms as a tool to isolate faulty assemblies in the signal separation group of your analyzer. You can compare the current values to preventive maintenance records or to the typical values listed in [Table A-1 on page A-8](#), or data trace plots that start in [“Typical Error Term Data” on page A-8](#).

To find assemblies related to error term failures, refer to plot descriptions in [“Typical Error Term Data” on page A-8](#). Each plot description lists common assemblies related to each error term. Identify the assembly and refer to [Chapter 4, “Troubleshooting.”](#)

---

**NOTE** Always suspect calibration devices, cables, or improper connector maintenance as the primary cause of an error term anomaly.

---

---

## Performing Measurement Calibration

A calibration must be performed to allow the analyzer to calculate the error terms before they can be used as a tool:

---

**CAUTION** Perform the following procedure only at a static-safe workstation, and wear a grounded wrist strap.

This is important. If not properly protected against, electrostatic discharge can seriously damage your analyzer, resulting in costly repair.

To reduce the chance of electrostatic discharge, follow all of the recommendations outlined in [“Electrostatic Discharge Protection”](#) on page 1-5, when performing the following calibration.

---

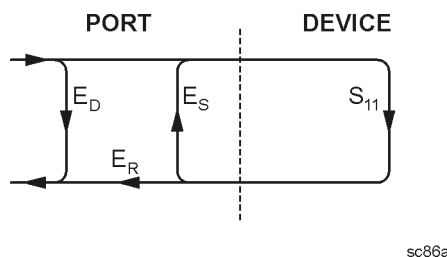
1. Connect a type-N cable to Port 2.
2. Perform a full 2-port calibration, **Full SOLT 2-Port**. Refer to the embedded help in the analyzer if necessary.

---

## Using Flowgraphs to Identify Error Terms

Flowgraphs are a graphical representation of signal flow through the measurement path. The flowgraphs in [Figure A-1](#) and [Figure A-2](#) illustrate the error terms associated with measurement calibration.

**Figure A-1 Flowgraph of One-Port Error Terms for Port 1**



where:

E = Error term

Subscript:

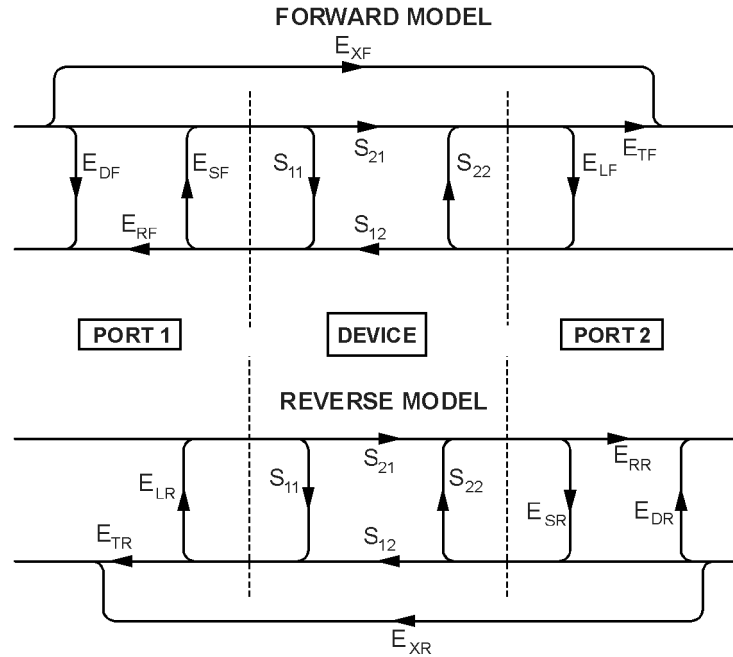
D = Directivity

S = Source Match

R = Reflection Tracking

The error terms are the same for a one port measurement on Port 2 ( $S_{22}$ ).

**Figure A-2 Flowgraph of Two-Port Error Terms**



sc87a.cdr

where:

$E$  = error term

1st Subscript:

- D = Directivity
- S = Source Match
- R = Reflection Tracking
- X = Crosstalk (Isolation)
- L = Load Match
- T = Transmission Tracking

2nd Subscript:

- F = forward measurement (Port 1 to Port 2)
- R = reverse measurement (Port 2 to Port 1)

---

## Accessing Error Terms

Error terms can be accessed either manually or programmatically:

### Manually

- “[Front Panel Access to Error Terms](#)” on page A-6

### Programmatically

- “[GPIB Access to Error Terms](#)” on page A-7
- “[COM/DCOM Access to Error Terms](#)” on page A-7

## Manual Access to Error Terms

### Front Panel Access to Error Terms

---

**NOTE** Ensure the calibration correction is active by making sure that **Correction on/OFF** has a check-mark in the **Calibration** menu.

---

To access the error terms from the front panel, perform the following steps:

1. In the **System** menu, point to **Service, Utilities**, and then click **Cal Set Viewer**.  
The **Cal Set Viewer** toolbar appears directly above the trace window.
2. In the **Cal Set** list, select a cal set.
3. Click the **Standards/ETerms** button to toggle between viewing the raw measurement data from the standard or the corrected error term data. Note that the title of the center box in the toolbar will toggle between **Standard** and **Error Term**.
4. In the **Standard** or **Error Term** list, select the standard or error term to view. Click the **View** check box.
5. Compare the displayed measurement trace to the equivalent data trace plots that start in “[Typical Error Term Data](#)” on page A-8, to previously measured data, or to the uncorrected performance specifications listed in [Table A-1 on page A-8](#).
6. Print numerical data or print a plot of the measurement results.
7. To exit the **Cal Set Viewer**: In the **System** menu, point to **Service, Utilities**, and then click **Cal Set Viewer**.

## **Programmatic Access to Error Terms**

### **GPIB Access to Error Terms**

You can access error terms by way of GPIB with Standard Commands for Programmable Instruments (SCPI).

For more information on GPIB and SCPI, refer to the embedded help in the analyzer. Type in keyword “errors, systematic” in the index.

### **COM/DCOM Access to Error Terms**

You can access error terms by way of Component Object Model (COM) or Distributed Component Object Model (DCOM) software architecture.

For more information on COM and DCOM, refer to the embedded help in the analyzer. Type in keyword “errors, systematic” in the index.

## Typical Error Term Data

The error term descriptions in this section include the following information:

- a table of the typical error terms
- typical plots of results
- significance of each error term
- guidelines to interpret each error term

The same description applies to both the forward (F) and reverse (R) terms. The plots shown with each description are typical of a working system following a full 2-port calibration as performed in [“Performing Measurement Calibration” on page A-4](#).

**IMPORTANT** Typical data are listed here as a convenience. More detailed instrument specifications are listed in the embedded help in the network analyzer.

**Table A-1 Typical Error Term Data**

Parameter	Frequency Range			
	300 kHz to 1.3 GHz	1.3 GHz to 3 GHz	3 GHz to 6 GHz	6 GHz to 9 GHz
Directivity	>33 dB <sup>a</sup>	>27 dB	>20 dB	>13 dB
Source Match	>20 dB	>17 dB >15 dB (Opt. 015)	>15 dB >13 dB (Opt. 015)	>14 dB >12 dB (Opt. 015)
Load Match	>20 dB	>17 dB > 5 dB (Opt. 015)	>15 dB >13 dB (Opt. 015)	>15 dB >13 dB (Opt. 015)
Reflection Tracking	±1.5 dB	±1.5 dB	±2.5 dB	±3.0 dB
Transmission Tracking	±1.5 dB	±1.5 dB	±2.5 dB	±3.0 dB

a. The directivity typical value is 30 dB from 300 kHz to 1 MHz.

### If Error Terms Seem Worse than Typical Values

To verify that the system still conforms to specifications, perform a system verification. Refer to [Chapter 3, “Tests and Adjustments.”](#)



## Directivity ( $E_{DF}$ and $E_{DR}$ )

$E_{DF}$  and  $E_{DR}$  are the uncorrected forward and reverse directivity error terms of the system. The directivity error of the test port is determined by measuring the  $S_{11}$  and  $S_{22}$  reflection of the calibration kit load. The load has a much better return loss specification than does the uncorrected test port. Therefore, any power detected from this measurement is assumed to be from directivity error.

The measurements most affected by directivity errors are measurements of low reflection devices.

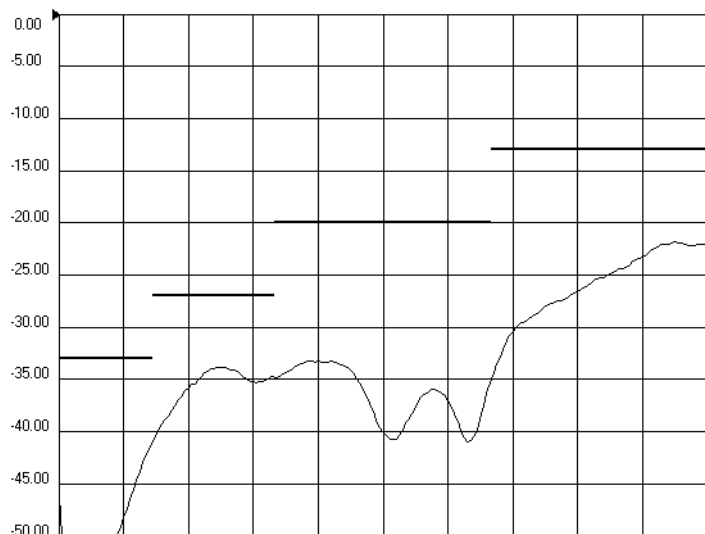
### Typical Cause of Failure

The *calibration kit load* is the most common cause of directivity specification failure.

If the load has been gaged and its performance independently verified, suspect the analyzer *test port coupler*.

To troubleshoot, refer to “[Checking the Signal Separation Group](#)” on page 4-41.

**Figure A-3 Typical  $E_{DF}/E_{DR}$  Without Cables**



## Source Match ( $E_{SF}$ and $E_{SR}$ )

$E_{SF}$  and  $E_{SR}$  are the forward and reverse uncorrected source match terms of the driven port. They are obtained by measuring the reflection ( $S_{11}$ ,  $S_{22}$ ) of an open, and a short that are connected directly to the ports. Source match is a measure of the match of the coupler, as well as the match between all components from the source to the output port.

The measurements most affected by source match errors are reflection and transmission measurements of highly reflective DUTs.

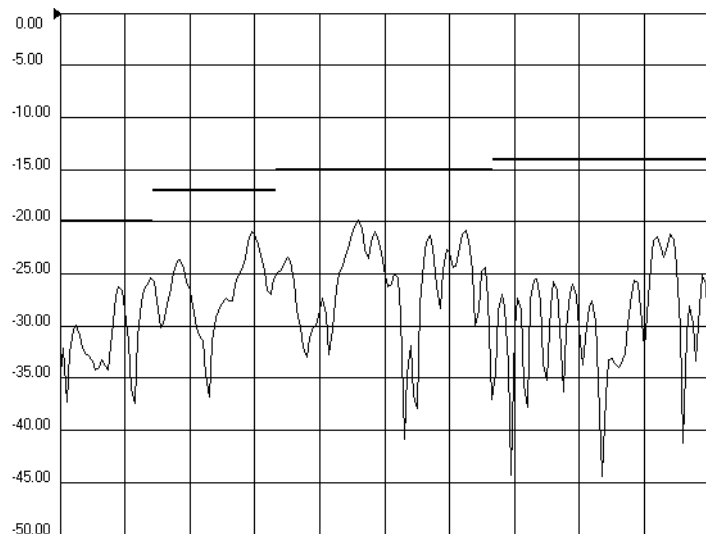
### Typical Cause of Failure

The *calibration kit open or short* is the most common cause of source match specification failure.

If the open or short performance has been independently verified, suspect the analyzer *switch splitter, step attenuator, or coupler*.

To troubleshoot, refer to “[Checking the Signal Separation Group](#)” on page 4-41.

**Figure A-4 Typical  $E_{SF}/E_{SR}$  Without Cables**



## Load Match ( $E_{LF}$ and $E_{LR}$ )

Load match is a measure of the impedance match of the test port that terminates the output of a 2-port device. The match of test port cables is included in this response. Load match error terms are characterized by measuring the  $S_{11}$  and  $S_{22}$  responses of a “thru” configuration during the calibration procedure.

The measurements most affected by load match errors are all transmission measurements, and reflection measurements of a low insertion loss two-port device, such as an airline.

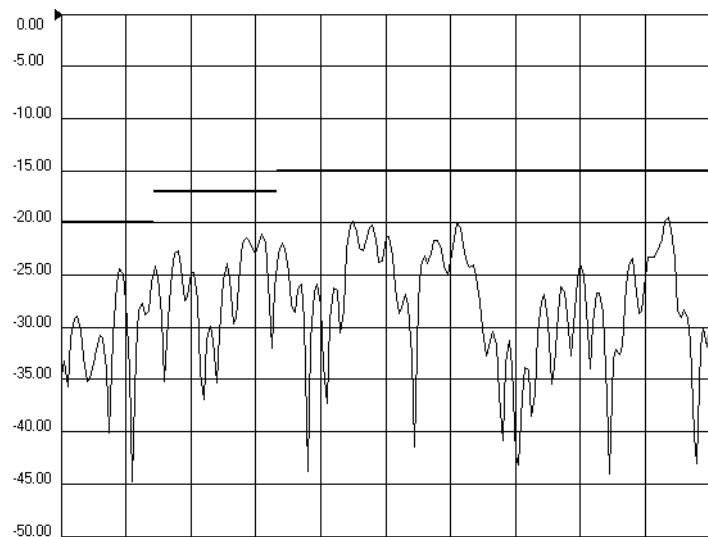
### Typical Cause of Failure

The *calibration kit load* or a *bad “thru” cable* is the most common cause of load match specification failure.

If the load and cable performance are independently verified, then suspect the analyzer *test port coupler*, *step attenuator*, or the *test receiver* at the bad port.

To troubleshoot, refer to “[Checking the Receiver Assembly Group](#)” on page 4-45 or to “[Checking the Signal Separation Group](#)” on page 4-41.

**Figure A-5 Typical  $E_{LF}/E_{LR}$**



## Reflection Tracking ( $E_{RF}$ and $E_{RR}$ )

Reflection tracking is the difference between the frequency response of the reference path (R1 or R2 path) and the frequency response of the reflection test path (A or B input path). These error terms are characterized by measuring the reflection ( $S_{11}$ ,  $S_{22}$ ) of the open and the short during the measurement calibration.

All reflection measurements are affected by the reflection tracking errors.

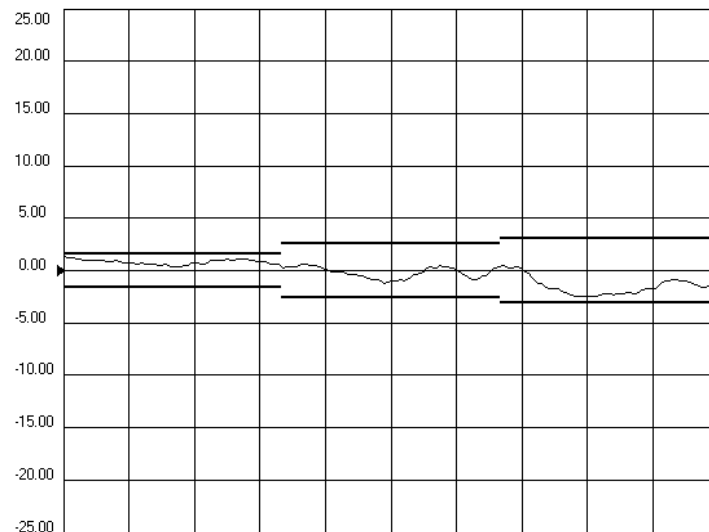
### Typical Cause of Failure

The *calibration kit open or short* is the most common cause of reflection tracking specification failure. If the open or short performance has been independently verified, suspect the following:

- If both  $E_{RF}$  and  $E_{RR}$  fail
  - suspect the analyzer *switch splitter*
- If either  $E_{RF}$  or  $E_{RR}$  fails
  - suspect the *coupler, step attenuator, or the test receiver* of the failed port

To troubleshoot, refer to “[Checking the Receiver Assembly Group](#)” on page 4-45 or to “[Checking the Signal Separation Group](#)” on page 4-41.

**Figure A-6 Typical  $E_{RF}/E_{RR}$**



## Transmission Tracking ( $E_{TF}$ and $E_{TR}$ )

Transmission tracking is the difference between the frequency response of the reference path (including the R input) and the frequency response of the transmission test path (including the A or B input) while measuring transmission. The response of the test port cables is included. These terms are characterized by measuring the transmission ( $S_{21}$ ,  $S_{12}$ ) of the “thru” configuration during the measurement calibration.

All transmission measurements are affected by transmission tracking errors.

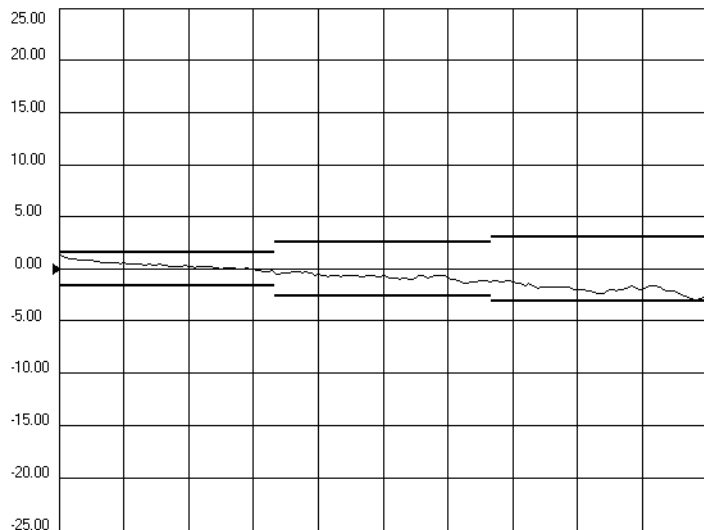
### Typical Cause of Failure

The *test port cable* is the most common cause of transmission tracking specification failure. If the test port cable performance has been independently verified, suspect the following:

- If both  $E_{TF}$  and  $E_{TR}$  fail
  - suspect the analyzer *switch splitter*
- If either  $E_{TF}$  or  $E_{TR}$  fails
  - suspect the *coupler, step attenuator, or the test receiver* of the failed port

To troubleshoot, refer to “[Checking the Receiver Assembly Group](#)” on page 4-45 or to “[Checking the Signal Separation Group](#)” on page 4-41.

**Figure A-7 Typical  $E_{TF}/E_{TR}$**



## Isolation ( $E_{XF}$ and $E_{XR}$ )

Isolation is the uncorrected forward and reverse isolation error terms that represent leakage between the test ports and the signal paths. The isolation error terms are characterized by measuring transmission ( $S_{21}$ ,  $S_{12}$ ) with loads attached to both ports during the measurement calibration.

Isolation errors affect transmission measurements primarily where the measured signal level is very low. The measurements most affected by isolation error terms are DUTs with large insertion loss. Since these terms are low in magnitude, they are usually noisy (not very repeatable).

There are no specifications for the isolation error terms. However, [Figure A-8](#) shows the typical isolation response in a 10 Hz bandwidth.

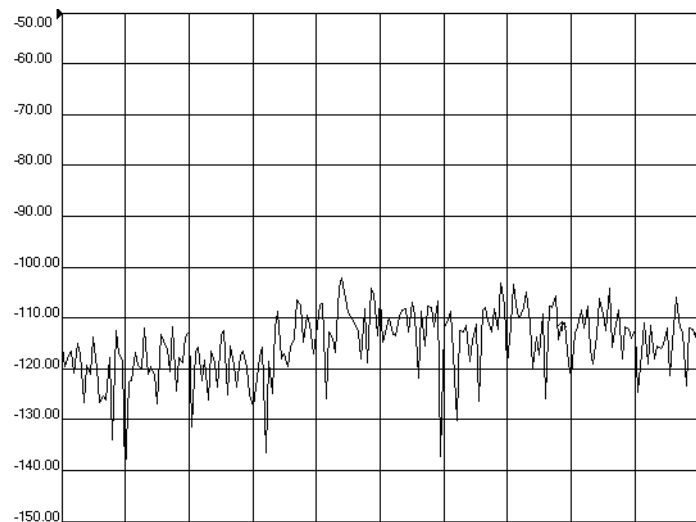
### Typical Cause of Failure

A loose cable connection or leakage between components in the test set are the most likely cause of isolation problems.

After verifying the cable and its connections, suspect the analyzer *switch splitter*, *step attenuator*, *coupler*, or *receivers*.

To troubleshoot, refer to “[Checking the Receiver Assembly Group](#)” on page 4-45 or to “[Checking the Signal Separation Group](#)” on page 4-41.

**Figure A-8 Typical  $E_{XF}/E_{XR}$  With 10 Hz Bandwidth**



---

## **B Option Enable Utility**

---

## Information in This Appendix

---

**NOTE** For more in-depth information on option enable, refer to the embedded help in the analyzer.

---

### Appendix B at-a-Glance

Section Title	Summary of Content	Start Page
<a href="#">Accessing the Option Enable Utility</a>	How to access the option enable utility within the analyzer's menu system.	<a href="#">Page B-3</a>
<a href="#">Enabling or Removing Options</a>	How to add or remove options from the analyzer's option list.	<a href="#">Page B-4</a>
<a href="#">Repairing and Recovering Option Data</a>	How to recover lost option data.	<a href="#">Page B-5</a>
<a href="#">Installing or Changing a Serial Number</a>	How to install a new serial number for the analyzer or change the existing serial number.	<a href="#">Page B-6</a>



---

## Accessing the Option Enable Utility

To start the option enable application:

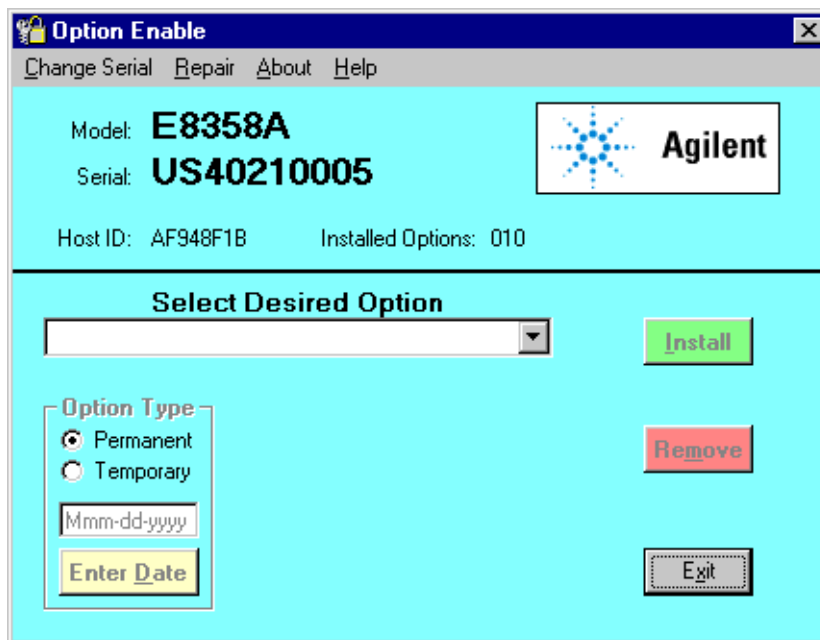
- On the **System** menu, point to **Service**, and then click **Option Enable**.
- The dialog box illustrated in [Figure B-1](#) is displayed.

---

**NOTE** Some applications require a keyword that is provided by Agilent. If you do not have the required keyword, contact Agilent for assistance. Refer to [“Contacting Agilent” on page 2-9](#).

---

**Figure B-1 Option Enable Dialog Box**



---

## Enabling or Removing Options

There are two types of options:

- **Hardware:** Hardware options involve adding additional hardware to the analyzer. After the proper hardware has been installed in the analyzer, the option can be enabled using the option enable utility.  
It is necessary to re-enable all hardware options if the A16 test set motherboard is replaced
- **Software:** Software options add features or functionality to the analyzer without the need for additional hardware. They are enabled using the option enable utility.  
It is necessary to re-enable all software options if the A10 frequency reference board is replaced.

To enable or remove an option:

1. Start the option enable utility. Refer to [“Accessing the Option Enable Utility”](#) on page B-3.
2. Click the arrow in the **Select Desired Option** box. A list of available options, similar to the list below, will appear.
  - 010 - Time Domain
  - UNL - Bias Tees w/Atten
  - 014 - Configurable Test Set
  - 016 - Receiver Attenuators
  - 080 - Frequency Offset Mode
  - 081 - Reference Transfer Switch
  - 082 - Active Device Meas Appl
  - 083 - Mixer Measurement Appl
  - ??? - Enter Unlisted Option
3. Click on the option that you wish to either enable or remove, and then click **Enable** or **Remove**, whichever is appropriate.
4. If the desired option is not available in the list, select **Enter Unlisted Option**. A dialog box appears that will allow you to enter the option number. Enter the option number and follow the instructions on the display.

---

## Repairing and Recovering Option Data

License, option, and model number data are stored in an EPROM on the A10 frequency reference board and written into the `gen.lic` file on the hard disk drive. If the data stored in either of these items is lost, it can be recovered from the other item.

If the data on both the hard disk drive and the frequency reference board is lost, it can not be recovered. Contact Agilent for assistance. Refer to [“Contacting Agilent” on page 2-9](#).

### Recovery of Data After Repair

- If the A10 frequency reference board is replaced, use the **Repair** selection to recover data that has been lost as a result of the repair:
  1. Select **Repair** from the **Option Enable** menu bar (see [Figure B-1](#)).
  2. Click the **Freq Ref board has been replaced** check box.
  3. Click **Begin Repair**. The data is written from the `gen.lic` file into the EPROM.
- If the hard disk drive is replaced, a new `gen.lic` file is automatically created when the **Network Analyzer** application starts, by retrieving the data from the EPROM.

### Recovery of Data if Option or Model Numbers are Incorrect

If the analyzer option or model numbers are not listed correctly on the analyzer display, in either the Option Enable Dialog Box or the About Network Analyzer display, you should regenerate the options license file, `gen.lic`:

1. Exit the **Network Analyzer** application.
2. Remove (or rename) the existing `gen.lic` file:
  - a. Open **Windows Explorer** and navigate to `C:\Program Files\Agilent\Network Analyzer`.
  - b. Delete (or rename) `gen.lic`.
3. Exit the **Windows Explorer** application.
4. Open the **Network Analyzer** application. The application will generate a new `gen.lic` file when it starts.
5. Check the option listing:
  - a. On the **System** menu, point to **Service**, and then click **Option Enable**, or
  - b. On the **Help** menu, click **About Network Analyzer**.
6. If the options are still not listed correctly, contact Agilent Technologies. Refer to [“Contacting Agilent” on page 2-9](#).

---

## Installing or Changing a Serial Number

It is necessary to reinstall the instrument serial number if the A16 test set motherboard is replaced.

---

**IMPORTANT** Use extreme care when entering the serial number, as only one attempt is allowed.

---

1. To change a serial number, select **Change Serial** from the **Option Enable** menu bar (see [Figure B-1](#)). The current serial number is displayed. If no serial number has previously been entered, the word “NONE” will be displayed.
2. Type the new serial number into the space provided, click **Serial**.

---

**NOTE** To change an incorrect serial number, a clear-code password is required. Contact Agilent to obtain the clear-code. Refer to [“Chapter Two at-a-Glance” on page 2-2](#).

---

---

# C Firmware Upgrades

---

## Information in This Appendix

This appendix provides instructions for installing firmware upgrades in your PNA series RF network analyzer.

### Appendix C at-a-Glance

Section Title	Summary of Content	Start Page
<a href="#">Downloading from the Internet</a>	How to download firmware upgrades from the Internet.	<a href="#">Page C-2</a>
<a href="#">Downloading Using Option 099, Firmware Upgrade</a>	How to download firmware upgrades from a CD-ROM.	<a href="#">Page C-3</a>

---

## Downloading from the Internet

If your network analyzer is connected to the Internet, there are two methods available for downloading new firmware:

- Download directly from: <http://www.agilent.com/find/pna>. (Select your analyzer's model number in this website to view available upgrades.)
- On the **System** menu, point to **Service**, and then click **AgileUpdate**. **AgileUpdate** compares the firmware revision currently installed in your network analyzer to the latest version available and assists you in downloading and installing the most recent version. This is available only on analyzers with firmware revision A.01.20 and higher.

---

## Downloading Using Option 099, Firmware Upgrade

Option 099 provides a firmware upgrade kit containing a CD-ROM that contains firmware upgrades for your network analyzer. Refer to [“Option 099, Firmware Upgrade”](#), on page 2-4 for additional information.

Two procedures are provided for updating the analyzer firmware using the upgrade kit:

- [Downloading from a USB CD Drive Connected to the Analyzer](#)
- [Downloading from a Shared CD Drive Over the LAN](#)

### Installation Requirements

- The network analyzer must be in proper working condition prior to installing this option. Any necessary repairs must be made before proceeding with this installation.
- This installation does not require removal of the analyzer’s protective outer covers.
- The analyzer must be powered up and operating to perform this installation.

### Downloading from a USB CD Drive Connected to the Analyzer

- A mouse and a keyboard must be connected to the network analyzer.
- A CD drive must be connected to the network analyzer. This procedure has been verified using the CD drive accessory specified in [“USB Accessories”](#), on page 6-28. It has not been verified using other USB CD drives.

### Installation Procedure

1. Exit all applications; the analyzer display should show the PC desktop icons.
2. Insert the upgrade CD into your analyzer’s CD drive.
3. Click **My Computer**, and then click your analyzer’s CD drive.
4. On the CD drive menu, click on the program file listed to begin the installation.
5. Follow the instructions as they appear. Select your network analyzer’s hard disk drive as the destination for the files being installed.

### Downloading from a Shared CD Drive Over the LAN

- If your PC and your network analyzer are both connected to the same LAN, proceed to [“Downloading Over the LAN.”](#)
- If your PC and your network analyzer are NOT connected to a LAN, you can connect them using a crossover cable. A crossover cable can be purchased or can be constructed from a standard LAN cable. Refer to [“Constructing a Crossover Cable”](#), on page 4-25 for details.

## Downloading Over the LAN

This procedure assumes that the network analyzer and the computer are both connected to the same LAN or are connected using a crossover cable.

*From your PC:*

1. Insert the upgrade CD in your PC's CD drive.
2. Right click on **Network Neighborhood**, and then click **Properties**. Record the Computer Name here: \_\_\_\_\_ . Click **Cancel**.
3. Double-click **My Computer**. Click on your PC's CD drive. On the **File** menu, click **Sharing**. Under the **Sharing** tab, click **Share as**. Type a **Share Name** and record it here: \_\_\_\_\_ . *Do not use the default letter that is displayed.* Click **Cancel** to close the dialog box.

*From your network analyzer:*

4. On the PC desktop, click **My Computer**, click **Tools**, and then click **Map Network Drive**.
5. The network analyzer will choose the next available drive letter. Record this drive letter here: \_\_\_\_\_ .
6. In the **Map Network Drive** window, click the **Folder** box (this is the **Path** box on the PC) and type the path of your PC's CD drive in the form \\computername\sharename. You recorded the computername in step 2 and the sharename in step 3.

---

**NOTE** If you are logged onto the analyzer using the same logon as for your PC, it is not necessary to select "Connect using a different user name". If, however, you are not logged onto your analyzer using the same logon or you prefer to connect under a different user name, click this hyperlink and type the user name and password. If the user name is in a different domain, use the format: domain\username.

---

7. To automatically connect to the shared drive each time you log on, check **Reconnect at logon**.
8. Click **Finish**.
9. Your PC's CD drive should now be visible on the display as the drive letter you recorded in step 5 with the share name you assigned in step 3.
10. A window listing the contents of the CD installed in your PC's CD drive is displayed.
11. On the CD drive menu, click on the program file listed to begin the installation.
12. Follow the instructions as they appear. Select your network analyzer's hard disk drive as the destination for the files being installed.



---

# D Operating System Recovery

---

## Information in This Appendix

### Appendix D at-a-Glance

Section Title	Summary of Content	Start Page
<a href="#">Overview</a>	Overview of the analyzer's hard disk drive file storage system and the impact of the operating system recovery procedure on that file storage system.	<a href="#">Page D-3</a>
<a href="#">System Recovery Procedure</a>	Step-by-step instructions for how to restore the operating system on your analyzer.	<a href="#">Page D-4</a>

---

## Overview

This recovery procedure will completely restore the operating system of the PNA series network analyzer to the original factory condition. It will not function if the hard drive is damaged.

If you have made an emergency repair disk, you may be able to recover from some Windows system problems without the loss of data. Refer to Windows 2000 Help or contact your systems administrator.

Use this procedure for the following types of situations:

- If you are recovering from a corrupted operating system.
- If you have security concerns where all previous usage remnants need to be eliminated.
- If the network analyzer must be in a known configuration, such as for rental companies.

The hard drive in the PNA series network analyzer has two partitions (drives):

- **C:** drive—contains the Windows 2000 operating system (NTFS format). This is the normally used partition and it contains all the programs and other needed files.
- **D:** drive—is the Disaster Recovery Partition. It contains a compressed image of the C: drive as it existed when shipped from the factory, plus its support files. It may also contain other items such as drivers or firmware. **DO NOT USE THIS DRIVE FOR NORMAL DAY-TO-DAY USE.**

---

**IMPORTANT** The recovery procedure will erase the entire C: drive and the following information will be lost:

- all changes and additions made to the network analyzer since its purchase (except options)
- all user accounts and passwords
- all added programs
- all saved instrument states
- all user configurations and Windows settings

---

The above listed information can be saved by copying it to a floppy disk or to a folder on the D: drive; the D: drive will not be affected by the restoration process. In addition, factory instrument calibration will not be affected if no changes have been made since the original factory calibration. If changes have been made through the service routines, copy all files that are prefixed with mxcalfile\_ in the C:/Program Files/Agilent/Network Analyzer directory to the D:/Calfiles directory. Permanent instrument options should not be lost.

---

## System Recovery Procedure

1. Click **Start**, **Shutdown**, and then **Restart**.

---

**NOTE** Normally, you can boot from the D: drive (recovery partition) which will allow you to erase and restore the C: drive. This is an available selection during the normal boot-up process. If this boot-up selection process is not functioning due to a damaged operating system, proceed to [“If the Operating System Does Not Boot from the Hard Disk Drive” on page D-5](#).

---

2. After the Agilent logo displays on the screen, you will have several seconds to select an alternative operating system from the default of Windows 2000.
  - a. Select the **Recovery** partition. A brief “splash” screen will appear indicating that you are booting from the recovery partition.
3. The analyzer will display a warning about proceeding and give you two chances to abort. After the second warning, if not aborted, the restoration process begins immediately.

Restoration takes from 30 to 60 minutes. There is no user interaction required. Near the end of the process, the network analyzer will reboot several times. The network analyzer application may start before the process is complete. Do not attempt to use the analyzer until the network analyzer application is running and all activity has been stopped for at least one minute.

Once the operating system is completely recovered, you can restore any files that you saved. The mxcalfile\_ files that were stored on the D:/Calfiles directory will be restored automatically. Other files must be moved or copied manually.

---

**NOTE** If the network analyzer options are lost, rename the C:/Program Files/Agilent/Network Analyzer/gen.lic file to gen.bak, and then restart the network analyzer application. This should regenerate the options automatically and recreate the gen.lic file.

---

After recovery, you may notice that, upon power up, the system pauses for 30 seconds to allow selection of the operating system. This time delay can be decreased to 5 seconds. To do this:

1. Click **Start**, point to **Settings**, and then click **Control Panel**.
2. Double-click **System**.
3. In the **System Properties** window, click on the **Advanced** tab, and then click **Startup and Recovery**.
4. Modify **Display list of operating systems for xx seconds**, where xx is the desired time value. The factory recommended setting is 5 seconds.
5. Click **OK** in the **Startup and Recovery** window. Click **OK** in the **System Properties** window. Close the **Control Panel** window.

## If the Operating System Does Not Boot from the Hard Disk Drive

If the network analyzer is unable to boot from the hard disk drive, then you must make a DOS boot disk. To make this disk, you will need:

- a floppy disk
- a computer that is currently running DOS or Windows® 95/98/ME/XP. Windows® NT or Windows® 2000 cannot be used.

To create the DOS boot disk:

1. Right click on the **A:** drive.
2. Select **Format**.
3. Select **Make System Disk** (or copy system files).

To boot from the DOS boot disk:

4. Insert the newly created system disk into the network analyzer floppy disk drive and restart the operating system. The network analyzer should detect this disk and boot from it. If not, proceed to [“If the Operating System Does Not Boot from the Floppy Disk Drive” on page D-6](#).
5. At the DOS prompt (A:\>) type `CD C:` and press **Enter**. You are really changing to the D: drive because a DOS operating system does not recognize the NTFS format and assumes the first valid drive is C:.
6. Type **Autoexc.bat** and press **Enter**.
7. Now that the analyzer system has booted, continue with the restoration procedure at step 2 of [“System Recovery Procedure” on page D-4](#).

Windows®, Windows® 95, Windows® 98, Windows® ME, Windows® XP, Windows® NT, and Windows® 2000 are U.S. registered trademarks of Microsoft Corporation.

## If the Operating System Does Not Boot from the Floppy Disk Drive

You may have to change the network analyzer Bios settings to have it scan the floppy disk drive before booting from the hard disk drive. Due to Bios revisions, the exact procedure may vary slightly from the following:

1. Attach a keyboard to the network analyzer and restart the network analyzer.
2. When the Agilent logo appears, press function key **F2**, on the keyboard, several times. The **Bios** menu will appear after several seconds.
3. Using the keyboard arrows, select **Boot**. Use the keyboard to edit the file to select booting from the floppy disk drive before attempting to boot from the hard disk drive.

---

**NOTE** Once the restoration process is complete and the analyzer is functioning properly, remove the floppy disk and use this same procedure to change back to booting from the hard disk drive. If you do not do this, an error will result each time the analyzer is powered up with a floppy disk installed.

---

4. Select **Save**, and then **Exit**.
5. Now that the Bios has been changed to allow the system to detect the DOS boot disk in the floppy disk drive, continue with the procedure at step 5 of [“If the Operating System Does Not Boot from the Hard Disk Drive”](#) on page D-5.

## Numerics

### 1284-C port

- rear panel connector, 5-25
- troubleshooting, 4-21

### 35 dB step attenuators

- illustrated, 6-15
- operation, 5-12
- part number, 6-14
- troubleshooting, 4-46

### 70 dB step attenuators

- illustrated, 6-13, 6-15
- operation, 5-11
- part number, 6-12, 6-14

## A

### A1 keypad assembly

- illustrated, 6-9
- operation, 5-22
- part number, 6-8
- removal and replacement, 7-10
- test, 4-17, 4-19
- test values, 4-18
- troubleshooting, 4-17

### A2 display assembly

- illustrated, 6-9
- operation, 5-22
- part number, 6-8
- removal and replacement, 7-10
- troubleshooting, 4-13, 4-17

### A3 front panel interface board assembly

- illustrated, 6-9
- operation, 5-24
- part number, 6-8
- removal and replacement, 7-10
- troubleshooting, 4-13, 4-17

### A4 power supply assembly

- illustrated, 6-11
- operation, 5-26
- part number, 6-10
- removal and replacement, 7-14
- troubleshooting, 4-7

### A6 SPAM board assembly

- illustrated, 6-11
- operation
  - analog, 5-21
  - digital, 5-24
- part number, 6-10
- removal and replacement, 7-16
- troubleshooting, 4-45, 4-46

### A8 fractional-N synthesizer board assembly

- illustrated, 6-11
- operation, 5-8
- part number, 6-10

removal and replacement, 7-16

test nodes, 4-34

troubleshooting, 4-38

band 1, 4-39

bands 2–6, 4-39

### A10 frequency reference

#### board assembly

- illustrated, 6-11
- operation, 5-8
- part number, 6-10
- removal and replacement, 7-16
- test nodes, 4-33
- troubleshooting, 4-37
  - band 0, 4-38
  - band 1–6, 4-38

### A11 phase lock board assembly

- illustrated, 6-11
- operation, 5-8
- part number, 6-10
- removal and replacement, 7-18
- test nodes, 4-33
- troubleshooting, 4-40

### A12 source assembly

- illustrated, 6-11
- operation, 5-9
- part numbers, 6-10
- removal and replacement, 7-20
- test nodes, 4-32
- troubleshooting, 4-31

### A14 motherboard assembly

- illustrated, 6-11
- operation, 5-24, 5-25, 5-26
- part number, 6-10
- removal and replacement, 7-22
- troubleshooting, 4-10, 4-12
- voltage checks, 4-8

### A15 CPU board assembly

- illustrated, 6-11
- operation, 5-24
- part numbers, 6-10
- removal and replacement, 7-24
- troubleshooting, 4-10, 4-13, 4-21

### A16 test set motherboard assembly

- illustrated, 6-13, 6-15
- operation, 5-15
- part number, 6-12, 6-14
- removal and replacement, 7-26
- troubleshooting, 4-46, 4-47

### A17 LO distribution assembly

- illustrated, 6-13, 6-15
- operation, 5-8, 5-15
- part number, 6-12, 6-14
- removal and replacement, 7-28
- troubleshooting, 4-45

### A18 channel A receiver module

- illustrated, 6-13, 6-15
- operation, 5-15
- part numbers, 6-12, 6-14
- removal and replacement, 7-30
- troubleshooting, 4-46

### A19 channel R1 receiver module

- illustrated, 6-13, 6-15
- operation, 5-15
- part numbers, 6-12, 6-14
- removal and replacement, 7-30
- troubleshooting, 4-46

### A20 channel R2 receiver module

- illustrated, 6-13, 6-15
- operation, 5-15
- part numbers, 6-12, 6-14
- removal and replacement, 7-30
- troubleshooting, 4-46

### A21 channel B receiver module

- illustrated, 6-13, 6-15
- operation, 5-15
- part numbers, 6-12, 6-14
- removal and replacement, 7-30
- troubleshooting, 4-46

### A22 switch splitter

- illustrated, 6-13, 6-15
- operation, 5-10
- part numbers, 6-12, 6-14
- removal and replacement, 7-32
- troubleshooting, 4-43, 4-44

### A23 test port 1 coupler

- illustrated, 6-13, 6-15
- operation, 5-10
- part numbers, 6-12, 6-14
- removal and replacement, 7-34
- troubleshooting, 4-43, 4-44

### A24 test port 2 coupler

- illustrated, 6-13, 6-15
- operation, 5-10
- part numbers, 6-12, 6-14
- removal and replacement, 7-34
- troubleshooting, 4-43, 4-44

### A25 70 dB step attenuator

- illustrated, 6-13, 6-15
- operation, 5-11
- part number, 6-12, 6-14
- removal and replacement, 7-36
- troubleshooting, 4-43, 4-44

### A26 70 dB step attenuator

- illustrated, 6-13, 6-15
- operation, 5-11
- part number, 6-12, 6-14
- removal and replacement, 7-36

- troubleshooting, 4-43, 4-44
  - A27 35 dB step attenuator**
    - illustrated, 6-15
    - operation, 5-12
    - part number, 6-14
    - removal and replacement, 7-38
    - troubleshooting, 4-46
  - A28 35 dB step attenuator**
    - illustrated, 6-15
    - operation, 5-12
    - part number, 6-14
    - removal and replacement, 7-38
    - troubleshooting, 4-46
  - A30 floppy disk drive assembly**
    - illustrated, 6-23, 6-25
    - operation, 5-25
    - part numbers, 6-22, 6-25
    - removal and replacement, 7-40
  - A31 hard disk drive assembly**
    - illustrated, 6-24
    - operation, 5-25
    - part numbers, 6-24
    - removal and replacement, 7-42
  - accessories**
    - CD-RW drive, 2-4
    - in operator's check, 3-11
    - in test port cable checks, 3-13
    - USB
      - part numbers, 6-28
    - USB hub, 2-4
  - accuracy**
    - dynamic accuracy test, 3-35
    - frequency test, 3-31
  - adapters required for servicing, 2-7**
  - adding**
    - options, B-4
  - adjustments**
    - frequency
      - at 10 MHz, 3-47
      - at 3.8 MHz, 3-48
    - LO power, 3-46
    - post-repair, 7-53
    - receiver calibration, 3-44
    - source calibration, 3-43
    - system, 3-1, 3-42, B-1, C-1
      - getting ready, 3-4
  - administrator password, 7-46**
    - Agilent, 7-46
  - Agilent, 7-46**
    - contacting, 2-9
    - support, 2-8
  - airline handling precautions, 3-24**
  - analyzer**
    - block diagram
      - configurable test set, Option 015, 5-13
      - digital control group, 5-23
      - digital processor group, 5-23
      - receiver group, 5-16
      - signal separation group, 5-11
      - source group, 5-6
    - covers
      - illustrated, 6-27
      - part numbers, 6-26
      - removal and replacement, 7-6
    - display lamp
      - replacement illustrated, 7-13
      - replacement procedure, 7-12
    - external replaceable parts
      - illustrated, 6-27
      - part numbers, 6-26
    - feet
      - illustrated, 6-27
      - part numbers, 6-26
    - frequency range and max output power, 5-4
    - front panel interconnects, 5-24
    - functional groups, 5-3
      - digital control, 5-4
      - digital processor, 5-4
      - power supply, 5-4
      - receiver group, 5-4
      - signal separation, 5-4
      - synthesized source, 5-4
    - internal replaceable parts
      - illustrated, 6-23, 6-25
      - part numbers, 6-22, 6-25
    - miscellaneous replaceable parts
      - part numbers, 6-28
    - mounting in equipment rack, 2-5
    - operation
      - 35 dB step attenuators, 5-12
      - 70 dB step attenuators, 5-11
      - configurable test set, Option 015, 5-12
      - CPU board, 5-24
      - data acquisition subgroup, 5-24
      - digital control group, 5-22
      - digital processor group, 5-22
      - display assembly, 5-22
      - floppy disk drive, 5-25
      - front panel interface board, 5-24
      - front panel subgroup, 5-22
      - hard disk drive, 5-25
      - keypad assembly, 5-22
      - LO distribution assembly, 5-8, 5-15
      - main RAM, 5-25
      - processing subgroup, 5-24
      - receiver group, 5-15
      - receiver modules, 5-15
      - signal separation group, 5-10
      - source group, 5-5
      - SPAM board—analogue, 5-21
      - SPAM board—digital, 5-24
      - switch splitter, 5-10
      - test port couplers, 5-10
      - test set motherboard, 5-15
    - options, 2-3
    - rear panel
      - interconnects, 5-9, 5-17, 5-25
    - strap handle
      - illustrated, 6-27
      - part number, 6-26
    - system block diagram, 5-3
    - system operation
      - theory of, 5-3
    - warmup time, 3-4
- ANSI/NCSL Z540-1-1994**
  - non-type verification, 3-9
  - verification, 3-8
- assemblies**
  - location of part numbers, 6-7
  - rebuilt-exchange
    - procedure, 6-5
  - rebuilt-exchange program, 6-5
  - replacement
    - cautions about, 7-2
    - list of procedures, 7-4
    - sequence, 6-4, 7-2
    - warnings about, 7-2
- attenuator range**
  - check, 3-10
  - operator's check, 3-10
- attenuator—35 dB step**
  - removal and replacement
    - illustrated, 7-39
    - procedure, 7-38
- attenuator—70 dB step**
  - removal and replacement
    - illustrated, 7-37
    - procedure, 7-36
- AUX I/O connector, 5-17**
  - pin assignments, 5-20
- ## B
- B1 fan**
    - removal and replacement, 7-49
  - band modes**
    - operation
      - band 0, 5-7
      - bands 1–6, 5-7
    - source group
      - configurations, 5-5



operation, 5-5  
troubleshooting  
band 1, 4-39  
bands 1–6, 4-38, 4-45  
bands 2–6, 4-39

**battery disposal, 1-6**

**before applying power, 1-3**

**block diagram**  
configurable test set,  
Option 015, 5-13  
digital control group, 5-23  
digital processor group, 5-23  
receiver group, 5-16  
signal separation group, 5-11  
source group, 5-6

**bottom assembly–Option 015**  
replaceable cables  
illustrated, 6-21  
part numbers, 6-20  
replaceable parts  
illustrated, 6-15  
part numbers, 6-14

**bottom assembly–standard**  
replaceable cables  
illustrated, 6-19  
part numbers, 6-18  
replaceable parts  
illustrated, 6-13  
part numbers, 6-12

**C**

**cable**  
substitution, 3-23  
test port  
checks, 3-10, 3-13, 3-14, 3-15,  
3-16, 3-18  
connector repeatability  
failure, 3-19  
insertion loss failure, 3-15  
magnitude and phase stability  
failure, 3-17  
return loss failure, 3-14

**cables**  
GPIB  
part numbers, 6-29  
in bottom assembly–Option 015  
illustrated, 6-21  
part numbers, 6-20  
in bottom assembly–standard  
illustrated, 6-19  
part numbers, 6-18  
in top assembly  
illustrated, 6-17  
part numbers, 6-16  
location of part numbers, 6-7  
required for servicing, 2-7

**calibration**  
certificate and data, Option  
UK6, 2-5  
certificate of, 3-7  
coefficients test, 3-34  
commercial, Option R-50C-001,  
2-8  
kits, 3-7  
required for servicing, 2-7  
substitution, 3-23  
options available, 2-8  
receiver, 3-44  
source, 3-43  
standards compliant,  
Option R-50C-002, 2-8

**care of connectors, 3-5**

**caution, 1-3**

**CD-RW drive, 2-4**

**CE mark, 1-6**

**certificate of calibration, 3-7**

**certificate of calibration,  
Option UK6, 2-5**

**changing**  
a serial number, B-6  
HANDLER I/O connector  
pinout, 7-52

**channel A receiver module**  
illustrated, 6-13, 6-15  
part numbers, 6-12, 6-14  
troubleshooting, 4-46

**channel B receiver module**  
illustrated, 6-13, 6-15  
part numbers, 6-12, 6-14  
troubleshooting, 4-46

**channel R1 receiver module**  
illustrated, 6-13, 6-15  
part numbers, 6-12, 6-14  
troubleshooting, 4-46

**channel R2 receiver module**  
illustrated, 6-13, 6-15  
part numbers, 6-12, 6-14  
troubleshooting, 4-46

**checks**  
attenuator range, 3-10  
cable  
insertion loss failure, 3-15  
magnitude and phase stability  
failure, 3-17  
return loss failure, 3-14  
of test port cables, 3-10, 3-13  
operator's, 3-10  
accessories used in, 3-11  
dialog box, 3-11  
failure of, 3-11  
performing, 3-10  
Port 1, 3-11  
Port 2, 3-11

preliminary, 3-10  
switch repeatability, 3-10  
system, 3-1, B-1, C-1  
getting ready, 3-4  
test port cable  
accessories used in, 3-13  
connector repeatability, 3-18  
connector repeatability  
failure, 3-19  
insertion loss, 3-15  
magnitude and phase  
stability, 3-16  
performing, 3-13  
return loss, 3-14

**COM, A-7**

**commercial calibration,  
Option R-50C-001, 2-8**

**compression test, receiver,  
3-32**

**configurable test  
set, Option 015, 2-4**  
block diagram, 5-13  
operation, 5-12

**configuration**  
high dynamic range, 5-14  
diagram, 5-14  
Option 015, 5-12

**configurations**  
source group  
band modes, 5-5

**connector**  
care  
principles of, 3-5  
quick reference, 3-5  
protective end caps  
part numbers, 6-29  
repeatability check  
failure of, 3-19  
of test port cables, 3-18

**connector repeatability check**  
test port cables, 3-18

**connectors**  
front panel, 5-24  
Probe Power, 5-24  
USB, 5-24  
rear panel, 5-9, 5-17, 5-25  
1284-C, 5-25  
AUX I/O, 5-17, 5-20  
Display, 5-25  
EXT 10 MHz REF IN, 5-9  
EXT 10 MHz REF OUT, 5-9  
EXT AM, 5-9  
EXT DET, 5-9  
GPIB, 5-25  
HANDLER I/O, 5-17, 5-19,  
7-52  
PARALLEL, 5-25

RS-232, 5-25  
SERIAL, 5-25  
TEST SET I/O, 5-17, 5-18  
USB, 5-25  
VGA, 5-25

**contacting Agilent**, 2-9

**controllers**  
troubleshooting with, 4-22

**coupler, test port**  
removal and replacement  
illustrated, 7-35  
procedure, 7-34

**covers, analyzer**  
illustrated, 6-27  
part numbers, 6-26  
removal and replacement  
illustrated, 7-7  
procedure, 7-6

**CPU board**  
illustrated, 6-11  
operation, 5-24  
part numbers, 6-10  
removal and replacement  
illustrated, 7-25  
procedure, 7-24

**cross talk, system test**, 3-35

**cross talk, test port test**, 3-35

**cross-over cable, LAN**, 4-25

**CSA mark**, 1-6

**C-tick mark**, 1-6

## D

**data acquisition**  
operation, 5-24

**data acquisition and processing**  
subgroup, 5-22

**data storage**  
floppy disk, 5-25  
hard disk, 5-25  
IDE, 5-25

**data, option**  
recovering, B-5  
repairing, B-5

**DCOM**, A-7

**description**  
functional  
digital control group, 5-4  
digital processor group, 5-4  
power supply group, 5-4  
receiver group, 5-4  
signal separation group, 5-4  
synthesized source group, 5-4

**device connections**  
system verification, 3-26

**digital control**  
functional description of, 5-4  
operation, 5-22

**digital control group**  
block diagram, 5-23

**digital processing and control**  
functional group, 5-3

**digital processor**  
functional description of, 5-4  
operation, 5-22

**digital processor group**  
block diagram, 5-23

**directivity**  
cause of failure, A-9  
definition of, A-9  
measurements affected by, A-9  
specifications, A-8

**disabling**  
options, B-4

**display assembly**  
illustrated, 6-9  
operation, 5-22  
parts list, 6-8  
removal and replacement  
procedure, 7-10  
troubleshooting, 4-13, 4-17

**display inverter**  
removal and replacement  
illustrated, 7-13  
procedure, 7-12

**display lamp**  
removal and replacement  
illustrated, 7-13  
procedure, 7-12

**Display port**  
rear panel connector, 5-25

**display test**  
running, 4-19

**disposal, battery**, 1-6

**documentation**  
optional, 1-iv  
part numbers, 6-28  
standard, 1-iv

**dynamic range, high configuration**, 5-14

## E

**earth ground**, 1-3

**electrostatic discharge**, *See* ESD

**electrostatic discharge**, *see* ESD

**emissions requirements**  
German FTZ, 1-7

**enabling**  
options, B-4

**environment, operating**  
specifications, 3-4  
verification, 3-4

**equipment rack**  
horizontal spacing, 2-5  
mounting analyzer in, 2-5

**equipment, service test**  
required, 2-6

**error terms**  
access to, A-6  
via COM/DCOM commands, A-7  
via front panel, A-6  
via SCPI commands (using GPIB), A-7  
cause of failure to, A-3  
descriptions, A-8  
directivity, A-9  
flowgraph of one port, A-4  
flowgraph of two port, A-5  
identifying using flowgraphs, A-4  
isolation, A-14  
load match, A-11  
magnitude  
affected by, A-3  
monitoring over time, A-3  
reflection tracking, A-12  
shape affected by, A-3  
source match, A-10  
transmission tracking, A-13  
typical data, A-8  
table of, A-8  
using as diagnostic tool, A-3  
using to aid troubleshooting, A-3  
worse than typical values, A-8

**ESD**  
protection, 1-5, 3-4, 4-3, 7-3, A-4

**ESD supplies**  
part numbers, 6-28

**exchange**  
rebuilt assemblies  
program, 6-5

**exchange module procedure**, 6-5

**EXT 10 MHz REF IN connector**  
rear panel, 5-9

**EXT 10 MHz REF OUT connector**  
rear panel, 5-9

**EXT DET connector**  
rear panel, 5-9

**EXT. AM INPUT connector**  
rear panel, 5-9

**extended frequency range**,  
Option 006, 2-3  
**extended frequency range**,  
Option 009, 2-3  
**extender board**  
measurement points, 4-8  
voltages, 4-8  
**external analyzer**  
replaceable parts  
illustrated, 6-27  
part numbers, 6-26  
**external monitor**, 4-13

## F

**failure**  
of connector repeatability check,  
3-19  
of insertion loss check, 3-15  
of magnitude and phase  
stability check, 3-17  
of operator's check, 3-11  
of return loss check, 3-14  
of system verification, 3-27  
flowchart, 3-27  
**fan**  
removal and replacement, 7-49  
troubleshooting, 4-12  
**feet, analyzer**  
illustrated, 6-27  
part numbers, 6-26  
**firmware upgrade**  
downloading from the internet,  
C-2  
installing using Option 099, C-3  
Option 099, 2-4  
**floppy disk**  
data storage, 5-25  
**floppy disk drive**  
illustrated, 6-23, 6-25  
operation, 5-25  
part number, 6-22, 6-25  
removal and replacement  
illustrated, 7-41  
procedure, 7-40  
**flowgraph**  
of one port error terms, A-4  
of two port error terms, A-5  
using to identify error terms,  
A-4  
**Fourier transform**, 2-3  
**fractional-N synthesizer**  
illustrated, 6-11  
operation, 5-8  
part number, 6-10  
removal and replacement  
illustrated, 7-17

procedure, 7-16  
troubleshooting, 4-38  
band 1, 4-39  
bands 2-6, 4-39  
**frequencies**  
subsweep, 5-5  
**frequency accuracy**  
test, 3-31  
**frequency adjustment**  
at 10 MHz, 3-47  
at 3.8 MHz, 3-48  
**frequency range**  
and max output power, 5-4  
extended, Option 006, 2-3  
extended, Option 009, 2-3  
**frequency reference board**  
illustrated, 6-11  
operation, 5-8  
part number, 6-10  
removal and replacement  
illustrated, 7-17  
procedure, 7-16  
**front panel**  
connectors  
Probe Power, 5-24  
USB, 5-24  
interconnects, 5-24  
knob  
part number, 6-8  
test, 4-19  
troubleshooting, 4-17  
operation, 5-22  
speaker, 5-24  
subgroup, 5-22  
**front panel assembly**  
removal and replacement  
illustrated, 7-9  
procedure, 7-8  
replaceable parts  
illustrated, 6-9  
part numbers, 6-8  
**front panel interface board**  
illustrated, 6-9  
operation, 5-24  
part number, 6-8  
removal and replacement  
procedure, 7-10  
troubleshooting, 4-13, 4-17  
**front panel knob**  
test, 4-17  
**front panel subassemblies**  
removal and replacement  
illustrated, 7-11  
procedures, 7-10  
**FTZ emission requirements**,  
1-7  
**functional groups**, 5-3

**fuseholder**  
part number, 6-25  
**fuseholder cap**  
part number, 6-25  
**fuses**  
part numbers, 6-29

## G

**general safety considerations**,  
1-3  
**German requirements**  
FTZ emission, 1-7  
noise, 1-7  
 **GPIB, A-7**  
cables  
part numbers, 6-29  
port  
rear panel connector, 5-25  
running test software, 4-22  
troubleshooting, 4-22  
systems check, 4-22  
**ground, safety earth**, 1-3  
**groups**  
functional, 5-3

## H

**handle kits**  
part numbers, 6-29  
**HANDLER I/O connector**, 5-17  
pin assignments, 5-19  
changing, 5-19  
reconfiguring pinout, 7-52  
**handles**  
with rack mount, 2-5  
**handling airlines**  
precautions, 3-24  
**hard disk**  
data storage, 5-25  
**hard disk drive**  
copying files from, 7-42  
illustrated, 6-24  
installing backup files onto, 7-47  
operation, 5-25  
part number, 6-24  
removal and replacement  
illustrated, 7-44  
procedure, 7-42  
replaceable hardware  
illustrated, 6-24  
replaceable parts  
illustrated, 6-24  
part numbers, 6-24  
service position procedure, 7-44  
unique files located on, 7-42

## hardware

- in hard disk drive
  - illustrated, 6-24
  - part numbers, 6-24
- in internal analyzer
  - illustrated, 6-23, 6-25
  - part numbers, 6-22, 6-25
  - location of part numbers, 6-7
  - options, B-4

## high dynamic range

- configuration, 5-14
- diagram, 5-14

## hub

- USB, 2-4

## I

### ICES-001 mark, 1-6

### IDE data storage, 5-25

### insertion loss check

- failure of, 3-15
- test port cables, 3-15

### installing

- a serial number, B-6

### instruction documentation

- symbol, 1-6

### instrument markings, 1-6

### instrument specifications, 3-6

### interconnects

- front panel, 5-24
  - Probe Power, 5-24
  - USB, 5-24
- rear panel, 5-9, 5-17, 5-25
  - 1284-C, 5-25
  - AUX I/O, 5-17, 5-20
  - Display, 5-25
  - EXT 10 MHz REF IN, 5-9
  - EXT 10 MHz REF OUT, 5-9
  - EXT AM, 5-9
  - EXT DET, 5-9
  - GPIB, 5-25
  - HANDLER I/O, 5-17, 5-19, 7-52
  - LAN, 5-25
  - PARALLEL, 5-25
  - RS-232, 5-25
  - SERIAL, 5-25
  - TEST SET I/O, 5-17, 5-18
  - USB, 5-25
  - VGA, 5-25

### internal analyzer

- replaceable hardware
  - illustrated, 6-23, 6-25
- replaceable parts
  - illustrated, 6-23, 6-25
  - part numbers, 6-22, 6-25

### IP address, LAN, 4-23

### ISM1-A mark, 1-6

### isolation

- cause of failure, A-14
- definition of, A-14
- measurements affected by, A-14
- specifications, A-8

## K

### keypad assembly

- illustrated, 6-9
- operation, 5-22
- part number, 6-8
- removal and replacement
  - procedure, 7-10
- test, 4-17, 4-19
- troubleshooting, 4-17

### kits

- calibration, 3-7
  - required for servicing, 2-7
- handle
  - part numbers, 6-29
- rack mount
  - part numbers, 6-29
- upgrade
  - part numbers, 6-28
- verification, 3-7
  - required for servicing, 2-7

### knob

- front panel
  - part number, 6-8
- test, 4-17, 4-19
- troubleshooting, 4-17

## L

### LAN

- connector
  - rear panel, 5-25
- cross-over cable, 4-25
- IP address, 4-23
- ping command, 4-23
- ping to and from, 4-23
- subnet mask, 4-23
- testing between analyzers, 4-25
- troubleshooting, 4-23

### LCD display

- troubleshooting, 4-13

### linearity

- source power
  - test, 3-31
- test port output power
  - test, 3-31

### lithium battery disposal, 1-6

### LO distribution assembly (LODA)

- illustrated, 6-13, 6-15
- operation, 5-8, 5-15
- part number, 6-12, 6-14
- removal and replacement
  - illustrated, 7-29
  - procedure, 7-28

### load match

- cause of failure, A-11
- definition of, A-11
- measurements affected by, A-11, A-13
- specifications, A-8

### locating

- assembly part numbers, 6-7
- cable part numbers, 6-7
- hardware part numbers, 6-7
- miscellaneous part numbers, 6-7
- part numbers
  - by reference designator, 6-6
  - by type of part, 6-7

## M

### magnitude check

- failure of, 3-17
- test port cables, 3-16

### maintenance

- cleaning, 2-3
- preventive
  - effect on error terms, A-3

### max output power

- and frequency range, 5-4

### measurement

- traceability, 3-22
- path, 3-22
- uncertainty, 3-21

### measurement system

- troubleshooting, 4-27

### measuring

- high-dynamic range devices, 2-4
- high-power devices, 2-4

### midweb

- removal and replacement, 7-49
- illustrated, 7-50

### midweb fans

- troubleshooting, 4-12

### miscellaneous replaceable parts

- location of part numbers, 6-7
- part numbers, 6-28

### modifying

- HANDLER I/O connector
  - pinout, 7-52

### module exchange procedure, 6-5

### monitor, external, 4-13

## **motherboard**

- illustrated, 6-11
- part number, 6-10
- removal and replacement
  - illustrated, 7-23
  - procedure, 7-22

## **motherboard, test set**

- removal and replacement
  - illustrated, 7-52

## **N**

**N10149 mark**, 1-6

**network analyzer**, *See* analyzer.

**noise floor, test**, 3-33

**noise requirements**, 1-7

**noise, trace noise test**, 3-32

**Non-ANSI/NCSL Z540-1-1994**

- verification, 3-9

## **O**

### **OCXO (oven-controlled crystal oscillator)**

- frequency adjustment, 3-47
- theory of operation, 5-8

### **operating**

- environment
  - specifications, 3-4
  - verification, 3-4
- system
  - recovery, D-1

### **operation**

- 35 dB step attenuators, 5-12
- 70 dB step attenuators, 5-11
- band modes
  - band 0, 5-7
  - band1 1–6, 5-7
- configurable test set,
  - Option 015, 5-12
- CPU board, 5-24
- data acquisition, 5-24
- digital control, 5-22
- digital processor, 5-22
- display assembly, 5-22
- floppy disk drive, 5-25
- fractional-N synthesizer, 5-8
- frequency reference board, 5-8
- front panel, 5-22
- front panel interface board, 5-24
- hard disk drive, 5-25
- keypad assembly, 5-22
- LO distribution assembly, 5-8,
  - 5-15
- main RAM, 5-25

- phase lock board, 5-8
- power supply, 5-26
- processing subgroup, 5-24
- receiver group, 5-15
- receiver modules, 5-15
- signal separation group, 5-10
- source, 5-5
- source assembly, 5-9
- source group, band modes, 5-5
- SPAM board–analog, 5-21
- SPAM board–digital, 5-24
- switch splitter, 5-10
- test port couplers, 5-10
- test set motherboard, 5-15

### **operator's check**, 3-10

- accessories used in, 3-11
- attenuator range, 3-10
- dialog box, 3-11
- failure of, 3-11
- performing, 3-10
- Port 1, 3-11
- Port 2, 3-11
- switch repeatability, 3-10

### **option**

- analyzer, 2-3
- calibration, 2-8
- data
  - recovering, B-5
  - repairing, B-5
- enable utility
  - accessing, B-3
  - dialog box, B-3
- enabling and removing, B-4
- hardware, B-4
- service and support, 2-8
- software, B-4

### **Option 006, extended frequency range**, 2-3

### **Option 009, extended frequency range**, 2-3

### **Option 010, time domain**, 2-3

### **Option 015, configurable test set**, 2-4

- block diagram, 5-13
- normal configuration, 5-12
- operation, 5-12
- replaceable parts
  - illustrated, 6-15
  - part numbers, 6-14

### **Option 099, firmware upgrade**, 2-4

### **Option 1CM, rack mount without handles**, 2-5

### **Option 1CP, rack mount with handles**, 2-5

### **Option UK6, calibration certificate and data**, 2-5

### **Option R-50C-001**

- commercial calibration, 2-8

### **Option R-50C-002**

- standards compliant
  - calibration, 2-8

### **ordering information**

- replaceable parts, 6-3

### **output power, source**

- accuracy test, 3-30
- linearity, 3-31

### **output power, test port**

- accuracy test, 3-30
- linearity, 3-31

## **P**

### **paint, touch-up**

- part numbers, 6-29

### **PARALLEL port**

- rear panel connector, 5-25
- troubleshooting, 4-21

### **part numbers**

- accessories
  - USB, 6-28
- cables
  - for bottom
    - assembly–Option 015, 6-20
  - for bottom
    - assembly–standard, 6-18
  - for top assembly, 6-16
  - GPIB, 6-29
- documentation, 6-28
- ESD supplies, 6-28
- fuses, 6-29
- handle kits, 6-29
- hardware
  - in hard disk drive, 6-24
  - in internal analyzer, 6-22,
    - 6-25

### **kits**

- calibration, 2-7
- handle, 6-29
- rack mount, 6-29
- verification, 2-7

### **locating**

- by reference designator, 6-6
- by type of part, 6-7
- for assemblies, 6-7
- for cables, 6-7
- for hardware, 6-7
- for miscellaneous parts, 6-7
- protective end caps
  - for connectors, 6-29
- rack mount kits, 6-29
- replaceable parts
  - analyzer covers, 6-26

- analyzer feet, 6-26
  - analyzer strap handle, 6-26
  - external analyzer, 6-26
    - for bottom
      - assembly—Option 015, 6-14
    - for bottom
      - assembly—standard, 6-12
    - for front panel assembly, 6-8
    - for top assembly, 6-10
    - in hard disk drive, 6-24
    - in internal analyzer, 6-22, 6-25
    - miscellaneous analyzer, 6-28
  - supplies
    - ESD, 6-28
  - tools, service, 6-28
  - touch-up paint, 6-29
  - upgrade kits, 6-28
  - USB accessories, 6-28
- parts**
- external analyzer
    - illustrated, 6-27
    - part numbers, 6-26
  - in bottom assembly—Option 015
    - part numbers, 6-14
  - in bottom assembly—Option 015
    - illustrated, 6-15
  - in bottom assembly—standard
    - illustrated, 6-13
    - part numbers, 6-12
  - in front panel assembly
    - illustrated, 6-9
    - part numbers, 6-8
  - in hard disk drive
    - illustrated, 6-24
  - in hard disk drive assembly
    - part numbers, 6-24
  - in internal analyzer
    - illustrated, 6-23, 6-25
    - part numbers, 6-22, 6-25
  - in top assembly
    - illustrated, 6-11
    - part numbers, 6-10
  - locating
    - by reference designator, 6-6
    - by type of part, 6-7
  - miscellaneous
    - part numbers, 6-28
  - replaceable
    - listing of, 6-6
    - ordering information, 6-3
- password**
- Agilent administrator, 7-46
- performance**
- tests, 3-30
    - calibration coefficients, 3-34
    - description of, 3-7
    - dynamic accuracy, 3-35
    - frequency accuracy, 3-31
    - noise floor, 3-33
    - power meter accuracy, 3-37
    - receiver compression, 3-32
    - source power accuracy, 3-30
    - source power linearity, 3-31
    - system crosstalk, 3-35
    - test port crosstalk, 3-35
    - test port output power
      - accuracy, 3-30
    - test port output power linearity, 3-31
    - trace noise, 3-32
  - verification
    - ANSI/NCSL Z540-1-1994, 3-8
    - non-ANSI/NCSL Z540-1-1994, 3-9
- phase lock board**
- illustrated, 6-11
  - operation, 5-8
  - part number, 6-10
  - removal and replacement
    - illustrated, 7-19
    - procedure, 7-18
  - troubleshooting, 4-40
- phase stability check**
- failure of, 3-17
  - test port cables, 3-16
- pin assignments, connectors**
- AUX I/O, 5-20
  - HANDLER I/O, 5-19
    - changing, 7-52
  - TEST SET I/O, 5-18
- ping**
- command, LAN, 4-23
  - from network, 4-24
  - to analyzer, 4-23
- pinout, connectors**
- AUX I/O, 5-20
  - HANDLER I/O, 5-19
    - changing, 7-52
  - TEST SET I/O, 5-18
- pixel**
- damaged, 4-19
  - definition, 4-19
- PMYO (permanent-magnet YIG oscillator)**
- frequency adjustment, 3-48
  - theory of operation, 5-9
- Port 1**
- check, 3-11
  - typical power output, 4-41
- Port 2**
- check, 3-11
  - typical power output, 4-42
- post-repair procedures, 7-53**
- power meter accuracy test, 3-37**
- power supply**
- check, 4-7
  - functional description of, 5-4
  - functional group, 5-3
  - if all voltages are missing, 4-10
  - operation, 5-26
  - voltage checks, 4-8
- power supply assembly**
- illustrated, 6-11
  - part number, 6-10
  - removal and replacement
    - illustrated, 7-15
    - procedure, 7-14
- power, source**
- accuracy test, 3-30
  - linearity test, 3-31
- power, test port output**
- accuracy test, 3-30
  - linearity test, 3-31
- precautions**
- handling airlines, 3-24
- pre-repair procedures**
- caution about, 7-3
  - warnings about, 7-3
- preventive maintenance**
- effect on error terms, A-3
- probe power**
- connector, 5-24
  - measurement points, 4-7
  - troubleshooting, 4-17
- processing subgroup**
- operation, 5-24
- protection**
- against ESD, 1-5, 3-4, 4-3, 7-3, A-4
- protective end caps**
- for connectors
    - part numbers, 6-29
- ## R
- rack mount kits**
- part numbers, 6-29
  - with handles, Option 1CP, 2-5
  - without handles, Option 1CM, 2-5
- RAM, main**
- operation, 5-25
- rear panel**
- connectors
    - 1284-C, 5-25
    - AUX I/O, 5-17, 5-20
    - Display, 5-25
    - EXT 10 MHz REF IN, 5-9

- EXT AM, 5-9
- EXT DET, 5-9
- GPIB, 5-25
- HANDLER I/O, 5-17, 5-19, 7-52
- LAN, 5-25
- PARALLEL, 5-25
- RS-232, 5-25
- SERIAL, 5-25
- TEST SET I/O, 5-17, 5-18
- USB, 5-25
- VGA, 5-25
- interconnects, 5-9, 5-17, 5-25
- troubleshooting, 4-21
- rebuilt-exchange assemblies**
  - program, 6-5
- receiver**
  - accuracy
    - dynamic accuracy test, 3-35
  - calibration, 3-44
  - compression test, 3-32
  - control of, 5-17
  - dynamic accuracy test, 3-35
  - functional description of, 5-4
  - functional group, 5-3
  - linearity
    - dynamic accuracy test, 3-35
- receiver display**
  - running the test, 4-27
- receiver group**
  - block diagram, 5-16
  - operation, 5-15
  - troubleshooting, 4-45
- receiver module**
  - illustrated, 6-13, 6-15
  - operation, 5-15
  - part numbers, 6-12, 6-14
  - removal and replacement
    - illustrated, 7-31
    - procedure, 7-30
  - troubleshooting, 4-46
- receiver output**
  - troubleshooting, 4-46
- reconfiguring**
  - HANDLER I/O connector
    - pinout, 7-52
- recovery**
  - of operating system, D-1
  - of option data, B-5
- reflection tracking**
  - cause of failure, A-12
  - definition of, A-12
  - measurements affected by, A-12
  - specifications, A-8
- removing**
  - options, B-4
- repair**
  - of option data, B-5
  - post-repair procedures, 7-53
  - procedures
    - caution about, 7-3
    - list of, 7-4
    - warnings about, 7-3
- replaceable cables**
  - in bottom assembly—Option 015
    - illustrated, 6-21
    - part numbers, 6-20
  - in bottom assembly—standard
    - illustrated, 6-19
    - part numbers, 6-18
  - in top assembly
    - illustrated, 6-17
    - part numbers, 6-16
- replaceable hardware**
  - in hard disk drive
    - illustrated, 6-24
    - part numbers, 6-24
  - in internal analyzer
    - illustrated, 6-23, 6-25
    - part numbers, 6-22, 6-25
- replaceable parts**
  - external analyzer
    - illustrated, 6-27
    - part numbers, 6-26
  - in bottom assembly—Option 015,
    - 6-14
    - illustrated, 6-15
  - in bottom assembly—standard,
    - 6-12
    - illustrated, 6-13
  - in front panel assembly, 6-8
    - illustrated, 6-9
  - in hard disk drive
    - illustrated, 6-24
    - part numbers, 6-24
  - in internal analyzer
    - illustrated, 6-23, 6-25
    - part numbers, 6-22, 6-25
  - in top assembly, 6-10
    - illustrated, 6-11
  - listing of, 6-6
  - locating
    - by reference designator, 6-6
    - by type of part, 6-7
  - miscellaneous analyzer
    - part numbers, 6-28
  - ordering information, 6-3
- replacement**
  - A1 keypad assembly
    - procedure, 7-10
  - A2 display assembly
    - procedure, 7-10
- A3 front panel interface board
  - assembly
    - procedure, 7-10
- A4 power supply assembly
  - illustrated, 7-15
  - procedure, 7-14
- A6 SPAM board
  - illustrated, 7-17
  - procedure, 7-16
- A8 fractional-N synthesizer board
  - illustrated, 7-17
  - procedure, 7-16
- A10 frequency reference board
  - illustrated, 7-17
  - procedure, 7-16
- A11 phase lock board
  - illustrated, 7-19
  - procedure, 7-18
- A12 source assembly
  - illustrated, 7-21
  - procedure, 7-20
- A14 motherboard
  - illustrated, 7-23
  - procedure, 7-22
- A15 CPU board
  - illustrated, 7-25
  - procedure, 7-24
- A16 test set motherboard
  - illustrated, 7-27, 7-52
  - procedure, 7-26
- A17 LO distribution assembly
  - illustrated, 7-29
  - procedure, 7-28
- A18, A19, A20, and A21 receiver modules
  - illustrated, 7-31
  - procedure, 7-30
- A22 switch splitter
  - illustrated, 7-33
  - procedure, 7-32
- A23 and A24 test port couplers
  - illustrated, 7-35
  - procedure, 7-34
- A25 and A26 70 dB step attenuators
  - illustrated, 7-37
  - procedure, 7-36
- A27 and A28 35 dB step attenuators
  - illustrated, 7-39
  - procedure, 7-38
- A30 floppy disk drive
  - illustrated, 7-41
  - procedure, 7-40
- A31 hard disk drive
  - illustrated, 7-44

- procedure, 7-42
  - analyzer covers
    - illustrated, 7-7
    - procedure, 7-6
  - assembly
    - cautions about, 7-2
    - list of procedures, 7-4
    - sequence, 6-4, 7-2
    - warnings about, 7-2
  - display inverter
    - illustrated, 7-13
    - procedure, 7-12
  - display lamp
    - illustrated, 7-13
    - procedure, 7-12
  - fan, 7-49
  - front panel assembly
    - illustrated, 7-9
    - procedure, 7-8
  - front panel subassemblies
    - illustrated, 7-11
    - procedures, 7-10
  - midweb
    - illustrated, 7-50
    - procedure, 7-49
  - replacement sequence**, 4-3
  - return loss check**
    - failure of, 3-14
    - test port cables, 3-14
  - rotary pulse generator (RPG)**
    - part number, 6-8
    - test, 4-17, 4-19
    - troubleshooting, 4-17
  - RS-232 port**
    - rear panel connector, 5-25
    - troubleshooting, 4-21
- S**
- safety**
    - considerations, 1-3
    - earth ground, 1-3
    - symbols, 1-3
  - SCPI**, A-7
  - serial bus test**, 4-31
    - dialog box, 4-32
    - performing, 4-31
  - serial number**
    - changing, B-6
    - installing, B-6
  - SERIAL port**
    - rear panel connector, 5-25
    - troubleshooting, 4-21
  - service**
    - contacting Agilent, 2-9
    - options, 2-8
  - position, hard disk drive
    - assembly, 7-44
  - procedures
    - caution about, 7-3
    - post-repair, 7-53
    - warnings about, 7-3
  - test equipment
    - required, 2-6
  - tools
    - part numbers, 6-28
  - warnings, 1-4
  - warranty
    - standard, 2-8
    - three-year return to Agilent, 2-8
  - shipment for service or repair**, 2-10
  - signal separation**
    - functional description of, 5-4
    - functional group, 5-3
  - signal separation group**
    - block diagram, 5-11
    - operation, 5-10
    - troubleshooting, 4-41
  - simplified block diagram**
    - source, 5-5
  - software**
    - options, B-4
  - source**
    - calibration, 3-43
    - operation, 5-5
    - power accuracy test, 3-30
    - power linearity test, 3-31
  - source assembly**
    - illustrated, 6-11
    - operation, 5-9
    - part numbers, 6-10
    - removal and replacement
      - illustrated, 7-21
      - procedure, 7-20
      - troubleshooting, 4-31
  - source functional group**, 5-3
    - simplified block diagram, 5-5
  - source group**
    - block diagram, 5-6
  - source match**
    - cause of failure, A-10
    - definition of, A-10
    - measurements affected by, A-10
    - specifications, A-8
  - SPAM board**
    - illustrated, 6-11
    - operation
      - analog, 5-21
      - digital, 5-24
    - part number, 6-10
    - removal and replacement
      - illustrated, 7-17
      - procedure, 7-16
      - troubleshooting, 4-46
  - speaker**
    - front panel, 5-24
    - troubleshooting, 4-17
  - specification**
    - stabilization, warm up time, 3-4
  - specifications**
    - directivity, A-8
    - instrument, 3-6
    - isolation, A-8
    - load match, A-8
    - reflection tracking, A-8
    - source match, A-8
    - system, 3-6
    - transmission tracking, A-8
  - stabilization**
    - warm up time, 3-4
  - standards compliant calibration**, Option R-50C-002, 2-8
  - static safety parts**
    - required for servicing, 2-7
  - step attenuator-35 dB**
    - illustrated, 6-15
    - part number, 6-14
    - removal and replacement
      - illustrated, 7-39
      - procedure, 7-38
      - troubleshooting, 4-46
  - step attenuator-70 dB**
    - illustrated, 6-13, 6-15
    - part number, 6-12, 6-14
    - removal and replacement
      - illustrated, 7-37
      - procedure, 7-36
  - storage data, IDE**, 5-25
  - strap handle, analyzer**
    - illustrated, 6-27
    - part number, 6-26
  - subgroup**
    - data acquisition and processing, 5-22
    - front panel, 5-22
  - subnet mask, LAN**, 4-23
  - substitution**
    - cable, 3-23
    - calibration kit, 3-23
  - subsweep frequencies**, 5-5
  - supplies, ESD**
    - part numbers, 6-28
  - support**
    - contacting Agilent, 2-9
    - options, 2-8
    - organization, 2-8



## switch repeatability

- check, 3-10
- operator's check, 3-10

## switch splitter

- illustrated, 6-13, 6-15
- operation, 5-10
- part numbers, 6-12, 6-14
- removal and replacement illustrated, 7-33
- procedure, 7-32

## synthesized source

- functional description of, 5-4

## system

- adjustments, 3-1, 3-42, B-1, C-1
- frequency at 10 MHz, 3-47
- frequency at 3.8 MHz, 3-48
- getting ready, 3-4
- LO power, 3-46
- receiver calibration, 3-44
- source calibration, 3-43
- checks, 3-1, B-1, C-1
  - getting ready, 3-4
- cross talk test, 3-35
- specifications, 3-6
- verification, 3-1, 3-7, 3-20, B-1, C-1
  - device connections, 3-26
  - dialog box, 3-25
  - example of results, 3-28, 3-29
  - failure flowchart, 3-27
  - failure of, 3-27
  - getting ready, 3-4
  - interpreting results, 3-28
  - performing, 3-23
  - procedure, 3-25
  - test setup, 3-25
  - what it verifies, 3-20

## system, operating

- recovery, D-1

## T

### test

- calibration coefficients, 3-34
- dynamic accuracy, 3-35
- frequency accuracy, 3-31
- noise floor, 3-33
- performance
  - frequency accuracy, 3-31
  - source power accuracy, 3-30
- test port output power accuracy, 3-30
- power meter accuracy, 3-37
- receiver compression, 3-32
- source power linearity, 3-31
- system crosstalk, 3-35
- test port crosstalk, 3-35

- test port output power linearity, 3-31

- trace noise, 3-32

### test equipment

- required for service, 2-6
- required for servicing, 2-6

### test nodes

- on A12 source assembly, 4-32

### test port

- cross talk test, 3-35
- dynamic accuracy test, 3-35
- noise floor test, 3-33
- output power accuracy test, 3-30
- output power linearity test, 3-31

### test port 1 coupler

- illustrated, 6-13, 6-15
- part numbers, 6-12, 6-14

### test port 2 coupler

- illustrated, 6-13, 6-15
- part numbers, 6-12, 6-14

### test port cable checks, 3-10

- accessories used in, 3-13
- connector repeatability, 3-18
- connector repeatability failure, 3-19
- insertion loss, 3-15
- insertion loss failure, 3-15
- magnitude and phase stability, 3-16
- magnitude and phase stability failure, 3-17
- performing, 3-13
- return loss, 3-14
- return loss failure, 3-14

### test port coupler

- operation, 5-10
- removal and replacement illustrated, 7-35
- procedure, 7-34

### TEST SET I/O connector, 5-17

- pin assignments, 5-18

### test set motherboard

- illustrated, 6-13
- operation, 5-15
- part number, 6-12, 6-14
- removal and replacement illustrated, 7-27, 7-52
- procedure, 7-26
- replaceable parts illustrated, 6-15

### test setup

- system verification, 3-25

### tests

- adjustments, 3-42
- performance, 3-7, 3-30
- serial bus, 4-31
- dialog box, 4-32

- performing, 4-31

### tests nodes

- on A10 frequency reference, 4-33
- on A11 phase lock, 4-33
- on A8 fractional-N synthesizer, 4-34

### time domain, Option 010, 2-3

### tools

- required for servicing, 2-7
- service, part numbers, 6-28

### top assembly

- replaceable cables illustrated, 6-17
- part numbers, 6-16
- replaceable parts illustrated, 6-11
- part numbers, 6-10

### touch-up paint

- part numbers, 6-29

### trace noise

- test, 3-32

### traceability

- measurement, 3-22
- path, 3-22

### transmission tracking

- cause of failure, A-13
- definition of, A-13
- specifications, A-8

### troubleshooting

- 1284-C port, 4-21
- 2nd LO, 4-38
- A1 front panel keypad, 4-17
- A10 frequency reference board, 4-37, 4-38
- A11 phase lock board, 4-40
- A12 source assembly, 4-31
- A14 motherboard assembly, 4-10, 4-12
- A15 CPU board, 4-10, 4-13, 4-21
- A16 test set motherboard assembly, 4-46
- A17 LO distribution assembly, 4-45
- A18 channel A receiver module, 4-46
- A19 channel R1 receiver module, 4-46
- A2 display assembly, 4-13, 4-17
- A20 channel R2 receiver module, 4-46
- A21 channel B receiver module, 4-46
- A22 switch splitter, 4-43, 4-44
- A23 test port 1 coupler, 4-43, 4-44

A24 test port 2 coupler, 4-43, 4-44  
A25 70 dB step attenuator, 4-43, 4-44  
A26 70 dB step attenuator, 4-43, 4-44  
A27 35 dB step attenuator, 4-46  
A28 35 dB step attenuator, 4-46  
A3 front panel interface board, 4-13, 4-17  
A4 power supply, 4-7  
A6 SPAM board, 4-45, 4-46  
A8 fractional-N synthesizer board, 4-38  
band 0, 4-38  
band 1, 4-39  
bands 1–6, 4-45  
bands 2–6, 4-39  
display assembly, 4-13  
error term failure  
  suspect devices, A-3  
fans, 4-12  
front panel knob, 4-17  
front panel USB, 4-17  
GPIB port, 4-22  
LAN, 4-23  
LCD display, 4-13  
measurement system, 4-27  
order of removal of boards, 4-10  
PARALLEL port, 4-21  
ping command, 4-23  
power output of A, B, R1, R2, 4-41  
power supply check, 4-7  
power up, 4-6  
probe power, 4-17  
rear panel, 4-21  
receiver assembly group, 4-45  
receiver output, 4-46  
RPG, 4-17  
RS-232 port, 4-21  
running the receiver display, 4-27  
SERIAL port, 4-21  
signal separation group, 4-41  
source assembly group, 4-31  
speaker, 4-17  
traces  
  A, B, R1, R2, 4-27  
typical power output  
  Port 1, 4-41  
  Port 2, 4-42  
USB, 4-21  
using controllers to system  
  troubleshoot, 4-22  
using error terms, A-3  
using the extender board, 4-8

VGA port, 4-21

## U

**uncertainty**  
  measurement, 3-21  
**upgrade**  
  configurable test set,  
    Option 015, 2-4  
  time domain, Option 010, 2-3  
**upgrade kits**  
  extended frequency range,  
    Option 006, 2-3  
  extended frequency range,  
    Option 009, 2-3  
  part numbers, 6-28  
**upgrade, firmware**  
  downloading from the internet,  
    C-2  
  installing using Option 099, C-3  
  Option 099, 2-4  
**USB**  
  port  
    front panel connector, 5-24  
    rear panel connector, 5-25  
  troubleshooting, 4-21  
**USB accessories**  
  CD-RW drive, 2-4  
  hub, 2-4  
  part numbers, 6-28  
**USB hub, 2-4**  
**utility**  
  option enable  
    accessing, B-3  
    dialog box, B-3

## V

**VCO (voltage-controlled oscillator)**  
  defined, 5-5  
**verification**  
  ANSI/NCSL Z540-1-1994, 3-8  
  kits, 3-7  
    required for servicing, 2-7  
  non-ANSI/NCSL Z540-1-1994,  
    3-9  
  of operating environment, 3-4  
  of operating specifications, 3-4  
  system, 3-1, 3-7, 3-20, B-1, C-1  
    device connections, 3-26  
    dialog box, 3-25  
    example of results, 3-28, 3-29  
    failure flowchart, 3-27  
    failure of, 3-27  
    getting ready, 3-4

  interpreting results, 3-28  
  performing, 3-23  
  procedure, 3-25  
  test setup, 3-25  
  what it verifies, 3-20

**VGA monitor, 4-13**

**VGA port**

  rear panel connector, 5-25  
  troubleshooting, 4-21

## W

**warm up**

  analyzer, 3-4

**warning, 1-3**

**warnings for servicing, 1-4**

**warranty**

  service  
    one-year return to Agilent, 2-8  
    standard, 2-8

**Windows, 2-6**

## Y

**YIG (yttrium-iron-garnet)**

  defined, 5-5

**YIG oscillator**

  PMYO frequency adjustment,  
    3-48

**YTO (YIG-tuned oscillator)**

  defined, 5-8

  theory of operation, 5-9