

Agilent E5052A Signal Source Analyzer

Service Guide

Sixth Edition



Manufacturing No. E5052-90150

November 2007

Notices

The information contained in this document is subject to change without notice.

This document contains proprietary information that is protected by copyright. All rights are reserved. No part of this document may be photocopied, reproduced, or translated to another language without the prior written consent of Agilent Technologies.

Microsoft®, MS-DOS®, Windows®, Visual C++®, Visual Basic®, VBA® and Excel® are registered

UNIX is a registered trademark in U.S. and other countries, licensed exclusively through X/Open Company Limited.

Portions ©Copyright 1996, Microsoft Corporation. All rights reserved.

© Copyright 2004, 2005, 2006, 2007 Agilent Technologies

Manual Printing History

The manual's printing date and part number indicate its current edition. The printing date changes when a new edition is printed. (Minor corrections and updates that are incorporated at reprint do not cause the date to change.) The manual part number changes when extensive technical changes are incorporated.

November 2004	First Edition
February 2005	Second Edition (part number: E5052-90110, changes for firmware version A.01.50)
August 2005	Third Edition (part number: E5052-90120, update service information for serial prefix MY442, and changes for firmware version A.02.00)
June 2006	Fourth Edition (part number: E5052-90130, changes for firmware version A.02.50)
December 2006	Fifth Edition (part number: E5052-90140)
November 2007	Sixth Edition (part number: E5052-90150)

Safety Summary

The following general safety precautions must be observed during all phases of operation, service, and repair of this instrument. Failure to comply with these precautions or with specific WARNINGS elsewhere in this manual may impair the protection provided by the equipment. Such noncompliance would also violate safety standards of design, manufacture, and intended use of the instrument. Agilent Technologies assumes no liability for the customer's failure to comply with these precautions.

NOTE	The E5052A complies with INSTALLATION CATEGORY II as well as POLLUTION DEGREE 2 in IEC61010-1. The E5052A is an INDOOR USE product.
NOTE	The LEDs in the E5052A are Class 1 in accordance with IEC60825-1, CLASS 1 LED PRODUCT
NOTE	This equipment is MEASUREMENT CATEGORY I (CAT I). Do not use for CAT II, III, or IV.
NOTE	This equipment is tested with stand-alone condition or with the combination with the accessories supplied by Agilent Technologies against the requirement of the standards described in the Declaration of Conformity. If it is used as a system component, compliance of related regulations and safety requirements are to be confirmed by the builder of the system.

- **Ground the Instrument**
To avoid electric shock, the instrument chassis and cabinet must be grounded with the supplied power cable's grounding prong.
- **DO NOT Operate in an Explosive Atmosphere**
Do not operate the instrument in the presence of inflammable gasses or fumes. Operation of any electrical instrument in such an environment clearly constitutes a safety hazard.
- **Keep Away from Live Circuits**
Operators must not remove instrument covers. Component replacement and internal adjustments must be made by qualified maintenance personnel. Do not replace components with the power cable connected. Under certain conditions, dangerous voltage levels may remain even after the power cable has been disconnected. To avoid injuries, always disconnect the power and discharge circuits before touching them.
- **DO NOT Service or Adjust the Instrument Alone**
Do not attempt internal service or adjustment unless another person, capable of rendering first aid and resuscitation, is present.
- **DO NOT Substitute Parts or Modify the Instrument**
To avoid the danger of introducing additional hazards, do not install substitute parts or perform unauthorized modifications to the instrument. Return the instrument to an Agilent Technologies Sales and Service Office for service and repair to ensure that

safety features are maintained in operational condition.

- Dangerous Procedure Warnings

Warnings, such as the example below, precede potentially dangerous procedures throughout this manual. Instructions contained in the warnings must be followed.

WARNING

Dangerous voltage levels, capable of causing death, are present in this instrument. Use extreme caution when handling, testing, and adjusting this instrument.

- Do not connect the measuring terminals to mains.

Safety Symbols

General definitions of safety symbols used on the instrument or in manuals are listed below.



Instruction Manual symbol: the product is marked with this symbol when it is necessary for the user to refer to the instrument manual.



Alternating current.



Direct current.



On (Supply).



Off (Supply).



In position of push-button switch.



Out position of push-button switch.



Frame (or chassis) terminal. A connection to the frame (chassis) of the equipment which normally include all exposed metal structure.



Stand-by.

WARNING

This warning sign denotes a hazard. It calls attention to a procedure, practice, condition or the like, which, if not correctly performed or adhered to, could result in injury or death to personnel.

CAUTION

This Caution sign denotes a hazard. It calls attention to a procedure, practice, condition or the like, which, if not correctly performed or adhered to, could result in damage to or destruction of part or all of the product.

NOTE

Note denotes important information. It calls attention to a procedure, practice, condition or the like, which is essential to highlight.

Certification

Agilent Technologies certifies that this product met its published specifications at the time of shipment from the factory. Agilent Technologies further certifies that its calibration measurements are traceable to the United States National Institute of Standards and Technology, to the extent allowed by the Institution's calibration facility, or to the calibration facilities of other International Standards Organization members.

Documentation Warranty

The material contained in this document is provided "as is," and is subject to being changed, without notice, in future editions. Further, to the maximum extent permitted by applicable law, Agilent disclaims all warranties, either express or implied with regard to this manual and any information contained herein, including but not limited to the implied warranties of merchantability and fitness for a particular purpose. Agilent shall not be liable for errors or for incidental or consequential damages in connection with the furnishing, use, or performance of this document or any information contained herein. Should Agilent and the user have a separate written agreement with warranty terms covering the material in this document that conflict with these terms, the warranty terms in the separate agreement will control.

Exclusive Remedies

The remedies provided herein are buyer's sole and exclusive remedies. Agilent Technologies shall not be liable for any direct, indirect, special, incidental, or consequential damages, whether based on contract, tort, or any other legal theory.

Assistance

Product maintenance agreements and other customer assistance agreements are available for Agilent Technologies products.

For any assistance, contact your nearest Agilent Technologies Sales and Service Office. Addresses are provided at the back of this manual.

Typeface Conventions

Sample (bold)

Boldface type is used when a term is defined or emphasised.

Sample (Italic)

Italic type is used for emphasis.

Sample key / [Sample] key

Indicates a hardkey (key on the front panel or external keyboard) labeled "Sample." "key" may be omitted.

Sample menu/button/box

Indicates a menu/button/box on the screen labeled "Sample" which can be selected/executed by clicking. "menu," "button," or "box" may be omitted.

Sample block/toolbar

Indicates a block (group of hardkeys) or a toolbar (setup toolbar) labeled "Sample."

Sample 1 - Sample 2 - Sample 3

Indicates a sequential operation of **Sample 1**, **Sample 2**, and **Sample 3** (menu, button, or box). "-" may be omitted.

1. General Information

Precautions	16
Software Installed	16
Organization of Service Guide	17
Instrument Covered by This Manual	19
Required Equipment	20

2. Performance Tests

Introduction	24
Test Equipment Required	24
Individual Test Description	25
1. RF IN Port VSWR Test	25
2. Frequency Measurement Test	28
3. Power Measurement Accuracy Test	37
4. SSB Phase Noise Sensitivity Test	47
5. SA Relative Level Accuracy Test	50
6. DC Power Voltage Test	56
7. DC Power Current Measurement Test	59
E5052A Performance Test Calculation Sheet	64
Introduction	64
SA Relative Level Accuracy Test	64
E5052A Performance Test Record	66
RF IN Port VSWR Test	66
Frequency Measurement Test	66
Power Measurement Accuracy Test	68
SSB Phase Noise Sensitivity Test (for Standard)	70
SSB Phase Noise Sensitivity Test (for Option 011)	70
SA Relative Level Accuracy Test	70
DC Power Voltage Test	72
DC Current Measurement Test	72

3. Adjustment

Safety Considerations	74
Warm-up for Adjustment	74
Required Equipment	74
Required Adjustment after Replacing Assembly	75
Writing ID	75
DC Control Voltage Adjustment	75
DC Power Voltage Adjustment	76
DC Power Current Adjustment	76
Reference Frequency Adjustment	76
Pre-LO Sampler PLL BW Adjustment	77
Receiver DC offset Adjustment	77
PM Offset Adjustment	77
PM Linearity Adjustment	78
PM Temp Adjustment	79
PM Flatness Adjustment	79
Receiver RF Flatness Adjustment	80

Contents

Receiver IF Gain/Flatness Adjustment	80
LO Sampler PLL BW Adjustment	81
Phase Noise BW Adjustment	81
4. Troubleshooting	
Introduction	84
How to exit from the E5052A Measurement View	85
To Troubleshoot the Instrument	86
Primary Trouble Isolation	86
No Display troubleshooting	88
Booting Process Troubleshooting	91
Troubleshooting Using Service Function	96
Power On Test	96
Contents of the power on test results	97
Power On Test Failure Troubleshooting	99
Function Specific Troubleshooting	100
To Check the Device Driver	101
To Check the Front Panel	103
To Check the Touch Panel	104
To Check the LCD	104
To Check the External Keyboard	105
To Check the Mouse	105
To Check the FDD	105
To Check the Video output	106
To Check the External Trigger Input	106
To Check the LAN	106
To Check the Printer Parallel/USB Port	110
To Check the GPIB	111
To Check the 24-bit I/O port	111
To Check the Ref Oven	111
To Check the USB (USBTMC) Interface Card	111
Performance test failure troubleshooting	112
Recommended adjustment for performance test failure	112
Adjustment failure troubleshooting	113
Performance test failure troubleshooting	113
To configure the A20 Digital Motherboard and BIOS	115
To Identify the Motherboard Installed	115
Configure the Motherboard	115
Testing DRAM on the Motherboard	115
To Confirm or Set the BIOS Options	116
5. Replaceable Parts	
Ordering Information	124
Direct Mail Order System	124
Exchange Assemblies	124
Replaceable Parts List	125
Power Cables and Plug Configurations	125
Top View (Major Assemblies) for Serial Prefix MY441	126

Top View (Major Assemblies) for Serial Prefix MY442	128
Top View (Cables) for Serial Prefix MY441.	130
Top View (Cables) for Serial Prefix MY442.	132
Top View (Miscellaneous Parts) for Serial Prefix MY441	134
Top View (Miscellaneous Parts) for Serial Prefix MY442	136
Top View (Under Power Supply)	138
Front View (Analog Boards)	139
Front View (Cables)	140
Front View (Miscellaneous)	141
Front Panel	142
Rear View for Serial Prefix MY441	144
Rear View for Serial Prefix MY442	145
Cover Assembly for Serial Prefix MY441	146
Cover Assembly for Serial Prefix MY442	147
PCI DSP Card and GPIB Card Assembly for Serial Prefix MY441	149
PCI DSP Card and GPIB Card Assembly for Serial Prefix MY442.	150
FDD Assembly	152
Mass Storage Disk Drive Assembly for Serial Prefix MY441	153
Removable Hard Disk Assembly for Serial Prefix MY442	154
Analog Mother Board Assembly.	156
Power Supply Assembly	157
Power Distribution and Oven Assembly.	158
Freq/Power Detector Module Attachment Assembly	159
DC Source Board Attachment Assembly	160
Local Synthesize Module Assembly.	161
Phase Detector Board Assembly.	162
Chassis Assembly	163
Front Assembly (Front Keyboard)	164
Front Assembly (LCD)	165
Front Assembly (Standby Switch / Cover)	166
Front Assembly (Inverter).	167
Front Assembly (Cover 1).	168
Front Assembly (Cover 2).	169
Label on Rear Face	170
Other Parts.	171
6. Replacement Procedure	
Replacing an Assembly	174
Required Tools	175
Outer Cover Removal.	176
Tools Required	176
Procedure.	176
Front Panel Removal	178
Tools required	178
Procedure.	178
A27 Mass storage Disk Drive Assembly Replacement	180
Tools Required	180
Save Backup Files to the PC.	180
Removal Procedure	180

Replacement Procedure	181
Restore Backup Files onto the New HDD	181
Adjustments for the New HDD	182
Calibration of the Touch Screen	182
A27 Removable Hard Disk Drive Replacement for E5052A Serial Prefix MY442 and above.	183
Tools Required	183
Save Backup Files to the PC.	183
Removal Procedure.	183
Replacement Procedure	184
Restore Backup Files onto the New HDD	185
Adjustments for the New HDD	185
Calibration of the Touch Screen	185
Removable Hard Disk Interface Board Removal for Serial Prefix MY442 and above.	187
Tools Required	187
Removal procedure.	187
Replacement Procedure	187
A28 FDD Replacement	189
Tools Required	189
Removal procedure.	189
Replacement Procedure	189
A50 Power Supply Assembly Replacement.	190
Tools Required	190
Removal Procedure.	190
Replacement Procedure	190
A25 24 Bit I/O Board Replacement	191
Tools Required	191
Removal Procedure.	191
Replacement Procedure	191
A20 Digital Motherboard Replacement	192
Tools Required	192
Removal Procedure.	192
Replacement Procedure	192
A1 Freq / Power Detector Module Replacement	194
Tools Required	194
Removal Procedure.	194
Replacement Procedure	194
A2 DC Source Board Replacement	195
Tools Required	195
Removal Procedure.	195
Replacement Procedure	196
A3 ADC/DSP Board Replacement.	197
Tools Required	197
Removal Procedure.	197
Replacement Procedure	197
A4/A5 Local Synthesize Module Replacement	198
Tools Required	198
Removal Procedure.	198
Replacement Procedure	198
A6 Phase Detector Board Replacement	199

Tools Required	199
Removal Procedure	199
Replacement Procedure	199
Fan Replacement	200
Tools Required	200
Removal Procedure	200
Replacement Procedure	200
A10 Analog Motherboard Replacement	201
Tools Required	201
Removal Procedure	201
Replacement Procedure	202
A12 Power Distribution Board Replacement	203
Tools Required	203
Removal Procedure	203
Replacement Procedure	203
A11 10 MHz Oven Replacement	204
Tools Required	204
Removal Procedure	204
Replacement Procedure	204
A21 PCI DSP / A24 GPIB Card Replacement	205
Tools Required	205
Removal Procedure	205
Replacement Procedure	205
A21 PCI DSP / A24 GPIB Card Replacement for Serial Prefix MY442 and above	207
Tools Required	207
Removal Procedure	207
Replacement Procedure	207
USB (USBTMC) Interface Card Replacement for E5052A Serial Prefix MY442 and above	209
Tools Required	209
Removal Procedure	209
Replacement Procedure	209
A22 Front Keyboard Replacement	211
Tools Required	211
Removal Procedure	211
Replacement Procedure	211
A52 Inverter Board Replacement	213
Tools Required	213
Removal Procedure	213
Replacement Procedure	213
A51 LCD Replacement	215
Tools Required	215
Removal Procedure	215
Replacement Procedure	215
LCD Backlight Replacement	217
Tools Required	217
Removal Procedure	217
Replacement Procedure	217
BNC Connector(front) Replacement	218
Tools Required	218

Removal Procedure	218
Replacement Procedure	219
7. Post-Repair Procedures	
Post-Repair Procedures	222
A. Manual Changes	
Manual Changes	226
B. System Recovery	
System Recovery	228
Types of system recoveries	228
Notes on executing system recovery	228
Procedure to execute the factory recovery	229
Procedure to create the user backup image	232
Procedure to execute the user recovery	235
Initial Registration of E5052A	238
Calibration of the Touch Screen	241
C. Firmware Update	
Firmware Update	244
Required Equipment	244
How to make E5052A Firmware Installation Disk	244
How to update the E5052A firmware	244
D. Computer Virus Check	
Computer Virus Check	250
Required equipment	250
How to check the drive C and F of E5052A	250
E. Power Requirement	
Power Supply and Blown Fuses	260
Verification of the power supply	260
Verification and connection of power cable	260
Blown fuses	262
Starting the E5052A	263
Turning the Power ON and OFF	263
Disconnection from supply source	264
F. Messages	
Error Messages	267
A	267
D	268
E	269
F	269
I	270
L	270

M 271
N 271
O 271
P 271
R 272
S 273
T 273
U 273

1 General Information

The Service Guide is a guide to servicing the E5052A Signal Source Analyzer. The guide contains information requisite to do performance tests, adjustments, troubleshooting, and repairs.

Precautions

This section describes cautions that must be observed in operating the E5052A.

Software Installed

The Windows operating system installed in this machine is customized for more effective operation, and has different functions that are not part of the Windows operating system for ordinary PCs (personal computers).

Therefore, do not attempt to use the system in ways other than those described in this manual or to install Windows-based software (including anti-virus software) for ordinary PCs as doing so may cause malfunctions.

Also note the followings.

- Do not update the Windows operating system installed in this machine to the Windows operating system for ordinary PCs. Doing so will cause malfunctions.
- Do not attempt to update VBA (Visual Basic for Applications) software installed in this machine to its equivalent developed for ordinary PCs. Doing so will cause malfunctions.
- Do not allow any computer virus to infect the system. This machine has no virus check function nor anti-virus software installed.

Agilent Technologies will not be held liable for any failure or damage arising from negligence regarding these prohibitions and warnings.

NOTE

If the pre-installed software is damaged somehow, resulting in errant behavior by the machine, perform a system recovery. For further details of system recovery, refer to Appendix B.

Organization of Service Guide

Tabs are used to divide the major chapter and appendix of this manual. The contents of each chapter and appendix in this manual is as follows;

Chapter 1 , “General Information,”

The Service Guide is a guide to servicing the E5052A Signal Source Analyzer. The guide contains information requisite to do performance tests, adjustments, troubleshooting, and repairs.

Chapter 2 , “Performance Tests,”

This chapter provides information on how to verify the E5052A performance.

Chapter 3 , “Adjustment,”

This chapter provides the adjustment information for the E5052A to ensure that it is within its specifications. The adjustment must be performed Agilent’s qualified service personnel. If you need the adjustment for your E5052A, it should be sent to the nearest Agilent Technologies service office.

Chapter 4 , “Troubleshooting,”

This chapter provides the procedure to isolate a faulty assembly in the E5052A.

Chapter 5 , “Replaceable Parts,”

This chapter contains information for ordering replacement parts for the E5052A.

Chapter 6 , “Replacement Procedure,”

This chapter provides procedure for removing and replacing the major assemblies in the E5052A.

Chapter 7 , “Post-Repair Procedures,”

This chapter lists the procedures required to verify the E5052A operation after an assembly is replaced with a new one.

Appendix A , “Manual Changes,”

This appendix contains the information required to adapt this manual to versions or configurations of the E5052A manufactured earlier than the current printing date of this manual. The information in this manual applies directly to E5052A units with the serial number that is printed on the title page of this manual.

Appendix B , “System Recovery,”

This appendix describes how to recover the operating system (Windows 2000) when the operating system has been damaged.

Appendix C , “Firmware Update,”

This appendix describes how to update the E5052A firmware. When you want to update the E5052A firmware, refer to this appendix.

General Information
Organization of Service Guide

Appendix D , “Computer Virus Check,”

This appendix describes an example of how to check the system of E5052A for computer viruses using computer viruses check software.

Appendix E , “Power Requirement,”

Appendix F, “Messages,”

The E5052A can display error messages as well as messages that indicate the internal operating status of the equipment. This appendix explains what these messages mean. They are listed in alphabetical order.

Instrument Covered by This Manual

Agilent Technologies uses a two-part, ten-character serial number label (See Figure 1-1) attached to the instrument's rear panel. The first five characters are the serial prefix and the last five digits are the suffix.

Figure 1-1

Serial Number Label Example



e5052apj029

An instrument manufactured after the printing date of this manual may have serial number prefix that is not listed on the title page. This unlisted serial number prefix indicates the instrument is different from those described in this manual. The manual for this new instrument may be accompanied by a yellow Manual Changes supplement or have a different manual part number. This sheet contains “change information” that explains how to adapt the manual to the newer instrument.

In addition to change information, the supplement may contain information for correcting errors (Errata) in the manual. To keep this manual as current and accurate as possible, Agilent Technologies recommends that you periodically request the latest Manual Changes supplement. The supplement for this manual is identified by this manual's printing data and is available from Agilent Technologies. If the serial prefix or number of an instrument is lower than that on the title page of this manual, see Appendix A, Manual Changes. For information concerning, a serial number prefix that is not listed on the title page or in the Manual change supplement, contact the nearest Agilent Technologies office.

Required Equipment

Table 1-1 lists the recommended equipment for performing maintenance on the E5052A.

Table 1-1 Recommended Test Equipment

Equipment	Critical specifications	Recommended Model	Qty.	Use* ¹
Signal Generator	Frequency: 10 MHz to 7 GHz Low SSB Phase Noise	Agilent E8257D W/opt. UNR, UNT	1	P,A
Network Analyzer	Frequency: 10 M to 3 GHz	Agilent E5070B/71B	1	P
Power Meter	No Substitute	Agilent E4419B	1	P,A
Power Sensor	No Substitute	Agilent 8481A	1	P,A
Power Amplifier	Gain: 35 dB, Freq range: 10M to 3 GHz	R&K A3000-2H-R	1	P,A
Power Amplifier	Gain: 35 dB, Freq range: 3 G to 7 GHz	Agilent 83020A	1	P,A
Multimeter	No Substitute	Agilent 3458A	1	P,A
Calibration Kit	Frequency: 10 M to 7 GHz	Agilent 85032F	1	P
Frequency Counter	Frequency: 10 MHz	Agilent 53181A w/Opt.010	1	T
Step Attenuator	Attenuator range: 0 dB to 50 dB Step: 10dB, Freq range: 10 M to 7 GHz	Agilent 8496H	1	P,A
Blocking Capacitor	No Substitute	Agilent 11742A	1	P,A
Power divider	No substitute	Agilent 11636A	1	P
Fixed attenuator (3 dB)	50 Ω, N(m)-N(f), 3 dB	Agilent 8491A w/Opt.003	2	P,A
Power Splitter	N(f) 50 Ω in, N(f) 50 Ω out	Agilent 11667A	1	P,A
Band Pass Filter	70 MHz, Band width 10 kHz	FILTRONETICS FN-2063M	1	P
Low Pass Filter	70 MHz	Mini-Circuits SLP-70	1	A
Resistor	141 Ω, 1 W	Agilent p/n 0698-3615 (47ohm), 3 ea	1	P, A
50 Ω Termination	50 Ω (N)	Agilent 909C wit Opt. 012	1	A
50 Ω Termination	50 Ω (BNC)	Agilent 11593A	1	A
Handler I/O Test Kit	No substitute	Agilent p/n E5070-65001	1	T

Table 1-1 Recommended Test Equipment

Equipment	Critical specifications	Recommended Model	Qty.	Use *1
Cable	BNC(m)-BNC(m) Cable, 61 cm	Agilent p/n 8120-1839	2	P,A,T
	BNC(m)-BNC(m) Cable, 122 cm	Agilent p/n 8120-1840	2	P,A
	Coaxial cable with Type-N (m) connectors, 61 cm (24 in)	Agilent N6314A (p/n 8120-8862)	4	P,A
Adapter	N(f)-SMA(m) Adapter	Agilent p/n 1250-1562	2	P,A
	N(f)-N(f) Adapter	Agilent p/n 1250-0777	1	P,A
	N(m)-N(m) Adapter	Agilent p/n 1250-1475	1	P,A
	N(f)-BNC(m) Adapter	Agilent p/n 1250-1477	1	P
	BNC Tee Adapter	Agilent p/n 1250-0781	1	A
	Dual Banana-BNC(f)	Agilent p/n 1251-2277	1	P,A
Torque Wrench	Size: 3/4 inch Torque: 136 N-cm	Agilent p/n 8710-1766	1	P,A
Personal Computer with GPIB board	Windows 2000, VEE 6.0		1	A

*1.P: Performance Tests, A: Adjustment, T: Troubleshooting

Table 1-2 Alternative Test Equipment

Equipment	Critical specifications	Model	Qty.	Use *1
Signal Generator	Frequency: 10 MHz to 7 GHz Low SSB Phase Noise	Agilent E8257C w/Opt. UNR, UNT	1	P,A
Network Analyzer	Frequency: 10 M to 3 GHz	Agilent 8753ES	1	P
Multimeter	No Substitute	Agilent 34401A	1	P,A
Power Meter	No Substitute	Agilent E4419A	1	P,A
Step Attenuator	Attenuator range: 0 dB to 50 dB Step: 10dB, Freq range: 10 M to 7 GHz	Agilent 8495H	1	P,A

*1.P: Performance Tests, A: Adjustment, T: Troubleshooting

General Information
Required Equipment

2 Performance Tests

This chapter provides information on how to verify the E5052A performance.

Introduction

This chapter provides the performance tests procedures for Agilent E5052A. The performance test names are listed in Table 2-1. The test procedures are described sequentially in the following pages.

NOTE Allow the analyzer to warm up for at least 30 minutes before you execute any of the performance tests.

Perform all performance tests in an ambient temperature of 23 ± 5 °C

NOTE The performance tests should be performed periodically. The recommended test interval is 12 months.

The test interval depends on maintenance and the environmental conditions under which the instrument is used. You may find that the interval could be shortened or lengthened; however, such a decision should be based on substantial quantitative data.

Table 2-1 List of the E5052A performance tests

Para.	Title
1	RF IN Port VSWR Test
2	Frequency Measurement Test
3	Power Measurement Accuracy Test
4	SSB Phase Noise Sensitivity Test
5	SA Relative Level Accuracy Test
6	DC Power Voltage Test
7	DC Power Current Measurement Test

Test Equipment Required

The required equipment for the performance test is listed in Table 1-1 and Table 1-2. Use only calibrated equipment when doing the performance test.

Individual Test Description

1. RF IN Port VSWR Test

Description

This test checks the VSWR of the E5052A's RF IN port with a network analyzer. The VSWR is checked at 10 MHz to 3 GHz.

Specification

@23 ± 5 °C

VSWR	< 1.6 @ 10 MHz to 30 MHz
	< 1.2 @ 30 MHz to 2 GHz
	< 1.3 @ 2 GHz to 3 GHz

Test equipment

Network Analyzer	Agilent E5070B/5071B
Calibration Kit	Agilent 85032F
N(m)-N(m) cable, 61 cm	Agilent N6314A(p/n 8120-8862)

Procedure

Step 1. Preset the Network Analyzer. Then set the Network Analyzer as follows.

Parameter	Value
Measurement Mode	S11
Cal Kit	85032F
Trigger Sweep	Hold
Sweep Type	Segment
Source Power	0 dBm, ON
Data Format	SWR
Maker Display	ON
Search Range	ON

Performance Tests
Individual Test Description

Step 2. Set the values as shown below.

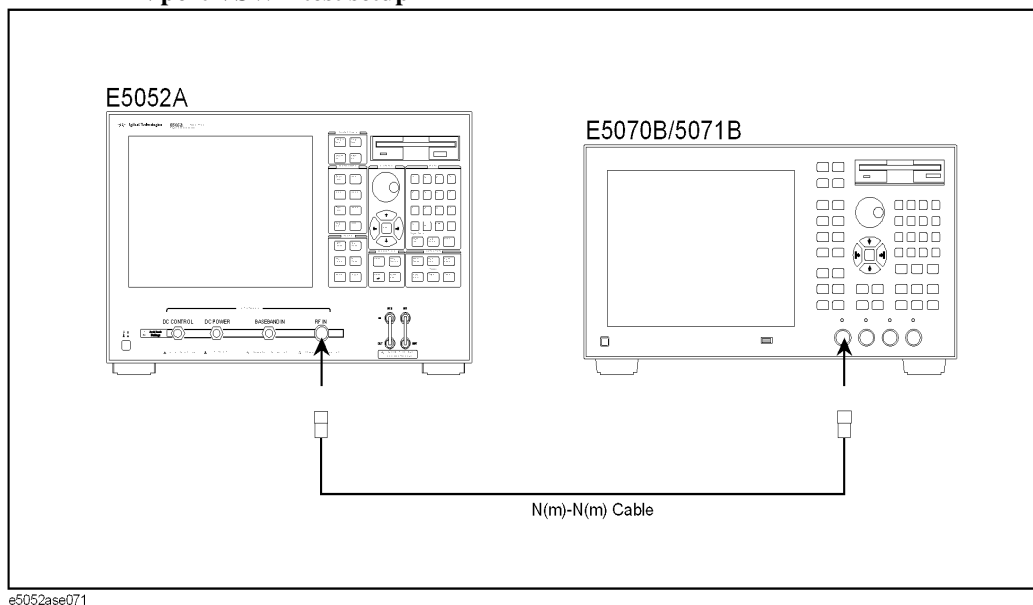
Table 2-2 Network Analyzer Segment Table

Segment Number	Start Frequency	Stop Frequency	point	Power
1	10 MHz	39.5 MHz	60	10 dBm
2	40 MHz	99 MHz	60	10 dBm
3	100 MHz	3 GHz	294	10 dBm

Step 3. Perform the 1-port calibration for port 1. The calibration kit (open/short/load) is connected to the end of the N-N cable connected to port 1.

Step 4. Connect the test equipment as shown in Figure 2-1.

Figure 2-1 RF IN port VSWR test setup



NOTE

Figure 2-1 shows the test setup for the Network Analyzer with 4-port option (opt. 413/414).

For 2-port and 3-port options (opt. 213/214/313/314), connect the N(m)-N(m) cable to port 1 as well.

Step 5. Press **[Preset] - Factory** to initialize the E5052A, then set the E5052A as follows. In case of installing the firmware revision 1.00/1.10, press **[Preset] - OK**.

Setting

Attenuator : 0 dB

Operation

[Attn] - Input Attenuator - [0] - [x1]

Step 6. Make the single sweep measurement for the Network Analyzer.

Step 7. Set the start frequency and the end frequency of the marker search range shown in Table 2-3.

Table 2-3 Network Analyzer Search Range Table

Search Position	Start Frequency	Stop Frequency
1	10 MHz	30 MHz
2	30 MHz	2 GHz
3	2 GHz	3 GHz

Step 8. Make the search of maximum for the Network Analyzer.

Step 9. Record the VSWR in the Performance Test Record.
(“Test result“ column for the RF input impedance test)

Step 10. Set the E5052A as follows, and repeat Step 6 through 9.

Setting

Attenuator : 5 dB

Operation

[Attn] - Input Attenuator - [5] - [x1]

2. Frequency Measurement Test

Description

This test checks the frequency measurement accuracy of the E5052A. The frequency measurement is checked for each frequency band and each frequency resolution of the E5052A

Specification

@23 ± 5 °C

Frequency accuracy ± (resolution + time base accuracy) @ 10 MHz to 7 GHz
 Frequency Resolution: 10 Hz, 1 kHz, and 64 kHz
 Internal time base stability: ±5 ppm

Test equipment

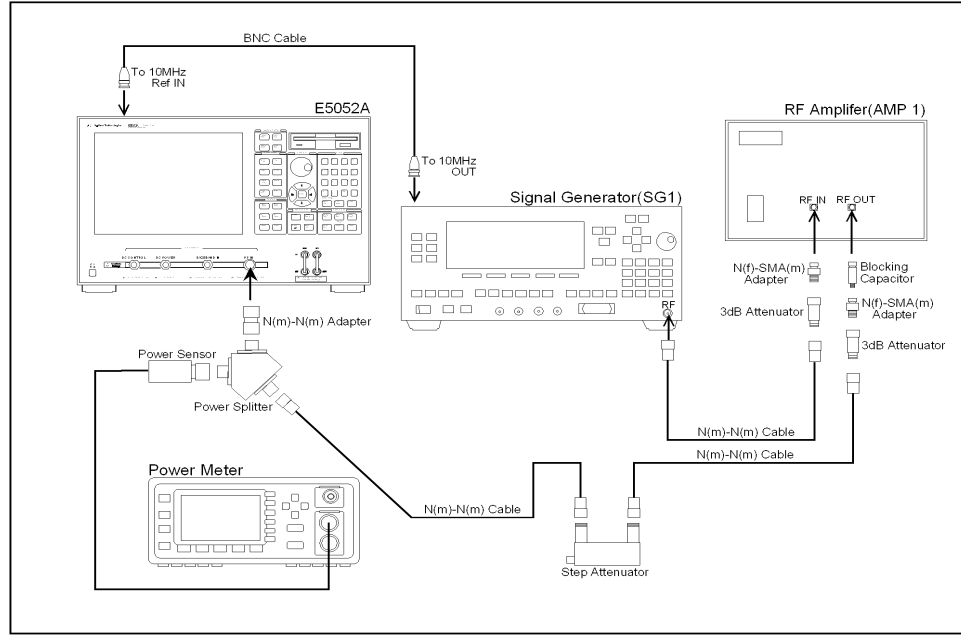
Signal Generator	Agilent E8257D
RF Amplifier (AMP 1)	R&K A3000-2H-R
RF Amplifier (AMP 2)	Agilent 83020A
Power Meter	Agilent E4419B
Power Sensor	Agilent 8481A
Step Attenuator	Agilent 8496H
Power Splitter	Agilent 11667A
Blocking Capacitor	Agilent 11742A
N(f)-SMA(m) adapter, 2 ea.	Agilent p/n 1250-1562
3 dB Fixed Attenuator, 2 ea.	Agilent 8491A Opt.003
N(m)-N(m) cable 61cm, 3 ea.	Agilent N6314A (p/n 8120-8862)
N(m)-N(m) Adapter	Agilent p/n 1250-1475
BNC cable, 122cm	Agilent p/n 8120-1840

Procedure for Standard

- Step 1.** Connect the power sensor to the power meter. Perform the zero adjustment and the calibration for the power meter.
- Step 2.** Connect the test equipment as shown in Figure 2-2

Figure 2-2

Frequency Measurement Test setup 1 for Standard



2. Performance Test

Step 3. Press **[Preset] - Factory** to initialize the E5052A, then set the E5052A as follows. In case of installing the firmware revision 1.00/1.10, press **[Preset] - OK**.

E5052A settings

- Measurement View : FP-Freq
- Mode : Tester
- Trigger Mode : Hold
- Attenuator : 0 dB
- Averaging Factor : 10
- Averaging : ON
- Averaging Trigger : ON

Key strokes

- [Meas/View] - Freq & Power**
- [Trigger] - Mode - Tester**
- [Trigger] - Trigger to Freq & Power - Hold**
- [Attn] - Input Attenuator - [0] - [x1]**
- [Avg/BW] - Ave Factor - [1] - [0] - [x1]**
- [Ave-BW] - Averaging - ON**
- [Trigger] - Ave Trigger - ON**

Step 4. Preset the Signal Generator.

Step 5. Turn on the power of AMP1.

Step 6. Set the E5052A as follows.

E5052A settings

- Frequency Band : 10 M - 1.5 GHz
- Frequency Resolution : 64 kHz
- Trigger Mode : Continuous

Key strokes

- [Setup] - Frequency Band - 10M-1.5GHz**
- [Setup] - Frequency Resolution - 64kHz**
- [Trigger] - Single**

Performance Tests
Individual Test Description

Step 7. Set the Signal Generator, Power Meter and Step Attenuator as follows.

Instrument	Setting
Signal Generator	Frequency : 10 MHz Power : -15 dBm , RF Output : ON
Power Meter	Frequency : 10 MHz
Step Attenuator	Attenuator : 40 dB

Step 8. Adjust the signal generator output level until the Power Meter reading is -15 dBm ± 0.1 dB.

NOTE The output level changes with setting conditions.
Refer to the Table 2-4.

Step 9. Set the E5052A as follows.

E5052A settings	Key strokes
Trigger Mode : Hold	[Trigger] - Hold

Step 10. Note the E5052A reading as frequency.

Test Result (Hz) = E5052A reading (Freq) - Test Frequency

Record the calculated test result on the Performance Test Record.

Step 11. Set the Signal Generator output mode “OFF”.

Step 12. Set each conditions for E5052A, Signal Generator, Power Meter and Step Attenuator in accordance with the Table 2-4, and repeat Step 6 through 11.

Table 2-4 Frequency Measurement Test Point 1 for Standard

E5052A			Signal Generator		Power Meter		Step ATT
ATT [dB]	Freq Resolution [Hz]	Freq Band [Hz]	Freq [Hz]	Power [dBm]	Freq [Hz]	Target Level [dBm]	ATT [dB]
0	64 k	10 M - 1.5 G	10 M	-4	10 M	-15	40
	1 k						
	10						
0	64 k	10 M - 1.5 G	30 M	-4	30 M	-20	40
	1 k						
	10						

Table 2-4 Frequency Measurement Test Point 1 for Standard

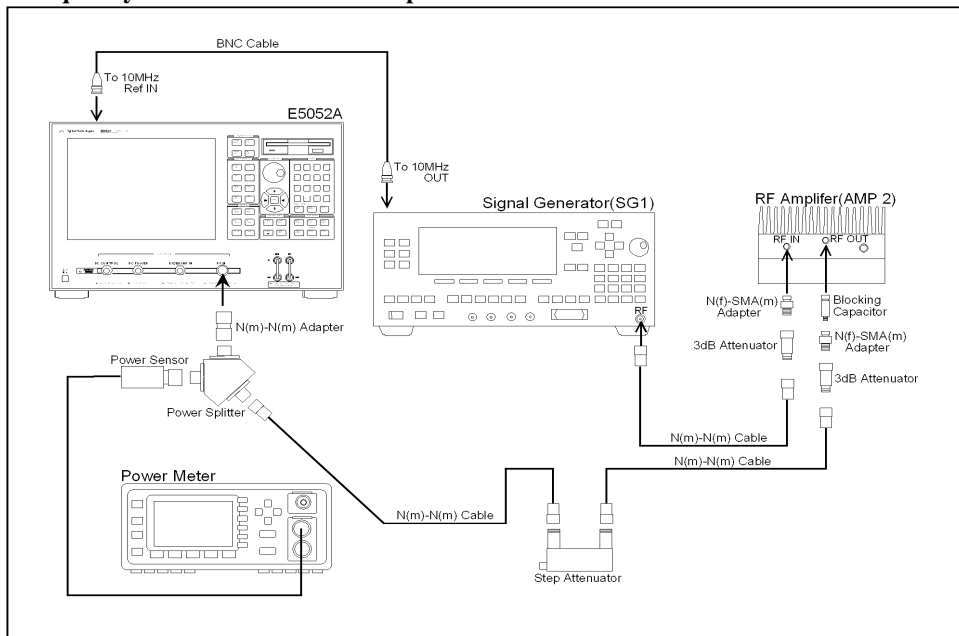
E5052A			Signal Generator		Power Meter		Step ATT
ATT [dB]	Freq Resolution [Hz]	Freq Band [Hz]	Freq [Hz]	Power [dBm]	Freq [Hz]	Target Level [dBm]	ATT [dB]
0	64 k	10 M - 1.5 G	1.5 G	-4	1.5 G	-20	40
	1 k						
	10						
15	64 k	10 M - 1.5 G	10 M	-6	10 M	+20	0
	1 k						
	10						
15	64 k	10 M - 1.5 G	1.5 G	-6	1.5 G	+20	0
	1 k						
	10						
0	64 k	300 M - 7 G	300 M	-4	300 M	-20	40
	1 k						
	10						
15	64 k	300 M - 7 G	300 M	-6	300 M	+20	0
	1 k						
	10						

Step 13. Turn off the power of AMP1.

Step 14. Connect the test equipment as shown in Figure 2-3

Figure 2-3

Frequency Measurement Test setup 2 for Standard



Step 15. Turn on the power of AMP2.

Step 16. Set each conditions for E5052A, Signal Generator, Power meter and Step ATT in accordance with the Table 2-5, and repeat Step 6 through 11.

Table 2-5

Frequency Measurement Test Point 2 for Standard

E5052A			Signal Generator		Power Meter		Step ATT
ATT [dB]	Freq Resolution [Hz]	Freq Band [Hz]	Freq [Hz]	Power [dBm]	Freq [Hz]	Target Level [dBm]	ATT [dB]
0	64 k	300 M - 7 G	7 G	-4	7 G	-20	40
	1 k						
	10						
15	64 k	300 M - 7 G	7 G	-6	7 G	+20	0
	1 k						
	10						

Step 17. Turn off the power of AMP2.

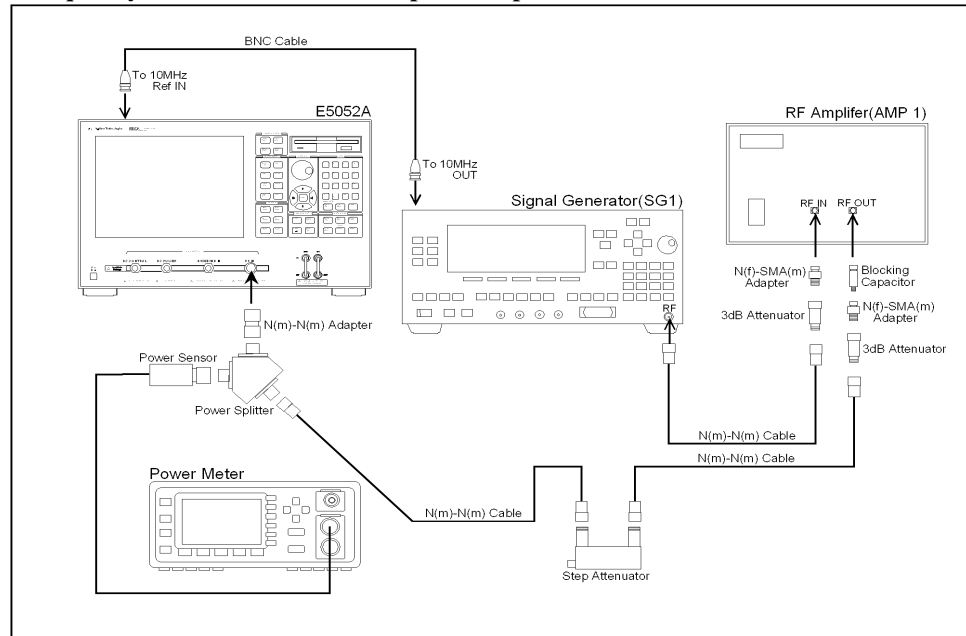
Procedure for Option 011

Step 1. Connect the power sensor to the power meter. Perform the zero adjustment and the calibration for the power meter.

Step 2. Connect the test equipment as shown in Figure 2-4

Figure 2-4

Frequency Measurement Test setup 1 for Option 011



Step 3. Press **[Preset] - Factory** to initialize the E5052A, then set the E5052A as follows. In case of installing the firmware revision 1.00/1.10, press **[Preset] - OK**.

E5052A settings

Measurement View : FP
Trigger Mode : Hold
Attenuator : 0 dB
Averaging Factor : 10
Averaging : ON
Averaging Trigger : ON

Key strokes

[Meas/View] - Freq & Power
[Trigger] - Trigger to Freq & Power - Hold
[Atten] - Input Attenuator - [0] - [x1]
[Ave/BW] - Ave Factor - [1] - [0] - [x1]
[Ave-BW] - Averaging - ON
[Trigger] - Ave Trigger - ON

Step 4. Preset the Signal Generator.

Step 5. Turn on the power of AMP1.

Step 6. Set the E5052A as follows.

E5052A settings

Frequency Band : 10 M - 1.5 GHz
Frequency Resolution : 64 kHz
Trigger Mode : Continuous

Key strokes

[Setup] - Frequency Band - 10M-1.5GHz
[Setup] - Frequency Resolution - 64kHz
[Trigger] - Single

Performance Tests
Individual Test Description

Step 7. Set the Signal Generator, Power Meter and Step Attenuator as follows.

Instrument	Setting
Signal Generator	Frequency : 10 MHz Power : -15 dBm , RF Output : ON
Power Meter	Frequency : 10 MHz
Step Attenuator	Attenuator : 40 dB

Step 8. Adjust the signal generator output level until the Power Meter reading is -15 dBm ± 0.1 dB.

NOTE The output level changes with setting conditions.
Refer to the Table 2-6.

Step 9. Set the E5052A as follows.

E5052A settings	Key strokes
Trigger Mode : Hold	[Trigger] - Hold

Step 10. Note the E5052A reading as Frequency.

Test Result (Hz) = E5052A reading (Frequency) - Test Frequency
Record the calculated test result on the Performance Test Record.

Step 11. Set the Signal Generator output mode “OFF”.

Step 12. Set each conditions for E5052A, Signal Generator, Power Meter and Step Attenuator in accordance with the Table 2-6, and repeat Step 6 through 11.

Table 2-6 Frequency Measurement Test Point 1 for Option 011

E5052A			Signal Generator		Power Meter		Step ATT
ATT [dB]	Freq Resolution [Hz]	Freq Band [Hz]	Freq [Hz]	Power [dBm]	Freq [Hz]	Target Level [dBm]	ATT [dB]
0	64 k	10 M - 1.5 G	10 M	-4	10 M	-15	40
	1 k						
	10						
0	64 k	10 M - 1.5 G	30 M	-4	30 M	-20	40
	1 k						
	10						

Table 2-6 Frequency Measurement Test Point 1 for Option 011

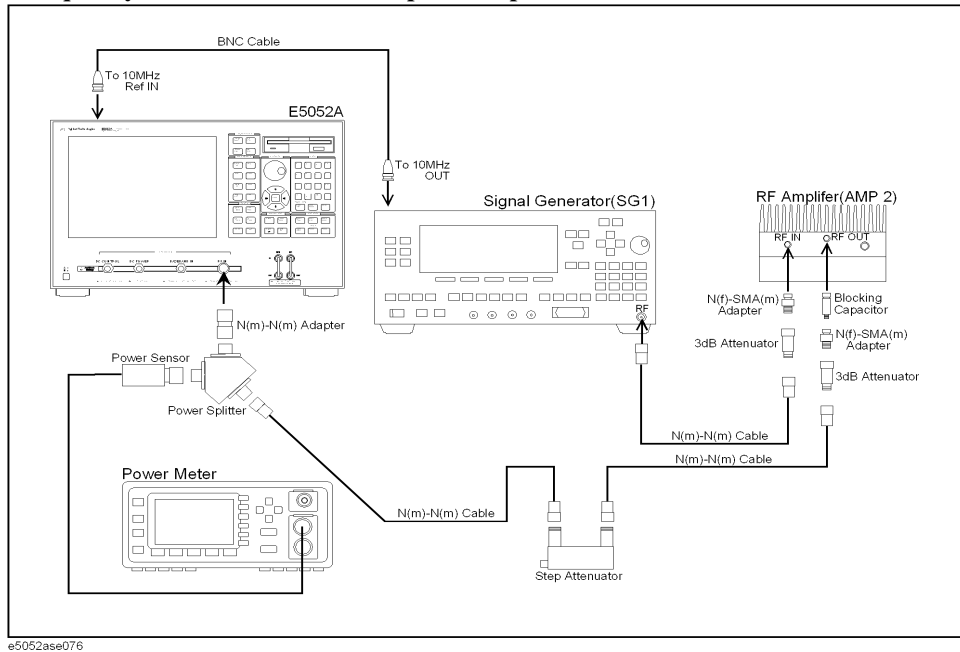
E5052A			Signal Generator		Power Meter		Step ATT
ATT [dB]	Freq Resolution [Hz]	Freq Band [Hz]	Freq [Hz]	Power [dBm]	Freq [Hz]	Target Level [dBm]	ATT [dB]
0	64 k	10 M - 1.5 G	1.5 G	-4	1.5 G	-20	40
	1 k						
	10						
15	64 k	10 M - 1.5 G	10 M	-6	10 M	+20	0
	1 k						
	10						
15	64 k	10 M - 1.5 G	1.5 G	-6	1.5 G	+20	0
	1 k						
	10						
0	64 k	300 M - 7 G	300 M	-4	300 M	-20	40
	1 k						
	10						
15	64 k	300 M - 7 G	300 M	-6	300 M	+20	0
	1 k						
	10						

Step 13. Turn off the power of AMP1.

Step 14. Connect the test equipment as shown in Figure 2-5

Figure 2-5

Frequency Measurement Test setup 2 for Option 011



Step 15. Turn on the power of AMP2.

Step 16. Set each conditions for E5052A, Signal Generator, Power meter and Step ATT in accordance with the Table 2-7, and repeat Step 6 through 11.

Table 2-7

Frequency Measurement Test Point 2 for Option 011

E5052A			Signal Generator		Power Meter		Step ATT
ATT [dB]	Freq Resolution [Hz]	Freq Band [Hz]	Freq [Hz]	Power [dBm]	Freq [Hz]	Target Level [dBm]	ATT [dB]
0	64 k	300 M - 7 G	7 G	-4	7 G	-20	40
	1 k						
	10						
15	64 k	300 M - 7 G	7 G	-6	7 G	+20	0
	1 k						
	10						

Step 17. Turn off the power of AMP2.

3. Power Measurement Accuracy Test

Description

This test checks the RF power measurement accuracy of the E5052A. The measurement power level for this test is set at -20 dBm to 20 dBm in 10 dB step.

Specification

@23 ± 5 °C

Accuracy (Peak Voltage Response) ± 0.5 dB @ 30 MHz to 3 GHz, > -10 dBm
± 1 dB @ < 30MHz, or > 3 GHz, or ≤ -10 dBm

Test equipment

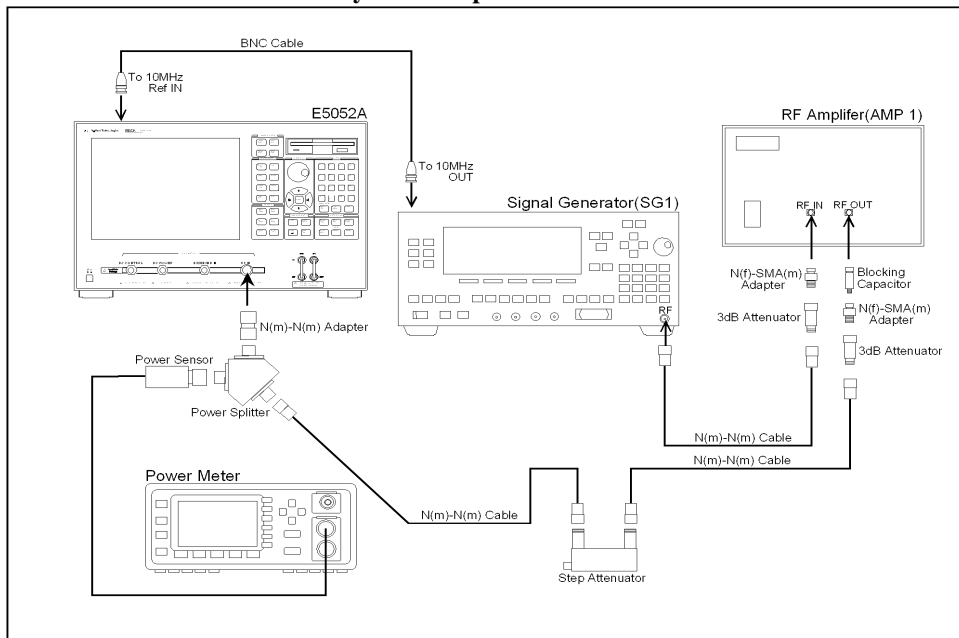
Signal Generator	Agilent E8257D
RF Amplifier (AMP 1)	R&K A3000-2H-R
RF Amplifier (AMP 2)	Agilent 83020A
Power Meter	Agilent E4419B
Power Sensor	Agilent 8481A
Step Attenuator	Agilent 8496H
Power Splitter	Agilent 11667A
Blocking Capacitor	Agilent 11742A
N(f)-SMA(m) adapter, 2 ea.	Agilent p/n 1250-1562
3 dB Fixed Attenuator, 2 ea.	Agilent 8491A Opt.003
N(m)-N(m) cable 61cm, 3 ea.	Agilent N6314A (p/n 8120-8862)
N(m)-N(m) Adapter	Agilent p/n 1250-1475
BNC cable, 122cm	Agilent p/n 8120-1840

Procedure for Standard

- Step 1.** Connect the power sensor to the power meter. Perform the zero adjustment and the calibration for the power meter.
- Step 2.** Connect the test equipment as shown in Figure 2-6.

Figure 2-6

Power Measurement Accuracy Test setup 1 for Standard



Step 3. Press **[Preset] - Factory** to initialize the E5052A, then set the E5052A as follows. In case of installing the firmware revision 1.00/1.10, press **[Preset] - OK**.

E5052A settings	Key strokes
Measurement View : FP-Power	[Meas/View] - Freq & Power
Mode : Tester	[Trigger] - Mode - Tester
Trigger Mode : Hold	[Trigger] - Trigger to Freq & Power - Hold

Step 4. Preset the Signal Generator and Power Meter.

Step 5. Turn on the power of AMP1.

Step 6. Set the E5052A as follows.

E5052A settings	Key strokes
Frequency Band : 10 M - 1.5 GHz	[Setup] - Frequency Band - 10M-1.5GHz
Attenuator : 0 dB	[Attn] - Input Attenuator - [0] - [x1]
Trigger Mode : Continuous	[Trigger] - Continuous

NOTE

When measurement frequency is 300 MHz to 7 GHz, set Frequency Band of the E5052A to [300M - 7GHz].

Step 7. Set the Signal Generator, Power Meter and Step Attenuator as follows.

Instrument	Setting
Signal Generator	Frequency : 1 GHz Power : -20 dBm , RF Output : ON
Power Meter	Frequency : 1 GHz
Step Attenuator	Attenuator : 30 dB

Step 8. Adjust the signal generator output level until the power meter reading is -20 dBm ± 0.1 dB.

NOTE

The output level changes with setting conditions.

When AMP1 is used, refer to the Table 2-8.

When AMP2 is used, refer to the Table 2-9.

Step 9. Press **[Trigger] - Hold** to make a measurement.

Step 10. Note the E5052A reading as Power.

Test Result (dB) = E5052A reading (Power) - Power Meter reading

Record the calculated test result on the Performance Test Record.

Step 11. Set the Signal Generator output mode “OFF”.

Step 12. Set each conditions for E5052A, Signal Generator, Power Meter and Step ATT in accordance with the Table 2-8, and repeat Step 6 through 11.

Table 2-8

Power Measurement Accuracy Test Point 1 for Standard

E5052A		Signal Generator		Power Meter		Step ATT
ATT [dB]	Freq Band [Hz]	Power [dBm]	Freq [Hz]	Freq [Hz]	Target Level [dBm]	ATT [dB]
0	300 M - 7 G	-4	2.0125 G	2.0125 G	-20	40
0	10 M - 1.5 G	-4	10 M	10 M	-10	30
0	10 M - 1.5 G		1 G	1 G		30
0	300 M - 7 G		2.0125 G	2.0125 G		30
0	10 M - 1.5 G	-4	10 M	10 M	0	20
0	10 M - 1.5 G		1 G	1 G		20
0	300 M - 7 G		2.0125 G	2.0125 G		20

Table 2-8 Power Measurement Accuracy Test Point 1 for Standard

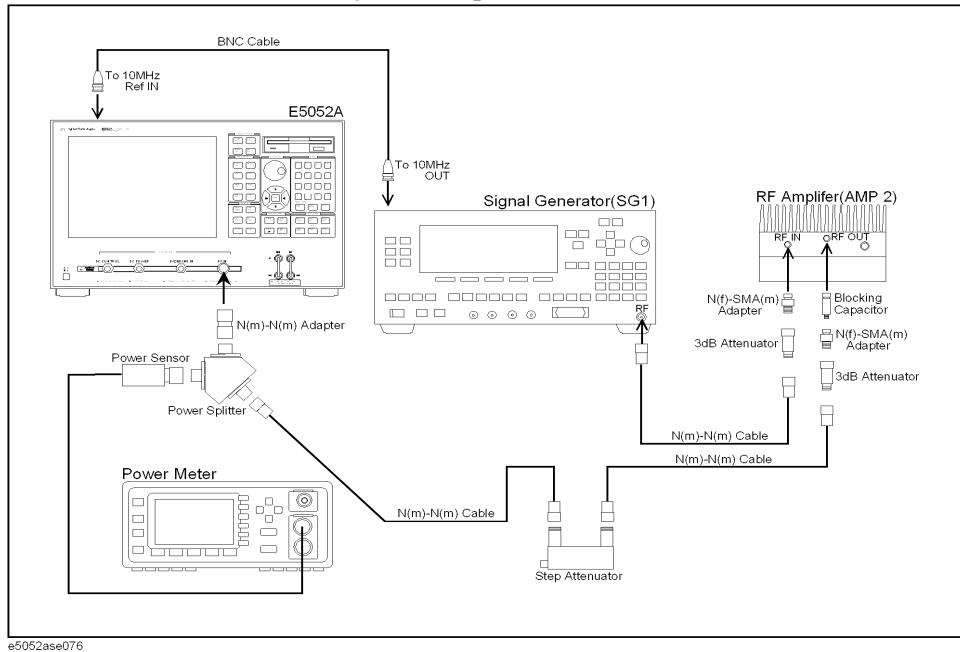
E5052A		Signal Generator		Power Meter		Step ATT
ATT [dB]	Freq Band [Hz]	Power [dBm]	Freq [Hz]	Freq [Hz]	Target Level [dBm]	ATT [dB]
5	10 M - 1.5 G	-4	10 M	10 M	+10	10
5	10 M - 1.5 G		1 G	1 G		10
5	300 M - 7 G		2.0125 G	2.0125 G		10
15	10 M - 1.5 G	-6	10 M	10 M	+20	0
15	10 M - 1.5 G		1 G	1 G		0
15	300 M - 7 G		2.0125 G	2.0125 G		0

Step 13. Turn off the power of AMP1.

Step 14. Connect the test equipment as shown in Figure 2-7

Figure 2-7

Power Measurement Accuracy Test setup 2 for Standard



Step 15. Turn on the power of AMP2.

Step 16. Set each conditions for E5052A, Signal Generator, Power meter and Step ATT in accordance with the Table 2-9, and repeat Step 6 through 10.

Table 2-9 Power Measurement Accuracy Test Point 2 for Standard

E5052A		Signal Generator		Power Meter		Step ATT
ATT [dB]	Freq Band [Hz]	Power [dBm]	Freq [Hz]	Freq [Hz]	Target Level [dBm]	ATT [dB]
0	300 M - 7 G	-4	3.0125 G	3.0125 G	-20	40
0	300 M - 7 G		4.0125 G	4.0125 G		40
0	300 M - 7 G		5.0125 G	5.0125 G		40
0	300 M - 7 G		6.0125 G	6.0125 G		40
0	300 M - 7 G		7 G	7 G		40
0	300 M - 7 G	-4	3.0125 G	3.0125 G	-10	30
0	300 M - 7 G		4.0125 G	4.0125 G		30
0	300 M - 7 G		5.0125 G	5.0125 G		30
0	300 M - 7 G		6.0125 G	6.0125 G		30
0	300 M - 7 G		7 G	7 G		30
0	300 M - 7 G	-4	3.0125 G	3.0125 G	0	20
0	300 M - 7 G		4.0125 G	4.0125 G		20
0	300 M - 7 G		5.0125 G	5.0125 G		20
0	300 M - 7 G		6.0125 G	6.0125 G		20
0	300 M - 7 G		7 G	7 G		20
5	300 M - 7 G	-4	3.0125 G	3.0125 G	+10	10
5	300 M - 7 G		4.0125 G	4.0125 G		10
5	300 M - 7 G		5.0125 G	5.0125 G		10
5	300 M - 7 G		6.0125 G	6.0125 G		10
5	300 M - 7 G		7 G	7 G		10
15	300 M - 7 G	-6	3.0125 G	3.0125 G	+20	0
15	300 M - 7 G		4.0125 G	4.0125 G		0
15	300 M - 7 G		5.0125 G	5.0125 G		0
15	300 M - 7 G		6.0125 G	6.0125 G		0
15	300 M - 7 G		7 G	7 G		0

Performance Tests
Individual Test Description

Step 17. Turn off the power of AMP2.

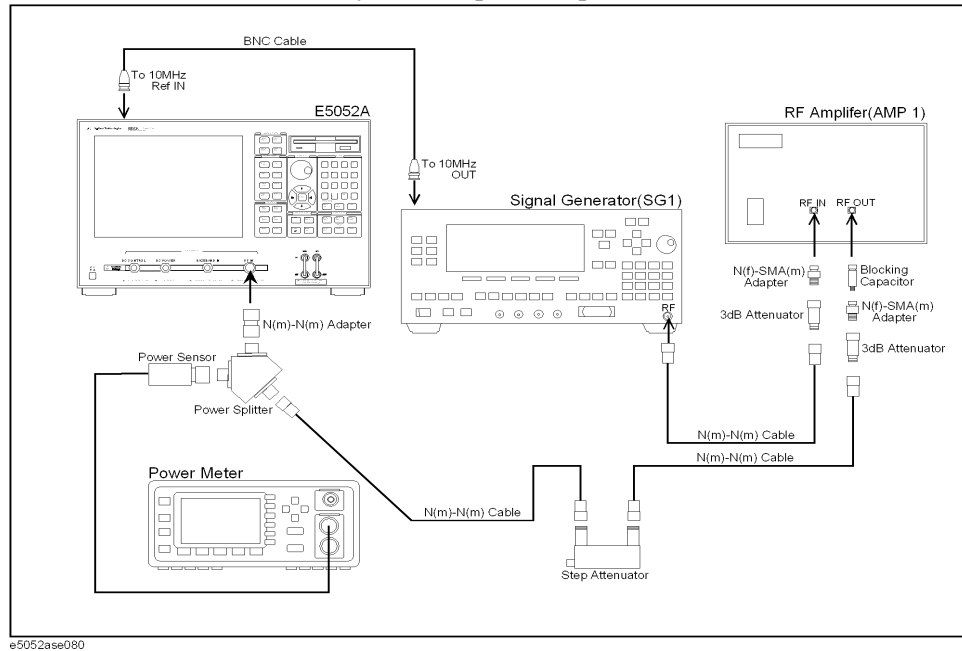
Procedure for Option 011

Step 1. Connect the power sensor to the power meter. Perform the zero adjustment and the calibration for the power meter.

Step 2. Connect the test equipment as shown in Figure 2-8

Figure 2-8

Power Measurement Accuracy Test setup 1 for Option 011



Step 3. Press **[Preset] - Factory** to initialize the E5052A, then set the E5052A as follows. In case of installing the firmware revision 1.00/1.10, press **[Preset] - OK**.

E5052A settings	Key strokes
Measurement View : FP-Power	[Meas/View] - Freq & Power
Trigger Mode : Hold	[Trigger] - Trigger to Freq & Power - Hold

Step 4. Preset the Signal Generator and Power Meter.

Step 5. Turn on the power of AMP1.

Step 6. Set the E5052A as follows.

E5052A settings	Key strokes
Frequency Band : 10 M - 1.5 GHz	[Setup] - Frequency Band - 10M-1.5GHz
Attenuator : 0 dB	[Attn] - Input Attenuator - [0] - [x1]
Trigger Mode : Continuous	[Trigger] - Continuous

NOTE When measurement frequency is 300 MHz to 7 GHz, set Frequency Band of the E5052A to [300M - 7GHz].

Step 7. Set the Signal Generator, Power Meter and Step Attenuator as follows.

Instrument	Setting
Signal Generator	Frequency : 1 GHz Power : -20 dBm , RF Output : ON
Power Meter	Frequency : 1 GHz
Step Attenuator	Attenuator : 30 dB

Step 8. Adjust the signal generator output level until the power meter reading is $-20 \text{ dBm} \pm 0.1 \text{ dB}$.

NOTE The output level changes with setting conditions.
When AMP1 is used, refer to the Table 2-10.
When AMP2 is used, refer to the Table 2-11.

Step 9. Press **[Trigger] - Hold** to make a measurement.

Step 10. Note the E5052A reading as Power.

Test Result (dB) = E5052A reading (Power) - Power Meter reading

Record the calculated test result on the Performance Test Record.

Step 11. Set the Signal Generator output mode “OFF”.

Step 12. Set each conditions for E5052A, Signal Generator, Power Meter and Step ATT in accordance with the Table 2-10, and repeat Step 6 through 11.

Table 2-10 Power Measurement Accuracy Test Point 1 for Option 011

E5052A		Signal Generator		Power Meter		Step ATT
ATT [dB]	Freq Band [Hz]	Power [dBm]	Freq [Hz]	Freq [Hz]	Target Level [dBm]	ATT [dB]
0	300 M - 7 G	-4	2.0125 G	2.0125 G	-20	40
0	10 M - 1.5 G	-4	10 M	10 M	-10	30
0	10 M - 1.5 G		1 G	1 G		30
0	300 M - 7 G		2.0125 G	2.0125 G		30

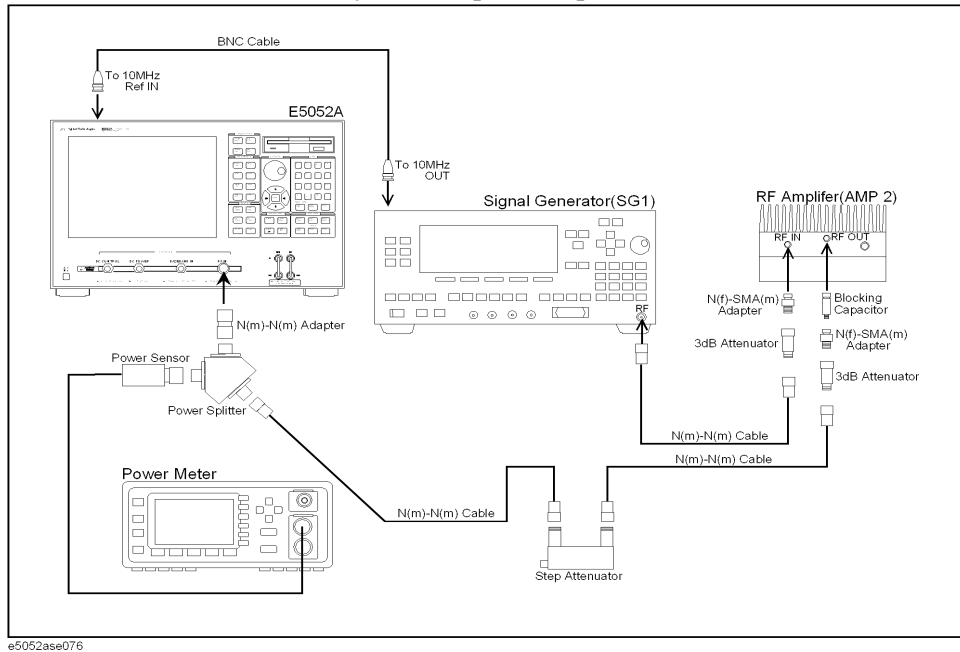
Table 2-10 Power Measurement Accuracy Test Point 1 for Option 011

E5052A		Signal Generator		Power Meter		Step ATT
ATT [dB]	Freq Band [Hz]	Power [dBm]	Freq [Hz]	Freq [Hz]	Target Level [dBm]	ATT [dB]
0	10 M - 1.5 G	-4	10 M	10 M	0	20
0	10 M - 1.5 G		1 G	1 G		20
0	300 M - 7 G		2.0125 G	2.0125 G		20
5	10 M - 1.5 G	-4	10 M	10 M	+10	10
5	10 M - 1.5 G		1 G	1 G		10
5	300 M - 7 G		2.0125 G	2.0125 G		10
15	10 M - 1.5 G	-6	10 M	10 M	+20	0
15	10 M - 1.5 G		1 G	1 G		0
15	300 M - 7 G		2.0125 G	2.0125 G		0

Step 13. Turn off the power of AMP1.

Step 14. Connect the test equipment as shown in Figure 2-9

Figure 2-9 Power Measurement Accuracy Test setup 2 for Option 011



Step 15. Turn on the power of AMP2.

Step 16. Set each conditions for E5052A, Signal Generator, Power meter and Step ATT in

accordance with the Table 2-11, and repeat Step 6 through 10.

Table 2-11 Power Measurement Accuracy Test Point 2 for Opt.011

E5052A		Signal Generator		Power Meter		Step ATT
ATT [dB]	Freq Band [Hz]	Power [dBm]	Freq [Hz]	Freq [Hz]	Target Level [dBm]	ATT [dB]
0	300 M - 7 G	-4	3.0125 G	3.0125 G	-20	40
0	300 M - 7 G		4.0125 G	4.0125 G		40
0	300 M - 7 G		5.0125 G	5.0125 G		40
0	300 M - 7 G		6.0125 G	6.0125 G		40
0	300 M - 7 G		7 G	7 G		40
0	300 M - 7 G	-4	3.0125 G	3.0125 G	-10	30
0	300 M - 7 G		4.0125 G	4.0125 G		30
0	300 M - 7 G		5.0125 G	5.0125 G		30
0	300 M - 7 G		6.0125 G	6.0125 G		30
0	300 M - 7 G		7 G	7 G		30
0	300 M - 7 G	-4	3.0125 G	3.0125 G	0	20
0	300 M - 7 G		4.0125 G	4.0125 G		20
0	300 M - 7 G		5.0125 G	5.0125 G		20
0	300 M - 7 G		6.0125 G	6.0125 G		20
0	300 M - 7 G		7 G	7 G		20
5	300 M - 7 G	-4	3.0125 G	3.0125 G	+10	10
5	300 M - 7 G		4.0125 G	4.0125 G		10
5	300 M - 7 G		5.0125 G	5.0125 G		10
5	300 M - 7 G		6.0125 G	6.0125 G		10
5	300 M - 7 G		7 G	7 G		10
15	300 M - 7 G	-6	3.0125 G	3.0125 G	+20	0
15	300 M - 7 G		4.0125 G	4.0125 G		0
15	300 M - 7 G		5.0125 G	5.0125 G		0
15	300 M - 7 G		6.0125 G	6.0125 G		0
15	300 M - 7 G		7 G	7 G		0

Performance Tests
Individual Test Description

Step 17. Turn off the power of AMP2.

4. SSB Phase Noise Sensitivity Test

Description

This test checks the SSB phase noise sensitivity of the E5052A. The carrier frequency for this test is 70 MHz.

Specification

@Standard, <150 kHz optim., correlation = 1, +5 dBm input, start frequency = 1 Hz, measurement quality = normal, measurement time = 17.7 sec

Input Frequency	Offset from carrier (Hz)					
	1 k	10 k	100 k	1 M	10 M	40 M
10 MHz	-148.5	-156.5	-166.5	-168.5	-	-
100 MHz	-148.5	-156.5	-163.5	-168.5	-170.0	-
1 GHz	-128.5	-137.5	-144.5	-160.5	-170.0	-170.0
3 GHz	-119.0	-128.0	-133.7	-149.7	-163.2	-166.7
7 GHz	-111.6	-120.6	-127.0	-143.0	-156.5	-160.0

@Option 011, <150 kHz optim., +5 dBm input, start frequency = 10 Hz, measurement quality = normal, measurement time = 4.4 sec

Input Frequency	Offset from carrier (Hz)					
	1 k	10 k	100 k	1 M	10 M	40 M
10 MHz	-145.5	-153.5	-160.0	-160.0	-	-
100 MHz	-145.5	-153.5	-160.0	-160.0	-160.0	-
1 GHz	-125.5	-134.5	-141.5	-157.5	-160.0	-160.0
3 GHz	-116.0	-125.0	-130.7	-146.7	-160.0	-160.0
7 GHz	-108.6	-117.6	-124.0	-140.0	-153.5	-157.0

Test equipment

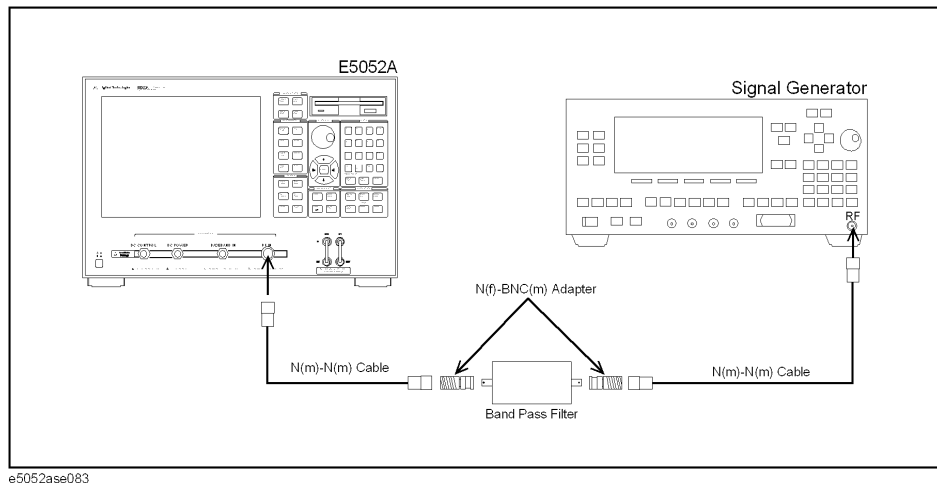
Signal Generator	Agilent E8257D option UNR, UNT
Band Pass Filter	70 MHz, Band width 10 kHz, FILTRONETICS FN-2063M
N(m)-N(m) cable 61cm, 2 ea.	Agilent N6314A (p/n 8120-8862)
N(f)-BNC(m) Adapter, 2 ea.	Agilent p/n 1250-1477

Performance Tests
Individual Test Description

Procedure

Step 1. Connect the test equipment as shown in Figure 2-10.

Figure 2-10 SSB Phase Noise Sensitivity test setup



Step 2. Press **[Preset] - Factory** to initialize the E5052A, then set the E5052A as follows. In case of installing the firmware revision 1.00/1.10, press **[Preset] - OK**.

for Standard : Table 2-12

for Option 011 : Table 2-13

Table 2-12 E5052A Settings Value (for Standard)

E5052A settings	Key strokes
Trigger Mode : Hold	[Trigger] - Trigger to Phase Noise - Hold
Frequency Band : 39 M - 101 MHz	[Setup] - Frequency Band - 39M-101MHz
Start Frequency : 1 Hz	[Start/Center] - 1Hz
Stop Frequency : 10 MHz	[Stop/Span] - 10MHz
IF Gain : 50 dB	[Setup] - IF Gain - [5] - [0] - [x1]
Correlation : 1	[Avg/BW] - Correlation - [1] - [x1]
Attenuator : 0 dB	[Attn] - Input Attenuator - [0] - [x1]
Maker 1's Position : 1 MHz	[Marker] - Marker 1 - [1] - [M/u]
Maker 2's Position : 3 MHz	[Marker] - Marker 2 - [3] - [M/u]
Maker 3's Position : 7 MHz	[Marker] - Marker 3 - [7] - [M/u]

Table 2-13 E5052A Settings Value (for Option 011)

E5052A settings	Key strokes
Trigger Mode : Hold	[Trigger] - Trigger to Phase Noise - Hold
Frequency Band : 39 M - 101 MHz	[Setup] - Frequency Band - 39M-101MHz
Start Frequency : 100 Hz	[Start/Center] - 100Hz
Stop Frequency : 10 MHz	[Stop/Span] - 10MHz
Attenuator : 0 dB	[Attn] - Input Attenuator - [0] - [x1]
Maker 1's Position : 1 MHz	[Marker] - Marker 1 - [1] - [M/u]
Maker 2's Position : 3 MHz	[Marker] - Marker 2 - [3] - [M/u]
Maker 3's Position : 7 MHz	[Marker] - Marker 3 - [7] - [M/u]

Step 3. Preset the Signal Generator. Then set the Signal Generator as follows.

Instrument	Setting
Signal Generator	Frequency : 70 MHz Power : 8 dBm , RF Output : ON

Step 4. Press **[Trigger] - Single** of E5052A to make a measurement.

Step 5. Record the Phase Noise in the Performance Test Record.

5. SA Relative Level Accuracy Test

Description

This test checks the relative level accuracy for the spectrum monitor of the E5052A. The mixed signals generated by two signal generators are used, and the carrier frequencies for this test are 100 MHz and 1 GHz.

Specification

@23 ± 5 °C

Relative level accuracy ± 1.5 dB @ ratio of -10 dBm to -60 dBm during sweep

Test Equipment

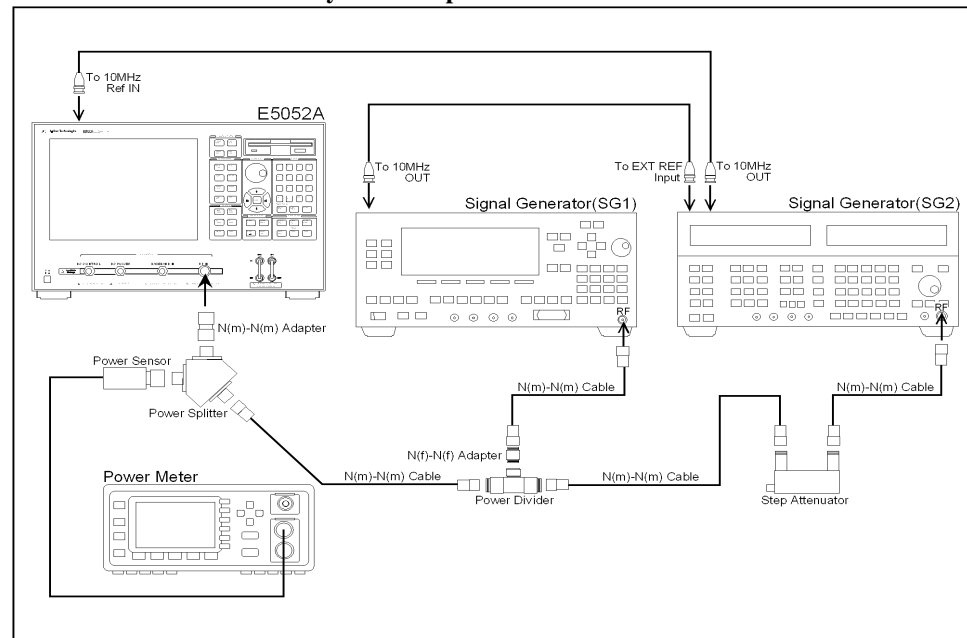
Signal Generator 1	Agilent E8257D
Signal Generator 2 (or Sweeper)	Agilent E5070B/71B (use of the source)
Power Meter	Agilent E4419B
Power Sensor	Agilent 8481A
Step Attenuator	Agilent 8496H
Power Splitter	Agilent 11667A
N(m)-N(m) Adapter	Agilent p/n 1250-1475
N(f)-N(f) Adapter	Agilent p/n 1250-0777
Power Divider	Agilent 11636A
N(m)-N(m) cable 61cm, 4 ea.	Agilent N6314A (p/n 8120-8862)
BNC cable, 122 cm, 2 ea.	Agilent p/n 8120-1840

Procedure

- Step 1.** Connect the power sensor to the power meter. Perform the zero adjustment and the calibration for the power meter.
- Step 2.** Connect the test equipment as shown in Figure 2-11

Figure 2-11

SA Relative Level Accuracy Test setup



Step 3. Press **[Preset] - Factory** to initialize the E5052A, then set the E5052A as follows. In case of installing the firmware revision 1.00/1.10, press **[Preset] - OK**.

E5052A settings	Key strokes
Measurement View : SP	[Meas/View] - Spectrum Monitor
Trigger Mode : Hold	[Trigger] - Trigger to Spectrum Monitor - Hold
Attenuator : 0 dB	[Attn] - Input Attenuator - [0] - [x1]
SPAN : 15 MHz	[Stop/Span] - Span - [1] - [5] - [M/u]
RBW : 1562.5 Hz	[Avg/BW] - RBW - [1] - [5] - [6] - [2] - [.] - [5] - [x1]
Number of Average : 16	[Avg/Bw] - Avg Factor - [1] - [6] - [x1]
Averaging Mode: ON	[Avg/BW] - Averaging ON off
Maker Display : ON	[Marker] - Marker 1 Check
Search Range (X) Mode : Bandmarker	[Marker Search] - Search Range (X) - Bandmarker
Band Marker X : ON	[Marker Search] - Band Marker X - Band Marker X ON off
Band Marker (X) Span : 500 kHz	[Marker Fctn] - Band Marker X - Span - [5] - [0] - [0] - [k/m]

Step 4. Preset the Signal Generator 1 , Signal Generator 2 and Power Meter.

Performance Tests
Individual Test Description

Step 5. Set the E5052A as follows.

E5052A settings	Key strokes
Center Frequency : 100 MHz	[Start/Center] - Center - [1] - [0] - [0] - [M/u]

Step 6. Set the Signal Generator 1, Signal Generator 2 , Power Meter and Step Attenuator as follows.

Instrument	Setting
Signal Generator 1	Frequency : 100 MHz Power : 2 dBm , RF Output : ON
Signal Generator 2	Frequency : 92.5 MHz Power : 2 dBm , RF Output : OFF
Power Meter	Frequency : 100 MHz
Step Attenuator	Attenuator : 0 dB

Step 7. Record the power meter reading in the calculation sheet. (PM1 column for the SA Relative Level Accuracy Test.)

Step 8. Set the Signal Generator 1, Signal Generator 2 and Power Meter as follows.

Instrument	Setting
Signal Generator 1	RF Output : OFF
Signal Generator 2	RF Output : ON, Sweep Time : 10 Sec.
Power Meter	Frequency : 92.5 MHz

Step 9. Record the power meter reading in the calculation sheet. (PM2 column for the SA Relative Level Accuracy Test.)

Step 10. Set the Signal Generator 1, Signal Generator 2 and Step Attenuator as follows.

Instrument	Setting
Signal Generator 1	RF Output : ON
Signal Generator 2	RF Output : ON
Step Attenuator	Attenuator : 50 dB

Step 11. Press **[Trigger] - Continuous**, and **[Avg/BW] - Averaging Restart** to make a measurement. Wait until a trace for the average of 16 swept measurements is displayed.

NOTE

The number of averaging times is displayed in the averaging status (lower right) of the measurement windows.

Step 12. Set the E5052A as follows.

E5052A settings	Key strokes
Trigger Mode : Hold	[Trigger] - Hold
Band Marker (X) Center : 100 MHz	[Marker Fctn] - Band Marker X - Center - [1] - [0] - [0] - [M/u]

Step 13. Press **[Marker Search] - Search Max** to move the marker to the Signal Generator 1 frequency point. Note the E5052A reading in the calculation sheet. (SA1 column for the SA Relative Level Accuracy Test.)

Step 14. Set the E5052A as follows.

E5052A settings	Key strokes
Band Marker (X) Center : 92.5 MHz	[Marker Fctn] - Band Marker X - Center - [9] - [2] - [.] - [5] - [M/u]

Step 15. Press **[Marker Search] - Search Max** to move the marker to the Signal Generator 2 frequency point. Note the E5052A reading in the calculation sheet. (SA2 column for the SA Relative Level Accuracy Test.)

Step 16. Calculate the following formula:

$$\text{Test Result (dB)} = (\text{SA2} - \text{SA1}) - (\text{PM2} - \text{PM1} - \text{Cal. value of Step attenuator (SATT)})$$

Record the test result on the Performance Test Record.

Step 17. Set each conditions for E5052A, Signal Generator 1, Signal Generator 2, Power Meter and Step ATT in accordance with the Table 2-14, and repeat Step 5 through 16.

Table 2-14 SA Relative Level Accuracy Test Point

E5052A	Signal Generator 1	Signal Generator 2	Power* ¹ Meter	Step* ² ATT
100 MHz	100 MHz	93.5 MHz	100 MHz 93.5 MHz	0 dB 50 dB
		94.5 MHz	100 MHz 94.5 MHz	0 dB 50 dB
		95.5 MHz	100 MHz 95.5 MHz	0 dB 50 dB
		96.5 MHz	100 MHz 96.5 MHz	0 dB 50 dB
		97.5 MHz	100 MHz 97.5 MHz	0 dB 50 dB
		98.5 MHz	100 MHz 98.5 MHz	0 dB 50 dB
		99.5 MHz	100 MHz 99.5 MHz	0 dB 50 dB
		100.5 MHz	100 MHz 100.5 MHz	0 dB 50 dB
		101.5 MHz	100 MHz 101.5 MHz	0 dB 50 dB
		102.5 MHz	100 MHz 102.5 MHz	0 dB 50 dB
		103.5 MHz	100 MHz 103.5 MHz	0 dB 50 dB
		104.5 MHz	100 MHz 104.5 MHz	0 dB 50 dB
		105.5 MHz	100 MHz 105.5 MHz	0 dB 50 dB
		106.5 MHz	100 MHz 106.5 MHz	0 dB 50 dB
107.5 MHz	100 MHz 107.5 MHz	0 dB 50 dB		

Table 2-14

SA Relative Level Accuracy Test Point

E5052A	Signal Generator 1	Signal Generator 2	Power* ¹ Meter	Step* ² ATT
1000 MHz	1000 MHz	993.5 MHz	1000 MHz 993.5 MHz	0 dB 50 dB
		994.5 MHz	1000 MHz 994.5 MHz	0 dB 50 dB
		995.5 MHz	1000 MHz 995.5 MHz	0 dB 50 dB
		996.5 MHz	1000 MHz 996.5 MHz	0 dB 50 dB
		997.5 MHz	1000 MHz 997.5 MHz	0 dB 50 dB
		998.5 MHz	1000 MHz 998.5 MHz	0 dB 50 dB
		999.5 MHz	1000 MHz 999.5 MHz	0 dB 50 dB
		1000.5 MHz	1000 MHz 1000.5 MHz	0 dB 50 dB
		1001.5 MHz	1000 MHz 1001.5 MHz	0 dB 50 dB
		1002.5 MHz	1000 MHz 1002.5 MHz	0 dB 50 dB
		1003.5 MHz	1000 MHz 1003.5 MHz	0 dB 50 dB
		1004.5 MHz	1000 MHz 1004.5 MHz	0 dB 50 dB
		1005.5 MHz	1000 MHz 1005.5 MHz	0 dB 50 dB
		1006.5 MHz	1000 MHz 1006.5 MHz	0 dB 50 dB
1007.5 MHz	1000 MHz 1007.5 MHz	0 dB 50 dB		

*1. The upper frequency is the measuring frequency for the power meter, when the SG1's output mode is turned on.

The lower frequency is the measuring frequency for the power meter, when the SG2's output mode is turned on.

*2. The upper attenuation is for setting the Step ATT, when the power level of the Signal Generator is measured in the Power Meter.

The lower attenuation is for setting the Step ATT, when the power level of the Signal Generator is measured in the E5052A.

6. DC Power Voltage Test

Description

This test checks the accuracy of the DC Power output voltage.

Specification

@23 ± 5 °C

Setting accuracy ± (0.2 % + 2 mV) @ 0 V to 16 V

Test Equipment

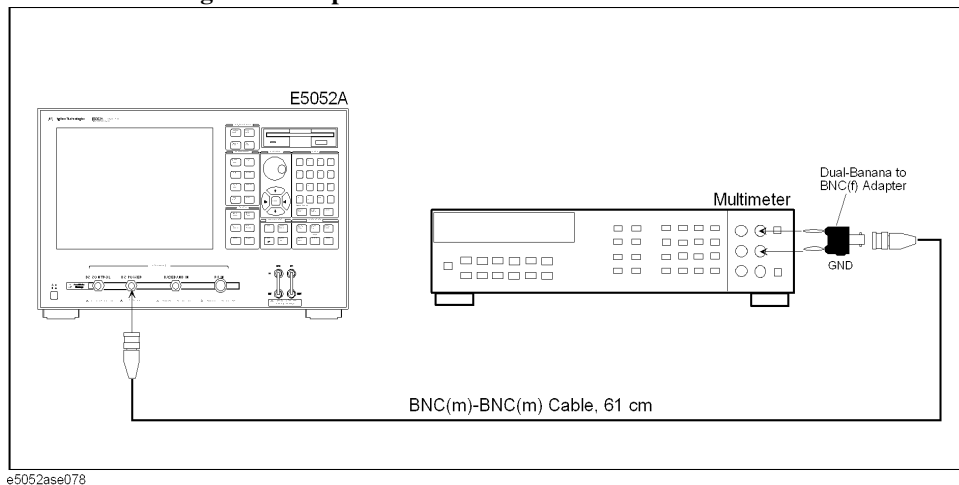
Multimeter	Agilent 3458A
BNC cable, 61 cm	Agilent p/n 8120-1839
Dual Banana-BNC(f) adapter	Agilent p/n 1251-2277

Procedure

Step 1. Connect the test equipment as shown in Figure 2-12

Figure 2-12

DC Power Voltage Test setup



Step 2. Press **[Preset] - Factory** to initialize the E5052A, then set the E5052A as follows. In case of installing the firmware revision 1.00/1.10, press **[Preset] - OK**.

E5052A settings

Trigger Mode : Hold

Key strokes

[Trigger] - Hold

Step 3. Preset the Multimeter. Then set the Multimeter as follows.

Instrument	Setting
Multimeter	Trigger Mode : Hold, Measurement Mode : DCV Number of Power Line Cycles : 100

Step 4. Set the Multimeter as follows.

Instrument	Setting
Multimeter	Select Range : 100 mV

NOTE

When DC Power Voltage is 1 , set the measurement range to 1 V.
When DC Power is 2 to 10 V, set the measurement range to 10 V.
When DC Power is 12 to 16 V, set the measurement range to 100 V.

Step 5. Set the E5052A as follows.

E5052A settings	Key strokes
DC Power Voltage : 0 V	[DC Power] - DC Power Voltage - [0] - [x1]
DC Power Output : ON	[DC Power] - DC Power Output ON off

Step 6. Make the single sweep measurement for the Multimeter.

Step 7. Read the Multimeter measurement result, and calculate the following formula:

$$\text{Test Result (mV)} = (\text{DC Power} - \text{Multimeter reading})$$

Record the result on the Performance Test Record.

Step 8. Set the E5052A as follows.

E5052A settings	Key strokes
DC Power Output : OFF	[DC Power] - DC Power Output on OFF

Step 9. Set each conditions for E5052A and Multimeter in accordance with the Table 2-15, and repeat Step 4 through 8.

Table 2-15

DC Power Voltage Test Point

E5052A (Setting Voltage)	Multimeter (Setting Range)
1 V	1 V
2 V	10 V
5 V	10 V

Table 2-15

DC Power Voltage Test Point

E5052A (Setting Voltage)	Multimeter (Setting Range)
10 V	10 V
12 V	100 V
16 V	100 V

7. DC Power Current Measurement Test

Description

This test checks the accuracy of the DC Power current measurement function. This test uses a 141 Ω resistor to define the DC Power current.

Specification

@23 ± 5 °C

Accuracy ± (0.2 % of reading + 160 μA) @ 0 mA to 80 mA

Test Equipment

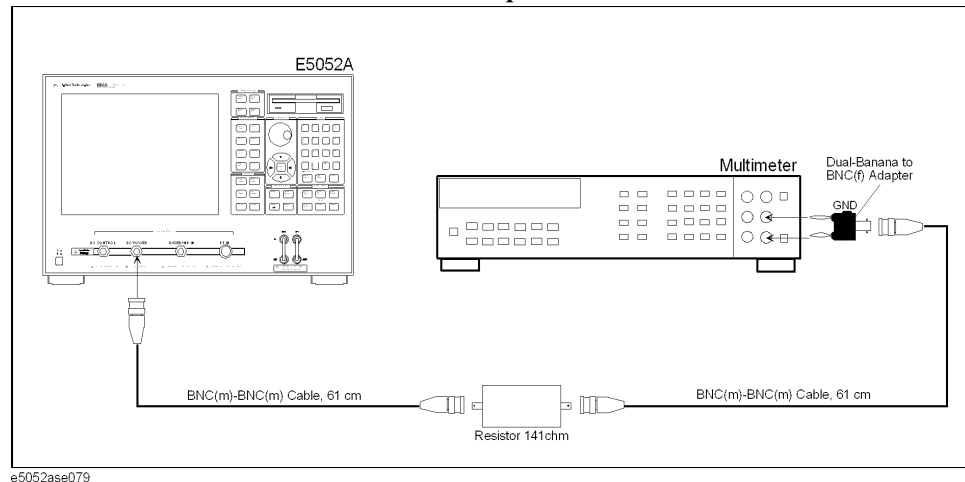
Multimeter	Agilent 3458A
Resistor	141 Ω, 1 W (Agilent p/n 0698-3615 (47 Ω), 3ea)
BNC cable, 61 cm, 2 ea.	Agilent p/n 8120-1839
Dual Banana-BNC(f) adapter	Agilent p/n 1251-2277

Procedure for Standard

Step 1. Connect the test equipment as shown in Figure 2-13

Figure 2-13

DC Power Current Measurement Test setup for Standard



Step 2. Press [**Preset**] - **Factory** to initialize the E5052A, then set the E5052A as follows. In case of installing the firmware revision 1.00/1.10, press [**Preset**] - **OK**.

E5052A settings

Measurement View :
FP-Current

Mode : Tester

Key strokes

[**Meas/View**] - **Freq & Power**

[**Trigger**] - **Mode - Tester**

Performance Tests
Individual Test Description

E5052A settings	Key strokes
Trigger Mode : Hold	[Trigger] - Trigger to Freq & Power - Hold

Step 3. Preset the Multimeter. Then set the Multimeter as follows.

Instrument	Setting
Multimeter	Trigger Mode : Continuous Measurement Mode : DCI Number of Power Line Cycles : 100

Step 4. Set the Multimeter as follows.

Instrument	Setting
Multimeter	Select Range : 1 mA

NOTE

When the setting voltage is 0.3 to 1.41 V, set the measurement range of the Multimeter to 10 mA.

When the setting voltage is 3.0 to 11.3 V, set the measurement range of the Multimeter to 100 mA.

Step 5. Set the E5052A as follows.

E5052A settings	Key strokes
DC Power Voltage : 0.15 V	[DC Power] - DC Power Voltage - [0] - [.] - [1] - [5] - [x1]
DC Power Output : ON	[DC Power] - DC Power Output ON off
Trigger Mode : Continuous	[Trigger] - Continuous

Step 6. Make the single sweep measurement for the Multimeter.

Step 7. Press [Trigger] - Single to make a measurement of the E5052A.

Step 8. Note the Multimeter reading as Current value.

NOTE

Check whether the current value of Multimeter and Table 2-16 is approximation.

Step 9. Note the E5052A reading as Current value.

Step 10. Calculate the following formula:

Test Result (uA) = E5052A reading(Current) - Multimeter reading

Record the test result on the Performance Test Record.

Step 11. Set the each conditions for E5052A and Multimeter in accordance with the Table 2-16, and

repeat Step 4 through 10.

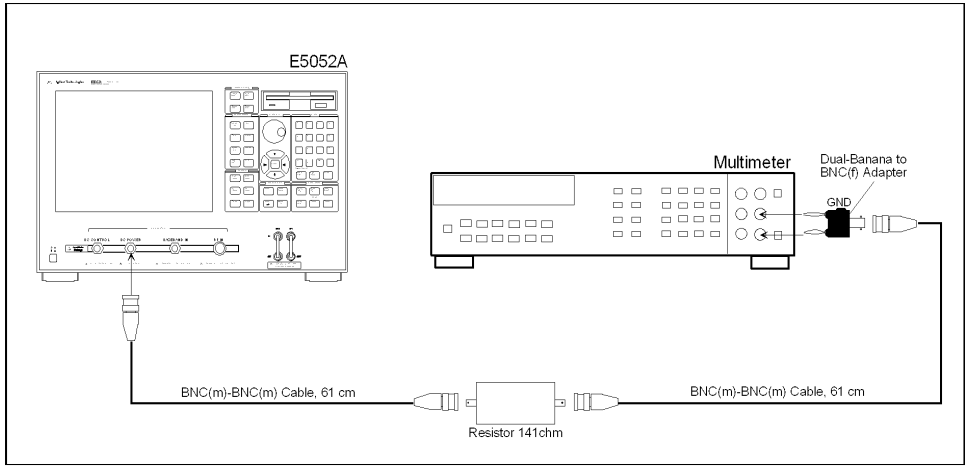
Table 2-16 DC Power Current Test Point for Standard

Multimeter		E5052A
Current Through Resistor	Setting Range	Setting Voltage
2 mA	10 mA	0.3 V
5 mA	10 mA	0.7 V
10 mA	10 mA	1.41 V
20 mA	100 mA	3.0 V
50 mA	100 mA	7.0 V
80 mA	100 mA	11.3 V

Procedure for Option 011

Step 1. Connect the test equipment as shown in Figure 2-14

Figure 2-14 DC Power Current Measurement Test setup for Option 011



e5052ase079

Step 2. Press **[Preset] - Factory** to initialize the E5052A, then set the E5052A as follows. In case of installing the firmware revision 1.00/1.10, press **[Preset] - OK**.

- | | |
|------------------------|---|
| E5052A settings | Key strokes |
| Measurement View : FP | [Meas/View] - Freq & Power |
| Trigger Mode : Hold | [Trigger] - Trigger to Freq & Power - Hold |

Performance Tests
Individual Test Description

Step 3. Preset the Multimeter. Then set the Multimeter as follows.

Instrument	Setting
Multimeter	Trigger Mode : Continuous Measurement Mode : DCI Number of Power Line Cycles : 100

Step 4. Set the Multimeter as follows.

Instrument	Setting
Multimeter	Select Range : 1 mA

NOTE

When the setting voltage is 0.3 to 1.41 V, set the measurement range of the Multimeter to 10 mA.

When the setting voltage is 3.0 to 11.3 V, set the measurement range of the Multimeter to 100 mA.

Step 5. Set the E5052A as follows.

E5052A settings	Key strokes
DC Power Voltage : 0.15 V	[DC Power] - DC Power Voltage - [0] - [.] - [1] - [5] - [x1]
DC Power Output : ON	[DC Power] - DC Power Output ON off
Trigger Mode : Continuous	[Trigger] - Continuous

Step 6. Make the single sweep measurement for the Multimeter.

Step 7. Press **[Trigger] - Single** to make a measurement of the E5052A.

Step 8. Note the Multimeter reading as Current value.

NOTE

Check whether the current value of Multimeter and Table 2-17 is approximation.

Step 9. Note the E5052A reading as Current value.

Step 10. Calculate the following formula:

Test Result (uA) = E5052A reading(Current) - Multimeter reading

Record the test result on the Performance Test Record.

Step 11. Set the each conditions for E5052A and Multimeter in accordance with the Table 2-17, and repeat Step 4 through 10.

Table 2-17 DC Power Current Test Point for Option 011

Multimeter		E5052A
Current Through Resistor	Setting Range	Setting Voltage
2 mA	10 mA	0.3 V
5 mA	10 mA	0.7 V
10 mA	10 mA	1.41 V
20 mA	100 mA	3.0 V
50 mA	100 mA	7.0 V
80 mA	100 mA	11.3 V

2. Performance Test

E5052A Performance Test Calculation Sheet

Introduction

This section contains calculation sheets for each performance test that requires additional calculations to determine the final test result.

Use the calculation sheet in this section as an aid for recording raw measurement data and calculating the performance test results.

Calculation sheet entries are provided only for performance tests in which calculations are required to obtain the test results.

SA Relative Level Accuracy Test

Sheet for Low Frequency (100 MHz)

Frequency [Hz]		Power meter reading [dBm]		E5052A reading [dBm]		Cal value of Step Att [dB]	Test Result [dB]	Test result equation
SG1	SG2	PM1	PM2	SA1	SA2	SATT	Result	
100 M	92.5 M							$\text{Result} = (\text{SA2} - \text{SA1}) - (\text{PM2} - \text{PM1} - \text{SATT})$
	93.5 M							
	94.5 M							
	95.5 M							
	96.5 M							
	97.5 M							
	98.5 M							
	99.5 M							
	100.5 M							
	101.5 M							
	102.5 M							
	103.5 M							
	104.5 M							
	105.5 M							
106.5 M								
107.5 M								

Sheet for High Frequency (1 GHz)

Frequency [Hz]		Power meter reading [dBm]		E5052A reading [dBm]		Cal value of Step Att [dB]	Test Result [dB]	Test result equation
SG1	SG2	PM1	PM2	SA1	SA2	SATT	Result	
1 G	992.5 M							Result = (SA2 - SA1) - (PM2 - PM1 - SATT)
	993.5 M							
	994.5 M							
	995.5 M							
	996.5 M							
	997.5 M							
	998.5 M							
	999.5 M							
	1000.5 M							
	1001.5 M							
	1002.5 M							
	1003.5 M							
	1004.5 M							
	1005.5 M							
	1006.5 M							
1007.5 M								

2. Performance Test

E5052A Performance Test Record

Agilent Technologies E5052A Signal Source Analyzer

Serial Number:		Option:	
Temperature:	°C	Test Date:	
Humidity:	% R.H.	Tested by:	

RF IN Port VSWR Test

@ Input Attenuator = 0 dB

Frequency range [Hz]	Test limit	Test result	Measurement uncertainty
10 M - 30 M	< 1.6		± 0.05
30 M - 2 G	< 1.2		± 0.01
2 G - 3 G	< 1.3		± 0.02

@ Input Attenuator = 5 dB

Frequency range [Hz]	Test limit	Test result	Measurement uncertainty
10 M - 30 M	< 1.6		± 0.05
30 M - 2 G	< 1.2		± 0.01
2 G - 3 G	< 1.3		± 0.02

Frequency Measurement Test

@ Frequency Band: 10 MHz - 1.5 GHz, Power Level: -15 dBm

Frequency [Hz]	Frequency Resolution [Hz]	Test Limit [Hz]	Test result [Hz]
10 M	64 k	± 64 k	
10 M	1 k	± 1 k	
10 M	10	± 10	

@ Frequency Band: 10 MHz - 1.5 GHz, Power Level: -20 dBm

Frequency [Hz]	Frequency Resolution [Hz]	Test Limit [Hz]	Test result [Hz]
30 M	64 k	± 64 k	
30 M	1 k	± 1 k	
30 M	10	± 10	
1.5 G	64 k	± 64 k	
1.5 G	1 k	± 1 k	
1.5 G	10	± 10	

@ Frequency Band: 10 MHz - 1.5 GHz, Power Level: +20 dBm

Frequency [Hz]	Frequency Resolution [Hz]	Test Limit [Hz]	Test result [Hz]
10 M	64 k	± 64 k	
10 M	1 k	± 1 k	
10 M	10	± 10	
1.5 G	64 k	± 64 k	
1.5 G	1 k	± 1 k	
1.5 G	10	± 10	

@ Frequency Band: 300 MHz - 7 GHz, Power Level: -20 dBm

Frequency [Hz]	Frequency Resolution [Hz]	Test Limit [Hz]	Test result [Hz]
300 M	64 k	± 64 k	
300 M	1 k	± 1 k	
300 M	10	± 10	
7 G	64 k	± 64 k	
7 G	1 k	± 1 k	
7 G	10	± 10	

Performance Tests
E5052A Performance Test Record

@ Frequency Band: 300 MHz - 7 GHz, Power Level: +20 dBm

Frequency [Hz]	Frequency Resolution [Hz]	Test Limit [Hz]	Test result [Hz]
300 M	64 k	± 64 k	
300 M	1 k	± 1 k	
300 M	10	± 10	
7 G	64 k	± 64 k	
7 G	1 k	± 1 k	
7 G	10	± 10	

Power Measurement Accuracy Test

@ -20 dBm

Frequency [Hz]	Test limit [dB]	Test result [dB]	Measurement uncertainty [dB]
1 G	± 1.0		± 0.13
2.0125 G	± 1.0		± 0.14
3.0125 G	± 1.0		± 0.15
4.0125 G	± 1.0		± 0.16
5.0125 G	± 1.0		± 0.16
6.0125 G	± 1.0		± 0.17
7 G	± 1.0		± 0.18

@ -10 dBm

Frequency [Hz]	Test limit [dB]	Test result [dB]	Measurement uncertainty [dB]
10 M	± 1.0		± 0.14
1 G	± 0.5		± 0.13
2.0125 G	± 0.5		± 0.13
3.0125 G	± 1.0		± 0.13
4.0125 G	± 1.0		± 0.16
5.0125 G	± 1.0		± 0.16
6.0125 G	± 1.0		± 0.17

Frequency [Hz]	Test limit [dB]	Test result [dB]	Measurement uncertainty [dB]
7 G	± 1.0		± 0.18

@ 0 dBm

Frequency [Hz]	Test limit [dB]	Test result [dB]	Measurement uncertainty [dB]
10 M	± 1.0		± 0.14
1 G	± 0.5		± 0.13
2.0125 G	± 0.5		± 0.13
3.0125 G	± 1.0		± 0.13
4.0125 G	± 1.0		± 0.16
5.0125 G	± 1.0		± 0.16
6.0125 G	± 1.0		± 0.17
7 G	± 1.0		± 0.18

@ +10 dBm

Frequency [Hz]	Test limit [dB]	Test result [dB]	Measurement uncertainty [dB]
10 M	± 1.0		± 0.14
1 G	± 0.5		± 0.13
2.0125 G	± 0.5		± 0.13
3.0125 G	± 1.0		± 0.13
4.0125 G	± 1.0		± 0.16
5.0125 G	± 1.0		± 0.16
6.0125 G	± 1.0		± 0.17
7 G	± 1.0		± 0.19

@ +20 dBm

Frequency [Hz]	Test limit [dB]	Test result [dB]	Measurement uncertainty [dB]
10 M	± 1.0		± 0.14
1 G	± 0.5		± 0.13

Performance Tests
E5052A Performance Test Record

Frequency [Hz]	Test limit [dB]	Test result [dB]	Measurement uncertainty [dB]
2.0125 G	± 0.5		± 0.13
3.0125 G	± 1.0		± 0.13
4.0125 G	± 1.0		± 0.16
5.0125 G	± 1.0		± 0.16
6.0125 G	± 1.0		± 0.17
7 G	± 1.0		± 0.19

SSB Phase Noise Sensitivity Test (for Standard)

CW Frequency: 70 MHz, Correlation = 1, Start frequency = 1 Hz

Offset Frequency [Hz]	Test limit [dB/Hz]	Test result [dB/Hz]
1 M	< -168.5	
3 M	< -169.0	
7 M	< -169.7	

SSB Phase Noise Sensitivity Test (for Option 011)

CW Frequency: 70 MHz, Start frequency = 10 Hz

Offset Frequency [Hz]	Test limit [dB/Hz]	Test result [dB/Hz]
1 M	< -160.0	
3 M	< -160.0	
7 M	< -160.0	

SA Relative Level Accuracy Test

CW Frequency: 100 MHz

Offset Frequency [Hz]	Test limit [dB]	Test result [dB]	Measurement uncertainty [dB]
-7.5 M	± 1.5		± 0.17
-6.5 M	± 1.5		± 0.17
-5.5 M	± 1.5		± 0.16

Offset Frequency [Hz]	Test limit [dB]	Test result [dB]	Measurement uncertainty [dB]
-4.5 M	± 1.5		± 0.17
-3.5 M	± 1.5		± 0.18
-2.5 M	± 1.5		± 0.17
-1.5 M	± 1.5		± 0.18
-0.5 M	± 1.5		± 0.17
+0.5 M	± 1.5		± 0.18
+1.5 M	± 1.5		± 0.18
+2.5 M	± 1.5		± 0.17
+3.5 M	± 1.5		± 0.16
+4.5 M	± 1.5		± 0.19
+5.5 M	± 1.5		± 0.17
+6.5 M	± 1.5		± 0.18
+7.5 M	± 1.5		± 0.18

CW Frequency: 1 GHz

Offset Frequency [Hz]	Test limit [dB]	Test result [dB]	Measurement uncertainty [dB]
-7.5 M	± 1.5		± 0.23
-6.5 M	± 1.5		± 0.24
-5.5 M	± 1.5		± 0.23
-4.5 M	± 1.5		± 0.24
-3.5 M	± 1.5		± 0.23
-2.5 M	± 1.5		± 0.21
-1.5 M	± 1.5		± 0.24
-0.5 M	± 1.5		± 0.23
+0.5 M	± 1.5		± 0.23
+1.5 M	± 1.5		± 0.23
+2.5 M	± 1.5		± 0.25
+3.5 M	± 1.5		± 0.25
+4.5 M	± 1.5		± 0.24

Performance Tests
E5052A Performance Test Record

Offset Frequency [Hz]	Test limit [dB]	Test result [dB]	Measurement uncertainty [dB]
+5.5 M	± 1.5		± 0.22
+6.5 M	± 1.5		± 0.22
+7.5 M	± 1.5		± 0.24

DC Power Voltage Test

DC POWER Voltage [V]	Test limit [mV]	Test result [mV]	Measurement uncertainty [mV]
0	± 2.0		± 0.059
1	± 4.0		± 0.065
2	± 6.0		± 0.031
5	± 12.0		± 0.30
10	± 22.0		± 0.44
12	± 26.0		± 0.86
16	± 34.0		± 0.52

DC Current Measurement Test

DC Current [mA]	Test limit [μ A]	Test result [μ A]	Measurement uncertainty [μ A]
1	± 162.0		± 2.5
2	± 164.0		± 2.5
5	± 170.0		± 2.5
10	± 180.0		± 3.8
20	± 200.0		± 4.1
50	± 260.0		± 5.3
80	± 320.0		± 6.8

3 Adjustment

This chapter provides the adjustment information for the E5052A to ensure that it is within its specifications. The adjustment must be performed Agilent's qualified service personnel. If you need the adjustment for your E5052A, it should be sent to the nearest Agilent Technologies service office.

Safety Considerations

This manual contains NOTES, CAUTIONs, and WARNINGs that must be followed to ensure the safety of the operator and to keep the instrument in a safe and serviceable condition. The adjustment must be performed by Agilent's qualified service personnel.

WARNING

Any interruption of the protective ground conductor (inside or outside the equipment) or disconnection of the protective ground terminal can make the instrument dangerous. Intentional interruption of the protective ground system for any reason is prohibited.

Warm-up for Adjustment

Warm-up the E5052A for at least 30 minute before performing any of the following Adjustment procedures to ensure proper results and correct instrument operation.

Required Equipment

Table 1-1 on page 20 lists the equipment required to perform the Adjustment procedures described in this chapter. Use only calibrated test equipment when adjusting the E5052A.

Required Adjustment after Replacing Assembly

After replacing the following assembly, the adjustment items described in Table 3-1 must be required. The adjustment must be performed Agilent's qualified service personnel. If you need the adjustment for your E5052A, it should be sent to the nearest Agilent Technologies service office.

Table 3-1 Required Adjustment Item after Replacing Assembly

Replaced Assembly	Adjustment Item														
	Writing ID	DC Control Voltage Adjustment	DC Power Voltage Adjustment	DC Power Current Adjustment	Reference Frequency Adjustment	Pre-LO Sampler PLL BW Adjustment	Receiver DC offset Adjustment	PM Offset Adjustment	PM Linearity Adjustment	PM Temp Adjustment	PM Flatness Adjustment	Receiver RF Flatness Adjustment	Receiver IF Gain/Flatness Adjustment	LO Sampler PLL BW Adjustment	Phase Noise BW Adjustment
A1 Freq/Power Det.					√	√	√	√	√	√	√	√	√	√	√
A2 DC Source		√	√	√											
A3 ADC/DSP					√	√	√					√	√	√	√
A4/A5 Local Synt					√	√	√					√	√	√	√
A6 Phase Det					√	√	√					√	√	√	√
HDD		√	√	√	√	√	√	√	√	√	√	√	√	√	√
A21 PCI DSP Card	√														

Writing ID

This item writes the serial number and the option structure into the E5052A.

Required equipment for the writing ID

None

DC Control Voltage Adjustment

The purpose of this procedure is to adjust the DC control voltage of the DC source of the A2 DC Source board.

Adjustment

Required Adjustment after Replacing Assembly

Required equipment for DC control voltage adjustment

Description	Recommended Model
Multimeter	Agilent 3458A
BNC(f)-Banana Adapter	Agilent p/n 1251-2277
BNC(m)-BNC(m) Cable, 61 cm	Agilent p/n 8120-1839

DC Power Voltage Adjustment

The purpose of this procedure is to adjust the DC power voltage of the A2 DC source board.

Required equipment for the DC power voltage adjustment

Description	Recommended Model
Multimeter	Agilent 3458A
BNC(f)-Banana Adapter	Agilent p/n 1251-2277
BNC(m)-BNC(m) Cable, 61 cm	Agilent p/n 8120-1839

DC Power Current Adjustment

The purpose of this procedure is to adjust the DC power current measurement of the A1 freq/power detector module.

Required equipment for the DC power current adjustment

Description	Recommended Model
Multimeter	Agilent 3458A
141 ohm Load	Agilent p/n 0698-3615 (47 Ω), 3ea
BNC(f)-Banana Adapter	Agilent p/n 1251-2277
BNC Tee Adapter	Agilent p/n 1250-0781
BNC(m)-BNC(m) Cable, 61 cm	Agilent p/n 8120-1839

Reference Frequency Adjustment

The purpose of this procedure is to adjust the reference frequency of the A4/A5 local synthesize modules.

Required equipment for reference frequency adjustment

Description	Recommended Model
Signal Generator	Agilent E8257D option UNR, UNT
N(m)-N(m) Cable	Agilent N6314A (p/n 8120-8862)

Pre-LO Sampler PLL BW Adjustment

The purpose of this procedure is to pre-adjust the LO sampler PLL BW of the A4/A5 local synthesizer modules.

Required equipment for the Pre-LO sampler PLL BW adjustment

Description	Recommended Model
Signal Generator	Agilent E8257D option UNR, UNT
N(m)-N(m) Cable	Agilent N6314A (p/n 8120-8862)

Receiver DC offset Adjustment

The purpose of this procedure is to adjust the DC offset of the Receiver section (A6 Phase detector board and A3 ADC/DSP board).

Required equipment for the receiver DC offset adjustment

Description	Recommended Model
50 ohm (N) Termination	Agilent 909C opt.012
50 ohm (BNC) Termination	Agilent 11593A

PM Offset Adjustment

The purpose of this procedure is to adjust the PM offset of the A1 freq/power detector module.

Required equipment for the PM offset adjustment

Description	Recommended Model
Signal Generator	Agilent E8257D option UNR, UNT
Power Amplifier (35dB)	R & K A3000-2H-R
Step Attenuator	Agilent 8496H
Attenuator (3dB)	Agilent 8491A option 003
Blocking Capacitor	Agilent 11742A
Low Pass Filter	Mini-Circuits SLP-70 (70MHz)
Power Splitter	Agilent 11667A
Power Sensor	Agilent 8481A
Power Meter	Agilent E4419A/B
N(m)-N(m) Cable	Agilent N6314A (p/n 8120-8862)
N(m)-N(m) Adapter	Agilent p/n 1250-1475
N(f)-SMA(m) Adapter	Agilent p/n 1250-1562

PM Linearity Adjustment

The purpose of this procedure is to adjust the PM linearity of the A1 freq/power detector module.

Required equipment for the PM linearity adjustment

Description	Recommended Model
Signal Generator	Agilent E8257D option UNR, UNT
Power Amplifier (35dB)	R & K A3000-2H-R
Step Attenuator	Agilent 8496H
Attenuator (3dB)	Agilent 8491A option 003
Blocking Capacitor	Agilent 11742A
Low Pass Filter	Mini-Circuits SLP-70 (70MHz)
Power Splitter	Agilent 11667A
Power Sensor	Agilent 8481A
Power Meter	Agilent E4419A/B
N(m)-N(m) Cable	Agilent N6314A (p/n 8120-8862)
N(m)-N(m) Adapter	Agilent p/n 1250-1475
N(f)-SMA(m) Adapter	Agilent p/n 1250-1562

PM Temp Adjustment

The purpose of this procedure is to adjust the PM temp of the A1 freq/power detector module.

Required equipment for the PM temp adjustment

None

PM Flatness Adjustment

The purpose of this procedure is to adjust the PM flatness of the A1 freq/power detector module.

Required Adjustment after Replacing Assembly**Required equipment for the PM flatness adjustment**

Description	Recommended Model
Signal Generator	Agilent E8257D option UNR, UNT
Power Splitter	Agilent 11667A
Power Sensor	Agilent 8481A
Power Meter	Agilent E4419A/B
N(m)-N(m) Cable	Agilent N6314A (p/n 8120-8862)
N(m)-N(m) Adapter	Agilent p/n 1250-1475

Receiver RF Flatness Adjustment

The purpose of this procedure is to adjust the RF flatness of the A6 phase detector board.

Required equipment for the receiver RF flatness adjustment

Description	Recommended Model
Signal Generator	Agilent E8257D option UNR, UNT
Power Amplifier (35dB)	R & K A3000-2H-R
Power Amplifier (35dB)	Agilent 83020A
50 ohm (BNC) Termination	Agilent 11593A
Power Sensor	Agilent 8481A
Power Meter	Agilent E4419A/B
Power Splitter	Agilent 11667A
N(m)-N(m) Cable	Agilent N6314A (p/n 8120-8862)
N(m)-N(m) Adapter	Agilent p/n 1250-1475

Receiver IF Gain/Flatness Adjustment

The purpose of this procedure is to adjust the IF gain / flatness of the A6 phase detector board.

Required equipment for the receiver IF gain/flatness adjustment

Description	Recommended Model
Signal Generator	Agilent E8257D option UNR, UNT
50 ohm Termination	Agilent 909C opt.012
Power Sensor	Agilent 8481A
Power Meter	Agilent E4419A/B
Power Splitter	Agilent 11667A
N(m)-N(m) Cable	Agilent N6314A (p/n 8120-8862)
N(m)-N(m) Adapter	Agilent p/n 1250-1475

LO Sampler PLL BW Adjustment

The purpose of this procedure is to adjust the LO sampler PLL BW of the A4/A5 local synthesizer modules.

Required equipment for the LO sampler PLL BW adjustment

Description	Recommended Model
Signal Generator	Agilent E8257D option UNR, UNT
N(m)-N(m) Cable	Agilent N6314A (p/n 8120-8862)

Phase Noise BW Adjustment

The purpose of this procedure is to adjust the phase noise BW of the phase detector board.

Required equipment for the phase noise BW adjustment

Description	Recommended Model
Signal Generator	Agilent E8257D option UNR, UNT
N(m)-N(m) Cable	Agilent N6314A (p/n 8120-8862)

Adjustment
Required Adjustment after Replacing Assembly

4 Troubleshooting

This chapter provides the procedure to isolate a faulty assembly in the E5052A.

Introduction

WARNING These servicing instructions are for use by qualified personnel only. To avoid possible electrical shock, do not perform any servicing unless you are qualified to do so.

WARNING The opening of covers or removal of parts is likely to expose dangerous voltages. Disconnect the instrument from its power supply beforehand.

CAUTION Many of the assemblies in the instrument are very susceptible to damage from ESD (electrostatic discharge). Perform the following procedures only at a static-safe workstation and wear a grounding strap.

CAUTION DO NOT operate without following instructions. Programs or files in the instrument may be broken.

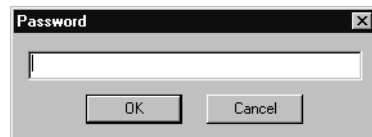
How to exit from the E5052A Measurement View

You need to exit from the E5052A Measurement View to perform some troubleshooting. The following is the procedure to exit from the E5052A Measurement View.

- Step 1.** Connect the mouse and external keyboard to the connectors on the E5052A rear panel.
- Step 2.** Turn the instrument on.
- Step 3.** Press **System** key.
- Step 4.** Click **Service Menu - Administrator Menu**. Password dialog box opens as shown in Figure 4-1.

Figure 4-1

Password dialog box



- Step 5.** Enter the password **E5052** in the Password box and then click "OK" button.
- Step 6.** Click **Exit E5052A - OK** on the menu bar. Then the E5052A exit the Measurement View, then windows desktop screen appears with 4 icons (My Computer, My Network Places, Recycle Bin, and E5052A.)

NOTE If you wish to return to the Measurement View, double-click "E5052A" icon.

NOTE If you need to shut down the E5052A and again turn on, perform in accordance with the following procedure.

- a. To get "Start" menu bar displayed, move the pointer to the bottom of the screen with mouse.
- b. Click "Start" and "Shut Down..." in the pull down menu. "Shut Down Windows" dialog box opens.
- c. Select "Shut down" button in the pull down menu.
- d. Click "OK" button in the dialog box.

To Troubleshoot the Instrument

This section describes basic procedural flow of troubleshooting when servicing the E5052A. The primary procedural tool in this section is the flowchart. The flowchart contains entire troubleshooting path from a failure symptom to the isolation of faulty assembly, and will direct you to the completion of repair in an ordinary manner through the possible failure symptoms. Reference letters (Yes/No) on the flowcharts point to procedural steps that briefly explain the troubleshooting method to be performed next.

Primary Trouble Isolation

The primary trouble isolation procedure can be performed without disassembling the E5052A. Figure 4-2 shows the trouble isolation flow chart.

Step 1. Turn the instrument power on

About a few minutes after the E5052A is turned on, the measurement view is displayed on the screen. The display on the screen should be similar to Figure 4-9, “Measurement view,” on page 95.

Step 2. Check the display

- If no display appears on the LCD after the E5052A is turned on, go to “No Display troubleshooting” on page 88.
- If the E5052A stops in booting process despite something being displayed on the LCD, go to “Booting Process Troubleshooting” on page 91.
- The power-on self test is performed once automatically before the measurement starts. If the power-on self test fails, go to “Troubleshooting Using Service Function” on page 96.

Step 3. Check the basic function

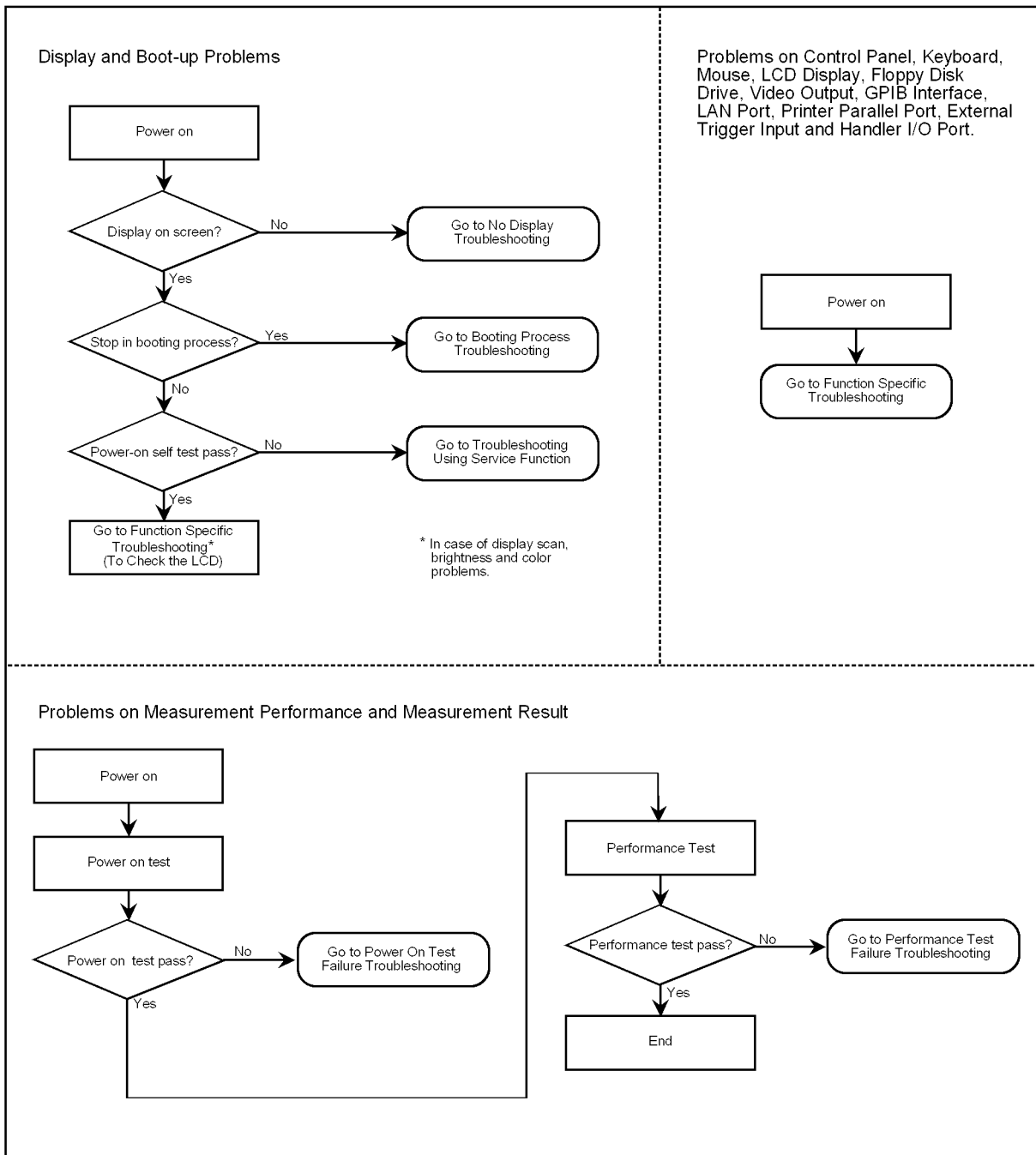
If the front-panel/keyboard/mouse controls, LCD display, data storage, remote interface or another function (except for measurement part) does not work correctly, go to “Function Specific Troubleshooting” on page 100.

Step 4. Check the measurement function

If the instrument fails performance tests, go to “Performance test failure troubleshooting” on page 112.

If the measurement function does not work correctly, perform the Power On Test provided in the E5052A’s service function. When the Power On Test fails, go to “Power On Test Failure Troubleshooting” on page 99.

Figure 4-2 Primary trouble isolation flowchart



e5052ase086

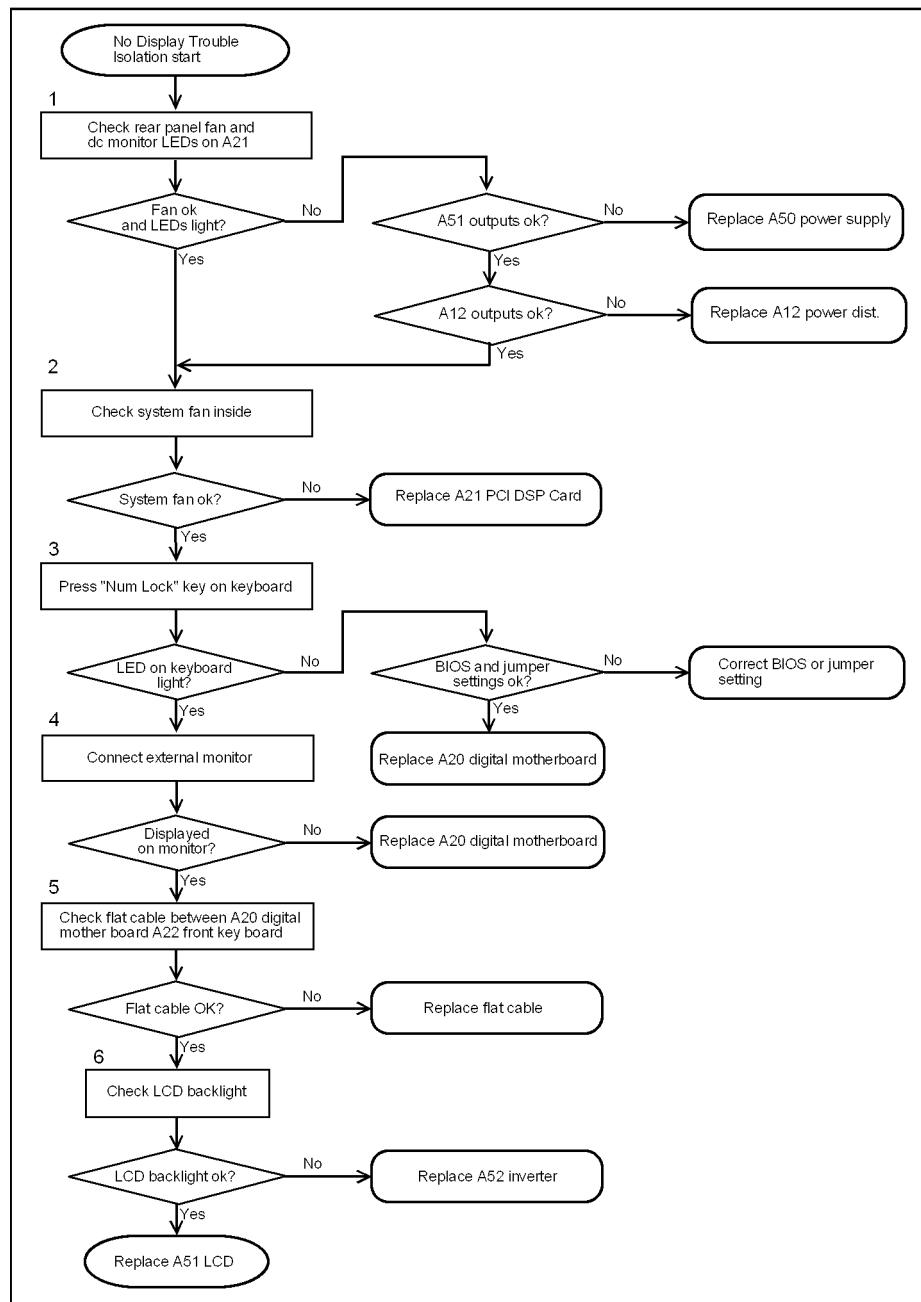
No Display troubleshooting

If the E5052A displays nothing despite it is powered from proper ac power line, isolate the failure in accordance with the procedure shown in Figure 4-3.

Connect the keyboard to the E5052A rear panel connector, turn the power on and start trouble isolation. The methods of trouble isolation are described in the procedural step 1 to 6.

Figure 4-3

No display trouble isolation procedure



e5052ase104

Step 1. Check fan operation and DC monitor LED

If the rear panel fan (blower) doesn't run, a failure in A50 ATX power supply is assumed. Remove the E5052A outer cover and check if the following LEDs light:

- +3.3 V and +5 V dc monitor LEDs on A21 PCI DSP card

NOTE

To check all the outputs of the A50, measure the dc voltages at the output lead connectors with a DMM. The dc output voltages and lead color information is provided in the module cover label of the A50.

To check all the outputs of the A12 power distribution board, measure the dc voltages at the voltage test pins with a DMM.

Step 2. Check system fans inside.

If the system fans on the chassis inside the E5052A don't run, problem seems in the A21 PCI DSP card or the flat cable between the A21 and the A22 front panel keyboard. In this case, remove the E5052A outer cover and make sure whether the fan run or not.

If a beep and a power shutdown occur immediately after power is turned on, there is a possibility that the fan won't run. The power shutdown occurs the moment the system fan stops by any anomaly. In this case, check the fan that doesn't run.

If the power shutdown occurs without a beep, the problem seems in the A21 or the A20 digital motherboard.

NOTE

Before replacing the board, check if the jumper setting on the A20 is correct as described in "Configure the Motherboard" on page 115.

Step 3. Check LED of "Num Lock" key

Press "Num Lock" key on the keyboard. If the LED in the key doesn't light as shown in Figure 4-4, a problem seems in the A20 digital motherboard.

Figure 4-4

LED of the Num Lock key



e5061ase048

Make sure the following before replacing the A20.

- Whether all the connections to the A20 are normal or not. Check if there is any disconnection or connection working loose.
- Whether the jumper setting on the A20 is correct or not as described in "Configure the

Troubleshooting

No Display troubleshooting

Motherboard” on page 115.

- Whether BIOS options are correct or not as described in “To Confirm or Set the BIOS Options” on page 116.

Step 4. Checking with the external monitor

Connect an external VGA monitor to the VIDEO output on the E5052A rear panel.

- If something is displayed on the external monitor, the problem is present around the LCD. Also check the A21 and A22 because the ON/OFF setting of the LCD backlight is controlled by the A21 through the A22.
- If nothing is displayed even on the external monitor, the problem seems in the A20 digital motherboard.

Step 5. Checking flat cable

Check a flat cable between the A20 and A22.

Step 6. Check around the backlight

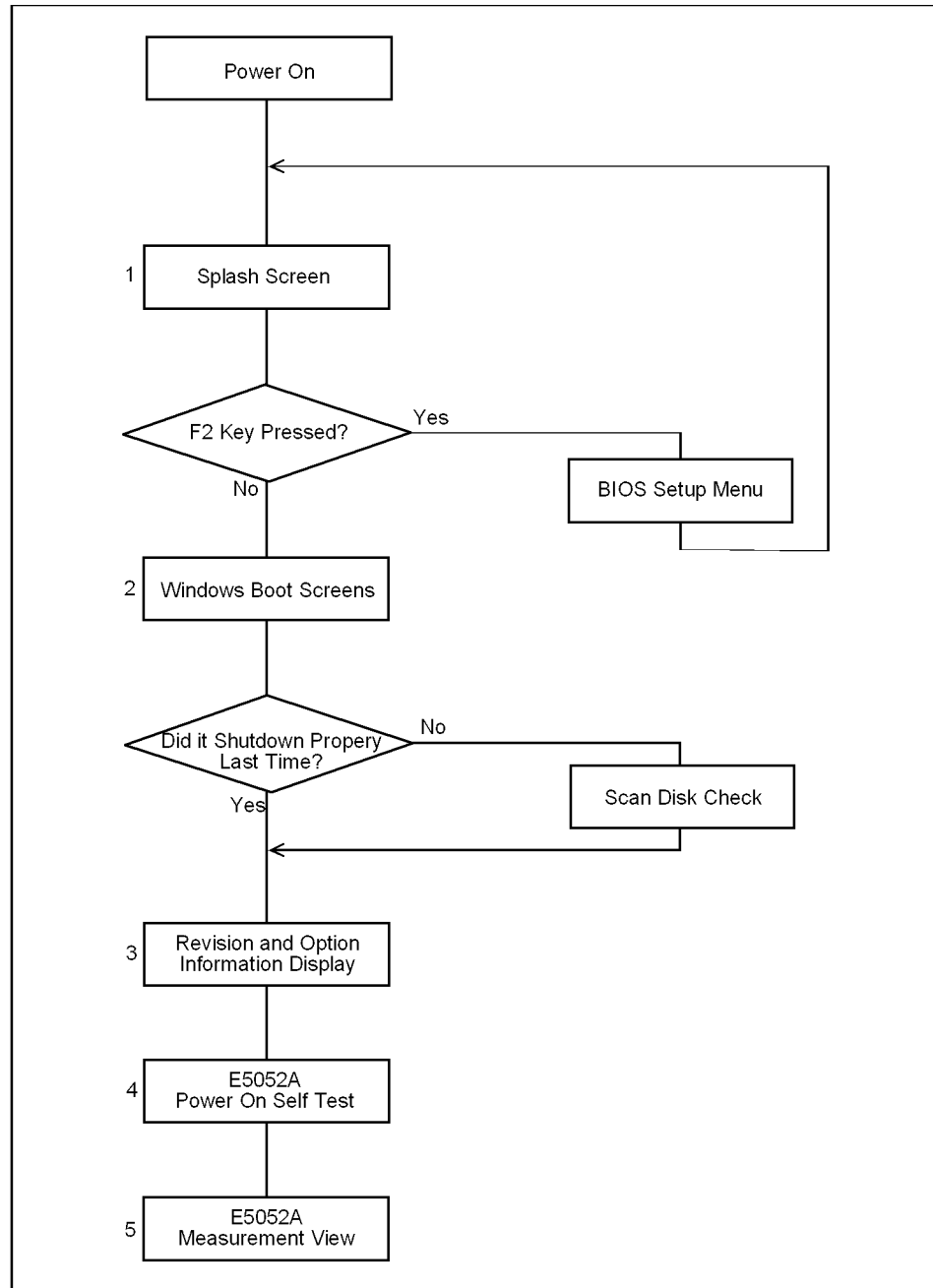
Check A52 inverter board and a cable between the A52 and A22. Also check the cables between the A51 LCD and A52. If the cables are normal, check the A51 LCD.

Booting Process Troubleshooting

Figure 4-5 represents the booting process flow in the E5052A. If the E5052A stops in the booting process, troubleshoot using the following step-by-step procedure.

Figure 4-5

Booting process flowchart



e5052ase087

Troubleshooting

Booting Process Troubleshooting

Step 1. Splash Screen

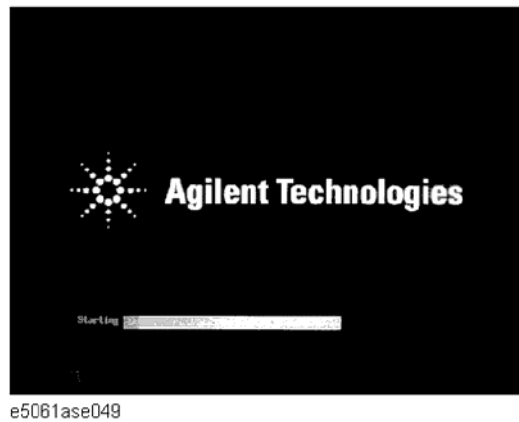
The splash screen is displayed with Agilent logo as shown in Figure 4-6.

If the splash screen is displayed, you can assume that the A20 digital motherboard is functioning correctly.

NOTE

While the splash screen is displayed, if you want to run the BIOS setup utility, push F2 key as soon as in the screen.

Figure 4-6 Splash Screen

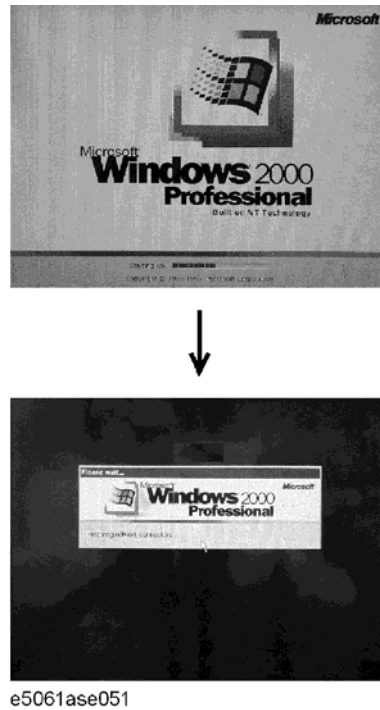


Step 2. Windows boot screens

The Windows boot screens are displayed. The Windows boot screens consists of two screens. Each screen is displayed in the order as shown in Figure 4-7. If the Windows boot screens are displayed, it is assumed that the A27 HDD works. While the Window screens are displayed, Windows operating system is starting up.

Figure 4-7

Windows boot screens



If you encounter the following problems, try to reinstall the operating system before replacing the A27.

- "xxx file is missing" is displayed on DOS screen.
- The Window boot screen is not displayed after the splash screen is displayed.
- Windows always boots up with Safe Mode.

NOTE

If the E5052A was turned off without shutdown process, Microsoft Scandisk runs while the windows boot screens are displayed. If a serious problem is found in the scandisk, reinstall the operating system. For details of the operating system installation, refer to Appendix B, "System Recovery," on page 227. If the operating system still doesn't boot up properly after reinstallation, replace the A27.

NOTE

The operating system automatically checks the device drivers, which are necessary to use the E5052A functions and are installed in the system before the E5052A is shipped from Agilent factory. If the operating system doesn't detect them, a message box is displayed. In this case, install the device driver.

Step 3. Revision and option information

The firmware revision and hardware option information along with copyright declaration is displayed as shown in Figure 4-8. The E5052A firmware quickly starts up just before this display appears. While the revision and option information is displayed, the applications of various devices in the system are initialized.

Figure 4-8

Firmware revision and option information



e5052ase101

If the display whited out, entirely blued or appeared with a dialog box, a mass storage problem is suspected. Try to perform the mass storage recovery procedure.

NOTE

If a message of "Will Shut Down in Five Seconds" is displayed in place of "Initializing.." and the shutdown occurs, the A21 board fails in starting up. The following message may be displayed before the shutdown occurs:

"Fatal Error: Failed to Initialize DSP Driver":

or "Fatal Error: Failed to Initialize DSP":

This message indicates that the A21 board doesn't work or is not properly connected to the A20.

"Fatal Error: Failed to Update DSP Code":

If this happened, the A21 board failed in writing DSP program into flash ROM when the firmware was installed first or updated to the newest version. A problem in the A21 or A20 is suspected.

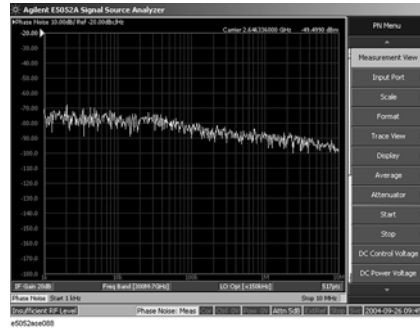
Step 4. Power-on self test

The power-on self test is executed once automatically before the measurement starts. While the power-on self test is in progress, "Executing power on test" is displayed. If the power-on test fails, an error message is displayed at the left in the instrument status bar. For more details, refer to "Troubleshooting Using Service Function" on page 96.

Step 5. Measurement view

The measurement view as shown in Figure 4-9 is displayed after the system initialization is completed without problem.

Figure 4-9 Measurement view



Troubleshooting Using Service Function

The Agilent E5052A has a service function to diagnose the analog measurement section and internal dc power supply voltages. The Power On Test of the service function makes it possible to isolate a faulty board assembly. The following paragraphs describe the procedure to perform the Power On Test.

Power On Test

Power-on self-test always takes place once the E5052A is turned on. When a failure is detected, a message "Power on self test failed" is displayed. The content of the power-on self-test includes the dc power supply voltage, source PLL synthesizer and level controller (ALC) tests. When the power on self-test failed, perform the Power On Test in Service Function Menu to narrow down failure possibilities.

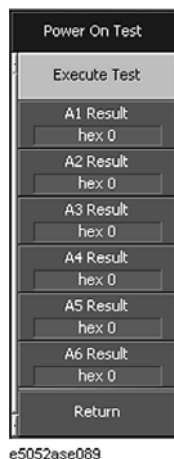
The following procedure can be used to restart the power-on self test as required.

- a. Press **System** key.
- b. Click **Service Menu** and, then, click **Service Function - Service Functions** in the softkeys.
- c. Password dialog box opens. Enter the password **kid** in the Password box and then click "OK" button.
- d. Click **Service Functions**. Then click **Power On test**.
- e. Click **Execute Test** to restart the test. Wait until the power-on test ends.
- f. The test results can be displayed with result softkeys (**A1 Result** through **A6 Result**) as shown in Figure 4-10. The A1 through A6 mean the analog sections (boards) of the E5052A.

NOTE

When "hex 0" status is displayed in the results softkey, the corresponding analog section passes. When other status is displayed in the results softkey, the corresponding analog section fails.

Figure 4-10 Power On Test softkey menu



Contents of the power on test results

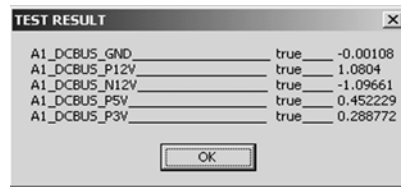
The power on test contains 6 test results shown in Figure 4-10. Each test result can display various operating characteristics of the analog measurement section. You can identify a failure section with the test results. When the Power On Test is done, “true” or “false” is indicated for each test item.

A1 Result

Figure 4-11 is an example of the A1 Result.

Figure 4-11

A1 Result example



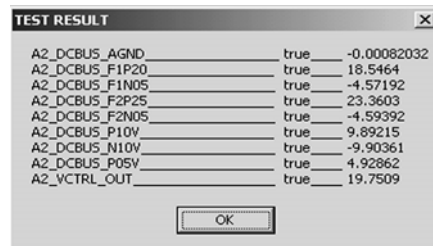
e5052ase090

A2 Result

Figure 4-12 is an example of the A2 Result.

Figure 4-12

A2 Result example



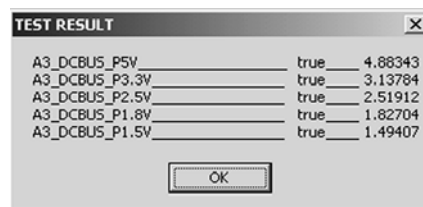
e5052ase091

A3 Result

Figure 4-13 is an example of the A3 Result.

Figure 4-13

A3 Result example



e5052ase092

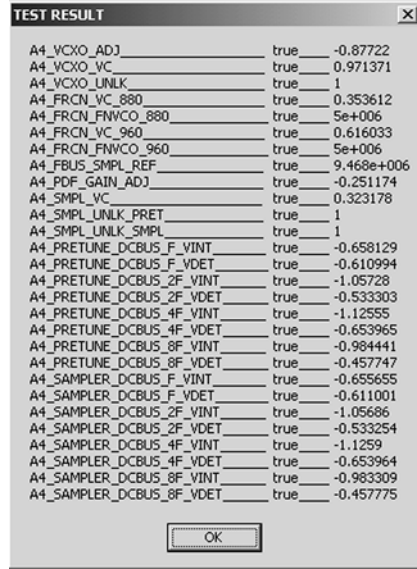
Troubleshooting
Troubleshooting Using Service Function

A4 Result

Figure 4-14 is an example of the A4 Result.

Figure 4-14

A4 Result example



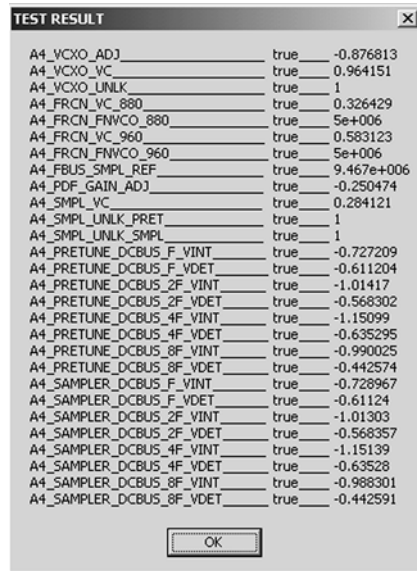
e5052ase093

A5 Result

Figure 4-15 is an example of the A5 Result.

Figure 4-15

A5 Result example



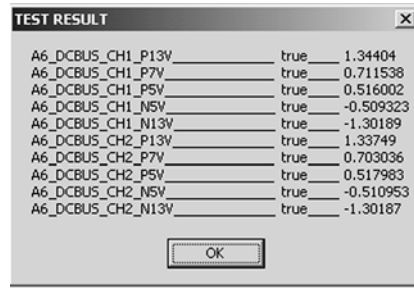
e5052ase094

A6 Result

Figure 4-16 is an example of the A6 Result.

Figure 4-16

A6 Result example



e5052ase095

Power On Test Failure Troubleshooting

Table 4-1 represents the contents of the test results and the relationships of failed tests to probable faulty board assemblies. If the instrument fails the power on test, replace the faulty board assembly as shown in Table 4-1.

Table 4-1

Power on test failure troubleshooting information

Test result	Probable faulty board assembly					
	A1 F/P Detect	A2 DC Source	A3 ADC/DSP	A4 Local Synth	A5 Local Synth	A6 Phase Detect
A1 Result	###					
A2 Result	#	###				
A3 Result	#		###			
A4 Result	#			###		
A5 Result	#				###	
A6 Result	#					###

###: Most suspicious assembly

##: Suspicious assembly

#: Possible faulty assembly

Function Specific Troubleshooting

If the E5052A exhibits a failure symptom that is related to a specific function or control such as a front panel key control, display, data storage, remote control interface, printer interface, external trigger, external keyboard or mouse, isolate the trouble using the Function Specific Troubleshooting procedures described below. The major functions of the E5052A and the troubleshooting procedure for each function are shown in Table 4-2.

Table 4-2 Major functions and troubleshooting procedures

Function	Description	Troubleshooting
Front panel keys	All the E5052A functions except for VBA and service functions can be set and controlled via the front panel keys.	Refer to “To Check the Front Panel” on page 103.
Touch panel	The E5052A has a touch screen display that allows all the functions in the menu bars, setup windows and dialog boxes to be set by a touch to the screen panel.	Refer to “To Check the Touch Panel” on page 104.
LCD display	Almost all the information including the measurement value, setup state, result data processing, menu bar, softkey label and others are indicated on the 10.4-inch color LCD display.	Refer to “To Check the LCD” on page 104.
External keyboard	The external keyboard can be used for the entry of numerical and character data when it is connected to the keyboard interface connector (PS-2) on the rear panel.	Refer to “To Check the External Keyboard” on page 105.
Mouse	The mouse can be used to move the pointer on the LCD display, select a function and change a setting, when it is connected to the mouse interface connector (PS-2) on the rear panel.	Refer to “To Check the Mouse” on page 105.
Floppy disk drive	The 3.5-inch floppy disk drive on the front panel is used to save the E5052A setup state and measurement data in a 3.5-inch, 1.4 MB floppy disk in MS-DOS compatible format.	Refer to “To Check the FDD” on page 105.
Video output	An external color monitor can be used to display the same information as the E5052A LCD display, when it is connected to the Video output connector (24-pin D-Sub) on the rear panel.	Refer to “To Check the Video output” on page 106.
External trigger input	The external trigger input terminal (BNC) on the rear panel allows an external trigger source to be used for measurement trigger.	Refer to “To Check the External Trigger Input” on page 106.
LAN port	The LAN interface port on the rear panel allows the E5052A to be connected to 10/100 Base-T Ethernet.	Refer to “To Check the LAN” on page 106.

Table 4-2 Major functions and troubleshooting procedures

Function	Description	Troubleshooting
Printer parallel port	A specified printer can be used to print the E5052A measurement display, setup display and others, when it is connected to the Printer port (36-pin D-Sub) on the rear panel.	Refer to “To Check the Printer Parallel/USB Port” on page 110.
GPIB Interface	The GPIB compatibility allows the E5052A to be operated as a talker/listener on IEEE 488 interface bus.	Refer to “To Check the GPIB” on page 111.
24-bit I/O port	The 24-bit I/O port can be used to transfer a comparator decision output data to and perform timing synchronization with an external handler.	Refer to in “To Check the 24-bit I/O port” on page 111.
Ref Oven	A 10 MHz high stability signal is outputted.	Refer to in “To Check the Ref Oven” on page 111.
USB (USBTMC) Interface	The GPIB compatibility allows the E5052A to be operated as a talker/listener on IEEE 488 interface bus.	Refer to in “To Check the USB (USBTMC) Interface Card” on page 111.

To Check the Device Driver

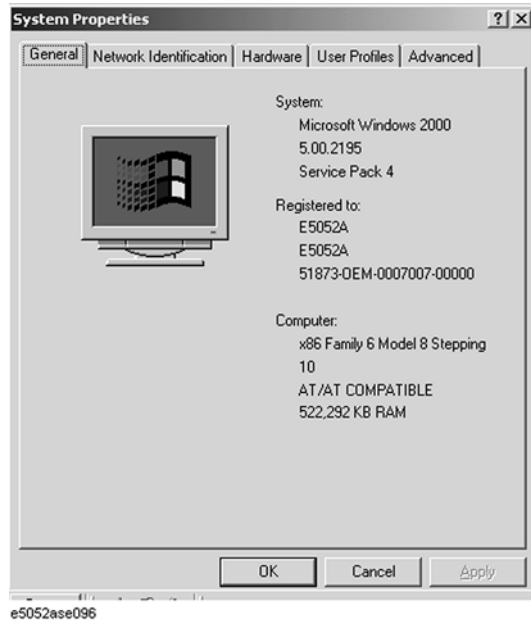
Make sure first whether the E5052A device drivers are installed properly or not by the following procedure, if a function of specific device in the E5052A doesn't work.

- Step 1.** Exit from the E5052A measurement view in accordance with the procedure described in “How to exit from the E5052A Measurement View” on page 85. Then, Windows desktop screen is displayed.
- Step 2.** Click "My Computer" with the right button and select "Properties" as shown in Figure 4-17. Then, the System Properties(Figure 4-18) will appear.

Figure 4-17 Opening System Property Window

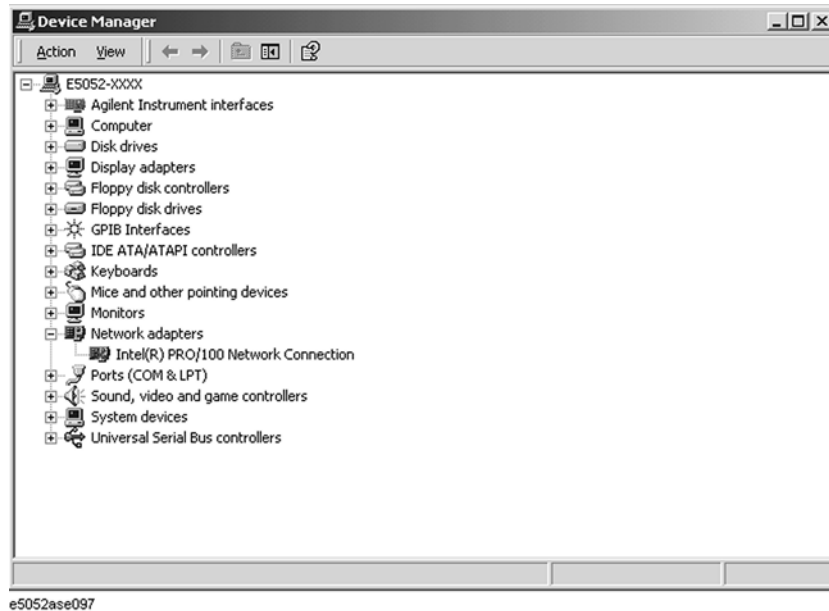


Figure 4-18 System Properties Window (General)



Step 3. Click Hardware tab and Device Manager button. The operating system detects all the necessary device drivers and displays the device names as shown in Figure 4-19.

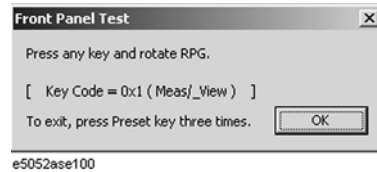
Figure 4-19 System Properties Window (Hardware)



Click the icon with the right button and click Property to show the detail of the status as shown in Figure 4-20.

Figure 4-22

Key code and key name display example



Step 5. To exit the front panel test, press **Preset** key three times.

- If multiple keys fail to work, a problem in A22 front panel keyboard or A21 PCI DSP card is suspected. Also check the flat cable between the A21 and A22.
- If only a specific key doesn't work, check first if the key is subsided in the panel.
- If the rotary knob doesn't work, check the A22 board involving the RPG.

To Check the Touch Panel

Procedure

By touching the LCD display panel, select or change the setting of a function in the softkey menu and, then, perform the same operation with hardkeys.

- If the touch panel doesn't work correctly whereas the hardkeys function normally, a failure seems in the touch screen controller assembly (5183-4184) or touch-panel LCD assembly (E5070-60102). (The touch panel is not replaceable independently of the LCD.)
- Check the cable between the touch screen controller and the serial interface connector on the A20 digital motherboard.
- If no problem is found in the above checks, a failure in the A20 digital motherboard is suspected.

To Check the LCD

Procedure

Step 1. Press **System** key.

Step 2. Click **Service Menu** and, then, **Test Menu** in the softkeys menu.

Step 3. Click **Display Test** in the test menu. The whole of the LCD screen turns Red, Green, Blue, White and Black every 2 seconds and returns to the measurement view. If the color test screen doesn't appear correctly, perform step 4.

Step 4. Connect an external VGA monitor to the VIDEO output port on the E5052A rear panel.

- If the monitor screen view is the same as the LCD display, the problem seems in the A20 board.
- If only the LCD display has a problem, check the flat cable between the A22 front panel keyboard and A31 LCD connector.
- If the LCD is not illuminated with backlight, check A52 inverter board and the cable

between the A52 and A22. Also check the cables between the A51 LCD and A52.

- If the cables are normal, check the A51 LCD.

To Check the External Keyboard

Procedure

- Step 1.** Connect the external keyboard to the E5052A rear panel connector.
- Step 2.** Turn the instrument on.
- Step 3.** Press **Meas/View** key.
- Step 4.** Press **↑** and **↓** keys on the external keyboard, and verify that the cursor on the menu bar moves up and down. If it doesn't work, the external keyboard or the A20 digital motherboard may be faulty.

To Check the Mouse

Procedure

- Step 1.** Connect the mouse to the E5052A rear panel connector.
- Step 2.** Turn the instrument on.
- Step 3.** Move the mouse and verify that the mouse pointer moves smoothly. If it doesn't move smoothly, check first whether a foreign substance (dust, lint, etc.) is in the track ball hole of the mouse or not.
- Step 4.** Verify that the mouse buttons work normally. If any button doesn't work or the mouse pointer doesn't move, a failure in the mouse or the A20 digital motherboard is suspected.

To Check the FDD

Procedure

- Step 1.** Connect the external keyboard to the E5052A rear panel connector.
- Step 2.** Turn the instrument on.
- Step 3.** Insert a 1.44 MB floppy disk, formatted in DOS format, into the FDD slot.
- Step 4.** Press **Save/Recall** key, and click **Save State** in the menu bar.
- Step 5.** Click **File Dialog...** to open the "Save As" dialog box.
- Step 6.** Select 3 1/2 Floppy [A:] from "Save in" pull-down menu.
- Step 7.** Enter **e5052a** in the file name box from the keyboard.
- Step 8.** Click "Save" button.
- Step 9.** Press **Save/Recall** key, and click **Recall State** in the menu bar.
- Step 10.** Click **File Dialog...** to open the "Open" dialog box.

Troubleshooting

Function Specific Troubleshooting

- Step 11.** Select 3 1/2 Floppy [A:] from "Look in" pull-down menu.
- Step 12.** Select e5052a file from the file menu or enter **e5052a** in the file name box.
- Step 13.** Click "Open" button.

If the file save or recall operation fails, a failure in the A28 FDD or the flat cable between the A28 and A20 digital motherboard is suspected.

To Check the Video output

Procedure

- Step 1.** Connect an external VGA color monitor to the Video output port on the E5052A rear panel.
- Step 2.** Turn the external monitor on.
- Step 3.** Verify that the monitor screen view is the same as the display on the LCD. If the monitor screen view is abnormal, a failure seems in the A20 digital motherboard.

To Check the External Trigger Input

Procedure

- Step 1.** Press **[Preset]** - **Factory** to initialize the E5052A. In case of installing the firmware revision 1.00/1.10, press **[Preset]** - **OK**.
- Step 2.** Press **[Trigger]** key.
- Step 3.** Click **Source** and, then, **External** in the menu bar to set the trigger mode to "External".
- Step 4.** Connect a BNC Short or 50 Ω termination to the Ext Trig connector on the rear panel and disconnect it. Thereby a measurement trigger should be generated and a measurement result (trace) should be refreshed.
- Step 5.** If no trigger occurs, a failure in the A21 PCI DSP card is suspected.

To Check the LAN

Procedure

- Step 1.** Connect a LAN cable between the LAN port on the rear panel and an external computer (PC).

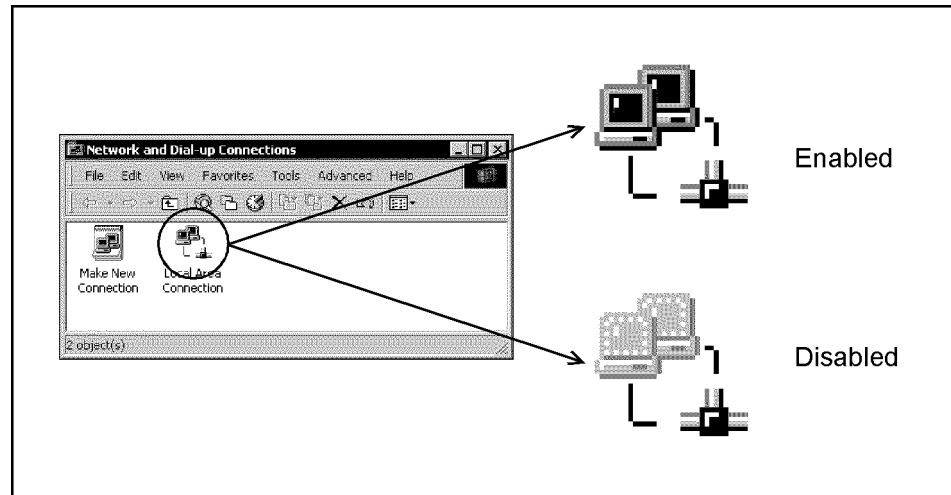
NOTE

Use a crossed LAN cable to enable the peer-to-peer communication between the E5052A and the PC. If the E5052A needs to be connected to the PC via a multi port Hub, use a straight LAN cable.

- Step 2.** Press **[System]** key.
- Step 3.** Click - **Misc Setup - Network Setup - Network Configuration** in the softkey menu to show the Network and Dial-up Connections window as shown in the left of Figure 4-23.

Figure 4-23

Network and Dial-up Connections window



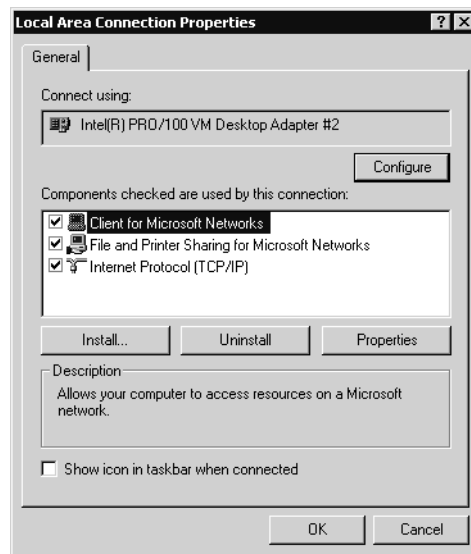
Step 4. Check the Local Area Connection icon to confirm whether the network connection is enabled or disabled. The meaning of the icon is shown in the right of Figure 4-23. If the connection is disabled, Double-click the Local Area Connection icon.

Step 5. Set up the IP address/subnet mask as follows.

- a. Click the Local Area Connection icon with the right button and click "Properties". This opens the "Local Area Connection Properties" dialog box as shown in Figure 4-24.

Figure 4-24

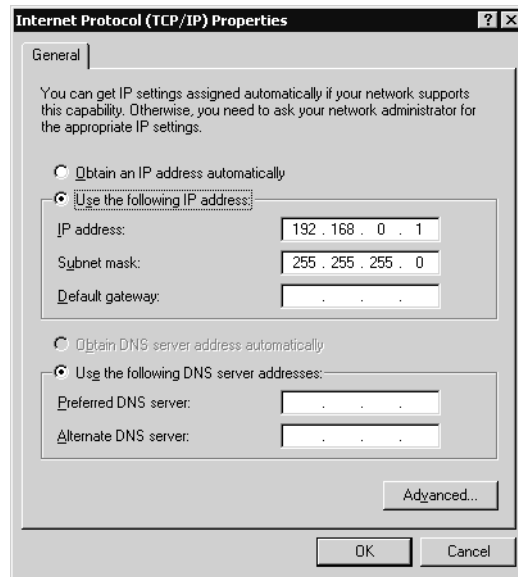
Network dialog box



- b. Click "Internal Protocol (TCP/IP)" icon.

- c. Click the "Properties" button. This opens the "TCP/IP Properties" dialog box as shown in Figure 4-25.

Figure 4-25 TCP/IP Properties dialog box (IP Address tab)



- d. If the IP Address and the Subnet Mask are already assigned, go to Step 6. If they are not assigned yet, enter them as follows:

IP Address 192.168.0.1
Subnet Mask 255.255.255.0
Default Gateway blank

To enter a specific IP Address and Subnet Mask, click "Use the following IP address" option button to select it. Input your IP address in the "IP Address" box and your subnet mask in the Subnet Mask box (overwrite the initial values).

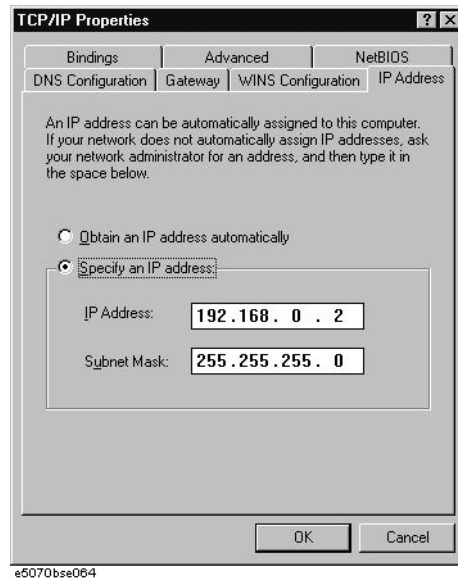
- e. Double-click "My Computer" icon on Windows desktop of the external PC. And double-click **Control Panel**. The Control Panel window will appear.

NOTE

From Step e to Step h are procedures for Windows

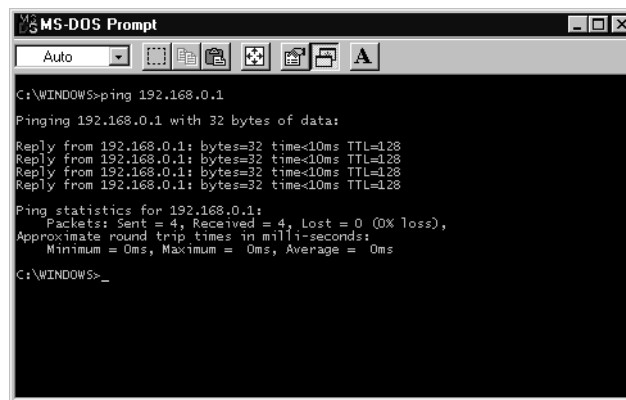
- f. In the Control Panel window, double-click **Network**. The Network dialog box will appear. In the **Configuration** tab, select **TCP/IP** (display it in reverse video) and press the **Properties** button.
- g. The dialog box appears. If **Specify an IP address** has been selected, record the IP address and subnet mask.
- h. If the **Obtain an IP address automatically** has been selected, select the **Specify an IP address**. Enter the IP address xxx.xxx.xxx.y and subnet mask xxx.xxx.xxx.xxx as shown in Figure 4-26. The letters x represent the IP address and subnet mask of the E5052A. The letter y is different from the IP address of the E5052A. Press the **OK** button. Then, restart the external PC.

Figure 4-26 Network Dialog Box (“IP Address” Tab)



- Step 6.** By clicking “OK” button, the network settings take effect. Verify the E5052A LAN settings and response to a command from the external computer as follows:
- On the external computer, click "Start" button in the Windows Start menu bar using a mouse.
 - Click "Programs" and "MS-DOS Prompt" (or "Command Prompt") to open the DOS (Command) Prompt window.
 - Type a ping command followed by the E5052A IP address as "ping xxx.xxx.xxx.xxx" (where, xxx.xxx.xxx.xxx is the IP address such as 192.168.0.1 assigned in step 3-d.) Press **Enter** key on the keyboard.
 - The external computer displays a message of ping command response from the E5052A. Figure 4-27 shows an example of normal result that indicates the IP address, packet size, and a response time counted by the computer. The ping command is repeated 4 times.

Figure 4-27 Example of normal ping command test result



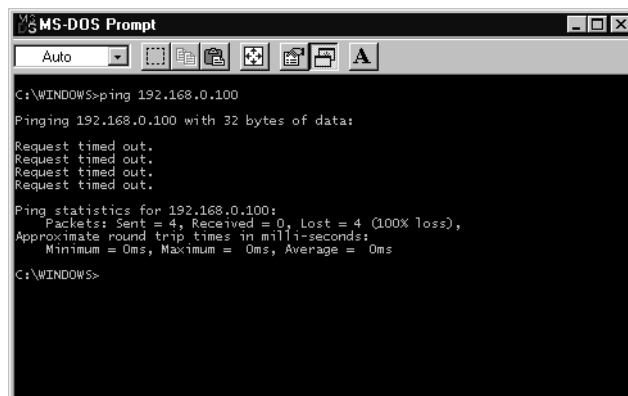
If the E5052A doesn't return the response, the external computer displays a message of

Troubleshooting

Function Specific Troubleshooting

"Request timed out" as shown in Figure 4-28. In this case, a failure in the A20 digital motherboard is suspected.

Figure 4-28 Example of no response for ping command



To Check the Printer Parallel/USB Port

Test equipment

It is recommended that the following compatible printer be used.

Manufacturer	Recommended printer (as of July 2004)
Hewlett Packard	HP DeskJet 5650

Printer cable: Parallel cable

Procedure

- Step 1.** Connect the printer cable between the printer and the E5052A printer parallel port. Turn the printer on.
- Step 2.** Press **[Preset]** - **Factory** to initialize the E5052A. In case of installing the firmware revision 1.00/1.10, press **[Preset]** - **OK**.
- Step 3.** Press **[System]** key.
- Step 4.** Click **Printer Setup** in the softkey menu.
- Step 5.** Depending on the printer used, Click "hp deskjet 5650" icon with the right button in the Property window. Then, click "Set as Default Printer" button.
- Step 6.** Click **Print** in the softkey menu. Confirm the printout of the display image.
- Step 7.** If the printer fails to work, the problem seems in the A20 digital motherboard, printer driver or connection of the printer cable.

To Check the GPIB

Procedure

Perform the E5052A performance test program. If the controller cannot detect the E5052A, the problem seems in the A24 GPIB card or the connection of the GPIB cable.

To Check the 24-bit I/O port

Procedure

This check is performed using a handler I/O test kit (p/n E5070-65001) as a substitute for the handler.

- Step 1.** Connect the flat cable of handler I/O test kit to “J2” connector of the kit.
- Step 2.** Connect the cable of the kit to the 24-bit I/O port connector on the rear panel.
- Step 3.** Check the 24-bit I/O port by executing “24bitI-Otest.vba”.

NOTE

The program “24bitI-Otest.vba” can be downloaded from the Agilent Technologies web site to a floppy disk using your computer’s FDD.

- Step 4.** If the check failed, a failure in the A25 24-bit I/O board is suspected.

To Check the Ref Oven

Procedure

This check is performed using a frequency counter and a power meter.

- Step 1.** Connect the frequency counter to the Ref Oven connector, and then verify that the frequency value is $10 \text{ MHz} \pm 1 \text{ Hz}$.
- Step 2.** Connect the power meter to the Ref Oven connector, and then verify that the power value is $2.5 \text{ dBm} \pm 3 \text{ dB}$.
- Step 3.** If the check failed, a failure in the A11 10 MHz Oven is suspected.

To Check the USB (USBTMC) Interface Card

Procedure

Connect the USB cable between the controller PC and the E5052A. Turn the controller PC on. If the E5052A cannot detect the controller PC, the problem seems in the USB (USBTMC) Interface Card or the A20 digital motherboard is suspected.

Performance test failure troubleshooting

This section describes the adjustment and troubleshooting procedures used when the E5052A fails the performance tests. If the performance of the instrument is critical for the test limits and seems to be adjustable, perform first the adjustment(s) related to the failed test. When the test result is far from the tolerance of the test or the performance is not adjustable, isolate the faulty assembly in accordance with the "Performance tests failure troubleshooting procedure".

Recommended adjustment for performance test failure

Table 4-3 shows the recommended adjustments when the performance test fails. Select the adjustment program corresponding to the recommended adjustment and perform the adjustment. Note that adjustment items for the A3 or A4/5 are the same as the A6.

When RF IN Port VSWR test fails, check first whether the connections of the RF semi-rigid cables are tight or loose. Also check for possible disconnection (impairment) of the cables and connectors.

Table 4-3

Recommended adjustment for performance test failure

Test Num.	First failed test	Recommended adjustment				
		A1	A2	A3	A4/5	A6
1	RF IN Port VSWR Test					
2	Frequency Measurement Test	√				√
3	Power Measurement Accuracy Test	√				
4	SSB Phase Noise Sensitivity Test					√
5	SA Relative Level Accuracy Test					√
6	DC Power Voltage Test		√			
7	DC Power Current Measurement Test		√			

Adjustment failure troubleshooting

Table 4-4 represents the relationships between the failed adjustment and probably faulty assembly. Note that this table lists some typical cases. There are possibilities that another assembly may be faulty.

Table 4-4 Adjustment failure troubleshooting information

Adj Num.	First failed adjustment	Probable faulty board assembly				
		A1	A2	A3	A4/5	A6
1	DC Control Voltage		###			
2	DC Power Voltage		###			
3	DC Power Current	###	##			
4	Reference Frequency	#			###	
5	Pre-LO Sampler PLL BW				###	
6	Receiver DC offset			#		###
7	PM Offset	###				
8	PM Linearity	###				
9	PM Temp	###				
10	PM Flatness	###				
11	Receiver RF Flatness	#		##	#	###
12	Receiver IF Gain/Flatness			##	#	###
13	LO Sampler PLL BW	#		##	#	###
14	Phase Noise BW			#	###	#

###: Most suspicious assembly

##: Suspicious assembly

#: Possible faulty assembly

Performance test failure troubleshooting

Table 4-5 represents the relationships between the failed test and probable faulty assembly. If the performance test failure cannot be removed by a proper adjustment, replace the assembly shown in this table.

Note that this table lists some typical cases. There are possibilities that another assembly may be faulty.

NOTE

When RF IN Port VSWR test fails, check first whether the connections of the RF semi-rigid cables between the suspicious assembly and others are tight or loose. Also

Troubleshooting
Performance test failure troubleshooting

check for possible disconnection (impairment) of the cables and connectors.

Table 4-5 Performance test failure troubleshooting information

Test No.	First failed test	Probable faulty board assembly					
		A1	A2	A3	A4	A5	A6
1	RF IN Port VSWR Test	###					
2	Frequency Measurement Test	##		#		#	###
3	Power Meas. Accuracy Test	###					
4	SSB Phase Noise Sensitivity Test			#	##	##	###
5	SA Relative Level Accuracy Test			#		##	###
6	DC Power Voltage Test		###				
7	DC Power Current Meas. Test	#	###				

###: Most suspicious assembly

##: Suspicious assembly

#: Possible faulty assembly

To configure the A20 Digital Motherboard and BIOS

When you replace the A20 digital motherboard, you need to confirm the jumper settings for the specific CPU installed. The jumper settings information is provided in “Configure the Motherboard” on page 115.

You also need to confirm the BIOS options using the BIOS setup utility procedure. The BIOS setup procedure is described in “To Confirm or Set the BIOS Options” on page 116.

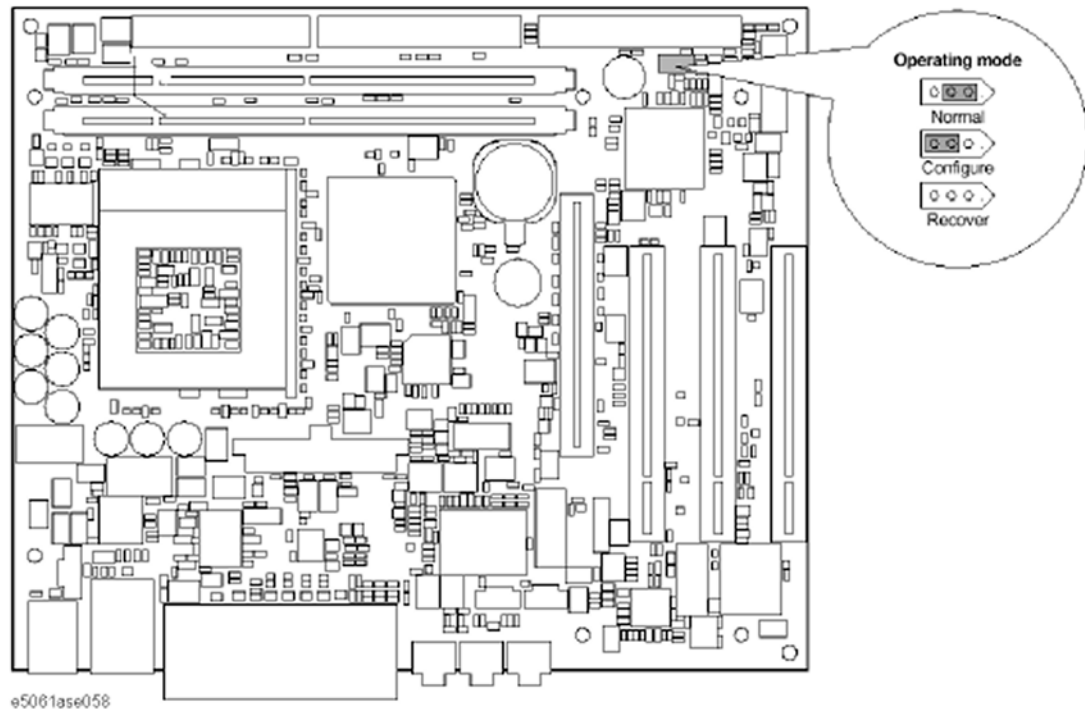
To Identify the Motherboard Installed

Confirm the splash screen is displayed in the beginning of the boot process as shown in Figure 4-6.

Configure the Motherboard

There is a jumper on the A20 digital motherboard that must be configured to the correct setting. Confirm that the jumper setting is “Normal” as shown in Figure 4-29.

Figure 4-29 A20 digital motherboard jumpers location and settings



Testing DRAM on the Motherboard

When the A20 digital motherboard is replaced with a new one, it is advisable to perform the DRAM test before proceeding to the BIOS setup utility procedure. Confirm the DRAM count in accordance with the following procedure.

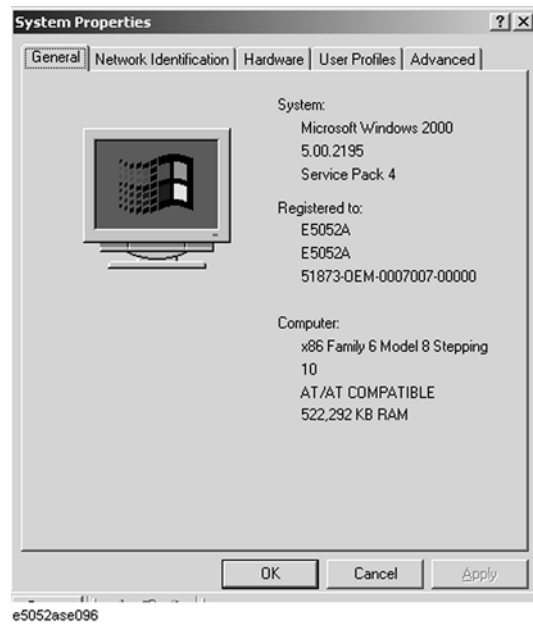
Step 1. Connect the external keyboard and mouse to the E5052A rear panel connectors.

To configure the A20 Digital Motherboard and BIOS

- Step 2.** Turn the instrument on. Wait until the E5052A boots up. Do not press any key until the E5052A measurement view appears.
- Step 3.** Press **[System]** key on the front panel.
- Step 4.** Click **Misc Setup** in the softkey menu.
- Step 5.** Click **Control Panel...** in the softkey menu.
- Step 6.** Scroll the function viewer to find "System" icon and double-click "System". This opens "System Properties" window as shown in Figure 4-30.

Figure 4-30

System Properties window



- Step 7.** Verify that "522,292 KB RAM" is displayed in the Computer profile as shown in Figure 4-30. If it is not correct, the A20 board is faulty.
- Step 8.** Click "OK" button to close the window.
- Step 9.** Turn the E5052A off before proceeding to the next step "To Confirm or Set the BIOS Options".

To Confirm or Set the BIOS Options

BIOS is the PC's built-in program describing the standard procedure of basic inputs and outputs for the system hardware. BIOS involves the system BIOS, start-up program and BIOS setup utility. The E5052A starts up first with the BIOS when the power is turned on. Use the following procedure to confirm or set the BIOS options, known as the BIOS setup utility.

Run the BIOS setup utility

Use the external keyboard to select and set various options in the BIOS setup utility. Do not operate the E5052A front panel until you exit the BIOS option setup procedure.



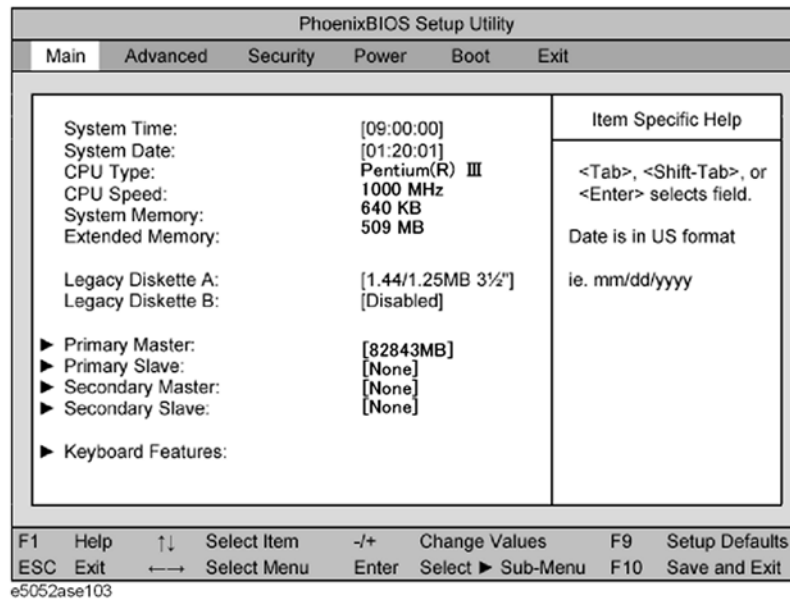






- Procedure**
- Step 1.** Connect the external keyboard to the E5052A rear panel connector.
 - Step 2.** Turn the instrument on.
 - Step 3.** Press F2 key as soon as the splash screen as shown in Figure 4-6 is displayed. Wait a few seconds until the message "Enter CURRENT Password:" appears.
 - Step 4.** Press  key (The LED in the key lights.)
 - Step 5.** Enter password "e5052" and press . Then BIOS setup utility main menu is displayed as shown in Figure 4-31.

Figure 4-31 BIOS setup utility main menu



- Step 6.** The BIOS setup utility has primary menus, most of which have sub-menus. Brief descriptions and reference pages for these menus are provided in Table 4-6. The details of the BIOS option settings in each menu and sub-menus are described on the page listed in the table.
- Step 7.** Select a desired menu using   keys. Select an item in the menu or sub-menu window using   keys. To perform an operation, use  key.

NOTE If you want to exit the BIOS option setting and exit the BIOS setup utility without saving changes in the setup, select "Exit Discarding Changes" and press  key at the Exit

Menu.

Table 4-6 BIOS setup utility primary menus and references

Menu	Options	Ref. page
Main	Product description including processor and memory fitted Date and time IDE disks found and sub-menus for extra configuration	on page 116
Advanced	Start-up display mode (silent-boot etc.) Operating system type (ACPI etc.) Advanced chipset configuration Processor cache control PCI space configuration I/O devices configuration Advanced hard disk drive options System monitoring Version information	on page 119
Security	Passwords and permissions	on page 121
Power	Action after AC-reconnect Power savings modes and timers	-
Boot	Selects device boot order	on page 120
Exit	Save with or without changes Load/save default settings (from flash ROM)	on page 121

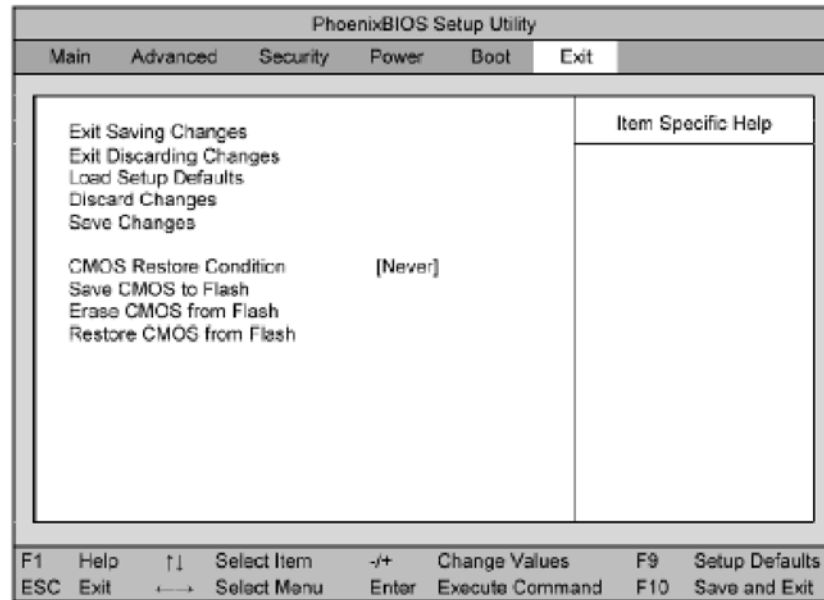
Load Setup Defaults

NOTE

Perform the following procedure only when the A20 digital motherboard is replaced. Jump to “Advanced Menu” when you check whether the BIOS options are correctly set or not.

Exit menu shown below is displayed by choosing "Exit" using keys and by pressing key at the BIOS Setup Utility main menu. Select “Load Setup Default” using keys. The dialog box “Setup Confirmation” prompts you to select Y (Yes) or N (No). Press and to load the manufacture Setup Defaults into the BIOS ROM. As a result, almost all of the BIOS options are automatically configured to the optimal settings for the E5052A.

Figure 4-32 Exit menu (for Load Setup Defaults)



e5081ase057

Advanced Menu

The Advanced Menu shown below is displayed by choosing "Advanced" using **←** **→** keys and by pressing **Enter** key at the BIOS Setup Utility main menu. Select "Advanced OS Options" using **↑** **↓** keys. The current setup states are displayed as shown in Figure 4-34. If "Installed OS" or "Enable ACPI" is incorrect, select it using **↑** **↓** keys, and change the setting by pressing **+** **-** keys.

If you want to exit from this page and return to main menu, press **Esc** key.

Figure 4-33 Advanced Menu

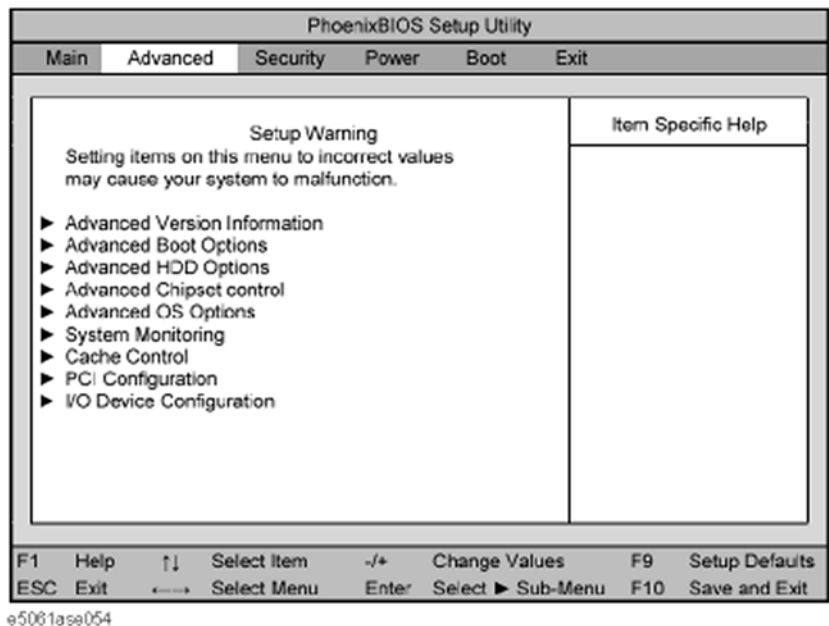
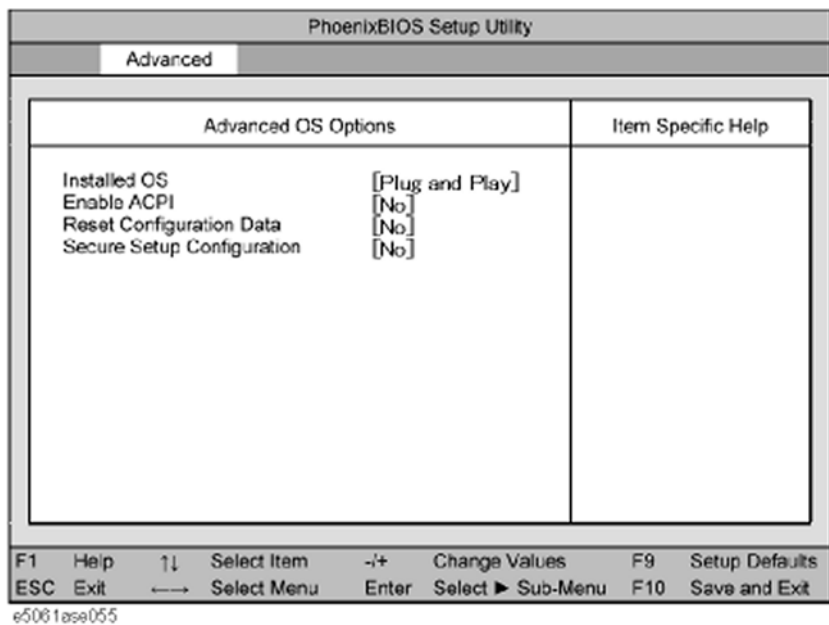


Figure 4-34 Advanced OS Options Sub-menu



Boot Menu

The Boot Menu shown below is displayed by choosing "Boot" using keys and by pressing key at the BIOS Setup Utility main menu. The current setup states are displayed as shown in Figure 4-35. If the setup is incorrect, select it using keys, and change the setting by pressing keys.


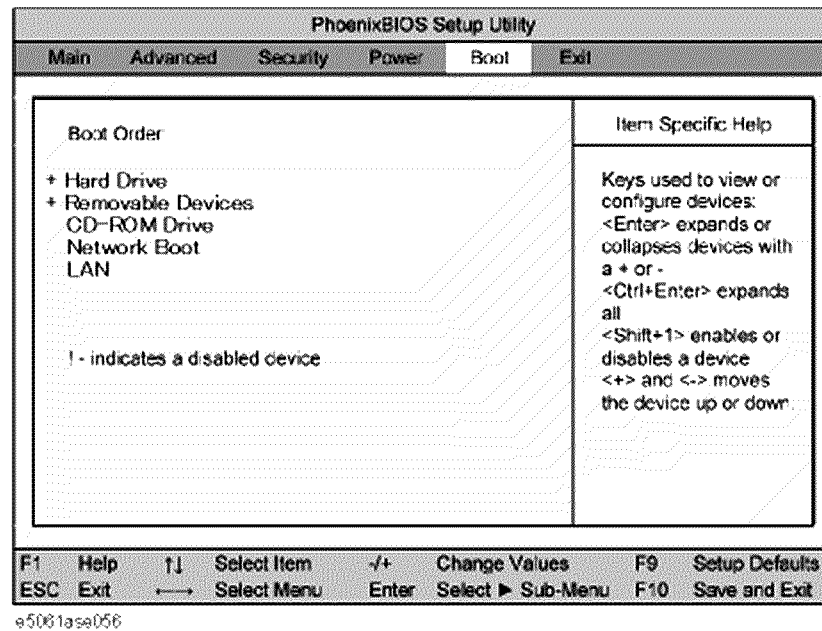
If you want to exit from this page and return to main menu, press  key.









Figure 4-35

Boot Menu














Change Supervisor Password

A password needs to be entered to execute the BIOS setup utility. If a password has not been assigned in the E5052A, set the password using this BIOS setup utility as follows.

- a. Select "Security" using   keys at the BIOS Setup Utility main menu and press  key.
- b. Select "Set Supervisor password" using   keys and press  key.
- c. Enter the password of "e5052". Never set another password.
- d. Press  key.
- e. If a message of "New supervisor password installed. Press any key to continue" is displayed, press  key.

Save & Exit Setup

When you want to change and save a BIOS option, Select "Exit" using   keys at the BIOS Setup Utility main menu and press  key. Select "Save CMOS to Flash" using   and press  key. Then select "Exit Saving Changes" using   and press  key. A message of "SAVE to CMOS and EXIT (Y/N)?" is displayed. Press  and  keys.

The BIOS setup utility is closed after the current settings are saved.

Exit Without Saving

If you cancel the changes in the BIOS option settings, select "Exit Discarding Change" using keys at the Exit Menu and press key. Then, a message of "Quit Without Saving (Y/N)?" is displayed. Press and keys.

The BIOS setup utility is closed without saving the current settings.

5 **Replaceable Parts**

This chapter contains information for ordering replacement parts for the E5052A.

Ordering Information

To order a part in the replaceable parts lists, quote the Agilent Technologies part number, indicate the quantity required, and address the order to the nearest Agilent Technologies Sales Office.

To order a part not listed in the replaceable parts lists, include the instrument model number, the description and function of the part, and the quantity of parts required. Address the order to the nearest Agilent Technologies Sales Office.

Direct Mail Order System

Within the USA, Agilent Technologies can supply parts through a direct mail order system. There are several advantages to this system:

- Direct ordering and shipping from the Agilent Technologies parts center in California, USA.
- No maximum or minimum on any mail order. (There is a minimum amount for parts ordered through a local Agilent Technologies Sales Office when the orders require billing and invoicing.)
- Prepaid transportation. (There is a small handling charge for each order.)
- No invoices.

In order for Agilent Technologies to provide these advantages, please send a check or money order with each order.

Mail order forms and specific ordering information are available through your local Agilent Technologies Sales Office. Addresses and telephone numbers are located in a separate document shipped with the manuals.

Exchange Assemblies

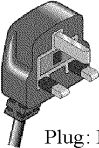
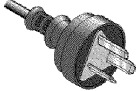
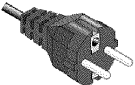
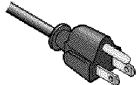

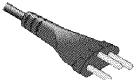
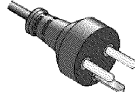
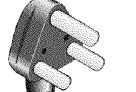
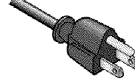



Under the rebuilt-exchange assembly program, certain factory-repaired and tested assemblies are available on a trade-in basis. These assemblies are offered at lower cost than a new assembly, but meet all factory specifications required of a new assembly.

The defective assembly must be returned for credit under the terms of the rebuilt-exchange assembly program. Any spare assembly stock desired should be ordered using the new assembly part number.

Replaceable Parts List

Power Cables and Plug Configurations

Figure 5-1 Power Cables and Plug Configurations

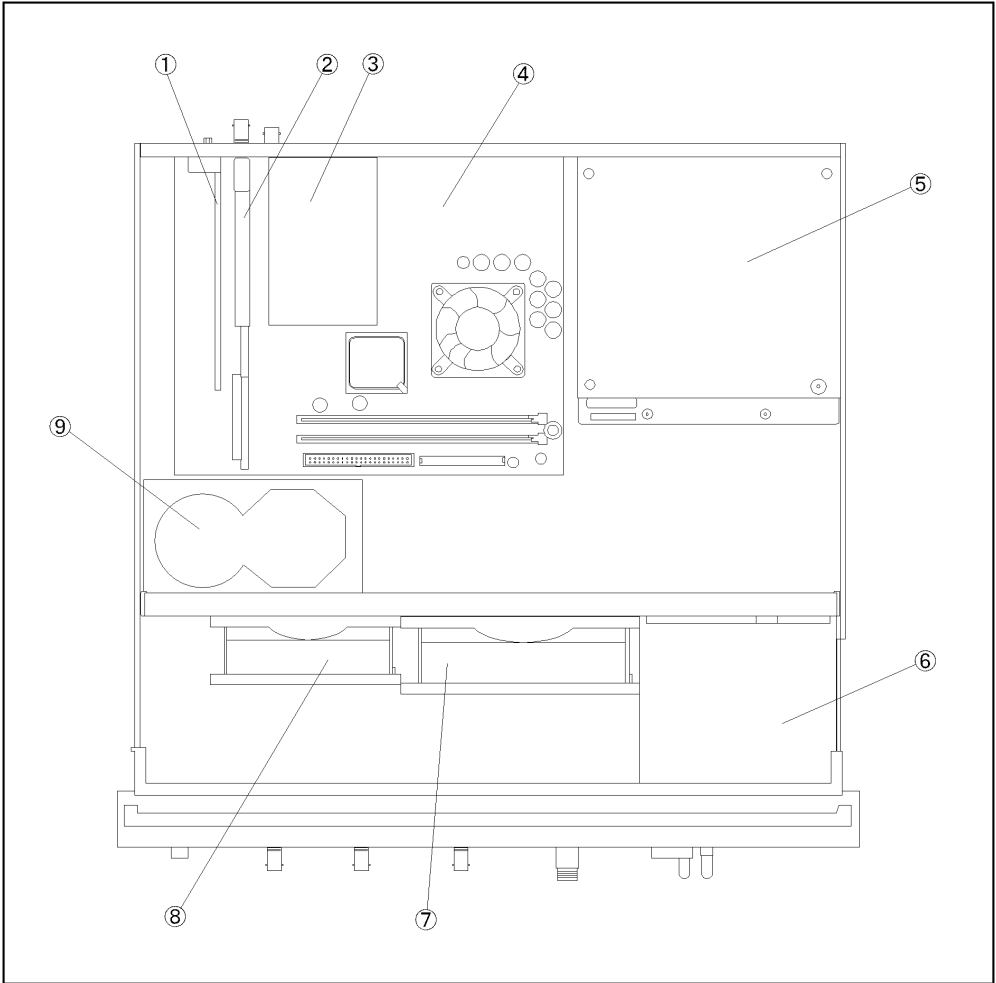
<p>OPTION 900</p>  <p>United Kingdom</p> <p>Plug: BS 1363/A, 250V, 10A Cable: 8120-1351, 8120-8705</p>	<p>OPTION 901</p>  <p>Australia/New Zealand</p> <p>Plug: AS 3112, 250V, 10A Cable: 8120-1369</p>
<p>OPTION 902</p>  <p>Continental Europe</p> <p>Plug: CEE 7 Standard Sheet VII, 250V, 10A Cable: 8120-1689</p>	<p>OPTION 903</p>  <p>U.S./Canada</p> <p>Plug: NEMA 5-15P, 125V, 10A Cable: 8120-1378</p>
<p>OPTION 904</p>  <p>U.S./Canada</p> <p>Plug: NEMA 6-15P, 250V, 6A Cable: 8120-0698</p>	<p>OPTION 906</p>  <p>Switzerland</p> <p>Plug: SEV Type 12, 250V, 10A Cable: 8120-2104</p>
<p>OPTION 912</p>  <p>Denmark</p> <p>Plug: SR 107-2-D, 250V, 10A Cable: 8120-2956</p>	<p>OPTION 917</p>  <p>India/Republic of S. Africa</p> <p>Plug: IEC 83-B1, 250V, 10A Cable: 8120-4211</p>
<p>OPTION 918</p>  <p>Japan</p> <p>Plug: JIS C 8303, 125V, 12A Cable: 8120-4753</p>	<p>OPTION 920</p>  <p>Argentina</p> <p>Plug: Argentine Resolution 63, Annex IV, 250V, 10A Cable: 8120-6870</p>
<p>OPTION 921</p>  <p>Chile</p> <p>Plug: CEI 23-16, 250V, 10A Cable: 8120-6978</p>	<p>OPTION 922</p>  <p>China</p> <p>Plug: GB 1002, 250V, 10A Cable: 8120-8376</p>
<p>NOTE: Each option number includes a 'family' of cords and connectors of various materials and plug body configurations (straight, 90° etc.).</p>	

power_e

Top View (Major Assemblies) for Serial Prefix MY441

Figure 5-2

Top View (Major Assemblies) for Serial Prefix MY441



e5052ase017

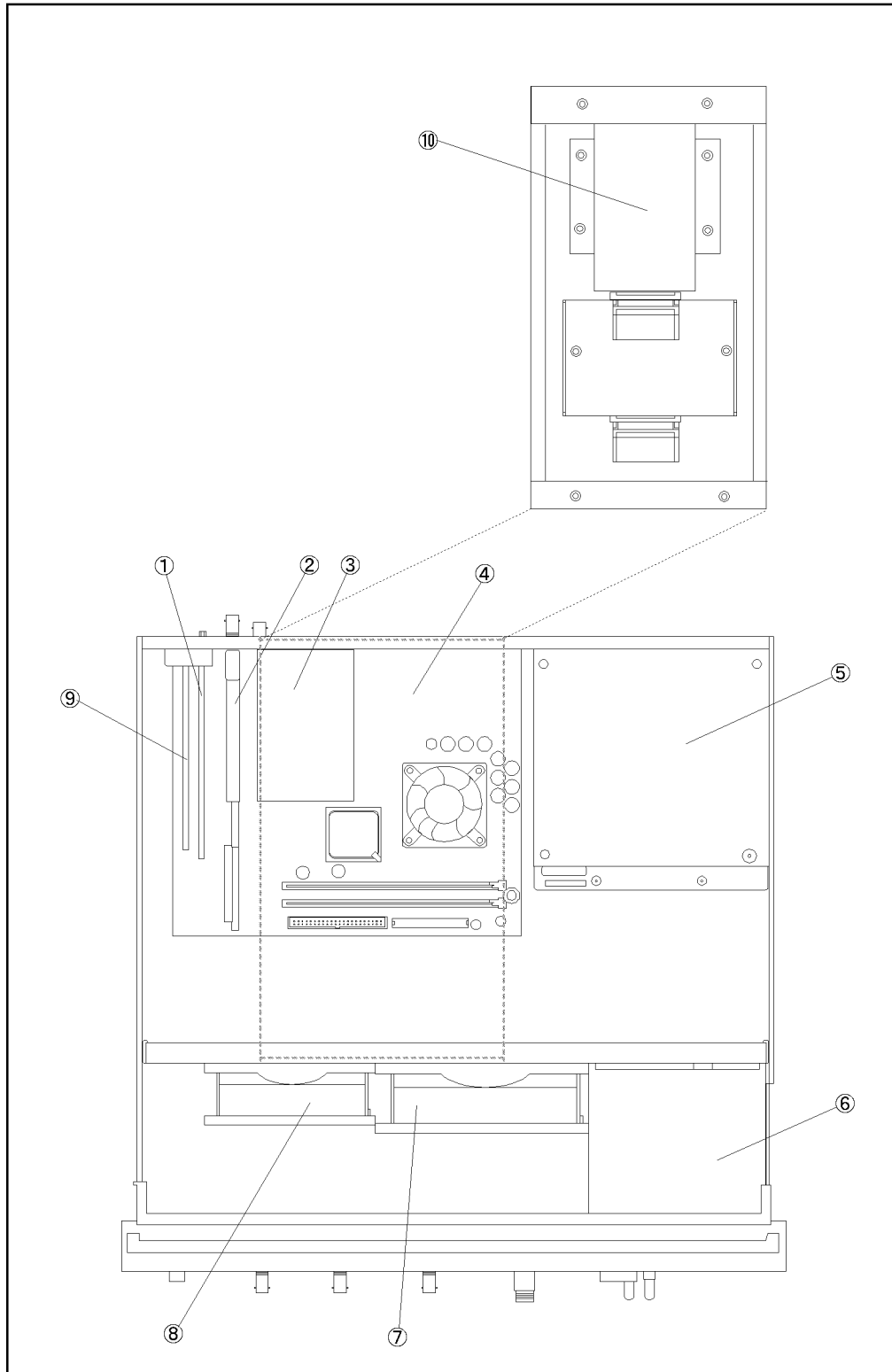
Table 5-1 Top View (Major Assemblies) for Serial Prefix MY441

Ref. Desig.	Agilent Part Number	Qty.	Description
1	See Table 5-17	1	A24 GPIB CARD ASSEMBLY
2	See Table 5-17	1	A21 PCI DSP CARD ASSEMBLY
3	E5052-66525	1	A25 24 BIT I/O BOARD
4	E5052-62005	1	A20 DIGITAL MOTHERBOARD ASSEMBLY
5	See Table 5-23	1	A50 POWER SUPPLY ASSEMBLY
6	See Table 5-19	1	A28 FDD ASSEMBLY
7	E5052-61645	1	FAN ASSEMBLY
8	E5070-61005	1	FAN ASSEMBLY
9	See Table 5-20	1	A27 MASS STORAGE DISK DRIVE ASSEMBLY

Top View (Major Assemblies) for Serial Prefix MY442

Figure 5-3

Top View (Major Assemblies) for Serial Prefix MY442



e5052ase3001

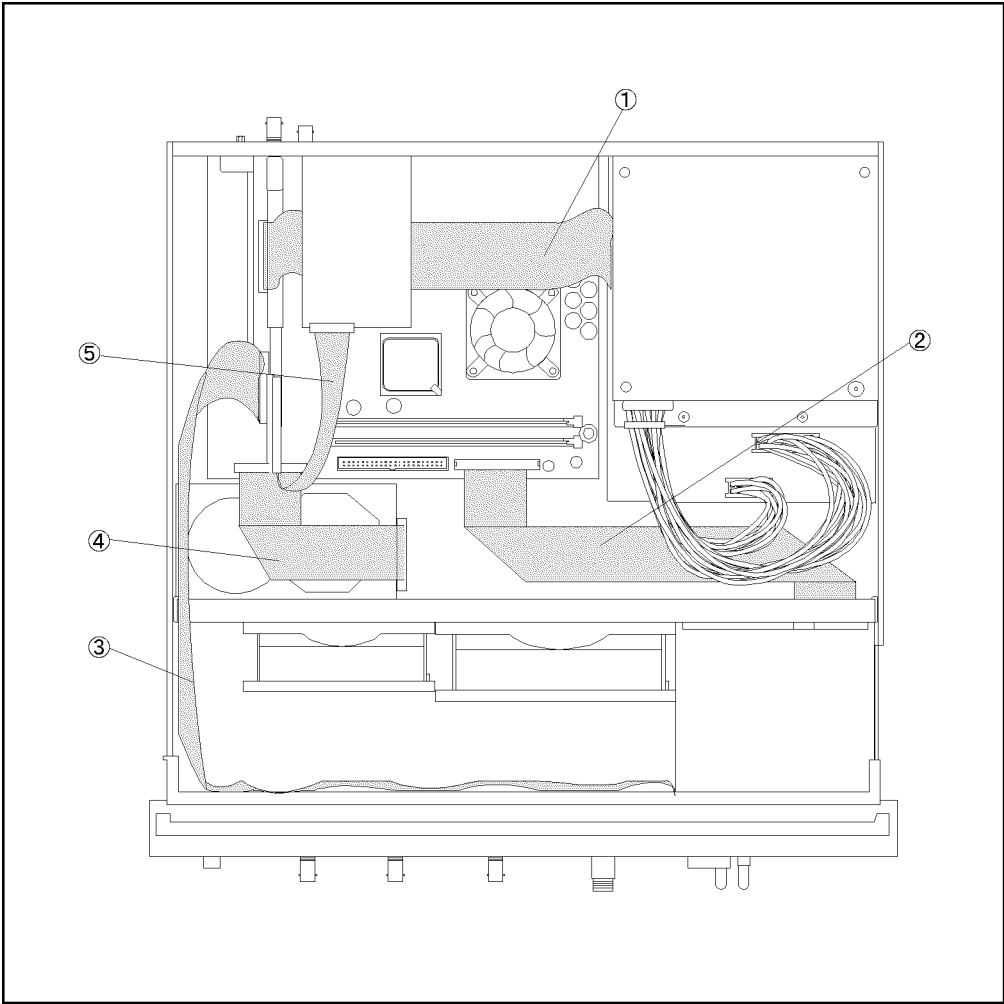
Table 5-2 Top View (Major Assemblies) for Serial Prefix MY442

Ref. Desig.	Agilent Part Number	Qty.	Description
1	See Table 5-18	1	A24 GPIB CARD ASSEMBLY
2	See Table 5-18	1	A21 PCI DSP CARD ASSEMBLY
3	E5052-66525	1	A25 24 BIT I/O BOARD
4	E5052-62005	1	A20 DIGITAL MOTHERBOARD ASSEMBLY
5	See Table 5-23	1	A50 POWER SUPPLY ASSEMBLY
6	See Table 5-19	1	A28 FDD ASSEMBLY
7	E5052-61645	1	FAN ASSEMBLY
8	E5070-61005	1	FAN ASSEMBLY
9	0960-2357	1	USB (USBTMC) INTERFACE CARD
10	See Table 5-21	1	A27 REMOVABLE HARD DISK ASSEMBLY

Top View (Cables) for Serial Prefix MY441

Figure 5-4

Top View (Cables) for Serial Prefix MY441



e5052ase3003

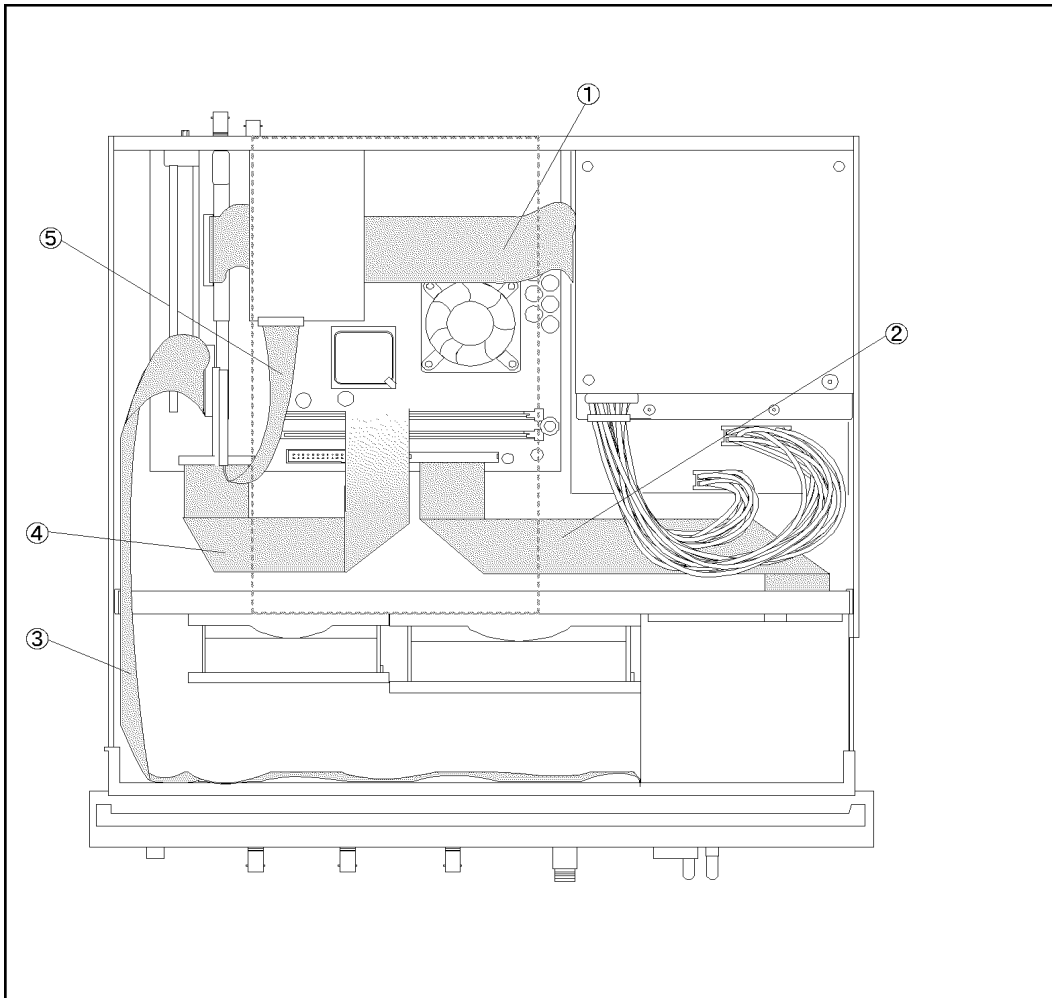
Table 5-3 **Top View (Cables) for Serial Prefix MY441**

Ref. Desig.	Agilent Part Number	Qty.	Description
1	E5052-61628	1	FLAT RIBBON ASSEMBLY
2	E5052-61629	1	FLAT RIBBON ASSEMBLY
3	E5052-61637	1	FLAT CABLE ASSEMBLY
4	E5070-61624	1	FLAT CABLE ASSEMBLY
5	E5070-61616	1	FLAT CABLE ASSEMBLY

Top View (Cables) for Serial Prefix MY442

Figure 5-5

Top View (Cables) for Serial Prefix MY442



e5052ase3004

Table 5-4 **Top View (Cables) for Serial Prefix MY442**

Ref. Desig.	Agilent Part Number	Qty.	Description
1	E5052-61628	1	FLAT RIBBON ASSEMBLY
2	E5052-61629	1	FLAT RIBBON ASSEMBLY
3	E5052-61637	1	FLAT CABLE ASSEMBLY
4	E5070-61624	1	FLAT CABLE ASSEMBLY
5	E5070-61616	1	FLAT CABLE ASSEMBLY

Top View (Miscellaneous Parts) for Serial Prefix MY441

Figure 5-6

Top View (Miscellaneous Parts) for Serial Prefix MY441

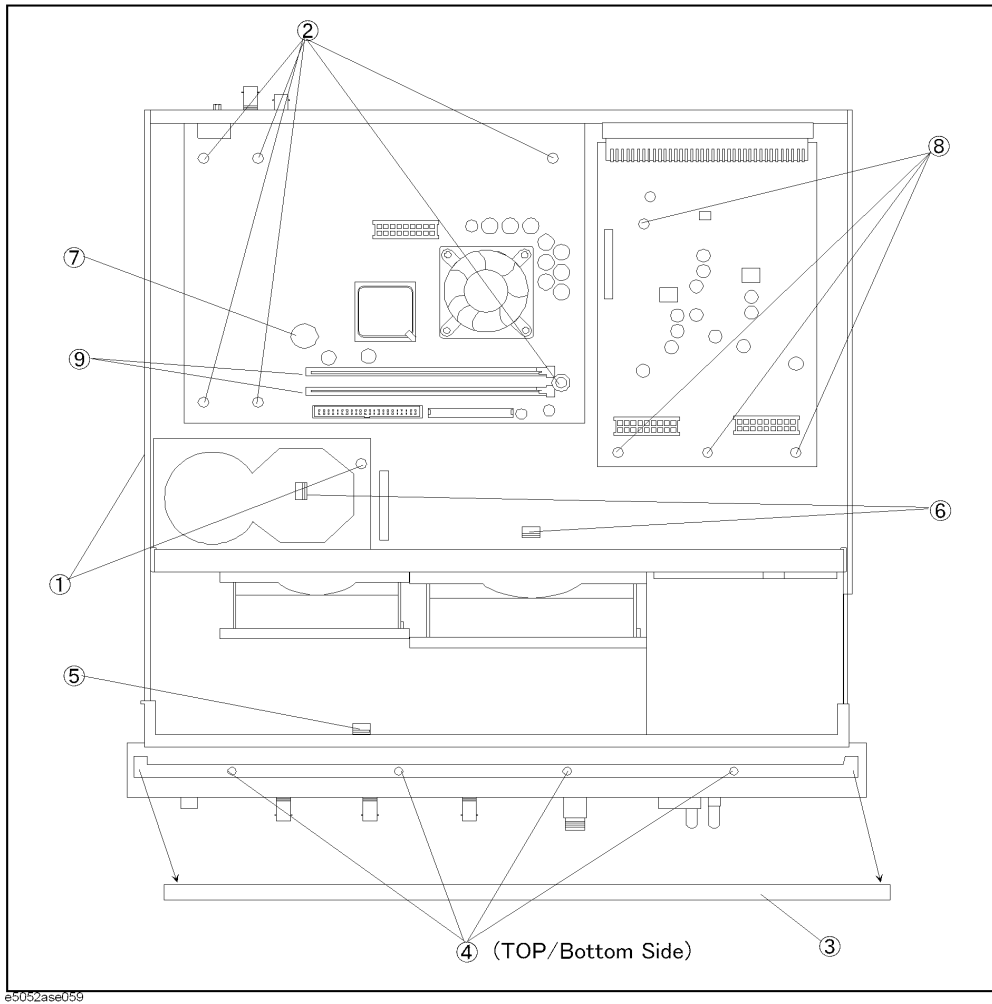


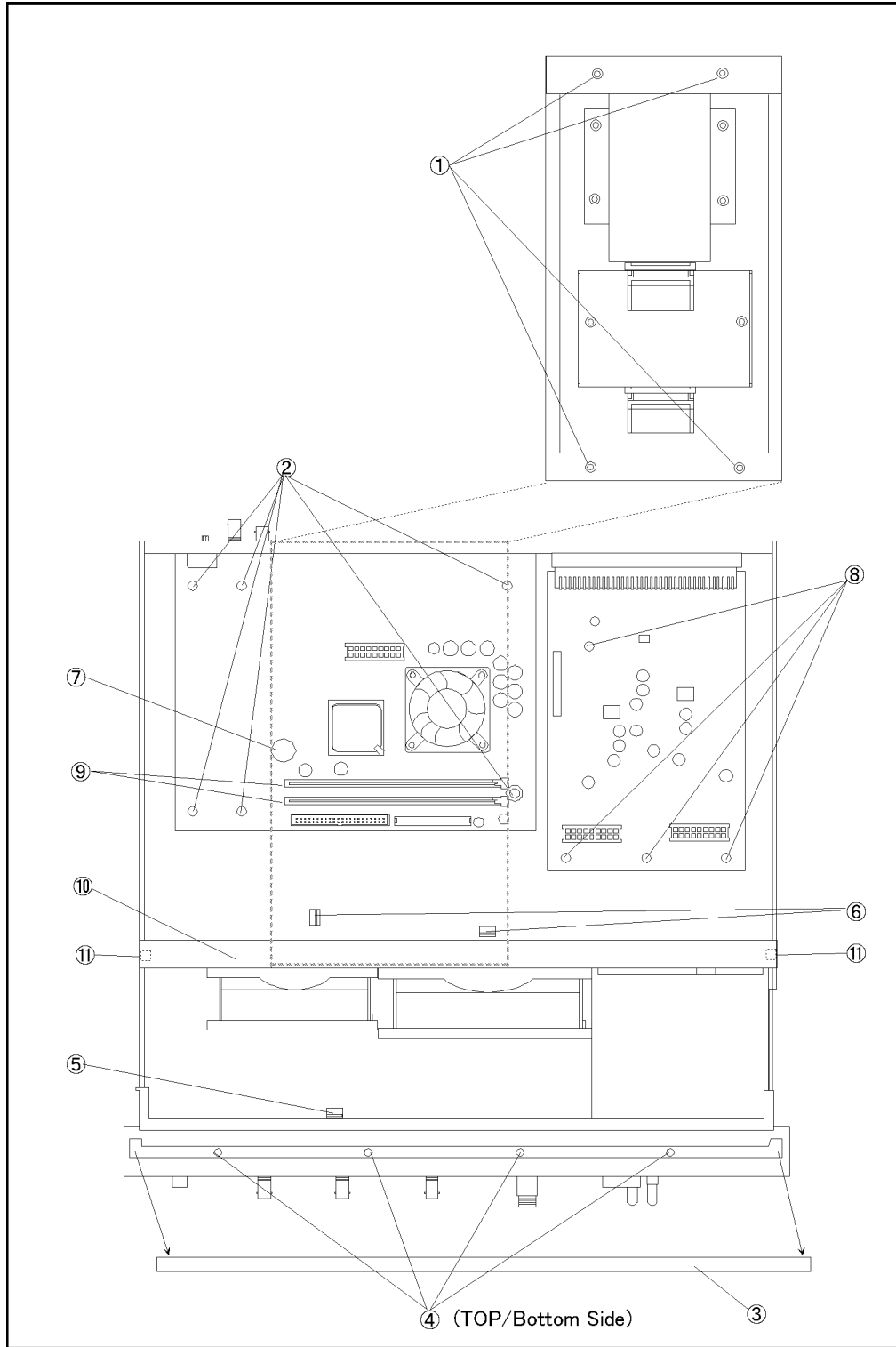
Table 5-5 Top View (Miscellaneous Parts) for Serial Prefix MY441

Ref. Desig.	Agilent Part Number	Qty.	Description
1	0515-0430	2	SCREW-MACH M3.0 x L6 PN T10
2	0515-0430	6	SCREW-MACH M3.0 x L6 PN T10
3	5041-9176	1	TRIM STRIP
4	0515-1382	7	SCREW-MACH M3.5 x L6 FL T15
5	1400-0611	2	CLAMP CABLE
6	1400-0611	2	CLAMP CABLE
7	1420-0356	1	BATTERY LITHIUM (CR2032), 3V, .22A-HR
8	0515-0430	1	SCREW-MACH M3.0 x L6 PN T10
9	1400-3207	2	CABLE TIE

Top View (Miscellaneous Parts) for Serial Prefix MY442

Figure 5-7

Top View (Miscellaneous Parts) for Serial Prefix MY442



e5052ase3005

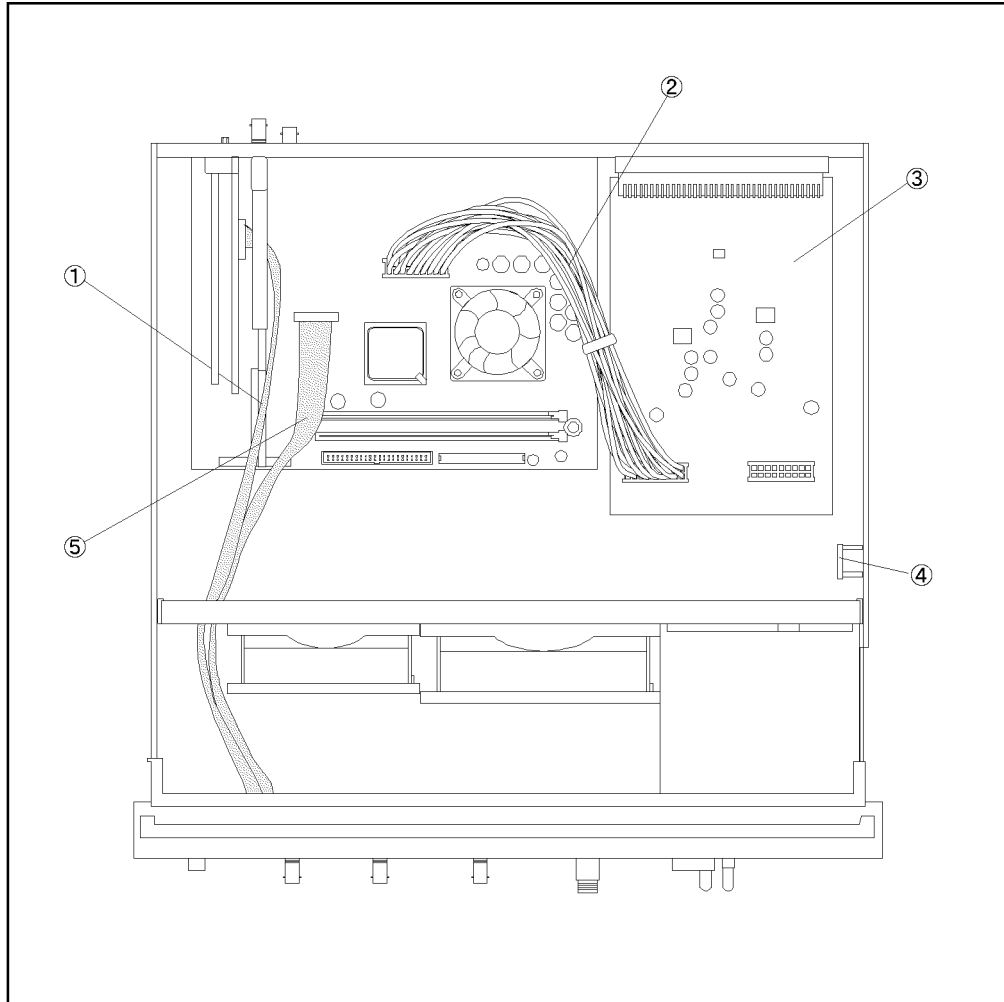
Table 5-6 Top View (Miscellaneous Parts) for Serial Prefix MY442

Ref. Desig.	Agilent Part Number	Qty.	Description
1	0515-1946	4	SCREW-MACH M3.0 x L6 FL T10
2	0515-0430	6	SCREW-MACH M3.0 x L6 PN T10
3	5041-9176	1	TRIM STRIP
4	0515-1382	7	SCREW-MACH M3.5 x L6 FL T15
5	1400-0611	2	CLAMP CABLE
6	1400-0611	2	CLAMP CABLE
7	1420-0356	1	BATTERY LITHIUM (CR2032), 3V, .22A-HR
8	0515-0430	1	SCREW-MACH M3.0 x L6 PN T10
9	1400-3207	2	CABLE TIE
10	E5052-01251	1	ANGLE
11	0515-1946	2	SCREW-MACH M3.0 x L6 FL T10

Top View (Under Power Supply) for S/N MY44200836 and below

Figure 5-8

Top View (Under Power Supply)



e5052ase3006

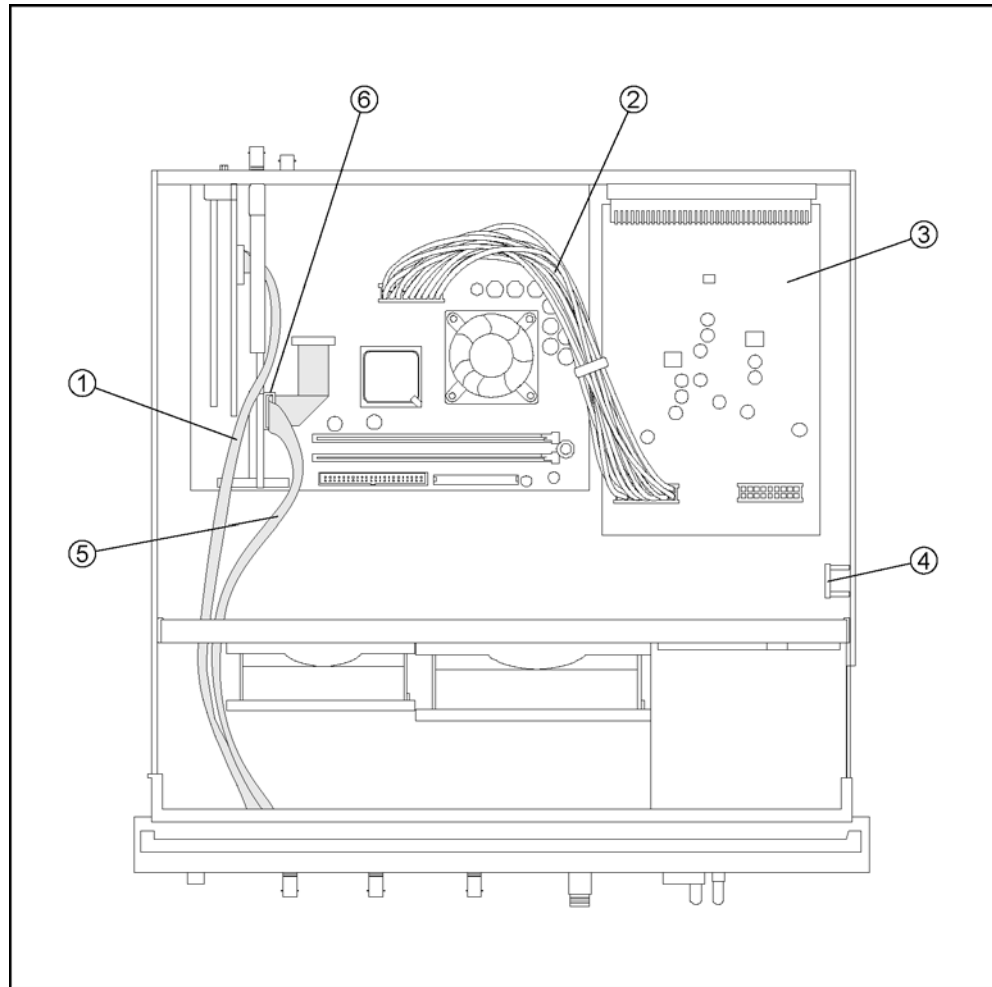
Table 5-7 **Top View (Under Power Supply)**

Ref. Desig.	Agilent Part Number	Qty.	Description
1	E5052-61630	1	FLAT RIBBON CABLE
2	E5052-61631	1	WIRE ASSEMBLY
3	E5052-66513	1	A12 POWER DISTRIBUTION
4	E4991-66505	1	A11 10MHz OVEN
5	E5052-61626	1	FLAT FLEXIBLE CABLE DVI

Top View (Under Power Supply) for S/N MY44200837 and above

Figure 5-9

Top View (Under Power Supply)



e5052ase6001

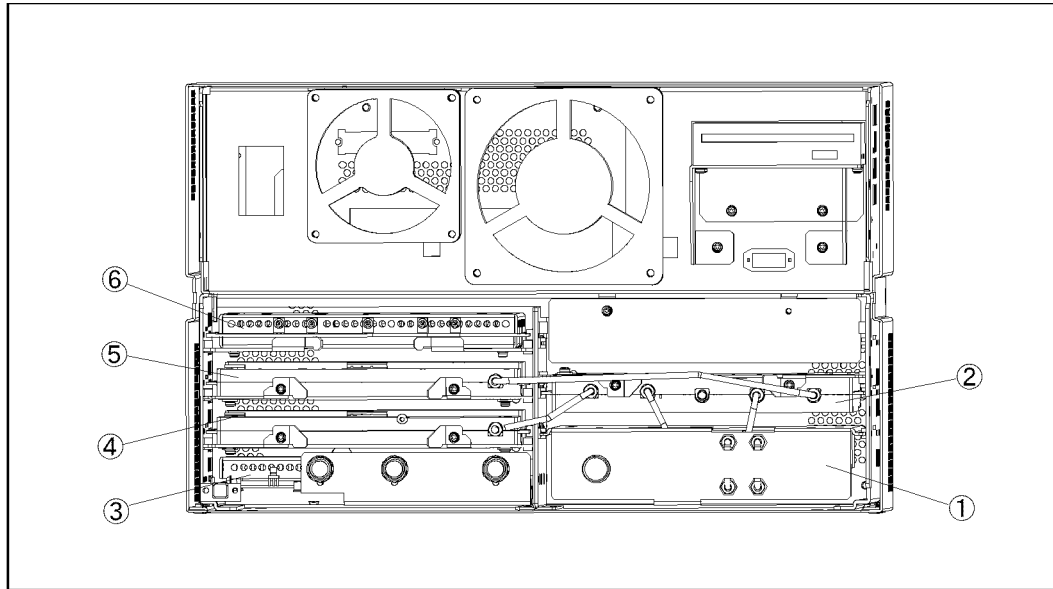
Table 5-8

Top View (Under Power Supply)

Ref. Desig.	Agilent Part Number	Qty.	Description
1	E5052-61630	1	FLAT RIBBON CABLE
2	E5052-61631	1	WIRE ASSEMBLY
3	E5052-66513	1	A12 POWER DISTRIBUTION
4	E4991-66505	1	A11 10MHz OVEN
5	E5052-61626	1	FLAT FLEXIBLE CABLE DVI
6	1400-3361	1	CLAMP-CABLE

Front View (Analog Boards)

Figure 5-10 Front View (Analog Boards)



e5052ase020

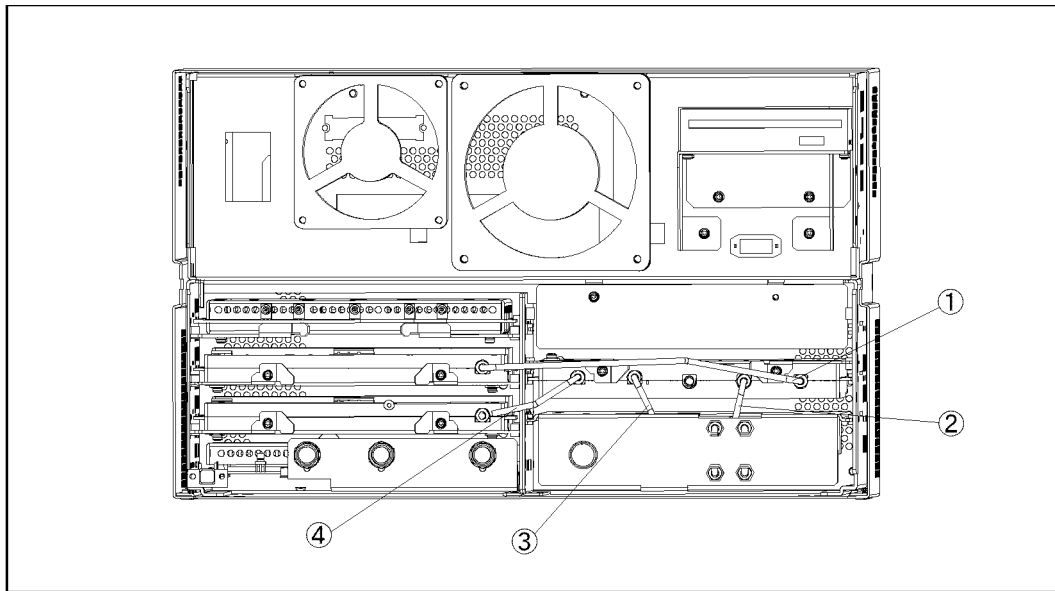
Table 5-9 Front View (Analog Boards)

Ref. Desig.	Agilent Part Number	Qty.	Description
1	E5052-62101	1	A1 FREQ/POWER DETECTOR MODULE
	E5052-69101	1	RSTRD E5052-62101 FREQ/POWER
2	See Table 5-28	1	A6 PHASE DETECTOR BOARD ASSEMBLY
3	E5052-62002	1	A2 DC SOURCE BOARD ASSEMBLY
4	See Table 5-27	1	A5 LOCAL SYNTHESIZE MODULE
5	See Table 5-27	1	A4 LOCAL SYNTHESIZE MODULE
6	E5052-62003	1	A3 ADC/DSP BOARD ASSEMBLY
	E5052-69003	1	RSTRD E5052-62003 ADC/DSP

Front View (Cables)

Figure 5-11

Front View (Cables)



e5052ase021

Table 5-10

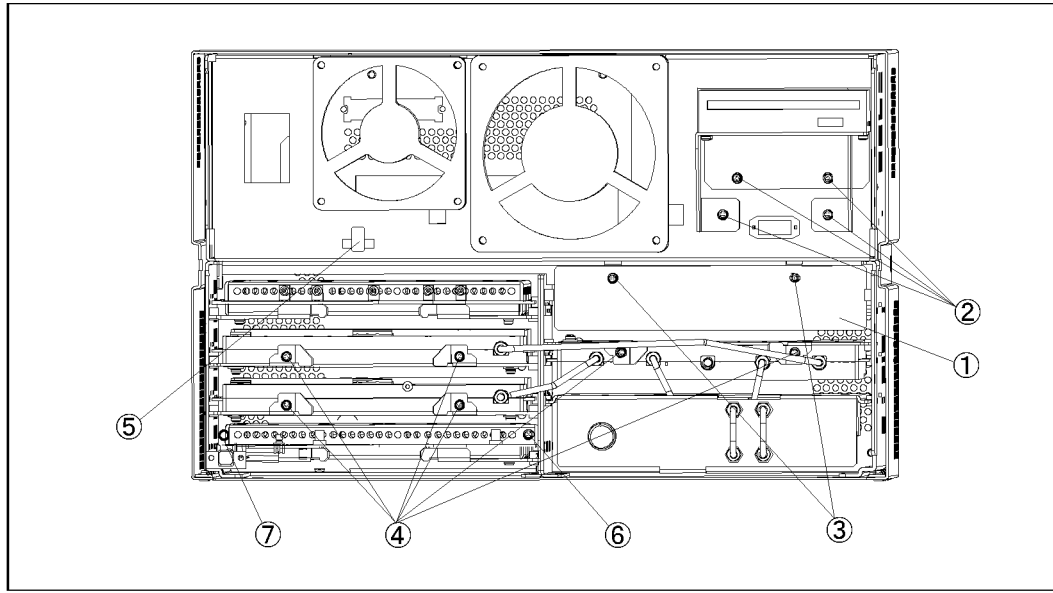
Front View (Cables)

Ref. Desig.	Agilent Part Number	Qty.	Description
1	E5052-61621	1	RF CABLE ASSEMBLY SRGD
2	E5052-61619	1	RF CABLE ASSEMBLY SRGD
3	E5052-61620	1	RF CABLE ASSEMBLY SRGD
4	E5052-61622	1	RF CABLE ASSEMBLY SRGD

Front View (Miscellaneous)

Figure 5-12

Front View (Miscellaneous)



e5052ase022

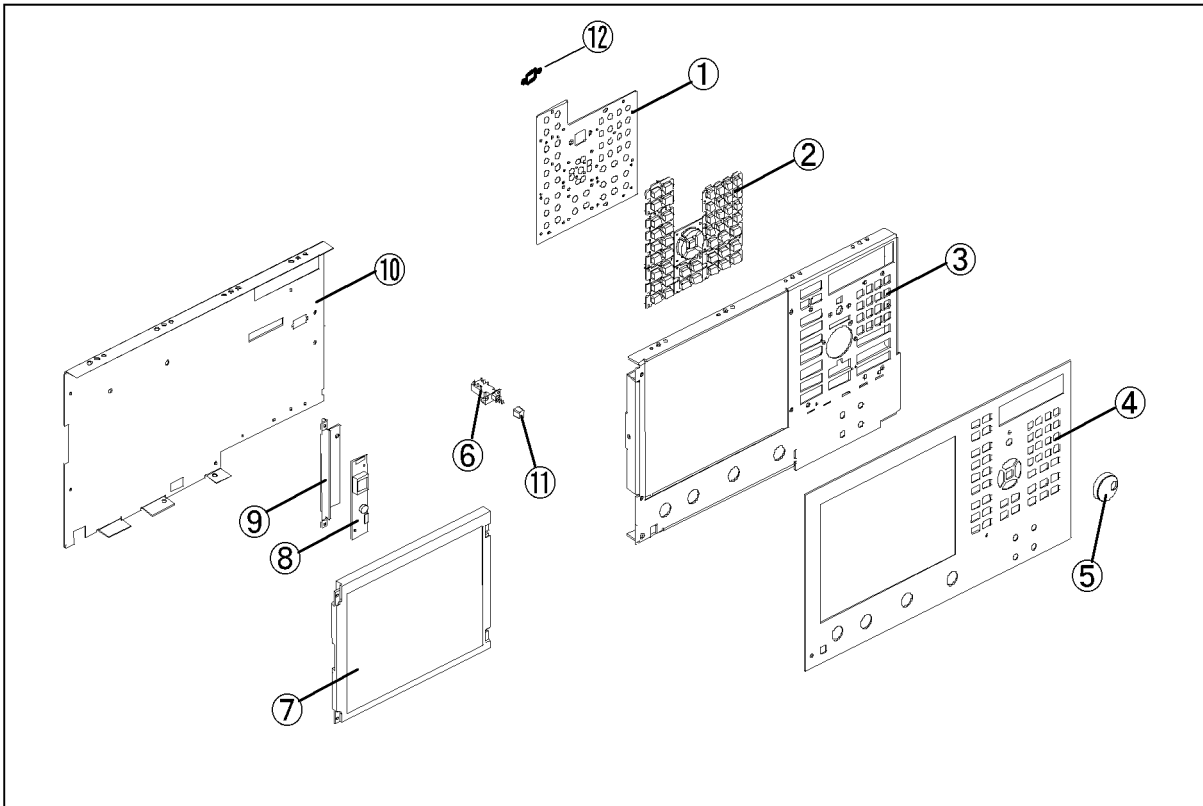
Table 5-11 Front View (Miscellaneous)

Ref. Desig.	Agilent Part Number	Qty.	Description
1	E5052-04004	1	COVER
2	0515-0372	4	SCREW-MACH M3.0 x L8 PN T10
3	0515-0430	2	SCREW-MACH M3.0 x L6 PN T10
4	0515-0430	6	SCREW-MACH M3.0 x L6 PN T10
5	1400-1334	1	CALMP CABLE
6	0515-0430	1	SCREW-MACH M3.0 x L6 PN T10
7	0515-0430	1	SCREW-MACH M3.0 x L6 PN T10 (for Serial Prefix MY442 and above)

Front Panel

Figure 5-13

Front Panel



e5052ase013

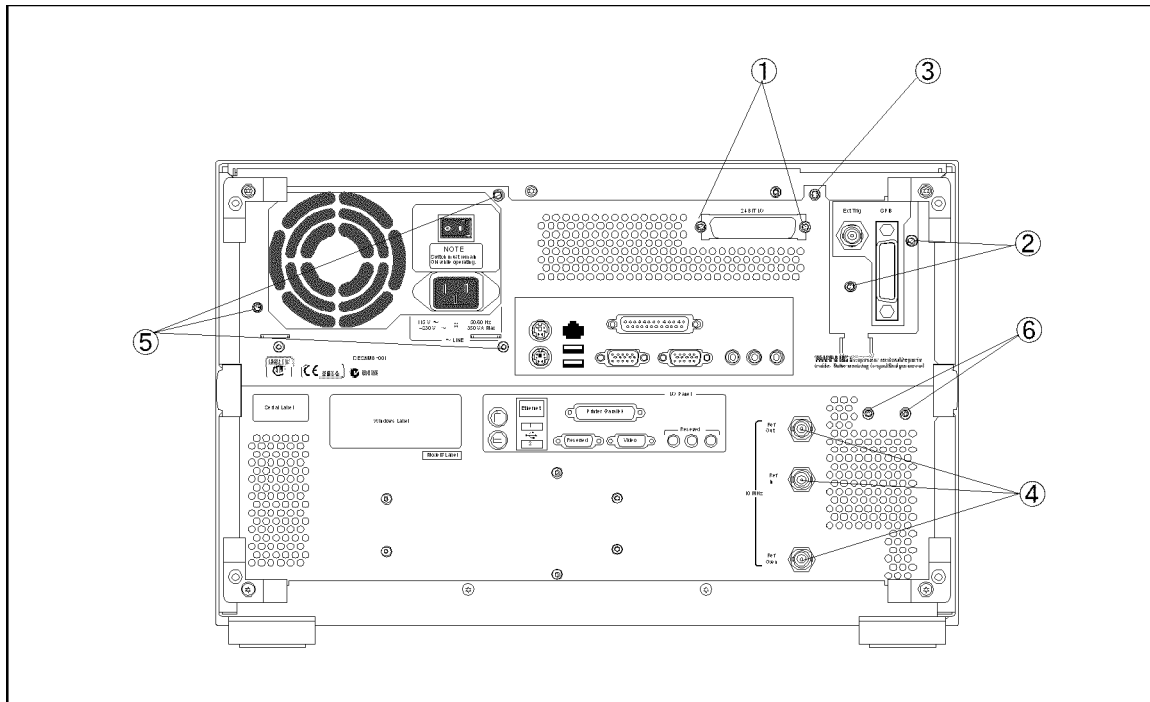
Replaceable Parts
Replaceable Parts List

Table 5-12 **Front Panel**

Ref. Desig.	Agilent Part Number	Qty.	Description
1	E5062-66522	1	A22 FRONT PANEL KEYBOARD
2	E5052-25101	1	KEYPAD RUBBER
3	E5052-00202	1	PANEL SUB
4	E5052-00201	1	PANEL FRONT
5	5182-7594	1	KNOB
6	E5070-61901	1	STANDBY SWITCH ASSEMBLY
7	E5070-60102	1	LCD-FILTER ASSEMBLY
8	0950-4091	1	A52 INVERTER LS700
9	E5052-01290	1	BRACKET INVERTER
10	E5052-00601	1	COVER SHIELD
11	0371-3953	1	KEY CAP
12	3100-3711	1	SWITCH- ROTARY

Rear View for Serial Prefix MY441

Figure 5-14 Rear View for Serial Prefix MY441



e5052ase001

Table 5-13 Rear View for Serial Prefix MY441

Ref. Desig.	Agilent Part Number	Qty.	Description
1	0515-0372	2	SCREW-MACH M3.0 x L8 PN T10
2	0515-0372	2	SCREW-MACH M3.0 x L8 PN T10
3	0515-0430	1	SCREW-MACH M3.0 x L6 PN T10
4	2950-0035	3	NUT-HEX-DBL-CHAM
	2190-0102	3	WSHR-LK INTL T
5	0515-0372	3	SCREW-MACH M3.0 x L8 PN T10
6	0515-0430	2	SCREW-MACH M3.0 x L6 PN T10

Cover Assembly for Serial Prefix MY441

Figure 5-16 Cover Assembly for Serial Prefix MY441

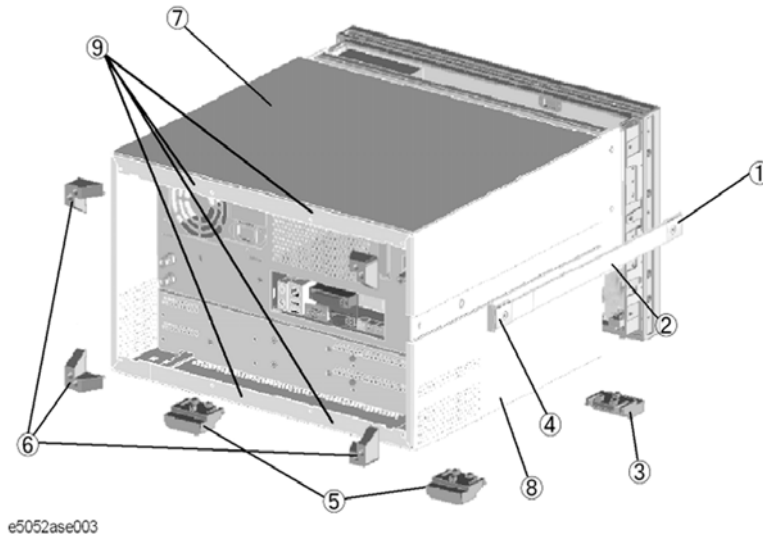
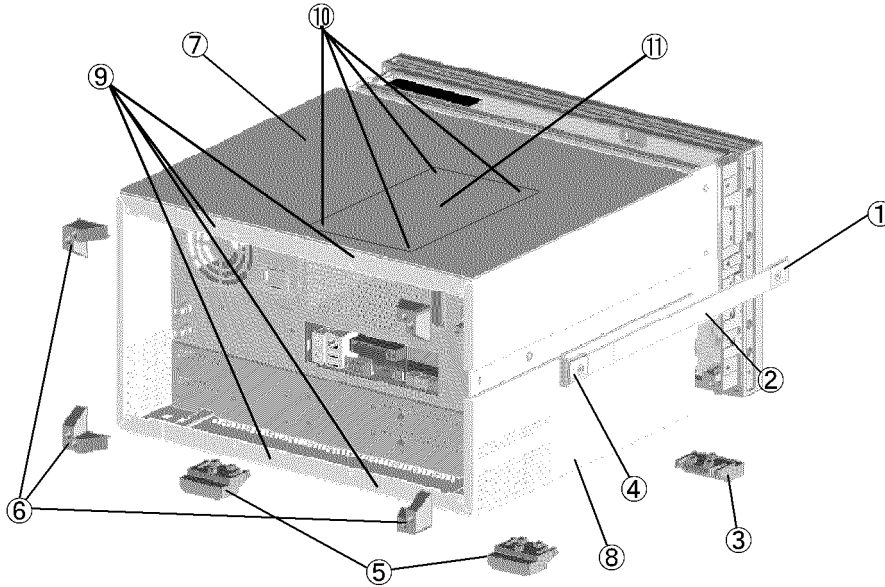


Table 5-15 Cover Assembly for Serial Prefix MY441

Ref. Desig.	Agilent Part Number	Qty.	Description
1	5041-9186	1	STRAP HANDLE FRT
	0515-2049	1	SCREW-MACH M5.0 x L16 FL T20
2	08720-00081	1	STRAP HANDLE
3	5041-9167	2	FOOT FL
	1460-1345	2	WIREFORM
	5021-2840	2	KEY LOCK
4	5041-9187	1	STRAP HANDLE REAR
	0515-2049	2	SCREW-MACH M5.0 x L16 FL T20
5	5041-9167	2	FOOT FL
	5021-2840	2	KEY LOCK
6	E5100-40002	4	STANDOFF
	0515-1402	4	SCREW-MACH M3.5 x L8 PN T15
7	E5052-60002	1	COVER ASSEMBLY
8	0515-0430	4	SCREW-MACH M3.0 x L6 PN T10
9	0515-1402	4	SCREW-MACH M3.5 x L8 PN T15

Cover Assembly for Serial Prefix MY442

Figure 5-17 Cover Assembly for Serial Prefix MY442



e5052ase3008

Table 5-16 Cover Assembly for Serial Prefix MY442

Ref. Desig.	Agilent Part Number	Qty.	Description
1	5041-9186	1	STRAP HANDLE FRT
	0515-2049	1	SCREW-MACH M5.0 x L16 FL T20
2	08720-00081	1	STRAP HANDLE
3	5041-9167	2	FOOT FL
	1460-1345	2	WIREFORM
	5021-2840	2	KEY LOCK
4	5041-9187	1	STRAP HANDLE REAR
	0515-2049	2	SCREW-MACH M5.0 x L16 FL T20
5	5041-9167	2	FOOT FL
	5021-2840	2	KEY LOCK
6	E5100-40002	4	STANDOFF
	0515-1402	4	SCREW-MACH M3.5 x L8 PN T15
7	E5052-60012	1	COVER ASSEMBLY
8	0515-0430	4	SCREW-MACH M3.0 x L6 PN T10
9	0515-1402	4	SCREW-MACH M3.5 x L8 PN T15

Table 5-16 **Cover Assembly for Serial Prefix MY442**

Ref. Desig.	Agilent Part Number	Qty.	Description
10	0515-2156	4	SCREW-MACH M3.0 x L4 FL T10
11	E5070-01252	1	LID

PCI DSP Card and GPIB Card Assembly for Serial Prefix MY441

Figure 5-18 PCI DSP Card and GPIB Card Assembly for Serial Prefix MY441

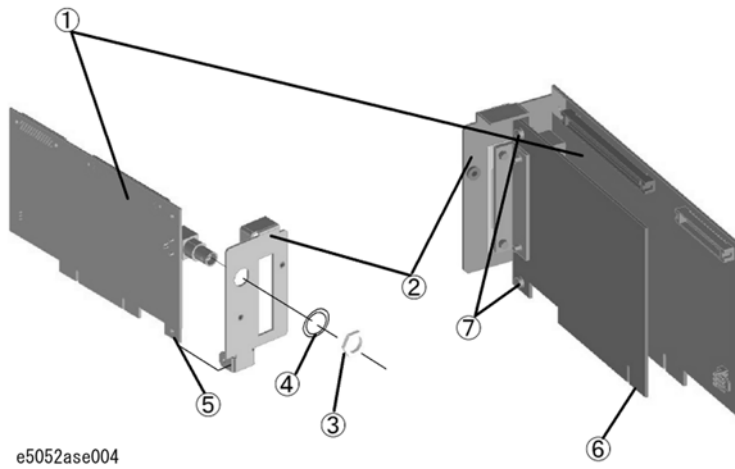


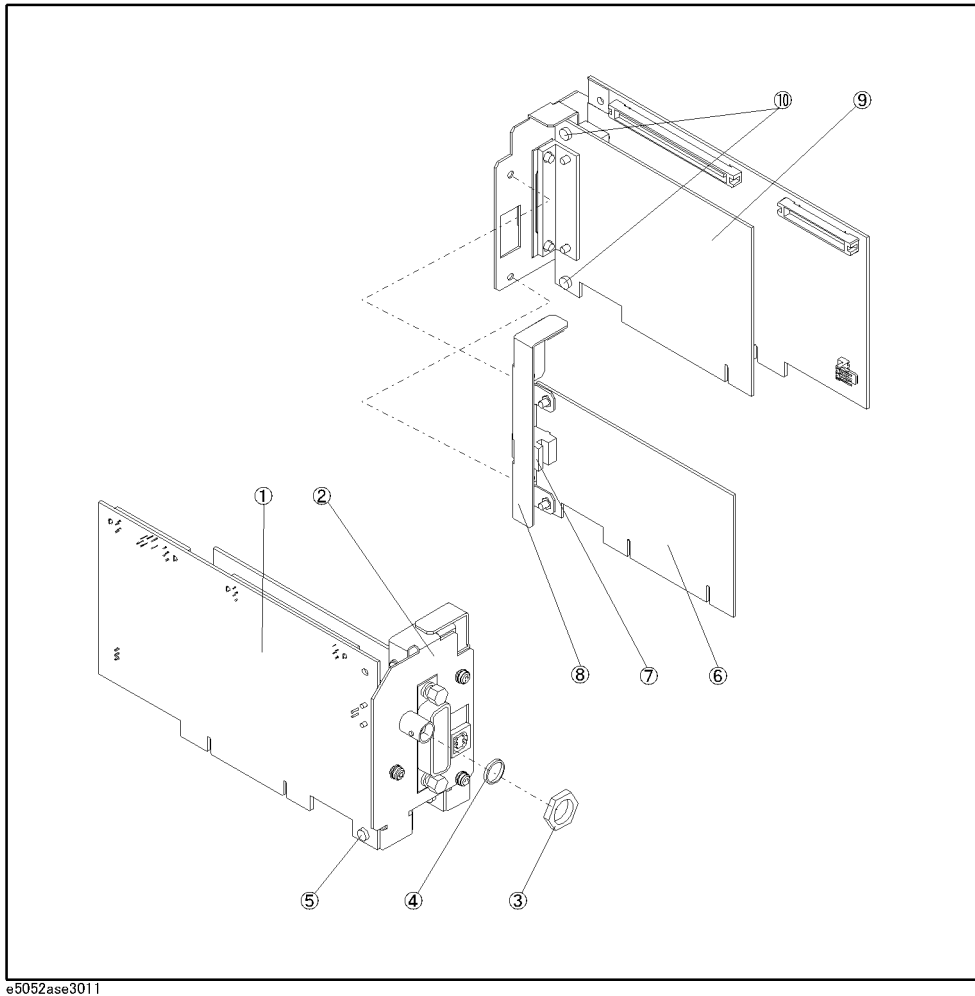
Table 5-17 PCI DSP Card and GPIB Card Assembly for Serial Prefix MY441

Ref. Desig.	Agilent Part Number	Qty.	Description
1	E5052-66521	1	A21 PCI DSP CARD
2	E5052-01295	1	ANGLE PCI W/GPIB
3	2950-0054	1	NUT-HEX-DBL-CHAM
4	2190-0054	1	WSHR-LK INTL T
5	0515-0430	1	SCREW-MACH M3.0 x L6 PN T10
6	E5062-65000	1	A24 PCI GPIB CARD
7	0515-0430	2	SCREW-MACH M3.0 x L6 PN T10

PCI DSP Card and GPIB Card Assembly for Serial Prefix MY442

Figure 5-19

PCI DSP Card and GPIB Card Assembly for Serial Prefix MY442



e5052ase3011

Replaceable Parts
Replaceable Parts List

Table 5-18 PCI DSP Card and GPIB Card Assembly for Serial Prefix MY442

Ref. Desig.	Agilent Part Number	Qty.	Description
1	E5052-66521	1	A21 PCI DSP CARD
2	E5052-01296	1	ANGLE PCI W/GPIB
3	2950-0054	1	NUT-HEX-DBL-CHAM
4	2190-0054	1	WSHR-LK INTL T
5	0515-0430	1	SCREW-MACH M3.0 x L6 PN T10
6	0960-2357	1	USB (USBTMC) INTERFACE CARD
7	0363-0170	1	GASKET
8	E5052-01297	1	ANGLE PCI W/USB
9	E5062-65000	1	A24 PCI GPIB CARD
10	0515-0430	2	SCREW-MACH M3.0 x L6 PN T10

FDD Assembly

Figure 5-20

FDD Assembly

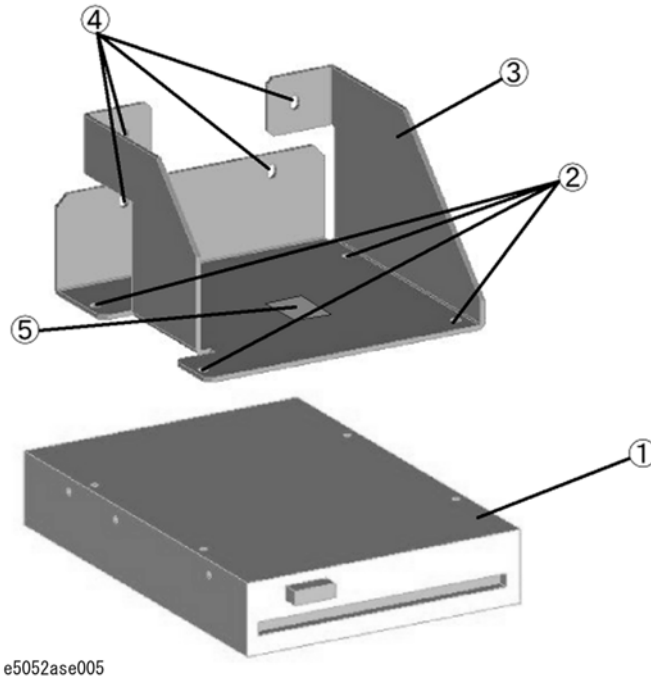


Table 5-19 FDD Assembly

Ref. Desig.	Agilent Part Number	Qty.	Description
1	0950-3334	1	A28 FDD 3.5
2	0515-0430	4	SCREW-MACH M3.0 x L6 PN T10
3	E5052-01209	1	ANGLE FDD
4	0515-0372	4	SCREW-MACH M3.0 x L8 PN T10
5	1400-1334	1	CLAMP-CABLE

Mass Storage Disk Drive Assembly for Serial Prefix MY441

Figure 5-21 Mass Storage Disk Drive Assembly for Serial Prefix MY441

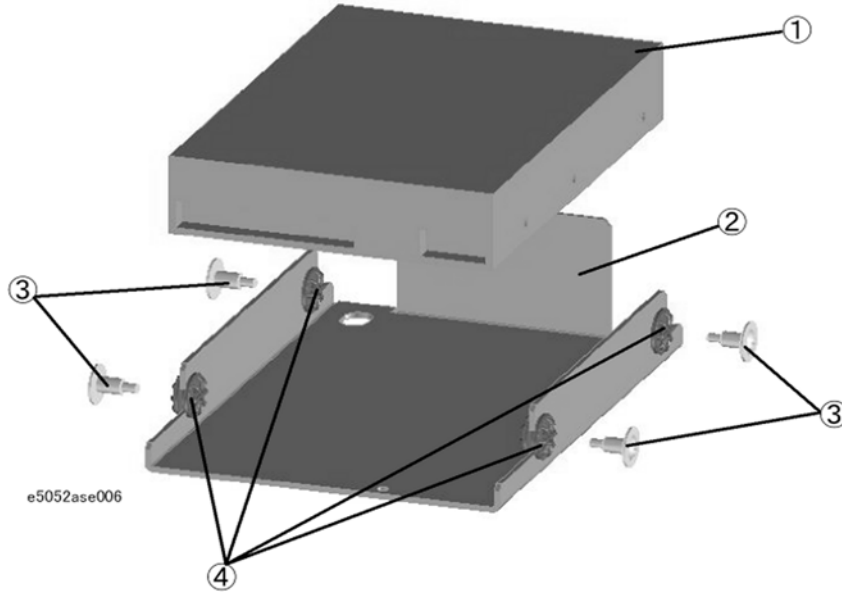


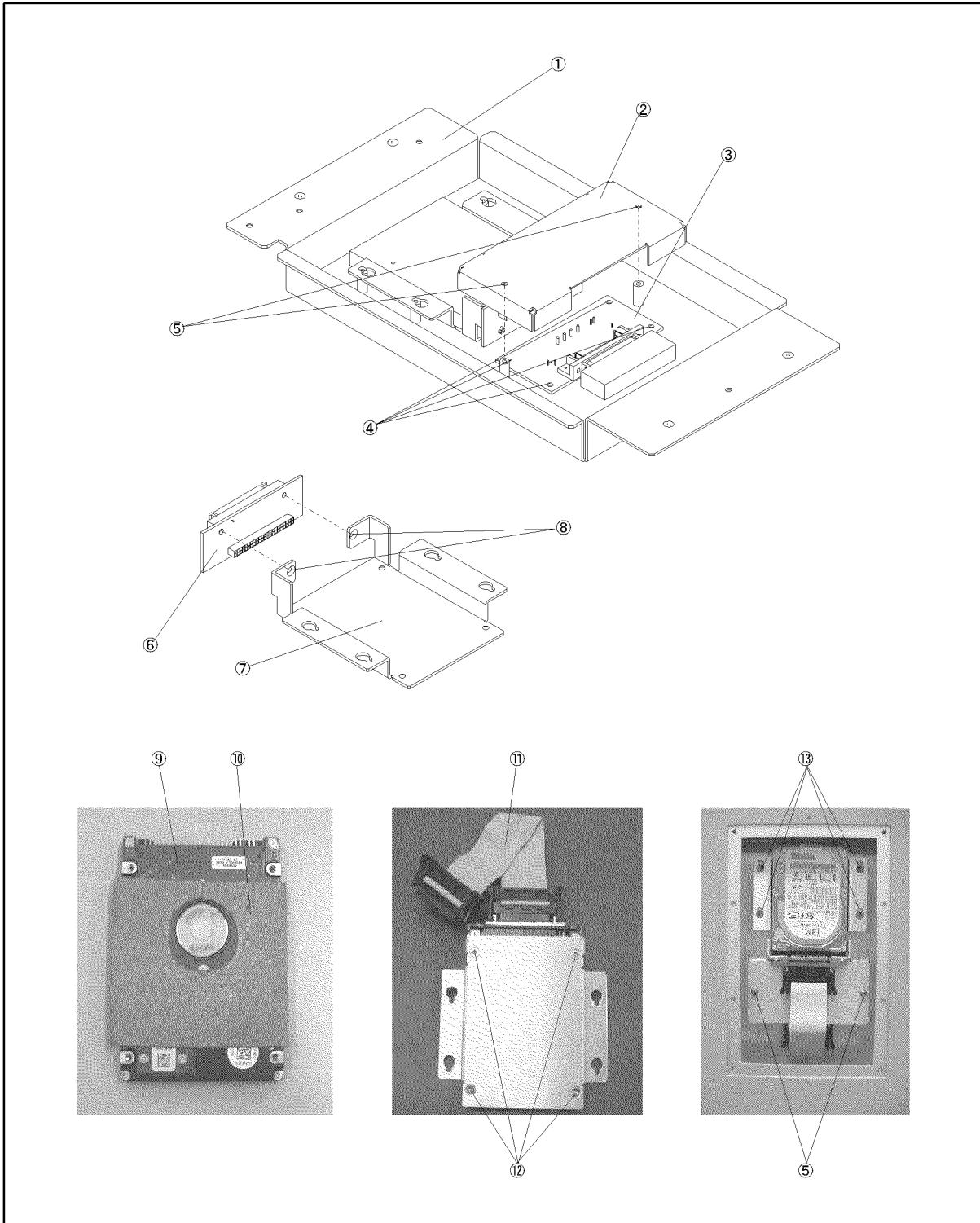
Table 5-20 Mass Storage Disk Drive Assembly for Serial Prefix MY441

Ref. Desig.	Agilent Part Number	Qty.	Description
1	E5052-85200	1	A27 HDD INSTALLED
2	E5052-01223	1	ANGLE HDD
3	3030-1245	4	SCREW-SHLDR 6-32
4	0400-0356	4	GROMMET-RND

Removable Hard Disk Assembly for Serial Prefix MY442

Figure 5-22

Removable Hard Disk Assembly for Serial Prefix MY442



e5052ase3010

Replaceable Parts
Replaceable Parts List

Table 5-21 Removable Hard Disk Assembly for Serial Prefix MY442

Ref. Desig.	Agilent Part Number	Qty.	Description
1	E5052-01252	1	CASE
2	E5070-01253	1	COVER
3	E5070-66534	1	INTERFACE BD PCA
4	0515-0430	4	SCREW-MACH M3.0 x 6 PN T10
5	0515-0430	2	SCREW-MACH M3.0 x 6 PN T10
6	E5070-66535	1	CONNECTOR BD PCA
7	E5070-01255	1	HDD BRACKET
8	0515-2028	2	SCREW-MACH M2.5 x 6 FL T8
9	E5052-86200	1	HDD FOR E5052 REV.2.00
10	E5070-25051	1	HEAT TRANSFER SHEET
11	E5070-61638	1	FLAT CABLE ASSY
12	0515-2146	4	SCREW-MACH M3.0 x 4 FL T10
13	0515-0374	4	SCREW-MACH M3.0 x 10 PN T10

Analog Mother Board Assembly

Figure 5-23 Analog Mother Board Assembly

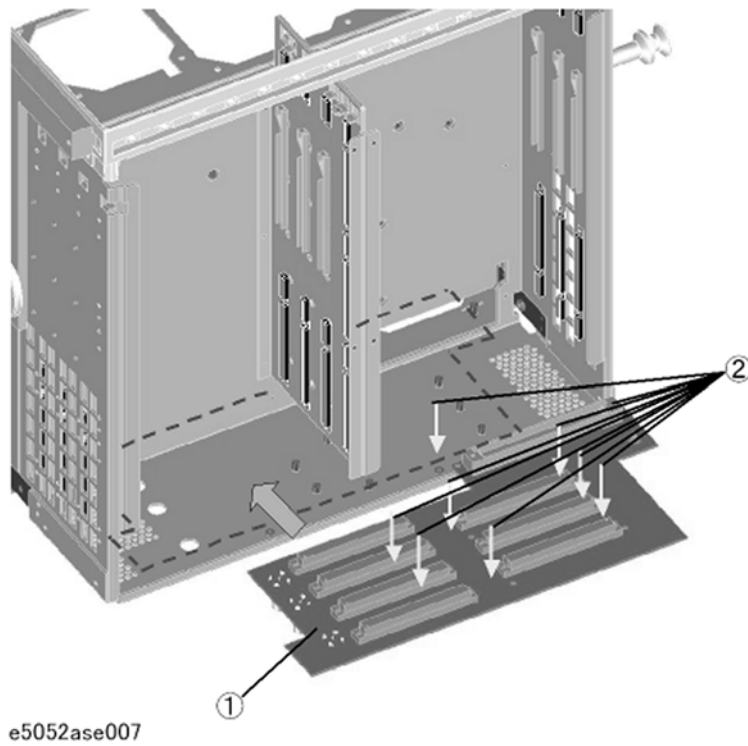


Table 5-22 Analog Mother Board Assembly

Ref. Desig.	Agilent Part Number	Qty.	Description
1	E5052-66510	1	A10 ANALOG MOTHER BOARD (for Sserial Prefix MY441)
	E5052-66520	1	A10 ANALOG MOTHER BOARD (for Serial Prefix MY442 and above)
2	0515-0372	9	SCREW-MACH M3.0 x L8 PN T10

Power Supply Assembly

Figure 5-24 Power Supply Assembly

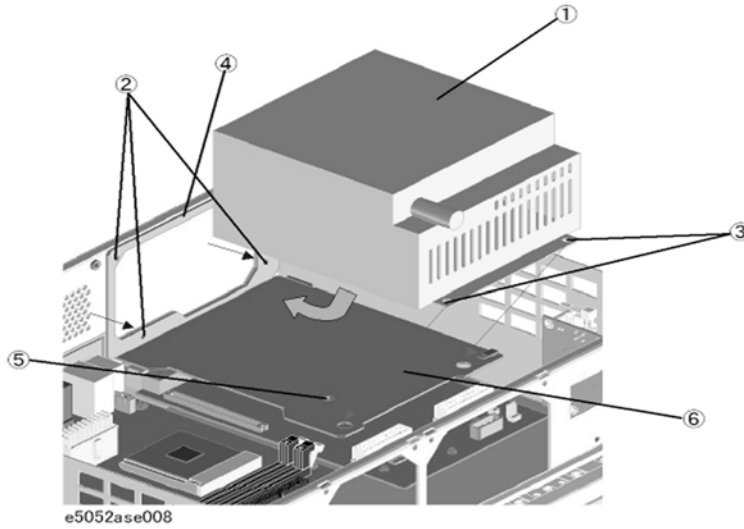


Table 5-23 Power Supply Assembly

Ref. Desig.	Agilent Part Number	Qty.	Description
1	0950-4836	1	A50 POWER SUPPLY
2	0515-0372	3	SCREW-MACH M3.0 x L8 PN T10
3	0515-2143	2	SCREW-MACH M4.0 x L6 PN T15
4	E5052-00607	1	PLATE (for Serial Prefix MY441)
	E5052-00617	1	PLATE (for Serial Prefix MY442 and above)
5	0515-1946	1	SCREW-MACH M3.0 x L6 FL T10
6	E5052-00606	1	PLATE (for Serial Prefix MY441)
	E5052-00616	1	PLATE (for Serial Prefix MY442 and above)

Power Distribution and Oven Assembly

Figure 5-25 Power Distribution Oven Assembly

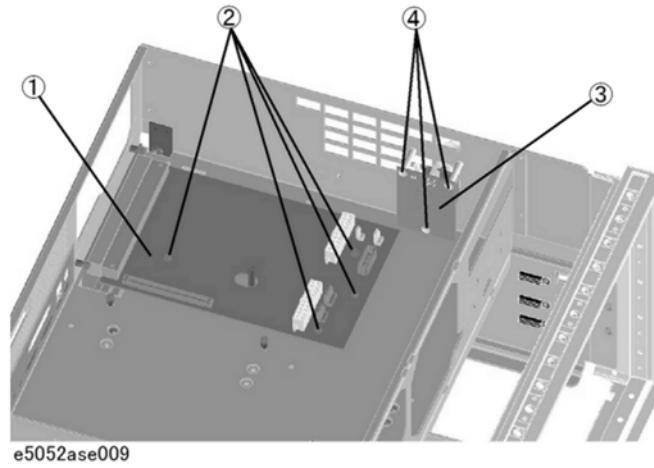


Table 5-24 Power Distribution and Oven Assembly

Ref. Desig.	Agilent Part Number	Qty.	Description
1	E5052-66513	1	A12 POWER DISTRIBUTION
2	0515-0430	4	SCREW-MACH M3.0 x L6 PN T10
3	E4991-66505	1	A11 10 MHz OVEN
4	0515-0430	3	SCREW-MACH M3.0 x L6 PN T10

Freq/Power Detector Module Attachment Assembly

Figure 5-26 Freq/Power Detector Module Attachment Assembly

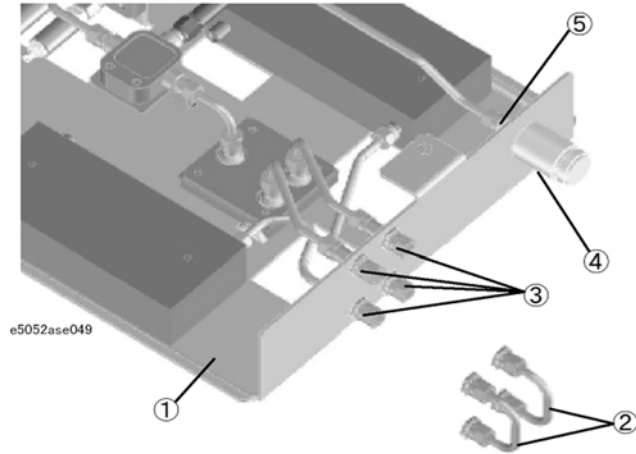


Table 5-25 Freq/Power Detector Module Attachment Assembly

Ref. Desig.	Agilent Part Number	Qty.	Description
1	E5052-01201	1	BRACKET
2	E5052-61611	2	RF CBL ASSY SRGD
3	1250-1251	4	ADAPTER-COAX F-SMA
4	86290-60005	1	CONNECTOR TYPE N
5	2950-0132	1	NUT-HEX-DBL-CHAM
	2190-0104	1	WASHER-LK INTL

DC Source Board Attachment Assembly

Figure 5-27

DC Source Board Attachment Assembly

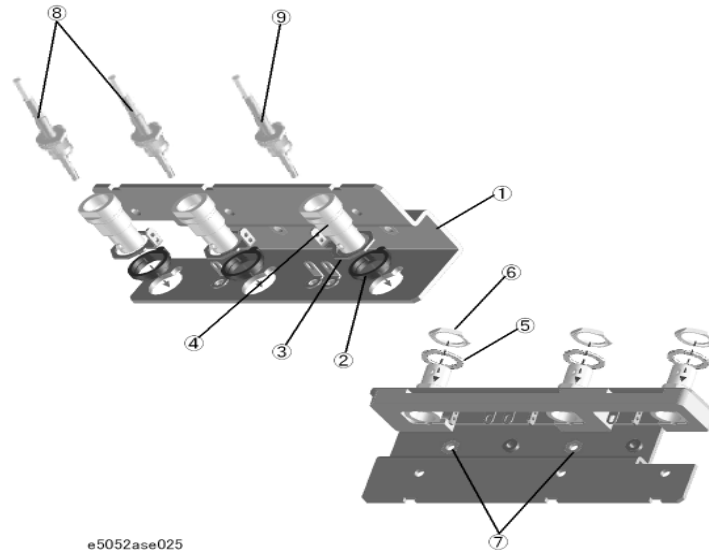


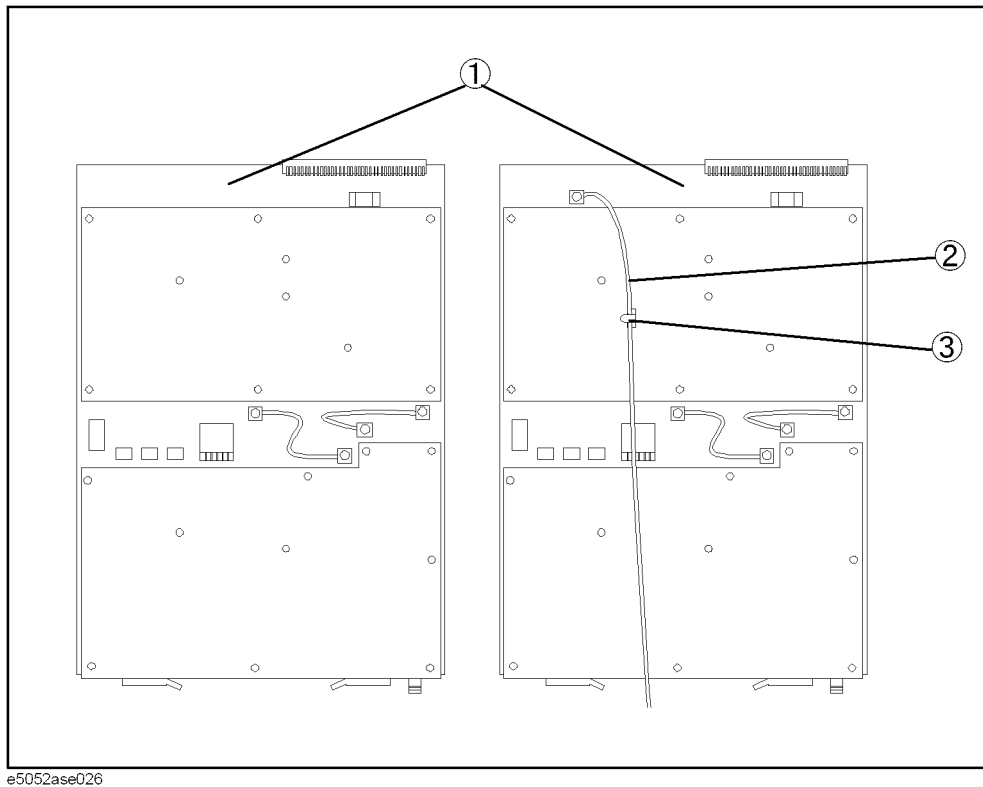
Table 5-26

DC Source Board Attachment Assembly

Ref. Desig.	Agilent Part Number	Qty.	Description
1	E5052-01205	1	ANGLE
2	5040-3325	3	INSULATOR BNC
3	04284-01211	3	PLATE
4	1250-0252	3	BODY-RF CONNECTOR SERIES BNC; STRAIGHT
5	5040-3324	3	INSULATOR BNC
6	2950-0035	3	NUT-HEX-DBL-CHAM
7	0515-0372	2	SCREW-MACH M3.0 x L8 PN T10
8	E5052-61642	2	CABLR ASSY
9	E5052-61625	1	RF CBL ASSY

Local Synthesize Module Assembly

Figure 5-28 Local Synthesize Module Assembly



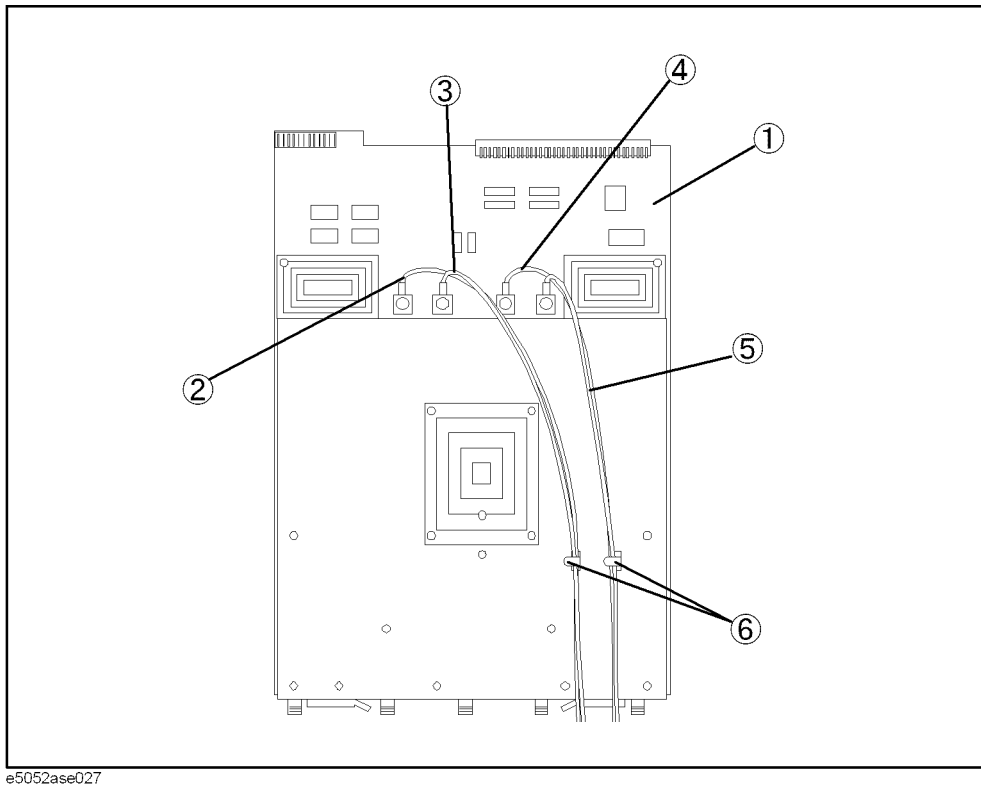
e5052ase026

Table 5-27 Local Synthesize Module Assembly

Ref. Desig.	Agilent Part Number	Qty.	Description
1	E5052-62004	2	LOCAL SYNTHESIZE MODULE ASSY
	E5052-69004	2	RSTRD E5052-62004 SYNTHESIZE
2	E5052-61605	1	RF CABLE ASSY
3	1400-1334	1	CLAMP-CABLE

Phase Detector Board Assembly

Figure 5-29 Phase Detector Board Assembly



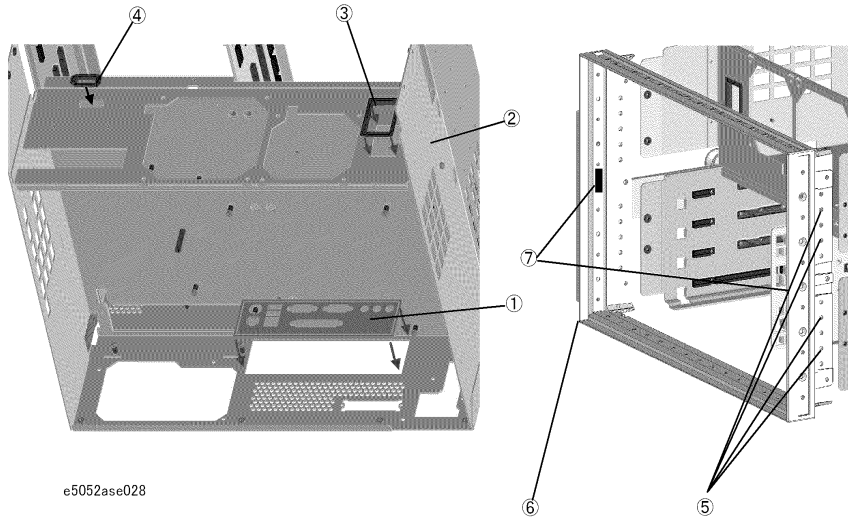
e5052ase027

Table 5-28 Phase Detector Board Assembly

Ref. Desig.	Agilent Part Number	Qty.	Description
1	E5052-62006	1	PHASE DETECTOR BOARD ASSY
	E5052-69006	1	RSTRD E5052-62006 PHASE DET
2	E5052-61601	1	RF CABLE ASSY
3	E5052-61602	1	RF CABLE ASSY
4	E5070-61604	1	RF CABLE ASSY
5	E5052-61603	1	RF CABLE ASSY
6	1400-1334	2	CLAMP-CABLE

Chassis Assembly

Figure 5-30 Chassis Assembly



e5052ase028

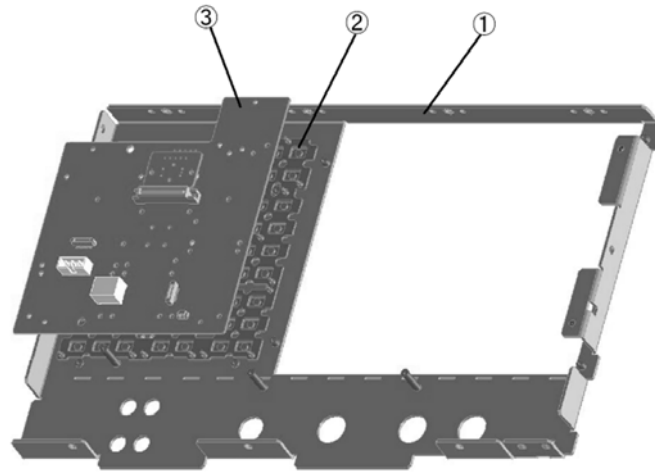
Table 5-29 Chassis Assembly

Ref. Desig.	Agilent Part Number	Qty.	Description
1	8160-1630	1	I/O SHIELD
2	E5052-60001	1	CHASSIS ASSEMBLY (for Serial Prefix MY441)
	E5052-60011	1	CHASSIS ASSEMBLY (for Serial Prefix MY442 and above)
3	0400-0254	1	GROMMET-CHANNEL
4	1400-3156	1	CLAMP-CABLE NYLON 6/6
5	0515-2113	8	SCREW-MACH M4.0 x L8 PN T15
6	5022-7129	1	FRONT FRAME
	8160-0641	1	GASKET BRAID (135cm)
7	0363-0310	2	GASKET BRAID (3.4cm)

Front Assembly (Front Keyboard)

Figure 5-31

Front Assembly (Front Keyboard)



e5052ase029

Table 5-30

Front Assembly (Front Keyboard)

Ref. Desig.	Agilent Part Number	Qty.	Description
1	E5052-00202	1	PANEL SUB
2	E5052-25101	1	KEYPAD RUBBER
3	E5062-66522	1	FRONT PANEL KEYBOARD

Front Assembly (LCD) for S/N MY44200836 and below

Figure 5-32 Front Assembly (LCD)

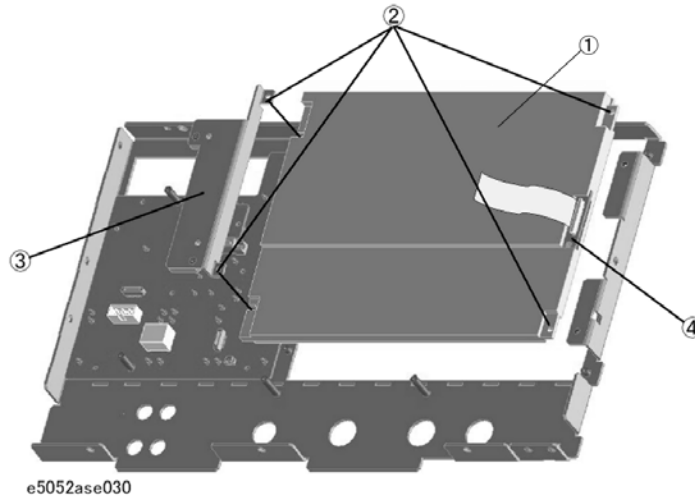
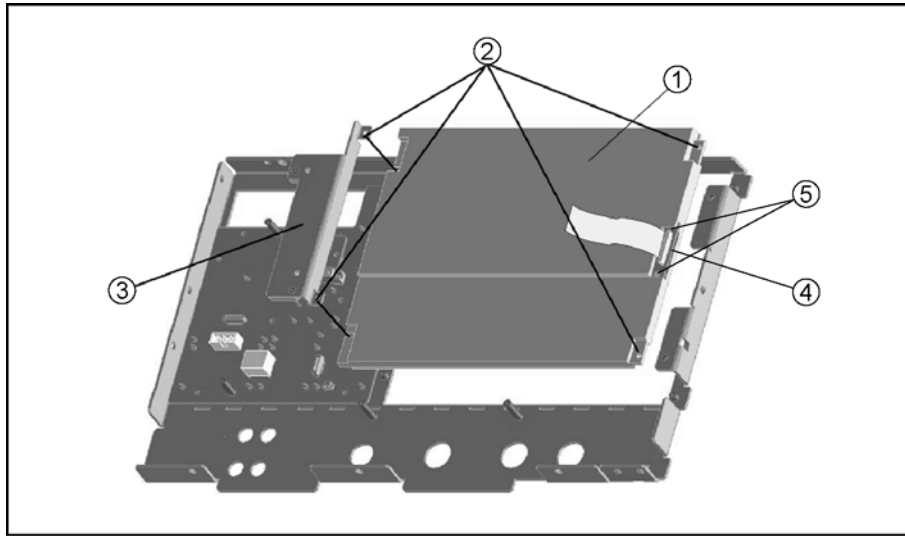


Table 5-31 Front Assembly (LCD)

Ref. Desig.	Agilent Part Number	Qty.	Description
1	E5070-60102	1	LCD TPANEL ASSY
2	0515-1402	4	SCREW-MACH M3.5 x L8 PN T15
3	See Table 5-35	1	FRONT ASSEMBLY (INVERTER)
4	E5070-66531	1	LCD ADA

Front Assembly (LCD) for S/N MY44200837 and above

Figure 5-33 Front Assembly (LCD)



e5052ase6002

Table 5-32 Front Assembly (LCD)

Ref. Desig.	Agilent Part Number	Qty.	Description
1	E5070-60102	1	LCD TPANEL ASSY
2	0515-1402	4	SCREW-MACH M3.5 x L8 PN T15
3	See Table 5-35	1	FRONT ASSEMBLY (INVERTER)
4	E5070-66531	1	LCD ADA
5	5188-4418	2	SELF-TAPPING SCREW

Front Assembly (Standby Switch / Cover) for S/N MY44200836 and below

Figure 5-34 Front Assembly (Standby Switch / Cover)

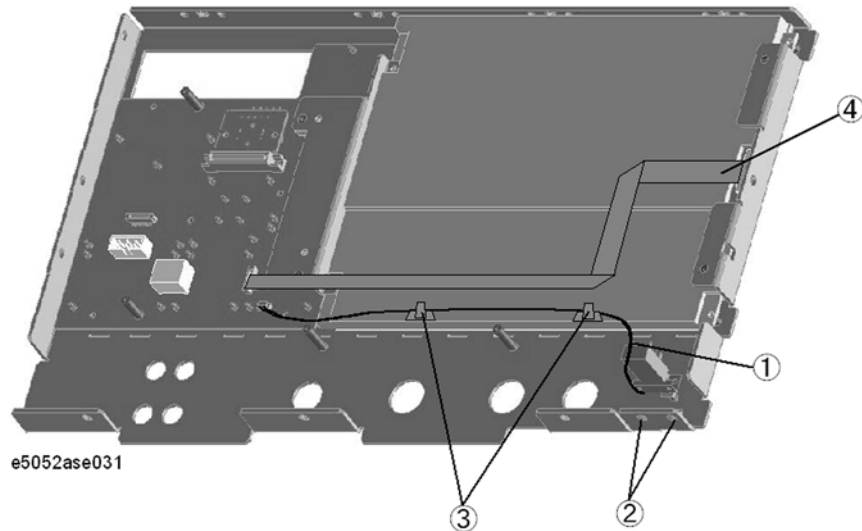
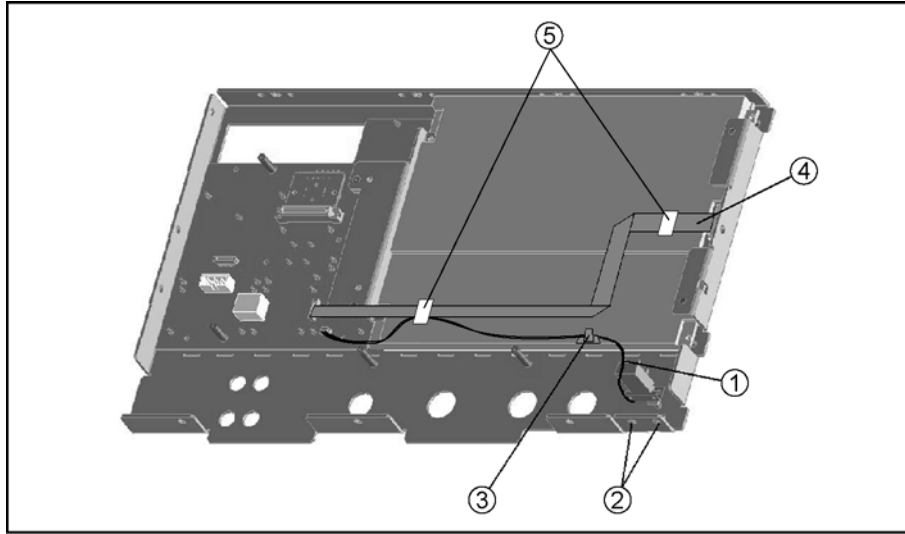


Table 5-33 Front Assembly (Standby Switch / Cover)

Ref. Desig.	Agilent Part Number	Qty.	Description
1	E5070-61901	1	WIRE ASSEMBLY W/STANDBY SWITCH
	0371-3953	1	KEY CAP
2	0515-2028	2	SCREW-MACH M2.5 x L6 FL T8
3	1400-1334	2	CLAMP-CABLE
4	E5062-61612	1	FLAT FLEXIBLE CABLE-LCD

Front Assembly (Standby Switch / Cover) for S/N MY44200837 and above

Figure 5-35 Front Assembly (Standby Switch / Cover)



e5052ase6003

Table 5-34 Front Assembly (Standby Switch / Cover)

Ref. Desig.	Agilent Part Number	Qty.	Description
1	E5070-61901	1	WIRE ASSEMBLY W/STANDBY SWITCH
	0371-3953	1	KEY CAP
2	0515-2028	2	SCREW-MACH M2.5 x L6 FL T8
3	1400-1334	1	CLAMP-CABLE
4	E5062-61612	1	FLAT FLEXIBLE CABLE-LCD
5	1400-3360	2	CLAMP-CABLE 21MM

Front Assembly (Inverter)

Figure 5-36 Front Assembly (Inverter)

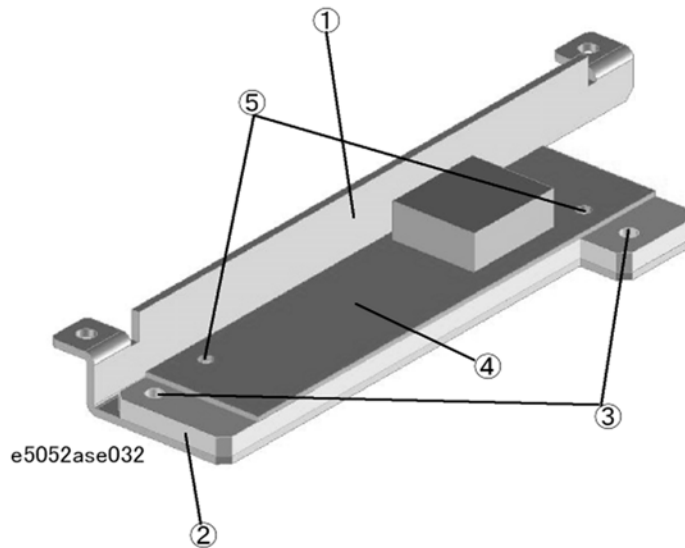


Table 5-35 Front Assembly (Inverter)

Ref. Desig.	Agilent Part Number	Qty.	Description
1	E5052-01290	1	BRACKET INVERTER
2	E5052-24007	1	SPACER
3	0515-0430	2	SCREW-MACH M3.0 x L6 PN T10
4	0950-4091	1	INVERTER LS700
5	0515-1974	2	SCREW-MACH M2.5 x L4 PN T8

Front Assembly (Cover 1)

Figure 5-37

Front Assembly (Cover 1)

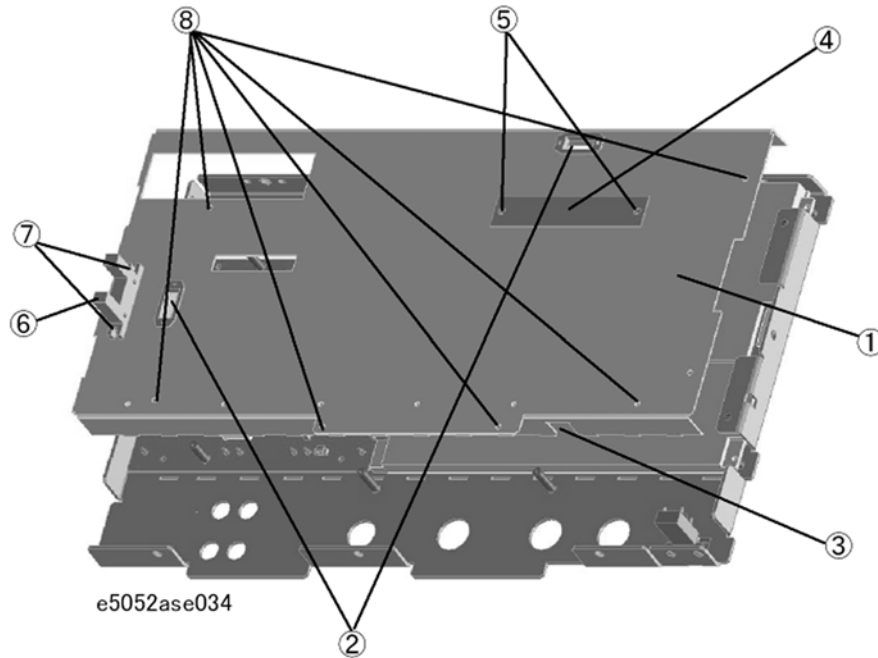


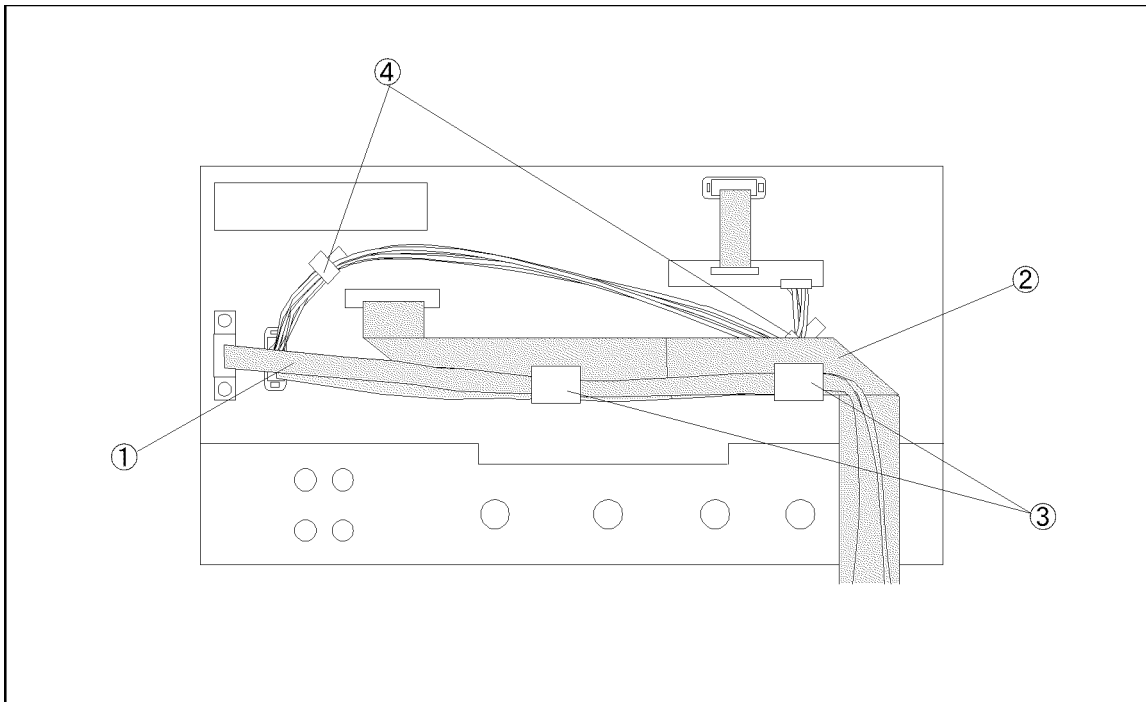
Table 5-36

Front Assembly (Cover 1)

Ref. Desig.	Agilent Part Number	Qty.	Description
1	E5052-00601	1	COVER SHIELD
2	1400-3156	2	CLAMP-CABLE NYLON 6/6
3	1400-1048	1	SADDLE-EDGE
4	5183-4184	1	CNTR TOUCH PANEL
5	0515-0430	2	SCREW-MACH M3.0 x L6 PN T10
6	E5070-61657	1	FLAT CBL ASSY
7	0515-0374	2	SCREW-MACH M3.0 x L10 PN T10
8	0515-0430	6	SCREW-MACH M3.0 x L6 PN T10

Front Assembly (Cover 2)

Figure 5-38 Front Assembly (Cover 2)



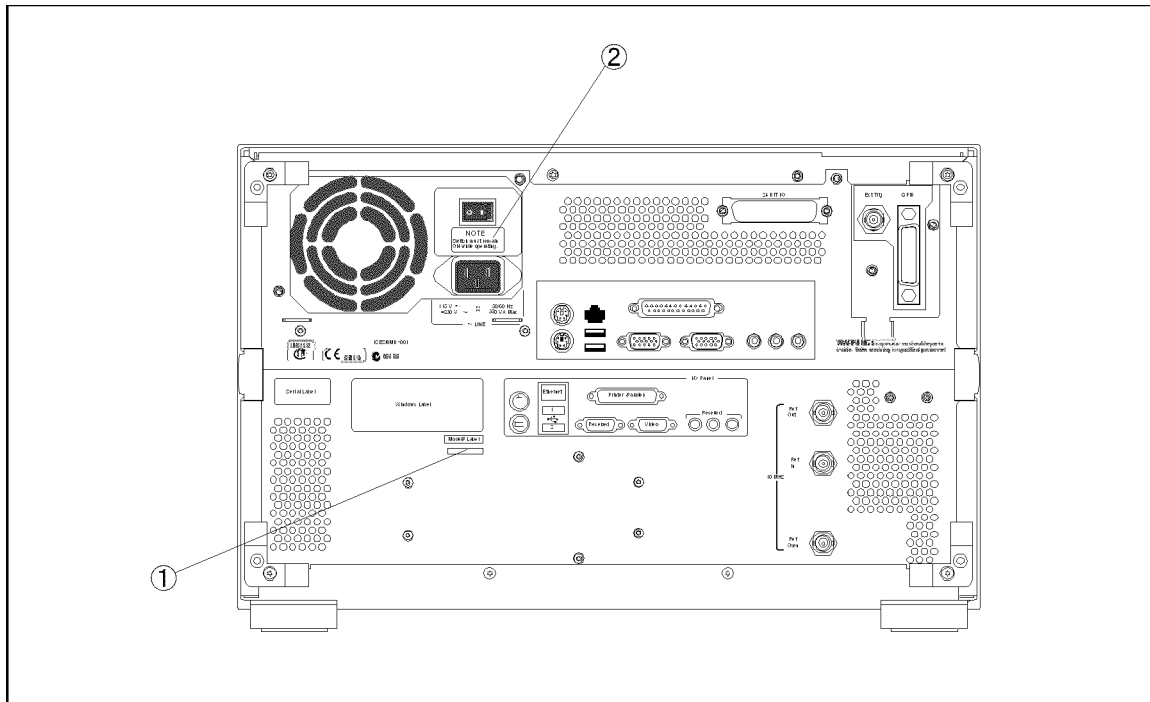
e5052ase035

Table 5-37 Front Assembly (Cover 2)

Ref. Desig.	Agilent Part Number	Qty.	Description
1	E5052-61630	1	FLAT RIBBON CABLE ASSEMBLY
2	E5052-61637	1	FLAT CABLE ASSEMBLY
3	1400-0611	2	CLAMP CABLE
4	1400-1334	2	CLAMP CABLE

Label on Rear Face

Figure 5-39 Label on Rear Face



e5052ase002

Table 5-38 Label on Rear Face

Ref. Desig.	Agilent Part Number	Qty.	Description
1	5183-4088	1	LABEL (OPTION 011)
2	E5070-87103	1	LABEL (NOTE for Switch)

Other Parts

Table 5-39 **Other Parts**

Agilent Part Number	Qty.	Description
E5052-900x0 ^{*1}	1	USER'S GUIDE
E5052-900x1 ^{*1}	1	PROGRAMMER'S GUIDE
E5052-900x2 ^{*1}	1	VBA PROGRAMMER'S GUIDE
E5052-901x0 ^{*1}	1	SERVICE GUIDE
E5052-9050x ^{*1}	1	CD-ROM (DOCUMENTATION)
1150-7846	1	MOUSE
1150-7970	1	KEYBOARD

*1. The number indicated by "x" in the part number of each manual, or CD-ROM, 0 for the first edition, is incremented by 1 each time a revision is made. The latest edition comes with the product.

6 Replacement Procedure

This chapter provides procedure for removing and replacing the major assemblies in the E5052A.

Replacing an Assembly

The following steps show the sequence for replacing an assembly in a E5052A Signal Source Analyzer.

1. Identify the faulty group. Refer to Chapter 4, “Troubleshooting.”
2. Order a replacement assembly. Refer to Chapter 5, “Replaceable Parts.”
3. Replace the faulty assembly and determine what adjustments are necessary. Refer to This chapter and Chapter 7, “Post-Repair Procedures.”
4. Perform the necessary adjustments. Refer to Chapter 3, “Adjustment.”
5. Perform the necessary performance tests. Refer to Chapter 2, “Performance Tests.”

WARNING These servicing instructions are for use by qualified personnel only. To avoid electrical shock, do not perform any servicing unless you are qualified to do so.

WARNING The opening of covers or removal of parts is likely to expose dangerous voltages. Disconnect the instrument from its power supply.

CAUTION Many of the assemblies in this instrument are very susceptible to damage from ESD(electrostatic discharge). Perform the following procedures only at a static-safe workstation and wear a grounding strap.

Required Tools

The following tools are required for repair of E5052A.

Table 6-1 Required Tools

Assembly	TORX screwdriver				flat edge screwdriver	torque screwdriver TORX T10	pozidriv screwdriver	hex key	open wrench			open torque wrench
	T8	T10	T15	T20					1.5 mm	9/16 in.	5/8 in.	
Outer Cover		√	√	√								
Front Panel		√	√	√	√							√
Mass Storage Disk Drive		√	√	√			√					
Removable Hard Disk Drive	√	√	√									
Removable Hard Disk Interface		√	√	√								
FDD		√	√	√								
Power Supply		√	√	√		√						
24 Bit I/O		√	√	√								
Digital Motherboard		√	√	√								
Freq / Power Detector		√	√	√	√							√
DC source		√	√	√	√							√
ADC/DSP		√	√	√	√							√
Local Synthesize		√	√	√	√							√
Phase Detector		√	√	√	√							√
Fan		√	√	√	√			√				√
Analog Motherboard		√	√	√	√				√			√
Power Distribution		√	√	√								
10MHz Oven		√	√	√								
PCI DSP / GPIB		√	√	√						√		
USB Interface		√	√	√								
Front Keyboard		√	√	√	√			√				√
Inverter	√	√	√	√	√							√
LCD		√	√	√	√							√
LCD Backlight		√	√	√	√							√
BNC Connector		√	√	√	√						√	√

Outer Cover Removal

Tools Required

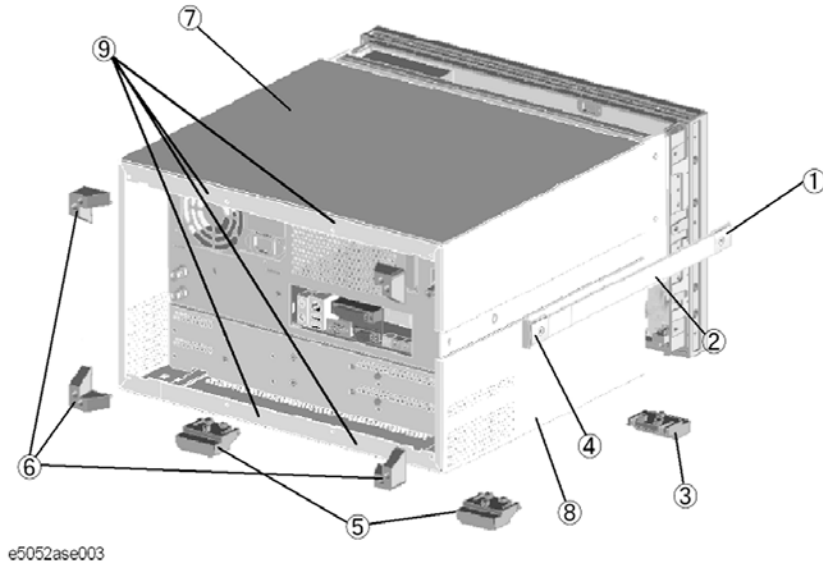
- TORX screwdriver, T10, T15 and T20

Procedure

Refer to Figure 6-1 for this procedure.

- Step 1.** Disconnect the power cable from the E5052A.
- Step 2.** Remove the four TORX T15 screws (item 6) fastening the four rear feet
- Step 3.** Remove the four TORX T15 screws (item 9) fastening the cover.
- Step 4.** Remove the four TORX T20 screws (item 1,4) fastening the side strap handles.
- Step 5.** Remove the four bottom feet (item 3, 5).
- Step 6.** Remove the four TORX T10 screws (item 8) from the bottom.
- Step 7.** Slide the outer cover and remove it carefully.

Figure 6-1 Outer Cover Removal



Front Panel Removal

Tools required

- TORX screwdriver T10, T15 and T20
- Flat edge screwdriver
- Open-end torque wrench, 5/16 inch (set to 10 in-lb) (for reconnecting SMA connector)

Procedure

Refer to Figure 6-2 for this procedure.

Step 1. Remove the outer cover as described in “Outer Cover Removal” on page 176.

Step 2. Disconnect the two semi-rigid cables (item 1) from the front panel.

NOTE

When reconnecting the semi-rigid cables, make sure that the cables are connected to the same connectors from which they previously came.

Step 3. Remove the top trim (item 2) using a flat edge driver.

Step 4. Remove the seven TORX T15 screws (item 3) fastening front panel.

Step 5. Gradually push the front panel assembly towards the outside.

Step 6. Release the cable (red and black) (item 8) from the cable clamp under the FDD.

Step 7. Release the mylar cable and flat cables from the cable clamps (item 5).

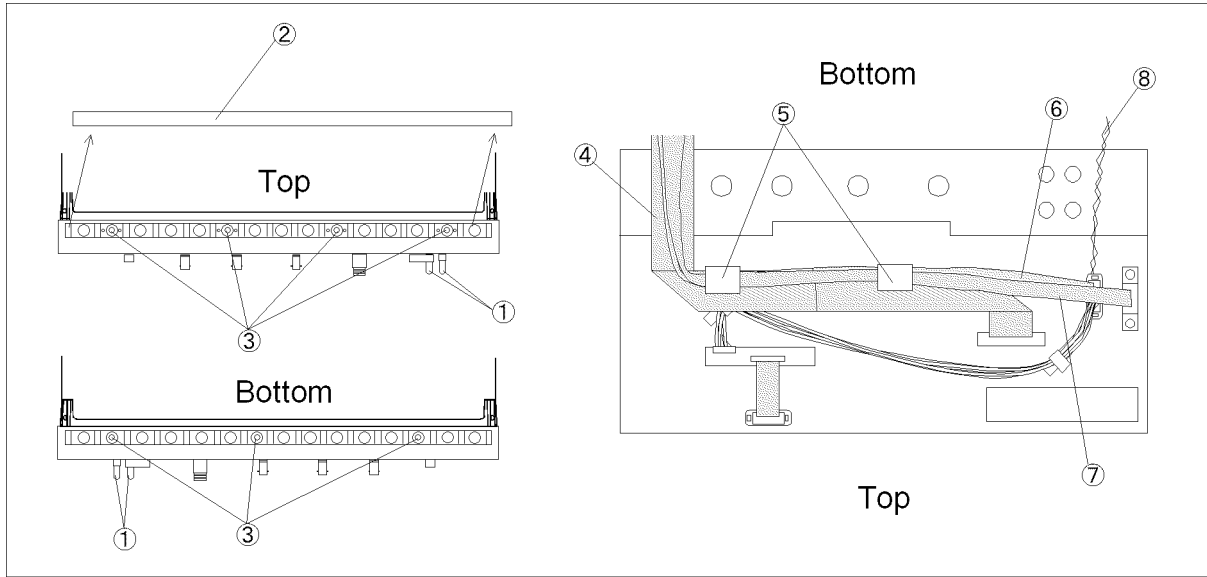
Step 8. Disconnect the cables (item 4, 7) from the front panel.

NOTE

Keep the mylar cable (item 6) connected.

The mylar cable and its connector are very fragile. It’s recommended that you should replace the mylar cable when the cable is disconnected and reconnected frequently.

Figure 6-2 Front Panel Removal



e5052ase048

A27 Mass storage Disk Drive Assembly Replacement

Tools Required

- TORX screwdriver T10, T15 and T20
- Pozidriv screwdriver, pt size #2 (medium)

Save Backup Files to the PC

When the mass storage disk drive is readable, you have to perform the following steps. For details of the adjustment program, refer to Chapter 3 on page 73.

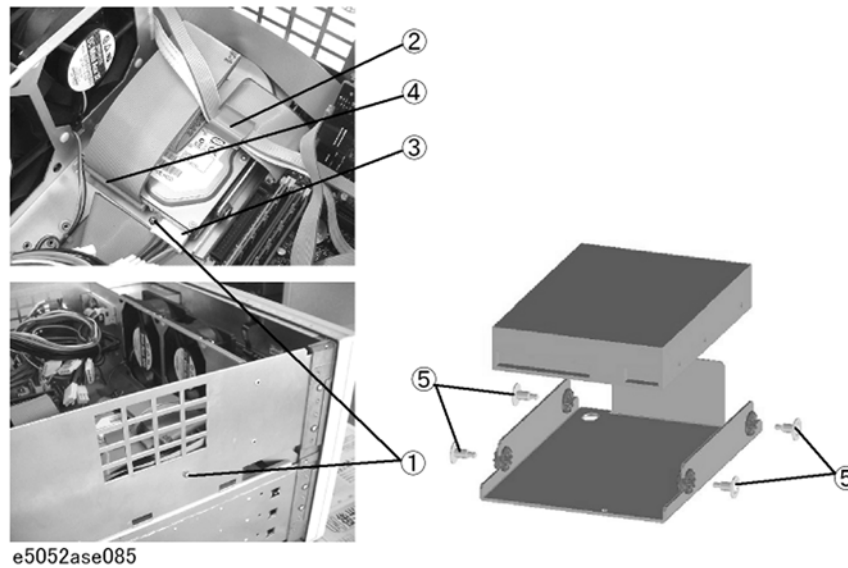
- Step 1.** Run the adjustment program.
- Step 2.** Input the GPIB address of the E5052A.
- Step 3.** Input the serial number of the E5052A.
- Step 4.** Perform the adjustment using “Backup” in Spot Adjustment of the program.

Removal Procedure

Refer to Figure 6-3 for this procedure.

- Step 1.** Remove the outer cover as described in “Outer Cover Removal” on page 176.
- Step 2.** Remove the two TORX T10 screws (item 1) fastening the Mass storage Disk Drive assembly.
- Step 3.** Release the mylar cable and flat cable from the cable clamp (item 2).
- Step 4.** Disconnect the power supply cable from the HDD (item 3).
- Step 5.** Disconnect the flat cable from the HDD (item 4).
- Step 6.** Lift the Mass storage Disk Drive assembly.
- Step 7.** Remove the four screws (item 5) fastening the HDD.

Figure 6-3 A27 Mass storage Disk Drive Assembly Removal



Replacement Procedure

- Step 1.** Reverse the order of the removal procedure.
- Step 2.** When the “Backup” in Spot Adjustment has been done, restore backup files onto the new mass storage disk drive as described in “Restore Backup Files onto the New HDD” on page 181.
- Step 3.** If the “Backup” in Spot Adjustment has not been done, restore backup files onto the new mass storage disk drive as described in “Adjustments for the New HDD” on page 182.
- Step 4.** Calibrate the touch screen as described in “Calibration of the Touch Screen” on page 182.

Restore Backup Files onto the New HDD

The Backup files are stored into the PC. The file must be restored in the new mass storage disk drive with the adjustment program. For the details of the adjustment program, refer to Chapter 3, “Adjustment,” on page 73.

- Step 1.** Run the adjustment program.
- Step 2.** Input the GPIB address of the E5052A.
- Step 3.** Input the serial number of the E5052A.
- Step 4.** Perform the adjustment using “Recovery” in Spot Adjustment of the program.

Adjustments for the New HDD

- Step 1.** Run the adjustment program.
- Step 2.** Input the GPIB address of the E5052A.
- Step 3.** Input the serial number of the E5052A.
- Step 4.** Perform the adjustment using “HDD” in Spot Adjustment of the program.

Calibration of the Touch Screen

When you have replaced the HDD on a E5052A, you have to calibrate the touch screen. Follow the procedure described below to calibrate the touch screen.

- Step 1.** Press [System].
- Step 2.** Press **Service Menu**.
- Step 3.** Press **Test Menu**.
- Step 4.** Press **Adjust Touch Screen**.

The touch screen calibration screen (Figure 6-4) appears.

Figure 6-4

Touch Panel Calibration Screen



- Step 5.** Touch the x mark on the upper left with your finger. The mark x appears also on the lower left, upper right, and lower right. Touch the x marks in that order with your finger.

Touching the four locations described above with your finger automatically concludes the touch screen calibration.

NOTE

With no operation on the touch screen calibration screen for a preset time, it automatically closes and the previous measurement screen reappears.

A27 Removable Hard Disk Drive Replacement for E5052A Serial Prefix MY442 and above

Tools Required

- TORX screwdriver T8, T10 and T15

Save Backup Files to the PC

When the removable hard disk drive is readable, you have to perform the following steps. For details of the adjustment program, refer to Chapter 3 on page 73.

- Step 1.** Run the adjustment program.
- Step 2.** Input the GPIB address of the E5052A.
- Step 3.** Input the serial number of the E5052A.
- Step 4.** Perform the adjustment using “Backup” in Spot Adjustment of the program.

Removal Procedure

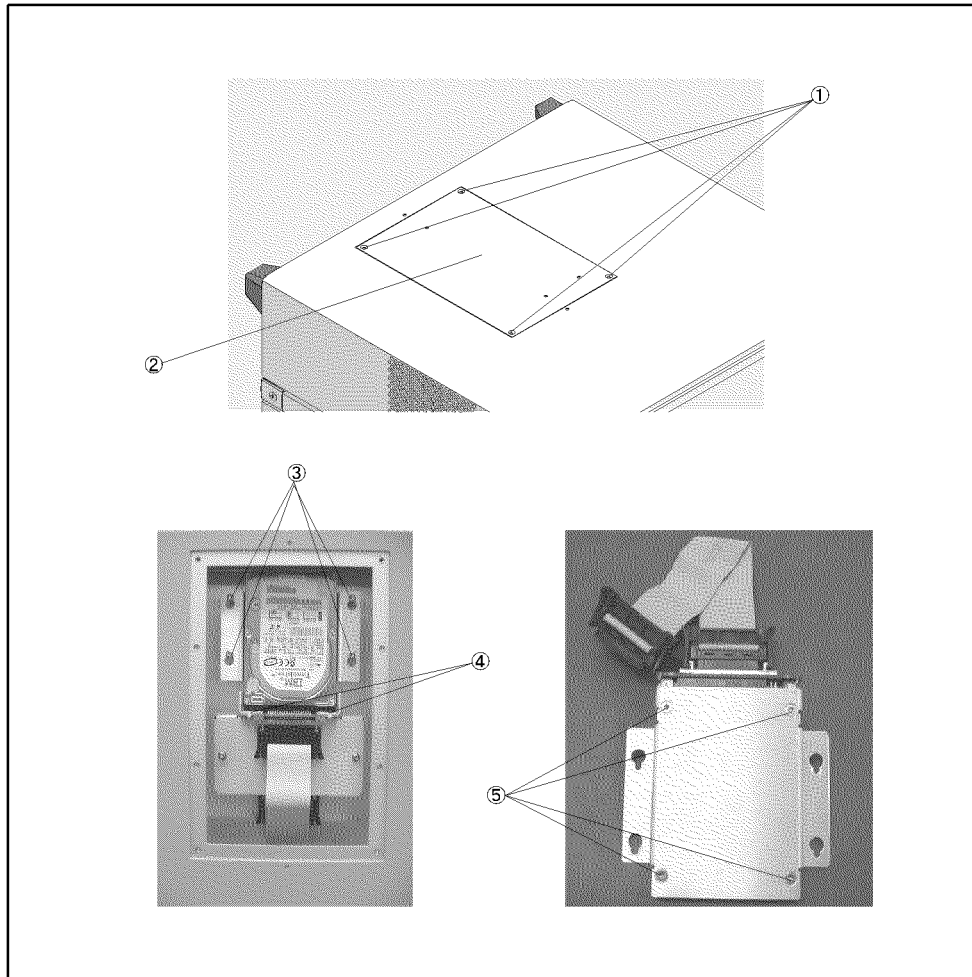
Refer to Figure 6-5 for this procedure.

- Step 1.** Remove the four TORX T15 screws (item 1) fastening the lid (item 2).
- Step 2.** Remove the four TORX T10 screws (item 3) fastening the HDD bracket.
- Step 3.** Remove the two TORX T8 screws (item 4).
- Step 4.** Remove the four TORX T10 screws (item 5), and remove the HDD bracket.
- Step 5.** Remove the hard disk drive from the connector board.

Replacement Procedure
A27 Removable Hard Disk Drive Replacement for E5052A Serial Prefix MY442 and above

Figure 6-5

A27 Removable Hard Disk Drive Removal



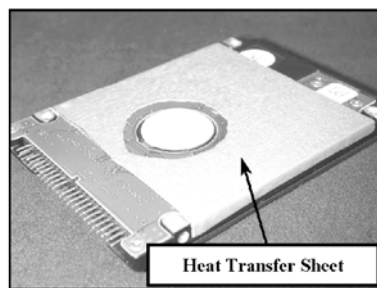
e5052ase3012

Replacement Procedure

Step 1. Stick the heat transfer sheet to the hard disk drive rear side (Refer to Figure 6-6).

Figure 6-6

Heat Transfer Sheet



e5070bse4013

Step 2. Replace the removable hard disk drive by inverse procedure of removal.

Replacement Procedure

A27 Removable Hard Disk Drive Replacement for E5052A Serial Prefix MY442 and above

- Step 3.** When the “Backup” in Spot Adjustment has been done, restore backup files onto the new removable hard disk drive as described in “Restore Backup Files onto the New HDD” on page 185.
- Step 4.** If the “Backup” in Spot Adjustment has not been done, restore backup files onto the new removable hard disk drive as described in “Adjustments for the New HDD” on page 185.
- Step 5.** Calibrate the touch screen as described in “Calibration of the Touch Screen” on page 185.

Restore Backup Files onto the New HDD

The Backup files are stored into the PC. The file must be restored in the new removable hard disk drive with the adjustment program. For the details of the adjustment program, refer to Chapter 3, “Adjustment,” on page 73.

- Step 1.** Run the adjustment program.
- Step 2.** Input the GPIB address of the E5052A.
- Step 3.** Input the serial number of the E5052A.
- Step 4.** Perform the adjustment using “Recovery” in Spot Adjustment of the program.

Adjustments for the New HDD

- Step 1.** Run the adjustment program.
- Step 2.** Input the GPIB address of the E5052A.
- Step 3.** Input the serial number of the E5052A.
- Step 4.** Perform the adjustment using “HDD” in Spot Adjustment of the program.

Calibration of the Touch Screen

When you have replaced the HDD on a E5052A, you have to calibrate the touch screen. Follow the procedure described below to calibrate the touch screen.

- Step 1.** Press [System].
- Step 2.** Press **Service Menu**.
- Step 3.** Press **Test Menu**.
- Step 4.** Press **Adjust Touch Screen**.

The touch screen calibration screen (Figure 6-7) appears.

Figure 6-7

Touch Panel Calibration Screen



Step 5. Touch the x mark on the upper left with your finger. The mark x appears also on the lower left, upper right, and lower right. Touch the x marks in that order with your finger.

Touching the four locations described above with your finger automatically concludes the touch screen calibration.

NOTE

With no operation on the touch screen calibration screen for a preset time, it automatically closes and the previous measurement screen reappears.

Removable Hard Disk Interface Board Removal for Serial Prefix MY442 and above

Tools Required

- TORX screwdriver, T10, T15, and T20

Removal procedure

Refer to Figure 6-8 for this procedure.

- Step 1.** Remove the outer cover as described in “Outer Cover Removal” on page 176.
- Step 2.** Remove the four TORX T10 screw (item 1).
- Step 3.** Unscrew the four TORX T10 screw (item 2) that hold the removable hard disk.
- Step 4.** Carefully remove the flat cable (item 3) . Release the cable’s connector by pressing the locking hooks at the sides of the connector.
- Step 5.** Lift the removable hard disk with the flat cable.
- Step 6.** Remove the two TORX T10 screw (item 4).
- Step 7.** Remove the inner cover.
- Step 8.** Turn over the removable hard disk case. Disconnect the power cable (item 5) and flat cable (item 6) .
- Step 9.** Remove the four TORX T10 screw (item 7).

Replacement Procedure

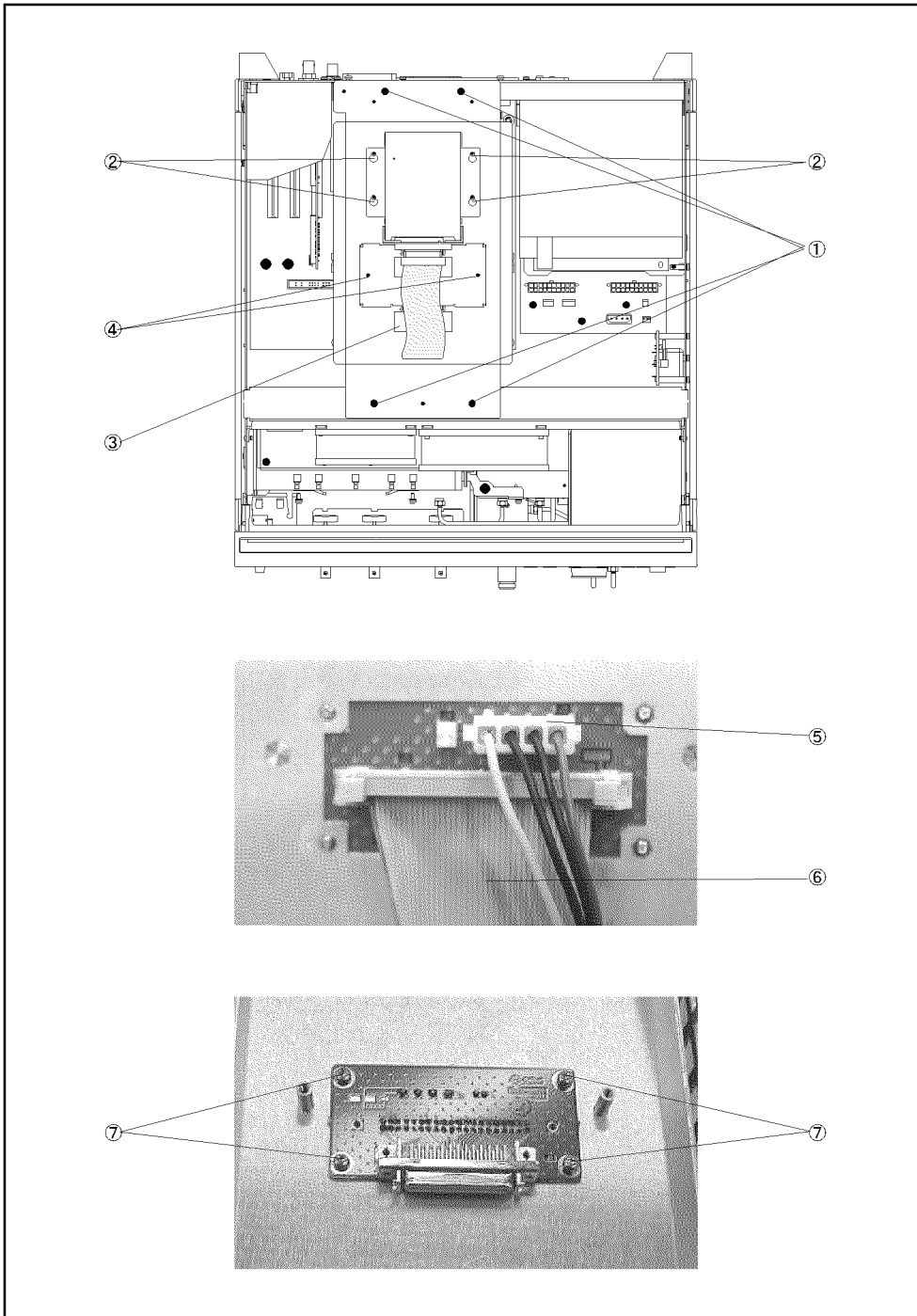
- Step 1.** Replace the removable hard disk interface by inverse procedure of removal.

Replacement Procedure

Removable Hard Disk Interface Board Removal for Serial Prefix MY442 and above

Figure 6-8

Removable Hard Disk Interface Board Removal



e5052ase3013

A28 FDD Replacement

Tools Required

- TORX screwdriver, T10, T15, and T20

Removal procedure

Refer to Figure 6-9 for this procedure.

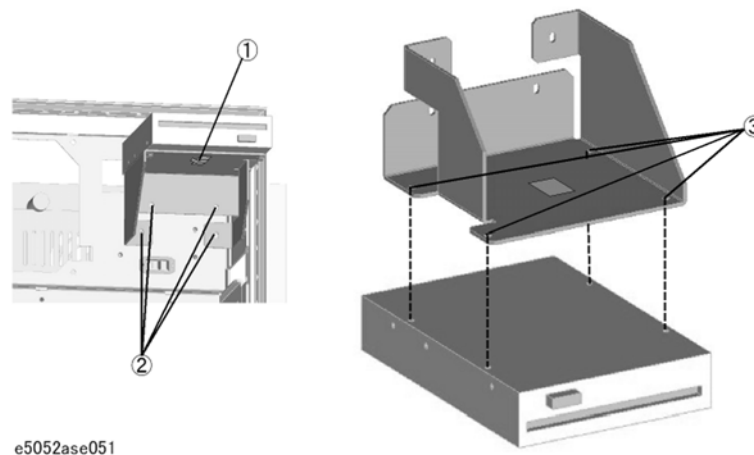
- Step 1.** Remove the outer cover as described in “Outer Cover Removal” on page 176.
- Step 2.** Remove the front panel as described in “Front Panel Removal” on page 178.
- Step 3.** Disconnect the power supply cable from the FDD.
- Step 4.** Disconnect the flat cable from the FDD.
- Step 5.** Release the clamped cable from the clamp (item 1) of under the FDD.
- Step 6.** Remove four TORX T10 screws (item 2) fastening the FDD assembly.
- Step 7.** Slide the FDD assembly forward.
- Step 8.** Remove the four TORX T10 screws (item 3) fastening the FDD to the mount.

Replacement Procedure

- Step 1.** Fasten the angle to the new FDD, and then fasten it to the mount as shown in Figure 6-9.
- Step 2.** Reverse the order of the removal procedure.

Figure 6-9

A28 FDD Removal



A50 Power Supply Assembly Replacement

Tools Required

- TORX screwdriver, T10, T15, and T20
- torque screwdriver, TORX T10 (set to 7 in-lb)

Removal Procedure

Refer to Figure 6-10 for this procedure.

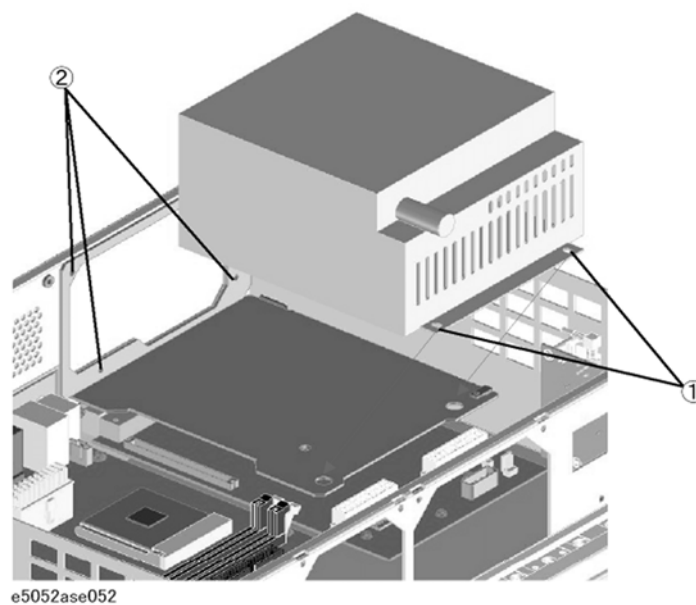
- Step 1.** Remove the outer cover as described in “Outer Cover Removal” on page 176.
- Step 2.** Disconnect the power supply cables for the FDD, HDD and power distribution board.
- Step 3.** Remove the two TORX T20 screws (item 1) fastening the plate for power supply.
- Step 4.** Remove the three TORX T10 screws (item 2) from the rear panel.
- Step 5.** Lift the power supply assembly toward front side.

Replacement Procedure

- Step 1.** Reverse the order of the removal procedure.

NOTE Fasten the TORX T10 screws (item 2) using a torque screwdriver.

Figure 6-10 A50 Power Supply Assembly Removal



A25 24 Bit I/O Board Replacement

Tools Required

- TORX screwdriver, T10, T15, and T20

Removal Procedure

Refer to Figure 6-11 for this procedure.

Step 1. Remove the outer cover as described in “Outer Cover Removal” on page 176.

Step 2. Disconnect the flat cable (item 1) from the 24 bit I/O board.

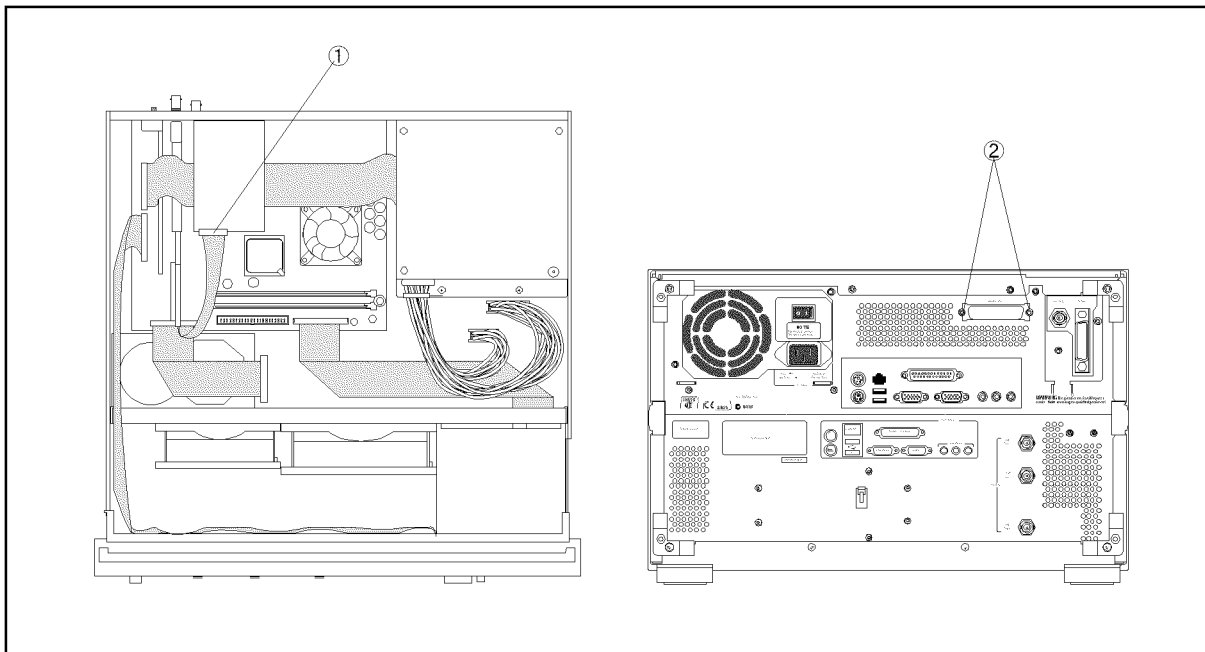
Step 3. Remove the two TORX T10 screws (item 2) fastening the 24 bit I/O board.

Step 4. Slide the 24 bit I/O board.

Replacement Procedure

Step 1. Reverse the order of the removal procedure.

Figure 6-11 A25 24 Bit I/O Board Removal



e5052ase053

A20 Digital Motherboard Replacement

Tools Required

- TORX screwdriver, T10, T15, and T20

Removal Procedure

Refer to Figure 6-12 for this procedure.

- Step 1.** Remove the mouse, the external keyboard and the parallel printer cable if they are connected to the rear panel.
- Step 2.** Remove the outer cover as described in “Outer Cover Removal” on page 176.
- Step 3.** Remove the following assemblies.
- 24 Bit I/O board (refer to “A25 24 Bit I/O Board Replacement” on page 191).
 - PCI DSP CARD / GPIB Card assembly (refer to “A21 PCI DSP / A24 GPIB Card Replacement” on page 205).
- Step 4.** Disconnect the following cables.
- Connected to the Front Panel (item 1).
 - Connected to the Power Board (item 2).
 - Connected to the FDD (item 3).
 - Connected to the HDD (item 4).
 - Connected to the Front Panel (display) (item 5).

NOTE

The mylar cable (item 5) and its connector are very fragile. It’s recommended to replace the mylar cable when the cable is disconnected and connected frequently.

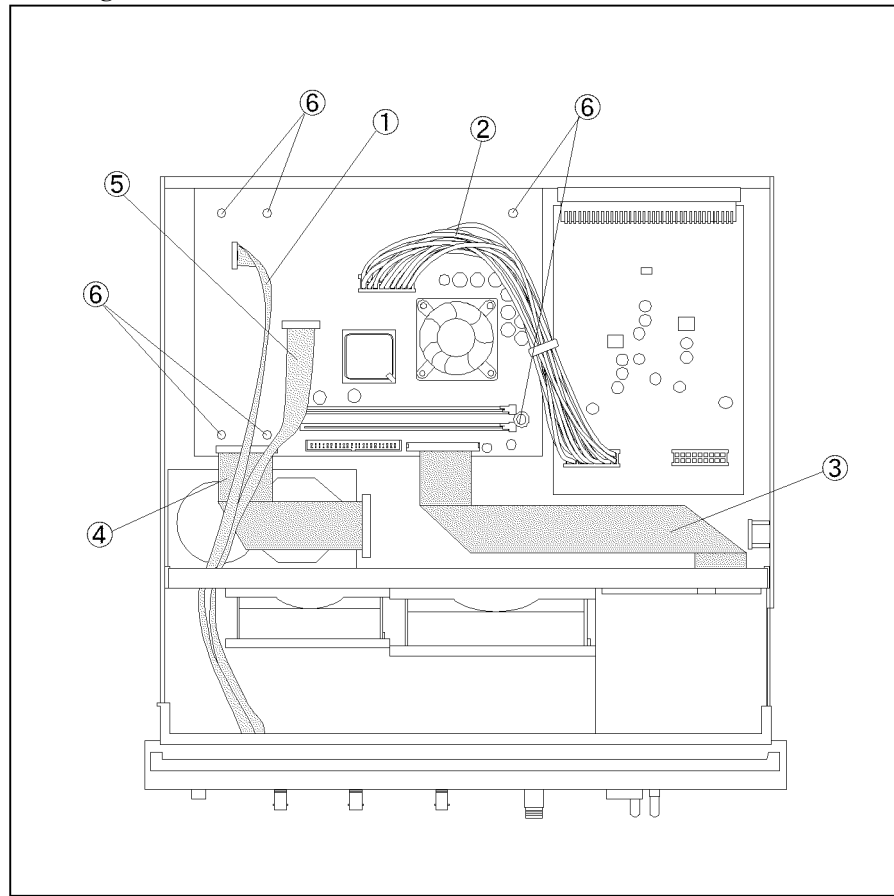
- Step 5.** Remove six TORX T10 screws (item 6) fastening the digital motherboard.
- Step 6.** Lift the digital motherboard.

Replacement Procedure

- Step 1.** Clamp the two clips using the new cable tie for DIMM memorys.
- Step 2.** Reverse the order of the removal procedure.

Figure 6-12

A20 Digital Motherboard Removal



e6052ase072

A1 Freq / Power Detector Module Replacement

Tools Required

- TORX screwdriver, T10, T15, and T20
- Flat edge screwdriver
- Open-end torque wrench, 5/16 inch (set to 10 in-lb) (for reconnecting SMA connector)

Removal Procedure

Refer to Figure 6-13 for this procedure.

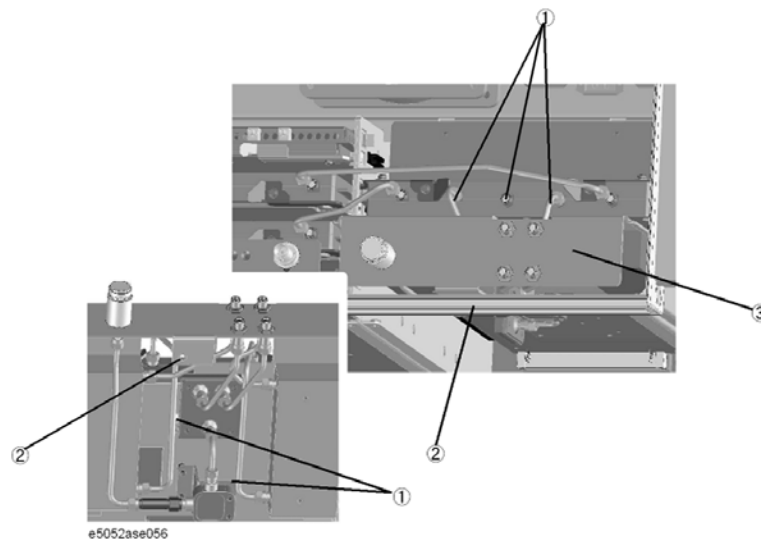
- Step 1.** Remove the outer cover as described in “Outer Cover Removal” on page 176
- Step 2.** Remove the front panel as described in “Front Panel Removal” on page 178.
- Step 3.** Disconnect the semi-rigid cables and RF cable(item 1).
- Step 4.** Remove the TORX T15 screw fastening the freq / power detector module bracket (item 2).
- Step 5.** Slide out the freq / power detector module (item 3).

Replacement Procedure

- Step 1.** Reverse the order of the removal procedure.

NOTE Fasten the semi rigid cable using a torque wrench for replacement.

Figure 6-13 A1 Freq/Power Detector Module Removal



A2 DC Source Board Replacement

Tools Required

- TORX screwdriver, T10, T15, and T20
- Flat edge screwdriver
- Open-end torque wrench, 5/16 inch (set to 10 in-lb) (for reconnecting SMA connector)

Removal Procedure

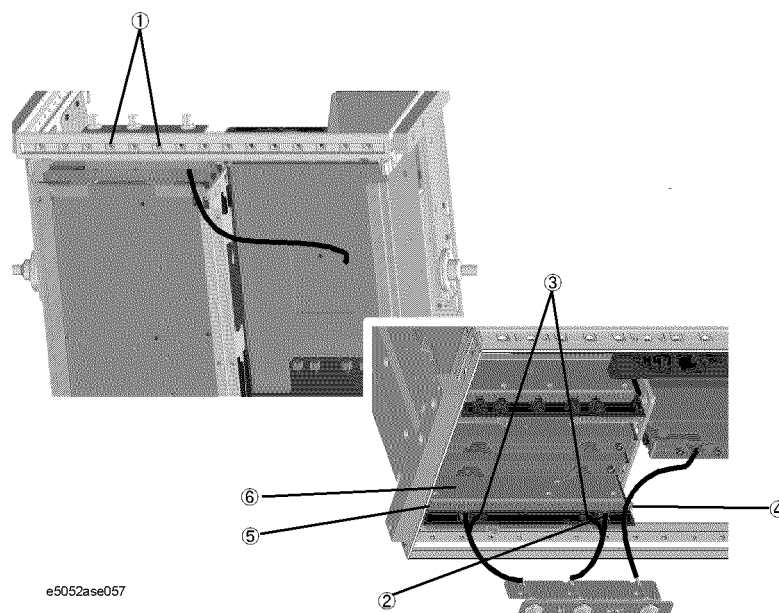
Refer to Figure 6-14 for this procedure.

- Step 1.** Remove the outer cover as described in “Outer Cover Removal” on page 176
- Step 2.** Remove the front panel as described in “Front Panel Removal” on page 178.
- Step 3.** Remove two TORX T15 screws (item 1).
- Step 4.** Remove a TORX T10 screw (item 4) .
- Step 5.** Remove a TORX T10 screw (item 5) for serial prefix MY442 and above.
- Step 6.** Slide out the DUT Power board (item 6).
- Step 7.** Disconnect the RF cables (item 2).
- Step 8.** Remove two TORX T10 screws (item 3).

NOTE

Remove the BNC connector as described in “BNC Connector(front) Replacement” on page 218.

Figure 6-14 A2 DC Source Board Removal



Replacement Procedure
A2 DC Source Board Replacement

Replacement Procedure

Step 1. Reverse the order of the removal procedure.

NOTE Fasten the semi rigid cable using a torque wrench for replacement.

A3 ADC/DSP Board Replacement

Tools Required

- TORX screwdriver, T10, T15, and T20
- Flat edge screwdriver
- Open-end torque wrench, 5/16 inch (set to 10 in-lb) (for reconnecting SMA connector)

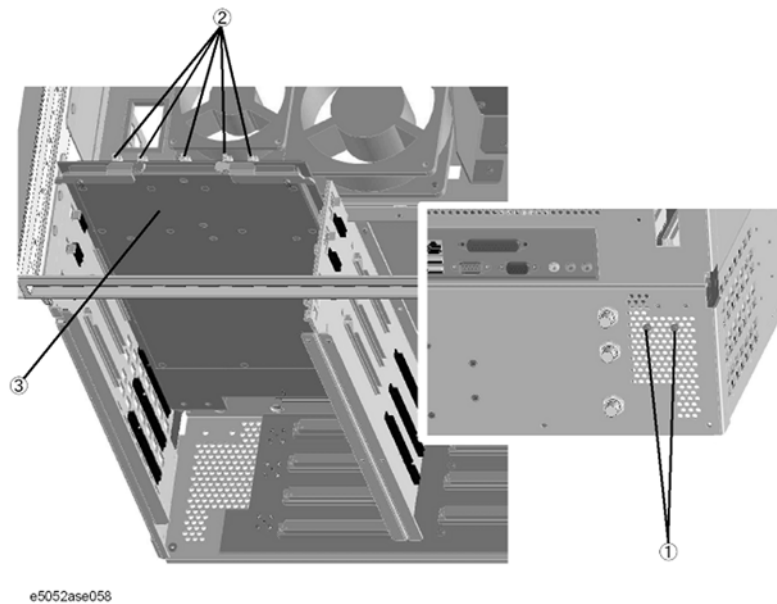
Removal Procedure

Refer to Figure 6-15 for this procedure.

- Step 1.** Remove the outer cover as described in “Outer Cover Removal” on page 176
- Step 2.** Remove the front panel as described in “Front Panel Removal” on page 178.
- Step 3.** Remove two TORX T10 screws (item 1).
- Step 4.** Disconnect the RF cables (item 2).
- Step 5.** Slide out the ADC/DSP board (item 3).

Figure 6-15

A3 ADC/DSP Board Removal



Replacement Procedure

- Step 1.** Reverse the order of the removal procedure.

NOTE

Fasten the semi rigid cable using a torque wrench for replacement.

A4/A5 Local Synthesize Module Replacement

Tools Required

- TORX screwdriver, T10, T15, and T20
- Flat edge screwdriver
- Open-end torque wrench, 5/16 inch (set to 10 in-lb) (for reconnecting SMA connector)

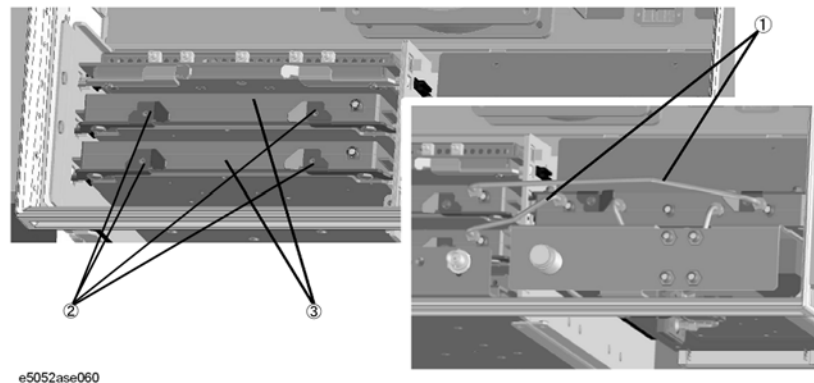
Removal Procedure

Refer to Figure 6-16 for this procedure.

- Step 1.** Remove the outer cover as described in “Outer Cover Removal” on page 176.
- Step 2.** Remove the front panel as described in “Front Panel Removal” on page 178.
- Step 3.** Disconnect the semi-rigid cables (item 1).
- Step 4.** Remove each two TORX T10 screws (item 2).
- Step 5.** Slide out the Local Synthesize module (item 3).

Figure 6-16

A4/A5 Local Synthesize Module Removal



Replacement Procedure

- Step 1.** Reverse the order of the removal procedure.

NOTE

Fasten the semi rigid cable using a torque wrench for replacement.

A6 Phase Detector Board Replacement

Tools Required

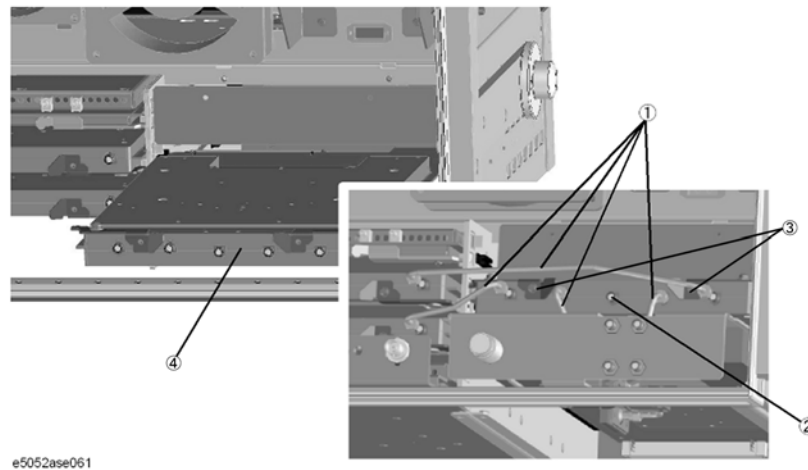
- TORX screwdriver, T10, T15, and T20
- Flat edge screwdriver
- Open-end torque wrench, 5/16 inch (set to 10 in-lb) (for reconnecting SMA connector)

Removal Procedure

Refer to Figure 6-17 for this procedure.

- Step 1.** Remove the outer cover as described in “Outer Cover Removal” on page 176.
- Step 2.** Remove the front panel as described in “Front Panel Removal” on page 178.
- Step 3.** Disconnect the all semi-rigid cables (item 1).
- Step 4.** Disconnect the RF cable (item 2).
- Step 5.** Remove two TORX T10 screws (item 3).
- Step 6.** Slide out the Phase Detector board (item 4).

Figure 6-17 **A6 Phase Detector Board Removal**



Replacement Procedure

- Step 1.** Reverse the order of the removal procedure.

NOTE Fasten the semi rigid cable using a torque wrench for replacement.

Fan Replacement

Tools Required

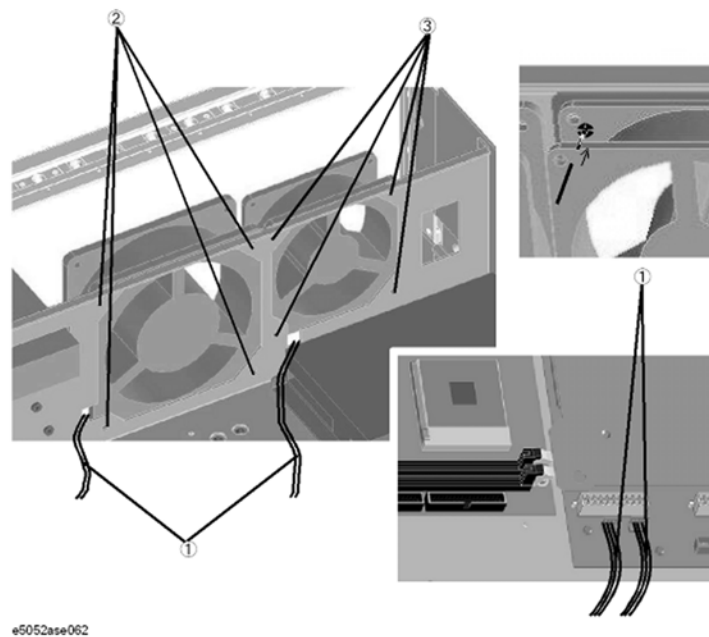
- TORX screwdriver, T10,T15 and T20
- Flat edge screwdriver
- Open-end torque wrench, 5/16 inch (set to 10 in-lb) (for reconnecting SMA connector)
- A fine stick such as Hex key, 1.5mm

Removal Procedure

Refer to Figure 6-18 for this procedure.

- Step 1.** Remove the outer cover as described in “Outer Cover Removal” on page 176.
- Step 2.** Remove the front panel as described in “Front Panel Removal” on page 178.
- Step 3.** Disconnect the fan cables (item 1) from the analog board.
- Step 4.** Remove the four white rivets (plastic)(item 2) fastening the fan.
- Step 5.** Remove the four black rivets (plastic)(item 3) fastening the fan using the fine stick.

Figure 6-18 Fan Removal



Replacement Procedure

- Step 1.** Reverse the order of the removal procedure.

A10 Analog Motherboard Replacement

Tools Required

- TORX screwdriver, T10, T15, and T20
- Flat edge screwdriver
- Open-end wrench, 9/16 inch
- Open-end torque wrench, 5/16 inch (set to 10 in-lb) (for reconnecting SMA connector)

Removal Procedure

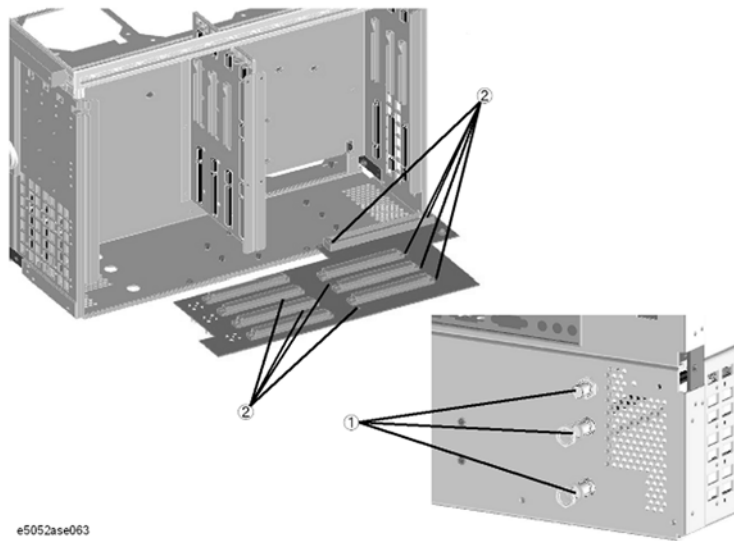
Refer to Figure 6-19 for this procedure.

- Step 1.** Remove the outer cover as described in “Outer Cover Removal” on page 176.
- Step 2.** Remove the front panel as described in “Front Panel Removal” on page 178.
- Step 3.** Remove the Freq/Power Detector module as described in “A1 Freq / Power Detector Module Replacement” on page 194.
- Step 4.** Remove the ADC/DSP board as described in “A3 ADC/DSP Board Replacement” on page 197.
- Step 5.** Remove the Local Synthesize module as described in “A4/A5 Local Synthesize Module Replacement” on page 198.
- Step 6.** Remove the Phase Detector board as described in “A6 Phase Detector Board Replacement” on page 199.
- Step 7.** Remove the Power supply as described in “A50 Power Supply Assembly Replacement” on page 190
- Step 8.** Disconnect the cables connected to the analog motherboard.
- Step 9.** Remove the three 9/16 inch nuts (item 1) fastening the rear panel.
- Step 10.** Remove the nine TORX T10 screws (item 2) fastening the analog motherboard.

Replacement Procedure
A10 Analog Motherboard Replacement

Figure 6-19

A10 Analog Motherboard Removal



Replacement Procedure

Step 1. Reverse the order of the removal procedure.

A12 Power Distribution Board Replacement

Tools Required

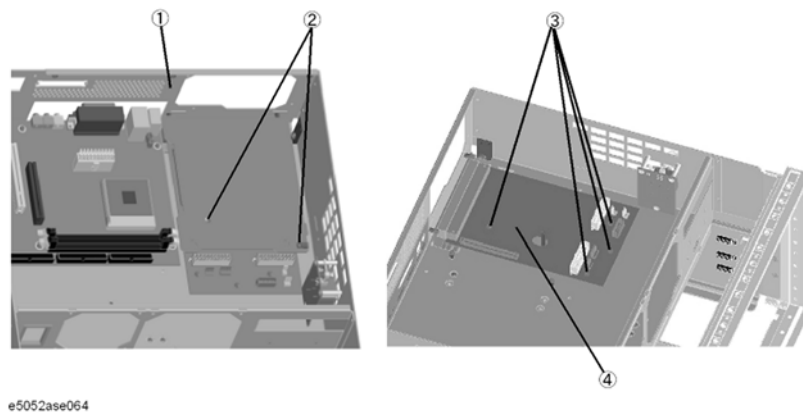
- TORX screwdriver, T10, T15, and T20

Removal Procedure

Refer to Figure 6-20 for this procedure.

- Step 1.** Remove the outer cover as described in “Outer Cover Removal” on page 176.
- Step 2.** Remove the Power supply as described in “A50 Power Supply Assembly Replacement” on page 190.
- Step 3.** Remove the rear plate (item 1).
- Step 4.** Remove the two TORX T10 screws (item 2) fastening the plate.
- Step 5.** Disconnect the cables from the Power Distribution board.
- Step 6.** Remove the four TORX T10 screws (item 3) fastening the Power Distribution board.
- Step 7.** Slide out the Power Distribution board (item 4).

Figure 6-20 A12 Power Distribution Board Removal



Replacement Procedure

- Step 1.** Reverse the order of the removal procedure.

A11 10 MHz Oven Replacement

Tools Required

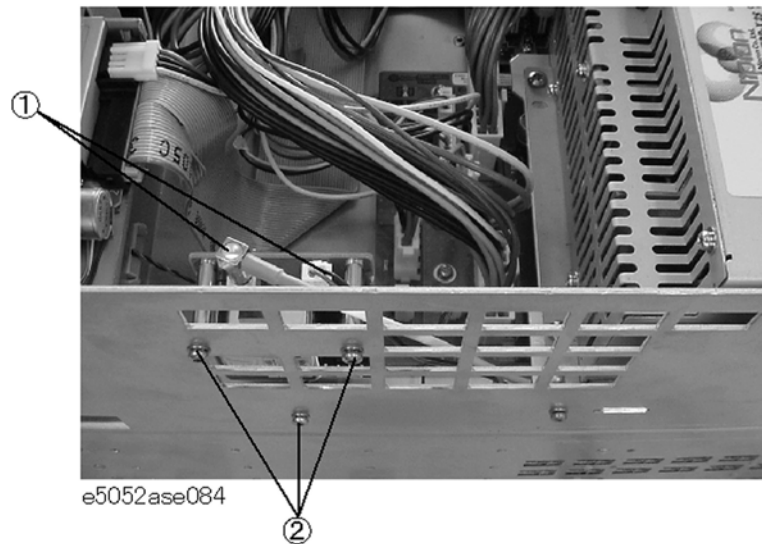
- TORX screwdriver, T10, T15, and T20

Removal Procedure

Refer to Figure 6-21 for this procedure.

- Step 1.** Remove the outer cover as described in “Outer Cover Removal” on page 176.
- Step 2.** Disconnect the cables from the Oven (item 1).
- Step 3.** Remove the three TORX T10 screws (item 2) fastening the Oven.

Figure 6-21 A11 10 MHz Oven Removal



Replacement Procedure

- Step 1.** Reverse the order of the removal procedure.

A21 PCI DSP / A24 GPIB Card Replacement

Tools Required

- TORX screwdriver, T10, T15, and T20
- Open-end wrench, 5/8 inch

Removal Procedure

Refer to Figure 6-22 for this procedure.

- Step 1.** Remove the outer cover as described in “Outer Cover Removal” on page 176.
- Step 2.** Remove the three TORX T10 screws (item 1) fastening the angle.
- Step 3.** Disconnect the flat cable (item 2) from the 24 bit I/O board.
- Step 4.** Disconnect the flat cable (item 3) from the Power Distribution board.
- Step 5.** Disconnect the flat cable (item 4) from the front panel.
- Step 6.** Remove two TORX T10 screws (item 5) fastening the PCI DSP Card/GPIB Card assembly to the rear panel.
- Step 7.** Disconnect the assembly from the Digital Motherboard and Lift it.
- Step 8.** Remove the PCI DSP Card or GPIB Card.

For removing the PCI DSP Card.

- Remove the 5/8 inch nut (item 6) fastening the angle.
- Remove the TORX T10 screw (item 7) fastening the angle.

For removing the GPIB Card.

- Remove two TORX T10 screws (item 8) fastening the angle.

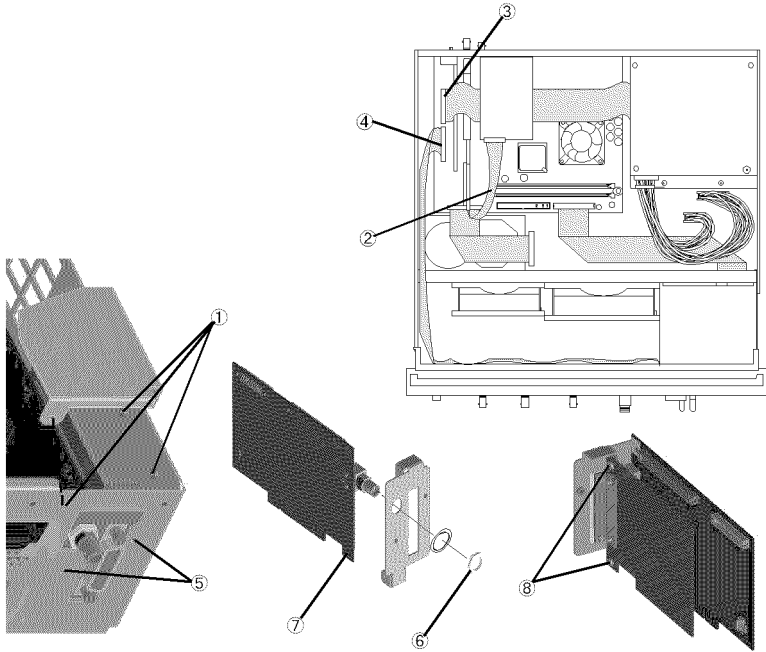
Replacement Procedure

- Step 1.** Reverse the order of the removal procedure.

Replacement Procedure
A21 PCI DSP / A24 GPIB Card Replacement

Figure 6-22

A21 PCI / A24 GPIB Card Removal



e5052ase066

A21 PCI DSP / A24 GPIB Card Replacement for Serial Prefix MY442 and above

Tools Required

- TORX screwdriver, T10, T15, and T20
- Open-end wrench, 5/8 inch

Removal Procedure

Refer to Figure 6-22 for this procedure.

- Step 1.** Remove the outer cover as described in “Outer Cover Removal” on page 176.
- Step 2.** Remove the three TORX T10 screws (item 1) fastening the angle.
- Step 3.** Disconnect the flat cable (item 2) from the 24 bit I/O board.
- Step 4.** Disconnect the flat cable (item 3) from the Power Distribution board.
- Step 5.** Disconnect the flat cable (item 4) from the front panel.
- Step 6.** Remove the three TORX T10 screws (item 5) fastening the PCI DSP Card/GPIB Card assembly to the rear panel.
- Step 7.** Disconnect the USB(USBTMC) interface card from the Digital Motherboard and Lift it.
- Step 8.** Disconnect the assembly from the Digital Motherboard and Lift it.
- Step 9.** Remove the PCI DSP Card or GPIB Card.

For removing the PCI DSP Card.

- Remove the 5/8 inch nut (item 6) fastening the angle.
- Remove the TORX T10 screw (item 7) fastening the angle.

For removing the GPIB Card.

- Remove the two TORX T10 screws (item 8) fastening the angle.

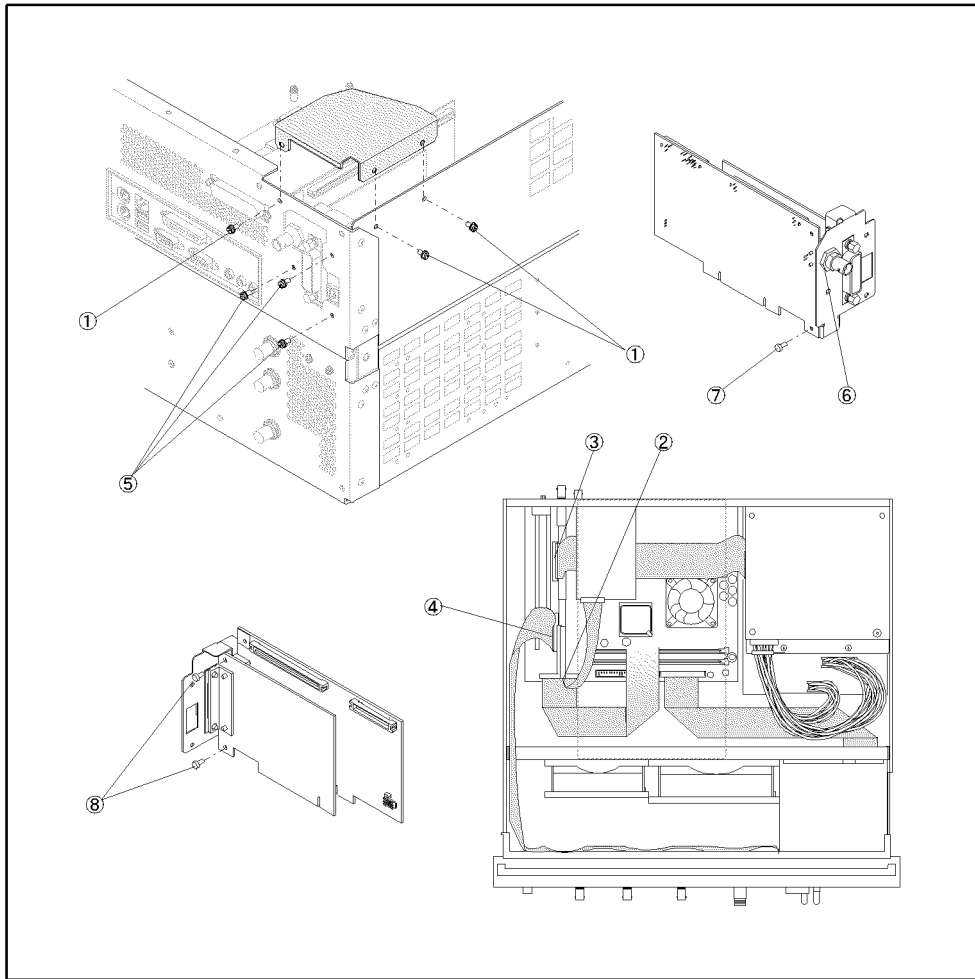
Replacement Procedure

- Step 1.** Reverse the order of the removal procedure.

Replacement Procedure
A21 PCI DSP / A24 GPIB Card Replacement for Serial Prefix MY442 and above

Figure 6-23

A21 PCI / A24 GPIB Card Removal



e5052ase3014

USB (USBTMC) Interface Card Replacement for E5052A Serial Prefix MY442 and above

Tools Required

- TORX screwdriver, T10, T15, and T20

Removal Procedure

Refer to Figure 6-24 for this procedure.

- Step 1.** Remove the outer cover as described in “Outer Cover Removal” on page 176.
- Step 2.** Remove the three TORX T10 screws (item 1) fastening the angle.
- Step 3.** Remove two TORX T10 screws (item 2) fastening the PCI DSP Card/GPIB Card assembly to the rear panel.
- Step 4.** Lift the USB (USBTMC) interface card (item 3) from the Digital Motherboard.

Replacement Procedure

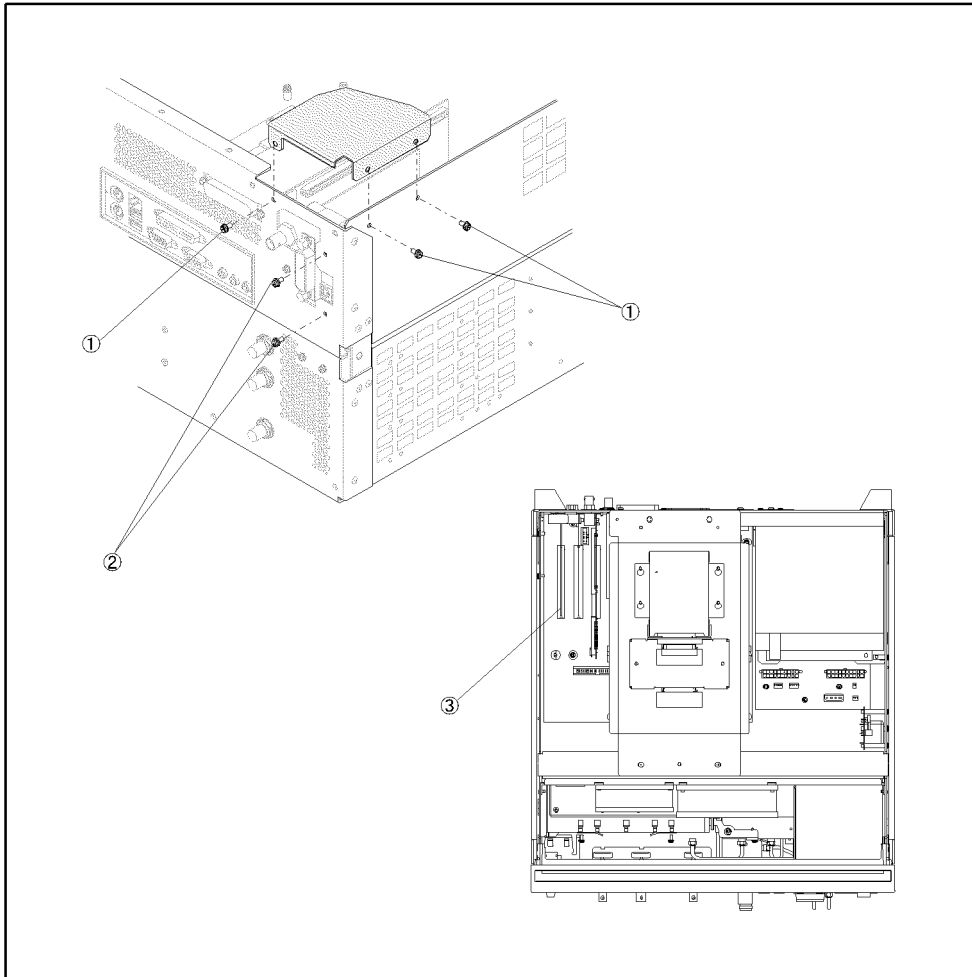
- Step 1.** To replace the USB (USBTMC) interface card, reverse the order of the removal procedure.

NOTE

It is not necessary to replace the angle that comes with the replaceable part for the USB interface. Replace only the board and use the existing angle. However, should it be necessary the angle, make sure the gasket (0.012 m (2 pieces)) are fitted.

Replacement Procedure
**USB (USBTMC) Interface Card Replacement for E5052A Serial Prefix MY442
and above**

Figure 6-24 USB (USBTMC) Interface Card Removal for prefix MY442 and above



e5052ase3015

A22 Front Keyboard Replacement

Tools Required

- TORX screwdriver, T10, T15, and T20
- Flat edge screwdriver
- Open-end torque wrench, 5/16 inch (set to 10 in-lb) (for reconnecting SMA connector)
- Hex key, 1.5 mm

Removal Procedure

Refer to Figure 6-25 for this procedure.

- Step 1.** Remove the front panel as described in “Front Panel Removal” on page 178.
- Step 2.** Release the clamped cables from the clamps (item 1) on the cover.
- Step 3.** Disconnect the cable (item 4).

NOTE

Keep the mylar cable (item 5) connected.

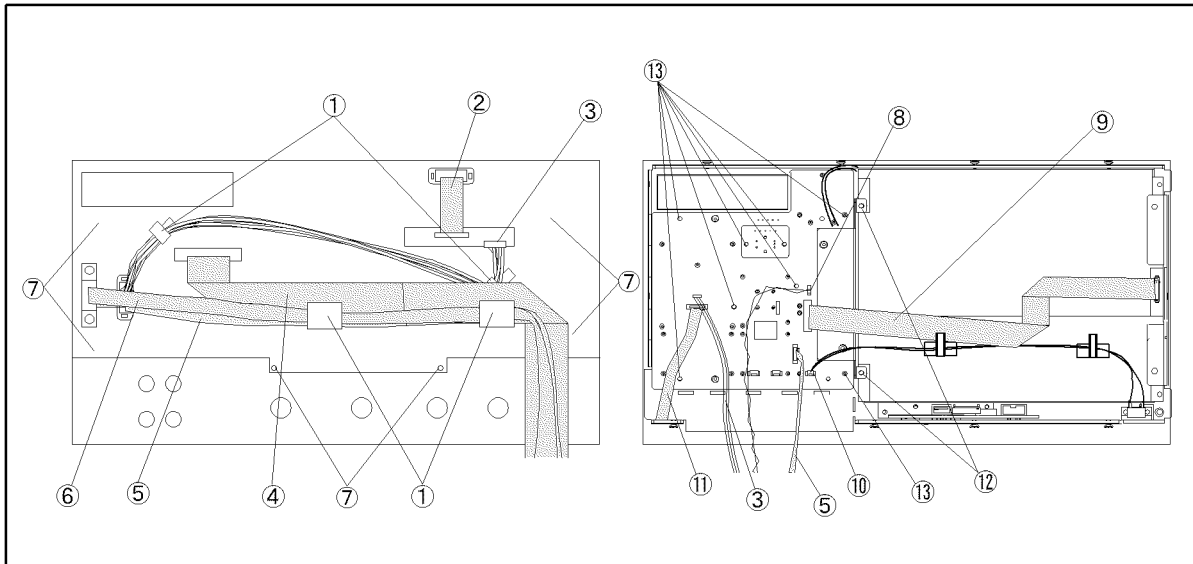
- Step 4.** Disconnect the cables (item 2, 3, and 6) from the touch screen controller.
- Step 5.** Remove the six TORX T10 screws (item 7) fastening the cover to the front panel.
- Step 6.** Disconnect the cable (item 11) from the front keyboard.
- Step 7.** Disconnect the cables (item 3, 5, 8, 9 and 10) from the front keyboard.
- Step 8.** Remove the knob from the front panel with a 1.5 mm hex key.
- Step 9.** Remove the two TORX T15 screws (item 12) fastening the inverter assembly.
- Step 10.** Remove the eight TORX T10 screws (item 13) fastening the front panel keyboard.
- Step 11.** Separate the keyboard into the board and the rubber key.

Replacement Procedure

- Step 1.** Insert the whole jut of the rubber key into the hole on the new front panel keyboard.
- Step 2.** Reverse the order of removal procedure.

Replacement Procedure
A22 Front Keyboard Replacement

Figure 6-25 A22 Front Keyboard Removal



e5052ase047

A52 Inverter Board Replacement

Tools Required

- TORX screwdriver, T8, T10, T15, and T20
- Open-end torque wrench, 5/16 inch (set to 10 in-lb) (for reconnecting SMA connector)
- Flat edge screwdriver

Removal Procedure

Refer to Figure 6-26 for this procedure.

- Step 1.** Remove the front panel as described in “Front Panel Removal” on page 178.
- Step 2.** Release the clamped cables from the clamps (item 1) on the cover.
- Step 3.** Disconnect the cable (item 4).

NOTE

Keep the mylar cable (item 5) connected.

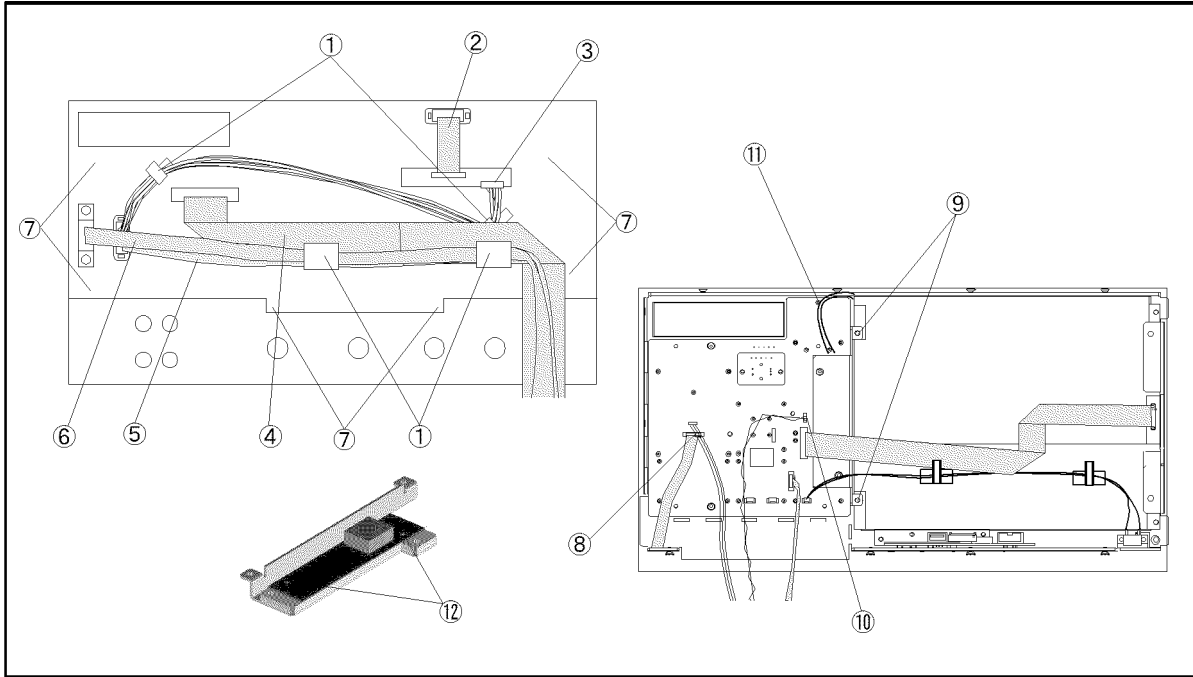
- Step 4.** Disconnect the cables (item 2, 3, and 6) from the touch screen controller.
- Step 5.** Remove the six TORX T10 screws (item 7) fastening the cover to the front panel.
- Step 6.** Disconnect the cable (item 8).
- Step 7.** Remove the two TORX T15 screws (item 9) fastening the inverter assembly.
- Step 8.** Disconnect the cables (item 10, 11).
- Step 9.** Remove the two TORX T8 screws (item 12) fastening the inverter to the bracket.

Replacement Procedure

- Step 1.** Fasten the new Inverter board to the bracket.
- Step 2.** Reverse the order of the removal procedure.

Replacement Procedure
A52 Inverter Board Replacement

Figure 6-26 **A52 Inverter Board Removal**



e5052ase068

A51 LCD Replacement

Tools Required

- TORX screwdriver, T10, T15, and T20
- Open-end torque wrench, 5/16 inch (set to 10 in-lb) (for reconnecting SMA connector)
- Flat edge screwdriver

Removal Procedure

Refer to Figure 6-27 for this procedure.

- Step 1.** Remove the front panel as described in “Front Panel Removal” on page 178.
- Step 2.** Release the clamped cables from the clamps (item 1) on the cover.
- Step 3.** Disconnect the cable (item 4).

NOTE Keep the mylar cable (item 5) connected.

- Step 4.** Disconnect the cables (item 2, 3, and 6) from the touch screen controller.
- Step 5.** Remove the six TORX T10 screws (item 7) fastening the cover to the front panel.
- Step 6.** Disconnect the cable from the front keyboard (item 8).
- Step 7.** Release the cable from the clamps (item 9) on the LCD.
- Step 8.** Remove the two TORX T15 screws (item 10) fastening the inverter assembly.
- Step 9.** Disconnect the cable (item 11).
- Step 10.** Remove the four TORX T15 screws (item 12) fastening the LCD to the front panel.
- Step 11.** Disconnect the connector (item 13) from the LCD adapter.

Replacement Procedure

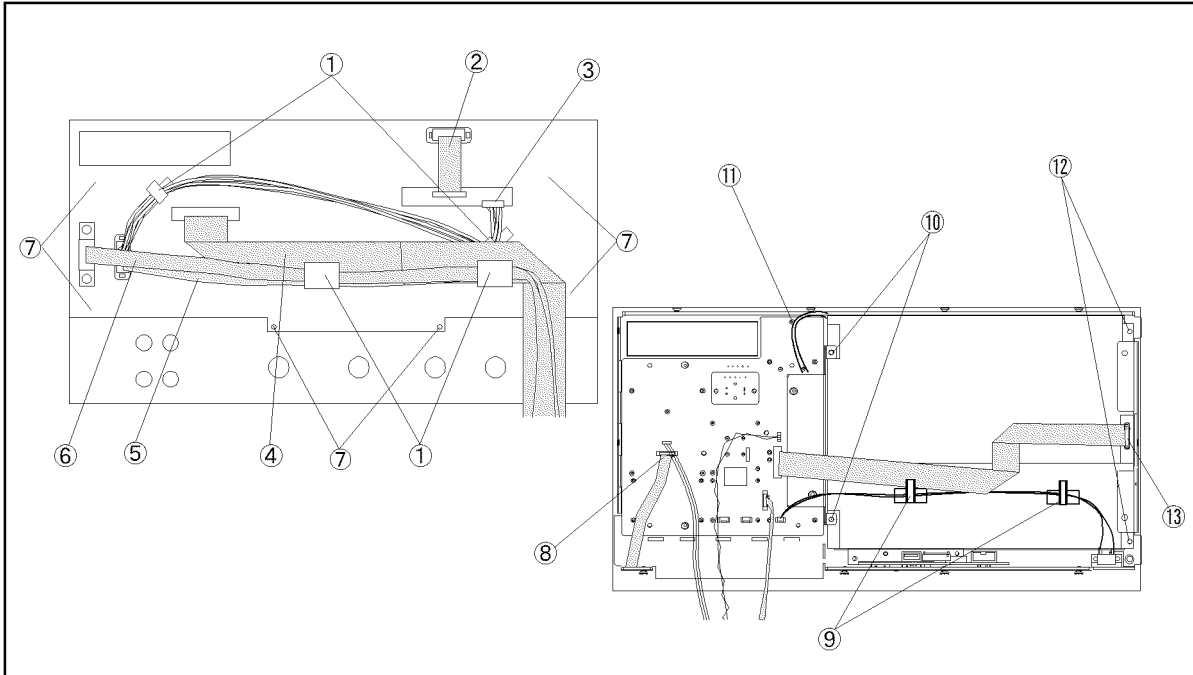
- Step 1.** Reverse the order of the removal procedure.

NOTE Fasten the TORX T15 screws (item 10, 12) using a torque screwdriver (set to 1.02 N-m / 9.0 lb-in).

- Step 2.** When you have replaced the LCD on a E5052A, you have to calibrate the touch screen. Follow the procedure described on “Calibration of the Touch Screen” on page 182.

Replacement Procedure
A51 LCD Replacement

Figure 6-27 A51 LCD Removal



e5052ase069

LCD Backlight Replacement

Tools Required

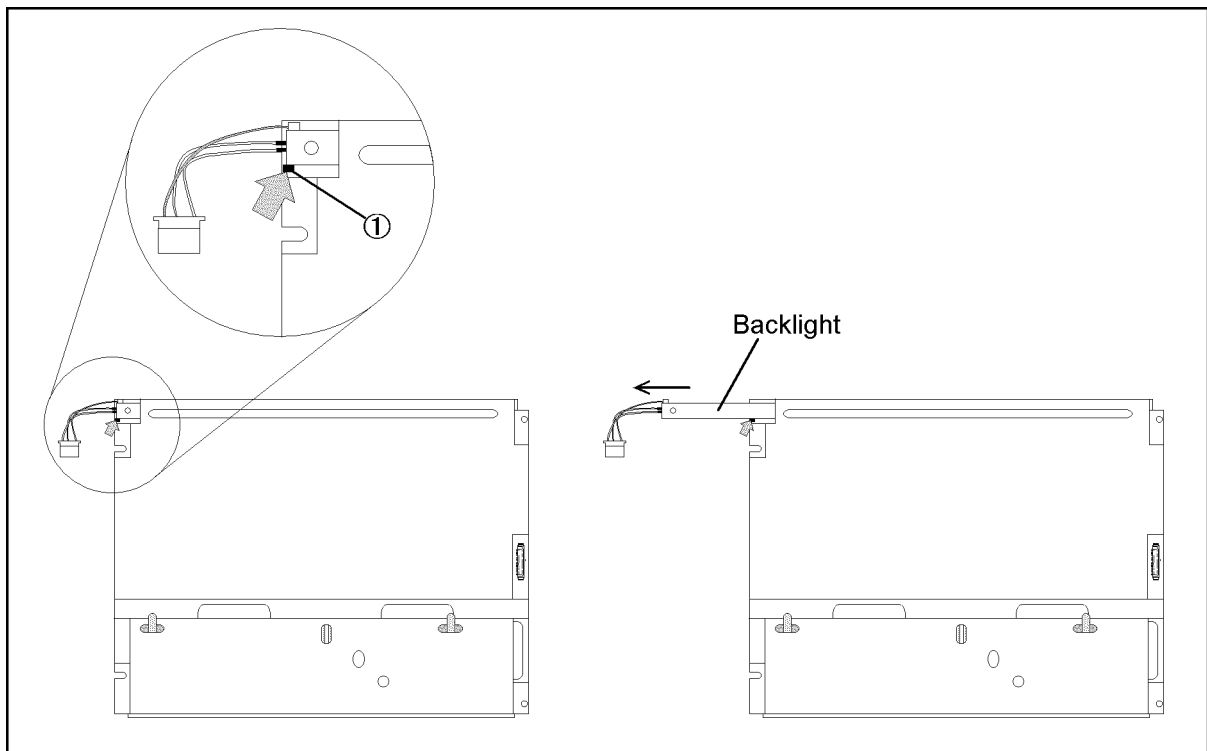
- TORX screwdriver, T10, T15, and T20
- Open-end torque wrench, 5/16 inch (set to 10 in-lb) (for reconnecting SMA connector)
- Flat edge screwdriver

Removal Procedure

Refer to Figure 6-28 for this procedure.

- Step 1.** Remove the LCD as described in “A51 LCD Replacement” on page 215.
- Step 2.** Push the stopper (item 1) and slide the backlight as shown in Figure 6-28.

Figure 6-28 LCD Backlight Removal



e5070bse100

Replacement Procedure

- Step 1.** Reverse the order of the removal procedure.

BNC Connector(front) Replacement

Tools Required

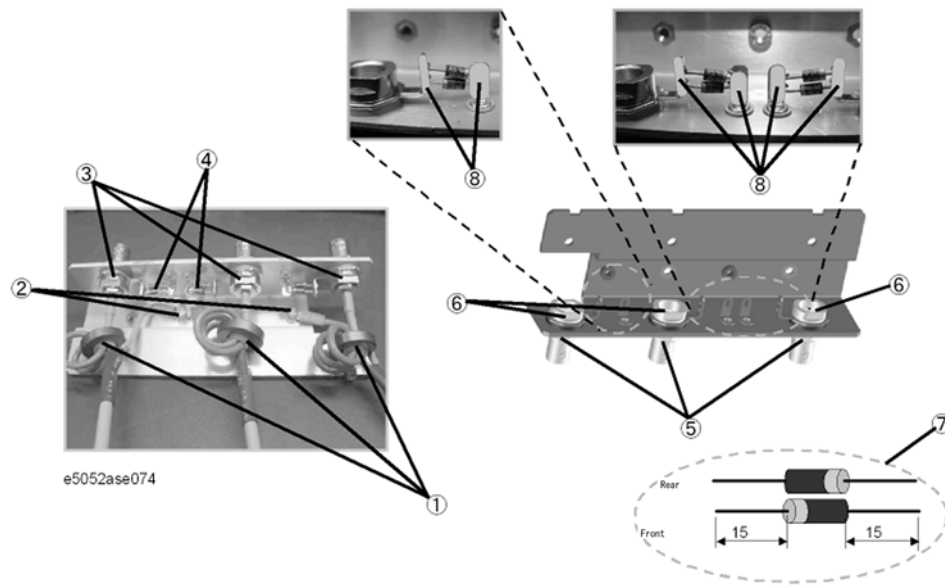
- TORX screwdriver, T10, T15, and T20
- Open-end torque wrench, 5/16 inch (set to 10 in-lb) (for reconnecting SMA connector)
- Open-end wrench, 3/8 inch
- Flat edge screwdriver

Removal Procedure

Refer to Figure 6-29 for this procedure.

- Step 1.** Remove the outer cover as described in “Outer Cover Removal” on page 176.
- Step 2.** Remove the front panel as described in “Front Panel Removal” on page 178.
- Step 3.** Remove the DC Source board as described in “A2 DC Source Board Replacement” on page 195.
- Step 4.** Cut the cable tie (item 1) which ties cable.
- Step 5.** Remove the two TORX T10 screws (item 2) fastening the angle.
- Step 6.** Remove the three cable assembly (item 3) fastening the angle.
- Step 7.** If the diode is to be replaced, unsolder the diode (item 4).
- Step 8.** Remove a 9/16 inch nut (item 5) fastening the angle.
- Step 9.** Remove the three RF connector (item 6) fastening the angle.

Figure 6-29 Connector(front) Removal



Replacement Procedure

- Step 1.** When the diode is replaced, cut the new diode leads as show in the figure (item 7).
Solder the new diode as show in the figure (item 8).

NOTE Ensure that the polarity of the diode is correct.

- Step 2.** Reverse the order of the removal procedure.

Replacement Procedure
BNC Connector(front) Replacement

7**Post-Repair Procedures**

This chapter lists the procedures required to verify the E5052A operation after an assembly is replaced with a new one.

Post-Repair Procedures

Table 7-1 *Post Repair Procedures* lists the required procedures that must be performed after the replacement of an assembly. These are the recommended minimum procedures to ensure that the replacement is successfully completed.

Table 7-1 Post-Repair Procedures

Replaced Assembly or Part	Required Adjustments Correction Constants (CC)	Verification
A1 Freq/Power Detector module	Perform the following required adjustments using “A1 Freq/Power Det.” in Spot Adjustment of the program. Reference Frequency Adjustment Pre-LO Sampler PLL BW Adjustment Receiver DC offset Adjustment PM Offset Adjustment PM Linearity Adjustment PM Temp Adjustment PM Flatness Adjustment Receiver RF Flatness Adjustment Receiver IF Gain/Flatness Adjustment LO Sampler PLL BW Adjustment Phase Noise BW Adjustment	“Power On Test” on page 96 RF IN Port VSWR Test Frequency Measurement Test Power Measurement Accuracy Test SSB Phase Noise Sensitivity Test SA Relative Level Accuracy Test
A2 DC Source Board	Perform the following required adjustments using “A2 DC Source” in Spot Adjustment of the program. DC Control Voltage Adjustment DC Power Voltage Adjustment DC Power Current Adjustment	“Power On Test” on page 96 DC Power Voltage Test DC Power Current Measurement Test
A3 ADC/DSP Board	Perform the following required adjustments using “A3 ADC/DSP” in Spot Adjustment of the program. Reference Frequency Adjustment Pre-LO Sampler PLL BW Adjustment Receiver DC offset Adjustment Receiver RF Flatness Adjustment Receiver IF Gain/Flatness Adjustment LO Sampler PLL BW Adjustment Phase Noise BW Adjustment	“Power On Test” on page 96 RF IN Port VSWR Test Frequency Measurement Test Power Measurement Accuracy Test SSB Phase Noise Sensitivity Test SA Relative Level Accuracy Test

Table 7-1 Post-Repair Procedures

Replaced Assembly or Part	Required Adjustments Correction Constants (CC)	Verification
A4/A5 Local Synthesize module	<p>Perform the following required adjustments using “A4/A5 Local Synt” in Spot Adjustment of the program.</p> <p>Reference Frequency Adjustment Pre-LO Sampler PLL BW Adjustment Receiver DC offset Adjustment Receiver RF Flatness Adjustment Receiver IF Gain/Flatness Adjustment LO Sampler PLL BW Adjustment Phase Noise BW Adjustment</p>	<p>“Power On Test” on page 96</p> <p>RF IN Port VSWR Test Frequency Measurement Test Power Measurement Accuracy Test SSB Phase Noise Sensitivity Test SA Relative Level Accuracy Test</p>
A6 Phase Detector Board	<p>Perform the following required adjustments using “A6 Phase Det” in Spot Adjustment of the program.</p> <p>Reference Frequency Adjustment Pre-LO Sampler PLL BW Adjustment Receiver DC offset Adjustment Receiver RF Flatness Adjustment Receiver IF Gain/Flatness Adjustment LO Sampler PLL BW Adjustment Phase Noise BW Adjustment</p>	<p>“Power On Test” on page 96</p> <p>RF IN Port VSWR Test Frequency Measurement Test Power Measurement Accuracy Test SSB Phase Noise Sensitivity Test SA Relative Level Accuracy Test</p>
A11 10 MHz Oven	No adjustment needed	“To Check the Ref Oven” on page 111
A12 Power Distribution Board	No adjustment needed	<p>Inspect the Booting Process</p> <p>“Power On Test” on page 96</p>
A10 Analog Motherboard	No adjustment needed	<p>Inspect the Booting Process</p> <p>When the symptom of failure is out of specification, perform the performance test.</p>
A20 Digital Motherboard	Set jumpers and BIOS parameters on the A20. For details, see “To configure the A20 Digital Motherboard and BIOS” on page 115.	Inspect the Booting Process
A21 PCI DSP Card	<p>Perform the following required adjustments using “PCI DSP Card” in Spot Adjustment of the program.</p> <p>Writing ID</p>	<p>Inspect the Booting Process</p> <p>“To Check the Front Panel” on page 103 “To Check the External Trigger Input” on page 106</p>
A22 Front Panel Keyboard	No adjustment needed	“To Check the Front Panel” on page 103
A24 GPIB Board	No adjustment needed	“To Check the GPIB” on page 111
USB (USBTMC) Interface Card	No adjustment needed	“To Check the USB (USBTMC) Interface Card” on page 111

7. Post-Repair Procedures

Table 7-1 Post-Repair Procedures

Replaced Assembly or Part	Required Adjustments Correction Constants (CC)	Verification
A25 24-bit I/O Board	No adjustment needed	“To Check the 24-bit I/O port” on page 111
A27 Mass Storage Disk Drive A27 Removable Hard Disk Drive	Perform “HDD” (Hard Disk Drive) in Spot Adjustment of the program. DC Control Voltage Adjustment DC Power Voltage Adjustment DC Power Current Adjustment Reference Frequency Adjustment Pre-LO Sampler PLL BW Adjustment Receiver DC offset Adjustment PM Offset Adjustment PM Linearity Adjustment PM Temp Adjustment PM Flatness Adjustment Receiver RF Flatness Adjustment Receiver IF Gain/Flatness Adjustment LO Sampler PLL BW Adjustment Phase Noise BW Adjustment	Inspect the Booting Process RF IN Port VSWR Test Frequency Measurement Test Power Measurement Accuracy Test SSB Phase Noise Sensitivity Test SA Relative Level Accuracy Test DC Power Voltage Test DC Power Current Measurement Test
A28 FDD	No adjustment needed	“To Check the FDD” on page 105
A50 Power Supply Assembly	No adjustment needed	Inspect the Booting Process
LCD with Touch panel	Calibration of the Touch Screen	Inspect the Booting Process “To Check the LCD” on page 104
A52 Inverter Board	No adjustment needed	Inspect the Booting Process

A **Manual Changes**

This appendix contains the information required to adapt this manual to versions or configurations of the E5052A manufactured earlier than the current printing date of this manual. The information in this manual applies directly to E5052A units with the serial number that is printed on the title page of this manual.

Manual Changes

To adapt this manual to your E5052A, refer to Table A-1 and Table A-2.

Table A-1 Manual Changes by Serial Number

Serial Prefix or Number	Make Manual Changes

Table A-2 Manual Changes by Firmware Version

Version	Make Manual Changes

The ten-character serial number is stamped on the serial number plate (Figure A-1) on the rear panel.

Figure A-1 Serial Number Plate Example



e5052apj029

B System Recovery

This appendix describes how to recover the operating system (Windows 2000) when the operating system has been damaged.

System Recovery

By executing system recovery, you can return the system of the E5052A (the Windows operating system and the firmware) to the factory state (at the time of purchase ^{*1}).

Types of system recoveries

The following two types of system recoveries are available.

Factory recovery

Returns the contents of the C drive to the factory state.

User recovery ^{*2}

Returns the contents of the C drive to a user-specified state. To use this function, you must prepare for recovery in advance. For information on preparation, see “Procedure to create the user backup image” on page 232. For information on the execution, see “Procedure to execute the user recovery” on page 235.

Notes on executing system recovery

Executing system recovery causes the following:

- In addition to the Windows operating system and the firmware, the following settings of the E5052A are returned to the factory state.
 - Network setting
 - GPIB setting
 - Printer setting
- The driver for the supported printer installed after purchase is deleted.
- You need to execute initial registration again.


Files you created using the save function (files in the F drive) are not affected, but we recommend backing them up before executing system recovery for precautionary purposes. For more information on backup, refer to “Making Backup Files” as described in E5052A User’s Guide.

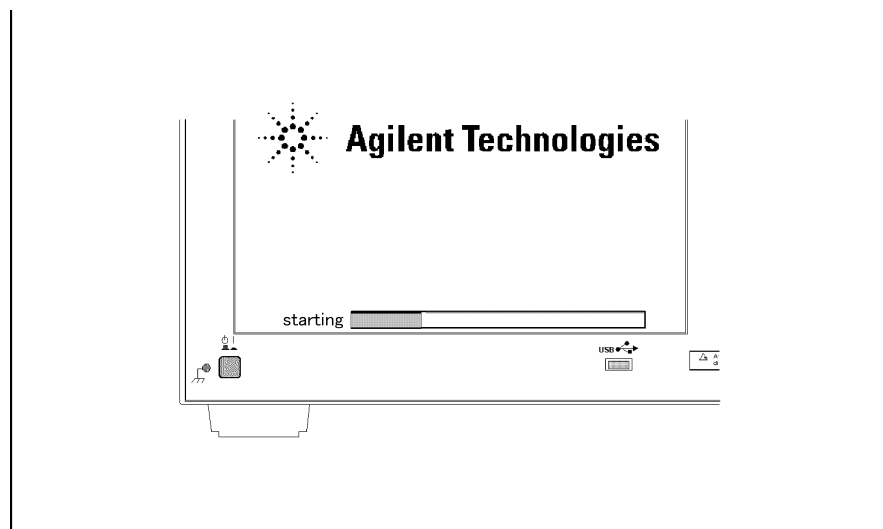
*1. If the hard disk failed and has been replaced after purchase, the state when the replacement was performed is recovered.

*2. This function is available when the volume label on the hard disk is CL250 or higher.

Procedure to execute the factory recovery

NOTE You need the keyboard for this operation.

- Step 1.** Shut down the E5052A.
- Step 2.** Connect the keyboard to the E5052A.
- Step 3.** Insert the disk for the system recovery which is furnished with the E5052A into the floppy disk drive of the E5052A.
- Step 4.** Press the standby switch of the E5052A to turn it on.
- Step 5.** When the screen as shown in the figure below appears, press and hold  of the keyboard until this screen disappears.






e5061buj034

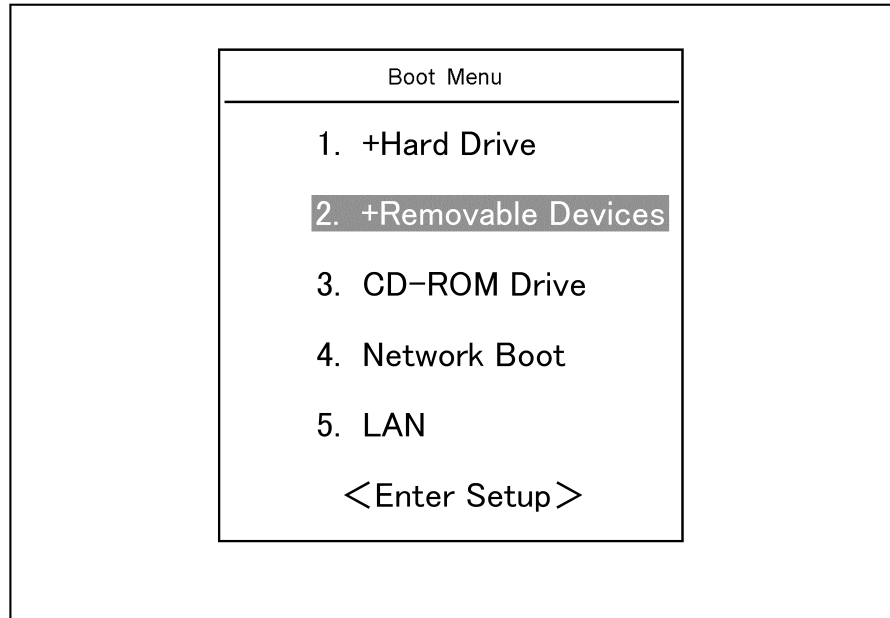
NOTE After several seconds, the next screen appears automatically even if you do not press any key, so do not miss it.



If the above message does not appear, the instrument is at fault; contact your local Agilent customer center listed at the end of this manual or distributor.

System Recovery

System Recovery

Step 6. The following screen appears. Select “+Removable Devices” with   of the keyboard, and press  of the keyboard.



Step 7. The message as shown below appears. Press  of the keyboard. If you want to cancel the system recovery, press  here.

```
Agilent Technologies System Utilities
Recovery & Backup Options (for the E5052A)
```

```
Choose One of the following:
```

-
- ```
1. Recover Factory Backup Image
2. Create User Backup Image
3. Recover User Backup Image
4. Exit
```
- 

```
Enter a Choice: _
```

#### NOTE

If the above message does not appear, the instrument or the disk for the system recovery is at fault; contact your local Agilent customer center listed at the end of this manual or distributor.



- Step 8.** The message as shown below appears. Press **C** of the keyboard. If you want to cancel the system recovery, press **E** here.

You chose to Restore your system by installing the original factory installed OS and system software.

WARNING: Press C to Continue only if you are sure that you want to proceed. The C: Drive will be completely overwritten with no chance of recovering any data. Use Option 1 to recover the system from a serious malfunction caused by corrupted or inadvertently deleted files on the system's primary C: partition.

Press C to Continue or E to Exit: \_

- Step 9.** The message as shown below appears. Press **C** of the keyboard to start the system recovery. If you want to cancel the system recovery, press **E** here.

CAUTION! Interrupting this process may leave the system in an unstable state. Allow the software to complete the backup and recovery process. This may take up to 20 minutes depending on the system configuration.

Press C to Continue or E to Exit: \_

---

**CAUTION**

**Never turn off the power during the system recovery because doing so may cause serious damage to the E5052A.**

- Step 10.** The system recovery will be complete in about 5 minutes. When the system recovery is complete, the message as shown below appears. Press **Ctrl**, **Alt**, and **Delete** of the keyboard at the same time to restart.

Remove the disk and Press CLT+ALT+DEL to restart your system.

---

**NOTE**

If the above message does not appear, the instrument is at fault; contact your local Agilent customer center listed at the end of this manual or distributor.

- Step 11.** After restart, the screen for initial registration appears. Execute initial registration. For information on the execution procedure, refer to “Initial Registration of E5052A” on page 238.

- Step 12.** For the E5052A equipped touch screen, execute the calibration of the touch screen. For information on the execution procedure, refer to “Calibration of the Touch Screen” on page 241.

### Procedure to create the user backup image

This section describes how to create the user backup image. The C drive contents saved in this creation are recalled when when the user recovery function is executed.


---

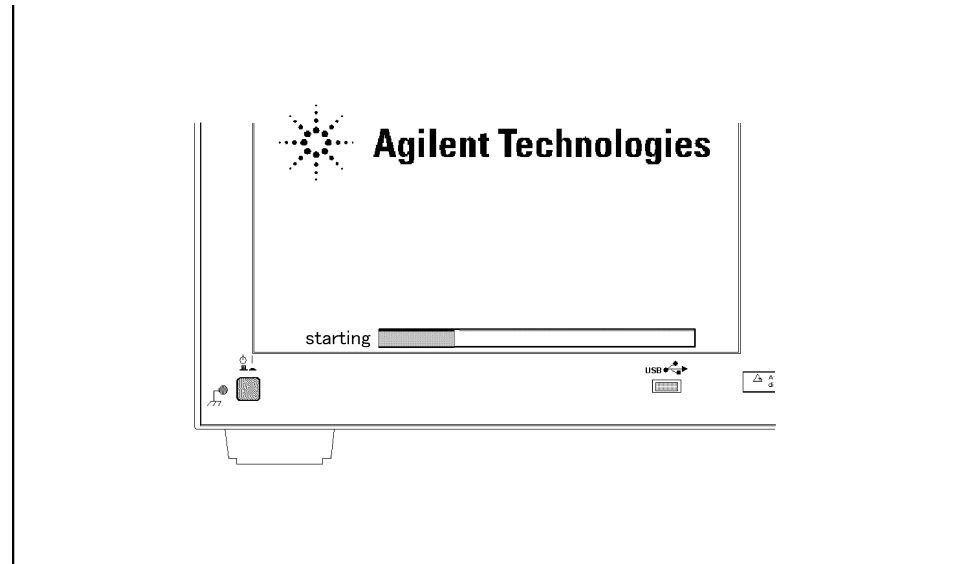
**NOTE** This function is available when the volume label on the hard disk is CL250 or higher.

---

**NOTE** You need the keyboard for this operation.

---

- Step 1.** Shut down the E5052A.
- Step 2.** Connect the keyboard to the E5052A.
- Step 3.** Insert the disk for the system recovery into the floppy disk drive of the E5052A.
- Step 4.** Press the standby swith of the E5052A to turn it on.
- Step 5.** When the screen as shown in the figure below appears, press and hold the  on the keyboard until this screen disappears.






e5061buj034

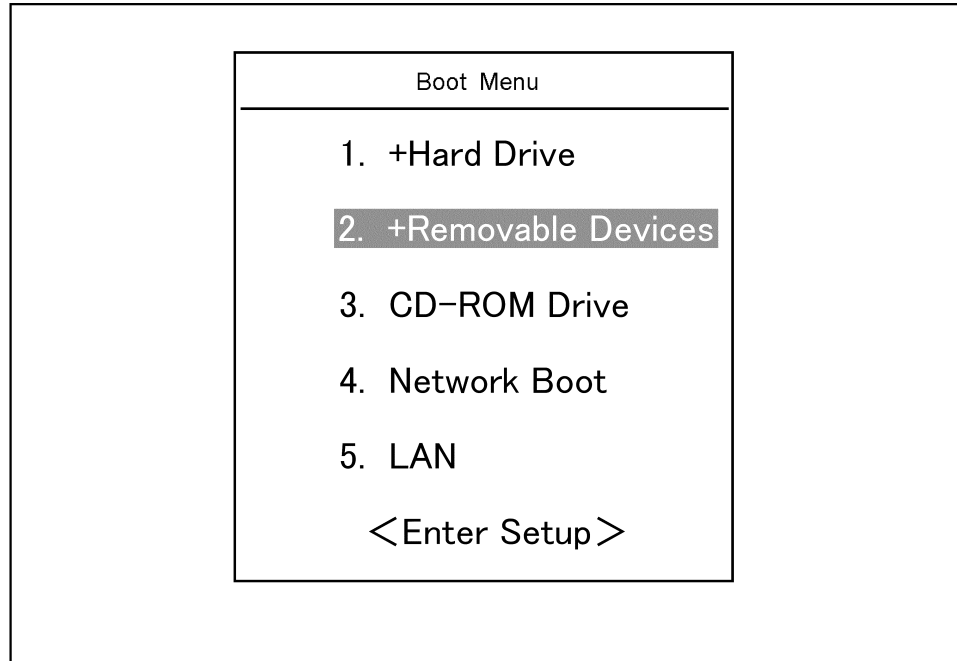
---



**NOTE** After several seconds, the next screen appears automatically even if you do not press any key, so do not miss it.

If the above message does not appear, the instrument is at fault; contact your local Agilent customer center listed at the end of this manual or distributor.

---

**Step 6.** The following screen appears. Select “+Removable Device” with   of the keyboard, and press  of the keyboard.



**Step 7.** The message as shown below appears. Press  of the keyboard. If you want to cancel creation of the user backup image, press  at this point.

```

Agilent Technologies System Utilities
Recovery & Backup Options for the E5052A

```

Choose One of the following:

- 
1. Recover Factory Backup Image
  2. Create User Backup Image
  3. Recover User Backup Image
  4. Exit
- 

Enter a Choice: \_

**NOTE**

If the above message does not appear, the instrument or the disk for the system recovery is at fault; contact your local Agilent customer center listed at the end of this manual or distributor.

## System Recovery

### System Recovery

**Step 8.** The message as shown below appears. Press **C** of the keyboard. If you want to cancel creation of the user backup image, press **E** at this point.

```
You chose to create a backup image file of your system.
```

```
The system will perform a quick integrity check of the file structure on the C: Drive. It will then copy the C: partition to an image file and store it on the System Recovery partition.
```

```
Press C to Continue or E to Exit: _
```

**Step 9.** The message as shown below appears. Press **C** of the keyboard to start creating the user backup image. If you want to cancel creation of the user backup image, press **E** at this point.

```
CAUTION! Interrupting this process may leave the system in an unstable state. Allow the software to complete the backup and recovery process. This may take up to 20 minutes depending on the system configuration.
```

```
Press C to Continue or E to Exit: _
```

---

#### CAUTION

**Never turn off the power during creating the user backup image because doing so may cause serious damage to the E5052A.**

---

**Step 10.** Creation of user backup image will be complete in about 5 minutes. When it is complete, the message as shown below appears. Press **Ctrl**, **Alt**, and **Delete** of the keyboard at the same time to restart.

```
Remove the disk and Press CLT+ALT+DEL to restart your system.
```

---

#### NOTE

If the above message does not appear, the instrument is at fault; contact your local Agilent customer center listed at the end of this manual or distributor.

---

### Procedure to execute the user recovery

Returns the contents of the C drive to a user-specified state. To use this function, you must create the user backup image in advance. For more information, see “Procedure to create the user backup image” on page 232.


---

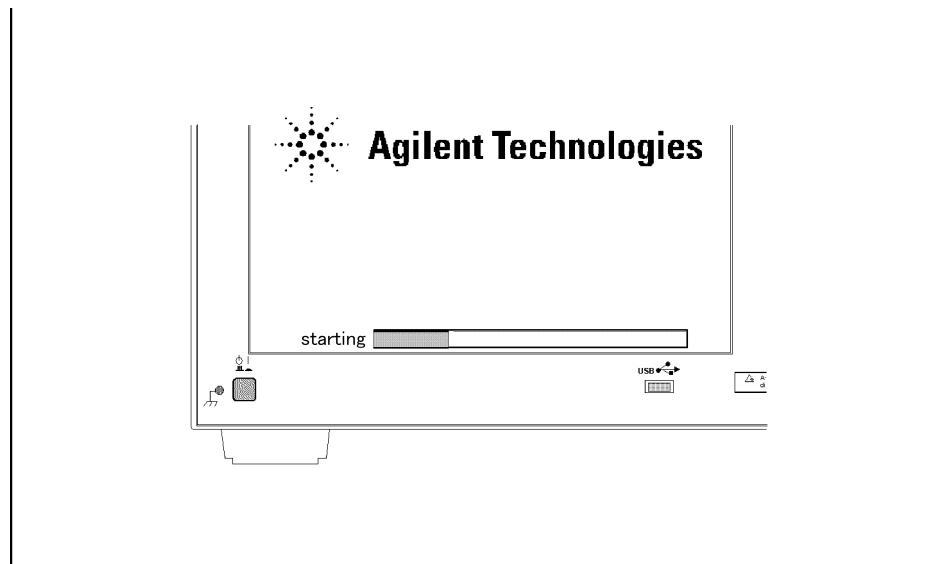
**NOTE** This function is available when the volume label on the hard disk is CL250 or higher.

---

**NOTE** You need the keyboard for this operation.

---

- Step 1.** Shut down the E5052A.
- Step 2.** Connect the keyboard to the E5052A.
- Step 3.** Insert the disk for the system recovery into the floppy disk drive of the E5052A.
- Step 4.** Press the standby swith of the E5052A to turn it on.
- Step 5.** When the screen as shown in the figure below appears, press and hold the  on the keyboard until this screen disappears.






---

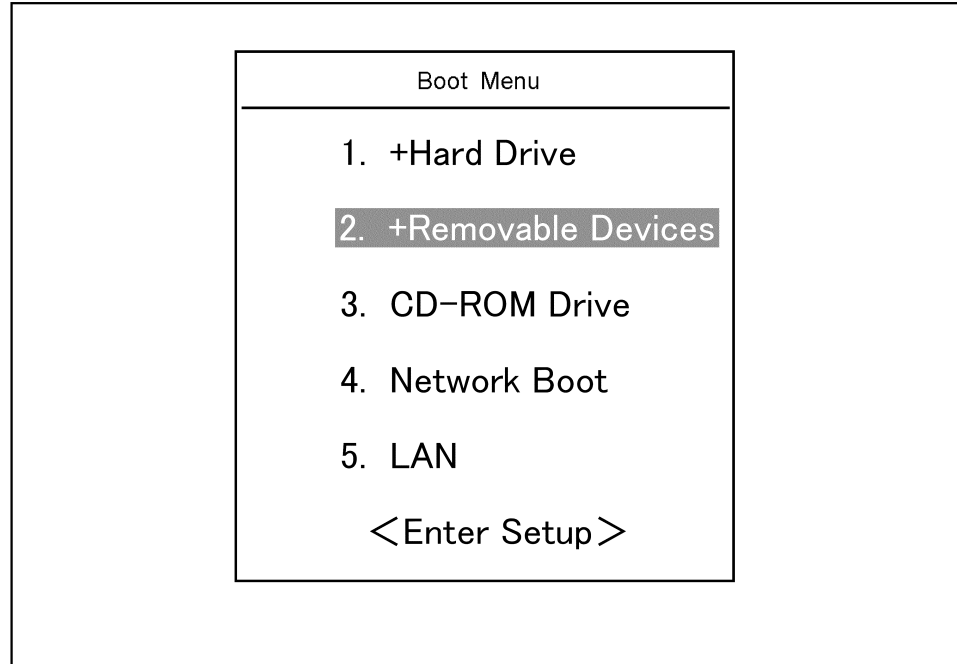
**NOTE** After several seconds, the next screen appears automatically even if you do not press any key, so do not miss it.



If the above message does not appear, the instrument is at fault; contact your local Agilent customer center listed at the end of this manual or distributor.

---

System Recovery  
System Recovery

**Step 6.** The following screen appears. Select “+Removable Device” with   of the keyboard and press  of the keyboard.



**Step 7.** The message as shown below appears. Press  of the keyboard. If you want to cancel the user recovery, press  at this point.

```
Agilent Technologies System Utilities
Recovery & Backup Options for the E5052A
```

Choose One of the following:

- 
1. Recover Factory Backup Image
  2. Create User Backup Image
  3. Recover User Backup Image
  4. Exit
- 

Enter a Choice: \_

**NOTE**

If the above message does not appear, the instrument or the disk for the system recovery is at fault; contact your local Agilent customer center listed at the end of this manual or distributor.

- Step 8.** The message as shown below appears. Press **C** of the keyboard. If you want to cancel the user recovery, press **E** at this point.

You chose to recover your own system backup image file.

WARNING: Press C to Continue only if you are sure that you want to proceed. The C: partition will be completely overwritten with no chance of recovering any data. Use Option 3 to recover the system from a serious malfunction caused by corrupted or inadvertently deleted files on the system's primary C: partition.

Press C to Continue or E to Exit: \_

- Step 9.** The message as shown below appears. Press **C** of the keyboard to start the user recovery. If you want to cancel the user recovery, press **E** at this point.

CAUTION! Interrupting this process may leave the system in an unstable state. Allow the software to complete the backup and recovery process. This may take up to 20 minutes depending on the system configuration.

Press C to Continue or E to Exit: \_

---

**CAUTION**

**Never turn off the power during the user recovery because doing so may cause serious damage to the E5052A.**

- Step 10.** The user recovery will be complete in about 5 minutes. When it is complete, the message as shown below appears. Press **Ctrl**, **Alt**, and **Delete** of the keyboard at the same time to restart.

Remove the disk and Press CLT+ALT+DEL to restart your system.

---

**NOTE**

If the above message does not appear, the instrument is at fault; contact your local Agilent customer center listed at the end of this manual or distributor.

---

## Initial Registration of E5052A

When you start up the E5052A for the first time or after executing system recovery, you need to perform the initial registration of the Windows 2000 operating system of the E5052A.

---

**NOTE** You cannot use the front panel keys during the initial registration of the E5052A so be sure to connect the mouse and keyboard before turning on the power.

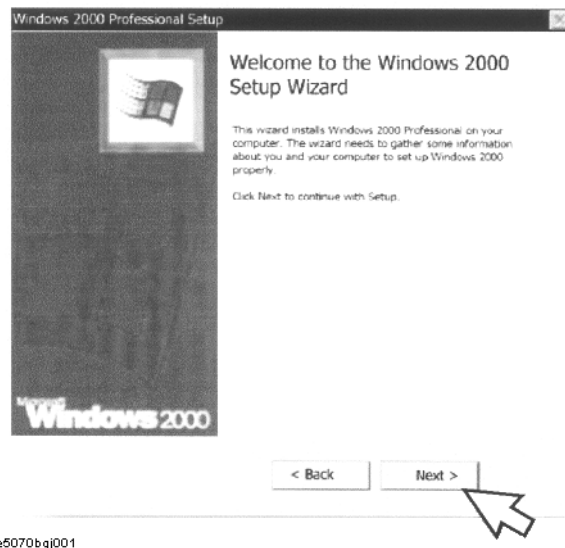
---

**NOTE** If you perform the following procedure incorrectly, a message asking you whether to return to the previous registration screen and perform the registration appears. In this case, follow the instruction to return to the previous registration screen.

**Step 1.** Turns on the E5052A.

**Step 2.** The Windows 2000 Professional Setup wizard appears. Click the **Next >** button (Figure B-1).

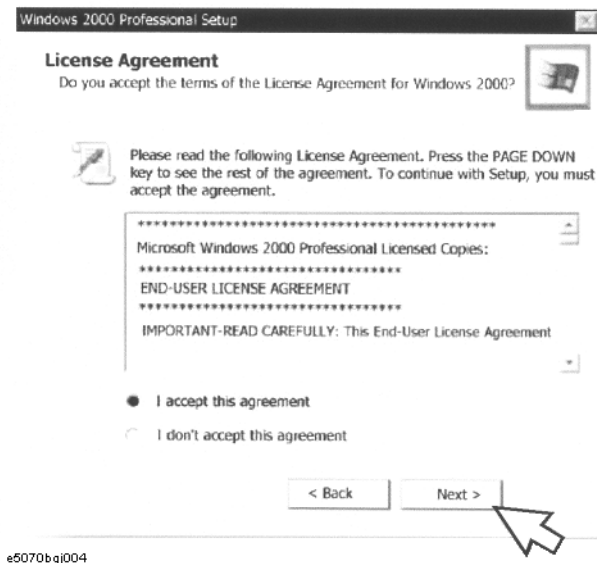
**Figure B-1** Windows 2000 Professional Setup wizard





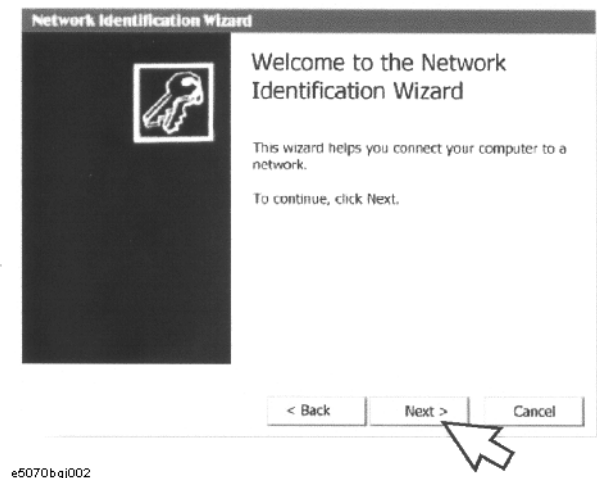
**Step 3.** In the Windows 2000 Professional Setup dialog box, select the **I accept this agreement** box and click the **Next >** button (Figure B-2). Then, the Windows 2000 operating system restarted automatically.

**Figure B-2** Windows 2000 Professional Setup dialog box



**Step 4.** The Network Identification wizard appears. Click the **Next >** button (Figure B-3).

**Figure B-3** Network Identification wizard

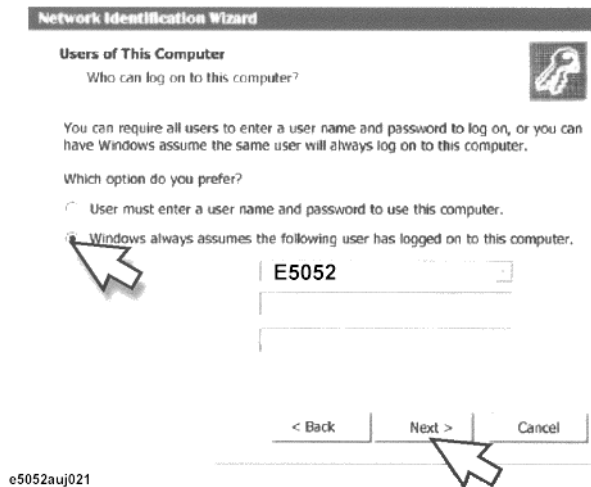


B. System Recovery

System Recovery  
Initial Registration of E5052A

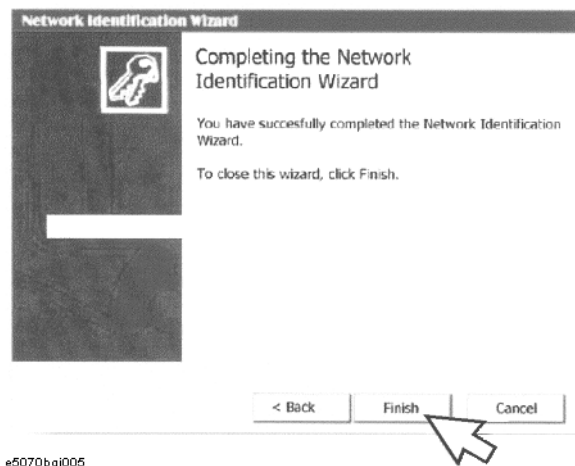
**Step 5.** In the Network Identification Wizard dialog box (1/2), select the **Windows always assumes the following user has logged on to this computer** box and check that **E5052** is in the **User Name** box. If not, type in **E5052**. Then type in **E5052** both in **Password box** and **Confirm password box**. Click the **Next>** button (Figure B-4).

**Figure B-4** Network Identification Wizard dialog box (1/2)



**Step 6.** In the Network Identification Wizard dialog box (2/2), click the **Finish** button to finish the initial registration of the E5052A (Figure B-5). Then, the measurement display of the E5052A appears.

**Figure B-5** Network Identification Wizard dialog box (2/2)



## Calibration of the Touch Screen

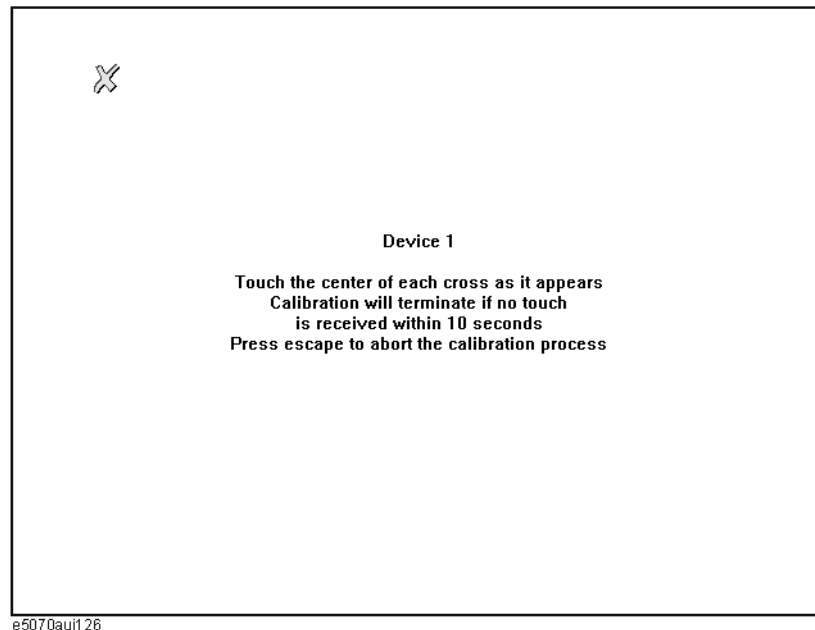
After you have executed system recovery on the E5052A, you have to calibrate the touch screen. Follow the procedure described below to calibrate the touch screen.

- Step 1.** Press **System**.
- Step 2.** Press **Service Menu**.
- Step 3.** Press **Test Menu**.
- Step 4.** Press **Adjust Touch Screen**.

The touch screen calibration screen (Figure B-6) appears.

Figure B-6

### Touch Panel Calibration Screen



- Step 5.** Touch the x mark on the upper left with your finger. The mark x appears also on the lower left, upper right, and lower right. Touch the x marks in that order with your finger.

Touching these four locations automatically finishes the touch screen calibration.

### NOTE

With no operation on the touch screen's calibration screen at this time, it automatically closes and the previous measurement screen reappears.

System Recovery  
**Calibration of the Touch Screen**

---

## **C** **Firmware Update**

This appendix describes how to update the E5052A firmware. When you want to update the E5052A firmware, refer to this appendix.

## Firmware Update

### Required Equipment

- E5052A (with keyboard and mouse).
- Four blank floppy disks (DOS format).

### How to make E5052A Firmware Installation Disk

The following is the procedure to make the E5052A Firmware Installation Disk.

**Step 1.** Copy the following files from Agilent Technologies web site to the four floppy disks using your computer's FDD.

- disk1 (1 of 5) -- E5052.msi, Setup.vbs
- disk2 (2 of 5) -- E50521.cab
- disk3 (3 of 5) -- E50522.cab
- disk4 (4 of 5) -- E50523.cab
- disk5 (5 of 5) -- E50524.cab

### How to update the E5052A firmware

It is possible to update the E5052A firmware, but not the following software by this procedure.

- OS (Operating System)
- VBA (Visual Basic for Application)
- Calibration Constant Data

The following is the procedure to update the E5052A firmware.

**Step 1.** Prepare the E5052A firmware installation disks (five disks).

**Step 2.** Connect the mouse and the keyboard to the E5052A rear panel. Then turn the E5052A on.

**Step 3.** Exit from the E5052A Measurement Display.

1. Press **System** key.
2. Press **Service Menu - Administrator Menu** on the menu bar, and the Password dialog box will appear.
3. Enter the password **E5052** into the Password box.
4. Press **Exit E5052A - OK** on the menu bar.

**Step 4.** Double-click the "My Computer" icon on the Windows desktop.

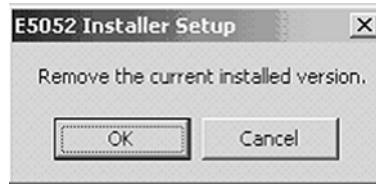
**Step 5.** Insert the E5052A firmware installation disk1 (1 of 5) into the FDD of the E5052A.

**Step 6.** Double-Click the “3 1/2 Floppy [A:]” icon.

**Step 7.** Remove the old version of the firmware using the following procedure.

1. Double-Click “**Setup.vbs**” icon. The E5052A Setup Wizard (uninstall) will start automatically as shown in Figure C-2.
2. Click on the **OK** button as shown in Figure C-1.

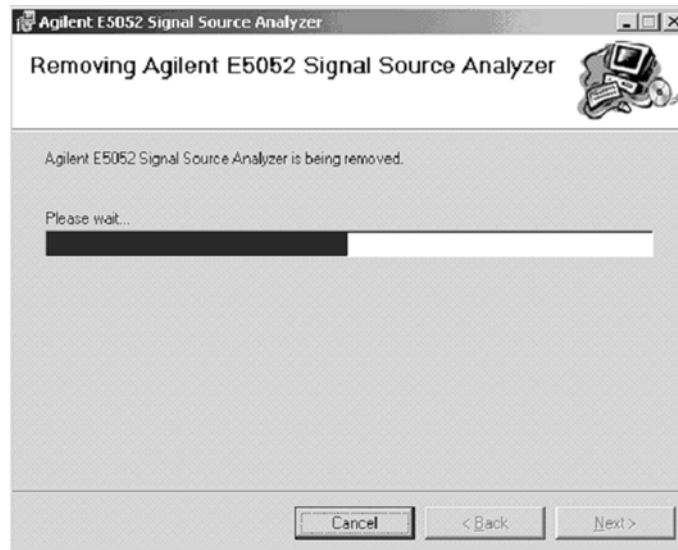
**Figure C-1** E5052A Setup Wizard (uninstall)



e5052ase082

3. Please wait until “Uninstall Wizard” (Figure C-2) disappears.

**Figure C-2** E5052A Uninstall Wizard



e5052ase043

**Step 8.** Install the new version of the firmware using the following procedure.

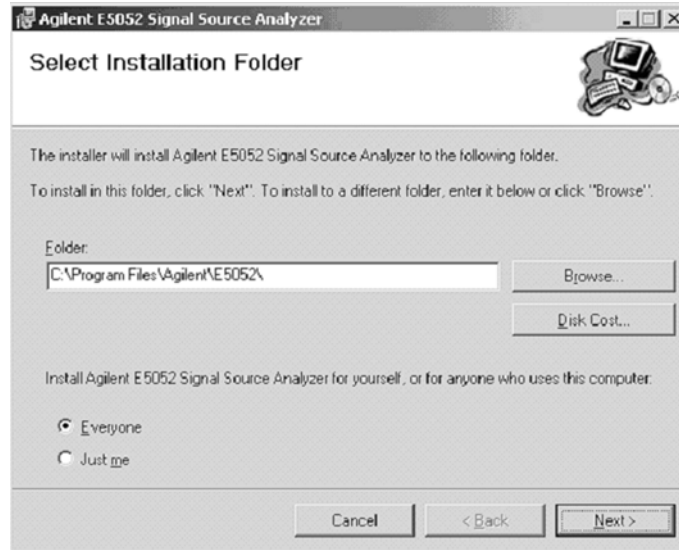
1. After the disk1 installation is finished, insert the firmware installation disk2 “E50521.cab” into the FDD of the E5052A, then click **OK**.
2. After the disk2 installation is finished, insert the firmware installation disk3 “E50522.cab” into the FDD of the E5052A, then click **OK**.
3. After the disk3 installation is finished, insert the firmware installation disk4 “E50523.cab” into the FDD of the E5052A, then click **OK**.
4. After the disk4 installation is finished, insert the firmware installation disk5

## Firmware Update Firmware Update

“E50524.cab” into the FDD of the E5052A, then click **OK**.

5. The E5052A Setup Wizard will start automatically as shown in Figure C-3.

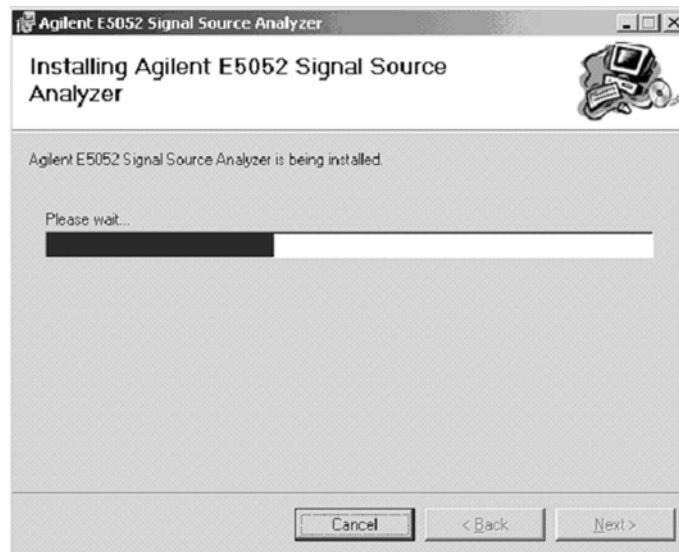
**Figure C-3** E5052A Setup Wizard (install)



e5052ase044

6. Click on the **“Next”** to continue the firmware installation on the E5052A Setup Wizard as shown in Figure C-3.
7. Please wait until “Install Wizard” (Figure C-4) disappears.

**Figure C-4** E5052A Install Wizard

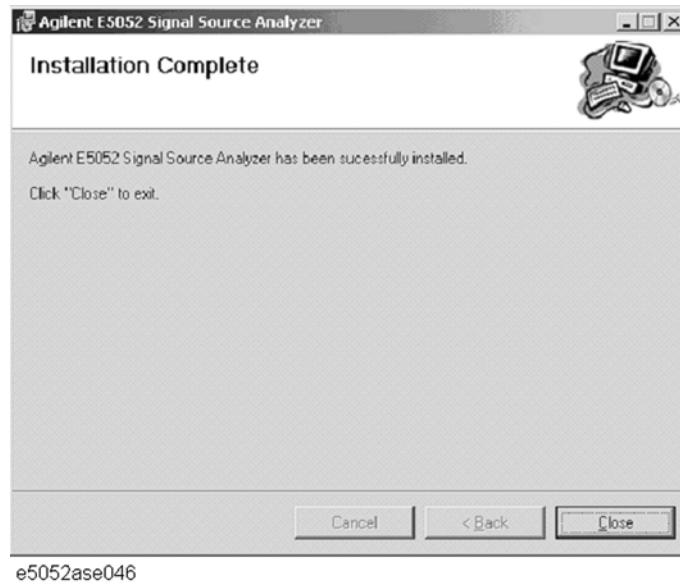


e5052ase045

8. Since Figure C-5 is displayed after installation is completed, please push the **“Close”** button.



Figure C-5 E5052A Setup Wizard (Completed)



- Step 9.** Double-click "**E5052A**" icon on the Windows desktop, and the measurement screen will appear.
- Step 10.** Turn the E5052A off, and then turn the E5052A on.
- Step 11.** Press **[System]** - **Product Information**. Confirm the firmware revision you have just installed.

Firmware Update  
**Firmware Update**

---

## **D Computer Virus Check**

This appendix describes an example of how to check the system of E5052A for computer viruses using computer viruses check software.

## Computer Virus Check

The E5052A should be protected against computer viruses. If you need to check the system of E5052A for computer viruses, it's recommended that an external PC installed anti-virus software is used to access E5052A's built-in drive (C and F) via LAN and perform virus scan.

The E5052A has no virus function nor anti-virus software installed. The Windows operating system installed in this instrument is customized for more effective operation. Installing Windows-based software (including anti-virus software) for ordinary PCs into this instrument may affect the behavior of the instrument during measurement.

### Required equipment

- E5052A (with keyboard and mouse).
- An external PC installed anti-virus software such as "Norton AntiVirus®".
- A crossed LAN cable (It enables the peer-to-peer communication between the E5052A and the PC.)

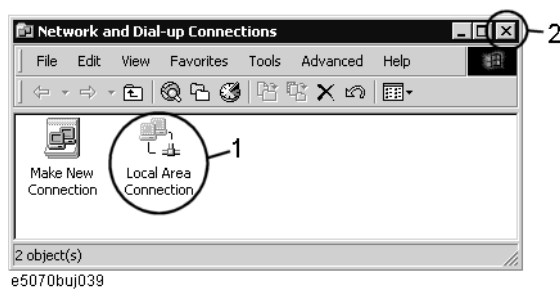
### How to check the drive C and F of E5052A

The following is an example procedure to check the drive C and F of E5052A using the external PC.

**Step 1.** Set up the E5052A for file sharing.

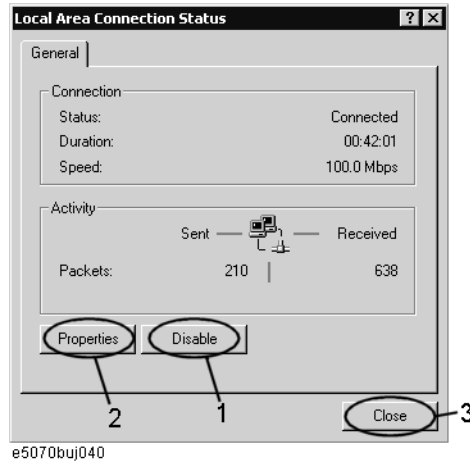
1. Connect the E5052A to the PC using the crossed LAN cable.
2. Press **[System]** key.
3. Press **Misc Setup - Network Setup - Network Configuration**. The Network and Dial-up Connections window will appear.

**Figure D-1** Network and Dial-up Connections window



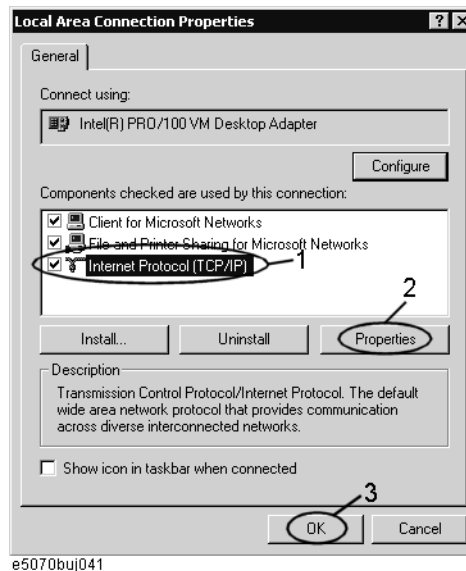
4. Double-click the Local Area Connection icon (1 in Figure D-1) in the Network and dial-up connections window to enable the network connection function. The Local Area Connection Status dialog box appears. Click the **Properties** button.

**Figure D-2** Local Area Connection Status dialog box



5. The Local Area Connection Properties dialog box (Figure D-3) appears. Select (highlight) **Internet protocol (TCP/IP)** (1 in Figure D-3) and then click the **Properties** button (2 in Figure D-3).

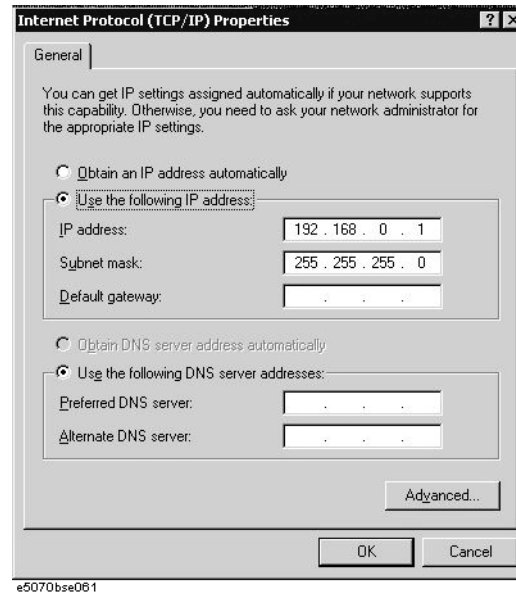
**Figure D-3** Local Area Connection Properties dialog box



6. The Internet Protocol (TCP/IP) Properties dialog box (Figure D-4 ) appears. If **Obtain an IP address automatically** has been selected, you select **Use the following IP address** (1 in Figure D-4) and then enter the IP address 192.168.0.1 (2 in Figure D-4) and subnet mask 255.255.255.0 (3 in Figure D-4).

If a specific IP address and subnet mask have been assigned, press the **OK** button.

Figure D-4 Internet Protocol (TCP/IP) Properties dialog box

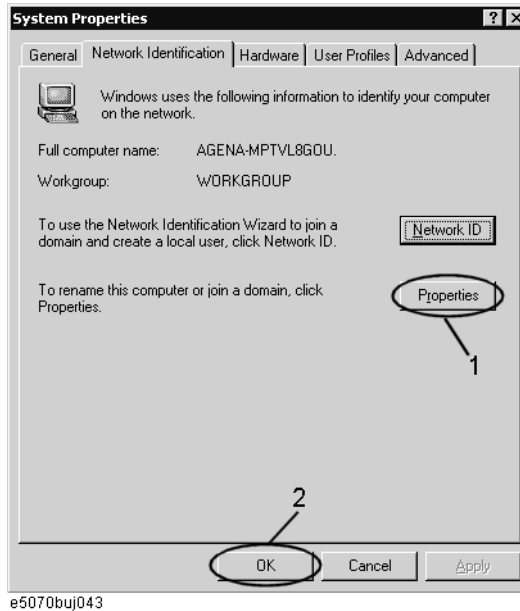


7. In the Internet Protocol (TCP/IP) Properties dialog vbox, click the **OK** button (6 in Figure D-4 ).
8. In the Local Area Connection Properties dialog box, click the **OK** button (3 in Figure D-3).
9. In the Local Area Connection Status dialog box, click the **Close** button (3 in Figure D-2).
10. Click the **x** button (2 in Figure D-1) in the upper right of the Network and Dial-up Connection window.

**Step 2.** Confirm the computer name of the E5052A.

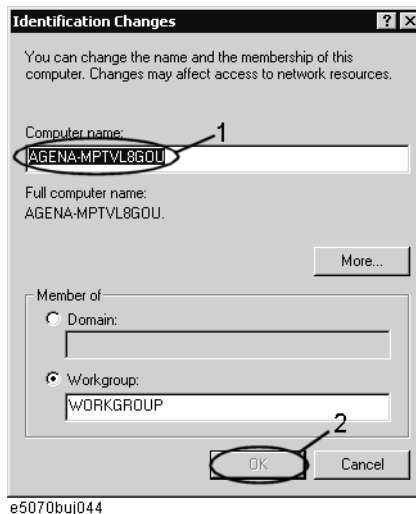
1. Press **System** key.
2. Press **Misc Setup - Network Setup - Network Identification**.
3. The System Properties dialog box as shown in Figure D-5 will appear. Click the **Properties** button (1 in Figure D-5).

Figure D-5 System Properties dialog box



4. The Identification Change dialog box (Figure D-6) appears. Confirm the computer name in the **Computer Name** box (1 in Figure D-6).

Figure D-6 Identification Change dialog box

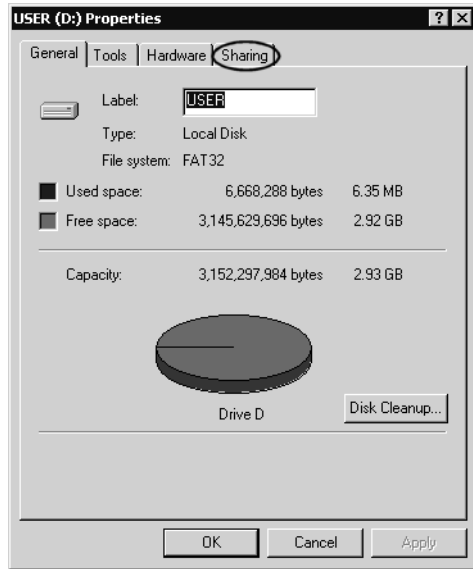


5. Turn the E5052A power off and then turn it on.

**Step 3.** Set for sharing the hard disk (C or F drive) in the E5052A.

1. Press **Save/Recall** , and then press **Explore ....**
2. The Windows Explorer opens. Right click on **(C:)** or **USER (F:)** and then click **Properties** in the File menu.
3. The (C:) or USERS(F:) Properties dialog box (Figure D-7) appears. Select the **Sharing** tab.

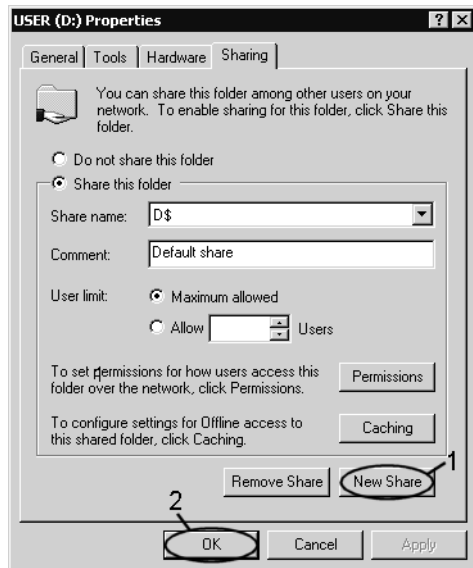
Figure D-7 USERS(F:) Properties dialog box (General tab)



e5070buj047

4. Select the **Share this folder** if (C:) is selected. Click the **New Share** button (1 in Figure D-8).

Figure D-8 USERS(F:) Properties dialog box (Sharing tab)



e5070buj048

5. The New Share dialog box (Figure D-9) appears. Enter the share name (name used when accessed from the external PC) in the **Share Name** box (1 in Figure D-9) and click the **OK** button (2 in Figure D-9).



**Figure D-9** New Share dialog box

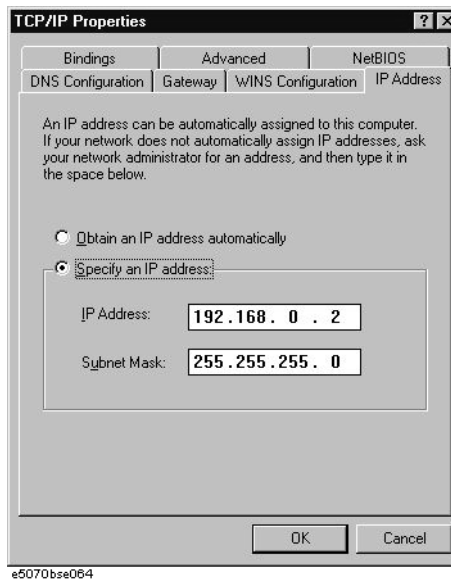


6. In the (C:) or USERS(F:) Properties dialog box, click the **OK** button (2 in Figure D-8).

**Step 4.** Set up the external PC's IP address and subnet mask.

1. Double-click **"My Computer"** icon on Windows desktop of the external PC. And double-click **Control Panel**. The Control Panel window will appear.
2. In the Control Panel window, double-click **Network**. The Network dialog box shown in fig will appear. In the **Configuration** tab, select **TCP/IP** (display it in revers video) and press the **Properties** button.
3. The dialog box appears. If **Specify an IP address** has been selected, record the IP address and sbnet mask.
4. If the **Obtain an IP address automatically** has been selected, select the **Specccify an IP address**. Enter the IP address xxx.xxx.xxx.y and subnet mask xxx.xxx.xxx.xxx as shown in Figure D-10. The letters x represent the IP address and subnet mask of the E5052A. The letter y is different from the IP address of the E5052A. Press the **OK** button. Then, restart the external PC.

**Figure D-10** Network Dialog Box ("IP Address" Tab)



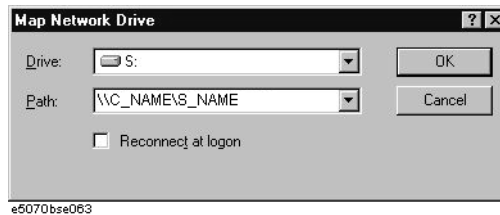
**Step 5.** Connect the drive of E5052A to the PC, and check the drive using anti-virus software.

1. Click **Programs - Window Explorer** on the Start Menu to start up the PC's Explorer. Click **Tools - Map Network Drive** on the menu of the Explorer.

## Computer Virus Check Computer Virus Check

2. Select a suitable drive name, enter the network path as shown in Figure D-11, and then press the **OK** button. For example, the network path is \\C\_NAME\S\_NAME.

**Figure D-11** Map Network Drive Dialog Box



**C\_NAME** in the network path is the computer name of the E5052A you confirmed on 4 of Step 2.

**S\_NAME** in the share name of the C or F drive of the E5052A you entered on 5 of Step 3.

3. The dialog box to enter the user name and the password appears. Enter the user name **agena** and then click the **OK** button.
4. The network path will appear on the PC's Explorer. Confirm that the network path you enter is connected to the PC.
5. Execute the anti-virus software on the PC, and the menu for the anti-virus software will appear. Check the drive you entered on 2 of Step 5. For the operation of anti-virus software, refer to its manual.
6. Check if the drives C and F are infected.

**Step 6.** Disconnect the drives of E5052A from the PC.

1. Click **Programs - Window Explorer** on the Start Menu to start up the PC's Explorer. Click **Tools - Disconnect Network Drive** on the menu of the Explorer. Disconnect Network dialog box will appear.
2. Select Network Drive you checked, and press the **OK** button. The drive will disappear from the Explorer.

---

**NOTE**

If no drive has been infected, proceed the next step.

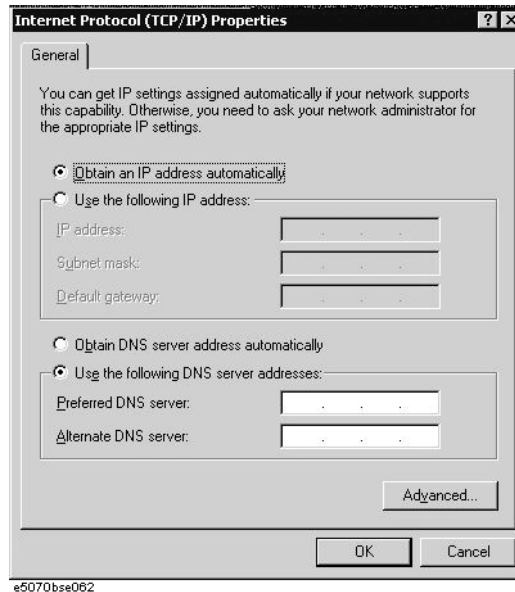
If the drive C or D has been infected, replace the HDD of the E5052A.

---

**Step 7.** Change the IP address and subnet mask of the E5052A if you select **Use the following IP address** and entered the IP address and subnet mask on the 6 of Step 1.

1. Press **System** key.
2. Press **Misc Setup - Network Setup - Network Configuration**.
3. Double-click the Local Area Connection icon (1 in Figure D-1) in the Network and Dial-up Connections window. The Local Area Connection Status dialog box (Figure D-2) appears. Click the **Properties** button (2 in Figure D-2).
4. The dialog box (Figure D-12) appears. Select **Obtain an IP address automatically** and press the **OK** button.

Figure D-12 Internet Protocol (TCP/IP) Properties dialog box



5. In the Internet Protocol (TCP/IP) Properties dialog vbox, click the **OK** button (6 in Figure D-4 ).
6. In the Local Area Connection Properties dialog box, click the **OK** button (3 in Figure D-3).
7. The Local Network dialog box will appear, press the **Yes** button to restart the instrument.

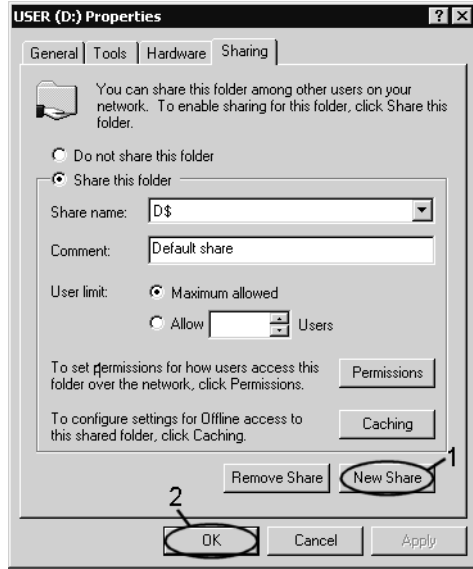
**Step 8.** Change the IP address and subnet mask of the external PC.

1. Double-click "**My Computer**" icon on Windows desktop of the external PC. And double-click **Control Panel**. The Control Panel window will appear.
2. In the Control Panel window, double-click **Network**. The Network dialog box appears. In the **Configuration** tab, select **TCP/IP** (display it in revers video) and press the **Properties** button.
3. The dialog box appears. If **Specify an IP address** has been selected on Step 4, enter the IP address and sbnet mask you recorded on 3 of Step 4.
4. If the **Obtain an IP address automatically** has been selected on Step 4, select the **Obtain an IP address automatically**.
5. Press the **OK** button. Then, restart the external PC.

**Step 9.** Disable the C drive of the E5052A when you checked the C drive.

1. Press **Save/Recall**., and then press **Explore ....**
2. The Windows Explorer opens. Select (highlight) **(C:)** and then click **Properties** in the File menu.
3. The (C:) Properties dialog box (Figure D-7) appears. Select the **Sharing** tab.
4. Select the **Do not share this folder**, and then **OK** button.

Figure D-13 (C:) Properties dialog box (Sharing tab)



5. Turn the E5052A power off.

---

# **E**      **Power Requirement**

---

## Power Supply and Blown Fuses

Before turning on the E5052A power, check the following important items.

### Verification of the power supply

Confirm that the power supplied to the E5052A meets the following requirements:

|                           | Requirements                       |
|---------------------------|------------------------------------|
| Voltage                   | 90 to 132 VAC or 198 to 264 VAC *1 |
| Frequency                 | 47 to 63 Hz                        |
| Maximum power consumption | 500 VA                             |

\*1. Switched automatically by the E5052A in conformity to the voltage used.

### Verification and connection of power cable

The three-wire power cable attached to the E5052A has one wire serving as a ground. Using this power cable allows the E5052A to be grounded, thereby protecting you against electrical shock from the power outlet.

**Step 1.** Confirm that the power cable is not damaged.

---

**WARNING** NEVER use a power cable showing any sign of damage. Faulty cables can cause electrical shock.

---

**Step 2.** Use the supplied cable to connect between the power cable receptacle (Figure E-2 on page 264) on the rear panel of the E5052A and a three-wire power outlet, with the grounding prong firmly connected in the ground slot.

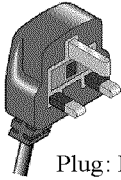
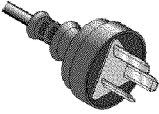
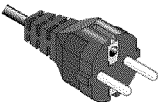
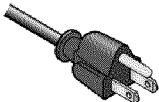

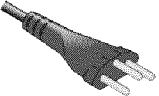
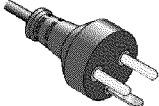
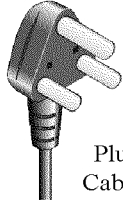
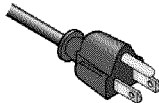
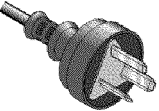
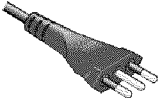
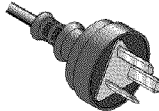
---

**WARNING** Use the supplied power cable with grounding wire to securely ground the E5052A.

---

Figure E-1 shows the power cable options.

**Figure E-1 Power cable options**

|                                                                                                                                                                                                                            |                                                                                                                                                                                                                                |
|----------------------------------------------------------------------------------------------------------------------------------------------------------------------------------------------------------------------------|--------------------------------------------------------------------------------------------------------------------------------------------------------------------------------------------------------------------------------|
| <p>OPTION 900                      United Kingdom</p>  <p>Plug: BS 1363/A, 250V, 10A<br/>         Cable: 8120-1351, 8120-8705</p>         | <p>OPTION 901                      Australia/New Zealand</p>  <p>Plug: AS 3112, 250V, 10A<br/>         Cable: 8120-1369</p>                 |
| <p>OPTION 902                      Continental Europe</p>  <p>Plug: CEE 7 Standard Sheet VII, 250V, 10A<br/>         Cable: 8120-1689</p> | <p>OPTION 903                      U.S./Canada</p>  <p>Plug: NEMA 5-15P, 125V, 10A<br/>         Cable: 8120-1378</p>                        |
| <p>OPTION 904                      U.S./Canada</p>  <p>Plug: NEMA 6-15P, 250V, 6A<br/>         Cable: 8120-0698</p>                       | <p>OPTION 906                      Switzerland</p>  <p>Plug: SEV Type 12, 250V, 10A<br/>         Cable: 8120-2104</p>                       |
| <p>OPTION 912                      Denmark</p>  <p>Plug: SR 107-2-D, 250V, 10A<br/>         Cable: 8120-2956</p>                        | <p>OPTION 917                      India/Republic of S. Africa</p>  <p>Plug: IEC 83-B1, 250V, 10A<br/>         Cable: 8120-4211</p>       |
| <p>OPTION 918                      Japan</p>  <p>Plug: JIS C 8303, 125V, 12A<br/>         Cable: 8120-4753</p>                          | <p>OPTION 920                      Argentina</p>  <p>Plug: Argentine Resolution 63, Annex IV, 250V, 10A<br/>         Cable: 8120-6870</p> |
| <p>OPTION 921                      Chile</p>  <p>Plug: CEI 23-16, 250V, 10A<br/>         Cable: 8120-6978</p>                           | <p>OPTION 922                      China</p>  <p>Plug: GB 1002, 250V, 10A<br/>         Cable: 8120-8376</p>                               |

**NOTE:** Each option number includes a 'family' of cords and connectors of various materials and plug body configurations (straight, 90° etc.).

power\_e

E: Power Requirement

Power Requirement  
**Power Supply and Blown Fuses**

**Blown fuses**

If the fuse appears to have blown during operation, this instrument may be subject to failure and must be repaired.

The product uses the following fuse type: UL/CSA Type, Slow-Blo, 8 A-250 V.

---

**WARNING**

---

**Do NOT replace the fuse yourself; doing this may expose you to dangerous electrical shock.**



---





## Starting the E5052A

This section explains how to turn on/off the E5052A power, how to cut off the power supply in an emergency, and how to set the internal clock.

### Turning the Power ON and OFF




Perform the following steps to turn the power ON or OFF.

#### Turning the Power ON

- Step 1.** If the standby switch (  ) in the lower-left part of the front panel is in the depressed (  ) position, press it to put it in the popped-up position (  ).
- Step 2.** Press the standby switch to put it in the depressed position (  ).  
This operation turns ON the power, and the E5052A starts the self-test.
- Step 3.** Confirm that the self-test indicates normal operation.

Normal operation is confirmed by the self-test if no error message appears.


#### Turning the Power OFF

- Step 1.** Use either of the following methods to turn the power OFF.
- Press the standby switch (  ) in the lower-left part of the front panel (now in the depressed (  ) position) to put it in the popped-up (  ) position.
  - Send the shutdown command from an external controller.

These operations will start the E5052A shutdown process (required software and hardware processes for turning the power off), and the power will turn OFF after a few seconds.

---

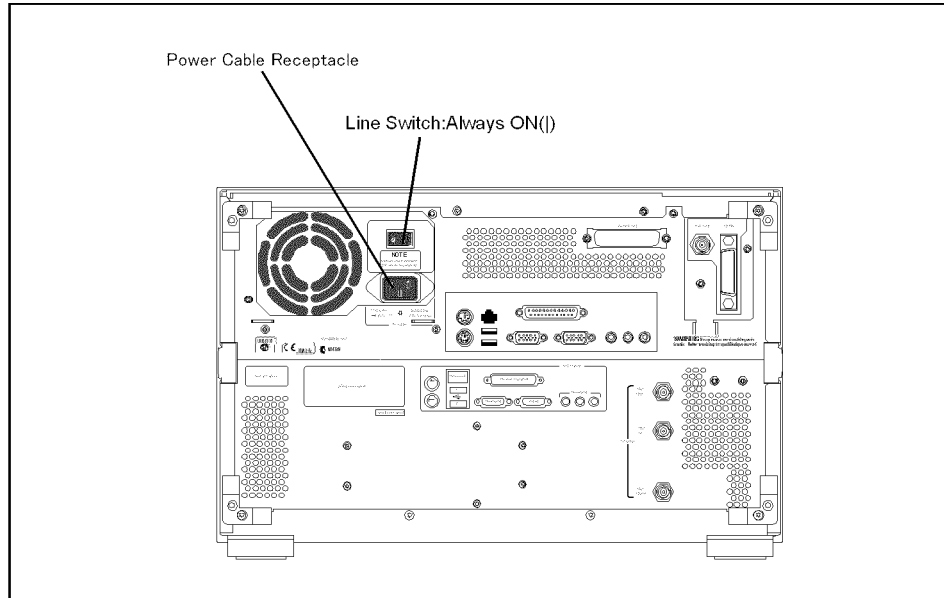
#### NOTE

Under normal circumstances, always press the standby switch (  ), or send the shutdown command from an external controller, to execute the E5052A shutdown process. **Never cut off the power supply directly by disconnecting the power cable plug from the rear panel of the unit.**

If the power supply is cut off directly by disconnecting the power cable plug from the instrument or the AC outlet, the shutdown process is not carried out and there is a risk of damage to the E5052A's software or hardware.

Figure E-2

Line switch (Always ON) and power cable receptacle



e5052aue013

### Disconnection from supply source

The power supply of the E5052A is cut off by disconnecting the plug of the power cable (on either AC outlet side or E5052A side). When it is necessary to disconnect the power supply in order to avoid shock hazards, etc., pull out the power cable plug from either the AC outlet side or the E5052A side.

---

## **F** Messages

The E5052A can display error messages as well as messages that indicate the internal operating status of the equipment. This appendix explains what these messages mean. They are listed in alphabetical order.

Messages showing the status of the E5052A are displayed in the lower-left area of the E5052A LCD screen. These messages include error messages that occur during the

## Messages

execution of GPIB commands and others that indicate the internal status of the equipment.

Error messages are indicated following the character string “[Err]” and can be read out by a GPIB command. Other kinds of messages are indicated without the “[Err]” character string and cannot be read out by a GPIB command. This section explains the meaning of each message and how to resolve the problem it indicates.

## Error Messages

An error message is displayed against a red background in the instrument message/warning area in the lower-left part of the screen. Touching **Entry Off** key at the front panel or executing the **:DISPlay:MESSage:CLEar** command clears the error message. Moreover, about a specific error message, when a sweep is started again, the display of an error message may disappear. Errors caused by operation of a front panel key simply appear on the display; with a few exceptions, these are not stored in the error queue.

The log of an error message, a maximum of 100 pieces are recorded, and it can go back and check from the newest error. The following procedures perform the procedure of elimination of an error check and an error log. This operation can be performed only from a front panel. It cannot be operated by the "SCPI" command.

### [System] - Error Log - View Error Log

### [System] - Error Log - Clear Error Log

An error with a positive error number is one uniquely defined for this instrument. On the other hand, an error with a negative error number is basically one defined for common GPIB devices in IEEE488.2

## A

120

### AFC Failed

This error message appears when the Automatic frequency control function could not follow the fluctuation in the measurement condition or automatic frequency control function was set on, however, the power or control voltage is not being applied to the DUT. For the corrective actions, refer to the error message "AFC out of loop" and the warning message "DC output on required in AFC".

330

### AFC out of loop

The Automatic frequency control function could not follow the fluctuation in the measurement condition, and did not converge on the target frequency. Possible problems and corrective action are shown below.

- Press **[DC Control]** - **Auto Freq Control - Sensitivity** to specify a proper tuning sensitivity.
- Press **[DC Control]** - **Auto Freq Control - Max Iteration** to specify a value larger than the current setting.
- Press **[DC Control]** - **Auto Freq Control - Max Ctrl Voltage Limit** to specify a maximum value larger than the current setting. Be careful not to set a value that exceeds the DUT's maximum acceptable value.
- Press **[DC Control]** - **DC control Delay** to specify a value larger than the current setting.

51

### A21 flash ROM write error

This error occurs when writing the system calibration data to ROM on the A21 board fails. Contact Agilent Technologies' Customer Contact given at the end of this guide or the company from which you bought the device.

## D

- 222      **Data out of range**
- A data element (not violating the standard) outside the range defined by this instrument has been received. This error occurs, for example, when an integer-based command for which the parameter can be rounded exceeds the range of -65536 to +65536 or when a real-number-based command for which the parameter can be rounded exceeds the range of -9.9e37 to +9.9e37.
- 280      **DC control overload**
- The current through the DC CONTROL connector is too large.
- 270      **DC power overload**
- The current through the DC POWER connector is too large.
- 373      **Downconverter Fan Stop**
- This error occurs when the fan of the downconverter stops. Contact Agilent Technologies' Customer Contact given at the end of this guide or the company from which you bought the device.
- 354      **Downconverter IF not found**
- This error occurs when the down-converted signal does not fall into the expected IF range. The deviation between the set nominal frequency and the actual input signal's frequency may be too large. Execute the carrier search function, and set a correct nominal frequency.
- 352      **Downconverter Oven Cold**
- This error may occur due to the unlocked PLL because the oven is not heated sufficiently for some time after the downconverter is turned on. Heat the oven for some time with the power on.
- 374      **Downconverter P5V power fail**
- This error occurs when the 5-V power of the downconverter fails. A device failure is suspected. Contact Agilent Technologies' Customer Contact given at the end of this guide or the company from which you bought the device.
- 353      **Downconverter Ref Input Level Low**
- This error occurs when the level of the 10-MHz reference signal to the downconverter is low.
- 372      **Downconverter Ref PLL unlocked**
- This error occurs when the PLL circuit of the downconverter is unlocked during measurement. This error may occur when the carrier frequency of the measurement sample is unstable.
- It may occur also due to the same reason as "Downconverter Oven Cold."
- 375      **Downconverter test failed**
- This error occurs when the self-test of the downconverter fails. A device failure is suspected. Contact Agilent Technologies' Customer Contact given at the end of this guide or the company from which you bought the device.
- 371      **Downconverter Unlock local**
- This error occurs when the local of the downconverter cannot be locked. A device failure is

suspected. Contact Agilent Technologies' Customer Contact given at the end of this guide or the company from which you bought the device.

## E

-200

### Execution error

An error associated with execution has been generated for which this instrument cannot specify the error message. This code shows the occurrence of an error associated with execution, as defined in 11.5.1.1.5, IEEE488.2.

## F

72

### Failed to copy file

This error occurs when copying a file (MMEM:COPY command) fails.

74

### Failed to create directory

This error occurs when creating a directory (MMEM:MDIR command) fails.

73

### Failed to delete file

This error occurs when deleting a file (MMEM:DEL command) fails.

91

### Failed to execute user defined key

In the user menu function, this error occurs when a disabled softkey is executed.

61

### Failed to hide trace

In the user window, this error occurs when the show trace "OFF" command is executed to turn off the remaining trace on the window. At least one trace should be visible at all times.

60

### Failed to hide window

This error occurs when the show window "OFF" command is executed to turn off the remaining window on the screen. At least one window should be visible at all times.

70

### Failed to read file

This error occurs when a VBA project file (MMEM:LOAD:PROG command) or other type of file cannot be read normally.

90

### Failed to stop program

This error occurs when stopping a program fails.

71

### Failed to write file

This error occurs when the display image (MMEM:STOR:IMAG command) for the LCD screen, a VBA project file (MMEM:STOR:PROG command) or other type of file cannot be written normally.

-257

### File name error

A file name error. This message appears when an error exists in the file name and thus a command is not executed correctly. This error occurs, for example, when you try to copy to an improper file name.

-256

### File name not found

The file name specified is not found and thus the command is not executed correctly. This error occurs, for example, when you try to read a file that does not exist in a disk or a disk

## Messages

### File transfer failed

is not correctly inserted into the drive.

80

#### **File transfer failed**

This error occurs when writing data into or reading data from a file (MMEM:DATA command) fails.

## I

213

#### **IF A/D overflow**

This message appears when the internal IF level is too high and it exceeds the internal A/D converter input range. In the phase noise measurement, check that the DUT's carrier signal is within the selected frequency band. Also, the message may appear if a DUT that has a large noise level and an unstable output level is measured. When measuring phase noise in such a case, decrease the IF Gain value or increase the sweep start value if possible. In the spectrum monitor measurement, decrease the DUT's carrier level, or set the reference level or input attenuator value larger than the current setting. In the transient measurement, decrease the DUT's carrier level, or set the max input level or input attenuator value larger than the current setting.

260

#### **IF Level Overload**

The IF level is too high. Set the input attenuator value larger than the current setting.

312

#### **IF not found**

The IF signal cannot be found. In the phase noise measurement, this error occurs when no signal is inputted to the RF IN, or the input level to the RF IN is too low. Also, the message may appear if a DUT that has an unstable output level is measured. Aside from the above reasons, there is the possibility of a device failure. Contact an Agilent Technologies sales office or the company from which you bought the device.

-224

#### **Illegal parameter value**

The parameter value is improperly set.

-282

#### **Illegal program name**

This error occurs when a nonexistent VBA program name is specified by the PROG:SEL:NAME command.

-213

#### **Init ignored**

Because another measurement is in progress, the request for initiating a measurement ("INIT" command) is ignored.

250

#### **Insufficient IF Level**

The IF level is too low. Set the input attenuator value smaller than the current setting.

230

#### **Insufficient RF Level**

The input level to the RF IN connector is too low.

## L

101

#### **License installation failed**

This error occurs when an invalid license code is input during installation of the E5001 SSA-J license.



|      |                                                                                                                                                                                                                                                                                                                                                                                                                                                                                                            |
|------|------------------------------------------------------------------------------------------------------------------------------------------------------------------------------------------------------------------------------------------------------------------------------------------------------------------------------------------------------------------------------------------------------------------------------------------------------------------------------------------------------------|
| 77   | <b>Load VBA program failed</b><br>This error occurs when loading a VBA program file fails.                                                                                                                                                                                                                                                                                                                                                                                                                 |
|      | <b>M</b>                                                                                                                                                                                                                                                                                                                                                                                                                                                                                                   |
| 20   | <b>Marker search failed</b><br>This error occurs when marker search fails.                                                                                                                                                                                                                                                                                                                                                                                                                                 |
| -109 | <b>Missing parameter</b><br>The number of parameters is less than that required for the command, or the parameter has not been entered.                                                                                                                                                                                                                                                                                                                                                                    |
|      | <b>N</b>                                                                                                                                                                                                                                                                                                                                                                                                                                                                                                   |
| 351  | <b>No downconverter unit connected</b><br>This error occurs when the downconverter is not turned on or when the USB (USBTMC) cable is not connected even though the downconverter is enabled. Disable the downconverter, turn on the downconverter, or connect the USB (USBTMC) cable.                                                                                                                                                                                                                     |
| 111  | <b>No signal found</b><br>This error message appears when a carrier is outside the selected frequency band or the attenuator is improperly set during the execution of <b>Carrier to</b> function. Set the attenuator to 0 in case you measure a DUT whose output is less than -15dBm.                                                                                                                                                                                                                     |
|      | <b>O</b>                                                                                                                                                                                                                                                                                                                                                                                                                                                                                                   |
| 100  | <b>Option not installed</b><br>The command received has been ignored because of the mismatch between the contents of an option for this instrument and the command.<br>This error is not generated by front key operations.                                                                                                                                                                                                                                                                                |
|      | <b>P</b>                                                                                                                                                                                                                                                                                                                                                                                                                                                                                                   |
| -220 | <b>Parameter error</b><br>When a parameter-related error other than Errors -221 through -229 occurs, that error is displayed.                                                                                                                                                                                                                                                                                                                                                                              |
| -108 | <b>Parameter not allowed</b><br>The number of parameters exceeds that required for the command.<br>See the command reference to confirm the required number of parameters.                                                                                                                                                                                                                                                                                                                                 |
| 210  | <b>Phase lock loop unlocked</b><br>This error occurs when the PLL circuit of the instrument becomes unlocked while the measurement is in progress. This message may appear if the DUT's carrier signal is unstable. If this message is displayed in the phase noise measurement, the following problems and corrective actions are shown below. <ul style="list-style-type: none"><li>• The DUT's noise level is too large, or a large level spurious component exists in the measurement range.</li></ul> |

## Messages

### PLL frequency range over

Verify the spectrum of the DUT's output signal.

Decrease the IF Gain value, or increase the sweep start value when possible.

- The DUT's output signal is being modulated in frequency.

Stop the frequency modulation.

- A large harmonics component is included in the DUT's output signal.

Insert a low-pass filter between the DUT's output terminal and the E5052A RF IN connector to eliminate the harmonics component.

211

### PLL frequency range over

This error occurs when the internal PLL circuit becomes unlocked while the measurement is in progress. This error may occur when the frequency of the input signal is out of range.

212

### PLL Input overflow

This error occurs when the internal PLL circuit becomes unlocked while the measurement is in progress. This error may occur when the level of the input signal is too large.

200

### Power on test failed

This error occurs when the power-on test fails, indicating a failure of the instrument. Contact an Agilent Technologies sales office or the company from which you bought the instrument.

40

### Printer error

This error occurs when the previous printing is still in progress or the printer fails (offline, short of paper, etc.) at the time of outputting the display image on the LCD screen to the printer (HCOP:IMM command).

41

### Print failed

This error occurs when printing fails for reasons other than Error 40, Printer error.

-284

### Program currently running

This error occurs when the PROG:SEL:STAT RUN command is executed when the VBA program is in the Run state.

-286

### Program runtime error

An error occurring when VBA is executed.

## R

75

### Recall failed

This error occurs when reading an instrument status file (State01.sta, etc.) (MMEM:LOAD:STAT command) fails.

220

### RF freq out of range

This error occurs when the DUT's output frequency is not within the measurement range.

240

### RF level overload

This error occurs when the input to the RF IN port exceeds the maximum input level in the measurement. The measurement value obtained in such a case is not correct. In the worst case, a failure (damage to the receiver) may occur.

## S

76

### Save failed

This error occurs when writing an instrument status file (State01.sta, etc.) (MMEM:STOR:STAT command) fails.

78

### Save VBA program failed

This error occurs when saving a VBA program file fails.

-310

### System error

One of the errors designated as “system errors” in this instrument has occurred.

## T

110

### Target freq out of range

This error indicates the 2nd, 3rd, or nth order harmonics is not within the E5052A measurement range. At this time, the previous measurement conditions still remain (any of sweep parameters are not changed).

-223

### Too much data

The block-, expression-, or character-string-type program data that have been received conform with the standard but exceed the amount that can be processed under the conditions of the memory or conditions specific to memory-related devices. In this instrument, this error occurs when the number of characters exceeds 254 in a character-string parameter.

-211

### Trigger ignored

This instrument receives and detects a trigger command (“TRIG”) or an external trigger signal, but it is ignored due to the timing conditions (the instrument is not in the wait-for-trigger state, for example). Change the setup so that a trigger command or an external trigger signal can be sent after the instrument has entered the wait-for-trigger state.

## U

-113

### Undefined header

A command not defined in this instrument, although not illegal in the syntactic structure, has been received. See the command reference and use correct commands.

311

### Unlock local

This error occurs when the internal Local signal of the instrument cannot be unlocked. There is the possibility of a device failure. Contact an Agilent Technologies sales office or the company from which you bought the device.

Messages  
**Unlock local**

# REGIONAL SALES AND SUPPORT OFFICES

*For more information about Agilent Technologies test and measurement products, applications, services, and for a current sales office listing, visit our web site: <http://www.agilent.com/find/tmdir>. You can also contact one of the following centers and ask for a test and measurement sales representative. 21/01/2004*

## **United States:**

Test and Measurement Call Center  
(tel) 1 800 452-4844  
(fax) 1 888 900-8921

## **Australia/New Zealand:**

(tel) (61 3) 9210-5555 (Australia)  
(fax) (61 3) 9210-5899  
(tel) (64 4) 939-0636 (New Zealand)  
(fax) (64 4) 972-5364

## **Canada:**

Test and Measurement Call Center  
(tel) 1 877 894-4414  
(fax) 1 888 900-8921

## **Asia Pacific:**

(tel) (65) 6375-8100  
(fax) (65) 6836-0252  
Email: [tm\\_asia@agilent.com](mailto:tm_asia@agilent.com)

## **China:**

(tel) 800 810-0189  
(fax) 800 820-2816

## **Europe:**

(tel) (31 20) 547-2323  
(fax) (31 20) 547-2390

## **Japan:**

Call Center  
(tel) 0120 421-345  
(tel) (81) 426 56-7832  
(fax) (81) 426 56-7840

## **Korea:**

(tel) (82 2) 2004-5004  
(fax) (82 2) 2004-5115

## **Latin America:**

(tel) (305) 269-7500  
(fax) (305) 269-7599

## **Taiwan:**

(tel) 0800 047 866  
(fax) 0800 286 331