

Service Guide

Agilent Technologies E4418B/E4419B Power Meters



Agilent Technologies

Agilent Technologies Part no. E4418-90059

Revision C

September 2003

© Copyright 1998, 2003 Agilent Technologies

All rights reserved. Reproduction, adaptation, or translation without prior written permission is prohibited, except as allowed under the copyright laws.

Printed in the UK.

Legal Information

Notice

Information contained in this document is subject to change without notice. Agilent Technologies makes no warranty of any kind with regard to this material, including, but not limited to, the implied warranties of merchantability and fitness for a particular purpose. Agilent Technologies shall not be liable for errors contained herein or for incidental or consequential damages in connection with the furnishings, performance, or use of this material. No part of this document may be photocopied, reproduced, or translated to another language without the prior written consent of Agilent Technologies.

Certification

Agilent Technologies certifies that this product met its published specifications at the time of shipment from the factory. Agilent Technologies further certifies that its calibration measurements are traceable to the United States National Institute of Standards and Technology, to the extent allowed by the Institute's calibration facility, and to the calibration facilities of other International Standards Organization members.

Warranty

This Agilent Technologies instrument product is warranted against defects in material and workmanship for a period of one year from date of shipment. During the warranty period, Agilent Technologies will at its option, either repair or replace products which prove to be defective. For warranty service or repair, this product must be returned to a service facility designated by Agilent Technologies. Buyer shall prepay shipping charges to Agilent Technologies and Agilent Technologies shall pay shipping charges, duties, and taxes for products returned to Agilent Technologies from another country. Agilent Technologies warrants that its software and firmware designated by Agilent Technologies for use with an instrument will execute its programming instructions when properly installed on that instrument. Agilent Technologies does not warrant that the operation of the instrument, or firmware will be uninterrupted or error free.

Legal Information

Limitation of Warranty

The foregoing warranty shall not apply to defects resulting from improper or inadequate maintenance by Buyer, Buyer-supplied software or interfacing, unauthorized modification or misuse, operation outside of the environmental specifications for the product, or improper site preparation or maintenance. NO OTHER WARRANTY IS EXPRESSED OR IMPLIED. AGILENT TECHNOLOGIES SPECIFICALLY DISCLAIMS THE IMPLIED WARRANTIES OF MERCHANTABILITY AND FITNESS FOR A PARTICULAR PURPOSE.

Exclusive Remedies

THE REMEDIES PROVIDED HEREIN ARE BUYER'S SOLE AND EXCLUSIVE REMEDIES. HP SHALL NOT BE LIABLE FOR ANY DIRECT, INDIRECT, SPECIAL, INCIDENTAL, OR CONSEQUENTIAL DAMAGES, WHETHER BASED ON CONTRACT, TORT, OR ANY OTHER LEGAL THEORY.

Equipment Operation

Warnings and Cautions

This guide uses warnings and cautions to denote hazards.

WARNING

A warning calls attention to a procedure, practice or the like, which, if not correctly performed or adhered to, could result in injury or the loss of life. Do not proceed beyond a warning until the indicated conditions are fully understood and met.

Caution

A caution calls attention to a procedure, practice or the like which, if not correctly performed or adhered to, could result in damage to or the destruction of part or all of the equipment. Do not proceed beyond a caution until the indicated conditions are fully understood and met.

Personal Safety Considerations

WARNING

This is a Safety Class I product (provided with a protective earthing ground incorporated in the power cord). The mains plug shall only be inserted in a socket outlet provided with a protective earth contact. Any interruption of the protective conductor, inside or outside the instrument, is likely to make the instrument dangerous. Intentional interruption is prohibited.

If this instrument is not used as specified, the protection provided by the equipment could be impaired. This instrument must be used in a normal condition (in which all means of protection are intact) only.

No operator serviceable parts inside. Refer servicing to qualified personnel. To prevent electrical shock, do not remove covers.

For continued protection against fire hazard, replace the line fuse(s) only with fuses of the same type and rating (for example, normal blow, time delay, etc.). The use of other fuses or material is prohibited.

General Safety Considerations

WARNING

Before this instrument is switched on, make sure it has been properly grounded through the protective conductor of the ac power cable to a socket outlet provided with protective earth contact. Any interruption of the protective (grounding) conductor, inside or outside the instrument, or disconnection of the protective earth terminal can result in personal injury.

Caution

Any adjustments or service procedures that require operation of the instrument with protective covers removed should be performed only by trained service personnel.

Markings



The CE mark shows that the product complies with all the relevant European legal Directives (if accompanied by a year, it signifies when the design was proven).



Group 1
Class A

This is the symbol of an Industrial Scientific and Medical Group 1 Class A product.



The CSA mark is a registered trademark of the Canadian Standards Association.



External Protective Earth Terminal.

While this is a Class I product, provided with a protective earthing conductor in a power cord, an external protective earthing terminal has also been provided. This terminal is for use where the earthing cannot be assured. At least an 18AWG earthing conductor should be used in such an instance, to ground the instrument to an assured earth terminal.

IEC 1010-1 Compliance

This instrument has been designed and tested in accordance with IEC Publication 1010-1 +A1:1992 Safety Requirements for Electrical Equipment for Measurement, Control and Laboratory Use and has been supplied in a safe condition. The instruction documentation contains information and warnings which must be followed by the user to ensure safe operation and to maintain the instrument in a safe condition.

Statement of Compliance

This product has been designed and tested for compliance with IEC 60529 (1989) Degrees of Protection Provided by Enclosures (IP Code). Level IPx4 is attained if, and only if, the carry case (Agilent part number 34141A) is fitted.

User Environment

This product is designed for use in a sheltered environment (avoiding extreme weather conditions) in accordance with Pollution Degree 3 defined in IEC 60664-1, with the carry case (Agilent part number 34141A) fitted over the instrument.

The product is suitable for indoor use only, when this carry case is not fitted.

Installation Instructions

To avoid unnecessary over-temperature conditions, while this carry case is fitted do not apply an ac mains supply voltage, only operate your power meter from the battery pack.

List of Related Publications

The Agilent E4418B and Agilent E4419B *User's Guides* are also available in the following languages:

- English Language User's Guide - Standard
- German Language User's Guide - Option ABD
- Spanish Language User's Guide - Option ABE
- French Language User's Guide - Option ABF
- Italian Language User's Guide - Option ABZ
- Japanese Language User's Guide - Option ABJ

Agilent E4418B/E4419B Service Guide is available by ordering Option 915.

Agilent E4418B/E4419B CLIPs (Component Location and Information Pack) is available by ordering E4418-90031.

Sales and Service Offices

For more information about Agilent Technologies test and measurement products, applications, services, and for a current sales office listing, visit our web site: <http://www.agilent.com>

You can also contact one of the following centers and ask for a test and measurement sales representative.

Asia Pacific:

Agilent Technologies
19/F, Cityplaza One, 1111 King's Road,
Taikoo Shing, Hong Kong, SAR
(tel) (852) 2599 7889
(fax) (852) 2506 9233

Japan:

Agilent Technologies Japan Ltd.
Measurement Assistance Center
9-1, Takakura-Cho, Hachioji-Shi
Yokyo, 192-8510
(tel) (81) 426 56 7832
(fax) (81) 426 56 7840

Australia/New Zealand:

Agilent Technologies Australia Pty Ltd
347 Burwood Highway
Forest Hill, Victoria 3131
(tel) 1-800 629 485 (Australia)
(fax) (61 3) 9272 0749
(tel) 0 800 738 378 (New Zealand)
(fax) (64 4) 802 6881

Canada:

Agilent Technologies Canada Inc.
5150 Spectrum Way,
Mississauga, Ontario
L4W 5G1
(tel) 1 877 894 4414

Sales and Service Offices

Europe:

Agilent Technologies
Test & Measurement
European Marketing Organization
P.O. Box 999
1180 AZ Amstelveen
The Netherlands
(tel) (31 20) 547 9999

Latin America:

Agilent Technologies
Latin American Region Headquarters
5200 Blue Lagoon Drive, Suite #950
Miami, Florida 33126
U.S.A.
(tel) (305) 267 4245
(fax) (305) 267 4286

United States:

Agilent Technologies
Test and Measurement Call Center
P.O. Box 4026
Englewood, CO 80155-4026
(tel) 1 800 452 488

In any correspondence or telephone conversations, refer to the power sensor by its model number and full serial number. With this information, the Agilent Technologies representative can quickly determine whether your unit is still within its warranty period.

Returning Your Power Meter for Service

Use the information in this section if you need to return your power meter to Agilent Technologies.

Package the Power Meter for Shipment

Use the following steps to package the power meter for shipment to Agilent Technologies for service:

1. Fill in a blue service tag (available at the end of this guide) and attach it to the power meter. Please be as specific as possible about the nature of the problem. Send a copy of any or all of the following information:
 - n Any error messages that appeared on the power meter display.
 - n Any information on the performance of the power meter.

Caution

Power meter damage can result from using packaging materials other than those specified. Never use styrene pellets in any shape as packaging materials. They do not adequately cushion the power meter or prevent it from shifting in the carton. Styrene pellets cause power meter damage by generating static electricity and by lodging in the rear panel.

2. Use the original packaging materials or a strong shipping container that is made of double-walled, corrugated cardboard with 159 kg (350 lb) bursting strength. The carton must be both large enough and strong enough to accommodate the power meter and allow at least 3 to 4 inches on all sides of the power meter for packing material.
3. Surround the power meter with at least 3 to 4 inches of packing material, or enough to prevent the power meter from moving in the carton. If packing foam is not available, the best alternative is SD-240 Air Cap™ from Sealed Air Corporation (Commerce, CA 90001). Air Cap looks like a plastic sheet covered with 1-1/4 inch air filled bubbles. Use the pink Air Cap to reduce static electricity. Wrap the power meter several times in the material to both protect the power meter and prevent it from moving in the carton.
4. Seal the shipping container securely with strong nylon adhesive tape.
5. Mark the shipping container “FRAGILE, HANDLE WITH CARE” to ensure careful handling.
6. Retain copies of all shipping papers.

About this Guide

Chapter 1: Specifications

This chapter lists the power meter's specifications and describes how to interpret these specifications.

Chapter 2: Performance Tests

This chapter contains procedures which allow you to test the power meter's electrical performance to its specifications.

Chapter 3: Adjustments

This chapter contains checks and adjustments that ensure proper performance of the power meter.

Chapter 4: Theory of Operation

This chapter describes how each of the power meter's individual assemblies operate.

Chapter 5: Replaceable Parts

This chapter details the power meter's replaceable parts. It also explains how to assemble and disassemble the power meter.

Chapter 6: Troubleshooting

This chapter contains troubleshooting flow charts designed to isolate faults in the Rmt I/O, GP-IB and RS232/422 interface ports.

Appendix A: "Measurement Uncertainty Analysis – Instrument Accuracy Test"

Appendix B: "Measurement Uncertainty Analysis – Power Reference Level Test"

Table of Contents

	Page
Specifications	1
Introduction.....	1-2
Power Meter Specifications	1-3
Meter	1-3
Accuracy	1-4
1 mW Power Reference	1-5
Power Meter Supplemental Characteristics	1-6
Measurement Speed	1-6
Zero Drift of Sensors	1-6
Measurement Noise.....	1-7
Settling Time	1-9
Power Sensor Specifications	1-12
Battery Option 001 Operational Characteristics	1-13
General Characteristics.....	1-14
Rear Panel Connectors.....	1-14
Environmental Characteristics	1-15
General Conditions.....	1-15
Operating Environment	1-15
Storage Conditions	1-15
General	1-16
Dimensions	1-16
Weight	1-16
Safety	1-16
Remote Programming	1-17
Non-Volatile Memory	1-17
Performance Tests	1
Introduction.....	2-2
Equipment Required	2-3
Performance Test Record	2-4
Performance Tests	2-4
Calibration Cycle	2-4
Test Procedures	2-4
Zero Test.....	2-5
Specification.....	2-5
Description.....	2-5

Equipment	2-5
Test Setup	2-5
Procedure	2-6
Instrument Accuracy Test	2-7
Specification	2-7
Description	2-7
Test Procedure 1	2-7
Equipment	2-7
Test Setup	2-8
Procedure	2-8
Test Procedure 2	2-11
Equipment	2-11
Test Setup	2-11
Procedure	2-12
Power Reference Level Test	2-15
Description	2-15
Equipment	2-17
Test Setup	2-17
Procedure	2-17
Agilent E-Series Power Sensor Interface Test	2-19
Procedure	2-19
Agilent E-Series Power Sensor Functional Test	2-20
Description	2-20
Equipment	2-20
Procedure	2-20
Performance Test Record	2-23
Adjustments	1
Introduction	3-2
Safety Considerations	3-2
Equipment Required	3-3
Post-Repair Adjustments	3-3
Power Reference Oscillator Frequency Adjustment	3-4
Description	3-4
Equipment	3-4
Procedure	3-4
Power Reference Oscillator Level Adjustment	3-6
Description	3-6
Equipment	3-8
Procedure	3-8
Measurement Uncertainty	3-10
Display Brightness and Contrast Adjustment	3-11
Introduction	3-11

Procedure	3-11
Theory of Operation	1
Introduction	4-2
A1 Power Supply/Battery Charger	4-3
A2 Processor Assembly	4-4
A3 Front Panel Assembly	4-7
A4 Comms Assembly	4-8
A5 Daughter Assembly	4-9
A6 Measurement Assembly	4-10
A8 Rechargeable Battery Assembly	4-12
Replaceable Parts	1
Introduction	5-2
Assembly Part Numbers	5-3
Power Supply Assembly Types	5-5
Front Panel Connector Repair	5-6
Firmware Upgrades	5-7
Downloading Firmware	5-7
Assembly and Disassembly Guidelines	5-8
Removing the Power Meter Cover	5-8
Removing the A1 Power Supply Assembly	5-9
Removing the A2 Processor Assembly	5-10
Removing the A4 Comms Assembly	5-11
Removing the A5 Daughter or A6 Measurement Assemblies	5-12
Removing the A7 Fan Assembly	5-13
Removing the Power Meter RAM Battery (BT1)	5-14
Removing the A3 Front Panel Assembly	5-15
Replacing the Front Panel Power Reference Cable Assembly	5-18
Replacing the Rear Panel Power Sensor Cable Assemblies (Options 002 and 003)	5-19
Replacing the Rear Panel Power Reference Cable Assembly (Option 003)	5-21
Replacing the Rear Panel Recorder Output Cable Assembly	5-22
Replacing The Chassis Assembly	5-23
Troubleshooting	1
Introduction	6-2
Suggested Diagnostic Equipment	6-2
Measurement Uncertainty Analysis Instrument Accuracy Test 1	
Measurement Introduction	A-2
Uncertainties	A-3
Define the Measurand	A-3

Define the Measurement Equation	A-3
Sensitivity Coefficients C_i :.....	A-8
Combined Standard Uncertainty $uc(y)$:	A-9
Expanded Uncertainty $kuc(y)$:.....	A-9

Measurement Uncertainty Analysis Power Reference Level Test1

Measurement Introduction.....	B-2
Define the Measurand.....	B-2
Define the Measurement Equation	B-2
Uncertainty Equation	B-4
Voltage Measurements Uncertainty	B-4
Mismatch	B-5
Calibration factor	B-7
Sensor Calibration Factor Drift.....	B-7
Resistance	B-8
Repeatability.....	B-8
Sensitivity Coefficients (C_i)	B-10
Combined Standard Uncertainty ($uc(y)$).....	B-12
Expanded Uncertainty	B-12

1

———— Specifications

Introduction

This chapter details the power meter's specifications and supplemental characteristics.

Specifications describe the warranted performance and apply after a 30 minute warm-up. These specifications are valid over the power meter's operating and environmental range unless otherwise stated and after performing a zero and calibration.

Supplemental characteristics, which are shown in italics, are intended to provide information useful in applying the power meter by giving typical, but non-warranted performance parameters. These characteristics are shown in italics or denoted as "typical", "nominal" or "approximate".

For information on measurement uncertainty calculations, refer to Agilent Application Note 64-1A, "Fundamentals of RF and Microwave Power Measurements", Literature Number 5965-6630.

Power Meter Specifications

Meter

Frequency Range

100 kHz to 110 GHz, power sensor dependent

Power Range

-70 dBm to +44 dBm (100 pW to 25 W), power sensor dependent

Power Sensors

Compatible with all Agilent 8480 series power sensors and Agilent E-series power sensors.

Single Sensor Dynamic Range

90 dB maximum (Agilent E-series power sensors)
50 dB maximum (Agilent 8480 series power sensors)

Display Units

Absolute: Watts or dBm

Relative: Percent or dB

Display Resolution

Selectable resolution of:

1.0, 0.1, 0.01 and 0.001 dB in logarithmic mode, or
1, 2, 3 and 4 significant digits in linear mode

Default Resolution

0.01 dB in logarithmic mode
3 digits in linear mode

Accuracy

Instrumentation

Absolute: ± 0.02 dB (Logarithmic) or $\pm 0.5\%$ (Linear). (Refer to the power sensor linearity specification in your power sensor manual to assess overall system accuracy.)

Relative: ± 0.04 dB (Logarithmic) or $\pm 1.0\%$ (Linear). (Refer to the power sensor linearity specification in your power sensor manual to assess overall system accuracy.)

Zero Set (digital settability of zero): Power sensor dependent (refer to Table 1-1). For Agilent E-series power sensors, this specification applies when zeroing is performed with the sensor input disconnected from the POWER REF.

Table 1-1: Zero Set Specifications

Power Sensor	Zero Set
Agilent 8481A	± 50 nW
Agilent 8481B	± 50 μ W
Agilent 8481D	± 20 pW
Agilent 8481H	± 5 μ W
Agilent 8482A	± 50 nW
Agilent 8482B	± 50 μ W
Agilent 8482H	± 5 μ W
Agilent 8483A	± 50 nW
Agilent 8485A	± 50 nW
Agilent 8485D	± 20 pW
Agilent R8486A	± 50 nW
Agilent R8486D	± 30 pW
Agilent Q8486A	± 50 nW
Agilent Q8486D	± 30 pW
Agilent V8486A	± 200 nW
Agilent W8486A	± 200 nW
Agilent 8487A	± 50 nW
Agilent 8487D	± 20 pW
Agilent E4412A	± 50 pW
Agilent E4413A	± 50 pW

1 mW Power Reference¹

- Power Output: 1.00 mW (0.0 dBm).
- Accuracy: (for two years)
±0.9% (0 to 55 °C).
±0.6% (25±10 °C).
±0.5% (23±3 °C).
- Frequency: 50 MHz nominal.
- SWR²: 1.06 maximum (1.08 maximum for option 003).
- Connector Type: Type N (f), 50 ohms.

1. National metrology institutes of member states of the Metre Convention, such as the National Institute of Standards and Technology in the USA, are signatories to the Comité International des Poids et Mesures Mutual Recognition Arrangement. Further information is available from the Bureau International des Poids et Mesures, at <http://www.bipm.fr/>

2. This SWR specification is only warranted for the E4418B and the E4419B Power Meters with serial prefix GB4331xxxx and above. Prior to this prefix the values shown are supplemental characteristics.

Power Meter Supplemental Characteristics

Measurement Speed

Over the GP-IB, three measurement speed modes are available as shown, along with the typical maximum measurement speed for each mode:

- **Normal:** 20 readings/second
- **x2:** 40 readings/second
- **Fast:** 200 readings/second, for Agilent E-series power sensors only

Maximum measurement speed is obtained using binary output in free run trigger mode.

Zero Drift of Sensors

Power sensor dependent (refer to Table 1-3).

Measurement Noise

Power sensor dependent (refer to Table 1-2 and Table 1-3).

Averaging effects on measurement noise. Averaging over 1 to 1024 readings is available for reducing noise. Table 1-3 provides the measurement noise for a particular power sensor with the number of averages set to 16 for normal mode and 32 for x2 mode. Use the “Noise Multiplier” for the appropriate mode (normal or x2) and number of averages to determine the total measurement noise value.

For example, for an Agilent 8481D power sensor in normal mode with the number of averages set to 4, the measurement noise is equal to:

$$(<45 \text{ pW} \times 2.75) = <124 \text{ pW}$$

Table 1-2: Noise Multiplier

Number of Averages	1	2	4	8	16	32	64	128	256	512	1024
<i>Noise Multiplier (Normal Mode)</i>	5.5	3.89	2.75	1.94	1.0	0.85	0.61	0.49	0.34	0.24	0.17
<i>Noise Multiplier (x2 mode)</i>	6.5	4.6	3.25	2.3	1.63	1.0	0.72	0.57	0.41	0.29	0.2

Table 1-3: Power Sensor Specifications \pm

Power Sensor	Zero Drift¹	Measurement Noise²
Agilent 8481A	< ± 10 nW	<110 nW
Agilent 8481B	< ± 10 μ W	<110 μ W
Agilent 8481D	< ± 4 pW	<45 pW
Agilent 8481H	< ± 1 μ W	<10 μ W
Agilent 8482A	< ± 10 nW	<110 nW
Agilent 8482B	< ± 10 μ W	<110 μ W
Agilent 8482H	< ± 1 μ W	<10 μ W
Agilent 8483A	< ± 10 nW	<110 nW
Agilent 8485A	< ± 10 nW	<110 nW
Agilent 8485D	< ± 4 pW	<45 pW
Agilent R8486A	< ± 10 nW	<110 nW
Agilent R8486D	< ± 6 pW	<65 pW
Agilent Q8486A	< ± 10 nW	<110 nW
Agilent Q8486D	< ± 6 pW	<65 pW
Agilent W8486A	< ± 40 nW	<450 nW
Agilent 8487A	< ± 10 nW	<110 nW
Agilent 8487D	< ± 4 pW	<45 pW
Agilent E4412A	< ± 15 pW	<70 pW
Agilent E4413A	< ± 15 pW	<70 pW

1. Within 1 hour after zero set, at a constant temperature, after a 24 hour warm-up of the power meter.
2. The number of averages at 16 (for normal mode) and 32 (for x2 mode), at a constant temperature, measured over a 1 minute interval and 2 standard deviations. For Agilent E-series power sensors the measurement noise is measured within the low range. Refer to the relevant power sensor manual for further information.

Settling Time

0 to 99% settled readings over the GP-IB.

For Agilent 8480 series power sensors

Manual filter, 10 dB decreasing power step:

Table 1-4: Settling Time

Number of Averages	1	2	4	8	16	32	64	128	256	512	1024
<i>Settling Time (s)</i> <i>(Normal Mode)</i>	0.15	0.2	0.3	0.5	1.1	1.9	3.4	6.6	13	27	57
<i>Response Time (s)</i> <i>(x2 mode)</i>	0.15	0.18	0.22	0.35	0.55	1.1	1.9	3.5	6.9	14.5	33

*Auto filter, default resolution, 10 dB decreasing power step,
normal and x2 speed modes:*

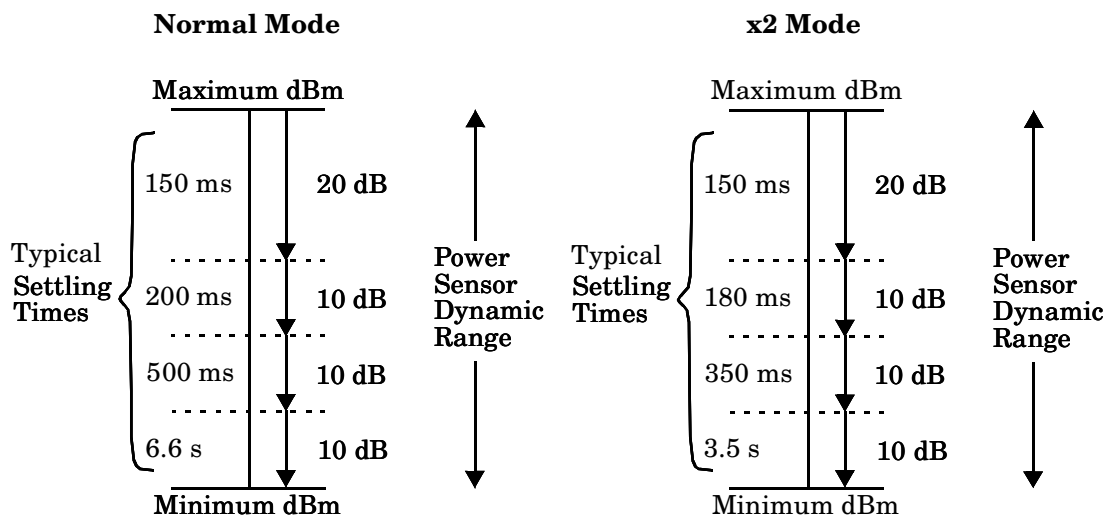

For Agilent E-series power sensors

In FAST mode, within the range -50 dBm to +17 dBm, for a 10 dB decreasing power step, the settling time is 10 ms¹ for the Agilent E4418B and 20 ms¹ for the Agilent E4419B

¹When a decreasing power step crosses the power sensor's auto-range switch point, add 25 ms. Refer to the relevant power sensor manual for further information.

For Agilent E-series power sensors in normal and x2 speed modes, manual filter, 10 dB decreasing power step:

Table 1-5: Settling Time

Number of Averages	1	2	4	8	16	32	64	128	256	512	1024
Settling Time (s) (Normal Mode)	0.07	0.12	0.21	0.4	1	1.8	3.3	6.5	13	27	57
Response Time (s) (x2 mode)	0.04	0.07	0.12	0.21	0.4	1	1.8	3.4	6.8	14.2	32

Auto filter, default resolution, 10 dB decreasing power step, normal and x2 speed modes:

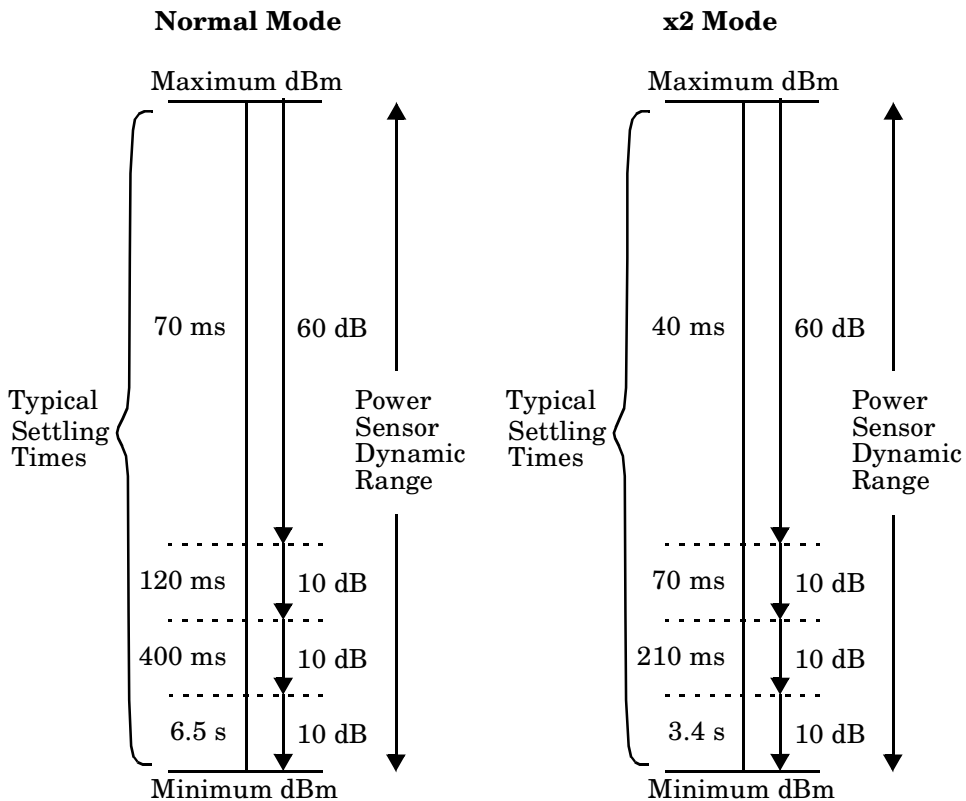

Power Sensor Specifications

Definitions

Zero Set

In any power measurement, the power meter must initially be set to zero with no power applied to the power sensor. Zero setting is accomplished within the power meter by digitally correcting for residual offsets.

Zero Drift

This parameter is also called long term stability and is the change in the power meter indication over a long time (usually one hour) for a constant input power at a constant temperature, after a defined warm-up interval.

Measurement Noise

This parameter is also known as short term stability and is specified as the change in the power meter indication over a short time interval (usually one minute) for a constant input power at a constant temperature.

Battery Option 001 Operational Characteristics

The following information describes characteristic performance based at a temperature of 25 °C unless otherwise noted. Characteristics describe product performance that is useful in the application of the product, but is not covered by the product warranty.

Typical Operating Time

Up to 2 hours with LED backlight on; up to 3 hours with LED backlight off.

Charge Time

< 2 hours to charge fully from an empty state: 50 minutes charging enables 1 hour of operation with LED backlight ON; 35 minutes charging enables 1 hour of operation with the LED backlight OFF. Power meter is operational whilst charging.

Service Life

To 70% of initial capacity at 25 °C: approximately 450 charge/discharge cycles.

Chemistry

Nickel Metal Hydride.

Weight

1 kg.

General Characteristics

Rear Panel Connectors

Recorder Output(s)

Analog 0-1 Volt, 1 k Ω output impedance, BNC connector

GP-IB

Allows communication with an external GP-IB controller.

RS-232/422

Allows communication with an external RS-232 or RS422 controller. Male Plug 9 position D-subminiature connector.

Remote Input/Output

A TTL logic level is output when the measurement exceeds a predetermined limit. TTL inputs are provided to initiate zero and calibration cycles. RJ-45 series shielded modular jack assembly.

TTL output: high = 4.8 V max; low = 0.2 V max

TTL input: high = 3.5 V min, 5 V max; low = 1 V max, -0.3 V min

Ground

Binding post, accepts 4 mm plug or bare-wire connection

Line Power

- **Input Voltage Range:** 85 to 264 Vac, automatic selection
- **Input Frequency Range:** 50 to 440 Hz
- **Power Requirement:** approximately 50 VA (14 Watts)

Environmental Characteristics

General Conditions

Complies with the requirements of the EMC Directive 89/336/EEC. This includes Generic Immunity Standard EN 50082-1: 1992 and Radiated Interference Standard EN 55011:1991 / CISPR11:1990, Group 1 - Class A.

Operating Environment

Temperature

0°C to 55°C

Maximum Humidity

95% at 40°C (non-condensing)

Minimum Humidity

15% at 40°C (non-condensing)

Maximum Altitude

3,000 meters (9,840 feet)

Storage Conditions

Storage Temperature

-20°C to +70°C

Non-Operating Maximum Humidity

90% at 65°C (non-condensing)

Non-Operating Maximum Altitude

15,240 meters (50,000 feet)

General

Dimensions

The following dimensions exclude front and rear panel protrusions:
212.6 mm W x 88.5 mm H x 348.3 mm D (8.5 in x 3.5 in x 13.7 in)

Weight

Net

Agilent E4418B, 4.0 kg (8.8 lb) - 5.0 kg (11.0 lb) with option 001

Agilent E4419B, 4.1 kg (9.0 lb) - 5.1 kg (11.2 lb) with option 001

Shipping

Agilent E4418B, 7.9 kg (17.4 lb) - 8.9 kg (19.6 lb) with option 001

Agilent E4419B, 8.0 kg (17.6 lb) - 9.0 kg (19.8 lb) with option 001

Safety

Conforms to the following Product Specifications:

- EN61010-1: 1993/IEC 1010-1:1990+A1/CSA C22.2 No. 1010-1:1993
- EN60825-1: 1994/IEC 825-1: 1993 Class 1
- Low Voltage Directive 72/23/EEC

Remote Programming

Interface

GP-IB interface operates to IEEE 488.2. RS-232 and RS-422 interfaces are supplied as standard.

Command Language

SCPI standard interface commands.

Agilent E4418B is HP 437B code compatible.

HP E4419B is HP 438A code compatible

Agilent E4418B/E4419B GP-IB Compatibility

SH1, AH1, T6, TE0, L4, LE0, SR1, RL1, PP1, DC1, DT1, C0

Non-Volatile Memory

Battery

Lithium Polycarbon Monoflouride, approximate lifetime 5 years at 25°C.

2

———— Performance Tests

Introduction

The procedures in this chapter test the power meter's electrical performance using the specifications in Chapter 1 as the performance standards. All tests can be performed without access to the interior of the power meter. A simpler operational test is included in "Self Test" of the *User's Guide*.

Note

For valid performance tests, the following conditions must be met:

- a. The power meter and test equipment must have a 30 minute warm-up for all specifications.
 - b. The line voltage for the power meter must be 85 to 264 Vac and the line frequency must be 50 to 440 Hz.
 - c. The ambient temperature must be 0⁰ to 55⁰C.
-

Equipment Required

Table 2-1 lists all the equipment required for the adjustments and performance tests. If substitutions must be made, the equipment used must meet the critical specifications.

Table 2-1: Required Equipment

Equipment Required	Model Number	Critical Specification	Usage¹
Digital Multimeter	Agilent 3458A	Range 0 to 20 V Resolution 0.01 V	P and A
DC Calibrator	Datron 4000A <i>or</i> Fluke 5720A		P
Range Calibrator	Agilent 11683A <i>or</i> Agilent 11683A Opt H01	Option H01 is essential for accurate verification. (See analysis in Appendix A). The Standard 11683A can be used for indication only.	P
Frequency Counter	Agilent 53132A	Range 10 Hz to 50 MHz Resolution 1 Hz	P and A
Power Meter	Agilent 432A	Range 1 mW Transfer Accuracy 0.2%	P and A
Thermistor Mount	Agilent 478A Opt H75/H76 <i>or</i> Agilent 8478B Opt H01	SWR<1.05 at 50 MHz Accuracy ±0.2% at 50 MHz.	P and A
Power Sensor	Agilent E-series power sensor		P
30 dB Attenuator	Agilent 11708A <i>or</i> Agilent 8491A Option 030		P
Power Sensor Cable	Agilent 11730A <i>or</i> Agilent E9288A		P and A

1. P = Performance Tests, A = Adjustments

Performance Test Record

Results of the performance tests may be tabulated in Table 2-7, “Performance Test Record,” on page 2-23. The Performance Test Record lists all of the performance test specifications and the acceptable limits for each specification. If performance test results are recorded during an incoming inspection of the power meter, they can be used for comparison during periodic maintenance. The test results may also prove useful in verifying proper adjustments after repairs are made.

Performance Tests

The performance tests given in this chapter are suitable for incoming inspection or preventive maintenance. During any performance test, all shields and connecting hardware must be in place.

The tests are designed to verify published power meter specifications. Perform the tests in the order given and record the data in Table 2-7 on page 2-23 and/or in the data spaces provided at the end of each procedure.

Calibration Cycle

This power meter requires periodic verification of performance to ensure that it is operating within specified tolerances. The performance tests described in this chapter should be performed once every two years. Under conditions of heavy usage or severe operating environments, the tests should be more frequent. Adjustments that may be required are described in Chapter 3.

Test Procedures

It is assumed that the person performing the following tests understands how to operate the specified test equipment. Equipment settings, other than those for the power meter, are stated in general terms. It is assumed that the person will select the proper cables, adapters, and probes required for test setups illustrated in this chapter.

Zero Test

Specification

Electrical Characteristics	Performance Limits
Accuracy: Zero set (Digital settability of zero)	$\pm 0.0764 \mu\text{W}^1$

1. This performance limit is determined by the zero set specification of the power sensor used in the measurement plus the measurement noise. The range calibrator has a zero set specification of $\pm 0.05 \mu\text{W}$. The calibrator measurement noise specification is 110 nW at 16 averages. At 512 averages a noise multiplier of 0.24 is required, giving a measurement noise specification of $0.0264 \mu\text{W}$ (0.24×110).

Description

After the power meter is initially calibrated and zeroed, the change in the digital readout is monitored. This test also takes drift and noise into account, since drift, noise and zero readings cannot be separated.

Equipment

Range Calibrator Agilent 11683A
Power Sensor Cable Agilent 11730A

Test Setup

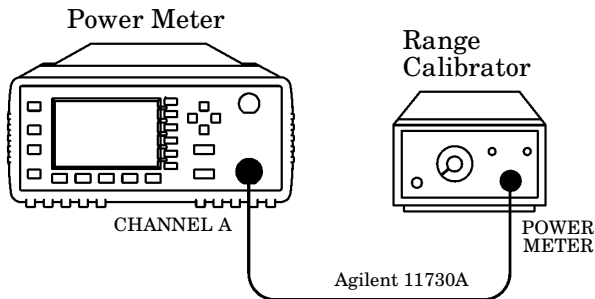

Figure 2-1: Zero Test Setup

Procedure

The following procedure should be performed for the Zero Test.

Note

The procedure details the key presses required on the Agilent E4418B. For the Agilent E4419B the equivalent key presses should be performed on both channels.

1. Connect the equipment as shown in Figure 2-1.
2. Switch the power meter on.
3. Press **Preset Local** then **Confirm**.
4. Press **dBm/W**, **W** for a reading in watts.
5. Set the range calibrator as follows:
 RANGE..... 3 μ W
 POLARITY..... NORMAL
 FUNCTION..... STANDBY
 LINE..... ON

Note

When switching the range calibrator to STANDBY, allow enough time for the range calibrator to settle to its zero value before attempting to zero the power meter. This settling would appear on the power meter display as downward drift. When the drift has reached minimum, (typically less than 60 seconds), the range calibrator is settled.

6. On the power meter press **System Inputs**, **Input Settings**, **More**, **Filter**, **Filter On**, **Mode Man**, **Length**, and set the filter length to 512 in the pop up window then press **Enter**.
7. On the power meter press **Zero Cal**, **Zero**. Wait approximately 10 seconds for the wait symbol to disappear.
8. Wait 30 seconds then verify that the power meter's reading is within $\pm 0.05 \mu$ W. Record the reading.

Table 2-2: Zero Test Results

Min	Channel A Actual Result	Channel B Actual Result (Agilent E4419B Only)	Max
-76.40 nW	_____	_____	+76.40 nW

Instrument Accuracy Test

Specification

Electrical Characteristics	Performance Limits
Accuracy	$\pm 0.5\%$ or ± 0.02 dB ¹

1. This performance limit does not include the corresponding sensor power linearity specification.

Description

The power meter accuracy is verified for various power inputs. There are two different methods described here that can be used to perform this test, although one of these methods has a relatively high measurement uncertainty values associated with it.

Test Procedure 1

Note

The measurement uncertainty of this test procedure is relatively high at power levels of 30uW and below, as it uses a standard 11683A Range Calibrator. As such, this test procedure should be used for indication only.

Equipment

Range Calibrator Agilent 11683A
Power Sensor Cable..... Agilent 11730A

Test Setup

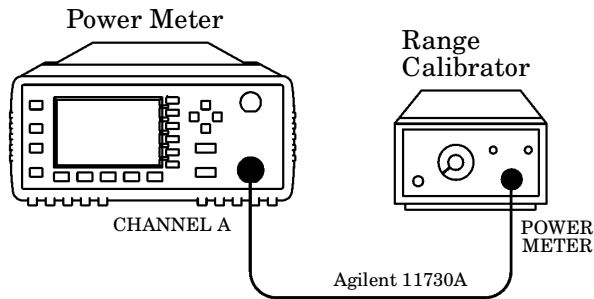

Figure 2-2: Instrument Accuracy Test Setup

Procedure

The following procedure should be performed for the Instrument Accuracy Test.

Note

The procedure details the key presses required on the Agilent E4418B. For the Agilent E4419B the equivalent key presses should be performed on both channels.

1. Connect the equipment as shown in Figure 2-2.
2. Switch the power meter on.
3. Press **Preset** then **Confirm**.
4. Press **dBm/W**, **W** for a reading in watts.
5. Set the range calibrator as follows:
RANGE..... 3 μ W
POLARITY..... NORMAL
FUNCTION..... STANDBY
LINE ON

Note

When switching the range calibrator to STANDBY, allow enough time for the range calibrator to settle to its zero value before attempting to zero the power meter. This settling would appear on the power meter display as downward drift. When the drift has reached minimum, (typically less than 60 seconds), the range calibrator is settled.

6. On the power meter press **System Inputs**, **Input Settings**, **More**, **Filter**, **Filter On**, **Mode Man**, **Length**, and set the filter length to 512 in the pop up window then press **Enter**.
7. On the power meter press **Zero Cal**, **Zero**. Wait approximately 10 seconds for the wait symbol to disappear. Verify that the display reads $0 \pm 0.05 \mu\text{W}$.
8. Set the range calibrator's FUNCTION switch to CALIBRATE.
9. Set the range calibrator's RANGE switch to 1 mW.
10. Press **Cal** to calibrate the power meter.
11. Set the range calibrator's RANGE switch to the positions shown in Table 2-3 on page 2-10. For each setting, verify that the power meter's reading is within the limits shown.

Table 2-3: Instrument Accuracy Results (For Indication Only)

Range Calibrator Setting	Min ¹	Channel A Actual Results	Channel B Actual Results (Agilent E4419 B only)	Max ¹
3 μ W	3.100 μ W	_____	_____	3.230 μ W
10 μ W	9.900 μ W	_____	_____	10.10 μ W
30 μ W	31.40 μ W	_____	_____	31.80 μ W
100 μ W	99.50 μ W	_____	_____	100.5 μ W
300 μ W	314.00 μ W	_____	_____	318.00 μ W
1 mW	0.995 mW	_____	_____	1.005 mW
3 mW	3.141 mW	_____	_____	3.171 mW
10 mW	9.984 mW	_____	_____	10.08 mW
30 mW	31.63 mW	_____	_____	31.94 mW
100 mW	100.9 mW	_____	_____	101.8 mW

1. These performance limits are determined by the zero set specification of the power sensor used in the measurement plus the measurement noise.

Note The nominal outputs for the 3 μ W, 30 μ W, 300 μ W, 3 mW, 10 mW, 30 mW and, 100 mW settings are 3.16 μ W, 31.6 μ W, 316 μ W, 3.156 mW, 10.03 mW, 31.78 mW, and 101.3 mW respectively.

Note It is not necessary to check instrument accuracy in dBm. The power meter uses the same internal circuitry to measure power and mathematically converts watts to dBm.

Test Procedure 2

Note

This test procedure makes use of a 11683A Range Calibrator fitted with option H01. The measurement uncertainty of this test procedure is significantly lower than the previously described method (refer to Appendix A for a description of the measurement uncertainty analysis). As such, this test procedure should be used to ensure the power meter meets its published specification.

Equipment

- Range Calibrator: Agilent 11683A Option H01
- Power Sensor Cable: Agilent 11730A
- DC Range Calibrator: Datron 4000A

Test Setup

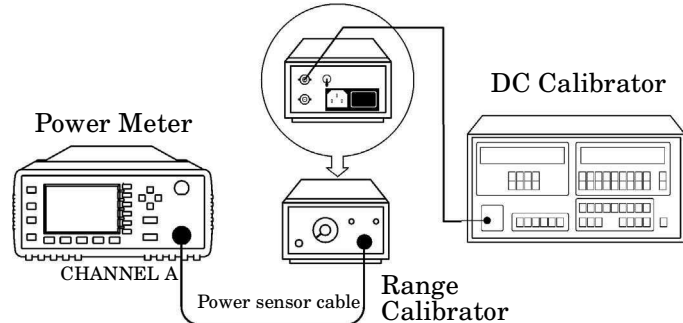

Figure 2-3: Instrument Accuracy (Average Path) Test Setup

Procedure

The following procedure should be performed for the Instrument Accuracy Test.



Note

The procedure details the key presses required on the Agilent E4418B. For the Agilent E4419B the equivalent key presses should be performed on both channels.

1. Connect the equipment as shown in Figure 2-3.
 2. Unplug the range calibrator's power cord. Due to a ground loop design problem with the 11683A option H01 range calibrator, it will not operate properly unless ground loops are eliminated. The instrument will continue to operate with no power applied, and disconnecting the power cord eliminates the problem.
-

WARNING

There is a small risk of mild electrical shock from the chassis of the 11683A option H01 range calibrator unless the power meter is connected.

3. Figure 2-3 shows the HI/LO outputs of the DC calibrator connected to the DC reference input of the range calibrator. Ensure that the Guard and LO output of the DC calibrator are floating, and are not connected to the earth ground.
4. Switch the power meter on.
5. Press  then **Confirm**.
6. Press , **W** for a reading in watts.
7. Press  on the power meter, and set the **Resolution** value to 4.
8. Set the range calibrator as follows:
 - RANGE: 100 mW
 - POLARITY: NORMAL
 - FUNCTION: STANDBY
 - REF SWITCH: EXT
 - LINE: OFF

Note

When switching the range calibrator to STANDBY, allow enough time for the range calibrator to settle to its zero value before attempting to zero the power meter. This settling would appear on the power meter display as downward drift. When the drift has reached minimum, (typically less than 60 seconds), the range calibrator is settled.

9. Set the DC calibrator as follows:
 - SET VALUE: 0 (ZERO)
 - FUNCTION: DC
 - OUTPUT: OFF
10. On the power meter press **System Inputs**, **Input Settings**, **More**, **Filter**, **Filter On**, **Mode Man**, **Length**, and set the filter length to 512 in the pop up window then press **Enter**.
11. On the power meter press **Zero Cal**, **Zero**. Wait approximately 10 seconds for the wait symbol to disappear. Verify that the display reads $0 \pm 0.05 \mu\text{W}$.
12. Set the DC calibrator output to 144.93mV, and set the output switch to '+'.
13. Press **Cal** to calibrate the power meter.

Performance Tests
Instrument Accuracy Test

14. Set the DC calibrator output to the values shown in Table 2-4. For each setting, set the filter length of the power meter to the corresponding value, and verify that the power meter reading is within the limits shown. Refer to step 10 for details on how to setup the filter length

Table 2-4: Instrument Accuracy Results

DC Calibrator Setting	Effective Power Applied	Power Meter Filter Setting	Meas Unc	Lower Limit	Ch A Result	Ch B Result	Upper Limit
458.31uV	3.1623 uW	256	0.028 uW	3.0977uW			3.2269uW
1.4493mV	10uW	256	0.027 uW	9.904 uW			10.096uW
4.5831mV	31.6228uW	256	0.027 uW	31.428uW			31.819uW
14.493mV	100uW	64	0.073 uW	99.49uW			100.51uW
45.831mV	316.2278uW	64	0.104 uW	314.72uW			317.74uW
144.93mV	1mW	16	0.2 uW	0.9954mW			1.0047mW
459.12mV	3.1623mW	16	0.9 uW	3.1477mW			3.1769mW
1.4588V	10mW	16	1.6 uW	9.954mW			10.046mW
4.6872V	31.6228mW	16	4.8 uW	31.477mW			31.769mW
15.588V	100mW	16	18.5 uW	99.54mW			100.46mW

Note

The test limits shown in this table do not take into account the corresponding measurement uncertainty values.

Power Reference Level Test

Electrical Characteristics	Performance Limits	Conditions
Power reference	1 mW	Internal 50 MHz oscillator factory set to $\pm 0.4\%$ traceable to National Physical Laboratory (NPL), UK.
Power reference accuracy setting	$\pm 0.1\%$	Guardbanded Test Line Limits.
Power reference accuracy after 2 years	$\pm 0.5\%$ ($23 \pm 3^\circ\text{C}$)	Worst case power meter accuracy, taking into account the possibility of oscillator drift and operation at 55 degrees.

Description

This test verifies the power level accuracy of the internal 50 MHz oscillator—also called the power reference oscillator. The power reference oscillator output is factory adjusted to 1 mW $\pm 0.4\%$. This accuracy includes a performance limit of 0.1% and a system measurement uncertainty figure of 0.3% (traceable to the National Physical Laboratory (NPL), UK). Refer to Appendix B for the measurement uncertainty of the system.

Note

The setting of the oscillator output accuracy is determined from the system measurement uncertainty plus any chosen test line limit.

For example, if a test line limit of 1 mW $\pm 0.2\%$ was chosen while maintaining a system measurement uncertainty of $\pm 0.3\%$, the overall accuracy of the test setup for the 1 mW power output becomes $0.3\% + 0.2\%$, giving a setting accuracy of 0.5%.

If an equivalent measurement system is employed for post-factory test, the power reference oscillator output can again be set to 1 mW $\pm 0.4\%$. This setting is sufficient to ensure that the power reference oscillator meets the accuracy specification of $\pm 0.5\%$ after 2 years. This specification includes the $\pm 0.4\%$ setting and also takes into account other factors that will contribute to determining the accuracy after 2 years. The complete breakdown of the $\pm 0.5\%$ specification is as follows:

- Test line limit: 0.1%.
- System uncertainty: 0.3%.
- 2 year oscillator drift: 0.04%.
- Delta environment: $<0.06\%$.

The same equipment used to measure the accuracy of the power reference oscillator can also be used to set it to the post-factory accuracy of $\pm 0.4\%$ (for further information refer to chapter 3, Adjustments).

The following procedure ensures maximum accuracy in measuring power reference oscillator output using Agilent test instruments of known capability. Signal acquisition criteria may vary if alternative test instruments are used. In such cases refer to the manufacturer's guidelines for further information.

The test is performed using Equation 2-4:

Equation 2-4: Power Level Provided By The Reference Oscillator

$$P_{\text{meas}} = \frac{2V_{\text{comp}}(V_1 - V_0) + V_0^2 - V_1^2}{4R(\text{CalibrationFactor})}$$

The components of this equation are defined as follows:

- V_0 is the voltage measured between V_{comp} and V_{RF} with no power applied and after the Agilent 432A has been zeroed.
- V_1 is the voltage measured between V_{comp} and V_{RF} with power applied. This power is approximately 1 mW.
- V_{comp} is the voltage between the Agilent 432A V_{comp} connector and chassis ground with power applied.
- R is the resistance of the mount resistor in the Agilent 432A power meter. For further information refer to Appendix A.
- Calibration Factor is the value of the thermistor mount at 50 MHz

Equipment

- Test power meter: Agilent 432A.
- Thermistor mount: Agilent 478A option H75 or H76.
- Digital voltmeter (DVM): Agilent 3458A.

Test Setup

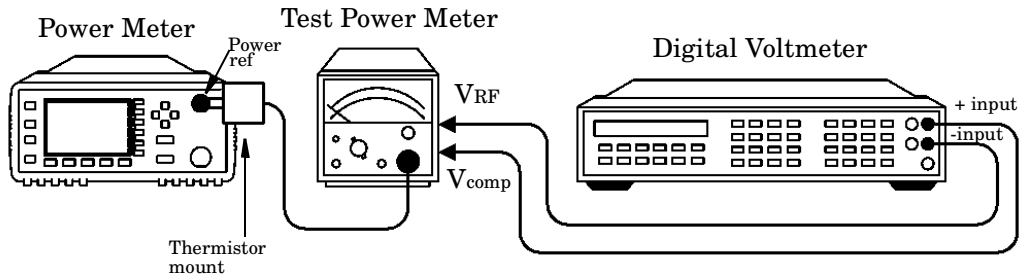

Figure 2-4: Power Reference Level Test Setup

Procedure

Use the following procedure to perform the power reference level test:

Note

The procedure details the key presses required on the Agilent E4418B. For the Agilent E4419B the equivalent key presses should be performed on both channels.

1. Set the DVM to measure resistance:
Connect the DVM between the V_{RF} connector on the rear panel of the Agilent 432A and pin 1 on the thermistor mount end of the sensor cable. Verify that no power is applied to the Agilent 432A.
2. Round off the DVM reading to two decimal places and note this value as the internal bridge resistance (R) of the Agilent 432A (approximately 200 Ω).
 - R _____ Ω
3. Connect the equipment as shown in Figure 2-4, ensuring that the DVM input leads are isolated from chassis ground.

Note

Ensure that the Agilent 432A and the power meter under test have been powered on for at least 30 minutes before moving to step 4.

Performance Tests
Power Reference Level Test

4. Preset the power meter:
 Press , then **Confirm** on the power meter.
 Set the Agilent 432A RANGE switch to Coarse Zero. Adjust the front panel Coarse Zero control to obtain a zero meter indication.
5. Zero the Agilent 432A test power meter:
 - Fine zero the Agilent 432A on the most sensitive range.
 - Set the RANGE switch to 1 mW.
6. Set the DVM to measure microvolts.
7. Connect the positive and negative input leads to the V_{comp} and V_{RF} connectors respectively, on the rear panel of the test power meter.
8. Observe the reading on the DVM. If less than 400 μV , proceed to the next step. If 400 μV or greater, press and hold the test power meter Fine Zero switch and adjust the Coarse Zero control so that the DVM indicates 200 μV or less. Release the Fine Zero switch and proceed to the next step.
9. Round the DVM reading to two decimal places.
 Record this reading as V_0 .
 - V_0 _____
10. Turn the power reference on:
 Press , **Power Ref Or.**
11. Round the DVM reading to two decimal places.
 Record this reading as V_1 .
 - V_1 _____
12. Disconnect the DVM negative input lead from the V_{RF} connector on the Agilent 432A. Reconnect it to the Agilent 432A chassis ground.
13. Observe the DVM reading. Record the reading as V_{comp} .
 - V_{comp} _____
14. Calculate the Power Reference Oscillator power using equation 2-4.
15. Verify that P_{meas} is within the limits shown in Table 2-5 and record the reading in the table.

Table 2-5: Power Reference Level Test Result

Min	Max	Actual Result
0.999 mW	1.001 mW	_____

Agilent E-Series Power Sensor Interface Test

The Agilent E-series power sensors have their sensor calibration tables stored in EEPROM which enables the frequency and calibration factor data to be downloaded automatically by the power meter. The frequency and calibration factor data have checksums which are compared with the data downloaded by the power meter. For the Agilent E4419B dual channel power meter, this test should be performed on both channels.

Procedure

1. When there is no power sensor connected to the Channel A input the message “No Sensor” (“No Sensor ChA” on the Agilent E4419B) appears on the measurement window.
2. Connect the Agilent E-series power sensor to the power meter’s Channel A input. The message “Reading Sensor ChA” appears. When all the data is downloaded this message disappears and a reading is displayed on the measurement window. If the download fails, a warning message and error flag are displayed on the front panel. Also, SCPI error message “-310, System Error” is generated.
3. For the Agilent E4419B repeat these steps for Channel B.

Agilent E-Series Power Sensor Functional Test

Description

This test verifies that the meter/sensor combination can make RF measurements.

The Agilent E-series power sensors operate over a 90 dB dynamic range (-70 to +20 dBm). However, since there is an amplifier in these power sensors, the voltages presented to the power sensor connector are always within the range of voltages available from the Agilent 11683A range calibrator.

Equipment

Power Sensor Cable..... Agilent 11730A
Reference Attenuator Agilent 11708A
Agilent E-series power sensor

Procedure

To complete the Functional Test the following procedure should be performed.

Note

The procedure details the key presses required on the Agilent E4418B. For the Agilent E4419B the equivalent key presses should be performed on both channels.

1. Connect the equipment as shown in Figure 2-5.

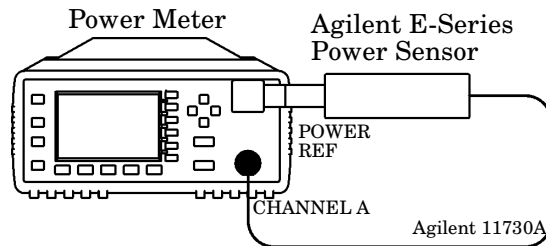

Figure 2-5: Sensor Functional Test Setup

2. Press **Preset** then **Confirm**.
3. On the power meter press **Zero Cal**, **Zero**. Wait approximately 10 seconds for the wait symbol to disappear. Verify that the display reads 0 ± 50 pW.
4. Press **Cal** to calibrate the power meter.
5. Turn the power reference on by pressing
 - **Zero Cal**, **Power Ref Off On** on the Agilent E4418B.
 - **Zero Cal**, **Cal**, **More**, **Power Ref Off On** on the Agilent E4419B.
6. Connect the 30 dB attenuator as shown in Figure 2-6.

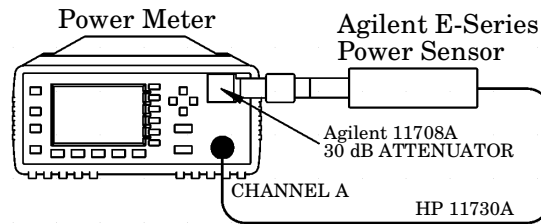

Figure 2-6: Sensor Functional Test Setup with Attenuator

7. Press **System Inputs**, **Input Settings**, and select **Range** to “LOWER”. This switches to the power sensor’s low range.
8. Verify that the display reads -30 dBm ± 1 dB. Record the reading.
9. Press **Range** and set to “UPPER”. This switches to the power sensor’s upper range.
10. Verify that the display reads -30 dBm ± 1 dB. Record the reading.
11. Press **Range** and set to “LOWER”.
12. Disconnect the 30 dB attenuator and reconnect as shown in Figure 2-5.
13. Verify that an overload error is displayed on the status line at the top of the power meter’s display.
14. Press **Range** and set to “UPPER”.
15. Verify that the display reads 0 dBm ± 1 dB. Record the reading.

Table 2-6: Functional Test Result

Test	Channel A Overload Error	Channel B Overload Error (Agilent E4419B Only)
Low Range, 30 dB pad		
Upper Range, 30 dB pad		
Low Range, no pad		
High Range, no pad		

Performance Test Record

Model Agilent E4418B/E4419B Power Meter

Tested by _____

Serial Number _____

Date _____

Table 2-7: Performance Test Record

Test	Min Result	Channel A Actual Result	Channel B Actual Result	Max Result
Zero Test	-76.40 nW			+76.40 nW
Instrument Accuracy				
3.1623 μ W	3.0977 μ W	_____	_____	3.2269 μ W
10 μ W	9.904 μ W	_____	_____	10.096 μ W
31.6228 μ W	31.428 μ W	_____	_____	31.819 μ W
100 μ W	99.49 μ W	_____	_____	100.51 μ W
316.227 μ W	314.72 μ W	_____	_____	317.74 μ W
1 mW	0.9954 mW	_____	_____	1.0047 mW
3.1623 mW	3.1477 mW	_____	_____	3.1769 mW
10 mW	9.954 mW	_____	_____	10.046 mW
31.6228 mW	31.477 mW	_____	_____	31.769 mW
100 mW	99.54 mW	_____	_____	100.46 mW
Power Reference				
P_{meas}	0.999 mW	_____	_____	1.001 mW
Interface Test	Pass/Fail	_____	_____	Pass/Fail
Functional Test				
Low Range, 30 dBm pad	Pass/Fail	_____	_____	Pass/Fail
Low Range, 30 dBm pad	Pass/Fail	_____	_____	Pass/Fail
Low Range, no pad	Pass/Fail	_____	_____	Pass/Fail
Upper Range, no pad	Pass/Fail	_____	_____	Pass/Fail

Performance Tests
Performance Test Record

Test	Min Result	Channel A Actual Result	Channel B Actual Result	Max Result
Output Standing Wave Ratio Test¹	N/A	_____	_____	1.06 ^{1, 2} 1.08 ^{1, 3}

1. This test is not channel related.
2. For instruments with the 50MHz 1mW output (power ref) connector mounted on the front panel.
3. For instruments with the 50MHz 1mW output (power ref) connector mounted on the rear panel. This applies to models E4416A and E4417A with option 003 fitted.

3

———— **Adjustments**

Introduction

This chapter describes adjustments and checks which ensure proper performance of the power meter. Adjustments are not normally required on any fixed periodic basis, and normally are performed only after a performance test has indicated that some parameters are out of specification. Performance tests should be completed after any repairs that may have altered the characteristics of the power meter. The test results will make it possible to determine if adjustments are required. Allow 30 minutes for the power meter to warm up, and then remove the cover, for access to the test and adjustment points.

To determine which performance tests and adjustments to perform after a repair, see “Post-Repair Adjustments”, on page 3-3.

Safety Considerations

This warning must be followed for your protection and to avoid damage to the equipment being used.

WARNING

Adjustments described in this chapter are performed with power applied to the instrument and with protective covers removed. Maintenance should be performed only by trained personnel who are aware of the hazards involved. When the maintenance procedure can be performed without power, the power should be removed.

Equipment Required

The adjustment procedures include a list of recommended test equipment. The test equipment is also identified on the test setup diagrams.

Post-Repair Adjustments

Table 3-1 lists the adjustments related to repairs or replacement of any of the assemblies.

Table 3-1: Post Repair Adjustments, Tests, and Checks

Assembly Replaced	Related Adjustments, Performance Tests or Self Tests
A1 Power Supply	Self Test.
A2 Processor Assembly	Frequency and Level Adjustments, Power Reference Level Test, Display Brightness and Contrast Adjustment.
A3 Front Panel Assembly	Instrument Accuracy Test, Display Brightness and Contrast Adjustment.
A4 Comms Assembly	All automated Tests and Serial Interface Self Test.
A5 Daughter Assembly	Instrument Accuracy Test.
A6 Measurement Assembly	Zero Test, Instrument Accuracy Test.
W1 or W2 Power Sensor Cable	Instrument Accuracy Test, Zero Test.
BT1 Lithium Battery	Battery Self Test.
Power Reference Cable Kits	Power Reference Level Test.

Power Reference Oscillator Frequency Adjustment

Note

Adjustment of the power reference oscillator frequency may also affect the output level of the oscillator. Therefore, after the frequency is adjusted to 50.0 ± 0.5 MHz, the output level should be checked as described in “Power Reference Oscillator Level Adjustment”, on page 3-6.
The power reference oscillator frequency is a nominal specification.

Description

Variable inductor A2L9 is adjusted to set the power reference oscillator output frequency to 50.0 ± 0.5 MHz. This frequency is a supplemental characteristic.

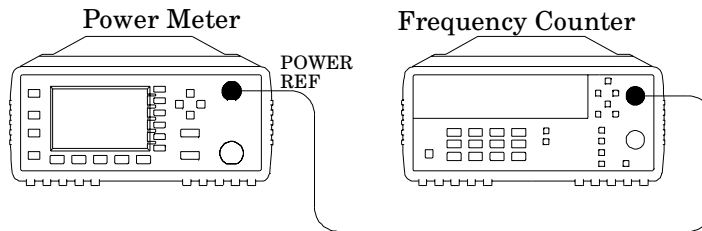

Figure 3-1: Adjustment Setup

Equipment

Frequency Counter..... Agilent 53132A

Procedure

1. Ensure that the power meter has been powered on for at least 30 minutes before making any measurements.
2. Connect the equipment as shown in Figure 3-1. Set up the counter to measure frequency.

3. Turn the power reference on by pressing
 - **Zero Cal**, Power Ref Off On on the Agilent E4418B.
 - **Zero Cal**, Cal, **More**, Power Ref Off On on the Agilent E4419B.
4. Observe the reading on the frequency counter. If it is 50.0 ± 0.5 MHz, no adjustment of the power reference oscillator frequency is necessary. If it is not within these limits, adjust the power reference oscillator frequency as described in step 5 and step 6.
5. Remove the power meter cover.
6. Adjust A2L9 to obtain a 50.0 ± 0.5 MHz indication on the frequency counter. Refer to Figure 3-2 for the position of A2L9.

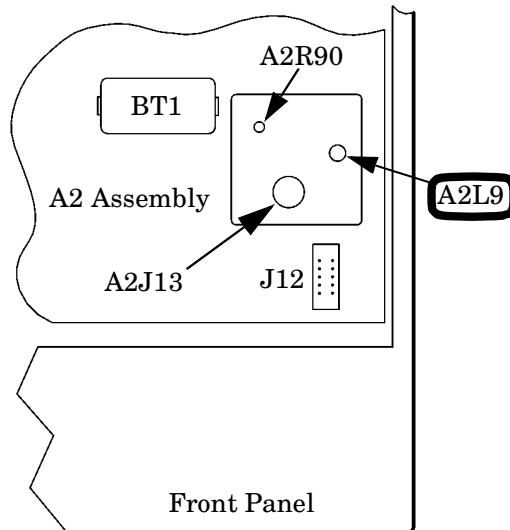

Figure 3-2: A2L9 Adjustment Location

Power Reference Oscillator Level Adjustment

Description

This test adjusts the power level accuracy of the internal 50 MHz oscillator—also called the power reference oscillator.

The power reference oscillator output is factory adjusted to 1 mW $\pm 0.4\%$. This accuracy includes a performance limit of 0.1% and a system measurement uncertainty figure of 0.3% (traceable to the National Physical Laboratory (NPL), UK).

Note

The setting of the oscillator output accuracy is determined from the system measurement uncertainty plus any chosen test line limit. For example, if a test line limit of 1 mW $\pm 0.2\%$ was chosen while maintaining a system measurement uncertainty of $\pm 0.3\%$, the overall accuracy of the test setup for the 1 mW power output becomes 0.3% + 0.2%, giving a setting accuracy of 0.5%.

If an equivalent measurement system is employed for post-factory test, the power reference oscillator output can again be set to 1 mW $\pm 0.4\%$. This setting is sufficient to ensure that the power reference oscillator meets the accuracy specification of $\pm 0.5\%$ after 2 years. This specification includes the $\pm 0.4\%$ setting and also takes into account other factors that will contribute to determining the accuracy after 2 years. The complete breakdown of the $\pm 0.5\%$ specification is as follows:

- Test line limit: 0.1%.
- System uncertainty: 0.3%.
- 2 year oscillator drift: 0.04%.
- Delta environment: <0.06%.

The following adjustment procedure ensure the power reference oscillator meets the post-factory accuracy setting of $\pm 0.4\%$.

Note

To ensure maximum accuracy in re-adjusting the power reference oscillator output, this procedure provides step-by-step instructions for using Agilent test instruments of known capability. Signal acquisition criteria may vary if alternative test instruments are used. In such cases refer to the manufacturer's guidelines for further information.

Note The power meter may be returned to the nearest Agilent Technologies office to have the power reference oscillator checked and/or adjusted.

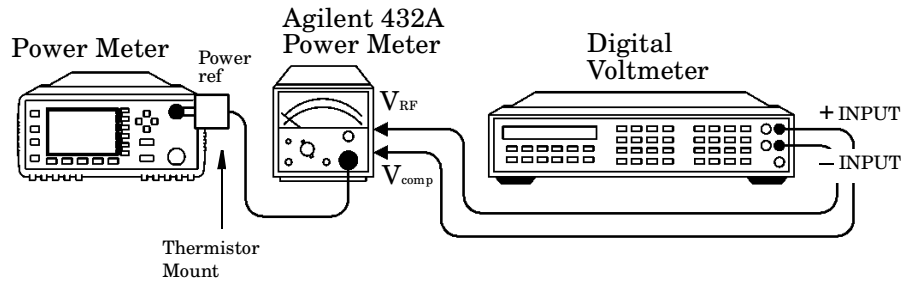

Figure 3-3: Adjustment Setup

For this adjustment the following mathematical assumptions are made:

Equation 1:

$$P_{\text{meas}} = \frac{2V_{\text{comp}}(V_1 - V_0) + V_0^2 - V_1^2}{4R(\text{CalibrationFactor})}$$

can be manipulated to give the following:

Equation 2:

$$V_1 = V_{\text{comp}} + V_0 - \sqrt{V_{\text{comp}}^2 - (10)^{-3}(4R)(\text{CalibrationFactor})}$$

by using the following assumptions:

$$V_0^2 - V_1^2 = -(V_1 - V_0)^2$$

The error in doing this is:

$$-(V_1^2 + V_0^2 - 2V_1V_0) - (V_0^2 - V_1^2) = -2V_0^2 + 2V_1V_0 = 2V_0(V_1 - V_0)$$

So if $2V_0(V_1 - V_0) \ll 2V_{\text{comp}}(V_1 - V_0)$, that is, $V_0 \ll V_{\text{comp}}$ then the error can be ignored. In practice $V_{\text{comp}} \sim 4\text{Volts}$ and $V_0 < 400\mu\text{V}$. The error is less than 0.01%.

Power Reference Oscillator Level Adjustment

By substituting equation 3 into equation 1 and manipulating the result you get:

$$0 = (V_1 - V_0)^2 - 2V_{\text{comp}}(V_1 - V_0) + 4(10^{-3})R(\text{CalibrationFactor})$$

This quadratic can be solved to give equation 2.

The definitions of the terms in equation 2 are:

- V_0 is the voltage measured between V_{comp} and V_{RF} with no power applied and after the Agilent 432A has been zeroed.
- V_1 is the voltage measured between V_{comp} and V_{RF} with power applied. This power is approximately 1 mW.
- V_{comp} is the voltage between the Agilent 432A V_{comp} connector and chassis ground with power applied.
- R is the resistance of the mount resistor in the Agilent 432A power meter.
- Calibration Factor is the value of the thermistor mount at 50 MHz.

Equipment

- Test power meter: Agilent 432A.
- Thermistor Mount: Agilent 478A Option H75 or H76.
- Digital Voltmeter (DVM): Agilent 3458A.

Procedure**Note**

The procedure details the key presses required on the Agilent E4418B. For the Agilent E4419B the equivalent key presses should be performed on both channels.

1. Set up the DVM to measure resistance. Connect the DVM between the V_{RF} connector on the rear panel of the Agilent 432A and pin 1 on the thermistor mount end of the sensor cable. Verify that no power is applied to the Agilent 478A
2. Round off the DVM reading to two decimal places and record this value as the internal bridge resistance (R) of the test power meter (approximately 200 Ω).
 - R (Internal Bridge Resistance) _____ Ω

3. Connect the equipment as shown in Figure 3-3. The leads should be isolated from ground. Ensure that the power reference oscillator is off. Ensure that both the power meter under test and the Agilent 432A have been powered on for at least 30 minutes before proceeding to the next step.
4. Set the Agilent 432A range switch to coarse zero and adjust the front panel coarse zero control to obtain a zero meter indication.
5. Fine zero the Agilent 432A on the most sensitive range, then set the range switch to 1 mW.

Note

Ensure that the DVM input leads are isolated from chassis ground when performing the next step.

6. Set up the DVM to measure microvolts.
7. Connect the positive and negative input leads, respectively, to the V_{comp} and V_{RF} connectors on the rear panel of the Agilent 432A.
8. Observe the reading on the DVM. If less than 400 μV , proceed with the next step. If 400 μV or greater, press and hold the Agilent 432A fine zero switch and adjust the coarse zero control so that the DVM indicates 200 μV or less. Then release the fine zero switch and proceed to the next step.
 9. Round off the DVM reading to the nearest microvolt and record this value as V_0 .
 - V_0 _____ μV
 - Disconnect the DVM negative input lead from the V_{RF} connector on the test power meter and reconnect it to chassis ground.
 10. Turn the power reference on by pressing
 -  Power Ref On
11. Record the reading on the DVM to two decimal places. This is V_{comp} .
 - V_{comp} _____ V
12. Reconnect the negative lead to the V_{RF} connector on the rear panel of the Agilent 432A. The DVM is now set up to measure V_1 which represents the power reference oscillator output level.
13. Calculate the required value of V_1 using equation 2.

$$V_1 = V_{comp} + V_0 - \sqrt{V_{comp}^2 - (10)^{-3} (4R)(\text{CalibrationFactor})}$$

Adjustments
Power Reference Oscillator Level Adjustment

14. Remove the power meter's cover and adjust A2R90 until the DVM indicates the calculated value of V_1 . Refer to Figure 3-4 for the position of A2R90:

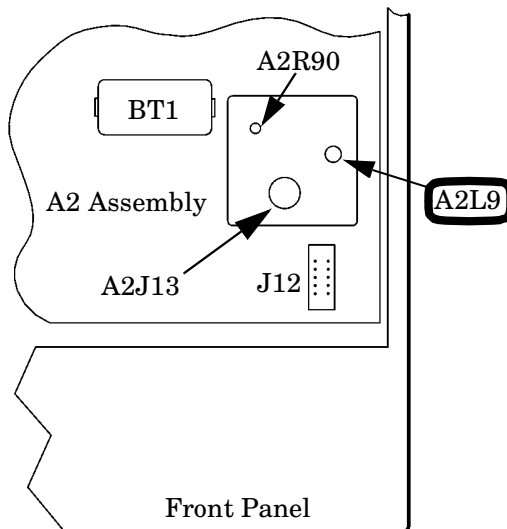

Figure 3-4: A2R90 Adjustment Location

Measurement Uncertainty

Refer to Appendix B “Measurement Uncertainty Analysis – Power Reference Level Test”

Display Brightness and Contrast Adjustment



Introduction

The following procedure should be performed whenever a front panel assembly or processor assembly are replaced.

The brightness is controlled automatically after executing the `Set Brightness` softkey, located under the `Service` softkey menu.

Note The contrast adjustment is subjective and varies according to individual user requirements.

Procedure

1. Access the `Display` softkey menu and use the  softkey to increase the contrast, or the  softkey to decrease the contrast of the display.
2. When the desired display contrast level is obtained, press the `Set Contrast` softkey, located under the `Service` softkey menu.

Adjustments
Display Brightness and Contrast Adjustment

4

———— Theory of Operation

Introduction

This chapter describes how each of the power meter's assemblies operate. A block diagram is included at the end of the chapter giving you an overall view of the power meter's operation.

A1 Power Supply/Battery Charger

The A1 power supply/battery charger is a 20 W, 47 to 440 Hz switching power supply producing three dc voltages, (+5 V, +12 V, -12 V) used to power the subassemblies, and a constant current supply to recharge the optional +12 V rechargeable Battery Module (Agilent Part Number E9287A) when operating from an ac power source. The power supply can be driven either by AC power voltages in the range 85 to 264 V or by the A8 Rechargeable Battery Module.

The signal line Power_on, from the A2 processor assembly to the A1 power supply assembly, indicates the status of the front panel POWER switch. This signal line enables and disables the dc voltage outputs of the power supply assembly to the A2 processor assembly when driven by the A8 battery assembly. The charging current for the rechargeable battery module is independent of the state of the Power_on line.

A logic low on the Power_on line indicates that the front panel POWER switch is in standby mode and the three dc voltage outputs from the power supply are disabled. A logic high on this line indicates that the POWER switch is in the On mode and the three dc voltages from the power supply are enabled. Power is distributed to the meter subassemblies via the processor assembly (See “A2 Processor Assembly”, on page 4-4).

If fitted, the A8 rechargeable battery module controls the charging current while ac power is connected to the meter. The fan assembly is active under the following conditions:

1. ac power connected and the POWER switch set to On.
or
2. ac power connected, POWER switch set to Standby and optional +12 V rechargeable battery module fitted.

The ac line fuse is located in the line input module on the power meter's rear panel (Agilent Part Number 2110-0957). The fuse holder contains a spare fuse as standard on shipment.

A2 Processor Assembly

The processor assembly contains the microcontroller and associated circuits, the power-on/ standby control and switching, the 1 mW reference calibrator, the recorder outputs, TTL input/output, and the front panel drivers. It provides that platform on which the power meter can run, facilitating the system inputs and outputs.

Regulated DC voltages at +12 V, -12 V and +5 V are converted by the A1 power supply assembly when AC power is connected to the rear panel or the optional rechargeable battery is fitted. The DC voltages are connected and distributed to the rest of the system by circuits on the processor assembly. When the  key on the front panel is pressed a bistable latch changes state. This, in turn, applies the correct gate voltages to turn on three MOSFET switches, which connects the power supply unit voltages to the distributed power buses. The bistable latch is connected to a permanent power-supply which has the backup of battery power when AC mains is removed from the power meter. The +12 V supply is used to power the fan. This is filtered to decouple it from the rest of the system. When the optional rechargeable battery is fitted and the meter is in standby and connected to the ac power supply, the rechargeable battery will recharge and the fan will be powered on.

The reference oscillator has a 50 MHz oscillator circuit with automatic level control (ALC). The oscillator output is level detected and that level is compared to a temperature stable precision reference voltage. This comparison produces an error signal that gives negative feedback control of the oscillator output power. The frequency and power level of the calibrator are factory set to provide a 50 MHz 1 mW transfer standard. The precision reference voltage and the ALC control signal are both measured in the calibrator self test. The calibrator is switched on or off using a signal from the microcontroller. The front panel LED indicator is switched with a separate microcontroller signal. The recorder outputs are driven from a dual 12 bit DAC which is driven by the microcontroller. The dual DAC outputs are buffered, filtered and scaled to give a 1 V full scale output nominal.

The recorder is a 12 bit DAC driven by the microcontroller. The DAC output is buffered, filtered and scaled to give a 1 V full scale output with a nominal 1 k Ω output impedance.

Circuitry for the keyboard driver includes some damage protection, but it is basically a direct connection from the keypad row and column matrix to the microcontroller's control lines.

The LCD controller on the A3 front panel assembly is configured as a memory mapped peripheral, and as such requires only to be fed with the appropriate address, data and control lines from the microcontroller circuits. The bias voltage for the LCD is produced by a DC to DC converter that takes the +5 V (DIST) voltage and converts that to a nominal +21 V. The DC to DC converter is adjusted by a combination of the contrast control signal from the microcontroller and the temperature sense voltage that is generated on the A3 front panel assembly. The temperature sense voltage helps to compensate for the normal variation of LCD contrast with temperature. Current to the LCD's LED backlight array is sourced from a constant current circuit that compensates for variation in LED knee voltage. A control input to this circuit from the front panel temperature sense voltage allows for de-rating of the maximum LED current at high operating temperatures. A control input from the microcontroller allows the optimum backlight brightness to be factory set. The temperature sense voltage, LED current and LCD bias voltage are all measured at self test.

An analog multiplexer provides means by which several diagnostic points can be switched to the A6 measurement assembly(s) for analogue to digital conversion. The microcontroller uses this function to perform self test.

A6 measurement assembly(s) to microcontroller communication is conducted on a serial interface bus, the Internal Serial Bus (ISB). The ISB is connected to the bi-directional serial port on the microcontroller via buffers. The system clock and some control signals are connected to the measurement modules. The measurement module interface is completed with the distribution of switched and direct power (+12 V, -12 V and +5 V).

The TTL outputs are connected to the A6 processor assembly via in line resistors located on the A4 interface assembly. A TTL logic level is output from the processor assembly when the user defined windows based limits are exceeded.

The TTL inputs are connected to the processor card via in line resistors located on the interface card and can be used to initiate zero and calibration cycles on the power meter.

The microcontroller circuits that control all the above functions, and provide platform for the system software to run on, comprise the microcontroller itself, memory, and clock and logic circuits. The logic circuits have the function of ensuring the correct sequencing and decoding of the control signals for the various peripherals. The crystal oscillator clock circuit is buffered and distributed to the A4 interface assembly and the A5 daughter assembly. The program memory for the microcontroller is FLASH EEPROM to allow for in-circuit programming. The static RAM is split into volatile and non-volatile blocks, with the power for the non-volatile RAM being connected to the permanent (battery backed) power supply.

Note

It is advisable to replace the RAM battery A2BT1 every three years. If the battery fails or drops below 3 V the RAM will lose the following information when power is disconnected from the meter:

- Unit Serial Number
- Revision letter of Processor Card
- Unit Option
- User defined setups
- User defined sensor calibration tables

A3 Front Panel Assembly

The front panel assembly is made up of a liquid crystal display (LCD), a keypad and, depending on the power meter option, a power reference cable assembly and a sensor cable assembly(s).

There are two inputs to the front panel assembly:

- the flex circuit from connector A2J4 of the processor assembly which controls the keypad.
- the ribbon cable from A2J3 of the processor assembly which controls the LCD display.

The power meter self tests contain display tests. These are accessed by pressing **System Inputs**, **More**, **Service**, **Self Test**, **Individual Display**.

A4 Comms Assembly

The comms assembly contains the circuitry required for remote control of the power meter. This assembly supports parallel and serial interfaces.

The GP-IB interface is supported by a protocol controller integrated circuit and two physical interface buffers. The system clock is divided by four to provide the GP-IB controller integrated circuit clock signal.

The RS232 and RS422 interface is supported by a single Universal Asynchronous Receiver/Transceiver (UART) integrated circuit and a programmable transceiver. The programmable transceiver can be configured for either RS232 or RS422. The remote interface is designated a DTE (Data Terminal Equipment).

The programmable baud rate generator in the UART is driven from the system clock (16.67 MHz) which allows baud rates in the range 50 to 115.2 K.

The whole assembly is connected to data, address, and control signals from the A2 processor assembly.

The comms assembly also provides a filtered path for the single/dual recorder output signal and the TTL input and output signals. It also provides ESD protection for the RS232.422, TTL I/O, and Recorder outputs.

A5 Daughter Assembly

The A5 daughter assembly is loaded vertically into the A2 processor assembly. The Agilent E4418B has five connectors on the A5 daughter assembly:

- two 6-way connectors route the signal lines between the rechargeable battery assembly and the A1 power supply/charger assembly, and provide an interface for the signal lines that are monitored by the A2 processor assembly.
- a 48-way connector provides the interface for the A2 processor assembly signals.
- a 36-way slotted post connector provides the interface for the A6 measurement assembly.
- a 2-way connector for production test only.

The Agilent E4419B has an additional 36-way slotted post connector.

A6 Measurement Assembly

There is one measurement assembly in the Agilent E4418B and two in the Agilent E4419B.

The measurement assembly amplifies and converts the chopped AC signal produced by the power sensor (either Agilent 8480 series power sensors or Agilent E-series power sensors) into a 32 bit digital word. This digital word is proportional to the input RF power level applied to the power sensor. The measurement assembly also measures the sensor resistor voltage to detect whether a power sensor is present. If a power sensor is connected it determines the model, and whether it's connected to the front or rear panel. This assembly produces the differential drive signal for the power sensor's chopper. When an Agilent E-series power sensor is present this assembly converts and corrects the power sensor's temperature dependent voltage.

With reference to the block diagram at the end of this chapter, the chopped AC input signal is amplified by the input amplifier. This operational amplifier in combination with a single bipolar transistor in the power sensor, produce a feedback amplifier which has a gain of approximately 500. The "Feedback" line shown sets the gain and also biases the transistor. The differential amplifier removes any common mode noise or interference. It uses a special ground wire ("Sensor Ground"), connected close to the RF bulkhead in the power sensor as it's second input.

The band pass filter represents the filtering action of the input amplifier. When the power meter is working with an Agilent E-series power sensor the equalizer is switched on to reduce the high pass cut off frequency of the input amplifier. This improves the settling time in fast mode operation.

The output of the equalizer is split into two paths. One path is amplified by a gain of 100. Both signals are each converted to digital words by the dual analog to digital converter (ADC). The ADC's sampling rate is set to a frequency 200 times above the chop rate for the Agilent 8480 series power sensors and 100 times above the chop rate for the Agilent E-series power sensors.

The Digital Signal Processor (DSP) converts the chopped signals into digital words proportional to the input level. It compares both levels, calibrates the gain and decides which level is output to the host processor (after additional filtering) via the "Internal Serial Bus".

The DSP chip controls the logic which sets the chopper driver voltage and frequency control. For the:

- Agilent 8480 series power sensors this is 0 V and -10 V at 217 Hz.
- Agilent E-series power sensors this is +7 V and -3 V at 434 Hz.

The DSP also controls logic to allow the AUX ADC to measure a number of voltages, and when requested, send the relevant data to the host processor. The AUX ADC digitizes a voltage which is produced by the Agilent E-series power sensors and is proportional to temperature. This voltage is required for temperature compensation. This AUX ADC also tests the sensor resistor wires to check sensor continuity. Lastly, use is made of this AUX ADC for the power meter's self test of both the measurement assembly and the A2 processor assembly. The results are reported back to the A2 processor assembly via the "Internal Serial Bus".

The Agilent E-series power sensors have built in serial EEPROM and range switching which is controlled or accessed via the measurement assembly. The "N-Chop" sensor wire used by the Agilent 8480 series power sensors doubles as a serial clock and the sensor resistor line doubles as a bi-directional serial data line. The "Auto Zero" line is also used as a serial bus enable control.

The wire labelled "Auto Zero" is grounded to the "Sensor Ground" line when an Agilent 8480 series power sensor is used. Autozeroing is accomplished without the need for this signal in the power meter.

All clocks are derived from the 16.67 MHz system clock which is generated on the A2 processor assembly and distributed on the A5 daughter assembly.

A8 Rechargeable Battery Assembly

The A8 Rechargeable Battery Assembly allows the EPM power meter with option 001 fitted to operate when no AC power input is available. The battery pack contains a health monitoring circuit which the A2 processor assembly can interrogate. The A8 battery assembly connects to the A2 processor assembly and the PSU/battery charger circuit via the A5 Daughter Assembly.

There are three connections from the rechargeable battery assembly to the A1 psu/charger assembly, +12V, 0V, and Signal 1. The Signal 1 line is an indicator line which signals when the battery is below a threshold limit. When this line goes low, indicating there is insufficient charge left in the Battery Assembly to continue operating the power meter, it will cause the A1 psu/charger assembly to shut down.

There is one connection, the communications line, from the A8 Battery Module to the A2 processor assembly. This line provides serial communications with the processor assembly on battery pack status information, such as amount of charge remaining. When there is less than 10 minutes run time charge remaining in the battery an error message "Battery Power Low" is displayed on the power meter front panel display.

The battery assembly can only be recharged when fitted to a power meter with the battery option fitted. The charge current from the charging circuit is controlled by a module contained within the Battery assembly. When the ac power is connected the battery assembly regulates the charging current based on the discharge state of the battery.

The battery should fully charge from empty within 2 hours. At 25 degrees C this will give the meter 2 hours operational time. The A8 Battery module has a lifetime of approximately 450 charge/discharge cycles after which the battery can still be used, but will only have approximately 70% of its original capacity. The battery capacity may be reduced whilst charging at temperatures above 35 degrees C.

Note:- partially discharging and recharging the battery module will reduce its lifetime. It is advised that periodically the battery assembly should have its charge fully cycled i.e. fully discharged and then fully recharged.

Remove this page and replace with pullout.fm.

5

———— **Replaceable Parts**

Introduction

This chapter contains details of some of the higher level components and assemblies which can be ordered from Agilent Technologies. It also details how to assemble and disassemble the power meter for repair.

To order parts contact your local Agilent Technologies Sales and Service Office.

To return your power meter for servicing at a qualified service center refer to “Contacting Agilent Technologies” in chapter 2 of the *User's Guide*.

Assembly Part Numbers

Reference Designator	Description	Agilent Part Number
A1	Power Supply Assembly Refer to “Power Supply Assembly Types”, on page 5-5 to help with the selection.	0950-2649 or 0950-3681
	Power Supply and Charger Assembly (Option 001)	0950-3681
A2	Processor Assembly Kit	
	New	E4418-60031
	Refurbished	E4418-69028
A301	Front Panel Assembly for: Agilent E4418B and Agilent E4418B Option 002	
	New	E4418-61030
	Refurbished	E4418-69030
A302	Front Panel Assembly for: Agilent E4418B Option 003	
	New	E4418-61031
	Refurbished	E4418-69031
A303	Front Panel Assembly for: Agilent E4419B and Agilent E4419B Option 002	
	New	E4419-61001
	Refurbished	E4419-69001

Replaceable Parts
Assembly Part Numbers

Reference Designator	Description	Agilent Part Number
A304	Front Panel Assembly for: Agilent E4419B Option 003	
	New	E4419-61002
	Refurbished	E4419-69002
A4	Comms Assembly	E4418-60012
A5	Daughter Assembly for: Agilent E4418B	E4418-60015
	Daughter Assembly for: Agilent E4419B	E4419-60003
A6	Measurement Assembly	E4418-60007
A7	Fan Assembly	E4418-61004
BT1	Lithium (RAM) Battery	1420-0338
BT2	Rechargeable Battery Opt 001	E9287A
MP1	Bail Handle	34401-45011
MP2	Front Bumper	34401-86011
MP3	Rear Bumper	34401-86012
MP4	Outer Cover for: Agilent E4418/9B Agilent E4418/9B Option 001	E4418-61027
		E4418-61016
MP5	Rear Bezel	E4418-20008
MP6	Instrument Chassis Assembly (Includes push-fit line module)	E4418-61025
MP6J1	Push-Fit Line Module	E4418-61002
Battery Module Cover		E4418-61019
W3	Recorder Output Cable Assy	E4418-61015
Sensor Cable Assembly Kit		E4418-61036

Reference Designator	Description	Agilent Part Number
	Front Power Reference Cable Kit	E4418-61811
	Rear Power Reference Cable Kit	E4418-61813

Power Supply Assembly Types

Before ordering an A1 Power Supply Assembly, check connector J2 and compare it to Figure 5-1 and Figure 5-2 and select the appropriate model. The J2 connector is found nearest the fan assembly.

Figure 5-1: 0950-2649 Power Supply Assembly

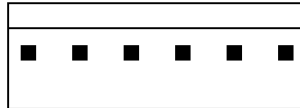
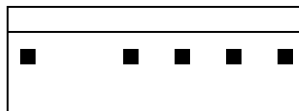

Figure 5-2: 0950-3681 Power Supply and Charger Assembly





Front Panel Connector Repair

The front panel assembly is an exchange assembly. However, if front panel sensor cables or power reference cables are faulty they should be replaced by ordering the appropriate kit and following the assembly/disassembly procedure. The instrument accuracy test should then be carried out to verify the functionality of the new part.

Firmware Upgrades

The power meter's firmware can be upgraded using a PC. The current firmware is available on the World Wide Web. A firmware upgrade package (Part Number E4418-61035) can be purchased for users who do not have access to the World Wide Web. The upgrade package contains instructions and a disc pack. The firmware can be upgraded via the GP-IB connector or the serial RS232/422 connector.

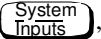
To determine the firmware version in your power meter, press:

- , , **Service**, **Version**.

Contact your local Service Center if you require a firmware upgrade. Refer to “Sales and Service Offices”, on page -ix for details of your local Service Center.

Downloading Firmware

Instrument Firmware should be downloaded after the processor board is replaced. Firmware can be accessed by Agilent Technologies Service Centers using the World Wide Web.

Assembly and Disassembly Guidelines

The guidelines in this section describe the removal and replacement of the major assemblies in the Agilent E4418B and Agilent E4419B power meters.

Once an assembly has been replaced, refer to “Post-Repair Adjustments”, on page 3-3 to ensure that the correct performance tests and adjustments are carried out.

WARNING

Refer to the safety symbols on the power meter and “Equipment Operation”, on page -v before operating this power meter with the cover removed. Failure to comply with the safety precautions can result in severe or fatal injury.

WARNING

Before carrying out any assembly or disassembly of the power meter ensure that you disconnect the power cord. Even with the power meter switched off there are potentially dangerous voltages present on the power supply assembly.

Removing the Power Meter Cover

Remove the optional battery if fitted before removing the cover.

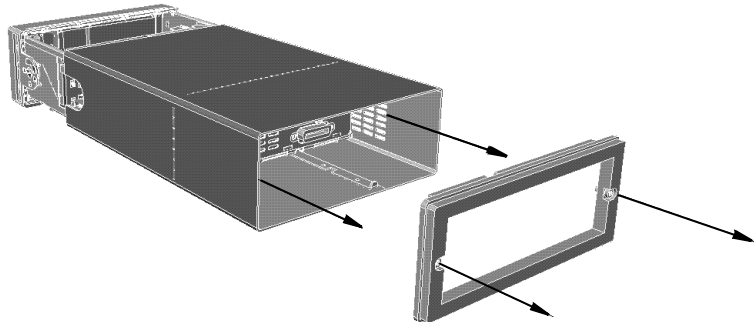

When replacing the power meter cover retighten the captive screws in the rear bezel using a 9 lb/in T15 screw driver.

Removing the A1 Power Supply Assembly

1. Remove the power supply cover by lifting it out.
2. Disconnect the line input module from the chassis and power supply assembly.
3. Disconnect the cable assembly from the power supply which connects to the A2 processor assembly.
4. Unscrew the power supply assembly and lift out the power supply. (When replacing these screws use a 9 lb/in T15 screw driver.)

WARNING

When replacing the power supply unit in the power meter ensure that all earth wiring is reconnected. There are two terminals to check:

The first is the force fit connector to the power supply unit itself. It is essential that the gap between the terminal and the adjacent large capacitor is maximized. Fit the connector so that its flat side faces towards the large capacitor.

The second, a closed loop terminal bonded to the chassis with an M3.5 machine screw (use a 9 lb/in T15 screw driver).

All the protective earth wiring can be identified by the insulation color green with a yellow stripe.

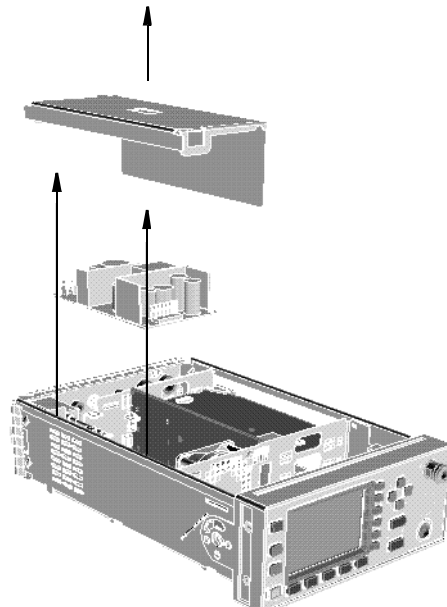

Removing the A2 Processor Assembly

1. Remove the A5 daughter and A6 measurement assemblies as described on page 5-12.
2. Move the A2 plastic support bracket to its forward position using the two side levers, unclip the flexi-cable retaining bar on the front panel keypad and front panel LCD cable connectors and disconnect the cable.
3. Disconnect the following cables from the A2 processor assembly:
 - n power reference semi-rigid
 - n fan connector
 - n power supply connector
4. Turn the power meter upside down and remove the three screws as shown. (When replacing these screws use a 6 lb/in T10 screw driver.)
5. Push the A2 processor assembly towards the front panel to release it from the 50-pin connector. Lift it upwards to remove.

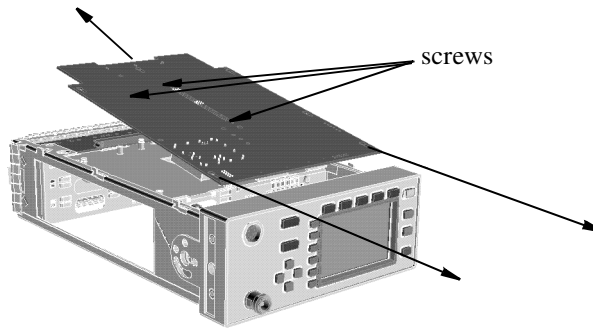

Note When re-assembling the processor board, ensure the A2 plastic support bracket is returned to its locked position.

Note After replacing a processor board, the Power Reference Frequency and Level must be checked. For further information refer to “Performance Tests”, on page 2-1.

Note After replacing a processor board, the display brightness and contrast must be adjusted. See “Adjustments”, on page 3-1.

Note Firmware should be downloaded to the instrument after the processor board is replaced. Refer to “Downloading Firmware”, on page 5-7.

Removing the A4 Comms Assembly

1. Remove the A2 processor, A5 daughter and A6 measurement assemblies as shown on page 5-10 and page 5-12.
2. Disconnect the line power module from the A1 power supply and the chassis.
3. Disconnect the earth wire screw. (When replacing this screw use a 9 lb/in T15 screw driver.)
4. Remove the two screws on the underside of the deck assembly. Remove the assembly by sliding forward and tilting up from the rear (when replacing these screws use a 21 lb/in T15 screw driver).

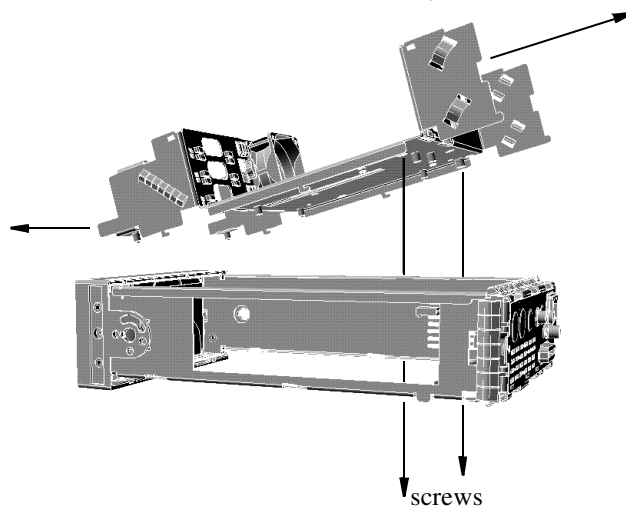

5. Unscrew the GP-IB and RS232/422 connectors from the rear panel. (When replacing these screws use a 6 lb/in 9/32 in socket.)
6. Disconnect the Recorder cable for channel A from J23 pins 1,2,3. Disconnect the Recorder cable for channel B from J23 pins 4,5,6.
7. Lift the A4 Comms assembly from the two standoffs and slide it out.

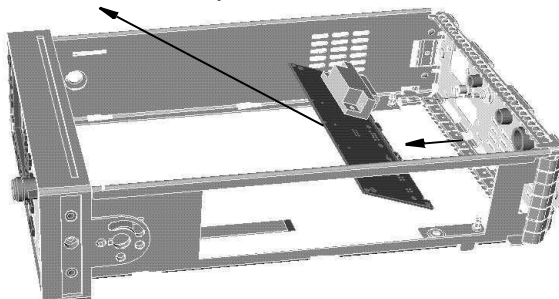

Removing the A5 Daughter or A6 Measurement Assemblies

1. Disconnect the flex circuit from measurement assembly.

Note

Care should be taken when disconnecting the flex circuit from the measurement assembly.

The flex circuit assembly is released by pushing the connector tab forward and lifting.

To replace the flex circuit, loop it as shown on page 5-17, and connect the flex circuit as shown in the figures below.

2. Slide out the measurement assembly from the side of the power meter.
3. The daughter assembly is removed vertically.

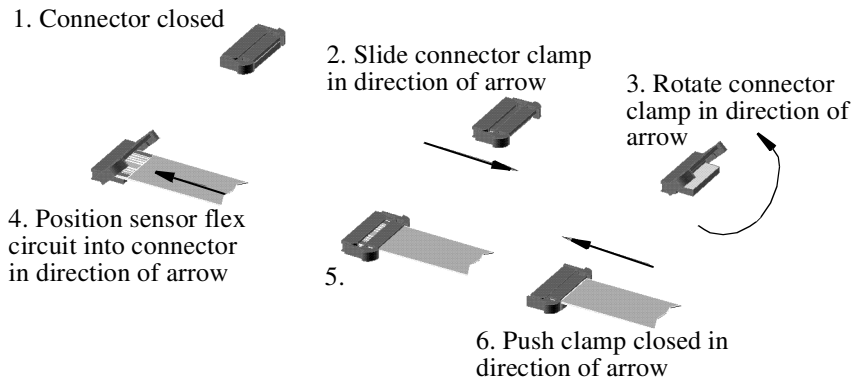
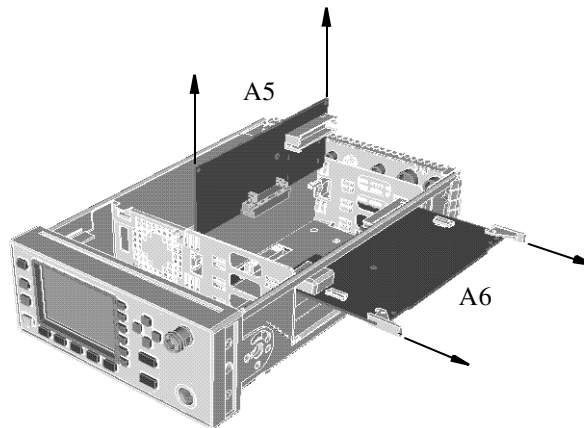

Removing the A7 Fan Assembly

1. Remove the A1 power supply assembly as shown on page 5-9.
2. Remove the pins which attach the fan to the chassis.
3. Remove the fan cable connector from the A2 processor assembly to release the fan.

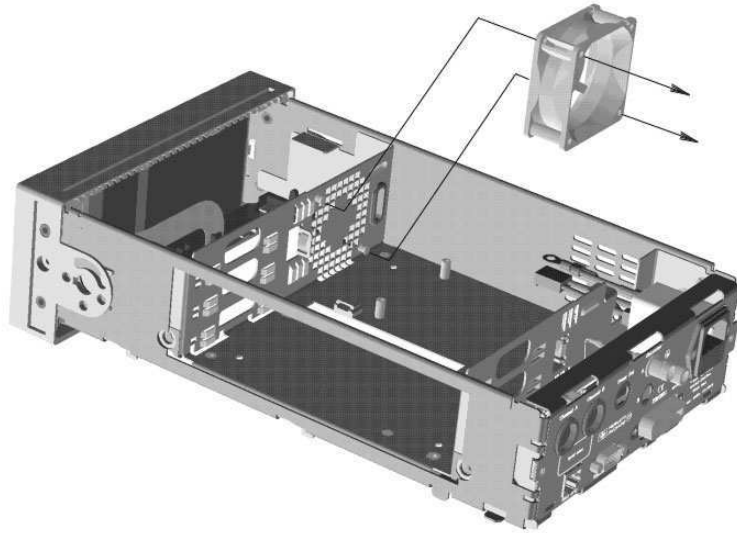

Removing the Power Meter RAM Battery (BT1)

1. Remove the A2 processor assembly as described on page 5-10.
2. Remove the A2J1 link to disconnect the battery from the rest of the circuitry.
3. Verify the battery protection circuitry by:
 - n ensuring that there are no electrical short circuits across the battery terminals.
 - n ensure that there are no voltages present which could apply a charging voltage.
4. Once the protection circuit has been verified remove the battery. The battery is siliconed to the assembly. It may be necessary to remove it using a scalpel.
5. Store the battery individually in an anti-static (dissipative) bag or suitable non-conductive packaging.
6. After replacing the battery secure it using a tie wrap. This should be secured from the top of the A2 processor assembly. The recommended tie wrap part number is 1400-1154.
7. Replace the A2J1 link.

WARNING

This power meter uses a lithium battery which may explode if mishandled. The battery should not be subjected to short circuit of the battery terminals or to excessive heat.

Do not recharge this battery or dispose of it by burning. Check local country regulatory requirements on the disposal of lithium batteries.

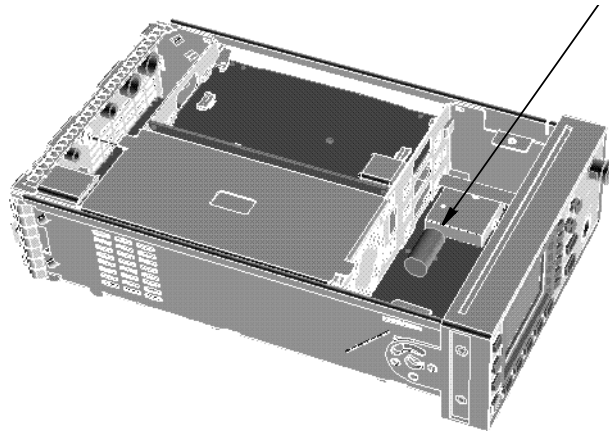

Removing the A3 Front Panel Assembly

1. Disconnect the following cables from the A2 processor assembly:
 - n power reference semi-rigid (When replacing use the torques detailed on page 5-18.)
 - n front panel keypad
 - n front panel LCD

Note

Care should be taken when disconnecting the front panel keyboard and LCD. Move the A2 plastic support bracket to its forward position using the two side levers, unclip the flexi-cable retaining bar on the front panel keypad and front panel LCD cable connectors and disconnect the cable.

2. Disconnect the flex circuit from the measurement assembly.

Note

Care should be taken when disconnecting the flex circuit from the measurement assembly.

The flex circuit assembly is released by pushing the connector tab forward and lifting.

To replace the flex circuit, loop it as shown on page 5-17, and connect the flex circuit as shown in the figures on page 5-12.

3. Remove the center screw from the right hand side of the front panel.
4. Remove the front panel by pressing in the metal tab on the front panel as shown and push down on the side of the chassis until the standoffs are cleared from the holes.

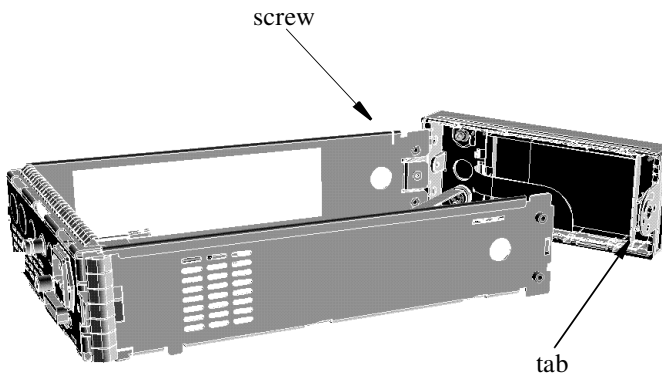

Note

After replacing a front panel assembly, the display brightness and contrast must be adjusted. Refer to Chapter 3 “Adjustments”.

Replacing the Front Panel Power Sensor Cable Assemblies

1. Remove the front panel from the power meter. (Refer to “Removing the A3 Front Panel Assembly”, on page 5-15 for details on removing the front panel.)
2. Replace the power sensor cable assembly(s) using the replacement kit.

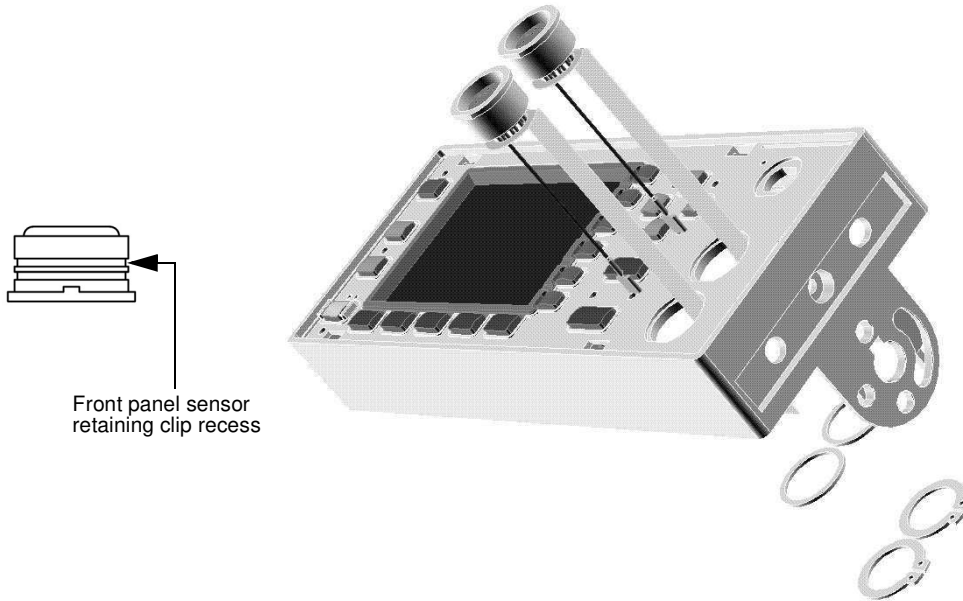

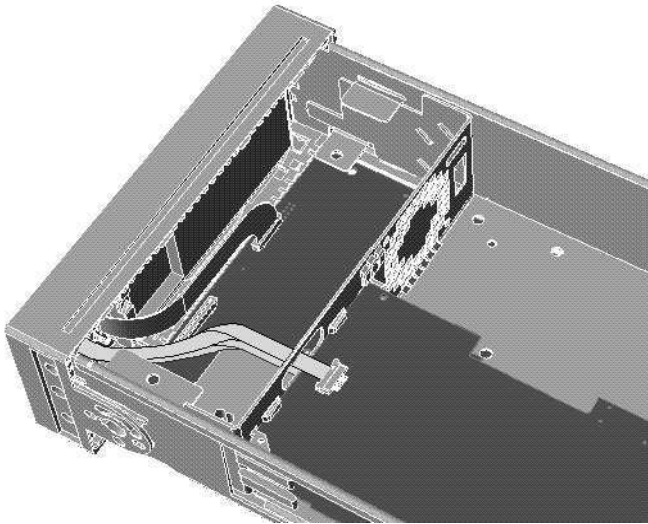
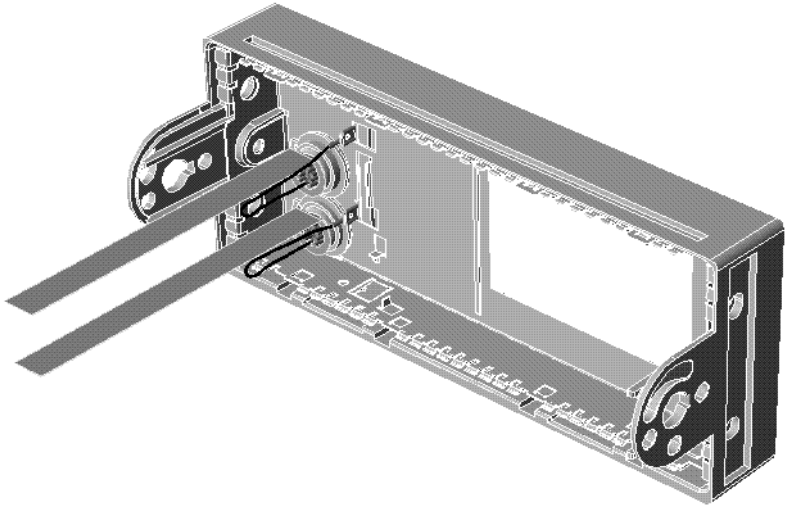

Replacing the Front Panel Power Reference Cable Assembly

1. Remove the front panel from the power meter. (Refer to “Removing the A3 Front Panel Assembly”, on page 5-15 for details on removing the front panel.)
2. Replace the power reference output cable assembly using the replacement kit and the torques indicated on the following diagrams.

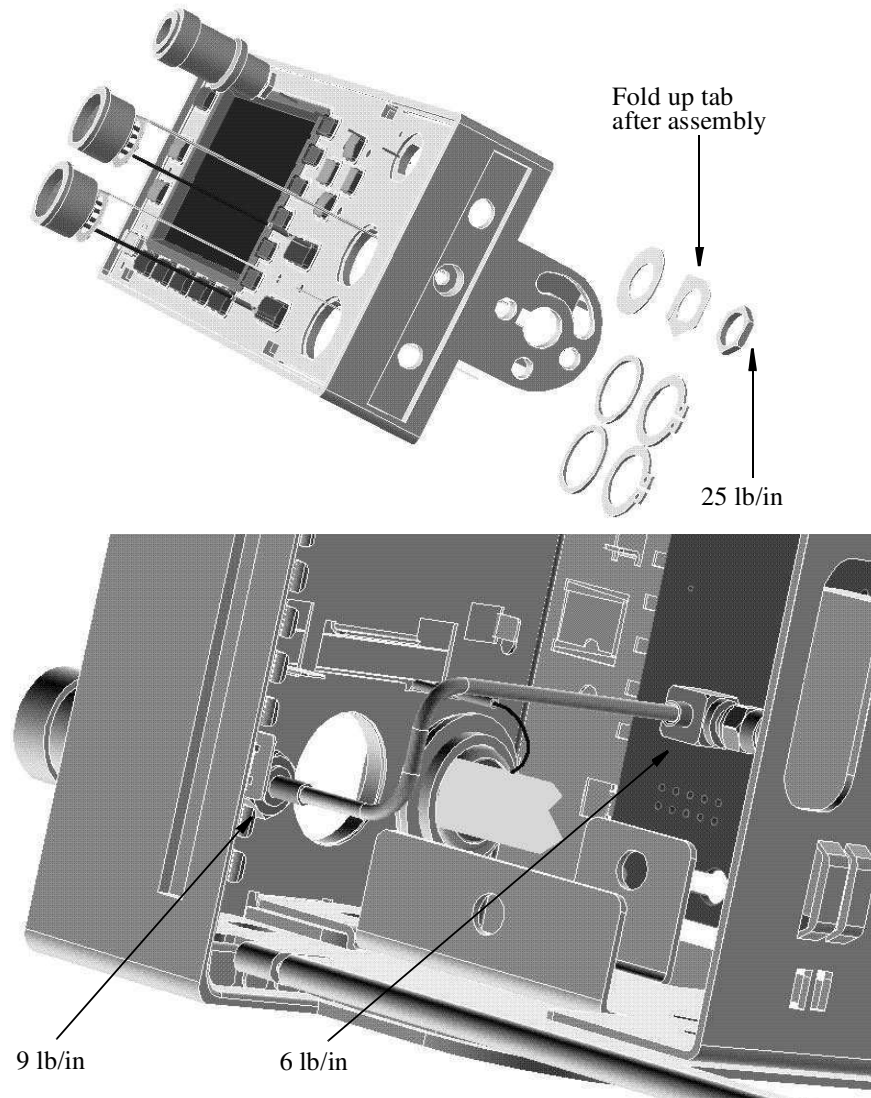

Replacing the Rear Panel Power Sensor Cable Assemblies (Options 002 and 003)

1. Disassemble the power meter to allow access to the rear panel connectors. This is done by following steps 1 through 3 of the A4 comms assembly removal procedure on page 5-11.
2. Replace the power sensor cable assembly(s) using the replacement kits. The inner recess on the power sensor cable is used to locate the circlip when assembling to the rear chassis.

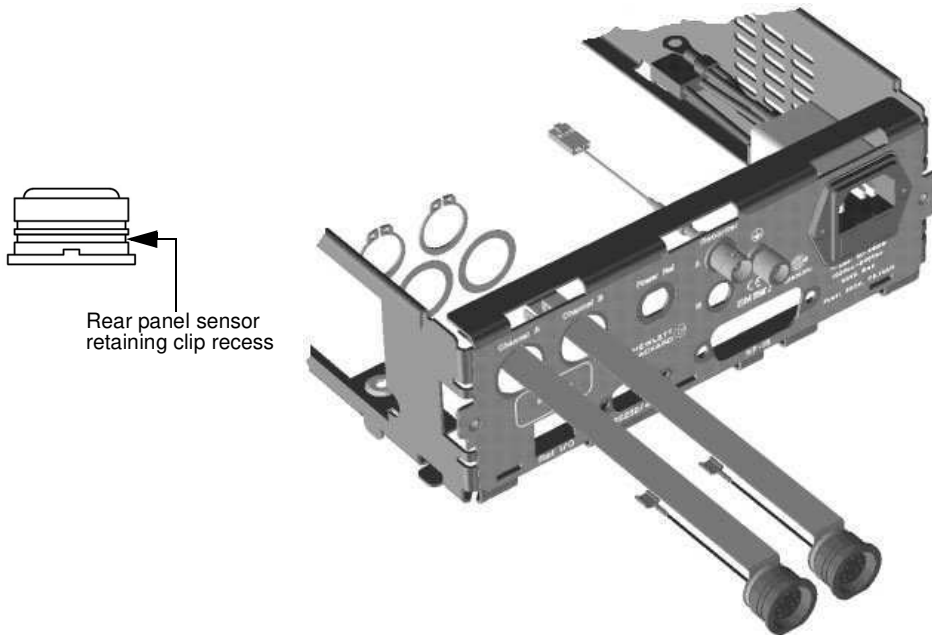

Replaceable Parts
Assembly and Disassembly Guidelines

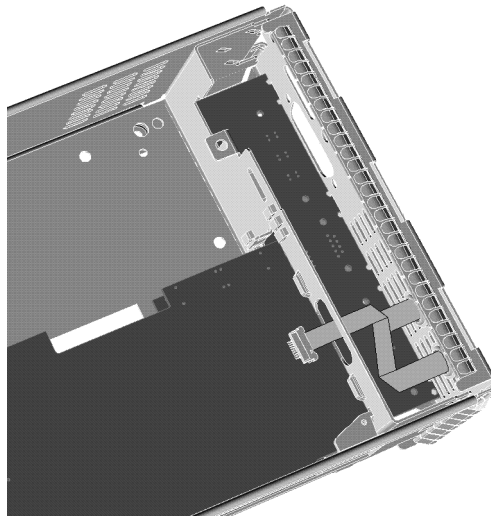
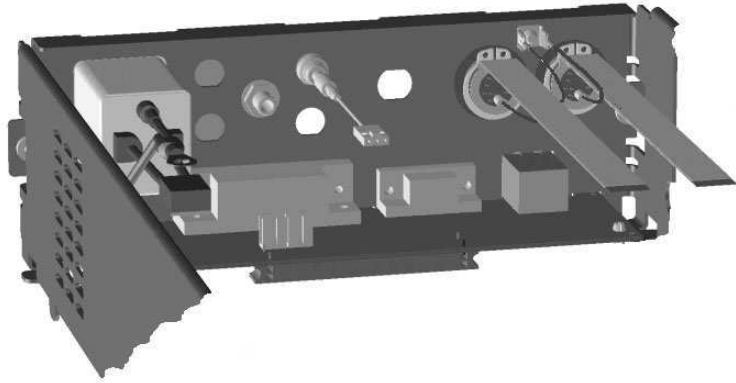

Replacing the Rear Panel Power Reference Cable Assembly (Option 003)

1. Disassemble the power meter down to allow access to the rear panel connectors. (Refer to “Removing the A4 Comms Assembly”, on page 5-11.)
2. Replace the power reference cable assembly using the replacement kit and the torques indicated on the following diagrams.

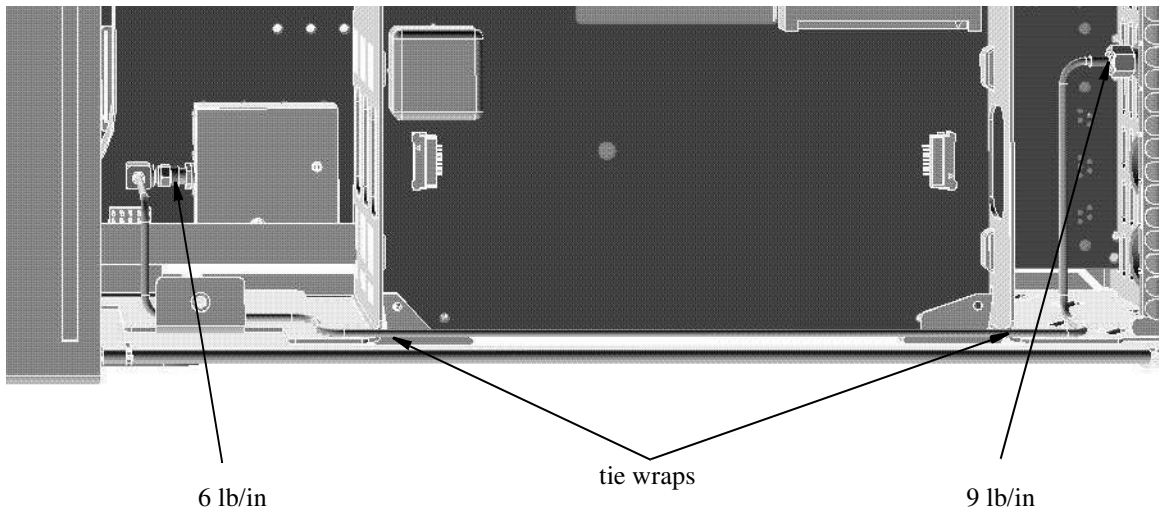
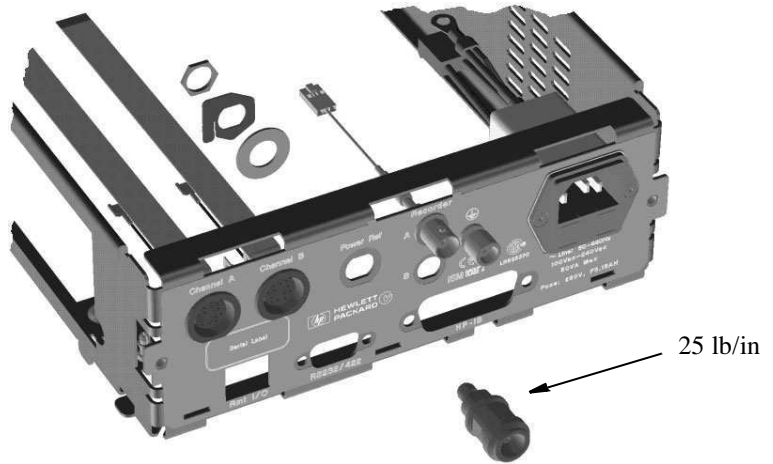

Replacing the Rear Panel Recorder Output(s) Cable Assembly

1. Disassemble the power meter down to allow access to the rear panel connectors. (Refer to “Removing the A4 Comms Assembly”, on page 5-11).
2. Replace the recorder output cable assembly using the replacement kit and the torque indicated on the following diagram.

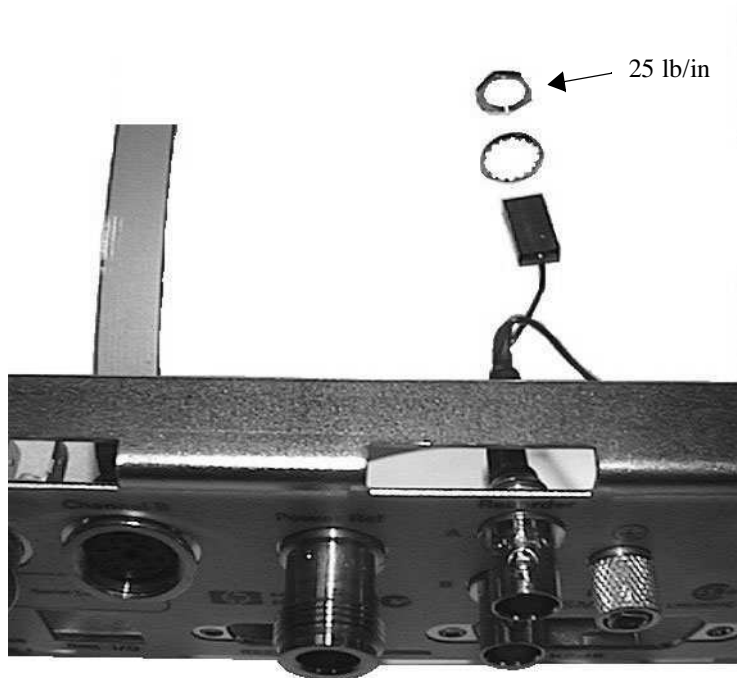

Note

Recorder output A connects to A4 J23 and recorder output B connects to A4 J24.

Replacing The Chassis Assembly

1. Remove the Power Meter Cover as shown in “Removing the Power Meter Cover”, on page 5-8.
2. Disassemble the power meter down to allow access to the rear panel connectors (Refer to “Removing the A4 Comms Assembly”, on page 5-11).
3. For Standard or Option #002 units, disconnect the Power Reference Cable from the Front Panel Assembly.
4. For Option #003 units, disconnect the Power Reference Cable from the Chassis Assembly (rear panel).
5. Remove the A3 Front Panel Assembly as shown in “Removing the A3 Front Panel Assembly”, on page 5-15.
6. For Option #002 or Option #003 units, remove the Rear Panel Power Sensor Cable Assemblies as shown in “Replacing the Rear Panel Power Sensor Cable Assemblies (Options 002 and 003)”, on page 5-19.
7. For Option #003 units, remove the Rear Panel Power Reference Connector as shown in “Replacing the Rear Panel Power Reference Cable Assembly (Option 003)”, on page 5-21.
8. Remove the Recorder Output(s) Cable Assembly as shown on page 5-21.
9. Remove all blanking plugs from the rear panel.
10. Obtain the new Chassis Assembly, and then re-assemble the Power Meter by following steps 1 to 9 in reverse order.

WARNING

When replacing the power supply unit in the power meter ensure that all earth wiring is reconnected. There are two terminals to check, the first is the force fit connector to the power supply unit itself and the second a closed loop terminal bonded to the chassis with an M3.5 machine screw (use a 9 lb/in T15 screw driver). All the protective earth wiring can be identified by the insulation color green with a yellow stripe.

WARNING

Once re-assembly is complete, the unit must be safety-tested in accordance with local guidelines & procedures. This safety-test may take the form of an Earth Continuity Test, Hi-Pot Test, etc.

Replaceable Parts
Assembly and Disassembly Guidelines

6

———— Troubleshooting

Introduction

This chapter enables qualified service personnel to diagnose suspected faults with the power meter Rmt I/O (Remote Input/Output) signal lines and RS232/422 serial port.

If there is a problem when attempting to use the RS232/422 serial interface or the remote I/O functions, consult the User's Guide and confirm that all the user setups are correct before proceeding with the following fault finding flow charts.

Suggested Diagnostic Equipment

1. Digital multi-meter capable of measuring voltage and resistance, for example, Agilent E4975.
2. Signal source capable of producing 300 ms TTL single shot pulses, for example, Agilent 33120A.
3. +5 V TTL logic level source.
4. RS232 self test connector - 9 way 'D' type female connector with the following pins wired together:
Pin 2 (Rx) to Pin 3 (Tx)
Pin 4 (DTR) to Pin 6 (DSR)
Pin 7 (RTS) to Pin 8 (CTS)
5. RS422 self test connector - 9 way 'D' type female connector with the following pins wired together:
Pin 1 (CTS-) to Pin 9 (RTS-)
Pin2 (Rx-) to Pin 4 (Tx-)
Pin 3 (Tx+) to Pin6 (Rx+)
Pin7 (RTS+) to Pin 8 (CTS+)
6. 8 way RJ45 plug with flying leads wired to pins 2, 3, 4, 5 and 6 to apply and monitor signals on the remote TTL I/O connector.
7. HP-IB controller and cable - required to apply "*RST" command through the rear panel GP-IB connector.

Note

In the following flowcharts a **bold** font indicates the label of a soft/hard key the user must select.

Figure 6-1: Troubleshooting Guide -Upper Window TTL Output

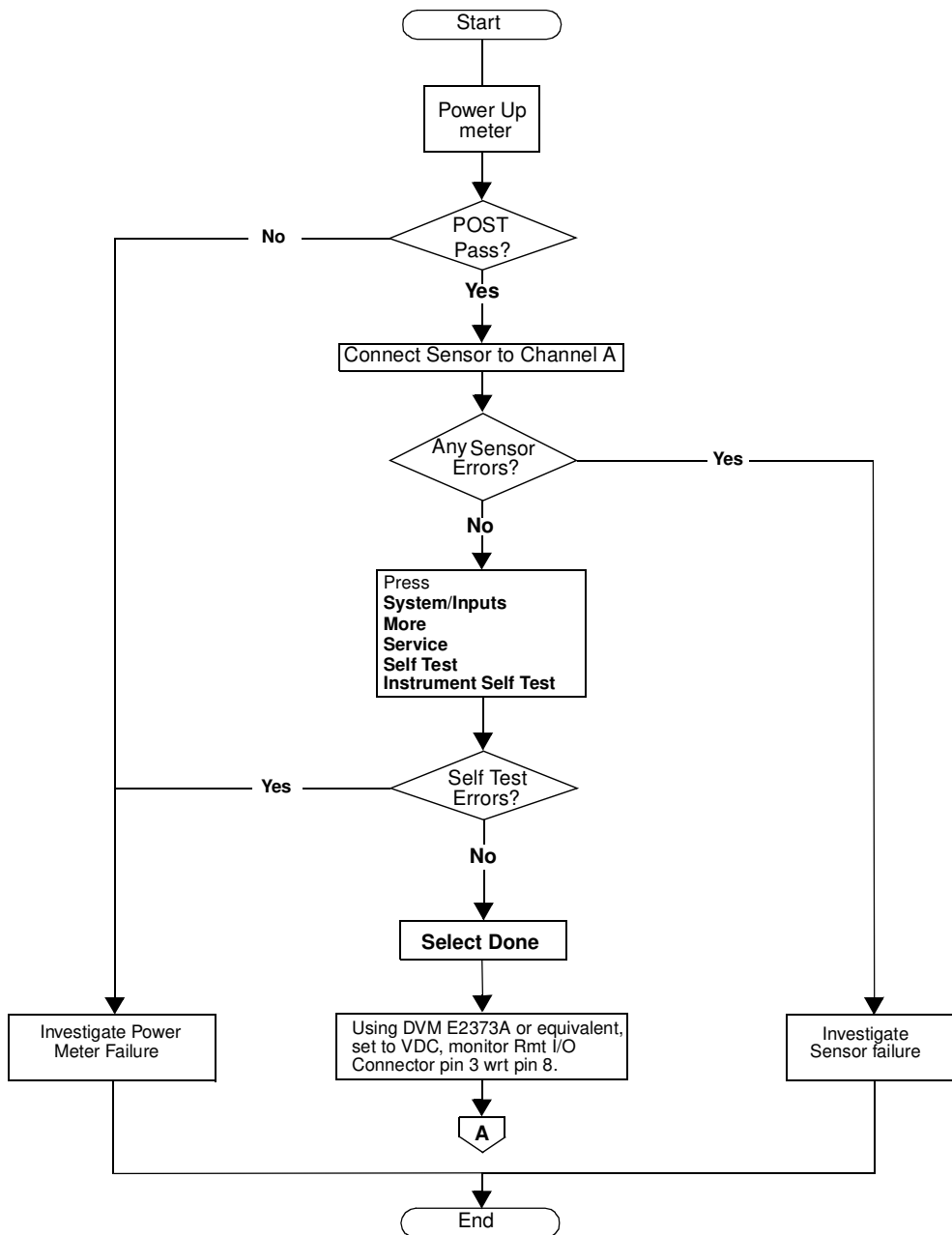

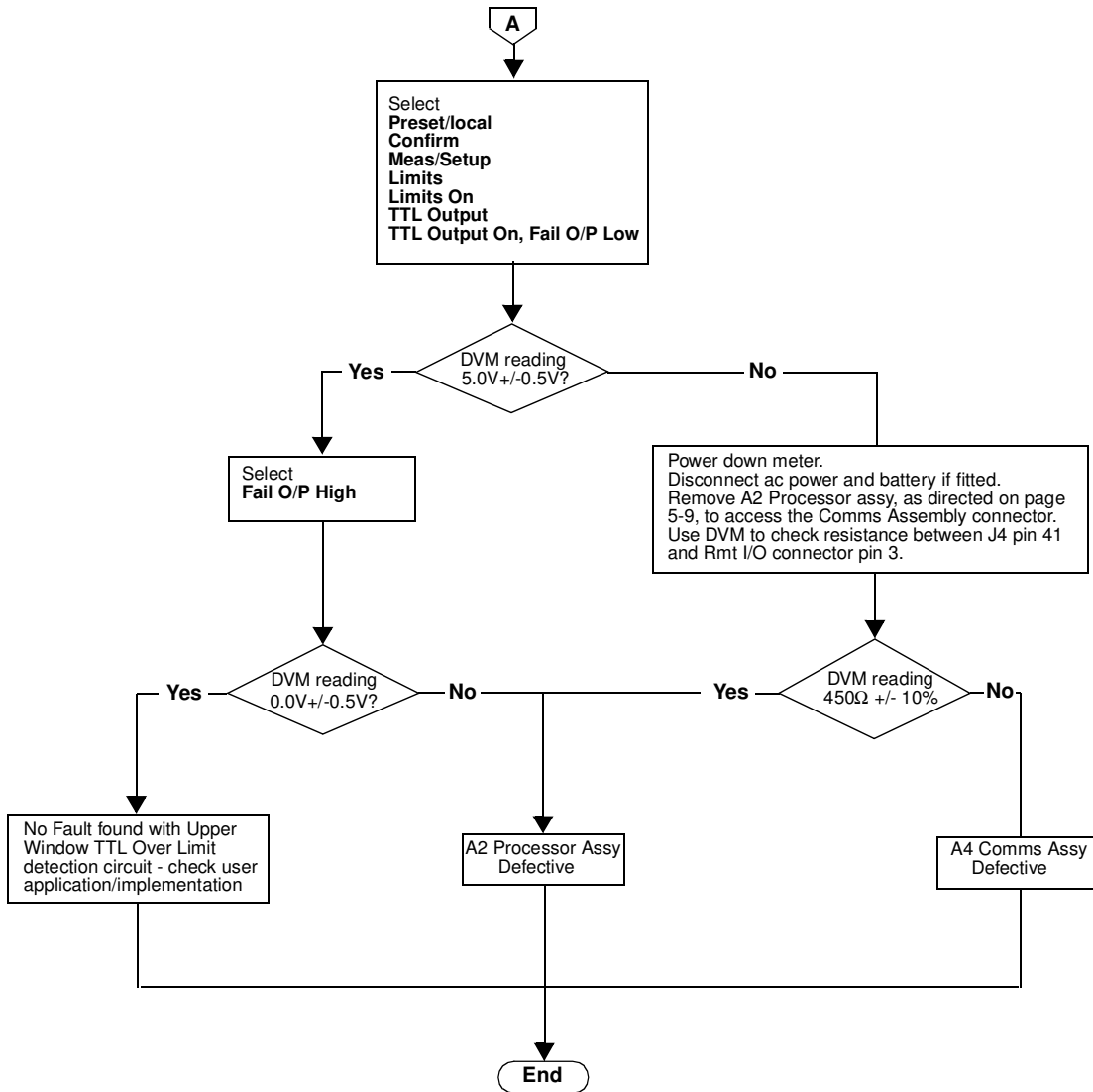
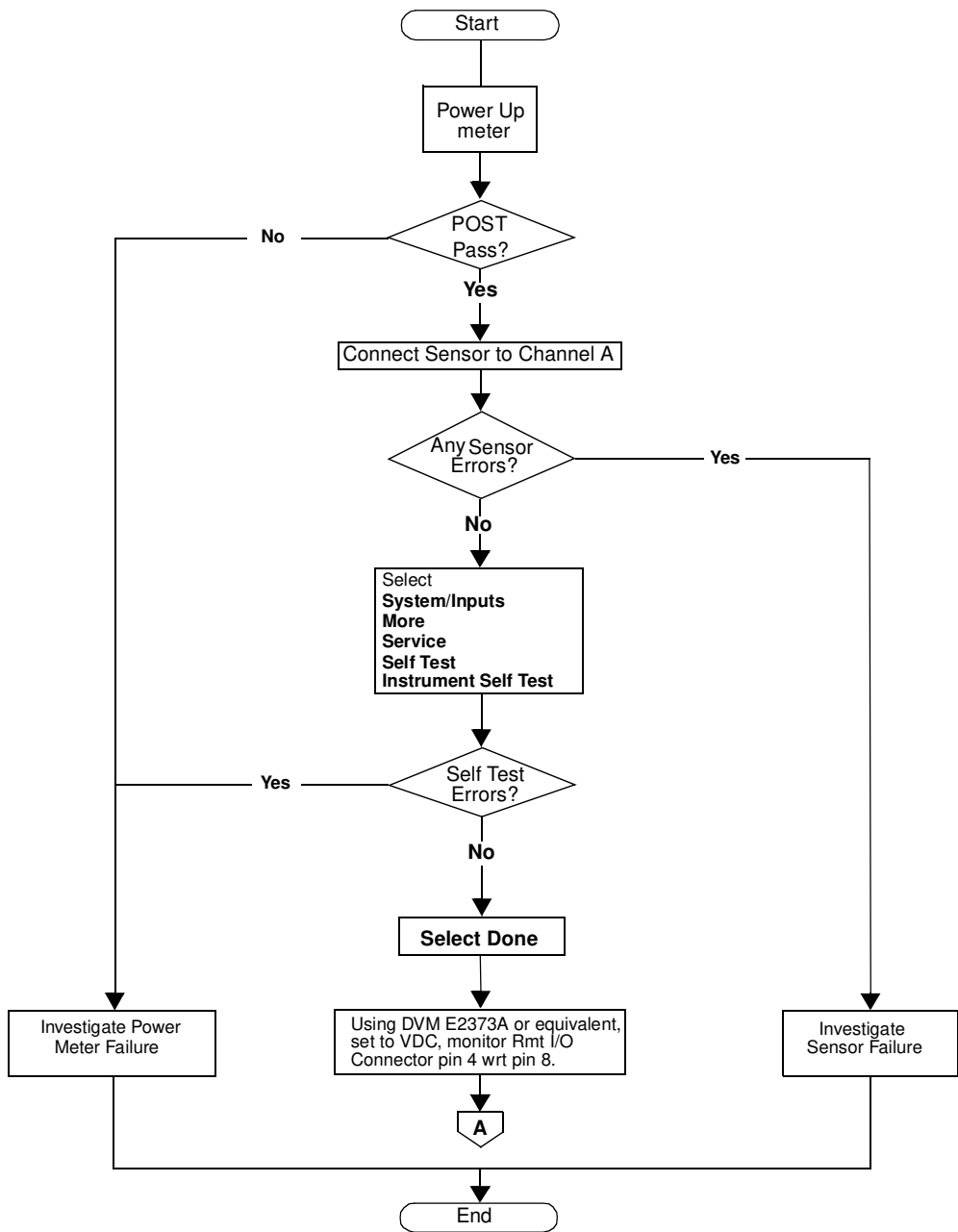

Figure 6-2: Troubleshooting Guide - Lower Window TTL Output



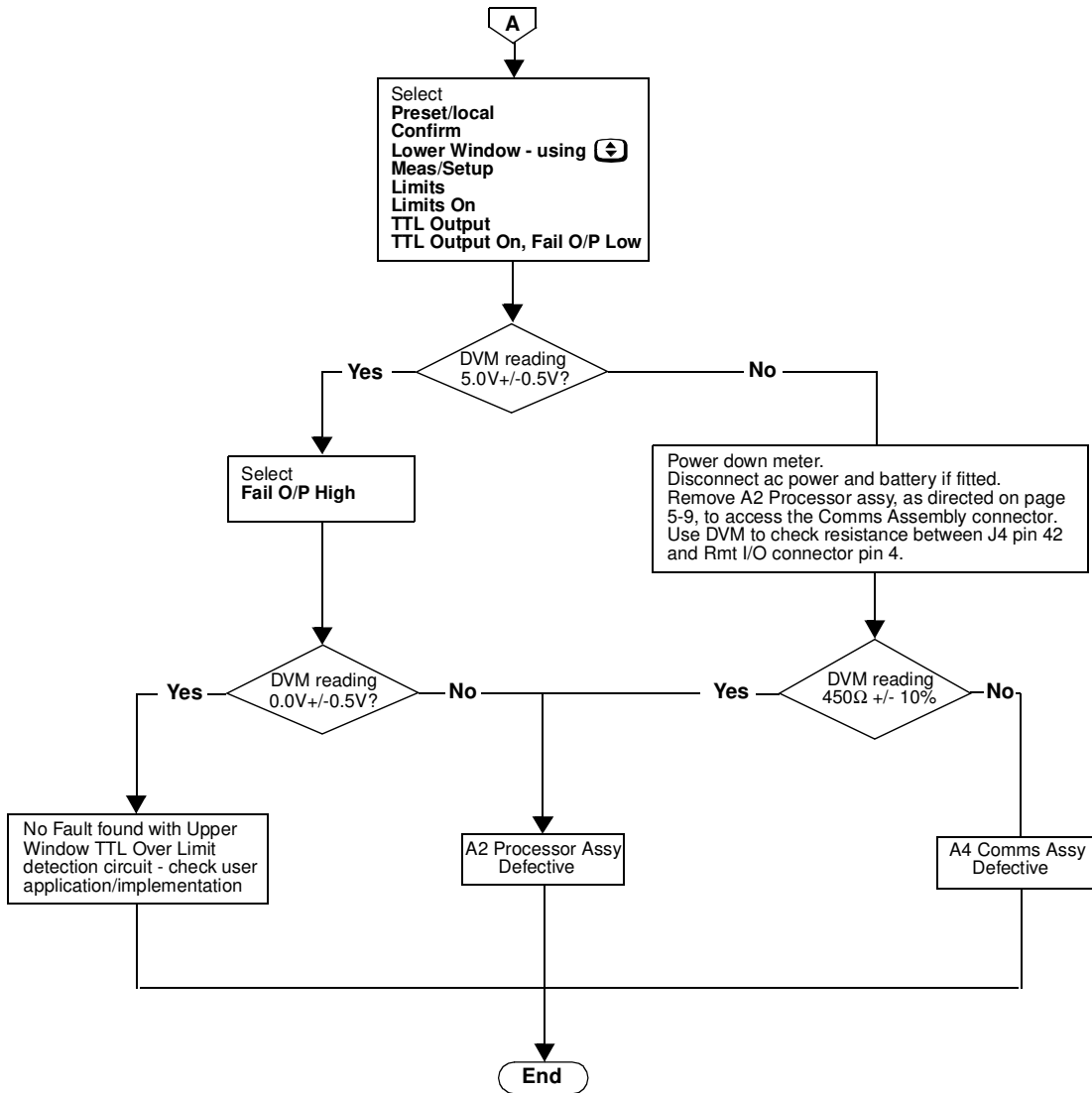
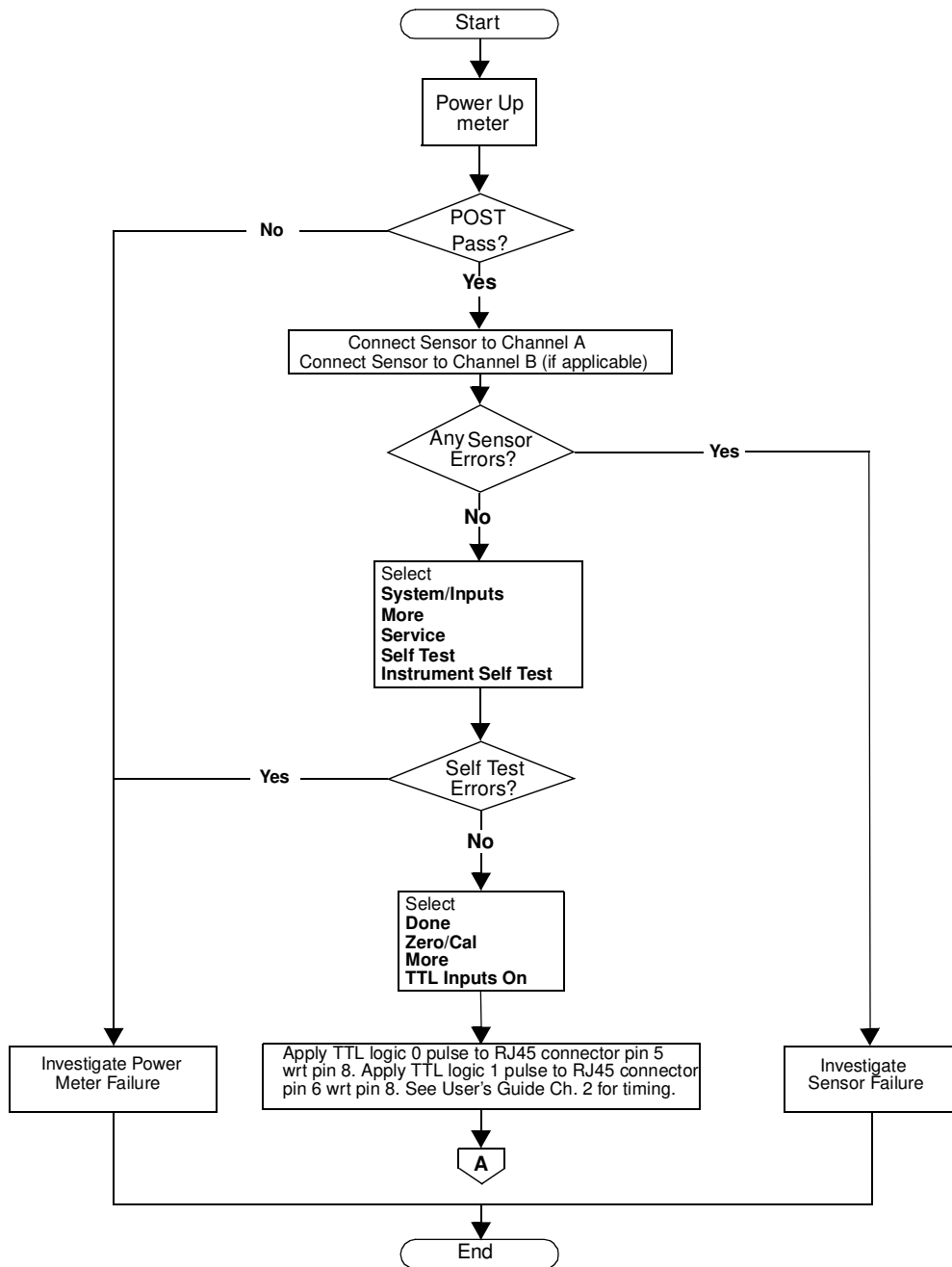
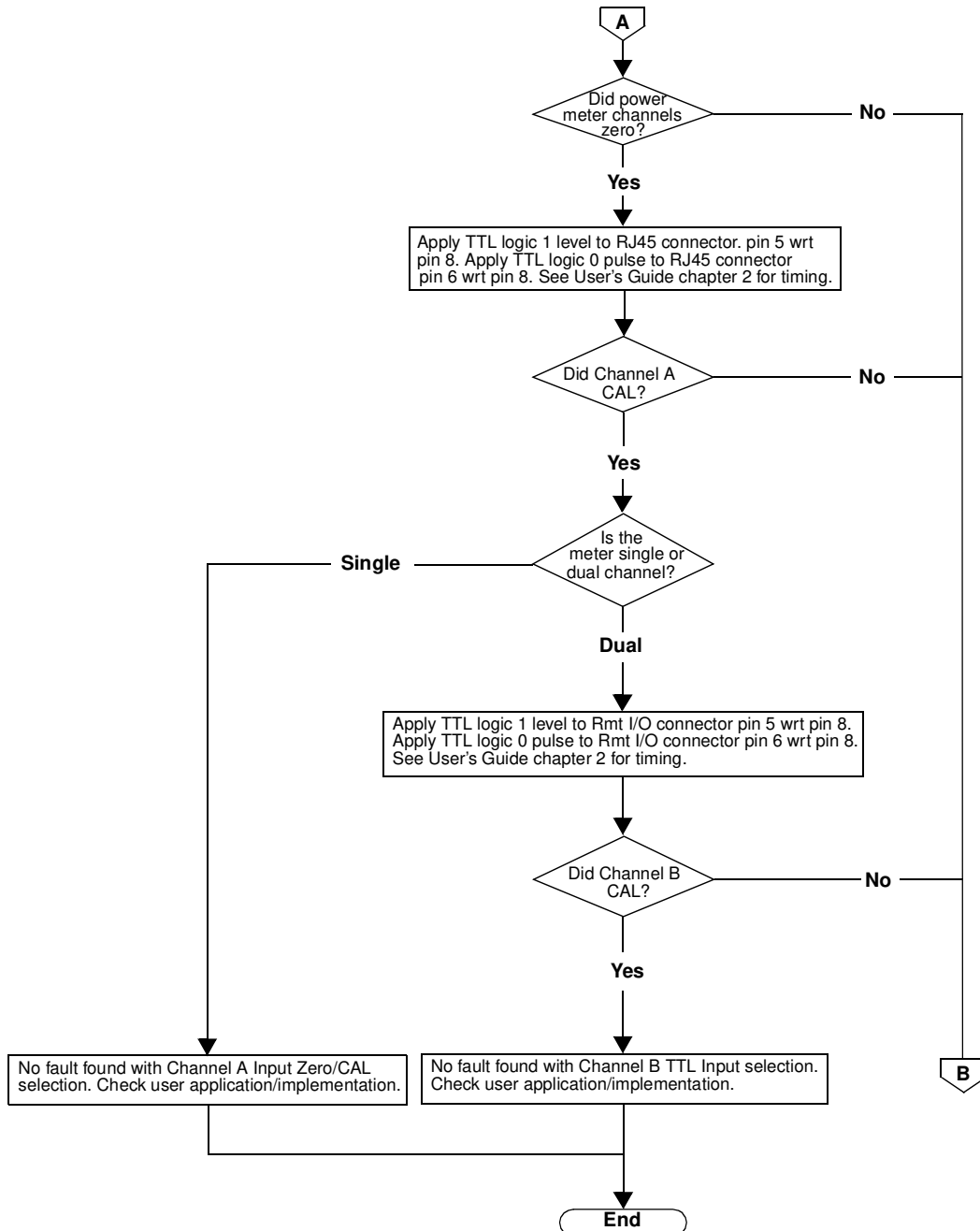

Figure 6-3: Troubleshooting Guide - TTL Inputs





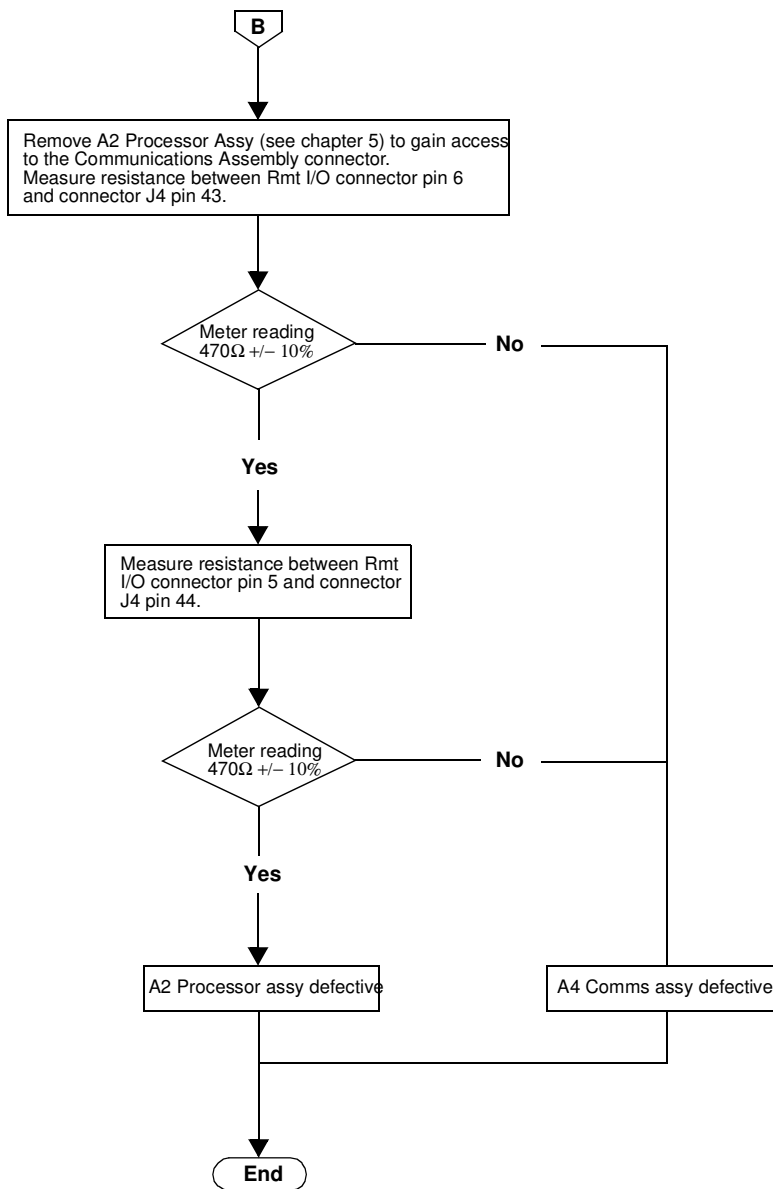
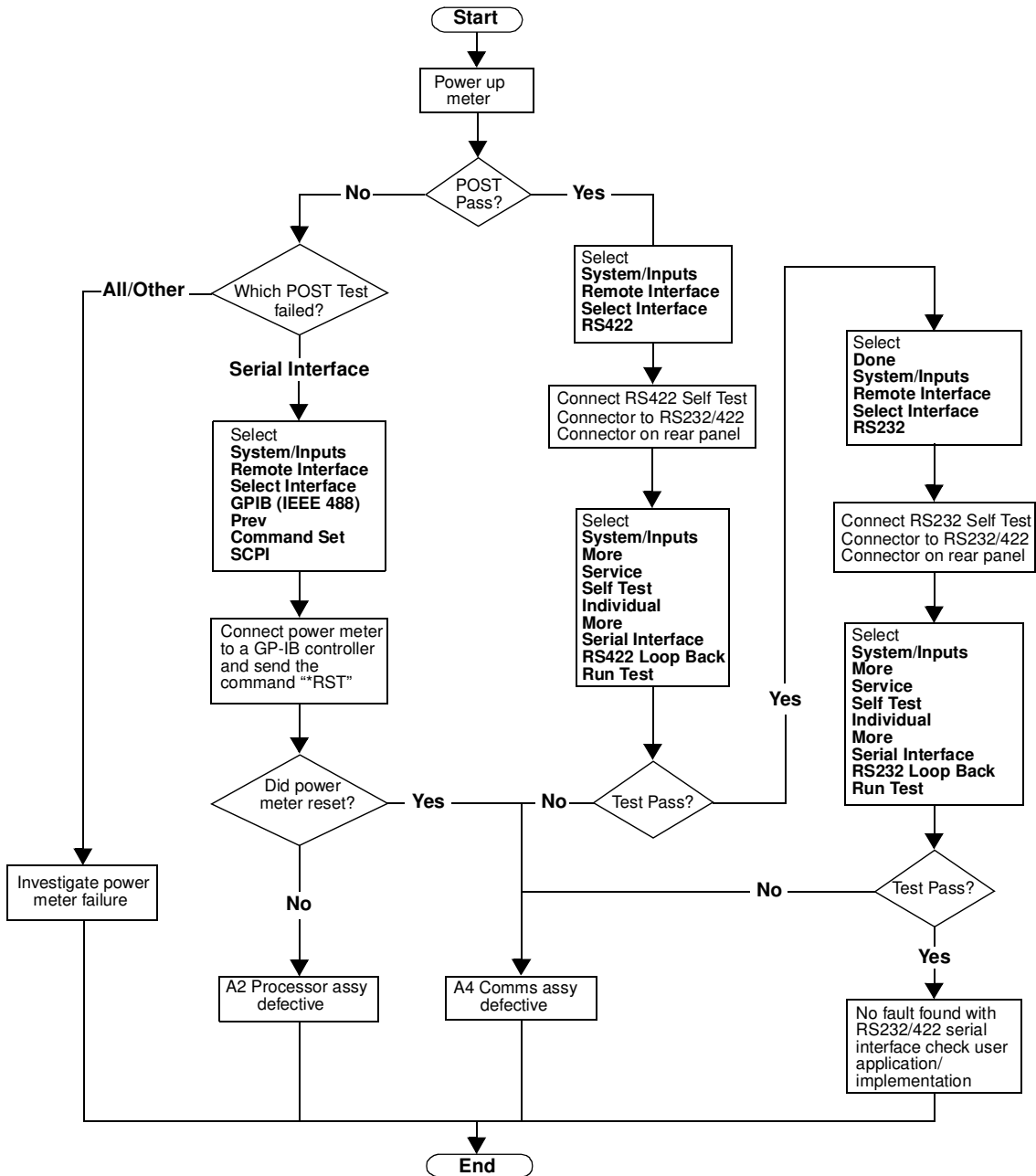

Figure 6-4: Troubleshooting Guide - RS232/422 Interface



Appendix A

Measurement Uncertainty Analysis – Instrument Accuracy Test

Note

The Measurement Uncertainty Analysis described in this Appendix uses different test equipment from that listed in this Service Guide. However, the equipment used, and the Measurement Uncertainty results, are similar enough to make the analysis useful. For example, the 11683A H01 Range Calibrator performs the same function as the modified 8482A used in this analysis. Similarly, the Datron/Fluke DC Calibrator performs the same function as the combined 3245/3458A setup.

Measurement Introduction

In the Instrument Accuracy test the DUT measures power levels output from the test station from -25dBm to $+20\text{dBm}$.

A modified 8482A sensor is used to perform this measurement; it has had its thermocouple sensor (RF to DC converter) removed. This allows extremely accurate DC levels to be injected into the sensor from a 3245 Universal Source. The output from the universal source is measured at the head of the sensor by a 3458 DMM. In effect there is now zero measurement uncertainty associated with the Universal Source, as the 3458 DMM has assumed all the uncertainty.

In this test, DC signals are injected into the modified sensor. These are made in 5dB steps, from -25dBm to $+20\text{dBm}$. A conversion from voltage to power is required to achieve this. The measurement setup is shown in Figure A-1.

Figure A-1: Measurement Setup

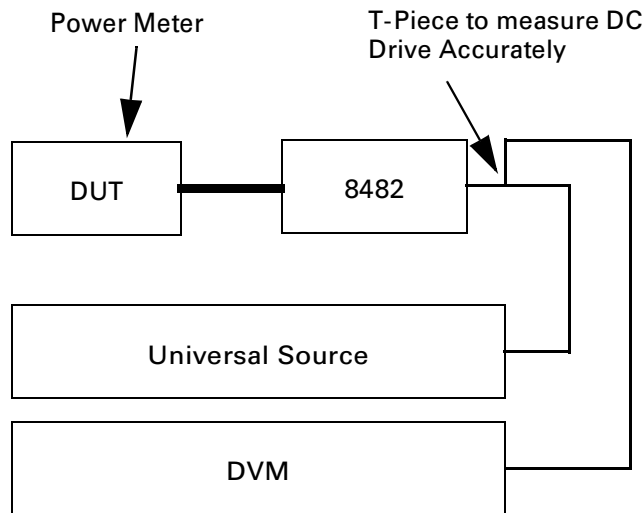

Uncertainties

Universal Source:	No Uncertainties
DMM:	Yes (Type B)
8482:	No ¹
Extraneous signals, cables connectors and	Yes (Type A)

1. There is no uncertainty involved within the 8482A sensor, as a relative power is being measured. Before any measurement is made, an equivalent voltage to 0dBm is applied to the 8482 sensor to allow the power meter calibration. It is not important if the sensor creates an offset during this calibration procedure, provided this offset is present throughout all the different power levels. The 8482A sensor is **linear** from -25dBm up to 0dBm, and hence the same offset would always be present. Between 0dBm and 20dBm, look up tables are employed to counteract the non-linear behavior of the sensor at higher power levels.

Example: Consider a DC voltage from the Universal Source applied to the 8482A sensor, producing a power of 0.2dBm instead of 0dBm (for example, a 0.2dBm offset). The measuring device (for example, the power meter) takes this 0.2dBm value as being 0dBm, and adjusts itself accordingly. Now throughout every measurement level, the 8482A and the power meter has the same 0.2dBm offset (because the sensor is linear).

Define the Measurand

The *measurand* is the Measurement Accuracy of the DUT.

Define the Measurement Equation

~~Measurement Accuracy = DUT Measure - Test System Power~~

Where:

$$\text{Test System Power} = (\text{Measure voltage} \times \text{Volts/Power Conversion}) + \text{Test Station Error}$$

Note Test Station Error (TSE) is the error contribution of the cables, connectors, noise, and so forth, that cannot be measured independently.

Note The measurement uncertainty only relates to the test station, in this case, a power meter is the most accurate method of measuring power. Hence the reason the *DUT Measure* component can be ignored in the measurement equation. However, taking a number of measurements of the test system with the same power meter, averages out the error resolution or minimize it to the extent where the magnitude error is many times smaller than the station error.

Hence: Measurement Accuracy = $f(MV, TSE)$

The Measurement Uncertainty is not calculated from different sensor and power meter combinations, rather it is taken care of in the Customer Limit specification setting. Hence using the same power meter and making measurements a number of times will give us the uncertainty of the test station, without the uncertainty associated with the meter itself. By taking n samples of the same meter/DUT in effect we are averaging out the error associated with the DUT's measurement capability leaving us with a raw test station uncertainty which is made up from TSE and the DMM error, for example, the Measured Voltage (MV).

The method that is used to calculate the Measurement Uncertainty of our test station is a combination of Type A and Type B analysis in line with the ISO Expression of Measurement Uncertainty Guide.

Uncertainty Equation

$$u^2(MA) = [C_{TSE} \cdot u(TSE)]^2 + [C_{MV} \cdot u(MV)]^2$$

TSE

The Measurement Uncertainty of the Measurement Accuracy is calculated from testing the same DUT at 5dB step power level from -25dBm to +20dBm.

Standard Uncertainty $u(x_i)$:

Table A-1 shows the standard deviation of the 30 readings from the DUT at various power levels.

Table A-1: Standard Uncertainty Results

Power Level	Standard Deviation of 30 Readings	Conversion to Linear Units Standard Uncertainty
$u(x(-25))$ 3.162uW	0.0132dB	0.0097uW
$u(x(-20))$ 10uW	0.0038dB	0.009uW
$u(x(-15))$ 31.62uW	0.0013dB	0.0095uW
$u(x(-10))$ 100uW	0.0015dB	0.035uW
$u(x(-5))$ 316.2uW	0.0004dB	0.03uW
$u(x(0))$ 1mW	0.0003dB	0.00007mW
$u(x(5))$ 3.16227mW	0.0003dB	0.00022mW
$u(x(10))$ 10mW	0.0003dB	0.000690mW
$u(x(15))$ 31.62277mW	0.0003dB	0.0022mW
$u(x(20))$ 100mW	0.0004dB	0.0092mW

The distributions are all normal.

3458A DMM Uncertainty:

The uncertainty of the voltage measured by the 3458A is:

$$\text{Error} = (\text{ppm of reading} + \text{ppm of range}) + (\text{factory traceability}) + (\text{temperature coefficient})$$

Conditions: 1 Year Calibration and temperature variance +/-5°C with ACAL on dc volts.

Reference: 3458A Operating Manual Appendix A

Factory Traceability: From 6ppm to 0.5ppm Standard Uncertainty depending on range.

Worst case error on 0.1V range:

$$\begin{aligned} \text{Error} &= ((9\text{ppm} \times 100\text{mV}) + (3\text{ppm} \times 100\text{mV})) + (6\text{ppm} \times 100\text{mV}) + 5((0.15\text{ppm} \times 100\text{mV}) + 100\text{mV}) \\ &= \mathbf{2.375\mu\text{V}} \end{aligned}$$

Percentage Error = 0.002375%

Voltage Error	Distribution	Standard Uncertainty
2.375uV	Rectangular	1.371uV

Worst case error on 1V range

$$\begin{aligned} \text{Error} &= ((8\text{ppm} \times 1.0\text{V}) + (0.3\text{ppm} \times 1.0\text{V})) + (1\text{ppm} \times 1.0\text{V}) + 5((0.15\text{ppm} \times 1.0\text{V}) + (0.1\text{ppm} \times 1.0\text{V})) \\ &= \mathbf{10.55\mu\text{V}} \end{aligned}$$

Percentage Error = 0.001055%

Voltage Error	Distribution	Standard Uncertainty
10.55uV	Rectangular	6.09uV

Worst case error on 10V range

$$\begin{aligned} \text{Error} &= ((8\text{ppm} \times 10.0\text{V}) + (0.05\text{ppm} \times 10.0\text{V})) + (1\text{ppm} \times 10.0\text{V}) + 5((0.15\text{ppm} \times 10.0\text{V}) + (0.01\text{ppm} \times 10.0\text{V})) \\ &= \mathbf{98.5\mu\text{V}} \end{aligned}$$

Percentage Error = 0.000985%

Voltage Error	Distribution	Standard Uncertainty
98.5uV	Rectangular	56.8uV

Worst case error on 15.8V maximum power setting

$$\text{Error} = ((10\text{ppm} \times 15.8\text{V}) + (0.3\text{ppm} \times 100.0\text{V})) + (0.5\text{ppm} \times 15.8\text{V}) + 5((0.15\text{ppm} \times 15.8\text{V}) + (0.1\text{ppm} \times 100\text{V}))$$

$$= 257.75\mu\text{V}$$

Percentage Error = 0.00163%

Voltage Error	Distribution	Standard Uncertainty
257.75uV	Rectangular	148.8uV

The relationship between the applied voltage from the Universal Source to the corresponding power is given from:

$$1\text{mW} = 0.14493\text{mV}$$

This is a linear relationship, for example, 0.1mW is equal to 0.014493volts. This relationship is valid between 0dBm and -30dBm.

However, above 0dBm a look up table is used for voltage to mW conversion. This is due to the sensors non linear behavior at higher power levels. The voltage correction at the appropriate points is shown in Table A-2.

Table A-2: Voltage Correction Multiplier

Power (mW)	Voltage Correction Multiplier
1	1
10	1.006577
100	1.075533

Therefore to attain a power of 100mW as shown in the Table A-2, instead of applying 14.4493 Volts, the actual amount of voltage required from the Universal Source would be:

$$14.4493 \times 1.075533 = 15.6\text{Volts}$$

By using the DMM Uncertainties calculated previously the worst case voltage and corresponding power errors can be calculated.

Power Setting (mW)	Applied Volts	DMM Error on Range Standard Uncertainty (uV)	Worst Case Voltage Error on Range (%)	Worst Case Power Error on Range
0.001	0.14493mV	<1.371uV	0.946%	0.00946uW
0.01	1.4493mV	<1.371uV	0.0946%	0.00946uW
0.1	14.493mV	1.371uV	0.00946%	0.00946uW
1	144.93mV	6.09uV	0.00420%	0.042uW
10	1.4588V	56.8uV	0.00389%	0.389uW
100	15.6V	148.8uV	0.00095%	0.95uW

Sensitivity Coefficients Ci:

The partial derivatives of the measurement equation $Y = f(MV, TSE)$ equal 1.

TSE is derived from a number of readings taken by the test station to characterize the cabling, connectors noise and so forth. Therefore no measurement equation exists to differentiate. It is a measured value of magnitude.

Hence:

$$C_{TSE} = \frac{d}{dTSE} TSE = 1$$

The DMM Measured Voltage also has a sensitivity coefficient equal to 1. As with the TSE the Measured Voltage is not computed from an equation. Is it a real value that the DMM actually measures.

Hence:

$$C_{MV} = \frac{d}{dMV} MV = 1$$

Combined Standard Uncertainty $u_c(y)$:

There is no correlation associated with this measurement

Hence:

$$u_c^2(y) = \sum [C_{TSE} \cdot u(TSE)]^2, [cMV \cdot u(MV)]^2$$

Table A-3 shows the combined standard uncertainty at all the power levels from 3uW (-25dBm) to 100mW (20dBm).

Table A-3: Combined Standard Uncertainty.

Power	$u(TSE)$	$u(MV)$ (Converted)	$u_c(y)$	$k u_c(y)$ $k=2$
3.16uW	0.0097uW	0.00946uW	0.0135uW	0.0271uW
10uW	0.009uW	0.00946uW	0.0131uW	0.0262uW
31.6uW	0.0095uW	0.00946uW	0.0134uW	0.0268uW
100uW	0.035uW	0.00946uW	0.0363uW	0.0725uW
316uW	0.03uW	0.042uW	0.0516uW	0.1032uW
1mW	0.00007mW	0.000042mW	0.000082mW	0.00016mW
3.16mW	0.00022mW	0.000389mW	0.000447mW	0.00089mW
10mW	0.00069mW	0.000389mW	0.000792mW	0.00158mW
31.6mW	0.0022mW	0.00095mW	0.00239mW	0.00479mW
100mW	0.0092mW	0.00095mW	0.00924mW	0.01850mW

Expanded Uncertainty $k u_c(y)$:

The Expanded Uncertainty for each power level is given in the table above, using Agilent Technologies’s standard 95% confidence level gives a coverage factor of 2.

$$K = 2$$

Appendix B

Measurement Uncertainty Analysis – Power Reference Level Test

Measurement Introduction

In the Power Reference Level Test, the output from the DUT's 1mW Power Ref connector is measured.

A 432A Power Meter and an 8478B H01 Power Sensor are required for this test. Also the H01 power sensor's calibration factor uncertainty at 50MHz must be no greater than $\pm 0.2\%$.

A 3458A DMM is required to read the V_{ref} and V_{comp} outputs of the 432A. This is preferred to estimating an inaccurate visual reading from the 432A front panel.

Define the Measurand

The *measurand* is the output power of the 1mW reference in the DUT.

Define the Measurement Equation

$$P_{meas} = \frac{2 \cdot V_{comp} \cdot (V_1 - V_0) + V_0^2 - V_1^2}{4 \cdot R \cdot CF \cdot M_s}$$

where,

V_0 is the voltage measured between V_{comp} and V_{ref} with no power applied, for example, the reference switched off and after the 432A has been zeroed.

V_1 is the voltage measured between V_{comp} and V_{ref} with power applied, for example, the reference switched on.

V_{comp} is the voltage between the 432A V_{comp} rear connector and chassis ground with power applied.

R is mount resistance of the 432A meter.

CF is the value of the Calibration Factor of the Thermistor mount at 50MHz.

M_s is the mismatch magnitude between the DUT reference and the 8478B sensor, which is equal to:

$$M_s = 2 \cdot P_s \cdot P_d$$

where,

P_s is the reflection coefficient of the source (i.e. the DUT) and P_d is the reflection coefficient of the 8478B detector.

Hence,

$$P_{meas} = f(V_{comp}, V_1, V_0, R, CF, M_s)$$

Consider the measurement setup that exists in Figure B-1

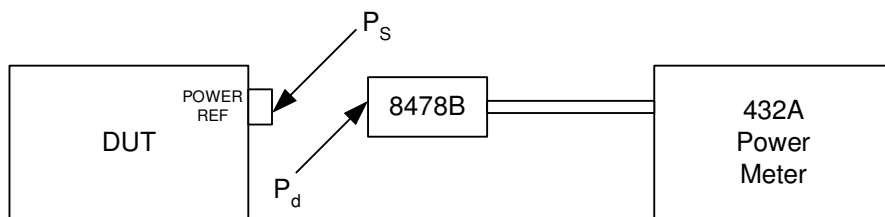

Figure B-1: Measurement Setup

P_o is the total power output from the DUT. Of this power a proportion related to P_d is reflected back towards the source. The power subjected on the 432 would be:

$$P_o(1 - P_d^2)$$

But because a proportion of this total power related to P_d has been reflected P_s will again cause a reflection giving:

$$P_o(1 \pm P_s P_d)^2$$

So the total power incident or measured by the 432 Power meter is given by:

$$\left(P_o(1 - P_d^2) \right) / \left(1 \pm P_s P_d \right)^2$$

Note

In all cases P_d is extremely small therefore P_d^2 terms tend to zero leaving.

Measurement Introduction

:

$$M_S \text{ Uncertainty} = 1/(1 \pm 2P_S P_d)$$

The equation above includes the worst-case mismatch magnitude $2P_S P_d$ and is in the form where various powers can be multiplied by the equation to find worst-case power levels with respect to mismatch.

Note

From the above mismatch uncertainty equation if P_d is zero, for example, the 8478B sensor is exactly 50 ohms then there is NO mismatch uncertainty. This has not yet been achieved but efforts will be made in the future to try to achieve as near as possible to a ‘zero’ level of mismatch uncertainty and hence have negligible mismatch when calibrating products.

Uncertainty Equation

General form of uncertainty equation is:

$$u^2(y) = \sum_{i=1}^N c_i^2 u^2(x_i) + 2 \left(\sum_{i=1}^N \sum_{j=i+1}^N c_i c_j u(x_i, x_j) \right)$$

Hence,

$$u^2(1mW) = |CV_0 \cdot u(V_0)|^2 + |CV_1 \cdot u(V_1)|^2 + |CV_{comp} \cdot u(V_{comp})|^2 + |CR \cdot u(R)|^2 \\ + |CCF \cdot u(CF)|^2 + |CM_S \cdot u(M_S)|^2 + |C_{Rep} \cdot u(Rep)|^2 + |C_{Drift} \cdot u(Drift)|^2$$

Assuming that there is no correlation exists between the 8 input variables.

Voltage Measurements Uncertainty

Since the manufacturer’s data is used to determine the standard uncertainty, the analysis used is the **Type A** method.

The 3458A DMM Uncertainty is calculated with reference to the Appendix ‘A’ of the 3458A Operating Manual.

A normal distribution is assumed, as the 3458A Manual has not specified the type of distribution used on the measurement.

Both V_0 and V_1 values are calculated by subtracting V_{ref} from V_{comp} as measured at the output of the 432A using a 3458A DMM. The approximate values of V_{comp} and V_{ref} for no power (V_0) and for 1mW power (V_1) are 5V with the DMM on the 10V scale.

For the 3458A DMM, the specified accuracy for the 10 volt scale is:

8ppm of Reading + 0.5ppm of Range

with;

0.15ppm of Reading + 0.01ppm of Range per °C (temp coefficient Tcal ±5 °C)

± 8.75 ppm of Reading + 0.55ppm of Range

Therefore,

$$U(V_{comp}) = U(V_{ref}) = \pm \left[\frac{8.75 \times 5}{1000000} + \frac{0.55 \times 10}{1000000} \right] = \pm 49.25 \mu V$$

For V_0 and V_1 , two measurements are taken, so the uncertainty is equated to the RSS of using two DMMs;

Voltage measurement	Uncertainty
U(Vcomp)	49.25 μV
U(V ₀)	69.65 μV
U(V ₁)	69.65 μV

Mismatch

The Mismatch uncertainty was previously determined as being:

$$MsUncertainty(magnitude) = 2P_s P_d$$

Note

This is the worst-case uncertainty for mismatch and occurs when the incident and reflected waves are 180 degrees out of phase.

Consider the model below:

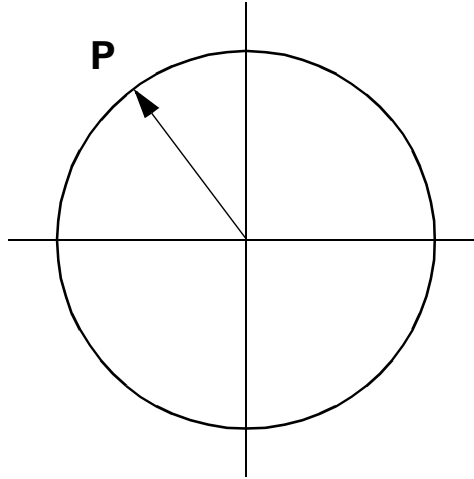

An estimate of the moduli of P_d and P_s are each less than a specified value. P_s and P_d each lie **within** a circle of radius P . Assuming P_d and P_s have equal probability of lying anywhere **within** the circle the standard uncertainty of Mismatch becomes

$$u(M_s) = \pm \frac{\max P_s \cdot \max P_d}{\sqrt{2}}$$

P_s is the reflection coefficient of the source, which is specified as less than 1.05.

$$\text{VSWR} < 1.05$$

The reference is designed to have a VSWR of less than 1.05.

$$\text{VSWR} < 1.05$$

Hence,

$$P_s(\max) = P_d(\max) = \frac{\text{VSWR} - 1}{\text{VSWR} + 1} = \frac{1.05 - 1}{1.05 + 1} = 0.0244$$

So $u(M_s)$ from the equation above equals:

$$u(M_s) = \pm \frac{(0.0244) \times (0.0244)}{\sqrt{2}} = 0.00042$$

Mismatch Uncertainty $U(M_s)$ worst case

$$UM_s = 2P_s P_d = 2\sqrt{2} \times u(M_s) = 0.0012$$

Calibration factor

The calibration factors supplied with the power sensor take into account the performance of the sensor with respect to frequency. This value is of secondary importance when calculating the overall uncertainty of the 1mW reference.

The information that is appropriate is the Uncertainty of the Calibration Factor. The power sensor must be calibrated such that:

$$\text{Uncertainty of Calibration Factor} < 0.2\%$$

Therefore,

$$U(\text{CF}) = 0.002$$

Sensor Calibration Factor Drift

The Agilent Standards Laboratory at South Queensferry has determined the following average sensor drift value.

$$\text{Average Sensor Drift} < 0.06\% \text{ per year}$$

Therefore

$$U(\text{Drift}) = 0.0006$$

Note

This value is only valid for 8478B sensors calibrated to 0.2% accuracy.

Resistance

The uncertainty of the resistance measurement on the 3458A DMM is given from:

$$\text{Error} = (\text{ppm of reading} + \text{ppm of range}) + (\text{temperature coefficient}) + (\text{factory traceability})$$

with: -

Conditions: - 1 Year Cal and temperature variance +/- 5°C without ACAL

Reference: - 3458A Operating Manual Appendix A

For 1kΩ scale the specified accuracy is;

$$10\text{ppm of reading} + 0.5\text{ppm of range}$$

with: -

1ppm of Reading + 0.1ppm of Range per °C (temp coefficient Tcal ±5 °C)

and, 3ppm of Reading (for factory traceability)

Therefore,

$$\begin{aligned} U(R) &= \left[\frac{200 \times (10 + 5 + 3)}{1000000} + \frac{1000 \times (0.5 + 0.5)}{1000000} \right] \\ &= (0.0036 + 0.0010) \\ &= 0.0046\Omega \end{aligned}$$

Repeatability

To verify the overall repeatability of the measurement, the test was repeated 20 times, using the same DUT. For each test cycle, the *Power Reference Level Test* and the *Power Reference Level Adjust* tests, were carried out; at no point during these tests was the 1mW on the DUT adjusted. The thermistor was disconnected and reconnected between each test with the sensor position rotated each time. The results for this evaluation are shown in Table B-1.

Table B-1: Measurement Repeatability Results

Measurement	ADJUST REF.	REF. LEVEL TEST
1	0.999548951	0.999499495
2	0.999541333	0.999554257
3	0.999449078	0.999414037
4	0.999546994	0.999509401
5 ¹	0.999138526	0.9991726
6	0.999647055	0.999454911
7	0.999539391	0.999515949
8	0.999567191	0.999558795
9	0.999600963	0.999554633
10	0.999405584	0.999377721
11	0.999523392	0.999566084
12	0.999504386	0.999504323
13	0.999443652	0.999463611
14	0.999513893	0.999553753
15	0.999589288	0.999496811
16	0.999485404	0.999529486
17	0.999559381	0.999534985
18	0.999524217	0.99948097
19	0.999523013	0.999518899
20	0.999534276	0.999488886
Max	0.999647	0.999566084

Table B-1: Measurement Repeatability Results

Measurement	ADJUST REF.	REF. LEVEL TEST
Min	0.999406	0.999377721
Average	0.999529	0.999504053
SD	5.67E-05	5.01868E-05

1. Measurement 5 was discounted from the calculations as being an extraneous measurement.

The readings in Table B-1 are in milli-Watts, therefore the Standard Deviation (worse case) is: - U (Rep) = 0.057 μ Watts

Sensitivity Coefficients (Ci)

$$1 \text{ mW Power Measured} = f(V_{\text{comp}}, V_1, V_0, R, CF, M_S)$$

The sensitivity coefficients should be evaluated using the best estimate of V_{comp} , V_1 , V_0 , R , CF and M_S . The nominal values for V_{comp} , V_1 , V_0 , R , and CF are

V_{comp}	= 4.857 V
V_1	= 83.12 mV
V_0	= 96.17 μ V
R^1	= 200 Ω
CF^2	= 97.5%
	= 0.975

1. The resistance on the 432A Power meters is set to 200ohms for this test
2. The average Calibration Factor from the previous six sensors on the Production Line

The best guess for the Mismatch of the $P_S P_d$ is = 1. Output power of the source as shown earlier is:

$$M_S = P_{\text{out}}(1 \pm (2 \cdot P_S \cdot P_d)) \approx 1$$

This equation shows that if an infinite amount of readings of mismatch were taken between $P_S P_d$ the mean value would equal 1.

Using the above values gives

$$Ci_{V_{\text{comp}}} = \left[\frac{d}{dV_{\text{comp}}} \right]_{\text{PM}} = \frac{2(V_1 - V_0)}{4RCFM_s} = 2.129 \times 10^{-4} \frac{V}{\Omega}$$

$$Ci_{V_1} = \left[\frac{d}{dV_1} \right]_{\text{PM}} = \frac{2V_{\text{comp}} - 2V_1}{4RCFM_s} = 1.224 \times 10^{-2} \frac{V}{\Omega}$$

$$Ci_{V_0} = \left[\frac{d}{dV_0} \right]_{\text{PM}} = \frac{(-2)V_{\text{comp}} + 2V_0}{4RCFM_s} = -1.245 \times 10^{-2} \frac{V}{\Omega}$$

$$Ci_R = \left[\frac{d}{dR} \right]_{\text{PM}} = \frac{(-2)V_{\text{comp}}(V_1 - V_0) + V_0^2 - V_1^2}{4R^2CFM_s} = -4.727 \times 10^{-6} \frac{W}{\Omega}$$

$$Ci_{CF} = \left[\frac{d}{dCF} \right]_{\text{PM}} = \frac{(-2)V_{\text{comp}}(V_1 - V_0) + V_0^2 - V_1^2}{4RCF^2M_s} = -9.696 \times 10^{-4} W$$

$$Ci_{Ms} = \left[\frac{d}{dMs} \right]_{\text{PM}} = \frac{(-2)V_{\text{comp}}(V_1 - V_0) + V_0^2 - V_1^2}{4RCFM_M^2} = -9.454 \times 10^{-4} W$$

Combined Standard Uncertainty ($uc(y)$)

Table B-2: Combined Standard Uncertainty

Symbol	Source of Uncertainty	Value	Probability Distribution	Divisor	Ci	Ui / μ W
U(V ₀)	Two Voltage measurements on a 3458A DMM	69.65 μ V	Normal	2	2.129×10^{-04} V/ Ω	0.007
U(V ₁)	Two Voltage measurements on a 3458A DMM	69.45 μ V	Normal	2	1.224×10^{-02} V/ Ω	0.426
U(V _{comp})	Voltage measurement on 3458A DMM	49.25 μ V	Normal	2	-1.245×10^{-02} V/ Ω	0.307
U(R)	4 wire Resistance measurement on 3458A DMM	0.0046 Ω	Normal	2	-4.727×10^{-06} W/ Ω	0.012
U(CF)	Calibration factor for Thermistor	0.002	Normal	2	-9.696×10^{-04} W	1.070
U(M _s)	Mismatch between the DUT and the Thermistor	0.0012	U shaped	$\sqrt{2}$	-9.454×10^{-04} W	0.885
U(Drift)	Drift of 8478B Thermistor	0.0006	Normal	2	1.00×10^{-03} W	0.6
U(Rep)	Repeatability of the complete measurement	0.057 μ W	Normal	1	1	0.057
U _c	Combined Uncertainty		Normal			1.515
U ¹	Expanded Uncertainty	k=2	Normal			3.030

¹ Using Agilent's standard 95.5% confidence the coverage factor is k = 2.00

Expanded Uncertainty

The expanded uncertainty is: **U = 3.030 μ W**, as a percent of 1.000 mW: **U = 0.303%**

Index

A

- A1 power supply/Battery Charger assembly 4-3
- A2 processor assembly 4-4
- A3 front panel assembly 4-7
- A4 interface assembly 4-8
- A5 daughter assembly 4-9
- A6 measurement assembly 4-10
- absolute accuracy, specification 1-4
- accuracy
 - of power reference 1-5
- accuracy, of power reference 1-5
- adjustments 3-2
 - display brightness and contrast adjustment 3-11
 - power reference oscillator frequency adjustment 3-4
 - power reference oscillator level adjustment 3-6
- Agilent E-series power sensor
 - functional test 2-20
 - interface test 2-19
- Agilent Technologies
 - offices 1-ix
- altitude characteristic 1-15
- assembly part numbers 5-3

B

- battery (option 001) specification 1-13
- battery (RAM) replacement 5-14
- battery option 001
 - charge time 1-13
 - chemistry 1-13
 - service life 1-13
 - typical operating time 1-13
 - weight 1-13

C

- calibration cycle 2-4
- caution 1-v
- characteristics 1-2
- CLIPs package 1-viii
- comms assembly
 - replacement 5-11
- connector, Recorder Output 1-14
- connectors
 - GP-IB 1-14
 - remote input output 1-14
 - RS232 1-14
 - RS422 1-14

D

- danger 1-v
- daughter assembly
 - description 4-9
 - replacement 5-12
- dimensions of instrument 1-16
- display
 - resolution, specification 1-3
 - units, specification 1-3
- documents 1-viii

E

- environmental characteristics 1-15

F

- fan assembly replacement 5-13
- firmware upgrades 5-7
- frequency adjustment 3-4
- frequency range 1-14
 - specification 1-3
- frequency, characteristic of power reference 1-5
- front panel assembly 4-7
 - replacement 5-15

front panel repair 5-6

G

GP-IB

connector characteristic 1-14

H

humidity characteristic 1-15

I

IEC 1010-1 1-vii

instrument accuracy test 2-7

interface assembly 4-8

L

legal information 1-iii

level adjustment 3-6

line power characteristic 1-14

M

markings 1-vi

measurement

noise characteristic 1-6

noise definition 1-12

speed 1-6

measurement assembly description 4-10

measurement assembly replacement 5-12

memory 1-17

N

noise, characteristic 1-7

non-volatile memory 1-17

O

operating environment 1-15

operation 4-2

oscillator adjustment 3-4, 3-6

P

packaging for service 1-xi

parts 5-2

performance test record 2-23

performance tests 2-2

Agilent E-series power sensor functional
test 2-20

Agilent E-series power sensor interface

test 2-19

instrument accuracy test 2-7

power reference level test 2-15

zero test 2-5

post-repair adjustments 3-3

power

sensors 1-3

power characteristic 1-14

power output 1-5

power range, specification 1-3

power reference

oscillator frequency 3-4

oscillator level adjustment 3-6

specification 1-5

power reference cable

replacement 5-18, 5-21

power reference level test 2-15

power reference oscillator level adjustment 3-6

power sensor

cable replacement 5-16, 5-19

power supply

assembly description 4-3

replacement 5-9

processor assembly

description 4-4

replacement 5-10

R

recorder output cable

replacement 5-22

Recorder Output connector

characteristic 1-14

relative accuracy, specification 1-4

replace

comms assembly 5-11

daughter assembly 5-12

fan assembly 5-13

front panel 5-6, 5-15

measurement assembly 5-12

power reference cable 5-18, 5-21

power sensor cable 5-16, 5-19

power supply 5-9

processor assembly 5-10

RAM battery 5-14

recorder output cable 5-22

replaceable parts 5-2
returning for service 1-xi
Rmt I/O 1-14
RS232

connector characteristics 1-14
RS422
connector characteristics 1-14

S

safety 1-v, 1-16
sales and service offices 1-ix
service
offices 1-ix
packaging for 1-xi
returning for 1-xi
settling time, characteristic 1-9
single sensor dynamic range, specification 1-3
size of instrument 1-16
specifications 1-2
speed of measurement 1-6
SWR, characteristic of power reference 1-5

T

telephone numbers of Agilent Technologies 1-ix
temperature characteristic 1-15
test equipment 2-3
test record 2-23
troubleshooting
equipment 6-2
lower window TTL o/p 6-5
RS232/422 interface 6-10
TTL inputs 6-7
upper window TTL o/p 6-3

U

upgrades 5-7
user environment 1-vii
user's guides 1-viii

V

vice 1-ix
voltage 1-14

W

warm-up 1-2
warning 1-v

warranty 1-iii
weight of instrument 1-16

Z

zero
drift definition 1-12
drift of sensors, characteristic 1-6
zero set
definition 1-12
specification 1-4
zero test 2-5

