



Agilent Technologies
E1465A/E1466A/E1467A
Relay Matrix Switch Modules
User's Manual



Agilent Technologies

Manual Part Number: E1465-90013
Printed in U.S.A. E0301

Front Matter	7
Agilent Technologies Warranty Statement	7
U.S. Government Restricted Rights	7
Safety Symbols	8
Warnings	8
Documentation History	8
Declaration Of Conformity.....	9
Chapter 1 - Getting Started	11
Using This Chapter	11
Matrix Modules Description.....	11
Programming the Matrix Modules	15
Addressing the Modules	15
Example: Closing Relays (BASIC)	16
Example: Closing Relays (Turbo C)	17
Chapter 2 - Configuring the Matrix Modules	19
Using This Chapter	19
WARNINGS and CAUTIONS	19
Configuring the Switch Module	20
Switch Module Connectors	20
Setting the Logical Address Switch	21
Setting the Interrupt Level	21
Installing the Switch Module in a Mainframe	23
Configuring the Terminal Modules.....	24
Terminal Module Connectors	24
Wiring the Terminal Modules	27
Attaching the Terminal Modules to the Switch Module	29
Configuring Larger Matrixes.....	30
Creating Larger Matrixes	30
Creating a 32x32 Matrix	30
Creating a 4x256 Matrix	32
Creating an 8x96 Matrix	33
Creating Larger Matrixes with Multiple Mainframes	34
Chapter 3 - Using the Matrix Modules	35
Using This Chapter	35
Matrix Modules Commands	35
Power-on and Reset Conditions	36
Matrix Modules Identification.....	36
Example: Matrix Module Identification (BASIC)	36
Example: Matrix Module Identification (TURBO C)	37
Switching Channels	38
Example: Opening/Closing Channels (BASIC)	38
Example: Channel Sequencing (BASIC)	38

Scanning Channels	39
Example: Scanning Channels Using TTL Triggers (BASIC)	39
Example: Scanning Using Trig In/Out Ports (BASIC)	41
Querying Matrix Modules	42
Example: Querying Channel Closure (BASIC)	42
Using the Scan Complete Bit	42
Example: Using the Scan Complete Bit (BASIC)	43
Saving and Recalling States	44
Example: Saving and Recalling States (BASIC)	44
Detecting Error Conditions	45
Example: Detecting Error Conditions (BASIC)	45
Example: Detecting Error Conditions (TURBO C)	45
Synchronizing Matrix Modules	46
Example: Synchronizing a Matrix Module (BASIC)	46
Understanding Matrix Modules	47
Advantages of Latching Relays	47
Matrix Module Operations	47
Chapter 4 - Matrix Modules Command Reference	49
Using This Chapter	49
Command Types	49
Common Command Format	49
SCPI Command Format	49
SCPI Command Reference	51
ABORt	52
ARM	53
ARM:COUNT	53
ARM:COUNT?	54
DISPlay	55
DISPlay:MONitor:CARD	55
DISPlay:MONitor[:STATe]	56
INITiate	57
INITiate:CONTInuous	57
INITiate:CONTInuous?	58
INITiate[:IMMEdiate]	58
OUTPut	59
OUTPut:EXTernal[:STATe]	59
OUTPut:EXTernal[:STATe]?	60
OUTPut[:STATe]	60
OUTPut[:STATe]?	61
OUTPut:TTLTrgn[:STATe]	61
OUTPut:TTLTrgn[:STATe]?	62
[ROUte:]	63
[ROUte:]CLOSe	63
[ROUte:]CLOSe?	64
[ROUte:]OPEN	65
[ROUte:]OPEN?	66
[ROUte:]SCAN	66
STATus	68
STATus:OPERation:CONDition?	70
STATus:OPERation:ENABle	70
STATus:OPERation:ENABle?	70

STATus:OPERation[:EVENT]?	71
STATus:PRESet	71
SYSTem	72
SYSTem:CDEscription?	72
SYSTem:CPON	73
SYSTem:CTYPE?	73
SYSTem:ERRor?	74
TRIGger	75
TRIGger[:IMMediate]	75
TRIGger:SOURce	76
TRIGger:SOURce?	77
SCPI Commands Quick Reference.....	78
IEEE 488.2 Common Commands Reference	79
Appendix A - Matrix Modules Specifications	81
Appendix B - Register-Based Programming	83
About This Appendix	83
Register Programming vs. SCPI Programming.....	83
Addressing the Registers.....	83
The Base Address	84
Register Offset	84
Register Descriptions	86
Reading and Writing to the Registers	86
Manufacturer Identification Register	86
Device Type Register	86
Status/Control Register	86
Relay Control Register	88
Programming Examples.....	90
Example: Reading the Registers (BASIC)	90
Example: Reading the Registers (C/HP-UX)	91
Example: Making Measurements (BASIC)	92
Example: Making Measurements (C/HP-UX)	93
Example: Scanning Channels (BASIC)	95
Example: Scanning Channels (C/HP-UX)	96
Appendix C - Matrix Modules Error Messages	99
Error Types	99
Error Messages.....	100
Appendix D - Relay Life	101
Replacement Strategy.....	101
Relay Life Factors	101
End-of-Life Determination	101
Index	103

AGILENT TECHNOLOGIES WARRANTY STATEMENT

AGILENT PRODUCT: E1465A/E1466A/E1467A Relay Matrix Switch Modules

DURATION OF WARRANTY: 3 years

1. Agilent Technologies warrants Agilent hardware, accessories and supplies against defects in materials and workmanship for the period specified above. If Agilent receives notice of such defects during the warranty period, Agilent will, at its option, either repair or replace products which prove to be defective. Replacement products may be either new or like-new.

2. Agilent warrants that Agilent software will not fail to execute its programming instructions, for the period specified above, due to defects in material and workmanship when properly installed and used. If Agilent receives notice of such defects during the warranty period, Agilent will replace software media which does not execute its programming instructions due to such defects.

3. Agilent does not warrant that the operation of Agilent products will be interrupted or error free. If Agilent is unable, within a reasonable time, to repair or replace any product to a condition as warranted, customer will be entitled to a refund of the purchase price upon prompt return of the product.

4. Agilent products may contain remanufactured parts equivalent to new in performance or may have been subject to incidental use.

5. The warranty period begins on the date of delivery or on the date of installation if installed by Agilent. If customer schedules or delays Agilent installation more than 30 days after delivery, warranty begins on the 31st day from delivery.

6. Warranty does not apply to defects resulting from (a) improper or inadequate maintenance or calibration, (b) software, interfacing, parts or supplies not supplied by Agilent, (c) unauthorized modification or misuse, (d) operation outside of the published environmental specifications for the product, or (e) improper site preparation or maintenance.

7. TO THE EXTENT ALLOWED BY LOCAL LAW, THE ABOVE WARRANTIES ARE EXCLUSIVE AND NO OTHER WARRANTY OR CONDITION, WHETHER WRITTEN OR ORAL, IS EXPRESSED OR IMPLIED AND AGILENT SPECIFICALLY DISCLAIMS ANY IMPLIED WARRANTY OR CONDITIONS OF MERCHANTABILITY, SATISFACTORY QUALITY, AND FITNESS FOR A PARTICULAR PURPOSE.

8. Agilent will be liable for damage to tangible property per incident up to the greater of \$300,000 or the actual amount paid for the product that is the subject of the claim, and for damages for bodily injury or death, to the extent that all such damages are determined by a court of competent jurisdiction to have been directly caused by a defective Agilent product.

9. TO THE EXTENT ALLOWED BY LOCAL LAW, THE REMEDIES IN THIS WARRANTY STATEMENT ARE CUSTOMER'S SOLE AND EXCLUSIVE REMEDIES. EXCEPT AS INDICATED ABOVE, IN NO EVENT WILL AGILENT OR ITS SUPPLIERS BE LIABLE FOR LOSS OF DATA OR FOR DIRECT, SPECIAL, INCIDENTAL, CONSEQUENTIAL (INCLUDING LOST PROFIT OR DATA), OR OTHER DAMAGE, WHETHER BASED IN CONTRACT, TORT, OR OTHERWISE.

FOR CONSUMER TRANSACTIONS IN AUSTRALIA AND NEW ZEALAND: THE WARRANTY TERMS CONTAINED IN THIS STATEMENT, EXCEPT TO THE EXTENT LAWFULLY PERMITTED, DO NOT EXCLUDE, RESTRICT OR MODIFY AND ARE IN ADDITION TO THE MANDATORY STATUTORY RIGHTS APPLICABLE TO THE SALE OF THIS PRODUCT TO YOU.

U.S. Government Restricted Rights

The Software and Documentation have been developed entirely at private expense. They are delivered and licensed as "commercial computer software" as defined in DFARS 252.227- 7013 (Oct 1988), DFARS 252.211-7015 (May 1991) or DFARS 252.227-7014 (Jun 1995), as a "commercial item" as defined in FAR 2.101(a), or as "Restricted computer software" as defined in FAR 52.227-19 (Jun 1987)(or any equivalent agency regulation or contract clause), whichever is applicable. You have only those rights provided for such Software and Documentation by the applicable FAR or DFARS clause or the Agilent standard software agreement for the product involved.



E1465A/E1466A/E1467A Relay Matrix Switch Modules User's Manual
Edition 7

Copyright © 1991, 1993, 1995, 1996, 2001 Agilent Technologies, Inc. All rights reserved.

Documentation History

All Editions and Updates of this manual and their creation date are listed below. The first Edition of the manual is Edition 1. The Edition number increments by 1 whenever the manual is revised. Updates, which are issued between Editions, contain replacement pages to correct or add additional information to the current Edition of the manual. Whenever a new Edition is created, it will contain all of the Update information for the previous Edition. Each new Edition or Update also includes a revised copy of this documentation history page.

Edition 1	July, 1991
Edition 2	July, 1993
Edition 3	June, 1995
Edition 4	January, 1996
Edition 5	May, 1996
Edition 6	November, 1996
Edition 7	March, 2001

Safety Symbols



Instruction manual symbol affixed to product. Indicates that the user must refer to the manual for specific WARNING or CAUTION information to avoid personal injury or damage to the product.



Indicates the field wiring terminal that must be connected to earth ground before operating the equipment — protects against electrical shock in case of fault.

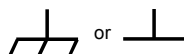

Frame or chassis ground terminal—typically connects to the equipment's metal frame.



Alternating current (AC)



Direct current (DC).



Warning. Risk of electrical shock.

WARNING

Calls attention to a procedure, practice, or condition that could cause bodily injury or death.

CAUTION

Calls attention to a procedure, practice, or condition that could possibly cause damage to equipment or permanent loss of data.

WARNINGS

The following general safety precautions must be observed during all phases of operation, service, and repair of this product. Failure to comply with these precautions or with specific warnings elsewhere in this manual violates safety standards of design, manufacture, and intended use of the product. Agilent Technologies assumes no liability for the customer's failure to comply with these requirements.

Ground the equipment: For Safety Class 1 equipment (equipment having a protective earth terminal), an uninterruptible safety earth ground must be provided from the mains power source to the product input wiring terminals or supplied power cable.

DO NOT operate the product in an explosive atmosphere or in the presence of flammable gases or fumes.

For continued protection against fire, replace the line fuse(s) only with fuse(s) of the same voltage and current rating and type. DO NOT use repaired fuses or short-circuited fuse holders.

Keep away from live circuits: Operating personnel must not remove equipment covers or shields. Procedures involving the removal of covers or shields are for use by service-trained personnel only. Under certain conditions, dangerous voltages may exist even with the equipment switched off. To avoid dangerous electrical shock, DO NOT perform procedures involving cover or shield removal unless you are qualified to do so.

DO NOT operate damaged equipment: Whenever it is possible that the safety protection features built into this product have been impaired, either through physical damage, excessive moisture, or any other reason, REMOVE POWER and do not use the product until safe operation can be verified by service-trained personnel. If necessary, return the product to Agilent for service and repair to ensure that safety features are maintained.

DO NOT service or adjust alone: Do not attempt internal service or adjustment unless another person, capable of rendering first aid and resuscitation, is present.

DO NOT substitute parts or modify equipment: Because of the danger of introducing additional hazards, do not install substitute parts or perform any unauthorized modification to the product. Return the product to Agilent for service and repair to ensure that safety features are maintained.



Manufacturer's Name: Agilent Technologies, Inc.
Manufacturer's Address: Basic, Emerging and Systems Technologies Product Generation Unit
815 14th Street S.W.
Loveland, CO 80537 USA

Declares, that the product

Product Name: Relay Matrix Switch Modules
Model Number: E1465A/E1466A/E1467A
Product Options: This declaration includes all options of the above product(s).

Conforms with the following European Directives:

The product herewith complies with the requirements of the Low Voltage Directive 73/23/EEC and the EMC Directive 89/336/EEC and carries the CE Marking accordingly.

Conforms with the following product standards:

EMC	Standard	Limit
	IEC 61326-1:1997 + A1:1998 / EN 61326-1:1997 + A1:1998	
	CISPR 11:1997 + A1:1997 / EN 55011-1991	Group 1, Class A ^[1]
	IEC 61000-4-2:1995+A1998 / EN 61000-4-2:1995	4 kV CD, 8 kV AD
	IEC 61000-4-3:1995 / EN 61000-4-3:1995	3 V/m, 80-1000 MHz
	IEC 61000-4-4:1995 / EN 61000-4-4:1995	0.5 kV signal lines, 1 kV power lines
	IEC 61000-4-5:1995 / EN 61000-4-5:1995	0.5 kV line-line, 1 kV line-ground
	IEC 61000-4-6:1996 / EN 61000-4-6:1996	3 V, 0.15-80 MHz
	IEC 61000-4-11:1994 / EN 61000-4-11:1994	1 cycle, 100%
	Canada: ICES-001:1998	
	Australia/New Zealand: AS/NZS 2064.1	
Safety	IEC 61010-1:1990+A1:1992+A2:1995 / EN 61010-1:1993+A2:1995	
	Canada: CSA C22.2 No. 1010.1:1992	
	UL 3111-1	

Supplemental Information:

[1] The product was tested in a typical configuration with Agilent Technologies test systems.

September 5, 2000

Date

Name

Quality Manager

Title

For further information, please contact your local Agilent Technologies sales office, agent or distributor.
Authorized EU-representative: Agilent Technologies Deutschland GmbH, Herrenberger Straße 130, D 71034 Böblingen, Germany

Notes:

Using This Chapter

This chapter gives guidelines to get started using the E1465A, E1466A, and E1467 Relay Matrix Switch Modules (matrix modules), including:

- Matrix Modules Description 11
- Programming the Matrix Modules. 15

Matrix Modules Description

The E1465A, E1466A, and E1467A Relay Matrix Switch modules are VXIbus C-Size register-based modules that can operate with a command module, such as an E1406A. Four 4x16 submatrixes are implemented on the PC board with 256 latching relays. Terminal modules convert the submatrixes into 4x64 (E1466A), 8x32 (E1467A), or 16x16 (E1465A) matrixes.

Agilent plug-in modules installed in a mainframe or used with a command module are treated as independent *instruments*, each having a unique secondary GPIB address. Each instrument is assigned a dedicated error queue, input and output buffers, status registers, and if applicable, dedicated mainframe/command module memory space for readings or data. An instrument may be composed of a single plug-in module or multiple plug-in modules.

NOTE *The matrix model number is determined by the terminal module connected to the PC board. If no terminal module is connected, the relay matrix switch module defaults to an E1466A. To program the E1465A and E1467A, make certain the terminal module is connected.*

The **E1465A Relay Matrix** module (Figure 1-1) provides a 16x16 two-wire crosspoint matrix. This 16x16 matrix is created by connecting the terminal module. The terminal module connects the columns of the submatrixes of A, B, C, and D.

The **E1466A Relay Matrix** module (Figure 1-2) provides a 4x64 two-wire crosspoint matrix. This 4x64 matrix is created by connecting the terminal module. The terminal module connects the rows of submatrixes A, B, C, and D.

The **E1467A Relay Matrix** module (Figure 1-3) provides an 8x32 two-wire crosspoint matrix. This 8x32 matrix is created by connecting the terminal module. The terminal module connects the rows of submatrixes A and C, and rows of submatrixes B and D. The columns of submatrixes A and B, and columns of submatrixes C and D are also connected.

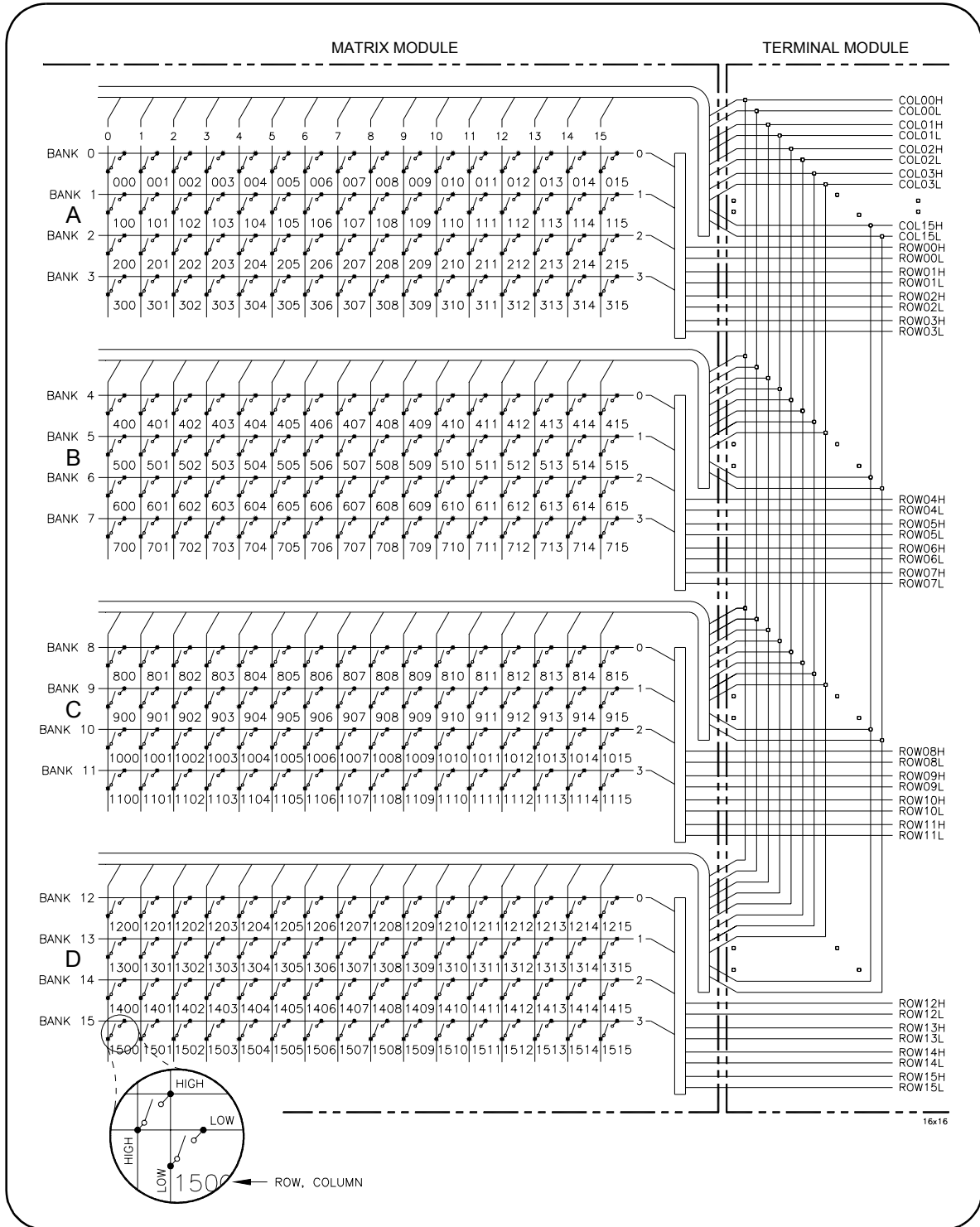

Figure 1-1. E1465A 16x16 Relay Matrix Module

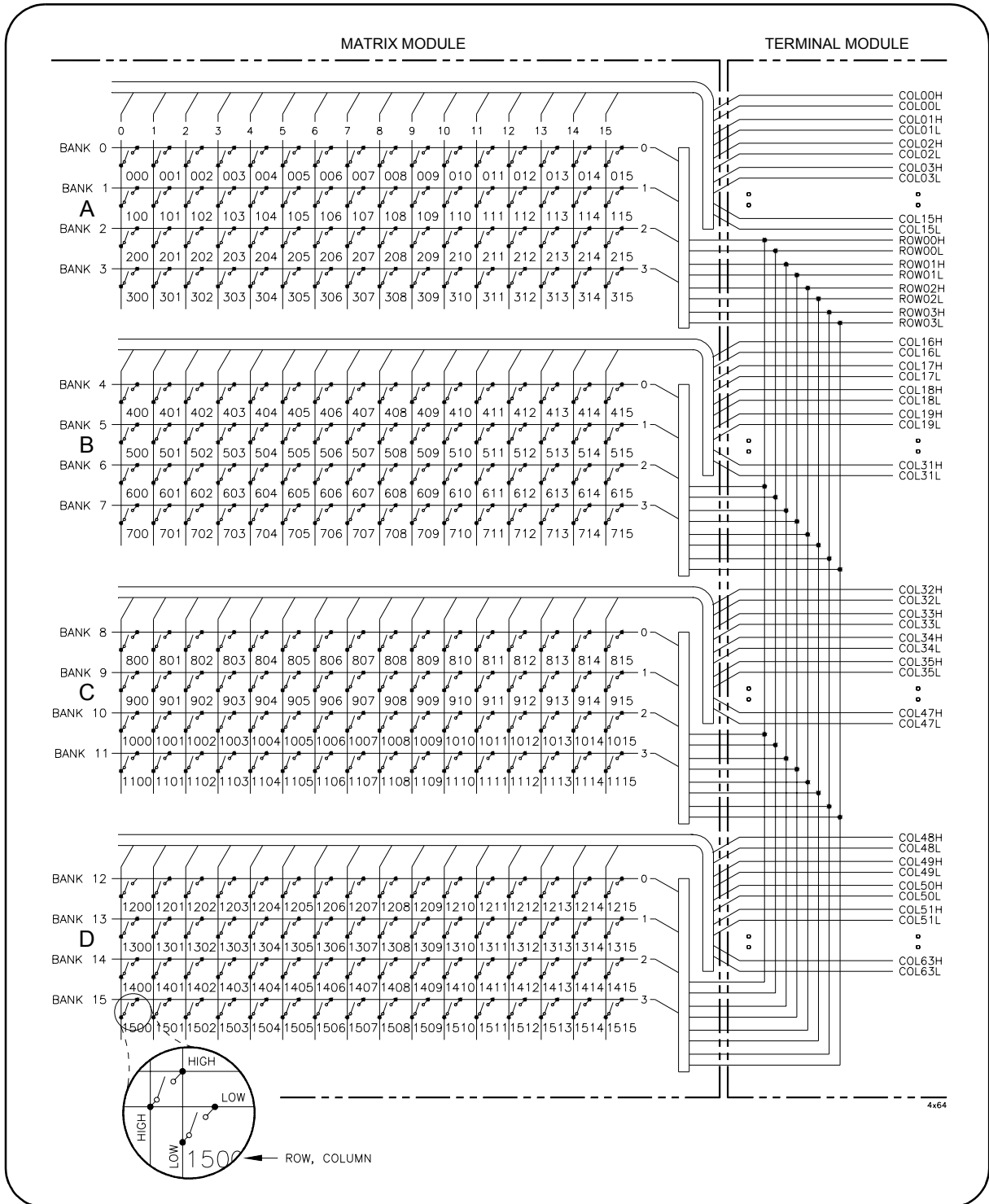

Figure 1-2. E1466A 4x64 Relay Matrix Module

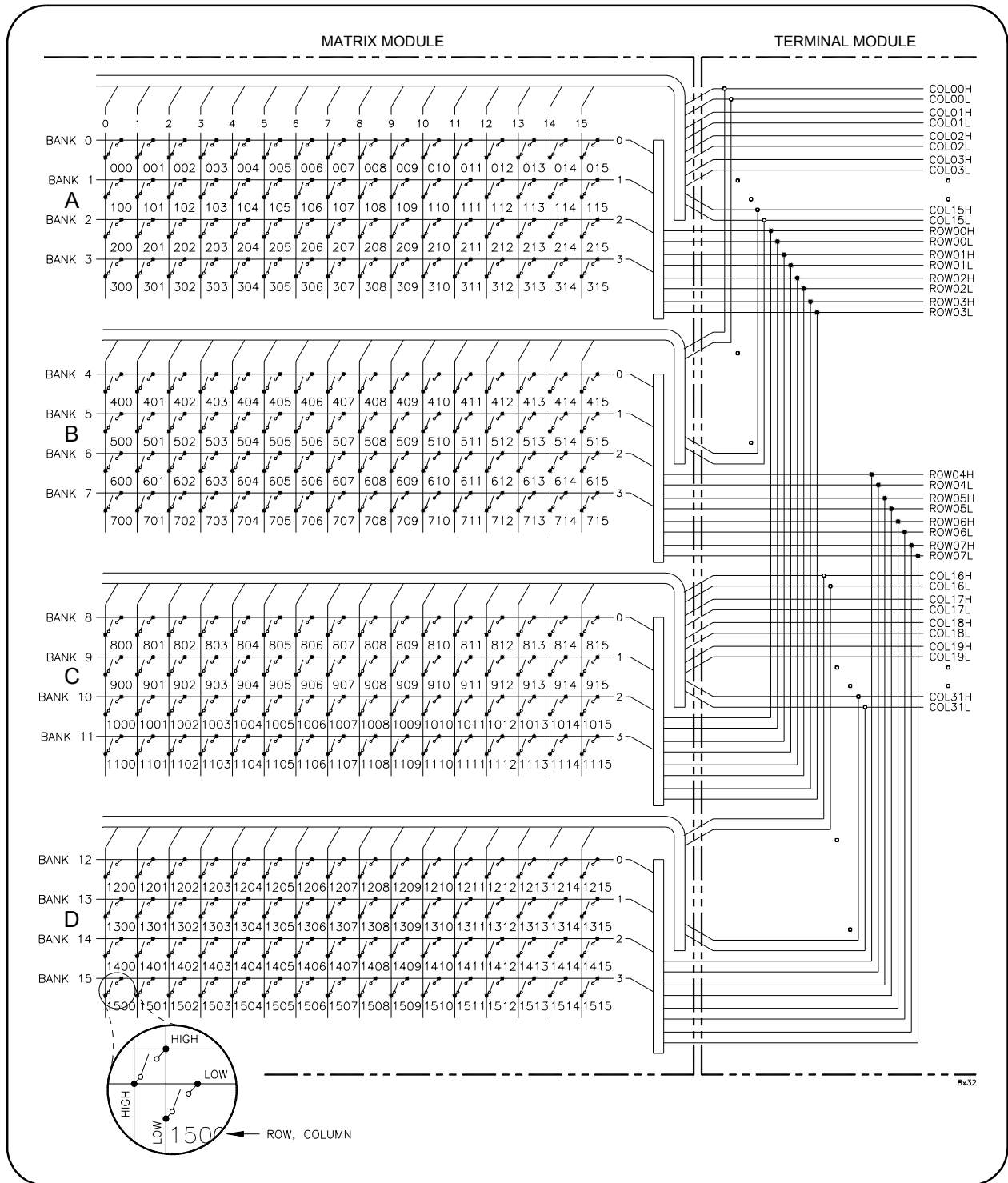

Figure 1-3. E1467A 8x32 Relay Matrix Module

Programming the Matrix Modules

There are several ways you can program the matrix modules. One way is to write directly to the registers. This method can provide better throughput speed, but requires more knowledge of the matrix design. See *Appendix B* for information on register-based programming.

Another way to program the matrix module is to use a command module and Standard Commands for Programmable Instruments (SCPI). With SCPI commands, the command module parses the commands and writes to the appropriate relay module register. The examples in this manual use the SCPI programming language. See *Appendix B* for examples on writing directly to the registers.

Addressing the Modules

To address specific channels (relays) within a matrix module, you specify the SCPI command and matrix module channel list. The following are the most commonly used SCPI commands:

- CLOSe *channel_list* Closes the relays specified
- OPEN *channel_list* Opens the relays specified
- SCAN *channel_list* Closes the relays specified, one at a time

Channel List

The *channel_list* is a combination of the card number and the channel numbers. The *channel_list* takes the form of *@ssrrcc* where *ss* = matrix module card number (00-99), *rr* = row number of the matrix module, and *cc* = column number of the matrix module.

Card Number

The card number (*ss* of the *channel_list*) identifies the switch module within a switchbox. The card number assigned depends on the switch configuration used. Leading zeroes can be ignored for the card number.

For a single-module switchbox configuration, the card number is always 01. For a multiple-module switchbox configuration, multiplexer modules are set to successive logical addresses. The multiplexer module with the lowest logical address is always card number 01. The card number with the next successive logical address is 02, etc.

Figure 1-4 illustrates card numbers and logical addresses of a typical multiple-module switchbox configuration. *Chapter 2* shows an example of addressing a switchbox configuration.

Channel Addresses

The channel address is the *rrcc* of the *channel_list*. This address determines which relay will be addressed. Use a comma (,) to form a channel list or use a colon (:) to form a channel range. You can address single channels (*@ssrrcc*), multiple channels (*@ssrrcc,ssrrcc,...*), sequential channels (*@ssrrcc:ssrrcc*), groups of sequential channels (*@ssrrcc:ssrrcc,ssrrcc:ssrrcc*), or any combination.

Only valid channels can be accessed in a channel list or channel range. Also, the channel range must be from a lower channel number to a higher channel number. For example, CLOS (*@10000:20303*) is acceptable, but CLOS (*@20303:10000*) generates an error. Table 1-1 shows the matrix modules channel numbers for the three matrix modules.

Table 1-1. Matrix Modules Channel Numbers

Matrix Module	Rows (rr)	Columns (cc)
E1465A 16x16 Relay Matrix Switch	00 - 15	00 - 15
E1466A 4x64 Relay Matrix Switch	00 - 03	00 - 63
E1467A 8x32 Relay Matrix Switch	00 - 07	00 - 31

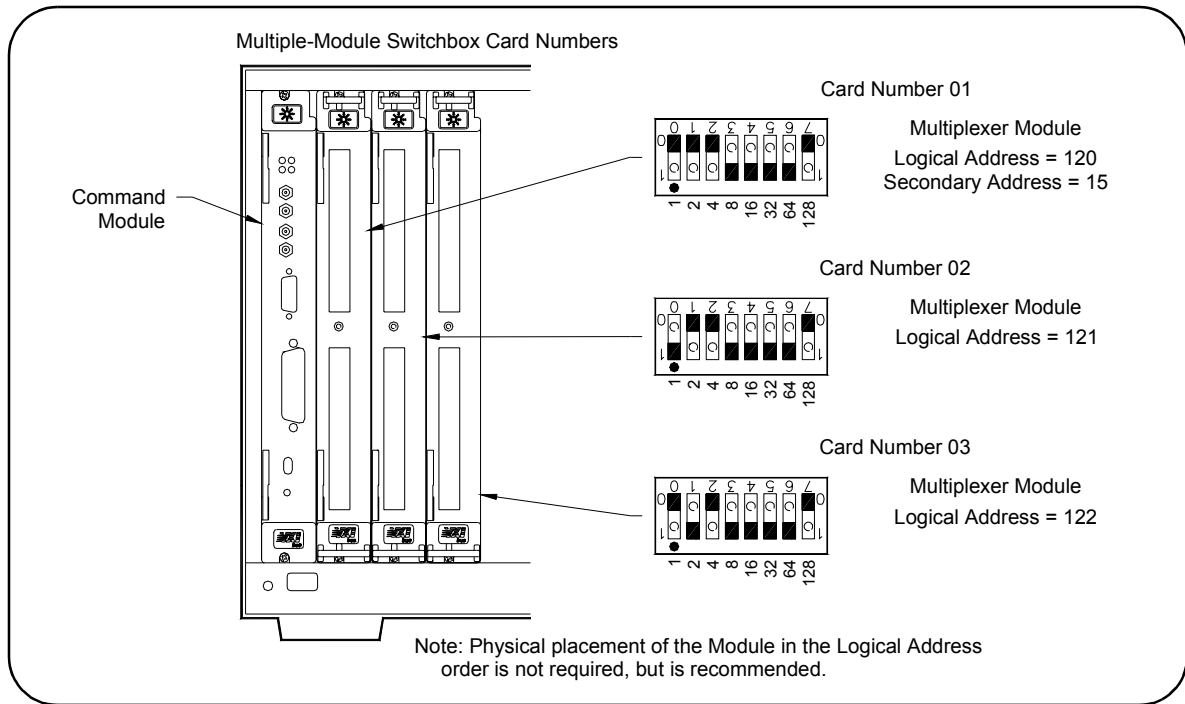

Figure 1-4. Card Numbers in a Multiple-Module Switchbox

Example: Closing Relays (BASIC)

This example assumes a PC running BASIC and a GPIB interface. The program closes row 03, column 12 of an E1465A 16x16 matrix module at logical address 120 (secondary address = $120/8 = 15$) and queries the result. The result is returned to the controller and displayed (1 = relay closed, 0 = relay open). See *Chapter 4* for information on the SCPI commands.

```

10 OUTPUT 70915; "*RST"           ! Resets the module
20 OUTPUT 70915; "CLOS (@10312)"  ! Closes row 03, column 12 on
                                   module number 1
30 OUTPUT 70915; "CLOS? (@10312)" ! Query channel 10312
40 ENTER 70915; Value             ! Enter result into variable Value
50 PRINT Value                    ! Print results (should print "1"
                                   to indicate that the channel is
                                   closed)
60 END                             ! Terminate program
    
```

Example: Closing Relays (Turbo C)

This example assumes a PC with a GPIB Interface card (with command library) running Borland Turbo C. The program closes row 03, column 12 of an E1465A 16x16 matrix module at logical address 120 (secondary address = $120/8 = 15$) and queries the result. The result is returned to the controller and displayed (1 = relay closed, 0 = relay open). See *Chapter 4* for information on the SCPI commands.

```
#include <stdio.h>
#include <chpib.h>                /*Include file for GPIB*/

#define ISC 7L
#define MATRIX 70915L            /*Matrix default address*/
#define TASK1 "*RST"            /*Reset*/
#define TASK2 "CLOS (@10312)"   /*Close row 3, column 12*/
#define TASK3 "CLOS? (@10312)" /*Query row 3, column 12*/

main()
{
    char into[257];
    int length = 256;

    /*Output commands to matrix module*/
    error_handler (IOTIMEOUT (7L,5.0), "TIMEOUT");
    error_handler (IOOUTPUTS (MATRIX, TASK1, 4), "OUTPUT command");
    error_handler (IOOUTPUTS (MATRIX, TASK2, 15), "OUTPUT
        command");
    error_handler (IOOUTPUTS (MATRIX, TASK3, 15), "OUTPUT
        command");

    /*Enter from matrix*/

    error_handler (IOENTERS (MATRIX, into, &length), "ENTER command");
    printf("Now let's see if the switch is closed: %s",into);
    return;
}
int error_handler (int error, char *routine)
{
    char ch;
    if (error != NOERR)
    {
        printf ("\n Error %d %s \n", error, errstr(error));
        printf (" in call to GPIB function %s \n\n", routine);
        printf ("Press 'Enter' to exit: ");
        scanf ("%c", &ch);
        exit(0);
    }
    return 0;
}
```

Notes:

Chapter 2

Configuring the Matrix Modules

Using This Chapter

This chapter gives guidelines to connect external wiring to the E1465A, E1466A, and E1467A Relay Matrix Switch modules (matrix module) and shows how to connect multiple modules together to form larger matrixes. This chapter includes:

- WARNINGS and CAUTIONS19
- Configuring the Switch Module.20
- Configuring the Terminal Modules24
- Configuring Larger Matrixes30

WARNINGS and CAUTIONS

WARNING SHOCK HAZARD. Only service-trained personnel who are aware of the hazards involved should install, remove, or configure matrix modules. Remove all power sources from the mainframe and installed modules before installing or removing a module.

CAUTION MAXIMUM INPUTS. The maximum voltage that can be applied to any terminal is 200 Vdc/170 Vrms. The maximum current that can be applied to any row or column is 1 A dc or ac peak. The maximum power that can be applied to any terminal is 30 W or 62.5 VA (resistive).

CAUTION STATIC ELECTRICITY. Static electricity is a major cause of component failure. To prevent damage to the electrical components in a matrix module, observe anti-static techniques when removing or installing the module or when working on the module.

Configuring the Switch Module

This section gives guidelines to configure the E1465A/E1466A/E1467A switch module, including:

- Switch Module Connectors
- Setting the Logical Address Switch
- Setting the Interrupt Level
- Installing the Switch Module in a Mainframe

Switch Module Connectors

Figure 2-1 shows the front panel of the E1465/66/67A switch module and the connector pin-out that mates to the terminal module.

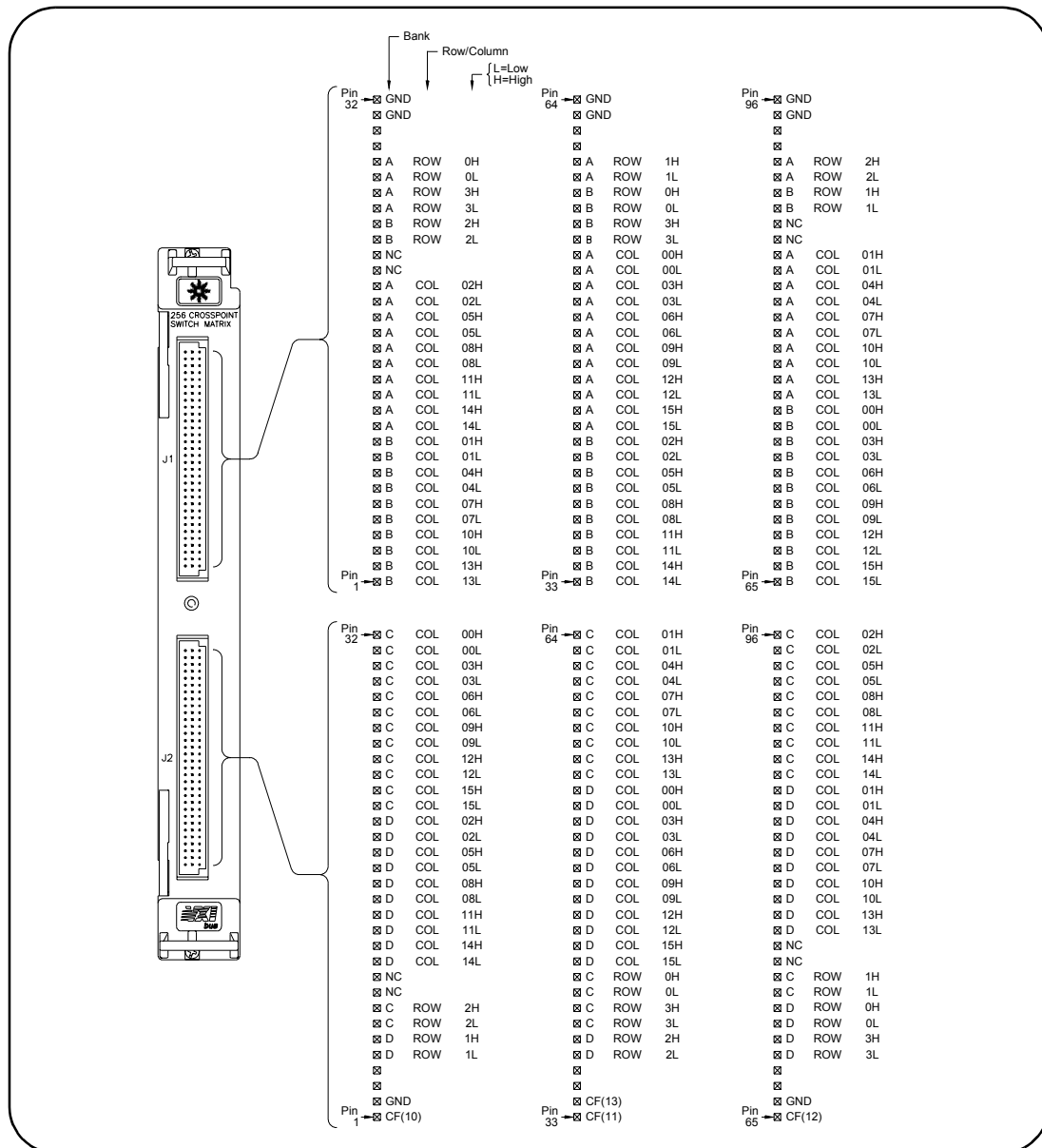

Figure 2-1. Relay Matrix Switch Module Pin-out

Setting the Logical Address Switch

The logical address switch (LADDR) factory setting is 120. Valid address values are from 1 to 255. The matrix module can be configured as a single instrument or as a switchbox. See Figure 2-2 for switch position information.

NOTE *The address switch selected value must be a multiple of 8 if the module is the first module in a switchbox used with a VXIbus command module and is being instructed by SCPI commands.*

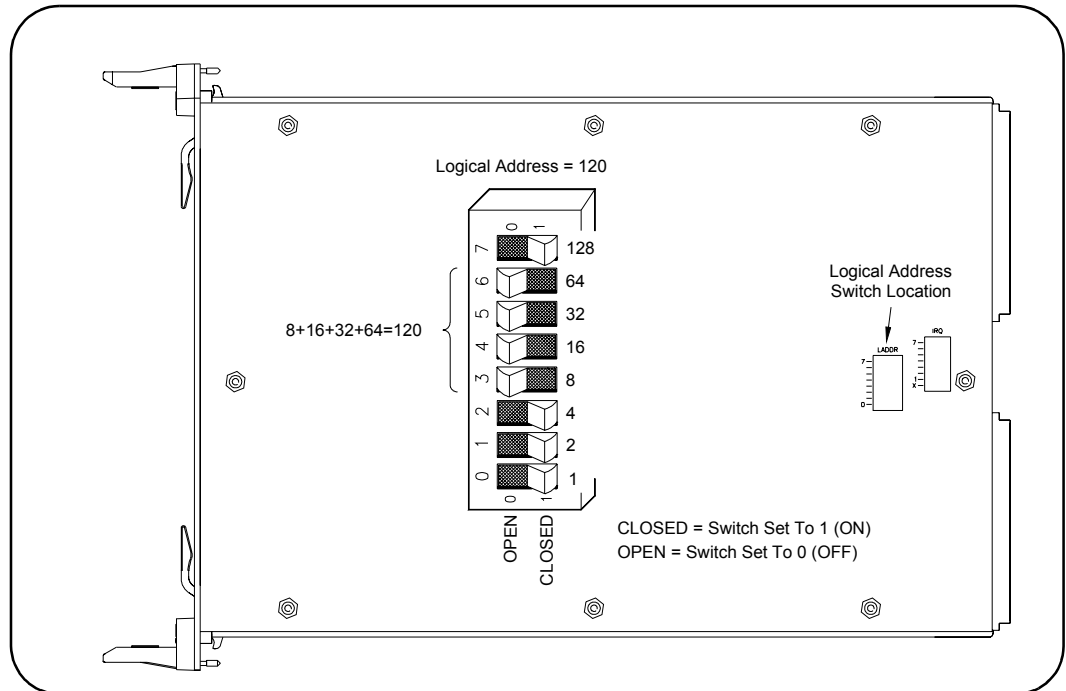

Figure 2-2. Setting the Module Logical Address

Setting the Interrupt Level

The matrix module generates an interrupt after a channel has been closed. These interrupts are sent to, and acknowledgements are received from, the command module (such as an E1406A) via the VXIbus backplane interrupt lines. For applications where the matrix module is installed in a C-Size mainframe and is a servant of the command module, the interrupt line jumper does not have to be moved. See Figure 2-3 to change the interrupt line.

You can select seven different interrupt line levels. Line X disables the interrupt and should not be used. The module's factory setting is line 1. To change the setting, remove the four-pin jumper (part number 1258-0247) from the old line location and reinstall the jumper in the new line location.

If you are setting the interrupt line to something other than 1, see the *E1406A Command Module User's Manual* for additional information. If the four-pin jumper is not used, the two jumper locations must have the same interrupt line selected.

NOTE When the E1406A Command Module is the resource manager, the interrupt line jumper must be installed in position 1. However, if you are using an embedded computer with the E1406A Command Module, interrupt line 2 should be selected. The Level X interrupt line should not be used under normal operating conditions.

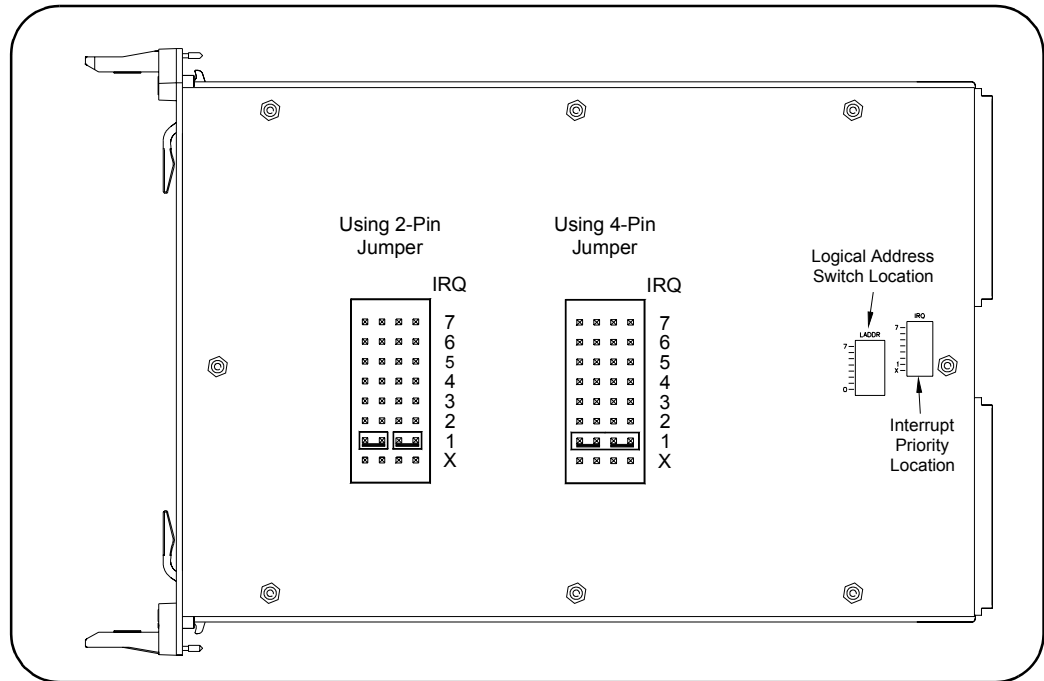

Figure 2-3. Setting the Interrupt Level

Installing the Switch Module in a Mainframe

E1465/66/67A Relay Matrix Switch modules may be installed in any slot (except slot 0) in a C-size VXIbus mainframe. See Figure 2-4 to install the module in a mainframe.

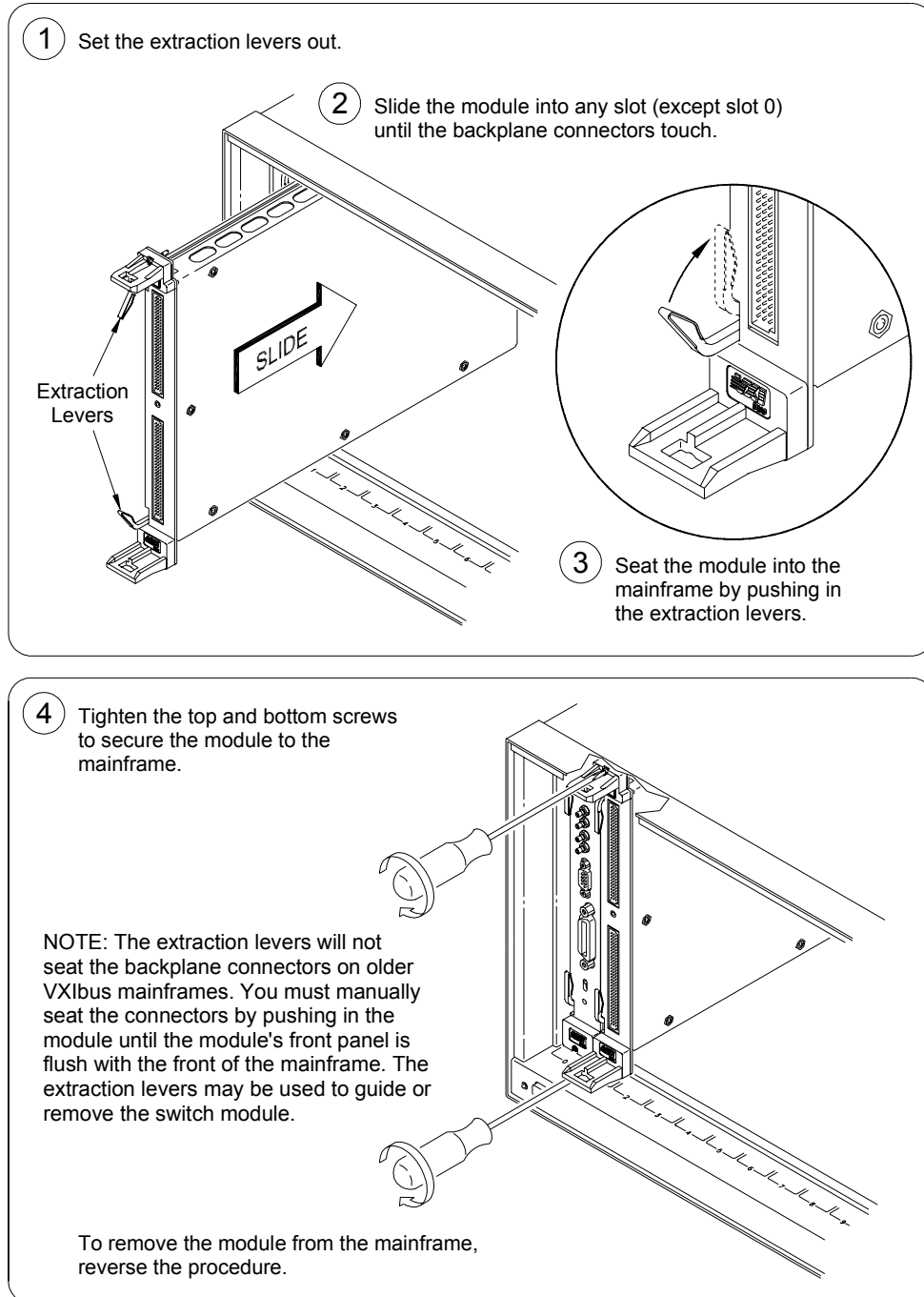

Figure 2-4. Installing the Switch Module in a VXIbus Mainframe

Configuring the Terminal Modules

This section gives guidelines to configure the E1465A/E1466A/E1467A terminal modules, including:

- Terminal Module Connectors
- Wiring Terminal Modules
- Connecting Terminal Modules to the Switch Module

Terminal Module Connectors

Figure 2-5 shows the E1465A terminal module connectors and associated row/column designators. Figure 2-6 shows the E1466A terminal module connectors and associated row/column designators. Figure 2-7 shows the E1467A terminal module connectors and associated row/column designators.

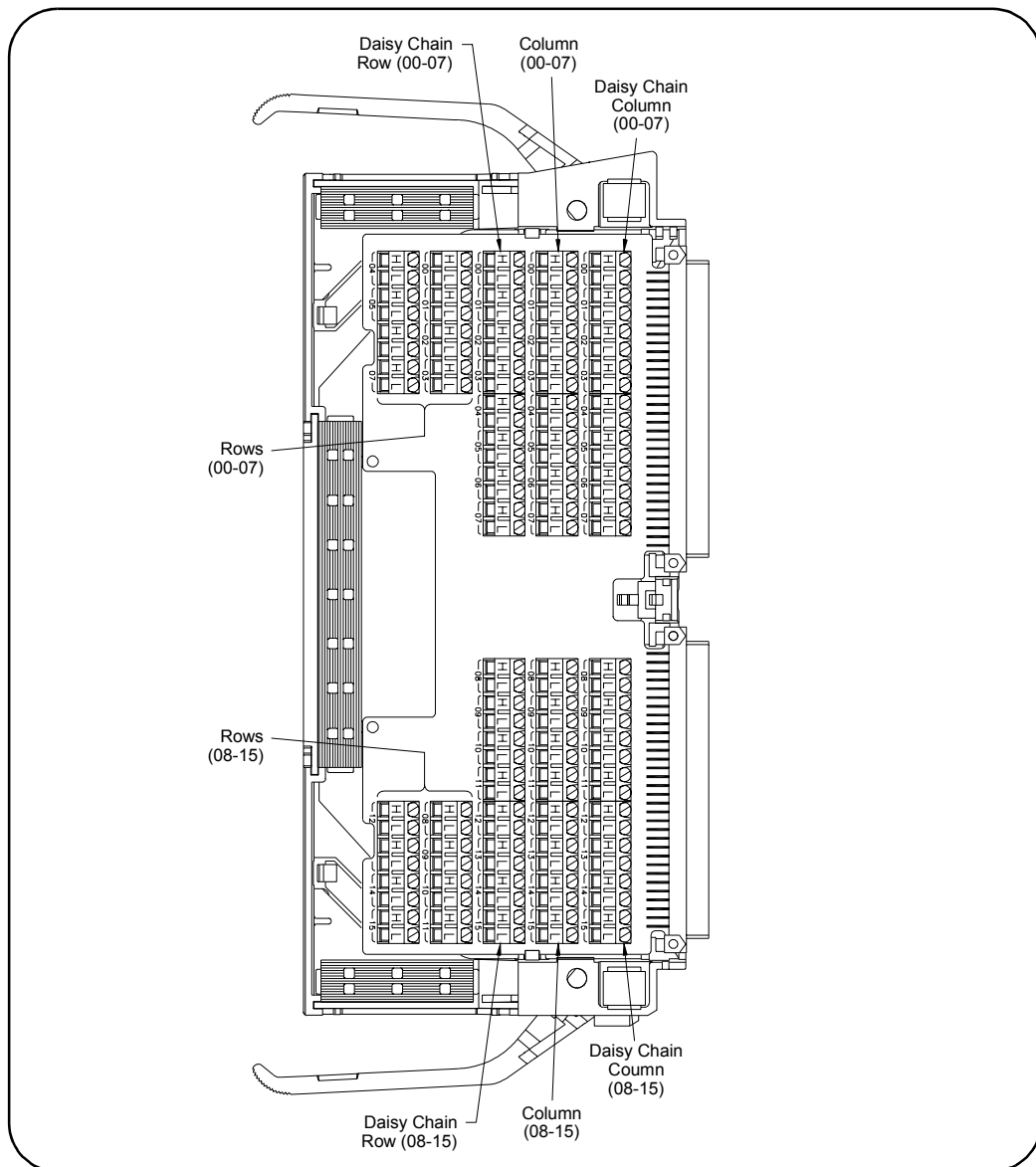

Figure 2-5. E1465A Terminal Module

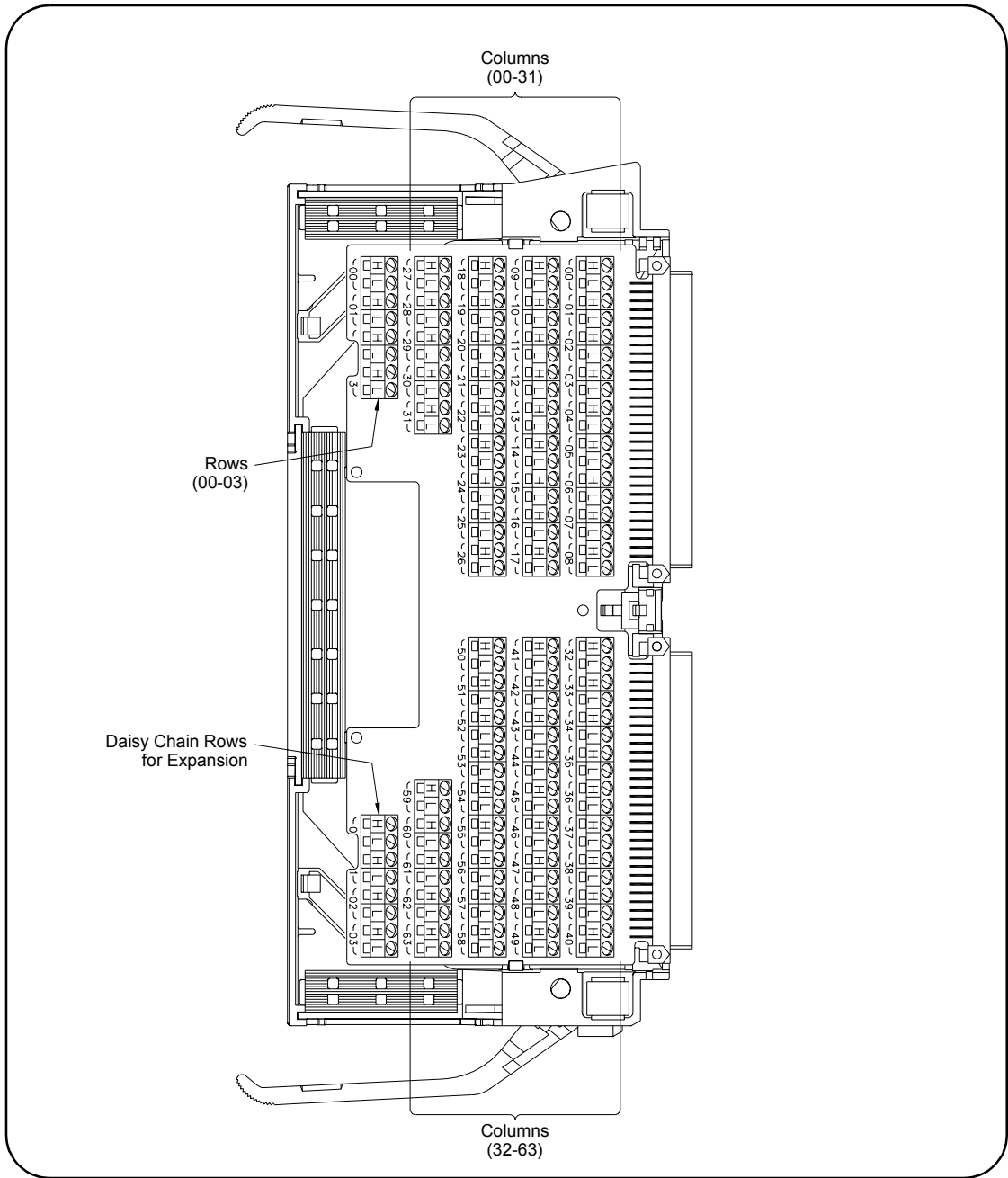

Figure 2-6. E1466A Terminal Module

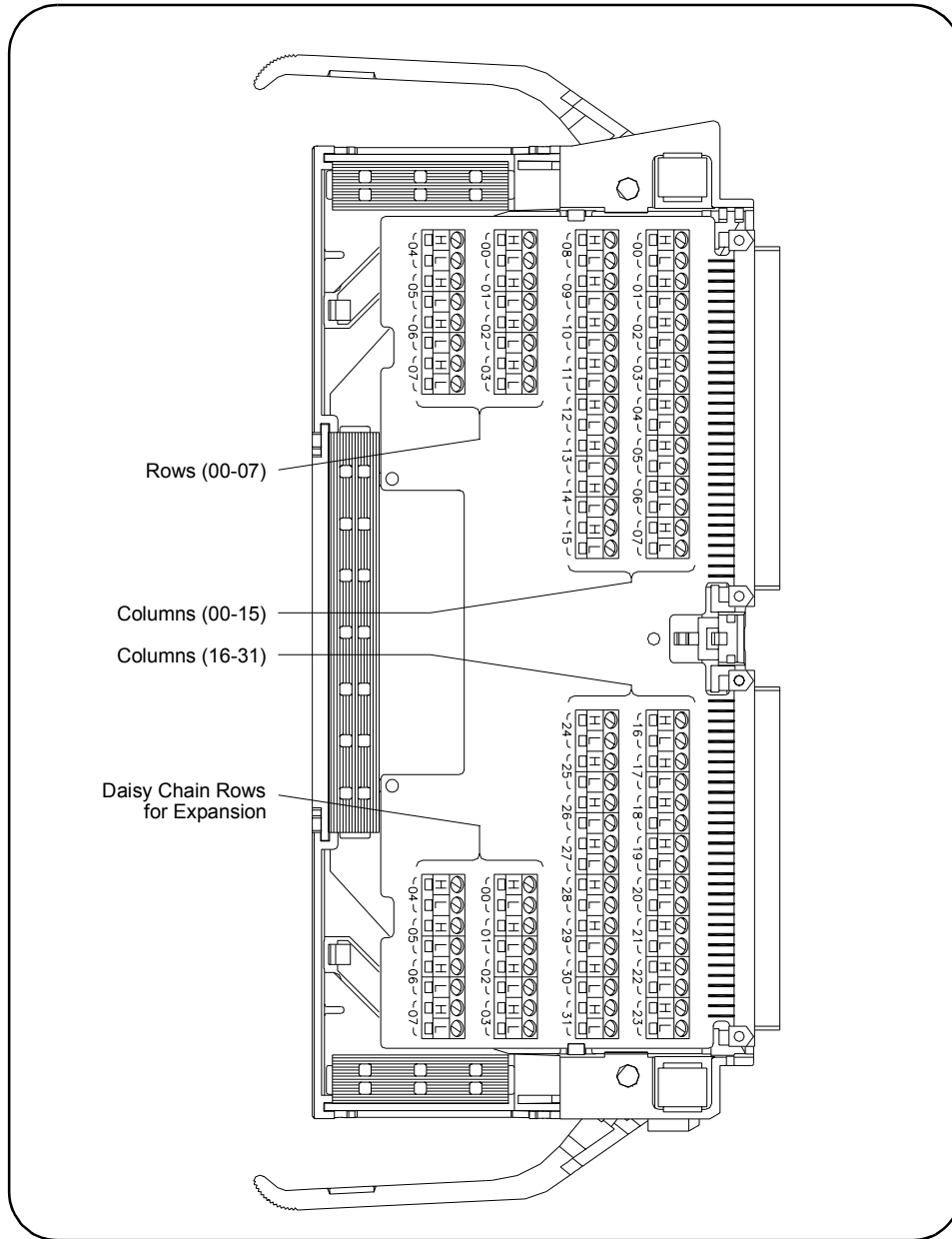

Figure 2-7. E1467A Terminal Module

Wiring the Terminal Modules

Figures 2-8 and 2-9 give guidelines to connect user wiring to the terminal module assembly. Expansion connectors allow you to create larger matrixes. See "Configuring Larger Matrixes" for details.

User wiring to the matrix modules is to the High (H) and Low (L) terminal connections. Maximum terminal wire size is No. 16 AWG. Wire ends should be stripped 6 mm (0.25 in.) and tinned. When wiring all channels, use a smaller gauge wire (No. 20 - 22 AWG).

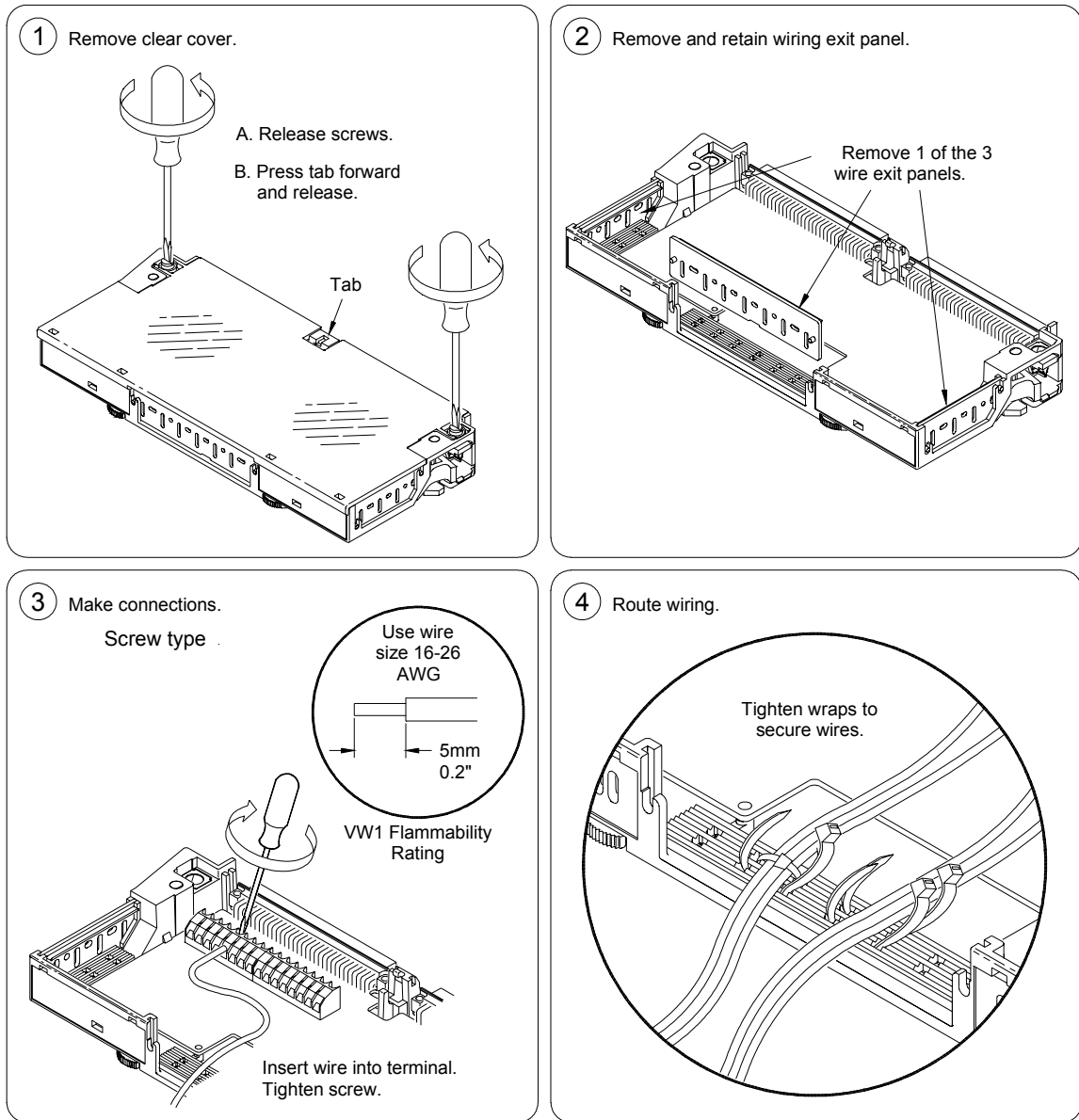

Figure 2-8. Wiring the Terminal Module

Continued on next page

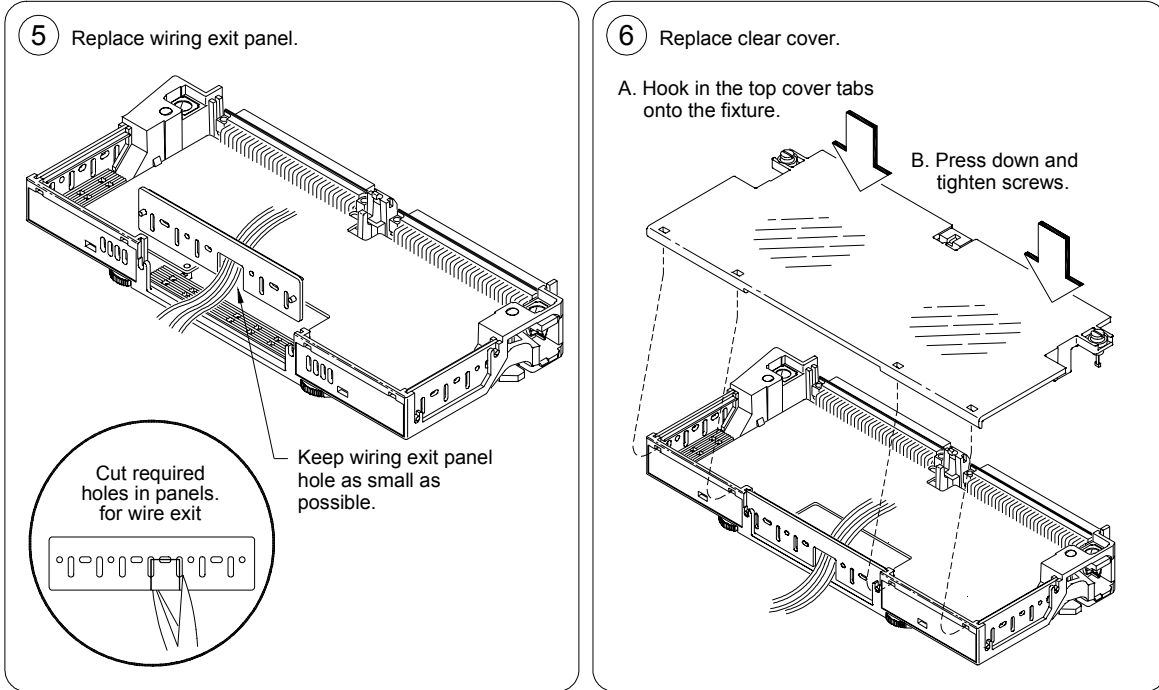

Figure 2-9. Wiring the Terminal Module
Continued from previous page

Attaching the Terminal Modules to the Switch Module

Figure 2-10 shows how to attach the E1465A, E1466A, or E1467A terminal modules to the switch module.

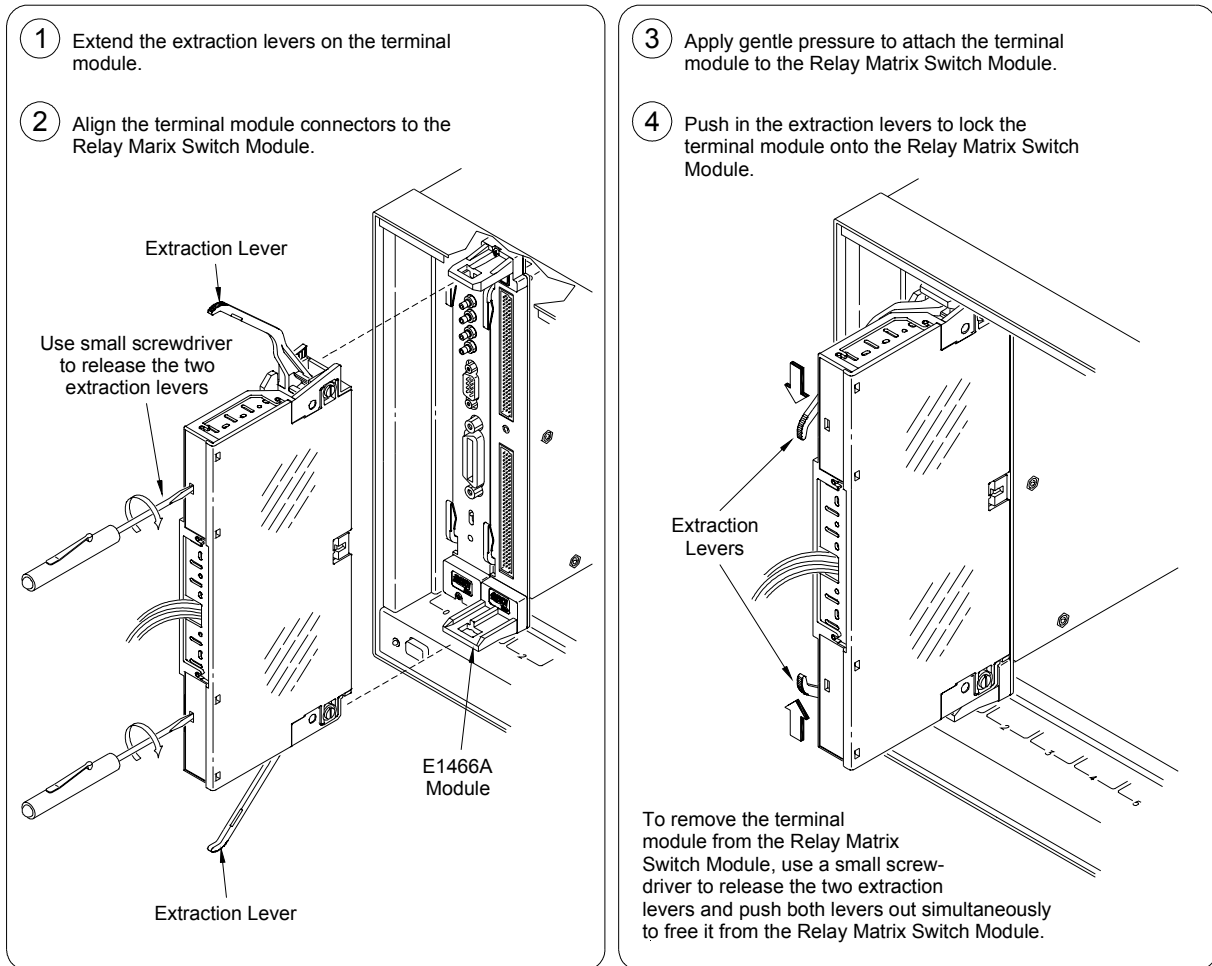

Figure 2-10. Attaching the Terminal Modules to the Switch Module

Configuring Larger Matrixes

This section gives guidelines to create larger matrixes, including:

- Creating Larger Matrixes
- Creating a 32x32 Matrix
- Creating a 4x256 Matrix
- Creating an 8x96 Matrix
- Creating Larger Matrixes with Multiple Mainframes

Creating Larger Matrixes

You can create larger matrixes with the matrix modules by using the E1466-80002 Daisy Chain Expansion cable. With larger matrixes, more crosspoints become available. A C-Size mainframe can have up to 3,072 two-wire crosspoints. You can make a larger matrix by connecting the rows or columns of one terminal module to the corresponding rows or columns of the next terminal module. Only the E1465A has a column expansion. You can also create larger matrixes by connecting multiple mainframes together.

When using multiple modules, the modules should be configured as a switchbox. That is, the first switch card (module) has a logical address that is a multiple of 8 and succeeding switch cards have sequential logical addresses. For example, if you use the matrix default address of 120 for the first card, the remaining cards in the switchbox would have logical addresses of 121, 122, 123, etc.

When using multiple modules configured as a switchbox, you must address the modules as a switchbox. For example, if you want to close row 00, column 05 on the second card, use CLOSe @20005).

Creating a 32x32 Matrix

Figure 2-11 shows how to connect four E1465A 16x16 modules to create a 32-row by 32-column matrix. This configuration requires 16 E1466-80002 Daisy Chain Expansion cables. The daisy chain rows of modules 1 and 3 are connected to the rows of cards 2 and 4 to increase the number of columns.

The daisy chain columns of cards 1 and 3 are connected together and the daisy chain columns of cards 2 and 4 are connected together. For example, to connect row 16 to column 15 use CLOSe (@30015). This command will close the relay on card 3, row 00, column 15. The following table shows which cards support applicable rows and columns.

Cards (Modules)	Rows/Columns
Cards 1 and 2	Rows 00 - 15
Cards 3 and 4	Rows 16 - 31
Cards 1 and 3	Columns 00 - 15
Cards 2 and 4	Columns 16 - 31

E1465A TERMINAL MODULES

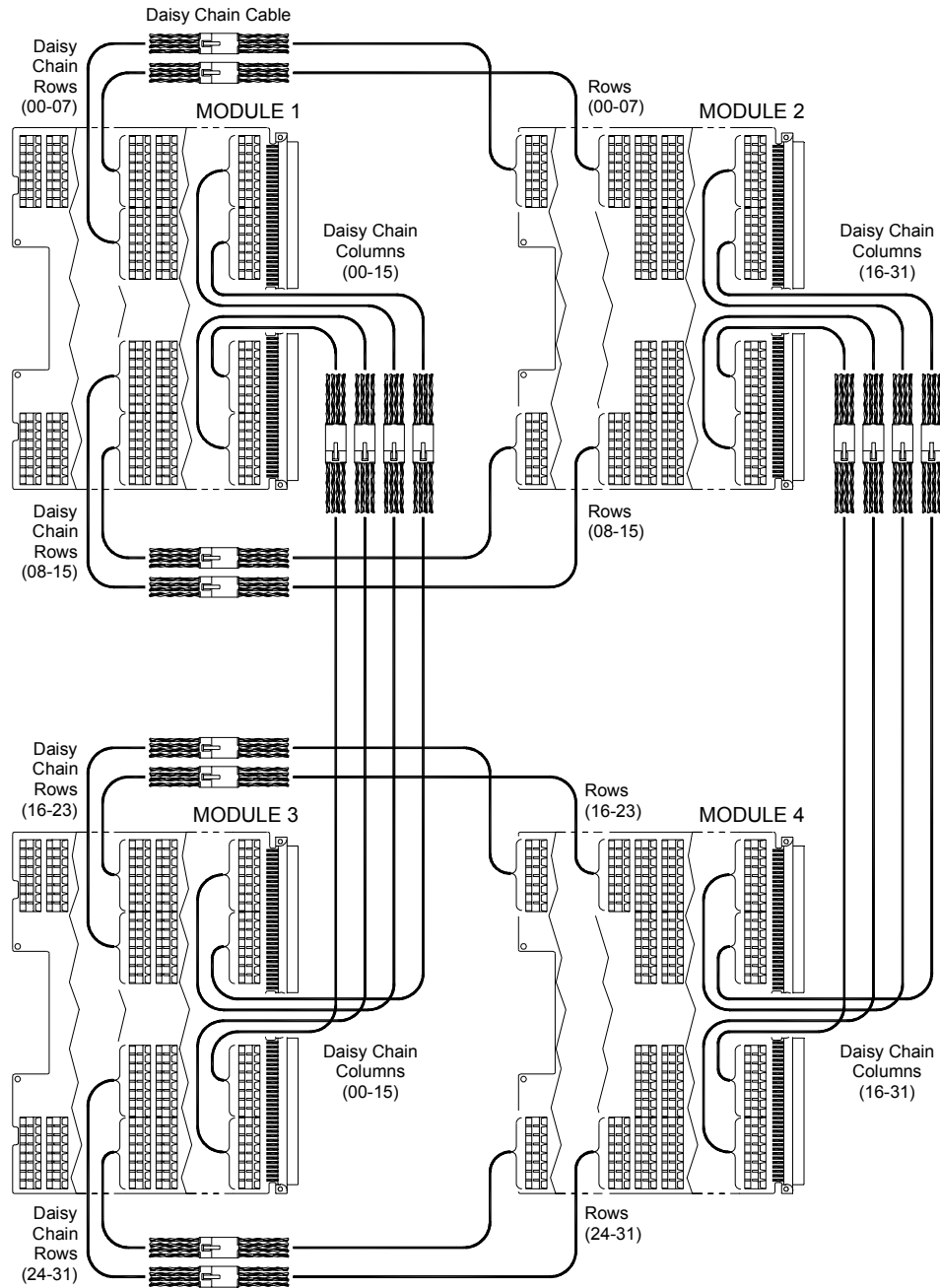

Figure 2-11. Creating a 32x32 Matrix

Creating a 4x256 Matrix

Figure 2-12 shows how to connect four E1466A 4x64 modules to create a 4-row by 256-column matrix. This configuration requires three E1466-80002 Daisy Chain Expansion cables. The daisy chain rows of the first module are connected to the rows of the next module. The daisy chain rows of the second module are then connected to the rows of the next module, etc.

You can continue this pattern to create even larger matrixes. For example, to connect row 03 to column 255, use CLOSe (@40363). This command will close the relay on card 4, row 3, column 63.

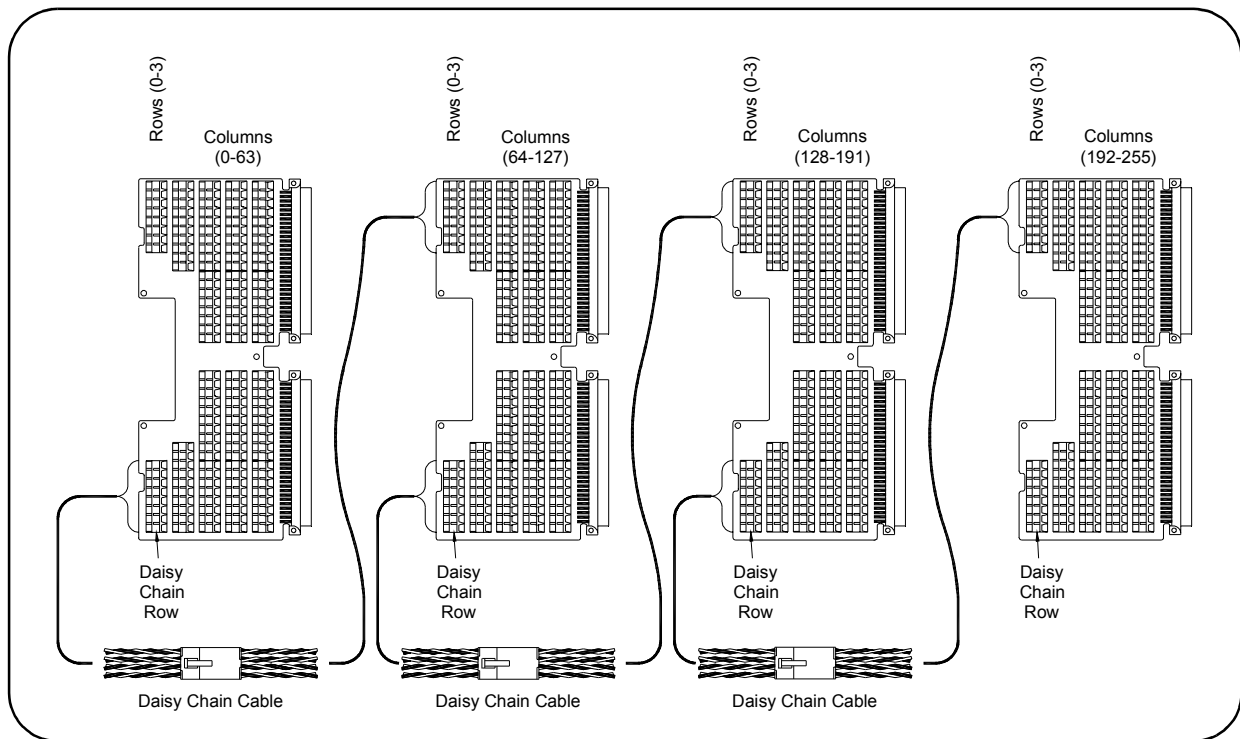

Figure 2-12. Creating a 4x256 Matrix

Creating an 8x96 Matrix

Figure 2-13 shows how to connect three E1467A 8x32 modules to create an 8-row by 96-column matrix. This configuration requires four E1466-80002 Daisy Chain Expansion cables. The daisy chain rows of the first module are connected to the rows of the next module. The daisy chain rows of the second module are then connected to the rows of the next module, etc.

You can continue this pattern to create even larger matrixes. For example, to connect row 4 to column 32, use CLOSe (@20400). This command closes the relay on card 2, row 4, column 00.

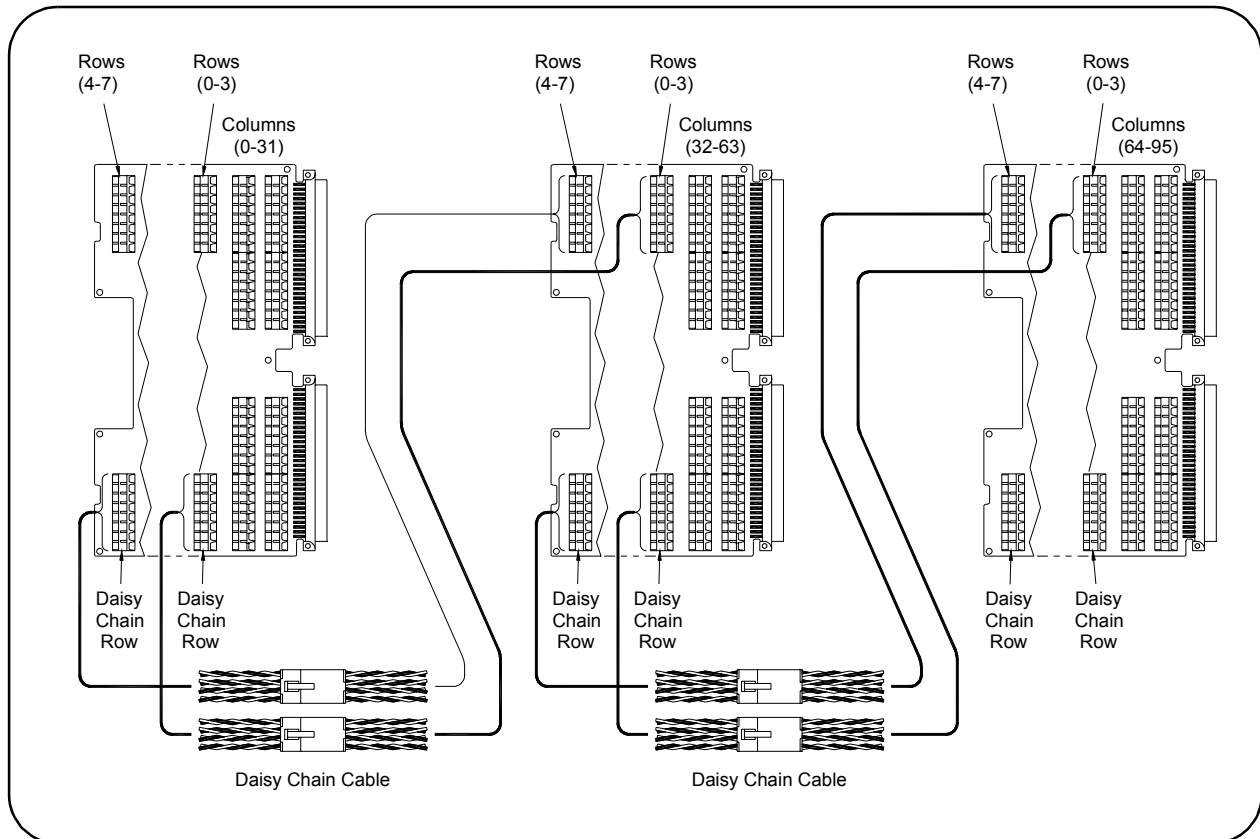

Figure 2-13. Creating an 8x96 Matrix

Creating Larger Matrixes with Multiple Mainframes

Figure 2-14 shows one way to connect C-Size mainframes together using GPIB. The matrix switch modules in each mainframe are then configured as switchboxes. The switchbox card numbers are 1, 2, 3, etc. in each mainframe and each mainframe has a different address.

For example, to address the second module in the second mainframe, use OUTPUT 70815; "CLOSe (@20001)", where the interface select code is 7, the command module primary address is 08, and the matrix module's secondary address is 15. This address selects card 2, row 00, column 01.

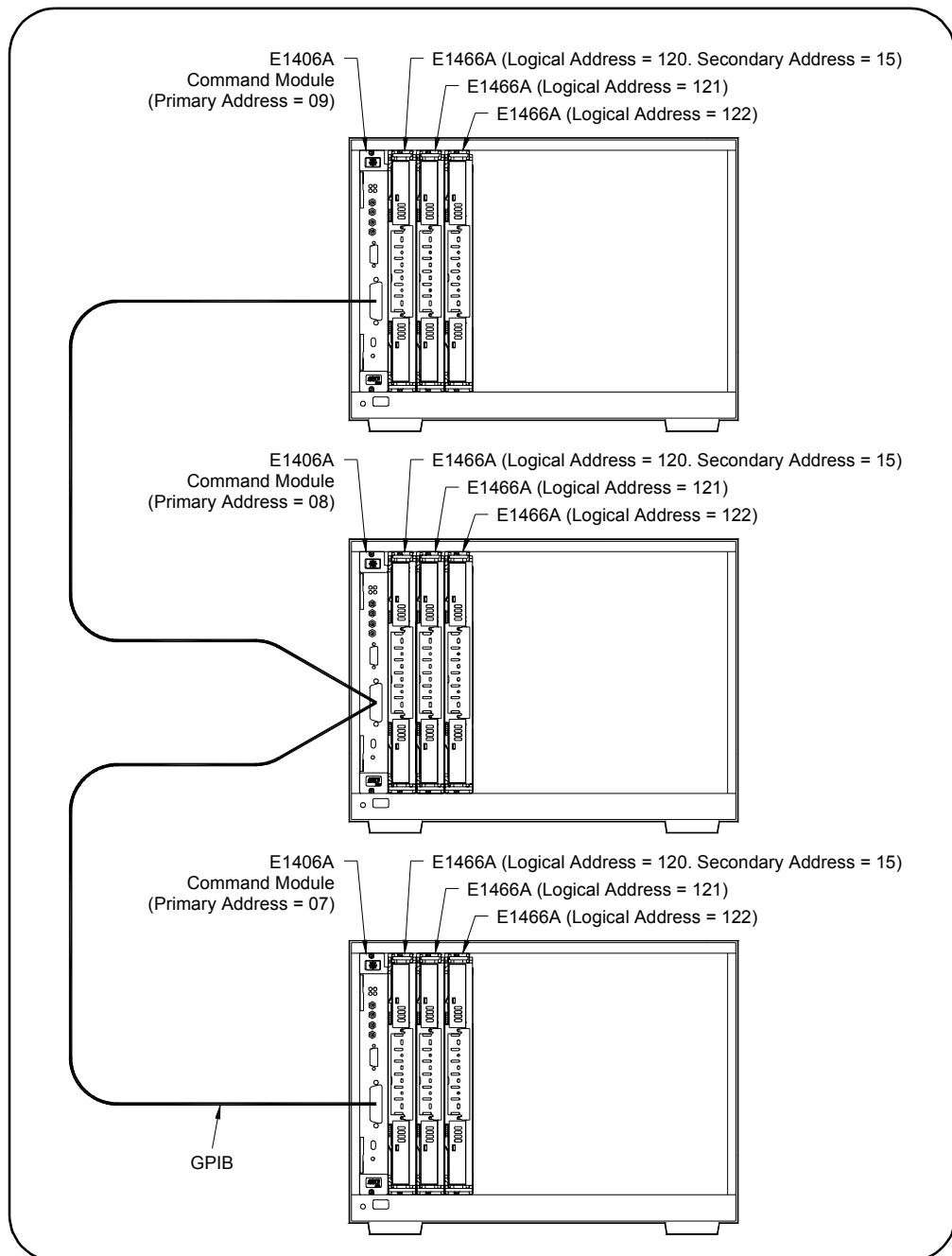

Figure 2-14. Creating Larger Matrixes with Multiple Mainframes

Chapter 3

Using the Matrix Modules

Using This Chapter

This chapter uses typical examples to show ways to use the E1465A, E1466A, and E1467A Relay Matrix Switch modules (matrix modules). See Chapter 4 for command information. Chapter contents are:

- Matrix Modules Commands35
- Power-on and Reset Conditions36
- Matrix Modules Identification36
- Switching Channels38
- Scanning Channels39
- Querying Matrix Modules42
- Using the Scan Complete Bit42
- Saving and Recalling States44
- Detecting Error Conditions45
- Synchronizing Matrix Modules46
- Understanding Matrix Modules47

NOTE *All examples in this chapter use GPIB select code 7, primary address 09, and secondary address 15 (LADDR = 120) for the matrix modules.*

Matrix Modules Commands

Table 3-1 explains some of the SCPI commands used in this chapter. See Chapter 4 for more information on these commands.

Table 3-1. Matrix Modules Commands Used in Chapter 3

SCPI Command	Command Description
[ROUTE:]CLOSe <channel_list>	Closes the channels in the <channel_list>
[ROUTE:]CLOSe? <channel_list>	Queries the state of the channels in the <channel_list>
[ROUTE:]OPeN <channel_list>	Opens the channels in the <channel_list>
[ROUTE:]OPeN? <channel_list>	Queries the state of the channels in the <channel_list>
[ROUTE:]SCAN <channel_list>	Closes the channels in the <channel_list>, one at a time
INITiate[:IMMediate]	Starts scan sequence and closes first channel in the <channel_list>
TRIGger:SOURce <source>	Selects the trigger source to advance the scan

Power-on and Reset Conditions

The matrix modules use latching relays and the relay state remains unchanged during power-up and power-down. However, if an E1406A Command Module is used, the firmware opens all relays during power-up and a when *RST (reset) is executed. See Table 3-2 for default values.

Table 3-2. *RST (Reset) Default Conditions

Parameter	Default	Description
ARM:COUNT	1	Number of scanning cycles is 1
TRIGger:SOURce	IMM	Will advance scanning cycles automatically
INITiate:CONTInuous	OFF	Number of scanning cycles is set by ARM:COUNT
OUTPut[:STATe]	OFF	Trigger output from EXT or TTL sources is disabled

Matrix Modules Identification

The following programs use the *RST, *CLS, *IDN?, CTYP?, and CDES? commands to reset and identify the matrix modules. For example, a typical printout for the E1465A 16x16 matrix module will be similar to:

```
HEWLETT-PACKARD,SWITCHBOX,0,A.04.00
16 x 16 Matrix Switch
HEWLETT-PACKARD,E1465A,0,A.04.00
```

Example: Matrix Module Identification (BASIC)

```
10 DIM A$(50), B$(50), C$(50)           ! Dimensions three string
                                         ! variables to fifty characters
20 OUTPUT 70915;"*RST; *CLS"           ! Outputs the commands to reset
                                         ! and clears the status register
30 OUTPUT 70915;"*IDN?"               ! Queries for module identification
40 ENTER 70915; A$                     ! Enters the results into A$
50 OUTPUT 70915;"SYST:CDES? 1"       ! Outputs the command for a card
                                         ! description
60 ENTER 70915; B$                     ! Enters the results into B$
70 OUTPUT 70915;"SYST:CTYP? 1"       ! Outputs the command for the
                                         ! card type
80 ENTER 70915; C$                     ! Enters the results into C$
90 PRINT A$, B$, C$                   ! Prints the contents of variables
                                         ! A$, B$, and C$
100 END
```

Example: Matrix Module Identification (TURBO C)

```
#include <stdio.h>
#include <chpib.h>           /* Include file for GPIB*/

#define ISC 7L
#define MATRIX 70915L       /* Matrix default address*/
#define TASK1 "*RST;*CLS;*IDN?" /* Reset, clear, and query id*/
#define TASK2 "SYST:CDES? 1"  /* Command for card description*/
#define TASK3 "SYST:CTYP? 1"  /* Command for card type*/

main( )
{
    char into1[51], into2[51], into3[51];
    int length = 50;

    /* Output and enter commands to matrix module*/

    error_handler (IOTIMEOUT (7L,5.0), "TIMEOUT");

    error_handler (IOOUTPUTS (MATRIX, TASK1, 15), "OUTPUT command");
    error_handler (IOENTERS (MATRIX, into1, &length), "ENTER command");

    error_handler (IOOUTPUTS (MATRIX, TASK2, 12), "OUTPUT command");
    error_handler (IOENTERS (MATRIX, into2, &length), "ENTER command");

    error_handler (IOOUTPUTS (MATRIX, TASK3, 12), "OUTPUT command");
    error_handler (IOENTERS (MATRIX, into3, &length), "ENTER command");

    printf("IDENTIFICATION: %s",into1);
    printf("CARD DESCRIPTION: %s",into2);
    printf("CARD TYPE: %s",into3);
    return;
}

int error_handler (int error, char *routine)
{
    char ch;
    if (error != NOERR)
    {
        printf ("\n Error %d %s \n", error, errstr(error));
        printf (" in call to GPIB function %s \n\n", routine);
        printf ("Press 'Enter' to exit: ");
        scanf ("%c", &ch);
        exit(0);
    }
    return 0;
}
```

Switching Channels

Use CLOSe <channel_list> to close one or more matrix module channels and OPEN <channel_list> to open the channel(s). channel_list has the form @ssrrcc where ss = card number (01-99), rr is the row number, and cc = column number. See Table 3-3 for row and column definitions for the modules.

To OPEN or CLOSe multiple channels, place a comma (,) between the channel numbers. For example, to close channels 10103 and 10201, execute CLOS (@10103,10201). To OPEN or CLOSe a continuous range of channels, place a colon (:) between the first and last channel numbers.

Table 3-3. Matrix Modules Channel Numbers

Matrix Module	Rows (rr)	Columns (cc)
E1465A 16 x 16 Relay Matrix	00 - 15	00 - 15
E1466A 4 x 64 Relay Matrix	00 - 03	00 - 63
E1467A 8 x 32 Relay Matrix	00 - 07	00 - 31

Example: Opening/Closing Channels (BASIC)

This BASIC program shows one way to close and open row 2, column 14 on an E1466A matrix module (card #1). In the program, implied commands are those that appear in square brackets ([]) in the command syntax. The brackets are not part of the command and are not sent to the instrument. For example, in the following program, ROUTe can be eliminated and just the CLOSe or OPEN command can be used.

```
10 DISP "TEST E1465A Matrix"
20 OUTPUT 70915; "ROUT:CLOS (@10214)"
30 OUTPUT 70915; "ROUT:OPEN (@10214)"
40 END
```

Example: Channel Sequencing (BASIC)

This example BASIC program sequences through each channel on an E1466A 4x64 matrix module.

```
10 OUTPUT 70915;"*RST"           ! Reset the module
20 FOR Row = 0 TO 3              ! Loop to step through all
                                ! rows in the matrix
30   FOR Col = 0 TO 63          ! Loop to step through all
                                ! columns in the matrix
40     Addr=10000+100*row+Col    ! Calculates channel to close
50     OUTPUT 70915; "CLOS (@ ";Addr;")"
                                ! Closes the channel
60   NEXT Col                  ! Sequences through each
                                ! column in the matrix
70 NEXT Row                    ! Sequences through each row
                                ! in the matrix
80 END
```

Scanning Channels

Scanning matrix module channels consists of closing a sequence of channels one channel at a time. Single scan, multiple scans, or continuous scanning modes are available. TRIGGER:SOURce specifies the source to advance the scan. OUTPUT can be used to enable the E1406A Command Module Trig Out port or TTL Trigger bus lines (0-7).

Example: Scanning Channels Using TTL Triggers (BASIC)

This example uses the E1406A Command Module TTL Trigger Bus Lines to synchronize matrix module channel closures to an E1412A system multimeter. For measurement synchronization, the E1406A TTL Trigger Bus Line 0 is used by the matrix module to trigger the multimeter to perform a measurement. The E1406A TTL Trigger Bus Line 1 is used by the multimeter to advance the matrix module channel scan.

Note that these trigger bus lines are not actual hardware connections. Triggering is accomplished by the E1406A firmware. Row 00 (High and Low) of an E1465A 16x 6 matrix module is connected to the voltmeter's High and Low. The columns are then scanned, switching in different DUTs (devices under test).

Figure 3-1 shows how to connect the matrix module to the multimeter module. The connections shown with dotted lines are not actual hardware connections, but indicate how the firmware operates to accomplish the triggering.

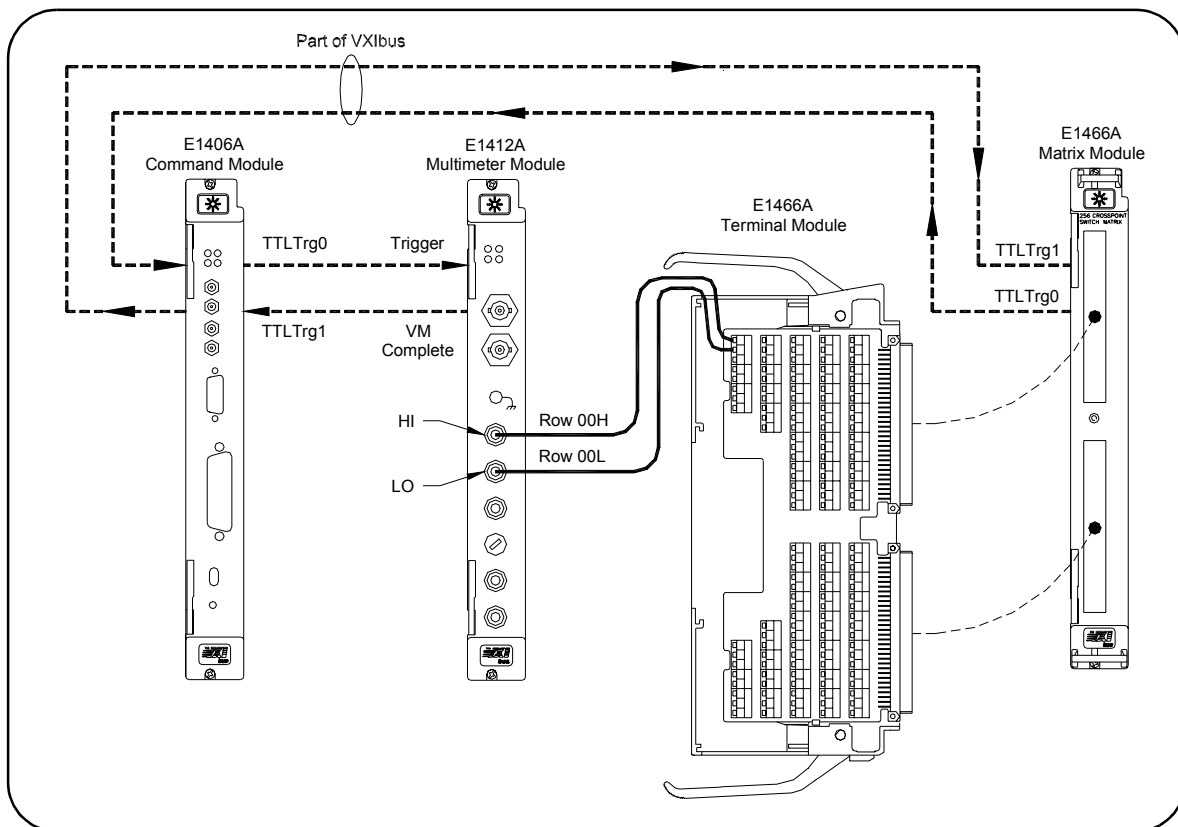

Figure 3-1. Example: Scanning Using TTL Triggers

This BASIC example program sets up the multimeter (GPIB address 70903) to scan making two-wire resistance measurements. The E1465A matrix module is set to scan row 00, columns 00 to 15.

```
10  ALLOCATE REAL Rdgs(1:16)
20  OUTPUT 70915; "*RST;*CLS"      ! Reset and clear the matrix
                                   ! module
30  OUTPUT 70903; "*RST;*CLS"     ! Reset and clear the multimeter
40  OUTPUT 70903; "ABORT;:TRIG:SOUR TTLTRG0"
                                   ! Multimeter triggers on TTL
                                   ! Trigger line 0
50  OUTPUT 70903; "OUTP:TTLTRG1:STAT ON"
                                   ! Multimeter pulses TTL Trigger
                                   ! line 1 on measurement
                                   ! complete
60  OUTPUT 70903; "CONF:RES AUTO,DEF"
                                   ! Set multimeter function to
                                   ! Resistance
70  OUTPUT 70903; "TRIG:DEL 0;COUN 16;:CAL:ZERO:AUTO ON"
                                   ! Set multimeter Range, NPLC
                                   ! functions
80  OUTPUT 70903; "*OPC?"
90  ENTER 70903; Check             ! Check to see if multimeter ready
100 OUTPUT 70903; "INIT"          ! When multimeter is ready,
                                   ! initialize trigger
110 OUTPUT 70915; "TRIG:SOUR TTLTRG1"
                                   ! Set matrix module to be
                                   ! triggered by TTL Trigger line 1
120 OUTPUT 70915; "OUTPUT:TTLT0:STATE ON"
                                   ! Matrix module pulses TTL
                                   ! Trigger line 0 on channel closed
130 OUTPUT 70915; "SCAN (@10000:10015"
                                   ! Scan list is Row 0, Columns
                                   ! 0 to 15
140 OUTPUT 70915; "INIT"          ! Initiate scan
150 OUTPUT 70903; "FETCH?"
160 ENTER 70903; Rdgs(*)          ! Enter readings
170 PRINT Rdgs(*)                 ! Print readings
180 END
```

Example: Scanning Using Trig In/Out Ports (BASIC)

This example uses the E1406A Command Module Trig In and Trig Out ports to synchronize the matrix module channel closures to an external 3457A voltmeter at address 722. Figure 3-2 shows how to connect the voltmeter to the command module and to the matrix module.

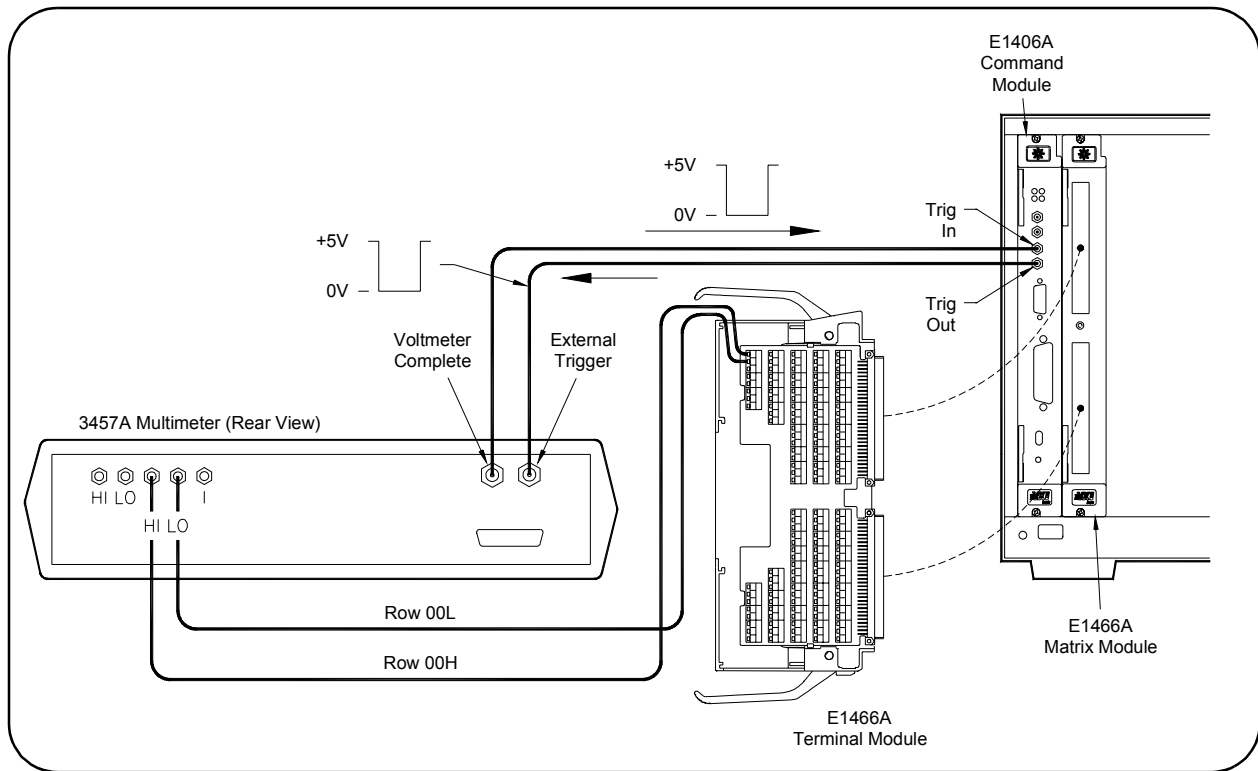

Figure 3-2. Example: Scanning Using Trig In and Trig Out Ports

```

10  OUTPUT 722; "TRIG EXT; DCV; MEM FIFO"
                                     ! Set voltmeter for external
                                     ! trigger, DCV measurements,
                                     ! memory first in, first out storage

20  OUTPUT 70915; "*RST;*CLS"        ! Reset and clear the matrix
                                     ! module

30  OUTPUT 70915; "OUTP ON"          ! Enable the E1406A Trig Out port

40  OUTPUT 70915; "TRIG:SOUR:EXT"    ! Set trigger source to external
                                     ! triggering

50  OUTPUT 70915; "SCAN (@10000:10015)"
                                     ! Set matrix measurement mode
                                     ! and define channel list

60  OUTPUT 70915; "INIT"             ! Initiate scan
70  WAIT 2                           ! Wait 2 seconds
80  FOR Channels = 1 to 16
90    ENTER 722;Results
100   PRINT Results
110  NEXT Channels
120  END

```

Querying Matrix Modules

All query commands end with a "?". These commands are used to determine a specific state of the matrix module. Data are sent to the output buffer where it can be retrieved into a computer. CLOSe? <channel_list> and OPEN? <channel_list> return the current state of the specified channel.

These commands return "1" if the operation is true and return "0" if the operation is false. A maximum of 128 channels can be queried at one time. Therefore, to query more than 128 channels, you must enter the query data in two separate commands. See Chapter 4 for more information on query commands.

Example: Querying Channel Closure (BASIC)

This BASIC example program closes a range of channels on an E1467A 8x32 matrix module and queries the results.

```
10 DIM Chan1$(128), Chan2$(128)      ! Dimensions two string variables
                                       ! to 128 characters each
20 OUTPUT 70915;"CLOS (@10000:10731)"
                                       ! Closes rows 00 through 07 and
                                       ! columns 00 through 31
30 OUTPUT 70915;"CLOS? (@10000:10331)"
                                       ! Queries rows 00 through 03
                                       ! and columns 00 through 31
40 ENTER 70915; Chan1$                ! Enters the results of the first
                                       ! 128 channel closures
50 OUTPUT 70914;"CLOS? (@10400:10731)"
                                       ! Queries rows 04 through 07
                                       ! and columns 00 through 31
60 ENTER 70915; Chan2$                ! Enters the results of the second
                                       ! 128 channel closures
70 PRINT "Channels closed";Chan1$, Chan2$
                                       ! Prints all channels closed
                                       ! (should print 1s)

80 END
```

Using the Scan Complete Bit

The Scan Complete Bit (bit 8) in the OPERation Status Register (in the command module) can be used to determine when a scanning cycle completes. (No other bits in this register apply to the switchbox.) Bit 8 has a decimal value of 256 and can be read directly using STAT:OPER?. See STATus:OPERation[:EVENT]? in Chapter 4.

When enabled by STAT:OPER:ENAB 256, the Scan Complete Bit is reported as Bit 7 of the Status Byte Register. You can use the GPIB Serial Poll or the IEEE 488.2 Common command *STB? to read the Status Register.

When Bit 7 of the Status Byte Register is enabled by *SRE 128 to assert a GPIB Service Request (SRQ), the computer can be interrupted when the Scan Complete Bit is set, after the scanning cycle completes. This allows the controller to do other operations while the scanning cycle is in progress.

Example: Using the Scan Complete Bit (BASIC)

This example monitors bit 7 in the Status Byte Register to determine when the scanning cycle is complete. The computer interfaces with an E1406A Command Module over GPIB. The GPIB select code is 7, primary address is 09, and secondary address is 15.

```

10 OUTPUT 70915;"*RST; *CLS"      ! Reset and clear the matrix
                                   module
20 OUTPUT 70915; "STATUS:OPER:ENABLE 256"
                                   ! Enable Scan Complete Bit
30 OUTPUT 70915; "TRIG:SOUR IMM" ! Set matrix module for
                                   continuous triggering
40 OUTPUT 70915; "SCAN (@10000:10015)"
                                   ! Select channels to scan
50 OUTPUT 70915; "*OPC?"          ! Wait for operation complete
60 ENTER 70915; A$
70 PRINT "*OPC? = ";A$
80 OUTPUT 70915; "STAT:OPER:ENAB?!" Query OPERation Status
                                   register contents
90 ENTER 70915; A$
100 PRINT "STAT:OPER:ENAB? = ";A$
110 OUTPUT 70915; "*STB?"        ! Query Status Byte register
                                   contents
120 ENTER 70915; A$
130 PRINT "Switch Status = ";A$
140 OUTPUT 70915; "INIT"        ! Start scan cycle
150 I = 0                        ! Initialize counter value
160 WHILE (I=0)                 ! Stay in loop until value is
                                   returned from SPOLL (70915)
170     I = SPOLL(70915)
180     PRINT "Waiting for scan to complete: SPOLL = ";I
190 END WHILE
200 I = SPOLL(70915)
210 PRINT "Scan complete: SPOLL = ";I
220 END

```

Saving and Recalling States

*SAV <numeric_state> stores the current state of the matrix modules channels. Up to 10 states can be stored by specifying <numeric_state> as an integer 0 through 9. The following states are stored: Channel relay states (open or closed), ARM:COUNT, TRIGger:SOURce, OUTPut[:STATe], and INITiate:CONTinuous.

*RCL <numeric_state> recalls the specified previously stored state. If the specified <numeric_state> does not exist, the matrix module configures to its power-on/reset states (see Table 3-2).

Example: Saving and Recalling States (BASIC)

This program shows one way to save and recall matrix modules states.

```
10 DIM A$(30)                ! Dimensions string variable
                             ! A$ to 30 characters
20 OUTPUT 70915; "CLOS (@10000:10015)
                             ! Closes channels on a matrix
                             ! module
30 OUTPUT 70915; "*SAV 5"    ! Saves state as numeric state 5
40 OUTPUT 70915; "*RST; *CLS" ! Resets and clears the matrix
                             ! module
50 OUTPUT 70915; "CLOS? (@10000:10020)"
                             ! Query to see which channels
                             ! are closed

60 ENTER 70915;A$
70 PRINT "Channels Closed: ";A$
80 OUTPUT 70915; "*RCL 5"    ! Recall numeric state 5
90 OUTPUT 70915; "CLOS? (@10000:10200)"
                             ! Check if recalled channels are
                             ! closed

100 ENTER 70915; A$
110 PRINT "Channels Closed: ";A$ ! Prints 1s for first 16 channels
                             ! closed and 0s for remaining 5
                             ! channels

120 END
```

Detecting Error Conditions

SYSTem:ERRor? requests a value from instrument's error register. This register contains an integer in the range [-32768 to 32767]. The response takes the form <err_number>,<err_message>, where <err_number> is the value of the instrument's error and <err_message> is a short description of the error.

If no error occurs, the switchbox responds with 0,"No error". If there has been more than one error, the instrument will respond with the first error in its error queue. Subsequent queries continue to read the error queue until it is empty. The maximum <err_message> string length is 255 characters.

Example: Detecting Error Conditions (BASIC)

This BASIC example program attempts an illegal channel closure for the E1466A 4x64 matrix module and polls for the error message.

```
10 DIM Err_num$(256)           ! Dimensions Err_num$ for 256
                                ! characters
20 OUTPUT 70915; "CLOS (@10500)" ! Try to close an illegal channel
30 OUTPUT 70915; "SYST:ERR?"    ! Check for a system error
40 ENTER 70915; Err_num$       ! Enter the errors into Err_num$
50 PRINT Err_num$              ! Prints error +2001, "Invalid
                                ! channel number"

60 END
```

Example: Detecting Error Conditions (TURBO C)

This Turbo C example program attempts an illegal channel closure for the E1466A 4x64 matrix module and polls for the error message.

```
#include <stdio.h>
#include <chplib.h>           /* Include file for GPIB*/

#define ISC 7L
#define MATRIX 70915L        /* Matrix module default address*/
#define TASK1 "CLOSE (@10500)" /* Command for illegal switch closure*/
#define TASK2 "SYST:ERR?"    /* Command for system error*/

main()
{
    char into[257];
    int length = 256;

    /* Output commands to matrix module*/

    error_handler (IOTIMEOUT (7L,5.0), "TIMEOUT");
    error_handler (IOOUTPUTS (MATRIX, TASK1, 15), "OUTPUT
        command");
    error_handler (IOOUTPUTS (MATRIX, TASK2, 9), "OUTPUT command");
```

```

/*Enter from matrix module*/

    error_handler (IOENTERS (MATRIX, into, &length), "ENTER command");
    printf("Print the errors: %s",into);
    return;
}
int error_handler (int error, char *routine)
{
    char ch;
    if (error != NOERR)
    {
        printf ("\n Error %d %s \n", error, errstr(error));
        printf (" in call to GPIB function %s \n\n", routine);
        printf ("Press 'Enter' to exit: ");
        scanf ("%c", &ch);
        exit(0);
    }
    return 0;
}

```

Synchronizing Matrix Modules

This section gives guidelines to synchronize matrix modules with measurement instruments.

Example: Synchronizing a Matrix Module (BASIC)

This BASIC example program shows how to synchronize matrix modules with measurement instruments. In this example, a matrix module switches a signal to a multimeter. The program verifies that the channel is closed before the multimeter begins its measurement.

```

10 OUTPUT 70915; "*RST"           ! Reset the module
20 OUTPUT 70915; "CLOS (@10012)" ! Close a channel
30 OUTPUT 70915; "*OPC?"         ! Wait for operation complete
40 ENTER 70915; Opc_value
50 OUTPUT 70915; "CLOS? (@10012)" !Test that the channel is closed
60 ENTER 70915;A
70 IF A=1 THEN
80   OUTPUT 70903;"MEAS:VOLT:DC?" ! When channel is closed,
                                   measure the voltage
90   ENTER 70903; Meas_value
100  PRINT Meas_value             ! Print the measured value
110 ELSE
120   PRINT "Channel did not close"
130 END IF
140 END

```

Understanding Matrix Modules

This section provides internal configuration details about the E1465, E1466A, and E1467A matrix modules, including advantages of latching relays and module operation.

Advantages of Latching Relays

There are several advantages to using the E1465A/E1466A/E1467A latching relays, as follows. The main disadvantage of latching relays is that the relay state is unchanged at power-on, power-off, or following a reset. Therefore, the device's firmware must ensure that all relays are open following these conditions.

- With 256 relays on the dense matrix relay module, latching relays prevent excessive current being drawn from the power supply if the user closes too many relays accidentally. Energy is saved since power is not continually applied to keep a latching relay closed.
- By not continually applying power, the relay coil does not heat up. This is important because the two metal contacts inside the relay, in effect, form a thermocouple. Thus, temperature differences on the relay contacts cause thermal EMF (electromotive force) to be generated.
- The life of a latching relay is usually longer than that of a nonlatching relay because of the power that must be continually applied to close a nonlatching relay.
- In conventional switch module designs, the module interrupts the central processing unit (CPU) each time a relay is opened or closed. For the E1465A/E1466A/E1467A matrix relay modules, the CPU is interrupted one time after all relays in the specified channel list have been opened or closed. Thus, system throughput speed is increased.

Matrix Module Operations

The following paragraphs describe matrix module operations (see Figure 3-3).

- A command is sent to the matrix module and is stored in FIFO memory.
- Once the data is in memory, the VME Timing PAL (programmable array logic) asserts DTACK*. This signals the CPU on the matrix module's commander that it is now free to service other tasks.
- The VME Timing PAL signals the FIFO Interface PAL to execute the command. During execution, the Data Bus FIFO EMPTY* flag signals the FIFO Interface PAL to read the Data Bus and Address Bus FIFO and generate 7 msec pulses to activate the relays. Only one 7 msec pulse is required per relay bank (up to 16 relays).

- The FIFO Interface PAL reads the Data Bus and Address Bus FIFO until the EMPTY* flag signals the FIFO Interface PAL the FIFO memory is empty.
- When the FIFO is empty, the FIFO Interface PAL signals the VME Timing PAL which asserts IRQ*. This interrupts the command module CPU after the last relay has been activated.
- Because the matrix module asserts IRQ* after the last relay is activated, the CPU is not continually interrupted. Thus, system throughput is enhanced.

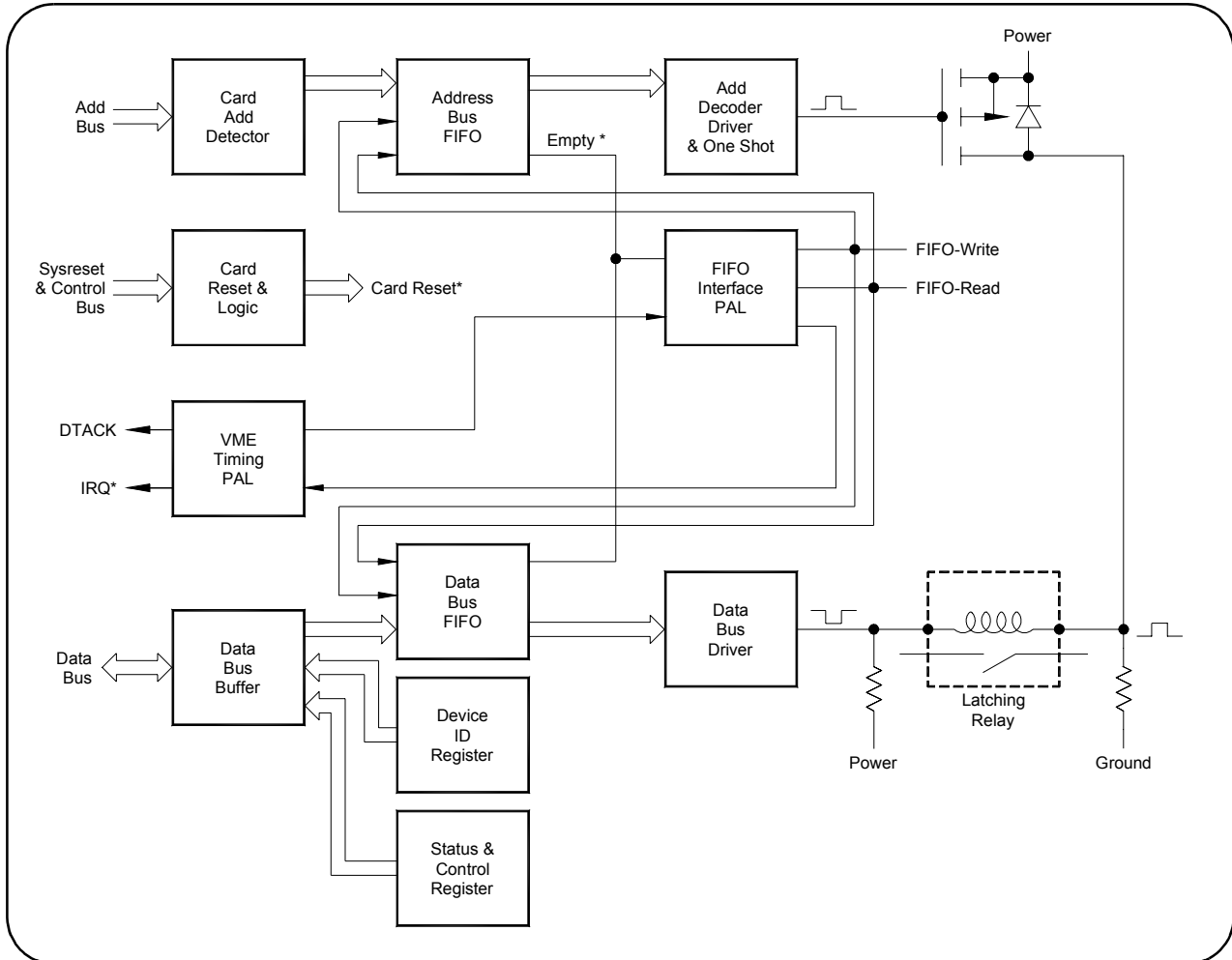

Figure 3-3. Matrix Modules Block Diagram

Chapter 4

Matrix Modules Command Reference

Using This Chapter

This chapter describes Standard Commands for Programmable Instruments (SCPI) and summarizes IEEE 488.2 Common (*) commands applicable to the E1465A, E1466A, and E1467A Relay Matrix Switch modules. This chapter contains the following sections:

- Command Types.49
- SCPI Command Reference51
- SCPI Commands Quick Reference78
- IEEE 488.2 Common Commands Reference.79

Command Types

Commands are separated into two types: IEEE 488.2 Common commands and SCPI commands.

Common Command Format

The IEEE 488.2 standard defines the Common commands that perform functions like reset, self-test, status byte query, etc. Common commands are four or five characters in length, always begin with the asterisk character (*), and may include one or more parameters. The command keyword is separated from the first parameter by a space character. Some examples of Common commands are shown below:

*RST *ESR 32 *STB?

SCPI Command Format

The SCPI commands perform functions like closing switches, opening switches, scanning channels, querying instrument states or retrieving data. A subsystem command structure is a hierarchical structure that usually consists of a top level (or root) command, one or more lower-level commands, and their parameters. The following example shows part of a typical subsystem:

```
[ROUTe:]  
  CLOSe<channel_list>  
  SCAN <channel_list>
```

[ROUTe:] is the root command, CLOSe and SCAN are second-level commands with parameters. There must be a space between the second-level command (such as CLOSe) and the parameter (<channel_list>).

Command Separator

A colon (:) always separates one command from the next lower-level command as shown below:

```
[ROUTE:]SCAN
```

Colons separate the root command from the second-level command ([ROUTE:]SCAN).

Abbreviated Commands

The command syntax shows most commands as a mixture of upper- and lowercase letters. The uppercase letters indicate the abbreviated spelling for the command. For shorter program lines, send the abbreviated form. For better program readability, you may send the entire command. The instrument will accept either the abbreviated form or the entire command.

For example, if the command syntax shows TRIGger, then TRIG and TRIGGER are both acceptable forms. Other forms of TRIGger, such as TRIGG or TRIGGE will generate an error. You may use uppercase or lowercase letters. Therefore, TRIGGER, trigger, and TrigGeR are all acceptable.

Implied Commands

Implied commands are those that appear in square brackets ([]) in the command syntax. (*The brackets are not part of the command and are not sent to the instrument.*) Suppose you send a second-level command but do not send the preceding implied command. In this case, the instrument assumes you intend to use the implied command and it responds as if you had sent it. Examine the portion of the [ROUTE:] subsystem shown below:

```
[ROUTE:]  
  CLOSe<channel_list>
```

The root command [ROUTE:] is an implied command (indicated by square brackets ([])). To make a query about a channel's present status, you can send either of the following command statements:

```
ROUT:CLOSe? <channel_list> or CLOSe? <channel_list>
```

Linking Commands

Linking IEEE 488.2 Common Commands with SCPI Commands. Use a semicolon (;) between the commands. For example, *RST;OUTP ON or TRIG:SOUR HOLD;:*RST.

Linking Multiple SCPI Commands. Use both a semicolon (;) and a colon (:) between the commands, such as ARM:COUN 1;:TRIG SOUR EXT.

Parameters The following table contains explanations and examples of parameter types you might see later in this chapter.

Type	Explanations and Examples
Boolean	Represents a single binary condition that is either true or false (ON, OFF, 1.0). Any non-zero value is considered true.
Discrete	Selects from a finite number of values. These parameters use mnemonics to represent each valid setting. An example is the TRIGger:SOURce <source> command where <source> can be BUS, EXTERNAL, HOLD, IMMEDIATE, or TTLTrgn.
Numeric	Commonly used decimal representations of numbers including optional signs, decimal points, and scientific notation. Examples are 123, 123E2, -123, -1.23E2, .123, 1.23E-2, 1.23000E-01. Special cases include MINimum, MAXimum, DEFault and INFinity.
Optional	<p>Parameters shown within square brackets ([]) are optional parameters. <i>(The brackets are not part of the command and are not sent to the instrument.)</i> If you do not specify a value for an optional parameter, the instrument chooses a default value.</p> <p>For example, consider the ARM:COUNT? [<MIN MAX>] command. If you send the command without specifying a parameter, the present ARM:COUNT value is returned. If you send the MIN parameter, the command returns the minimum count available. If you send the MAX parameter, the command returns the maximum count available. Be sure to place a space between the command and the parameter.</p>

SCPI Command Reference

This section describes the Standard Commands for Programmable Instruments (SCPI) commands for the E1465A, E1466A, and E1467A Relay Matrix Switch Modules. Commands are listed alphabetically by subsystem and within each subsystem.

ABORt

The ABORt command stops a scan in progress when the scan is enabled via the interface and the trigger source is TRIGger:SOURce BUS or TRIGger:SOURce HOLD.

Subsystem Syntax ABORt

Comments **ABORt Actions:** The ABORt command terminates the scan and invalidates the current channel list.

Stopping Scan Enabled Via Interface: When a scan is enabled via an interface, an interface CLEAR command can be used to stop the scan. When the scan is enabled via the interface and TRIG:SOUR BUS or HOLD is set, you can use ABORt to stop the scan.

Restarting a Scan: Use INIT to restart the scan.

Related Commands: ARM, INITiate:CONTInuous,[ROUTE:]SCAN, TRIGger

Example **Stopping a Scan with ABORt**

This example stops a (continuous) scan in progress.

```
TRIG:SOUR BUS                ! Trigger command will be via
                              ! backplane (bus) interface
                              ! (*TRG generates trigger)

INIT:CONT ON                 ! Set continuous scanning
SCAN(@10000:10003)          ! Scan channels 00 to 03
INIT                         ! Start scan, close channel 00
.
.
ABOR                          ! Abort scan in progress
```

ARM

The ARM subsystem selects the number of scanning cycles (1 to 32,767) for each INITiate command.

Subsystem Syntax

ARM
:COUNT <number> MIN | MAX
:COUNT? [<MIN | MAX>]

ARM:COUNT

ARM:COUNT <number> MIN | MAX allows scanning to occur a multiple of times (1 to 32,767) with one INITiate command when INITiate:CONTinuous OFF | 0 is set. MIN sets 1 cycle and MAX sets 32,767 cycles.

Parameters

Name	Type	Range of Values	Default Value
<number>	numeric	1 - 32,767 MIN MAX	1

Comments

Number of Scans: Use only numeric values between 1 and 32767, MIN, or MAX for the number of scanning cycles.

Related Commands: ABORt, INITiate[:IMMEDIATE]

***RST Condition:** ARM:COUNT 1

Example

Setting Ten Scanning Cycles

This example sets a relay matrix for 10 scans of channels 10000 through 10003. When the scan sequence completes, channels 10000 through 10003 are closed.

```
ARM:COUN 10                ! Set 10 scans per INIT command
SCAN(@10000:10003)        ! Scan channels 10000-10003
INIT                       ! Start scan, close channel 10000
```

ARM:COUNT?

ARM:COUNT? [<MIN | MAX>] returns the current number of scanning cycles set by ARM:COUNT. The current number of scan cycles is returned when MIN or MAX is not specified. With MIN or MAX as a parameter, MIN returns "1" and MAX returns "32,767".

Parameters

Name	Type	Range of Values	Default Value
MIN MAX	numeric	MIN = 1, MAX = 32,767	current cycle

Comments **Related Commands:** INITiate[:IMMediate]

Example Querying Number of Scans

This example sets a switchbox for 10 scanning cycles and queries the number of scan cycles set. The ARM:COUNT? command returns 10.

```
ARM:COUNT 10                                    ! Set 10 scans per INIT  
ARM:COUNT?                                      ! Query number of scans
```

DISPlay

The DISPlay subsystem monitors the channel state of the selected module in a switchbox. This subsystem operates with an E1406A Command Module when a display terminal is connected.

Subsystem Syntax

```
DISPlay
:MONitor
:CARD <number> | AUTO
[:STATe] <mode>
```

DISPlay:MONitor:CARD

DISPlay:MONitor:CARD <number> | AUTO selects the module in a switchbox to be monitored.

Parameters

Name	Type	Range of Values	Default Value
<number> AUTO	numeric	1 - 99	AUTO

Comments

Selecting a Specific Module to be Monitored: Use DISPlay:MONitor:CARD to send the card number for the switchbox to be monitored.

Selecting the Present Module to be Monitored: Use DISPlay:MONitor:CARD AUTO to select the last module addressed by a switching command (for example, [ROUTe:]CLOSe).

***RST Conditions:** DISPlay:MONitor:CARD AUTO

Example

Select Module #2 in a Switchbox for Monitoring

```
DISP:MON:CARD 2 ! Selects module #2 in a switchbox
```

DISPlay:MONitor[:STATe]

DISPlay:MONitor[:STATe] *<mode>* turns the monitor mode ON or OFF.

Parameters

Name	Type	Range of Values	Default Value
<i><mode></i>	boolean	ON OFF 1 0	OFF 0

Comments

Monitoring Switchbox Channels: DISPlay:MONitor:STATe ON or DISPlay:MONitor:STATe 1 turns the monitor mode ON to show the channel state of the selected module. DISPlay:MONitor:STATe OFF or DISPlay:MONitor:STATe 0 turns the channel monitor OFF.

Selecting the Module to be Monitored: Use DISPlay:MONitor:CARD *<number>* AUTO to select the module.

Monitor Mode with a Matrix Module: When monitoring mode is turned ON, a hexadecimal number representing the channels closed will be displayed at the bottom of the display terminal. For example, for an E1466A with row 0, columns 0-3 closed, will look like the following:

R0: 0000 0000 0000 000F R1: 0000 0000 0000 0000 R2: 0000 0000 ... etc.

*RST Condition: DISPlay:MONitor[:STATe]OFF | 0

Example

Enabling Monitor Mode

DISP:MON:CARD 2

! Select module #2 in a switchbox

DISP:MON 1

! Turn monitor mode ON

INITiate

The INITiate command subsystem selects continuous scanning cycles and starts the scanning cycle.

Subsystem Syntax

```
INITiate  
:CONTInuous <mode>  
:CONTInuous?  
[:IMMEDIATE]
```

INITiate:CONTInuous

INITiate:CONTInuous <mode> enables or disables continuous scanning cycles for the matrix modules.

Parameters

Name	Type	Range of Values	Default Value
<mode>	boolean	ON OFF 1 0	OFF 0

Comments

Continuous Scanning Operation: Continuous scanning is enabled with INITiate:CONTInuous ON or INITiate:CONTInuous 1. Sending INITiate:IMMEDIATE closes the first channel in the channel list. Each trigger from the source specified by TRIGger:SOURce advances the scan through the channel list. A trigger at the end of the channel list closes the first channel in the channel list and the scan cycle repeats.

Noncontinuous Scanning Operation: Noncontinuous scanning is enabled with INITiate:CONTInuous OFF or INITiate:CONTInuous 0. Sending INITiate:IMMEDIATE closes the first channel in the channel list. Each trigger from the source specified by TRIGger:SOURce advances the scan through the channel list. At the end of the scanning cycle, the last channel in the channel list is opened.

Stopping Continuous Scan: See the ABORt command.

Related Commands: ABORt, ARM:COUNT, TRIGger:SOURce

***RST Condition:** INITiate:CONTInuous OFF | 0

Example Enabling Continuous Scanning

This example enables continuous scanning of channels 10000 through 10003 of a single-module switchbox. Since TRIGger:SOURce IMMEDIATE (default) is set, use an interface clear command (such as CLEAR) to stop the scan.

```
INIT:CONT ON                ! Enable continuous scanning
SCAN(@10000:10003)         ! Define channel list
INIT                        ! Start scan cycle, close channel
                           10000
```

INITiate:CONTinuous?

INITiate:CONTinuous? queries the scanning state. With continuous scanning enabled, the command returns "1" (ON). With continuous scanning disabled, the command returns "0" (OFF).

Example Querying Continuous Scanning State

This example enables continuous scanning of a matrix module and queries the state. Since continuous scanning is enabled, INIT:CONT? returns "1".

```
INIT:CONT ON                ! Enable continuous scanning
INIT:CONT?                  ! Query continuous scanning state
```

INITiate[:IMMEDIATE]

INITiate[:IMMEDIATE] starts the scanning process and closes the first channel in the channel list. Successive triggers from the source specified by TRIGger:SOURce advance the scan through the channel list.

Comments **Starting the Scanning Cycle:** INITiate:IMMEDIATE starts scanning by closing the first channel in the channel list. Each trigger received advances the scan to the next channel in the channel list. An invalid channel list definition causes an error (see [ROUTE:]SCAN).

Stopping Scanning Cycles: See the ABORt command.

Example Enabling a Single Scan

This example enables a single scan of channels 10000 through 10003 of a matrix module. The trigger source to advance the scan is immediate (internal) triggering set with TRIGger:SOURce IMMEDIATE (default).

```
SCAN(@10000:10003)         ! Scan channels 10000 - 10003
INIT                        ! Begin scan, close channel 10000
                           (use immediate triggering)
```

OUTPut

The OUTPut command subsystem enables or disables the different trigger lines of the E1406A Command Module.

Subsystem Syntax

```
OUTPut
:EXternal
  [:STATe] <mode>
  [:STATe]?
[:STATe] <mode>
[:STATe]?
:TTLTrgn (:TTLTrg0 through :TTLTrg7)
  [:STATe] <mode>
  [:STATe]?
```

OUTPut:EXternal[:STATe]

OUTPut:EXternal[:STATe] <mode> enables or disables the "Trig Out" port on the E1406A Command Module to output a trigger when a channel is closed during a scan. ON | 1 enables the port and OFF | 0 disables the port.

Parameters

Name	Type	Range of Values	Default Value
<mode>	boolean	ON OFF 1 0	OFF 0

Comments

Enabling "Trig Out" Port: When enabled, a pulse is output from the "Trig Out" port after each scanned switchbox channel is closed. If disabled, a pulse is not output from the port after channel closures. The output pulse is a +5V negative-going pulse.

"Trig Out" Port Shared by Switchboxes: When enabled, the "Trig Out" port is pulsed by any switchbox each time a scanned channel is closed. To disable the output for a specific module, send OUTPut:EXternal[:STATe] OFF or OUTPut:EXternal[:STATe] 0 for that module.

One Output Selected at a Time: Only one output (TTLTrg or EXternal) can be enabled at one time. Enabling a different output source will automatically disable the active output.

Related Commands: [ROUTe:]SCAN, TRIGger:SOURce

***RST Condition:** OUTPut:EXternal[:STATe] OFF (port disabled)

Example Enabling "Trig Out" Port

OUTP:EXT ON

! Enable "Trig Out" port to output pulse after each scanned channel is closed

OUTPut:EXTErnal[:STATe]?

OUTPut:EXTErnal[:STATe]? queries the present state of the "Trig Out" port on the E1406A Command Module. The command returns "1" if the port is enabled or "0" if the port is disabled.

Example Query "Trig Out" Port Enable State

This example enables the "Trig Out" port and queries the enable state. OUTPut:EXTErnal[:STATe]? returns "1" since the port is enabled.

OUTP:EXT ON

! Enable E1406A "Trig Out" port

OUTP:EXT?

! Query port enable state

OUTPut[:STATe]

OUTPut[:STATe] <mode> enables or disables the "Trig Out" port on the E1406A Command Module. OUTPut[:STATe] ON | 1 enables the port and OUTPut[:STATe] OFF | 0 disables the port. This command functions the same as OUTPut:EXTErnal[:STATe].

Parameters

Name	Type	Range of Values	Default Value
<mode>	boolean	ON OFF 1 0	OFF 0

Comments *RST Condition: OUTPut[:STATe] OFF (port disabled)

Example Enabling "Trig Out" Port

OUTP ON

! Enable "Trig Out" port to output pulse after each scanned channel is closed

OUTPut[:STATe]?

OUTPut[:STATe]? queries the present state of the E1406A Command Module "Trig Out" port. The command returns "1" if the port is enabled or "0" if the port is disabled. This command functions the same as OUTPut:EXTErnal[:STATe]?

Example Query "Trig Out" Port Enable State

This example enables the E1406A Command Module "Trig Out" port and queries the enable state. OUTPut[:STATe]? returns "1" since the port is enabled.

```
OUTP ON                ! Enable "Trig Out" port
OUTP?                  ! Query port enable state
```

OUTPut:TTLTrgn[:STATe]

OUTPut:TTLTrgn[:STATe] <mode> selects and enables which TTL Trigger bus line (0 to 7) will output a trigger when a channel is closed during a scan. This is also used to disable a selected TTL Trigger bus line. "*n*" specifies the TTL Trigger bus line (0 to 7) and *<mode>* enables (ON or 1) or disables (OFF or 0) the specified TTL Trigger bus line.

Parameters

Name	Type	Range of Values	Default Value
<i>n</i>	numeric	0 to 7	N/A
<i><mode></i>	boolean	ON OFF 1 0	OFF 0

Comments **Enabling TTL Trigger Bus:** When enabled, a pulse is output from the selected TTL Trigger bus line (0 to 7) after each channel in the switchbox is closed during a scan. If disabled, a pulse is not output. The output is a negative-going pulse.

One Output Selected at a Time: Only one output (TTLTrg or EXTErnal) can be enabled at one time. Enabling a different output source will automatically disable the active output. For example, if TTLTrg1 is the active output and TTLTrg4 is enabled, TTLTrg1 will become disabled and TTLTrg4 will become the active output.

Related Commands: [ROUTE:]SCAN, TRIGger:SOURce, OUTPut:TTLTrgn[:STATe]?

***RST Condition:** OUTPut:TTLTrgn[:STATe] OFF (disabled)

Example Enabling TTL Trigger Bus Line 7

OUTP:TTLT7:STAT 1

*! Enable TTL Trigger bus line 7 to
output pulse after each scanned
channel is closed*

OUTPut:TTLTrgn[:STATe]?

OUTPut:TTLTrgn[:STATe]? queries the present state of the specified TTL Trigger bus line. The command returns "1" if the specified TTLTrg bus line is enabled or "0" if disabled.

Example Query TTL Trigger Bus Enable State

This example enables TTL Trigger bus line 7 and queries the enable state. OUTPut:TTLTrgn? returns "1" since the port is enabled.

OUTP:TTLT7:STAT 1

! Enable TTL Trigger bus line 7

OUTP:TTLT 7?

! Query bus enable state

[ROUTe:]

The [ROUTe:] command subsystem controls switching and scanning operations for relay matrix switch modules in a switchbox.

Subsystem Syntax

```
[ROUTe:]  
  CLOSe <channel_list>  
  CLOSe? <channel_list>  
  OPEN <channel_list>  
  OPEN? <channel_list>  
  SCAN <channel_list>
```

NOTE *There must be a space between the second level command (CLOSe, for example) and the parameter <channel_list>.*

[ROUTe:]CLOSe

[ROUTe:]CLOSe <channel_list> closes the relay matrix channels specified by <channel_list>. <channel_list> has the form (@ssrrcc) where ss = matrix module card number (01-99), rr = matrix module row number, and cc = matrix module column number.

Parameters

Name	Type	Range of Values	Default Value
<channel_list>	numeric	<u>E1465A</u> : rr: 00 - 15 cc: 00 - 15 <u>E1466A</u> : rr: 00 - 03 cc: 00 - 63 <u>E1467A</u> : rr: 00 - 07 cc: 00 - 31	N/A

Comments Closing Channels:

- To close a single channel use ROUT:CLOS (@ssrrcc)
- To close multiple channels use ROUT:CLOS (@ssrrcc,ssrrcc,...)
- To close sequential channels use ROUT:CLOS (@ssrrcc:ssrrcc)
- To close groups of sequential channels use ROUT:CLOS (@ssrrcc:ssrrcc,ssrrcc:ssrrcc)
- or any combination of the above

NOTE *Closure order for multiple channels with a single command is not guaranteed. Channel numbers can be in the <channel_list> in any random order.*

Related Commands: [ROUTE:]OPEN, [ROUTE:]CLOSE?

***RST Condition:** All channels open.

Example **Closing Matrix Modules Channels**

This example closes channels 10100 and 20013 of a two-module switchbox (card numbers 01 and 02).

```
CLOS(@10100,20013)           ! Closes row 1, column 00 of card
                              #1 and row 00, column 13 of card
                              #2.
```

[ROUTE:]CLOSE?

[ROUTE:]CLOSE? <channel_list> returns the current state of the channel(s) queried. <channel_list> has the form (@ssrrcc) where cc = card number (01-99) and nn = channel number (00-31). The command returns "1" if channel(s) are closed or returns "0" if channel(s) are open.

Comments **Query is Software Readback:** ROUTE:CLOSE? returns the current software state of the channel(s) specified. It does not account for relay hardware failures.

A maximum of 128 channels can be queried at one time. If you want to query more than 128 channels, you must enter the query data in two separate commands.

Example **Querying Channel Closure**

This example closes channels 100 and 213 of a two-module switchbox and queries channel closure. Since the channels are programmed to be closed "1,1" is returned as a string.

```
CLOS(@100,213)               !Close channels 100 and 213
CLOS?(@100,213)              !Query channels 100 and 213
                              state
```

[ROUTe:]OPEN

[ROUTe:]OPEN <channel_list> opens the relay matrix channels specified by <channel_list>. <channel_list> has the form (@ssrrcc) where ss = matrix module card number (01-99), rr = matrix module row number, and cc = matrix module column number.

Parameters

Name	Type	Range of Values	Default Value
<channel_list>	numeric	<u>E1465A</u> : rr: 00 - 15 cc: 00 - 15 <u>E1466A</u> : rr: 00 - 03 cc: 00 - 63 <u>E1467A</u> : rr: 00 - 07 cc: 00 - 31	N/A

Comments

Opening Channels:

- To open a single channel use ROUT:OPEN (@ssrrcc)
- To open multiple channels use ROUT:OPEN (@ssrrcc,ssrrcc,...)
- To open sequential channels use ROUT:OPEN (@ssrrcc:ssrrcc)
- To open groups of sequential channels use ROUT:OPEN (@ssrrcc:ssrrcc,ssrrcc:ssrrcc)
- or any combination of the above

Opening Order: Opening order for multiple channels with a single command is not guaranteed.

Related Commands: [ROUTe:]CLOSE, [ROUTe:]OPEN?

***RST Condition:** All channels open.

Example

Opening Matrix Modules Channels

This example opens channels 10100 and 20013 of a two-module switchbox (card numbers 01 and 02).

```
OPEN(@10100,20013)           ! Opens channels 10100 and  
                               20013
```

[ROUTe:]OPEN?

[ROUTe:]OPEN? <channel_list> returns the current state of the channel(s) queried. <channel_list> has the form (@ssrrcc) where ss = matrix module card number (01-99), rr = matrix module row number, and cc = matrix module column number. The command returns "1" if channel(s) are open or returns "0" if channel(s) are closed.

Comments **Query is Software Readback:** ROUTe:OPEN? returns the current software state of the channel(s) specified. It does not account for relay hardware failures.

A maximum of 128 channels can be queried at one time: If you want to query more than 128 channels, you must enter the query data in two separate commands.

Example Querying Channel Open State

This example opens channels 10100 and 20013 of a two-module switchbox and queries channel 20013 state. Since channel 20013 is programmed to be open, "1" is returned.

```
OPEN(@10100,20013)           ! Open channels 10100 and 20013
OPEN?(@20013)                ! Query channel 20013 state
```

[ROUTe:]SCAN

[ROUTe:]SCAN <channel_list> defines the channels to be scanned. <channel_list> has the form (@ssrrcc) where cc = card number 01-99) and nn = channel number (00-31).

Parameters

Name	Type	Range of Values	Default Value
<channel_list>	numeric	<u>E1465A</u> : rr: 00 - 15 cc: 00 - 15 <u>E1466A</u> : rr: 00 - 03 cc: 00 - 63 <u>E1467A</u> : rr: 00 - 07 cc: 00 - 31	N/A

Comments **Defining Scan List:** When ROUTe:SCAN is executed, the channel list is checked for valid card and channel numbers. An error is generated for an invalid channel list.

Scanning Channels:

- To scan a single channel use ROUT:SCAN (@ssrcc)
- To scan multiple channels use ROUT:SCAN (@ssrcc,ssrcc,...)
- To scan sequential channels use ROUT:SCAN (@ssrcc:ssrcc)
- To scan groups of sequential channels use ROUT:SCAN (@ssrcc:ssrcc,ssrcc:ssrcc)
- or any combination of the above

NOTE *Channel numbers can be in the <channel_list> in any random order.*

Scanning Operation: When a valid channel list is defined, INITiate[:IMMEDIATE] begins the scan and closes the first channel in the <channel_list>. Successive triggers from the source specified by TRIGger:SOURce advance the scan through the <channel list>. At the end of the scan, the last trigger opens the last channel.

Stopping Scan: See ABORT

Related Commands: TRIGger, TRIGger:SOURce

***RST Condition:** All channels open.

Example Scanning Using External Device

See "Scanning Channels" in Chapter 3 for examples of scanning programs using external instruments.

STATus

The STATus subsystem reports the bit values of the OPERation Status Register. It also allows you to unmask the bits you want reported from the Standard Event Status Register and to read the summary bits from the Status Byte Register.

Subsystem Syntax

```
STATus
:OPERation
:CONDition?
:ENABle <unmask>
:ENABle?
[:EVENT?]
:PRESet
```

As shown in Figure 3-1, the STATus subsystem for the E1463A Form C Switch includes the Status Byte Register, the Standard Event Status Register, OPERation Status Register, and Output Queue. The Standard Event Status Register (*ESE?) and the Status Byte Register (*STB?) are under IEEE 488.2 control.

Status Byte Register

In the Status Byte register, the Operation Status bit (OPR), Request Service bit (RQS), Standard Event bit (ESB), Message Available bit (MAV) and Questionable Data bit (QUE) (bits 7, 6, 5, 4 and 3 respectively) can be queried with the *STB? command.

Standard Event Status Register

In the Standard Event Status Register, you can use *ESE? to query the "unmask" value (the bits to be logically ORed into the Summary bit). The registers are queried using decimal-weighted bit values. Decimal equivalents for bits 0 through 15 are shown in Figure 3-1.

OPERation Status Register

Using STATus:OPERation:ENABle 256 allows only bit 8 to generate a Summary bit from the OPERation Status Register, since the decimal value for bit 8 is 256. The decimal values can also be used in the inverse manner to determine the bits set from the value returned by STATus:OPERation:EVENT? or STATus:OPERation:CONDition?.

The Form C switch driver uses only bit 8 of the OPERation Status Register. This bit is called the *Scan Complete* bit and is set whenever a scan operation completes. Since completion of a scan operation is an event in time, bit 8 will never appear set when STATus:OPERation:CONDition? is queried. However, you can find bit 8 set by using STATus:OPERation:EVENT?.

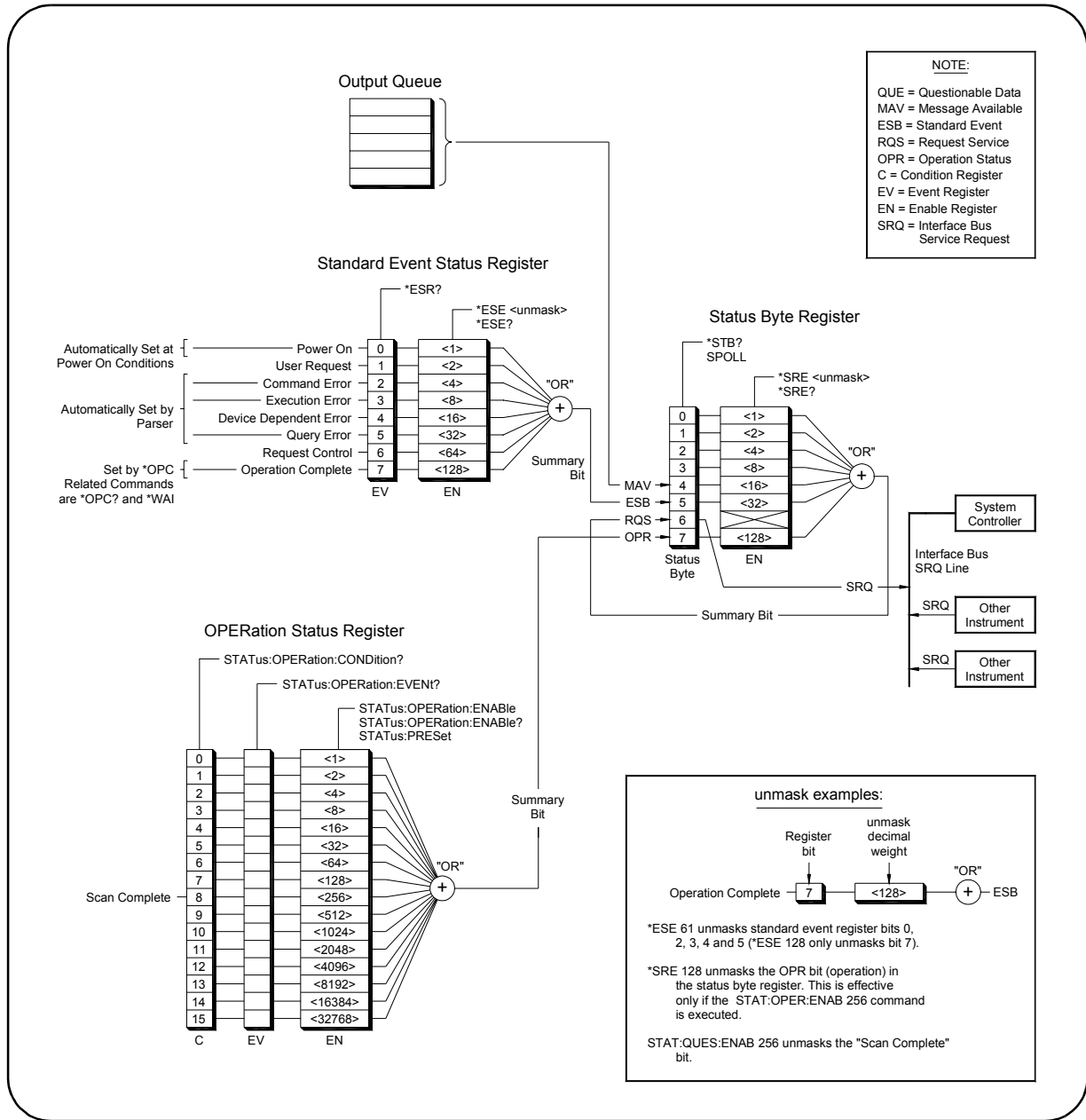

Figure 4-1. E1465A/E1466A/E1467A Status System Register Diagram

STATus:OPERation:CONDition?

STATus:OPERation:CONDition? returns the state of the Condition Register in the OPERation Status Register. The state represents conditions that are part of the instrument's operation. The switch module driver does not set bit 8 in the OPERation Status Register (see STATus:OPERation[:EVENT]?).

STATus:OPERation:ENABLE

STATus:OPERation:ENABLE <unmask> sets an enable mask to allow events recorded in the Event Register of the OPERation Status Register to send a Summary bit to the Status Byte Register (bit 7). For matrix modules, when bit 8 in the OPERation Status Register is set to 1 and bit 8 is enabled by STATus:OPERation:ENABLE, bit 7 in the Status Byte Register is set to 1.

Parameters

Name	Type	Range of Values	Default Value
<unmask>	numeric	0 through 65,535	N/A

Comments **Setting Bit 7 of the Status Byte Register:** STATus:OPERation:ENABLE 256 sets bit 7 (OPR) of the Status Byte Register to 1 after bit 8 (Scan Complete) of the OPERation Status Register is set to 1.

Related Commands: [ROUTE:]SCAN

Example Enabling OPERation Status Register Bit 8

STAT:OPER:ENAB 256

! Enable bit 8 of the OPERation Status Register to be reported to bit 7 (OPR) in the Status Byte Register

STATus:OPERation:ENABLE?

STATus:OPERation:ENABLE? returns the bit value of the Enable Register within the OPERation Status Register.

Comments **Output Format:** STATus:OPERation:ENABLE? returns a decimal-weighted value from 0 to 65,535 indicating the bits set to true.

Maximum Value Returned: The value returned is the value set by STATus:OPERation:ENABLE <unmask>. However, the maximum decimal-weighted value used in this module is 256 (bit 8 in the Condition Register within the OPERation Status Register is set to true).

Example Querying the Enable Register in the OPERATION Status Register

STAT:OPER:ENAB?

*! Query the Enable Register in the
OPERation Status Register*

STATus:OPERation[:EVENT]?

STATus:OPERation[:EVENT]? returns which bits in the Event Register within the OPERATION Status Register are set. The Event Register indicates that a time-related instrument event has occurred.

Comments **Setting Bit 8 of the OPERATION Status Register:** Bit 8 (Scan Complete) is set to 1 after a scanning cycle completes. Bit 8 returns to 0 (zero) after sending STATus:OPERation[:EVENT]?

Returned Data after sending STATus:OPERation[:EVENT]?: The command returns "+256" if bit 8 of the OPERATION Status Register is set to 1. The command returns "+0" if bit 8 of the OPERATION Status Register is set to 0.

Event Register Cleared: Reading the Event Register within the OPERATION Status Register with STATus:OPERation:EVENT? clears the Event Register.

Aborting a Scan: Aborting a scan will leave bit 8 set to 0.

Related Commands: [ROUTE:]SCAN

Example Reading the OPERATION Status Register After a Scanning Cycle

STAT:OPER?

*! Return the bit values of the Event
Register within the OPERATION
Status Register*

read the register value

*+ 256 shows bit 8 is set to 1.
+0 shows bit 8 is set to 0.*

STATus:PRESet

STATus:PRESet affects only the Enable Register within the OPERATION Status Register by setting all Enable Register bits to 0. It does not affect either the Status Byte Register or the Standard Event Status Register. STATus:PRESet does not clear any of the Event Registers.

SYSTEM

The SYSTEM subsystem returns the error numbers and error messages in the error queue of a switchbox. It can also return the types and descriptions of modules (cards) in a switchbox.

Subsystem Syntax

```
SYSTEM  
:CDEscription? <number>  
:CPON <number> | ALL  
:CTYPe? <number>  
:ERRor?
```

SYSTEM:CDEscription?

SYSTEM:CDEscription? <number> returns the description of a selected module (card) in a switchbox.

Parameters

Name	Type	Range of Values	Default Value
<number>	numeric	1 through 99	N/A

Comments

E1465A Module Description: SYSTEM:CDEscription? returns:

"16 x 16 Matrix Switch"

E1466A Module Description: SYSTEM:CDEscription? returns:

"4 x 64 Matrix Switch"

E1467A Module Description: SYSTEM:CDEscription? returns:

"8 x 32 Matrix Switch"

Example

Reading the Description of a Module

```
SYST:CDES? 1
```

*! Return description of module
card #1*

SYSTem:CPON

SYSTem:CPON <number> | ALL sets the selected module (card) in a switchbox to its power-on state.

Parameters

Name	Type	Range of Values	Default Value
<number>	numeric	1 through 99 ALL	N/A

Comments **Matrix Module Power-on State:** The power-on state is all channels (relays) open. *RST opens all channels of all modules in a switchbox, while SYSTem:CPON <number> opens the channels in only the module (card) specified in the command.

Example **Setting Module to Power-on State**

SYST:CPON 1

! Set card #1 to power-on state

SYSTem:CTYPE?

SYSTem:CTYPE? <number> returns the module (card) type of a selected module in a switchbox.

Parameters

Name	Type	Range of Values	Default Value
<number>	numeric	1 through 99	N/A

Comments **E1465A Matrix Module Model Number:** SYSTem:CTYPE? <number> returns:

HEWLETT-PACKARD,E1465A,0,A.04.00

where the 0 after E1465A is the module serial number (always 0) and A.04.00 is an example of the module revision code number.

E1466A Matrix Module Model Number: SYSTem:CTYPE? <number> returns:

HEWLETT-PACKARD,E1466A,0,A.04.00

where the 0 after E1466A is the module serial number (always 0) and A.04.00 is an example of the module revision code number.

E1467A Matrix Module Model Number: SYSTem:CTYPe? <number> returns:

HEWLETT-PACKARD,E1467A,0,A.04.00

where the 0 after E1467A is the module serial number (always 0) and A.04.00 is an example of the module revision code number.

Example **Reading the Model Number of a Module**

SYST:CTYP? 1 *! Returns the model number*

SYSTem:ERRor?

SYSTem:ERRor? returns the error numbers and corresponding error messages in the error queue of a matrix module. See Appendix C for a listing of matrix module error numbers and messages.

Comments **Error Numbers/Messages in the Error Queue:** Each error generated by a matrix module stores an error number and corresponding error message in the error queue. The error message can be up to 255 characters long.

Clearing the Error Queue: An error number/message is removed from the queue each time SYSTem:ERRor? is sent. The errors are cleared first-in, first-out. When the queue is empty, each following SYSTem:ERRor? command returns +0, "No error". To clear all error numbers/messages in the queue, execute *CLS.

Maximum Error Numbers/Messages in the Error Queue: The queue holds a maximum of 30 error numbers/messages for each switchbox. If the queue overflows, the last error number/message in the queue is replaced by -350, "Too many errors". The least recent error numbers/messages remain in the queue and the most recent errors are discarded.

Example **Reading the Error Queue**

SYST:ERR? *! Query the error queue*

TRIGger

The TRIGger command subsystem controls the triggering operation of matrix modules in a switchbox.

Subsystem Syntax

```
TRIGger  
[:IMMEDIATE]  
:SOURce <source>  
:SOURce?
```

TRIGger[:IMMEDIATE]

TRIGger[:IMMEDIATE] causes a trigger event to occur when the defined trigger source is TRIGger:SOURce BUS or TRIGger:SOURce HOLD.

Comments

Executing TRIGger[:IMMEDIATE]: Before TRIGger[:IMMEDIATE] will execute, a channel list must be defined with [ROUTE:]SCAN <channel_list> and an INITiate[:IMMEDIATE] must be executed

BUS or HOLD Source Remains: If selected, TRIGger:SOURce BUS or TRIGger:SOURce HOLD remains in effect after triggering a switchbox with TRIGger[:IMMEDIATE].

Related Commands: INITiate, [ROUTE:]SCAN

Example

Advancing Scan Using TRIGger

This example scans a single-module switchbox from channel 10000 through 10003. Since TRIGger:SOURce HOLD is set, the scan is advanced one channel each time TRIGger is executed.

```
TRIG:SOUR HOLD           ! Set trigger source to HOLD  
SCAN(@10000:10003)      ! Define channel list  
INIT                     ! Begin scan, close channel 10000  
loop statement           ! Start count loop  
TRIG                     ! Advance scan to next channel  
increment loop           ! Increment loop count
```

TRIGger:SOURce

TRIGger:SOURce <source> specifies the trigger source to advance the <channel_list> during scanning.

Parameters

Parameter Name	Parameter Type	Parameter Description
BUS	discrete	*TRG or GET command
EXternal	discrete	"Trig In" port
HOLD	discrete	Hold Triggering
IMMEDIATE	discrete	Immediate Triggering
TTLTrgn	numeric	TTL Trigger Bus Line 0 - 7

Comments

Enabling the Trigger Source: TRIGger:SOURce only selects the trigger source. INITiate[:IMMEDIATE] enables the trigger source.

Using the TRIGger Command: You can use TRIGger[:IMMEDIATE] to advance the scan when TRIGger:SOURce BUS or TRIGger:SOURce HOLD is selected.

Using External Trigger Inputs: With TRIGger:SOURce EXTERNAL selected, only one switchbox at a time can use the external trigger input at the E1406A "Trig In" port. The trigger input is assigned to the first switchbox requesting the external trigger source (with a TRIGger:SOURce EXTERNAL command).

Assigning External Trigger: A switchbox assigned with TRIGger:SOURce EXTERNAL remains assigned to that source until the switchbox trigger source is changed to BUS, HOLD, or IMMEDIATE. When the source is changed, the external trigger source is available to the next switchbox requesting it (with a TRIGger:SOURce EXTERNAL command). If a switchbox requests an external trigger input already assigned to another switchbox, an error is generated.

Using Bus Triggers: To trigger the switchbox with bus triggers when TRIGger:SOURce BUS selected, use the IEEE 488.2 common command *TRG or the GPIB Group Execute Trigger (GET) command.

"Trig Out" Port Shared by Switchboxes: When enabled, the E1406A Command Module "Trig Out" port is pulsed by any switchbox each time a scanned channel is closed. To disable the output for a specific module send OUTPUT:EXTERNAL[:STATE] OFF or OUTPUT:EXTERNAL[:STATE] 0 for that module.

One Output Selected at a Time: Only one output (TTLTrg or EXTERNAL) can be enabled at one time. Enabling a different output source will automatically disable the active output.

Related Commands: ABORt, [ROUTe:]SCAN, OUTPut

***RST Condition:** TRIGger:SOURce IMMEDIATE

Example Scanning Using External Triggers

This example uses external triggering (TRIGger:SOURce EXTernal) to scan channels 0000 through 0003 of a single-module switchbox. The trigger source to advance the scan is the input to the "Trig In" port on the E1406A Command Module. When INIT is executed, the scan is started and channel 0000 is closed. Then, each trigger received at the "Trig In" port advances the scan to the next channel.

```
TRIG:SOUR EXT                ! Select external triggering
SCAN(@10000:10003)          ! Scan channels 0000 - 0003
INIT                          ! Begin scan, close channel 0000
trigger externally           ! Advance scan to next channel
```

Example Scanning Using Bus Triggers

This example uses bus triggering (TRIG:SOUR BUS) to scan channels 0000 through 0003 of a single-module switchbox. The trigger source to advance the scan is the *TRG command (as set with TRIGger:SOURce BUS). When INIT is executed, the scan is started and channel 0000 is closed. Then, each *TRG command advances the scan to the next channel.

```
TRIG:SOUR BUS                ! Select interface (bus) triggering
SCAN(@10000:10003)          ! Scan channels 0000 - 0003
INIT                          ! Begin scan, close channel 0000
loop statement               ! Loop to scan all channels
*TRG                         ! Advance scan using bus
                             ! triggering
increment loop               ! Increment loop count
```

TRIGger:SOURce?

TRIGger:SOURce? returns the current trigger source for the switchbox. The command returns BUS, EXT, HOLD, IMM, or TTLT for sources BUS, EXTernal, HOLD, IMMEDIATE, or TTLTrgn, respectively.

Example Querying the Trigger Source

This example sets external triggering and queries the trigger source. Since external triggering is set, TRIG:SOUR? returns "EXT".

```
TRIG:SOUR EXT                ! Set external trigger source
TRIG:SOUR?                   ! Query trigger source
```

SCPI Commands Quick Reference

The following table summarizes the SCPI Commands for the E1465A, E1466A, and E1467A Relay Matrix Switch Modules.

Command		Description
ABORT	ABORT	Aborts a scan in progress
ARM	:COUNT <number> MIN MAX :COUNT? [MIN MAX]	Multiple scans per INIT command Queries number of scans
DISPlay	:MONitor:CARD <number> AUTO :MONitor[:STATe] <mode>	Selects module to be monitored Turns monitor mode on or off
INITiate	:CONTinuous <mode> :CONTinuous? [:IMMediate]	Enables/disables continuous scanning Queries continuous scan state Starts a scanning cycle
OUTPut	[:EXtErnal][:STATe] <mode> [:EXtErnal][:STATe]? [:STATe] <mode> [:STATe]? :TTLTrgn[:STATe] <mode> :TTLTrgn[:STATe]?	Enables/disables the Trig Out port on the E1406 Queries port enable state Enables/disables the Trig Out port on the E1406 Queries port enable state Enables/disables TTL trigger bus line pulse Queries TTL trigger bus line state
[ROUTE:]	CLOSE <channel_list> CLOSE? <channel_list> OPEN <channel_list> OPEN? <channel_list> SCAN <channel_list>	Closes channel(s) Queries channel(s) closed Opens channel(s) Queries channel(s) opened Defines channels for scanning
STATus	:OPERation:CONDition? :OPERation:ENABle <unmask> :OPERation:ENABle? :OPERation[:EVENT]? :PRESet	Returns status of the Condition Register Enables the Operation Event Register to set a bit in the Status Register Query the contents in the Operation Status Register Returns status of the Operation Status Register Sets Enable Register to 0
SYSTem	:CDEscription? <number> :CTYPe? <number> :CPON <number> ALL :ERRor?	Returns description of module in a switchbox Returns the module type Sets specified module to its power-on state Returns error number/message to error queue
TRIGger	[:IMMediate] :SOURce BUS :SOURce EXtErnal :SOURce HOLD :SOURce IMMediate :SOURce TTLTrgn :SOURce?	Causes a trigger to occur Trigger source is *TRG Trigger source is Trig In (on the E1406) Hold off triggering Continuous (internal) triggering Trigger source is TTL trigger bus line (0 - 7) Query scan trigger source

IEEE 488.2 Common Commands Reference

The following table lists the IEEE 488.2 Common (*) commands that apply to the E1465A, E1466A, and E1467A Relay Matrix Switch Modules. The operation of some of these commands is described in Chapter 3 of this manual. For more information on Common commands, refer to the user's manual for your mainframe or to the ANSI/IEEE Standard 488.2-1987.

Command	Title	Command Description
*CLS	Clear Status Register	Clears all status registers (see STATus:OPERation[:EVENT]?).
*ESE	Event Status Enable	Enables Status Register bits.
*ESE?	Event Status Enable Query	Queries the current contents in the Standard Event Status Register
*ESR?	Event Status Register Query	Queries and clears the current contents in the Standard Event Status Register
*IDN?	Identification Query	Returns identification string of the Switchbox.
*OPC	Operation Complete	Sets the Request for OPC flag when all pending operations have completed. Also, sets OPC bit in the Standard Event Status Register.
*OPC?	Operation Complete Query	Returns a "1" to the output queue when all pending operations have completed. Used to synchronize between multiple instruments.
*RCL	Recall Instrument State	Recalls previously stored configuration.
*RST	Reset	Opens all channels and sets the module to a known state.
*SAV	Save Instrument State	Stores the current configuration in specified memory.
*SRE	Service Request Enable	Sets the Service Request Enable Register bits and corresponding Serial Poll Status Register bits to generate a service request.
*SRE?	Service Request Enable Query	Queries the current contents in the Service Request Enable Register.
*STB?	Read Status Byte Query	Queries the current contents in the Status Byte Register.
*TRG	Trigger	Triggers the module to advance the scan when scan is enabled and trigger source is TRIGger:SOURce BUS.
*TST?	Self-Test Query	Returns +0 if self-test passes. Returns +cc01 for firmware error. Returns +cc02 for bus error. Returns +cc10 if an interrupt was expected but not received. Returns +cc11 if the busy bit was not held for 10 msec.
*WAI	Wait to Continue	Prevents an instrument from executing another command until the operation caused by the previous command is finished. Since all instruments normally perform sequential operations, executing this command causes no change.

Notes:

Appendix A

Matrix Modules Specifications

General			
Module Size/Device Type: C-size VXIbus, Register based, A16/D16, Interrupter (levels 1-7, jumper selectable)	Relay Life: @ No Load: 5×10^7 Operations @ Full Load: 10^5 Operations		
Power Requirements: Voltage: <table style="display: inline-table; vertical-align: middle;"><tr><td style="padding: 0 10px;">$\frac{+5V}{0.10}$</td><td style="padding: 0 10px;">$\frac{+12V}{0.18}$</td></tr></table> Peak Module Current (A)	$\frac{+5V}{0.10}$	$\frac{+12V}{0.18}$	Watts/slot: 5 W Cooling/slot: 0.08 mm H ₂ O @ 0.42 Liter/sec for 10°C rise Operating Temperature: 0° - 55°C Operating Humidity: 65% RH, 0° - 40°C
$\frac{+5V}{0.10}$	$\frac{+12V}{0.18}$		
Terminals: Screw type, maximum wire size 18 AWG			
Input Characteristics			
Maximum Voltage Terminal to Terminal: 200 Vdc or 170 Vac _{rms} (238 Vac peak to peak)	Maximum Voltage Terminal to Chassis: 200 Vdc or 170 Vac _{rms} (238 Vac peak to peak)		
Maximum Current per Channel (non-inductive): 1 Adc or 1 A ac peak	Maximum Power per Channel: 30 Wdc or 62.5 VA ac resistive load		
DC Performance			
Closed Channel Resistance: Initial: <4.0 Ω End of Life: <10.0 Ω	Insulation Resistance (between any two points, single module): $10^8 \Omega$ at 40°C, 95% RH $10^9 \Omega$ at 25°C, 40% RH		
Thermal Offset per Channel: <5 μV (differential H-L)			
AC Performance			
Bandwidth (-3 dB): Zload = Zsource = 50 Ω >10 MHz (for worst crosspoint)	Closed Channel Capacitance (Hi-Low, Lo-Chassis): Hi to Lo: <270 pF Hi to GND: <430 pF Lo to GND: <440 pF		
Crosstalk between Channels: See tables on next page			

E1465A Crosstalk Between Channels

Specifications are for 16 x 16 matrix, for $Z(\text{load}) = Z(\text{source}) = 50 \Omega$. AC specifications apply with no more than one crosspoint closed per row or column. Typical is defined as the worst crosspoint test result from one or two matrix modules.

Within a Card (worst path)	<10 kHz	<100 kHz	<1 MHz
Closed Path to Closed Path (typical)	- 78 dB	- 57 dB	- 41 dB
Open Row to Open Row (typical)	- 93 dB	- 73 dB	- 56 dB
Open Row to Open Column (typical)	- 84 dB	- 63 dB	- 47 dB
Open Column to Open Column (typical)	- 86 dB	- 65 dB	- 48 dB
Module to Module (Represents 16 x 32 Configuration)*	<10 kHz	<100 kHz	<1 MHz
Closed Path to Closed Path (typical)	- 78 dB	- 55 dB	- 43 dB
Open Row to Open Row (typical)	- 84 dB	- 66 dB	- 52 dB
Open Row to Open Column (typical)	- 84 dB	- 63 dB	- 48 dB
Open Column to Open Column (typical)	- 93 dB	- 72 dB	- 48 dB

E1466A Crosstalk Between Channels

Specifications are for 4 x 64 matrix, for $Z(\text{load}) = Z(\text{source}) = 50 \Omega$. AC specifications apply with no more than one crosspoint closed per row or column. Typical is defined as the worst crosspoint test result from one or two matrix modules.

Within a Card (worst path)	<10 kHz	<100 kHz	<1 MHz
Closed Path to Closed Path (typical)	- 72 dB	- 50 dB	- 34 dB
Open Row to Open Row (typical)	- 73 dB	- 52 dB	- 37 dB
Open Row to Open Column (typical)	- 84 dB	- 64 dB	- 47 dB
Open Column to Open Column (typical)	- 92 dB	- 70 dB	- 52 dB
Module to Module (Represents 4 x 128 Configuration)*	<10 kHz	<100 kHz	<1 MHz
Closed Path to Closed Path (typical)	- 66 dB	- 45 dB	- 29 dB
Open Row to Open Row (typical)	- 68 dB	- 46 dB	- 29 dB
Open Row to Open Column (typical)	- 84 dB	- 64 dB	- 48 dB
Open Column to Open Column (typical)	- 92 dB	- 71 dB	- 52 dB

E1467A Crosstalk Between Channels

Specifications are for 8 x 32 matrix, for $Z(\text{load}) = Z(\text{source}) = 50 \Omega$. AC specifications apply with no more than one crosspoint closed per row or column. Typical is defined as the worst crosspoint test result from one or two matrix modules.

Within a Card (worst path)	<10 kHz	<100 kHz	<1 MHz
Closed Path to Closed Path (typical)	- 75 dB	- 54 dB	- 38 dB
Open Row to Open Row (typical)	- 91 dB	- 59 dB	- 43 dB
Open Row to Open Column (typical)	- 85 dB	- 64 dB	- 47 dB
Open Column to Open Column (typical)	- 92 dB	- 71 dB	- 54 dB
Module to Module (Represents 8 x 64 Configuration)*	<10 kHz	<100 kHz	<1 MHz
Closed Path to Closed Path (typical)	- 72 dB	- 51 dB	- 33 dB
Open Row to Open Row (typical)	- 74 dB	- 53 dB	- 38 dB
Open Row to Open Column (typical)	- 92 dB	- 72 dB	- 56 dB
Open Column to Open Column (typical)	- 82 dB	- 64 dB	- 50 dB

*Chaining Cable (part number E1466-80002) used to connect modules

Appendix B

Register-Based Programming

About This Appendix

This appendix contains information you can use for register-based programming of the E1465A, E1466A, and E1467A Relay Matrix Switch modules. The contents include:

- Register Programming vs. SCPI Programming83
- Addressing the Registers83
- Register Descriptions86
- Programming Examples90

Register Programming vs. SCPI Programming

The E1465A Relay Matrix Switch modules are register-based modules that do not support the VXIbus word serial protocol. When a SCPI command is sent to the module, the E1406 Command Module parses the command and programs the switch at the register level.

NOTE *If SCPI is used to control this module, register programming is not recommended. The SCPI driver maintains an image of the card state. The driver will be unaware of changes to the card state if you alter the card state by using register writes.*

Register-based programming is a series of **reads** and **writes** directly to the module registers. This increases throughput speed since it eliminates command parsing and allows the use of an embedded controller. Also, if slot 0, the resource manager, and the computer GPIB interface are provided by other devices, a C-size system can be downsized by removing the command module.

Addressing the Registers

Register addresses for register-based devices are located in the upper 25% of VXI A16 address space. Every VXI device (up to 256 devices) is allocated a 32-word (64-byte) block of addresses. With 19 registers, the E1465A/E1466A/E1467A modules each use 19 of the 64 addresses allocated.

The Base Address

When reading or writing to a switch register, a hexadecimal or decimal *register address* is specified. This address consists of a *base address* plus a *register offset*. The base address used in register-based programming depends on whether the A16 address space is outside or inside the E1406 Command Module.

Figure B-1 shows the register address location within A16 as it might be mapped by an embedded controller. Figure B-2 shows the location of A16 address space in the E1406 Command Module.

A16 Address Space Outside the Command Module

When the E1406 Command Module is not part of your VXIbus system (see Figure B-1), the switch's base address is computed as:

$$\begin{aligned} &\text{Command Module Address} + C000_{16} + (\text{LADDR} * 64)_{16} \\ &\text{or} \\ &\text{Command Module Address} + 49,152 + (\text{LADDR} * 64) \end{aligned}$$

where $C000_{16}$ (49,152) is the starting location of the register addresses, LADDR is the matrix module's logical address, and 64 is the number of address bytes per VXI device. For example, the matrix module's factory-set logical address is 120 (78_{16}). If this address is not changed, the switch will have a base address of:

$$\begin{aligned} C000_{16} + (120 * 64)_{16} &= C000_{16} + 1E00_{16} = \mathbf{DE00_{16}} \\ &\text{or} \\ 49,152 + (120 * 64) &= 49,152 + 7680 = \mathbf{56,832} \end{aligned}$$

A16 Address Space Inside the Command Module or Mainframe

When the A16 address space is inside the E1406 Command Module (see Figure B-2), the matrix module's base address is computed as:

$$\begin{aligned} &1FC000_{16} + (\text{LADDR} * 64)_{16} \\ &\text{or} \\ &2,080,768 + (\text{LADDR} * 64) \end{aligned}$$

where $1FC000_{16}$ (2,080,768) is the starting location of the VXI A16 addresses, LADDR is the matrix module's logical address, and 64 is the number of address bytes per register-based device. Again, the matrix module's factory-set logical address is 120. If this address is not changed, the switch module will have a base address of:

$$\begin{aligned} 1FC000_{16} + (120 * 64)_{16} &= 1FC000_{16} + 1E00_{16} = \mathbf{1FDE00_{16}} \\ &\text{or} \\ 2,080,768 + (120 * 64) &= 2,080,768 + 7680 = \mathbf{2,088,448} \end{aligned}$$

Register Offset

The register offset is the register's location in the block of 64 address bytes. For example, the matrix module's Status Register has an offset of 04_{16} . When you write a command to this register, the offset is added to the base address to form the register address:

$$\begin{aligned} 1FDE00_{16} + 04_{16} &= \mathbf{1FDE04_{16}} \\ &\text{or} \\ 2,088,448 + 4 &= \mathbf{2,088,452} \end{aligned}$$

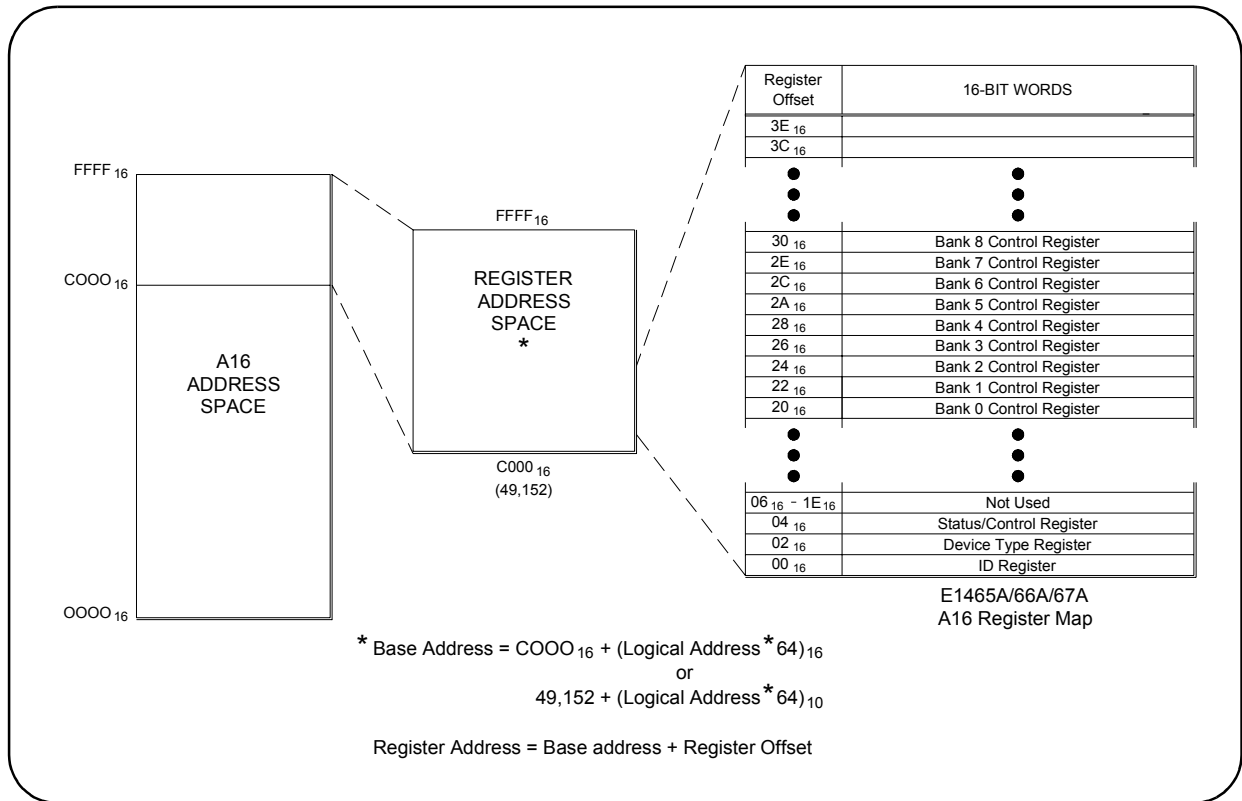

Figure B-1. Registers Within A16 Address Space

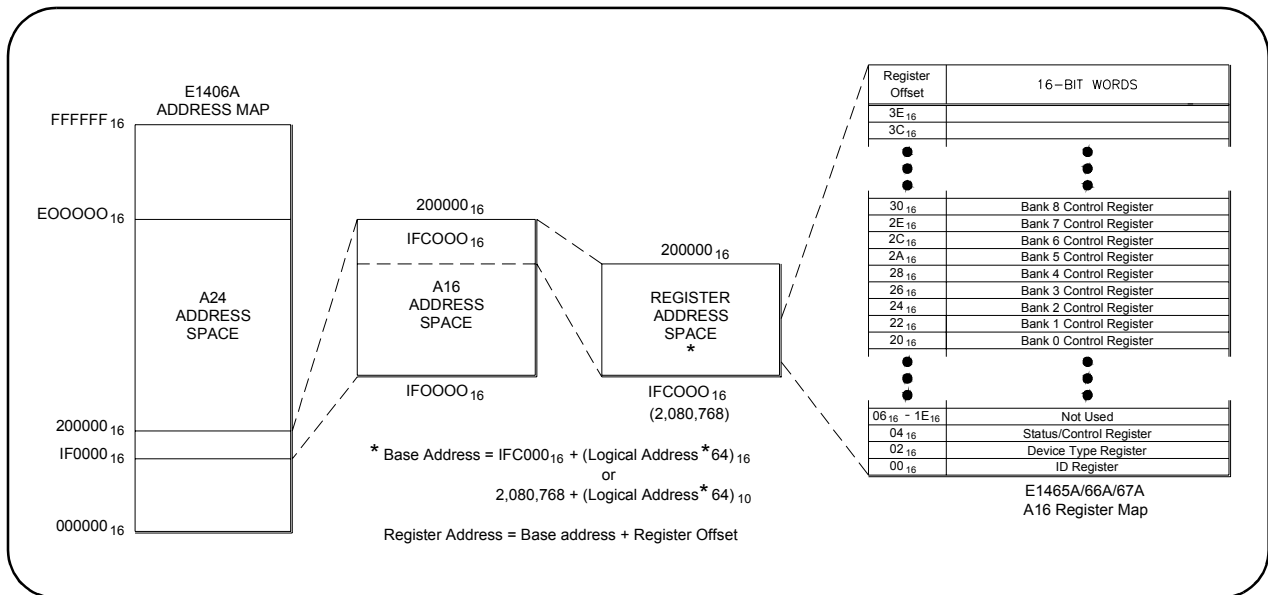

Figure B-2. Registers Within the E1406 A16 Address Space

Register Descriptions

Each matrix module contains two read registers, one read/write register, and 16 write registers. This section describes each matrix module register.

Reading and Writing to the Registers

Example programs are provided at the end of this appendix that show how to read and write to these registers. You can read or write to the following matrix module registers.

- Manufacturer Identification Register (read only)
- Device Type Register (base + 02₁₆) (read only)
- Status/Control Register (base + 04₁₆) (read or write)
- 16 Relay Control Registers (write only)

Manufacturer Identification Register

The Manufacturer Identification Register is at offset address 00₁₆ and returns FFFF₁₆. This shows that Hewlett-Packard is the manufacturer and the module is an A16 register-based module. This register is read only.

b+00 ₁₆	15	14	13	12	11	10	9	8	7	6	5	4	3	2	1	0
Write	Undefined															
Read	Manufacturer ID - Returns FFFF ₁₆ = Hewlett-Packard A16 only register-based device.															

Device Type Register

The Device Type Register is at offset address 02₁₆ and returns 0122₁₆ for an E1465A/E1466A/E1467A module. This register is read only.

b+02 ₁₆	15	14	13	12	11	10	9	8	7	6	5	4	3	2	1	0
Write	Undefined															
Read	0122 ₁₆															

Status/Control Register

The Status/Control Register is at offset address 04₁₆ and informs the user about the module's status and configuration. This register is read and write.

b+04 ₁₆	15	14	13	12	11	10	9	8	7	6	5	4	3	2	1	0
Write	Not Used									E	Not Used					SR
Read	X	MS	Module ID			X	X	B	E	X	X	1	1	X	X	

Reading the Status/Control Register

For Status/Control register reads, three bits are defined as follows.

- **MODID (bit 14):** 0 indicates the module has been selected by MODID (module ID) and a 1 indicates the module has not been selected. For example, if an E1466A matrix module is not busy (bit 7 = 1) and the interrupt is enabled (bit 6 = 0), a read of the Status/Control Register (base + 04₁₆) returns DBBF.
- **Module ID (bits 10 - 13):** The following bit representations determine the module configuration (E1465A/66A/67A determined by the terminal module attached).

Model/Bits	(13)	(12)	(11)	(10)
E1465A	1	0	0	1
E1466A	0	1	1	0
E1467A	0	1	0	1

- **Busy (bit 7):** 0 indicates the module is busy. Each relay requires about 7 ms execution time during which time the matrix module is busy. Bit 7 of this register is used to inform the user of a busy condition.
- **Enable (bit 6):** 0 indicates the interrupt is enabled. The interrupt generated after a channel has been closed can be disabled. Bit 6 of this register is used to inform the user of the interrupt status.

Writing to the Status/Control Register

You can only write to bits 0 and 6 of the Status/Control Register.

- **Enable (bit 6):** Writing a "1" to this bit disables the interrupt function of the module.
- **Soft Reset (bit 0):** Writing a "1" to this bit does not soft reset the module. To reset each relay in register-based programming, you must write all 0s to all 16 banks to open all relays.

NOTE *When writing to the registers it is necessary to write "0" to bit 0 after the reset has been performed before any other commands can be programmed and executed. SCPI commands take care of this automatically.*

Relay Control Register

There are 16 relay control registers: Bank 0 Relay Control Register (base + 20_{16}) through Bank 15 Relay Control Register 2 (base + $3E_{16}$). These registers are used to open and close the specified matrix relays. Reading any Relay Control Register will always return $FFFF_{16}$ regardless of the channel states.

The numbers in the register maps indicate the channel number to be written to. To close a relay, you must write a 1 to the bit. For example, $WRITEIO-16,(DE00_{16});0010_{16}$ closes bit 4 of bank 0 (channel 004), where $DE00_{16}$ is the base address, 20_{16} is the offset address, and 0010 is the hexadecimal number to send a 1 to bit 4.

Bank 0 Relay Control Register

Address	15	14	13	12	11	10	9	8	7	6	5	4	3	2	1	0
Base+ 20_{16}	015	014	013	012	011	010	009	008	007	006	005	004	003	002	001	000

Bank 1 Relay Control Register

Address	15	14	13	12	11	10	9	8	7	6	5	4	3	2	1	0
Base+ 22_{16}	115	114	113	112	111	111	109	108	107	106	105	104	103	102	101	100

Bank 2 Relay Control Register

Address	15	14	13	12	11	10	9	8	7	6	5	4	3	2	1	0
Base+ 24_{16}	215	214	213	212	211	210	209	208	207	206	205	204	203	202	201	200

Bank 3 Relay Control Register

Address	15	14	13	12	11	10	9	8	7	6	5	4	3	2	1	0
Base+ 26_{16}	315	314	313	312	311	310	309	308	307	306	305	304	303	302	301	300

Bank 4 Relay Control Register

Address	15	14	13	12	11	10	9	8	7	6	5	4	3	2	1	0
Base+ 28_{16}	415	414	413	412	411	410	409	408	407	406	405	404	403	402	401	400

Bank 5 Relay Control Register

Address	15	14	13	12	11	10	9	8	7	6	5	4	3	2	1	0
Base+ $2A_{16}$	515	514	513	512	511	510	509	508	507	506	505	504	503	502	501	500

Bank 6 Relay Control Register

Address	15	14	13	12	11	10	9	8	7	6	5	4	3	2	1	0
Base+ $2C_{16}$	615	614	613	612	611	610	609	608	607	606	605	604	603	602	601	600

Bank 7 Relay Control Register

Address	15	14	13	12	11	10	9	8	7	6	5	4	3	2	1	0
Base+2E ₁₆	715	714	713	712	711	710	709	708	707	706	705	704	703	702	701	700

Bank 8 Relay Control Register

Address	15	14	13	12	11	10	9	8	7	6	5	4	3	2	1	0
Base+30 ₁₆	815	814	813	812	811	810	809	808	807	806	805	804	803	802	801	800

Bank 9 Relay Control Register

Address	15	14	13	12	11	10	9	8	7	6	5	4	3	2	1	0
Base+32 ₁₆	915	914	913	912	911	910	909	908	907	906	905	904	903	902	901	900

Bank 10 Relay Control Register

Address	15	14	13	12	11	10	9	8	7	6	5	4	3	2	1	0
Base+34 ₁₆	1015	1014	1013	1012	1011	1010	1009	1008	1007	1006	1005	1004	1003	1002	1001	1000

Bank 11 Relay Control Register

Address	15	14	13	12	11	10	9	8	7	6	5	4	3	2	1	0
Base+36 ₁₆	1115	1114	1113	1112	1111	1110	1109	1108	1107	1106	1105	1104	1103	1102	1101	1100

Bank 12 Relay Control Register

Address	15	14	13	12	11	10	9	8	7	6	5	4	3	2	1	0
Base+38 ₁₆	1215	1214	1213	1212	1211	1210	1209	1208	1207	1206	1205	1204	1203	1202	1201	1200

Bank 13 Relay Control Register

Address	15	14	13	12	11	10	9	8	7	6	5	4	3	2	1	0
Base+3A ₁₆	1315	1314	1313	1312	1311	1310	1309	1308	1307	1306	1305	1304	1303	1302	1301	1300

Bank 14 Relay Control Register

Address	15	14	13	12	11	10	9	8	7	6	5	4	3	2	1	0
Base+3C ₁₆	1415	1414	1413	1412	1411	1410	1409	1408	1407	1406	1405	1404	1403	1402	1401	1400

Bank 15 Relay Control Register

Address	15	14	13	12	11	10	9	8	7	6	5	4	3	2	1	0
Base+3E ₁₆	1515	1514	1513	1512	1511	1510	1509	1508	1507	1506	1505	1504	1503	1502	1501	1500

Programming Examples

This section provides example programs in BASIC and C/HP-UX, including:

- Example: Reading the Registers (BASIC)
- Example: Reading the Registers (C/HP-UX)
- Example: Making Measurements (BASIC)
- Example: Making Measurements (C/HP-UX)
- Example: Scanning Channels (BASIC)
- Example: Scanning Channels (C/HP-UX)

Example: Reading the Registers (BASIC)

This BASIC programming example reads the Manufacturer ID Register, Device Type Register and Status Register on the E1466A matrix module.

```
10 !*****
20 ! ***** READREG *****
30 !*****
40 OPTION BASE 1
50 !Set up arrays to store register names and addresses
60 DIM Reg_name$(1:3)[32], Reg_addr(1:3)
70 !
80 !Read register names and addresses into the arrays
90 READ Reg_name$(*)
100 READ Reg_addr(*)
110 !
120 !Set base address variable
130 Base_addr = DVAL("DE00",16)
140 !
150 !Map the A16 address space in the controller
160 !
170 CONTROL 16,25;2
180 !Call the subprogram Read_regs
190 Read_regs(Base_addr, Reg_name$(*), Reg_addr(*))
200 !
210 DATA Identification register, Device register, Status register
220 DATA 00, 02, 04
230 END
.
.
.
300 !This subprogram steps through a loop that reads each register
310 !and prints its contents
320 SUB Read_regs(Base_addr, Reg_name$(*), Reg_addr(*))
330 !
340 For Number = 1 to 3
350 Register = READIO(-16,Base_addr + Reg_addr(number))
360 PRINT Reg_name$(number); " = "; IVAL$(Register,16)
370 Next Number
380 SUBEND
```

Example: Reading the Registers (C/HP-UX)

This C/HP-UX programming example reads the Manufacturer ID Register, Device Type Register and Status Register on the E1466A matrix module.

```
/******  
***** readreg.c *****  
*****  
#include <sys/vxi.h> /*source file for controller VXI drivers*/  
#include <fcntl.h>  
#include <stdio.h>  
  
#define logical_address 120 /*logical address of the matrix module*/  
  
int fd;  
typedef unsigned short word;  
typedef struct dev_regs{ /*set up pointers*/  
    unsigned short id_reg;  
    unsigned short device_type;  
    unsigned short status_reg;  
    unsigned short bank0_channels;  
  
} DEV_REGS;  
  
main( )  
{  
/*open the controller VXI interface*/  
fd=open("/dev/vxi/primary",O_RDWR);  
if (fd){  
    perror("open");  
    exit(1);  
}  
/*retrieve the A16 pointers*/  
dev=(struct dev_regs *)vxi_get_a16_addr(fd,logical_address);  
  
/*sub to read the registers*/  
read_reg(dev);  
/*END of main program*/  
}  
  
/*SUB READ_REG*/  
  
int read_reg(reg_ptr)  
DEV_REGS *reg_ptr;  
{  
/*read the ID register*/  
printf("\n ID Register = 0x%x\n",reg_ptr->id_reg);  
/*read the Device Type register*/  
printf("\n Device Type Register = 0x%x\n",reg_ptr->device_type);  
/*read the Status register*/  
printf("\n Status Register = 0x%x\n",reg_ptr->status_reg);  
return;  
}
```

Example: Making Measurements (BASIC)

This BASIC programming example closes bit 1 on bank 0, waits for a measurement to be made, and then opens the channel. You must insert your own programming code for the measurement part of this program. For example, if you are using the E1411B, see the *E1326B/E1411B Multimeter User's Manual* for programming examples.

```
10 !*****
20 !*****          MAKEMEAS          *****
30 !*****
40 OPTION BASE 1
50 !Set up arrays to store register names and addresses
60 DIM Reg_name$(1:1)[32], Reg_addr(1:1)
70 !
80 !Read register names and address into the arrays
90 READ Reg_name$(*)
100 READ Reg_addr(*)
110 !
120 !Set base address variable
130 Base_addr = DVAL("DE00",16)
140 !
150 !Map the A16 address space in the controller
160 CONTROL 16,25;2
170 !Call the subprogram Make_meas
180 Make_meas(Base_addr, Reg_addr(*))
190 !
200 DATA Bank0 channels register
210 DATA 06
220 END
.
.
.
280 !This subprogram closes bit 1 of bank0 channels, waits for the
290 !channel to be closed, makes a measurement, and then opens
300 !the relay.
310 SUB Make_meas(Base_addr, Reg_addr(*))
320 !
330   WRITEIO -16, Base_addr + Reg_addr(1); 1
340   REPEAT
350     UNTIL BIT(READIO(-16,Base_addr+4),7)
.
.   !Make Measurements
.
380   WRITEIO -16, Base_addr + Reg_addr(1);0
390 SUBEND
```

Example: Making Measurements (C/HP-UX)

This C/HP-UX programming example closes bit 1 on bank 0, waits for a measurement to be made, and then opens the channel. You must insert your own programming code for the measurement part of this program. For example, if you are using the E1411B, see the *E1326B/E1411B Multimeter User's Manual* for programming examples.

The sub `ver_time` allows time for switch closures. This sub should print a time around 7 ms. If the time is less, you must change the value of `j` in the for loop. For example, instead of 7000, you might need to use 10000.

```

/*****
***          makemeas.c          ***
*****/
#include <time.h>
#include <sys/vxi.h>      /*source file for controller VXI drivers*/
#include <fcntl.h>
#include <stdio.h>

#define logical_address 120  /*logical address of matrix module*/

int fd;
typedef unsigned short word;
typedef struct dev_regs{    /*set up pointers*/
                        unsigned short id_reg;
                        unsigned short device_type;
                        unsigned short status_reg;
                        unsigned short bank0_channels;

} DEV_REGS;

main( )
{

/*open the controller VXI interface*/
fd=open("/dev/vxi/primary",O_RDWR);
if (fd){
    perror("open");
    exit(1);
}
/*retrieve the A16 pointers*/
dev=(struct dev_regs *)vxi_get_a16_addr(fd,logical_address);

/*sub to verify the time to close the switch*/
ver_time( );
/*sub to close switch and make measurement*/
make_meas(dev);
} /* *END of main program*/

```

Continued on next page

```

/*SUB VER_TIME*/

ver_time( )
{
struct timeval first,
                second,
                lapsed;

struct timezone tzp;
gettimeofday(&first,&tzp);
for (j=0; j<=7000; j ++);
gettimeofday ($second,&tzp);

if (first.tv_usec > second.tv_usec)
    {
    second.tv_usec +=1000000;
    second.tv_sec--;
    }

lapsed.tv_usec = second.tv_usec - first.tv_usec;
lapsed.tv_sec = second.tv_sec - first.tv_sec;

printf("Elapsed time for closing a channel is: %ld sec %ld usec \n",
lapsed.tv_sec, lapsed.tv_usec);
}

/*SUB MAKE_MEAS*/

int make_meas(reg_ptr)
DEV_REGS *reg_ptr;
{

/*close bit 1 of bank0 */
reg_ptr->bank0_channels=0x0001;
for (j=0; j<=7000; j ++); /*wait for switch to close*/
printf("\n Making Measurement");

                .
                .
                .
                /*make measurements*/
                .
                .

/*open bit 1 of bank0*/
reg_ptr->bank0_channels=0x0000;
return;
}

```

Example: Scanning Channels (BASIC)

This BASIC programming example scans through the bank 0 channels (closing one switch at a time) and makes measurements between switch closures. You must insert your own programming code for the measurement part of this program. For example, if you are using the E1411B, see the *E1326B/E1411B Multimeter User's Manual* for programming examples.

```
10  !*****
20  !*****          SCANNING          *****
30  !*****
40  OPTION BASE 1
50  !Set up arrays to store register names and addresses
60  DIM Reg_name$(1:1)[32], Reg_addr(1:1)
70  !
80  !Read register names and addresses into the arrays
90  READ Reg_name$(*)
100 READ Reg_addr(*)
110 !Set base address variable
120 Base_addr = DVAL("DE00",16)
130 !
140 !Map the A16 address space in the controller
150 CONTROL 16,25;2
160 !Call the subprogram Scan_meas
170 Scan_meas(Base_addr, Reg_addr(*))
180 !
190 DATA Bank0 channels register
200 DATA 06
210 END
.
.
.
270 !This subprogram sets all bits in bank0 open then scans through
280 !bank 0, closing one channel at a time (waits for the channel to
290 !be closed) so a measurement can be made.
300 SUB Scan_meas(Base_addr, Reg_addr(*))
310 !
320 WRITEIO -16, Base_addr + Reg_addr(1);0
330 FOR I= 0 to 15
340   WRITEIO -16, Base_addr + Reg_addr(1);2^I
350   REPEAT
360     UNTIL BIT(READIO(-16,Base_addr+4),7)
370     PRINT "Making Measurements"
.
.
.
.           !Make Measurements
.
420 NEXT I
430 WRITEIO -16,Base_addr + Reg_addr(1);0
440 SUBEND
```

Example: Scanning Channels (C/HP-UX)

This C/HP-UX programming example scans through the bank 0 channels (closing one switch at a time) and makes measurements between switch closures. You must insert your own programming code for the measurement part of this program. For example, if you are using the E1411B, see the *E1326B/E1411B Multimeter User's Manual* for programming examples.

NOTE *The sub ver_time allows time for the switches to close. The program should print a time around 7 ms. If the time is less, you must change the value of j in the for loop. For example, instead of 7000, you might need to use 10000.*

The math.h include file requires a -lm option when compiling this program.

```
/******  
/**          scanning.c          **/  
/******  
#include <time.h>  
#include <math.h>    /*file to perform math functions*/  
#include <sys/vxi.h> /*source file for controller VXI drivers*/  
#include <fcntl.h>  
#include <stdio.h>  
  
#define logical_address 120    /*logical address of Form C Switch*/  
#define lastch 15  
  
int fd, i, j, reg;  
double y;  
typedef unsigned short word;  
typedef struct dev_regs{      /*set up pointers*/  
    unsigned short id_reg;  
    unsigned short device_type;  
    unsigned short status_reg;  
    unsigned short dummy[13];  
    unsigned short bank0_channels;  
  
} DEV_REGS;  
main( )  
{  
    /*open the controller VXI interface*/  
    fd=open("/dev/vxi/primary",O_RDWR);  
    if (fd) {  
        perror("open");  
        exit(1);  
    }  
    /*retrieve the A16 pointers*/  
    dev=(struct dev_regs*)vxi_get_a16_addr(fd,logical_address);
```

Continued on next page

```

/*sub to verify the time to close the switch*/
ver_time( );
/*sub to close a set of switches and make measurements*/
scan_meas(dev);
}                               /*END of main program*/

/*SUB VER_TIME*/
ver_time( )
{
struct timeval first,
                second,
                lapsed;

struct timezone tzp;
gettimeofday(&first,&tzp);
for (j=0; j<=7000; j ++);
gettimeofday ($second,&tzp);
if (first.tv_usec > second.tv_usec)
    {
        second.tv_usec +=1000000;
        second.tv_sec--;
    }

lapsed.tv_usec = second.tv_usec - first.tv_usec;
lapsed.tv_sec = second.tv_sec - first.tv_sec;

printf("Elapsed time for closing a channel is: %ld sec %ld usec \n",
lapsed.tv_sec, lapsed.tv_usec);
}

/*SUB SCAN_MEAS*/
int scan_meas(reg_ptr)
DEV_REGS *reg_ptr;
{
/*set bank0 to 000 */

reg_ptr->bank0_channels=0x000;
i=0;
for (i=0;i=lastch;i ++)
    {
        y=i;
        reg=pow(2.0,y);
        reg_ptr-bank0_channels=reg;
        for (j=0; j<=7000; j ++); /*wait for switch to be closed*/
        printf("\n Making Measurement");

        .
        .
        .
    }
return;
}

```

Notes:

Appendix C

Matrix Modules Error Messages

Error Types

Table C-2 lists the error messages generated by the E1465A, E1466A, or E1467A Relay Matrix Switch modules firmware when programmed by SCPI. Errors with negative values are governed by the SCPI standard and are categorized in Table C-1. Error numbers with positive values are not governed by the SCPI standard. See the *E1406A Command Module User's Manual* for further details on these errors.

Table C-1. Error Types

Range	Error Types Description
-199 to -100	Command Errors (syntax and parameter errors).
-299 to -200	Execution Errors (instrument driver detected errors)
-399 to -300	Device Specific Errors (instrument driver errors that are not command nor execution errors).
-499 to -400	Query Errors (problem in querying an instrument)

Error Messages

Table C-2. Error Messages

Code	Error Message	Potential Cause(s)
-109	Missing Parameter	Sending a command requiring a channel list without the channel list.
-211	Trigger Ignored	Trigger received when scan not enabled. Trigger received after scan complete. Trigger too fast.
-213	INIT Ignored	Attempting to execute an INIT command when a scan is already in progress.
-224	Illegal Parameter Value	Attempting to execute a command with a parameter not applicable to the command.
-310	System Error	Too many characters in the channel list expression.
+1500	External Trigger Source Already Allocated	Assigning an external trigger source to a switchbox when the trigger source has already been assigned to another switchbox.
+2000	Invalid Card Number	Addressing a module (card) in a switchbox that is not part of the switchbox.
+2001	Invalid Channel Number	Attempting to address a channel of a module in a switchbox that is not supported by the module (e.g., channel 99 of matrix module).
+2006	Command Not Supported On This Card	Sending a command to a module (card) in a switchbox that is unsupported by the module.
+2008	Scan List Not Initialized	Executing an INIT without a channel list defined.
+2009	Too Many Channels In Channel List	Attempting to address more channels than available in the switchbox.
+2011	Empty Channel List	No valid channels are specified in the <i><channel_list></i> .
+2012	Invalid Channel Range	Invalid channel(s) specified in SCAN <i><channel_list></i> command. Attempting to begin scanning when no valid <i><channel_list></i> is defined.
+2600	Function Not Supported On This Card	Sending a command to a module (card) in a switchbox that is not supported by the module or switchbox.

Replacement Strategy

Electromechanical relays are subject to normal wear-out. Relay life depends on several factors. The replacement strategy depends on the application. If some relays are used more often or at a higher load than other relays, the relays can be individually replaced as needed.

If all relays see similar loads and switching frequencies, the entire circuit board can be replaced when the end of relay life approaches. The sensitivity of the application should be weighed against the cost of replacing relays with some useful life remaining.

NOTE *Relays that wear out normally or fail due to misuse should not be considered defective and are not covered by the product's warranty.*

Relay Life Factors

Some effects of loading and switching frequency on relay life follow.

- **Relay Load.** In general, higher power switching reduces relay life. In addition, capacitive/inductive loads and high inrush currents (for example, turning on a lamp or starting a motor) reduces relay life. Exceeding specified maximum inputs can cause catastrophic failure.
- **Switching Frequency.** Relay contacts heat up when switched. As the switching frequency increases, the contacts have less time to dissipate heat. The resulting increase in contact temperature also reduces relay life.

End-of-Life Determination

A preventive maintenance routine can prevent problems caused by unexpected relay failure. The end of life of a relay can be determined by using one or more of three methods: contact resistance maximum value, contact resistance variance, and/or number of relay operations. The best method (or combination of methods), as well as the failure criteria, depends on the application in which the relay is used.

- **Contact Resistance Maximum Value.** As the relay begins to wear out, its contact resistance increases. When the resistance exceeds a predetermined value, the relay should be replaced.
- **Contact Resistance Variance.** The stability of the contact resistance decreases with age. Using this method, the contact resistance is measured several (5-10) times, and the variance of the measurements is determined. An increase in the variance indicates deteriorating performance.
- **Number of Relay Operations.** Relays can be replaced after a predetermined number of contact closures. However, this method requires knowledge of the applied load and life specifications for the applied load.

A

- ABORt subsystem, 52
- addressing matrix modules, 15
- addressing registers, 83
- ARM subsystem
 - ARM:COUNT, 53
 - ARM:COUNT?, 54
- attaching terminal modules to switch module, 29

B

- base address, 84

C

- cautions, 19
- common commands
 - *CLS, 79
 - *ESE, 79
 - *ESE?, 79
 - *ESR?, 79
 - *IDN?, 79
 - *OPC, 79
 - *OPC?, 79
 - *RCL, 79
 - *RST, 79
 - *SAV, 79
 - *SRE, 79
 - *SRE?, 79
 - *STB?, 79
 - *TRG, 79
 - *TST?, 79
 - *WAI, 79
- format, 49
- configuring
 - larger matrixes, 30
 - matrix modules, 19
 - switch modules, 20
 - terminal modules, 24
- creating larger matrixes, 30

D

- declaration of conformity, 9
- detecting error conditions, 45
- Device Type register, 86

- DISPlay subsystem

- DISPlay:MONitor:CARD, 55
 - DISPlay:MONitor[:STATe], 56

- documentation history, 8

E

- E1465A matrix module, description, 11
- E1466A matrix module, description, 11
- E1467A matrix module, description, 11
- error conditions, detecting, 45
- error messages, 100
- error types, 99
- examples
 - Advancing Scan Using TRIGger, 75
 - Channel Sequencing (BASIC), 38
 - Closing Form C Switch Channels, 64
 - Closing Relays (BASIC), 16
 - Closing Relays (Turbo C), 17
 - Detecting Error Conditions (BASIC), 45
 - Detecting Error Conditions (TURBO C), 45
 - Enabling "Trig Out" Port, 60
 - Enabling a Single Scan, 58
 - Enabling Continuous Scanning, 58
 - Enabling Monitor Mode, 56
 - Enabling OPERation Status Register Bit 8, 70
 - Enabling TTL Trigger Bus Line 7, 62
 - Making Measurements (BASIC), 92
 - Making Measurements (C/HP-UX), 93
 - Matrix Module Identification (BASIC), 36
 - Matrix Module Identification (TURBO C), 37
 - Opening Matrix Modules Channels, 65
 - Opening/Closing Channels (BASIC), 38
 - Querying "Trig Out" Port Enable State, 60–61
 - Querying Channel Closure, 64
 - Querying Channel Closure (BASIC), 42
 - Querying Channel Open State, 66
 - Querying Continuous Scanning State, 58
 - Querying Number of Scans, 54
 - Querying the OPERation Status Register, 71
 - Querying the Trigger Source, 77
 - Querying TTL Trigger Bus Enable State, 62
 - Reading the Description of a Module, 72
 - Reading the Error Queue, 74

E (continued)

examples (cont'd)

- Reading the Model Number of a Module, 74
- Reading the OPERation Status Register, 71
- Reading the Registers (BASIC), 90
- Reading the Registers (C/HP-UX), 91
- Saving and Recalling States (BASIC), 44
- Scanning Channels (BASIC), 95
- Scanning Channels (C/HP-UX), 96
- Scanning Channels Using TTL Trigs (BASIC), 39
- Scanning Using Bus Triggers, 77
- Scanning Using External Device, 67
- Scanning Using External Triggers, 77
- Scanning Using Trig In/Out Ports (BASIC), 41
- Select Module for Monitoring, 55
- Setting Ten Scanning Cycles, 53
- Stopping a Scan with ABORT, 52
- Synchronizing a Matrix Module (BASIC), 46
- Using the Scan Complete Bit (BASIC), 43

I

IEEE 488.2 commands reference, 79

INITiate subsystem

- INITiate:CONTInuous, 57
- INITiate:CONTInuous?, 58
- INITiate[:IMMEDIATE], 58

installing switch module in mainframe, 23

instruments, definition, 11

interrupt level, setting, 21

L

latching relays, advantages, 47

Logical Address Switch, setting, 21

M

Manufacturer ID register, 86

matrix modules

- addressing, 15
- addressing registers, 83
- attaching terminal modules, 29
- command types, 49
- configuring, 19
- configuring switch modules, 20
- configuring terminal modules, 24
- creating a 32x32 matrix, 30
- creating a 4x256 matrix, 32
- creating an 8x96 matrix, 33
- creating larger matrixes, 30

matrix modules (cont'd)

- creating larger matrixes (multiple mainframes), 34
- description, 11
- error messages, 100
- error types, 99
- installing switch module in mainframe, 23
- programming, 15
- querying, 42
- register base address, 84
- register-based programming, 83
- relay life, 101
- setting interrupt level, 21
- setting Logical Address Switch, 21
- specifications, 81
- switch module connectors, 20
- terminal module connectors, 24
- wiring terminal modules, 27

matrixes, configuring larger, 30

module identification, 36

O

offset, register, 84

OUTPut subsystem

- OUTPut:EXTernal[:STATe], 59
- OUTPut:EXTernal[:STATe]?, 60
- OUTPut:TLTrgn[:STATe], 61
- OUTPut:TLTrgn[:STATe]?, 62
- OUTPut[:STATe], 60
- OUTPut[:STATe]?, 61

P

parameters, 51

power-on conditions, 36

programming matrix modules, 15

programming, register-based, 83

Q

querying matrix modules, 42

R

register offset, 84

register types, 86

register-based programming, 83

registers

- addressing, 83
- base address, 84
- definitions, 86
- Device Type, 86
- Manufacturer ID, 86

R (continued)

registers (cont'd)

offset, 84

Relay Control, 88

StatusControl, 86

types, 86

Relay Control register, 88

relay life, 101

relay matrixes

commands, 35

detecting error conditions, 45

latching relays, 47

module block diagram, 48

module identification, 36

module operations, 47

power-on conditions, 36

reset conditions, 36

saving and recalling states, 44

scanning channels, 39

switching channels, 38

synchronizing modules, 46

understanding the modules, 47

using Scan Complete bit, 42

relays

end-of-life determination, 101

relay life factors, 101

replacement strategy, 101

reset conditions, 36

restricted rights statement, 7

[ROUTE:] subsystem

[ROUTE:]CLOSE, 63

[ROUTE:]CLOSE?, 64

[ROUTE:]OPEN, 65

[ROUTE:]OPEN?, 66

[ROUTE:]SCAN, 66

S

safety symbols, 8

saving and recalling states, 44

Scan Complete bit, using, 42

scanning channels, 39

SCPI command reference, 51

SCPI commands

abbreviated commands, 50

command reference, 51

command separator, 50

format, 49

implied commands, 50

linking commands, 50

parameters, 51

quick reference, 78

specifications, 81

STATus subsystem

STATus:OPERation:CONDition?, 70

STATus:OPERation:ENABle, 70

STATus:OPERation:ENABle?, 70

STATus:OPERation[:EVENT]?, 71

STATus:PRESet, 71

StatusControl register, 86

switching channels, 38

synchronizing relay matrix switch modules, 46

SYSTEM subsystem

SYSTEM:CDEscription?, 72

SYSTEM:CPON, 73

SYSTEM:CTYPE?, 73

SYSTEM:ERRor?, 74

T

terminal module connectors, 24

terminal modules, attaching to switch module, 29

terminal modules, configuring, 24

terminal modules, wiring, 27

TRIGger subsystem

TRIGger:SOURce, 76

TRIGger:SOURce?, 77

TRIGger[:IMMEDIATE], 75

U

understanding relay matrix switch modules, 47

W

WARNINGS, 8, 19

warranty statement, 7

wiring terminal modules, 27