



Agilent E1441A Function/Arbitrary Waveform Generator User/Service and SCPI Programming Manual

Where to Find it - Online and Printed Information:

System installation (hardware/software)	VXIbus Configuration Guide* Agilent VIC (VXI installation software)*
Module configuration and wiring	This Manual
SCPI programming	This Manual
SCPI example programs	This Manual, Driver Disk
SCPI command reference	This Manual
Register-Based Programming	This Manual
VXI <i>plug&play</i> programming	VXI <i>plug&play</i> Online Help
VXI <i>plug&play</i> example programs	VXI <i>plug&play</i> Online Help
VXI <i>plug&play</i> function reference	VXI <i>plug&play</i> Online Help
Soft Front Panel information	VXI <i>plug&play</i> Online Help
VISA language information	Agilent VISA User's Guide
Agilent VEE programming information	Agilent VEE User's Manual



**Supplied with Agilent Command Modules, Embedded Controllers, and VXLink.*



Agilent Technologies



Manual Part Number: E1441-90003
Printed in Malaysia E0406

AGILENT WARRANTY STATEMENT	7
Safety Symbols	8
WARNINGS	8
Declaration of Conformity	9
User Notes	10-12

Chapter 1

Agilent E1441A Function/Arbitrary Waveform Generator Module Setup	13
General Information	13
Setting the Module Address Switch	14
Interrupt Priority	15
Installing into the Mainframe	15
Faceplate Indicators and Connectors	16
Initial Operation	17
Example Programs	18

Chapter 2

Agilent E1441A Application Information	19
Functional Capabilities	19
Output Configuration	19
Amplitude Modulation (AM)	28
Frequency Modulation (FM)	30
FM Carrier Waveform Shape	31
Burst Modulation	33
Frequency-Shift Keying (FSK) Modulation	40
Frequency Sweep	43
Arbitrary Waveforms	46
Built-In Arbitrary Waveforms	48
Phase-Lock Capabilities (Opt 001)	49
Triggering the Function Generator	52
System-Related Operations	55
Error Conditions	55
Self-Test	55
Memory Locations	56
Firmware Revision Query	56
SCPI Language Version Query	56
Power-On and Reset State	57
Application Program Examples	58
C Language Programs	58
Compiling and Linking a C Program	58
Example Programs	58

Chapter 3	
Agilent E1441A SCPI Command Reference	65
CALibration	73
DATA	77
FORMat	84
MEMory	85
OUTPut	87
PHASe	90
[SOURce:]	92
APPLY Commands	96
FM COMMANDS	104
Frequency-Shift Keying (FSK) Commands	108
Selecting an Arbitrary Waveform	110
STATus	117
SYSTem	120
TRIGger	121
IEEE 488.2 Common Command Reference	124
Agilent E1441A Power-On and Reset State	130
SCPI Command Quick Reference	131
Appendix A	
Agilent E1441A Specifications	135
Appendix B	
Agilent E1441A Error Messages	141
Execution Errors	141
Self-Test Errors	147
Calibration Errors	147
Arbitrary Waveform Errors	149
Option 001 Phase-Lock Errors	151
Appendix C	
Agilent E1441A Function Generator Tutorial	153
Direct Digital Synthesis	153
Signal Imperfections	155
Output Amplitude Control	156
Floating Signal Generators	157
Attributes of AC Signals	157
Modulation	158
Appendix D	
Service Procedures	163
Closed-Case Electronic Calibration	164
Agilent Technologies Calibration Services	164
Calibration Interval	164
Time Required for Calibration	164
Automated Verification and Calibration Procedures	164
Recommended Test Equipment	165

Test Considerations.....	165
Performance Verification Tests	166
Self-Test	166
Quick Performance Check	167
Performance Verification Tests	167
Frequency Verification	167
Function Gain and Linearity Verification.....	168
DC Function Offset Verification	168
AC Amplitude Verification	169
Amplitude Flatness Verification	171
AM Modulation Depth Verification	172
Optional Performance Verification Tests	172
Square Wave Duty Cycle Verification	172
Distortion Verification	173
Calibration Security Code.....	174
Unsecuring the Function Generator (Lost Security Code)	175
Calibration Count.....	176
Calibration Message	176
General Calibration/Adjustment Procedure.....	177
Aborting a Calibration in Progress	178
Frequency and Burst Rate Adjustment	178
Function Gain and Linearity Adjustment	179
AC Amplitude Adjustment (High-Z).....	180
Modulation Adjustment	181
AC Amplitude Adjustment (50 Ohms).....	182
DC Output Adjustment	184
Duty Cycle Adjustment	185
AC Amplitude Flatness Adjustment	185
Error Messages	188
Performance Test Record.....	190
Test Limits	190
Measurement Uncertainty	190
Test Accuracy Ratio (TAR)	190
Index	199

Certification

Agilent Technologies, Inc. certifies that this product met its published specifications at the time of shipment from the factory. Agilent Technologies further certifies that its calibration measurements are traceable to the United States National Institute of Standards and Technology (formerly National Bureau of Standards), to the extent allowed by that organization's calibration facility, and to the calibration facilities of other International Standards Organization members.

AGILENT TECHNOLOGIES WARRANTY STATEMENT

PRODUCT: E1441A

DURATION OF WARRANTY: 1 year

1. Agilent warrants Agilent hardware, accessories and supplies against defects in materials and workmanship for the period specified above. If Agilent receives notice of such defects during the warranty period, Agilent will, at its option, either repair or replace products which prove to be defective. Replacement products may be either new or like-new.
2. Agilent warrants that Agilent software will not fail to execute its programming instructions, for the period specified above, due to defects in material and workmanship when properly installed and used. If Agilent receives notice of such defects during the warranty period, Agilent will replace software media which does not execute its programming instructions due to such defects.
3. Agilent does not warrant that the operation of Agilent products will be interrupted or error free. If Agilent is unable, within a reasonable time, to repair or replace any product to a condition as warranted, customer will be entitled to a refund of the purchase price upon prompt return of the product.
4. Agilent products may contain remanufactured parts equivalent to new in performance or may have been subject to incidental use.
5. The warranty period begins on the date of delivery or on the date of installation if installed by Agilent. If customer schedules or delays Agilent installation more than 30 days after delivery, warranty begins on the 31st day from delivery.
6. Warranty does not apply to defects resulting from (a) improper or inadequate maintenance or calibration, (b) software, interfacing, parts or supplies not supplied by Agilent Technologies, (c) unauthorized modification or misuse, (d) operation outside of the published environmental specifications for the product, or (e) improper site preparation or maintenance.
7. TO THE EXTENT ALLOWED BY LOCAL LAW, THE ABOVE WARRANTIES ARE EXCLUSIVE AND NO OTHER WARRANTY OR CONDITION, WHETHER WRITTEN OR ORAL, IS EXPRESSED OR IMPLIED AND AGILENT SPECIFICALLY DISCLAIMS ANY IMPLIED WARRANTY OR CONDITIONS OF MERCHANTABILITY, SATISFACTORY QUALITY, AND FITNESS FOR A PARTICULAR PURPOSE.
8. Agilent will be liable for damage to tangible property per incident up to the greater of \$300,000 or the actual amount paid for the product that is the subject of the claim, and for damages for bodily injury or death, to the extent that all such damages are determined by a court of competent jurisdiction to have been directly caused by a defective Agilent product.
9. TO THE EXTENT ALLOWED BY LOCAL LAW, THE REMEDIES IN THIS WARRANTY STATEMENT ARE CUSTOMER'S SOLE AND EXCLUSIVE REMEDIES. EXCEPT AS INDICATED ABOVE, IN NO EVENT WILL AGILENT OR ITS SUPPLIERS BE LIABLE FOR LOSS OF DATA OR FOR DIRECT, SPECIAL, INCIDENTAL, CONSEQUENTIAL (INCLUDING LOST PROFIT OR DATA), OR OTHER DAMAGE, WHETHER BASED IN CONTRACT, TORT, OR OTHERWISE.

FOR CONSUMER TRANSACTIONS IN AUSTRALIA AND NEW ZEALAND: THE WARRANTY TERMS CONTAINED IN THIS STATEMENT, EXCEPT TO THE EXTENT LAWFULLY PERMITTED, DO NOT EXCLUDE, RESTRICT OR MODIFY AND ARE IN ADDITION TO THE MANDATORY STATUTORY RIGHTS APPLICABLE TO THE SALE OF THIS PRODUCT TO YOU.

U.S. Government Restricted Rights

The Software and Documentation have been developed entirely at private expense. They are delivered and licensed as "commercial computer software" as defined in DFARS 252.227- 7013 (Oct 1988), DFARS 252.211-7015 (May 1991) or DFARS 252.227-7014 (Jun 1995), as a "commercial item" as defined in FAR 2.101(a), or as "Restricted computer software" as defined in FAR 52.227-19 (Jun 1987)(or any equivalent agency regulation or contract clause), whichever is applicable. You have only those rights provided for such Software and Documentation by the applicable FAR or DFARS clause or the Agilent standard software agreement for the product involved.

IEC Measurement Category II Overvoltage Protection

This is a measurement Category II product designed for measurements at voltages up to 300V from earth, including measurements of voltages at typical mains socket outlets. The product should not be used to make voltage measurements on a fixed electrical installation including building wiring, circuit breakers, or service panels.

E1441A Function/Arbitrary Waveform Generator User / Service and SCPI Programming Manual



Agilent Technologies

Edition 3 Rev 2

Copyright © 1999-2006 Agilent Technologies, Inc. All Rights Reserved.

Documentation History

All Editions and Updates of this manual and their creation date are listed below. The first Edition of the manual is Edition 1. The Edition number increments by 1 whenever the manual is revised. Updates, which are issued between Editions, contain replacement pages to correct or add additional information to the current Edition of the manual. Whenever a new Edition is created, it will contain all of the Update information for the previous Edition. Each new Edition or Update also includes a revised copy of this documentation history page.

Edition 1 October 1997
Edition 2 November 1997
Edition 3 January 1999
Edition 3 Rev 2 April 2006

Trademarks

Microsoft® is a U.S. registered trademark of Microsoft Corporation
Windows NT® is a U.S. registered trademark of Microsoft Corporation
Windows® and MS Windows® are U.S. registered trademarks of Microsoft Corporation

Safety Symbols



Instruction manual symbol affixed to product. Indicates that the user must refer to the manual for specific WARNING or CAUTION information to avoid personal injury or damage to the product.



Indicates the field wiring terminal that must be connected to earth ground before operating the equipment—protects against electrical shock in case of fault.

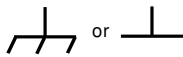

Frame or chassis ground terminal—typically connects to the equipment's metal frame.



Alternating current (AC)



Direct current (DC).



Indicates hazardous voltages.

WARNING

Calls attention to a procedure, practice, or condition that could cause bodily injury or death.

CAUTION

Calls attention to a procedure, practice, or condition that could possibly cause damage to equipment or permanent loss of data.

WARNINGS

The following general safety precautions must be observed during all phases of operation, service, and repair of this product. Failure to comply with these precautions or with specific warnings elsewhere in this manual violates safety standards of design, manufacture, and intended use of the product. Agilent Technologies, Inc. assumes no liability for the customer's failure to comply with these requirements.

Ground the equipment: For Safety Class 1 equipment (equipment having a protective earth terminal), an uninterruptible safety earth ground must be provided from the mains power source to the product input wiring terminals or supplied power cable.

DO NOT operate the product in an explosive atmosphere or in the presence of flammable gases or fumes.

For continued protection against fire, replace the line fuse(s) only with fuse(s) of the same voltage and current rating and type. DO NOT use repaired fuses or short-circuited fuse holders.

Keep away from live circuits: Operating personnel must not remove equipment covers or shields. Procedures involving the removal of covers or shields are for use by service-trained personnel only. Under certain conditions, dangerous voltages may exist even with the equipment switched off. To avoid dangerous electrical shock, DO NOT perform procedures involving cover or shield removal unless you are qualified to do so.

DO NOT operate damaged equipment: Whenever it is possible that the safety protection features built into this product have been impaired, either through physical damage, excessive moisture, or any other reason, REMOVE POWER and do not use the product until safe operation can be verified by service-trained personnel. If necessary, return the product to an Agilent Technologies Sales and Service Office for service and repair to ensure that safety features are maintained.

DO NOT service or adjust alone: Do not attempt internal service or adjustment unless another person, capable of rendering first aid and resuscitation, is present.

DO NOT substitute parts or modify equipment: Because of the danger of introducing additional hazards, do not install substitute parts or perform any unauthorized modification to the product. Return the product to an Agilent Technologies Sales and Service Office for service and repair to ensure that safety features are maintained.

DECLARATION OF CONFORMITY

According to ISO/IEC Guide 22 and CEN/CENELEC EN 45014

Manufacturer's Name: Agilent Technologies, Incorporated
Manufacturer's Address: *Measurement Product Generation Unit*
815 14th ST. S.W.
Loveland, CO 80537 USA

Declares, that the product

Product Name: Arbitrary Waveform Generator
Model Number: E1441A
Product Options: *This declaration covers all options of the above product(s).*

Conforms with the following European Directives:

The product herewith complies with the requirements of the Low Voltage Directive 73/23/EEC and the EMC Directive 89/336/EEC and carries the CE Marking accordingly

Conforms with the following product standards:

EMC	Standard	Limit
	<i>IEC 61326-1:1997+A1:1998 / EN 61326-1:1997+A1:1998 CISPR 11:1997 +A1:1997 / EN 55011:1998 IEC 61000-4-2:1995+A1:1998 / EN 61000-4-2:1995 IEC 61000-4-3:1995 / EN 61000-4-3:1995 IEC 61000-4-4:1995 / EN 61000-4-4:1995 IEC 61000-4-5:1995 / EN 61000-4-5:1995 IEC 61000-4-6:1996 / EN 61000-4-6:1996 IEC 61000-4-11:1994 / EN 61000-4-11:1994</i>	<i>Group 1 Class A ^[1] 4kV CD, 8kV AD 3 V/m, 80-1000 MHz 0.5kV signal lines, 1kV power lines 0.5 kV line-line, 1 kV line-ground 3V, 0.15-80 MHz 1 cycle, 100%</i>
	<i>Canada: ICES-001:1998 Australia/New Zealand: AS/NZS 2064.1</i>	
Safety	<i>IEC 61010-1:1990+A1:1992+A2:1995 / EN 61010-1:1993+A2:1995 Canada: CSA C22.2 No. 1010.1:1992 UL 3111-1:1994</i>	

Supplemental Information:

^[1] *The product was tested in a typical configuration with Agilent Technologies test systems.*

September 5, 2000

Date



Name

Quality Manager

Title

For further information, please contact your local Agilent Technologies sales office, agent or distributor.

Authorized EU-representative: Agilent Technologies Deutschland GmbH, Herrenberger Straße 130, D 71034 Böblingen, Germany

Notes:

Notes:

Notes:

Chapter 1

Agilent E1441A

Function/Arbitrary Waveform Generator

Module Setup

General Information

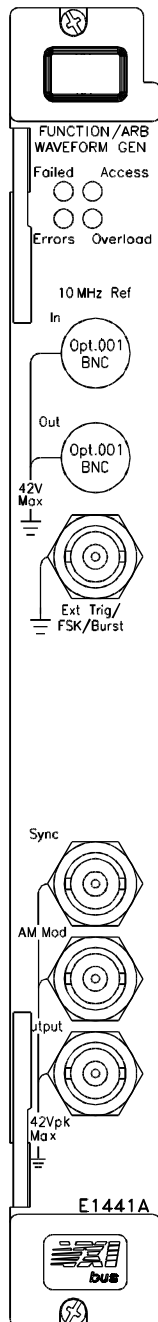

This chapter provides general module information followed by the tasks you must perform to set up your module and verify your installation was successful. Chapter contents are:

- [Setting the Module Address Switch](#) page 14
- [Interrupt Priority](#) page 15
- [Installing into the Mainframe](#) page 15
- [Faceplate Indicators and Connectors](#) page 16
- [Initial Operation](#) page 17

- The Agilent E1441A Function Generator and Arbitrary Waveform Generator (FUNC/ARB WAVEFORM GEN) is a VXIbus C-size message-based slave device.
- Programming the Agilent E1441A can either be through a command module using a GPIB interface or an embedded controller. In either case you can use the Standard Commands for Programmable Instruments (SCPI; See “[Agilent E1441A SCPI Command Reference](#)” on page 65.) with the Standard Instrument Control Language (SICL).
- A *VXIplug&play* driver is supplied on a CD Rom with the Agilent E1441A. All documentation for the use of this driver is contained on-line.
- Option 001 provides a ± 1 ppm timebase which gives 10 times the frequency stability of the standard timebase. It also provides you the ability to control phase offset.

Setting the Module Address Switch

The logical address switch factory setting is 80. Valid addresses are from 1 to 254 for static configuration (the address you set on the switch) and address 255 for dynamic configuration. The Agilent E1441A supports dynamic configuration of the address. This means the address is set program- matically by the resource manager when it encounters a module with address 255 that supports dynamic configuration.

If you install more than one Function Generator, each module must have a different logical address. If you use a VXIbus command module, the logical address must be a multiple of eight (e.g., 80, 88, 96, etc.) Each instrument must have a unique secondary address which is the logical address divided by eight.

Note When using an Agilent E1405A/B or E1406A as the VXIbus resource manager with SCPI commands, the Function Generator's address switch value must be a multiple of 8.

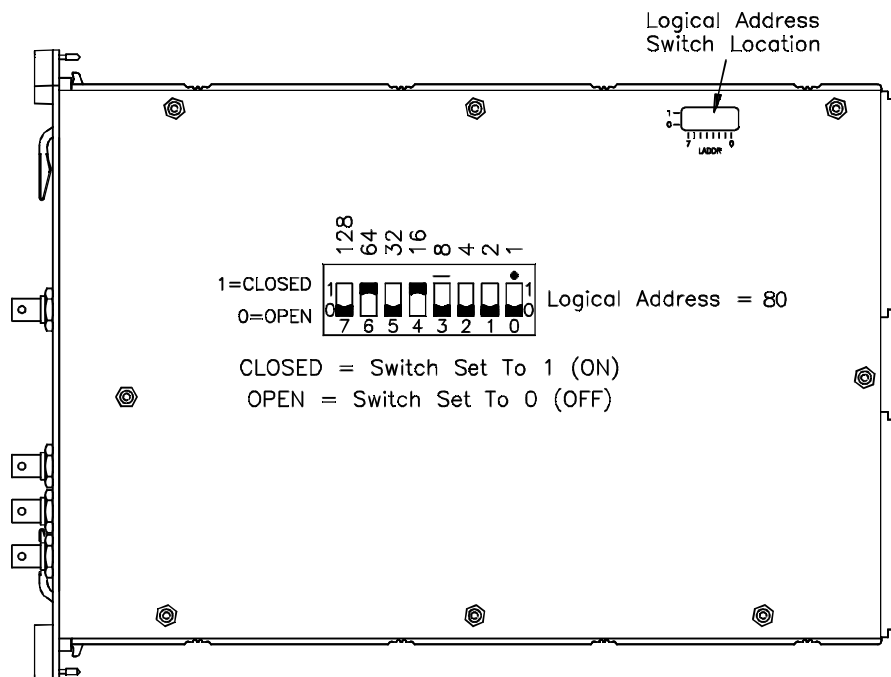

Figure 1-1. Setting the Logical Address

Interrupt Priority

The Agilent E1441A Function Generator / Arbitrary Waveform Generator is a VXIbus interrupter. However, there is no interrupt priority level setting to be made on the module. Interrupt priority level, setup and activation are configured on the resource manager. For example, you configure the interrupt priority on the Agilent E1405B and E1406A Command Modules using the DIAGnostic:INTerrupt command subsystem. Refer to your resource manager's documentation for information on setting your system's interrupt priority.

Installing into the Mainframe

The Agilent E1441A should always be installed to the right of an existing VXIbus module with no empty slots between them. The soft black gasket on the Agilent E1441A's left panel must contact an adjacent module in order to provide the module's specified Electromagnetic Compatibility (EMC).

WARNING To prevent electrical shock in the case of equipment or field wiring failure, tighten the faceplate (module retaining) screws.

Faceplate Indicators and Connectors

Faceplate Indicators

"Failed" turns on momentarily during the function generator's power-on self-test. If the function generator successfully establishes internal communication, the indicator turns off. If the function generator fails to establish internal communication, the indicator remains on.

"Access" turns on only when the resource manager is communicating with the function generator.

"Errors" turns on only when an error is present in the function generator's error queue. The error can result from improperly executing a command or the function generator being unable to pass a part of self-test or calibration. Use the SYST:ERR? command repeatedly to clear the error queue. A response of +0, "No error" indicates the error queue is empty. See Appendix B, Agilent E1441A Function Generator Error Messages, for a list of all errors.

"Overload" turns on when the function generator senses a signal applied to the output terminal that exceeds the present output level. The output terminal is disconnected while the "Overload" light is on.

Option 001 Phase-Lock 10 MHz Reference Terminals

These connectors allow synchronization between multiple Agilent E1441As or to an external 10 MHz clock signal. Additionally, option 001 allows phase offset control.

Standard Input/Output Terminals

The function generator's faceplate contains the following terminals:

1. External Trigger/FSK/Burst modulation input terminal
2. Sync signal output terminal for all standard output functions
3. AM Modulation input terminal
4. Output terminal

Note The outer shell of the "Ext Trig/FSK/Burst" BNC connector is connected to chassis. All other BNC connectors are floating.

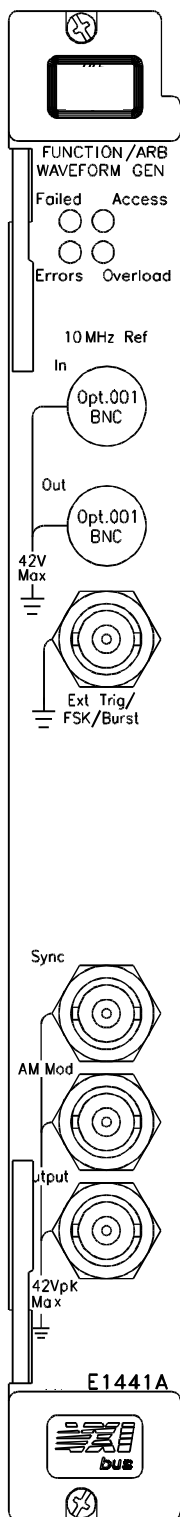

Figure 1-2. Function Generator Terminals

Initial Operation

To program the Function Generator using SCPI, you must select the interface address and SCPI commands to be used. Guidelines to select SCPI commands for the Function Generator follow. See the Agilent 75000 Series C Installation and Getting Started Guide for interface addressing.

Note This discussion applies only to SCPI (Standard Commands for Programmable Instruments) programming. The program is written using Agilent VISA function calls. Agilent VISA allows you to execute on VXIplug&play system frameworks that have the VISA I/O layer installed (visa.h include file).

Programming the Function Generator

Example: Perform a Function Generator Self-Test and Read the Result.

Programming the Function Generator using Standard Commands for Programmable Instruments (SCPI) requires that you select the controller language (e.g., C, C++, Basic, etc.), interface address and SCPI commands to be used. See the "C-Size Installation and Getting Started Guide" (or equivalent) for interfacing, addressing and controller information.

The following C program verifies communication between the controller, mainframe and Function Generator. It resets the module (*RST), queries the identity of the module (*IDN?) and initiates a self-test of the Function Generator. See the program 1441init.c on the Instrument Drivers CD.

```
#include <stdio.h>
#include <visa.h>

/** FUNCTION PROTOTYPE **/
void err_handler (ViSession vi, ViStatus x);

#define DEVICE_ADDRESS "GPIB0::9::10::INSTR"
void main(void)
{
    char buf[512] = {0};

    #if defined(_BORLANDC_) && !defined(_WIN32_)
        _InitEasyWin();
    #endif

    ViStatus err;
    ViSession defaultRM, funcgen;

    /* Open resource manager and Function Generator sessions*/
    viOpenDefaultRM (&defaultRM);
    viOpen(defaultRM, DEVICE_ADDRESS, VI_NULL, VI_NULL, &funcgen);

    /* Set the timeout value to 10 seconds. */
    viSetAttribute(funcgen, VI_ATTR_TMO_VALUE, 10000);
```

```

/* Reset the module, and clear status regs. */
err=viPrintf(funcgen, "*RST;*CLS\n");
if(err != VI_SUCCESS) err_handler(funcgen, err);

/* Query the module identification. */
err=viPrintf(funcgen, "*IDN?\n");
if(err != VI_SUCCESS) err_handler(funcgen, err);
err=viScanf(funcgen, "%t", &buf);
if(err != VI_SUCCESS) err_handler(funcgen, err);
printf("Module ID = %s\n\n", buf);

/* Perform a module self-test. */
err=viQueryf(funcgen, "*TST?\n", "%t", &buf);
if(err != VI_SUCCESS) err_handler(funcgen, err);
printf("Self-test response (0 passed) = %s\n\n", buf);

/* Check for system errors. */
err=viQueryf(funcgen, "syst:err?\n", "%t", buf);
if(err != VI_SUCCESS) err_handler(funcgen, err);
printf("System error response = %s\n\n", buf);

/* Close Instrument Session */
err=viClose(funcgen);
if(err != VI_SUCCESS) err_handler(funcgen, err);

} /* end of main */

/** Error handling function **/
void err_handler(ViSession funcgen, ViStatus err)
{
char buf[1024] = {0};
viStatusDesc(funcgen, err, buf);
printf("ERROR = %s\n", buf);
return;
}

```

Example Programs

Several example programs, including a performance verification program and an adjustment program, can be found on the Agilent Universal Instrument Drivers CD. The directory path is <drive>:\examples\hpe1441.

Agilent E1441A Application Information

This chapter provides information for using the Agilent E1441A Function / Arbitrary Waveform Generator in seven parts:

- [Functional Capabilities](#) page 19
- [Phase-Lock Capabilities \(Opt 001\)](#) page 49
- [Triggering the Function Generator](#) page 52
- [System-Related Operations](#) page 55
- [Power-On and Reset State](#) page 57
- [Application Program Examples](#) page 58

Functional Capabilities

This section provides detailed information about the functional capabilities of the function generator. This section is divided into the following topics:

- [“Output Configuration”](#) on page 19
- [“Amplitude Modulation \(AM\)”](#) on page 28
- [“Frequency Modulation \(FM\)”](#) on page 30
- [“Burst Modulation”](#) on page 33
- [“Frequency-Shift Keying \(FSK\) Modulation”](#) on page 40
- [“Frequency Sweep”](#) on page 43
- [“Arbitrary Waveforms”](#) on page 46

See also [“Command Index by Function”](#) on page 65.

[Chapter 3, Agilent E1441A SCPI Command Reference](#), lists the syntax for the SCPI commands available to program the function generator.

Throughout this manual, the following conventions are used for SCPI command syntax for remote interface programming.

Square brackets ([]) indicate optional keywords or parameters.

Triangle brackets (< >) indicate that you must substitute a value for the enclosed parameter.

A vertical bar (|) separates multiple parameter choices.

Output Configuration

This section contains information to help you configure the function generator for outputting waveforms. You may never have to change some of the parameters discussed here, but they are provided to give you the flexibility you might need. Topics covered on output configuration are:

- Output Function
- Output Frequency
- Output Amplitude
- DC Offset Voltage
- Output Units
- Duty Cycle
- Output Termination
- SYNC Signal
- Instrument Storage State

Note The Agilent E1441A functions do not all have the same maximum limit for frequency and amplitude. Therefore, when changing functions, you can generate a "Settings conflict" error when the new function's frequency or amplitude has a maximum value less than the current output setting. The function generator automatically adjusts to the maximum value of the function you specify and generates the new output signal.

Output Function The function generator can output five standard waveforms including sine, square, triangle, ramp, and noise. You can also select one of five predefined arbitrary waveforms or download your own custom waveforms. You can internally modulate any of the standard waveforms (including arbitrary) using AM, FM, FSK, or burst modulation. Linear or logarithmic frequency sweeping is available for any of the standard waveforms (except noise) and arbitrary waveforms. *The default function is sine wave.*

Possible Conflict with Output Frequency: The output frequency is automatically adjusted if you select a function whose maximum frequency is *less than* that of the currently active function. For example, if you output a 1 MHz sine wave and then change the function to triangle wave, the function generator will adjust the output to 100 kHz (the upper limit for triangle waves). See [Table 2-1](#). A -221, "Settings conflict" error is generated and the frequency is adjusted.

Possible Conflict with Output Amplitude: The output amplitude is automatically adjusted if you select a function whose maximum amplitude is *less than* that of the currently active function. This conflict may arise when the output units are *Vrms* or *dBm* due to the differences in crest factor for the output functions. For example, if you output a 5 *Vrms* square wave (into 50 ohms) and then change the function to sine wave, the function generator will adjust the output amplitude to 3.535 *Vrms* (the upper limit for sine waves in *Vrms*). See [Table 2-4](#). A -221, "Settings conflict" error is generated and the amplitude is adjusted.

Valid Function/ Modulation Modes

The following matrix shows which output functions are allowed with each modulation mode. Each "X" indicates a valid combination. If you change to a function that is not allowed with the selected modulation, the modulation mode is turned off

Table 2-1.

	Sine	Square	Triangle	Ramp	Noise	Arb
AM Carrier	X	X	X	X		X
AM Modulating Wave	X	X	X	X	X	X
FM Carrier	X	X	X	X		X
FM Modulating Wave	X	X	X	X	X	X
FSK Modulation	X	X	X	X		X
Burst Modulation	X	X	X	X		X
Frequency Sweep	X	X	X	X		X

Use the following command to select the output function:

```
FUNCTION:SHAPE SIN|SQU|TRI|RAMP|NOIS|USER|DC
```

You can also use the `APPLY` command to select the function, frequency, amplitude, and offset with a single command. Because the `APPLY` command also changes duty cycle, modulation type, trigger source, and trigger slope, you must place the `APPLY` command first in any sequence of configuration commands.

Output Frequency

As shown below, the output frequency range depends on the function currently selected. The table shows functions in descending order of the maximum frequency. *The default frequency is 1 kHz for all functions.*

Table 2-2.

Parameter Name	Parameter Type	Function	Minimum Frequency	Maximum Frequency	Default Units
frequency	numeric	Sine	100 μ Hz	15 MHz	Hz
		Square	100 μ Hz	15 MHz	Hz
		Built-In Arb	100 μ Hz	5 MHz	Hz
		Ramp	100 μ Hz	100 kHz	Hz
		Triangle	100 μ Hz	100 kHz	Hz

For *arbitrary waveforms* that you create and download to memory, the maximum frequency depends on the number of points specified in the waveform. As shown below, the maximum output frequency decreases as you specify more points in the waveform. The five built-in arbitrary waveforms can be output at a maximum of 5 MHz.

Table 2-3.

Number of Arb Points	Minimum Frequency	Maximum Frequency
8 to 8,192 (8k)	100 mHz	5 MHz
8,193 to 12,287 (12k)	100 mHz	2.5 MHz
12,288 to 16,000	100 mHz	200 kHz

Possible Conflict with Function Change: The output frequency is automatically adjusted if you select a function whose maximum frequency is *less than* that of the currently active function. For example, if you output a 1 MHz sine wave and then change the function to triangle wave, the function generator will adjust the output to 100 kHz (the upper limit for triangle waves). A -221, “*Settings conflict*” error is generated and the frequency is adjusted.

Possible Conflict with Duty Cycle (square wave only): For output frequencies above 5 MHz, the duty cycle is limited to values between 40% and 60% (below 5 MHz, the range is 20% to 80%). The duty cycle is automatically adjusted if you select a frequency that is not valid with the present duty cycle. For example, if you set the duty cycle to 70% and then change the frequency to 8 MHz, the function generator will automatically adjust the duty cycle to 60% (the upper limit for this frequency). A -221, “*Settings conflict*” error is generated and the duty cycle is adjusted.

Use the following command to set the output frequency:

```
FREQuency <frequency> | MINimum | MAXimum
```

You can also use the APPLY command to select the function, frequency, amplitude, and offset with a single command. Because the APPLY command also changes duty cycle, modulation type, trigger source, and trigger slope, you must place the APPLY command first in any sequence of configuration commands.

Output Amplitude

As shown below, the output amplitude range depends on the function currently selected and the output termination. *The default amplitude is 100 mVpp (into 50 ohms) for all functions.*

Table 2-4.

Parameter Name	Parameter Type	Function	Output Termination	Minimum Amplitude	Maximum Amplitude	Default Units
amplitude	numeric	Sine	50Ω	50 mVpp	10 Vpp	Vpp
		Square	50Ω	50 mVpp	10 Vpp	
		Triangle	50Ω	50 mVpp	10 Vpp	
		Ramp	50Ω	50 mVpp	10 Vpp	
		Noise	50Ω	50 mVpp	10 Vpp	
		Built-In Arbs	50Ω	50 mVpp	10 Vpp	
amplitude	numeric	Sine	Open Circuit	100 mVpp	20 Vpp	Vpp
		Square	Open Circuit	100 mVpp	20 Vpp	
		Triangle	Open Circuit	100 mVpp	20 Vpp	
		Ramp	Open Circuit	100 mVpp	20 Vpp	
		Noise	Open Circuit	100 mVpp	20 Vpp	
		Built-In Arbs	Open Circuit	100 mVpp	20 Vpp	

For *arbitrary waveforms*, the maximum amplitude will be limited if the data points do not span the full range of the output DAC (Digital-to-Analog Converter). For example, the built-in “SINC” waveform does not use the full range of values between ± 1 and therefore its maximum amplitude is 6.084 Vpp (into 50 ohms).

Possible Conflict with Function Change: The output amplitude is automatically adjusted if you select a function whose maximum amplitude is *less than* that of the currently active function. This conflict may arise when the output units are *Vrms* or *dBm* due to the differences in crest factor for the output functions. For example, if you output a 5 Vrms square wave (into 50 ohms) and then change the function to sine wave, the function generator will adjust the output amplitude to 3.535 Vrms (the upper limit for sine waves in Vrms). A -221, “*Settings conflict*” error is generated and the amplitude is adjusted.

Output Amplitude and Output Termination: The output amplitude is automatically adjusted (and no error is generated) if you change the output termination. For example, if you set the amplitude to 10 Vpp and then change the termination from 50 ohms to “high impedance”, the displayed amplitude will *double* to 20 Vpp. If you change from “high impedance” to 50 ohms, the displayed amplitude will drop in half. [See “Output Termination” on page 25.](#) for more information.

Offset Voltage Restrictions: The output amplitude (in Vpp) and the dc offset voltage must obey the following restrictions. If the specified amplitude is not valid, the function generator will automatically adjust it to

the maximum value allowed with the present offset voltage. (V_{max} is either 10 volts for a high impedance termination or 5 volts for a 50 ohm termination; V_{pp} is the output amplitude in volts peak-to-peak.)

$$|V_{offset}| + \frac{V_{pp}}{2} \leq V_{max} \quad \text{and} \quad |V_{offset}| \leq 2V_{pp}$$

A -221, “Settings conflict” error is generated and the amplitude is adjusted.

A momentary glitch occurs in the output waveform at certain voltages due to output attenuator switching. This positive-going glitch occurs when the output voltage crosses the break-point voltage either from a lower voltage or a higher voltage. The voltages are shown below (in V_{pp}) for a 0 volt dc offset: .252, .399, .502, .796, 1, 1.59, 2.0, 3.17, 3.99, 6.32, 7.96

The output voltage will momentarily drop to 0 volts at certain voltages due to output relay switching. This occurs when the output voltage crosses the break-point voltage either from a lower voltage or a higher voltage. The voltages are shown below (in V_{pp}) for a 0 volt dc offset: .317, .632, 1.26, 2.52, 5.02

You can set the units for output amplitude to V_{pp} , V_{rms} , or dBm. [See “Output Units” on page 25.](#) for more information.

For *dc volts*, the output level is actually controlled by setting the offset voltage. You can set the dc voltage to any value between ± 5 Vdc into 50 ohms or ± 10 Vdc into an open circuit. [See “DC Offset Voltage” on page 24.](#) for more information.

Use the following command to set the output amplitude:

```
VOLTage <amplitude>|MINimum|MAXimum
```

You can also use the `APPLY` command to select the function, frequency, amplitude, and offset with a single command. Because the `APPLY` command also changes duty cycle, modulation type, trigger source, and trigger slope, you must place the `APPLY` command first in any sequence of configuration commands.

DC Offset Voltage

At power-on, the dc offset is set to 0 volts. You can set the offset to a positive or negative number with the restrictions shown below. If the specified offset voltage is not valid, the function generator will automatically adjust it to the maximum dc voltage allowed with the present amplitude. (V_{max} is either 10 volts for a high impedance termination or 5 volts for a 50 ohm termination; V_{pp} is the output amplitude in volts peak-to-peak.)

$$|V_{offset}| + \frac{V_{pp}}{2} \leq V_{max} \quad \text{and} \quad |V_{offset}| \leq 2V_{pp}$$

A -221, “Settings conflict” error is generated and the offset is adjusted.

DC Offset and Output Termination: The offset voltage is automatically adjusted (and no error is generated) if you change the output termination. For example, if you set the offset to 100 mVdc and then change the

termination from 50 ohms to “high impedance”, the displayed offset will *double* to 200 mVdc. If you change from “high impedance” to 50 ohms, the displayed offset will drop in half. *See “Output Termination” on page 25. for more information.*

For *dc volts*, the output level is actually controlled by setting the offset voltage. You can set the dc voltage to any value between ± 5 Vdc into 50 ohms or ± 10 Vdc into an open circuit.

Use the following command to set the dc offset:

```
VOLTage:OFFSet <offset>|MINimum|MAXimum
```

You can also use the `APPLY` command to select the function, frequency, amplitude, and offset with a single command. Because the `APPLY` command also changes duty cycle, modulation type, trigger source, and trigger slope, you must place the `APPLY` command first in any sequence of configuration commands.

Output Units

Applies only to output amplitude (does not affect offset). At power-on, the units for output amplitude are *volts peak-to-peak*.

Output units: Vpp, Vrms, or dBm. *The default is Vpp.*

The unit setting is stored in *volatile* memory; the units are set to “Vpp” when power has been off or after a remote interface reset.

Use the following command to select the units of the output signal:

```
VOLTage:UNIT VPP|VRMS|DBM|DEFault
```

Output Termination

Applies only to output amplitude and offset voltage. The function generator has a fixed output impedance of 50 ohms on the *OUTPUT* terminal. You can specify whether you are terminating the output into a 50 ohm load or an open circuit. Incorrect impedance matching between the function generator and your load will result in an amplitude or offset which does not match the specified signal level.

Output termination: 50 Ω or High impedance. *The default is 50 Ω .* See [Table 2-4](#) for a list of amplitude limits for all functions.

The output termination setting is stored in *volatile* memory; 50 Ω is selected when power has been off or after a remote interface reset.

The amplitude (or dc offset) is automatically adjusted (and no error is generated) if you change the output termination. For example, if you set the amplitude to 10 Vpp and then change the termination from 50 ohms to “high impedance”, the amplitude will *double* to 20 Vpp. If you change from “high impedance” to 50 ohms, the amplitude will drop in half.

If you specify a 50 ohm termination but are actually terminating into an open circuit, the output will be *twice* the value specified. For example, if you set the offset to 100 mVdc (and specify a 50 ohm termination) but do not connect a 50 Ω load, the actual offset will be 200 mVdc.

Use the following command to set the output termination:

```
OUTPut:LOAD 50|INFinity|MINimum|MAXimum
```

Duty Cycle

Applies only to square waves. Duty cycle is specified as a percentage and represents the amount of time per cycle that the square wave is high.

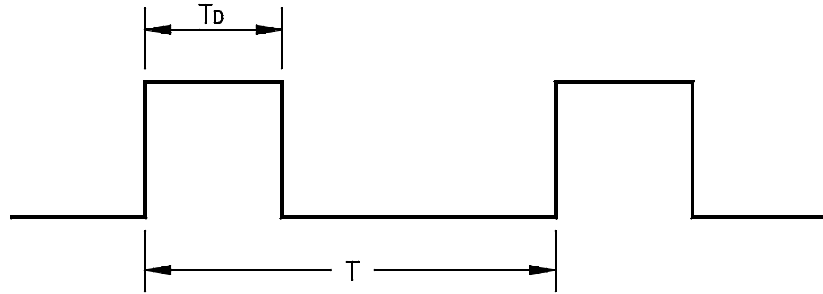

$$\text{Duty Cycle} = \frac{T_D}{T} \left(\text{Where } T = \frac{1}{\text{frequency}} \right)$$

Figure 2-1.

Duty cycle: 20% to 80%, in 1% increments (*frequency* \leq 5 MHz).
40% to 60%, in 1% increments (*frequency* $>$ 5 MHz).
The default is 50%.

The duty cycle is stored in *volatile* memory; the duty cycle is set to 50% when power has been off or after a remote interface reset. The **APPLY** command automatically sets the duty cycle to 50% for square waves.

Before attempting to set the duty cycle, you must enable the square wave function. No error is generated, but the specified duty cycle is remembered when you change to the square wave function.

The duty cycle setting is remembered when you change from square wave to another function. When you return to the square wave function, the previous duty cycle is used.

Possible Conflict with Output Frequency: The duty cycle is automatically adjusted if you select a frequency that is not valid with the present duty cycle. For example, if you set the duty cycle to 70% and then change the frequency to 8 MHz, the function generator will automatically adjust the duty cycle to 60% (the upper limit for this frequency).

Use the following command to set the duty cycle:

```
PULSe:DCYCLe <percent>|MINimum|MAXimum
```

The **APPLY** command automatically sets the duty cycle to 50% for square waves.

Sync Signal

A sync signal output is provided on the front-panel *Sync* terminal. All of the standard output functions (except dc and noise) have an associated sync signal. For certain applications where you may not want to output the

sync signal, you can disable the *Sync* terminal.

By default, the sync signal is routed to the *Sync* terminal (enabled).

When the sync signal is disabled, the output level on the *Sync* terminal is indeterminate (it might be a TTL “high” or a TTL “low”).

For *sine*, *square*, *triangle*, and *ramp* waveforms, the sync signal is a TTL “high” when the waveform's output is positive, relative to zero volts (or the dc offset value). The signal is a TTL “low” when the output is negative, relative to zero volts (or the dc offset value).

For *arbitrary* waveforms, a momentary TTL “high” pulse (> 200 ns) is output which corresponds to the first downloaded point in the waveform.

For *AM* and *FM*, the sync signal is referenced to the modulating signal (not the carrier). A momentary TTL “high” pulse (> 200 ns) is output at each zero-crossing point of the modulating signal.

For the *counted burst mode*, a TTL “low” signal is output while the specified number of cycles is output (for the duration of the burst). After the specified number of cycles has been output, the sync signal goes “high” until the next burst.

For the *external gated burst mode*, the sync signal is a TTL “high” when the output is positive, relative to zero volts (or the dc offset value). The signal is a TTL “low” when the output is negative, relative to zero volts (or the dc offset value).

For *FSK*, a momentary TTL “high” pulse (> 200 ns) is output on the transition to the “hop” frequency.

For *frequency sweeps*, the sync signal is a TTL “low” at the start of the sweep (when the start frequency is output) and is a TTL “high” at the end of the sweep (when the stop frequency is output).

Use the following command to set the SYNC signal mode:

```
OUTPut:SYNC OFF|ON
```

Setting is stored in volatile memory.

Instrument State Storage

You can store up to four different instrument states in non-volatile memory. This enables you to recall the entire instrument configuration using the *RCL common command.

Four memory locations (numbered 0, 1, 2, and 3) are available to store instrument configurations. The state storage feature “remembers” the function (including arbitrary waveforms), frequency, amplitude, dc offset, duty cycle, as well as any modulation parameters. To recall a stored state, you must use the same memory location used previously to store the state. The instrument state in memory location 0 can become the “*RST” or power-up state by setting MEMory:STATe:RECall:AUTO ON. See reference for this command on page 85

You cannot recall the instrument state from a memory location that was not

previously specified as a storage location. For example, an error is generated if you attempt to recall from memory location “2” but have never stored to that location.

A +810, “*State has not been stored*” error is generated if nothing is stored in the specified memory location.

Any arbitrary waveforms downloaded to “VOLATILE” memory *are not* remembered. However, if an arbitrary waveform is being output from *non-volatile* memory when the state is stored, the waveform data is stored. The stored waveform is output when the instrument state is recalled.

If you delete an arbitrary waveform after storing the state, the waveform data is lost and the function generator will output the “SINC” waveform in place of the deleted waveform when the state is recalled.

Use the following commands to save and recall states:

```
*SAV 0 | 1 | 2 | 3  
*RCL 0 | 1 | 2 | 3
```

You can delete individual stored states and clear the memory location. If nothing is stored in the specified memory location, a +810, “*State has not been stored*” error is generated. Do not delete state 0 or an error +772 will be generated. See “772” on page 148.

```
MEMory:STATe:DELeTe 0 | 1 | 2 | 3
```

Amplitude Modulation (AM)

A modulated waveform consists of a *carrier waveform* and a *modulating waveform*. In AM, the amplitude of the carrier is varied by the amplitude of the modulating waveform. The function generator will accept an internal modulating signal, an external modulating signal, or both. Topics covered on amplitude modulation are:

- AM Carrier Waveform Shape
- AM Carrier Frequency
- Amplitude Modulating Waveform Shape
- Amplitude Modulating Waveform Frequency
- Amplitude Modulation Depth
- Amplitude Modulating Source

Only one modulation mode can be enabled at a time. When you enable AM, the previous modulation mode is turned off.

Use the following command to select AM modulation: To ensure proper operation, you should enable AM *after* you have set up the other modulation parameters.

```
AM:STATe OFF | ON
```

AM Carrier Waveform Shape

AM carrier shape: Sine, Square, Triangle, Ramp, or Arbitrary waveform. *The default is Sine.*

You *cannot* use the noise function or dc volts as the AM carrier waveform.

Use the following command to select the shape of the output function:

```
FUNCTION:SHAPE SINusoid|SQUare|TRIangle|RAMP|USER|DC
```

You can also use the APPLy command to select the function, frequency, amplitude, and offset with a single command. Because the APPLy command also changes duty cycle, modulation type, trigger source, and trigger slope, you must place the APPLy command first in any sequence of configuration commands.

AM Carrier Frequency

Carrier frequency: 100 μ Hz to 15 MHz (100 kHz for triangle and ramp).
The default is 1 kHz.

For *arbitrary waveforms*, the maximum carrier frequency depends on the number of points specified in the waveform. The five built-in arbitrary waveforms can be output at a maximum of 5 MHz.

Use the following command to set the carrier frequency:

```
FREQuency <frequency>|MINimum|MAXimum
```

Amplitude Modulating Waveform Shape

The function generator will accept an internal modulating signal, an external modulating signal, or both.

Modulating waveform shape (internal source): Sine, Square, Triangle, Ramp, Noise, or Arbitrary waveform. *The default is Sine.*

You can use the noise function as the modulating waveform. However, you *cannot* use the noise function or dc volts as the carrier waveform.

Use the following command to set the modulating waveform shape:

```
AM:INTernal:FUNCTion SIN|SQU|TRI|RAMP|NOIS|USER
```

Amplitude Modulating Waveform Frequency

The function generator will accept an internal modulating signal, an external modulating signal, or both.

Modulating frequency (internal source): 10 MHz to 20 kHz. *The default is 100 Hz.*

The sync signal for AM is referenced to the modulating signal (not the carrier). A momentary TTL “high” pulse (> 200 ns) is output at each zero-crossing point of the modulating signal. The signal is output from the front-panel SYNC terminal.

Use the following command to set the modulating waveform frequency:

```
AM:INTernal:FREQuency <frequency>|MINimum|MAXimum
```

Amplitude Modulation Depth

The *modulation depth* is expressed as a percentage and represents the extent of the amplitude variation. At 0% modulation, the output amplitude is half of the selected value. At 100% modulation, the output amplitude equals the selected value.

Modulation depth: 0% to 120%. *The default is 100%.*

Use the following command to set the modulation depth:

```
AM:DEPTH <depth in percent>|MINimum|MAXimum
```

Amplitude Modulating Source

The function generator will accept an internal modulating signal, an external modulating signal, or both.

Modulating source: Internal-External (both) or External only. *The default is Both (internal-external).*

The External modulating source is always enabled.

When both sources are enabled (*internal-external*), the function generator adds the internal and external modulating signals (the carrier waveform is actually modulated with two waveforms).

When the internal source is disabled (*external only*), the carrier waveform is expecting a modulating signal on the *AM Modulation* terminal.

You apply the external modulating waveform to the *AM Modulation* terminal. The *modulation depth* is controlled by the signal level present (5 volts **peak** corresponds to 100% modulation).

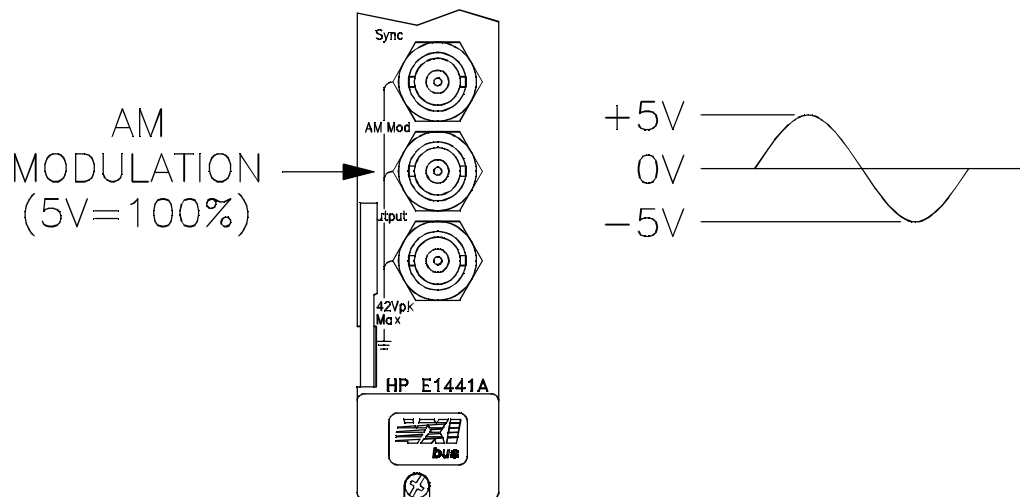

Figure 2-2. AM Modulation Input Signal

Use the following command to set the modulating source:

```
AM:SOURce BOTH|EXTernal
```

Frequency Modulation (FM)

A modulated waveform consists of a *carrier waveform* and a *modulating waveform*. In FM, the frequency of the carrier is varied by the amplitude of the modulating waveform. The function generator will accept *only* an internal FM modulating signal (no external source is available). Topics covered on frequency modulation are:

- FM Carrier Waveform Shape

- FM Carrier Frequency
- Frequency Modulating Waveform Shape
- Frequency Modulating Waveform Frequency
- Peak Frequency Deviation

Only one modulation mode can be enabled at a time. When you enable FM, the previous modulation mode is turned off.

Use the following command to enable FM modulation: To ensure proper operation, you should enable FM *after* you have set up the other modulation parameters.

```
FM:STATe OFF|ON
```

FM Carrier Waveform Shape

FM carrier shape: Sine, Square, Triangle, Ramp, or Arbitrary waveform. *The default is Sine.*

You *cannot* use the noise function or dc volts as the FM carrier waveform.

Use the following command to set the shape of the carrier waveform:

```
FUNction:SHAPE SINusoid|SQUare|TRIangle|RAMP|USER
```

You can also use the `APPLY` command to select the function, frequency, amplitude, and offset with a single command. Because the `APPLY` command also changes duty cycle, modulation type, trigger source, and trigger slope, you must place the `APPLY` command first in any sequence of configuration commands.

FM Carrier Frequency

Carrier frequency: 10 mHz to 15 MHz (100 kHz for triangle and ramp). *The default is 1 kHz.*

For *arbitrary waveforms*, the maximum carrier frequency depends on the number of points specified in the waveform. The five built-in arbitrary waveforms can be output at a maximum of 5 MHz.

The carrier frequency must always be greater than or equal to the *peak frequency deviation*. If you attempt to set the carrier frequency to a value less than the deviation, the function generator will auto-matically adjust the carrier frequency to equal the present deviation. A -221, “*Settings conflict*” error is generated and the carrier frequency is adjusted.

The sum of the carrier frequency and *peak frequency deviation* must be less than or equal to the maximum frequency for the selected function *plus 100 kHz* (15.1 MHz for sine and square, 200 kHz for triangle and ramp, and 5.1 MHz for arbitrary waveforms). If you attempt to set the carrier frequency to a value that is not valid, the function generator will automatically adjust the carrier frequency to equal the present deviation. A -221, “*Settings conflict*” error is generated and the deviation is adjusted.

Use the following command to set the carrier frequency:

```
FREquency <frequency>|MINimum|MAXimum
```

FM Waveform Shape

The function generator will accept *only* an internal modulating signal. You cannot modulate with an external source.

Modulating waveform shape (internal source): Sine, Square, Triangle, Ramp, Noise, or Arbitrary waveform. *The default is Sine.*

You can use the noise function as the modulating waveform. However, you *cannot* use the noise function or dc volts as the carrier waveform.

Use the following command to set the modulating waveform shape:

```
FM:INTernal:FUNCTion SIN|SQU|TRI|RAMP|NOIS|USER
```

FM Waveform Frequency

The function generator will accept *only* an internal modulating signal. You cannot modulate with an external source.

Modulating frequency: 10 mHz to 10 kHz. *The default is 10 Hz.*

The sync signal for FM is referenced to the modulating signal (not the carrier). A momentary TTL “high” pulse (> 200 ns) is output at each zero-crossing point of the modulating signal. The signal is output from the front-panel *SYNC* terminal.

Use the following command to set the modulating waveform frequency:

```
FM:INTernal:FREQuency <frequency>|MINimum|MAXimum
```

FM Peak Frequency Deviation

The *peak frequency deviation* represents the variation in frequency of the modulating waveform from the carrier frequency.

Peak frequency deviation: 10 mHz to 7.5 MHz. *The default is 100 Hz.*

The *carrier frequency* must always be greater than or equal to the peak frequency deviation. If you attempt to set the deviation to a value greater than the carrier frequency (with FM enabled), the function generator will automatically adjust the deviation to equal the present carrier frequency. A -221, “*Settings conflict*” error is generated and the deviation is adjusted.

The sum of the *carrier frequency* and peak frequency deviation must be less than or equal to the maximum frequency for the selected function *plus 100 kHz* (15.1 MHz for sine and square, 200 kHz for triangle and ramp, and 5.1 MHz for arbitrary waveforms). If you attempt to set the deviation to a value that is not valid, the function generator will automatically adjust the deviation to the maximum value allowed with the present carrier frequency. A -221, “*Settings conflict*” error is generated and the deviation is adjusted.

Use the following command to set the peak frequency deviation:

```
FM:DEVIation <peak deviation in Hz>|MINimum|MAXimum
```

Burst Modulation

You can configure the function generator to output a burst of waveform cycles. *The function generator can produce a burst using sine, square, triangle, ramp, and arbitrary waveforms.* Topics covered on burst modulation are:

- “Burst Modes” on page 33
 - “Counted Burst Mode” on page 33
 - “Gated Burst Mode” on page 35
- “Burst Trigger Source” on page 35
 - “For Counted Burst Mode” on page 35
 - “For Gated Burst Mode” on page 36
- “Burst Carrier Frequency” on page 36
- “Burst Count” on page 38
- “Burst Rate” on page 39
- “Burst Phase” on page 39

Only one modulation mode can be enabled at a time. When you enable the burst mode, the previously enabled modulation mode is turned off.

Use the following command to enable burst modulation: To ensure proper operation, you should enable the burst mode *after* you have set up the other modulation parameters.

```
BM:STATe OFF|ON
```

Burst Modes

There are two major modes of burst modulation; the "counted" burst, and the "gated" burst modes. In counted mode, the length of the burst is controlled by cycle count (BM:NCYCles). In gated mode, the duration of the burst is controlled by an external "gate" signal. The BM:SOURce command selects between the two modes:

```
BM:SOURce INTernal           this selects the "counted" mode  
BM:SOURce EXTernal          this selects the "gated" mode
```

Counted Burst Mode

A counted burst is started by a trigger signal from either an internal trigger timer (TRIG:SOUR INTernal), or an external signal (TRIG:SOUR EXTernal|TTLTRG<n>|BUS). The duration of the burst is set by specifying the number of waveform cycles (BM:NCYCles).

[Figure 2-3](#) shows the operation of the counted burst mode with internal

trigger source.

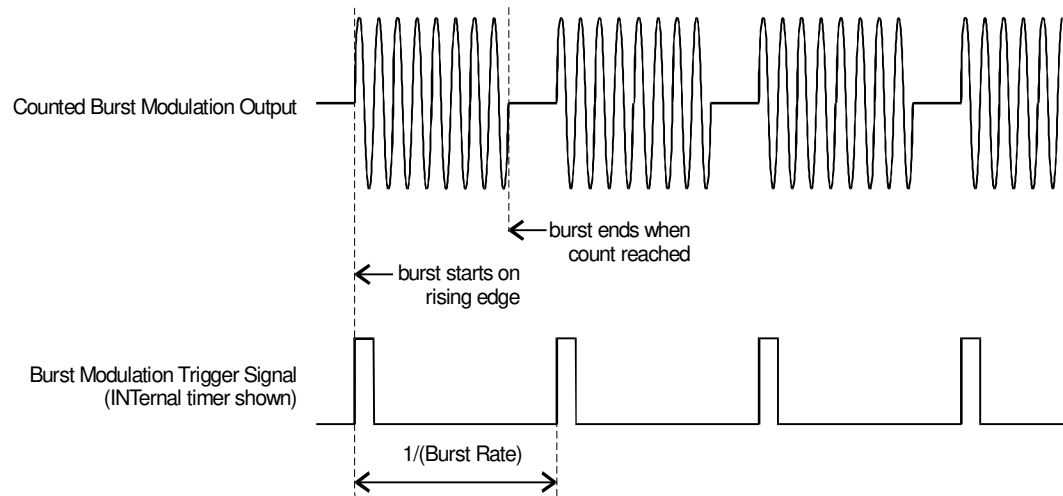

Figure 2-3. Counted Burst Mode with INTERNAL Trigger

The command sequence to configure this mode is:

```

APPLY:<shape> <freq>, <ampl>, <offset>    set up wave form
BM:STATE ON                               enable burst modulation
BM:SOURce INTernal                         this selects the "counted" mode
TRIG:SOURce INTernal                       trigger from internal trigger
                                           timer
BM:NCYCles <cycle_count>                  set the burst count
BM:INTernal:RATE <frequency>              set the burst rep rate
  
```

Figure 2-3 shows the operation of the counted burst mode with external trigger source.

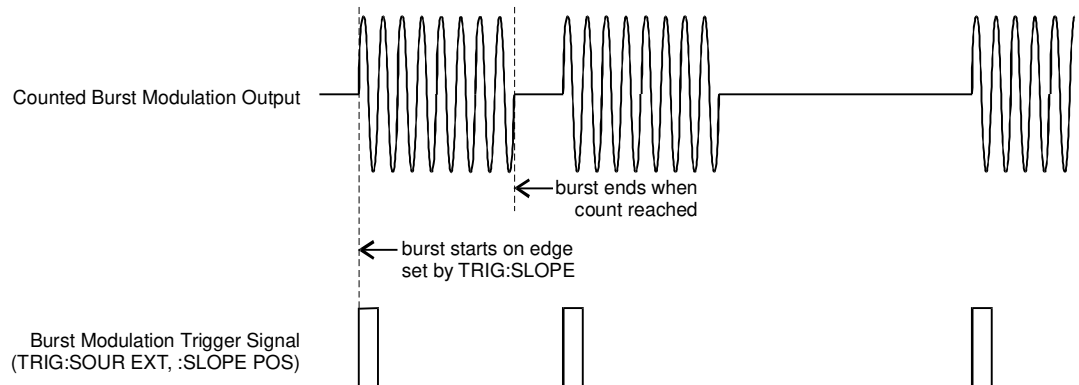

Figure 2-4. Counted Burst Mode with EXTERNAL Trigger

The command sequence to configure this mode is:

```

APPLY:<shape> <freq>, <ampl>, <offset>    set up wave form
BM:STATE ON                               enable burst modulation
BM:SOURce INTernal                         this selects the "counted" mode
TRIG:SOURce EXTERNAL|TTLTRG<0-7>|BUS     use external trigger
BM:NCYCles <cycle_count>                  set the burst count
  
```

Gated Burst Mode

There is only one form of the gated burst mode. The burst is controlled by a gating signal that is supplied from an external trigger source. The burst starts when the trigger signal is set to a TTL "high" level. The burst ends when the gating signal returns to a TTL "low" level.

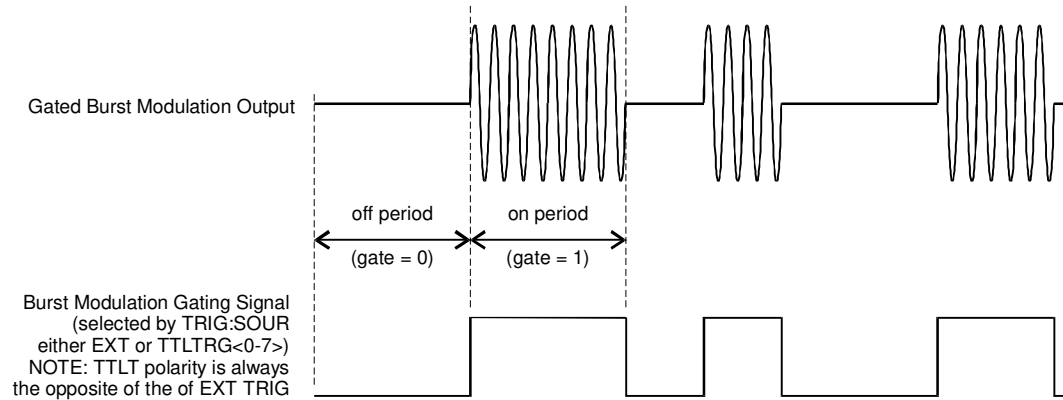

Figure 2-5. Gated Burst Mode

The command sequence to configure this mode is:

```
APPLY:<shape> <freq> , <ampl> , <offset>      set up wave form
BM:SOURce EXTERNAL                          this selects the "gated" mode
TRIG:SOURce EXTERNAL | TTLTRG<0-7>          trigger from external signal
BM:STATE ON                                  AFTER all modulation AND
                                              trigger selection, enable BMod
```

Table 2-5 shows an overview of the allowable burst mode configurations

Table 2-5. Burst Mode Configurations

	Burst Source (BM:SOUR)	Trigger Source TRIG:SOUR	Burst Count (BM:NCYC)	Burst Rate (BM:INT:RATE)	Burst Phase (BM:PHAS)
Counted Burst Modes	INTERNAL	INTERNAL	Available	Available	Available
		EXTERNAL, BUS, or TTLTRG<n>	Available	Not Used	Available
Gated Burst Mode	External	EXTERNAL or TTLTRG<n.>	Not Used	Not Used	Not Used

Burst Trigger Source For Counted Burst Mode

When the burst mode is set to "counted" (BM:SOUR INTERNAL), a trigger

signal is required to start the waveform burst. The TRIGger:SOURce choices are:

IMMEDIATE	Not available in Burst Modulation; specifying IMM actually selects EXTERNAL
INTERNAL	(the power-on/*RST default) This selects the internal trigger timer. The timer's repetition rate is then set by the BM:INTERNAL:RATE command.
BUS	Burst can be triggered by a Group Execute Trigger (GET) IEEE-488.1 command or the *TRG IEEE-488.2 common command.
EXTERNAL	This selects the "Ext Trig/FSK/Burst" connector as the source of the trigger signal.
TTLTRG<n>	Selects one of the 8 (TTLTRG0 through TTLTRG7)VXIbus TTL trigger lines as the trigger source.

For Gated Burst Mode

When the burst mode is "gated" (BM:SOUR EXTERNAL), the waveform burst is controlled (gated) by an external trigger. The choices for TRIG:SOUR are:

EXTERNAL	Selects the "EXT Trig/FSK/Burst" connector as the source of the burst gating signal. Driven to a TTL "high", the waveform is output. When at a TTL "low", the output is at the DC offset voltage.
TTLTrg<n>	Selects one of the 8 (TTLTRG0 through TTLTRG7)VXIbus TTL trigger lines as the burst gating signal. When the TTLTRG line is true, the waveform is output. When the line is false, the output is at the DC offset voltage.
Bus, IMM, and INT	These are not valid choices for gated burst mode. Specifying any of these selects EXTERNAL.

Use the following command to select a trigger source for burst modulation:

```
TRIGger:SOURce EXTERNAL|BUS|TTLTrg<0 - 7>
```

See "Triggering the Function Generator" on page 52. for more information

Burst Carrier Frequency

The *carrier frequency* defines the repetition rate of the burst waveform in the triggered and external gated modes. In the triggered mode, the number of cycles specified by the *burst count* are output at the frequency of the carrier signal. In the external gated mode, the carrier frequency is output when the external gate signal is true (TTL high).

Keep in mind that the carrier frequency is different than the “burst rate” which specifies the interval between bursts (triggered mode only).

Burst Carrier frequency: 10 mHz to 5 MHz (100 kHz for triangle and ramp). The default is 1 kHz. You can use sine, square, ramp, triangle, or arbitrary waveforms for the carrier waveshape.

Be sure to note the restrictions for carrier frequency and burst count shown on the following pages.

For *arbitrary waveforms* used as the carrier waveform, the maximum frequency depends on the number of points specified in the waveform. The five built-in arbitrary waveforms can be output at a maximum of 5 MHz (*be sure to note the restrictions below*).

Table 2-6.

Number of Arb Points	Minimum Frequency	Maximum Frequency
8 to 8,192 (8k)	100 mHz	5 MHz
8,193 to 12,287 (12k)	100 mHz	2.5 MHz
12,288 to 16,000	100 mHz	200 kHz

For *sine*, *square*, and *arbitrary* waveforms (does not apply to ramp and triangle waveforms), the relationship between the carrier frequency and the minimum burst count is shown below.

Table 2-7.

Carrier Frequency	Minimum Burst Count
10 mHz to 1 MHz	1
>1 MHz to 2 MHz	2
>2 MHz to 3 MHz	3
>3 MHz to 4 MHz	4
>4 MHz to 5 MHz	5

If you attempt to set the carrier frequency to a value that is not valid, the function generator will automatically adjust the frequency to the maximum value allowed with the present burst count. A -221, “*Settings conflict*” error is generated and the carrier frequency is adjusted.

For *all waveforms* used with burst, if the carrier frequency is set less than or equal to 100 Hz, the following relationship applies.

$$\frac{\text{Burst Count}}{\text{Carrier Frequency}} \leq 500 \text{ seconds for Carrier} \leq 100 \text{ Hz}$$

If you attempt to set the carrier frequency to a value that is not valid, the function generator will automatically adjust the frequency to the minimum value allowed with the present burst count. A -221, “Settings conflict” error is generated and the frequency is adjusted.

For the *counted burst* mode, the sync signal is a TTL “low” while the specified number of cycles is output (for the duration of the burst). After the specified number of cycles has been output, the sync signal goes “high” until the next burst. The sync signal is output from the front-panel SYNC terminal.

For the *external gated* burst mode, the sync signal is a TTL “high” when the output is positive, relative to zero volts (or the dc offset value). The signal is a TTL “low” when the output is negative, relative to zero volts (or the dc offset value). The sync signal is output from the front-panel SYNC terminal.

Use the following command to set the frequency:

```
FREQUENCY <frequency> | MINimum | MAXimum
```

You can also use the APPLY command to select the function, frequency, amplitude, and offset of the carrier with a single command. Because the APPLY command also changes duty cycle, modulation type, trigger source, and trigger slope, you must place the APPLY command first in any sequence of configuration commands.

Burst Count The *burst count* defines the number of cycles to be output per burst. *Used only in the "counted" burst mode (internal or external trigger).*

Certain combinations of burst count and carrier frequency are not allowed. If you attempt to specify a burst count that is not valid, the function generator will automatically adjust the count to the maximum value allowed with the present carrier frequency.

Make sure you note the restrictions in “Burst Carrier Frequency” before setting the burst count.

Burst count: 1 to 50,000 cycles, in 1 cycle increments. You can also select an infinite burst count. *The default is 1 cycle.*

When the *internal* trigger timer is selected (TRIG:SOUR INT), the specified number of cycles is output each time the timed trigger occurs. the repetition rate of the trigger timer is set by BM:INTernal:RATE <freq>.

When an *external* trigger source is selected (TRIG:SOUR EXT|TTLTRG<n>), the *burst count* and *burst phase* remain in effect but the *burst rate* is ignored. The specified number of cycles is output each time a trigger signal is applied to the selected trigger source. The

function generator is triggered on the *rising edge* of the trigger source.

When the "gated" burst mode is selected, the burst count, burst rate, and burst phase are ignored (these parameters are used for the counted burst mode only).

Use the following command to set the burst count:

```
BM:NCYCles <# cycles>|INFinity|MINimum|MAXimum
```

Burst Rate The *burst rate* defines the frequency at which *internally* triggered bursts are generated. The burst rate frequency defines the interval between bursts. *Used only in the counted burst mode (with TRIG:SOUR INTERNAL).*

Keep in mind that the burst rate is different than the "carrier frequency" which specifies the frequency of the burst signal.

Burst rate: 10 mHz to 50 kHz. *The default is 100 Hz.*

When in "counted" burst mode, but with an *external* trigger source selected (TRIG:SOUR EXT|TTLTRG<n>), the *burst count* and *burst phase* remain in effect but the *burst rate* is ignored.

When the "gated" burst mode is selected, the burst count, burst rate, and burst phase are ignored (these parameters are used for the counted burst mode only).

It is possible to specify a burst rate which is too fast for the function generator to output with the specified carrier frequency and burst count. If the burst rate is too high, the function generator will internally adjust it as needed to allow repeated triggering the burst. The adjustment is handled internally by the function generator (the burst queried will be the same as specified).

Use the following command to set the burst rate:

```
BM:INTernal:RATE <frequency>|MINimum|MAXimum
```

Burst Phase The *burst phase* defines the starting phase of the burst.

Burst phase: -360 degrees to +360 degrees, in 0.001 degree increments. *The default is 0 degrees.*

For *sine*, *square*, *triangle*, and *ramp* waveforms, 0 degrees is the point at which the waveform crosses zero volts (or the dc offset value), in a positive-going direction.

For *arbitrary* waveforms, 0 degrees is the first data point downloaded to memory.

When the "gated" burst mode is selected, the burst count, burst rate, and burst phase are ignored (these parameters are used for the "counted" burst mode only).

Use the following command to set the burst phase:

```
BM:PHASe <degrees>|MINimum|MAXimum
```

Frequency-Shift Keying (FSK) Modulation

You can configure the function generator to “shift” its output frequency between two preset values using FSK modulation. The rate at which the output shifts between the two frequencies (called the “carrier frequency” and the “hop frequency”) is determined by the internal rate generator or the signal level on the “Ext Trig/FSK/Burst terminal”. *The function generator can produce an FSK waveform using sine, square, triangle, ramp, and arbitrary waveforms.* Topics covered on frequency-shift keying modulation are:

- “FSK Carrier Frequency” on page 40
- “FSK “Hop” Frequency” on page 41
- “FSK Rate” on page 41
- “FSK “Hop” Source” on page 42
 - “Internal Hop Source” on page 42
 - “External Hop Source” on page 42

Only one modulation mode can be enabled at a time. When you enable FSK, the previous modulation mode is turned off.

Use the following command to enable frequency-shift keying: To ensure proper operation, you should enable FSK *after* you have set up the other modulation parameters.

```
FSKey:STATe OFF|ON
```

FSK Carrier Frequency

FSK Carrier frequency: 10 mHz to 15 MHz (100 kHz for triangle and ramp). *The default is 1 kHz.* You can use sine, square, ramp, triangle, or arbitrary waveforms for the carrier waveform.

For *arbitrary waveforms*, the maximum carrier frequency depends on the number of points specified in the waveform. The five built-in arbitrary waveforms can be output at a maximum of 5 MHz.

Table 2-8.

Number of Arb Points	Minimum Frequency	Maximum Frequency
8 to 8,192 (8k)	100 mHz	5 MHz
8,193 to 12,287 (12k)	100 mHz	2.5 MHz
12,288 to 16,000	100 mHz	200 kHz

For an externally-controlled FSK waveform, the carrier frequency is output when a “low” TTL level is applied to the source selected by the TRIG:SOUR command. The hop frequency is output when a “high” TTL level is applied.

For FSK, the sync signal is referenced to the FSK “hop” signal (not the carrier). A momentary TTL “high” pulse (> 200 ns) is output on the transition to the “hop” frequency. The signal is output from the front-panel *Sync* terminal.

Use the following command to set the frequency:

```
FREQuency <frequency> |MINimum|MAXimum
```

You can also use the `APPLY` command to select the function, frequency, amplitude, and offset of the carrier with a single command. Because the `APPLY` command also changes duty cycle, modulation type, trigger source, and trigger slope, you must place the `APPLY` command first in any sequence of configuration commands.

FSK “Hop” Frequency

Hop frequency: 10 mHz to 15 MHz (100 kHz for triangle and ramp). *The default is 100 Hz.* You can use sine, square, ramp, triangle, or arbitrary waveforms for the hop frequency waveshape.

For *arbitrary waveforms*, the maximum hop frequency depends on the number of points specified in the waveform. The five built-in arbitrary waveforms can be output at a maximum of 5 MHz.

Table 2-9.

Number of Arb Points	Minimum Frequency	Maximum Frequency
8 to 8,192 (8k)	100 mHz	5 MHz
8,193 to 12,287 (12k)	100 mHz	2.5 MHz
12,288 to 16,000	100 mHz	200 kHz

For an externally-controlled FSK waveform, the carrier frequency is output when a “low” TTL level is applied to the *FSK* terminal. The hop frequency is output when a “high” TTL level is applied.

For FSK, the sync signal is referenced to the FSK “hop” signal (not the carrier). A momentary TTL “high” pulse (> 200 ns) is output on the transition to the “hop” frequency. The signal is output from the front-panel *SYNC* terminal.

Use the following command to set the FSK frequency:

```
FSKey:FREQuency <frequency> |MINimum|MAXimum
```

FSK Rate

The *FSK rate* is the rate at which the output frequency “shifts” between the carrier frequency and the hop frequency when you select the internal FSK source (`FSK:SOUR INTernal`).

FSK rate (internal source): 10 mHz to 50 kHz. *The default is 10 Hz.*

The FSK rate is ignored when the external source is selected.

Use the following command to set the FSK rate:

```
FSKey:INTernal:RATE <rate in Hz> |MINimum|MAXimum
```

FSK "Hop" Source FSK source: Internal or External. *The default is Internal.*

Internal Hop Source

When FSK:SOUR is INTernal, the rate at which the output frequency “shifts” between the carrier frequency and hop frequency is determined by the *FSK rate* specified. [Figure 2-6](#) shows FSK operation with INTernal hop control

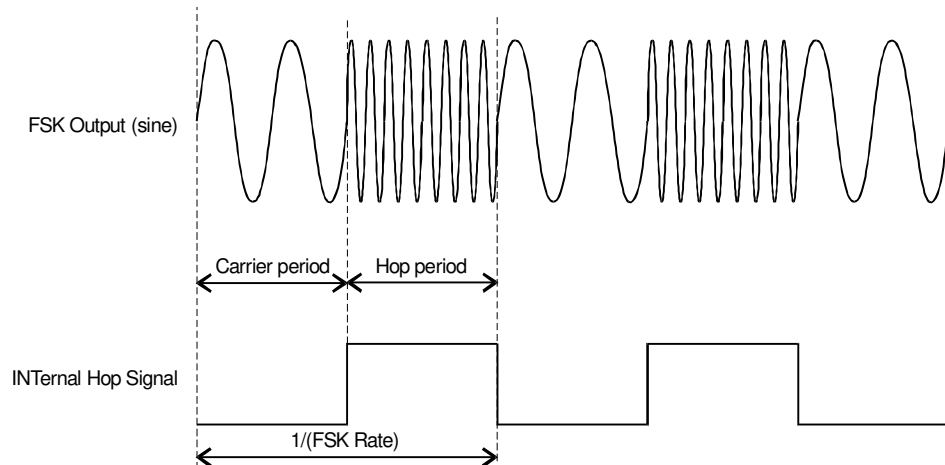

Figure 2-6. Frequency Shift Keying with INTernal Hop Signal

External Hop Source

When FSK:SOUR is EXTernal, the output frequency is determined by the signal level of the source selected by the TRIG:SOUR command. When a “low” TTL level is present on the Ext Trig BNC, the carrier frequency is output. When a “high” TTL level is present on the Ext Trig BNC, the hop frequency is output. This logic sense is inverted for the TTLTRG lines. [Figure 2-7](#) shows FSK operation with external hop control

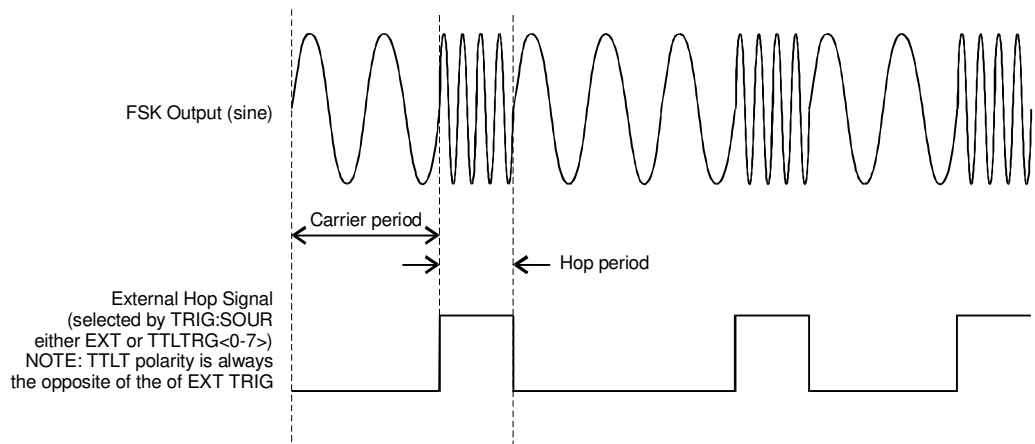

Figure 2-7. Frequency Shift Keying with EXTernal Hop Signal

Use the following command to select the external FSK source:

```
FSKey:SOURce EXTernal          select ext FSK source
TRIGger:SOURce EXT | TTLT<0-7> now select which ext source
```

Frequency Sweep

In the frequency sweep mode, the function generator “steps” from the *start frequency* to the *stop frequency* at a *sweep rate* which you specify. You can sweep up or down in frequency, and with either linear or logarithmic spacing. You can also configure the function generator to output a single sweep (one pass from start frequency to stop frequency) by applying an external trigger. *The function generator can produce a frequency sweep for sine, square, triangle, ramp, or arbitrary waveforms.* Topics covered on frequency sweep are:

- “Sweep Start and Stop Frequencies” on page 43
- “Sweep Time” on page 43
- “Sweep Mode” on page 44
- “Sweep Trigger Source” on page 44

Only one modulation mode can be enabled at a time. When you enable the sweep mode, the previous modulation mode is turned off.

Use the following command to enable the frequency sweep: To ensure proper operation, you should enable the sweep mode *after* you have set up the other modulation parameters.

```
SWEep:STATe OFF | ON
```

Sweep Start and Stop Frequencies

The *start frequency* and *stop frequency* set the upper and lower frequency bounds for the sweep. The function generator begins at the start frequency, sweeps to the stop frequency, and then resets back to the start frequency.

Start and Stop frequencies: 10 mHz to 15 MHz (100 kHz for triangle and ramp). The sweep is phase continuous over the full frequency range. *The default start frequency is 100 Hz. The default stop frequency is 1 kHz.* The *RST command sets the start frequency to 10 mHz (*minimum*) and the stop frequency to 15 MHz (*maximum*).

For *arbitrary waveforms*, the maximum start or stop frequency depends on the number of points specified in the waveform. The five built-in arbitrary waveforms can be output at a maximum of 5 MHz.

To sweep *up* in frequency, set the start frequency < stop frequency.

To sweep *down* in frequency, set the start frequency > stop frequency.

The sync signal is a TTL “low” at the start of the sweep (when the start frequency is output) and is a TTL “high” at the end of the sweep (when the stop frequency is output). The signal is output from the front-panel SYNC terminal.

Use the following command set the start and stop frequencies:

```
FREquency:START <frequency> | MINimum | MAXimum
FREquency:STOP <frequency> | MINimum | MAXimum
```

Sweep Time

The *sweep time* specifies the number of seconds required to sweep from the

start frequency to the stop frequency. The number of frequency points in the sweep depends on the sweep time you select and is automatically calculated by the function generator.

Sweep time: 1 ms to 500 seconds. *The default is 1 second.*

The function generator computes between 2,048 and 4,096 frequency points from the start frequency to the stop frequency.

Use the following command to set the sweep time:

```
SWEep:TIME <seconds>|MINimum|MAXimum
```

Sweep Mode

You can sweep with either linear or logarithmic spacing. The output frequency of a *linear* sweep changes linearly during the duration of the sweep. For *logarithmic* spacing, the output frequency changes exponentially during the duration of the sweep.

Sweep mode: Linear or Logarithmic. *The default is Linear.*

Use the following command to set the sweep mode:

```
SWEep:SPACing LINear|LOGarithmic
```

Sweep Trigger Source External Sources

In the *triggered sweep* mode (TRIG:SOUR other than IMMEDIATE), the function generator outputs a single sweep each time a trigger is received. After one sweep from the start frequency to the stop frequency, the function generator waits for the next trigger while outputting the start frequency. [Figure 2-8](#) shows the frequency sweep operation with "external" trigger (IMMEDIATE, EXTERNAL, TTLTRG<n>, or BUS). The default is IMM.

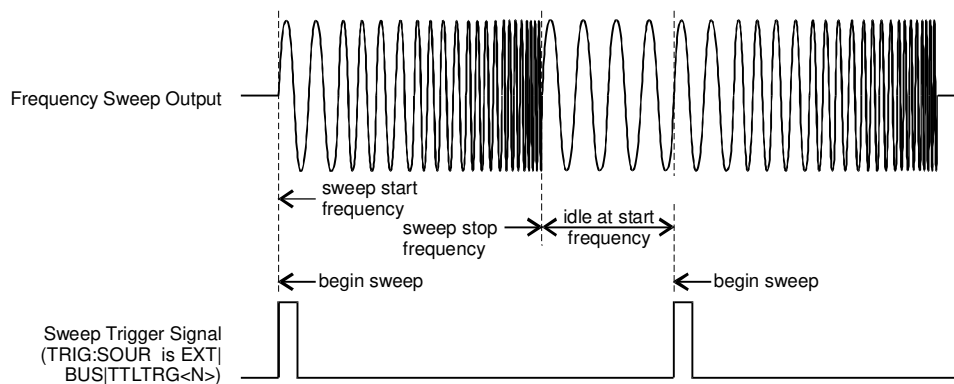

Figure 2-8. Frequency Sweep with "EXTERNAL" Trigger

Internal Source

When the *internal* trigger source is selected (TRIG:SOUR IMMEDIATE), the function generator repeatedly outputs a frequency sweep at a rate

determined by the *sweep rate* specified. [Figure 2-9](#) shows the frequency sweep operation with internal trigger source.

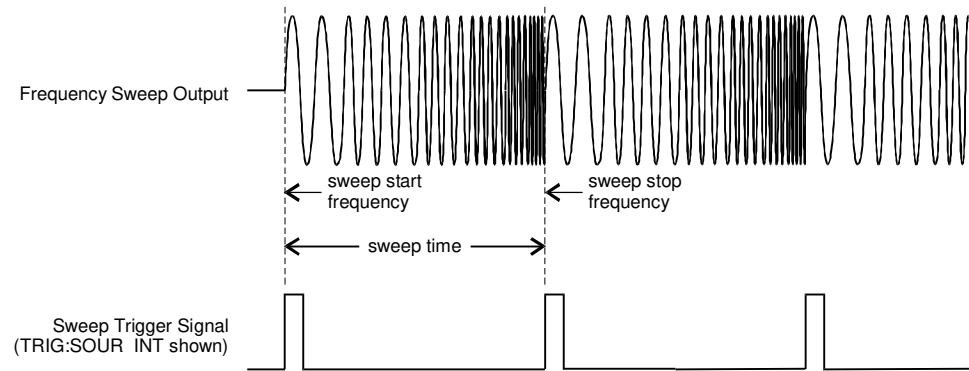

Figure 2-9. Frequency Sweep with Internal Trigger

Use the following command to set the sweep trigger source:

```
TRIGger:SOURce IMMEDIATE|EXTERNAL|TTLTRG<0-7>|BUS
```

See [“Triggering the Function Generator” on page 52](#). for more information.

Arbitrary Waveforms

There are five built-in arbitrary waveforms stored in non-volatile memory. You can also download up to four user-defined arbitrary waveforms into non-volatile memory. Each waveform can contain between 8 and 16,000 data points. Topics covered on arbitrary waveforms are:

- Creating Arbitrary Waveforms
- Creating and Storing an Arbitrary Waveform
- Built-In Arbitrary Waveforms

Creating Arbitrary Waveforms

For most applications, it is not necessary to create a waveform of any specific length since the function generator will automatically sample the available data to produce an output signal. In fact, it is generally best to create arbitrary waveforms which use all available data (16,000 points long and the full range from 0 to 4,095 DAC codes). For the Agilent E1441A, you do not have to change the length of the waveform to change its output frequency. All you have to do is create a waveform of any length and then adjust the function generator's output frequency. Remember, if you create an arbitrary waveform that includes three cycles of the same waveshape, the output frequency will actually be three times the value you set with the frequency command.

When creating arbitrary waveforms, *you* have control of both the amplitude quantization and phase truncation errors. For example, phase truncation harmonics will be generated when a waveform is created using the full amplitude range of the DAC (12 bits) but is created using only 1,000 waveform data points. In this case, the amplitude quantization errors will be near the noise floor while the time quantization error will produce harmonics near the -60 dBc level. Similarly, amplitude quantization harmonics will be generated when you create a waveform using less than the full amplitude resolution of the function generator. For example, if you use only one-fifth of the available amplitude resolution, amplitude quantization will produce harmonics below the -60 dBc level.

When importing data from instruments such as oscilloscopes, the data will generally range between 1,024 and 4,096 time points and between 64 and 256 amplitude points.

When creating arbitrary waveforms, the function generator will always attempt to replicate the finite-length time record to produce a periodic version of the data in waveform memory. As shown on the next page, it is possible that the shape and phase of a signal may be such that a transient is introduced at the end point. When the waveshape is repeated for all time, this end-point transient will introduce *leakage error* in the frequency domain because many spectral terms are required to describe the discontinuity.

Leakage error is caused when the waveform record does not include an integer number of cycles of the fundamental frequency. Power from the fundamental frequency, and its harmonics, is transferred to spectral components of the rectangular sampling function. Instead of the expected narrow spectral lines, leakage can cause significant spreading around the desired spectral peaks. You can reduce leakage errors by adjusting the window length to include an integer number of cycles or by including more cycles within the window to reduce the residual end-point transient size. Some signals are composed of discrete, non-harmonically related

frequencies. Since these signals are non-repetitive, all frequency components cannot be harmonically related to the window length. You should be careful in these situations to minimize end-point discontinuities and spectral leakage.

Creating and Storing an Arbitrary Waveform

The following is an overview of the steps required to download and output an arbitrary waveform. The commands used for arbitrary waveforms are listed on page

Chapter 2, “Application Programs”, contains an example program which shows the use of arbitrary waveforms. You may find it useful to refer to the program after reading the following section in this chapter.

1. Select the waveform frequency, amplitude, and offset.

Use the `APPLY` command or the equivalent `FREQ`, `VOLT`, and `VOLT:OFFS` commands to select the frequency, amplitude, and offset of the arbitrary waveform. Because the `APPLY` command also changes duty cycle, modulation type, trigger source, and trigger slope, you must place the `APPLY` command first in any sequence of configuration commands.

2. Download the data points into volatile memory.

You can download between 8 and 16,000 points per waveform. The waveform can be downloaded as floating-point values or binary integer values. Use the `DATA VOLATILE` command to download floating-point values between -1 and +1. Use the `DATA:DAC VOLATILE` command to download binary integer values between -2047 and +2047.

To ensure that binary data is downloaded properly, you must select the order in which the bytes are downloaded using the `FORM:BORD` command.

3. Copy the arbitrary waveform to non-volatile memory.

You can output the arbitrary waveform directly from volatile memory (as described in step 2) or you can copy the waveform to non-volatile memory. Use the `DATA:COPY` command to copy the waveform to non-volatile memory.

4. Select the arbitrary waveform to output.

You can select one of the five built-in arbitrary waveforms, one of four user-defined waveforms, or the waveform currently downloaded to volatile memory. Use the `FUNC:USER` command to select the waveform.

5. Output the currently selected arbitrary waveform.

Use the `FUNC:SHAP USER` command to output the waveform previously selected with the `FUNC:USER` command.

Built-In Arbitrary Waveforms

The five built-in arbitrary waveforms are shown below.

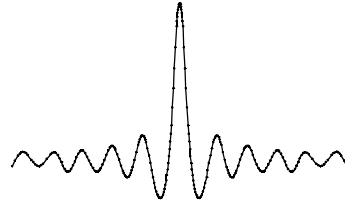

Sinc

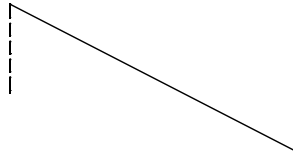

Negative Ramp

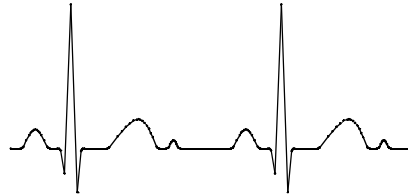

Cardiac

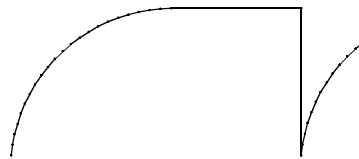

Exponential Rise

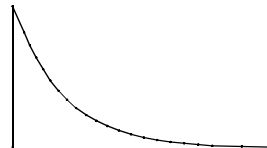

Exponential Fall

Figure 2-10.

Phase-Lock Capabilities (Opt 001)

This section gives an overview of the basic techniques used to program the Phase-Lock option (option 001). This section is only an overview and does not give all of the details you will need to write your own application programs. Refer to “Application Program Examples,” later in this chapter for more details and examples. Also refer to the programming reference manual that came with your computer for details on outputting command strings and entering data.

To Phase Lock to an External Clock Signal (requires Option 001)

The front-panel *10 MHz Ref In* terminal allows you to synchronize one or more function generators with an external 10 MHz signal. The following statements show how to configure a single instrument for synchronization with an external signal:

```
APPL:SIN 10E+6, 5.0
PHAS:ADJ -90 DEG
PHAS:REF
```

*Select sine function at 10 MHz
Set phase offset to -90 degrees
Set phase reference to zero*

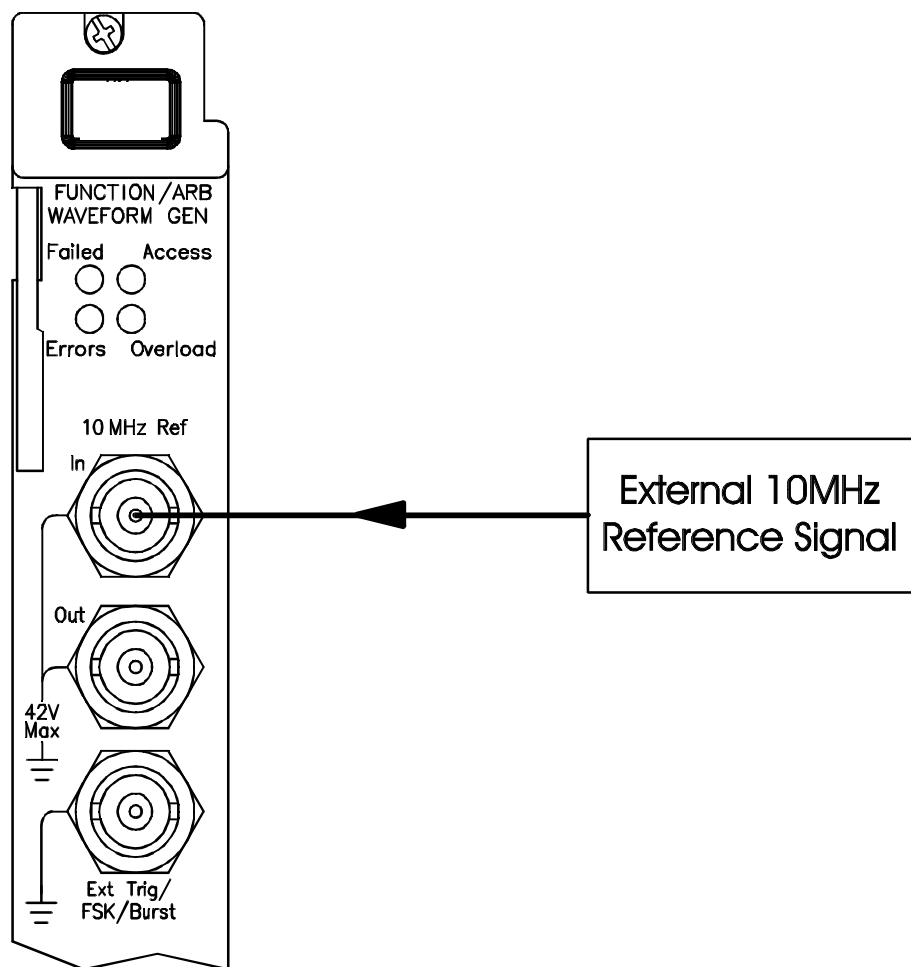

Figure 2-11.

To Phase Lock Multiple Function Generators (requires Option 001)

The front-panel *10 MHz Ref Out* and *10 MHz Ref In* terminals allow you to synchronize multiple function generators. The following statements show you how to synchronize two function generators at 10 kHz (send the commands to both function generators):

```
APPL:SIN 10E+3, 5.0
PHAS:ADJ -90 DEG
PHAS:REF
```

Select sine function at 10 kHz
Set phase offset to -90 degrees
Set phase reference to zero

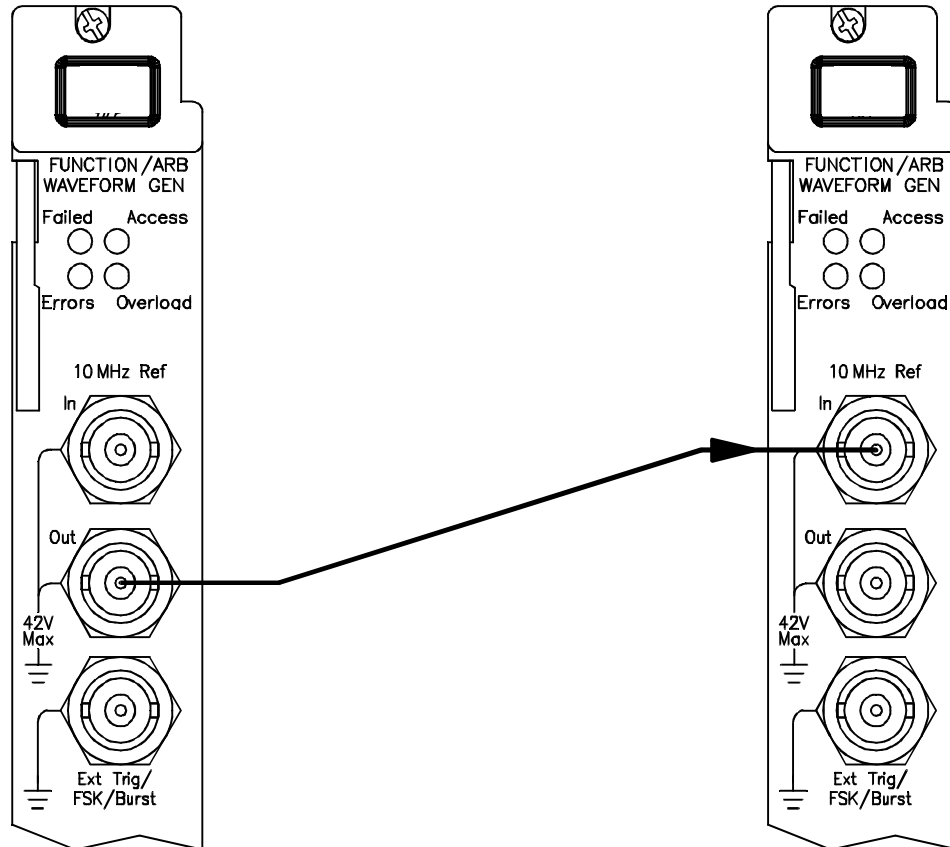

Figure 2-12.

To Phase Lock Using the Counted Burst Mode (requires Option 001)

In the counted burst mode, you can synchronize phase-lock signals using an external trigger from the faceplate *Ext Trig* terminal or VXibus TTLTRG lines. The following statements show you how to synchronize two function generators in the counted burst mode using the *Ext Trig* terminal (send the commands to both function generators):

Send these commands to both function generators:

```
APPL:SIN 10E+3, 5.0
BM:NCYC INF
TRIG:SOUR EXT
BM:STAT ON
```

Set both to the same frequency
Set burst count to "INFINITY"
Set trigger source to external
Enable the BMod LAST

Send this command only to the "left" function generator:

```
OUTP:TRIG:IMM
```

source trigger signal from "left" instrument to right instrument

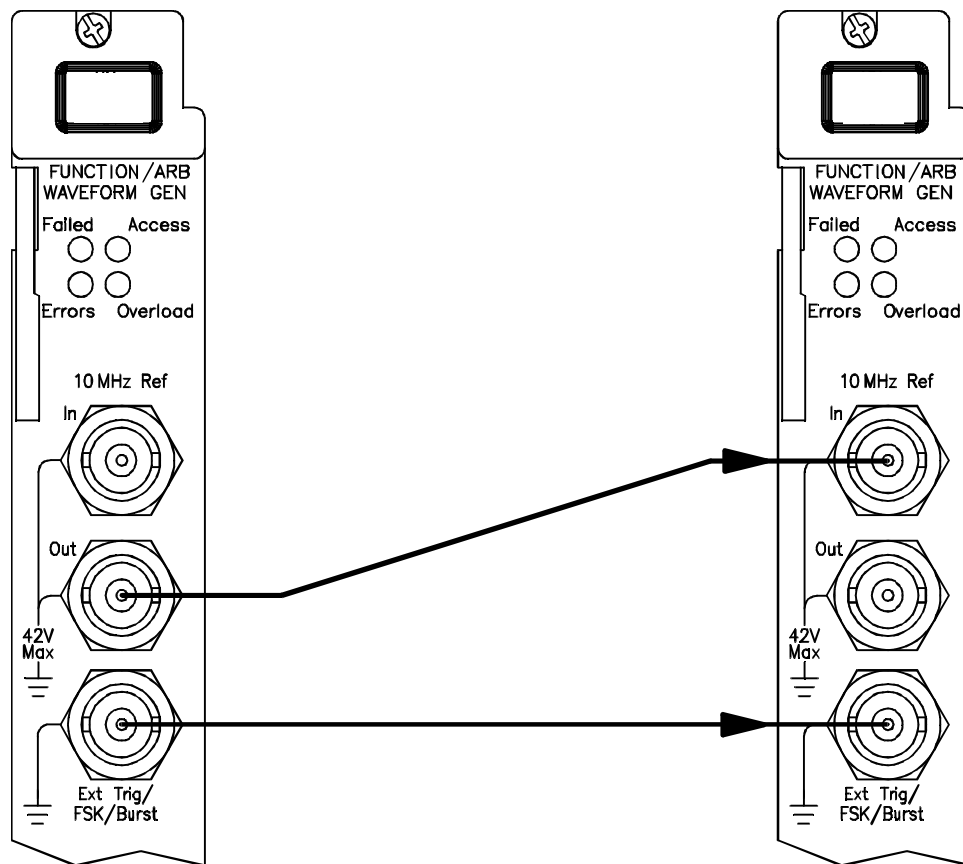

Figure 2-13.

To use TTLTRG lines send these commands to both generators:

```
APPL:SIN 10E+3, 5.0
BM:NCYC INF
OUTP:TTLT4 ON
TRIG:SOUR TTLT4
BM:STAT ON
```

Set both to the same frequency
Set burst count to "INFINITY"
Enable TTLT4 line to source
Set trigger source to TTLT4 line
Enable the burst mode LAST

Send this command only to the "left" function generator:

```
OUTP:TRIG:IMM
```

source trigger signal from "left"

You don't have to connect between the Ext Trig terminals when using the TTLTRG lines.

Triggering the Function Generator

*Applies only to counted bursts and frequency sweep, not gated modes such as Gated Bursts, or FSK modulation. You can issue triggers for bursts and sweeps using *internal* triggering or *external* triggering. Topics covered on triggering are:*

- [“Trigger Source Choices” on page 52](#)
- [“Ext Trig / FSK / Burst Input Terminal” on page 54](#)

Trigger Slope

The Agilent E1441A includes a choice of trigger polarity when the source in an external or one of the 8 VXibus TTLTRG lines. The command to select the trigger polarity is:

TRIGger:SLOPe POSitive | NEGative

Note TRIG:SLOPE selects the slope of the *trigger source* only. Where the external trigger sources ("Ext Trig" and TTLTRG lines) are being used as a *gating signal* for Burst and FSK, the setting of TRIG:SLOPE is ignored

POS: (*RST state) For TRIG:SOUR EXT (Ext Trig/FSK/Burst terminal); triggers on positive going TTL signal.
For TRIG:SOUR TTLT<0-7>; triggers on negative going signal on VXibus TTLTRG line (ground true logic)

NEG: For TRIG:SOUR EXT (Ext Trig/FSK/Burst terminal); triggers on negative going TTL signal.
For TRIG:SOUR TTLT<0-7>; triggers on positive going signal on VXibus TTLTRG line (+ true logic)

Trigger Source Choices

Again, the applies only to counted burst and sweep. You must specify the source from which the function generator will accept a trigger.

The function generator will accept a software (bus) trigger, a hardware trigger from the *Ext Trig* terminal or VXibus TTLTRG lines, or an immediate internal trigger.

The trigger source setting is stored in *volatile* memory; the source is set to immediate when power has been off or after resetting the module.

To select the trigger source, use the following command.

```
TRIGger:SOURce BUS|EXTernal|IMMediate|TTLTrg<0-7>
```

The APPLY command automatically sets the trigger source to IMMEDIATE

Internal Triggering

Internal triggering is enabled when you turn on the function generator. In this mode, the function generator uses a repetitive trigger signal that internally triggers waveform bursts or frequency sweeps. The rate at which the internal timer generates triggers is dependant on the burst rate, or sweep time set (See “Burst Rate” on page 39. and See “Sweep Time” on page 43.).

To select the internal trigger source for counted bursts, use the following commands:

```
SOUR:BM:STATE ON
SOUR:BM:SOURCE INTernal
TRIGGER:SOURCE INTernal
```

To select the internal trigger source for frequency sweeps, use the following commands:

```
SOUR:SWEEP:STATE ON
TRIGGER:SOURCE IMMEDIATE
```

The *RST and APPLy commands automatically sets the trigger source to IMMEDIATE.

External Triggering (Including TTLTRG lines)

In this trigger mode, the function generator will accept a hardware trigger applied to the *Ext Trig* terminal, or one of the VXIbus TTLTRG lines. The function generator outputs one burst or initiates one sweep each time one of these trigger inputs receives the proper polarity of signal edge (set by TRIG:SLOPE). NOTE that the default logical sense of the TTLTRG lines, as defined by the VXIbus standard, is *negative true*. See also “*Ext Trig / FSK / Burst Input Terminal*” on page 54.

Use the following command to set the trigger source to external:

```
TRIGger:SOURce EXTernal
```

Use the following command to set the trigger source to one of the VXIbus TTLTRG lines:

```
TRIGger:SOURce TTLTrg<0-7>
```

Software (BUS) Triggering

When TRIG:SOUR is BUS, the function generator can be triggered by sending an GPIB bus trigger command. The function generator outputs one burst or initiates one sweep each time the trigger command is received.

To select the bus trigger source, send the following command.

```
TRIGGER:SOURCE BUS
```

To trigger the function generator send the *TRG (trigger) command.

You can also trigger the function generator from the GPIB interface via the

command module by sending the IEEE-488 Group Execute Trigger (GET) message.

Ext Trig / FSK / Burst Input Terminal

The input requirement for an external trigger, FSK input or Burst input is a TTL positive-going (when TRIG:SLOPE is POS) or negative-going (when TRIG:SLOPE is NEG) pulse that must be >2 microsecond in duration.

The Ext/FSK/Burst Input terminal is used in the following modes:

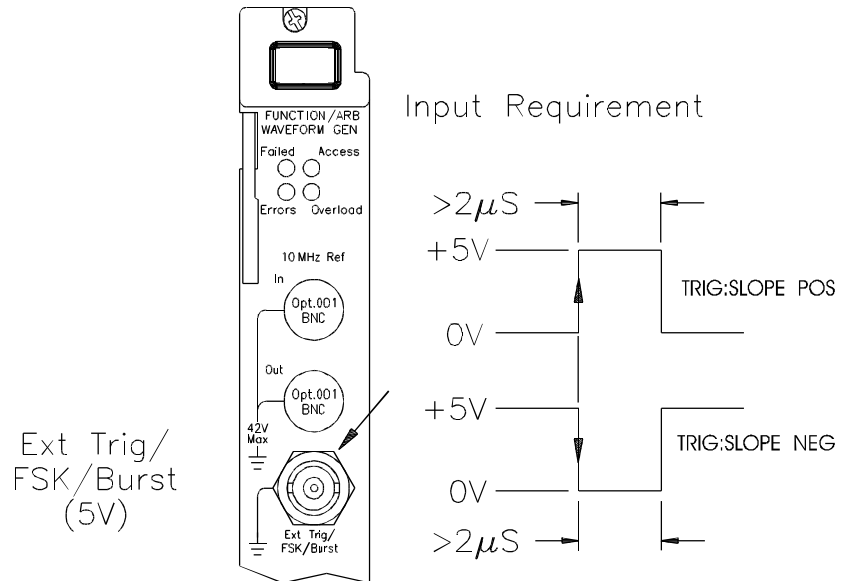

Figure 2-14.

Triggered Sweep Mode: Execute `TRIG:SOUR EXT` or `TTLT<0-7>` to enable the triggered sweep mode (sweeps must be enabled). When the *edge* (polarity set by TRIG:SLOPE) of a TTL pulse is received on the *Ext Trig* terminal or VXibus TTLTRG line, the function generator outputs a single sweep.

Externally-Modulated FSK Mode: To enable the externally-modulated mode, execute `FSK:SOUR EXT` when FSK is enabled. When a *low* TTL level is present, the FSK carrier frequency is output. When a *high* TTL level is present, the FSK “hop” frequency is output.

Counted Burst Mode: Execute `TRIG:SOUR EXT` to enable the counted burst mode (burst must be enabled). When the *rising edge* of a TTL pulse is received, the function generator outputs a burst waveform with the specified number of cycles.

External Gated Burst Mode: To enable the external gated mode, execute `BM:SOUR EXT` when burst is enabled. When a *high* TTL level is present, the function generator outputs the carrier waveform. When a *low* TTL level is present, the output is disabled.

System-Related Operations

This section gives information on topics such as error conditions and self-test. This information is not directly related to waveform generation but is an important part of operating the function generator. Topics covered on system-related operations are:

- Error Conditions
- Self-Test
- Memory State
- Firmware Revision Query
- SCPI Language Version Query

Error Conditions

When the faceplate **Errors** LED turns on, one or more command syntax or hardware errors have been detected. A record of up to 20 errors can be stored in the function generator's *error queue*. See Appendix B, "Error Messages," for a complete listing of the errors.

Errors are retrieved in first-in-first-out (FIFO) order. The first error returned is the first error that was stored. When you have read all errors from the queue, the **Errors** LED turns off.

If more than 20 errors have occurred, the last error stored in the queue (the most recent error) is replaced with -350, "Too many errors". No additional errors are stored until you remove errors from the queue. If no errors have occurred when you read the error queue, the function generator responds with +0, "No error".

The error queue is cleared when power has been off or after a *CLS (clear status) command has been executed. The *RST (reset) command *does not* clear the error queue.

Use the following command to check for system errors:

SYSTem:ERRor? *Reads one error from the error queue*

Errors have the following format (the error string may contain up to 80 characters):

-113,"Undefined header"

Self-Test

A *power-on* self-test occurs automatically when you turn on the function generator. This limited test assures you that the function generator is operational.

A *complete* self-test runs a series of tests and takes approximately 10 seconds to execute. If all tests pass, you can have a high confidence that the function generator is fully operational.

If the self-test fails, the **Errors** LED turns on the function generator should be returned to Agilent Technologies for service.

Use the following command to perform a self-test:

*TST?

Returns “0” if the self-test passes or “1” if it fails. If the self-test fails, an error message is also generated with additional information on why the test failed. *Use the SYSTem:ERRor? command to read the error queue.*

Memory Locations

Four memory locations (numbered 0, 1, 2 and 3) are available to store instrument configuration states. See the *SAV, *RCL and MEMory commands for more information.

Firmware Revision Query

The function generator has two microprocessors for control of various internal systems. You can query the function generator to determine which revision of firmware is installed for each microprocessor.

The function generator returns two numbers. The first number is the firmware revision number for the *main generator processor* and the second is for the *input/output processor*.

Use the following command to query the firmware version:

*IDN?

Returns “GPIB,E1441A,0,A.01.00-A.01.09”

Be sure to dimension a string variable with at least 41 characters.

SCPI Language Version Query

You can determine the SCPI version with which the function generator is in compliance by sending a query from the remote interface.

Use the following command to query the SCPI version:

SYSTem:VERSion?

Returns a string in the form “YYYY.V” where the “Y's” represent the year of the version, and the “V” represents a version number for that year (for example, 1993.0).

Power-On and Reset State

Feature	Power-On and Reset State
Output Configuration	
Function	Sine wave
Frequency	1 kHz
Amplitude (into 50 ohms)	100 mV peak-to-peak
Offset	0.00 Vdc
Output Units	Volts peak-to-peak
Output Termination	50 ohms
Modulation	
AM Carrier Waveform	1 kHz Sine wave
AM Modulating Waveform	100 Hz Sine wave
AM Depth	100%
FM Carrier Waveform	1 kHz Sine wave
FM Modulating Waveform	10 Hz Sine wave
FM Peak Frequency Deviation	100 Hz
Burst Carrier Frequency	1 kHz Sine wave
Burst Count	1 cycle
Burst Rate	100 Hz
Burst Starting Phase	0 degrees
FSK Carrier Frequency	1 kHz Sine wave
FSK"Hop" Frequency	100 Hz Sine wave
FSK Rate	10 Hz
Modulation State	Off
Sweep Start / Stop Frequency	100 Hz / 1 kHz
Sweep Time	1 second
Sweep Mode	Linear
Triggering Operations	
Trigger Source	Internal
Calibration	
Calibration State	Doesn't change with *RST or power-down. See page 74

Note The power-on state will state will be different if you have enabled the auto-recall mode. See [“MEMory:STATe:RECall:AUTO OFF | ON | 0 | 1”](#) on page 85.

Application Program Examples

This section provides programs that demonstrate several applications of the Agilent E1441A. You can use these examples to help you learn the capabilities of the Agilent E1441A and then to help you develop programs for your specific application.

C Language Programs

All of the C Language example programs in this section are written for the Agilent 82341A GPIB Interface Card using the Agilent VISA I/O Library.

Compiling and Linking a C Program

You can find Specific instructions for compiling C language programs for the PC in the Agilent VISA User's Guide. See the section "Compiling and Linking an Agilent VISA Program."

Example Programs

Burst Modulation Program

```
/* 1441brst.C - This program sets up a 10,000 cycle sine wave burst with */
/* a 270 degree starting phase. An offset voltage is added to the burst */
/* to create a haversine. */

#include <stdio.h>
#include <visa.h>

/** FUNCTION PROTOTYPE **/
void err_handler (ViSession vi, ViStatus x);

#define DEVICE_ADDRESS "GPIB-VXI0::80::INSTR"

void main(void)
{
    char buf[512] = {0};

    ViStatus err;
    ViSession defaultRM, funcgen;

    /* Open resource manager and Function Generator sessions*/
    err=viOpenDefaultRM(&defaultRM);
    if(err != VI_SUCCESS) err_handler(funcgen, err);
    else printf("default RM opened OK\n");

    err=viOpen(defaultRM, DEVICE_ADDRESS, VI_NULL,VI_NULL, &funcgen);
    if(err != VI_SUCCESS) err_handler(funcgen, err);
    else printf("instrument session opened OK\n");

    /* Set the timeout value to 10 seconds. */
    viSetAttribute(funcgen, VI_ATTR_TMO_VALUE, 10000);

    /* Reset the module. */
    err=viPrintf(funcgen, "*RST\n");
    if(err != VI_SUCCESS) err_handler(funcgen, err);
```

```

/* Set the output amplitude to be set for 50 ohm load. */
err=viPrintf(funcgen, "OUTPut:LOAD 50\n");
if(err != VI_SUCCESS) err_handler(funcgen, err);

/* configure the E1441A to output a 5 Vp-p, 5 kHz sine wave */
/* with a 2.5V offset */
err=viPrintf(funcgen, "SOURce:APPLy:SIN 5000, 2, 2.5\n");
if(err != VI_SUCCESS) err_handler(funcgen, err);

/* set the burst modulation source, set 10,000 burst cycles, */
/* a 270 degree starting phase, a 1 Hz burst rate, enable */
/* the burst state, and output the burst when a negative */
/* going trigger is received on "EXT TRIG" BNC connector */
err=viPrintf(funcgen, "SOURce:BM:SOURce INTernal\n"); /* counted burst mode */
if(err != VI_SUCCESS) err_handler(funcgen, err);

err=viPrintf(funcgen, "SOURce:BM:NCYcles 10000\n"); /* 10000 cycle bursts */
if(err != VI_SUCCESS) err_handler(funcgen, err);

err=viPrintf(funcgen, "SOURce:BM:PHASe 270\n"); /* 270 degree phase */
if(err != VI_SUCCESS) err_handler(funcgen, err);

err=viPrintf(funcgen, "TRIGger:SOURce EXTernal\n"); /* "EXT" trig BNC */
if(err != VI_SUCCESS) err_handler(funcgen, err);

err=viPrintf(funcgen, "TRIGger:SLOPe NEG\n"); /* "trigger on negative edge */
if(err != VI_SUCCESS) err_handler(funcgen, err);

err=viPrintf(funcgen, "SOURce:BM:STATe ON\n"); /* enable burst mode */
if(err != VI_SUCCESS) err_handler(funcgen, err);

/* Now short "EXT TRIG" BNC connector to start 2 second burst */

/* Check for system errors. */
err=viQueryf(funcgen, "syst:err?\n", "%t", buf);
if(err != VI_SUCCESS) err_handler(funcgen, err);
printf("System error response = %s\n\n", buf);

/* close the device session */
viClose(funcgen);
} /* end of main */

/** Error handling function */
void err_handler(ViSession funcgen, ViStatus err)
{
char buf[1024] = {0};
viStatusDesc(funcgen, err, buf);
printf("ERROR = %s\n", buf);
return;
}

```

AM Modulation and Instrument State Storage

```
/* 1441_AM.C - This program sets up the E1441A to output an AM waveform. */
/* The program also stores the configuration in memory for subsequent */
/* recall. */

#include <stdio.h>
#include <visa.h>

/** FUNCTION PROTOTYPE */
void err_handler (ViSession vi, ViStatus x);

#define DEVICE_ADDRESS "GPIB-VXI0::80::INSTR"

void main(void)
{
    char buf[512] = {0};

    ViStatus err;
    ViSession defaultRM, funcgen;

    /* Open resource manager and Function Generator sessions*/
    err=viOpenDefaultRM(&defaultRM);
    if(err != VI_SUCCESS) err_handler(funcgen, err);

    err=viOpen(defaultRM, DEVICE_ADDRESS, VI_NULL,VI_NULL, &funcgen);
    if(err != VI_SUCCESS) err_handler(funcgen, err);

    /* Set the timeout value to 10 seconds. */
    viSetAttribute(funcgen, VI_ATTR_TMO_VALUE, 10000);

    /* Reset the module. */
    err=viPrintf(funcgen, "*RST\n");
    if(err != VI_SUCCESS) err_handler(funcgen, err);

    /* Set the output amplitude to be set for 50 ohm load. */
    err=viPrintf(funcgen, "OUTPut:LOAD 50\n");
    if(err != VI_SUCCESS) err_handler(funcgen, err);

    /* configure the E1441A to output a 5 Vp-p, 5 kHz sine wave */
    /* with a 2.5V offset. APPLY command is first since it */
    /* presets some functions that follow */
    err=viPrintf(funcgen, "SOURce:APPLY:SIN 5000, 2, 2.5\n");
    if(err != VI_SUCCESS) err_handler(funcgen, err);

    /* set the amplitude modulation source, set a modulation depth */
    /* of 80%, the modulation waveshape to sine, the modulating */
    /* frequency to 200 Hz, and enable AM modulation */
    err=viPrintf(funcgen, "SOURce:AM:SOURce BOTH\n"); /* AM from internal */
    if(err != VI_SUCCESS) err_handler(funcgen, err);

    err=viPrintf(funcgen, "SOURce:AM:DEPTh 80\n"); /* mod depth 80% */
    if(err != VI_SUCCESS) err_handler(funcgen, err);

    err=viPrintf(funcgen, "SOURce:AM:INTernal:FUNCTion SIN\n"); /* AM shape SIN */
    if(err != VI_SUCCESS) err_handler(funcgen, err);

    err=viPrintf(funcgen, "SOURce:AM:INTernal:FREQuency 200\n"); /* AM freq 200 Hz */
    if(err != VI_SUCCESS) err_handler(funcgen, err);
}
```

```

err=viPrintf(funcgen, "SOURCE:AM:STATE ON\n"); /* enable AM mode */
if(err != VI_SUCCESS) err_handler(funcgen, err);

/* save this configuration in E1441A memory location 1, use a */
err=viPrintf(funcgen, "*SAV 1\n");
if(err != VI_SUCCESS) err_handler(funcgen, err);

/* Check for system errors. */
err=viQueryf(funcgen, "syst:err?\n", "%t", buf);
if(err != VI_SUCCESS) err_handler(funcgen, err);
printf("System error response = %s\n\n", buf);

/* close the device session */
viClose(funcgen);
} /* end of main */

/** Error handling function */
void err_handler(ViSession funcgen, ViStatus err)
{
char buf[1024] = {0};
viStatusDesc(funcgen, err, buf);
printf("ERROR = %s\n", buf);
return;
}

```

Arbitrary Waveform Example

```

/* 1441_arb.C - This program sets up the E1441A to output an AM waveform. */
/* The program also stores the configuration in memory for subsequent */
/* recall. */

#include <stdio.h>
#include <visa.h>
#include <math.h>

/** FUNCTION PROTOTYPE */
void err_handler (ViSession vi, ViStatus x);

#define DEVICE_ADDRESS "GPIB-VXI0::80::INSTR"

void main(void)
{
char buf[512] = {0};

ViStatus err;
ViSession defaultRM, funcgen;

/* program variables */
ViInt16 i;
ViReal64 j;
ViReal64 sinxwave[4096];

ViReal64 pi;
ViReal64 max_v;
ViInt16 idx;

```

```

/* define pi for sin(x)/x calculation, initialize other variables */
pi = 3.141592654;
max_v = 0;
idx = 0;

/* do this for Borland EasyWin programs */
#ifdef __BORLANDC__ && !defined (__WIN32__)
  _InitEasyWin();
#endif

/* Open resource manager and Function Generator sessions*/
err=viOpenDefaultRM(&defaultRM);
if(err != VI_SUCCESS) err_handler(funcgen, err);

err=viOpen(defaultRM, DEVICE_ADDRESS, VI_NULL, VI_NULL, &funcgen);
if(err != VI_SUCCESS) err_handler(funcgen, err);

/* Set the timeout value to 10 seconds. */
viSetAttribute(funcgen, VI_ATTR_TMO_VALUE, 10000);

/* compute sin(x)/x waveform */
for (i=-2047; i<2048; i++)
{
  j = (ViReal64)i;
  if(i==0) j=1.E-38;
  sinxwave[i+2048] = ((sin(2*pi*0.53125*j/256))/(0.53125*j/256)*0.159154943092);
}
/* download the computed waveform into E1441A volatile memory */
err = viPrintf(funcgen,"DATA VOLATILE");

for ( i=0; i < 4096; i++ )
{
  err = viPrintf( funcgen, ",%f", sinxwave[i] );
}

err = viPrintf(funcgen,"\n");
if(err != VI_SUCCESS) err_handler(funcgen, err);

/* copy the arbitrary waveform data from volatile memory to a */
/* named non-volatile memory location */
err=viPrintf(funcgen, "DATA:COPY MYSINE\n");
if(err != VI_SUCCESS) err_handler(funcgen, err);

/* select the user defined arbitrary waveform by name */
err=viPrintf(funcgen, "SOURCE:FUNCTION:USER MYSINE\n");
if(err != VI_SUCCESS) err_handler(funcgen, err);

/* configure the E1441A to output a 5 Vp-p, 5 kHz arb wave */
/* APPLY command is first since it sets some functions that */
/* follow */
err=viPrintf(funcgen, "SOURCE:APPLY:USER 5000, 5, 0\n");
if(err != VI_SUCCESS) err_handler(funcgen, err);

/* Check for system errors. */
err=viQueryf(funcgen, "sys:err?\n", "%t", buf);
if(err != VI_SUCCESS) err_handler(funcgen, err);
printf("System error response = %s\n\n", buf);

```

```
/* close the device session */
viClose(funcgen);
} /* end of main */

/** Error handling function */
void err_handler(ViSession funcgen, ViStatus err)
{
char buf[1024] = {0};
viStatusDesc(funcgen, err, buf);
printf("ERROR = %s\n", buf);
return;
}
```

Agilent E1441A SCPI Command Reference

This chapter describes the Standard Commands for Programmable Instruments (SCPI) and IEEE 488.2 common (*) commands applicable to the Agilent E1441A Function / Arbitrary Waveform Generator.

- [Command Index by Function](#) page 65
- [Command Fundamentals](#) page 70
- [SCPI Command Reference](#) page 72
- [IEEE 488.2 Common Command Reference](#) page 124
- [SCPI Command Quick Reference](#) page 131

Command Index by Function

The APPLY commands

[SOURCE:]APPLY:SINusoid [<frequency>[,<amplitude>[,<offset>]]].	page 100
[SOURCE:]APPLY:SQUare [<frequency>[,<amplitude>[,<offset>]]].	page 101
[SOURCE:]APPLY:TRIangle [<frequency>[,<amplitude>[,<offset>]]].	page 101
[SOURCE:]APPLY:RAMP [<frequency>[,<amplitude>[,<offset>]]].	page 100
[SOURCE:]APPLY:NOISe [<frequency DEF>[,<amplitude DEF>[, <offset>]]].	page 100
[SOURCE:]APPLY:DC[<frequency DEF>[,<amplitude DEF>[, <offset>]]].	page 100
[SOURCE:]APPLY:USER [<frequency>[,<amplitude>[,<offset>]]].	page 101
[SOURCE:]APPLY?.	page 101

Output Configuration Commands

[SOURCE:]FUNCTION:SHAPE SIN SQU TRI RAMP NOIS DC USER.	page 111
[SOURCE:]FUNCTION:SHAPE?	page 112
[SOURCE:]FREQUENCY <frequency> MIN MAX	page 106
[SOURCE:]FREQUENCY? [MIN MAX].	page 107
[SOURCE:]PULSE:DCYCLE <percent> MIN MAX.	page 112
[SOURCE:]PULSE:DCYCLE? [MIN MAX]	page 113
[SOURCE:]VOLTAGE <amplitude> MIN MAX	page 114
[SOURCE:]VOLTAGE? [MIN MAX].	page 115
[SOURCE:]VOLTAGE:OFFSET <offset> MIN MAX	page 115
[SOURCE:]VOLTAGE:OFFSET? [MIN MAX]	page 116
[SOURCE:]VOLTAGE:UNIT VPP VRMS DBM DEF.	page 116
[SOURCE:]VOLTAGE:UNIT?	page 116
OUTPUT:LOAD 50 INFINITY MIN MAX	page 87
OUTPUT:LOAD? [MIN MAX].	page 87

OUTPut:SYNC OFF ON	page 88
OUTPut:SYNC?	page 88
MEMory:STATe:DELeTe 0 1 2 3	page 85
*SAV 0 1 2 3	page 128
*RCL 0 1 2 3	page 127

Modulation Commands

[SOURce:]AM:DEPT _h <depth in percent> MIN MAX	page 93
[SOURce:]AM:DEPT _h ? [MIN MAX]	page 94
[SOURce:]AM:INT _{ernal} :FUNCT _{ion} SIN SQU TRI RAMP NOIS USER	page 94
[SOURce:]AM:INT _{ernal} :FUNCT _{ion} ?	page 94
[SOURce:]AM:INT _{ernal} :FREQU _{ency} <frequency> MIN MAX	page 94
[SOURce:]AM:INT _{ernal} :FREQU _{ency} ? [MIN MAX]	page 94
[SOURce:]AM:SOUR _{ce} BOTH EXT _{ernal}	page 94
[SOURce:]AM:SOUR _{ce} ?	page 95
[SOURce:]AM:STAT _e OFF ON	page 95
[SOURce:]AM:STAT _e ?	page 95
[SOURce:]FM:DEVI _{ation} <peak deviation in Hz> MIN MAX	page 105
[SOURce:]FM:DEVI _{ation} ? [MIN MAX]	page 105
[SOURce:]FM:INT _{ernal} :FUNCT _{ion} SIN SQU TRI RAMP NOIS USER	page 106
[SOURce:]FM:INT _{ernal} :FUNCT _{ion} ?	page 106
[SOURce:]FM:INT _{ernal} :FREQU _{ency} <frequency> MIN MAX	page 105
[SOURce:]FM:INT _{ernal} :FREQU _{ency} ? [MIN MAX]	page 106
[SOURce:]FM:STAT _e OFF ON	page 106
[SOURce:]FM:STAT _e ?	page 106
[SOURce:]BM:NCYC _{les} <# cycles> INFI _{nity} MIN MAX	page 102
[SOURce:]BM:NCYC _{les} ? [MIN MAX]	page 102
[SOURce:]BM:PHAS _e <degrees> MIN MAX	page 103
[SOURce:]BM:PHAS _e ? [MIN MAX]	page 103
[SOURce:]BM:INT _{ernal} :RATE <frequency> MIN MAX	page 103
[SOURce:]BM:INT _{ernal} :RATE? [MIN MAX]	page 104
[SOURce:]BM:SOUR _{ce} INT _{ernal} EXT _{ernal}	page 104
[SOURce:]BM:SOUR _{ce} ?	page 104
[SOURce:]BM:STAT _e OFF ON	page 104
[SOURce:]BM:STAT _e ?	page 104
[SOURce:]FSKey:FREQU _{ency} <frequency> MIN MAX	page 109
[SOURce:]FSKey:FREQU _{ency} ? [MIN MAX]	page 109
[SOURce:]FSKey:INT _{ernal} :RATE <rate in Hz> MIN MAX	page 109
[SOURce:]FSKey:INT _{ernal} :RATE? [MIN MAX]	page 109
[SOURce:]FSKey:SOUR _{ce} INT _{ernal} EXT _{ernal}	page 109
[SOURce:]FSKey:SOUR _{ce} ?	page 110
[SOURce:]FSKey:STAT _e OFF ON	page 110
[SOURce:]FSKey:STAT _e ?	page 110
TRIGger:SOUR _{ce} BUS EXT _{ernal} IMM _{ediate} TTLTrg<n>	page 121
TRIGger:SOUR _{ce} ?	page 123

Sweep Commands

[SOURCE:]FREQUENCY:START <frequency> MIN MAX	page 107
[SOURCE:]FREQUENCY:START? [MIN MAX]	page 108
[SOURCE:]FREQUENCY:STOP <frequency> MIN MAX	page 108
[SOURCE:]FREQUENCY:STOP? [MIN MAX]	page 108
[SOURCE:]SWEep:SPACing LINear LOGarithmic	page 113
[SOURCE:]SWEep:SPACing?	page 113
[SOURCE:]SWEep:TIME <time> MIN MAX	page 113
[SOURCE:]SWEep:TIME? [MIN MAX]	page 113
[SOURCE:]SWEep:STATe OFF ON	page 114
[SOURCE:]SWEep:STATe?	page 114
TRIGger:SOURce BUS EXternal IMMediate TTLTrg<n>	page 121
TRIGger:SOURce?	page 123

Arbitrary Waveform Commands

[SOURCE:]FUNCTION:USER <arb name> VOLATILE	page 110
[SOURCE:]FUNCTION:USER?	page 111
[SOURCE:]FUNCTION:SHAPE SIN SQU TRI RAMP NOIS DC USER	page 111
[SOURCE:]FUNCTION:SHAPE?	page 112
DATA VOLATILE, <value>, <value>,. . .	page 77
DATA:DAC VOLATILE, <binary block>[(<value>, <value>,. . .)]	page 78
DATA:ATTRibute:AVERAge? [<arb name>]	page 79
DATA:ATTRibute:CFACtor? [<arb name>]	page 79
DATA:ATTRibute:POINts? [<arb name>]	page 80
DATA:ATTRibute:PTPeak? [<arb name>]	page 80
DATA:CATalog?	page 81
DATA:COpy <destination arb name> [,VOLATILE]	page 81
DATA:DELeTe <arb name>	page 82
DATA:DELeTe:ALL	page 83
DATA:NVOLatile:CATalog?	page 83
DATA:NVOLatile:FREE?	page 83
FORMat:BORDER NORMal SWAPped	page 84
FORMat:BORDER?	page 84

Trigger Commands

TRIGger:SLOPe Positive NEGative	page 121
TRIGger:SLOPe?	page 121
TRIGger:SOURce BUS EXternal IMMediate TTLTrg<n>	page 121
TRIGger:SOURce?	page 123
*TRG	page 129

System-Related Commands

SYSTem:ERRor?	page 120
SYSTem:VERsion?	page 120
MEMory:STATe:DELete 0 1 2 3	page 85
MEMory:STATe:RECall:AUTO OFF ON 0 1	page 85
MEMory:STATe:RECall:AUTO?	page 86
*IDN?	page 126
*RST	page 127
*TST?	page 129
*SAV 0 1 2 3	page 128
*RCL 0 1 2 3	page 127

Calibration Commands

CALibration:COUNT?	page 73
CALibration:SECure:CODE <new code>	page 74
CALibration:SECure:STATe OFF ON, <code>	page 74
CALibration:SECure:STATe?	page 75
CALibration:SETup <0 1 2 3 ... 84>	page 75
CALibration:SETup?	page 75
CALibration:STRing <quoted string>	page 75
CALibration:STRing?	page 76
CALibration:VALue <cal_value>	page 76
CALibration:VALue?	page 76

Status Reporting Commands

SYSTem:ERRor?	page 120
*CLS	page 125
*ESE <unmask>	page 125
*ESE?	page 125
*ESR?	page 125
*OPC	page 126
*OPC?	page 126
*OPT?	page 126
*PSC 0 1	page 127
*PSC?	page 127
*SRE <unmask>	page 128
*SRE?	page 129
*STB?	page 129
*WAI	page 129

The IEEE-488.2 Common Commands

*CLS.....	page 125
*ESE <unmask>.....	page 125
*ESE?.....	page 125
*ESR?.....	page 125
*IDN?.....	page 126
*OPC.....	page 126
*OPC?.....	page 126
*OPT?.....	page 126
*PSC 0 1.....	page 127
*PSC?.....	page 127
*RST.....	page 127
*SAV 0 1 2 3.....	page 128
*RCL 0 1 2 3.....	page 127
*SRE <unmask>.....	page 128
*SRE?.....	page 129
*STB?.....	page 129
*TST?.....	page 129
*WAI.....	page 129

Option 001 Phase-Lock Commands

PHASe:ADJust <radians> <degrees>DEG [MIN]MAX.....	page 90
PHASe:ADJust?.....	page 91
PHASe:REFeRence.....	page 91
PHASe:UNLock:ERRor:STATe OFF ON.....	page 91
PHASe:UNLock:ERRor:STATe?.....	page 91
OUTPut:TRIGger:IMMediate.....	page 88
OUTPut:TRIGger:STATe OFF ON.....	page 88
OUTPut:TRIGger:STATe?.....	page 88
OUTPut:TTLTrg<n>[:STATe] ON OFF.....	page 88
OUTPut:TTLTrg<n>[:STATe]?.....	page 89
*OPT?.....	page 126

Command Fundamentals

Commands are separated into two types: IEEE 488.2 Common Commands and SCPI Commands.

Common Command Format

The IEEE 488.2 standard defines the Common commands that perform functions like reset, self-test, status byte query, etc. Common commands are four or five characters in length, always begin with the asterisk character (*), and may include one or more parameters. The command keyword is separated from the first parameter by a space character. Some examples of common commands are shown below:

```
*RST          *ESR 32          *STB?
```

SCPI Command Format

The SCPI commands perform functions such as making measurements, querying instrument states, or retrieving data. A command subsystem structure is a hierarchical structure that usually consists of a top level (or root) command, one or more low-level commands, and their parameters. The following example shows the root command CALibration and its lower-level subsystem commands:

```
CALibration
:COUNT?
:SECure:CODE < new code>
:SECure:STATe OFF | ON, <code>
:SECure:STATe?
:SETup < 0 | 1 | 2 | 3 | . . . | 84
:SETup?
:STRing < quoted string>
:STRing?
:VALue < value>
:VALue?
```

CALibration is the root command, COUNT?, SECure, SETup, SETup?, STRing and STRing? are second level commands, and CODE, STATe and STATe? are third level commands.

Command Separator

A colon (:) always separates one command from the next lower level command as shown below:

```
CALibration:SECure:STATe?
```

Colons separate the root command from the second level command (CALibration:SECure) and the second level from the third level (SECure:STATe?).

Abbreviated Commands

The command syntax shows most commands as a mixture of upper and lower case letters. The upper case letters indicate the abbreviated spelling for the command. For shorter program lines, send the abbreviated form. For better program readability, you may send the entire command. The instrument will accept either the abbreviated form or the entire command.

For example, if the command syntax shows FREQuency, then FREQ and FREQUENCY are both acceptable forms. Other forms of FREQuency, such as FREQU or FREQUEN will generate an error. You may use upper or lower case letters. Therefore, FREQUENCY, frequency, and FrEqUeNcY are all acceptable.

Implied Commands

Implied commands are those which appear in square brackets ([]) in the command syntax. (Note that the brackets are not part of the command and are not sent to the instrument.) Suppose you send a second level command but do not send the preceding implied command. In this case, the instrument assumes you intend to use the implied command and it responds as if you had sent it. Examine the partial SOURce subsystem shown below:

```
[SOURce:]  
  FUNCtion  
    [:SHAPE] "<shape>"(e.g., <shape> = SQUare)  
    [:SHAPE]?  
  FREQuency <frequency> | MINimum | MAXimum  
  FREQuency? [ MINimum|MAXimum ]
```

The root command SOURce: is an implied command. For example, to set the function generator's function to a square wave, you can send either of the following command statements:

```
SOUR:FUNC SQU      or      FUNC SQU
```

Parameters

Parameter Types. The following table contains explanations and examples of parameter types you might see later in this chapter.

Parameter Type	Explanations and Examples
Numeric	Accepts all commonly used decimal representations of number including optional signs, decimal points, and scientific notation. 123, 123E2, -123, -1.23E2, .123, 1.23E-2, 1.23000E-01. Special cases include MINimum, MAXimum, and DEFault.
Boolean	Represents a single binary condition that is either true or false. ON, OFF, 1, 0
Discrete	Selects from a finite number of values. These parameters use mnemonics to represent each valid setting. An example is the TRIGger:SOURce <source> command where source can be BUS, EXT, or IMM.

Optional Parameters. Parameters shown within square brackets ([]) are optional parameters. (Note that the brackets are not part of the command and are not sent to the instrument.) If you do not specify a value for an optional parameter, the instrument chooses a default value. For example, consider the AM:DEPT_h? [MIN | MAX] command. If you send the command without specifying a MINimum or MAXimum parameter, the present AM:DEPT_h value is returned. If you send the MIN parameter, the command returns the minimum AM modulation depth available. If you send the MAX parameter, the command returns the maximum AM modulation depth available. Be sure to place a space between the command and the parameter.

Linking Commands

Linking IEEE 488.2 Common Commands with SCPI Commands. Use a semicolon between the commands. For example:

```
*RST;OUTP:LOAD INF      or      TRIG:SOUR BUS;*TRG
```

Linking Multiple SCPI Commands. Use both a semicolon and a colon between the commands. For example:

```
OUTP:LOAD 50;:APPL:RAMP
```

SCPI Command Reference

This section describes the Standard Commands for Programmable Instruments (SCPI) for the Agilent E1441A Function / Arbitrary Waveform Generator. Commands are listed alphabetically by subsystem and also within each subsystem.

Command Guides

Command guides are printed in the top margin of each page. The left guide indicates the first command listed on that page. The right guide indicates the last command listed on that page. If a single command appears on a page, the left and right guides will be the same.

CALibration

The CALibration command subsystem allows you to enter a security code to prevent accidental or unauthorized calibrations of the function generator. The function generator is secured when you receive it (see the factory- shipped security code in the CALibration:SECure:CODE command). You must unsecure the function generator by entering the correct security code before you can calibrate it (see CALibration:SECure:STATe OFF|ON command).

Subsystem Syntax

```
CALibration?  
CALibration  
:COUNT?  
:SECure:CODE <new code>  
:SECure:STATe OFF | ON, <code>  
:SECure:STATe?  
:SETup <0 | 1 | 2 | 3 | . . . | 86>  
:SETup?  
:STRing <quoted string>  
:STRing?  
:VALue <value>  
:VALue?
```

CALibration?

CALibration? performs a calibration using the specified calibration value set by the CALibration:VALue command.

Comments

- Execution of this command begins the electronic adjustment for the function and range the function generator is set to. The adjustment is performed based on the value stated in the CAL:VAL command and the function generator expects that value at the input terminals.
- Returns "+0" to indicate there are no calibration errors and calibration was performed. A "1" is returned if a calibration error occurs and a calibration is unable to be performed.
- An error message is reported to the output buffer if a calibration is unable to be performed.
- You must set CALibration:SECure:STATe OFF <code> to allow a calibration to be performed. This requires that you know the calibration secure code. The secure state enabled prevents unauthorized calibration of the function generator.

:COUNT?

CALibration:COUNT? queries the function generator to determine the number of times a point calibration has occurred. A complete calibration of the function generator increases the count by the number of points calibrated. It is not a record of complete calibrations. The count is stored in non-volatile memory.

- Comments**
- *RST does not change the calibration count stored in non-volatile memory.

Example Querying the number of occurrences of point calibrations:

CAL:COUN?

Query the calibration count

:SECure:CODE

CALibration:SECure:CODE <new code> enters a new calibration security code. To change the security code, first unsecure the function generator using the old security code with CAL:SEC:STAT OFF, <old code>. Then, enter the new code with CAL:SEC:CODE <new code>. The calibration security code may contain up to 12 characters. The security code is stored in non-volatile memory.

- Comments**
- The security code is set to "HP_E1441" when the function generator is shipped from the factory. The security code is stored in non-volatile memory, and does not change when power has been off or after a remote interface reset.
 - The security code <new code> can contain up to 12 alphanumeric characters. The first character must be a letter. The remaining characters can be letters or numbers or an underscore. You do not have to use all 12 characters but the first character must be a letter.
 - If you forget or lose the active security code, you can disable the security feature by adding a jumper inside the function generator. You then enter a new code and remove the jumper. See “Unsecuring the Function Generator (Lost Security Code)” on page 175.

Example Enter a new calibration security code:

CAL:SEC:STAT OFF, HP_E1441
 CAL:SEC:CODE the_new_code

*Unsecure with the old code.
 Enter a new calibration code
 (a maximum of 12 characters).*

:SECure:STATe

CALibration:SECure:STATe OFF | ON, <code> unsecures or secures the function generator for calibration. The calibration code must be the code set by the CAL:SEC:CODE command. The state is stored in non-volatile memory.

Parameters

Parameter Name	Parameter Type	Range of Values	Default Units
OFF ON	boolean	OFF 0 ON 1	none
code	discrete	up to 12 characters set by :SEC:CODE	none

- Comments**
- You can substitute decimal values for the OFF (“0”) and ON (“1”) parameters.
 - The function generator calibration is secured when shipped from the factory and the security code is set to "HP_E1441".
 - *RST does not change the state.

Example Set the calibration state to unsecured:

```
CAL:SEC:STAT OFF, HP_E1441
```

Unsecure function generator calibration.

:SECure:STATe?

CALibration:SECure:STATe? returns a "1" or "0" to show whether the calibration security state is enabled (1) or disabled (0). The number is sent to the output buffer.

Example Query the calibration security state:

```
CAL:SEC:STAT?
enter statement
```

Query function generator calibration security state
Enter value into computer.

:SETup

CALibration:SETup <0 | 1 | 2 | 3 | ... | 84> configure the function generator's internal state for each of the calibration steps to be performed.

:SETup?

CALibration:SETup? queries the calibration setup number. Returns a value between 0 and 84.

:STRing

CALibration:STRing <*quoted string*> allows you to record calibration information about your function generator while CAL:SEC:STAT is OFF. For example, you can store information such as the last calibration date and/or the next calibration due date. The calibration message may contain up to 40 characters. The string is stored in non-volatile memory.

Parameters

Parameter Name	Parameter Type	Range of Values	Default Units
<i>quoted string</i>	discrete	alphanumeric	none

- Comments**
- The calibration message can contain up to 40 characters.
 - Calibration security state must be OFF to store a string.

- The calibration message is stored in non-volatile memory and does not change when power has been off or after a remote interface reset.

Example Enter calibration information to record the next calibration date:

CAL:STR 'Cal 4/4/YY, Due 10/4/YY' *Enter a calibration message to record the cal date of April 4 and next cal due date as October 4 (YY = year of due date).*

:STRing?

CALibration:STRing? queries the calibration message and returns a quoted string (or a null string " " if nothing is present).

Example Query the calibration message:

CAL:STR?
enter statement *Query the calibration message.
Enter value into computer.*

:VALue

CALibration:VALue <cal_value> specifies the value of the known calibration signal used by the calibration procedure. See “General Calibration/Adjustment Procedure” on page 177..

Parameters

Parameter Name	Parameter Type	Range of Values	Default Units
cal_value	numeric	See Cal/Adj on page 177	none

Comment • *RST does not affect the calibration value.

Example Enter the known value for the calibration source signal:

CAL:VAL 10.0 *Enter calibration value .*

:VALue?

CALibration:VALue? queries the present calibration value.

Example Query the calibration value:

CAL:VAL?
enter statement *Query the calibration value.
Enter value into computer.*

DATA

Subsystem Syntax

```
DATA VOLATILE, <value>,<value>,...
DATA:DAC VOLATILE, <binary block> | <value>,<value>,...
DATA
:ATTRibute:AVERage? [<arb name>]
:ATTRibute:CFACTOR? [<arb name>]
:ATTRibute:POINTS? [<arb name>]
:ATTRibute:PTPeak? [<arb name>]
:CATalog?
:COPY <destination arb name> [,VOLATILE]
:DELeTe <arb name>
:DELeTe:ALL
:NVOLatile:CATalog?
:NVOLatile:FREE?
```

VOLATILE

DATA VOLATILE, <value>, <value>, . . . is used to download *floating-point* values between *-1* and *+1* into volatile memory. You can download between 8 and 16,000 points per waveform.

Comments

- The values *-1* and *+1* correspond to the peak values of the waveform. For example, if you set the amplitude to 10 Vpp, “*-1*” corresponds to *-5* volts and “*+1*” corresponds to *+5* volts.
- The maximum amplitude will be limited if the data points do not span the full range of the output DAC (Digital-to-Analog Converter). For example, the built-in “SINC” waveform does not use the full range of values between ± 1 and therefore its maximum amplitude is 6.084 Vpp (into 50 ohms).
- Downloading floating-point values (using DATA VOLATILE) is slower than downloading binary values (using DATA:DAC VOLATILE) but is more convenient when using trigonometric functions which return values between *-1* and *+1*.
- The DATA VOLATILE command overwrites the previous waveform in VOLATILE memory (no error is generated). Use the DATA:COPY command to copy the waveform to non-volatile memory.
- Up to four user-defined waveforms can be stored in non-volatile memory. Use the DATA:DEL command to delete the waveform in VOLATILE memory or any of the four user-defined waveforms in non-volatile memory. Use the DATA:CAT? command to list all waveforms currently stored in volatile and non-volatile memory (and the built-in waveforms).
- After downloading the waveform data to memory, use the FUNC:USER command to choose the active waveform and the FUNC:SHAP USER command to output it.

- The following statement shows how to use the DATA VOLATILE command to download nine points to volatile memory:

```
"DATA VOLATILE, 1,.75,.5,.25,0,-.25,-.5,-.75,-1"
```

:DAC VOLATILE

DATA:DAC VOLATILE, <binary block>|(<value>, <value>, . . .) downloads *binary integer* values between -2047 and +2047 into volatile memory. You can download between 8 and 16,000 points per waveform in IEEE-488.2 binary block format or as a list of values. The binary range of values corresponds to the values available using internal 12-bit DAC (Digital-to-Analog Converter) codes.

Comments

- The values -2047 and +2047 correspond to the peak values of the waveform. For example, if you have set the output amplitude to 10 Vpp, “-2047” corresponds to -5 volts and “+2047” corresponds to +5 volts.
- The maximum amplitude will be limited if the data points do not span the full range of the output DAC (Digital-to-Analog Converter). For example, the built-in “SINC” waveform does not use the full range of values between ± 1 and therefore its maximum amplitude is 6.084 Vpp (into 50 ohms).
- The DATA:DAC VOLATILE command overwrites the previous waveform in VOLATILE memory (no error is generated). Use the DATA:COPY command to copy the waveform to non-volatile memory.
- Up to four user-defined waveforms can be stored in non-volatile memory. Use the DATA:DEL command to delete the waveform in VOLATILE memory or any of the four user-defined waveforms in non-volatile memory. Use the DATA:CAT? command to list all waveforms currently stored in volatile and non-volatile memory (and the built-in waveforms).
- After downloading the waveform data to memory, use the FUNC:USER command to choose the active waveform and the FUNC:SHAP USER command to output it.
- The following statement shows how to use the DATA:DAC VOLATILE command to download eight integer points using the binary block format (*see also “Using the IEEE-488.2 Binary Block Format” below*):

```
"DATA:DAC VOLATILE, #216 Binary Data
```

- The following statement shows how to download eight integer points (eight <value>s) with the DATA:DAC VOLATILE command:

```
"DATA:DAC VOLATILE, 2047,1536,1024,512,0,-512,-1536,-2047"
```

Downloading a Binary Block of Data

Using the IEEE-488.2 Binary Block Format

In the binary block format, a *block header* precedes the waveform data. The block header has the following format:

```
#532000
```

where:# = Start of data block

5 = Number of digits to follow

32000 = Even number of bytes to follow
(32,000 bytes = 16,000 points)

The function generator represents binary data as 12-bit integers;the data is sent as two bytes. Therefore, **the total number of bytes is always twice the number of data points in the waveform** (and must always be an *even number*). For example, 32,000 bytes are required to download a waveform with 16,000 points.

Use the FORM:BORD command to select the byte order for binary transfers in block mode. If you specify FORM:BORD NORM (default), the most-significant byte (MSB) of each data point is sent first. If you specify FORM:BORD SWAP, the least-significant byte (LSB) of each data point is sent first. Most PCs use the “swapped” byte order.

:ATTRibute:AVERage?

DATA:ATTRibute:AVERage? [<arb name>] queries the arithmetic *average* of all data points for the specified arbitrary waveform. The default *arb name* is the arbitrary waveform currently active (selected with FUNC:USER command).

Parameters

- The arb name may contain up to 8 characters. The first character *must* be a letter (A-Z), but the remaining characters can be numbers (0-9) or the underscore character (“_”). Blank spaces are not allowed. If you specify a name with more than 8 characters, a +783, “*Arb waveform name too long*” error is generated.
- The function generator *does not* distinguish between upper- and lower-case letters for the arbitrary waveform name. Therefore, **ARB_1** and **arb_1** are the same name. All characters are converted to upper case.

Comments

- If you query a waveform that is not currently stored in memory, a +785, “*Specified arb waveform does not exist*” error is generated.

:ATTRibute:CFACTOR?

DATA:ATTRibute:CFACTOR? [<arb name>] queries the crest factor of all data points for the specified arbitrary waveform. Crest factor is the ratio of the peak value to the RMS value of the waveform. The default arb name is the arbitrary waveform currently active (selected with FUNC:USER command).

Parameters

- The arb name may contain up to 8 characters. The first character *must* be a letter (A-Z), but the remaining characters can be numbers (0-9) or the underscore character (“_”). Blank spaces are not allowed. If you specify a name with more than 8 characters, a +783, “*Arb waveform name too long*” error is generated.
- The function generator *does not* distinguish between upper- and lower-case letters for the arbitrary waveform name. Therefore, **ARB_1** and **arb_1** are the same name. All characters are converted to upper case.

Comments

- If you query a waveform that is not currently stored in memory, a +785, “*Specified arb waveform does not exist*” error is generated.

:ATTRibute:POINTs?

DATA:ATTRibute:POINTs? [<arb name>] queries the number of points in the specified arbitrary waveform. Returns a value between 8 and 16,000 points. The default *arb name* is the arbitrary waveform currently active (selected with FUNC:USER command).

Parameters

- The arb name may contain up to 8 characters. The first character *must* be a letter (A-Z), but the remaining characters can be numbers (0-9) or the underscore character (“_”). Blank spaces are not allowed. If you specify a name with more than 8 characters, a +783, “*Arb waveform name too long*” error is generated.
- The function generator *does not* distinguish between upper- and lower-case letters for the arbitrary waveform name. Therefore, **ARB_1** and **arb_1** are the same name. All characters are converted to upper case.

Comments

- If you query a waveform that is not currently stored in memory, a +785, “*Specified arb waveform does not exist*” error is generated.

:ATTRibute:PTPeak?

DATA:ATTRibute:PTPeak? [<arb name>] queries the *peak-to-peak* value of all data points for the specified arbitrary waveform. The default *arb name* is the arbitrary waveform currently active (selected with FUNC:USER command).

Parameters

- The arb name may contain up to 8 characters. The first character *must* be a letter (A-Z), but the remaining characters can be numbers (0-9) or the underscore character (“_”). Blank spaces are not allowed. If you specify a name with more than 8 characters, a +783, “*Arb waveform name too long*” error is generated.
- The function generator *does not* distinguish between upper- and lower-case letters for the arbitrary waveform name. Therefore, **ARB_1** and **arb_1** are the same name. All characters are converted to upper case.

- Comments**
- This command returns a value between “0” and “+1.0”, with “+1.0” indicating full amplitude available (100%).
 - The maximum peak-to-peak amplitude will be limited if the data points do not span the full range of the output DAC (Digital-to- Analog Converter). For example, the built-in “SINC” waveform does not use the full range of values between ± 1 and therefore its maximum peak-to-peak amplitude is 6.084 Vpp (into 50 ohms).
 - If you query a waveform that is not currently stored in memory, a +785, “*Specified arb waveform does not exist*” error is generated.

:CATalog?

DATA:CATalog? lists the names of *all* waveforms currently downloaded to memory. Returns the names of the five built-in waveforms (non-volatile memory), “VOLATILE” if a waveform is currently downloaded to volatile memory, and all user-defined waveforms downloaded to non-volatile memory.

- Comments**
- A series of quoted strings separated with commas is returned:

```
"SINC","NEG_RAMP","EXP_RISE","EXP_FALL",
"CARDIAC","VOLATILE","ARB_1","ARB_2"
```

- Use the DATA:DEL command to delete the waveform in VOLATILE memory or any of the user-defined waveforms in non-volatile memory.

:COPY

DATA:COPY <destination arb name> [,VOLATILE] copies the waveform from volatile memory to the specified name in non-volatile memory.

The source to be copied is always the waveform in “VOLATILE” memory and the “*copy to*” destination is always in non-VOLATILE memory. You cannot copy to VOLATILE memory. Therefore, the VOLATILE parameter is optional and can be omitted.

- Parameters**
- The arb name may contain up to 8 characters. The first character *must* be a letter (A-Z), but the remaining characters can be numbers (0-9) or the underscore character (“_”). Blank spaces are not allowed. If you specify a name with more than 8 characters, a +783, “*Arb waveform name too long*” error is generated.
 - The function generator *does not* distinguish between upper- and lower-case letters for the arbitrary waveform name. Therefore, **ARB_1** and **arb_1** are the same name. All characters are converted to upper case.

- Comments**
- The following built-in waveform names are reserved and cannot be used with the DATA:COPY command: SINC, NEG_RAMP, EXP_RISE, EXP_FALL, and

CARDIAC. If you specify one of the built-in waveforms, a +782, “Cannot overwrite a built-in arb waveform” error is generated.

- If you copy to a waveform name that already exists, the previous waveform is overwritten (no error is generated). The five built-in waveforms are protected; you cannot overwrite any of them.
- Up to four user-defined waveforms can be stored in non-volatile memory. If memory is full and you try to copy a new waveform to non-volatile memory, a +781, “Not enough memory” error is generated. Use the DATA:DEL command to delete the waveform in VOLATILE memory or any of the four user-defined waveforms in non-volatile memory. Use the DATA:CAT? command to list all waveforms currently stored in volatile and non-volatile memory.

Example The following statement uses the DATA:COPY command to copy the waveform currently in volatile memory to non-volatile memory with file name ARB_1:

```
"DATA:COPY ARB_1, VOLATILE"
```

```
"DATA:COPY ARB_1"(optional "VOLATILE" parameter omitted)
```

:DElete

DATA:DElete <arb name> deletes the specified arbitrary waveform from memory. You can delete the waveform in volatile memory or any of the four user-defined waveforms in non-volatile memory.

Parameters

- The arb name may contain up to 8 characters. The first character *must* be a letter (A-Z), but the remaining characters can be numbers (0-9) or the underscore character (“_”). Blank spaces are not allowed. If you specify a name with more than 8 characters, a +783, “Arb waveform name too long” error is generated.
- The function generator *does not* distinguish between upper- and lower-case letters for the arbitrary waveform name. Therefore, **ARB_1** and **arb_1** are the same name. All characters are converted to upper case.

Comments

- You cannot delete the arbitrary waveform that is currently being output. If you attempt to delete the waveform being output, a +787, “Cannot delete an active arb waveform” error is generated.
- You cannot delete any of the five built-in arbitrary waveforms. If you attempt to delete one of the built-in waveforms, a +786, “Cannot delete a built-in arb waveform” error is generated.
- Use the DATA:DEL:ALL command to delete the waveform in VOLATILE memory and all user-defined non-volatile waveforms *all at once*. If one of the waveforms is currently being output, a +787, “Cannot delete an active arb waveform” error is generated. The active waveform *is not* deleted but all of the other waveforms are deleted.

:DEL:ALL

DATA:DELeTe:ALL deletes all user-defined arbitrary waveforms from memory. This command deletes the waveform in VOLATILE memory and all user-defined waveforms in non-volatile memory. The five built-in waveforms in non-volatile memory *are not* deleted.

Comments

- The colon before the ALL parameter is required.

DATA:DELeTe:ALL

If you insert a space instead of a colon, the function generator will attempt to delete an arbitrary waveform with the name “ALL”. If no such waveform is stored in memory, a +785, “*Specified arb waveform does not exist*” error is generated.

- You cannot delete the arbitrary waveform that is currently being output. If you attempt to delete the waveform being output, a +787, “*Cannot delete an active arb waveform*” error is generated.
- You cannot delete any of the five built-in arbitrary waveforms. If you attempt to delete one of the built-in waveforms, a +786, “*Cannot delete a built-in arb waveform*” error is generated.
- Use the DATA:DEL <arb name> command to delete stored waveforms *one at a time*.

:NVOLatile:CATalog?

DATA:NVOLatile:CATalog? lists the names of all user-defined arbitrary waveforms currently downloaded to non-volatile memory. Returns the names of up to four waveforms in non-volatile memory.

Comments

- A series of quoted strings separated with commas is returned (see example below). If no user-defined waveforms are currently downloaded to non-volatile memory, the command returns a null string ("").

"ARB_1","ARB_2","ARB_3","ARB_4"

- Use the DATA:DEL command to delete the waveform in VOLATILE memory or any of the user-defined waveforms in non-volatile memory.

:NVOLatile:FREE?

DATA:NVOLatile:FREE? queries the number of non-volatile *memory slots* available to store user-defined waveforms. Non-volatile waveform memory is divided into four 16k-point slots. The command returns the available memory slots to store user-defined waveforms: “0” (memory full), “1”, “2”, “3”, or “4”.

FORMat

The FORMat command is used to set the byte order for making binary block transfers.

Subsystem Syntax FORMat
 :BORDer NORMal | SWAPped
 :BORDer?

:BORDer

FORMat:BORDer NORMal|SWAPped is used only for binary block transfers to specify the byte order during transfer. Select the byte order for binary transfers in the block mode using the DATA:DAC command. *The default is NORM.*

Parameters

Parameter Name	Description
NORMal (default)	The most-significant byte (MSB) of each data point is sent first.
SWAPped	The least-significant byte (LSB) of each data point is sent first. Most PCs use the “swapped” byte order.

Comments

- The function generator represents binary data as 12-bit integers, which are sent as two bytes. Each data point in the waveform requires 12 bits, which must be transferred as 16 bits (two bytes) on the function generator's 8-bit interface.
- **Related Commands:**
- ***RST Condition:** FORMat:BORDer NORMal

Example Change byte-order from the default NORMal to SWAPped
 (least-significant byte of each data point is sent first).

:BORDer?

FORMat:BORDer? queries the byte order configuration (NORMal or SWAPped). Returns “NORM” or “SWAP”.

MEMory

Subsystem Syntax MEMory
:STATe:DELeTe 0 | 1 | 2 | 3
:STATe:RECall:AUTO OFF | ON | 0 | 1
:STATe:RECall:AUTO?

:STATe:DELeTe

MEMory:STATe:DELeTe 0|1|2|3 deletes a previously stored configuration state and clears the memory location. If nothing is stored in the specified memory location, a +810, "State has not been stored" error is generated.

Comments

- Four memory locations, 0, 1, 2 and 3, are available to store configurations. The Agilent E1441A uses memory location "0" to store an alternate power-on state. If this state has been deleted (MEM:STAT:DEL 0), error 772 "Nonvolatile system memory checksum failure" will be generated when the instrument is powered up.
- The MEMory:STATe:DELeTe command deletes configuration states that were stored in non-volatile memory by the *SAV command.
- **Related Commands:** *RCL, *SAV

:STATe:RECall:AUTO

MEMory:STATe:RECall:AUTO OFF | ON | 0 | 1 You can configure the function generator to automatically recall the instrument state stored with the *SAV 0 command. The stored state is recalled when the power is turned on or when the VXI Mainframe goes through a system reset (such as pressing the reset button on the Agilent E1406A Command Module). The "auto-recall" mode is disabled when the generator is shipped from the factory.

comments

- When the auto-recall mode is "OFF" (factory default), the function generator powers up in its default configuration. (See "Agilent E1441A Power-On and Reset State" on page 130.)
- When the auto-recall mode is "ON", the function generator powers up with the *SAV 0 configuration.
- The *SAV 0 settings are stored in non-volatile memory, and do not change when power has been off or after a remote interface reset.

Note The state of the auto-recall mode is itself part of the information stored with *SAV 0. You must execute MEM:STAT:REC:AUTO and then *SAV 0 to affect the auto-recall state.

- Any arbitrary waveforms downloaded to VOLATILE memory are not "remembered". However, if an arbitrary waveform is being output from NON-VOLATILE memory when the state is stored, that waveform is output when the state is recalled.

Usage <set up the desired instrument state>
MEM:STAT:REC:AUTO ON
*SAV 0
<change instrument settings>
<cycle power>
<*RCL 0 automatically done at power up>
MEM:STAT:REC:AUTO OFF
*SAV 0
<instrument returns to default state at power up>

STATe:RECall:AUTO?

MEMory:STATe:RECall:AUTO? Queries the current setting of the "auto-recall" mode.

Comments • **Returned Value:** 0 or 1

OUTPut

Subsystem OUTPut
Syntax :LOAD 50 | INFinity | MINimum | MAXimum
:LOAD? MINimum | MAXimum
:SYNC OFF | ON
:SYNC?
:TRIGger:IMMediate
:TRIGger:STATe OFF | ON
:TRIGger:STATe?
:TTLTrg<n>[:STATe] <mode>
:TTLTrg<n>[:STATe]?

:LOAD

OUTPut:LOAD 50|INFinity|MIN|MAX selects the output termination for output amplitude and offset voltage. The function generator has a fixed output impedance of 50 ohms on the "Output" terminal. You can specify whether you are terminating the output into a 50 ohm load or an open circuit. Incorrect impedance matching between the function generator and your load will result in an amplitude or offset which does not match the specified signal level. *The output load setting is stored in volatile memory.*

Parameters

Parameter Name	Sets output termination to:
50 (default)	50Ω
INFinity	"high impedance"
MIN	50Ω
MAX	"high impedance"

Comments

- The amplitude (or dc offset) is automatically adjusted if you change the output termination (and no error is generated). For example, if you set the amplitude to 10 Vpp and then change the termination from 50 ohms to "high impedance", the amplitude will *double* to 20 Vpp. If you change from "high impedance" to 50 ohms, the amplitude will drop in half.
- If you specify a 50 ohm termination but are actually terminating into an open circuit, the output will be *twice* the value specified. For example, if you set the offset to 100 mVdc (and specify a 50 ohm termination) but are actually terminating the output into an open circuit, the actual offset will be 200 mVdc.
- ***RST Condition:** OUTPut:LOAD 50

:LOAD?

OUTPut:LOAD? [MIN|MAX] queries the output impedance. Returns "50" or "9.9E+37".

:SYNC

OUTPut:SYNC OFF|ON disables or enables output from the *SYNC* terminal.

Parameters OFF disables the "Sync" output at the front panel BNC connector (see comment below about output level when disabled).
ON enables the "Sync" output. *The default is "ON".*

The SYNC output mode is stored in volatile memory.

Comments

- The output level on the *SYNC* terminal is indeterminate (it might be a TTL "high" or a TTL "low") when the sync signal is disabled.
- ***RST Condition:** "ON"

:SYNC?

OUTPut:SYNC? queries the state of the *SYNC* terminal. Returns "0" (OFF) or "1" (ON).

:TRIGger:IMMediate

OUTPut:TRIGger:IMMediate outputs a TTL positive-going pulse from the front-panel *Ext Trig* terminal IMMEDIATELY regardless of the present setting of the **OUTP:TRIG:STAT** command. IF **OUTP:TTLT<n>:STATE** is ON, that VXibus TTLTRG line will output a negative-going pulse.

Comments

- You use this command to issue an immediate external trigger for synchronizing phase-lock signals using the *Ext Trig* terminal or VXibus TTLTRG lines.

:TRIGger:STATe

OUTPut:TRIGger:STATe OFF|ON This command performs no operation. It is included for compatibility with the Agilent 33120A Function Generator.

:TRIGger:STATe?

OUTPut:TRIGger:STATe? This command performs no operation. It is included for compatibility with the Agilent 33120A Function Generator.

:TTLTrg<n>[:STATe]

OUTPut:TTLTrg<n>[:STATe] ON|OFF enables or disables the function generator from sourcing a trigger signal on a VXibus TTLTRG line (value of <n> selects the line and can range from 0 through 7). *The default setting is disabled (OFF). The setting is stored in volatile memory.*

Usage `OUTP:TTLT2 ON`
 `OUTPUT:TTLTRG7:STATE ON`

enable TTLTRG2 line to source a trigger
enable TTLTRG7 line to source a trigger

:TTLTrg<n>[:STATE]?

OUTPut:TTLTrg<n>[:STATE]? queries the current state for TTLTRG line <n>.

- **Return Value:** Returns 0 or 1.

PHASe

Only valid with Option 001

The PHASe command subsystem is valid only with the Phase-Lock option (option 001). This command allows you to control the phase offset of the output waveform. You can also enable the phase-lock error reporting to generate an error when phase-lock is lost (unlocked). See the STATus command for querying the questionable data registers and status byte to verify the unlock condition.

Subsystem Syntax

```
PHASe
:ADJust <radians> | <degrees> DEG | MINimum | MAXimum
:ADJust?
:REFerence
:UNLock:ERRor:STATe OFF | ON
:UNLock:ERRor:STATe?
```

:ADJust

PHASe:ADJust <radians>|<degrees>DEG |MIN|MAX adjusts the phase offset of the output waveform in radians or in degrees (must specify DEG following the parameter if specified in degrees). Select from -2π radians to $+2\pi$ radians. The default is 0 radians. MIN = -2π radians; MAX = $+2\pi$ radians. *The phase offset setting is stored in volatile memory.*

Parameters

Parameter Name	Parameter Type	Range of Values	Default Units
<i>radians</i>	numeric	-2π to $+2\pi$	radians
<i>degrees</i>	numeric	-360° to $+360^\circ$	must specify DEG

Comments

- You must specify "DEG" following the phase value if you specify the phase in degrees instead of radians. For example, to specify a -90° phase offset, use the following command:

```
PHAS:ADJ -90 DEG
```

- For sine, square, triangle, and ramp waveforms:*

Zero (0) radians is the point at which the waveform crosses zero volts (or the dc offset value) in a positive-going direction.

- For arbitrary waveforms:*

Zero (0) radians is the first point downloaded to memory.

- The phase adjustment for phase-lock is independent of the burst phase as set by the BM:PHAS command. See ["Burst Modulation" on page 33](#) for more information.

:ADJust?

PHASe:ADJust? queries the phase offset setting. Returns the phase offset value in radians (even if you specify the phase offset in degrees).

:REFerence

PHASe:REFerence sets the zero-phase reference point upon command execution. This command does not change the phase offset as set with the PHAS:ADJ command but only changes the phase reference. There is no query form to this command e.g., there is no PHAS:REF? command.

:UNLock:ERRor:STATe

PHASe:UNLock:ERRor:STATe OFF|ON enables or disables the generation of an error if phase-lock is lost. *The default setting is disabled (OFF). The setting is stored in volatile memory.*

- Comments**
- When you have enabled (ON) the unlock error state and phase-lock is lost, error 580, "Phase-locked loop is unlocked" is generated.

:UNLock:ERRor:STATe?

PHASe:UNLock:ERRor:STATe? queries the state of unlock error generation. Returns "0" if it is disabled (OFF) or "1" if it is enabled (ON).

[SOURCE:]

The SOURCE subsystem commands allow you the flexibility to change individual parameters when programming the function generator. These are the instrument's low-level commands.

Subsystem Syntax

```
[SOURCE:]
AM:DEPTH <depth in percent>|MINimum|MAXimum
AM:DEPTH? [MINimum|MAXimum]
AM:INTERNAL:FUNCTION SINusoid|SQUare|TRIangle|RAMP|NOISe|USER
AM:INTERNAL:FUNCTION?
AM:INTERNAL:FREQUENCY <frequency>|MINimum|MAXimum
AM:INTERNAL:FREQUENCY?
AM:SOURCE BOTH|EXTERNAL
AM:SOURCE?
AM:STATE OFF|ON
AM:STATE?

APPLY:DC [<frequency | DEFAULT>[,<amplitude | DEFAULT>[,<offset>]]]
APPLY:NOISE [<frequency | DEFAULT>[,<amplitude | DEFAULT>[,<offset>]]]
APPLY:RAMP [<frequency>[,<amplitude>[,<offset>]]]
APPLY:SINusoid [<frequency>[,<amplitude>[,<offset>]]]
APPLY:SQUare [<frequency>[,<amplitude>[,<offset>]]]
APPLY:TRIangle [<frequency>[,<amplitude>[,<offset>]]]
APPLY:USER [<frequency>[,<amplitude>[,<offset>]]]
APPLY?

BM:NCYCLES <number of cycles>|MINimum|MAXimum
BM:NCYCLES? [MINimum|MAXimum]
BM:PHASE <degrees>|MINimum|MAXimum
BM:PHASE? [MINimum|MAXimum]
BM:INTERNAL:RATE <frequency>|MINimum|MAXimum
BM:INTERNAL:RATE? [MINimum|MAXimum]
BM:SOURCE INTERNAL|EXTERNAL
BM:SOURCE?
BM:STATE OFF|ON
BM:STATE?

FM:DEVIATION <peak deviation in Hz>|MINimum|MAXimum
FM:DEVIATION? [MINimum|MAXimum]
FM:FUNCTION SINusoid|SQUare|TRIangle|RAMP|NOISe|USER
FM:FUNCTION?
FM:INTERNAL:FREQUENCY <frequency>|MINimum|MAXimum
FM:INTERNAL:FREQUENCY? [MINimum|MAXimum]
FM:STATE OFF|ON
FM:STATE?

FREQUENCY <frequency> | MINimum | MAXimum
FREQUENCY? [ MINimum | MAXimum ]
FREQUENCY:START <frequency> | MINimum | MAXimum
FREQUENCY:START? [ MINimum | MAXimum ]
FREQUENCY:STOP <frequency> | MINimum | MAXimum
FREQUENCY:STOP? [ MINimum | MAXimum ]

FSKEY:FREQUENCY <frequency> | MINimum | MAXimum
FSKEY:FREQUENCY? [ MINimum | MAXimum ]
FSKEY:INTERNAL:RATE <rate in Hz> | MINimum | MAXimum
FSKEY:INTERNAL:RATE? [ MINimum | MAXimum ]
FSKEY:SOURCE INTERNAL | EXTERNAL
```

```

FSKey:SOURce?
FSKey:STATe OFF|ON
FSKey:STATe?

FUNCtion:USER <arb name> | VOLATILE
FUNCtion:USER?
FUNCtion:SHAPe
FUNCtion:SHAPe?

PULSe:DCYCLe <percent> | MINimum | MAXimum
PULSe:DCYCLe? [ MINimum | MAXimum ]

SWEep:SPACing LINear | LOGarithmic
SWEep:SPACing?
SWEep:TIME <seconds> | MINimum | MAXimum
SWEep:TIME? [ MINimum | MAXimum ]
SWEep:STATe OFF | ON
SWEep:STATe?

VOLTage <amplitude> | MINimum | MAXimum
VOLTage? [ MINimum | MAXimum ]
VOLTage:OFFSet <offset> | MINimum | MAXimum
VOLTage:OFFSet? [ MINimum | MAXimum ]
VOLTage:UNIT VPP | VRMS | DBM | DEFault
VOLTage:UNIT?

```

Amplitude Modulation (AM) Commands

Use the APPLY command or the equivalent FUNC:SHAP, FREQ, VOLT, and VOLT:OFFS commands to configure the carrier waveform. Set the carrier frequency between 100 μ Hz and 15 MHz (100 kHz maximum for triangle and ramp). The default is 1 kHz.

AM:DEPTH

[SOURce:]AM:DEPTH <depth in percent>|MIN|MAX sets the internal modulation depth in percent. Select from 0% to 120%. *The default is 100%. MIN = 0%. MAX = 120%. The percent of AM depth is stored in volatile memory.*

Parameters

Parameter Name	Parameter Type	Range of Values	Default Units
<i>depth in percent</i>	numeric	0 to 120	percent

Comments

- If you select the *external* modulating source (AM:SOUR EXT), the modulation depth is controlled by the signal level present on the *AM Modulation* terminal (5 volts **peak** corresponds to 100% modulation).
- ***RST Condition:** 100%

AM:DEPTH?

[SOURce:]AM:DEPTH? [MIN|MAX] queries the modulation depth. Returns a value in percent.

AM:INTernal:FUNction

[SOURce:]AM:INTernal:FUNction SIN|SQU|TRI|RAMP|NOIS|USER selects the shape of the *modulating* waveform.

Used only when the *internal* modulation source is selected (AM:SOUR BOTH). You can use the noise function as the modulating waveform. However, you *cannot* use the noise function or dc volts as the carrier waveform. [*Stored in volatile memory*]

- *RST Condition: SINusoid

AM:INTernal:FUNction?

[SOURce:]AM:INTernal:FUNction? queries the shape of the internal modulating waveform. Returns “SIN”, “SQU”, “TRI”, “RAMP”, “NOIS”, or “USER”.

AM:INTernal:FREQuency

[SOURce:]AM:INTernal:FREQuency <frequency> [MIN|MAX] sets the frequency of the *modulating* waveform. Used only when the *internal* modulation source is selected (AM:SOUR BOTH). Select from 10 mHz to 20 kHz. MIN = 10 mHz. MAX = 20 kHz. [*Stored in volatile memory*]

- *RST Condition: 100 Hz

Parameters

Parameter Name	Parameter Type	Range of Values	Default Units
<i>frequency</i>	numeric	10E-03 to 20E+03	Hz

AM:INTernal:FREQuency?

[SOURce:]AM:INTernal:FREQuency? [MIN|MAX] queries the internal modulating frequency. Returns a value in hertz.

AM:SOURce

[SOURce:]AM:SOURce BOTH|EXTernal selects the source of the modulating signal. The function generator will accept an internal modulating signal, an external modulating signal, or both. [*Stored in volatile memory*]

Comments

- The External modulating source is always enabled.
- When both sources are enabled (*internal-external*), the function generator adds the internal and external modulating signals (the carrier waveform is actually modulated with two waveforms).
- When only the external source is enabled (AM:SOURce EXT, internal source disabled), the carrier waveform is modulated only by the external waveform.
- You apply the external modulating waveform to the *AM Modulation* (AM Mod) terminal. The *modulation depth* is controlled by the signal level present (5 volts **peak** corresponds to 100% modulation).
- ***RST Condition:** BOTH

AM:SOURce?

[SOURce:]AM:SOURce? queries the modulating source. Returns “BOTH” or “EXT”.

AM:STATe

[SOURce:]AM:STATe OFF|ON disables or enables Amplitude Modulation. To ensure proper operation, you should enable AM *after* you have set up the other modulation parameters. Only one modulation mode can be enabled at a time. When you enable AM, the previous modulation mode is turned off.

- ***RST Condition:** 0 (OFF)

AM:STATe?

[SOURce:]AM:STATe? queries the state of AM. Returns “0” (OFF) or “1” (ON).

APPLY Commands

The APPLY command provides the most straightforward method to program the function generator. It allows you to select the output function, output frequency, output amplitude and a dc offset voltage on which the output signal resides in a single command.

Note The APPLY commands not only set the instrument's function, frequency, amplitude, and offset, it also sets Duty Cycle to 50%, turns Modulation OFF, sets the TRIG:SOUR to IMM, and sets the TRIG:SLOPE to POS. Because of this, where a sequence of commands is needed to configure the instrument, and one of them will be a SOUR:APPLY command, the APPLY command must be first.

APPLY Command Parameters

Each APPLY command specifies the function to be output followed by three parameters.

Subsystem Syntax

APPLY:<FUNCTION> [<frequency> | DEFault[,<amplitude> | DEFault[,<offset>]]]

Syntax Example

Executing the following statement will output a sine wave with frequency of 5 kHz and amplitude of 3 Vpp with a -2.5 volt offset:

```
"APPL:SIN 5.0E+3, 3.0, -2.5"          default units are hertz, Vpp, VDC
```

Because of the use of optional parameters in the APPLY commands (enclosed in square brackets), you must specify *frequency* to use the *amplitude* parameter, and you must specify both *frequency* and *amplitude* to use the *offset* parameter. The following statement is valid (*frequency* and *amplitude* are specified; *offset* is omitted):

```
"APPL:SIN 5.0E+3, 3.0"
```

However, you CANNOT specify *amplitude* or *amplitude* and *offset* without specifying a *frequency*.

Parameter Name	Parameter Type	Range of Values	Default Setting
<i>frequency</i>	numeric	100 μ Hz - 15 MHz (see the following section titled "Output Frequency")	1 kHz
<i>amplitude</i>	numeric	50 mVpp - 20 Vpp (see the following section titled "Output Amplitude")	100 mVpp (into 50 ohms)
<i>offset</i>	numeric	see equation below	0 Vdc

$$|V_{offset}| + \frac{V_{pp}}{2} \leq V_{max} \quad \text{and} \quad |V_{offset}| \leq 2V_{pp}$$

- You can substitute "MINimum", "MAXimum" or "DEFault" in place of a specific value for any of the above three parameters. MIN selects the lowest value, MAX selects the highest value and DEF selects the default setting.

Output Frequency Minimum frequency is the same for all functions. Maximum frequency is dependent on the function selected as shown in the following table.

Function	Minimum Frequency	Maximum Frequency
Sine	100 μ Hz	15 MHz
Square	100 μ Hz	15 MHz
Built-In Arbs ^a	100 μ Hz	200 kHz, 2.5 MHz or 5 MHz ^b
Ramp	100 μ Hz	100 kHz
Triangle	100 μ Hz	100 kHz

a. There are five built-in arbitrary waveforms stored in non-volatile memory: sinc, negative ramp, exponential rise, exponential fall and cardiac. These waveforms are shown on page 48. The five built-in arbitrary waveforms can be output at a maximum of 5 MHz.

b. Maximum frequency for arbitrary waveforms *you* generate depends on the number of points specified in the waveform. The maximum output frequency decreases as you specify more points in the waveform (see below).

Number of Arb Points	Minimum Frequency	Maximum Frequency
8 to 8,192 (8k)	100 μ Hz	5 MHz
8,193 to 12,287 (12k)	100 μ Hz	2.5 MHz
12,288 to 16,000	100 μ Hz	200 kHz

- **Possible Output Frequency Conflict with a Function Change:** The output frequency is automatically adjusted if you change the function from SINE or SQUARE (MAX frequency = 15 MHz) to RAMP, TRIANGLE or a Built-In Arb, if the current frequency is greater than that of the maximum frequency of the new function. For example, the maximum frequency of a sine wave is 15 MHz while the maximum frequency for a triangle wave is 100 kHz. If the current output is a sine wave at 1 MHz and you change the function to triangle wave which cannot output at 1 MHz, the function generator automatically adjusts the output to the upper frequency limit for a triangle wave (100 kHz). *This function change will also generate a -221 "Settings conflict" error.*
- **Possible Conflict with Duty Cycle (square wave only):** For output frequencies above 5 MHz, the duty cycle is limited to values between 40% and 60% (below 5 MHz, the range is 20% to 80%). The duty cycle is

automatically adjusted if you select a frequency that is not valid with the present duty cycle. For example, if you set the duty cycle to 70% and then change the frequency to 8 MHz, the function generator will automatically adjust the duty cycle to 60% (the upper limit for this frequency). A -221 "Settings conflict" error will be generated and the duty cycle is automatically adjusted.

Output Amplitude

The output amplitude range depends on the function currently selected and the output termination. You can substitute "MINimum", "MAXimum" or "DEFault" in place of a specific value for the amplitude parameter. MIN selects the smallest amplitude for the selected function (50 mVpp into 50 ohms). MAX selects the largest amplitude (10 Vpp into 50 ohms). The default units for amplitude is volts peak to peak (Vpp). This can be overridden by including a units suffix in each amplitude parameter (vpp, vrms, dbm), or to change the default units from Vpp to another, use the SOUR:VOLT:UNIT command. The default amplitude is 100 mVpp (into 50 ohms) for all functions.

Function	Output Termination	Minimum Amplitude	Maximum Amplitude	Default Value
Sine, Square, Triangle, Ramp, Noise, Built-In Arbs ¹	50Ω	50 mVpp	10 Vpp	100 mVpp
Sine, Square, Triangle, Ramp, Noise, Built-In Arbs ¹	Open Circuit	100 mVpp	20 Vpp	100 mVpp

¹There are five built-in arbitrary waveforms stored in non-volatile memory: sinc, negative ramp, exponential rise, exponential fall and cardiac. These waveforms are shown on page 48.

- For *arbitrary waveforms*, the maximum amplitude will be limited if the data points do not span the full range of the output DAC (Digital-to-Analog Converter). For example, the built-in "SINC" waveform does not use the full range of values between ± 1 and therefore its maximum amplitude is 6.084 Vpp (into 50 ohms).
- You can set the units for output amplitude to Vpp, Vrms, or dBm with the VOLTage:UNIT command. See "Output Units" on page 25. for more information.
- **Possible Conflict with Function Change:** The output amplitude is automatically adjusted if you select a function whose maximum amplitude is *less than* that of the currently active function. This conflict may arise when the output units are Vrms or dBm due to the differences in crest factor for the output functions. For example, if you output a 5 Vrms square wave (into 50 ohms) and then change the function to sine wave, the function generator will adjust the output amplitude to 3.535 Vrms (the upper limit for sine waves in Vrms). A -221, "Settings conflict" error is generated and the amplitude is

automatically adjusted.

- **Output Amplitude and Output Termination:** The output amplitude is automatically adjusted (and no error is generated) if you change the output termination. For example, if you set the amplitude to 10 Vpp and then change the termination from 50 ohms to “high impedance”, the displayed amplitude will *double* to 20 Vpp. If you change from “high impedance” to 50 ohms, the displayed amplitude will drop in half. *See “Output Termination” on page 25. for more information.*
- A momentary glitch occurs in the output waveform at certain voltages due to output attenuator switching. This positive-going glitch occurs when the output voltage crosses the break-point voltage either from a lower voltage or a higher voltage. The voltages are shown below (in Vpp) for a 0 volt dc offset:
.252, .399, .502, .796, 1, 1.59, 2.0, 3.17, 3.99, 6.32, 7.96
- The output voltage will momentarily drop to 0 volts at certain voltages due to output relay switching. This occurs when the output voltage crosses the break-point voltage either from a lower voltage or a higher voltage. The voltages are shown below (in Vpp) for a 0 volt dc offset: .317, .632, 1.26, 2.52, 5.02

For the *offset* parameter of the APPLY command, you can substitute “MINimum”, “MAXimum”, or “DEFault” in place of a specific value for the parameter. MIN selects the smallest dc offset voltage for the selected function (0 volts). MAX selects the largest offset for the selected function. *The default offset voltage is 0 volts for all functions.*

- You can set the offset to a positive or negative number with the restrictions shown below. If the specified offset voltage is not valid, the function generator will automatically adjust it to the maximum dc voltage allowed with the present amplitude. (V_{max} is the maximum peak-to-peak amplitude for the selected output termination; V_{pp} is the output amplitude in volts peak-to-peak.) A -221, “Settings conflict” error is generated and the offset is automatically adjusted.

$$|V_{offset}| + \frac{V_{pp}}{2} \leq V_{max} \quad \text{and} \quad |V_{offset}| \leq 2V_{pp}$$

- **DC Offset and Output Termination:** The offset voltage is automatically adjusted (and no error is generated) if you change the output termination. For example, if you set the offset to 100 mVdc and then change the termination from 50 ohms to “high impedance”, the displayed offset will *double* to 200 mVdc. If you change from “high impedance” to 50 ohms, the displayed offset will drop in half.
- For *dc volts*, the output level is actually controlled by setting the offset voltage. You can set the dc voltage to any value between ± 5 Vdc into 50 ohms or ± 10 Vdc into an open circuit.

Comments

- Four low-level commands are required to program the function generator with the same output as the APPLY syntax example.

```
"FUNC:SHAP SIN"  
"FREQ 5.0E+3"  
"VOLT 3.0"  
"VOLT:OFFS -2.5"
```

Select the function wave shape
Set frequency to 5 kHz
Set amplitude to 3 Vpp
Set offset to -2.5 Vdc

APPLY:DC

[SOURCE:]APPLY:DC [<frequency|DEF>[,<amplitude|DEF>[, <offset>]] is used to output a dc voltage with the amplitude level specified by the offset parameter.

Comment

The frequency and amplitude parameters are ignored in this command but you **MUST** specify a value or "DEF". If values are specified, they are stored and used when you make a subsequent function change without specifying new frequency or amplitude values. For example, to output a +5V dc voltage, execute the following command:

```
"APPL:DC DEF, DEF, 5"
```

APPLY:NOISe

[SOURCE:]APPLY:NOISe [<frequency|DEF>[,<amplitude|DEF>[, <offset>]] is used to output noise with the specified amplitude and dc offset.

Comment

The frequency parameter is ignored for this command but you **MUST** specify a value or "DEF" to allow the command to accept the amplitude and offset parameters. If you specify a frequency value, the value is remembered when you change to a different function. For example:

```
"APPL:NOIS DEF, 3.0, -2.5"
```

APPLY:RAMP

[SOURCE:]APPLY:RAMP [<frequency>[,<amplitude>[,<offset>]] is used to output a ramp wave with the specified frequency, amplitude, and dc offset. For example, a ramp wave with the same parameters as the syntax example is shown below:

```
"APPL:RAMP 5.0E+3, 3.0, -2.5"
```

APPLY:SINusoid

[SOURCE:]APPLY:SINusoid [<frequency>[,<amplitude>[,<offset>]] is used to output a sine wave with the specified frequency, amplitude and dc offset. For example, the command for a sine wave shown in the syntax example for a 5 kHz, 3 Vpp with -2.5Vdc offset is repeated below:

```
"APPL:SIN 5.0E+3, 3.0, -2.5"
```

APPLy:SQUare

[SOURCE:]APPLy:SQUare [*<frequency>* [,*<amplitude>* [,*<offset>*]]] is used to output a square wave with the specified frequency, amplitude and dc offset. For example, a square wave with the same parameters as the syntax example is shown below:

```
"APPL:SQU 5.0E+3, 3.0, -2.5"
```

Comments

- **Square Wave Frequency and Possible Conflict with Duty Cycle:**
For output frequencies above 5 MHz, the duty cycle is limited to values between 40% and 60% (below 5 MHz, the range is 20% to 80%). The duty cycle is automatically adjusted if you select a frequency that is not valid with the present duty cycle. For example, if you set the duty cycle to 70% and then change the frequency to 8 MHz, the function generator will automatically adjust the duty cycle to 60% (the upper limit for this frequency). A -221 "Settings conflict" error is also generated.

APPLy:TRIangle

[SOURCE:]APPLy:TRIangle [*<frequency>* [,*<amplitude>* [,*<offset>*]]] is used to output a triangle wave with the specified frequency, amplitude and dc offset. For example, a triangle wave with the same parameters as the syntax example is shown below:

```
"APPL:TRI 5.0E+3, 3.0, -2.5"
```

APPLy:USER

[SOURCE:]APPLy:USER [*<frequency>* [,*<amplitude>* [,*<offset>*]]] is used to output the arbitrary waveform currently selected by the FUNC:USER command. The waveform is output using the specified frequency, amplitude and dc offset.

Comments

- See [“Arbitrary Waveforms” on page 46](#). for more information on creating and downloading user-defined arbitrary waveforms to non-volatile memory.

APPLy?

[SOURCE:]APPLy? is used to query the function generator's present configuration and return a quoted string.

Comments

- The function, frequency, amplitude and offset voltage are returned as shown in the sample string below (the quotation marks are returned as part of the string):

```
"SIN +5.000000000000E+03,+3.000000E+00,-2.500000E+00"
```

BURST MODULATION COMMANDS

Use the APPLY command or the equivalent FUNC:SHAP, FREQ, VOLT, and VOLT:OFFS commands to configure the carrier waveform. Set the carrier frequency between 100 µHz and 5 MHz (100 kHz maximum for triangle and ramp). The default is 1 kHz.

BM:NCYCles

[SOURce:]BM:NCYCles <# cycles>|INFinity|MIN|MAX sets the number of cycles to be output per burst (counted burst mode only). Select from 1 cycle to 50,000 cycles, in 1 cycle increments. *The default is 1 cycle. MIN = 1 cycle. MAX = 50,000 cycles. [Stored in volatile memory]*

Comments

- For *sine*, *square*, and *arbitrary* waveforms (does not apply to ramp and triangle waveforms), the relationship between the carrier frequency and the minimum burst count is shown below.

Carrier Frequency	Minimum Burst Count
10 mHz to 1 MHz	1
>1 MHz to 2 MHz	2
>2 MHz to 3 MHz	3
>3 MHz to 4 MHz	4
>4 MHz to 5 MHz	5

- If you attempt to set the carrier frequency to a value that is not valid, the function generator will automatically adjust the frequency to the maximum value allowed with the present burst count. A -221, “Settings conflict” error is generated and the carrier frequency is adjusted.
- For *all waveforms* used with burst, if the carrier frequency is set less than or equal to 100 Hz, the following relationship applies.

$$\frac{\text{BurstCount}}{\text{CarrierFrequency}} \leq 500 \text{ seconds}$$

- If you attempt to set the carrier frequency to a value that is not valid, the function generator will automatically adjust the frequency to the minimum value allowed with the present burst count. A -221, “Settings conflict” error is generated and the frequency is automatically adjusted.

BM:NCYCles?

[SOURce:]BM:NCYCles? [MIN|MAX] queries the burst count. Returns an integer between 1 and 50,000, or +9.90000E+37 (in the case of INF).

BM:PHASe

[SOURCE:]BM:PHASe <degrees>|MIN|MAX sets the starting phase for the burst (counted burst mode only). Select from -360 degrees to +360 degrees, in 0.001 degree increments. *The default is 0 degrees.* MIN = -360 degrees. MAX = +360 degrees. [*Stored in volatile memory*]

Parameters

Parameter Name	Parameter Type	Range of Values	Default Units
<i>degrees</i>	numeric	-360 to +360	degrees

Comments

- For *sine*, *square*, *triangle*, and *ramp* waveforms, 0 degrees is the point at which the waveform crosses zero volts (or the dc offset value), in a positive-going direction. For *arbitrary* waveforms, 0 degrees is the first point downloaded to memory.

BM:PHASe?

[SOURCE:]BM:PHASe? [MIN|MAX] queries the starting phase. Returns a value in degrees.

BM:INTernal:RATE

[SOURCE:]BM:INTernal:RATE <frequency>|MIN|MAX sets the burst rate for internally triggered bursts (counted burst mode). The burst rate frequency defines the interval between bursts. Select from 10 mHz to 50 kHz. *The default is 100 Hz.* MIN = 10 mHz. MAX = 50 kHz. [*Stored in volatile memory*]

Parameters

Parameter Name	Parameter Type	Range of Values	Default Units
<i>frequency</i>	numeric	10E-03 to 50E+03	Hz

Comments

- The burst rate setting is used only when *internal* triggering is enabled (triggered mode). The burst rate is ignored when single triggering or external triggering is enabled.
- It is possible to specify a burst rate which is too fast for the function generator to output with the specified carrier frequency and burst count. If the burst rate is too high, the function generator will internally adjust it as needed to continuously re-trigger the burst. The adjustment is handled internally by the function generator (querying the burst rate returns the value specified not the adjusted to value).

BM:INTernal:RATE?

[SOURCE:]BM:INTernal:RATE? [MIN|MAX] queries the burst rate. Returns a value in hertz.

BM:SOURce

[SOURCE:]BM:SOURce INTernal|EXTernal selects the burst modulation source. In the *external gated burst* mode, the output waveform is either “on” or “off” based on the level of the signal applied to the front-panel *Ext Trig* terminal or VXIbus TTLTRG line selected by TRIG:SOUR). *The default is INT.* [*Stored in volatile memory*]

Comments

- When the *internal* burst source is selected, the external gated mode is disabled.
- When the *external gate* source is selected, the output is enabled or disabled based on the logic level of the gate signal applied to the *Ext Trig* terminal. When the gate signal is true (TTL high), the function generator outputs a continuous waveform. When the gate signal is false (TTL low), the output is turned off (zero volts or the dc offset level).
- When the *external gate* source is selected, the burst count, burst rate, burst phase, and burst trigger source are ignored (these parameters are used for the counted burst mode only).

BM:SOURce?

[SOURCE:]BM:SOURce? queries the present burst modulation source. Returns “INT” or “EXT”.

BM:STATe

[SOURCE:]BM:STATe OFF|ON disables or enables burst modulation. To ensure proper operation, you should enable the burst mode *after* you have set up the other modulation parameters. Only one modulation mode can be enabled at a time. When you enable the burst mode, the previous modulation mode is turned off.

BM:STATe?

[SOURCE:]BM:STATe? queries the state of burst modulation. Returns “0” (OFF) or “1” (ON).

FM COMMANDS

Use the APPLY command or the equivalent FUNC:SHAP, FREQ, VOLT, and VOLT:OFFS commands to configure the carrier waveform. Set the carrier frequency

between 100 μ Hz and 15 MHz (100 kHz maximum for triangle and ramp). The default is 1 kHz.

FM:DEVIation

[SOURCE:]FM:DEVIation <peak deviation in Hz>|MIN|MAX sets the peak frequency deviation in hertz. This value represents the variation in frequency of the modulating waveform from the carrier frequency. Select from 10 mHz to 7.5 MHz. *The default is 100 Hz.*

MIN = 10 mHz. MAX = 7.5 MHz. [*Stored in volatile memory*]

Parameters

Parameter Name	Parameter Type	Range of Values	Default Units
<i>frequency</i>	numeric	10E-03 to 7.5E+06	Hz

Comments

- The *carrier frequency* must always be greater than or equal to the peak frequency deviation. If you attempt to set the deviation to a value greater than the carrier frequency (with FM enabled), the function generator will automatically adjust the deviation to equal the present carrier frequency. A -221, “Settings conflict” error is generated and the deviation is adjusted.
- The sum of the *carrier frequency* and peak frequency deviation must be less than or equal to the maximum frequency for the selected function *plus 100 kHz* (15.1 MHz for sine and square, 200 kHz for triangle and ramp, and 5.1 MHz for arbitrary waveforms). If you attempt to set the deviation to a value that is not valid, the function generator will automatically adjust the deviation to the maximum value allowed with the present carrier frequency. A -221, “Settings conflict” error is generated and the deviation is adjusted.

FM:DEVIation?

[SOURCE:]FM:DEVIation? [MIN|MAX] queries the peak frequency deviation. Returns a value in hertz.

FM:INTernal:FREQUENCY

[SOURCE:]FM:INTernal:FREQUENCY <frequency>|MIN |MAX sets the frequency of the *modulating* waveform. Select from 10 mHz to 10 kHz. *The default is 10 Hz.* MIN = 10 mHz. MAX = 10 kHz. [*Stored in volatile memory*]

Parameters

Parameter Name	Parameter Type	Range of Values	Default Units
<i>frequency</i>	numeric	10E-03 to 10E+03	Hz

FM:INTernal:FREQuency?

[SOURCE:]FM:INTernal:FREQuency? [MIN|MAX] queries the modulating frequency. Returns a value in hertz.

FM:INTernal:FUNcTion

[SOURCE:]FM:INTernal:FUNcTion SIN|SQU|TRI|RAMP |NOIS |USER selects the shape of the *modulating* waveform. You can use the noise function as the modulating waveform. However, you *cannot* use the noise function or dc volts as the carrier waveform. *The default is SINusoid.* [*Stored in volatile memory*]

FM:INTernal:FUNcTion?

[SOURCE:]FM:INTernal:FUNcTion? queries the shape of the modulating waveform. Returns “SIN”, “SQU”, “TRI”, “RAMP”, “NOIS”, or “USER”.

FM:STATe

[SOURCE:]FM:STATe OFF|ON disables or enables Frequency Modulation. To ensure proper operation, you should enable FM *after* you have set up the other modulation parameters. Only one modulation mode can be enabled at a time. When you enable FM, the previous modulation mode is turned off.

FM:STATe?

[SOURCE:]FM:STATe? queries the state of FM. Returns “0” (OFF) or “1” (ON).

FREQuency

[SOURCE:]FREQuency <frequency>|MIN|MAX sets the output frequency. MIN selects the lowest frequency allowed for the currently active function. MAX selects the highest frequency allowed for the currently active function. *The default frequency is 1 kHz for all functions.* *Stored in volatile memory.*

Parameters

Parameter Name	Parameter Type	Function	Minimum Frequency	Maximum Frequency	Default Units
frequency	numeric	Sine	100 μ Hz	15 MHz	Hz
		Square	100 μ Hz	15 MHz	Hz
		Built-In Arb	100 μ Hz	5 MHz	Hz
		Ramp	100 μ Hz	100 kHz	Hz
		Triangle	100 μ Hz	100 kHz	Hz

Comments

- For *arbitrary waveforms* that you create and download to memory, the maximum frequency depends on the number of points specified in the waveform. As shown below, the maximum output frequency decreases as you specify more points in the waveform. The five built-in arbitrary waveforms can be output at a maximum of 5 MHz.

Number of Arb Points	Minimum Frequency	Maximum Frequency
8 to 8,192 (8K)	100 μ Hz	5 MHz
8,193 to 12,787 (12K)	100 μ Hz	2.5 MHz
12,288 to 16,000	100 μ Hz	200 KHz

- *Possible Conflict with Function Change*: The output frequency is automatically adjusted if you select a function whose maximum frequency is *less than* that of the currently active function. For example, if you output a 1 MHz sine wave and then change the function to triangle wave, the function generator will adjust the output to 100 kHz (the upper limit for triangle waves). A -221, “Settings conflict” error is generated and the frequency is adjusted.

FREQuency?

[SOURce:]FREQuency? [MIN|MAX] queries the frequency setting for the function currently active. Returns a value in hertz.

FREQuency:START

[SOURce:]FREQuency:START <frequency>|MIN|MAX sets the start frequency. Select from 10 mHz to 15 MHz (100 kHz for triangle and ramp). The sweep is phase continuous over the full frequency range. *The default is 100 Hz.* MIN = 10 mHz. MAX = 15 MHz. *The start frequency setting is stored in volatile memory.*

Parameters

Parameter Name	Parameter Type	Range of Values	Default Units
<i>frequency</i>	numeric	10E-03 to 15E+06	Hz

FREQUENCY:START?

[SOURCE:]FREQUENCY:START? [MIN|MAX] queries the start frequency. Returns a value in hertz.

FREQUENCY:STOP

[SOURCE:]FREQUENCY:STOP <frequency> [MIN|MAX] sets the stop frequency. Select from 10 mHz to 15 MHz (100 kHz for triangle and ramp). The sweep is phase continuous over the full frequency range. *The default is 1 kHz.* MIN = 10 mHz. MAX = 15 MHz. [*Stored in volatile memory*]

Parameters

Parameter Name	Parameter Type	Range of Values	Default Units
<i>frequency</i>	numeric	10E-03 to 15E+06	Hz

FREQUENCY:STOP?

[SOURCE:]FREQUENCY:STOP? [MIN|MAX] queries the stop frequency. Returns a value in hertz.

Frequency-Shift Keying (FSK) Commands

Use the APPLY command or the equivalent FUNC:SHAP, FREQ, VOLT, and VOLT:OFFS commands to configure the carrier waveform. Set the carrier frequency between 100 μ Hz and 15 MHz (100 kHz maximum for triangle and ramp). The default is 1 kHz.

FSKey:FREQuency

[SOURce:]FSKey:FREQuency <frequency>|MIN|MAX sets the FSK “hop” frequency. Select from 10 mHz to 15 MHz (100 kHz for triangle and ramp). *The default is 100 Hz. MIN = 10 mHz. MAX = 15 MHz. The FSK frequency setting is stored in volatile memory.*

Parameters

Parameter Name	Parameter Type	Range of Values	Default Units
<i>frequency</i>	numeric	10E-03 to 15E+06	Hz

FSKey:FREQuency?

[SOURce:]FSKey:FREQuency? [MIN|MAX] queries the FSK “hop” frequency. Returns a value in hertz.

FSKey:INTernal:RATE

[SOURce:]FSKey:INTernal:RATE <rate in Hz>|MIN|MAX sets the rate at which the output frequency “shifts” between the carrier and hop frequency (FSK:SOUR INT only). Select from 10 mHz to 50 kHz. *The default is 10 Hz. MIN = 10 mHz. MAX = 50 kHz. The FSK internal rate setting is stored in volatile memory.*

Parameters

Parameter Name	Parameter Type	Range of Values	Default Units
<i>rate</i>	numeric	10E-03 to 50E+03	Hz

Comments

- *The FSK rate is ignored when the external source is selected (FSK:SOUR EXT).*

FSKey:INTernal:RATE?

[SOURce:]FSKey:INTernal:RATE? [MIN|MAX] queries the FSK rate. Returns a value in hertz.

FSKey:SOURce

[SOURce:]FSKey:SOURce INTernal|EXTernal selects an internal or external FSK source. *The default is INT. [Stored in volatile memory]*

Comments

- *When the internal source is selected, the rate at which the output frequency “shifts” between the carrier frequency and hop frequency is determined by the FSK rate specified (FSK:INT:RATE).*

- When the *external* source is selected, the output frequency is determined by the signal level on the source selected by the TRIG:SOUR command. When a “low” TTL level is present, the carrier frequency is output. When a “high” TTL level is present, the hop frequency is output.
- The maximum external FSK rate is 1 MHz.

FSKey:SOURce?

[SOURce:]FSKey:SOURce? queries the internal FSK source. Returns “INT” or “EXT”.

FSKey:STATe

[SOURce:]FSKey:STATe OFF|ON disables or enables FSK modulation. To ensure proper operation, you should enable FSK *after* you have set up the other modulation parameters. Only one modulation mode can be enabled at a time. When you enable FSK, the previous modulation mode is turned off.

FSKey:STATe?

[SOURce:]FSKey:STATe? queries the state of the FSK mode. Returns “0” (OFF) or “1” (ON).

Selecting an Arbitrary Waveform

FUNCTION:USER

[SOURce:]FUNCTION:USER <arb name>|VOLATILE selects one of the five built-in arbitrary waveforms, one of four user-defined waveforms, or the waveform currently downloaded to VOLATILE memory.

Parameters

- The arb name may contain up to 8 characters. The first character *must* be a letter (A-Z), but the remaining characters can be numbers (0-9) or the underscore character (“_”). Blank spaces are not allowed. If you specify a name with more than 8 characters, a +783, “Arb waveform name too long” error is generated.
- The function generator *does not* distinguish between upper- and lower-case letters for the arbitrary waveform name. Therefore, **ARB_1** and **arb_1** are the same name. All characters are converted to upper case.

Comments

- The names of the five built-in arbitrary waveforms are:
“SINC”
“NEG_RAMP”
“EXP_RISE”
“EXP_FALL”
“CARDIAC”
- To select the waveform currently stored in volatile memory, specify the VOLATILE parameter. The keyword “VOLATILE” does not have a short form. The correct syntax is: "FUNC:USER VOLATILE"
- The FUNC:USER command *does not* output the selected waveform. Use the FUNC:SHAP USER command to output the waveform.
- If you select an arbitrary waveform name that is not currently downloaded, a +785, “*Specified arb waveform does not exist*” error is generated.
- Use the DATA:CAT? command to list the names of the five built-in waveforms (non-volatile), “VOLATILE” if a waveform is currently downloaded to volatile memory, and the names of any user-defined waveforms (non-volatile).

Example The following statement shows how to use the FUNC:USER command:
"FUNC:USER NEG_RAMP"

FUNCTION:USER?

[SOURCE:]FUNCTION:USER? queries the arbitrary waveform currently selected. Returns “SINC”, “NEG_RAMP”, “EXP_RISE”, “EXP_FALL”, “CARDIAC”, “VOLATILE”, or the name of any user-defined waveforms in non-volatile memory.

FUNCTION:SHAPE

[SOURCE:]FUNCTION:SHAPE SIN|SQU|TRI|RAMP|NOIS|DC|USER selects the function specified. The USER parameter will output the arbitrary waveform currently selected by the FUNC:USER command. The specified waveform is output using the previously selected frequency, amplitude, and offset settings.

Comments

- Use the FREQ, VOLT, and VOLT:OFFS commands to select the frequency, amplitude, and offset of the waveform. Or, use the APPLY command to select the function, frequency, amplitude, and offset with a single command.
- As shown in the following table, you can use the arbitrary waveform function with all of the modulation modes. Each “X” indicates a valid combination.

	Sine	Square	Triangle	Ramp	Noise	Arb
AM Carrier	X	X	X	X		X
AM Modulating Wave	X	X	X	X	X	X
FM Carrier	X	X	X	X		X
FM Modulating Wave	X	X	X	X	X	X
FSK Modulation	X	X	X	X		X
Burst Modulation	X	X	X	X		X
Frequency Sweep	X	X	X	X		X

- For arbitrary waveforms, the maximum amplitude will be limited if the data points do not span the full range of the output DAC (Digital- to-Analog Converter). For example, the built-in “SINC” waveform does not use the full range of values between ± 1 and therefore its maximum amplitude is 6.084 Vpp (into 50 ohms).
- For arbitrary waveforms an inherent offset may be present (if the average of the waveform is not equal to zero). The function generator calculates the average of the data points and compares the average to zero volts. If the average is not within two DAC (Digital-to-Analog Converter) counts of zero volts, an inherent offset is present.

FUNCTION:SHAPE?

[SOURCE:]FUNCTION:SHAPE? queries the output function. Returns “SIN”, “SQU”, “TRI”, “RAMP”, “NOIS”, “DC”, or “USER”.

PULSE:DCYCLE

[SOURCE:]PULSE:DCYCLE <percent>|MIN|MAX sets the duty cycle in percent for *square waves only*. Duty cycle represents the amount of time per cycle that the square wave is high. *The default is 50%.* [Stored in volatile memory]

Parameters

Parameter Name	Parameter Type	Range of Values	Default Units
<i>percent</i>	numeric	20 to 80 (see comments)	percent

Comments

- Duty cycle: 20% to 80%, in 1% increments (*frequency \leq 5 MHz*).
40% to 60%, in 1% increments (*frequency > 5 MHz*).
The default is 50%.
- The duty cycle setting is remembered when you change from square wave to another function. When you return to the square wave function, the previous duty cycle is used. The APPLY command automatically sets the duty cycle to

50% for square waves.

- *Possible Conflict with Output Frequency:* The duty cycle is automatically adjusted if you select a frequency that is not valid with the present duty cycle. For example, if you set the duty cycle to 70% and then change the frequency to 8 MHz, the function generator will automatically adjust the duty cycle to 60% (the upper limit for this frequency). A -221, “Settings conflict” error is generated and the duty cycle is adjusted.

PULSe:DCYCLE?

[SOURce:]PULSe:DCYCLE? [MIN|MAX] queries the duty cycle setting. Returns a value in percent.

SWEep:SPACing

[SOURce:]SWEep:SPACing LINear|LOGarithmic selects linear or logarithmic spacing for the sweep. *The default is Linear. [Stored in volatile memory]*

SWEep:SPACing?

[SOURce:]SWEep:SPACing? queries the sweep mode. Returns “LIN” or “LOG”.

SWEep:TIME

[SOURce:]SWEep:TIME <time>|MIN|MAX sets the number of seconds required to sweep from the start frequency to the stop frequency. Select from 1 ms to 500 seconds. *The default is 1 second. MIN = 1 ms. MAX = 500 seconds. The sweep time setting is stored in volatile memory.*

Parameters

Parameter Name	Parameter Type	Range of Values	Default Units
<i>time</i>	numeric	1 ms to 500 sec	seconds

Comments

- The number of frequency points in the sweep depends on the sweep time you select and is automatically calculated by the function generator.

SWEep:TIME?

[SOURce:]SWEep:TIME? [MIN|MAX] queries the sweep time. Returns a value with units of seconds.

SWEEp:STATe

[SOURce:]SWEEp:STATe OFF|ON disables or enables the sweep mode. To ensure proper operation, you should enable the sweep mode *after* you have set up the other sweep parameters. Only one modulation mode can be enabled at a time. When you enable the sweep mode, the previous modulation mode is turned off.

SWEEp:STATe?

[SOURce:]SWEEp:STATe? queries the state of the sweep mode. Returns “0” (OFF) or “1” (ON).

VOLTage

[SOURce:]VOLTage <amplitude>|MIN|MAX sets the output amplitude for the currently active function. MIN selects the smallest amplitude allowed for the selected function (50 mVpp into 50 ohms). MAX selects the largest amplitude allowed (10 Vpp into 50 ohms). *The default amplitude is 100 mVpp (into 50 ohms).* [Stored in volatile memory]

Parameters

Parameter Name	Parameter Type	Function	Output Termination	Minimum Amplitude	Maximum Amplitude	Default Units
amplitude	numeric	Sine	50Ω	50 mVpp	10 Vpp	Vpp
		Square	50Ω	50 mVpp	10 Vpp	
		Triangle	50Ω	50 mVpp	10 Vpp	
		Ramp	50Ω	50 mVpp	10 Vpp	
		Noise	50Ω	50 mVpp	10 Vpp	
		Built-In Arbs	50Ω	50 mVpp	10 Vpp	
amplitude	numeric	Sine	Open Circuit	100 mVpp	20 Vpp	Vpp
		Square	Open Circuit	100 mVpp	20 Vpp	
		Triangle	Open Circuit	100 mVpp	20 Vpp	
		Ramp	Open Circuit	100 mVpp	20 Vpp	
		Noise	Open Circuit	100 mVpp	20 Vpp	
		Built-In Arbs	Open Circuit	100 mVpp	20 Vpp	

Comments

- For *arbitrary waveforms*, the maximum amplitude will be limited if the data points do not span the full range of the output DAC (Digital-to-Analog Converter). For example, the built-in “SINC” waveform does not use the full range of values between ± 1 and therefore its maximum amplitude is 6.084 Vpp (into 50 ohms).

- You can set the units for output amplitude to Vpp, Vrms, or dBm. *See the VOLT:UNIT command for more information.*
- For *dc volts*, the output level is actually controlled by setting the offset voltage. You can set the dc voltage to any value between ± 5 Vdc into 50 ohms or ± 10 Vdc into an open circuit. *See the VOLT:OFFS command for more information.*
- *Possible Conflict with Function Change:* The output amplitude is automatically adjusted if you select a function whose maximum amplitude is *less than* that of the currently active function. This conflict may arise when the output units are *Vrms* or *dBm* due to the differences in crest factor for the output functions. For example, if you output a 5 Vrms square wave (into 50 ohms) and then change the function to sine wave, the function generator will adjust the output amplitude to 3.535 Vrms (the upper limit for sine waves in Vrms). A-221, “Settings conflict” error is generated and the amplitude is adjusted.
- *Output Amplitude and Output Termination:* The output amplitude is automatically adjusted (and no error is generated) if you change the output termination. For example, if you set the amplitude to 10 Vpp and then change the termination from 50 ohms to “high impedance”, the amplitude will *double* to 20 Vpp. If you change from “high impedance” to 50 ohms, the amplitude will drop in half. *See the OUTP:LOAD command for more information.*

VOLTage?

[SOURce:]VOLTage? [MIN|MAX] queries the output amplitude for the currently selected function. Returns the magnitude of the output amplitude. Units are not returned but are in the units set by the most recent VOLT:UNIT command.

VOLTage:OFFSet

[SOURce:]VOLTage:OFFSet <offset>|MIN|MAX sets the dc offset voltage for the currently active function. MIN selects the smallest dc offset voltage for the selected function (0 volts). MAX selects the largest offset for the selected function. *The default offset voltage is 0 volts for all functions. The offset voltage setting is stored in volatile memory.*

Parameters

Parameter Name	Parameter Type	Range of Values	Default Units
<i>offset</i>	numeric	0V to MAX (see comments)	Vdc

Comments

- You can set the offset to a positive or negative number with the restrictions shown below. If the specified offset voltage is not valid, the function generator will automatically adjust it to the maximum dc voltage allowed with the present amplitude. (*Vmax* is the maximum peak-to-peak amplitude for the

selected output termination; V_{pp} is the output amplitude in volts peak-to-peak.) A -221, “Settings conflict” error is generated and the offset is adjusted.

$$|V_{offset}| + \frac{V_{pp}}{2} \leq V_{max} \quad \text{and} \quad |V_{offset}| \leq 2V_{pp}$$

- **DC Offset and Output Termination:** The offset voltage is automatically adjusted (and no error is generated) if you change the output termination. For example, if you set the offset to 100 mVdc and then change the termination from 50 ohms to “high impedance”, the offset will *double* to 200 mVdc. If you change from “high impedance” to 50 ohms, the offset will drop in half. *See the OUP:LOAD command for more information.*
- For *dc volts*, the output level is actually controlled by setting the offset voltage. You can set the dc voltage to any value between ± 5 Vdc into 50 ohms or ± 10 Vdc into an open circuit.

VOLTage:OFFSet?

[SOURCE:]VOLTage:OFFSet? [MIN|MAX] queries the dc offset voltage for the currently selected function. Returns a value in dc volts.

VOLTage:UNIT

[SOURCE:]VOLTage:UNIT VPP|VRMS|DBM|DEF selects the output units for amplitude only (does not affect offset). The default is VPP. [Stored in volatile memory]

VOLTage:UNIT?

[SOURCE:]VOLTage:UNIT? queries the units selected. Returns “VPP”, “VRMS”, or “DBM”.

STATus

The STATus subsystem reports the bit values of the Questionable Data/Signal Register. It also allows you to unmask the bits you want reported from the Standard Event Register and to read the summary bits from the Status Byte Register.

The Questionable Data/Signal Register group consists of a condition register, and event register and an enable register. The commands in the STATus:QUEStionable subsystem control and monitor these registers.

Subsystem Syntax

```
STATus
:PRESet
:QUEStionable
[:EVENT]?
:CONDition?
:ENABle <unmask>
:ENABle?
```

Comments

- The STATus system contains four registers, two of which are under IEEE 488.2 control; the Standard Event Status Register (*ESE?) and the Status Byte Register (*STB?). The Operational Status bit (OPR), Service Request bit (RSQ), Standard Event summary bit (ESB), Message Available bit (MAV) and Questionable Data bit (QUE) in the Status Byte Register (bits 7, 6, 5, 4 and 3 respectively) can be queried with the *STB? command. Use the *ESE? command to query the "unmask" value for the Standard Event Status Register (the bits you want logically OR'd into the summary bit). The registers are queried using decimal weighted bit values. See Figure 3-1 on page 119.

:PRESet

STATus:PRESet command affects only the enable register by setting all enable register bits to 0. It does not affect either the "status byte" or the "standard event status". PRESet does not clear any of the event registers.

:QUEStionable :CONDition?

STATus:QUEStionable:CONDition? returns a decimal-weighted number representing the bits set in the Questionable Data condition register.

:QUEStionable [:EVENT]?

STATus:QUEStionable[:EVENT]? returns a decimal-weighted number representing the bits set in the Questionable Data/Signal Register's event register. This command clears all bits in the event register when executed.

:QUESTionable :ENABLE

STATus:QUESTionable:ENABLE <unmask> enables (unmasks) bits in the Questionable Data/Signal Register's enable register to be reported to the summary bit (setting Status Byte Register bit 3 true). The event register bits are not reported in the Status Bytes Register unless specifically enabled.

:QUESTionable :ENABLE?

STATus:QUESTionable:ENABLE? returns a decimal-weighted number representing the bits enabled in the Questionable Data/Signal Register's enable register signifying which bits will set QUE in the Status Byte.

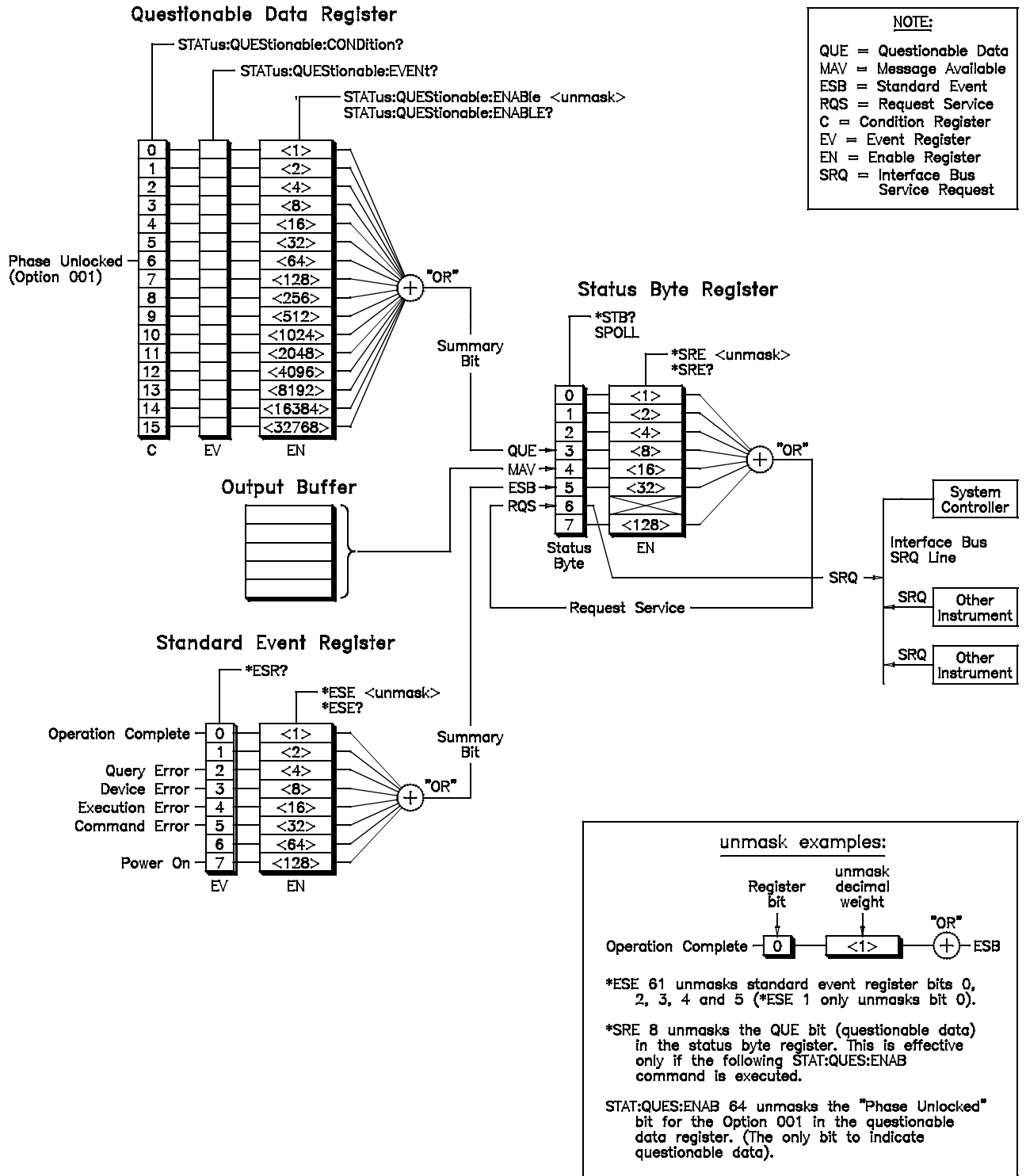

Figure 3-1.

SYSTem

The SYSTem command subsystem returns error numbers and their associated messages from the error queue. You can also query the SCPI version to which this instrument complies.

Subsystem Syntax SYSTem
 :ERRor?
 :VERSion?

:ERRor?

SYSTem:ERRor? returns the error numbers and corresponding error messages in the error queue. See Appendix B in this manual for a listing of the error numbers, messages and descriptions.

- Comments**
- When an error is generated by the function generator, it stores an error number and corresponding message in the error queue.
 - One error is removed from the error queue each time the SYSTem:ERRor? command is executed. The errors are cleared in a first-in, first-out (FIFO) order. This means that if several errors are waiting in the queue, each SYSTem:ERRor? query returns the oldest (not the most recent) error. That error is then removed from the queue.
 - When the error queue is empty, subsequent SYSTem:ERRor? queries return +0, "No error". To clear all errors from the queue, execute the *CLS command.
 - The error queue has a maximum capacity of 20 errors. If the queue overflows, the last error is replaced with -350, "Too many errors". No additional errors are accepted by the queue until space becomes available (until you remove some of the errors by reading them).

Example Reading the Error Queue

```
SYST:ERR?  
enter statement
```

*Query the error queue.
Enter readings into computer.*

:VERSion?

SYSTem:VERSion? returns the SCPI version number to which this instrument complies.

- Comments**
- The information returned is in the format "YYYY.R" where "YYYY" is the year and "R" is the revision number within that year.

TRIGger

Applies only to burst modulation, FSK, and frequency sweep. You can issue triggers for bursts and sweeps using an *immediate* trigger, an *external* trigger, or a *bus* trigger. For gated burst modulation and FSK, the external trigger source acts as a gate signal rather than a trigger signal. That is, while the signal source supplies a high level, the gated burst outputs, and the FSK "hop" frequency is output. While the "trigger" signal source is low, no burst is output, and FSK outputs its carrier frequency. The TRIGger command subsystem allows you to specify the source of the trigger as well as the polarity of the active edge.

NOTE that the default logical sense of the TTLTRG lines, as defined by the VXIbus standard, is *negative true*.

Subsystem Syntax

```
TRIGger
:SLOPe POSitive | NEGative
:SLOPe?
:SOURce BUS | EXTernal | IMMEDIATE | TTLTrg0-7
:SOURce?
```

:SLOPe

TRIGger:SLOPe Positive | NEGative selects the slope if the *trigger source* only. Where the external trigger sources are being used as a *gating signal* for Burst and FSK, TRIG:SLOPE will be ignored.

Parameters

POS: (*RST state) For TRIG:SOUR EXT (Ext Trig/FSK/Burst terminal); triggers on positive going TTL signal.
For TRIG:SOUR TTLT<0-7>; triggers on negative going signal on VXIbus TTLTRG line (ground true logic)

NEG: For TRIG:SOUR EXT (Ext Trig/FSK/Burst terminal); triggers on negative going TTL signal.
For TRIG:SOUR TTLT<0-7>; triggers on positive going signal on VXIbus TTLTRG line (+ true logic)

:SLOPe?

TRIGger:SLOPe? returns the currently set trigger slope.

Comments

- **Returns:** "POS" or "NEG"

:SOURce

TRIGger:SOURce BUS|EXTernal|IMMEDIATE|TTLTrg<n> selects the source from which the function generator will accept a trigger.

Parameters

- **BUS:** A software trigger; the Group Execute Trigger (GET) bus command or

the *TRG IEEE-488.2 common command.

- **EXT:** A hardware trigger input to the function generator's faceplate External Trigger ("Ext Trig") BNC connector. The trigger signal must have a pulse period greater than one (2) microseconds.
- **IMMediate:** The trigger system is always true (an internal trigger is always present and accepted upon issuing a trigger command).
- **TTLTrg0-7:** One of the eight VXibus trigger lines (TTLT0 through TTLT7)
- *The default trigger source is IMMediate. The trigger source setting is stored in volatile memory*

Comments

- When the *Immediate* (internal) source is selected, the function generator outputs continuously when the burst mode or sweep mode is enabled. The APPLY command automatically sets the trigger source to IMMediate.
- When the *External* source is selected, the function generator will accept a hardware trigger applied to the front-panel *Ext Trig* terminal. The function generator outputs one burst or initiates one sweep each time each time *Ext Trig* receives the edge of a TTL pulse (polarity set by TRIG:SLOPE). For FSK and Gated Burst mode, the level of the signal on *Ext Trig* gates the FSK "hop" frequency, or gates the burst signal on or off (TRIG:SLOPE has no effect on the gating sense).
- Except for its actual polarity always being the reverse of the *Ext Trig* input, the TTLTrg<0-7> lines control the function generator in the same way as described above in *External*.
- When the *Bus* (software) source is selected, the function generator outputs one burst or initiates one sweep each time a bus trigger command is received. BUS only applies to functions that are truly triggered (counted bursts and frequency sweeps), not to gated functions (gated bursts and FSK). To trigger the function generator, send a VXibus trigger (TTLT0-7) or use the *TRG (trigger) command. *You can also trigger the function generator from the GPIB interface by sending the IEEE-488 Group Execute Trigger (GET) message (e.g., TRIGGER 70911).*
- Send the *WAI (wait) command to ensure synchronization when the *Bus* source is selected. The function generator waits for all pending operations to complete following the *WAI command before it executes any additional commands. For example, the following command string guarantees that the first trigger is accepted and executed before the second trigger is recognized.

```
"TRIG:SOUR BUS;*TRG;*WAI;*TRG;*WAI"
```

- You can use the *OPC? (operation complete query) command or the *OPC (operation complete) command to signal when the burst or sweep is complete. The *OPC? command returns "1" to the output buffer when the burst or sweep is complete. The *OPC command sets the "operation complete" bit (bit 0) in the Standard Event register when the burst or sweep is complete.
- For FSK operation, the trigger sources of "IMM" and "BUS" will actually use

the external trigger faceplate BNC connector.

- **Related Commands:**

- ***RST Condition:** TRIG:SOUR IMM

Example Setting an External Trigger Source to Trigger a 5V peak-to-peak, 5 Second Logarithmic Sweep from 2 MHz to 10 MHz for Each External Trigger:

```
APPL:SIN 2E06,5
FREQ:STAR 2E06
FREQ:STOP 1E07
SWE:TIME 5
SWE:SPAC LOG
TRIG:SOUR EXT
SWE:STAT ON
```

*Function: 2 MHz, 5 Vpp sinewave (0V offset).
Sweep start frequency = 2 MHz.
Sweep stop frequency = 10 MHz.
Sweep time = 5 seconds.
Sweep spacing is logarithmic.
Trigger source is "Ext Trig" BNC on front panel.
Sweep state is enabled.*

:SOURce?

TRIGger:SOURce? queries the present trigger source setting. Returns “IMM”, “EXT”, or “BUS”.The quoted string is sent to the output buffer.

Example Querying the Trigger Source

```
TRIG:SOUR EXT
TRIG:SOUR?
enter statement
```

*Trigger source is external BNC on function generator front panel.
Query function generator to return trigger source setting.
Enter quoted string into computer.*

IEEE 488.2 Common Command Reference

The following table lists the IEEE 488.2 Common (*) Commands listed by functional group that can be executed by the Agilent E1441A Function / Arbitrary Waveform Generator. However, commands are listed alphabetically in the reference. Examples are shown in the reference when the command has parameters or returns a non-trivial response; otherwise, the command string is as shown in the table. For additional information, refer to IEEE Standard 488.2-1987.

Category	Command	Title	Description
System Data	*IDN?	Identification	Returns the identification string and function generator firmware versions. HEWLETT-PACKARD,E1441A,0,A.0x.0x-A.0x.0x
	*OPT?	Option query	Returns "1:PLL" if the phase-lock option 001 is present.
Internal Operations	*RCL	Recall state from memory	Recalls the specified stored instrument configuration state (one of four).
	*RST	Reset	Resets the function generator to the settings shown in the "Power-On and Reset State" table following the individual common command descriptions.
	*SAV	Save state to memory	Saves the present instrument configuration state in the specified memory location (one of four locations).
Internal Operations	*TST?	Self-Test	Returns "0" if self-test passes. Returns "1" if self-test fails. Use SYST:ERR? to retrieve the error from the function generator. See "Self-Test Errors" in Appendix B for a complete list of error numbers and their description. Return function generator to Agilent Technologies for repair if repair is required.
Synchronization	*OPC	Operation Complete	Operation Complete Command
	*OPC?	Operation Complete Query	Operation Complete Query
	*WAI	Wait to Complete	Wait-to-Continue Command
Status & Event	*CLS	Clear Status	Clear Status Command
	*ESE <mask>	Event Status Enable	Standard Event Status Enable Command
	*ESE?	Event Status Enable Query	Standard Event Status Enable Query
	*ESR?	Event Status Register Query	Standard Event Status Register Query
	*SRE <mask>	Service Request Enable	Service Request Enable Command
	*SRE?>	Service Request Enable Query	Service Request Enable Query
	*STB?	Read Status Byte Query	Read Status Byte Query
Bus Operation	*TRG	Bus Trigger	When the function generator is in the wait-for-trigger state and the trigger source is TRIGger:SOURce BUS use *TRG to trigger the function generator.

Figure 3-2.

*CLS

***CLS** clears the Standard Event Status Register, the Operation Status Register, the Questionable Signal Register and the error queue. This clears the corresponding summary bits (3, 5, and 7) in the Status Byte Register. ***CLS** does not affect the enable masks of any of the Status Registers.

- Comments**
- **Coupled command:** No
 - **Related Commands:** STATus:PRESet
 - ***RST Condition:** none

*ESE

***ESE <unmask>** enables one or more event bits of the Standard Event Status Register to be reported in bit 5 (the Standard Event Status Summary Bit) of the Status Byte Register. *unmask* is the sum of the decimal weights of the bits to be enabled.

The query form returns the current enable mask.

Parameters

ParameterName	ParameterType	Range of Values	Default Units
<i>unmask</i>	numeric	0 through 255	none

A 1 in a bit position enables the corresponding event; a 0 disables it.

- Comments**
- **Coupled command:** No
 - **Related Commands:** *ESR?, *SRE, *STB?
 - ***RST Condition:** unaffected
 - **Power-On Condition:** no events are enabled

Example Enable all error events

*ESE 60

Enable error events

*ESE?

***ESE?** queries the current setting of the Event Status Enable mask register.

*ESR?

***ESR?** returns the value of the Standard Event Status Register. The register is then cleared (all bits 0).

- Comments**
- **Coupled command:** No
 - ***RST Condition:** none
 - **Power-On Condition:** register is cleared

*IDN?

***IDN?** returns identification information for the Agilent E1441A. The response consists of four fields:

HEWLETT-PACKARD,E1441A,0,A.01.00-A.01.09

The first two fields identify this instrument as model number Agilent E1441A manufactured by Agilent Technologies (Agilent spun off of HP in November 1999; firmware will still say Hewlett-Packard). The third field is 0 since the serial number of the Agilent E1441A is unknown to the firmware. The last field indicates the revision level of the inguard-outguard firmware.

Note The firmware revision field will change whenever the firmware is revised. A.01.00-A.01.00 is the initial revision. The first two digits indicate the major revision number, and increment when functional changes are made. The last two digits indicate the functional fix level.

Comments

- **Coupled command:** No
- ***RST Condition:** none
- **Power-On Condition:** register is cleared

*OPC

***OPC** causes the Agilent E1441A to wait for all pending operations to complete. The Operation Complete bit (bit 0) in the Standard Event Status Register is then set.

Comments

- **Coupled command:** No
- **Related commands:** *OPC?, *WAI
- ***RST Condition:** none

*OPC?

***OPC?** causes the Agilent E1441A to wait for all pending operations to complete. A single ASCII "1" is then placed in the output queue.

Comments

- **Coupled command:** No
- **Related commands:** *OPC, *WAI
- ***RST Condition:** none

*OPT? (option 001)

***OPT?** queries the presence of the Phase-Lock option (option 001). Returns "1:PLL" if the option is present or "0" if the option is not present. The "10 MHz Ref" In and Out BNC connectors accompany this option.

*PSC

***PSC 0 | 1** enables/disables power-on status clear. Clears the Status Byte and Standard Event register enable masks when power is turned on (*PSC 1). When *PSC 0 is in effect, the Status Byte and Standard Event register enable masks are not cleared when power is turned on. The default setting is 1 (enabled to clear).

Note In order for the *PSC setting to remain in effect through a power failure, a *SAV 0 must be executed after the *PSC command.

*PSC?

***PSC?** queries the PSC setting. Returns "0" (*PSC 0) or "1" (*PSC 1).

*RCL

***RCL 0 | 1 | 2 | 3** recalls a previously stored instrument configuration. Four memory locations, 0, 1, 2 and 3, are available to store configurations.

Comments

- You cannot recall the instrument configuration from a memory location that was not previously specified as a storage location. For example, an error is generated if you attempt to recall from memory location "2" but have not saved to that location with the *SAV command. *A +810, "State has not been stored" error is generated if nothing is stored in the specified memory location you are trying to recall.*
- **Coupled command:** No
- **Related commands:** *SAV, MEMory:STATe:DELeTe
- ***RST Condition:** none

*RST

***RST** resets the Agilent E1441A as follows:

- Sets all commands to the power-on/reset state (see the table following these common commands or at the end of Chapter 2).
- Aborts all pending operations.

*RST does not affect:

- The output queue
- The Service Request and Standard Event Status Enable Registers
- The enable masks for the Questionable Signal Registers
- Calibration data

Comments

- **Coupled command:** No
- ***RST Condition:** none

*SAV

***SAV 0 | 1 | 2 | 3** saves up to four different instrument configurations. Four memory locations, 0, 1, 2 and 3, are available to store configurations. This configuration storage feature "remembers" the function (including arbitrary waveforms), frequency, amplitude, dc offset, duty cycle, as well as any modulation parameters.

Comments

- Configurations saved to location 0 are recalled when the function generator is powered-up.
- Any arbitrary waveforms downloaded to "VOLATILE" memory *are not* saved. However, if an arbitrary waveform is being output from non-volatile memory when the configuration is stored, the waveform data is stored. The stored waveform is output when its correspond- ing instrument configuration is recalled.
- If you delete an arbitrary waveform after storing a configuration containing that waveform, the waveform data is lost and the function generator will output the "SINC" built-in arbitrary waveform when the corresponding configuration is recalled.
- **Coupled command:** No
- **Related commands:** *RCL, MEMory:STATe:DELeTe
- ***RST Condition:** none

*SRE

***SRE <unmask>** specifies which bits of the Status Byte Register are enabled to generate a IEEE-488.1 service request. Event and summary bits are always set and cleared in the Status Byte Register regardless of the enable mask. *unmask* is the sum of the decimal weights of the bits to be enabled.

The query form returns the current enable mask.

Parameters

Parameter Name	Parameter Type	Range of Values	Default Units
<i>unmask</i>	numeric	0 through 255	none

A 1 in a bit position enables service request generation when the corresponding Status Byte Register bit is set; a 0 disables it.

Comments

- **Coupled command:** No
- ***RST Condition:** unaffected
- **Power-On Condition:** no bits are enabled

Example Enable service request on Message Available bit

*SRE 16

Enable request on MAV

*SRE?

***SRE?** queries the Status Byte Enable register. The function generator returns a decimal value that corresponds to the binary-weighted sum of all bits set in the register.

*STB?

***STB?** returns the value of the Status Byte Register. Bit 6 (decimal weight 64) is set if a service request is pending.

- Comments**
- **Coupled command:** No
 - **Related commands:** *SRE
 - ***RST Condition:** none

*TRG

***TRG** causes the Agilent E1441A to trigger if the TRIG:SOUR is BUS. Triggers are used to start Burst Mode and Sweep Mode only.

- Comments**
- **Coupled command:** Yes
 - ***RST Condition:** TRIGger:SOURce IMMEDIATE

*TST?

***TST?** causes the Agilent E1441A to execute its internal self-test and returns a value indicating the results of the test.

A zero response indicates that the self-test passed. Any non-zero response indicates that the test failed. Use the SYST:ERR? command to read the error and description from the error queue. Note the error number and description returned in the error message. See Appendix B, Error Messages, for information on interpreting the error number and description response(s).

The settings for all SCPI commands are unchanged by this command.

- Comments**
- Sending a Device Clear interface command to the Agilent E1441A while self-test is executing may generate self-test errors.
 - **Coupled command:** No
 - ***RST Condition:** none

*WAI

***WAI** causes the Agilent E1441A to wait for all pending operations to complete before executing any further commands.

- Comments**
- **Related commands:** *OPC, *OPC?

Agilent E1441A Power-On and Reset State

Feature	Power-On and Reset State
Output Configuration	
Function	Sine wave
Frequency	1 kHz
Amplitude (into 50 ohms)	100 mV peak-to-peak
Offset	0.00 Vdc
Output Units	Volts peak-to-peak
Output Termination	50 ohms
Modulation	
AM Carrier Waveform	1 kHz Sine wave
AM Modulating Waveform	100 Hz Sine wave
AM Depth	100%
FM Carrier Waveform	1 kHz Sine wave
FM Modulating Waveform	10 Hz Sine wave
FM Peak Frequency Deviation	100 Hz
Burst Carrier Frequency	1 kHz Sine wave
Burst Count	1 cycle
Burst Rate	100 Hz
Burst Starting Phase	0 degrees
FSK Carrier Frequency	1 kHz Sine wave
FSK"Hop" Frequency	100 Hz Sine wave
FSK Rate	10 Hz
Modulation State	Off
Sweep Start / Stop Frequency	100 Hz / 1 kHz
Sweep Time	1 second
Sweep Mode	Linear
Triggering Operations	
Trigger Source	Internal
Calibration	
Calibration State	Does not change with *RST or power-down. See page 74

Note The power-on state will state will be different if you have enabled the auto-recall mode. See [“MEMory:STATe:RECall:AUTO OFF | ON | 0 | 1”](#) on page 85.

SCPI Command Quick Reference

The following tables summarize SCPI commands for the Agilent E1441A Function / Arbitrary Waveform Generator.

Command		Description
CALibration	:COUNt? :SECure:CODE <new code> :SECure:STATe 1 0 ON OFF, <code> :SECure:STATe? :STRing <quoted string> :STRing? :VALue <cal value> :VALue? :ZERO:AUTO 1 0 ON OFF :ZERO:AUTO?	Query number of cal operations. Enters a new security code. Enables/disables the security code. Queries the security state. Lets you store info about your calibration. Queries the cal string. Sets the calibration value. Queries the calibration value. Enable/disable autozero mode. Query autozero mode.
CALibration?		Initiates the calibration process using the cal valueset by CAL:VALue.
DATA	VOLATILE :DAC VOLATILE :ATTRibute:AVERAge? [<arb name>] :ATTRibute:CFACTOR? [<arb name>] :ATTRibute:POINts? [<arb name>] :ATTRibute:PTPeak? [<arb name>] :CATalog? :COPY <destination arb name> [,VOLATILE] :DELeTe <arb name> :DELeTe:ALL :NVOLatile:CATalog? :NVOLatile:FREE?	
FORMat	:BORDER NORMAl SWAPped :BORDER?	
MEMory	:STATe:DELeTe 0 1 2 3	
OUTPut	:LOAD 50 INFinity MIN MAX :LOAD? MIN MAX :SYNC OFF ON :SYNC? :TRIGger:IMMediate :TRIGger:STATe OFF ON :TRIGger:STATe? :TTLTrg<n>[:STATe] ON OFF :TTLTrg<n>[:STATe]?	Opt. 001: "Ext Trig" BNC output. Opt. 001: Enables/disables "Ext Trig". Opt. 001: Queries trigger state.
PHASe	:ADJust? :REFerence :UNLock:ERRor:STATe OFF ON :UNLock:ERRor:STATe?	Opt. 001: Query the phase offset setting. Opt. 001: Set zero-phase reference point. Opt. 001: Enable/disable error reporting. Opt. 001: Query error reporting state.

Command	Description
[SOURce:]	<p> AM:DEPTH <depth in percent> MIN MAX AM:DEPTH? [MIN MAX] AM:INTernal:FUNCTion SINusoid SQUare TRIangle RAMP NOISe USER AM:INTernal:FUNCTion? AM:INTernal:FREQuency <frequency> MIN MAX AM:INTernal:FREQuency? AM:SOURce BOTH EXTernal AM:SOURce? AM:STATe OFF ON AM:STATe? </p> <p> APPLy:SINusoid [<frequency>[,<amplitude>[,<offset>]]] APPLy:SQUare [<frequency>[,<amplitude>[,<offset>]]] APPLy:TRIangle [<frequency>[,<amplitude>[,<offset>]]] APPLy:RAMP [<frequency>[,<amplitude>[,<offset>]]] APPLy:NOISe [<frequency>[,<amplitude>[,<offset>]]] APPLy:DC [<frequency>[,<amplitude>[,<offset>]]] APPLy:USER [<frequency>[,<amplitude>[,<offset>]]] APPLy? </p> <p> BM:NCYCles <number of cycles> MIN MAX BM:NCYCles? [MIN MAX] BM:PHASe <degrees> MIN MAX BM:PHASe? [MIN MAX] BM:INTernal:RATE <frequency> MIN MAX BM:INTernal:RATE? [MIN MAX] BM:SOURce INTernal EXTernal BM:SOURce? BM:STATe OFF ON BM:STATe? </p> <p> FM:DEViation <peak deviation in Hz> MIN MAX FM:DEViation? [MIN MAX] FM:FUNCTion SINusoid SQUare TRIangle RAMP NOISe USER FM:FUNCTion? FM:INTernal:FREQuency <frequency> MIN MAX FM:INTernal:FREQuency? [MIN MAX] FM:STATe OFF ON FM:STATe? </p> <p> FREQuency <frequency> MIN MAX FREQuency? [MIN MAX] </p> <p> FREQuency:STARt <frequency> MIN MAX FREQuency:STARt? [MIN MAX] FREQuency:STOP <frequency> MIN MAX FREQuency:STOP? [MIN MAX] </p>

Command	Description
[SOURce:]	FSKey:FREQUency <frequency> MIN MAX FSKey:FREQUency? [MIN MAX] FSKey:INTernal:RATE <rate in Hz> MIN MAX FSKey:INTernal:RATE? [MIN MAX] FSKey:SOURce INTernal EXTernal FSKey:SOURce? FSKey:STATe OFF ON FSKey:STATe? FUNCtion:USER <arb name> VOLATILE FUNCtion:USER? FUNCtion[:SHAPe] USER FUNCtion[:SHAPe]? PULSe:DCYClE <percent> MIN MAX PULSe:DCYClE? [MIN MAX] SWEep:SPACing LINear LOGarithmic SWEep:SPACing? SWEep:TIME <seconds> MIN MAX SWEep:TIME? [MIN MAX] SWEep:STATe OFF ON SWEep:STATe? VOLTage <amplitude> MIN MAX VOLTage? [MIN MAX] VOLTage:OFFSet <offset> MIN MAX VOLTage:OFFSet? [MIN MAX] VOLTage:UNIT VPP VRMS DBM DEFault VOLTage:UNIT?
SYSTem	:ERRor? :VERSion?
TRIGger	:SLOPe POSitive NEGative :SLOPe? :SOURce BUS EXT IMM TTLT<0 - 7> :SOURce?

Appendix A

Agilent E1441A Specifications

Waveforms **Standard Waveforms:** Sine, Square, Triangle, Ramp, Noise, DC volts, Sine (x)/x, Negative Ramp, Exponential Rise, Exponential fall, Cardiac

Arbitrary Waveforms:
 Waveform Length: 8 to 16,000 points
 Amplitude Resolution: 12 bits (including sign)
 Sample Rate: 40 MSa / sec
 Non-Volatile Memory: Four (4) 16k waveforms

Frequency Characteristics **Sine:** 100 μ Hz - 15 MHz
Square: 100 μ Hz - 15 MHz
Triangle: 100 μ Hz - 100 kHz
Ramp: 100 μ Hz - 100 kHz
Noise (Gaussian): 10 MHz bandwidth
Arbitrary Waveforms:
 8 to 8,192 points 100 μ Hz - 5 MHz
 8,193 to 12,287 points 100 μ Hz - 2.5 MHz
 12,288 to 16,000 points 100 μ Hz to 200 kHz
Resolution: 10 μ Hz or 10 digits
Accuracy: 10 ppm in 90 days
 20 ppm in 1 year
 18° C - 28° C
Temperature Coefficient: <2 ppm/ ° C
Aging: <10 ppm/yr

Sinewave Spectral Purity **Harmonic Distortion**
 DC to 20 kHz: < -70 dBc
 20 kHz to 100 kHz: < -60 dBc
 100 kHz to 1 Mhz: < -45 dBc
 1 Mhz to 15 Mhz: < -35 dBc
Total Harmonic Distortion
 DC to 20 kHz: < 0.04%
 Spurious (non-harmonic)
 Output (DC to 1 Mhz): < -65 dBc
 Output (1 Mhz): < -65 dBc + 6 dB/octave
Phase Noise: < -52 dBc in a 30 kHz band

Signal Characteristics

Square wave

Rise/Fall Time:	< 20 ns
Overshoot:	< 2%
Asymmetry:	1% + 5 ns
Duty Cycle:	20% to 80% (to 5 MHz) 40% to 60% (to 15 MHz)

Triangle, Ramp, Arb

Rise/Fall Time:	100 ns (typical)
Linearity:	< 0.1% of peak output
Settling Time:	< 250 ns to 0.5% of final value
Jitter:	< 25 ns

Output Characteristics ^(1,5)

Amplitude (into 50Ω): ⁽²⁾	50 mVpp - 10 Vpp
Accuracy (at 1 kHz):	±1% of specified output
Flatness (sine wave relative to 1 kHz)	
100 kHz:	±1%(0.1 dB)
100 kHz to 1 Mhz:	±1.5%(0.15 dB)
1 Mhz to 15 Mhz:	±2%(0.2 dB)
Offset (into 50Ω): ⁽³⁾	±5 Vpk ac + dc
Accuracy: ⁽⁴⁾	±2% of setting + 2 mV
Output Impedance:	50 ohms fixed
Resolution:	3 digits, Amplitude and Offset
Output Units:	Vpp, Vrms, dBm
Isolation:	42 Vpk maximum to earth
Protection:	Short-circuit protected ±15 Vpk overdrive < 1 minute

(1) Add 1/10th of output amplitude and offset specification per °C for operation outside of 18°C to 28°C range.

(2) 100 mVpp - 20 Vpp amplitude into open-circuit load.

(3) Offset \leq X peak-to-peak amplitude.

(4) For square wave outputs, add 2% of output amplitude additional error.

(5) See [“Option 001 Specifications” on page 139.](#)

Modulation Characteristics	AM Modulation	Carrier -3dB Freq:	15 MHz (typical)	
		Modulation:	Any internal waveform plus Arb	
		Frequency:	10 mHz to 20 kHz ($\pm 0.05\%$ to 2.5 kHz, then decreases linearly to $\pm 0.4\%$ at upper limit)	
		Depth:	0% to 120%	
		Source:	Internal/External	
		FM Modulation	Modulation:	Any internal waveform plus Arb
			Frequency:	10 mHz to 10 kHz ($\pm 0.05\%$ to 600 Hz, then decreases linearly to $\pm 0.8\%$ at upper limit)
			Peak Deviation:	10 mHz to 15 MHz
			Source:	Internal Only
		Burst Modulation	Carrier Frequency:	5 MHz max.
			Count:	1 to 50,000 cycles, or Infinite
			Start Phase:	-360° to $+360^\circ$
		Internal Rate:	10 mHz to 50 kHz $\pm 1\%$	
		Gate Source:	Internal or External Gate (1)	
		Trigger Source:	Single, External, or Internal Rate	
	FSK Modulation	Frequency Range:	10 mHz to 15 MHz ($\pm 0.05\%$ to 600 Hz, then decreases linearly to $\pm 4\%$ at upper limit)	
		Internal Rate:	10 mHz to 50 kHz	
		Source:	Single, External, or Internal	
Frequency Sweep	Type:		Linear or Logarithmic	
	Direction:		Up or Down	
	Start F / Stop F:		10 mHz to 15 MHz	
	Time:		1 ms to 500 sec $\pm 0.1\%$	
	Source:		Single, External, or Internal	
Faceplate Inputs⁽⁵⁾	External AM Modulation:		± 5 Vpk = 100% Modulation 5 k Ω Input Resistance	
	External Trigger/FSK Burst Gate: ⁽¹⁾		TTL (high true)	
	Latency:		1.3 μ s	
	Jitter:		25 ns	
VXIbus TTLTRG inputs	TTLT<0-7> Trigger/FSK Burst Gate: ⁽¹⁾		TTLTRG (low true)	
	Latency:		1.15 μ s	
	Jitter:		25 ns	

System Characteristics

Configuration Times ⁽²⁾

Function Change: ⁽³⁾	80 ms
Frequency Change: ⁽³⁾	10 ms
Amplitude Change: ⁽³⁾	30 ms
Offset Change:	20 ms
Select User Arb:	550 ms
Modulation Parameter Change:	<350 ms

Arb Download Times:

Table 3-1.

Arb Length	Binary	ASCII Integer	ASCII Real ⁽⁴⁾
16,000 points	8 sec	81 sec	100 sec
8,192 points	4 sec	42 sec	51 sec
4,096 points	2.5 sec	21 sec	26 sec
2,048 points	1.5 sec	11 sec	13 sec

(1) Trigger source ignored when External Gate is selected.

(2) Time to change parameter and output the new signal.

(3) Modulation or sweep off.

(4) Times for 5-digit and 12-digit numbers.

(5) See [“Option 001 Specifications” on page 139.](#)

General Specifications

Agilent E1441A Available Power (Amps):

+5V: peak measurement (I_{pm}): 0.50
dynamic measurement (I_{dm}): 0.10

+12V: peak measurement (I_{pm}): 2.50
dynamic measurement (I_{dm}): 0.12

Cooling/Slot:

Average Watts/Slot: 25.0
deltaP mm H₂O: 0.10
Air Flow liters/s: 2.00

Operating Environment: 0° C to 55° C (Option 001 to 50° C
65% Relative Humidity to 40° C

Storage Environment: -40° C to 70° C

State Storage Memory: Four memory locations available (0, 1, 2 and 3)

Warm-up Time: 30 minutes

Programming Language: SCPI-1993, IEEE-488.2

Option 001 Specifications

Timebase Accuracy:

Setability:	< 0.01 ppm
Stability:	±1 ppm 0°C - 50°C
Aging:	< 1 ppm in first 30 days (continuous operation)
	$\frac{10^{-7}}{\text{month}}$ (after first 30 days)

Faceplate Input: (Ext Ref In terminal)

Lock Range:	10 MHz ±50 Hz
Level:	-10 dBm to +15 dBm, +25 dBm or 10Vpp absolute maximum input
Impedance:	50Ω ±2%, 42 Vpk isolation from earth
Lock Time:	< 2 seconds

Faceplate Output: (Ref Out terminal)

Frequency:	10 MHz
Level:	>1 Vpp squarewave into 50Ω

Phase Offset:

Range:	±360 degrees
Resolution:	0.001 degrees
Accuracy:	25 ns

Trigger:

Level:	5 V "zero-going" pulse
Pulse Width:	> 2 μs
Fanout:	Four (4) Agilent E1441As (or Agilent E33120As)

Appendix B

Agilent E1441A Error Messages

Errors are retrieved in first-in-first-out (FIFO) order. The first error returned (SYST:ERR? command) is the first error that was stored. When you have read all errors from the queue, the next execution of SYST:ERR? returns +0, "No error". Since no indication is given that an operation has caused an error, your application program should query the error queue regularly.

If more than 20 errors have occurred, the last error stored in the queue (the most recent error) is replaced with -350, "Too many errors". No additional errors are stored until you remove errors from the queue. If no errors have occurred when you read the error queue, the function generator responds with +0, "No error".

The error queue is cleared when power has been off or after a *CLS (clear status) command has been executed. The *RST (reset) command *does not* clear the error queue.

SYSTem:ERRor? *Reads one error from the error queue*

Errors have the following format (the error string may contain up to 80 characters):

-113,"Undefined header"

Execution Errors

- 101 Invalid character**
An invalid character was found in the command string. You may have inserted a character such as #, \$, or % in the command header or within a parameter. Example: TRIG:SOUR BUS#
- 102 Syntax error**
Invalid syntax was found in the command string. You may have inserted a blank space before or after a colon (or before a comma) in the command header. Example: APPL:SIN ,1
- 103 Invalid separator**
An invalid separator was found in the command string. You may have used a comma instead of a colon, semicolon, or blank space – or you may have used a blank space instead of a comma. Example: TRIG:SOUR,BUS or APPL:SIN 1 1000
- 105 GET not allowed**
A Group Execute Trigger (GET) is not allowed within a command string.

- 108 Parameter not allowed**
More parameters were received than were expected for the command. You may have entered an extra parameter, or you added a parameter to a command that does not accept a parameter. Example: APPL? 10
- 109 Missing parameter**
Fewer parameters were received than were expected for the command. You omitted one or more parameters that are required for the command. Example: OUTP:LOAD
- 112 Program mnemonic too long**
A command header was received which contained more than the maximum 12 characters allowed. Example: OUTP:SYNCHRONIZATION ON
- 113 Undefined header**
A command was received that is not valid for the function generator. You may have misspelled the command or it may not be a valid command. If you are using the short form of the command, remember that it may contain up to four letters. Example: TRIGG:SOUR BUS
- 121 Invalid character in number**
An invalid character was found in the number specified for a parameter value. Example: *ESE #B01010102
- 123 Exponent too large**
A numeric parameter was found whose exponent was larger than 32,000. Example: BMOD:NCYC 1E34000
- 124 Too many digits**
A numeric parameter was found whose mantissa contained more than 255 digits, excluding leading zeros.
- 128 Numeric data not allowed**
A numeric parameter was received but a character string was expected. Example: DISP:TEXT 123
- 131 Invalid suffix**
A suffix was incorrectly specified for a numeric parameter. You may have misspelled the suffix. Example: SWE:TIME 0.5 SECS
- 138 Suffix not allowed**
A suffix was received following a numeric parameter which does not accept a suffix. Example: BM:PHAS 10 DEG (this command does not allow a suffix).
- 148 Character data not allowed**
A discrete parameter was received but a character string or a numeric parameter was expected. Check the list of parameters to verify that you have used a valid parameter type. Example: DISP:TEXT ON

- 151 Invalid string data**
An invalid character string was received. Check to see if you have enclosed the character string in single or double quotes and that the string contains valid ASCII characters.
- 158 String data not allowed**
A character string was received but is not allowed for the command. Check the list of parameters to verify that you have used a valid parameter type.
Example: BMOD:NCYC 'TEN'
- 161 Invalid block data**
Applies only to the DATA:DAC VOLATILE command. For a definite-length block, the number of bytes of data sent does not match the number of bytes that you specified in the block header. For an indefinite-length block, an *EOI* (End-or-Identify) was received without an accompanying *<new line>* character.
- 168 Block data not allowed**
Block data was received but is not allowed for the command. Check to see if you have sent the correct data type with the command.
- 170 to -178 Expression errors**
The function generator does not accept mathematical expressions.
- 211 Trigger ignored**
A Group Execute Trigger (GET) or *TRG was received but the trigger was ignored. Make sure that you have selected the correct trigger source.
- 221 Settings conflict; amplitude has been adjusted**
The requested output amplitude is not valid. The output amplitude is automatically adjusted to be compatible with the present configuration. This error will be generated in the following instances:
- The output amplitude is automatically adjusted if you select a function whose maximum amplitude is *less than* that of the currently active function. This conflict may arise when the output units are *Vrms* or *dBm* due to the differences in crest factor.
- If the specified amplitude is not valid, the function generator will automatically adjust it to the maximum value allowed with the present offset voltage. The output amplitude (in *Vpp*) and the dc offset voltage must obey the following restrictions. (*Vmax* is either 10 volts for a high impedance termination or 5 volts for a 50 ohm termination.)
- 221 Settings conflict; cannot adjust phase in present configuration**
Option 001 Phase-Lock Only. The phase cannot be adjusted real-time if an arbitrary waveform is selected, a modulation mode (other than burst) is enabled, or if burst is enabled with a burst count other than infinity.

- 221 Settings conflict; *duty cycle* has been adjusted**
The requested duty cycle is not valid. For output frequencies above 5 MHz, the duty cycle is limited to values between 40% and 60% (below 5 MHz, the range is 20% to 80%). The duty cycle is automatically adjusted if you select a frequency that is not valid with the present duty cycle percentage. For example, if you set the duty cycle to 70% and then change the frequency to 8 MHz, the function generator will automatically adjust the duty cycle to 60% (the upper limit for this frequency).
- 221 Settings conflict; *fm deviation* has been adjusted**
The requested FM *peak frequency deviation* is not valid. The sum of the *carrier frequency* and peak frequency deviation must be less than or equal to the maximum frequency for the selected function *plus 100 kHz* (15.1 MHz for sine and square, 200 kHz for triangle and ramp, and 5.1 MHz for arbitrary waveforms). If you attempt to set the deviation to a value that is not valid, the function generator will automatically adjust the deviation to the maximum value allowed with the present carrier frequency.
- 221 Settings conflict; *frequency* has been adjusted**
The requested output (or carrier) frequency is not valid. The output frequency is automatically adjusted if you select a function whose maximum frequency is *less than* that of the currently active function. For example, if you output a 1 MHz sine wave and then change the function to triangle wave, the function generator will adjust the output to 100 kHz (the upper limit for triangle waves).
- 221 Settings conflict; *fsk frequency* has been adjusted**
The requested FSK “hop” frequency is not valid. The FSK frequency is automatically adjusted if you select a function whose maximum frequency is *less than* that of the currently active function. For example, if you set the FSK frequency to 1 MHz in the sine function and then change the function to triangle wave, the function generator will adjust the frequency to 100 kHz (the upper limit for triangle waves).
- 221 Settings conflict; *offset* has been adjusted**
The requested offset voltage is not valid with the present output amplitude. The offset is automatically adjusted to the maximum value allowed with the present output amplitude. The output amplitude (in *V_{pp}*) and the dc offset voltage must obey the following restrictions. (*V_{max}* is either 10 volts for a high impedance termination or 5 volts for a 50 ohm termination.)
- 221 Settings conflict; *start frequency* has been adjusted**
The requested start frequency is not valid. The start frequency is automatically adjusted if you select a function whose maximum frequency is *less than* that of the currently active function. For example, if you set the start frequency to 200 kHz in the sine wave function and then change the function to triangle wave, the function generator will adjust the output to 100 kHz (the upper limit for triangle waves).

- 221 Settings conflict; *stop frequency* has been adjusted**
The requested stop frequency is not valid. The stop frequency is automatically adjusted if you select a function whose maximum frequency is *less than* that of the currently active function. For example, if you set the stop frequency to 1 MHz in the sine wave function and then change the function to triangle wave, the function generator will adjust the output to 100 kHz (the upper limit for triangle waves).
- 221 Settings conflict; *previous modulation* has been disabled**
Only one modulation state can be enabled at a time. When you enable a modulation state, the previous modulation state is turned off. For example, if AM is on and then you enable FM, the function generator will turn off AM first.
- 222 Data out of range**
A numeric parameter value is outside the valid range for the command. Example: BMOD:NCYC -3 or FREQ 16 MHZ
- 222 Data out of range; *amplitude***
The requested output amplitude exceeds the upper limit for the selected function. This error applies only to the APPLy command. See “*Output Amplitude*”.
- 222 Data out of range; *frequency***
The requested output (or carrier) frequency exceeds the upper limit for the selected function. This error applies only to the APPLy command. See “*Output Frequency*”.
- 222 Data out of range; *offset***
The requested offset voltage exceeds the upper limit for the selected function or output amplitude. This error applies only to the APPLy command. See “*DC Offset Voltage*”.
- 223 Too much data**
A character string was received but could not be executed because the string length was more than 60 characters. This error can be generated by the CALibration:STRing and DISPlay:TEXT commands.
- 224 Illegal parameter value**
A discrete parameter was received which was not a valid choice for the command. You may have used an invalid parameter choice. Example: DISP:STAT XYZ (**XYZ** is not a valid choice).
- 330 Self-test failed**
The function generator's self-test failed from the remote interface (*TST? command). In addition to this error, one or more specific errors may be reported. See also “*Self-Test Errors,*” .

- 350 Too many errors**
The error queue is full because more than 20 errors have occurred. No additional errors are stored until you remove errors from the queue. The error queue is cleared when power has been off, or after a *CLS (clear status) command has been executed.
- 410 Query INTERRUPTED**
A command was received which sends data to the output buffer, but the output buffer contained data from a previous command (the previous data is not overwritten). The output buffer is cleared when power has been off, or after a device clear has been executed.
- 420 Query UNTERMINATED**
The function generator was addressed to talk (i.e., to send data over the interface) but a command has not been received which sends data to the output buffer. For example, you may have executed an APPLY command (which does not generate data) and then attempted an ENTER statement to read data from the remote interface.
- 430 Query DEADLOCKED**
A command was received which generates too much data to fit in the output buffer and the input buffer is also full. Command execution continues but all data is lost.
- 440 Query UNTERMINATED after indefinite response**
The *IDN? command must be the last query command within a command string. Example: *IDN?;;SYST:VERS?
- 501** Isolator UART framing error
- 502** Isolator UART overrun error
- 511** RS-232 framing error
- 512** RS-232 overrun error
- 513** RS-232 parity error
- 521** Input buffer overflow
- 522** Output buffer overflow
- 550 Command not allowed in local**
You should always execute the SYSTem:REMOte command before sending other commands over the RS-232 interface. This error is also generated if you attempt to execute the DISP:TEXT command while in the local mode (this command is allowed in remote only).
- 580 Phase-locked loop is unlocked**
Option 001 Phase-Lock Only. The function generator has detected an “unlock” condition. You must execute the PHAS:UNL:ERR:STAT ON

command to enable this error.

- 800 Block length must be even**
The function generator represents binary data for arbitrary waveforms as a 12-bit integers, which is sent as *two* bytes (DATA:DAC VOLATILE command only). An odd number of bytes is not accepted because the function generator would not know how to interpret the last single byte.
- 810 State has not been stored**
The memory location specified in the *RCL command was not used in a previous *SAV command. You cannot recall the instrument state from a memory location that was not previously specified as a storage location.

Self-Test Errors

The following errors indicate failures that may occur during a self-test. Refer to the *Service Guide* for more information.

- 590 I/O processor reset**
- 601 Trigger test failed**
- 602 RAM read/write failed**
- 603 Waveform RAM readback failed**
- 604 Modulation RAM readback failed**
- 606 Waveform ASIC failed**
- 607 SYNC signal detection failure, Bessel filter path**
- 608 SYNC signal detection failure, Elliptic filter path**
- 625 I/O processor does not respond**
- 626 I/O processor failed self-test**

Calibration Errors

The following errors indicate failures that may occur during a calibration. Refer to the *Service Guide* for more information.

- 701 Cal security disabled by jumper**
The calibration security feature has been disabled with a jumper inside the function generator. When applicable, this error will occur at power-on to warn you that the function generator is unsecured.

- 702 Cal secured**
The function generator is secured against calibration.
- 703 Invalid secure code**
An invalid calibration security code was received when attempting to unsecure or secure the function generator. You must use the same security code to unsecure the function generator as was used to secure it, and vice versa. The security code may contain up to 12 alphanumeric characters. The first character *must be* a letter.
- 704 Secure code too long**
A security code was received which contained more than 12 characters.
- 705 Cal aborted**
A calibration in progress is aborted when you press any front-panel key, send a device clear, or change the local/remote state of the instrument.
- 706 Cal value out of range**
The specified calibration value (CAL:VALUE) is invalid for the presently selected function.
- 707 Cal signal measurement out of range**
The specified calibration value (CAL:VALUE) does not match the signal applied to the function generator.
- 708 Flatness cal failed**
- 760 RAM checksum failure**
- 770 Nonvolatile arb waveform memory checksum failure**
- 771 Nonvolatile cal memory checksum failure**
- 772 Nonvolatile system memory checksum failure**
This error may occur at power-up if memory location "0" has been deleted (MEM:STAT:DEL 0 executed). Use *SAV 0 to store any valid state. Please see the “[MEMory:STATe:RECall:AUTO OFF | ON | 0 | 1](#)” command on page 85 for details on using the *SAV 0 state for an alternate power-up state
- 773 Nonvolatile state memory checksum failure**
- 774 Nonvolatile memory erase failure**
- 775 Nonvolatile memory write failure**
- 780 to 788** [See “Arbitrary Waveform Errors” on page 149.](#)
- 800 Block length must be even**
The function generator represents binary data for arbitrary waveforms as a 12-bit integers, which is sent as *two* bytes (DATA:DAC VOLATILE

command only). An odd number of bytes is not accepted because the function generator would not know how to interpret the last single byte.

- 810 State has not been stored**
The memory location specified in the *RCL command was not used in a previous *SAV command. You cannot recall the instrument state from a memory location that was not previously specified as a storage location.
- 850 Cal setup invalid**
- 851 Negative offset gain cal required (CAL:SETup 50)**
- 852 Flatness DAC gain cal required (CAL:SETup 64)**
- 853 AM cal 1 required (CAL:SETup 30)**
- 854 AM cal 2 required (CAL:SETup 31)**
- 855 Cal load resistance not specified (CAL:SETup 33)**
- 856 Square wave positive offset cal required (CAL:SETup 60)**
- 857 Square wave 50% duty cycle cal required (CAL:SETup 62)**

Arbitrary Waveform Errors

The following errors indicate failures that may occur during an arbitrary waveform download. Refer to the Arbitrary Waveform Commands for more information specific to the use of arbitrary waveform commands. These commands are summarized on page <Reference> in the "Table of Contents by Function" for Chapter 3, SCPI Command Reference.

- 780 VOLATILE arb waveform has not been loaded**
The DATA:COPY command copies the waveform downloaded into VOLATILE memory to the specified name. You must download the waveform using the DATA VOLATILE or DATA:DAC VOLATILE command prior to a copy operation.
- 781 Not enough memory to store new arb waveform; use DATA:DELeTe**
Up to four user-defined waveforms can be stored in non-volatile memory. Use the DATA:DEL command to delete the waveform in VOLATILE memory or any of the four user-defined waveforms in non-volatile memory. Use the DATA:CAT? command to list all waveforms currently stored in volatile and non-volatile memory.
- 782 Cannot overwrite a built-in arb waveform**
You cannot overwrite the names of the five built-in arbitrary waveforms. The following names are reserved and cannot be used with the DATA:COPY command: SINC, NEG_RAMP, EXP_RISE, EXP_FALL, and CARDIAC.

- 783 Arb waveform name too long**
The arb name can contain up to 8 characters (used with DATA:COPY command). The first character *must* be a letter (A-Z), but the remaining characters can be numbers (0-9) or the underscore character (“_”). Blank spaces are not allowed.
- 784 Name of source arb waveform for copy must be VOLATILE**
The DATA:COPY command copies the arbitrary waveform downloaded into VOLATILE memory to the specified name. The source for the copy operation is always “VOLATILE” (you cannot copy from any other name).
- 785 Specified arb waveform does not exist**
The arb name specified with the FUNC:USER or DATA:DEL command has not been downloaded into memory. Use the DATA:CAT? command to list all waveforms currently downloaded. To download a waveform into memory, use the DATA VOLATILE or DATA:DAC VOLATILE commands.
- This error may also be generated if you insert a space instead of a colon before the ALL parameter in the DATA:DEL:ALL command. *The colon before the ALL parameter is required* – otherwise, the function generator will attempt to delete the arbitrary waveform with the name “ALL”.
- 786 Cannot delete a built-in arb waveform**
You cannot delete any of the five built-in arbitrary waveforms. The following names are reserved and cannot be deleted with the DATA:DEL command: SINC, NEG_RAMP, EXP_RISE, EXP_FALL, and CARDIAC.
- 787 Cannot delete the currently selected active arb waveform**
You cannot delete the arbitrary waveform that is currently being output. Either select a different arbitrary waveform or change to a different output function.
- 788 Cannot copy to VOLATILE arb waveform**
The DATA:COPY command copies the arbitrary waveform from volatile memory to the specified name in non-volatile memory. The source for the copy operation is always “VOLATILE” (you cannot copy from any other name) and you cannot copy *to* VOLATILE.
- 800 Block length must be even**
The function generator represents binary data as a 12-bit integers, which is sent as *two* bytes (DATA:DAC VOLATILE command only). An odd number of bytes is not accepted because the function generator would not know how to interpret the last single byte.
- 810 State has not been stored**
The memory location specified in the *RCL command was not used in a previous *SAV command. You cannot recall the instrument state from a memory location that was not previously specified as a storage location.

Option 001 Phase-Lock Errors

- 221 Settings conflict; cannot adjust phase in present configuration**
The phase cannot be adjusted real-time if an arbitrary waveform is selected, a modulation mode (other than burst) is enabled, or if burst is enabled with a burst count other than infinity. Occurs only with Option 001 Phase-Lock.

- 580 Phase-locked loop is unlocked**
The function generator has detected an "unlock" condition. You must execute the PHAS:UNL:ERR:STAT ON command to enable this error.

Appendix C

Agilent E1441A Function Generator

Tutorial

The Agilent E1441A is capable of producing a variety of signal waveshapes. You may want to learn more about the internal operations of the instrument in order to achieve the greatest performance from the function generator. This appendix serves that purpose by describing basic signal generation concepts and giving specific details on the internal operations of the Agilent E1441A function generator.

- [Direct Digital Synthesis](#) page 153
- [Signal Imperfections](#) page 155
- [Output Amplitude Control](#) page 156
- [Attributes of AC Signals](#)..... page 157
- [Modulation](#) page 158

Direct Digital Synthesis

Digital signal processing methods are used in many everyday applications. Whether it is a digital audio compact disc player, an electronic synthesized piano, or a voice-synthesized telephone message system, complex waveforms can be easily created or reproduced using digital signal generation methods.

The Agilent E1441A uses a signal-generation technique called *direct digital synthesis* or DDS. The basic principle behind DDS is not unlike an audio compact disc. As shown below for digital audio, a stream of digital data representing the sampled analog signal shape is sequentially addressed from a disc. This data is applied to the digital port of a digital-to-analog converter (DAC) which is clocked at a constant rate. The digital data is then converted into a series of voltage steps approximating the original analog signal shape. After filtering the voltage steps, the original analog waveshape will be recovered. The incoming data can be of any arbitrary shape, as long as it matches the requirements of the particular DAC (16 bits for digital audio players).

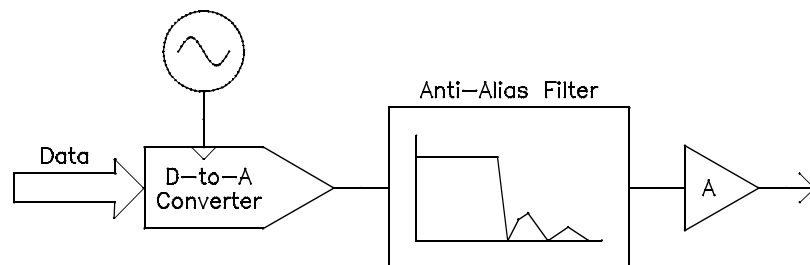

Figure C-1.

A direct digital synthesis (DDS) signal generator differs from a digital audio player because of its very precise control of the data stream input to the DAC. In a DDS system, the amplitude values for one complete cycle of the output waveshape are stored sequentially in random access memory (RAM) as shown in the figure below. As RAM addresses are changed, the DAC converts the waveshape data into a voltage

waveform (whose data values are loaded in RAM). The frequency of the voltage waveform is proportional to the rate at which the RAM addresses are changed.

The Agilent E1441A represents amplitude values by 4,096 discrete voltage levels (or 12-bit vertical resolution). Waveforms may contain between 8 points and 16,000 points of 12-bit amplitude values. The number of points in RAM representing one complete cycle of the waveshape (or 360°) is called its *length* or *horizontal resolution*. Each RAM address corresponds to a phase increment equal to $360^\circ / \text{points}$, where *points* is the waveform length. Therefore, sequential RAM addresses contain the amplitude values for the individual points (0° to 360°) of the waveform.

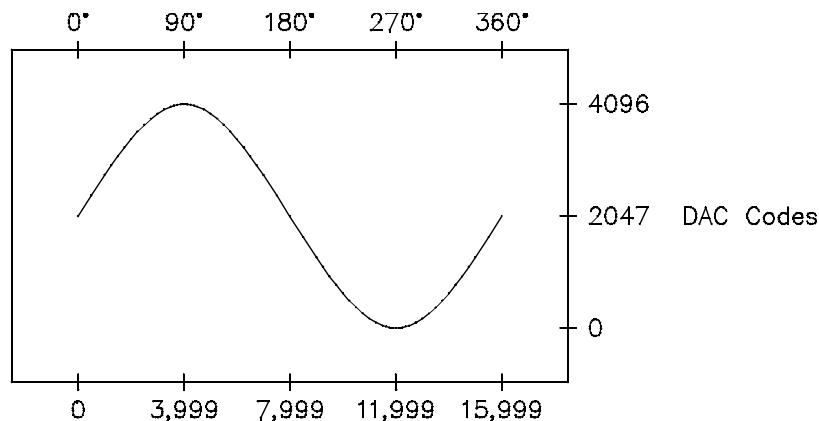

Figure C-2.

Direct digital synthesis (DDS) generators use a *phase accumulation* technique to control waveform RAM addressing. Instead of using a counter to generate sequential RAM addresses, an “adder” is used. On each clock cycle, the constant loaded into the phase increment register (*PIR*) is added to the present result in the phase accumulator (see below). The most- significant bits of the phase accumulator output are used to address waveform RAM — the upper 14 bits ($2^{14} = 16,384$ RAM addresses) for the Agilent E1441A. By changing the PIR constant, the number of clock cycles required to step through the entire waveform RAM changes, thus changing the output frequency. When a new PIR constant is loaded into the register, the waveform output frequency changes phase continuously following the next clock cycle.

The Agilent E1441A uses a 48-bit phase accumulator which yields $F_{clk} / 2^{48}$ or approximately 142 nHz frequency resolution internally. The phase accumulator output (the upper 14 bits) will step sequentially through each RAM address for smaller PIR values (lower frequencies). However, when the PIR is loaded with a larger value, the phase accumulator output will skip some RAM addresses, automatically “sampling” the data stored in RAM. Therefore, as the output frequency is increased, the number of output samples per waveshape cycle will decrease. In fact, different groups of points may be output on successive waveform cycles.

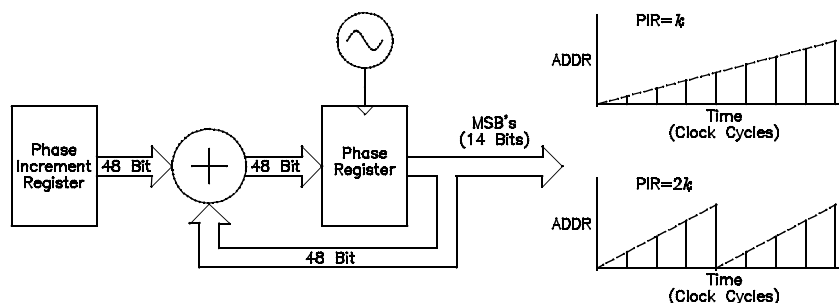

Figure C-3.

The maximum output frequency, with the condition that every waveshape point in RAM is output every waveform cycle, is defined by:

$$F_{out} = F_{clk} / \text{Points}$$

The minimum number of points required to accurately reproduce a waveshape will determine the maximum useful output frequency using the same equation.

The rule governing waveforms is referred to as the Nyquist Sampling Theorem, which states that you must include at least two points from the highest frequency component of the signal you are attempting to reproduce.

Signal Imperfections

Most signal imperfections are easiest to observe in the frequency domain using a spectrum analyzer. Sampling theory predicts the location and size of spurious signals resulting from the sampling processes used by DDS generators. In fact, since DDS generators use a fixed sampling rate (40 MHz for the Agilent E1441A), spurious signals can be removed with a fixed frequency “anti-alias” filter. A 17 MHz, ninth-order elliptical filter providing a sharp cut-off (in excess of 60 dB attenuation for signals greater than 19 MHz) is used for sine wave outputs. A 10 MHz, seventh-order Bessel filter is used for non-sine wave outputs. The Bessel filter provides slower amplitude roll-off for anti-alias filtering, but maintains linear phase response to minimize shape distortion for complex waveshapes. The Agilent E1441A automatically selects the appropriate filter when the output function is selected.

All digital-to-analog converters, including those used in DDS generators, produce spurious signals resulting from non-ideal performance. These spurious signals are harmonically related to the desired output signal. At lower frequencies, the Agilent E1441A's 12-bit waveform DAC produces spurious signals near the -74 dBc level (decibels below the carrier or output signal) as described by the equation on the following page. The Agilent E1441A uses the complete vertical resolution ($N=1$) of the DAC for all internal waveshapes, thus minimizing amplitude quantization error.

At higher output frequencies, additional DAC errors produce non-harmonic spurious outputs. These are signals “folded back” or aliased to a frequency within the signal bandwidth. A “perfect” DAC will also produce a wideband noise floor due to amplitude quantization. The noise floor for a 12-bit DAC will be near the -74 dBc level; this corresponds to a noise density of -148 dBc/Hz for sine wave outputs from the Agilent E1441A.

$$\text{Amplitude Quantization} \leq - (20 \times \log_{10}(N \times 4096) + 1.8) \text{ dBc}$$

where “N” is the fraction of available DAC codes used to describe the signal waveshape ($0 \leq N \leq 1$).

Another type of waveform error visible in the frequency domain is *phase truncation error*. This error results from time quantization of the output waveform. Whenever a waveshape is described by a finite number of horizontal points (length), it has been sampled in time (or quantized) causing a phase truncation error. Spurious signals caused by phase truncation introduce jitter into the output waveform. This may be regarded as time (and phase) displacement of output zero crossings.

Phase truncation causes phase modulation of the output signal which results in spurious harmonics (see the equation below). For lower output frequencies, the phase accumulator periodically *does not* advance RAM addresses, causing the DAC to deliver the same voltage as recorded on the previous clock cycle. Therefore, the phase “slips” back by $360^\circ / \text{points}$ before continuing to move forward again. When RAM address increments are the same on each cycle of the output, phase truncation error (and jitter) are essentially zero. All standard waveshapes in the Agilent E1441A are generated with at least 16,000 waveform points which results in spurious signals below the wide-band noise floor of the DAC.

$$\text{Phase Truncation Harmonics} \leq -20 \times \log_{10}(P) \text{ dBc}$$

where “P” is the number of waveform points in RAM.

Output Amplitude Control

The Agilent E1441A uses a 12-bit digital-to-analog converter (*DAC*) to convert the digital representation of a signal to an analog output voltage. The DAC can create waveforms represented by 4,096 (2^{12}) discrete amplitude levels. All 4,096 amplitude codes are used for the built-in waveforms. Output levels from full maximum to minimum output are controlled by applying varying amounts of signal gain or attenuation to the signal created by the DAC as shown in the block diagram below. The output waveform is always described by the full 12-bit vertical resolution. You can download user-defined arbitrary waveforms using less than the full 12-bit vertical resolution; however, it is recommended that you always use the full DAC amplitude resolution to minimize amplitude quantization errors as previously discussed.

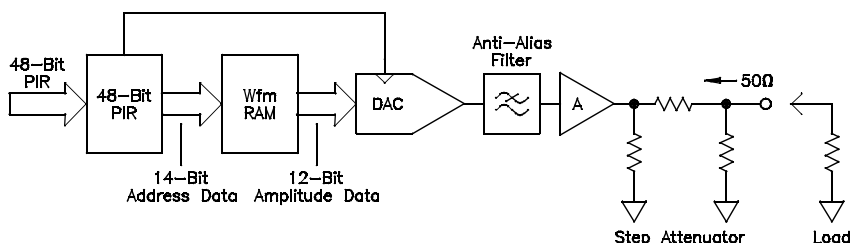

Figure C-4.

The Agilent E1441A has a fixed output source resistance of 50 ohms (see next diagram). During calibration, output amplitudes are calibrated for both the open-circuit voltage (no load) and the terminated output voltage (loaded). The terminated output amplitude is calibrated for an exact 50 ohm load. Since the function generator's output resistance and the load resistance form a voltage divider, the measured output voltage of the function generator will vary with load resistance value and accuracy. When the function generator's output is loaded with a 0.2% accuracy termination, an additional (negligible) 0.2% amplitude error is created. Using a 5% accuracy termination will add 5% additional error to specified output amplitudes.

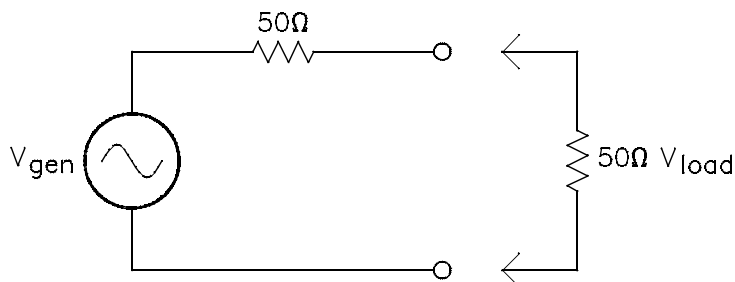

Figure C-5.

If the function generator's output is measured with no load connected, the output will be approximately *twice* the displayed amplitude (V_{gen} instead of V_{load}). In some applications, you might continually use the function generator in a “no-load” conditions. In such applications, remembering to *double* the function generator's displayed amplitude can cause many errors. The Agilent E1441A allows you to specify the function generator's load condition using the OUTPUT:LOAD command; thus enabling the function generator to display the correct output amplitude.

Floating Signal Generators

Many applications require a test signal which is isolated from earth ground for connection to powered circuits, to avoid ground loops, or to minimize other common mode noise. A floating signal generator such as the Agilent E1441A has both sides of the output BNC connector isolated from chassis (earth) ground. As shown in the figure below, any voltage difference between the two ground reference points (V_{ground}) causes a current to flow through the function generator's output common lead. This can cause errors such as noise and offset voltage (usually power- line frequency related), which are added to the output voltage.

The best way to eliminate ground loops is to maintain the function generator's isolation from earth ground. The function generator's isolation impedance will be reduced as the frequency of the V_{ground} source increases due to low-to-earth capacitance C_{le} (approximately 4000 pF for the Agilent E1441A). If the function generator must be earth-referenced, be sure to connect it (and the load) to the same common ground point. This will reduce or eliminate the voltage difference between devices. Also, make sure the function generator and load are connected to the same electrical outlet if possible.

Attributes of AC Signals

The most common ac signal is the sine wave. In fact, all periodic waveshapes are composed of sine waves of varying frequency, amplitude, and phase added together. The individual sine waves are harmonically related to each other — that is to say, the sine wave frequencies are integer multiples of the lowest (or fundamental) frequency of the waveform. Unlike dc signals, the amplitude of ac waveforms varies with time as shown in the following figure.

A sine wave can be uniquely described by any of the parameters indicated -- the peak-to-peak value, or RMS value, and its period (T) or frequency (1/T).

The magnitude of a sine wave can be described by the RMS value (effective heating value), the peak-to-peak value (2 x zero-to-peak), or the average value. Each value conveys information about the sine wave. The table below shows several common waveforms with their respective peak and RMS values.

Each waveshape exhibits a zero-to-peak value of "V" volts. Crest factor refers to the ratio of the peak-to-RMS value of the waveform.

RMS The RMS value is the only measured amplitude characteristic of a waveform that does not depend on waveshape. Therefore, the RMS value is the most useful way to specify ac signal amplitudes. The RMS value (or equivalent heating value) specifies the ability of the ac signal to deliver power to a resistive load (heat). The RMS value is equal to the dc value which produces the same amount of heat as the ac waveform when connected to the same resistive load.

For a dc voltage, this heat is directly proportional to the amount of power dissipated in the resistance. For an ac voltage, the heat in a resistive load is proportional to the average of the instantaneous power dissipated in the resistance. This has meaning only for periodic signals. The RMS value of a periodic waveform can be obtained by taking the dc values at each point along one complete cycle, squaring the values at each point, finding the average value of the squared terms, and taking the square-root of the average value. This method leads to the RMS value of the waveform regardless of the signal shape.

Peak-to-Peak and Peak Value The zero-to-peak value is the maximum positive voltage of a waveform. Likewise, the peak-to-peak value is the magnitude of the voltage from the maximum positive voltage to the most negative voltage peak. The peak or peak-to-peak amplitude of a complex ac waveform does not necessarily correlate to the RMS heating value of the signal. When the specific waveform is known, you can apply a correction factor to convert peak or peak-to-peak values to the correct RMS value for the waveform.

Average Value The average value of an ac waveform is the average of the instantaneous values measured over one complete cycle. For sine waves, the average amplitude is zero since the waveform has equal positive and negative half cycles. Since the quantity of interest is the heating value of the signal, the average value of a sine wave is taken to mean the average of the full-wave rectified waveform. The RMS value of a sine wave is equal to *1.11 times* the sine wave average amplitude. *This relationship does not hold true for other waveshapes.*

dBm The decibel (*dB*) is commonly used to describe RMS voltage or power ratios between two signals. By itself, a decibel value has no particular meaning. Decibels are a ratio or comparison unit and have no absolute meaning without knowledge of a reference or comparison unit. When power comparisons are made to a 1 mW reference level, the letter *m* is added to give “dBm”. For power ratios such as dBm, it is common to specify the resistance loading the voltage source. Often the system resistance is added to the units by indicating “dBm (50Ω)” for a 50Ω resistance system.

$$\text{dB} = 10 \times \log_{10} (P / P_{\text{ref}})$$

$$\text{dBm} = 10 \times \log_{10} (P / 0.001)$$

$$\text{where power } P = V^2/R$$

For a 50Ω resistance, 1 mW of power corresponds to 0.224 VRMS.

Use the following conversions to determine dBm levels when connecting 75Ω or 600Ω load resistances.

$$\text{dBm (75 } \Omega) = \text{dBm (50 } \Omega) - 1.75$$

$$\text{dBm (600 } \Omega) = \text{dBm (50 } \Omega) - 10.79$$

Modulation

Modulation is the process of combining a high-frequency carrier signal and a low-frequency information signal. How these signals are combined is determined by the specific type of modulation used. The two most common types of modulation are *amplitude modulation (AM)* and *frequency modulation (FM)*. The information signal that modulates (or varies) the carrier waveform can be of any form — sine wave, square wave, arbitrary wave, or random noise. In general, the carrier signal may also be of any shape, but it is usually a sine wave of constant amplitude and frequency for most communications systems. During modulation, the simple carrier waveform is converted into a complex waveform by the lower-frequency information signal. Generally, the higher-frequency carrier waveform is used to efficiently transmit the complex modulated signal over long distances.

Amplitude Modulation (AM) Amplitude Modulation is a process of producing a waveform whose amplitude varies as a function of the instantaneous amplitude of the modulating information signal. In other words, the information signal creates an amplitude “envelope” around the carrier signal. The Agilent E1441A implements “double sideband transmitted carrier” amplitude modulation similar to a typical AM radio station.

A constant is added to the AM modulating signal so that the sum is always greater than zero (for <100% modulation) as this equation shows:

$$\frac{1 + D \times A_m \langle t \rangle \times \sin(2\pi \times F_c \times T)}{2}$$

where: “D” is the modulation depth ($0 \leq D \leq 1.2$).

“A_m” is the modulating signal with peak amplitude ≤1.

“F_c” is the carrier frequency.

An AM waveform with 80% modulation depth. The carrier waveform is a 5 kHz sine wave and the modulating waveform is a 200 Hz sine wave.

In amplitude modulation, the amplitude of the carrier varies between zero and twice its normal value for 100% modulation. The *percent modulation depth* is the ratio of the peak information signal amplitude to the constant. **When amplitude modulation is selected, the Agilent E1441A automatically reduces its peak-to-peak amplitude by one-half so that a 100% modulation depth signal can be output.** Amplitude settings are defined to set the 100% peak-to-peak amplitude independent of the modulation depth setting. *Vrms and dBm amplitude settings are not accurate in AM since signals are very complex.*

Frequency Modulation (FM) Frequency Modulation is a process of producing a wave whose frequency varies as a function of the instantaneous amplitude of the modulating information signal. The extent of carrier frequency change is called *deviation*. The frequency deviations are caused by the amplitude changes of the modulating information signal. You can set the amount of the peak frequency in FM with the *deviation* parameter.

In frequency modulation, “100% modulation” has a different meaning than in AM. Modulation of 100% in FM indicates a variation of the carrier by the amount of the full permissible deviation. Since the modulating signal only varies frequency, the amplitude of the signal remains constant regardless of the modulation. The function generator uses the *deviation* parameter to describe the peak frequency change above or below the carrier in response to a corresponding amplitude peak of the modulating signal. For FM signals, the bandwidth of the modulated signal can be approximated by:

$$BW \approx 2 \times (\text{Deviation} + \text{Information Signal Bandwidth}) \quad \text{For wideband FM}$$

$$BW \approx 2 \times (\text{Information Signal Bandwidth}) \quad \text{For narrowband FM}$$

Narrowband FM occurs when the ratio of the deviation frequency to the information signal bandwidth is approximately 0.01 or less. Wideband commercial FM radio stations in the United States use a 75 kHz peak deviation (150 kHz peak-to-peak) and audio signals band-limited to 15 kHz to achieve 200 kHz channel-to-channel spacing from the 180 kHz bandwidth.

Frequency Sweep The Agilent E1441A performs phase-continuous frequency sweeping — stepping from the sweep start frequency to the sweep stop frequency with between 2,048 and 4,096 discrete frequency steps. The direction of frequency sweeps can be varied by setting the stop frequency either above or below the start frequency. Individual frequency steps are either linearly or logarithmically spaced based on the *sweep mode* setting. Like FSK modulation (described on the next page), the sweep function is also a special case of frequency modulation (FM). All of the FM operations described on the previous page also apply to sweep when the following translations are applied:

$$\text{Carrier Frequency} = \frac{\text{Start Frequency} + \text{Stop Frequency}}{2}$$

$$\text{Deviation} = \frac{\text{Start Frequency} - \text{Stop Frequency}}{2}$$

The modulation waveshape for sweeps is a ramp wave or exponential wave for linear or log sweeps, respectively. The logic sense of the ramp or exponential modulation signal (positive or negative ramp) is selected when the stop frequency is either larger or smaller than the start frequency. Like the FM function, changes to sweep parameters cause the generator to automatically compute a modulation signal and download it into modulation RAM. Similarly, the *sweep time* parameter adjusts the period of the modulating waveform. The sweep function also allows triggered operation. This is like frequency modulating with a single cycle burst of the modulating signal beginning when a trigger is received. Trigger signals can come

from the front-panel *Ext Trig* terminal or from BUS triggers.

A sine wave sweep from 50 Hz to 5 kHz with linear 1 second sweep time.

Frequency Shift Key Modulation In Frequency-Shift Keying modulation (*FSK*), the function generator's output frequency alternates between the carrier frequency and a second "hop" frequency. The rate of frequency hops is controlled either by an internal source or from an external logic input. FSK is essentially a special case of frequency modulation (FM) where the hop frequency is another way of specifying both the deviation and the modulating signal shape.

The modulating signal shape is always a square wave with an amplitude of zero to +1. The deviation is either positive or negative depending on whether the hop frequency is larger or smaller than the present carrier frequency (as shown below). The internal FSK rate generator specifies the period of the modulating square wave signal. When selected, the external FSK input replaces the internal FSK rate generator to directly control the frequency hop rate. A TTL "low" input always selects the carrier frequency and a TTL "high" always selects the hop frequency. The logic sense of the external FSK input can effectively be changed by interchanging the carrier and hop frequency values.

$$\text{Deviation} = \text{Hop Frequency} - \text{Carrier Frequency}$$

An FSK waveform with a 3 kHz carrier waveform and 500 Hz "hop" waveform (the FSK rate is 100 Hz).

Burst Modulation In burst modulation, the function generator turns the carrier wave output "on" and "off" in a controlled manner. The carrier output can be controlled using either triggered or externally-gated methods.

When configured for *triggered* operation, the function generator can output a carrier waveform with a user-specified number of complete cycles. Each time a trigger is received, the specified number of complete cycles is output. You can also specify a starting waveform phase in triggered operation. Zero degrees is defined as the first data point in waveform memory. The function generator will output the start phase as a dc output level while waiting for the next trigger. Output dc offset voltages are not affected by burst modulation — they are independently produced and summed into the function generator's output amplifier.

A three-cycle bursted sine wave with 100 Hz burst rate.

In *gated burst* mode operation, the front-panel *Burst* terminal is used to directly (and asynchronously) turn off the waveform DAC output. The burst count, burst rate, and burst phase settings have no effect in this mode. When the burst signal is true (TTL "high"), the function generator outputs the carrier waveform continuously. When the burst signal is false (TTL "low"), the waveform DAC is forced to a zero output level. Like triggered burst operation, the output dc offset voltage is not affected by the external burst gate signal.

For *triggered burst* operation, the function generator creates an internal modulation signal which is exactly synchronous with the carrier waveform. This internal modulation signal is used to halt waveform memory addressing when the last data point is reached. This modulation signal effectively "gates" the output "on" and "off" for the specified number of carrier wave cycles. The modulation signal is then triggered by another internal burst rate signal generator which controls how often the specified carrier burst is output. In external triggered burst operation, the modulation signal trigger source is set to the function generator's front-panel *Ext Trig* terminal. This source replaces the internal burst rate signal generator for pacing triggered bursts.

Changes to the burst count, burst rate, burst phase, or carrier frequency will cause the function generator to automatically compute a new modulation signal and download it into modulation RAM. *It is not possible for the function generator to burst single cycles for all carrier frequencies* because the internal modulation signal generator is not as capable as the main carrier signal generator.

The table below shows the function generator's carrier frequency and burst count limitations (for sine, square and arbitrary waveforms only).

Table C-1.

Carrier Frequency	Minimum Burst Count
10 mHz to 1 MHz	1
>1 MHz to 2 MHz	2
>2 MHz to 3 MHz	3
>3 MHz to 4 MHz	4
>4 MHz to 5 MHz	5

Internal Modulation Source Internally, the function generator incorporates a second, lower speed and lower resolution DDS arbitrary waveform generator to produce the modulating signal independent of the carrier signal. Internal modulation waveshapes range in length from 2,048 points to 4,096 points. User-defined arbitrary waveforms are automatically expanded or compressed in length as needed to fit within the required modulation waveform constraints. Linear interpolation is performed on user-defined arbitrary waveforms while the lengths of standard waveshapes are varied by decimation. Due to the modulation sample rate and waveform size limitations, the best case modulation signal frequency accuracy is approximately 0.05% of setting.

Unlike the main signal output discussed previously, modulation waveshapes are sampled using a variable “point clock” to sample data loaded in modulation waveform RAM. Internally, the modulation point clock (C) and modulation waveform length are automatically adjusted to produce the modulation signal frequency desired. For frequencies greater than C/2048, all modulation shapes are sampled up to the maximum modulating frequency. A new modulation waveform is computed and loaded into modulation RAM each time the modulation type, modulation waveshape, or modulation frequency is changed. Data in standard arbitrary waveform memory is not affected by modulation signal changes (data is expanded or compressed and loaded directly into separate modulation RAM following computation). No expansion or compression is performed on the modulation waveform data for certain modulation frequencies.

You can use the equations on the next page to determine specific waveform lengths and modulation frequencies when more precise control is needed. *Normally, you should not have to perform these calculations.*

The function generator incorporates an internal 8-bit (± 7 bits peak) digital-to-analog converter (DAC) to create an analog copy of the modulation signal for amplitude modulation (AM). This signal is internally applied to a conventional four-quadrant analog multiplier circuit to achieve amplitude modulation. Similarly, the generator uses digital signal processing to combine the carrier and modulation signals for frequency modulation (FM). The FM modulation signal maintains 12-bit resolution for frequency values.

The following equations and example describe the capabilities and limitations of the Agilent E1441A's internal modulation signal generator.

Parameter Definitions:

$$\text{Maximum Point Clock (C)} = \begin{matrix} 5 \text{ MSa/ s} & (\text{for AM}) \\ 1.25 \text{ MSa/ s} & (\text{for FM}) \end{matrix}$$

$$\text{Modulation Prescaler (S)} = \text{integer numbers (truncated) from } 1, 2, 3, \dots 2^{20}$$

$$\text{Constant (k)} = \begin{matrix} 4,900 & (\text{for AM}) \\ 624 & (\text{for FM}) \end{matrix}$$

$$\text{Modulation Frequency (F)} = \begin{matrix} 10 \text{ mHz to } 20 \text{ kHz} & (\text{for AM}) \\ 10 \text{ mHz to } 10 \text{ kHz} & (\text{for FM}) \end{matrix}$$

$$\text{Points (P)} = \text{values from } 2,048 \text{ to } 4,096,$$

even numbers only (*rounded down*)

Equations:

Compute the modulation pre-scaler divider:

$$S = \frac{k}{F} \quad (\text{truncated to integer value } \geq 1)$$

Compute the number of points for the modulation waveform length:

$$P = \frac{2 \times C}{(1 + S) \times F} \quad (\text{rounded down to even number})$$

Waveshapes are automatically expanded or compressed to match length “P” computed above and downloaded into modulation RAM.

Example: Assume that you need to phase-continuously frequency hop between the following nine frequencies every 200 μ s.

15.0 MHz, 1.001 MHz, 9.780 MHz, 12.375 MHz, 0.5695 MHz,
3.579 MHz, 0.8802 MHz, 0.6441 MHz, and 10.230 MHz.

Solution: Create a modulation arbitrary waveform that is precisely sampled in FM modulation.

$$F_s = 1 / (9 \times 200 \mu\text{s}) = 555.555 \text{ kHz} \quad (\text{effective point clock})$$

$$\text{Points (P)} = (C/S) / F_s = 2250$$

S=1. If P greater than 4096, divide C by the smallest S to bring P within range. Round down to an even P value.

$$\text{Modulation Frequency (F)} = (C/S) / 2 \times 2250 = 555.55555 \text{ Hz}$$

Round down in sixth digit to get modulation frequency to set.

Set the *modulation frequency* to 555.555 Hz.

Set the *carrier frequency* to $(\text{Max F} + \text{Min F}) / 2 = 7.784750 \text{ MHz}$.

Set *deviation (pk) frequency* to $(\text{Max F} - \text{Min F}) / 2 = 7.215250 \text{ MHz}$

Create and download a nine-segment arbitrary waveform with the values shown below. Each segment is 250 points long (2250/9) for a total of 2,250 points. Use the DATA VOLATILE command download to achieve 12-bit frequency resolution for each point.

$$y = mX + b$$

To Check: Enable FM by sending the following commands:

```
"FM:STATE ON"  
"FM:INT:FREQ 555.555"  
"DIAG:PEEK? 0,0,0"  
enter results < Prescale# (S) >,< Points (P) >
```

Appendix D

Service Procedures

This chapter contains procedures for verification of the function generator's performance followed by procedures for making adjustments (calibration). The chapter is divided into the following sections:

- Closed-Case Electronic Calibration page 164
- Agilent Technologies Calibration Services page 164
- Calibration Interval page 164
- Time Required for Calibration page 164
- Automated Verification and Calibration Procedures page 164
- Recommended Test Equipment page 165
- Test Considerations page 165
- Performance Verification Tests page 166
- Frequency Verification page 167
- Function Gain and Linearity Verification page 168
- DC Function Offset Verification page 168
- AC Amplitude Verification page 169
- Amplitude Flatness Verification page 171
- AM Modulation Depth Verification page 172
- Optional Performance Verification Tests page 172
- Calibration Security Code page 174
- Unsecuring the Function Generator (Lost Security Code) .. page 175
- Calibration Count page 176
- Calibration Message page 176
- General Calibration/Adjustment Procedure page 177
- Aborting a Calibration in Progress page 178
- Frequency and Burst Rate Adjustment page 178
- Function Gain and Linearity Adjustment page 179
- AC Amplitude Adjustment (High-Z) page 180
- Modulation Adjustment page 181
- AC Amplitude Adjustment (50 Ohms) page 182
- DC Output Adjustment page 184
- Duty Cycle Adjustment page 185
- AC Amplitude Flatness Adjustment page 185
- Error Messages page 188
- Error Messages page 188

Closed-Case Electronic Calibration

The function generator features closed-case electronic calibration since no internal mechanical adjustments are required for calibration. The function generator calculates correction factors based upon the input reference value you set. The new correction factors are stored in non-volatile memory until the next calibration adjustment is performed. (Non-volatile memory does not change when power has been off or after a remote interface reset.)

Agilent Technologies Calibration Services

When your function generator is due for calibration, contact your local Agilent Technologies Service Center for a low-cost recalibration. The Agilent E1441A Function Generator is supported on automated calibration systems which allows Agilent to provide this service at competitive prices. Calibrations to MIL-STD-45662 are also available competitively.

Calibration Interval

The function generator should be calibrated on a regular interval determined by the measurement accuracy requirements of your application. A 1-year or 2-year interval is adequate for most applications. Agilent Technologies does not recommend extending calibration intervals beyond 2 years for any application.

Whatever calibration interval you select, Agilent Technologies recommends that complete re-adjustment always be performed at the calibration interval. This will increase your confidence that the Agilent E1441A will remain within specification for the next calibration interval. This criteria for re-adjustment provides the best long-term stability. Performance data measured using this method can be used to extend future calibration intervals.

Time Required for Calibration

The Agilent E1441A can be automatically calibrated under computer control. With computer control you can perform the complete calibration procedure and performance verification tests in less than 15 minutes. Manual calibrations using the recommended test equipment will take approximately 45 minutes.

Automated Verification and Calibration Procedures

Performance verification and adjustment programs are provided on the Agilent Universal Instrument Drivers CD. The directory path to these programs is <drive>:\examples\hpe1441. The program names are 1441ver.c and 1441adj.c for verification and adjustment respectively.

These programs were developed on a 486 IBM compatible PC running Windows NT®. The computer is equipped with an Agilent 82341 GPIB interface and Agilent VISA for GPIB software.

The programs automate the majority of the procedures using an Agilent 34401A benchtop Multimeter or an Agilent E1412A VXI Multimeter.

Recommended Test Equipment

The test equipment recommended for the performance verification and adjustment procedures is listed below. If the exact instrument is not available, use the accuracy requirements shown to select substitute calibration standards.

Table D-1. Recommended Test Equipment

Instrument	Requirements	Recommended Model	Use ^a
50 Ω feedthrough load	50 $\Omega \pm 0.1 \Omega$		Q,P,O,T
6 1/2 digit Digital Multimeter (DMM)	20 VDC $\pm 0.01\%$ Integrating ACrms 10 VACrms $\pm 0.1\%$	Agilent 34401A	Q,P,T
Thermal Voltage Converter (50 Ω termination, 3V input) or Power Meter or Wideband ACrms Meter	1kHz to 15 MHz 100 kHz to 15 MHz 1 VAC rms $\pm 0.5\%$ 1 kHz to 20 MHz	Ballantine 1395A-3 (or equivalent 3V TVC) Agilent 437A with Agilent 8482A and 20 dB attenuator —	Q,P
Frequency Meter	1 ppm accuracy	Agilent 53131A	Q,P,T
Oscilloscope	100 MHz	Agilent 54602A	T
Spectrum Analyzer	Response to 90 MHz	Agilent 3588A	O

a.Q = Quick Verification O= Optional Verification Tests
P = Performance Verification Tests T = Troubleshooting

Test Considerations

Verify that you have selected the correct power line voltage prior to attempting any test procedure to ensure proper instrument operation.

For optimum performance, all test procedures should comply with the following recommendations:

- Verify the function generator is set to its reset state (*RST).
- Assure that the calibration ambient temperature is stable and between 18° C and 28° C.
- Assure ambient relative humidity is less than 80%.
- Allow a 30 minute warm-up period before verification or adjustment.
- Use only RG-58 or equivalent 50 Ω cable.
- Keep cables as short as possible, consistent with the impedance requirements.

Performance Verification Tests

The performance verification tests use the function generator's specifications listed in "Agilent E1441A Specifications" on page 135.

You can perform four different levels of performance verification tests:

- **Self-Test** A series of internal verification tests that give a high confidence that the function generator is operational.
- Q** • **Quick Verification** A combination of the internal self-tests and selected verification tests.
- P** • **Performance Verification Tests** An extensive set of tests that are recommended as an acceptance test when you first receive the function generator or after performing adjustments.
- O** • **Optional Verification Tests** Tests *not* performed with every calibration. These tests can be used to verify additional instrument specifications following repairs to specific circuits.

In all cases, the function generator's command set is used to configure its output. Use the "Agilent E1441A" column in the following verification tables to determine which commands to use and what parameter value should be sent with them.

Self-Test

A *power-on* self-test occurs automatically when you turn on the function generator. This limited test assures you that the function generator is operational.

A *complete* self-test runs a series of tests and takes approximately 10 seconds to execute. If all tests pass, you can have a high confidence that the function generator is fully operational.

If the self-test fails, the faceplate **Errors** LED turns on.

Use the following command to perform a self-test:

*TST?

Returns "0" if the self-test passes or "1" if it fails. If the self-test fails, an error message is also generated with additional information on why the test failed. *Use the SYSTem:ERRor? command to read the error queue. See "Self-Test Errors" on page 147 for more information.*

Quick Performance Check

The quick performance check is a combination of internal self-test and an abbreviated performance test (specified by the letter **Q** in the performance verification tests). This test provides a simple method to achieve high confidence in the function generator's ability to functionally operate and meet specifications. These tests represent the absolute minimum set of performance checks recommended following any service activity. Auditing the function generator's performance for the quick check points (designated by a **Q**) verifies performance for "normal" accuracy drift mechanisms. *This test does not check for abnormal component failures.*

To perform the quick performance check, do the following:

- Set the function generator to reset state (*RST).
- Perform a complete self-test (*TST?).
- Perform only the performance verification tests indicated with the letter **Q**.

If the function generator fails the quick performance check, adjustment or repair is required.

Performance Verification Tests

The performance verification tests are recommended as acceptance tests when you first receive the function generator. The acceptance test results should be compared against the 1 year test limits. After acceptance, you should repeat the performance verification tests at every calibration interval.

If the function generator fails performance verification, adjustment or repair is required.

Frequency Verification

This test verifies the frequency accuracy of the two sources in the function generator. All output frequencies are derived from a single generated frequency, and only one frequency point is checked. The second test verifies the burst rate frequency.

Set the function generator for each output indicated in the table below. Use a frequency meter to measure the output frequency. Compare the measured results to the test limits shown in the table. This is a 50 Ω output termination test.

Table D-2. Frequency Verification

Agilent E1441A							Measurement	
	Function	Out Term ^a	Ampl	Freq	Burst Rate	Burst Count	Nominal	Error
Q	Sine wave	50 Ω	3.5 Vrms	1.00 kHz	—	—	1.00 kHz	± 0.01 Hz
Q	Square wave	50 Ω	3.5 Vrms	1.00 kHz	500 Hz	1 CYC	500 Hz	± 5 Hz

a. The E1441A has a fixed output impedance of 50 Ω on the "Output" terminal. Use the OUTPut:LOAD 50 | INFinity | MIN | MAX command to set the output termination. HIGH Z assumes no load on output. 50 Ω assumes a 50 $\Omega \pm 0.1$ Ω load on output.

Function Gain and Linearity Verification

This test verifies the output amplitude accuracy specification for sine wave, triangle wave, ramp, and square wave outputs.

Set the function generator for each output indicated in the table below. Use a DMM to measure the function generator ACrms output voltage. Compare the measured results to the test limits shown in the table. This is a HIGH Z output termination test.

Table D-3. Function Gain and Linearity Verification

Agilent E1441A					Measurement	
	Function	Out Term ^a	Ampl	Freq	Nominal	Error
Q	Sine wave	HIGH Z	7.0 Vrms	1.0 kHz	7.0 Vrms	± 0.07 Vrms
	Sine wave	HIGH Z	5.7 Vrms	1.0 kHz	5.7 Vrms	± 0.057 Vrms
	Triangle wave	HIGH Z	5.7 Vrms	100 Hz	5.7 Vrms	± 0.057 Vrms
	Ramp wave	HIGH Z	5.7 Vrms	100 Hz	5.7 Vrms	± 0.057 Vrms
Q	Square wave	HIGH Z	10.0 Vrms	100 Hz	10.0 Vrms	± 0.1 Vrms
	Square wave	HIGH Z	8.0 Vrms	100 Hz	8.0 Vrms	± 0.08 Vrms

a. The E1441A has a fixed output impedance of 50 Ω on the "Output" terminal. Use the OUTPUT:LOAD 50 | INFINITY | MIN | MAX command to set the output termination. HIGH Z assumes no load on output. 50 Ω assumes a 50 Ω ± 0.1 Ω load on output.

DC Function Offset Verification

This test verifies the DC offset and DC output specifications.

Set the function generator for each output indicated in the table below. Use a DMM to measure the function generator DCV output. Compare the measured results to the test limits shown in the table. This is a HIGH Z output termination test.

Table D-4. DC Function Offset Verification

Agilent E1441A				Measurement	
	Function	Out Term ^a	Ampl	Nominal	Error
Q	DC Volts	HIGH Z	10.0 VDC	10.0 VDC	± 0.20 VDC
	DC Volts	HIGH Z	-10.0 VDC	-10.0 VDC	± 0.20 VDC

a. The E1441A has a fixed output impedance of 50 Ω on the "Output" terminal. Use the OUTPUT:LOAD 50 | INFINITY | MIN | MAX command to set the output termination. HIGH Z assumes no load on output. 50 Ω assumes a 50 Ω ± 0.1 Ω load on output.

AC Amplitude Verification

This procedure is used to check the output amplitude calibration of the function generator. Verification checks are performed to check the accuracy of the pre-attenuator and post attenuator. *Make sure you have read "Test Considerations" on page 165.*

Set the function generator for each output indicated in the table on the next page. Use a DMM to measure the ACrms output voltage of the function generator. Compare the measured results to the test limits shown in the table. This is a HIGH Z output termination test.

Table D-5. AC Amplitude Verification (High Z)

Agilent E1441A					Measurement	
	Function	Out Term ^a	Ampl	Freq	Nominal	Error
Q	Sine wave	HIGH Z	7.0 Vrms	1.00 kHz	7.0 Vrms	± 0.070 Vrms
	Sine wave	HIGH Z	5.7 Vrms	1.00 kHz	5.7 Vrms	± 0.057 Vrms
	Sine wave	HIGH Z	5.5 Vrms	1.00 kHz	5.5 Vrms	± 0.055 Vrms
	Sine wave	HIGH Z	4.4 Vrms	1.00 kHz	4.4 Vrms	± 0.044 Vrms
	Sine wave	HIGH Z	3.5 Vrms	1.00 kHz	3.5 Vrms	± 0.035 Vrms
	Sine wave	HIGH Z	2.8 Vrms	1.00 kHz	2.8 Vrms	± 0.028 Vrms
	Sine wave	HIGH Z	2.2 Vrms	1.00 kHz	2.2 Vrms	± 0.022 Vrms
	Sine wave	HIGH Z	1.7 Vrms	1.00 kHz	1.7 Vrms	± 0.017 Vrms
	Sine wave	HIGH Z	1.4 Vrms	1.00 kHz	1.4Vrms	± 0.014 Vrms
	Sine wave	HIGH Z	1.1 Vrms	1.00 kHz	1.1 Vrms	± 0.011 Vrms
Q	Sine wave	HIGH Z	0.88 Vrms	1.00 kHz	0.88 Vrms	± 0.0088 Vrms
	Sine wave	HIGH Z	0.70 Vrms	1.00 kHz	0.70 Vrms	± 0.0070 Vrms
	Sine wave	HIGH Z	0.55 Vrms	1.00 kHz	0.55 Vrms	± 0.0055 Vrms
	Sine wave	HIGH Z	0.44 Vrms	1.00 kHz	0.44 Vrms	± 0.0044 Vrms
	Sine wave	HIGH Z	0.35 Vrms	1.00 kHz	0.35 Vrms	± 0.0035 Vrms
	Sine wave	HIGH Z	0.28 Vrms	1.00 kHz	0.28 Vrms	± 0.0028 Vrms
	Sine wave	HIGH Z	0.22 Vrms	1.00 kHz	0.22 Vrms	± 0.0022 Vrms
	Sine wave	HIGH Z	0.17 Vrms	1.00 kHz	0.17 Vrms	± 0.0017 Vrms
	Sine wave	HIGH Z	0.14 Vrms	1.00 kHz	0.14 Vrms	± 0.0014 Vrms
	Sine wave	HIGH Z	0.11 Vrms	1.00 kHz	0.11 Vrms	± 0.0011 Vrms
Q	Sine wave	HIGH Z	0.088 Vrms	1.00 kHz	0.088Vrms	± 0.00088 Vrms
	Sine wave	HIGH Z	0.070 Vrms	1.00 kHz	0.070 Vrms	± 0.00070 Vrms
	Sine wave	HIGH Z	0.055 Vrms	1.00 kHz	0.055 Vrms	± 0.00055 Vrms
	Sine wave	HIGH Z	0.044 Vrms	1.00 kHz	0.044 Vrms	± 0.00044 Vrms
Q	Sine wave	HIGH Z	0.036 Vrms	1.00 kHz	0.036 Vrms	± 0.00036 Vrms

a. The E1441A has a fixed output impedance of 50 Ω on the "Output" terminal. Use the OUTPut:LOAD 50 | INFinity | MIN | MAX command to set the output termination. HIGH Z assumes no load on output. 50 Ω assumes a 50 Ω ± 0.1 Ω load on output.

Install the 50 Ω feedthrough load between the DMM and the function generator output. Set the function generator for each output indicated in the table on the next page. Use a DMM to measure the ACrms output voltage of the function generator. Compare the measured results to the test limits shown in the table. This is a 50 Ω output termination test.

Table D-6. AC Amplitude Verification (50 Ohms)

Agilent E1441A					Measurement	
	Function	Out Term ^a	Ampl	Freq	Nominal	Error
Q	Sine wave	50 Ω	3.5 Vrms	1.0000 kHz	3.5 Vrms	± 0.035 Vrms
	Sine wave	50 Ω	2.8 Vrms	1.0000 kHz	2.8 Vrms	± 0.028 Vrms
	Sine wave	50 Ω	2.2 Vrms	1.0000 kHz	2.2 Vrms	± 0.022 Vrms
	Sine wave	50 Ω	1.7 Vrms	1.0000 kHz	1.7 Vrms	± 0.017 Vrms
	Sine wave	50 Ω	1.4Vrms	1.0000 kHz	1.4Vrms	± 0.014 Vrms
	Sine wave	50 Ω	1.1 Vrms	1.0000 kHz	1.1 Vrms	± 0.011 Vrms
Q	Sine wave	50 Ω	0.88 Vrms	1.0000 kHz	0.88 Vrms	± 0.0088 Vrms
	Sine wave	50 Ω	0.70 Vrms	1.0000 kHz	0.70 Vrms	± 0.0070 Vrms
	Sine wave	50 Ω	0.55 Vrms	1.0000 kHz	0.55 Vrms	± 0.0055 Vrms
	Sine wave	50 Ω	0.44 Vrms	1.0000 kHz	0.44 Vrms	± 0.0044 Vrms
	Sine wave	50 Ω	0.35 Vrms	1.0000 kHz	0.35 Vrms	± 0.0035 Vrms
	Sine wave	50 Ω	0.28 Vrms	1.0000 kHz	0.28 Vrms	± 0.0028 Vrms
	Sine wave	50 Ω	0.22 Vrms	1.0000 kHz	0.22 Vrms	± 0.0022 Vrms
	Sine wave	50 Ω	0.17 Vrms	1.0000 kHz	0.17 Vrms	± 0.0017 Vrms
	Sine wave	50 Ω	0.14 Vrms	1.0000 kHz	0.14 Vrms	± 0.0014 Vrms
	Sine wave	50 Ω	0.11 Vrms	1.0000 kHz	0.11 Vrms	± 0.0011 Vrms
	Sine wave	50 Ω	0.088Vrms	1.0000 kHz	0.088Vrms	± 0.00088 Vrms
	Sine wave	50 Ω	0.070 Vrms	1.0000 kHz	0.070 Vrms	± 0.00070 Vrms
	Sine wave	50 Ω	0.055 Vrms	1.0000 kHz	0.055 Vrms	± 0.00055 Vrms
	Sine wave	50 Ω	0.044 Vrms	1.0000 kHz	0.044 Vrms	± 0.00044 Vrms
Q	Sine wave	50 Ω	0.035 Vrms	1.0000 kHz	0.035 Vrms	± 0.00035 Vrms
	Sine wave	50 Ω	0.028 Vrms	1.0000 kHz	0.028 Vrms	± 0.00028 Vrms
	Sine wave	50 Ω	0.022 Vrms	1.0000 kHz	0.022 Vrms	± 0.00022 Vrms
	Sine wave	50 Ω	0.018 Vrms	1.0000 kHz	0.018 Vrms	± 0.00018 Vrms

a. The E1441A has a fixed output impedance of 50 Ω on the "Output" terminal. Use the OUTPut:LOAD 50 | INFinity | MIN | MAX command to set the output termination. HIGH Z assumes no load on output. 50 Ω assumes a 50 $\Omega \pm 0.1$ Ω load on output.

Amplitude Flatness Verification

This test verifies the output amplitude flatness specification at selected frequencies. If you use a Temperature Voltage Converter (TVC) (the recommended method) or a wide band ACrms voltmeter (with a 50 Ω feed through load), perform this procedure as described. If you are using a measurement device that requires a transfer measurement (for example, a power meter), make the transfer in the reference measurement at 100 kHz.

Set the function generator to the first output indicated in the table below and make a reference measurement. Set each function generator output shown in the table below. Measure the output of the function generator. Compare the amplitude level measured to the reference measurement +/- the error shown in the table. This test is a 50 Ω output termination test.

Table D-7. Amplitude Flatness Verification

Agilent E1441A					Measurement	
	Function	Out Term ^a	Ampl	Freq	Nominal	Error
Q	Sine wave	50 Ω	3.0 Vrms	1.00 kHz	<reference>	
	Sine wave	50 Ω	3.0 Vrms	100.00 kHz	<reference>	± 0.03 Vrms
	Sine wave	50 Ω	3.0 Vrms	500.00 kHz	<reference>	± 0.045 Vrms
Q	Sine wave	50 Ω	3.0 Vrms	1.00 MHz	<reference>	± 0.045 Vrms
	Sine wave	50 Ω	3.0 Vrms	3.00 MHz	<reference>	± 0.06 Vrms
	Sine wave	50 Ω	3.0 Vrms	5.00 MHz	<reference>	± 0.06 Vrms
	Sine wave	50 Ω	3.0 Vrms	7.00 MHz	<reference>	± 0.06 Vrms
	Sine wave	50 Ω	3.0 Vrms	9.00 MHz	<reference>	± 0.06 Vrms
	Sine wave	50 Ω	3.0 Vrms	11.00 MHz	<reference>	± 0.06 Vrms
	Sine wave	50 Ω	3.0 Vrms	13.00 MHz	<reference>	± 0.06 Vrms
Q	Sine wave	50 Ω	3.0 Vrms	15.00 MHz	<reference>	± 0.06 Vrms

a. The E1441A has a fixed output impedance of 50 Ω on the "Output" terminal. Use the `OUTPut:LOAD 50 | INFinity | MIN | MAX` command to set the output termination. HIGH Z assumes no load on output. 50 Ω assumes a 50 $\Omega \pm 0.1$ Ω load on output.

AM Modulation Depth Verification

This test verifies the modulation depth specification.

Select each function generator output in the table below. Use a DMM to measure the function generator ACrms output voltage. Compare the measured results to the test limits shown in the table. This is a HIGH Z output termination test.

Table D-8. AM Modulation Verification

Agilent E1441A								Measurement	
	Function	Out Term ^a	Ampl	Freq	AM Modulation			+	
					Shape	Freq	Depth	Nominal	Error
Q	Sine wave	HIGH Z	1.0 Vrms	1.00 kHz	Sinewave	100 Hz	0%	0.50 Vrms	±0.005 Vrms
	Sine wave	HIGH Z	1.0 Vrms	1.00 kHz	Sinewave	100 Hz	100%	0.61 Vrms	±0.0061 Vrms

a. The E1441A has a fixed output impedance of 50 Ω on the "Output" terminal. Use the OUTPUT:LOAD 50 | INFINITY | MIN | MAX command to set the output termination. HIGH Z assumes no load on output. 50 Ω assumes a 50 Ω ± 0.1 Ω load on output.

Optional Performance Verification Tests

These tests are *not* intended to be performed with every calibration. They are provided as an aid for verifying additional instrument specifications.

Square Wave Duty Cycle Verification

This test verifies the duty cycle specification of the squarewave output.

Select each function generator output in the table below. Use an *integrating* DMM to measure the VDC output of the function generator. Compare the measured results to the test limits shown in the table. This is a HIGH Z output termination test.

NOTE: You make a DC voltage measurement on this test.

Table D-9. Square Wave Duty Cycle Verification

	Function	Out Term ^a	Ampl	Freq	Duty Cycle	Nominal	Error
O	Square wave	HIGH Z	1.0 Vrms	300.00 Hz	50%	0.00 VDC	±0.020 VDC
O	Square wave	HIGH Z	1.0 Vrms	300.00 Hz	25%	- 0.50 VDC	±0.020 VDC
O	Square wave	HIGH Z	1.0 Vrms	300.00 Hz	75%	+ 0.50 VDC	±0.020 VDC

a. The E1441A has a fixed output impedance of 50 Ω on the "Output" terminal. Use the OUTPUT:LOAD 50 | INFINITY | MIN | MAX command to set the output termination. HIGH Z assumes no load on output. 50 Ω assumes a 50 Ω ± 0.1 Ω load on output.

Note

The DMM used for this test must be an integrating multimeter. If the first step does not measure 0 VDC, use an oscilloscope for this test. Do not use an auto-ranging function on the DMM for this test. Fix the DMM measurement range at 10 VDC.

Distortion Verification

This test checks the Harmonic Distortion at selected frequencies and harmonics. This test requires the use of a spectrum analyzer with dynamic range, frequency range, and resolution bandwidth adequate for the measurement.

Select each function generator output in the table below. Use a spectrum analyzer connected to the function generator output. Set the fundamental frequency reference to 0 dB and measure the 2nd through 5th harmonic frequencies relative to this reference. This test is a 50 Ω output termination test.

Table D-10. Distortion Verification

	Agilent E1441A				Measurement					
	Function	Out Term ^a	Ampl	Freq	Fundamental	harmonic				Amt below reference
						2nd	3rd	4th	5th	
O	Sine wave	50 Ω	1.1 Vrms	20.00 kHz	reference	40 kHz	60 kHz	80 kHz	100 kHz	> 70 dB
O	Sine wave	50 Ω	1.1 Vrms	100.00 kHz	reference	200 kHz	300 kHz	400 kHz	500 kHz	> 60 dB
O	Sine wave	50 Ω	1.1 Vrms	1.00 MHz	reference	2 MHz	3 MHz	4 MHz	5 MHz	> 45 dB
O	Sine wave	50 Ω	1.1 Vrms	15.00 MHz	reference	30 MHz	45 MHz	60 MHz	75 MHz	> 35 dB

a. The E1441A has a fixed output impedance of 50 Ω on the "Output" terminal. Use the OUTPUT:LOAD 50 | INFINITY | MIN | MAX command to set the output termination. HIGH Z assumes no load on output. 50 Ω assumes a 50 Ω \pm 0.1 Ω load on output.

Calibration Security Code

This feature allows you to enter a security code (electronic key) to prevent accidental or unauthorized calibrations of the function generator. When you first receive your function generator, it is secured. Before you can adjust calibration constants you *must* unsecure the function generator by entering the correct security code.

- The security code is set to “HP_E1441” when the function generator is shipped from the factory. The security code is stored in *non-volatile* memory, and *does not* change when power has been off or after a remote interface reset.
- To secure the function generator from the remote interface, the security code may contain up to 12 alphanumeric characters as shown below. The first character *must* be a letter, but the remaining characters can be letters or numbers. You do not have to use all 12 characters but the first character must always be a letter.

A _ _ _ _ _ _ _ _ _ _ (12 characters)

To unsecure for calibration

Use the following command:

```
CALibration:SECure:STATe ON | OFF,<secure code>
```

- use ON or OFF to control the security state (ON for secured, OFF for unsecured). When OFF, <secure code> string must match that sent with state ON.

Since the function generator is shipped from the factory with the security code "HP_E1441", you can initially unsecure the module by sending the following command:

```
CAL:SEC:STAT OFF,HP_E1441
```

To re-secure

Once you have unsecured the instrument, you can re-secure by sending the CAL:SEC:STAT command with state ON, optionally including the securitycode.

```
CAL:SEC:STAT ON[,YOUR_CODE] secure code not required to re-enable security.
```

- *If you forget your security code, you can disable the security feature by connecting a jumper inside the function generator, and then entering a new code. See the procedure on the following page.*

To change security code

Once you have unsecured the instrument, you can change the security code by sending the CAL:SEC:CODE <new code> command.

```
CAL:SEC:CODE YOUR_NEWCODE be sure to remember this code
```

Unsecuring the Function Generator

(Lost Security Code)

To unsecure the function generator without the correct security code, follow the steps below. A procedure to unsecure the function generator is given on page 174. Also see “Electrostatic Discharge (ESD) Precautions” in chapter 6 before beginning this procedure.

1. Turn off power to the VXI mainframe, disconnect all input connection, and remove the module from the mainframe.
2. Remove the instrument’s left cover (tall cover):
 - A. First loosen the nuts around each BNC connectors. This is to avoid damaging the cover-to-faceplate EMC gasket.
 - B. Remove the seven Torx screws holding the cover.
 - C. While gently pulling the right side of the faceplate away from the cover’s EMC gasket, lift that end of the cover. Once the gasket is clear of the faceplate, remove the cover from the instrument.
3. Install a VXIbus extender card into the mainframe and install the instrument into the extender.
4. Apply power to the mainframe.
5. Apply a short between the two exposed metal pads on JM101 (located near U106 and U205) Figure D-1.

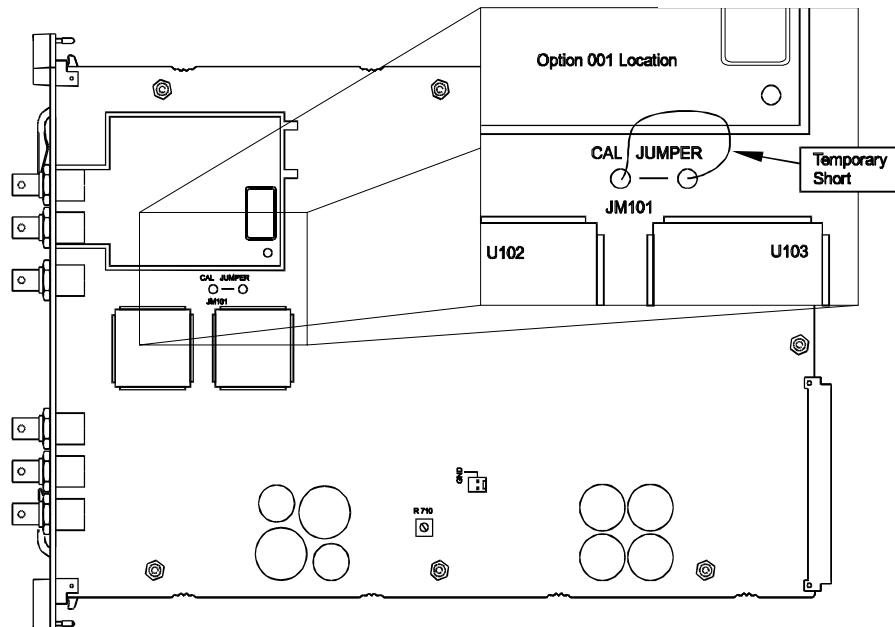

Figure D-1. Unsecuring the Agilent E1441A (without security code)

6. While maintaining the short, enter any unsecure code. The function generator is now unsecured.

7. Remove the short at JM101.
8. Turn off and reassemble the function generator, taking particular care to avoid damaging the cover's EMC gasket. Do not over-tighten the BNC connector nuts as the connector bodies are insulating plastic.
9. The function generator is now unsecured and you can enter a new security code. Be sure you take note of the new security code.

Calibration Count

The calibration count feature provides an independent “serialization” of your calibrations. You can determine the number of times that your function generator has been calibrated. By monitoring the calibration count, you can determine whether an unauthorized calibration has been performed. Since the value increments by one for each calibration, a complete calibration increases the value by approximately 85 counts.

- The calibration count is stored in *non-volatile* memory and *does not* change when power has been off or after a remote interface reset. Your function generator was calibrated before it left the factory. When you receive your function generator, read the calibration count to determine its value.
- The calibration count increments up to a maximum of 32,767 after which it wraps around to 0. There is no way provided to program or reset the calibration count. It is an independent electronic calibration “serialization” value.

Calibration Message

You can use the calibration message feature to record calibration information about your function generator. For example, you can store such information as the last calibration date, the next calibration due date, the function generator's serial number, or even the name and phone number of the person to contact for a new calibration.

You can record information in the calibration message only from the remote interface. You can read the message from either the front-panel menu or the remote interface.

- The calibration message may contain up to 40 characters. The function generator can display up to 11 characters of the message on the front panel; any additional characters are truncated.
- The calibration message is stored in *non-volatile* memory, and *does not* change when power has been off or after a remote interface reset.

General Calibration/Adjustment Procedure

The adjustment procedures described in in this appendix use the CALibrate subsystem commands to generate and set internal calibration constants. This general SCPI command procedure is the same for all calibration setups.

1. Unsecure the function generator See “Calibration Security Code” on page 174. Use the following SCPI command

```
CAL:SEC:STAT OFF, <sec_code>      set secure state off; enable cal
```

2. Send the Calibration Setup. Use the following SCPI commands:

```
CALibrate:SETup <setup_number>    configures the output
```

3. Use the recommended instrument to measure the actual output of the Agilent E1441A
4. Send the measured value to the Agilent E1441A with the CAL:VALue command. The function generator will correct its output and store the new calibration constant. Use the following SCPI command:

```
CAL:VALue <measured_val>          set the calibration value
```

5. Initiate the calibration process. Use the command:

```
CAL?                               performs calibration and  
                                   updates the cal constant  
<read the CAL? response; 0 = cal OK, 1 = cal error>
```

6. Repeat steps 2 through 5 for each calibration setup.

Calibration Example

The following example command sequence demonstrates making the Frequency and Burst Rate adjustments.

```
/* Adjust main frequency generator */  
CAL:SEC:STAT OFF, <sec_code>      secure state off  
CALibrate:SETup 00                configure frequency cal  
                                   (setup 00)  
*OPC?                             wait for output to stabilize  
<enter "1" from *opc? when complete>  
<read the frequency counter value>  
CAL:VALue <counter_value>        set calibration value  
CAL?                              perform calibration  
<read the CAL? response; "0"=cal OK, "1"=cal error>  
  
/* Adjust burst rate timing, pulse output */  
CALibrate:SETup 01                configures burst rate cal  
                                   (setup 01)  
*OPC?                             wait for output to stabilize  
<enter "1" from *opc? when complete>  
<read the frequency counter value>  
CAL:VALue <counter_value>        set calibration value  
CAL?                              perform calibration
```

<read the CAL? response; "0"=cal OK, "1"=cal error>

Aborting a Calibration in Progress

Sometimes it may be necessary to abort a calibration after the procedure has already been initiated. When performing a calibration from the remote interface, you can abort a calibration by issuing a remote interface device clear message.

Frequency and Burst Rate Adjustment

The function generator stores two calibration constants related to frequency and burst rate output. The constants are calculated from the adjustment value entered and are stored at the completion of each setup.

1. Use a frequency meter to measure the function generator output frequency for SETUP 00 in the following table. These adjustments use a 50 Ω output termination.

Table D-11. Frequency and Burst Rate Adjustment Setups

SETUP	Nominal Output		
	FREQUENCY	AMPLITUDE	
00 ^a	1.00 kHz	10 Vpp	Adjustment for main frequency generator, sine wave output
01	500 Hz	10 Vpp	Adjustment for burst rate timing, pulse output.

- a. A new calibration (SETUP 86 - Rev 4.0) has been added as an alternative to SETUP 00. The new calibration outputs a 10 MHz sine wave, rather than the 1 MHz signal used for SETUP 00. The new calibration reduces slew rate dependent errors in the frequency measurement and is especially important when calibrating the Phase-Lock Assembly (Option 001). Note that either setup is sufficient to calibrate the carrier frequency and you don't need to perform both.
2. Send the CAL:VALue <measured frequency> to the function generator.
 3. Send the CAL? command to the function generator to initiate the calibration.
 4. Repeat steps 1, 2 and 3 for SETUP 01.
 5. Perform the "Frequency Verification" on page 167.

Function Gain and Linearity Adjustment

The function generator stores six calibration constants related to function gain and linearity. The constants are calculated from the adjustment value entered. *If the calibration procedure is aborted before all setup steps have been completed, no calibration constants are stored.*

1. Use a DMM to measure the function generator ACrms output voltage for SETUP 02 in the following table. These adjustments use a HIGH Z output termination.

Table D-12. Function Gain and Linearity Adjustment Setups

SETUP	Nominal Output		
	FREQUENCY	AMPLITUDE	
02	1 kHz	7.07 V rms	Adjustment for sine wave gain.
03	1 kHz	5.6 V rms	Adjustment for amplitude linearity.
04	100 Hz	5.6 V rms	Adjustment for triangle wave gain.
05	100 Hz	5.6 V rms	Adjustment for ramp gain.
06	100 Hz	10.0 V rms	Adjustment for square wave gain.
07	100 Hz	1.1 Vrms	Adjustment for square wave linearity.

2. Send the CAL:VALue <measured Vac> to the function generator.
3. Send the CAL? command to the function generator to initiate the calibration.
4. Repeat steps 1, 2 and 3 for SETUP 03 through 07.
5. Perform the “Function Gain and Linearity Verification” on page 168.

AC Amplitude Adjustment (High-Z)

The function generator stores twenty-two calibration constants related to HIGH Z output, and sixteen calibration constants related to 50 Ω output. The constants are calculated from the adjustment value entered. The calibration constants are stored following completion of SETUP 22 (HIGH Z output) and the calibration procedure may be aborted after that point. *No calibration constants are stored if the procedures are aborted at any other setup.*

1. Use a DMM to measure the function generator ACrms output voltage for SETUP 08. These adjustments use a HIGH Z output termination.

Table D-13. AC Amplitude (High Z) Adjustment Setups

SETUP	Nominal Output		Adjustment for:
	FREQUENCY	AMPLITUDE	
08	1 kHz	5.5 V rms	2 dB Output Attenuator
09	1 kHz	4.4 V rms	4 dB Output Attenuator
10	1 kHz	3.5 V rms	6 dB Output Attenuator
11	1 kHz	2.8 V rms	8 dB Output Attenuator
12	1 kHz	2.2 V rms	10 dB Output Attenuator
13	1 kHz	1.7 V rms	12 dB Output Attenuator
14	1 kHz	1.4 V rms	14 dB Output Attenuator
15	1 kHz	1.1 V rms	16 dB Output Attenuator
16	1 kHz	0.88 V rms	18 dB Output Attenuator
17	1 kHz	0.70 V rms	20 dB Output Attenuator
18	1 kHz	0.55 V rms	22 dB Output Attenuator
19	1 kHz	0.44 V rms	24 dB Output Attenuator
20	1 kHz	0.35 V rms	26 dB Output Attenuator
21	1 kHz	0.28 V rms	28 dB Output Attenuator
22	1 kHz	0.22 V rms	30 dB Output Attenuator
23	1 kHz	5.5 V rms	2 dB Pre-attenuator
24	1 kHz	4.4 V rms	4 dB Pre-attenuator
25	1 kHz	3.5 V rms	6 dB Pre-attenuator
26	1 kHz	2.8 V rms	8 dB Pre-attenuator
27	1 kHz	2.2V rms	10 dB Pre-attenuator
28	1 kHz	1.7 V rms	12 dB Pre-attenuator
29	1 kHz	1.4 Vrms	14 dB Pre-attenuator

2. Send the CAL:VALue <measured Vac> to the function generator.
3. Send CAL? command to the function generator to initiate calibration.
4. Repeat steps 1, 2 and 3 for SETUP 09 through 29.
5. Perform the “AC Amplitude Verification” on page 169.

Modulation Adjustment

The function generator stores three calibration constants related to amplitude modulation depth. The constants are calculated from the adjustment value entered. *If the calibration procedure is aborted before all setup steps have been completed, no calibration constants are stored.*

1. Use a DMM to measure the function generator ACrms output voltage for SETUP 30 in the following table. These adjustments use a HIGH Z output termination.

Table D-14. Modulation Adjustment Setups

SETUP	Nominal Output		Adjustment for:
	FREQUENCY	AMPLITUDE	
30	1 kHz	3.5 Vrms	0% modulation depth.
31	1 kHz	0.707 Vrms	50% modulation depth.
32	1 kHz	6.36 Vrms	100% modulation depth.

2. Send the CAL:VALue <measured Vac> to the function generator.
3. Send the CAL? command to the function generator to initiate the calibration.
4. Repeat steps 1, 2 and 3 for SETUP 31 through 32.
5. Perform the “AM Modulation Depth Verification” on page 172.

Note **NEW CALIBRATION:** A new calibration (SETUP 85 – Rev 4.0) has been added to eliminate a small residual error in the AM amplitude system which could potentially cause a failure of the AM amplitude verification. The new calibration operates just like the other AM calibrations (SETUP 30, 31, 32) in that the external measurement is AC Vrms with no load. The new calibration is not allowed until the other AM gain calibrations (SETUP 30, 31, 32) are performed.

The new algorithm is designed such that the calibration should not be required again once the function generator has been calibrated at the factory. However, if you change any critical analog components which determine amplitude in AM modulation, you should perform the calibration again.

AC Amplitude Adjustment (50 Ohms)

1. The function generator stores sixteen calibration constants related to 50 Ω output. The constants are calculated from the adjustment value entered. The calibration constants are stored following completion of SETUP 49 and the calibration procedure may be aborted after that point. *No calibration constants are stored if the procedures are aborted at any other setup.*
2. Use the DMM to measure the resistance of a 50 Ω feedthrough load. Record the measurement for step 3. You can measure the load and cable resistance (recommended procedure) or just the load as shown below.

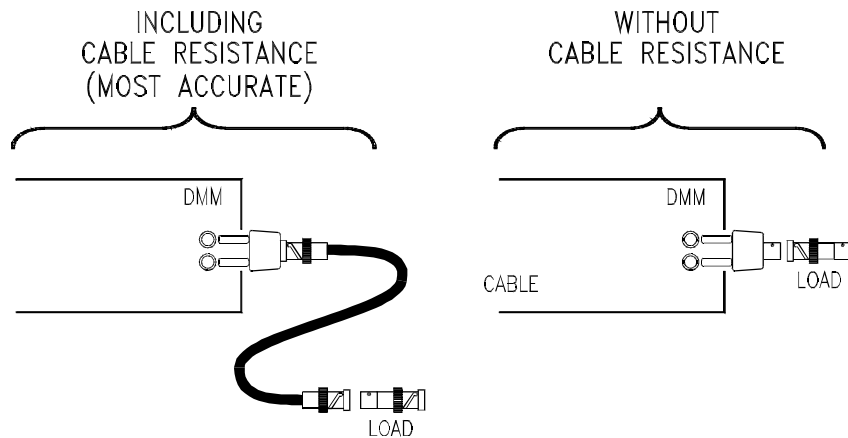

Figure D-2. 50 Ohm Feedthrough/Cable Resistance Measurement

3. Enter the following SETUP 33 and measure the value of the 50 Ω feedthrough load (and cable). Send the CAL:VALue <measured Ω > to the function generator. This number will be used to calculate the 50 Ω output amplitude calibration constants.

Table D-15. 50 Ohm Adjustment Setup

	Nominal Input	
SETUP	LOAD Z	
33	50 Ω	Enter measured value of load.

Note Once the value of the 50 Ω load and cable are entered, use the SAME load and cable for all 50 Ω tests.

4. Use the DMM to measure the function generator ACrms output voltage for SETUP 34 in the table on the next page. These adjustments use the 50 Ω load and cable measured in step 2 and connected as shown in Figure D-3.

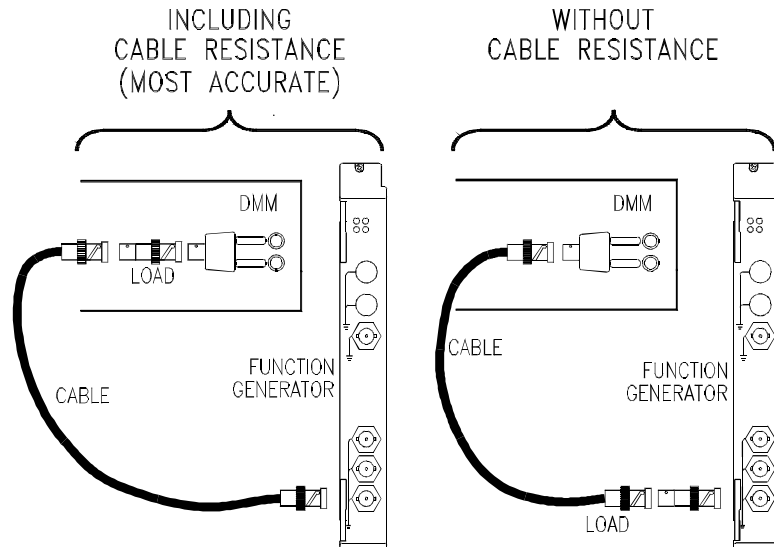

Figure D-3. AC Amplitude (50 Ohms) Adjustment Connection

Table D-16. AC Amplitude (50 Ohms) Adjustment Setups

SETUP	Nominal Output+		Adjustment for:
	FREQUENCY	AMPLITUDE	
34	1 kHz	3.5 Vrms	0 dB Output Attenuator
35	1 kHz	2.8 Vrms	2 dB Output Attenuator
36	1 kHz	2.23 Vrms	4 dB Output Attenuator
37	1 kHz	1.77 Vrms	6 dB Output Attenuator
38	1 kHz	1.41 Vrms	8 dB Output Attenuator
39	1 kHz	1.12 Vrms	10 dB Output Attenuator
40	1 kHz	.887 Vrms	12 dB Output Attenuator
41	1 kHz	.704 Vrms	14 dB Output Attenuator
42	1 kHz	.559 Vrms	16 dB Output Attenuator
43	1 kHz	.442 Vrms	18 dB Output Attenuator
44	1 kHz	.350 Vrms	20 dB Output Attenuator
45	1 kHz	.281 Vrms	22 dB Output Attenuator
46	1 kHz	.223 Vrms	24 dB Output Attenuator
47	1 kHz	.177 Vrms	26 dB Output Attenuator
48	1 kHz	.141 Vrms	28 dB Output Attenuator
49	1 kHz	.112 Vrms	30 dB Output Attenuator

5. Send the CAL:VALue <measured Vac> to the function generator.
6. Send CAL? command to the function generator to initiate calibration.
7. Repeat steps 4, 5 and 6 for SETUP 35 through 49.
8. Perform the “AC Amplitude Verification” on page 169.

DC Output Adjustment

The function generator stores nine calibration constants related to DC volts output. The constants are calculated from the adjustment value entered. The calibration constants are stored following completion of SETUP 59. *No calibration constants are stored if the procedures are aborted at any other setup.*

1. Use a DMM to measure the function generator DCV output voltage for SETUP 50 in the following table. These adjustments use a HIGH Z output termination.

Table D-17. DC Output Adjustment Setups

	Nominal Output	
SETUP	DC Volts	Adjustment for:
50	- 8.0 VDC	Negative offset gain
51	8.0 VDC	Positive offset gain
52	0.0 VDC	AM offset
53	0.0 VDC	2 dB Pre-attenuator offset.
54	0.0 VDC	4 dB Pre-attenuator offset.
55	0.0 VDC	6 dB Pre-attenuator offset.
56	0.0 VDC	8 dB Pre-attenuator offset.
57	0.0 VDC	10 dB Pre-attenuator offset.
58	0.0 VDC	12 dB Pre-attenuator offset.
59	0.0 VDC	14 dB Pre-attenuator offset.

2. Send the CAL:VALue <measured Vdc> to the function generator.
3. Send the CAL? command to the function generator to initiate the calibration.
4. Repeat steps 1, 2 and 3 for SETUP 51 through 59.
5. Perform the “DC Function Offset Verification” on page 168.

Duty Cycle Adjustment

The function generator stores two calibration constants related to squarewave offset and two calibration constants related to squarewave duty cycle. The constants are calculated from the adjustment value entered. The calibration constants are stored following completion of SETUP 63. *No calibration constants are stored if the procedures are aborted at any other setup.*

1. Use a DMM to measure the function generator DCV output voltage for SETUP 60 in the following table. These adjustments use a HIGH Z output termination.

Note For this test, the DMM must be set to a fixed range capable of measuring from +10 V to -10 V. Do not use an auto-ranging function for this test.

Table D-18. Duty Cycle Adjustment Setups

	Nominal Output	+	
SETUP	FREQUENCY	AMPLITUDE	
60	—	10.0 VDC	Positive squarewave offset.
61	—	-10.0 VDC	Negative squarewave offset.
62	300 Hz	0.0 VDC	50% duty cycle squarewave.
63	300 Hz	5.0 VDC	75% duty cycle squarewave

2. Send the CAL:VALue <measured Vdc> to the function generator.
3. Send the CAL? command to the function generator to initiate the calibration.
4. Repeat steps 1, 2 and 3 for SETUP 61 through 63.
5. Perform the “Square Wave Duty Cycle Verification” on page 172.

AC Amplitude Flatness Adjustment

The function generator stores eleven calibration constants related to AC Amplitude Flatness from 1 kHz to 15 MHz. The constants are calculated from the adjustment value entered and one of two calculation constants related to the type of measurement device you are using. The calibration constants are stored following completion of SETUP 82. *No calibration constants are stored if the procedures are aborted at any other setup.*

This procedure can be performed with one of three types of measurement device; a broadband ACrms voltmeter, a power meter, or a thermal voltage converter. The procedure differs slightly depending upon the type of measurement device used. These adjustments use a 50 Ω output termination.

1. Use a broadband ACrms voltmeter to measure the ACrms output voltage of the function generator for SETUP 64 in table D-19 then go to step 3 to enter that value. Go to step 2 if using a power meter.

Table D-19. AC Flatness Adjustment Setup (broadband AC Voltmeter)

	Nominal Output	+	
SETUP	FREQUENCY	AMPLITUDE	Reference for:
64	1 kHz	3.0 V rms	1 kHz flatness DAC gain

2. A. If you are using a broadband ACrms voltmeter, proceed to step 3.
 B. If you are using a power meter capable of measurements at 1 kHz, use the power meter to measure the function generator output for SETUP 83 in table D-20 then go to step 3 to enter that value. (If your power meter does not measure to 1 kHz, see the transfer measurement procedure below).

Table D-20. AC Flatness Adjustment Setup (power meter)

	Nominal Output	+	
SETUP	FREQUENCY	AMPLITUDE	Reference for:
83	1 kHz	3.0 V rms	V rms, dBm

Power Meter Transfer Measurement Procedure (> 1 kHz)

If you are using a power meter not capable of measurement to 1 kHz, you can perform the transfer measurement at a different frequency. For example, the Agilent 437A Power Meter with the Agilent 8482A probe and 20 dB attenuator are specified to a low frequency of 100 kHz. To use this measurement device, perform step 1, then use SETUP 65 (instead of SETUP 64) to obtain a 100 kHz output. Measure the output with the power meter, record the measured value, perform SETUP 83 and enter the recorded value from SETUP 64 (not a new measurement). Then, perform step 3 (you will use SETUP 65 twice). *This procedure assumes the function generator output is flat from 1 kHz to 100 kHz.*

- C. If you are using a Thermal Voltage Converter (TVC), use the TVC to measure the function generator output and enter the measurement for SETUP 84 in table D-21. (TVC values entered are in mVDC).

Table D-21. AC Flatness Adjustment Setup (thermal converter)

SETUP	FREQUENCY	AMPLITUDE	Reference for:
84	1 kHz	3.0 V rms	Thermal Voltage Converter

3. Send the CAL:VALue <measured Vac> to the function generator.
4. Send the CAL? command to the function generator to initiate the calibration.
5. Configure SETUP 65 in Table D-22 and repeat steps 3 and 4 for SETUP 65 through 82 in table D-22.

Table D-22. AC Flatness Adjustment Setups

SETUP	Nominal Output		Adjustment for:
	FREQUENCY	AMPLITUDE	
65	100 kHz	3.0 V rms	100 kHz amplitude flatness
66	500 kHz	3.0 V rms	500 kHz amplitude flatness
67	1 MHz	3.0 V rms	1 MHz amplitude flatness
68	3 MHz	3.0 V rms	3 MHz amplitude flatness
69	5 MHz	3.0 V rms	5 MHz amplitude flatness
70	7 MHz	3.0 V rms	7 MHz amplitude flatness
71	9 MHz	3.0 V rms	9 MHz amplitude flatness
72	10 MHz	3.0 V rms	10 MHz amplitude flatness
73	10.5 MHz	3.0 V rms	10.5 MHz amplitude flatness
74	11 MHz	3.0 V rms	11 MHz amplitude flatness
75	11.5 MHz	3.0 V rms	11.5 MHz amplitude flatness
76	12 MHz	3.0 V rms	12 MHz amplitude flatness
77	12.5 MHz	3.0 V rms	12.5 MHz amplitude flatness
78	13 MHz	3.0 V rms	13 MHz amplitude flatness
79	13.5 MHz	3.0 V rms	13.5 MHz amplitude flatness
80	14 MHz	3.0 V rms	14 MHz amplitude flatness
81	14.5 MHz	3.0 V rms	14.5 MHz amplitude flatness
82	15 MHz	3.0 V rms	15 MHz amplitude flatness

6. Perform the “Amplitude Flatness Verification” on page 171.

Error Messages

The following tables are abbreviated lists of function generator's error messages. They are intended to include errors which are likely to be encountered during the procedures described in this chapter. See “Agilent E1441A Error Messages” on page 141 for a more complete list of error messages.

Table D-23. System Error Messages

Error	Error Message
-330	Self-test Failed
-350	Too many errors
501	Isolator UART framing error
502	Isolator UART overrun error
521	Input buffer overflow
522	Output buffer overflow
550	Command not allowed in Local

Table D-24. Self-Test Error Messages

Error	Error Message
602	RAM read/write fail
603	Waveform RAM readback failed
604	Modulation RAM readback failed
605	Serial configuration readback failed
606	Waveform ASIC failed
607	SYNC signal detection failure
608	SYNC signal detection failure
625	I/O Processor not responding
626	I/O Processor failed self-test
627	I/O Processor reset; possible low power line voltage

Table D-25. Calibration Error Messages

Error	Error Message
701	Cal security disabled by jumper
702	Cal secured
703	Invalid secure code
704	Secure code too long
705	Cal aborted
706	Cal value out of range
707	Cal signal measurement out of range
708	Flatness cal failed
709	Cannot calibrate frequency while externally locked (Option 001)
760	RAM checksum failure
850	Cal setup invalid
851	Negative offset gain cal required (CAL:SETup 50)
852	Flatness DAC gain cal required (CAL:SETup 64)
853	AM cal 1 required (CAL:SETup 30)
854	AM cal 2 required (CAL:SETup 31)
855	Cal load resistance not specified (CAL:SETup 33)
856	Square wave positive offset cal required (CAL:SETup 60)
857	Square wave 50% duty cycle cal required (CAL:SETup 62)
858	AM cal 3 required (CAL:SETup 32)

Performance Test Record

Copy and use Table D-26, *Performance Test Record*, to record performance verification test results for the Agilent E1441A. This table shows Agilent E1441A instrument accuracy, Agilent 34401A/E1412A Multimeter measurement uncertainty, and test accuracy ratio (TAR) values.

Test Limits Test limits are defined using the specifications in *Appendix A of this manual*.

Measurement Uncertainty For the performance verification tests in this manual, the measurement uncertainties are based on the 90-day accuracy specifications for the Agilent 34401A Multimeter and the Agilent E1412A VXi Multimeter.

Test Accuracy Ratio (TAR) Test Accuracy Ratio (TAR) for the Agilent E1441A is defined as Agilent E1441A Accuracy divided by Measurement Uncertainty, where accuracy = maximum allowable value - expected reading. That is:

$$TAR = \frac{\text{Maximum Value} - \text{Expected Reading}}{\text{Measurement Uncertainty}}$$

For TARs that exceed 10:1, the entry is ">10:1".

Table D-26. Performance Test Record for the Agilent E1441A (Page 2 of 7)

Test Equipment Used: Description	Model No.	Trace No.	Cal Due Date
1. _____	_____	_____	_____
2. _____	_____	_____	_____
3. _____	_____	_____	_____
4. _____	_____	_____	_____
5. _____	_____	_____	_____
6. _____	_____	_____	_____
7. _____	_____	_____	_____
8. _____	_____	_____	_____
9. _____	_____	_____	_____
10. _____	_____	_____	_____
11. _____	_____	_____	_____
12. _____	_____	_____	_____
13. _____	_____	_____	_____
14. _____	_____	_____	_____
15. _____	_____	_____	_____
16. _____	_____	_____	_____
17. _____	_____	_____	_____
18. _____	_____	_____	_____
19. _____	_____	_____	_____
20. _____	_____	_____	_____

Table D-26. Performance Test Record for the Agilent E1441A (Page 3 of 7)

Agilent E1441A Frequency Accuracy						
Function	Output	Minimum	Measured	Maximum	M.U.	TAR
Sine wave	3.5V @ 1.0 kHz	999.99 Hz		1000.01 Hz	0.55e-3	>10:1
Square wave	3.5V @ 1.0 kHz 500 Hz burst rate	495 Hz		505 Hz	1e-4	>10:1

Agilent E1441A Function Gain and Linearity						
Function	Output	Minimum	Measured	Maximum	M.U.	TAR
Sine wave	7.0V @ 1.0 kHz	6.93 Vrms		7.07 Vrms	6.5e-3	>10:1
Sine wave	5.7V @ 1.0 kHz	5.643 Vrms		5.757 Vrms	5.9e-3	9.7:1
Triangle wave	5.7V @ 100 Hz	5.643 Vrms		5.757 Vrms	5.9e-3	9.7:1
Ramp wave	5.7V @ 100 Hz	5.643 Vrms		5.757 Vrms	5.9e-3	9.7:1
Square wave	10V @ 100 Hz	9.9 Vrms		10.1 Vrms	8e-3	12.5:1
Square wave	8.0 V @ 100 Hz	7.92 Vrms		8.08 Vrms	7e-3	11.4:1

Agilent E1441A DC Function Offset						
Function	Output	Minimum	Measured	Maximum	M.U.	TAR
DC Volts	10.0 Vdc	9.8 Vdc		10.2 Vdc	0.25e-3	>10:1
DC Volts	-10.0 Vdc	-10.2 Vdc		-9.8 Vdc	0.25e-3	>10:1

Table D-26. Performance Test Record for the Agilent E1441A (Page 4 of 7)

Agilent E1441A AC Amplitude (High Z)						
Function	Output	Minimum	Measured	Maximum	M.U.	TAR
Sine wave	7V @ 1 kHz	6.930 Vrms		7.07 Vrms	6.50e-3	>10:1
Sine wave	5.7V @ 1 kHz	5.643 Vrms		5.757 Vrms	5.85e-3	9.74:1
Sine wave	5.5V @ 1 kHz	4.950 Vrms		5.555 Vrms	5.75e-3	9.56:1
Sine wave	4.4V @ 1 kHz	4.356 Vrms		4.444 Vrms	5.20e-3	8.46:1
Sine wave	3.5V @ 1 kHz	3.465 Vrms		3.535 Vrms	4.75e-3	7.36:1
Sine wave	2.8V @ 1 kHz	2.772 Vrms		2.828 Vrms	4.40e-3	6.36:1
Sine wave	2.2V @ 1 kHz	2.178 Vrms		2.222 Vrms	4.10e-3	5.36:1
Sine wave	1.7V @ 1 kHz	1.683 Vrms		1.717 Vrms	3.85e-3	4.42:1
Sine wave	1.4V @ 1 kHz	1.386 Vrms		1.414 Vrms	3.70e-3	3.78:1
Sine wave	1.1V @ 1 kHz	1.089 Vrms		1.111 Vrms	3.55e-3	3.10:1
Sine wave	0.88V @ 1 kHz	0.8712 Vrms		0.8888 Vrms	0.74e-3	>10:1
Sine wave	0.70V @ 1 kHz	0.6930 Vrms		0.7070 Vrms	0.65e-3	>10:1
Sine wave	0.55V @ 1 kHz	0.5445 Vrms		0.5555 Vrms	0.58e-3	9.48:1
Sine wave	0.44V @ 1 kHz	0.4356 Vrms		0.4444 Vrms	0.52e-3	8.46:1
Sine wave	0.35V @ 1 kHz	0.3465 Vrms		0.3535 Vrms	0.48e-3	7.29:1
Sine wave	0.28V @ 1 kHz	0.2772 Vrms		0.2828 Vrms	0.44e-3	6.36:1
Sine wave	0.22V @ 1 kHz	0.2178 Vrms		0.2222 Vrms	0.41e-3	5.36:1
Sine wave	0.17V @ 1 kHz	0.1683 Vrms		0.1717 Vrms	0.39e-3	4.36:1
Sine wave	0.14V @ 1 kHz	0.1386 Vrms		0.1414 Vrms	0.37e-3	3.78:1
Sine wave	0.11V @ 1 kHz	0.1089 Vrms		0.1111 Vrms	0.36e-3	3.06:1
Sine wave	0.088V @ 1 kHz	0.08712 Vrms		0.08888 Vrms	80e-6	>10:1
Sine wave	0.070V @ 1 kHz	0.06930 Vrms		0.07070 Vrms	75e-6	9.3:1
Sine wave	0.055V @ 1kHz	0.05445 Vrms		0.05555 Vrms	68e-6	8.1:1
Sine wave	0.044V @ 1 kHz	0.04356 Vrms		0.04444 Vrms	62e-6	7.1:1
Sine wave	0.036V @ 1 kHz	0.03564 Vrms		0.03636 Vrms	58e-6	6.2:1

Table D-26. Performance Test Record for the Agilent E1441A (Page 5 of 7)

Agilent E1441A AC Amplitude (50 Ohms)						
Function	Output	Minimum	Measured	Maximum	M.U.	TAR
Sine wave	3.5V @ 1 kHz	3.465 Vrms		3.535 Vrms	4.75e-3	7.37:1
Sine wave	2.8V @ 1 kHz	2.772 Vrms		2.828 Vrms	4.40e-3	6.36:1
Sine wave	2.2V @ 1 kHz	2.178 Vrms		2.222 Vrms	4.10e-3	5.37:1
Sine wave	1.7V @ 1 kHz	1.683 Vrms		1.717 Vrms	3.85e-3	4.42:1
Sine wave	1.4V @ 1 kHz	1.386 Vrms		1.414 Vrms	3.70e-3	3.78:1
Sine wave	1.1V @ 1 kHz	1.089 Vrms		1.111 Vrms	3.55e-3	3.10:1
Sine wave	0.88V @ 1 kHz	0.8712 Vrms		0.8888 Vrms	0.74e-3	>10:1
Sine wave	0.70V @ 1 kHz	0.6930 Vrms		0.7070 Vrms	0.65e-3	>10:1
Sine wave	0.55V @ 1 kHz	0.5445 Vrms		0.5555 Vrms	0.57e-3	9.65:1
Sine wave	0.44V @ 1 kHz	0.4356 Vrms		0.4444 Vrms	0.52e-3	8.46:1
Sine wave	0.35V @ 1 kHz	0.3465 Vrms		0.3535 Vrms	0.47e-3	7.45:1
Sine wave	0.28V @ 1 kHz	0.2772 Vrms		0.2828 Vrms	0.44e-3	6.36:1
Sine wave	0.22V @ 1 kHz	0.2178 Vrms		0.2222 Vrms	0.41e-3	5.37:1
Sine wave	0.17V @ 1 kHz	0.1683 Vrms		0.1717 Vrms	0.38e-3	4.47:1
Sine wave	0.14V @ 1 kHz	0.1386 Vrms		0.1414 Vrms	0.37e-3	3.78:1
Sine wave	0.11V @ 1 kHz	0.1089 Vrms		0.1111 Vrms	0.35e-3	3.14:1
Sine wave	0.088V @ 1 kHz	0.08712 Vrms		0.08888 Vrms	84e-6	>10:1
Sine wave	0.070V @ 1 kHz	0.06930 Vrms		0.07070 Vrms	75e-6	9.30:1
Sine wave	0.055V @ 1 kHz	0.05445 Vrms		0.05555 Vrms	68e-6	8.10:1
Sine wave	0.044V @ 1 kHz	0.04356 Vrms		0.04444 Vrms	62e-6	7.10:1
Sine wave	0.035V @ 1 kHz	0.03465 Vrms		0.03535 Vrms	58e-6	6.03:1
Sine wave	0.028V @ 1 kHz	0.02772 Vrms		0.02828 Vrms	54e-6	5.19:1
Sine wave	0.022V @ 1 kHz	0.02178 Vrms		0.02222 Vrms	51e-6	4.31:1
Sine wave	0.018V @ 1 kHz	0.01782 Vrms		0.01818 Vrms	49e-6	3.67:1

Table D-26. Performance Test Record for the Agilent E1441A (Page 6 of 7)

Agilent E1441A Amplitude Flatness						
Function	Output	Minimum	Measured	Maximum	M.U.	TAR
Sine wave	3.0V @ 1 kHz	reference		reference	NA	Pass /Fail
Sine wave	3.0V @ 100 kHz	ref - 0.030V		ref + 0.030V	NA	Pass /Fail
Sine wave	3.0V @ 500 kHz	ref - 0.045V		ref + 0.045V	NA	Pass /Fail
Sine wave	3.0V @ 1 MHz	ref - 0.045V		ref + 0.045V	NA	Pass /Fail
Sine wave	3.0V @ 3 MHz	ref - 0.060V		ref + 0.060V	NA	Pass /Fail
Sine wave	3.0V @ 5 MHz	ref - 0.060V		ref + 0.060V	NA	Pass /Fail
Sine wave	3.0V @ 7 MHz	ref - 0.060V		ref + 0.060V	NA	Pass /Fail
Sine wave	3.0V @ 9 MHz	ref - 0.060V		ref + 0.060V	NA	Pass /Fail
Sine wave	3.0V @ 11 MHz	ref - 0.060V		ref + 0.060V	NA	Pass /Fail
Sine wave	3.0V @ 13 MHz	ref - 0.060V		ref + 0.060V	NA	Pass /Fail
Sine wave	3.0V @ 15 MHz	ref - 0.060V		ref + 0.060V	NA	Pass /Fail

Agilent E1441A AM Modulation						
Function	Output	Minimum	Measured	Maximum	M.U.	TAR
Sine wave Modulated	1.0V @ 1 kHz 100 Hz, 0%	0.495 Vrms		0.505 Vrms	0.8e-3	6.25:1
Sine wave Modulated	1.0V @ 1 kHz 100 Hz, 100%	0.6039 Vrms		0.6161 Vrms	0.8e-3	7.63:1

Optional Performance Verification Tests

Table D-26. Performance Test Record for the Agilent E1441A (Page 7 of 7)

Agilent E1441A Square Wave Duty Cycle						
Function	Output	Minimum	Measured	Maximum	M.U.	TAR
Square wave	1V @ 300 Hz 50% duty cycle	-0.02Vdc		0.02Vdc	25e-6	>10:1
Square wave	1V @ 300 Hz 25% duty cycle	-0.52Vdc		-0.48Vdc	25e-6	>10:1
Square wave	1V @ 300 Hz 75% duty cycle	0.48Vdc		0.52Vdc	25e-6	>10:1

Agilent E1441A Distortion						
Function	Output	Minimum	Measured	Maximum	M.U.	TAR
Sine wave	1.1V @ 20 kHz	reference		reference	NA	Pass/Fail
2nd Harmonic	40 kHz	>70dB		NA	NA	Pass/Fail
3rd Harmonic	60 kHz	>70dB		NA	NA	Pass/Fail
4th Harmonic	80 kHz	>70dB		NA	NA	Pass/Fail
5th Harmonic	100 kHz	>70dB		NA	NA	Pass/Fail
Sine wave	1.1V @ 100 kHz	reference		reference	NA	Pass/Fail
2nd Harmonic	200 kHz	>60dB		NA	NA	Pass/Fail
3rd Harmonic	300 kHz	>60dB		NA	NA	Pass/Fail
4th Harmonic	400 kHz	>60dB		NA	NA	Pass/Fail
5th Harmonic	500 kHz	>60dB		NA	NA	Pass/Fail
Sine wave	1.1V @ 1 MHz	reference		reference	NA	Pass/Fail
2nd Harmonic	2 MHz	>45dB		NA	NA	Pass/Fail
3rd Harmonic	3 MHz	>45dB		NA	NA	Pass/Fail
4th Harmonic	4 MHz	>45dB		NA	NA	Pass/Fail
5th Harmonic	5 MHz	>45dB		NA	NA	Pass/Fail
Sine wave	1.1V @ 15 MHz	reference		reference	NA	Pass/Fail
2nd Harmonic	30 MHz	>35dB		NA	NA	Pass/Fail
3rd Harmonic	45 MHz	>35dB		NA	NA	Pass/Fail
4th Harmonic	60 MHz	>35dB		NA	NA	Pass/Fail
5th Harmonic	75 MHz	>35dB		NA	NA	Pass/Fail

Symbols

*CLS, 124–125
 *ESE, 124
 *ESE?, 124
 *ESR?, 124–125
 *IDN?, 56, 124, 126
 *OPC, 122, 124, 126
 *OPC?, 122, 124, 126
 *RCL, 127
 *RST, 124, 127
 *SAV, 128
 *SRE, 124, 128
 *SRE?, 124, 129
 *STB?, 124, 129
 *TRG, 53, 122, 124, 129
 *TST?, 124, 129
 *WAI, 122, 124, 129

A

abbreviated commands, 70
 Aborting a Calibration in Progress, 178
 AC Amplitude Adjustment (50 Ohms), 182
 AC Amplitude Adjustment (High-Z), 180
 AC Amplitude Flatness Adjustment, 185
 AC Amplitude Verification, 169
 AC signals, 157
 ac signals, attribute diagram, 157
 Access indicator, 16
 address switch
 location, 14
 setting, 14
 Agilent Technologies Calibration Services, 164
 AM (amplitude modulation)
 carrier frequency range, 29
 carrier waveshape, 28
 modulating frequency range, 29, 94
 modulating source, 30, 94
 modulating waveshape, 29, 94
 modulation depth, 29, 93
 operation, 28
 sync signal, 29
 technical description, 158
 AM Modulation Depth Verification, 172
 AM Modulation terminal, 30, 93
 amplitude

and output termination, 23, 114–115
 arb waveform limitations, 112, 114
 conflict with function, 23, 115
 limits, 22, 114
 restrictions with offset, 23
 selecting units, 24–25, 115
 selection, 22, 114
 Amplitude Control, 156
 Amplitude Flatness Verification, 171
 angle, burst modulation, 39, 103
 APPLy command, optional parameters, 96
 APPLy command, parameters, 96
 APPLy command, using with option 001, 50
 APPLy commands (SOURce subsystem), 96
 APPLy:DC, 100
 APPLy:NOISe, 100
 APPLy:RAMP, 100
 APPLy:SINusoid, 100
 APPLy:SQUare, 101
 APPLy:TRIangle, 101
 APPLy:USER, 101
 APPLy?, 101
 arbitrary waveform
 amplitude limitations, 112, 114
 average value, 79
 binary data, 78
 built-in waveforms, 48, 111
 catalog listing, 81, 83
 copy name, 81
 crest factor value, 79
 delete waveform, 82
 floating-point data, 77
 frequency limits, 22, 107
 inherent offset, 112
 internal operation, 46
 memory available, 83
 memory limitations, 82
 modulation matrix, 111
 name rules, 79–82, 110
 peak-to-peak value, 80
 query points, 80
 recalling arbs with a stored configuration, 127
 reserved names, 81
 storing arbs with configuration (*SAV), 128
 arbitrary waveform errors, 149
 arbitrary waveforms, built-in, 48

attributes, [157](#)
Attributes of AC signals, [157](#)
Automating Calibration Procedures, [164](#)
average value, [158](#)
average, of arb data points, [79](#)

B

binary block format, [78–79](#)
binary block header, [79](#)
binary data
 block format, [78](#)
 byte order, [84](#)
binary, arb waveform data, [78](#)
block format, binary data, [78](#)
block header, binary, [79](#)
boolean parameters, [71](#)
built-in arb waveforms, [111](#)
burst
 burst modulation, [160](#)
burst count, [38, 102](#)
 restrictions, [37–38, 102](#)
burst frequency, [39, 103](#)
Burst input terminal, [54](#)
burst modulation
 burst count restrictions, [37–38, 102](#)
 burst count selection, [38](#)
 burst count setting, [102](#)
 carrier frequency range, [36](#)
 gate source, [104](#)
 internal rate, [39, 103](#)
 operation, [33](#)
 starting phase, [39, 103](#)
 sync signal, [38](#)
 technical description, [160](#)
 trigger source, [35](#)
burst phase, [39, 103](#)
burst rate, [39, 103](#)
bus triggering, [53, 122](#)
byte order, binary data, [84](#)

C

Calibration, [164, 174, 177](#)
calibration, [176](#)
Calibration Count, [176](#)
calibration errors, [147](#)
Calibration Interval, [164](#)
Calibration Message, [176](#)
calibration message
 string length, [176](#)
calibration procedure related, [188](#)

Calibration Security Code, [174](#)
calibration security code
 changing, [74](#)
 disabling, [74](#)
 enabling, [74](#)
CALibration subsystem, [73](#)
 CALibration
 COUNT?, [73](#)
 SECure
 CODE, [74](#)
 STATE, [74](#)
 STATE?, [75](#)
 SETup, [75](#)
 SETup?, [75](#)
 STRing, [75](#)
 STRing?, [76](#)
 VALue, [76](#)
 VALue?, [76](#)
 CALibration?, [73](#)
carrier frequency
 AM, [29](#)
 burst modulation, [36](#)
 FM, [31](#)
 FSK, [40](#)
carrier waveshape
 AM, [28](#)
 FM, [31](#)
catalog, of arb waveform names, [81, 83](#)
clearing the error queue, [120](#)
clearing the status conditions at power-up, [127](#)
closed-case electronic, [164](#)
Closed-case electronic calibration, [164](#)
*CLS, [124–125](#)
command Fundamentals, [70](#)
command reference, [65, 72](#)
 (*) common commands, [124](#)
 CALibration subsystem, [73](#)
 DATA subsystem, [77](#)
 FORMat subsystem, [84](#)
 MEMory subsystem, [85](#)
 OUTPut subsystem, [87](#)
 PHASe subsystem, [90](#)
 SOURce subsystem, [92](#)
 STATus subsystem, [117–118](#)
 SYSTem subsystem, [120](#)
 TRIGger subsystem, [121](#)
command reference, SCPI commands, [72](#)
command separator, [70](#)
command subsystems, description, [65](#)
commands
 abbreviated, [70](#)

- alphabetical listing, 65
- common command format, 70
- implied, 71
- linking, 71
- parameter types, 71
- quick reference, 131
- SCPI command format, 70
- separators, 70
- upper case vs. lower case, 70

common (*) command

- *CLS, 124–125
- *ESE, 124–125
- *ESE?, 124–125
- *ESR?, 124–125
- *IDN?, 124, 126
- *OPC, 124, 126
- *OPC?, 124, 126
- *RCL, 127
- *RST, 124, 127
- *SAV, 128
- *SRE, 124, 128
- *SRE?, 124, 129
- *STB?, 124, 129
- *TRG, 124, 129
- *TST?, 124, 129
- *WAI, 124, 129

format, 70

PSC, 127

reference, 124

common (*) commands

- *PSC?, 127

Common Command Reference, 124

configuration state

- deleting, 85

- recalling, 127

- saving, 128

Connectors, faceplate, 16

copy, arb waveform name, 81

Count, 176

crest factor, of arb data points, 79

cycles, number of, 38, 102

D

data points, number in arb waveform, 80

DATA subsystem, 77

DATA

ATTRibute

- AVERage?, 79

- CFACTOR?, 79

- POINTs?, 80

- PTPeak?, 80

- CATalog?, 81

- COPY, 81

- DACVOLATILE, 78

- DELeTe, 82

 - ALL, 83

- NVOLatile

 - CATalog?, 83

 - FREE?, 83

 - DATAVOLATILE, 77

dBm, 25, 116

dBm value, 158

DC Function Offset Verification, 168

dc offset

- and arb waveforms, 112

- and dc voltage function, 25, 116

- and output termination, 24, 116

- selection, 24, 115

DC Output Adjustment, 184

degrees (DEG)

- phase offset setting, 90

deviation, peak frequency, 32, 105

direct digital synthesis, 153

discrete parameters, 71

Distortion Verification, 173

download

- binary data, 78

- floating-point data, 77

downloading a binary block of data, 79

duty cycle

- conflict with frequency, 26, 112

- definition, 26

- selection, 26, 112

Duty Cycle Adjustment, 185

dynamic addressing, 14

E

Error Messages, 188

error messages, 141–150

error queue

- capacity, 120

- clearing, 55, 120, 141

- reading, 120

ERRor, see SYSTem subsystem, 120

errors

- error queue, 55

Errors indicator, 16

- *ESE, 124–125

- *ESE?, 124–125

- *ESR?, 124–125

example programs, 18

Example programs (VXIplug&play). See online help.

execution errors, [141](#)
Ext Trig Terminal, [54](#)
Ext Trig/FSK/Burst input terminal, [54](#)
 logic levels, [54](#)
external rate, FSK, [110](#)
external source, sweep, [44](#)
external triggering, [53](#), [122](#)

F

Faceplate indicators and Connectors, [16](#)
Face-plate Inputs, [137](#)
Failed indicator, [16](#)
firmware revision, [56](#)
floating, [157](#)
Floating signal generators, [157](#)
floating-point, arb waveform data, [77](#)
FM (frequency modulation)
 carrier frequency range, [31](#)
 carrier waveshape, [31](#)
 modulating frequency range, [32](#), [105](#)
 modulating waveshape, [32](#), [106](#)
 operation, [30](#)
 peak frequency deviation, [105](#)
 sync signal, [32](#)
 technical description, [159](#)
format
 common command, [70](#)
 SCPI command, [70](#)
FORMat subsystem, [84](#)
 FORMat
 BORDER, [84](#)
 BORDER?, [84](#)
frequency
 arb waveform limits, [22](#), [107](#)
 conflict with duty cycle, [22](#)
 conflict with function, [22](#), [107](#)
 limits, [106](#)
 selection, [21](#), [106](#)
Frequency and Burst Rate Adjustment, [178](#)
Frequency Characteristics, [135](#)
frequency deviation, FM, [32](#), [105](#)
Frequency Sweep, [137](#)
frequency sweep, [43](#)
 sweep, [43](#)
Frequency Verification, [167](#)
Frequency-Shift Keying (FSK), [40](#)
FSK
 carrier frequency range, [40](#)
 internal rate, [41](#), [109](#)
 maximum external rate, [110](#)
 modulating (hop) frequency, [41](#), [109](#)

operation, [40](#)
source, [42](#), [109](#)
sync signal, [40](#)
technical description, [160](#)

FSK input terminal, [54](#)
Function Gain and Linearity Adjustment, [179](#)
Function Gain and Linearity Verification, [168](#)
Function Generator Tutorial, [153](#)
Function reference (VXIplug&play). See online help.
function, conflict with amplitude, [20](#)
function, conflict with frequency, [20](#)
function, modulation matrix, [20](#)

G

gate source, burst modulation, [104](#)
General Calibration/Adjustment Procedure, [177](#)
General Information, [13](#)
general procedure, [177](#)
General Specifications, [138](#)
GET (group execute trigger), [53](#), [122](#)
ground loops, [157](#)
Group Execute Trigger (GET), [53](#), [122](#)

H

hop frequency, FSK, [41](#), [109](#)

I

*IDN?, [124](#), [126](#)
IEEE 488.2 Common Commands, [124](#)
implied commands, [71](#)
Indicators, faceplate, [16](#)
inherent offset, arb waveforms, [112](#)
initial operation, [17](#)
interface triggering, [53](#), [122](#)
internal burst rate, [39](#), [103](#)
internal FSK rate, [41](#), [109](#)
internal operations, arbitrary waveforms, [46](#)
internal triggering, [53](#), [122](#)
interrupt priority, [15](#)

J

Jumper, security, [175](#)

L

linear spacing, sweep, [44](#), [113](#)
linking commands, [71](#)
logarithmic spacing, sweep, [44](#), [113](#)
logic levels
 Ext Trig/FSK/Burst input terminal, [54](#)

M

Measurement Uncertainty, 190
memory available, arb waveforms, 83
memory locations, 128
memory locations "0, 1, 2 & 3", 85, 127
MEMory subsystem, 85
 MEMory
 STATe
 DELEte, 85
messages, error, 141
modulating frequency
 AM, 29, 94
 FM, 32, 105
 FSK, 41, 109
modulating source, AM, 30, 94
modulating waveshape
 AM, 29, 94
 FM, 32, 106
Modulation, 158
Modulation Adjustment, 181
Modulation Characteristics, 137
modulation depth
 AM, 29, 93
 with external source, 30, 93

N

noise, and FM, 106
number of cycles, burst modulation, 38, 102
numeric parameters, 71
Nyquist Sampling Theorem, 155

O

offset
 and arb waveforms, 112
 and dc voltage function, 25, 116
 and output termination, 24, 116
 selection, 24, 115
*OPC, 124, 126
*OPC?, 124, 126
Option 001
 Specifications, 139
Option 001 commands
 OUTPut
 TRIGger
 IMMediate, 88
 STATe, 88
 STATe?, 88
 PHASe
 ADJust, 90
 ADJust?, 91

REFerence, 91

UNLock

ERRor

 STATe, 91

 STATe?, 91

option 001 phase-lock errors, 151
optional parameters, 71
optional parameters, APPLy command, 96
Optional Performance Verification Tests, 172
Output, 156
Output Amplifier Adjustment (Optional), 188
output amplitude
 and output termination, 23, 114–115
 arb waveform limitations, 112, 114
 conflict with function, 23, 115
 limits, 22, 114
 restrictions with offset, 23
 selecting units, 24–25, 115
 selection, 22, 114
Output Amplitude Control, 156
Output Characteristics, 136
Output Configuration, 19
output frequency
 arb waveform limits, 22, 107
 conflict with duty cycle, 22
 conflict with function, 22, 107
 limits, 106
 selection, 21, 106
output function
 conflict with amplitude, 20
 conflict with frequency, 20
 modulation matrix, 20
OUTPut subsystem, 87
 OUTPut
 LOAD, 87
 LOAD?, 87
 SYNC, 88
 SYNC?, 88
 TRIGger
 IMMediate (option 001), 88
 STATe (option 001), 88
 STATe? (option 001), 88
output termination
 selection, 25, 87
output termination, schematic, 156
output units
 amplitude, 115
 output amplitude, 25, 116
Overload indicator, 16

P

parameters
 boolean, 71
 discrete, 71
 numeric, 71
 optional, 71
 types of, 71

peak deviation, FM, 32, 105

peak frequency deviation, FM, 32, 105

peak value, 157

peak-to-peak value, 157
 of arb data points, 80

percent modulation (depth), 29
 modulation depth, 29

percentage, duty cycle, 112

Performance Test Record, 190

Performance Verification Tests, 166–167

phase offset setting, 90

phase offset, querying, 91

phase reference, setting, 91

PHASe subsystem (option 001), 90

 PHASe
 ADJust, 90
 ADJust?, 91
 REFerence, 91
 UNLock

 ERRor
 STATe, 91
 STATe?, 91

phase, burst modulation, 39, 103

phase-lock error
 enabling, 91
 generation, 91
 querying, 91

phase-lock errors (option 001), 151

Plug&Play
 VXIplug&play, 13

Plug&Play. See online help.

points, number in arb waveform, 80

power-down
 recalling the last instrument configuration, 127

power-on state, 57, 130

programming the function generator, 17

programs
 example, 18

Q

Quick Performance Check, 167

quick reference
 IEEE 488.2 Common Commands, 124
 SCPI commands, 131

R

radians
 phase offset setting, 90

*RCL, 127

reading the error queue, 120

recalling an instrument configuration, 127

Recommended Test Equipment, 165

reserved names, arb waveforms, 81

reset state, 57, 130

revision number, firmware, 56

RMS value, 157

*RST, 124, 127

rules, arb waveform names, 81

S

*SAV, 128

saving instrument configurations, 128

SCPI command reference, 72, 131

SCPI commands
 abbreviated, 70
 command format, 70
 implied, 71
 linking with common (*) commands, 71
 parameters, 71
 quick reference, 131
 specifying, 17

SCPI, programming examples
 application SCPI command strings, 58

SCPI, version query, 56

Security Code, 174

security code
 lost code, 175

security code, calibration
 changing, 74
 disabling, 74
 enabling, 74

Security jumper, 175

self-test
 complete, 55, 166
 power-on, 55, 166

self-test errors, 147

shift rate, FSK, 41, 109

SICL, Standard Instrument Control Language, 13

Signal Characteristics, 136

Signal generators, 157

Signal Imperfections, 155

Sinewave Spectral Purity, 135

soft front panel
 VXIplug&play Online Help, 13

Soft front panel (VXIplug&play). See online help.

software triggering, 53, 122

SOURce, [92](#)
 AM
 DEPTh, [93](#)
 DEPTh?, [94](#)
 INTernal
 FREQuency, [94](#)
 FUNction, [94](#)
 FUNction?, [94](#)
 SOURce, [94](#)
 SOURce?, [95](#)
 STATe, [95](#)
 APPLY?, [101](#)
 BM
 INTernal
 RATE, [103](#)
 NCYCles, [102](#)
 NCYCles?, [102](#)
 PHASe, [103](#)
 PHASe?, [103](#)
 RATE?, [104](#)
 SOURce, [104](#)
 SOURce?, [104](#)
 STATe, [104](#)
 STATe?, [104](#)
 FM
 DEViation, [105](#)
 INTernal
 FREQuency, [105](#)
 FREQuency?, [106](#)
 FUNction, [106](#)
 FUNction?, [106](#)
 STATe, [106](#)
 STATe?, [106](#)
 FREQuency, [106](#)
 START, [107](#)
 STOP, [108](#)
 STOP?, [108](#)
 FREQuency?, [94](#), [107–108](#)
 FSKey
 FREQuency, [109](#)
 FREQuency?, [109](#)
 INTernal
 RATE, [109](#)
 RATE?, [109](#)
 SOURce, [109](#)
 SOURce?, [110](#)
 STATe, [110](#)
 STATe?, [110](#)
 FUNction
 SHAPe, [111](#)
 SHAPe?, [112](#)
 USER, [110](#)
 USER?, [111](#)
 PULSe
 DCYClE, [112](#)
 DCYClE?, [113](#)
 STATe?, [95](#)
 SWEep
 SPACing, [113](#)
 SPACing?, [113](#)
 STATe, [114](#)
 STATe?, [114](#)
 TIME, [113](#)
 TIME?, [113](#)
 VOLTage, [114](#)
 OFFSet, [115](#)
 OFFSet?, [116](#)
 UNIT, [116](#)
 UNIT?, [116](#)
 VOLTage?, [115](#)
 spacing, linear sweep, [44](#), [113](#)
 spacing, logarithmic sweep, [44](#), [113](#)
 Specifications
 Option 001, [139](#)
 Square Wave Duty Cycle Verification, [172](#)
 *SRE, [124](#), [128](#)
 *SRE?, [124](#), [129](#)
 Standard Commands for Programmable Instrument
 SCPI, [13](#), [65](#)
 start frequency, sweep, [43](#), [107](#)
 starting phase, burst modulation, [39](#), [103](#)
 state storage
 operation, [27](#)
 state storage (configuration state)
 delete state, [85](#)
 state, power-on and reset, [57](#), [130](#)
 STATus subsystem, [117–118](#)
 STATus:PRESet, [117](#)
 STATus:QUEStionable:CONDition?, [117](#)
 STATus:QUEStionable:ENABle, [118](#)
 STATus:QUEStionable:ENABle?, [118](#)
 STATus:QUEStionable[[:EVENTt]]?, [117](#)
 *STB?, [124](#), [129](#)
 stop frequency, sweep, [43](#), [108](#)
 stored configuration states
 delete state, [85](#)
 stored states
 operation, [27](#)
 storing instrument configurations, [128](#)

- swapped byte order, [84](#)
- sweep
 - linear spacing, [44](#), [113](#)
 - logarithmic spacing, [44](#), [113](#)
 - operation, [43](#)
 - start frequency, [43](#), [107](#)
 - stop frequency, [43](#), [108](#)
 - sweep time, [43](#), [113](#)
 - sweep time query, [113](#)
 - sync signal, [43](#)
 - technical description, [159](#)
 - trigger source, [44](#)
- sweep example, logarithmic, [123](#)
- sync signal
 - AM, [29](#)
 - enabling/disabling, [26](#), [88](#)
 - FM, [32](#)
 - for all functions, [26](#)
 - FSK, [40](#)
 - gated burst mode, [38](#)
 - sweep, [43](#)
 - triggered burst mode, [38](#)
- SYNC terminal, [27](#), [88](#)
- System Characteristics, [138](#)
- SYSTem subsystem, [120](#)
 - SYSTem
 - ERRor?, [120](#)
 - VERSion?, [120](#)
- SYSTem subsystem, [120](#)

T

- terminal, Ext Trig/FSK/Burst, [54](#)
 - Ext Trig/FSK/Burst input terminal, [54](#)
- terminals
 - input, [16](#)
- termination, schematic, [156](#)
- termination, selection, [25](#), [87](#)
- Test Accuracy Ratio (TAR), [190](#)
- Test Considerations, [165](#)
- time
 - sweep time, [43](#), [113](#)
 - sweep time query, [113](#)
- Time Required for Calibration, [164](#)
- *TRG, [124](#), [129](#)
- TRIGger, [121](#)
 - SLOPe, [121](#)
 - SLOPe?, [121](#)
- trigger source, [121](#)
 - FSK, [42](#), [109](#)
 - sweep, [44](#)
 - triggered burst mode, [35](#)

- TRIGger subsystem, [121](#)
 - TRIGger
 - SOURce, [121](#)
 - SOURce?, [123](#)
- trigger, sources, [52](#)
- triggering
 - external, [53](#), [122](#)
 - internal, [53](#)
 - internal (immediate), [122](#)
 - overview, [52](#)
 - software (bus), [53](#), [122](#)
- troubleshooting, error messages, [141](#)
- *TST?, [124](#), [129](#)

U

- units
 - amplitude, [115](#)
 - output amplitude, [25](#), [116](#)
- unlocked error, phase-lock loop (option 001), [151](#)
- Unsecure the Function Generator, [175](#)
- Unsecuring (without code), [175](#)

V

- Vpp, [25](#), [116](#)
- Vrms, [25](#), [116](#)
- VXIbus TTLTRG inputs, [137](#)
- VXIplug&play information, [13](#)
- VXIplug&play. See online help.

W

- *WAI, [124](#), [129](#)
- WARNINGS
 - Electical shock, tighten screws, [15](#)
- Waveforms, [135](#)

Z

- zero-phase reference point, [91](#)