

Service Guide

**Agilent Technologies
8719ET/20ET/22ET
8719ES/20ES/22ES
Network Analyzers**



Agilent Technologies

Part Number 08720-90397

Printed in USA

June 2002

Supersedes February 2001

© Copyright 1999 – 2002 Agilent Technologies, Inc.

Notice

The information contained in this document is subject to change without notice.

Agilent Technologies makes no warranty of any kind with regard to this material, including but not limited to, the implied warranties of merchantability and fitness for a particular purpose. Agilent Technologies shall not be liable for errors contained herein or for incidental or consequential damages in connection with the furnishing, performance, or use of this material.

Warranty Information

THE MATERIAL CONTAINED IN THIS DOCUMENT IS PROVIDED "AS IS," AND IS SUBJECT TO BEING CHANGED, WITHOUT NOTICE, IN FUTURE EDITIONS. FURTHER, TO THE MAXIMUM EXTENT PERMITTED BY APPLICABLE LAW, AGILENT DISCLAIMS ALL WARRANTIES, EITHER EXPRESS OR IMPLIED WITH REGARD TO THIS MANUAL AND ANY INFORMATION CONTAINED HEREIN, INCLUDING BUT NOT LIMITED TO THE IMPLIED WARRANTIES OF MERCHANTABILITY AND FITNESS FOR A PARTICULAR PURPOSE. AGILENT SHALL NOT BE LIABLE FOR ERRORS OR FOR INCIDENTAL OR CONSEQUENTIAL DAMAGES IN CONNECTION WITH THE FURNISHING, USE, OR PERFORMANCE OF THIS DOCUMENT OR ANY INFORMATION CONTAINED HEREIN. SHOULD AGILENT AND THE USER HAVE A SEPARATE WRITTEN AGREEMENT WITH WARRANTY TERMS COVERING THE MATERIAL IN THIS DOCUMENT THAT CONFLICT WITH THESE TERMS, THE WARRANTY TERMS IN THE SEPARATE AGREEMENT WILL CONTROL.

Certification

Agilent Technologies Company certifies that this product met its published specifications at the time of shipment from the factory. Agilent Technologies further certifies that its calibration measurements are traceable to the United States National Institute of Standards and Technology, to the extent allowed by the Institute's calibration facility, and to the calibration facilities of other International Standards Organization members.

Regulatory Information

The regulatory information is located in [Chapter 15](#) , “[Safety and Regulatory Information.](#)”

Assistance

Product maintenance agreements and other customer assistance agreements are available for Agilent Technologies products. For any assistance, contact your nearest Agilent Technologies sales or service office. See [Table 15-1 on page 15-3](#) for the nearest office.

Safety Notes

The following safety notes are used throughout this manual. Familiarize yourself with each of the notes and its meaning before operating this instrument. All pertinent safety notes for using this product are located in [Chapter 15](#) , “[Safety and Regulatory Information](#).”

WARNING **Warning denotes a hazard. It calls attention to a procedure which, if not correctly performed or adhered to, could result in injury or loss of life. Do not proceed beyond a warning note until the indicated conditions are fully understood and met.**

CAUTION Caution denotes a hazard. It calls attention to a procedure that, if not correctly performed or adhered to, would result in damage to or destruction of the instrument. Do not proceed beyond a caution sign until the indicated conditions are fully understood and met.

How to Use This Guide

This guide uses the following conventions:

Front-Panel Key

This represents a key physically located on the instrument.

SOFTKEY

This represents a “softkey,” a key whose label is determined by the instrument’s firmware.

Screen Text

This represents text displayed on the instrument’s screen.

Documentation Map

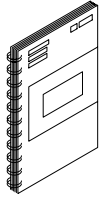

The *Installation and Quick Start Guide* provides procedures for installing, configuring, and verifying the operation of the analyzer. It also will help you familiarize yourself with the basic operation of the analyzer.

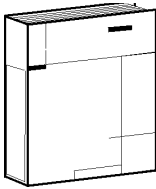

The *User's Guide* shows how to make measurements, explains commonly-used features, and tells you how to get the most performance from your analyzer.

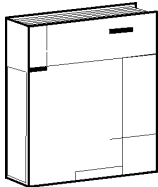

The *Reference Guide* provides reference information, such as specifications, menu maps, and key definitions.

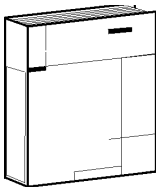

The *Programmer's Guide* provides general GPIB programming information, a command reference, and example programs. The *Programmer's Guide* contains a CD-ROM with example programs.

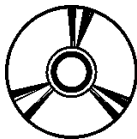

The **CD-ROM** provides the *Installation and Quick Start Guide*, the *User's Guide*, the *Reference Guide*, and the *Programmer's Guide* in PDF format for viewing or printing from a PC.

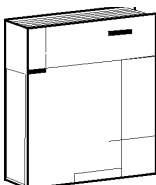

The *Service Guide* provides information on calibrating, troubleshooting, and servicing your analyzer. The *Service Guide* is not part of a standard shipment and is available only as Option 0BW, or by ordering part number 08720-90397. A CD-ROM with the *Service Guide* in PDF format is included for viewing or printing from a PC.

1. Service Equipment and Analyzer Options

Information in This Chapter	1-2
Service Test Equipment	1-3
Principles of Microwave Connector Care	1-6
Analyzer Options	1-7
Option 1D5, High Stability Frequency Reference	1-7
Option 004, Step Attenuator (ET Models)	1-7
Option 007, Mechanical Transfer Switch (ES Models)	1-7
Option 010, Time Domain	1-7
Option 012, Direct Access Receiver Configuration (ES Models)	1-7
Option 085, High Power System (ES Models)	1-8
Option 089, Frequency Offset Mode (ES Models)	1-8
Option 400, Four-Sampler Test Set (ES Models)	1-8
Option 1CP, Rack Mount Flange Kit With Handles	1-8
Option 1CM, Rack Mount Flange Kit Without Handles	1-8
Service and Support Options	1-9
Option W01	1-9
Option W31	1-9
Option W50	1-9
Option W51	1-9
Option W32	1-9
Option W52	1-9
Option W34	1-9
Option W54	1-10

2. System Verification and Performance Tests

Sections in This Chapter	2-2
How to Test the Performance of Your Analyzer	2-3
ANSI/NCSL Z540-1-1994 Verification	2-3
Non-ANSI/NCSL Z540-1-1994 Verification	2-3
Instrument Verification Cycle	2-4
Preliminary Tests	2-6
Required Equipment and Tools	2-6
Check the Temperature and Humidity	2-6
Clean and Gauge All Connectors	2-7
Perform the Internal Test	2-7
Procedure to Perform Operator's Check	2-8
Check the Test Port Cables	2-9
System Verification	2-15
General Information	2-16
Equipment Initialization	2-20
Measurement Calibration	2-22
Verification Device Measurements	2-25
Performing the Verification Tests	2-26
If the System Fails the Verification Test	2-30
Interpreting the Verification Results	2-31
Performance Tests	2-33
Frequency Accuracy Performance Test	2-34
Level Accuracy Performance Test	2-36

Contents

Source Linearity Performance Test	2-38
Dynamic Range Performance Test	2-42
Performance Test Record	2-46
3. Adjustments and Correction Constants	
Information on This Chapter	3-2
A7 Switch Positions	3-4
Source Pretune Correction Constants (Test 43)	3-6
Analog Bus Correction Constants (Test 44)	3-8
IF Step Correction Constants (Test 47)	3-9
ADC Offset Correction Constants (Test 48)	3-10
Serial Number Correction Constants (Test 49)	3-11
Protected Option Numbers Correction Constants (Test 50)	3-13
Unprotected Hardware Option Correction Constants	3-15
Output Power Adjustments	3-17
Preparing the Instrument	3-17
Setting the Main Power DAC to Preset Values	3-18
Setting the Potentiometers to the Minimum Levels	3-19
Adjusting the Mid Band Power	3-20
Adjusting the Low Band Power	3-21
Adjusting the High Band Power (8722ET/ES)	3-21
Fine Tuning the Flatness	3-22
Power Linearity Adjustment	3-24
Preparatory Steps	3-24
Blanking Adjustment (Test 54)	3-30
Preparing the Instrument	3-30
Initialize EEPROMs (Test 53)	3-32
EEPROM Backup Disk Procedure	3-33
Correction Constants Retrieval Procedure	3-35
Loading Firmware	3-36
Loading Firmware into an Existing CPU	3-36
In Case of Difficulty	3-36
Loading Firmware into a New CPU	3-37
Reference Assembly VCO Tune Adjustment	3-39
Frequency Accuracy Adjustment	3-41
In Case of Difficulty	3-43
API Spur Avoidance and 100 kHz FM Sideband Adjustment	3-44
FM Sideband Adjustment (100 kHz Spurs)	3-44
API Adjust	3-46
Raw Offset Correction Constants	3-48
Raw Offset for the R Channel (ET/ES Models)	3-49
Raw Offset for the A and B Channels (ES Models)	3-51
Raw Offsets for the A and B Channels (ET Models)	3-54
Sampler Calibration Correction Constants (Test 51)	3-58
4. Start Troubleshooting Here	
Information on This Chapter	4-2
Assembly Replacement Sequence	4-3

Contents

Having Your Analyzer Serviced	4-4
Step 1. Initial Observations	4-5
Initiate the Analyzer Self-Test	4-5
Step 2. Operator's Check	4-7
Description	4-7
Procedure to Perform Operator's Check.	4-8
In Case of Difficulty	4-9
Step 3. GPIB Systems Check	4-10
If Using a Plotter or Printer	4-11
If Using an External Disk Drive	4-11
Troubleshooting Systems with Multiple Peripherals	4-12
Troubleshooting Systems with Controllers	4-12
Step 4. Faulty Group Isolation	4-13
Power Supply Check.	4-14
Check the Rear Panel LEDs	4-14
Check the Post Regulator (A8) LEDs	4-14
Digital Control Check.	4-15
Observe the Power Up Sequence	4-15
Verify Internal Tests Passed	4-16
Source Check	4-17
Phase Lock Error Messages	4-17
Check Source Output Power	4-18
No Oscilloscope or Power Meter? Try the ABUS	4-20
Receiver Check	4-21
Checking the R Channel Output (ET and ES Models)	4-22
Checking the A Channel Output (ES Models)	4-23
Checking the B Channel Output (ET and ES Models)	4-24
Switch Repeatability Check (ES Models)	4-25
Accessories Check.	4-26
Overall Instrument Block Diagrams.	4-27
8719ES and 8720ES Standard, Option 007, 012, 085, 089, 1D5	4-27
8719ES and 8720ES Option 400, 012, 085, 1D5	4-28
8722ES Standard, Option 007, 012, 085, 089, 1D5	4-29
8722ES Option 400, 012, 089, 1D5.	4-30
8719ET and 8720ET Standard, Option 004	4-31
8722ET Standard, Option 004	4-32
5. Power Supply Troubleshooting	
Information on This Chapter	5-2
Power Supply Troubleshooting Flowchart	5-3
Assembly Replacement Sequence	5-4
Simplified Block Diagram of Power Supply Group	5-5
Start Here	5-6
Check the Green LED and Red LED on the Preregulator (A15)	5-6
Check the Green LEDs on the Post Regulator (A8)	5-6
Measure the Post Regulator (A8) Voltages	5-7
If the Green LED of the Preregulator (A15) Is Off or Blinking	5-8
Check the Line Voltage, Selector Switch, and Fuse	5-8
If the Red LED of the Preregulator (A15) Is On	5-9

Contents

Check the Post Regulator (A8)	5-9
Verify the Preregulator (A15)	5-10
Check for a Faulty Assembly	5-11
Check the Operating Temperature	5-12
Inspect the Motherboard	5-12
If the Green LEDs of the Post Regulator (A8) Are Not All ON	5-13
Maintain A15W1 Cable Connection	5-13
Check the Post Regulator (A8) Fuses and Voltages	5-13
Remove the Assemblies	5-14
Briefly Disable the Shutdown Circuitry	5-15
Inspect the Motherboard	5-16
Error Messages	5-17
Check the Fuses and Isolate A8	5-17
Fan Troubleshooting	5-18
Fan Speeds	5-18
Check the Fan Voltages	5-18
Short A8TP3 to Ground	5-18
Intermittent Problems	5-19
Power Supply Block Diagram	5-21
6. Digital Control Troubleshooting	
Information on This Chapter	6-2
Assembly Replacement Sequence	6-3
CPU Board (A7) Troubleshooting	6-4
A7 Switch Positions	6-4
Checking the CPU (A7) Red LED Patterns	6-5
Display Troubleshooting (A18,A19)	6-7
Evaluating Your Display	6-7
Red, Green, or Blue Pixels Specifications	6-7
Dark Pixels Specifications	6-8
Newtons Rings	6-8
Troubleshooting the GSP (A19) and the Display (A18)	6-9
Measure the Supply Voltages Applied to the GSP (A19)	6-9
Run Display Test 55	6-10
Inspect Ribbon Cable Repeat Display Test 55	6-10
Perform Walking One Pattern	6-10
Run Display Tests 59-61	6-12
Front Panel Troubleshooting (A1/A2)	6-13
Check Front Panel LEDs After Preset	6-13
Identify the Stuck Key	6-14
Inspect Cables	6-16
Test Using a Controller	6-16
Run the Internal Diagnostic Tests	6-17
If the Fault Is Intermittent	6-19
Repeat Test Function	6-19
GPIO Failures	6-19
Digital Control Block Diagram	6-21

Contents

7. Source Troubleshooting

Information on This Chapter	7-2
Source Troubleshooting Flowchart	7-3
Assembly Replacement Sequence	7-4
Start Troubleshooting Here	7-5
Power Not within Specifications	7-6
Phase Lock Error Message Displayed	7-6
Broadband Phase Lock Problems	7-8
Swap IF Output Cables to Check R Sampler Assembly (A64)	7-9
Check Open Loop Power	7-11
Check Reference Board (A12)	7-13
Check Fractional-N Digital (A14) with ABUS	7-14
Check the Fractional-N Analog (A13) and Fractional-N Digital (A14) with a Spectrum Analyzer	7-15
Check the VCO (A14) Range with Oscilloscope	7-16
Substituting Tuning Voltages to Check the VCO	7-16
Divide-by-N (A14) Circuit Check	7-17
A14-to-A13 Digital Control Signals Check	7-17
Pulse Generator (A52) Check with Oscilloscope	7-19
Pulse Generator (A52) Check with Spectrum Analyzer	7-20
Band-Related Problems	7-22
Broadband Power Problems	7-26
ALC/Signal Separation Check	7-26
Step Attenuator (A69) Check	7-27

8. Receiver Troubleshooting

Information on This Chapter	8-2
Assembly Replacement Sequence	8-2
All Signal Paths Look Abnormal	8-3
2nd LO Check	8-3
4 MHz Check	8-3
At Least One Signal Path Looks Normal	8-4
Directional Coupler Check	8-7
A and B Sampler Check by Substitution	8-8
Sampler Voltage Check	8-9
2nd Converter Check	8-9

9. Accessories Troubleshooting

Information on This Chapter	9-2
Inspect and Gauge Connectors	9-3
Inspect the Error Terms	9-4
Isolate the Fault in the RF Path	9-5
Verify the RF Cable	9-6
Verify Shorts and Opens by Substitution	9-7

10. Service Key Menus and Error Messages

Information on This Chapter	10-2
Error Messages	10-3

Contents

Service Menus - Internal Diagnostics	10-3
Tests Menu	10-5
Test Options Menu	10-6
Self Diagnose Softkey	10-8
Test Descriptions	10-8
Service Menu - Service Features	10-15
Service Modes Menu	10-17
Service Modes More Menu	10-19
Analog Bus on OFF	10-20
Description of the Analog Bus (ANAB)	10-20
The Main ADC	10-20
The Frequency Counter	10-20
Analog In Menu	10-21
Analog Bus Nodes	10-22
PEEK/POKE Menu	10-29
Firmware Revision Softkey	10-30
GPIB Service Mnemonic Definitions	10-31
Invoking Tests Remotely	10-31
Analog Bus Codes	10-32
Service Related Error Messages in Alphabetical Order	10-33

11. Error Terms

Information on This Chapter	11-2
Error Terms Can Also Serve a Diagnostic Purpose	11-3
Measurement Calibration Procedure	11-4
Error Term Inspection	11-5
If Error Terms Seem Worse than Typical Values	11-7
Uncorrected Performance	11-8
Error Term Descriptions	11-10
Directivity (EDF and EDR)	11-11
Source Match (ESF and ESR)	11-12
Reflection Tracking (ERF and ERR)	11-13
Isolation (Crosstalk, EXF and EXR)	11-14
Load Match (ELF and ELR)	11-15
Transmission Tracking (ETF and ETR)	11-16

12. Theory of Operation

Information on This Chapter	12-2
System Operation	12-3
Functional Groups of the Analyzer	12-5
Power Supply Theory	12-6
A15 Preregulator	12-6
A8 Post Regulator	12-7
Voltage Indications: the Green LEDs	12-8
Digital Control Theory	12-9
A1 Front Panel	12-9
A2 Front Panel Processor	12-9
A7 CPU/A10 Digital IF	12-9

Contents

A18 Display	12-10
A19 Graphics System Processor (GSP)	12-11
A20 Inverter	12-11
A16 Rear Panel	12-11
Source Group Theory	12-13
Source Pretune	12-14
A14/A13 Fractional-N Synthesizer	12-14
A52 Pulse Generator: the Harmonic Comb	12-14
A64 R Sampler: Down-Converting the Signals	12-14
A11 Phase Lock: Comparing Phase and Frequency	12-15
Tuning the YIG Oscillator	12-15
Phase Locked Sweep	12-15
A12 Reference: The Crystal Reference Frequencies	12-16
Source Block: The YIG Oscillator Signals	12-16
ALC: Automatic Leveling Control	12-18
Signal Separation: ES Models Only	12-19
A58 M/A/D/S Modulator, Amplifier, Detector, Splitter	12-19
A58 M/A/D and A74 Switch Splitter (Option 400 Only)	12-20
A69 Step Attenuator	12-20
A74 Transfer Switch	12-21
A56 Lower Front Panel Assembly	12-21
A60 and A61 DC Bias Tees	12-21
A62 and A63 Directional Couplers	12-21
Signal Separation: ET Models Only	12-22
A58 M/A/D/S Modulator, Amplifier, Detector, Splitter	12-22
A69 Step Attenuator (All ET Option 004 Models)	12-23
A23 DC Block (8719ET Option 004 and 8720ET Option 004 Only)	12-23
A62 Directional Couplers	12-23
Receiver Theory	12-24
Samplers and Second Converters	12-24
A10 Digital IF	12-25

13. Replaceable Parts

Information on This Chapter	13-2
Assembly Replacement Sequence	13-3
Rebuilt-Exchange Assemblies	13-4
Ordering Information	13-4
Replaceable Part Listings	13-6
Top Assemblies	13-8
Bottom Assemblies and Cables	13-12
Front RF Assemblies	13-64
Top Cables	13-66
Rear Cables, All Models	13-69
Front Cables, All Models	13-70
Front Panel Assembly, Inside	13-72
Rear Panel Assembly	13-74
Rear Panel Assembly, Option 1D5	13-76
Hardware, Top	13-78
Hardware, Bottom	13-80

Contents

Hardware, Front	13-82
Hardware, Preregulator	13-83
Chassis Parts, Outside	13-84
Chassis Parts, Inside	13-86
Miscellaneous Part Numbers	13-87

14. Assembly Replacement and Post-Repair Procedures

Information on This Chapter	14-2
Assembly Replacement Sequence	14-3
Procedures in This Chapter	14-4
Replacing the Line Fuse	14-5
Removing the Covers	14-6
Removing the top cover	14-6
Removing the side covers	14-6
Removing the bottom cover	14-6
Removing the Front Panel Assembly	14-8
Removing the Front Panel Interface and Keypad Assemblies	14-10
Removing the Display Lamp and Assembly	14-12
Removing the Rear Panel Assembly	14-14
Removing the Rear Panel Interface Board Assembly	14-16
Removing the Source Assemblies	14-18
Removing the A7 CPU Board Assembly	14-20
Removing the A7BT1 Battery	14-22
Removing the A15 Preregulator Assembly	14-24
Removing the A19 Graphics Processor Assembly	14-26
Removing the A3 Disk Drive Assembly	14-28
Removing the A62, A63 Test Port Couplers and LED Board Assemblies	14-30
Removing the A26 High Stability Frequency Reference (Option 1D5) Assembly	14-32
Removing the B1 Fan Assembly	14-34
Post-Repair Procedures	14-35

15. Safety and Regulatory Information

General Information	15-2
Maintenance	15-2
Assistance	15-3
Shipment for Service	15-3
Safety Symbols	15-4
Instrument Markings	15-5
Lithium Battery Disposal	15-5
Safety Considerations	15-6
Safety Earth Ground	15-6
Before Applying Power	15-6
Servicing	15-7
General	15-8
Compliance with German FTZ Emissions Requirements	15-9
Compliance with German Noise Requirements	15-9

1 Service Equipment and Analyzer Options

Information in This Chapter

This chapter contains information on the required equipment used to test and repair the network analyzer. A list of analyzer options and service support options is included at the end of the chapter.

Sections in This Chapter

- [Service Test Equipment on page 1-3](#)
- [Principles of Microwave Connector Care on page 1-6](#)
- [Analyzer Options on page 1-7](#)
- [Service and Support Options on page 1-9](#)

Service Test Equipment

Required Equipment	Critical Specifications	Recommended Model or HP/Agilent Part Number	Use
Test Instruments			
Frequency Counter	Freq: 0.050 to 20 GHz Accuracy: 3ppm max	5350B, 53150A	P,A,T
Frequency Counter	Freq: 0.050 to 26.5 GHz Accuracy: 3ppm max	5351B, 53151A	P,A,T
Spectrum Analyzer	Max Freq: 1.8 GHz RBW: 300 Hz	8591E	A,T
Power Meter	Accuracy: ± 0.02 dB	436A, 437B, 438A E4418A (EPM-441A) E4419A (EPM-442A)	P,A,T
Power Sensor	Freq: 0.050 to 20.05 GHz Range: -30 to +20 dBm	8485A	P,A,T
Power Sensor	Freq: 0.050 to 40 GHz Range: -30 to +20 dBm	8487A	P,A,T
Digital Voltmeter	Resolution: 10 mV	Any	T
Oscilloscope	Bandwidth: 100 MHz	Any	T
Printer	Raster graphics capability	Any	P
Calibration and Verification Kits			
2.4 mm Calibration Kit	No substitute	85056A	P,A,T
2.4 mm Verification Kit	No substitute	85057B	P
3.5 mm Calibration Kit	No substitute	85052B	P,A,T
3.5 mm Verification Kit ¹	No substitute	85053B	P
7 mm Calibration Kit	No substitute	85050B	P,T
7 mm Verification Kit ²	No substitute	85051B	P
Type-N Calibration Kit	No substitute	85054B	P,T
Type-N Verification Kit ³	No substitute	85055A	P
<i>P - Performance Tests A - Adjustments T - Troubleshooting</i>			

1. Verification can only be done up to 26.5 GHz on the Agilent 8722ET/ES while using the 3.5 mm Verification Kit.
2. Verification can only be done up to 18 GHz, while using the 7mm Verification Kit.
3. Verification can only be done up to 18 GHz, while using the Type-N Verification Kit.

Required Equipment	Critical Specifications	Recommended Model or HP/Agilent Part Number	Use
Adapters and Loads			
RF Load	3.5 mm(f), 50 ohm	00902-60004 (Part of 85052B)	P
RF Load	2.4 mm(f), 50 ohm	00901-60004 (Part of 85056A)	P
RF Short	3.5 mm (f)	85052-60007 (Part of 85052B)	P
RF Short	2.4mm (f)	85056-60021 (Part of 85056A)	P
RF Open	3.5 mm(f)	85052-60009 (Part of 85052B)	A
RF Open	2.4 mm(f)	85056-60023 (Part of 85056A)	A
RF Adapter	3.5 mm(f) to 3.5 mm(f)	85052-60012 (Part of 85052B)	P,A
RF Adapter	2.4 mm(f) to 2.4 mm(f)	85056-60006 (Part of 85056A)	P,A
RF Power Splitter	3.5 mm	11667B	T
RF Power Splitter	2.4 mm	11667C	T
RF Fixed Attenuator	3.5 mm	8493C Opt. 010	A
RF Fixed Attenuator	2.4 mm	8490D Opt. 010	A
RF Adapter	2.4 mm (f) to Type-N (f)	11903B	A
RF Adapter	3.5 mm (f) to Type-N (f)	1250-1745 (2 total)	A
Cables			
RF Cable	BNC 50 ohm, 24 inch	8120-2582	A
RF Cable	Type-N (m) connectors, 50W, 24-inch	11500C (2 total)	P,A
RF Cable Set	3.5 mm connectors	85131F	P,A,T
RF Cable Set	7 mm connectors to 3.5 mm	85132F	P
RF Cable Set	2.4 mm connectors	85133F	P,A,T
Extension Cables	SMB (f) to BNC (m) (4 ft. length)	8120-5048	T
Extension Cables	SMB (m) to SMB (f)	8120-5040	A,T
Coax Cable	BNC (m) to BNC (m), 50W	10503A	A
GPIB Cables	1 meter length	10833A	A
<i>P - Performance Tests</i>		<i>A - Adjustments</i>	
		<i>T - Troubleshooting</i>	

Required Equipment	Critical Specifications	Recommended Model or HP/Agilent Part Number	Use
Tools and Static Safety Parts			
Non-Metallic Adjust Tool		8830-0024	A
Tool Kit	No substitute	08722-60018	P,A,T
Anti-Static Wrist Strap		9300-1367	A,T
Anti-Static Wrist Strap Cord		9300-0980	A,T
Static Control Table Mat and Earth Ground Wire		9300-0797	A,T
Floppy Disk	one 3.5-inch formatted 1.44 MB	N/A	A
<i>P - Performance Tests A - Adjustments T - Troubleshooting</i>			

Principles of Microwave Connector Care

Proper connector care and connection technique are critical for accurate and repeatable measurements.

Refer to the calibration kit documentation for connector care information. Prior to making connections to the network analyzer, carefully review the information about inspecting, cleaning, and gauging connectors.

Practicing good connector care and connection technique extends the life of these devices. In addition, you obtain the most accurate measurements.

For additional connector care instruction, contact your nearest Agilent Technologies sales or service office about course numbers HP/Agilent 85050A+24A and HP/Agilent 85050A+24D.

See the following table for quick reference tips about connector care.

Table 1-1 Connector Care Quick Reference

Handling and Storage	
Do Keep connectors clean Extend sleeve or connector nut Use plastic end-caps during storage	Do Not Touch mating-plane surfaces Set connectors contact-end down
Visual Inspection	
Do Inspect all connectors carefully Look for metal particles, scratches, and dents	Do Not Use a damaged connector - ever
Connector Cleaning	
Do Try compressed air first Use isopropyl alcohol Clean connector threads	Do Not Use any abrasives Get liquid into plastic support beads
Gauging Connectors	
Do Clean and zero the gauge before use Use the correct gauge type Use correct end of calibration block Gauge all connectors before first use	Do Not Use an out-of-spec connector
Making Connections	
Do Align connectors carefully Make preliminary connection lightly Turn only the connector nut Use a torque wrench for final connect	Do Not Apply bending force to connection Over tighten preliminary connection Twist or screw any connection Tighten past torque wrench “break” point

Analyzer Options

Option 1D5, High Stability Frequency Reference

Option 1D5 offers ± 0.05 ppm temperature stability from 0 to 55 °C (referenced to 25 °C).

Option 004, Step Attenuator (ET Models)

This option adds a 55 dB step attenuator into the RF output path.

Option 007, Mechanical Transfer Switch (ES Models)

This option replaces the solid state transfer switch with a mechanical transfer switch, providing the analyzer with greater power handling capability. Because the mechanical transfer switch has less loss than the solid state transfer switch, the output power of an Option 007 analyzer is 5 dB higher.

Option 010, Time Domain

This option allows the analyzer to display the time domain response of a network by computing the inverse Fourier transform of the frequency domain response. The analyzer shows the response of a test device as a function of time or distance. Displaying the reflection coefficient of a network versus time determines the magnitude and location of each discontinuity. Displaying the transmission coefficient of a network versus time determines the characteristics of individual transmission paths. Time domain operation retains all accuracy inherent with the active error correction.

Option 012, Direct Access Receiver Configuration (ES Models)

This option provides front panel access to the A and B samplers. This allows direct access to the sampler inputs for improved sensitivity in applications such as antenna tests, or for the insertion of attenuators between the couplers and samplers. Direct access to the B (A) sampler provides increased dynamic range in the forward (reverse) direction.

Option 085, High Power System (ES Models)

This option is designed to permit the measurement of high power devices. With an external power amplifier, this configuration will allow up to 20 Watts (+43 dBm) of output at the test ports. The maximum test port input power is 1 Watt (+30 dBm) CW, but jumpers on the front panel allow the insertion of high power attenuators or isolators. This allows test device output levels up to the power limits of the inserted components. Additionally, there is an external reference input that allows the external amplifier's frequency response and drift to be ratioed out, and there are internally controlled step attenuators between the couplers and samplers to prevent overload. A network analyzer with this option can be configured to operate as a normal instrument (with slightly degraded output power level and accuracy) or as an instrument capable of making single connection multiple measurements. Bias tees are not part of the signal separation circuitry of the Option 085. Because of high output power, Option 085 is only available with a mechanical transfer switch similar to Option 007. Option 085 also includes direct access to the receiver (Option 012).

Option 089, Frequency Offset Mode (ES Models)

This option adds the ability to offset the source and receiver frequencies for frequency translation measurements. This provides the analyzer with mixer measurement capability. It also provides a graphical setup that allows easy configuration of your frequency translation measurement.

Option 400, Four-Sampler Test Set (ES Models)

This option reconfigures the analyzer's test set to ratio out the characteristics of the test port transfer switch, and to include a second reference channel that allows full accuracy with a TRL measurement calibration.

NOTE The 8722ES option 400 is optimized to operate with a test port cable length of one meter. It may be necessary to set up the 8722ES Option 400 in the step sweep mode if you are operating the analyzer with test port cables or fixturing with an electronic length greater than one meter.

Option 1CP, Rack Mount Flange Kit With Handles

Option 1CP is a rack mount kit containing a pair of flanges, *with handles*, and the necessary hardware to mount the analyzer in an equipment rack with 482.6 mm (19 inches) horizontal spacing.

Option 1CM, Rack Mount Flange Kit Without Handles

Option 1CM is a rack mount kit containing a pair of flanges, *without handles*, and the necessary hardware to mount the analyzer in an equipment rack with 482.6 mm (19 inches) horizontal spacing.

Service and Support Options

The analyzer's standard warranty is a *three-year return to Agilent* service warranty.

The following service and support options are available at the time you purchase an Agilent 8719ET/ES, Agilent 8720ET/ES, or an Agilent 8722ET/ES network analyzer.

Option W01

This option converts the standard three-year return to Agilent Technologies service warranty to a *one-year on-site* service warranty. This option may not be available in all areas.

Option W31

This option converts the standard three-year return to Agilent Technologies service warranty to a *three-year on-site* service warranty. This option may not be available in all areas.

Option W50

This option adds two years to the standard three-year return to Agilent Technologies warranty for a total of a *five-year return to Agilent Technologies* service warranty.

Option W51

This option converts the standard three-year return to Agilent Technologies service warranty to a *five-year on-site* service warranty. This option may not be available in all areas.

Option W32

This option provides yearly return to Agilent Technologies for a commercial calibration for a period of three years. The calibration provided is traceable to national standards.

Option W52

This option provides yearly return to Agilent Technologies for a commercial calibration for a period of five years. The calibration provided is traceable to national standards.

Option W34

This option provides yearly return to Agilent Technologies for a Standards Compliant Calibration for a period of three years. This type of calibration meets the ANSI/NCSL Z540-1-1994 standard.

Option W54

This option provides yearly return to Agilent Technologies for a Standards Compliant Calibration for a period of five years. This type of calibration meets the ANSI/NCSL Z540-1-1994 standard.

NOTE

If the previous service and support options were not purchased along with the analyzer, there are many other repair and calibration options available from Agilent Technologies' support organization. These options cover a range of on-site services and agreements with varying response times as well as return to Agilent Technologies agreements and per-incident pricing. Contact the nearest Agilent Technologies sales or service office for details. Refer to [Chapter 15](#) , "Safety and Regulatory Information."

2 System Verification and Performance Tests

Sections in This Chapter

This chapter consists of five sections.

How to Test the Performance of Your Analyzer

- [ANSI/NCSL Z540–1–1994 Verification, on page 2-3](#)
- [Non-ANSI/NCSL Z540–1–1994 Verification, on page 2-3](#)
- [Instrument Verification Cycle, on page 2-4](#)
- [ANSI/NCSL Z540–1–1994 Test Path Verification Flowchart, on page 2-4](#)
- [Non-ANSI/NCSL Z540–1–1994 Test Path Verification Flowchart, on page 2-5](#)

Preliminary Tests

- [Check the Temperature and Humidity, on page 2-6](#)
- [Clean and Gauge All Connectors, on page 2-7](#)
- [Perform the Internal Test, on page 2-7](#)
- [Procedure to Perform Operator’s Check, on page 2-8](#)
- [Check the Test Port Cables, on page 2-9](#)

System Verification

- [Equipment Initialization, on page 2-20](#)
- [Measurement Calibration, on page 2-22](#)
- [Verification Device Measurements, on page 2-25](#)
- [Interpreting the Verification Results, on page 2-31](#)

Performance Tests

- [Frequency Accuracy Performance Test, on page 2-34](#)
- [Level Accuracy Performance Test, on page 2-36](#)
- [Source Linearity Performance Test, on page 2-38](#)
- [Dynamic Range Performance Test, on page 2-42](#)

Performance Test Records

- [Performance Test Record, on page 2-46](#)

How to Test the Performance of Your Analyzer

There are two different ways to verify the performance of your analyzer. One method meets ANSI/NCSL Z540–1–1994 standards, and the other method does not. To determine which type of verification you wish to perform, refer to the following descriptions and flow charts.

ANSI/NCSL Z540–1–1994 Verification

This type of verification consists of conducting the preliminary checks, system verification, and the performance tests *without stopping to troubleshoot*. Exceptions will only be made in case of catastrophic failure or cable connector damage. In order to obtain data of how the analyzer was performing at the time of verification, these tests must be done even if you are aware that the analyzer will not pass. Obtaining the data (system verification printout and performance test record) at this point is necessary so that you will understand that your measurements may not have been accurate. You must wait until after the ANSI/NCSL Z540–1–1994 verification is complete before troubleshooting and repairing any problems. After troubleshooting, consult [Table 14-1 on page 14-35](#) to find the necessary adjustment procedures. Then repeat the system verification and performance tests, generating a new set of data.

Non-ANSI/NCSL Z540–1–1994 Verification

This type of verification consists of conducting the preliminary checks, system verification, and performance tests, *but stopping at any point if the analyzer fails a test*. You will troubleshoot and repair the first problem encountered without continuing to other tests. After troubleshooting, consult [Table 14-1 on page 14-35](#) to find the necessary adjustment procedures. Then repeat the system verification and performance tests. As the analyzer passes the system verification and all the tests, you will print out the system verification results and fill in the performance test record.

Instrument Verification Cycle

The performance of the network analyzer should be verified at least once per year. The following flowcharts illustrate the test path for both types of verifications.

Figure 2-1 ANSI/NCSS Z540-1-1994 Test Path Verification Flowchart

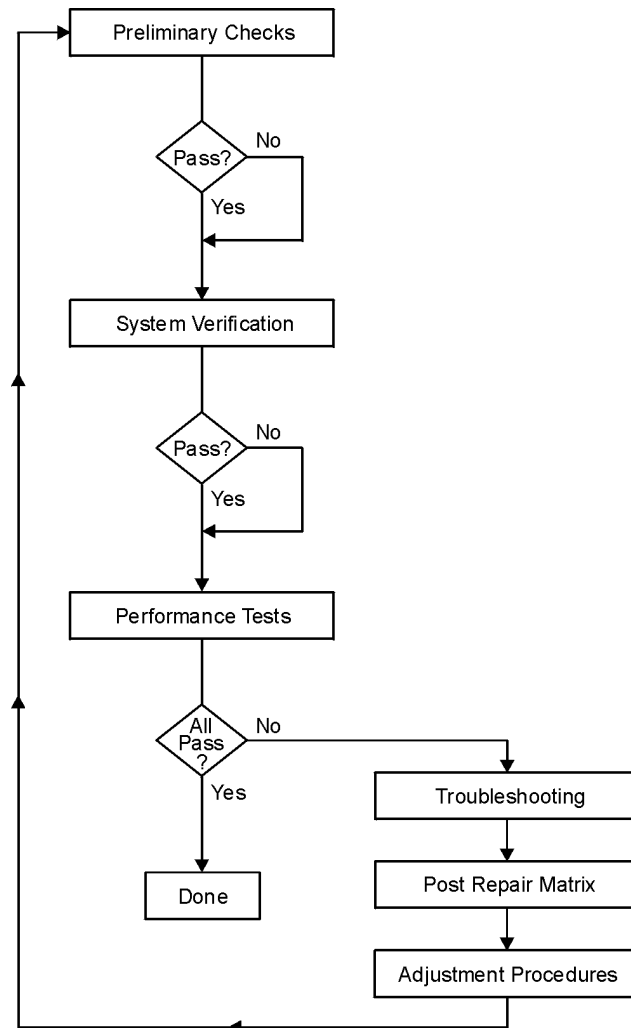

sb51e

Figure 2-2 Non-ANSI/NCSL Z540-1-1994 Test Path Verification Flowchart

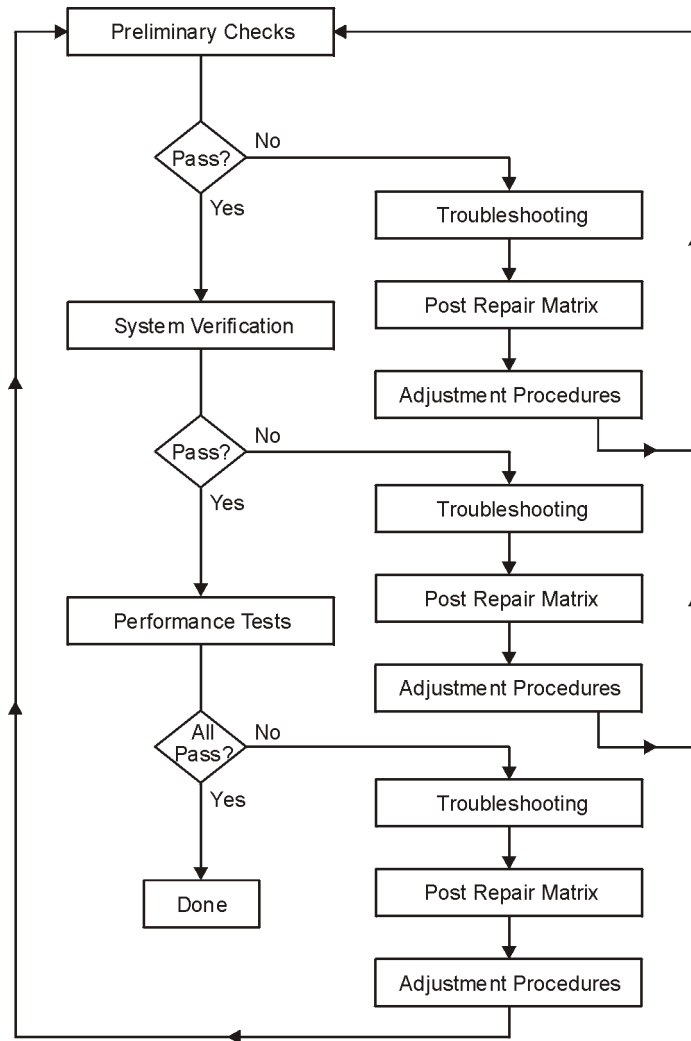

sb532e

Preliminary Tests

CAUTION Use an antistatic work surface and wrist strap to lessen the chance of electrostatic discharge.

Required Equipment and Tools

Equipment Description	8719/20	8722
Calibration Kit	85052B	85056A
RF Cable Set	85131F	85133F
Verification Kit	85053B	85057B

Check the Temperature and Humidity

1. Measure the temperature and humidity of the environment and record the values in [Table 2-14, “Performance Test Record for All Models,”](#) on page 2-46. The performance is specified at an ambient temperature of $+23 \pm 3$ °C. Therefore, the environmental temperature must remain in the range of $+20$ °C to $+26$ °C. Once the measurement calibration has been done, the ambient temperature must be held to range of ± 1 °C.
2. Open the calibration and verification kits and place all the devices on top of the foam so they will reach room temperature. The temperature of the devices is important because device dimensions and therefore the electrical characteristics change with temperature.
3. Switch on the power to the analyzer.

NOTE To achieve the maximum system stability, allow the analyzer to warm up for at least 30 minutes.

Clean and Gauge All Connectors

CAUTION To prevent damage to the calibration kit and verification kit devices always replace or repair any damaged connectors before proceeding with these tests.

NOTE Always use adapters when verifying a system with SMA connectors.

1. Visually inspect all the connectors for any burrs, gold flakes, or places where the gold is worn.
2. Clean all the connectors with alcohol and foam-tipped swabs. Dry the connectors with a dry foam-tipped swab.
3. Visually inspect the calibration block and the end of the connector gauge before any measurements are made.
4. Gauge all devices, cables, and test port connectors. Refer to the calibration kit manuals for the correct use of gauges.

Perform the Internal Test

This quick, automated internal test may save time by indicating an instrument fault before doing the performance tests. The tests performed are described in [Chapter 10](#) , “[Service Key Menus and Error Messages.](#)”

NOTE To achieve the maximum system stability, allow the analyzer to warm up for at least 30 minutes.

To run the analyzer internal test, press the following:

Presets **PRESET: FACTORY** **Presets**

System **SERVICE MENU** **TESTS**

INTERNAL TESTS **EXECUTE TEST**

A PASS message will appear on the display if the instrument passes this test.

Procedure to Perform Operator's Check

PORT 1 or REFLECTION port Check

1. Connect a short to PORT 1 (REFLECTION port on ET models).
2. Press the following:

Ⓟ PRESET: FACTORY **Ⓟ**

Ⓢ SERVICE MENU TESTS EXTERNAL TESTS

EXECUTE TEST CONTINUE

- If the message PRESS [CONTINUE] appears on the display during the test, that particular attenuator setting check has failed. Press **CONTINUE** to check the other attenuator settings.
- If the message FAIL appears on the analyzer display, the analyzer has failed the PORT 1 operation check. Refer to the flow charts on [page 2-4](#) and [page 2-5](#).
- If the message DONE appears on the analyzer display, the analyzer has passed the PORT 1 operation check.

PORT 2 Check (ES Models)

3. Connect the short to PORT 2.
4. Press the following:

Ⓟ PRESET: FACTORY **Ⓟ**

Ⓢ SERVICE MENU TESTS

22 **x1** EXECUTE TEST CONTINUE

- If the message PRESS [CONTINUE] appears on the display during the test, that particular attenuator setting check has failed. Press **CONTINUE** to check the other attenuator settings.
- If the message FAIL appears on the analyzer display, the analyzer has failed the PORT 2 operation check. Refer to the flow charts on [page 2-4](#) and [page 2-5](#).
- If the message DONE appears on the analyzer display, the analyzer has passed the PORT 2 operation check.

Transmission Port Check (ET Models)

5. Connect an RF cable from the REFLECTION port to the TRANSMISSION port.
6. Press the following:

Ⓟ PRESET: FACTORY **Ⓟ**

Ⓢ SERVICE MENU TESTS

22 **x1** EXECUTE TEST CONTINUE

- If the message `PRESS [CONTINUE]` appears on the display during the test, that particular attenuator setting check has failed. Press `CONTINUE` to check the other attenuator settings.
- If the message `FAIL` appears on the analyzer display, the analyzer has failed the TRANSMISSION port operation check. Refer to the flow charts on [page 2-4](#) and [page 2-5](#).
- If the message `DONE` appears on the analyzer display, the analyzer has passed the TRANSMISSION port operation check.

Check the Test Port Cables

A bad cable can cause a failure in the verification test. The following tests are not required, but are recommended to verify the performance of the test port cable.

- [Cable Return Loss, on page 2-9](#)
- [Cable Insertion Loss, on page 2-11](#)
- [Cable Magnitude and Phase Stability, on page 2-12](#)

NOTE The illustrations depicting the analyzer display were made using an Agilent 8722ES model. Other analyzer displays may appear different, depending on model and options.

Cable Return Loss

1. Press `[Preset]` `PRESET: FACTORY` `[Preset]`.
2. Perform a one-port calibration on PORT 1 (REFLECTION port on ET models). For detailed calibration procedures, refer to the “Calibrating for Increased Measurement Accuracy” chapter in the analyzer user’s guide.
3. Connect the test port cable to PORT 1 (REFLECTION port on ET models). Connect a broadband load to the other end of the cable. Tighten to the specified torque for the connector type.
4. To measure return loss, press the following:
ES models: `[Meas]` `Refl: FWD S11 (A/R)`
ET models: `[Meas]` `REFLECTION`
5. Press `[Marker Search]` `SEARCH: MAX` to find the worst-case return loss. Refer to the cable manual to see if it meets the return loss specification. If not, the cable should be either repaired or replaced. For an example of a typical return loss measurement, see [Figure 2-3](#).

Figure 2-3 Typical Return Loss Measurement of Test Port Cables

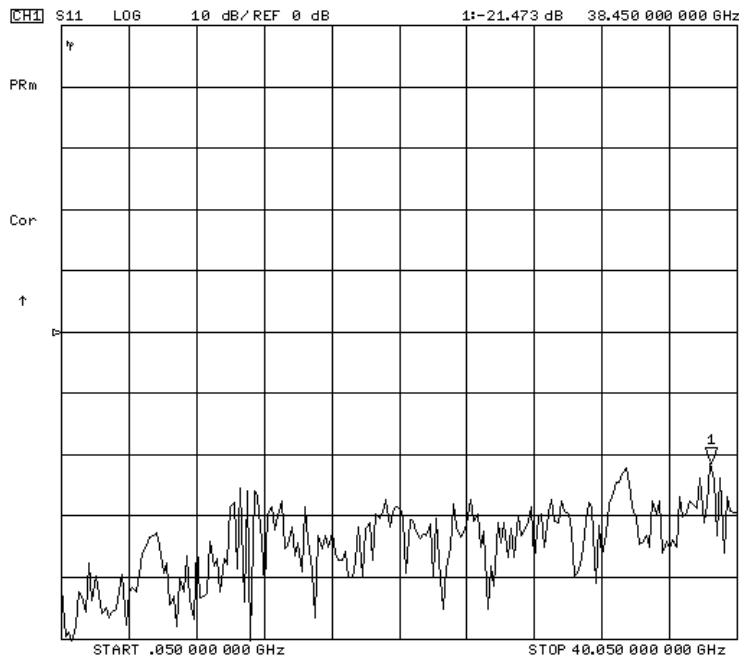

Cable Insertion Loss

1. Keep the test port cable connected to PORT 1 (REFLECTION port on ET models).
2. Connect an RF short to the other end of the cable.
3. Press **Marker Search** **SEARCH: MIN** to find the worst-case insertion loss. The displayed response is twice the actual loss. Divide the response by two and refer to the cable manual to see if it meets the insertion loss specification. If the insertion loss specification is not met, the cable should be either repaired or replaced. For an example of a typical insertion loss measurement, see [Figure 2-4](#).

Figure 2-4 Typical Insertion Loss Measurements of Cables

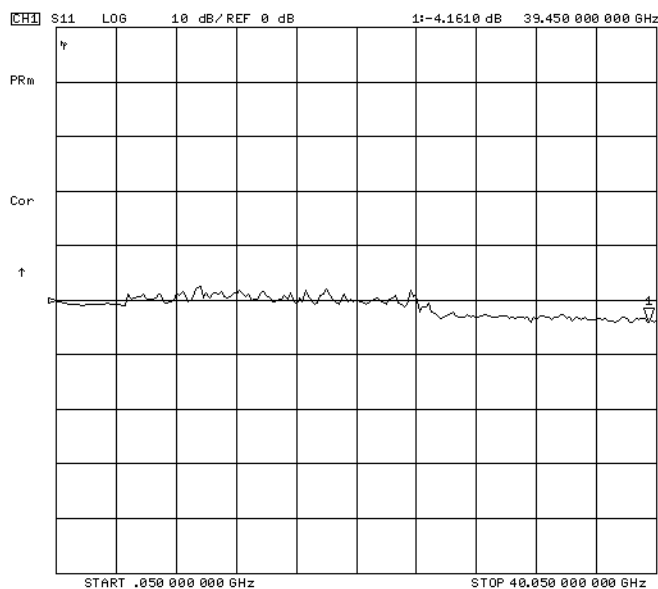

Cable Magnitude and Phase Stability

1. Connect the cable to PORT 1 (REFLECTION port on ET models), then connect a short to end of the cable.

2. To measure magnitude and phase stability, press the following:

(Display) **DUAL | QUAD SETUP** **DUAL CHANNEL ON**
(Chan 1) (Meas) **Refl: FWD S11 (A/R)** (Format) **LOG MAG**
(Avg) **AVERAGING FACTOR** (64) (x1) **AVERAGING ON**
(Chan 2) (Meas) **Refl: FWD S11 (A/R)** (Format) **PHASE**
(Avg) (64) (x1) **AVERAGING ON**

3. Hold the test cable in a straight line, to provide a good reference.

4. Press (Sweep Setup) **MEASURE RESTART** and wait for the analyzer to average the measurement 64 times, by observing the counter on the left side of the display.

5. Press the following:

(Chan 1) (Display) **DATA → MEMORY** **DATA/MEM**
(Chan 2) (Display) **DATA → MEMORY** **DATA/MEM**

6. Make a gradual 90° bend in the middle of the cable and restart the measurement averaging by pressing (Avg) **AVERAGING RESTART**.

7. To change the scale of the displayed traces, press the following:

(Chan 1) (Scale Ref) **SCALE/DIV** (↓)
(Chan 2) (Scale Ref) **SCALE/DIV** (↓)

8. To mark the end of the cable's specified range, place a marker on the highest specified frequency of the cable. Press (Marker), enter the specified frequency, and press (G/n).

9. Place a marker on the largest deflection that goes above and below the reference line and is within the specified frequency range. For a typical response of cable magnitude and phase stability, see [Figure 2-5](#).

In this S11 measurement, the displayed trace results from energy being propagated down the cable and reflected back from the short. Therefore, the measured deflection value must be divided in half to reach the correct value. If the cable does not meet the specifications in the cable manual, it should be either repaired or replaced.

Figure 2-5 Typical Cable Magnitude and Phase Stability Response

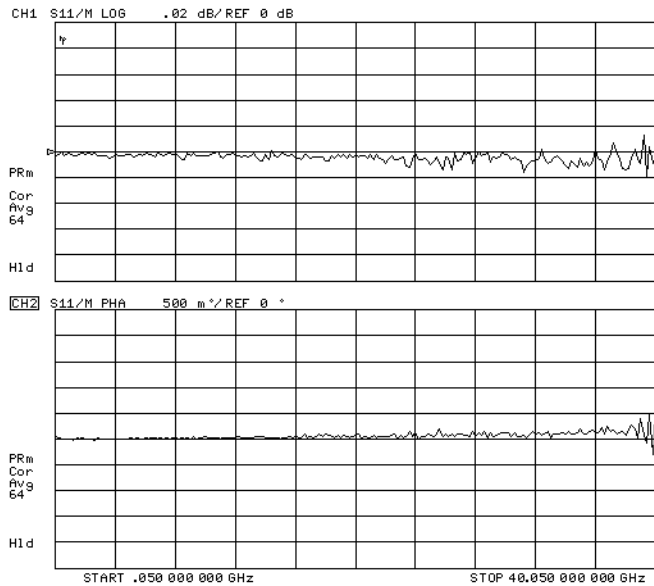

Cable Connector Repeatability

1. Keep the test port cable connected to PORT 1 (REFLECTION port on ET models).
2. To measure the cable connector repeatability, connect a broadband termination to the end of the cable.
3. Press the following:

Chan 1 **Display**

DUAL | QUAD SETUP **DUAL CHANNEL OFF**

Display **DISPLAY: DATA**

Avg **AVERAGING FACTOR** **128** **x1** **AVERAGING ON**

Wait until the analyzer has averaged the measurement 128 times by observing the counter on the left side of the display.

4. To normalize the data trace press the following:

Display **DATA → MEMORY** **DATA-MEM**

Scale Ref **REFERENCE VALUE** **-50** **x1**

SCALE/DIV **20** **x1**

5. Disconnect and then reconnect the cable to the test port. Tighten the connection to the specified torque for the connector type. Look at the trace for spikes or modes.
6. To re-normalize the data trace of the reconnected cable press the following:

Display **DATA → MEMORY**

- Repeat steps 4 and 5 at least three times to look for modes. (Modes appear when a harmonic of the source fundamental frequency is able to propagate through the cable or connector). It is helpful to be able to plot the trace each time to compare several connections. If any mode appears each time the cable is connected and reconnected, measurement integrity will be affected. The cable connector or cable should be repaired or replaced. For a typical response of cable connector repeatability, see [Figure 2-6](#).

NOTE The connector repeatability measurement should be done at the test port as well as at the end of the test port cable.

Check PORT 2 for ES Models

- Perform a one-port calibration on PORT 2. For detailed calibration procedures, refer to “Calibrating for Increased Measurement Accuracy” in the analyzer user’s guide.
- Repeat Steps 1 through 7 for PORT 2.

Figure 2-6 Typical Cable Connector Repeatability Response

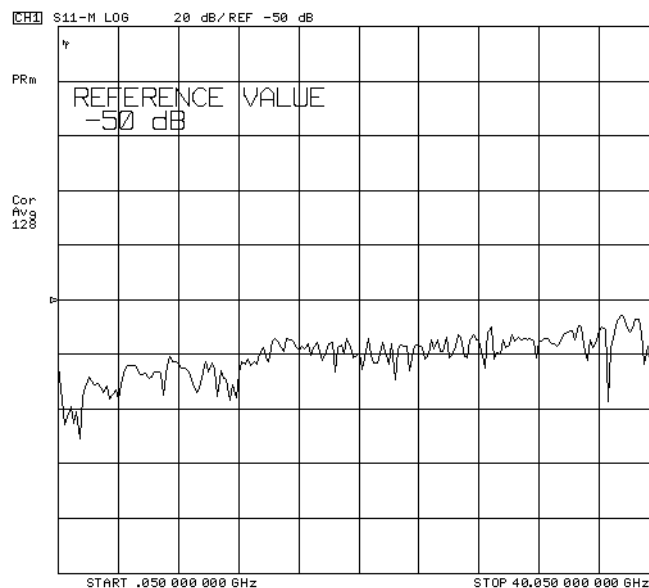

System Verification

System verification is used to verify system-level error-corrected uncertainty limits for network analyzer measurements. The verification procedure is automated and is contained in the firmware of the analyzer.

The system verification section consists of five parts:

1. [General Information, on page 2-16](#)
2. [Equipment Initialization, on page 2-20](#)
3. [Measurement Calibration, on page 2-22](#)
4. [Verification Device Measurements, on page 2-25](#)
5. [Interpreting the Verification Results, on page 2-31](#)

The device data provided with the verification kit has a traceable path to a national standard. The difference between the supplied traceable data and the measured data must fall within the total uncertainty limits at all frequencies for the system verification to pass.

The total measurement uncertainty limits for the system verification are the sum of the factory measurement uncertainties for the verification devices and the uncertainties associated with the system being verified. You can determine your system measurement uncertainty limits by referring to the analyzer reference guide.

IMPORTANT When a network analyzer system passes these tests, it does not guarantee that the analyzer meets all of the performance specifications. However, it does show that the system being verified measures the same devices with the same results as a factory system which has had all its specifications verified and its total measurement uncertainty minimized.

General Information

Verification Kit

The kit consists of the following:

- 20 dB and 40 dB attenuator
- 25 Ω mismatch airline
- 50 Ω airline
- A 3.5 inch disk containing the factory measured verification data and uncertainty limits for each device in the kit

Measurement Uncertainty

Measurement uncertainty is defined as the sum of the residual systematic (repeatable) and random (non-repeatable) errors in the measurement system after calibration. The systematic errors are directivity, source match, load match, reflection and transmission frequency tracking, and isolation (crosstalk). Random errors include errors due to noise, drift, connector repeatability, and test cable stability. A complete description of system errors and how they affect measurements is provided in the analyzer reference guide.

Any measurement result is the vector sum of the actual test device response plus all error terms. The precise effect of each error term depends on its magnitude and phase relationship to the actual test device response. When the phase of an error response is not known, phase is assumed to be worst-case (-180 to $+180^\circ$). Random errors such as noise and connector repeatability are generally combined in a root-sum-of-the-squares (RSS) manner.

Measurement Traceability

To establish a measurement traceability path to a national standard for a network analyzer system, the overall system performance is verified through the measurement of devices that have a traceable path. This is accomplished by measuring the devices in an Agilent verification kit.

The measurement of the devices in the verification kit has a traceable path because the factory system that measured the devices is calibrated and verified by measuring standards that have a traceable path to the National Institute of Standards and Technology (NIST) (see [Figure 2-7](#)). This chain of measurements defines how the verification process brings traceability to the network analyzer system.

Figure 2-7 (NIST) Traceability Path for Calibration and Verification Standard

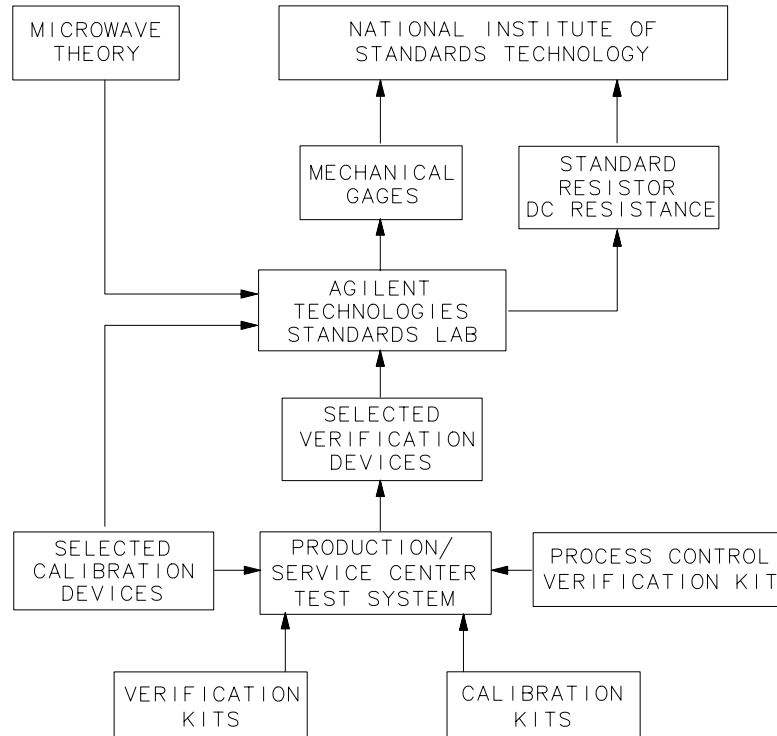

sb66d

What the System Verification Verifies

The system verification procedure verifies the minimum network analyzer system. A minimum analyzer system includes the following:

- Network Analyzer
- Calibration Kit
- Test Port Cables

NOTE Additional equipment or accessories used with the above system are not verified by system verification.

Required Equipment and Accessories

The following equipment and accessories are required to verify the network analyzer system. (For information on compatible printers, refer to the user’s guide).

- HP Printer
- Centronics or GPIB Interface Cable
- Verification Kit
- Calibration Kit
- RF Cable Set

Analyzer warmup time: 30 minutes

Table 2-1 8719ET/ES and 8720ET/ES Supported System Configurations

Description	3.5 mm	7 mm	Type-N
Calibration Kit	85052B/C/D	85050B/C/D	85054B/D
Verification Kit	85053B	85051B	85055A
Cables	85131C/D/E/F	85132C/D/E/F	85131C/D/E/F 3.5 mm 85130C (3.5 mm to Type-N adaptor set)

Table 2-2 8722ET/ES Supported System Configurations

Description	2.4 mm	3.5 mm
Calibration Kit	85056A/D	85052B/C/D
Verification Kit	85057B	85053B
Cables	85133C/D/E/F	85131C/D/E/F

Cable Substitution

The test port cables specified for the network analyzer system have been characterized for connector repeatability, magnitude and phase stability with flexing, return loss, insertion loss, and aging rate. Since test port cable performance is a significant contributor to the system performance, cables of lower performance will increase the uncertainty of your measurement. Refer to the plots in the cable tests (earlier in this chapter) that show the performance of good cables. It is highly recommended that the test port cables to be regularly tested.

If the system verification is performed with non-HP/Agilent cables and fails, but is then repeated with HP/Agilent cables and passes, the non-HP/Agilent cables are at fault. It must be documented in the comments area of the performance verification printout that non-HP/Agilent cables were used in the system. The effects of the non-specified cables cannot be taken into account in the system verification procedure.

See supported system configurations in [Table 2-1](#) and [Table 2-2 on page 2-18](#).

Calibration Kit Substitution

The accuracy of the network analyzer system is dependent on how well the standards are defined in your calibration kit.

The measurement uncertainties for the system assume a calibration with an HP/Agilent calibration kit. Calibrations made with user defined or modified calibration kits are not subject to the system specifications, although a procedure similar to the standard verification procedure may be used.

See supported system configurations in [Table 2-1](#) and [Table 2-2 on page 2-18](#).

Equipment Initialization

1. Connect a printer to the analyzer and cables to PORT 1 and PORT 2 (REFLECTION port and TRANSMISSION port on ET models), as shown in [Figure 2-8](#). Let the analyzer warm up for at least 30 minutes. One cable should have a male connector and the other a female connector.

Figure 2-8 System Verification Test Setup

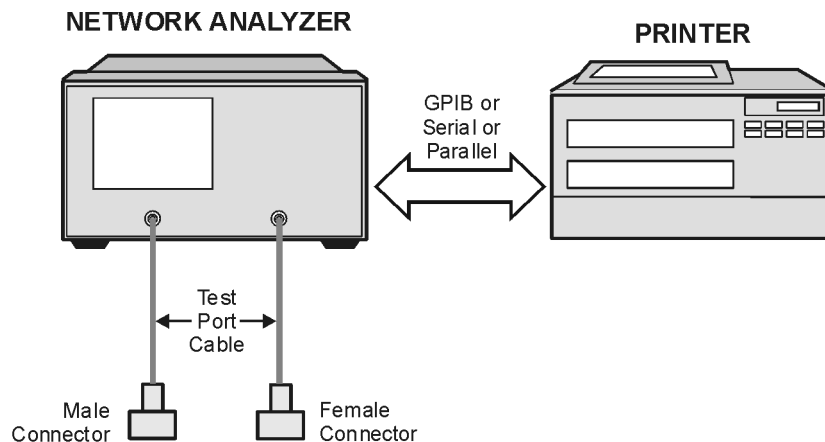

sb515e

2. While the equipment is warming up, review the [“Principles of Microwave Connector Care,”](#) on page 1-6. Good connection technique with clean, undamaged connectors is critical for accurate measurement results.
3. Insert the verification kit disk into the analyzer disk drive.
4. Press the following:
(Preset) PRESET: FACTORY (Preset)
(Save/Recall) SELECT DISK INTERNAL DISK
5. If you want a printout of the verification data in tabular form, as shown on [page 2-32](#), press the following:

(System) SERVICE MENU TEST OPTIONS RECORD ON

If graphics (plots) of the display and a list are desired on the printout, as shown on [page 2-31](#) and [page 2-32](#), press the following:

DUMP GRAPHICS ON

NOTE If you switch on the record function at this point, you *cannot* switch it off later during the verification procedure.

6. Position the paper in the printer so that printing starts at the top of the page.

7. If you have difficulty with the printer, check the following:
 - If the interface on your printer is GPIB, verify that the printer address is set to 701 (or change the setting in the analyzer to match the printer).
 - If the interface on your printer is serial or parallel, be sure that you selected the printer port and the printer type correctly (refer to the user's guide for more information on how to perform these tasks).
8. Press **Cal** **CAL KIT** **SELECT CAL KIT** and select the type of calibration kit used.
9. Press the following:
System **SERVICE MENU**
TESTS **SYS VER TESTS**
EXECUTE TEST
10. The analyzer displays `Sys Ver Init DONE` when the initialization procedure is complete.

CAUTION At this point, *do not* preset the analyzer or recall another instrument state. You must use the instrument state from this procedure for the next procedure.

Measurement Calibration

1. Continue with cables connected to PORT 1 and PORT 2 (REFLECTION port and TRANSMISSION port on ET models) (see Figure 2-9).

Figure 2-9 Connections for Measurement Calibration Standards

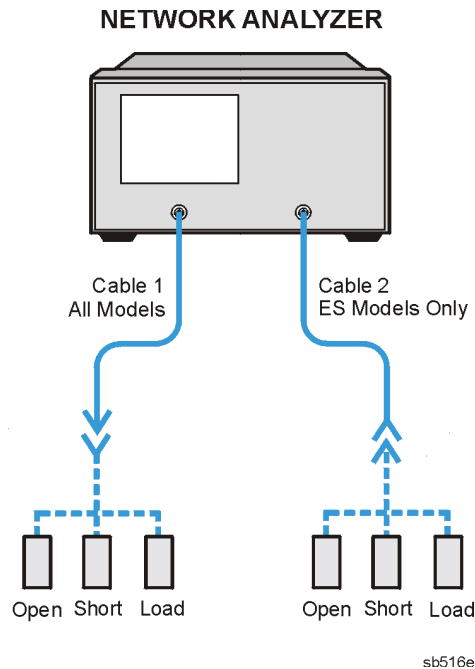

2. Press the following:

ES models: **Cal** **CALIBRATE MENU** **FULL 2-PORT** **REFLECTION**

ET models: **Cal** **CALIBRATE MENU** **ENHANCED RESPONSE**
TRAN/REFL ENH. RESP. **REFLECTION**

Port 1 Calibration

3. Connect the open that is supplied in the calibration kit to cable 1.
4. Press **FORWARD:OPEN**.
5. When the analyzer finishes measuring the standard, connect the short that is supplied in the calibration kit to cable 1.
6. Press **FORWARD:SHORT**.
7. When the analyzer finishes measuring the standard, connect the 50 Ω termination that is supplied in the calibration kit to cable 1.
8. Press **FORWARD:LOADS**.

NOTE For broadband measurements, use either a broadband load or a combination of lowband (or broadband) and sliding loads. Use the same loads used during normal calibrations.

9. Press either **BROADBAND** or **SLIDING**, depending on which device is used. If you select **SLIDING**, you must also measure a lowband load to complete the loads calibration.
10. When the measurement is complete, press **DONE:LOADS**. Leave the load connected to cable 1.

ES Models

11. If you are calibrating an ES analyzer, go to [“Port 2 Calibration \(ES Models\),” on page 2-23.](#)

ET Models

12. If you are calibrating an ET analyzer, press **STANDARDS DONE**.
13. The analyzer briefly displays **COMPUTING CAL COEFFICIENTS**.
14. Connect a load to the **TRANSMISSION** port and press **ISOLATION FWD ISOLN**. After the isolation calibration completes, go to [“Thru Calibration,” on page 2-24.](#)

Port 2 Calibration (ES Models)

15. When the analyzer finishes measuring the standard, connect the open that is supplied in the calibration kit to cable 2.
16. Press **REVERSE:OPEN**.
17. When the analyzer finishes measuring the standard, connect the short that is supplied in the calibration kit to cable 2.
18. Press **REVERSE:SHORT**.
19. When the analyzer finishes measuring the standard, connect the 50Ω termination to cable 2.
20. Press **REVERSE:LOADS**.
21. Press either **BROADBAND** or **SLIDING**, depending on which device is used. If you select **SLIDING**, you must also measure a lowband load to complete the loads calibration.
22. When the measurement is complete, press **DONE:LOADS STANDARDS DONE**. Leave the load connected to cable 2.
23. The analyzer briefly displays **COMPUTING CAL COEFFICIENTS**.
24. Press **ISOLATION DO BOTH FWD + REV**.
25. After the isolation calibration completes, go to [“Thru Calibration,” on page 2-24.](#)

Thru Calibration

26. Connect the two test port return cables together to form a “thru” configuration, as shown in [Figure 2-10](#).

Figure 2-10 Thru Connections

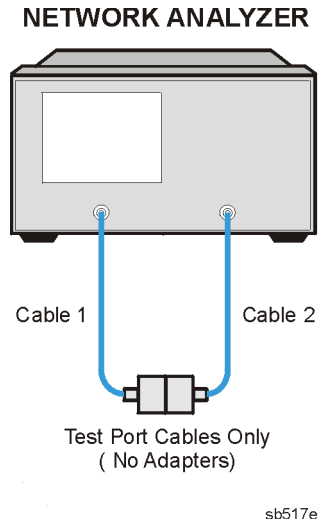

27. Press the following:

ES models: TRANSMISSION DO BOTH FWD + REV

ET models: TRANSMISSION DO BOTH FWD THRU

28. After the sweep press the following:

ES models: STANDARDS DONE DONE 2-PORT CAL

ET models: STANDARDS DONE DONE FWD ENH. RESP.

29. To save the calibration into the analyzer internal memory, press the following:

(Save/Recall) SELECT DISK INTERNAL MEMORY

Rotate the knob to select Register 1 (REG1) on the display. Then press:

RETURN SAVE STATE

IMPORTANT Step 29 is crucial to the correct recall of the calibration during subsequent measurements. The calibration *MUST* be stored in Register 1 (REG1) of **INTERNAL MEMORY** to be properly recalled.

30. When the analyzer finishes saving the instrument state, press **SELECT DISK**
INTERNAL DISK.

31. After the calibration is complete go to [“Verification Device Measurements,”](#) on [page 2-25](#).

Verification Device Measurements

NOTE Measurement calibration must be complete before the verification tests are performed.

The following verification procedure is automated by the analyzer firmware. For each verification device, the analyzer reads a file from the verification disk and sequentially measures the magnitude and phase for all four S-parameters on the ES models and two S-parameters (S11 and S21) on the ET models. [Table 2-3](#) lists the verification device number, the corresponding test number and the verification device type.

Table 2-3 Verification Kit Device and Test Numbers

Verification Device	Test Number	Device Description
1	27	20 dB attenuator
2	28	40 dB attenuator
3	29	50Ω airline
4	30	25Ω mismatch airline

1. Press **(System) SERVICE MENU TESTS (27) (x1)**.
2. In the active entry area on the display, the following will be displayed:
TEST 27 Ver Dev 1
3. If the record function was already switched as in step 5 on [page 2-20](#), or if a printout is not desired, go to step 4. Otherwise press the following:
(System) SERVICE MENU TEST OPTIONS RECORD ON
If graphics (plots) of the display and a list are desired on the printout, press the following:
DUMP GRAPHICS ON
RETURN TESTS
4. Press **EXECUTE TEST**.

Performing the Verification Tests

1. When prompted, insert the 20 dB attenuator (Ver Dev 1) as shown in [Figure 2-11](#).

Figure 2-11 Verification Device Connections

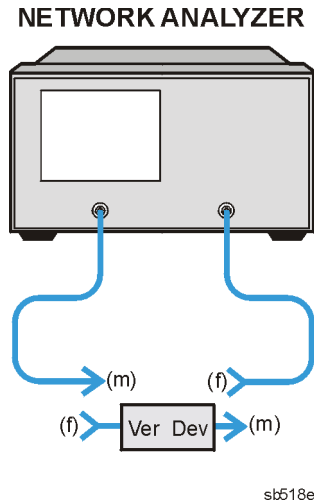

2. To start the tests, press **CONTINUE**.
3. If the record function is off (printout is not required), the program will pause after each S-parameter measurement and you will need to press **CONTINUE** after each measurement.

NOTE For ES models, there are eight measurements (magnitude and phase for each of the four S-parameters for each verification device).

For ET models, there are four measurements (magnitude and phase for each forward S-parameter for each verification device).

NOTE Although the performance for all four S-parameters on ES models are measured, only the uncertainties associated with the items indicated in [Table 2-4](#) will be used for the system verification. The other characteristics are less important for verifying system performance and they will not appear on the printout. If a measurement fails, note which device and S-parameter failed, and continue on with the remaining tests.

Table 2-4 Supported System Configurations for all ES Models

Verification Device	S11/S22 Magnitude	S11/S22 Phase	S21/S12 Magnitude	S21/S12 Phase
20 dB attenuator	x		x	x
40 dB attenuator	x		x	x
Airline	x	x	x	x
Stepped impedance airline	x	x	x	x

On the ET models, two S-parameters are measured (S11 and S21). See [Table 2-5](#) for the uncertainties that are used for system verification.

Table 2-5 Supported System Configurations for all ET Models

Verification Device	S11 Magnitude	S11 Phase	S21 Magnitude	S21 Phase
20 dB attenuator	x		x	x
40 dB attenuator	x		x	x
Airline	x	x	x	x
Stepped impedance airline	x	x	x	x

NOTE Measured data is displayed as DATA.
 Factory data is displayed as MEMORY.

4. When all measurements are complete, the **TESTS** softkey menu will appear. Disconnect the verification device.
5. Enter Test 28 (using step keys, entry keys, or front panel knob). Repeat steps 1 through 4 in this section with the 40 dB attenuator (Ver Dev 2).
6. Enter Test 29 (using step keys, entry keys, or front panel knob). Repeat steps 1 through 4 in this section with the 50Ω airline (Ver Dev 3). For an example of how to perform proper airline connections, refer to [Figure 2-12](#) and [Figure 2-13](#).

CAUTION Be very careful not to drop the airline's center or outer conductor. Irreparable damage will result if these devices are dropped.

During this procedure, you will be touching the exposed center conductor of the test port with the center conductor of the airline. Ground yourself to prevent electrostatic discharge (ESD).

Figure 2-12 Aligning the Center Conductor

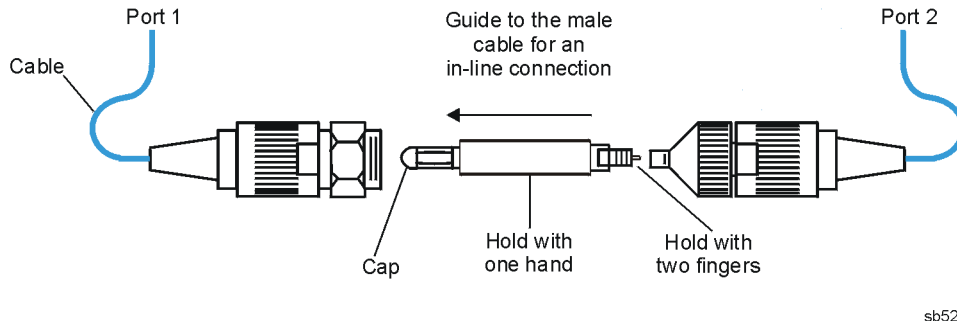
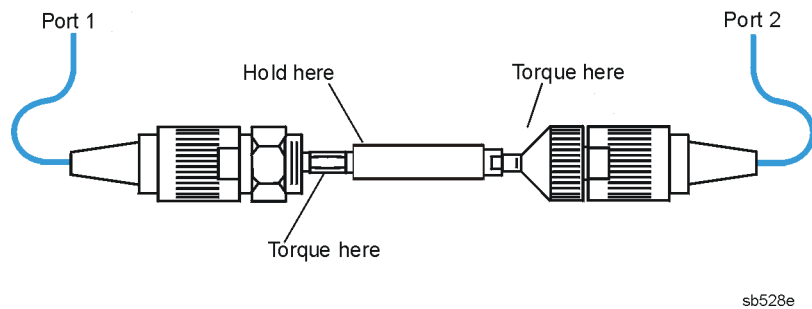

Figure 2-13 Torquing the Connection



7. Enter Test 30 (using step keys, entry keys, or front panel knob). Repeat steps 1 through 4 of this section with the 25Ω mismatch airline (Ver Dev 4). Refer to [Figure 2-12](#) and [Figure 2-13](#).
8. When **DUMP GRAPHICS** is active, the printout of the measurements shows both a plot of the measurement and a list of the measured frequencies with corresponding data. The plot includes the measured data trace, factory supplied data trace and uncertainty limits. The listing includes measured data and uncertainty limits. If there is a failure at any frequency, an asterisk will be displayed next to the measured data and the out-of-specification measured data on the plot will be blanked out.

In Case of Difficulty

NOTE Inspect all connections. *DO NOT* disconnect the cables from the analyzer test ports. This *will invalidate* the calibration that you have done earlier.

- Repeat “[Verification Device Measurements](#),” on page 2-25. Be sure to make good connections for each verification device measurement.
- If the analyzer still fails the test, check the measurement calibration as follows:
 1. Press **(Preset) PRESET: FACTORY (Preset)**.
 2. Recall the calibration by pressing **(Save/Recall) SELECT DISK INTERNAL MEMORY RETURN**.
 3. Use the front panel knob to highlight the calibration you want to recall and press **RECALL STATE**.
 4. Connect the short to cable 1.
 5. Press **(Meas) Refl: FWD S11 (A/R) (Sweep Setup) TRIGGER MENU CONTINUOUS**.
 6. Press **SCALE/REF SCALE/DIV (.05) (x1)**.

ES Models (Check PORT 2)

7. Check that the trace response is 0.00 ± 0.05 dB.
8. Disconnect the short and connect it cable 2.
9. Press **(Meas) Refl: REV S22(B/R)**.
10. Check that the trace response is 0.00 ± 0.05 dB.
11. If any of the trace responses are out of the specified limits, repeat “[Measurement Calibration](#),” on page 2-22 and “[Verification Device Measurements](#),” on page 2-25.
12. Refer to [Chapter 4](#), “[Start Troubleshooting Here](#)” for more troubleshooting information.

If the System Fails the Verification Test

- Disconnect and reconnect the device that failed the verification. Then measure the device again.

If the performance verification still fails:

- Continue to measure the rest of the verification devices and printout the results of all four measurement parameters.
- Print the error terms and examine them for anomalies near the failure frequencies. Refer to [Chapter 11](#), “Error Terms.”
- Make another measurement calibration and follow the flow chart in [Figure 2-14](#).

Figure 2-14 Verification Fails Flowchart

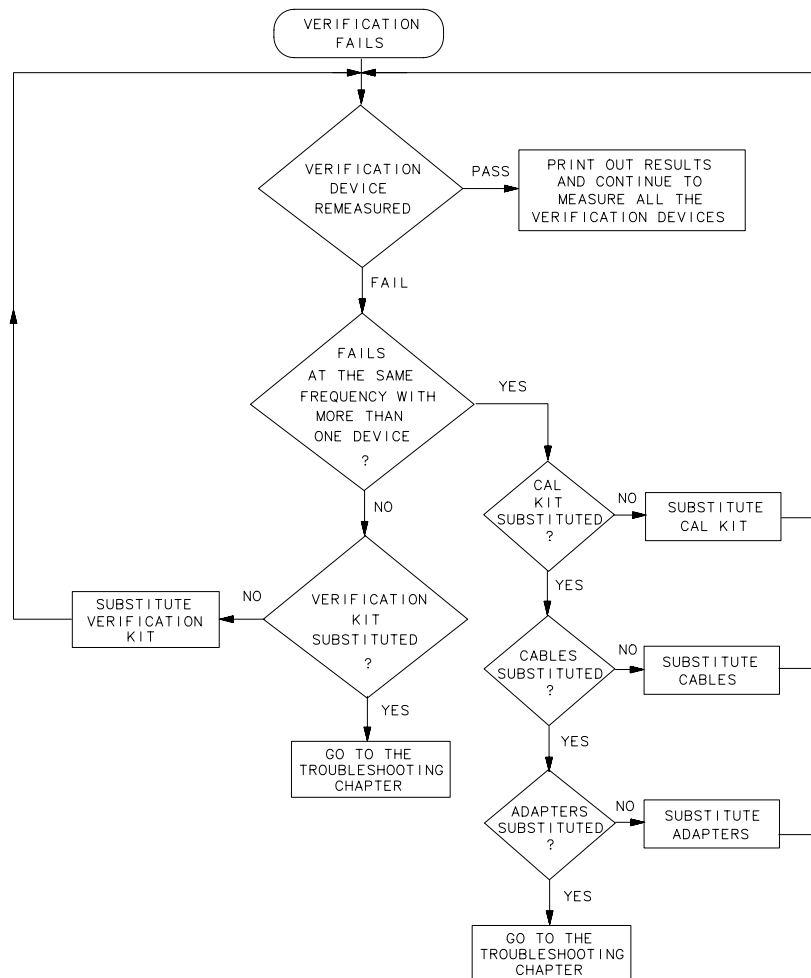

sb69d

Interpreting the Verification Results

Figure 2-15 and Figure 2-16 show examples of typical verification results, with dump graphics activated (**DUMP GRAPHICS ON**). These printouts include a comparison of the data from your measurement results with the traceable data and corresponding uncertainty specifications. Use these printouts to determine whether your measured data falls within the total uncertainty limits at all frequencies.

NOTE If you only want a tabular list (as in Figure 2-16), activate **RECORD ON** .

Figure 2-15 Printout of Graphical Verification Results

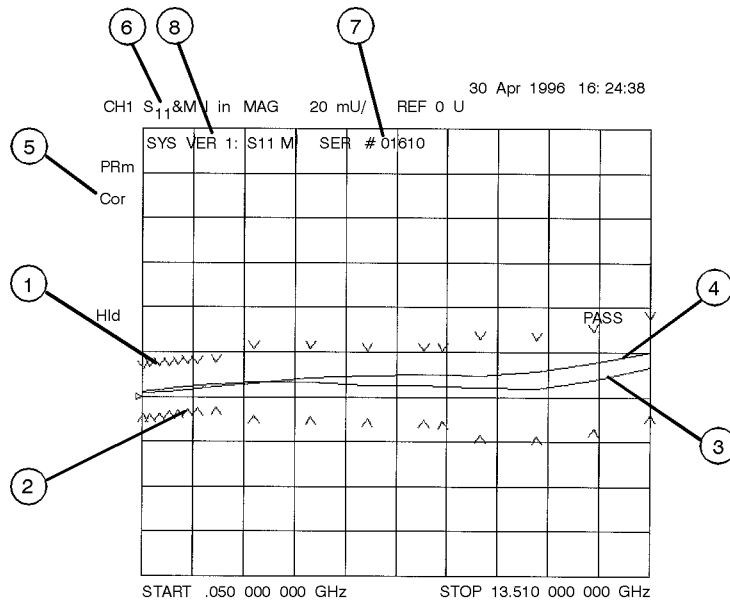

sb6156d

The callouts in Figure 2-15 are defined as:

1. Upper limit points as defined by the total system uncertainty specifications.
2. Lower limit points as defined by the total system uncertainty specifications.
3. Data measured at the factory.
4. Results of measurement.
5. Correction is turned on.
6. Measurement parameter (S11 and memory, displayed in linear magnitude).
7. Serial number of device (01610).
8. Device being measured (SYS VER 1).

Figure 2-16 Printout of Tabular Verification Results

STIMULUS GHz	CH1 S12	Margin	Upper Lim	Lower Lim
.050 000 000	-20.04 dB	.063 dB	-19.976 dB	-20.197 dB
.250 000 000	-20.105 dB	.103 dB	-19.983 dB	-20.208 dB
.500 000 000	-20.113 dB	.101 dB	-19.987 dB	-20.214 dB
.750 000 000	-20.12 dB	.103 dB	-19.983 dB	-20.224 dB
1.000 000 000	-20.126 dB	.104 dB	-19.984 dB	-20.23 dB
1.250 000 000	-20.136 dB	.098 dB	-19.989 dB	-20.234 dB
1.500 000 000	-20.155 dB	.082 dB	-19.992 dB	-20.237 dB
2.000 000 000	-20.197 dB	.048 dB	-19.999 dB	-20.246 dB
3.000 000 000	-20.19 dB	.125 dB	-19.957 dB	-20.315 dB
4.500 000 000	-20.192 dB	.149 dB	-19.976 dB	-20.342 dB
6.000 000 000	-20.212 dB	.152 dB	-19.993 dB	-20.365 dB
7.500 000 000	-20.206 dB	.181 dB	-20.016 dB	-20.388 dB
8.000 000 000	-20.22 dB	.180 dB	-20.025 dB	-20.4 dB
9.000 000 000	-20.235 dB	.262 dB	-19.961 dB	-20.498 dB
10.000 000 000	-20.257 dB	.261 dB	-19.986 dB	-20.518 dB
12.000 000 000	-20.295 dB	.254 dB	-20.017 dB	-20.55 dB
13.500 000 000	-20.307 dB	.265 dB	-20.041 dB	-20.574 dB
15.000 000 000	-20.317 dB	.280 dB	-20.036 dB	-20.622 dB
16.500 000 000	-20.412 dB	.238 dB	-20.061 dB	-20.65 dB
18.000 000 000	-20.46 dB	.205 dB	-20.076 dB	-20.666 dB
19.500 000 000	-20.345 dB	.257 dB	-20.087 dB	-20.675 dB
20.000 000 000	-20.346 dB	.259 dB	-20.087 dB	-20.675 dB

sb531e

The callouts in [Figure 2-16](#) are defined as:

1. Frequency of the data points, in GHz.
2. Results of the measurement.
3. Upper limit line as defined by the total system uncertainty specification.
4. Lower limit line as defined by the total system uncertainty specification.
5. Difference between the measured results and the limit line. A positive number indicates a pass. An asterisk (*) indicates a fail.

Performance Tests

The performance tests verify that the analyzer meets its published specifications. Data from these tests should be recorded on the “[Performance Test Record](#),” beginning on [page 2-46](#).

This section includes the following performance tests:

- [Frequency Accuracy Performance Test](#), on page 2-34.
- [Level Accuracy Performance Test](#), on page 2-36.
- [Source Linearity Performance Test](#), on page 2-38.
- [Dynamic Range Performance Test](#), on page 2-42.

Frequency Accuracy Performance Test

This test checks the frequency accuracy of the analyzer at or near its maximum frequency.

Table 2-6 Required Equipment

Equipment Description	8719ET/ES 8720ET/ES	8722ET/ES
Frequency Counter	53150A or 5350B	53151A or 5351B
RF Cable Set	85131F	85133F

Analyzer warmup time: 30 minutes.

NOTE On the frequency counter, set the resolution to 1kHz or less.

1. Connect the equipment as shown in [Figure 2-17](#) and press the following:

PRESET: FACTORY
 CW FREQ

Figure 2-17 Frequency Range and Accuracy Test Setup

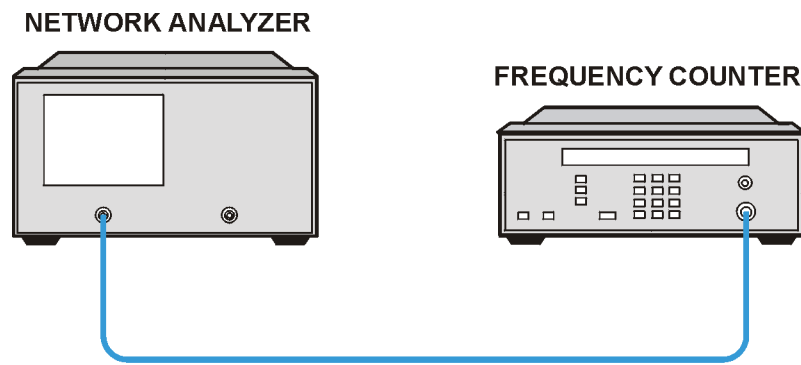

sb519e

2. Select the analyzer CW frequency:
 - Agilent 8719ET/ES, press
 - Agilent 8720ET/ES, press
 - Agilent 8722ET/ES, press
3. Record the frequency counter reading for each frequency point in the results section on the "Frequency Accuracy" performance test record at the end of this chapter.

If the Analyzer Fails This Test

- If the frequency measured is close to the specification limits (either in or out of specification), check the time base accuracy of the counter used.
- If the analyzer fails by a significant margin, the master time base probably needs adjustment. In this case, refer to the “[Frequency Accuracy Adjustment](#)” procedure in [Chapter 3](#) , “[Adjustments and Correction Constants](#).”
- See [Chapter 7](#) , “[Source Troubleshooting](#),” for related troubleshooting information.

Level Accuracy Performance Test

This test checks the maximum variation in output power across the frequency range of the analyzer.

Table 2-7 Required Equipment

Equipment Description	8719ET/ES 8720ET/ES	8722ET/ES
HP/Agilent Power Meter	436A, 437B, 438A E4418A (EPM-441A) or E4419A (EPM-442A)	
HP/Agilent Power Sensor	8485A	8487A
Adapter 3.5-mm (f) to 3.5-mm (f)	P/N 85052-60012 (part of 85052B)	N/A
Adapter 2.4-mm (f) to 2.4-mm (f)	N/A	P/N 85056-60006 (part of 85056A)

Analyzer warmup time: 30 minutes.

1. Zero and calibrate the power meter.
2. Set the calibration factor on the power meter to the average value of the power sensor between 50 MHz and 20 GHz (40 GHz for 8722ET/ES).

For example, if the power sensor calibration factor is 100% at 50 MHz and 92% at 20 GHz (40 GHz for 8722ET/ES), set the calibration factor to 96%.

3. Connect the equipment as shown in [Figure 2-18](#).

Figure 2-18 Power Test Setup

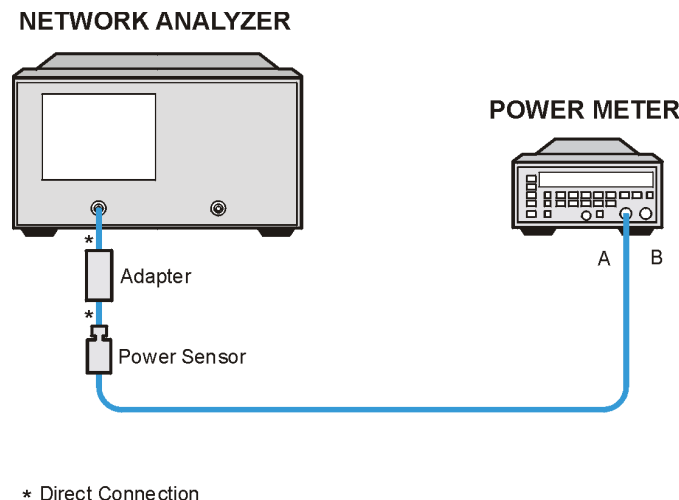

sb520e

4. On the analyzer, press the following:

Presets **PRESET: FACTORY** **Presets**

Sweep Setup **POWER** **PWR RANGE MAN** **POWER RANGES** **RANGE 0**

5. Enter the power value listed in [Table 2-8](#) and then press **x1**.

Table 2-8 Power Values for Flatness Test

Analyzer Model Type	Test Power Setting
8719ES and 8720ES	0 dBm
8719ET and 8720ET 8719ES Option 007 8720ES Option 007	5 dBm
8722ES	-10 dBm
8722ET 8722ES Option 007	-5 dBm

6. To set a 300 second sweep, press **Sweep Setup** **SWEEP TIME** **300** **x1**.

7. To initiate a single sweep, press **Sweep Setup** **TRIGGER MENU** **SINGLE**.

8. During the sweep, notice the minimum and maximum power level readings, and record these in the “Min.” and “Max.” columns on the “Level Accuracy” performance test record.

The analyzer remains at each frequency point for 1.5 seconds to allow the power meter sufficient time to settle.

If the Analyzer Fails This Test

1. Ensure that the power meter and power sensor are operating to specification.
2. Inspect the connectors for damage. Poor match at these connections can generate power reflections and cause the analyzer to appear to be out of limits.
3. Marginal failures (especially at the high or low end) may be due to the power sensor calibration factor approximation method. A calibration factor approximation of $\pm 4\%$, as in the above example, induces an error of about 0.15 dB. To eliminate the calibration factor approximation as the cause of failure, do the following:
 - a. Press **Sweep Setup** **CW FREQ** and rotate the knob to the frequency in question.
 - b. Set the calibration factor on the power meter to the value indicated by the power sensor.
 - c. The corrected power level reading should be between the limits shown in the “Level Accuracy” performance test record.
4. The source relies on the power adjustments for proper performance, refer to [Chapter 3](#), “Adjustments and Correction Constants.” If failures still occur, after you have made the power adjustments, refer to [Chapter 7](#), “Source Troubleshooting.”

Source Linearity Performance Test

This test checks the Source Power Linearity.

Table 2-9 Required Equipment

Equipment Description	8719ET/ES and 8720ET/ES	8722ET/ES
50Ω RF Load	P/N 00902-60004 (Part of the 85052B)	P/N 00901-60004 (Part of the 85056A)

1. Connect a 50Ω load to PORT 1 (REFLECTION port on ET models).

2. Press **[Preset] PRESET: FACTORY [Preset]**.

3. To measure R channel, press the following:

[Meas] INPUT PORTS R

[Marker Fctn] MARKER MODE MENU MARKERS: DISCRETE

4. To set the IF bandwidth to 10 Hz, press the following:

[Avg] IF BW [10] [x1]

[Sweep Setup] POWER PWR RANGE MAN POWER RANGES RANGE 0

Table 2-10 Power Value Settings for Testing Linearity

Power Settings	8719ES 8720ES	8719ET, 8720ET, 8719ES Option 007, 8720ES Option 007	8722ES	8722ET, 8722ES Option 007
P_{Ref}	-5 dBm	0 dBm	-10 dBm	-5 dBm
P_1 ($P_{Ref} - 5$ dB)	-10 dBm	-5 dBm	-15 dBm	-10 dBm
P_2 ($P_{Ref} - 10$ dB)	-15 dBm	-10 dBm	-20 dBm	-15 dBm
P_3 ($P_{Ref} + 5$ dB)	0 dBm	+5 dBm	-5 dBm	0 dBm
P_4 ($P_{Ref} + 10$ dB)	+5 dBm	+10 dBm	NA	NA

8719ET/ES and 8720ET/ES Models

1. Refer to [Table 2-10](#) and set the analyzer to the power value that is listed in the P_{Ref} row for the particular analyzer under test. After you enter the value, press **(x1)**.
2. Wait for the analyzer to complete a full sweep.
3. Press **(Display)** **DATA** → **MEMORY** **DATA/MEM** .
4. Press **(Marker)** **Δ MODE MENU** **FIXED MKR POSITION** **FIXED MKR VALUE**
(0) **(x1)**.

Recording P_1 Data

5. Press **(Sweep Setup)** **POWER** .
6. Enter the power value that is listed in the P_1 row of [Table 2-10](#) for the particular analyzer under test. After you enter the value, press **(x1)**.
7. Wait for the analyzer to complete a full sweep.
8. Press **(Marker Search)** **SEARCH: MAX** .
9. Read the marker value from the analyzer display and add 5 dB. Record the calculated value in the “ P_1 Max.” column of the “Source Linearity” performance test record.
10. Press **SEARCH: MIN** .
11. Read the marker value from the analyzer display and add 5 dB. Record the calculated value in the “ P_1 Min.” column of the “Source Linearity” performance test record.

Recording P_2 Data

12. Repeat steps 5 through 11, except in step 6 enter the power value in the P_2 row and in step 11 read the marker and add 10 dB to arrive at the calculated value. Record the calculated value in the “ P_2 Max.” and “ P_2 Min.” columns of the “Source Linearity” performance test record.

Recording P_3 Data

13. Repeat steps 5 through 11, except in step 6 enter the power value in the P_3 row and in step 11 read the marker and subtract 5 dB to arrive at the calculated value. Record the calculated value in the “ P_3 Max.” and “ P_3 Min.” columns of the “Source Linearity” performance test record.

Recording P_4 Data

14. Repeat steps 5 through 11, except in step 6 enter the power value in the P_4 row and in step 11 read the marker and subtract 10 dB to arrive at the calculated value. Record the calculated value in the “ P_4 Max.” and “ P_4 Min.” columns of the “Source Linearity” performance test record.

8722ET/ES Models

1. Press **Stop** **20** **G/n**.
2. Press **Sweep Setup** **POWER**.
3. Refer to [Table 2-10](#) and set the analyzer to the power value that is listed in the P_{Ref} row for the particular analyzer under test. After you enter the value, press **x1**.
4. Wait for analyzer to complete one full sweep.
5. Press **Display** **DATA → MEMORY** **DATA/MEM**.
6. Press **Marker** **Δ MODE MENU** **FIXED MKR POSITION** **FIXED MKR VALUE** **0** **x1**.

Recording P_1 Data

7. Press **Sweep Setup** **POWER**.
8. Enter the power value that is listed in the P_1 row of [Table 2-10](#) for the particular analyzer under test. After you enter the value, press **x1**.
9. Wait for analyzer to complete one full sweep.
10. Press **Marker Search** **SEARCH: MAX**.
11. Read the marker value from the analyzer display and add 5 dB. Record the calculated value in the 8722ET/ES (0.05 – 20 GHz) “ P_1 Max.” column of the “Source Linearity” performance test record.
12. Press **SEARCH: MIN**.
13. Read the marker value from the analyzer display and add 5 dB. Record the calculated value in the 8722ET/ES (0.05 – 20 GHz) “ P_1 Min.” column of the “Source Linearity” performance test record.

Recording P_1 Data for the 20 GHz to 40 GHz Band

14. To record data for P_1 data in the 20 GHz to 40 GHz band, press **Start** **20** **G/n**.
15. Press **Stop** **40** **G/n**.
16. Repeat steps 2 through 13 of the section, except record the values in the 8722ET/ES (20 – 40 GHz) “ P_1 Max.” and “ P_1 Min.” columns of the “Source Linearity” performance test record.

Recording P₂ Data

17. To record data for P₂ data in the 50 MHz to 40 GHz band, press **(Start)** **(50)** **(M/μ)**.
18. Repeat steps 2 through 7 of this section of the procedure.
19. Enter the power value that is listed in the P₂ row of [Table 2-10](#) for the particular analyzer under test. After you enter the value, press **(x1)**.
20. Wait for the analyzer to complete one full sweep.
21. Press **(Marker Search)** **SEARCH: MAX**.
22. Read the marker value from the analyzer display and add 10 dB. Record the calculated value in the 8722ET/ES (0.05 – 40 GHz) “P₂ Max.” column of the “Source Linearity” performance test record.
23. Press **SEARCH: MIN**.
24. Read the marker value from the analyzer display and add 10 dB. Record the calculated value in the 8722ET/ES (0.05 – 40 GHz) “P₂ Min.” column of the “Source Linearity” performance test record.

Recording P₃ Data

25. To record data for P₃ data in the 50 MHz to 20 GHz band, press **(Start)** **(50)** **(M/μ)**.
26. Press **(Stop)** **(20)** **(G/n)**.
27. Repeat steps 2 through 7 of this section of the procedure.
28. Enter the power value that is listed in the P₃ row of [Table 2-10](#) for the particular analyzer under test. After you enter the value, press **(x1)**.
29. Wait for analyzer to complete one full sweep.
30. Press **(Marker Search)** **SEARCH: MAX**.
31. Read the marker value from the analyzer display and subtract 5 dB. Record the calculated value in the 8722ET/ES (0.05 – 20 GHz) “P₃ Max.” column of the “Source Linearity” performance test record.
32. Press **SEARCH: MIN**.
33. Read the marker value from the analyzer display and subtract 5 dB. Record the calculated value in the “P₃ Min.” column of the “Source Linearity” performance test record.

If the Analyzer Fails This Test

- The source relies on the power linearity adjustment for correct performance. Refer to [Chapter 3](#), “Adjustments and Correction Constants,” and perform the “Power Linearity Adjustment” procedure. Then repeat this test.
- If the analyzer repeatedly fails this test, refer to [Chapter 7](#), “Source Troubleshooting.”

Dynamic Range Performance Test

This test checks the dynamic range of the analyzer.

Table 2-11 Required Equipment

Equipment Description	8719ET/ES and 8720ET/ES	8722ET/ES
HP/Agilent Calibration Kit	85052B	85056A
HP/Agilent RF Cable Set	85131F	85133F

Analyzer warmup time: 30 minutes.

Entering Frequency Points

1. Press **[Preset] PRESET: FACTORY [Preset]**.
2. To enter the values for the first frequency segment and power value, press the following:

[Sweep Setup] SWEEP TYPE MENU EDIT LIST ADD

[Start] 50 [M/μ]

[Stop] 50.000101 [M/μ]

NUMBER of POINTS 11 [x1] DONE

MORE LIST POWER ON SEGMENT POWER

Enter the power level from [Table 2-12](#) and press **[x1] [Return] DONE**.

Table 2-12 Power Levels for the Frequency Segment Values

Model	Power dBm
ES Models	
8719ES and 8720ES	5
8719ES and 8720ES Option 007	10
8722ES (50MHz to 20 GHz)	-5
(20.0 GHz to 40.05 GHz)	-10
8722ES Option 007 (50MHz to 20 GHz)	0
(20.0 GHz to 40.05 GHz)	-5
ET Models	
8719ET and 8720ET	5
8722ET (50MHz to 20 GHz)	0
(20.0 GHz to 40.05 GHz)	-5

- Repeat step 2 (beginning with **ADD**) to enter the values for the remaining frequency segments and power levels of your analyzer. Refer to [Table 2-13](#) for the frequency segment values.

Table 2-13 Frequency Segment Values

Segment		Start Frequency	Stop Frequency	Number of Points
All Models	1	50 MHz	50.000101 MHz	11
All Models	2	839.999899 MHz	840 MHz	11
All Models	3	0.84 GHz	8 GHz	201
8719ET/ES	4	8 GHz	13.51 GHz	101
8720ET/ES	4	8 GHz	20.05 GHz	151
8722ET/ES	4	8 GHz	20 GHz	151
8722ET/ES	5	20 GHz	40.05 GHz	201

- When all of the frequency segments have been entered, press the following:

DONE LIST FREQ ALL SEGS SWEEP

Test Setup

- To set up the PORT 1 measurement (REFLECTION measurement on ET Models), press the following:

For ES Models:

Meas **Trans: FWD S21 (B/R)**

Format **LIN MAG**

Avg **IF BW** **10** **x1**

Scale Ref **2** **x1**

For ET Models:

Meas **TRANSMISSN**

Format **LIN MAG**

Avg **IF BW** **10** **x1**

Scale Ref **2** **x1**

Calibration

6. Connect a thru (RF cable) between PORT 1 and PORT 2 on ES models (REFLECTION and TRANSMISSION on ET models).

7. To start the measurement calibration, press the following:

Cal **CALIBRATE MENU** **RESPONSE & ISOL'N** **RESPONSE** **THRU**

8. Remove the thru and connect 50Ω terminations to PORT 1 and PORT 2 on ES models (REFLECTION port and TRANSMISSION port on ET models).

9. To continue the measurement calibration, press the following:

Avg **AVERAGING FACTOR** **8** **x1** **AVERAGING ON**

Cal **RESUME CAL SEQUENCE** **ISOL'N STD**

NOTE This measurement takes several minutes

10. When the analyzer beeps or the message, PRESS 'DONE' IF FINISHED WITH STD(s), appears on the display, press the following:

DONE:RESP ISOL'N CAL

Measurement and Data Collection

11. Press **Sweep Setup** **TRIGGER MENU** **SINGLE**.

12. When the single sweep has been taken, press the following:

Scale Ref **AUTOSCALE**

Marker Fctn **MARKER MODE MENU** **MARKERS: DISCRETE**

Marker **MARKER 1** **50** **M/μ** **MARKER 2** **50.000101** **M/μ**

Marker Fctn **MARKER MODE MENU** **MKR STATS ON**

Marker **Δ MODE MENU** **Δ REF=1**

13. Read the mean value and standard deviation from the analyzer display. Calculate the dynamic range, using the following equation.

$$20 \times \log [(3 \times \text{Standard Deviation}) + \text{Mean Value}]$$

Record the calculated value in the "S21 / Transmission" column of the "Dynamic Range" performance test record for your analyzer.

14. Repeat steps 12 and 13 (beginning with **Marker** **MARKER 1**), placing marker 1 and marker 2 at the start and stop of the remaining frequency ranges that are listed in [Table 2-13](#).

If the Analyzer Fails This Test

- First suspect the connections, the calibration standards and the cable. Visually inspect all of the connectors and repeat the test.
- In case of repeat failure, gauge the connectors, refer to the [“Principles of Microwave Connector Care,”](#) on page 1-6.
- Recheck the output power of the source.
- Refer to the [Chapter 4 , “Start Troubleshooting Here,”](#) for additional help.

Performance Test Record

The complete system performance verification record includes the printout from the total system uncertainty test, these test records, and a certificate of calibration.

Use the following pages to record the results of the performance tests. You may wish to photocopy these pages and keep them as master copies.

Table 2-14 Performance Test Record for All Models

Test Facility _____		Report Number _____	
_____		Date _____	
_____		Date of Last System Calibration _____	
_____		_____	
Tested by _____		Customer _____	
Analyzer Model _____	Calibration Kit S/N _____	Verification Kit Model _____	
Serial Number _____	Test Port Cables _____	Verification Kit S/N _____	
Calibration Kit _____	Measurement Calibration Technique _____		
Ambient temperature °C _____		Relative Humidity _____	
Ambient temperature at measurement calibration _____ °C		Ambient temperature at performance verification _____ °C	
Test Equipment Used	Model Number	Trace Number	Cal Due Date
1. Frequency Counter	_____	_____	_____
2. Power Meter	_____	_____	_____
3. Power Sensor	_____	_____	_____
4. Spectrum Analyzer	_____	_____	_____
Special Notes: This system verification applies to total measurement uncertainty and frequency accuracy specifications. _____			

Frequency Accuracy				
Frequency Point	Minimum Specifications	Results	Maximum Specifications	Measurement Uncertainty ^a
13.5 (8719ET/ES)	13.499865 GHz	_____	13.500135 GHz	±2.35 kHz
20.0 (8720ET/ES)	19.999800 GHz	_____	20.000200 GHz	±3.00 kHz
26.0 (8722ET/ES)	25.999740 GHz	_____	26.000260 GHz	±3.60 kHz

^a The measurement uncertainty is based on equipment specified in “Service Test Equipment,” on page 1-3.

Level Accuracy					
Model Type	Minimum	PORT 1 or REFLECTION		Maximum	Measurement Uncertainty ^a
		Min.	Max.		
8719ES 8720ES	-2.0 dBm	_____	_____	+2.0 dBm	±0.30 dB
8719ET 8720ET 8719ES (Opt. 007) 8720ES (Opt. 007)	+3.0 dBm	_____	_____	+7.0 dBm	±0.30 dB
8722ES	-13.0 dBm	_____	_____	-7.0 dBm	±0.35 dB
8722ET 8722ES (Opt. 007)	-8.0 dBm	_____	_____	-2.0 dBm	±0.30 dB

^a The measurement uncertainty is based on equipment specified in “Service Test Equipment,” on page 1-3.

Source Linearity					
Power Level and Model Type	Minimum Specification	Results		Maximum Specification	Measurement Uncertainty
		Min.	Max.		
P₁					
8719ET/ES, 8720ET/ES 8719ES Opt. 007, 8720ES Opt. 007	-0.35 dB	_____	_____	0.35 dB	±0.03 dB
8722ET/ES, 8722ES Opt. 007 Freq. range (0.05 – 20 GHz)	-0.35 dB	_____	_____	0.35 dB	±0.03 dB
8722ET/ES, 8722ES Opt. 007 Freq. range (20 – 40 GHz)	-0.60 dB	_____	_____	0.60 dB	±0.03 dB
P₂					
8719ET/ES, 8720ET/ES 8719ES Opt. 007, 8720ES Opt. 007	-0.60 dB	_____	_____	0.60 dB	±0.04 dB
8722ET/ES, 8722ES Opt. 007 Freq. range (0.05 – 40 GHz)	-0.60 dB	_____	_____	0.60 dB	±0.04 dB
P₃					
8719ET/ES, 8720ET/ES 8719ES Opt. 007, 8720ES Opt. 007	-0.35 dB	_____	_____	0.35 dB	±0.03 dB
8722ET/ES, 8722ES Opt. 007 Freq. range (0.05 – 20 GHz)	-0.35 dB	_____	_____	0.35 dB	±0.03 dB
P₄					
8719ET/ES, 8720ET/ES 8719ES Opt. 007, 8720ES Opt. 007	-1.0 dB	_____	_____	1.0 dB	±0.04 dB

Power Settings	8719ES 8720ES	8719ET, 8720ET 8719ES Option 007 8720ES Option 007	8722ES	8722ET 8722ES Option 007
P_{Ref}	-5 dBm	0 dBm	-10 dBm	-5 dBm
$P_1 (P_{Ref} - 5 \text{ dB})$	-10 dBm	-5 dBm	-15 dBm	-10 dBm
$P_2 (P_{Ref} - 10 \text{ dB})$	-15 dBm	-10 dBm	-20 dBm	-15 dBm
$P_3 (P_{Ref} + 5 \text{ dB})$	0 dBm	+5 dBm	-5 dBm	0 dBm
$P_4 (P_{Ref} + 10 \text{ dB})$	+5 dBm	+10 dBm	NA	NA

Dynamic Range				
Model Type and Frequency Range	Specification		Results	Measurement Uncertainty
	Not Option 007	Option 007	S21 / Transmission	
8719ET and 8720ET				
50 MHz to 840 MHz	102 dB	N/A	_____	±0.29 dB
840 MHz to 20.05 GHz	104 dB	N/A	_____	±0.29 dB
8719ES and 8720ES				
50 MHz to 840 MHz	77 dB	82	_____	±0.29 dB
840 MHz to 20.05 GHz	100 dB	105	_____	±0.29 dB
8722ET				
50 MHz to 840 MHz	98 dB	N/A	_____	±0.29 dB
840 MHz to 8 GHz	102 dB	N/A	_____	±0.29 dB
8 GHz to 20 GHz	100 dB	N/A	_____	±0.29 dB
20 GHz to 40.05 GHz	89 dB	N/A	_____	±0.29 dB
8722ES				
50 MHz to 840 MHz	67 dB	72 dB	_____	±0.29 dB
840 MHz to 8 GHz	93 dB	98 dB	_____	±0.29 dB
8 GHz to 20 GHz	91 dB	96 dB	_____	±0.29 dB
20 GHz to 40.05 GHz	80 dB ^a	85 dB ^a	_____	±0.29 dB
^a For Option 085 or Option 012, subtract 3 dB.				

3 Adjustments and Correction Constants

Information on This Chapter

The accuracy of the analyzer is achieved and maintained through mechanical adjustments, electrical adjustments, and correction constants (CCs). The correction constants are empirically derived data that are stored in memory and then recalled to refine the instrument's measurements and to determine its proper operation.

Anytime the CPU (A7) assembly is replaced, all of the correction constants must be regenerated and stored to the new CPU assembly board. Agilent Technologies recommends that you store the correction constant data to 3.5 inch disk as a backup. The procedure for storing correction constant data to 3.5 inch disk can be found in [“EEPROM Backup Disk Procedure” on page 3-33](#).

Additionally, there are adjustments and correction constants that must be performed following the replacement of an assembly. Refer to [Table 14-1 on page 14-35](#) of [Chapter 14 , “Assembly Replacement and Post-Repair Procedures,”](#) in order to determine which adjustments and correction constants procedures to perform.

This chapter contains the following adjustment procedures:

- "A7 Switch Positions," on page 3-4
- "Source Pretune Correction Constants (Test 43)," on page 3-6
- "Analog Bus Correction Constants (Test 44)," on page 3-8
- "IF Step Correction Constants (Test 47)," on page 3-9
- "ADC Offset Correction Constants (Test 48)," on page 3-10
- "Serial Number Correction Constants (Test 49)," on page 3-11
- "Protected Option Numbers Correction Constants (Test 50)," on page 3-13
- "Unprotected Hardware Option Correction Constants," on page 3-15
- "Output Power Adjustments," on page 3-17
- "Power Linearity Adjustment," on page 3-24
- "Blanking Adjustment (Test 54)," on page 3-30
- "Initialize EEPROMs (Test 53)," on page 3-32
- "EEPROM Backup Disk Procedure," on page 3-33
- "Correction Constants Retrieval Procedure," on page 3-35
- "Loading Firmware," on page 3-36
- "Reference Assembly VCO Tune Adjustment," on page 3-39
- "Frequency Accuracy Adjustment," on page 3-41
- "API Spur Avoidance and 100 kHz FM Sideband Adjustment," on page 3-44
- "Raw Offset Correction Constants," on page 3-48
- "Sampler Calibration Correction Constants (Test 51)," on page 3-58

A7 Switch Positions

The A7 switch allows you to set up your analyzer to alter correction constants (CCs).

NOTE Before moving the A7 switch, perform “[EEPROM Backup Disk Procedure](#),” on [page 3-33](#) to save your correction constants.

Required Equipment and Tools

To move the switch position, use a non-metallic adjust tool, HP/Agilent part number 8830-0024.

1. Remove the power cord from the analyzer.
2. Set the analyzer on its side.
3. Remove the two corner standoffs from the bottom of the instrument with the T-10 TORX screwdriver.
4. Loosen the captive screw on the bottom cover's back edge, with the T-15 TORX screwdriver.
5. Slide the cover toward the rear of the instrument.

CAUTION Use proper ESD procedures when performing the following steps.

6. Move the A7 switch, as shown in [Figure 3-1](#).
 - Move the A7 Switch to the ALT position before you run any of the correction constant adjustment routines. This is the position for altering the analyzer's correction constants.
 - Move the A7 Switch to the NRM position after you have run correction constant adjustment routines. This is the position for normal operation.
7. Reconnect the power cord and switch on the instrument.

Figure 3-1 Switch Positions for A7 CPU Assembly

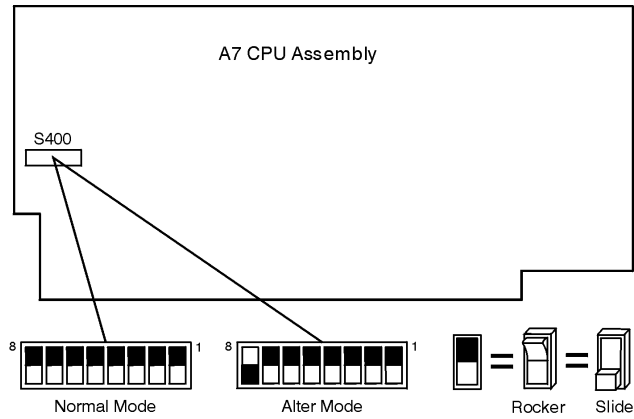

Source Pretune Correction Constants (Test 43)

This procedure generates pretune values for correct phase-locked loop operation.

Required Equipment

Equipment Description	8719ET/ES 8720ET/ES	8722ET/ES
HP/Agilent Frequency counter	53150A 5350B	53151A 5351B
HP/Agilent RF cable	85131F	85133F

Analyzer warmup time: 30 minutes.

1. Make sure the A7 Switch is in the alter position (ALT).
2. Connect the equipment as shown in [Figure 3-2](#) and then press the following:

Preset **PRESET: FACTORY** **Pre**set
System **SERVICE MENU TESTS**
ADJUSTMENT TESTS EXECUTE TEST YES

Figure 3-2 Source Pretune Correction Constants Setup

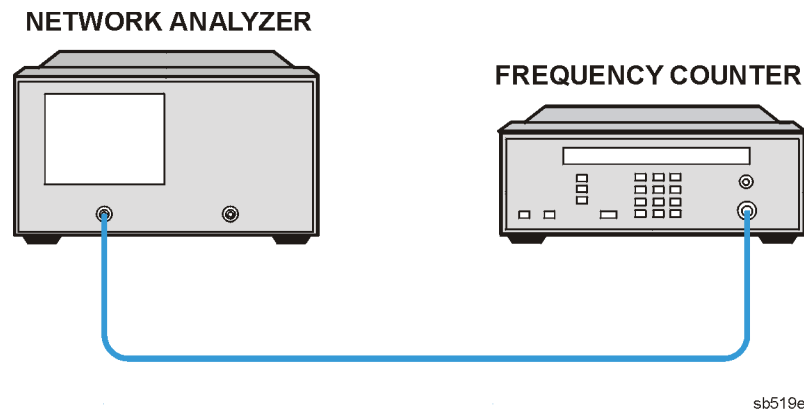

3. When the prompt, Set source to 2.345 GHz, then continue appears, use the front panel knob to adjust the frequency of the analyzer source to within 5 MHz of 2.345 GHz. Press **CONTINUE** when the frequency is set.
4. For the 8722ET/ES, when the prompt Set source to 19.550 GHz appears on the display, the continue prompt appears next. Use the front panel knob to adjust the frequency of the analyzer source to within 5 MHz of 19.550 GHz. Press **CONTINUE** when the frequency is set.

5. When `Pretune Adj DONE` is displayed, press **Preset**.
6. If no more correction constant routines are going to be performed, return the A7 Switch to the NRM position and perform the [“EEPROM Backup Disk Procedure”](#) on page 3-33.

In Case of Difficulty

If any error messages appear, refer to [Chapter 7](#), “[Source Troubleshooting](#),” or contact the nearest Agilent Technologies sales or service office.

Analog Bus Correction Constants (Test 44)

This procedure calibrates the analog bus by using three reference voltages (ground, +0.37 volts and +2.5 volts), then stores the calibration data as correction constants in EEPROMs.

Analyzer warmup time: 30 minutes.

1. Make sure the A7 Switch is in the alter position (ALT).
2. Press the following:

PRESET: FACTORY

SERVICE MENU TESTS

EXECUTE TEST YES

3. Observe the analyzer for the results of the adjustment routine:
 - If the analyzer displays `ABUS Cor DONE`, you have completed this procedure.
 - If the analyzer displays `ABUS Cor FAIL`, repeat the test.
4. If no more correction constant routines are going to be performed, return the A7 Switch to the NRM position and perform the [“EEPROM Backup Disk Procedure”](#) on page 3-33.

In Case of Difficulty

- Refer to [Chapter 6](#), “[Digital Control Troubleshooting](#),” or contact the nearest Agilent Technologies sales or service office.

IF Step Correction Constants (Test 47)

These correction constants compensate for IF amplifier linearity difference between gain stages.

Required Equipment and Tools

Equipment Description	8719ET/ES 8720ET/ES	8722ET/ES
HP/Agilent RF cable	85131F	85133F
HP/Agilent RF open	part number 85052-60009	part number 85052-60023
HP/Agilent RF fixed attenuator	8493C Option 010,006,020	8490D Option 010,006,020

Analyzer warmup time: 30 minutes.

1. Make sure the A7 Switch is in the alter position (ALT).
2. Press the following:

[Preset] PRESET: FACTORY [Preset]

[System] SERVICE MENU TESTS

[47] [x1] EXECUTE TEST YES CONTINUE

Follow the instructions on the display.

3. Observe the analyzer for the results of the adjustment routine:
If the message IF Step Cor DONE is displayed, you have completed this procedure.
4. If no more correction constant routines are going to be performed, return the A7 Switch to the NRM position and perform the [“EEPROM Backup Disk Procedure,”](#) on page 3-33.

In Case of Difficulty

- If the message CAUTION:TROUBLE! CHECK SETUP AND START OVER is displayed, check that the RF cable is connected from PORT 1 to PORT 2 (REFLECTION port and TRANSMISSION port on the ET models). Then repeat this adjustment routine.
- If the analyzer continues to fail the adjustment routine, refer to [Chapter 6](#) , “[Digital Control Troubleshooting](#),” or contact the nearest Agilent Technologies sales or service office.

ADC Offset Correction Constants (Test 48)

These correction constants improve the dynamic accuracy by shifting small signals to the most linear part of the ADC quantizing curve.

Analyzer warmup time: 30 minutes.

1. Make sure the A7 Switch is in the alter position (ALT).
2. Press the following:

PRESET: FACTORY

SERVICE MENU TESTS

EXECUTE TEST YES

NOTE Test 48 takes about three minutes.

3. Observe the analyzer for the results of the adjustment routine:
 - If the analyzer displays `ADC OfS Cor DONE`, you have completed this procedure.
 - If the analyzer displays `ADC OfS Cor FAIL`, repeat the test.
4. If no more correction constant routines are going to be performed, return the A7 Switch to the NRM position and perform the [“EEPROM Backup Disk Procedure,”](#) on page 3-33.

In Case of Difficulty

- If the analyzer displays `ADC OfS Cor FAIL` after repeating the test, refer to [Chapter 6](#), [“Digital Control Troubleshooting,”](#) or contact the nearest Agilent Technologies sales or service office.

Serial Number Correction Constants (Test 49)

This procedure stores the analyzer serial number in the A7 CPU assembly EEPROMs.

CAUTION Perform this procedure *only* if the A7 CPU assembly has been replaced.

Analyzer warmup time: None.

1. Make sure the A7 Switch is in the alter position (ALT).
2. Record the ten character serial number that is on the analyzer rear panel identification label.

NOTE The serial number may also be entered using the optional external keyboard. Plug the keyboard into the “DIN KYBD” connector on the rear panel and press **(Preset)**.

3. To erase the HP/Agilent logo, press the following:

(Preset) **PRESET: FACTORY** **(Preset)**

(Display) **MORE** **TITLE** **ERASE TITLE**

4. Enter the serial number by rotating the front panel knob to position the arrow below each character of the instrument serial number, and then pressing **SELECT LETTER** to enter each character. Enter a total of ten characters: two letters and eight digits.

Press **(←)** if you make a mistake.

5. Press **DONE** when you have finished entering the title. Double check that the correct serial number appears in the title area. If you made a mistake at this point, return to step 3.

CAUTION You *cannot* correct mistakes after you perform step 6, unless you contact the nearest Agilent Technologies sales or service center, for a clear serial number keyword. Then you must perform “[Protected Option Numbers Correction Constants \(Test 50\)](#)” and repeat this procedure.

6. Press **(System)** **SERVICE MENU** **TESTS** **(49)** **(x1)** **EXECUTE TEST** **YES** .

7. Observe the analyzer for the results of the routine:

If the analyzer displays the message Serial Cor DONE, you have completed this procedure.

8. If no more correction constant routines are going to be performed, return the A7 Switch to the NRM position and perform the “[EEPROM Backup Disk Procedure,](#)” on page 3-33.

In Case of Difficulty

- If the analyzer does not display `DONE`, then the serial number that you entered in steps 3 and 4 did not match the required format or a serial number was already stored. Check the serial number recognized by the analyzer:
 1. Press the following:
Ⓟ PRESET: FACTORY Ⓟ
Ⓢ SERVICE MENU FIRMWARE REVISION
 2. Look for the serial number displayed on the analyzer screen.
 3. Rerun this adjustment test if the serial number is not displayed.
- If the analyzer continues to fail this adjustment routine, contact the nearest Agilent Technologies sales or service office.

Protected Option Numbers Correction Constants (Test 50)

This procedure stores the instrument's protected option(s) information in A7 CPU assembly EEPROMs.

You can also use this procedure to remove the serial number. You will need a unique keyword from Agilent Technologies. Refer to step 6 in “[Serial Number Correction Constants \(Test 49\)](#),” on page 3-11.

CAUTION Perform this procedure *only* if the A7 CPU assembly has been replaced and the “[Serial Number Correction Constants \(Test 49\)](#)” procedure has been performed.

Analyzer warmup time: **None**

1. Remove the instrument bottom cover and record the keyword label(s) that are located on the exposed sheet metal next to the CPU assembly (A7). Note that the individual keyword for each option is installed in the instrument.

NOTE If the instrument does not have a label, then contact the nearest Agilent Technologies sales or service office. Be sure to include the full serial number of the instrument.

2. Make sure the A7 Switch is in the alter position (ALT).

NOTE The serial number may also be entered using the optional external keyboard. Plug the keyboard into the “DIN KYBD” connector on the rear panel and press **(Preset)**.

3. To erase the HP/Agilent logo, press the following:

(Preset) **PRESET: FACTORY** **(Preset)**

(Display) **MORE** **TITLE** **ERASE TITLE**

CAUTION Do not confuse “I” with “1” (one) or “O” with “0” (zero).

4. Enter the keyword by rotating the front panel knob to position the arrow below each character of the keyword, and then pressing **SELECT LETTER** to enter each letter.

Press **(←)** if you made a mistake.

5. Press **DONE** when you have finished entering the keyword.

6. Press the following:

System **SERVICE MENU** **TESTS**

50 **x1** **EXECUTE TEST** **YES**

7. Observe the analyzer for the results of the adjustment routine:

- If the analyzer displays `Option Cor DONE`, you have completed this procedure.

8. If no more correction constant routines are going to be performed, return the A7 Switch to the NRM position and perform the [“EEPROM Backup Disk Procedure,”](#) on page 3-33.

In Case of Difficulty

- If the analyzer displays `Option Cor FAIL`, check the keyword used in step 4 and make sure it is correct. Pay special attention to the letters “I” or “O”, the numbers “1” or “0”. Repeat this entire adjustment test.
- If the analyzer continues to fail the adjustment routine, refer to [Chapter 6](#), [“Digital Control Troubleshooting,”](#) or contact the nearest Agilent Technologies sales or service office.

Unprotected Hardware Option Correction Constants

This procedure stores the instrument's unprotected option(s) information in A7 CPU assembly EEPROMs.

Analyzer warmup time: **None.**

1. Make sure the A7 Switch is in the alter position (ALT).
2. Record the installed options that are printed on the rear panel of the analyzer.
3. Press **(System) SERVICE MENU PEEK/POKE PEEK/POKE ADDRESS** .
4. For the address of each unprotected hardware option, refer to [Table 3-1](#). Enter the address for the specific installed hardware option that needs to be enabled or disabled. Follow the address entry by pressing **(x1)**.
 - Pressing **POKE (-1) (x1)** after an address entry enables the option.
 - Pressing **POKE (0) (x1)** after an address entry disables the option.

Table 3-1 PEEK/POKE Addresses Unprotected Hardware Options

Hardware Option	PEEK/POKE Address
1D5	1619001529
004	1619001531
8722ET/ES	1619001533
085	1619001534
007	1619001535
089	1619001536
400	1619001537
012	1619001538

5. Repeat steps 3 and 4 for all of the unprotected options that you want to enable or disable.
6. After you have entered all of the instrument's hardware options, press the following:
(Preset) PRESET: FACTORY (Preset)
(System) SERVICE MENU FIRMWARE REVISION
7. View the analyzer display for the listed options.
8. If no more correction constant routines are going to be performed, return the A7 Switch to the NRM position and perform the [“EEPROM Backup Disk Procedure,”](#) on page 3-33.

In Case of Difficulty

- If any of the installed options are missing from the list, return to step 2 and reenter the missing option(s).
- If the analyzer continues to fail, contact the nearest Agilent Technologies sales or service office.

Output Power Adjustments

This procedure instructs you how to set the output power of your network analyzer across the frequency bands by adjusting potentiometers on the source interface board (A59).

Required Equipment and Tools

Equipment Description	8719ET/ES 8720ET/ES	8722ET/ES
HP/Agilent Power Meter	436A, 437B, 438A, E4418A (EPM-441A) or E4419A (EPM-442A)	
HP/Agilent Power Sensor	8485A	8487A
Adapter 3.5-mm (f) to 3.5-mm (f)	part number 85052-60012 (part of 85052B)	N/A
Adapter 2.4-mm (f) to 2.4-mm (f)	N/A	part number 85056-60006 (part of 85056A)
RF Cable	85131F	85133F
GPIB Cable	10833A	
Non-Metallic Adjustment Tool	8830-0024	
Antistatic Wrist Strap	9300-1367	
Antistatic Wrist Strap Cord	9300-0980	
Static-control Table Mat and Earth Ground Wire	9300-0797	

Analyzer warmup time: 30 minutes.

Preparing the Instrument

1. Make sure the A7 Switch is in the alter position (ALT).
2. Zero and calibrate the power meter.
3. With the analyzer turned off, remove the top two corner standoffs and the top cover.
4. Locate the metal source assembly cover that is on the top-left, front-side of the instrument.

5. Unplug the flexible SMB cables coming out of the source assembly cover.

NOTE The 8719ET/ES and the 8720ET/ES have two SMB cables. The 8722ET/ES have four SMB cables. All cables are clearly marked for easy re-assembly.

6. Remove the 3 screws on source assembly cover and lift it off the frame.
7. Reattach the SMB cables to the proper connectors.
8. Turn the analyzer on. If it does not phase lock, check the cable connections.

Setting the Main Power DAC to Preset Values.

For each PEEK/POKE location listed in [Table 3-2](#), do the following:

1. Press the following:

PRESET: FACTORY

SERVICE MENU **PEEK/POKE**

2. Press **PEEK POKE ADDRESS**, enter the peek/poke address from [Table 3-2](#), and press .
3. Press **POKE**, enter the poke value from [Table 3-2](#), and press .
4. Repeat steps 2 and 3 for the remaining peek/poke addresses.

Table 3-2 Main Power DAC Peek/Poke Location Table

DAC	Peek/Poke Address	Poke Value for the 8719ET/ES 8720ET/ES	Poke Value for the 8722ET/ES
Low power	1619001442	1	1
Low power	1619001443	0	200
Mid power	1619001444	3	5
Mid power	1619001445	49	172
High Power	1619001446	10	10
High Power	1619001447	12	12

NOTE Your analyzer may display the message CAUTION TEST PORT OVERLOAD, REDUCE POWER. Ignore this message and continue with the procedure.

Setting the Potentiometers to the Minimum Levels.

1. Locate the Source Interface board (A59). For locations of the potentiometers, see [Figure 3-3](#).
2. Set the low band power potentiometer (A59 R4) at the center of its range.
3. Set the offset potentiometers (A59 R70, R71, R80) to their full counter-clockwise position.

The end stops, on 10-turn potentiometers, are indicated by a clicking sound.

4. Set the slope potentiometers (A59 R86, R87, R88) to their full clockwise position.

Figure 3-3 Location of Output Power Adjustment Potentiometers

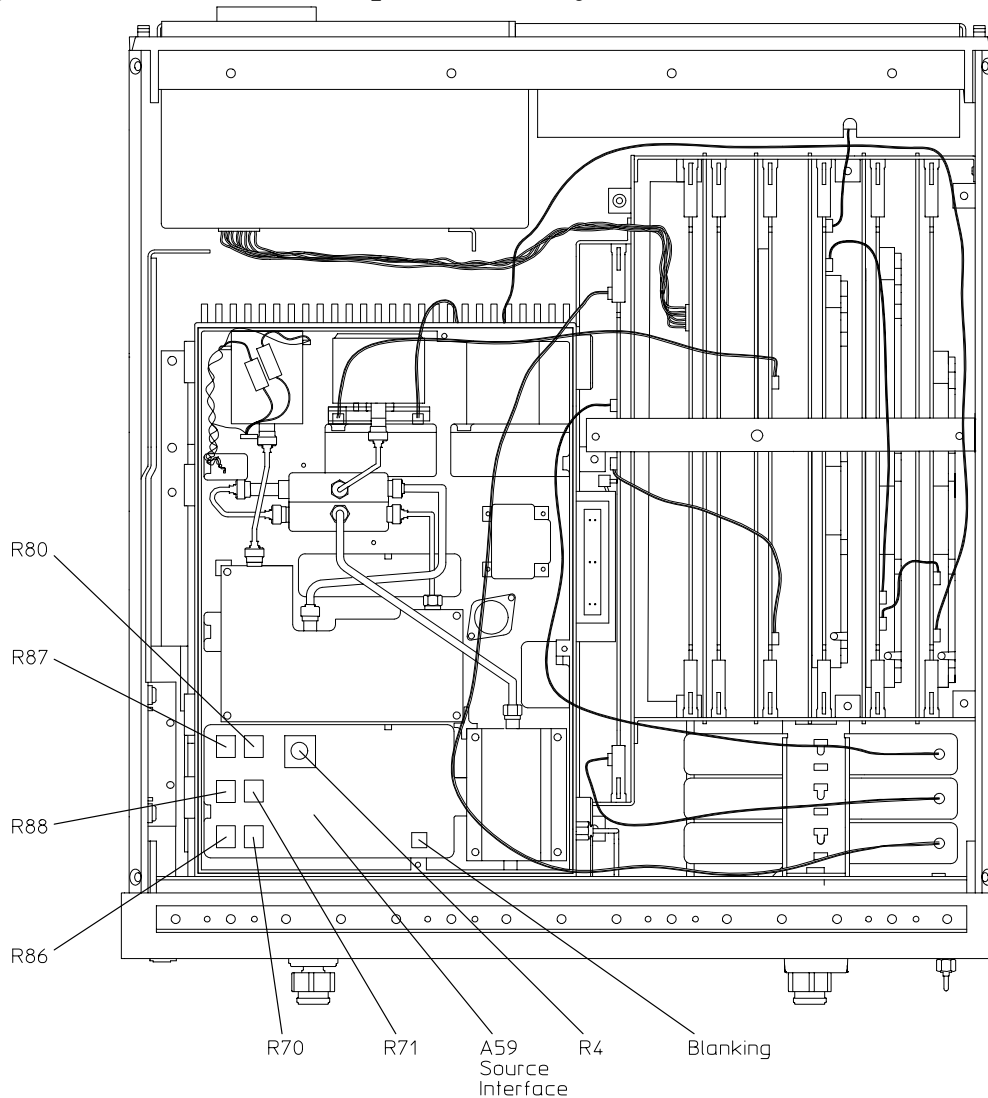

sb525e

Adjusting the Mid Band Power

1. Connect the equipment as shown in [Figure 3-4](#).

Figure 3-4 Setup for Output Power Adjustments

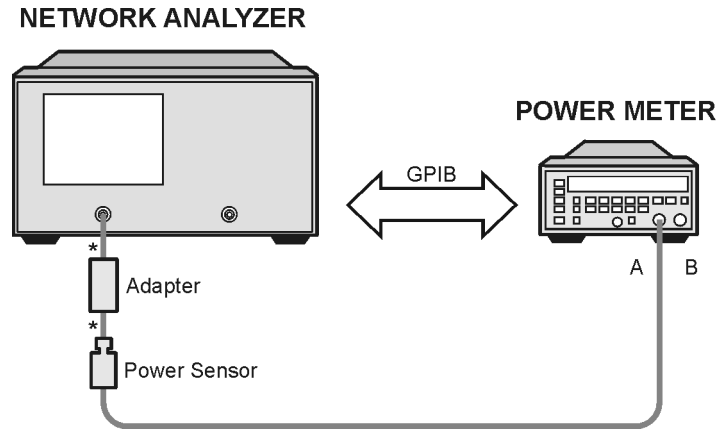

* Direct Connection

sb535e

Table 3-3 Output Power Adjustment Values

Model/Option	Power A (dBm)	Power B (dBm)
8719ES and 8720ES	-3	0
8719ET and 8720ET 8719ES Option 007 8720ES Option 007	+2	+5
8722ES	-13	-10
8722ET 8722ES Option 007	-8	-5

2. Press the following:

Preset

Sweep Setup POWER

PWR RANGE MAN POWER RANGES RANGE 0

Enter the value from the “Power A” column in [Table 3-3](#). Press **x1**.

3. Press **[Sweep Setup]** **CW FREQ** **[2.56]** **[G/n]**.
4. To switch the power DAC on, press the following:
[System] **SERVICE MENU** **SERVICE MODES**
SRC ADJUST MENU **POWER DAC[ON]**
[1000] **[x1]**
5. Adjust the mid band power offset resistor (A59 R71) for a power meter reading that is equal to the value (± 0.1 dB) listed under “Power A” in [Table 3-3](#).
6. Press **[Sweep Setup]** **CW FREQ** **[20]** **[G/n]**.
7. Adjust the mid band power slope resistor (A59 R88) for a power meter reading that is equal to the value (± 0.1 dB) listed under “Power A” in [Table 3-3](#).
8. The adjustments in step 5 and step 7 interact with each other, so repeat both adjustments until both are in specification.

Adjusting the Low Band Power

1. Press **[50]** **[M/ μ]**.
2. Adjust the low band power offset resistor (A59 R70) for a power meter reading that is equal to the value (± 0.1 dB), from the “Power A” column in [Table 3-3](#).
3. Press **[2.3]** **[G/n]**.
4. Adjust the low band power slope resistor (A59 R86) for a power meter reading that is equal to the value (± 0.1 dB), from the “Power A” column in [Table 3-3](#).

Adjusting the High Band Power (8722ET/ES)

1. Press **[20.1]** **[G/n]**.
2. Adjust the high band power offset resistor (A59 R80) for a power meter reading that is equal to the value (± 0.1 dB), from the “Power A” column in [Table 3-3](#).
3. Press **[40]** **[G/n]**.
4. Adjust the high band power slope resistor (A59 R87) for a power meter reading that is equal to the value (± 0.1 dB), from the “Power A” column in [Table 3-3](#).

Fine Tuning the Flatness

1. Press **(Preset)**.
2. Press **POWER PWR RANGE MAN POWER RANGES RANGE 0**.
3. Enter the value from the “Power B” column, in [Table 3-3](#), for the particular analyzer that you are adjusting.
4. Press the following:

(Sweep Setup) SWEEP TYPE MENU STEP SWEEP ON

(Sweep Setup) NUMBER of POINTS (101) (x1)

(Avg) IF BW (300) (x1)

(Meas) INPUT PORTS R

(Scale Ref) (.5) (x1)

5. Press **(Local) SYSTEM CONTROLLER (Cal) PWRMTR CAL**.
6. Press **NUMBER of READINGS (2) (x1)**.
7. Press **ONE SWEEP TAKE CAL SWEEP**.
Wait for the analyzer to finish the power meter calibration.
8. Connect an RF cable between PORT 1 and PORT 2 (REFLECTION and TRANSMISSION ports on the ET models).
9. Press **(Save/Recall) SAVE STATE FILE UTILITIES RENAME FILE ERASE TITLE** rename file “PWRCAL” by rotating the front panel knob to position the arrow under the desired letter and press **SELECT LETTER**. When the file is renamed, press **DONE**.
10. Press **(Cal) CALIBRATE MENU RECEIVER CAL (Meas) INPUT PORTS B**.
11. Enter the power value in “Power B” column of [Table 3-3](#) and then press **TAKE RCVR CAL SWEEP**.

12. Switch off the power meter calibration by pressing the following:

(Cal) PWRMTR CAL [ONE SWEEP] PWRMTR CAL OFF

The analyzer's trace now represents power flatness.

13. Adjust the slope and offset of all the bands for a flatness of:

- ± 1.5 dB in the 0.05 GHz to 20 GHz range
- ± 2.5 dB in the 20 GHz to 40 GHz range

In Case of Difficulty

- With the power meter connected to PORT 1 (REFLECTION port on the ET models), check for available power and modulator functionality by adjusting the power DAC from 0 to 4095.

The power should vary from -20 dB to $+4$ dB from the maximum specified power in most cases. (At some of the frequencies you may not be able to tune above maximum power.)

- If your analyzer is not operating correctly, as indicated from the results of the previous step, refer to [Chapter 7](#), “[Source Troubleshooting](#),” or contact the nearest Agilent Technologies sales or service office.

Power Linearity Adjustment

IMPORTANT “Power Linearity Adjustment” is a continuation of “Output Power Adjustments” on page 3-17. “Output Power Adjustments” must be performed first. The receiver calibration from “Output Power Adjustments” must be kept on before starting this test.

Preparatory Steps

1. If you haven't already done so, perform the procedure "Output Power Adjustments," on page 3-17.
2. Connect a cable between PORT 1 and PORT 2 (REFLECTION port and TRANSMISSION port on the ET models).
3. Press **(Power)** and enter the power value listed as “P3” in Table 3-4. Press **(x1)**.

Table 3-4 Power Linearity Adjustment Values

Power Settings	8719ES, 8720ES	8719ET, 8720ET 8719ES Option 007 8720ES Option 007	8722ES	8722ET 8722ES Option 007
P1 ¹	5 dBm	10 dBm	-5 dBm	0 dBm
P2	-5 dBm	0 dBm	-10 dBm	-5 dBm
P3	-15 dBm	-10 dBm	-20 dBm	-15 dBm

1. P1 only applies to 20 GHz for the 8722ET/ES.

4. Press **(Scale Ref)** **(.5)** **(x1)** **REFERENCE VALUE**. Enter the power value listed as “P3” in Table 3-4, then press **(x1)**. After the “P3” value is entered, press **(Marker Fctn)** **MARKER MODE MENU** **MKR STATS ON**. The marker stats will appear on the display.

The displayed trace should be centered on the reference (± 0.5 dB).

- If the trace is not centered on the reference, continue with the next step.
- If the trace is centered on the reference, go to “Adjusting the Power Linearity” on page 3-25.

5. To switch on the power DAC, press **(System)** **SERVICE MENU** **SERVICE MODES** **SRC ADJUST MENU** **PWR DAC ON** .

- For the 8719ET/ES or 8720ET/ES, press **(258)** **(x1)** .

- For the 8722ET/ES, press **(459)** **(x1)** .

6. Adjust the front panel knob until the mean value is equal to “P2”. Record the “MAIN POWER DAC” number.

(Example: Power DAC# = 461)

7. To switch off the power DAC, press **PWR DAC OFF** .

8. Press **(Save/Recall)** **SAVE STATE** .

9. Divide the previously recorded DAC number by 256.

(Example: 461/256)

10. To store the quotient, press the following:

(System) **SERVICE MENU** **PEEK/POKE**

PEEK/POKE ADDRESS

(1619001442) **(x1)** **POKE**

Enter the quotient and then press **(x1)** .

(Example quotient = 1)

11. To store the remainder by press the following:

PEEK/POKE ADDRESS **(1619001443)**

(x1) **POKE**

Enter the remainder and then press **(x1)** .

(Example remainder = 205)

12. Press **(Preset)** .

13. Press **(Save/Recall)** **RECALL STATE** . Verify that the mean is equal to the “P2” value.

Adjusting the Power Linearity

1. Press **(Power)** and enter the power level that is listed as “P3” in [Table 3-4](#).

Press **(x1)** **(Cal)** **CALIBRATE MENU** **RECEIVER CAL** **TAKE RCVR CAL SWEEP** .

2. Press **(Power)** and enter the power level that is listed as “P2” in [Table 3-4](#), then press **(x1)** .

3. Press **Scale Ref** **REFERENCE VALUE** and enter the value listed as “P2” in [Table 3-4](#), and then press **x1**.

The displayed trace should be centered on the reference (± 0.5 dB).

- If the trace is not centered on the reference, continue with the next step.
 - If the trace is centered on the reference, go to [“Entering the Power Levels.”](#)
4. To switch on the power DAC, press the following:
System **SERVICE MENU** **SERVICE MODES**
SRC ADJUST MENU **PWR DAC ON** **2580** **x1**
 5. Adjust the front panel knob until the mean value is P2. Record the “MAIN POWER DAC” number.
 6. To switch off the power DAC, press **PWR DAC OFF**.
 7. Press **Save/Recall** **SAVE STATE**.
 8. Divide the previously recorded DAC number by 256.
 9. To store the quotient, press the following:

System **SERVICE MENU** **PEEK/POKE**
PEEK/POKE ADDRESS **1619001444** **x1** **POKE**

Enter the quotient and then press **x1**.

10. To store the remainder, press the following:

PEEK/POKE ADDRESS **1619001445** **x1** **POKE**

Enter the remainder and then press **x1**.

11. Press **Preset**.
12. Press **Save/Recall** **RECALL STATE** and verify the mean value is equal to “P2.”

Entering the Power Levels

13. Enter the Power levels.

For 8719ET/ES and 8720ET/ES Models:

Press **Power** and enter the power level that is listed as “P2” in [Table 3-4](#).

Press **x1** **Cal** **CALIBRATE MENU** **RECEIVER CAL** **TAKE RCVR CAL SWEEP**.

For 8722ET/ES Models:

Press (Stop) (20) (G/n).

Press (Power) and enter the power level that is listed as “P2” in [Table 3-4](#).

Press (x1) (Cal) **CALIBRATE MENU** **RECEIVER CAL** **TAKE RCVR CAL SWEEP** .

14. Press (Power) and enter the power level that is listed as “P2” in [Table 3-4](#), then press (x1).

15. Press (Scale Ref) **REFERENCE VALUE** and enter the value listed as “P2” in [Table 3-4](#) and then press (x1).

The displayed trace should be centered on the reference (± 0.5 dB).

- If the trace is not centered on the reference, continue with the next step.
- If the trace is centered on the reference, go to [“Low Band Adjustment” on page 3-28](#).

16. To switch on the power DAC, press the following:

(System) **SERVICE MENU** **SERVICE MODES**
SRC ADJUST MENU **PWR DAC ON** (2580) (x1)

17. Adjust the front panel knob until the mean value is P1. Record the “MAIN POWER DAC” number.

18. To switch off the power DAC, press **PWR DAC OFF** .

19. Press (Save/Recall) **SAVE STATE** .

20. Divide the previously recorded DAC number by 256.

21. To store the quotient, press the following:

(System) **SERVICE MENU** **PEEK/POKE**
PEEK/POKE ADDRESS (1619001446) (x1) **POKE**

Enter the quotient and then press (x1).

22. To store the remainder, press the following:

PEEK/POKE ADDRESS (1619001447) (x1) **POKE**

Enter the remainder and then press (x1).

23. Press (Preset).

24. Press (Save/Recall) **RECALL STATE** and verify the mean value is equal to “P1.”

Low Band Adjustment

1. Connect the equipment as shown in [Figure 3-5](#).

Figure 3-5 Setup for Power Adjustments

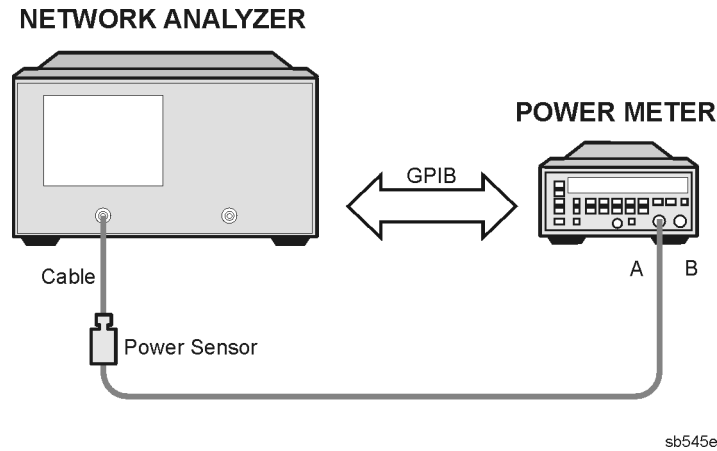

Table 3-5 Low Band Adjustment Values

Model	Power A	Power B	Power C
8719ES and 8720ES	- 3 dBm	10 dBm	7 dBm
8719ET and 8720ET 8719ES Option 007 8720ES Option 007	2 dBm	15 dBm	12 dBm
8722ES	- 13 dBm	- 5 dBm	- 8 dBm
8722ET 8722ES Option 007	- 8 dBm	0 dBm	- 3 dBm

2. Press the following:

[Preset] PRESET FACTORY [Preset]

[System] SERVICE MENU

SERVICE MODES SRC ADJUST MENU ALC OFF

[Stop] [2.54] [G/n]

[Meas] INPUT PORTS R

[Power], enter the power level from “Power A” in [Table 3-5](#), then press **[x1]**

[Cal] PWR MTR CAL ONE SWEEP TAKE CAL SWEEP

3. Connect the cable to PORT 2 (TRANSMISSION Port on ET models) and press the following:

Cal **CALIBRATE MENU** **RECEIVER CAL**

Meas **INPUT PORTS** **B**

4. Press **Power**, and enter the power level from “Power B” in [Table 3-5](#), then press **x1**.
5. Adjust A59R4 until the minimum value of the trace on the display equals “Power C” in [Table 3-5](#). For the location of A59R4, see [Figure 3-3 on page 3-19](#).
6. If no more correction constant routines are going to be performed, return the A7 switch to the NRM position and perform the [“EEPROM Backup Disk Procedure,” on page 3-33](#).

In Case of Difficulty

- If the analyzer fails the “Power Linearity Performance Test” do the following:
 - If the analyzer fails the performance test for the power levels listed as P2, P3, repeat the ["Power Linearity Adjustment," on page 3-24](#)
 - If the analyzer fails the performance test for the power level listed as P2, repeat the ["Output Power Adjustments," on page 3-17](#) and the ["Power Linearity Adjustment," on page 3-24](#).
- If the analyzer is still not passing the “Power Linearity Performance Test,” check for available power and modulator functionality by adjusting the power DAC from 0 to 4095 (refer to the [“Output Power Adjustments”](#) procedure).

The power should vary from –20 dB to +4 dB from the maximum specified power in most cases. (At some of the frequencies you may not be able to tune above maximum power.)

- If the analyzer is operating correctly, as indicated from the results of the previous step, repeat the [“Output Power Adjustments”](#) procedure.
- If the analyzer is not operating correctly, as indicated from the results of the previous step, refer to [Chapter 7](#), [“Source Troubleshooting,”](#) or contact the nearest Agilent Technologies sales or service office.

Blanking Adjustment (Test 54)

This adjustment sets the output power level during retrace. If incorrectly adjusted, the first data points in a sweep may not be stable.

Required Equipment and Tools

Equipment Description	8719ET/ES 8720ET/ES	8722ET/ES
Power Meter	436A, 437B, 438A, E4418A (EPM-441A) or E4419A (EPM-442A)	
Power Sensor	8485A	8487A
Adapter 3.5-mm (f) to 3.5-mm (f)	part number 85052-60012 (part of 85052B)	N/A
Adapter 2.4-mm (f) to 2.4-mm (f)	N/A	part number 85056-60006 (part of 85056A)
Non-Metallic Adjustment Tool	part number 8830-0024	

Analyzer warmup time: 30 minutes.

Power meter warmup time: 30 minutes.

Preparing the Instrument

1. With the analyzer turned off, remove the top two corner standoffs and the top cover.
2. Locate the metal source assembly cover that is on the top-left, front-side of the instrument.
3. Unplug the flexible SMB cables coming out of the source assembly cover.

NOTE The 8719ET/ES and the 8720ET/ES have 2 SMB cables. The 8722ET/ES have 4 SMB cables. All cables are clearly marked for easy re-assembly.

4. Remove the 3 screws on source assembly cover and lift it off the frame.
5. Reattach the SMB cables to the proper connectors.
6. Turn the analyzer on. If it does not phase lock, check the cable connections.
7. Zero and calibrate the power meter and connect the power sensor to PORT 1 (REFLECTION port on the ET models).
8. Press **[Preset] FACTORY: PRESET [Preset] [Sweep Setup] CW FREQ [50.5] [M/μ]**.
9. Press **[System] SERVICE MENU TESTS [54] [x1] EXECUTE TEST**.
10. For the location of the blanking adjustment, refer to [Figure 3-6](#). Adjust it to obtain the value indicated on the analyzer display.

11. When the adjustment is complete, press **CONTINUE**.

Figure 3-6 Location of Blanking Adjustment

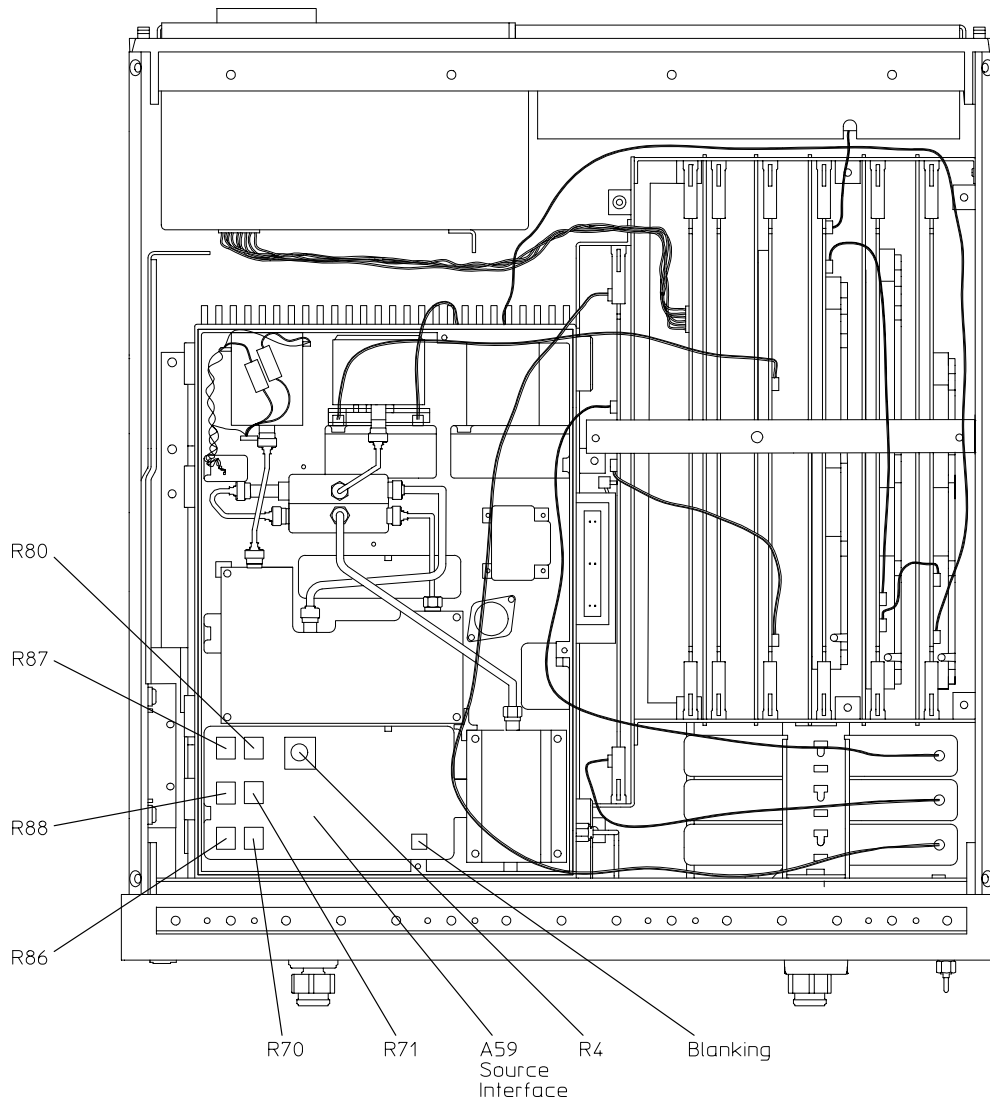

sb525e

In Case of Difficulty

If you are unable to perform this adjustment, refer to [Chapter 7, “Source Troubleshooting,”](#) or contact the nearest Agilent Technologies sales or service office.

Initialize EEPROMs (Test 53)

This internal service test performs the following functions:

- *destroys* all correction constants and all unprotected options
- initializes certain EEPROM address locations to zeroes
- replaces the display intensity correction constants with default values

NOTE This routine *will not* alter the serial number or protected option number correction constants (Tests 49 and 50, respectively).

a. Press the following:

FACTORY: PRESET

SERVICE MENU

TESTS

EXECUTE TEST YES

12. Restore the analyzer's correction constants by referring to the [“Correction Constants Retrieval Procedure”](#) on page 3-35.
13. If you don't have the correction constants backed up on a disk, run all the internal service routines in the following order:
- a. [Unprotected Hardware Option Correction Constants](#), on page 3-15
 - b. [Analog Bus Correction Constants \(Test 44\)](#), on page 3-8
 - c. [Source Pretune Correction Constants \(Test 43\)](#), on page 3-6
 - d. [ADC Offset Correction Constants \(Test 48\)](#), on page 3-10
 - e. [IF Step Correction Constants \(Test 47\)](#), on page 3-9
 - f. [Raw Offset Correction Constants](#), on page 3-48
 - g. [Sampler Calibration Correction Constants \(Test 51\)](#), on page 3-58

EEPROM Backup Disk Procedure

The correction constants that are unique to your instrument are stored in EEPROM on the CPU (A7) assembly. By creating an EEPROM backup disk, you will have a copy of all the correction constant data for that analyzer, should you need to replace the CPU (A7) assembly in the future.

Required Equipment and Tools

Equipment Description	8719ET/ES 8720ET/ES	8722ET/ES
3.5-inch Floppy Disk	One formatted 1.44 MB disk	

1. Insert a 3.5-inch disk into the analyzer disk drive.
2. If the disk is not formatted, follow these steps:
 - a. Press the following:
(Preset) FACTORY: PRESET (Preset)
(Save/Recall) FILE UTILITIES FORMAT DISK
 - b. Select the format type:
 - To format a LIF disk, select **FORMAT:LIF**.
 - To format a DOS disk, select **FORMAT:DOS**.
 - c. Press **FORMAT INT DISK** and answer **YES** at the query.
3. Press the following:

(System) SERVICE MENU SERVICE MODES
MORE STORE EEPR ON
(Save/Recall) SELECT DISK INTERNAL DISK
RETURN SAVE STATE

NOTE The analyzer creates a default file "FILE00". The filename appears in the upper-left corner of the display. The file type "ISTATE(E)" indicates that the file is an instrument state with EEPROM backup.

NOTE If you are using an external keyboard to enter data, you must press **(Preset)** after plugging it in the DIN keyboard connector on the rear panel.

4. Press **FILE UTILITIES** **RENAME FILE** **ERASE TITLE** . Use the front panel knob and the **SELECT LETTER** softkey (or an external keyboard) to rename the file “FILE00” TO “N12345” where 12345 represents the last 5 digits of the instrument's serial number. (The first character in the filename must be a letter). When you are finished renaming the file, press **DONE** .
5. Write the following information on the disk label:
 - analyzer serial number
 - date backup was made
 - “EEPROM Backup Disk”

In Case of Difficulty

- Insert another disk in to the analyzer disk drive and press **Save/Recall** .
- The analyzer should display a catalog of the disk contents. If the catalog does not appear, refer to [Chapter 6](#) , “[Digital Control Troubleshooting](#),” or contact the nearest Agilent Technologies sales or service office.

Correction Constants Retrieval Procedure

By using the current EEPROM backup disk, you can download the correction constants into your network analyzer.

Required Equipment and Tools

You will need your analyzer's current EEPROM backup disk.

Analyzer warmup time: None required.

1. Make sure the A7 Switch is in the alter position (ALT).
2. Insert the your current analyzer's "EEPROM backup disk" into the analyzers disk drive.
3. Press **(Save/Recall)** **SELECT DISK** **INTERNAL DISK** . Use the front panel knob to highlight the file "N12345" where N12345 represents the file name of the EEPROM backup disk for the analyzer. On the factory shipped EEPROM backup disk, the filename is FILE1.
4. Press **RETURN** **RECALL STATE** to download the correction constants data into the analyzer's EEPROMs.
5. Perform the procedure, "[Unprotected Hardware Option Correction Constants](#)" on [page 3-15](#).
6. Press **(Preset)** **FACTORY: PRESET** **(Preset)** and verify that good data was transferred by performing a simple measurement.
7. If no more correction constant routines are going to be performed, return the A7 switch back to its normal position (NRM).

In Case of Difficulty

- Insert another disk in to the analyzer disk drive and press **(Save/Recall)**.
- The analyzer should display a catalog of the disk contents. If the catalog does not appear, refer to [Chapter 6](#) , "[Digital Control Troubleshooting](#)," or contact the nearest Agilent Technologies sales or service office.

Loading Firmware

The following procedures will load firmware for new or existing CPU boards.

Required Equipment and Tools

- Firmware disk for your network analyzer.

Analyzer warmup time: None required.

Loading Firmware into an Existing CPU

Use this procedure for upgrading firmware in an operational instrument whose CPU board has not been changed.

1. Turn off the network analyzer.
2. Insert the firmware disk into the instrument's disk drive.
3. Turn the instrument on. The firmware will be loaded automatically during power-on. The front panel LEDs should step through a sequence as firmware is loaded. The display will be blank during this time.

At the end of a successful loading, the LEDs for Channel 1 and PORT 1 (REFLECTION port on ET models) will remain on and the display will indicate the version of firmware that was loaded.

In Case of Difficulty

If the firmware did not load successfully, LED patterns on the front panel can help you isolate the problem.

- If the following LED pattern is present, the firmware disk is not for use with your instrument model. Check that the firmware disk matches your analyzer model.

LED Pattern							
Chan 1	Chan 2	Chan 3	Chan 4	R	L	T	S
*	*						

- If any of the LED patterns in the table on [page 3-37](#) are present, the firmware disk may be defective.

LED Pattern							
Chan 1	Chan 2	Chan 3	Chan 4	R	L	T	S
				*			
	*			*			
*				*			
*	*			*			
					*		
	*				*		
*					*		
*	*				*		
				*	*		
	*			*	*		
*				*	*		
				*			*
	*			*			*

- If any other LED pattern is present, the CPU board is defective.

Loading Firmware into a New CPU

When the CPU board has been replaced in the analyzer, use this procedure to load the firmware.

1. Turn off the network analyzer.
2. Insert the firmware disk into the instrument's disk drive.
3. Turn the instrument on. The firmware will be loaded automatically during power-on. The front panel LEDs should step through a sequence as firmware is loaded. The display will be blank during this time.

At the end of a successful loading, the LEDs for Channel 1 and PORT 1 (REFLECTION port on ET models does NOT have an LED) will remain on and the display will indicate the version of firmware that was loaded.

In Case of Difficulty

If the firmware did not load successfully, LED patterns on the front panel can help you isolate the problem.

- If the following LED pattern is present, an acceptable firmware filename was not found on the disk. (The required format for a firmware file name is 8720ET_07._60 or 8720ES_07._60). Check that the firmware disk matches your network analyzer model.

LED Pattern							
Chan 1	Chan 2	Chan 3	Chan 4	R	L	T	S
	*						

- If any of the following LED patterns are present, the firmware disk may be defective.

LED Pattern							
Chan 1	Chan 2	Chan 3	Chan 4	R	L	T	S
				*			
	*			*			
*				*			
*	*			*			
					*		
	*				*		
*					*		
*	*				*		
				*	*		
	*			*	*		
*				*	*		
				*			*
	*			*			*

- If any other LED pattern is present, the CPU board is defective.

NOTE If firmware did not load, a red LED on the CPU board will be flashing.

If the following LED pattern is present on the CPU board, suspect the disk drive or associated cabling:

*	*	*		*	*				
(front of instrument ↓)									

Reference Assembly VCO Tune Adjustment

This adjustment centers the reference assembly voltage controlled oscillator (VCO) in its tuning range.

Required Equipment and Tools

Equipment Description	All Models
Extender board, large	part number 08720-60151 (Part of tool kit part number 08722-60018)
SMB (m) to SMB (f) Extension Cables	part number 8120-5040
Non-Metallic Adjustment Tool	part number 8830-0024

Analyzer warmup time: 30 minutes.

1. Switch off the analyzer.
2. Remove the upper corner standoffs and the instrument top cover. In order to access the VCO TUNE adjustment screw on the Reference (A12) assembly, install the Reference assembly onto the extender board. Use SMB extension cables as required (the EXT REF cable need not be reconnected now). The Reference (A12) assembly is the PC board with the red tabs.

3. Press the following:

Presets **FACTORY: PRESET** **Presets**

Sweep Setup **CW FREQ** **SWEEP TIME [AUTO]**

2 **x1** **System** **SERVICE MENU** **ANALOG BUS ON**

Meas **ANALOG IN Aux Input**

ANALOG BUS **15** **x1** to display VCO Tune.

4. Press **MARKER** and **Scale Ref** **SCALE / DIV** **.5** **x1**.

Figure 3-7 VCO Tune Adjustment Location

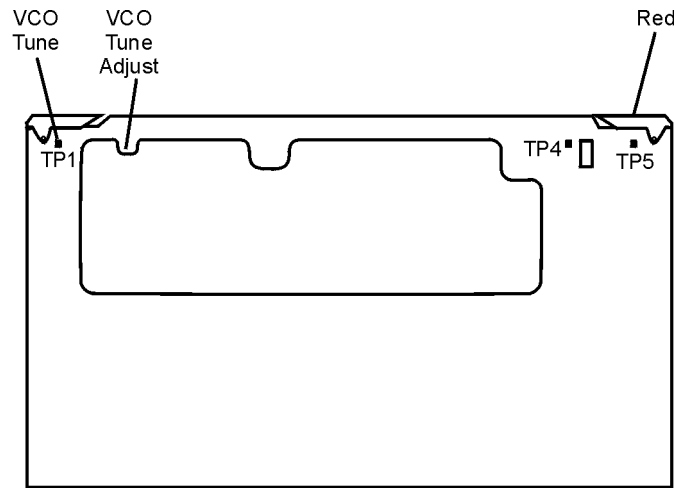

sb539e

5. Adjust VCO TUNE with a non-metallic adjustment tool to $0.0\text{ V} \pm 500\text{ mV}$ (within one division of the reference line).

The adjustment is sensitive, and if out of adjustment may display an irregular waveform. If so, slowly tune through the entire adjustment range to obtain a flat trace, then carefully tune for 0.0 V . Once the adjustment is done, it should be rechecked with the reference board reinstalled in the instrument, and at operating temperature.

In Case of Difficulty

If VCO TUNE cannot be adjusted as specified, and the instrument passes the Analog Bus Correction Constants (Test 44) adjustment, the Reference (A12) assembly must be replaced or contact the nearest Agilent Technologies sales or service office.

Frequency Accuracy Adjustment

This adjustment sets the voltage controlled crystal oscillator (VCXO) frequency to maintain the instrument's frequency accuracy.

Required Equipment and Tools

Equipment Description	8719ET/ES 8720ET/ES	8722ET/ES
Frequency Counter	53150A or 5350B	53151A or 5351B
RF cable	85131F	85133F
Non-metallic Adjustment Tool	part number 8830-0024	
Antistatic Wrist Strap	part number 9300-1367	
Antistatic Wrist Strap Cord	part number 9300-0980	
Static-control Table Mat and Earth Ground Wire	part number 9300-0797	

Network Analyzer warmup time: 30 minutes.

1. Remove the upper corner standoffs and analyzer top cover.
2. Connect the equipment as shown in [Figure 3-8](#).

IMPORTANT Make sure that the frequency counter and network analyzer references are *not* connected.

Figure 3-8 Frequency Accuracy Adjustment Setup

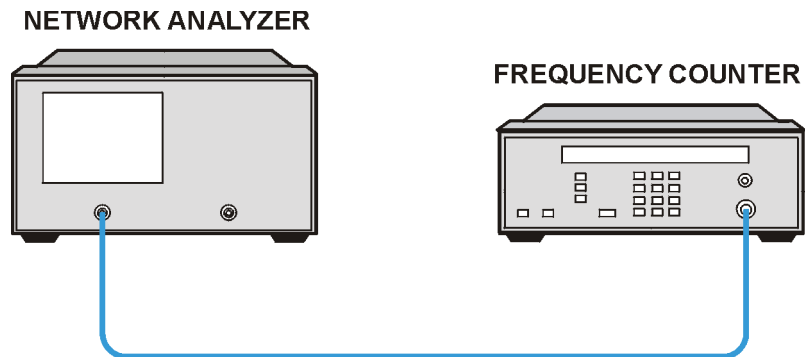

sb519e

NOTE **For Option 1D5 Instruments Only:** Remove the rear panel BNC to BNC jumper that is connected between the “EXT REF” and the “10 MHz Precision Reference,” as shown in [Figure 3-10](#).

3. Press **[Preset]** **FACTORY: PRESET** **[Preset]** **[Sweep Setup]** **CW FREQ** and select the frequency:
 - For the 8719ET/ES, press **[13.5]** **[G/n]**.
 - For the 8720ET/ES, press **[20]** **[G/n]**.
 - For the 8722ET/ES, press **[26]** **[G/n]**.
4. No adjustment is required when the frequency counter measurement results are within specification:
 - ± 135 kHz for 8719ET/ES
 - ± 200 kHz for 8720ET/ES
 - ± 260 kHz for 8722ET/ES

Otherwise, locate the Reference (A12) assembly (red extractors) and adjust the VCXO ADJ (see [Figure 3-9](#)) for a frequency measurement within specifications.

Figure 3-9 Location of the VCXO ADJ Adjustment

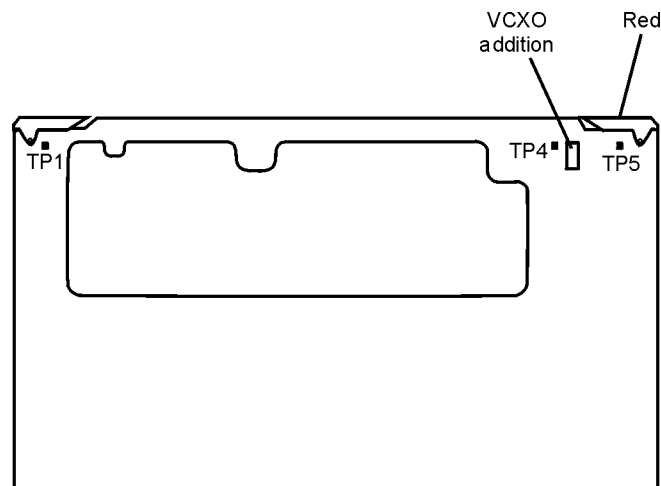

sb540e

NOTE To increase the accuracy of this adjustment, steps 5 and 6 are recommended.

5. Replace the instrument covers and wait 15 minutes to allow the analyzer to reach its precise operating temperature.
6. Recheck the CW frequency and adjust if necessary.

Instruments with Option 1D5 Only

7. Reconnect the BNC to BNC jumper between the “EXT REF” and the “10 MHz Precision Reference” as shown in [Figure 3-10](#).

Figure 3-10 High Stability Frequency Adjustment Location

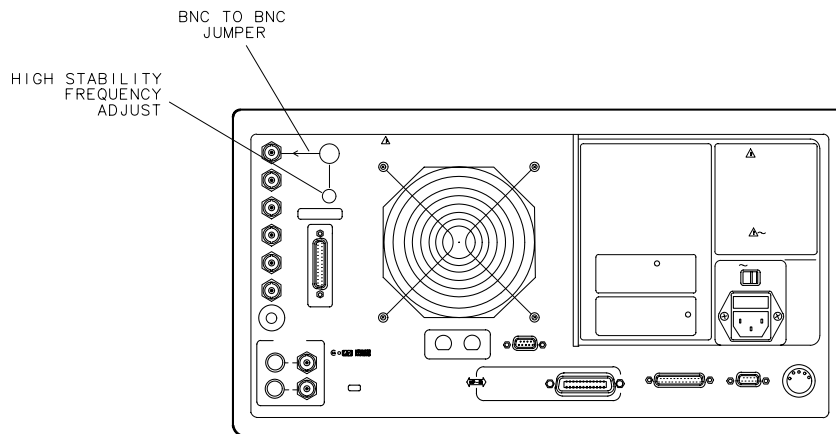

sb629d

8. Insert a narrow screwdriver and adjust the high-stability frequency reference potentiometer for a CW frequency measurement within specification.

In Case of Difficulty

- If you cannot adjust the CW frequency within specification, replace the Reference (A12) assembly or contact the nearest Agilent Technologies sales or service office.

API Spur Avoidance and 100 kHz FM Sideband Adjustment

This adjustment minimizes the spurs caused by the API (analog phase interpolator, on the fractional-N assembly) circuits. It also improves the sideband characteristics.

Required Equipment and Tools

Equipment Description	8719ET/ES 8720ET/ES	8722ET/ES
Spectrum Analyzer	8591E Opt. 130	
RF cable 50 ohm, Type N, 24 inch	11500C	
RF cable 50 ohm, 24 inch BNC type	part number 8120-2582	
Non-metallic Adjustment Tool	part number 8830-0024	
Adapter 2.4-mm (f) to Type-N (f)	N/A	11903B
Adapter 3.5 mm (f) to Type-N (f)	part number 1250-1745	N/A
Antistatic Wrist Strap	part number 9300-1367	
Antistatic Wrist Strap Cord	part number 9300-0980	
Static-control Table Mat and Earth Ground Wire	part number 9300-0797	

Network Analyzer warmup time: 30 minutes.

Spectrum Analyzer warmup time: 30 minutes.

FM Sideband Adjustment (100 kHz Spurs)

1. The object of this test is to make the spur levels for all 3 frequencies equal. Connect the equipment as in [Figure 3-11](#).

Figure 3-11 Test Setup for Sideband Adjustment

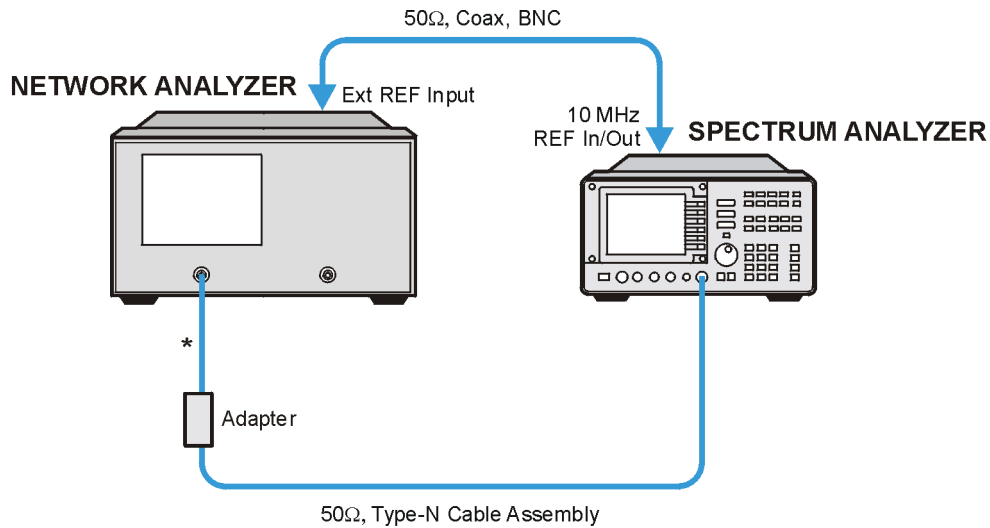

* Direct Connection

sb527e

2. Set the spectrum analyzer measurement parameters to the values in [Table 3-6](#):

Table 3-6 Spectrum Analyzer Setup Values

Parameter	Value
Reference Level	0 dBm
Scale	10 dB/division
Attenuator (ATTN)	10 dB
Video Bandwidth (VBW)	1 kHz
Resolution Bandwidth (RBW)	300 Hz
Span	100 Hz

3. On the spectrum analyzer, press **FREQ** **Center FREQ** and enter the spectrum analyzer frequency from # 1 from [Table 3-7](#), press **MHZ**.

Table 3-7 Frequency Inputs

Frequency	Network Analyzer Frequency	Spectrum Analyzer Frequency
# 1	386 MHZ	385.899997 MHZ
# 2	530 MHZ	529.899997 MHZ
# 3	698 MHZ	697.899997 MHZ

4. On the network analyzer, press **Preset** **FACTORY: PRESET** **Preset** **Sweep Setup** **CW FREQ** and enter the network analyzer frequency #1 from [Table 3-7](#), then press **M/μ**.
5. Refer to [Figure 3-12](#), and adjust the 100 kHz (A13R77) for a null (minimum amplitude) on the spectrum analyzer. The minimum signal may drop down into the noise floor.

Figure 3-12 Location of API and 100 kHz Adjustments

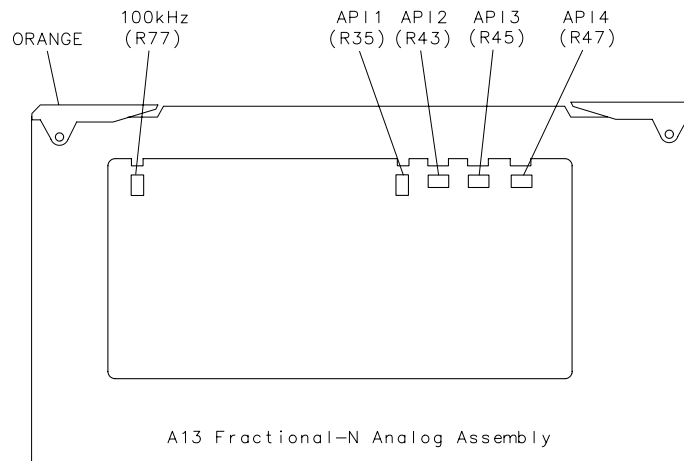

sg69d

6. Repeat steps 4 through 6 for frequencies # 2 and # 3 from [Table 3-7](#), using the same adjustment (A13R77).

API Adjust

1. On the spectrum analyzer, set the Video Resolution Bandwidth (VBW) to 10 Hz and the Resolution Bandwidth to 30 Hz.
2. On the spectrum analyzer, set the center frequency for 910.063 MHz.
3. On the network analyzer, press **CW FREQ** **910.060** **M/μ**.
4. Adjust the API1 (A13R35) for a null (minimum amplitude) on the spectrum analyzer.
5. On the spectrum analyzer, set the center frequency for 910.009 MHz.
6. On the network analyzer, press **CW FREQ** **910.006** **M/μ**.
7. Adjust the API2 (A13R43) for a null (minimum amplitude) on the spectrum analyzer.
8. On the spectrum analyzer, set the center frequency for 910.0036 MHz.
9. On the network analyzer, press **CW FREQ** **910.0006** **M/μ**.

10. Adjust the API3 (A13R45) for a null (minimum amplitude) on the spectrum analyzer.
11. On the spectrum analyzer, set the center frequency for 910.00306 MHz.
12. On the network analyzer, press **CW FREQ** .
13. Adjust the API4 (R47) for a null (minimum amplitude) on the spectrum analyzer.

In Case of Difficulty

- If this adjustment cannot be performed satisfactorily, repeat the entire procedure.
- If the analyzer repeatedly fails this adjustment, replace the A13 board assembly or contact the nearest Agilent Technologies sales or service office.

Raw Offset Correction Constants

This procedure sets the raw offsets for the A,B, and R channels, in preparation for performing the “[Sampler Calibration Correction Constants \(Test 51\)](#),” on page 3-58.

Required Equipment and Tools

Equipment Description	8719ET/ES 8720ET/ES	8722ET/ES
Power Meter	436A, 437B, 438A, E4418A (EPM-441A) or E4419A (EPM-442A)	
Power Sensor	8485A	8487A
Adapter 3.5-mm (f) to 3.5-mm (f)	part number 85052-60012 (part of 85052B)	N/A
Adapter 2.4-mm (f) to 2.4-mm (f)	N/A	part number 85056-60006 (part of 85056A)
RF Cable Set	85131F	85133F
RF Open	part number 85052-60009 (part of 85052B)	part number 85056-60023 (part of 85056A)

Analyzer and power meter warmup time: 30 minutes.

1. Make sure the A7 Switch is in the alter position (ALT).
2. Zero and calibrate the power meter.
3. Connect the equipment as shown in [Figure 3-13](#).

Figure 3-13 Setup for the R Channel (ET/ES Models)

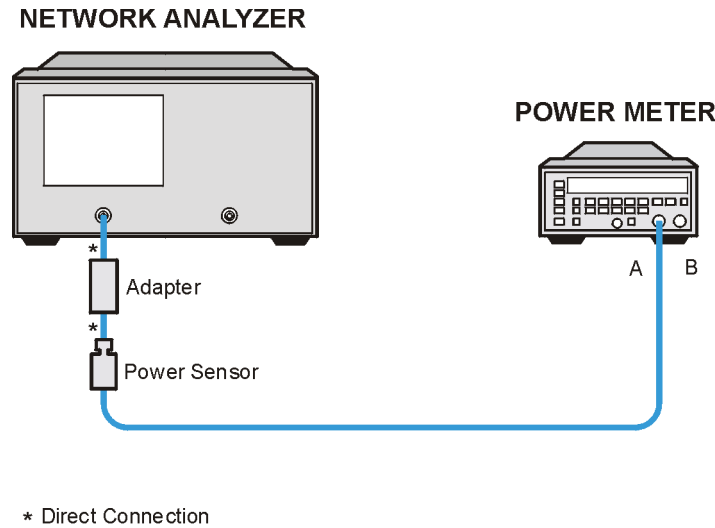

sb520e

Raw Offset for the R Channel (ET/ES Models)

1. Press the following:

Presets **FACTORY PRESET** **Presets**

System **SERVICE MENU** **SERVICE MODES** **MORE** **SAMPLER COR OFF**

Stop **10** **G/n**

Meas **INPUT PORTS** **R**

Marker Search **SEARCH: MAX**

Note the maximum frequency and write it down.

2. Press **Sweep Setup** **CW FREQ**, and enter the maximum frequency point from step 1.

Press **G/n** **Marker Search** **SEARCH: MAX**.

Note the maximum marker reading (MMR) and write it down.

3. Enter the power sensor calibration factor for the maximum frequency point into the power meter.

NOTE Refer to the power sensor manual for instructions on how to enter a calibration factor into the power meter. If the exact frequency is not listed on the power sensor, use a value that is between the two nearest points.

4. The objective is to set the maximum marker reading (MMR) to 4 dB higher than the power meter reading. Perform the following mathematical operation.
 - a. Calculate the difference (Δ) between the power meter reading (PMR) and the maximum marker reading (MMR) and then add 4.

$$\Delta = (\text{PMR} + 4) - \text{MMR}$$

NOTE The Δ can be a positive or negative value.

5. If the magnitude of Δ is less than 0.15 dB, then the offset for the R channel is correctly set. For ES models, go to “[Raw Offset for the A and B Channels \(ES Models\)](#)” on page 3-51. For ET Models, go to “[Raw Offsets for the A and B Channels \(ET Models\)](#)” on page 3-54. If the magnitude is greater than 0.15 dB, continue to the next step.
6. Press the following:

(System) SERVICE MENU

PEEK POKE PEEK/POKE ADDRESS

(1619001376) (x1) PEEK

Note the PEEK value displayed under the PEEK label.

7. Calculate the new value by adding the PEEK value to Δ multiplied by 4.
new value = current value + ($\Delta \times 4$)

NOTE Round the new value to the nearest integer.

8. Press **(Poke)** and enter the new value, press **(x1)**.
9. To get the analyzer to use the new poke value, press **(Preset)**.
10. Press the following:

(Meas) INPUT PORTS R

(Sweep Setup) CW FREQ and enter the frequency from step 1.

(System) SERVICE MENU SERVICE MODES MORE SAMPLER COR OFF

(x1) MARKER SEARCH SEARCH:MAX

The maximum marker reading is MMR.

11. Recalculate Δ by taking the power meter reading (PMR), adding 4 and then subtracting the maximum marker reading (MMR).

$$\Delta = (\text{PMR} + 4) - (\text{MMR})$$

If the magnitude of Δ is less than 0.15 dB, then the offset for the R channel is correctly set. For ES models, go to “[Raw Offset for the A and B Channels \(ES Models\)](#)” on page 3-51. For ET Models, go to “[Raw Offsets for the A and B Channels \(ET Models\)](#)” on page 3-54. If the magnitude is greater than 0.15 dB, repeat steps 1 through 11 until the R channel raw offset correction constant is achieved.

Raw Offset for the A and B Channels (ES Models)

1. Connect the equipment as shown in [Figure 3-14](#).

Figure 3-14 Setup for the A and B Channels (ES Models)

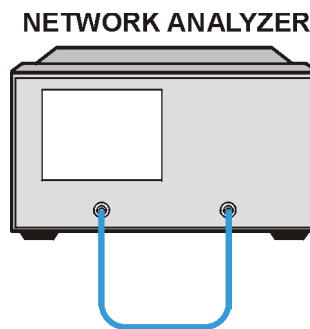

sb543e

2. Press the following:

Preset

Meas **INPUT PORTS** **A**

TESTPORT 2

Stop **10** **G/n**

System **SERVICE MENU** **SERVICE MODES** **MORE** **SAMPLER COR OFF**

Marker Search **SEARCH: MAX**

Note the frequency and write it down.

3. Press **Sweep Setup** **CW FREQ**, and enter the maximum frequency point from step 2.

Press **G/n** **Marker Search** **SEARCH: MAX**. Note the maximum marker reading (MMR) and write it down.

Press **Power**. Note the displayed test port power (TPP) and write it down.

4. The objective is to set the maximum marker reading (MMR) to 4 dB higher than the test port power. Perform the following mathematical operation.
 - a. Calculate the difference (Δ) between the test port power (TPP) and the maximum marker reading (MMR) and then add 4.

$$\Delta = (\text{TPP} + 4) - \text{MMR}$$

NOTE The Δ can be a positive or negative value.

5. If the magnitude of Δ is less than 0.15 dB, then the offset for the A channel is correctly set. Go to [“Raw Offset for the B Channel \(ES Models\)” on page 3-53](#). If the magnitude is greater than 0.15 dB, continue to the next step.
6. Press the following:

(System) SERVICE MENU

PEEK POKE PEEK/POKE ADDRESS

(1619001372) (x1) PEEK

Note the PEEK value displayed under the PEEK label.

7. Calculate the new value by adding the PEEK value to Δ multiplied by 4.
new value = current value + ($\Delta \times 4$)

NOTE Round the new value to the nearest integer.

8. Press **(Poke)** and enter the new value into the poke address; press **(x1)**.
9. To get the analyzer to use the new poke value, press **(Preset)**.
10. Press the following:

(Meas) INPUT PORTS A

(Sweep Setup) CW FREQ and enter the frequency from step 2.

(System) SERVICE MENU SERVICE MODES MORE SAMPLER COR OFF

(x1) MARKER SEARCH SEARCH:MAX

The maximum marker reading is MMR.

11. Recalculate Δ by taking the test port power (TPP), adding 4 and then subtracting the maximum marker reading (MMR).

$$\Delta = (\text{TPP} + 4) - (\text{MMR})$$

If the magnitude of Δ is less than 0.15 dB, then the offset for the A channel is correctly set. Go to [“Raw Offset for the B Channel \(ES Models\)” on page 3-53](#). If the magnitude is greater than 0.15 dB, repeat steps 2 through 11 until the A channel raw offset correction constant is achieved.

Raw Offset for the B Channel (ES Models)

12. Press the following:

Preset
Meas **INPUT PORTS** **B**
TESTPORT 1
Stop **10** **G/n**
System **SERVICE MENU** **SERVICE MODES** **MORE** **SAMPLER COR OFF**
Marker Search **SEARCH: MAX**

Note the frequency and write it down.

13. Press **Sweep Setup** **CW FREQ**, and enter the maximum frequency point from step 12.

Press **G/n** **Marker Search** **SEARCH: MAX**. Note the maximum marker reading (MMR) and write it down.

Press **Power**. Note the displayed test port power (TPP) and write it down.

14. The objective is to set the maximum marker reading (MMR) to 4 dB higher than the power meter reading. Perform the following mathematical operation.

- a. Calculate the difference (Δ) between the test port power meter reading (TPP) and the maximum marker reading (MMR) and then add 4.

$$\Delta = (\text{TPP} + 4) - \text{MMR}$$

NOTE The Δ can be a positive or negative value.

15. If the magnitude of Δ is less than 0.15 dB, then the offset for the B channel is correctly set. Go to “[Sampler Calibration Correction Constants \(Test 51\)](#)” on page 3-58. If the magnitude is greater than 0.15 dB, continue to the next step.

16. Press the following:

System **SERVICE MENU**
PEEK POKE **PEEK/POKE ADDRESS**
1619001374 **x1** **PEEK**

Note the PEEK value displayed under the PEEK label.

17. Calculate the new value by adding the PEEK value to Δ multiplied by 4.

$$\text{new value} = \text{current value} + (\Delta \times 4)$$

NOTE Round the new value to the nearest integer.

18. Press **Poke** and enter the new value into the poke address; press **x1**.

19. To get the analyzer to use the new poke value, press **Preset**.

20. Press the following:

Meas **INPUT PORTS** **B**

Sweep Setup **CW FREQ** and enter the frequency from step 12.

System **SERVICE MENU** **SERVICE MODES** **MORE** **SAMPLER COR OFF**

x1 **MARKER SEARCH** **SEARCH:MAX**

The maximum marker reading is MMR.

21. Recalculate Δ by taking the test port power (TPP), adding 4 and then subtracting the maximum marker reading (MMR).

$$\Delta = (\text{TPP} + 4) - (\text{MMR})$$

If the magnitude of Δ is less than 0.15 dB, then the offset for the B channel is correctly set. Go to [“Sampler Calibration Correction Constants \(Test 51\)” on page 3-58](#). If the magnitude is greater than 0.15 dB, repeat steps 12 through 21 until the B channel raw offset correction constant is achieved.

Raw Offsets for the A and B Channels (ET Models)

1. Connect an open to the REFLECTION port.

2. Press the following:

Preset

Meas **INPUT PORTS** **A**

Stop **10** **G/n**

System **SERVICE MENU** **SERVICE MODES** **MORE** **SAMPLER COR OFF**

Marker Search **SEARCH: MAX**

Note the maximum frequency and write it down.

3. Press **Sweep Setup** **CW FREQ**, and enter the maximum frequency point from step 2.

Press **G/n** **Marker Search** **SEARCH: MAX**. Note the maximum marker reading (MMR) and write it down.

Press **Power**. Note the displayed test port power (TPP) and write it down.

4. The objective is to set the maximum marker reading (MMR) to 4 dB higher than the power meter reading. Perform the following mathematical operation.
 - a. Calculate the difference (Δ) between the test port power meter reading (TPP) and the maximum marker reading (MMR) and then add 4.

$$\Delta = (\text{TPP} + 4) - \text{MMR}$$

NOTE The Δ can be a positive or negative value.

5. If the magnitude of Δ is less than 0.15 dB, then the offset for the A channel is correctly set. Go to [“Raw Offset for the B Channel \(ET Models\)” on page 3-56](#). If the magnitude is greater than 0.15 dB, continue to the next step.
6. Press the following:

(System) SERVICE MENU

PEEK POKE PEEK/POKE ADDRESS

(1619001372) (x1) PEEK

Note the PEEK value displayed under the PEEK label.

7. Calculate the new value by adding the PEEK value to Δ multiplied by 4.

$$\text{new value} = \text{current value} + (\Delta \times 4)$$

NOTE Round the new value to the nearest integer.

8. Press **(Poke)** and enter the new value into the poke address; press **(x1)**.
9. To get the analyzer to use the new poke value, press **(Preset)**.
10. Press the following:

(Meas) INPUT PORTS A

(Sweep Setup) CW FREQ and enter the frequency from step 2.

(System) SERVICE MENU SERVICE MODES MORE SAMPLER COR OFF

(x1) MARKER SEARCH SEARCH:MAX

The maximum marker reading is MMR.

11. Recalculate Δ by taking the test port power (TPP), adding 4 and then subtracting the maximum marker reading (MMR).

$$\Delta = (\text{TPP} + 4) - (\text{MMR})$$

If the magnitude of Δ is less than 0.15 dB, then the offset for the A channel is correctly set. Go to [“Raw Offset for the B Channel \(ET Models\)” on page 3-56](#). If the magnitude is greater than 0.15 dB, repeat steps 1 through 11 until the A channel raw offset correction constant is achieved.

Raw Offset for the B Channel (ET Models)

12. Connect the equipment as shown in [Figure 3-15](#).

Figure 3-15 Setup for Calculating the Raw Offset for the B Channel (ET Models)

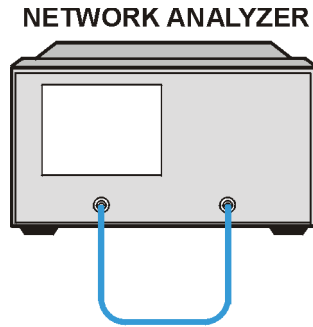

sb543e

13. Press the following:

Preset

Meas INPUT PORTS B

Stop 10 G/n

System SERVICE MENU SERVICE MODES MORE SAMPLER COR OFF

Marker Search SEARCH: MAX

Note the frequency and write it down.

14. Press **Sweep Setup CW FREQ**, and enter the maximum frequency point from step 13.

Press **G/n Marker Search SEARCH: MAX**. Note the maximum marker reading (MMR) and write it down.

Press **Power**. Note the displayed test port power (TPP).

15. The objective is to set the maximum marker reading (MMR) to 4 dB higher than the power meter reading. Perform the following mathematical operation.

- Calculate the difference (Δ) between the test port power meter reading (TPP) and the maximum marker reading (MMR) and then add 4.

$$\Delta = (\text{TPP} + 4) - \text{MMR}$$

NOTE The Δ can be a positive or negative value.

16. If the magnitude of Δ is less than 0.15 dB, then the offset for the B channel is correctly set. Go to [“Sampler Calibration Correction Constants \(Test 51\)”](#) on page 3-58. If the magnitude is greater than 0.15 dB, continue to the next step.

17. Press the following:

(System) SERVICE MENU
PEEK POKE PEEK/POKE ADDRESS
(1619001374) (x1) PEEK

Note the PEEK value displayed under the PEEK label.

18. Calculate the new value by adding the PEEK value to Δ multiplied by 4.

$$\text{new value} = \text{current value} + (\Delta \times 4)$$

NOTE Round the new value to the nearest integer.

19. Press **(Poke)** and enter the new value into the poke address; press **(x1)**.

20. To get the analyzer to use the new poke value, press **(Preset)**.

21. Press the following:

(Meas) INPUT PORTS B
(Sweep Setup) CW FREQ and enter the frequency from step 13.
(System) SERVICE MENU SERVICE MODES MORE SAMPLER COR OFF
(x1) MARKER SEARCH SEARCH:MAX

The maximum marker reading is MMR.

22. Recalculate Δ by taking the test port power (TPP), adding 4 and then subtracting the maximum marker reading (MMR).

$$\Delta = (\text{TPP} + 4) - (\text{MMR})$$

If the magnitude of Δ is less than 0.15 dB, then the offset for the A channel is correctly set. Go to [“Sampler Calibration Correction Constants \(Test 51\)”](#) on page 3-58. If the magnitude is greater than 0.15 dB, repeat steps 12 through 22 until the B channel raw offset correction constant is achieved.

In Case of Difficulty

- Ensure that the power meter and power sensor are operating to specification.
- If you are unable to perform this adjustment, refer to [Chapter 8](#), “[Receiver Troubleshooting](#),” or contact the nearest Agilent Technologies sales or service office.

Sampler Calibration Correction Constants (Test 51)

Required Equipment and Tools

Equipment Description	8719ET/ES 8720ET/ES	8722ET/ES
Power Meter ¹	436A, 437B, 438A, E4418A (EPM-441A) or E4419A (EPM-442A)	
Power Sensor	8485A	8487A
Adapter 3.5-mm (f) to 3.5-mm (f)	part number 85052-60012 (Part of 85052B)	N/A
Adapter 2.4-mm (f) to 2.4-mm (f)	N/A	part number 85056-60006 (Part of 85056A)
HP/Agilent RF Cable Set	85131F	85133F
RF Open	part number 85052-60009 (Part of 85052B)	part number 85056-60023 (Part of 85056A)

1. The EPM-441A and EPM-442A, *with versions prior to A 2.02.00 firmware*, cannot be controlled by the analyzer. These versions do not have the 438A command set firmware. These models may be upgraded at an Agilent Technologies service center.

Analyzer and power meter warmup time: 30 minutes.

IMPORTANT Perform “[Raw Offset Correction Constants](#),” on page 3-48 before performing this test.

1. Make sure the A7 Switch is in the alter position (ALT).
2. Press **PRESET FACTORY** .
3. Connect the equipment as in [Figure 3-16](#).

Figure 3-16 Setup for Sampler Calibration

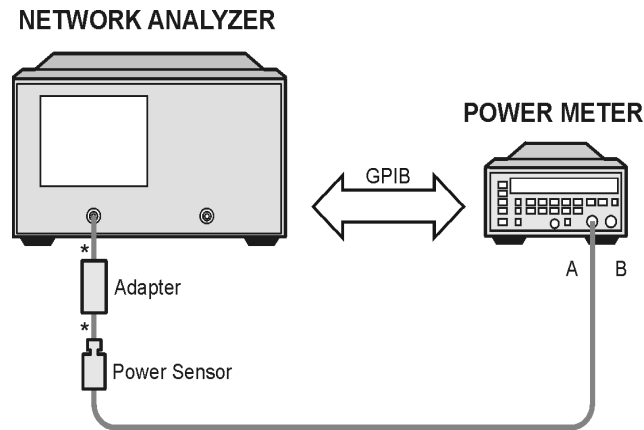

* Direct Connection

ch535e

Power Meter Setup

4. Zero and calibrate the power meter.
5. To set up the power meter address, press **Local** **SET ADDRESSES** **ADDRESS: P MTR** **GPIB** on the analyzer.

NOTE The default power meter GPIB address is 13. Make sure this address is the same as the power meter's GPIB address. Otherwise, use the analyzer's front panel keypad to enter the correct GPIB address or change the address in the power meter.

6. Press **POWER MTR:[POWER METER TYPE]** until the correct power meter model number appears in the brackets.

NOTE If you are using an HP/Agilent E4418A or a HP/Agilent E4419A, select **[438A/437]** power meter type from the analyzer menu. On the power meter softkey menu press:
437B on the E4418A
438A on the E4419A

7. Press **Cal** **PWRMTR CAL**.
8. Press **LOSS/SENSR LISTS** **CAL FACTOR SENSOR A**. Refer to the back of the power sensor to locate the different calibration factor values along with their corresponding frequencies.

NOTE The analyzer's calibration factor sensor table can hold a *maximum* of 12 calibration factor data points.

The following softkeys are included in the sensor calibration factor entries menu:

- SEGMENT** press to select a point where you can use the front panel knob or entry keys to enter a value.
- EDIT** press to edit or change a previously entered value.
- DELETE** press to delete a point from the sensor calibration factor table.
- ADD** press this key to add a point into the sensor calibration factor table.
- CLEAR LIST** press this key to erase the entire sensor calibration factor table.
- DONE** press this key when done entering points to the sensor calibration factor table.

9. As an example, the following are the keystrokes for entering the first two calibration factor data points for the HP/Agilent 8485A power sensor (assuming CF% = 99.5 at 50 MHz and CF% = 98.4 at 20 GHz):

- a. From the sensor calibration factor entries menu, press **ADD**.
- b. Press **FREQUENCY** . If you make an entry error, press and re-enter the correct value again.
- c. Press **CAL FACTOR** .
- d. Press **DONE** to terminate the first calibration factor data point entry.
- e. To enter the second calibration factor data point, press **ADD**.
- f. Press **FREQUENCY** .
- g. Press **CAL FACTOR** .
- h. To terminate the second calibration factor data point entry, press **DONE**.
- i. Press **SEGMENT** and use the front panel knob to scroll through the sensor calibration factors table. Check to be sure all values are entered correctly. If you see an error, use the front panel knob to point to the data point you want to modify and press **EDIT**.

10. Enter the power sensor calibration factors and press **DONE**.

11. Press the following:

- SERVICE MENU**
- SERVICE MODES** **MORE**
- SAMPLER COR OFF**

Performing the Sampler Calibration

12. Press the following:

System **SERVICE MENU** **TESTS**

51 **x1** **EXECUTE TEST** **YES**

13. Follow the instructions on the analyzer display.

14. Observe the analyzer display for the results of the test.

- If the analyzer displays **SAMPLER COR -DONE-**, the test has passed, go to step 5.
- If the analyzer displays **SAMPLER COR -FAIL-**, repeat the test.

15. Move the A7 switch back to its normal position (NRM) if you are finished working on the instrument.

16. Perform the [“EEPROM Backup Disk Procedure,”](#) on page 3-33.

In Case of Difficulty

- Ensure that the power meter and power sensor are operating to specification.
- If you are unable to perform this adjustment, refer to [Chapter 8](#), [“Receiver Troubleshooting,”](#) or contact the nearest Agilent Technologies sales or service office.

4 Start Troubleshooting Here

Information on This Chapter

The information in this chapter helps you:

- Identify the portion of the analyzer that is at fault.
- Locate the specific troubleshooting procedures to identify the assembly or peripheral at fault.

To identify the portion of the analyzer at fault, follow these procedures in this order:

[Step 1. Initial Observations, on page 4-5](#)

[Step 2. Operator's Check, on page 4-7](#)

[Step 3. GPIB Systems Check, on page 4-10](#)

[Step 4. Faulty Group Isolation, on page 4-13](#)

Assembly Replacement Sequence

The following steps show the sequence to replace an assembly in the network analyzer.

- Step 1.** Identify the faulty group. Begin with this chapter and follow up with the appropriate troubleshooting chapter that identifies the faulty assembly.
- Step 2.** Order a replacement assembly. Refer to [Chapter 13](#) , “Replaceable Parts.”
- Step 3.** Replace the faulty assembly and determine what adjustments are necessary. Refer to [Chapter 14](#) , “Assembly Replacement and Post-Repair Procedures.”
- Step 4.** Perform the necessary adjustments. Refer to [Chapter 3](#) , “Adjustments and Correction Constants.”
- Step 5.** Perform the necessary performance tests. Refer to [Chapter 2](#) , “System Verification and Performance Tests.”

Having Your Analyzer Serviced

The analyzer has a three year return to Agilent Technologies warranty. If the analyzer should fail any of the following tests, do the following:

1. Call the local Agilent Technologies sales or service office. See [Chapter 15](#) , “[Safety and Regulatory Information](#)” to identify your nearest office. When you call the sales and service office, have the following information prepared:
 - the model number of your analyzer
 - the serial number of your analyzer
 - the firmware revision of your analyzer
 - a description of the problem including any failed tests or error messages
2. Agilent Technologies will issue a Return Material Authorization (RMA) number and the address where the analyzer should be shipped.
3. Ship the analyzer, using the original or comparable anti-static packaging materials.

Step 1. Initial Observations

Initiate the Analyzer Self-Test

1. Disconnect all devices and peripherals from the analyzer.
2. Switch on the analyzer and press **Preset** **PRESET: FACTORY** **Preset**.
3. Watch for the indications shown in [Figure 4-1](#) to determine if the analyzer is operating correctly.

NOTE On ET models, there is no TRANSMISSION LED on the front panel.

Figure 4-1 Preset Sequence for ET and ES Models

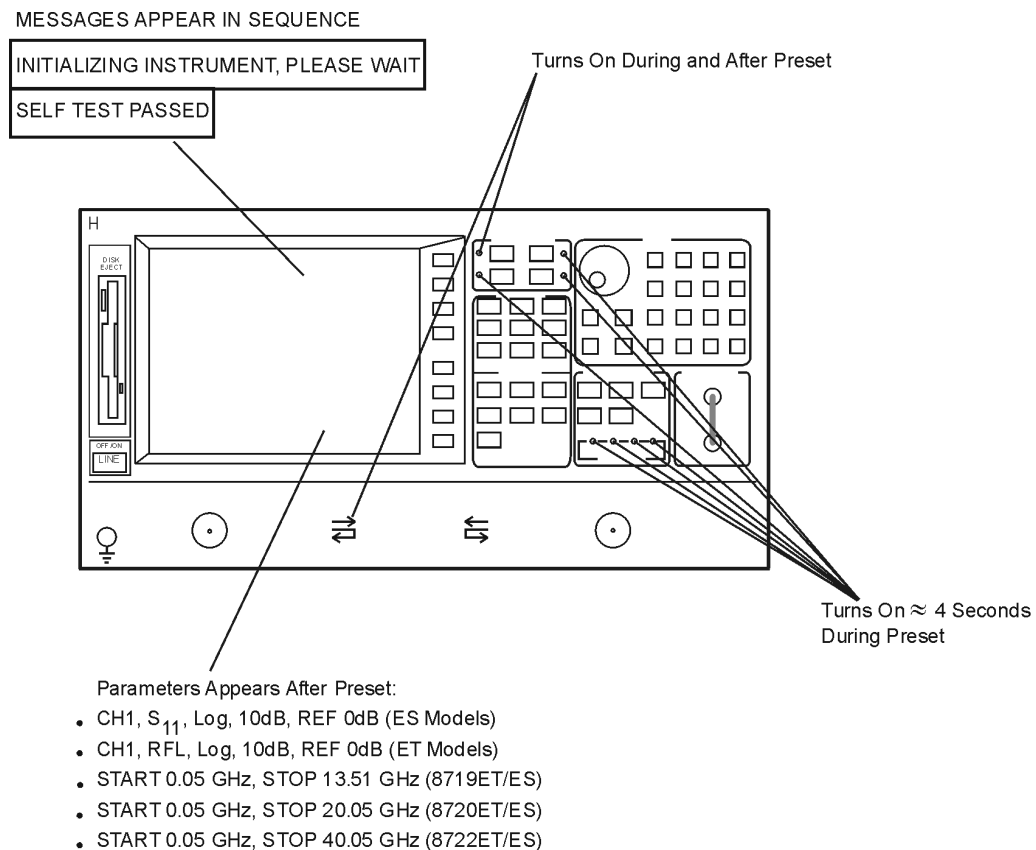

sb534e

If the Self-Test Failed

1. Check the AC line power to the analyzer.
2. Check the fuse (rating listed on rear panel, spare inside holder).
3. Check the line voltage setting (use small screwdriver to change).
4. If the problem persists, refer to [“Step 4. Faulty Group Isolation”](#) on page 4-13.

Step 2. Operator's Check

Description

The operator's check consists of two softkey initiated tests: Op Ck Port 1 (Test 21) and Op Ck Port 2 (Test 22).

On the ES models, a short is connected to PORT 1 and PORT 2 to reflect all the source energy back into the analyzer for an S11 and S22 measurement. To achieve full reflection for ET models, a short is connected to the REFLECTION port. An RF cable is connected between the REFLECTION and TRANSMISSION ports for Op Ck Port 2.

On ES models, the first part of Op Ck Port 1 checks the repeatability of the transfer switch. An S11 measurement is stored in memory and the switch is toggled to PORT 2 and then back to PORT 1 where another S11 measurement is made. The difference between the memory trace and the second trace is switch repeatability.

The remaining parts of both tests exercise the internal attenuator in 5 dB steps over a 55 dB range. For ET models, without Option 004, a single measurement is made.

The resulting measurements must fall within a limit testing window to pass the test. The window size is based on both source and receiver specifications.

The operator's check determines that:

1. The source is phase-locked across the entire frequency range.
2. All three samplers are functioning properly.
3. The transfer switch is operational (ES models only).
4. The attenuator steps 5 dB at a time (ES and ET Option 004 models only).
5. A rough check of the receiver's linearity.

Table 4-1 Required Accessories

Type of Device	HP/Agilent Part Number
Short 3.5 mm (f) (8719ET/ES and 8720ET/ES)	85052-60007 (part of calibration kit 85052B)
Short 2.4 mm (f) (8722ET/ES)	85056-60021 (part of calibration kit 85056A)
Cable 3.5 mm (8719ET and 8720ET)	85131F
Cable 2.4 mm (f) (8722ET)	85133F

Procedure to Perform Operator's Check

Analyzer warmup time: 30 minutes

PORT 1 or REFLECTION port check

1. Connect a short to PORT 1 (REFLECTION port on ET models).
2. Press the following:

[Preset] PRESET: FACTORY [Preset]

[System] SERVICE MENU TESTS EXTERNAL TESTS

EXECUTE TEST CONTINUE

- If the message **PRESS [CONTINUE]** appears on the display during the test, that particular attenuator setting check has failed. Press **CONTINUE** to check the other attenuator settings.
- If the message **FAIL** appears on the analyzer display, the analyzer has failed the PORT 1 operation check. Refer to the flow charts on [page 2-4](#) and [page 2-5](#).
- If the message **DONE** appears on the analyzer display, the analyzer has passed the PORT 1 operation check.

PORT 2 Check (ES Models)

3. Connect the short to PORT 2.
4. Press the following:

[Preset] PRESET: FACTORY [Preset]

[System] SERVICE MENU TESTS

[22] [x1] EXECUTE TEST CONTINUE

- If the message **PRESS [CONTINUE]** appears on the display during the test, that particular attenuator setting check has failed. Press **CONTINUE** to check the other attenuator settings.
- If the message **FAIL** appears on the analyzer display, the analyzer has failed the PORT 2 operation check. Refer to the flow charts on [page 2-4](#) and [page 2-5](#).
- If the message **DONE** appears on the analyzer display, the analyzer has passed the PORT 2 operation check.

Transmission Port Check (ET Models)

5. Connect an RF cable from the REFLECTION port to the TRANSMISSION port.
6. Press the following:

Preset **PRESET: FACTORY** **Preset**

System **SERVICE MENU** **TESTS**

22 **x1** **EXECUTE TEST** **CONTINUE**

- If the message **PRESS [CONTINUE]** appears on the display during the test, that particular attenuator setting check has failed. Press **CONTINUE** to check the other attenuator settings.
- If the message **FAIL** appears on the analyzer display, the analyzer has failed the TRANSMISSION port operation check. Refer to the flow charts on [page 2-4](#) and [page 2-5](#).
- If the message **DONE** appears on the analyzer display, the analyzer has passed the TRANSMISSION port operation check.

In Case of Difficulty

1. Make sure that the connection is tight. Repeat the test.
2. Visually inspect the connector interfaces and clean if necessary (see [“Principles of Microwave Connector Care”](#) on [page 1-6](#)).
3. Verify that the short meets published specifications.
4. Substitute another short, and repeat the test.
5. Finally, refer to the detailed tests located in this section, or fault isolation procedures located in the troubleshooting sections.

Step 3. GPIB Systems Check

Check the analyzer's GPIB functions with a *known working* passive peripheral (such as a plotter, printer, or disk drive).

1. Connect the peripheral to the analyzer using a *known good* GPIB cable.
2. Press **Local** **SYSTEM CONTROLLER** to enable the analyzer to control the peripheral.
3. Then press **SET ADDRESSES** and the appropriate softkeys to verify that the device addresses will be recognized by the analyzer. The factory default addresses are:

Table 4-2 Factory Set GPIB Addresses

Device	GPIB Address
All Analyzers	16
Plotter port	5
Printer port	1
Disk (external)	0
Controller	21
Power meter	13

NOTE You may use other addresses with two provisions:

- Each device must have its own address.
- The address set on each device must match the one recognized by the analyzer (and displayed).

Peripheral addresses are often set with a rear panel switch. Refer to the manual of the peripheral to read or change its address.

If Using a Plotter or Printer

1. Ensure that the plotter or printer is set up correctly:
 - Power is on.
 - Pens and paper loaded.
 - Pinch wheels are down.
 - Some plotters need to have P1 and P2 positions set.
2. Press **Copy** and then **PLOT** or **PRINT MONOCHROME** .
 - If the result is a copy of the analyzer display, the printing/plotting features are functional in the analyzer. Continue with [“Troubleshooting Systems with Multiple Peripherals”](#) and [“Troubleshooting Systems with Controllers”](#) on page 4-12, or go to [“Step 4. Faulty Group Isolation”](#) on page 4-13.
 - If the result is not a copy of the analyzer display, refer to [Chapter 6](#) , [“Digital Control Troubleshooting.”](#)

If Using an External Disk Drive

1. Select the external disk drive. Press **Save/Recall** **SELECT DISK** **EXTERNAL DISK** .
2. Verify that the address is set correctly. Press **Local** **SET ADDRESSES** **ADDRESS:DISK** .
3. Ensure that the disk drive is set up correctly:
 - Power is on.
 - An initialized disk in the correct drive.
 - Correct disk unit number and volume number. (Press **Local** to access the softkeys that display the numbers; default is 0 for both.)
 - With hard disk (Winchester) drives, make sure the configuration switch is properly set (see drive manual).
4. Press **Start** **1** **G/n** **Save/Recall** **SAVE STATE** . Then press **Preset** **PRESET: FACTORY** **Preset** **SAVE/RECALL** **RECALL STATE** .
 - If the resultant trace starts at 1 GHz, the GPIB system is functional in the analyzer. Continue with [“Troubleshooting Systems with Multiple Peripherals”](#) and [“Troubleshooting Systems with Controllers”](#) on page 4-12, or go to [“Step 4. Faulty Group Isolation”](#) on page 4-13.
 - If the resultant trace does not start at 1 GHz, suspect the GPIB function of the analyzer. Refer to [Chapter 6](#) , [“Digital Control Troubleshooting.”](#)

Troubleshooting Systems with Multiple Peripherals

Connect any other system peripherals (but not a controller) to the analyzer one at a time and check their functionality. Any problems observed are in the peripherals, cables, or are address problems (see previous section).

Troubleshooting Systems with Controllers

Passing the preceding checks indicates that the analyzer's peripheral functions are normal. Therefore, if the analyzer has not been operating properly with an external controller, check the following:

- The GPIB interface hardware is incorrectly installed or not operational. (See the "Operating Concepts" chapter in the user's guide.)
- The programming syntax is incorrect. (Refer to your programmer's guide.)

If the analyzer appears to be operating unexpectedly but has not completely failed, go to ["Step 4. Faulty Group Isolation" on page 4-13](#).

Step 4. Faulty Group Isolation

The five functional groups are:

- Power Supplies
- Digital Control
- Source
- Receiver
- Accessories

Descriptions of these groups are provided in [Chapter 12](#), “Theory of Operation.”

IMPORTANT The checks in the following pages must be performed in the order presented. If one of the procedures fails, it is an indication that the problem is in the functional group checked. Go to the troubleshooting information for the indicated group to isolate the problem to the defective assembly.

Figure 4-2 Troubleshooting Organization

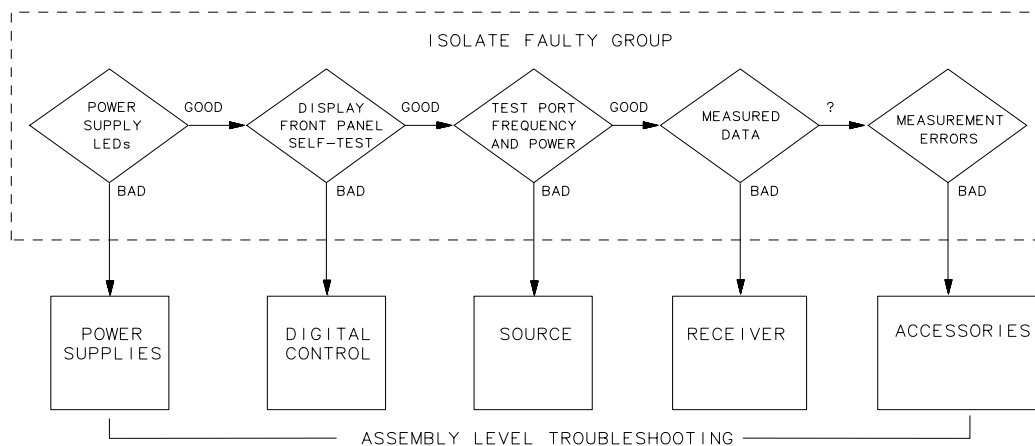

sg645d

Power Supply Check

Check the Rear Panel LEDs

Switch on the analyzer and look directly at the rear panel. Notice the condition of the two LEDs on the preregulator (A15). (See [Figure 4-3](#).)

- The upper (red) LED should be off.
- The lower (green) LED should be on.

Figure 4-3 A15 Preregulator LEDs

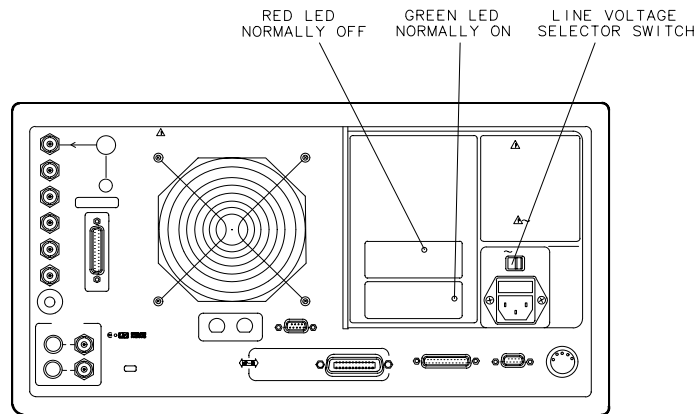

sb618d

Check the Post Regulator (A8) LEDs

Remove the analyzer's top cover. Switch on the power. Inspect the green LEDs along the top edge of the post-regulator (A8) assembly.

- All 9 green LEDs should be on.
- The fan should be audible.

In case of difficulty, refer to [Chapter 5](#), “Power Supply Troubleshooting.”

Digital Control Check

Observe the Power Up Sequence

Switch the analyzer power off, then on. The following should take place within a few seconds:

- On the front panel observe the following:
 1. All ten ES model and eight ET model amber LEDs illuminate.
 2. On the ES models, the TRANS REV and REFL REV LEDS near PORT 2 illuminate.
 3. The amber LEDs go off after a few seconds, except the Chan 1 LED. At the same moment, the TRANS REV and REFL REV LEDS near PORT 2 goes off.

NOTE On ET models, there is no TRANSMISSION LED on the front panel.

- The display should come up bright and focused.
- Five red LEDs on the A9 CPU board should illuminate and then turn off. They can be observed through a small opening in the rear panel.

Figure 4-4 Front-Panel Power Up Sequence for ET and ES Models

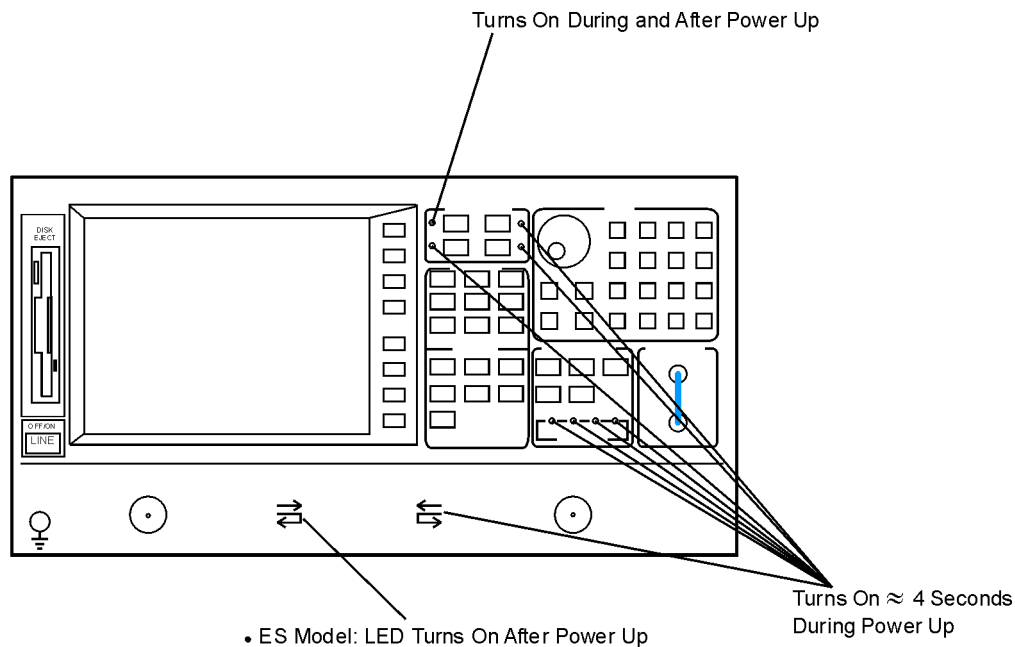

sb541e

Verify Internal Tests Passed

1. Press the following:

[Preset] **PRESET: FACTORY** **[Preset]**

[System] **SERVICE MENU** **TESTS**

INTERNAL TESTS **EXECUTE TEST**

The display should indicate:

TEST

0 ALL INT PASS

- If your display shows the above message, go to step 2. Otherwise, continue with this step.
 - If phase lock error messages are present, this test may stop without passing or failing. In this case, continue with [“Source Check” on page 4-17](#).
 - If you have unexpected results, or if the analyzer indicates a specific test failure, refer to [Chapter 5](#), [“Power Supply Troubleshooting.”](#) The analyzer reports the first failure detected.
 - If the analyzer indicates failure but does not identify the test, press **[Home]** to search for the failed test. Then refer to [Chapter 6](#), [“Digital Control Troubleshooting.”](#) Likewise, if the response to front panel or GPIB commands is unexpected, troubleshoot the digital control group.
2. Press **[19]** **[x1]** **EXECUTE TEST** to perform the Analog Bus test.
 - If this test fails, refer to [Chapter 6](#), [“Digital Control Troubleshooting.”](#)
 - If this test passes, continue with [“Source Check” on page 4-17](#).

Source Check

Phase Lock Error Messages

The following list contains all phase lock error messages and their descriptions.

- NO IF FOUND: CHECK R INPUT LEVEL

The first IF was not detected during the pretune stage of phase lock.

- NO PHASE LOCK: CHECK R INPUT LEVEL

The first IF was detected at the pretune stage but phase lock could not be acquired thereafter.

- PHASE LOCK LOST

Phase lock was acquired but then lost.

- PHASE LOCK CAL FAILED

An internal phase lock calibration routine is automatically executed at power-on, when pretune values drift, or when phase lock problems are detected. A problem aborted a calibration attempt.

- POSSIBLE FALSE LOCK

The analyzer is achieving phase lock but possibly on the wrong harmonic comb tooth.

- SWEEP TIME TOO FAST

The fractional-N and the digital IF circuits have lost synchronization.

The error messages listed above usually indicate a source failure or improper instrument configuration.

For ES Models, Check the R Channel

As a preliminary step, ensure that all option jumper cables are properly connected. To ensure that the R channel input is receiving at least -35 dBm power, perform the following steps:

1. Perform steps 1 and 2 of [“Source Pretune Correction Constants \(Test 43\)” on page 3-6](#). Make note of the DAC number that is displayed and then abort the procedure.
2. Press the following:
(System) SERVICE MENU SERVICE MODES
SRC ADJUST MENU DACNUM HIGH BAND
3. Enter the DAC number determined from step 1 and press **(x1)**.
4. Disconnect the front panel R CHANNEL jumper.
5. Zero and calibrate a power meter. Connect the power sensor to R CHANNEL OUT.
6. The power meter should read greater than -35 dBm.

Check Source Output Power

1. Zero and calibrate the power meter. Set the calibration factor to the 1 GHz value. (See the power meter manual for instructions on setting the calibration factor.)
2. Connect the equipment as shown in Figure 4-5.

Figure 4-5 Equipment Setup for Source Power Check

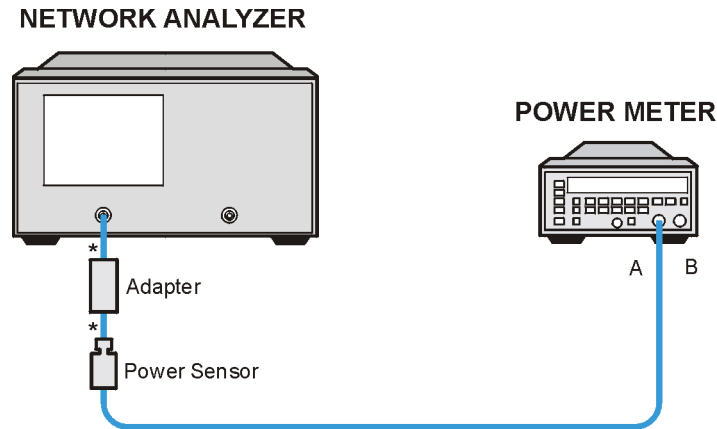

* Direct Connection

sb520e

3. Press **[Preset]** **PRESET: FACTORY** **[Preset]** on the analyzer to initialize the instrument.

Checking the Source Output Power for the 8719ET/ES and 8720ET/ES

1. To check power at 1 GHz, for the 8719ET/ES and 8720ET/ES, press the following:

[Power] **[0]** (**[5]** on ET models and the ES Option 007 models) **[x1]** **[Return]**
CW FREQ **[1]** **[G/n]**

The power should be within ± 2 dBm of the set value.

8719ET/ES Frequency Point Checks

2. To check power at 2, 5, 10, and 13.5 GHz, press **[Home]** and set the power meter to the corresponding calibration factor for that frequency. Repeat until the 13.5 GHz frequency is completed.

The power should be within ± 2 dBm of the set value for each frequency point.

8720ET/ES Frequency Point Checks

3. To check power at 2, 5, 10, and 20 GHz, press **[Home]** and set the power meter to the corresponding calibration factor for that frequency. Repeat until the 20.0 GHz frequency is completed.

The power should be within ± 2 dBm of the set value for each frequency point.

Checking the Power for PORT 2 (ES Models)

4. Press **Meas** **Refl: REV S22 (B/R)** and connect the power sensor to PORT 2. Repeat steps 1 through 3 for PORT 2. If the power is not within specification at either port, go to [Chapter 7](#), “Source Troubleshooting.”

Checking the Source Output Power for the 8722ET/ES

1. To check power at 1 GHz, for the 8722ET/ES, press the following:

Power **-10** (**-5** on ET models and the ES Option 007 models) **x1** **Return**
CW FREQ **1** **G/n**

The power should be within ± 3 dBm of the set value.

2. To check power at 2, 5, 10, 20, and 40 GHz, press **Home** and set the power meter to the corresponding calibration factor for that frequency. Repeat until the 40.0 GHz frequency is completed.

The power should be within ± 3 dBm of the set value for each frequency point.

Checking the Power for PORT 2 (ES Models)

3. Press **Meas** **Refl: REV S22 (B/R)** and connect the power sensor to PORT 2. Repeat steps 1 and 2 for PORT 2. If the power is not within specification at either port, continue troubleshooting by going to [Chapter 7](#), “Source Troubleshooting.”

No Oscilloscope or Power Meter? Try the ABUS

Monitor ABUS node 9.

Press the following:

Pres **PRESET: FACTORY** **Pres**

Syst **SERVICE MENU** **ANALOG BUS ON**

Meas **ANALOG IN Aux Input** **9** **x1**

Scale Ref **AUTOSCALE**

The display should resemble the [Figure 4-6](#). If any of the above procedures provide unexpected results, or if error messages are present, refer to [Chapter 7](#), “Source Troubleshooting.”

Figure 4-6 0.25 V/GHz Waveform at Abus Node 9

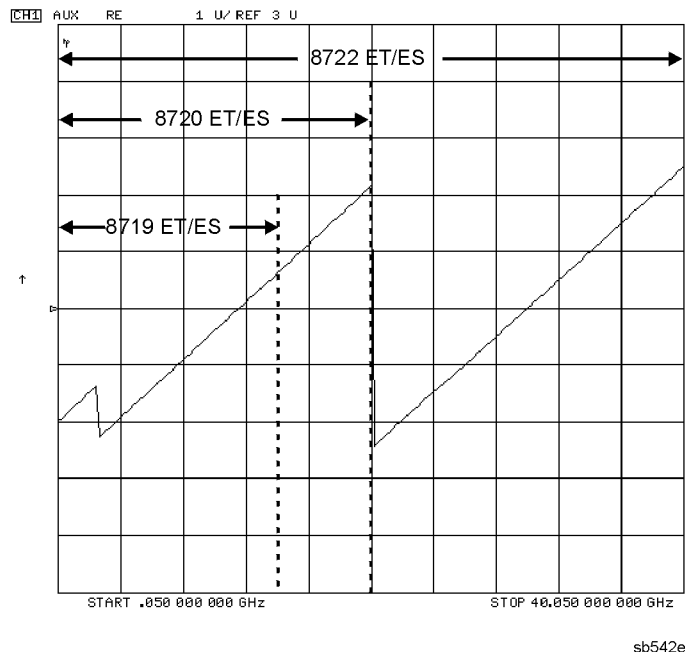

Receiver Check

Check the frequency response for the R, A, and B channels of the analyzer. If any input shows unexpected results, go to [Chapter 8](#), “Receiver Troubleshooting.”

Table 4-3 Frequency Response (Characteristic)

Model Type	Channel	Frequency Band	Frequency Response (Characteristic)	
ES	R	0.05 – 20.05 GHz	±1.5 dB	
		20.05 – 32.00 GHz	±2.5 dB	
		32.00 – 40.05 GHz	+2.5 dB, –6.0 dB	
	A and B	0.05 – 500 GHz	+2.5 dB, –28 dB	
		0.5 – 20.05 GHz	±2.5 dB	
		20.05 – 32.00 GHz	±3.0 dB	
		32.00 – 40.05 GHz	+3.0 dB, –6.0 dB	
	ET	R	0.05 – 20.05 GHz	±1.5 dB
			20.05 – 32.00 GHz	±2.5 dB
			32.00 – 40.05 GHz	+2.5 dB, –6.0 dB
B		0.05 – 20.05 GHz	±2.5 dB	
		20.05 – 32.00 GHz	±3.0 dB	
		32.00 – 40.05 GHz	+3.0 dB, –6.0 dB	

Checking the R Channel Output (ET and ES Models)

1. Connect the equipment as shown in [Figure 4-5](#).

Figure 4-7 Setup for the R Channel Receiver Check (ES and ET Models)

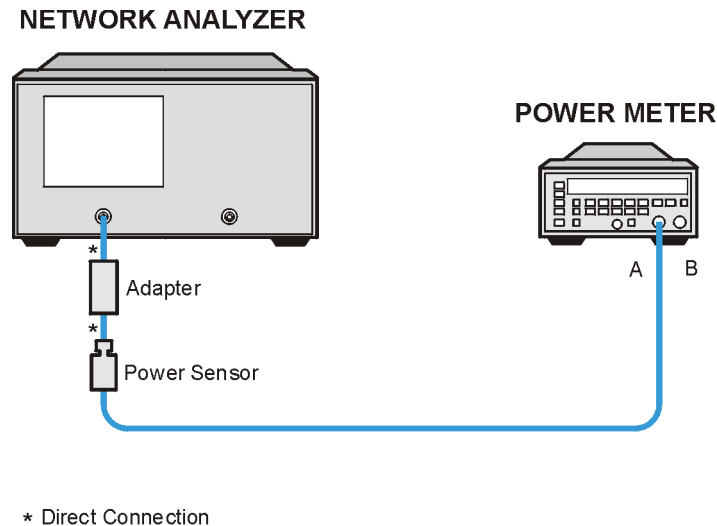

sb520e

2. Zero and calibrate the power meter. Set the calibration factor to the 1 GHz value. (See the power meter manual for instructions on setting the calibration factor.)
3. Press the following:
Presets **PRESET: FACTORY** **Presets**
4. Press the following:
Meas **INPUTPORTS** **R**
Sweep Setup **CW FREQ** **Marker**
5. Calculate the difference between the power meter reading and the marker reading on the analyzer display. This power difference is the frequency response of the R channel.
6. Repeat steps 4 and 5 at the frequency points where a problem is suspected or check different frequency points across the band (set the calibration factor on the power meter for each frequency measured). For the characteristic values of the frequency response, see [Table 4-3 on page 4-21](#).

Checking the A Channel Output (ES Models)

7. Connect the equipment as shown in [Figure 4-8](#).

Figure 4-8 Setup for the A Channel Receiver Check (ET and ES Models)

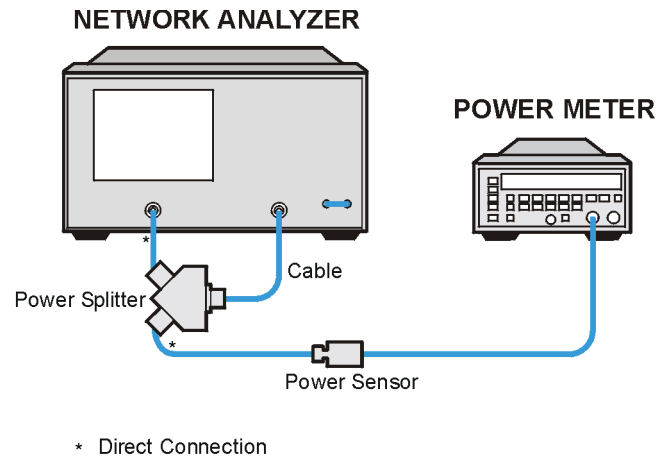

sb546e

8. Zero and calibrate the power meter.

9. Press the following:

Meas **INPUTPORTS** **A** **TESTPORT 2**

10. Press the following:

Sweep Setup **CW FREQ** **Marker**

11. Calculate the difference between the power meter reading and the marker reading on the analyzer display. This power difference is the frequency response of the A channel.

12. Repeat steps 10 and 11 at the frequency points where a problem is suspected or check different frequency points across the band (set the calibration factor on the power meter for each frequency measured). For the characteristic values of the frequency response, see [Table 4-3 on page 4-21](#).

Checking the B Channel Output (ET and ES Models)

13. Connect the equipment as shown in [Figure 4-9](#).

Figure 4-9 Setup for the B Channel Receiver Check (ES Models)

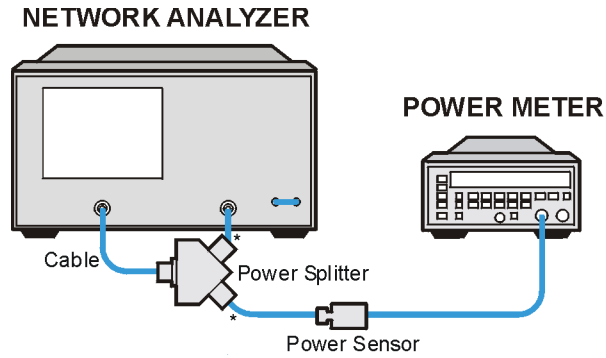

* Direct Connection

sb547e

14. Zero and calibrate the power meter.

15. Press the following:

Meas **INPUTPORTS** **B** **TESTPORT 1**

16. Press the following:

Sweep Setup **CW FREQ** **Marker**

17. Calculate the difference between the power meter reading and the marker reading on the analyzer display. This power difference is the frequency response of the B channel.

18. Repeat steps 16 and 17 at the frequency points where a problem is suspected or check different frequency points across the band (set the calibration factor on the power meter for each frequency measured). For the characteristic values of the frequency response, see [Table 4-3 on page 4-21](#).

In Case of Difficulty

- Make sure the power meter and power sensor are operating correctly.
- Enter the exact power meter calibration factor for the frequencies that are failing. Refer to the power meter user's guide.
- Measure the RF power splitter tracking and the cable loss. Account for these losses in the frequency response calculations.

Switch Repeatability Check (ES Models)

Calibration does not compensate for the repeatability of the transfer switch in instruments. As a result, the switch can be a source of error. To check the switch, use the following procedure:

1. To set the analyzer bandwidth to 100 Hz and to take 16 averages, press the following:

Presets **PRESET: FACTORY** **Presets**
Avg **IF BW** **100** **x1**
AVERAGING FACTOR **16** **x1** **AVERAGING ON**

2. To access the response calibration menu, press **Cal** **CALIBRATE MENU** **RESPONSE**.
3. Connect a short to PORT 1 and press **SHORT**.
4. To display data/memory and scale the trace, press **Display** **DATA→MEM** **DATA/MEM** **Scale Ref** **.05** **x1**.
5. Press **Meas** and then repeatedly (6 to 12 times) press **Ref1: REV S22 (B/R)** **Ref1: FWD S11 (A/R)** to switch the transfer switch back and forth. Return to the S11 measurement condition. After 16 averages, the trace should look similar to [Figure 4-10](#).

Figure 4-10 Typical Switch Repeatability Trace

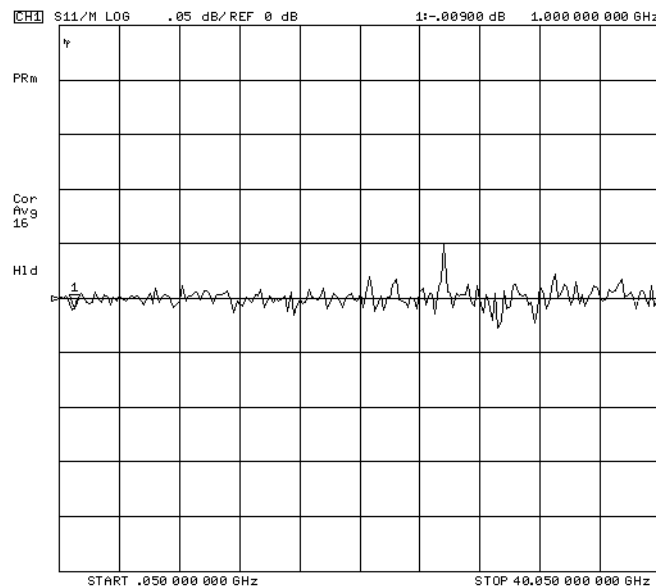

6. Press **Meas** **Ref1: REV S22 (B/R)**.
7. Connect a short to PORT 2 and repeat steps 2, 4 and 5.

Accessories Check

If the analyzer has passed all of the above checks but is still making incorrect measurements, suspect the system accessories. Accessories such as RF or interconnect cables, calibration or verification kit devices, and adapters can all induce system problems.

Reconfigure the system as it is normally used and reconfirm the problem. Continue with [Chapter 9](#) , “[Accessories Troubleshooting](#).”

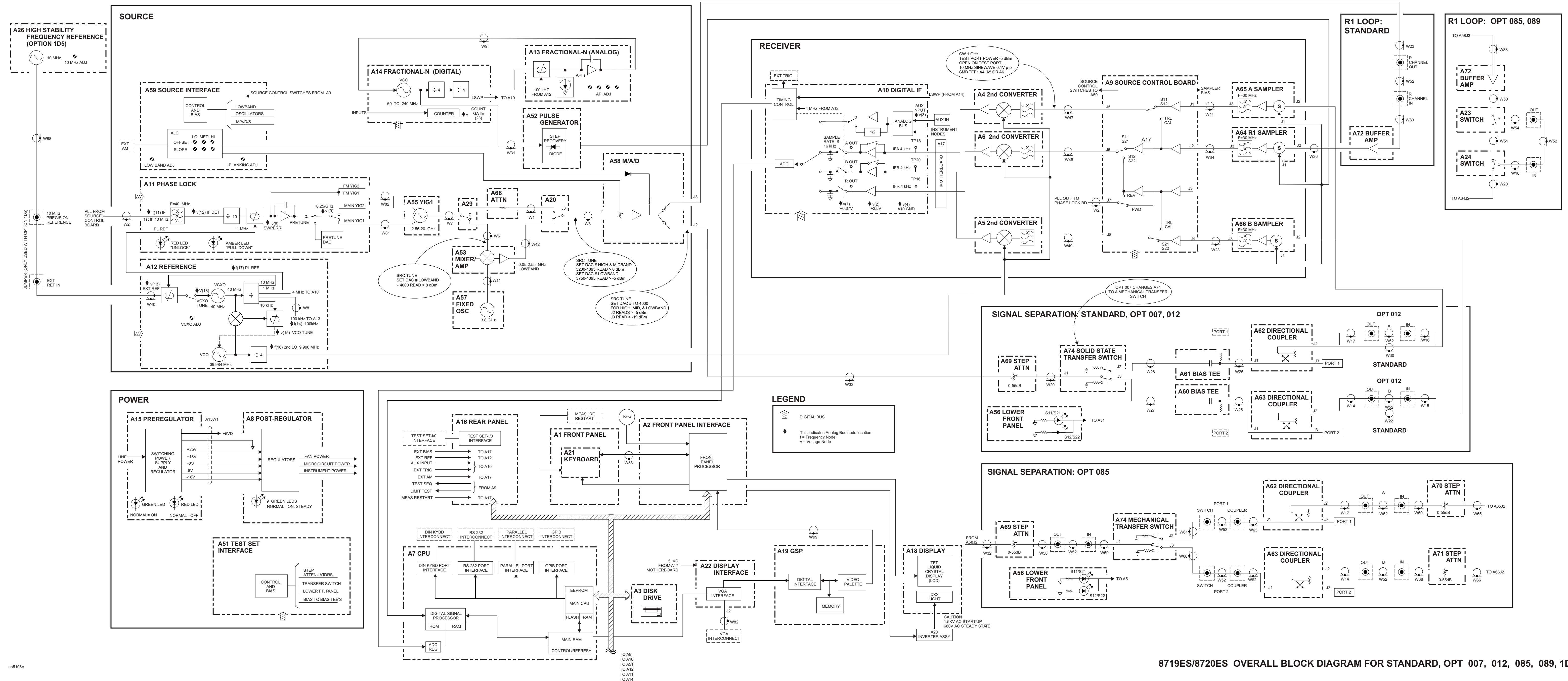

8719ES/8720ES OVERALL BLOCK DIAGRAM FOR OPT 400, 012, 089, 1D5

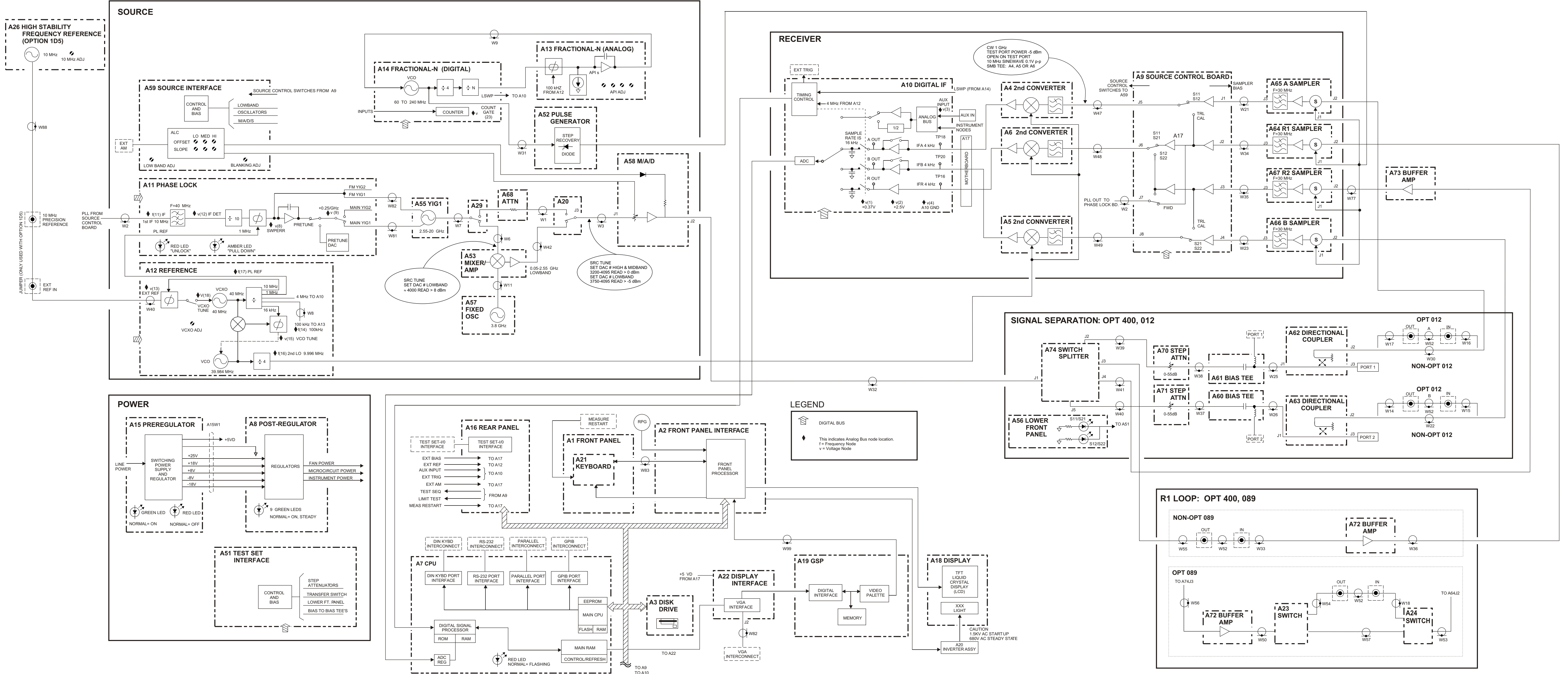

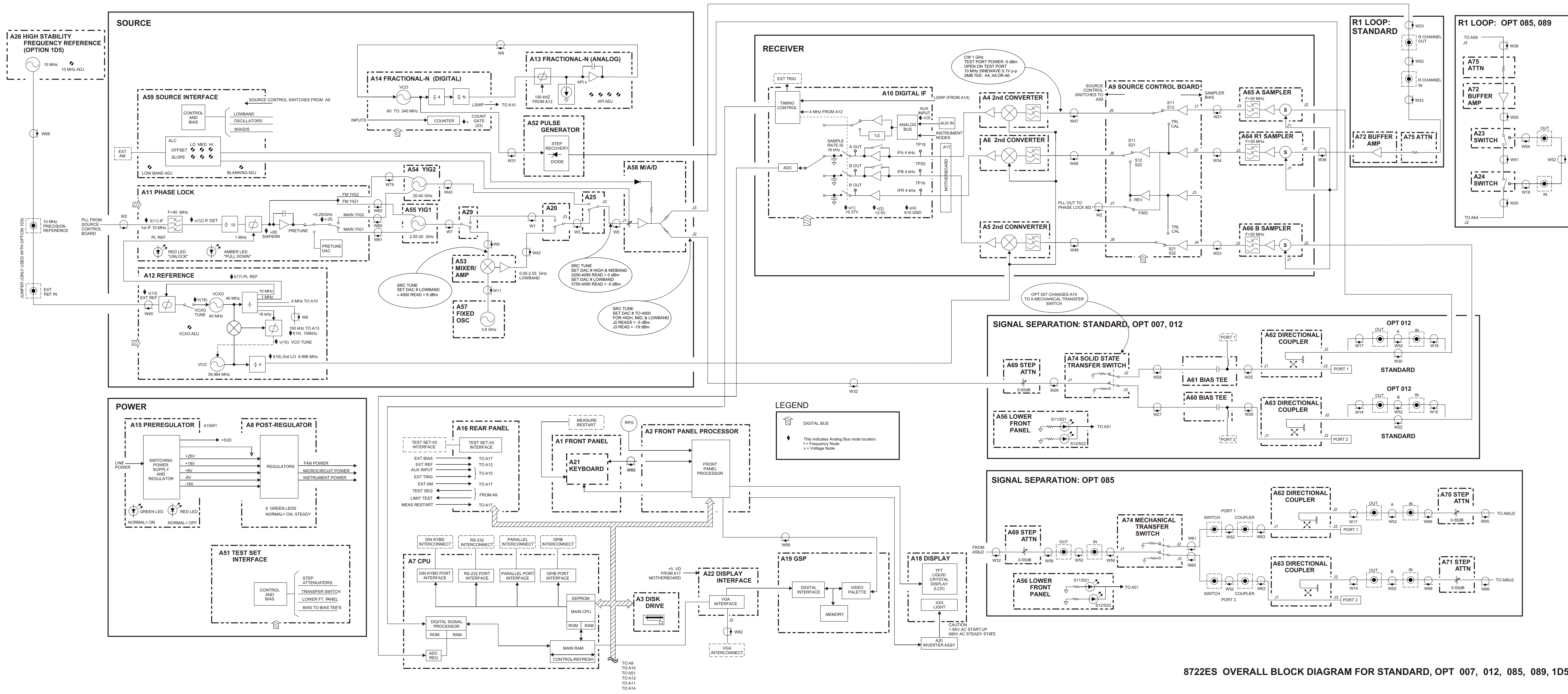

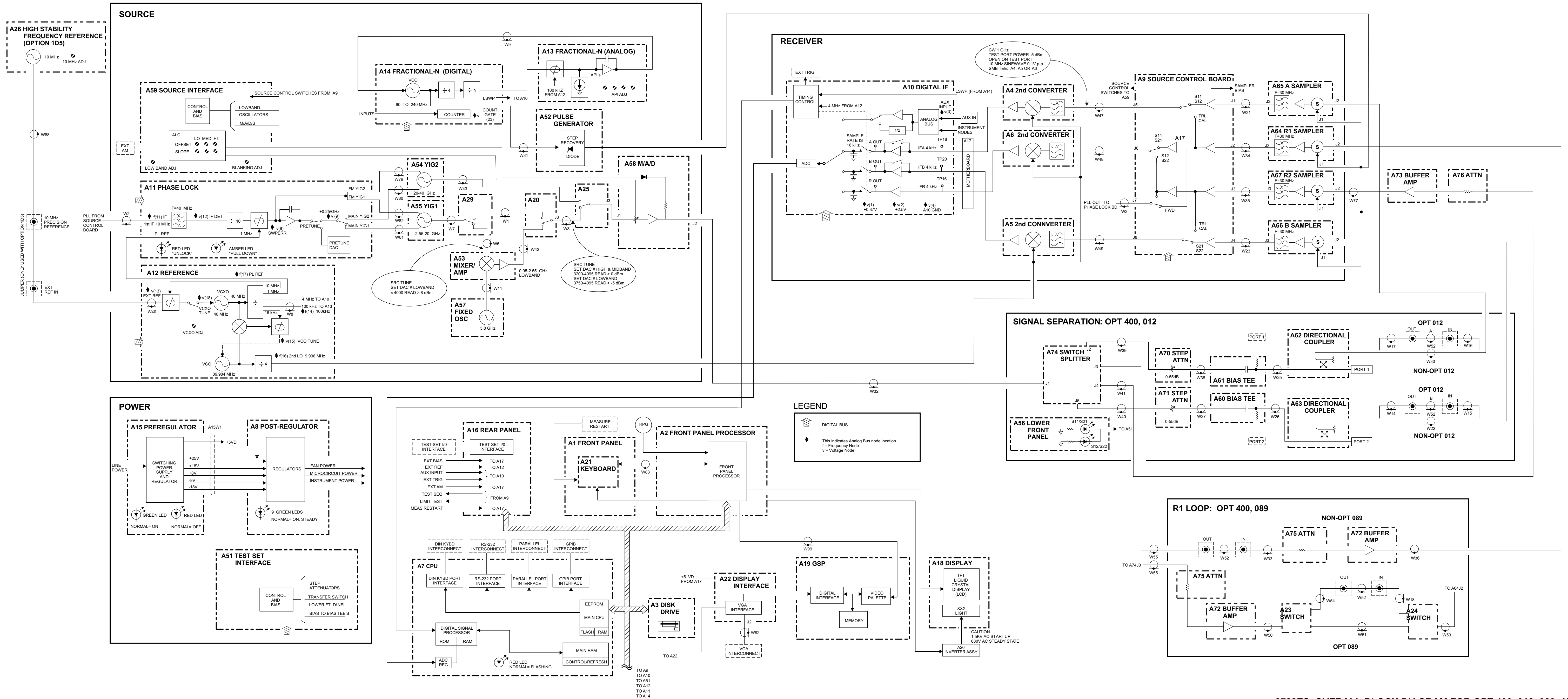

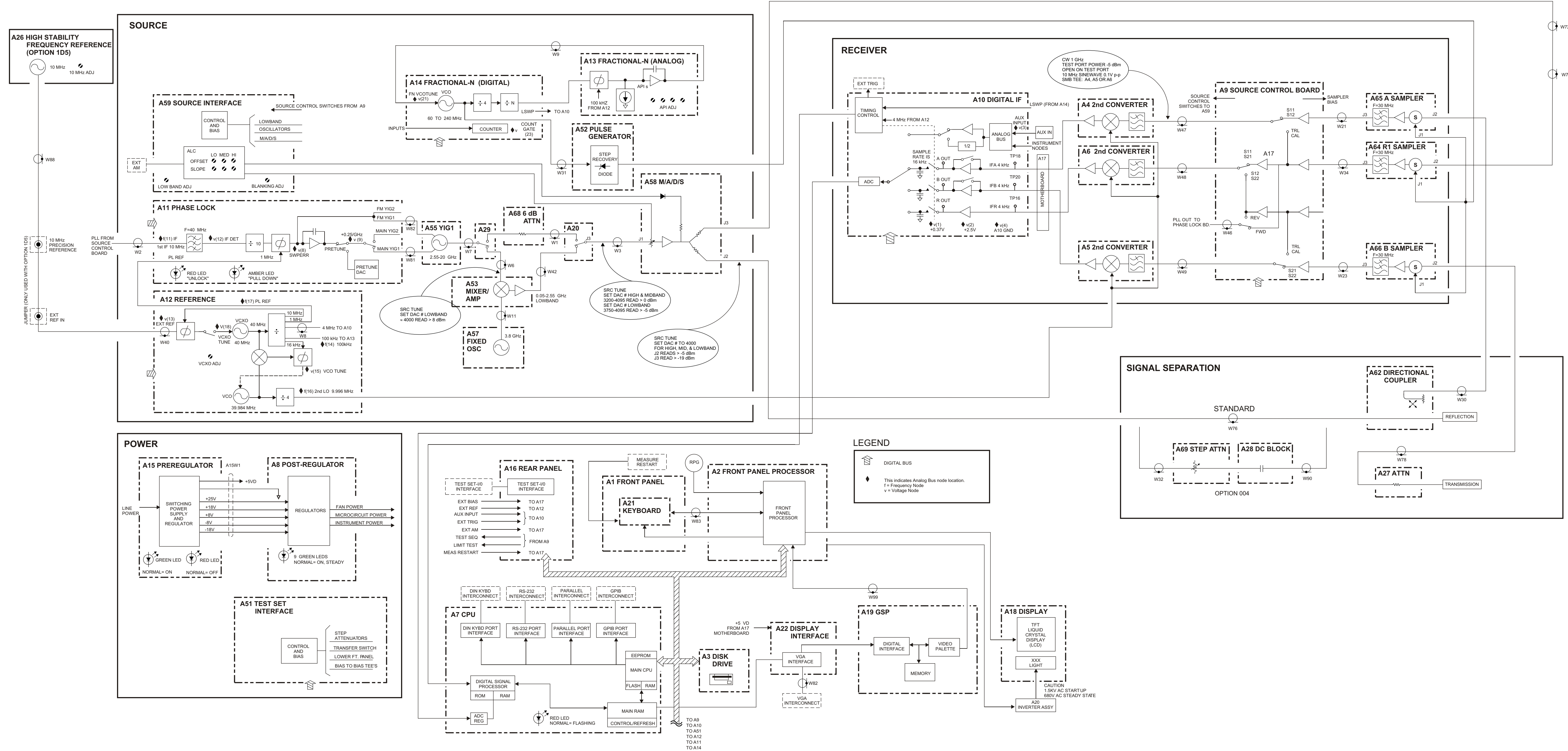

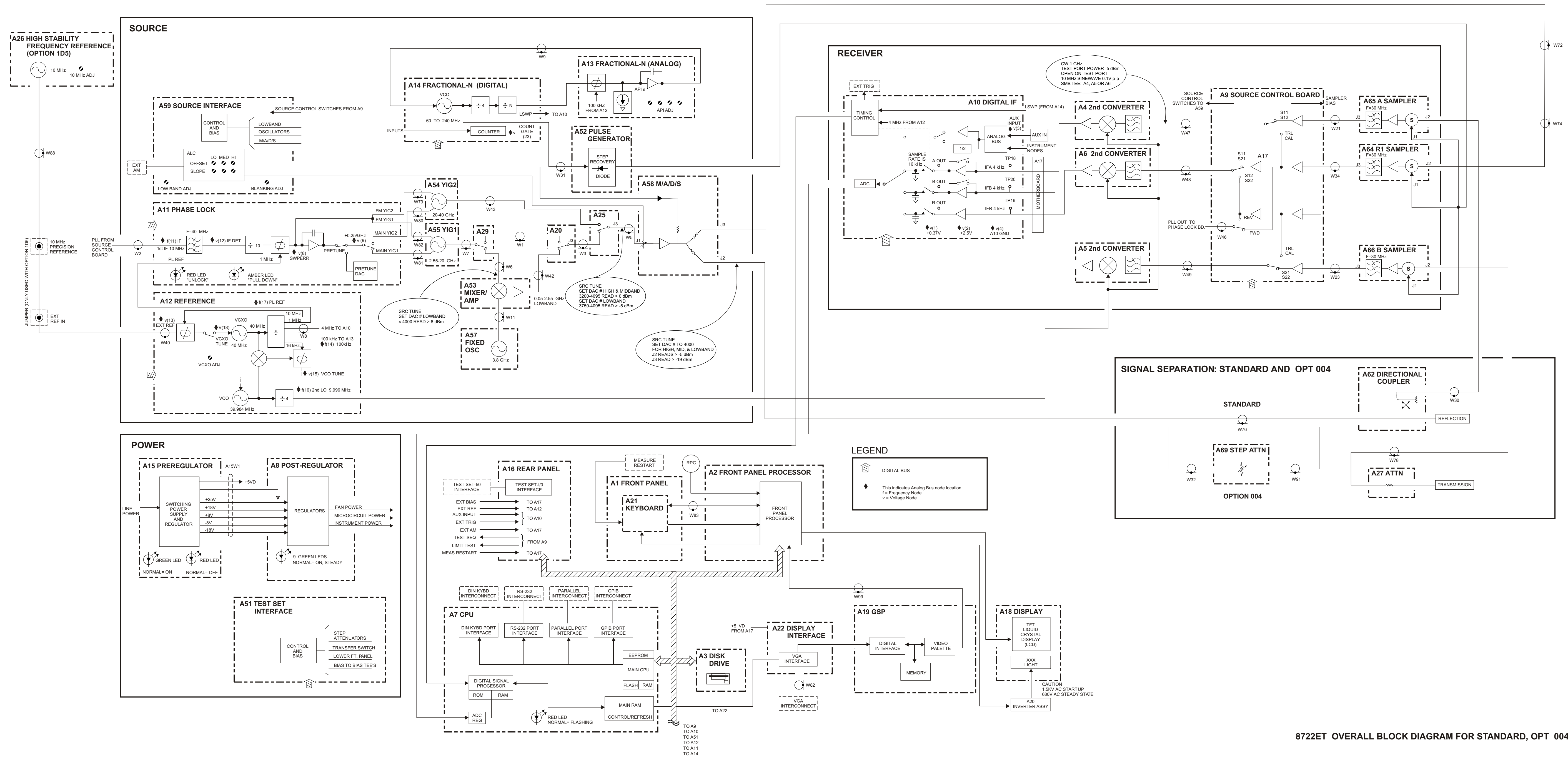

5 Power Supply Troubleshooting

Information on This Chapter

Use this procedure only if you have read [Chapter 4](#) , “[Start Troubleshooting Here](#).” Follow the procedures in the order given, unless:

- An error message appears on the display; refer to “[Error Messages](#)” on page 5-17.
- The fan is not working; refer to “[Fan Troubleshooting](#)” on page 5-18.

The power supply group assemblies consist of the following:

- Post regulator (A8)
- Preregulator (A15)

Power Supply Troubleshooting Flowchart

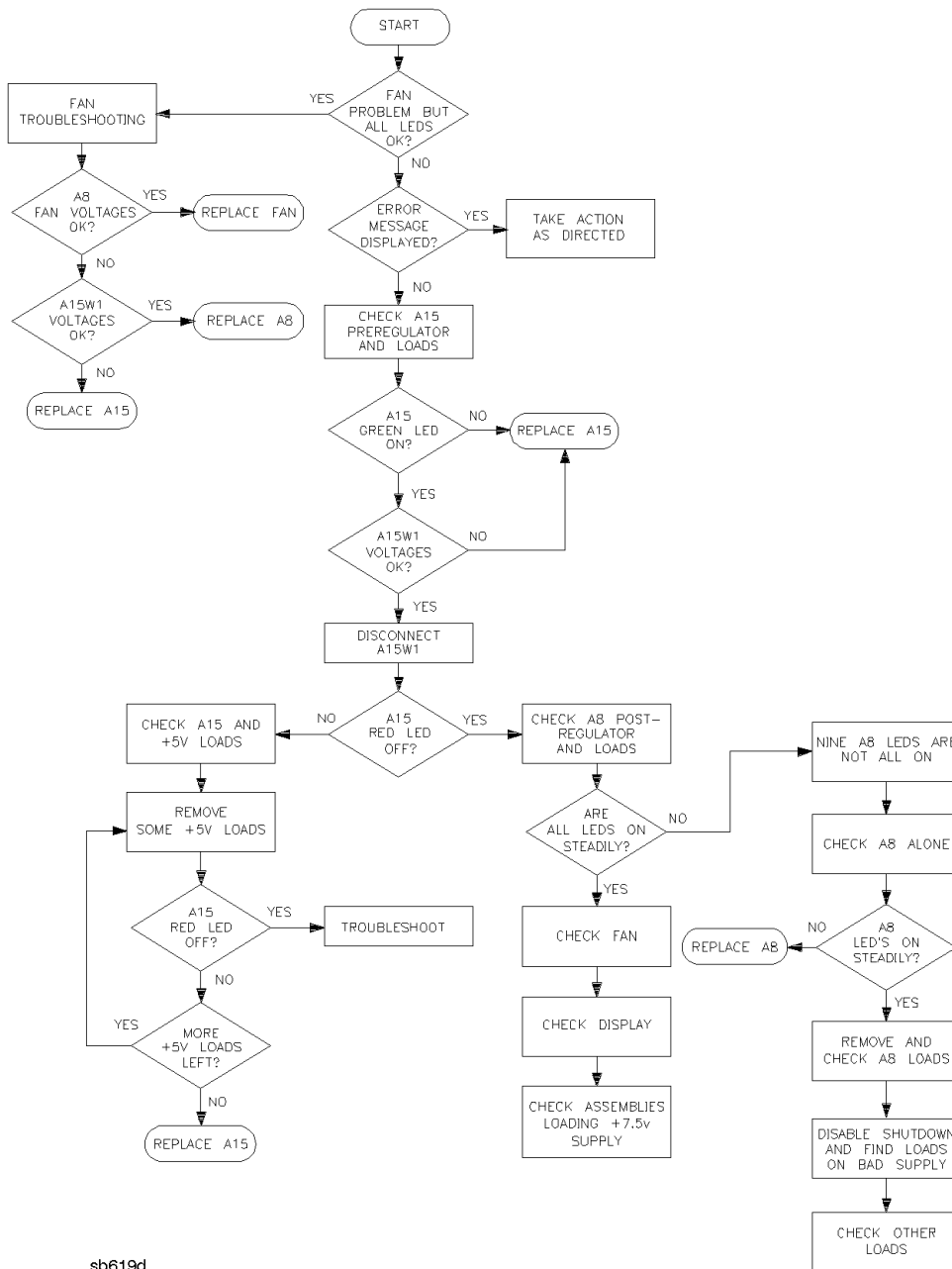

sb619d

Assembly Replacement Sequence

The following steps show the sequence to replace an assembly in the network analyzer.

- Step 1.** Identify the faulty group. Begin with [Chapter 4](#) , “[Start Troubleshooting Here.](#)” Follow up with the appropriate troubleshooting chapter that identifies the faulty assembly.
- Step 2.** Order a replacement assembly. Refer to [Chapter 13](#) , “[Replaceable Parts.](#)”
- Step 3.** Replace the faulty assembly and determine what adjustments are necessary. Refer to [Chapter 14](#) , “[Assembly Replacement and Post-Repair Procedures.](#)”
- Step 4.** Perform the necessary adjustments. Refer to [Chapter 3](#) , “[Adjustments and Correction Constants.](#)”
- Step 5.** Perform the necessary performance tests. Refer to [Chapter 2](#) , “[System Verification and Performance Tests.](#)”

Simplified Block Diagram of Power Supply Group

Figure 5-1 shows the power supply group in simplified block diagram form. Refer to the detailed block diagram of the power supply located at the end of this chapter to see voltage lines and specific connector pin numbers.

Figure 5-1 Power Supply Group Simplified Block Diagram

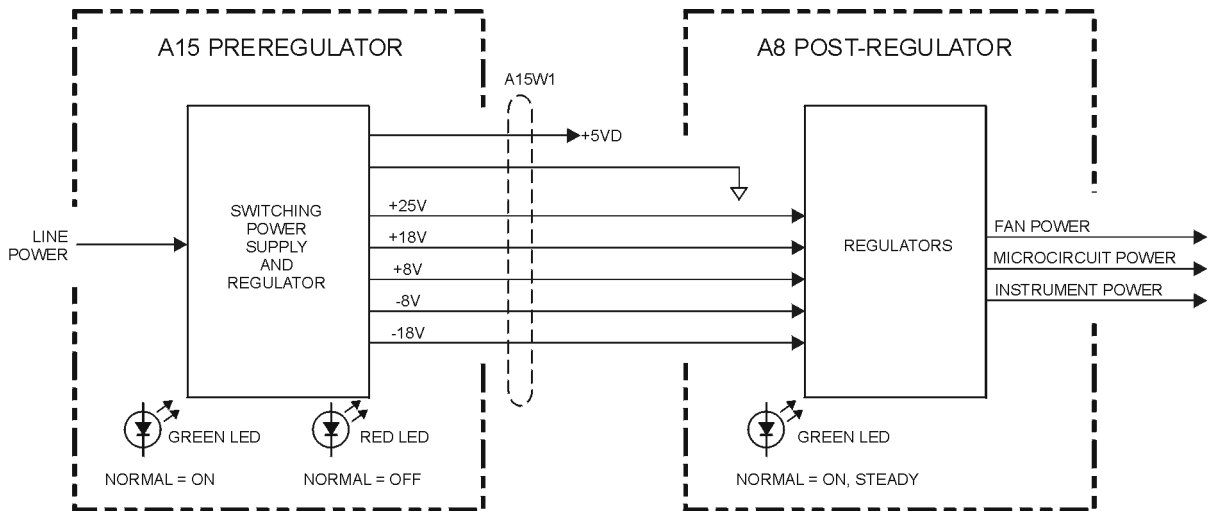

sb533e

Start Here

Check the Green LED and Red LED on the Preregulator (A15)

Switch on the analyzer and look at the rear panel of the analyzer. Check the two power supply diagnostic LEDs on the preregulator (A15) casting by looking through the holes located to the left of the line voltage selector switch (see [Figure 5-2](#)).

During normal operation, the bottom (green) LED is on and the top (red) LED is off. If these LEDs are normal, then A15 is 95% verified. Proceed to the next section [“Check the Green LEDs on the Post Regulator \(A8\).”](#)

- If the green LED is not on steadily, refer to [“If the Green LED of the Preregulator \(A15\) Is Off or Blinking”](#) on page 5-8.
- If the red LED is on or flashing, refer to [“If the Red LED of the Preregulator \(A15\) Is On”](#) on page 5-9.

Figure 5-2 Location of the Preregulator (A15) Diagnostic LEDs

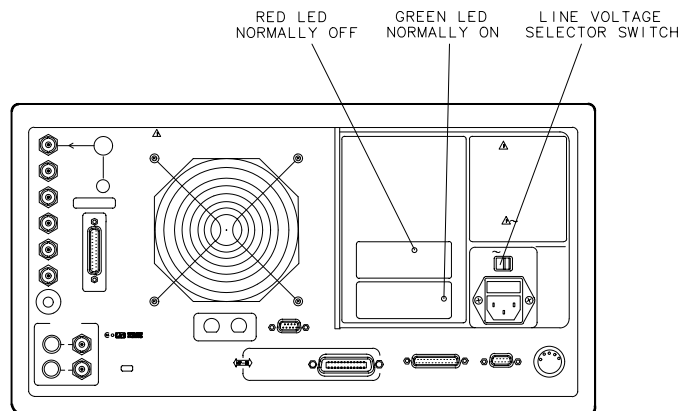

sb618d

Check the Green LEDs on the Post Regulator (A8)

Remove the top cover of the analyzer and locate the post regulator (A8); use the location diagram under the top cover if necessary. Check to see if the green LEDs on the top edge of A8 are all on. There are nine green LEDs (one is not visible without removing the PC board stabilizer).

- If all of the green LEDs on the top edge of A8 are on, there is a 95% confidence level that the power supply is verified. To confirm the last 5% uncertainty of the power supply, continue to the next section [“Measure the Post Regulator \(A8\) Voltages.”](#)
- If any LED on A8 is off or flashing, refer to [“If the Green LEDs of the Post Regulator \(A8\) Are Not All ON”](#) on page 5-13.

Measure the Post Regulator (A8) Voltages

Measure the DC voltages on the test points of A8 with a voltmeter. Refer to [Figure 5-3](#) for test point locations, and [Table 5-1](#) for supply voltages and limits.

Figure 5-3 Post Regulator (A8) Test Point Locations

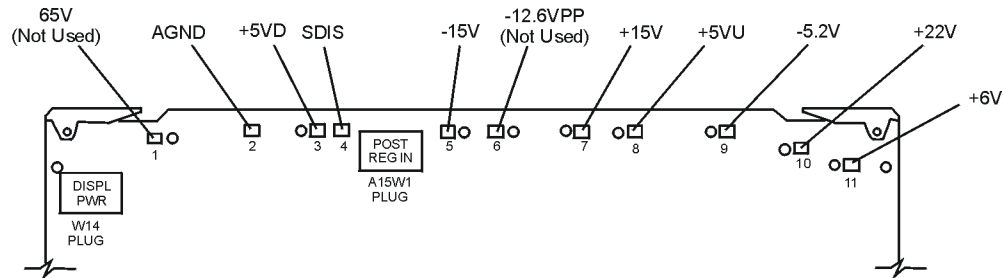

sb544e

Table 5-1 Post Regulator (A8) Test Point Voltages

TP	Supply	Range
1	+65 V (Not Used)	+64.6 to +65.4
2	AGND	n/a
3	+5 VD	+4.9 to +5.3
4	SDIS	n/a
5	-15 V	-14.4 to -15.6
6	-12.6 PP (Not Used)	-12.1 to -12.8
7	+15 V	+14.5 to +15.5
8	+5 VU	+5.05 to +5.35
9	-5.2 V	-5.0 to -5.4
10	+22V	+21.3 to +22.7
11	+6 V	+5.8 to +6.2

If the Green LED of the Preregulator (A15) Is Off or Blinking

If the green LED is not on steadily, the line voltage is not enough to power the analyzer.

Check the Line Voltage, Selector Switch, and Fuse

Check the main power line cord, line fuse, line selector switch setting, and actual line voltage to see that they are all correct. [Figure 5-4](#) shows how to remove the line fuse, using a small flat-blade screwdriver to pry open the fuse holder. [Figure 5-2](#) shows the location of the line voltage selector switch. Use a small flat-blade screwdriver to select the correct switch position.

NOTE Refer to [“Hardware, Preregulator”](#) on page 13-83 for the correct line fuse description and part number.

If the A15 green LED is still not on steadily, replace A15.

Figure 5-4 Removing the Line Fuse

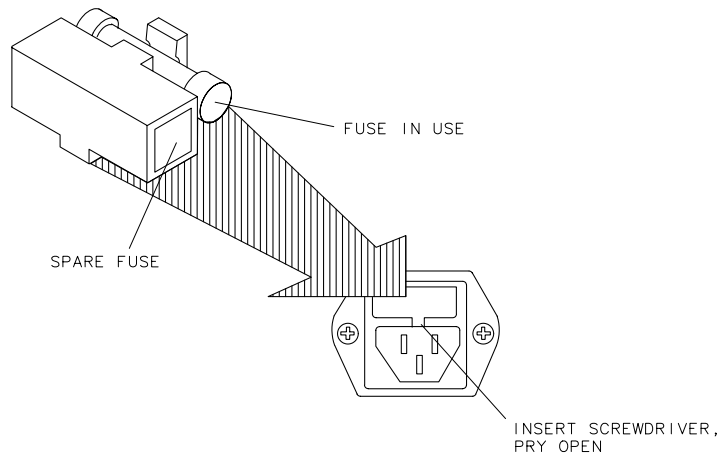

qq652d

If the Red LED of the Preregulator (A15) Is On

If the red LED is on or flashing, the power supply is shutting down. Use the following procedures to determine which assembly is causing the problem.

Check the Post Regulator (A8)

1. Switch off the analyzer.
2. Disconnect the cable (A15W1) from A8. (See [Figure 5-5](#).)
3. Switch on the analyzer and observe the red LED on A15.
 - If the red LED goes out, the problem is probably A8. To first verify that the inputs to A8 are correct, continue to [“Verify the Preregulator \(A15\)”](#) on page 5-10.
 - If the red LED is still on, the problem is probably A15, or one of the assemblies obtaining power from it. Go to [“Check for a Faulty Assembly”](#) on page 5-11.

Figure 5-5 Power Supply Cable Locations

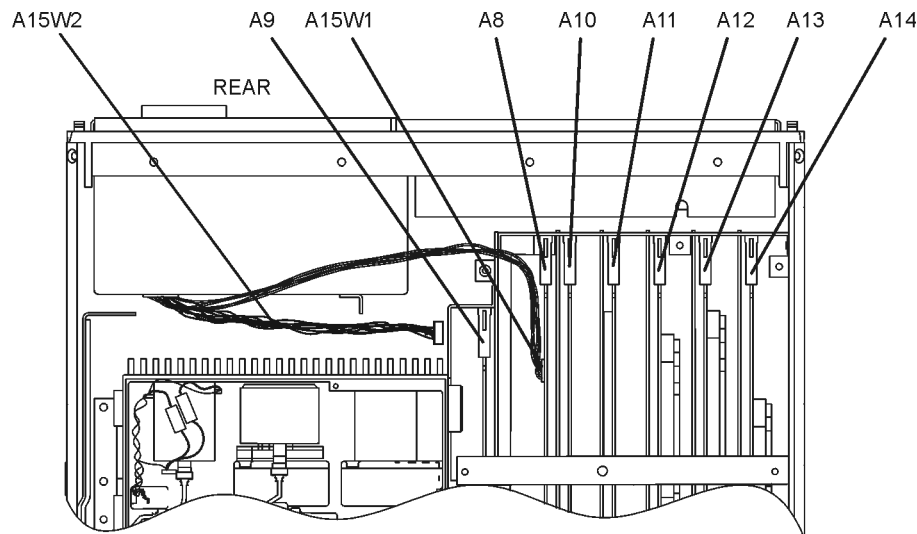

sb592e

Verify the Preregulator (A15)

Verify that the preregulator (A15) is supplying the correct voltages to the post regulator (A8). Use a voltmeter with a small probe to measure the output voltages of A15W1's plug. Refer to [Table 5-2](#) and [Figure 5-6](#).

- If the voltages are not within tolerance, replace A15.
- If the voltages are within tolerance, A15 is verified. Go to [“Check for a Faulty Assembly” on page 5-11](#).

Table 5-2 Output Voltages

Pin	A15W1P1 (Disconnected) Voltages	A8J2 (Connected) Voltages	A15 Preregulator Mnemonic
1	N/C	N/C	N/C
2	+100 to +125	+100 to +125	(not used)
3,4	+22.4 to +33.6	+17.0 to +18.4	+18 V
5,6	-22.4 to -33.6	-17.0 to -18.4	-18 V
7	N/C	+7.4 to +8.0	N/C
8	+9.4 to +14	+7.4 to +8.0	+8 V
9,10	-9.4 to -14	-6.7 to -7.3	-8 V
11	+32 to +48	+24.6 to +26.6	+25 V
12	N/C	+24.6 to +26.6	N/C

NOTE: The +5 VD supply must be loaded by one or more assemblies at all times, or the other voltages will not be correct. It connects to the motherboard connector A17J3 Pin 4.

Figure 5-6 A15W1 Plug Detail

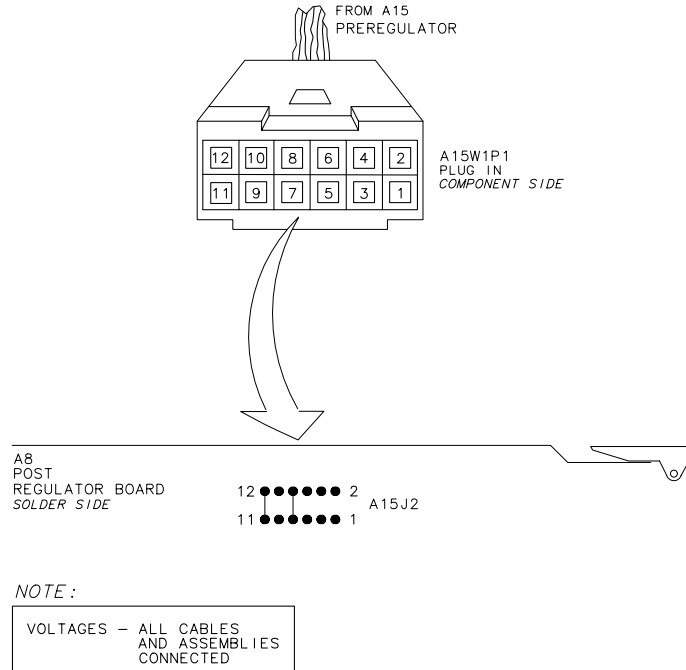

sb6130d

Check for a Faulty Assembly

This procedure checks for a faulty assembly that might be shutting down the preregulator (A15) via one of the following lines (refer to [Figure 5-1](#)).

- A15W1 connecting to the post regulator (A8)
- the +5VCPU line through the motherboard
- the +5VDIG line through the motherboard

Do the following:

1. Switch off the analyzer.
2. Ensure that A15W1 is reconnected to A8 (refer to [Figure 5-5](#)).

NOTE *Always switch off the analyzer before removing or disconnecting assemblies.*

To identify specific cables and assemblies that are not shown in this chapter, refer to [Chapter 13](#), “Replaceable Parts.”

When extensive disassembly is required, refer to [Chapter 14](#), “Assembly Replacement and Post-Repair Procedures.”

3. Remove or disconnect the assemblies listed in [Table 5-3](#) one at a time and in the order shown. The assemblies are sorted from most to least accessible. [Table 5-3](#) also lists any associated assemblies that receive power from the assembly that is being removed. After each assembly is removed or disconnected, switch on the analyzer and observe the red LED on the preregulator (A15).
 - If the red LED goes out, then the particular assembly removed (or the one receiving power from it) is faulty.
 - If the red LED is still on after you have checked all of the assemblies listed in [Table 5-3](#), continue with the next section [“Check the Operating Temperature.”](#)

Table 5-3 Recommended Order for Removal/Disconnection for Troubleshooting the Preregulator (A15) Assembly

Assembly to Remove	Removal or Disconnection Method	Other Assemblies that Receive Power from the Removed Assembly
1. Frac N Digital (A14)	Remove from Card Cage	None
2. Test Set Interface (A51)	Disconnect W89	Transfer Switch (S4) LED Front Panel (A56)
3. CPU (A7)	Disconnect W91 from A7	Disk Drive (A3)
4. Display Interface (A22)	Disconnect W37	Display (A18)
5. Front Panel Interface (A2)	Disconnect W83 from A2	Front Panel Keyboard (A1)

Check the Operating Temperature

The temperature sensing circuitry inside the preregulator (A15) may be shutting down the supply. Make sure the temperature of the open air operating environment does not exceed 55 °C (131 °F), and that the analyzer fan is operating.

- If the fan does not seem to be operating correctly, go to [“Fan Troubleshooting” on page 5-18.](#)
- If there does not appear to be a temperature problem, it is likely that A15 is faulty.

Inspect the Motherboard

If the red LED is still on after replacement or repair of the preregulator (A15), switch off the analyzer and inspect the motherboard for solder bridges, and other noticeable defects. Use an ohmmeter to check for shorts. The +5VD, +5VCPU, or +5VDSense lines may be bad. Refer to the block diagram at the end of this chapter and troubleshoot these suspected power supply lines on the motherboard (A17).

If the Green LEDs of the Post Regulator (A8) Are Not All ON

The green LEDs along the top edge of the post regulator (A8) are normally on.

Flashing LEDs on A8 indicate that the shutdown circuitry on it is protecting power supplies from overcurrent conditions by repeatedly shutting them down. This may be caused by supply loading on A8 or on any other assembly in the analyzer.

Maintain A15W1 Cable Connection

1. Switch off the analyzer.
2. Remove A8 from its motherboard connector, but keep the A15W1 cable connected to it.
3. Short A8TP2 (AGND) (see [Figure 5-3](#)) to chassis ground with a clip lead.
4. Switch on the analyzer and observe the green LEDs on the A8.
 - If any green LEDs other than +5VD are still off or flashing, continue with the next section “[Check the Post Regulator \(A8\) Fuses and Voltages.](#)”
 - If all LEDs are now steadily lit except for the +5VD LED, the preregulator (A15) and post regulator (A8) are working properly and the trouble is excessive loading somewhere after the motherboard connections at A8. Go to “[Remove the Assemblies](#)” on page 5-14.

Check the Post Regulator (A8) Fuses and Voltages

Check the fuses along the top edge of the Post Regulator (A8). If any A8 fuse has burned out, replace it. If it burns out again when power is applied to the analyzer, A8 or A15 is faulty. Determine which assembly has failed as follows.

1. Remove the A15W1 cable at A8. (See [Figure 5-5](#).)
2. Measure the voltages at A15W1P1 (see [Figure 5-6](#)) with a voltmeter having a small probe.
3. Compare the measured voltages with those in [Table 5-2](#).
 - If the voltages are within tolerance, replace A8.
 - If the voltages are not within tolerance, replace A15.

If the green LEDs are now on, the preregulator (A15) and post regulator (A8) are working properly and the trouble is excessive loading somewhere after the motherboard connections at A8. Continue with the next section “[Remove the Assemblies.](#)”

Remove the Assemblies

1. Switch off the analyzer.
2. Install A8. Remove the jumper from A8TP2 (AGND) to chassis ground.
3. Remove or disconnect all the assemblies listed below (see [Figure 5-5 on page 5-9](#)).
Always switch off the analyzer before removing or disconnecting an assembly.
 - Digital IF (A10)
 - Phase lock (A11)
 - Reference (A12)
 - Fractional-N analog (A13)
 - Fractional-N digital (A14)
 - GSP Interface (A22) (disconnect A17W2)
4. Switch on the analyzer and observe the green LEDs on A8.
 - If any of the green LEDs are off or flashing, it is not likely that any of the assemblies listed above are causing the problem. Go to [“Briefly Disable the Shutdown Circuitry” on page 5-15](#).
 - If all green LEDs are now on, one or more of the above assemblies may be faulty. Continue with the next step.
5. Switch off the analyzer.
6. Reconnect cable A17W2.
7. Switch on the analyzer and observe the LEDs.
 - If the LEDs are off or blinking, replace the A19 GSP assembly.
 - If the LEDs are still on, continue with the next step.
8. Switch off the analyzer.
9. Reinstall each assembly one at a time. Switch on the analyzer after each assembly is installed. The assembly that causes the green LEDs to go off or flash could be faulty.

NOTE It is possible, however, that this condition is caused by the A8 post regulator not supplying enough current. To check this, reinstall the assemblies in a different order to change the loading. If the same assembly appears to be faulty, replace that assembly. If a different assembly appears faulty, A8 is most likely faulty (unless both of the other assemblies are faulty).

Briefly Disable the Shutdown Circuitry

In this step, you shutdown and disable the protective circuitry for a short time, forcing on the supplies (including shorted supplies) with a 100% duty cycle.

CAUTION Damage to components or to circuit traces may occur if A8TP4 (SDIS) is shorted to chassis ground for more than a few seconds while supplies are shorted.

1. Connect A8TP4 (SDIS) to chassis ground with a jumper wire.
2. Switch on the analyzer and note the test points of any LEDs that are off. *Immediately remove the jumper wire.*
3. Refer to the block diagram at the end of this chapter and do the following:
 - Note the mnemonics of any additional signals that may connect to any A8 test point that showed a fault in the previous step.
 - Cross reference all assemblies that use the power supplies whose A8 LEDs went out when A8TP4 (SDIS) was connected to chassis ground.
 - Make a list of these assemblies.
 - Delete the following assemblies from your list as they have already been verified earlier in this section.

Digital IF (A10)

Phase lock (A11)

Reference (A12)

Fractional-N analog (A13)

Fractional-N digital (A14)

Display (A18)

Display Interface (A22)

4. Switch off the analyzer.

NOTE *Always switch off the analyzer before removing or disconnecting assemblies.*

To identify specific cables and assemblies that are not shown in this chapter, refer to [Chapter 13](#) , “Replaceable Parts.”

When extensive disassembly is required, refer to [Chapter 14](#) , “Assembly Replacement and Post-Repair Procedures.”

5. Of those assemblies that are left on the list, remove or disconnect them from the analyzer one at a time. [Table 5-4 on page 5-16](#) shows the best order in which to remove them, sorting them from most to least accessible. [Table 5-4](#) also lists any associated assemblies that are supplied by the assembly that is being removed. After each assembly is removed or disconnected, switch on the analyzer and observe the LEDs.
 - If all the LEDs light, the assembly removed (or one receiving power from it) is faulty.
 - If the LEDs are still not on steadily, continue with the next section [“Inspect the Motherboard.”](#)

Table 5-4 Recommended Order for Removal/Disconnection for Troubleshooting the A8 Board

Assembly to Remove	Removal or Disconnection Method	Other Assemblies That Receive Power from the Removed Assembly
1. CPU Board (A7)	Disconnect W87	None
2. R Sampler (A4)	Unplug from A17 and Remove	None
3. A Sampler (A5)	Unplug from A17 and Remove	None
4. B Sampler (A6)	Unplug from A17 and Remove	None
5. Source Control (A9)	Disconnect W91	None
6. Front Panel Interface (A2)	Disconnect W84	Front Panel Keyboard (A1)
7. Test Set Interface (A51)	Disconnect W89	Transfer Switch (S4) LED Front Panel (A56)

Inspect the Motherboard

Inspect the motherboard (A17) for solder bridges and shorted traces. In particular, inspect the traces that carry the supplies whose LEDs faulted when A8TP4 (SDIS) was grounded earlier.

Error Messages

Three error messages are associated with the power supplies functional group. They are shown here.

- POWER SUPPLY SHUT DOWN!

One or more supplies on the A8 post regulator assembly is shut down due to one of the following conditions: overcurrent, overvoltage, or undervoltage. Refer to [“If the Green LEDs of the Post Regulator \(A8\) Are Not All ON” on page 5-13](#).

- POWER SUPPLY HOT!

The temperature sensors on the post regulator (A8) assembly detect an overtemperature condition. The regulated power supplies on A8 have been shut down.

Check the temperature of the operating environment; it should not be greater than +55 °C (131 °F). The fan should be operating and there should be at least 15 cm (6 in) spacing behind and all around the analyzer to allow for proper ventilation.

Check the Fuses and Isolate A8

Check the fuses associated with each of these supplies near the A8 test points. If these fuses keep burning out, a short exists. Try isolating A8 by removing it from the motherboard connector, but keeping the cable A15W1 connected to A8J2. Connect a jumper wire from A8TP2 to chassis ground. If either the +15 V or –12.6 V fuse blows, or the associated green LEDs do not light, replace A8.

If the +15 V and –12.6 V green LEDs light, troubleshoot for a short between the motherboard connector pins XA8P2 pins 6 and 36 (–12.6 V) and the front panel probe power connectors. Also check between motherboard connector pins XA8P2 pins 4 and 34 (+15 V) and the front-panel probe power connectors.

Fan Troubleshooting

Fan Speeds

The fan speed varies depending upon temperature. It is normal for the fan to be at high speed when the analyzer is just switched on, and then change to low speed when the analyzer is cooled.

Check the Fan Voltages

If the fan is dead, refer to the A8 post regulator block diagram at the end of this chapter. The fan is driven by the +18 V and -18 V supplies coming from the A15 preregulator. Neither of these supplies is fused.

The -18 V supply is regulated on A8 in the fan drive block, and remains constant at approximately -14 volts. It connects to the A17 motherboard via pin 32 of the A8P1 connector.

The +18 V supply is regulated on A8 but changes the voltage to the fan, depending on air-flow and temperature information. Its voltage ranges from approximately -1.0 volts to +14.7 volts, and connects to the A17 motherboard via pin 31 of the A8P1 connector.

Measure the voltages of these supplies while using an extender board to allow access to the PC board connector, A8P1.

Short A8TP3 to Ground

If there is no voltage at A8P1 pins 31 and 32, switch off the analyzer. Remove A8 from its motherboard connector (or extender board) but keep the cable A15W1 connected to A8 (see [Figure 5-5](#)). Connect a jumper wire between A8TP3 and chassis ground. Switch on the analyzer.

- If all the green LEDs on the top edge of A8 light (except +5VD), replace the fan.
- If other green LEDs on A8 do not light, refer to “[If the Green LEDs of the Post Regulator \(A8\) Are Not All ON](#)” on page 5-13.

Intermittent Problems

PRESET states that appear spontaneously (without pressing

PRESET: FACTORY) typically signal a power supply or A7 CPU problem. Since the A7 CPU assembly is the easiest to substitute, do so. If the problem ceases, replace the A7. If the problem continues, replace the A15 preregulator assembly.

This page intentionally left blank.

**POWER SUPPLY BLOCK DIAGRAM
8719/20/22ET/ES**

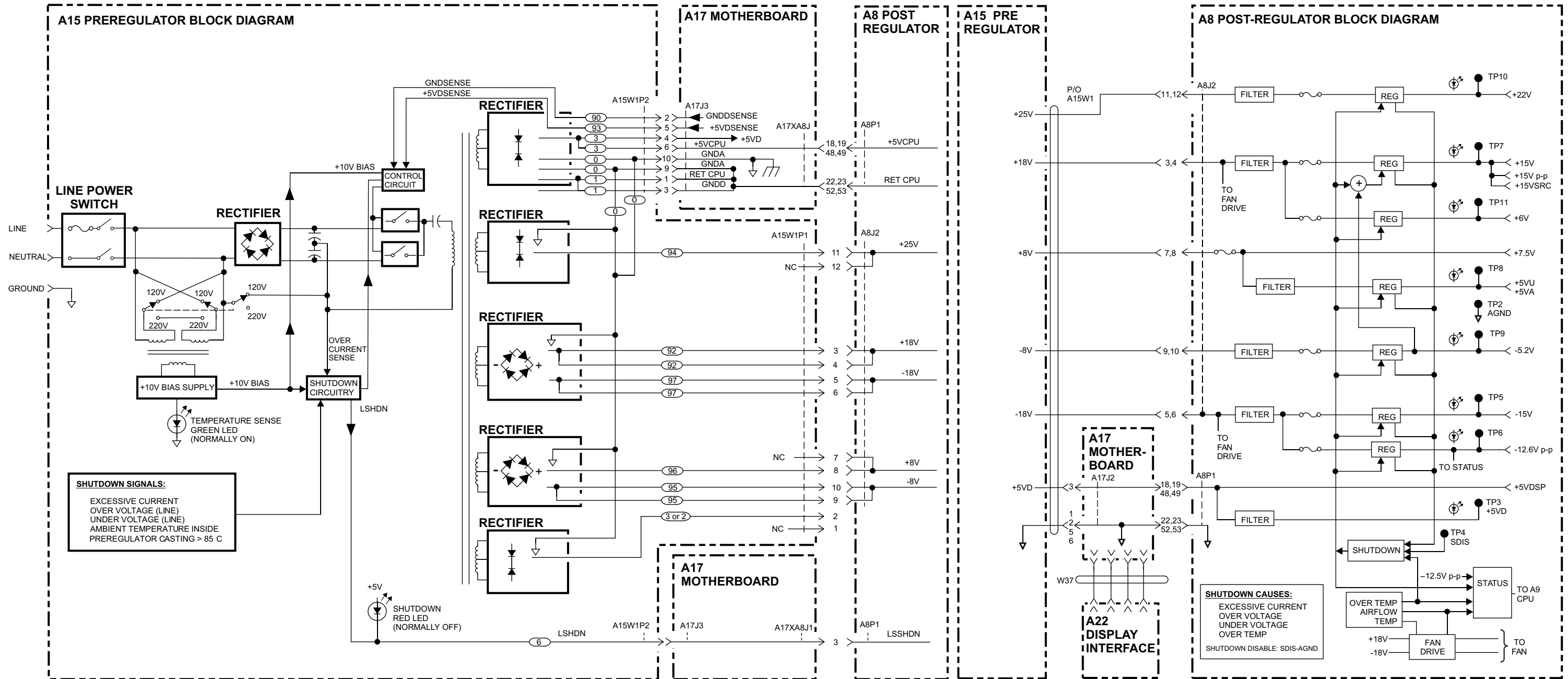

**POWER SUPPLY BLOCK DIAGRAM
8719/20/22ET/ES**

sb530e

6 Digital Control Troubleshooting

Information on This Chapter

Use this procedure only if you have read [Chapter 4](#) , “Start Troubleshooting Here.”

The digital control group assemblies consist of the following:

- Front panel keyboard (A1)
- Front panel processor (A2)
- CPU board (A7)
- Source control board (A9)
- Digital IF board (A10)
- Rear panel (A16)
- Display (A18)
- GSP (Graphical System Processor) (A19)
- Test Set interface (A51)

Begin with “[CPU Board \(A7\) Troubleshooting](#)” on [page 6-4](#), then proceed to the assembly that you suspect has a problem. If you suspect a GPIB problem, refer to “[GPIB Failures](#)” on [page 6-19](#).

Assembly Replacement Sequence

The following steps show the sequence to replace an assembly in the network analyzer.

- Step 1.** Identify the faulty group. Begin with [Chapter 4 , “Start Troubleshooting Here.”](#) Follow up with the appropriate troubleshooting chapter that identifies the faulty assembly.
- Step 2.** Order a replacement assembly. Refer to [Chapter 13 , “Replaceable Parts.”](#)
- Step 3.** Replace the faulty assembly and determine what adjustments are necessary. Refer to [Chapter 14 , “Assembly Replacement and Post-Repair Procedures.”](#)
- Step 4.** Perform the necessary adjustments. Refer to [Chapter 3 , “Adjustments and Correction Constants.”](#)
- Step 5.** Perform the necessary performance tests. Refer to [Chapter 2 , “System Verification and Performance Tests.”](#)

CPU Board (A7) Troubleshooting

A7 Switch Positions

The A7 switch position must be in the Normal position (NRM) for these procedures. This is the position for normal operating conditions. To move the switch to the Normal position (NRM) position, do the following:

NOTE Before moving the A7 switch, perform “[EEPROM Backup Disk Procedure](#)” on [page 3-33](#) to save your correction constants.

1. Remove the power line cord from the analyzer.
2. Set the analyzer on its side.
3. Remove the two corner bumpers from the bottom of the instrument with a T-15 TORX screwdriver.
4. Loosen the captive screw on the bottom cover's back edge.
5. Slide the cover toward the rear of the instrument.

CAUTION Be sure to observe proper ESD procedures and precautions when performing the following step.

6. Move the switch to the Normal position (NRM) as shown in [Figure 6-1](#).
7. Replace the bottom cover, corner bumpers, and power cord.

Figure 6-1 Jumper Positions on the CPU (A7)

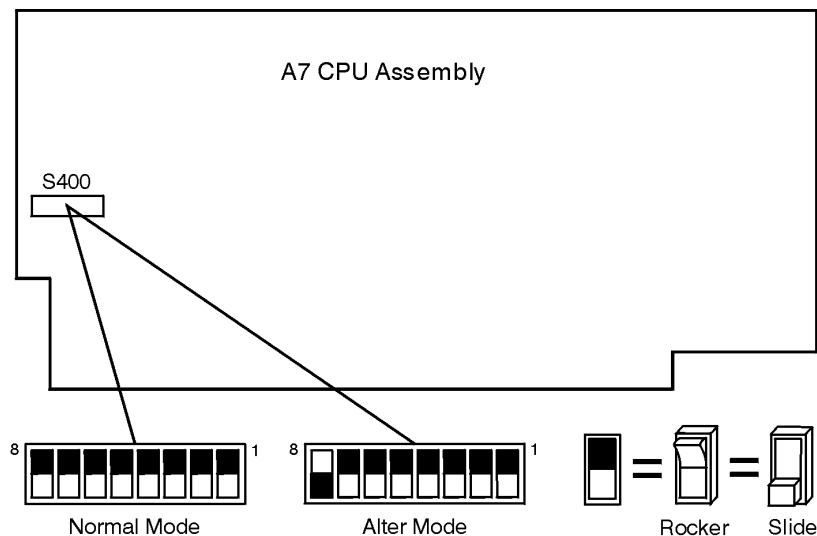

sb6165d

Checking the CPU (A7) Red LED Patterns

The CPU board (A7) has five (of eight) red LEDs that can be viewed through a small opening in the rear panel of the analyzer (see [Figure 6-2](#)).

NOTE Four of the eight LEDs are easily viewed. The fifth LED can be viewed by looking into the opening at a left angle.

1. Cycle the power while observing the five red LEDs.

Cycle the power on the analyzer and observe the five red LEDs. After an initial pattern, the five LEDs on the CPU board (A7) should remain off.

- If the LEDs remained off, then proceed to the assembly that you suspect has a problem.
- If the LEDs did not remain off, switch off the power and remove the bottom cover for further troubleshooting.

Figure 6-2 CPU LED Window on Rear Panel

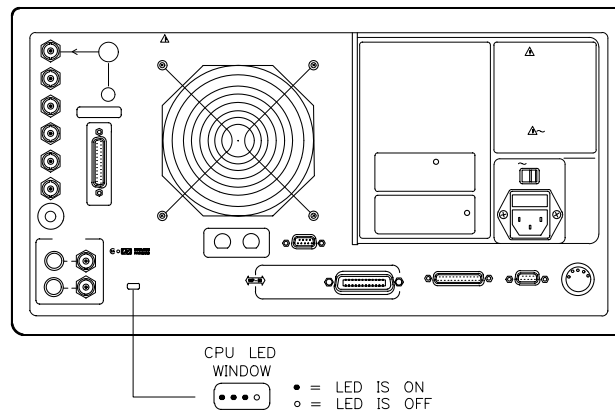

sb61d

2. Cycle the power while observing all eight red LEDs.

With the analyzer positioned bottom up, cycle the power and observe the eight red LEDs while looking from the front of the instrument.

NOTE If firmware did not load, a red LED on the CPU board will be flashing. Refer to [“Loading Firmware” on page 3-36](#).

3. Evaluate results.

- If either of the following LED patterns remain, go to “[Display Troubleshooting \(A18,A19\)](#)” on page 6-7. (* = LED is on).

* * * 0 * * 0 *

* * * 0 * * * 0

(front of instrument ↓)

- If any other LED patterns remain, replace the CPU board (A7) after verifying the power supply.

Display Troubleshooting (A18,A19)

This section contains the following information:

- Evaluating your display
- Troubleshooting the GSP (A19) and the Display (A18)

Evaluating Your Display

There are four criteria against which your display is measured:

- Background Lamp Intensity
- Green, Red or Blue Dots
- Black Dots
- Newtons Rings

Evaluate the display as follows:

- If either the GSP (A19), CPU board (A7) or Backlight Inverter (A20) assemblies are replaced, perform a visual inspection of the display.
- If it appears that there is a problem with the display, refer to the troubleshooting information for the assembly replaced.

Red, Green, or Blue Pixels Specifications

Red, green, or blue “stuck on” pixels may appear against a black background. To test for these dots, press the following:

(System) SERVICE MENU TESTS (66) (x1) EXECUTE TEST CONTINUE

In a properly working display, the following will not occur:

- complete rows or columns of stuck pixels
- more than 5 stuck pixels (not to exceed a maximum of 2 red or blue, and 3 green)
- 2 or more consecutive stuck pixels
- stuck pixels less than 6.5 mm apart

Dark Pixels Specifications

Dark “stuck on” pixels may appear against a white background. To test for these dots, press the following:

(System) SERVICE MENU TESTS (62) (x1) EXECUTE TEST CONTINUE

In a properly working display, the following will not occur:

- more than 12 stuck pixels (not to exceed a maximum of 7 red, green, or blue)
- more than one occurrence of 2 consecutive stuck pixels
- stuck pixels less than 6.5 mm apart

Newtons Rings

To check for the patterns known as Newtons Rings, change the display to white by pressing the following keys:

(System) SERVICE MENU TESTS (62) (x1) EXECUTE TEST CONTINUE

Figure 6-3 illustrates acceptable and non-acceptable examples of Newtons Rings.

Figure 6-3 Newtons Rings

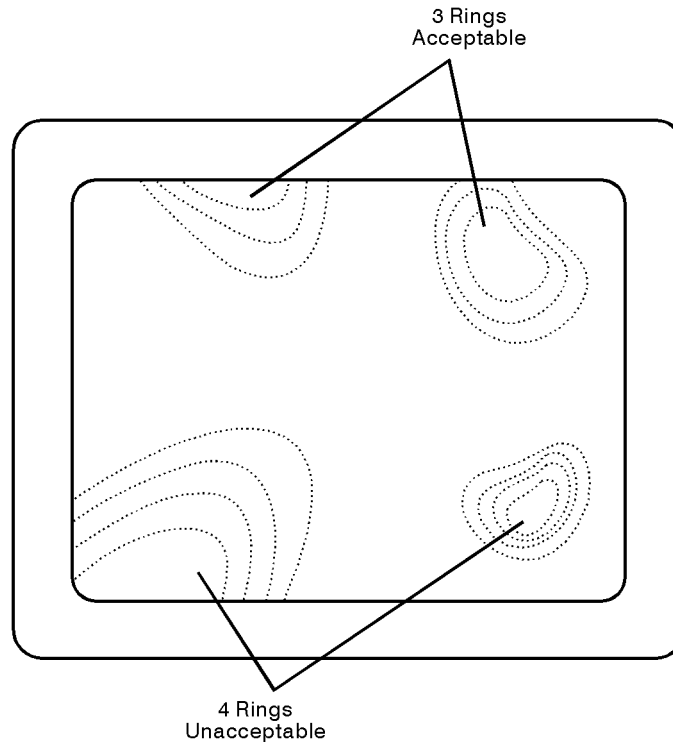

sb6123d

Troubleshooting the GSP (A19) and the Display (A18)

Measure the Supply Voltages Applied to the GSP (A19)

Measure the power supply voltages at the GSP (A19) assembly that come from the motherboard (A17) assembly. Unplug the wire harness (J3) from the back of the GSP interface. Check pins 2 and 3 for $+5.16 \pm 0.1$ V (see [Figure 6-4](#)).

If the voltages are incorrect, refer to [Chapter 5](#), “Power Supply Troubleshooting.”

Figure 6-4 GSP (A19) Voltages

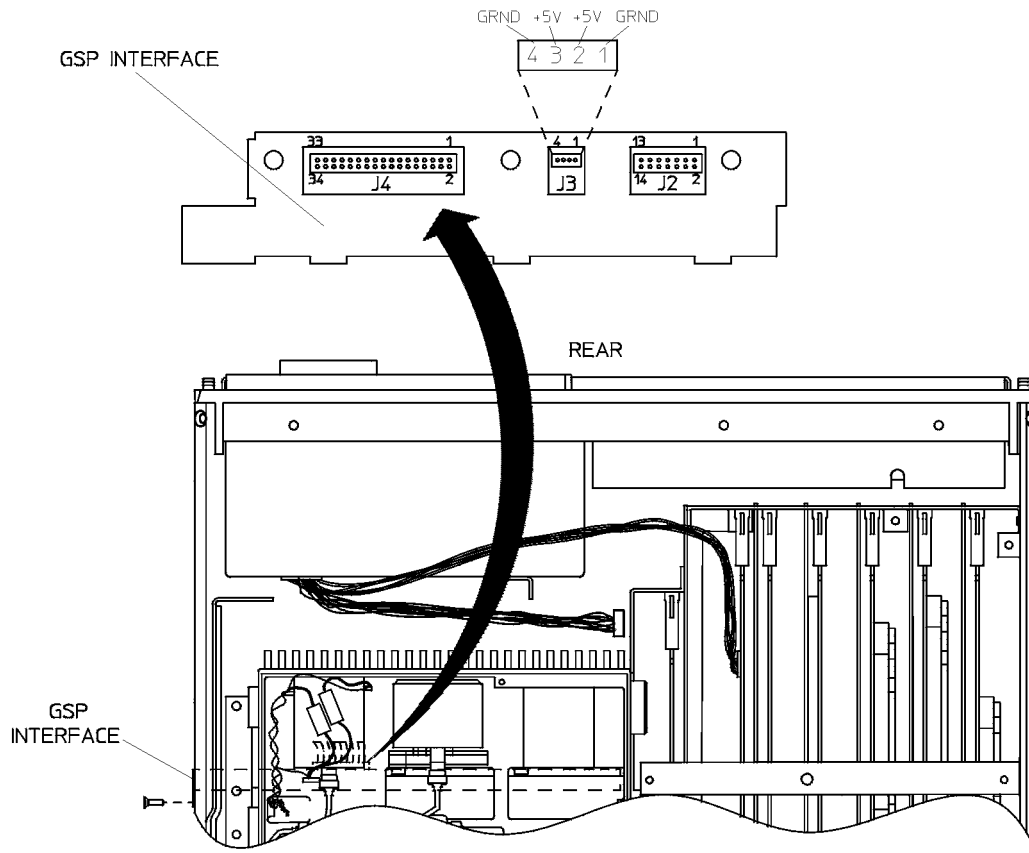

sb593e

Run Display Test 55

1. Press the following:

PRESET: FACTORY

SERVICE MENU TESTS DISPLAY TESTS

EXECUTE TEST CONTINUE

- If the analyzer passes the test, it will display 55 DISP/CPU COM PASS. Press **PRESET: FACTORY** and go to [“Run Display Tests 59-61”](#) on page 6-12.
- If the analyzer fails the test, the display will appear blank and the front panel LEDs will stay on. Continue with the next check.

Inspect Ribbon Cable Repeat Display Test 55

Inspect the ribbon cable (W20) that connects the CPU board (A7) to the GSP (A19) for a loose connection. Repeat [“Run Display Test 55.”](#) If the analyzer fails the test, a walking one pattern will be continuously transferred from the CPU, through the cable, to the GSP. Immediately go to the next check.

Perform Walking One Pattern

Use an oscilloscope and a probe to verify that a walking one pattern is transferring from the CPU board (A7). The walking one pattern similar to the one shown in [Figure 6-6](#) and is found on pins 3 through 10, and 13 through 20. (See [Figure 6-5](#).)

- If the signal is present at the A7 connector of the ribbon cable, verify that it is present at the other end of the cable.
- If the signal is not present, replace the cable.

Figure 6-5 Pin Locations on the GSP (A19)

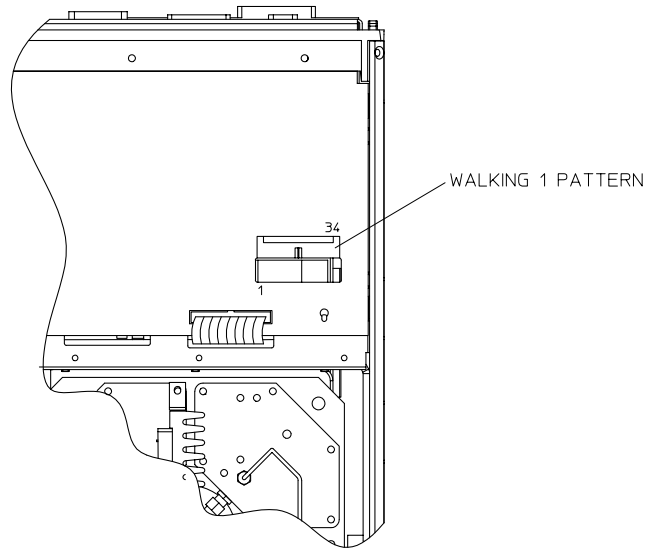

sb6146d

Figure 6-6 CPU (A7) Walking One Pattern

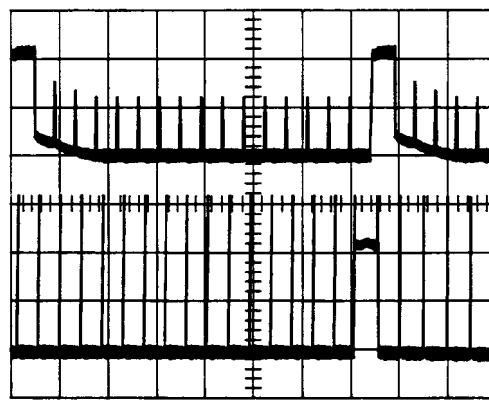

sg601s

Run Display Tests 59-61

1. Press the following:

(Preset) **PRESET: FACTORY** **(Preset)**

(System) **SERVICE MENU**

TESTS **DISPLAY TESTS** **(59)** **(x1)**

EXECUTE TEST **CONTINUE**

2. If the analyzer passes the test, the Test number, description and PASS is displayed.
3. Press **(Home)** and perform display tests 59 through 61 (substitute the next test number where **(59)** was used). Watch for the analyzer display and front panel LEDs to flash.
 - If the analyzer fails any of the tests (59 through 61), replace the A19 assembly.
 - If all of the following is true, replace the A18 display assembly.
 - CPU passes the LED test.
 - GSP passes all of the internal display tests (59 through 61).
 - Power supply checks out.

Front Panel Troubleshooting (A1/A2)

Check Front Panel LEDs After Preset

1. Press **Preset** on the analyzer.
2. Observe that all front panel LEDs turn on and, within five seconds after releasing **Preset**, all but the CHAN and TRANS FWD and REFL FWD LEDs turn off.
 - If all the front panel LEDs either stay on or off, there is a control problem between the CPU board (A7) and the front panel set (A1/A2). See [“Inspect Cables” on page 6-16](#).
 - If you suspect that one or more LEDs are burned out, then replace the keypad assembly (A1).

NOTE TRANS FWD and REFL FWD LEDs, and TRANS REV and REFL REV LEDs problems may be caused by the malfunction of the LED board or the transfer switch

- If, at the end of the turn on sequence, the channel 1 LED is not on and all GPIB status LEDs are not off, continue with [“Identify the Stuck Key” on page 6-14](#).

Identify the Stuck Key

Match the front panel LED pattern with the patterns in [Table 6-1](#). The LED pattern identifies the stuck key. Free the stuck key or replace the front panel part causing the problem. (The Chan 3 and Chan 4 LEDs are not used. * = LED is on. The footswitch is an accessory that can be set up through a rear panel port.)

Table 6-1 Front-Panel Key Codes





















Decimal Number	LED Pattern						Key
	Chan 1	Chan 2	R	L	T	S	
0							
1						*	
2					*		
3					*	*	
4				*			
5				*		*	
6				*	*		
7				*	*	*	
8			*				
9			*			*	
10			*		*		
11			*		*	*	
12			*	*			
13			*	*		*	
14			*	*	*		
15			*	*	*	*	
16		*					Footswitch
17		*				*	
18		*			*		
19		*			*	*	
20		*		*			
21		*		*		*	

Table 6-1 Front-Panel Key Codes (Continued)

Decimal Number	LED Pattern						Key
	Chan 1	Chan 2	R	L	T	S	
22		*		*	*		Save/Recall
23		*		*	*	*	Copy
24		*	*				
25		*	*			*	Entry Off
26		*	*		*		Scale Ref
27		*	*		*	*	Cal
28		*	*	*			Marker Fctn
29		*	*	*		*	Power
30		*	*	*	*		Sweep Setup
31	Not Used						
32	*						Chan 2
33	*					*	Chan 4
34	*				*		Format
35	*				*	*	Avg
36	*			*			Marker Search
37	*			*		*	Stop
38	*			*	*		Span
39	Not used						
40	*		*				Chan 1
41	*		*			*	Chan 3
42	*		*		*		Meas
43	*		*		*	*	Display
44	*		*	*			Marker
45	*		*	*		*	Start
46	*		*	*	*		Center
47	*		*	*	*	*	Return

Table 6-1 Front-Panel Key Codes (Continued)

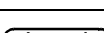
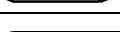
Decimal Number	LED Pattern						Key
	Chan 1	Chan 2	R	L	T	S	
48	*	*					softkey 1
49	*	*				*	softkey 2
50	*	*			*		softkey 3
51	*	*			*	*	softkey 4
52	*	*		*			softkey 5
53	*	*		*		*	softkey 6
54	*	*		*	*		softkey 7
55	*	*		*	*	*	softkey 8

Inspect Cables

Remove the front panel assembly and visually inspect the ribbon cable that connects the front panel to the motherboard. Also, inspect the interconnecting ribbon cable between the front panel keyboard (A1) and the front panel processor (A2). Make sure the cables are properly connected. Replace any bad cables.

Test Using a Controller

If a controller is available, write a simple command to the analyzer. If the analyzer successfully executes the command, the problem is either the front panel processor (A2) or the ribbon cable (W17) that connects the front panel processor (A2) to the motherboard (A17).

Run the Internal Diagnostic Tests

The analyzer incorporates 20 internal diagnostic tests. Most tests can be run as part of one or both major test sequences: all internal (test 0) and preset (test 1).

1. To perform all internal tests, press the following:

(System) **SERVICE MENU** **TESTS** **INTERNAL TESTS** **EXECUTE TEST**

2. Then press **(Home)** to see the results of the preset test. If either sequence fails, press the **(Home)** key to find the first occurrence of a FAIL message for tests 2 through 20. If a test does fail **RETURN** **SELF DIAGNOSE**. This routine will list the boards that are the most probable cause of failure. See [Table 6-2](#) for further troubleshooting information.

Table 6-2 Internal Diagnostic Test with Commentary

Failed Test	Seq. *	Probable Failed	Assemblies [†] : Comments and Troubleshooting Hints
0 All Int	M	See Chapter 4 , “ Start Troubleshooting Here. ”	Executes tests 3-11, 13-16,20.
1 Preset	M	See Chapter 4 , “ Start Troubleshooting Here. ”	Executes tests 2-11, 14-16. Runs at power-on or preset.
2 ROM	P,AI	CPU board (A7)	Repeats on fail; refer to “ CPU Board (A7) Troubleshooting ” on page 6-4
3 CMOS RAM	P,AI	CPU board (A7)	Replace A7.
4 Main DRAM	P,AI	CPU board (A7)	Repeats on fail; replace A7.
5 DSP Wr/Rd	P,AI	CPU board (A7)	Replace A7.
6 DSP RAM	P,AI	CPU board (A7)	Replace A7.
7 DSP ALU	P,AI	CPU board (A7)	Replace A7.
8 DSP Intrpt	P,AI	CPU board (A7) or Digital IF (A10)	Remove A10, rerun test. If fail, replace CPU board (A7). If pass, replace A10.
9 DIF Control	P,AI	CPU board (A7) or Digital IF (A10)	Most likely A7 assembly.
10 DIF Counter	P,AI	Digital IF (A10) or CPU board (A7) or Reference (A12)	Check analog bus node 17 for 1 MHz. If correct, A12 is verified; suspect A10.
11 DSP Control	P,AI	Digital IF (A10) or CPU board (A7)	Most likely A10.
12 Fr Pan Wr/Rd	M	Front Panel interface (A2) or Front Panel keyboard (A1) or CPU board (A7)	Run test 23. If fail, replace A2. If pass, problem is on bus between A7 and A2 or on A7 assembly.
13 GPIB (CPU Board)	AI	CPU board (A7)	Check A7J2 pin 48 for 4 MHz clock signal. If signal is bad, replace A7.
14 Post-reg	P,AI	Preregulator (A15) or Post regulator (A8) or Destination assembly	See Chapter 5 , “ Power Supply Troubleshooting. ”
15 Frac-N Cont	P,AI	Fractional-N digital (A14)	Replace A14.
16 Sweep Trig	P,AI	Fractional-N digital (A14) or Digital IF (A10)	Most likely A14
17 ADC Lin	M	Digital IF (A10)	Replace A10.
18 ADC Ofs	M	Digital IF (A10)	Replace A10.
19 ABUS Test	M	Digital IF (A10)	Replace A10.
20 FN Count	AI	Fractional-N digital (A14) or Fractional -N analog (A13) or Digital IF (A10)	Most likely A14 or A13, as previous tests check A10. See Chapter 7 , “ Source Troubleshooting. ”

* P = part of Preset sequence; AI =part of ALL INTERNAL sequence; M= Manual.
[†] in decreasing order of probability.

If the Fault Is Intermittent

Repeat Test Function

If the failure is intermittent, do the following:

1. To switch on the repeat function, press the following:

System **SERVICE MENU** **TEST OPTIONS** **REPEAT ON**

2. Then press the following:

RETURN **TESTS**

3. Select the test desired and press the following:

EXECUTE TEST

4. Press **Preset** to stop the function. The test repeat function is explained in [Chapter 10](#), “Service Key Menus and Error Messages.”

GPIB Failures

If you have performed “[Step 3. GPIB Systems Check](#)” on page 4-10 and you are certain that there is a GPIB problem in the analyzer, replace the CPU board (A7).

This page intentionally left blank.

DIGITAL CONTROL GROUP BLOCK DIAGRAM
8719/20/22ET/ES

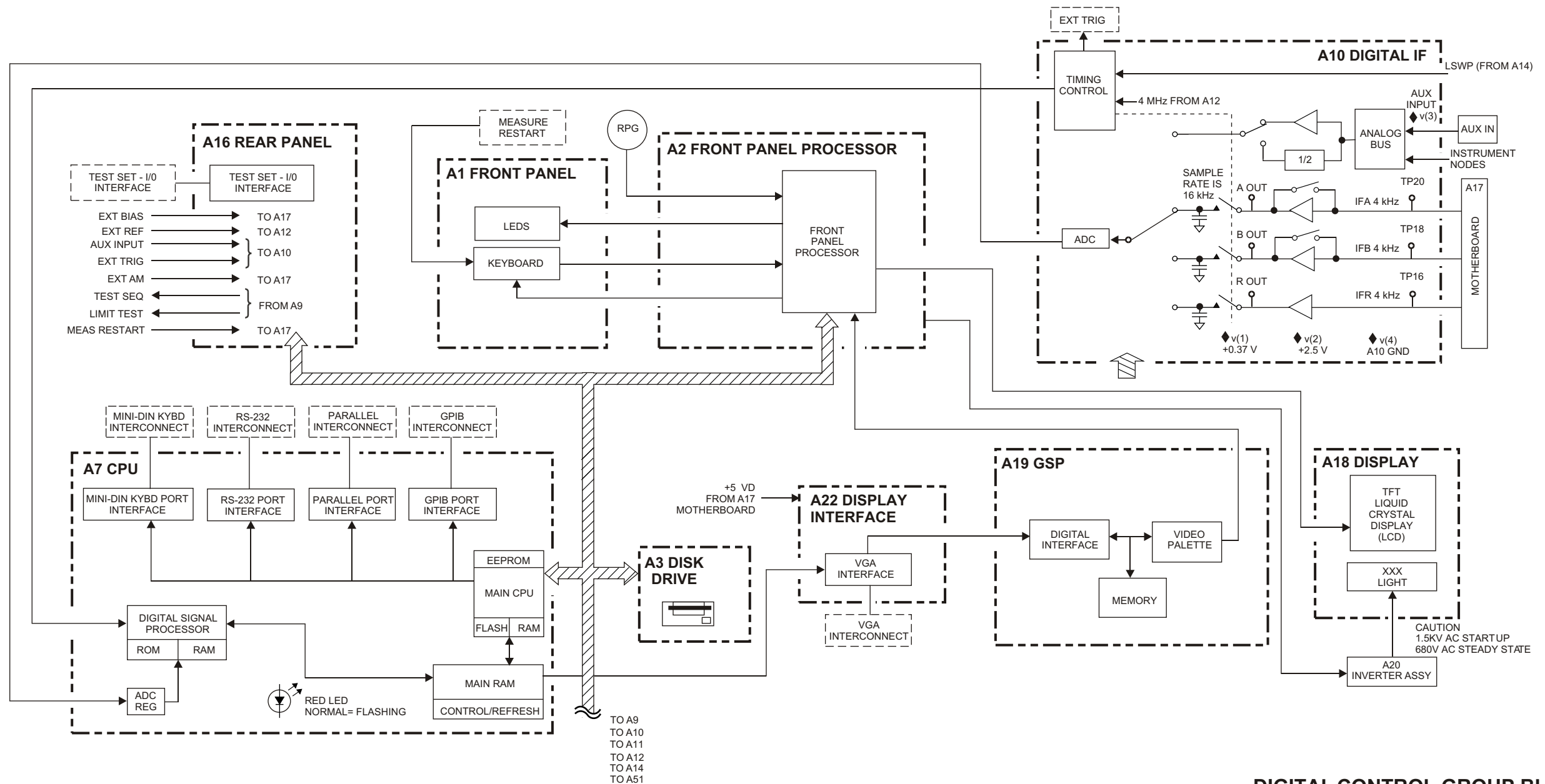

DIGITAL CONTROL GROUP BLOCK DIAGRAM
8719/20/22ET/ES

sb529e

7 Source Troubleshooting

Information on This Chapter

Use this procedure only if you have read [Chapter 4](#) , “[Start Troubleshooting Here.](#)”

This chapter is divided into two sections to address the following types of problems:

- Incorrect power levels
- Phase lock error

Begin with the flowchart, “[Source Troubleshooting Flowchart](#)” on page 7-3.

Source Troubleshooting Flowchart

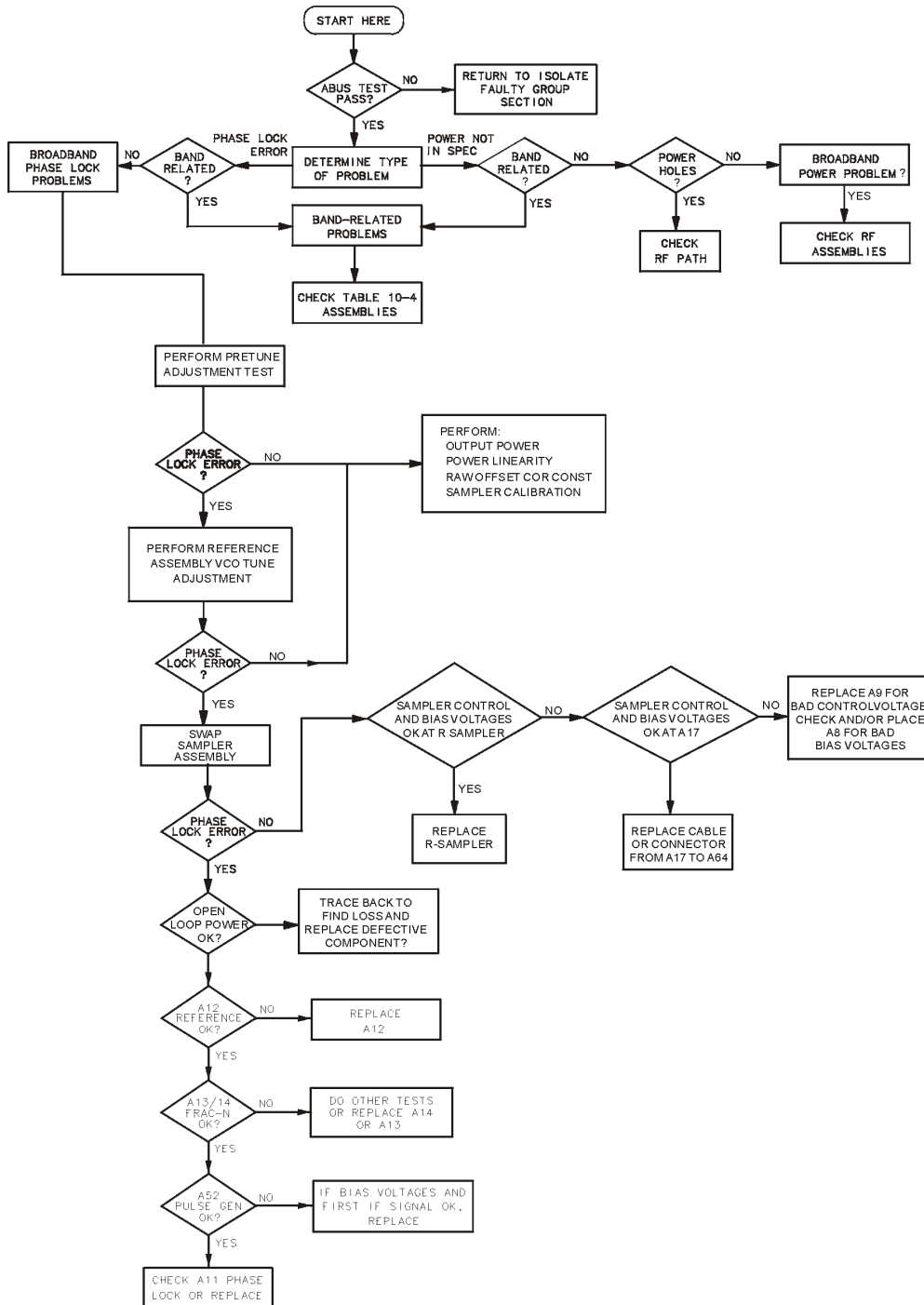

sb585e

Assembly Replacement Sequence

The following steps show the sequence to replace an assembly in the network analyzer.

- Step 1.** Identify the faulty group. Begin with [Chapter 4](#) , “[Start Troubleshooting Here.](#)” Follow up with the appropriate troubleshooting chapter that identifies the faulty assembly.
- Step 2.** Order a replacement assembly. Refer to [Chapter 13](#) , “[Replaceable Parts.](#)”
- Step 3.** Replace the faulty assembly and determine what adjustments are necessary. Refer to [Chapter 14](#) , “[Assembly Replacement and Post-Repair Procedures.](#)”
- Step 4.** Perform the necessary adjustments. Refer to [Chapter 3](#) , “[Adjustments and Correction Constants.](#)”
- Step 5.** Perform the necessary performance tests. Refer to [Chapter 2](#) , “[System Verification and Performance Tests.](#)”

Start Troubleshooting Here

1. Make sure all of the assemblies are firmly seated.
2. Verify that the analog bus is working by pressing the following:
(System) SERVICE MENU TESTS (19) (x1) EXECUTE TEST
 - If the analyzer fails the test, return to [“Step 4. Faulty Group Isolation”](#) on page 4-13.
 - If the test passes, continue with this section.
3. Make sure that input R has a signal of at least -35 dBm (about 0.01 Vp-p into 50 ohms) at all times to maintain phase lock. To make this measurement, perform the following steps:
 - a. Perform steps 1 and 2 of [“Source Pretune Correction Constants \(Test 43\)”](#) on page 3-6. Make note of the DAC number that is displayed and then abort the procedure.
 - b. Press the following:
**(System) SERVICE MENU SERVICE MODES SRC ADJUST MENU
DAC NUM HIGH BAND**
 - c. Enter the DAC number determined from step 3a and press **(x1)**.
 - d. Zero and calibrate a power meter.
 - e. **For ET analyzers:**

On ET models, there are two ways to measure the R-channel sampler assembly power.

 1. Remove the bottom cover and disconnect the semirigid cable (W74) to the RF INPUT (J2) of the R-channel sampler. Connect a 2.4 mm (f) barrel, flexible cable, and the power sensor to W74.

CAUTION Be careful not to damage the center pins of the semirigid cable. Some flexing of the cable will have to be done to attach the power sensor. Do not over bend the cable.

2. Remove the front panel and disconnect the junction between the cables W72 and W74. Connect the power sensor to W72.
 - If the power level is at least -35 dBm, proceed to [“Phase Lock Error Message Displayed”](#) on page 7-6.
 - If the power level is lower, proceed to [“Power Not within Specifications”](#) on page 7-6.

For ES Models:

Disconnect the front panel R CHANNEL jumper.

NOTE For ES Option 089 analyzers, press the following:

(System) INSTR. MODE EXT R CHAN

Connect the power meter to R CHANNEL OUT and measure the power out.

- If the power level is at least -35 dBm, proceed to [“Phase Lock Error Message Displayed” on page 7-6](#).
- If the power level is lower, proceed to [“Power Not within Specifications” on page 7-6](#).

Power Not within Specifications

Perform these power adjustments from [Chapter 3](#), [“Adjustments and Correction Constants”](#):

1. [“Output Power Adjustments” on page 3-17](#)
 2. [“Power Linearity Adjustment” on page 3-24](#)
 3. [“Blanking Adjustment \(Test 54\)” on page 3-30](#)
- If power holes exist, use the block diagram (located at the end of [Chapter 4](#), [“Start Troubleshooting Here”](#)) and the location diagrams (in [Chapter 13](#), [“Replaceable Parts”](#)) to check the cables and connections in the RF path.
 - If power levels are not ± 2 dB of the setting (8719ET/ES and 8720ET/ES) or ± 3 dB of setting (8722ET/ES) in only one or two bands, go to [“Band-Related Problems” on page 7-22](#).
 - If power levels are incorrect in all bands, go to [“Broadband Power Problems” on page 7-26](#).

Phase Lock Error Message Displayed

1. To view the 0.25V/GHz signal to the YIG oscillator, press the following:

(Preset) PRESET: FACTORY (Preset)

(System) SERVICE MENU ANALOG BUS ON

(Meas) ANALOG IN Aux Input (9) (x1)

(Scale Ref) AUTO SCALE

Notice that for each band, the waveform should start and stop exactly as shown in [Figure 7-1](#), with only one ramp in each band. A problem in one band should not affect the appearance of the waveform in other bands.

Figure 7-1 0.25 V/GHz Waveform at Abus Node 9

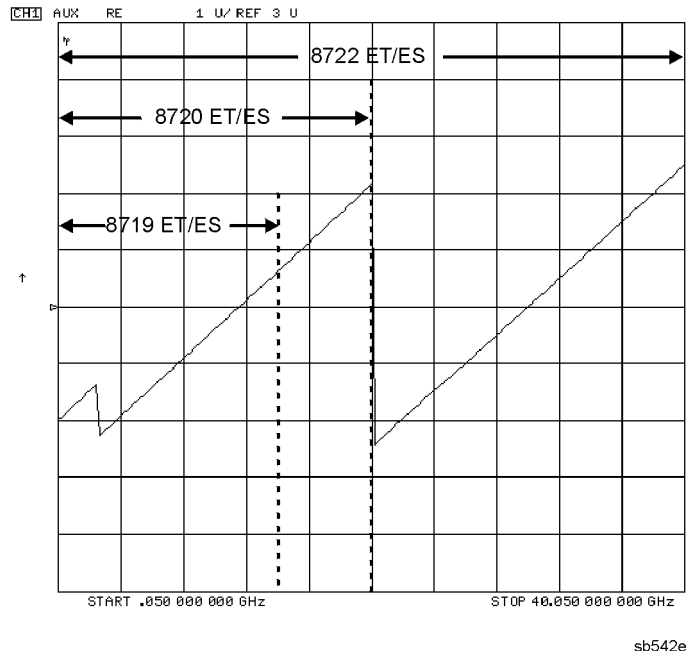

- If the waveform appears normal in one but not all frequency bands, go to [“Band-Related Problems”](#) on page 7-22.
- If the waveform appears abnormal in all frequency bands, refer to [“Broadband Phase Lock Problems”](#) on page 7-8.

Broadband Phase Lock Problems

Phase lock problems can be caused by incorrect pretune correction constants.

1. To fix this potential problem, perform [“Source Pretune Correction Constants \(Test 43\)” on page 3-6 from Chapter 3 , “Adjustments and Correction Constants.”](#)
2. Then press **[Preset] PRESET: FACTORY [Preset]** to see if the phase lock problem persists.
3. If the phase lock problem persists, perform the [“Reference Assembly VCO Tune Adjustment” on page 3-39](#). If this fixes the problem, perform the following adjustments from [Chapter 3](#) .
 - a. [“Output Power Adjustments” on page 3-17](#)
 - b. [“Power Linearity Adjustment” on page 3-24](#)
 - c. [“Raw Offset Correction Constants” on page 3-48](#)
 - d. [“Sampler Calibration Correction Constants \(Test 51\)” on page 3-58](#)

If the phase lock problem persists, continue with step 4.

4. The phase lock problem could be caused by a fault in one of these source assemblies:

A12 reference	A13 fractional-N analog	A14 fractional-N digital
A23,A24 R channel switches (Options 085,089)	A67 R2 sampler assembly (Option 400 only)	A72 R channel buffer amp
A25 source switch (8722ET/ES)	A51 test set interface	A52 pulse generator
A5,A6 source switches	A9 source control board	A11 phase lock
A54 YIG 2 (8722ET/ES only)	A55 YIG 1	A59 source interface board
A58 M/A/D/S	A64 R sampler assembly	A76 attenuator
A68 6 dB Attenuator (8719ET/ES and 8720ET/ES)	S5 R channel switches (Options 085,089)	A73 R2 channel butter amp (Option 400 only)
A73 R2 channel buffer amp (Option 400 only)	A74 transfer switch (Option 400)	

Continue to [“Swap IF Output Cables to Check R Sampler Assembly \(A64\)” on page 7-9](#).

Swap IF Output Cables to Check R Sampler Assembly (A64)

1. Replace the IF OUTPUT cable of A66J3 (B sampler assembly) with the IF OUTPUT cable removed from A64J3 (R sampler assembly).

NOTE For ES option 400 models with R2 phase lock problems, replace the IF OUTPUT cable at A66J3 (B sampler assembly) with the IF OUTPUT cable from A67J3 (R2 sampler assembly).

2. Press **Meas** **Ref: REV S22 (B/R)** (ignore the trace).
3. If the phase lock problem persists, the R sampler assembly was not the problem. Continue with [“Check Open Loop Power” on page 7-11](#) or [“8722ET/ES Models” on page 7-12](#).
4. If the phase lock error message disappears, either the control voltage, bias voltage, RF signal or the R sampler assembly itself is faulty.
5. Swap back the IF OUTPUT cables and check for approximately 0.04V on the green sampler control wire of A64J3 (R sampler assembly).
 - If the control voltage is good, continue to step 6.
 - If the control voltage is bad, check for 0.04 V at J18 (R1) on the motherboard (A17), which is the pin located farthest to the rear.
 - If the voltage at J18 is good and bad at the sampler assembly, then either the cable between the motherboard and sampler assembly is bad or the connectors associated with the cable is defective.
 - If the voltage at J18 is bad, then the problem points to the source control board (A9). Replace A9.
6. Check the +15 V and –15 V bias voltages at the sampler assembly.
 - If the bias voltages are good, continue to step 7.
 - If the bias voltages are bad, check for the +15 V and –15 V supply voltages at J18 on the motherboard (A17). The +15 V pin is second from the rear and the –15 V pin is third from the rear.
 - If the voltage at J18 is good and bad at the sampler assembly, then either the cable between the motherboard and sampler assembly is bad or the connectors associated with the cable is defective.
 - If the voltage is bad at J18, then check the +15V (TP7) and –15 V (TP5) at the post regulator (A8). If the post regulator voltages are good, then replace the motherboard (A17).

NOTE If 2.4 mm flexible cables and 2.4 mm power sensors are not available for the 8722ET/ES, use 3.5 mm to 2.4 mm adapters (HP/Agilent 11901D 2.4 mm (f) to 3.5 mm (m) and HP/Agilent 11901B 2.4 (f) mm to 3.5 mm (f)) to interface with your 3.5 mm equipment.

7. If the control and bias voltages are good, use a power meter and the flexible cable from the tool kit to troubleshoot the RF signal path. To prepare to troubleshoot, enter the service mode by pressing the following:

(System) **SERVICE MENU** **SERVICE MODES**
SRC ADJUST MENU **DAC NUM HIGH BAND** (4000) (x1)

NOTE For ES Option 089 analyzers, press the following:

(System) **INSTR. MODE** **EXT R CHAN**

8. To measure RF signal of the R-channel, do the following:

For ES analyzers:

Disconnect the front panel R-channel jumper.

Connect the power sensor to the R CHANNEL OUT port and look for the following power levels:

- For the 8719ES and 8720ES, the power should be at least -18 dBm.
- For the 8722ES, the power should be at least -27 dBm.

For ET analyzers:

On ET models, there are two ways to measure the R-channel sampler assembly power.

- a. Remove the bottom cover and disconnect the semirigid cable (W74) to the RF INPUT (J2) of the R-channel sampler. Connect a 2.4 mm (f) barrel, flexible cable, and the power sensor to W74.
-

CAUTION Be careful not to damage the center pins of the semirigid cable. Some flexing of the cable will have to be done to attach the power sensor. Do not over bend the cable.

- b. Remove the front panel and disconnect the junction between the cables W72 and W74. Connect the power sensor to W72.
- For the 8719ET and 8720ET, the power should be at least -18 dBm.
 - For the 8722ET, the power should be at least -27 dBm.
9. If the power level is correct, replace the R sampler assembly (A64). If the power level is not correct, replace the M/A/D/S (A58).
-

Check Open Loop Power

The open loop power procedure is divided into one for 8719ET/ES and 8720ET/ES models and one for 8722ET/ES models.

8719ET/ES and 8720ET/ES Models

1. Set up the ES and ET models as following:

For ES analyzers:

Disconnect the front panel R-channel jumper.

Connect the power meter to the R CHANNEL OUT port.

NOTE For ES Option 089 analyzers, press the following:

(System) INSTR. MODE EXT R CHAN

For ET analyzers:

On ET models, there are two ways to measure the R-channel sampler assembly power.

- a. Remove the bottom cover and disconnect the semirigid cable (W74) to the RF INPUT (J2) of the R-channel sampler. Connect a 2.4 mm (f) barrel, flexible cable, and the power sensor to W74.

CAUTION Be careful not to damage the center pins of the semirigid cable. Some flexing of the cable will have to be done to attach the power sensor. Do not over bend the cable.

- b. Remove the front panel and disconnect the junction between the cables W72 and W74. Connect the power sensor to W72.

2. To measure the low band power, press the following:

(System) SERVICE MENU SERVICE MODES
SRC ADJUST MENU DAC NUM LOW BAND (4000) (x1)

The power should be at least -23 dBm.

3. To measure high band power, press **DAC NUM HIGH BAND (4000) (x1)**.

The power should be at least -18 dBm.

4. You may have to change the DAC number slightly to achieve a good power reading. If power is correct, proceed with [“Check Reference Board \(A12\)” on page 7-13](#).
5. If the high band power level is lower than -18 dBm, check A55 YIG 1 power at A5J3.
6. Connect a power meter to A5J3 and measure the power while varying the DAC NUM HIGH BAND values from about 3200 to 4095.
 - If the power at A5J3 is greater than 0 dBm, replace the M/A/D/S (A58).
 - If the power is less than 0 dBm, check YIG 1 output power at the A53 end of W6.

- Power greater than 10 dBm indicates there is proper power coming out of the YIG at about 4.5 GHz. If the analyzer is not phase locking at this frequency in normal operation, the problem is with the RF cabling, A5 (source switch) or A6 (source switch).
- If no power is present, check the lowband YIG bias voltages on pin 3 (+15V) and pin 2 (+22V) of the J1 connector. Pin 3 is located on the left and pin 2 is located in the middle of the J1 connector. If the voltages are correct, replace the YIG.

8722ET/ES Models

- Set up the ES and ET models as following:

For ES analyzers:

Disconnect the front panel R-channel jumper.

Connect the power meter to the R CHANNEL OUT port.

NOTE For ES Option 089 analyzers, press the following:

(System) INSTR. MODE EXT R CHAN

For ET analyzers:

On ET models, there are two ways to measure the R-channel sampler assembly power.

- Remove the bottom cover and disconnect the semirigid cable (W74) to the RF INPUT (J2) of the R-channel sampler. Connect a 2.4 mm (f) barrel, flexible cable, and the power sensor to W74.

CAUTION Be careful not to damage the center pins of the semirigid cable. Some flexing of the cable will have to be done to attach the power sensor. Do not over bend the cable.

- Remove the front panel and disconnect the junction between the cables W72 and W74. Connect the power sensor to W72.
- To measure the low band power, press the following:

(System) SERVICE MENU SERVICE MODES
SRC ADJUST MENU DAC NUM LOW BAND (4000) (x1)

The power should be at least -32 dBm.

- To measure mid band power, press **DAC NUM MID BAND (4000) (x1)**.

The power should be at least -32 dBm.

- To measure high band power, press **DAC NUM HIGH BAND (4000) (x1)**.

The power should be at least -27 dBm.

- You may have to change the DAC number slightly to achieve a good power reading. If power is correct, proceed with [“Check Reference Board \(A12\)” on page 7-13](#).

6. If the power level is not correct, connect a power meter to the source switch (A25J3) and check the power of the YIG oscillator.
 - High band power should be greater than +3 dBm for DAC numbers from 2400 to 4095.
 - Mid band power should be greater than +5 dBm for DAC numbers from 3300 to 4095.
 - Low band power should be greater than -2 dBm for DAC numbers from 3700 to 4095.
7. Low power in high or mid band indicates a problem with the associated YIG or switches. Trace back along the signal path to find where the power is lost. Low power in the low band only is a problem with the low band assemblies A53 or A57, the A5 (source switch) or A6 source switches, or the RF cables. Activate the signal path under test by selecting the proper **DAC NUM XXX BAND**.
8. If no power is present, check both YIG bias voltages on pin 3 (+15V) and pin 2 (+22V) of the J1 connector. Pin 3 is located on the left and pin 2 is located in the middle of the J1 connector. If the voltages are correct, replace the appropriate YIG.

Check Reference Board (A12)

1. To check the 100 kHz signal from A12, press the following:

(Preset) PRESET: FACTORY (Preset)
(System) SERVICE MENU ANALOG BUS ON
(Meas) ANALOG IN Aux Input
ANALOG BUS (14) (x1) COUNTER: ON

2. The analyzer should display ANALOG BUS INPUT 14 100kHz cnt: .100 MHz.
3. Press **(17) (x1)** to check the 1 MHz signal.
The analyzer should display 17 PL Ref cnt: 1.000 MHz.
4. If either counter reading is incorrect, the A12 reference assembly is probably faulty and should be replaced. However, it is also possible that there is a faulty counter, A14 fractional-N digital, or A10 digital IF assembly. Replace A12 if problem persists.

Check Fractional-N Digital (A14) with ABUS

1. To setup the fractional-N tuning voltage, press the following:

- (Preset)** **PRESET: FACTORY** **(Preset)**
- (Sweep Setup)** **SWEEP TYPE MENU** **LOG FREQ**
- (System)** **SERVICE MENU** **ANALOG BUS ON**
- (Meas)** **ANALOG IN Aux Input** **COUNTER: ANALOG BUS**
- (Format)** **LOG MAG**
- (21)** **(x1)** **(Scale Ref)** **AUTO SCALE**

Compare the fractional-N tuning voltage to [Figure 7-2](#).

Figure 7-2 Fractional-N Tuning Voltage Waveform at Abus Node 21

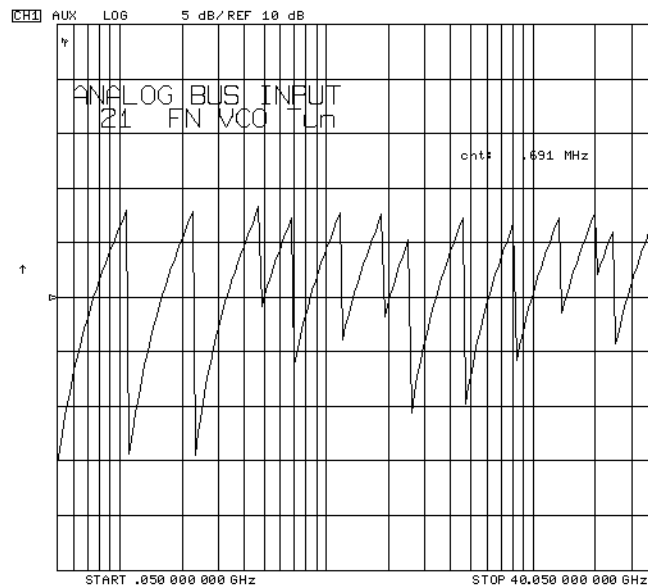

2. Press **COUNTER:FRAC N** **(Sweep Setup)** **CW FREQ** and set the instrument to the frequencies of column one in [Table 7-1](#).

Table 7-1 VCO Range Check Frequencies

Front Panel	Displayed Counter Value
50 MHz	119.988 to 120.012 MHz
109.999 MHz	239.975 to 240.024 MHz

- If the voltage waveform resembles [Figure 7-2 on page 7-14](#), but the counter values do not match [Table 7-1](#), A14 is the most probable fault.

- If the voltage waveform and the counter values are bad, continue with “[Substituting Tuning Voltages to Check the VCO](#)” on page 7-16.
- If the instrument passes both checks, the probability is greater than 90% that A13 and A14 are functional: go to “[Pulse Generator \(A52\) Check with Oscilloscope](#)” on page 7-19, “[Pulse Generator \(A52\) Check with Spectrum Analyzer](#)” on page 7-20, or “[Check the VCO \(A14\) Range with Oscilloscope](#)” on page 7-16 to confirm.

Check the Fractional-N Analog (A13) and Fractional-N Digital (A14) with a Spectrum Analyzer

1. Press the following:

Pres **PRESET: FACTORY** **Pres**

System **SERVICE MENU** **SERVICE MODES** **FRACN TUNE ON**

2. Set the parameters on the spectrum analyzer:

- start frequency = 50 MHz
- stop frequency = 250 MHz
- bandwidth = 300 kHz

3. Remove the instrument bottom cover and disconnect the A52J1 cable from the A52 Pulse Generator.

4. Connect the spectrum analyzer to the output of A14 via the A52J1 cable.

5. Slowly turn the network analyzer front panel knob to tune the signal across the entire frequency range.

You should see a signal that is about 0 dBm at 120 MHz and below. You should see the signal drop approximately 2.5 dB above 120 MHz.

6. Look for sidebands on the signal.

The signal should appear very clean without any sidebands present, however, you will observe source harmonics.

- If any sidebands do appear on the signal, there could be a faulty A13 fractional-N analog assembly.
- If you see pieces of the signal dropping out (possibly in steps) when you are tuning the signal across the frequency range, there could be a faulty A14 fractional-N digital assembly.
- If a clean signal appears across the entire frequency range, you can assume that the A13 (fractional-N analog) and the A14 (fractional-N digital) assemblies are working correctly.

Check the VCO (A14) Range with Oscilloscope

1. Connect an oscilloscope to A14TP1 (labeled VCO/2, yellow tabs- rear multi pin connector).
2. Press the following:
Preset **PRESET: FACTORY** **Preset**
System **SERVICE MENU** **SERVICE MODES** **FRACN TUNE ON**
3. Vary the fractional-N VCO frequency with the front panel knob.
4. If the waveforms do not resemble [Figure 7-3](#) at the frequencies indicated, replace A14. (The amplitude of the waveforms will vary from 3V to 10V p-p.)

Figure 7-3 VCO/2 Waveforms at A14TP1

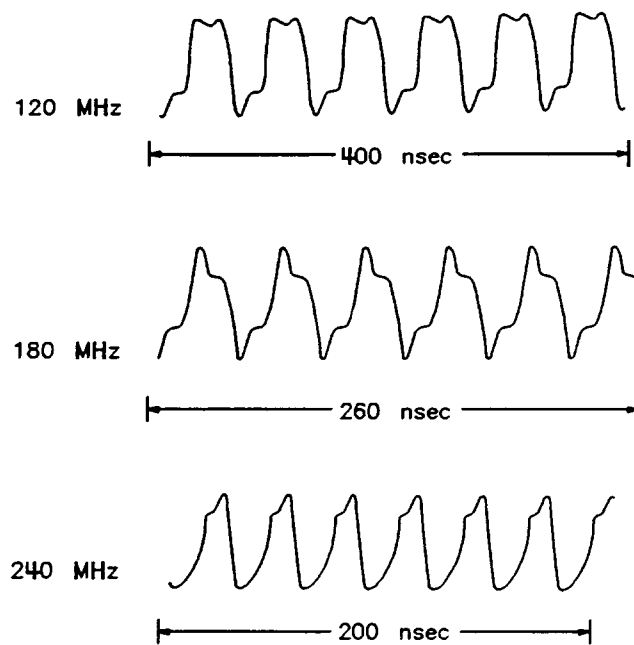

sb634d

Substituting Tuning Voltages to Check the VCO

The tuning voltage range of the VCO is approximately +1 to +14 volts. This procedure substitutes power supplies for the normal voltages from A13 to check the frequency range of the A14 VCO.

1. Turn off the analyzer.
2. Remove the A13 assembly (orange tabs).
3. Put the A14 assembly on an extender board. It is not necessary to connect the cables while the A14 is on the extender board.

- Turn on the analyzer.
- To set the internal counter to the frac-N node, press the following:

(System) **SERVICE MENU** **ANALOG BUS ON**

(Meas) **ANALOG IN Aux Input** **COUNTER: FRAC-N**

- In turn, jumper each of the three supply voltages to A14TP14 and observe the frequency as shown in [Table 7-2](#). A variation of $\pm 10\%$ is expected. The counter frequency needs to be extremely out of specification to constitute a failure.

Table 7-2 VCO Exercise Matrix

Supply Test Point	Voltage Mnemonic	A14 Test Point	Counter Frequency
A8TP7	+15V	A14TP14	\cong 240 MHz
A8TP8	+5VU	A14TP14	\cong 155 MHz
A8TP2	AGND	A14TP14	\cong 105 MHz

- If the frequency changes are not correct, replace A14.
- If the frequency changes are correct, continue with “[Divide-by-N \(A14\) Circuit Check](#)” next.

Divide-by-N (A14) Circuit Check

NOTE The A13 assembly should still be out of the instrument and the A14 assembly on an extender board.

- Jumper A14TP14 to the +5VU supply.
- Connect an oscilloscope to A14J3 (labeled VCO/N OUT).
- Press **(System)** **SERVICE MENU** **SERVICE MODES** **FRACN TUNE ON**.
- Vary the fractional-N frequency from 120 MHz to 242 MHz.
 - If the period of the signal does not vary from 7.5 μ sec to 15.5 μ sec, replace A14. A variation of $\pm 10\%$ is expected. The counter frequency needs to be extremely out of specification to constitute a failure.
 - If the period does vary as prescribed, remove the jumper and reinsert A14. Always turn off the analyzer before removing or replacing any assembly.

A14-to-A13 Digital Control Signals Check

- Place A13 on the extender board and reconnect all of the flexible cables (the one to A14J1 is optional).
- The A14 assembly generates a TTL cycle start (CST) signal every 10 microseconds when the VCO is oscillating.

3. Connect an oscilloscope to A14TP3 (CST). (Suggested vertical scale: 2.0V/div.)
4. Press **(Sweep Setup) TRIGGER MENU HOLD** to stop the sweep. This will make triggering on these waveforms easier.
5. If there is no signal, replace A14.
6. Use the CST signal as an external trigger for the oscilloscope and observe the signals listed in [Figure 7-4](#). Since these TTL signals are generated by A14 to control A13, check them at A13 first.

The signals should look similar to the waveforms in [Figure 7-4](#).

Table 7-3 A14-to-A13 Digital Control Signal Locations

Mnemonic	A13 Location	A14 Location
CST	none	TP3
L FNHOLD	P2-2	P2-2
FNBIAS	P2-5	P2-5
API1	P2-32	P2-32
API2	P2-3	P2-3
API3	P2-34	P2-34
API4	P2-4	P2-4
API5	P2-35	P2-35
FNLATCH	P1-28	P1-58

Figure 7-4 A14 TTL Signals at A14TP3

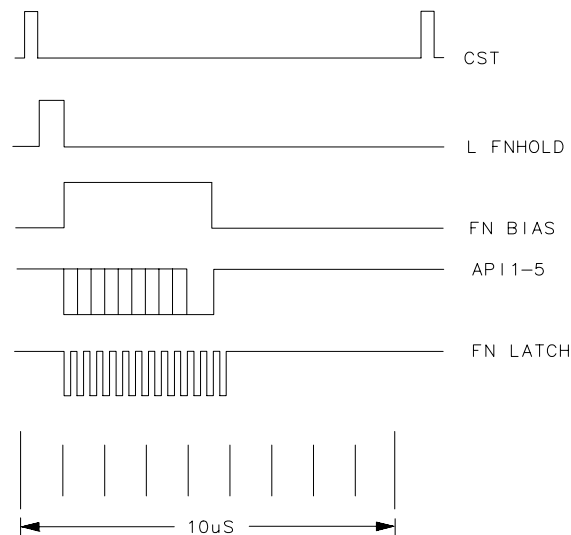

sb631d

- If these signals are bad, replace A14. If the signals are bad, replace A13.

Pulse Generator (A52) Check with Oscilloscope

1. Monitor the 1st IF signal at the output of A65 A sampler assembly: disconnect the SMB cable from A65 and connect an oscilloscope to the sampler assembly IF output. Connect a frequency counter to PORT 1. Then perform these steps:
 - a. To set the fractional-N VCO to 180 MHz, press the following:

PRESET: FACTORY
 SERVICE MENU **SERVICE MODES**
FRACN TUNE ON

Press **SRC ADJUST MENU** **DAC NUM LOW BAND** and rotate the front panel knob to change the DAC number to about 4013. Readjust the DAC number as required to measure an output frequency of about 0.91 GHz.

NOTE The frequency counter may have to be removed from PORT 1 to provide enough of a reflection to see signal on the scope.

2. Now the oscilloscope should display the IF signal as a sine wave of about 10 MHz. The actual frequency can be expressed as this equation:

$$\text{Oscilloscope frequency} = (\text{counter frequency}) - (180 \text{ MHz}) \times (\text{harmonic})$$
3. Repeat steps 1b and 2 using the information in the second through fourth rows of [Table 7-4](#). Substitute **DAC NUM LOW BAND** with the appropriate band.

Table 7-4 First IF Settings

DAC Number Band	Approximate DAC Number Displayed	Approximate Source Frequency On Counter	Harmonic	Oscilloscope Frequency
Low	4013	0.910 GHz	5	10 MHz
Mid (8722ET/ES Only)	3541	3.610 GHz	26	10 MHz
High	4004	4.690 GHz	26	10 MHz
High (8722ET/ES Only)	2529	20.17 GHz	112	10 MHz

- If the IF signals are correct, replace the A11.
- If the IF signals are incorrect, check the pulse generator bias voltages at the motherboard (A17J19).
 - pin 4 = -5.2 V
 - pin 3 = +15 V
 - pin 2 = -15 V
 - pin 1 = GND

If the voltages are correct, replace the A52 pulse generator.

Pulse Generator (A52) Check with Spectrum Analyzer

1. Connect the spectrum analyzer to the network analyzer A65, A sampler assembly (J3) IF output.

2. Set the parameters on the spectrum analyzer:

- center frequency = 10 MHz
- span = 10 MHz
- marker = 10 MHz

3. On the network analyzer, to set the fractional-N VCO to 180 MHz, press the following:

Presets **PRESET: FACTORY** **Presets**
System **SERVICE MENU** **SERVICE MODES**
FRACN TUNE ON **180** **M/u**
SRC ADJUST MENU **DAC NUM LOW BAND** **4000** **x1**

4. Slowly turn the network analyzer front panel knob until the spectrum analyzer measures an output frequency of about 10 MHz.

- If the 10 MHz signal appeared, disregard the rest of this step and continue with the next step.
- If the 10 MHz signal didn't appear, connect the R sampler assembly IF OUTPUT (J3) to the spectrum analyzer input.
 - If the 10 MHz signal appears on the R sampler assembly but not on the A sampler assembly, the A sampler assembly is faulty.
 - If the 10 MHz signal didn't appear at either the A sampler assembly or the R sampler assembly, connect the network analyzer's PORT 1 to the spectrum analyzer input.
- Set the parameters on the spectrum analyzer:
 - center frequency = 0.7 GHz
 - span = 200 MHz

You should see a signal near the center frequency.

- If a signal is present, the A52 pulse generator is the most probable fault.

5. Reconnect the spectrum analyzer to the A sampler assembly (J3).

6. On the spectrum analyzer, set these parameters:

- center frequency = 10 MHz
- span = 10 MHz
- marker = 10 MHz

7. Press **DAC NUM HIGH BAND** on the network analyzer, and slowly turn the front panel knob to get a signal of about 10 MHz displayed on the spectrum analyzer.
8. Reconnect the network analyzer's PORT 1 to spectrum analyzer input.
9. On the spectrum analyzer, set these parameters:

8719ET/ES and 8720ET/ES models:

- center frequency = 4.45 GHz
- span = 200 MHz

8722ET/ES models:

- center frequency = 23.4 GHz
- span = 200 MHz

You should see a signal near the center frequency.

- If the signals appeared for both the low band and high band, you can assume that all the assemblies are working correctly, with the exception of the A11 phase-lock assembly.
- If the high band signal didn't appear, there could be a faulty A68 attenuator, A25 switch (8722ET/ES only), A5 (source switch), A6 (source switch), or the associated cables.
- If the low band signal didn't appear, there could be a faulty A57 fixed oscillator, A53 mixer/amp, A25 switch (8722ET/ES only), A5 (source switch), A6 (source switch), or the associated cables.
- If neither low band or high band signal appears, there could be a faulty A54 YIG oscillator (8722ET/ES only), A55 YIG oscillator, A11 phase-lock, A58 M/A/D/S, or the associated cables.

Band-Related Problems

Table 7-5 lists assemblies potentially responsible for band-related problems.

Table 7-5 Assemblies Potentially Responsible for Band-Related Problems

Low Band	Mid Band (8722ET/ES Only)	High Band
A57	A55	A59
A53	A5 (source switch)	A5 (source switch)
A5 (source switch)	A6 (source switch)	A6 (source switch)
A6 (source switch)	A59	A25 switch (8722ET/ES)
A59		A54 (8722ET/ES)

NOTE Problems in RF components, crimped RF cables, and improper connections which generally cause power holes in an RF signal may cause symptoms that indicate a band-related problem.

Start by measuring power at A5J3 (source switch) (A25J3 switch, 8722ET/ES only). If the power here is good, then all of the band related components are verified. To check other components, continue troubleshooting with “[Broadband Power Problems](#)” on page 7-26.

Keep the following points in mind.

- Remove the instrument covers.
- Cables having improper connections can be the problem in all cases.
- Use the flexible RF cable from the tool kit to measure power at otherwise inaccessible connections.
- Before replacing suspect assemblies, check bias voltages on A54 (YIG oscillator), A55 (YIG oscillator), and A57 (cavity oscillator).
 - A54 and A55: +22 V middle pin, +15 V left pin on J1.
 - A57: +20 V left pin, -10 V right pin.

Low Band Problems:

1. Calibrate and zero a power meter and connect it to A5J3 on ET models (A25J3 for 8722ET/ES).
2. To measure power at J3, press the following:

(System) **SERVICE MENU** **SERVICE MODES**
SRC ADJUST MENU **DAC NUM LOW BAND** (4000) (x1)

- If greater than -5 dBm for DAC numbers from 50 MHz (DAC # $\cong 3650$) to about 1.1 GHz (DAC # $\cong 4095$), troubleshoot the cabling and components from A5J3 (A25J3 for 8722ET/ES) to the R sampler assembly A64J2 (refer to the overall block diagram at the end of [Chapter 4](#)).
 - If less than -5 dBm at A5J3 (A25J3 for Agilent 8722ET/ES), the problem is in the A53 mixer/amp, A57 fixed oscillator, A5 (source switch), or A6 (source switch) or A25 on 8722ET/ES models.
3. Measure power at the A53 end of cable (W6).
 - If power is greater than $+8$ dBm, A6 (source switch) and A55 (low band YIG) are good.
 - If power is less than $+8$ dBm, continue with step 4.
 4. Measure power at the A6 end of cable (W7).
 - If power is greater than $+8.5$ dBm, A6 (source switch) is good. Replace A55 (YIG).
 5. Measure power on the A5 (source switch) end of (W42).
 - If the power is greater than -5 dBm, replace A5 (source switch).
 - If the power is less than -5 dBm, the problem is the A53 mixer amp or the A57 fixed oscillator. Replace the A53 first and if the problem persists, replace the A57.

Mid Band Problems: (8722ET/ES Only)

1. Press the following:

System SERVICE MENU SERVICE MODES
SRC ADJUST MENU DAC NUM MID BAND 4000 x1

(SRC tune in the mid band is capable of tuning the instrument from about 2.4 to 5 GHz). Loss of lock in mid band only may likely be due to a bad cable or connection.

2. The following components may be at fault. Refer to the overall block diagram at the end of [Chapter 4](#) for information.

A5 (source switch) A6 (source switch) A58 M/A/D/S A55 YIG 1 A25 (switch)

3. Since the analyzer phase locked in lowband, all of the phase lock circuitry is working. Look for low power as a cause of phase lock errors.
4. Check power at A25J3.
 - If the power at A25J3 is less than -1 dBm, check the insertion loss of A5 (source switch), A6 (source switch), A25 and the associated cables.
 - If the power at A5J3 is greater than -1 dBm, the problem is probably above 5 GHz. Proceed with the next steps.

5. Check all RF cabling and connections.

- If any of the cables or connectors are bad, have them repaired or replaced.
- If the cables and connectors are good, replace the A55 YIG 1. If mid band problems still persist, then replace the A58 M/A/D/S.

High Band Problems: (8719ET/ES and 8720ET/ES Only)

1. Press the following:

(System) SERVICE MENU SERVICE MODES

SRC ADJUST MENU DAC NUM HIGH BAND **(4000) (x1)**

(SRC tune in the high band is capable of tuning the instrument from about 2.4 to 5 GHz). Loss of lock in high band only may likely be due to a bad cable or connection.

2. The following components may be at fault. Refer to the overall block diagram at the end of [Chapter 4](#) for information.

A5 (source switch) A6 (source switch) A58 M/A/D/S A55 YIG 1

3. Since the analyzer phase locked in lowband, all of the phase lock circuitry is working. Look for low power as a cause of phase lock errors.

4. Check power at A5J3.

- If the power at A5J3 is less than 0 dBm, check the insertion loss of A5 (source switch), A6 (source switch), and the associated cabling.
- If the power at A5J3 is greater than 0 dBm, the problem is probably above 5 GHz. Proceed with the next steps.

5. Check all RF cabling and connections.

- If any of the cables or connectors are bad, have them repaired or replaced.
- If the cables and connectors are good, replace the A55 YIG 1. If high band problems still persist, then replace the A58 M/A/D/S.

High Band Problems: (8722ET/ES Only)

1. Press the following:

(System) SERVICE MENU SERVICE MODES

SRC ADJUST Menu DAC NUM HIGH BAND **(4000) (x1)**

(SRC tune in the high band is capable of tuning the instrument from about 19.5 to 24 GHz.) Loss of lock in high band only may likely be due to a bad cable or connection.

2. The following components may be at fault. Refer to the overall block diagram at the end of [Chapter 4](#) for information.

A25 (switch) A6 (source switch) A58 M/A/D/S A54 YIG 2

3. Since the analyzer phase locked in low and/or mid band, all of the phase lock circuitry is working, so look for low power as a cause of phase lock errors.
4. Check power at the output of A25 switch at J3.
 - If the power is less than +5 dBm, check the insertion loss of A25 switch and the associated cabling.
 - If the power out of the A25 switch is greater than +5 dBm, the problem is probably above 24 GHz. Proceed with the next steps.
5. Check all RF cabling and connections.
 - If any of the cables or connectors are bad, have them repaired or replaced.
 - If the cables and connectors are good, replace the A54 YIG 2. If high band problems still persist, then replace the A58 M/A/D/S.

Broadband Power Problems

This section assumes that a power problem exists across the full frequency range, and that no error message is displayed. On ES models, the problem may affect PORT 1, PORT 2, or both. On ET models, the problem may affect the REFLECTION port. Suspect assemblies include:

A69 step attenuator	A59 source interface board	A5 (source switch)
A74 transfer switch	A58 M/A/D/S	A61 bias tee
A62 directional coupler	A60 bias tee	A6 (source switch)
A55 YIG1	A63 directional coupler	A25 switch (8722ET/ES Only)
A54 YIG2 (8722ET/ES Only)	A74 switch splitter (Option 400 Only)	

ALC/Signal Separation Check

1. Press **Sweep Setup** **CW FREQ** **3** **G/n**.

2. **For ES Models:**

Choose which port to begin troubleshooting by pressing the following:

Meas **Ref1: FWD S11 (A/R)** for PORT1 or **Ref1: FWD S22 (B/R)** for PORT 2

For ET Models:

Troubleshoot the REFLECTION port by pressing the following:

Meas **REFLECTION**

1. To disable the ALC eliminate modulator control, press **System** **SERVICE MENU** **SERVICE MODES** **SRC ADJUST MENU** **ALC OFF**. Use a power meter to measure the power at the faulty port.

2. **For 8719ET/ES and 8720ET/ES**

If you measure at least +5 dBm (+10 dBm on ET models and ES Option 007 models) at the port, replace the A59 source interface board assembly.

For ES Models Only

- If you measure less than +5 dBm (+10 dBm on Option 007 models) at the port, press **Meas** and **Ref1: REV S22 (B/R)** or **Ref1: FWD S11 (A/R)** and measure power at the other port.
- If you measure less than +5 dBm (+10 dBm on Option 007 models) at the other port, continue with “[Step Attenuator \(A69\) Check](#)” next.
- If you measure at least +5 dBm (+10 dBm on Option 007models) at the other port, either the directional coupler or the bias tee or the transfer switch (A25) is faulty. The power loss through each of these components should be negligible.

For 8722ET/ES

- If you measure at least -8 dBm (-3 dBm on ET models and ES Option 007 models) at the port, replace the A59 source interface board assembly.

For ES Models Only

- If you measure less than -8 dBm (-3 dBm on Option 007 models) at the port, press **Meas** and **Ref1: REV S22 (B/R)** or **Ref1: FWD S11 (A/R)** and measure power at the other port.
- If you measure less than -8 dBm (-3 dBm on Option 007 models) at the other port, continue with “[Step Attenuator \(A69\) Check](#)” next.
- If you measure at least -8 dBm (-3 dBm on Option 007 models) at the other port, either the directional coupler or the bias tee or the transfer switch (A25) is faulty. The power loss through each of these components should be negligible.

Step Attenuator (A69) Check

1. Measure the input and output power of the step attenuator; the loss should be negligible if the attenuator is set to 0 dB.
2. If the 5 dB attenuation steps seem inconsistent, perform the “[Step 2. Operator’s Check](#)” on page 4-7.

8 Receiver Troubleshooting

Information on This Chapter

Use this procedure only if you have read [Chapter 4](#) , “[Start Troubleshooting Here.](#)” Follow the procedures in the order given, unless instructed otherwise.

This section can be used to determine which receiver assembly of the instrument is faulty. The two receiver assemblies that affect all three signal paths are the digital IF (A10) and reference assemblies (A12). The receiver assemblies that are associated with specific signal paths are listed in [Table 8-1](#).

Table 8-1 Receiver Assemblies and Associated Paths

Signal Path	Port	Directional Coupler	Sampler Assembly	2nd Converter
R or R1	internal	NA	A64	A6
R2 (Option 400)	internal	NA	A67	A6
A	1	A62	A65	A4
B	2	A63	A66	A5

Assembly Replacement Sequence

The following steps show the sequence to replace an assembly in the network analyzer.

- Step 1.** Identify the faulty group. Begin with [Chapter 4](#) , “[Start Troubleshooting Here.](#)” Follow up with the appropriate troubleshooting chapter that identifies the faulty assembly.
- Step 2.** Order a replacement assembly. Refer to [Chapter 13](#) , “[Replaceable Parts.](#)”
- Step 3.** Replace the faulty assembly and determine what adjustments are necessary. Refer to [Chapter 14](#) , “[Assembly Replacement and Post-Repair Procedures.](#)”
- Step 4.** Perform the necessary adjustments. Refer to [Chapter 3](#) , “[Adjustments and Correction Constants.](#)”
- Step 5.** Perform the necessary performance tests. Refer to [Chapter 2](#) , “[System Verification and Performance Tests.](#)”

All Signal Paths Look Abnormal

For the receiver to operate properly, the digital IF (A10) and 2nd converter assemblies must receive signals from the reference assembly (A12). Those signals are the 2nd LO and the 4 MHz signal.

2nd LO Check

To check the 2nd LO signal with the analog bus counter, press the following:

Presets **PRESET: FACTORY** **Presets**

System **SERVICE MENU** **ANALOG BUS ON**

Meas **ANALOG IN Aux Input** **COUNTER: ANALOG BUS** **16** **x1**

- If the counter reads 9.996 MHz, continue with [“4 MHz Check.”](#)
- If the counter does not read 9.996 MHz, perform the [“Reference Assembly VCO Tune Adjustment”](#) on page 3-39.
 - If the adjustment is successful and the problem is cured, for verification perform the [“Frequency Accuracy Performance Test”](#) on page 2-34.
 - If the adjustment is unsuccessful or the problem persists, replace the A12 assembly. (A12 is indicated by red tabs.)

4 MHz Check

1. Switch off the analyzer.
2. Remove the Digital IF (A10) board (indicated by black tabs) and install it onto the extender board (HP/Agilent part number 08753-60155, part of the 08722-60018 tool kit).
3. Use an oscilloscope to observe the 4 MHz signal at A10P2 pin 6 which is labeled on the extender board.
 - If the 4 MHz sine wave signal is present at A10P2 pin 6, replace A10.
 - If the 4 MHz sine wave signal is not present at A10P2 pin 6, check signal at A12P2 pin 36 by connecting a SMB(f) to SMB(f) cable and a SMB(m) barrel adaptor to extend the “FN REF” cable front SMB connector. The “Ext Ref” cable (rear SMB connector) does not have to be connected for this test. (A12 is indicated by red tabs.)
 - If the 4 MHz signal is not present at A12P2 pin 36, replace A12.
 - If the 4 MHz signal is present at A12 (but not A10), check the motherboard trace.

At Least One Signal Path Looks Normal

One normal signal path indicates that at least one sampler, one 2nd converter, A12, and much of A10 are functional. Therefore, substitution is a convenient troubleshooting approach. If two signal paths are abnormal, repeat the steps of this section for each suspect signal path.

1. To see the traces of signal path A or R, connect a short to PORT 1 on ES models (REFLECTION port on ET models).

Press the following:

Pres **PRESET: FACTORY** **Pres**

Meas **INPUT PORTS** **R**, or **A**

System **SERVICE MENU** **SERVICE MODES**

MORE **SAMPLR COR OFF**

2. To see the traces of signal path B or R2 (if the instrument is an ES model Option 400), connect a short to PORT 2 on ES models. On ET models, connect an RF cable to the REFLECTION and TRANSMISSION ports. Then press the following:

Pres **PRESET: FACTORY** **Pres**

Meas **INPUT PORTS** **R** or

(**B** **TESTPORT 2** on ES models) (**B** on ET models)

System **SERVICE MENU** **SERVICE MODES**

MORE **SAMPLR COR OFF**

3. For examples of the normal signal traces, refer to [Figure 8-1 on page 8-6](#). For signal trace nominal power levels, refer to [Table 8-2 on page 8-5](#).

NOTE The illustrations depicting the analyzer display were made using an 8722ES model with nominal test port power. Other analyzer displays may appear different, depending on model and options.

- Even if the R signal path trace is abnormal, the R sampler is nonetheless good (or there would be a phase lock problem). Go directly to [“2nd Converter Check” on page 8-9](#).
- If the A or B signal path is very low and the R signal path is normal, go to [“A and B Sampler Check by Substitution” on page 8-8](#).
- If the A or B signal path appears slightly low, the problem is possibly a faulty directional coupler or, more probably, a lossy sampler. To isolate the fault, continue with [“Directional Coupler Check” on page 8-7](#).

Table 8-2 Nominal Power Levels

Analyzer Model Type	Nominal Power Level
8719ES and 8720ES	+5 dBm
8719ET and 8720ET 8719ES Option 007 and 8720ES Option 007	+10 dBm
8722ES	-10 dBm
8722ET and 8722ES Option 007	-5 dBm

Figure 8-1 Typical R, R2, A, and B Traces

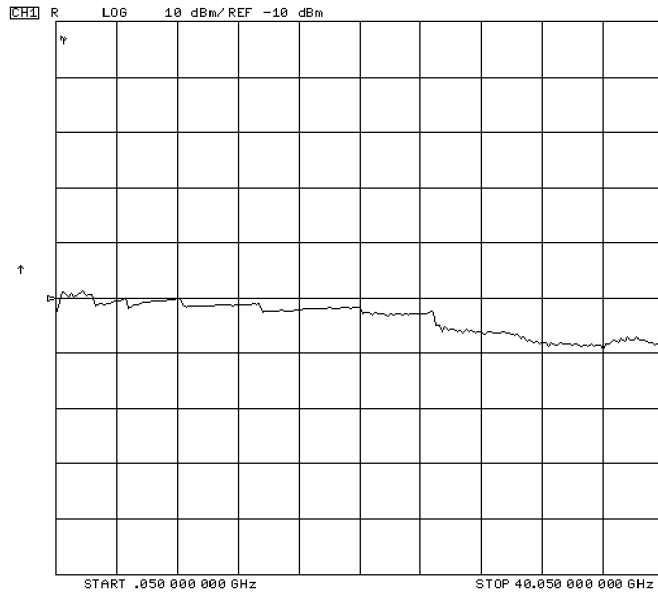

Typical R or R2
Channel Signal
Path

sb550e

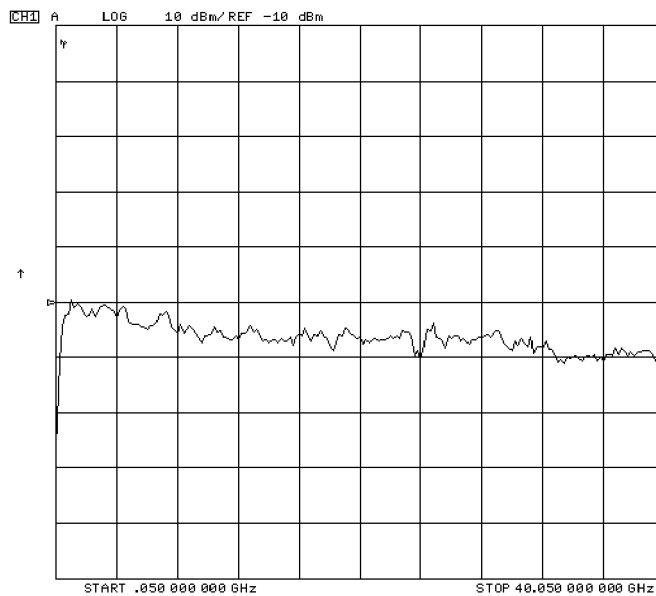

Typical A or B
Channel Signal
Path

sb551e

Directional Coupler Check

1. For the 8719ET/ES and 8720ET/ES, set the output power to -10 dBm by pressing **Power** **-10** **x1**.
2. For the 8722ET/ES, set the output power to -15 dBm by pressing **Power** **-15** **x1**.

For ES Models, set up the following

3. Connect an RF flexible cable from the output of the transfer switch (A74) directly to the 2.4 mm RF INPUT (J2) of the suspect sampler. Use 3.5 mm to 2.4 mm adapters where necessary. This connection bypasses the step attenuator, bias tee, and the coupler.

IMPORTANT To disconnect the semirigid cable of the A74 transfer switch, it may be necessary to disconnect additional semirigid cables and loosen the transfer switch. Be careful not to damage the center pin when disconnecting the cable.

For ET Models, set up the following

4. For standard ET models, connect an RF flexible cable from the cable (W76) that connects the M/A/D/S (A58) to the directional coupler (A62) to the 2.4 mm RF INPUT (J2) of the suspect sampler. (Make the connection at the coupler end of the cable).
For ET Option 004 models, connect an RF flexible cable from the cable (W32) that connects the M/A/D/S (A58) to the step attenuator (A69) to the 2.4 mm RF INPUT (J2) of the suspect sampler. (Make the connection at the attenuator end of the cable).

Checking the Operation of the Sampler

5. To measure the signal at the A sampler, on ET models press **Meas** **INPUT PORTS** **A** (on ES models press **TESTPORT 1** or **TESTPORT 2** depending on which side of the transfer switch is being tested).

To measure the signal at the B channel, on ET models press **Meas** **INPUT PORTS** **B** (on ES models press **TESTPORT 1** or **TESTPORT 2** depending on which side of the transfer switch is being tested).

Compare the responses to the examples in [Figure 8-1 on page 8-6](#) and the nominal power levels in [Table 8-2 on page 8-5](#). Expect the nominal power level to be a little higher due to the reduced loss created by the bypassed components.

- If the trace is similar (with the exception of the coupler roll-off below 500 MHz) to [Figure 8-1 on page 8-6](#), the sampler is good. Therefore, the coupler, step attenuator, or bias tee is lossy. Test the path by substituting the components one at a time and comparing the response to [Figure 8-1 on page 8-6](#), or measure the insertion loss directly. Minor power variations are probably due to the flexible cable and are of no concern.
- If the trace is abnormally low, the coupler is good and the sampler is at fault. Troubleshoot the associated sampler by referring to [“Sampler Voltage Check” on page 8-9](#).

A and B Sampler Check by Substitution

1. For the 8719ET/ES and 8720ET/ES, set the output power to -10 dBm by pressing **Power** **-10** **x1**.
2. For the 8722ET/ES, set the output power to -15 dBm by pressing **Power** **-15** **x1**.

For ES Models, set up the following

3. Connect an RF flexible cable from the output of the transfer switch (A74) directly to the 2.4 mm RF INPUT (J2) of the suspect sampler. Use 3.5 mm to 2.4 mm adapters where necessary. This connection bypasses the step attenuator, bias tee, and the coupler.

IMPORTANT To disconnect the semirigid cable of the A74 transfer switch, it may be necessary to disconnect additional semirigid cables and loosen the transfer switch. Be careful not to damage the center pin when disconnecting the cable.

For ET Models, set up the following

4. For standard ET models, connect an RF flexible cable from the cable (W76) that connects the MADS (A58) to the directional coupler (A62) to the 2.4 mm RF INPUT (J2) of the suspect sampler. (Make the connection at the coupler end of the cable.)

For ET Option 004 models, connect an RF flexible cable from the cable that connects the MADS (A58) to the step attenuator (A69) to the 2.4 mm RF INPUT (J2) of the suspect sampler. (Make the connection at the attenuator end of the cable.)

5. Connect the IF output cable for the R sampler, to the IF Output of the suspect sampler.

Checking the Operation of the Sampler

6. Press **Preset** **PRESET: FACTORY** **Preset** and see whether the instrument phase locks. Disregard the trace.
 - If the instrument phase locks and no error message is displayed, the sampler under test is normal. Go to [“2nd Converter Check” on page 8-9](#).
 - If the instrument displays the PHASE LOCK CAL FAIL error message, either the sampler or its control and bias voltages are faulty. Continue with [“Sampler Voltage Check.”](#)

Sampler Voltage Check

NOTE The BIAS CONTROL line is not used.

1. Measure the SAMPLER CONTROL voltage (green wire) at the suspect sampler. The voltage should be about +0.04 V when the sampler is on.
 - If the sampler control voltage is wrong, replace A51, the interface assembly. (Do NOT replace the sampler: the problem is in the control signals.)
 - If the sampler control voltage is correct, proceed to the next step.
2. Check the +15 V and –15 V supply voltages.
 - If the supply voltages are within 5% of nominal, replace the sampler.
 - If the supply voltages are incorrect, then check the +15V (TP7) and –15 V (TP5) at the post regulator (A8). If the post regulator voltages are good, then replace the motherboard (A17). If the voltages are incorrect change the post regulator.

2nd Converter Check

NOTE Repair signal path R before troubleshooting signal path A or B.

Faulty R Signal Path:

1. If R is the bad signal path, substitute A6 (R 2nd converter) with a 2nd converter from a working signal path.
2. Press **Meas** **INPUT PORTS** **R** and compare the trace to the signal path R trace of Figure 8-1.
 - If the trace appears normal, replace the faulty 2nd converter.
 - If the trace appears abnormal, replace A10.

Faulty A or B Signal Path:

1. If A is the bad signal path, remove A6 (the working R signal path 2nd converter) and install A4 (the suspect A signal path 2nd converter) in its place.
2. If B is the bad signal path, substitute A6 with A5.
3. Press **Meas** **INPUT PORTS** **R** and compare the trace to the signal path R trace of Figure 8-1.
 - If the trace appears normal, the substitute 2nd converter is good. Replace A10.
 - If the trace appears abnormal, the substitute 2nd converter is faulty. Replace A4 or A5.

9 Accessories Troubleshooting

Information on This Chapter

Use this procedure only if you have read [Chapter 4](#) , “[Start Troubleshooting Here.](#)” Follow the procedures in the order given, unless instructed otherwise.

Measurement failures can be divided into two categories:

- Failures which don't affect the normal functioning of the analyzer but cause incorrect measurement data.
- Failures which impede the normal functioning of the analyzer or prohibit the use of a feature.

This chapter addresses the first category of failures which are usually caused by the following:

- operator errors
- faulty calibration devices or connectors
- bad cables or adapters
- improper calibration techniques
- RF cabling problems within the analyzer

These failures are checked using the following procedures:

- “[Inspect and Gauge Connectors](#)” on page 9-3
- “[Inspect the Error Terms](#)” on page 9-4

Inspect and Gauge Connectors

1. Check for damage to the mating contacts of the test port center conductors and loose connector bulkheads. If the center pin depth is incorrect, replace the entire connector assembly. (See [Chapter 14](#), “[Assembly Replacement and Post-Repair Procedures.](#)”)
2. Inspect the calibration kit devices for bent or broken center conductors and other physical damage. Refer to the calibration kit operating and service manual for information on gauging and inspecting the device connectors.

If any calibration device is obviously damaged or out of mechanical tolerance, replace the device.

Inspect the Error Terms

Error terms are a measure of a “system”: a network analyzer, calibration kit, and any cables used. As required, refer to [Chapter 11](#) , “[Error Terms](#),” for the following:

- The specific measurement calibration procedure used to generate the error terms.
- The routines required to extract error terms from the instrument.
- Typical error term data.

Use [Table 9-1](#) to cross-reference error term data to system faults.

Table 9-1 Components Related to Specific Error Terms

Component	Directivity	Source Match	Reflection Tracking	Isolation (Crosstalk)	Load Match	Transmission Tracking
Calibration Kit						
load	X			X		
open/short		X	X		X	
Analyzer						
coupler	X	X	X	X	X	X
bias tee		X	X	X	X	X
transfer switch		X	X	X	X	X
step attenuator		X	X		X	X
sampler			X	X *		X
A10 digital IF				X		
test port connectors	X	X	X	X	X	X
External cables					X	X
* This component is likely to contribute to crosstalk at 4 GHz.						

If you detect problems using error term analysis, use the following approach to isolate the fault:

1. Check the cable by examining the load match and transmission tracking terms. If those terms are incorrect, go to [“Verify the RF Cable” on page 9-6](#).
2. Verify the calibration kit devices:
 - **Loads:** If the directivity error term looks good, the load and the test port are good. On ES models, if directivity looks bad, connect the same load on the other test port and measure its directivity. If the second port looks bad, as if the problem had shifted with the load, replace the load. If the second port looks good, as if the load had not been the problem, troubleshoot the first port.

On ET models, if directivity looks bad, substitute a known good load to the REFLECTION port. If the directivity is still bad, troubleshoot the REFLECTION port. If the directivity is good, the load is bad.

- **Shorts and opens:** If the source match and reflection tracking terms look good, the shorts and the opens are good. If these terms look bad while the rest of the terms look good, proceed to [“Verify Shorts and Opens by Substitution” on page 9-7](#).

Isolate the Fault in the RF Path

Since the calibration devices have been verified, the problem exists in the test port connector, the coupler, or elsewhere in the internal RF path. [Table 9-1](#) shows which assemblies affect each error term. If more than one error term is bad, note which assemblies are common to each of the bad terms. These are the suspects.

The method of fault isolation that must be used is assembly substitution.

Assembly Substitution Fault Isolation

IMPORTANT Before trying this, be sure to inspect the front-panel test-port connector for obvious damage. Tighten all semi-rigid cable connectors inside the instrument with a calibrated torque wrench.

At this point, the error term problem has been isolated to a specific port and you should have a list of suspected assemblies.

1. On ES models, swap identical assemblies between the PORT 1 and PORT 2 signal paths and then regenerate the error terms.

NOTE On ET models where a duplicate assembly is not present, the analyzer will have to be sent in to your local Agilent Technologies service center. Refer to [Chapter 13 , “Replaceable Parts,”](#) for instructions for returning an analyzer.

2. If the problem moves from one port to another, you have found the offending assembly.

Verify the RF Cable

The load match error term is a good indicator of cable problems. You can further verify a faulty cable by measuring the reflection of the cable.

1. Press **(Preset)** **PRESET: FACTORY** **(Preset)**.
2. Perform a one-port calibration on PORT 1 (REFLECTION port on ET models). For detailed calibration procedures, refer to the “Optimizing Measurement Results” chapter in the analyzer user’s guide.
3. Connect the test port cable to PORT 1 (REFLECTION port on ET models). Connect a broadband load to the other end of the cable. Tighten to the specified torque for the connector type.
4. To measure return loss, press the following:
ES models: **(Meas)** **Refl: FWD S11 (A/R)**
ET models: **(Meas)** **REFLECTION**
5. Press **(Marker Search)** **SEARCH: MAX** to find the worst-case return loss. Refer to the cable manual to see if it meets the return loss specification. If not, the cable should be either repaired or replaced. For an example of a typical return loss measurement, see [Figure 9-1](#).

Figure 9-1 Typical Return Loss Measurement of Test Port Cables

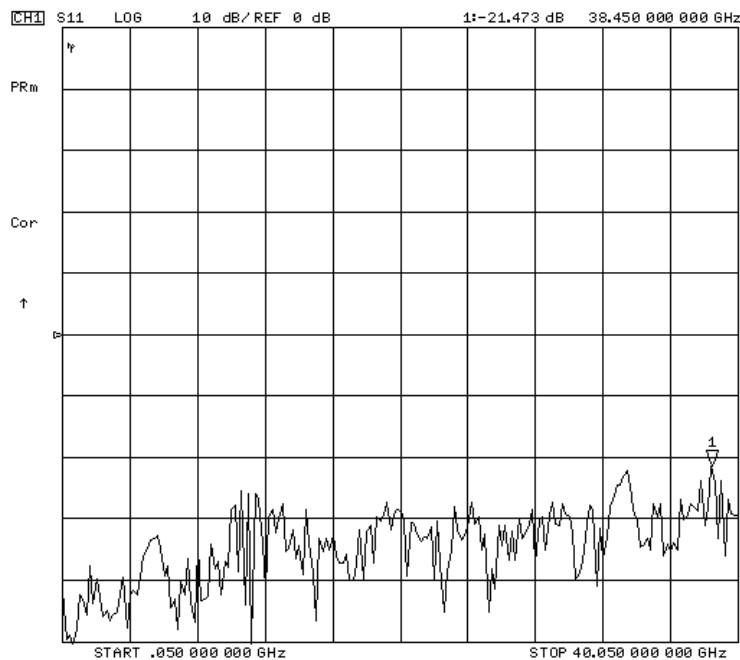

Verify Shorts and Opens by Substitution

Substitute a known good short and open of the same connector type and sex as the short and open in question. If the devices are not from one of the standard calibration kits, refer to your analyzer user's guide for information on how to use the **MODIFY CAL KIT** function. Set aside the short and open that are causing the problem.

1. Perform an S11 one-port calibration on ES models (REFLECTION one-port calibration on ET models) using the known good short and open. Then press **Format** **SMITH CHART** to view the devices in Smith chart format.

2. Connect the known good short to PORT 1 (REFLECTION port on ET models). Press **Scale Ref** **ELECTRICAL DELAY** and turn the front panel knob to enter enough electrical delay so that the trace appears as a dot at the left side of the circle, as in [Figure 9-2](#).

Replace the good short with the questionable short. If the questionable short is good, the trace should appear very similar to the known good short.

3. Connect the known good open to PORT 1 (REFLECTION port on ET models). Press **Scale Ref** **ELECTRICAL DELAY** and turn the front panel knob to enter enough electrical delay so that the trace appears as a dot at the right side of the circle, as in [Figure 9-3 on page 9-8](#).

Replace the good open with the questionable open. If the questionable open is good, the trace should appear very similar to the known good open.

Figure 9-2 Typical Smith Chart Trace of a Good Short

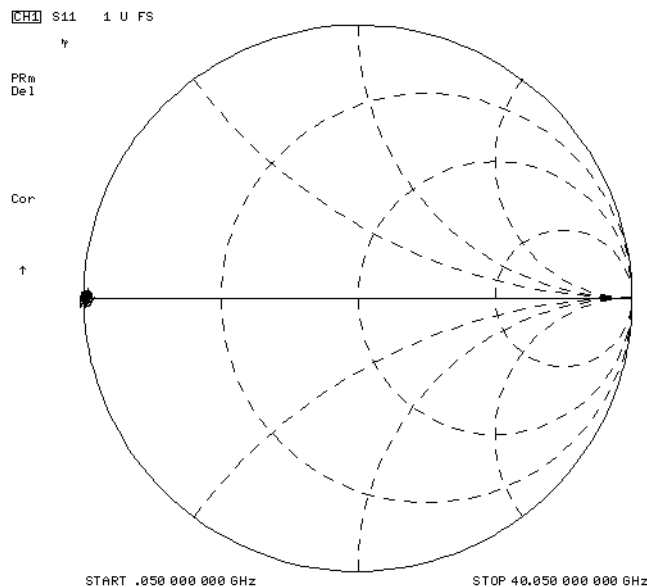
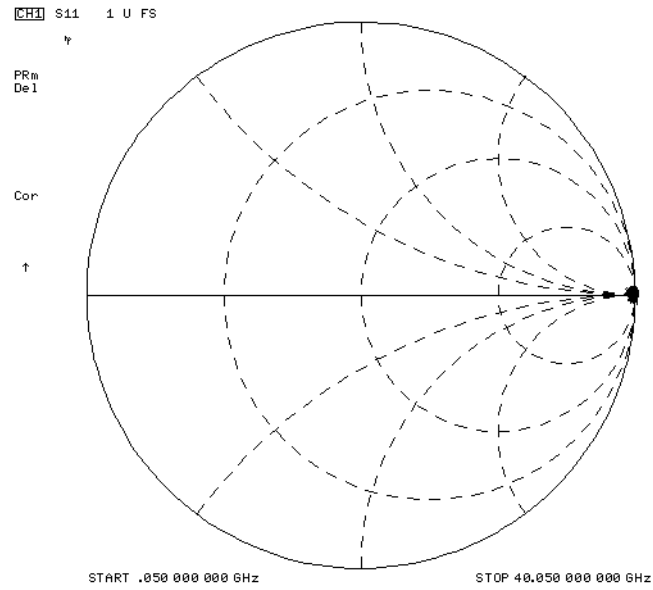

Figure 9-3 Typical Smith Chart Traces of a Good Open



10 Service Key Menus and Error Messages

Information on This Chapter

The service menus aid you in performing the following service functions:

- test
- verify
- adjust
- control
- troubleshoot

The menus are divided into two groups that are described in the following sections:

- [“Service Menus - Internal Diagnostics” on page 10-3](#)

This consists of the first three keys on the menu (Tests, Test Options, and SELF-DIAG).

- [“Service Menu - Service Features” on page 10-15](#)

This consists of the next four keys on the menu (Service Modes, Analog Bus on off, PEEK/POKE, and Firmware Revision).

When applicable, the GPIB mnemonic is written in parentheses following the key. See [“GPIB Service Mnemonic Definitions” on page 10-31](#).

NOTE Throughout this service guide, these conventions are used:

- **Hardkey** are labeled front panel keys.
 - **SOFTKEYS** are display defined keys (in the menus).
 - (GPIB COMMANDS) when applicable, follow the keystrokes in parentheses.
-

Error Messages

The displayed error messages that pertain to service functions are defined in “[Service Related Error Messages in Alphabetical Order](#)” on page 10-33 to help you:

- Understand the message.
- Solve the problem.

Service Menus - Internal Diagnostics

The internal diagnostics menus are shown in [Figure 10-1, “Internal Diagnostics Menu Map,”](#) and described in the following sections. The internal diagnostic menus are accessed by pressing **(System)** **SERVICE MENU** and then one of the following softkeys.

- **TESTS**
- **TEST OPTIONS**
- **SELF-DIAGNOSE**

Figure 10-1 Internal Diagnostics Menu Map

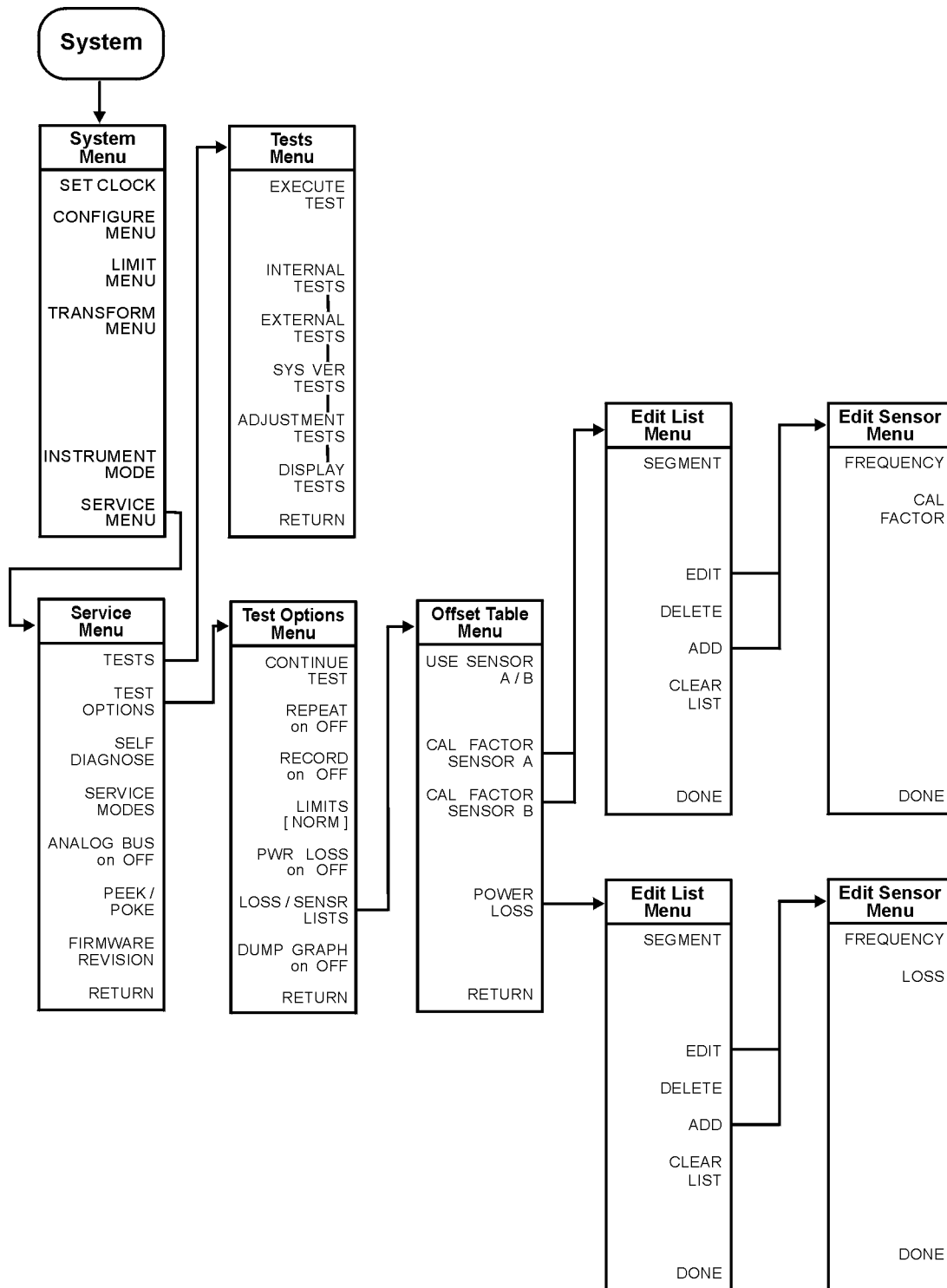

sb582e

Tests Menu

To access this menu, press **(System) SERVICE MENU TESTS**.

TESTS (TEST [D]) accesses a menu that allows you to select or execute the service tests. The default is set to internal test 1.

NOTE Descriptions of tests in each of the categories are given in [“Test Descriptions” on page 10-8](#).

The tests are divided by function into the following categories:

Test Category	Range of Tests
Internal Tests	(0–20)
External Tests	(21–25)
System Verification Tests	(26–42)
Adjustment Tests	(43–54)
Display Tests	(55–61)
Test Patterns	(62–76)

To access the (default) test in each category, press the test category softkey. To access the other tests, use the numeric keypad, step keys, or front panel knob. The test number, name, and status abbreviation will be displayed in the active entry area of the display.

[Table 10-1](#) shows the test status terms that appear on the display, its definition, and the equivalent GPIB code. The GPIB command to output the test status of the most recently executed test is OUTPTESS. For more information, refer to [“GPIB Service Mnemonic Definitions” on page 10-31](#).

Table 10-1 Test Status Terms

Test Status Terms	Definition	GPIB Code
PASS	PASS	0
FAIL	FAIL	1
-IP-	IN PROGRESS	2
(NA)	NOT AVAILABLE	3
-ND-	NOT DONE	4
DONE	DONE	5

- EXECUTE TEST** (EXET) runs the selected test and may display these softkeys:
- **CONTINUE** (TESR1) continues the selected test.
 - **YES** (TESR2) alters correction constants during adjustment tests.
 - **NEXT** (TESR4) displays the next choice.
 - **SELECT** (TESR6) chooses the option indicated.
 - **ABORT** (TESR8) terminates the test and returns to the tests menu.

INTERNAL TESTS evaluates the analyzer's internal operation. These tests are completely internal and do not require external connections or user interaction.

EXTERNAL TESTS evaluate the analyzer's external operation. These additional tests require some user interaction (such as keystrokes).

SYS VER TESTS verifies the analyzer system operation by examining the contents of the measurement calibration arrays. The procedure is in [Chapter 2](#), “[System Verification and Performance Tests](#).” Information about the calibration arrays is provided in [Chapter 11](#), “[Error Terms](#).”

ADJUSTMENT TESTS generates and stores the correction constants. For more information, refer to [Chapter 3](#), “[Adjustments and Correction Constants](#).”

Test Options Menu

To access this menu, press **System** **SERVICE MENU** **TEST OPTIONS**.

- TEST OPTIONS** accesses softkeys that affect the way tests (routines) run, or supply necessary additional data.
- CONTINUE TEST** (TESR1) resumes the test from where it was stopped.
- REPEAT on OFF** (TO2) toggles the repeat function on and off. When the function is ON, the selected test will run 10,000 times unless you press any key to stop it. The analyzer shows the current number of passes and fails.
- RECORD on OFF** (TO1) toggles the record function on and off. When the function is ON, certain test results are sent to a printer via GPIB. This is especially useful for correction constants. The instrument must be in system controller mode or pass control mode to print. Refer to the “[Printing, Plotting, and Saving Measurement Results](#)” chapter in the analyzer’s user’s guide.

LIMITS[NORM/SPCL] selects either normal (NORM) or Special (SPCL) (tighter) limits for the Operator's Check. The SPCL limits are useful for a guard band.

POWER LOSS (POWLLIST) accesses the following Edit List menu to allow modification of the external power loss data table.

LOSS/SENSR LISTS accesses the power loss/sensor lists menu:

- **USE SENSOR A/B** selects the A or B power sensor calibration factor list for use in power meter calibration measurements.
- **CAL FACTOR SENSOR A (CALFSENA)** accesses the Edit List menu to allow modification of the calibration data table for power sensor A.
- **CAL FACTOR SENSOR B (CALFSENB)** accesses the Edit List menu to allow modification of the calibration data table for power sensor B.
- **POWER LOSS (POWLLIST)** accesses the Edit List menu to allow modification of the external power loss data table that corrects coupled-arm power loss when a directional coupler samples the RF output.

DUMP GRAPH generates printed graphs of verification results when activated during a system verification.

Edit List Menu

To access this menu, press **(System) SERVICE MENU TEST OPTIONS LOSS/SENSR LISTS** and then press one of the following: **CAL FACTOR SENSOR A** or **CAL FACTOR SENSOR B** or **POWER LOSS**.

SEGMENT selects a segment (frequency point) to be edited, deleted from, or added to the current data table. Works with the entry controls.

EDIT (SEDI[D]) allows modification of frequency, cal factor and loss values previously entered in the current data table.

DELETE (SDEL) deletes frequency, cal factor and loss values previously entered in the current data table.

ADD (SADD) adds new frequency, cal factor and loss values to the current data table up to a maximum of 12 segments (frequency points, PTS).

CLEAR LIST (CLEL) deletes the entire current data table (or list) when **YES** is pressed. Press **NO** to avoid deletion.

DONE (EDITDONE) returns to the previous menu.

Self Diagnose Softkey

You can access the self diagnosis function by pressing **(System)** **SERVICE MENU** **SELF DIAGNOSE**. This function examines, in order, the pass/fail status of all internal tests and displays **NO FAILURE FOUND** if no tests have failed.

If a failure is detected, the routine displays the assembly or assemblies most probably faulty and assigns a failure probability factor to each assembly.

Test Descriptions

The analyzer has up to 80 routines that test, verify, and adjust the instrument. This section describes those tests.

Internal Tests

This group of tests runs without external connections or operator interaction. All return a **PASS** or **FAIL** condition. All of these tests run on power-up and preset except as noted.

- 0 **ALL INT** – Runs only when selected. It consists of internal tests 3-11, 13-16, and 20. Use the front panel knob to scroll through the tests and see which failed. If all pass, the test displays a **PASS** status. Each test in the subset retains its own test status.
- 1 **PRESET** – Runs the following subset of internal tests: first, the ROM/RAM tests 2, 3, and 4; then tests 5 through 11, 14, 15, and 16. If any of these tests fail, this test returns a **FAIL** status. Use the front panel knob to scroll through the tests and see which failed. If all pass, this test displays a **PASS** status. Each test in the subset retains its own test status. This same subset is available over GPIB as “TST?”. It is not performed upon remote preset.
- 2 **ROM** – Part of the ROM/RAM tests and cannot be run separately. For more information, refer to [Chapter 6](#), “[Digital Control Troubleshooting](#).”
- 3 **SRAM RAM** – Verifies the A7 CPU SRAM (long-term) memory with a non-destructive write/read pattern. A destructive version that writes over stored data at power on can be enabled by changing the 4th switch position of the A7 CPU switch as shown in [Figure 10-2](#).

Figure 10-2 Switch Positions on the A7 CPU Board

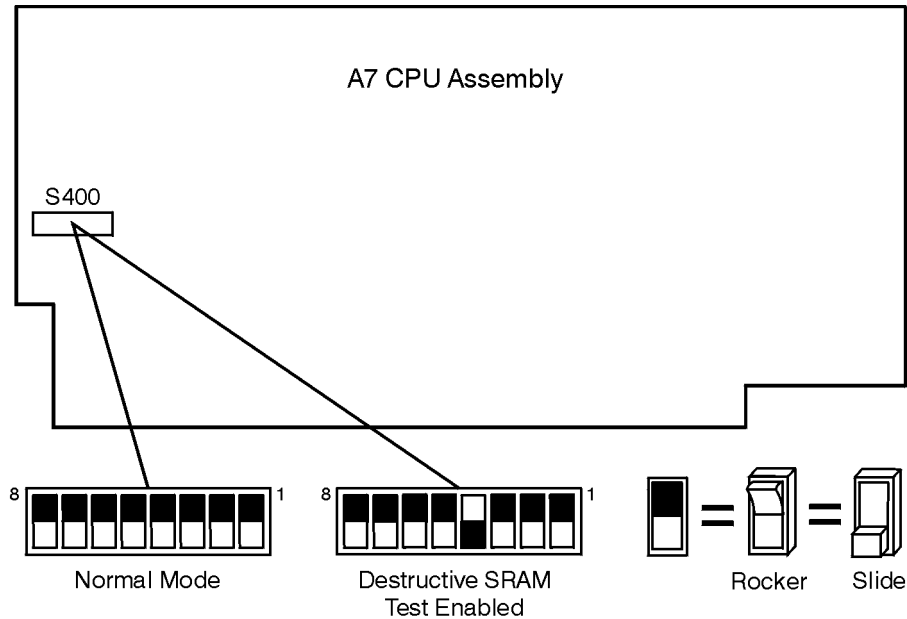

sb6169d

- 4 **Main DRAM** – Verifies the A7 CPU main memory (DRAM) with a non-destructive write/read test pattern. A destructive version of this test is run during power-on.
For additional information, see [“Internal Tests” on page 10-8](#) and [Chapter 6 , “Digital Control Troubleshooting.”](#)
- 5 **DSP Wr/Rd** – Verifies the ability of the main processor and the DSP (digital signal processor), both on the A7 CPU assembly, to communicate with each other through DRAM. This also verifies that programs can be loaded to the DSP, and that most of the main RAM access circuits operate correctly.
- 6 **DSP RAM** – Verifies the A7 CPU RAM associated with the digital signal processor by using a write/read pattern.
- 7 **DSP ALU** – Verifies the A7 CPU high-speed math processing portions of the digital signal processor.
- 8 **DSP Intrpt** – Tests the ability of the A7 CPU digital signal processor to respond to interrupts from the A10 digital IF ADC.
- 9 **DIF Control** – Tests the ability of the A7 CPU main processor to write/read to the control latches on the A10 digital IF.
- 10 **DIF Counter** – Tests the ability of the A7 CPU main processor to write/read to the triple divider on the A10 CPU. It tests the A7 CPU data buffers and A10 digital IF, the 4 MHz clock from the A12 reference.

- 11 **DSP Control** – Tests the ability of the A7 CPU digital signal processor to write to the control latches on the A10 digital IF. Feedback is verified by the main processor. It primarily tests the A10 digital IF, but failures may be caused by the A7 CPU.
- 12 **Fr Pan Wr/Rd** – Tests the ability of the A7 CPU main processor to write/read to the front panel processor. It tests the A2 front panel interface and processors A7 CPU data buffering and address decoding. (See also tests 23 and 24 on [page 10-11](#)) This runs only when selected.
- 13 **GPIB** – Tests the ability of the A7 CPU main processor to write/read to the rear panel control elements. It tests the GPIB chip on the A7 CPU board and A7 CPU data buffering and address decoding. (It does not test the GPIB interface; for GPIB interface checking, see the your user’s guide). This runs only when selected or with ALL INTERNAL.
- 14 **Post Reg** – Polls the status register of the A8 post-regulator, and flags these conditions: heat sink too hot, inadequate air flow, or post-regulated supply shutdown.
- 15 **Frac N Cont** – Tests the ability of the A7 CPU main processor to write/read to the control element on the A14 fractional-N (digital) assembly. The control element must be functioning, and the fractional-N VCO must be oscillating (although not necessarily phase-locked) to pass.
- 16 **Sweep Trig** – Tests the sweep trigger (L SWP) line from the A14 fractional-N to the A10 digital IF. The receiver with the sweep synchronizes L SWP.
- 17 **ADC Lin** – Tests the linearity of the A10 digital IF ADC using the built-in ramp generator. The test generates a histogram of the ADC linearity, where each data point represents the relative “width” of a particular ADC code. Ideally, all codes have the same width; different widths correspond to non-linearizes.
- 18 **ADC Ofs** – This runs only when selected. It tests the ability of the offset DAC, on the A10 digital IF, to apply a bias offset to the IF signals before the ADC input. This runs only when selected.
- 19 **ABUS Test** – Tests analog bus accuracy, by measuring several analog bus reference voltages (all nodes from the A10 digital IF). This runs only when selected.
- 20 **FN Count** – Uses the internal counter to count the A14 fractional-N VCO frequency (120 to 240 MHz) and the divided fractional-N frequency (100 kHz). It requires the 100 kHz signal from A12 and the counter gate signal from A10 to pass.

External Tests

These tests require either external equipment and connections or operator interaction of some kind to run. Tests 30 and 60 are comprehensive front panel checks, more complete than test 12, that checks the front panel keys and knob entry.

- 21 **Op Ck Port 1** – Part of “[Step 2. Operator’s Check](#)” on page 4-7. The procedure requires the external connection of a short to PORT 1.
- 22 **Op Ck Port 2** – Same as 21, but tests PORT 2.
- 23 **Fr Pan Seq** – Tests the front panel knob entry and all A1 front panel keys, as well as the front panel microprocessor on the A2 assembly. It prompts the user to rotate the front panel knob, then press each key in an ordered sequence. It continues to the next prompt only if the current prompt is correctly satisfied.
- 24 **Fr Pan Diag** – Similar to 23 above, but you rotate the front panel knob or presses the keys in any order. This test displays the command the instrument received.
- 25 **ADC Hist** – Factory use only.

System Verification Tests

These tests apply mainly to system-level, error-corrected verification and troubleshooting. Tests 26 to 30 are associated with the system verification procedure, documented in [Chapter 2](#) , “[System Verification and Performance Tests.](#)” Tests 31 to 42 facilitate examining the calibration coefficient arrays (error terms) resulting from a measurement calibration; refer to [Chapter 11](#) , “[Error Terms.](#)”

- 26 **Sys Ver Init** – Recalls the initialization state for system verification from an analyzer verification disk, in preparation for a measurement calibration. It must be done before service internal tests 27, 28, 29 or 30 are performed.
- 27 **Ver Dev 1**– Recalls verification limits from disk for verification device #1 in all applicable S-parameter measurements. It performs pass/fail limit testing of the current measurement.
- 28 **Ver Dev 2** – Same as 28 above for device #2.
- 29 **Ver Dev 3** – Same as 28 above for device #3.
- 30 **Ver Dev 4** – Same as 28 above for device #4.
- 31-42 **Cal Coef 1-12** – Copies error term data from a measurement calibration array to display memory. A measurement calibration must be complete and active. The definition of calibration arrays depends on the current calibration type. After execution, the memory is automatically displayed. For details, refer to [Chapter 11](#) , “[Error Terms.](#)”

Adjustment Tests

These tests are used in the procedures located in Chapter 3 , “Adjustments and Correction Constants,” except as noted.

- 43 **Pretune Adj** – Generates source pretune values for proper phase-locked loop operation. Run test 44 first.
- 44 **ABUS Cor** – Measures three fixed voltages on the ABUS, and generates new correction constants for ABUS amplitude accuracy in both high resolution and low resolution modes. Use this test before running test 43, above.
- 45 NOT USED.
- 46 **Disp 2 Ex** – Not used in “Adjustments.” Writes the “secondary test pattern” to the display for adjustments. Press **(Preset)** to exit this routine.
- 47 **IF Step Cor** – Measures the gain of the IF amplifiers (A and B only) located on the A10 digital IF, to determine the correction constants for absolute amplitude accuracy. It provides smooth dynamic accuracy and absolute amplitude accuracy in the –30 dBm input power region.
- 48 **ADC Ofs Cor** – Measures the A10 Digital IF ADC linearity characteristics, using an internal ramp generator, and stores values for the optimal operating region. During measurement, IF signals are centered in the optimal region to improve low-level dynamic accuracy.
- 49 **Serial Cor** – Stores the serial number (input in the Display Title menu) in EEPROM. This routine will not overwrite an existing serial number.
- 50 **Option Cor** – Stores the option keyword (required for Option 007, 010 or any combination).
- 51 **Sampler Cor** – Generates sampler correction constants to correct the frequency response.
- 52 **Power Adj** – Measures power linearity at the test port. It also generates correction constants to improve power linearity.
- 53 **Init EEPROM** – Initializes certain EEPROM addresses to zeros and resets the display intensity correction constants to the default values. Also, the test will not alter the serial number and correction constants for Option 007 or 010.
- 54 **Blanking Adj** – Allows adjustment of the output power level during retrace.

Display Tests

These tests do not return a PASS/FAIL condition. All six amber front panel LEDs will turn off if the analyzer passes. The display will be blank; press **Ⓟ** to exit the test. If any of the six LEDs remain on, the analyzer has failed.

- 55 **Disp/cpu com** – Checks to confirm that the CPU can communicate with the A19 GSP board. The CPU writes all zeros, all ones, and then a walking one pattern to the GSP and reads them back. If the test fails, the CPU repeats the walking 1 pattern until **Ⓟ** is pressed.
- 56 **DRAM cell** – Tests the DRAM on GSP (A19) by writing a test pattern to the DRAM and then verifying that it can be read back.
- 57 **Main VRAM** – Tests the VRAM by writing all zeros to one location in each bank and then writing all ones to one location in each bank. Finally a walking one pattern is written to one location in each bank.
- 58 **VRAM bank** – Tests all the cells in each of the 4 VRAM banks.
- 59 **VRAM/video** – Verifies that the GSP is able to successfully perform both write and read shift register transfers. It also checks the video signals LHSYNC, LVSYNC, and LBLANK to verify that they are active and toggling.
- 60 **RGB outputs** – Confirms that the analog video signals are correct and it verifies their functionality.
- 61 **Inten DAC** – Verifies that the intensity DAC can be set both low and high.

Test Patterns

Test patterns are used in the factory for adjustments, diagnostics, and troubleshooting, but most are not used for field service. Test patterns are executed by entering the test number (62 through 76), then pressing **EXECUTE TEST** **CONTINUE**. The test pattern will be displayed and the softkey labels blanked. To increment to the next pattern, press softkey 1; to go back to a previous pattern, press softkey 2. To exit the test pattern and return the softkey labels, press softkey 8 (bottom softkey). The following is a description of the test patterns.

- 62 **Test Pat 1** – Displays an all white screen for verifying the light output of the A18 display and checks for color purity.
- 63-65 **Test Pat 2-4** – Displays a red, green, and blue pattern for verifying the color purity of the display and also the ability to independently control each color.
- 66 **Test Pat 5** – Displays an all black screen. This is used to check for stuck pixels.

- 67 **Test Pat 6** – Displays a 16-step gray scale for verifying that the A19 GSP board can produce 16 different amplitudes of color (in this case, white). The output comes from the RAM on the GSP board; it is then split. The signal goes through a video DAC and then to an external monitor or through some buffer amplifiers and then to the internal LCD display. If the external display looks good but the internal display is bad, then the problem may be with the display or the cable connecting it to the GSP board. This pattern is also very useful when using an oscilloscope for troubleshooting. The staircase pattern it produces will quickly show missing or stuck data bits.
- 68 **Test Pat 7** – Displays the following seven colors: Red, Yellow, Green, Cyan, Blue, Magenta and White.
- 69 **Test Pat 8** – This pattern is intended for use with an external display. The pattern displays a color rainbow pattern for showing the ability of the A19 GSP board to display 15 colors plus white. The numbers written below each bar indicate the tint number used to produce that bar (0 & 100=pure red, 33=pure green, 67=pure blue).
- 70 **Test Pat 9** – Displays colors Red, Green, and Blue at four different intensity levels. You should see 16 color bands across the screen. Starting at the left side of the display the pattern is: Black four bands of Red (each band increasing in intensity) Black four bands of Green (each band increasing in intensity) Black four bands of Blue (each band increasing in intensity) and Black. If any one of the four bits for each color is missing the display will not look as described.
- 71 **Test Pat 10** – Displays a character set for showing all the different types and sizes of characters available. Three sets of characters are drawn in each of the three character sizes. 125 characters of each size are displayed.
- 72 **Test Pat 11** – Displays a bandwidth pattern for verifying the bandwidth of the EXTERNAL display. It consists of multiple alternating white and black vertical stripes. Each stripe should be clearly visible. A limited bandwidth would smear these lines together. This is used to test the quality of the external monitor.
- 73 **Test Pat 12** – Displays a repeating gray scale for troubleshooting, using an oscilloscope. It is similar to the 16 step gray-scale but is repeated 32 times across the screen. Each of the 3 outputs of the video palette will then show 32 ramps (instead of one staircase) between each horizontal sync pulse. This pattern is used to troubleshoot the pixel processing circuit of the A19 GSP board.
- 74 **Test Pat 13** – Displays a convergence pattern for measuring the accuracy of the color convergence of the external monitor.
- 75-76 **Test Pat 14-15** – Displays crosshatch and inverse crosshatch patterns for testing color convergence, linearization alignment. This is useful when aligning the LCD display in the bezel.

Service Menu - Service Features

The service feature menus are shown in [Figure 10-3 on page 10-16](#) and are described in the “[Service Modes Menu](#)” on page 10-17. The internal diagnostic menus are accessed by pressing **(System)** **SERVICE MENU** and then one of the following softkeys:

- **SERVICE MODES**
- **ANALOG BUS on OFF**
- **PEEK/POKE**
- **FIRMWARE REVISION**

Figure 10-3 Service Feature Menu Map

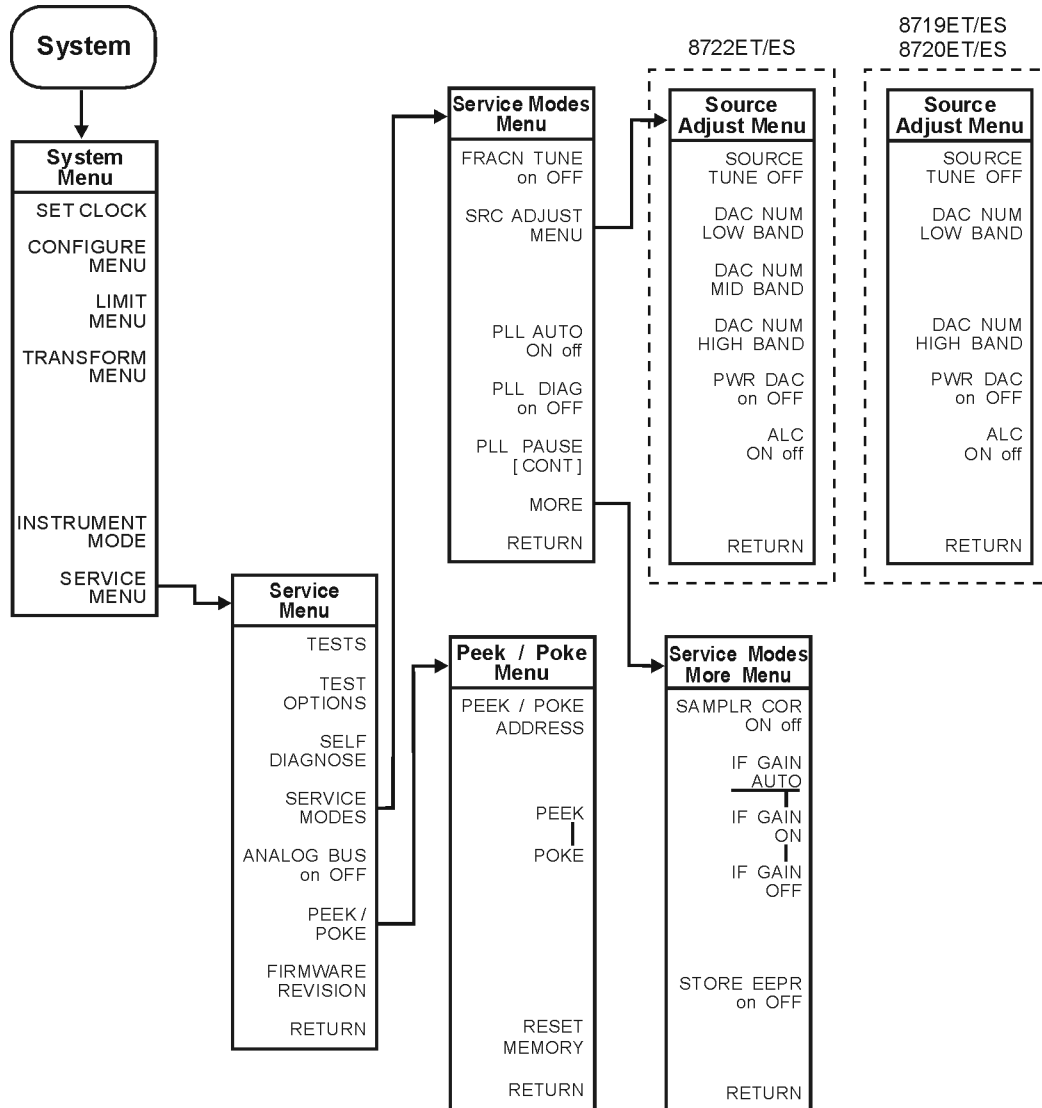

sb583e

Service Modes Menu

To access this menu, press **(System)** **SERVICE MENU** **SERVICE MODES** .

- SERVICE MODES** allows you to control and monitor various circuits for troubleshooting.
- FRACN TUNE on OFF** (SM1) tests the A13 and A14 fractional-N circuits. It allows you to directly control and monitor the output frequency of the fractional-N synthesizer (60 MHz to 240 MHz).
- Set the instrument to CW sweep mode and then set FRACN TUNE ON. Change frequencies with the front panel keys or knob. The output of the A14 assembly can be checked at A14J1 HI OUT (in high band) or A14J2 LO OUT (in low band) with an oscilloscope, a frequency counter, or a spectrum analyzer. Signal jumps and changes in shape at 20 MHz and 30 MHz when tuning up in frequency, and at 29.2 MHz and 15 MHz when tuning down, are due to switching of the digital divider. This mode can be used with the SRC TUNE mode as described in [Chapter 7](#) , “[Source Troubleshooting](#).”
- SRC ADJUST MENU** accesses the functions that allow you to adjust the source:

NOTE If the instrument displays the **PHASE LOCK CAL FAILED** message, use the **DAC NUM XXX BAND** keys of the Source Adjustment Menu. The relationship between DAC numbers and frequency varies between instruments. The DAC numbers, provided in the description, and frequencies are guidelines only.

- **SOURCE TUNE OFF** (SM2D) disables the source frequency tune modes.
- **DAC NUM XXX BAND** tests the pretune functions of the phase lock and source assemblies. These keys allow entry of digital data directly into the DAC on the A11 phase lock assembly. When in this mode:
 - Instrument does not attempt to phase lock.
 - Residual FM increases.
- **DAC NUM LOW BAND** (SM2L) allows you to enter DAC numbers in the range of 3650 through 4095 to generate test port output frequencies from 50 MHz to 1.1 GHz.
- **DAC NUM MID BAND** (SM2M) (8722ET/ES only) allows you to enter DAC numbers in the range of 2900 through 4095 to generate test port output frequencies from 2.3 GHz to 4.9 GHz.

- **DAC NUM HIGH BAND** (SM2H) (8719ET/ES and 8720ET/ES) allows you to enter DAC numbers in the range of 2900 through 4095 to generate test port output frequencies from 2.3 GHz to 4.9 GHz.
- **DAC NUM HIGH BAND** (SM2H) (8722ET/ES) allows you to enter DAC numbers in the range of 2020 through 4095 to generate test port output frequencies from 18.2 GHz to 23.2 GHz.
- **PWR DAC ON off** This controls the amplitude of the reference oscillator. This DAC is located on the A59 source interface board.
- **ALC ON off** toggles the automatic leveling control (ALC) on and off.

PLL AUTO ON off (SM4) automatically attempts to determine new pretune values when the instrument encounters phase lock problems (for example, “harmonic skip”). With **PLL AUTO OFF**, the frequencies and voltages do not change, as when they are attempting to determine new pretune values, so troubleshooting the phase-locked loop circuits is more convenient. This function may also be turned off to avoid pretune calibration errors in applications where there is a limited frequency response in the R (reference) channel. For example, in a high power test application, using band limited filters for R channel phase locking.

PLL DIAG on OFF (SM5) displays a phase lock sequence at the beginning of each band. This sequence normally occurs very rapidly, making it difficult to troubleshoot phase lock problems. Switching this mode ON slows the process down, allowing you to inspect the steps of the phase lock sequence (pretune, acquire, and track) by pausing at each step. The steps are indicated on the display, along with the channel (C1 or C2) and band number (B1 through B13).

This mode can be used with PLL PAUSE to halt the process at any step. It can also be used with the analog bus counter.

PLL PAUSE is used only with PLL DIAG mode. **CONT** indicates that it will continuously cycle through all steps of the phase lock sequence. **PAUSE** holds it at any step of interest. This mode is useful for troubleshooting phase-locked loop problems.

MORE accesses the Service Modes More menu.

Service Modes More Menu

To access this menu, press **(System)** **SERVICE MENU** **SERVICE MODES** **MORE** .

SAMPLR COR ON off

is used to turn the sampler correction on and off. In the off mode, the actual frequency response of the receiver is displayed. In the on mode, the corrections are applied to the frequency response.

IF GAIN AUTO

is used for normal operating conditions and works in conjunction with IF GAIN ON and OFF. The A10 assembly includes a switchable attenuator section and an amplifier that amplifies low-level 4 kHz IF signals (for A and B inputs only). This mode allows the A10 IF section to automatically determine if the attenuator should be switched in or out. The switch occurs when the A or B input signal is approximately -30 dBm.

IF GAIN ON

locks out the A10 IF attenuator sections for checking the A10 IF gain amplifier circuits, regardless of the amplitude of the A or B IF signal. Turning this ON switches out both the A and B attenuation circuits; they cannot be switched independently. Be aware that input signal levels above -30 dBm at the sampler input will saturate the ADC and cause measurement errors.

IF GAIN OFF

switches in both of the A10 IF attenuators for checking the A10 IF gain amplifier circuits. Small input signals will appear noisy, and raise the apparent noise floor of the instrument.

STORE EEPR on OFF

allows you to store the correction constants that reside in non-volatile memory (EEPROM) onto a disk. Correction constants improve instrument performance by compensating for specific operating variations due to hardware limitations (refer to [Chapter 3](#) , “[Adjustments and Correction Constants.](#)”) Having this information on disk is useful as a backup, in case the constants are lost (due to a CPU board failure). Without a disk backup, the correction constants can be regenerated manually, although the procedures will take longer.

Analog Bus on OFF

To access the analog bus, press **System** **SERVICE MENU**.

Description of the Analog Bus (ANAB)

The analog bus is a single multiplexed line that networks 23 nodes within the instrument. It can be controlled from the front panel, or through GPIB, to make voltage and frequency measurements just like a voltmeter, oscilloscope, or frequency counter. The next few paragraphs provide general information about the structure and operation of the analog bus. For a description of each individual node, see [“Analog Bus Nodes” on page 10-22](#). To see where the nodes are located in the instrument, refer to the “Overall Block Diagram,” in [Chapter 4](#), [“Start Troubleshooting Here.”](#)

The analog bus consists of a source section and a receiver section. The source can be the following:

- any one of the 23 nodes described in [“Analog Bus Nodes” on page 10-22](#)
- the A14 fractional-N VCO
- the A14 fractional-N VCO divided down to 100 kHz

The receiver portion can be the following:

- the main ADC
- or the frequency counter on the fractional-N VCO (A14) board

When analog bus traces are displayed, frequency is the x-axis. For a linear x-axis in time, switch to CW time mode (or sweep a single band).

The Main ADC

The main ADC is located on the A10 digital IF assembly and makes voltage measurements in two ranges. See **RESOLUTION** under [“Analog In Menu” on page 10-21](#).

The Frequency Counter

The frequency counter is located on the A14 assembly and can count one of three sources:

- selected analog bus node
- A14 fractional-N VCO (FRAC N)
- A14 fractional-N VCO divided down to 100 kHz (DIV FRAC N) (frequency range is 100 kHz to 16 MHz)

The counts are triggered by the phase lock cycle: one at each pretune, acquire, and track for each bandswitch. The counter works in swept modes or in CW mode. It can be used in conjunction with **SERVICE MODES** for troubleshooting phase lock and source problems.

To read the counter over GPIB, use the command OUTPCNTR.

Notes

- The display and marker units (U) correspond to volts.
- About 0.750 MHz is a typical counter reading with no ac signal present.
- Anything occurring during bandswitches is not visible.
- Fast-moving waveforms may be sensitive to sweep time.
- The analog bus input impedance is about 50K ohms.
- Waveforms up to approximately 200 Hz can be reproduced.

Analog In Menu

Select this menu to monitor voltage and frequency nodes, using the analog bus and internal counter.

To switch on the analog bus and access the Analog In menu, press:

(System) **SERVICE MENU** **ANALOG BUS ON off** **(Meas)** **ANALOG IN Aux Input**

The **RESOLUTION [LOW]** key toggles between low and high resolution.

Table 10-2 Descriptions of Jumper Positions

Resolution	Maximum Signal	Minimum Signal
LOW	+0.5 V	-0.5 V
HIGH	+10 V	-10 V

AUX OUT on OFF

allows you to monitor the analog bus nodes (except nodes 1, 2, 3, 4, 9, 10, 12) with external equipment (oscilloscope, voltmeter, etc.). To do this, connect the equipment to the AUX INPUT BNC connector on the rear panel and press **AUX OUT on OFF** until **ON** selected.

CAUTION To prevent damage to the analyzer, first connect the equipment to the rear panel AUX INPUT, and before turning the function ON.

COUNTER: OFF

switches the internal counter off and removes the counter from the display. The counter can be switched on with one of the next three keys. (Using the counter slows the sweep.) The counter bandwidth is 16 MHz unless otherwise noted for a specific node.

NOTE OUTPCNTR is the GPIB command to output the counter's frequency data.

ANALOG BUS

switches the counter to monitor the analog bus.

- FRAC N** switches the counter to monitor the A14 fractional-N VCO frequency at the node shown on the “Overall Block Diagram,” in [Chapter 4](#) , “[Start Troubleshooting Here.](#)”
- DIV FRACN** switches the counter to monitor the A14 fractional-N VCO frequency after it has been divided down to 100 kHz for phase locking the VCO.

Analog Bus Nodes

The following paragraphs describe the 23 analog bus nodes. They are listed in numerical order and are grouped by assembly. For node locations, refer to the “Overall Block Diagram,” in [Chapter 4](#) .

Press **(System)** **SERVICE MENU** **ANALOG BUS ON** **(Meas)** **ANALOG IN AUX INPUT** , and then use the front panel keys or knob to select an analog bus node. Terminate the entry by pressing **(x1)**.

A10 Digital IF

1. **+0.37V** (+0.37V reference)

Check for a flat line at approximately +0.37V. This is used as the voltage reference in the Analog Bus Correction Constants adjustment for calibrating out the analog bus high/low resolution gain and offset errors. The absolute voltage level is not critical, but it should be the same in high and low resolution.

2. **+2.50V** (+2.50V reference)

Check for a flat line at approximately +2.5V. This voltage is used in the Analog Bus Correction Constants adjustment as a reference for calibrating the analog bus low resolution circuitry.

3. **Aux Input** (Rear panel input)

This selects the rear panel AUX INPUT to drive the analog bus for making voltage and frequency measurements. It can be used to look at test points within the instrument on the display (using the display as an oscilloscope). Connect the test point of interest to the AUX INPUT BNC connector on the rear panel. This feature can be useful if an oscilloscope is not available. Also, it can be used for testing voltage-controlled devices by connecting the driving voltage of the DUT to the AUX IN connector. You can look at the driving voltage on one display channel while displaying the DUT S-parameter response on the other display channel.

With **AUX OUT** turned ON, you can examine analog bus nodes with external equipment (see **AUX OUT on OFF** in “[Analog In Menu](#)” on page 10-21). See the “Overall Block Diagram,” in [Chapter 4](#) . For GPIB considerations, refer to “[GPIB Service Mnemonic Definitions](#)” on page 10-31.

4. **A10 Gnd** (Ground reference)

This is used in “[Analog Bus Correction Constants \(Test 44\)](#)” on page 3-8 as a reference for calibrating the analog bus low and high resolution circuitry.

A11 Phase Lock

5. **A11 Gnd** (Ground reference)
6. **A11 Gnd** (Ground reference)
7. **A11 Gnd** (Ground reference)
8. **Swp Err** (Phase error voltage)

This node measures the voltage at the output of the phase comparator on the A11 phase lock assembly. This error voltage corresponds to the difference in frequency between the divided IF and the 1 MHz reference frequency from the A12 assembly. See [Figure 10-4](#) for a typical display.

Figure 10-4 Node 8: Swp Err, Phase Error Voltage

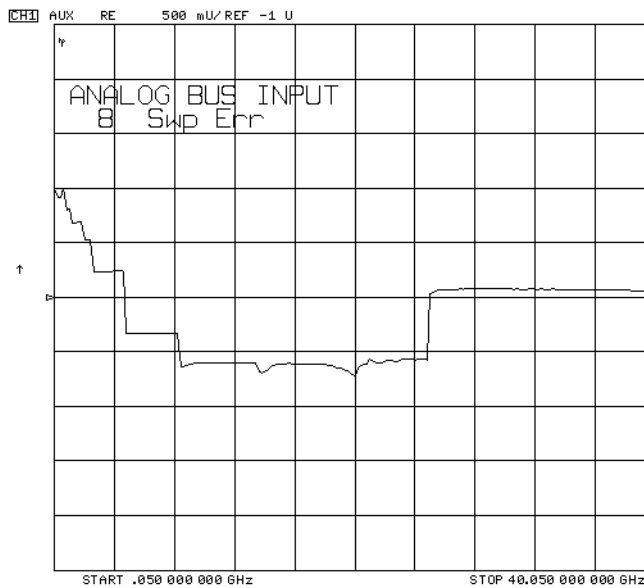

9. 0.25V/GHz (Source oscillator tuning voltage)

This node displays the tuning voltage ramp used to tune the source oscillators. You should see a voltage ramp like the one shown in [Figure 10-5](#). If this waveform is correct, you can be confident that the A11 phase lock assembly, the source assemblies, the A13/A14 fractional-N assemblies, and the A52 pulse generator are working properly and the instrument is phase locked. If you see anything else, refer to [Chapter 7](#), “[Source Troubleshooting](#).”

Figure 10-5 Node 9: 0.25V/GHz, Source Tuning Voltage

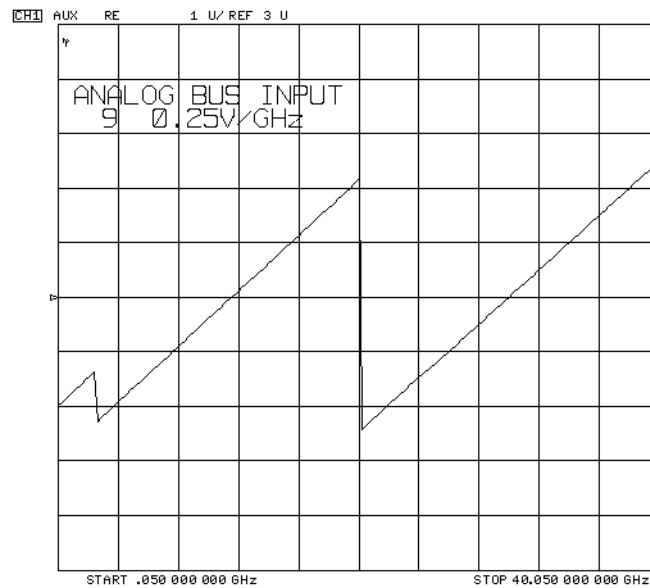

10.A11 Gnd (Ground reference)

11. **IF** (IF used for phase lock)

Counter ON: analog bus Reading: 10 MHz

This node displays the IF frequency (see [Figure 10-6](#)) as it enters the A11 phase lock assembly via the A7 ALC assembly. This signal comes from the R sampler output and is used to phase lock the source.

Figure 10-6 Location of Internal Counter Reading on Display

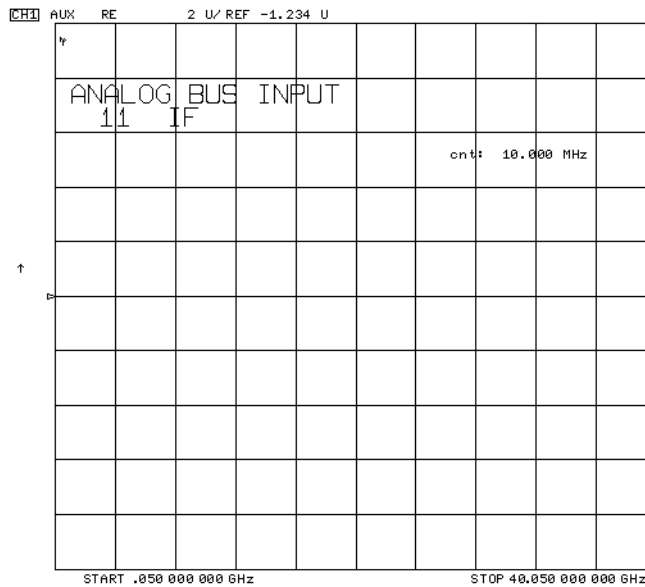

12. **IF Det** (IF on A11 phase lock after 40 MHz filter)

This node detects the IF as a voltage at the output of the 40 MHz filter on the A11 phase lock assembly. The trace should be a flat line at about -1.7 V as shown in [Figure 10-7](#).

Figure 10-7 Node 12: Typical IF Detector Voltage Trace

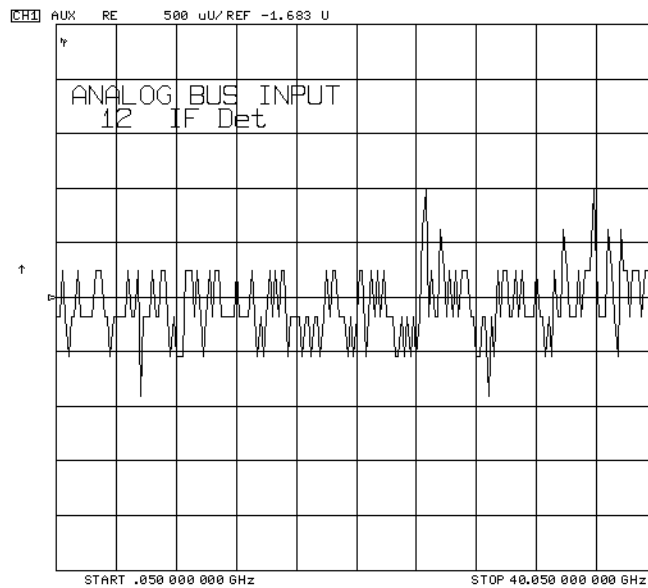

A12 Reference

13. **Ext Ref** (Rear panel external reference input)

This node is used to detect an external reference voltage. If an external reference (timebase) is used, the voltage level should be about -0.6 V. If an external reference is not used, the voltage level should be about -0.87 V.

14. **100 kHz** (100 kHz reference frequency)

Counter ON: analog bus

Reading: 0.100 MHz

This node counts the A12 100 kHz reference signal that is used on A13 (the fractional-N analog assembly) as a reference frequency for the phase detector.

15. **VCO Tune** (A12 VCO tuning voltage)

This node displays the tuning voltage for the A12 VCO. It is used in the reference assembly VCO tune adjustment.

16.**2nd LO** (2nd converter reference)

Counter ON: analog bus

Reading: 9.996 MHz

This node counts the 2nd LO used by the 2nd converter assemblies to produce the 2nd IF of 4 kHz.

17.**PL Ref** (Phase lock reference)

Counter ON: analog bus

Reading: 1 MHz

This node counts the reference signal used by the phase comparator circuit on the A11 phase lock assembly.

18.**VCXO Tune** (40 MHz VCXO tuning voltage)

This node displays the voltage used to fine tune the A12 reference VCXO to 40 MHz. You should see a flat line at some voltage level (the actual voltage level varies between instruments). Anything other than a flat line indicates that the VCXO is tuning to different frequencies. Refer to the [“Frequency Accuracy Adjustment”](#) on page 3-41.

19.**A12 Gnd** (Ground reference)

20.**A12 Gnd** (Ground reference)

A14 Fractional-N (Digital)

21.FN VCO Tun (A14 FN VCO tuning voltage)

This node displays the A14 FN VCO tuning voltage. This voltage comes from the A13 fractional-N (analog) assembly and is the return path for the fractional-N phase-locked loop. If the A13 and A14 assemblies are functioning properly and the VCO is phase locked, the trace should look like the trace shown in [Figure 10-8](#) when in Log Freq. sweep mode. Any other waveform indicates that the FN VCO is not phase locked. The vertical lines in the trace indicate the band crossings. (The counter can also be enabled to count the VCO frequency. Use CW mode.)

Figure 10-8 Node 21: FN VCO Tun, FN VCO Tuning Voltage

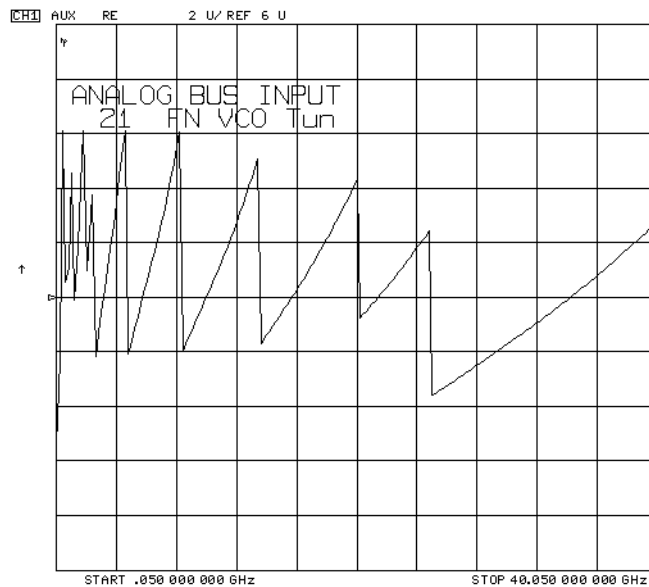

22.A14 Gnd (Ground reference)

23.Count Gate (Analog bus counter gate)

This node checks the analog bus counter gate signal. You should see a flat line at +5V. The counter gate activity occurs during bandswitches, and therefore is not visible on the analog bus. To view the bandswitch activity, look at this node on an oscilloscope, using **AUX OUT ON** (refer to **AUX OUT on OFF** under the “Analog Bus Menu” heading).

PEEK/POKE Menu

To access this menu, press **SYSTEM** **SERVICE MENU** **PEEK/POKE** .

PEEK/POKE Allows you to edit the content of one or more memory addresses. The keys are described below.

CAUTION The PEEK/POKE capability is intended for service use only.

PEEK/POKE ADDRESS

(PEEL[D])

accesses any memory address and shows it in the active entry area of the display. Use the front panel knob, entry keys, or step keys to enter the memory address of interest.

PEEK (PEEK)

Displays the data at the accessed memory address.

POKE (POKE[D])

allows you to change the data at the memory address accessed by the **PEEK/POKE ADDRESS** softkey. Use the front panel knob, entry keys, or step keys to change the data. The A7CC jumper must be in the "ALT" position in order to poke.

RESET MEMORY

Resets or clears the memory where instrument states are stored. To do this, press **RESET MEMORY** **Preset** .

Firmware Revision Softkey

Press **SYSTEM** **SERVICE MENU** **FIRMWARE REVISION** to display the current firmware revision information. The number and implementation date appear in the active entry area of the display as shown in [Figure 10-9](#). The analyzer's serial number and installed options are also displayed. Another way to display the firmware revision information is to cycle the line power.

Figure 10-9 Location of Firmware Revision Information on Display

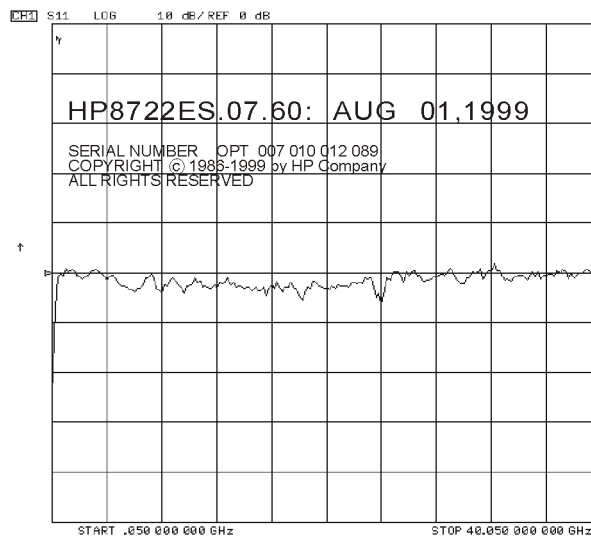

sb584e

GPIB Service Mnemonic Definitions

All service routine keystrokes can be made through GPIB in one of the following approaches:

- sending equivalent remote GPIB commands (Mnemonics have been documented previously with the corresponding keystroke.)
- invoking the System Menu (MENUSYST) and using the analyzer mnemonic (SOFTn), where “n” represents the softkey number. (Softkeys are numbered 1 to 8 from top to bottom.)

An GPIB overview is provided in the “Operating Concepts” chapter in the analyzer user’s guide. GPIB programming information is also provided in the programmer’s guide.

Invoking Tests Remotely

Many tests require a response to the displayed prompts. Since bit 1 of the Event Status Register B is set (bit 1 = service routine waiting) any time a service routine prompts the user for an expected response, you can send an appropriate response using one of the following techniques:

- Read event status register B to reset the bit.
- Enable bit 1 to interrupt (ESNB[D]). See “Error Reporting” of the analyzer programmer’s guide.
- Respond to the prompt with a TESRn command (see “Tests Menu” on page 10-5).

Symbol Conventions

[]	An optional operand
D	A numerical operand
< >	A necessary appendage
	An either/or choice in appendages

Analog Bus Codes

ANAI[D]	Measures and displays the analog input. The preset state input to the analog bus is the rear panel AUX IN. The other 22 nodes may be selected with D only if the ABUS is enabled (ANABon).
OUTPCNTR	Outputs the counter's frequency data.
OUTPERRO	Reads any prompt message sent to the error queue by a service routine.
OUTPTESS	Outputs the integer status of the test most recently executed. Status codes are those listed under "TST?".
TST?	Executes the power-on self test (internal test 1) and outputs an integer test status. Status codes are as follows: 0 = pass 1 = fail 2 = in progress 3 = not available 4 = not done 5 = done

Service Related Error Messages in Alphabetical Order

This section contains an alphabetical list of the error messages that pertain to servicing the analyzer. The information in the list includes explanations of the displayed messages and suggestions to help solve the problem.

NOTE The error messages that pertain to measurement applications are included in the analyzer's reference guide.

ADDITIONAL STANDARDS NEEDED

Error Number 68 **Error correction for the selected calibration class cannot be computed until you have measured all the necessary standards.**

ADDRESSED TO TALK WITH NOTHING TO SAY

Error Number 31 **You have sent a read command to the analyzer (such as ENTER 716) without first requesting data with an appropriate output command (such as OUTPDATA). The analyzer has no data in the output queue to satisfy the request.**

ANALOG BUS DISABLED IN 6KHZ IF BW

Error Number 212 **When you press Avg **IF BW[6000]**, the analog bus is disabled and not available for use in troubleshooting. For a description of the analog bus, see ["Analog Bus on OFF"](#) on page 10-20.**

ANALOG INPUT OVERLOAD

Error Number 60 **The power level of the analog input is too high. Reduce the power level of the analog input source.**

BATTERY FAILED. STATE MEMORY CLEARED

Error Number 183 **The battery protection of the non-volatile CMOS memory has failed. The CMOS memory has been cleared. Refer to [Chapter 14, "Assembly Replacement and Post-Repair Procedures,"](#) for battery replacement instructions. See the "Preset State and Memory Allocation," chapter in the analyzer's reference guide for more information about the CMOS memory.**

BATTERY LOW! STORE SAVE REGS TO DISK

Error Number 184 **The battery protection of the non-volatile CMOS memory is in danger of failing. If this occurs, all of the instrument state registers stored in CMOS memory will be lost. Save these states to a disk and refer to [Chapter 14, "Assembly Replacement and Post-Repair Procedures,"](#) for battery replacement instructions. See the "Preset State and Memory Allocation," chapter in the analyzer's reference guide for more information about the CMOS memory.**

BLOCK INPUT ERROR

Error Number 34 The analyzer did not receive a complete data transmission. This is usually caused by an interruption of the bus transaction. Clear by pressing the **Local** key or aborting the I/O process at the controller.

BLOCK INPUT LENGTH ERROR

Error Number 35 The length of the header received by the analyzer did not agree with the size of the internal array block. Refer to the analyzer's programmers guide for instructions on using analyzer input commands.

CALIBRATION ABORTED

Error Number 74 You have changed the active channel during a calibration so the calibration in progress was terminated. Make sure the appropriate channel is active and restart the calibration.

CALIBRATION REQUIRED

Error Number 63 A calibration set could not be found that matched the current stimulus state or measurement parameter. You will have to perform a new calibration.

CANNOT READ/WRITE 1 FILE SYSTEM

Error Number 203 The disk is being accessed by the analyzer and is found to contain an 1 (hierarchical file system) or files nested within subdirectories. The analyzer does not support 1. Replace the disk medium with a LIF or DOS formatted disk that does not contain files nested within subdirectories.

CAUTION: POWER OUT MAY BE UNLEVELED

Error Number 179 There is either a hardware failure in the source or you have attempted to set the power level too high. The analyzer allows the output power to be set higher or lower than the specified available power range. However, these output powers may be un-leveled or unavailable. Check to see if the power level you set is within specifications. If it is, refer to [Chapter 7](#) , "Source Troubleshooting."

CORRECTION CONSTANTS NOT STORED

Error Number 3 A store operation to the EEPROM was not successful. You must change the position of the jumper on the A7 CPU assembly. Refer to "[A7 Switch Positions](#)" on page 3-4.

CORRECTION TURNED OFF

Error Number 66 Critical parameters in your current instrument state do not match the parameters for the calibration set, therefore correction has been turned off. The critical instrument state parameters are sweep type, start frequency, frequency span, and number of points.

CURRENT PARAMETER NOT IN CAL SET

Error Number Correction is not valid for your selected measurement parameter. Either change
64 the measurement parameters or perform a new calibration.

DEADLOCK

Error Number A fatal firmware error occurred before instrument preset completed. Call your
111 nearest Agilent Technologies sales or service office.

DEVICE: not on, not connect, wrong addr

Error Number The device at the selected address cannot be accessed by the analyzer. Verify
119 that the device is switched on, and check the GPIB connection between the
 analyzer and the device. Ensure that the device address recognized by the
 analyzer matches the GPIB address set on the device itself.

DISK HARDWARE PROBLEM

Error Number The disk drive is not responding correctly. If using an external disk drive, refer
39 to the disk drive operating manual.

DISK MESSAGE LENGTH ERROR

Error Number The analyzer and the external disk drive aren't communicating properly. Check
190 the GPIB connection and then try substituting another disk drive to isolate the
 problem instrument.

DISK: not on, not connected, wrong addr

Error Number The disk cannot be accessed by the analyzer. Verify power to the disk drive, and
38 check the GPIB connection between the analyzer and the disk drive. Ensure
 that the disk drive address recognized by the analyzer matches the GPIB
 address set on the disk drive itself.

DISK READ/WRITE ERROR

Error Number There may be a problem with your disk. Try a new floppy disk. If a new floppy
189 disk does not eliminate the error, suspect hardware problems.

FILE NOT COMPATIBLE WITH INSTRUMENT

Information You cannot recall user graphics that had been saved on an earlier model of
Message analyzer with a monochrome display.

ILLEGAL UNIT OR VOLUME NUMBER

Error Number The disk unit or volume number set in the analyzer is not valid. Refer to the
46 disk drive operating manual.

INITIALIZATION FAILED

Error Number 47 The disk initialization failed, probably because the disk is damaged.

INSUFFICIENT MEMORY, PWR MTR CAL OFF

Error Number 154 There is not enough memory space for the power meter calibration array. Increase the available memory by clearing one or more save/recall registers, or by reducing the number of points.

NO CALIBRATION CURRENTLY IN PROGRESS

Error Number 69 The **RESUME CAL SEQUENCE** softkey is not valid unless a calibration is already in progress. Start a new calibration.

NO FAIL FOUND

Service Error Number 114 The self-diagnose function of the instrument operates on an internal test failure. At this time, no failure has been detected.

NO FILE(S) FOUND ON DISK

Error Number 45 No files of the type created by an analyzer store operation were found on the disk. If you requested a specific file title, that file was not found on the disk.

NO IF FOUND: CHECK R INPUT LEVEL

Error Number 5 The first IF signal was not detected during pretune. Check the front panel R channel jumper. If there is no visible problem with the jumper, refer to [Chapter 7, "Source Troubleshooting."](#)

NO SPACE FOR NEW CAL.CLEAR REGISTERS

Error Number 70 You cannot store a calibration set due to insufficient memory. You can free more memory by clearing a saved instrument state from an internal register (which may also delete an associated calibration set, if all the instrument states using the calibration kit have been deleted). You can store the saved instrument state and calibration set to a disk before clearing them. After deleting the instrument states, press **Preset** to run the memory packer.

NOT ALLOWED DURING POWER METER CAL

Error Number 198 When the analyzer is performing a power meter calibration, the GPIB bus is unavailable for other functions such as printing or plotting.

NOT ENOUGH SPACE ON DISK FOR STORE

Error Number The store operation will overflow the available disk space. Insert a new disk or
44 purge files to create free disk space.

OVERLOAD ON INPUT A, POWER REDUCED

Error Number You have exceeded approximately +14 dBm at one of the test ports. The RF
58 output power is automatically reduced to -85 dBm. The annotation P↓ appears
in the left margin of the display to indicate that the power trip function has been
activated. When this occurs, reset the power to a lower level, then toggle the
SOURCE PWR on OFF softkey to switch on the power again.

OVERLOAD ON INPUT B, POWER REDUCED

Error Number You have exceeded approximately +14 dBm at one of the test ports. The RF
59 output power is automatically reduced to -85 dBm. The annotation P↓ appears
in the left margin of the display to indicate that the power trip function has been
activated. When this occurs, reset the power to a lower level, then toggle the
SOURCE PWR on OFF softkey to switch on the power again.

PARALLEL PORT NOT AVAILABLE FOR COPY

Error Number You have defined the parallel port as general purpose I/O (GPIO) for sequencing.
167 The definition was made under the **Local** key menus. To access the parallel
port for copy, set the selection to **PARALLEL [COPY]** .

PARALLEL PORT NOT AVAILABLE FOR GPIO

Error Number You have defined the parallel port as COPY for sequencing in the GPIB menu.
165 To access the parallel port for general purpose I/O (GPIO), set the selection to
PARALLEL [GPIO] .

PHASE LOCK CAL FAILED

Error Number An internal phase lock calibration routine is automatically executed at
4 power-on, preset, and any time a loss of phase lock is detected. This message
indicates that phase lock calibration was initiated and the first IF detected, but
a problem prevented the calibration from completing successfully. Perform the
“[Source Pretune Correction Constants \(Test 43\)](#)” on page 3-6. This message may
appear if you connect a mixer between the RF output and R input before turning
on frequency offset mode. Ignore it: it will go away when you turn on frequency
offset. This message may also appear if you turn on frequency offset mode before
you define the offset.

PHASE LOCK FAILURE

Error Number The first IF signal was detected at pretune, but phase lock could not be acquired.
7 Refer to [Chapter 7](#) , “[Source Troubleshooting](#).”

PHASE LOCK LOST

Error Number Phase lock was acquired but then lost. Refer to [Chapter 7](#) , “[Source Troubleshooting](#).”
8

POSSIBLE FALSE LOCK

Error Number Phase lock has been achieved, but the source may be phase locked to the wrong harmonic of the synthesizer. Perform the “[Source Pretune Correction Constants \(Test 43\)](#)” on page 3-6.
6

POWER METER INVALID

Error Number The power meter indicates an out-of-range condition. Check the test setup.
116

POWER METER NOT SETTLED

Error Number Sequential power meter readings are not consistent. Verify that the equipment is set up correctly. If so, preset the instrument and restart the operation.
118

POWER SUPPLY HOT!

Error Number The temperature sensors on the A8 post-regulator assembly have detected an over-temperature condition. The power supplies regulated on the post-regulator have been shut down. Refer to [Chapter 5](#) , “[Power Supply Troubleshooting](#).”
21

POWER SUPPLY SHUT DOWN!

Error Number One or more supplies on the A8 post-regulator assembly have been shut down due to an over-current, over-voltage, or under-voltage condition. Refer to [Chapter 5](#) , “[Power Supply Troubleshooting](#).”
22

PRINTER: error

Error Number The parallel port printer is malfunctioning. The analyzer cannot complete the copy function.
175

PRINTER: not handshaking

Error Number The printer at the parallel port is not responding.
177

PRINTER: not on, not connected, wrong addr

Error Number The printer does not respond to control. Verify power to the printer, and check the GPIB connection between the analyzer and the printer. Ensure that the printer address recognized by the analyzer matches the GPIB address set on the printer itself.
24

PWR MTR: NOT ON/CONNECTED OR WRONG ADDR

Error Number 117 The power meter cannot be accessed by the analyzer. Verify that the power meter address and model number set in the analyzer match the address and model number of the actual power meter.

SAVE FAILED.INSUFFICIENT MEMORY

Error Number 151 You cannot store an instrument state in an internal register due to insufficient memory. Increase the available memory by clearing one or more save/recall registers and pressing **(Preset)**, or by storing files to a disk.

SELF TEST #n FAILED

Service Error Number 112 Internal test #n has failed. Several internal test routines are executed at instrument preset. The analyzer reports the first failure detected. Refer to the internal tests and the self-diagnose feature descriptions earlier in this chapter.

SOURCE POWER TURNED OFF, RESET UNDER POWER MENU

Information Message You have exceeded the maximum power level at one of the inputs and power has been automatically reduced. The annotation P↓ indicates that power trip has been activated. When this occurs, reset the power and then press **(Power)** **SOURCE PWR on OFF** to switch on the power. This message follows error numbers 57, 58, and 59.

SWEEP MODE CHANGED TO CW TIME SWEEP

Error Number 187 If you select external source auto or manual instrument mode and you do not also select CW mode, the analyzer is automatically switched to CW.

SWEEP TIME TOO FAST

Error Number 12 The fractional-N and digital IF circuits have lost synchronization. Refer to the [Chapter 6 , “Digital Control Troubleshooting.”](#)

TEST ABORTED

Error Number 113 You have prematurely stopped a service test.

TEST PORT OVERLOAD, REDUCE POWER

Error Number 57 You have exceeded approximately +14 dBm at one of the test ports (or 0 dBm at the A or B sampler, Option 012 only). When this occurs, reduce the power to a lower level.

TROUBLE!CHECK SET-UP AND START OVER

Service Error Your equipment setup for the adjustment procedure in progress is not correct.
Number 115 Refer to [Chapter 3](#) , “Adjustments and Correction Constants.” Start the
 procedure again.

WRONG DISK FORMAT, INITIALIZE DISK

Error Number You have attempted to store, load, or read file titles, but your disk format does
77 not conform to the Logical Interchange Format (LIF) or DOS format. You must
 initialize the disk before reading or writing to it.

11 Error Terms

Information on This Chapter

The analyzer generates and stores factors in internal arrays when a measurement error-correction (measurement calibration) is performed. These factors are known by the following names:

- error terms
- E-terms
- measurement calibration coefficients

The analyzer creates error terms by measuring well-defined calibration devices over the frequency range of interest and comparing the measured data with the ideal model for the devices. The differences represent systematic (repeatable) errors of the analyzer system. The resulting calibration coefficients are good representations of the uncorrected performances. For details on the various levels of error-correction, refer to the “Optimizing Measurement Results” chapter of the analyzer user’s guide. For details on the theory of error-correction, refer to the “Operating Concepts” chapter of the analyzer user’s guide.

Error Terms Can Also Serve a Diagnostic Purpose

Specific parts of the analyzer and its accessories directly contribute to the magnitude and shape of the error terms. Since we know this correlation and we know what typical error terms look like, we can examine error terms to monitor system performance (preventive maintenance) or to identify faulty components in the system (troubleshooting).

- **Preventive Maintenance:** A stable, repeatable system should generate repeatable error terms over long time intervals, for example, six months. If you print or plot the error terms, you can periodically compare current error terms with the record. A sudden shift in error terms reflects a sudden shift in systematic errors, and may indicate the need for troubleshooting. A long-term trend often reflects drift, connector and cable wear, or gradual degradation, indicating the need for further investigation and preventive maintenance. Yet, the system may still conform to specifications. The cure is often as simple as cleaning and gaging connectors or inspecting cables.
- **Troubleshooting:** If a subtle failure or mild performance problem is suspected, the magnitude of the error terms should be compared against values generated previously with the same instrument and calibration kit. This comparison will produce the most precise view of the problem.

However, if previously generated values are not available, compare the current values to the typical values listed in [Table 11-3](#) and [Table 11-4](#), and shown graphically on the plots in [“Error Term Descriptions” on page 11-10](#). If the magnitude exceeds its limit, inspect the corresponding system component. If the condition causes system verification to fail, replace the component.

Consider the following while troubleshooting:

- ✓ All parts of the system, including cables and calibration devices, can contribute to systematic errors and impact the error terms.
- ✓ Connectors must be clean, gaged, and within specification for error term analysis to be meaningful.
- ✓ Avoid unnecessary bending and flexing of the cables following measurement calibration, minimizing cable instability errors.
- ✓ Use good connection technique during measurement and calibration. The connector interface must be repeatable. For information on connection technique and on cleaning and gauging connectors, refer to [“Principles of Microwave Connector Care” on page 1-6](#).
- ✓ Use error term analysis to troubleshoot minor, subtle performance problems. Refer to [Chapter 4](#), [“Start Troubleshooting Here,”](#) if a blatant failure or gross measurement error is evident.
- ✓ It is often worthwhile to perform the procedure twice (using two distinct measurement calibrations) to establish the degree of repeatability. If the results do not seem repeatable, check all connectors and cables.

Measurement Calibration Procedure

1. Refer to “[Measurement Calibration](#)” on page 2-22 and perform the full 2-port calibration on ES models or the enhanced response cal on ET models with the following modifications:
2. Connect a testport cable with a female connector to PORT 2 (TRANSMISSION port on ET models). Use the female standards (open, short, load) on PORT 1 (REFLECTION Port on ET models) and the male standards (open, short, load) on the cable.
3. For the isolation measurement, select from the following two options:
 - If you will be measuring devices with a dynamic range less than 90 dB, press:
OMIT ISOLATION ISOLATION DONE
 - If you will be measuring devices with a dynamic range greater than 90 dB, follow these steps:
 - a. Leave the cables connected and connect impedance-matched loads to the test ports (or reference test ports).

NOTE If you will be measuring highly reflective devices, such as filters, use the test device, connected to the reference plane and terminated with a load, for the isolation standard on PORT 1 (REFLECTION port on ET models). Connect a load to PORT 2 (TRANSMISSION port on ET models).

- b. Press **(Avg) AVERAGING ON AVERAGING FACTOR (8) (x1)**.
- c. Press **(Avg) IF BW (10) (x1)** to change the IF bandwidth to 10 Hz.
- d. Press the following:
(Cal) RESUME CAL SEQUENCE ISOLATION
ES models: **DO BOTH FWD + REV**
ET models: **FWD ISOL'N**
- e. Return the averaging and bandwidth to the original state of the measurement, and press the following:
(Cal) RESUME CAL SEQUENCE
ES models: **DONE | 2-PORT CAL**
ET models: **DONE FWD ISOL' ENH RESP**

Error Term Inspection

Table 11-1 (ES models) and Table 11-2 (ET models) list the calibration coefficients along with their corresponding test numbers. Refer to the appropriate table when performing this procedure.

Table 11-1 Calibration Coefficient Terms and Tests for ES Models

Calibration Coefficient	Calibration Type				Test Number
	Response	Response and Isolation*	1-port	2-port	
1	E_R or E_T	E_X (E_D)	E_D	E_{DF}	31
2		E_T (E_R)	E_S	E_{SF}	32
3			E_R	E_{RF}	33
4				E_{XF}	34
5				E_{LF}	35
6				E_{TF}	36
7				E_{DR}	37
8				E_{SR}	38
9				E_{RR}	39
10				E_{XR}	40
11				E_{LR}	41
12				E_{TR}	42
NOTES:					
Meaning of first subscript: D=directivity; S=source match; R=reflection tracking; X=crosstalk; L=load match; T=transmission tracking.					
Meaning of second subscript: F=forward; R=reverse.					
* Response and Isolation cal yields: E_X or E_T if a transmission parameter (S_{21} , S_{12}) or E_D or E_R if a reflection parameter (S_{11} , S_{22})					

Table 11-2 Calibration Coefficient Terms and Tests for ET Models

Calibration Coefficient	Calibration Type				Test Number
	Response	Response and Isolation*	1-port	Enhanced Response	
1	E_R or E_T	$E_X(E_D)$	E_D	E_{DF}	31
2		$E_T(E_R)$	E_S	E_{SF}	32
3			E_R	E_{RF}	33
4				E_{XF}	34
5				E_{LF}	35
6				E_{TF}	36
7				Not Used	37
8				Not Used	38
9				Not Used	39
10				Not Used	40
11				Not Used	41
12				Not Used	42
NOTES:					
Meaning of first subscript: D=directivity; S=source match; R=reflection tracking; X=crosstalk; L=load match; T=transmission tracking.					
Meaning of second subscript: F=forward					
* Response and Isolation cal yields: E_X or E_T if a transmission parameter (S_{21}, S_{12}) or E_D or E_R if a reflection parameter (S_{11}, S_{22})					

NOTE If the correction is not active, press **[Cal]** **CORRECTION ON** .

1. Press **[System]** **SERVICE MENU TESTS** **[31]** **[x1]** **EXECUTE TEST** .

The analyzer copies the first calibration measurement trace for the selected error term into memory and then displays it. [Table 11-1](#) (ES models) and [Table 11-2](#) (ET models) list the test numbers.

2. Press **[Scale Ref]** and adjust the scale and reference to study the error term trace.
3. Press **[Marker]** and use the front panel knob to determine the error term magnitude.

4. Compare the displayed measurement trace to the trace shown in “[Error Term Descriptions](#)” on page 11-10 and to previously measured data. If data is not available from previous measurements, refer to the typical uncorrected performance specifications listed in [Table 11-3](#) and [Table 11-4](#).
5. Print or plot the measurement results:
 - a. Connect a printer or plotter to the analyzer.
 - b. Press **(Local)** **SYSTEM CONTROLLER** **SET ADDRESSES** and select the appropriate peripheral to verify that the GPIB address is set correctly on the analyzer.
 - c. Press **(Save/Recall)** and then choose either **PRINT** or **PLOT**.
 - d. Press **(Display)** **MORE** **TITLE** and title each data trace so that you can identify it later.

NOTE For detailed information on creating hardcopies, refer to the “Printing, Plotting, and Saving Measurement Results” chapter in the analyzer user’s guide.

6. Repeat steps 1 through 5 for each test number that corresponds to a calibration coefficient (see [Table 11-1](#) and [Table 11-2](#)).

If Error Terms Seem Worse than Typical Values

1. To verify that the system still conforms to specifications, perform a system verification, refer to [Chapter 2](#), “[System Verification and Performance Tests](#).”
2. If system verification fails, refer to [Chapter 4](#), “[Start Troubleshooting Here](#).”

Uncorrected Performance

The following tables show typical performance without error-correction. RF cables are not used except as noted. Related error terms should be within these values.

Table 11-3 8719ET/ES and 8720ET/ES Uncorrected Port Performance

Parameter and Option	Frequency Range			
	0.05 to 0.5 GHz	0.5 to 2 GHz	2 to 8 GHz	8 to 20 GHz
Directivity (ES and ET models) ¹	24 dB	27 dB	21 dB	16 dB
Source Match (ES Standard) ¹	12 dB	12 dB	10 dB	8 dB
Source Match (ET Standard) ¹	16 dB	20 dB	14 dB	11 dB
Source Match (ES Option 400) ¹	20 dB	20 dB	11 dB	10 dB
Source Match (ES Option 007) ¹	16 dB	20 dB	14 dB	11 dB
Source Match (ES Option 085) ¹	16 dB	18 dB	14 dB	8 dB
Load Match (ES Standard) ¹	22 dB	20 dB	12 dB	10 dB
Load Match (ET Standard) ¹	22 dB	22 dB	22 dB	17 dB
Load Match (ES Option 400) ¹	20 dB	17 dB	12 dB	10 dB
Load Match (ES Option 007) ¹	26 dB	24 dB	15 dB	12 dB
Load Match (ES Option 085) ¹	26 dB	24 dB	15 dB	10 dB
Reflection Tracking (ES and ET models) ²	±3 dB	±3 dB	±3 dB	±3 dB
Transmission Tracking (ES ² and ET ¹ models)	±3 dB	±3 dB	±3 dB	±3 dB
Crosstalk (ES models) ³	75 dB ⁴	95 dB	91 dB	86 dB
Crosstalk (ET models) ³	101 dB	101 dB	101 dB	93 dB

1. Does not include the effect of the cable set on the test ports.
2. Excludes roll-off below 500 MHz, which is typically -18 dB at 100 MHz, and -25 dB at 50 MHz.
3. Measurement Conditions: normalized to a thru, measured with two shorts, 10Hz IF bandwidth, averaging factor of 8, alternate mode, source power set to the lesser of maximum power out or the maximum receiver power.
4. Limited by noise floor.

Table 11-4 8722ET/ES Uncorrected Port Characteristics

Parameter and Option	Frequency Range				
	0.05 to 0.5 GHz	.5 to 2 GHz	2 to 8 GHz	8 to 20 GHz	20 to 40 GHz
Directivity (ES and ET models) ¹	23 dB	23 dB	21 dB	16 dB	15 dB
Source Match (ES Standard, Option 400) ¹	17 dB	17 dB	12 dB	11 dB	7 dB
Source Match (ET Models) ¹	16 dB	20 dB	14 dB	11 dB	10 dB
Source Match (ES Option 007, Option 085) ¹	17 dB	17 dB	15 dB	11 dB	8 dB
Load Match (ES Standard, Option 400) ¹	18 dB	18 dB	15 dB	12 dB	10 dB
Load Match (ES Option 007, Option 085) ¹	21 dB	21 dB	17 dB	13 dB	10 dB
Load Match (ET Models) ¹	22 dB	20 dB	20 dB	20 dB	15 dB
Reflection Tracking (ES Models) ²	±3 dB	±3 dB	±3 dB	±3 dB	±6 dB
Reflection Tracking (ET models) ²	±3 dB	±3 dB	±3 dB	±3 dB	±4 dB
Transmission Tracking (ES Models) ²	±3 dB	±3 dB	±3 dB	±3 dB	±6 dB
Transmission Tracking (ET Models) ¹	±3 dB	±3 dB	±3 dB	±3 dB	±3 dB
Crosstalk (ES Models) ³	60 dB ⁴	85 dB	85 dB	82 dB	72 dB
Crosstalk (ET Models) ³	95 dB	95 dB	95 dB	88 dB	82 dB

1. Does not include the effect of the cable set on the test ports.
2. Excludes roll-off below 500 MHz, which is typically -18 dB at 100 MHz, and -25 dB at 50 MHz.
3. Measurement Conditions: normalized to a thru, measured with two shorts, 10 Hz IF bandwidth, averaging factor of 8, alternate mode, source power set to the lesser of maximum power out or the maximum receiver power.
4. Limited by noise floor.

Error Term Descriptions

The error term descriptions in this section include the following information:

- significance of each error term
- typical results following a full 2-port error-correction
- guidelines to interpret each error term

The same description applies to both the forward (F) and reverse (R) terms. The plots shown with each are typical of a working system following a full 2-port calibration as performed in “[Measurement Calibration Procedure](#)” on page 11-4.

NOTE The illustrations depicting the analyzer display were made using an 8722ES model. Other analyzer displays may appear different, depending on model and options.

It may be helpful to define some of the terms used in the error term descriptions that follow:

- **R signal path:** refers to the reference signal path. It includes the A58 M/A/D/S, A64 R sampler, and associated semirigid coax cables.
- **A input path:** refers to the port 1 input path and includes the A58 M/A/D/S, A69 step attenuator, A74 transfer switch, A61 bias tee, A62 directional coupler, A65 A sampler, and associated semirigid coax cables.
- **B input path:** refers to the port 2 input path and includes the A58 M/A/D/S, A69 step attenuator, A74 transfer switch, A60 bias tee, A63 directional coupler, A66 B sampler, and associated semirigid coax cables.

Directivity (EDF and EDR)

These are the uncorrected forward and reverse directivity error terms of the system. The directivity error of the test port is determined by measuring the S11 and S22 reflection of the calibration kit load. The load has a much better return loss specification than does the uncorrected test port, therefore any power detected from this measurement is assumed to be due to directivity error.

Significant System Components. The load used in the calibration is the most important component. The test port connector, the cable, and the coupler also greatly affect the measured directivity error.

Affected Measurements. The measurements most affected by directivity errors are measurements of low reflection devices.

Figure 11-1 Typical EDF/EDR without Cables

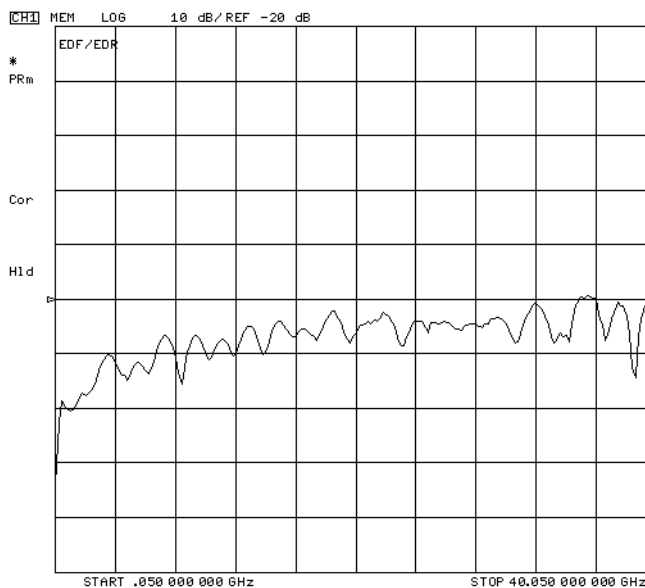

Source Match (ESF and ESR)

Description

These are the forward and reverse uncorrected source match terms of the driven port. They are obtained by measuring the reflection (S11, S22) of an open and then a short connected directly to the ports. Source match is a measure of the match between the coupler and test set connector, as well as the match between all components from the source to the output port.

Significant System Components. The open and short calibration devices are important, as are the coupler and test port connectors. The power splitter, bias tees, step attenuator, and transfer switch may also contribute to source match errors.

Affected Measurements. The measurements most affected by source match errors are reflection and transmission measurements of highly reflective DUTs.

Figure 11-2 Typical ESF/ESR without Cables

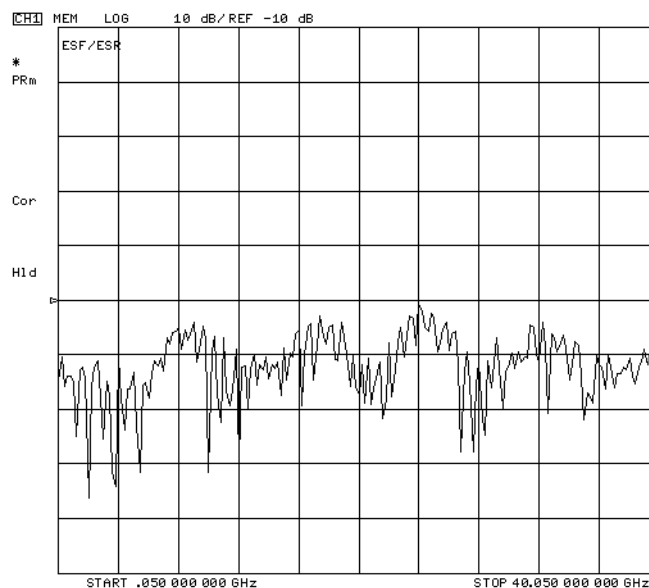

Reflection Tracking (ERF and ERR)

Reflection tracking is the difference between the frequency response of the reference path (R path) and the frequency response of the reflection test path (A or B input path). These error terms are characterized by measuring the reflection (S11, S22) of the open and the short during the measurement calibration. Note that coupler response is included in this error term. Typically, this appears as a roll-off below 500 MHz, which is typically -18 dB at 100 MHz, and -25 dB at 50 MHz.

Significant System Components. The open and short calibration devices have an effect on reflection tracking. But large variations in this error term may indicate a problem in one of the signal paths. Suspect the R signal path if the problem appears in both ERF and ERR. Troubleshoot the A or B input paths first if only one reflection tracking term is affected.

Affected Measurements. All reflection measurements (high or low return loss) are affected by the reflection tracking errors.

Figure 11-3 Typical ERF/ERR

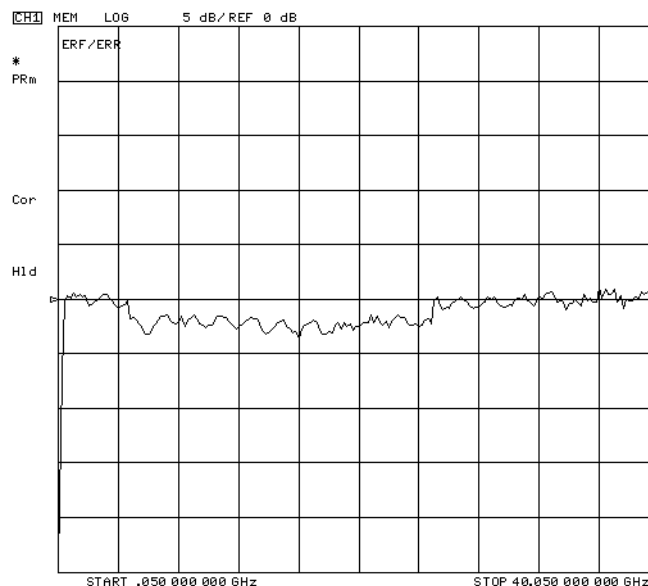

Isolation (Crosstalk, EXF and EXR)

These are the uncorrected forward and reverse isolation error terms that represent leakage between the test ports and the signal paths. The isolation error terms are characterized by measuring transmission (S_{21} , S_{12}) with loads attached to both ports during the measurement calibration. Since these terms are low in magnitude, they are usually noisy (not very repeatable).

Significant System Components. Loose cable connections or leakage between components in the lower box are the most likely cause of isolation problems. The transfer switch, bias tees, couplers, and samplers are the most susceptible components.

Affected Measurements. Isolation errors affect transmission measurements, primarily where the measured signal level is very low. An example is a transmission measurement where the insertion loss of the DUT is large.

Figure 11-4 Typical EXF/EXR with 3 kHz Bandwidth

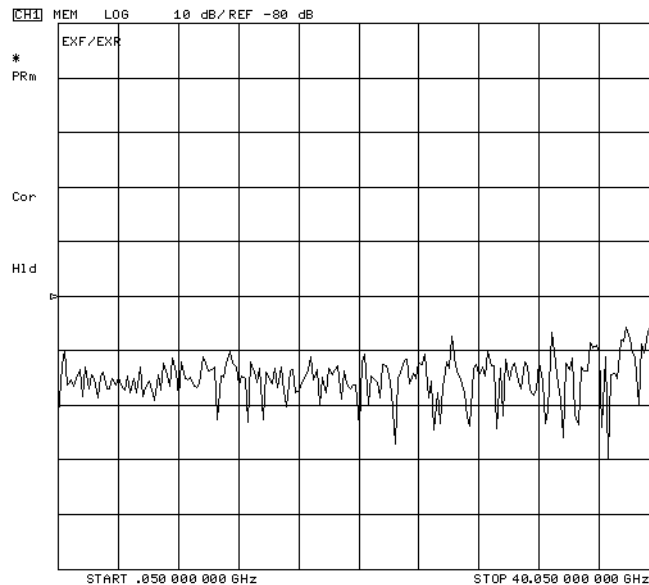

Load Match (ELF and ELR)

Load match is a measure of the impedance match of the test port that terminates the output of a 2-port device. The match of test port cables is included. Load match error terms are characterized by measuring the S11 and S22 responses of a “thru” configuration during the calibration procedure.

Significant System Components. Large variations in the forward or reverse load match error terms may indicate a bad “thru” cable or a poor connection of the cable to the test port.

Affected Measurements. The measurements most affected by load match errors are all transmission measurements, and reflection measurements of a low insertion loss two-port device, such as an airline.

Figure 11-5 Typical ELF/ELR

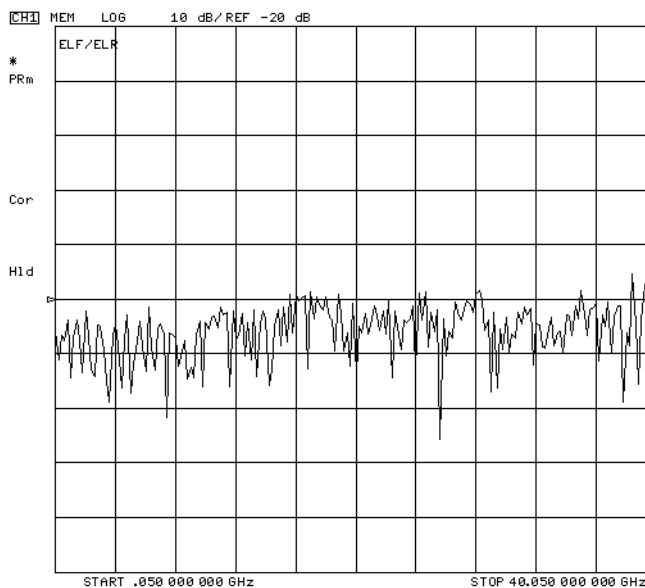

Transmission Tracking (ETF and ETR)

Transmission tracking is the difference between the frequency response of the reference path (including R input) and the frequency response of the transmission test path (including A or B input) while measuring transmission. The response of the test port cables is included. These terms are characterized by measuring the transmission (S21, S12) of the “thru” configuration during the measurement calibration. Note that coupler response is included in this error term. Typically, this appears as a roll-off below 500 MHz, which is typically -18 dB at 100 MHz, and -25 dB at 50 MHz

Significant System Components. Large variations in this error term probably indicate a problem in the reference signal path (if both ETF and ETR are bad) or in the A or B input path. The “thru” cable also has an effect on transmission tracking.

Affected Measurements. All transmission measurements are affected by transmission tracking errors.

Figure 11-6 Typical ETF/ETR

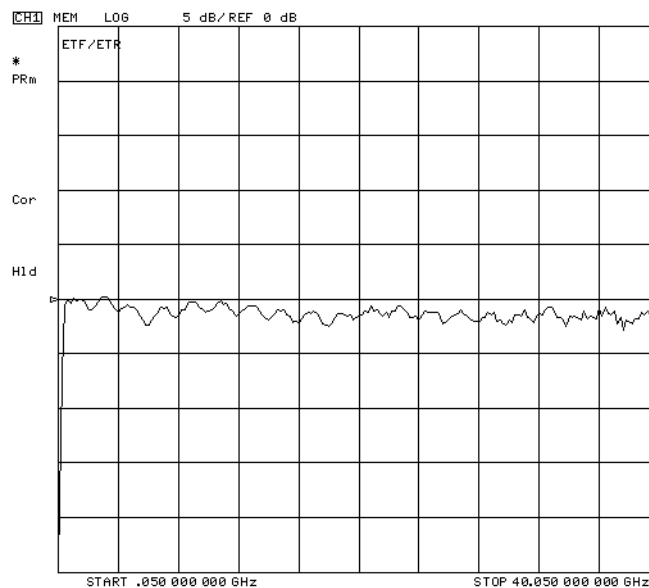

12 Theory of Operation

Information on This Chapter

This chapter provides a general description of the system, and operating theory of the network analyzer functional groups. Operation is explained to the assembly level only: component-level circuit theory is not provided. Simplified block diagrams illustrate the operation of each functional group. Overall block diagrams are located at the end of [Chapter 4](#) , “[Start Troubleshooting Here.](#)”

System Operation

The 8719ET/ES, 8720ET/ES, and 8722ET/ES microwave network analyzers integrate a synthesized source, signal separation devices, a three or four channel receiver for measurement of test device characteristics, and a large-screen display. [Figure 12-1](#) is a simplified block diagram of the network analyzer system.

Figure 12-1 Simplified System Block Diagram

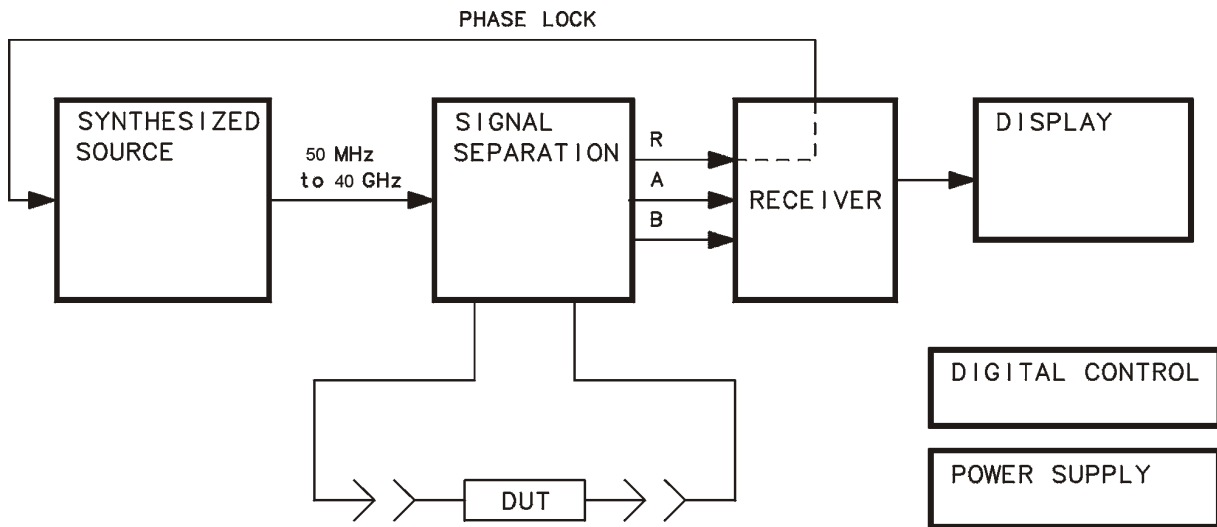

sb587e

The built-in synthesized source of the analyzer generates a swept or continuous wave (CW) signal in the following ranges:

8719ET/ES	8720ET/ES	8722ET/ES
50 MHz to 13.51 GHz	50 MHz to 20.05 GHz	50 MHz to 40.05 GHz

The source output power is leveled by an internal ALC (automatic leveling control) circuit. The output maximum power levels at the front panel are listed in [Table 12-1 on page 12-4](#). A portion of the source signal is routed to the R sampler receiver, and fed back to the source for phase lock.

Table 12-1 Maximum Leveled Power

Model Type	Power dBm
ES Models	
8719ES and 8720ES	+5
8719ES Option 007 and 8720ES Option 007	+10
8722ES (50 MHz to 20 GHz)	-5
(20.0 GHz to 40.05 GHz)	-10
8722ES Option 007 (50 MHz to 20 GHz)	0
(20.0 GHz to 40.05 GHz)	-5
ET Models	
8719ET and 8720ET	+10
8722ET (50 MHz to 20 GHz)	0
(20.0 GHz to 40.05 GHz)	-5

The signal separation devices separate the source signal into a reference path and a test path. They provide attenuation for the source signal, RF path switching to allow forward and reverse measurements, and external connections for the device under test (DUT). The signal transmitted through or reflected from the DUT goes to the receiver for comparison with the reference signal.

The receiver converts the source signal to a 4 kHz intermediate frequency (IF) for signal processing, retaining both magnitude and phase characteristics. The IF is converted to digital signals, which are processed into magnitude and phase information. The processed and formatted data is finally routed to the display and to the GPIB for remote operation.

In addition to the analyzer, the system includes cables for interconnections and calibration standards for accuracy enhancement.

Functional Groups of the Analyzer

The operation of the analyzer is most logically described in five functional groups. Each group consists of several major assemblies, and performs a distinct function in the instrument. Some assemblies are related to more than one group, and all the groups are to some extent interrelated and affect each other's performance.

Power Supply. The power supply functional group provides power for the other assemblies in the instrument.

Digital Control. The digital control group provides control to all assemblies in the network analyzer. The graphics signal processor (GSP) provides an interface between the CPU and the display.

Source. The source group supplies a phase-locked and leveled microwave signal to the device under test.

Signal Separation. The signal separation group performs the function of an S-parameter test set, dividing the source signal into a reference path and a test path, and providing connections to the device under test.

Receiver. The receiver group measures and processes the input signals for display.

The following pages describe the operation of the assemblies within each of the functional groups.

Power Supply Theory

The power supply functional group consists of the A15 preregulator and the A8 post regulator. These two assemblies comprise a switching power supply that provides regulated dc voltages to power all assemblies in the analyzer. The A15 preregulator is enclosed in a casting at the rear of the instrument behind the display. It is connected to the A8 post regulator by a wire bus A15W1. Figure 12-2 is a simplified block diagram of the power supply group.

Figure 12-2 Power Supply Functional Group, Simplified Block Diagram

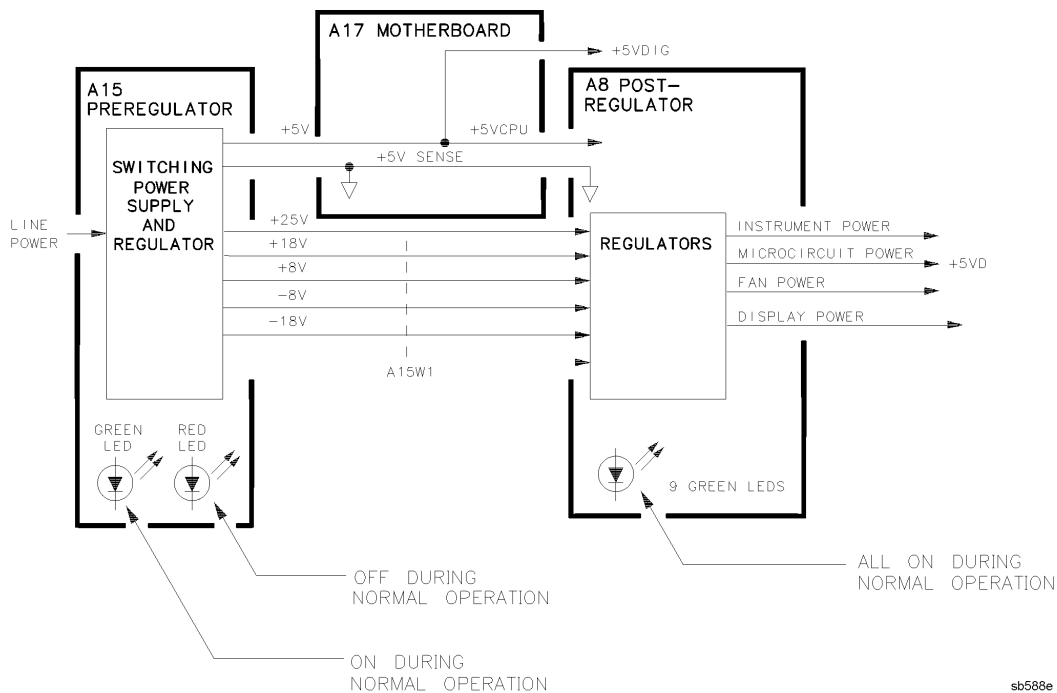

sb588e

A15 Preregulator

The A15 preregulator steps down and rectifies the line voltage. It provides a fully regulated +5 V digital supply, and several preregulated voltages that go to the A8 post regulator assembly for additional regulation.

The A15 preregulator assembly includes the line power module, a 60 kHz switching preregulator, and overvoltage protection for the +5 V digital supply. It provides LEDs, visible from the rear of the instrument, to indicate either normal or shutdown status.

Line Power Module

The line power module includes the line power switch, voltage selector switch, and main fuse. The line power switch is activated from the front panel. The voltage selector switch, accessible at the rear panel, adapts the analyzer to local line voltages of approximately 115 V or 230 V (with 350 VA maximum). The main fuse, which prevents the input side of the preregulator from drawing too much line current, is also accessible at the rear panel. Refer to the analyzer installation and quick start guide for line voltage tolerances and other power considerations.

Preregulated Voltages

The switching preregulator converts the line voltage to several dc voltages. The regulated +5 V digital supply goes directly to the motherboard. The following partially regulated voltages are routed through A15W1 to the A8 post regulator for final regulation:

+25 V +18 V -18 V +8 V -8 V

Regulated +5 V Digital Supply

The +5 V digital supply is regulated by the control circuitry in the A15 preregulator. It goes directly to the motherboard, and from there to all assemblies requiring a low noise digital supply. A +5 V sense line returns from the motherboard to the A15 preregulator. The +5 V CPU is derived from the +5 V digital supply in the A8 post regulator and goes directly to the A19 graphics system processor.

In order for the preregulator to function, the +5 V digital supply must be loaded by one or more assemblies, and the +5 V sense line must be working. If not, the other preregulated voltages will not be correct.

Shutdown Indications: the Green LED and Red LED

The green LED is on during normal operation. The green LED is off when line power is not connected, not switched on, or set too low, or if the line fuse has blown.

The red LED, which is off during normal operation, lights to indicate a fault in the +5 V supply. This may be an over/under line voltage, over line current, or overtemperature condition. For troubleshooting information, refer to [Chapter 5 , “Power Supply Troubleshooting.”](#)

A8 Post Regulator

The A8 post regulator filters and regulates the dc voltages received from the A15 preregulator. It provides fusing and shutdown circuitry for individual voltage supplies. It distributes regulated constant voltages to individual assemblies throughout the instrument. It includes the overtemperature shutdown circuit, the variable fan speed circuit, and the air flow detector. Nine green LEDs provide status indications for the individual voltage supplies.

Refer to the Power Supply Block Diagram located at the end of [Chapter 5 , “Power Supply Troubleshooting”](#) to see the voltages provided by the A8 post regulator.

Voltage Indications: the Green LEDs

The nine green LEDs along the top edge of the A8 assembly are on in normal operation, to indicate the correct voltage is present in each supply. If they are off or flashing, a problem is indicated. For troubleshooting information, refer to [Chapter 5](#), “Power Supply Troubleshooting.”

Shutdown Circuit

The shutdown circuit is triggered by overcurrent, overvoltage, undervoltage, or overtemperature. It protects the instrument by causing the regulated voltage supplies to be shut down. It also sends status messages to the A7 CPU to trigger warning messages on the analyzer display. The voltages that are not shut down are the +5VD and +5VCPU digital supplies from the preregulator, the fan supplies, and the display supplies. The shutdown circuit can be disabled momentarily for troubleshooting purposes by using a jumper to connect the SDIS line (A8TP4) to ground.

Variable Fan Circuit and Air Flow Detector

The fan power is derived directly from the +18 V and -18 V supplies from the A15 preregulator. The fan is not fused, so that it will continue to provide airflow and cooling when the instrument is otherwise disabled. If overheating occurs, the main instrument supplies are shut down and the fan runs at full speed. An overtemperature status message is sent to the A7 CPU to initiate a warning message on the analyzer display. The fan also runs at full speed if the air flow detector senses a low output of air from the fan. (Full speed is normal at initial power on.)

Display Power

The A8 assembly supplies +5VCPU to the A22 GSP interface board. The +5VCPU is routed to the A19 GSP where it is regulated to +3.3 V and sent to the display. The A19 GSP also controls and supplies power to the A20 backlight inverter. The voltages generated by the inverter are then routed to the display. Display power is not connected to the protective shutdown circuitry so that the A18 display assemblies can operate during troubleshooting when other supplies do not work.

NOTE **If blanking pulses from the A19 GSP are not present, then +3.3 V will not be sent to the display.**

Digital Control Theory

The digital control functional group consists of the following assemblies:

- A1 Front Panel
- A2 Front Panel Processor
- A7 CPU
- A10 Digital IF
- A16 Rear Panel
- A18 Display
- A19 GSP
- A20 Inverter

These assemblies combine to provide digital control for the entire analyzer. They provide math processing functions, as well as communications between the analyzer and an external controller or peripherals. A block diagram of the digital control functional group is located at the end of [Chapter 6](#), “[Digital Control Troubleshooting](#).”

A1 Front Panel

The A1 front panel assembly provides user interface with the analyzer. It includes the keyboard for local user inputs, and the front panel LEDs that indicate instrument status. The front panel knob is not electrically connected to the front panel, but provides user inputs directly to the front panel processor.

A2 Front Panel Processor

The A2 front panel processor detects and decodes user inputs from the front panel and the RPG, and transmits them to the CPU. It has the capability to interrupt the CPU to provide information updates. It controls the front panel LEDs that provide status information.

A7 CPU/A10 Digital IF

The A7 CPU assembly contains the main central processing unit (CPU), the digital signal processor, memory storage, and interconnect port interfaces. The main CPU is the master controller for the analyzer, including the other dedicated microprocessors. The memory includes EEPROM, DRAM, flash ROM, SRAM, and boot ROM.

Data from the receiver is serially clocked into the A7 CPU assembly from the A10 digital IF. The data taking sequence is triggered either from the A14 fractional-N assembly, externally from the rear panel, or by firmware on the A7 CPU assembly.

Main CPU

The main CPU is a 32-bit microprocessor that maintains digital control over the entire instrument through the instrument bus. The main CPU receives external control information from the front panel or GPIB, and performs processing and formatting operations on the raw data in the main RAM. It controls the digital signal processor (DSP), the front panel processor, the display processor, and the interconnect port interfaces. In addition, when the analyzer is in the system controller mode, the main CPU controls peripheral devices through the peripheral port interfaces.

The main CPU has a dedicated flash ROM that contains the operating system for instrument control. Front panel settings are stored in SRAM, with a battery providing at least 5 years of backup storage when external power is off.

Main RAM

The main random access memory (RAM) is shared memory for the CPU and the digital signal processor. It stores the raw data received from the digital signal processor, while additional calculations are performed on it by the CPU. The CPU reads the resulting formatted data from the main RAM and converts it to GSP commands. It writes these commands to the GSP for output to the analyzer display.

EEPROM

Electrically-erasable programmable read only memory (EEPROM) contains factory set correction constants unique to each instrument. These constants correct for hardware variations to maintain the highest measurement accuracy. The correction constants can be updated by executing the routines in [Chapter 3](#), “Adjustments and Correction Constants.”

Digital Signal Processor (DSP)

The digital signal processor (DSP) receives the digitized data from the A10 digital IF. It computes discrete Fourier transforms to extract the complex phase and magnitude data from the 4 kHz IF signal. The resulting raw data is written into the main RAM.

A18 Display

The A18 display is an 8.4 inch LCD with associated drive circuitry. It receives a +3.3 V power supply from the A19 GSP, along with the voltage generated from the A20 backlight inverter. It receives the following signals from the A19 GSP:

- digital TTL horizontal sync
- digital TTL vertical sync
- blanking
- data clock
- digital TTL red video
- digital TTL green video
- digital TTL blue video

A19 Graphics System Processor (GSP)

The A19 graphics system processor provides an interface between the A7 CPU and the A18 display. The CPU (A7) converts the formatted data to GSP commands and writes it to the GSP. The GSP processes the data to obtain the necessary video signals and sends the signals to the A18 display. It also produces VGA compatible RGB output signals which are sent to the A22 GSP interface and then routed to the A16 rear panel. The assembly receives one power supply voltage from the A22 GSP interface: +5V_{CPU}, which is used for processing and supplying power to the A20 backlight inverter and the A18 display.

A20 Inverter

The A20 backlight inverter assembly supplies the ac voltage for the backlight tube in the A18 display assembly. This assembly takes the +5.16V_{dc} from the A1 mother board and converts it to approximately 680 Vac. There are two control lines:

- Digital ON/OFF
- Analog Brightness
 - 100% intensity is 0 V
 - 50% intensity is 4.5 V

A16 Rear Panel

The A16 rear panel includes the following interfaces:

- **TEST SET I/O INTERCONNECT.** This provides control signals and power to operate duplexer test adapters.
- **EXT REF.** This allows for a frequency reference signal input that can phase lock the analyzer to an external frequency standard for increased frequency accuracy.

The analyzer automatically enables the external frequency reference feature when a signal is connected to this input. When the signal is removed, the analyzer automatically switches back to its internal frequency reference.
- **10 MHZ PRECISION REFERENCE. (Option 1D5)** This output is connected to the EXT REF (described above) to improve the frequency accuracy of the analyzer.
- **AUX INPUT.** This allows for a dc or ac voltage input from an external signal source, such as a detector or function generator, which you can then measure, using the S-parameter menu. (You can also use this connector as an analog output in service routines.)
- **EXT AM.** This allows for an external analog signal input that is applied to the ALC circuitry of the analyzer's source. This input analog signal amplitude modulates the RF output signal.
- **EXT TRIG.** This allows connection of an external negative-going TTL-compatible signal that will trigger a measurement sweep. The trigger can be set to external through softkey functions.

- **TEST SEQ.** This outputs a TTL signal that can be programmed in a test sequence to be high or low, or pulse (10 μ seconds) high or low at the end of a sweep for a robotic part handler interface.
- **LIMIT TEST.** This outputs a TTL signal of the limit test results as follows:
 - Pass: TTL high
 - Fail: TTL low
- **VGA OUTPUT.** This provides a video output of the analyzer display that is capable of being viewed on VGA monitor.

Source Group Theory

The source functional group produces a stable output signal by phase locking a YIG oscillator to a synthesized voltage controlled oscillator (VCO). The full frequency range of the source is generated in subsweeps by harmonic mixing.

The output at the front panel ports is a swept or a CW signal. Maximum leveled output powers are listed in [Table 12-1 on page 12-4](#). [Figure 12-3](#) illustrates the operation of the source functional group.

Figure 12-3 Source Functional Group, Simplified Block Diagram

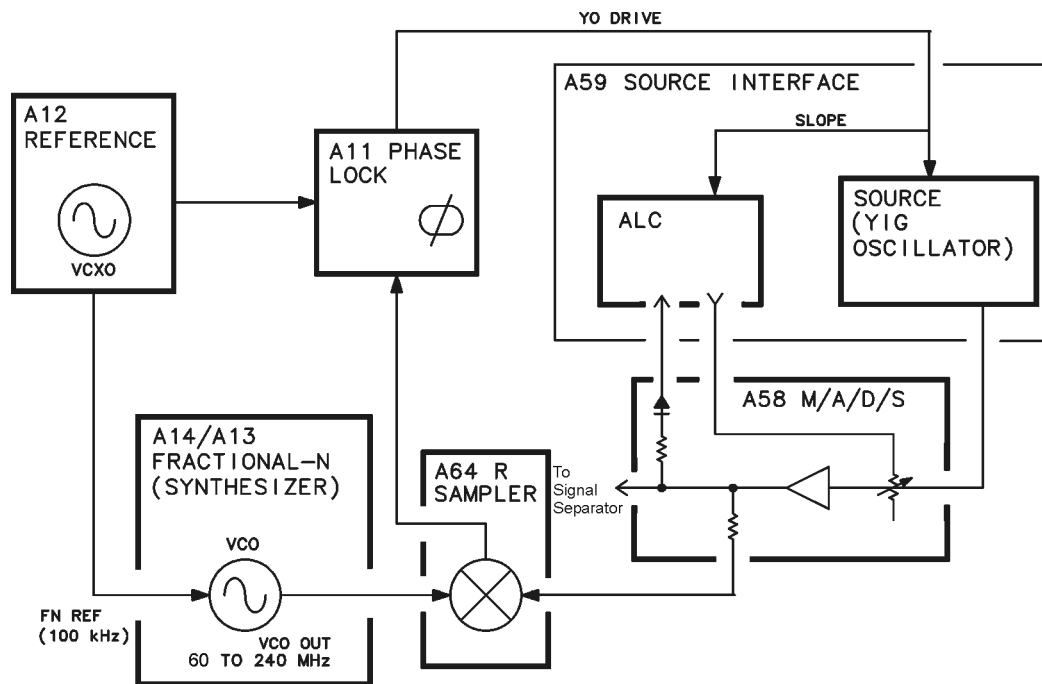

sb594e

The subsweep sequence takes place in the following steps. The following list describes the details of this process, and provides additional information on the assemblies in the source group.

1. The source is pretuned low. The source signal (SOURCE OUT) is fed to the R sampler.
2. A signal (VCO OUT) is generated by the VCO in the fractional-N synthesizer.
3. A comb of harmonics (1st LO) is produced in the pulse generator.
4. A synthesizer harmonic (1st LO) and the source signal (SOURCE OUT) are mixed in the sampler. A difference frequency (1st IF) is generated.
5. The 1st IF signal from the R sampler is fed back and compared to a reference. A tune current is generated.
6. The tune current is used to set the frequency of the source (YIG Oscillator).

7. Phase lock is acquired and a synthesized subsweep is generated. The source tracks the synthesizer.

Source Pretune

The pretune DAC (digital-to-analog converter) in the A11 phase lock assembly sets the source YIG oscillator frequency to approximately 2.4 GHz. This signal (SOURCE OUT) is input to the R sampler assembly.

A14/A13 Fractional-N Synthesizer

The A14/A13 fractional-N assemblies comprise the synthesizer. The source feedback circuit phase locks the YIG oscillator to the synthesizer output signal as explained in [“A11 Phase Lock: Comparing Phase and Frequency” on page 12-15.](#)

The VCO in the A14 fractional-N (digital) assembly generates a swept or CW signal in the range of 60 to 240 MHz, such that a harmonic is 10 MHz above the desired source frequency. This is divided down and phase locked (in the A13 assembly) to a 100 kHz signal FN REF from the A12 reference. A programmable divider is set to some number, N, such that the integer part of the expression $FVCO/N$ is equal to 100 kHz. To achieve frequencies between integer multiples of the reference, the divider is programmed to divide by N part of the time and by N+1 part of the time. The ratio of the divisions yields an average equal to the desired fractional frequency. API (analog phase interpolator) current sources in the A13 assembly correct for phase errors caused by the changing of the “divide by number.” The resulting synthesized signal goes to the pulse generator.

A52 Pulse Generator: the Harmonic Comb

The signal from the synthesizer drives a step recovery diode (SRD) in the A52 pulse generator assembly. The SRD generates a comb of harmonic multiples (1st LO) of the VCO frequency, which goes to the samplers. One of the harmonics is 10 MHz above the desired start frequency.

A64 R Sampler: Down-Converting the Signals

The A64 assembly is part of the receiver functional group. It is also included here because it is an integral part of the source phase locking scheme. In the R sampler, the 1st LO signal from the pulse generator is mixed with the SOURCE OUT signal from the source. The difference is the intermediate frequency (IF), which is nominally 10 MHz. For phase locking, part of this IF signal is routed back to the A11 phase lock assembly. (Additional information on the sampler assemblies is provided in [“Receiver Theory” on page 12-24.](#))

A11 Phase Lock: Comparing Phase and Frequency

The 10 MHz 1st IF signal from the A64 sampler is fed back to the A11 phase lock assembly. The IF signal is amplified, limited, and filtered to produce a 10 MHz square wave by the A11 phase lock assembly. The 10 MHz squarewave is then divided down to 1 MHz, and applied to a phase/frequency detector that compares it to a crystal controlled 1 MHz signal (PL REF) from the A12 reference assembly (see [“A12 Reference: The Crystal Reference Frequencies”](#) on page 12-16). Any phase or frequency difference between these two signals produces a proportional dc voltage.

Tuning the YIG Oscillator

The output of the phase/frequency detector is filtered to remove any 1 MHz feedthrough, and is fed to an integrator. The output of the integrator is converted to a tune current. This brings the appropriate YIG oscillator closer to the desired frequency, which in turn reduces the phase/frequency detector output voltage. When the voltage is reduced to zero, and the divided-down 1st IF frequency is equal to the 1 MHz reference frequency PL REF, phase lock is achieved.

Phase Locked Sweep

When the source is phase locked to the synthesizer at the start frequency, the synthesizer starts to sweep. The phase-locked loop forces the source to track the synthesizer, maintaining a constant 10 MHz 1st IF signal.

The full sweep is generated in a series of subsweeps, by phase locking the source signal to the harmonic multiples of the synthesizer. At the transitions between subsweeps, phase lock is broken, the source is held at this frequency. [Table 12-2](#) lists the subsweep frequencies from the synthesizer and the source.

Table 12-2 Sub sweep Frequencies

Band	Synthesizer (MHz)	Harmonic Number (N)	Source (MHz) Frequency
Low	60 to 120	1	50 - 110
	120 to 240	1	110 - 230
	120 to 240	2	230 - 470
	160 to 236	3	470 - 698
	141.6 to 236	5	698 - 1170
	147.5 to 236	8	1170 - 1878
	157.3 to 213.3	12	1878 - 2550
High Mid (8722ET/ES)	128 to 236	20	2550 - 4710
	131.1 to 220/6	36	4710 - 8256
	142.5 to 234	58	8256 - 13562
	159.7 to 235.4	85	13562 - 20000
High (8722ET/ES)	178.7 to 223.3	112	20000 - 25000
	148.9 to 238.2	168	25000 - 40000

A12 Reference: The Crystal Reference Frequencies

This assembly provides stable reference frequencies to the rest of the instrument by dividing down the output of a 40 MHz VCXO (voltage-controlled crystal oscillator). One of the divided-down signals is the 100 kHz FN REF for phase locking the synthesizer signal in A13. Another is the 1 MHz main phase-locked loop reference signal PL REF that goes to the phase comparator in A11. (The 2nd LO signal and the timing signal for the A10 digital IF assembly are explained in [“Signal Separation: ES Models Only” on page 12-19.](#)) The EXT REF rear panel input provides the option of using an external reference with a frequency of 1, 2, 5, or 10 MHz, instead of the internal 40 MHz VCXO.

Source Block: The YIG Oscillator Signals

The source block includes two YIG oscillators and a 3.8 GHz fixed oscillator. The outputs of these oscillators produce the source signal. In phase-locked operation, this signal tracks the stable output of the synthesizer. [Figure 12-4](#) illustrates the assemblies in the source block.

Figure 12-4 Simplified Diagram of the Source Block Diagram

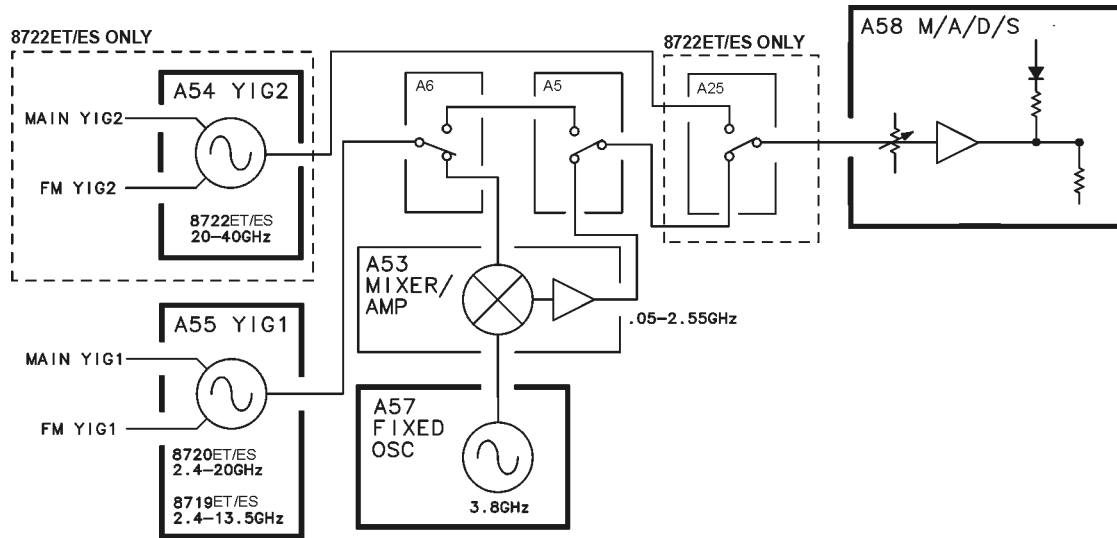

sb590e

The YIG oscillator has a main coil and an FM coil. These are analogous to the woofer and the tweeter in a stereo speaker: the woofer reproduces low frequencies and the tweeter reproduces high frequencies. Similarly in the YIG oscillator, the main coil allows large, slow changes in frequency but cannot respond to high frequency deviations, which are sent to the faster-acting FM coils.

The tune current from the A11 phase lock assembly splits into two paths. One path is lowpass filtered, removing high frequency components, and goes to the YIG main coil; the other path is highpass filtered, removing low frequency components, and goes to the YIG FM coils. The filters are matched in stop-band response, such that one picks up where the other leaves off.

Table 12-3 Frequency Bands for All Models

Band	Frequency Range
Low for all models	50 MHz to 2.55 GHz
High for 8719ET/ES models	2.55 GHz to 13.05 GHz
High for 8720ET/ES models Mid for the 8722ET/ES models	2.55 GHz to 20.05 GHz
High for the 8722ET/ES models	20.05 GHz to 40.05 GHz

In the low band (for all models), the 3.85 to 6.35 GHz output of YIG1 and the fixed 3.8 GHz output of the A57 fixed oscillator are mixed in the A53 mixer/amplifier assembly. In this band, A5 and A6 switch A53 into the circuit.

The high band of the 8719ET/ES and 8720ET/ES (mid band of 8722ET/ES) uses the full band output of YIG1.

The high band of the 8722ET/ES uses the output of YIG2.

In the A58 M/A/D/S microcircuit, the YIG oscillator signal is modulated by the ALC OUT signal (explained in “[ALC: Automatic Leveling Control](#)”) to provide power control and leveling.

ALC: Automatic Leveling Control

A portion of the source output is detected in the M/A/D/S and sent back to the source interface board ALC circuit. This circuit generates a control signal which is sent to the modulator in the M/A/D/S to control the power. The tune voltage from the main coil drive is used to change the source amplitude as a function of frequency, thus compensating the source for losses in the transfer switch, bias tees, and couplers.

Signal Separation: ES Models Only

Figure 12-5 Signal Separation Simplified Block Diagram

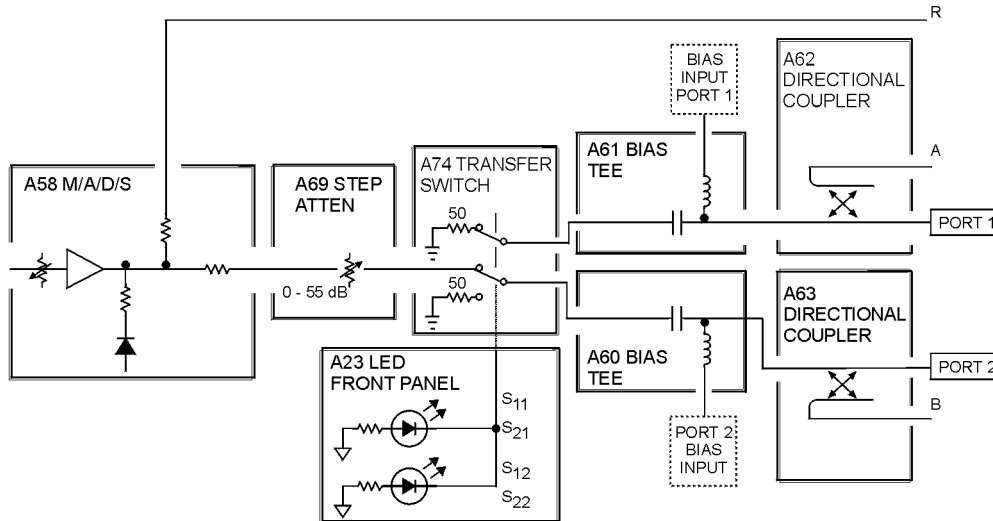

sb589e

A58 M/A/D/S Modulator, Amplifier, Detector, Splitter

The M/A/D/S microcircuit accomplishes four separate functions:

- The modulator controls the output power proportionally to the signal produced by the ALC circuit on the source interface board.
- The amplifier provides up to +30 dB of amplification. For maximum PORT 1 and PORT 2 output power levels, refer to [Table 12-1 on page 12-4](#).
- The detector outputs a voltage that is proportional to the RF power out of the amplifier. This voltage is used by the ALC circuit on the source interface board.
- The power source divides the source signal into two parts. One signal is routed directly to the A64 R sampler and the other is sent through the A69 step attenuator, A74 transfer switch, A60/A61 bias tees, A62/A63 directional couplers and to the test ports (PORT 1 /PORT 2).

The M/A/D/S microcircuit is controlled by the ALC circuitry on the source interface board. The CPU provides fine control of the test port power for applications such as power sweep.

A58 M/A/D and A74 Switch Splitter (Option 400 Only)

The M/A/D (Modulator/Amplifier/Detector) microcircuit accomplishes three functions:

The modulator controls the output power proportionally to the signal produced by the ALC circuit on the source interface board.

The amplifier can provide +30 dB of amplification. For maximum PORT 1 and PORT 2 output power levels, refer to [Table 12-1 on page 12-4](#).

The detector outputs a voltage that is proportional to the RF power out of the amplifier. The voltage is used by the ALC circuit on the source interface board.

The switch splitter (A74) divides three inputs:

- a path routed directly to A64 (R1 sampler)
- a path routed directly to the A67 (R2 sampler)
- a path switched to the appropriate output port (through A70/71 step attenuators, A60/61 bias tees, and A62/63 directional couplers)

Figure 12-6 Option 400 Signal Separation Simplified Block Diagram

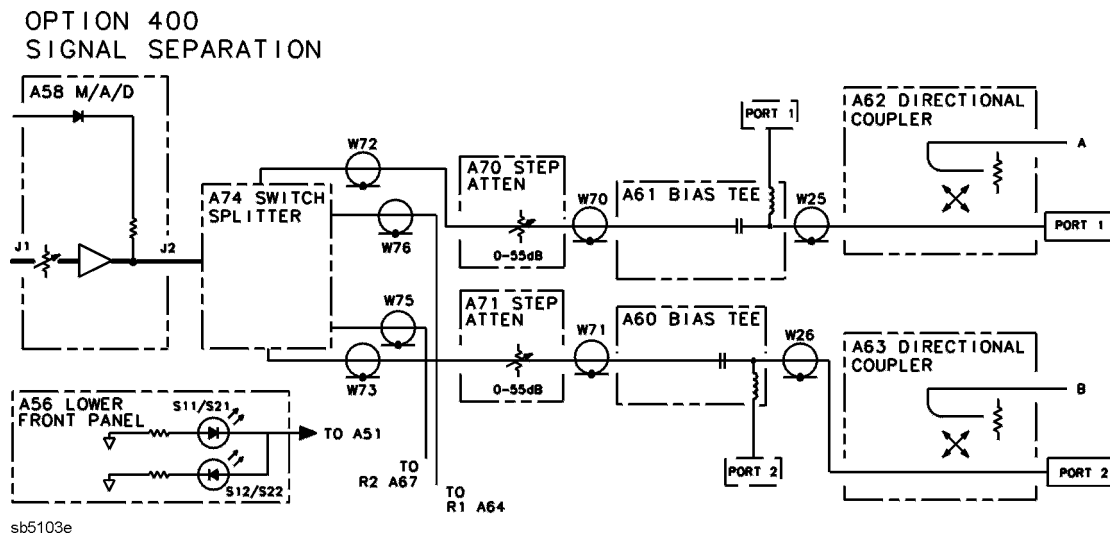

A69 Step Attenuator

The step attenuator provides coarse power control for the source signal. It is an electro-mechanical attenuator, controlled by the A7 CPU, that provides 0 to 55 dB of attenuation in 5 dB steps. It adjusts the power level to the device under test (DUT) without changing the level of the incident power in the reference path.

A74 Transfer Switch

The output of the step attenuator is fed into the A74 transfer switch. This is a solid-state switch. It switches between the PORT 1 and PORT 2 measurement paths, automatically enabling alternate forward and reverse measurements. In addition, A74 provides an internal termination for the measurement port that is inactive.

A56 Lower Front Panel Assembly

LEDs on the lower front panel indicate the status of the transfer switch.

A60 and A61 DC Bias Tees

The dc bias tees provide a means of biasing active devices with an external dc voltage connected to the rear panel DC BIAS CONNECT ports. The dc voltage is applied directly to the center conductor of the test port connectors. A blocking capacitor ensures that the bias current goes only to the device under test, and not back into the source. Likewise, an inductor in the bias path prevents RF from being imposed on the external dc supply.

A62 and A63 Directional Couplers

The test signal goes into the through-line arm of the couplers, and from there to the test ports and the device under test (DUT). The coupled arm of the couplers carries the signal reflected from or transmitted through the device under test to the receiver for measurement. The coupling coefficient of the directional couplers is nominally 14 dB from 840 MHz to 40.05 GHz and 40 dB at 50 MHz.

Signal Separation: ET Models Only

Figure 12-7 Signal Separation Simplified Block Diagram

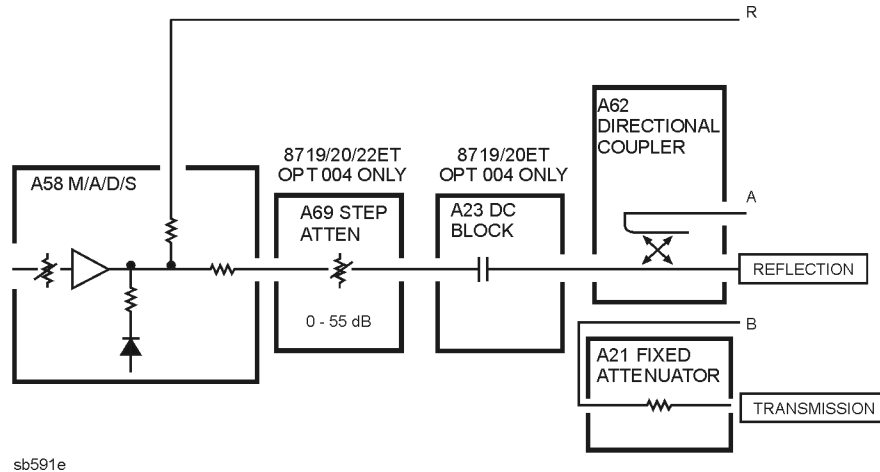

A58 M/A/D/S Modulator, Amplifier, Detector, Splitter

The M/A/D/S microcircuit accomplishes four separate functions:

The modulator controls the output power proportionally to the signal produced by the ALC circuit on the source interface board.

The amplifier provides up to +30 dB of amplification. For the maximum reflection output power levels refer to [Table 12-1 on page 12-4](#).

The detector outputs a voltage that is proportional to the RF power out of the amplifier. This voltage is used by the ALC circuit on the source interface board.

The source divides the source signal into two parts. One signal is routed directly to the A64 R sampler and the other is sent through the A69 step attenuator (ET Option 004 models only), A23 dc block (8719ET Option 004 and 8720ET Option 004 only), A62 directional coupler, and out to the REFLECTION port. The TRANSMISSION port is routed through the A21 fixed attenuator pad and then to the A66 B sampler.

The M/A/D/S microcircuit is controlled by the ALC circuitry on the source interface board. The CPU provides fine control of the test port power for applications such as power sweep.

A69 Step Attenuator (All ET Option 004 Models)

The step attenuator provides coarse power control for the source signal. It is an electro-mechanical attenuator, controlled by the A7 CPU, that provides 0 to 55 dB of attenuation in 5 dB steps. It adjusts the power level to the device under test (DUT) without changing the level of the incident power in the reference path.

A23 DC Block (8719ET Option 004 and 8720ET Option 004 Only)

The dc block prevents a dc voltage from entering the analyzer by way of a device under test (DUT).

A62 Directional Couplers

The test signal goes into the through-line arm of the coupler, and from there to the REFLECTION port and the device under test (DUT). The coupled arm of the coupler carries the signal reflected from the DUT to the receiver for measurement. The coupling coefficient of the directional couplers is nominally 14 dB (840 MHz to 40.05 GHz) and (40 dB at 50 MHz)

Receiver Theory

The receiver measures and processes the input signals into digital information for display. [Figure 12-8](#) is a simplified block diagram of the receiver functional group. The A12 reference assembly, which is part of the source group, is also included in the illustration to show how the 2nd LO signal is derived.

Figure 12-8 Receiver Functional Group Simplified Block Diagram

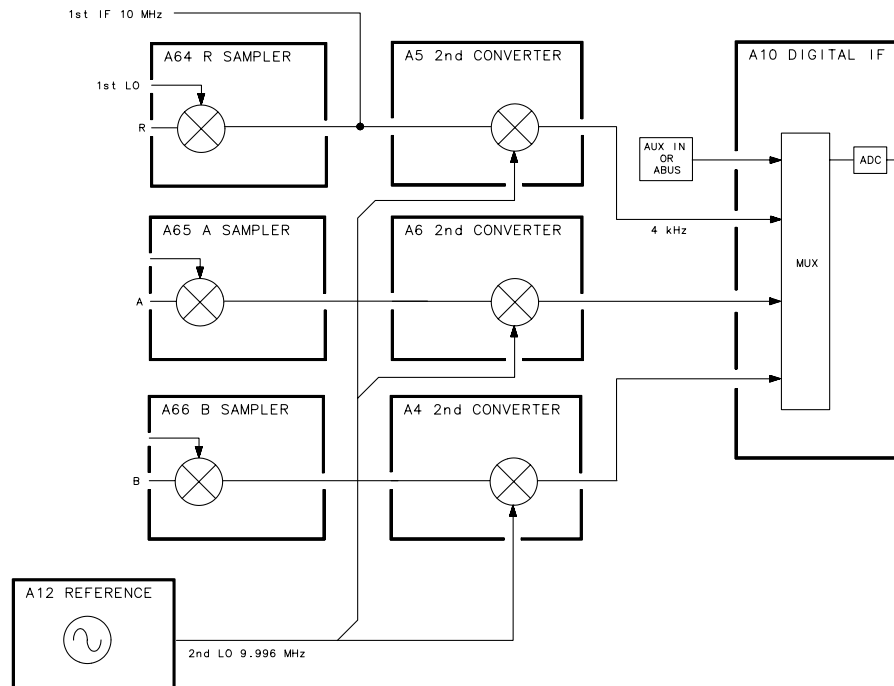

sb624d

Samplers and Second Converters

Each input signal goes to a sampler and then to the second converter assembly (R, A, and B) that down-converts the signal to a fixed 4 kHz 2nd IF.

The 1st LO signal is a comb of harmonics of the synthesizer signal, produced by a step recovery diode in the A52 pulse generator. Refer to [“Source Group Theory”](#) on page 12-13 for details.

A64/A65/A66 (A67 Option 400) Samplers. The signal from the source is mixed with the 1st LO harmonics in the samplers. One of the harmonic signals is 10 MHz above the desired frequency. The mixing products are filtered, leaving only the difference between that harmonic and the source frequency. This fixed 10 MHz signal (1st IF) is calculated as follows:

$$F_{IF} = N \times F_{VCO} - F_S \text{ (where } N \text{ is the harmonic number)}$$

Part of the 1st IF signal from the R sampler is fed back to the A11 phase lock assembly to complete the source phase-locked loop. The 1st IF from all three samplers goes to the corresponding second converters. The A67 sampler is only used in option 400 instruments and is only functional during measurements with a TRL calibration.

2nd LO Signal. The stable 2nd LO signal is produced in the A12 reference assembly by phase locking and mixing a 39.984 MHz VCO with the 40 MHz VCXO to derive a difference of 16 kHz. This is compared to a 16 kHz reference produced by dividing 40 MHz by 2500. The phase-locked output of the 39.984 MHz oscillator is divided by 4 to provide the 9.996 MHz 2nd LO signal.

A4/A5/A6 Second Converters. The 1st IF and the 2nd LO are mixed in the second converter. The resulting difference frequency is a constant 4 kHz 2nd IF signal that retains the amplitude and phase characteristics of the measured signal. The 2nd IF signals from all three second converter assemblies are input to the A10 digital IF assembly.

A10 Digital IF

In this assembly, the 2nd IF signals from the A and B second converters go through a gain stage. Signals less than -30 dB on these two signal paths are amplified by 24 dB to ensure that they can be detected by the ADC (analog-to-digital converter). For troubleshooting purposes, the gain can be forced on or off by using the service menus (refer to [Chapter 8](#), “[Receiver Troubleshooting](#)”). The R path signal is fixed at a level high enough to maintain phase lock, and therefore requires no amplification.

All three signals are sampled at a 16 kHz rate set by a divided-down 4 MHz clock pulse from the A12 reference assembly. The signals are sequentially multiplexed into the ADC, where they are converted to digital form. The ADC conversions are triggered by timing signals from the CPU or the synthesizer, or an external signal at the rear panel EXT TRIG connector. The digitized data is serially clocked into the A7 CPU assembly to be processed into magnitude and phase data.

The processed and formatted data is finally routed to the display, and to the GPIB for remote operation. Refer to “[Digital Control Theory](#)” on [page 12-9](#) and to the “Operating Concepts” chapter of the user’s guide for more information on signal processing.

An additional input to the A10 assembly is the analog bus (ABUS), a built-in service tool for testing analog circuits within the instrument. This is a single multiplexed line that networks analog nodes throughout the instrument, or monitors an external input at the rear panel AUX INPUT connector. It is controlled by the CPU, and used like an oscilloscope or frequency counter to make internal voltage and frequency measurements.

13 Replaceable Parts

Information on This Chapter

This chapter contains information for ordering replacement parts for the 8719ET/ES, 8720ET/ES, and 8722ET/ES network analyzers. Replaceable parts include the following:

- major assemblies
- cables
- hardware

Assembly Replacement Sequence

The following steps show the sequence to replace an assembly in the network analyzer.

- Step 1.** Identify the faulty group. Begin with [Chapter 4 , “Start Troubleshooting Here.”](#) Follow up with the appropriate troubleshooting chapter that identifies the faulty assembly.
- Step 2.** Order a replacement assembly. Refer to this chapter.
- Step 3.** Replace the faulty assembly and determine what adjustments are necessary. Refer to [Chapter 14 , “Assembly Replacement and Post-Repair Procedures.”](#)
- Step 4.** Perform the necessary adjustments. Refer to [Chapter 3 , “Adjustments and Correction Constants.”](#)
- Step 5.** Perform the necessary performance tests. Refer to [Chapter 2 , “System Verification and Performance Tests.”](#)

Rebuilt-Exchange Assemblies

Under the rebuilt-exchange assembly program, certain factory-repaired and tested modules (assemblies) are available on a trade-in basis. These assemblies are offered for lower cost than a new assembly, but meet all factory specifications required of a new assembly.

The defective assembly must be returned for credit under the terms of the rebuilt-exchange assembly program. Any spare assembly stock desired should be ordered using the new assembly part number. [Figure 13-1](#) illustrates the module exchange procedure.

Ordering Information

To order a part listed in the replaceable parts lists, quote the Agilent Technologies part number, indicate the quantity required, and address the order to the nearest Agilent Technologies office. The sales or service offices table is located in [Chapter 15](#), “[Safety and Regulatory Information](#).”

To order a part that is not listed in the replaceable parts lists, include the instrument model number, complete instrument serial number, the description and function of the part, and the number of parts required. Address the order to the nearest Agilent Technologies office.

Figure 13-1 Module Exchange Procedure

The module exchange program described here is a fast, efficient, economical method of keeping your instrument in service.

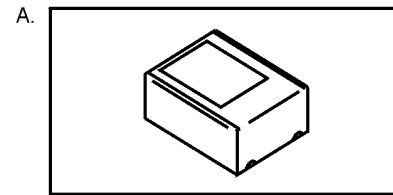
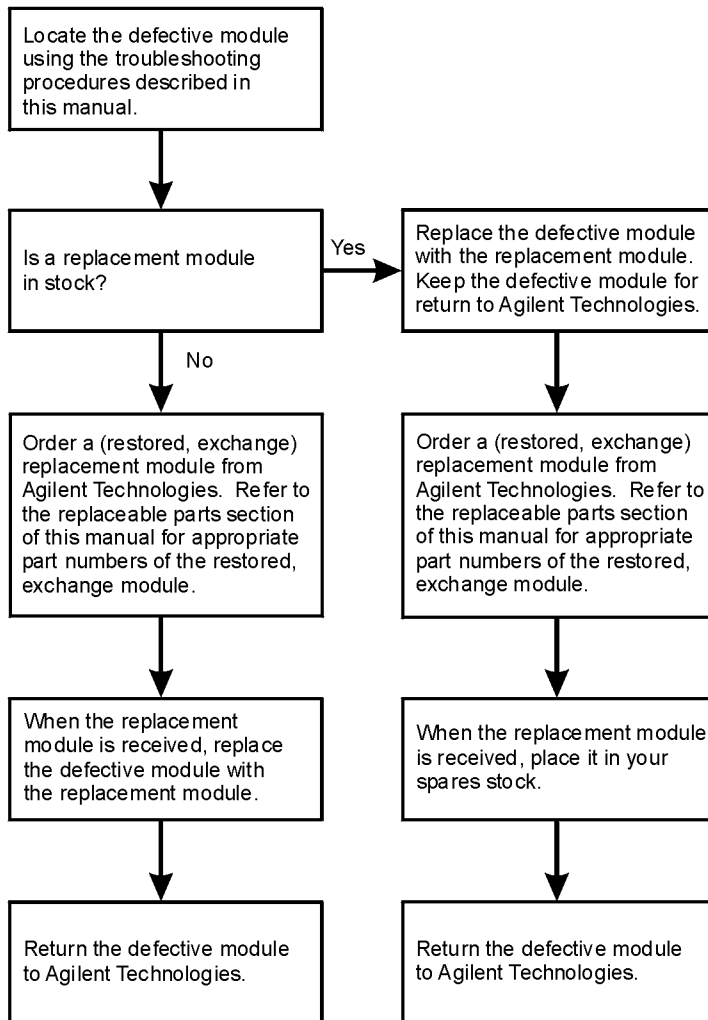

Restored, exchange modules are shipped individually in boxes as shown above. In addition to the module, the box contains an exchange-assembly failure report and a return-shipping label.

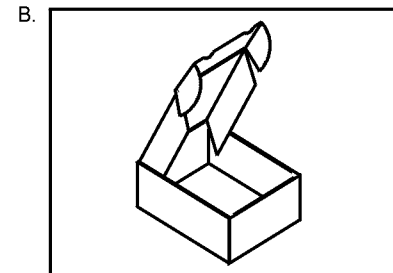

Open the box carefully so that it can be used to return the defective module to Agilent Technologies. Complete the exchange-assembly failure report. Remove the return-shipping label from inside the box. Place the defective module and the failure report in the box. Seal the box with tape.

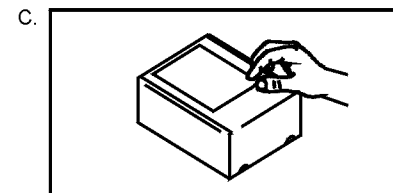

For shipping within the USA, affix the return-shipping label over the existing label. Mail the box to Agilent Technologies. (Postage is paid by Agilent Technologies on boxes mailed within the USA.) Outside the USA, address and mail the box to the nearest Agilent Technologies office. Do not use the return-shipping label.

formt120

Replaceable Part Listings

The following section lists the replacement part numbers and descriptions for the 8719ET/ES, 8720ET/ES, and 8722ET/ES network analyzer. Illustrations with reference designators are provided after the tables with the exception of “[Front Cables, All Models.](#)” For the cables front, refer the block diagrams at the end of [Chapter 4](#) , “[Start Troubleshooting Here.](#)”

- [Top Assemblies \(on page 13-8\)](#)
- [Bottom Assemblies and Cables \(on page 13-12\)](#)
 - [8719ES and 8720ES Standard and Option 007 \(on page 13-13\)](#)
 - [8719ES and 8720ES Options 012, 012+007 \(on page 13-15\)](#)
 - [8719ES and 8720ES Options 089, 089+007 \(on page 13-17\)](#)
 - [8719ES and 8720ES Options 089+012, 089+012+007 \(on page 13-19\)](#)
 - [8719ES and 8720ES Options 085, 085+089 \(on page 13-21\)](#)
 - [8719ES and 8720ES Option 400 \(on page 13-23\)](#)
 - [8719ES and 8720ES Option 400+012 \(on page 13-25\)](#)
 - [8719ES and 8720ES Option 400+089 \(on page 13-27\)](#)
 - [8719ES and 8720ES Option 400+012+089 \(on page 13-29\)](#)
 - [8722ES Standard \(on page 13-31\)](#)
 - [8722ES Option 007 \(on page 13-33\)](#)
 - [8722ES Option 012 \(on page 13-35\)](#)
 - [8722ES Option 007+012 \(on page 13-37\)](#)
 - [8722ES Option 089 \(on page 13-39\)](#)
 - [8722ES Option 089+007 \(on page 13-41\)](#)
 - [8722ES Option 089+012 \(on page 13-43\)](#)
 - [8722ES Option 089+007+012 \(on page 13-45\)](#)
 - [8722ES Option 085, 085+089 \(on page 13-47\)](#)
 - [8722ES Option 400 \(on page 13-49\)](#)
 - [8722ES Option 400+012 \(on page 13-51\)](#)
 - [8722ES Option 400+089 \(on page 13-53\)](#)
 - [8722ES Option 400+012+089 \(on page 13-55\)](#)

- 8719ET and 8720ET Standard (on page 13-57)
- 8719ET and 8720ET Option 004 (on page 13-59)
- 8722ET Standard (on page 13-61)
- 8722ET Option 004 (on page 13-63)
- Front RF Assemblies (on page 13-64)
- Top Cables (on page 13-66)
- Rear Cables, All Models (on page 13-69)
- Front Cables, All Models (on page 13-70)
- Front Panel Assembly, Inside (on page 13-72)
- Rear Panel Assembly (on page 13-74)
- Rear Panel Assembly, Option 1D5 (on page 13-76)
- Hardware, Top (on page 13-78)
- Hardware, Bottom (on page 13-80)
- Hardware, Front (on page 13-82)
- Hardware, Preregulator (on page 13-83)
- Chassis Parts, Outside (on page 13-84)
- Chassis Parts, Inside (on page 13-86)
- Miscellaneous Part Numbers (on page 13-87)
 - Service Tools
 - Documentation
 - ES Upgrade Kits
 - ET Upgrade Kits
 - Protective Caps for Connectors
 - Fuses used on the A8 Post Regulator
 - GPIB Cables
 - Touch-up Paint
 - ESD Supplies
 - Keyboard Overlay and Rack Mount Parts

Top Assemblies

Reference Designator	Models	Options	HP/Agilent Part Number	Qty.	Description
A3	All	All	08720-60190	1	Disk Drive Replacement Kit
A4, A5, A6	All	All	08720-60156	1	Assy-Second Converter
A8 ¹	All	All	08722-60099	1	Bd Assy-Post Regulator
A8 ¹	All	All	08722-69099	1	Bd Assy-Post Regulator (Rebuilt-Exchange)
A9	All	All	08720-60129	1	Bd Assy-Source Control
A10	All	All	08753-60958	1	Bd Assy-Digital IF
A11	All	All	08720-60181	1	Bd Assy-Phase Lock
A12	All	All	08720-60252	1	Bd Assy-Reference
A12	All	All	08720-69252	1	Bd Assy-Reference (Rebuilt-Exchange)
A13	All	All	08720-60258	1	Bd Assy-Frac N Analog
A13	All	All	08720-69258	1	Bd Assy-Frac N Analog (Rebuilt-Exchange)
A14	All	All	08720-60179	1	Bd Assy-Frac N Digital
A14	All	All	08720-69179	1	Bd Assy-Frac N Digital (Rebuilt-Exchange)
A15	All	All	08753-60098	1	Assy-PreRegulator
A15	All	All	08753-69098	1	Assy-PreRegulator (Rebuilt-Exchange)
A53	All	All	5086-7583	1	Assy-Low Band
A53	All	All	5086-6583	1	Assy-Low Band (Rebuilt-Exchange)
A54	8722ET/ES	All	08722-60032	1	Assy-YIG Oscillator 20 GHz To 40 GHz
A55	8722ET/ES, 8720ET/ES	All	08720-60082	1	Assy-YIG Oscillator 2.4 GHz To 20 GHz
A55	8719ET/ES	All	08719-60009	1	Assy-YIG Oscillator 2.4 GHz To 13.5 GHz
A56	All ES Models	All	08720-60182	1	LED Board
A57	All	All	08720-60073	1	Assy-Fixed Oscillator

Reference Designator	Models	Options	HP/Agilent Part Number	Qty.	Description
A58	8719ET/ES, 8720ET/ES	Standard	5086-7519	1	Assy-M/A/D/S
A58	8719ET/ES, 8720ET/ES	Standard	5086-6519	1	Assy-M/A/D/S (Rebuilt-Exchange)
A58	8719ES, 8720ES	400	5086-7974	1	Assy-M/A/D/2
A58	8719ES, 8720ES	400	5086-6974	1	Assy-M/A/D/2 (Rebuilt-Exchange)
A58	8722ET/ES	Standard	5086-7615	1	Assy-Super M/A/D/S
A58	8722ET/ES	Standard	5086-6615	1	Assy-Super M/A/D/S (Rebuilt-Exchange)
A58	8722ES	400	5086-7980	1	Assy-M/A/D/2
A58	8722ES	400	5086-6980	1	Assy-M/A/D/2 (Rebuilt-Exchange)
A59	All	All	08720-60322	1	Bd Assy-Source Interface
A68	8719ET/ES, 8720ET/ES	All	0955-0462	1	Attenuator 6 dB
P1	All	All	1826-0423	1	IC-Voltage Regulator
A25	8722ET/ES	All	5086-7589	1	Assy-Switch 40 Ghz
A20,A29	All	All	08415-60057	1	Assy-Microwave Switch

1. For fuse part numbers on the A8 Post Regulator, refer to [“Miscellaneous Part Numbers”](#) on page 13-87.

8719ET/ES and 8720ET/ES Major Assemblies, Top

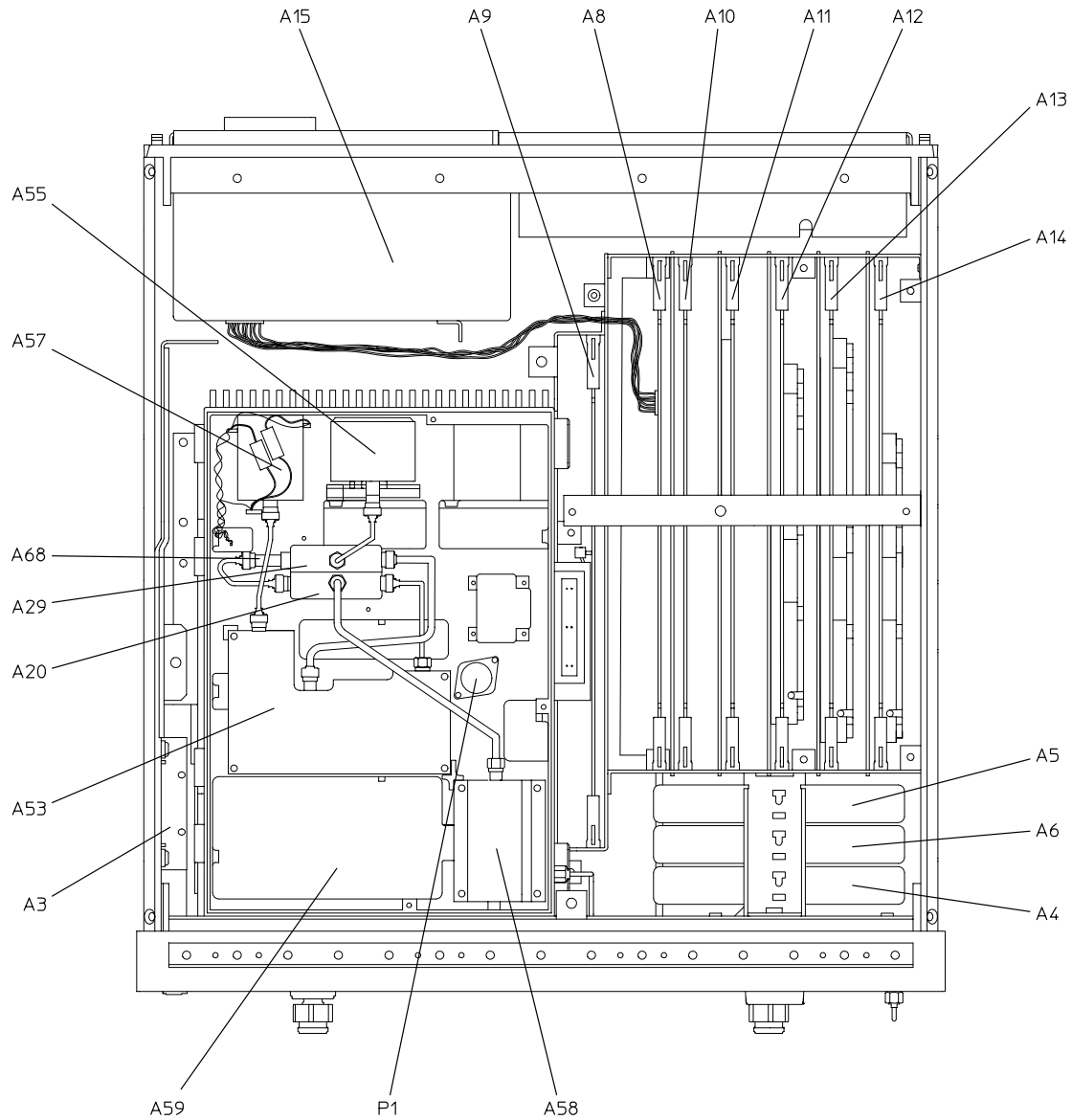

sb548e

8722ET/ES Major Assemblies, Top

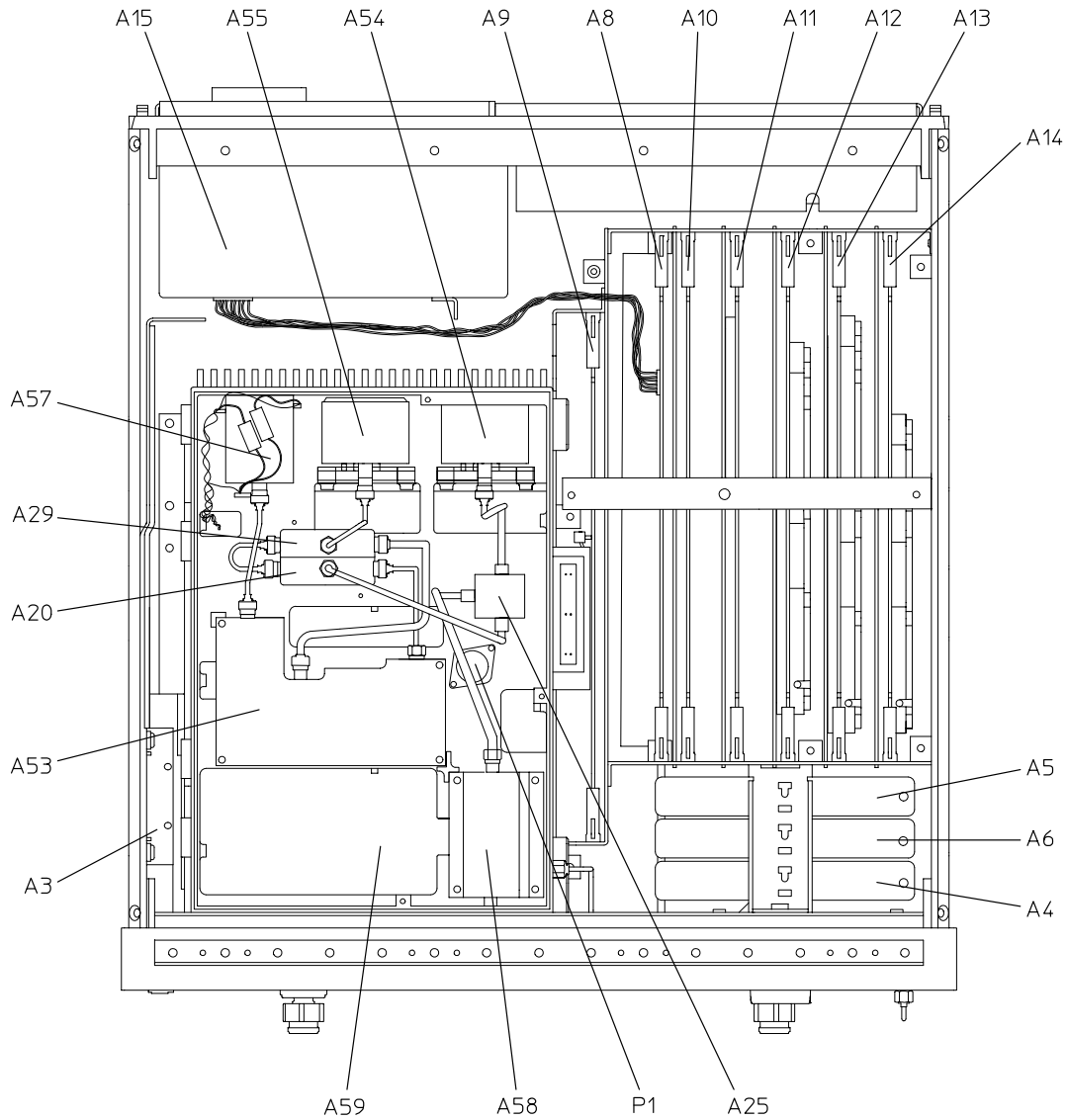

sb549e

Bottom Assemblies and Cables

8719ES and 8720ES Standard and Option 007

Ref. Desig.	Options	HP/Agilent Part Number	Qty	Description
A7		08720-60253	1	CPU Repair Kit
A7		08720-69253	1	CPU Repair Kit (Rebuilt-Exchange)
A17		08720-60264	1	Motherboard
A51		08720-60274	1	Bd Assy-Test Set Interface
A52		5086-7456	1	Assy-Pulse Generator
A52		5086-6456	1	Assy-Pulse Generator (Rebuilt-Exchange)
A60,A61		5086-7458	2	Bias Tee
A60,A61		5086-6458	2	Bias Tee (Rebuilt-Exchange)
A64,A65,A66		5086-7614	3	Assy-Sampler
A64,A65,A66		5086-6614	3	Assy-Sampler (Rebuilt-Exchange)
A69		33321-60050	1	Attenuator 0-55 dB
A74	STD	5086-7642	1	Transfer Switch
A74		5086-6642	1	Transfer Switch (Rebuilt-Exchange)
A74	007	08720-60006	1	Transfer Switch
A98		08720-60121	1	Frequency Converter
A98		08720-69121	1	Frequency Converter (Rebuilt-Exchange)
W22		08720-20033	1	A63 to A66
W25	STD	08720-20249	1	A61 to A62
W25	007	08720-20259	1	A61 to A62
W26		08720-20025	1	A60 to A63
W27		08720-20011	1	A74 to A60
W28		08720-20248	1	A74 to A61
W29		08720-20009	1	A69 to A74
W30		08720-20026	1	A62 to A65
W32		08720-20021	1	A58 to A69
W36		08720-20312	1	A72 to A64
W52		08720-20098	1	External Link

8719ES and 8720ES Standard and Option 007

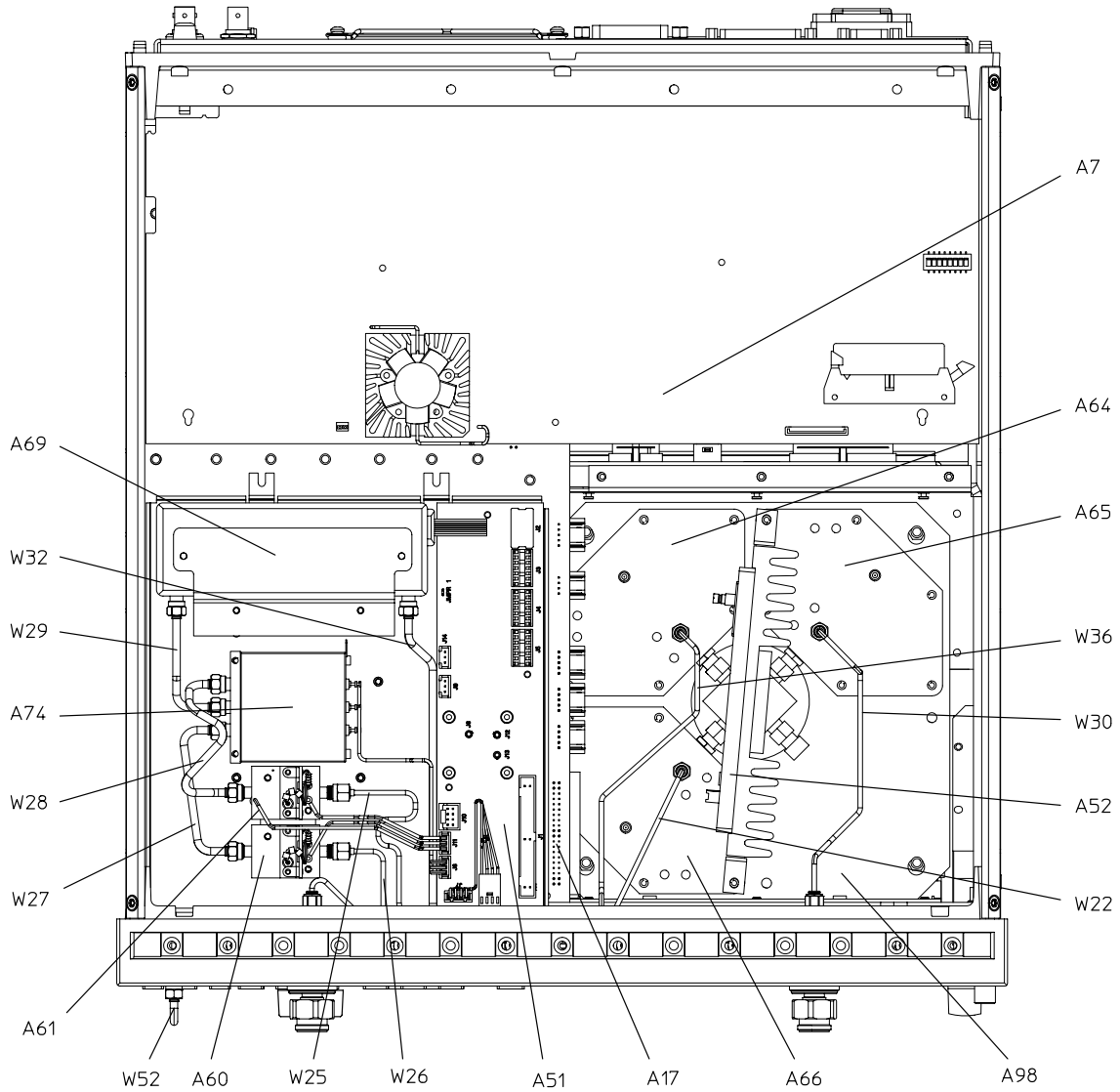

sb553e

**Bottom Assemblies and Cables for 8719ES and 8720ES
 Options 012, 012+007**

Ref. Desig.	Options	HP/Agilent Part Number	Qty	Description
A7		08720-60253	1	CPU Repair Kit
A7		08720-69253	1	CPU Repair Kit (Rebuilt-Exchange)
A17		08720-60264	1	Motherboard
A51		08720-60274	1	Bd Assy-Test Set Interface
A52		5086-7456	1	Assy-Pulse Generator
A52		5086-6456	1	Assy-Pulse Generator (Rebuilt-Exchange)
A60,A61		5086-7458	2	Bias Tee
A60,A61		5086-6458	2	Bias Tee (Rebuilt-Exchange)
A64,A65,A66		5086-7614	3	Assy-Sampler
A64,A65,A66		5086-6614	3	Assy-Sampler (Rebuilt-Exchange)
A69		33321-60050	1	Attenuator 0-55 dB
A74	012+007	08720-60006	1	Transfer Switch
A74	012	5086-7642	1	Transfer Switch
A74	012	5086-6642	1	Transfer Switch (Rebuilt-Exchange)
A98		08720-60121	1	Frequency Converter
A98		08720-69121	1	Frequency Converter (Rebuilt-Exchange)
W14		08720-20154	1	A63 to Front Panel B-Out
W15		08720-20058	1	Front Panel B-In to A66
W16		08720-20104	1	Front Panel A-In to A65
W17		08720-20164	1	A62 to Front Panel A-Out
W25	012+007	08720-20249	1	A61 to A62
W25	012	08720-20259	1	A61 to A62
W26		08720-20025	1	A60 to A63
W27		08720-20011	1	A74 to A60
W28		08720-20248	1	A74 to A61
W29		08720-20009	1	A69 to A74
W32		08720-20021	1	A58 to A69
W36		08720-20312	1	A72 to A64
W52		08720-20098	3	External Link

8719ES and 8720ES Options 012, 012+007

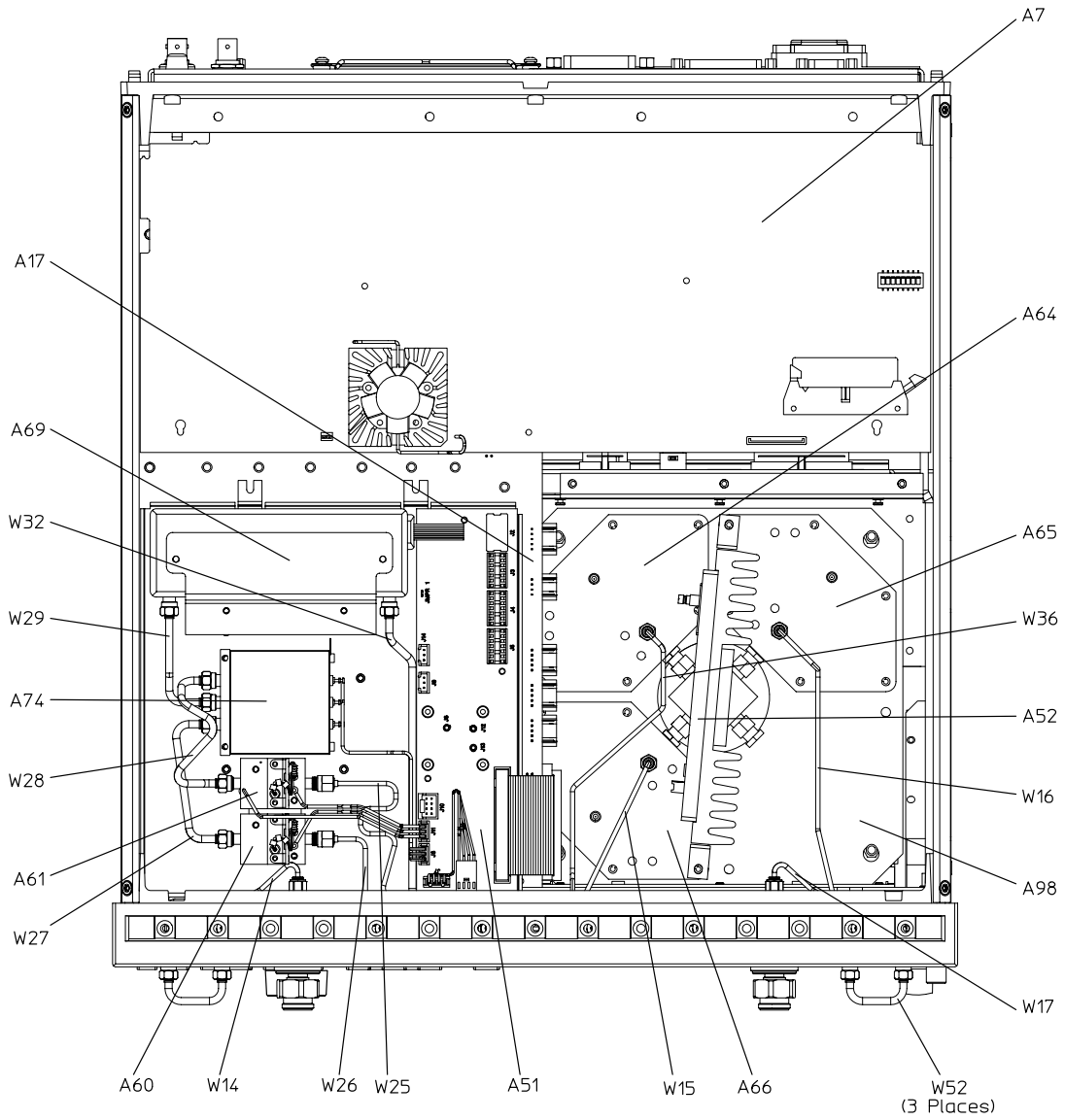

sb554e

Bottom Assemblies and Cables for 8719ES and 8720ES Options 089, 089+007

Ref. Desig.	Options	HP/Agilent Part Number	Qty	Description
A7		08720-60253	1	CPU Repair Kit
A7		08720-69253	1	CPU Repair Kit (Rebuilt-Exchange)
A17		08720-60264	1	Motherboard
A23,A24		5086-7589	2	R-channel Switches
A23,A24		5086-6589	2	R-channel Switches (Rebuilt-Exchange)
A51		08720-60274	1	Bd Assy-Test Set Interface
A52		5086-7456	1	Assy-Pulse Generator
A52		5086-6456	1	Assy-Pulse Generator (Rebuilt-Exchange)
A60,A61		5086-7458	2	Bias Tee
A60,A61		5086-6458	2	Bias Tee (Rebuilt-Exchange)
A64,A65,A66		5086-7614	3	Assy-Sampler
A64,A65,A66		5086-6614	3	Assy-Sampler (Rebuilt-Exchange)
A69		33321-60050	1	Attenuator 0-55 dB
A74	089	5086-7642	1	Transfer Switch
A74	089	5086-6642	1	Transfer Switch (Rebuilt-Exchange)
A74	089+007	08720-60006	1	Transfer Switch
A98		08720-60121	1	Frequency Converter
A98		08720-69121	1	Frequency Converter (Rebuilt-Exchange)
W18		08720-20105	1	Front Panel R-In to A2
W20		08720-20281	1	A24 to A64
W22		08720-20033	1	A63 to A66
W25	089+007	08720-20249	1	A61 to A62
W25	089	08720-20259	1	A61 to A62
W26		08720-20025	1	A60 to A63
W27		08720-20011	1	A74 to A60
W28		08720-20248	1	A74 to A61
W29		08720-20009	1	A69 to A74
W30		08720-20026	1	A62 to A65
W32		08720-20021	1	A58 to A69
W50		08720-20314	1	A72 to A23

Ref. Desig.	Options	HP/Agilent Part Number	Qty	Description
W51		08720-20279	1	A23 to A24
W52		08720-20098	1	External Link
W54		08720-20282	1	A23 to Front Panel R-Channel Out

8719ES and 8720ES Options 089, 089+007

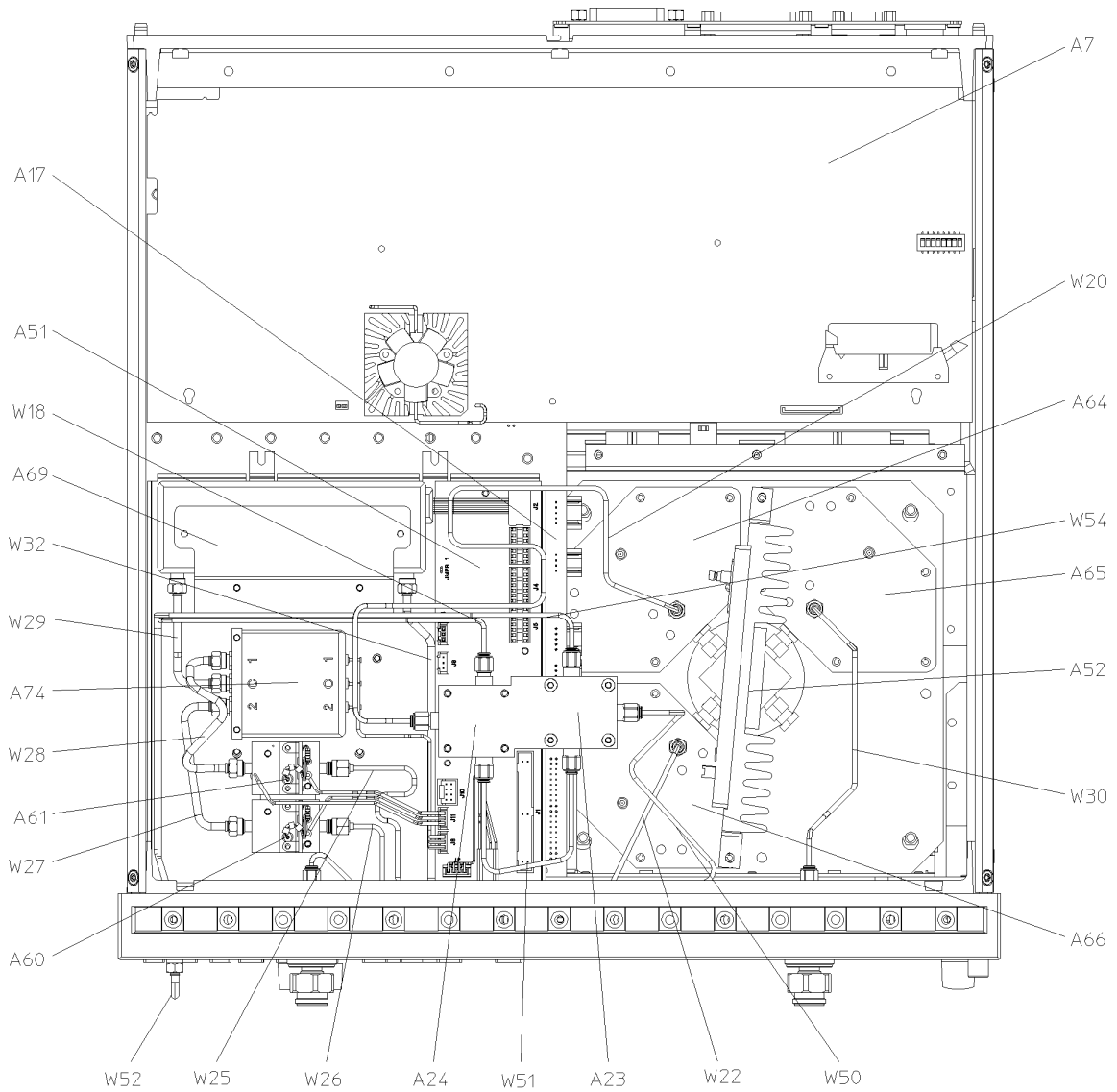

sb557e

**Bottom Assemblies and Cables for 8719ES and 8720ES
 Options 089+012, 089+012+007**

Ref. Desig.	Options	HP/Agilent Part Number	Qty	Description
A7		08720-60253	1	CPU Repair Kit
A7		08720-69253	1	CPU Repair Kit (Rebuilt-Exchange)
A17		08720-60264	1	Motherboard
A23,A24		5086-7589	2	R-channel Switches
A23,A24		5086-6589	2	R-channel Switches (Rebuilt-Exchange)
A51		08720-60274	1	Bd Assy-Test Set Interface
A52		5086-7456	1	Assy-Pulse Generator
A52		5086-6456	1	Assy-Pulse Generator (Rebuilt-Exchange)
A60,A61		5086-7458	2	Bias Tee
A60,A61		5086-6458	2	Bias Tee (Rebuilt-Exchange)
A64,A65,A66		5086-7614	3	Assy-Sampler
A64,A65,A66		5086-6614	3	Assy-Sampler (Rebuilt-Exchange)
A69		33321-60050	1	Attenuator 0-55 dB
A74	089+012	5086-7642	1	Transfer Switch
A74	089+012	5086-6642	1	Transfer Switch (Rebuilt-Exchange)
A74	089+012+007	08720-60006	1	Transfer Switch
A98		08720-60121	1	Frequency Converter
A98		08720-69121	1	Frequency Converter (Rebuilt-Exchange)
W14		08720-20154	1	A63 to Front Panel B-Out
W15		08720-20058	1	Front Panel B-In to A66
W16		08720-20104	1	Front Panel A-In to A65
W17		08720-20164	1	A62 to Front Panel A-Out
W18		08720-20105	1	Front Panel R-In to A246
W20		08720-20281	1	A24 to A64
W25	089+012+007	08720-20249	1	A61 to A62
W25	089+012	08720-20259	1	A61 to A62
W26		08720-20025	1	A60 to A63
W27		08720-20011	1	A74 to A60
W28		08720-20248	1	A74 to A61
W29		08720-20009	1	A69 to A74

Ref. Desig.	Options	HP/Agilent Part Number	Qty	Description
W32		08720-20021	1	A58 to A69
W50		08720-20314	1	A72 to A23
W51		08720-20279	1	A23 to A24
W52		08720-20098	3	External Link
W54		08720-20282	1	A23 to Front Panel R-Channel Out

8719ES and 8720ES Options 089+012, 089+012+007

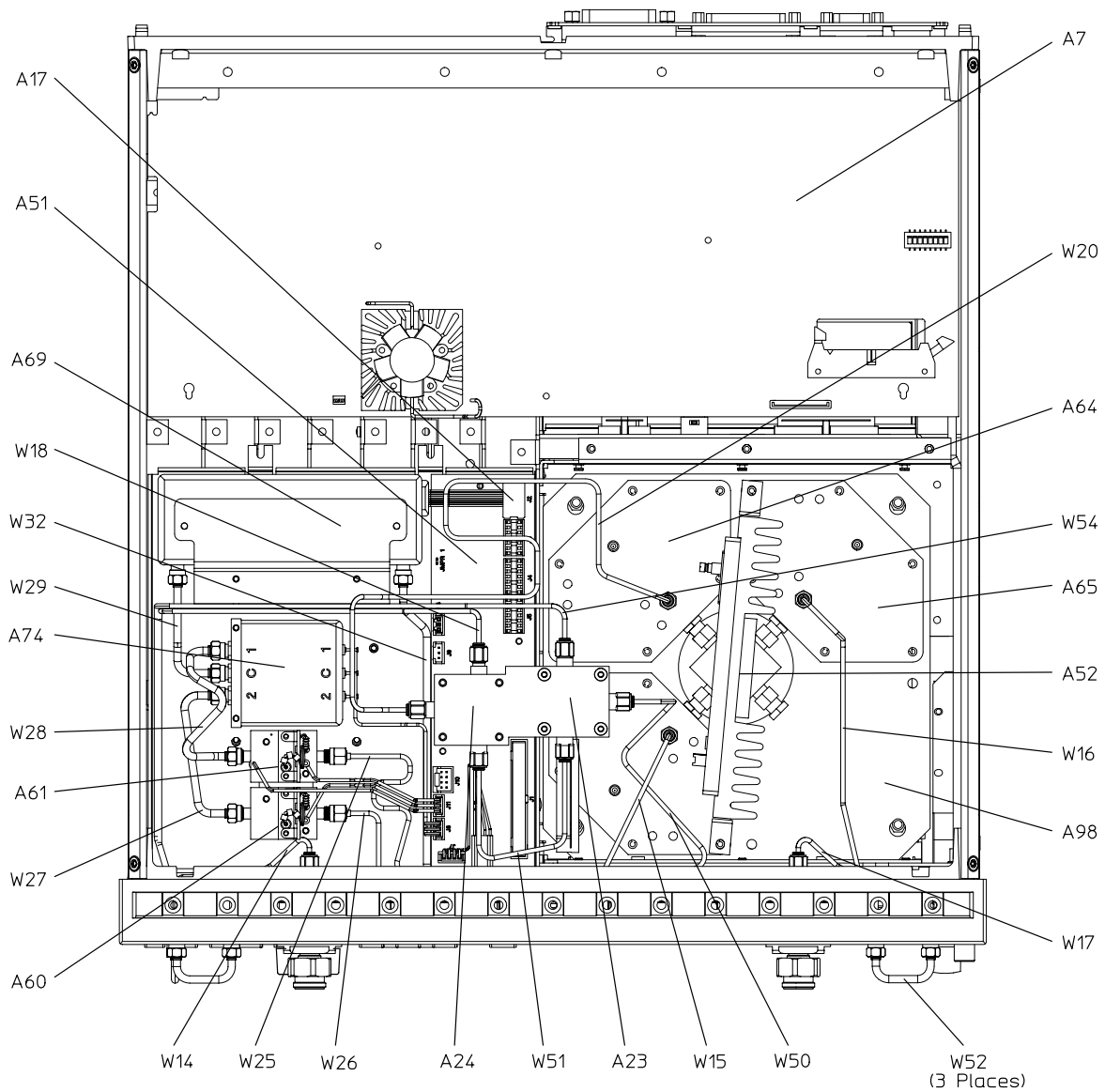

sb558e

**Bottom Assemblies and Cables for 8719ES and 8720ES
 Options 085, 085+089**

Ref. Desig.	Options	HP/Agilent Part Number	Qty	Description
A7		08720-60253	1	CPU Repair Kit
A7		08720-69253	1	CPU Repair Kit (Rebuilt-Exchange)
A17		08720-60264	1	Motherboard
A23,A24		5086-7589	1	R-channel Switches
A23,A24		5086-6589	2	R-channel Switches (Rebuilt-Exchange)
A51		08720-60274	1	Bd Assy-Test Set Interface
A52		5086-7456	1	Assy-Pulse Generator
A52		5086-6456	1	Assy-Pulse Generator (Rebuilt-Exchange)
A64,A65,A66		5086-7614	3	Assy-Sampler
A64,A65,A66		5086-6614	3	Assy-Sampler (Rebuilt-Exchange)
A69,A70,A71		33326-60006	3	Attenuator 0-55 dB
A74		33311J	1	Transfer Switch
A98		08720-60121	1	Frequency Converter
A98		08720-69121	1	Frequency Converter (Rebuilt-Exchange)
W14		08720-20154	1	A63 to Front Panel B-Out
W17		08720-20164	1	A62 to Front Panel A-Out
W20		08720-20281	1	A24 to A64
W32		08720-20146	1	A58 to A69
W50		08720-20314	1	A72 to A23
W51		08720-20279	1	A23 to A24
W52		08720-20098	6	External Link
W54		08720-20282	1	A23 to Front Panel R-Channel Out
W58		08720-20135	1	A69 to Rear Panel Source Out
W59		08720-20144	1	Rear Panel Source to A74
W60		08720-20161	1	A74 to Front Panel A-Switch
W61		08720-20159	1	A74 to Front Panel B-Switch
W65		08720-20158	1	A70 to A65
W66		08720-20157	1	A71 to A76
W68		08720-20165	1	Front Panel B-In to A71
W69		08720-20166	1	Front Panel A-In to A70

8719ES and 8720ES Options 085, 085+089

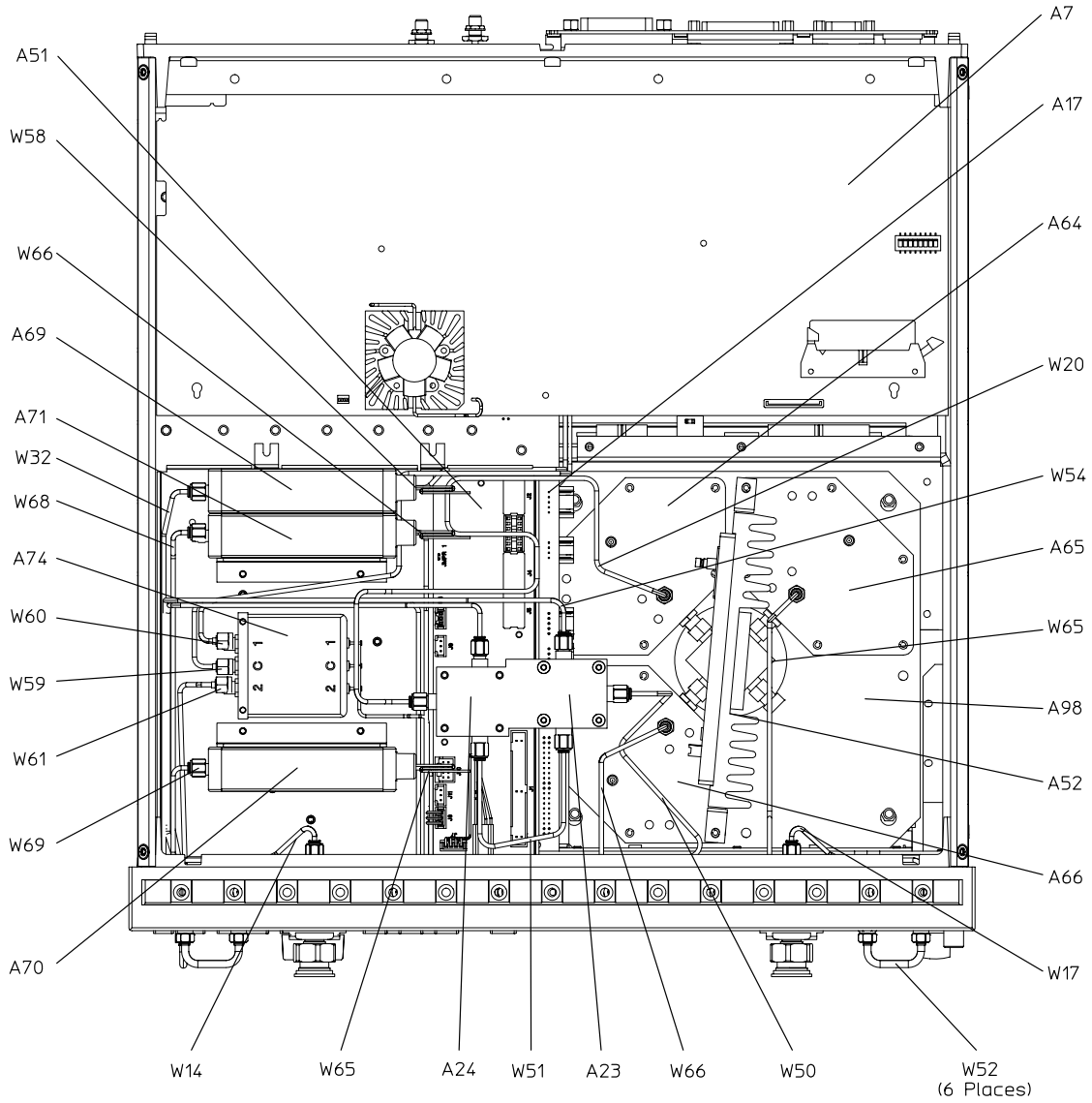

sb560e

Bottom Assemblies and Cables for 8719ES and 8720ES Option 400

Ref. Desig.	Options	HP/Agilent Part Number	Qty	Description
A7		08720-60253	1	CPU Repair Kit
A7		08720-69253	1	CPU Repair Kit (Rebuilt-Exchange)
A17		08720-60264	1	Motherboard
A51	400	08720-60275	1	Bd Assy-Test Set Interface
A52		5086-7456	1	Assy-Pulse Generator
A52		5086-6456	1	Assy-Pulse Generator (Rebuilt-Exchange)
A60,A61		5086-7458	2	Bias Tee
A60,A61		5086-6458	2	Bias Tee (Rebuilt-Exchange)
A64,A65, A66,A67		5086-7614	4	Assy-Sampler
A64,A65, A66,A67		5086-6614	4	Assy-Sampler (Rebuilt-Exchange)
A70,A71		33326-60006	2	Attenuator 0-55 dB
A74		5086-7975	1	Switch Splitter
A74		5086-6975	1	Switch Splitter (Rebuilt-Exchange)
A99		08720-60124	1	Frequency Converter
A99		08720-69124	1	Frequency Converter (Rebuilt-Exchange)
W22		08720-20033	1	A63 to A66
W25		08720-20259	1	A61 to A62
W26		08720-20025	1	A60 to A63
W30		08720-20026	1	A62 to A65
W32		08720-20173	1	A58 to A69
W36		08720-20312	1	A72 to A64
W37		08720-20136	1	A71 to A60
W38		08720-20145	1	A70 to A61
W39		08720-20169	1	A74 to A70
W40		08720-20168	1	A74 to A71
W41		08720-20316	1	A74 to A73
W52		08720-20098	1	External Link
W55		08720-20172	1	A74 to Rear Panel Source Out
W77		08720-20315	1	A73 to A67

8719ES and 8720ES Option 400

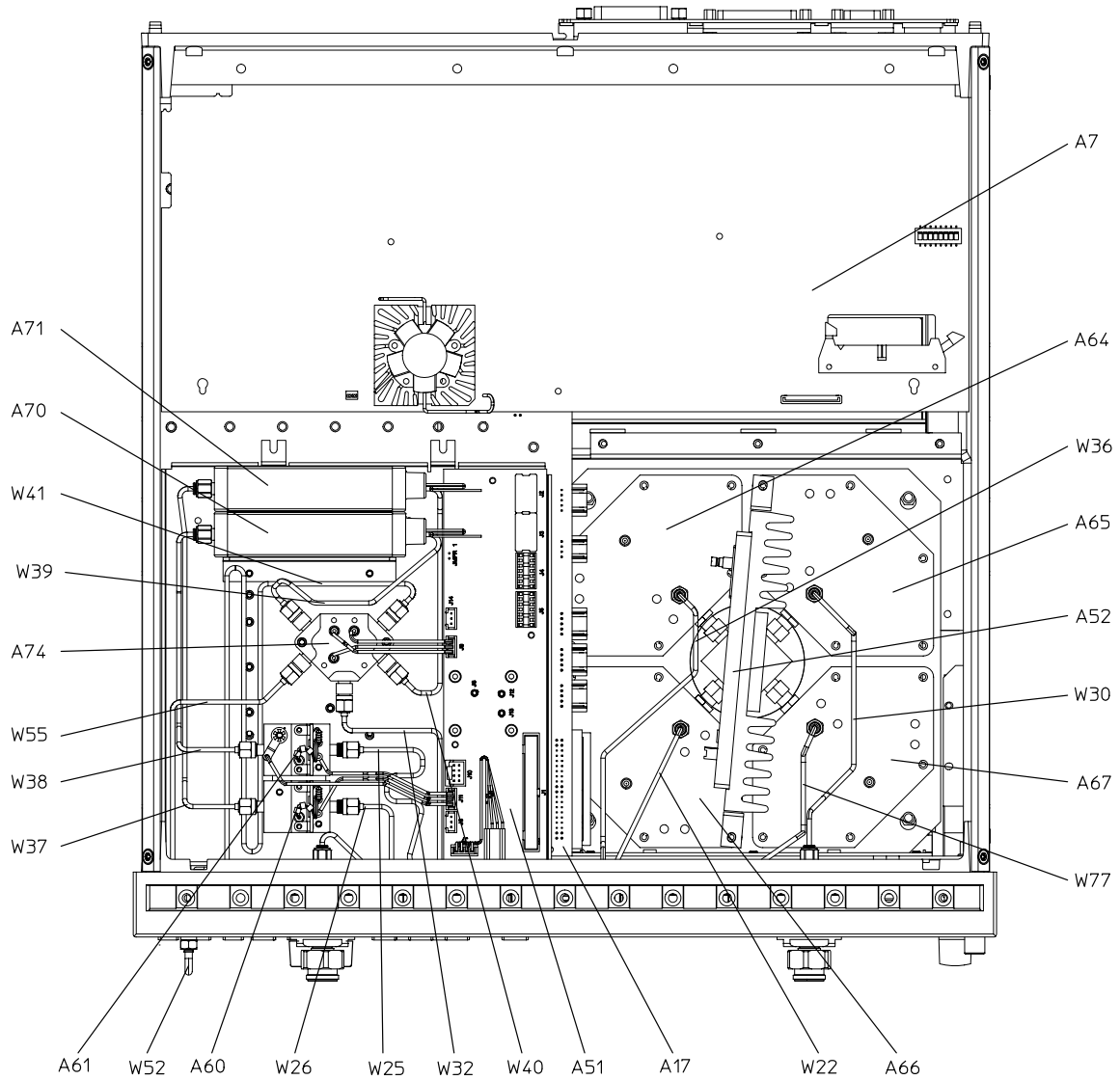

sb561e

Bottom Assemblies and Cables for 8719ES and 8720ES Option 400+012

Ref. Desig.	Options	HP/Agilent Part Number	Qty	Description
A7		08720-60253	1	CPU Repair Kit
A7		08720-69253	1	CPU Repair Kit (Rebuilt-Exchange)
A17		08720-60264	1	Motherboard
A51	400	08720-60275	1	Bd Assy-Test Set Interface
A52		5086-7456	1	Assy-Pulse Generator
A52		5086-6456	1	Assy-Pulse Generator (Rebuilt-Exchange)
A60,A61		5086-7458	2	Bias Tee
A60,A61		5086-6458	2	Bias Tee (Rebuilt-Exchange)
A64,A65,A66, A67		5086-7614	4	Assy-Sampler
A64,A65,A66, A67		5086-6614	4	Assy-Sampler (Rebuilt-Exchange)
A70,A71		33326-60006	2	Attenuator 0-55 dB
A74		5086-7975	1	Switch Splitter
A74		5086-6975	1	Switch Splitter (Rebuilt-Exchange)
A99		08720-60124	1	Frequency Converter
A99		08720-69124	1	Frequency Converter (Rebuilt-Exchange)
W15		08720-20058	1	Front Panel B-In to A66
W16		08720-20104	1	Front Panel A-In to A65
W25		08720-20259	1	A61 to A62
W26		08720-20025	1	A60 to A63
W32		08720-20173	1	A58 to A69
W36		08720-20312	1	A72 to A64
W37		08720-20136	1	A71 to A60
W38		08720-20145	1	A70 to A61
W39		08720-20169	1	A74 to A70
W40		08720-20168	1	A74 to A71
W41		08720-20316	1	A74 to A73
W52		08720-20098	1	External Links
W55		08720-20172	1	A74 to Front Panel R-Channel OUT
W77		08720-20315	1	A73 to A67

8719ES and 8720ES Option 400+012

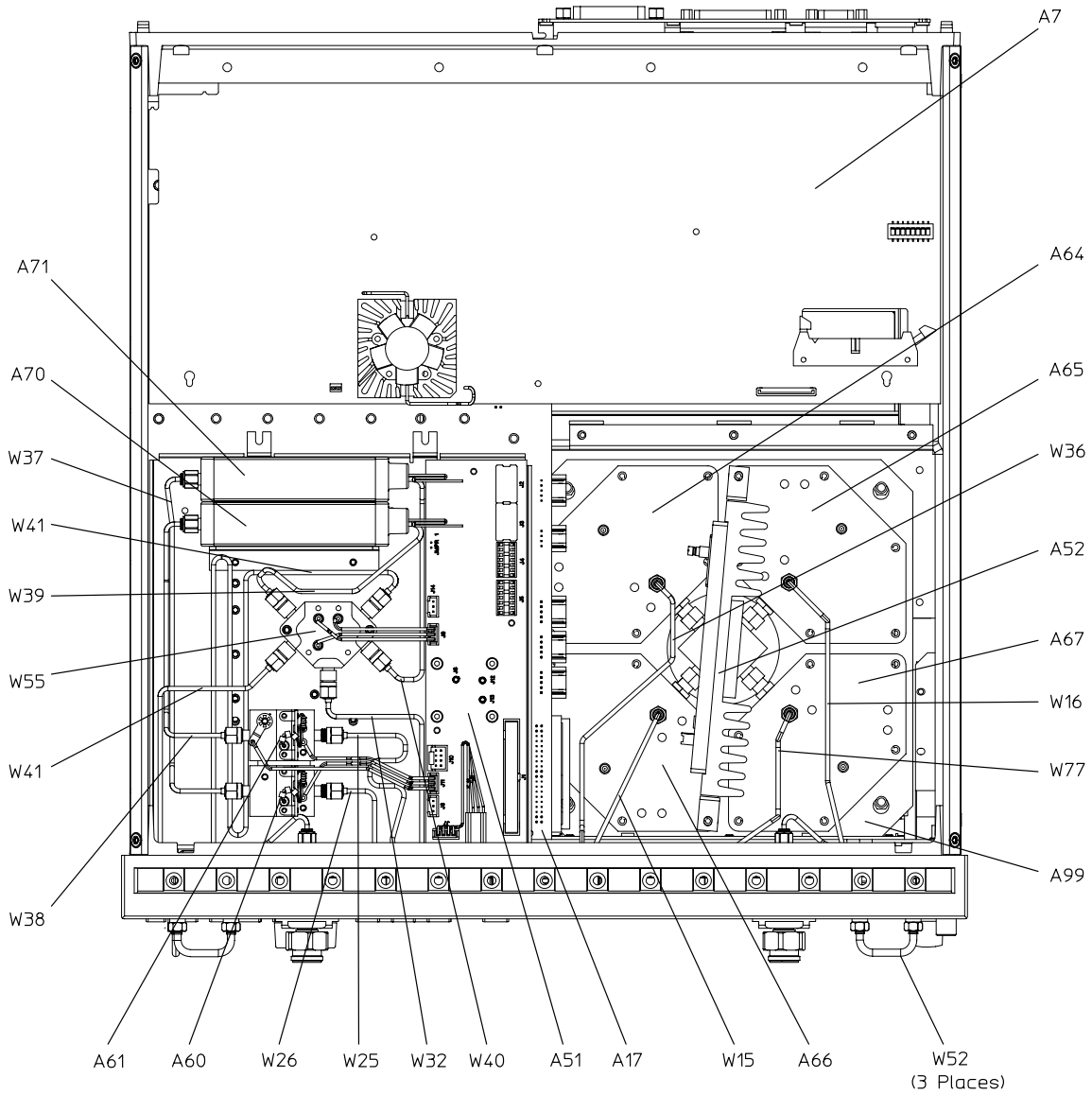

sb562e

Bottom Assemblies and Cables for 8719ES and 8720ES Option 400+089

Ref. Desig.	Options	HP/Agilent Part Number	Qty	Description
A7		08720-60253	1	CPU Repair Kit
A7		08720-69253	1	CPU Repair Kit (Rebuilt-Exchange)
A17		08720-60264	1	Motherboard
A23, A24		5086-7589	2	R-Channel Switch
A23,A24		5086-6589	2	R-channel Switches (Rebuilt-Exchange)
A51	400	08720-60275	1	Bd Assy-Test Set Interface
A52		5086-7456	1	Assy-Pulse Generator
A52		5086-6456	1	Assy-Pulse Generator (Rebuilt-Exchange)
A60,A61		5086-7458	2	Bias Tee
A60,A61		5086-6458	2	Bias Tee (Rebuilt-Exchange)
A64,A65, A66,A67		5086-7614	4	Assy-Sampler
A64,A65, A66,A67		5086-6614	4	Assy-Sampler (Rebuilt-Exchange)
A70,A71		33326-60006	2	Attenuator 0-55 dB
A74		5086-7975	1	Switch Splitter
A74		5086-6975	1	Switch Splitter (Rebuilt-Exchange)
A99		08720-60124	1	Frequency Converter
A99		08720-69124	1	Frequency Converter (Rebuilt-Exchange)
W18		08720-20105	1	Front Panel R-Channel IN to A24
W22		08720-20033	1	A63 to A66
W25		08720-20259	1	A61 to A62
W26		08720-20025	1	A60 to A63
W30		08720-20026	1	A62 to A65
W32		08720-20173	1	A58 to A69
W37		08720-20136	1	A71 to A60
W38		08720-20145	1	A70 to A61
W39		08720-20169	1	A74 to A70
W40		08720-20168	1	A74 to A71
W41		08720-20316	1	A74 to A73
W50		08720-20314	1	A72 to A23
W52		08720-20098	1	External Links

Ref. Desig.	Options	HP/Agilent Part Number	Qty	Description
W53		08720-20281	1	A24 to A64
W54		08720-20282	1	A23 to Front Panel R-Channel Out
W56		08720-20317	1	A74 to A72
W57		08720-20279	1	A23 to A24
W77		08720-20315	1	A73 to A67

8719ES and 8720ES Option 400+089

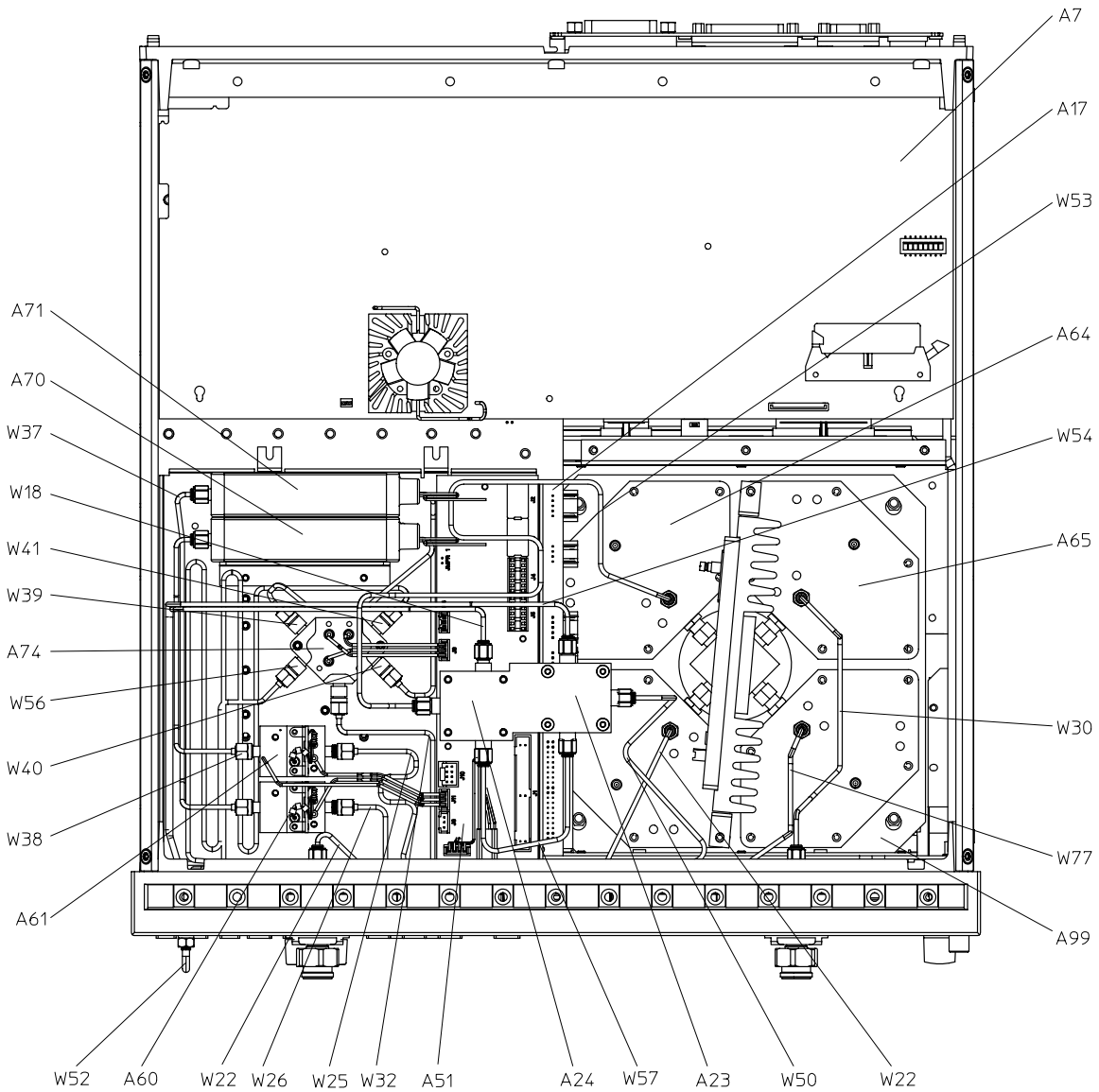

Bottom Assemblies and Cables for 8719ES and 8720ES Option 400+012+089

Ref.Desig.	Options	HP/Agilent Part Number	Qty	Description
A7		08720-60253	1	CPU Repair Kit
A7		08720-69253	1	CPU Repair Kit (Rebuilt-Exchange)
A17		08720-60264	1	Motherboard
A23,A24		5086-7589	2	R-channel Switches
A23,A24		5086-6589	2	R-channel Switches (Rebuilt-Exchange)
A51	400	08720-60275	1	Bd Assy-Test Set Interface
A52		5086-7456	1	Assy-Pulse Generator
A52		5086-6456	1	Assy-Pulse Generator (Rebuilt-Exchange)
A60,A61		5086-7458	2	Bias Tee
A60,A61		5086-6458	2	Bias Tee (Rebuilt-Exchange)
A64,A65, A66,A67		5086-7614	4	Assy-Sampler
A64,A65, A66,A67		5086-6614	4	Assy-Sampler (Rebuilt-Exchange)
A70,A71		33326-60006	2	Attenuator 0-55 dB
A74		5086-7975	1	Switch Splitter
A74		5086-6975	1	Switch Splitter (Rebuilt-Exchange)
A99		08720-60124	1	Frequency Converter
A99		08720-69124	1	Frequency Converter (Rebuilt-Exchange)
W14		08720-20154	1	A63 to Front Panel B-Out
W15		08720-20058	1	Front Panel B-In to A66
W16		08720-20104	1	Front Panel A-In to A65
W17		08720-20164	1	A62 to Front Panel A-Out
W18		08720-20105	1	Front Panel R-In to A246
W25		08720-20259	1	A61 to A62
W26		08720-20025	1	A60 to A63
W32		08720-20173	1	A58 to A69
W38		08720-20145	1	A70 to A61
W39		08720-20169	1	A74 to A70
W40		08720-20168	1	A74 to A71
W41		08720-20316	1	A74 to A73
W50		08720-20314	1	A72 to A23
W52		08720-20098	3	External Link
W53		08720-20281	1	A24 to A64
W54		08720-20282	1	A23 to Front Panel R-Channel Out
W56		08720-20317	1	A74 to A72

Ref. Desig.	Options	HP/Agilent Part Number	Qty	Description
W57		08720-20279	1	A23 to A24
W77		08720-20315	1	A73 to A67

8719ES and 8720ES Option 400+012+089

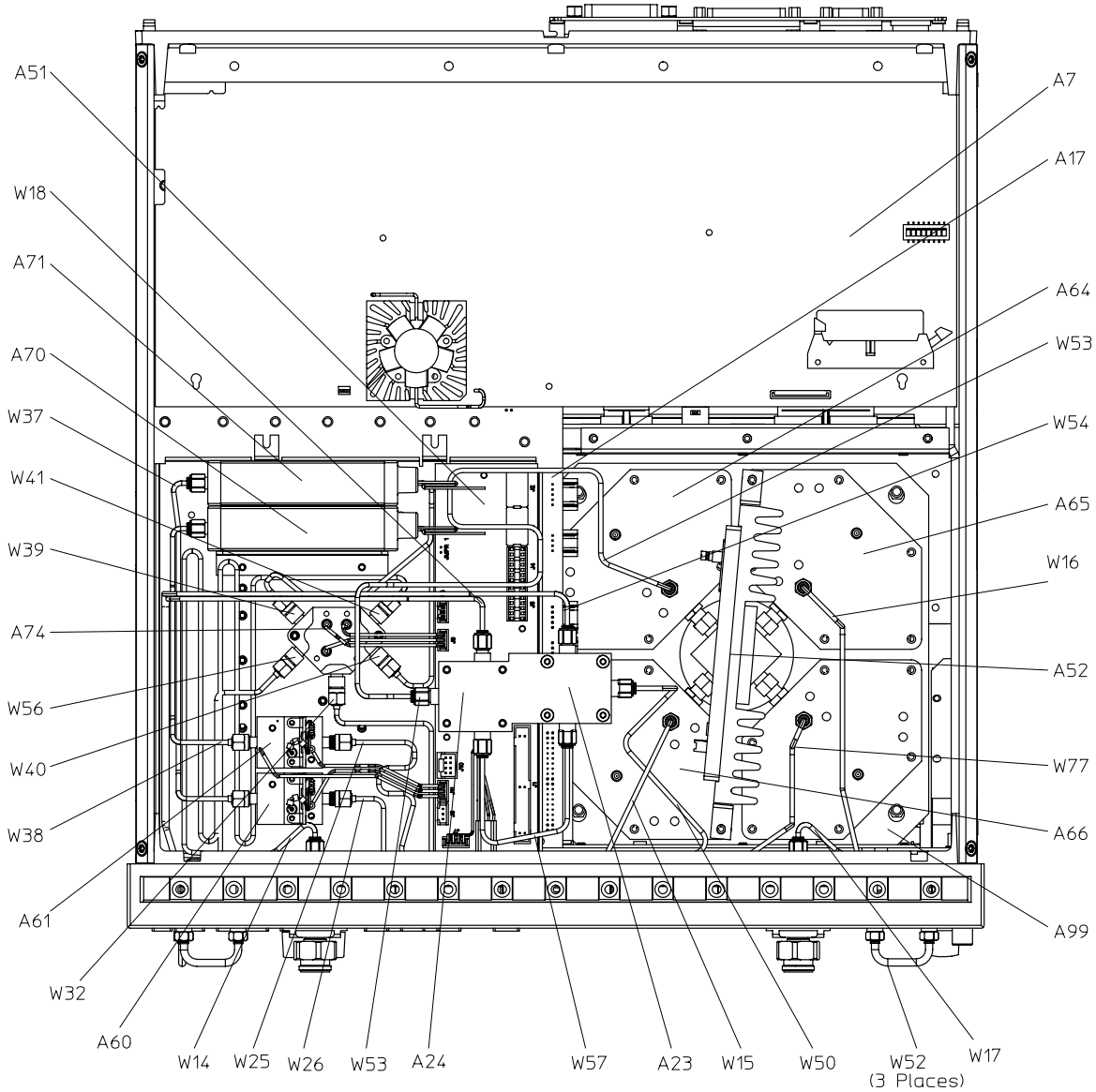

sb5109e

Bottom Assemblies and Cables for 8722ES Standard

Ref. Desig.	Options	HP/Agilent Part Number	Qty	Description
A7		08720-60253	1	CPU Repair Kit
A7		08720-69253	1	CPU Repair Kit (Rebuilt-Exchange)
A17		08720-60264	1	Motherboard
A51		08720-60274	1	Bd Assy-Test Set Interface
A52		5086-7456	1	Assy-Pulse Generator
A52		5086-6456	1	Assy-Pulse Generator (Rebuilt-Exchange)
A60,A61		5086-7484	2	Bias Tee
A60,A61		5086-6484	2	Bias Tee (Rebuilt-Exchange)
A64,A65,A66		5086-7614	3	Assy-Sampler
A64,A65,A66		5086-6614	3	Assy-Sampler (Rebuilt-Exchange)
A69		33326-60006	1	Attenuator 0-55 dB
A74		85331-60033	1	Transfer Switch
A98		08720-60121	1	Frequency Converter
A98		08720-69121	1	Frequency Converter (Rebuilt-Exchange)
W22		08720-20033	1	A63 to A66
W25		08722-20056	1	A61 to A62
W26		08722-20057	1	A60 to A63
W27		08722-20074	1	A74 to A60
W28		08722-20073	1	A74 to A61
W29		08722-20072	1	A69 to A74
W30		08720-20026	1	A62 to A65
W32		08722-20069	1	A58 to A69
W36		08720-20041	1	A72 to A64
W52		08722-20024	1	External Link

8722ES Standard

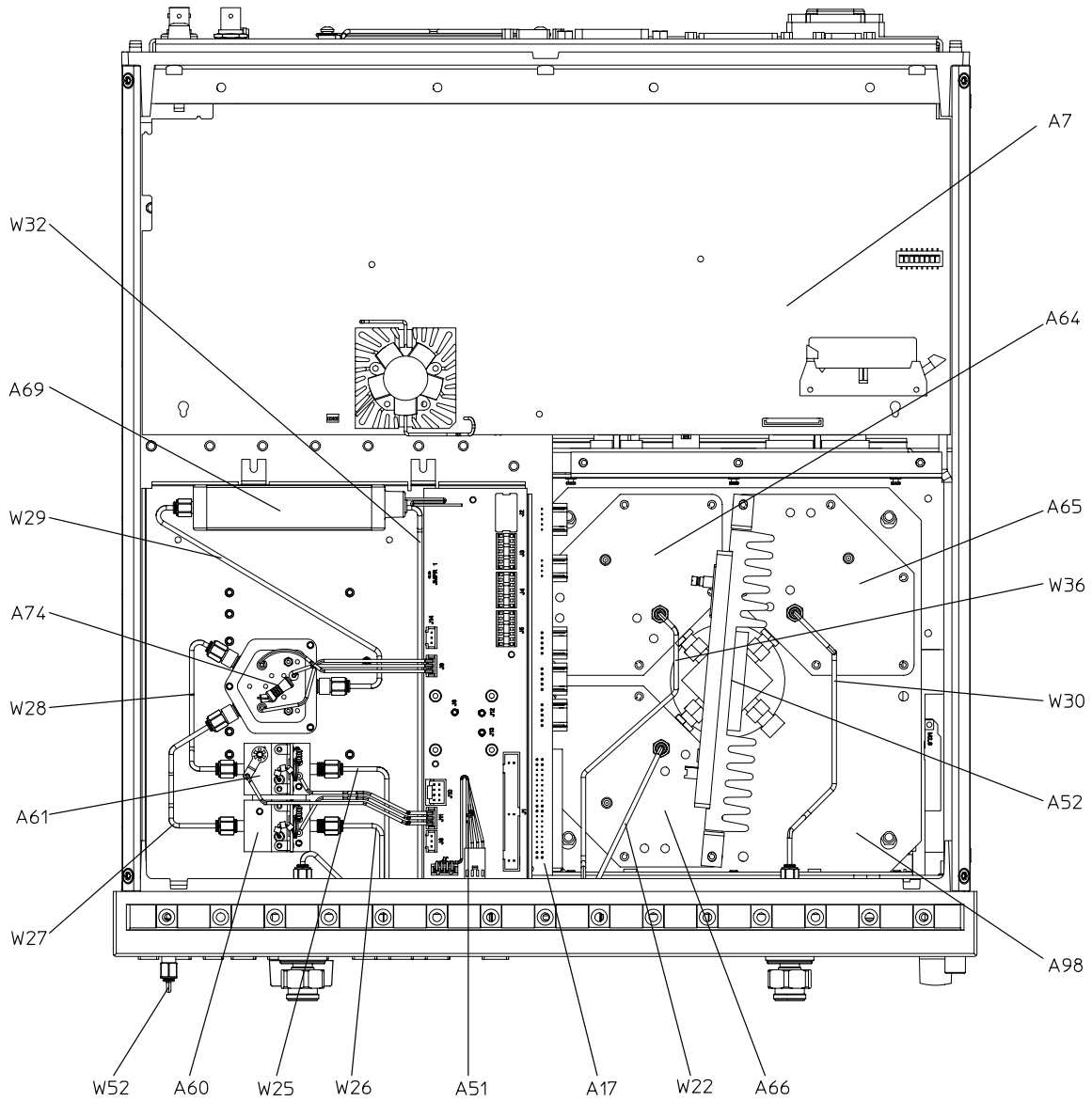

sb565e

Bottom Assemblies and Cables for 8722ES Option 007

Ref. Desig.	Options	HP/Agilent Part Number	Qty	Description
A7		08720-60253	1	CPU Repair Kit
A7		08720-69253	1	CPU Repair Kit (Rebuilt-Exchange)
A17		08720-60264	1	Motherboard
A51		08720-60274	1	Bd Assy-Test Set Interface
A52		5086-7456	1	Assy-Pulse Generator
A52		5086-6456	1	Assy-Pulse Generator (Rebuilt-Exchange)
A60,A61		5086-7484	2	Bias Tee
A60,A61		5086-6484	2	Bias Tee (Rebuilt-Exchange)
A64,A65,A66		5086-7614	3	Assy-Sampler
A64,A65,A66		5086-6614	3	Assy-Sampler (Rebuilt-Exchange)
A69		33326-60006	1	Attenuator 0-55 dB
A74 ¹		08722-60098	1	Transfer Switch
A98		08720-60121	1	Frequency Converter
A98		08720-69121	1	Frequency Converter (Rebuilt-Exchange)
W22		08720-20033	1	A63 to A66
W25		08722-20056	1	A61 to A62
W26		08722-20057	1	A60 to A63
W27		08722-20078	1	A74 to A60
W28		08722-20077	1	A74 to A61
W29		08722-20076	1	A69 to A74
W30		08720-20026	1	A62 to A65
W32		08722-20069	1	A58 to A69
W36		08720-20041	1	A72 to A64
W52		08722-20024	1	External Link

1. The A74 switch has 2 interconnect cables that are not shown. Part number is 08722-20010.

8722ES Option 007

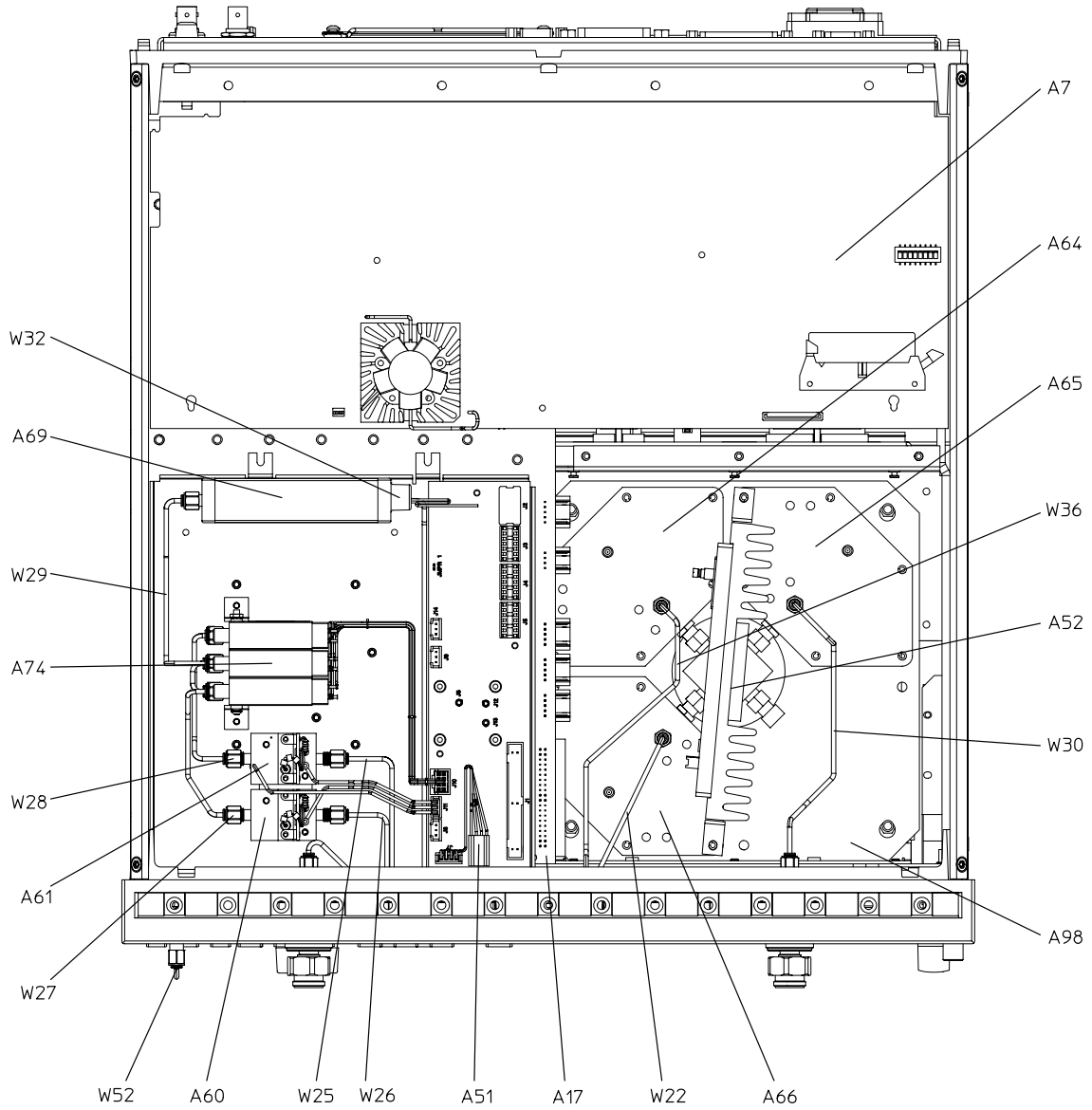

sb566e

Bottom Assemblies and Cables for 8722ES Option 012

Ref. Desig.	Options	HP/Agilent Part Number	Qty	Description
A7		08720-60253	1	CPU Repair Kit
A7		08720-69253	1	CPU Repair Kit (Rebuilt-Exchange-Exchange)
A17		08720-60264	1	Motherboard
A51		08720-60274	1	Bd Assy-Test Set Interface
A52		5086-7456	1	Assy-Pulse Generator
A52		5086-6456	1	Assy-Pulse Generator (Rebuilt-Exchange)
A60,A61		5086-7484	2	Bias Tee
A60,A61		5086-6484	2	Bias Tee (Rebuilt-Exchange)
A64,A65,A66		5086-7614	3	Assy-Sampler
A64,A65,A66		5086-6614	3	Assy-Sampler (Rebuilt-Exchange)
A69		33326-60006	1	Attenuator 0-55 dB
A74		85331-60033	1	Transfer Switch
A98		08720-60121	1	Frequency Converter
A98		08720-69121	1	Frequency Converter (Rebuilt-Exchange)
W14		08722-20102	1	A63 to Front Panel B-Out
W15		08722-20079	1	Front Panel B-In to A66
W16		08722-20081	1	Front Panel A-In to A65
W17		08722-20102	1	A62 to Front Panel A-Out
W25		08722-20056	1	A61 to A62
W26		08722-20057	1	A60 to A63
W27		08722-20074	1	A74 to A60
W28		08722-20073	1	A74 to A61
W29		08722-20072	1	A69 to A74
W32		08722-20069	1	A58 to A69
W36		08720-20041	1	A72 to A64
W52		08722-20024	3	External Link

8722ES Option 012

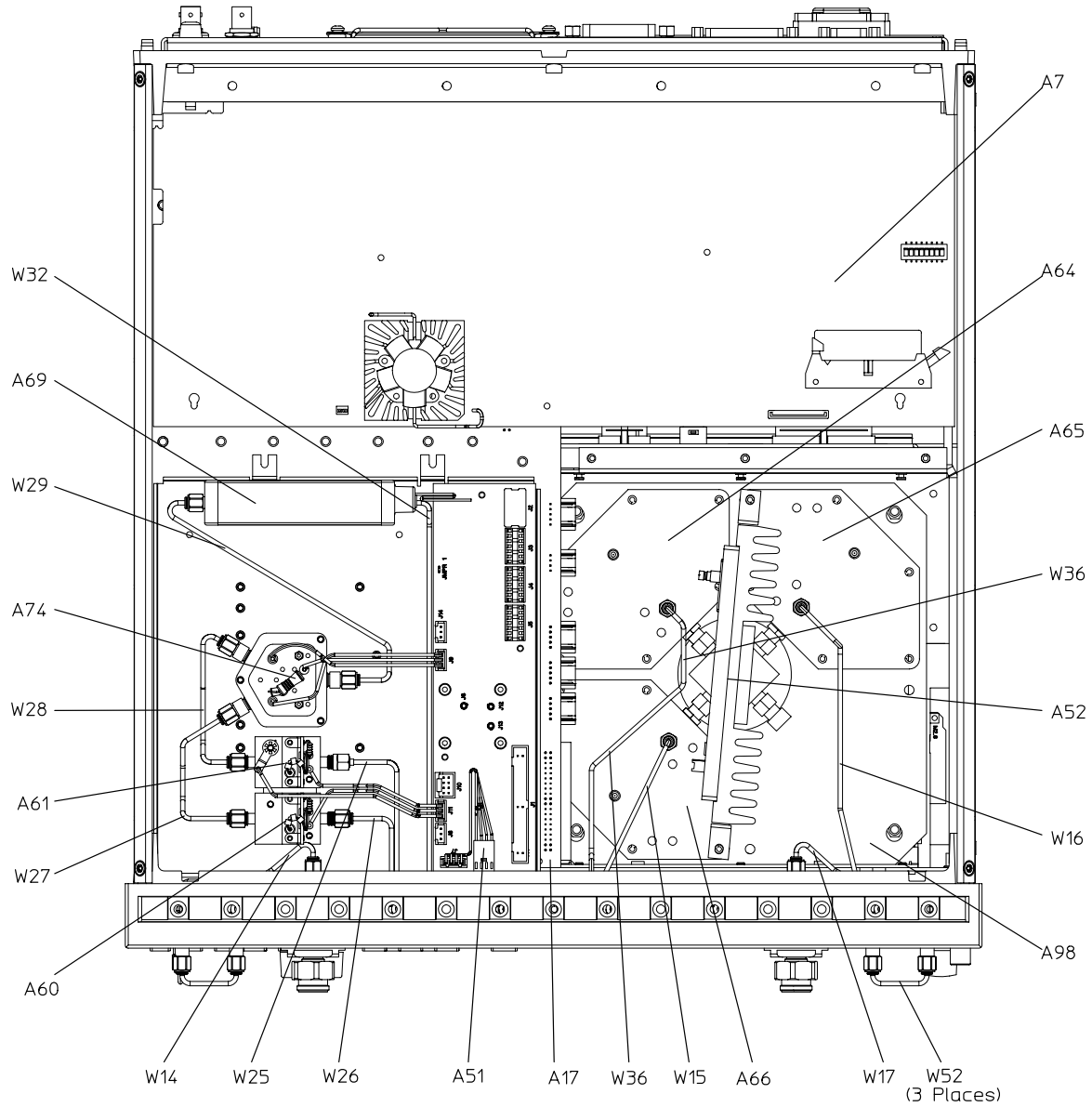

sb567e

Bottom Assemblies and Cables for 8722ES Options 007+012

Ref. Desig.	Options	HP/Agilent Part Number	Qty	Description
A7		08720-60253	1	CPU Repair Kit
A7		08720-69253	1	CPU Repair Kit (Rebuilt-Exchange)
A17		08720-60264	1	Motherboard
A51		08720-60274	1	Bd Assy-Test Set Interface
A52		5086-7456	1	Assy-Pulse Generator
A52		5086-6456	1	Assy-Pulse Generator (Rebuilt-Exchange)
A60,A61		5086-7484	2	Bias Tee
A60,A61		5086-6484	2	Bias Tee (Rebuilt-Exchange)
A64,A65,A66		5086-7614	3	Assy-Sampler
A64,A65,A66		5086-6614	3	Assy-Sampler (Rebuilt-Exchange)
A69		33326-60006	1	Attenuator 0-55 dB
A74 ¹		08722-60098	1	Transfer Switch
A98		08720-60121	1	Frequency Converter
A98		08720-69121		Frequency Converter (Rebuilt-Exchange))
W14		08722-20102	1	A63 to Front Panel B-Out
W15		08722-20079	1	Front Panel B-In to A66
W16		08722-20081	1	Front Panel A-In to A65
W17		08722-20102	1	A62 to Front Panel A-Out
W25		08722-20056	1	A61 to A62
W26		08722-20057	1	A60 to A63
W27		08722-20078	1	A74 to A60
W28		08722-20077	1	A74 to A61
W29		08722-20076	1	A69 to A74
W32		08722-20069	1	A58 to A69
W36		08720-20041	1	A72 to A64
W52		08722-20024	3	External Link

1. The A74 switch has 2 interconnect cables that are not shown. Part number is 08722-20010.

8722ES Option 007+012

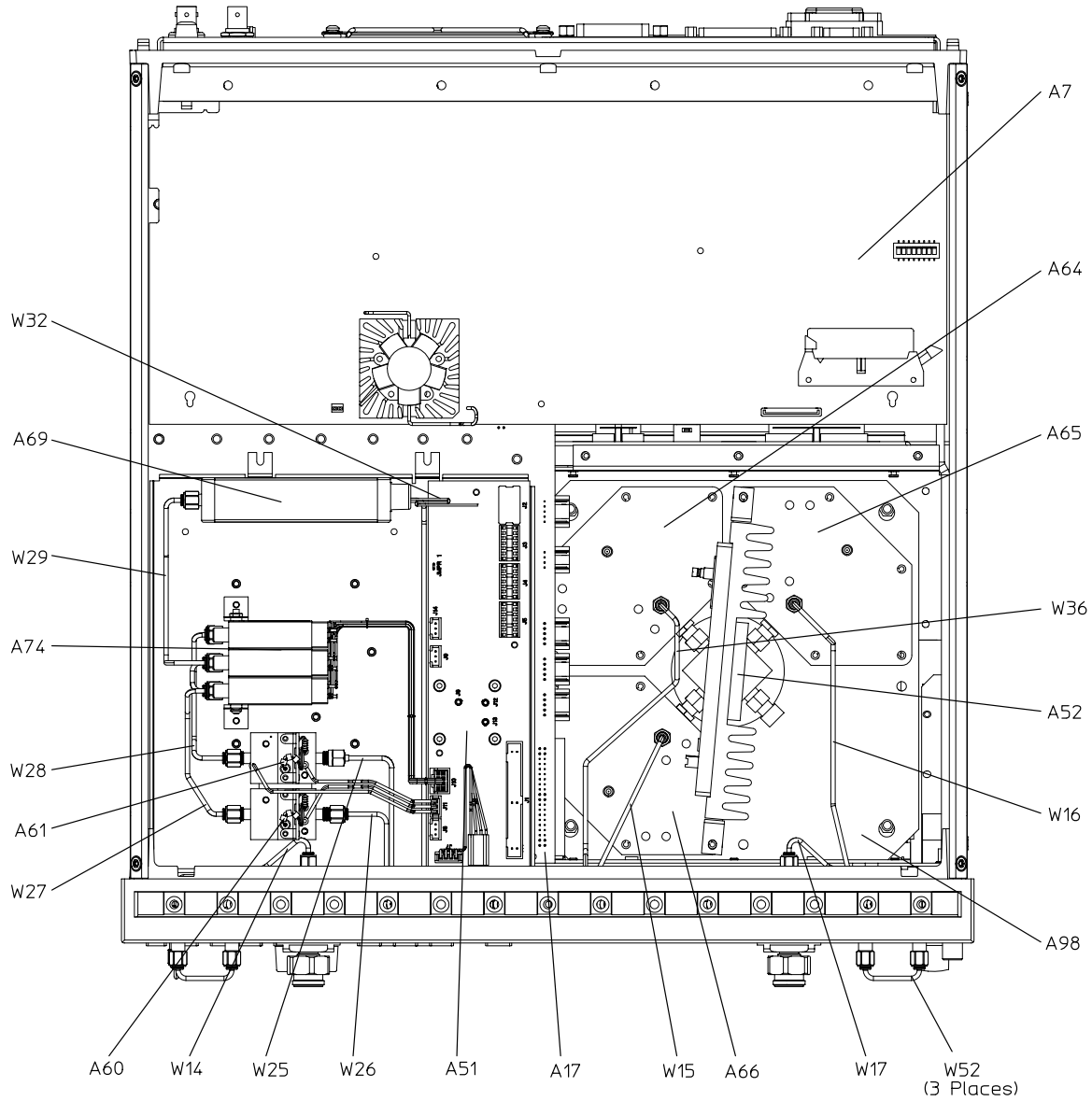

sb568e

Bottom Assemblies and Cables for 8722ES Option 089

Ref. Desig.	Options	HP/Agilent Part Number	Qty	Description
A7		08720-60253	1	CPU Repair Kit
A7		08720-69253	1	CPU Repair Kit (Rebuilt-Exchange)
A17		08720-60264	1	Motherboard
A23,A24		5086-7589	2	R-channel Switches
A23,A24		5086-6589	2	R-channel Switches (Rebuilt-Exchange)
A51		08720-60274	1	Bd Assy-Test Set Interface
A52		5086-7456	1	Assy-Pulse Generator
A52		5086-6456	1	Assy-Pulse Generator (Rebuilt-Exchange)
A60,A61		5086-7484	2	Bias Tee
A60,A61		5086-6484	2	Bias Tee (Rebuilt-Exchange)
A64,A65,A66		5086-7614	3	Assy-Sampler
A64,A65,A66		5086-6614	3	Assy-Sampler (Rebuilt-Exchange)
A69		33326-60006	1	Attenuator 0-55 dB
A74		85331-60033	1	Transfer Switch
A98		08720-60121	1	Frequency Converter
A98		08720-69121		Frequency Converter (Rebuilt-Exchange)
W18		08722-20058	1	Front Panel R-Channel IN to A24
W20		08720-20281	1	A24 to A64
W22		08720-20033	1	A63 to A66
W25		08722-20056	1	A61 to A62
W26		08722-20057	1	A60 to A63
W27		08722-20078	1	A74 to A60
W28		08722-20077	1	A74 to A61
W29		08722-20076	1	A69 to A74
W30		08720-20026	1	A62 to A65
W32		08722-20069	1	A58 to A69
W50		08720-20278	1	A72 to A23
W51		08720-20279	1	A23 to A24
W52		08722-20024	1	External Link
W54		08722-20132	1	A23 to Front Panel R-Channel OUT

8722ES Option 089

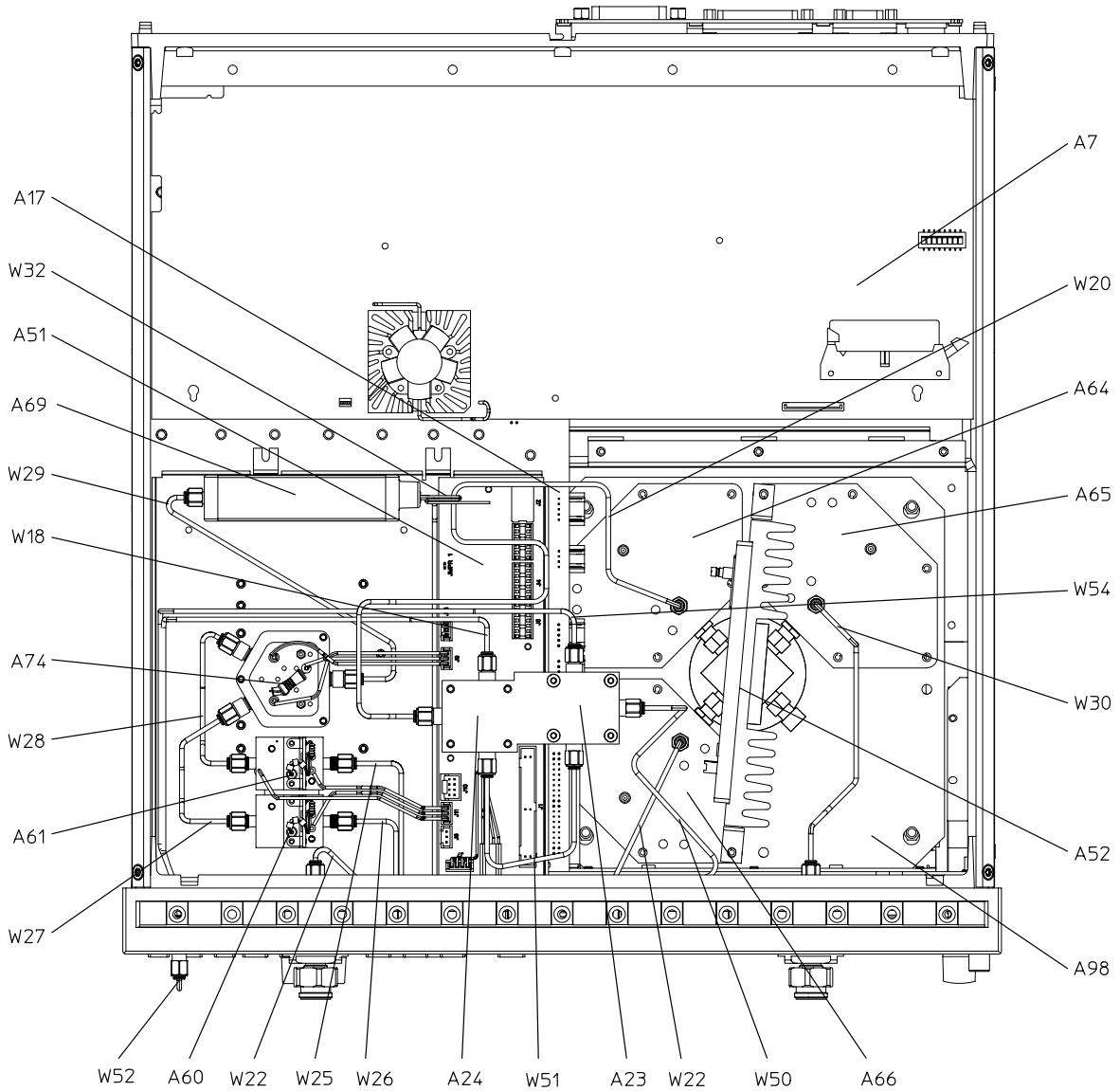

sb569e

Bottom Assemblies and Cables for 8722ES Option 089+007

Ref. Desig.	Options	HP/Agilent Part Number	Qty	Description
A7		08720-60253	1	CPU Repair Kit
A7		08720-69253	1	CPU Repair Kit (Rebuilt-Exchange)
A17		08720-60264	1	Motherboard
A23, A24		5086-7589	2	R-Channel Switch
A23,A24		5086-6589	2	R-channel Switches (Rebuilt-Exchange)
A51		08720-60274	1	Bd Assy-Test Set Interface
A52		5086-7456	1	Assy-Pulse Generator
A52		5086-6456	1	Assy-Pulse Generator (Rebuilt-Exchange)
A60,A61		5086-7484	2	Bias Tee
A60,A61		5086-6484	2	Bias Tee (Rebuilt-Exchange)
A64,A65,A66		5086-7614	3	Assy-Sampler
A64,A65,A66		5086-6614	3	Assy-Sampler (Rebuilt-Exchange)
A69		33326-60006	1	Attenuator 0-55 dB
A74 ¹		08722-60098	1	Transfer Switch
A98		08720-60121	1	Frequency Converter
A98		08720-69121	1	Frequency Converter (Rebuilt-Exchange)
W18		08722-20058	1	Front Panel R-Channel IN to A24
W20		08720-20281	1	A24 to A64
W22		08720-20033	1	A63 to A66
W25		08722-20056	1	A61 to A62
W26		08722-20057	1	A60 to A63
W27		08722-20078	1	A74 to A60
W28		08722-20277	1	A74 to A61
W29		08722-20076	1	A69 to A74
W30		08720-20026	1	A62 to A65
W32		08722-20069	1	A58 to A69
W50		08720-20278	1	A72 to A23
W51		08720-20279	1	A23 to A24
W52		08722-20024	1	External Link
W54		08722-20132	1	A23 to Front Panel R-Channel OUT

1. The A74 switch has 2 interconnect cables that are not shown. Part number is 08722-20010.

8722ES Option 089+007

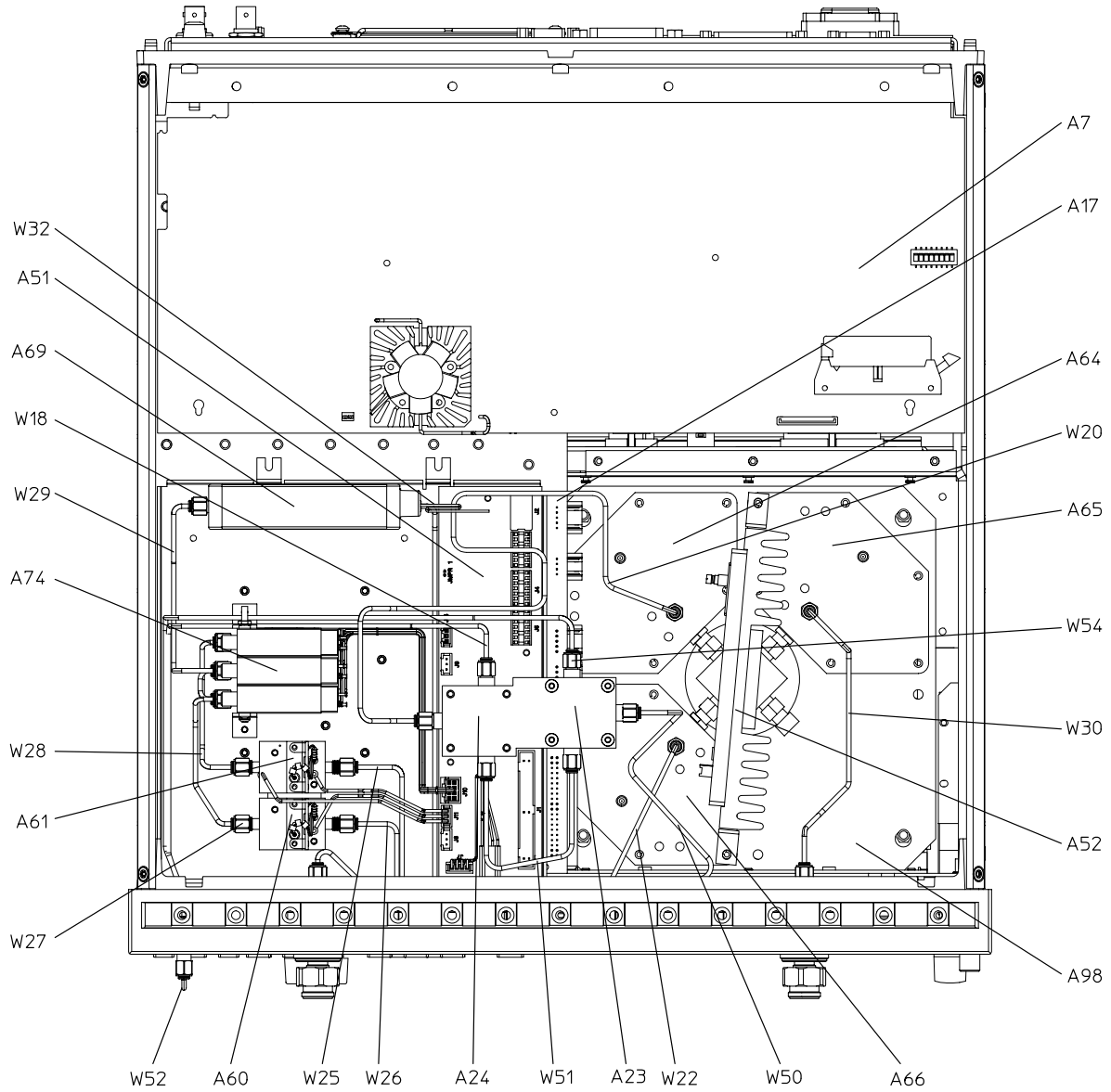

sb570e

Bottom Assemblies and Cables for 8722ES Option 089+012

Ref. Desig.	Options	HP/Agilent Part Number	Qty	Description
A7		08720-60253	1	CPU Repair Kit
A7		08720-69253	1	CPU Repair Kit (Rebuilt-Exchange)
A17		08720-60264	1	Motherboard
A23, A24		5086-7589	2	R-Channel Switch
A23,A24		5086-6589	2	R-channel Switches (Rebuilt-Exchange)
A51		08720-60274	1	Bd Assy-Test Set Interface
A52		5086-7456	1	Assy-Pulse Generator
A52		5086-6456	1	Assy-Pulse Generator (Rebuilt-Exchange)
A60,A61		5086-7484	2	Bias Tee
A60,A61		5086-6484	2	Bias Tee (Rebuilt-Exchange)
A64,A65,A66		5086-7614	3	Assy-Sampler
A64,A65,A66		5086-6614	3	Assy-Sampler (Rebuilt-Exchange)
A69		33326-60006	1	Attenuator 0-55 dB
A74		85331-60033	1	Transfer Switch
A98		08720-60121	1	Frequency Converter
A98		08720-69121	1	Frequency Converter (Rebuilt-Exchange)
W14		08722-20102	1	A63 to Front Panel B-Out
W15		08722-20079	1	Front Panel B-In to A66
W16		08722-20081	1	Front Panel A-In to A65
W17		08722-20102	1	A62 to Front Panel A-Out
W18		08722-20058	1	Front Panel R-Channel to A24
W20		08720-20281	1	A24 to A64
W25		08722-20056	1	A61 to A62
W26		08722-20057	1	A60 to A63
W27		08722-20074	1	A74 to A60
W28		08722-20073	1	A74 to A61
W29		08722-20072	1	A69 to A74
W32		08722-20069	1	A58 to A69
W38		08722-20130	1	A58 to A75
W50		08720-20278	1	A72 to A23
W51		08720-20279	1	A23 to A24
W52		08722-20024	3	External Link

Ref. Desig.	Options	HP/Agilent Part Number	Qty	Description
W54		08722-20132	1	A23 to Front Panel R-Channel OUT

8722ES Option 089+012

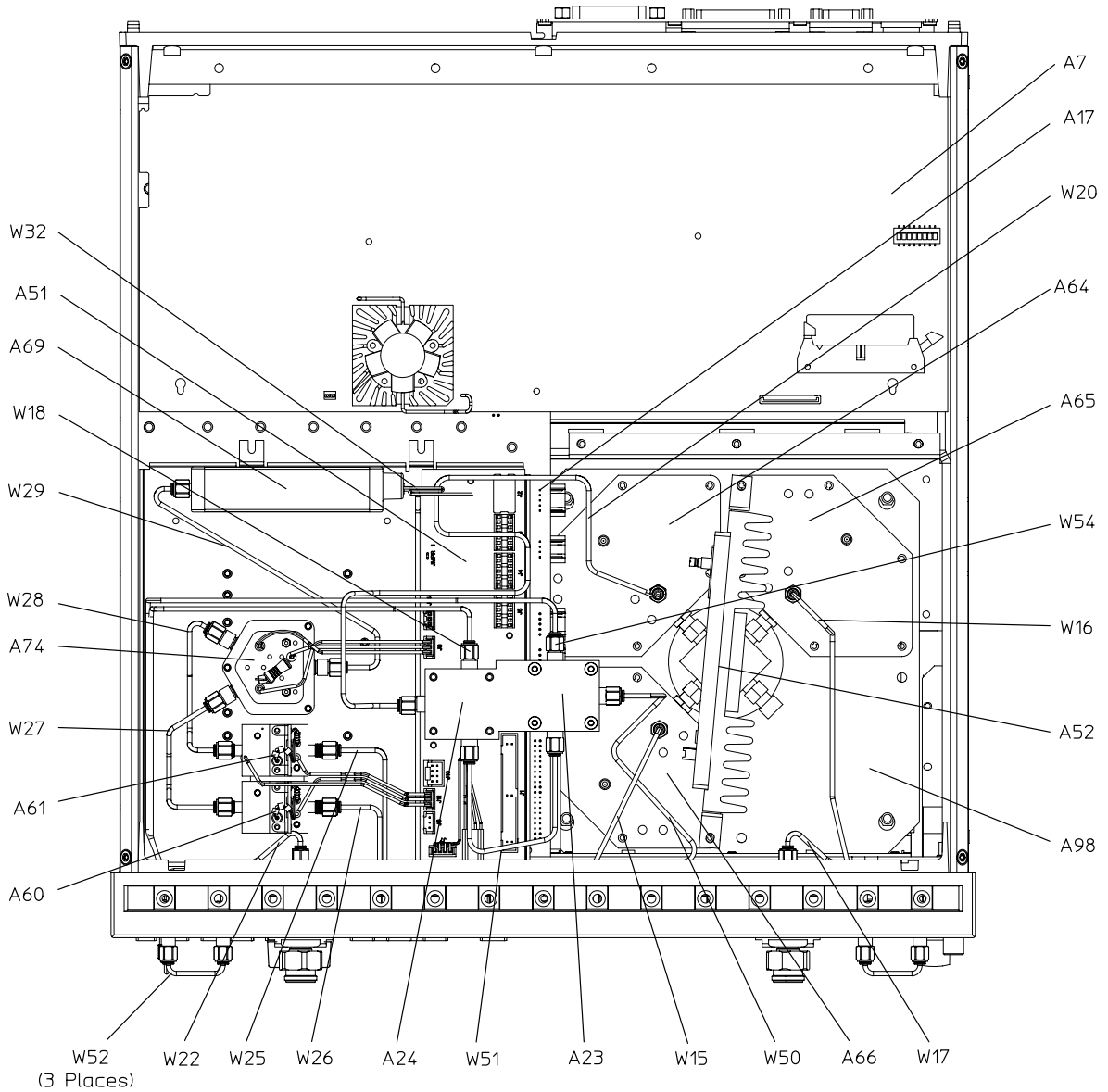

sb571e

Bottom Assemblies and Cables for 8722ES Option 089+007+012

Ref. Desig.	Options	HP/Agilent Part Number	Qty	Description
A7		08720-60253	1	CPU Repair Kit
A7		08720-69253	1	CPU Repair Kit (Rebuilt-Exchange)
A17		08720-60264	1	Motherboard
A23,A24		5086-7589	2	R-channel Switches
A23,A24		5086-6589	2	R-channel Switches (Rebuilt-Exchange)
A51		08720-60274	1	Bd Assy-Test Set Interface
A52		5086-7456	1	Assy-Pulse Generator
A52		5086-6456	1	Assy-Pulse Generator (Rebuilt-Exchange)
A60,A61		5086-7484	2	Bias Tee
A60,A61		5086-6484	2	Bias Tee (Rebuilt-Exchange)
A64,A65,A66		5086-7614	3	Assy-Sampler
A64,A65,A66		5086-6614	3	Assy-Sampler (Rebuilt-Exchange)
A69		33326-60006	1	Attenuator 0-55 dB
A74 ¹		08722-60098	1	Transfer Switch
A98		08720-60121	1	Frequency Converter
A98		08720-69121	1	Frequency Converter (Rebuilt-Exchange))
W14		08722-20102	1	A63 to Front Panel B-Out
W15		08722-20079	1	Front Panel B-In to A66
W16		08722-20081	1	Front Panel A-In to A65
W17		08722-20102	1	A62 to Front Panel A-Out
W18		08722-20058	1	Front Panel R-Channel IN to A24
W20		08720-20281	1	A24 to A64
W25		08722-20056	1	A61 to A62
W26		08722-20057	1	A60 to A63
W27		08722-20078	1	A74 to A60
W28		08722-20077	1	A74 to A61
W29		08722-20076	1	A69 to A74
W32		08722-20069	1	A58 to A69
W50		08720-20278	1	A72 to A23
W51		08720-20279	1	A23 to A24

Ref. Desig.	Options	HP/Agilent Part Number	Qty	Description
W52		08722-20024	3	External Link
W54		08722-20132	1	A23 to Front Panel R-Channel OUT

- The A74 switch has 2 interconnect cables that are not shown. Part number is 08722-20010.

8722ES Option 089+007+012

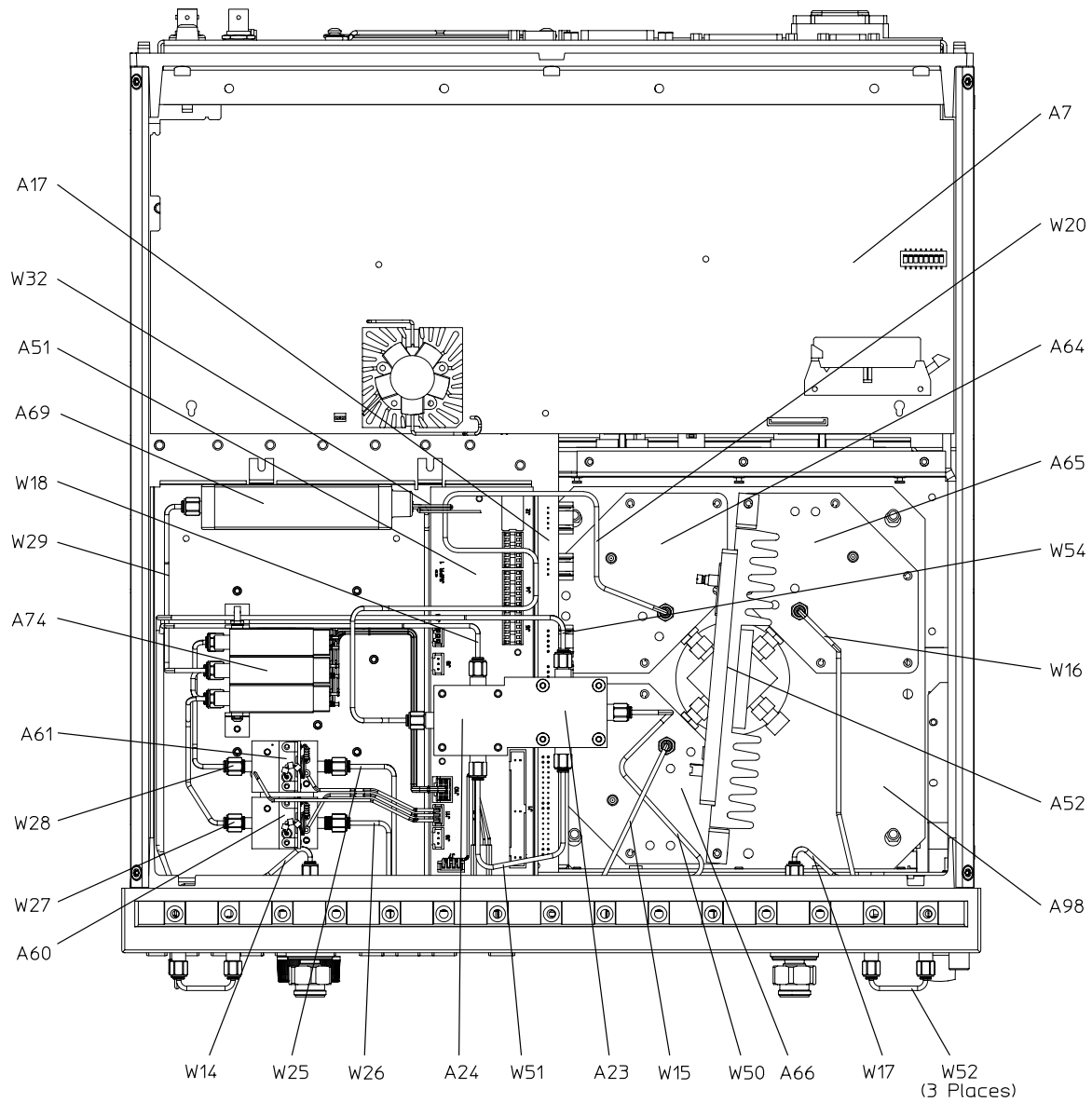

sb572e

Bottom Assemblies and Cables for 8722ES Option 085, 085+089

Ref. Desig.	Options	HP/Agilent Part Number	Qty	Description
A7		08720-60253	1	CPU Repair Kit
A7		08720-69253	1	CPU Repair Kit (Rebuilt-Exchange)
A17		08720-60264	1	Motherboard
A23,A24		5086-7589	2	R-channel Switches
A23,A24		5086-6589	2	R-channel Switches (Rebuilt-Exchange)
A51		08720-60274	1	Bd Assy-Test Set Interface
A52		5086-7456	1	Assy-Pulse Generator
A52		5086-6456	1	Assy-Pulse Generator (Rebuilt-Exchange)
A64,A65,A66		5086-7614	3	Assy-Sampler
A64,A65,A66		5086-6614	3	Assy-Sampler (Rebuilt-Exchange)
A69,A70,A71		33326-60006	3	Attenuator 0-55 dB
A74 ¹		08722-60098	1	Transfer Switch
A98		08720-60121	1	Frequency Converter
A98		08720-69121	1	Frequency Converter (Rebuilt-Exchange)
W14		08722-20102	1	A63 to Front Panel B-Out
W17		08722-20102	1	A62 to Front Panel A-Out
W18		08722-20058	1	Front Panel R-Channel IN to A24
W20		08720-20281	1	A24 to A64
W32		08722-20086	1	A58 to A69
W50		08720-20278	1	A72 to A23
W51		08720-20279	1	A23 to A24
W52		08722-20024	6	External Link
W54		08722-20132	1	A23 to Front Panel R-Channel Out
W58		08722-20085	1	A69 to Rear Panel Source Out
W59		08722-20084	1	Rear Panel Source to A74
W60		08722-20098	1	A74 to Front Panel A-Switch
W61		08722-20097	1	A74 to Front Panel B-Switch
W65		08720-20158	1	A70 to A65
W66		08720-20157	1	A71 to A76
W68		08722-20099	1	Front Panel B-In to A71
W69		08722-20101	1	Front Panel A-In to A70

1. The A74 switch has 2 interconnect cables that are not shown. Part number is 08722-20010.

8722ES Option 085, 085+089

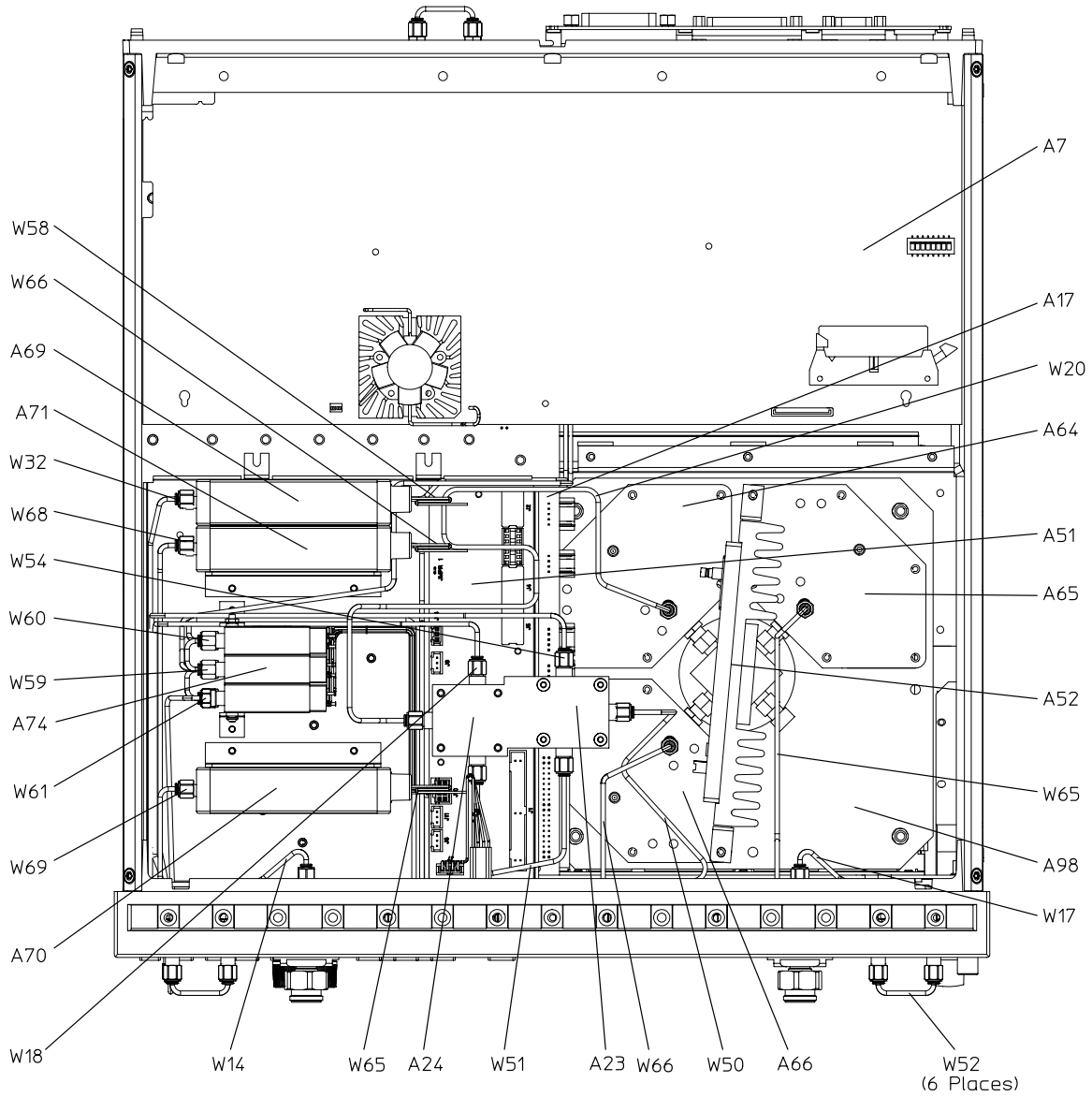

sb573e

Bottom Assemblies and Cables for 8722ES Option 400

Ref. Desig.	Options	HP/Agilent Part Number	Qty	Description
A7		08720-60253	1	CPU Repair Kit
A7		08720-69253	1	CPU Repair Kit (Rebuilt-Exchange)
A17		08720-60264	1	Motherboard
A51		08720-60274	1	Bd Assy-Test Set Interface
A52		5086-7456	1	Assy-Pulse Generator
A52		5086-6456	1	Assy-Pulse Generator (Rebuilt-Exchange)
A60,A61		5086-7484	2	Bias Tee
A60,A61		5086-6484	2	Bias Tee (Rebuilt-Exchange)
A64,A65, A66,A67		5086-7614	4	Assy-Sampler
A64,A65, A66,A67		5086-7614	3	Assy-Sampler
A70,A71		33326-60006	2	Attenuator 0-55 dB
A74		5087-7002	1	Switch Splitter
A74		5087-6002	1	Switch Splitter (Rebuilt-Exchange)
A99		08720-60124	1	Frequency Converter
A99		08720-69124		Frequency Converter (Rebuilt-Exchange)
W22		08720-20033	1	A63 to A66
W25		08722-20056	1	A61 to A62
W26		08722-20057	1	A60 to A63
W30		08720-20026	1	A62 to A65
W32		08722-20054	1	A58 to A74
W36		08720-20041	1	A72 to A64
W37		08722-20059	1	A71 to A60
W38		08722-20061	1	A70 to A61
W39		08722-20063	1	A74 to A70
W40		08722-20062	1	A74 to A71
W41		08722-20936	1	A74 to A76
W52		08722-20024	1	External Link
W55		08722-20065	1	A74 to Front Panel R-Channel OUT
W77		08720-20103	1	A73 to A67

8722ES Option 400

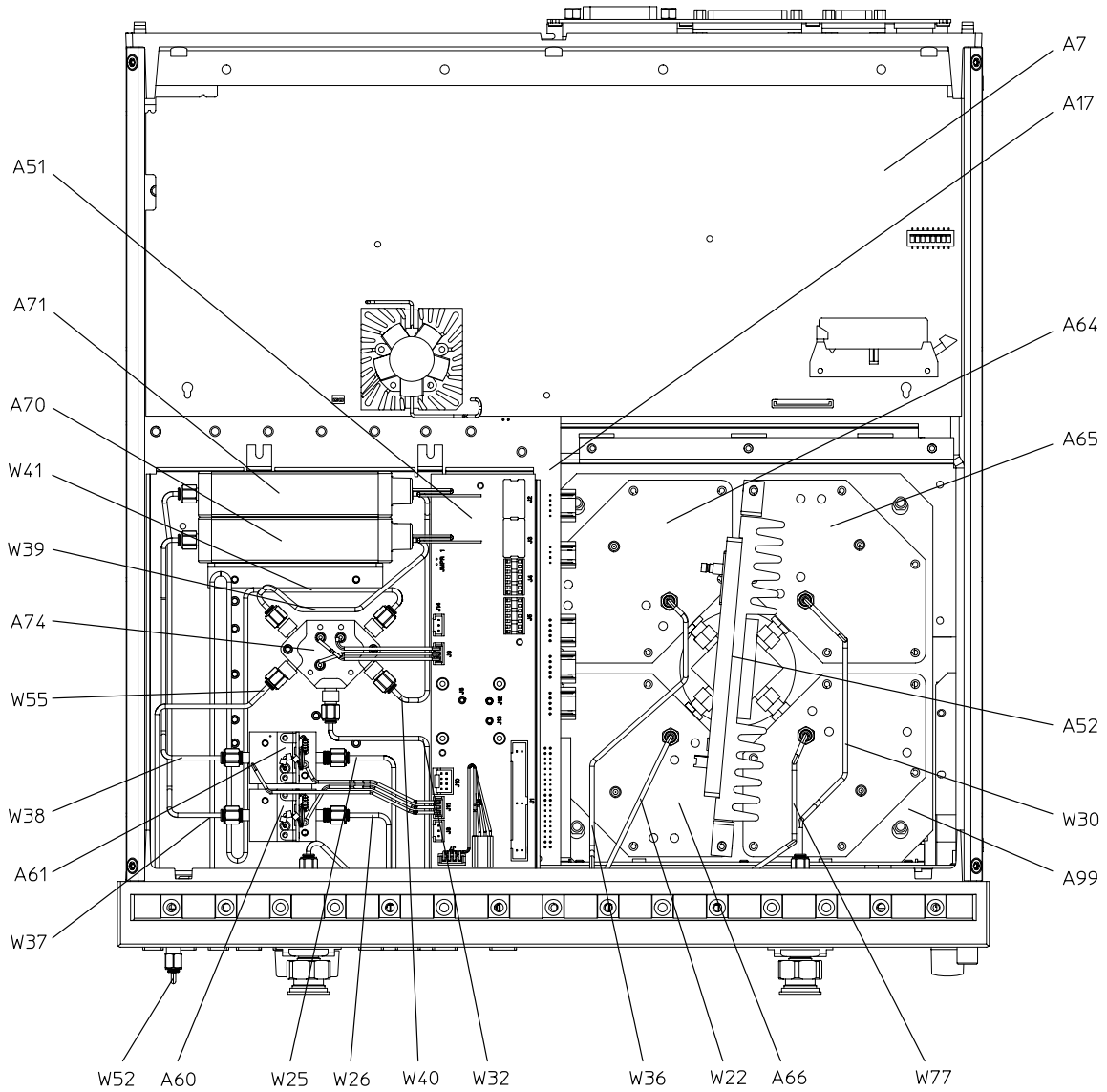

sb574e

Bottom Assemblies and Cables for 8722ES Option 400+012

Ref. Desig.	Options	HP/Agilent Part Number	Qty	Description
A7		08720-60253	1	CPU Repair Kit
A7		08720-69253	1	CPU Repair Kit (Rebuilt-Exchange)
A17		08720-60264	1	Motherboard
A51		08720-60274	1	Bd Assy-Test Set Interface
A52		5086-7456	1	Assy-Pulse Generator
A52		5086-6456	1	Assy-Pulse Generator (Rebuilt-Exchange)
A60,A61		5086-7484	2	Bias Tee
A60,A61		5086-6484	2	Bias Tee (Rebuilt-Exchange)
A64,A65, A66,A67		5086-7614	4	Assy-Sampler
A64,A65, A66,A67		5086-6614	4	Assy-Sampler (Rebuilt-Exchange)
A70,A71		33326-60006	2	Attenuator 0-55 dB
A74		5087-7002	1	Switch Splitter
A74		5087-6002	1	Switch Splitter (Rebuilt-Exchange)
A99		08720-60124	1	Frequency Converter
A99		08720-69124		Frequency Converter (Rebuilt-Exchange)
W14		08722-20102	1	A63 to Front Panel B-Out
W15		08722-20079	1	Front Panel B-In to A66
W16		08722-20081	1	Front Panel A-In to A65
W17		08722-20102	1	A62 to Front Panel A-Out
W25		08722-20056	1	A61 to A62
W26		08722-20057	1	A60 to A63
W32		08722-20054	1	A58 to A74
W36		08720-20041	1	A72 to A64
W37		08722-20059	1	A71 to A60
W38		08722-20061	1	A70 to A61
W39		08722-20063	1	A74 to A70
W40		08722-20062	1	A74 to A71
W41		08722-20936	1	A74 to A76
W52		08722-20024	3	External Link

Ref. Desig.	Options	HP/Agilent Part Number	Qty	Description
W55		08722-20065	1	A74 to Front Panel R-Channel OUT
W77		08720-20103	1	A73 to A67

8722ES Option 400+012

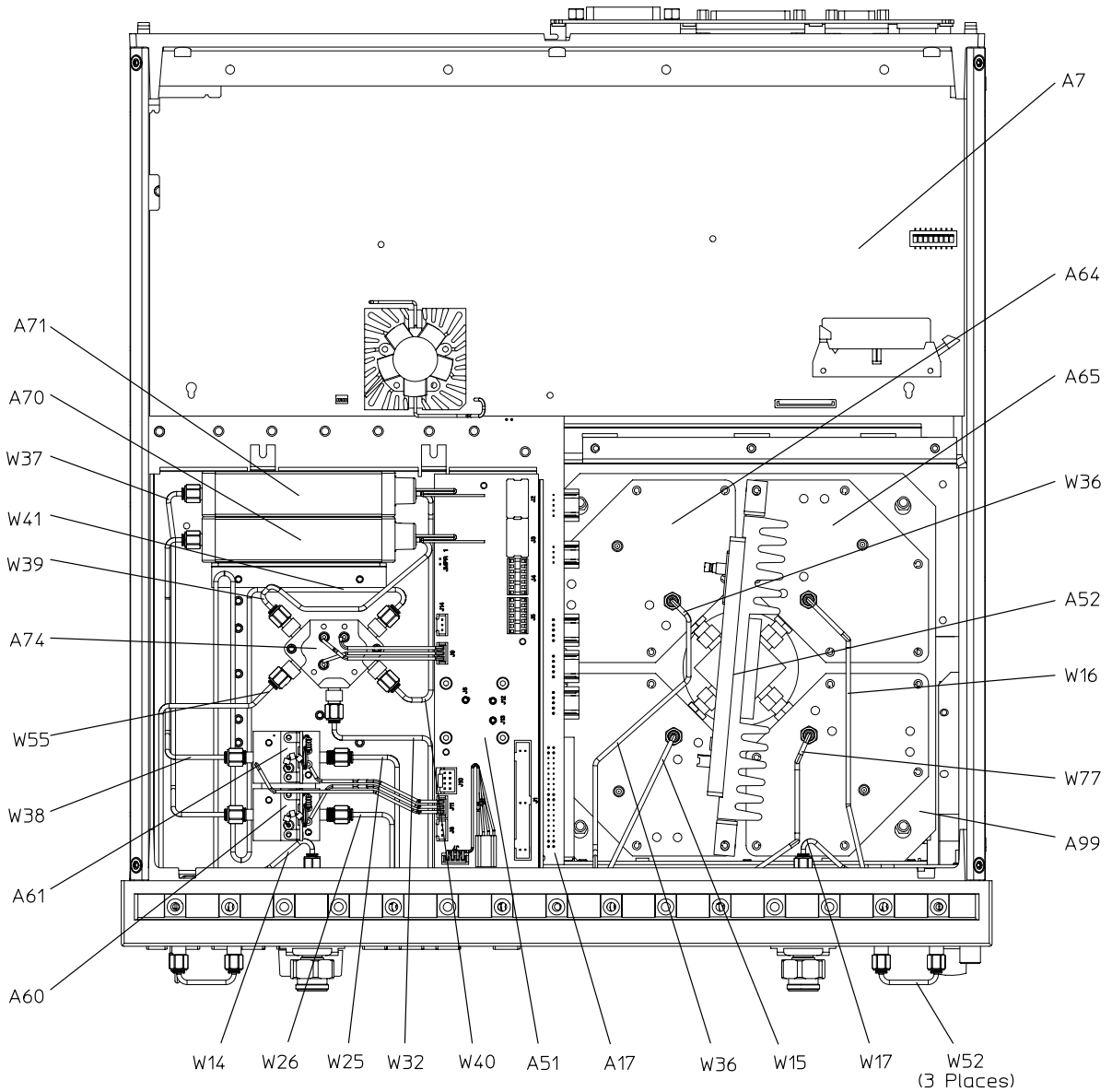

sb575e

Bottom Assemblies and Cables for 8722ES Option 400+089

Ref. Desig.	Options	HP/Agilent Part Number	Qty	Description
A7		08720-60253	1	CPU Repair Kit
A7		08720-69253	1	CPU Repair Kit (Rebuilt-Exchange)
A17		08720-60264	1	Motherboard
A23,A24		5086-7589	2	R-channel Switches
A23,A24		5086-6589	2	R-channel Switches (Rebuilt-Exchange)
A51		08720-60274	1	Bd Assy-Test Set Interface
A52		5086-7456	1	Assy-Pulse Generator
A52		5086-6456	1	Assy-Pulse Generator (Rebuilt-Exchange)
A60,A61		5086-7484	2	Bias Tee
A60,A61		5086-6484	2	Bias Tee (Rebuilt-Exchange)
A64,A65, A66,A67		5086-7614	4	Assy-Sampler
A64,A65, A66,A67		5086-6614	4	Assy-Sampler (Rebuilt-Exchange)
A70,A71		33326-60006	2	Attenuator 0-55 dB
A74		5087-7002	1	Switch Splitter
A74		5087-6002	1	Switch Splitter (Rebuilt-Exchange)
A75		08490D#003	1	Fixed Attenuator (3 dB)
A99		08720-60124	1	Frequency Converter
A99		08720-69124		Frequency Converter (Rebuilt-Exchange)
W25		08722-20056	1	A61 to A62
W26		08722-20057	1	A60 to A63
W32		08722-20054	1	A58 to A74
W37		08722-20059	1	A71 to A60
W38		08722-20061	1	A70 to A61
W39		08722-20063	1	A74 to A70
W40		08722-20062	1	A74 to A71
W41		08722-20936	1	A74 to A76
W51		08720-20279	1	A23 to A24
W52		08722-20024	1	External Link
W56		08722-20135	1	A74 to A75

Ref. Desig.	Options	HP/Agilent Part Number	Qty	Description
W77		08720-20103	1	A73 to A67

8722ES Option 400+089

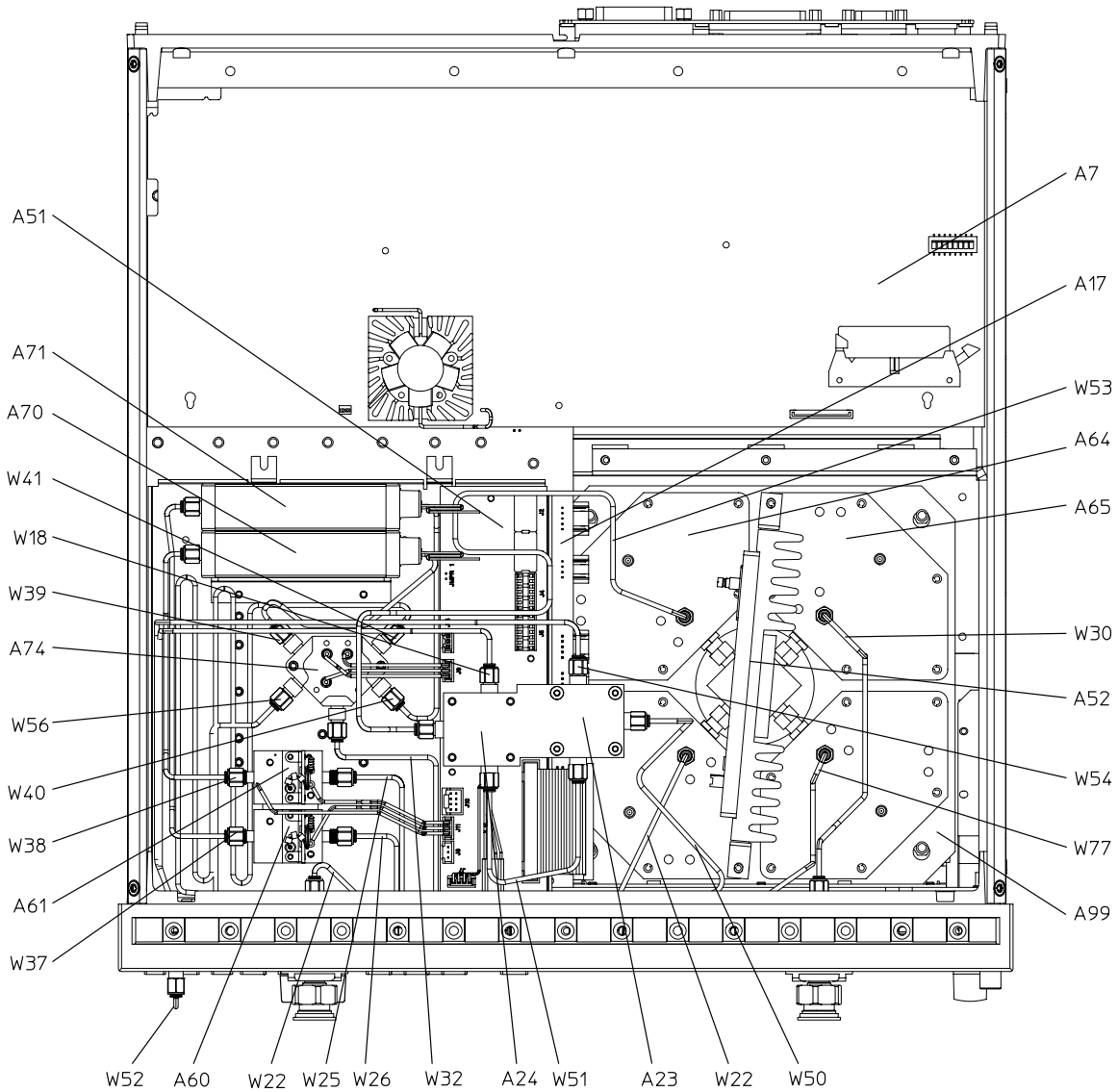

sb576e

Bottom Assemblies and Cables for 8722ES Option 400+012+089

Ref. Desig.	Options	HP/Agilent Part Number	Qty	Description
A7		08720-60253	1	CPU Repair Kit
A7		08720-69253	1	CPU Repair Kit (Rebuilt-Exchange)
A17		08720-60264	1	Motherboard
A51		08720-60274	1	Bd Assy-Test Set Interface
A52		5086-7456	1	Assy-Pulse Generator
A52		5086-6456	1	Assy-Pulse Generator (Rebuilt-Exchange)
A60,A61		5086-7484	2	Bias Tee
A60,A61		5086-6484	2	Bias Tee (Rebuilt-Exchange)
A64,A65, A66,A67		5086-7614	4	Assy-Sampler
A64,A65, A66,A67		5086-6614	4	Assy-Sampler (Rebuilt-Exchange)
A70,A71		33321-60006	2	Attenuator 0-55 dB
A74		5087-7002	1	Switch Splitter
A74		5087-6002	1	Switch Splitter (Rebuilt-Exchange)
A99		08720-60124	1	Frequency Converter
A99		08720-69124	1	Frequency Converter (Rebuilt-Exchange)
W14		08722-20102	1	A63 to Front Panel B-Out
W15		08722-20079	1	Front Panel B-In to A66
W16		08722-20081	1	Front Panel A-In to A65
W17		08722-20102	1	A62 to Front Panel A-Out
W18		08722-20058	1	Front Panel R-Channel IN to A24
W25		08722-20056	1	A61 to A62
W26		08722-20057	1	A60 to A63
W32		08722-20054	1	A58 to A74
W37		08722-20059	1	A71 to A60
W38		08722-20061	1	A70 to A61
W39		08722-20063	1	A74 to A70
W40		08722-20062	1	A74 to A71
W41		08722-20936	1	A74 to A76
W50		08720-20278	1	A72 to A23
W51		08720-20279	1	A23 to A24
W52		08722-20024	3	External Link

Ref. Desig.	Options	HP/Agilent Part Number	Qty	Description
W53		08720-20281	1	A24 to A61
W54		08722-20132	1	A23 to Front Panel R-Channel Out
W56		08722-20135	1	A74 to A75
W77		08720-20103	1	A73 to A67

8722ES Option 400+012+089

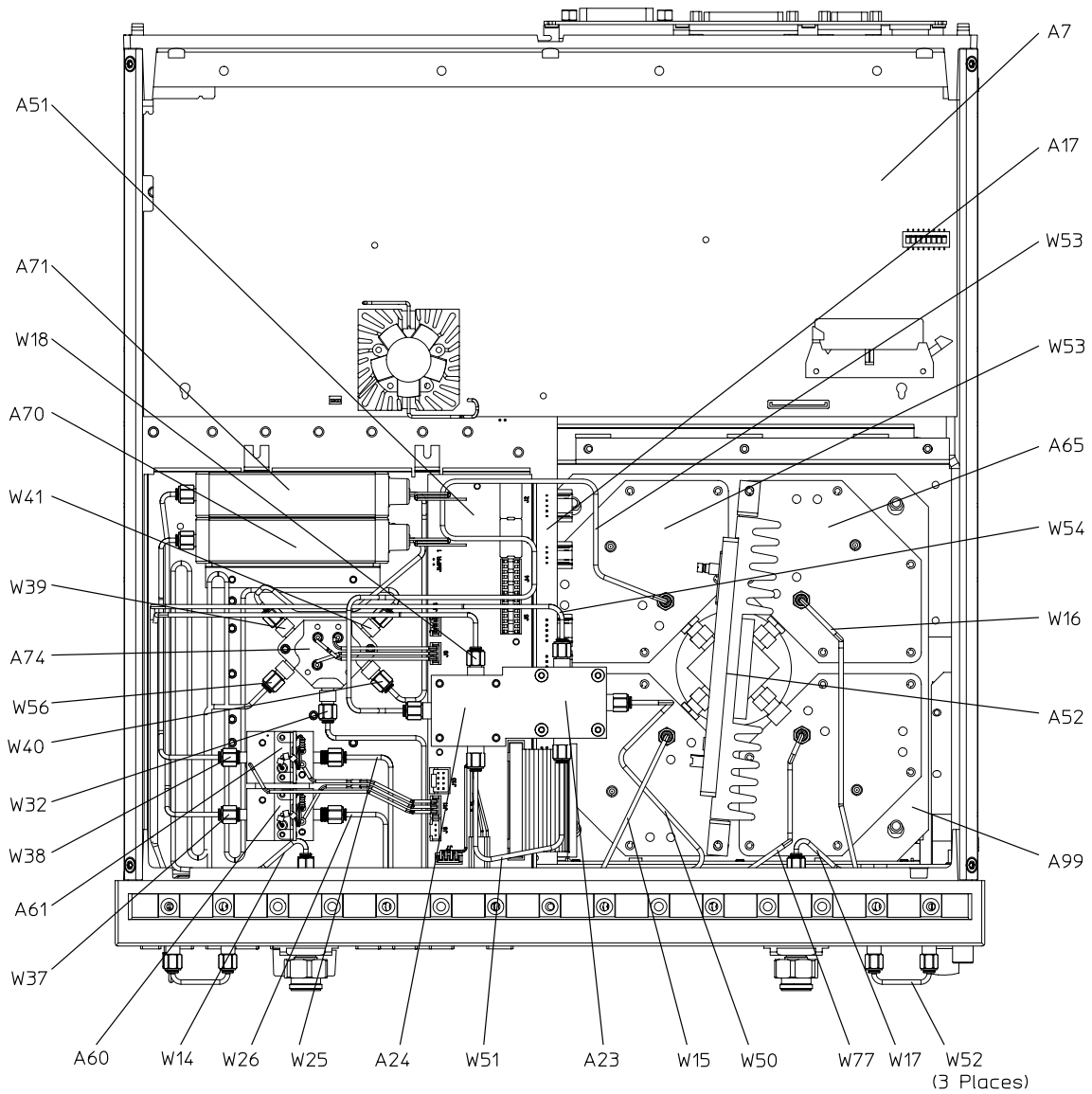

sb577e

Bottom Assemblies and Cables 8719ET and 8720ET Standard

Ref. Desig.	Options	HP/Agilent Part Number	Qty	Description
A7		08720-60253	1	CPU Repair Kit
A7		08720-69253	1	CPU Repair Kit (Rebuilt-Exchange)
A17		08720-60264	1	Motherboard
A28		11742A	1	Blocking Capacitor
A52		5086-7456	1	Assy-Pulse Generator
A52		5086-6456	1	Assy-Pulse Generator (Rebuilt-Exchange)
A64,A65,A66		5086-7614	3	Assy-Sampler
A64,A65,A66		5086-6614	3	Assy-Sampler (Rebuilt-Exchange)
A98		08720-60121	1	Frequency Converter
A98		08720-69121	1	Frequency Converter (Rebuilt-Exchange)
W30		08720-20026	1	A62 to A65
W74		08720-20266	1	W72 to A64
W78		08720-20254	1	A21 to A66

8719ET and 8720ET Standard

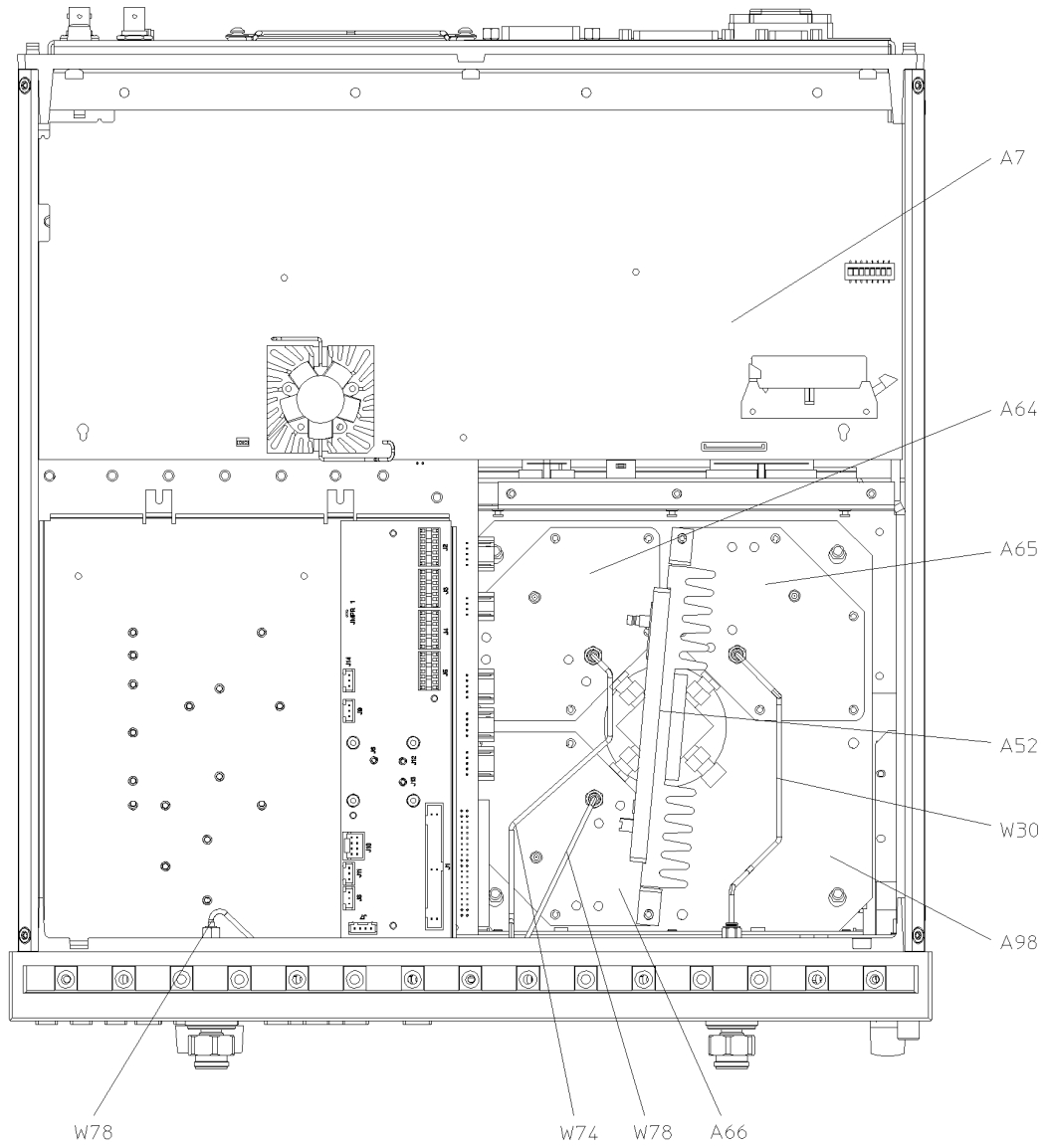

sb578e

Bottom Assemblies and Cables 8719ET and 8720ET Option 004

Ref. Desig.	Options	HP/Agilent Part Number	Qty	Description
A7		08720-60253	1	CPU Repair Kit
A7		08720-69253	1	CPU Repair Kit (Rebuilt-Exchange)
A17		08720-60264	1	Motherboard
A28		11742A	1	Blocking Capacitor
A51		08720-60274	1	Bd Assy-Test Set Interface
A52		5086-7456	1	Assy-Pulse Generator
A52		5086-6456	1	Assy-Pulse Generator (Rebuilt-Exchange)
A64,A65,A66		5086-7614	3	Assy-Sampler
A64,A65,A66		5086-6614	3	Assy-Sampler (Rebuilt-Exchange)
A69		33321-60050	1	Attenuator 0-55 dB
A98		08720-60121	1	Frequency Converter
A98		08720-69121	1	Frequency Converter (Rebuilt-Exchange)
W30		08720-20026	1	A62 to A65
W32		08720-20021	1	A58 to A69
W74		08720-20266	1	W72 to A64
W78		08720-20255	1	A21 to A66
W90		08720-20256	1	A28 to A62

8719ET and 8720ET Option 004

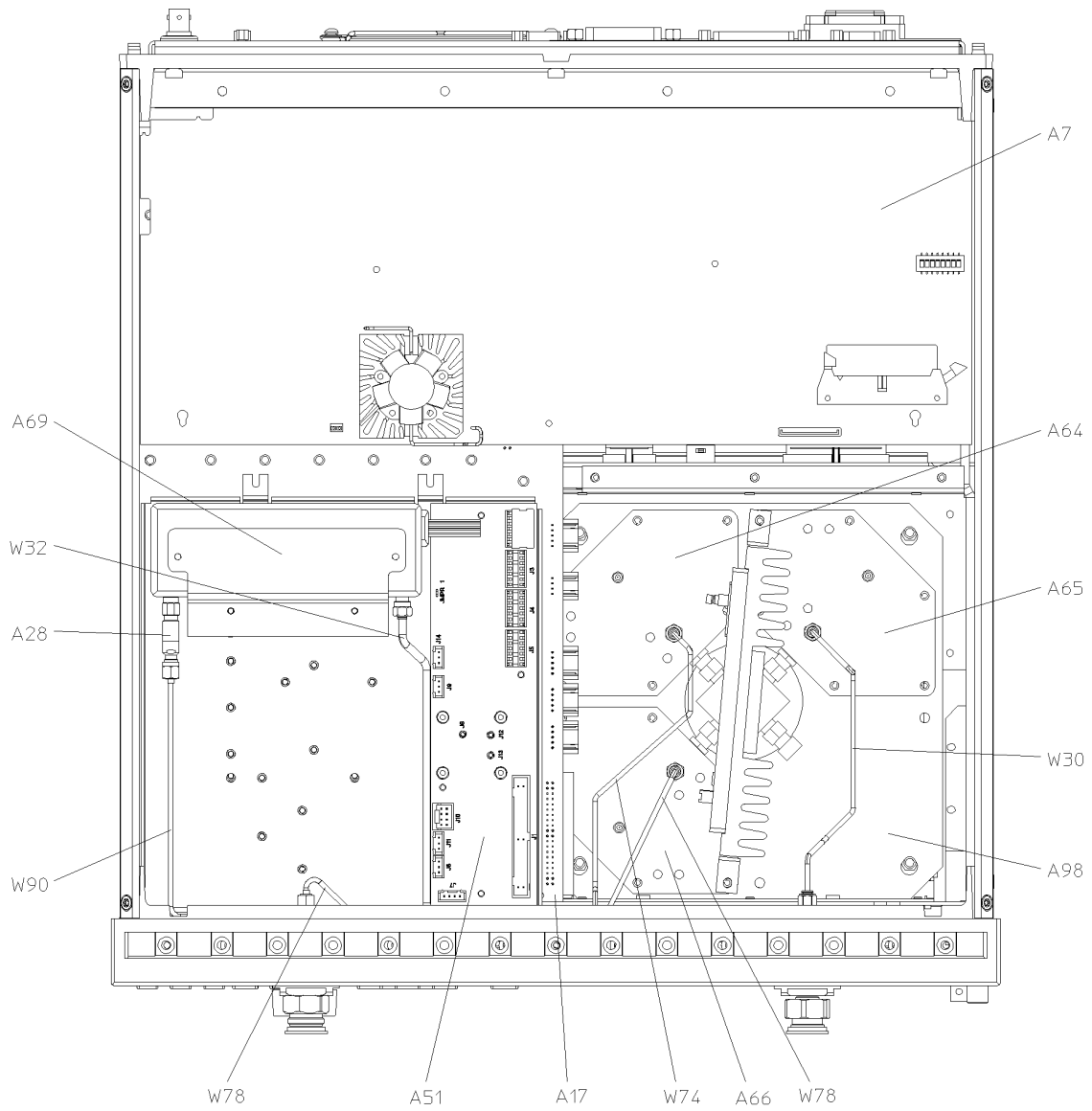

sb579e

Bottom Assemblies and Cables, 8722ET Standard

Ref. Desig.	Options	HP/Agilent Part Number	Qty	Description
A7		08720-60253	1	CPU Repair Kit
A7		08720-69253	1	CPU Repair Kit (Rebuilt-Exchange)
A17		08720-60264	1	Motherboard
A52		5086-7456	1	Assy-Pulse Generator
A52		5086-6456	1	Assy-Pulse Generator (Rebuilt-Exchange)
A64,A65,A66,		5086-7614	3	Assy-Sampler
A64,A65,A66		5086-6614	3	Assy-Sampler (Rebuilt-Exchange)
A98		08720-60121	1	Frequency Converter
A98		08720-69121	1	Frequency Converter (Rebuilt-Exchange)
W30		08720-20026	1	A62 to A65
W74		08720-20266	1	W72 to A64
W78		08722-20125	1	A21 to A66

8722ET Standard

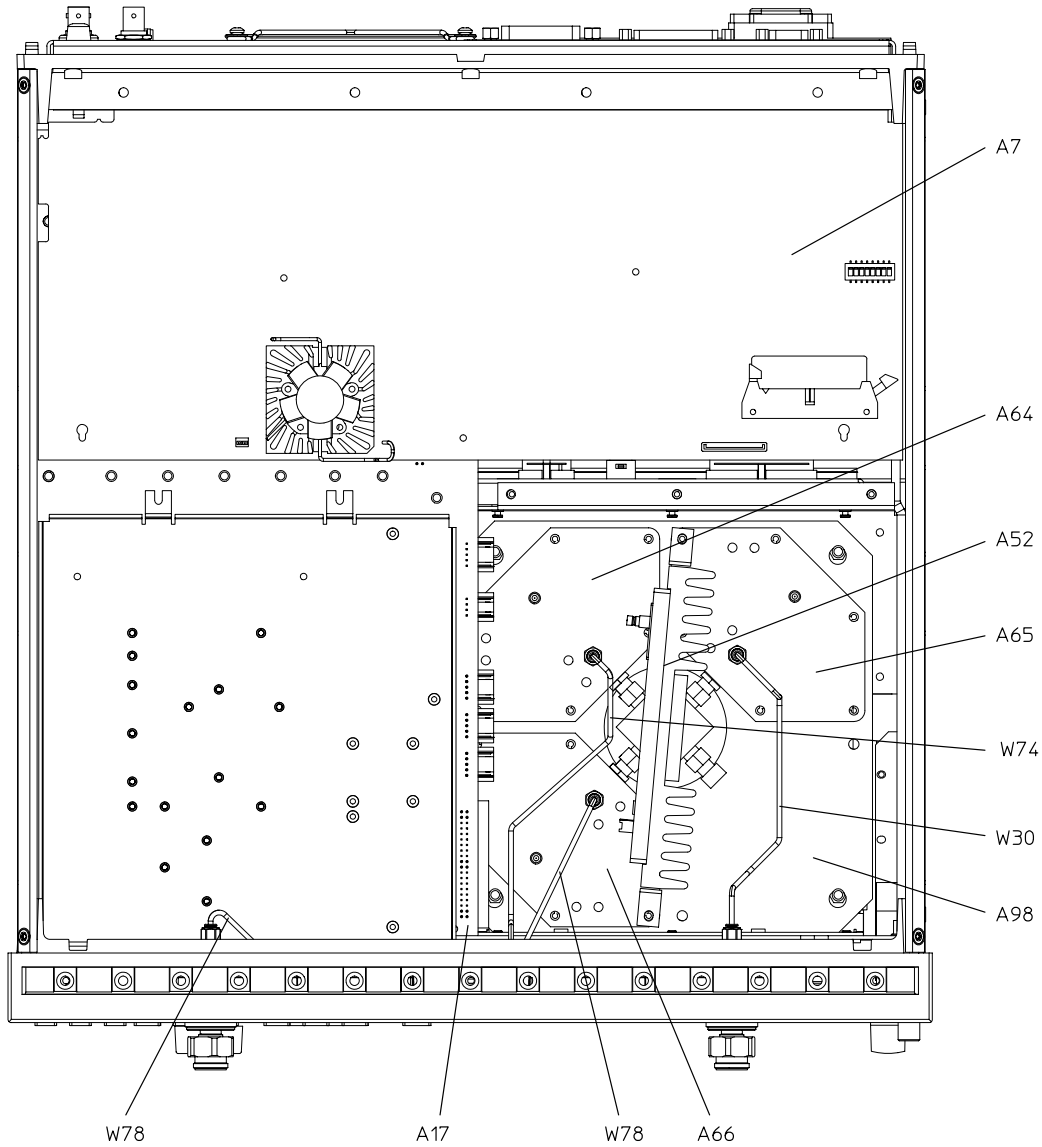

sb580e

Bottom Assemblies and Cables 8722ET Option 004

Ref. Desig.	Options	HP/Agilent Part Number	Qty	Description
A7		08720-60253	1	CPU Repair Kit
A7		08720-69253	1	CPU Repair Kit (Rebuilt-Exchange)
A17		08720-60264	1	Motherboard
A51		08720-60274	1	Bd Assy-Test Set Interface
A52		5086-7456	1	Assy-Pulse Generator
A52		5086-6456	1	Assy-Pulse Generator (Rebuilt-Exchange)
A64,A65,A66,		5086-7614	3	Assy-Sampler
A64,A65,A66		5086-6614	3	Assy-Sampler (Rebuilt-Exchange)
A69		33326-60006	2	Attenuator 0-55 dB
A98		08720-60121	1	Frequency Converter
A98		08720-69121	1	Frequency Converter (Rebuilt-Exchange)
W30		08720-20026	1	A62 to A65
W32		08722-20069	1	A58 to A69
W74		08720-20266	1	W72 to A64
W78		08722-20124	1	A21 to A66
W91		08722-20125	1	A69 to A62

8722ET Option 004

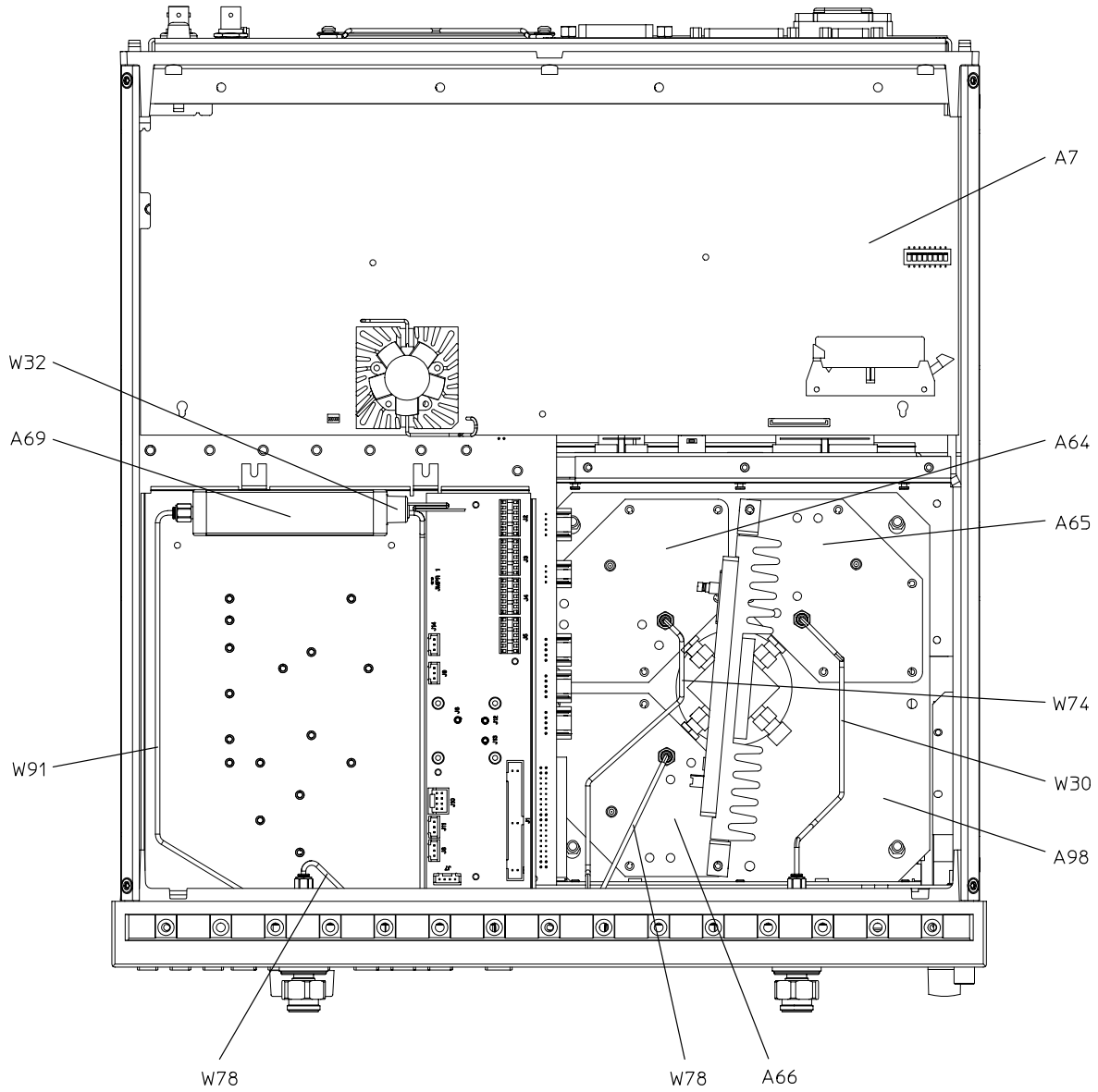

sb581e

Front RF Assemblies

Ref. Desig.	Agilent Models	Options	HP/Agilent Part Number	Qty	Description
1	8719ET 8720ET	All	5064-3949	1	Test Port Connector
1	8722ET	All	5064-3950	1	Test Port Connector
A19	All	All	08720-60261	1	GSP Board
A22	All	All	08720-60152	1	Display Interface Board
A27	8719ET/ES 8720ET/ES	All	8493C Opt. 010	1	Attenuator
A27	8722ET/ES	All	8490C Opt. 010	1	Attenuator
A56	All ES Models	All	08720-60182	1	LED Board
A62	8719ET/ES 8720ET/ES	All	5086-7968	1	RF Coupler
A62	8719ET/ES 8720ET/ES	All	5086-6968	1	RF Coupler (Rebuilt-Exchange)
A62	8722ET/ES	All	5086-7518	1	RF Coupler
A62	8722ET/ES	All	5086-6518	1	RF Coupler (Rebuilt-Exchange)
A63	8719ES 8720ES	All	5086-7968	1	RF Coupler
A63	8719ES 8720ES	All	5086-6968	1	RF Coupler (Rebuilt-Exchange)
A63	8722ES	All	5086-7518	1	RF Coupler
A63	8722ES	All	5086-6518	1	RF Coupler (Rebuilt-Exchange)
A72	All ES Models	All	5087-7115	1	R Channel Buffer Amplifier
A72	All ES Models	All	5087-6115	1	R Channel Buffer Amp. (Rebuilt-Exchange)
A73	All ES Models	400	5087-7115	1	R Channel Buffer Amplifier
A73	All ES Models	400	5087-6115	1	R Channel Buffer Amp. (Rebuilt-Exchange)
A75	8722ES	Non Opt. 400 Non Opt. 089 Non Opt. 085	8490D OPT 006	1	Attenuator 6 dB
A75	8722ES	089 085	8490D OPT 003	1	Attenuator 3 dB
A75	8722ES	400	8490D OPT 010	1	Attenuator 10 dB
A76	8722ES	400	8490D OPT 010	1	Attenuator 10 dB
W99	All	All	8120-6890	1	Ribbon Cable

Front Assembly, ET Models

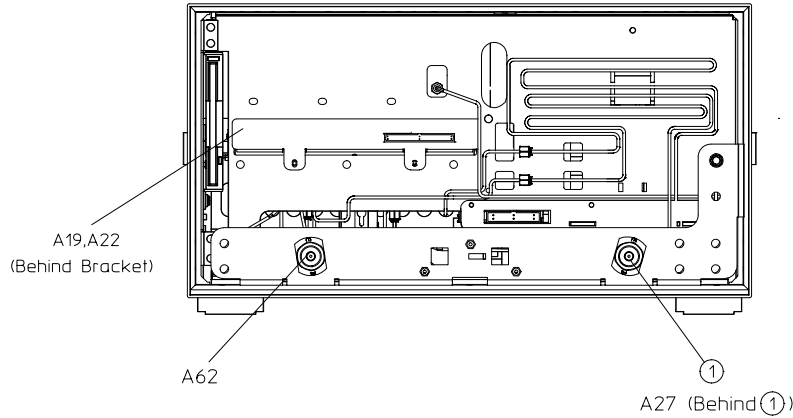

sb5111e

Front Assembly, 8719ES and 8720ES

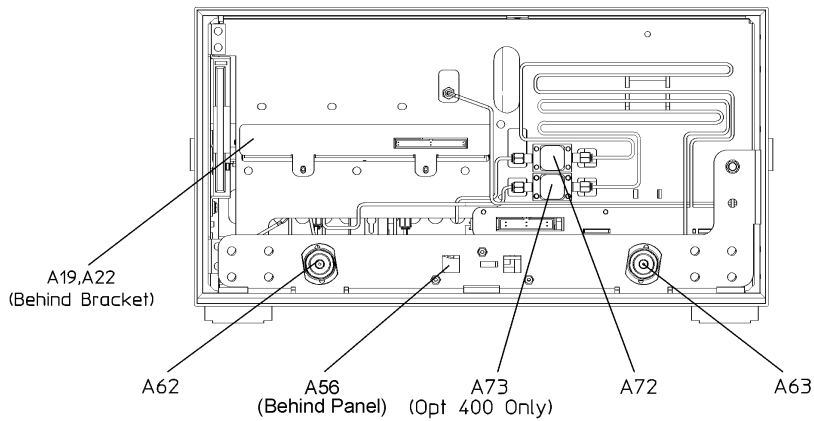

871920es_front_assy

Front Assembly, 8722ES

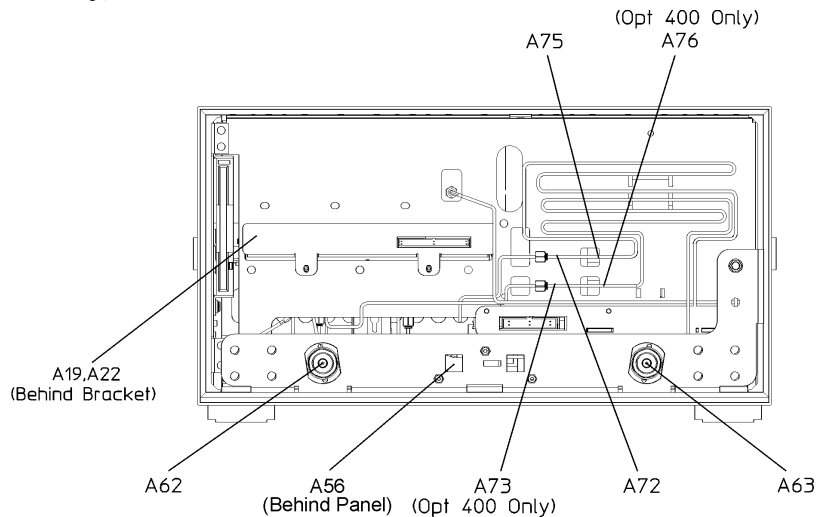

8722es_front_assy

Top Cables

Ref. Desig.	Agilent Models	Options.	Type ¹	HP/Agilent Part Number	Qty	Description
W1	8719ET/ES 8720ET/ES	All	SR	08720-20064	1	A68 To A20
W1	8722ET/ES	All	SR	08720-20014	1	A29 To A20
W2	All	All	F	08720-60141	1	A9J7 To A11J1
W3	8719ET/ES 8720ET/ES	All	SR	08720-20062	1	A20 To A58
W3	8722ET/ES	All	SR	08722-20017	1	A20 To A25
W5	8722ET/ES	All	SR	08720-20266	1	A25 To A58
W6	All	All	SR	08720-20068	1	A29 To A53
W7	All	All	SR	08720-20063	1	A55 To A29
W8	All	All	F	08415-60040	1	A12 To A13
W9	All	All	F	08415-60041	1	A14 To A13
W11	All	All	SR	08720-20065	1	A57 To A53
W31	All	All	F	08415-60035	1	A52 To A14
W42	All	All	SR	08720-20061	1	A53 To A20
W43	8722ET/ES	All	SR	08722-20016	1	A54 To A25
W47	All	All	F	08720-60132	1	A9J5 To A4
W48	All	All	F	08720-60134	1	A9J6 To A6
W49	All	All	F	08720-60133	1	A9J8 To A5
W79	8722ET/ES	All	F	08514-60033	1	A11J3 To A54J2
W80	8722ET/ES	All	F	08720-60131	1	A17J15 To A54
W81	All	All	F	08720-60144	1	A17J15 To A55
W82	All	All	F	08415-60031	1	A55 To A11

1. F is Flexible Coax Cable
 SR is Semirigid Coax Cable

8719ET/ES and 8720ET/ES Cables, Top

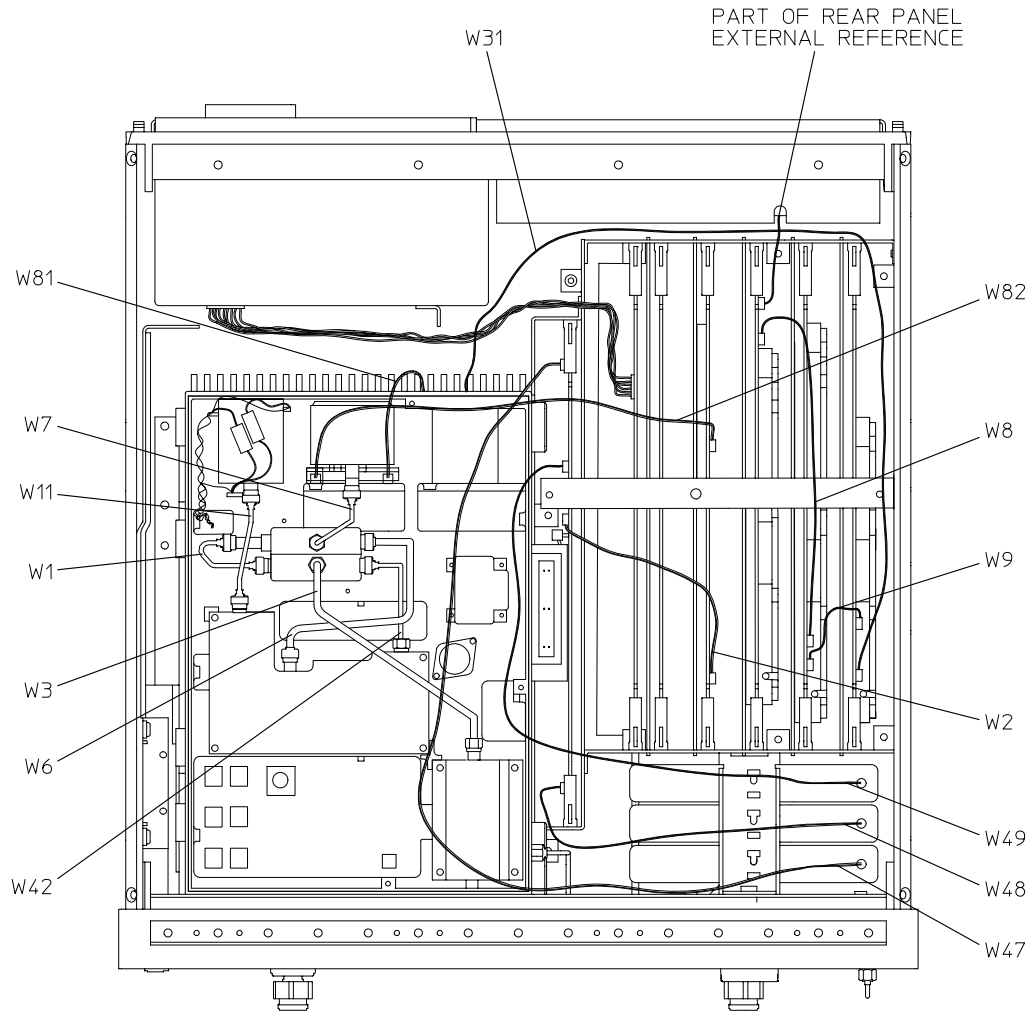

sb5101e

8722ET/ES Cables, Top

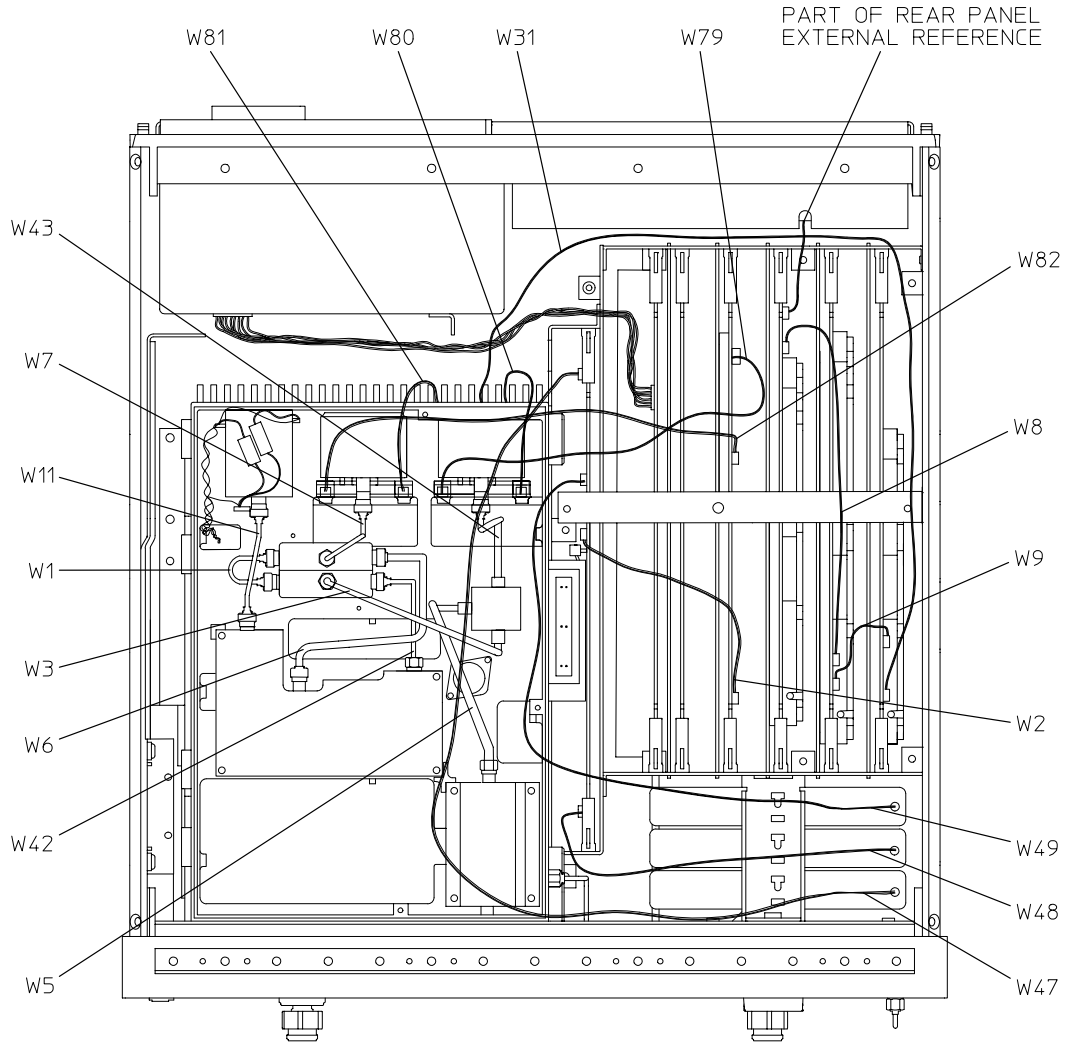

sb5100e

Rear Cables, All Models

Ref. Desig.	Agilent Models	Options	Type ¹	HP/Agilent Part Number	Qty	Description
W58	8719ES 8720ES	085	SR	08720-20135	1	A69 To Rear Panel Source Out
W58	8722ES	085	SR	08722-20085	1	A69 To Rear Panel Source Out
W59	8719ES 8720ES	085	SR	08720-20144	1	Rear Panel Source In To A74
W59	8722ES	085	SR	08722-20084	1	Rear Panel Source In To A74
W82	All	All	14W	8120-6876	1	VGA Out To A22J2
W85	All	All	3W	8120-6859	1	A16 To A17
W86	All	All	2W	8120-6382	1	A7 To A17
W87	All	All	50W	8120-6379	1	A7 To A17

1. *n*W is an abbreviation for Wire Bundle (*n* is the number of wires in the bundle)

Rear Panel All Models

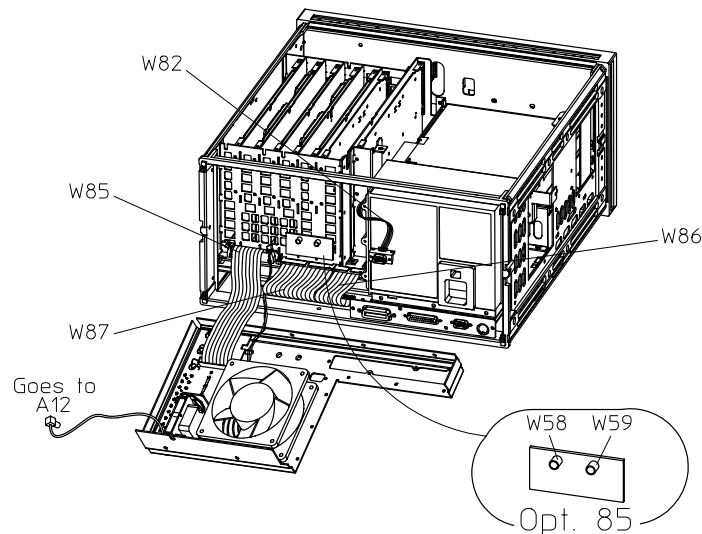

sb682d

Front Cables, All Models

Ref. Desig.	Agilent Models	Options	Type	HP/ Part Number	Qty	Description
W18	8719ES 8720ES	085,089	SR	08720-20105	1	Front Panel R- Channel In to A24
W18	8722ES	085,089	SR	08722-20058	1	Front Panel R-Channel In to A24
W20	8719ES 8720ES 8722ES	085,089	SR	08720-20281	1	A24 to A64
W23	8719ES	Standard 007,012	SR	08720-20047	1	A58 to Front Panel R Channel Out
W23	8722ES	Standard 007,012	SR	08722-20071	1	A58 to Front Panel R Channel Out
W30	8719ET 8720ET 8722ET	All	SR	08720-20026	1	A62 to A65
W32	8719ET 8720ET	004	SR	08720-20021	1	A58 to A69
W32	8722ET	004	SR	08722-20069	1	A58 to A69
W33	8719ES 8720ES	Standard 007,012,400	SR	08720-20311	1	Front Panel R Channel In To A72
W33	8722ES	Standard 007,012,400	SR	08722-20075	1	Front Panel R Channel In To A75
W36	8719ES 8720ES	Standard 007,012,400	SR	08720-20312	1	A72 To A64
W36	8722ES	Standard 007,012,400	SR	08720-20041	1	A72 To A64
W38	8719ES 8720ES	085,089	SR	08720-20313	1	A58 to A72
W38	8722ES	085,089	SR	08722-20130	1	A58 to A75
W41	8719ES 8720ES	400	SR	08720-20316	1	A74 to A73
W41	8722ES	400	SR	08722-20936	1	A74 to A76
W50	8719ES 8720ES 8722ES	085,089	SR	08720-20314	1	A72 to A23
W53	8719ES 8720ES	400+089	SR	08720-20281	1	A24 to A64

Ref. Desig.	Agilent Models	Options	Type	HP/ Part Number	Qty	Description
W54	8719ES 8720ES	085,089	SR	08720-20282	1	A23 to Front Panel R- Channel Out
W54	8722ES	085,089	SR	08722-20132	1	A23 to Front Panel R- Channel Out
W55	8719ES 8720ES	400	SR	08720-20172	1	A74 to Front Panel R- Channel Out
W55	8722ES	400	SR	08722-20065	1	A74 to Front Panel R- Channel Out
W56	8719ES 8720ES	400+089	SR	08720-20317	1	A74 to A72
W56	8722ES	400,089	SR	08722-20135	1	A74 to A72
W72	8719ET 8720ET	All	SR	08720-20253	1	A58 to W74
W72	8722ET	All	SR	08722-20123	1	A58 to W74
W74	8719ET 8720ET 8722ET	All	SR	08720-20266	1	W72 to A64
W76	8719ET 8720ET	Std.	SR	08720-20254	1	A58 to A62
W76	8722ET	Standard	SR	08722-20122	1	A58 to A62
W77	8719ES 8720ES	400	SR	08720-20315	1	A73 to A67
W78	8719ET 8720ET	All	SR	08720-20255	1	A21 to A66
W78	8722ET	All	SR	08722-20124	1	A21 to A66
W90	8719ET 8720ET	004	SR	08720-20256	1	A23 to A62
W91	8722ET	004	SR	08722-20125	1	A69 to A62

Front Panel Assembly, Inside

Ref. Desig.	Models	Options	HP/Agilent Part Number	Qty	Description
1	All	All	08753-00150	1	Display Hold Down
2	All	All	2090-0386	1	Display Lamp
3	All	All	08720-0094	4	Display Glass Clips
4	All	All	1000-0995	1	Display Glass
5	All	All	08720-00096	2	Gasket
6	All	All	2190-0067	1	Washer Lk .256
			2950-0006	1	Nut Hex 1/4-32
			1510-0038	1	Ground Post
7	All ES	STD,089	08720-60305	1	Front Panel Frame (without nameplate)
7	All ES	012	08720-60306	1	Front Panel Frame (without nameplate)
7	All ES	085	08720-60307	1	Front Panel Frame (without nameplate)
7	All ES	012 + 085	08720-60308	1	Front Panel Frame (without nameplate)
8	All	All	E4400-40003	1	RPG Knob (Front Round Knob)
9	All	All	1990-1864	1	RPG (Includes Cable And Hardware)
10	All	All	08720-40016	1	Flubber Keypad
11	All	All	0515-0430	9	Screw Sm 3.0 6 Cwpntx
12	All	All	0515-0665	4	Screw Smm 3.0 14 Cwpntx
13	All	All	0515-0372	3	Screw Smm 3.0 8 Cwpntx
14	All	All	1400-1439	2	Cable-Clips Inverter Cable
15	All	All	08753-20948	1	Cover for Inverter
16	All	All	8120-8842	1	Ribbon Cable (5R) A2 to A20
17	All	All	08720-60074	1	Ribbon Cable (50R) A2 to A17
18	All	All		1	Ribbon Cable (50R) A2 to GSP
19	All	All	8120-8409	1	Ribbon Cable (31R) A2 to A18
20	All	All	8120-8439	1	Ribbon Cable (31R) A2 to A1
21	8719ES	All	08719-80038	1	Nameplate, 8719ES
21	8719ET	All	08719-80035	1	Nameplate, 8719ET

Ref. Desig.	Models	Options	HP/Agilent Part Number	Qty	Description
21	8720ES	All	08720-80099	1	Nameplate, 8720ES
21	8720ET	All	08720-80098	1	Nameplate, 8720ET
21	8722ES	All	08722-80027	1	Nameplate, 8722ES
21	8722ET	All	08722-80026	1	Nameplate, 8722ET
22	All ET	All	08720-80106	1	Front Panel Overlay
23	All ET	All	08720-80102	1	Test Set Overlay
A1	All	All	08720-60267	1	Bd Assy-keyboard
A18	All	All	2090-0361	1	Assy-color LCD
A2	All	All	08720-60260	1	Bd Assy-Front Panel Interface
A20	All	All	0950-3379	1	Assy-Inverter

Front Panel Assembly, Inside

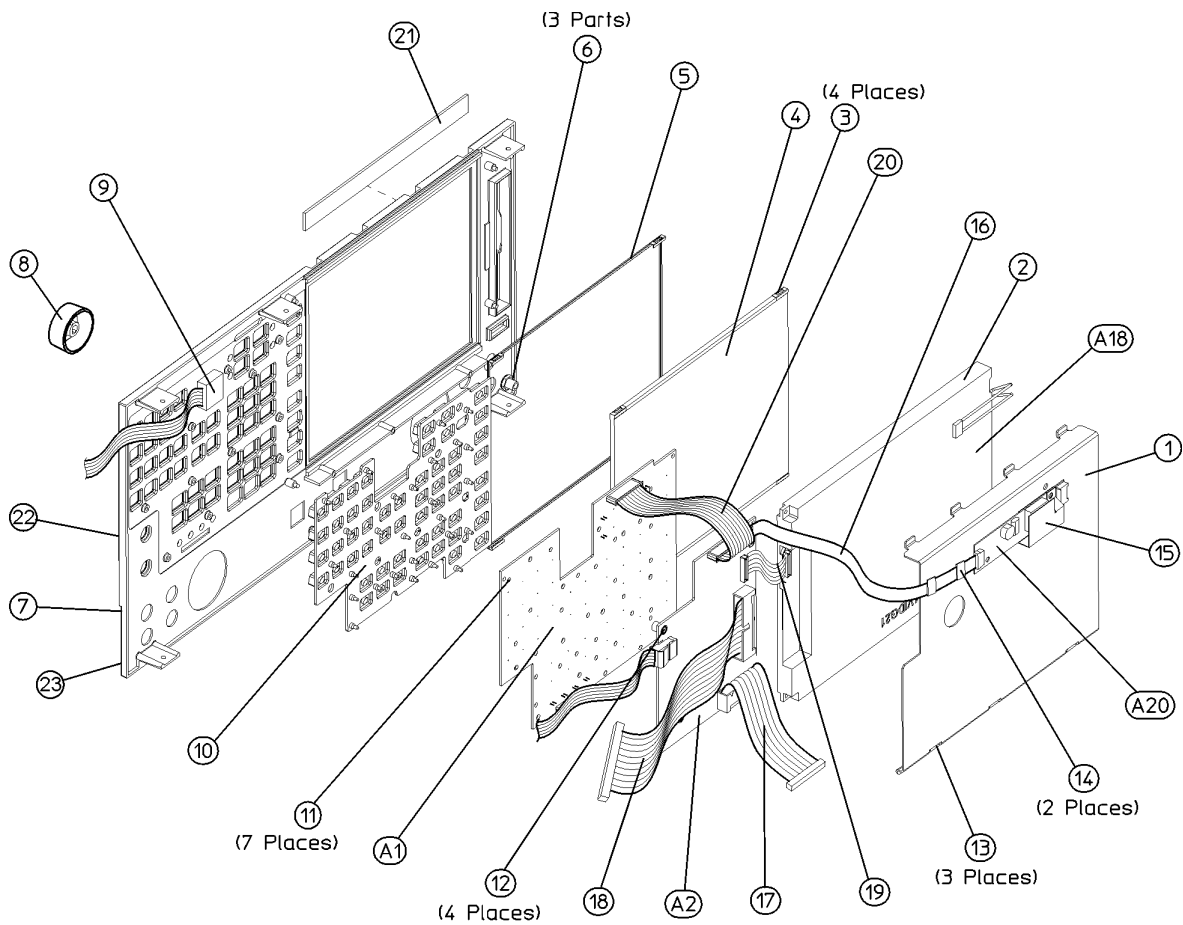

872x_fp_assy_inside

Rear Panel Assembly

Ref. Desig.	Models	Options	HP/Agilent Part Number	Qty	Description
1	All	All	8120-6407	1	W85-A17 to A16
2	All	All	85047-60005	2	Assy-fuse
3	ET Models	All	08753-60255	1	Bd Assy-rear Panel Interface (A16)
3	ES Models	All	08720-60138	1	Bd Assy-rear Panel Interface (A16)
4	All	All	08753-60026	1	Assy-external Reference Cable
5	All	All	08415-60036	1	Assy-fan
6	All	All	1251-2942	4	Fastener Conn RP Lock
7	All	All	2190-0034	2	Washer Lk.194ID10
7	All	All	0380-0644	2	Nut Std .327L 6-32
8	All	All	1251-2942	4	Fastener Conn RP Lock
9	All	All	0515-2040	4	Screw SMM 3.5 16 PCFLTX
10	All	All	0515-0372	10	Screw SMM 3.0 8 CWPNTX
11	All	All	08720-00071	1	Rear Panel
12	All	All	3160-0281	1	Fan Guard
15	All	All	2190-0102	1	washer LK.472ID
15	All	All	2950-0035	8	Nut Hex 15/32-32
16	All	All	0400-0271	8	Grommet SN.5-515ID
17	All	All	2110-0047	2	Fuse
17	All	All	1400-0112	2	Fuse Cap

Rear Panel Assembly

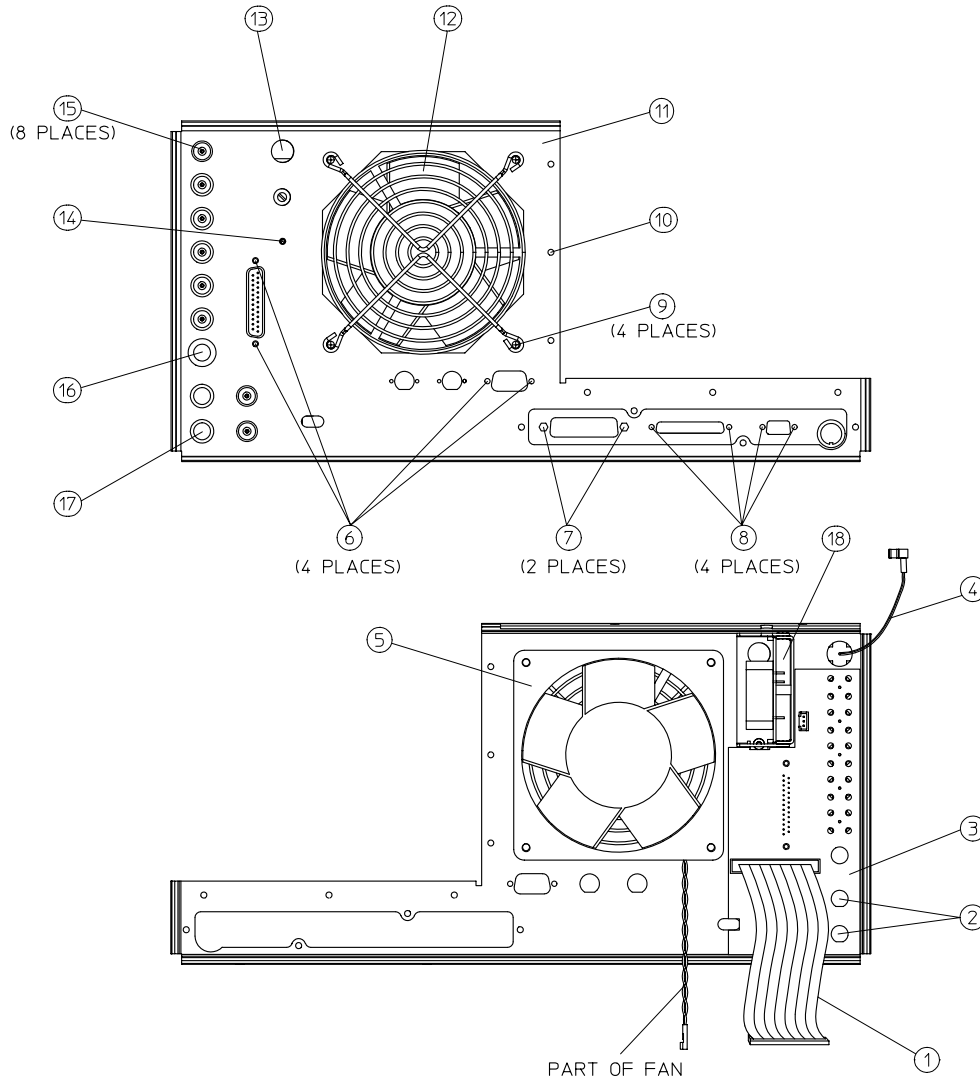

sb6102d

Rear Panel Assembly, Option 1D5

Ref. Desig.	Models	Option	HP/Agilent Part Number	Qty	Description
1	All ES	1D5	1250-1859	1	Adapter-coax
2	All ES	1D5	0515-0374	1	Screw-Machine M3.0×10 CW-PN-TX
3	All ES	1D5	3050-1546	1	Washer-Flat .505ID NY
4	All ES	1D5	2190-0068	1	Washer-Lock .505ID
5	All ES	1D5	0590-1310	1	Nut-Specialty 1/2-28
6	All ES	1D5	0515-0430	1	Screw-Machine M3.0×6 CW-PN-TX
7	All ES	1D5	08753-00078	1	Bracket-OSC BD
A26	All ES	1D5	08753-60158	1	Bd Assy-High Stability Freq Ref
W88	All ES	1D5	8120-6458	1	RP Interface (A16J3) to High-Stability Freq Ref (A26J1)

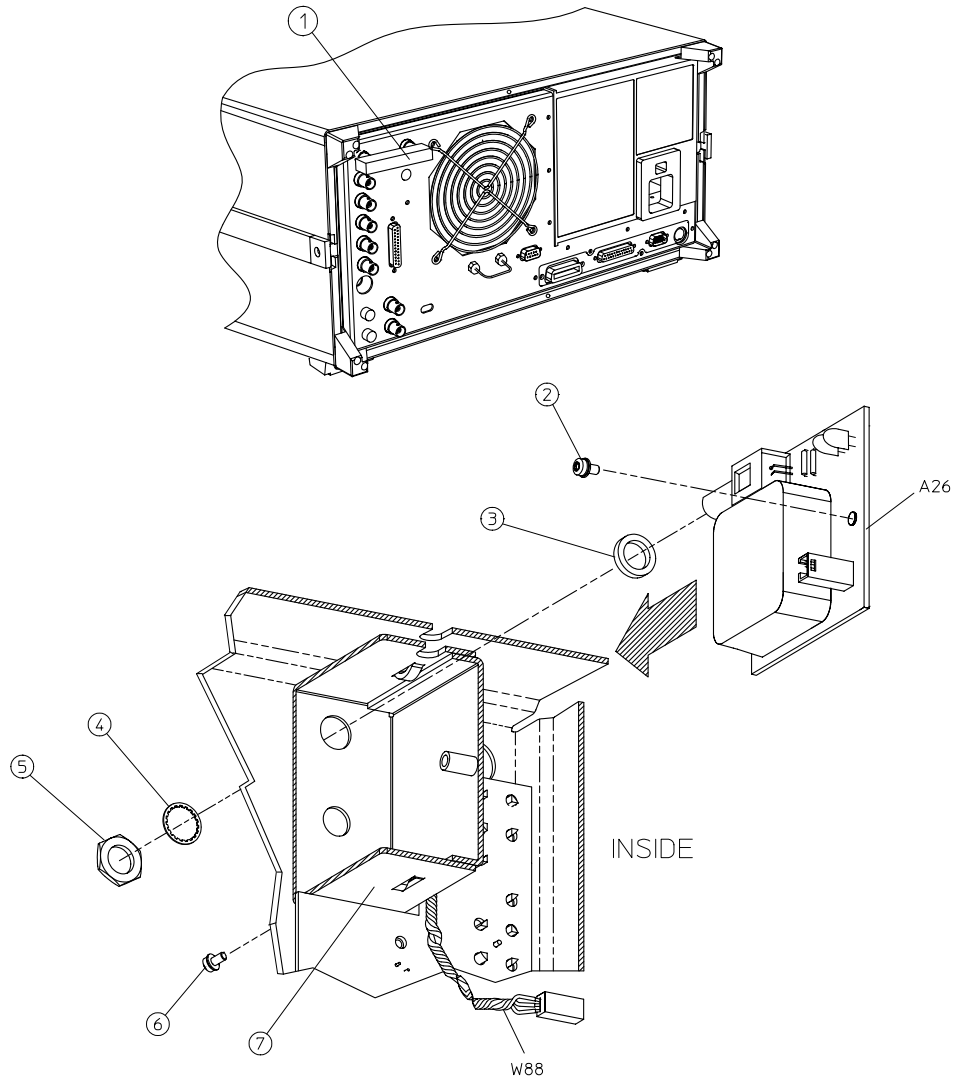

sb6129d

Hardware, Top

Ref. Desig.	Models	Option	HP/Agilent Part Number	Qty	Description
1	All	All	08720-40004	3	Locator Hold Downs
2	All	All	08720-00066	1	Can Hold Down
3	All	All	0515-2035	1	Screw SMM 3.0 16 PCFLTX
4	All	All	08753-20062	1	PC Stabilizer Cap
5	All	All	08720-40011	1	PC Board Stabilizer
6	All	All	0515-2086	16	Screw SMM 4.0 7 PCFLTX
7	All	All	0515-0458	4	Screw SMM 3.5 10 CWPNTX
8	All	All	0515-0431	2	Screw SMM 3.5 6 CWPNTX
9	All	All	0515-0430	3	Screw SMM 3.0 6 CWPNTX
10	All	All	08720-00023	1	Source Hold Down
11	All	All	0515-0377	2	Screw SMM 3.5 10 CWPNTX
12	All	All	08720-00038	1	Source Cover
13	All	All	0515-1400	3	Screw SMM 3.5 8 PCFLTX
14	All	All	08720-20185	1	Source Casting

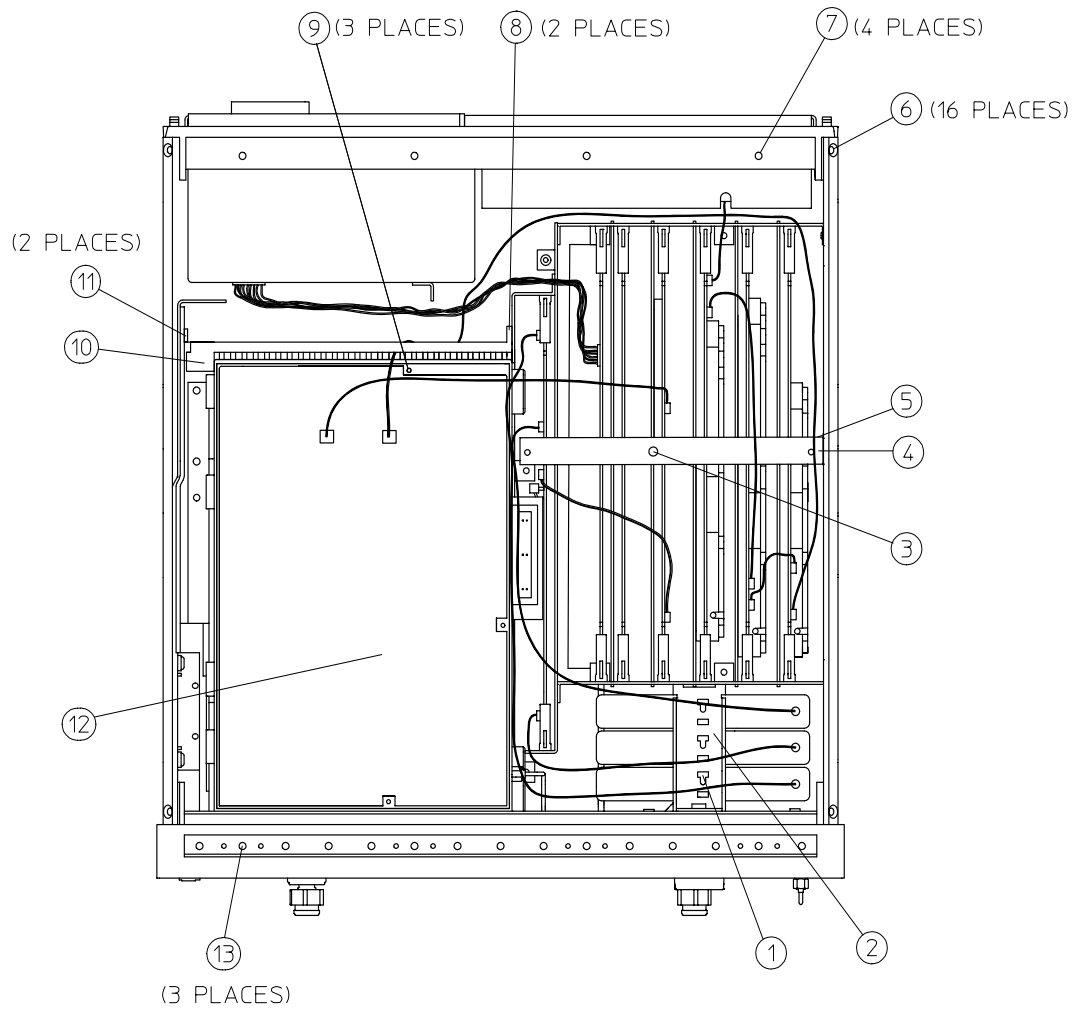

sb6116d

Hardware, Bottom

Ref. Desig.	Models	Options	HP/Agilent Part Number	Qty	Description
1	All	All	0515-0430	1	Screw Smm 3.0 6 Cwpntx
2	All	All	0515-0458	4	Screw Smm 3.5 8 Cwpntx
3	All	All	0515-0430	2	Screw Smm 3.0 6 Pcfltx
4	All	All	0515-2086	6	Screw Smm 4.0 7 Pcfltx
5	All	All	0515-1400	4	Screw Smm 3.5 8 Pcfltx
6	All	All	0515-0433	4	Screw Smm 4.0 8 Cwpntx
6	All	All	3050-0001	4	Washer Fl .172id 8
7	All	All	0515-0375	4	Screw Smm 3.0 6 Cwpntx
8	All	All	0515-0430	4	Screw Smm 3.0 6 Cwpntx
9	All	All	0515-1400	1	Screw Smm 3.5 8 Pcfltx
10	All	All	2200-0105	2	Screw Sm 440 .312 Pcfltx
11	All	All	0515-0375	4	Screw Smm 3.0 16 Cwpntx
12	All	All	0515-0375	2	Screw Smm 3.0 16 Cwpntx
13	All	All	0515-0666	2	Screw Smm 3.0 18 Cwpntx
14	All	All	0515-0665	3	Screw Smm 3.0 14 Cwpntx
15	All	All	0515-0430	2	Screw Smm 3.0 6 Cwpntx
16	All	All	08722-00016	2	Switch Bracket
17	All	All	0515-2194	1	Screw Smm 3.0 50 Cwpntx
18	All	All	0535-0031	1	Nut Hex Smm 3.0
19	All	All	08720-00113	1	Bracket, Attenuator

Illustration of Hardware, Bottom

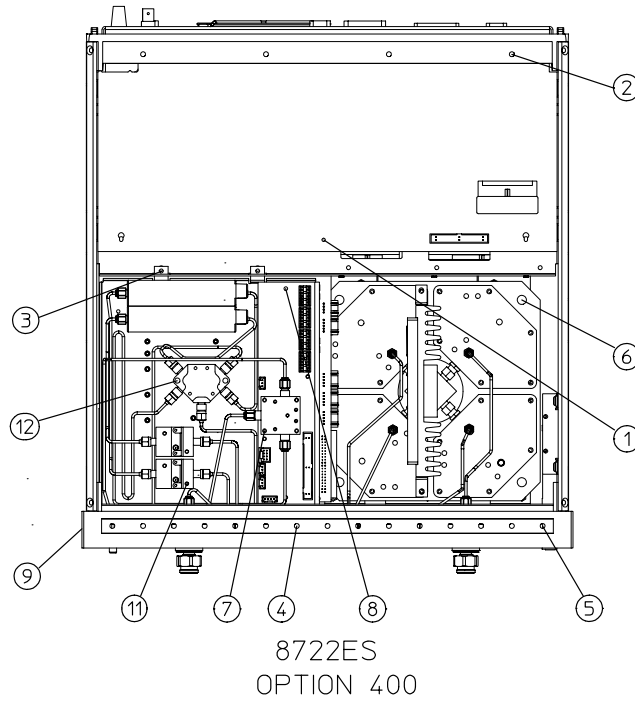
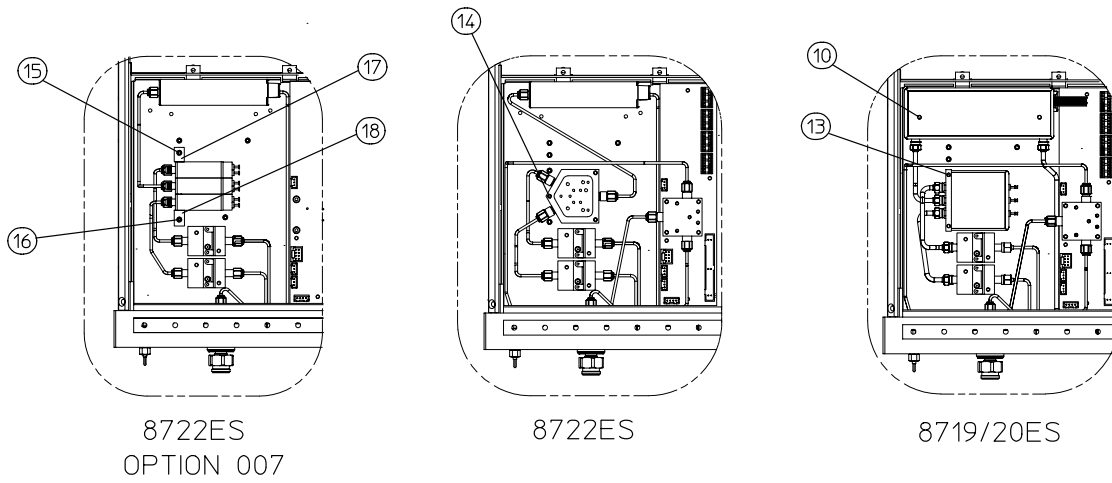

sb599e

Hardware, Front

Ref. Desig.	Agilent Models	Option	HP/Agilent Part Number	Qty	Description
1	All	All	0515-0382	3	Screw SMM 4.0 12 CWPNTX
2	All	All	08753-00152	1	Disk Drive Bracket
2	All	All	0505-1934	4	Screw SMM 2.5 6 CWPNTX
3	All	All	08720-00077	1	Actuator Switch Arm
3	All	All	08753-40015	1	AC Line Button
4	All	All	0515-0430	2	Screw SMM 3.0 6 CWPNTX
5	All	All	0515-2086	6	Screw SMM 4.0 7 PCFLTX
6	All	All	0515-1400	1	Screw Smm 3.5 8 Pcfltx
7	All	All	08720-00093	1	Cable Mounting Bracket
8	All	All	5022-1087	2	Nut-Flange
9	8719ET 8720ET	All	5064-3949	1	Test Port Connector Replacement Kit
9	8722ET	All	5064-3950	1	Test Port Connector Replacement Kit
10	All	All	0515-0430	3	Screw SMM 3.0 6

Illustration Hardware, Front

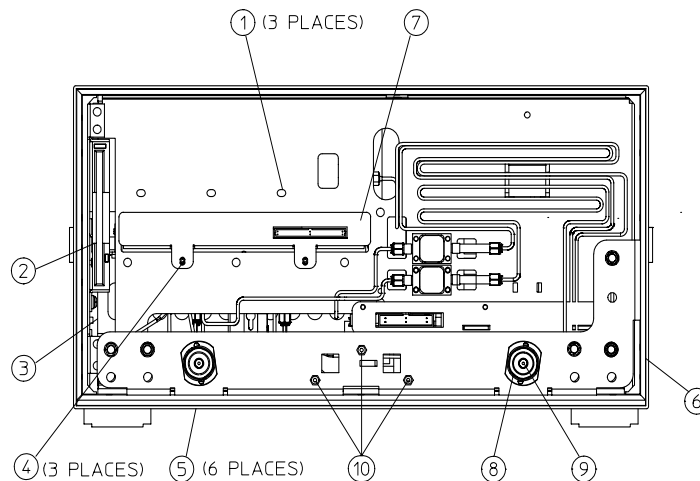

sb6113d

Hardware, Preregulator

Ref. Desig.	Models	Options	HP/Agilent Part Number	Qty	Description
1	All	All	2110-1059	1	FUSE, T 5A 125V, UL LISTED/CSA CERTIFIED TO 248 STANDARD (for 115V operations)
1	All	All	2110-1036	1	FUSE, T 4A H 250V, BUILT TO IEC127-2/5 STANDARD (for 230V operations)
2	All	All	08753-00065	1	Bracket-Preregulator
3	All	All	0515-1400	2	Screw-Machine M3.5x8 CW-FL-TX
A15	All	All	08753-60098	1	Preregulator-Assy
A15	All	All	08753-69098	1	Preregulator-Assy (Rebuilt-Exchange)

Illustration of Hardware, Preregulator

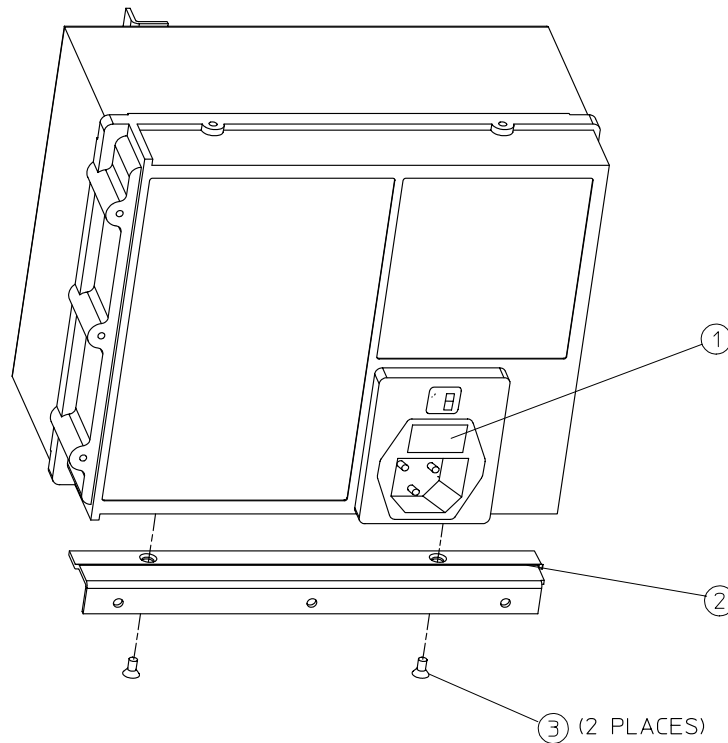

sg691d

Chassis Parts, Outside

Ref. Desig.	Models	Options	HP/Agilent Part Number	Qty	Description
1	All	All	5041-9176	2	Trim Strip
2	All	All	08720-00078	1	Cover-Top
3	All	All	5041-9188	4	Rear Standoff
4	All	All	0515-2318	4	Screw SMM 3.5 8 PCPNTX
5	All	All	5041-9187	2	Rear Cap-Side Strap
6	All	All	0515-1384	4	Screw SMM 5.0 10 PCFLTX
7	All	All	08720-00081	2	Side Strap
8	All	All	08720-00080	2	Cover-Side
9	All	All	5041-9186	2	Front Cap-Side Strap
10	All	All	08720-00079	2	Cover-Bottom
11	All	All	1460-1345	2	Foot Elevator
12	All	All	5041-9167	4	Foot

Illustration of Chassis Parts, Outside

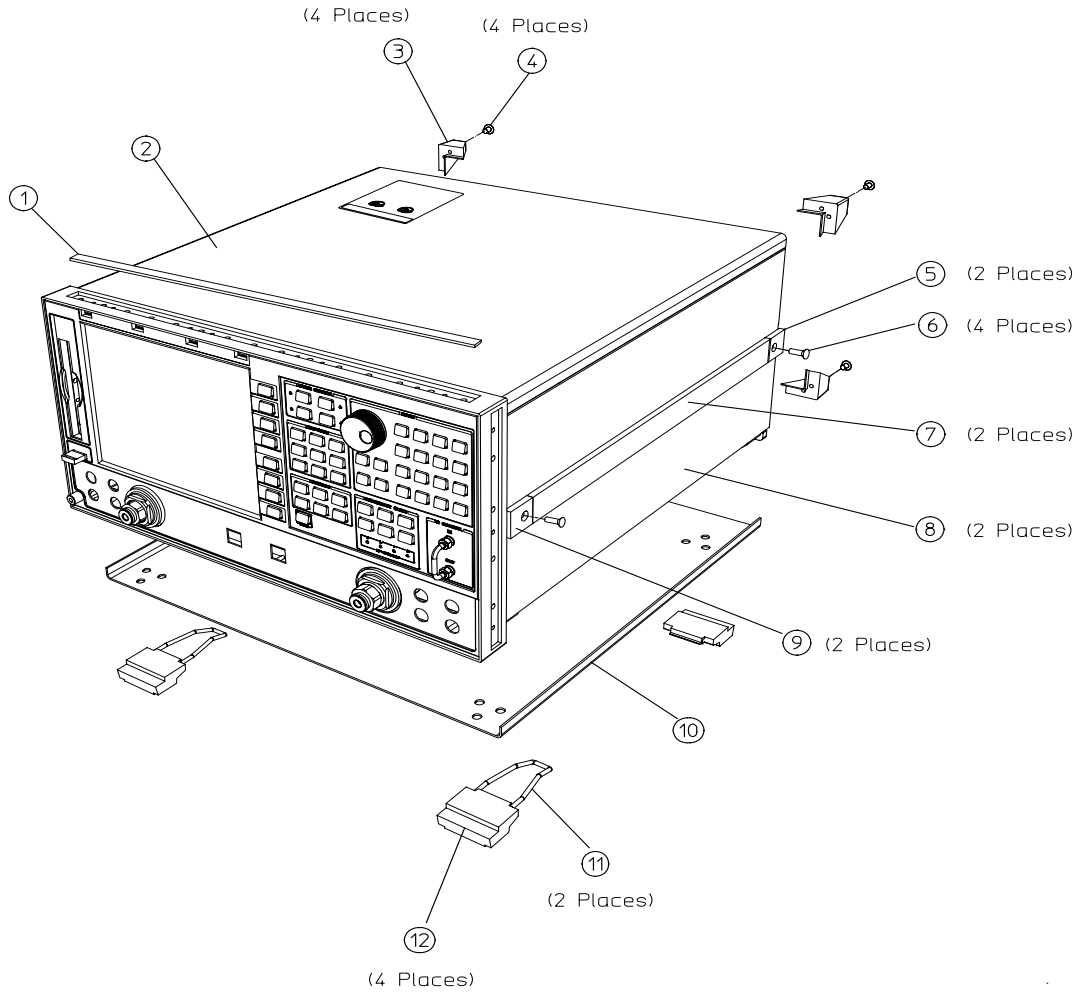

sb56e

Chassis Parts, Inside

Ref. Desig.	Models	Options	HP/Agilent Part Number	Qty	Description
1	All	All	5022-1190	1	Front Panel Frame
2	All	All	0515-0375	1	Screw SMM 3.0 16 CWPNTX
3	All	All	08720-00076	1	Memory Deck
4	All	All	0515-0458	4	Screw SMM 3.5 8 CWPNTX
5	All	All	5021-5808	1	Rear Frame
6	All	All	0515-2086	16	Screw SMM 4.0 7 PCFLTX
7	All	All	08720-20131	4	Side Struts
8	All	All	08720-60116	1	Assy-Chassis
9	All	All	0950-2782	1	Disk Drive
A17	All	All	08720-60264	1	BD Assy-Motherboard

Illustration of Chassis Parts, Inside

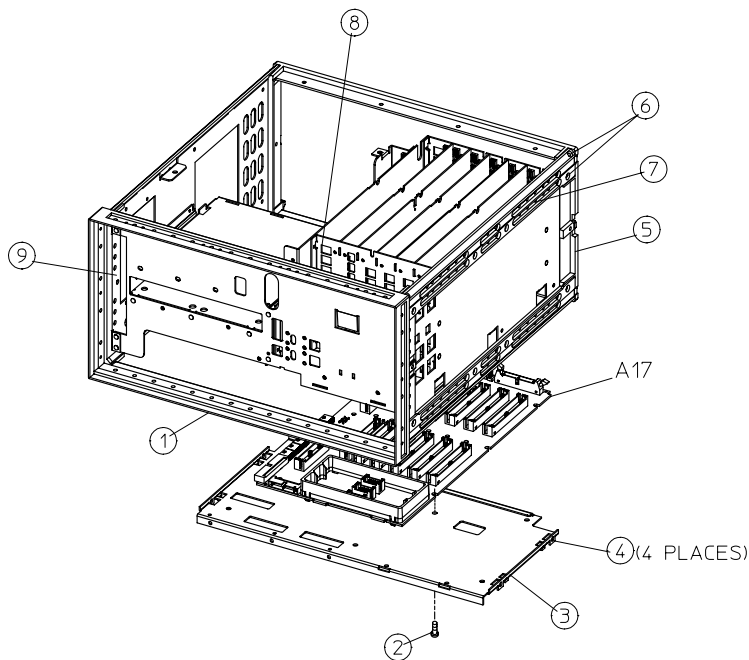

sb6103d

Miscellaneous Part Numbers

Description	HP/Agilent Part Number
Service Tools	
TOOL KIT for All Models -- <i>includes the following:</i>	08722-60018
Adapter 2.4-mm (F) APC 3.5 (F)	11901B
Adapter 2.4-mm (F) APC 3.5 (M)	11901D
Extender Board Assembly-for 2nd Converters	08415-60019
Extender Board Assembly	08753-60155
Source Control Extender Board Assembly	08720-60151
Adapter-SMB (M) TO SMB (M)	1250-0669
Adapter-SMB (M) TO BNC (F)	1250-1237
Adapter-SMA (F) TO SMA (F)	1250-1158
Adapter-SMA (M) TO SMA (M)	1250-1159
SMB Tee	1250-1391
Fuse .5A 125 V	2110-0046
Fuse 1A 125 V	2110-0047
Fuse 2A 125 V	2110-0425
Fuse 4A 125 V	2110-0476
Fuse 3.15A 250 V	2110-0655
Cable Assembly-Extender RF	5061-1022
Cable Assembly-SMA Flex	8120-4396
Wrench-Open Ended 5.5	8710-1770
Bag-antistatic 12.0 X 15.0D	9222-1132
Cable Second Converter/IF	8120-5040
Documentation	
Agilent Technologies 8719ET/ES, 8720ET/ES, 8722ET/ES Manual Set on CD-ROM -- <i>includes all manuals listed in the manual set</i>	08720-90418
8719ET/ES, 8720ET/ES, 8722ET/ES Manual Set -- <i>includes the following manuals:</i>	08720-90390
Installation and Quick Start Guide	08720-90391
User's Guide	08720-90392
Reference Guide	08720-90393
Programmer's Guide	08753-90475
8719ET/ES, 8720ET/ES, 8722ET/ES Service Guide -- <i>includes the following:</i>	08720-90397
8719ET/ES, 8720ET/ES, 8722ET/ES Service Guide on CD-ROM	08720-90419

Description	HP/Agilent Part Number
ES Upgrade Kits¹	
Mechanical Transfer Switch Upgrade Kit	Option 007
Time Domain Capability Upgrade Kit	Option 010
Direct Sampler Access Upgrade Kit	Option 012
High-Power S-parameter Test Set Upgrade Kit	Option 085
Frequency Offset Mode Upgrade Kit	Option 089
Firmware Upgrade Kit	Option 099
High-Stability Frequency Reference Upgrade Kit	Option 1D5
Fourth Sampler And TRL Calibration Firmware Upgrade Kit	Option 400
ET Upgrade Kits²	
Source Attenuator Upgrade Kit	Option 004
Time Domain Capability Upgrade Kit	Option 010
Firmware Upgrade Kit	Option 099
High-Stability Frequency Reference Upgrade Kit	Option 1D5
Protective Caps for Connectors	
Female GPIB Connector	1252-5007
Female Parallel Port	1252-4690
RS-232 Connector	1252-4697
Female 3.5 mm Test Ports	1401-0245
Fuses used on the A8 Post Regulator	
Fuse 2A 125 V Non-Time Delay 0.25×0.27	2110-0425
Fuse 0.75A 125 V Non-Time Delay 0.25×0.27	2110-0424
Fuse 4A 125 V Non-Time Delay 0.25×0.27	2110-0476
Fuse 1A 125 V Non-Time Delay 0.25×0.27	2110-0047
Fuse 0.5A 125 V Non-Time Delay 0.25×0.27	2110-0046
For Line Fuse part numbers, refer to “Hardware, Preregulator” on page 13-83.	

1. Order the model number (8719ESU, 8720ESU, 8722ESU) plus the upgrade option designation.
2. Order the model number (8719ETU, 8720ETU, 8722ETU) plus the upgrade option designation.

Description	HP/Agilent Part Number
GPIB Cables	
GPIB Cable, 1M (3.3 FT)	10833A
GPIB Cable, 2M (6.6 FT)	10833B
GPIB Cable, 4M (13.2 FT)	10833C
GPIB Cable, 0.5M (1.6 FT)	10833D
Touch-up Paint	
Dove Gray <i>for use on frame around front panel and painted portion of handles</i>	6010-1146
French Gray <i>for use on side, top, and bottom covers</i>	6010-1147
Parchment White <i>for use on rack mount flanges, rack support flanges, and front panels</i>	6010-1148
ESD Supplies	
Adjustable Antistatic Wrist Strap	9300-1367
5 Ft. Grounding Cord <i>for wrist strap</i>	9300-0980
2 × 4 Ft. Antistatic Table Mat With 15 Ft. Ground Wire	9300-0797
Antistatic Heel Strap <i>for use on conductive floors</i>	9300-1126
Keyboard Overlay and Rack Mount Parts	
Keyboard Overlay <i>for external keyboard</i>	08753-80131
System Rack Kit, Also Order The Following:	85043D
Filler Panel-7 Inch	40104A
Rack Mount Flange Kit, <i>for instruments with handles</i>	5063-9223
Rack Mount Flange Kit, <i>includes instrument handles</i>	5063-9236
Rack Mount Flange Kit, <i>instrument handles not included</i>	5063-9216
Front Handle	5063-9229

14 Assembly Replacement and Post-Repair Procedures

Information on This Chapter

This chapter contains procedures for removing and replacing the major assemblies of the Agilent 8719ET/ES, Agilent 8720ET/ES, and Agilent 8722ET/ES network analyzers. A table showing the corresponding post-repair procedures for each replaced assembly is located in [“Post-Repair Procedures” on page 14-35](#).

Assembly Replacement Sequence

The following steps show the sequence to replace an assembly in the network analyzer.

- Step 1.** Identify the faulty group. Begin with [Chapter 4 , “Start Troubleshooting Here.”](#) Follow up with the appropriate troubleshooting chapter that identifies the faulty assembly.
- Step 2.** Order a replacement assembly. Refer to [Chapter 13 , “Replaceable Parts.”](#)
- Step 3.** Replace the faulty assembly and determine what adjustments are necessary. Refer to this chapter.
- Step 4.** Perform the necessary adjustments. Refer to [Chapter 3 , “Adjustments and Correction Constants.”](#)
- Step 5.** Perform the necessary performance tests. Refer to [Chapter 2 , “System Verification and Performance Tests.”](#)

WARNING **These servicing instructions are for use by qualified personnel only. To avoid electrical shock, do not perform any servicing unless you are qualified to do so.**

WARNING **The opening of covers or removal of parts is likely to expose dangerous voltages. Disconnect the instrument from all voltage sources while it is being opened.**

WARNING **The power cord is connected to internal capacitors that may remain live for 10 seconds after disconnecting the plug from its power supply.**

CAUTION Many of the assemblies in this instrument are very susceptible to damage from ESD (electrostatic discharge). Perform the following procedures only at a static-safe workstation and wear a grounding strap.

Procedures in This Chapter

The following sections describe the assembly replacement procedures for the 8719ET/ES, 8720ET/ES, and 8722ET/ES assemblies:

- [Replacing the Line Fuse, on page 14-5](#)
- [Removing the Covers, on page 14-6](#)
- [Removing the Front Panel Assembly, on page 14-8](#)
- [Removing the Front Panel Interface and Keypad Assemblies, on page 14-10](#)
- [Removing the Display Lamp and Assembly, on page 14-12](#)
- [Removing the Rear Panel Assembly, on page 14-14](#)
- [Removing the Rear Panel Interface Board Assembly, on page 14-16](#)
- [Removing the Source Assemblies, on page 14-18](#)
 - [M/A/D/S \(A58\)](#)
 - [YIG 1 \(A54\)](#)
 - [YIG 2 \(A55\)](#)
 - [Cavity Oscillator \(A57\)](#)
- [Removing the A7 CPU Board Assembly, on page 14-20](#)
- [Removing the A7BT1 Battery, on page 14-22](#)
- [Removing the A15 Preregulator Assembly, on page 14-24](#)
- [Removing the A19 Graphics Processor Assembly, on page 14-26](#)
- [Removing the A3 Disk Drive Assembly, on page 14-28](#)
- [Removing the A62, A63 Test Port Couplers and LED Board Assemblies, on page 14-30](#)
- [Removing the A26 High Stability Frequency Reference \(Option 1D5\) Assembly, on page 14-32](#)
- [Removing the B1 Fan Assembly, on page 14-34](#)

NOTE After replacing the assemblies, perform the corresponding adjustment and verification tests located in [“Post-Repair Procedures” on page 14-35](#).

Replacing the Line Fuse

Tools Required

- small slot screwdriver

Removal

WARNING For continued protection against fire hazard, replace line fuse only with same type and rating (115 V operation: T 5A 125V UL/CSA; 230V operation: T 4A H 250V IEC). The use of other fuses or materials is prohibited.

1. Disconnect the power cord.
2. Use a small slot screwdriver to pry open the fuse holder.
3. Replace the failed fuse with one of the correct rating for the line voltage. See [“Hardware, Preregulator” on page 13-83](#) to find the part number.

Replacement

1. Replace the fuse holder.

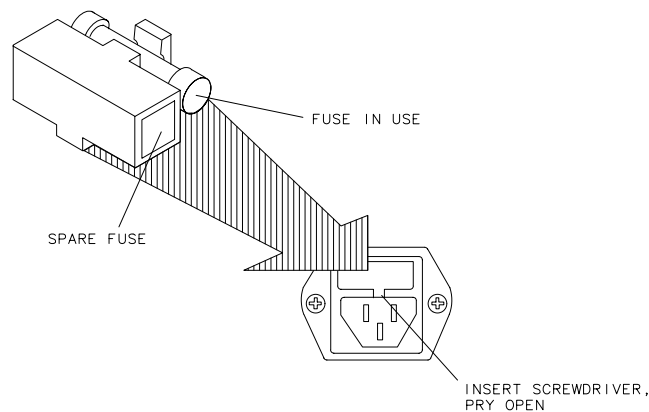

qq652d

Removing the Covers

Tools Required

- T-10 TORX screwdriver
- T-15 TORX screwdriver
- T-20 TORX screwdriver

Removing the top cover

1. Remove both upper rear feet (item 1) by loosening the attaching screws (item 2).
2. Loosen the top cover screw (item 3).
3. Slide cover off.

Removing the side covers

1. Remove the top cover.
2. Remove the lower rear foot (item 4) that corresponds to the side cover you want to remove by loosening the attaching screw (item 5).
3. Remove the handle assembly (item 6) by loosening the attaching screws (item 7).
4. Slide cover off.

Removing the bottom cover

1. Remove both lower rear feet (item 4) by loosening the attaching screws (item 5).
2. Loosen the bottom cover screw (item 8).
3. Slide cover off.

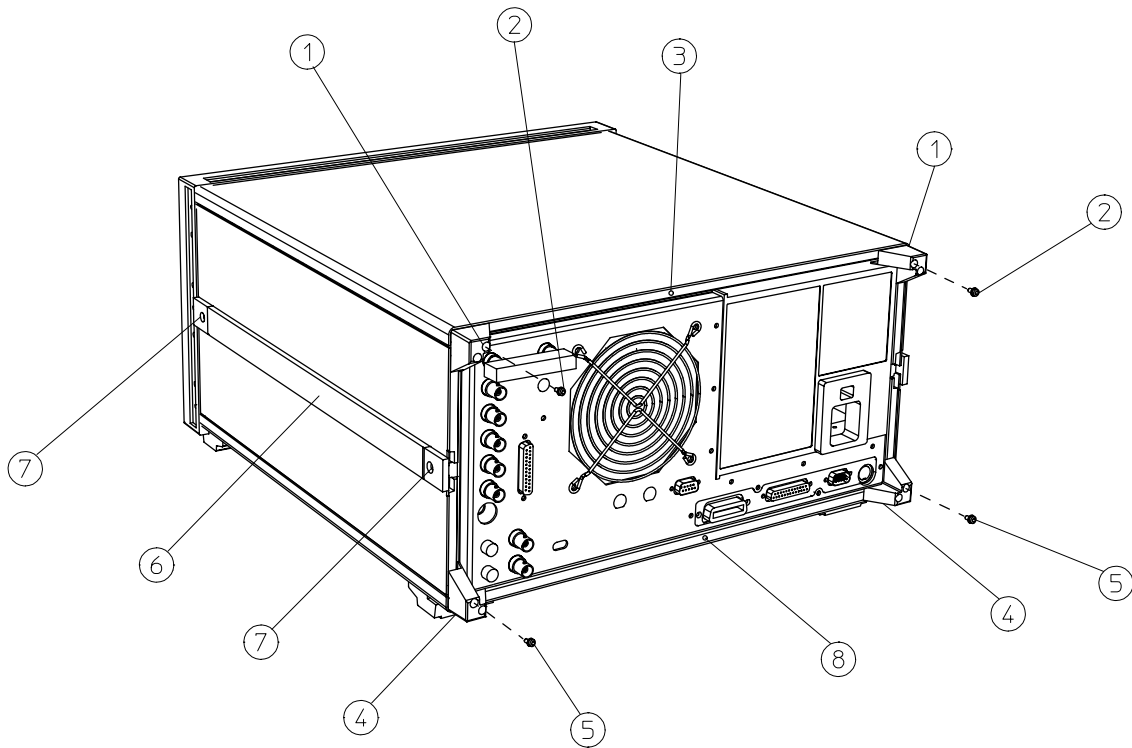

sb686d

Removing the Front Panel Assembly

Tools Required

- T-10 TORX screwdriver
- T-15 TORX screwdriver
- small slot screwdriver
- ESD (electrostatic discharge) grounding wrist strap
- 5/16-inch open-end torque wrench (set to 10 in-lb)

Removal

1. Disconnect the power cord.
2. Remove the front bottom feet (item 1).
3. Remove all the RF cables that are attached to the front panel (item 2).

NOTE Options may differ from figure and have more than one RF cable on the front panel.

4. Remove the Line button (item 3).
5. Remove the trim strips (item 4) from the top edge of the front frame by prying under the strip with a small slot screwdriver.
6. Remove the 7 screws (item 5) from the top and bottom edges of the frame.
 - a. Remove all 4 flathead screws from the top and the 3 flathead screws from the bottom.

NOTE The 3 bottom screws are on both ends and in the middle. They look like the screws from the top. Do not remove the other 6 screws from the bottom.

7. Slide the front panel over the test port connectors.
8. Disconnect the ribbon cables (item 6) and (item 7). The front panel is now free from the instrument.

Replacement

1. Reverse the order of the removal procedure.

NOTE When reconnecting semirigid cables, torque them to 10 in-lb.

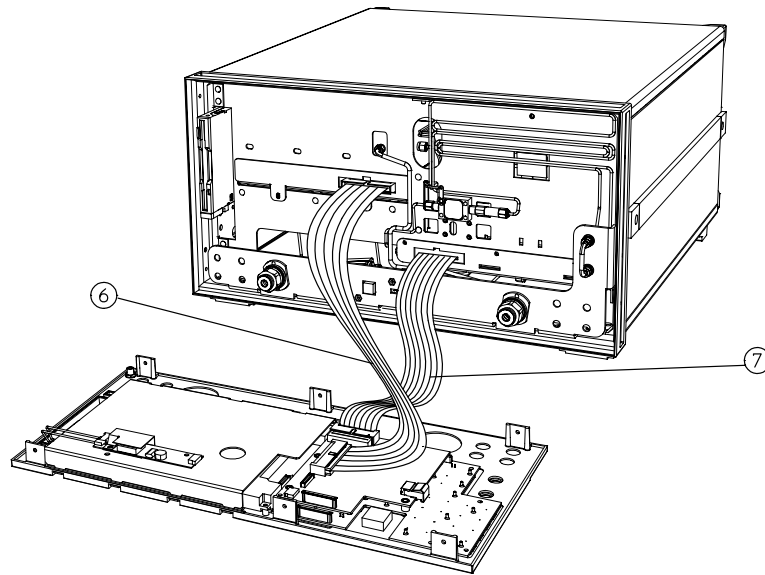
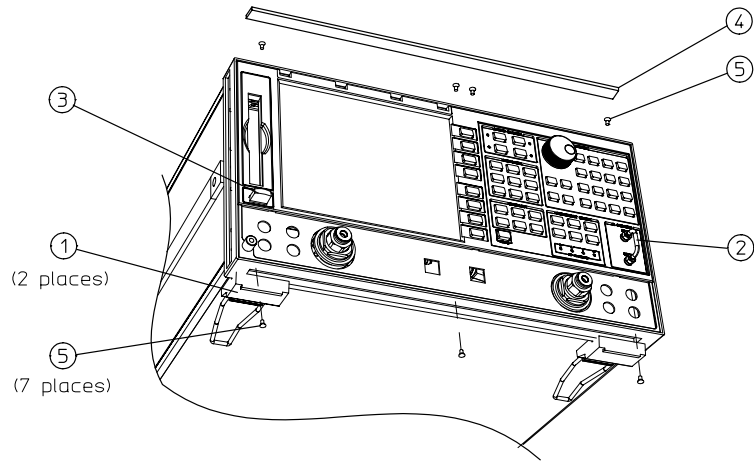

sb55e

Removing the Front Panel Interface and Keypad Assemblies

Tools Required

- T-10 TORX screwdriver
- T-15 TORX screwdriver
- small slot screwdriver
- ESD (electrostatic discharge) grounding wrist strap
- 5/16-inch open-end torque wrench (set to 10 in-lb)

Removal

1. Remove the front panel assembly from the analyzer, refer to [“Removing the Front Panel Assembly” on page 14-8](#).
2. Remove the 4 ribbon cables (item 1 through 4) from the front panel interface board.
3. Remove the 4 screws (item 5), that attach the interface board.

NOTE If the front panel interface board is to be replaced, install the new board at this point and reverse steps 1 through 3 to complete the process.

4. Remove the 7 screws (item 6) from the A1 keypad board.
5. Remove the 3 screws (item 7) from the display cover.
6. Lift the display assembly slightly and slide out the A1 keypad board.

Replacement

1. Reverse the order of the removal procedure.

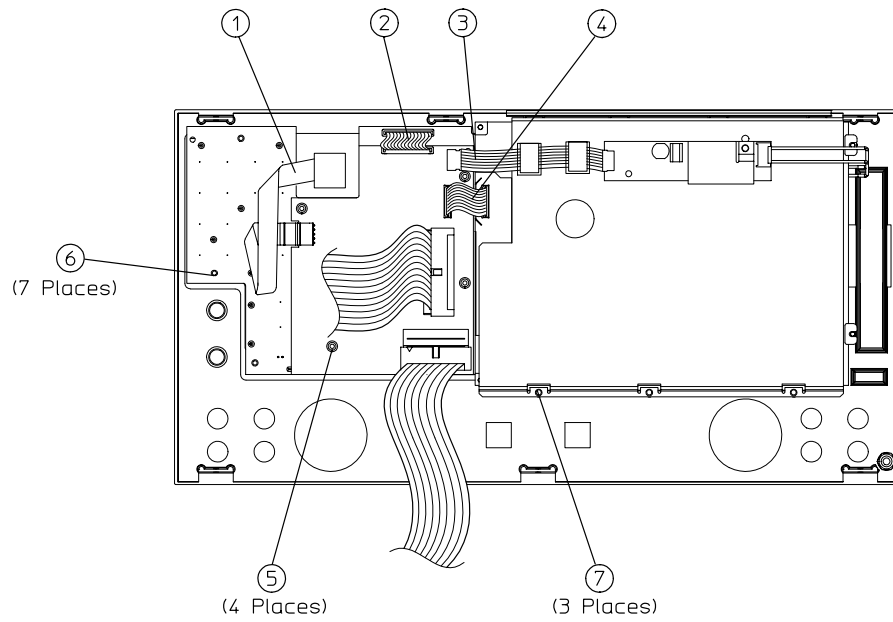

sb598e

Removing the Display Lamp and Assembly

Tools Required

- T-10 TORX screwdriver
- T-15 TORX screwdriver
- small slot screwdriver
- ESD (electrostatic discharge) grounding wrist strap
- 5/16-inch open-end torque wrench (set to 10 in-lb)

Removal

1. Remove the front panel assembly (A1), refer to [“Removing the Front Panel Assembly” on page 14-8](#).
2. Remove the 2 ribbon cables between:
 - (Item 1) the inverter assembly (A20) and the front panel interface board (A2)
 - (Item 2) the inverter assembly (A20) and the display assembly (A18)
3. Remove the 3 screws (item 3) that attach the display cover to the front panel.
4. Lift the display from the front panel and remove the 2 screws (item 4) from the outside of the display.
5. Pull the lamp (item 5) out with a curving side motion, as shown.

Replacement

1. Reverse the order of the removal procedure.

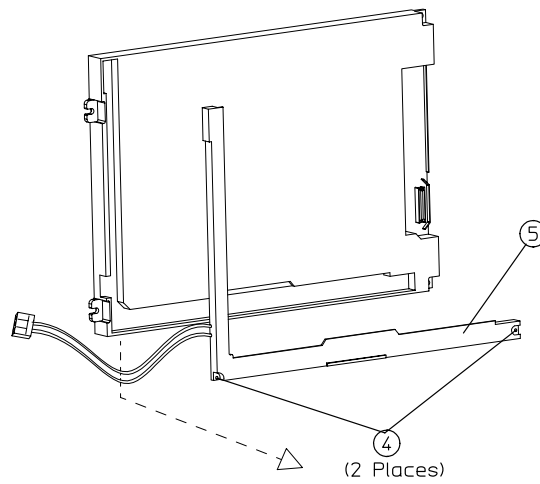
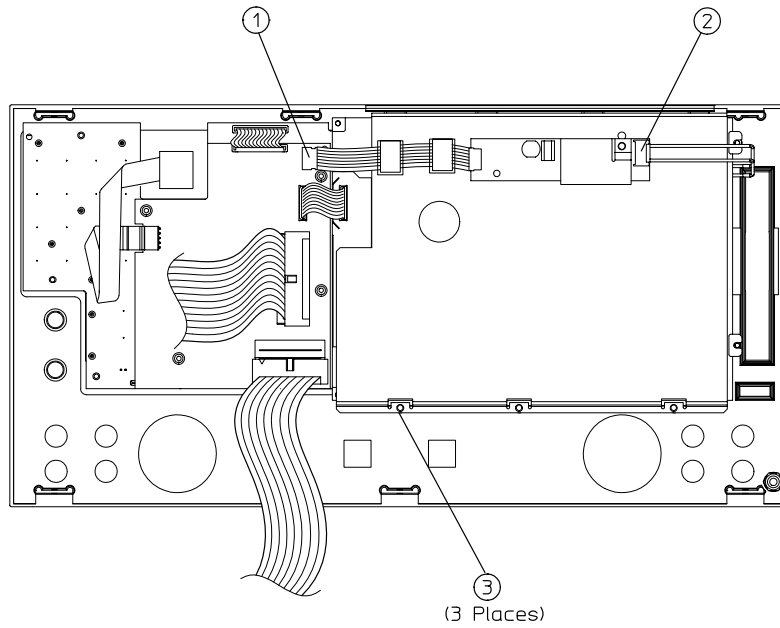

sb597e

Removing the Rear Panel Assembly

Tools Required

- T-10 TORX screwdriver
- T-15 TORX screwdriver
- ESD (electrostatic discharge) grounding wrist strap

Removal

1. Disconnect the power cord and remove the top (item 1) and bottom covers, refer to [“Removing the Covers” on page 14-6](#).
2. Remove the 4 rear standoffs (item 2).
3. If the analyzer has Option 1D5, remove the BNC jumper from the high stability frequency reference (item 3).
4. If the analyzer has Option 085, remove the RF cable (item 4) and the connectors' attaching hardware (item 5).
5. Remove the hardware (item 6) that attaches the RS-232 connector to the rear panel.
6. Remove the 4 screws (item 7) that attach the interface bracket to the rear panel.
7. Remove the 6 screws (item 8 and item 9) that attach the preregulator to the rear panel.
8. Remove the 8 screws (item 10) from the rear frame: 4 from the top edge and 4 from the bottom edge.
9. Remove the screw from the pc board stabilizer and remove the stabilizer.
10. Lift the reference board (A12) from its motherboard connector and disconnect the flexible RF cable (item 11).
11. Pull the rear panel away from the frame. Disconnect the ribbon cable (item 12) from the motherboard connector, pressing down and out on the connector locks. Disconnect the wiring harness (item 13) from the motherboard.

Replacement

1. Reverse the order of the removal procedure.

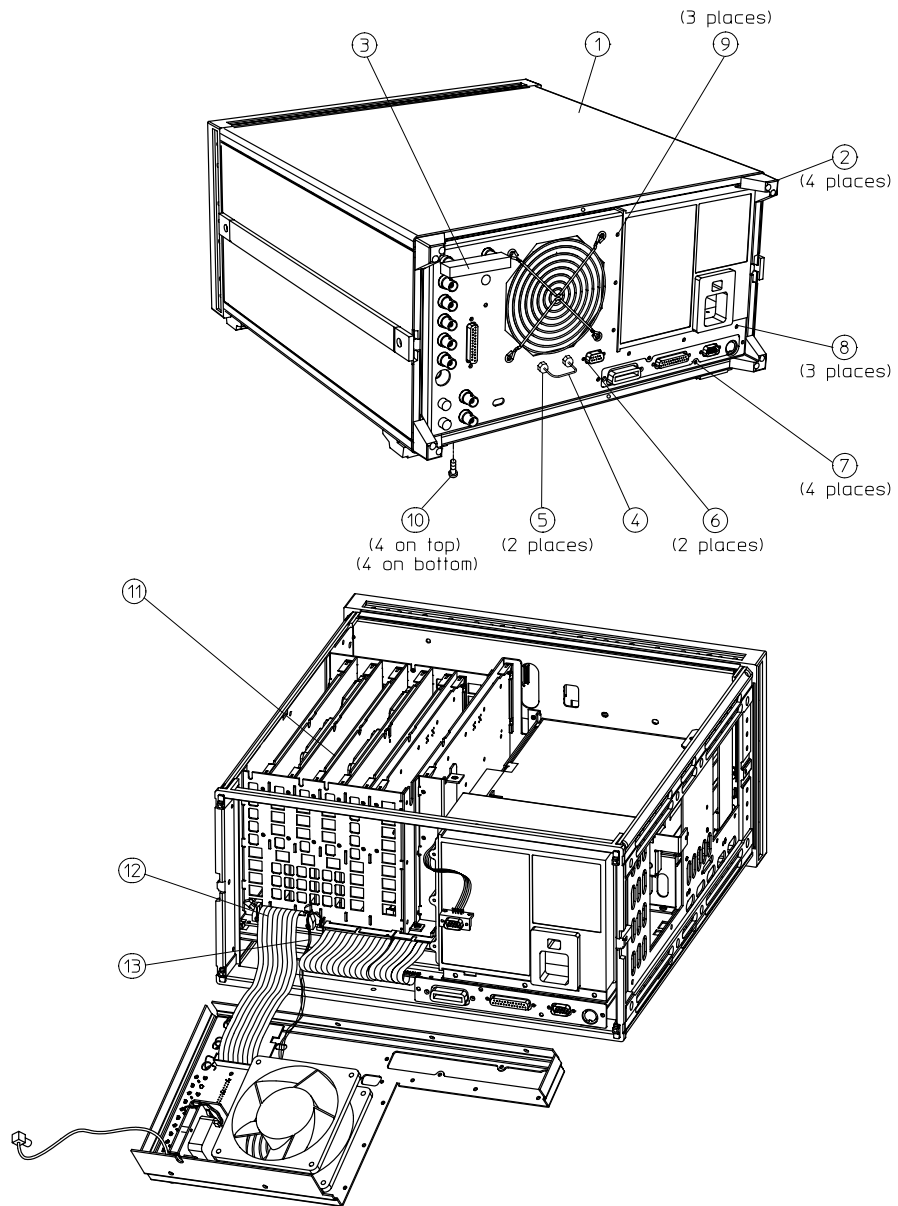

sb694d

Removing the Rear Panel Interface Board Assembly

Tools Required

- T-10 TORX screwdriver
- T-15 TORX screwdriver
- ESD (electrostatic discharge) grounding wrist strap

Removal

1. Disconnect the power cord and remove the top and bottom covers; refer to [“Removing the Covers” on page 14-6](#).
2. If the analyzer has Option 1D5, remove the high-stability frequency reference jumper (item 1).
3. Remove the hardware that attaches the 9 BNC connectors to the rear panel (item 2).
4. Remove the hardware that attaches the test set I/O interconnect to the rear panel (item 3).
5. Remove the rear panel from the analyzer (refer to [“Removing the Rear Panel Assembly” on page 14-14](#)).
6. If the analyzer has option 1D5, disconnect the cable (item 4) from the rear panel interface board.
7. Disconnect the ribbon cable (item 5) from the rear panel interface board.
8. Disconnect the wiring for the 3 BNC connectors and remove the attaching hardware (item 6).
9. Remove the MEAS RESTART connector from the interface board, approaching it from the outside of the rear panel assembly (item 7).

Replacement

1. Reverse the order of the removal procedure.

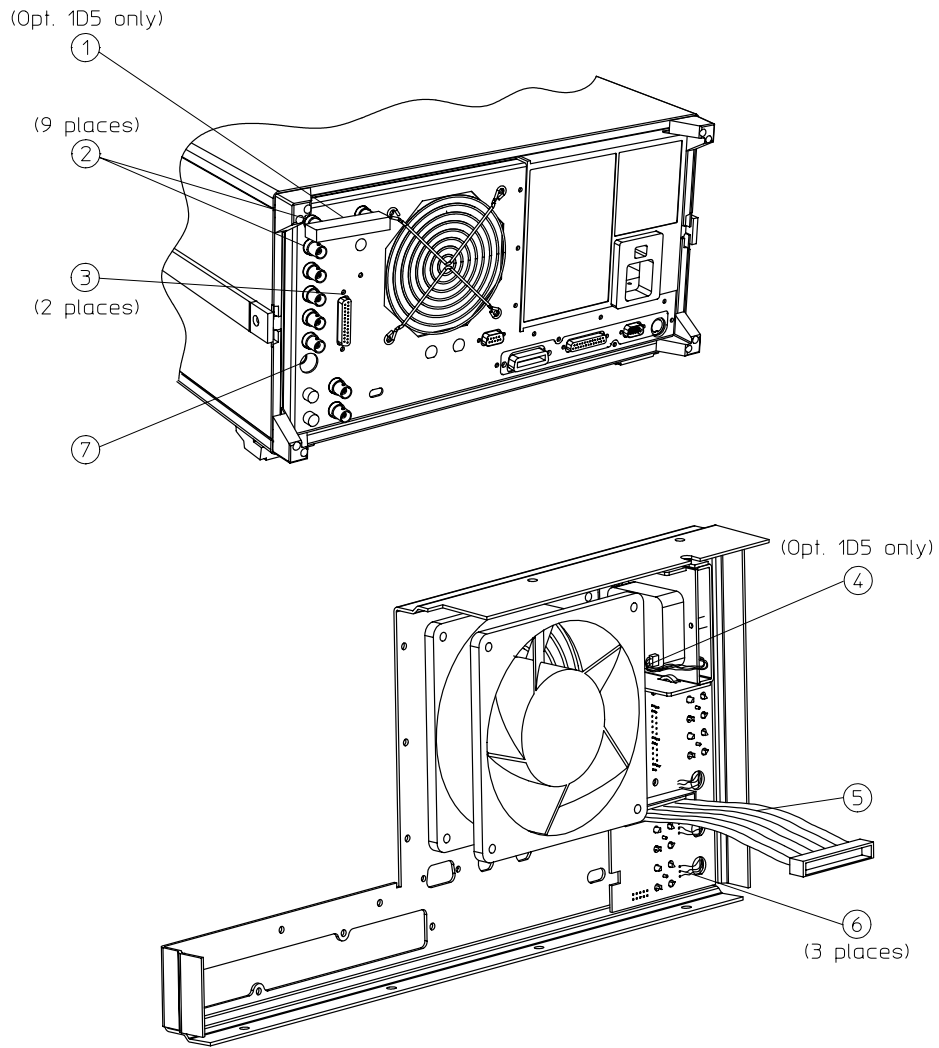

sb679d

Removing the Source Assemblies

Tools Required

- T-15 TORX screwdriver
- 5/16-inch open-end torque wrench (set to 10 in-lb)
- ESD (electrostatic discharge) grounding wrist strap

Start Removal

1. Disconnect the power cord and remove the top cover; refer to [“Removing the Covers” on page 14-6](#).
2. Remove the front panel (refer to [“Removing the Rear Panel Assembly” on page 14-14](#)).
3. Remove the source module cover.

A58 M/A/D/S Removal

4. Disconnect the cables (item 1) and (item 2 for all but Option 400) from the M/A/D/S.
5. Remove the 4 screws (item 3) from each corner of the assembly.

Oscillator Removal

6. Remove the 3 screws (item 4) that attach the source module to the analyzer.
7. Disconnect the cables (item 1) and (item 2 for all but Option 400) from the M/A/D/S.
8. Remove the 4 screws (item 5) and (item 6) from the source module bracket. Remove the bracket.
9. Lift the source module out of the analyzer.
10. Remove a screw (item 7) from the back of the oscillator.
11. Disconnect attaching RF cables.

A59 Source Interface Board Removal

12. Remove the 3 screws (item 4) that attach the source module to the analyzer.
13. Disconnect the cables (item 2) and (item 3 for all but Option 400) from the M/A/D/S.
14. Remove the 4 screws (item 4) and (item 5) from the source module bracket. Remove the bracket.
15. Lift the source module out of the analyzer.
16. Remove 3 screws to detach the bottom source module cover.
17. Remove 4 screws that attach the source control board to the source module frame.
18. Place one hand on the top of the A59 board, with your thumb near the A58 M/A/D/S, to push the board. Place your other hand on the bottom side of the A59, with your thumb and index finger put through the drilled holes, to pull the board.

Replacement

1. Reverse the order of the removal procedure.

NOTE When replacing the A59 source interface board, push the board evenly on all the microcircuit pins.

Check all the pin sockets from the back of the A59 board to ensure that all of the pins are inserted. For the 8722ET/ES models, you may need an eye glass to inspect the shallow pins of the S1 high band switch.

When replacing the source module into the analyzer, push the cables aside before seating the module.

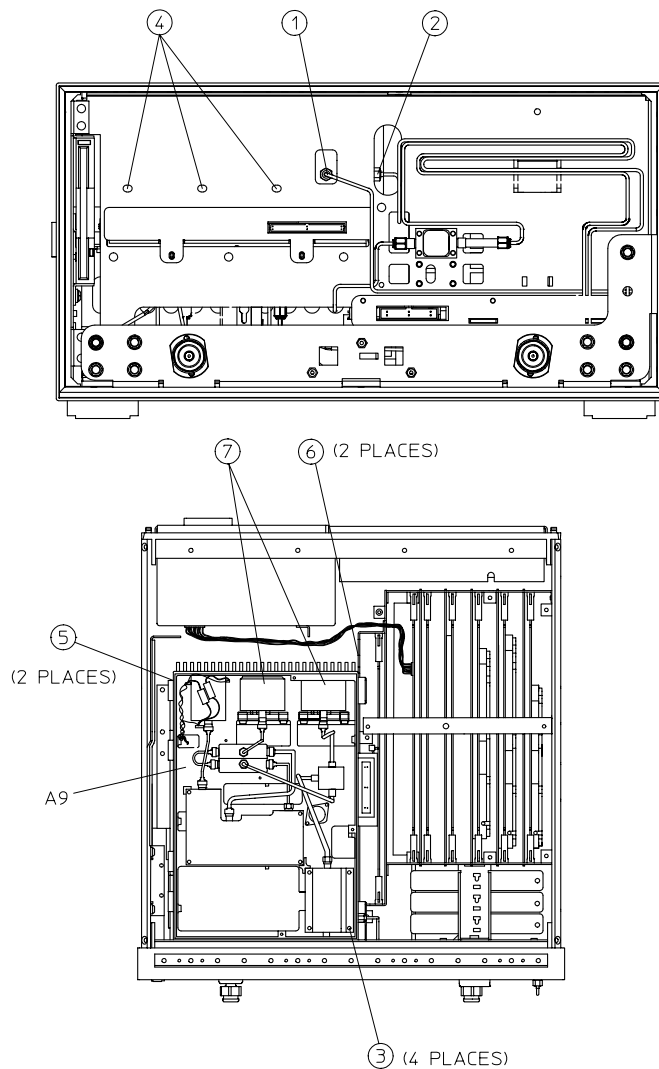

sb6134d

Removing the A7 CPU Board Assembly

Tools Required

- T-10 TORX screwdriver
- ESD (electrostatic discharge) grounding wrist strap

Removal

1. Disconnect the power cord.
2. Remove the 4 bottom feet and bottom cover; refer to [“Removing the Covers” on page 14-6](#).
3. Remove the 4 screws (item 1) on the rear panel.
4. Turn the analyzer over and remove the screw (item 2) that secures the CPU board to the deck.
5. Disconnect the ribbon cable (item 3).
6. Disconnect the ribbon cable (item 4) from the CPU board.
7. Slide the board towards the front of the instrument so that it disconnects from the 3 standoffs (item 5).
8. Disconnect the ribbon attached at the rear of the CPU board.
9. Lift the board off of the standoffs.

Replacement

1. Reverse the order of the removal procedure.

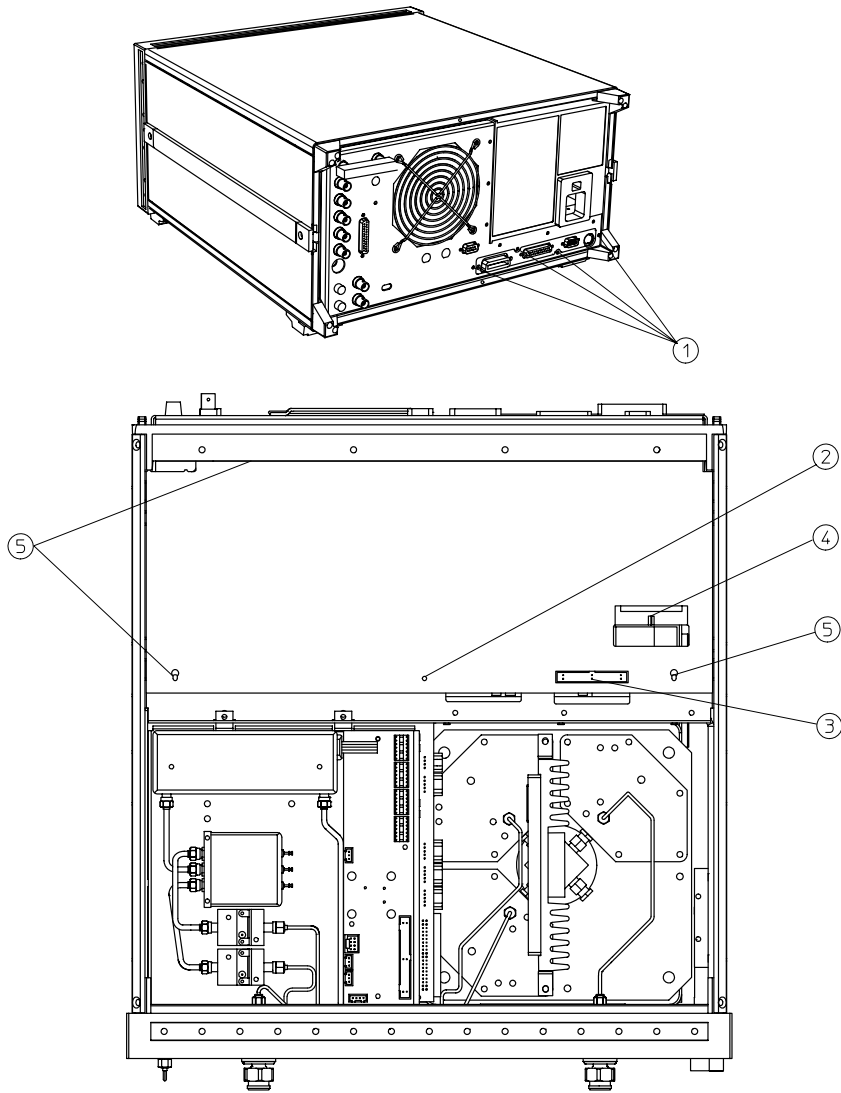

sb6108d

Removing the A7BT1 Battery

Tools Required

- T-10 TORX screwdriver
- ESD (electrostatic discharge) grounding wrist strap
- soldering iron with associated soldering tools

Removal

1. Remove the A7 CPU board; refer to [“Removing the A7 CPU Board Assembly” on page 14-20](#).
2. Unsolder and remove A7BT1 from the A7 CPU board.

WARNING **Battery A7BT1 contains lithium. The battery may explode if it is incorrectly replaced. Do not incinerate or puncture this battery. Either dispose of the discharged battery, according to manufacturer’s instructions, or collect as small chemical waste.**

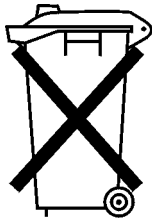

DO NOT THROW BATTERIES AWAY BUT
COLLECT AS SMALL CHEMICAL WASTE.

sk780a

Replacement

1. Make sure the new battery is inserted into the A7 board with the correct polarity.
2. Solder the battery into place.
3. Replace the A7 CPU board; refer to [“Removing the A7 CPU Board Assembly” on page 14-20](#).

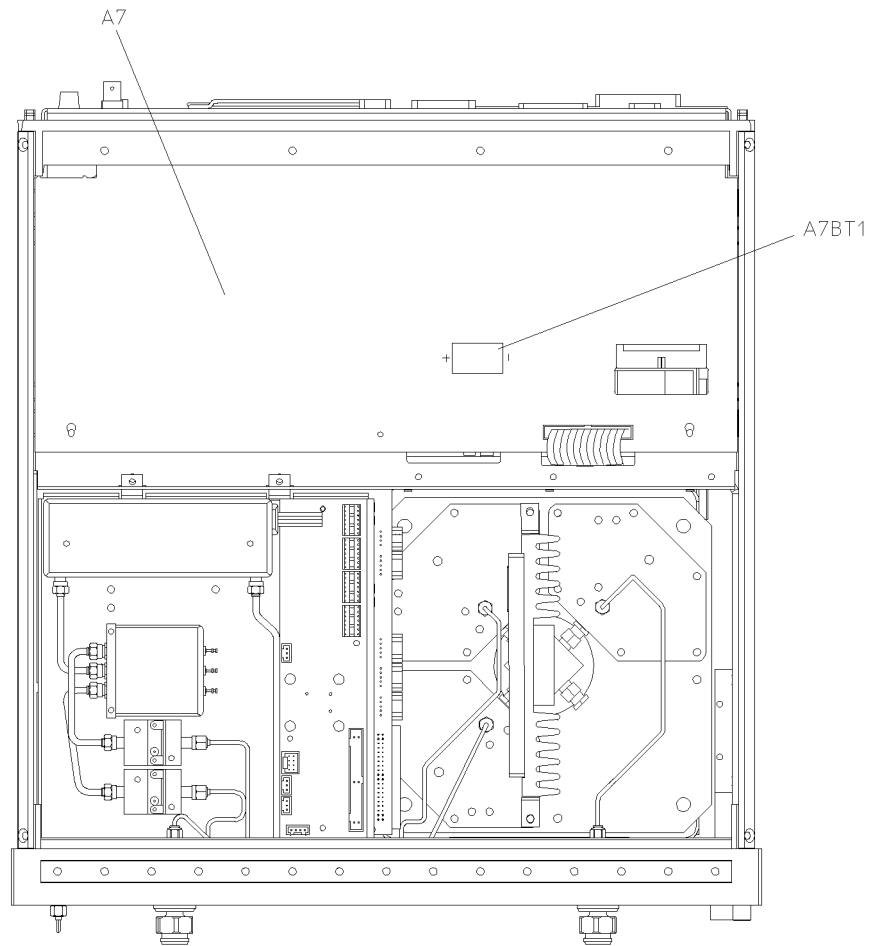

sb595e

Removing the A15 Preregulator Assembly

Tools Required

- T-10 TORX screwdriver
- T-15 TORX screwdriver
- ESD (electrostatic discharge) grounding wrist strap

Removal

1. Remove the rear panel; refer to [“Removing the Rear Panel Assembly”](#) on page 14-14.
2. Disconnect the wire bundles (item 1) (item 2) from the analyzer.
3. Remove the preregulator (A15) from the frame.

Replacement

1. Reverse the order of the removal procedure.

NOTE

- When reinstalling the preregulator (A15), make sure the 3 grommets on the wiring bundles are seated in the slots on the back side of the preregulator and also in the slot in the card cage wall.
 - After reinstalling the preregulator (A15), be sure to set the line voltage selector to the appropriate setting, 115 V or 230 V.
-

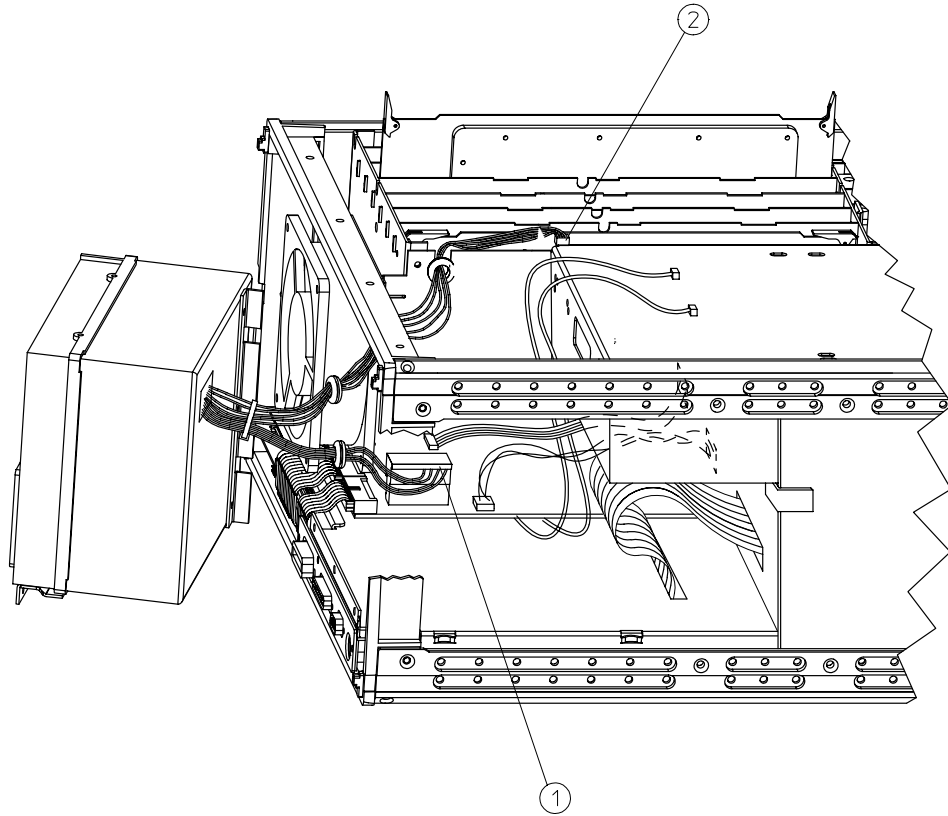

sb652d

Removing the A19 Graphics Processor Assembly

Tools Required

- T-10 TORX screwdriver
- T-15 TORX screwdriver
- ESD (electrostatic discharge) grounding wrist strap

Removal

1. Disconnect the power cord and remove the front panel; refer to [“Removing the Front Panel Assembly” on page 14-8](#).
2. Disconnect the 2 ribbon cables (item 1) and (item 2).
3. Remove the 2 screws (item 3) that attach the GSP to the front of the analyzer.
4. Pull the GSP (A19) board (item 4) out of the analyzer.

Replacement

1. Reverse the order of the removal procedure.

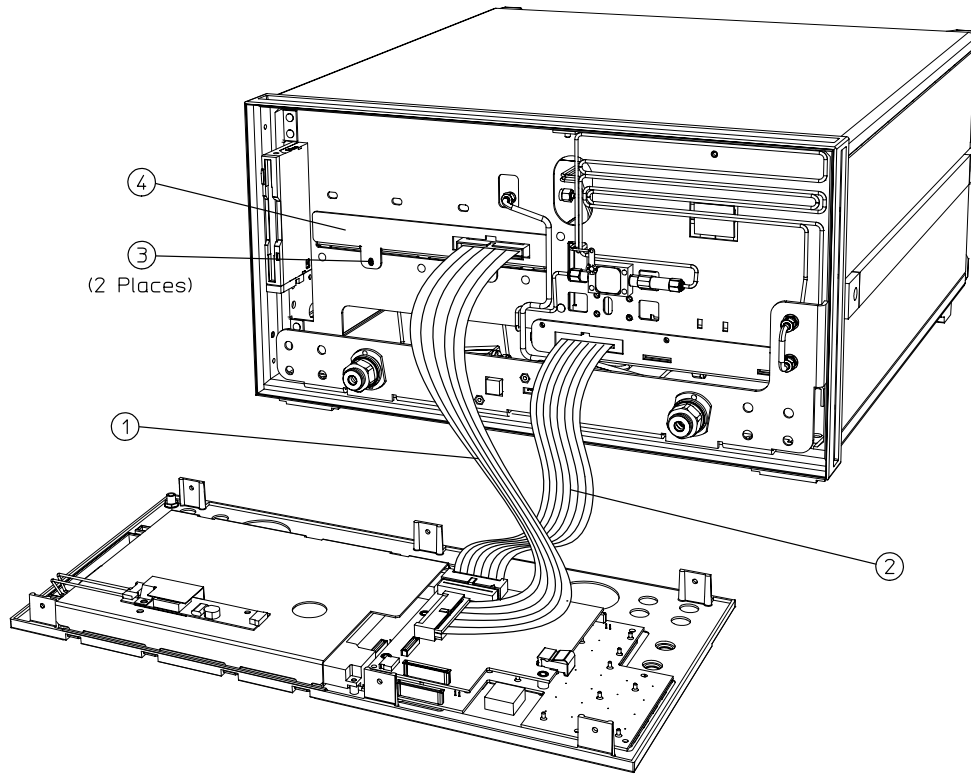

sb596e

Removing the A3 Disk Drive Assembly

Tools Required

- T-8 TORX screwdriver
- T-10 TORX screwdriver
- T-15 TORX screwdriver
- small slot screwdriver
- ESD (electrostatic discharge) grounding wrist strap

Removal

1. Disconnect the power cord and remove the bottom and left side covers, refer to [“Removing the Covers” on page 14-6](#).
2. Remove the front panel; refer to [“Removing the Front Panel Assembly” on page 14-8](#).
3. Turn the instrument upside-down and disconnect the ribbon cable (item 1) from the CPU board.
4. Remove the 4 screws (item 2) that secure the disk drive bracket to the side of the frame.
5. Slide the disk drive out of the instrument.
6. Remove the 4 screws (item 3) that secure the disk drive to the bracket.

Replacement

1. Reverse the order of the removal procedure.

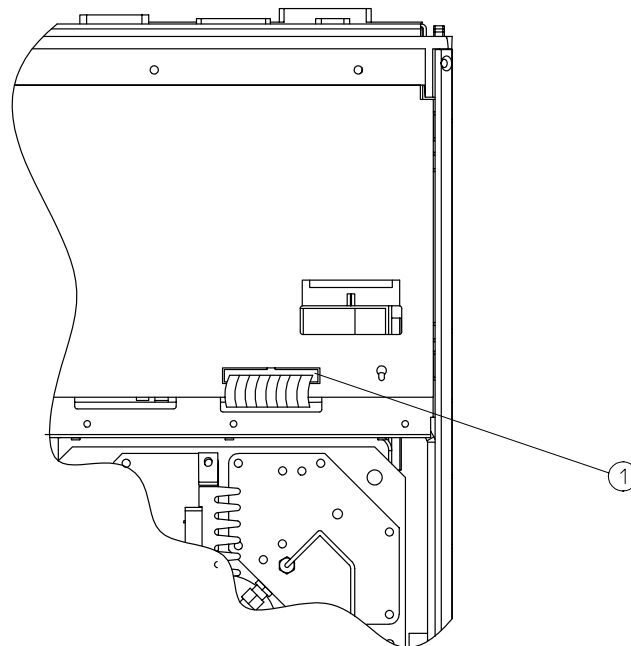
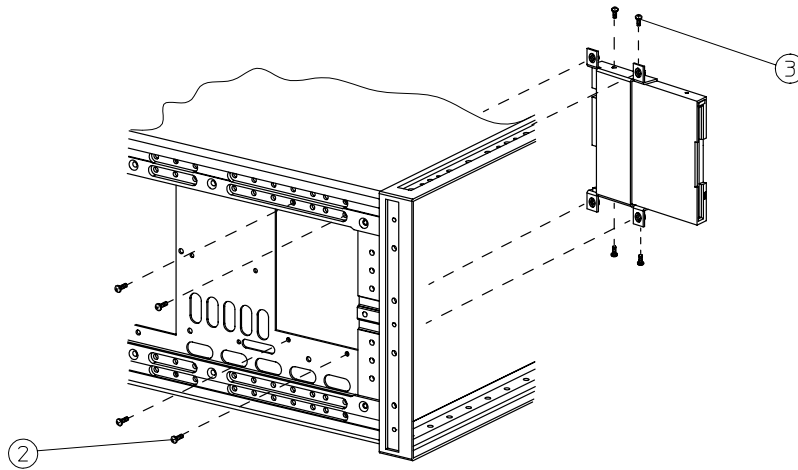

sb659d

Removing the A62, A63 Test Port Couplers and LED Board Assemblies

Tools Required

- T-10 TORX screwdriver
- T-15 TORX screwdriver
- small slot screwdriver
- ESD (electrostatic discharge) grounding wrist strap
- 5/16-inch open-end torque wrench (set to 10 in-lb)

Removal

1. Remove the bottom cover; refer to [“Removing the Covers” on page 14-6](#).
2. Remove the front panel; refer to [“Removing the Front Panel Assembly” on page 14-8](#).
3. Reaching the connections from the bottom of the analyzer, disconnect the 4 RF cables attached to the couplers: 2 from the back of the couplers and 2 from between the couplers.
4. Remove the 6 screws (item 1) from the bottom edge of the front panel frame.
5. Remove the screw (item 2) from the right side of the coupler bracket.
6. Remove the coupler nuts (item 3).

LED Board Removal

7. Remove the 3 screws (item 4) that attach the LED board to the coupler bracket.

Replacement

1. Reverse the order of the procedure.

NOTE When reconnecting semirigid cables, torque the connections to 10 in-lb.

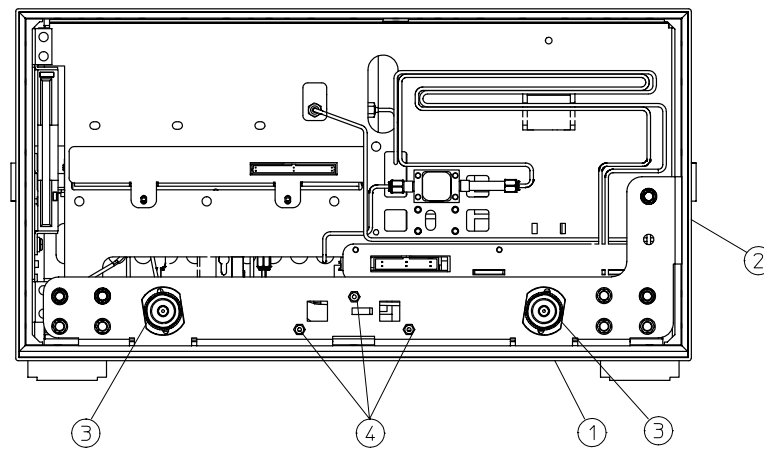

sb6135d

Removing the A26 High Stability Frequency Reference (Option 1D5) Assembly

Tools Required

- T-10 TORX screwdriver
- T-15 TORX screwdriver
- 9/16-inch hex-nut driver
- ESD (electrostatic discharge) grounding wrist strap

Removal

1. Remove the rear panel; refer to [“Removing the Rear Panel Assembly”](#) on page 14-14.
2. Disconnect W30 from the high stability frequency reference board (A26).
3. Remove the BNC connector nut and washer from the "10 MHz PRECISION REFERENCE" connector (item 1) on the rear panel.
4. Remove the screw (item 4) that attaches the 1D5 assembly to the rear panel.
5. Remove the screw (item 2) that secures the high stability frequency reference board (A26) to the bracket.
6. Slide the board out of the bracket. Be careful not to lose the plastic spacer washer (item 3) that is on the BNC connector as the board is being removed.

Replacement

1. Reverse the order of the removal procedure.

NOTE Before reinserting the high stability frequency reference board (A26) into the bracket, be sure the plastic spacer washer (item 3) is on the BNC connector.

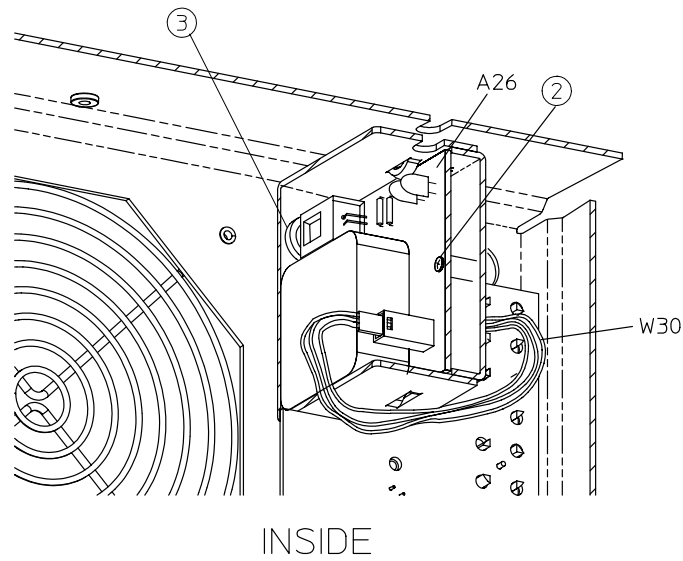
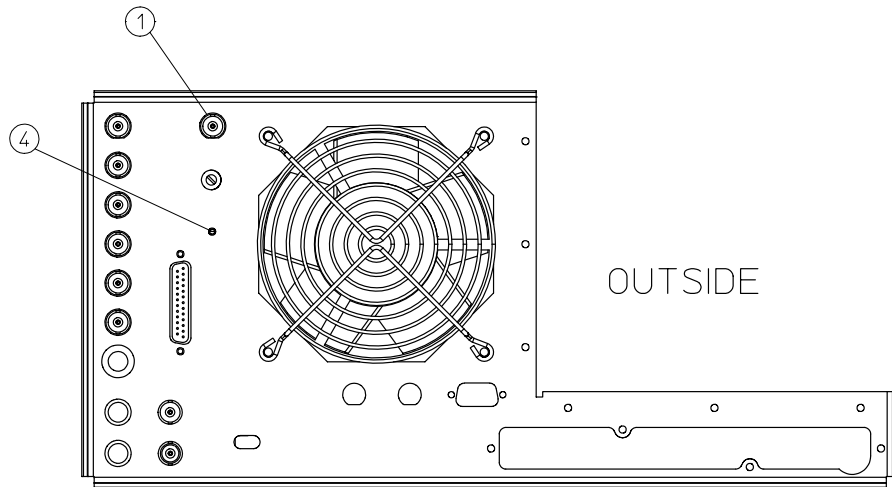

sb658d

Removing the B1 Fan Assembly

Tools Required

- 2.5-mm hex-key driver
- T-10 TORX screwdriver
- T-15 TORX screwdriver
- ESD (electrostatic discharge) grounding wrist strap

Removal

1. Remove the rear panel; refer to [“Removing the Rear Panel Assembly”](#) on page 14-14.
2. Remove the 4 screws (item 1) that secure the fan and fan cover to the rear panel.

Replacement

1. Reverse the order of the removal procedure.

NOTE The fan should be installed so that the direction of the air flow is away from the instrument. There is an arrow on the fan chassis indicating the air flow direction.

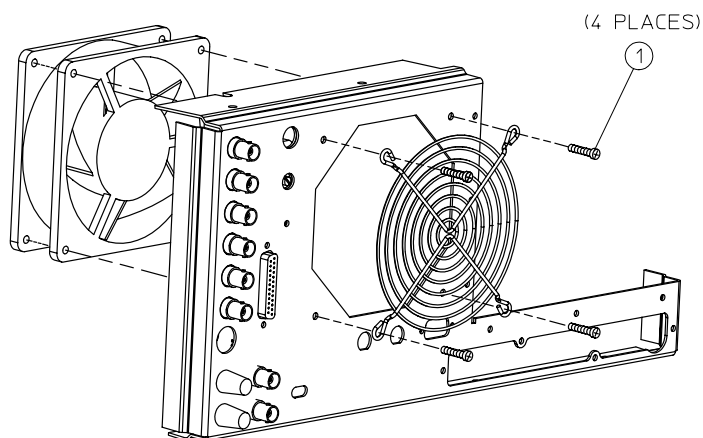

sb687d

Post-Repair Procedures

After the replacement of an assembly, you must perform the service procedures listed in [Table 14-1](#).

NOTE Perform the procedures in the order that they are listed in the table.

Table 14-1 Related Service Procedures

Replaced Assembly	Adjustments / Correction Constants (CC)	Verification
A1 Front Panel Keyboard	None	Internal Test 0 Internal Test 12 Internal Test 23
A2 Front Panel Processor	None	Internal Test 0 Internal Test 12 Internal Test 23
A4/A5/A6 Second Converter	Raw Offset CC Sampler Calibration CC (Test 51)	Frequency Accuracy Performance Test Dynamic Range Performance Test
A52 Pulse Generator	Raw Offset CC Sampler Calibration CC (Test 51)	Frequency Accuracy Performance Test Dynamic Range Performance Test
A8 Post Regulator	None	Internal Test 0 Check A8 test point voltages
A7 CPU ^a	A7 Switch Positions Load Firmware CC Retrieval Serial Number CC (Test 49) Option Number CC (Test 50) Analog Bus CC (Test 44) Source Pretune CC (Test 43) IF Step CC (Test 47) Raw Offset CC Sampler Calibration CC (Test 51) EEPROM Backup Disk	Frequency Accuracy Performance Test Level Accuracy Performance Test Source Linearity Performance Test Dynamic Range Performance Test
A9 Source Control	Raw Offset CC Sampler Calibration CC (Test 51)	Frequency Accuracy Performance Test Dynamic Range Performance Test
A10 Digital IF	A7 Switch Positions Analog Bus CC (Test 44) IF Amplifier CC (Test 47)	Dynamic Range Performance Test Internal Test 17 Internal Test 18 Internal Test 19

- a. If you have an EEPROM backup disk available, you only need to perform the first three tests listed.

Replaced Assembly	Adjustments / Correction Constants (CC)	Verification
A11 Phase Lock	A7 Switch Positions Analog Bus CC (Test 44) Source Pretune (Tests 43)	Frequency Accuracy Performance Test
A12 Reference	Reference Assembly VCO Tune	Frequency Accuracy Performance Test
A13 Fractional-N (Analog)	A7 Switch Positions Analog Bus CC (Test 44) Fractional-N Spur Avoidance and F M Sideband Adjustment	Internal Test 20 Frequency Accuracy Performance Test
A14 Fractional-N (Digital)	A7 Switch Positions Analog Bus CC (Test 44)	Internal Test 20 Frequency Accuracy Performance Test
A15 Preregulator	None	Internal Test 0
A16 Rear Panel Interface	None	No test available
A17 Motherboard	None	Internal Test 0
A18 Display	None	Internal Tests 62–76
A19 Graphics System Processor	None	Internal Tests 55–76
A51 Test Set Interface	None	Op Ck Port1 (Test 21) Op Ck Port2 (Test 22)
A53 Low Band Assembly	Output Power Adjustments Power Linearity Adjustments	Frequency Accuracy Performance Test Level Accuracy Performance Test Source Linearity Performance Test
A54 YIG2 20–40 GHz (8722ET/ES)	Source Pretune CC (Test 43) Output Power Adjustments Power Linearity Adjustments	Frequency Accuracy Performance Test Level Accuracy Performance Test Source Linearity Performance Test
A55 YIG1 2.4-20 GHz	Source Pretune CC (Test 43) Output Power Adjustments Power Linearity Adjustments	Frequency Accuracy Performance Test Level Accuracy Performance Test Source Linearity Performance Test
A56 LED Board	None	Observe LEDs when switching from S11 to S22
A57 Fixed Oscillator	Output Power Adjustments Power Linearity Adjustments	Frequency Accuracy Performance Test Level Accuracy Performance Test Source Linearity Performance Test
A58 M/A/D/S	Output Power Adjustments Power Linearity Adjustments	Level Accuracy Performance Test Source Linearity Performance Test
A59 Source Interface	Output Power Adjustments Power Linearity Adjustments	Level Accuracy Performance Test Source Linearity Performance Test
A60/61 DC Bias Tees	Output Power Adjustments Power Linearity Adjustments	Level Accuracy Performance Source Linearity Performance Test

Replaced Assembly	Adjustments / Correction Constants (CC)	Verification
A62/A63 (Directional Couplers)	Output Power Adjustments Power Linearity Adjustments	Level Accuracy Performance Test Source Linearity Performance Test
A64 R1 Sampler	Raw Offset CC Sampler Cal CC	Frequency Accuracy Performance Test Dynamic Range Performance Test
A64 R2 Sampler (Option 400)	Raw Offset CC Sampler Cal CC	Frequency Accuracy Performance Test Dynamic Range Performance Test
A65 A Sampler	Raw Offset CC Sampler Cal CC	Frequency Accuracy Performance Test Dynamic Range Performance Test
A66 B Sampler	Raw Offset CC Sampler Cal CC	Frequency Accuracy Performance Test Dynamic Range Performance Test
A69 (55 dB Step Attenuator)	Raw Offset CC Sampler Cal CC	Frequency Accuracy Performance Test
A70 (Step Attenuator)	Output Power Adjustments Power Linearity Adjustments	Level Accuracy Performance Test Source Linearity Performance Test
A71 (Step Attenuator)	Output Power Adjustments Power Linearity Adjustments	Level Accuracy Performance Test Source Linearity Performance Test
S1 Switch (8722ES)	Output Power Adjustments Power Linearity Adjustments	Level Accuracy Performance Test Source Linearity Performance Test
S2/S3 Switches	Output Power Adjustments Power Linearity Adjustments	Level Accuracy Performance Test Source Linearity Performance Test
S4 Transfer Switch	Output Power Adjustments Power Linearity Adjustments	Level Accuracy Performance Test Source Linearity Performance Test

15 Safety and Regulatory Information

General Information

Maintenance

Clean the cabinet, using a dry or damp cloth only.

WARNING **To prevent electrical shock, disconnect the analyzer from mains before cleaning. Use a dry cloth or one slightly dampened with water to clean the external case parts. Do not attempt to clean internally.**

Assistance

Product maintenance agreements and other customer assistance agreements are available for Agilent Technologies products.

For any assistance, contact your nearest Agilent Technologies Sales and Service Office.

Shipment for Service

If you are sending the instrument to Agilent Technologies for service, ship the analyzer to the nearest Agilent service center for repair, including a description of any failed test and any error message. Ship the analyzer using the original or comparable antistatic packaging materials.

Table 15-1 Agilent Technologies Sales and Service Offices

Online assistance: www.agilent.com/find/assist		
United States (tel) 1 800 452 4844	Latin America (tel) (305) 269 7500 (fax) (305) 269 7599	Canada (tel) 1 877 894 4414 (fax) (905) 282-6495
Europe (tel) (+31) 20 547 2323 (fax) (+31) 20 547 2390	Australia (tel) 1 800 629 485 (fax) (+61) 3 9210 5947	New Zealand (tel) 0 800 738 378 (fax) (+64) 4 495 8950
Japan (tel) (+81) 426 56 7832 (fax) (+81) 426 56 7840	Singapore (tel) 1 800 375 8100 (fax) (65) 836 0252	Malaysia (tel) 1 800 828 848 (fax) 1 800 801 664
India (tel) 1 600 11 2929 (fax) 000 800 650 1101	Hong Kong (tel) 800 930 871 (fax) (852) 2506 9233	Taiwan (tel) 0800 047 866 (fax) (886) 2 25456723
Philippines (tel) (632) 8426802 (tel) (PLDT subscriber only) 1 800 16510170 (fax) (632) 8426809 (fax) (PLDT subscriber only) 1 800 16510288	Thailand (tel) (outside Bangkok) (088) 226 008 (tel) (within Bangkok) (662) 661 3999 (fax) (66) 1 661 3714	People's Republic of China (tel) (preferred) 800 810 0189 (tel) (alternate) 10800 650 0021 (fax) 10800 650 0121

Safety Symbols

The following safety symbols are used throughout this manual. Familiarize yourself with each of the symbols and its meaning before operating this instrument.

CAUTION Caution denotes a hazard. It calls attention to a procedure that, if not correctly performed or adhered to, would result in damage to or destruction of the instrument. Do not proceed beyond a caution note until the indicated conditions are fully understood and met.

WARNING **Warning denotes a hazard. It calls attention to a procedure which, if not correctly performed or adhered to, could result in injury or loss of life. Do not proceed beyond a warning note until the indicated conditions are fully understood and met.**

Instrument Markings



The instruction documentation symbol. The product is marked with this symbol when it is necessary for the user to refer to the instructions in the documentation.



The CE mark is a registered trademark of the European Community. (If accompanied by a year, it is when the design was proven.)



The CSA mark is a registered trademark of the Canadian Standards Association.



This is a symbol of an Industrial Scientific and Medical Group 1 Class A product.

ICES / NMB-001

This is a marking to indicate product compliance with the Canadian Interference-Causing Equipment Standard (ICES-001).



The C-Tick mark is a registered trademark of the Australian Spectrum Management Agency.

Lithium Battery Disposal

If the battery on the CPU board (A7) becomes ready for disposal. Dispose of it to your country's requirements. If required, you may return the battery to the nearest Agilent Technologies sales or service office for disposal. For replacement of the battery, refer to [“Removing the A7BT1 Battery” on page 14-22](#).

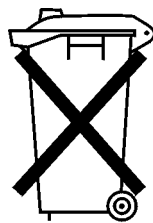

**DO NOT THROW BATTERIES AWAY BUT
COLLECT AS SMALL CHEMICAL WASTE.**

sk780a

Safety Considerations

NOTE This instrument has been designed and tested in accordance with IEC Publication 1010, Safety Requirements for Electronics Measuring Apparatus, and has been supplied in a safe condition. This instruction documentation contains information and warnings which must be followed by the user to ensure safe operation and to maintain the instrument in a safe condition.

Safety Earth Ground

WARNING This is a Safety Class I product (provided with a protective earthing ground incorporated in the power cord). The mains plug shall only be inserted in a socket outlet provided with a protective earth contact. Any interruption of the protective conductor, inside or outside the instrument, is likely to make the instrument dangerous. Intentional interruption is prohibited.

WARNING Always use the three-prong AC power cord supplied with this product. Failure to ensure adequate earth grounding by not using this cord may cause product damage.

Before Applying Power

CAUTION The front panel LINE switch disconnects the mains circuits from the mains supply after the EMC filters and before other parts of the instrument.

CAUTION Make sure that the analyzer line voltage selector switch is set to the voltage of the power supply and the correct fuse is installed.

CAUTION If this product is to be energized via an autotransformer make sure the common terminal is connected to the neutral (grounded side of the mains supply).

Servicing

WARNING No operator serviceable parts inside. Refer servicing to qualified personnel. To prevent electrical shock, do not remove covers.

WARNING These servicing instructions are for use by qualified personnel only. To avoid electrical shock, do not perform any servicing unless you are qualified to do so.

WARNING The opening of covers or removal of parts is likely to expose dangerous voltages. Disconnect the instrument from all voltage sources while it is being opened.

WARNING Adjustments described in this document may be performed with power supplied to the product while protective covers are removed. Energy available at many points may, if contacted, result in personal injury.

WARNING Danger of explosion if battery is incorrectly replaced. Replace only with the same or equivalent type recommended. Discard used batteries according to manufacturer's instructions.

WARNING The power cord is connected to internal capacitors that may remain live for 5 seconds after disconnecting the plug from its power supply.

WARNING For continued protection against fire hazard, replace line fuse only with same type and rating (115 V operation: T 5A 125V UL/CSA; 230V operation: T 4A H 250V IEC). The use of other fuses or materials is prohibited.

General

WARNING To prevent electrical shock, disconnect the analyzer from mains before cleaning. Use a dry cloth or one slightly dampened with water to clean the external case parts. Do not attempt to clean internally.

WARNING If this product is not used as specified, the protection provided by the equipment could be impaired. This product must be used in a normal condition (in which all means for protection are intact) only.

CAUTION This product is designed for use in Installation Category II and Pollution Degree 2 per IEC 1010 and 664 respectively.

CAUTION VENTILATION REQUIREMENTS: When installing the product in a cabinet, the convection into and out of the product must not be restricted. The ambient temperature (outside the cabinet) must be less than the maximum operating temperature of the product by 4° C for every 100 watts dissipated in the cabinet. If the total power dissipated in the cabinet is greater than 800 watts, then forced convection must be used.

WARNING Install the instrument according to the enclosure protection provided. This instrument does not protect against the ingress of water. This instrument protects against finger access to hazardous parts within the enclosure.

Compliance with German FTZ Emissions Requirements

This network analyzer complies with German FTZ 526/527 Radiated Emissions and Conducted Emission requirements.

Compliance with German Noise Requirements

This is to declare that this instrument is in conformance with the German Regulation on Noise Declaration for Machines (Laermangabe nach der Maschinenlaermverordnung –3. GSGV Deutschland).

Acoustic Noise Emission/Geraeuschemission	
LpA<70 dB	Lpa<70 dB
Operator Position	am Arbeitsplatz
Normal Operation	normaler Betrieb
per ISO 7779	nach DIN 45635 t. 19

Numerics

- 1 MHz signal [7-13](#)
- 10 dB pads, recommended part numbers [1-4](#)
- 100kHz signal [7-13](#)
- 2.4 mm recommended part numbers
 - cables [1-4](#)
 - RF adapters [1-4](#)
 - RF loads [1-4](#)
 - RF open [1-4](#)
- 2nd Converter Check [8-9](#)
- 2nd LO check [8-3](#)
- 3.5 mm recommended part numbers
 - cables [1-4](#)
 - RF adapters [1-4](#)
 - RF loads [1-4](#)
 - RF opens [1-4](#)
- 4 MHz check [8-3](#)

A

- A channel output check [4-23](#)
- A7 switch positions [6-4](#)
- accessories troubleshooting [9-2](#)
- accuracy of frequency adjustment [3-41](#)
- adapters, recommended part numbers [1-4](#)
- ADC analog bus location [10-20](#)
- ADC offset correction constants adjustment [3-10](#)
- ADDITIONAL STANDARDS NEEDED [10-33](#)
- ADDRESSED TO TALK WITH NOTHING TO SAY [10-33](#)
- adjustment
 - A7 CC jumper positions [3-4](#)
 - ADC offset correction constants (test 48) [3-10](#)
 - analog bus correction constants (test 44) [3-8](#)
 - fractional-N spur avoidance and FM sideband [3-44](#)
 - frequency accuracy [3-41](#)
 - IF amplifier correction constants (test 47) [3-9](#)
 - initialize EEPROMs (test 53) [3-32](#)
 - option numbers correction constants (test 50) [3-13](#)
 - serial number correction constants (test 49) [3-11](#)
 - source pretune correction constants (test 43) [3-6](#)
 - test descriptions [10-12](#)

- adjustments, service equipment [1-3, 1-4](#)
- ALC
 - automatic leveling control description of [12-18](#)
- ALC/Signal Separation Check [7-26](#)
- ALT and NRM jumper position adjustment [3-4](#)
- ALTER and NORMAL jumper position adjustment [3-4](#)
- amplifier
 - (IF) adjustment [3-9](#)
 - description (ES models) [12-19](#)
- analog bus
 - codes [10-32](#)
 - correction constants adjustment [3-8](#)
 - description of [10-20](#)
 - frequency counter location(A14) [10-20](#)
 - main ADC location [10-20](#)
- ANALOG BUS DISABLED IN 6KHZ IF BW [10-33](#)
- analog bus nodes
 - A10 digital IF [10-22](#)
 - A11 phase lock [10-23](#)
 - A12 reference [10-26](#)
 - A14 fractional-N (digital) [10-28](#)
 - description of [10-22](#)
- analog in menu [10-21](#)
- ANALOG INPUT OVERLOAD [10-33](#)
- analyzer options [1-2](#)
 - descriptions [1-7](#)
- analyzer, shipping for service [4-4](#)
- ANSI/NCSL Z540-1-1994
 - test path verification flowchart [2-4](#)
 - verification description [2-3](#)
- ANSI/NCSL Z540-1-1994,non
 - test path verification flowchart [2-5](#)
- assemblies
 - bottom part numbers for 8719/20ES
 - option 400 [13-22](#)
 - options 012, 012+007 [13-14](#)
 - options 085, 085+089 [13-20](#)
 - options 089+012, 089+012+007 [13-18](#)
 - options 089, 089+007 [13-16](#)
 - options 400+012 [13-24](#)
 - options 400+012+089 [13-28](#)
 - options 400+089 [13-26](#)
 - standard and option 007 [13-12](#)

- bottom part numbers for 8719/20ET
 - option 004 [13-58](#)
 - standard [13-56](#)
- bottom part numbers for 8722ES
 - option 007 [13-32](#)
 - option 012 [13-34](#)
 - option 089 [13-38](#)
 - option 400 [13-48](#)
 - options 007+012 [13-36](#)
 - options 085, 085+089 [13-46](#)
 - options 089+007 [13-40](#)
 - options 089+007+012 [13-44](#)
 - options 089+012 [13-42](#)
 - options 400+012 [13-50](#)
 - options 400+012+089 [13-54](#)
 - options 400+089 [13-52](#)
 - standard [13-30](#)
- bottom part numbers for 8722ET
 - option 004 [13-62](#)
 - standard [13-60](#)
- cables top [13-66](#)
- front panel inside [13-72](#)
- front part numbers [13-64](#)
- part numbers for top [13-8](#)
- rear cables [13-69](#)
- rear panel [13-74](#)
- assembly
 - removal
 - CPU board [14-20](#)
 - disk drive [14-28](#)
 - display lamp [14-12](#)
 - fan [14-34](#)
 - front panel [14-8](#)
 - front panel interface [14-10](#)
 - GSP (A19) [14-26](#)
 - high stability frequency reference (option 1D5) [14-32](#)
 - keypad [14-10](#)
 - LED board [14-30](#)
 - preregulator board (A15) [14-24](#)
 - rear panel [14-14](#)
 - rear panel interface [14-16](#)
 - source board [14-18](#)
 - test port coupler [14-30](#)
 - replacement [14-2](#)
 - replacement sequence [7-4](#)
- attenuator
 - (A69) check [7-27](#)
 - recommended part numbers [1-4](#)

B

- B channel output check [4-24](#)

Index

- background lamp intensity 6-7, 7-7, 7-14
- backup EEPROM disk 3-33
- band problems
 - high 7-24
 - mid 7-22
- band-related problems 7-22
- BATTERY FAILED. STATE
 - MEMORY CLEARED 10-33
- BATTERY LOW! STORE SAVE REGS TO DISK 10-33
- battery, removal of A7 14-22
- bias voltages
 - sampler assembly 7-9
- blanking adjustment 3-30
- block diagram
 - network analyzer system 12-3
 - signal separation option 400 12-20
 - simplified power supply 5-5, 12-6
 - simplified source flow 12-17
 - simplified source group 12-13
- BLOCK INPUT ERROR 10-34
- BLOCK INPUT LENGTH ERROR 10-34
- BNC cables, recommended part numbers 1-4
- broadband phase lock problems 7-8
- broadband power problems 7-26
- C**
- cable connector repeatability
 - how to perform 2-13
 - typical response 2-14
- cables
 - check for performance 2-9
 - recommended part numbers 1-4
- calibration
 - how to do 2-22
 - measurement test setup 2-22
 - port 1 2-22
 - port 2 2-23
 - thru 2-24
- CALIBRATION ABORTED 10-34
- calibration kits
 - recommended models 1-3
- CALIBRATION REQUIRED 10-34
- CANNOT READ/WRITE 1 FILE SYSTEM 10-34
- CAUTION
 - POWER OUT MAY BE UNLEVELED 10-34
- CC procedures
 - ADC offset (test 48) 3-10
 - analog bus (test 44) 3-8
 - IF amplifier (test 47) 3-9
 - initialize EEPROMs (test 53) 3-32
 - option numbers (test 50) 3-13
 - serial number (test 49) 3-11
 - source pretune (test 43) 3-6
- CC terms and tests
 - ES models 11-5
 - ET models 11-6
- check
 - 2nd converter 8-9
 - 2nd LO 8-3
 - A channel output 4-23
 - A14 to A13 digital control signals 7-17
 - ALC/signal separation 7-26
 - B channel output 4-24
 - control voltage on sampler assembly 7-9
 - CPU red LED patterns 6-5
 - digital control 4-15
 - directional coupler 8-7
 - divide-by-N (A14) circuit 7-17
 - fan voltages 5-18
 - fractional-N analog (A13)
 - fractional-N digital (A14) with spectrum analyzer 7-15
 - fractional-N digital (A14) 7-14
 - line voltage, selector switch, fuse 5-8
 - open loop power 19 and 20 models 7-11
 - open loop power 22 models 7-12
 - operating temperature 5-12
 - operator's 4-7
 - PORT 1 4-8
 - PORT 2 4-8
 - post regulator (A8) fuses and voltages 5-13
 - post regulator LED's 4-14
 - post regulator(A8) 5-9
 - post regulator(A8) green LED 5-6
 - power supply 4-14
 - preregulator (A15) LED (green and red) 5-6
 - pulse generator (A52) with oscilloscope 7-19
 - R channel output 4-22
 - R sampler assembly(A64) 7-9
 - R2 sampler assembly Option 400 7-9
 - rear panel LED's 4-14
 - receiver 4-21
 - reference board (A12) 7-13
 - REFLECTION port 4-8
 - sampler voltage 8-9
 - source 4-17
 - source output power 4-18
 - step attenuator (A69) 7-27
 - switch repeatability 4-25
 - TRANSMISSION port 4-9
 - VCO (A14) with oscilloscope 7-16
- connector care 1-6
- connector repeatability
 - cable 2-13
- control voltage
 - sampler assembly 7-9
- controllers
 - troubleshooting with 4-12
- correction constants
 - ADC offset (test 48) 3-10
 - analog bus (test 44) 3-8
 - IF amplifier (test 47) 3-9
 - initialize EEPROMs (test 53) 3-32
 - option numbers (test 50) 3-13
 - serial number (test 49) 3-11
 - source pretune (test 43) 3-6
- CORRECTION CONSTANTS NOT STORED 10-34
- CORRECTION TURNED OFF 10-34
- covers removal of 14-6
- CPU (A7) board
 - rear panel LED window 6-5
 - removal 14-20
 - troubleshooting 6-4
 - walking one pattern 6-11
- CPU main
 - description of 12-10
- CPU/A10 digital IF
 - description of 12-9
- crimped RF cables 7-22
- crosstalk description 11-14
- crosstalk uncorr port performance 11-8
- CURRENT PARAMETER NOT IN CAL SET 10-35
- D**
- dark pixels specifications 6-8
- DC bias tees
 - description of 12-21
- DEADLOCK 10-35
- detector description (ES models) 12-19
- DEVICE
 - not on, not connect, wrong addr 10-35
- digital control 12-5
 - check 4-15

Index

- signal locations 7-18
- signals A14 to A13 7-17
- theory 12-9
- digital signal processor (DSP)
 - description of 12-10
- digital supply
 - description of 12-7
- directional coupler check 8-7
- directional couplers
 - description 12-21
- directivity (EDF and EDR)
 - description 11-11
- directivity (ES and ET models) 11-8
- DISK
 - not on, not connected, wrong addrs 10-35
- disk drive removal 14-28
- DISK HARDWARE PROBLEM 10-35
- DISK MESSAGE LENGTH ERROR 10-35
- DISK READ/WRITE ERROR 10-35
- display
 - black dots 6-7, 7-7, 7-14
 - four steps for evaluating 6-7, 7-7, 7-14
 - power supply voltages to GSP(A19) 6-9
 - troubleshooting 6-7, 7-7, 7-14
- display (A18)
 - troubleshooting with GSP(A19) 6-9
- display lamp and assembly
 - removal 14-12
- display test descriptions 10-13
- display troubleshooting (A18,A19) 6-7, 7-7, 7-14
- divide-by-N (A14) circuit check 7-17
- documentation 13-87
- dynamic range performance test 2-42
- dynamic range test record 2-50
- E**
- EDF and EDR description 11-11
- EEPROM
 - description of 12-10
- ELF and ELR description 11-15
- equipment
 - EEPROM backup disk
 - procedure 3-33
 - fractional-N spur avoidance and FM sideband adjustment 3-44
 - frequency accuracy adjustment 3-41
 - IF amplifier correction
 - constants adjustment 3-9
 - service 1-2
 - ERF and ERR description 11-13
 - error messages 10-3
 - ADDITIONAL STANDARDS NEEDED 10-33
 - ADDRESSED TO TALK WITH NOTHING TO SAY 10-33
 - ANALOG BUS DISABLED IN 6KHZ IF BW 10-33
 - ANALOG INPUT OVERLOAD 10-33
 - BATTERY FAILED. STATE MEMORY CLEARED 10-33
 - BATTERY LOW! STORE SAVE REGS TO DISK 10-33
 - BLOCK INPUT ERROR 10-34
 - BLOCK INPUT LENGTH ERROR 10-34
 - CALIBRATION ABORTED 10-34
 - CALIBRATION REQUIRED 10-34
 - CANNOT READ/WRITE 1 FILE SYSTEM 10-34
 - CAUTION
 - POWER OUT MAY BE UNLEVELED 10-34
 - CORRECTION CONSTANTS NOT STORED 10-34
 - CORRECTION TURNED OFF 10-34
 - CURRENT PARAMETER NOT IN CAL SET 10-35
 - DEADLOCK 10-35
 - DEVICE
 - not on, not connect, wrong addrs 10-35
 - DISK
 - not on, not connected, wrong addrs 10-35
 - DISK HARDWARE PROBLEM 10-35
 - DISK MESSAGE LENGTH ERROR 10-35
 - DISK READ/WRITE ERROR 10-35
 - FILE NOT COMPATIBLE WITH INSTRUMENT 10-35
 - ILLEGAL UNIT OR VOLUME NUMBER 10-35
 - INITIALIZATION FAILED 10-36
 - INSUFFICIENT MEMORY, PWR MTR CAL OFF 10-36
 - NO CALIBRATION CURRENTLY IN PROGRESS 10-36
 - NO FAIL FOUND 10-36
 - NO FILE(S) FOUND ON DISK 10-36
 - NO IF FOUND
 - CHECK R INPUT LEVEL 10-36
 - NO SPACE FOR NEW CAL.CLEAR REGISTERS 10-36
 - NOT ALLOWED DURING POWER METER CAL 10-36
 - NOT ENOUGH SPACE ON DISK FOR STORE 10-37
 - OVERLOAD ON INPUT A, POWER REDUCED 10-37
 - OVERLOAD ON INPUT B, POWER REDUCED 10-37
 - PARALLEL PORT NOT AVAILABLE FOR COPY 10-37
 - PARALLEL PORT NOT AVAILABLE FOR GPIO 10-37
 - PHASE LOCK CAL FAILED 10-37
 - PHASE LOCK FAILURE 10-37
 - PHASE LOCK LOST 10-38
 - POSSIBLE FALSE LOCK 10-38
 - POWER METER INVALID 10-38
 - POWER METER NOT SETTLED 10-38
 - POWER SUPPLY HOT! 10-38
 - POWER SUPPLY SHUT DOWN! 10-38
 - PRINTER
 - error 10-38
 - not handshaking 10-38
 - not on, not connected, wrong addrs 10-38
 - PWR MTR
 - NOT ON/CONNECTED OR WRONG ADDR 10-39
 - SAVE FAILED.INSUFFICIENT MEMORY 10-39
 - SELF TEST #n FAILED 10-39
 - SOURCE POWER TURNED OFF, RESET UNDER POWER MENU 10-39
 - SWEEP MODE CHANGED TO CW TIME SWEEP 10-39
 - SWEEP TIME TOO FAST 10-39

Index

TEST ABORTED 10-39
TEST PORT OVERLOAD,
REDUCE POWER 10-39
TROUBLE!CHECK SET-UP
AND START OVER 10-40
WRONG DISK FORMAT,
INITIALIZE DISK 10-40

error messages description 10-33

error numbers

definitions 10-33

error terms

components related to 9-4

description 11-10

inspecting 9-4

inspection 11-5

types 11-2

verifying 11-4

ES models 7-9

signal separations 12-19

ESF and ESR description 11-12

E-terms 11-2

ETF and ETR description 11-16

EXF and EXR description 11-14

external test descriptions 10-11

F

fan removal 14-34

fan troubleshooting 5-18

FILE NOT COMPATIBLE WITH
INSTRUMENT 10-35

firmware revision softkey

on display 10-30

FM sideband and spur avoidance
adjustment 3-44

fractional-N Digital (A14) checks
with ABUS 7-14

fractional-N spur avoidance and
FM sideband adjustment 3-44

fractional-N synthesizer

description of 12-14

fractional-N tuning voltage

waveform at Abus Node 21

7-14

frequency accuracy

adjustment 3-41

performance tests 2-34

test record 2-47

frequency counter analog bus

location(A14) 10-20

front panel

description 12-9

LED pattern after Preset 6-13

front panel assembly removal
14-8

front panel interface removal

14-10

front panel troubleshooting

(A1/A2) 6-13

functional group fault isolation

4-13

functional group types 4-13

functional groups

description 12-5

fuse check 5-8

G

GPIB

plotter and printer check 4-11

GPIB addresses

factory set 4-10

GPIB service mnemonic

definitions 10-31

GPIB systems check 4-10

graphics system processor (GSP)

description of 12-11

green, red or blue dots 6-7, 7-7,

7-14

GSP (A19)

applied voltages 6-9

pin locations 6-11

removal 14-26

troubleshooting 6-9

H

high band problems 7-24

how to

adjust

ADC offset correction

constants 3-10

analog bus correction

constants 3-8

fractional-N spur avoidance

and FM sideband 3-44

frequency accuracy 3-41

IF amplifier correction

constants 3-9

option numbers correction

constants 3-13

serial number correction

constants 3-11

source pretune correction

constants 3-6

backup the EEPROM disk 3-33

initialize EEPROMs 3-32

position the A7 CC jumper 3-4

I

IF amplifier correction constants
adjustment 3-9

ILLEGAL UNIT OR VOLUME
NUMBER 10-35

improper connections 7-22

INITIALIZATION FAILED 10-36

initialize EEPROMs 3-32

insertion loss

how to do 2-11

typical response 2-11

instrument markings 15-5

INSUFFICIENT MEMORY, PWR

MTR CAL OFF 10-36

internal diagnostic test

running 6-17

table of tests 6-18

internal diagnostics

menu map 10-4

internal test descriptions 10-8

internal test, performing 2-7

isolation description 11-14

J

jumper position adjustment 3-4

jumper positions on the CPU (A7)

6-4

K

keypad assemblies removal 14-10

keys, identifying stuck 6-14

L

LED board removal 14-30

level accuracy

performance test 2-36

test record 2-47

line fuse

check 5-8

replacing of 14-5

line power module

description 12-7

line voltage check 5-8

load match

description 11-15

uncorrected port performance

11-8

loads, recommended part

numbers 1-4

loads, verifying 9-4

low band problems 7-22

M

M/A/D/S, description (ES models)
12-19

magnitude and phase stability

how to for cables 2-12

maintenance 15-2

maximum leveled power, table of

all network analyzer 12-4

measurement calibration

coefficients 11-2

- test setup [2-22](#)
 - measurement traceability
 - description [2-16](#)
 - measurement uncertainty
 - description [2-16](#)
 - measuring the signal [7-5](#), [7-6](#)
 - menu
 - analog in description men [10-21](#)
 - internal diagnostics [10-3](#)
 - PEEK and POKE [10-29](#)
 - service key [10-2](#)
 - service modes more [10-19](#)
 - test [10-5](#)
 - test options [10-6](#)
 - menus, service modes [10-17](#)
 - microwave connector care [1-6](#)
 - mid band problems [7-23](#)
 - N**
 - network analyzer, block diagram [12-3](#)
 - newtons rings [6-7](#), [7-7](#), [7-14](#)
 - NIST traceability path for calibration and verification standard [2-17](#)
 - NO CALIBRATION CURRENTLY IN PROGRESS [10-36](#)
 - NO FAIL FOUND [10-36](#)
 - NO FILE(S) FOUND ON DISK [10-36](#)
 - NO IF FOUND
 - CHECK R INPUT LEVEL [10-36](#)
 - NO SPACE FOR NEW CAL.CLEAR REGISTERS [10-36](#)
 - non-ANSI/NCSL Z540-1-1994 verification
 - description [2-3](#)
 - non-ANSI/NCSL Z540-1-1994 verification description [2-3](#)
 - NORMAL and ALTER jumper position adjustment [3-4](#)
 - NOT ALLOWED DURING POWER METER CAL [10-36](#)
 - NOT ENOUGH SPACE ON DISK FOR STORE [10-37](#)
 - NRM and ALT jumper position adjustment [3-4](#)
 - N-type cables, recommended part numbers [1-4](#)
 - number (option) adjustment [3-13](#)
 - number (serial) adjustment [3-11](#)
 - O**
 - offset (ADC) adjustment [3-10](#)
 - open loop power
 - measuring on 19 and 20 models [7-11](#)
 - measuring on 22 models [7-12](#)
 - opens, verifying [9-5](#)
 - operating temperature checking [5-12](#)
 - operation verification
 - post-repair [14-35](#)
 - operator's check [4-7](#)
 - how to perform [2-8](#)
 - option 004, step attenuator
 - description [1-7](#)
 - option 007, mechanical transfer switch description [1-7](#)
 - option 010, time domain description [1-7](#)
 - option 012, direct access receiver configuration description [1-7](#)
 - option 085, high power system description [1-8](#)
 - option 089, frequency offset mode description [1-8](#)
 - option 1CM, rack mount flange kit without handles description [1-8](#)
 - option 1CP, rack mount flange kit with handles description [1-8](#)
 - option 1D5, removing the A26 high stability frequency reference [14-32](#)
 - option 400 signal separation
 - block diagram simplified [12-20](#)
 - option 400, four-sampler test set description [1-8](#)
 - option numbers correction
 - constants adjustment [3-13](#)
 - output power, source check [4-18](#)
 - OVERLOAD ON INPUT A, POWER REDUCED [10-37](#)
 - OVERLOAD ON INPUT B, POWER REDUCED [10-37](#)
 - P**
 - pads, 10 dB, recommended part numbers [1-4](#)
 - PARALLEL PORT NOT AVAILABLE FOR COPY [10-37](#)
 - PARALLEL PORT NOT AVAILABLE FOR GPIO [10-37](#)
 - part numbers
 - 8719/20ES bottom [13-12](#)
 - option 400 [13-22](#)
 - options 012, 012+007 [13-14](#)
 - options 085, 085+089 [13-20](#)
 - options 089+012, 089+012+007 [13-18](#)
 - options 089, 089+007 [13-16](#)
 - options 400+012 [13-24](#)
 - options 400+012+089 [13-28](#)
 - options 400+089 [13-26](#)
 - 8719/20ET bottom
 - option 004 [13-58](#)
 - standard [13-56](#)
 - 8722ES bottom
 - option 007 [13-32](#)
 - option 012 [13-34](#)
 - option 089 [13-38](#)
 - option 400 [13-48](#)
 - options 007+012 [13-36](#)
 - options 085, 085+089 [13-46](#)
 - options 089+007 [13-40](#)
 - options 089+007+012 [13-44](#)
 - options 089+012 [13-42](#)
 - options 400+012 [13-50](#)
 - options 400+012+089 [13-54](#)
 - options 400+089 [13-52](#)
 - standard [13-30](#)
 - 8722ET bottom
 - option 004 [13-62](#)
 - standard [13-60](#)
 - cables top [13-66](#)
 - front cables [13-70](#)
 - front panel assembly [13-72](#)
 - hardware bottom [13-80](#)
 - hardware preregulator [13-83](#)
 - hardware top [13-78](#)
 - rear cables [13-69](#)
 - rear panel [13-74](#)
 - RF assemblies in front [13-64](#)
 - service tools [13-87](#)
 - top assemblies [13-8](#)
- PEEK/POKE Menu [10-29](#)
- performance test
 - dynamic range [2-42](#)
 - frequency accuracy [2-34](#)
 - level accuracy [2-36](#)
 - record [2-46](#)
 - source linearity [2-38](#)
- performance tests [2-1](#), [2-33](#)
- post-repair [14-35](#)
 - service equipment to use [1-3](#), [1-4](#)
- phase lock
 - broadband problems [7-8](#)
 - comparing phase and frequency description of [12-15](#)
 - error message displayed [7-6](#)
 - error messages [4-17](#)
 - measuring signal power on R channel [7-5](#)

- PHASE LOCK CAL FAILED 10-37
- PHASE LOCK FAILURE 10-37
- PHASE LOCK LOST 10-38
- phase lock problem
 - common faulty assemblies 7-8
- phase locked sweep
 - description of 12-15
- pin locations, GSP (A19) 6-11
- pixels specifications
 - dark 6-8
 - red green or blue 6-7
- plotter or printer GPIB check 4-11
- PORT 1 check 4-8
- PORT 2 Check 4-8
- POSSIBLE FALSE LOCK 10-38
- post regulator (A8)
 - checking fuses and voltages 5-13
 - checking operation of 5-9
 - description 12-7
 - green LED check 5-6
 - green LED's not all on 5-13
 - LED check 4-14
 - measuring the voltages 5-7
- post-repair procedures 14-2, 14-35
 - table of 14-35
- power adjustments 3-17
- power holes 7-22
- POWER METER INVALID 10-38
- POWER METER NOT SETTLED 10-38
- power splitter, recommended part numbers 1-4
- power supply 12-5, 12-6
 - check 4-14
 - troubleshooting 5-2
 - troubleshooting flowchart 5-3
- POWER SUPPLY HOT! 10-38
- POWER SUPPLY SHUT DOWN! 10-38
- preregulated voltages 12-7
- preregulator (A15)
 - check green and LED 5-6
 - description 12-6
 - is green LED blinking? 5-8
 - is red LED on? 5-9
 - removal 14-24
 - verifying operation of 5-10
- preset sequence for ET and ES models 4-5
- PRINTER
 - error 10-38
 - not handshaking 10-38
 - not on, not connected, wrong addrs 10-38
- procedures
 - A7 CC jumper positions 3-4
 - ADC offset correction constants (test 48) 3-10
 - analog bus correction constant (test 44) 3-8
 - EEPROM backup disk 3-33
 - fractional-N spur avoidance and FM sideband adjustment 3-44
 - Frequency Accuracy Adjustment 3-41
 - IF amplifier correction constants (test 47) 3-9
 - initialize EEPROMs (test 53) 3-32
 - option numbers correction constant (test 50) 3-13
 - serial number correction constant (test 49) 3-11
 - Source Pretune Correction Constants (Test 43) 3-6
- pulse generator (A52)
 - check oscilloscope 7-19
 - check spectrum analyzer 7-20
 - harmonic comb description 12-14
- PWR MTR
 - NOT ON/CONNECTED OR WRONG ADDR 10-39
- R**
 - R channel output check 4-22
 - R Sampler Assembly (A64)
 - swapping IF cables to troubleshoot phaselock problems 7-9
 - R, R2, A, and B sampler assembly traces 8-6
 - R2 Sampler Assembly (Option 400)
 - swapping IF cables to troubleshoot phaselock problems 7-9
- RAM main
 - description of 12-10
- R-channel sampler
 - ES models 7-6
 - ET models 7-5
- rear panel
 - assembly removal 14-14
 - CPU LED pattern 6-5
 - description of 12-11
 - interface board removal 14-16
 - LED check 4-14
- receiver 12-5
 - 2nd LO check 8-3
 - 4 MHz check 8-3
- assemblies and associated paths 8-2
 - check 4-21
 - directional coupler check 8-7
 - troubleshooting 8-2
- reference assembly VCO tune adjustment 3-39
- reference board (A12)
 - checking 7-13
- reference, crystal reference
 - frequencies description 12-16
- REFLECTION port check 4-8
- reflection tracking (ERF and ERR) description 11-13
 - uncorrected port performance 11-8
- removing
 - high stability freq. ref. assembly 14-32
 - LED board 14-30
 - line fuse 5-8
 - test port couplers 14-30
 - the ABT1 battery 14-22
 - the covers 14-6
 - the CPU board 14-20
 - the disk drive assembly (A3) 14-28
 - the display lamp and assembly 14-12
 - the fan assembly 14-34
 - the front panel 14-8
 - the front panel interface and keyboard assemblies 14-10
 - the GSP board 14-26
 - the preregulator board 14-24
 - the rear panel assembly 14-14
 - the rear panel interface board 14-16
 - the source assembly 14-18
- replacing, the line fuse 14-5
- return loss
 - test port cable check 2-9
 - typical display of test port cables 2-10
- RF adapters
 - recommended Agilent part numbers 1-4
- RF components
 - problems with 7-22
- RF path
 - isolating fault in 9-5
- RF signal of the R-channel
 - measuring of on ES models 7-10
 - measuring of on ET models 7-10

S

sampler

- A and B check by substitution 8-8
 - assembly, control bias voltages 7-9
 - control voltage check 7-9
 - signal down-conversion description 12-14
 - voltage check 8-9
- sampler check 8-7
- SAVE FAILED.INSUFFICIENT MEMORY 10-39
- selector switch check 5-8
- self diagnose softkey 10-8
- SELF TEST #n FAILED 10-39
- self-test
 - how to initiate 4-5
- serial number correction
 - constants adjustment 3-11
- service equipment 1-2
- service feature menu map 10-16
- service key menus 10-2
 - internal diagnostics 10-3
 - service features 10-15
- service modes menu 10-17
- service modes more menu 10-19
- service test equipment 1-3
- service, how to get analyzer 4-4
- setup
 - fractional-N spur avoidance and FM sideband adjustment 3-45
 - frequency accuracy adjustment 3-41
- shipment for service 15-3
- shorts, RF, recommended part numbers 1-4
- shorts, verifying 9-5
- shutdown circuitry
 - disable of 5-15
- signal separation 12-5
 - ES model theory 12-19
 - ES simplified block diagram 12-19
 - ET Models 12-22
- Smith chart traces 9-7
- source 12-5
 - band-related problems 7-22
 - broadband power problems 7-26 check 4-17
 - group theory 12-13
 - phaselock troubleshooting 7-9
 - step attenuator (A69) check 7-27
 - troubleshooting 7-2
 - troubleshooting flowchart 7-3

- what to do if power is incorrect at R channel 7-6
 - where to start troubleshooting 7-5
- source linearity
 - performance test 2-38
 - test record 2-48

source match (ESF and ESR) description 11-12
 - uncorrected performance 11-8

SOURCE POWER TURNED OFF, RESET UNDER POWER MENU 10-39

source pretune
 - correction constants adjustment 3-6
 - description 12-14

splitter
 - description (ES models) 12-19
 - recommended part numbers 1-4

spur avoidance and FM sideband adjustment 3-44

step attenuator (A69)
 - check 7-27
 - description 12-20

steps to take if R power incorrect 7-6

stuck key table, LED patterns 6-14

subsweep frequencies
 - table of all models 12-16

supported system configurations 2-18

swapping IF cables 7-9

SWEEP MODE CHANGED TO CW TIME SWEEP 10-39

SWEEP TIME TOO FAST 10-39

switch positions, A7 CPU board 6-4

switch repeatability check 4-25

system operation 12-3
 - theory 12-3

system verification 2-1, 2-15
 - equipment initialization 2-20
 - equipment needed 2-18
 - post-repair 14-35
 - test setup 2-20
 - tests 10-11
 - what it verifies 2-17

T

- temperature and humidity check 2-6
- terminations, recommended part numbers 1-4
- TEST ABORTED 10-39

test equipment

- required types 1-3, 1-4
 - service 1-3, 1-4
 - table of 1-3
- test options menu 10-6
- test pattern descriptions 10-13
- test port coupler removal 14-30
- TEST PORT OVERLOAD, REDUCE POWER 10-39
- test record, performance test 2-46
- test setup
 - frequency accuracy 2-34
 - measurement calibration 2-22
 - power meter 2-36
 - system verification 2-20
- test status terms 10-5
- tests
 - adjustment description of 10-12
 - display description of 10-13
 - external descriptions 10-11
 - internal description of 10-8
 - menu 10-5
 - options menu 10-6
 - performance 2-33
 - system verification 10-11
 - test pattern description 10-13
- theory 12-6
 - digital control 12-9
 - power supply 12-6
 - source group 12-13
 - system operation 12-3
- transfer switch description 12-21
- transmission port check 4-9
- transmission tracking
 - description 11-16
 - uncorrected port performance 11-8
- TROUBLE!CHECK SET-UP AND START OVER 10-40
- troubleshooting
 - accessories 9-2
 - band-related problems 7-22
 - broadband phaselock problems 7-8
 - broadband power problems 7-26
 - CPU (A7) board 6-4
 - display (A18,A19) 6-7
 - fan 5-18
 - front panel (A1/A2) 6-13
 - GSP (A19) and the Display(A18) 6-9
 - organization 4-13
 - phaselock by swapping IF cables 7-9
 - power supply flowchart 5-3
 - receiver signal paths 8-3

Index

service equipment to use [1-3](#),
[1-4](#)
source [7-6](#)
source flowchart [7-3](#)
using controllers to system
troubleshoot [4-12](#)

U

uncorrected performance [11-8](#)

V

VCO
tuning range [7-16](#)
VCO (A14)
substituting tuning voltages
[7-16](#)
VCO range check frequencies [7-14](#)
VCO tune adjustment [3-39](#)
VCO/2 Waveforms at A14TP1
[7-16](#)
verification
ANSI/NCSL Z540-1-1994
description [2-3](#)
device measurements [2-25](#)
non-ANSI/NCSL Z540-1-1994
description [2-3](#)
post-repair procedures [14-35](#)
results, interpreting [2-31](#)
system [2-15](#)
tests, performing [2-26](#)
verification kit
contents [2-16](#)
device and test numbers [2-25](#)
recommended models [1-3](#)
verifying shorts and opens by
substitution [9-7](#)

W

walking one pattern
how to perform [6-10](#)
WRONG DISK FORMAT,
INITIALIZE DISK [10-40](#)

Y

YIG oscillator
bias voltages [7-13](#)
depiction of 0.25 V/GHz
Waveform at Abus Node 9
[7-7](#), [7-14](#)
signal flow [12-16](#)
tuning description [12-15](#)
viewing the 0.25V/GHz signal
[7-6](#)