

Service Guide

Agilent Technologies 8564E/EC and 8565E/EC Spectrum Analyzers



Agilent Technologies

Manufacturing Part Number: 08564-90040

**Printed in USA
March 2001**

Supersedes: December 1999

© Copyright 1995 – 2001 Agilent Technologies, Inc.

Notice

Agilent Technologies makes no warranty of any kind with regard to this material, including but not limited to, the implied warranties of merchantability and fitness for a particular purpose.

Agilent Technologies shall not be liable for errors contained herein or for incidental or consequential damages in connection with the furnishing, performance, or use of this material.

All Rights Reserved. Reproduction, adaptation, or translation without prior written permission is prohibited, except as allowed under the copyright laws.

The information contained in this document is subject to change without notice.

Certification

Agilent Technologies certifies that this product met its published specifications at the time of shipment from the factory.

Agilent Technologies further certifies that its calibration measurements are traceable to the United States National Institute of Standards and Technology, to the extent allowed by the Institute's calibration facility, and to the calibration facilities of other International Standards Organization members.

General Safety Considerations

The following safety notes are used throughout this manual.

Familiarize yourself with these notes before operating this instrument.

WARNING

Warning denotes a hazard. It calls attention to a procedure which, if not correctly performed or adhered to, could result in injury or loss of life. Do not proceed beyond a warning note until the indicated conditions are fully understood and met.

CAUTION

Always use the three-prong AC power cord supplied with this product. Failure to ensure adequate grounding may cause product damage.

CAUTION Caution denotes a hazard. It calls attention to a procedure that, if not correctly performed or adhered to, could result in damage to or destruction of the instrument. Do not proceed beyond a caution sign until the indicated conditions are fully understood and met.

WARNING **This is a Safety Class 1 Product (provided with a protective earth ground incorporated in the power cord). The mains plug shall be inserted only in a socket outlet provided with a protected earth contact. Any interruption of the protective conductor inside or outside of the product is likely to make the product dangerous. Intentional interruption is prohibited.**

WARNING **No operator serviceable parts inside. Refer servicing to qualified personnel. To prevent electrical shock do not remove covers.**

WARNING ***Before this instrument is switched on, make sure it has been properly grounded through the protective conductor of the ac power cable to a socket outlet provided with protective earth contact.***

Any interruption of the protective (grounding) conductor, inside or outside the instrument, or disconnection of the protective earth terminal can result in personal injury.

If this instrument is used in a manner not specified by Agilent Technologies, the protection provided by the instrument may be impaired.

There are many points in the instrument which can, if contacted, cause personal injury. Be extremely careful. Any adjustments or service procedures that require operation of the instrument with protective covers removed should be performed only by trained service personnel.

CAUTION *Before this instrument is switched on, make sure its primary power circuitry has been adapted to the voltage of the ac power source.*

Failure to set the ac power input to the correct voltage could cause damage to the instrument when the ac power cable is plugged in.

This product conforms to Enclosure Protection IP 2 0 according to IEC-529. The enclosure protects against finger access to hazardous parts within the enclosure; the enclosure does not protect against the entrance of water.

Warranty

This Agilent Technologies instrument product is warranted against defects in material and workmanship for a period of one year from date of shipment. During the warranty period, Agilent Technologies will, at its option, either repair or replace products that prove to be defective.

For warranty service or repair, this product must be returned to a service facility designated by Agilent Technologies. Buyer shall prepay shipping charges to Agilent Technologies and Agilent Technologies shall pay shipping charges to return the product to Buyer. However, Buyer shall pay all shipping charges, duties, and taxes for products returned to Agilent Technologies from another country.

Agilent Technologies warrants that its software and firmware designated by Agilent Technologies for use with an instrument will execute its programming instructions when properly installed on that instrument. Agilent Technologies does not warrant that the operation of the instrument, or software, or firmware will be uninterrupted or error-free.

LIMITATION OF WARRANTY

The foregoing warranty shall not apply to defects resulting from improper or inadequate maintenance by Buyer, Buyer-supplied software or interfacing, unauthorized modification or misuse, operation outside of the environmental specifications for the product, or improper site preparation or maintenance.

NO OTHER WARRANTY IS EXPRESSED OR IMPLIED.
AGILENT TECHNOLOGIES SPECIFICALLY DISCLAIMS THE
IMPLIED WARRANTIES OF MERCHANTABILITY AND FITNESS
FOR A PARTICULAR PURPOSE.

EXCLUSIVE REMEDIES

THE REMEDIES PROVIDED HEREIN ARE BUYER'S SOLE AND EXCLUSIVE REMEDIES. AGILENT TECHNOLOGIES SHALL NOT BE LIABLE FOR ANY DIRECT, INDIRECT, SPECIAL, INCIDENTAL, OR CONSEQUENTIAL DAMAGES, WHETHER BASED ON CONTRACT, TORT, OR ANY OTHER LEGAL THEORY.

1. General Information

Introduction	26
How to Use this Guide	27
Conventions Used in this Guide:	27
Documentation Outline.	27
Differences Between 8560 EC-Series and E-Series Spectrum Analyzers.	28
Instrument Variations	29
Serial Numbers and Repair Information	30
Service Kit	32
Electrostatic Discharge	33
Reducing Potential for ESD Damage	34
Static-Safe Accessories	34
Returning Instruments for Service	35
Service Tag	35
Original Packaging	35
Other Packaging	35
Recommended Test Equipment	37
Sales and Service Offices	44

2. Adjustment/Diagnostic Software

Introduction	48
Safety Considerations	49
Which Adjustments Should Be Performed?	50
Adjustment Tools Table 2-1 on page 51	50
Instrument Service Position	51
Getting Started	54
Spectrum Analyzers	54
Controller (Computer)	54
Test Equipment	55
Warm-up Time	55
Equipment Connections	57
Using the Adjustment/Diagnostic Software	58
To Load the Program	58
To Use the Adjustment Program	59
Automated Adjustments	62
1. Initial Information	63
2. LO Frequency	64
Assembly Adjusted	64
Related Performance Tests	64
Procedure	64
3. YTO FM Coil	66
Assembly Adjusted	66
Related Performance Tests	66
Procedure	66
4. LOMA Adjustments	68
Assembly Adjusted	68
Related Performance Test	68
Procedure	68
5. Fast Zero Span (E-Series, Non-Option 007)	69

Contents

Assembly Adjusted	69
Related Performance Test	69
Procedure	69
6. 3rd Amp/2nd IF Align	71
Assembly Adjusted	71
Related Performance Test	71
Procedure	71
7. Cal Out Adjustment	72
Assembly Adjusted	72
Related Performance Test	72
Procedure	72
8. Front End Cal	73
Assembly Adjusted	73
Related Performance Tests	73
Procedure	73
9. IF Bandpass Poles	74
Assembly Adjusted	74
Related Performance Test	74
Procedure	74
10. IF Amplitude	75
Assembly Adjusted	75
Related Performance Tests	75
Procedure	75
11. DC Log Adjustment	76
Assembly Adjusted	76
Related Performance Tests	76
Procedure	76
12. Sampling Oscillator	78
Assembly Adjusted	78
Related Performance Test	78
Procedure	78
To Use the Diagnostics	79
DAC Control	79
Latch Control	83
Display IF CAL Data	83
Cal Oscillator Control	84
IF Diagnostics	85
RF Diagnostics	85
3. Manual Adjustment Procedures	
Introduction	90
Safety Considerations	91
Which Adjustments Should Be Performed?	91
Test Equipment	91
Adjustable and Factory-Selected Components	92
Adjustment Tools	92
Instrument Service Position	92
1. High Voltage Power Supply Adjustment (8564E and 8565E)	99
Assembly Adjusted	99

Related Performance Test	99
Description	99
Equipment	100
Procedure	100
2. Display Adjustment (8564E and 8565E).....	102
Assembly Adjusted	102
Related Performance Test	102
Description	102
Equipment	102
Procedure	103
Preliminary Adjustments	103
Cutoff Adjustment	103
Deflection Adjustments	103
Intensity Adjustments	106
Fast Zero Span Adjustments (Non-Option 007, E-series Instruments Only)	108
3. IF Bandpass Adjustment	110
Assembly Adjusted	110
Related Performance Test	110
Description	110
Equipment	111
Procedure	111
LC Bandpass Adjustments	112
XTAL Bandpass Adjustments	114
4. IF Amplitude Adjustments	116
Assembly Adjusted	116
Related Performance Tests	116
Description	116
Equipment	117
Procedure	118
A5 Reference Attenuator Adjustment	119
A5 Adjustment Verification	120
5. DC Log Amplifier Adjustments	121
Assembly Adjusted	121
Related Performance Tests	121
Description	121
Equipment	122
A4 Limiter Phase Adjustment	123
A4 Linear Fidelity Adjustment	124
A4 LOG Fidelity Adjustment	124
6. Sampling Oscillator Adjustment	126
Assembly Adjusted	126
Related Performance Test	126
Description	126
Equipment	126
Procedure	127
Sampling Oscillator Adjustment	127
Sampler Match Adjustment	128
7. YTO Adjustment	130
Assembly Adjusted	130

Related Performance Tests130
Description130
Equipment131
Procedure131
YTO Main Coil Adjustments131
YTO FM Coil Adjustments133
8. Calibrator Amplitude Adjustment134
Assembly Adjusted134
Related Performance Test134
Description134
Equipment134
Procedure135
9. 10 MHz Reference Adjustment — OCXO136
Assembly Adjusted136
Related Performance Test136
Description136
Equipment137
Procedure138
10. 10 MHz Reference Adjustment — TCXO (Option 103)140
Assembly Adjusted140
Related Performance Test140
Description140
Equipment141
Procedure141
11. Demodulator Adjustment142
Assembly Adjusted142
Related Performance Test142
Description142
Equipment143
Procedure143
12. External Mixer Bias Adjustment145
Assembly Adjusted145
Related Performance Test145
Description145
Equipment145
Procedure146
13. External Mixer Amplitude Adjustment147
Assembly Adjusted147
Related Performance Test147
Description147
Equipment148
Procedure148
14. Signal ID Oscillator Adjustment (serial prefix 3517A and below)151
Assembly Adjusted151
Related Performance Test151
Description151
Equipment152
Procedure152
15. 16 MHz PLL Adjustment155

Contents

Assembly Adjusted	155
Related Performance Tests	155
Description	155
Equipment	156
Procedure	156
16. 600 MHz Reference Adjustment (serial prefix 3406A and above)	159
Assembly Adjusted	159
Related Performance Test	159
Description	159
Equipment	159
Procedure	159
3a. Manual Adjustment Procedures: 3335A Source not Available	
What You'll Find in This Chapter	162
Required Test Equipment	163
4a. IF Amplitude Adjustments	164
Assembly Adjusted	164
Related Performance Tests	164
Description	164
Equipment	165
Procedure	165
A5 Reference Attenuator Adjustment	167
A5 Adjustment Verification	167
5a. DC Log Amplifier Adjustments	169
Assembly Adjusted	169
Related Performance Tests	169
Description	169
Equipment	170
A4 Limiter Phase Adjustment	171
A4 Linear Fidelity Adjustment	172
A4 LOG Fidelity Adjustment	173
4. Assembly Replacement	
Introduction	176
Access to Internal Assemblies	177
Cable Color Code	178
Procedure 1. Spectrum Analyzer Cover	179
Removal/Replacement	179
Procedure 2A. A1 Front Frame/A18 LCD (8564EC and 8564EC)	180
Removal of the Front Frame	180
Removal of the Display Driver Board, Inverter Board, and LCD	182
Removal of the Backlights	183
Removal of the Line Switch from the Front Panel	183
Removal of the Keyboard	185
Replacement of the Front Frame	185
Replacement of the Display Driver Board, Inverter Board, and LCD	187
Replacing the Backlights	189
Replacement of the Line Switch	189

Contents

Replacement of the Keyboard	189
Procedure 2B. A1 Front Frame/A18 CRT	191
Removal	191
Replacement	197
Procedure 3. A1A1 Keyboard/Front Panel Keys	200
Removal	200
Replacement	200
Procedure 4. A1A2 RPG	201
Removal	201
Replacement	201
Procedure 5. A2, A3, A4, and A5 Assemblies	202
Removal	202
Replacement	203
Procedure 6A. A6 Power Supply Assembly (8564EC and 8565EC)	209
Removal	209
Replacement	211
Procedure 6B. A6 Power Supply Assembly (8564E and 8565E)	212
Removal	212
Replacement	213
Procedure 7. A6A1 High Voltage Assembly (8564E and 8565E)	216
Removal	216
Replacement	218
Procedure 8. A7 through A13 Assemblies	220
A7 LO Multiplier/Amplifier (LOMA)	222
Removal	222
Replacement	222
A8 Low Band Mixer	223
Removal	223
Replacement	223
A9 Input Attenuator	224
Removal	224
Replacement	225
A10/A12 RYTHM/SBTX	227
Removal	227
Replacement	227
A11 YTO	228
Removal	228
Replacement	228
A13 Second Converter	230
Removal	230
Replacement	230
Procedure 9. A14 and A15 Assemblies	231
Removal	231
Replacement	232
Procedure 10. A16 Fast ADC and A17 CRT Driver (8564E and 8565E)	234
Removal	234
Replacement	235
Procedure 11. B1 Fan	237
Removal/Replacement	237

Contents

Procedure 12. BT1 Battery	238
Removal/Replacement	238
Procedure 13. Rear Frame/Rear Dress Panel	239
Removal	239
Replacement	241
Procedure 14. W3 Line Switch Cable (8564E and 8565E)	244
Removal	244
Replacement (Using Contact Removal Tool, part number 8710-1791)	250
Replacement (without Contact Removal Tool)	251
Procedure 15. EEROM	254
Removal/Replacement	254
Procedure 16. A21 OCXO	256
Removal	256
Replacement	258
5. Replaceable Parts	
Introduction	260
Ordering Information	261
Direct Mail-Order System	261
Direct Phone-Order System	262
Parts List Format	263
Firmware-Dependent Part Numbers	264
Replaceable Parts	270
6. Major Assembly and Cable Locations	
Introduction	304
7. General Troubleshooting	
Introduction	316
Assembly Level Text	316
Block Diagrams	316
Assembly Test Points	317
Ribbon Cables	317
Service Cal Data Softkey Menus	322
Troubleshooting to a Functional Section	324
Error Messages	326
Viewing Multiple Messages	327
Error Message Elimination	327
System Analyzer Programming Errors (100 to 150)	327
ADC Errors (200 to 299)	329
LO and RF Hardware/Firmware Failures (300 to 399)	330
Automatic IF Errors (400 to 599)	334
System Errors (600 to 651)	346
Digital and Checksum Errors (700 to 799)	346
Battery Problem (718)	348
Model/Option Number Errors (719 to 720)	348
RAM Check Error (721)	349
System Errors (750 to 759)	349

Contents

Fast ADC Error (760)349
Option Module Errors (800 to 899)349
User-Generated Errors (900 to 999)350
Block Diagram Description351
RF Section353
Synthesizer Section357
IF Section359
ADC/Interface Section360
Controller Section362
Display/Power Supply Section363
8. ADC/Interface Section	
Introduction378
Keyboard/RPG Problems382
Keyboard Interface382
RPG Interface383
Triggering or Video Gating Problems385
Preselector Peaking Control (Real Time DAC)388
Flatness Control (RF Gain DACs)389
A3 Assembly Video Circuits391
Log Offset/Log Expand393
Video MUX394
Video Filter395
Video Filter Buffer Amplifier396
Positive/Negative Peak Detectors397
Peak Detector Reset398
Rosenfell Detector399
ADC MUX400
Variable Gain Amplifier (VGA)402
Track and Hold402
A3 Assembly ADC Circuits403
ADC Control Signals403
ADC Start/Stop Control404
ADC ASM405
ADC405
Ramp Counter406
A3 Assembly Control Circuits407
Analog Bus Drivers407
Analog Bus Timing408
Interface Strobe Select409
A16 Assembly Fast ADC Circuits (Option 007 in 8564E and 8565E instruments)411
Video Input Scaling Amplifiers and Limiter411
8-Bit Flash ADC412
Peak/Pit Detection413
32 K-Byte Static RAM414
A16 Assembly Fast ADC Control Circuits (Option 007 in 8564E and 8565E instruments)	.415
CPU Interface and Control Registers415
Reference Clock418
Clock and Sample Rate Generator418

Trigger	419
16-Bit Post-Trigger Counter	420
15-Bit (32 K) Circular Address Counter	420
Video Trigger Comparator	421
9. IF Section	
Introduction	428
Troubleshooting Using the Diagnostic Software	430
Troubleshooting the Cal Oscillator on A4 Using Diagnostic Software	431
Troubleshooting A5 Using Diagnostic Software	435
Automatic IF Adjustment	437
Parameters Adjusted	438
Requirements	439
Performance Test Failures	441
IF Gain Uncertainty Performance Test	441
Scale Fidelity Performance Test	442
Resolution Bandwidths Performance Tests	442
Log Amplifier (P/O A4 Assembly)	443
Log Amplifier	443
Linear Amplifiers	444
Video Offset	447
Video Output	447
Frequency Counter Prescaler/Conditioner	448
AM/FM Demodulator	448
4.8 kHz IF Filters	449
10.7 MHz IF Filters	450
4.8 kHz and 10.7 MHz IF Filters	450
10.6952 MHz VCXO	451
Input Switch	451
LO Switch	452
Synchronous Detector	452
Log Offset/Gain Compensation	453
Video MUX	454
A5 IF Assembly	455
IF Signature	456
Common IF Signature Problems	462
1 MHz Resolution Bandwidth Problems	465
30 kHz Resolution Bandwidth Problems	466
3 kHz and 10 kHz Resolution Bandwidth Problems	467
Step Gains	468
Cal Oscillator (P/O A4 Assembly)	469
Cal Oscillator Unlock at Beginning of IF Adjust	470
Inadequate CAL OSC AMPTD Range	471
300 Hz to 3 kHz Resolution Bandwidth Out of Specification	472
Low-Pass Filter	478
Sweep Generator	479
AM/FM Demodulation, Audio Amplifier, and Speaker	479

10. Controller Section

Introduction	488
Digital Signature Analysis (8564E and 8565E)	490
Display Problems (8564E and 8565E)	491
Line Generators	491
Blanking	492
Display Jumbled or Trace Off Screen	494
Intensity	498
Bad Characters or Graticule	499
Long Lines Dimmer than Short Lines	499
Analog Zero Span Problems (8564E and 8565E, Non-Option 007)	502
Frequency-Count Marker Problems (8564EC and 8565EC)	503
Frequency-Count Marker Problems (8564E and 8565E)	504
Frequency Counter (8564EC and 8565EC)	505
Frequency Counter (8564E and 8565E)	507
Video Input Scaling Amplifiers and Limiter (8564EC and 8565EC)	509
12-Bit Flash ADC (8564EC and 8565EC)	511
32 K-Byte Static RAM (8564EC and 8565EC)	512
Reference Clock (8564EC and 8565EC)	513
16 MHz Harmonic Filter (8564EC and 8565EC)	514
State- and Trace-Storage Problems	515
Keyboard Problems	516

11. Synthesizer Section

Introduction	522
Test Connector Locations	524
Troubleshooting Test Setup	527
Confirming a Faulty Synthesizer Section	528
General PLL Troubleshooting	534
PLL Locked at Wrong Frequency	534
Unlocked PLL	535
Unlocked Reference PLL (100 MHz VCXO)	537
Operation (100 MHz VCXO)	537
Troubleshooting (100 MHz VCXO)	537
Third LO Driver Amplifier (100 MHz VCXO)	541
Unlocked Reference PLL (600 MHz SAWR)	542
Operation (600 MHz SAWR)	542
Troubleshooting (600 MHz SAWR)	542
Third LO Driver Amplifier (600 MHz SAWR)	545
Unlocked Offset Lock Loop (Sampling Oscillator)	547
Operation	547
Troubleshooting	547
Unlocked YTO PLL	551
Operation	551
Troubleshooting an Unlocked YTO PLL	553
Unlocked Fractional N PLL	560
Operation	560
Confirming an Unlocked Condition	560
Fractional N PLL	561

Contents

Frequency Span Accuracy Problems	568
Determining the 1st LO Span	568
Confirming Span Problems	569
YTO Main Coil Span Problems (LO Spans >20 MHz)	570
YTO FM Coil Span Problems (LO Spans 2.01 MHz to 20 MHz)	570
Fractional N Span Problems (LO Spans \leq 2 MHz)	572
1st LO Span Problems (All Spans)	572
1st LO Span Problems (Multiband Sweeps)	573
Phase Noise Problems	575
Phase Noise in Locked versus Unlocked Spans	575
Reference versus Reference PLL Phase Noise	576
Fractional N versus Offset PLL or YTO PLL Phase Noise	576
Fractional N PLL Phase Noise (08564-60007 Only)	576
Sampler and Sampler IF	577
Sweep Generator Circuit	579
A21 OCXO	585
12. RF Section	
Introduction	594
Troubleshooting Using the Diagnostic Software	595
Low Band Problems	599
High Band Problems	600
Low and High Band Problems	601
A7 LO Multiplier and Distribution Amplifier	602
A8 Low Band Mixer	604
A9 Input Attenuator	605
A10 YIG-Tuned Filter/Mixer (RYTHM)	608
A12 Switched Barium-Tuned Mixer (SBTX)	609
A13 Second Converter	610
A14 Frequency Control Assembly	612
LO Multiplier/Amplifier Drive	612
Control Latch for Band-Switch Drivers	615
YTF Driver Circuit	615
A15 RF Assembly	621
Confirming a Faulty Third Converter	621
Confirming Third Converter Output	621
Third Converter	622
Flatness Compensation Control	624
PIN Switch Drivers	624
SIG ID Oscillator (Option 008)	625
10 MHz Reference	626
13. Display/Power Supply Section	
Introduction	634
LCD Display (8564EC and 8565EC)	635
Overview of A17 Display Driver Board	636
Troubleshooting the LCD Display	637
Blank Display	637

Contents

Dim Display639
Troubleshooting Using the VGA Port639
Troubleshooting Using Part Substitution639
CRT Display (8564E and 8565E)641
Troubleshooting Using the TAM643
Blank Display (Using the TAM)645
Blank Display646
Blanking Signal647
Display Distortion648
Focus Problems650
Intensity Problems652
Power Supply654
Troubleshooting Using the TAM (8564E and 8565E only)657
A6 Power Supply Assembly658
Dead Power Supply658
Line Fuse Blowing660
Supply Restarting Every 1.5 Seconds (Kick Start)661
Low Voltage Supplies661
High Voltage Supplies (8564E and 8565E)662
CRT Supply Dropping Out (8564E and 8565E)663
Blanking Signal (8564E and 8565E)663
Buck Regulator Control664
DC-DC Converter Control665
Power Up665
14. Component-Level Information Packets	
Introduction672

Figures

Figure 1-1 . Serial Number Label Example	30
Figure 1-2 . Earlier Serial Number Label Example	31
Figure 1-3 . Example of a Static-Safe Workstation	33
Figure 1-4 . Spectrum Analyzer Shipping Container and Cushioning Materials	36
Figure 2-1 . LO Frequency Adjustment Setup	64
Figure 2-2 . LO Frequency Adjustment Locations	65
Figure 2-3 . YTO FM Coil Adjustment Locations	67
Figure 2-4 . A14J18 and A14J15 Pin Locations	68
Figure 2-5 . A2 Fast Zero Span Adjustment Locations	70
Figure 2-6 . IF Amplitude Adjustment Setup	75
Figure 2-7 . DC Log Adjustment Setup	76
Figure 2-8 . DC Log Adjustment Locations	77
Figure 2-9 . CAL Oscillator Swept Output, 20 kHz Width	84
Figure 2-10 . Diagnostic Software Connection Locations, A14 and A15	87
Figure 2-11 . Diagnostic Software Connection Locations, RF Section	88
Figure 3-1 . High Voltage Power Supply Adjustment Setup	100
Figure 3-2 . Display Adjustment Setup	102
Figure 3-3 . CRT Adjust Pattern	105
Figure 3-4 . A2 Display Adjustment Locations	107
Figure 3-5 . IF Bandpass Adjustment Setup	110
Figure 3-6 . A5J6 Pin Locations	112
Figure 3-7 . IF Amplitude Adjustment Setup	117
Figure 3-8 . IF Amplitude Adjustment Locations	118
Figure 3-9 . DC Log Adjustment Setup	122
Figure 3-10 . DC Log Adjustment Locations	123
Figure 3-11 . Sampler Adjustment Setup	126
Figure 3-12 . A15J200 Pin Locations	127
Figure 3-13 . YTO Adjustment Setup	130
Figure 3-14 . YTO Adjustment Locations	132
Figure 3-15 . Calibrator Amplitude Adjustment Setup	134
Figure 3-16 . 10 MHz Reference Adjustment Setup and Adjustment Location	137
Figure 3-17 . 10 MHz Reference Adjustment Setup — TCXO	140
Figure 3-18 . Demodulator Adjustment Setup	142
Figure 3-19 . Demodulator Adjustment Locations	144
Figure 3-20 . External Mixer Bias Adjustment Setup	145
Figure 3-21 . External Mixer Amplitude Adjustment Setup	147
Figure 3-22 . Signal ID Oscillator Adjustment Setup	151
Figure 3-23 . Signal ID Oscillator Adjustment Jumper Location	153
Figure 3-24 . 16 MHz PLL Adjustment Setup	155
Figure 3-25 . 16 MHz PLL Adjustment Location	157
Figure 3a-1 . IF Amplitude Adjustment Setup	164
Figure 3a-2 . IF Amplitude Adjustment Locations	165
Figure 3a-3 . DC Log Adjustment Setup	170
Figure 3a-4 . DC Log Adjustment Locations	171
Figure 4-1 . Hinged Assemblies	179

Figures

Figure 4-2 . LCD Assembly - Exploded View	184
Figure 4-3 . Discharging High Voltage on the CRT	193
Figure 4-4 . A18 and Line Switch Assembly Mounting Screws	194
Figure 4-5 . Front-Frame Mounting Screws	195
Figure 4-6 . Installing the CRT and Front-Frame Assemblies	196
Figure 4-7 . Placing the CRT into the Front Frame	198
Figure 4-8 . A2, A3, A4, and A5 Assembly Removal	203
Figure 4-9 . Assembly Cables (1 of 3) – EC- Series	204
Figure 4-10 . Assembly Cables (2 of 3) – EC-series	205
Figure 4-11 . Assembly Cables (3 of 3)– E-series.	205
Figure 4-12 . Coaxial Cable Clip – EC-Series	206
Figure 4-13 . Coaxial Cable Clip – E-Series	207
Figure 4-14 . GPIB and A1A1 W1 Cable Placement	208
Figure 4-15 . Power Supply Cover	210
Figure 4-16 . Power Supply Cover	211
Figure 4-17 . A6 Power Supply Connections	214
Figure 4-18 . Power Supply Cover	215
Figure 4-19 . A16 Fast ADC and A17 CRT Driver Mounting Screws	218
Figure 4-20 . 8564E/ECand 8565E/EC Assembly Locations	221
Figure 4-21 . A9 Attenuator Removal	224
Figure 4-22 . A9 and A10/A12 Mounting Screws	226
Figure 4-23 . A11 Mounting Screws at Right Side Frame	229
Figure 4-24 . A14 and A15 Assembly Removal	231
Figure 4-25 . A14 and A15 Assembly Cables	233
Figure 4-26 . A16 and A17 Mounting Screws	235
Figure 4-27 . A16 Cable Routing	236
Figure 4-28 . Main Deck Screws	241
Figure 4-29 . A6 Power Supply Cover	243
Figure 4-30 . W3 Dress and Connection to A6 Power Supply	246
Figure 4-31 . Line Switch Mounting Screw and Cable Dress	248
Figure 4-32 . W3 Cable Connector	249
Figure 4-33 . Side Frame Mounting Screws	252
Figure 4-34 . A21 OCXO Mounting Screws	257
Figure 5-1 . Assembly Screw Mounting Locations	279
Figure 5-2 . Parts Identification, Cover Assembly	287
Figure 5-3 . Parts Identification, Main Chassis (8564E and 8565E)	289
Figure 5-4 . Parts Identification, RF Section (8564E and 8565E)	291
Figure 5-5 . Parts Identification, Front Frame (8564E and 8565E)	293
Figure 5-6 . Parts Identification, Rear Frame (8564E and 8565E).	295
Figure 5-7 . Parts Identification, Chassis (8564EC and 8565EC)	297
Figure 5-8 . Parts Identification, Front Frame (8564EC and 8565EC).	299
Figure 5-9 . Parts Identification, Rear Frame (8564EC and 8565EC)	301
Figure 6-1 . Hinged Assemblies	306
Figure 6-2 . Top View (A2 and A3 Unfolded) – EC-Series.	307
Figure 6-3 . Top View (A2, A3, A4, and A5 Unfolded) – EC-Series	308

Figures

Figure 6-4 . Top View (A2, A3, A4, and A5 Unfolded) – E-Series	309
Figure 6-5 . Bottom View (A15 Unfolded)	310
Figure 6-6 . Bottom View (A15 and A14 Unfolded)	311
Figure 6-7 . A16 Fast ADC (Option 007)	312
Figure 6-8 . 8564E/EC and 8565E/EC Front End	313
Figure 6-9 . Rear View EC-Series	314
Figure 6-10 . Rear View E-Series	314
Figure 7-1 . Assembly Test Points	318
Figure 7-2 . Ribbon Cable Connections (1 of 3)	319
Figure 7-3 . Ribbon Cable Connections (2 of 3)	320
Figure 7-4 . Ribbon Cable Connections (3 of 3) – EC-Series Only	321
Figure 7-5 . Service Cal Data Menu	323
Figure 7-6 . Functional Sections	352
Figure 7-7 . Phase Lock Loops	358
Figure 7-8 . Simplified Block Diagram	365
Figure 7-9 . Overall Block Diagram (1 of 5)	367
Figure 7-9 . Overall Block Diagram (2 of 5)	369
Figure 7-9 . Overall Block Diagram (3 of 5)	371
Figure 7-9 . Overall Block Diagram (4 of 5)	373
Figure 7-9 . Overall Block Diagram (5 of 5)	375
Figure 8-1 . A3 Test Connectors	380
Figure 8-2 . A3 Test Connector Pin Locations	381
Figure 8-3 . A3 Interface Assembly Block Diagram	423
Figure 8-4 . Fast ADC (Option 007) Block Diagram	425
Figure 9-1 . A4 and A5 Test Connectors	430
Figure 9-2 . A4 and A5 Test Connector Pin Locations	431
Figure 9-3 . CAL Oscillator Swept Output, 20 kHz Width	433
Figure 9-4 . CAL Oscillator Swept Output, 10 kHz Width	433
Figure 9-5 . CAL Oscillator Swept Output, 4 kHz Width	434
Figure 9-6 . CAL Oscillator Swept Output, 2 kHz Width	434
Figure 9-7 . IF Section Troubleshooting Simplified Block Diagram	436
Figure 9-8 . IF Adjust Signature	458
Figure 9-9 . Detailed IF Adjust Signature (1)	459
Figure 9-10 . Detailed IF Adjust Signature (2)	459
Figure 9-11 . Detailed IF Adjust Signature (3)	460
Figure 9-12 . Detailed IF Adjust Signature (4)	460
Figure 9-13 . Detailed IF Adjust Signature (5)	461
Figure 9-14 . Noisy Signature	463
Figure 9-15 . Noise with Correct Shape	463
Figure 9-16 . Region B Amplitude Variation	464
Figure 9-17 . Region B Amplitude Offset	464
Figure 9-18 . Faulty Crystal Short	465
Figure 9-19 . Faulty LC Pole	466
Figure 9-20 . Faulty Crystal Symmetry	467
Figure 9-21 . Output Waveform, 10 kHz Resolution Bandwidth	474

Figures

Figure 9-22 . Output Waveform, 3 kHz Resolution Bandwidth	475
Figure 9-23 . Output Waveform, 1 kHz Resolution Bandwidth	476
Figure 9-24 . Output Waveform, 300 Hz Resolution Bandwidth	477
Figure 9-25 . Failed Crystal Set Symptoms	478
Figure 9-26 . A4 Log Amplifier/Cal Oscillator Block Diagram (1 of 2)	481
Figure 9-26 . A4 Log Amplifier/Cal Oscillator Block Diagram (2 of 2)	483
Figure 9-27 . A5 IF Assembly Block Diagram	485
Figure 10-1 . A2 Test Connectors	489
Figure 10-2 . A2 Test Connector Pin Locations	489
Figure 10-3 . Line Generator Output Waveforms	492
Figure 10-4 . Blanking Waveforms	493
Figure 10-5 . Expanded Blanking Waveforms	494
Figure 10-6 . Switch Driver Waveform LCHAR	495
Figure 10-7 . Distorted X/Y Line Generator Waveforms	497
Figure 10-8 . Expanded X/Y Line Generator Waveforms	497
Figure 10-9 . Normal X/Y Line Generator Waveforms	498
Figure 10-10 . Delta X Waveform	500
Figure 10-11 . Delta Y Waveform	501
Figure 10-12 . DEF1 Synchronization	502
Figure 10-13 . A2 Controller Block Diagram (E-Series)	517
Figure 10-14 . A2 Controller Block Diagram (EC-Series)	519
Figure 11-1 . A14 and A15 Assembly Test Connectors	524
Figure 11-2 . Test Connector Pin Locations	525
Figure 11-3 . YTO Loop Test Setup	531
Figure 11-4 . Sampler and Sampling Oscillator Test Setup	532
Figure 11-5 . PLL Locked at Wrong Frequency	535
Figure 11-6 . Unlocked PLL	536
Figure 11-7 . Troubleshooting an Unlocked YTO PLL	554
Figure 11-8 . VCO Bias Voltages for A14 Assemblies 08564-60014 and Above	564
Figure 11-8a . VCO Bias Voltages for A14 Assembly 08564-60007	565
Figure 11-9 . 8564E/EC Sweep and Scan Ramps	574
Figure 11-10 . 8565E/EC Sweep and Scan Ramps	574
Figure 11-11 . Simplified Synthesizer Section	581
Figure 11-12 . Simplified A14 Assembly Block Diagram	582
Figure 11-13 . Simplified A15 Assembly Block Diagram (100 MHz PLL)	583
Figure 11-13a . Simplified A15 Assembly Block Diagram (600 MHz PLL)	584
Figure 11-14 . Frequency Control Block Diagram	587
Figure 11-15 . RF Block Diagram For A15 08563-60054, 08563-60055, or 08563-60056 ..	589
Figure 11-16 . RF Block Diagram For A15 <08563-60054, 08563-60055, or 08563-60056	591
Figure 12-1 . Diagnostic Software Connection Locations, A14 and A15	596
Figure 12-2 . Diagnostic Software Connection Locations, RF Section	597
Figure 12-3 . A14J10, Solder Side of A14 (Ignore Pin Numbers on Mating Connector) ...	602
Figure 12-4 . A7 LO Multiplier/Amplifier Drive	614
Figure 12-5 . 8564E/EC Rear Panel SWP Output	617
Figure 12-6 . 8565E/EC Rear Panel SWP Output	617

Figures

Figure 12-7 . 8564E/EC Signal at A14J15 Pin 1	618
Figure 12-8 . 8565E/EC Signal at A14J15 Pin 1	618
Figure 12-9 . 10 MHz Reference at A15J302	627
Figure 12-10 . 10 MHz TTL Reference at U304 Pin 13	628
Figure 12-11 . RF Section, Troubleshooting Block Diagram	631
Figure 13-1 . Simplified LCD Block Diagram	636
Figure 13-2 . Probe Power Socket	638
Figure 13-3 . Location of +5V supply pins on J1 of A17 and J8 of A2	640
Figure 13-4 . Power Supply and CRT Block Diagram	642
Figure 13-5 . A17 Test Connector	644
Figure 13-6 . Probe Power Socket	646
Figure 13-7 . Simplified Power Supply Block Diagram	655
Figure 13-8 . Buck Regulator Waveform	660
Figure 13-9 . A6 Power Supply Block Diagram	667
Figure 13-10 . A17 CRT Driver Block Diagram	669
Figure 14-1 . 8564/65 EC-Series Interconnect Block Diagram	677
Figure 14-2 . 8564/65 E-Series Interconnect Block Diagram	679

Table 1-1 . Instrument Variations	29
Table 1-2 . Service Kit Contents	32
Table 1-3 . Static-Safe Accessories	34
Table 1-4 . Recommended Test Equipment.	37
Table 1-5 . Agilent Technologies Sales and Service Offices.	45
Table 2-1 . Related Adjustments	51
Table 2-2 . Test Equipment Required for Automated Adjustments	56
Table 2-3 . DAC Control Recommended Instrument State	80
Table 2-4 . Latch Control Recommended Instrument State	83
Table 3-1 . Related Adjustments	93
Table 3-2 . Adjustable Components.	96
Table 3-3 . Factory Selected Components.	98
Table 3-4 . Factory-Selected LC Filter Capacitors	113
Table 3-5 . LC Factory-Selected Capacitor Selection	113
Table 3-6 . Factory-Selected XTAL Filter Capacitors.	114
Table 3-7 . XTAL Factory-Selected Capacitor Selection	115
Table 3-8 . Capacitor Part Numbers	115
Table 3-9 . Sampling Adjustments.	128
Table 3-10 . Conversion Loss Data	149
Table 3a-1 . Recommended Test Equipment	163
Table 4-1 . Required Tools	178
Table 5-1 . Reference Designations.	264
Table 5-2 . Abbreviations	265
Table 5-3 . Reference Designations, Abbreviations, and Multipliers	269
Table 5-4 . Replaceable Parts.	270
Table 5-5 . Replaceable Parts –8564E/EC and 8565E/EC	279
Table 5-6 . Parts List, Cover Assembly –8564E/EC and 8565E/EC (see Figure 5-2)	280
Table 5-7 . Parts List, Main Chassis – 8564EC and 8565EC (see Figure 5-7)	280
Table 5-8 . Parts List, Main Chassis –8564E and 8565E (See Figure 5-3).	281
Table 5-9 . Parts List, RF Section –8564E/EC and 8565E/EC (See Figure 5-4)	282
Table 5-10 . Parts List, Front Frame – 8564EC and 8565EC (see Figure 5-8).	283
Table 5-11 . Parts List, Front Frame –8564E and 8565E (See Figure 5-5).	284
Table 5-12 . Parts List, Rear Frame –8564EC and 8565EC (See Figure 5-9).	285
Table 5-13 . Parts List, Rear Frame –8564E and 8565E (See Figure 5-6)	285
Table 7-1 . Location of Assembly Troubleshooting Text	325
Table 8-1 . W2 Control Cable Connections (1 of 2)	379
Table 8-2 . Table 8-1. W2 Control Cable Connections (2 of 2)	380
Table 8-3 . Keyboard Matrix	382
Table 8-4 . Counter Frequencies	384
Table 8-5 . Trigger MUX Truth Table.	385
Table 8-6 . A3U102 Latch Outputs	396
Table 8-7 . HMUX_SELO/1 versus Detector Mode	399
Table 8-8 . Logic Levels at A3U108	401
Table 8-9 . Demultiplexer A3U410 Truth Table	410
Table 8-10 . Demultiplexer A3U500 Truth Table	410

Tables

Table 8-11 . LP/Q Truth Table	413
Table 8-12 . Control Word at Primary Address (U3 and U4).	416
Table 9-1 . Sweep Width Settings.	432
Table 9-2 . IF Gain Application Guidelines (ATTEN=10 dB).	445
Table 10-1 . Gate Times	506
Table 10-2 . Gate Times	508
Table 11-1 . Troubleshooting Suspected Faulty Circuits	525
Table 11-2 . Center Frequency Tuning Values.	529
Table 11-3 . Sampling Oscillator Test Frequencies	533
Table 11-4 . Sampling Oscillator PLL Divide Numbers	548
Table 11-5 . Amplifier Polarities	553
Table 11-6 . Voltages in FM Coil and Main Loop Drivers	558
Table 11-7 . Main Coil Coarse and Fine DACs Voltages.	558
Table 11-8 . Postscaler Divide Numbers	561
Table 11-9 . Unlocked Fractional N Troubleshooting Areas (08564-60014 and Above) . . .	562
Table 11-10 . Table 11-9a. Unlocked Fractional N Troubleshooting Areas (08564-60007) .	562
Table 11-11 . Divider and Integrator Troubleshooting.	566
Table 11-12 . Sweep Signal Destination versus Span.	568
Table 11-13 . Harmonic Mixing Number versus Center Frequency	569
Table 11-14 . Settings of Sweep Switches	571
Table 11-15 . Settings of Sweep Switches	575
Table 12-1 . Procedures To Use For Isolating Faults	598
Table 12-2 . Attenuator Control Truth Table (W11 connected to A14J6)	606
Table 12-3 . Attenuator Control Truth Table (W11 connected or disconnected from A14J6)	606
Table 12-4 . Attenuator Control Truth Table (W11 connected or disconnected from A14J6)	607
Table 12-5 . Sweep + Tune Multiplier Values	619
Table 12-6 . RF Section Mnemonic Table	629
Table 13-1 . Automatic Fault Isolation References	643
Table 13-2 . TAM Tests versus Test Connectors	644
Table 13-3 . W1 Power-Cable Connections	656
Table 13-4 . Automatic Fault Isolation References	657
Table 14-1 . CLIPs Available for the 8564E, 8564EC, 8565E, and 8565EC Spectrum Analyzers	673

1 **General Information**

Introduction

This *8564E/EC and 8565E/EC Spectrum Analyzers Service Guide* contains information required to adjust and service the 8561E, 8561EC, 8563E, and 8563EC to the assembly level.

How to Use this Guide	page 27
Differences Between E-series and EC-series Analyzers ..	page 28
Instrument Variations	page 29
Serial Number and Repair Information.....	page 30
Service Kit	page 32
Electrostatic Discharge.....	page 33
Returning Instrument for Service.....	page 35
Recommended Test Equipment.....	page 37

How to Use this Guide

Chapters 1 through 5 contain adjustments and parts information that can be used to adjust your spectrum analyzer and to help you fix problems.

Chapter 6, “General Troubleshooting”, can be used to identify the location of a problem to a board or functional area in the spectrum analyzer.

Chapters 7 through 13, which cover functional areas, can then be used to help you localize the problem further.

Conventions Used in this Guide:

Screen Text	This font indicates text displayed on the screen
Key	This font indicates a softkey or a hardkey
8564E/EC, 8565E/EC	These terms are used to refer to both E-series and EC-series instruments

Documentation Outline

8560 E-Series and EC-Series Spectrum Analyzer Calibration Guide

- Tells you how to run verification software.
- Tells you what your spectrum analyzer’s specifications are.
- Tells you how to test your spectrum analyzer.

8560 E-Series and EC-Series Spectrum Analyzer User’s Guide

- Tells you how to make measurements with your spectrum analyzer.
- Tells you how to install your spectrum analyzer.
- Tells you how to program your spectrum analyzer.

8560 E-Series and EC-Series Spectrum Analyzer Quick Reference Guide

- Is an abbreviated version of the *8560 E-Series and EC-Series Spectrum Analyzer’s User’s Guide*.
- Provides you with a listing of all remote programming commands.

8560 E-Series Spectrum Analyzer Component Level Information

- Provides schematics and parts lists for the instrument.

Differences Between 8560 EC-Series and E-Series Spectrum Analyzers

Features	8560 EC-Series	8560 E-Series
Display	<ul style="list-style-type: none"> — LCD display — color — display not adjustable — backlight bulbs are replaceable (replace both bulbs when display is dim) — requires A17 LCD driver board 	<ul style="list-style-type: none"> — CRT display — monochrome — display adjustable for intensity, focus, and quadrature — requires high voltage module (HVM), which is included in the A6 power supply — requires A17 CRT driver board
Fast ADC sweep times (FADC) enables sweep times of 30 ms to 50 μ s	<ul style="list-style-type: none"> — FADC is standard — FADC circuitry integrated into A2 controller board 	<ul style="list-style-type: none"> — FADC is available as an option (Option 007) — separate A16 FADC board required
VGA port	<ul style="list-style-type: none"> — located on rear panel — always active — does not require user interface 	Not available

In all other operational respects the EC-series and E-series are identical. Unless otherwise noted, the information in this manual applies to all 8564EC, 8565EC, 8564E and 8565E instruments.

NOTE

FADC is a standard feature, and not an option in 8560 EC-series instruments. However, it is still necessary that option “007” be in the instrument’s serial ID string. For this reason, if you press the **Datecode & Options** key, the message shown on the display will indicate that option 007 is present. In addition, a statement on the rear panel of the instrument reads “Option 007 must be in serial ID string.”

NOTE

Diagrams that illustrate features common to E-series and EC-series instruments are shown with E-series instruments. Where there are differences between E-series and EC-series features, separate diagrams are provided for E-series and for EC-series instruments.

Instrument Variations

There are options available to the 8564E/EC and 8565E/EC. The following table lists these options and identifies the assemblies which are unique to them.

Table 1-1 Instrument Variations

Option	Added	Deleted
8564E/EC and 8565E/EC Option 001 (2nd IF Output)	W19 Cable Assembly Rear-Panel J10	
8564E/EC and 8565E/EC Option 005 (add Alternative Sweep Output)	W58 Cable Assembly	
8564E/EC and 8565E/EC Option 006 (Frequency Coverage Down to 30 Hz)	A8 Low Band Mixer (Opt 006)	A8 Low Band Mixer (Std)
8564E and 8565E Option 007 (Fast ADC) -Fast ADC is available as an option for 8564E and 8565E instruments -Fast ADC is a standard feature on 8564EC and 8565EC instruments which does not require additional assemblies	A16 Fast ADC Assembly A3 Interface Assembly (Opt 007) W20 Cable Assembly (Opt 007) W59 Cable Assembly	A3 Interface Assembly (Std) W20 Cable Assembly (Std)
8564E/EC and 8565E/EC Option 008 (SIG ID)	A15 RF Assembly (Opt 008)	A15 RF Assembly (Std)
8564E/EC and 8565E/EC Option 103 (Delete OCXO)	A15 RF Assembly (Opt 103)	A15 RF Assembly (Std) W49 Cable Assembly W50 Cable Assembly A21 OCXO

Serial Numbers and Repair Information

Agilent Technologies makes frequent improvements to its products to enhance performance, usability, or reliability. Agilent Technologies service personnel have access to complete records of design changes to each type of equipment, based on the equipment's serial number. Whenever you contact Agilent Technologies about a product, have the complete serial number available to ensure obtaining the most complete and accurate information possible.

The serial number label is usually attached to the rear of the product. The serial number has two parts: the prefix (two letters and the first four numbers), and the suffix (the last four numbers).

Figure 1-1

Serial Number Label Example

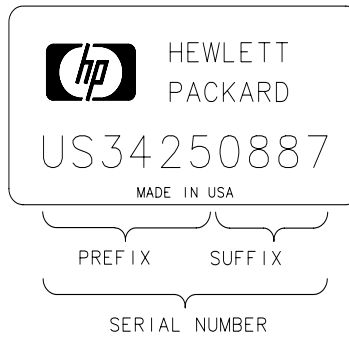

sz155e

The two letters identify the country in which the unit was manufactured. The four numbers of the prefix are a code identifying the date of the last major design change incorporated in your Agilent Technologies product. The four-digit suffix is a sequential number and, coupled with the prefix, provides a unique identification for each unit produced. Whenever you list the serial number or refer to it in obtaining information about your Agilent Technologies product, be sure to use the complete number, including the full prefix and the suffix.

Units which were produced before the serial number format was changed may also be covered by this documentation. On earlier serial number labels, the prefix consists of the first four numbers and a single letter. The suffix is a five-digit sequential number.

Figure 1-2 **Earlier Serial Number Label Example**



sz156e

It is important that you realize that the new serial number format (US00000000) is always considered "above" the earlier format (0000A00000) when you encounter change information such as "...serial prefix 3425A and above" or "...serial number 3425A00564 and above."

Service Kit

The spectrum analyzer service kit (part number 08562-60021) contains service tools required to repair the instrument. Refer to [Table 1-2](#) for a list of items in the service kit.

Table 1-2 Service Kit Contents

Description	Quantity	Part Number
Cable Puller	1	5021-6773
PC Board Prop	1	5021-7459
Line Filter Assembly	1	5061-9032
Line Switch Cable	1	5062-0728
Extender Cable	1	5062-0737
BNC to SMB (snap-on) Cable	2	85680-60093
Connector Extractor Tool Kit	1	8710-1791

Electrostatic Discharge

Electrostatic discharge (ESD) can damage or destroy electronic components. Therefore, all work performed on assemblies consisting of electronic components should be done at a static-free workstation.

Figure 1-3 is an example of a static-safe workstation using two kinds of ESD protection:

- Conductive table mat and wrist-strap combination
- Conductive floor mat and heel-strap combination

These methods may be used together or separately.

Figure 1-3 Example of a Static-Safe Workstation

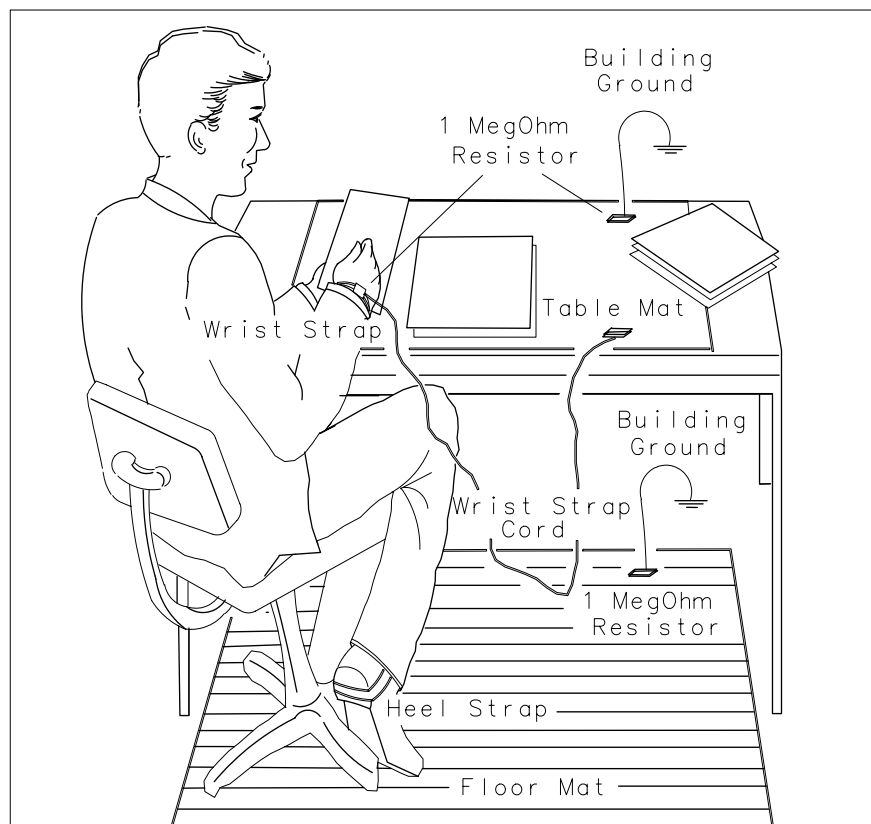

ORMAT46

Reducing Potential for ESD Damage

The suggestions that follow may help reduce ESD damage that occurs during instrument testing and servicing.

- Before connecting any coaxial cable to an spectrum analyzer connector for the first time each day, momentarily ground the center and outer connectors of the cable.
- Personnel should be grounded with a resistor-isolated wrist strap before touching the center pin of any connector and before removing any assembly from the unit.
- Be sure all instruments are properly earth-grounded to prevent build-up of static discharge.

Static-Safe Accessories

Table 1-3 **Static-Safe Accessories**

Part Number	Description
9300-0797	Set includes: 3M static control mat 0.6 m × 1.2 m (2 ft × 4 ft) and 4.6 cm (15 ft) ground wire. (The wrist-strap and wrist-strap cord are not included. They must be ordered separately.)
9300-0980	Wrist-strap cord, 1.5 m (5 ft)
9300-1383	Wrist-strap, color black, stainless steel, without cord, four adjustable links and 7 mm post-type connection.
9300-1169	ESD heel-strap (reusable 6 to 12 months).

Returning Instruments for Service

Service Tag

If you are returning the instrument to Agilent Technologies for servicing, fill in and attach a blue service tag. Service tags are supplied in the back of this chapter.

Please be as specific as possible about the nature of the problem. If you have recorded any error messages that appeared on the screen, or have completed a performance test record, or have any other specific data on the performance of the spectrum analyzer, please send a copy of this information with the unit.

Original Packaging

Before shipping, pack the unit in the original factory packaging materials if they are available. If the original materials are unavailable, identical packaging materials may be acquired through any Agilent Technologies Sales and Service Office. Descriptions of the packaging materials are listed in [Figure 1-4 on page 36](#).

Other Packaging

CAUTION

Spectrum analyzer damage can result from using packaging materials other than those specified. Never use styrene pellets in any shape as packaging materials. They do not adequately cushion the equipment or prevent it from shifting in the carton. They cause equipment damage by generating static electricity and by lodging in the spectrum analyzer fan.

Repackage the spectrum analyzer in the original packaging materials or with commercially available materials described in steps 4 and 5, below.

1. Attach a completed service tag to the instrument.
2. Install the front-panel cover on the instrument.
3. Wrap the instrument in antistatic plastic to reduce the possibility of damage caused by electrostatic discharge.
4. Use the original materials or a strong shipping container that is double-walled, corrugated cardboard carton with 159 kg (350 lb) bursting strength. The carton must be both large enough and strong enough to accommodate the spectrum analyzer and allow at least 3 to 4 inches on all sides of the spectrum analyzer for packing material.

5. Surround the equipment with at least 3 to 4 inches of packing material, or enough to prevent the equipment from moving in the carton. If packing foam is unavailable, the best alternative is SD-240 Air Cap™ from Sealed Air Corporation (Commerce, CA 90001). Air Cap looks like a plastic sheet covered with 1-1/4 inch air-filled bubbles. Use the pink-colored Air Cap to reduce static electricity. Wrap the equipment several times in this material to both protect the equipment and prevent it from moving in the carton.
6. Seal the shipping container securely with strong nylon adhesive tape.
7. Mark the shipping container "FRAGILE, HANDLE WITH CARE" to assure careful handling.
8. Retain copies of all shipping papers.

Figure 1-4

Spectrum Analyzer Shipping Container and Cushioning Materials

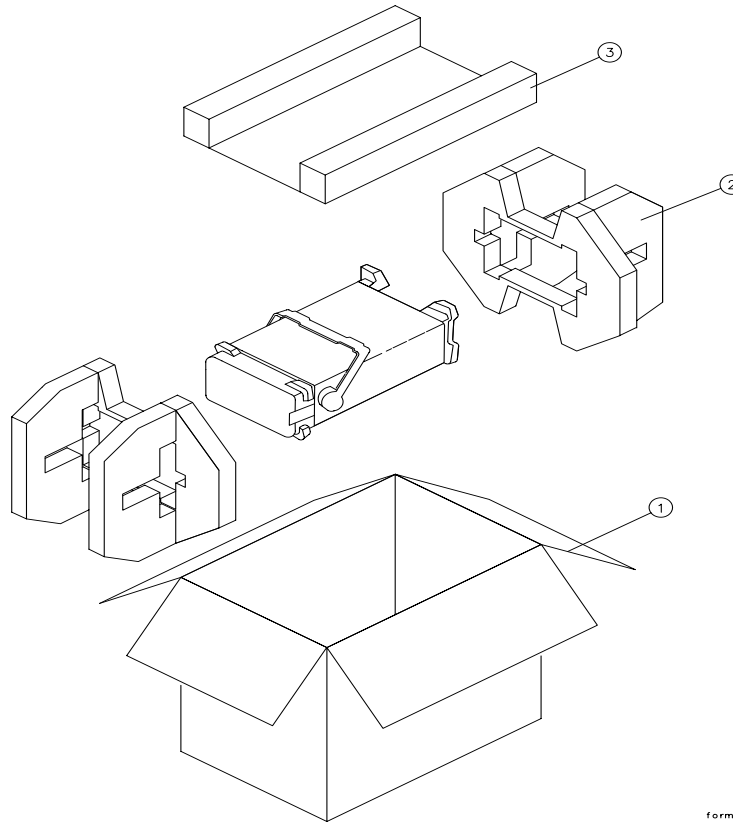

formt112

Item	Part Number	Description
1	9211-6969	Outer Carton
2	9220-5073	Pads (2)
3	9220-5072	Top Tray

Recommended Test Equipment

Table 1-4 lists the recommended test equipment required for operation verification, performance tests, adjustments, troubleshooting, and the Test and Adjustment Module. Any equipment that meets the critical specifications given in the table can be substituted for the recommended model(s). Operation verification, and the performance tests, are located in the calibration guide.

Table 1-4 Recommended Test Equipment

Instrument	Critical Specifications for Equipment Substitution	Recommended Model	Use
Sources Synthesized sweeper <i>(two required for 8560E/EC, 8561E/EC and 8563E/EC)</i> <i>(one required for 8564E/EC and 8565E/EC)</i>	Frequency range: 8560E/EC, 10 MHz to 12.0 GHz 8561E/EC, 10 MHz to 12.0 GHz 8563E/EC, 10 MHz to 26.5 GHz Frequency accuracy (CW): 1×10^{-9} /day Leveling modes: Internal & External Modulation modes: AM & Pulse Power level range: -80 to +16 dBm	8340A/B* 83630A Option 001, 008	P,A,T, M,V
Synthesized sweeper <i>(for 8564E/EC and 8565E/EC)</i>	Frequency range: 8564E/EC, 10 MHz to 40.0 GHz 8565E/EC, 10 MHz to 50.0 GHz Frequency accuracy (CW): 1×10^{-9} /day Leveling mode: Internal Power level range: -35 to +16 dBm	83650A Option 001, 008	P,A,T, V
Synthesizer/ level generator	Frequency range: 200 Hz to 80 MHz Frequency accuracy: 1×10^{-7} /month Flatness: ± 0.15 dB Attenuator accuracy: $< \pm 0.09$ dB External 10 MHz reference input Frequency resolution: 1 Hz	3335A*, †	P,A,T, M,V
Synthesized signal generator	Frequency range: 100 kHz to 2.5 GHz Residual SSB phase noise at 1 GHz: <-73 dBc/Hz at 10 Hz offset <-107 dBc/Hz at 1 kHz offset <-124 dBc/Hz at 10 kHz offset <-124 dBc/Hz at 100 kHz offset	8663A	P,V
Pulse/function generator	Frequency range: 10 kHz to 50 MHz Pulse width: 200 ns; Output amplitude: 5 V peak-to-peak Functions: pulse & triangle Pulse rise time: <100 ns TTL sync output	8116A	P,A

Table 1-4 Recommended Test Equipment

Instrument	Critical Specifications for Equipment Substitution	Recommended Model	Use
AM/FM signal generator	Frequency range: 1 MHz to 200 MHz Frequency modulation mode Modulation oscillator frequency: 1 kHz FM peak deviation: 5 kHz	8640B 8642A	A
Counters Frequency standard	Output frequency: 10 MHz Accuracy: $<1 \times 10^{-10}$	5061B	P,A
Microwave frequency counter	Frequency range: 9 MHz to 26.5 GHz Timebase accuracy (aging): $<5 \times 10^{-10}$ /day External frequency reference input	5343A* Option 001	P,A,M,V
Universal counter	Modes: TI A→B, frequency count Time interval measurement range: 100 ns to 120 s Frequency count range: 400 Hz to 11 MHz Frequency resolution: 1 mHz Timebase accuracy (aging): $<3 \times 10^{-7}$ /month External 10 MHz reference input	5334A/B	P
Receivers Spectrum analyzer (for 8560E/EC Option 002)	Frequency range: 300 kHz to 7 GHz Relative amplitude accuracy: 300 kHz to 2.7 GHz: $<\pm 1.8$ dB 300 kHz to 7 GHz: $<\pm 4.0$ dB Absolute amplitude accuracy: 3.9 GHz to 6.9 GHz: $<\pm 2.7$ dB Frequency accuracy: $<\pm 10$ kHz at 7 GHz	8566B*	P,A,T
Spectrum analyzer	Frequency range: 300 kHz to 7 GHz Amplitude range: -70 dBm to +20 dBm	8566B*	A,T
Measuring receiver	Compatible w/power sensors dB relative mode Resolution: 0.01 dB Reference accuracy: $<\pm 1.2\%$	8902A*	P,A,T, M,V
Sensors Power sensor (for 8560E/EC or 8561E/EC)	Frequency range: 10 MHz to 12 GHz Maximum SWR: 1.40 (10 to 30 MHz) 1.18 (30 to 50 MHz) 1.10 (50 MHz to 2 GHz) 1.18 (2 to 12.4 GHz)	8481A*	P,A,T, M,V
Power sensor	Frequency range: 250 MHz to 350 MHz Power range: 100 nW to 10 μ W Maximum SWR: 1.15 (250 to 350 MHz)	8481D	P,A

Table 1-4 Recommended Test Equipment

Instrument	Critical Specifications for Equipment Substitution	Recommended Model	Use
Power sensor	Frequency range: 100 kHz to 2.9 GHz Maximum SWR: 1.1 (1 MHz to 2.0 GHz) 1.30 (2.0 GHz to 2.9 GHz)	8482A*	P,A,T, M,V
Power sensor (for 8563E/EC)	Frequency range: 50 MHz to 26.5 GHz Maximum SWR: 1.15 (50 to 100 MHz) 1.10 (100 MHz to 2 GHz) 1.15 (2.0 to 12.4 GHz) 1.20 (12.4 to 18 GHz) 1.25 (18 to 26.5 GHz)	8485A*	P,A,T, M,V
Power sensor (for 8564E/EC and 8565E/EC)	Frequency range: 50 MHz to 50 GHz Maximum SWR: 1.15 (50 to 100 MHz) 1.10 (100 MHz to 2 GHz) 1.15 (2.0 to 12.4 GHz) 1.20 (12.4 to 18 GHz) 1.25 (18 to 26.5 GHz) 1.30 (26.5 to 40 GHz) 1.50 (40 to 50 GHz)	8487A	P,V
Other Equipment Controller	Required to run operation verification software and adjustment/diagnostic software (8564E/EC and 8565E/EC)	9816A, 9836A/C, 310, 320 332, 360 54501A*	V
Oscilloscope	Bandwidth (3 dB): dc to 100 MHz Two channels Minimum vertical deflection factor: ≤ 5 mV/div Minimum timebase setting: < 100 ns Digitizing display with time cursors Delta-t cursor accuracy in 500 ns/Div: < 0.1 μ s	11975	P,A,T
Amplifier	Frequency range: 8560E/EC, 2.0 to 2.9 GHz 8561E/EC, 2.0 to 6.5 GHz 8563E/EC, 2.0 to 8.0 GHz 8564E/EC, 2.0 to 8.0 GHz 8565E/EC, 2.0 to 8.0 GHz Minimum output power (leveled) 2.0 to 8.0 GHz: +16 dBm Output SWR (leveled): < 1.7	6114A	A
Power supply	Output voltage: ≥ 24 Vdc Output voltage accuracy: $< \pm 0.2$ V	5005A/B	T
Signature multimeter	Clock frequency > 10 MHz Time interval function		

Table 1-4 Recommended Test Equipment

Instrument	Critical Specifications for Equipment Substitution	Recommended Model	Use
Digital voltmeter	Range: -15 Vdc to +120 Vdc Accuracy: <±1 mV on 10 V range Input impedance: ≥1 M Ω	3456A*	A,T
Probes			
DVM test leads	≥36 inches, alligator clips, probe tips	34118A	A,T
High-frequency probe	No substitute	85024A	T
High-voltage probe	Voltage division ratio: 1000:1	34111A	T
Accessories			
Directional bridge	Frequency range: 1 to 80 MHz Coupling: 6 dB (nominal) Maximum coupling deviation: <1 dB (nominal) Directivity: 40 dB minimum Impedance: 50 Ω (nominal)	8721A	P
Directional coupler (for 8561E/EC) (two required)	Frequency range: 2.0 to 6.5 GHz Coupling: 16.0 dB (nominal) Maximum coupling deviation: ±1 dB (nominal) Directivity: 14 dB minimum Flatness: 0.75 dB maximum VSWR: <1.45 Insertion loss: <1.3 dB	0955-0098	P
Directional coupler (for 8563E/EC, 8564E/EC, and 8565E/EC) (two required)	Frequency range: 2.0 to 8.1 GHz Coupling: 16.0 dB (nominal) Maximum coupling deviation: ±1 dB (nominal) Directivity: 14 dB minimum Flatness: 0.75 dB maximum VSWR: <1.45 Insertion loss: <1.3 dB	0955-0098	P
10 dB step attenuator	Attenuation range: 30 dB Frequency range: dc to 80 MHz Connectors: BNC (f)	355D	P,V
1 dB step attenuator	Attenuation range: 12 dB Frequency range: dc to 80 MHz Connectors: BNC (f)	355C	P,V
20 dB fixed attenuator	Frequency range: dc to 18 GHz Attenuation accuracy: <±1 dB Maximum SWR: 1.2 (dc to 2.9 GHz)	8491B Option 020	P,V
10 dB fixed attenuator	Frequency range: dc to 18 GHz Attenuation accuracy: <±0.6 dB Maximum SWR: 1.2 (dc to 2.9 GHz) Connector: APC 3.5	8491B Option 010	P,V
Termination (for 8564E/EC and 8565E/EC)	Frequency range: dc to 50 GHz Impedance: 50 Ω Maximum SWR: <1.22 Connector: 2.4 mm (f)	85138B	P,V

Table 1-4 Recommended Test Equipment

Instrument	Critical Specifications for Equipment Substitution	Recommended Model	Use
Low-pass filter	Cutoff frequency: 50 MHz Rejection at 65 MHz: >40 dB Rejection at 75 MHz: >60 dB	0955-0306	P,M,V
Low-pass filter (for 8563E/EC, 8564E/EC and 8565E/EC) (two required)	Cutoff frequency: 1.8 GHz Rejection at >3 GHz: >45 dB 0.1 dB ripple	0955-0491	P
Low-pass filter (for 8561E/EC 8563E/EC, 8564E/EC and 8565E/EC) (two required)	Cutoff frequency: 4.4 GHz Rejection at 5.5 GHz: >40 dB	11689A	P
Power splitter (for 8560E/EC or 8561E/EC)	Frequency range: 1 kHz to 12 GHz Insertion loss: 6 dB (nominal) Output tracking: <0.25 dB Equivalent output SWR: <1.22	11667A	P,A,M,V
Power splitter (for 8563E/EC)	Frequency range: 1 kHz to 26.5 GHz Insertion loss: 6 dB (nominal) Output tracking: <0.25 dB, <18 GHz Equivalent output SWR: <1.22	11667B	P,A,M,V
Power splitter (for 8564E/EC and 8565E/EC)	Frequency range: 30 Hz to 50 GHz Insertion loss: 6 dB (nominal) Output tracking: <0.35 dB, <26.5 GHz <0.40 dB, <50 GHz Equivalent output SWR: 1.29, <26.5 GHz 1.50, <40 GHz 1.65, <50 GHz	11667C	P,A,V,T
Service accessory kit	No substitute	08562-60021	A,T
Tuning tool	No substitute	8710-1010	A
Cables			
Test cable	Connectors: BNC (m)-to-SMB (f) Length: ≥61 cm (24 in.)	85680-60093	A,M
Cable, RG-214/U	Connectors: Type N (m) Length: ≥91 cm (36 in.)	11500A	P,V
Cable	Connectors: SMA (m) Length: 24 to 36 inches	8120-1578	P
Cable, 50 Ω coaxial (five required)	Connectors: BNC (m) Length: ≥ 122 cm (48 in.)	10503A	P,A,V

Table 1-4 Recommended Test Equipment

Instrument	Critical Specifications for Equipment Substitution	Recommended Model	Use
Cable (two required)	Frequency range: 30 Hz to 26.5 GHz Maximum SWR: <1.4 at 26.5 GHz Maximum insertion loss: 3 dB Connectors: APC 3.5 (m), both ends Length: ≥ 61 cm (24 in.)	8120-4921	P,A,M,V
Cable (for 8564E/EC and 8565E/EC)	Frequency range: 30 Hz to 50 GHz Maximum SWR: <1.55 at 50 GHz Maximum insertion loss: 5.75 dB Connectors: 2.4 mm (f) to 2.4 mm (m) Length: ≥ 1 m (39 in.)	8120-6164	P,A,V,T
Cable, GPIB (eight required)	Required w/operation verification software Required w/85629B test & adjustment module Length: 2 m (6.6 ft.)	10833B	P,A,M
Adapters			
Adapter	Type N (f)-to-BNC (m)	1250-1477	P,A
Adapter (three required)	Type N (m)-to-BNC (f)	1250-1476	P,A,V
Adapter	Type N (f)-to-BNC (f)	1250-1474	P,V
Adapter	Type N (m)-to-N (m)	1250-1475	P
Adapter	Type N (f)-to-APC 3.5 (m)	1250-1750	A
Adapter(two required)	Type N (m)-to-APC 3.5 (m)	1250-1743	P,M,V
Adapter	Type N (m)-to-APC 3.5 (f)	1250-1744	P,V
Adapter	Type N (m)-to-BNC (m)	1250-1473	P
Adapter	Type N (m)-to-N (f)	1250-1472	P
Adapter (two required)	Type N (f)-to-APC 3.5 (f)	1250-1745	P,V
Adapter (two required)	Type N (m)-to-SMA (f)	1250-1250	P,V
Adapter	Type N (f)-to-SMA (f)	1250-1772	P
Adapter	BNC (f)-to-BNC (f)	1250-0059	A
Adapter	BNC tee (f) (m) (f)	1250-0781	P,A,M,V
Adapter	BNC (f)-to-SMA (m)	1250-1200	P,A,V
Adapter	BNC (f)-to-dual banana plug	1251-2816	A,T
Adapter (two required)	APC 3.5 (f)-to-APC 3.5 (f)	5061-5311	P,M,V
Adapter (two required)	APC 3.5 (m)-to-APC 3.5 (m)	1250-1748	P,V
Adapter	2.4 mm (f)-to-2.4 mm (f)	11900B	P,A,T,V
Adapter	APC 3.5 (f)-to-2.4 mm (f)	11901B	P

Table 1-4 Recommended Test Equipment

Instrument	Critical Specifications for Equipment Substitution	Recommended Model	Use
Adapter	APC 3.5 (m)-to-2.4 mm (f)	11901D	P
Adapter	Type N (f)-to-2.4 mm (f)	11903B	P,A,T,V
Adapter	Type N (f)-to-2.4 mm (m)	11903C	P
* Part of microwave workstation P = performance tests A = adjustments M= test & adjustment module T = troubleshooting V = operation verification			

Sales and Service Offices

Agilent Technologies has sales and service offices around the world providing complete support for Agilent Technologies products. To obtain servicing information, or to order replacement parts, contact the nearest Agilent Technologies Sales and Service Office listed in [Table 1-5 on page 45](#). In any correspondence, be sure to include the pertinent information about model numbers, serial numbers, and assembly part numbers.

NOTE

Within the USA, a toll-free phone number is available for ordering replacement parts. Refer to the section entitled, "Ordering Information" in [Chapter 4](#), "[Assembly Replacement](#)," for the phone number and more information.

Table 1-5 Agilent Technologies Sales and Service Offices

UNITED STATES		
Instrument Support Center Agilent Technologies (800) 403-0801		
EUROPEAN FIELD OPERATIONS		
Headquarters Agilent Technologies S.A. 150, Route du Nant-d'Avril 1217 Meyrin 2/ Geneva Switzerland (41 22) 780.8111	France Agilent Technologies France 1 Avenue Du Canada Zone D'Activite De Courtaboeuf F-91947 Les Ulis Cedex France (33 1) 69 82 60 60	Germany Agilent Technologies GmbH Agilent Technologies Strasse 61352 Bad Homburg v.d.H Germany (49 6172) 16-0
Great Britain Agilent Technologies Ltd. Eskdale Road, Winnersh Triangle Wokingham, Berkshire RG41 5DZ England (44 118) 9696622		
INTERCON FIELD OPERATIONS		
Headquarters Agilent Technologies 3495 Deer Creek Rd. Palo Alto, CA 94304-1316 USA (415) 857-5027	Australia Agilent Technologies Australia Ltd. 31-41 Joseph Street Blackburn, Victoria 3130 (61 3) 895-2895	Canada Agilent Technologies (Canada) Ltd. 17500 South Service Road Trans-Canada Highway Kirkland, Quebec H9J 2X8 Canada (514) 697-4232
Japan Agilent Technologies Japan, Ltd. Measurement Assistance Center 9-1, Takakura-Cho, Hachioji-Shi, Tokyo 192-8510, Japan TEL (81) -426-56-7832 FAX (81) -426-56-7840	Singapore Agilent Technologies Singapore (Pte.) Ltd. 150 Beach Road #29-00 Gateway West Singapore 0718 (65) 291-9088	Taiwan Agilent Technologies Taiwan 8th Floor, H-P Building 337 Fu Hsing North Road Taipei, Taiwan (886 2) 712-0404
China China Agilent Technologies 38 Bei San Huan X1 Road Shuang Yu Shu Hai Dian District Beijing, China (86 1) 256-6888		

2 Adjustment/Diagnostic Software

Introduction

Automated adjustment and diagnostic software is required to provide some of the spectrum analyzer adjustments. The software also provides automated diagnostics for troubleshooting. Instructions for using these programs are included in this chapter. The *8564E/8565E Adjustment/Diagnostic Software* is essential for proper adjustment of an 8564E/EC or 8565E/EC spectrum analyzer.

Never perform adjustments as routine maintenance. Adjustments should be performed after a repair or performance test failure. For information on which adjustments to perform, see [Table 2-1](#) on [page 51](#). Where both a manual and an automated adjustment number are shown for a given adjustment, either the manual OR the automated adjustment may be performed.

Some of the adjustments must be done manually. The manual adjustment procedures can be found in Chapter 3 of this service guide. The following lists identify all of the automated and manual adjustment procedures:

Automated Adjustments

1. Initial Information)..... [page 63](#)
2. LO Frequency [page 64](#)
3. YTO FM Coil [page 66](#)
4. LOMA Adjustments [page 68](#)
5. Fast Zero Span [page 69](#)
6. 3rd Amp/2nd IF Align [page 71](#)
7. Cal Out Adjustment [page 72](#)
8. Front End Cal [page 73](#)
9. IF Bandpass Poles [page 74](#)
10. IF Amplitude [page 75](#)
11. DC Log Adjustments [page 76](#)
12. Sampling Oscillator [page 78](#)

Manual Adjustments

1. High Voltage Power Supply Adjustment
2. Display Adjustment
3. IF Bandpass Adjustment
4. IF Amplitude Adjustments
5. DC Log Amplifier Adjustments
6. Sampling Oscillator Adjustment
7. YTO Adjustment
8. Calibrator Amplitude Adjustment
9. 10 MHz Reference Adjustment — OCXO
10. 10 MHz Reference Adjustment — TCXO (Option 103)
11. Demodulator Adjustment
12. External Mixer Bias Adjustment

13. External Mixer Amplitude Adjustment
14. Signal ID Oscillator Adjustment
15. 16 MHz PLL Adjustment
16. 600 MHz Reference Adjustment (serial prefix 3406A and above)

Safety Considerations

Although this instrument has been designed in accordance with international safety standards, this manual contains information, cautions, and warnings which must be followed to ensure safe operation and to prevent damage to the instrument. Service and adjustments should be performed only by qualified service personnel.

WARNING

Adjustments in this section are performed with power supplied to the instrument and protective covers removed. There are voltages at many points in the instrument which can, if contacted, cause personal injury. Be extremely careful. Adjustments should be performed only by trained service personnel.

Power is still applied to this instrument with the LINE switch in the off position. Before removing or installing any assembly or printed circuit board, remove the line-power cord.

Capacitors inside the instrument may still be charged, even if the instrument has been disconnected from its source of supply.

Use a nonmetallic adjustment tool whenever possible.

Which Adjustments Should Be Performed?

Table 2-1 on page 51 lists the adjustments that should be performed when an assembly is repaired or changed. It is important to perform the adjustments in the order indicated to ensure that the instrument meets its specifications.

Adjustment Tools Table 2-1 on page 51

For adjustments requiring a nonmetallic tuning tool, use fiber tuning tool, part number 8710-0033.

Two different tuning tools may be necessary for IF bandpass adjustments, depending upon the type of tuning slug used in the slug-tuned inductors. If the tuning slug requires a slotted tuning tool, use part number 8710-1010. If the tuning slug requires a forked tuning tool, use part number 8710-0772.

Never try to force an adjustment control. This is especially critical when tuning variable capacitors or slug-tuned inductors. Required service accessories, with part numbers, are listed under "Service Kit" in Chapter 1 .

Instrument Service Position

Refer to Chapter 4 for information on removing the spectrum analyzer cover assembly and accessing all internal assemblies.

Table 2-1 Related Adjustments

Assembly Changed or Repaired	Perform the following related adjustments in the order listed	Adjustment Number	
		Manual	Automated*
A1A1 keyboard	No related adjustment		
A1A2 RPG	No related adjustment		
A2 controller	16 MHz PLL adjustment	15	
	Display adjustment (8564E and 8565E only) If EEROM from old A2 controller could not be used in new A2 or if EEROM must be replaced, also perform the following adjustments:	2	
	LOMA adjustments		4
	External mixer amplitude adjustment or 3rd amp/2nd IF align [†]	13	6
	Front end cal		8
A3 interface	Display adjustment -fast zero span [†] (8564E and 8565E only)	2	5
	Front end cal		8
A4 log amp/cal osc	Display adjustment -fast zero span [†] (8564E and 8565E only)	2	5
	Demodulator adjustment	11	
	IF amplitude adjustment [†]	4	10
	DC log amplifier adjustment [†]	5	11
A5 IF	IF bandpass adjustment [†]	3	9
	IF amplitude adjustment [†]	4	10
A6 power supply	High voltage power supply adjustment (8564E and 8565E only)	1	
	Display adjustment (8564E and 8565E only)	2	
A6A1 HV module	High voltage power supply adjustment (8564E and 8565E only)	1	
	Display adjustment (8564E and 8565E only)	2	

*If any automated adjustment is required, you must first perform automated adjustment "1. Initial Information" on page 63.

Table 2-1 Related Adjustments

Assembly Changed or Repaired	Perform the following related adjustments in the order listed	Adjustment Number	
		Manual	Automated*
A7 LOMA	LOMA adjustments Front end cal (or perform the frequency response performance test in the 8560 E-Series and EC-Series Spectrum Analyzer Calibration Guide. The adjustment must be performed if the performance test fails).		4 8
A8 low band mixer	Front end cal		8
A9 input attenuator	Front end cal (or perform the frequency response performance test in the 8560 E-Series Spectrum Analyzer Calibration Guide. The adjustment must be performed if the performance test fails).		8
A10/A12 RYTHM/SB TX	Front end cal		8
A11 YTO	YTO adjustment [‡] LO frequency [‡] YTO FM coil [‡]	7	2 3
A13 2nd converter	Front end cal		8
A14 frequency control	Display adjustment -fast zero span [†] (8564E and 8565E only) YTO adjustment [‡] LO frequency [‡] YTO FM cal [‡] Front end cal	2 7	5 2 3 8
*If any automated adjustment is required, you must first perform automated adjustment "1. Initial Information"			
[†] Either the manual or the automated adjustment may be performed.			

Table 2-1 Related Adjustments

Assembly Changed or Repaired	Perform the following related adjustments in the order listed	Adjustment Number	
		Manual	Automated*
A15 RF	10 MHz reference adjustment (TCXO, Option 103) or CAL OUT adjustment [†]	15	7
	Calibrator amplitude adjustment or CAL OUT adjustment [†]	8	7
	External mixer bias adjustment	12	
	Sampling oscillator adjustment	6	12
	Signal ID oscillator adjustment	14	
	External mixer amplitude adjustment or 3rd amp/2nd IF align [†]	13	6
	Front end cal		8
A15U100 sampler	Sampling oscillator adjustment [†]	6	12
A17 CRT driver	Display adjustment (8564E and 8565E only)	2	
A18V1 CRT	Display adjustment (8564E and 8565E only)	2	
A19 GPIB	No related adjustment		
A21 OCXO	10 MHz reference adjustment (OCXO)	9	
*If any automated adjustment is required, you must first perform automated adjustment "1. Initial Information"			
[†] Either the manual or the automated adjustment may be performed.			
[‡] Perform either the manual "YTO adjustment" (7) or the automated "LO frequency" and "YTO FM coil" adjustments (2 and 3)			

Getting Started

First, make sure you have a compatible controller (computer) and the proper test equipment. The following paragraphs describe requirements for controllers and test equipment. Once the proper equipment is identified, proceed to ["Equipment Connections"](#)

Spectrum Analyzers

The *8564E/8565E Adjustment/Diagnostic Software* can be used to adjust or troubleshoot ONLY an 8564E/EC or an 8565E/EC.

Errors will occur if this software is used to test spectrum analyzers other than the 8564E/EC or 8565E/EC.

Controller (Computer)

The *8564E/8565E Adjustment/Diagnostic Software* requires using one of the following HP controllers and the HP BASIC operating system:

Controller

HP 9000 model 236 (HP 9836)

HP 9000 model 310

HP 9000 model 320

HP 9000 model 350

Operating System

HP BASIC 5.13 or later, and all BIN files

NOTE

When using an HP 9000 model 236 (HP 9836) controller, the graphics in the IF diagnostics program will be very distorted and difficult to read. The tabular data printed at the end of the IF diagnostics program (which contains the same text information as the graphics) is clearly readable.

Other HP 9000 Series 300 controllers are compatible with the adjustment/diagnostic software; however, the graph printouts might not be full width. This is especially true with medium- and high-resolution displays.

The *8564E/8565E Adjustment/Diagnostic Software* requires at least 4 Megabytes of free memory.

Test Equipment

Table 2-2 on page 56 lists the test equipment required to perform the automated adjustments. Test equipment which is not listed here is not compatible with the adjustment/diagnostic software. You do not need all the test equipment connected to perform the adjustments. You need only connect the equipment specified in each adjustment to run that adjustment.

Warm-up Time

Test Equipment Warm-up

Allow sufficient warm-up time for test equipment. Refer to their individual operating and service manuals for warm-up specifications.

Spectrum Analyzer Warm-up

Warm the spectrum analyzer up for at least 30 minutes before performing the first adjustment.

Table 2-2 Test Equipment Required for Automated Adjustments

Description	Model Number
Controller*	HP 9000 model 236 (HP 9836) or HP 9000 model 310 or HP 9000 model 320 or HP 9000 model 350
Synthesizer/level generator	3335A
Synthesized sweeper [†]	83650A
Spectrum analyzer [‡]	8566B (preferred) or 8563E (2nd choice) or 8563A or 8562A
Power meter	438A
4.2 GHz power sensor	8482A
50 GHz power sensor	8487A [§]
Frequency counter	5342A
Digital multimeter	3478A
Power splitter	11667C
Test and Adjustment Module (TAM)	85629B
Cable, 50 GHz coax	8120-6164
Cable, BNC-to-SMB (2 required)	85680-60093
Cable, BNC-to-BNC (3 required)	10503A
Cable, 36 inch SMA	8120-1578
Cable, GPIB (8 required)	10833A/B
<p>* 4 megabytes of free memory is required for the adjustment program.</p> <p>[†] The software menu shows the 8340 as the synthesized sweeper, but it drives the required 83650A (programming language set to "analyzer" mode).</p> <p>[‡] The software menu shows the 8566 as the spectrum analyzer, but it will drive the other three spectrum analyzers listed. If an 8566 is used, it must be an 8566B, not 8566A.</p> <p>[§] Must have calibration factors down to 10 MHz; a standard 8487A is only calibrated down to 50 MHz.</p>	

Equipment Connections

Computer (Controller) Setup

For HP 9000 model 236 computers, setup instructions are provided in Chapter 1, "Computer Installation," of the *BASIC Operating Manual*. For HP 9000 model 310, 320, or 350 computers, setup information is provided in the *Configuration Reference Manual* for the Series 300 computers.

GPIB Cables

All GPIB controlled test equipment should be connected to the internal GPIB of the controller (select code 7).

Using the Adjustment/Diagnostic Software

To Load the Program

NOTE

The *8564E/8565E Adjustment/Diagnostic Software* needs to be installed on either an HFS formatted hard disk system or an SRM system. It cannot be used with only a flexible disk drive.

1. If necessary, load HP BASIC into the computer memory. See the documentation for your computer for more information about loading HP BASIC.
2. Create a new directory on your hard disk drive or SRM node. For example, 8564eadj.
3. Download the 8564E/EC & 8565E/EC Adjustment/Diagnostics software from www.agilent.com/find/8560_software.
4. Unzip the download file to the directory created in step 2.
5. Use the MSI command to change to the mass storage device where the new directory (created in step 2) is located. For example, MSI ":,700,0" for an HFS system or MSI ":,21.0" for an SRM system.
6. Access the directory (created in step 2) using the MSI command, then type MSI "MANAGER/CAL_DATA/SENSOR_DATA". Press **RETURN** (or **ENTER**).
7. Type LOAD "PS_EDITOR", 1 and press **RETURN** (or **ENTER**).
8. Press New Sensor.

Go to step 14

14. At the prompt "Enter power sensor model #. Example, 8487", enter the first 4 digits of the model number of the power sensor for which you are entering calibration data. Do not enter any alpha characters; the power sensor model must be 4 digits. You will then be prompted to enter the last four digits of the power sensor serial number. For example, if the serial number is 2937A00564, enter 0564.

15. Press Edit Sensor.

NOTE

When entering the power sensor calibration data, be sure to enter the 50 MHz calibration factor. The 50 MHz calibration factor is not always explicitly listed in the table included with the power sensor, but is referred to as the "REF CF" (reference calibration factor).

When entering the power sensor calibration data for the 8487A, be sure to also enter a 10 MHz calibration factor. The standard 8487A is calibrated only down to 50 MHz, but the software uses it down to 10 MHz.

The calibration data does *not* have to be entered in frequency order. Frequencies may be entered in any order.

When editing, use the arrow keys (▲, ▼) to get to the entry that you want to edit. Use the **Backspace** key to delete characters, then enter new characters.

16. Enter the frequency (in MHz) and press **RETURN** (or **ENTER**).

17. Enter the calibration factor (for the corresponding frequency) and press **RETURN** (or **ENTER**).

18. Repeat steps 17 and 18 for all calibration points. Press "Q" when done.

19. Press Store Sensor when finished entering data for each power sensor.

20. Repeat steps 13 through 19 for any other power sensors that will be used.

21. Press quit.

To Use the Adjustment Program

1. MSI to the parent directory (created in "To Load the Program", step 2).
2. Type `LOAD "MANAGER/MANAGER", 1` and press **RETURN** (or **EXECUTE**).
3. Press Set inst addr.

4. At the prompt ENTER STATION NUMBER WHERE THE ADDRESS WILL BE USED, type 7, then RETURN (or ENTER).
5. Verify that the default GPIB addresses are the addresses actually set on all of the instruments.

NOTE If you change any of the GPIB addresses, press RECORD ADR before continuing.

6. Press EXIT-NO RECORD.
7. Press Test Dut.

CAUTION Be sure power to the 8564E/EC or 8565E/EC (DUT) is turned off before connecting the 85629B TAM to the DUT. Failure to do so may cause damage to the DUT or the TAM.

NOTE Initial Information must always be run first
The WR PROT/WR ENA on the A2 controller must be in the WR PROT (write protect) position.

8. Press Select, then CONTINUE.
9. Enter the power sensor "RP" numbers (last 4 digits of each serial number) for the 8482A and 8487A (shows 8485A POWER SENSOR on controller screen).
10. Enter employee number (or any number; an entry here is required to continue).
11. Press DONE.
12. Select Initial Information.
13. Enter the serial numbers (up to 5 digits) for the "tower" (A10/A12 RYTHM/SBTX) and the LOMA (A7 LO Multiplier/Amplifier).
Entering these serial numbers is optional.
14. Enter the voltages printed on the microcircuits. Be sure to enter the proper polarity, plus (+) or minus (-).

NOTE

All but two of the microcircuit entries required (M4 and M5) are voltages listed on the A7 LOMA. Although the label on A7 lists "Int B4, Int B5, SBTX B4, and SBTX B5", the software requires that you enter only "Int B4" (Int4) and "SBTX B4" (SBTX4).

M4 and M5 values are listed on the tower (A10/A12).

If the program is interrupted (power failure or the like) before DONE is pressed, none of the previously entered values under Initial Information will be saved. If this occurs, rerun Initial Information from the start.

15. When the last value required has been entered, press DONE.

16. Any of the listed adjustments can be selected next (Initial Information must always be run first).

NOTE

The 83650A must be in "Analyzer" mode. Check the 83650A user documentation for the correct setting of the rear panel switch.

For some adjustments, the user prompts are displayed on the spectrum analyzer display (DUT), not the controller display.

Use the 10 MHz reference out of the 83650A wherever a 10 MHz reference input to another instrument in the setup is required, except for adjustments using the 3335A. (The spectrum analyzer provides the 10 MHz reference to the 3335A.)

The program calls out an 8566, but an 8562A, 8563A, or 8563E can be used to make spectrum analyzer measurements. The 8566B or an 8560 E-Series spectrum analyzer is recommended for speed of measurement.

Automated Adjustments

The following automated adjustments can be performed in any order, EXCEPT number one (1) Initial Information. This initial information routine must ALWAYS be run first.

1. Initial Information

This Initial Information routine must ALWAYS be run first. Carefully follow the instructions and prompts that the software program displays. Any of the listed adjustments may be selected next.

2. LO Frequency

Assembly Adjusted

A14 frequency control assembly

Related Performance Tests

Frequency Readout Accuracy and Frequency Count Marker Accuracy

Procedure

Figure 2-1 LO Frequency Adjustment Setup

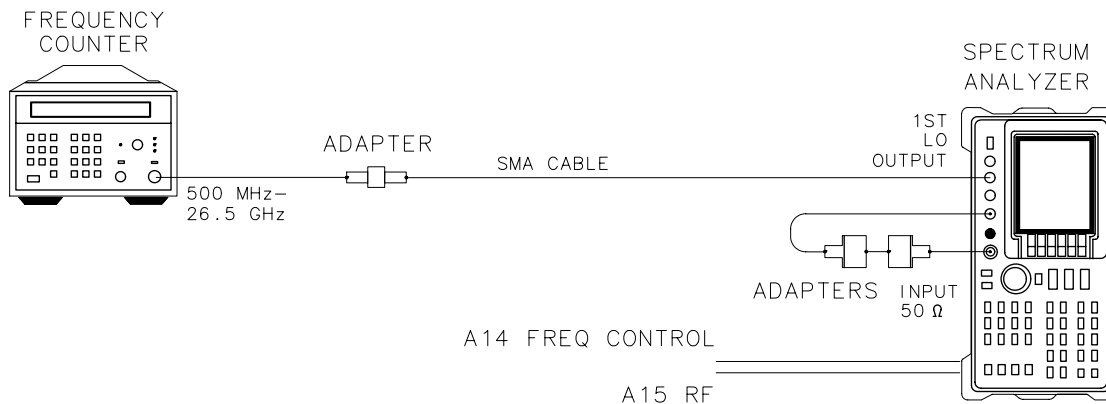

sz149e

1. Connect the equipment as shown in [Figure 2-1 on page 64](#) and carefully follow the instructions issued by the software program. See [Figure 2-2 on page 65](#) for adjustment locations.
2. Observe the upper right-hand corner of the spectrum analyzer display while making adjustments. Prompts will appear to let you know when the LO frequency is correctly adjusted.
3. Whenever this adjustment is performed, the YTO FM Coil (3) automated adjustment must also be performed.

Figure 2-2 **LO Frequency Adjustment Locations**

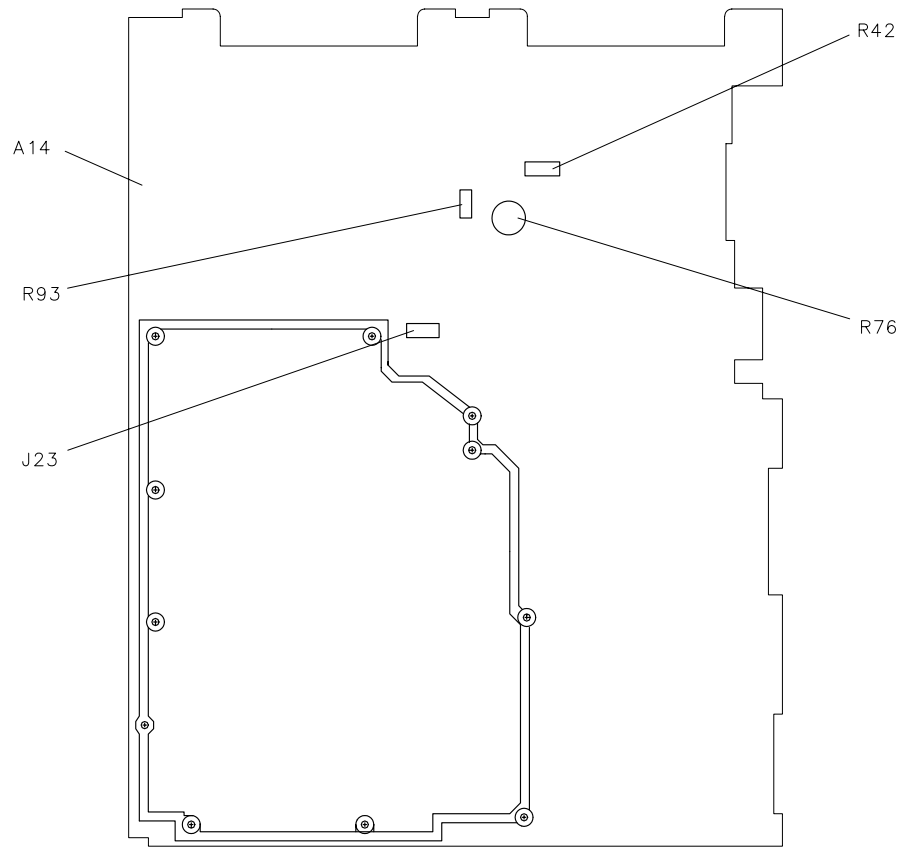

SP 116E

3. YTO FM Coil

Assembly Adjusted

A14 frequency control assembly

Related Performance Tests

Frequency Span Accuracy, Frequency Readout Accuracy, and Frequency Count Marker Accuracy

Procedure

1. Connect the CAL OUTPUT to the INPUT 50Ω on the spectrum analyzer being adjusted. See [Figure 2-3 on page 67](#) for adjustment locations.
2. Carefully follow the instructions issued by the software program.

Figure 2-3 **YTO FM Coil Adjustment Locations**

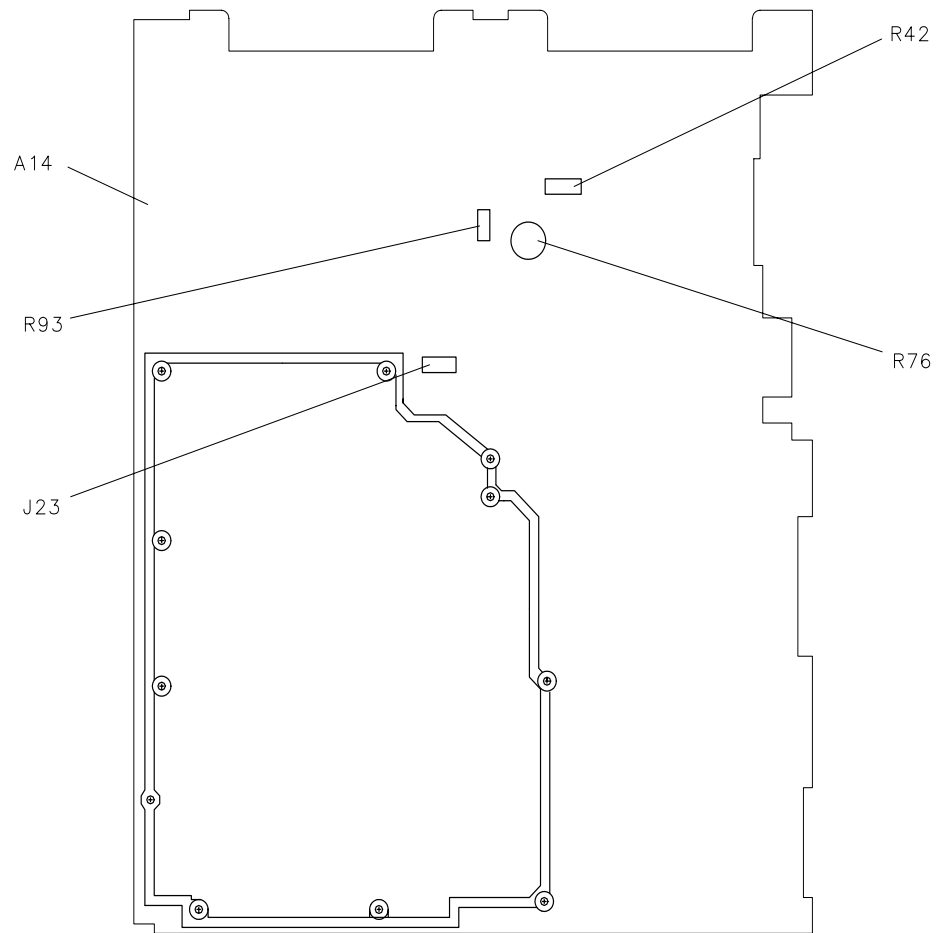

SP116E

4. LOMA Adjustments

Assembly Adjusted

A14 frequency control assembly

Related Performance Test

1ST LO OUTPUT Amplitude

Procedure

CAUTION

When connecting the 8587A power sensor to the 1 ST LO OUTPUT, be sure to use proper adapters. Failure to do so will result in damage to the expensive connector of the power sensor.

NOTE

On the DVM, "Front terminals" must be selected or the adjustment program will not run.

Carefully follow the instructions issued by the software program. See [Figure 2-4 on page 68](#) for test connector pin locations.

Figure 2-4 A14J18 and A14J15 Pin Locations

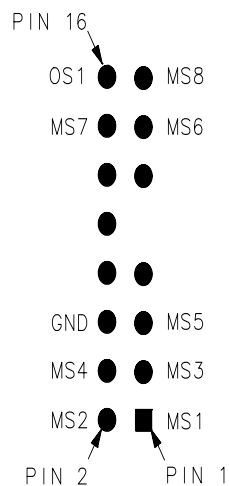

sz144e

5. Fast Zero Span (E-Series, Non-Option 007)

Assembly Adjusted

A2 controller assembly

Related Performance Test

Sweep Time Accuracy (Sweep Times <30 ms)

Procedure

1. Carefully follow the instructions issued by the software program. Use an 11667C where the power splitter is called out. See [Figure 2-5 on page 70](#) for adjustment locations.

CAUTION

When connecting the 11667C power splitter, be sure to use proper adapters where necessary. Failure to do so will result in damage to the expensive connectors of the power splitter.

Figure 2-5 A2 Fast Zero Span Adjustment Locations

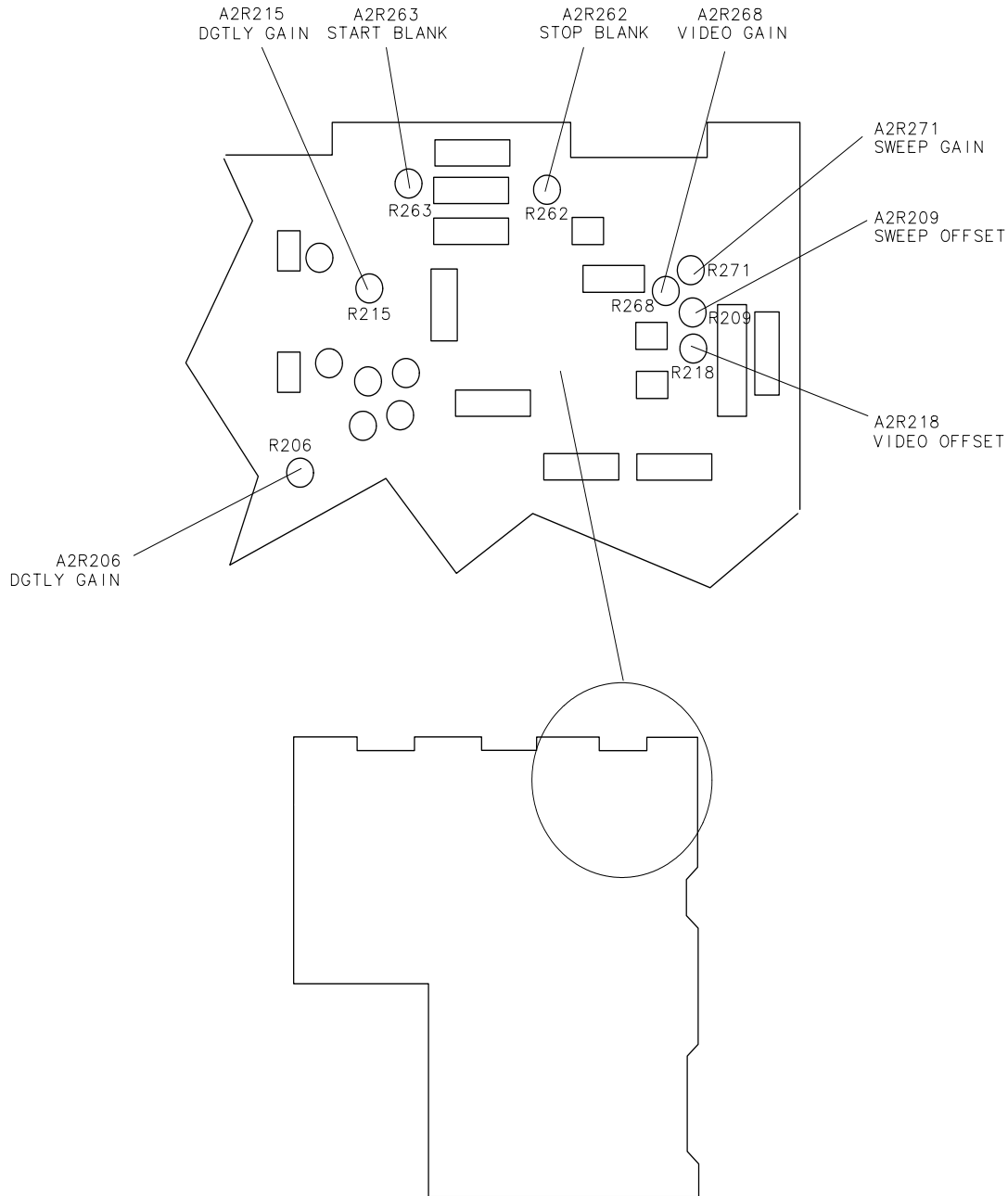

SK14

6. 3rd Amp/2nd IF Align

Assembly Adjusted

A15 RF assembly

Related Performance Test

IF Input Amplitude Accuracy

Procedure

CAUTION

When connecting the 11667C power splitter, be sure to use proper adapters where necessary. Failure to do so will result in damage to the expensive connectors of the power splitter.

1. Connect the input port of an 11667C power splitter to the 85650A output.
2. Connect one output port of the power splitter, through a 20-dB pad, to the front panel IF INPUT on the spectrum analyzer.
3. Carefully follow the instructions issued by the software program.

7. Cal Out Adjustment

Assembly Adjusted

A15 RF assembly

Related Performance Test

Calibrator Amplitude and Frequency Accuracy

Procedure

1. Connect the 8482A power sensor (through adapter) to the front panel CAL OUTPUT on the spectrum analyzer.
2. Carefully follow the instructions issued by the software program.
3. If the spectrum analyzer has Option 103, TCXO frequency reference, the TCXO will also be adjusted.

8. Front End Cal

Assembly Adjusted

A10/A12 RYTHM/SBTX (tower) A14 frequency control assembly
A15 RF assembly

Related Performance Tests

Displayed Average Noise Level Frequency Response

Procedure

1. Carefully follow the instructions issued by the software program.

NOTE

This test requires long waiting periods between adjustments. Total time required to complete the entire Front End Cal is approximately two (2) hours.

Make sure that the 10 MHz reference output from the 83650A is connected to the rear panel 10 MHz IN/OUT on the spectrum analyzer being adjusted.

The software program will tell you, "Waiting for instrument to warm up." If the spectrum analyzer being adjusted has already been on for more than 30 minutes, press CONTINUE on the controller.

9. IF Bandpass Poles

Assembly Adjusted

A5 IF assembly

Related Performance Test

Resolution Bandwidth Accuracy and Selectivity

Procedure

NOTE

Use special tuning tool, part number 8710-1010.

1. Carefully follow the instructions issued by the software program.
2. After each adjustment of a component, press RECHECK POLE (on controller) to determine the current DAC value.

10. IF Amplitude

Assembly Adjusted

A4 log amp/cal oscillator assembly A5 IF assembly

Related Performance Tests

IF Gain Uncertainty Scale Fidelity

Procedure

Figure 2-6 IF Amplitude Adjustment Setup

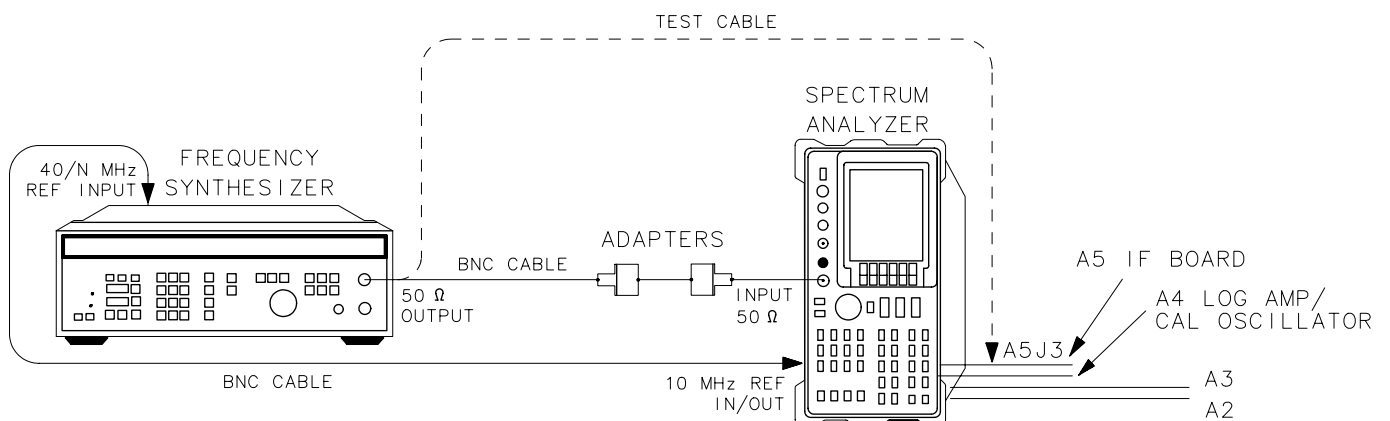

sz 148e

1. Connect equipment as shown in [Figure 2-6 on page 75](#) and carefully follow the instructions issued by the software program.

11. DC Log Adjustment

Assembly Adjusted

A4 log amp/cal oscillator assembly

Related Performance Tests

IF Gain Uncertainty Scale Fidelity

Procedure

NOTE These adjustments need only be done under the following conditions:

Limiter phase Only if a repair is made to blocks F, G, H, I, or J.

Linear fidelity Only if a repair is made to blocks C, D, F, G, H, I, J, K, O, IF gain accuracy, RBW switching, or log fidelity.

Log fidelity Only if a repair is made to blocks D, F, H, K, IF gain accuracy, RBW switching, or log fidelity.

Figure 2-7 DC Log Adjustment Setup

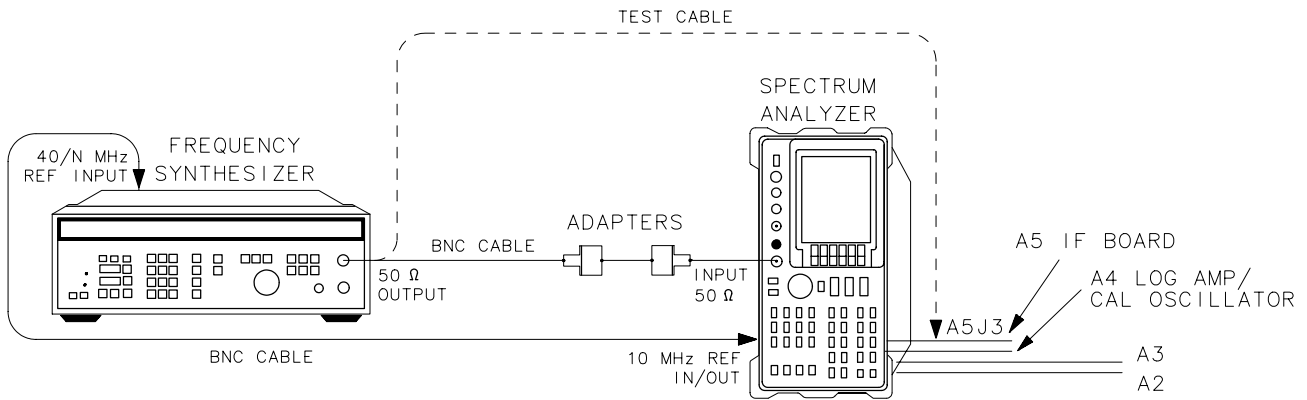

sz 148e

1. Connect the 3335A to the INPUT 50Ω of the spectrum analyzer being adjusted.
2. Carefully follow the instructions issued by the software program. See Figure 2-8, "DC Log Adjustment Locations," for adjustment locations.

Figure 2-8 DC Log Adjustment Locations

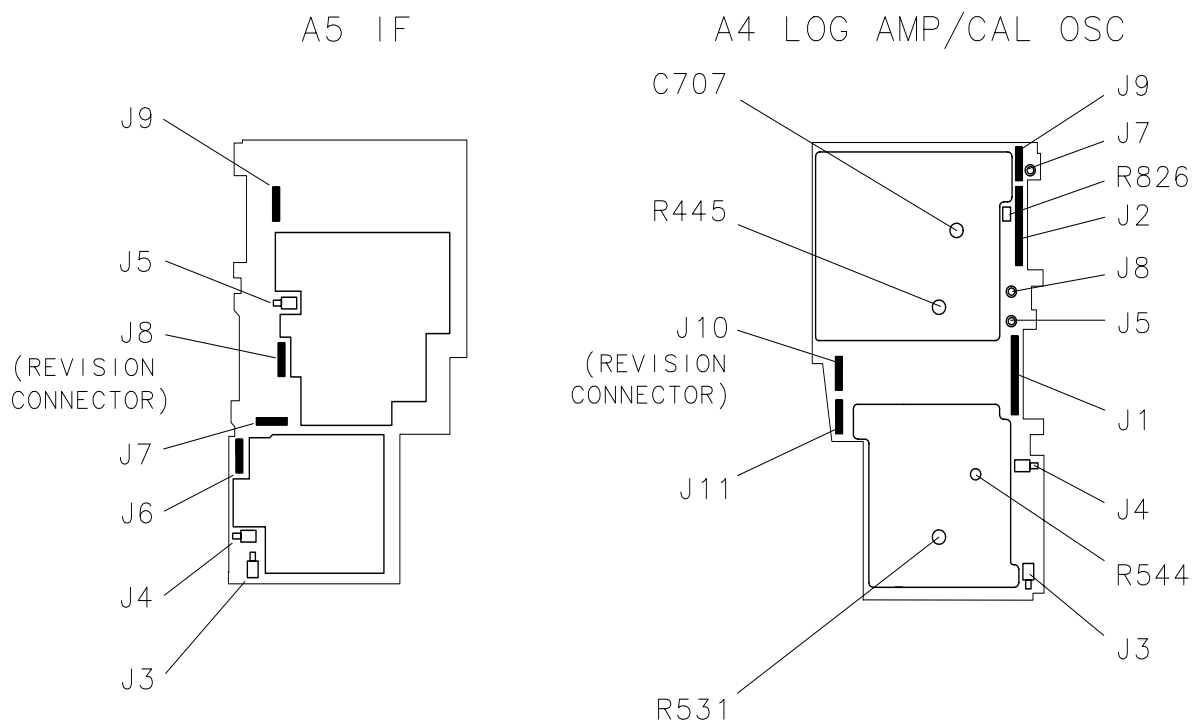

sj11e

12. Sampling Oscillator

Assembly Adjusted

A15 RF assembly

Related Performance Test

There is no related performance test for this adjustment.

Procedure

1. Carefully follow the instructions issued by the software program.

To Use the Diagnostics

NOTE

When performing DAC/LATCH Control or Cal Osc Control, freeze the spectrum analyzer by pressing **TRIG**, **EXTERNAL**, **SGL SWP**, **CAL**, then **IF ADJ OFF**. (Do not provide a trigger.) When it is necessary to observe the effects of changes on the display, set the spectrum analyzer for a long sweep time (> 10 seconds) and make changes during a sweep.

The program calls out an 8566, but an 8562A, 8563A, or 8563E can be used to make measurements that require using another spectrum analyzer. The 8566B or an 8560 E-Series spectrum analyzer is recommended for speed of measurement.

Cycle the DUT spectrum analyzer power when you are done doing diagnostics.

DAC Control

The DAC control program supplies the current DAC value and allows you to set some of the DACs in the spectrum analyzer. The recommended instrument state for the spectrum analyzer under test may differ, depending on which DAC is selected. See [Table 2-3 on page 80](#) for the recommended instrument state.

1. To preset state 1, set the spectrum analyzer as follows:

Center frequency any
Span any
Trigger External (with no trigger applied)
IF ADJ OFF
Sweep Single

2. Press **SAVE**, **SAVE STATE**, **STATE 1**.

3. To preset state 2, set the spectrum analyzer as follows:

Center frequency any
Span any
Reference level any
Resolution bandwidth any
Sweep time >10 seconds
Sweep CONTinue
Trigger FREE RUN

4. Press **SAVE**, **SAVE STATE**, **STATE 2**.

5. See [Table 2-3 on page 80](#) to set the recommended instrument state (**RECALL**, **RECALL STATE**, **STATE 1** or **STATE 2**) for each DAC selection.

6. Select the PC board that includes the DAC of interest, then select the DAC.
7. Use SELECT to set single values. (The default for entries is decimal, but hexadecimal or binary can be entered by appending either an "H" or a "B", respectively. For example, "A2H" or "10100010B".)
8. Use ADJUST for continuous changing of the DAC value. Position the arrow-tipped cursor to select the digit to be changed.
9. The UP, DOWN, and RAMP keys can also be used to exercise the DAC.

Table 2-3 DAC Control Recommended Instrument State

DAC	Reference Designator	Recommended Instrument State*
Intensity DAC	A2U212A	State 1
Focus DAC	A2U212B	State 1
LOMA Power DAC	A14U601A	State 1
LOMA Gate Bias DAC	A14U601B	State 1
LOMA Sampler Power DAC	A14U601C	State 1
LOMA SBTX Power DAC	A14U601D	State 1
YTO Fine DAC	A14U301A	State 1
YTO Coarse DAC	A14U301B	State 1
YTF Slope DAC	A14U409A	State 1
YTF Offset DAC	A14U409B	State 1
SBTX Bias DAC	A14U424A	State 1
Sampler Amplifier Gate Bias DAC	A14U424B	State 1
Main Coil Tune DAC	A14U314	Refer to "Check main coil tune DAC (steps 47-49)" under "Unlocked YTO PLL" in Chapter 11 ..
Scan Ramp DAC	A14U316	State 2
Span DAC	A14U315	State 2
Sweep Generator DAC	A14U307	State 2
RF Gain A DAC	A3U417A	Refer to "Flatness Control (RF Gain DACs)" in Chapter 8 .
*Refer to steps 1 and 3 of "DAC Control" for spectrum analyzer state settings, unless otherwise noted.		

Table 2-3 DAC Control Recommended Instrument State

DAC	Reference Designator	Recommended Instrument State*
RF Gain B DAC	A3U417B	Refer to "Flatness Control (RF Gain DACs)" in Chapter 8 .
RT DAC 1	A3U409B	State 1
Video Trigger DAC	A3U409A	State 1
Crystal 1 Center Frequency DAC	A5U812B	State 1
Crystal 2 Center Frequency DAC	A5U813B	State 1
Crystal 3 Center Frequency DAC	A5U809B	State 1
Crystal 4 Center Frequency DAC	A5U807B	State 1
Crystal 1 Bandwidth DAC	A5U812C	State 1
Crystal 2 Bandwidth DAC	A5U813C	State 1
Crystal 3 Bandwidth DAC	A5U809C	State 1
Crystal 4 Bandwidth DAC	A5U807C	State 1
Crystal 1 Symmetry DAC	A5U812D	State 1
Crystal 2 Symmetry DAC	A5U813D	State 1
Crystal 3 Symmetry DAC	A5U809D	State 1
Crystal 4 Symmetry DAC	A5U807D	State 1
LC 1 Center Frequency DAC	A5U810B	State 1
LC 2 Center Frequency DAC	A5U810D	State 1
LC 3 Center Frequency DAC	A5U806B	State 1
LC 4 Center Frequency DAC	A5U806D	State 1
LC 1 Bandwidth DAC	A5U810A	State 1
LC 2 Bandwidth DAC	A5U810C	State 1
LC 3 Bandwidth DAC	A5U806A	State 1
LC 4 Bandwidth DAC	A5U806C	State 1
Step Gain 1 DAC	A5U812A	State 1
Step Gain 2 DAC	A5U813A	State 1
Step Gain 3 DAC	A5U809A	State 1
Fine Attenuation DAC	A5U807A	State 1
Video Offset DAC	A4U102A	State 1
*Refer to steps 1 and 3 of "DAC Control" for spectrum analyzer state settings, unless otherwise noted.		

Table 2-3

DAC Control Recommended Instrument State

DAC	Reference Designator	Recommended Instrument State*
Log Offset Coarse DAC	A4U102B	State 1
Log Offset Fine DAC	A4U102C	State 1
Local Oscillator Tune DAC	A4U102D	State 1
*Refer to steps 1 and 3 of "DAC Control" for spectrum analyzer state settings, unless otherwise noted.		

Latch Control

Latch control is very similar to the DAC control diagnostics except you can control individual bits. Use state 1 setup (refer to step 1 in "DAC Control").

Table 2-4

Latch Control Recommended Instrument State

Latch	Reference Designator	Recommended Instrument State*
IF Latch 1	A5U808	State 1
IF latch 2	A5U811	State 1
Log Latch 1	A4U103	State 1
Log Latch 2	A4U104	State 1
Log Latch 3	A4U105	State 1
Control 1 Latch	A14U313	State 1
Control 2 Latch	A14U417	State 1
Scan Time Range Latch	A14U309	State 1
Span Attenuator Latch	A14U310	State 1
RF Attenuator Latch	A14U406	State 1
PIN Switch Latch	A14U425	State 1
Offset Lock Loop Latch	A15U904	State 1
RF Latch	A15U903	State 1
*Refer to steps 1 and 3 of "DAC Control" for spectrum analyzer state settings, unless otherwise noted.		

Display IF CAL Data

With the IF CAL data displayed, you can check for control problems using a logic probe on the latches. You can also check the DAC values. The DAC values for each filter pole should be within a 32 DAC-count range.

NOTE

When you change the spectrum analyzer state, you need to EXIT the "Display IF CAL Data" program and SELECT it again.

Cal Oscillator Control

1. Using another spectrum analyzer, look at the output of the cal oscillator. Refer to the A4 schematic diagram in the *8560 EC-Series Spectrum Analyzer Component Level Information* and *8560 E-Series Spectrum Analyzer Component Level Information*. The display on the test spectrum analyzer should be similar to that shown in [Figure 2-9 on page 84](#).

Figure 2-9 CAL Oscillator Swept Output, 20 kHz Width

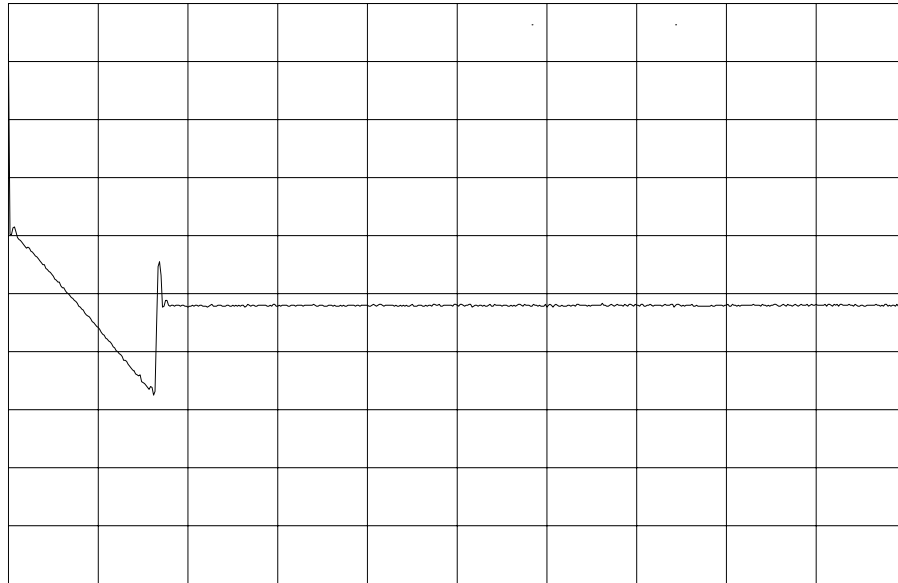

2. Use the up/down arrows (▲, ▼) on the controller keyboard to select CF, Sweep Width, or RF On/Off for the cal oscillator.
3. Use the left/right arrows (◀, ▶) to change parameters within each selection.

NOTE

You can select sweep width *only* when CF is at 10.7 MHz.

IF Diagnostics

CAUTION Be sure power to the 8564E/EC or 8565E/EC is turned off before connecting the 85629B TAM to the DUT. Failure to do so may cause damage to the DUT or the TAM.

Connect the 85629B test and adjustment module. Follow the program instructions, using the TAM's dc probe. An asterisk will appear at points of failure.

NOTE When performing IF Diagnostics, the values without MIN or MAX limits are for information only.

The individual filter poles may also be measured using an 3335A synthesizer and a spectrum analyzer (an 8566B or 8563E is preferred). Step gains can also be checked using the synthesizer and the spectrum analyzer.

RF Diagnostics

CAUTION Be sure power to the 8564E/EC or 8565E/EC is turned off before connecting the 85629B TAM to the DUT. Failure to do so may cause damage to the DUT or the TAM.

Be sure power to the 8564E/EC or 8565E/EC is turned off before connecting the test board, part number 08564-69201. Failure to do so may cause damage to the A14 frequency control assembly or some very expensive microcircuits (A7, A10 and A12).

NOTE Be sure there is a jumper connecting the two pins on J3, and a jumper connecting the two pins on J20 of the test board.

This program assumes a loss of 0.1 dB/GHz to avoid having to monitor the input power with a splitter and a power meter. It is therefore *IMPORTANT* to use a high-quality, low-loss cable from the source to the input of the spectrum analyzer under test. Part number 8120-6164 is recommended for this purpose.

1. Using the 8564E and 8565E adjustment/diagnostic software, select the RF diagnostics.
2. Connect the test board (P/N 08564-69201) between the A14 frequency control assembly and the microcircuits (A7 LOMA and A10/A12 RYTHM/SBTX). The test board is labeled μ CKT and INSTR SIDE.
 - a. Disconnect W16 from A14J9 and W12 from A14J10.
 - b. Connect W16 to J4 on the test board and W12 to J5 on the test board.
 - c. Connect J2 on the test board to A14J10 (use 24-conductor ribbon cable, part number 08564-60012).
 - d. Connect J1 on the test board to A14J9 (use 20-conductor ribbon cable, part number 8120-5526).
3. You will then be prompted to make different connections to the 85629B Test and Adjustment Module (TAM), a source or spectrum analyzer. Connection locations are shown in [Figure 2-10 on page 87](#) and [Figure 2-11 on page 88](#). Carefully follow the instructions on the controller display. Read the prompts *VERY* carefully! If a wrong connection is inadvertently made, the result could lead to a wrong determination of the fault. (The software could tell you that the SBTX/RYTHM is faulty, when in fact the real fault is in the A8 low band mixer, a much less expensive component.)
4. If a failure occurs, the diagnostic software indicates what failed, for example: Low Band, and then prompts you to perform the test(s) that exercises that function or area ("Low Band Check").

Figure 2-10 Diagnostic Software Connection Locations, A14 and A15

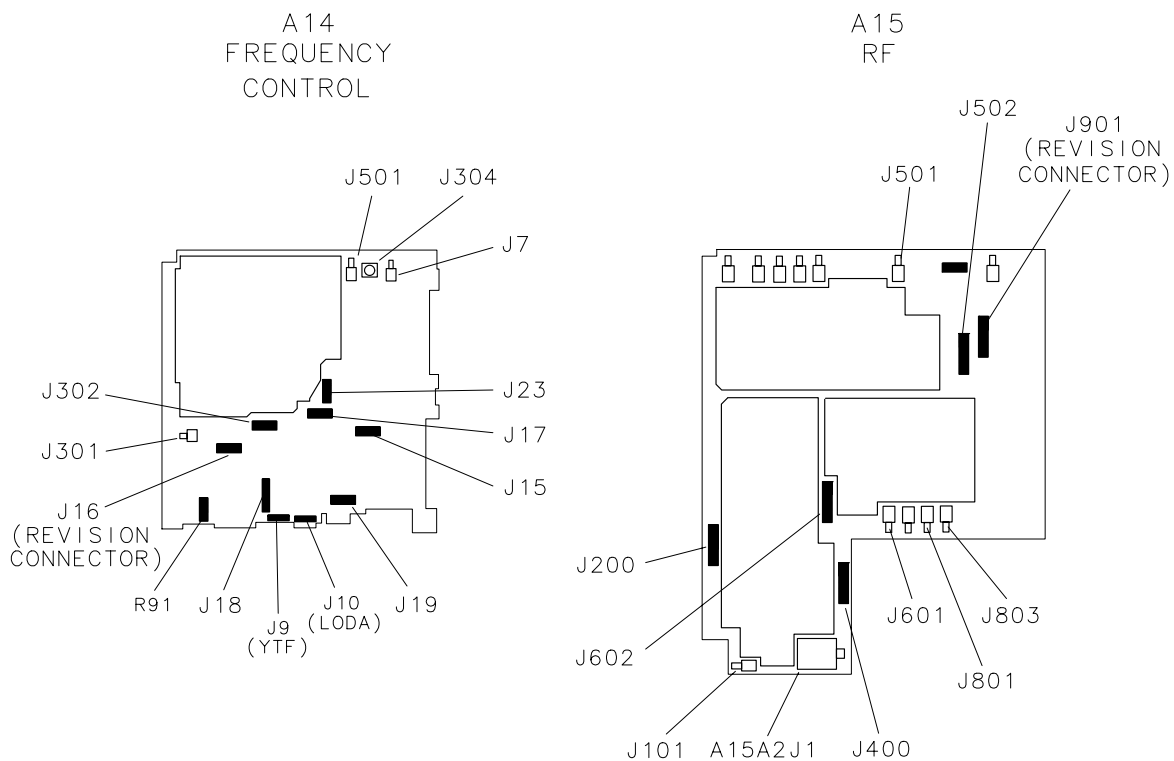

sz151e

Figure 2-11 Diagnostic Software Connection Locations, RF Section

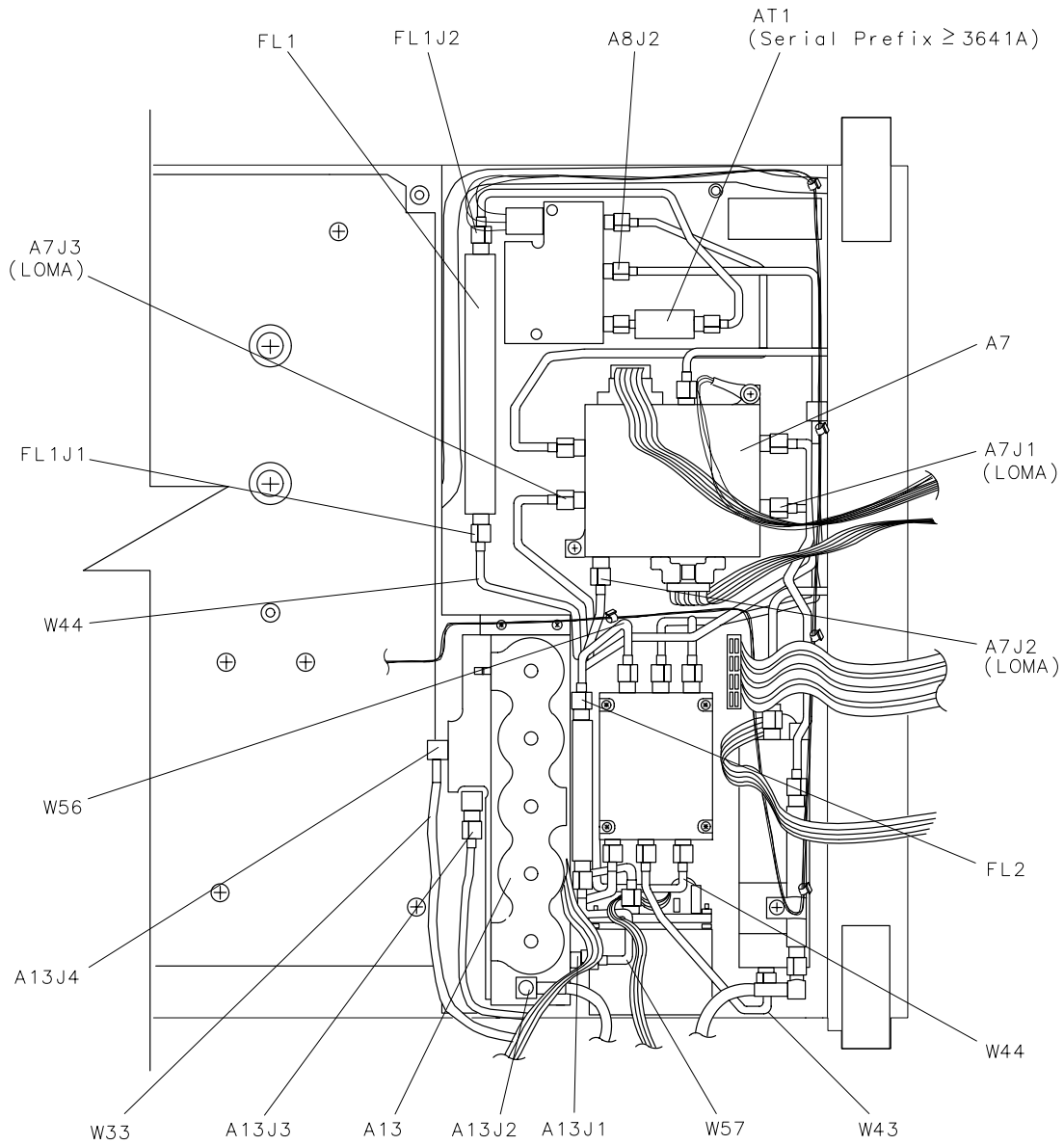

sm16e

3 Manual Adjustment Procedures

Introduction

This chapter contains information on manual adjustment procedures. Never perform adjustments as routine maintenance. Adjustments should be performed after a repair or performance test failure. For information on which adjustments to perform, refer to [Table 3-1 on page 93](#).

Information on automated adjustments can be found in [Chapter 2](#) of this service guide. Following is a list of the automated adjustments:

Automated Adjustments

1. Initial Information
2. LO Frequency
3. YTO FM Coil
4. LOMA Adjustments
5. Fast Zero Span
6. 3rd Amp/2nd IF Align
7. Cal Out Adjustment
8. Front End Cal
9. IF Bandpass Poles
10. IF Amplitude
11. DC Log Adjustments
12. Sampling Oscillator

Manual Adjustments

1. High Voltage Power Supply Adjustment (8561E and 8563E).....[page 99](#)
2. Display Adjustment (8561E and 8563E)..... [page 102](#)
3. IF Bandpass Adjustment [page 110](#)
4. IF Amplitude Adjustments [page 116](#)
5. DC Log Amplifier Adjustments [page 121](#)
6. Sampling Oscillator Adjustment [page 126](#)
7. YTO Adjustment [page 130](#)
8. Calibrator Amplitude Adjustment [page 134](#)
9. 10 MHz Reference Adjustment — OCXO [page 136](#)
10. 10 MHz Reference Adjustment — TCXO (Option 103) . [page 140](#)
11. Demodulator Adjustment [page 142](#)
12. External Mixer Bias Adjustment [page 145](#)
13. External Mixer Amplitude Adjustment [page 147](#)
14. Signal ID Oscillator Adjustment
(serial prefix 3517A and below) [page 151](#)
15. 16 MHz PLL Adjustment [page 155](#)
16. 600 MHz Reference Adjustment [page 159](#)

NOTE Before performing any adjustments, allow the spectrum analyzer to warm up for at least 5 minutes.

Safety Considerations

Although this instrument has been designed in accordance with international safety standards, this manual contains information, cautions, and warnings which must be followed to ensure safe operation and to prevent damage to the instrument. Service and adjustments should be performed only by qualified service personnel.

WARNING **Adjustments in this section are performed with power supplied to the instrument and protective covers removed. There are voltages at many points in the instrument which can, if contacted, cause personal injury. Be extremely careful. Adjustments should be performed only by trained service personnel.**

Power is still applied to this instrument with the LINE switch in the off position. Before removing or installing any assembly or printed circuit board, remove the line-power cord.

Capacitors inside the instrument may still be charged, even if the instrument has been disconnected from its source of supply.

Use a nonmetallic adjustment tool whenever possible.

Which Adjustments Should Be Performed?

[Table 3-1 on page 93](#) lists the manual adjustments that should be performed when an assembly is repaired or changed. It is important to perform the adjustments in the order indicated to ensure that the instrument meets its specifications.

Test Equipment

The equipment required for the manual adjustment procedures is listed in Table 1-5, "Recommended Test Equipment." Any equipment that satisfies the critical specifications given in the table may be substituted for the preferred test equipment.

If an 3335A is not available for performance tests, tests using alternate test equipment are available. See [Chapter 3a, "Manual Adjustment Procedures: 3335A Source not Available," on page 161](#).

Adjustable and Factory-Selected Components

[Table 3-2 on page 96](#) lists the adjustable components by reference designation and name. For each component, the table provides a description and lists the adjustment number.

Refer to [Table 3-3 on page 98](#) for a complete list of factory-selected components used in the instrument along with their functions. Factory-selected components are identified with an asterisk on the schematic diagrams.

Adjustment Tools

For adjustments requiring a nonmetallic tuning tool, use fiber tuning tool, part number 8710-0033.

Two different tuning tools may be necessary for IF bandpass adjustments, depending upon the type of tuning slug used in the slug-tuned inductors. If the tuning slug requires a slotted tuning tool, use part number 8710-1010. If the tuning slug requires a forked tuning tool, use part number 8710-0772.

Never try to force an adjustment control. This is especially critical when tuning variable capacitors or slug-tuned inductors. Required service accessories, with part numbers, are listed under [Service Kit](#), in [Chapter 1](#), “General Information.”

Instrument Service Position

Refer to [Chapter 4](#) for information on removing the spectrum analyzer cover assembly and accessing all internal assemblies.

Table 3-1 Related Adjustments

Assembly Changed or Repaired	Perform the following related adjustments in the order listed	Adjustment Number	
		Manual	Automated*
A1A1 keyboard	No related adjustment		
A1A2 RPG	No related adjustment		
A2 controller	16 MHz PLL adjustment	15	
	Display adjustment (8564E and 8565E only)	2	
	If EEROM from old A2 controller could not be used in new A2 or if EEROM must be replaced, also perform the following adjustments: LOMA adjustments		4
	External mixer amplitude adjustment or 3rd amp/2nd IF align [†]	13	6
	Front end cal		8
A3 interface	Display adjustment -fast zero span [†] (8564E and 8565E only)	2	5
	Front end cal		8
A4 log amp/cal osc	Display adjustment -fast zero span [†] (8564E and 8565E only)	2	5
	Demodulator adjustment	11	
	IF amplitude adjustment [†]	4	10
	DC log amplifier adjustment [†]	5	11
A5 IF	IF bandpass adjustment [†]	3	9
	IF amplitude adjustment [†]	4	10
A6 power supply	High voltage power supply adjustment (8564E and 8565E only)	1	
	Display adjustment (8564E and 8565E only)	2	
A6A1 HV module	High voltage power supply adjustment (8564E and 8565E only)	1	
	Display adjustment (8564E and 8565E only)	2	
*If any automated adjustment is required, you must first perform automated adjustment "1. Initial Information" on page 63.			
[†] Either the manual or the automated adjustment may be performed.			

Table 3-1 Related Adjustments

Assembly Changed or Repaired	Perform the following related adjustments in the order listed	Adjustment Number	
		Manual	Automated*
A7 LOMA	LOMA adjustments		4
	Front end cal (or perform the frequency response performance test in the 8560 E-Series and EC-Series Spectrum Analyzer Calibration Guide. The adjustment must be performed if the performance test fails).		8
A8 low band mixer	Front end cal		8
A9 input attenuator	Front end cal (or perform the frequency response performance test in the 8560 E-Series and EC-Series Spectrum Analyzer Calibration Guide. The adjustment must be performed if the performance test fails.)		8
A10/A12 RYTHM/SBTX	Front end cal		8
A11 YTO	YTO adjustment [‡]	7	
	LO frequency [‡]		2
	YTO FM coil [‡]		3
A13 2nd converter	Front end cal		8
A14 frequency control	Display adjustment -fast zero span [†] (E-series only)	2	5
	YTO adjustment [‡]	7	
	LO frequency [‡]		2
	YTO FM cal [‡]		3
	Front end cal		8
<p>*If any automated adjustment is required, you must first perform automated adjustment "1. Initial Information" on page 63.</p> <p>[†]Either the manual or the automated adjustment may be performed.</p> <p>[‡]Perform either the manual "YTO adjustment" (7) or the automated "LO frequency" and "YTO FM coil" adjustments (2 and 3).</p>			

Table 3-1 Related Adjustments

Assembly Changed or Repaired	Perform the following related adjustments in the order listed	Adjustment Number	
		Manual	Automated*
A15 RF	10 MHz reference adjustment (TCXO, Option 103) or CAL OUT adjustment [†]	15	7
	Calibrator amplitude adjustment or CAL OUT adjustment [†]	8	7
	External mixer bias adjustment	12	
	Sampling oscillator adjustment	6	12
	Signal ID oscillator adjustment	14	
	External mixer amplitude adjustment or 3rd amp/2nd IF align [†]	13	6
	Front end cal		8
A15U100 sampler	Sampling oscillator adjustment [†]	6	12
A17 CRT driver	Display adjustment (8564E and 8565E only)	2	
A18V1 CRT	Display adjustment (8564E and 8565E only)	2	
A19 GPIB	No related adjustment		
A21 OCXO	10 MHz reference adjustment (OCXO)	9	
<p>*If any automated adjustment is required, you must first perform automated adjustment "1. Initial Information" on page 63.</p> <p>[†]Either the manual or the automated adjustment may be performed.</p> <p>[‡]Perform either the manual "YTO adjustment" (7) or the automated "LO frequency" and "YTO FM coil" adjustments (2 and 3).</p>			

Table 3-2 Adjustable Components

Reference Designator	Adjustment Name	Adjustment Number	Description
A2R152	16 MHz PLL ADJ	22	Adjusts the free-running frequency of the 16 MHz CPU clock
A2R206	DGTL X GAIN	2	Adjusts the horizontal gain in the X line generator.
A2R209	SWEEP OFFSET	2	Adjusts the beginning of the trace to the leftmost vertical graticule line in fast-analog zero-span mode.
A2R215	DGTL Y GAIN	2	Adjusts the vertical gain in the Y line generator.
A2R218	VIDEO OFFSET	2	Adjusts the vertical position in fast-analog zero span to match the digital zero-span input.
A2R262	STOP BLANK	2	Adjusts the blanking at the end of a vector on the display.
A2R263	START BLANK	2	Adjusts the blanking at the start of a vector on the display.
A2R268	VIDEO GAIN	2	Adjusts the vertical gain in fast-analog zero span to match with the digital zero-span input.
A2R271	SWEEP GAIN	2	Adjusts the end of the trace to the rightmost vertical-graticule line in fast-analog zero-span mode.
A4C707	FM DEMOD	16	Adjusts the FM demodulation for a peak response.
A4R445	LIMITER PHASE	5	Adjusts Limiter Phase for peak response.
A4R531	LOG AMP TOS	5	Minimizes error to Top of Screen.
A4R544	LIN FIDELITY BOW	5	Minimizes Linearity Fidelity error.
A4R826	CAL OSC AMPTD	4	Sets calibration oscillator output power (nominally -35 dBm). This power is injected into the IF during the AUTO IF ADJUST routines.
A5L300	LC CTR 1	3	Adjusts center frequency of first stage of LC bandwidth filter to 10.7 MHz.
A5L301	LC CTR 2	3	Adjusts center frequency of second stage of LC bandwidth filter to 10.7 MHz.
A5L700	LC CTR 3	3	Adjusts center frequency of third stage of LC bandwidth filter to 10.7 MHz.
A5L702	LC CTR 4	3	Adjusts center frequency of fourth stage of LC bandwidth filter to 10.7 MHz.
A5R343	15 DB ATT	4	Adjusts the attenuation of the reference 15 dB attenuator for 15 db between minimum and maximum attenuation.

Table 3-2 Adjustable Components

Reference Designator	Adjustment Name	Adjustment Number	Description
A5T200	XTAL CTR 1	3	Adjusts center frequency of first stage of crystal bandwidth filter to 10.7 MHz.
A5T202	XTAL CTR 2	3	Adjusts center frequency of second stage of crystal bandwidth filter to 10.7 MHz.
A5T500	XTAL CTR 3	3	Adjusts center frequency of third stage of crystal bandwidth filter to 10.7 MHz.
A5T502	XTAL CTR 4	3	Adjusts center frequency of fourth stage of crystal bandwidth filter to 10.7 MHz.
A6R410	HV ADJ	1	Adjusts the voltage between A6TP405 and A6TP401 to the voltage marked on the A6A1 high voltage module.
A14R42	6.01 GHz	7	Adjusts the main coil tune driver current at a YTO frequency of 6.01 GHz (near the upper YTO frequency limit).
A14R76	FM SPAN	7	Adjusts the FM span accuracy by affecting the sensitivity of the FM coil driver.
A14R93	3.2 GHz	7	Adjusts the main coil fixed driver current at a YTO frequency of 3.2 GHz (near the lower YTO frequency limit).
A15C100	SMPL MATCH	6	Transforms the sampler input impedance to 50 ohms over the 285 to 297.2 MHz range.
A15C210	VCO RANGE	6	Adjusts the VCO tank capacitance so that 21V on the VCO tune line equals 298 MHz VCO frequency.
A15C629	SIG ID	19	Fine adjusts the 298 MHz SIG ID oscillator frequency to optimize its performance.
A15U302	10 MHz ADJ	15	Adjusts frequency of the temperature compensated crystal oscillator (TCXO) to 10 MHz.
A15R561	CAL AMP TD	13	Adjusts amplitude of the 300 MHz calibrator signal to -10.0 dBm.
A15R926	EXT BIAS ZERO	17	Adjusts zero bias point of external mixer bias.
A17R4	Z GAIN	2	Adjusts maximum intensity.
A17R11	CUTOFF	2	Adjusts intensity to turn off blanked lines.
A17R21	Z FOCUS	2	Adjusts focus for lines of different brightness.
A17R26	X FOCUS	2	Adjusts focus at the left and right corners of the display.
A17R34	COARSE FOCUS	2	Adjusts focus at the center of the display.
A17R55	X GAIN	2	Adjusts the horizontal-deflection amplifier gain.
A17R57	X POSN	2	Adjusts the CRT horizontal position.
A17R75	Y GAIN	2	Adjusts the vertical-deflection amplifier gain.
A17R77	Y POSN	2	Adjusts the CRT vertical position.

Table 3-2 Adjustable Components

Reference Designator	Adjustment Name	Adjustment Number	Description
A17R90	TRACE ALIGN	2	Adjusts the display axis rotation.
A17R92	DDD	2	Adjusts focus of the center of the display.
A17R93	ASTIG	2	Adjusts for the spot roundness on the CRT display.

Table 3-3 Factory Selected Components

Reference Designator	Adjustment Number	Basis of Selection
A5C204	3	Selected to optimize center frequency of LC tank that loads the crystal.
A5C216	3	Selected to optimize center frequency of LC tank that loads the crystal.
A5C326	3	Selected to optimize LC pole center frequency.
A5C327	3	Selected to optimize LC pole center frequency.
A5C505	3	Selected to optimize center frequency of LC tank that loads the crystal.
A5C516	3	Selected to optimize center frequency of LC tank that loads the crystal.
A5C717	3	Selected to optimize LC pole center frequency.
A5C718	3	Selected to optimize LC pole center frequency.

1. High Voltage Power Supply Adjustment (8564E and 8565E)

Assembly Adjusted

A6 power supply

Related Performance Test

There is no related performance test for this adjustment.

Description

The high voltage power supply is adjusted to the voltage marked on the A6A1 HV module. The A6A1 HV module is characterized in the factory to ensure that the display filament voltage is set to 6.0 V rms when the +110 Vdc (nominal) supply is set to the voltage marked on the HV module.

WARNING

To minimize shock hazard, use a nonmetallic adjustment tool when adjusting the A6 power supply.

The following procedure probes voltages that, if contacted, could cause personal injury or death.

NOTE

Adjustment of the high voltage power supply should not be a routine maintenance procedure. Any adjustments should be done only if the A6 power supply, A6A1 HV module, or A18V1 CRT (display) is repaired or replaced.

You must perform the display adjustments after this adjustment if either the display or HV module has been replaced.

Figure 3-1 High Voltage Power Supply Adjustment Setup

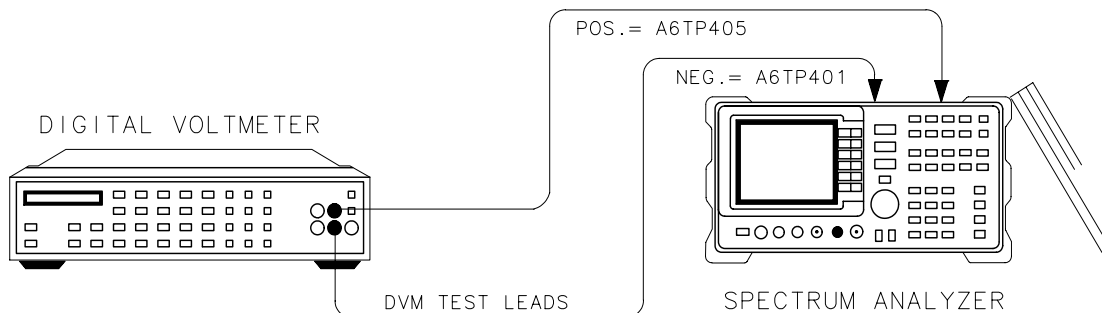

SK11

Equipment

Digital multimeter	3456A
DVM test leads	34118A

Procedure

WARNING

After disconnecting the ac power cord, allow capacitors in the high voltage supply to discharge for at least 30 seconds before removing the protective cover from the A6 power supply.

1. Turn the spectrum analyzer off by pressing **LINE**. Disconnect the power cord and remove the spectrum analyzer cover. Fold down the A2 controller, A3 interface, A4 log amplifier/cal oscillator, and A5 IF assemblies. Remove the A6 power supply cover.
2. Position the spectrum analyzer as shown in [Figure 3-1 on page 100](#). Connect the negative DVM lead to A6TP401 and the positive DVM lead to A6TP405 (you will place the positive DVM lead on the inductor (L401) lead which is adjacent to the label that reads "U401"; a white square outlines the area on the PC board where this lead is inserted into the A6 board).
3. Set the 3456A controls as follows:

Function	DC VOLTS
Range	1000 VOLTS
4. Reconnect the power cord to the spectrum analyzer and press **LINE** to the on position.
5. Record the voltage marked on the A6A1 HV module.

Voltage marked on A6A1 HV Module = _____ Vdc

1. High Voltage Power Supply Adjustment (8564E and 8565E)

6. Adjust A6R410 HV ADJ for a voltage equal to the voltage recorded in step 5.
7. Press **LINE** to turn the spectrum analyzer off and disconnect the power cord. Wait at least 30 seconds for the high voltage power supply capacitors to discharge.
8. Disconnect the DVM test leads from A6TP401 and A6TP405. Reinstall the power supply cover.

2. Display Adjustment (8564E and 8565E)

Assembly Adjusted

A2 controller A17 CRT driver

Related Performance Test

Sweep Time Accuracy (Sweep Times <30 ms)

Description

Coarse adjustment of the deflection amplifiers, Z-axis amplifiers, and line generators is done using the CRT adjust pattern. Fine adjustments use the graticule. The fast zero-span amplitude adjustments correct for differences between analog and digital display modes. The displayed sweep time accuracy is adjusted in the fast zero-span sweep adjustments.

Figure 3-2 Display Adjustment Setup

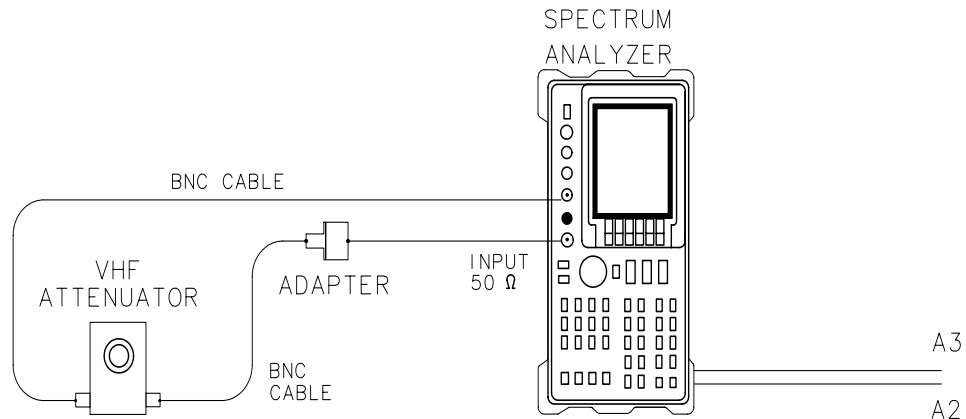

SK12

Equipment

10 dB VHF step attenuator 355D

Adapters

Type N (m) to BNC (f) 1250-1476

Cables

BNC, 122 cm (2 required) 10503A

Procedure

NOTE

Perform the 16 MHz PLL Adjustment in this chapter before proceeding with this adjustment.

1. Turn the spectrum analyzer off by pressing **LINE**. Remove the spectrum analyzer cover and fold out the A2 controller and A3 interface assemblies as illustrated in [Figure 3-2 on page 102](#). Connect the CAL OUTPUT to the INPUT. Adjustment locations are shown on the CRT neck for A17 adjustments and in [Figure 3-4 on page 107](#) for the A2 adjustments.

Preliminary Adjustments

2. Set A17R55 X GAIN, A17R75 Y GAIN, A17R92 DDD, A17R93 ASTIG, A2R206 DGTL X GAIN, A2R215 DGTL Y GAIN, A2R262 STOP BLANK, and A2R263 START BLANK to midrange. Also set the rear panel X POSN, Y POSN, and TRACE ALIGN to midrange.
3. Set A17R21 Z FOCUS, A17R26 X FOCUS, and A17R11 CUTOFF to midrange.
4. Set A17R4 Z GAIN fully clockwise.
5. Turn the spectrum analyzer on and allow it to warm up for at least 3 minutes. Adjust A17R11 CUTOFF until the display is visible and A17R34 COARSE FOCUS for best possible focus.

Cutoff Adjustment

6. Press **PRESET, DISPLAY, INTENSITY, 255 ENTER, STORE INTENSITY, MORE 1 of 2, FOCUS, 127 ENTER, STORE FOCUS**, then **GRAT ON OFF (OFF)**. Adjust A17R11 CUTOFF until the retrace line between the bottom of trace A and the annunciators at the bottom of the display just disappears.

Deflection Adjustments

7. Press **GRAT ON OFF (ON), MORE 2 of 2, INTENSITY, 80 ENTER, STORE INTENSITY, CAL, MORE 1 of 2**, and **CRT ADJ PATTERN**. Fold up the A3 interface assembly to access the adjustments on the A2 controller assembly.
8. Refer to [Figure 3-3 on page 105](#) for locating the lines used for adjusting DGTL X GAIN and DGTL Y GAIN. Each of these lines is actually two lines adjusted for coincidence. The two lines will form an "X" if they are not adjusted properly.
9. Adjust A2R206 DGTL X GAIN until the two vertical lines near the left edge of the display converge to one single line.

2. Display Adjustment (8564E and 8565E)

10. Adjust A2R215 DGTL Y GAIN until the two horizontal lines near the top edge of the display converge to one single line.
11. Adjust A2R262 STOP BLANK and A2R263 START BLANK for the sharpest corners of the outer box in the test pattern. The intensity of the corners should be the same as the middle of the lines between the corners.
12. Adjust the rear panel TRACE ALIGN until the leftmost line of the test pattern is parallel with the CRT bezel. See [Figure 3-3 on page 105](#).
13. Adjust the rear panel X POSN and A17R55 X GAIN until the leftmost "@" characters and the softkey labels appear just inside the left and right edges of the CRT bezel.
14. Adjust the rear panel Y POSN and A17R75 Y GAIN until the softkey labels align with their appropriate softkeys.
15. Press **PRESET**. If necessary, readjust STOP BLANK and START BLANK for the best-looking intersection of the graticule lines. This will be most noticeable along the center vertical and horizontal graticule lines.

Figure 3-3 CRT Adjust Pattern

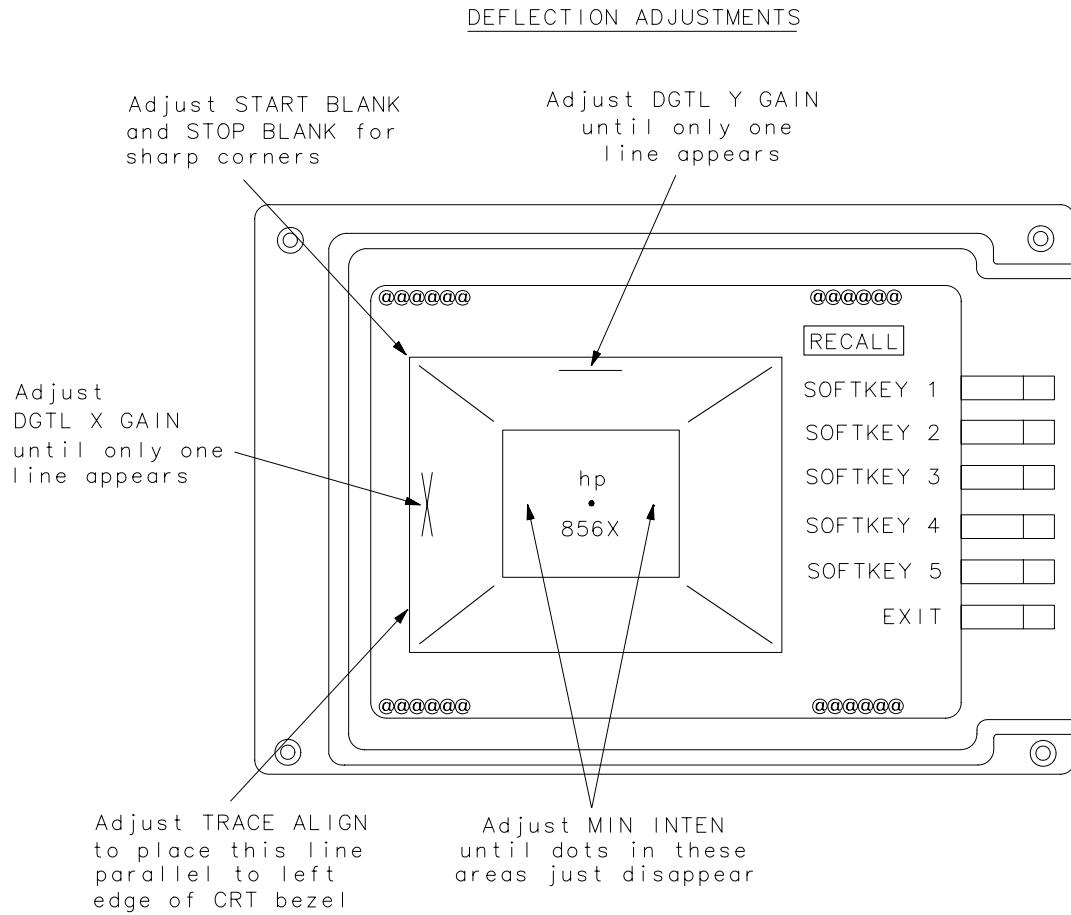

SK13

Intensity Adjustments

16. Press **AMPLITUDE** then set the **REF LVL** to -70 dB and the **LOG dB/DIV** to 1. This should almost completely fill the screen with the noise floor. Press **SGL SWP**. Adjust A17R4 Z GAIN until the intensity at the center of the screen is about medium. It should be fully illuminated, but not so bright that it burns the screen (15 NITs on a photometer/radiometer).
17. Press **CAL, MORE 1 of 2**, and **CRT ADJ PATTERN**. Locate the dot just underneath the HP logo. Adjust A17R93 ASTIG for the smallest round dot possible.
18. Adjust A17R34 COARSE FOCUS and A17R92 DDD for the best focus of the characters at the center of the screen.
19. Adjust A17R21 Z FOCUS for the best focus of the outside box of the test pattern.
20. Adjust A17R26 X FOCUS for best focus of the "@" characters at the corners of the test pattern.
21. Repeat steps 17 through 20 to obtain the best overall focus quality.

Figure 3-4 A2 Display Adjustment Locations

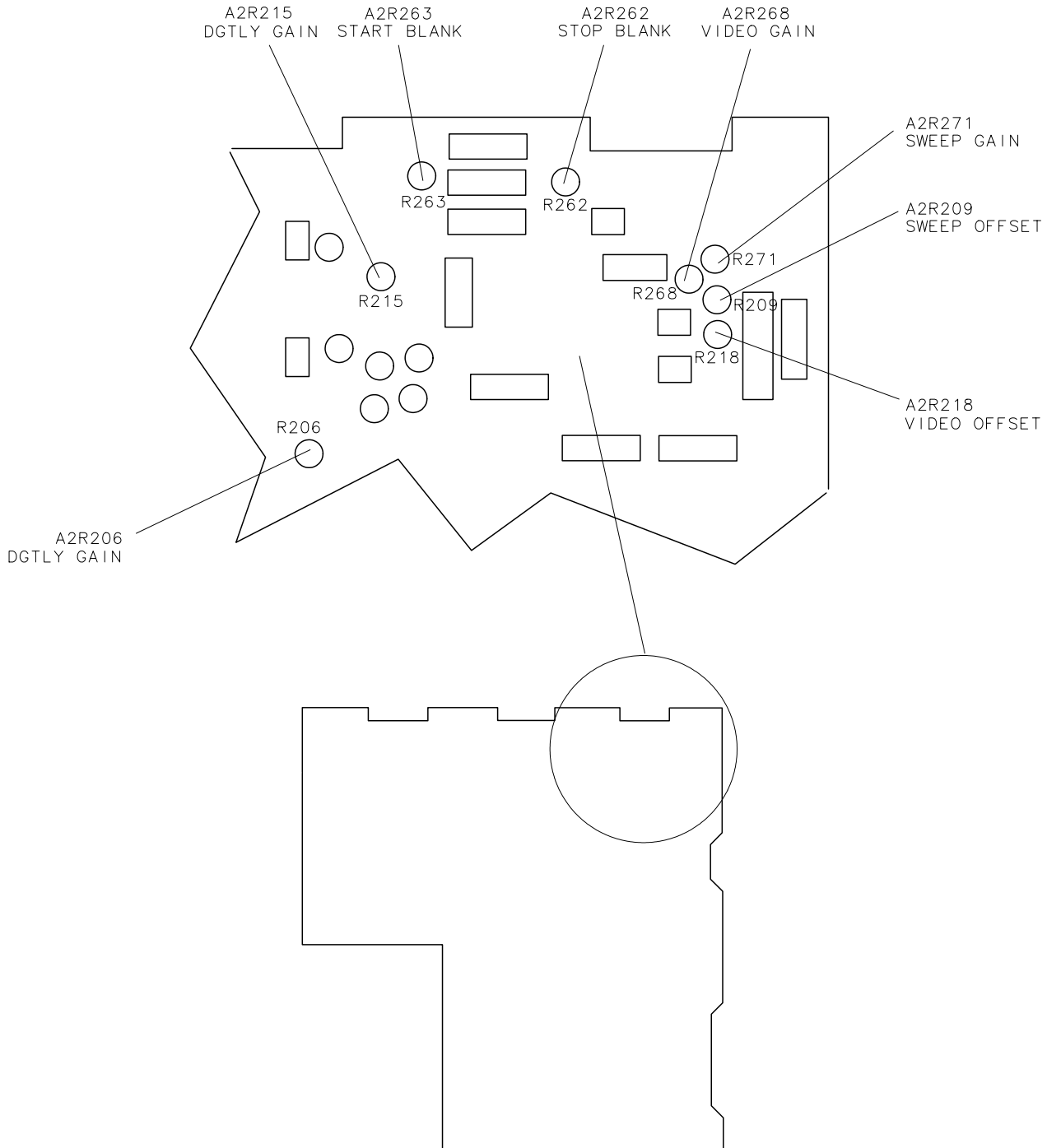

SK14

Fast Zero Span Adjustments (Non-Option 007, E-series Instruments Only)

22. Set A2R209 SWEEP OFFSET, A2R218 VIDEO OFFSET, and A2R268 VIDEO GAIN to midrange. Adjustment locations are shown in [Figure 3-4 on page 107](#) for these A2 adjustments.

23. Set the 355D to 30 dB attenuation.

24. Press **PRESET** on the spectrum analyzer, and connect the equipment as shown in [Figure 3-2 on page 102](#). Set the spectrum analyzer controls as follows:

Center frequency	300MHz
Span	0 Hz
Reference level	-40 dBm
Resolution bandwidth	1 kHz
Video bandwidth	300 Hz
Sweep time	50 ms

25. Press **MKR**, **MKR**→, **MARKER**→ **REFLVL**. If the marker is not at the top graticule, press **MARKER**→ **REF LVL** again.

26. Press **SAVE**, **SAVE STATE**, and **STATE 0**.

27. Set the sweep time to 10 ms.

28. Press **SAVE**, **SAVE STATE**, and **STATE 1**.

29. Adjust A2R209 SWEEP OFFSET to place the beginning of the trace at the leftmost vertical graticule line.

30. Adjust A2R271 SWEEP GAIN to place the end of the trace at the tenth vertical graticule line (one division from the right edge of the graticule).

31. Press **AMPLITUDE** and press the ↓ key seven times.

32. Press **SAVE**, **SAVE STATE**, and **STATE 2**.

33. Set the sweep time to 50 ms. Press **SAVE**, **SAVE STATE**, and **STATE 3**.

34. Press **RECALL**, **RECALL STATE**, and **STATE 1**.

35. Switch between **STATE 1** and **STATE 2**. Adjust A2R268 and A2R218 so that the trace in state 1 is lined up with the top line of the graticule and the state 2 trace is lined up with the eighth graticule down from the top (counting the top line). Repeat until the traces align to within ±0.2 divisions.

36. Adjust A2R209 and A2R271 until the start of sweep is aligned to the leftmost vertical graticule line and the end of the sweep is aligned with the right most vertical graticule line.

37. Press **STATE 2** and **STATE 3**. The two traces should be aligned within ±0.1 divisions.

38. Press **STATE 0** and **STATE 1**. The two traces should be aligned within ± 0.1 divisions.

3. IF Bandpass Adjustment

Assembly Adjusted

A5 IF assembly

Related Performance Test

Resolution Bandwidth Accuracy and Selectivity

Description

The center frequency of each IF bandpass filter pole is adjusted by DAC-controlled varactor diodes and an inductor (for the LC poles) or a transformer (for the crystal poles). The inductors and transformers are for coarse tuning and the varactors are for fine tuning by the microprocessor. The inductors and transformers are adjusted such that the varactor diodes are biased near the middle of their capacitance range. The varactor diode bias is measured with the DVM.

NOTE

This procedure is not a routine adjustment. It should be performed only if repairs to the A5 IF assembly are made. If the entire A5 IF assembly is replaced, the assembly arrives pre-adjusted from the factory and requires no further adjustment.

Figure 3-5 IF Bandpass Adjustment Setup

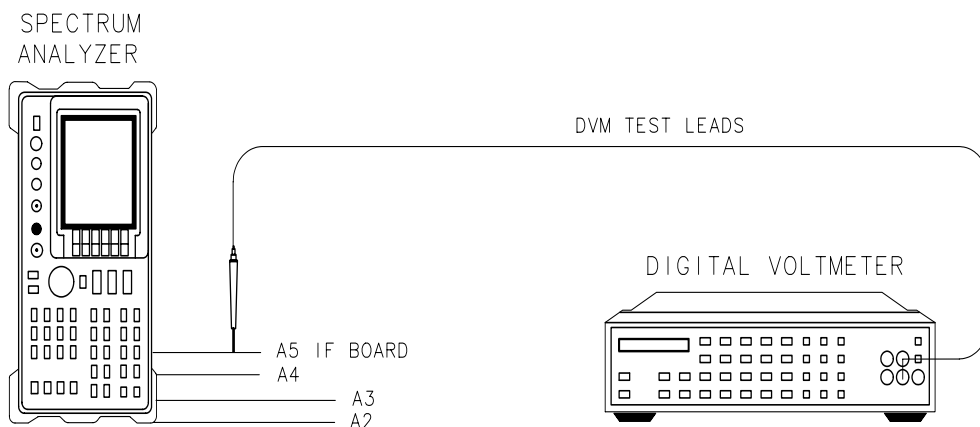

SK15

Equipment

Digital voltmeter	3456A
DVM test leads	34118A
Special tuning tool (use with slotted tuning slugs)	8710-1010
Special tuning tool (use with forked tuning slugs)	8710-0772

Procedure

1. Turn the spectrum analyzer off by pressing **LINE**. Disconnect the power cord. Remove the spectrum analyzer cover and fold down the A2 controller, A3 interface, A4 log amp, and A5 IF assemblies. Reconnect the power cord. Turn the spectrum analyzer on and allow it to warm up for at least 30 minutes.

2. Connect the negative DVM lead to pin 6 of A5J6. See [Figure 3-5 on page 110](#) and [Figure 3-6 on page 112](#). Set the 3456A controls as follows:

Function	DC VOLTS
Range	10 VOLTS

3. On the spectrum analyzer press **PRESET**, **SPAN**, **2**, **MHz**, **CAL**, and **IF ADJ ON OFF** so **OFF** is underlined.

Figure 3-6 **A5J6 Pin Locations**

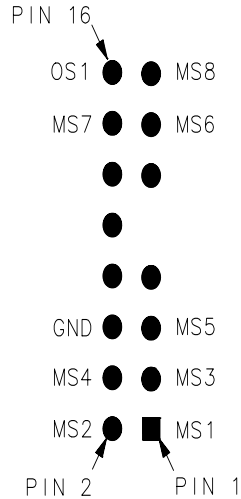

sz144e

LC Bandpass Adjustments

4. On the spectrum analyzer, press **ADJ CURR IF STATE**. Wait for the **IF ADJUST STATUS** message to disappear before continuing with the next step.
5. Read the voltage on A5TP5 (this is an empty-hole type of test point). If the voltage is less than +6.06 Vdc, turn A5L300 LC CTR 1 clockwise. If the voltage is greater than +6.26 Vdc, turn LC CTR 1 counterclockwise.
6. Repeat steps 1 and 2 until the voltage reads +6.16 Vdc \pm 100 mV.

NOTE

If the range for the LC CTR adjustment is insufficient, replace the appropriate factory-selected capacitor as listed in [Table 3-4 on page 113](#). To determine the correct replacement value, center the LC CTR adjustment and press **ADJ CURR IF STATE**. After the **IF ADJUST STATUS** message disappears, read the DVM display. Choose a capacitor value from [Table 3-5 on page 113](#), based on the DVM reading and the presently loaded capacitor value. [Table 3-8 on page 115](#) lists a few capacitor part numbers.

CAUTION

Turn the spectrum analyzer off by pressing **LINE** to the off position before removing or replacing any shield.

7. Move the positive DVM lead to A5TP6.
8. Adjust A5L301 LC CTR 2 by repeating steps 4 through 6.

9. Move the positive DVM test lead to A5TP2 (this is a resistor-lead type of test point).
10. Adjust A5L700 LC CTR 3 by repeating steps 4 through 6.
11. Move the positive DVM test lead to A5TP1 (this is a resistor-lead type of test point).
12. Adjust A5L702 LC CTR 4 using the procedure in steps 4 through 6.

Table 3-4 Factory-Selected LC Filter Capacitors

LC CTR Adjustment	Fixed Factory Select Capacitor
A5L300 LC CTR 1	A5C326
A5L301 LC CTR 2	A5C327
A5L700 LC CTR 3	A5C717
A5L702 LC CTR 4	A5C718

Table 3-5 LC Factory-Selected Capacitor Selection

DVM Reading (V)	Currently Loaded Capacitor Value (pF)						
	Replace 6.8 with:	Replace 8.2 with:	Replace 10 with:	Replace 12 with:	Replace 15 with:	Replace 18 with:	Replace 20 with:
0 to 1.5	*	*	*	*	*	*	*
1.5 to 2.5	18	18	*	*	*	*	*
2.5 to 3.5	15	15	18	18	*	*	*
3.5 to 4.5	10	12	15	15	18	*	*
4.5 to 5.5	8.2	10	12	15	18	*	*
5.5 to 6.5	No change	No change	No change	No change	No change	No change	No change
6.5 to 7.5	No change	No change	No change	No change	No change	No change	No change
7.5 to 8.5	*	6.8	8.2	10	12	15	18
8.5 to 9.5	*	*	6.8	8.2	12	15	18
9.5 to 10	*	*	6.8	8.2	10	12	15

* Indicates a condition that should not exist; suspect broken hardware.

XTAL Bandpass Adjustments

13. On the spectrum analyzer, press **SPAN**, 1, **MHz**, and **CAL**.
14. Move the positive DVM test lead to A5TP7.
15. On the spectrum analyzer, press **ADJ CURR IF STATE**. Wait for the **IF ADJUST STATUS** message to disappear before continuing to the next step.
16. Read the voltage displayed on the DVM. If the voltage is less than +6.06 Vdc, turn A5T200 XTAL CTR 1 clockwise. If the voltage is greater than +6.26 Vdc, turn XTAL CTR 1 counterclockwise.
17. Repeat steps 15 and 16 until the voltage reads +6.16 Vdc \pm 100 mV.

NOTE

If the range for the XTAL CTR adjustment is insufficient, replace the appropriate factory-selected capacitor as listed in [Table 3-6 on page 114](#). To determine the correct replacement value, center the XTAL CTR adjustment, and press **ADJ CURR IF STATE**. After the **IF ADJUST STATUS** message disappears, read the DVM display. Choose a capacitor value from [Table 3-7 on page 115](#), based on the DVM reading and the presently loaded capacitor value. [Table 3-8 on page 115](#) lists a few capacitor part numbers.

CAUTION

Turn the spectrum analyzer off by pressing **LINE** to the off position before removing or replacing any shield.

18. Move the positive DVM test lead to A5TP8.
19. Adjust A5T202 XTAL CTR 2 using the procedure in steps 15 through 17.
20. Move the positive DVM test lead to A5TP3.
21. Adjust A5T500 XTAL CTR 3 using the procedure in steps 15 through 17.
22. Move the positive DVM test lead to A5TP4.
23. Adjust A5T502 XTAL CTR 4 using the procedure in steps 15 through 17.

Table 3-6 Factory-Selected XTAL Filter Capacitors

XTAL CTR Adjustment	Fixed Factory Select Capacitor
A5T200 XTAL CTR 1	A5C204
A5T202 XTAL CTR 2	A5C216
A5T500 XTAL CTR 3	A5C505
A5T502 XTAL CTR 4	A5C516

Table 3-7 XTAL Factory-Selected Capacitor Selection

DVM Reading (V)	Currently Loaded Capacitor Value (pF)					
	Replace 15 with:	Replace 18 with:	Replace 20 with:	Replace 22 with:	Replace 24 with:	Replace 27 with:
0 to 1.5	*	*	*	*	*	*
1.5 to 2.5	27	*	*	*	*	*
2.5 to 3.5	22	27	27	*	*	*
3.5 to 4.5	18	22	24	27	27	*
4.5 to 5.5	18	20	22	24	27	*
5.5 to 6.5	No change	No change	No change	No change	No change	No change
6.5 to 7.5	No change	No change	No change	No change	No change	No change
7.5 to 8.5	*	15	18	18	22	24
8.5 to 9.5	*	15	15	18	20	24
9.5 to 10	*	*	15	18	20	24

* Indicates a condition that should not exist; suspect broken hardware.

Table 3-8 Capacitor Part Numbers

Capacitor Value (pF)	Part Number
6.8	0160-4793
8.2	0160-4792
10	0160-4791
12	0160-4790
15	0160-4789
18	0160-4788
20	0160-5699
22	0160-4787
24	0160-5903
27	0160-4786

4. IF Amplitude Adjustments

The IF amplitude adjustments consist of the cal oscillator amplitude adjustment and the reference 15 dB attenuator adjustment.

Assembly Adjusted

A4 log amp/cal oscillator A5 IF assembly

Related Performance Tests

IF Gain Uncertainty Scale Fidelity

Description

This adjustment sets the output amplitude of the A4 log amp/cal oscillator and the absolute amplitude of the reference 15 dB attenuator.

The output of the A4 log amp/cal oscillator is adjusted so that a -55 dBm signal applied to the 10.7 MHz IF input on the A5 IF assembly (A5J3) causes a displayed signal of -60 dBm. The effect of this adjustment is visible only after the **ADJ CURR IF STATE** sequence is complete. **ADJ CURR IF STATE** causes the IF gain adjustment to use the "new" output amplitude from the A4 log amp/cal oscillator.

This procedure also sets the attenuator of the reference 15 dB attenuator so that a source amplitude change of 50 dB combined with a spectrum analyzer reference level change of 50 dB displays an amplitude difference of 50 dB.

Figure 3-7 IF Amplitude Adjustment Setup

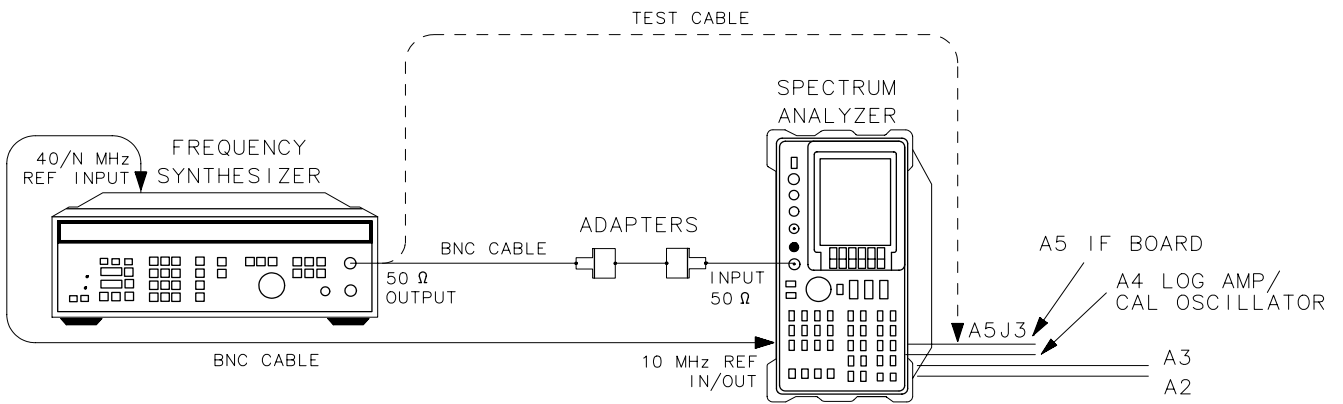

sz148e

Equipment

Frequency synthesizer 3335A

Adapters

Type N (m) to BNC (f) 1250-1476

Type N (f) to 2.4 mm (f) 11903B

Cables

BNC, 122 cm (48 in) 10503A

Test cable 85680-60093

Figure 3-8 IF Amplitude Adjustment Locations

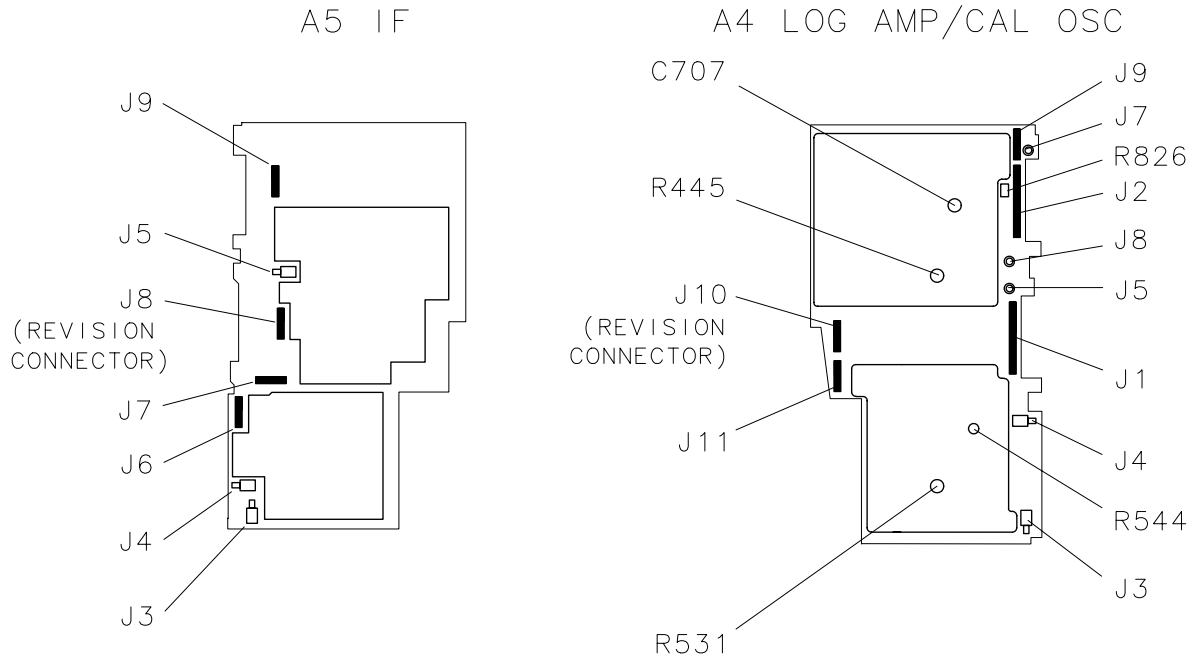

sj11e

NOTE The 15 dB reference attenuator adjustment is preset at the factory and need not be done if the entire A5 IF assembly is replaced.

Procedure

1. Press **LINE** to turn the spectrum analyzer off. Remove the spectrum analyzer cover and place the spectrum analyzer in the service position as illustrated in [Figure 3-7](#) “IF Amplitude Adjustment Setup,” on page 117.
2. Disconnect W29, violet coax cable, from A5J3. Connect the test cable between A5J3 and the 50Ω output of the 3335A. Press **LINE** to turn the spectrum analyzer on.
3. On the spectrum analyzer, press **MKR**, **CAL**, and **IF ADJ ON OFF** so **OFF** is underlined.
4. Set the 3335A controls as follows:

Frequency	10.7 MHz
Amplitude	-55 dBm
5. Note the marker value. Ideally it should read -60 dBm ±0.1 dB.

6. If the marker reads less than -60.1 dBm, rotate A4R826 CAL OSC AMPTD one-third turn clockwise for every 0.1 dB less than -60 dBm. If the marker reads greater than -59.9 dBm, rotate A4R826 CAL OSC AMPTD one-third turn counter clockwise for every 0.1 dB greater than -60 dBm. See [Figure 3-8 on page 118](#) for the location of A4R826. A change in the displayed amplitude will not be seen until **ADJ CURR IF STATE** is pressed.

NOTE

If A4R826 has inadequate range, refer to "Inadequate CAL OSC AMPTD Range" in Chapter 9.

7. Press **ADJ CURR IF STATE**. After allowing the analyzer time to complete the adjustments, the displayed amplitude and marker reading should change.
8. Repeat steps 7 and 8 until the marker reads -60 dBm ± 0.1 dB.
9. Disconnect the test cable from A5J3 and reconnect W29 to A5J3.

A5 Reference Attenuator Adjustment

10. Set the spectrum analyzer reference level to -60 dBm. If markers are displayed, press **MKR** and **MARKERS OFF**.
11. Set the 3335A **AMPLITUDE** to -60 dBm.
12. Connect a BNC cable between the 50Ω output of the 3335A and the spectrum analyzer INPUT 50Ω .
13. On the spectrum analyzer, press **CAL** and **REF LVL ADJ**. Use the front panel knob or step keys to place the peak of the displayed signal 3 dB to 5 dB below the reference level.
14. Press **PEAK SEARCH** and **MARKER DELTA** on the spectrum analyzer. Set the spectrum analyzer reference level to -10 dBm.
15. Change the 3335A **AMPLITUDE** to -10 dBm.
16. Press **CAL** on the spectrum analyzer.
17. Note the Δ MKR amplitude. Ideally, it should read 50.00 dB ± 0.1 dB.
18. If the Δ MKR amplitude is less than 49.9 dB, rotate A5R343 15 dB **ATTEN** one-half turn counterclockwise for each 0.1 dB less than 50.00 dB. If the Δ MKR amplitude is greater than 50.1 dB, rotate A5R343 15 dB **ATTEN** one-half turn clockwise for each 0.1 dB greater than 50.00 dB. Do not adjust A5R343 more than five turns before continuing with the next step.
19. Press **ADJ CURR IF STATE** on the spectrum analyzer. Note the Δ MKR amplitude reading.
20. Repeat steps 11 through 20 until the Δ MKR amplitude reading is 50.00 dB ± 0.1 dB.

A5 Adjustment Verification

21. On the spectrum analyzer, disconnect W29 from A5J3. Connect the test cable between A5J3 and the 50Ω output of the 3335A.
22. Set the spectrum analyzer reference level to -10 dBm.
23. Set the 3335A **AMPLITUDE** to -5 dBm.
24. Press **MKR** and **MARKER NORMAL** on the spectrum analyzer.
25. The **MARKER** amplitude should read -10 dBm ±0.13 dB. If the reading is outside of this range, repeat steps 4 through 21.
26. On the spectrum analyzer, reconnect W29 to A5J3. Press **PRESET** and set the controls as follows:

Center frequency	300 MHz
Span	0 Hz
Reference level	-10 dBm
Resolution bandwidth	300 kHz
27. Connect a BNC cable between the 8563E **CAL OUTPUT** and **INPUT 50Ω**.
28. On the spectrum analyzer, press **MKR CAL** and **REF LVL ADJ**.
29. Use the knob or step keys to adjust the **REF LEVEL CAL** setting until the **MKR** reads -10.00 dBm ±0.1 dB.
30. On the spectrum analyzer, press **STORE REF LVL**.

5. DC Log Amplifier Adjustments

There are three DC log adjustments; limiter phase, linear fidelity, and log fidelity.

Assembly Adjusted

A4 log amp/cal oscillator

Related Performance Tests

IF Gain Uncertainty Scale Fidelity

Description

These three adjustment need only be done under the following conditions:

- Limiter phase Only if a repair is made to blocks F, G, H, I, or J.
- Linear fidelity Only if a repair is made to blocks C, D, F, G, H, I, J, K, O, IF gain accuracy, RBW switching, or log fidelity.
- Log fidelity Only if a repair is made to blocks D, F, H, K, IF gain accuracy, RBW switching, or log fidelity.

If multiple adjustments are required they should be done in the following order:

1. Limiter Phase
2. Linear Fidelity
3. Log Fidelity

Figure 3-9 DC Log Adjustment Setup

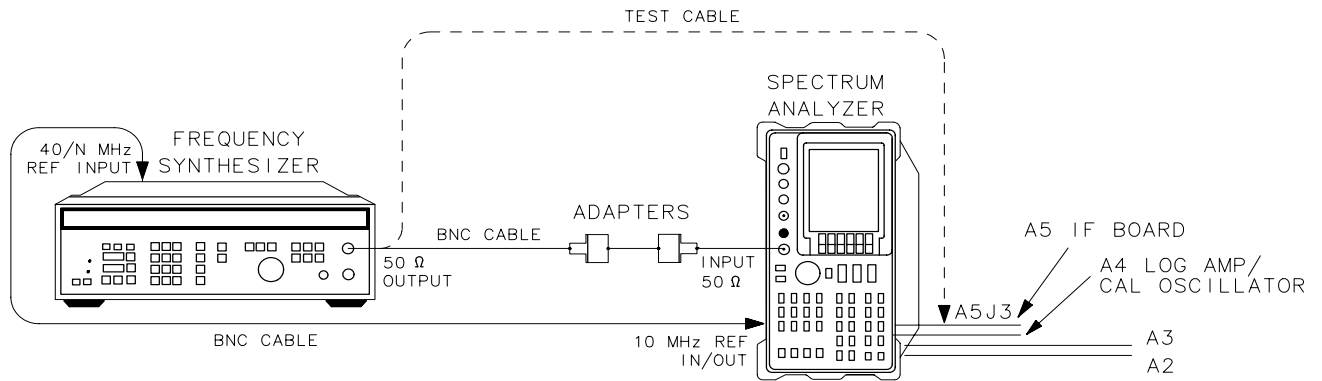

sz 148e

Equipment

Frequency synthesizer 3335A

Adapters

Type N (m) to BNC (f) 1250-1476

Type N (f) to 2.4 mm (f) 11903B

Cables

BNC, 122 cm (48 in) 10503A

Test cable 85680-60093

Figure 3-10 DC Log Adjustment Locations

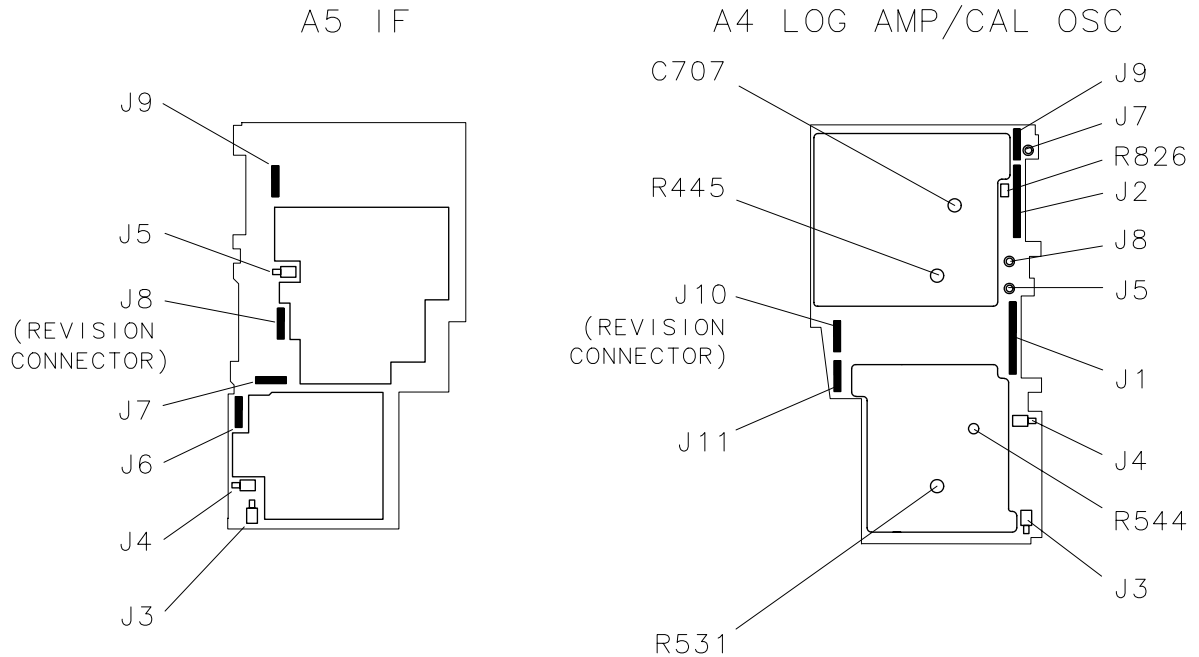

sj11

NOTE Adjustments should be made with all of the shields on and only after allowing at least a 20 minute warmup.

A4 Limiter Phase Adjustment

1. Press **LINE** to turn the spectrum analyzer off. Remove the spectrum analyzer cover and place the spectrum analyzer in the service position as illustrated in [Figure 3-9 on page 122](#). See [Figure 3-10 on page 123](#) for adjustment location.
2. Connect the 3335A 50Ω output to the spectrum analyzer 50Ω input. Press **LINE** to turn the spectrum analyzer on.
3. Set the spectrum analyzer controls as follows:

Center frequency	15 MHz
Span	0
Reference level	-10 dBm
dB/division	1 dB/DIV
Resolution bandwidth	300 kHz
IF ADJ	OFF

4. Set up an 3335A as follows:
Frequency 15 MHz
Amplitude -18 dBm
5. Press **CAL, ADJ CURR IF STATE**, wait for the analyzer to complete adjustments then press **MKR**.
6. Adjust A4R445 for maximum on-screen amplitude. Refer to [Figure 3-10 on page 123](#) for the location of A4R445.

A4 Linear Fidelity Adjustment

1. Press **LINE** to turn the spectrum analyzer off. Remove the spectrum analyzer cover and place the spectrum analyzer in the service position as illustrated in [Figure 3-9 on page 122](#). See [Figure 3-10 on page 123](#) for adjustment location.
2. Connect the 3335A 50Ω output to the spectrum analyzer 50Ω input. Press **LINE** to turn the spectrum analyzer on.
3. Press **PRESET AMPLITUDE, LINEAR, MORE 1 of 3, AMPTD UNITS, dBm, CAL, IF ADJ ON OFF (OFF)**.
4. Press **PEAK SEARCH, MARKER DELTA**.
5. Reduce the 3335A input power to -58 dBm.
6. If the delta marker amplitude reads -40 dB ±2 dB, no adjustment is necessary.
7. If the signal is lower on the screen than expected (delta marker amplitude reads less than -42dB) then adjust A4R544 (see [Figure 3-10 on page 123](#)) for an even lower level and press **CAL, ADJ CURR IF STATE**. Allow sufficient time for the analyzer to complete the adjustment.
8. If the signal is higher on the screen than expected (delta marker amplitude reads greater than -38 dB) then adjust A4R544 for an even higher level signal and press **CAL, ADJ CURR IF STATE**. Allow sufficient time for the analyzer to complete the adjustment.
9. Repeat steps 5 through 10.

A4 LOG Fidelity Adjustment

1. Press **LINE** to turn the spectrum analyzer off. Remove the spectrum analyzer cover and place the spectrum analyzer in the service position as illustrated in [Figure 3-9 on page 122](#). See [Figure 3-10, "DC Log Adjustment Locations,"](#) for adjustment location.
2. Connect the 3335 50Ω output to the spectrum analyzer 50Ω input. Press **LINE** to turn the spectrum analyzer on.

3. Press **PRESET, CAL, IF ADJ ON OFF (OFF), ADJ CURR IF STATE.**
4. Set the spectrum analyzer controls as follows:
 - Center frequency 15 MHz
 - Span 0
 - Resolution bandwidth 300 kHz
 - Reference level -10 dBm
5. Set up an 3335A as follows:
 - Frequency 15 MHz
 - Amplitude -10 dBm
6. Press **MKR, MARKER DELTA** on the spectrum analyzer.
7. Decrease the 3335A power to -26 dBm.
8. Calculate the error: EQUATION $\{\text{rm Error}\} = \{\text{rm delta}\ \text{marker}\ \text{reading}\} - \{\text{rm } 16\ \text{dB}\}$ EQUATION.
9. If the error is less than ± 0.2 dB, no adjustment is necessary.
10. Set the 3335A power to -10 dBm.
11. Adjust A4R531 (see [Figure 3-10, "DC Log Adjustment Locations,"](#)) to read two times the error. For example, if the calculated error is +0.75 dB, adjust A4R531 for a delta marker amplitude reading of +1.5 dB. Press **CAL, ADJ CURR IF STATE.**
12. Repeat steps 7 through 11.

6. Sampling Oscillator Adjustment

Assembly Adjusted

A15 RF assembly

Related Performance Test

There is no related performance test for this adjustment procedure.

Description

The sampling oscillator tank circuit is adjusted for a tuning voltage of 5.05 V dc when the sampling oscillator is set to 297.222 MHz. The voltage monitored is actually the tuning voltage divided by 4.05. The setting is then checked at other frequencies for the full tuning range of the sampling oscillator.

Figure 3-11 Sampler Adjustment Setup

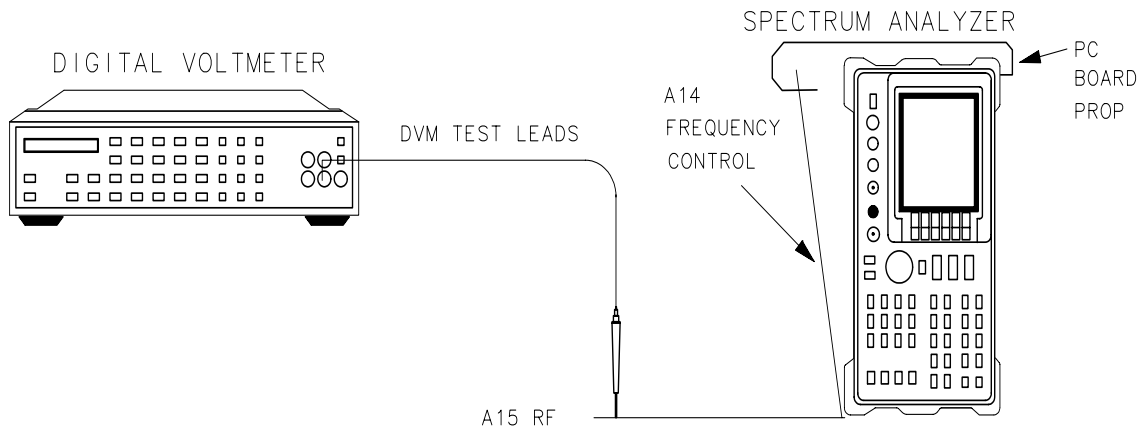

Equipment

Digital voltmeter	3456A
DVM test leads	34118A

Procedure

1. Press **LINE** to turn the spectrum analyzer off and disconnect the line power cord. Remove the spectrum analyzer cover and fold down the A15 RF and A14 frequency control assemblies. Prop up the A14 frequency control assembly. Reconnect the line power cord and press **LINE** to turn the spectrum analyzer on. Connect the equipment as illustrated in [Figure 3-11 on page 126](#).

2. Press **PRESET** on the spectrum analyzer and set the controls as follows:

Center frequency 2126 MHz
Span 0 Hz

3. Set the 3456A controls as follows:

Function DC VOLTS
Range 10V, MANUAL

Sampling Oscillator Adjustment

1. Connect the negative DVM test lead to A15J200 pin 6. Connect the positive DVM lead to A15J200 pin 13.
2. Adjust A15C210 VCO RANGE for a DVM reading of $5.05\text{ V} \pm 0.05\text{ V}$.

Figure 3-12 A15J200 Pin Locations

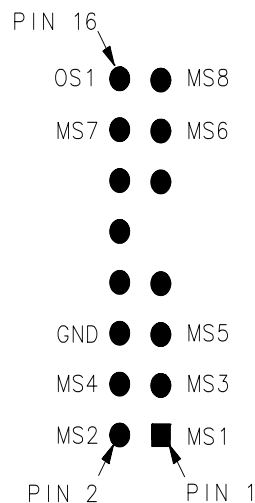

sz144e

Sampler Match Adjustment

1. Connect the negative DVM test lead to A15J400 pin 6, and the positive DVM test lead to A15J400 pin 1.
2. Press **FREQUENCY** and set the spectrum analyzer center frequency to 2302.3 MHz. This sets the sampling oscillator to 291.667 MHz.
3. Adjust A15C100 SMPL MATCH to peak the voltage displayed on the DVM.
4. Record the displayed voltage in [Table 3-9 on page 128](#) as the displayed voltage for the sampling oscillator frequency of 291.667 MHz.
5. Press **FREQUENCY** on the spectrum analyzer. Use the keypad to set the spectrum analyzer center frequency to the frequencies listed in [Table 3-9 on page 128](#). At each listed frequency, record the displayed voltage in the table.
6. If the difference between the maximum and minimum voltages is less than 0.50 V, and all voltage readings are between +0.5 and +2.5 Vdc, proceed to step 15.
7. Locate the center frequency at which the voltage is lowest. Use the keypad to set the spectrum analyzer to this frequency.
8. Readjust SMPL MATCH to set the displayed voltage to 0.8 ± 0.1 Vdc.
9. Set the spectrum analyzer center frequency to 2302.3 MHz and repeat steps 9 through 13.
10. Move the positive DVM test lead to A15J400 pin 3. Check that the measured voltage is the negative of the voltage at pin 1, within ± 0.1 Vdc.
11. Disconnect the DVM probes from A15J400.

Table 3-9 Sampling Adjustments

Center Frequency (MHz)	Sampling Oscillator (MHz)	Displayed Voltage (Vdc)				
		1st Trial	2nd Trial	3rd Trial	4th Trial	5th Trial
2156.3	285.000					
2176.3	286.364					
2230.3	288.462					
2263.3	290.000					
2302.3	291.667					
2158.3	293.478					

Table 3-9 Sampling Adjustments

Center Frequency (MHz)	Sampling Oscillator (MHz)	Displayed Voltage (Vdc)				
2196.3	295.000					
2378.3	296.471					
2422.3	297.222					

7. YTO Adjustment

Assembly Adjusted

A14 frequency control assembly

Related Performance Tests

Frequency Span Accuracy Frequency Readout Accuracy and Frequency Count Marker Accuracy

Description

The YTO main coil adjustments are made with the phase-lock loops disabled. The YTO endpoints are adjusted to bring these points within the capture range of the main loop. The YTO FM coil is adjusted to place the 300 MHz CAL OUTPUT signal at the center vertical graticule in a 20 MHz span.

Figure 3-13 YTO Adjustment Setup

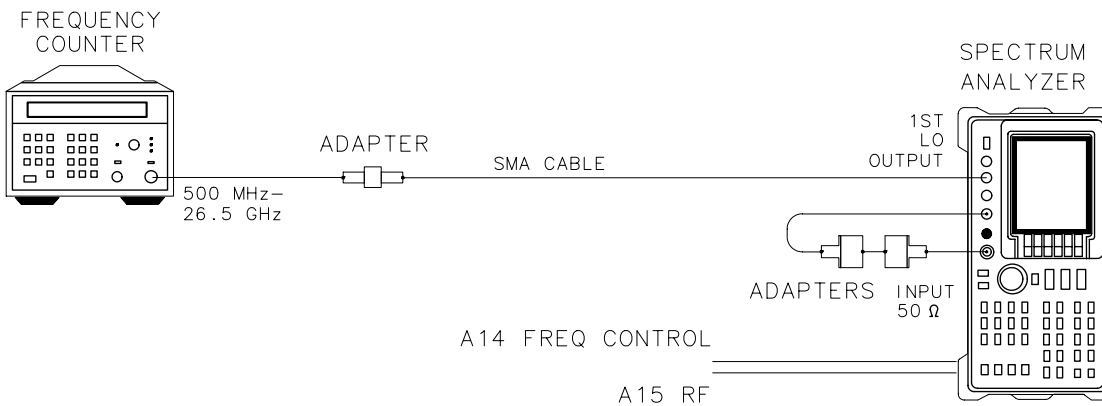

sz149e

Equipment

Microwave frequency counter 5343A Option 001

Adapters

Type N (m) to BNC (f) 1250-1476

Type N (f) to 2.4 mm (f) 11903B

APC 3.5 (f) to APC 3.5 (f) 5061-5311

Cables

BNC, 122 cm (48 in) 10503A

SMA, 61 cm (24 in) 8120-1578

Procedure

NOTE

This adjustment cannot be performed if preselected external mixer mode is selected.

The **SAVELOCK ON OFF** function must be OFF.

YTO Main Coil Adjustments

1. Press **LINE** to turn the spectrum analyzer off. Remove the spectrum analyzer cover and fold down the A15 RF and A14 frequency control assemblies.
2. Disconnect the 50Ω termination from the 1ST LO OUTPUT. Connect the equipment as shown in [Figure 3-13 on page 130](#). Press **LINE** to turn the spectrum analyzer on.
3. Move the jumper on A14J23 from the NORM position (pins 1 and 2 jumpered) to the TEST position (pins 2 and 3 jumpered). See [Figure 3-14“YTO Adjustment Locations,” on page 132](#) for the location on the A14 frequency control assemblies.
4. On the spectrum analyzer, press the following keys:
CONFIG, EXT MXR PRE UNPR, (UNPR) AUX CTRL, EXTERNAL MIXER, LOCK HARMONIC, 6 Hz SPAN, ZERO SPAN FREQUENCY, CENTER FREQ, 18.8893 GHz, SGL SWP SAVE, SAVE STATE, STATE 0 FREQUENCY, 35.7493 GHz SAVE, SAVE STATE, STATE 1 RECALL, RECALL STATE, STATE 0.
5. On the 5343A, press **SHIFT 7** and set the controls as follows:
Sample rate Fully counterclockwise
10 Hz–500 MHz/500 MHz–26.5 GHz switch
500 MHz–26.5 GHz

7. YTO Adjustment

6. Adjust A14R93 3.2 GHz for the appropriate frequency counter reading of 3.200 GHz \pm 1 MHz.
7. On the spectrum analyzer, press **STATE 1**.
8. Adjust A14R42 6.01 GHz for a frequency counter reading of 6.010 GHz \pm 1 MHz.
9. On the spectrum analyzer, press **STATE 0**.
10. Repeat steps 6 through 9 until both of these interacting adjustments meet their tolerances.

Figure 3-14 YTO Adjustment Locations

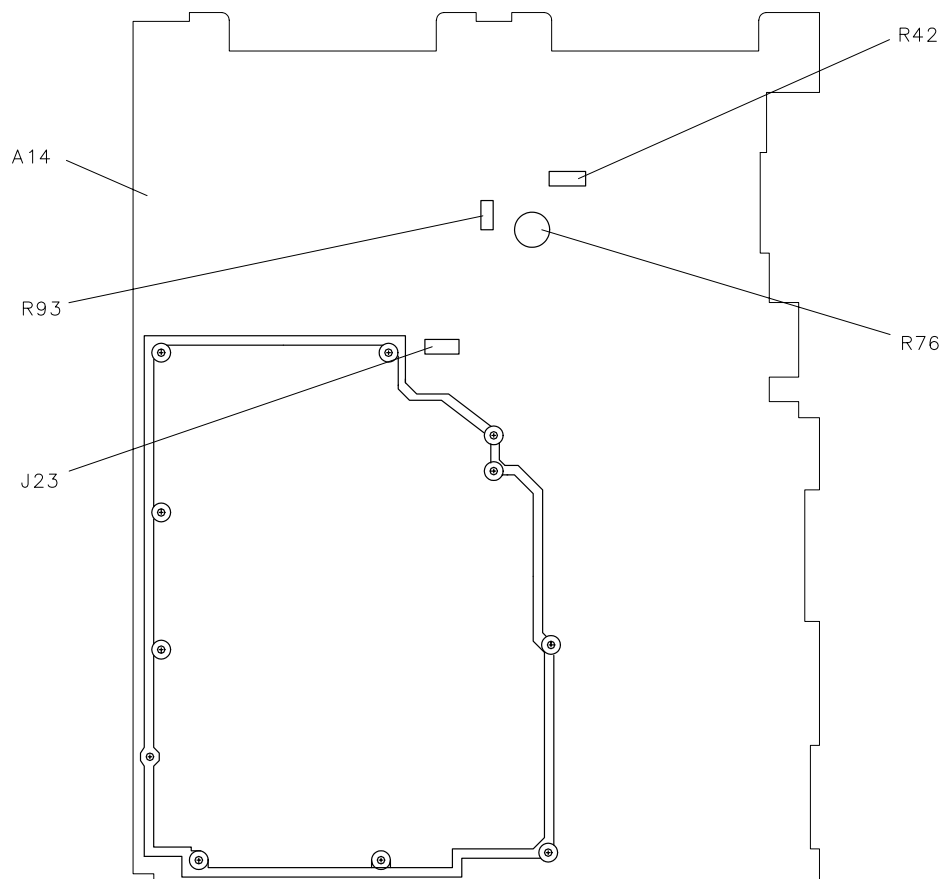

SP116E

11. Place the jumper on A14J23 in the NORM position (pins 1 and 2 jumpered).
12. Disconnect the SMA cable from the 1ST LO OUTPUT jack and reconnect the 50Ω termination on the 1ST LO OUTPUT.

YTO FM Coil Adjustments

13. On the spectrum analyzer, press **PRESET** and set the controls as follows:

Center frequency 300 MHz
Span 20 MHz

14. Adjust A14R76 FM SPAN until the 300 MHz CAL OUTPUT SIGNAL is aligned with the center vertical graticule line.

8. Calibrator Amplitude Adjustment

Assembly Adjusted

A15 RF assembly

Related Performance Test

Calibrator Amplitude and Frequency Accuracy

Description

The CAL OUTPUT amplitude is adjusted for -10.00 dBm measured directly at the front panel CAL OUTPUT connector.

Figure 3-15 Calibrator Amplitude Adjustment Setup

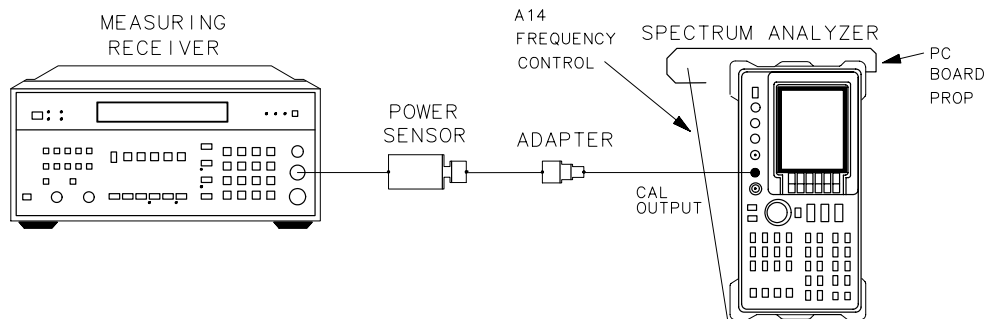

SK113

Equipment

Measuring receiver	8902A
Power sensor	8482A
Adapters	
Type N (f) to BNC (m)	1250-1477

Procedure

NOTE

The spectrum analyzer should be allowed to warm up for at least 30 minutes before performing this adjustment.

1. Place the spectrum analyzer in the service position shown in [Figure 3-15 on page 134](#). Prop the A14 frequency control board assembly in the service position.
2. Zero and calibrate the 8902A/8482A combination in log display mode. Enter the power sensor 300 MHz cal factor into the 8902A.
3. Connect the 8482A through an adapter directly to the spectrum analyzer CAL OUTPUT connector.
4. Adjust A15R561 CAL AMPTD for a -10.00 dBm reading on the 8902A display.

9. 10 MHz Reference Adjustment — OCXO

Assembly Adjusted

A21 OCXO assembly

NOTE

Replacement oscillators are factory adjusted after a complete warmup and after the specified aging rate has been achieved. Thus, readjustment should typically not be necessary after oscillator replacement and is generally not recommended.

Related Performance Test

10 MHz Reference Accuracy

Description

The frequency of the internal 10 MHz frequency reference is compared to a known frequency standard and adjusted for minimum frequency error. This procedure does not adjust the short-term stability or long-term stability of the A21 10 MHz ovenized crystal oscillator (OCXO). Stability is determined by the characteristics of the particular oscillator and the environmental and warmup conditions to which it has been recently exposed. The spectrum analyzer must be on continuously for at least 24 hours immediately prior to oscillator adjustment to allow both the temperature and frequency of the oscillator to stabilize.

Figure 3-16 10 MHz Reference Adjustment Setup and Adjustment Location

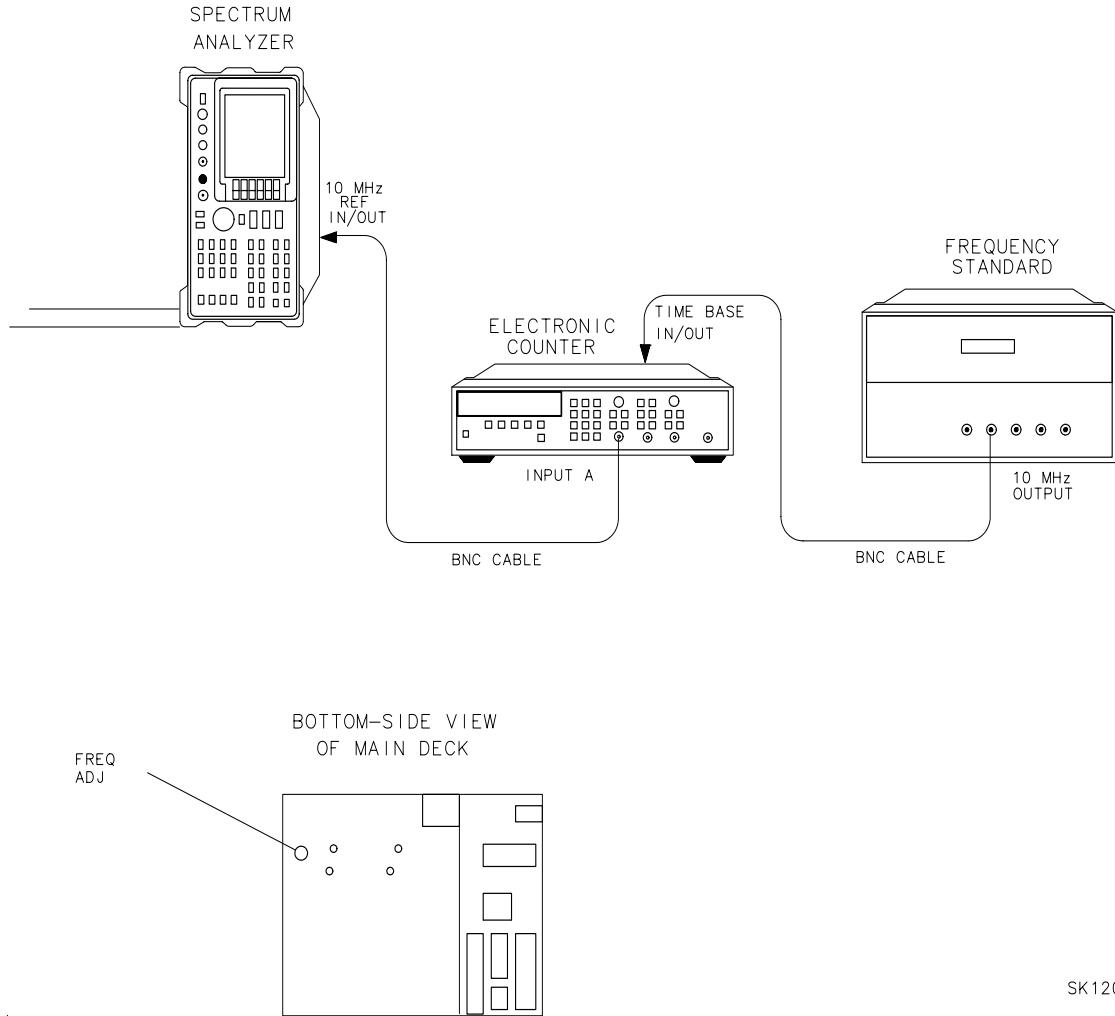

SK120

Equipment

- Frequency counter 5334A/B
- Frequency standard 5061B Cesium Beam Standard Cable
- BNC, 122 cm (2 required)..... 10503A

Procedure

NOTE Failure to allow a 24 hour minimum warmup time for OCXO frequency and temperature stabilization may result in oscillator misadjustment.

1. Connect equipment as shown in [Figure 3-16 on page 137](#) as follows:
 - a. Press **LINE** to turn the spectrum analyzer on. After the automatic power-on adjustment sequence is complete, press **PRESET** to ensure that the frequency reference is set to internal.
 - b. Allow the spectrum analyzer to remain powered on continuously for at least 24 hours to ensure that the A21 OCXO temperature and frequency stabilize.

NOTE If the reference is set to **10 MHz EXT**, press **10 MHz INT**. Allow the 24 hour warmup for the OCXO before continuing. When the 10 MHz reference is set to **10 MHz EXT**, the OCXO is not operating or warmed up.

- c. Connect the frequency standard to the frequency counter rear panel TIMEBASE IN/OUT connector.
 - d. Connect a BNC cable between the spectrum analyzer rear panel 10 MHz REF IN/OUT connector and INPUT A on the frequency counter.
2. Set the frequency counter controls as follows:

Function/data	FREQ A
Input	A
×10 Attenuator	OFF
AC	OFF (DC coupled)
50ΩZOFF (1 MΩ input impedance)
Auto Trigger	ON
100 kHz filter A	OFF
INT/EXT switch (rear panel)	EXT
3. Select a 1 second gate time on the 5334A/B frequency counter by pressing **GATE TIME, 1, GATE TIME**.
4. To offset the displayed frequency by -10.0 MHz, press **MATH, SELECT/ENTER, CHX/EEX, 10, CHS/EEX, 6, SELECT/ENTER, SELECT/ENTER**. The frequency counter should now display the difference between the frequency of the INPUT A signal and 10.0 MHz with a displayed resolution of 0.010 Hz (10 MHz).
5. Locate the **FREQ ADJ** control on the spectrum analyzer. This control is accessible through the center deck of the spectrum analyzer. See [Figure 3-16 on page 137](#).
6. Remove the dust-cap screw.

7. Use a nonconductive adjustment tool to adjust the **FREQ ADJ** control on the A21 OCXO for a frequency counter reading of 0.00 Hz.
8. On the 5334A/B frequency counter, select a 10-second gate time by pressing **GATE TIME**, 10, **GATE TIME**. The frequency counter should now display the difference between the frequency of the INPUT A signal and 10.0 MHz with a resolution of 0.001 Hz (1 mHz).
9. Wait at least two gate periods for the frequency counter to stabilize, then adjust the **FREQ ADJ** control on A21 OCXO for a stable frequency counter reading of 0.000 Hz \pm 0.010 Hz.
10. Replace the dust-cap screw to A21 OCXO.

10. 10 MHz Reference Adjustment — TCXO (Option 103)

Assembly Adjusted

A15 RF assembly

Related Performance Test

10 MHz Reference Output Accuracy (Option 103)

Description

The frequency counter is connected to the analyzer CAL OUTPUT. The CAL OUTPUT is locked to the 10 MHz frequency reference which yields better effective resolution. The temperature-compensated crystal oscillator (TCXO) is adjusted for a frequency counter reading of 300 MHz.

Figure 3-17 10 MHz Reference Adjustment Setup — TCXO

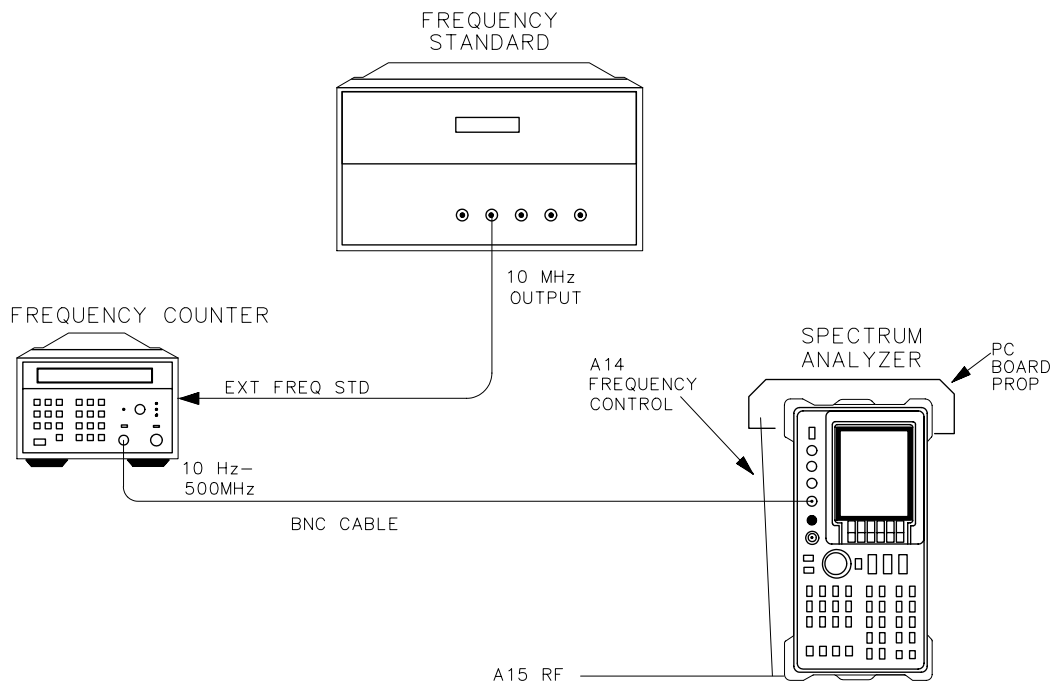

SP11E

Equipment

Microwave frequency counter 5343A Option 001
Frequency standard 5061B Cesium Beam Standard
(or any 10 MHz frequency standard with accuracy $<\pm 1 \times 10^{-10}$)

Cables

BNC, 122 cm (2 required) 10503A

Procedure

NOTE Allow the spectrum analyzer to warm up for at least 30 minutes before performing this adjustment.

1. Connect the equipment as shown in [Figure 3-17“10 MHz Reference Adjustment Setup — TCXO,”](#) on page 140. Prop up the A14 frequency control assembly.

2. Set the frequency counter controls as follows:

Sample rate Midrange
50Ω–1 MΩ switch 50Ω
10 Hz–500 MHz/500 MHz–26.5 GHz switch .. 10 Hz– 500 MHz

3. Press **AUX CTRL REAR PANEL**. Verify that the 10 MHz reference is set to **10 MHz INT**.

NOTE When the 10 MHz reference is set to **10 MHz EXT**, the TCXO is not operating and warmed up. If the reference is set to **10 MHz EXT**, set the reference to **10 MHz INT** and allow 30 minutes for the TCXO to warm up.

4. Remove dust cap from A15U302, TCXO. The dust cap is toward the rear of the spectrum analyzer.

5. Adjust 10 MHz ADJ on A15U302 for a frequency counter reading of 300.000000 MHz ± 30 Hz.

6. Replace the dustcap on A15U302.

11. Demodulator Adjustment

Assembly Adjusted

A4 log amplifier/cal oscillator assembly

Related Performance Test

There is no related performance test for this adjustment.

Description

A 5 kHz peak-deviation FM signal is applied to the INPUT 50Ω . The detected audio is monitored by an oscilloscope. FM DEMOD is adjusted to peak the response displayed on the oscilloscope.

Figure 3-18 Demodulator Adjustment Setup

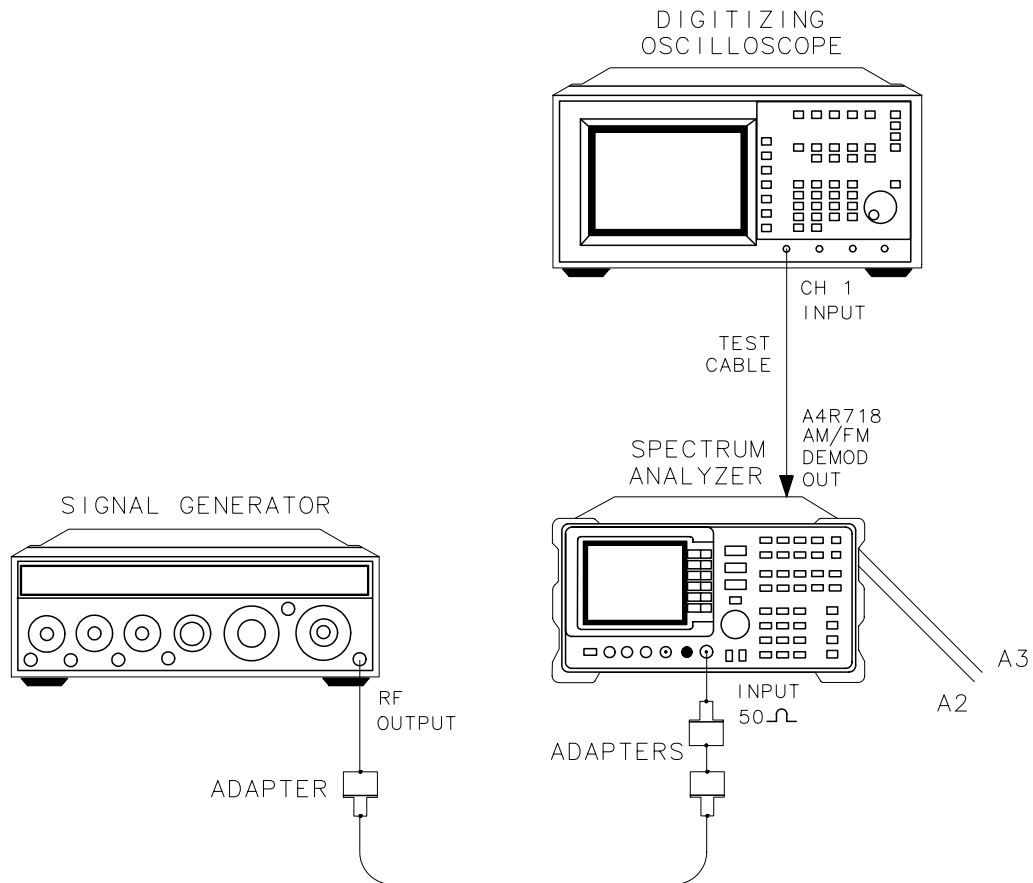

Equipment

AM/FM signal generator	8640B
Oscilloscope	54501A

Adapters

Type N (m) to BNC (f) (2 required)	1250-1476
Type N (f) to 2.4 mm (f)	11903B

Cables

BNC, 122 cm (48 in)	10503A
Oscilloscope probe	10432A

Procedure

1. Press **LINE** to turn the spectrum analyzer off. Place the spectrum analyzer in the service position as illustrated in [Figure 3-18 on page 142](#).
2. Connect the oscilloscope probe from the oscilloscope channel 1 input to probe A4C723 (the end closest to A4U707) as in [Figure 3-19 on page 144](#). Press **LINE** to turn the spectrum analyzer on. Connect the 8640B RF OUTPUT to the spectrum analyzer INPUT 50Ω .
3. Set the 8640B controls as follows:

Range MHz	61 to 128
Frequency	100.000 MHz
Output level	-10dBm
RF	ON
AM	OFF
FM	INT
Modulation frequency	1000 Hz
Peak deviation	5 kHz
Scale FM	(k/MHz)
4. Adjust the 8640B FM deviation vernier for a full-scale reading on the meter. Set the FM to off.

11. Demodulator Adjustment

5. Set the oscilloscope controls as follows:

- Channel 1 on
- Channel 2 off
- Channel 1 50 mV/division
- Channel 1 ac
- Channel 1 BW lim
- Time base 1.0 ms/division
- Trigger auto
- Trigger source 1
- Trigger level 0.0 V

6. On the spectrum analyzer, press **PRESET**, then set the controls as follows:

- Center frequency 100 MHz
- Span 5 MHz
- Reference level -10 dBm
- Resolution bandwidth 100 kHz

7. On the spectrum analyzer press: **PEAK SEARCH, MARKER →CF SPAN, ZERO SPAN AUX CTRL, AM/FM DEMOD, FM DEMOD ON OFF(ON) CAL, IF ADJ ON OFF (OFF) TRIG, and SWEEP CONT SGL (SGL)**. Set the volume control to midrange.

8. A 1 kHz sine wave should be observed on the oscilloscope. Rotate the volume knob on the front panel of the spectrum analyzer until the amplitude of the 1 kHz signal is at about 150 mV (3 divisions on the oscilloscope).

9. Adjust A4C707 FM DEMOD for a maximum peak-to-peak response on the oscilloscope.

10. Press **LINE** to turn the spectrum analyzer off. Disconnect the test cable from A4C723.

Figure 3-19 Demodulator Adjustment Locations

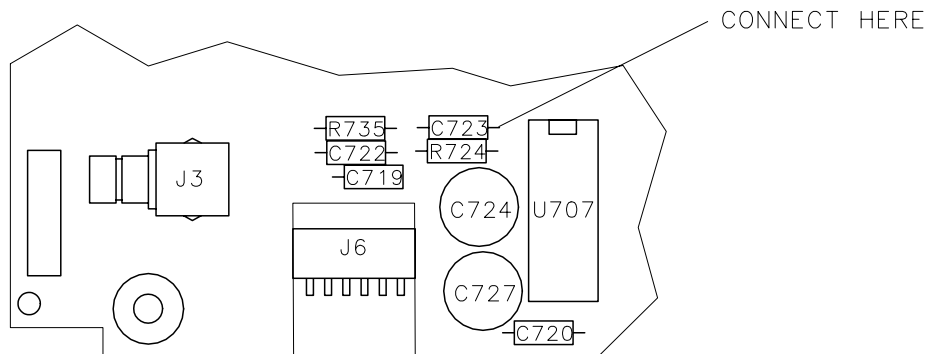

12. External Mixer Bias Adjustment

Assembly Adjusted

A15 RF assembly

Related Performance Test

There is no related performance test for this adjustment.

Description

A voltmeter is connected to the spectrum analyzer IF INPUT with the external mixer bias set to off. The bias is adjusted for a 0 Vdc output.

Figure 3-20 External Mixer Bias Adjustment Setup

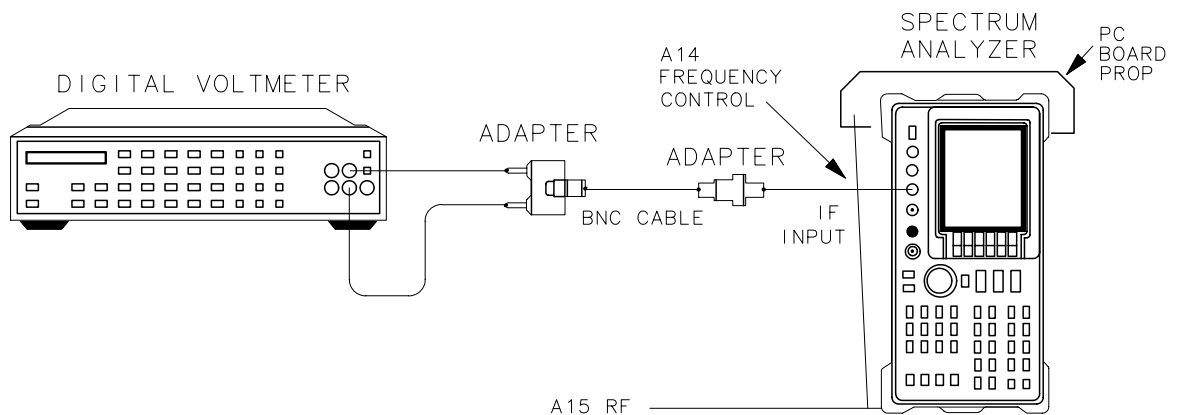

Equipment

DVM 3456A

Adapters

Type BNC (f) to SMA (m) 1250-1200

Type BNC (f) to dual banana plug 1251-2816

Cables

BNC, 122 cm (48 in) 10503A

Procedure

1. Press **LINE** to turn the spectrum analyzer off, and disconnect the ac power cord. Remove the spectrum analyzer cover and connect the equipment as illustrated in [Figure 3-20 on page 145](#). Fold down the A15 RF assembly. Reconnect the power cord and set the **LINE** switch to on.
2. Set the 3456A controls as follows:

Function	DC VOLTS
Range	0.1 V
Resolution	100 mV
3. On the spectrum analyzer press **AUX CTRL**, **EXTERNAL MIXER**, **BIAS**, then **BIAS OFF**.
4. Adjust A15R926 EXT BIAS ZERO for a DVM reading of 0.000 Vdc \pm 12.5 mV.

13. External Mixer Amplitude Adjustment

Assembly Adjusted

A15 RF assembly

Related Performance Test

IF Input Amplitude Accuracy

Description

The slope of the flatness compensation amplifiers is determined. The user-loaded conversion losses for K-band are recorded and reset to 30 dB. A 310.7 MHz signal is applied to the power sensor and the power level of the source is adjusted for a -30 dBm reading. The signal is then applied to the IF INPUT. The flatness compensation amplifiers are then adjusted (via DACs) to place the displayed signal at the reference level.

Figure 3-21 External Mixer Amplitude Adjustment Setup

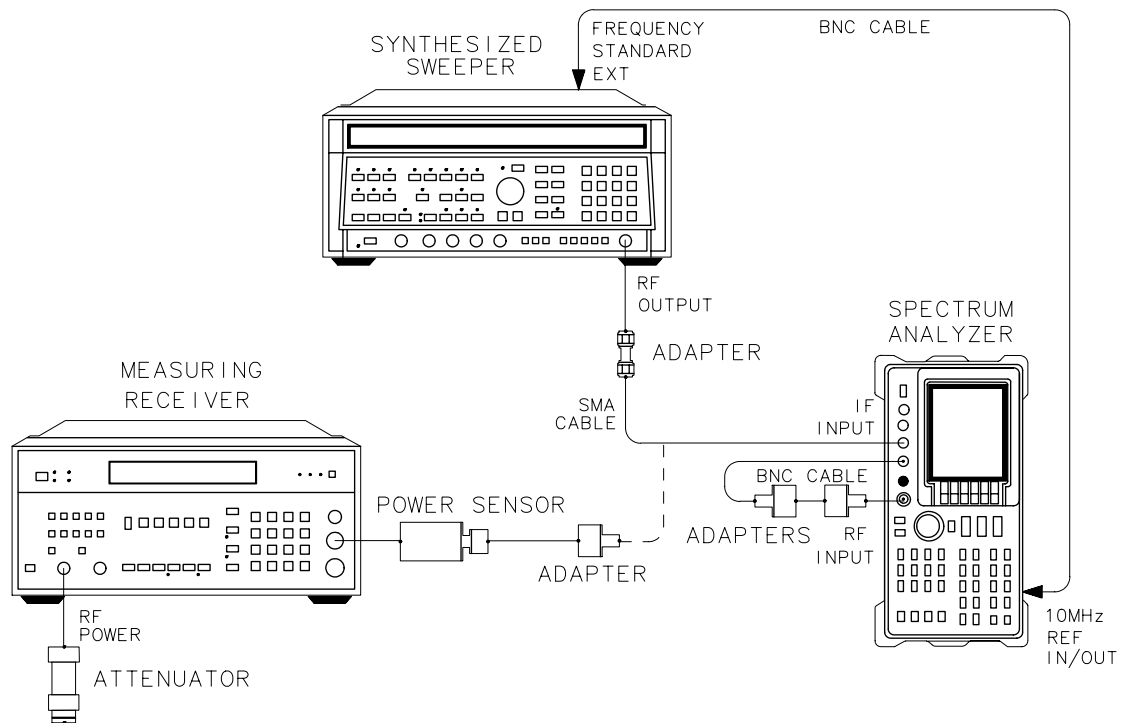

sz150e

Equipment

Synthesized sweeper	8340A/B
Measuring receiver	8902A
Power sensor	8481D
50 MHz reference attenuator	11708A
<i>(supplied with 8481D)</i>	

Adapters

Type N (f) to SMA (f).....	1250-1772
Type N (m) to BNC (f).....	1250-1476
Type APC 3.5 (f) to APC 3.5 (f)	5061-5311
Type N (f) to 2.4 mm (f).....	11903B

Cables

BNC, 122 cm (48 in).....	10503A
SMA, 61 cm (24 in).....	8120-1578

Procedure

1. Press **LINE** to turn the spectrum analyzer off and disconnect the power cord. Remove the spectrum analyzer cover and reconnect the power cord.
2. Set up the equipment as illustrated in [Figure 3-21 on page 147](#). Do not connect the SMA cable to the spectrum analyzer.
3. Move the WR PROT/WR ENA jumper on the A2 controller assembly to the WR ENA position. The jumper is on the edge of the A2 board assembly and can be moved without folding the board down.
4. Press **LINE** to turn the spectrum analyzer on. On the spectrum analyzer, press **CONFIG**, **EXT MXR PRE UNPR** (UNPR), **AUX CTRL**, **EXTERNAL MIXER**, **AMPTD CORRECT**, then **CNV LOSS VS FREQ**.
5. Press \Downarrow or \Downarrow to display the conversion loss value for each frequency listed in [Table 3-10 on page 149](#). Record any conversion loss reading *not equal* to 30 dB in [Table 3-10 on page 149](#) at the appropriate frequency.

6. If all conversion loss values equal 30 dB, skip to step 7, otherwise continue to step a.
 - a. Refer to [Table 3-10 on page 149](#) and press ↓ or ↓ to select a frequency at which the conversion loss value does not equal 30 dB.
 - b. Use the spectrum analyzer front panel keys to set the conversion loss value to 30 dB.
 - c. Repeat steps a and b for all frequencies having a conversion loss value other than 30 dB.
7. Press **INSTR PRESET** on the 8340A/B and set the controls as follows:

CW frequency 310.7 MHz
 Power level -30 dBm

Table 3-10

Conversion Loss Data

Frequency (GHz)	Conversion Loss (dB) (≠30 dB)
18	
20	
22	
24	
26	
27	

8. Connect the 8481D to the 11708A attenuator already connected to the 8902A RF power connector. Zero and calibrate the 8902A/8481D combination in log mode. Enter the power sensor 50 MHz cal factor into the 8902A. Connect the power sensor, through an adapter, to the SMA cable.
9. Adjust the 8340A/B **POWER LEVEL** until the power displayed on the 8902A reads -30 dBm ±0.05 dB.
10. On the spectrum analyzer, press **CAL, MORE 1 OF 2, SERVICE CAL DATA, 3RD IF AMP**, then **CAL 3RD AMP GAIN**.
11. Wait until the message **ADJUSTMENT DONE** appears in the active function block and press **EXT MXR REF CAL**.
12. Disconnect the SMA cable from the power-sensor/adapter and connect the cable to the spectrum analyzer **IF INPUT**.
13. Use the spectrum analyzer front panel knob, step keys, or keypad to change the amplitude of the displayed signal until the marker reads 0 dBm ±0.17 dB.
14. Press **PREV MENU, STORE DATA**, and **YES** on the spectrum analyzer.

13. External Mixer Amplitude Adjustment

15. Place the WR PROT/ WR ENA jumper on the A2 controller assembly in the WR PROT position.

NOTE

The following steps should only be performed if you need to replace the 30 dB conversion loss values to those recorded in [Table 3-10 on page 149](#).

16. Press **AUX CTRL**, **EXTERNAL MIXER**, **AMPTD CORRECT**, then **CNV LOSS VS FREQ** on the spectrum analyzer.

17. Press ↓ or ↓ to select frequencies where the conversion loss value was recorded in [Table 3-10 on page 149](#).

18. Use the spectrum analyzer front panel keys to enter the conversion loss values recorded for the frequency.

14. Signal ID Oscillator Adjustment (serial prefix 3517A and below)

Assembly Adjusted

A15 RF assembly

Related Performance Test

There is no related performance test for this adjustment.

Description

NOTE

This adjustment applies only to spectrum analyzers with Option 008 with A15 RF assembly 08563-60083 or earlier (serial prefix 3517A and below). Later A15 RF assemblies have no 298 MHz adjustment.

The frequency range of the 298 MHz signal ID oscillator is determined by counting the 10.7 MHz IF as A15C629 is rotated through its range of adjustment. The SIG ID oscillator is then set to the frequency determined by the following equation:

$$\text{Oscillator frequency} = 12.7\text{MHz} + \left(\frac{\text{Oscillator frequency range}}{4} \right)$$

Figure 3-22 Signal ID Oscillator Adjustment Setup

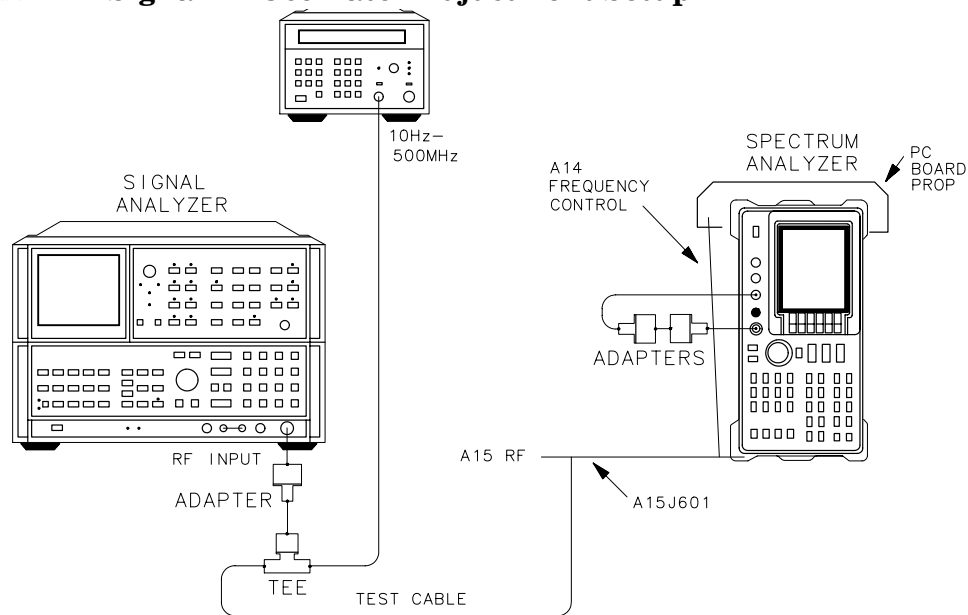

Equipment

Microwave frequency counter 5343A

Spectrum analyzer 8566A/B

Adapters

Type N (m) to BNC (f) (2 required) 1250-1476

BNC tee (f, m, f) 1250-0781

Type N (f) to 2.4 mm (f) 11903B

Cables

BNC, 122 cm (48 in) (2 required) 10503A

Test cable, BNC (m) to SMB (f)
85680-60093

Procedure

1. Press **LINE** to turn the spectrum analyzer off. Disconnect the power cord, and remove the spectrum analyzer cover. Fold down the A15 RF and A14 frequency control assemblies. Prop up the A14 frequency control assembly.
2. Connect the spectrum analyzer CAL OUTPUT to the INPUT 50Ω using an adapter. Disconnect the W29 cable from A15J601 (10.7 MHz IF out) and connect the SMB end of the test cable to A15J601. Connect the rest of the equipment as shown in [Figure 3-22 on page 151](#).
3. Remove the four screws holding the brace on the A15 RF assembly (near J2).
4. Connect a jumper between the leads of A15R914 and A15C904 (the ends near U908). See [Figure 3-23 on page 153](#) for the location of the components.
5. Reconnect the power cord and press **LINE** to turn the spectrum analyzer on. After the power-on sequence is complete, set the spectrum analyzer controls as follows:

Center frequency 300 MHz

Span 0 Hz

6. Press **CAL, IF ADJ ON OFF** so OFF is underlined, and **SGL SWP**.

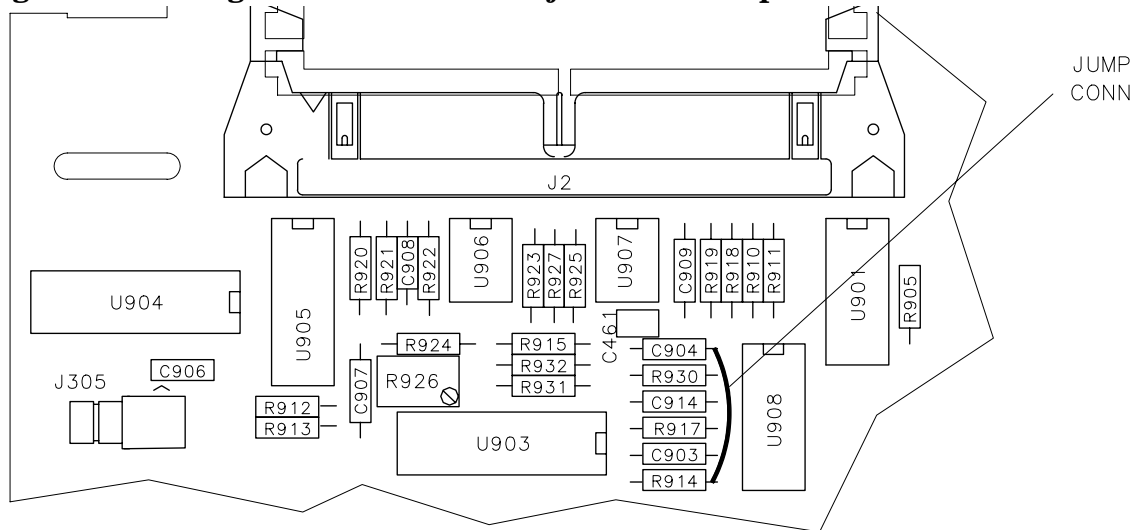
Figure 3-23 Signal ID Oscillator Adjustment Jumper Location

7. Press **INSTR PRESET** on the 8566A/B and set the controls as follows:

Center frequency 12.7 MHz
Span 500 kHz

8. Set the 5343A controls as follows:

Sample rate Fully counterclockwise
50 Ω –1 M Ω switch 50 Ω
10 Hz–500 MHz/500 MHz–26.5 GHz switch .. 10 Hz — 500 MHz

9. If no signal is displayed on the 8566A/B, adjust A15C629 SIG ID until a signal is displayed.

NOTE

If the 298 MHz SIG ID oscillator is severely mistuned, it might be necessary to widen the span on the 8566A/B to see the IF signal.

10. Rotate A15C629 SIG ID slightly while observing the 8566A/B display.

NOTE

The nominal counted frequency should be 12.7 MHz, not 10.7 MHz.

11. While observing the 8566A/B display, adjust A15C629 SIG ID for the highest obtainable frequency, with less than 3 dB decrease in amplitude from maximum. Read this frequency from the frequency counter and record as $F_{3 \text{ dB HIGH}}$.

$F_{3 \text{ dB HIGH}} =$ _____ MHz

14. Signal ID Oscillator Adjustment (serial prefix 3517A and below)

12. Observe the 8566A/B display as you adjust A15C629 SIG ID for the lowest obtainable frequency, with less than 3 dB decrease in amplitude from maximum. Record the frequency counter reading as $F_{3 \text{ dB LOW}}$.

$F_{3 \text{ dB LOW}} =$ _____ MHz

13. Calculate the difference between $F_{3 \text{ dB HIGH}}$ and $F_{3 \text{ dB LOW}}$, then divide results by four. Enter the result as F_{OFFSET} .

$F_{\text{OFFSET}} =$ _____ kHz

14. Add F_{OFFSET} to $F_{3 \text{ dB LOW}}$ recorded in step 10 and record the result as F_{SIGID} .

$F_{\text{SIGID}} =$ _____ MHz

15. Adjust A15C629 for a frequency counter reading equaling F_{SIGID} . The final adjusted frequency must equal 12.7 MHz \pm 50 kHz.

15. 16 MHz PLL Adjustment

Assembly Adjusted

A2 controller assembly

Related Performance Tests

Sweep Time Accuracy Gate Delay Accuracy and Gate Length Accuracy
Delayed Sweep Accuracy Fast Sweep Time Accuracy (Option 007)

Description

The 16 MHz CPU clock is phase locked to the 10 MHz reference. The output of the 16 MHz PLL loop integrator is adjusted for a clock frequency of approximately 14.4 MHz with the loop unlocked. This ensures that the CPU will still function and the display annotation will be distorted but readable, even if the 10 MHz reference to A2 is absent.

NOTE If necessary, perform the display adjustments after performing the following adjustment.

Figure 3-24 16 MHz PLL Adjustment Setup

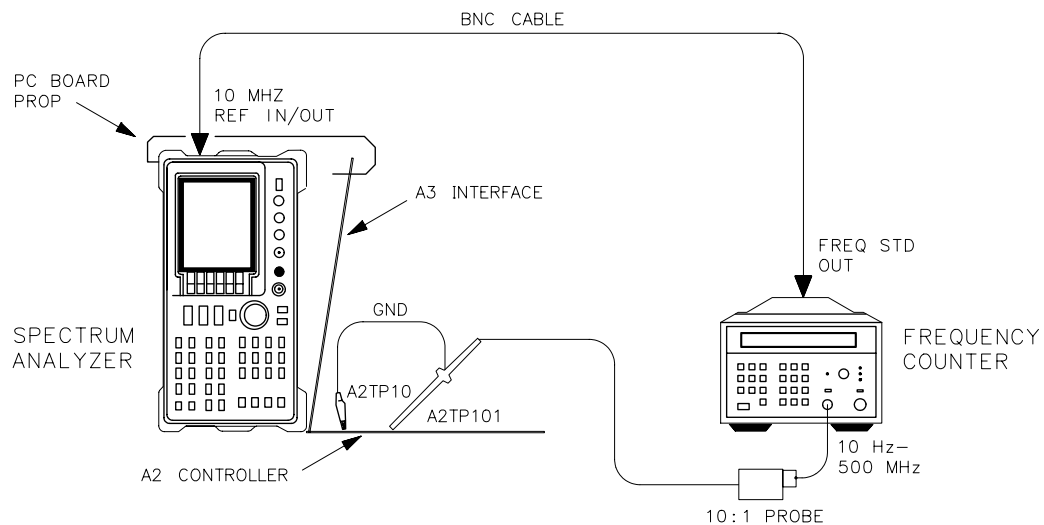

sj140e

Equipment

Microwave frequency counter	5343A
10:1 probe	10432A

Procedure

1. Press **LINE** to turn the spectrum analyzer off. Remove the spectrum analyzer cover and fold out the A2 controller and A3 interface assemblies. Use a pc board prop to hold up the A3 interface assembly, as shown in [Figure 3-24](#).
2. Connect the equipment as shown in [Figure 3-24](#). The 10:1 probe ground lead connects to A2TP10 and the probe tip connects to A2TP101.
3. The 16 MHz PLL adjustment location is shown in [Figure 3-25](#).

Figure 3-25 16 MHz PLL Adjustment Location

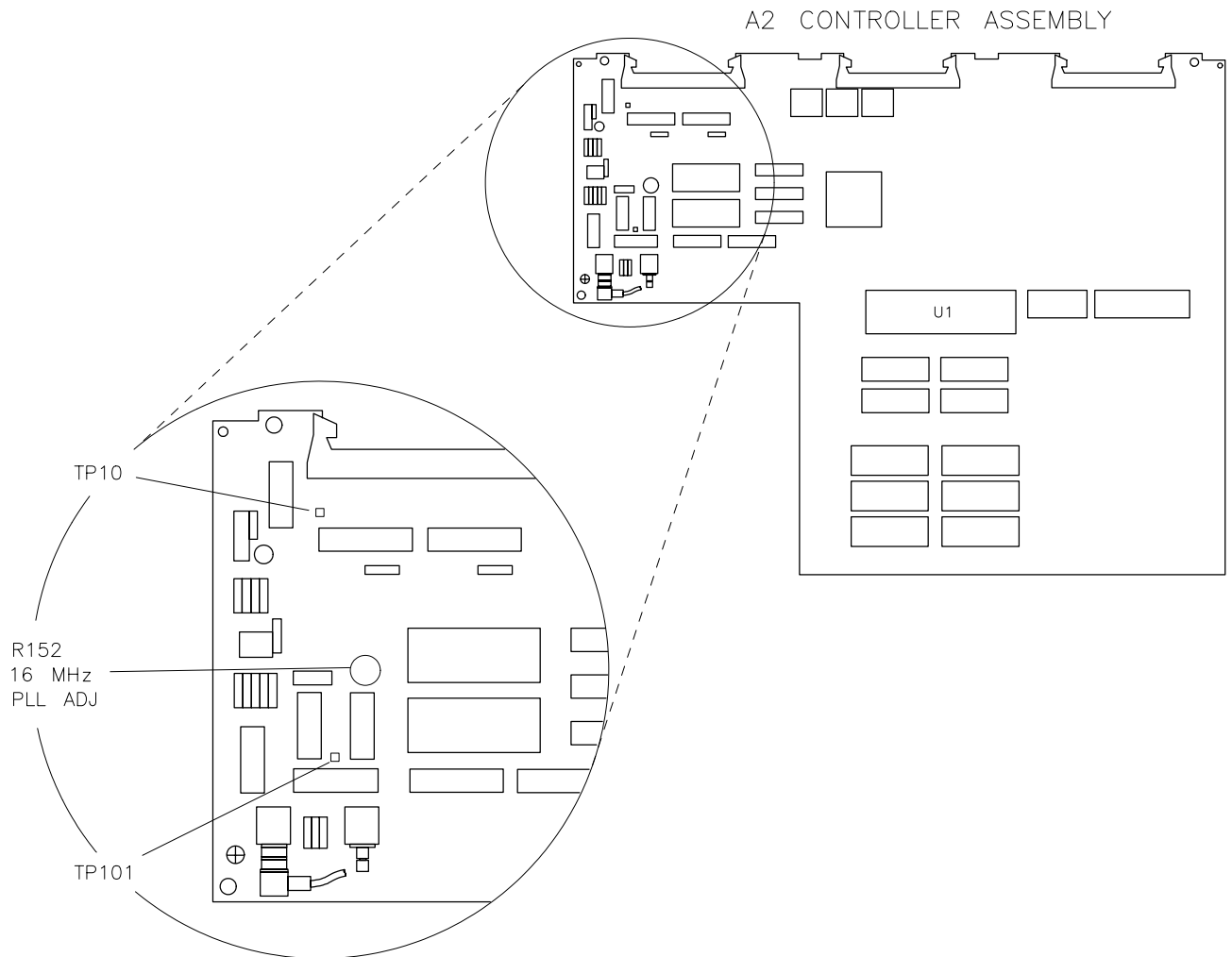

sj141e

15. 16 MHz PLL Adjustment

4. Press **LINE** to turn the spectrum analyzer on. Wait until the spectrum analyzer power-on adjustments have completed.
5. Set the microwave frequency counter as follows:
Sample rate Fully counterclockwise
10 Hz–500 MHz/500 MHz–26.5 GHz switch ... 10 Hz– 500 MHz
50 Ω /1 M Ω switch 1 M Ω
6. On the spectrum analyzer, press **AUX CTRL**, **REAR PANEL**, and **10 MHz EXT**.
7. Disconnect W22 (10 MHz frequency counter) from A2J8. The display will probably appear distorted and error messages may appear. Ignore the error messages.
8. Adjust A2R152 (16 MHz PLL ADJ) until the microwave frequency counter reads 14.4 MHz \pm 200 KHz.
9. Reconnect W22 to A2J8. The microwave frequency counter should read 16 MHz. If the counter reads 16 MHz and the display is still distorted, perform the display adjustments in [2. Display Adjustment \(8564E and 8565E\)](#), in this chapter.
10. On the spectrum analyzer, press **CAL**, **REALIGN LO and IF** to clear any error messages.

16. 600 MHz Reference Adjustment (serial prefix 3406A and above)

Assembly Adjusted

A15 RF assembly

Related Performance Test

There is no related performance test for this adjustment.

Description

The 100 MHz VCXO and the tripler are adjusted for a maximum signal level at 600 MHz. A spectrum analyzer is used to monitor the amplitude of the 600 MHz signal while performing these adjustments.

Equipment

Spectrum analyzer 8566A/B

Procedure

1. Press **LINE** to turn the spectrum analyzer off, disconnect the power cord, and remove the spectrum analyzer cover. Fold down the A15 RF and A14 frequency control assemblies. Prop up the A14 frequency control assembly.
2. Disconnect W33, gray/brown coax cable, from A15J701.
3. Connect the signal at A15J701 to the input of the 8566A/B spectrum analyzer.
4. Reconnect the power cord and press **LINE** to turn the spectrum analyzer on.
5. Set the center frequency of the 8566A/B to 600 MHz and set the frequency span and resolution bandwidth of the 8566A/B for the best display of the 600 MHz signal.
6. Set the peak of the 600 MHz signal near the top graticule line on the 8566A/B display and set to 1 dB per division.
7. Adjust A15C750, VCXO Adjust, for maximum amplitude.
8. Adjust A15C751 Tripler Adjust, for maximum amplitude. The level, after proper adjustment, should be between -3 and $+4.8$ dBm (typically 0 to $+1$ dBm).
9. Reconnect W33 to A15J701.

**3a Manual Adjustment Procedures:
3335A Source not Available**

What You'll Find in This Chapter

This chapter provides alternative procedures for the adjustment of the spectrum analyzer that do not require the use of the 3335A Synthesizer Level Generator. The 3335A has been discontinued. Because of the unavailability of the 3335A, new adjustments procedures are required that use different signal sources. If the 3335A is not available, substitute these procedures for those of the same number found in [Chapter 3](#) , “[Manual Adjustment Procedures.](#)”

Required Test Equipment

The following table lists the test equipment required to execute the adjustments in this chapter. These adjustments originally required the use of the 3335A Synthesizer Level Generator.

Table 3a-1 Recommended Test Equipment

Instrument	Critical Specifications for Equipment Substitution	Recommended Model
Sources		
Synthesized Signal Generator	Frequency range: 250 kHz to 3 GHz Frequency resolution: 1 Hz Attenuator resolution: 0.02 dB Level accuracy: ± 0.5 dB External 10 MHz Ref. Input	E4421B or E4422B, E4432B, E4433B
Cables		
Cable, 50 Ω coaxial <i>(four required)</i>	Connectors: BNC (m) Length: ≥ 122 cm (48 in.)	10503A
Cable	Test Cable	85680-60043
Adapters		
Adapter <i>(four required)</i>	Type N (m)-to-BNC (f)	1250-1476
Adapter	Type N (f)-to-2.4 mm (f)	11903B
Adapter	2.4 mm (f) to BNC (f)	1250-2187
Adapter <i>(Option 026 only)</i>	APC-3.5 (f) to APC-3.5 (f)	5061-5311
Adapter <i>(Option 026 only)</i>	APC-3.5 (f) to BNC-3.5 (f)	1250-1200

4a. IF Amplitude Adjustments

The IF amplitude adjustments consist of the cal oscillator amplitude adjustment and the reference 15 dB attenuator adjustment.

Assembly Adjusted

A4 log amp/cal oscillator A5 IF assembly

Related Performance Tests

IF Gain Uncertainty Scale Fidelity

Description

This adjustment sets the output amplitude of the A4 log amp/cal oscillator and the absolute amplitude of the reference 15 dB attenuator.

The output of the A4 log amp/cal oscillator is adjusted so that a -55 dBm signal applied to the 10.7 MHz IF input on the A5 IF assembly (A5J3) causes a displayed signal of -60 dBm. The effect of this adjustment is visible only after the **ADJ CURR IF STATE** sequence is complete. **ADJ CURR IF STATE** causes the IF gain adjustment to use the "new" output amplitude from the A4 log amp/cal oscillator.

This procedure also sets the attenuator of the reference 15 dB attenuator so that a source amplitude change of 50 dB combined with a spectrum analyzer reference level change of 50 dB displays an amplitude difference of 50 dB.

Figure 3a-1 IF Amplitude Adjustment Setup

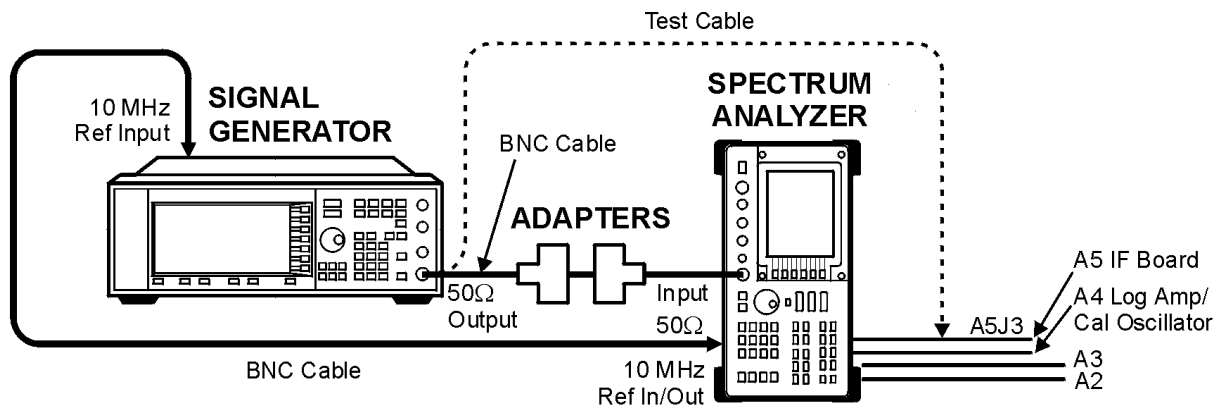

hj11e

Equipment

Signal Generator E4421B

Adapters

Type N (m) to BNC (f) 1250-1476

Type N (f) to 2.4 mm (f) 11903B

Cables

BNC, 122 cm (48 in) 10503A

Test cable 85680-60093

Figure 3a-2 IF Amplitude Adjustment Locations

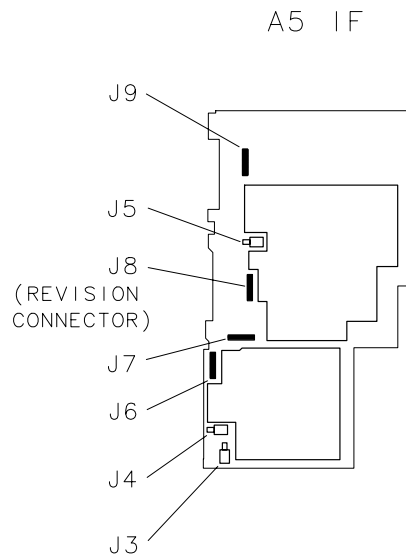

sj115c

NOTE The 15 dB reference attenuator adjustment is preset at the factory and need not be done if the entire A5 IF assembly is replaced.

Procedure

1. Press **LINE** to turn the spectrum analyzer off. Remove the spectrum analyzer cover and place the spectrum analyzer in the service position as illustrated in [Figure 3a-1](#).
2. Disconnect W29, violet coax cable, from A5J3. Connect the test cable between A5J3 and the RF output of the E4421B. Press **LINE** to turn the spectrum analyzer on.

4a. IF Amplitude Adjustments

3. Set the spectrum analyzer controls as follows:

- Center Frequency 10.7 MHz
- Span 200 kHz
- Reference Level -60 dBm
- Attenuator 0 dB
- dB/division 1 dB/DIV
- Resolution bandwidth 300 kHz
- Video bandwidth 100 Hz

4. On the spectrum analyzer, press **MKR**, **CAL**, and **IF ADJ ON OFF** so **OFF** is underlined.

5. Set the E4421B controls as follows:

- Frequency 10.7 MHz
- Amplitude -55 dBm
- Mod On/Off Off

6. Note the marker value. Ideally it should read -60 dBm ±0.1 dB.

7. If the marker reads less than -60.1 dBm, rotate A4R826 CAL OSC AMPTD one-third turn clockwise for every 0.1 dB less than -60 dBm. See [Figure 3a-2](#) for the location of A4R826. A change in the displayed amplitude will not be seen until **ADJ CURR IF STATE** is pressed.

8. If the marker reads greater than -59.9 dBm, rotate A4R826 CAL OSC AMPTD one-third turn counter clockwise for every 0.1 dB greater than -60 dBm. See [Figure 3a-2](#) for the location of A4R826. A change in the displayed amplitude will not be seen until **ADJ CURR IF STATE** is pressed.

NOTE

If A4R826 has inadequate range, refer to “[Inadequate CAL OSC AMPTD Range](#)” in [Chapter 9](#) .

9. On the spectrum analyzer, press **ADJ CURR IF STATE**. After allowing the analyzer time to complete the adjustments, the displayed amplitude and marker reading should change.

10. Repeat [step 7](#) and [step 9](#) until the marker reads -60 dBm ±0.1 dB.

11. Disconnect the test cable from A5J3 and reconnect W29 to A5J3.

A5 Reference Attenuator Adjustment

1. Set the spectrum analyzer reference level to -60 dBm. If markers are displayed, press **MKR** and **MARKERS OFF**.
2. Set the E4421B **AMPLITUDE** to -60 dBm.
3. Connect a BNC cable between the RF output of the E4421B and the spectrum analyzer INPUT 50Ω .
4. On the spectrum analyzer, press **CAL** and **REF LVL ADJ**. Use the front panel knob or step keys to place the peak of the displayed signal 3 dB to 5 dB below the reference level.
5. On the spectrum analyzer, press **PEAK SEARCH** and **MARKER DELTA**. Set the spectrum analyzer reference level to -10 dBm.
6. Change the 4421B **Amplitude** to -10 dBm.
7. On the spectrum analyzer, press **CAL**.
8. Note the Δ MKR amplitude. Ideally, it should read 50.00 dB ± 0.1 dB.
9. If the Δ MKR amplitude is less than 49.9 dB, rotate A5R343 15 dB ATTEN one-half turn counterclockwise for each 0.1 dB less than 50.00 dB. Do not adjust A5R343 more than five turns before continuing with the next step.
10. If the Δ MKR amplitude is greater than 50.1 dB, rotate A5R343 15 dB ATTEN one-half turn clockwise for each 0.1 dB greater than 50.00 dB. Do not adjust A5R343 more than five turns before continuing with the next step.
11. On the spectrum analyzer, press **ADJ CURR IF STATE**. Note the Δ MKR amplitude reading.
12. Repeat [step 1](#) through [step 11](#) until the Δ MKR amplitude reading is 50.00 dB ± 0.1 dB.

A5 Adjustment Verification

1. On the spectrum analyzer, disconnect W29 from A5J3. Connect the test cable between A5J3 and the RF output of the E4421B.
2. Set the spectrum analyzer reference level to -10 dBm.
3. Set the E4421B **Amplitude** to -5 dBm.
4. On the spectrum analyzer, press **MKR** and **MARKER NORMAL**.
5. The MARKER amplitude should read -10 dBm ± 0.13 dB. If the reading is outside of this range, repeat [step 4](#) of “[Procedure](#)” on [page 165](#) through “[A5 Reference Attenuator Adjustment](#)” [step 12](#).

4a. IF Amplitude Adjustments

6. On the spectrum analyzer, reconnect W29 to A5J3. Press **PRESET** and set the controls as follows:

Center frequency 300 MHz

Span 0 Hz

Reference level -10 dBm

Resolution bandwidth 300 kHz

7. Connect a BNC cable between the 8563E CAL OUTPUT and INPUT 50Ω .
8. On the spectrum analyzer, press **MKR CAL** and **REF LVL ADJ.**
9. Use the knob or step keys to adjust the REF LEVEL CAL setting until the MKR reads -10.00 dBm ±0.1 dB.
10. On the spectrum analyzer, press **STORE REF LVL.**

5a. DC Log Amplifier Adjustments

There are three DC log adjustments; limiter phase, linear fidelity, and log fidelity.

Assembly Adjusted

A4 log amp/cal oscillator

Related Performance Tests

IF Gain Uncertainty Scale Fidelity

Description

These three adjustment need only be done under the following conditions:

- | | |
|-----------------|---|
| Limiter phase | Only if a repair is made to blocks F, G, H, I, or J. |
| Linear fidelity | Only if a repair is made to blocks C, D, F, G, H, I, J, K, O, IF gain accuracy, RBW switching, or log fidelity. |
| Log fidelity | Only if a repair is made to blocks D, F, H, K, IF gain accuracy, RBW switching, or log fidelity. |

If multiple adjustments are required they should be done in the following order:

1. Limiter Phase
2. Linear Fidelity
3. Log Fidelity

Figure 3a-3 DC Log Adjustment Setup

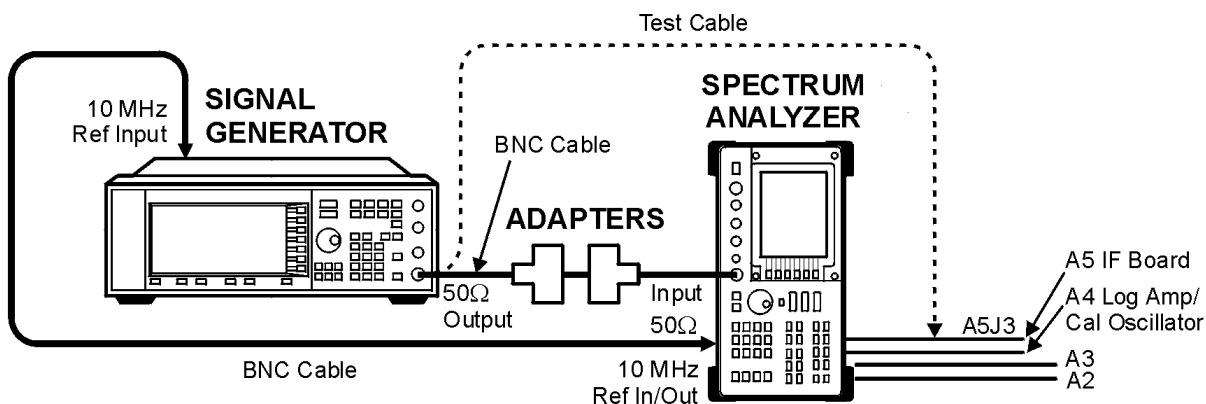

hj11e

Equipment

Signal Generator E4421B

Adapters

Type N (m) to BNC (f) 1250-1476

Type N (f) to 2.4 mm (f) 11903B

Cables

BNC, 122 cm (48 in) 10503A

Test cable 85680-60093

Figure 3a-4 DC Log Adjustment Locations

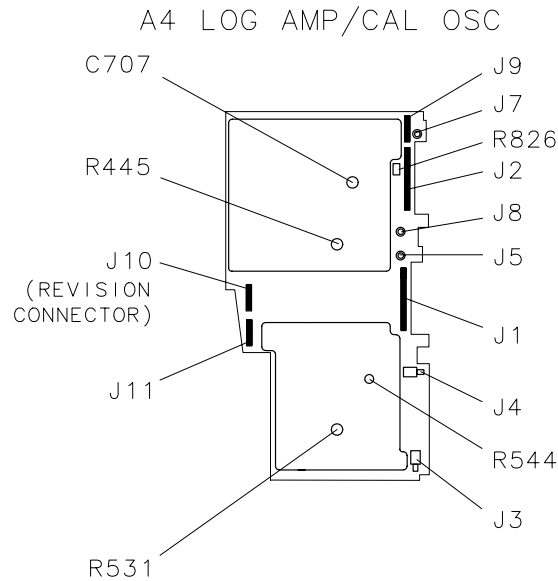

sj116c

NOTE Adjustments should be made with all of the shields on and only after allowing at least a 20 minute warmup.

A4 Limiter Phase Adjustment

1. Press **LINE** to turn the spectrum analyzer off. Remove the spectrum analyzer cover and place the spectrum analyzer in the service position as illustrated in [Figure 3a-3](#). See [Figure 3a-4](#) for adjustment location.
2. Connect the E4421B RF output to the spectrum analyzer 50Ω input. Press **LINE** to turn the spectrum analyzer on.
3. Set the spectrum analyzer controls as follows:

Center frequency 15 MHz
 Span 0 Hz
 Reference level -10 dBm
 dB/division 1 dB/DIV
 Resolution bandwidth 300 kHz
 IF ADJ OFF

5a. DC Log Amplifier Adjustments

4. Set up an E4421B as follows:
 - Frequency 15 MHz
 - Amplitude -18 dBm
 - Mod On/Off Off
5. On the spectrum analyzer, press **CAL** and **ADJ CURR IF STATE**, wait for the analyzer to complete adjustments then press **MKR**.
6. Adjust A4R445 for maximum on-screen amplitude. Refer to [Figure 3a-4](#) for the location of A4R445.

A4 Linear Fidelity Adjustment

1. Press **LINE** to turn the spectrum analyzer off. Remove the spectrum analyzer cover and place the spectrum analyzer in the service position as illustrated in [Figure 3a-3](#). See [Figure 3a-4](#) for adjustment location.
2. Connect the E4421B RF output to the spectrum analyzer 50Ω input. Press **LINE** to turn the spectrum analyzer on.
3. On the spectrum analyzer, press **PRESET AMPLITUDE**, **LINEAR**, **MORE 1 of 3**, **AMPTD UNITS**, **dBm**, **CAL**, and **IF ADJ ON OFF (OFF)**.
4. Set the spectrum analyzer controls as follows:
 - Center frequency 15 MHz
 - Span 5 MHz
 - Resolution bandwidth 300 kHz
 - Reference level -10 dBm
5. Set up an E4421B as follows:
 - Frequency 15 MHz
 - Amplitude -10 dBm
 - Mod On/Off Off
6. On the spectrum analyzer, press **PEAK SEARCH** and **MARKER DELTA**.
7. Reduce the E4421B input power to -58 dBm.
8. If the delta marker amplitude reads -40 dB ±2 dB, no adjustment is necessary.
9. If the signal is lower on the screen than expected (delta marker amplitude reads less than -42dB) then adjust A4R544 (see [Figure 3a-4](#)) for an even lower level and press **CAL** and **ADJ CURR IF STATE**. Allow sufficient time for the analyzer to complete the adjustment.

10. If the signal is higher than expected (delta marker amplitude reads greater than -38 dB) then adjust A4R544 for an even higher level signal and press **CAL** and **ADJ CURR IF STATE**. Allow sufficient time for the analyzer to complete the adjustment.
11. Repeat [step 7](#) through [step 10](#).

A4 LOG Fidelity Adjustment

1. Press **LINE** to turn the spectrum analyzer off. Remove the spectrum analyzer cover and place the spectrum analyzer in the service position as illustrated in [Figure 3a-3](#). See [Figure 3a-4](#) for adjustment location.
2. Connect the E4421B RF output to the spectrum analyzer 50Ω input. Press **LINE** to turn the spectrum analyzer on.
3. On the spectrum analyzer, press **PRESET**, **CAL**, **IF ADJ ON OFF (OFF)**, and **ADJ CURR IF STATE**.

4. Set the spectrum analyzer controls as follows:

Center frequency 15 MHz
Span 0 MHz
Resolution bandwidth 300 kHz
Reference level -10 dBm

5. Set up an E4421B as follows:

Frequency 15 MHz
Amplitude -10 dBm
Mod On/Off Off

6. On the spectrum analyzer, press **MKR** and **MARKER DELTA**.
7. Decrease the E4421B power to -26 dBm.
8. Calculate the error:

$$\text{Error} = \text{delta marker reading} - 16 \text{ dB}$$

9. If the error is less than ± 0.2 dB, no adjustment is necessary.
10. Set the E4421B power to -10 dBm.
11. Adjust A4R531 (see [Figure 3a-4](#)) to read two times the error. For example, if the calculated error is $+0.75$ dB, adjust A4R531 for a delta marker amplitude reading of $+1.5$ dB. Press **CAL** and **ADJ CURR IF STATE**.

12. Repeat [step 7](#) through [step 11](#).

4 Assembly Replacement

Introduction

This chapter describes the removal and replacement of all major assemblies. The following replacement procedures are provided:

	Page
Access to Internal Assemblies	page 177
Cable Color Code	page 178
Required Tools	page 178
Procedure 1. Spectrum Analyzer Cover	page 179
Procedure 2A. A1 Front Frame/A18 LCD (8564EC and 8565EC) ..	page 180
Procedure 2B. A1 Front Frame/A18 CRT (8564E and 8565E)	page 191
Procedure 3. A1A1 Keyboard/Front Panel Keys	page 200
Procedure 4. A1A2 RPG.....	page 201
Procedure 5. A2, A3, A4, and A5 Assemblies	page 176
Procedure 6A. A6 Power Supply Assembly(8564EC and 8565EC) ..	page 209
Procedure 6B. A6 Power Supply Assembly(8564E and 8565E)	page 212
Procedure 7. A6A1 High Voltage Assembly(8564E and 8565E) ...	page 216
Procedure 8. A7 through A13 Assemblies	page 220
A7 LO Multiplier/Amplifier (LOMA)	page 222
A8 Low Band Mixer	page 223
A9 Input Attenuator	page 224
A10/A12 (RYTHM/SBTX)	page 227
A11 YTO	page 228
A13 Second Converter	page 230
Procedure 9. A14 and A15 Assemblies	page 231
Procedure 10. A16 FADC and A17 CRT Driver(8564E and 8565E) ...	page 234
Procedure 11. B1 Fan	page 237
Procedure 12. BT1 Battery	page 238
Procedure 13. Rear Frame/Rear Dress Panel	page 239
Procedure 14. W3 Line Switch Cable (8464E and 8456E).....	page 244
Procedure 15. EEROM.....	page 254
Procedure 16. A21 OCXO	page 256

Tools required to perform the procedures are listed in [Table 4-1 on page 178](#).

The words *right* and *left* are used throughout the replacement procedures to indicate the side of the spectrum analyzer as viewed from the front panel. See [Figure 4-1 on page 179](#).

Numbers in parentheses are used throughout the replacement procedures to indicate numerical callouts on the figures.

CAUTION

The spectrum analyzer contains static-sensitive components. Read the section entitled, “[Electrostatic Discharge](#)” in [Chapter 1](#).

Access to Internal Assemblies

Servicing the 8564E/EC or the 8565E/EC requires the removal of the spectrum analyzer cover assembly and the folding down of six board assemblies. Four of these assemblies lay flat along the top of the spectrum analyzer and two lay flat along the bottom of the spectrum analyzer. All six assemblies are attached to the spectrum analyzer right side frame using hinges and fold out of the spectrum analyzer allowing access to all major assemblies. See [Figure 4-1 on page 179](#).

- To remove the spectrum analyzer cover assembly, refer to [“Procedure 1. Spectrum Analyzer Cover.”](#)
- To access the A2, A3, A4, and A5 assemblies, refer to [“Procedure 5. A2, A3, A4, and A5 Assemblies.”](#)
- To access the A14 and A15 assemblies, refer to [“Procedure 9. A14 and A15 Assemblies.”](#)
- To remove and replace the backlight cables, which illuminate the A18 LCD, refer to [“Procedure 2A. A1 Front Frame/A18 LCD \(8564EC and 8564EC\).”](#)
- To remove the A17 LCD board, refer to [“Procedure 2A. A1 Front Frame/A18 LCD \(8564EC and 8564EC\).”](#)
- To remove the A16 or A17 CRT board, refer to [“Procedure 10. A16 Fast ADC and A17 CRT Driver \(8564E and 8565E\).”](#)

NOTE

Diagrams that illustrate features common to E-series and EC-series instruments are shown with E-series instruments. Where there are differences between E-series and EC-series features, separate diagrams are provided for E-series and EC-series instruments.

Cable Color Code

Coaxial cables and wires will be identified in the procedures by reference designation or name followed by a color code. The code is identical to the resistor color code. The first number indicates the base color with second and third numbers indicating any colored stripes. For example, W23, coax 93, indicates a white cable with an orange stripe.

Table 4-1

Required Tools

Description	Part Number
5/16-inch open-end wrench	8720-0015
3-mm hex (Allen) wrench	8710-1366
4-mm hex (Allen) wrench	8710-1164
17-mm socket wrench	T362609
No. 4 hex (Allen) wrench	5020-0288
No. 6 hex (Allen) wrench	5020-0289
7 mm nut driver	8710-1217
3/8-inch nut driver	8720-0005
7/16-inch nut driver	8720-0006
9/16-inch nut driver (drilled out, end covered with heatshrink tubing)	8720-0008
Small No. 1 pozidrive screwdriver	8710-0899
Large No. 2 pozidrive screwdriver	8710-0900
T-8 TORX screwdriver	8710-1614
T-10 TORX screwdriver	8710-1623
T-15 TORX screwdriver	8710-1622
Long-nose pliers	8710-0030
Wire cutters	8710-0012

Procedure 1. Spectrum Analyzer Cover

Removal/Replacement

1. Disconnect the line-power cord, remove any adapters from the front panel connectors, and place the spectrum analyzer on its front panel.
2. If an 85620A Mass Memory Module or 85629B Test and Adjustment Module is mounted on the rear panel, remove it. Loosen (but do not remove) the four rear-bumper screws, using a 4 mm hex wrench. Pull the cover assembly off towards the rear of the instrument.

CAUTION

When replacing the spectrum analyzer cover, use caution to avoid damaging any cables.

3. When installing the cover assembly, be sure to locate the cover air vent holes on the bottom side of the spectrum analyzer. Attach with the four screws loosened in step 2, and tighten the four screws gradually to ensure that the cover is seated in the front frame gasket groove.
4. Torque each screw to 40 to 50 inch-pounds to ensure proper gasket compression to minimize EMI.

Figure 4-1 Hinged Assemblies

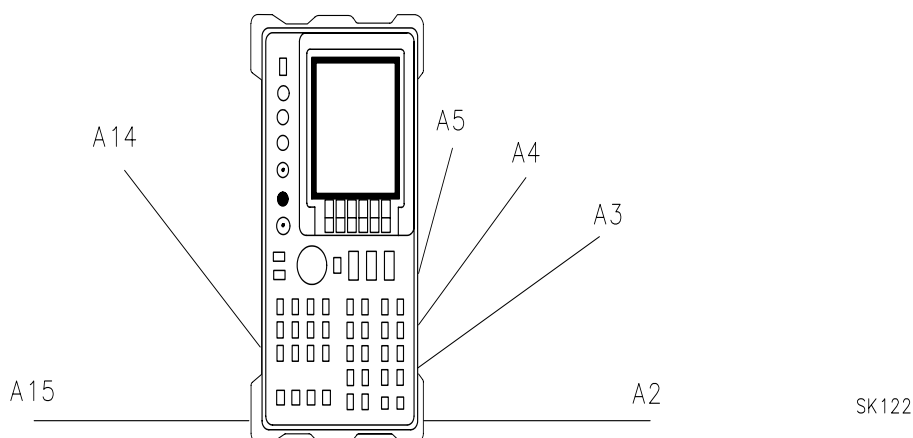

NOTE

Figure 4-1 shows an 8560 E-series instrument. In the assembly removal and replacement procedures the words “left” and “right” assume you are facing the front panel of the instrument, as shown in Figure 4-1, with A14 and A15 to your left, and A2 through A5 on your right. The 8560 EC-series instrument is identical except the A2 board is smaller.

Procedure 2A. A1 Front Frame/A18 LCD (8564EC and 8564EC)

Removal of the Front Frame

1. Remove the spectrum analyzer cover assembly as described in "Procedure 1. Spectrum Analyzer Cover." Place the instrument on its side, with the display section upper-most, as shown in [Figure 4-1 on page 179](#).
2. Fold out the A2, A3, A4, and A5 assemblies as described in steps 2 through 6 under "[Procedure 5. A2, A3, A4, and A5 Assemblies.](#)" Facing the front panel, the A2, A3, A4, and A5 assemblies will lay to your left.
3. Fold out the A14 and A15 assemblies as described in steps 3 through 4 under "[Procedure 9. A14 and A15 Assemblies.](#)" Facing the front panel, the A14 and A15 assemblies will lay to your right.
4. Disconnect ribbon cable A1A1W1, which connects HDR1 on the A1 front frame assembly and A3J602 on the A3 interface board.
5. Disconnect the following cables from the A2 controller board:
 - a. Ribbon cable W60, which connects J8 on the A2 controller board with J1 on the A17 display driver board.
 - b. W61, which connects J9 on the A2 controller board with J7 on the A17 display driver board.
6. Disconnect ribbon cable W64 from the J1 VGA port on the rear panel (do not disconnect W64 from the A17 display driver board).
7. Disconnect the W3 line switch cable from the power supply.
 - a. Remove the power supply cover. Use a T-6 TORX driver to remove the 3 screws (0515-2309) that secure the power supply cover to the power supply.
 - b. Remove the line switch connector from A6J2 on the power supply.
 - c. Loosen FL 1. Remove the two screws (0515-2332) which are used to secure FL 1 to the right side of the chassis.
 - d. After FL 1 has been loosened, route the W3 line switch cable through the opening behind FL 1, from the left to the right side of the instrument (if you still have difficulty routing W3 through the opening, use an open ended 5/16-inch wrench to further loosen, or disconnect FL 1).

To disconnect the line switch from the front panel, see "[Removal of the Front Frame](#)" on page 180.

8. Disconnect the following connectors which are attached to the inside of the A1 front panel assembly:

- a. INPUT 50 Ω RF connector. Use a 5/16-inch open-end wrench to disconnect cable W41 from the front panel. Loosen the opposite end of cable W41, which is connected to the attenuator.
- b. RF OUT 50 Ω connector *for Option 002 spectrum analyzers*. Use a 5/16-inch wrench to disconnect cable W47 from the front panel.
- c. 1ST LO OUTPUT connector. Disconnect cable W42 from A7J3 and from the front panel 1st LO OUTPUT connector.

To remove the 1st LO OUTPUT connector use a 5/16 socket and thread pliers. Use the pliers to hold the 1st LO connector in place, while loosening the connector inside the instrument with the 5/16-inch socket.

- d. 1ST LO OUTPUT connector *For Option 002 spectrum analyzers*. Disconnect W46 from the front panel.
- e. IF INPUT connector. Disconnect W36 from the front panel.

9. Remove the following from the face of the front panel:

- a. VOLUME knob. Use a 0.050 Allen wrench to remove the two screws (3030-0007) that secure the volume knob to the face of the front panel. If necessary, use a 5/16-inch nut driver to drill out the nut which secures the VOLUME potentiometer assembly. Cover the tip with heatshrink tubing or tape to avoid scratching the enameled front panel.
- b. CAL OUTPUT connector. Use a 9/16-inch nut driver to remove the dress nut that holds the front panel CAL OUTPUT connector to the front panel. If necessary, drill out the nut driver to fit over the BNC connectors and cover the tip with heatshrink tubing or tape to avoid scratching the enameled front panel.

10. Remove the front frame from the chassis of the instrument.

- a. Remove the screw (0515-1227) that secures the top of the attenuator to the inside of the front frame of the instrument.
- b. Remove the three screws (0515-1101) that secure the A1 front frame assembly to the bottom of the spectrum analyzer.
- c. Remove the three screws (0515-1101) that secure the A1 front frame assembly to the top of the spectrum analyzer.
- d. Remove the A1 front frame assembly from the chassis.

Note that the line switch cable is still attached to the front frame. To remove the line switch you must first remove the display driver and LCD assembly. For instructions on removing the line switch, see [“Removal of the Line Switch from the Front Panel” on page 183](#).

Removal of the Display Driver Board, Inverter Board, and LCD

After the front panel has been removed, follow these steps to remove the display driver and LCD:

1. Disconnect the following cables from the A17 display driver board. These can be disconnected through openings in the display driver shield. See [Figure 4-2 on page 184](#).
 - a. W60, a ribbon cable that connects J1 on the A17 display driver board with J8 on the A2 controller board.
 - b. W61, which connect J7 on the A17 display driver board with J9 on the A2 controller board.
2. Remove the four screws (0515-0665) that secure the display driver shield to the LCD backplate. Use a T-10 TORX driver set to 6 in./lbs. Remove the display driver shield.
3. Disconnect the following cables from the A17 display driver board:
 - a. W64, the VGA ribbon cable, which connects J4 on the A17 display driver board to J1 on the rear panel.
 - b. W63, a ribbon cable that connect J5 on the A17 display driver board with the LCD.
4. If you want to remove the A17A1 inverter board, proceed to step a. If you intend to keep the A17A1 inverter board secured to the A17 display driver board, proceed to step 4.
 - a. Remove the two screws (0515-0430) which secure the A17A1 inverter board to standoffs on the A17 display driver board.
 - b. Disconnect W62 from J6 on the A17 display driver board (do not disconnect W62 from the A17A1 inverter board, to which it is attached).
5. Remove the two backlight cables from the inverter board.
6. Remove the four screws (0515-0372) which secure the display driver board to the LCD backplate. Use a T-10 TORX driver. Remove the display driver board.
7. Remove four black cushions (0400-0333) from the inner-most posts on the LCD backplate.
8. Remove the two large screws (0515-0382) which secure the LCD backplate to the left side of the front panel chassis. Use a T-15 TORX driver.
9. Remove the four (0515-0430) screws which secure the LCD backplate to the right side of the front panel chassis. Use a T-8 TORX driver.

10. Carefully lift the display driver backplate over the two backlight cables and the W63 ribbon cable.
11. Remove the LCD assembly from the black rubber mount. Take care not to damage the backlight cables or W63 ribbon cable.
12. To remove the glass plate, first remove the LCD display from the display mount. Carefully remove the glass from the inside of the display mount.

NOTE

The LCD glass plate was originally placed in the LCD assembly in a clean room environment to ensure optimal performance of the LCD display. Take all possible precautions to ensure that the glass plate is clean before replacing it in the LCD assembly.

Removal of the Backlights

1. Remove the LCD assembly by following steps 1 through 12 in [“Removal of the Display Driver Board, Inverter Board, and LCD” on page 182](#).
2. Remove each backlight cable assembly (2090-0380). *Carefully* grasp the end of the metal backlight assembly, which is connected to the backlight cable, and pull the backlight out from its slot. The backlight cable slots are located at the top and at the bottom of the LCD.

NOTE

Whenever there is a need to replace a single backlight, both backlights must be replaced.

Removal of the Line Switch from the Front Panel

After the A1 front frame assembly, the A17 display driver, and the A18 LCD have been removed, you can proceed to remove the line switch. Follow these steps:

1. Remove the green LED from the line switch assembly on the front frame, by gently pulling on the orange and black cables (wrapped in shrink tubing), to which the LED is connected.
2. Remove the two screws (0515-1521) that secure the line switch to the front frame.
3. Remove the screw (0515-0430) that secures the striped green and white ground cable to the line switch.
4. Remove the line switch from the front panel.

Figure 4-2 LCD Assembly - Exploded View

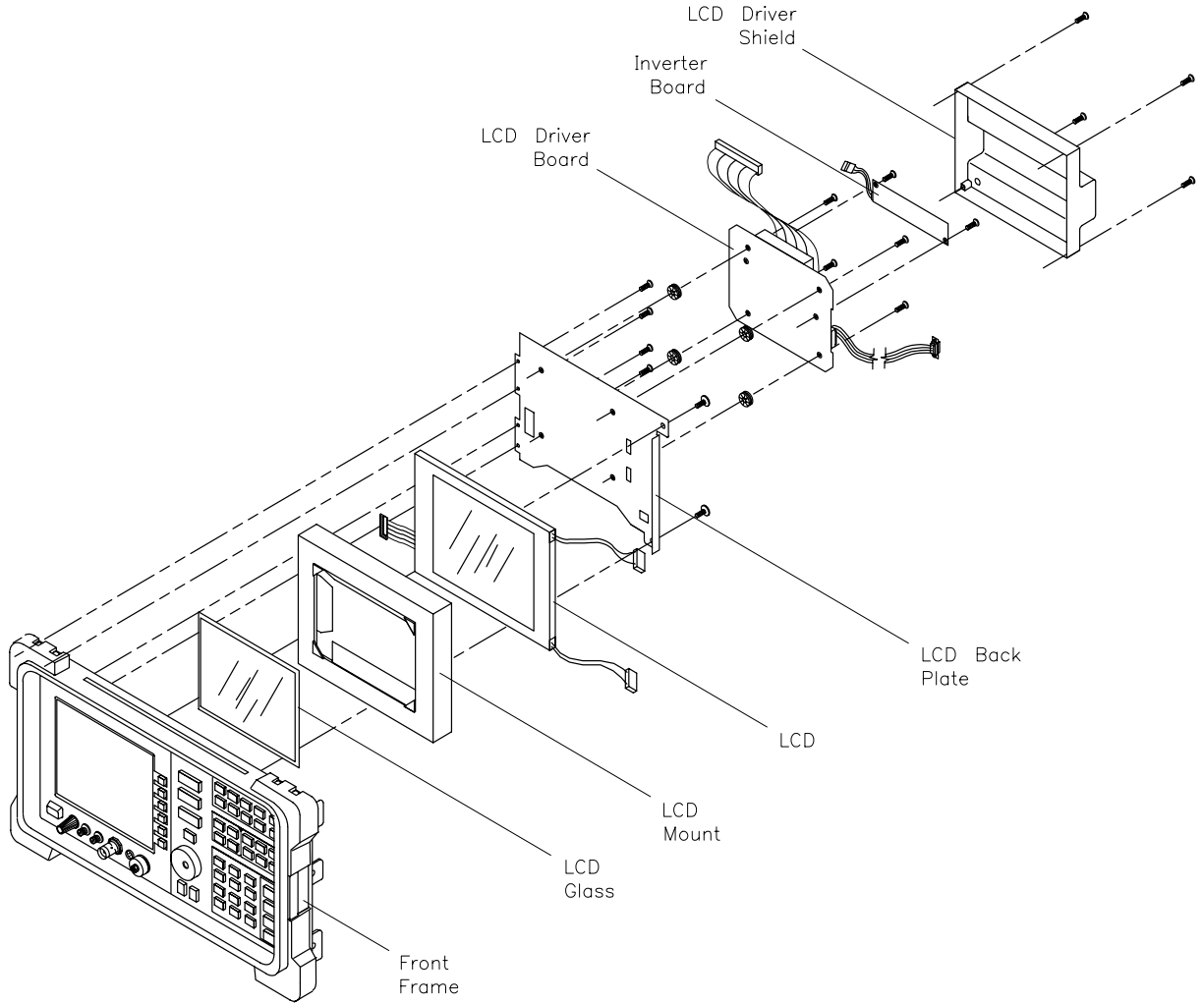

s1135c

Removal of the Keyboard

1. Disconnect cable A1A1W1 from HDR1 on the A1 front panel assembly and from A3J602 on the A3 interface board.
2. Disconnect the power probe cable from the probe power connector on the front frame PC board.
3. Unhook the RPG cable.
4. Remove the seven screws (0515-1934) that secure the front frame PC board to the front frame. Use a T-8 TORX driver set to 6-in/lbs.

Replacement of the Front Frame

1. Remove the cover assembly as described in “[Procedure 1. Spectrum Analyzer Cover.](#)” Place the instrument on its side, with the display section upper-most, as shown in [Figure 4-1 on page 179.](#)
2. Fold out the A14 and A15 assemblies as described in steps 3 through 4 under “[Procedure 9. A14 and A15 Assemblies.](#)” Facing the front panel, the A14, and A15 assemblies will lie to your right.
3. Fold out the A2, A3, A4, and A5 assemblies as described in steps 2 through 6 under “[Procedure 5. A2, A3, A4, and A5 Assemblies.](#)” Facing the front panel, the A2, A3, A4, and A5 assemblies will lie to your left.
4. Place the A1 front frame assembly in the chassis of the instrument.
 - a. Position the A1 front frame assembly in the chassis.
 - b. Insert the three screws (0515-1101) that secure the front frame chassis to the bottom of the spectrum analyzer.
 - c. Insert the three screws (0515-1101) that secure the front frame chassis to the top of the spectrum analyzer
 - d. Insert the screw (0515-1227) that secures the top of the attenuator to the inside of the A1 front frame assembly.
5. Secure the following connectors to the inside of the A1 front panel assembly.
 - a. INPUT 50 Ω RF connector. Use a 5/16-inch open-end wrench to connect cable W41 to the front panel from the attenuator.
 - b. RF OUT 50 Ω connector *for Option 002 spectrum analyzers.* Use a 5/16-inch open-end wrench to connect cable W47 to the front panel.

- c. 1ST LO OUTPUT connector. Connect cable W42 from A7J3 to the front panel 1st LO OUTPUT connector.

To replace the 1st LO OUTPUT connector use a 5/16 socket and thread pliers. Use the pliers to hold the 1st LO connector in place, while tightening the connector inside the instrument with the 5/16-inch socket.
 - d. 1ST LO OUTPUT connector *for Option 002 spectrum analyzers*. Connect W46 from the front panel.
 - e. IF INPUT connector. Connect W36 from the front panel.
6. Replace the following from the face of the front panel.
 - a. VOLUME knob and potentiometer. Use a 5/16-inch nut driver to secure the VOLUME potentiometer assembly. Use a 0.050 Allen wrench to replace the two screws (3030-0007) that secure the volume knob to the face of the front panel.
 - b. CAL OUTPUT connector. Replace the dress nut that holds the CAL OUTPUT connector to the front panel.
 7. If the line switch has been disconnected from the power supply you will have to route the W3 line switch cable from the right side of the instrument, through the opening behind FL 1, to the power supply on the left side of the instrument.
 - a. Loosen the two screws (0515-2332) that secure FL 1 to the instrument's chassis.
 - b. Route the W3 line switch cable from the right side of the instrument to the left side, through the opening that can now be accessed, since FL 1 has been loosened. If the opening is still tight, loosen or remove FL 1 using a 5/16 -inch wrench.
 - c. Secure the W3 line switch cable to the instrument chassis by routing it through the white collar, that is adjacent to the power supply assembly, on the chassis of the instrument.
 - d. Route the W3 line switch cable through the notched opening on the right side of the power supply, and insert the line switch connector into A6J2.

If the line switch has been disconnected from the front panel, see the instructions for its replacement on [page 189](#).

8. Replace the power supply cover by inserting the 3 screws (0515-2309) that secure the power supply cover to the power supply.
9. If the LCD assemblies have not been removed from the front panel assembly, you will need to reconnect the following cables, which are routed through openings in the display driver shield.

- a. W60, the large ribbon cable (80 lines) that goes to J8 on the A2 controller board.
- b. W61, a coax cable that connects to J10 on the A2 controller board.
- c. W64, the VGA ribbon cable (10 lines), that goes to J1 on the rear panel.

Replacement of the Display Driver Board, Inverter Board, and LCD

Follow these steps to replace the A18 LCD assembly, the A17 display driver, and the A17A1 inverter board.

NOTE

If the line switch assembly has been removed from the front panel, it must be replaced before you replace the display driver and LCD assemblies.

1. Place the front panel face down on your bench. The opening for the display will be on the right side of the front panel.
2. If the LCD glass plate has been removed, carefully insert the glass plate into the brackets on the front side of the rubber display mount. Make sure that the side of the glass which has a broad silver border (the left side, when facing the front of the display) is inserted into the side of the mount that has larger brackets, into which the glass plate will slide.

NOTE

The glass plate was originally placed in the LCD assembly in a clean room environment to ensure optimal performance of the LCD display. Take all possible precautions to ensure that the glass plate is clean before placing it in the LCD assembly.

3. Insert the LCD into the display mount. The LCD is correctly oriented when the small ribbon cable from the LCD extends through an opening in the right side of the display mount, and the two backlight cables extend through openings on the left side of the mount.
4. Carefully lower the LCD backplate onto the display mount. Ensure that the ribbon cable on the right, and the two backlight cables on the left, are inserted into the appropriate openings in the LCD backplate.
5. Lower the LCD backplate and LCD assembly, as a unit, into the display section on the right side of the A1 front frame chassis.

6. Secure the LCD backplate to the chassis.
 - a. Insert four (0515-0444) screws into the right side of the backplate. Use a T-8 TORX driver.
 - b. Insert two large (0515-0382) screws into the left side of the LCD backplate. Use a T-15 TORX driver.
7. Place the four black cushions (0400-0333) on the four inner-most posts on the LCD backplate.
8. Place the A17 display driver board on the four black cushions. Insert the four screws (0515-0372) that secure the A17 display driver board to the LCD backplate, into the posts on which you have set the cushions. Use a T-10 TORX driver.
9. If the A17A1 inverter board has been removed from the driver board, proceed to step a. below. If the inverter board is attached to the A17 display driver, proceed to step 10.
 - a. Connect the W62 cable from the A17A1 inverter board to J6 on the A17 display driver board.
 - b. Insert 2 screws (0515-0430) that secure the A17A1 inverter board to the standoffs on the A17 display driver board.
10. Reconnect ribbon cable W63, which connects the A18 LCD with J5 on the A17 display driver board.
11. Connect the two backlight cables from the A18 LCD to the two slotted connectors on the A17A1 inverter board.
12. Route W64, the VGA cable, from J1 on the rear panel, through the rectangular opening in the display driver shield, to J7 on the A17 display driver board (the display driver shield has not yet been secured to the LCD backplate).
13. Lower the display driver shield onto the LCD backplate. Insert four screws (0515-0665) that secure the LCD backplate to the display driver board shield. Use a T-10 TORX driver.
14. Route cable W61 from J9 on the A2 controller board, through the circular opening in the display driver shield, to J7 on the A17 display driver board.
15. Route cable W60 from J8 on the A2 controller board, through the rectangular opening in the display driver shield, to J7 on the A17 display driver board.
16. Connect ribbon cable A1A1W1 from J602 on the A3 interface board to HDR1 on the A1 front panel assembly.

Replacing the Backlights

1. If the LCD or backlights have not been removed from the front frame, follow the procedures outlined in [“Removal of the Front Frame” on page 180](#), [“Removal of the Display Driver Board, Inverter Board, and LCD” on page 182](#), and [“Removal of the Backlights” on page 183](#), as needed.
2. *Carefully* grasp the end of the replacement backlight cartridge (2090-0380), which is attached to the backlight cable, and insert the backlight into the backlight slot at the top of the LCD. Repeat for the backlight located at the bottom of the LCD.

NOTE

Whenever there is a need to replace a single backlight, both backlights must be replaced.

3. Insert the LCD into the display mount. The LCD assembly is correctly oriented when the small ribbon cable extends through an opening in the right side of the display mount.
4. Follow steps 4 through 17 of [“Replacement of the Display Driver Board, Inverter Board, and LCD” on page 187](#), to complete replacement of the LCD into the front panel. Follow the instructions in [“Replacement of the Front Frame” on page 185](#), to replace the front panel in the front frame.

Replacement of the Line Switch

After you have replaced the A1 front frame assembly you can replace the line switch by following these steps (note that the line switch must be replaced before the LCD and display driver can be replaced):

1. Insert the line switch into the A1 front frame assembly. Insert the two screws (0515-1521) that secure the line switch to the front frame.
2. Insert the screw (0515-0430) that secures the striped green and white ground cable for the line switch (this screw also secures the ground for the power probe; if the black cable from the power probe cable assembly is not secured to the ground, secure it also).
3. Carefully insert the green LED from the top-center of the line switch assembly into the LED opening in the A1 front frame assembly.

Replacement of the Keyboard

1. Insert the seven screws (0515-1934) that secure the front frame PC board to the A1 front frame assembly. Use a T-8 TORX driver.
2. Connect the RPG cable to the RPG connector on the front frame PC board.

3. Connect the power probe cable to the connector that is labelled “probe power” on the front frame PC board.
4. Connect A1A1W1 from HDR1 on A1 front frame assembly to A3J602 on the A3 interface board.

Procedure 2B. A1 Front Frame/A18 CRT

Removal

WARNING

The voltage potential at A6A1W3 is +9 kV. Disconnect at the CRT with caution! Failure to properly discharge A6A1W3 may result in *severe electrical shock* to personnel and damage to the instrument.

1. Remove the spectrum analyzer cover assembly as described in [“Procedure 1. Spectrum Analyzer Cover.”](#)
2. Fold out the A2, A3, A4, and A5 assemblies as described in [“Procedure 5. A2, A3, A4, and A5 Assemblies,”](#) steps 2 through 6.
3. Disconnect A1A1W1 from A3J602.
4. Place the spectrum analyzer top-side-up on the work bench.
5. Connect the spectrum analyzer line-power cord to provide proper grounding while discharging the A6A1W3 post-accelerator cable. Make sure that the spectrum analyzer line-power switch is in the off position.
6. Connect a high voltage probe (1000:1), such as the 34111A to a voltmeter with a 10 megohm input.
7. Connect the clip lead of the probe (ground) to the chassis of the spectrum analyzer.
8. Slip the tip of the high voltage probe under the rubber shroud of the A6A1W3 post-accelerator cable to obtain a reading on the voltmeter. See [Figure 4-3 on page 193](#).
9. Keep the high voltage probe on the post-accelerator connector until the voltage has dropped to a voltmeter reading of less than 5 mV (less than 5 V at the connector). This normally takes about 30 seconds.
10. Disconnect the line-power cord from the spectrum analyzer.

WARNING

To avoid possible electrical shock, in the next step, use a screwdriver having a conductive metal shank and tip, with an insulated handle.

11. Connect one end of a wire clip lead to a small screwdriver having a conductive shank and tip. Connect the other end of the clip lead to the CRT shield assembly as shown in [Figure 4-3 on page 193](#). Hold the insulated screwdriver handle and slip the tip of the screwdriver under the rubber shroud of the A6A1W3 post-accelerator cable, shorting the cable to ground through the CRT shield assembly. See [Figure 4-3 on page 193](#).
12. Using a small screwdriver with the shank in contact with the CRT shield assembly, slip the tip of the screwdriver under the A6A1W3 post-accelerator cable rubber shroud and short the cable to ground on the CRT shield assembly.
13. Pry out the black grommet protecting post-accelerator cable A6A1W3 from the CRT shield assembly.
14. Carefully unsnap the A6A1W3 post-accelerator cable from the CRT and discharge it by shorting the cable to chassis ground on the CRT shield assembly.
15. Place the spectrum analyzer on its right side frame with the front frame assembly hanging over the front edge of the workbench.
16. Fold out the A14 and A15 assemblies as described in steps 3 and 4 under [“Procedure 9. A14 and A15 Assemblies.”](#)

WARNING

The voltage potential at A6A1W3 is +9 kV. Failure to discharge A6A1W3 correctly may result in *severe electrical shock* to personnel and damage to the instrument.

Figure 4-3 Discharging High Voltage on the CRT

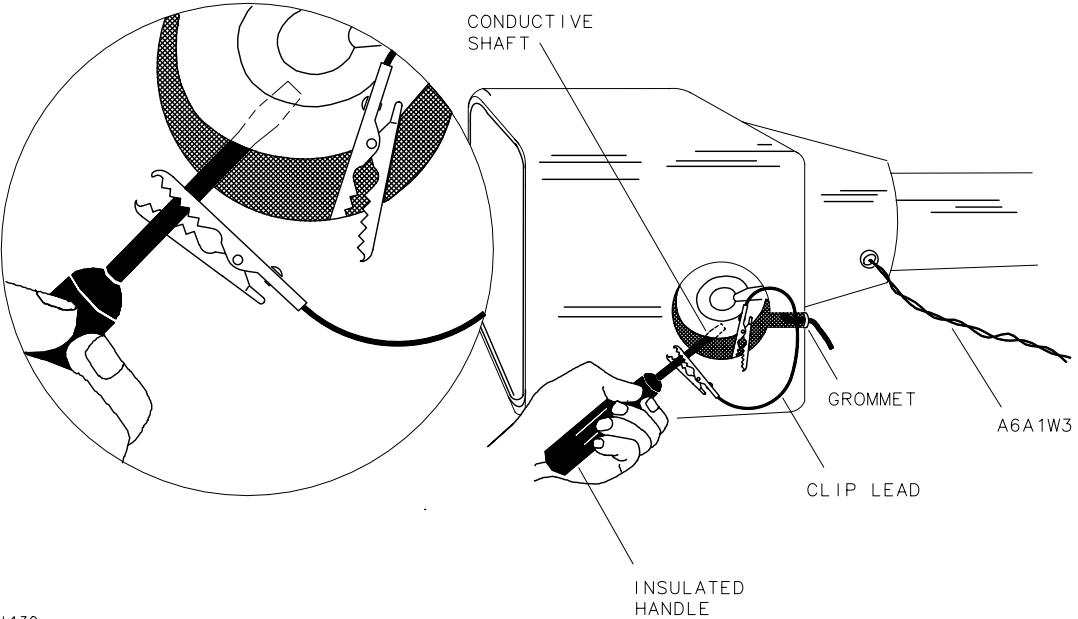
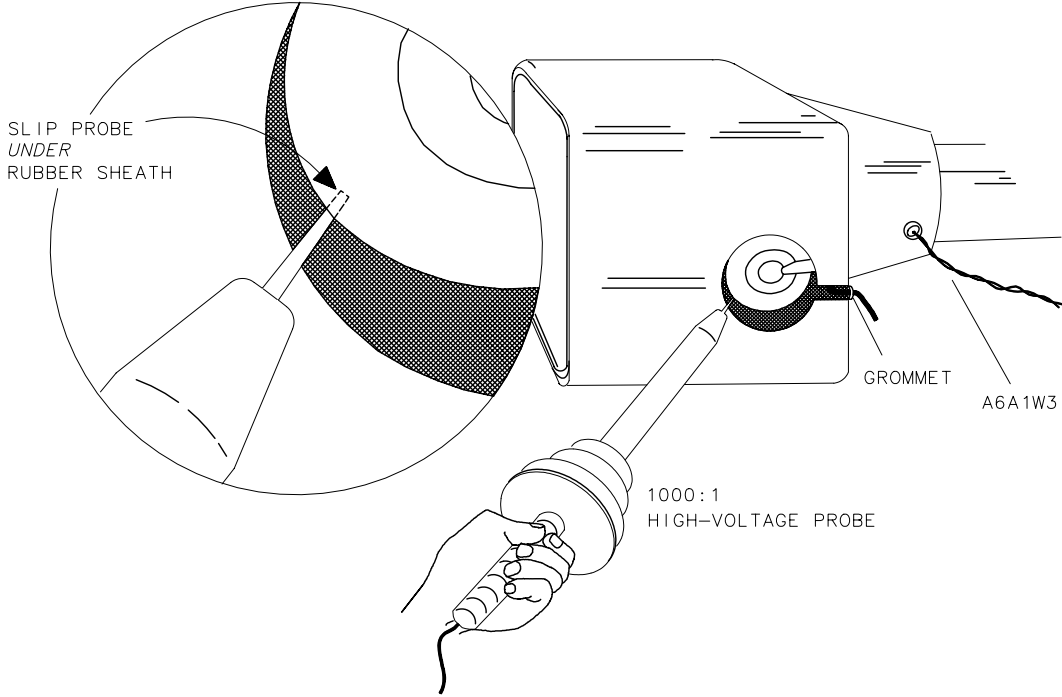

s 1130e

Figure 4-4 A18 and Line Switch Assembly Mounting Screws

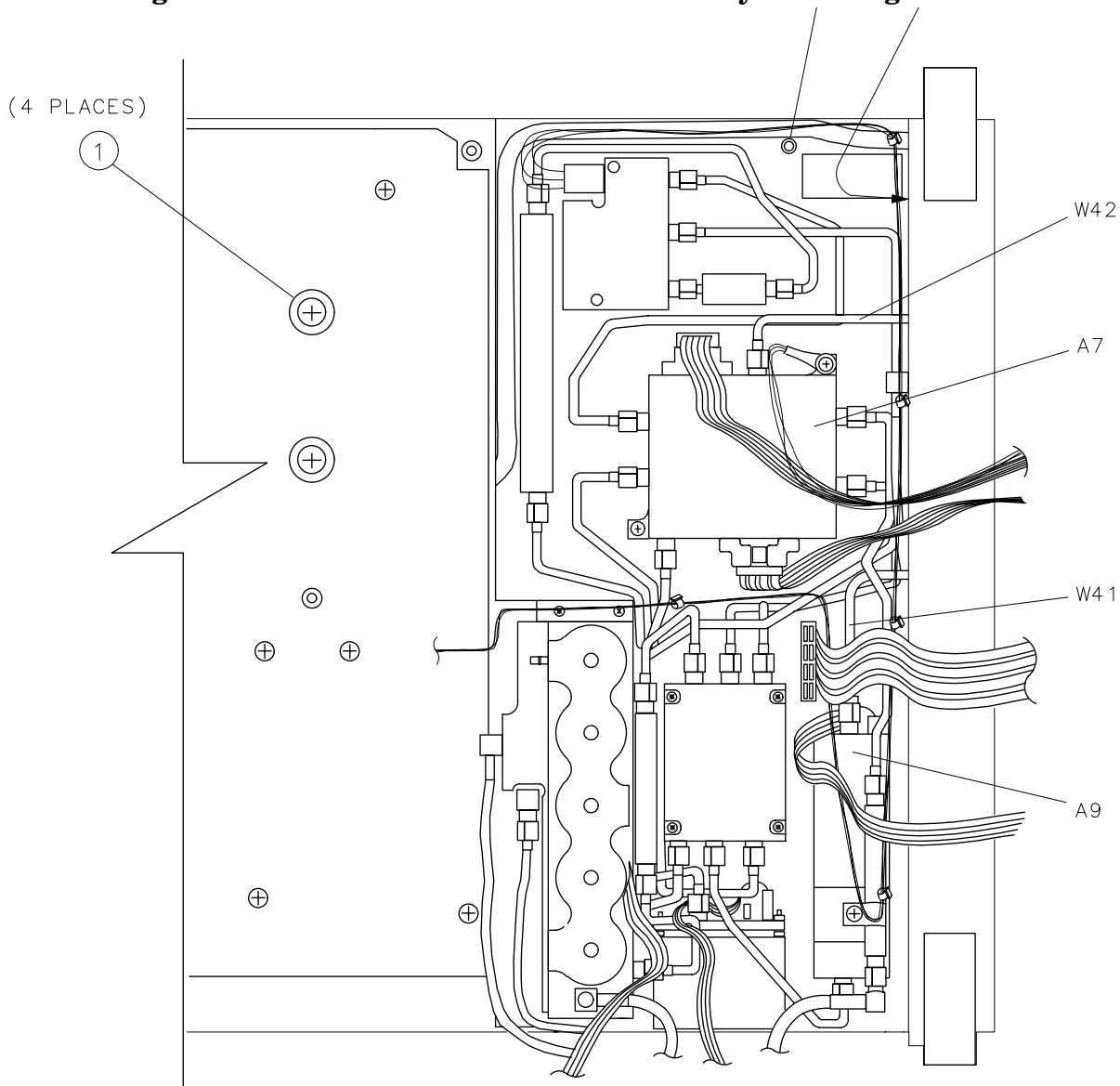

sm19e

17. Use a 5/16-inch open-end wrench to disconnect W41 from the A9 input attenuator and the front panel INPUT 50Ω connector.
18. Disconnect W42 from A7 and the front panel 1ST LO OUTPUT connector.
19. Disconnect W36, coax 86, from the front panel IF INPUT connector.
20. Remove the VOLUME knob and potentiometer from the front panel. If necessary, drill out the nut driver used to remove the VOLUME potentiometer and cover the tip with heatshrink tubing or tape to avoid scratching the front dress panel.

21. Use a 9/16-inch nut driver to remove the dress nut holding the front panel CAL OUTPUT connector to the front panel. If necessary, drill out the nut driver to fit over the BNC connectors and cover the tip with heatshrink tubing or tape to avoid scratching the enameled front panel.
22. Loosen screw (2) securing the line switch assembly to the front frame. This is a captive screw and cannot be removed from the line switch assembly. See [Figure 4-4 on page 194](#).
23. Gently remove the line switch assembly, using caution to avoid damaging A1W1 and power indicator LED A1W1DS1.
24. Remove A1W1 and A1W1DS1 from the line-power switch assembly.
25. Remove the three screws (1) securing the front-frame assembly to the spectrum analyzer right-side frame. See [Figure 4-5](#).

Figure 4-5 Front-Frame Mounting Screws

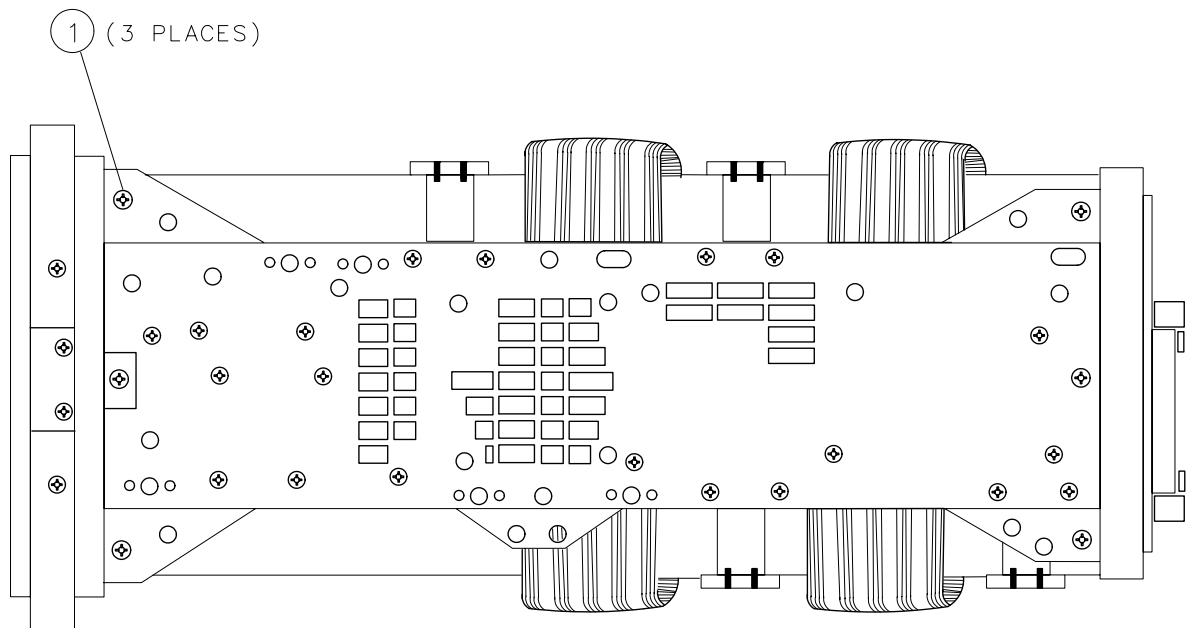

sz 126e

26. Remove the three screws securing the front-frame assembly to the spectrum analyzer left-side frame.
27. Remove the four screws (1) ([Figure 4-4 on page 194](#)) securing the CRT mounts to the deck.

Procedure 2B. A1 Front Frame/A18 CRT

28. Pull the cable tie (1) to free W9. See [Figure 4-6](#). Gently pry W9, the CRT cable, from the end of the CRT assembly.
29. Support the A18 CRT assembly while gently pulling the front frame and CRT out of the spectrum analyzer one or two inches.
30. Disconnect A18W1, the trace align wires, from A17J5. Remove the front-frame and CRT assemblies.
31. Gently pull the CRT assembly off of the front-frame assembly.

Figure 4-6 **Installing the CRT and Front-Frame Assemblies**

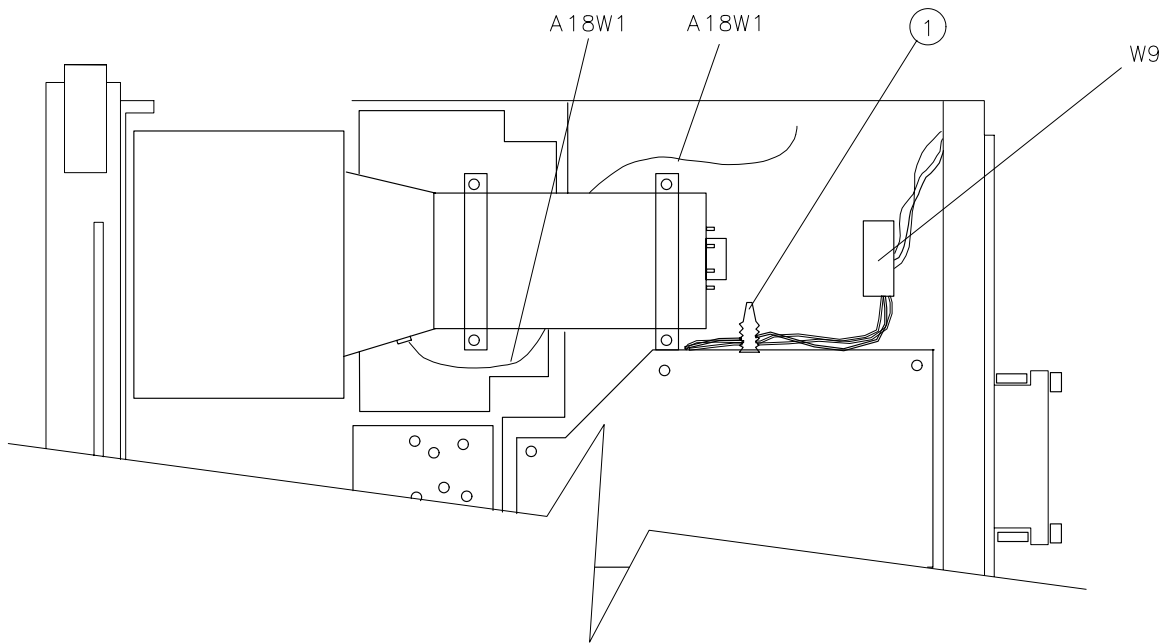

sm627e

Replacement

NOTE

Use care when handling the glass CRT EMI shield. The glass may be cleaned using thin-film cleaner (part number 8500-2163) and a lint-free cloth. When installing the glass shield, face the side of the glass with the silver coated edge towards the inside of the spectrum analyzer.

1. Place the spectrum analyzer on its right-side frame with the front end extending slightly over the front of the work bench.
2. Gently place the A18 CRT assembly into the A1 front-frame assembly as illustrated in [Figure 4-7 on page 198](#).
3. Place the front-frame and CRT assemblies into the spectrum analyzer, using caution to avoid pinching any cables.
4. Dress the A18W1 trace-align wires between the CRT assembly mounts and the A6 power supply top shield.

Figure 4-7 Placing the CRT into the Front Frame

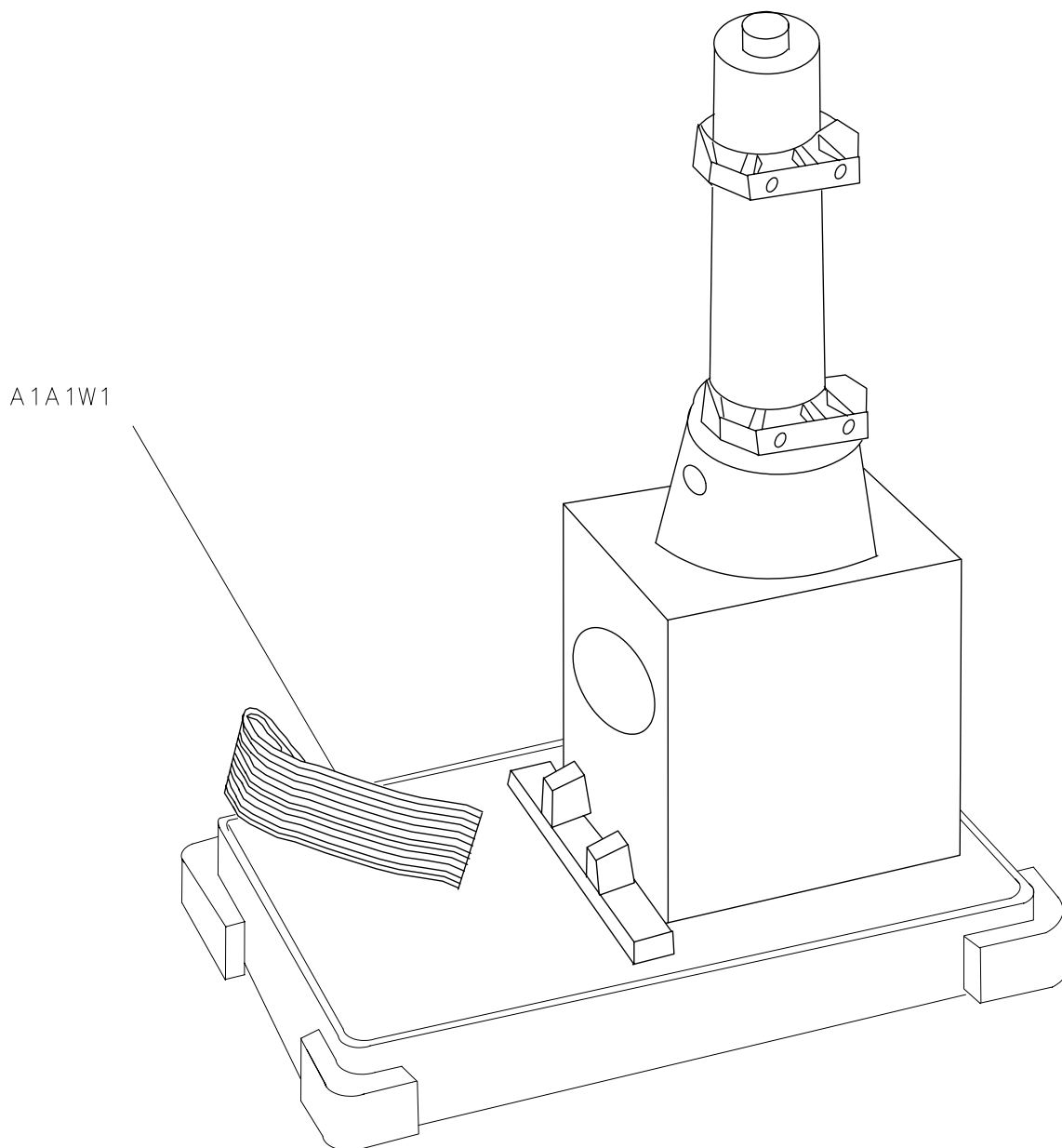

SK127

5. Connect A18W1 to A17J5.
6. Connect CRT cable W9 onto the end of the CRT assembly. Take care to avoid bending or damaging pins.
7. Fully seat the front frame and CRT assemblies into the spectrum analyzer.

8. Secure the front frame to the spectrum analyzer side frames, using three flathead screws per side. See [Figure 4-5 on page 195](#).
9. Retighten the four screws securing the CRT mounts to the deck.
10. Place W9 between the CRT assembly and the A6 power supply assembly top shield so that the W9 wires are below the surface of the top shield.
11. Connect W42 to A7J5 and the front panel 1ST LO OUTPUT connector.
12. Use a 9/16-inch nut driver to reconnect CAL OUTPUT connector to the front panel.
13. Connect the VOLUME potentiometer and knob to the front panel.
14. Connect W36, coax 86, to the front panel IF INPUT connector.
15. Use a 5/16-inch wrench to connect W41 to the A9 input attenuator and the front panel INPUT 50Ω connector.
16. Place LED A1W1DS1 into the line-power switch assembly.
17. Attach the line switch assembly into the front-frame using one panhead screw. Be sure to connect the line-power switch ground lug with the screw. The screw is captive.
18. Fold up the A14 and A15 assemblies as described in [“Procedure 9. A14 and A15 Assemblies,”](#) steps 3 through 5.
19. Place the spectrum analyzer top-side-up on the work bench and connect A1A1W1 to A3J602.
20. Snap post-accelerator cable A6A1W3 to the A18 CRT assembly.
21. Snap the black grommet protecting the A6A1W3 into the CRT shield.
22. Fold up assemblies A2, A3, A4, and A5 as described in [“Procedure 5. A2, A3, A4, and A5 Assemblies,”](#) steps 6 through 12.
23. Replace the spectrum analyzer cover assembly.
24. Connect the line-power cord and switch on the spectrum analyzer power. If the display does not operate properly, turn off spectrum analyzer power, disconnect the line cord, and recheck the spectrum analyzer.

Procedure 3. A1A1 Keyboard/Front Panel Keys

Removal

1. Remove the front frame from the spectrum analyzer. Place the front frame face down on the bench. For 8564EC and 8565EC instruments, follow the instructions in “[Procedure 2A. A1 Front Frame/A18 LCD \(8564EC and 8564EC\).](#)” For 8564E and 8565E instruments, follow the instructions in “[Procedure 2B. A1 Front Frame/A18 CRT.](#)”

For 8564EC and 8565EC instruments, proceed to step 3. For 8564E and 8565E instruments, proceed to step 2.

2. Remove the front frame center support.
3. Disconnect A1W1 from A1A1J3 and the RPG cable from A1A1J2.
4. Remove the nine screws holding the A1A1 keyboard assembly to the front frame and remove the assembly.
5. Remove the rubber keypad.

NOTE

In 8564E and 8565E instruments, the front panel softkey actuators are part of the CRT bezel assembly and are not replaceable. Should the softkeys become damaged, replace the bezel assembly.

Replacement

1. Install the rubber keypad, ensuring that the screw holes are visible through the pad.
2. Place the A1A1 keyboard assembly over the rubber keypad. Secure with nine panhead screws.
3. Connect the RPG cable to A1A1J2, and A1W1 to A1A1J3.

For 8564EC and 8565EC instruments, proceed to step 5. For 8564E and 8565E instruments, proceed to step 4.

4. Secure the center support to the front frame using two panhead screws. The arrow stamped on the center support should point to the top of the frame.
5. Install the front frame assembly. For 8564EC and 8565EC instruments, follow the instructions in “[Procedure 2A. A1 Front Frame/A18 LCD \(8564EC and 8564EC\).](#)” For 8564E and 8565E instruments, follow the instructions in “[Procedure 2B. A1 Front Frame/A18 CRT.](#)”

Procedure 4. A1A2 RPG

Removal

1. Remove the A9 input attenuator as described in “[Procedure 8. A7 through A13 Assemblies.](#)”
2. Disconnect the RPG cable from the A1A1 keyboard assembly.
3. If the serial number of your instrument is equal to or above 3738A00929 (8564E/EC) or 3738A00768 (8565E/EC) proceed to [step a](#). If the serial number of your instrument is below 3738A00929 (8564E) or 3738A00768 (8565E) proceed to [step b](#).
 - a. Pull the front panel RPG knob off of the face of the front panel of the spectrum analyzer. Proceed to [step 4](#).
 - b. Remove the set screw from the front panel RPG knob using a number 6 hex (Allen) wrench. Proceed to [step 4](#).
4. Use a 7/16-inch nut driver, set to 20-in./lbs., to remove the nut holding the RPG shaft to the front panel.
5. Remove the RPG.

Replacement

1. Place the RPG into the front frame with the cable facing the bottom of the spectrum analyzer. Place a lock washer and nut on the RPG shaft to hold it in the frame. If the serial number of your instrument is below 3738A00929 (8564E) or 3738A00768 (8565E) proceed to [step a](#). Otherwise, proceed to [step 2](#).
 - a. Insert the set screw into the RPG knob using a number 6 hex (Allen) wrench. Proceed to [step 2](#).
2. Use a 7/16-inch nut driver to secure the RPG assembly to the front frame.
3. Connect the RPG cable to A1A1J2.
4. Insert the RPG knob into the front panel assembly.
5. Replace the A9 input attenuator as described in “[Procedure 8. A7 through A13 Assemblies.](#)”

Procedure 5. A2, A3, A4, and A5 Assemblies

Removal

1. Remove the spectrum analyzer cover.
2. Place the spectrum analyzer on its right side frame.
3. Remove the eight screws holding the A2, A3, A4, and A5 assemblies to the top of the spectrum analyzer. These screws are labeled (2), (3), and (4) in [Figure 4-8 on page 203](#). They are also labeled on the back of the A2 board assembly.
4. Remove ribbon cable W4 from A2J6. See [Figure 4-8 on page 203](#).

CAUTION

Do not fold the board assemblies out of the spectrum analyzer one at a time. Always fold the A2 and A3 assemblies as a unit and the A4 and A5 assemblies as a unit. Folding out one assembly at a time binds the hinges attaching the assemblies and may damage an assembly and hinge.

5. The board assemblies are attached to the right side frame of the spectrum analyzer with two hinges. Fold both the A2 and A3 assemblies out of the spectrum analyzer as a unit.
6. Fold both the A4 and A5 assemblies out of the spectrum analyzer as a unit.
7. Remove the cables from the assembly being removed, as illustrated in [Figure 4-9 on page 204](#).
8. Remove the two screws that attach the assembly being removed to its two mounting hinges.

CAUTION

Do not torque shield TORX screws to more than 8 inch-pounds. Applying excessive torque will cause the screws to stretch.

NOTE

Diagrams that illustrate features common to E-series and EC-series instruments are shown with E-series instruments. Where there are differences between E-series and EC-series features separate diagrams are provided.

Figure 4-8 A2, A3, A4, and A5 Assembly Removal

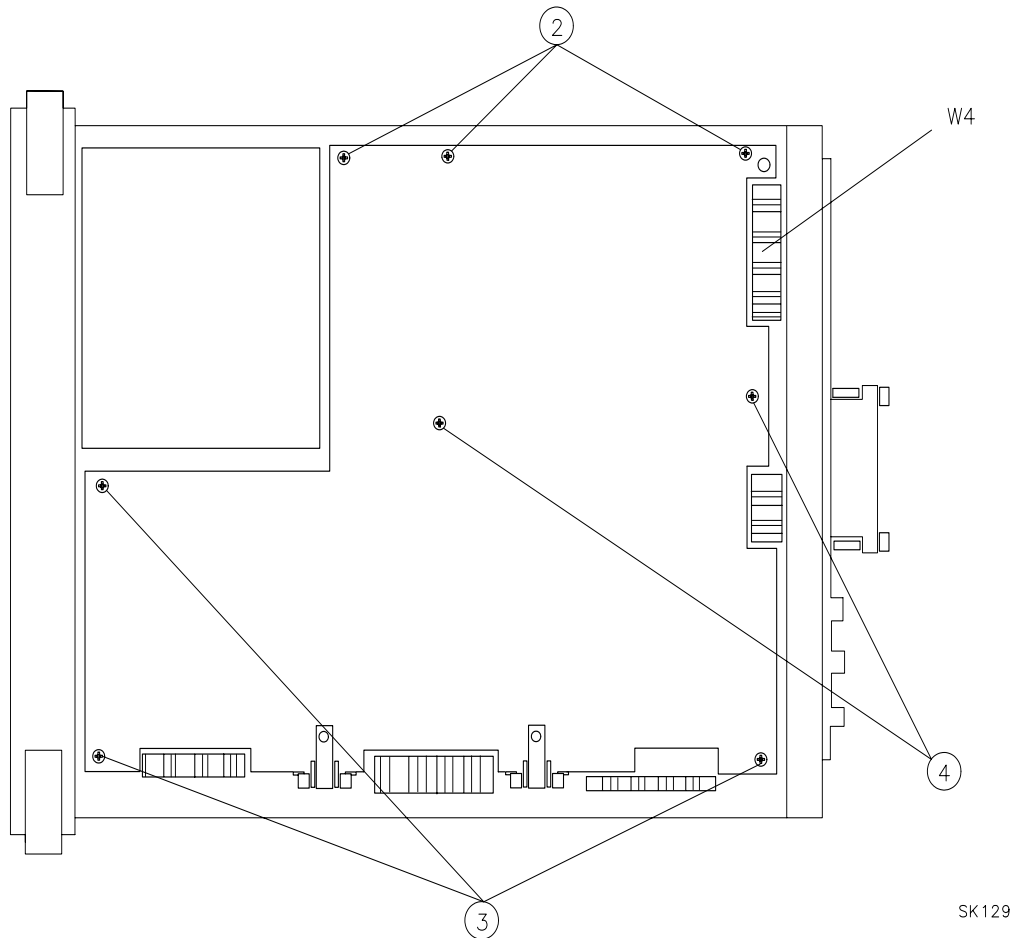

SK129

Replacement

1. Place the spectrum analyzer on its right side on the work bench.
2. Attach the assembly being installed to the two chassis hinges with two panhead screws.
3. Leave the assembly in the folded-out position and attach ribbon cables W1 and W2.
4. Attach all cables to the assembly, as illustrated in [Figure 4-9 on page 204](#).
5. Locate the cable clip on the inside of the right side frame. Make sure that the coaxial cables are routed properly on the clip as illustrated in [Figure 4-12 on page 206](#) for EC-series instruments, and in [Figure 4-13 on page 207](#) for E-series instruments.

Assembly Replacement
Procedure 5. A2, A3, A4, and A5 Assemblies

- Lay the A2, A3, A4, and A5 assemblies flat against each other in the folded-out position. Make sure that no cables become pinched between the two assemblies.

Figure 4-9 Assembly Cables (1 of 3) – EC- Series

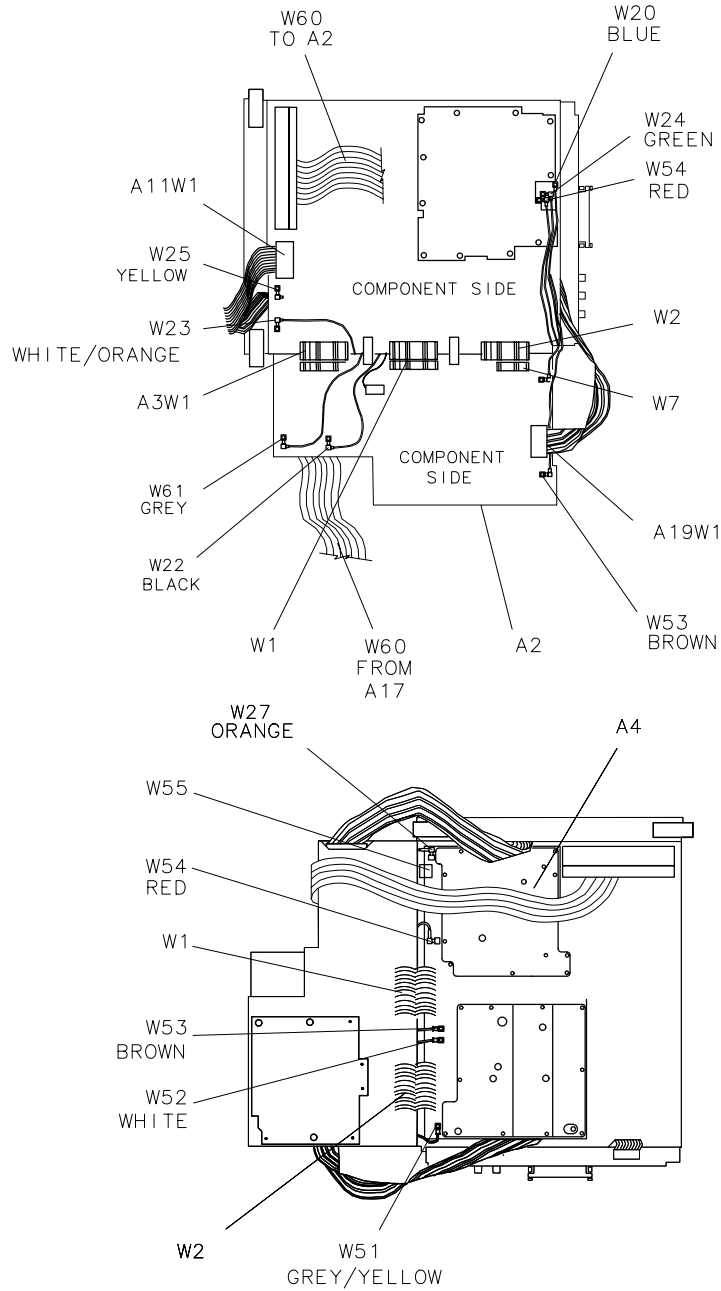

sp119c

Figure 4-10 Assembly Cables (2 of 3) – EC-series

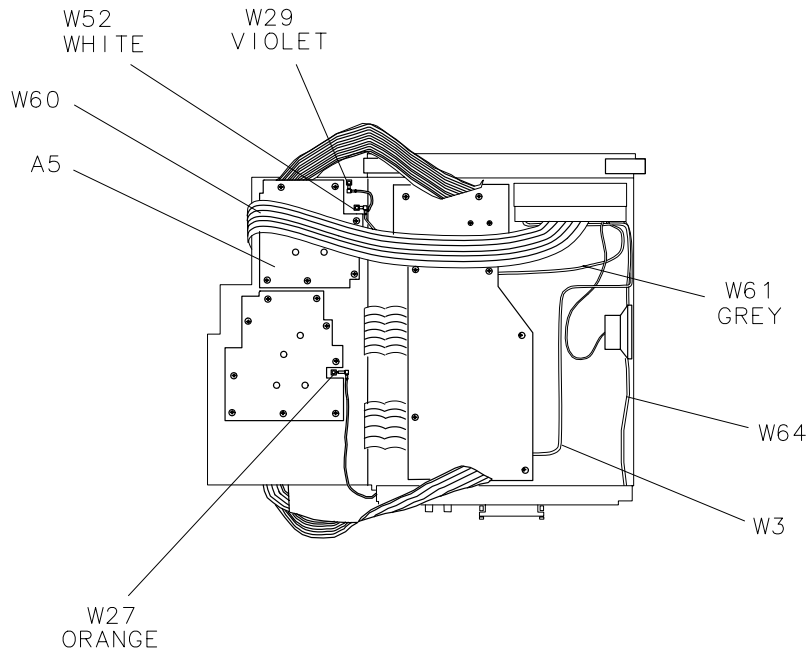

s1113c

Figure 4-11 Assembly Cables (3 of 3)– E-series

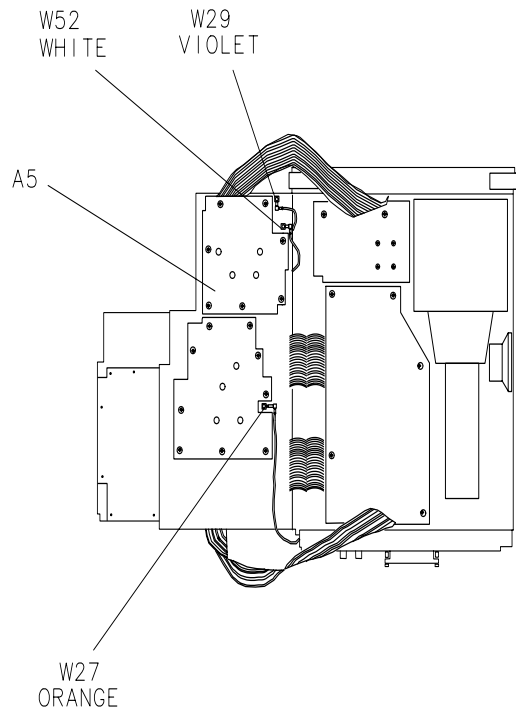

s118e

Figure 4-12 Coaxial Cable Clip – EC-Series

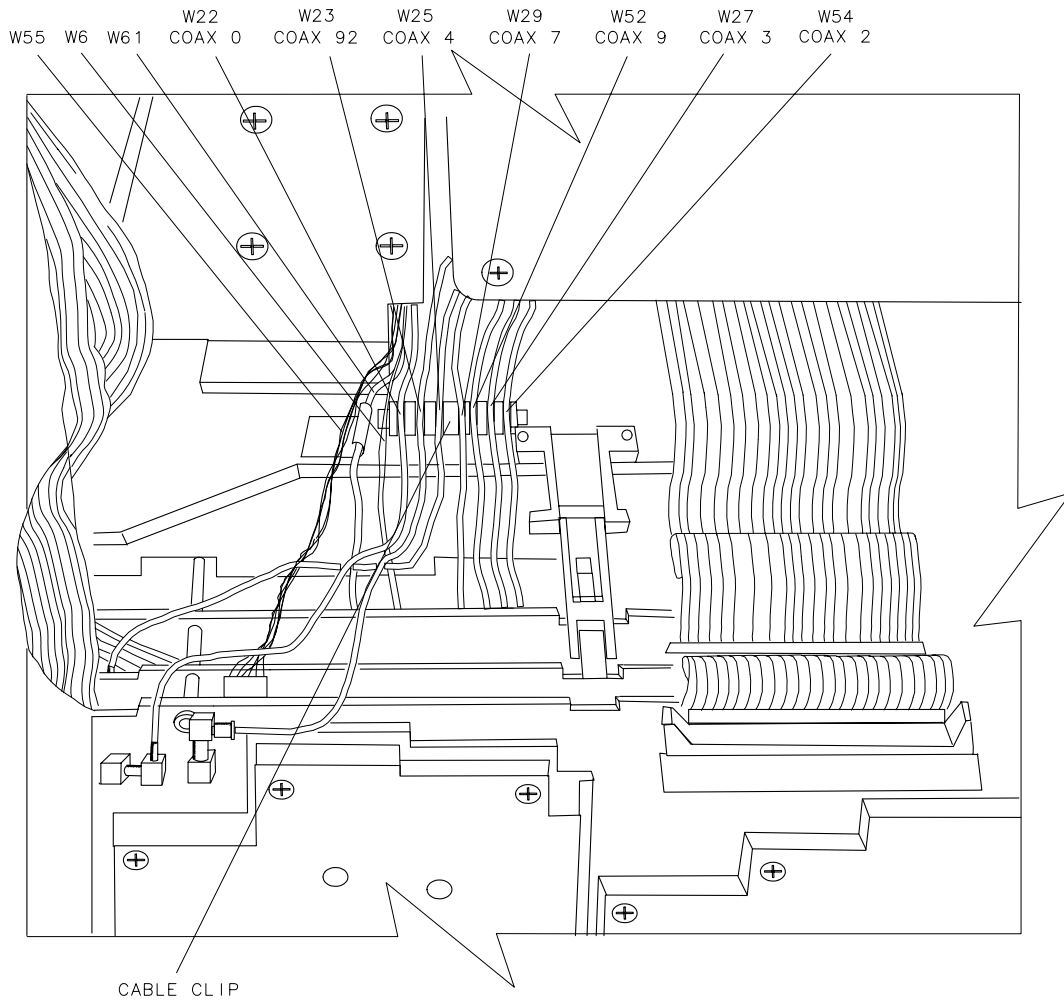

s1121c

7. Check to ensure that no cables will become pinched under the hinges when folding up the A4 and A5 assemblies.

8. Fold the A4 and A5 assemblies together as a unit into the spectrum analyzer. Use caution to avoid damaging any cable assemblies. The standoffs on the A5 assembly must fit into the cups on the A6 power supply top shield.
9. Fold the A2 and A3 assemblies together as a unit into the spectrum analyzer. Be sure to fold GPIB cable A19W1 between the A3 and A4 assemblies, using the two sets of hook and loop (Velcro) fasteners.
10. Fold ribbon cable A1A1W1 between A3 and A4 assemblies. Take care to dress the protective tubing as close to A3J602 connector as possible, so that the tubing does not fold with the cable. See [Figure 4-14 on page 208](#).
11. Attach ribbon cable W4 to A2J6 while folding up the assemblies.
12. Secure the assemblies using the eight screws removed in "Removal," step 3. See [Figure 4-8 on page 203](#).

Figure 4-13 Coaxial Cable Clip – E-Series

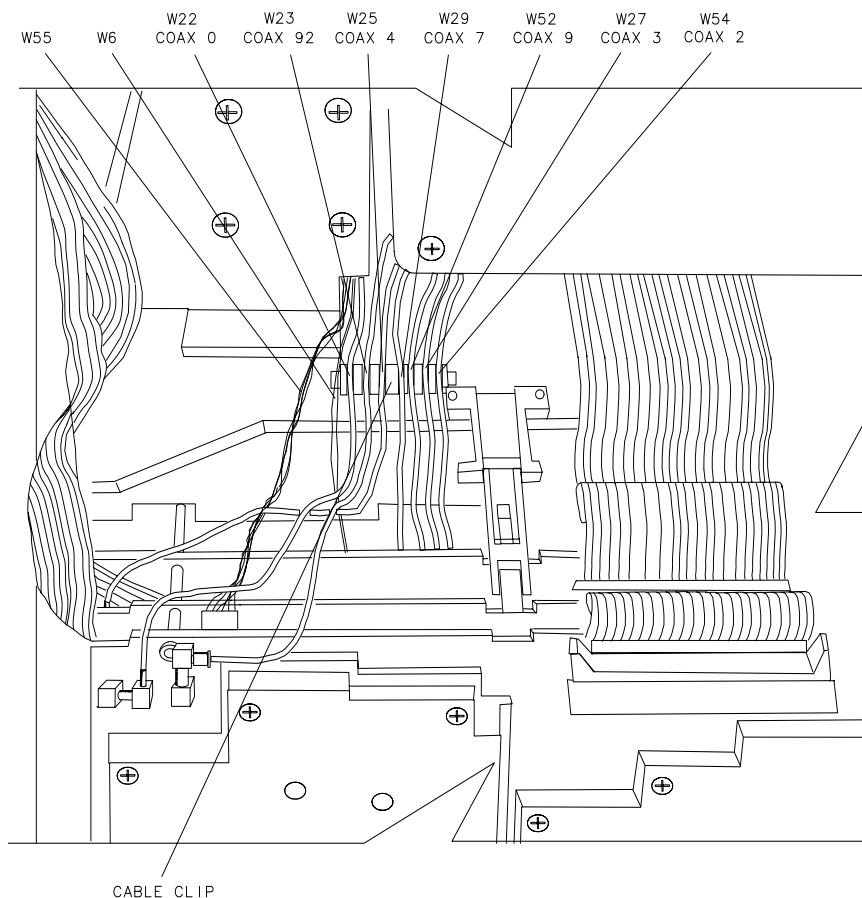

s119e

Figure 4-14 GPIB and A1A1 W1 Cable Placement

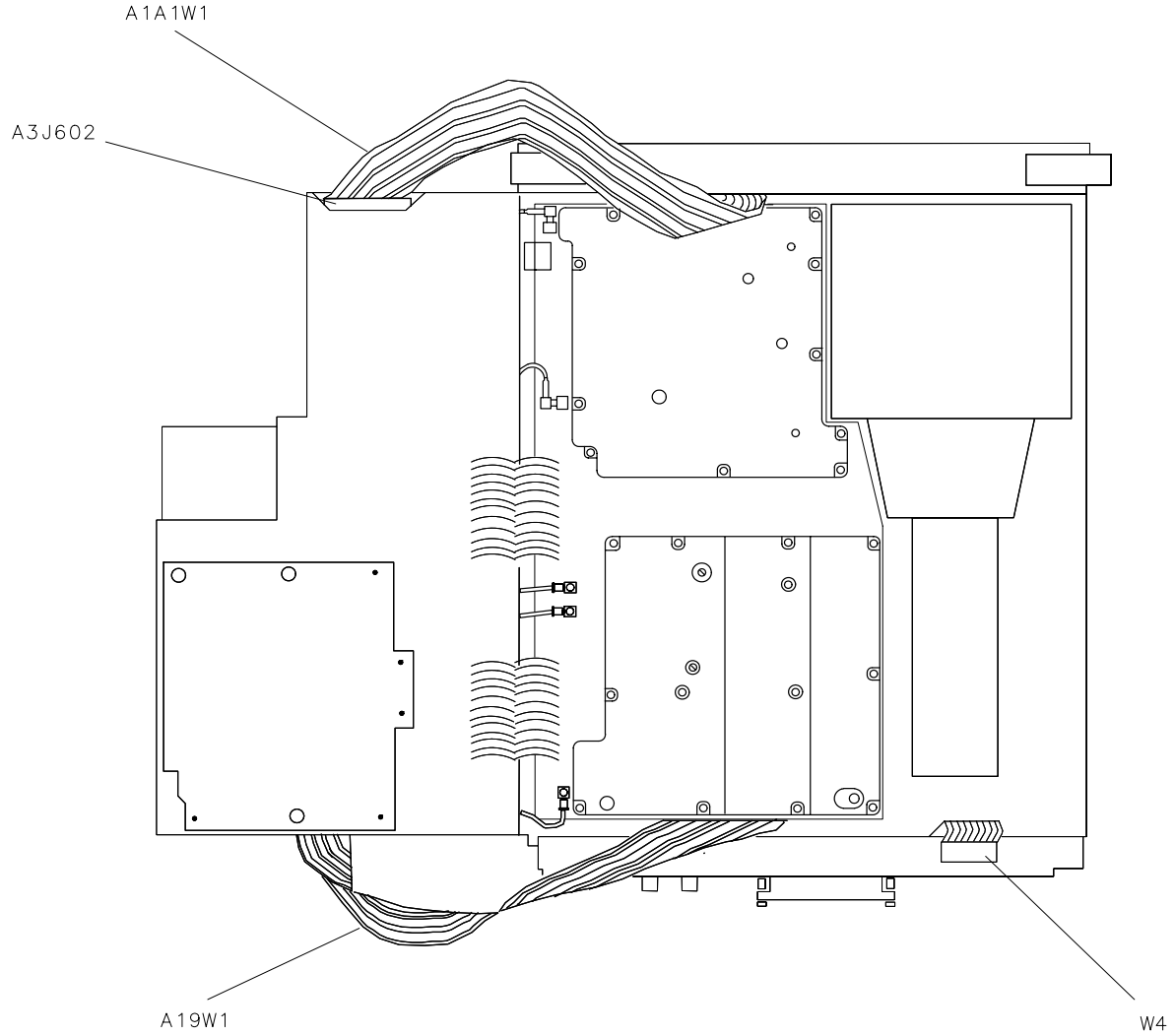

SK133

Procedure 6A. A6 Power Supply Assembly (8564EC and 8565EC)

Removal

WARNING

The A6 Power Supply assembly contains lethal voltages with lethal currents in all areas. Use extreme care when servicing this assembly. Always disconnect the power cord from the instrument before beginning this replacement procedure. Failure to follow this precaution will represent a shock hazard which may result in personal injury.

1. Disconnect the power cord from the spectrum analyzer.
2. Remove the spectrum analyzer cover assembly. Refer to [“Procedure 1. Spectrum Analyzer Cover.”](#)
3. Fold out the A2, A3, A4, and A5 assemblies as described in steps 2 through 6 under [“Procedure 5. A2, A3, A4, and A5 Assemblies.”](#)
4. Place the spectrum analyzer on the workbench with A2, A3, A4, and A5 folded out to the right.
5. Remove the three screws securing the power supply shield to the power supply and remove the shield. See [Figure 4-16 on page 211](#).
6. Disconnect all cables from the A6 power supply assembly. See [Figure 4-17 on page 214](#).
7. Use a T-10 TORX driver to remove the screws from the shield wall, the heatsink, the base of the power supply (0515-1950) and the A6 power supply assembly.
8. Remove the A6 power supply assembly by lifting from the regulator heatsink toward the front of the spectrum analyzer.

Figure 4-15 **Power Supply Cover**

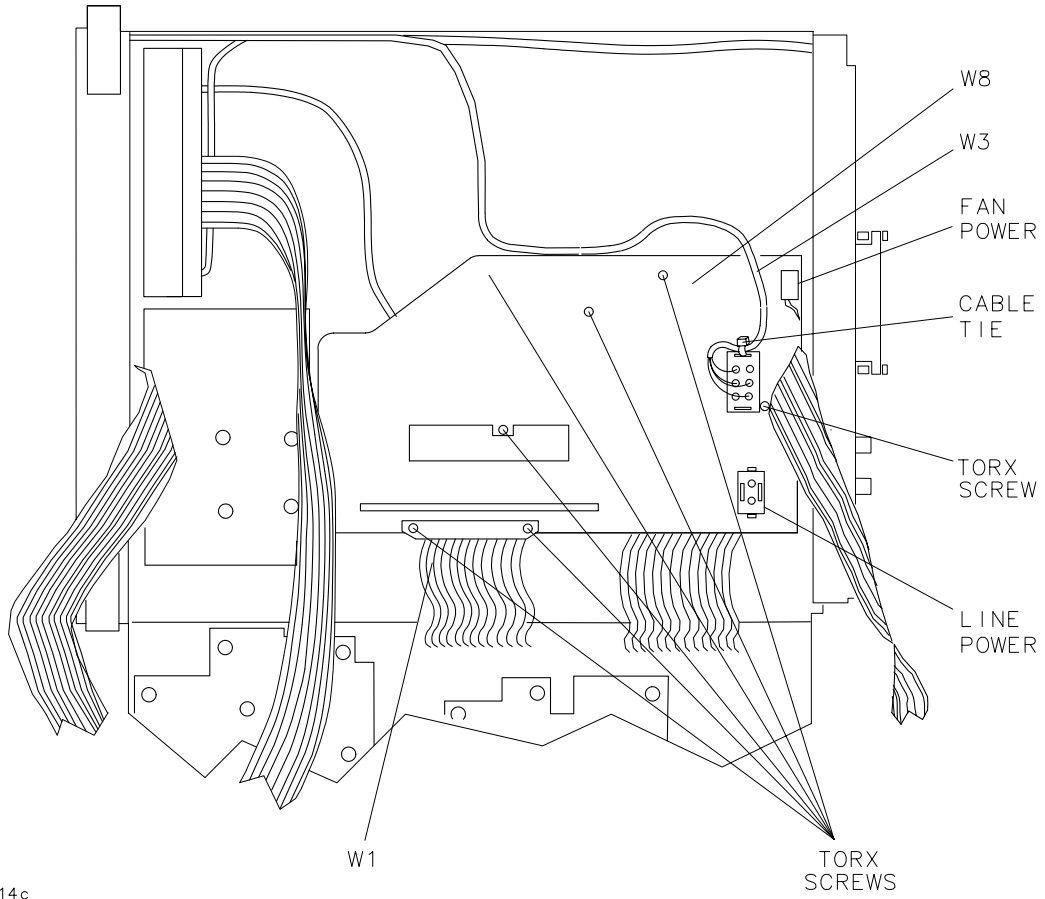

s1114c

Replacement

1. Ensure that the bottom shield wall is in place before replacing the A6 power supply assembly.
2. Attach the A6 power supply assembly to the spectrum analyzer chassis and top shield wall using the four screws, torqued to 10-inch lbs. Attach all other screws, torqued to 6-inch lbs.
3. Connect W1 to A6J1, W3 to A6J2, fan power wires to A6J3, W8 to A6J4, and the line-power jack to A6J101. See [Figure 4-17 on page 214](#).
4. Ensure that all cables are safely routed and will not be damaged when securing the A6 cover.
5. Secure the power supply cover shield to the power supply using three flathead screws (1). See [Figure 4-16 on page 211](#). One end of the cover fits into a slot provided in the rear frame assembly. Ensure that the extended portion of the cover shield is seated in the shield wall groove.
6. Fold the A2, A3, A4, and A5 assemblies into the spectrum analyzer as described in steps 6 through 12 under “[Procedure 5. A2, A3, A4, and A5 Assemblies.](#)”

Figure 4-16 Power Supply Cover

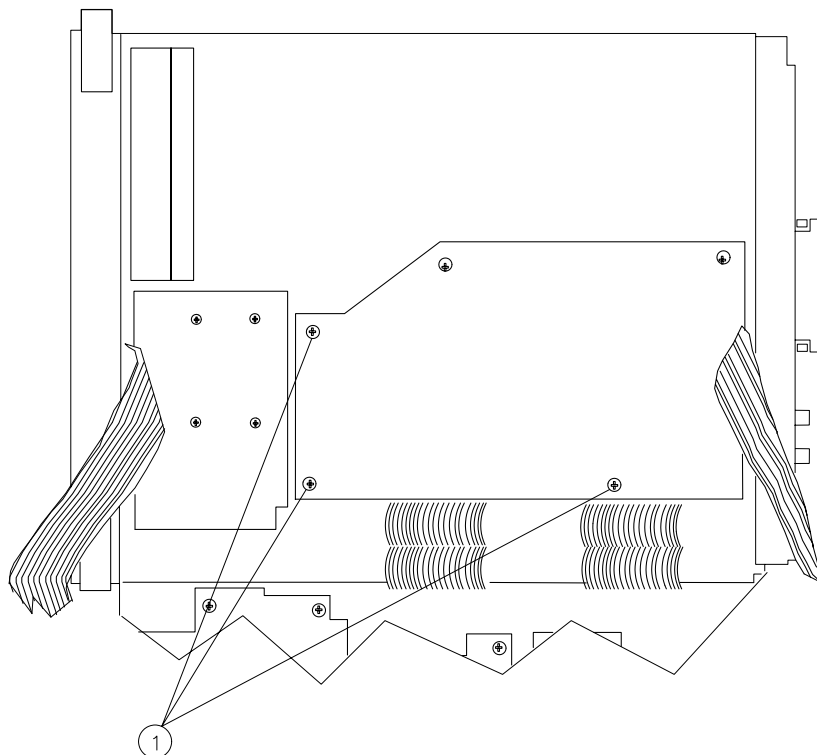

sp122c

Procedure 6B. A6 Power Supply Assembly (8564E and 8565E)

Removal

WARNING

The A6 power supply and A6A1 high voltage assemblies contain lethal voltages with lethal currents in all areas. Use extreme care when servicing these assemblies. Always disconnect the power cord from the instrument before beginning this replacement procedure. Failure to follow this precaution will present a shock hazard which may result in personal injury.

1. Disconnect the power cord from the spectrum analyzer.
2. Remove the spectrum analyzer cover assembly. Refer to [“Procedure 1. Spectrum Analyzer Cover.”](#)
3. Fold out the A2, A3, A4, and A5 assemblies as described in [“Procedure 5. A2, A3, A4, and A5 Assemblies,”](#) steps 2 through 6.
4. Place the spectrum analyzer top-side-up on the work bench with A2, A3, A4, and A5 folded out to the right.

WARNING

The voltage potential at A6A1W3 is +9 kV. Disconnect at the CRT with caution! Failure to properly discharge A6A1W3 may result in *severe electrical shock* to personnel and damage to the instrument.

5. Connect the spectrum analyzer line-power cord to provide proper grounding while discharging the A6A1W3 post-accelerator cable. Make sure that the spectrum analyzer line-power switch is in the off position.
6. Connect a high voltage probe (1000:1), such as the 34111A to a voltmeter with a 10 megohm input.
7. Connect the clip lead of the probe (ground) to the chassis of the spectrum analyzer.
8. Slip the tip of the high voltage probe under the A6A1W3 post-accelerator cable rubber shroud to obtain a reading on the voltmeter. See [Figure 4-3 on page 193](#).
9. Keep the high voltage probe on the post-accelerator connector until the voltage has dropped to a voltmeter reading of less than 5 mV (less than 5 V at the connector). This normally takes about 30 seconds.
10. Disconnect the line-power cord from the spectrum analyzer.

11. Using a small screwdriver with the shank in contact with the CRT shield assembly, slip the tip of the screwdriver under the A6A1W3 post-accelerator cable rubber shroud and short the cable to ground on the CRT shield assembly. See [Figure 4-3 on page 193](#).
12. Remove the three screws (1) securing the power supply shield to the power supply and remove the shield. See [Figure 4-18 on page 215](#).
13. Remove the three screws securing the A6A1 high voltage assembly to the A6 power supply assembly.
14. Disconnect ribbon cable A6A1W1 from A6J5 and lift the A6A1 assembly out of the way. See [Figure 4-17 on page 214](#).
15. Disconnect all cables from the A6 power supply assembly. See [Figure 4-17 on page 214](#).
16. Use a TORX screwdriver to remove the hardware from the shield wall, the heatsink, and the A6 power supply assembly.
17. Remove the A6 power supply assembly by lifting from the regulator heatsink toward front of spectrum analyzer.

Replacement

1. Ensure that the bottom shield wall is in place before replacing the A6 power supply assembly.
2. Attach the A6 power supply assembly to the spectrum analyzer chassis and top shield wall using the four screws.
3. Connect W1 to A6J1, W3 to A6J2, fan power wires to A6J3, W8 to A6J4, and the line-power jack to A6J101. See [Figure 4-17 on page 214](#).
4. Secure the A6A1 high voltage assembly to the A6 power supply assembly, using three panhead screws. Connect ribbon cable A6A1W1 to A6J5.
5. Snap post-accelerator cable A6A1W3 to the CRT assembly.

Figure 4-17 A6 Power Supply Connections

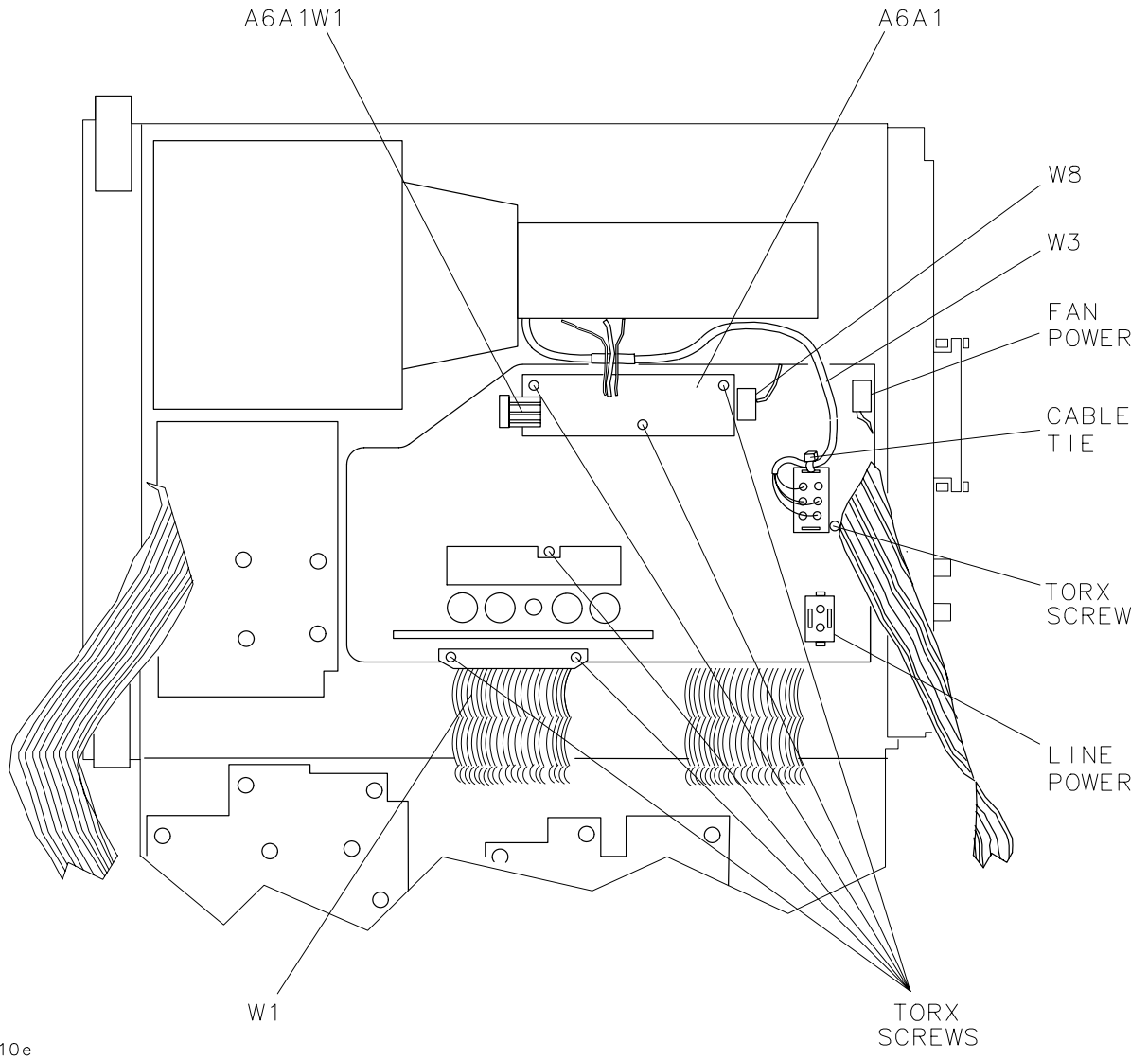

s1110e

6. Ensure that all cables are safely routed and will not be damaged when securing the A6 cover.

7. Secure the power supply cover shield to the power supply using three flathead screws (1). See [Figure 4-18 on page 215](#). One end of the cover fits into a slot provided in the rear frame assembly. Ensure that the extended portion of the cover shield is seated in the shield wall groove.
8. Fold the A2, A3, A4, and A5 assemblies into the spectrum analyzer as described in “[Procedure 5. A2, A3, A4, and A5 Assemblies,](#)” steps 6 through 12.

Figure 4-18 **Power Supply Cover**

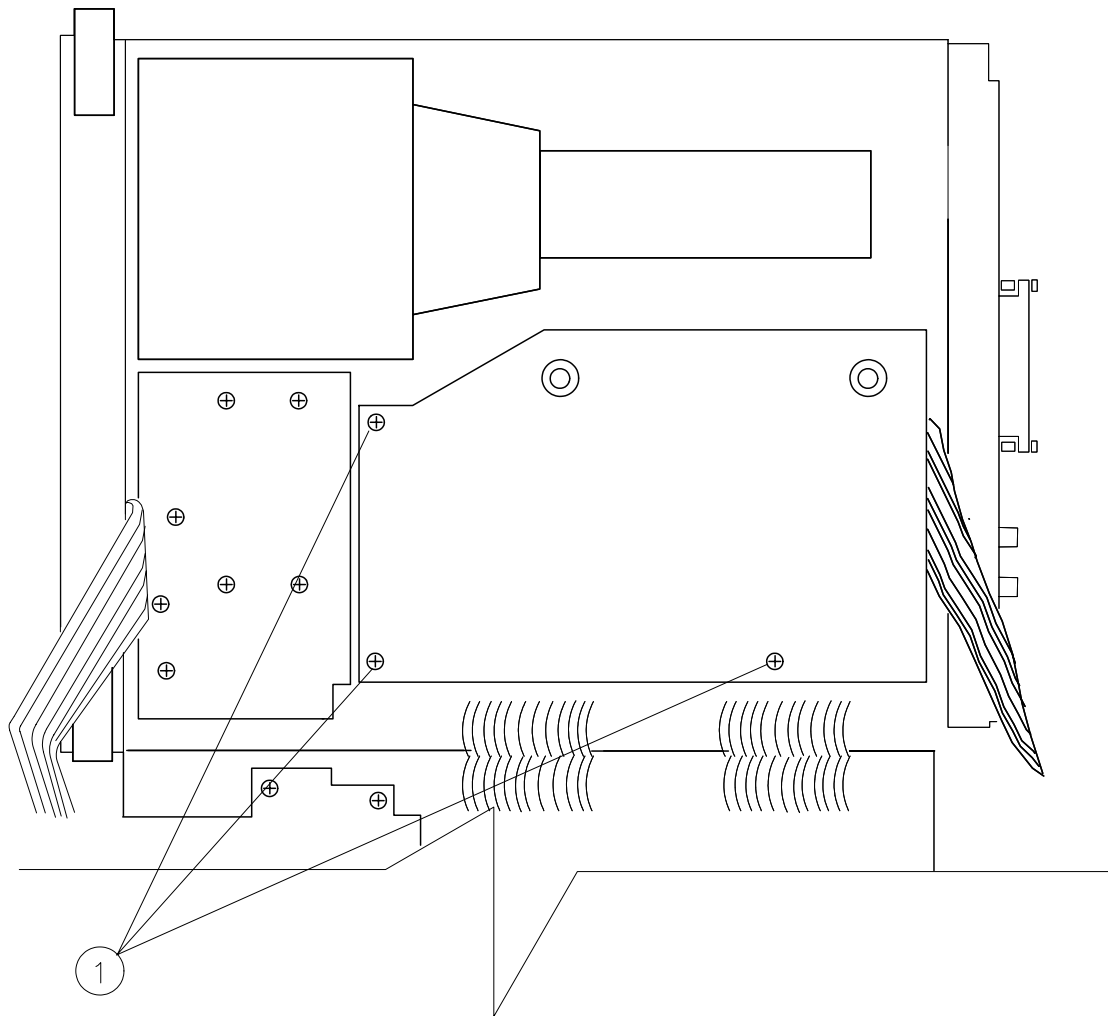

Procedure 7. A6A1 High Voltage Assembly (8564E and 8565E)

Removal

WARNING

The A6 power supply and A6A1 high voltage assemblies contain lethal voltages with lethal currents in all areas. Use extreme care when servicing these assemblies. Always disconnect the power cord from the instrument before beginning this replacement procedure. Failure to follow this precaution can represent a shock hazard which may result in personal injury.

1. Disconnect the power cord from the spectrum analyzer.
2. Remove the spectrum analyzer cover assembly as described in [“Procedure 1. Spectrum Analyzer Cover.”](#)
3. Fold out the A2, A3, A4, and A5 assemblies as described in [“Procedure 5. A2, A3, A4, and A5 Assemblies.”](#)
4. Place the spectrum analyzer top-side-up on the work bench.

WARNING

The voltage potential at A6A1W3 is +9 kV. Disconnect at the CRT with caution! Failure to properly discharge A6A1W3 may result in *severe electrical shock* to personnel and damage to the instrument.

5. Connect the spectrum analyzer line-power cord to provide proper grounding while discharging the A6A1W3 post-accelerator cable. Make sure that the spectrum analyzer line-power switch is in the off position.
6. Connect a high voltage probe (1000:1), such as the 34111A to a voltmeter with a 10 megohm input.
7. Connect the clip lead of the probe (ground) to the chassis of the spectrum analyzer.
8. Slip the tip of the high voltage probe under the A6A1W3 post-accelerator cable rubber shroud to obtain a reading on the voltmeter. See [Figure 4-3 on page 193](#).
9. Keep the high voltage probe on the post-accelerator connector until the voltage has dropped to a voltmeter reading of less than 5 mV (less than 5 V at the connector). This normally takes about 30 seconds.
10. Disconnect the line-power cord from the spectrum analyzer.

11. Using a small screwdriver with the shank in contact with the CRT shield assembly, slip the tip of the screwdriver under the A6A1W3 post-accelerator cable rubber shroud and short the cable to ground on the CRT shield assembly. See [Figure 4-3 on page 193](#).
12. Pry out the black grommet protecting post-accelerator cable A6A1W3 from the CRT shield assembly.
13. Carefully unsnap the A6A1W3 post-accelerator cable from the CRT and discharge it by shorting the cable to chassis ground on the CRT shield assembly.
14. Remove the three screws (1) securing the power supply shield to the power supply and remove the shield. See [Figure 4-18 on page 215](#).
15. Remove the three screws securing the A6A1 high voltage assembly to the A6 power supply assembly.
16. Disconnect ribbon cable A6A1W1 from A6J5. See [Figure 4-17 on page 214](#).
17. *For Option 007 spectrum analyzers:* Remove the two screws (1) securing two board-mounting posts to the left side frame and remove the posts. See [Figure 4-19 on page 218](#).
18. Remove the two left side frame screws (2) securing the A17 assembly (and A16 assembly in Option 007). *For Option 007 spectrum analyzers:* Lift up the A16 FADC assembly and swing it out of the spectrum analyzer. Do not remove any cables.
19. Lift up the A17 CRT driver assembly and disconnect A6A1W2 from A17J6. Do not remove any other cables from the A17 assembly.
20. Disconnect the tie wraps from the A6A1 assembly cables and remove the A6A1 high voltage assembly from the spectrum analyzer.

Figure 4-19 A16 Fast ADC and A17 CRT Driver Mounting Screws

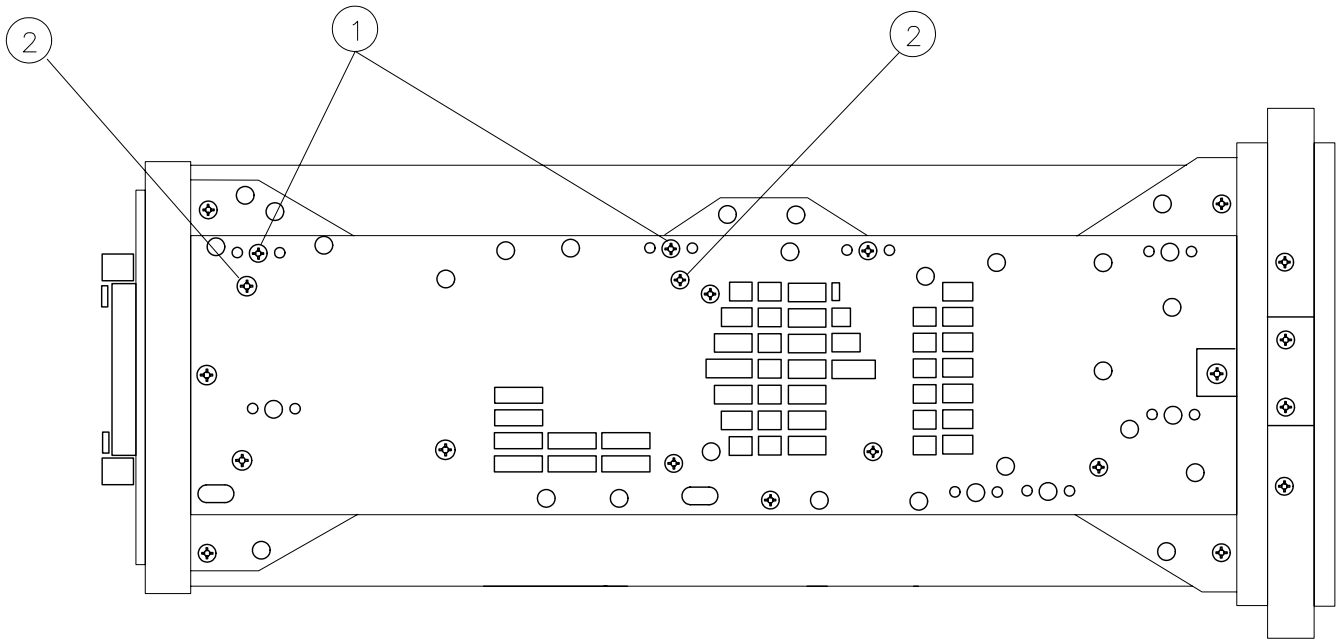

sz127e

Replacement

1. Secure the A6A1 high voltage assembly to the A6 power supply using three panhead screws. Connect ribbon cable A6A1W1 to A6J5.
2. Snap post-accelerator cable A6A1W3 to the CRT assembly.
3. Place the black grommet protecting the post-accelerator cable into the CRT shield.
4. Ensure that all cables are safely routed and will not be damaged when securing the A6 cover.
5. Secure the power supply cover shield to the power supply using three flathead screws (1). See [Figure 4-18 on page 215](#). One end of the cover fits into a slot provided in the rear frame assembly. Ensure that the extended portion of the cover shield is seated in the shield wall groove.
6. Connect A6A1W2 to A17J6.
7. Place the A17 CRT Driver assembly into the center-deck mounting slot nearest the CRT. Use caution when routing cables to avoid damage.

8. *For Option 007 spectrum analyzers:* Place the A16 FADC assembly into the center-deck mounting slot nearest the left side frame. Ensure that the A16 FADC assembly is properly seated in the right end of the slot.
9. Secure the A17 assembly (and A16 assembly in Option 007) with the two flathead screws removed in step 18 under "Removal." See [Figure 4-19 on page 218 \(2\)](#).
10. *For Option 007 spectrum analyzers:* Connect the two mounting posts to the left-side frame using the two screws removed in step 17 under "Removal." See [Figure 4-19 on page 218 \(1\)](#).
11. Fold the A2, A3, A4, and A5 assemblies into the spectrum analyzer and secure the spectrum analyzer cover assembly as described in ["Procedure 5. A2, A3, A4, and A5 Assemblies."](#)

Procedure 8. A7 through A13 Assemblies

A separate replacement procedure is supplied for each assembly listed below: *

- A7 LO Multiplier/Amplifier (LOMA)
- A8 Low Band Mixer
- A9 Input Attenuator
- A10/A12 RYTHM/SBTX
- A11 YTO
- A13 Second Converter

Before beginning a procedure, do the following:

1. Fold out the A14 and A15 assemblies as described in “[Procedure 9. A14 and A15 Assemblies.](#)”
2. If the A9 input attenuator, A11 YTO, or A10/A12 RYTHM/SBTX assembly is being removed, also fold down the A2, A3, A4, and A5 assemblies as described in “[Procedure 5. A2, A3, A4, and A5 Assemblies.](#)”

Use [Figure 4-20 on page 221](#) to locate the assemblies and cables called out in this procedure.

NOTE

Use a torque wrench to tighten all SMA connectors to 113 Ncm (10 in-lb). part number 8710-1655 can be used for this purpose. The style of torque wrench may vary, but in all cases do not tighten the connectors beyond the point at which the torque wrench "clicks" or "breaks-away."

Figure 4-20 8564E/EC and 8565E/EC Assembly Locations

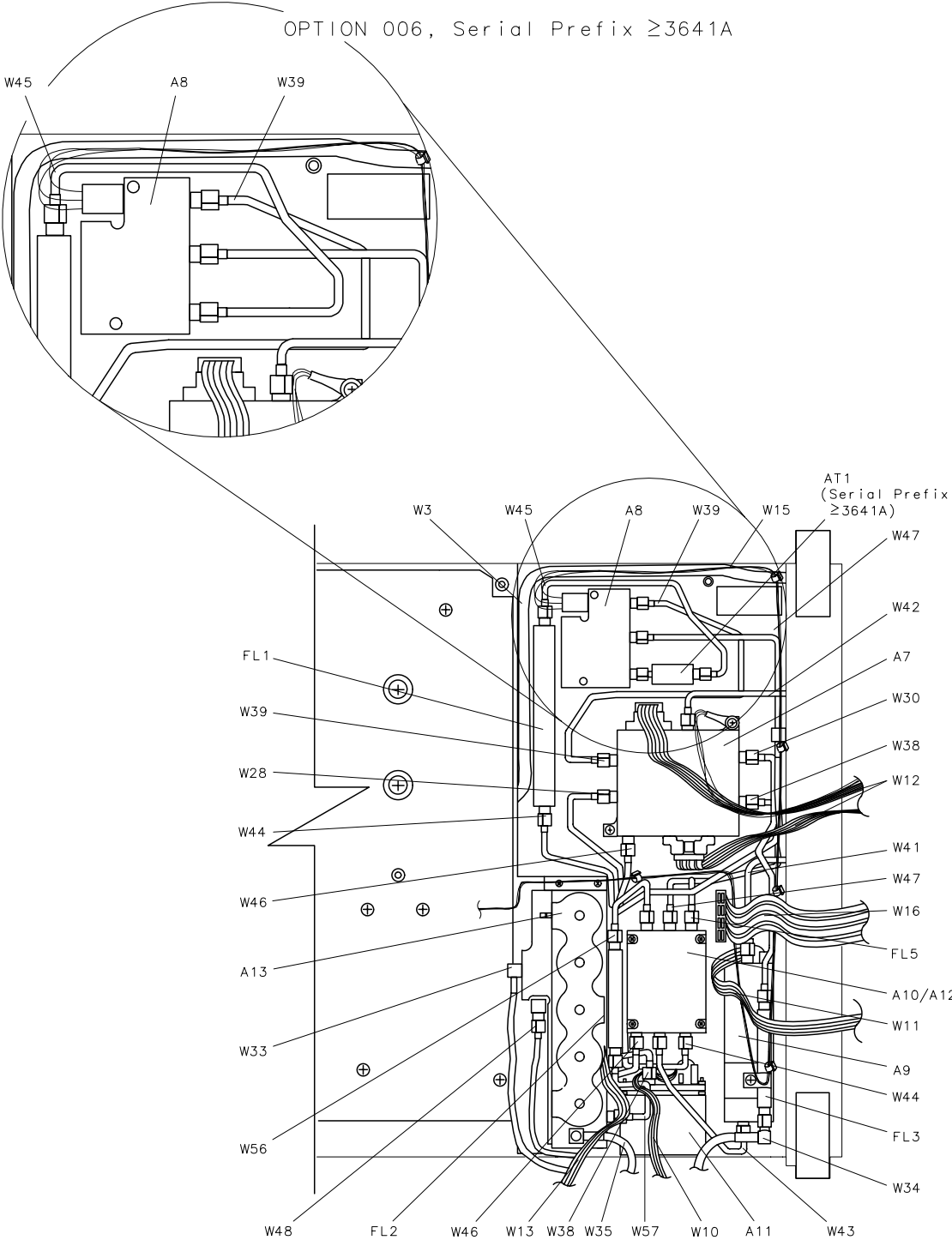

sm15e

A7 LO Multiplier/Amplifier (LOMA)

Removal

1. Remove the two screws securing the A7 assembly to the spectrum analyzer center deck.
2. Use a 5/16-inch wrench to disconnect W46, W28, W39, W42, W30, and W38 from the A7 assembly.
3. Remove W12 from the A7 assembly (two ribbon cable connectors and ground lug).
4. Remove the A7 assembly.

Replacement

1. Use a 5/16-inch wrench to attach W46, W28, W39, W42, W30, and W38 to the A7 assembly.
2. Connect cable W12 (both ribbon cable connectors) to the A7 assembly.
3. Use two panhead screws to secure A7 to the center deck. Be sure to attach the ground lug on the screw near the J5 SAMPLER connector of A7.
4. Torque all RF cable connections to 113 Ncm (10 in-lb).

A8 Low Band Mixer

Removal

1. Place the spectrum analyzer upside-down on the work bench with A14 and A15 folded out to the left.
2. For analyzers having serial number prefix <3641A: Use a 5/16-inch wrench to remove W45 between FL1 and A8J1.

For analyzers having serial number prefix $\geq 3641A$, or Option H13: Use a 5/16-inch wrench to remove W45 between FL1 and AT1. (For Option 006, remove W45 between FL1 and A8J1.)
3. Loosen W47 and W39 at A8J2, and A8J3.
4. Remove the two screws securing A8 to the center deck.
5. Remove W47 and W39 from the A8 assembly.
6. Remove AT1 from A8J1, if present.
7. For analyzers having serial number prefix $\geq 3641A$, or Option H13: disconnect W15 from A8.

Replacement

1. For analyzers having Option H13, or serial number prefix $\geq 3641A$ without Option 006: connect AT1 to A8J1.
2. Place A8 on the center deck and attach W56 and W39, using caution to avoid damaging any of the center conductor pins in the cable.
3. Use two panhead screws to secure A8 to the center deck. Reconnect W45 to FL1 and A8J1, or AT1.
4. Torque all semirigid coax connections on A8, FL1, and AT1 (if present) to 113 Ncm (10 in-lb). Ensure that all cable connections are tight.
5. For analyzers having serial number prefix $\geq 3641A$, or Option H13: connect W15 to A8.

A9 Input Attenuator

Removal

1. Place the spectrum analyzer upside-down on the work bench.
2. Disconnect W16 ribbon cable from the A10/A12 assembly and move it out of the way.
3. Remove screw (1) and the cable clamp securing FL3 to the attenuator mounting bracket. See [Figure 4-21 on page 224](#).

Figure 4-21 A9 Attenuator Removal

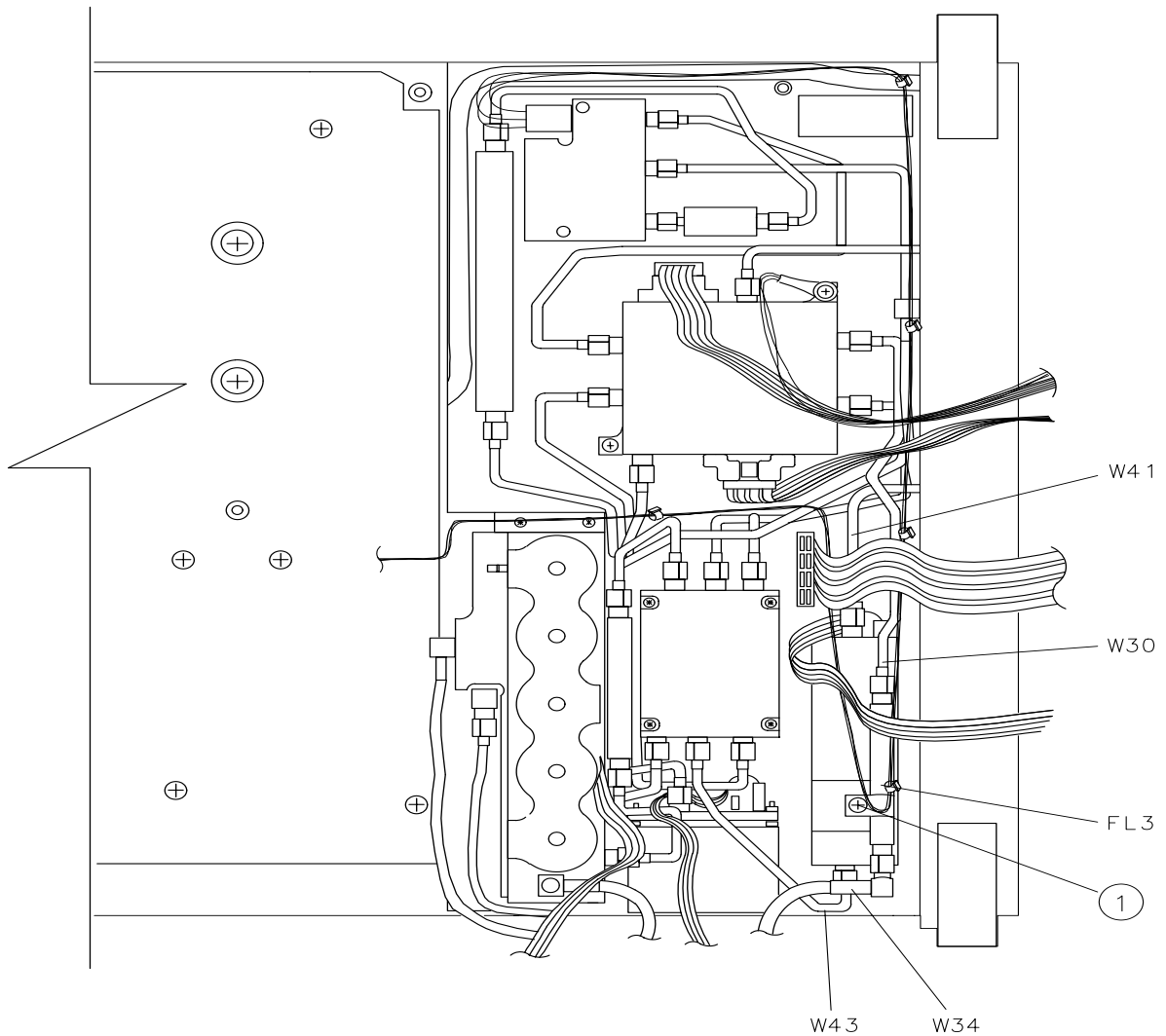

sm18e

4. Disconnect W30 from A7 and move this cable/filter out of the way.
5. Remove the three screws (2) securing the A9 input attenuator mounting bracket to the center deck. See [Figure 4-22 on page 226](#).
6. Loosen W43 from the attenuator connector, then disconnect the other end of W43 from A12J3 with a slight downward pressure to prevent damage to the center conductor pin.
7. Disconnect W41 from the front panel INPUT 50Ω connector, swinging the attenuator assembly upward to free the connection.
8. Remove the attenuator and disconnect the attenuator ribbon cable (W11), and the 2 semirigid coax cables (W41 and W43).
9. Remove the attenuator from the attenuator mounting bracket.

Replacement

1. Ensure that the bracket that secures the attenuator to the center deck is attached to the attenuator. For proper orientation of the attenuator when mounting the bracket, refer to [Figure 5-4 in chapter 5](#).
2. Connect the attenuator-control ribbon cable to the A9 input attenuator.
3. Loosely connect semirigid cable W43 to the attenuator assembly. See [Figure 4-21 on page 224](#).
4. Loosely connect semirigid cable W41 to the front panel RF INPUT connector.
5. Loosely connect the other end of W41 to the attenuator and swing the attenuator down into place.
6. Connect semirigid cable W43 to A12J3 and torque all semirigid cable connections to 113 Ncm (10 in-lb).
7. Attach the attenuator to the center deck with three panhead screws (2). See [Figure 4-22 on page 226](#).
8. Connect W30 to A7 and attach FL3 to the attenuator mounting bracket using a small cable clamp and one panhead screw (1). See [Figure 4-21 on page 224](#). Torque the connections to W30 and FL3 to 113 Ncm (10 in-lb).
9. Connect W16 ribbon cable to the A10/A12 assembly.

Figure 4-22 A9 and A10/A12 Mounting Screws

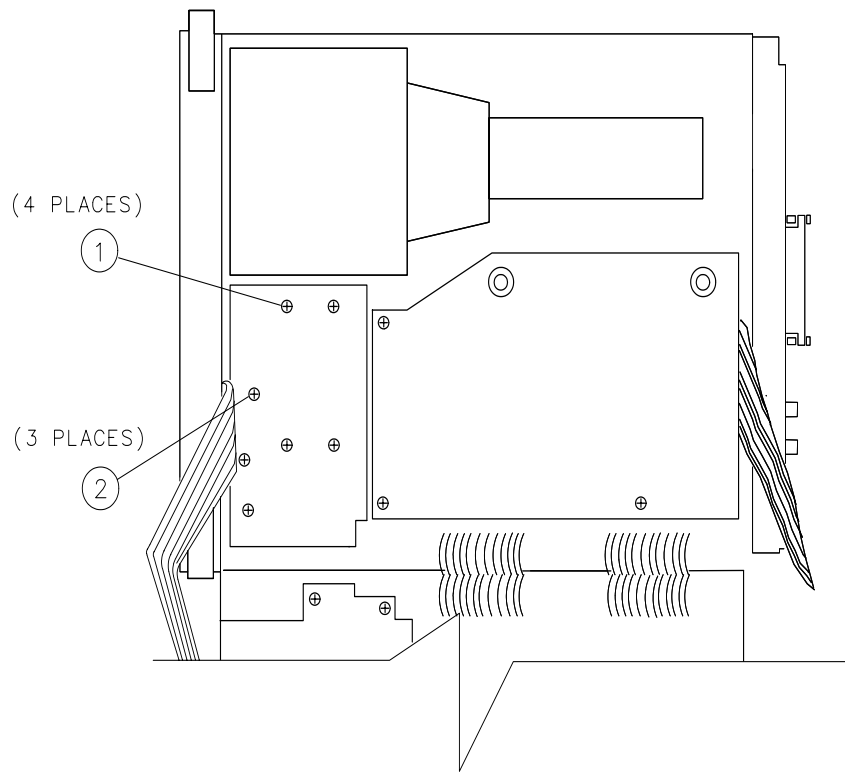

sz132e

A10/A12 RYTHM/SBTX

Removal

CAUTION

Do NOT remove the brackets from the A10/A12 assembly. If these brackets are removed and reinstalled, the performance of the spectrum analyzer will be altered. A new or rebuilt A10/A12 assembly includes new mounting brackets already attached to it.

1. Disconnect W16 ribbon cable from the A10/A12 assembly.
2. Use a 5/16-inch wrench to remove W43, W44, W46, and W47 from the A10/A12 assembly. See [Figure 4-20 on page 221](#).
3. Remove W56/FL2/W57 (as a unit) and set it aside.
4. Remove W28 from the A10/A12 assembly (beneath where W56/FL2/W57 was connected to the A10/A12 assembly).
5. Remove four screws (1) securing A10/A12 to the center deck. These screws are located on the top-side of the center deck as illustrated in [Figure 4-22, “A9 and A10/A12 Mounting Screws.”](#)
6. Carefully remove the A10/A12 assembly and disconnect W48 (gray cable).

Replacement

1. Orient the A10/A12 assembly for the proper cable connections.
2. Connect W48 (gray cable) to the A10/A12 assembly (beneath where W46 connects to the A10/A12 assembly). See [Figure 4-20 on page 221](#).
3. Connect W28 to the A10/A12 assembly (beneath where W56 connects to the A10/A12 assembly). See [Figure 4-20 on page 221](#).
4. Connect W43, W44, W46, and W47 to the A10/A12 assembly.
5. Connect W16 ribbon cable to the A10/A12 assembly.
6. Install W56/FL2/W57 and torque all RF cable connections to 113 Ncm (10 in-lb).
7. Secure the A10/A12 assembly to the spectrum analyzer center deck using four screws.

A11 YTO

Removal

1. Carefully disconnect W43 semirigid cable from A9J2 and A12J3 and move it out of the way.
2. Remove W56/FL2/W57 (as a unit) and disconnect W38 at the A11 assembly.
3. Remove four screws (1) securing A11 to the right-side frame. See [Figure 4-23, “A11 Mounting Screws at Right Side Frame.”](#) Remove the screws while holding onto A11.
4. Disconnect W10 ribbon cable from the A11 YTO assembly.

Replacement

1. Connect W10 ribbon cable to the A11 YTO assembly.
2. Orient the A11 assembly in the spectrum analyzer so its four mounting holes line up with the holes in the right side frame and the output connector is lined up with W38.
3. Secure the A11 assembly to the right side frame using four screws.
4. Connect W38 to A11.
5. Install W56/FL2/W57 between A12J1 and A13J1.
6. Reconnect W43 semirigid cable to A9J2 and A12J3 and torque all RF cable connections to 113 Ncm (10 in-lb).

Figure 4-23 A11 Mounting Screws at Right Side Frame

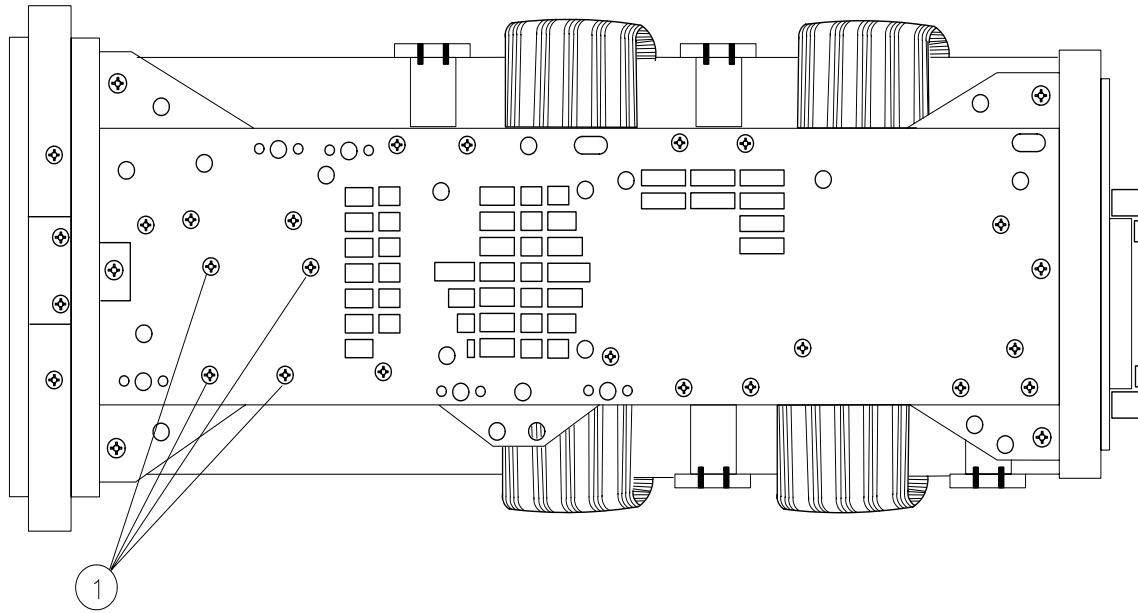

sz124e

A13 Second Converter

CAUTION

Turn off the spectrum analyzer power when replacing the A13 second converter assembly. Failure to turn off the power may result in damage to the assembly.

Removal

1. Place the spectrum analyzer upside-down on the work bench.
2. Disconnect W33, coax 81, and W35, coax 92, from the A13 assembly.
3. Disconnect W48, coax 8, from A13J3.
4. Disconnect W56/FL2/W57 (as a unit) and set it aside.
5. Remove the four screws securing A13 to the main deck and remove the assembly.
6. Disconnect ribbon cable W13 from the A13 assembly.

Replacement

1. Connect ribbon cable W13 to the A13 assembly.
2. Secure A13 to the spectrum analyzer main deck, using four panhead screws.
3. Connect W33, coax 81, to A13J4 600 MHz IN jack.
4. Connect W35, coax 92, to A13J2 310.7 MHz OUT jack.
5. Connect W48, coax 8, to A13J3. Route W48 under W35, coax 92.
6. Install W56/FL2/W57 and ensure that all of the connections on W56/FL2/W57 and on W48 are torqued to 113 Ncm (10 in-lb).

Procedure 9. A14 and A15 Assemblies

Removal

1. Remove the spectrum analyzer cover as described in "Procedure 1. Spectrum Analyzer Cover."
2. Place the spectrum analyzer on its right side frame.
3. Remove the eight screws (1) holding the A14 and A15 assemblies to the bottom of the spectrum analyzer. See [Figure 4-24 on page 231](#).

Figure 4-24 A14 and A15 Assembly Removal

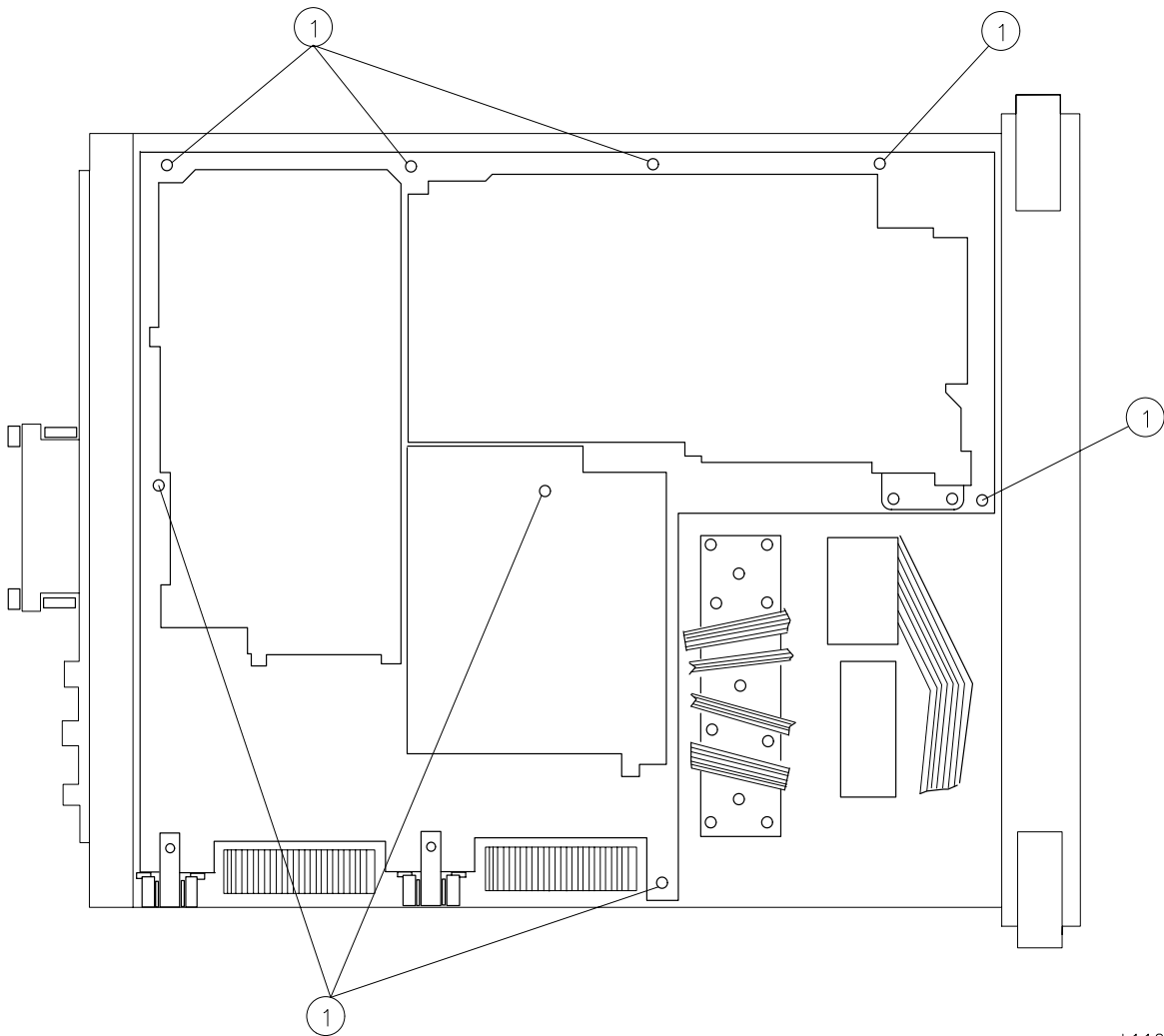

s1112e

CAUTION

DO NOT fold the board assemblies out of the spectrum analyzer one at a time. Always fold the A14 and A15 assemblies as a unit. Folding out one assembly at a time binds the hinges attaching the assemblies and may damage an assembly and hinge.

4. The board assemblies are attached to the spectrum analyzer right side frame with two hinges. Fold both the A14 and A15 assemblies out of the spectrum analyzer as a unit.
5. Remove all cables from the assembly being removed.
6. Remove the two screws that attach the assembly being removed to its two mounting hinges.

CAUTION

DO NOT torque shield screws to more than 5 inch-pounds. Applying excessive torque will cause the screws to stretch.

Replacement

1. Attach the removed assembly to the two chassis hinges with two panhead screws.
2. Attach all cables to the assembly as illustrated in [Figure 4-25 on page 233](#). When connecting W34 to A15, torque the SMA connector to 113 Ncm (10 in-lb).
3. Lay the A14 and A15 assemblies flat against each other in the folded out position. Make sure that no cables become pinched between the two assemblies. Ensure that all coaxial cables are clear of hinges and standoffs before continuing onto the next step.
4. Fold both board assemblies into the spectrum analyzer as a unit. Use caution to avoid damaging any cable assemblies.
5. Secure the assemblies using the eight screws removed in "Removal" step 3. See [Figure 4-24 on page 231](#).
6. Secure the spectrum analyzer cover assembly as described in "Procedure 1. Spectrum Analyzer Cover."

Figure 4-25 A14 and A15 Assembly Cables

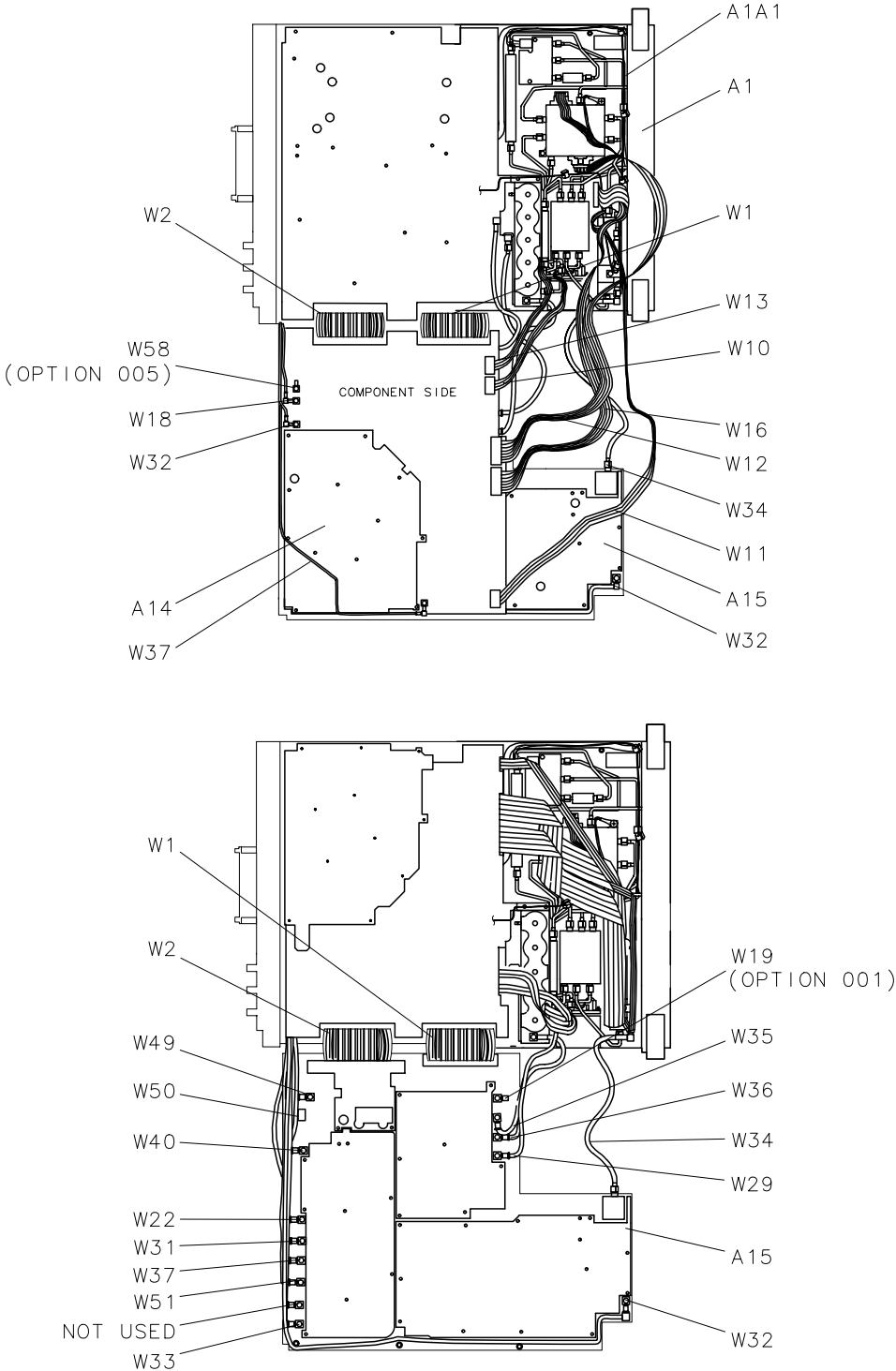

sm17e

Procedure 10. A16 Fast ADC and A17 CRT Driver (8564E and 8565E)

Removal

1. Remove the spectrum analyzer cover assembly and fold out the A2, A3, A4, and A5 assemblies as described in steps 3 through 6 under “[Procedure 5. A2, A3, A4, and A5 Assemblies.](#)”
2. Place the spectrum analyzer top-side-up on the work bench with A2, A3, A4, and A5 folded out to the right.
3. *For Option 007 spectrum analyzers:* Remove two screws (1) securing the two board-mounting posts to the left side frame, and remove the posts. See [Figure 4-26, “A16 and A17 Mounting Screws.”](#)
4. Remove two screws (2) securing the A17 assembly (and A16 assembly in Option 007) to the left side frame. Remove the two spacers (non-Option 007).
5. Pull the A17 assembly out of the spectrum analyzer.
6. *For Option 007 spectrum analyzers:* Pull the A16 assembly out of the spectrum analyzer.
7. Disconnect W7, W8, W9, A6A1W2, and A18W1 from the A17 CRT driver assembly.
8. *For Option 007 spectrum analyzers:* Disconnect all cables from the A16 Fast ADC assembly.

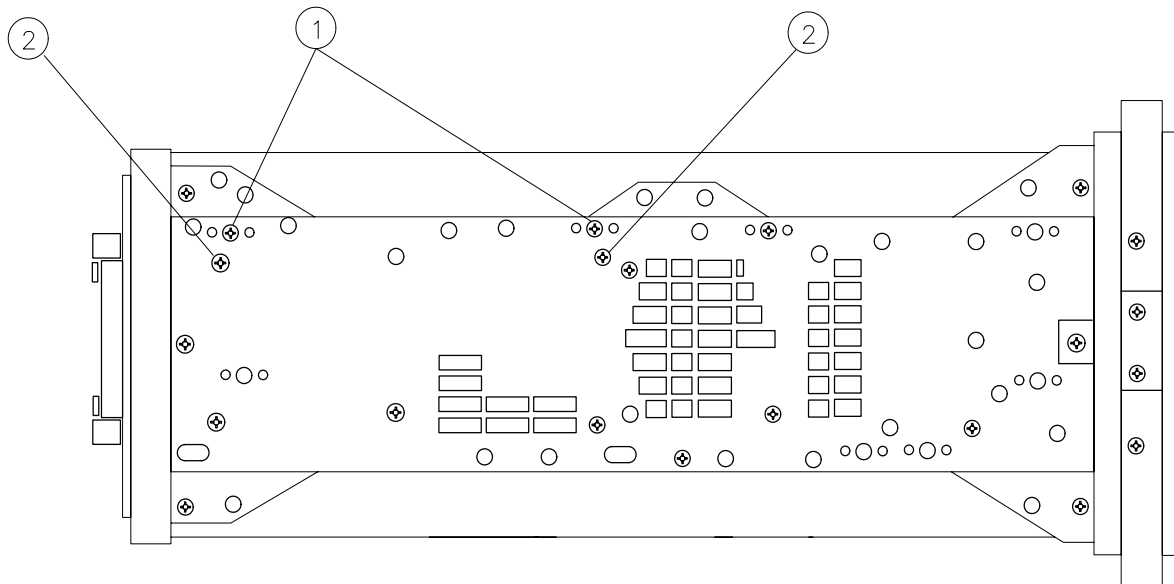
Figure 4-26 A16 and A17 Mounting Screws

sz127e

Replacement

1. Connect W7, W8, W9, A6A1W2, and A18W1 to the A17 CRT driver assembly. Place the assembly into the center-deck mounting slot next to the CRT assembly.
2. *For Option 007 spectrum analyzers:* Connect all A16 assembly cables as illustrated in [Figure 4-27 on page 236](#) which shows the left side frame removed so that proper A16 assembly cable routing may be viewed. Place the A16 assembly into the center-deck mounting slot nearest the left side frame.
3. Secure the A17 assembly (and A16 assembly in Option 007) to the left side frame using two flathead screws (and two spacers in non-Option 007). *For Option 007:* Attach the board mounts to the left side frame using two flathead screws (1). See [Figure 4-26 on page 235](#).
4. Place the spectrum analyzer on its right side frame.
5. Fold the A2, A3, A4, and A5 assemblies into the spectrum analyzer as described in [“Procedure 5. A2, A3, A4, and A5 Assemblies” on page 202](#).

Figure 4-27 **A16 Cable Routing**

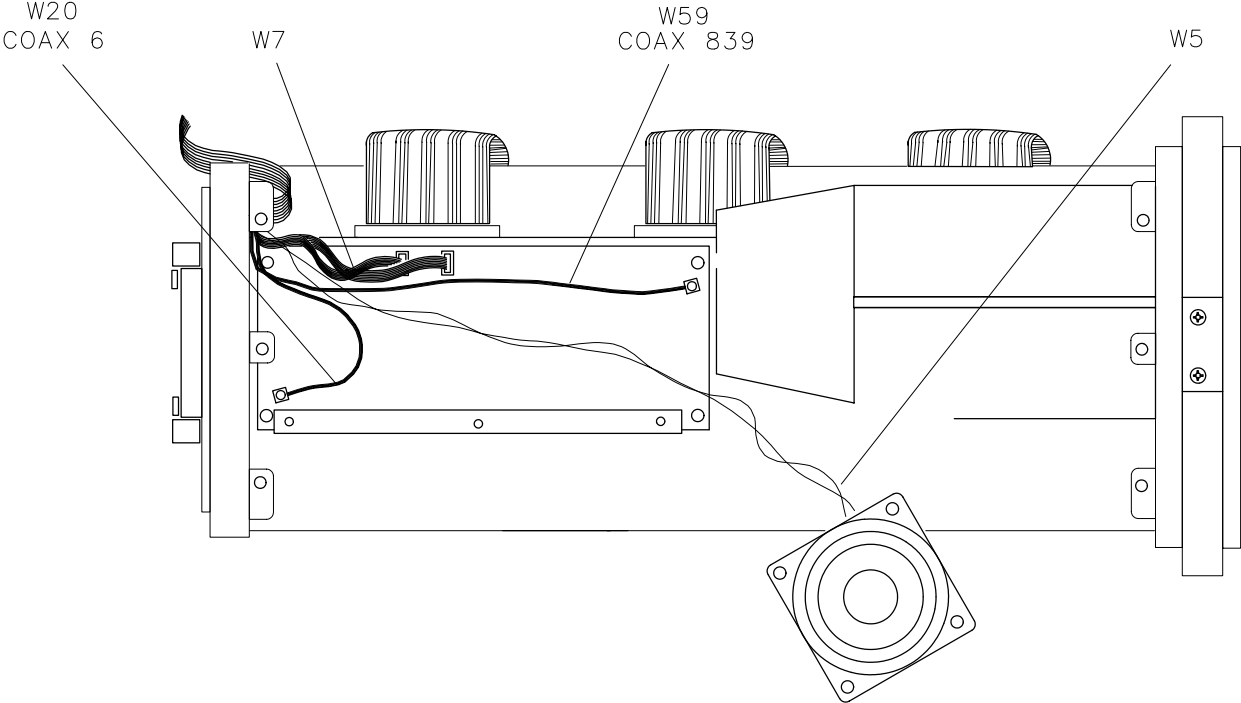

sj138e

Procedure 11. B1 Fan

Removal/Replacement

WARNING

Always disconnect the power cord from the instrument before beginning this replacement procedure. Failure to follow this precaution can present a shock hazard which may result in personal injury.

1. Remove the four screws securing the fan assembly to the rear frame.
2. Remove the fan and disconnect the fan wire from the A6 power supply assembly.
3. To reinstall the fan, connect the fan wire to A6J3 and place the wire into the channel provided on the left side of the rear frame opening. Secure the fan to the rear frame using four panhead screws.

NOTE

The fan must be installed so that the air enters through the front and sides of the instrument and exits out the rear of the instrument.

Procedure 12. BT1 Battery

WARNING

Battery BT1 contains lithium polycarbon monofluoride. Do not incinerate or puncture this battery. Dispose of discharged battery in a safe manner.

CAUTION

To avoid loss of the calibration constants stored on the A2 controller assembly, connect the spectrum analyzer to the main power source and turn on before removing the battery.

The battery used in this instrument is designed to last several years. An output voltage of +3.0 V is maintained for most of its useful life. Once this voltage drops to +2.6 V, its life and use are limited and the output voltage will deteriorate quickly. When the instrument is turned off, stored states and traces will only be retained for a short time and may be lost. Refer to [“State- and Trace-Storage Problems,”](#) in [Chapter 10](#) , [“Controller Section.”](#) The battery should be replaced if its voltage is +2.6 V or less.

Removal/Replacement

1. Remove any option module attached to the rear panel.
2. Locate the battery assembly cover on the spectrum analyzer rear panel. Use a screwdriver to remove the two flathead screws securing the cover to the spectrum analyzer.
3. Remove the old battery and replace it with the new one, ensuring proper polarity.
4. Measure the voltage across the new battery. Nominal new battery voltage is approximately +3.0 V. If this is not the case, check the battery cable and A2 controller assembly.
5. Secure the battery assembly into the spectrum analyzer.

Procedure 13. Rear Frame/Rear Dress Panel

Removal

WARNING **The A6 power supply (in E-series and EC-series instruments) and the A6A1 high voltage (in E-series instruments) assemblies contain lethal voltages with lethal currents in all areas. Use extreme care when servicing these assemblies. Always disconnect the power cord from the instrument before beginning this replacement procedure. Failure to follow this precaution can present a shock hazard which may result in personal injury.**

NOTE Diagrams that illustrate features common to E-series and EC-series instruments are shown with E-series instruments. Where features differ for E-series and EC-series instruments, separate diagrams are provided.

1. Disconnect the line-power cord from the spectrum analyzer.
2. Remove the spectrum analyzer cover, and place the spectrum analyzer on its right side frame.
3. Fold out the A2, A3, A4, and A5 assemblies as described in [“Procedure 5. A2, A3, A4, and A5 Assemblies,”](#) steps 3 through 5.
4. Disconnect the GPIB cable at A2J5.
5. Place the spectrum analyzer top-side-up on the work bench with A2 through A5 folded out to the right.

For EC-series instruments, proceed to [step 13](#). For E-series instruments proceed to [step 6](#).

WARNING **The voltage potential at A6A1W3 is +9 kV. Disconnect at the CRT with caution! Failure to properly discharge A6A1W3 may result in severe electrical shock to personnel and damage to the instrument.**

6. Connect the spectrum analyzer line-power cord to provide proper grounding while discharging the A6A1W3 post-accelerator cable. Make sure that the spectrum analyzer line-power switch is in the off position.

7. Connect a high-voltage probe (1000:1), such as the 34111A to a voltmeter with a 10 megohm input.
8. Connect the clip lead of the probe (ground) to the chassis of the spectrum analyzer.
9. Slip the tip of the high-voltage probe under the A6A1W3 post-accelerator cable's rubber shroud to obtain a reading on the voltmeter. See [Figure 4-2 on page 184](#).
10. Keep the high-voltage probe on the post-accelerator connector until the voltage has dropped to a voltmeter reading of less than 5 mV (less than 5 V at the connector). This normally takes about 30 seconds.
11. Disconnect the line-power cord from the spectrum analyzer.
12. Using a small screwdriver with the shank in contact with the CRT shield assembly, slip the tip of the screwdriver under the A6A1W3 post-accelerator cable's rubber shroud and short the cable to ground on the CRT shield assembly. See [Figure 4-2 on page 184](#).
13. Remove the three screws securing the power-supply shield to the power supply, and remove the shield. See (1) in [Figure 4-2 on page 184](#).
14. Disconnect the fan and line-power cables from A6J3 and A6J101 on the A6 power supply assembly.
15. Remove the two flathead screws that secure the rear-panel battery assembly, and remove the assembly. Remove the battery and unsolder the two wires attached to the battery assembly.
16. Use a 9/16-inch nut driver to remove the dress nuts holding the BNC connectors to the rear frame. If necessary, drill out the nut driver to fit over the BNC connectors, and cover it with heatshrink tubing or tape to avoid scratching the dress panel.
17. Remove four screws that secure the rear frame to the main deck. See (1) in [Figure 4-28 on page 241](#).
18. Remove the six screws that secure the rear frame to the left and right side frames.
19. Remove the knurled nut that secures the earphone jack. Carefully remove the jack using caution to avoid losing the lock washer located on the inside of the rear-frame assembly. Replace the washer and nut onto the jack for safekeeping.
20. Remove the rear-frame assembly.
21. To remove the rear dress panel, remove the two nuts located on the inside of the rear frame near the display adjustment holes.

Figure 4-28 Main Deck Screws

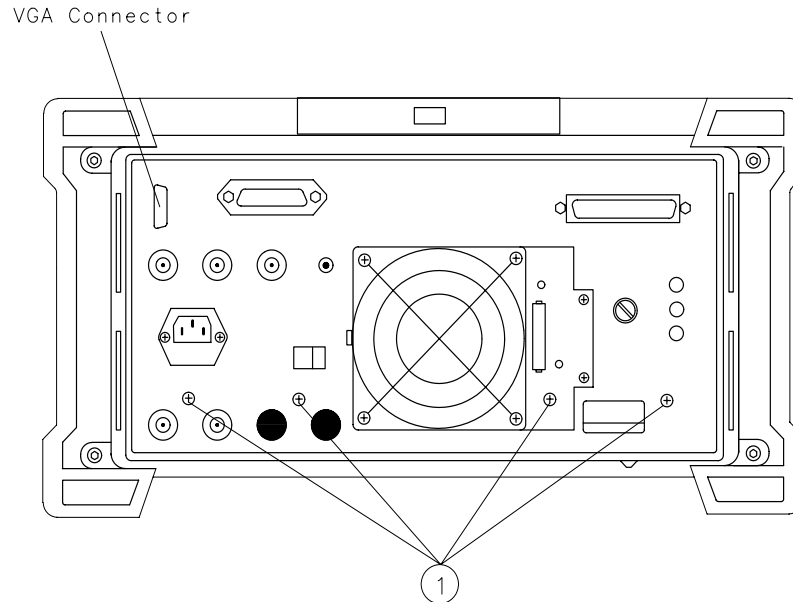

sp123c

Replacement

1. If the rear dress panel is removed, secure it to the rear frame using two nuts. Ensure that the dress panel is aligned with the frame.
2. Place the spectrum analyzer on its front panel allowing easy access to the rear-frame area.
3. Place the rear frame on the spectrum analyzer and secure the knurled nut on the earphone jack. A lock washer should be used on the inside of the rear frame and a flat washer on the outside.
4. Place the coax cable's BNC connectors into the appropriate rear-frame holes as described below. Use a 9/16-inch nut driver to attach the dress nuts holding the BNC connectors to the rear frame.

Rear Panel Jack		
EC-series	E-series	RF Cable
J1	n/a	W64
n/a	J1	W55
J4	J4	W24, coax 5
J5	J5	W23, coax 93
J6	J6	W25, coax 4
J7	n/a	W55
J8	J8	W18, coax 97
J9	J9	W31, coax 8
J11	J11	W58, coax 8

Procedure 13. Rear Frame/Rear Dress Panel

5. Secure the rear frame to the spectrum analyzer main deck, using four panhead screws (1). See [Figure 4-28 on page 241](#).
6. Secure the rear frame to the spectrum analyzer side frames using three flathead screws per side. Use caution to avoid damaging any coaxial cables.
7. Place the spectrum analyzer top-side-up on the work bench.
8. Pull the red and black battery wires through the rear-frame's battery-assembly hole. Solder the red wire to the battery-assembly's positive lug and the black wire to the negative lug. Replace the battery.
9. Secure the battery assembly to the rear frame, using two flathead screws.
10. Connect the fan and line-power cables to A6J3 and A6J101 on the A6 power supply.

For EC-series instruments, proceed to step 13. For E-series instruments proceed to step 11.
11. Snap the A6A1W3 post-accelerator cable to the CRT assembly.
12. Snap the black grommet protecting A6A1W3 into the CRT shield.
13. Ensure that all cables are safely routed and will not be damaged when securing the A6 cover.
14. Secure the power-supply cover shield to the power supply, using three flathead screws (1). One end of the cover fits into a slot provided in the rear-frame assembly. Ensure that the extended portion of the cover shield is seated in the shield wall groove. See [Figure 4-29 on page 243](#).
15. Connect the GPIB cable to A2J5.
16. Fold the A2, A3, A4, and A5 assemblies into the spectrum analyzer as described in procedure 5.

Figure 4-29 **A6 Power Supply Cover**

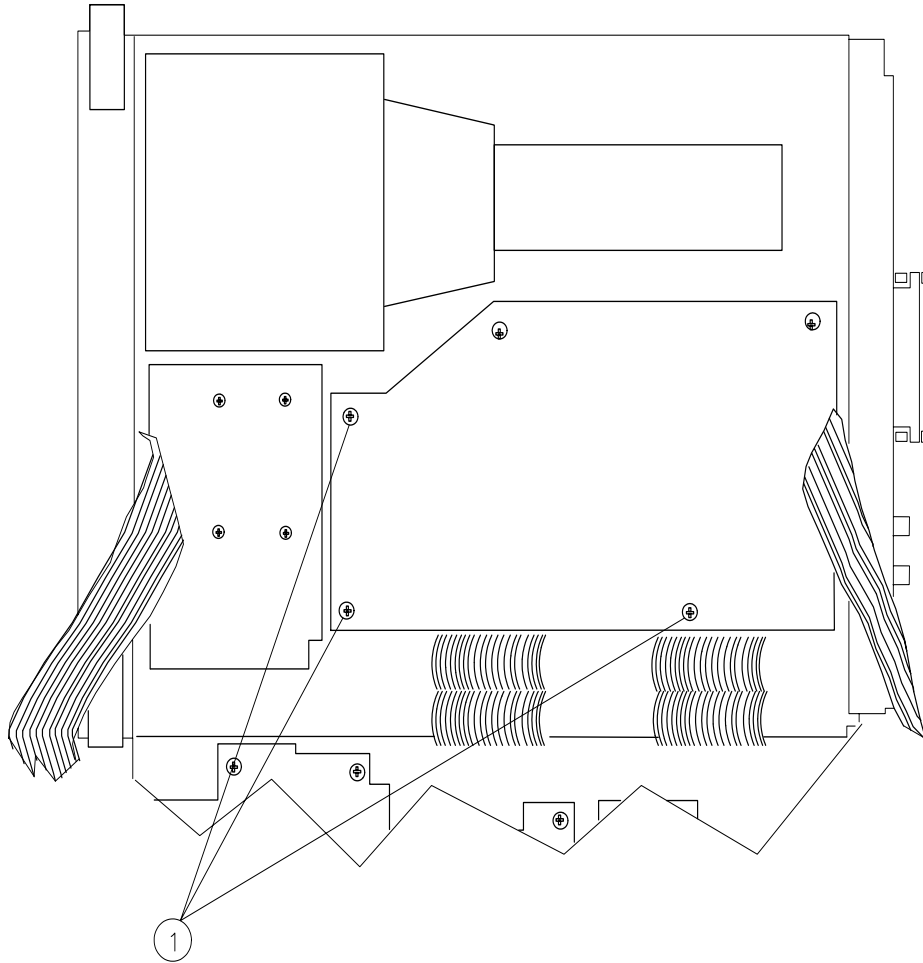

SP14E

Procedure 14. W3 Line Switch Cable (8564E and 8565E)

NOTE For the procedure for removing the line switch for 8564EC and 8565EC instruments see [“Removal of the Line Switch from the Front Panel”](#) on [page 183](#).

Removal

WARNING **Due to possible contact with high voltages, disconnect the spectrum analyzer line-power cord before performing this procedure.**

1. Remove the spectrum analyzer cover assembly as described in "Procedure 1. Spectrum Analyzer Cover."
2. Fold out the A2, A3, A4, and A5 assemblies as described in [“Procedure 5. A2, A3, A4, and A5 Assemblies,”](#) steps 3 through 5.
3. Disconnect A1A1W1 from A3J602.
4. Place the spectrum analyzer top-side-up on the work bench with A2 through A5 folded out to the right.

WARNING **The voltage potential at A6A1W3 is +9 kV. Disconnect at the CRT with caution! Failure to properly discharge A6A1W3 may result in *severe electrical shock* to personnel and damage to the instrument.**

5. Connect the spectrum analyzer line-power cord to provide proper grounding while discharging the A6A1W3 post-accelerator cable. Make sure that the spectrum analyzer line-power switch is in the off position.
6. Connect a high voltage probe (1000:1), such as the 34111A to a voltmeter with a 10 megohm input.
7. Connect the clip lead of the probe (ground) to the chassis of the spectrum analyzer.
8. Slip the tip of the high voltage probe under the A6A1W3 post-accelerator cable rubber shroud to obtain a reading on the voltmeter. See [Figure 4-3 on page 193](#).

9. Keep the high voltage probe on the post-accelerator connector until the voltage has dropped to a voltmeter reading of less than 5 mV (less than 5 V at the connector). This normally takes about 30 seconds.
10. Disconnect the line-power cord from the spectrum analyzer.
11. Using a small screwdriver with the shank in contact with the CRT shield assembly, slip the tip of the screwdriver under the A6A1W3 post-accelerator cable rubber shroud and short the cable to ground on the CRT shield assembly. See [Figure 4-3 on page 193](#).
12. Remove the three screws securing the power supply shield to the power supply, and remove the shield.
13. Pull the cable tie (1), [Figure 4-30 on page 246](#), to free W9 and the post-accelerator cables.
14. Disconnect W3 from A6J2.
15. Pull W3 up from between the power supply and the CRT assembly to release it from the cable clamp.
16. Place the spectrum analyzer on its right side frame.
17. Fold out the A14 and A15 assemblies as described in [“Procedure 9. A14 and A15 Assemblies,”](#) steps 3 and 4.
18. Loosen the screw (2) securing W3, the line switch assembly, to the front frame. The screw is captive. See [Figure 4-31 on page 248](#).

Figure 4-30 W3 Dress and Connection to A6 Power Supply

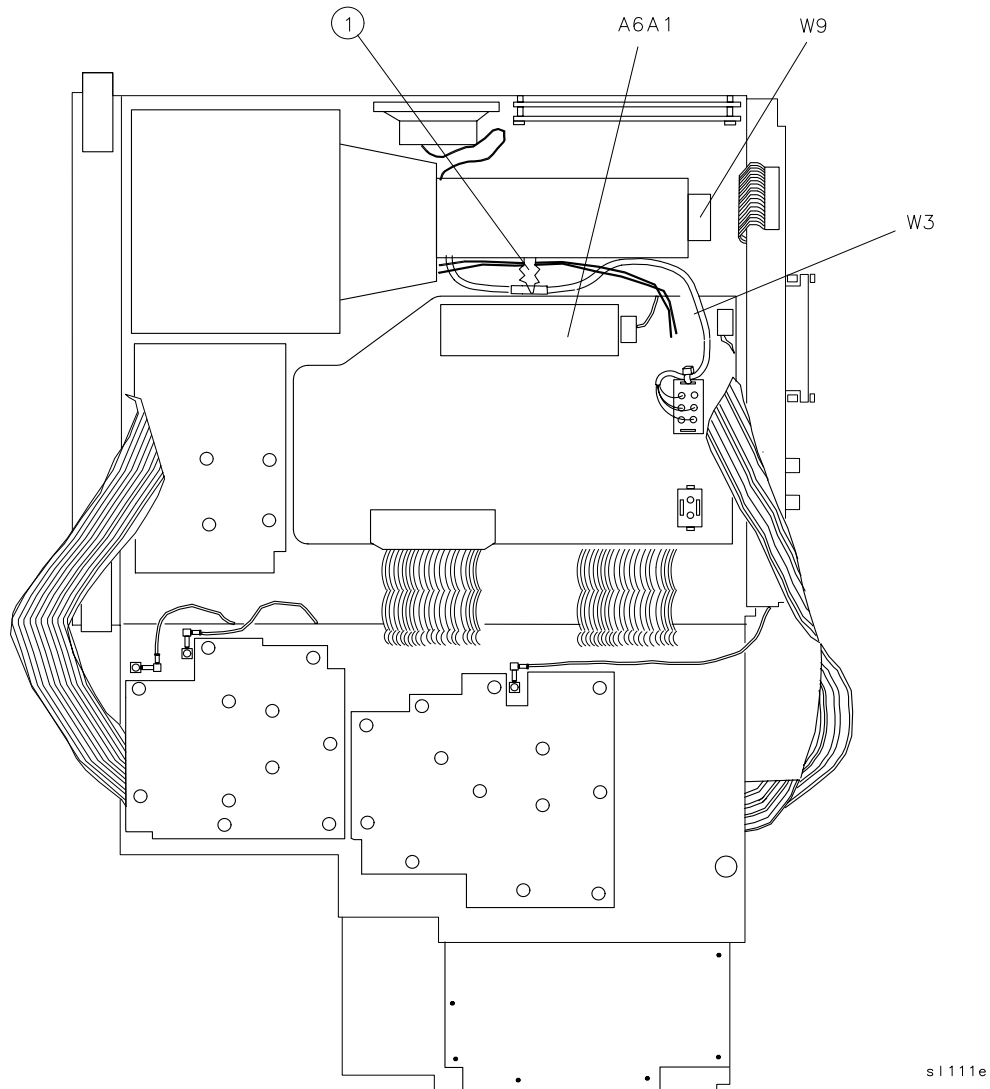

19. Remove A1W1 and A1W1DS1 from the line switch assembly. Let each hang freely.

NOTE

If contact removal tool, part number 8710-1791, is available, complete assembly removal by performing "Removal," steps 20 and 21. If not, skip to "Removal," step 22.

20. With wire cutters, clip the tie wrap holding the cable to the contact housing. From the top side of the spectrum analyzer, use contact removal tool, Part Number 8710-1791, to remove the four wires from the W3 connector. See [Figure 4-32 on page 249](#).

Procedure 14. W3 Line Switch Cable (8564E and 8565E)

21. Completely remove the cable from the instrument.
22. Remove the A1 Front-Frame assembly and A18 CRT assembly as described in “[Procedure 2A. A1 Front Frame/A18 LCD \(8564EC and 8564EC\)](#),” steps 16 through 29.
23. Remove the left side frame from the spectrum analyzer using the hardware listed below. (The side frame will still be attached by the speaker wires. Do not let it hang freely.)

Screw	Quantity
(1) SCREW-MACH M4 X 0.7 8 mm-LG FLAT HD	6
(2) SCREW-MACH M3 X 0.5 36 mm-LG FLAT HD	2
(3) SCREW-MACH M3 X 0.5 6 mm-LG FLAT HD	6

24. Remove the line switch cable assembly.

Figure 4-31 Line Switch Mounting Screw and Cable Dress

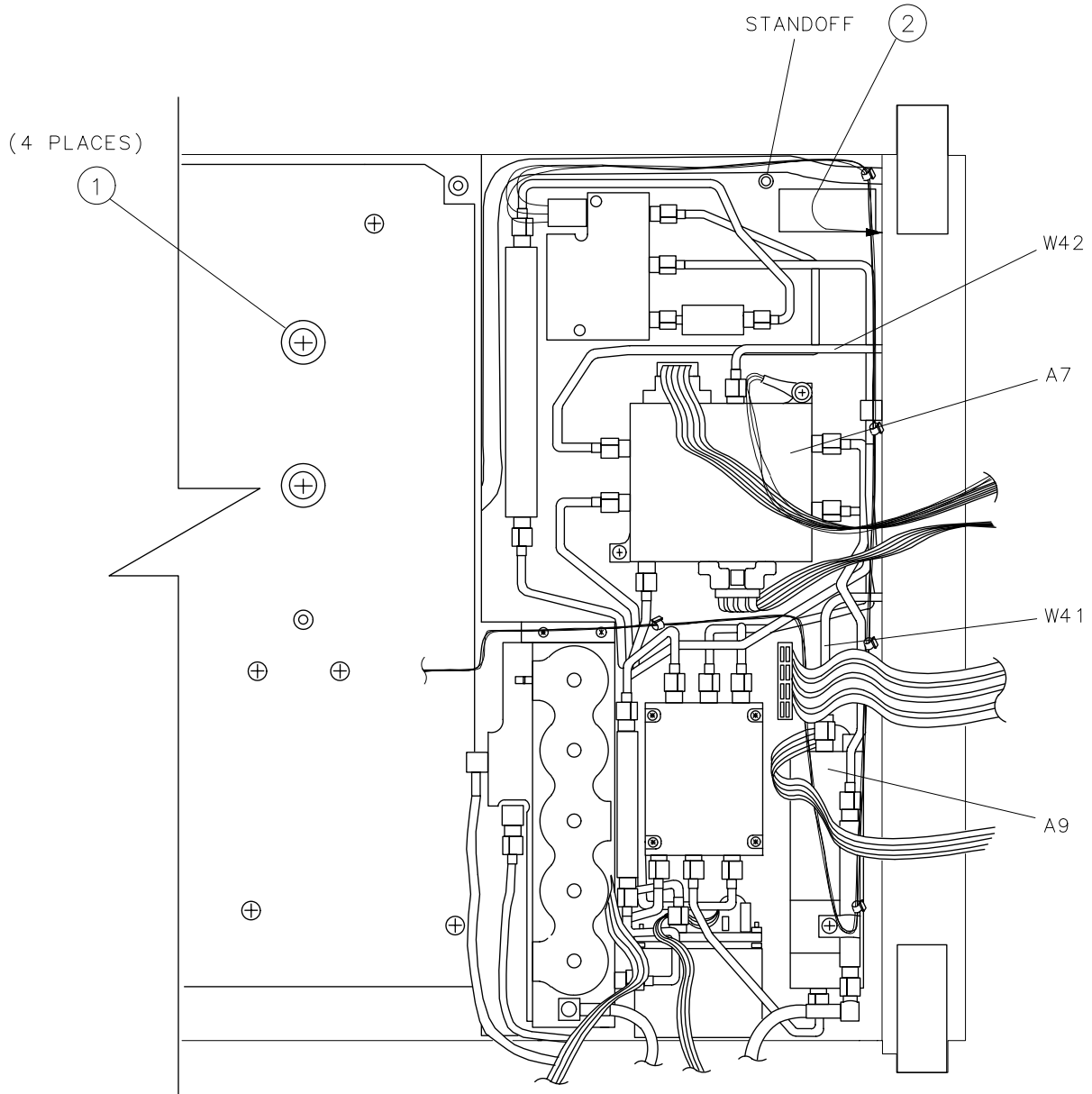

sm19e

Figure 4-32 W3 Cable Connector

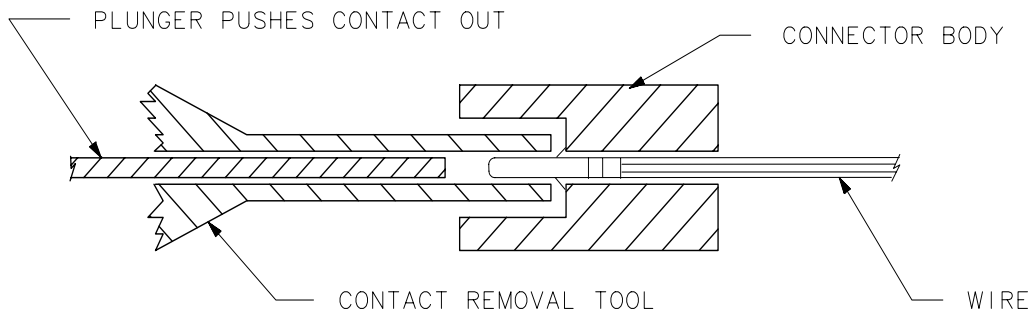
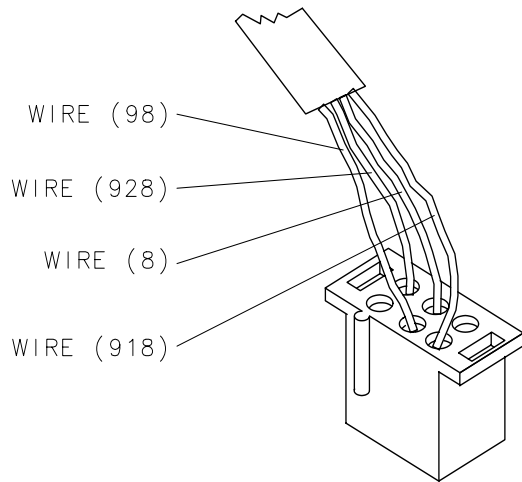
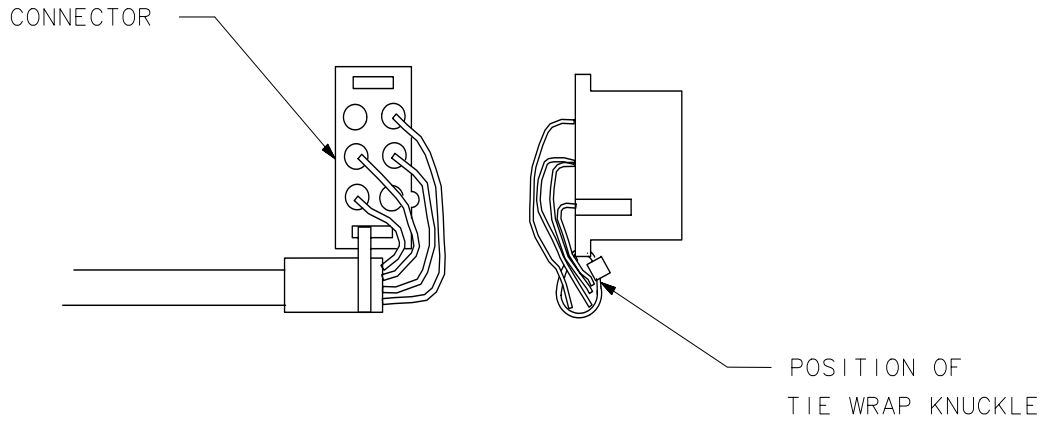

SK151

Replacement (Using Contact Removal Tool, part number 8710-1791)

1. Ensure that the action of the switch is working properly. With a pair of wire cutters, clip the tie wrap holding the cable to the contact housing of the replacement W3 assembly.
2. Using the contact removal tool, remove the four wires from the replacement cable assembly connector.
3. From the bottom side of the spectrum analyzer, insert the contact end of W3 through the slotted opening in the main deck. W3 should come through to the top side of the spectrum analyzer between the A18 CRT assembly and the post-accelerator cable.
4. Place LED A1W1DS1 into the line switch assembly.
5. Attach the line switch assembly into the front frame, using the captive panhead screw. Ensure the connection of the line switch grounding lug to the screw.
6. Dress W3 between the main deck standoff and the side frame. See [Figure 4-31, "Line Switch Mounting Screw and Cable Dress."](#)
7. On the top side of the spectrum analyzer, redress W3.
8. Insert the four contacts into the W3 connector.
9. Attach the cable to the connector housing using the supplied tie wrap.
10. Connect W3 to A6J2. Dress W3 into the slotted opening in the deck.
11. Connect A1A1W1 to A3J602.
12. Secure the power supply cover shield to the power supply, using three flathead screws. One end of the cover fits into a slot provided in the rear frame assembly. Ensure that the extended portion of the cover shield is seated in the shield wall groove.
13. Redress W3 and the other cable assemblies down between the CRT assembly and the power supply cover such that the W9 wires are below the surface of the power supply cover.
14. Fold up the A2, A3, A4, and A5 assemblies into the spectrum analyzer as described in ["Procedure 5. A2, A3, A4, and A5 Assemblies,"](#) steps 5 through 10.
15. Fold up A14 and A15 assemblies as described in ["Procedure 9. A14 and A15 Assemblies,"](#) steps 9 through 11.

Replacement (without Contact Removal Tool)

1. Lay the replacement line switch cable assembly between the side frame and main deck. Ensure that the action of the switch is working properly.
2. Attach the left side frame to the deck and rear frame. See [Figure 4-33 on page 252](#).

Screw Quantity

- (1) SCREW-MACH M4 X 0.7 8 mm-LG FLAT HD 6
- (2) SCREW-MACH M3 X 0.5 36 mm-LG FLAT HD 2
- (3) SCREW-MACH M3 X 0.5 6 mm-LG FLAT HD 6

3. Dress W3 between the main deck standoff and the side frame. See [Figure 4-31 on page 248](#).
4. Attach the A1 Front Frame assembly and the A18 CRT assembly as described in “[Procedure 2A. A1 Front Frame/A18 LCD \(8564EC and 8564EC\)](#),” steps 1 through 15.
5. Place LED A1W1DS1 into the line switch assembly.
6. Attach the line switch assembly into the front frame using the captive panhead screw. Be sure to connect the line switch grounding lug with the screw.

Figure 4-33 Side Frame Mounting Screws

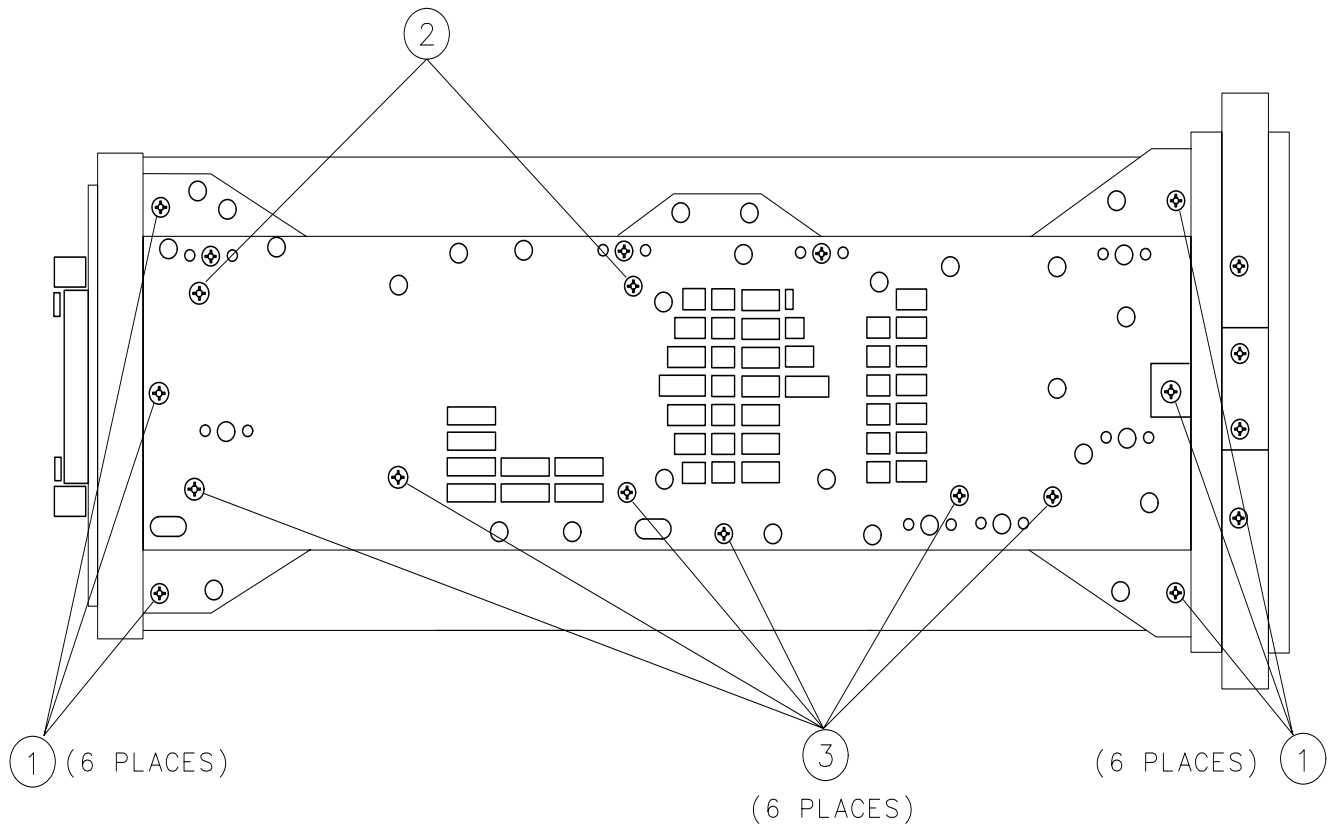

sm113e

7. On the top side of the spectrum analyzer, redress W3.
8. Connect W3 to A6J2. Dress W3 into the slotted opening in the deck.
9. Connect A1A1W1 to A3J602.
10. Secure the power supply cover shield to the power supply using three flathead screws. One end of the cover fits into a slot provided in the rear frame assembly. Ensure that the extended portion of the cover shield is seated in the shield wall groove. See [Figure 4-28 on page 241](#).
11. Place W3 and the other cable assemblies between the CRT assembly and the power supply cover so the W9 wires are below the surface of the power supply cover.
12. Fold up the A2, A3, A4, and A5 assemblies into the spectrum analyzer as described in [“Procedure 5. A2, A3, A4, and A5 Assemblies,”](#) steps 5 through 10.

13. Fold up A14 and A15 assemblies as described in “[Procedure 9. A14 and A15 Assemblies](#),” steps 3 through 5.
14. Replace the spectrum analyzer cover assembly.
15. Connect the line-power cord and switch the spectrum analyzer power on. If the spectrum analyzer does not operate properly, turn off the spectrum analyzer power, disconnect the line cord, and recheck the spectrum analyzer.

Procedure 15. EEROM

Removal/Replacement

CAUTION

The EEROM is replaced with the power on. Use a nonmetallic tool to remove the defective EEROM and install the new EEROM.

NOTE

In EC-series analyzers the EEROM reference designator is U23. In newer E-series analyzers the EEROM reference designator is U500. In older spectrum analyzers the EEROM reference designator is U501.

1. Turn the spectrum analyzer **LINE** switch off. Remove the spectrum analyzer cover assembly and fold out the A2, A3, A4, and A5 assemblies as described in “[Procedure 5. A2, A3, A4, and A5 Assemblies](#),” steps 3 through 5.
2. Turn the spectrum analyzer **LINE** switch on.
3. Set the WR PROT/WR ENA jumper on the A2 controller assembly to the WR ENA position.
4. Press **CAL, MORE 1 OF 2, SERVICE CAL DATA, COPY EEROM**. The spectrum analyzer will store the contents of the EEROM into the program RAM.
5. Using a nonmetallic tool, carefully remove the defective EEROM.
6. Carefully install a new EEROM.
7. Press **COPY TO EEROM**. The spectrum analyzer will store the contents of the program RAM into the new EEROM.
8. Turn the spectrum analyzer **LINE** switch off, then on, cycling the power. Allow the power-on sequence to finish.
9. If error message 701, 702, or 703 is displayed, press **RECALL, MORE**, and **RECALL ERRORS**. Use the STEP keys to view any other errors.
10. If error message 701 or 703 is displayed, perform the "Front End Cal" adjustment in the 8564E/8565E adjustment/diagnostic software (see [Chapter 2](#), “[Adjustment/Diagnostic Software](#)”).
11. If error message 719 or 720 is displayed, the model number and/or the option information has been corrupted. The spectrum analyzer must be returned to an Agilent Technologies customer service center to have this data restored.
12. If error message 704 is displayed, press **SAVE, SAVE PRSEL PK**, and **PRESET**.

- 13.If there are no errors after cycling the spectrum analyzer power, the EEROM is working properly, but the frequency-response correction data might be invalid. Check the spectrum analyzer frequency response.
- 14.Place the WR PROT/WR ENA jumper in the WR PROT position.
- 15.Fold the A2 and A3 assemblies into the spectrum analyzer as described in “[Procedure 5. A2, A3, A4, and A5 Assemblies.](#)”

Procedure 16. A21 OCXO

Removal

1. Remove the rear frame assembly as described in [“Procedure 13. Rear Frame/Rear Dress Panel,”](#) steps 1 through 20.
2. Place the spectrum analyzer on its right-side frame.
3. Fold out the A14 and A15 assemblies as described in "Procedure 9. A14 and A15 Assemblies Removal," steps 3 and 4.
4. Remove the three screws (1) securing the OCXO to the main deck. See [Figure 4-34, “A21 OCXO Mounting Screws.”](#)
5. Disconnect W49, coax 82, from the OCXO and disconnect W50 (orange cable) from the A15 RF assembly. Clip the tie wraps that hold W49 and W50 together and remove the OCXO from the spectrum analyzer (with the orange cable connected).

Figure 4-34 **A21 OCXO Mounting Screws**

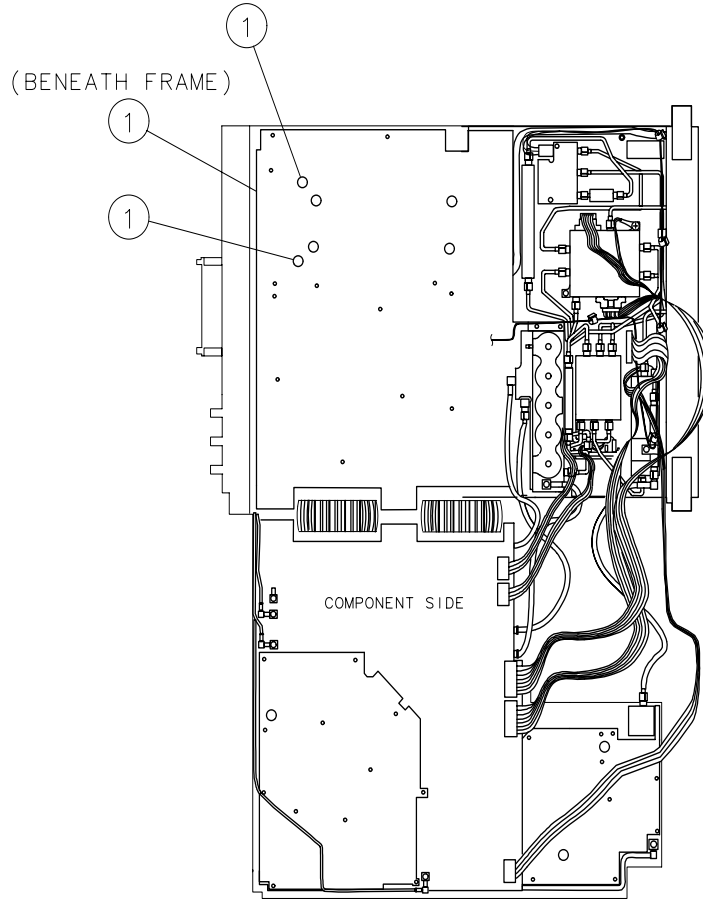

sm111e

Replacement

CAUTION

Ensure that the insulator is installed between the A21 OCXO and the main deck. Failure to do so will result in damage to the instrument by shorting the power supply.

1. Connect W49, coax 82, to the OCXO and position the OCXO in the spectrum analyzer. Dress W50, orange cable, next to W49 through the opening in the deck.
2. Secure the OCXO to the spectrum analyzer main deck using three screws (1) and insulating washers. See [Figure 4-34 on page 257](#).
3. Connect W50 to A15J306. Install tie wraps to hold W49 and W50 together.
4. Fold the A14 and A15 assemblies into the spectrum analyzer as described in [“Procedure 9. A14 and A15 Assemblies.”](#)
5. Perform the rear frame assembly replacement procedure described in [“Procedure 13. Rear Frame/Rear Dress Panel.”](#)

5 **Replaceable Parts**

Introduction

This chapter contains information on ordering all replaceable parts and assemblies. Locate the instrument parts in the following figures and tables:

Table 5-1 on page 264. Reference Designations
Table 5-2 on page 265. Abbreviations
Table 5-3 on page 269. Multiples
Table 5-4 on page 270. Replaceable Parts
Table 5-5 on page 279. Parts List, Assembly Mounting
Table 5-6 on page 280. Parts List, Cover Assembly
Table 5-7 on page 280. Parts List, Main Chassis (EC-series)
Table 5-8 on page 281. Parts List, Main Chassis (E-series)
Table 5-9 on page 282. Parts List, RF Section
Table 5-10 on page 283. Parts List, Front Frame (EC-series)
Table 5-11 on page 284. Parts List, Front Frame (E-series)
Table 5-12 on page 285. Parts List, Rear Frame (EC-series)
Table 5-13 on page 285. Parts List, Rear Frame (E-series)

Figure 5-1 on page 279. Parts Identification, Assembly Mounting
Figure 5-2 on page 287. Parts Identification, Cover Assembly
Figure 5-3 on page 289. Parts Identification, Main Chassis (E-series)
Figure 5-4 on page 291. Parts Identification, RF Section
Figure 5-5 on page 293. Parts Identification, Front Frame (E-series)
Figure 5-6 on page 295. Parts Identification, Rear Frame (E-series)
Figure 5-7 on page 297. Parts Identification, Main Chassis (EC-series)
Figure 5-8 on page 299. Parts Identification, Front Frame (EC-series)
Figure 5-9 on page 301. Parts Identification, Rear Frame (EC-series)

Ordering Information

To order a part or assembly, quote the part number, indicate the quantity required, and address the order to the nearest Agilent Technologies office. See [Table 1-5 on page 45](#).

To order a part that is not listed in the replaceable parts table, include the instrument model number, the description and function of the part, and the number of parts required. Address the order to the nearest Agilent Technologies office.

Direct Mail-Order System

Within the USA, Agilent Technologies can supply parts through a direct mail-order system. Advantages of using the system are as follows:

- Direct ordering and shipment from the Agilent Technologies Support Materials Organization in Roseville, California.
- No maximum or minimum on any mail order. (There is a minimum order amount for parts ordered through a local Agilent Technologies office when the orders require billing and invoicing.)
- Prepaid transportation. (There is a small handling charge for each order.)
- No invoices.

To provide these advantages, a check or money order must accompany each order. Mail-order forms and specific ordering information is available through your local Agilent Technologies Sales and Service office. See [Table 1-5 on page 45](#).

Direct Phone-Order System

Within the USA, a phone order system is available for regular and hotline replacement parts service. A toll-free phone number is available, and Mastercard and Visa are accepted.

Regular Orders: The toll-free phone number, (800) 227-8164, is available 6 am to 5 pm, Pacific time, Monday through Friday. Regular orders have a four-day delivery time.

Hotline Orders: Hotline service for ordering emergency parts is available 24 hours a day, 365 days a year. There is an additional hotline charge to cover the cost of freight and special handling.

The toll-free phone number is (800) 227-8164, is available 6 am to 5 pm, Pacific time, Monday through Friday and (916) 785-8HOT for after-hours, weekends, and holidays. Hotline orders are normally delivered the following business day.

Parts List Format

The following information is listed for each part:

1. The part number.
2. The total quantity (Qty) in the assembly. This quantity is given only once, at the first appearance of the part in the list.
3. The description of the part.
4. A five-digit code indicating a typical manufacturer of the part.
5. The manufacturer part number.

Firmware-Dependent Part Numbers

Refer to the following firmware note (part number 5962-5047):
8560 Series, 85620A, and 85629B Firmware Note.

Table 5-1 Reference Designations

REFERENCE DESIGNATIONS					
A	Assembly	F	Fuse	RT	Thermistor
AT	Attenuator, Isolator, Limiter, Termination	FL	Filter	S	Switch
		HY	Circulator	T	Transformer
B	Fan, Motor	J	Electrical Connector (Stationary Portion), Jack	TB	Terminal Board
BT	Battery			TC	Thermocouple
C	Capacitor			TP	Test Point
CP	Coupler	K	Relay	U	Integrated Circuit, Microcircuit
CR	Diode, Diode Thyristor, Step Recovery Diode, Varactor	L	Coil, Inductor		
		M	Meter		
		MP	Miscellaneous Mechanical Part	VR	Breakdown Diode (Zener), Voltage Regulator
DC	Directional Coupler	P	Electrical Connector (Movable Portion), Plug	W	Cable, Wire, Jumper
DL	Delay Line				
DS	Annunciator, Lamp, Light Emitting Diode (LED), Signaling Device (Visible)			Q	Silicon Controlled Rectifier (SCR), Transistor, Triode Thyristor
		Y	Crystal Unit (Piezoelectric, Quartz)		
E	Miscellaneous Electrical Part	R	Resistor	Z	Tuned Cavity, Tuned Circuit

Table 5-2 Abbreviations

ABBREVIATIONS					
A		C		CONT	Contact, Continuous, Control, Controller
A	Across Flats, Acrylic, Air (Dry Method), Ampere	C	Capacitance, Capacitor, Center Tapped, Cermet, Cold, Compression	CONV	Converter
ADJ	Adjust, Adjustment			CPRSN	Compression
ANSI	American National Standards Institute (formerly USASI-ASA)			CUP-PT	Cup Point
ASSY	Assembly	CCP	Carbon Composition Plastic	CW	Clockwise, Continuous Wave
AWG	American Wire Gage	CD	Cadmium, Card, Cord		
		CER	Ceramic	D	
B		CHAM	Chamfer	D	Deep, Depletion, Depth, Diameter, Direct Current
BCD	Binary Coded Decimal	CHAR	Character, Characteristic, Charcoal		
BD	Board, Bundle	CMOS	Complementary Metal Oxide Semiconductor		
BE-CU	Beryllium Copper			DAP-GL	Diallyl Phthalate Glass
BNC	Type of Connector			DBL	Double
BRG	Bearing, Boring	CNDCT	Conducting, Conductive, Conductivity, Conductor	DCDR	Decoder
BRS	Brass			DEG	Degree
BSC	Basic			D-HOLE	D-Shaped Hole
BTN	Button			DIA	Diameter
				DIP	Dual In-Line Package

Table 5-2 Abbreviations

D				HEX	Hexadecimal, Hexagon, Hexagonal
DIP-SLDR	Dip Solder	FDTHRU	Feedthrough		
D-MODE	Depletion Mode	FEM	Female		
DO	Package Type Designation	FIL-HD	Fillister Head	HLCL	Helical
		FL	Flash, Flat, Fluid	HP	Hewlett-Packard Company, High Pass
DP	Deep, Depth, Diameter Pitch, Dip	FLAT-PT	Flat Point		
		FR	Front		
DP3T	Double Pole Three Throw	FREQ	Frequency	I	
		FT	Current Gain Bandwidth Product (Transition Frequency), Feet, Foot	IN	Inch
DWL	Dowell			J	
E				JFET	Junction Field Effect Transistor
E-R	E-Ring	FXD	Fixed	K	
EXT	Extended, Extension, External, Extinguish			G	
F		GEN	General, Generator	KNRLD	Knurled
F	Fahrenheit, Farad, Female, Film (Resistor), Fixed, Flange, Frequency	GND	Ground	KVDC	Kilovolts
		GP	General Purpose, Group		Direct Current
		H		L	
FC	Carbon Film/Composition, Edge of Cutoff Frequency, Face			LED	Light Emitting Diode
		H	Henry, High		
		HDW	Hardware	LG	Length, Long
		HEX	Hexadecimal,	LIN	Linear, Linearity

Table 5-2 Abbreviations

L		N		PAN-HD	Pan Head
				PC	Printed Circuit
LK	Link, Lock	N	Nano, None	PCB	Printed Circuit Board
LKG	Leakage, Locking	N-CHAN	N-Channel		
LUM	Luminous	NH	Nanohenry	P-CHAN	P-Channel
		NM	Nanometer, Nonmetallic	PD	Pad, Power Dissipation
M		NO	Normally Open, Number	PF	Picofarad, Power Factor
M	Male, Maximum, Mega, Mil, Milli, Mode				
MA	Milliampere	NOM	Nominal	PKG	Package
MACH	Machined	NPN	Negative Positive Negative (Transistor)		
MAX	Maximum			PLSTC	Plastic
MC	Molded Carbon	NS	Nanosecond, Non-Shorting, Nose	PNL	Panel
MET	Metal, Metallized	NUM	Numeric	PNP	Positive Negative Positive (Transistor)
MHz	Megahertz			NYL	Nylon (Polyamide)
MINTR	Miniature	O		POLYE	Polyester
MIT	Miter	OA	Over-All	POT	Potentiometer
MLD	Mold, Molded	OD	Outside Diameter	POZI	Pozidrive Recess
MM	Magnetized Material, Millimeter	OP AMP	Operational Amplifier	PREC	Precision
				PRP	Purple, Purpose
MOM	Momentary	OPT	Optical, Option, Optional	PSTN	Piston
MTG	Mounting			PT	Part, Point, Pulse Time
MTLC	Metallic			PW	Pulse Width
SMA	Subminiature	P		Q	Figure of Merit
MW	Milliwatt	PA	Picoampere, Power Amplifier		

Table 5-2 Abbreviations

R		SPDT	Single Pole	UF	Microfarad
R	Range, Red, Resistance, Resistor, Right, Ring	SPST	Single Pole Single Throw	UH	Microhenry
		SQ	Square	UL	Microliter, Underwriters' Laboratories, Inc.
REF	Reference	SST	Stainless Steel		
RES	Resistance, Resistor	STL	Steel	UNHDND	Unhardened
RF	Radio Frequency	T		V	
RGD	Rigid			V	Variable, Violet, Volt, Voltage
RND	Round	T	Teeth, Temperature, Thickness, Time, Typical	VAC	Vacuum, Volts—Alternating Current
RR	Rear			VAR	Variable
S					
SAWR	Surface Acoustic Wave Resonator	PB	Lead (Metal),	VDC	Volts—Direct Current
SEG	Segment	TA	Ambient Temperature, Tantalum	W	
SGL	Single				
SI	Silicon, Square Inch	TC	Temperature Coefficient	W	Watt, Wattage, White, Wide, Width
SL	Slide, Slow			W/SW	With Switch
SLT	Slot, Slotted	THD	Thread, Threaded	WW	Wire Wound
SMA	Subminiature A Type (Threaded Connector)	THK	Thick	X	
		TO	Package Type Designation	X	By (Used with Dimensions), Reactance
SMB	Subminiature B Type (Slip-on Connector)	TPG	Tapping		
		TR-HD	Truss Head		
		TRMR	Trimmer	Y	
SMC	Subminiature C-Type (Threaded Connector)	TRN	Turn, Turns		
		TRSN	Torsion	YIG	Yttrium-Iron-Garnet
		U		Z	
SPCG	Spacing	UCD	Microcandela	ZNR	Zener

Table 5-3 Reference Designations, Abbreviations, and Multipliers

MULTIPLIERS					
Abbreviation	Prefix	Multiple	Abbreviation	Prefix	Multiple
T	tera	10^{12}	m	milli	10^{-3}
G	giga	10^9	μ	micro	10^{-6}
M	mega	10^6	n	nano	10^{-9}
k	kilo	10^3	p	pico	10^{-12}
da	deka	10	f	femto	10^{-15}
d	deci	10^{-1}	a	atto	10^{-18}
c	centi	10^{-2}			

Manufacturers Code List

Refer to the Manufacturers Code List in the *8560 E-Series and EC-Series Spectrum Analyzer Component Level Information*.

Replaceable Parts

Table 5-4 Replaceable Parts

Reference Designation	Part Number	Qty	Description	Mfr Code	Mfr Part Number
			ACCESSORIES SUPPLIED		
	5063-0274	1	FRONT COVER	28480	5063-0274
	85620A	1	MASS MEMORY MODULE	28480	85620A
	1810-0118	1	TERMINATION-COAXIAL SMA; 0.5W; 50Ω	16179	2003-6113-02
	1250-1200	1	ADAPTER, SMA (m) TO BNC (f)	28480	1250-1200
	1250-2187	1	ADAPTER, K (f) TO 2.4 mm (f)	28480	1250-2187
	1250-2188	1	ADAPTER, 2.4 mm (f) TO 2.4 mm (f)	28480	1250-2188
	10502A	1	50Ω COAX CABLE WITH BNC MALE	28480	10502A
	8710-1755	3	WRENCH-HEX KEY	55719	AWML4
			OPTION 908		
	5062-0800	1	RACK KIT WITH FLANGES (Includes Parts Listed Below)		
	5001-8739	2	PANEL-DRESS	28480	5001-8739
	5001-8740	2	PANEL-SUB	28480	5001-8740
	5001-8742	2	SUPPORT-REAR	28480	5001-8742
	5021-5807	2	FRAME-FRONT	28480	5021-5807
	5021-5808	2	FRAME-REAR	28480	5021-5808
	5021-5836	5	CORNER-STRUT	28480	5021-5836
	0510-1148	10	RETAINER-PUSH-ON KB-TO-SHFT EXT	11591	669
	0515-0886	16	SCREW-MACH M3 × 0.5 6MM-LG PAN-HD	28480	0515-0886
	0515-0887	8	SCREW-MACH M3.5 × 0.6 6MM-LG PAN-HD	28480	0515-0887
	0515-0889	12	SCREW-MACH M3.5 × 0.6 6MM-LG	28480	0515-0889
	0515-1241	8	SCREW-MACH M5 × 0.8 12 MM-LG PAN-HD	28480	0515-1241
	0515-1331	22	SCREW-METRIC SPECIALTY M4 × 0.7 THD; 7MM	28480	0515-1331
	5061-9679	2	MOUNT FLANGE	28480	5061-9679
	0515-1114	6	SCREW-MACH M4 × 0.7 10MM-LG PAN-HD	28480	0515-1114
	8710-1755		WRENCH-HEX KEY	55719	AWML4
	5958-6573	2	ASSEMBLY INSTRUCTIONS	28480	5958-6573
			OPTION 909		
	5062-1900	1	RACK KIT WITH FLANGES AND HANDLES (Includes Parts Listed Below)		
	5001-8739		PANEL-DRESS	28480	5001-8739
	5001-8740		PANEL-SUB	28480	5001-8740
	5001-8742		SUPPORT-REAR	28480	5001-8742
	5021-5807		FRAME-FRONT	28480	5021-5807
	5021-5808		FRAME-REAR	28480	5021-5808
	0510-1148		RETAINER-PUSH-ON KB-TO-SHFT EXT	11591	669
	0515-0886		SCREW-MACH M3 × 0.5 6MM-LG PAN-HD	28480	0515-0886

Table 5-4 Replaceable Parts

Reference Designation	Part Number	Qty	Description	Mfr Code	Mfr Part Number
	0515-0887		SCREW-MACH M3.5 × 0.6 6MM-LG PAN-HD	28480	0515-0887
	0515-0889		SCREW-MACH M3.5 × 0.6 6MM-LG	28480	0515-0889
	0515-1241		SCREW-MACH M5 × 0.8 12MM-LG PAN-HD	28480	0515-1241
	0515-1331		SCREW-METRIC SPECIALTY M4 × 0.7 THD; 7MM	28480	0515-1331
	5061-9501	2	FRONT HANDLE ASSEMBLY	28480	5061-9501
MAJOR ASSEMBLIES					
A1A1 (EC-series)	08563-60162	1	BD AY-KEYBOARD	28480	08563-60162
A1A1 (E-series)	08562-60140	1	BD AY-KEYBOARD	28480	08562-60140
A1A1W1	5062-8259	1	CABLE ASSEMBLY, RIBBON, KEYBOARD (A1A1J1 to A3J602)	28480	5062-8259
A1A2	1290-1525	1	RPG ASSEMBLY (Includes Cable) S/N ≤3728A00928 (8564) or 3728A00767 (8565)	28480	1290-1525
A1A2	0960-0745	1	RPG ASSEMBLY (Includes Cable) S/N ≥3728A00929 (8564) or 3728A00768 (8565)	28480	0960-0745
A1W1	8120-8153	1	CABLE ASSEMBLY, PROBE POWER/LED	28480	8120-8153
A2 (EC-series)	08563-60160	1	CONTROLLER ASSEMBLY*	28480	08563-60160
A2 (E-series)	08564-60010	1	CONTROLLER ASSEMBLY*	28480	08564-60010
A3	08563-60098	1	INTERFACE ASSEMBLY	28480	08563-60098
A4	08563-60076	1	LOG AMPLIFIER/CAL OSCILLATOR ASSEMBLY *	28480	08563-60076
A5	08563-60023	1	IF FILTER ASSEMBLY	28480	08563-60023
A6	08564-60008	1	POWER SUPPLY ASSEMBLY * (Includes A6A2, but does not include A6A1) Therefore, the rebuilt board number will be 08563-69065	28480	08564-60008
A6A1	5062-7089	1	HIGH VOLTAGE ASSEMBLY	28480	5062-7089
A6A2	08564-60009	1	REGULATOR BOARD ASSEMBLY	28480	08564-60009
A7	5086-7869	1	LO MULTIPLIER/AMPLIFIER (LOMA)	28480	5086-7869
	5086-6869		REBUILT A7, EXCHANGE REQUIRED	28480	5086-6869
A6A1	5062-7089	1	HIGH VOLTAGE ASSEMBLY	28480	5062-7089
A6A2	08564-60009	1	REGULATOR BOARD ASSEMBLY	28480	08564-60009
A7	5086-7869	1	LO MULTIPLIER/AMPLIFIER (LOMA)	28480	5086-7869
	5086-6869		REBUILT A7, EXCHANGE REQUIRED	28480	5086-6869
A8	5086-7908	1	LOW BAND MIXER (serial prefix <3641A)	28480	5086-7908
<p>* These board assemblies are part of the rebuilt board exchange program. To order a rebuilt board, use the same number as that of the new board with the exception of the 7th digit which should be a 9. Example: New board number is 08563-60065.</p>					

Table 5-4 Replaceable Parts

Reference Designation	Part Number	Qty	Description	Mfr Code	Mfr Part Number
MAJOR ASSEMBLIES (continued)					
Standard A8	5086-7748	1	LOW BAND MIXER(serial prefix <3641A)	28480	5086-7748
Option 006 A8	5086-7982	1	LOW BAND MIXER(serial prefix ≥3641A)	28480	5086-7982
A9	33325-60006	1	ATTENUATOR, 50 GHz, 60 dB	28480	33325-60006
A10/A12 8564E/EC	5086-7930	1	RYTHM/SBTX (INCLUDES FL5)	28480	5086-7930
A10/A12 8565E/EC	5086-6930		REBUILT A10/A12, EXCHANGE REQUIRED	28480	5086-6930
	5086-7883	1	RYTHM/SBTX (INCLUDES FL5)	28480	5086-7883
	5086-6883		REBUILT A10/A12, EXCHANGE REQUIRED	28480	5086-6883
A11	5086-7906	1	PORTABLE LVLVD YTO	28480	5086-7906
	5086-6906		REBUILT A11, EXCHANGE REQUIRED	28480	5086-6906
A13	5086-7957	1	SECOND CONVERTER	28480	5086-7957
A14	08564-60020	1	FREQUENCY CONTROL ASSEMBLY*	28480	08564-60020
A15	08563-60091	1	RF ASSEMBLY (Standard)*	28480	08563-60091
Standard A15	08563-60093	1	RF ASSEMBLY (SIG ID)*	28480	08563-60093
Option 008 A15	08563-60092	1	RF ASSEMBLY (TCXO/SIG ID)*	28480	08563-60092
Option 103 A15U100	5086-7806	1	SAMPLER	28480	5086-7806
A16 (E-series)	08563-60030	1	FAST ADC ASSEMBLY	28480	08563-60030
Option 007 A17 (EC-series)	08562-60161	1	LCD DRIVER	28480	08562-60161
A17A1 (EC-series)	0950-3644	1	LCD INVERTER BOARD	28480	0950-3644
A17 (E-series)	08563-60101	1	CRT ASSEMBLY	28480	08563-60101
A18 (EC-series)	08563-60170	1	LCD ASSEMBLY- INCLUDES LCD, LCD MOUNT, LCD GLASS and LCD backlights	28480	08563-60170
A18DS1 and A18DS2	2090-0380	1	Replaceable LCD Backlight Cartridge (part of LCD ASSEMBLY)	28480	2090-0380
A18 (E-series)		1	CRT ASSEMBLY (Order by Individual Parts)		
A18M (E-series)	5062-7095	1	CRT WIRING ASSEM. (Includes Shield A18L1, and A18W1)	28480	5062-7095

* These board assemblies are part of the rebuilt board exchange program. To order a rebuilt board, use the same number as that of the new board with the exception of the 7th digit which should be a 9. Example: New board number is 08563-60065. Therefore, the rebuilt board number will be 08563-69065.

Table 5-4 **Replaceable Parts**

Reference Designation	Part Number	Qty	Description	Mfr Code	Mfr Part Number
MAJOR ASSEMBLIES (continued)					
A18MP2 (E-series)	5041-3987	1	SPACER, CRT	28480	5041-3987
A18V1 (E-series)	2090-0225	1	TUBE, CRT 6.7 IN	28480	2090-0225
A18W1			CABLE ASSEMBLY, TWO WIRE, TRACE ALIGN (P/O A18MP1, A17J5 to A18L1)		
A19	08562-60042	1	GPIB ASSEMBLY	28480	08562-60042
A19W1	5061-9031	1	CABLE ASSEMBLY, RIBBON, GPIB (A2J5 to Rear Panel J2)	28480	5061-9031
A20	5062-7755	1	BATTERY ASSEMBLY (Includes W6)	28480	5062-7755
A21	5063-0245	1	OCXO 10.0 MHz	28480	5063-0245
AT1	0955-0994	1	DC BLOCK (serial prefix \geq 3641A and $<$ 3804A,, non-Option 006	28480	0955-0994
B1	5061-9036	1	FAN ASSEMBLY (Includes Wire)	28480	5061-9036
BT1	1420-0341	1	BATTERY 3.0 V 1.2 A-HR LITHIUM POLYCARBON MONOFLORIDE	08709	BR 213 A 55P
F1	2110-0709	1	THIONYL FUSE 5A 250V NTD FE IEC (230 VAC Operation)	16428	GDA-5
F1	2110-0756	1	FUSE 5A 125V NTD UL (115 VAC Operation)	28480	2110-0756
FL1	0955-0420	1	LOW PASS FILTER, 2.9 GHz	28480	0955-0420
FL2	0955-0519	1	LOW PASS FILTER, 4.4 GHz	28480	0955-0519
FL3	0955-0721	1	LOW PASS FILTER, 7.0 GHz	28480	0955-0721
FL4	5061-9032	1	LINE FILTER ASSEMBLY	28480	5061-9032
FL5		1	LOW PASS FILTER, 27 GHz (Not separately replaceable; P/O A10/A12 assembly.)		
LS1	9160-0282	1	LOUDSPEAKER 2.5 IN SQ (Part of W5)	28480	9160-0282
<p>CHASSIS MECHANICAL PARTS (See Figures 5-1 through 5-9 for a complete listing of mechanical chassis parts.)</p>					
<p>* These board assemblies are part of the rebuilt board exchange program. To order a rebuilt board, use the same number as that of the new board with the exception of the 7th digit which should be a 9. Example: New board number is 08563-60065. Therefore, the rebuilt board number will be 08563-69065.</p>					

Table 5-4 Replaceable Parts

Reference Designation	Part Number	Qty	Description	Mfr Code	Mfr Part Number
			ASSEMBLY SHIELDS		
A3 Assembly	5021-6723	1	PEAK DETECTOR (TOP)	28480	5021-6723
	5021-6724	1	PEAK DETECTOR (BOTTOM)	28480	5021-6724
	0515-2080	2	SCREW M2.5 14L	28480	0515-2080
	0515-1486	10	SCREW M2.5 9.5L	28480	0515-1486
	0905-0375	12	O-RING .070ID	28480	0905-0375
	2190-0583	12	WSHR LK M2.5ID	28480	2190-0583
A4 Assembly	5063-0220	1	AMP 1 (BOTTOM)	28480	5063-0220
	5063-0221	1	AMP 1 (TOP)	28480	5063-0221
	5063-0219	1	AMP 2 (TOP)	28480	5063-0219
	5063-0222	1	AMP 2 (BOTTOM)	28480	5063-0222
	0515-1486	4	SCREW SMM 2.5 10 PNTROX	28480	0515- 1486
	0515-2080	23	SCREW M2.5 14L	28480	0515-2080
	2190-0583	23	WSHR LK M2.5ID	28480	2190-0583
A5 Assembly	5021-6729	1	IF 1 (TOP)	28480	5021-6729
	5021-6730	1	IF 1 (BOTTOM)	28480	5021-6730
	5021-6731	1	IF 2 (TOP)	28480	5021-6731
	5021-6732	1	IF 2 (BOTTOM)	28480	5021-6732
	0515-2081	16	SCREW 5MM 2.5 16 PNPDS	28480	0515-2081
	0905-0375	16	O-RING .070ID	28480	0905-0375
	2190-0583	16	WSHR LK M2.5ID	28480	2190-0583
A14 Assembly	5063-0209	1	FC (TOP)	28480	5063-0209
	5063-0210	1	FC (BOTTOM)	28480	5063-0210
	0515-0951	13	SCREW 5MM 2.5 16 PNPDS	28480	0515-0951
	0905-0375	13	O-RING .070ID	28480	0905-0375
A15 Assembly	5021-6735	1	REF (TOP)	28480	5021-6735
	5021-6736	1	REF (BOTTOM)	28480	5021-6736
	5022-0047	1	SYNTHZR (TOP)	28480	5022-0047
	5022-0046	1	SYNTHZR (BOTTOM)	28480	5022-0046
	5021-6739	1	SIGPATH (TOP)	28480	5021-6739
	5021-6740	1	SIGPATH (BOTTOM)	28480	5021-6740
	5002-0631	1	BRACE, RF BD	28480	5002-0631
	0515-2081	2	SCREW	28480	0515-2081
	0515-2081	34	SCREW 5MM 2.5 16 PNPDS	28480	0515-2081
	0905-0375	36	O-RING .070ID	28480	0905-0375
	2190-0583	36	WSHR LK M2.5 ID	28480	2190-0583
	0515-0367	2	SCREW 2.5M X 8MM LG TORX	28480	0515- 0367

* These board assemblies are part of the rebuilt board exchange program. To order a rebuilt board, use the same number as that of the new board with the exception of the 7th digit which should be a 9. Example: New board number is 08563-60065. Therefore, the rebuilt board number will be 08563-69065.

Table 5-4 Replaceable Parts

Reference Designation	Part Number	Qty	Description	Mfr Code	Mfr Part Number
CABLE ASSEMBLIES					
W1	8120-5682	1	POWER CABLE, RIBBON	28480	8120-5682
W2	5061-9025	1	CONTROL CABLE, RIBBON	28480	5061-9025
W3	5062-0728	1	CABLE ASSEMBLY, LINE SWITCH	28480	5062-0728
W4	5061-9033	1	CABLE ASSEMBLY, RIBBON, OPTION	28480	5061-9033
W5			MODULE (A2J6 to Rear Panel J3)		
			NOT ASSIGNED		
W6	5062-0767	1	CABLE ASSEMBLY, BATTERY (A2J9 to Rear Panel Battery Holder)	28480	5062-0767
W7	8120-5697	1	CABLE ASSEMBLY, RIBBON, LINE GEN	28480	8120-5697
Non-Opt 007			(A2J3 to A17J1)		
W7	8120-6172	1	CABLE ASSEMBLY, RIBBON, LINE GEN	28480	8120-6172
Option 007			(A2J3 to A16J1/J2 and A17J1)		
W8	5061-9030	1	CABLE ASSEMBLY, DISPLAY POWER (A6J4 to A17J2)	28480	5061-9030
W9	5062-6482	1	CABLE ASSEMBLY, CRT, YOKE	28480	5062-6482
			(A17J3 and J7 to A18V1)		
W10	5062-0742	1	CABLE ASSEMBLY, RIBBON, A11 YTO DRIVE	28480	5062-0742
			(A14J3 to A11J1)		
W11	08562-60064	1	CABLE ASSEMBLY, RIBBON, A9 ATTEN. DRIVE (A14J6 to A9)	28480	08562-60064
W12	5063-0655	1	CABLE ASSEMBLY, A7 LOMA DRIVE	28480	5063-0655
W13	5062-0743	1	CABLE ASSEMBLY, RIBBON, A13 2ND CONV DRIVE (A14J12 to A13)	28480	5062-0743
W14			NOT ASSIGNED		
W15	08562-60188	1	CABLE ASESEMBLY, A8 DRIVE	28480	08562-60188
			(serial prefix ≥3641A)		
W16	8120-5676	1	CABLE ASSEMBLY, A10 (RYTHM)/A12 (SBTX) DRIVE (A14J9 to A10)	28480	8120-5676
W17			NOT ASSIGNED		
W18	5062-0721	1	CABLE ASSEMBLY, COAX 97, LO SWEEP	28480	5062-0721
			0.5 V/GHz (A14J7 to Rear Panel J8)		
W19	5062-0723	1	CABLE ASSEMBLY, COAX 83	28480	5062-0723
Option 001			2ND IF OUT (A15J803 to Rear Panel J10)		
CABLE ASSEMBLIES (CONTINUED)					
W20	5062-0717	1	CABLE ASSEMBLY, COAX 6, 0 SPAN VIDEO	28480	5062-0717
			(A3J103 to A2J4)		
W21			NOT ASSIGNED		
W22	5062-0709	1	CABLE ASSEMBLY, COAX 0, 10 MHz FREQ. COUNT (A15J302 to A2J8)	28480	5062-0709
W23	5062-0719	1	CABLE ASSEMBLY, COAX 93, EXT TRIG IN	28480	5062-0719
			(Rear Panel J5 to A3J600)		

Table 5-4 Replaceable Parts

Reference Designation	Part Number	Qty	Description	Mfr Code	Mfr Part Number
			CABLES (continued)		
W24	5062-0720	1	CABLE ASSEMBLY, COAX, 5 VIDEO OUT (A3J102 to Rear Panel J4)	28480	5062-0720
W25	5062-0718	1	CABLE ASSEMBLY, COAX 4, BLANKING OUT (A3J601 to Rear Panel J6)	28480	5062-0718
W26			NOT ASSIGNED		
W27	5062-0714	1	CABLE ASSEMBLY, FILTER 10.7 MHz (A5J5 to A4J3)	28480	5062-0714
W28	5022-0915	1	CABLE ASSEMBLY, SEMI-RIGID, RYTHM LO (A7J3 to A10J4)	28480	5022-0915
W29	5062-0711	1	CABLE ASSEMBLY, COAX 7, 10.7 IF (A15J601 to A5J3)	28480	5062-0711
W30	5022-0913	1	CABLE ASSEMBLY, SEMI-RIGID, LOMA/FL3 (A7J5 to FL3J1)	28480	5022-0913
W31	5062-0722	1	CABLE ASSEMBLY, COAX 8, 10 MHz REF IN/OUT (A15J301 to Rear Panel J9)	28480	5062-0722
W32	5062-0705	1	CABLE ASSEMBLY, COAX 87, SAMPLER IF (A15J101 to A14J501)	28480	5062-0705
W33	5062-0706	1	CABLE ASSEMBLY, COAX 81, 2ND LO DRIVE (A15J701 to A13J4)	28480	5062-0706
W34	8120-6367	1	CABLE ASSEMBLY, COAX 0, 1ST LO SAMP. (FL3J2 to A15A2J1)	28480	8120-6367
W35	5062-0710	1	CABLE ASSEMBLY, COAX 92, INT 2ND IF (A13J2 to A15J801)	28480	5062-0710
W36	5062-0725	1	CABLE ASSEMBLY, COAX 86, EXT 2ND IF (Front Panel J3 to A15J802)	28480	5062-0725
W37	5062-0707	1	CABLE ASSEMBLY, COAX 85, 10 MHz REF 1 (A15J303 to A14J301)	28480	5062-0707
W38	5022-0917	1	CABLE ASSEMBLY, SEMI-RIGID, 1ST LO (A11J2 to A7J1)	28480	5022-0917
W39	5022-0911	1	CABLE ASSEMBLY, SEMI-RIGID, 1ST MIXER LO (A7J4 to A8J3, serial prefix <3641A)	28480	5022-0911
W39	5022-2830	1	CABLE ASSEMBLY, SEMI-RIGID, 1ST MIXER LO (A7J4 to A8J3, serial prefix ≥3641A)	28480	5022-2830
W40	5062-0724	1	CABLE ASSEMBLY, COAX 89, CAL OUT (A15J501 to Front Panel J5)	28480	5062-0724
W41	5022-0918	1	CABLE ASSEMBLY, SEMI-RIGID, RF INPUT (Front panel J1 to A9J1)	28480	5022-0918
W42	5022-0909	1	CABLE ASSEMBLY, SEMI-RIGID, 1ST LO OUT (A7J6 to Front Panel J4, serial prefix <3641A)	28480	5022-0909
W42	5022-2831	1	CABLE ASSEMBLY, SEMI-RIGID, 1ST LO OUT (A7J6 to Front Panel J4, serial prefix ≥3641A)	28480	5022-2831

Table 5-4 Replaceable Parts

Reference Designation	Part Number	Qty	Description	Mfr Code	Mfr Part Number
			CABLES (continued)		
W43	5022-0908	1	CABLE ASSEMBLY, SEMI-RIGID, ATTEN/SBTX (A9J2 to A12J3)	28480	5022-0908
W44	5022-0906	1	CABLE ASSEMBLY, SEMI-RIGID, RYTHM LOW BAND OUT (A10J2 to FL1J1)	28480	5022-0906
W45	5022-0912	1	CABLE ASSEMBLY, SEMI-RIGID, MIXER INPUT (FL1J2 to A8J1, serial prefix <3641A)	28480	5022-0912
W45	5022-2832	1	CABLE ASSEMBLY, SEMI-RIGID, MIXER INPUT (FL1J2 to AT1, serial prefix ≥3641A and <3804A, non-Option 006)	28480	5022-2832
W45	5022-2828	1	CABLE ASSEMBLY, SEMI-RIGID, MIXER INPUT (FL1J2 to A8J1, serial prefix ≥3641A, Option 006)	28480	5022-2828
W46	5022-0907	1	CABLE ASSEMBLY, SEMI-RIGID, SBTX LO (A7J2 to A12J4)	28480	5022-0907
W47	5022-0916	1	CABLE ASSEMBLY, SEMI-RIGID, MIXER IF OUT (A8J2 to A12J5, serial prefix <3641A)	28480	5022-0916
W47	5022-2829	1	CABLE ASSEMBLY, SEMI-RIGID, MIXER IF OUT (A8J2 to A12J5, serial prefix ≥3641A)	28480	5022-2829
W48	8120-5660	1	CABLE ASSEMBLY, COAX 8, 1ST IF HI BAND (A10J1 to A13J3)	28480	8120-5660
W49	5062-4892	1	CABLE ASSEMBLY, COAX 82, A21 OCXO (A21 to A15J305)	28480	5062-4892
W50	5063-0245	1	CABLE ASSEMBLY, OCXO (A21 to A15, Includes A21)	28480	5063-0245
W51	5062-6478	1	CABLE ASSEMBLY, COAX 84, 10 MHz REF2 (A15J304 to A4J7)	28480	5062-6478
W52	5062-6477	1	CABLE ASSEMBLY, COAX 9, 10.7 MHz CAL SIG (A5J4 to A4J8)	28480	5062-6477
W53	5062-6476	1	CABLE ASSEMBLY, COAX 1, FREQ COUNTER (A2J7 to A4J5)	28480	5062-6476
W54	5062-6475	1	CABLE ASSEMBLY, COAX 2, VIDEO (A3J101 to A4J4)	28480	5062-6475
W55	5062-6471	1	CABLE ASSEMBLY, AUDIO OUT (A4J6 to SPEAKER, LS1 and Rear Panel J1)	28480	5062-6471
W56	5022-0910	1	CABLE ASSEMBLY, SEMI-RIGID, SBTX IF OUT (A12J1 to FL2)	28480	5022-0910
W57	5022-0184	1	CABLE ASSEMBLY, SEMI-RIGID (FL2 to A13J1)	28480	5022-0184

Table 5-4 Replaceable Parts

Reference Designation	Part Number	Qty	Description	Mfr Code	Mfr Part Number
			CABLES (continued)		
W58 Option 005	5062-0722	1	CABLE ASSEMBLY, COAX 8, ALTN SWP OUT (A14J20 to Rear Panel J11)	28480	5062-0722
W59	5063-0282	1	CABLE ASSEMBLY, COAX 839, FAST ADC	28480	5063-0282
W60	8120-6919	1	DISPLAY CABLE, RIBBON (A2J8 to A17J1)	28480	8120-6919
W61	8120-5026	1	CABLE, COAX (A2J9to A17J7)	28480	8120-5026
W62	8120-8482	1	CABLE, RIBBON (A17J6 to A17A1)	28480	8120-8482
W63	8120-8409	1	CABLE, RIBBON (A17J5 to A18)	28480	8120-8409
W64	8121-0062	1	VGA CABLE ASSEMBLY (A17J4 to J1 on rear panel)	28480	8121-0062
Option 007			CLOCK (A2J15 to A16J3)		
Option 005			(A14J20 to Rear Panel J11)		

Figure 5-1 Assembly Screw Mounting Locations

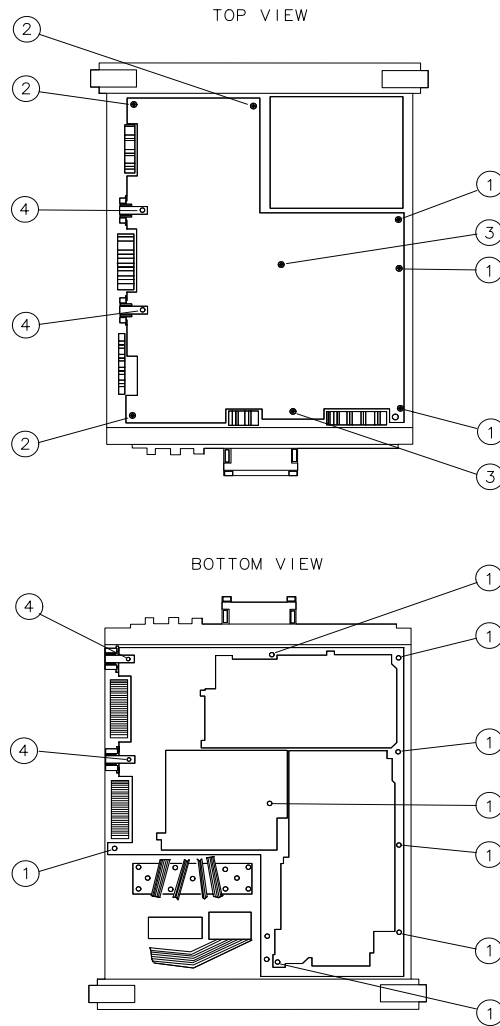

sp126e

Table 5-5 Replaceable Parts –8564E/EC and 8565E/EC

Item	Part Number	Qty	Description	Mfr Code	Mfr Part Number
1	0515-1349	11	SCREW-MACH M3 X 30MM-LG PAN-HD TORX	28480	0515-1349
2	0515-2310	3	SCREW-MACH M3 X 60MM-LG PAN-HD TORX	28480	0515-2310
3	0515-3208	2	SCREW-MACH M3 X 100MM-LG PAN-HD TORX	28480	0515-2308
4	0515-2332	12	SCREW-MACH M3 X 6MM-LG PAN-HD TORX	28480	0515-2332
4	0515-0664	2	SCREW-MACH M3 X 12MM-LG PAN-HD TORX	28480	0515-0664

Parts Identification, Assembly Mounting

Table 5-6 Parts List, Cover Assembly –8564E/EC and 8565E/EC (see Figure 5-2)

Item	Part Number	Qty	Description	Mfr Code	Mfr Part Number
1	5041-8911	1	BAIL HANDLE	28480	5041-8911
2	5041-8912	2	TRIM CAP	28480	5041-8912
3	0515-1114	4	SCREW MACH M4 X 10MM-LG PAN-HD	28480	0515-1114
4	1460-2164	2	SPRING-CPRSN .845 IN-OD 1.25-1N-OA-LG	28480	1460-2164
5	5021-6343	2	RING GEAR	28480	5021-6343
6	5021-6344	2	SOCKET GEAR	28480	5021-6344
7	5021-8667	2	HANDLE PLATE	28480	5021-8667
8	5001-8728	2	BACKUP PLATE	28480	5001-8728
9	0515-1367	6	SCREW MACH M4 X 8MM-LG 90DEG-FLT-HD	28480	0515-1367
10	0515-1133	2	SCREW-MACH M5 X 16MM-LG	28480	0515-1133
11	5001-8800	1	COVER	28480	5001-8800
12	5041-7238	1	MOISTURE DEFLECTOR-LF	28480	5041-7238
13	5041-3989	1	MOISTURE DEFLECTOR-RT	28480	5041-3989
14	5041-8913	2	SIDE TRIM	28480	5041-8913
15	0515-1114	2	SCREW-MACH M4 X 10MM-LG PAN-HD	28480	0515-1114
16	5041-8907	2	REAR FOOT	28480	5041-8907
17	0900-0024	4	O-RING .145-1N-XSECT-DIA SIL	51633	A5568-007
18	2190-0587	4	WASHER-LK HLCL 5.0 MM 5.1-MM-ID	28480	2190-0587
19	0515-1218	4	SCREW-SKT-HD-CAP M5 X 40MM-LG	28480	0515-1218
20	08562-80028	1	INSULATOR 292 X 355 MM .51 THK	28480	08562-80028

Table 5-7 Parts List, Main Chassis – 8564EC and 8565EC (see Figure 5-7)

Item	Part Number	Qty	Description	Mfr Code	Mfr Part Number
1	0515-2145	4	SCREW-MACH M3 X 8MM-LG PAN-HD TORX	28480	0515-2145
5	5002-1010	1	COVER, A6 POWER SUPPLY (Includes label)	28480	5002-1010
6	0515-2309	3	SCREW-MACH M3 X 0.5 45MM-LG TORX	28480	0515-2309
14	5002-1008	1	MAIN DECK	28480	5002-1008
15	5002-1002	1	FRONT END DECK	28480	5002-1002
16	0515-1101	4	SCREW-MACH M4 X 8MM-LG FLH-HD TORX	28480	0515-1101
17	0515-1227	2	SCREW MACH M3 X 6MM-LG FLH-HD TORX	28480	0515-1227
18	5021-7464	2	SIDE FRAME	28480	5021-7464
19	0515-1101	12	SCREW-MACH M4 X 8MM-LG FLH-HD TORX	28480	0515-1101
20	0515-1227	12	SCREW MACH M3 X 6MM-LG FLH-HD TORX	28480	0515-1227
21	0515-1227	8	SCREW MACH M3 X 6MM-LG FLH-HD TORX	28480	0515-1227
22	0515-1227	5	SCREW MACH M3 X 6MM-LG FLH-HD TORX	28480	0515-1227
23	5021-5484	5	MOUNTING POST	28480	5021-5484
24	5062-0750	2	HINGE, 2 BOARD	28480	5062-0750
25	5062-0751	2	HINGE, 4 BOARD	28480	5062-0751
26	5041-7250	1	CABLE CLAMP	28480	5041-7250
27	0515-2164	2	SCREW-MACH M3 X 35MM-LG TORX	28480	0515-2164
28	0515-1227	2	SCREW-MACH M3 X 6MM-LG FLH-HD TORX	28480	0515-1227

Table 5-7 Parts List, Main Chassis – 8564EC and 8565EC (see Figure 5-7)

Item	Part Number	Qty	Description	Mfr Code	Mfr Part Number
30	5063-0269	1	SHIELD WALL, TOP	28480	5063-0269
31	5063-0268	1	SHIELD WALL, BOTTOM	28480	5063-0268
33	0515-0430	2	SCREW-INVERTER BOARD	28480	0515-0430
34	0515-0372	4	SCREW-DISPLAY DRIVER	28480	0515-0372
35	0400-0333	4	STANDOFF CUSHIONS	28480	0400-0333
36	1000-1014	1	LCD GLASS PLATE	28480	1000-1014
37	5041-9632	1	LCD MOUNT	28480	5041-9632
38	5000-8314	1	LCD BACKPLATE	28480	5000-8314
39	5022-3667	1	LCD DRIVER SHIELD	28480	5022-3667
A17	08562-6016	1	LCD DRIVER BOARD	28480	08562-6016
A17A1	0950-60166	1	INVERTER BOARD	28480	0950-60166
A18	2090-0379	1	LCD ASSEMBLY - INCLUDES LCD GLASS, LCD MOUNT, AND A18DS1 and A18DS2 BACKLIGHT CABLES	28480	2090-0379

Table 5-8 Parts List, Main Chassis –8564E and 8565E (See Figure 5-3)

Item	Part Number	Qty	Description	Mfr Code	Mfr Part Number
1	0515-2145	4	SCREW-MACH M3 X 8MM-LG PAN-HD TORX	28480	0515-2145
3	0515-1715	3	SCREW-MACH M3 X 35MM-LG PAN-HD TORX	28480	0515-1715
4	0380-2052	2	SPACER .937LG .166ID	28480	0380-2052
5	5002-1010	1	COVER, A6 POWER SUPPLY (Includes label)	28480	5002-1010
6	0515-2309	3	SCREW-MACH M3 X 0.5 45MM-LG TORX	28480	0515-2309
7	5041-7246	1	BOARD MOUNT	28480	5041-7246
8	0515-1950	2	SCREW-MACH M3 X 8MM-LG PAN-HD TORX	28480	0515-1950
9	5041-8961	1	COVER, A17	28480	5041-8961
10	5021-5486	2	CRT MOUNT	28480	5021-5486
11	5001-5870	2	CRT MOUNT STRAP	28480	5001-5870
13	0515-2134	4	SCREW-MACH M3 X 10MM-LG PAN-HD TORX	28480	0515-2134
14	5002-1008	1	MAIN DECK	28480	5002-1008
15	5002-1002	1	FRONT END DECK	28480	5002-1002
16	0515-1101	4	SCREW-MACH M4 X 8MM-LG FLT-HD TORX	28480	0515-1101
17	0515-1227	2	SCREW MACH M3 X 6MM-LG FLT-HD TORX	28480	0515-1227
18	5021-7464	2	SIDE FRAME	28480	5021-7464
19	0515-1101	12	SCREW-MACH M4 X 8MM-LG FLT-HD TORX	28480	0515-1101
20	0515-1227	12	SCREW MACH M3 X 6MM-LG FLT-HD TORX	28480	0515-1227
21	0515-1227	8	SCREW MACH M3 X 6MM-LG FLT-HD TORX	28480	0515-1227
22	0515-1227	5	SCREW MACH M3 X 6MM-LG FLT-HD TORX	28480	0515-1227
23	5021-5484	5	MOUNTING POST	28480	5021-5484
24	5062-0750	2	HINGE, 2 BOARD	28480	5062-0750
25	5062-0751	2	HINGE, 4 BOARD	28480	5062-0751
26	5041-7250	1	CABLE CLAMP	28480	5041-7250
27	0515-2164	2	SCREW-MACH M3 X 35MM-LG TORX	28480	0515-2164

Table 5-8 Parts List, Main Chassis –8564E and 8565E (See Figure 5-3)

Item	Part Number	Qty	Description	Mfr Code	Mfr Part Number
28	0515-1227	2	SCREW-MACH M3 X 6MM-LG FLT-HD TORX	28480	0515-1227
29	5181-5040	1	LABEL, ASSEMBLY LOCATIONS	28480	5181-5040
30	5181-5046	1	LABEL, WARNING	28480	5181-5046
A18MP1	5062-7095	1	CRT WIRING ASSY (INCLUDES A18L1, A18W1)	28480	5062-7095
A18MP2	5041-3987	1	SPACER, CRT	28480	5041-3987
A18V1	2090-0225	1	TUBE, CRT	28480	2090-0225
A18W1			P/O A18MP1		
31	5041-7248	1	BOARD TRAY, A17	28480	5041-7248
32	5063-0268	1	SHLD WALL ASSY BOTTOM	28480	5063-0268
34	5063-0269	1	SHLD WALL ASSY TOP	28480	5063-0269
35	0515-0665	2	SCREW-MACH M3 X 14MM-LG FLT-HD TORX	28480	0515-0665

Table 5-9 Parts List, RF Section –8564E/EC and 8565E/EC (See Figure 5-4)

Item	Part Number	Qty	Description	Mfr Code	Mfr Part Number
1	0515-1032	2	SCREW-MACH M3 X 6MM-LG PAN-HD TORX	28480	0515-1032
2	0515-2332	2	SCREW-MACH M3 X 6MM-LG PAN-HD TORX	28480	0515-2332
3	0515-2332	2	SCREW-MACH M3 X 6MM-LG PAN-HD TORX	28480	0515-2332
4	5021-7467	1	FILTER CLAMP	28480	5021-7467
6	0515-2332	2	SCREW-MACH M3 X 6MM-LG PAN-HD TORX	28480	0515-2332
7	5002-1008	1	MAIN DECK	28480	5002-1008
8	0515-1227	2	SCREW-MACH M3 X 6MM-LG FLT-HD TORX	28480	0515-1227
9	5002-1002	1	FRONT END DECK	28480	5002-1002
11	0515-1032	4	SCREW-MACH M3 X 6MM-LG FLT-HD TORX	28480	0515-1032
12	2360-0461	4	SCREW-MACH 6-32 .375-IN-LG TORX	28480	2360-0461
13	0515-0372	1	SCREW-MACH M3 X 8MM-LG PAN-HD TORX	28480	0516-0372
14	0515-1250	2	SCREW-MACH M3 X 6MM-LG PAN-HD TORX	28480	0516-1250
15	5001-8731	1	ATTENUATOR BRACKET	28480	5001-8731
18	5002-1007	1	ATTENUATOR BRACKET	28480	5002-1007
19	0515-1250	2	SCREW-MACH M3 X 6MM-LG PAN-HD TORX	28480	0515-1250
20	0515-1227	3	SCREW-MACH M3 X 6MM-LG FLT-HD TORX	28480	0515-1227
22	0515-1227	6	SCREW-MACH M3 X 6MM-LG FLT-HD TORX	28480	0515-1227
23	0515-1410	2	SCREW-MACH M3 X 20MM-LG FLT-HD TORX	28480	0515-1410
24	5002-1009	1	EMI SHIELD	28480	5002-1009
25	0515-1521	10	SCREW-MACH M3 X 5MM FLT-HD TORX	28480	0515-1521

Table 5-10 Parts List, Front Frame – 8564EC and 8565EC (see Figure 5-8)

Item	Part Number	Qty	Description	Mfr Code	Mfr Part Number
1	08564-80055	1	8564EC - DRESS PANEL OVERLAY	28480	08564-80055
1	08565-80054	1	8565EC - DRESS PANEL OVERLAY	28480	08565-80054
1	08564-80056	1	8564EC (006) - DRESS PANEL OVERLAY	28480	08564-80056
1	08565-80055	1	8564EC (006) - DRESS PANEL OVERLAY	28480	08565-80055
2	5181-8245		CONNECTOR OVERLAY	28480	5181-8245
4	0370-3069	1	KNOB BASE 1-1/8 JGK .252-IN-IO (INCLUDES ITEM 5)	28480	0370-3069
5	3030-0022	2	SCREW-SET 6-32 .125-IN-LG SMALL CUP-PT	00000	DESCRIBE
6	2950-0043	1	NUT-HEX-DBL-CHAM 3/8-32-THD .094-IN-THK	00000	DESCRIBE
7	2190-0016	1	WASHER-LK INTL T 3/8 IN .377-IN-ID	28480	2190-0016
8	5181-8246	1	FRONT PANEL-DRESS	28480	5181-8246
9	5060-0467	1	PROBE POWER JACK	28480	5060-0467
10	0590-1251	1	NUT-SPCLY 15/32-32-THD .1-IN-THK .562-WD	00000	DESCRIBE
	6960-0171	1	PLUG-HOLE (Opt. 327)(not shown)	28480	6960-0171
11	1250-1666	2	ADAPTOR COAX STR F-SMA F-SMA	28480	1250-1666
12	0515-2145	12	SCREW-MACH M3 X 0.5 8MM-LG PAN-HD TX	28480	0515-2145
13	5062-4806	1	BUMPER KIT (Includes 4 bumpers)	28480	5062-4806
15	5021-5483	2	CATCH LATCH	28480	5021-5483
16	0515-0366	4	SCREW-MACH M2.5 X 0.45 6MM-LG PAN-HD TX	28480	0515-0366
17	5022-0199	1	FRONT FRAME	28480	5022-0199
18	8160-0520	1	RFI ROUND STRIP STL MSH/SIL RBR CU/SN	28480	8160-0520
19	0590-2563	1	NUT	28480	0590-2563
20	2190-0016	1	WASHER-LK INTL T 3/8 IN .377-IN-ID	28480	2190-0016
21	2950-0043	1	NUT-HEX-DBL-CHAM 3/8-32-THD .094-IN-THK	00000	DESCRIBE
22	5064-3970	1	RF INPUT ASSEMBLY	28480	5064-3968
22	5064-3969	1	8563EC (Option 026) - RF INPUT ASSEMBLY	28480	5064-3968
24	5041-9630		RUBBER KEYPAD (INCLUDES KEYCAPS)	28480	5041-9630
25	1990-1131	1	LED-LAMP LUM-INT=560UCD IF=20MA-MAX	2M627	LD-101MG
26	5063-3966	1	LINE SWITCH CABLE ASSEMBLY	28480	5063-3966
27	0900-0010	1	O-RING .101-IN-ID .07-IN-XSECT-DIA NTRL	51633	AS568-005
28	0515-0664	1	SCREW-MACHINE ASSEMBLYM3 X0.5 12MM-LG	28480	0515-0664
31	0515-1934	7	SCREW-MACH M2.5 X 0.45 6MM-LG PAN-HD TX (P/O A1W1)	28480	0515-1934
32	2100-4232	1	R-VC 20K 20% LOG	28480	2100-4232
33	3050-0014	2	WASHER-FL .250ID12	28480	3050-0014
34	2190-0067	1	WASHER-LK INTL .256-IN-ID	28480	2190-0067
35	2950-0072	1	NUT-HEX 1/4-32 THD	28480	2950-0072
36	0370-3079	1	KNOB RND .125 JG	28480	0370-3079

Table 5-11 Parts List, Front Frame –8564E and 8565E (See Figure 5-5)

Item	Part Number	Qty	Description	Mfr Code	Mfr Part Number
1	0515-1622	4	SCREW-SKT-HD-CAP M4 X 0.7 8MM-LG	28480	0515-1622
2	5041-8906	1	CRT BEZEL	28480	5041-8906
3	1000-0897	1	RFI CRT FACEPLATE	28480	1000-0897
4	0370-3069	1	KNOB BASE 1-1/8 JGK .252-IN-IO (INCLUDES ITEM 5)	28480	0370-3069
5	3030-0022	2	SCREW-SET 6-32 .125-IN-LG SMALL CUP-PT	00000	DESCRIBE
6	2950-0043	1	NUT-HEX-DBL-CHAM 3/8-32-THD .094-IN-THK	00000	DESCRIBE
7	2190-0016	1	WASHER-LK INTL T 3/8 IN .377-IN-ID	28480	2190-0016
8	08564-00001	1	FRONT PANEL-DRESS (Standard) (8564E)	28480	08564-00001
8	08564-00002	1	FRONT PANEL-DRESS (Option 006) (8564E)	28480	08564-00002
8	08565-00161	1	FRONT PANEL-DRESS (Standard) (8565E)	28480	08565-00161
8	08565-00162	1	FRONT PANEL-DRESS (Option 006) (8565E)	28480	08565-00162
9	5060-0467	1	PROBE POWER JACK	28480	5060-0467
10	0590-1251	1	NUT-SPCLY 15/32-32-THD .1-IN-THK .562-WD	00000	DESCRIBE
11	1250-1666	2	ADAPTOR COAX STR F-SMA F-SMA	28480	1250-1666
12	0515-2145	12	SCREW-MACH M3 X 0.5 8MM-LG PAN-HD TX	28480	0515-2145
13	5062-4806	1	BUMPER KIT (Includes 4 bumpers)	28480	5062-4806
14	0905-1018	4	O-RING .126TD	28480	0905-1018
15	5021-5483	2	CATCH LATCH	28480	5021-5483
16	0515-0366	4	SCREW-MACH M2.5 X 0.45 6MM-LG PAN-HDTX	28480	0515-0366
17	5022-0199	1	FRONT FRAME	28480	5022-0199
18	8160-0520	1	RFI ROUND STRIP STL MSH/SIL RBR CU/SN	28480	8160-0520
19	0535-0082	2	NVTM W LKWR M4	28480	0535-0082
20	2190-0016	1	WASHER-LK INTL T 3/8 IN .377-IN-ID	28480	2190-0016
21	2950-0043	1	NUT-HEX-DBL-CHAM 3/8-32-THD .094-IN-THK	00000	DESCRIBE
22	5062-6614	1	RF INPUT ASSEMBLY (Standard)	28480	5062-6614
23	0515-2145	2	SCREW-MACH M3 X 0.5 8MM-LG PAN-HD TX	28480	0515-2145
24	5041-8985	1	RUBBER KEYPAD (INCLUDES KEYCAPS)	28480	5041-8985
25	1990-1131	1	LED-LAMP LUM-INT=560UCD IF=20MA-MAX	2M627	LD-101MG
26	5041-1682	1	KEYCAP "LINE"	28480	5041-1682
27	0900-0010	1	O-RING .101-IN-ID .07-IN-XSECT-DIA NTRL	51633	AS568-005
28	0515-0664	1	SCREW-MACHINE ASSEMBLY M3 X 0.5 12MM-LG	28480	0515-0664
29	5021-5482	1	SUPPORT CENTER	28480	5021-5482
30	0515-1143	2	SCREW-MACH M4 X 0.7 16MM-LG PAN-HD TX	28480	0515-1143
31	0515-1934	9	SCREW-MACH M2.5 X 0.45 6MM-LG PAN-HDTX (P/O A1W1)	28480	0515-1934
32	2100-4232	1	R-VC 20K 20% LOG	28480	2100-4232
33	3050-0014	2	WASHER-FL .250ID12	28480	3050-0014
34	2190-0067	1	WASHER-LK INTL .256-IN-ID	28480	2190-0067
35	2950-0072	1	NUT-HEX 1/4-32 THD	28480	2950-0072
36	0370-3079	1	KNOB RND .125 JG	28480	0370-3079

Table 5-12 Parts List, Rear Frame –8564EC and 8565EC (See Figure 5-9)

Item	Part Number	Qty	Description	Mfr Code	Mfr Part Number
1	0515-1946	2	SCREW-MACH M3 6MM-LG FLT-HD TORX	28480	0515-1946
2	5062-7755	1	BATTERY HOLDER (INCLUDES WIRES)	28480	5062-7755
3	0515-2216	4	SCREW-MACH M4 40MM-LG PAN-HD TORX	28480	0515-2216
4	3160-0309	1	FAN GRILL	28480	3160-0309
5	0380-0012	4	SPACER-RND .875-IN-ID	28480	0380-0012
7	6960-0149	1	PLUG-HOLE TR-HD FOR 0.5-D-HOLE STL	05093	SS-48152
8	6960-0023	1	PLUG-HOLE DOME-HD FOR 0.312-D-HOLE STL	04213	D-2730-LC2
9	1250-1753	1	ADAPTOR-COAX STR F-SMA OPT 001 (INCLUDES WASHER AND NUT)	28480	1250-1753
10	0515-1946	2	SCREW-MACH M3 6MM-LG FLT-HD TORX	28480	0515-1946
11	0515-0684	1	SCREW-MACH M3 6MM-LG PAN-HD TORX	28480	0515-0684
12	2950-0035	1	NUT HEX 15/32THD	28480	2950-0035
13	1252-0995	1	CONNECTOR-TEL 2-CKT .141-SHK-DIA (INCLUDES NUT AND JACK)	28480	1252-0995
14	5002-1012	1	REAR PANEL-DRESS	28480	5002-1012
15	0515-2145	4	SCREW-MACH M3 6MMLG PAN-HD TORX	28480	0515-2145
16	8160-0520	1	RFI ROUND STRIP STL SPIRA .150	28480	8160-0520
17	5021-5479	1	REAR FRAME	28480	5021-5479
18	5021-6391	2	SCREW-CONNECTOR GPIB	28480	5021-6391
19	2200-0225	2	SCREW-MACH 4-40 .25-IN-LG TORX	28480	2200-0225
20	0535-0082	2	NUT M4.0 W/LOCKWR	28480	0535-0082
21	0515-0433	1	SCREW-MACH M3 6MM-LG PAN-HD TORX	28480	0515-0433
22	0535-0023	2	NUT-HEX DBL-CHAM M4 X 0.7 3.2MM-THK	28480	0535-0023
B1	5061-9036	1	FAN ASSEMBLY (INCLUDES WIRE)	28480	5061-9036
BT1	1420-0341	1	BATTERY 3.0V 1.2A-HR LITHIUM POLYCARBON MONOFLUORIDE	08709	BR 2/3A SSP
FL4	5061-9032	1	LINE FILTER MODULE	28480	5061-9032

Table 5-13 Parts List, Rear Frame –8564E and 8565E (See Figure 5-6)

Item	Part Number	Qty	Description	Mfr Code	Mfr Part Number
1	0515-1946	2	SCREW-MACH M3 6MM-LG FLT-HD TORX	28480	0515-1946
2	5062-7755	1	BATTERY HOLDER (INCLUDES WIRES)	28480	5062-7755
3	0515-2216	4	SCREW-MACH M4 40MM-LG PAN-HD TORX	28480	0515-2216
4	3160-0309	1	FAN GRILL	28480	3160-0309
5	0380-0012	4	SPACER-RND .875-IN-ID	28480	0380-0012
7	6960-0149	1	PLUG-HOLE TR-HD FOR 0.5-D-HOLE STL	05093	SS-48152
8	6960-0023	1	PLUG-HOLE DOME-HD FOR 0.312-D-HOLE STL	04213	D-2730-LC2
9	1250-1753	1	ADAPTOR-COAX STR F-SMA OPT 001 (INCLUDES WASHER AND NUT)	28480	1250-1753
10	0515-1946	2	SCREW-MACH M3 6MM-LG FLT-HD TORX	28480	0515-1946
11	0515-0684	1	SCREW-MACH M3 6MM-LG PAN-HD TORX	28480	0515-0684

Table 5-13 Parts List, Rear Frame –8564E and 8565E (See Figure 5-6)

Item	Part Number	Qty	Description	Mfr Code	Mfr Part Number
12	2950-0035	1	NUT HEX 15/32THD	28480	2950-0035
13	1252-0995	1	CONNECTOR-TEL 2-CKT .141-SHK-DIA (INCLUDES NUT AND JACK)	28480	1252-0995
14	5002-4049	1	REAR PANEL-DRESS	28480	5002-4049
15	0515-2145	4	SCREW-MACH M3 6MMLG PAN-HD TORX	28480	0515-2145
16	8160-0520	1	RFI ROUND STRIP STL SPIRA .150	28480	8160-0520
17	5022-3778	1	REAR FRAME	28480	5022-3778
18	5021-6391	2	SCREW-CONNECTOR GPIB	28480	5021-6391
19	2200-0225	2	SCREW-MACH 4-40 .25-IN-LG TORX	28480	2200-0225
20	0535-0082	2	NUT M4.0 W/LOCKWR	28480	0535-0082
21	0515-0433	1	SCREW-MACH M3 6MM-LG PAN-HD TORX	28480	0515-0433
22	0535-0023	2	NUT-HEX DBL-CHAM M4 X 0.7 3.2MM-THK	28480	0535-0023
23	8121-0062	1	VGA CONNETOR AND CABLE	28480	8121-0062
B1	5061-9036	1	FAN ASSEMBLY (INCLUDES WIRE)	28480	5061-9036
BT1	1420-0341	1	BATTERY 3.0V 1.2A-HR LITHIUM POLYCARBON MONOFLURIDE	08709	BR 2/3A SSP
FL4	5061-9032	1	LINE FILTER MODULE	28480	5061-9032

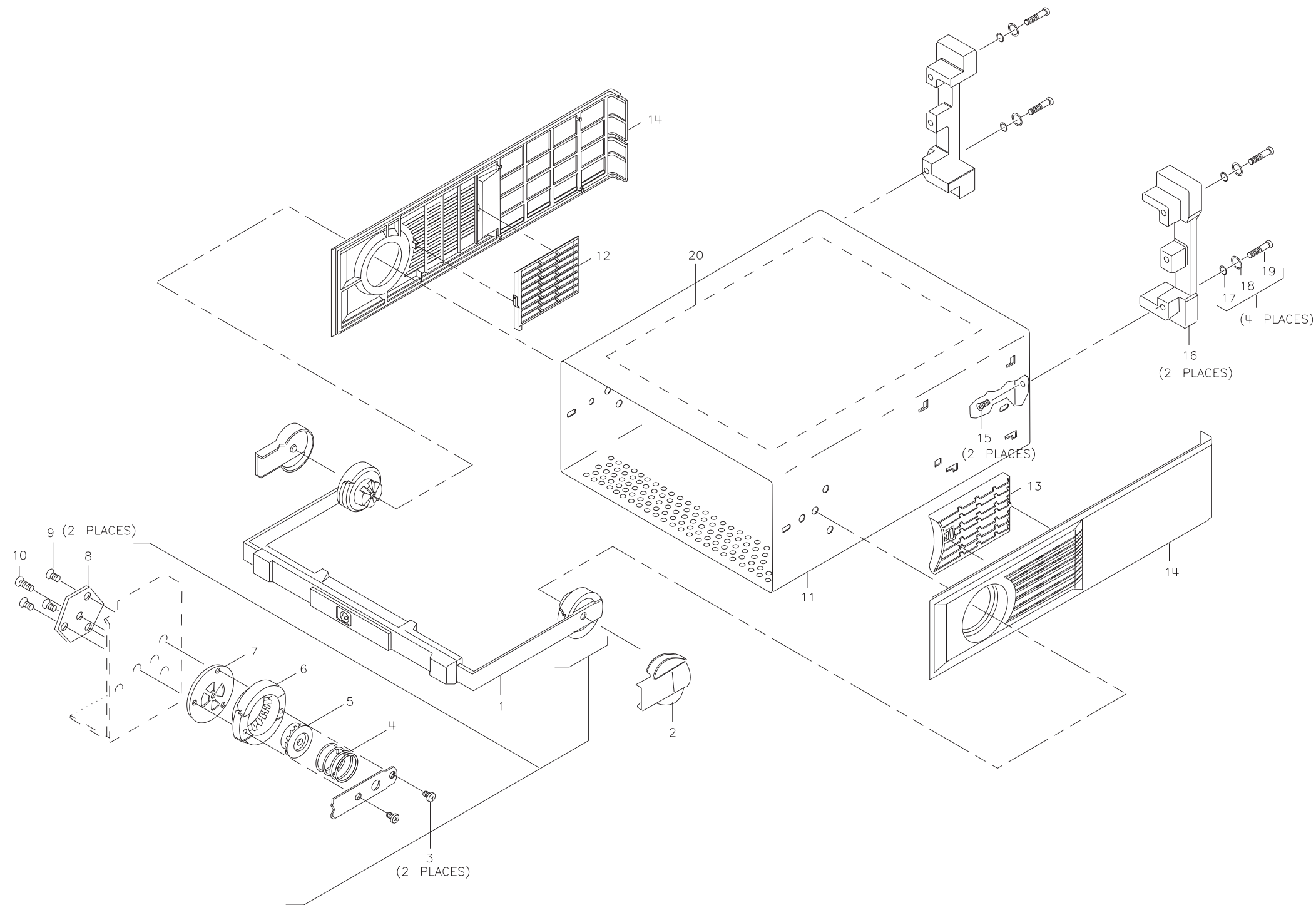
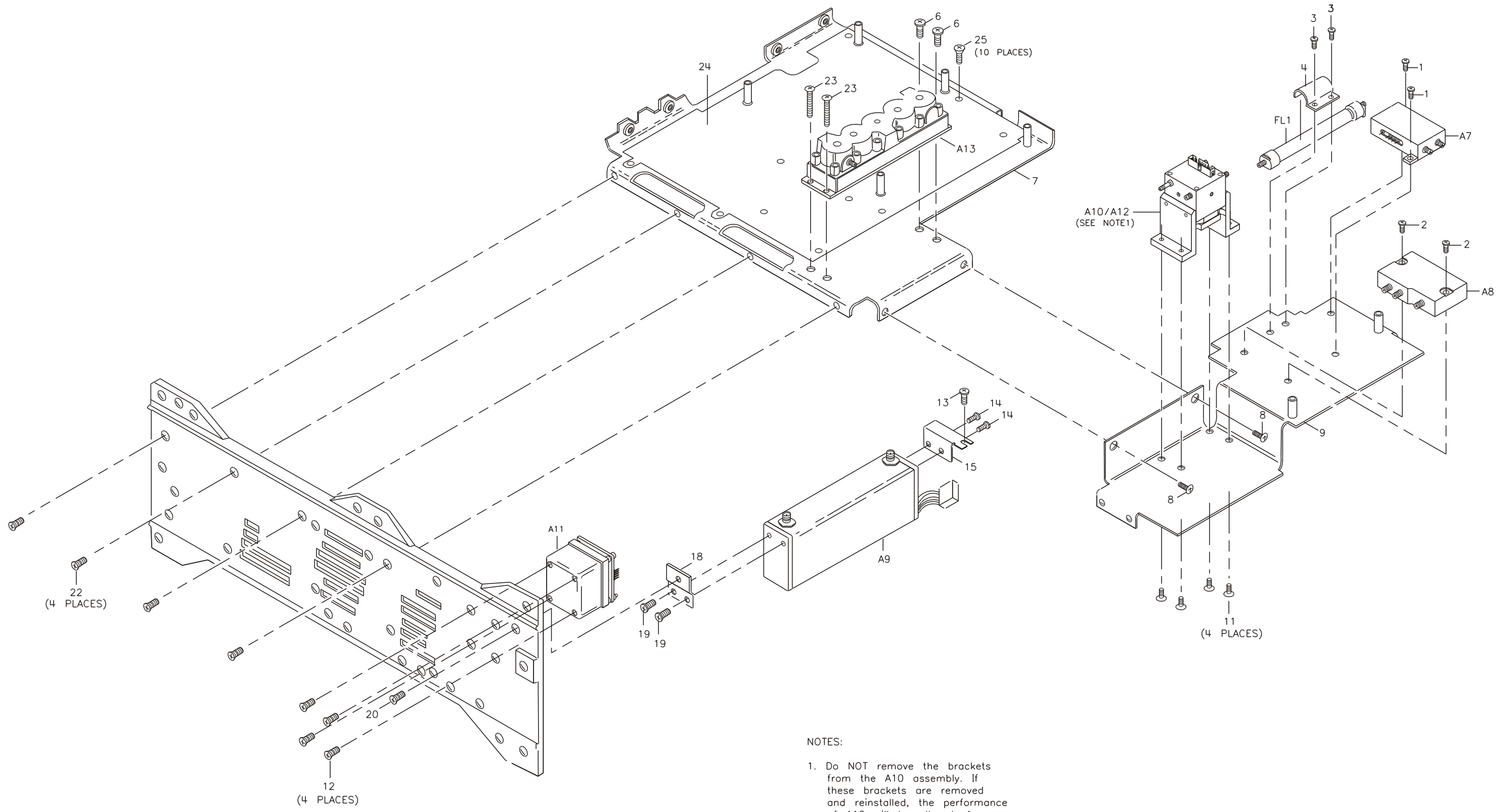

Figure 5-2. Parts Identification, Cover Assembly



sz18e

Figure 5-4. Parts Identification, RF Section, 8564E/EC and 8565E/EC

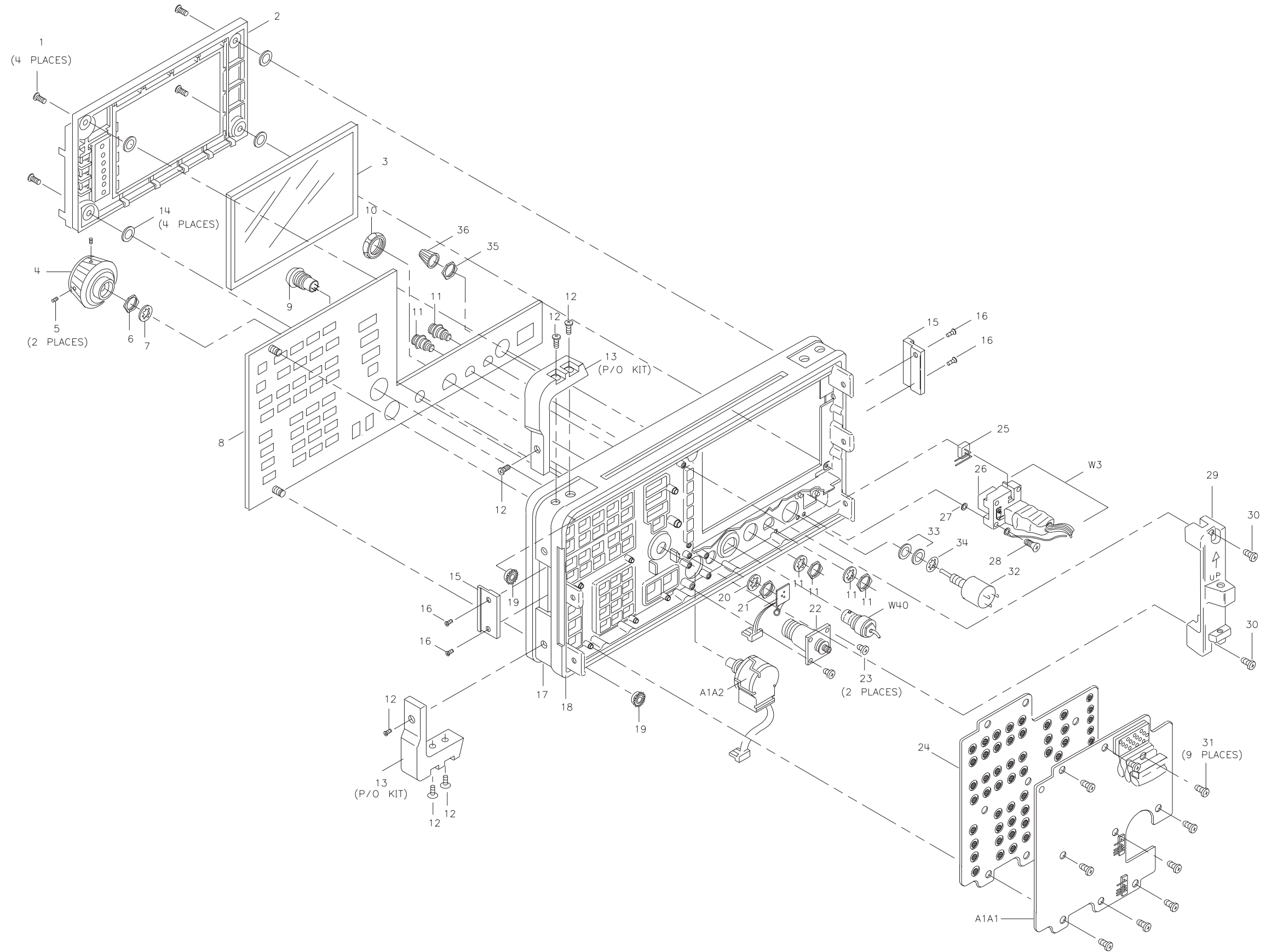

Figure 5-5. Parts Identification, Front Frame

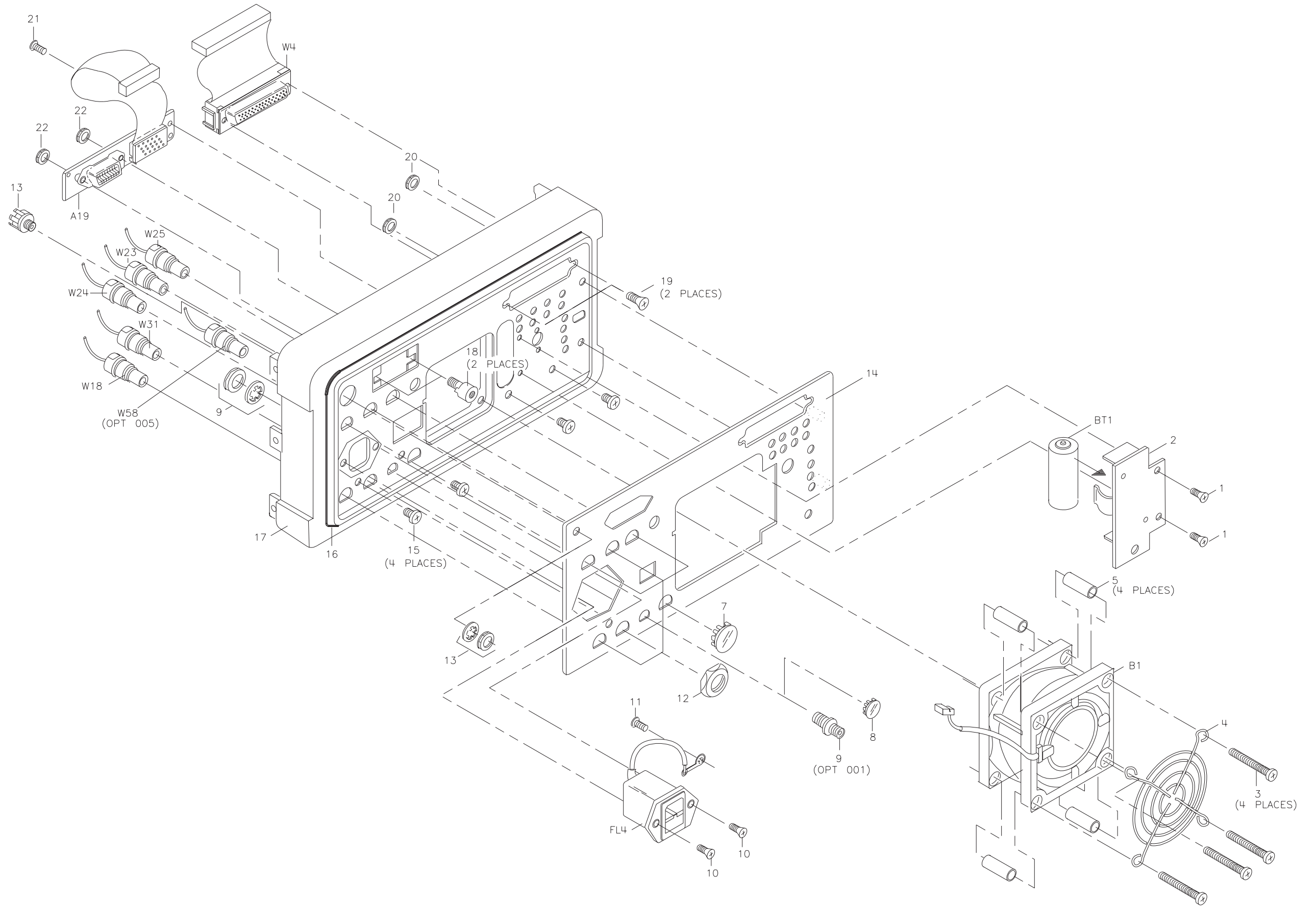

Figure 5-6. Parts Identification, Rear Frame

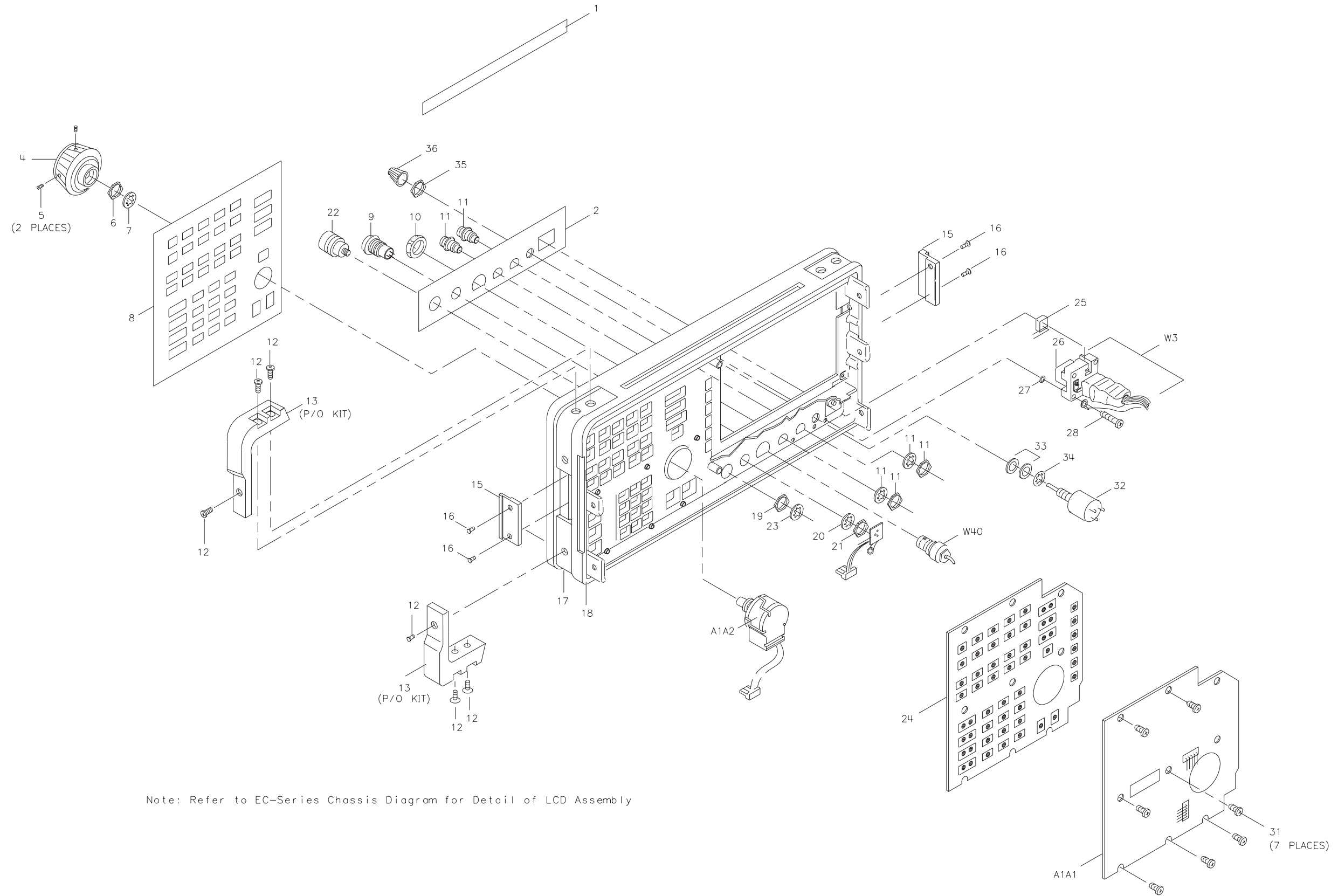

Figure 5-8. Parts Identification, Front Frame

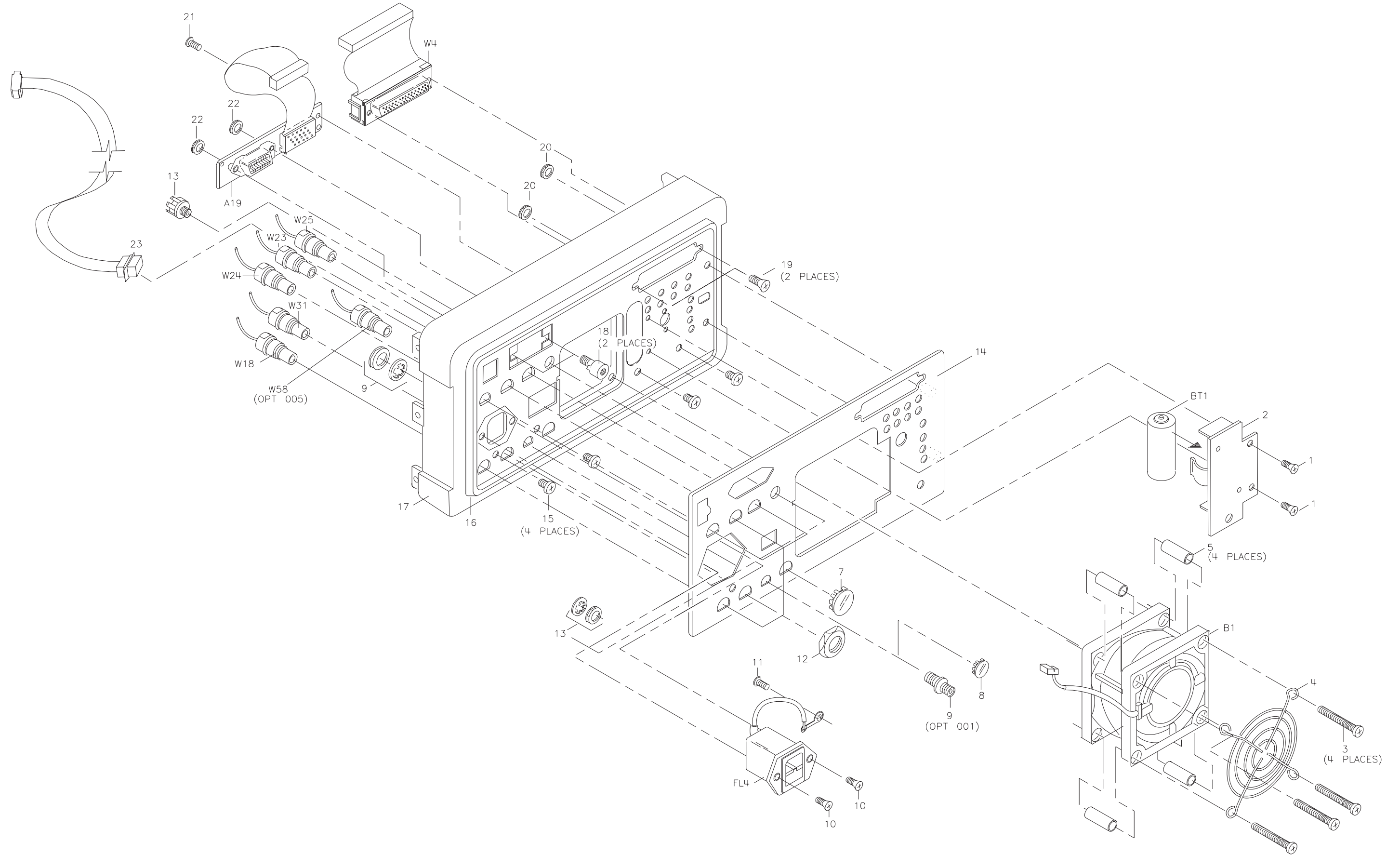

Figure 5-9. Parts Identification, Rear Frame

Introduction

This chapter identifies the instrument's assemblies and cables and contains the following figures:

Figure 6-1. Hinged Assemblies	page 306
Figure 6-2. Top View (A2 and A3 Unfolded) EC-Series	page 307
Figure 6-3. Top View (A2, A3, A4, A5 Unfolded) EC-Series	page 308
Figure 6-2. Top View (A2 Unfolded) E-Series	page 307
Figure 6-3. Top View (A2 and A3 Unfolded) E-Series	page 308
Figure 6-4. Top View (A2, A3, A4, A5 Unfolded) E-Series	page 309
Figure 6-5. Bottom View (A15 Unfolded).....	page 310
Figure 6-6. Bottom View (A15 and A14 Unfolded)	page 311
Figure 6-7. A16 Fast ADC (Option 007 in E-Series)	page 312
Figure 6-8. 8564E/EC and 8565E/EC Front End	page 313
Figure 6-9. Rear View EC-Series.....	page 314
Figure 6-9. Rear View E-Series	page 314

Use the list below to determine the figure(s) illustrating the desired assembly or cable.

Assemblies	Figure
A1 Front Frame	6-8
A1A1 Keyboard	6-8
A2 Controller	6-3, 6-4
A3 Interface	6-3, 6-4
A4 Log Amplifier/Cal Oscillator	6-3, 6-5
A5 IF Filter	6-3, 6-6
A6 Power Supply	6-6
A6A1 High Voltage Module	6-6
A7 LO Multiplier/Amplifier (LOMA)	6-10
A8 Low Band Mixer	6-10
A9 RF Attenuator	6-10
A10/A12 RYTHM/SBTX	6-10
A11 YTO	6-10
A13 Second Converter	6-10
A14 Frequency Control	6-3, 6-8
A15 RF	6-3, 6-8
A16 Fast ADC (Option 007)	6-6, 6-9
A17 LCD Driver (8564E and 8565E).....	6-2, 6-3
A17 CRT Driver	6-6
A18 LCD (8564E and 8565E)	6-2,6-3
A18 CRT Assembly	6-6
A19 GPIB	6-6
A20 Battery Assembly	6-11
A21 OCXO	6-6
B1 Fan	6-11
BT1 Battery	6-11
FL1 Low Pass Filter	6-10

FL2 Low Pass Filter	6-10
FL3 Low Pass Filter	6-10
FL4 Line Filter	6-11
FL5 Low Pass Filter	6-10
LS1 Speaker	6-6, 6-9

Cables	Figure
A1A1W1 Keyboard cable	6-4, 6-6
A3W1 Interface cable	6-4
A19W1 GPIB cable	6-4, 6-6
W1 Power cable, ribbon	6-4, 6-5, 6-6, 6-7
W2 Control cable, ribbon	6-4, 6-5, 6-6, 6-7
W3 Line switch cable	6-6, 6-10, 6-11
W4 Option module cable	6-6
W5 Speaker leads	6-9
W6 Battery cable (Part of A20 battery assembly)	6-4
W7 Line generator cable	6-4
W8 Display power cable	6-6
W9 CRT yoke cable	6-6
W10 A11 YTO drive cable	6-8, 6-10, 6-11
W11 A9 attenuator drive cable	6-8
W12 A7 LOMA drive cable	6-8, 6-10
W13 A13 Second converter drive cable	6-8, 6-10
W14 (NOT ASSIGNED)	
W15 (NOT ASSIGNED)	
W16 A10/A12 RYTHM/SBTX drive cable	6-8, 6-10
W17 (NOT ASSIGNED)	
W18 LO sweep (coax 97)	6-8
W19 Second IF out (coax 83)	6-7
W20 Zero-span video (coax 6)	6-4, 6-9
W21 (NOT ASSIGNED)	
W22 10 MHz frequency count (coax 0)	6-4, 6-7
W23 External trigger in (coax 93)	6-4
W24 Video out (coax 5)	6-4
W25 Blanking out (coax 4)	6-4
W26 (NOT ASSIGNED)	
W27 Filtered 10.7 MHz (coax 3)	6-5, 6-6
W28 RYTHM LO cable	6-10
W29 10.7 IF (coax 7)	6-6, 6-7
W30 LOMA/FL3 cable	6-10
W31 10 MHz Reference in/out (coax 8)	6-7
W32 Sampler IF (coax 87)	6-7, 6-8
W33 Second LO drive (coax 81)	6-7, 6-10
W34 1st LO Sampler (Coax 0)	6-7, 6-8, 6-10
W35 Int Second IF (Coax 92)	6-7, 6-10
W36 Ext Second IF (Coax 86)	6-7
W37 10 MHz Reference 1 (Coax 85)	6-7, 6-8
W38 Semirigid coax, A11J2 to A7J1	6-10
W39 Semirigid coax, A7J4 to A8J3	6-10

W40 Cal. Out (Coax 89)	6-7
W41 Semirigid coax, front-panel J1 to A9J1	6-10
W42 Semirigid coax, A7J6 to front-panel J4	6-10
W43 Semirigid coax, A9J2 to A12J3	6-10
W44 Semirigid coax, A10J2 to FL1J1	6-10
W45 Semirigid coax, FL1J2 to A8J1	6-10
W46 Semirigid coax, A7J2 to A12J4	6-10
W47 Semirigid coax, A12J5 to A8J2	6-10
W48 1st IF, High Band (coax 8)	6-10
W49 OCXO 10 MHz out (coax 82)	6-7
W50 OCXO power (part of A21 OCXO assembly)	6-7
W51 10 MHz Reference 2 (coax 84)	6-5, 6-7
W52 CAL oscillator out (coax 9)	6-6
W53 Frequency counter (coax 1)	6-4, 6-5
W54 Video (coax 2)	6-4, 6-5
W55 Audio out	6-5, 6-6
W56 Semirigid coax, A12J1 to FL2	6-10
W57 Semirigid coax, FL2 to A13J1	6-10
W58 ALT SWEEP OUT (Coax 8)	6-8
W59 8 MHz TTL (coax 839)	6-4, 6-9
W60 ribbon, A2J8 to A17J1	6-2, 6-3
W61 coax, J9 on A2 to J7 on A17 J7	6-2, 6-3
W62 ribbon, J6 on A17 to A17A1	6-2, 6-3
W63 ribbon, J5 on A17 to A18	6-2, 6-3
W64 , J4 on A17 to J1 on the rear panel (VGA port).....	6-2, 6-3

Figure 6-1 Hinged Assemblies

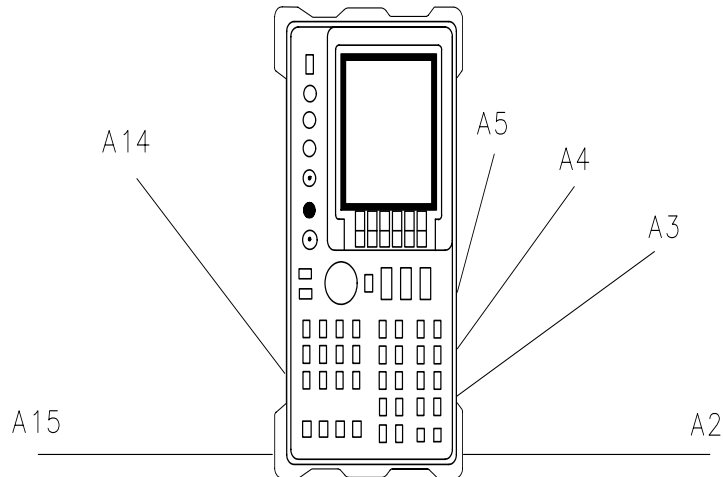

SK155

NOTE Figure 6-1 shows an 8560 E-series instrument. EC-series instruments are identical except the A2 board is smaller.

NOTE Diagrams that show features common to EC-series and E-series instruments are illustrated with E-series instruments. Where E-series and EC-series features are different, separate diagrams are provided.

Figure 6-2 Top View (A2 and A3 Unfolded) – EC-Series

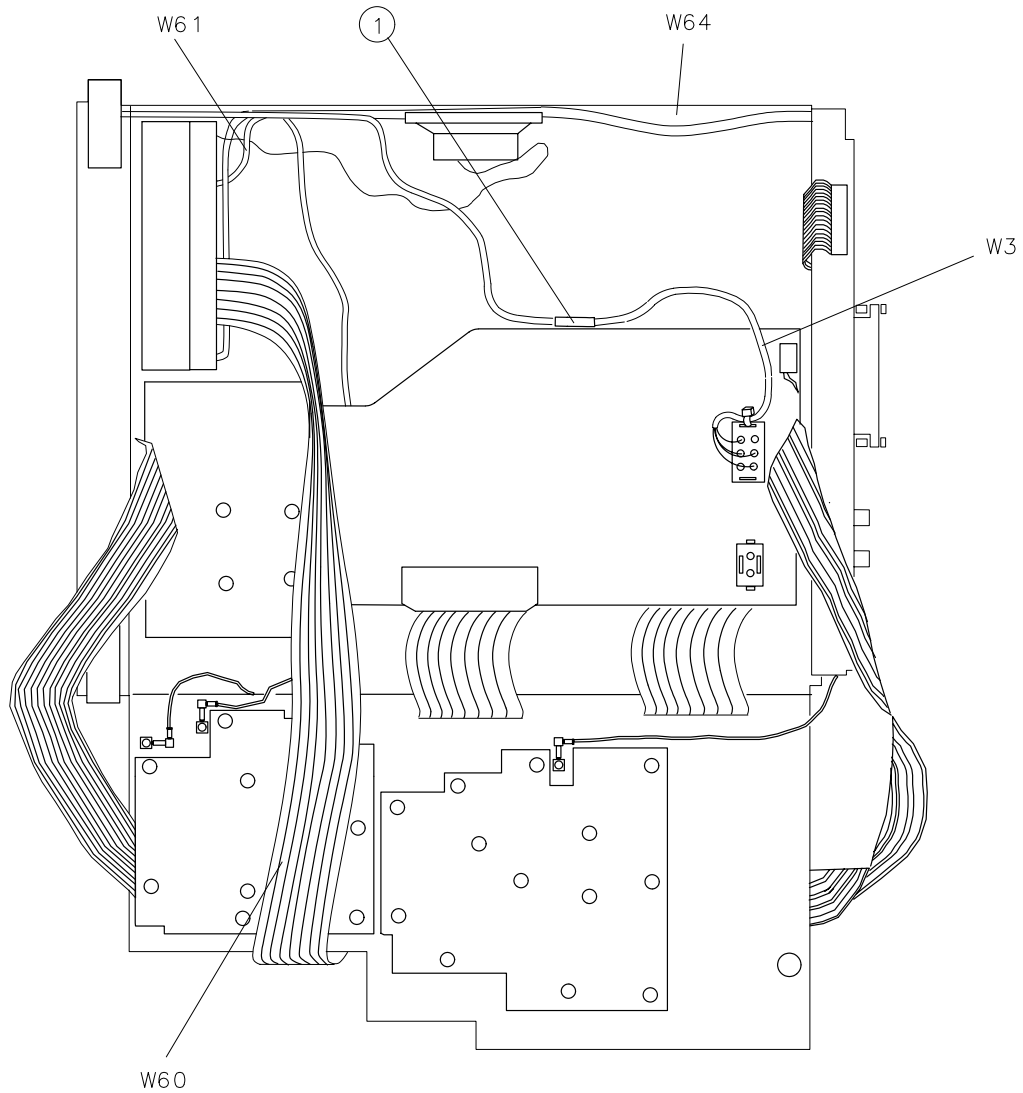

s1115c

Figure 6-3 Top View (A2, A3, A4, and A5 Unfolded) – EC-Series

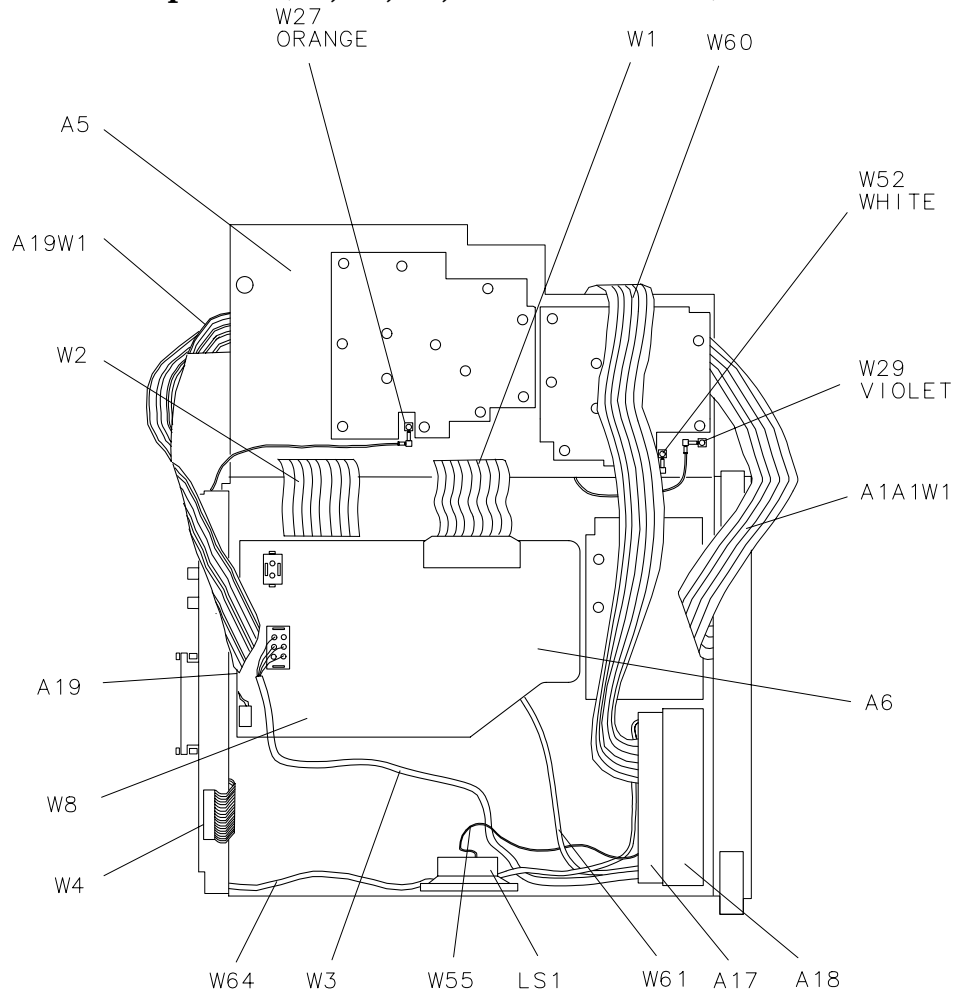

s1112c

Figure 6-4 Top View (A2, A3, A4, and A5 Unfolded) – E-Series

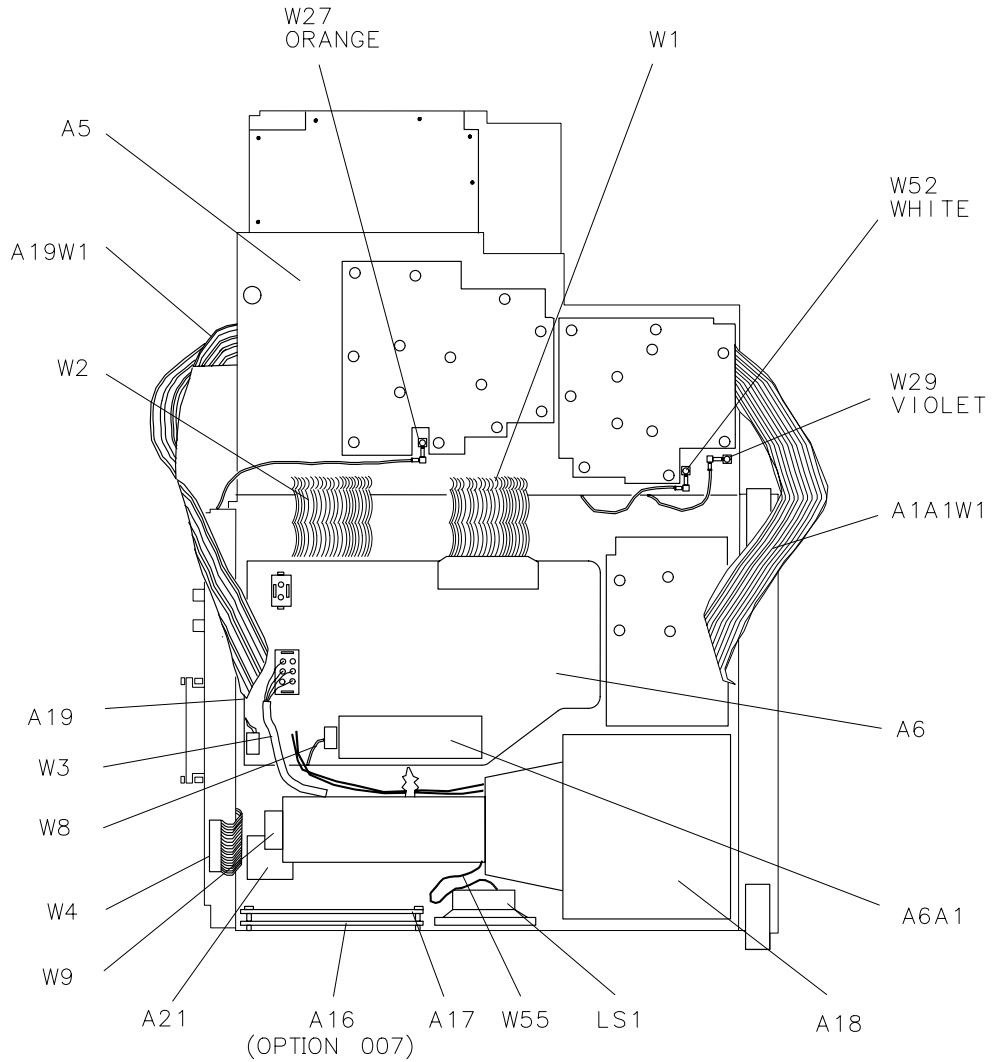

SP110E

Figure 6-5 **Bottom View (A15 Unfolded)**

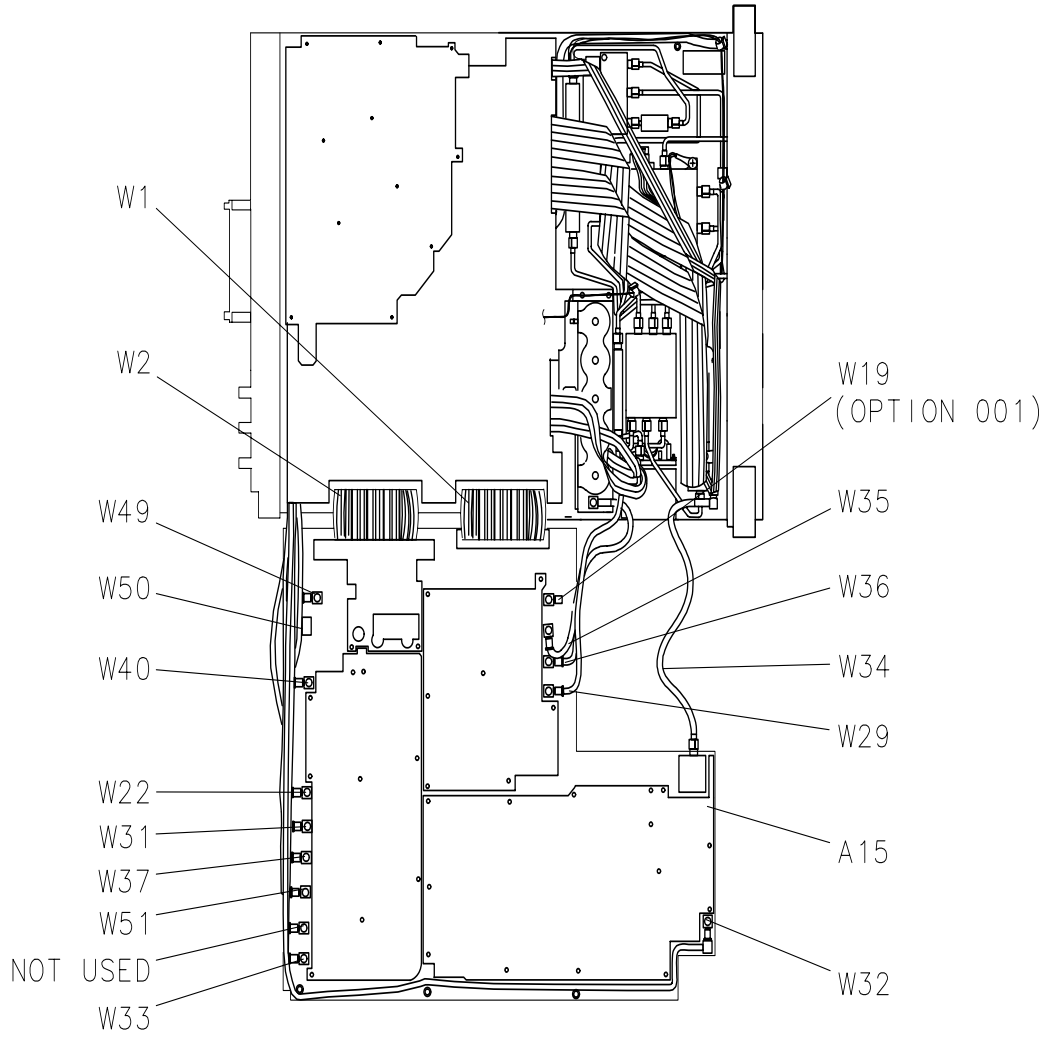

sm112e

Figure 6-6 **Bottom View (A15 and A14 Unfolded)**

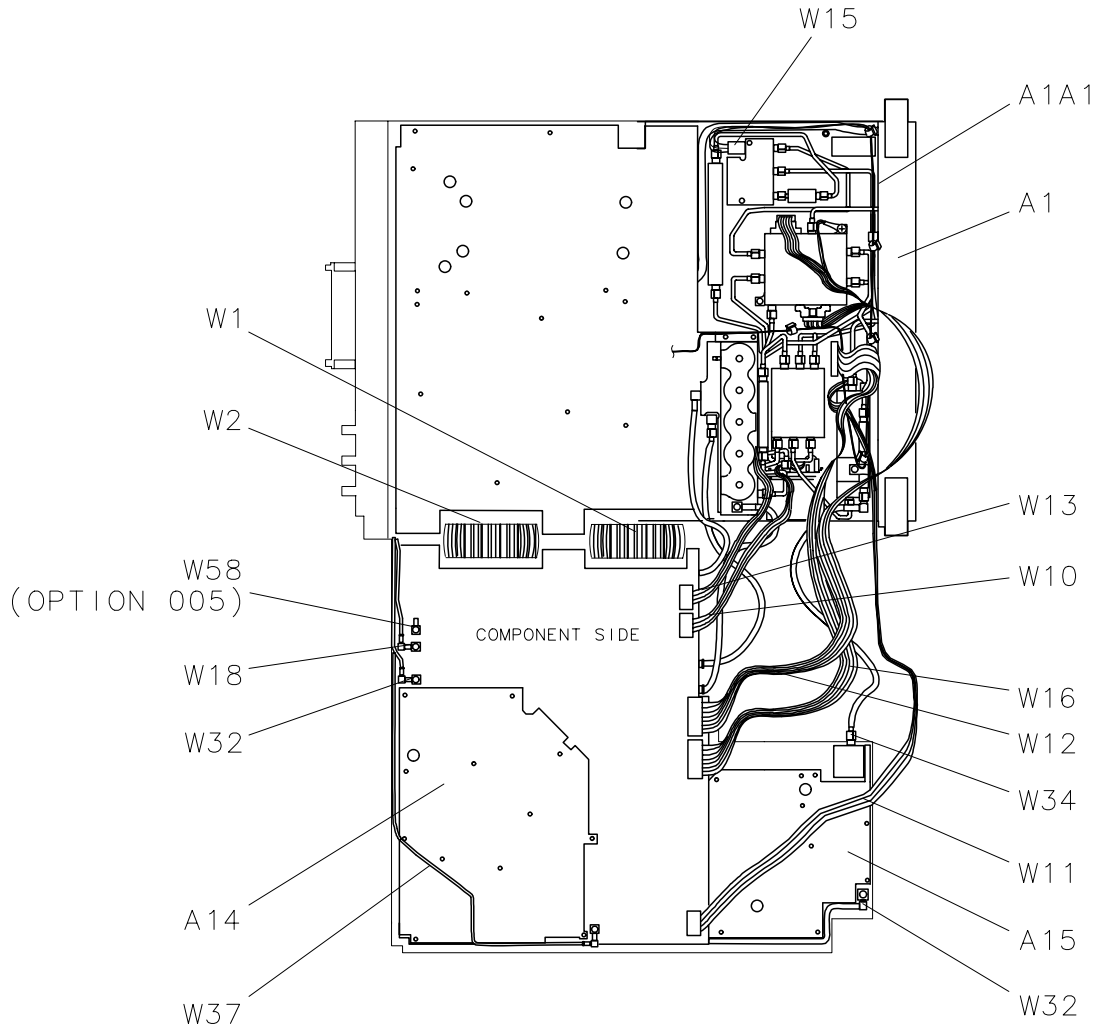

sm110e

Figure 6-7 **A16 Fast ADC (Option 007)**

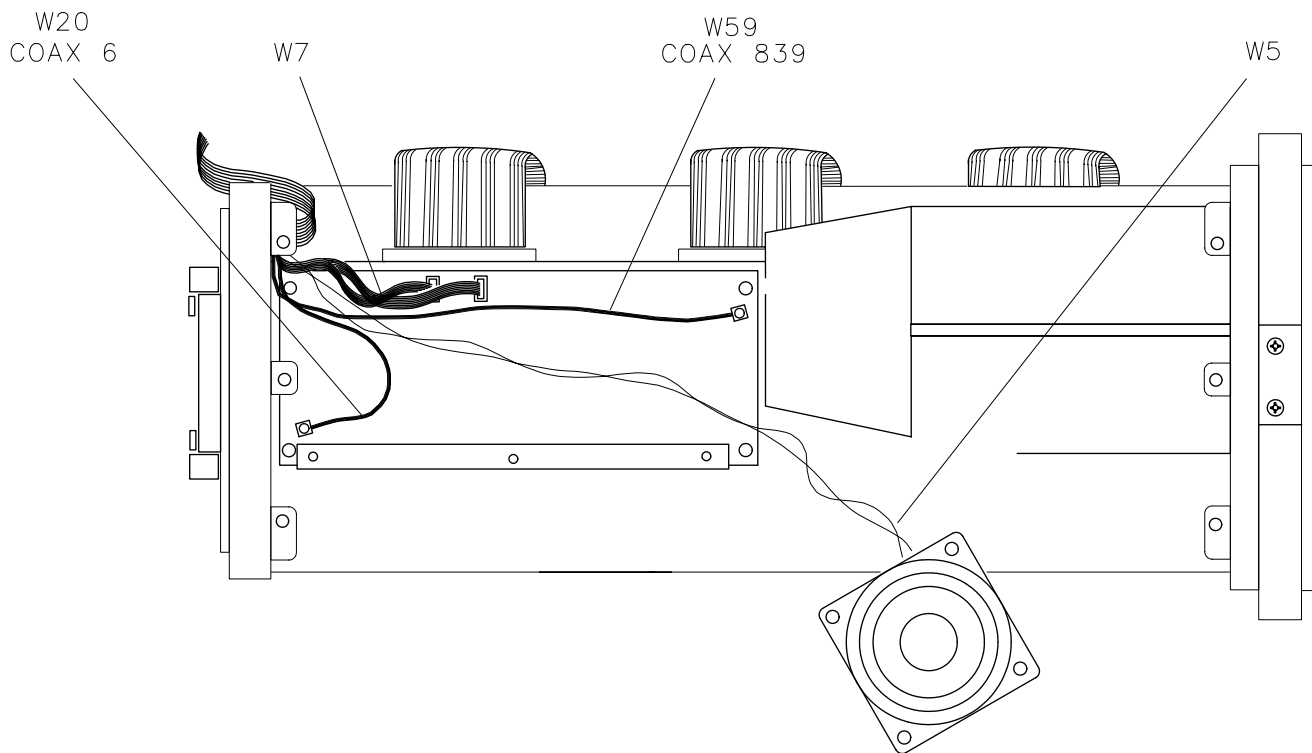

sj138e

Figure 6-8 8564E/EC and 8565E/EC Front End

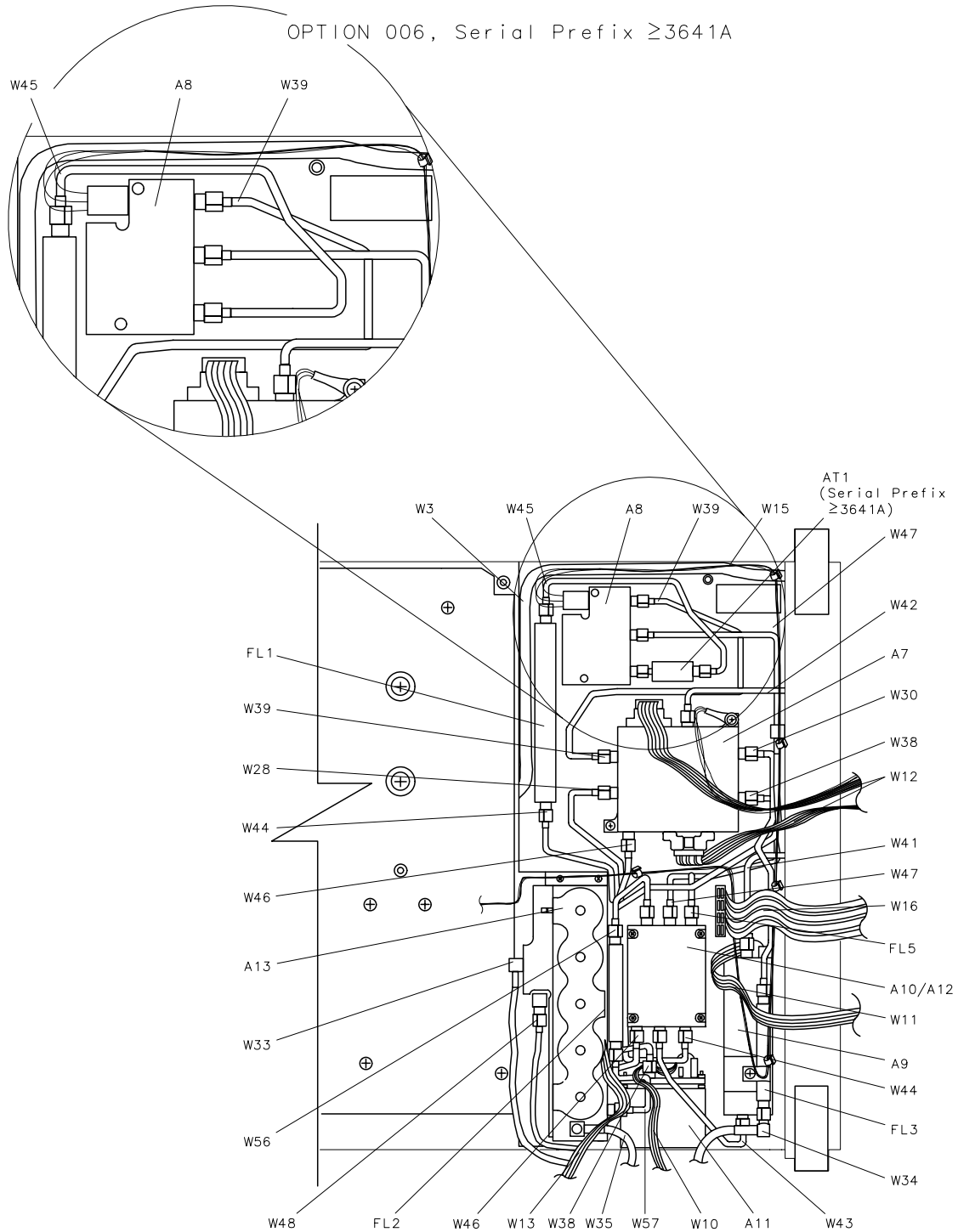

sm15e

Figure 6-9 Rear View EC-Series

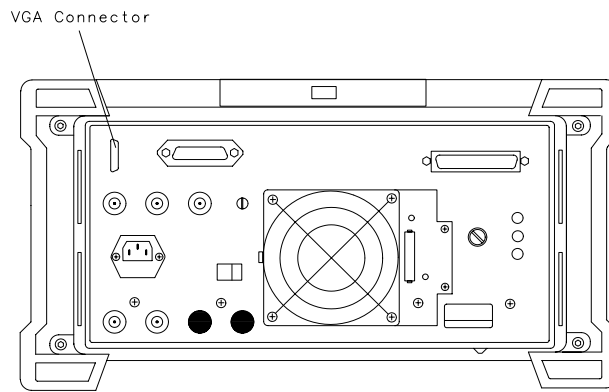

sj142c

Figure 6-10 Rear View E-Series

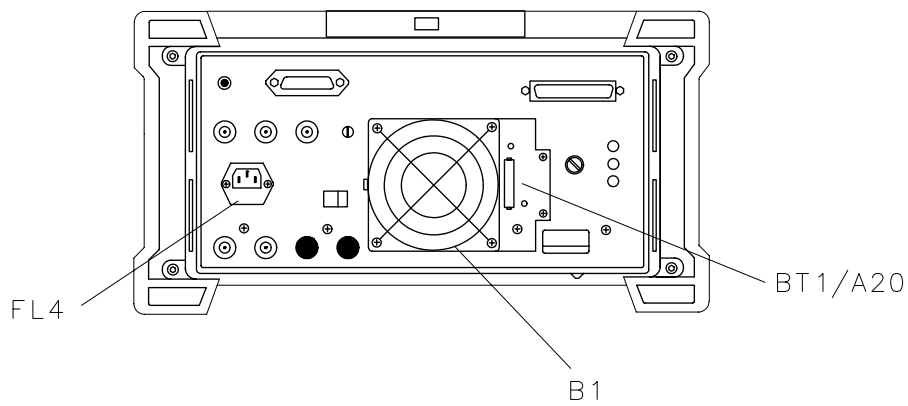

SK162

Introduction

This chapter provides information needed to troubleshoot your spectrum analyzer to one of the six major functional sections. Chapters 8 through 13 cover troubleshooting for each of these sections. Before troubleshooting, read the rest of this introduction. To begin troubleshooting, refer to [“Troubleshooting to a Functional Section” on page 324](#).

	Page
Troubleshooting to a Functional Section	page 324
Error Messages	page 326
Block Diagram Description	page 351

NOTE When a part or assembly is replaced, adjustment of the affected circuitry is usually required. Refer to the adjustment procedures in Chapters 2 and 3.

WARNING **Troubleshooting and repair of this instrument with the cover removed exposes high voltage points that, if contacted, may cause personal injury. Maintenance and repair of this instrument should be performed only by a skilled person who knows the hazards involved. Where maintenance can be performed without power applied, power should be removed. When any repair is completed, be sure that all safety features are intact and functioning and that all necessary parts are connected to their grounds.**

Assembly Level Text

To locate troubleshooting information for an individual assembly, refer to [Table 7-1 on page 325](#).

Block Diagrams

Instrument-level block diagrams are located at the end of this chapter. Power levels and voltages shown on block diagrams are provided only as a troubleshooting aid. They should not be used for making instrument adjustments.

Assembly Test Points

The spectrum analyzer board assemblies contain four types of test points: post, pad, extended component lead, and test jack. [Figure 7-1 on page 318](#) illustrates each type of test point as seen on both block diagrams and circuit boards. The name of the test point will be etched into the circuit board next to the test point (for example, TP2). In some instances, the test point will be identified on the board by its number only.

Pad

Each pad test point uses a square pad and a round pad etched into the board assembly. The square pad is the point being measured. The round pad supplies a grounding point for the test probe.

Test Jack

The test jack is a collection of test points located on a 16-pin jack. There are approximately 20 test jacks used throughout the spectrum analyzer. The pins on the test jack may be manually probed, provided caution is used to prevent accidental shorting between adjacent pins.

[Figure 7-1 on page 318](#) illustrates the pin configuration for the test jack. Line names are the same for all test jacks. The following mnemonics are used: MS (measured signal) and OS (output signal). Test jack test points are identified on block diagrams by both the jack/pin number and line name.

Ribbon Cables

Ribbon cables are used extensively in the spectrum analyzer. The following five cables use different pin numbering methods on the jacks (signal names remain the same but the pin numbers vary):

- W2, control cable
- W4, option cable
- A3W1, interface cable
- A19W1, GPIB cable

[Figure 7-2 on page 319](#) and [Figure 7-3 on page 320](#) illustrate the pin configurations of these five cables. Cables W1 and W2 use two pin numbering methods on their many jacks. These methods are identified in the interconnect and block diagrams by the letters "A" and "B" next to the jack designator (for example, J1(A)). Board assembly jacks connected to W1 will always be labeled J1. Board assembly jacks connected to W2 will always be labeled J2.

Figure 7-1 Assembly Test Points

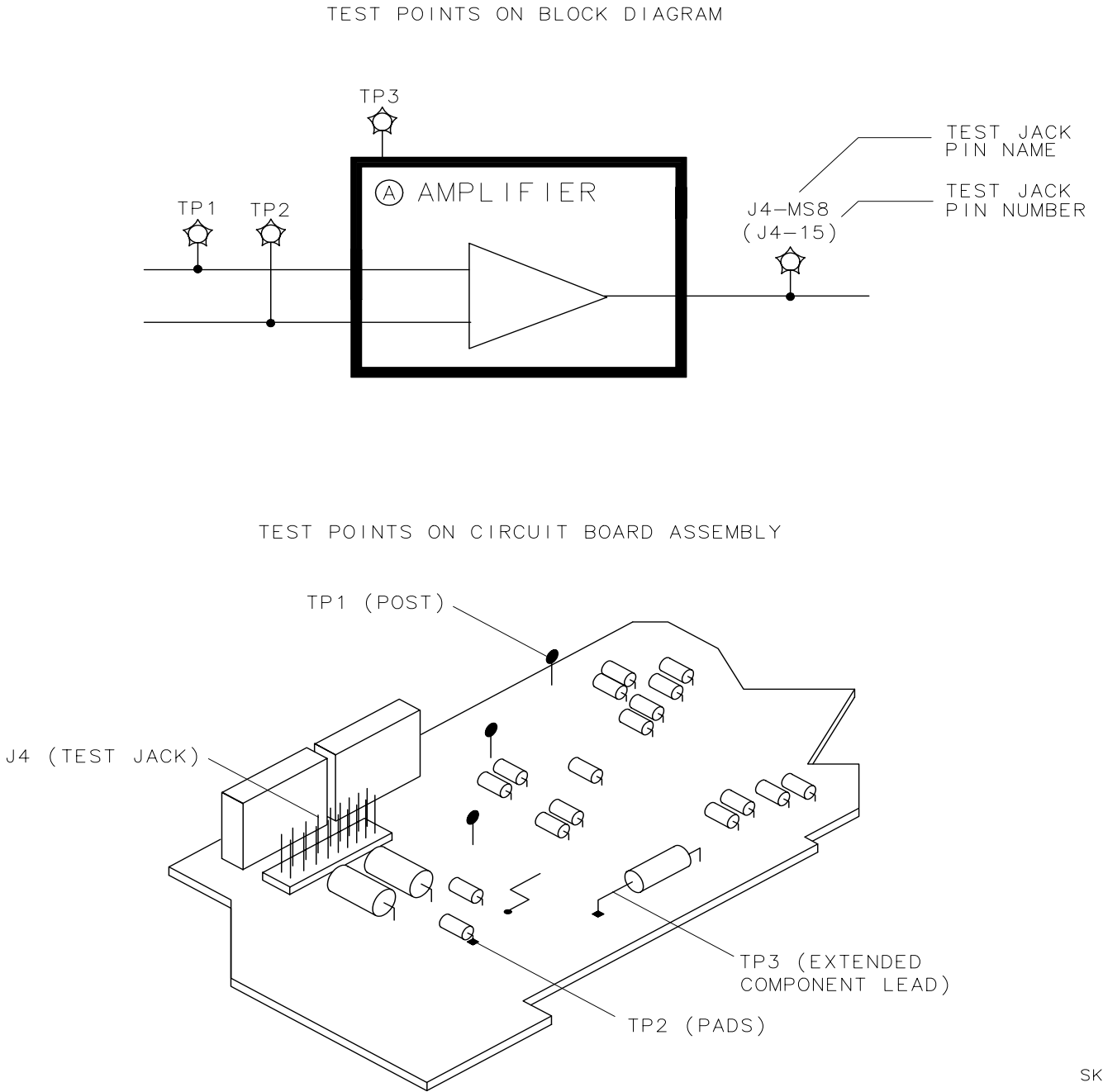

SK 163

Figure 7-4 on page 321 shows the pin configuration for the 80 pin, W60 cable that is found on EC-series instruments. The numbering of the pins is identical on the A2 Controller board and the A17 Display Driver board.

Figure 7-2 Ribbon Cable Connections (1 of 3)

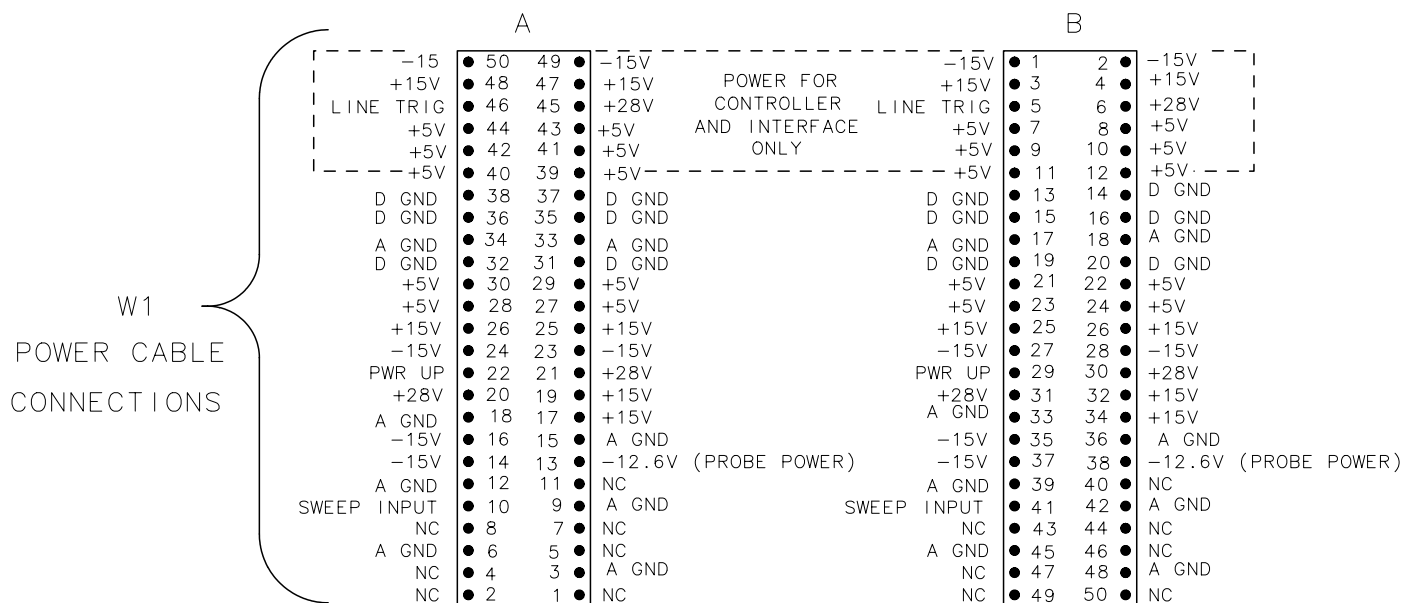

*NOTE: Sweep Input for the Controller or Interface boards only.

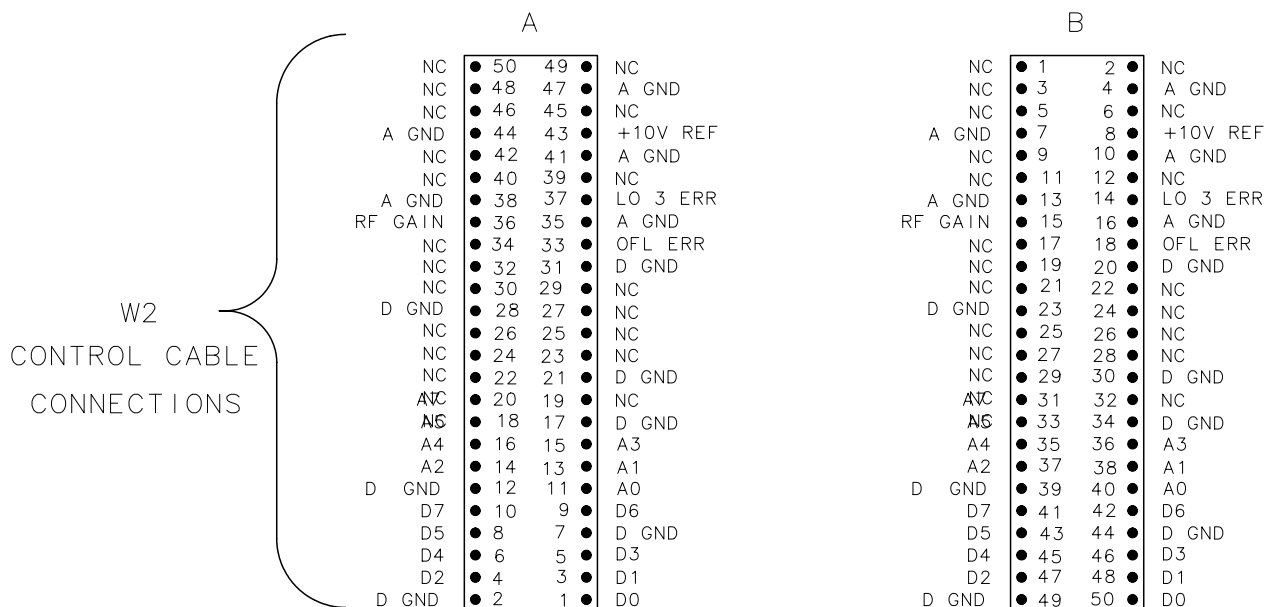

sp149e

Figure 7-3 Ribbon Cable Connections (2 of 3)

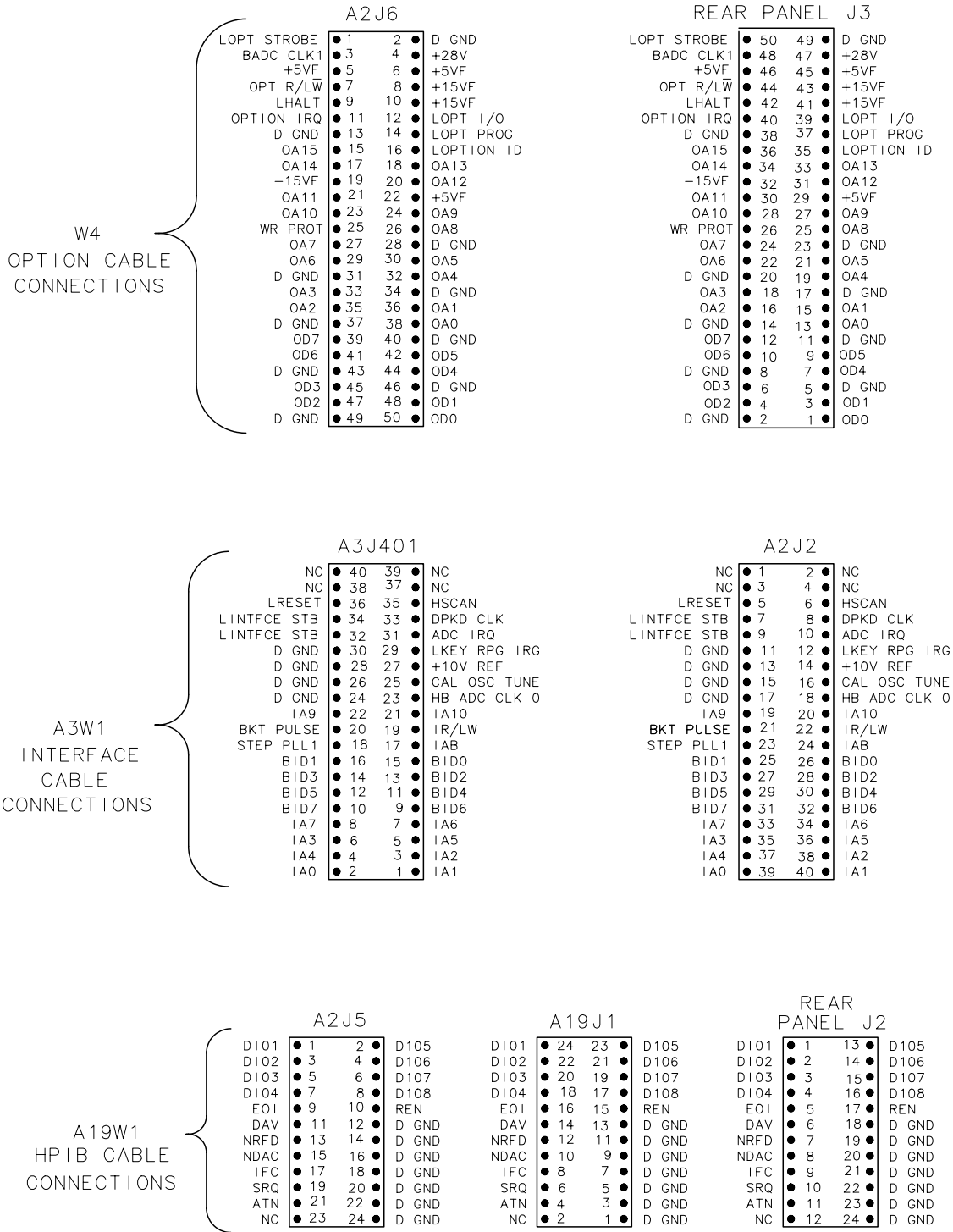

sp150e

Figure 7-4 Ribbon Cable Connections (3 of 3) – EC-Series Only

GND SX	● 80	● 79	addrmsx2
addrmsx 3	● 78	● 77	GND SX
addrmsx 6	● 76	● 75	addrmsx 7
GND SX	● 74	● 73	addrmsx 10
addrmsx 11	● 72	● 71	GND SX
NC	● 70	● 69	NC
6ND SX	● 68	● 67	NC
NC	● 66	● 65	GND SX
NC	● 64	● 53	NC
GND SX	● 62	● 61	DATAMX 2
DATAMX 3	● 60	● 59	GND SX
DATAMX 6	● 58	● 57	DATAMX 7
GND SX	● 56	● 55	DATAMX 10
DATAMX11	● 54	● 53	GNSD SX
DATAMX 14	● 52	● 51	DATAMX 15
GND SX	● 50	● 49	NC
_RESETMSX	● 48	● 47	GND SX
NC	● 46	● 45	+5V BKLT SX
+5VBKLT SX	● 44	● 43	+5VBKLT SX
+5VBLT SX	● 42	● 41	+5V SX
addrmsx 1	● 40	● 39	GND SX
addrmsx 4	● 38	● 37	addrmsx 5
gnd sx	● 36	● 35	addrmsx 8
addrmsx 9	● 34	● 33	GND SX
addrmsx 12	● 32	● 31	addrmsx 13
GND SX	● 30	● 29	NC
NC	● 28	● 27	GND SX
NC	● 26	● 25	NC
GND SX	● 24	● 23	DATAMX
DATAMX 1	● 22	● 21	GND SX
DATAMX 4	● 20	● 19	DATAMX 5
GND SX	● 18	● 17	DATAMX 8
DATAMX 9	● 16	● 15	GND SX
DATAMX 12	● 14	● 13	DATAMX 13
GND SX	● 12	● 11	LMUX-INSX
EN1SX	● 10	● 9	GND SX
NC	● 8	● 7	NC
GND SX	● 6	● 5	+5VBKLT SX
+5V BKLT SX	● 4	● 3	+5VBKLT SX
+5V BKLT SX	● 2	● 1	+5V SX

sj114c

Figure 7-4 shows A2J8 connections on 8560 EC-Series Instruments. Lines 2 – 5 and 42 – 44 supply +5V to the two LCD backlights. Lines 1 and 41 supply +5V to the A17A1 Inverter board. Lines 1 – 6 and 41 – 44 are identical on A17J1.

Service Cal Data Softkey Menus

The jumper on A2J12 is shipped from the factory in the WR PROT (write protect) position (jumper on pins 2 and 3). When the jumper is set to the WR ENA (write enable) position (jumper on pins 1 and 2), an additional service cal data menu is displayed under **CAL**. [Figure 7-5 on page 323](#) illustrates those areas of the service cal data menu that are available.

Figure 7-5 Service Cal Data Menu

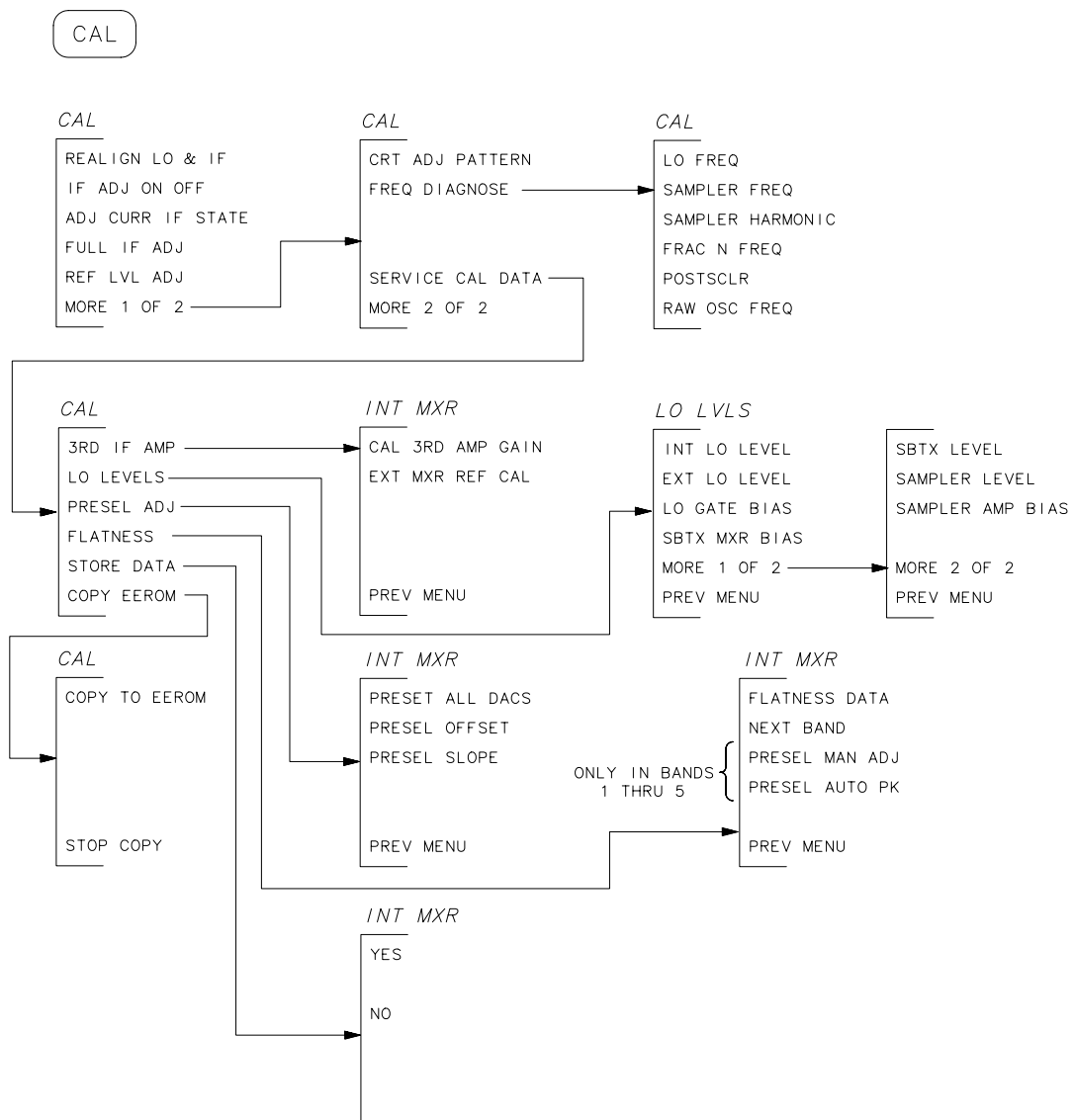

sz140e

Troubleshooting to a Functional Section

1. Refer to [Table 7-1 on page 325](#) for the location of troubleshooting information.
2. If error messages are displayed, refer to "Error Messages" in this chapter. You will find both error descriptions and troubleshooting information.
3. If a signal cannot be seen, and no error messages are displayed, the fault is probably in the RF Section. Refer to [Chapter 12 , "RF Section."](#)
4. Blank displays result from problems caused by either the controller or display/power supply sections. Because error messages 700 to 759 caused by the controller section cannot be seen on a blank display, use the following BASIC program to read these errors over GPIB. If the program returns an error code of 0, there are no errors.

```
10 DIM Err$(128)
20 OUTPUT 718;"ERR?;"
30 ENTER 718; Err$
40 PRINT Err$
50 END
```

- a. If there is no response over GPIB, set an oscilloscope to the following settings:
 - Sweep time 2 ms/div
 - Amplitude scale 1 V/div
 - b. The signals at A2J202 pin 3 and pin 14 should measure about 4 Vp-p. If the levels are incorrect, refer to [Chapter 10](#) and troubleshoot the A2 controller assembly.
 - c. Set the oscilloscope to the following settings:
 - Sweep time 1 ms/div
 - Amplitude scale 2 V/div
 - d. The signal at A2J202 pin 15 should consist of TTL pulses. If the signal is at a constant level (high or low), troubleshoot the A2 controller assembly.
5. Display problems such as intensity or distortion are caused by either the controller or display/power supply sections. Refer to [Chapter 10](#) or [Chapter 13](#) .

Table 7-1 Location of Assembly Troubleshooting Text

Instrument Assembly	Location of Troubleshooting Text
A1A1 keyboard	Chapter 8 ADC/Interface Section
A1A2 RPG	Chapter 8 ADC/Interface Section
A2 controller	Chapter 10 Controller Section
A3 interface	Chapter 8 ADC/Interface Section Chapter 9 IF Section
A4 log amplifier/cal oscillator	Chapter 9 IF Section
A5 IF	Chapter 9 IF Section
A6 power supply	Chapter 13 Display/Power Supply Section
A6A1 HV module	Chapter 13 Display/Power Supply Section
A6A2 regulator	Chapter 13 Display/Power Supply Section
A7 LOMA	Chapter 12 RF Section
A8 low band mixer	Chapter 12 RF Section
A9 input attenuator	Chapter 12 RF Section
A10 RYTHM	Chapter 12 RF Section
A11 YTO	Chapter 11 Synthesizer Section
A12 SBTX	Chapter 12 RF Section
A13 2nd converter	Chapter 12 RF Section
A14 frequency control	Chapter 11 Synthesizer Section Chapter 12 RF Section
A15 RF assembly	Chapter 11 Synthesizer Section Chapter 12 RF Section
A16 fast ADC	Chapter 8 ADC/Interface Section
A17 LCD driver	Chapter 13 Display/Power Supply Section
A17 CRT driver	Chapter 13 Display/Power Supply Section
A17 LCD	Chapter 13 Display/Power Supply Section
A18 CRT	Chapter 13 Display/Power Supply Section
A19 GPIB	Chapter 10 Controller Section
A21 OCXO	Chapter 11 Synthesizer Section
FL1, FL2	Chapter 12 RF Section

Error Messages

The spectrum analyzer displays error messages in the lower right-hand corner of the display. A number, or error code, is associated with each error message. These error messages alert the user to errors in spectrum analyzer function or use.

Multiple error messages may exist simultaneously. Refer to "Viewing Multiple Messages" below.

The following information can be found in this section:

Viewing Multiple Messages	7-11
Error Message Elimination	7-11
System Analyzer Programming Errors (100 to 150)	7-12
ADC Errors (200 to 299)	7-13
LO and RF Hardware/Firmware Failures (300 to 399)	
YTO Loop Errors (300 to 301)	7-15
YTO Loop Errors (317 to 320)	7-15
YTO Loop Error (331)	7-15
600 MHz Reference Loop (333)	7-16
Sampling Oscillator (335)	7-16
10 MHz Reference (336)	7-16
Fractional N PLL (337)	7-16
LOMA (Local Oscillator Multiplier/Amplifier) Leveling Loop Errors (338 to 340)	7-17
YTO Loop Settling Errors (351 to 354)	7-17
Sampling Oscillator (355)	7-17
Span Accuracy Calibration Errors (356 to 361)	7-18
Automatic IF Errors (400 to 599)	7-19
System Errors (600 to 651)	7-28
Digital and Checksum Errors (700 to 799)	
EEROM Checksum Errors (700 to 704)	7-29
Program ROM Checksum Errors (705 to 710).....	7-30
RAM Check Errors (711 to 716)	7-30
Microprocessor Error (717)	7-30
Battery Problem (718)	7-31
Model/Option Number Error (719 to 720)	7-31
RAM Check Error (721)	7-31
System Errors (750 to 759)	7-31
Fast ADC Error (760)	7-32
Option Module Errors (800 to 899)	7-32
User Generated Errors (900 to 999)	7-32

Viewing Multiple Messages

Although multiple errors may exist, the spectrum analyzer displays only one error message at a time. To view any additional messages, do the following:

1. Press **RECALL** and **MORE 1 OF 2**.
2. Press **RECALL ERRORS**. An error message is displayed in the active function block.
3. Use the up and down step keys to scroll through any other error messages which might exist, making note of each error code.

Error Message Elimination

When an error message is displayed, always perform the following procedure:

1. Press **SAVE** and **SAVE STATE**.
2. Store the current state in a convenient STATE register. (It may be necessary to set **SAVELOCK** to OFF.)
3. Press **CAL** and **REALIGN LO &IF**. Wait for the sequence to finish.
4. Press **RECALL** and **RECALL STATE**.
5. Recall the previously stored STATE.
6. If an error message is still displayed, refer to the following list of error messages for an explanation of the error.

System Analyzer Programming Errors (100 to 150)

Refer to the *8560 E-Series Spectrum Analyzers User's Guide* for information on programming the spectrum analyzer.

- | | | |
|-----|----------|---|
| 100 | NO PWRON | Power-on state is invalid; default state is loaded. Press SAVE, PWR ON STATE to clear error message. |
| 101 | NO STATE | State to be RECALLED not valid or not SAVED. |
| 102 | # ARGMTS | Command does not have enough arguments. |
| 103 | # ARGMTS | Command does not have enough arguments. |
| 104 | # ARGMTS | Command does not have enough arguments. |
| 105 | # ARGMTS | Command does not have enough arguments. |
| 106 | ABORTED! | Current operation is aborted; GPIB parser reset. |
| 107 | HELLO ?? | No GPIB listener is present. |
| 108 | TIME OUT | Spectrum analyzer timed out when acting as controller. |

109 CtrlFail Spectrum analyzer unable to take control of the bus.
110 NOT CTRL Spectrum analyzer is not system controller.
111 # ARGMTS Command does not have enough arguments.
112 ??CMD?? Unrecognized command.
113 FREQ NO! Command cannot have frequency units.
114 TIME NO! Command cannot have time units.
115 AMPL NO! Command cannot have amplitude units.
116 ?UNITS?? Unrecognizable units.
117 NOP NUM Command cannot have numeric units.
118 NOP EP Enable parameter cannot be used.
119 NOP UPDN UP/DN are not valid arguments for this command.
120 NOP ONOF ON/OFF are not valid arguments for this command.
121 NOP ARG AUTO/MAN are not valid arguments for this command.
122 NOP TRC Trace registers are not valid for this command.
123 NOP ABLK A-block format not valid here.
124 NOP IBLK I-block format not valid here.
125 NOP STRNG Strings are not valid for this command.
126 NO ? This command cannot be queried.
127 BAD DTMD Not a valid peak detector mode.
128 PK WHAT? Not a valid peak search parameter.
129 PRE TERM Premature A-block termination.
130 BAD TDF Arguments are only for TDF command.
131 ?? AM/FM AM/FM are not valid arguments for this command.
132 !FAV/RMP FAV/RAMP are not valid arguments for this command.
133 !INT/EXT INT/EXT are not valid arguments for this command.
134 ??? ZERO ZERO is not a valid argument for this command.
135 ??? CURR CURR is not a valid argument for this command.
136 ??? FULL FULL is not a valid argument for this command.
137 ??? LAST LAST is not a valid argument for this command.
138 !GRT/DSP GRT/DSP are not valid arguments for this command.
139 PLOTONLY Argument can only be used with PLOT command.
140 ?? PWRON PWRON is not a valid argument for this command.

- 141 BAD ARG Argument can only be used with FDIAG command.
- 142 BAD ARG Query expected for FDIAG command.
- 143 NO PRESL No preselector hardware to use command with.
- 144 COUPL?? Invalid COUPLING argument, expected AC or DC.

ADC Errors (200 to 299)

These errors are directly related to the ADC/interface section. Suspect a faulty A2 controller, A3 interface assembly or, in 8560 E-series analyzers with Option 007, the A16 fast ADC (FADC) assembly.

Errors 202 through 207 apply only to EC-series analyzers and E-series analyzers with fast ADC (Option 007).

200 SYSTEM ADC driver/ADC hardware/firmware interaction; check for other errors.

201 SYSTEM ADC controller/ADC hardware/firmware interaction; check for other errors.

202 FADC CAL Binary search failed during FADC linear offset calibration.

This error applies only to EC-series analyzers and E-series analyzers with fast ADC (Option 007).

203 FADC CAL Binary search failed during FADC log offset calibration.

This error applies only to EC-series analyzers and E-series analyzers with fast ADC (Option 007).

204 FADC CAL Binary search failed during FADC log expand offset calibration.

This error applies only to EC-series analyzers and E-series analyzers with fast ADC (Option 007).

205 FADC CAL Slope derivation failed during FADC linear offset calibration.

This error applies only to EC-series analyzers and E-series analyzers with fast ADC (Option 007).

206 FADC CAL Slope derivation failed during FADC log offset calibration.

This error applies only to EC-series analyzers and E-series analyzers with fast ADC (Option 007).

207 FADC CAL Slope derivation failed during FADC log expand offset calibration.

This error applies only to EC-series analyzers and E-series analyzers with fast ADC (Option 007).

250 OUTOF RG ADC input is outside of ADC range.

251 NO IRQ Microprocessor not receiving interrupt from ADC.

LO and RF Hardware/Firmware Failures (300 to 399)

YTO Loop Errors (300 to 301)

These errors often require troubleshooting the A14 frequency control assembly (synthesizer section) or the ADC circuits.

300 YTO UNLK YTO (1st LO) phase locked loop is unlocked. The ADC measures YTO_ERR voltage under phase-lock condition.

301 YTO UNLK YTO (1st LO) phase locked loop is unlocked. Same as ERR 300 except ERR 301 is set if the voltage is outside certain limits.

YTO Loop Errors (317 to 320)

These messages indicate that the YTO main coil coarse DAC (ERR 317) or fine DAC (ERR 318) is at its limit. If error codes 300 or 301 are not present, a hardware problem exists in the YTO loop but the loop can still acquire lock. Refer to Chapter 11 to troubleshoot the YTO PLL. The ADC circuit on the A3 interface assembly may also cause this error.

317 FREQ ACC Main coil coarse DAC at limit. The main coil coarse DAC is set to bring YTO ERR close enough to 0 volts for the main coil fine DAC to bring YTO ERR to exactly 0 volts. ERR 317 is set if the main coil coarse DAC is set to one of its limits before bringing YTO ERR close enough to 0 volts.

318 FREQ ACC Main coil fine DAC at limit. The main coil fine DAC is set to bring YTO ERR to 0 volts after the main coil coarse DAC has brought YTO ERR close to 0 volts. ERR 318 is set if the main coil fine DAC is set to one of its limits before bringing YTO ERR to 0 volts.

319 WARN COA YTO coarse tune DAC near limit.

320 WARN FIN YTO fine tune DAC near limit.

YTO Loop Error (331)

This error rarely occurs but is usually indicative of a digital hardware failure.

331 `FREQ ACC` Invalid YTO frequency. Firmware attempted to set the YTO to a frequency outside the range of the YTO (2.95 to 6.8107 GHz). Suspect a digital hardware problem, such as a bad RAM on the A2 controller assembly. Contact the factory.

600 MHz Reference Loop (333)

This error requires troubleshooting the A15 RF board assembly (synthesizer section) or the ADC circuits.

333 `600 UNLK` The 600 MHz reference oscillator PLL is unlocked. If error codes 302, 303, 304, 327 or 499 are also present, suspect the 10 MHz reference, the A21 OCXO, or the TCXO (Option 103), or the A15 RF assembly. ERR 333 is set if LO3ERR is outside of its prescribed limits.

Sampling Oscillator (335)

This error indicates an unlocked sampling oscillator (also known as the offset lock loop).

335 `SMP UNLK` Sampling oscillator PLL is unlocked. ERR 335 is set if OFL_ERR is outside its prescribed limits.

10 MHz Reference (336)

This message occurs during the internal IF calibration routines. The routine locks the cal oscillator to the internal 10 MHz reference, regardless of the setting of INT/EXT REF.

336 `10 MHz Ref` Calibration oscillator failed to lock within 5 seconds after going to internal 10 MHz reference. ERR 336 will not be cleared until a successful full calibration "LO Re-Align" is executed.

Fractional N PLL (337)

This error indicates an unlocked fractional N phase locked loop. This error only applies to the hardware in an 8560 E-series or EC-series spectrum analyzer.

337 `FN UNLK` Fractional N circuitry is unable to lock.

LOMA (Local Oscillator Multiplier/Amplifier) Leveling Loop Errors (338 to 340)

These errors are generated when one of the LOMA (local oscillator multiplier/amplifier) loops is unlevelled. These errors only apply to the hardware in an 8564E/EC or 8565E/EC spectrum analyzer.

- 338 LOMA AGC The LOMA main loop AGC is unlevelled. Error 338 may be displayed if the front panel LO OUTPUT is not terminated in 50 ohms. This error is usually accompanied by error codes 300 or 301. ERR 301 YTO UNLK is cleared once ERR 338 has been cleared. Check the output of the A11 YTO with the jumper on A14J23 in the TEST position. The YTO power output should be between +9 and +13 dBm. If the YTO is working properly, refer to "A7 LOMA Drive" in Chapter 12. The LOMA AGC voltage is monitored by the ADC. ERR 334 is set if LOMA AGC is outside of its prescribed limits. Refer to "A7 LOMA Drive" in Chapter 12.
- 339 SBTX AGC The LOMA SBTX (switched barium-tuned mixer) loop AGC is unlevelled. If ERR 338 LOMA AGC is also present, refer to ERR 338. Otherwise, refer to "A7 LOMA Drive" in Chapter 12.
- 340 SAMP AGC The LOMA (local oscillator multiplier/amplifier) sampler loop AGC is unlevelled. If ERR 338 LOMA AGC is also present, refer to ERR 338. Otherwise, refer to "A7 LOMA Drive" in Chapter 12.

YTO Loop Settling Errors (351 to 354)

These errors are generated when the YTO loop error voltage will not stabilize at an acceptable value during the YTO loop locking routines. These errors only apply to the hardware in an 8560 E-series or EC-series spectrum analyzer.

- 351 SETL FLD YTO error voltage is not settling.
- 352 TWID FLD Unable to bring YTO error voltage DAC's to quiescent point.
- 353 SRCH FLD No acceptable YTO DAC value found.
- 354 LK ITERS Cannot lock. Lock iteration routine terminated.

Sampling Oscillator (355)

This error indicates an unlocked sampling oscillator during the local oscillator (LO) alignment routine. This error only applies to the hardware in an 8560 E-series or EC-series spectrum analyzer.

- 355 SMP CAL Sampler unlock condition during calibration routine. This error remains until a successful recalibration is performed.

Span Accuracy Calibration Errors (356 to 361)

These errors are generated when the span accuracy calibration fails. The span accuracy calibration is done during "power up", IF calibration (every 5 minutes), and LO IF realignment routines. Span accuracy calibration sweeps occur during the retrace (dead time) of the main sweep ramp. The firmware then detects any span accuracy calibration errors. These errors only apply to firmware revisions 931216 and later.

- 356 SPAC CAL Sweep data problem finding "bucket 1" of the span accuracy calibration sweep. This error indicates a possible failure of the sweep generator, span attenuator, or main/FM coil sweep switches on the A14 frequency control assembly. Refer to [Chapter 11](#), "Synthesizer Section."
- 357 SPAC CAL Cannot find the "x" intersection for "bucket 1" of the span accuracy calibration sweep. This error indicates a possible failure of the sweep generator, span attenuator, or main/FM coil sweep switches on the A14 frequency control assembly. Refer to [Chapter 11](#), "Synthesizer Section."
- 358 SPAC CAL Sweep data problem finding "bucket 2" of the span accuracy calibration sweep. This error indicates a possible failure of the sweep generator, span attenuator, or main/FM coil sweep switches on the A14 frequency control assembly. Refer to [Chapter 11](#), "Synthesizer Section."
- 359 SPAC CAL Cannot find "x" intersection for "bucket 2" of the span accuracy calibration sweep. This error indicates a possible failure of the sweep generator, span attenuator, or main/FM coil sweep switches on the A14 frequency control assembly. Refer to [Chapter 11](#), "Synthesizer Section."

- 360 SPAC CAL The start bucket correction is out of range. This error indicates a possible failure of the sweep generator on the A14 frequency control assembly. Refer to “Sweep Generator Circuit,” in Chapter 11 , “Synthesizer Section.”
- 361 SPAC CAL The percent of span correction is out of range. This error indicates a possible failure of the sweep generator on the A14 frequency control assembly. Refer to “Sweep Generator Circuit,” in Chapter 11 , “Synthesizer Section.”

Automatic IF Errors (400 to 599)

These error codes are generated when the automatic IF adjustment routine detects a fault. This routine first adjusts amplitude parameters, then resolution bandwidths in this sequence: 300 kHz, 1 MHz, 100 kHz, 30 kHz, 10 kHz, 3 kHz, 1 kHz, 300 Hz, 100 Hz, 30 Hz, 10 Hz, 3 Hz, 1 Hz, and 2 MHz. The routine restarts from the beginning if a fault is detected. Parameters adjusted after the routine begins but before the fault is detected are correct; parameters adjusted later in the sequence are suspect. Refer to "Automatic IF Adjustment" in Chapter 8.

The IF Section relies on the ADC and video circuitry to perform its continuous IF adjustments. IF-related errors occur if the ADC, video circuitry, or A4 assembly linear path is faulty.

- 400 AMPL <300 Unable to adjust amplitude of resolution bandwidths less than 300 Hz.
- 401 AMPL 300 Unable to adjust amplitude of 300 Hz resolution bandwidth.
- 402 AMPL 1K Unable to adjust amplitude of 1 kHz resolution bandwidth.
- 403 AMPL 3K Unable to adjust amplitude of 3 kHz resolution bandwidth.
- 404 AMPL 10K Unable to adjust amplitude of 10 kHz resolution bandwidth.

Errors 405 to 416: When these 10K resolution bandwidth (RBW) error messages appear, use the following steps to check for errors 581 or 582:

1. Press **LINE** to turn the spectrum analyzer off.

2. Press **LINE** to turn the spectrum analyzer on and observe the lower right-hand corner of the display for 10 seconds.
3. If ERR 581 or ERR 582 appears, the fault is most likely caused by the cal oscillator. Refer to errors 581 and 582.
4. If ERR 581 or ERR 582 does not appear, troubleshoot the A5 IF assembly.

Multiple IF errors during IF adjust: If a FULL IF ADJ sequence (pressing **CAL** and **FULL IF ADJ**) results in IF errors while displaying IF ADJUST STATUS: AMPLITUDE, the cal oscillator on the A4 assembly might not be providing the correct output signal. Perform the following steps:

1. Disconnect W30 (white) from A5J4.
2. Connect W30 to the input of a second spectrum analyzer and set its controls as follows:

Center frequency..... 10.7 MHz
Reference level -30 dBm
3. Observe the spectrum analyzer display while pressing **FULL IF ADJ** on the spectrum analyzer. If a -35 dBm signal does not appear, troubleshoot the cal oscillator on the A4 assembly.
4. If a -35 dBm signal does appear, troubleshoot the A5 IF assembly.

- | | | |
|-----|---------|--|
| 405 | RBW 10K | Unable to adjust 10 kHz resolution bandwidth in first crystal pole. |
| 406 | RBW 10K | Unable to adjust 10 kHz resolution bandwidth in second crystal pole. |
| 407 | RBW 10K | Unable to adjust 10 kHz resolution bandwidth in third crystal pole. |
| 408 | RBW 10K | Unable to adjust 10 kHz resolution bandwidth in fourth crystal pole. |
| 409 | RBW 10K | Unable to adjust 10 kHz resolution bandwidth in first crystal pole. |
| 410 | RBW 10K | Unable to adjust 10 kHz resolution bandwidth in second crystal pole. |
| 411 | RBW 10K | Unable to adjust 10 kHz resolution bandwidth in third crystal pole. |

412	RBW	10K	Unable to adjust 10 kHz resolution bandwidth in fourth crystal pole.
413	RBW	10K	Unable to adjust 10 kHz resolution bandwidth in first crystal pole.
414	RBW	10K	Unable to adjust 10 kHz resolution bandwidth in second crystal pole.
415	RBW	10K	Unable to adjust 10 kHz resolution bandwidth in third crystal pole.
416	RBW	10K	Unable to adjust 10 kHz resolution bandwidth in fourth crystal pole.
417	RBW	3K	Unable to adjust 3 kHz resolution bandwidth in first crystal pole.
418	RBW	3K	Unable to adjust 3 kHz resolution bandwidth in second crystal pole.
419	RBW	3K	Unable to adjust 3 kHz resolution bandwidth in third crystal pole.
420	RBW	3K	Unable to adjust 3 kHz resolution bandwidth in fourth crystal pole.
421	RBW	10K	Unable to adjust 10 kHz resolution bandwidth in first crystal pole.
422	RBW	10K	Unable to adjust 10 kHz resolution bandwidth in second crystal pole.
423	RBW	10K	Unable to adjust 10 kHz resolution bandwidth in third crystal pole.
424	RBW	10K	Unable to adjust 10 kHz resolution bandwidth in fourth crystal pole.
425	RBW	3K	Unable to adjust 3 kHz resolution bandwidth in first crystal pole.
426	RBW	3K	Unable to adjust 3 kHz resolution bandwidth in second crystal pole.
427	RBW	3K	Unable to adjust 3 kHz resolution bandwidth in third crystal pole.
428	RBW	3K	Unable to adjust 3 kHz resolution bandwidth in fourth crystal pole.
429	RBW	<300	Unable to adjust resolution bandwidths less than 300 Hz. ADC handshake.
430	RBW	300	Unable to adjust 300 Hz resolution bandwidth. ADC handshake.

431	RBW	1K	Unable to adjust 1 kHz resolution bandwidth. ADC handshake.
432	RBW	3K	Unable to adjust 3 kHz resolution bandwidth. ADC handshake.
433	RBW	10K	Unable to adjust 10 kHz resolution bandwidth. ADC handshake.
434	RBW	300	300 Hz resolution bandwidth amplitude low in first crystal pole.
435	RBW	300	300 Hz resolution bandwidth amplitude low in second crystal pole.
436	RBW	300	300 Hz resolution bandwidth amplitude low in third crystal pole.
437	RBW	300	300 Hz resolution bandwidth amplitude low in fourth crystal pole.
438	RBW	1K	1 kHz resolution bandwidth amplitude low in first crystal pole.
439	RBW	1K	1 kHz resolution bandwidth amplitude low in second crystal pole.
440	RBW	1K	1 kHz resolution bandwidth amplitude low in third crystal pole.
441	RBW	1K	1 kHz resolution bandwidth amplitude low in fourth crystal pole.
442	RBW	3K	3 kHz resolution bandwidth amplitude low in first crystal pole.
443	RBW	3K	3 kHz resolution bandwidth amplitude low in second crystal pole.
444	RBW	3K	3 kHz resolution bandwidth amplitude low in third crystal pole.
445	RBW	3K	3 kHz resolution bandwidth amplitude low in fourth crystal pole.
446	RBW	10K	10 kHz resolution bandwidth amplitude low in first crystal pole.
447	RBW	10K	10 kHz resolution bandwidth amplitude low in second crystal pole.
448	RBW	10K	10 kHz resolution bandwidth amplitude low in third crystal pole.
449	RBW	10K	10 kHz resolution bandwidth amplitude low in fourth crystal pole.
450	IF	SYSTEM	IF hardware failure. Check other error messages.

- 451 IF SYSTM **IF** hardware failure. Check other error messages.
- 452 IF SYSTM **IF** hardware failure. Check other error messages.
- 454 AMPL Unable to adjust step gain amplifiers. Check other errors.
- 455 AMPL Unable to adjust fine attenuator of the step gain amplifiers.
- 456 AMPL Unable to adjust fine attenuator of the step gain amplifiers.
- 457 AMPL Unable to adjust fine attenuator of the step gain amplifiers.
- 458 AMPL Unable to adjust first step gain stage.
- 459 AMPL Unable to adjust first step gain stage.
- 460 AMPL Unable to adjust first step gain stage.
- 461 AMPL Unable to adjust second step gain stage.
- 462 AMPL Unable to adjust second step gain stage.
- 463 AMPL Unable to adjust third step gain stage.
- 464 AMPL Unable to adjust third step gain stage.
- 465 AMPL Unable to adjust third step gain stage.
- 466 LIN AMPL Unable to adjust linear amplifier scale.
- 467 LOG AMPL Unable to adjust step gain amplifiers.
- 468 LOG AMPL Unable to adjust third step gain stage.
- 469 LOG AMPL Unable to adjust step gain amplifiers.
- 470 LOG AMPL Unable to adjust third step gain stage.
- 471 RBW 30K Unable to adjust 30 kHz resolution bandwidth in first LC pole.
- 472 RBW 100K Unable to adjust 100 kHz resolution bandwidth in first LC pole.
- 473 RBW 300K Unable to adjust 300 kHz resolution bandwidth in first LC pole.
- 474 RBW 1M Unable to adjust 1 MHz resolution bandwidth in first LC pole.
- 475 RBW 30K Unable to adjust 30 kHz resolution bandwidth in second LC pole.
- 476 RBW 100K Unable to adjust 100 kHz resolution bandwidth in second LC pole.

477	RBW	300K	Unable to adjust 300 kHz resolution bandwidth in second LC pole.
478	RBW	1M	Unable to adjust 1 MHz resolution bandwidth in second LC pole.
483	RBW	10K	Unable to adjust 10 kHz resolution bandwidth.
484	RBW	3K	Unable to adjust 3 kHz resolution bandwidth.
485	RBW	1K	Unable to adjust 1 kHz resolution bandwidth.
486	RBW	300	Unable to adjust 300 Hz resolution bandwidth.
487	RBW	100	Unable to adjust 100 Hz resolution bandwidth.
488	RBW	100	Unable to adjust 100 Hz resolution bandwidth.
489	RBW	100	Unable to adjust 100 Hz resolution bandwidth.
490	RBW	100	Unable to adjust 100 Hz resolution bandwidth.
491	RBW	<300	Unable to adjust the resolution bandwidths less than 300 Hz. Crystal sweep gain problem.
492	RBW	300	Unable to adjust 300 Hz resolution bandwidth. Crystal sweep gain problem.
493	RBW	1K	Unable to adjust 1 kHz resolution bandwidth. Crystal sweep gain problem.
494	RBW	3K	Unable to adjust 3 kHz resolution bandwidth. Crystal sweep gain problem.
495	RBW	10K	Unable to adjust 10 kHz resolution bandwidth. Crystal sweep gain problem.
496	RBW	100	Unable to adjust 100 Hz resolution bandwidth. Inadequate Q.
497	RBW	100	Unable to adjust 100 Hz resolution bandwidth. Alignment problem.
498	RBW	100	Unable to adjust 100 Hz resolution bandwidth. Gain problem.
499	CAL	UNLK	Cal oscillator is unlocked. Verify the unlocked conditions as follows: <ol style="list-style-type: none">1. Place A4 in its service position and disconnect W51 (gray-yellow) from A4J7.2. Connect W51 to the input of another spectrum analyzer. This is the 10 MHz reference for the cal oscillator.

3. If a 10 MHz signal (approximately 0 dBm) is not present, suspect the A15 RF assembly, the A21 OCXO, or the A15 assembly TCXO (Option 103). If the 10 MHz reference is present, continue with step 4.
4. Reconnect W17 to A4J7 and monitor the tune voltage at A4J9 pin 3 with an oscilloscope.
5. Press **PRESET** on the spectrum analyzer under test.
6. If the voltage is either +15 Vdc or –15 Vdc, the cal oscillator is probably at fault. Normally, the voltage should be near +15 V during a sweep, and between –9 V and +9 V during retrace.

An *intermittent* error 499 indicates the cal osc phase-locked-loop probably can lock at 10.7 MHz, but cannot lock at the 9.9 and 11.5 MHz extremes. This may prevent the cal oscillator from adjusting the 1 MHz or 30 kHz through 300 kHz bandwidths. This symptom implies a failure in the oscillator, function block X. (See the A4 log amp/cal oscillator schematic sheet 4 of 4.) The oscillator is unable to tune the required frequency range with the –9 V to +9 V control voltage. Troubleshoot A4CR802 (most probable cause), L801, C808, C809, and U807.

- 500 AMPL 30K Unable to adjust amplitude of 30 kHz resolution bandwidth.
- 501 AMPL .1M Unable to adjust amplitude of 100 kHz resolution bandwidth.
- 502 AMPL .3M Unable to adjust amplitude of 300 kHz resolution bandwidth.
- 503 AMPL 1M Unable to adjust amplitude of 1 MHz resolution bandwidth.
- 504 AMPL 30K Unable to adjust amplitude of 30 kHz resolution bandwidth.
- 505 AMPL .1M Unable to adjust amplitude of 100 kHz resolution bandwidth.
- 506 AMPL .3M Unable to adjust amplitude of 300 kHz resolution bandwidth.
- 507 AMPL 1M Unable to adjust amplitude of 1 MHz resolution bandwidth.

- 508 AMPL 30K Unable to adjust amplitude of 30 kHz resolution bandwidth. Insufficient gain during LC bandwidth calibration.
- 509 AMPL .1M Unable to adjust amplitude of 100 kHz resolution bandwidth. Insufficient gain during LC bandwidth calibration.
- 510 AMPL .3M Unable to adjust amplitude of 300 kHz resolution bandwidth. Insufficient gain during LC bandwidth calibration.
- 511 AMPL 1M Unable to adjust amplitude of 1 MHz resolution bandwidth. Insufficient gain during LC bandwidth calibration.
- 512 RBW <300 Unable to adjust resolution bandwidths less than 300 Hz. Insufficient gain during crystal bandwidth calibration.
- 513 RBW 300 Unable to adjust 300 Hz resolution bandwidth. Insufficient gain during crystal bandwidth calibration.
- 514 RBW 1K Unable to adjust 1 kHz resolution bandwidth. Insufficient gain during crystal bandwidth calibration.
- 515 RBW 3K Unable to adjust 3 kHz resolution bandwidth. Insufficient gain during crystal bandwidth calibration.
- 516 RBW 10K Unable to adjust 10 kHz resolution bandwidth. Insufficient gain during crystal bandwidth calibration.
- 517 RBW 100 Unable to adjust 100 Hz resolution bandwidth. Crystal sweep problem.
- 518 RBW 300 Unable to adjust 300 Hz resolution bandwidth. Crystal sweep problem.
- 519 RBW 1K Unable to adjust 1 kHz resolution bandwidth. Crystal sweep problem.
- 520 RBW 3K Unable to adjust 3 kHz resolution bandwidth. Crystal sweep problem.
- 521 RBW 10K Unable to adjust 10 kHz resolution bandwidth. Crystal sweep problem.
- 522 RBW 10K Unable to adjust symmetry of 10 kHz resolution bandwidth in first crystal pole.
- 523 RBW 10K Unable to adjust symmetry of 10 kHz resolution bandwidth in second crystal pole.
- 524 RBW 10K Unable to adjust symmetry of 10 kHz resolution bandwidth in third crystal pole.

- 525 RBW 10K Unable to adjust symmetry of 10 kHz resolution bandwidth in fourth crystal pole.
- 526 RBW <300 ADC timeout during IF ADJUST of <300 Hz resolution bandwidth.
- 527 RBW <300 Step gain correction failed for <300 Hz resolution bandwidth. Check narrow bandwidth SGO attenuator.
- 528 RBW <300 Calibration of dc level at ADC failed for <300 Hz resolution bandwidth.
- 529 RBW <300 Invalid demodulated data for <300 Hz resolution bandwidth flatness and IF down-converter. Demod data for calibration may be bad.
- 530 RBW <300 Adjustment of VCXO down-converter failed with resolution bandwidths less than 300 Hz. Narrow bandwidth VCXO calibration failed.
- 531 RBW <300 Flatness correction data for resolution bandwidths <300 Hz not acceptable.
- 532 RBW <300 Absolute gain data for resolution bandwidths <300 Hz not acceptable.
- 533 RBW <300 ADC timeout adjusting resolution bandwidths less than 300 Hz. Timeout during data sampling narrow bandwidth chunk.
- 534 RBW <300 Unable to do frequency count of CAL OSC using IF down-converter when adjusting resolution bandwidths less than 300 Hz.
- 535 RBW <300 Unable to obtain adequate FM demod range to measure 500 Hz IF filter with resolution bandwidths less than 300 Hz.
- 536 RBW <300 Unable to auto-range chirp signal while setting VCXO or doing flatness calibration with resolution bandwidths less than 300 Hz.
- 537 RBW <300 Unable to auto-range CW CAL OSC signal to count VCXO signal with resolution bandwidths less than 300 Hz.
- 538 RBW <300 Shape of 500 Hz IF filter appears too noisy to adjust VCXO down-converter for resolution bandwidths less than 300 Hz.
- 539 RBW <300 Unable to auto-range the CW CAL OSC signal to pretune the VCXO for resolution bandwidths less than 300 Hz.

- 540 RBW <300 Unable to find CW CAL OSC signal during VCXO pretune at power-up with resolution bandwidths less than 300 Hz.
- 550 ID CALOSC CAL Oscillator ID. Indicates incompatible hardware. Cal Osc not expected
- 551 ID LOGBD LOG Board ID. Indicates incompatible hardware. Log board not expected.
- 552 LOG AMPL Unable to adjust amplitude of log scale.
- 553 LOG AMPL Unable to adjust amplitude of log scale.
- 554 LOG AMPL Unable to adjust amplitude of log scale.
- 555 LOG AMPL Unable to adjust amplitude of log scale.
- 556 LOG AMPL Unable to adjust amplitude of log scale.
- 557 LOG AMPL Unable to adjust amplitude of log scale.
- 558 LOG AMPL Unable to adjust amplitude of log scale.
- 559 LOG AMPL Unable to adjust amplitude of log scale.
- 560 LOG AMPL Unable to adjust amplitude of log scale.
- 561 LOG AMPL Unable to adjust amplitude of log scale. Possible problem in second step gain.
- 562 LOG AMPL Unable to adjust amplitude of log scale. Possible problem in second step gain.
- 563 LOG AMPL Unable to adjust amplitude of log scale. Possible problem in third step gain range.
- 564 LOG AMPL Unable to adjust amplitude of log scale.
- 565 LOG AMPL Unable to adjust amplitude of log scale.
- 566 LOG AMPL Unable to adjust amplitude of log scale.
- 567 LOG AMPL Unable to adjust amplitude of log scale. Possible problem in log offset/log expand stage.
- 568 LOG AMPL Unable to adjust amplitude of log scale. Possible problem in log offset/log expand stage.
- 569 LOG AMPL Unable to adjust amplitude of log scale. Possible problem in log offset/log expand stage.
- 570 LOG AMPL Unable to adjust amplitude of log scale. Possible problem in log offset/log expand stage.
- 571 AMPL Unable to adjust step gain amplifiers.
- 572 AMPL 1M Unable to adjust amplitude of 1 MHz resolution bandwidth.

General Troubleshooting
Error Messages

- 573 LOG AMPL Unable to adjust amplitude of log scale. Check video offset circuitry.
- 574 LOG AMPL Unable to adjust amplitude of log scale. Check video offset circuitry.
- 575 LOG AMPL Unable to adjust amplitude of log scale. Check video offset circuitry.
- 576 LOG AMPL Unable to adjust amplitude of log scale. Check video offset circuitry.
- 577 LOG AMPL Unable to adjust amplitude of log scale. Check video offset circuitry.
- 578 LOG AMPL Limiter calibration error from DC logger calibration.
- 579 LOG AMPL Attenuator CAL level error from DC logger calibration.
- 580 LOG AMPL Calibration level error from DC logger fidelity calibration.
- 581 AMPL Unable to adjust 100 kHz resolution bandwidth and resolution bandwidths less than or equal to 10 kHz. ADC/CALOSC handshake calibration problem in crystal sweep. Refer to Error 582.
- 582 AMPL Unable to adjust 100 kHz resolution bandwidth and resolution bandwidths less than or equal to 10 kHz. Bad CALOSC calibration in sweep rate. Test the 100 kHz resolution bandwidth filter 3 dB bandwidth as follows:
1. Connect the CAL OUTPUT signal (A4J8) to the INPUT 50Ω
 2. Press **PRESET** and set the controls as follows:
 - Center frequency 300 MHz
 - Span 500 kHz
 - Resolution bandwidth 100 kHz
 - Log dB/div 1 dB
 - Reference level adjust to place signal peak at top of the screen
 3. Press **PEAK SEARCH** and **MARKER DELTA** and turn the knob clockwise to position the marker until the delta MKR reads -3 dB ±0.1 dB.
 4. Press **MARKER DELTA** and move the marker to the other side of the peak until the delta MKR reads 0 dB ±0.1 dB.

5. If the delta MKR frequency is between 90 kHz and 110 kHz, the 100 kHz resolution bandwidth is working properly. If the frequency is outside these limits, read the following information on the A4 cal oscillator sweep generator.

If the 100 kHz resolution bandwidth works properly, the cal oscillator sweep generator is failing to sweep its oscillator frequency at the correct rate. The error is detected in sweeping on the skirts of the 100 kHz resolution bandwidth.

A properly operating sweep generator generates a series of negative-going parabolas. These parabolas generate the sweeps used to adjust resolution bandwidths of 10 kHz and below. Check the sweep generator with the following steps. Refer also to the “300 Hz to 3 kHz Resolution Bandwidth Out of Specification” troubleshooting text in [Chapter 9](#), “[IF Section](#).”

1. Remove the shields.
2. Connect an oscilloscope probe to A4U804C pin 8.
3. On the spectrum analyzer, press **CAL** and **FULL IF ADJ**.
4. Approximately 8 seconds after starting the **FULL IF ADJ**, check for negative-going parabolas (similar to half-sine waves) 5 ms wide and approximately –4 V at their peak. Refer to [Chapter 9](#), “[IF Section](#),” for more information on the A4 log amp/cal oscillator assembly.

583 RBW 30K Unable to adjust 30 kHz resolution bandwidth.
584 RBW 100K Unable to adjust 100 kHz resolution bandwidth.
585 RBW 300K Unable to adjust 300 kHz resolution bandwidth.
586 RBW 1M Unable to adjust 1 MHz resolution bandwidth.
587 RBW 30K Unable to adjust 30 kHz resolution bandwidth.
588 RBW 100K Unable to adjust 100 kHz resolution bandwidth.
589 RBW 300K Unable to adjust 300 kHz resolution bandwidth.
590 RBW 1M Unable to adjust 1 MHz resolution bandwidth.
591 LOG AMPL Unable to adjust amplitude of log scale.
592 LOG AMPL Unable to adjust amplitude of log scale.

- 593 LOG TUNE Limiter calibration tune error from DC logger calibration.
- 594 LOG OFST Attenuator calibration offset error from DC logger calibration.
- 595 LOG ATTN Attenuator calibration absolute error from DC logger calibration.
- 596 LOG FID Fidelity error from DC logger calibration.
- 597 LOG OFST Fidelity offset error from DC logger calibration.
- 598 LOG OFST Fidelity offset unstable from DC logger calibration.
- 599 LOG GAIN Fidelity gain error from DC logger calibration.

System Errors (600 to 651)

ADC timeout errors occur if the A2 controller assembly frequency counter is faulty. Refer to [Chapter 8](#) ,
[“ADC/Interface Section.”](#)

- 600 SYSTEM Hardware/firmware interaction; check other errors.
- 601 SYSTEM Hardware/firmware interaction; check other errors.
- 650 OUTOF RG ADC input is outside of the ADC range.
- 651 NO IRQ Microprocessor is not receiving interrupt from ADC.

Digital and Checksum Errors (700 to 799)

EEROM Checksum Errors (700 to 704)

Faults on the A2 controller assembly can cause these errors. Refer to [Chapter 10](#) , [“Controller Section.”](#) Although some of these errors might result in a blanked display, it is possible to read these errors over GPIB. Refer to [“Troubleshooting to a Functional Section”](#) on page 324.

The EEROM on the A2 controller assembly is used to store data for frequency response correction, elapsed time, focus, and intensity levels. Error codes from 700 to 703 indicate that some part of the data in EEROM is invalid. An EEROM error could result from either a defective EEROM or an improper sequence of storing data in EEROM. Check the EEROM with the following steps:

1. Place the WR PROT/WR ENA jumper on the A2 controller assembly in the WR ENA position.

2. On the spectrum analyzer, press **CAL MORE 1 OF 2, SERVICE CAL DATA, FLATNESS, and FLATNESS DATA.** Enter a value of 130. Press **PREV MENU, STORE DATA, YES, and DISPLAY.**
3. Press **INTEN**, enter an intensity value of 90, and press **STORE INTEN.**
4. Press **MORE 1 OF 2 FOCUS**, enter a focus value of 128, and press **STORE FOCUS.** Turn the **LINE** switch off, then on, cycling the power.
5. If errors are still present, the EEROM A2U501 is defective. Refer to the EEROM replacement procedure in [Chapter 4](#) .

- 700 EEROM Checksum error of EEROM A2U501.
- 701 AMPL CAL Checksum error of frequency response correction data.
- 702 ELAP TIM Checksum error of elapsed time data.
- 703 AMPL CAL Checksum error of frequency response correction data. Default values being used.
- 704 PRESELECT Checksum error of customer preselector peak data. External preselector data recalled in internal mode, or internal preselector data recalled in external mode. To clear the error, press **RECALL, MORE 1 OF 2, FACTORY PRSEL PK, SAVE, and SAVE PRSEL PK.**

Program ROM Checksum Errors (705 to 710)

The instrument power-on diagnostics perform a checksum on each programmed ROM (A2 controller assembly). If an invalid checksum is found for a particular ROM, an error code is generated. If a defective programmed ROM is found, replace it with another ROM with the same part number. Refer to [Chapter 5](#) , “Replaceable Parts.”

Although some of these errors might result in a blanked display, it is possible to read these errors over GPIB. Refer to “[Troubleshooting to a Functional Section](#)” on page 324.

- 705 ROM U306 Checksum error of program ROM A2U306.
- 706 ROM U307 Checksum error of program ROM A2U307.
- 707 ROM U308 Checksum error of program ROM A2U308.
- 708 ROM U309 Checksum error of program ROM A2U309.
- 709 ROM U310 Checksum error of program ROM A2U310.

710 ROM U311 Checksum error of program ROM A2U311.

RAM Check Errors (711 to 716)

The instrument power-on diagnostics check the program RAM. This includes the two RAMs used for STATE storage. If any STATE information is found to be invalid, all data in that RAM is destroyed. A separate error code is generated for each defective program RAM. All RAM is battery-backed. See “[State- and Trace-Storage Problems](#)” in [Chapter 10](#) .

711 RAM U303 Checksum error of system RAM A2U303.

712 RAM U302 Checksum error of system RAM A2U302.

713 RAM U301 Checksum error of system RAM A2U301.

714 RAM U300 Checksum error of system RAM A2U300.

715 RAM U305 Checksum error of system RAM A2U305.

716 RAM U304 Checksum error of system RAM A2U304.

Microprocessor Error (717)

717 BAD uP Microprocessor not fully operational. Refer to Chapter 10, “Controller Section.”

Battery Problem (718)

If STATE or TRACE data is found to be corrupt, the processor tests the display RAMs and the program RAMs containing the STATE information. If the RAMs are working properly, this error message is generated. To check the BT1 battery and the battery backup circuitry, refer to “[State- and Trace-Storage Problems](#)” in [Chapter 10](#) .

718 BATTERY? Nonvolatile RAM not working; check battery BT1. This error can also be generated if the battery has been disconnected then reconnected. If this is the cause, cycling power clears the error.

Model/Option Number Errors (719 to 720)

If one of these errors occurs, return the instrument to a service center for repair.

719 MODEL #? Could not read ID string from EEROM A2U501.

720 OPTION #? Cannot identify an option number.

RAM Check Error (721)

721 AMPC RAM Checksum error of the ampcor function correction data.

System Errors (750 to 759)

These errors often require troubleshooting the A2 controller and A3 interface assemblies.

750 SYSTEM Hardware/firmware interaction, zero divide. Check for other errors.

751 SYSTEM Hardware/firmware interaction, floating point overflow. Check for other errors.

752 SYSTEM Hardware/firmware interaction, floating point underflow. Check for other errors.

753 SYSTEM Hardware/firmware interaction, log error. Check for other errors.

754 SYSTEM Hardware/firmware interaction, integer overflow. Check for other errors.

755 SYSTEM Hardware/firmware interaction, square root error. Check for other errors.

756 SYSTEM Hardware/firmware interaction, triple overflow. Check for other errors.

757 SYSTEM Hardware/firmware interaction, BCD overflow. Check for other errors.

758 SYSTEM Unknown system error.

759 SYSTEM Hardware/firmware interaction. Code invoked for wrong instrument.

Fast ADC Error (760)

This error applies only to EC-series instruments and to E-series instruments with fast ADC (Option 007).

760 NO FADC The FADC board did not respond properly to initialization commands.

Option Module Errors (800 to 899)

These error codes are reserved for option modules, such as the 85629 test and adjustment module and the 85620A mass memory module. Refer to the option module manual for a listing of error messages.

User-Generated Errors (900 to 999)

These error codes indicate user-generated errors.

- 900 TG UNLVL Tracking generator output is unlevelled.
- 901 TGFrqLmt Tracking generator output unlevelled because START FREQ is set below tracking generator frequency limit (300 kHz).
- 902 BAD NORM The state of the stored trace does not match the current state of the spectrum analyzer.
- 903 A > DLMT Unnormalized trace A is off-screen with trace math or normalization on.
- 904 B > DLMT Calibration trace (trace B) is off-screen with trace math or normalization on.
- 905 EXT REF Unable to lock cal oscillator when set to external frequency reference. Check that the external 10 MHz reference is within tolerance.
- 906 OVENCOLD The oven-controlled crystal oscillator (OCXO) oven is cold.
- 907 DO IF CAL Unit is still performing IF calibrations, or is in need of IF calibrations which were not yet done due to an OVENCOLD condition. An OVENCOLD error is indicative of a bandwidth ≤ 1 kHz not getting calibrated.
- 908 BW>>SPCG Channel bandwidth is too wide, compared to the channel spacing, for a meaningful adjacent channel power computation.
- 909 SPANACP The frequency span is too small to obtain a valid adjacent channel power (ACP) measurement.
- 910 SPAN>ACP The frequency span is too wide, compared to the channel bandwidth, to obtain a valid adjacent channel power (ACP) measurement.
- 911 ACPSTATE Adjacent channel power (ACP) measurement has been compromised (invalid measurement parameters).
- 921 \uparrow AMP COR \uparrow Measurement data which would normally be displayed above the top graticule, and therefore has unspecified accuracy, has been corrected by the amplitude correction function (ampcor) to appear between the top and bottom graticule.
- 922 \downarrow AMP COR \downarrow Measurement data which would normally be displayed below the bottom graticule, and therefore has unspecified accuracy, has been corrected by the amplitude correction function (ampcor) to appear between the top and bottom graticule.

Block Diagram Description

The spectrum analyzer is comprised of the six main sections listed below. See [Figure 7-6 on page 352](#). The following descriptions apply to the simplified block diagram and overall block diagram located at the end of this chapter. Assembly level block diagrams are located in Chapters 8 through 13.

Figure 7-6 Functional Sections

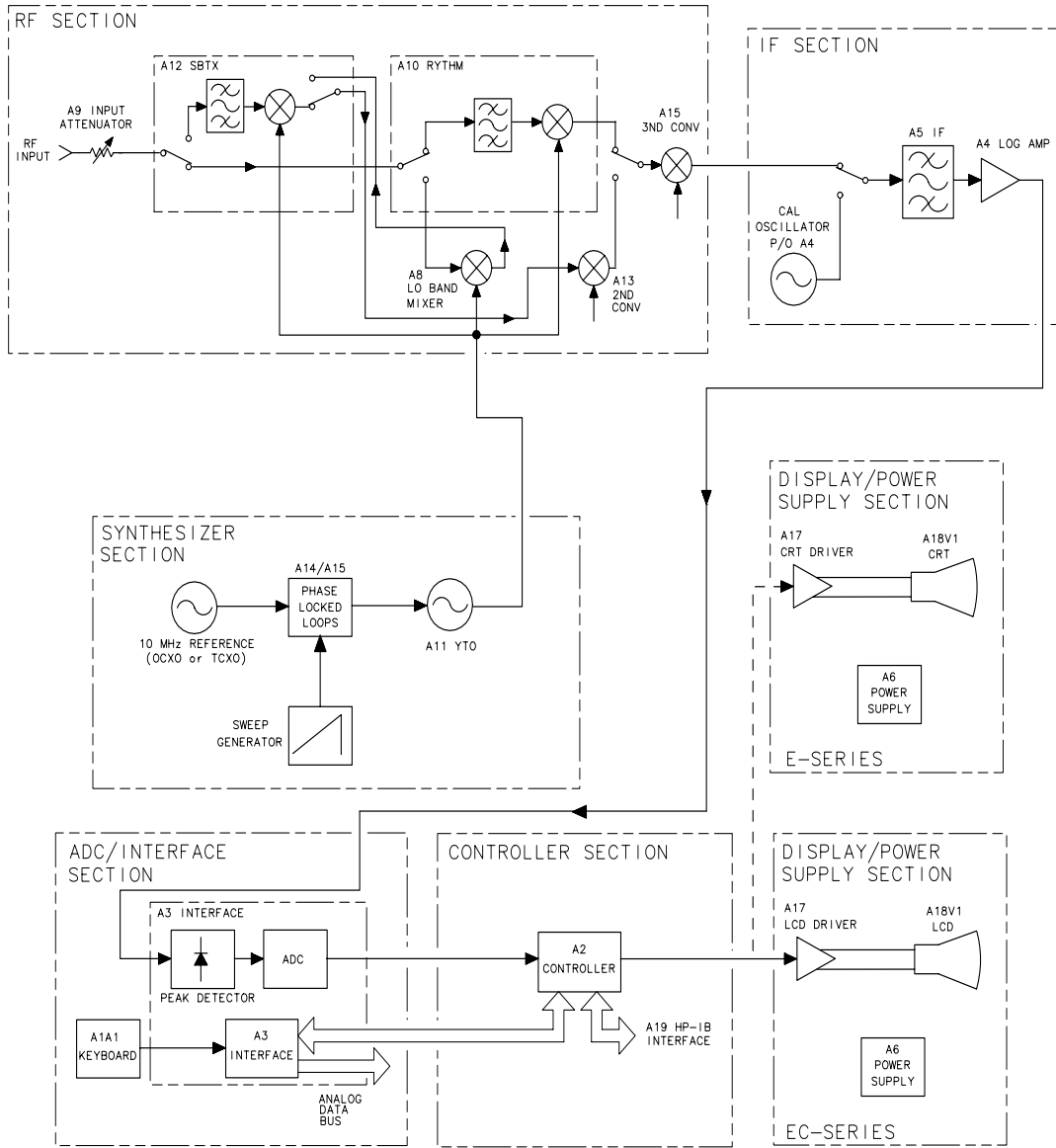

s1118c

RF Section

The RF section of the 8564E/EC and 8565E/EC includes the following assemblies:

- A7 LOMA (LO multiplier/amplifier)
- A8 low band mixer
- A9 input attenuator
- A10 RYTHM (YIG-tuned filter/mixer)
- A11 YTO (YIG-tuned oscillator)
- A12 SBTX (switched barium-tuned mixer)
- A13 second converter
- A14 frequency control assembly (also in synthesizer section)
- A15 RF assembly (also in synthesizer section)
- FL1, FL2, FL3, and FL5 low-pass filters

The RF section converts all input signals to a fixed IF of 10.7 MHz. The RF section microcircuits are controlled by signals from the A14 frequency control and A15 RF assemblies.

- Band 0 9 kHz to 2.9 GHz
- Bands 1 through 3 2.9 to 26.5 GHz
- Bands 4 and 5 26.5 to 50 GHz

Band 0 and bands 4 and 5 use triple conversion to produce the 10.7 MHz IF, and a fourth conversion used only in the digital resolution bandwidths (≤ 100 Hz). In band 0, A8 low band mixer up-converts the RF input to a 1st IF of 3.9107 GHz. In bands 4 and 5, A12 SBTX down-converts the RF input to a 1st IF of 3.9107 GHz. A13 second converter down-converts the 3.9107 GHz IF to an IF of 310.7 MHz. A third conversion on the A15 RF assembly down-converts the second IF to the 10.7 MHz third IF. A fourth conversion on the A4 log amplifier assembly down-converts the third IF to the 4.8 kHz fourth IF used only in the digital resolution bandwidths (≤ 100 Hz).

Bands 1 through 3 use double conversion. A third conversion is used for the digital resolution bandwidths (≤ 100 Hz). A10 RYTHM down-converts the RF input to a 1st IF of 310.7 MHz. Although this IF passes through the A13 second converter, it bypasses the second mixer. The second conversion on the A15 RF assembly down-converts the 310.7 MHz IF to 10.7 MHz. A third conversion on the A4 log amplifier assembly down-converts the second IF to the 4.8 kHz third IF used only in the digital resolution bandwidths (≤ 100 Hz).

A7 LOMA

The A7 LOMA (LO multiplier/amplifier) levels the output of the A11 YTO and distributes the YTO fundamental frequency to the front panel 1ST LO OUTPUT, A8 low band mixer, A10 RYTHM, and A15U100 sampler. It also doubles the YTO frequency and levels this signal for use by the A12 SBTX. The leveling circuitry is on the A14 frequency control assembly.

A8 Low Band Mixer (serial prefix <3641A)

A8 low band mixer is ac-coupled and contains a limiter. (Option 006 is dc-coupled.) The high band mixing is done in either the A10 YIG-tuned filter/mixer or the A12 SBTX. PIN diode switches in A10 and A12 direct the RF input to the appropriate mixer. A PIN diode switch in A7 LOMA directs the 1st LO to the appropriate mixer.

A8 Low Band Mixer (serial prefix ≥3641A)

A8 low band mixer is dc-coupled and contains a limiter. (Non-Option 006 analyzers have a dc block (AT1), connected to the input of A8.) The high-band mixing is done in either the A10 YIG-tuned filter/mixer or the A12 SBTX. PIN diode switches in A10 and A12 direct the RF input to the appropriate mixer. A PIN diode switch in A7 LOMA directs the 1st LO to the appropriate mixer. Power for the LO and RF amplifiers is provided via W15 from A14.

A9 Input Attenuator

The attenuator is a 50Ω precision, coaxial step attenuator. Attenuation in 10 dB steps from 0 dB to 70 dB is accomplished by switching the signal path through one or more of the three resistive pads. The attenuator automatically sets to 70 dB when the spectrum analyzer turns off, providing ESD protection. (Note that the input attenuator is not field-repairable.)

A10 YIG-Tuned Filter/Mixer

The YIG-tuned filter/mixer (RYTHM) is a combination of an RF switch, a microwave (2.9 GHz to 26.8 GHz) mixer, and a tracking preselector. The PIN diode switch directs the RF input to the appropriate mixer in the A10 RYTHM assembly or A8 low band mixer.

The tracking preselector is a YIG-tuned filter. It functions as a tunable bandpass filter for microwave signals. Coarse frequency control originates from slope and offset DACs located on the A14 frequency control assembly. (Slope and offset DAC values are loaded into EEROM.)

Fine frequency control originates from a preselector peak DAC located on the A3 interface assembly. Values for the preselector peak DAC are interpolated approximately every 17 MHz based upon data taken during the frequency response (flatness) adjustment. The preselector bandwidth varies from greater than 30 MHz, at 2.75 GHz, to greater than 60 MHz, at 26.5 GHz.

The mixer is ac coupled. It uses the first, second, and fourth harmonics, mixed with the 1st LOcal oscillator, to cover the frequency range. A PIN diode switch in A7 LOMA directs the 1st LO to the appropriate mixer. The A14 frequency control assembly provides PIN diode bias.

A11 YTO

A11 is a YTO (YIG-tuned oscillator). YIG (yttrium-iron-garnet) is a ferro-magnetic material which is polished into a small sphere and precisely oriented in a magnetic field. Changes in this magnetic field alter the frequency generated by the YTO. Current control of the magnetic field surrounding the YIG sphere tunes the oscillator to the desired frequency.

A12 Switched Barium-Tuned Mixer (SBTX)

The switched barium-tuned mixer (SBTX) is a combination of an RF switch, tracking preselector, millimeter (26.5 GHz to 50 GHz) mixer, and low-noise amplifier. The PIN diode switch directs the RF input to the appropriate mixer in the A12 SBTX or to A10 RYTHM, where it may be again switched to the A8 low band mixer.

The tracking preselector is a barium-tuned filter. It functions as a tunable bandpass filter for millimeter signals. Coarse frequency control originates from slope and offset DACs located on the A14 frequency control assembly. (Slope and offset DAC values are loaded into EEROM.)

Fine frequency control originates from a preselector peak DAC located on the A3 interface assembly. Values for the preselector peak DAC are interpolated approximately every 17 MHz based upon data taken during the frequency response adjustment ('front-end cal'). The preselector 3 dB bandwidth varies from approximately 200 MHz at 26.5 GHz to approximately 300 MHz at 50 GHz.

The millimeter mixer IF (3.9107 GHz) is fed through a low-noise amplifier and one input of a PIN diode switch before being sent to the A13 second converter. The other switch input accepts the IF output of the A8 low band mixer.

A13 Second Converter

The A13 second converter down-converts the 3.9107 GHz 1st IF (low-band and millimeter band) to a 310.7 MHz 2nd IF. In the microwave band, it passes the 310.7 MHz 1st IF from the A10 YIG-tuned filter/mixer to the A15 RF assembly. The converter generates a 3.6 GHz second LO by multiplying a 600 MHz reference. Bandpass filters remove unwanted harmonics of the 600 MHz driving signal. 1st IF and 2nd LO signals are filtered by cavity filters.

Second IF Amplifier (part of A15)

The second IF amplifier (SIFA) amplifies and filters the second IF. Access to this pre-filtered signal is available at the rear panel 2ND IF OUTPUT (Option 001 only).

The external mixing input from the front panel IF INPUT connector is also directed through the SIFA. A dc bias is placed onto the IF INPUT line for biasing external mixers.

Third Converter (part of A15)

The third converter down-converts the 310.7 MHz IF to 10.7 MHz. A PIN-diode switch selects the LO signal used. For normal operation, a 300 MHz LO signal is used. The signal is derived from the 600 MHz reference PLL. During signal identification (SIG ID ON), the 298 MHz SIG ID oscillator is fed to the double balanced mixer on alternate sweeps.

Flatness Compensation Amplifiers (part of A15)

The flatness compensation amplifiers amplify the output of the double-balanced mixer. The variable gain of the amplifier (0 to 45 dB) compensates for flatness variations within a band. Band conversion loss is compensated by step gain amplifiers in the IF section.

Control for the amplifiers originates from two DACs on the A3 Interface assembly. (DAC values are interpolated approximately every 17 MHz based on data obtained during the frequency response adjustment.) The flatness-compensation control circuitry on A15 converts the RF GAIN voltage, from A3, into two currents: RF GAIN1 and RF GAIN2. These currents drive PIN diodes in the flatness compensation amplifiers.

Synthesizer Section

The 1st LO is phase-locked to the 10 MHz standard internal to the instrument by four PLLs. See [Figure 7-7 on page 358](#).

The reference PLL supplies reference frequencies for the instrument. The three remaining PLLs tune and phase-lock the LO through its frequency range. To tune the LO to a particular frequency, the instrument microprocessor must set the programmable feedback dividers (N) and reference dividers (R) contained in each PLL.

Sweeping the 1st LO

The spectrum analyzer uses a method called lock and roll to sweep the 1st LO (A11 YTO) for LO spans >2 MHz. This involves phase-locking the spectrum analyzer at the start frequency during the retrace of the sweep, then sweeping through the desired frequency range in an unlocked condition. The sweep ramp, which sweeps the LO during the roll part of the lock and roll process, is generated on the A14 frequency control assembly. It is applied to either the main coil or the FM coil of the A11 YTO. For LO spans ≤2.0 MHz, the YTO PLL remains locked and the fractional N PLL sweeps while remaining phase locked. The frequency/span relationships are as follows:

A11 YTO Spanwidth	Sweep Applied To
20.1 MHz to 3.8107 GHz	A11 YTO main coil
2.01 MHz to 20.0 MHz	A11 YTO FM coil
100 Hz to 2 MHz	Fractional N phase locked loop

When the sweep ramp is applied to the YTO, the spectrum analyzer must prevent this loop from trying to compensate for changes in the output frequency. To accomplish this, the spectrum analyzer opens the PLL by disconnecting the YTO PLL phase detector output.

Reference PLL (part of A15)

The 100 MHz PLL output is routed through multipliers to provide 600 MHz for the second LO, and 300 MHz for the third LO and the sampling oscillator reference. In spectrum analyzers with A15 assemblies earlier than 08563-60054, 08563-60055, or 08563-60056, the PLL circuitry consists of a 600 MHz SAWR which is divided down to obtain the 300 MHz. The reference PLL is also divided down to 10 MHz for the fractional N PLL. The reference PLL is locked to a 10 MHz OCXO (oven-compensated crystal oscillator) or a TCXO (Option 103). The PLL can also be locked to an external frequency reference.

The 10 MHz reference also supplies the reference for the frequency counter on the A2 controller assembly, and the cal oscillator on the A4 assembly.

YTO PLL (A7, A11, part of A14, part of A15)

The YTO PLL produces the 1st LO of the instrument (3.0 to 6.81 GHz). The YTO output is mixed with a harmonic of the sampling oscillator in the sampler (A15A2), and the resulting frequency is phase-locked to the output of the fractional N PLL.

The A15U100 sampler mixes the LO signal from the A7 LOMA with a harmonic of the sampling oscillator. The mixing product, the sampler IF, is between 60 and 96 MHz (same frequency range as the fractional N PLL).

Offset Lock Loop (part of A15)

The 285 MHz to 297.2 MHz sampling oscillator is used to sample the YTO. By changing the offset lock loop programmable dividers, the YTO frequency can be changed.

Figure 7-7 Phase Lock Loops

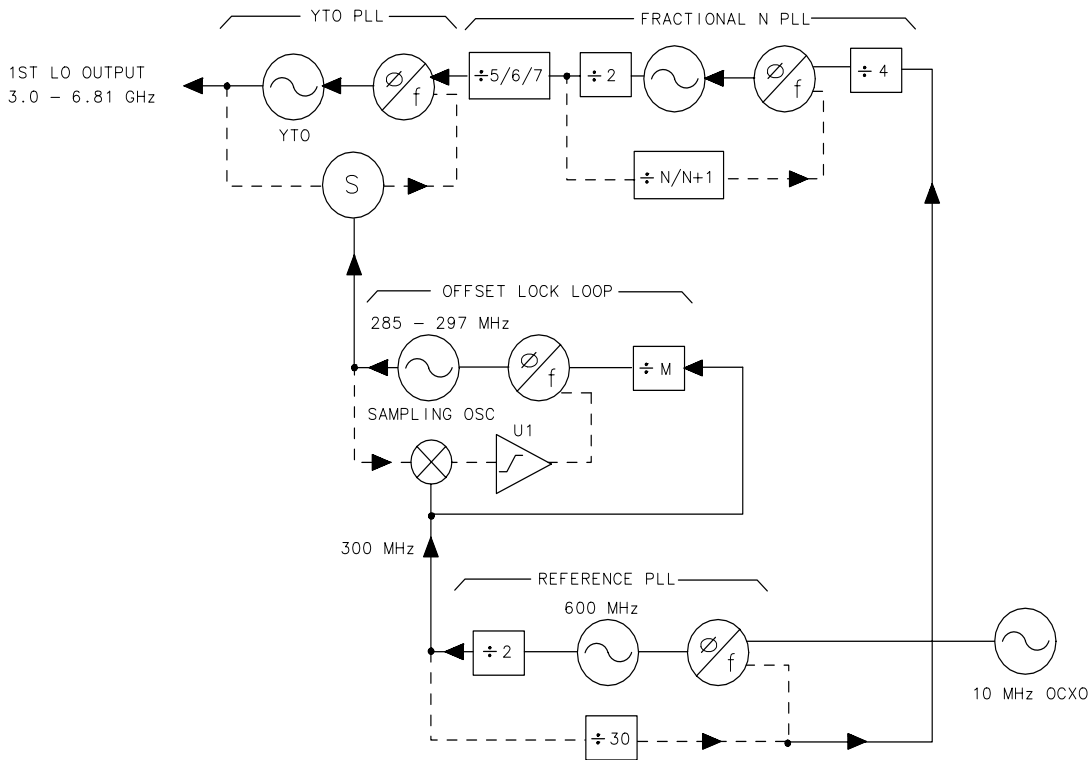

sp113e

Fractional N PLL (part of A14)

The fractional N PLL produces an output of 60 MHz to 96 MHz. This PLL output serves as the reference frequency for the YTO PLL. A one-to-one relationship in frequency tracking exists between the fractional N PLL and the YTO. A change of 1 MHz in the fractional N PLL will produce a 1 MHz change in the YTO frequency.

IF Section

The IF section processes the 10.7 MHz output of the RF section and sends the detected video to the ADC/interface section. The following major assemblies are included in this section:

- A3 interface assembly
- A4 log amplifier/calibration oscillator assembly
- A5 IF assembly

The spectrum analyzer uses trace-data manipulation to generate the 5 dB/DIV scale from the 10 dB/DIV scale. The A3 interface assembly amplifies and offsets the 10 dB/DIV video to generate the 2 dB/DIV scale. The 1 dB/DIV scale is generated from the 2 dB/DIV scale through trace data manipulation. The first 50 dB of IF gain (log and linear mode) is achieved using the linear step-gain amplifiers on the A5 assembly. The video-offset circuit on the A4 assembly provides the remaining 60 dB of log mode IF gain. The linear amplifiers on the A4 assembly provide 40 dB of linear mode gain. IF gain steps of less than 10 dB (regardless of the reference level) are accomplished on the A5 assembly.

A4 Log Amplifier/Cal Oscillator Assembly

The A4 log amplifier has separate log and linear amplifier paths. After amplification, the signal path consists of a linear detector, video log amp, buffer amplifier, video offset, and video buffer amplifier. Other auxiliary functions include the frequency counter prescaler/conditioner, the AM/FM demodulator, and down-conversion to 4.8 kHz for digital resolution bandwidths of 1 Hz through 100 Hz.

The cal oscillator, which is part of A4, supplies the stimulus signal for automatic IF adjustments. Normally, the oscillator operates only during retrace (for a few milliseconds) to adjust part of the IF. (All IF parameters will be re-adjusted approximately every five minutes.) With continuous IF adjust on, a group of IF parameters are adjusted during each retrace period (non-disruptive). If continuous IF adjust is off, the most recent IF calibration data will be used.

The IF parameters adjusted include step gains, log amplifier gain and offset, bandwidth centering, 3 dB bandwidth, bandwidth amplitude, crystal-filter symmetry, and oscillator frequency used in 1 Hz through 100 Hz resolution bandwidths.

The cal oscillator output has three forms (all -35 dBm):

- 10.7 MHz
- 9.9 to 11.5 MHz in 100 kHz steps
- Frequency sweeps from 20 kHz to 2 kHz centered at 10.7 MHz (lasting 5 to 60 ms respectively)

The purpose of these signals is:

- Adjust gains, log amps, and video slopes and offsets
- Adjust 3 dB bandwidth and center frequencies of LC resolution BW filters (30 kHz through 1 MHz).
- Adjust 3 dB bandwidth, symmetry, and gain of the crystal resolution BW filters (300 Hz through 10 kHz).
- Adjust gain and gain-vs-frequency for digital resolution bandwidths (1 Hz through 100 Hz).

A5 IF Assembly

The A5 IF assembly has four crystal filter poles, four LC filter poles, and step gain amplifiers. The crystal filters provide resolution bandwidths of 300 Hz to 10 kHz. The LC filters provide resolution bandwidths of 30 kHz to 2 MHz. All filter stages are in series. PIN diode switches bypass unwanted stages.

An automatic IF adjustment, in spectrum analyzer firmware, sets center frequency and 3 dB bandwidth of all filter poles through varactor and PIN diodes. The firmware also controls crystal-pole symmetry and the step gain amplification.

ADC/Interface Section

The ADC/interface section is the link between the controller section and the rest of the spectrum analyzer. It controls the RF, synthesizer, and IF sections through address and data lines on the W2 control cable (analog bus). Analog signals from these sections are monitored by the ADC (analog to digital converter) circuit on the ADC/interface section.

The ADC/interface section includes the A3 interface assembly, A1A1 keyboard, and A1A2 RPG (front panel knob). The A3 assembly includes log expand, video filter, peak detector, track-and-hold, real-time DACs, RF gain DACs, +10 V reference, and ADC circuitry. The digital section of the A3 assembly includes ADC ASM, sweep trigger, keyboard interface, RPG interface, and analog bus interface circuitry.

ADC

The spectrum analyzer can digitize signals with either the main ADC on the A3 interface assembly, or the optional A16 fast ADC (Option 007). The main ADC is used for digitizing video signals (when the sweep time is ≥ 30 ms) and various other signals such as PLL error voltages. The fast ADC is used only to digitize video signals for sweep times ≤ 30 ms.

Main ADC (part of A3 interface assembly) For slower sweep times (≤ 30 ms) the spectrum analyzer uses a successive-approximation type of ADC. The main ADC has a 10-bit resolution but it is realized with 12-bit hardware. The ADC algorithmic state machine (ADC ASM) controls the interface between the start/stop control and the ADC itself, switching between positive and negative peak detectors when the NORMAL detector mode is selected, and switching the ramp counter into the ADC for comparison to the analog sweep ramp.

Fast ADC When Option 007 is installed and sweep times ≤ 30 ms are selected, the spectrum analyzer digitizes video signals with the A16 fast ADC. The fast ADC uses an 8-bit flash ADC, sampled at a 12 MHz rate. Only POS PEAK, NEG PEAK, and SAMPLE detector modes are available with fast ADC; NORMAL detector mode is not available. Pretriggering is possible with fast ADC.

Log Expand/Video Functions

The A3 interface assembly performs log expand and offset functions. The log expand/log offset amplifier provides a 2 dB/Div log scale. When the main ADC is used, the 5 dB/Div scale is derived by multiplying the digitized 10 dB/Div trace data by two in the CPU. When the fast ADC is used, the 5 dB/Div scale is derived by amplifying the video signal by two. The 1 dB/Div scale is similarly derived by either multiplying the 2 dB/Div trace data by two (main ADC) or amplifying the video signal by two (fast ADC).

The spectrum analyzer uses two types of video filters. An RC low-pass circuit provides 300 Hz to 3 MHz video bandwidths. Video bandwidths ≤ 100 Hz are generated using digital filtering. Digitally filtered video bandwidths use a sample detector. When sample detection is selected, the effective video bandwidth is limited to approximately 450 kHz. When a digital filter is selected, a D appears along the left edge of the CRT, indicating that something other than the normal detector mode is being used.

After filtering, the video is sent to the positive and negative peak detectors. These detectors are designed for optimum pulse response. The positive peak detector resets at the end of each horizontal "bucket" (there are 601 such buckets across the screen). The negative peak detector resets at the end of every other bucket. When reset, the output of the peak detector equals its input.

Triggering

The spectrum analyzer has five trigger modes: free run, single, external, video, and line. The free run and single trigger signal comes from the 1 MHz ADC clock. The line trigger signal comes from the A6 power supply. Video triggering originates from the A3 video filter buffer circuit. External triggering requires either a high or low TTL logic level as determined by the setting of the trigger polarity function. The external trigger signal is received from a rear panel BNC connector. A DAC in the trigger circuit sets the video trigger level. The trigger circuit is responsible for setting HSCAN high.

Controller Section

The controller section includes the A2 controller assembly and A19 GPIB assembly. The battery on the rear panel provides battery backup for state and trace storage.

In 8564EC and 8565EC instruments the A2 contains the CPU, RAM, ROM, the display ASM, Fast ADC circuitry, GPIB interface, control, frequency counter, display RAM, option module interface, and EEROM.

In 8564E and 8565E instruments the A2 contains the CPU, RAM, ROM, the display ASM and line generators, CRT blanking, focus, intensity, GPIB interface, control, frequency counter, display RAM, option module interface, and EEROM. In 8561E and 8563E instruments the A2 assembly controls the A17 CRT driver through W7.

The A19 GPIB is a mechanical interface between the standard GPIB connector and the ribbon cable connector on the A2 controller assembly.

All four RAM ICs are battery-backed. The battery-backed RAM stores trace information (two display memory RAMs) and spectrum analyzer state information (two program RAMs). A total of eight traces and ten states may be stored. Typical battery life is five years with the lithium battery. Trace and state information may be retained for up to 30 minutes with a dead battery and power turned off. This is due to the very low data retention current of the RAM.

EEROM

The EEROM stores important amplitude-related correction data. This includes data for LO distribution amplifier DACs, preselector slope and offset DACs, RF gain DACs (flatness correction), and preselector peak DAC. The spectrum analyzer serial number, model number, and installed options are also stored in EEROM.

Firmware The spectrum analyzer firmware reads the model number and installed options from the EEROM to determine how to respond to certain keystrokes.

Display ASM Much of the miscellaneous digital control is performed by A2U100. U100 functions as the display ASM (algorithmic state machine) and character ROM. It also converts the 16-bit CPU data bus to an 8-bit data bus for the rest of the spectrum analyzer.

Display/Power Supply Section

A6 Power Supply

The A6 power supply is a switching supply operating at 40 kHz for low voltages in both EC-series and E-series instruments.

In E-series instruments, the power supply also provides the 30 kHz signal for the CRT supplies (cathode, filament, +110 Vdc, and post accelerator). The A6A1 high voltage module contains the high-voltage transformer and post-accelerator multiplier. Power is distributed through W8 to A17 and through W1 to the rest of the assemblies. A6A1W2 supplies CRT cathode and filament voltages to the A17 assembly

The speed of the spectrum analyzer fan is variable. A thermistor on A6 senses the temperature and adjusts the fan speed accordingly. This allows the spectrum analyzer to run quietly in most room-temperature environments and faster (louder) only when necessary.

A17 LCD Display Driver (EC-series)

The display is an LCD color flat panel screen with 640 X 480 VGA resolution. A connector for an external VGA is available at the rear panel. The A17A1 backlight supply provides the high voltage to supply the two backlights in the LCD display. The LCD display is not adjustable.

The display driver board consists of the Hitachi 7707 processor, an Actel FPGA, DRAM, SRAM, a filter circuit, and a video DAC. This board monitors the 8560 EC-series controller board, copies display instructions to local memory, creates a bitmap from the data, and generates the signals needed to drive the LCD and a VGA monitor. The video DAC converts the digital color information from the LCD to analog; these analog signals drive the RGB color lines on the VGA port on the rear panel.

A17 CRT Display Driver (E-series)

The line generators on the A2 assembly drive the A17 CRT driver. The A17 assembly contains X and Y deflection amplifiers, focus and intensity grid amplifiers, and miscellaneous CRT bias circuitry. The high voltage is supplied by A6A1 high voltage module.

In fast-analog zero-span mode (sweep times ≤ 30 ms without Option 007), the 0-SPAN VIDEO signal from A3 and the sweep ramp from A14 connects to the A17 CRT driver. The graticule and annotation are still digitally drawn.

HP 8564E/EC AND 8565E/EC SIMPLIFIED BLOCK DIAGRAM

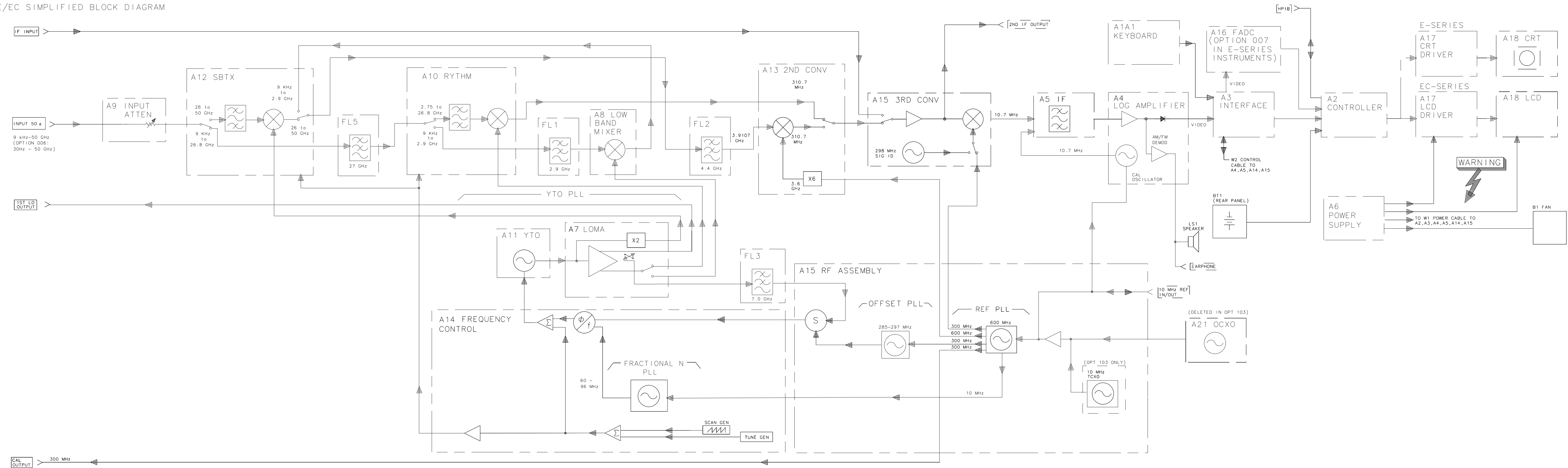

sm13c

FIGURE 7-8. SIMPLIFIED BLOCK DIAGRAM

HP 8564 E/EC 8565 E/EC OVERALL BLOCK DIAGRAM
(SHEET 1 OF 5)

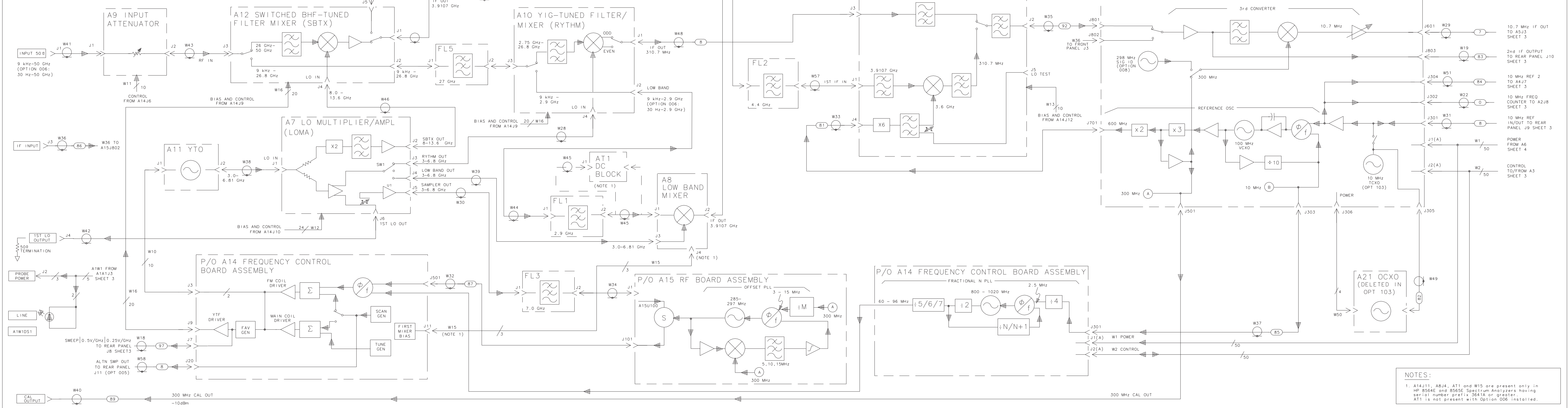

sm120c

FIGURE 7-9. 8564 E/EC AND 8565 E/EC OVERALL BLOCK DIAGRAM
(SHEET 1 OF 5, FOR A15 08563-60054, 08563-60055, or 08563-60056)

8564 E/EC AND 8565 E/EC OVERALL BLOCK DIAGRAM
(SHEET 2 OF 5)

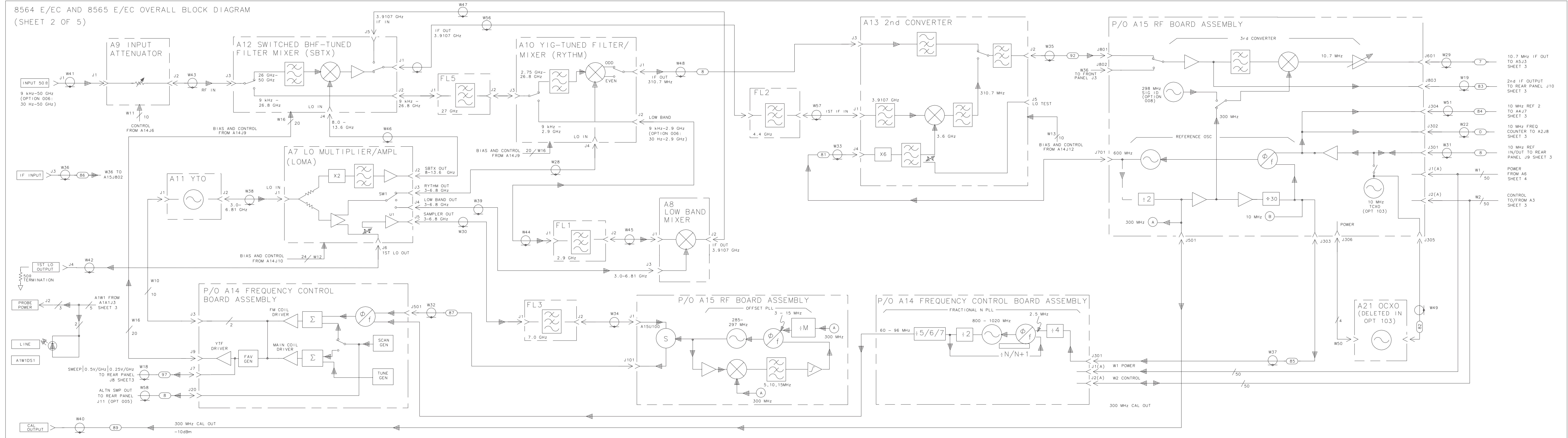

sm121c

FIGURE 7-9. 8564 E/EC AND 8565 E/EC OVERALL BLOCK DIAGRAM
(SHEET 2 OF 5, FOR A15 08563-60044, 08563-60045, or 08563-60046)

8564EC AND 8565EC OVERALL BLOCK DIAGRAM
(SHEET 3 OF 5)

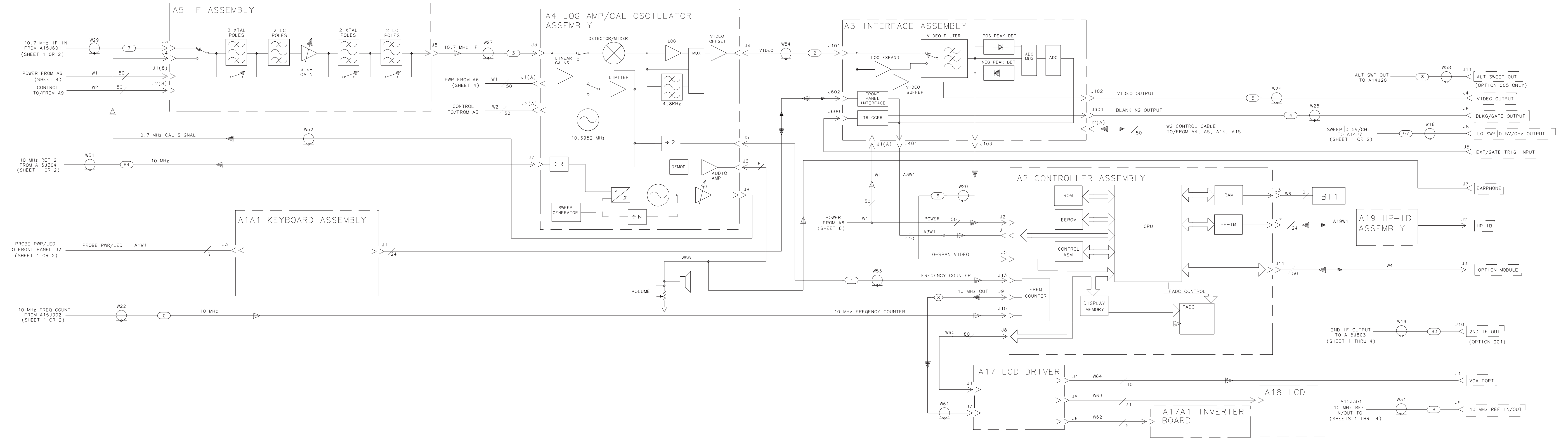

8564E AND 8565E OVERALL BLOCK DIAGRAM
(SHEET 4 OF 5)

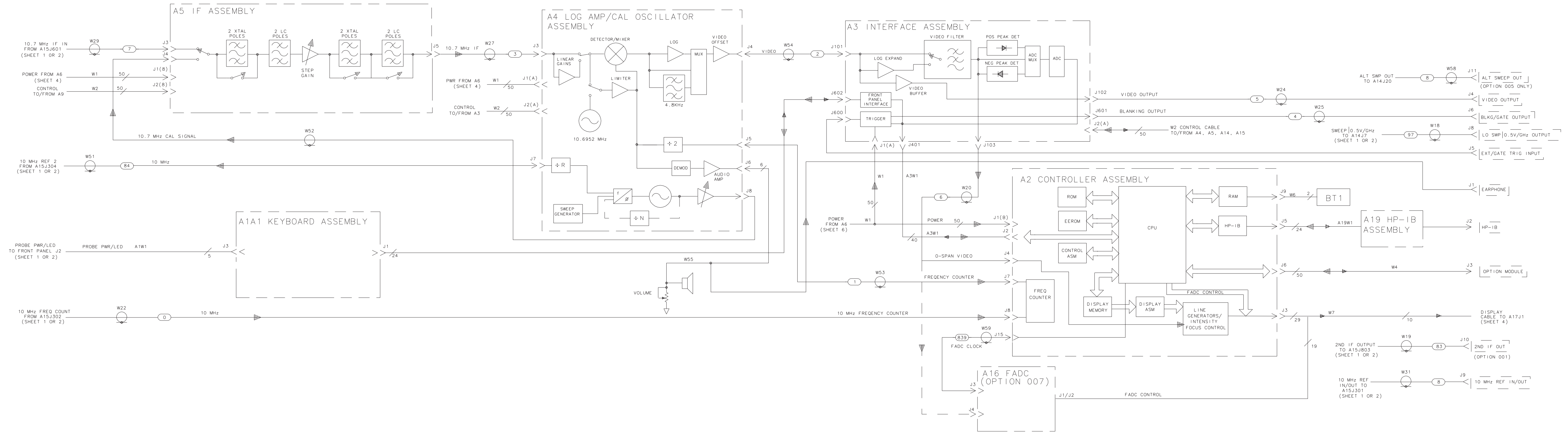

8564E AND 8565E OVERALL BLOCK DIAGRAM
(SHEET 5 OF 5)

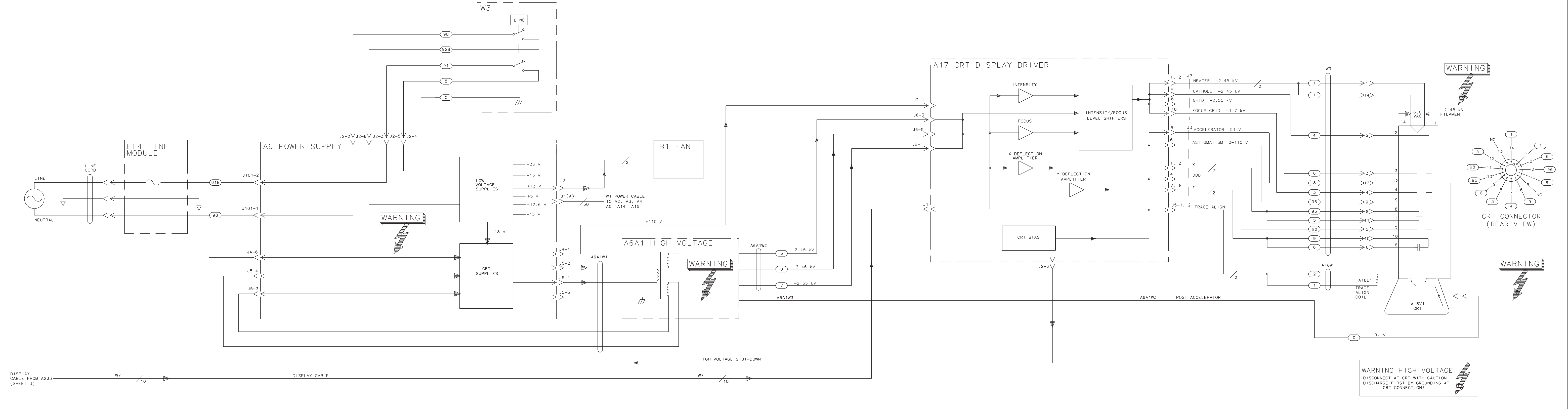

WARNING HIGH VOLTAGE
DISCONNECT AT CRT WITH CAUTION!
DISCHARGE FIRST BY GROUNDING AT
CRT CONNECTION!

8 **ADC/Interface Section**

Introduction

The ADC/Interface section includes the A1A1 keyboard, A1A2 RPG (rotary pulse generator), A3 interface, and A16 fast ADC (Option 007) assemblies. [Table 8-1 on page 379](#) lists signal versus pin numbers for control cable W2. [Figure 8-1 on page 380](#) illustrates the location of the test connectors on A3.

	Page
Keyboard/RPG Problems	page 382
Keyboard Interface	page 382
RPG Interface	page 383
Triggering or Video Gating Problems	page 385
Preselector Peaking Control (Real Time DAC)	page 388
Flatness Control (RF Gain DACs)	page 389
A3 Assembly Video Circuits	page 391
Log Offset/Log Expand	page 393
Video MUX	page 394
Video Filter	page 395
Video Filter Buffer Amplifier	page 396
Positive/Negative Peak Detectors	page 397
Peak Detector Reset	page 398
Rosenfell Detector	page 399
ADC MUX	page 400
Variable Gain Amplifier (VGA)	page 402
Track and Hold	page 402
A3 Assembly ADC Circuits	page 403
ADC Control Signals	page 403
ADC Start/Stop Control	page 404
ADC ASM	page 405
ADC	page 405
Ramp Counter	page 406
A3 Assembly Control Circuits	page 407
Analog Bus Drivers	page 407
Analog Bus Timing	page 408
Interface Strobe Select	page 409
A16 Assembly Fast ADC Circuits (8564E and 8565E, Option 007)	page 411
Video Input Scaling Amplifiers and Limiter	page 411
8-Bit Flash ADC	page 412
Peak/Pit Detection	page 413
32 K-Byte Static RAM	page 414
A16 Assembly Fast ADC Control Circuits (8564E and 8565E, Option 007)	page 415
CPU Interface and Control Registers	page 415
Reference Clock	page 418
Clock and Sample Rate Generator	page 418
Trigger	page 419

16-Bit Post-Trigger Counter page 420
 15-Bit (32 K) Circular Address Counter page 420
 Video Trigger Comparator page 421

Table 8-1 W2 Control Cable Connections (1 of 2)

Signal	A3J2 (pins)	A4J2 (pins)	A5J2 (pins)	A14J2 (pins)	A15J2 (pins)
D0	1*	1	50	1	1
D GND	2*	2	49	2	2
D1	3*	3	48	3	3
D2	4*	4	47	4	4
D3	5*	5	46	5	5
D4	6*	6	45	6	6
D GND	7*	7	44	7	7
D5	8*	8	43	8	8
D6	9*	9	42	9	9
D7	10*	10	41	10	10
A0	11*	11	40	11	11
D GND	12*	12	39	12	12
A1	13*	—	38	13	13
A2	14*	—	37	14	14
A3	15*	15	36	15	15
A4	16*	—	35	16	16
D GND	17*	17	34	17	17
A5	18*	—	33	18	—
A6	19*	—	32	—	—
A7	20*	—	31	20	—
D GND	21*	21	30	21	21
LRF_STB	22*	—	—	—	22
LFC_STB	23*	—	—	23	—
LIF_STB	24*	—	27	—	—
CAL OSC TUNE	25	25*	—	—	—
LLOG_STB	26*	26	—	—	—
VCMON	—	—	—	27	—
D GND	28*	28	23	28	28
RT PULSE	29*	—	—	—	—
HSCAN	30*	—	—	30	—
D GND	31*	31	20	31	31
RESERVED	—	—	—	—	—
OFL ERR	33	—	—	—	33*
R/T DAC3	34*	—	—	—	—

* Indicates signal source.

Table 8-2

Table 8-1. W2 Control Cable Connections (2 of 2)

Signal	A3J2 (pins)	A4J2 (pins)	A5J2 (pins)	A14J2 (pins)	A15J2 (pins)
A GND	35*	35	16	35	35
RF GAIN	36*	—	—	—	36
LO3 ERR	—	—	—	37	37*
A GND	38*	38	13	38	38
LVFC_ENABLE	39*	—	—	39	—
FC ERR	40	—	—	40*	—
A GND	41*	41	10	41	41
YTO ERR	42	—	—	42*	—
+10V REF	43*	43	—	—	43
A GND	44*	44	7	44	44
SCAN RAMP	45	—	—	45*	—
VIDEO TRIGGER	46*	—	—	—	—
A GND	47*	47	4	47	47
NC	—	—	—	—	—
R/T DAC2	49*	—	—	—	—
R/T DAC1	50*	—	—	50	—

* Indicates signal source.

Figure 8-1

A3 Test Connectors

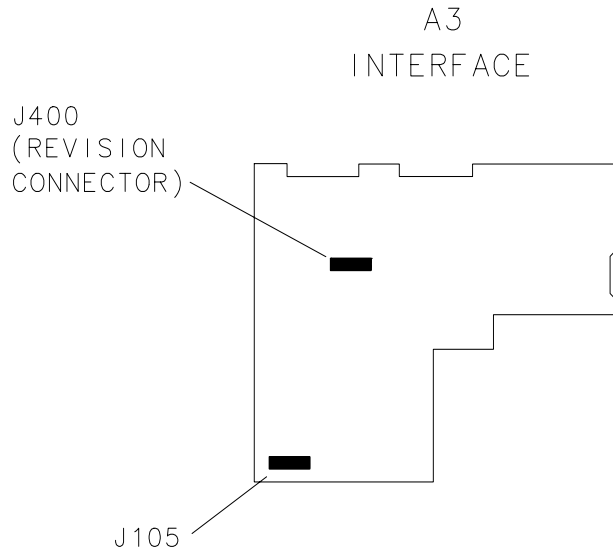

SK169

Figure 8-2 A3 Test Connector Pin Locations

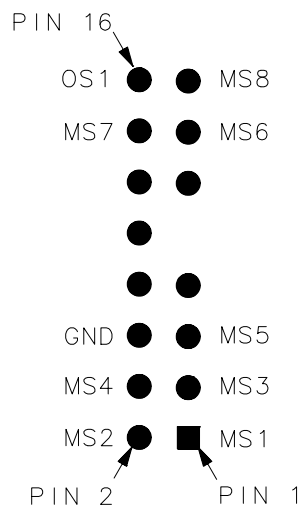

sz144e

Keyboard/RPG Problems

Keyboard Interface

Refer to function block G of A3 Interface Assembly Schematic Diagram (sheet 3 of 6) in the *8560 E-Series Spectrum Analyzer Component Level Information*.

A pressed key results in a low on a keyboard sense line (LKSNS0 through LKSNS7). This sets the output of NAND gate U607 high, generating KBD/RPG_IRQ. The CPU determines the key pressed by setting only one keyboard scan line (LKSCN0 through LKSCN5) low through U602 and reading the keyboard sense lines.

1. If none of the keys or RPG responds, check ribbon cable, A1A1W1. (This cable connects the A1A1 keyboard to the A3 interface assembly.) The keys are arranged in a row/column matrix, as shown in [Table 8-3 on page 382](#).
2. If an entire row or column of keys does not respond, and the RPG does respond, there might be an open or shorted wire in A1A1W1.

Table 8-3 Keyboard Matrix

	LKSNS0	LKSNS1	LKSNS2	LKSNS3	LKSNS4	LKSNS5	LKSNS6	LKSNS7
LKSCN0	CONFIG	SAVE	RECALL	GHz	MHz	kHz	Hz	PRESET
LKSCN1	MODULE	TRIG	DISP	9	6	3	BK SP	↑
LKSCN2	PEAK SEARCH	BW	TRACE	8	5	2	•	↓
LKSCN3	FREQ COUNT	AUTO COUPLE	MKR →	7	4	1	0	HOLD
LKSCN4	SWEEP	SK1	SK2	SK3	SK4	SK5	SK6	MKR
LKSCN5	AUX CTRL	MEAS/ USER	CAL	SGL SWP	COPY	FRE- QUENCY	SPAN	AMPLI- TUDE

3. Check that all inputs to NAND gate A3U607 (LKSNS lines) are high when no key is pressed. If any input is low, continue with the following:
 - a. Disconnect A1A1W1 from A3J602 and again check all inputs to U607.
 - b. If any input is low with A1A1W1 disconnected, suspect A3U604, A3U607, or A3U602.
 - c. Reconnect A1A1W1 to A3J602.

4. Monitor A3U607 pin 8 with a logic probe. A TTL high should be present when any key is held down. Monitor this point while pressing each key in succession.
5. Check that the LKSCN lines (outputs of A3J602 pins 1 through 6) read a TTL low with no key pressed. (Any TTL high indicates a faulty A3 Interface assembly.)
6. Check that a pulse is present at each LKSCN output of U602 when a key is pressed.
7. Check that only one input to U607 (LKSNS lines) goes low when a key is pressed.
8. Check that U602 pin 9 (LKBD_RESET) pulses low when a key is pressed.
9. If LKBD_RESET is incorrect and a pulse is not present at each of the LKSCN outputs of U602 when a key is pressed, check for LWRCLK and LSCAN_KBD.

RPG Interface

Refer to function block J of A3 Interface Assembly Schematic Diagram (sheet 3 of 6) in the *8560 E-Series Spectrum Analyzer Component Level Information*.

U608B latches the RPG direction from the two RPG outputs, RPG_COUNT and RPG_COUNT1. Counterclockwise RPG rotation produces low-going pulses which result in a high output on U608B. Clockwise RPG rotation results in a low output from U608B. U612A provides the edge to trigger one-shot U423B, which generates a 90 ms pulse. This pulse gates U610A for counting of RPG pulses by U606. Gates U610D and U614D prevent retriggering of U423B until its 90 ms pulse has timed out.

NOTE

Elsewhere, RPG_COUNT1 is referred to as RPG_01 and RPG_COUNT is referred to as RPG_02.

1. Monitor A3U401 pin 2 with a logic probe or oscilloscope. Pulses should be present as the RPG is rotated.
2. Monitor A3U608 pin 12 as the RPG is rotated. Pulses should be present.
3. If pulses are missing at both points, check for power and ground signals to A1A1W1 and A1A2W1. If both power and ground are there, the A1A2 RPG is probably defective.
4. If pulses are missing at only one point, check for an open or short on A1A1W1 and A1A2W1. If these cables are working properly, A1A2 RPG is probably defective.

5. Press **LINE** to turn spectrum analyzer off and disconnect A1A1W1 from A3J602. Jumper A3U608 pin 12 (RPG_COUNT1) to U608 pin 14 (+5 Vdc). Jumper U401 pin 2 (RPG_COUNT1) to U511 pin 11 (HDPKD_CLK). This provides a 7.8 kHz square wave to the RPG_COUNT input of the RPG Interface.
6. Press **LINE** to turn spectrum analyzer on.
7. Check A3U608 pin 9 for narrow, low-going pulses approximately every 90 ms.
8. Check A3U608 pin 13 (LRPG_RESET) for narrow, low-going pulses approximately every 90 ms.
9. Check A3U612 pin 5 for narrow, low-going pulses approximately every 90 ms.
10. Check U608 pin 5 (HRPG_IRQ) for narrow, high-going pulses approximately every 90 ms.
11. If HRPG_IRQ is correct but LRPG_RESET is incorrect, check U505 pin 13 (LKBD/RPG_IRQ) for narrow, low-going pulses approximately every 90 ms.
12. If HRPG_IRQ and LKBD/RPG_IRQ are correct but LRPG_RESET is incorrect, suspect a failure on the A2 controller assembly.
13. Check U610 pin 3 for a 7.8 kHz square wave. Check U606 pin 2 (HRPG_RESET) for narrow, high-going pulses approximately every 90 ms. Refer to [Table 8-4 on page 384](#) and check the frequencies at divide-by-16 counter A3U606.
14. If all the checks above are correct but the spectrum analyzer does not respond to the RPG, suspect a problem in either the A1A2 RPG or the A1A1 Keyboard.
15. Press **LINE** to turn spectrum analyzer off.
16. Reconnect A1A1W1 to A3J602 and remove all jumpers.

Table 8-4 Counter Frequencies

A3U606 pin #	Nominal Frequency (Hz)
3	3900
4	1950
5	975
6	488
11	244
10	122
9	61

Triggering or Video Gating Problems

Refer to function block H of A3 Interface Assembly Schematic Diagram (sheet 3 of 6) in the *8560 E-Series Spectrum Analyzer Component Level Information*.

The 1 MHz ADC clock provides synchronization in FREE RUN and SINGLE triggering. LINE triggering synchronization originates on the A6 power supply. Trigger MUX A3U613 selects between FREE RUN, VIDEO, LINE, and EXTERNAL trigger sources. The trigger signal sets the output of the HSCAN latch high. HBADC_CLK0 provides the trigger signal for FREE RUN. The VIDEO TRIG signal must be at least 25 mV (0.25 divisions) peak-to-peak to trigger in video trigger mode.

The 3 MHz video bandwidth is not available when using video gating. The trigger for Gated Video has two modes of operation, level mode and edge mode. In the edge mode, positive-edge or negative-edge triggering can be selected. Output 0 from pin 10 of A3U617 generates the gate delay and output 1 from pin 13 of A3U617 generates the gate length. The duration of these two time intervals is set using front-panel softkeys under the **SWEEP** key. The trigger input for Gated Video is the rear panel EXT/GATE TRIG INPUT (TTL > 10 kΩ).

1. Check that the trigger MUX is receiving the proper trigger source information by selecting each of the following trigger modes and checking the TRIG_SOURCE0 and TRIG_SOURCE1 lines as indicated in [Table 8-5](#) below.
2. If a trigger mode does not work, check that a trigger signal is present at the appropriate trigger MUX input, as indicated in [Table 8-5](#).

Table 8-5

Trigger MUX Truth Table

Trigger Mode	TRIG_SOURCE0 U613 pin 14	TRIG_SOURCE1 U613 pin 2	MUX Input Pin Number U613
FREE RUN	L	L	6
VIDEO	H	L	5
LINE	H	H	3
EXTERNAL	L	H	4

3. Check that the appropriate trigger MUX input signal is present at the trigger MUX output (A3U613 pin 7).
4. To check the video trigger level DAC, connect the positive lead of a DVM to A3J400 pin 1 and the negative DVM lead to A3TP4.
5. Press **TRIG** and **VIDEO**.
6. Press the **STEP ▼** key several times while noting the DVM reading and position of the video trigger level on the screen.

7. Check that the voltage displayed on the DVM changes by 1 V for each step of the VIDEO TRIG LEVEL.
8. If the voltage changes incorrectly, proceed as follows:
 - a. Check the -10 Vdc reference (A3U409 pin 4).
 - b. While using the front-panel knob to adjust the video trigger level, check for the presence of pulses on A3U409 pin 15 (LDAC2).
 - c. While using the front-panel knob to adjust the video trigger level, check for the presence of pulses on A3U409 pin 16 (LWRCLK).
 - d. Check that pulses are present on U409 pin 6 (IA0).
9. If the LWRCLK and LDAC2 signals are not correct, refer to [“Interface Strobe Select” on page 409](#)
10. If correct trigger pulses are present at the trigger MUX output (A3U613 pin 7), but the instrument does not appear to be sweeping, proceed as follows:
 - a. Press **PRESET**, **SWEEP**, and **DLY SWP ON OFF** until ON is underlined, then **DLY SWP []** 30 milliseconds.
 - b. Using an oscilloscope, check for activity at pins 1 and 3 of A3U615A.
 - c. If there is activity at pin 1 but not at pin 3 of A3U615A, suspect A3U616 or A3U617.
 - d. If there is activity at pin 1 and pin 3 of A3U615A, suspect A3U615. (Check pin 5 for activity.)
11. If there is a problem with Video Gating, proceed as follows:
 - a. Press **PRESET** and set the spectrum analyzer as follows:

Center frequency	300 MHz
Span	0 Hz
Sweep time	150 ms
 - b. Press **TRIG**, **EXTERNAL**, then **SWEEP** and **GATE ON OFF** until ON is underlined.
 - c. Press **GATE DLY []** 10 milliseconds, then press **GATE LEN []** 30 milliseconds.
 - d. Connect a pulse/function generator (such as an 8116A) to provide a 5 V peak-to-peak square wave (TTL level) to the spectrum analyzer rear panel EXT/GATE TRIG INPUT and also (using a BNC tee) to the channel 4 input of the oscilloscope (54501A).

- e. Set the pulse/function generator to NORMAL mode with a duty cycle of 50% and a frequency of 10 Hz.
- f. Press the following keys on the oscilloscope:

CLEAR DISPLAY

off frame axes grid highlight grid
connect dots off on highlight on

TRIG

source 1 2 3 4 highlight 4
level 2 V

TIMEBASE

TIMEBASE 50 ms/div

CHAN

CHANNEL 1 2 3 4 off on

highlight **CHANNEL 1 on**

set V/div to 0.2 V and offset to 0.6 V (10:1 probe used)

highlight **CHANNEL 4 on**

set V/div to 2 V and offset to 0 V

DISPLAY

DISPLAY norm avg env highlight norm

- g. Using a 10:1 probe connected to channel 1 of the oscilloscope, check for activity at pins 10 and 13 of A3U617.
- h. If either pin (or both) show no activity, check for activity at pin 21 (LTIMER) of A3U617.
- i. If LTIMER is not active, troubleshoot the Interface Strobe Select circuitry (block K).
- j. If there was activity at pins 10 and 13 of A3U617, suspect A3U616.

Preselector Peaking Control (Real Time DAC)

Refer to function block H of A3 Interface Assembly Schematic Diagram (sheet 3 of 6) in the *8560 E-Series Spectrum Analyzer Component Level Information*.

The spectrum analyzer uses a real-time DAC (R/T DAC1) to peak the preselector.

1. Press **PRESET** on the spectrum analyzer and set the span to 0 Hz.
2. Connect a positive DVM lead to A3J400 pin 3 and the negative DVM lead to A3TP4.
3. Press **MKR, AUX CTRL, INTERNAL MIXER, and PRESEL MAN ADJ.**
4. Monitor the DVM reading while changing the **PRESELECTOR TUNE** value from 0 to 255. The **PRESELECTOR TUNE** value is the setting of R/T DAC1.
5. Check that the DVM reading increases from 0 to approximately +10 Vdc as R/T DAC1 is set from 0 to 255.
6. If the voltage does not change as described, set the spectrum analyzer to single trigger mode and check the following:
 - a. Check that A3U409B pin 18 is at -10 Vdc.
 - b. Check for the presence of pulses at U409 pin 6 (IA0).
 - c. Check that pulses are present at U409 pin 15 (LDAC2).
 - d. Check that pulses are present at U409 pin 16 (LWRCLK).
7. If the LDAC2 or LWRCLK signals are incorrect, refer to [“Interface Strobe Select” on page 409](#)

Flatness Control (RF Gain DACs)

Refer to function block M of A3 Interface Assembly Schematic Diagram (sheet 4 of 6) in the *8560 E-Series Spectrum Analyzer Component Level Information*.

RF Gain DACs control the A15 assembly flatness compensation amplifiers. The RF Gain DACs are arranged so that the output of one DAC is the voltage reference for the other DAC. This results in an RF GAIN voltage which is exponentially proportional to the DAC settings. Each DAC is set to the same value. The A15 RF assembly converts the RF GAIN signal to a current for driving the PIN diode attenuators in the Flatness Compensation Amplifiers. The exponentially-varying voltage compensates for the nonlinear resistance-versus-current characteristic of the PIN diodes.

1. Place the WR PROT/WR ENA jumper on the A2 controller assembly in the WR ENA position.
2. Press **CAL**, **MORE 1 OF 2**, **SERVICE CAL DATA**, **FLATNESS**, and **FLATNESS DATA**. Press **NEXT BAND** until `FLATNESS BAND # 0` is displayed.
3. Press the **▲** key until `DATA @ 300 MHz` is displayed. Note the number directly below `DATA @ 300 MHz` this is the RF Gain DAC value.
4. Connect a positive DVM lead to A3J400 pin 13 and the negative DVM lead to A3TP4.
5. Check that the DVM reading increases from near 0 Vdc to between -1.3 and -1.9 Vdc as the RF Gain DAC setting is increased from 0 to 4095.
6. If the DVM readings are incorrect, press **PRESET**, **SGL SWP**, **CAL**, **MORE 1 OF 2**, **SERVICE CAL DATA**, **FLATNESS**, and **FLATNESS DATA**. Press **NEXT BAND** until `FLATNESS BAND # 0` is displayed. Press the **▲** key until `DATA @ 300 MHz` is displayed. Proceed as follows:
 - a. Check the +10 V reference.
 - b. Check for narrow, low-going pulses at A3U417 pin 13 (LWRCLK).
 - c. While rotating the front-panel knob, check for narrow, low-going pulses at A3U417 pin 1 (LDAC1) and pin 14 (LDACU1).
 - d. While rotating the front-panel knob, check for narrow, low-going pulses at U417 pin 16 (L_IA0) and pin 15 (IA4).
7. If the LWRCLK, LDAC1, or LDACU1 is incorrect, refer to the Interface Strobe Select block in this chapter.

8. Place the WR PROT/ WR ENA jumper on the A2 controller assembly in the WR PROT position. Press **PRESET**.

A3 Assembly Video Circuits

Voltages from A3J101 to the Variable Gain Amplifier on A3 correspond (approximately) to on-screen signal levels. (One volt corresponds to the top of the screen and zero volts corresponds to the bottom of the screen.) This is true for both log and linear settings except when the spectrum analyzer is in 1 dB/div or 2 dB/div. In these cases the log expand amplifier is selected, and 1 V corresponds to top-screen and 0.8 or 0.9 V corresponds to bottom-screen. The spectrum analyzer can be set to zero span at the peak of a signal to generate a constant dc voltage in the video circuits during sweeps.

1. Disconnect W26 from A3J101 and W20 from A2J4.
2. Connect W26 to A2J4.
3. Set the spectrum analyzer to the following settings:

Span	0 Hz
Sweep time	20 ms
Resolution bandwidth	1 MHz
Log/division	10 dB/DIV
4. If a trace is displayed, troubleshoot the A3 assembly. If a trace is absent, connect an oscilloscope to the rear panel BLKG/GATE OUTPUT.
5. The presence of a TTL signal (TTL low during 20 ms sweep) indicates a good A3 Interface Assembly. Troubleshoot the IF section.
6. If the BLKG/GATE OUTPUT is always at a TTL high or low, troubleshoot the trigger/video gating circuits on A3.
7. Reconnect W26 to A3J101 and W20 to A2J4.
8. Remove the A3 assembly shield.
9. If the video filters appear faulty, see to [“Video Filter” on page 395](#)
10. If there appears to be a peak detector problem, refer to [“Positive/Negative Peak Detectors” on page 397](#)
11. Connect the spectrum analyzer CAL OUTPUT to the INPUT 50Ω and set the controls as follows:

Center frequency	300 MHz
Span	0 Hz
Reference level	-10 dBm
12. If the spectrum analyzer works correctly in 5 dB/div and 10 dB/div but not in 1 dB/div or 2 dB/div, refer to [“Log Offset/Log Expand” on page 393](#) Continue with step 13 if the problem involves on-screen amplitude errors which appear to originate in the video chain.

13. Press **CAL** and **IF ADJ ON OFF** until OFF is underlined. Monitor A3TP9 with an oscilloscope. If the voltage is not approximately +1 Vdc, troubleshoot the Log Amplifier on A4. (Refer to the IF troubleshooting procedure in [Chapter 9](#), “IF Section.”)
14. To confirm proper video input to the video circuit, set the spectrum analyzer to Log 10 dB per division and change the reference level in 10 dB steps from -10 dBm to +30 dBm. At each 10 dB step, the input voltage should change 100 mV. The input level should be +0.6 Vdc for a +30 dBm reference level.

NOTE

The on-screen amplitude level will probably not change as expected, since the video circuitry is assumed to be faulty.

15. Monitor A3TP14 while stepping the reference level from -10 dBm to +30 dBm. If the voltage does not step approximately 100 mV per 10 dB step, refer to [“Video MUX” on page 394](#)
16. If the Video MUX is working properly, monitor A3TP15 with the oscilloscope and step the reference level from -10 dBm to +30 dBm. If the voltage does not change 100 mV per 10 dB step, refer to [“Video Filter” on page 395](#)
17. If the voltage at A3TP15 is correct, move the oscilloscope probe to A3TP17 and step the reference level between -10 dBm and +30 dBm. If the voltage does not change 100 mV per 10 dB step, refer to [“Video Filter Buffer Amplifier” on page 396](#)
18. If the voltage at A3TP17 is correct, move the oscilloscope probe to A3TP6. Set the following controls to keep the ADC MUX set to the MOD_VIDEO input during the sweep:

Sweep time	50 s
Detector mode	Sample
19. Step the reference level from -10 dBm to +30 dBm while monitoring the voltage change on the oscilloscope. If the voltage does not change 100 mV per 10 dB step, refer to [“ADC MUX” on page 400](#)
20. If the voltage at A3TP6 is correct, move the oscilloscope probe to A3TP8 and step the reference level between -10 dBm and +30 dBm. If the voltage at A3TP8 is not the same as that at A3TP6, replace A3U110.
21. If the voltage at A3TP8 and A3TP6 are equal, move the oscilloscope probe to A3TP7.
22. Change the reference level from -10 dBm to 0 dBm. The voltage change on A3TP7 should be between 630 mV and 770 mV. If the voltage change is outside of these limits, refer to [“Variable Gain Amplifier \(VGA\)” on page 402](#) The gain of the VGA should be $7 \pm 10\%$.

Log Offset/Log Expand

Refer to function block X of A3 Interface Assembly Schematic Diagram (sheet 5 of 6) in the *8560 E-Series Spectrum Analyzer Component Level Information*.

The log scales are modified using a combination of amplification and digital trace manipulation. The video input to the A3 assembly is either 10 dB/div or linear. To obtain the 5 dB/div scale, the CPU manipulates the trace data from the 10 dB/div scale. To obtain the 2 dB/div scale, the video signal is amplified and offset so that top-screen in 10 dB/div corresponds to top-screen in 2 dB/div. To obtain the 1 dB/div scale, the CPU manipulates trace data from the 2 dB/div scale.

In 2 dB/div, Log Offset/Log Expand amplifies the top 20 dB of the display. This is done by offsetting the video signal by -0.8 V and providing a gain of 5 to the top 0.2 V of the video signal. The -0.8 V offset is accomplished by sinking 2 mA through R114 by current source U105/Q101.

1. On the spectrum analyzer, press **PRESET**, **SPAN**, **ZERO SPAN**, **CAL**, and **IF ADJ OFF**.
2. Disconnect W26 (coax 2) from A3J101 and connect the output of a function generator to A3J101.
3. Set the function generator to the following settings:

Output	Sine wave
Amplitude	1 V pk-to-pk
DC Offset	+500 mV
Frequency	50 Hz
4. Set the spectrum analyzer sweep time to 50 ms.
5. Adjust the function generator amplitude and offset until the sine wave fills the entire graticule area.
6. Measure and note the function generator peak-to-peak voltage using an oscilloscope.

$$V_{(10 \text{ dB/div})} = \text{_____} \text{ V}$$

7. Set the spectrum analyzer to 2 dB/div.
8. Readjust the function generator amplitude and offset until the sine wave again fills the entire graticule area.
9. Measure the function generator peak-to-peak voltage and dc offset.

$$V_{(2 \text{ dB/div})} = \text{_____} \text{ V}$$

10. The ratio of voltage recorded in step 6 to the voltage recorded in step 9 should be $5 \pm 3\%$. If the ratio is not 5, troubleshoot the A3 Interface assembly.

11. Reconnect W26 to A3J101.

Video MUX

Refer to function block U of A3 Interface Assembly Schematic Diagram (sheet 5 of 6) in the *8560 E-Series Spectrum Analyzer Component Level Information*.

1. Press **PRESET** and set the spectrum analyzer controls as follows:

Center frequency 300 MHz
Span 0 Hz

2. Press **SGL SWP**, **CAL**, and **IF ADJ OFF**. Connect the CAL OUTPUT to the INPUT 50Ω connector.

3. Check for a TTL high on A3U104 pin 2 and a TTL low on U104 pin 10. Set the spectrum analyzer to 2 dB/div and check for a TTL high on A3U104 pin 10 and a TTL low on A3U104 pin 2.

4. If the logic levels on A3U104 are incorrect, check the LLOG_STB signal as follows:

a. Monitor A3U104 pin 9 with an oscilloscope or logic probe. Check that a 1 microsecond, low-going pulse is present when switching between 10 dB/div and 2 dB/div.

b. Check the inputs to A3U104 (pins 3 and 11) while switching between 10 dB/div and 2 dB/div.

c. If the logic signals are incorrect, refer to [“Analog Bus Drivers,” on page 407](#), and [“Analog Bus Timing” on page 408](#)

5. Check comparators A3U109A/C for proper outputs. The outputs should be high when the noninverting input is greater than the threshold voltage of +1.3 Vdc.

6. If A3U104 and A3U109 are working properly, set the **AMPLITUDE** and **REF LVL** to 0 dBm.

7. Monitor the voltage at A3TP14 while switching the spectrum analyzer between 10 dB/div and 2 dB/div. The voltage should switch between 0.8 and 0.4 Vdc.

8. If the voltage at A3TP14 is incorrect, suspect either A3Q220 or A3Q221.

9. The Video MUX will appear faulty if A3CR109 is shorted or leaky. Diode A3CR109 clamps the voltage at A3TP14 to -0.4 V when in log expand with less than 0.8 V at J101. To confirm this failure, lift the cathode of diode A3CR109 and perform steps 1 through 7 again.
10. To return the spectrum analyzer to automatic sweep, press **SWEEP**, **SWEEP CONT SGL** or press **PRESET**.

Video Filter

Refer to function block V of A3 Interface Assembly Schematic Diagram (sheet 5 of 6) in the *8560 E-Series Spectrum Analyzer Component Level Information*.

The spectrum analyzer uses digital filtering for 1 Hz to 100 Hz video bandwidths. An RC low-pass filter is used for 300 Hz to 3 MHz video bandwidths. Various series resistances and shunt capacitances switch into the video filter to change its cutoff frequency. The 3 MHz video bandwidth is not available when Gated Video is selected.

When sample detection is selected, the effective video bandwidth is limited to approximately 450 kHz by the track and hold circuitry.

When Gated Video is selected, the video signal is "gated" (turned on periodically for a set duration of time). This function is shown in block V of the block diagram as a series switch that allows the video signal to pass only when it is closed. The actual switch, U109B/CR118, shunts the video to ground (video signal is passed only when the switch is open). The control circuitry for this switch is described under "[Triggering or Video Gating Problems](#)" on page 385. The rear panel EXT/GATE TRIG INPUT provides the connection for triggering in the Gated Video mode. The gate output signal is available at the rear panel BLKG/GATE OUTPUT connector. Positive or negative edge mode, or level mode can be selected from the front panel.

1. Press **PRESET** and set the spectrum analyzer controls to the following settings:

Center frequency	225 MHz
Span	550 MHz
Sweep time	Uncoupled (MAN)

2. Press **CAL** and **IF ADJ OFF**.
3. Step the Video BW from 3 MHz to 10 kHz. At each step, the peak-to-peak deviation of the noise should decrease.
4. Step the Video BW down to 1 Hz. At each step, the amplitude of the LO feedthrough should decrease.
5. Refer to [Table 8-6 on page 396](#) and check for correct latched levels for the selected video bandwidth setting.

6. If the output of latch A3U102 is not correct, trigger an oscilloscope on LLOG_STB (U102 pin 9) and monitor U102 pin 1 and other latch inputs while changing the video bandwidth.
7. If the inputs are incorrect, troubleshoot the analog bus. Correct inputs with bad outputs indicate a faulty U102.
8. Check that the outputs of A3U111A, A3U111B, and A3U107A/B/C/D are correct for their inputs. The outputs should be high with noninverting inputs higher than the +1.4 V threshold voltage. If a voltage drop is noticed across these components, suspect A3CR109 or A3Q317B. Since no dc current flows through any of the series resistances or FETS (drain to source), no voltage drops should occur.
9. To return the spectrum analyzer to automatic sweep, press **SWEEP**, **SWEEP CONT SGL** or **PRESET**.

Table 8-6

A3U102 Latch Outputs

Video BW	Pin 2	Pin 5	Pin 7	Pin 10	Pin 12	Pin 15
300 Hz	H	L	L	L	L	L
1 kHz	L	L	L	L	L	H
3 kHz	L	H	L	L	L	L
10 kHz	L	L	L	L	H	L
30 kHz	H	L	H	L	L	L
100 kHz	L	L	H	L	L	H
300 kHz	L	H	H	L	L	L
1 MHz	L	L	H	L	H	L
3 MHz	L	L	L	H	L	L

Video Filter Buffer Amplifier

Refer to function block W of A3 Interface Assembly Schematic Diagram (sheet 5 of 6) in the *8560 E-Series Spectrum Analyzer Component Level Information*.

The video filter buffer amplifier provides outputs for video trigger, positive and negative peak detectors, and the analog zero-span (sweeps <30 ms). The zero-span video output is terminated in 500 ohms on the A2 Controller assembly. The amplifier is a high-input-impedance buffer amplifier with a gain of one when properly terminated.

Current source U307C provides twice the current of Q316. Resistor R145 and current source U307D shift the dc level. Resistor R260 terminates the peak detector inputs in 500 ohms. The unterminated gain is 1.1. Diode CR114 prevents latchup during positive overdrive conditions while CR113 protects Q318 during overdrive. Diode CR117 is a 12.7 V zener that limits the output of the peak detector to +1.5 V. Typically, limiting occurs at +1.1 V.

Positive/Negative Peak Detectors

Refer to function blocks Y and Z of A3 Interface Assembly Schematic Diagram (sheet 5 of 6) in the *8560 E-Series Spectrum Analyzer Component Level Information*.

The following information pertains to the positive peak detector and is applicable to troubleshooting the negative peak detector.

The positive peak detector consists of an input amplifier (A3U204 and A3Q210) followed by detector diodes (A3CR203 and A3CR204) and hold capacitor A3C217. Output amplifier A3Q206, Q211, and Q212 buffers the hold capacitor. Both the input and output amplifiers have a gain of one. Each amplifier has local feedback. On the output amplifier the emitter of Q212 connects to the gate of Q206. On the input amplifier the feedback goes through Q209 and Q208 back to the base of U204D. Global feedback occurs from the output amplifier through R223 back to the input amplifier U204D. The peak detector resets through Q207.

1. Press **PRESET** and set the spectrum analyzer controls as follows:

Center frequency	300 MHz
Span	500 MHz
Resolution bandwidth	AUTO
Video bandwidth	AUTO
Log dB/division	10 dB/DIV

2. If the spectrum analyzer does not meet the conditions in steps a through e below, the positive and negative peak detectors are probably faulty. Continue with step 3 to check the detectors.
 - a. The peak-to-peak deviation of the noise in NORMAL detector mode should be approximately two divisions. Press **TRACE**, **TRACE B**, **CLEAR WRITE B**, **VIEW B**, **TRACE A**, **MORE 1 of 3**, and **DETECTOR MODES**.
 - b. Select **DETECTOR POS PEAK** mode.
 - c. Confirm that the noise is about one-third division peak-to-peak. The noise should also be no higher than the top of the noise level in NORMAL detector mode.

- d. Select **DETECTOR NEG PEAK** mode. The noise should be about one-third of a division peak-to-peak. The noise should also be no lower than the bottom of the noise in **NORMAL** mode.
 - e. Select **DETECTOR SAMPLE** mode. Check that the noise appears between the top and bottom of the noise in **NORMAL** mode.
3. On the spectrum analyzer, connect the front-panel CAL OUTPUT to the INPUT 50Ω and set the controls to the following settings:
- | | |
|------------------------|----------|
| Center frequency | 300 MHz |
| Span | 0 Hz |
| Sweep time | 5 s |
| Detector mode | POS PEAK |
4. Monitor A3TP17 and A3TP16 simultaneously with an oscilloscope.
 5. Change the reference level from -10 dBm to +30 dBm and verify a voltage change at both A3TP17 and A3TP16 of 0.9 V to 0.5 V in 100 mV steps.
 6. Check the entire range of the detector by substituting a dc source at J101 and varying its output from 0 V to 1 V.
 7. If the peak detector appears latched up, check LPOS_RST (U422 pin 4) for a negative TTL level reset pulses. The reset pulses should occur every 130 μs and should be approximately 250 ns wide.
 8. If the reset pulses are absent, troubleshoot the Peak Detector Reset circuitry.
 9. If the reset pulses are present, check the gate of Q207. The pulses should be positive-going from -12.7 V to -1.35 V.
 10. The peak detector can be made into a unity gain amplifier by shorting the cathode of CR203 to the anode of CR204. If the peak detector functions normally as a unity gain amplifier, suspect Q208 or CR203 or CR204.

Peak Detector Reset

Refer to function block R of A3 Interface Assembly Schematic Diagram (sheet 4 of 6) in the *8560 E-Series Spectrum Analyzer Component Level Information*.

1. Press **PRESET** on the spectrum analyzer and set the controls as follows:

Center frequency	300 MHz
Span	0 Hz
Sweep time	5 s
Detector mode	POS PEAK
2. Check that HHOLD (A3U526 pin 11) has 18 μs wide pulses every 128 μs.

3. Check that HODD (U408 pin 5) is a square wave with a period of 16.7 ms ($2 \times \text{sweep time}/600$).
4. Check LPOS_RST (U422 pin 4) for 200 ns low-going pulses every 128 μs .
5. Check LNEG_RST (A3U422 pin 12) for 200 ns low-going pulses every 128 μs .
6. Set the detector mode to NORMAL and check that LNEG_RST (A3U422 pin 12) has two pulses spaced 40 μs apart and then a single pulse approximately 88 μs from the second pulse.
7. Check HMUX_SEL0 (A3U408 pin 3) and HMUX_SEL1 (A3U408 pin 9) according to [Table 8-7](#).

Table 8-7 HMUX_SELO/1 versus Detector Mode

Detector Mode	HMUX_SEL0 (U408 pin 3)	HMUX_SEL1 (U408 pin 9)
NORMAL	15 μs pulse every 128 μs	40 μs pulse every 128 μs
SAMPLE	H	H
POS PEAK	H	L
NEG PEAK	L	H

Rosenfell Detector

Refer to function block S of A3 Interface Assembly Schematic Diagram (sheet 4 of 6) in the *8560 E-Series Spectrum Analyzer Component Level Information*.

If both HPOS_HLDNG and HNEG_HLDNG are high during the same bucket, HROSENFELL will also be set high. This indicates that the video signal probably consists of noise, since it rose and fell during the same period. The HROSENFELL signal is valid only when the NORMAL (rosenfell) detector mode is selected.

1. Remove anything connected to the 8561E or 8563E front-panel INPUT 50 Ω connector. Press **PRESET** on the spectrum analyzer and set the controls as follows:

Center frequency 300 MHz
Span 0 Hz
Sweep time 5 s
Detector mode NORMAL

2. Check LPOS_RST and LNEG_RST as described in [“Peak Detector Reset” on page 398](#)

3. Check A3U423 pin 4 for two low-going 3.3 μ s pulses 40 μ s apart occurring every 130 μ s.
4. Check that HROSENFELL (A3U610 pin 6) has two pulses spaced approximately 40 μ s apart and then a third pulse 60 μ s from the second pulse. Each pulse should be approximately 10 μ s wide and low-going.
5. Monitor HROSENFELL with an oscilloscope while reducing the video bandwidth from 1 MHz to 1 kHz.
6. As the video bandwidth is decreased to 1 kHz, the HROSENFELL line should increasingly show a low logic level. With a video bandwidth of 1 kHz, a nearly flat line should be displayed on the CRT.
7. Set the sweep time to 50 ms. Externally trigger the oscilloscope using the spectrum analyzer rear panel BLKG/GATE OUTPUT.
8. Check that HPOS_HLDNG (A3U416 pin 4) is mostly high with a 1 MHz video bandwidth and mostly low with a 1 kHz video bandwidth.
9. Check that LNEG_HLDNG (U408A pin 13) is mostly high with a 1 MHz video bandwidth and mostly low with a 1 kHz video bandwidth.

ADC MUX

Refer to function block AA of A3 Interface Assembly Schematic Diagram (sheet 6 of 6) in the *8560 E-Series Spectrum Analyzer Component Level Information*.

The ADC MUX switches various inputs into the video path for conversion by the ADC. The SCAN RAMP input is used during sweeps having a width of equal to or greater than 2.01 MHz times N, to control the timing of the ADC operations. Some combination of MOD_VIDEO, NEG_PEAK, and POS_PEAK is used for the video signal to be converted by the ADC. The YTO ERR, FCMUX, CAL OSC TUNE, and OFL ERR inputs are used only during diagnostic and auto adjust routines and during retrace.

1. Set the spectrum analyzer to the following settings:

Center frequency	300 MHz
Span	0 Hz
Reference level	-10 dBm
Sweep time	50 s
DETECTOR MODE	SAMPLE

2. Refer to [Table 8-8](#) and check for correct logic levels at A3U108 pins 1, 15, and 16. Check for proper output signals at TP6. If the select lines are not changing, suspect the ADC ASM or the VGA/ADC MUX Control. If the select lines are changing, but the proper video inputs are not being switched to the output, replace U108. In SAMPLE mode, the input is MOD_VIDEO (pin 7); in POS PEAK mode, the input is POS_PEAK (pin 5); and in NEG PEAK mode, the input is NEG_PEAK (pin 6).
3. Check for the presence of the YTO ERR signal at A3J2 pin 42 with an oscilloscope probe.
4. If ERR 300 YTO UNLK or 301 YTO UNLK occurs and the voltage is near zero during a sweep and positive during retrace (YTO is being locked), the fault is on the A3 assembly. If a constant dc voltage is present, refer to the Synthesizer section troubleshooting procedure in Chapter 11.

Table 8-8 Logic Levels at A3U108

Detector Mode	U108 pin 1	U108 pin 15	U108 pin 16
SAMPLE	H	L	H
POS PEAK	H	L	L
NEG PEAK	L	L	H

5. Set the spectrum analyzer to the following settings:
 - Span 5 MHz
 - Sweep time 50 ms
6. Check for the presence of the SCAN RAMP signal by connecting an oscilloscope probe to A3J2 pin 45 (component side of A3J2). Connect the negative-probe lead to A3TP4.
7. A 0 to 10 V ramp should be present in both LINE and FREE RUN trigger modes. If the waveform is present only in LINE trigger, ADC control signal HBADC_CLK0 may be faulty. Refer to [“ADC Control Signals” on page 403](#).
8. If the scan ramp is present, but is not being switched to the output of U108, replace U108. If the scan ramp is absent in either mode, do the following:
 - a. Connect the oscilloscope probe to A3J400 pin 15 (HSCAN).
 - b. A TTL signal (high during 50 ms sweep time and low during retrace) should be present, indicating A3 is working properly. Refer to the Synthesizer section troubleshooting procedure in Chapter 11. A faulty TTL signal indicates a bad A3 Interface assembly.

9. Set the spectrum analyzer "ADC Control Signals" in this chapter to the following settings:

Sweep time 100 ms
Span 100 MHz

10. Press **CAL** and **IF ADJ ON** and check for the presence of the CAL OSC TUNE signal by monitoring A3J401 pin 25 with an oscilloscope. If ERR 499 CAL UNLK is displayed and a signal within the range of -10 V to +10 V is present during part of the retrace period, the fault is on the A3 assembly.

11. If a constant dc voltage is present during the sweep and all of the retrace period, refer to the IF Section troubleshooting procedure in Chapter 9, "IF Section."

Variable Gain Amplifier (VGA)

Refer to function block AB of A3 Interface Assembly Schematic Diagram (sheet 6 of 6) in the *8560 E-Series Spectrum Analyzer Component Level Information*.

The VGA provides adjustable gain in the video path. Its nominal gain of 7 can be adjusted $\pm 10\%$. U112 removes dc offset to keep U113 in its monotonic range. (Both U112 and U113 are set to the same value.) The DAC settings cannot be changed from the front panel.

Track and Hold

Refer to function block AC of A3 Interface Assembly Schematic Diagram (sheet 6 of 6) in the *8560 E-Series Spectrum Analyzer Component Level Information*.

1. Press **PRESET** on the spectrum analyzer and set the controls as follows:

Center frequency 300 MHz
Span 0 Hz
Detector mode Sample
Reference level -70 dBm
Log dB/division 2 dB/DIV
Sweep time 50 ms

2. Disconnect any signal from the spectrum analyzer input. A full scale display of sampled noise should be present.
3. Trigger an oscilloscope on the positive going edge of HHOLD (A3U506 pin 16).
4. The waveform at A3TP10 should be random noise with an average level of approximately 4 V. The noise should have a flat spot in its response while HHOLD is high, indicating proper operation of U114.

A3 Assembly ADC Circuits

The ADC consists of a 12-bit DAC, 12-bit successive approximation register (SAR), data multiplexers, and data latches. The ADC ASM (algorithmic state machine) controls the ADC. Eight inputs are controlled by the ADC MUX. These include a positive peak detector, negative peak detector, sampled video, scan ramp, YTO error voltage, FC MUX voltages, Cal Oscillator tune voltage, and offset lock error voltage. A MUX on the A14 frequency control assembly selects which voltage is sent to the ADC MUX on the FC MUX signal line.

During NORMAL detector mode sweeps, when noise is detected by the rosenfell detector, the ADC ASM automatically switches between POS PEAK and NEG PEAK.

ADC Control Signals

Refer to function blocks B and F of A3 Interface Assembly Schematic Diagram (sheet 2 of 6) in the *8560 E-Series Spectrum Analyzer Component Level Information*.

The ADC requires two signals from the A2 controller assembly: HBADC_CLK0 and HBBKT_PULSE. HBBKT_PULSE is used only in zero span. Use the following steps to verify the signals:

1. Disconnect W22 from A2J8.
2. If a 10 MHz TTL signal is absent on W22, refer to the 10 MHz Reference (on the A15 RF assembly) troubleshooting procedure in [Chapter 12 , “RF Section.”](#)
3. Set the spectrum analyzer **SPAN** to zero.
4. Reconnect W22.
5. With an oscilloscope probe, monitor A3J401 pin 20.
6. If TTL pulses are absent, the A2 controller assembly is faulty. Refer to [Chapter 10 , “Controller Section.”](#) The presence of TTL pulses indicates a faulty A3 assembly.
7. Monitor A3J401 pin 23 (HBADC_CLK0). If a 1 MHz TTL clock signal is present, HBADC_CLK0 is working properly.
8. If HBKT_PULSE or HBADC_CLK0 is missing, disconnect A3W1 from A2J2.
9. Monitor A2U5 pin 3 for HBKT_PULSE and A2U5 pin 7 for HBADC_CLK0.
10. If HBADC_CLK0 is absent, troubleshoot the A2 controller assembly.

11. HBKT_PULSE is absent, refer to the information on troubleshooting the frequency counter in [Chapter 10](#), “Controller Section.”
12. Reconnect A3W1 to A2J2.

ADC Start/Stop Control

Refer to function block B of A3 Interface Assembly Schematic Diagram (sheet 2 of 6) in the *8560 E-Series Spectrum Analyzer Component Level Information*.

The ADC Start/Stop Control determines the start time of all ADC conversions. Multiplexer A3U509 chooses the source of the start signal. Both HSTART_SRC and HBUCKET tell the ASM to start a conversion.

1. Press **PRESET** on the spectrum analyzer and set the following controls:

Span 0 Hz
Sweep time 60 s
Detector mode SAMPLE

2. Check for a TTL high at A3U509 pin 2 and a TTL low at A3U509 pin 14.
3. Set the detector mode to NORMAL.
4. Check that A3U509 pins 2 and 14 are both TTL low.
5. Set the spectrum analyzer to the following settings:

Span 1 MHz
Detector mode SAMPLE

6. Check for a TTL high at A3U509 pin 2 and a TTL low at A3U509 pin 14.
7. Press **CAL** and **REALIGN LO & IF**. During the realignment, A3U509 pin 2 should be TTL low and pin 14 should be TTL high until the 10 kHz and narrower resolution bandwidths are adjusted. If correct, the Start/Stop Control circuitry is being selected properly by the processor and U508 in the ADC Register block is working properly.

8. Press **PRESET** on the spectrum analyzer and set the controls as follows:

Span 0 Hz
Detector mode SAMPLE
Sweep time 400 ms

9. Check that A3U509 pin 7 has positive 15 μ s pulses with a 667 μ s period (sweep time/600). Check that A3U509 pin 9 has positive 15 μ s pulses with a 667 μ s period (sweep time/600). The pulses should be present during the sweep but absent during retrace.

10. Set the detector mode to NORMAL.
11. Check that A3U509 pin 9 has pulses every 130 μs and U509 pin 7 has pulses every 667 μs (although pulse widths may be changing).

ADC ASM

Refer to function block F of A3 Interface Assembly Schematic Diagram (sheet 2 of 6) in the *8560 E-Series Spectrum Analyzer Component Level Information*.

1. Press **PRESET** on the spectrum analyzer and set the controls as follows:
Span 0 Hz
Sweep time 60 s
Detector mode SAMPLE
2. Check that HSTART_SRC (U504 pin 4) goes TTL high, causing HHOLD (U506 pin 16) to go high 15 μs later.
3. Check that HSTART_ADC (U506 pin 15) goes TTL high 19 μs after HSTART_SRC goes high.
4. HHOLD should stay TTL high for approximately 18 μs , and HSTART_ADC should stay high for approximately 31 μs .
5. Check that LCMPLT (U504 pin 15) goes TTL low 12 μs after HSTART_ADC goes high (12 bits at 1 μs per bit). LCMPLT indicates that the successive approximation state machine (SASM) has completed the ADC conversion.
6. Check that LDONE (U506 pin 19) goes TTL low approximately 2 μs after LCMPLT goes low.

ADC

Refer to function block A of A3 Interface Assembly Schematic Diagram (sheet 2 of 6) in the *8560 E-Series Spectrum Analyzer Component Level Information*.

The successive approximation state machine (SASM) consists of A3U527 and A3U528. Upon the occurrence of HSTART_ADC, the SASM successively toggles bits from high to low starting with the most significant bit. The digital result is then converted to an analog current in DAC U518 and compared with the SAMPLED VIDEO. If the DAC current is too high, the output of U512 will be low, telling the SASM that the "guess" was high and that the bit just toggled should remain low. It then moves on to the next most significant bit until all 12 bits have been "guessed" at. Each "guess" takes 1 μs (one cycle of HBADC_CLK0), or 12 μs to complete a conversion. When the conversion is completed, the SASM sets LCMPLT low. The bits are written to the data bus by buffers U514 and U516.

1. Set the spectrum analyzer controls as follows:

Center frequency 300 MHz
Span 0 Hz
Sweep time 60 s
Detector mode SAMPLE

2. Trigger an oscilloscope on HSTART_ADC (U506 pin 15) and monitor the outputs of the SASM (U527 pins 18 and 19; U528 pins 14 through 23). Each bit should start high and be switched low. It will either stay low or return to a high state 1 μ s later, depending on the comparison at U512.
3. If the outputs do not exhibit this bit pattern, and the ADC ASM checks are working properly, suspect A3U527, U528, or one of the latches (U514/516). If the output of comparator U512 does not toggle back and forth during a conversion, suspect either U512 or one of the clipping diodes (CR500/CR501).

NOTE

Because currents are being summed at U512 pins 2 and 3, voltage levels at these points are difficult to interpret.

Ramp Counter

Refer to function block D of A3 Interface Assembly Schematic Diagram (sheet 2 of 6) in the *8560 E-Series Spectrum Analyzer Component Level Information*.

The ramp counter is used for sweeps with widths greater than 2.0 MHz times N. The analog sweep ramp is compared to the digital ramp counter. When the analog sweep ramp exceeds the DAC output generated for that ramp counter setting, HRAMP_COMP toggles high, indicating the end of a bucket. The ramp counter counts horizontal buckets. There are 601 buckets per sweep, so the ramp (bucket) counter counts from 0 to 600. The ramp counter is incremented by HRST_PK_ENA.

1. Press **PRESET** on the spectrum analyzer and set the controls as follows:

Span 5 MHz
Detector mode SAMPLE

2. For spans greater than 2.0 MHz times N0, HODD (A3U525 pin 3) is a square wave with a period defined by $(2 \times \text{sweep time}/600)$. For example, for a 6 s sweep time, HODD has a period of 20 ms. The ramp (bucket) counter will be odd every other bucket.

A3 Assembly Control Circuits

A digital control problem will cause the following three steps to fail:

1. On the spectrum analyzer, press **AMPLITUDE**, **ATTEN MAN**, 6, 0, and **dB**.
2. A click should be heard after pressing **dB** in step 1, unless **ATTEN** was previously set to 60 dB.
3. Press 1, 0, and **dB**. Another click should be heard. If no clicks were heard, but the **ATTEN** value displayed on the CRT changed, the digital control signals are not operating properly.

Analog Bus Drivers

Refer to function block N of A3 Interface Assembly Schematic Diagram (sheet 4 of 6) in the *8560 E-Series Spectrum Analyzer Component Level Information*.

1. Press **PRESET** on the spectrum analyzer, and set the controls as follows:
Span 0 Hz
Trigger Single
2. Monitor A3U401 pin 3 (LRF_STB) with an oscilloscope or logic probe. This is the strobe for the A15 RF Assembly.
3. Press **AUX CTRL** and **REAR PANEL** and check that pulses occur when toggling between **10 MHz INT** and **10 MHz EXT**.
4. Monitor U401 pin 5 (LFC_STB) with an oscilloscope or logic probe. This is the strobe for the A14 frequency control assembly.
5. Press **AMPLITUDE** and check that pulses occur when toggling between **ATTEN** settings of 10 and 20 dB.
6. Monitor U401 pin 7 (LIF_STB) with an oscilloscope or logic probe. This is the strobe for the A5 IF assembly.
7. Press **AMPLITUDE** and check that pulses occur when toggling between **REF LVL** settings of -10 dBm and -20 dBm.
8. Monitor U401 pin 9 (LLOG_STB) with an oscilloscope or logic probe. This is the strobe for the log amplifier on the A4 assembly.
9. Press **AMPLITUDE** and check that pulses occur when toggling between **LINEAR** and **LOG dB/DIV**.
10. To check the Address and Data Lines, place a jumper from A3TP1 and A3TP2 to A3U406 pin 20 (+5 V).

11. Check that address lines A0 through A7 and data lines D0 through D7 are all TTL high.
12. If any address or data line is low, press **LINE** to turn spectrum analyzer off and disconnect the W2 control cable from A3J2. Press **LINE** to turn spectrum analyzer on. Ignore any error messages.
13. Check that address lines A0 through A7 and data lines D0 through D7 are all high. If all address and data lines are high, suspect a fault either in W2 or one of the other four assemblies which connect to W2.
14. If any address or data line is low, check the appropriate input of either U405 (data lines) or U406 (address lines).
15. If a data line input is stuck low, check the data bus buffer. If an address line input is stuck low, check A3W1 and the A2 controller assembly.
16. If the appropriate input is high or toggling between high and low, suspect a failure in either U405 (data lines) or U406 (address lines).
17. Remove jumpers.

Analog Bus Timing

Refer to function block P of A3 Interface Assembly Schematic Diagram (sheet 4 of 6) in the *Spectrum Analyzer Component Level Information* and *8560 E-Series Spectrum Analyzer Component Level Information*.

Analog bus timing (ABT) generates the strobes for the A4, A5, A14, and A15 assemblies. The A14 frequency control assembly also requires a qualifier for its strobe, LVFC_ENABLE. A3U400 and A3U414 provide a 2 μ s delay between the time HANA_BUS goes high and the enable line to demultiplexer A3U407 goes low.

1. Press **PRESET** on the spectrum analyzer and set the controls as follows:

Center frequency	300 MHz
Span	100 MHz
2. Check that A3U407 pin 1 goes low approximately 2 μ s after HANA_BUS (A3U400 pin 3) goes high.
3. If HANA_BUS is absent, check for pulses on ABT A3U505 pin 2 and IA10 (A3U505 pin 5).
4. If A3U407 pin 1 is not delayed 2 μ s from HANA_BUS, check for the presence of the 1 MHz HBADC_CLK0.
5. If A3U407 pin 1 is not delayed 2 μ s from HANA_BUS and HBADC_CLK0 is correct, suspect a fault in either A3U414 or A3U400.

6. Press **PRESET** and set the controls as follows:
Span 0 Hz
Trigger SINGLE
7. Monitor A3U401 pin 3 (LR_STB) with an oscilloscope or logic probe. This is the strobe for the A15 RF assembly.
8. Press **AUX CTRL** and **REAR PANEL** and check that pulses occur when toggling between **10 MHz INT** and **10 MHz EXT**.
9. Monitor A3U401 pin 5 (LF_STB) with an oscilloscope or logic probe. This is the strobe for the A14 frequency control assembly.
10. Press **AMPLITUDE** and check that pulses occur when toggling between **ATTEN** settings of 10 and 20 dB.
11. Monitor A3U401B pin 7 (LIF_STB) with an oscilloscope or logic probe. This is the strobe for the A5 IF assembly.
12. Press **AMPLITUDE** and check that pulses occur when toggling between **REF LVL** settings of -10 dBm and -20 dBm.
13. Monitor A3U401B pin 9 (LLOG_STB) with an oscilloscope or logic probe. This is the strobe for the A4 log amplifier/cal oscillator assembly.
14. Press **AMPLITUDE** and check that pulses occur when toggling between **LINEAR** and **LOG DB/DIV**.

Interface Strobe Select

Refer to function block K of A3 Interface Assembly Schematic Diagram (sheet 3 of 6) in the *8560 E-Series Spectrum Analyzer Component Level Information*.

Interface strobe select generates the various strobes used by circuits on the A3 Interface Assembly. [Table 8-9 on page 410](#) and [Table 8-10 on page 410](#) are the truth tables for demultiplexers A3U410 and A3U500.

Table 8-9 Demultiplexer A3U410 Truth Table

Selected Output Line	IA1	IA2	IA3
Pin 15, LSCAN_KBD	L	L	L
Pin 14, LDACU1	H	L	L
Pin 13, LDAC1	L	H	L
Pin 12, LDAC2	H	H	L
Pin 11, LDAC3	L	L	H
Pin 10	H	L	H
Pin 9, LTIMER	L	H	H
Pin 7, LADC_REG1	H	H	H

Table 8-10 Demultiplexer A3U500 Truth Table

Selected Output Line	IA0	IA1	IA2
Pin 15, LSENSE_KBD	L	L	L
Pin 14, LINT_PRIOR	H	L	L
Pin 13, LADC_DATA1	L	H	L
Pin 12, LDAC_DATA0	H	H	L
Pin 11, HCNTR_LD0	L	L	H
Pin 10, HCNTR_LD1	H	L	H
Pin 9, LRPG_RD	L	H	H
Pin 7, LADC_REG0	H	H	H

A16 Assembly Fast ADC Circuits (Option 007 in 8564E and 8565E instruments)

The fast ADC consists of video signal scaling and limiting amplifiers, an 8-bit flash ADC, peak/pit detection of the digitized video signal, a 32 K-byte RAM, and the fast ADC control circuitry.

Video Input Scaling Amplifiers and Limiter

Refer to function block L of the A16 Fast ADC Assembly Schematic Diagram in the *8560 E-Series Spectrum Analyzer Component Level Information*.

The video input scaling amplifiers help provide scaling (10 dB/div, 5 dB/div, 2 dB/div, or 1 dB/div) and buffer the flash video output. When the GAINX2 control line is low, switch U44D is open and switch U44C is closed. Thus, the scaled video at TP26 virtually follows the video input (0 - 1 V). When the GAINX2 control line is high, switch U44C is open and switch U44D is closed. Amplifier U43 then provides a gain of $2(V_{in}) - 1$ V. Voltage clamp CR4 prevents the scaled video input to amplifier U45 from going more negative than -0.35 V or more positive than $+1.25$ V.

NOTE

When measuring voltages or waveforms on the A16 fast ADC assembly, connect the ground (or common) lead to the ground-plane trace on the A16 assembly. This digital ground plane is totally isolated from the chassis.

1. Press **PRESET** on the Option 007 spectrum analyzer and set the controls as follows:

Center frequency	300 MHz
Span	0 Hz
Reference level	-10 dBm
Log/division	10 dB/DIV
Sweep time	20 ms
2. Connect the CAL OUTPUT to the INPUT 50 Ω connector.
3. Adjust the Option 007 spectrum analyzer reference level to place the signal at the top graticule line on the CRT display.
4. Measure the dc level at TP25. If the voltage measured is not $+1.0 \pm 0.15$ V, troubleshoot the A3 interface assembly.
5. Measure the dc level at TP26. The level should be approximately the same as the level measured at TP25. If not, suspect switch U44.
6. Set the Option 007 spectrum analyzer scale to 5dB per division.

7. Adjust the Option 007 spectrum analyzer reference level to place the signal at the top graticule line on the CRT display.
8. Measure the dc level at TP25 and TP26. The level should be $+1.0 \pm 0.25$ V. If the level measured at TP26 differs from the level measured at TP25 by more than 0.25 volts, troubleshoot U43 and associated circuitry.
9. Disconnect the CAL OUTPUT signal from the INPUT 50 Ω connector.
10. The level at TP26 should drop to -0.35 Vdc. If the level is less (more negative) than -0.35 Vdc, replace voltage clamp CR4.
11. Measure the dc level of the flash video at TP27. The level should be near 0 Vdc with the signal at the bottom graticule line (no input to the spectrum analyzer).
12. Connect the CAL OUTPUT to the INPUT 50 Ω connector.
13. Measure the dc level of the flash video at TP27. The level should be near $+1.7$ Vdc.

8-Bit Flash ADC

Refer to function block I of the A16 fast ADC assembly schematic diagram in the *8560 E-Series Spectrum Analyzer Component Level Information*.

The flash ADC (U35) converts the analog video signal into 8-bit digital values at a fixed rate of 12 megasamples per second.

NOTE

When measuring voltages or waveforms on the A16 fast ADC assembly, connect the ground (or common) lead to the ground-plane trace on the A16 assembly. This digital ground plane is totally isolated from the chassis.

1. Press **PRESET** on the Option 007 spectrum analyzer and set the controls as follows:

Center frequency	300 MHz
Span	0 Hz
Reference level	-20 dBm
Log/division	5 dB/DIV
Sweep time	20 ms
2. Connect the CAL OUTPUT to the INPUT 50 Ω connector.
3. Pins 4 through 10 (ADC7-ADC1) and pin 21 (ADC0) of U35 should all be high (logic 1), corresponding to an ADC digital count of 255 for the analog input of $+2$ volts or greater.
4. Disconnect the CAL OUTPUT signal from the INPUT 50 Ω connector.

5. Pins 4 through 10 (ADC7-ADC1) and pin 21 (ADC0) of U35 should all be low (logic 0), corresponding to an ADC digital count of zero for the analog input of 0 volts or less.

Peak/Pit Detection

Refer to function block J of the A16 fast ADC assembly schematic diagram in the *8560 E-Series Spectrum Analyzer Component Level Information*.

Peak detection or pit (negative peak) detection can be enabled whenever the sample rate is less than 12 MHz (sweep times greater than 50 μ s). Peak detection uses the maximum value of all the samples taken within each bucket (between adjacent display points). Pit detection uses the minimum value of all the samples taken within each bucket. And sample detection uses the last sample of all the samples taken within each bucket.

The different detection modes are implemented by selectively clocking latch U30, depending on the state of LP/Q which is generated in PAL U1 (block A). When LP/Q is low, U30 is clocked by WCLK. When LP/Q is high, U30 is not clocked. LP/Q is a function of the 12M_SEL, SCLK-1, LSAMPLE, LPEAK, P_LO, and P_HI signals. See [Table 8-11](#).

If the sample rate is 12 MHz, 12M_SEL is high, which forces LP/Q low so that every sample is clocked into latch U30 and latched into RAM U32 (block K). If the sample rate is less than 12 MHz and the detection mode is peak or pit, the SCLK-1, LPEAK, P_LO, and P_HI signals control the LP/Q signal. In these detection modes, latch U30 stores the peak or pit value of the samples taken for each bucket. The 8-bit digital magnitude comparator, U31, compares the input byte (P) with the output byte (Q) from latch U30. When P is greater than Q, P_LO is low (0) and P_HI is high (1). When P is less than Q, P_LO is high (1) and P_HI is low (0). When P is equal to Q, P_LO and P_HI are both low (0). See [Table 8-11](#).

Table 8-11 LP/Q Truth Table

Mode	LP/Q	12M_SEL	SCLK-1	LSAMPLE	LPEAK	P_LO	P_HI
12MHz	L	H	X	X	X	X	X
SAMPLE	L	X	X	L	X	X	X
POS	L	L	L	H	L	L	H
PEAK	H	L	L	H	L	H	L
	H	L	L	H	L	L	L
NEG	H	L	L	H	H	L	H
PEAK	L	L	L	H	H	H	L
(Pit)	H	L	L	H	H	L	L
Clocking	L	L	H	H	X	X	X
Peak/Pit							
Sample							

32 K-Byte Static RAM

Refer to function block K of the A16 fast ADC assembly schematic diagram in the *8560 E-Series Spectrum Analyzer Component Level Information*.

The static RAM stores the flash ADC samples that are taken when the fast ADC circuitry is in the "write" mode. When not in the "write" mode, the static RAM is read by the CPU on the A2 controller assembly to retrieve the fast ADC data.

The 8-bit Q bus connects the outputs of latch U30 to the data port of static RAM U32.

A16 Assembly Fast ADC Control Circuits (Option 007 in 8564E and 8565E instruments)

The fast ADC control circuits consist of the CPU interface and control registers, the reference clock, a clock and sample rate generator, a trigger circuit, a 16-bit post-trigger counter, a 15-bit circular address counter, a video trigger comparator, and the reference and power supply circuits.

CPU Interface and Control Registers

Refer to function block A of the A16 fast ADC assembly schematic diagram in the *8560 E-Series Spectrum Analyzer Component Level Information*.

The A16 assembly digital interface to the A2 controller assembly consists of an 8-bit bi-directional data bus, one address line, a most-significant byte strobe, and a least-significant byte strobe.

The A16 fast ADC assembly can be accessed by firmware (on the A2 controller assembly) at two logical addresses. When the address line (ADDR3) is low, the primary address is selected. When the ADDR3 is high, the secondary address is selected. The data transfers between the A16 fast ADC assembly and the A2 controller assembly are clocked by the two strobe lines, MSB_STRB and LSB_STRB. 16-bit word transfers occur as two sequential byte transfers; the most-significant byte first, followed by the least-significant byte.

The primary address (ADDR3 low) contains the 16-bit control word written by the firmware on the A2 controller assembly. The secondary address (ADDR3 high) supports both 8-bit byte and 16-bit word reads and writes. There is no read/write line on the A16 fast ADC assembly to control the direction of data transfer. The fast ADC is preconfigured to read or write by setting the appropriate bits in the 16-bit control word. Refer to [Table 8-12 on page 416](#). If the control word is not correct, it may result in a bus conflict.

Table 8-12

Control Word at Primary Address (U3 and U4)

Bit	Mnemonic	State	Description
Bit 0	WRITE	1	Allows samples to be written to FADC memory. All on-board clocks running and samples being written to FADC memory. (FADC memory cannot be read by A2 controller in this mode.)
		0	All on-board clocks turned off and no samples being written to FADC memory. (FADC memory can be read by A2 controller.)
Bit 1	ARM	1	Arms the FADC assembly for a trigger. FADC assembly armed to accept trigger from HSWP line or video trigger.
		0	FADC assembly cannot be triggered.
Bit 2	GAINX2	1	Turns on X2 log expand amplifier. A16U43 turned on. (5 dB/div or 1 dB/div scale)
		0	A16U43 turned off. (10 dB/div, 2 dB/div, or linear scale)
Bit 3	VTRIG_POL	1	Controls digital video trigger polarity. Negative-edge video trigger.
		0	Positive-edge video trigger.
Bit 4	LSAMPLE	1	Enables sample detection mode. Sample detection mode disabled.
		0	Sample detection mode enabled.
Bit 5	LADCEN	1	Enables FADC memory for "writes". (Toggled in conjunction with bit 0.) Disables FADC memory for "writes".
		0	Enables FADC memory for "writes".
Bit 6	LLOADADDR	1	Enables load address counter. "Writes" to the address counter disabled.
		0	"Writes" to the address counter enabled.
Bit 7	LLOADPOST	1	Enables load post-trigger counter. "Writes" to the post-trigger counter disabled.
		0	"Writes" to the post-trigger counter enabled.
Bit 8	LVTRIG_EN	1	Enables digital video trigger on A16. Digital video trigger disabled.
		0	Digital video trigger enabled.

Table 8-12 Control Word at Primary Address (U3 and U4)

Bit	Mnemonic	State	Description
Bit 9	LREADCLK	1 0	Clocks counters during "read" mode. Used to load post-trigger counter or address counter. Also used to post-increment address counter following memory "reads". Read clock disabled. Read clock enabled.
Bit 10	LREADMEM	1 0	Enables read FADC memory. Read FADC memory disabled. Read FADC memory enabled.
Bit 11	LREADADDR	1 0	Enables read trigger address latch. "Reads" from trigger address latch disabled. "Reads" from trigger address latch enabled.
Bit 12	LRATELATCH	1 0	Enables load sample rate latch. "Writes" to the sample rate latch are disabled. "Writes" to the sample rate latch are enabled.
Bit 13	LRLSHSWP	1 0	Releases HSWP strobe. Release HSWP strobe disabled. Release HSWP strobe enabled.
Bit 14	LLOADTRIG	1 0	Enables load video trigger level. Load digital video trigger level disabled. Load digital video trigger level enabled.
Bit 15	LPEAK	1 0	Peak/pit detection mode control. Enables pit (negative-peak) detection mode if LSAMPLE (Bit 4) is also high. Enables peak detection mode if LSAMPLE (Bit 4) is high.

Reference Clock

Refer to function block B of the A16 fast ADC assembly schematic diagram in the *8560 E-Series Spectrum Analyzer Component Level Information*.

The reference clock circuitry takes the 8 MHz CMOS square wave clock from the A2 controller assembly (via W59, coax 839) and triples the frequency to 24 MHz. Inverters U5A and U5B provide the proper match for the 8 MHz clock input, and also the desired drive level into the 24 MHz bandpass filter. The 24 MHz bandpass filter consists of R5, C8, L1, C9, C10, L2, C11, L3, C12, L4, C13, C14, and R6. Inverters U6A and U6B provide amplification of the 24 MHz clock to produce CMOS levels, and also buffer the 24 MHz clock output.

Clock and Sample Rate Generator

Refer to function block C of the A16 fast ADC assembly schematic diagram in the *8560 E-Series Spectrum Analyzer Component Level Information*.

The clock and sample rate generator takes the 24 MHz reference clock signal and generates all of the various clock signals used on the A16 fast ADC assembly. The sample rate generator consists of CMOS latch U15, CMOS counters U14 and U16, and CMOS flip-flops U7B and U9A. The sample rate generator only controls the rate at which the static RAM address counter (15-bit circular address counter) and the 16-bit post-trigger counter are clocked (ACLK and PCLK respectively). The sample rate generator also controls the number of flash ADC samples taken per bucket. The range of the sample rate is 1 sample per bucket (12 MHz rate) to 256 samples per bucket (less than 12 MHz rate). SCLK-1 is an input to PAL U1 (block A) and affects the LP/Q signal to ensure that the first sample of a bucket is always clocked into latch U30 (block J) and written into static RAM U32 (block K) when the detection mode is peak or pit and the sample rate is less than 12 MHz. Refer to [Table 8-11 on page 413](#).

Trigger

Refer to function block D of the A16 fast ADC assembly schematic diagram in the *8560 E-Series Spectrum Analyzer Component Level Information*.

When the A16 fast ADC is triggered, the current static RAM address is latched into trigger address latches U27 and U28 (block G), and the post-trigger counter (U19, U20, U21, U22, and U47) begins counting. Samples continue to be written to consecutive addresses in RAM U32 until the post-trigger counter reaches its terminal count. The CPU on the A2 controller assembly monitors the HSWP line and starts a software timer when HSWP goes high after being triggered. The software timer is set to slightly longer than the post-trigger counter will be counting, so at the end of the "time-out", the post-trigger counter has already reached its terminal count. At the end of this "time-out", the CPU on the A2 controller assembly takes the fast ADC out of "write" mode and reads latches U27 and U28 to determine the static RAM address of the sample that was taken when the trigger occurred. The CPU then writes the trigger address (read at U27/U28) to the fast ADC static RAM address counter (15-bit circular address counter). If pre-trigger or post-trigger (delay) is being used, the CPU adds or subtracts appropriately and writes the "adjusted" trigger address to the static RAM counter. The CPU then begins reading the fast ADC data, starting from the trigger (or offset trigger) address.

The trigger circuitry is enabled by the ARM signal (bit 1 of the fast ADC control word). Once a trigger occurs, the fast ADC cannot be triggered again until the ARM line goes low (disarmed), then high again (armed).

The fast ADC is triggered by the HSWP line in **FREE RUN**, **LINE**, and **EXTERNAL** trigger modes. When **VIDEO** trigger is being used, a synchronous digital video trigger signal, VCLK, is generated by PAL U1 (block A) and U17A (block D).

16-Bit Post-Trigger Counter

Refer to function block E of the A16 fast ADC assembly schematic diagram in the *8560 E-Series Spectrum Analyzer Component Level Information*.

The 16-bit post-trigger counter controls the number of static RAM memory locations that will be written after the trigger occurs. This counter consists of U19, U20, U21, U22, and U47. The counter is loaded from the CPU on the A2 controller assembly when the A16 fast ADC assembly is in "read" mode. The CPU loads the counter by first setting the LLOADPOST (bit 7 of the fast ADC control word) and the LREADCLK (bit 9 of the fast ADC control word) to their low state. The CPU then writes the 16-bit word to the fast ADC secondary address. The rising edge of PCLK then latches the 16-bit data into the post-trigger counter.

The post-trigger counter begins counting upward in "write" mode on the first rising edge of PCLK after the LCOUNT signal from the trigger circuit goes low. The frequency of PCLK is the programmed sample rate. When the post-trigger counter reaches its terminal count, the LSTOP signal goes low and disables the static RAM address counter from further counting. LSTOP also forces LCOUNT high in NAND gate U11D, which disables the post-trigger counter.

15-Bit (32 K) Circular Address Counter

Refer to function block G of the A16 fast ADC assembly schematic diagram in the *8560 E-Series Spectrum Analyzer Component Level Information*.

This 15-bit programmable circular counter provides the address lines of the static RAM (U32). The counter consists of U23, U24, U25, and U26. It counts upward from 0 to 32767 and then back to 0 in a circular fashion. When a trigger occurs, latches U27 and U28 latch the current static RAM address so that the CPU on the A2 controller assembly can later read the latches and determine the static RAM address of the sample that was taken when the trigger occurred.

The CPU loads the address counter during "read" mode by first setting LLOADADDR (bit 6 of the fast ADC control word) and LREADCLK (bit 9 of the fast ADC control word) to their low state. The CPU then writes the 16-bit load value to the CPU secondary address. The rising edge of ACLK then latches the 16-bit data into the address counter.

After the address counter is loaded by the CPU during "read" mode, the static RAM is read by the CPU. The RAM is read by first setting LREADMEM (bit 10 of the fast ADC control word) and LREADCLK (bit 9 of the fast ADC control word) to their low state. Since the LREADCLK control bit is low, a negative-going pulse on the ACLK line will occur on every static RAM "read" by the CPU. This causes the address counter to increment at the end of each static RAM "read" so that the address counter automatically post-increments to the next address of RAM U32. In order for this address post-increment to occur, the LSTOP count enable signal from the post-trigger counter must be high. LSTOP goes low when the post-trigger counter reaches its terminal count in the "write" mode to stop the address counter from counting. When the fast ADC assembly is changed from "write" mode to "read" mode, LSTOP will be low. So the CPU on the A2 controller board must always first program the post-trigger counter to a value other than the terminal count (65535) to force LSTOP high.

Video Trigger Comparator

Refer to function block M of the A16 fast ADC assembly schematic diagram in the *8560 E-Series Spectrum Analyzer Component Level Information*.

This 8-bit digital magnitude comparator, U34, compares the digitized samples from the flash ADC (latch U29 output) to the programmed video trigger level. The video trigger level value on IOB2 through IOB7 is latched into the P input (top portion of U34) by the firmware on the A2 controller assembly when the fast ADC is in "read" mode. When the sample on the Q input is higher than the video trigger level on the P input, V_HI output is high, and V_LO output is low. When the Q input is lower than the P input, V_HI output is low and V_LO output is high. And when P is equal to Q, both V_HI and V_LO are low. These two signals (V_HI and V_LO) go to PAL U1 (block A) and are used to clock the video trigger generator (block D).

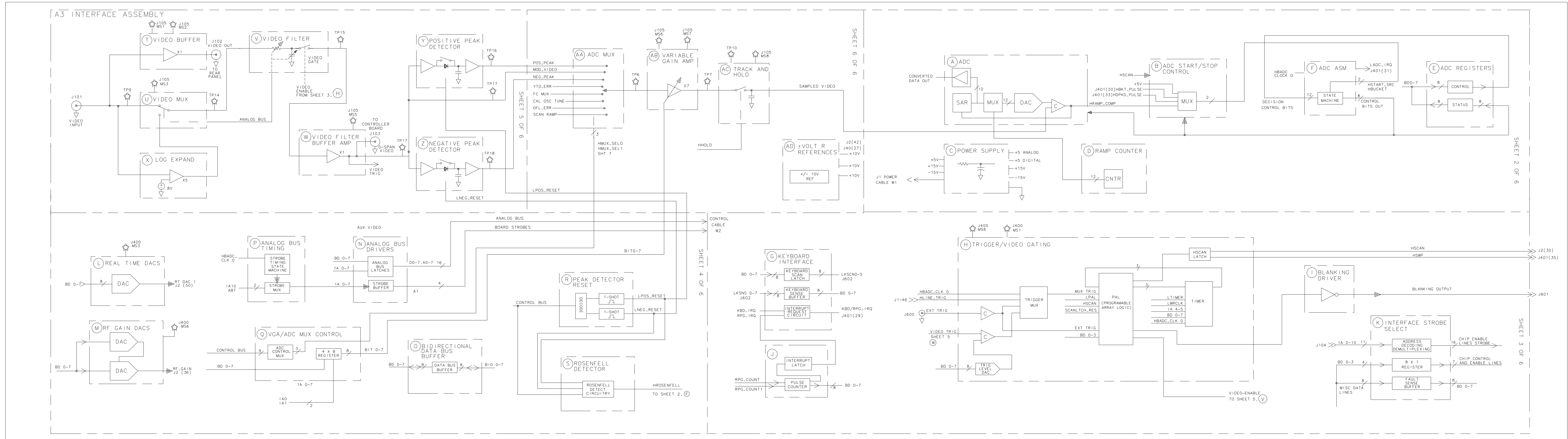

FIGURE 8-3. A3 INTERFACE ASSEMBLY BLOCK DIAGRAM

FAST ADC (OPTION 007)
BLOCK DIAGRAM

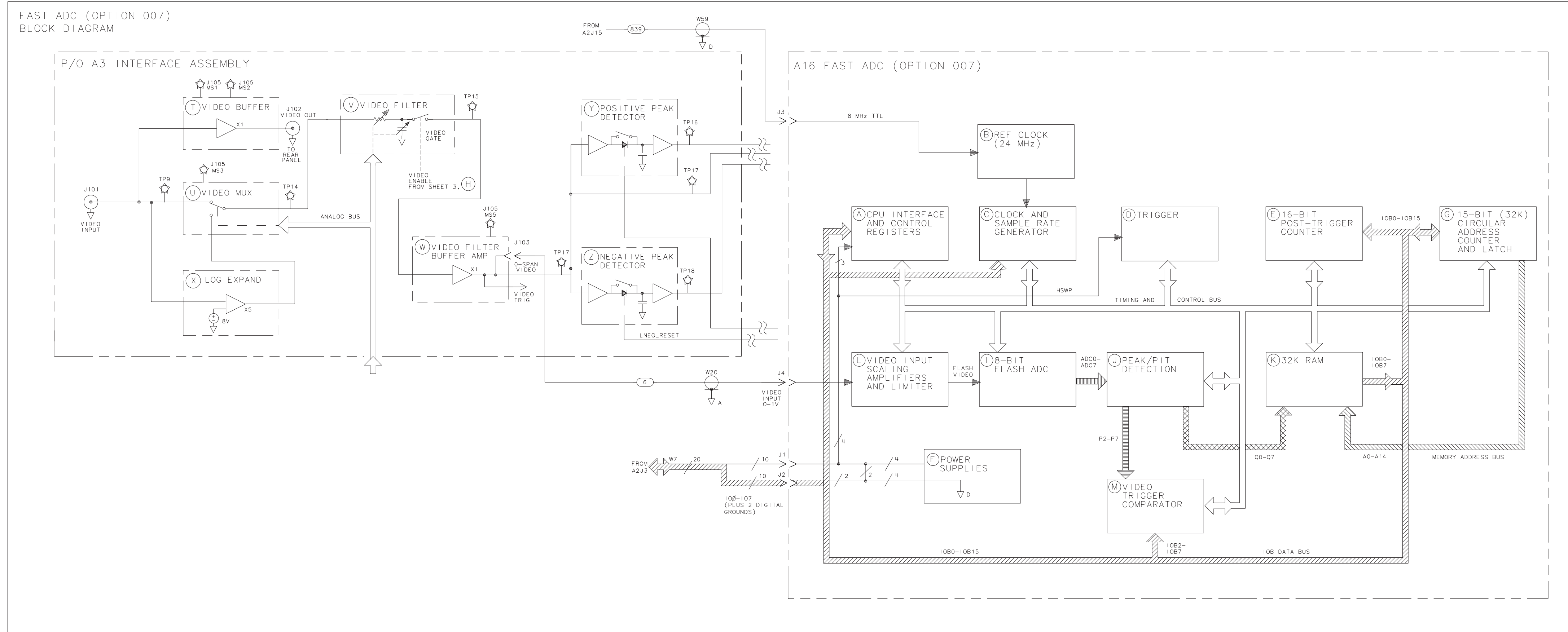

FIGURE 8-4. FAST ADC (OPTION 007) BLOCK DIAGRAM

9 IF Section

Introduction

The IF section contains the A4 log amplifier/cal oscillator and the A5 IF assemblies. [Figure 9-2 on page 431](#) illustrates the location of the A4 and A5 test connectors. [Figure 9-7 on page 436](#) illustrates the level and paths through the IF section.

Troubleshooting Using the Diagnostic Software	page 430
Troubleshooting the Cal Oscillator on A4	page 431
Using Diagnostic Software	
Troubleshooting A5 Using Diagnostic Software	page 435
Automatic IF Adjustment	page 437
Parameters Adjusted	page 438
Requirements	page 439
Performance Test Failures	page 441
IF Gain Uncertainty Performance Test	page 441
Scale Fidelity Performance Test	page 442
Resolution Bandwidths Performance Tests	page 442
Log Amplifier (P/O A4 Assembly)	page 443
Log Amplifier	page 443
Linear Amplifiers	page 444
Video Offset	page 447
Video Output	page 447
Frequency Counter Prescaler/Conditioner	page 448
AM/FM Demodulator	page 448
4.8 kHz IF Filters	page 449
10.7 MHz IF Filters	page 450
4.8 kHz and 10.7 MHz IF Filters	page 450
10.6952 MHz VCXO	page 451
Input Switch	page 451
LO Switch	page 452
Synchronous Detector	page 452
Limiter	page 453
Isolation Amplifier	page 453
Detector/Mixer	page 453
Log Offset/Gain Compensation	page 453
Log Offset Compensation	page 453
Log Gain Compensation	page 454
Video MUX	page 454
A5 IF Assembly	page 455
IF Signature	page 456
Common IF Signature Problems	page 462
1 MHz Resolution Bandwidth Problems	page 465
30 kHz Resolution Bandwidth Problems	page 466
3 kHz and 10 kHz Resolution Bandwidth Problems ...	page 467
Step Gains	page 468
Cal Oscillator (P/O A4 Assembly)	page 469

Cal Oscillator Unlock at Beginning of IF Adjust	page 470
Inadequate CAL OSC AMP TD Range	page 471
300 Hz to 3 kHz Resolution Bandwidth Out of Specification ..	page 472
Low-Pass Filter	page 478
Sweep Generator	page 479
AM/FM Demodulation, Audio Amplifier, and Speaker	page 479

Troubleshooting Using the Diagnostic Software

NOTE

Whenever the software program says "Connect the 8566 to", just about any spectrum analyzer with GPIB will work. However, an 8566B or 8563E is recommended for speed of measurement. (The 8562A and 8560A-Series spectrum analyzers are much slower when using the diagnostics program.)

For required hardware and instructions on how to load the 8564E/8565E adjustment/diagnostic software, refer to [Chapter 2](#), "Adjustment/Diagnostic Software." The diagnostic software can be used to quickly isolate a number of common problems that might cause the spectrum analyzer to fail. Carefully follow the instructions displayed by the software program.

Figure 9-1 A4 and A5 Test Connectors

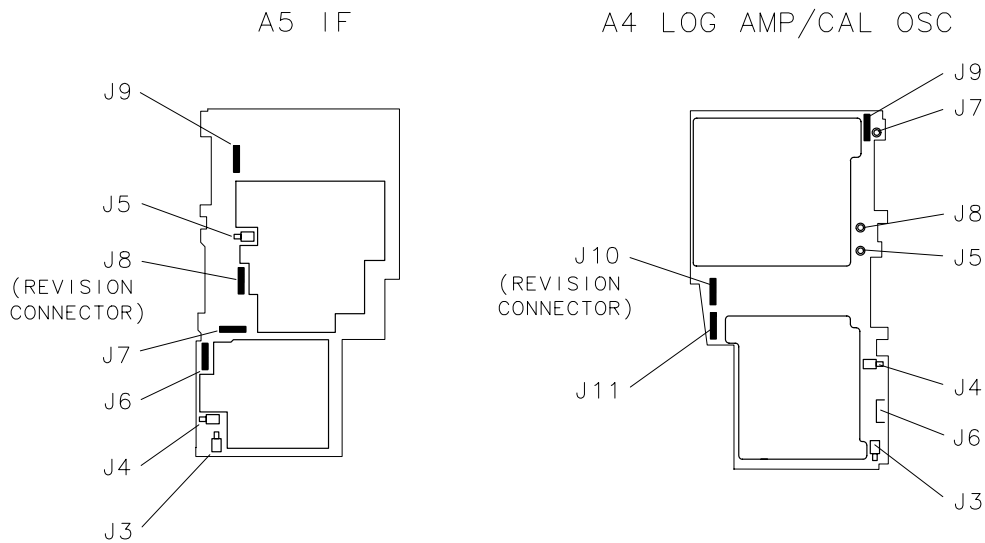

sp168e

Figure 9-2 A4 and A5 Test Connector Pin Locations

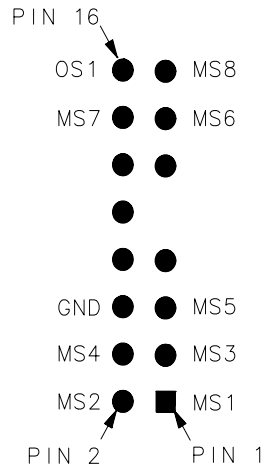

sz144e

NOTE

Because the cal oscillator circuitry on the A4 assembly is such an integral part of the IF adjustment, always check this assembly first, before checking the rest of the IF Section. A faulty cal oscillator can cause many apparent "faults" in the rest of the IF Section.

Troubleshooting the Cal Oscillator on A4 Using Diagnostic Software

1. From the 8564E/8565E adjustment/diagnostic software menu, select "CAL Oscillator Control."
2. Set the 8564E/EC or 8565E/EC to external trigger and press **SGL SWP**, **CAL**, and **IF ADJ OFF**.
3. Using a second spectrum analyzer, look at the output of the cal oscillator at A4J8. Set the second spectrum analyzer to external trigger (positive-edge) and use the signal at A4U104 pin 2, with ground connection at A4U104 pin 10, to externally trigger the second spectrum analyzer. (A 20-pin IC clip is recommended to avoid inadvertently shorting pins together on A4U104.)
4. Select cw frequencies of 9.9 MHz, 10.7 MHz, and 11.5 MHz in the diagnostic software menu. The amplitude should be -35 dBm at each frequency.
5. Select the 20 kHz sweep width in the software menu. The display on the second spectrum analyzer should be similar to that shown in [Figure 9-3 on page 433](#).

6. Select the 10 kHz sweep width in the software menu. The display on the second spectrum analyzer should be similar to that shown in [Figure 9-4 on page 433](#).
7. Select the 4 kHz sweep width in the software menu. The display on the second spectrum analyzer should be similar to that shown in [Figure 9-5 on page 434](#).
8. Select the 2 kHz sweep width in the software menu. The display on the second spectrum analyzer should be similar to that shown in [Figure 9-6 on page 434](#).
9. If the cal oscillator is not sweeping, check the output of the sweep generator circuit (A4U804 pin 8 of function block Z). A series of negative-going parabolas should occur. Frequency and amplitude vary, depending on the sweep width chosen. [Table 9-1](#) lists the RANGE, MA0, and MA1 values for the sweep widths.

Table 9-1**Sweep Width Settings**

Sweep Width	Sweep Time	Res BW Adjusted	RANGE A4U105 Pin 6	MA1 A4U105 Pin 2	MA0 A4U105 Pin 5
20 kHz	5 ms	10 kHz	+5 V	0 V	0 V
10 kHz	10 ms	3 kHz	+5 V	0 V	+5 V
4 kHz	30 ms	1 kHz	+5 V	+5 V	0 V
2 kHz	15 ms	300 Hz	+5 V	+5 V	+5 V

Figure 9-3 CAL Oscillator Swept Output, 20 kHz Width

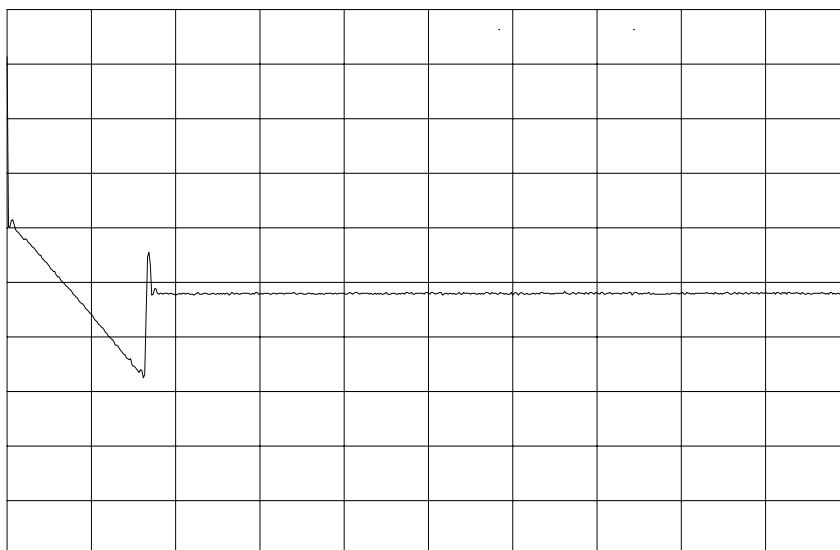

Figure 9-4 CAL Oscillator Swept Output, 10 kHz Width

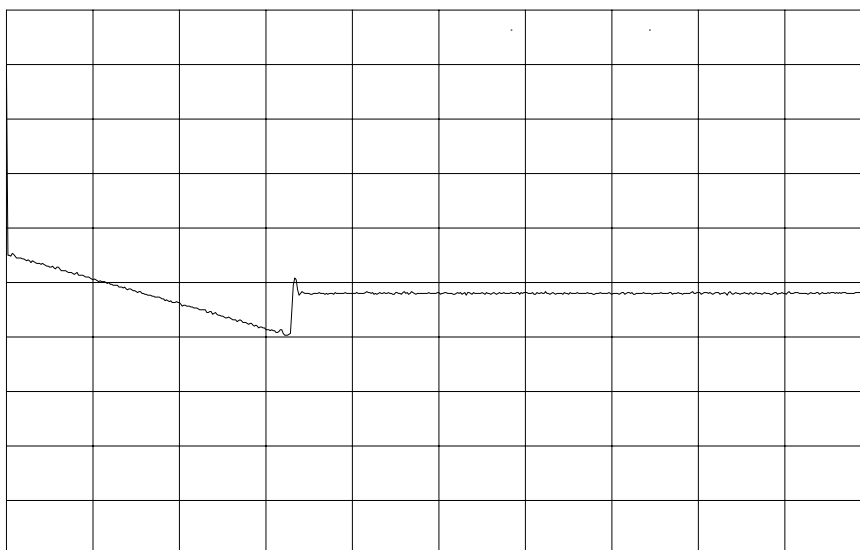

Figure 9-5 CAL Oscillator Swept Output, 4 kHz Width

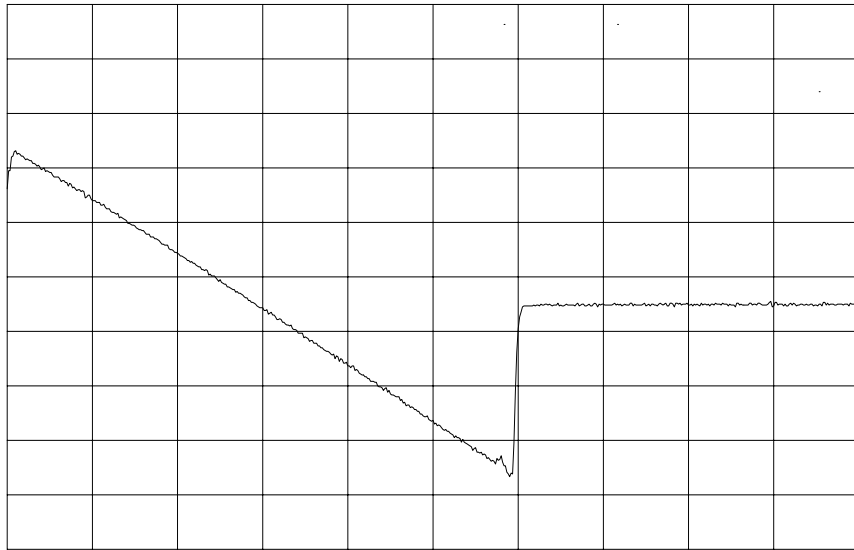
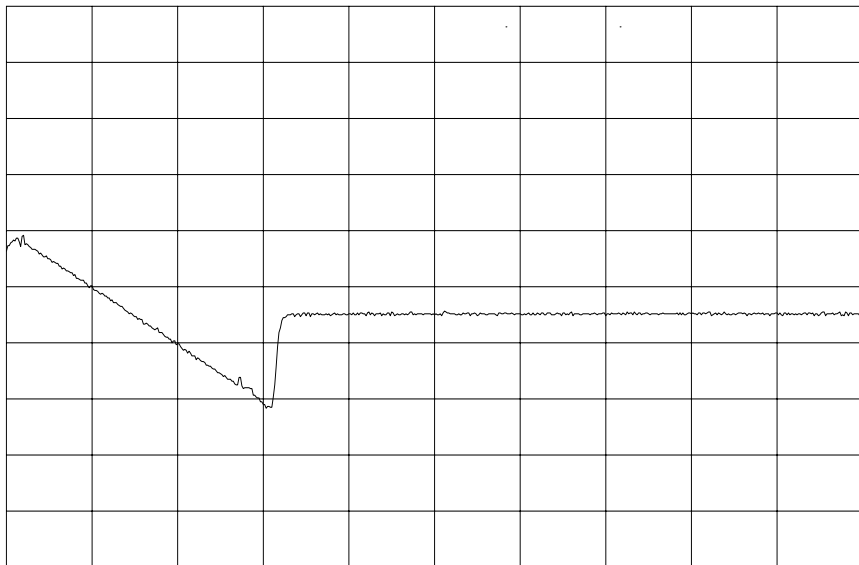

Figure 9-6 CAL Oscillator Swept Output, 2 kHz Width



Troubleshooting A5 Using Diagnostic Software

The IF diagnostics in the software include:

- DC probe (using the TAM)
- Gain checks
- LC frequency checks
- Xtal frequency checks

DC Probe

Using the up/down arrow, select "DC probe" in the IF diagnostics menu. Connect the TAM (Test and Adjustment Module) and use the dc probe as directed by the diagnostic software program. The current into each IF filter or amplifier stage is measured and compared to limits. This helps locate shorted or open components. An asterisk will appear at the points of failure. An @ indicates a measurement error (bad setup, GPIB not responding, test equipment error, or major failure).

NOTE

In the following gain and frequency checks, an 8566B or 8563E is the preferred spectrum analyzer.

Gain Checks

Using the up/down arrow, select "Gain checks" in the IF diagnostics menu. An 3335A synthesizer/level generator is used as a stimulus and a spectrum analyzer is used to measure the response. The gain of each stage is measured and compared to limits. An asterisk will appear at the points of failure. An "@" indicates a measurement error (bad setup, GPIB not responding, test equipment error, or major failure).

LC Frequency Checks

Using the up/down arrow, select "LC frequency checks" in the IF diagnostics menu. An 3335A synthesizer/level generator is used as a stimulus and a spectrum analyzer is used to measure the response. The center frequency tuning range and the bandwidth adjustment range are measured for each pole. The LC pole selection menu allows selection using the up/down arrows. Select "All Poles" first, unless a particular pole is suspected to have failed. An asterisk will appear at the points of failure. An "@" indicates a measurement error (bad setup, GPIB not responding, test equipment error, or major failure).

Xtal Frequency Checks

Using the up/down arrow, select "Xtal frequency checks" in the IF diagnostics menu. An 3335A synthesizer/level generator is used as a stimulus and a spectrum analyzer is used to measure the response. The symmetry adjustment range and the bandwidth adjustment range are measured for each pole. The Xtal pole selection menu allows selection using the up/down arrows. Select "All Poles" first, unless a particular pole is suspected to have failed. An asterisk will appear at the points of failure. An "@" indicates a measurement error (bad setup, GPIB not responding, test equipment error, or major failure).

Figure 9-7 IF Section Troubleshooting Simplified Block Diagram

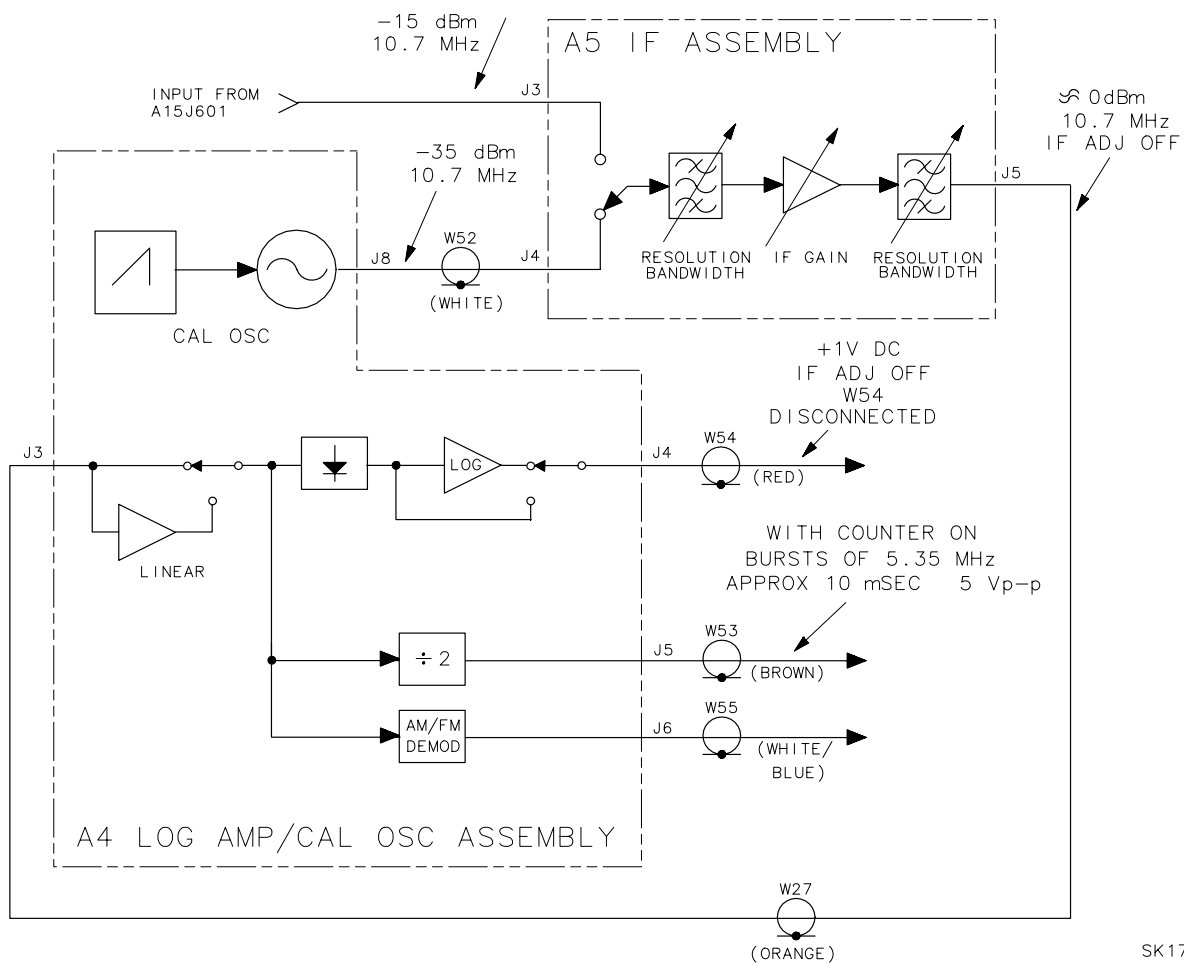

SK171

Automatic IF Adjustment

The 8564E/EC or 8565E/EC spectrum analyzer performs an automatic adjustment of the IF Section whenever needed.

The cal oscillator on the A4 assembly provides a stimulus signal which is routed through the IF during the retrace period.

The A3 Interface assembly measures the response using its analog-to-digital converter (ADC). The 8564E/EC or 8565E/EC spectrum analyzer turns the cal oscillator off during a sweep.

When IF ADJ is ON, the 8564E/EC or 8565E/EC spectrum analyzer readjusts part of the IF circuitry during each retrace period to readjust the IF completely every 5 minutes.

Automatic IF adjustment is performed upon the following conditions:

Power on: (unless **STOP ALIGN** is pressed). The IF parameter variables are initialized to values loaded in program ROM and all possible IF adjustments are made. If **STOP ALIGN** is pressed, the adjustment is halted.

If **REALIGN LO &IF** is selected: All possible IF adjustments (and LO adjustments) are made with the most recent IF parameter variables used as the starting point.

If **FULL IF ADJ** is selected: All possible IF adjustments are made with the most recent IF parameter variables used as the starting point. (**FULL IF ADJ** is located in the **CAL** menu.)

If **ADJ CURR IF STATE** is selected: All amplitude data and some resolution bandwidths are adjusted. The bandwidths adjusted are a function of the currently selected resolution bandwidth setting.

Between sweeps: IF ADJ must be set to ON. When IF ADJ is OFF, an A is displayed along the left side of the graticule.

If a **FULL IF ADJ** sequence cannot proceed beyond the amplitude portion, check the output of the cal oscillator on the A4 assembly as follows:

1. Disconnect cable W52 (coax 9) from A5J4. Connect cable W52 to the input of a second spectrum analyzer.
2. Set the second spectrum analyzer center frequency to 10.7 MHz and the reference level to -30 dBm.
3. On the 8564E/EC or 8565E/EC spectrum analyzer under test, press **FULL IF ADJ** and observe the display of the second spectrum analyzer.
4. If a -35 dBm signal does not appear, the cal oscillator is probably at fault.

Parameters Adjusted

The following IF parameters are adjusted in the sequence listed:

1. Amplitude
 - a. Video Offsets: analog (using log amplifier video offset DAC) and digital (applying stored constant to all readings)
 1. Linear Scale Offset
 2. Log Scale Offset
 1. Wideband and Narrowband modes
 2. 0 to 60 dB range in 10 dB steps
 3. 10 dB/division and 2 dB/division (log expand) modes
 - b. Step Gains (A5 IF Assembly)
 1. First Step Gain for 16 different DAC settings
 2. Second Step Gain for 16 different DAC settings
 3. Third Step Gain for 0, 15, and 30 dB attenuation relative to maximum gain
 4. Fine Attenuator for 32 evenly-spaced DAC settings
 - c. Log Amplifier Slopes and Fidelity
 1. Wideband (RES BW 300 kHz through 2 MHz) and Narrowband modes (RES BW 300 Hz through 100 kHz)
 2. 10 dB/division and 2 dB/division (log expand) modes
 - d. Linear Scale Gains - On the log amplifier assembly (P/O A4)
 - e. Peak Detector Offsets (both Positive and Negative Peak Detectors with respect to normal sample path used by Auto IF Adjust)
2. LC Bandwidths
 - a. 300 kHz resolution bandwidth center frequency, bandwidth, and gain
 - b. 1 MHz resolution bandwidth center frequency, bandwidth, and gain
 - c. 2 MHz resolution bandwidth gain
 - d. 100 kHz resolution bandwidth center frequency, bandwidth, and gain
 - e. 30 kHz resolution bandwidth center frequency, bandwidth, and gain

- f. Gain of all resolution bandwidth relative to the 300 kHz RES BW
3. Crystal Bandwidths
- a. The cal oscillator sweep rate is measured against the 100 kHz resolution bandwidth filter skirt. This result is used in compensating the sweeps used for adjusting the crystal bandwidths.
 - b. 10 kHz resolution bandwidth
 1. Center frequency of LC tank that loads the crystal
 2. Symmetry adjustment to cancel crystal case capacitance.
 3. Bandwidth
 - c. 3 kHz resolution bandwidth: center frequency of LC tank and bandwidth of resolution bandwidth
 - d. 1 kHz resolution bandwidth: bandwidth
 - e. 300 Hz resolution bandwidth: bandwidth
 - f. Gain of all resolution bandwidth relative to the 300 kHz RES BW.
4. Digital Bandwidths (1 Hz through 100 Hz; 10 Hz through 100 Hz if Option 103).
- a. VCXO (final LO) tuned to align digital bandwidths with crystal bandwidth center frequency.
 - b. Overall gain.
 - c. Gain variation with input frequency.

Requirements

For the Automatic IF Adjustment routine to work, the spectrum analyzer must provide the following basic functions:

- Power supplies
- Control signals
- ADC
- 10 MHz frequency reference to the A4 log amp/cal oscillator
- A15 RF assembly isolation from the RF signal during IF adjustment

A15 RF assembly isolation is a function of the REDIR signal in the A15 Flatness Compensation Control block.

The references against which the Automatic IF Adjustment routine aligns are:

- 10 MHz reference (A15)
- Linear scale fidelity, especially the 10 dB gain stage in A4 linear amplifier block
- 15 dB reference attenuator (A5)
- Cal Oscillator output power (A4)

Performance Test Failures

Failures in IF-Section-related performance tests may be investigated using the following information.

IF Gain Uncertainty Performance Test

Failure of this performance test indicates a possible problem with the 8564E/EC or 8565E/EC spectrum analyzer IF gain circuits. Assuming no major IF problems causing IF adjustment errors, IF gain problems in the first 50 dB of IF gain (REF LVLs of 0 dBm to -50 dBm with 10 dB ATTEN) are a result of faults on the A5 IF Assembly. IF gain problems in the next 60 dB of IF gain (REF LVLs of -60 dBm to -110 dBm, 10 dB ATTEN) result from log amplifier faults on the A4 assembly.

A signal level of -5 dBm is required at input (A5J3) for displaying a signal at top screen with 10 dB input attenuation and a 0 dBm reference level.

Isolate IF gain problems on the log amplifier assembly (A4) with the following steps:

1. On the 8564E/EC or 8565E/EC spectrum analyzer, press **PRESET**, **SPAN**, **ZEROSPAN**, **FREQUENCY**, 1 GHz, **AMPLITUDE**, -50 dBm.
2. Press **CAL** and **IF ADJ OFF**.
3. Disconnect cable W27 (coax 3) from A5J5 and connect cable W27 to the output of a signal generator.
4. Set the signal generator controls as follows:
Amplitude +10 dBm
Frequency 10.7 MHz
5. Simultaneously decrease the signal generator output and the 8564E/EC or 8565E/EC spectrum analyzer REF LVL in 10 dB steps. The signal displayed by the spectrum analyzer should remain at the reference level for each step. If the signal deviates from the reference level, troubleshoot the video offset circuitry on the A4 assembly.
6. Repeat steps 1 through 5 with the 8564E/EC or 8565E/EC spectrum analyzer set to linear.

Scale Fidelity Performance Test

Failure of this performance test indicates a possible problem with the A4 assembly:

- If the Linear, 5 dB/div, or 10 dB/div scales are out of specification, the fault is most likely on the log amplifier assembly (P/O A4).
- If only the 1 dB/div or 2 dB/div scales are out of specification, the fault is most likely on the A3 interface assembly.

Resolution Bandwidths Performance Tests

Most resolution bandwidth problems are a result of A5 IF assembly failures. The resolution bandwidths are adjusted in the following sequence using 300 kHz as the reference: 1 MHz, 2 MHz, 100 kHz, 30 kHz, 10 kHz, 3 kHz, 1 kHz, 300 Hz, 100 Hz, 30 Hz, 10 Hz, 3 Hz, and 1 Hz. The 3 Hz and 1 Hz bandwidths are not available with Option 103.

If the IF adjustment routine encountered an error, the previously adjusted resolution bandwidths should be working properly and default DAC values are used for the remaining resolution bandwidth settings.

If the IF bandpass adjustments and the automatic IF adjustments fail to bring the resolution bandwidths within specification, troubleshoot the A5 IF assembly.

Log Amplifier (P/O A4 Assembly)

The log amplifier on the A4 assembly performs several functions. It provides log and linear paths converting the 10.7 MHz IF signal to video. In addition it also provides offset circuitry, AM/FM demodulator circuitry, a frequency counter output, and down conversion of the 10.7 MHz IF to 4.8 kHz for use by the digital IF.

The log amp results are realized by using a wide dynamic range linear detector followed by a video log amp. The detector is used for both linear and log paths and contains a mixer that acts as the down converter mixer for the digital IF.

CAUTION

For troubleshooting, it is recommended that you use an active probe, such as an 85024A, and another spectrum analyzer. If an 1120A active probe is being used with a spectrum analyzer having dc coupled inputs, such as the 8566A/B, 8569A/B and the 8562A/B, either set the active probe for an ac-coupled output or use a dc-blocking capacitor between the active probe and the spectrum analyzer input. Failure to do this can result in damage to the spectrum analyzer or the probe.

Log Amplifier

Refer to function blocks K, L, and AE of A4 Log Amplifier Schematic Diagram (sheets 3 of 4 and 4 of 4) in the *8560 E-Series Spectrum Analyzer Component Level Information*. The log amplifier receives the detected video signal from the Detector/Mixer and outputs a voltage proportional to the log of the input voltage. The linear output is tapped off at the emitter of U501D. U507 provides input offset adjustment capability and adjusts the offset of the op amp formed by U501A, B, C, and D. Q502 is a buffer. Q501 switches in additional offset for digital RBWs. The logarithmic characteristic of the base-emitter junction of U502B is used in the feedback path to produce the logging affect. U502D is used to adjust for non-linearities in the linear mode. R531 is used to adjust log fidelity at the top of the screen.

Use the following steps to verify proper operation of the log amplifier chain:

1. Press **CAL** and **IF ADJ OFF**. Set the digital multimeter to read dc volts and connect the negative lead to the chassis of the 8564E/EC or 8565E/EC spectrum analyzer.
2. Remove W27 from A4J3 and inject a 10.7 MHz signal of +10 dBm into A4J3.
3. Set the 8564E/EC or 8565E/EC spectrum analyzer to log mode, with a resolution bandwidth of 300 kHz and single sweep.

4. Using the DMM, check the voltage at U503 pin 6.
5. Verify that this level is about -700 mV.
6. Adjust the source amplitude to place the signal at the reference level.
7. Reduce the input signal level in 10 dB steps, down to -60 dBm, while noting the voltage displayed on the DMM. The voltage should increase (become less negative) at a rate of 30 mV for each 10 dB decrease in input power. Troubleshoot the A4 assembly if the signal does not decrease properly.
8. Set the 8564E/EC or 8565E/EC spectrum analyzer resolution bandwidth to 100 kHz to place the wide/narrow filter in narrow mode.
9. Repeat steps 2 through 7.
10. If log fidelity is poor near the bottom of the screen or the 1 MHz resolution bandwidth is narrow, a fault might exist in the wide/narrow filter switch. (Refer to function block G of A4 log amplifier schematic diagram in the *8560 E-Series Spectrum Analyzer Component Level Information*.) Check this switch as follows:
 - a. Monitor voltages on A4U302 pins 1 and 7 while changing the 8564E/EC or 8565E/EC spectrum analyzer resolution bandwidth from 100 kHz to 300 kHz.
 - b. If the voltages do not come within a few volts of the +15 V and -15 V supplies, U103 and U302 are suspect.
 - c. Disconnect the digital multimeter and reconnect W27 to A4J3.

Linear Amplifiers

Refer to function block C of A4 log amplifier schematic diagram (sheet 2 of 4) in the *8560 E-Series Spectrum Analyzer Component Level Information*.

The linear amplifiers consist of two variable gain stages, U201C and U201E as well as the buffer amplifier A4U201B, A4U201D, and A4Q201. The linear amplifiers provide 0 to 40 dB of IF gain in 10 dB steps. The gain of A4U201C can be increased by 20 dB by turning on A4CR201 and A4CR210 with the control line LIN_20B. The gain of A4U201E can be increased by either 10 dB or 20 dB with the control lines LIN_10 or LIN_20A respectively. The gain can be selected by setting the reference level of the 8564E/EC or 8565E/EC spectrum analyzer.

Table 9-2 IF Gain Application Guidelines (ATTEN=10 dB)

Power into A4J3	Reference Level	Gain of A4U201C (Pin 8 in; Pin 3 out)	Gain of A4U201E (Pin 3 in; Pin 10 out)	Total Gain
+6 dBm	-50 dBm	0 dB	0 dB	0 dB
-4 dBm	-60 dBm	0 dB	10 dB	10 dB
-14dBm	-70 dBm	0 dB	20 dB	20 dB
-24 dBm	-80 dBm	20 dB	10 dB	30 dB
-34 dBm	-90 dBm	20 dB	20 dB	40 dB

Total gain can be measured by injecting the specified power into A4J3 and measuring the total gain provided by A4U201C and A4U201E. The following procedure provides a means of troubleshooting the linear amplifiers:

1. On the 8564E/EC or 8565E/EC spectrum analyzer, press **PRESET, SPAN, ZERO, SPAN, CAL, IF ADJ OFF, FREQUENCY, 1 GHz, AMPLITUDE, -50 dBm, LINEAR, MORE, AMPTD UNITS, dBm, and AMPLITUDE.**
2. Disconnect W27 (coax 3) from A4J3 and connect the output of a signal generator to A4J3.
3. Set the signal generator controls as follows:
Amplitude +6 dBm
Frequency 10.7 MHz
4. Simultaneously decrease the signal generator output and 8564E/EC or 8565E/EC spectrum analyzer REF LVL in 10 dB steps to -90 dBm. At each step, the signal displayed on the spectrum analyzer should be within one division of the previous position.
5. If a problem exists, isolate it by comparing the actual gain of A4U201C and A4U201E with those listed in the above gain guidelines.
6. Reconnect W27 (coax 3) to A4J3.

Video Offset

Refer to function block P of A4 log amplifier schematic diagram (sheet 3 of 4) in the *8560 E-Series Spectrum Analyzer Component Level Information*.

The circuit provides a programmable video offset, with a step size of 5 mV, from -300 mV to +900 mV.

1. On the 8564E/EC or 8565E/EC spectrum analyzer, press **PRESET**, **SPAN**, **ZERO SPAN**, **FREQUENCY**, 1 GHz, **AMPLITUDE**, -50 dBm, **CAL**, **IF ADJ OFF**.
2. Disconnect W27 (coax 3) from A4J3 and connect a signal generator to A4J3.
3. Set the signal generator controls as follows:

Amplitude	+10 dBm
Frequency	10.7 MHz
4. Simultaneously decrease the signal generator output and 8564E/EC or 8565E/EC spectrum analyzer reference level in 10 dB steps down to -110 dBm. At each step, the signal displayed on the spectrum analyzer should be close to the reference level.
5. Reconnect W27 (coax 3) to A4J3 and cycle the spectrum analyzer power. Press **STOP REALIGN** when it appears.
6. On the 8564E/EC or 8565E/EC spectrum analyzer, press **SWEEP**, **SINGLE**, **CAL**, and **IF ADJ OFF**.
7. The offset DAC, A4U102 pin 2, should now be at its default value of approximately +2.45 V. The voltage at U601 pin 3 should be approximately 0 V for a DAC output of 2.45 V.
8. If this default offset voltage is incorrect, DAC U102 is the most probable cause.

Video Output

1. On the 8564E/EC or 8565E/EC spectrum analyzer, press **PRESET**, **FREQUENCY**, 300 MHz, **SPAN**, 100 Hz, **AMPLITUDE**, -10 dBm, **SGL SWP**, **CAL** and **IF ADJ OFF**.
2. Connect the CAL OUTPUT to the INPUT 50Ω connector.
3. Disconnect W54 (coax 2) from A4J4. Connect a short SMB to SMB cable from A4J4 to an SMB tee and connect W54 to the tee. Connect a test cable from the tee to the input of an oscilloscope.

4. Set the oscilloscope controls as follows:

Amplitude scale	200 mV/div
Offset	+400 mV
Coupling	dc
Sweep time	50 μ s/division
5. The oscilloscope should display a 4.8 kHz sine wave.
6. Disconnect the cable from the CAL OUTPUT and the INPUT 50 Ω connectors.
7. Set the resolution bandwidth to 2 MHz.
8. Broadband noise should be displayed on the oscilloscope from approximately +200 mV to +400 mV.
9. As the **REF LVL** is decreased in 10 dB steps from -10 dBm to -70 dBm, the noise displayed on the oscilloscope should increase in 100 mV increments. If this response is not observed, refer to “[Step Gains](#)” and “[Video Offset](#)”.
10. Reconnect cable W54 to A4J4.

Frequency Counter Prescaler/Conditioner

Refer to function block Q of A4 log amplifier schematic diagram (sheet 4 of 4) in the *8560 E-Series Spectrum Analyzer Component Level Information*.

The frequency counter prescaler/conditioner divides the frequency by two, and then attenuates it. The circuit consists of frequency divider (U703A) and an output attenuator. The frequency divider turns on only when the instrument is counting.

AM/FM Demodulator

Refer to function block R of A4 Log Amplifier Schematic Diagram (sheet 4 of 4) in the *8560 E-Series Spectrum Analyzer Component Level Information*.

The demodulator circuitry on the log amplifier on A4 produces a low-level audio signal. This audio signal is then amplified by the audio amplifier on A4. The FM demodulator demodulates narrowband FM (5 kHz deviation) signals. The detector (block J) demodulates AM signals.

1. If demodulation problems occur when the spectrum analyzer is in the frequency domain, perform the Frequency Span Accuracy performance test and, if necessary, the YTO Adjustments procedure.

2. If an FM signal cannot be demodulated, perform the Demodulator Adjustment procedure. If the output of A4C707 cannot be adjusted as described in the Demodulator Adjustment procedure, troubleshoot the FM Demodulator or Audio MUX circuits on A4.

4.8 kHz IF Filters

Refer to function block N of A4 Log Amplifier Schematic Diagram (sheet 3 of 4) in the *8560 E-Series Spectrum Analyzer Component Level Information*.

Problems with the 4.8 kHz filters can result in spurious signals appearing 2.88 kHz to 3.52 kHz greater than the frequency of the desired response. Also, $ERR\ 536\ RBW < 300$ may occur when problems exist with the 4.8 kHz IF filters.

Measure the passband of the 4.8 kHz IF filters as described in the following procedure:

1. On the 8564E/EC or 8565E/EC spectrum analyzer, press **CAL, IF ADJ OFF, SPAN**, and 600 Hz.
2. Disconnect W27 from A4J3 and inject a 10.7 MHz signal of -20 dBm into A4J3.
3. Fine-tune the frequency of the signal generator to center the signal on the screen. Set the signal generator to sweep one 2 kHz span about this center frequency. Press **SGL SWP** on the 8564E/EC or 8565E/EC spectrum analyzer.
4. Set another spectrum analyzer, such as the 8566A/B, to 4.8 kHz center frequency and 2 kHz span.

CAUTION

If a dc block is not used, damage to the 8566A/B results. The 8566A/B and many other spectrum analyzers have dc-coupled inputs and cannot tolerate dc voltages on their inputs.

5. Connect the VIDEO OUTPUT (rear panel) of the 8564E/EC or 8565E/EC spectrum analyzer through a 20 dB attenuator and dc block to the input of the 8566A/B. Set the sweep time of the 8566A/B to 10 seconds.
6. Set the 8566A/B to single trigger and press TRACE A **CLEAR-WRITE**. Trigger a sweep of the 8566A/B and the signal generator simultaneously. The 8566A/B shows the passband of the 4.8 kHz IF filters. The 3 dB bandwidth of the filters should be 1.2 kHz. The passband of the filters should be flat within 2 dB over 800 Hz.
7. Reconnect W27 (coax 3) to A4J3.

10.7 MHz IF Filters

1. Press **PRESET**, **FREQUENCY**, 300 MHz, **SPAN**, 600 Hz, **CAL**, and **IF ADJ OFF**.
2. Disconnect W29 (coax 7) from A5J3. Set the signal generator for a 10.7 MHz signal at -50 dBm and connect it to A5J3.
3. Fine tune the frequency of the signal generator to center the signal on the 8564E/EC or 8565E/EC spectrum analyzer display. Set the signal generator to sweep one 2 kHz span about this center frequency.
4. On the 8564E/EC or 8565E/EC spectrum analyzer, press **SGL SWP**.
5. Disconnect W27 (coax 3) from A5J5. Connect a test cable from A5J5 to the input of an 8566A/B.
6. Set the 8566A/B as follows:

Center frequency	10.7 MHz
Span	2 kHz
Reference level	+10 dBm
Sweep	Single
7. Press **TRACE A CLEAR-WRITE** on the 8566A/B.
8. Trigger a sweep on the signal generator and on the 8566A/B simultaneously. The 8566A/B should display a 3 dB bandwidth of approximately 500 Hz.
9. Reconnect W27 (coax 3) to A5J5 and W29 (coax 7) to A5J3.

4.8 kHz and 10.7 MHz IF Filters

1. On the 8564E/EC or 8565E/EC spectrum analyzer, press **PRESET**, **FREQUENCY**, 300 MHz, **SPAN**, 600 Hz, **CAL**, and **IF ADJ OFF**.
2. Disconnect W29 (coax 7) from A5J3. Set the signal generator for a 10.7 MHz signal at -60 dBm and connect it to A5J3.
3. Fine tune the frequency of the signal generator to center the signal on the 8564E/EC or 8565E/EC spectrum analyzer display. Set the signal generator to sweep one 2 kHz span about this center frequency.
4. On the 8564E/EC or 8565E/EC spectrum analyzer, press **SGL SWP**.

CAUTION

Damage to the 8566A/B results if a dc block is not used. The 8566A/B and many other spectrum analyzers have dc-coupled inputs and cannot tolerate dc voltages on their inputs.

5. Set the 8566A/B to 4.8 kHz center frequency and 2 kHz span.
6. Connect the VIDEO OUTPUT (rear panel) of the 8564E/EC or 8565E/EC spectrum analyzer through a 20 dB attenuator and dc block to the input of the 8566A/B. Set the sweep time of the 8566A/B to 10 seconds.
7. Set the 8566A/B to single trigger and press TRACE A **CLEAR-WRITE**. Trigger a sweep on the 8566A/B and on the signal generator simultaneously. The 8566A/B should show a 3 dB bandwidth of 600 Hz \pm 100 Hz.
8. Reconnect W29 (coax 7) to A5J3.

10.6952 MHz VCXO

Refer to function block E of A4 log amplifier schematic diagram (sheet 2 of 4) in the *8560 E-Series Spectrum Analyzer Component Level Information*.

The purpose of the 10.6952 MHz voltage-controlled crystal oscillator (VCXO) is to provide an LO for down-converting the peak of the 10.7 MHz IF filter passband to 4.8 kHz. Since the peak of the passband of the 10.7 MHz IF filters is 10.7 MHz \pm 300 Hz, the frequency of the VCXO is between 10.6949 MHz and 10.6955 MHz. This frequency can best be measured at the collector of A4Q202.

The center frequency of the 300 Hz resolution-bandwidth filters and the 1 Hz to 100 Hz filters should differ no more than 10 Hz. If the center frequency is different by more than this, or if no signal is present in the 1 Hz to 100 Hz resolution-bandwidth settings, troubleshoot the 10.6952 MHz VCXO.

Error message ERR 539 may occur if the VCXO is not oscillating. If problems exist with the VCXO control voltage, error messages ERR 536 or ERR 530 may occur.

Between sweeps the VCXO, at times, is turned off. To prevent the oscillator from turning off, press **PRESET**, **FREQUENCY**, **0.3 GHz**, **SPAN**, **1 kHz**, **SGL SWP**, **CAL**, and **IF ADJ OFF**.

Input Switch

Refer to function block D of A4 Log Amplifier Schematic Diagram (sheet 2 of 4) in the *8560 E-Series Spectrum Analyzer Component Level Information*.

The input switch switches between log and linear modes. In addition it contains a 20 dB attenuator which is used only in digital resolution bandwidth settings. CR207, CR208, and CR209 form the input switch. CR205 and CR206 switch in R234 when in linear mode to maintain a constant impedance at J3. CR210, CR211, CR212, and CR221 switch the 20 dB attenuator in and out.

LO Switch

Refer to function block F of A4 log amplifier schematic diagram (sheet 2 of 4) in the *8560 E-Series Spectrum Analyzer Component Level Information*.

The LO switch switches the limiter input between the 10.7 MHz path or the 10.6952 MHz VCXO path.

Synchronous Detector

A wide dynamic range linear detector is realized by the limiter (block G), the isolation amplifier (block H), the LO amplifier (block I), and the detector/mixer (block J). The combination of these circuits form what is commonly known as a synchronous detector.

The input signal is split between two paths. One path flows through the isolation amplifier and the other path flows through the limiter and LO amplifier. The path flowing through the limiter generates the LO for the detector/mixer block. The path through the isolation amplifier drives the RF port.

To troubleshoot this group of circuits set the RBW to 300 kHz. Inject 10.7 MHz at +6 dBm into J3. Probe the gate of A4Q404 or A4Q405 with a scope. Look for a 0 to -3 V square wave. Decrease the input power from +6 dBm to -84 dBm in 10 dB steps. The square wave signal should remain unchanged. It is normal for the phase of the signal to jitter at the lowest signal levels.

The signals at the gates of A4Q404 and A4Q405 should be 180 degrees out of phase from each other. If they are not 180 degrees out of phase or one of the signals are not present, troubleshoot the LO Amplifier or the FETs in the mixer. If the signal is not a symmetrical square wave, troubleshoot the LO amplifier. If the signal drops out prematurely or is not present at all, troubleshoot the limiter or LO amplifier.

Repeat the procedure for an $RBW \leq 100$ kHz. If the log amplifier works in the 300 kHz RBW but not in the narrower RBWs, troubleshoot the log narrow filter in the limiter or isolation amplifier. A4CR302 and A4CR303 are varactor diodes in the limiter filter and are used to tune the filter.

Limiter

Refer to function block G of A4 log amplifier schematic diagram (sheet 2 of 4) in the *8560 E-Series Spectrum Analyzer Component Level Information*.

The limiter consists of 7 identical 20 dB gain stages. A "log narrow filter" is switched in for RBWs ≤ 100 kHz. This filter is switched in using the control lines NARROW between the 4th and 5th stages. During normal operation, the limiter serves to amplify even the smallest 10.7 MHz signals up to a level sufficient to drive the LO Amplifier and subsequent detector/mixer. This signal serves as the LO for the mixer circuitry.

Isolation Amplifier

Refer to function block H of A4 log amplifier schematic diagram (sheet 3 of 4) in the *8560 E-Series Spectrum Analyzer Component Level Information*.

The isolation amplifier prevents LO port to RF port feedthrough in the mixer from feeding back to the input of the limiter and causing loop oscillations. In addition, the isolation amplifier matches the phase of the non-limited signal path to the phase of the limited signal path. The isolation amplifier should have a gain of about 4 dB and also has a "log narrow filter" that is switched with the control line NARROWB.

Detector/Mixer

Refer to function block J of A4 log amplifier schematic diagram (sheet 3 of 4) in the *8560 E-Series Spectrum Analyzer Component Level Information*.

Sum and difference frequencies are produced in the Detector/Mixer. The difference frequency produces video (dc to approximately 3 MHz), since the two signals are at the same frequency. During digital resolution bandwidths the two signals are separated by about 4.8 kHz.

Log Offset/Gain Compensation

Refer to function blocks L and M of A4 log amplifier schematic diagram (sheet 3 of 4) in the *8560 E-Series Spectrum Analyzer Component Level Information*.

Log Offset Compensation

The gain of A4U503 is set to unity, with A4R539 and A4R540 combining for a gain of 0.5. Therefore, the gain from A4U503 pin 3 to A4U508 pin 3 should be 0.5.

Log Gain Compensation

The gain of A4U508 is nominally 6.8, measuring from pin 3 to pin 8. To check the log offset/gain compensation circuits inject a +10 dBm signal into J3 with the 8564E/EC or 8565E/EC spectrum analyzer set to log mode. Measure A4U503 pin 3, $V_{in}(1)$ and A4U508 pin 3, $V_{out}(1)$ and record the results. Decrease the input level to -40 dBm and make the same measurements recording $V_{in}(2)$ and $V_{out}(2)$.

The gain is then:

$$\frac{(V_{OUT}(1) - V_{OUT}(2))}{(V_{IN}(1) - V_{IN}(2))}$$

This gives an offset-independent gain measurement.

Video MUX

The video MUX switches the video output between linear, log and 4.8 kHz IF (for digital RBWs). The demod video is an unused feature. The easiest way to troubleshoot this circuit is to look for blown FETs. Bad FETs are characterized by having significant gate current. Only one of the signal lines LIN_VIDEO, IF_VIDEO or LOG_VIDEO should be high (+15 V) at any given time. The others should be low (-15 V). Also look for a voltage drop of several volts across the gate resistors R601, R605, R609, or R613 when in either the off or on state. This indicates gate current and thus a bad FET.

A5 IF Assembly

The input switch connects the IF to either the cal oscillator on the A4 assembly or the 10.7 MHz IF output from the A15 RF assembly. The automatic IF adjustment uses the cal oscillator on A4 at instrument turn-on and between sweeps to align the IF filters and step-gain amplifiers. During sweeps the input switch selects the 10.7 MHz IF output from A15. The LC filters are variable-bandwidth filters that provide resolution bandwidths from 30 kHz to 2 MHz. The automatic IF adjustment sets the bandwidths and center frequencies of each filter stage.

The crystal filters are variable-bandwidth filters that provide resolution bandwidths from 300 Hz to 10 kHz. The automatic IF adjustment sets the filter bandwidths and symmetry.

The step-gain amplifiers consist of the first step-gain stage, second step-gain stage, and third step-gain stage. These amplifiers provide gain when the 8564E/EC or 8565E/EC spectrum analyzer reference level is changed. The amplifiers also provide gain range to compensate for variations in the IF filter gains, which change with bandwidth and environmental conditions, and band conversion loss in the front end. Fixed-gain amplifiers shift the signal levels to lower the noise of the IF chain.

The assembly has two variable attenuators. The fine attenuator provides the 0.1 dB reference level steps. The reference 15 dB attenuator provides a reference for automatic adjustment of the step-gain amplifiers and the log amplifier. The reference 15 dB attenuator also provides gain for changes in spectrum analyzer reference level.

Various buffer amplifiers provide a high-input impedance to prevent loading of the previous filter pole and a low-output impedance to drive the next filter pole.

Digital control signals from the W2 control cable, the "analog bus," drive the control circuitry. At the beginning of each sweep the analog bus sets each control line for instrument operation. At the end of each sweep the analog bus sets each control line for the next portion of the automatic IF adjustment routine. IF adjustments continuously remove the effects of component drift as the spectrum analyzer temperature changes.

The assembly contains a reference limiting amplifier. This amplifier provides a known amount of limiting for the automatic IF adjustment routines. (Limiting occurs only during the automatic IF adjustment routines.) The LC34_Short switches are open during sweeps. The current in the reference limiter is increased during sweeps to prevent limiting.

CAUTION For troubleshooting, it is recommended that you use an active probe, such as an 85024A, and another spectrum analyzer. If an 1120A active probe is being used with a spectrum analyzer having dc-coupled inputs, such as the 8566A/B, 8569A/B and the 8562A/B, either set the active probe for an ac-coupled output or use a dc-blocking capacitor between the active probe and the spectrum analyzer input.

CAUTION Do not short control voltages to ground. These voltages are not short-circuit protected. DACs damaged by shorting these voltages might not fail until several weeks after the shorting takes place.

Do not short power supply voltages to ground. The 8564E/EC or 8565E/EC spectrum analyzer power supply current limiting cannot protect the resistors in series with the power supply.

NOTE Some transistors have collectors connected to the case. Electrical connection of the case to the collector might not be reliable, making collector voltage measurements on the transistor case unreliable.

IF Signature

1. Disconnect W27 (coax 3) from A5J5.
2. Connect an SMB tee to A5J5, using a short coaxial cable with SMB connectors.
3. Connect one output of the tee to cable W27 (coax 3).
4. Connect an 85024A active probe, with a 10:1 divider installed, to the other output of the tee.
5. Connect the output (type N connector) of the active probe to the input of the 8566A/B spectrum analyzer.
6. Connect the probe power cable to the 8564E/EC or 8565E/EC spectrum analyzer front panel PROBE POWER connector (you may need to use a probe power extension cable, 10131B).

7. Set the 8566A/B controls as follows:

Reference level +10 dBm
Center frequency 10.7 MHz
Span 0 Hz
Resolution bandwidth 300 kHz
Video bandwidth 300 kHz
Sweep time 5.5 s
Trigger Single

8. On the 8566A/B, press **SHIFT**, (trace A blank) to set detector to **SAMPLE** mode.

9. On the 8564E/EC or 8565E/EC spectrum analyzer, press **PRESET** and set the controls as follows:

Center frequency 300 MHz
Span 5 MHz

10. On the 8564E/EC or 8565E/EC spectrum analyzer, press **SGL SWP** and **CAL**.

11. Simultaneously press **SINGLE** on the 8566A/B and **ADJ CURR IF STATE** on the 8564E/EC or 8565E/EC spectrum analyzer. The IF signature is displayed on the 8566A/B display. It may be necessary to experiment with different time intervals between initiating the sweep on the 8566A/B and initiating the current IF state adjustment on the 8564E/EC or 8565E/EC spectrum analyzer.

12. Compare the IF signature to the signature of a properly operating spectrum analyzer illustrated in [Figure 9-8 on page 458](#). If the signatures do not closely resemble each other, a more detailed view of the signature may show the failed hardware.

a. Set the 8566A/B controls as follows:

Sweep time 550 ms
dB/division 5 dB
Reference level -5 dBm

- b. Press **SINGLE** on the 8566A/B and, a very short time later, press **ADJ CURR IF STATE** on 8564E/EC or 8565E/EC spectrum analyzer. [Figure 9-9 on page 459](#) through [Figure 9-13 on page 461](#) illustrate detailed IF signatures of a properly operating 8564E/EC or 8565E/EC spectrum analyzer. It may be necessary to experiment with different time intervals between initiating the sweep on the 8566A/B and initiating the current IF state adjustment on the 8564E/EC or 8565E/EC spectrum analyzer to obtain the waveforms shown. Note the changes in the 8566A/B video bandwidth and sweep time.

13.Reconnect W27 (coax 3) to A5J5.

Figure 9-8 IF Adjust Signature

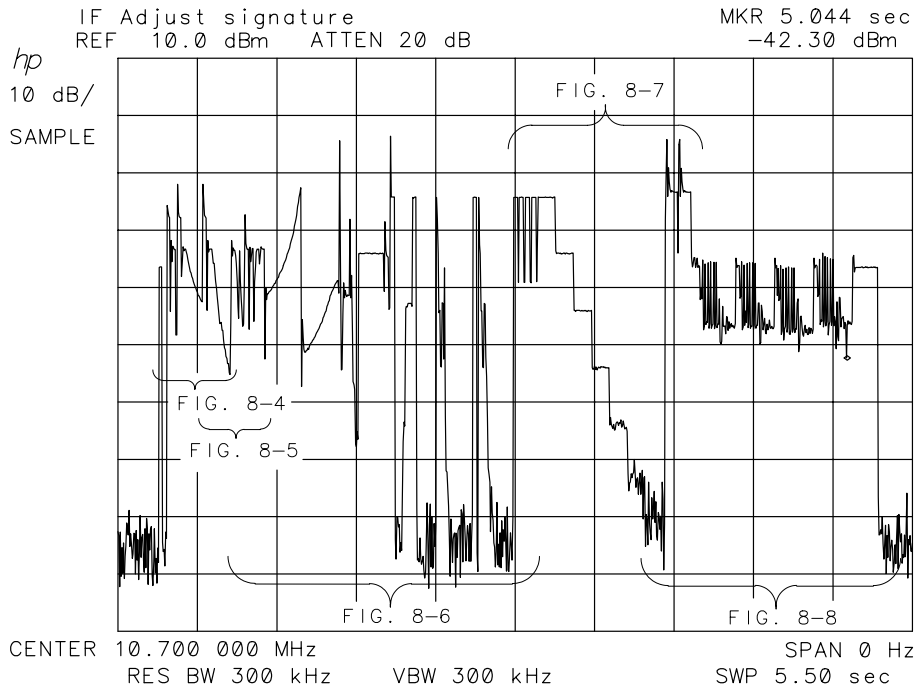

sp143e

Figure 9-9 Detailed IF Adjust Signature (1)

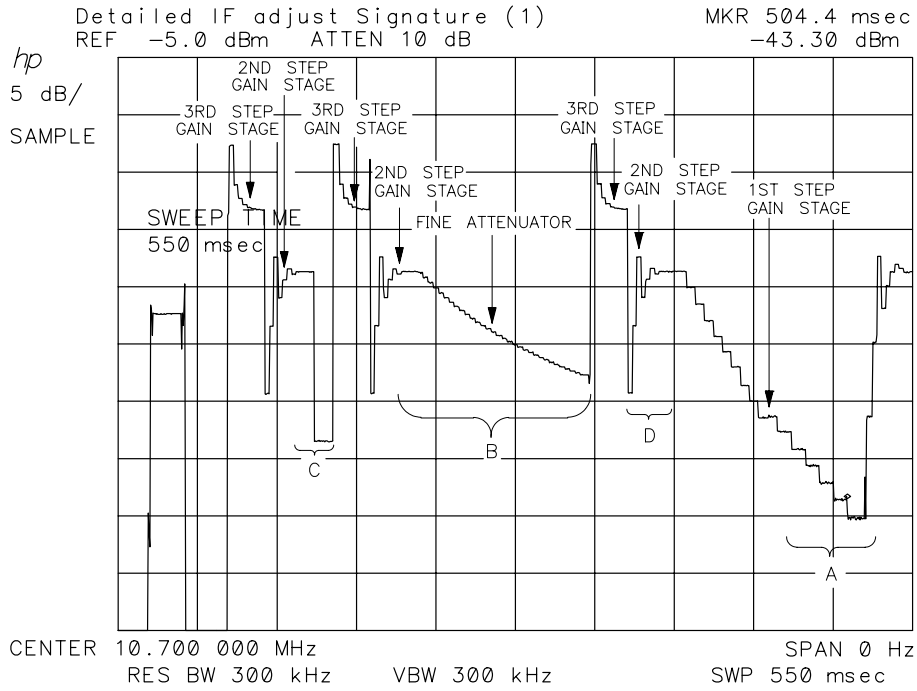

sp144e

Figure 9-10 Detailed IF Adjust Signature (2)

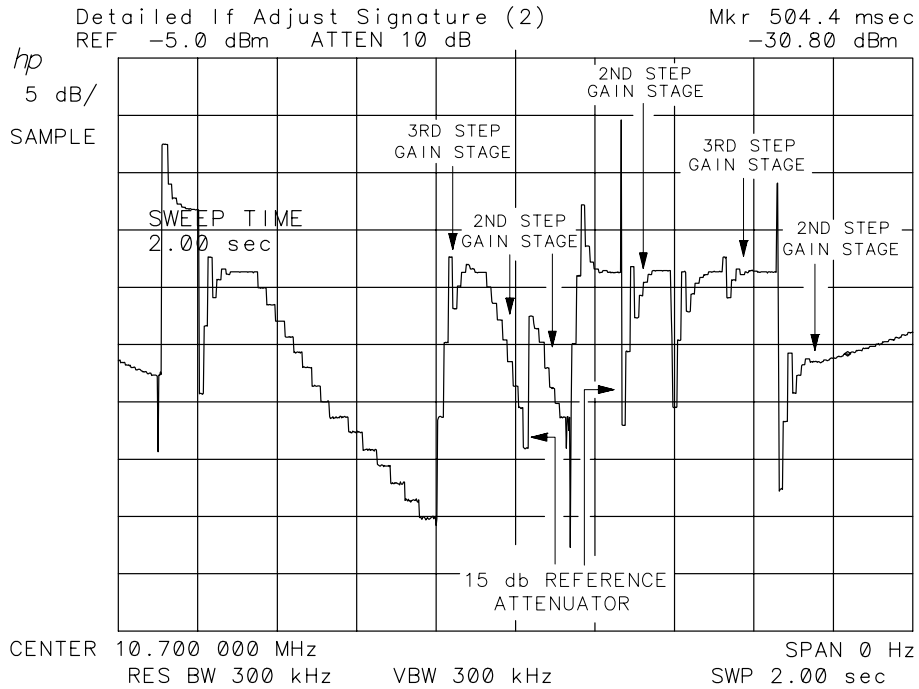

sp145e

Figure 9-11 Detailed IF Adjust Signature (3)

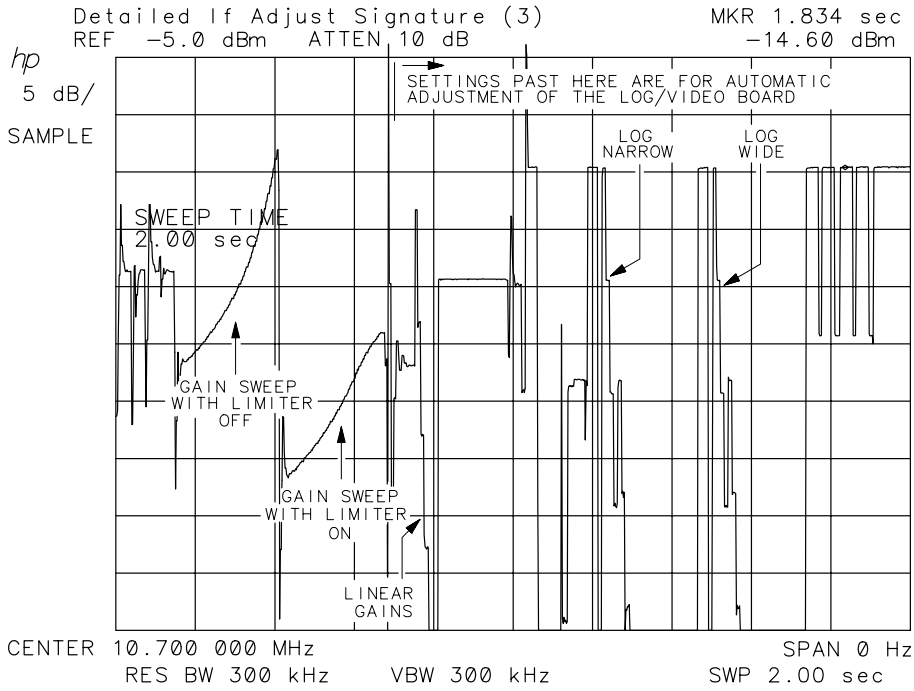

sp146e

Figure 9-12 Detailed IF Adjust Signature (4)

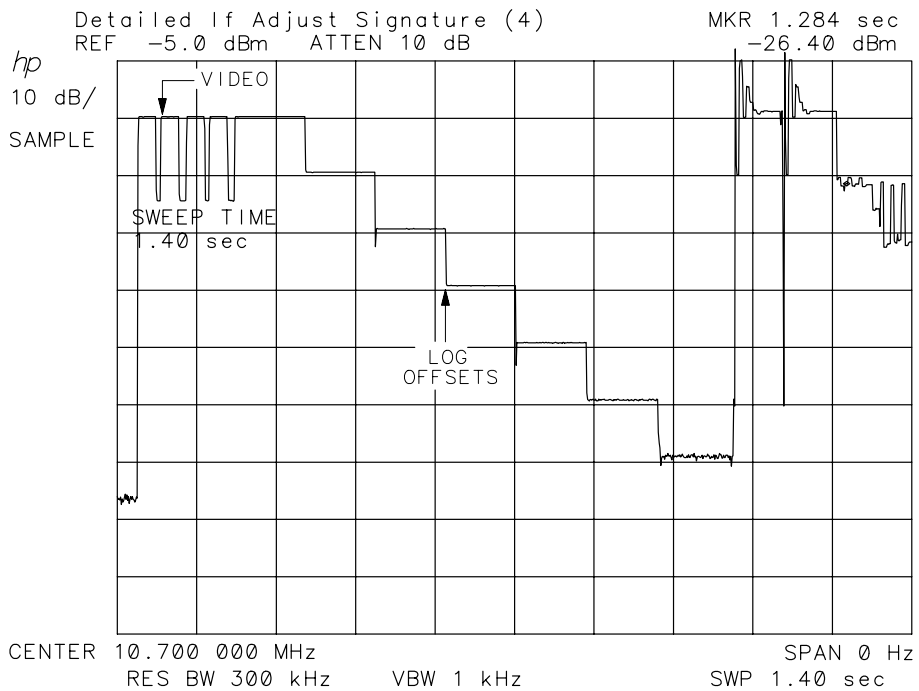

sp147e

Figure 9-13 Detailed IF Adjust Signature (5)

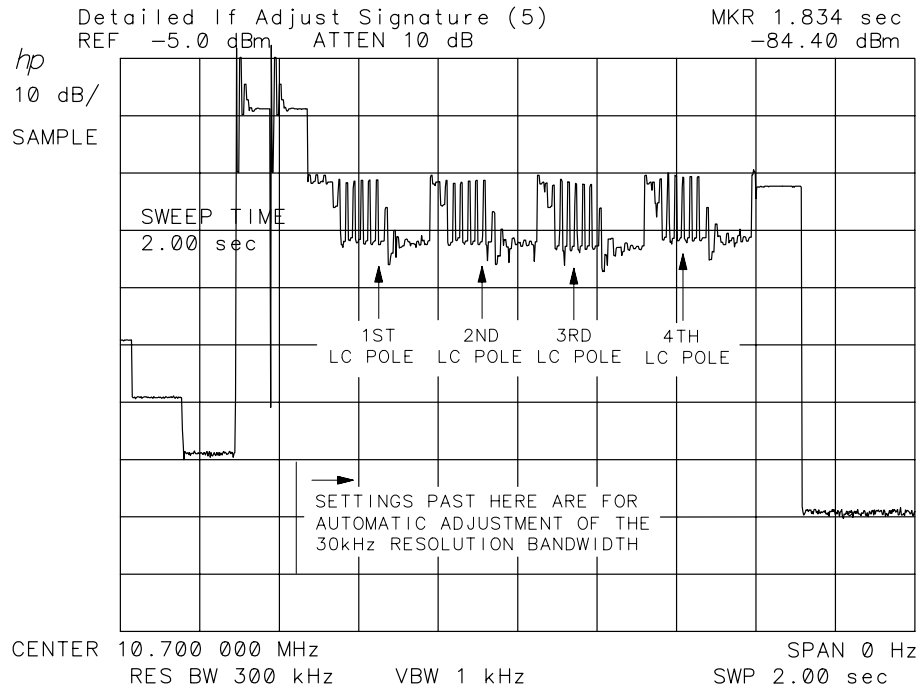

sp148e

Common IF Signature Problems

Region A of Figure 9-9, “Detailed IF Adjust Signature (1)” is noisy:

Suspect the first LC pole.

Region B of Figure 9-9 on page 459 is flat:

Suspect the third step-gain stage, the fine attenuator, or the fourth LC-pole output amplifier.

Region C of Figure 9-9, “Detailed IF Adjust Signature (1)” has no 15 dB step:

Suspect the reference 15 dB attenuator.

Region D of Figure 9-9 on page 459 is flat:

Suspect the second step-gain stage.

Entire signature noisy:

If the signature resembles Figure 9-14 on page 463, suspect a broken first step-gain stage or a break in the signal path in the input switch, first crystal pole, or second crystal pole.

Correct shape but noisy:

If the signature resembles Figure 9-15, “Noise with Correct Shape” suspect the second crystal-pole output amplifier.

Amplitude of Region B of Figure 9-16, “Region B Amplitude Variation” varies more than 12 dB:

Suspect the third step-gain stage output amplifier.

Region B of Figure 9-17, “Region B Amplitude Offset” is kinked:

Suspect the fourth LC-pole output amplifier.

Figure 9-14 **Noisy Signature**

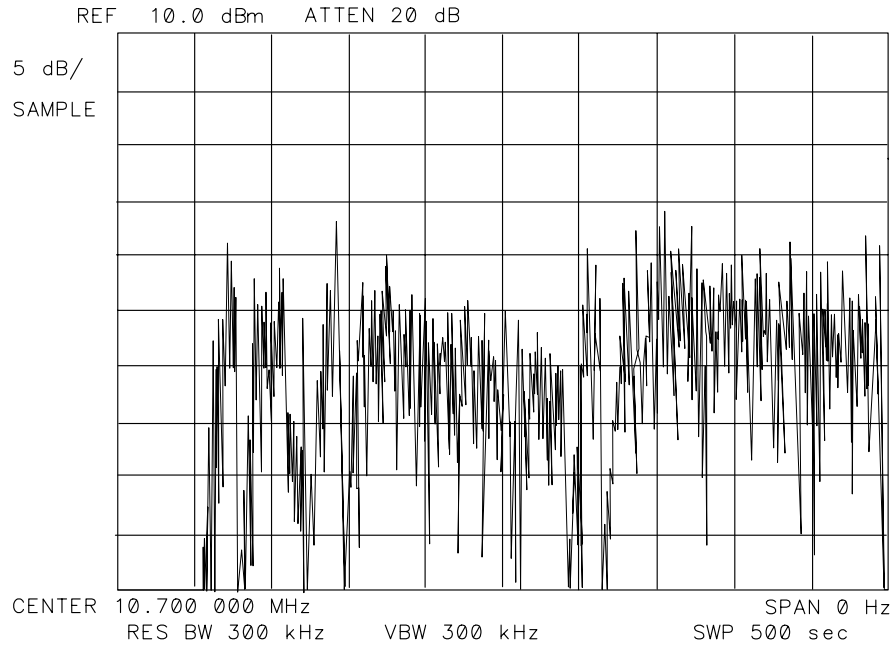

SK178

Figure 9-15 **Noise with Correct Shape**

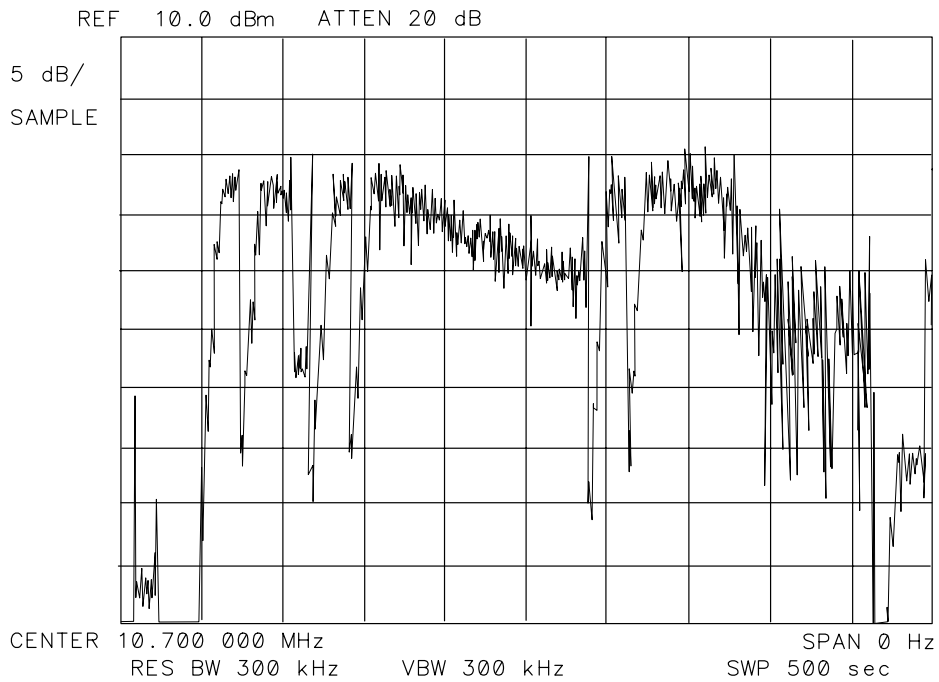

SK179

Figure 9-16 Region B Amplitude Variation

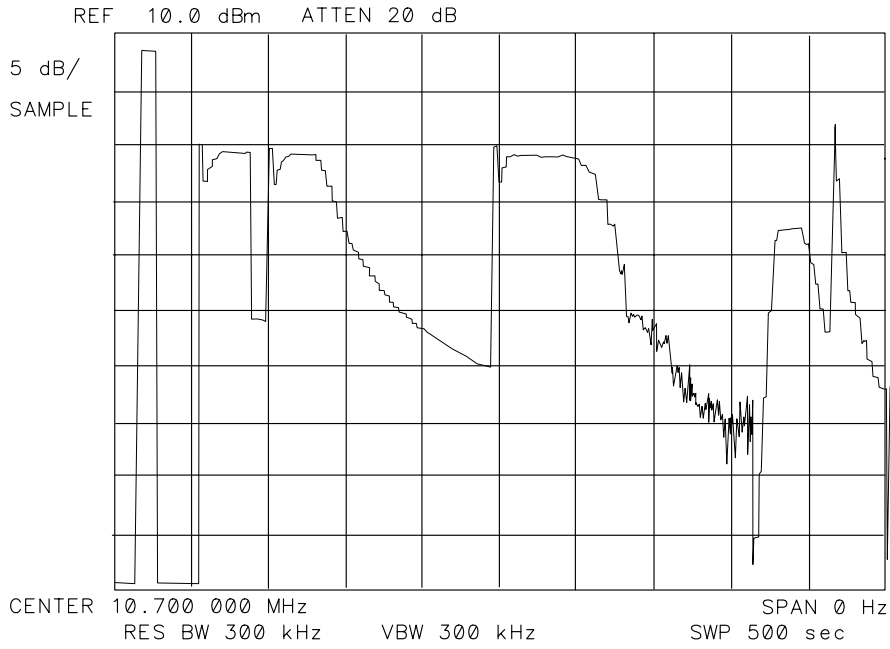

SK180

Figure 9-17 Region B Amplitude Offset

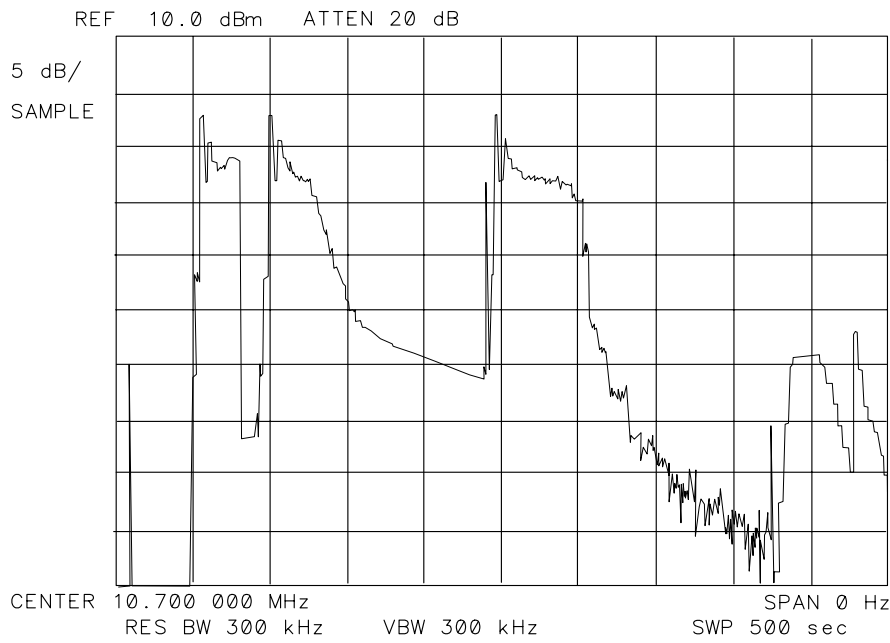

SK181

1 MHz Resolution Bandwidth Problems

Check the crystal shorting switches as follows:

1. On the 8564E/EC or 8565E/EC spectrum analyzer, press **PRESET** and set the controls as follows:

Resolution bandwidth	1 MHz
Span	500 kHz
Center frequency	300 MHz
2. On the 8564E/EC or 8565E/EC spectrum analyzer, connect the 300 MHz CAL OUTPUT to the INPUT 50Ω
3. If the trace flatness is not within 2.5 dB, a failure probably exists.
4. A trace similar to [Figure 9-18 on page 465](#) indicates a crystal short failure.
5. Press **SPAN** to set the spectrum analyzer to 3 MHz. A trace that slopes across the screen (see [Figure 9-19, "Faulty LC Pole"](#)) indicates a failed LC pole. To isolate the broken pole refer to the shape factor information in ["30 kHz Resolution Bandwidth Problems."](#)

Figure 9-18 **Faulty Crystal Short**

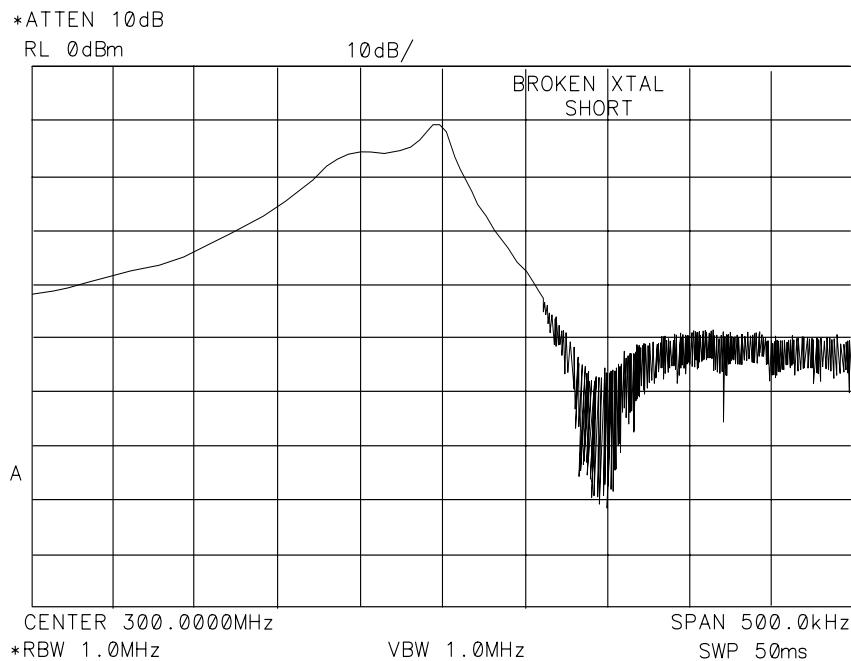

SK182

Figure 9-19 **Faulty LC Pole**

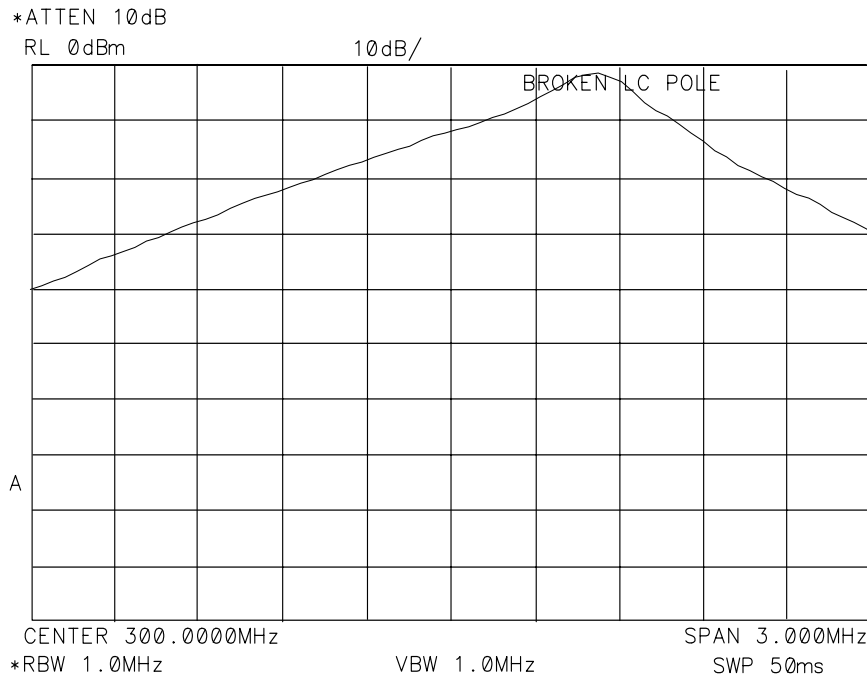

SK183

30 kHz Resolution Bandwidth Problems

Shape factor too high: Shape factor is the ratio of the 60 dB bandwidth to the 3 dB bandwidth. Shape factor should be less than 15:1. If one of the LC poles malfunctions, the shape factor may be the only indication of the failure. Isolate the non-functioning pole with the IF signature.

Region E of [Figure 9-13 on page 461](#) illustrates the four LC-pole adjustments. Take several signatures to examine the LC-pole adjustments. If one of the four sections of Region E is consistently longer than the others, the corresponding LC pole is faulty.

IF gain compression: FET transistors Q301, Q303, Q700, and Q701 can deteriorate with age. Measuring less than 0 volts on the FET source indicates a bad FET.

Bandwidth too wide: Check for contamination on the printed-circuit board. Clean the board as required.

3 kHz and 10 kHz Resolution Bandwidth Problems

Asymmetric Filter Response: Check the crystal symmetry control with the following steps:

1. Press **PRESET**.
2. Set the 8564E/EC or 8565E/EC spectrum analyzer controls as follows:
 - Resolution bandwidth 3 kHz
 - Span 100 kHz
 - Center frequency 300 MHz
3. On the 8564E/EC or 8565E/EC spectrum analyzer, connect the 300 MHz CAL OUTPUT to the INPUT 50Ω .
4. A trace similar to [Figure 9-20, “Faulty Crystal Symmetry”](#) indicates a failed crystal-symmetry circuit.

Narrow 10 kHz resolution bandwidth: Check for printed-circuit board contamination. Clean the board as required.

IF Gain Compression in 10 kHz resolution bandwidth: FET transistors Q202, Q203, Q501, and Q503 can deteriorate with age. Measuring less than 0 volts on the FET source indicates a bad FET.

Figure 9-20 **Faulty Crystal Symmetry**

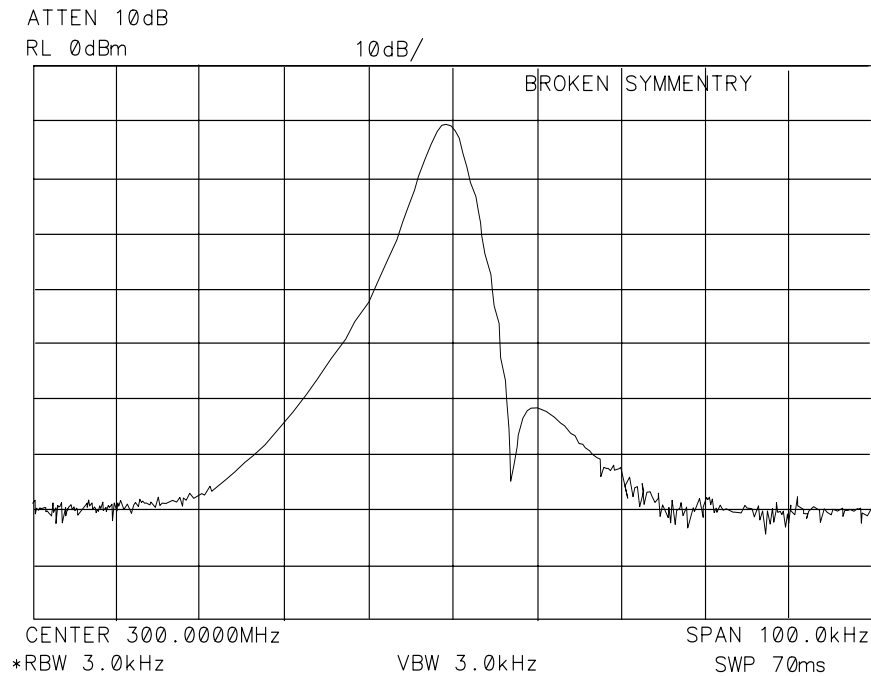

SK184

Step Gains

Refer to function blocks B, H, and I of A5 IF filter schematic diagram (sheets 1 of 3 and 2 of 3) in the *8560 E-Series Spectrum Analyzer Component Level Information*.

1. On the 8564E/EC or 8565E/EC spectrum analyzer, press **PRESET**, **SPAN**, **ZEROSPAN**, **FREQUENCY**, and 1 **GHz**.
2. Press **CAL** and **IF ADJ OFF**.
3. Disconnect W29 (coax 7) from A5J3 and W27 (coax 3) from A5J5.
4. Inject a -5 dBm, 10.7 MHz signal into A5J3.
5. Monitor the output of A5J5 with another spectrum analyzer.
6. Simultaneously decrease the signal generator output and 8564E/EC or 8565E/EC spectrum analyzer reference level in 10 dB steps down to a -50 dBm reference level.
7. At each step, the signal displayed on the other spectrum analyzer should be close to $+10$ dBm. (More subtle IF gain problems might require smaller signal generator and reference level steps.)
8. Reconnect W29 to A5J3 and W27 (coax 3) to A5J5.

Cal Oscillator (P/O A4 Assembly)

The cal oscillator on the A4 assembly supplies the stimulus signal for automatic IF adjustments. Normally, the oscillator operates only during retrace (for a few milliseconds) to adjust part of the IF. (All IF parameters are to be readjusted about every 5 minutes.) With continuous IF adjust ON, a group of IF parameters are adjusted during each retrace period (non-disruptive). If continuous IF adjust is OFF, the most recent IF calibration data is used.

The IF parameters adjusted include step gains, log amplifier gain and offset, bandwidth centering, 3 dB bandwidth, bandwidth amplitude, and crystal-filter symmetry.

The cal oscillator provides three types of output signals (all -35 dBm):

- 10.7 MHz
- 9.9 to 11.5 MHz in 100 kHz steps
- Frequency sweeps from 20 kHz to 2 kHz centered at 10.7 MHz (lasting 5 to 60 ms respectively)

The signals perform the following functions:

- Adjust gains, log amps, and video slopes and offsets.
- Adjust 3 dB bandwidth and center frequencies of LC resolution bandwidth filters (30 kHz through 1 MHz).
- Adjust 3 dB bandwidth, symmetry, and gain of the crystal resolution bandwidth filters (300 Hz through 10 kHz).

The cal oscillator uses a phase-locked loop (PLL). The oscillator (function block X) is locked to the instrument 10 MHz reference. The reference divider (function block U) divides the reference and delivers a 100 kHz TTL signal to the phase detector (function block V). The divide-by-N circuitry (function block Y) divides the oscillator output of 9.9 MHz to 11.5 MHz (by 99 to 115) resulting in a 100 kHz output to the phase detector. When the cal-oscillator PLL is locked, narrow positive and negative of equal width pulses occur at the phase detector output. Since the phase detector drives a low-input impedance at the loop integrator, observe the positive pulses at A4CR808 anode and negative pulses at A4CR809 cathode.

The loop integrator acts as a low-pass filter that filters the pulses and inverts the result. If the anode of A4CR808 is more positive (with respect to ground) than the cathode of A4CR809 is negative, the loop integrator output should saturate to approximately -13 V. Conversely, if the anode of A4CR808 is less positive than the cathode of A4CR809 is negative, the integrator should saturate to a positive voltage.

NOTE

If error messages ERR 581 AMPL or ERR 582 AMPL appears, refer to error message ERR 582 AMPL in [Chapter 6](#) and perform the procedure provided.

1. The oscillator output frequency should exceed 11.5 MHz if the CAL OSC TUNE line, A4U804 pin 14, exceeds +9 V. The oscillator frequency should be less than 9.9 MHz if CAL OSC TUNE is less than -9 V. The oscillator only operates when CALOSC_OFF is low (0 V).
2. If the cal oscillator remains locked (no error code ERR 499 displayed) but does not have the correct output level, troubleshoot the output leveling circuitry (function blocks AA, AB, and AC) or output attenuator (function block AD).

Cal Oscillator Unlock at Beginning of IF Adjust

1. Press **LINE** to turn the 8564E/EC or 8565E/EC spectrum analyzer off and then on. The words IF ADJUST STATUS appear on the display 10 seconds after the instrument is turned on (assuming the rest of the instrument is working correctly). Immediately observe the lower right corner of the display for error messages. If the message ERR 499 CAL UNLK appears (before errors ERR 561, ERR 562 and ERR 565), the cal oscillator is unable to phase-lock. Expect to see the ERR 499 message for only about 1 second.
2. If the 8564E/EC or 8565E/EC spectrum analyzer registers an unlocked cal oscillator, continue with step 3 to verify the presence of externally supplied signals.
3. Check A4U811 pin 9 for a 100 kHz TTL-level square wave verifying operation of A4U811, A4Q802, and the 10 MHz input signal from A4J7.
4. Check the +15 VF, +5 VF and -15 V power supplies, and +10 V reference on the A4 assembly.
5. Check that A4U807 pin 5 (CALOSC_OFF) becomes TTL low (0 V) at the start of a FULL IF ADJ (press **CAL** and **FULL IF ADJ**). The phase modulation output at A4U804 pin 8 should also remain at 0 volts. If these checks are correct, troubleshoot blocks V, W, X, and Y. See [Figure 9-26, "A4 Log Amplifier/Cal Oscillator Block Diagram \(2 of 2\)."](#)

Inadequate CAL OSC AMPTD Range

Refer to function block AC of A4 Log Amplifier Schematic Diagram in the *8560 E-Series Spectrum Analyzer Component Level Information*.

1. If A4R826, CAL OSC AMPTD, has inadequate range to perform the IF Amplitude Adjustment, press **CAL**.
2. Rotate A4R826 fully clockwise and disconnect W52 (coax 9) from A5J4.
3. Connect A5J4 to the input of a second spectrum analyzer.
4. Set the other spectrum analyzer controls as follows:

Center frequency	10.7 MHz
Reference level	-30 dBm
5. Observe the spectrum analyzer display while pressing **FULL IF ADJ**. The signal level should be greater than -34.55 dBm. If the signal level is incorrect, continue with step 7.
6. Rotate A4R826 fully counterclockwise. The signal should be less than -36.25 dBm. If the signal level is correct at both settings, troubleshoot the A5 IF assembly. If the signal level is incorrect, continue with step 7.
7. Troubleshoot the ALC loop on this assembly using the following steps:
 - a. Connect a positive DVM probe to A4J9 pin 4.
 - b. On the 8564E/EC or 8565E/EC spectrum analyzer, press **CAL**.
 - c. Press **FULL IF ADJ**. Observe the DVM reading between the displayed messages **IF ADJUST STATUS: 300 kHz RBW** and **IF ADJUST STATUS: 3 kHz RBW**. During this time period, the voltage should be within a 2 to 10 Vdc range.
 - d. Observe the DVM reading while **IF ADJUST STATUS: AMPLITUDE** is displayed. The reading should be within the 2 to 10 Vdc range.
 - e. If the DVM reading is outside the range in step c but inside the range in step d, suspect one of the reactive components in the filter.
8. If the ALC loop is working correctly (A4J9 pin 4 within the test tolerances given), then either the output attenuator is defective, or A4U810 pin 6 (in ALC loop integrator) is outside of its +3 to +6 Vdc range.
9. Reconnect W52 (coax 9) to A5J4.

300 Hz to 3 kHz Resolution Bandwidth Out of Specification

1. If the 3 dB bandwidth of one of these filters is incorrect, suspect a failure of one of the five available sweeps from the cal oscillator sweep generator (function block Z). These sweeps are generated by changing the switch settings of A4U803 which routes signals through A4U802 and A4U804.
2. Disconnect W52 (coax 9) from A4J8.
3. Connect an SMB tee to A4J8, using a short coaxial cable with SMB connectors.
4. Connect one output of the tee to cable W52 (coax 9).
5. Connect an 85024A active probe to the other output of the tee.
6. Connect the output (type N connector) of the active probe to the input of the 8566A/B spectrum analyzer.
7. Connect the probe power cable to the 8564E/EC or 8565E/EC spectrum analyzer front panel PROBE POWER connector (you may need to use a probe power extension cable, 10131B).
8. Press **INSTR PRESET** on the 8566A/B and set the controls as follows:

Center frequency	10.8 MHz
Span	0 Hz
Reference level	-43 dBm
Resolution bandwidth	100 kHz
Video bandwidth	10 kHz
Sweep time	50 ms
Scale	1 dB/division
Sweep	SINGLE
9. On the 8564E/EC or 8565E/EC spectrum analyzer, press **PRESET** and **CAL**.
10. Press **FULL IF ADJ**. When the display reads **ADJUSTING IF:**
10 kHz RBW, press **SINGLE** on the 8566A/B.
11. The 8566A/B screen illustrates frequency versus time of the output sweeps of the cal oscillator. See [Figure 9-21, "Output Waveform, 10 kHz Resolution Bandwidth."](#) The slope of the 8566A/B 100 kHz resolution bandwidth is used to detect frequency changes. Sweeps that vary (greater than 30 percent) from the normal levels, trigger error code **ERR 581** or **ERR 582**.
12. Press **FULL IF ADJ**. When the display reads **ADJUSTING IF: 3 kHz**, press **SINGLE** on the 8566A/B.

13. [Figure 9-22 on page 475](#) illustrates normal operation. Severe failures (slope error greater than 30 percent) and subtle 3 kHz resolution bandwidth errors (less than 30 percent) indicate a problem with A4U802, A4U803, A4U804, or A4U106.
14. Severe failure of the bandwidth accompanied by subtle errors in the output signal indicate an A5 failure.
15. Set the 8566A/B controls as follows:

Center frequency	10.710 MHz
Resolution bandwidth	10 kHz
Video bandwidth	1 kHz
Sweep time	200 ms
16. On the 8564E/EC or 8565E/EC spectrum analyzer, press **FULL IF ADJ.** When the message IF ADJUST STATUS: 1 kHz RBW appears, press **SINGLE** on the 8566A/B.
17. [Figure 9-23, “Output Waveform, 1 kHz Resolution Bandwidth”](#) illustrates normal operation. Severe failures (slope error greater than 30 percent) and subtle 3 kHz resolution bandwidth errors (less than 30 percent) indicate a problem with A4U802, U803, U804, or U106.
18. On the 8564E/EC or 8565E/EC spectrum analyzer, press **FULL IF ADJ.** When the message IF ADJUST STATUS: 300 Hz RBW appears, press **SINGLE** on the 8566A/B.
19. [Figure 9-24 on page 477](#) illustrates normal operation. Severe failures (slope error greater than 30 percent) and 3 kHz resolution bandwidth errors (less than 30 percent) indicate a problem with A4U802, U803, U804, or U106.
20. Reconnect W52 (white) to A4J8.

Figure 9-21 **Output Waveform, 10 kHz Resolution Bandwidth**

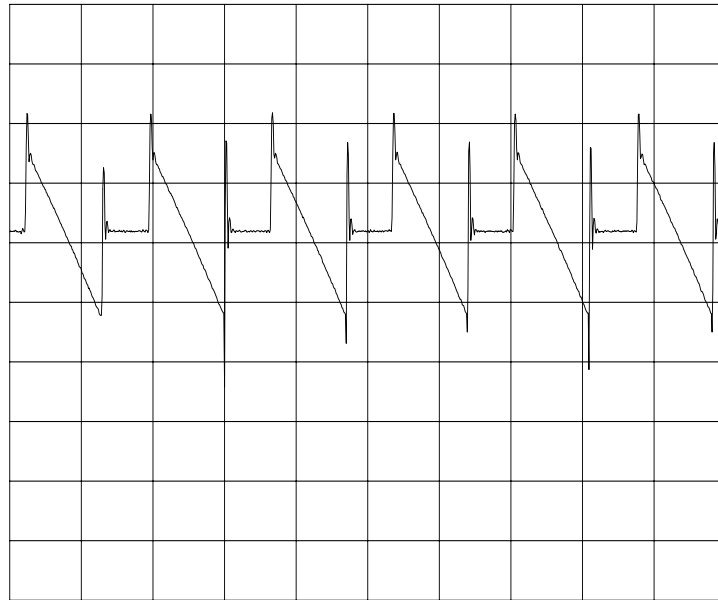

Figure 9-22 **Output Waveform, 3 kHz Resolution Bandwidth**

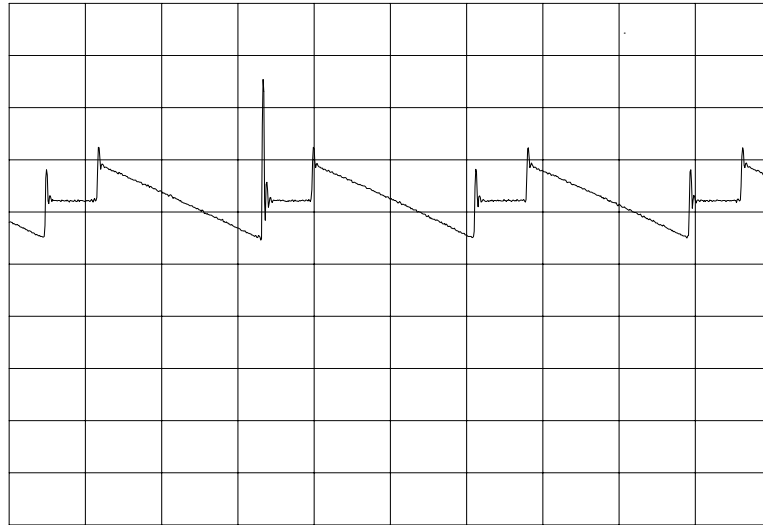

Figure 9-23 **Output Waveform, 1 kHz Resolution Bandwidth**

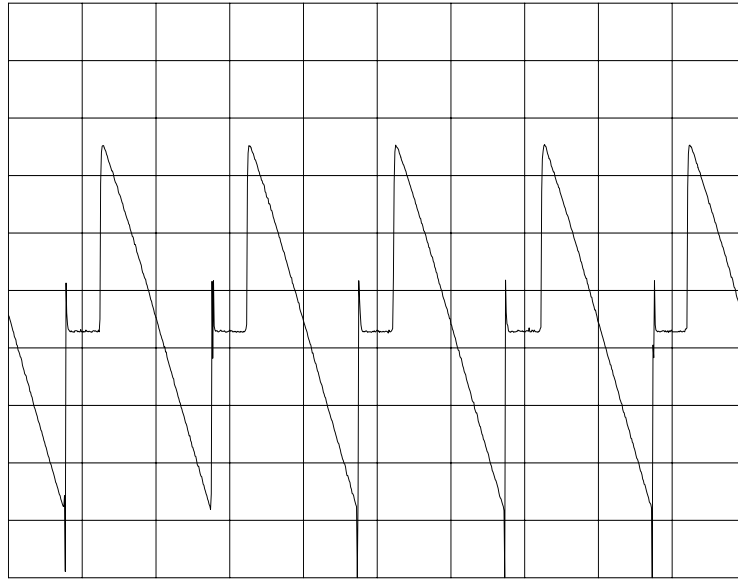

Figure 9-24 **Output Waveform, 300 Hz Resolution Bandwidth**

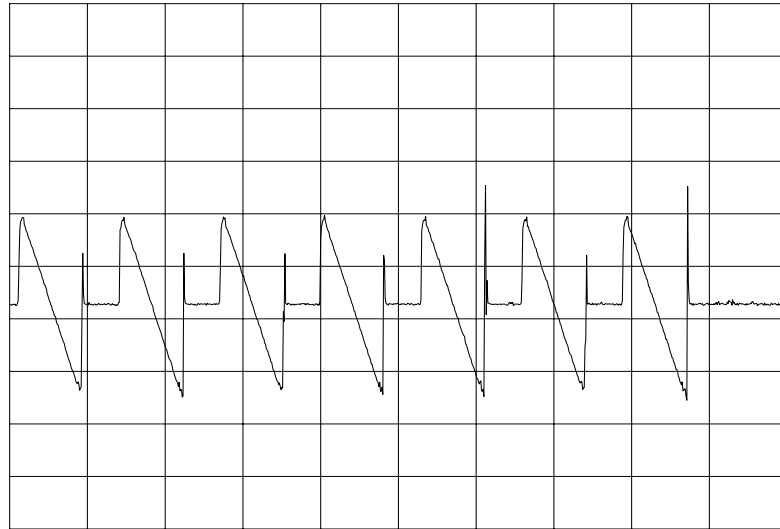
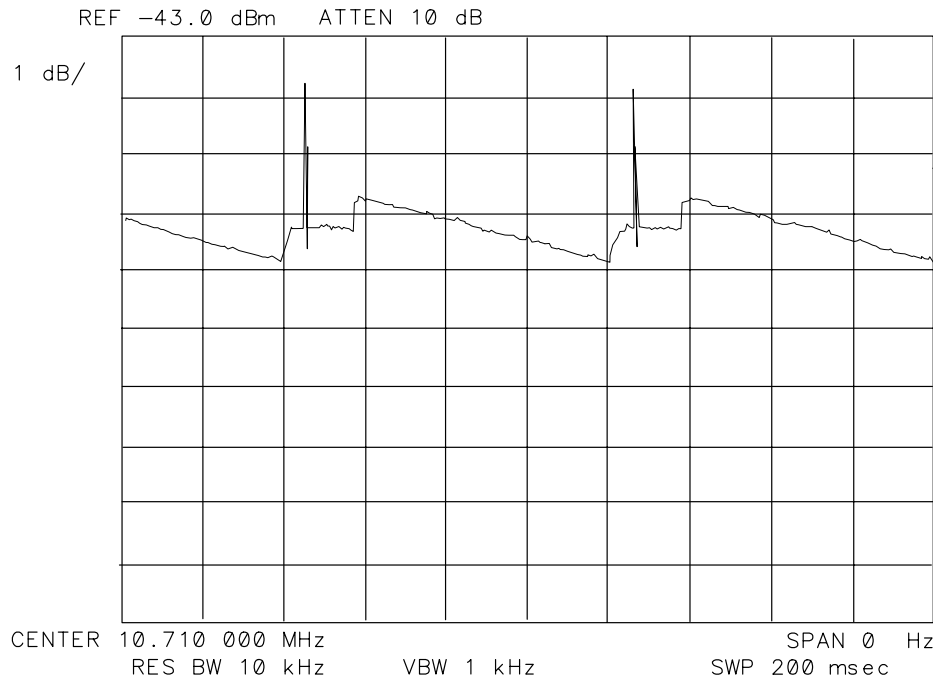

Figure 9-25 Failed Crystal Set Symptoms



SK189

Low-Pass Filter

Refer to function block AB of A4 Log Amplifier Schematic Diagram (sheet 4 of 4) in the *8560 E-Series Spectrum Analyzer Component Level Information*.

1. Connect a DVM positive probe to A4J9 pin 4.
2. On the 8564E/EC or 8565E/EC spectrum analyzer, press **CAL**.
3. Press **FULL IF ADJUST**. Observe the DVM reading between the displayed messages **IF ADJUST STATUS: 300 kHz RBW** and **IF ADJUST STATUS: 3 kHz RBW**. During this time period, the voltage should be within a 2 to 10 Vdc range.
4. Observe the DVM reading while **IF ADJUST STATUS: AMPLITUDE** is displayed. The reading should be within the 2 to 10 Vdc range.
5. If the DVM reading is outside the range in step 3 but inside the range in step 4, suspect one of the reactive components in the filter.

Sweep Generator

Refer to function block Z of A4 log amplifier schematic diagram (sheet 4 of 4) in the *8560 E-Series Spectrum Analyzer Component Level Information*.

A properly operating sweep generator generates a series of negative-going parabolas. Before the sweep, switches A4U802C and A4U802D turn on, shorting A4C802 and A4C801 (the output is at 0 volts). These switches open to start the sweep. The output of A4U804A, pin 1, is 0.35 V to 10 V, depending on the sweep width selected by A4U802A and A4U803A. This voltage appears across A4R801. Capacitor A4C801 integrates the current through A4R801. The output of A4U804B is a straight, negative-going ramp. Capacitor A4C802 and resistor A4R802 integrate the output of A4U804A which starts a negative ramp (A4U804C) at the beginning of the sweep. The ramp from A4U804B is added to the current in A4R802 via A4U803B. Integrating this ramp results in the parabolic output waveform.

AM/FM Demodulation, Audio Amplifier, and Speaker

Refer to function blocks R, S, and T of A4 Log Amplifier Schematic (sheet 4 of 4) Diagram in the *8560 E-Series Spectrum Analyzer Component Level Information*.

If the audio circuits are not functioning use the following procedure to isolate the problem:

1. Set an AM signal generator controls as follows:

Frequency	100 MHz
Amplitude	-6 dBm
Modulation type	80% AM
Modulation frequency	400 Hz

2. Set the 8564E/EC or 8565E/EC spectrum analyzer controls as follows:

Center frequency	100 MHz
Span	0 Hz
Sweep time	50 ms
Reference level	0 dBm
Resolution bandwidth	10 kHz
Amplitude scale	LINEAR

3. Adjust the 8564E/EC or 8565E/EC spectrum analyzer reference level and center frequency to display the 400 Hz modulation frequency eight divisions peak-to-peak.
4. On the 8564E/EC or 8565E/EC spectrum analyzer, press **AUX CTRL**, **AM/FM DEMOD**, **AM DEMOD ON**, and set the sweep time to 5 seconds.

5. Vary the volume and listen for the variation in speaker output level. Clipping is normal at the highest volume levels.
6. If the audio is not working correctly monitor the signal at A4U704 pin 3 with an oscilloscope. The signal should be 20 mV peak-to-peak ± 25 percent (with +2.5 V of dc bias). If the signal measures outside these limits, the fault is prior to the audio amplifier (block T).
7. If the signal is correct, troubleshoot the audio amplifier and speaker.

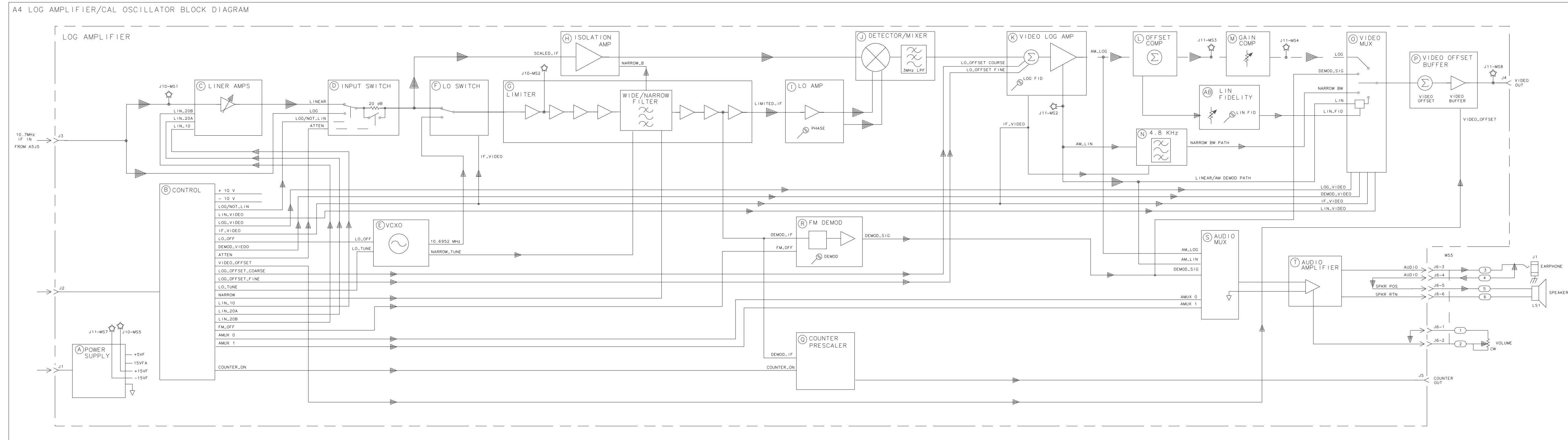

A4 LOG AMPLIFIER/CAL OSCILLATOR BLOCK DIAGRAM

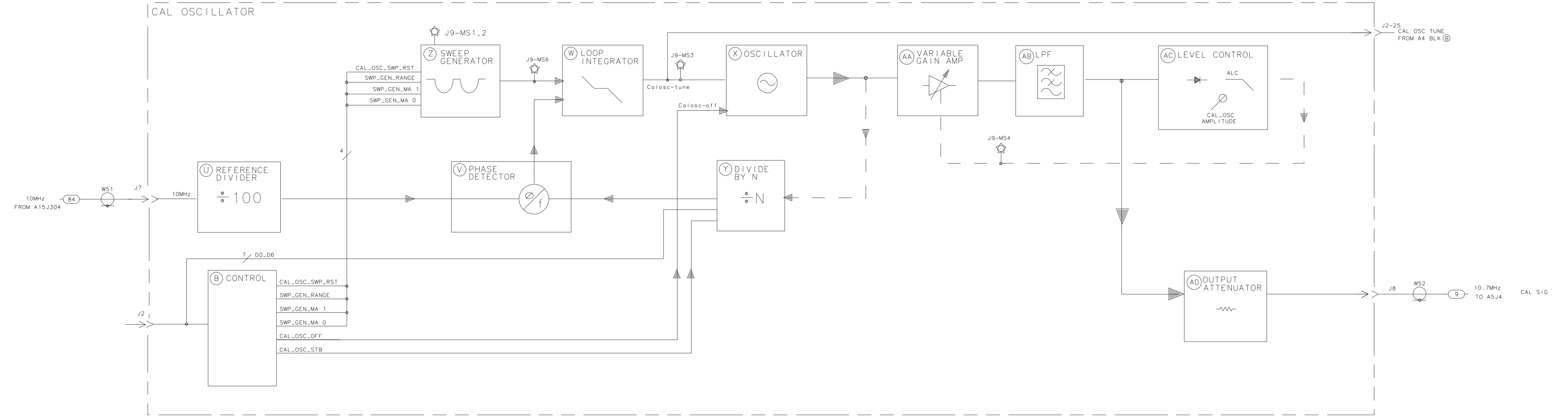

A5 IF ASSEMBLY BLOCK DIAGRAM

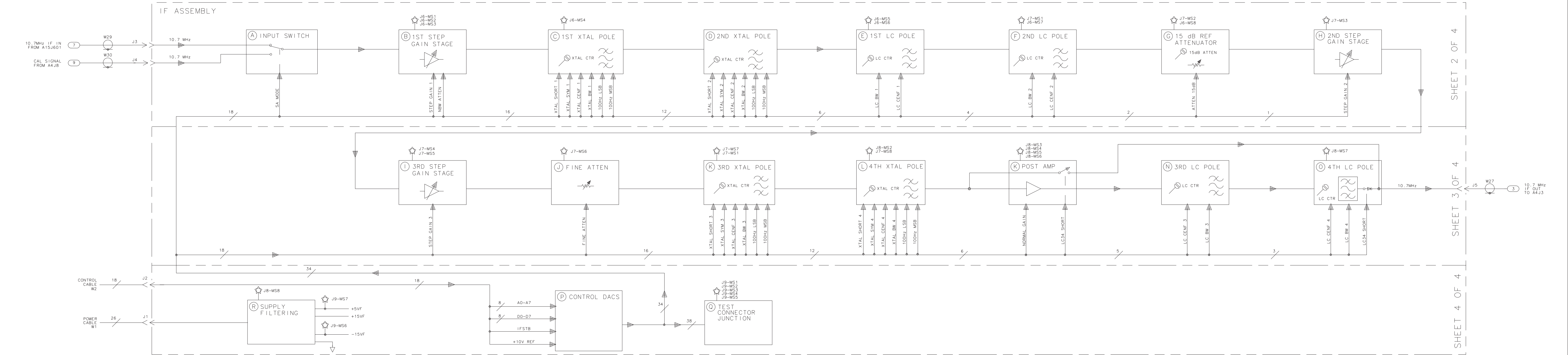

Introduction

The controller section includes the A2 controller assembly, A19 GPIB assembly, and BT1 battery. The presence of a display (graticule and annotation) verifies that most of A2 controller assembly is operating properly.

	Page
Digital Signature Analysis – DSA (E-Series)	page 490
Display Problems (E-Series)	page 491
Line Generators	page 491
Blanking	page 492
Display Jumbled or Trace Off Screen	page 494
Intensity	page 498
Bad Characters or Graticule	page 499
Long Lines Dimmer than Short Lines	page 499
Analog Zero Span Problems (E-series, Non-Option 007)	page 502
Frequency Count Marker Problems (EC-Series).....	page 503
Frequency Count Marker Problems (E-Series)	page 504
Frequency Counter (EC-Series).....	page 505
Frequency Counter (E-Series)	page 507
Video Input Scale Amplifiers and Limiters (EC-Series)	page 509
12-Bit Flash ADC (EC-Series).....	page 511
32 K-Byte Static RAM.....	page 512
Reference Clock (EC-Series)	page 513
16 MHz Harmonic Filter (EC-Series).....	page 514
State- and Trace- Storage Problems	page 515
Keyboard Problems	page 516

NOTE

When measuring voltages or waveforms, make ground connections to A2TP3. The metal board-standoffs are not grounded and should not be used when taking measurements. [Figure 10-1 on page 489](#) shows the location of the A2 test connectors.

Figure 10-1 A2 Test Connectors

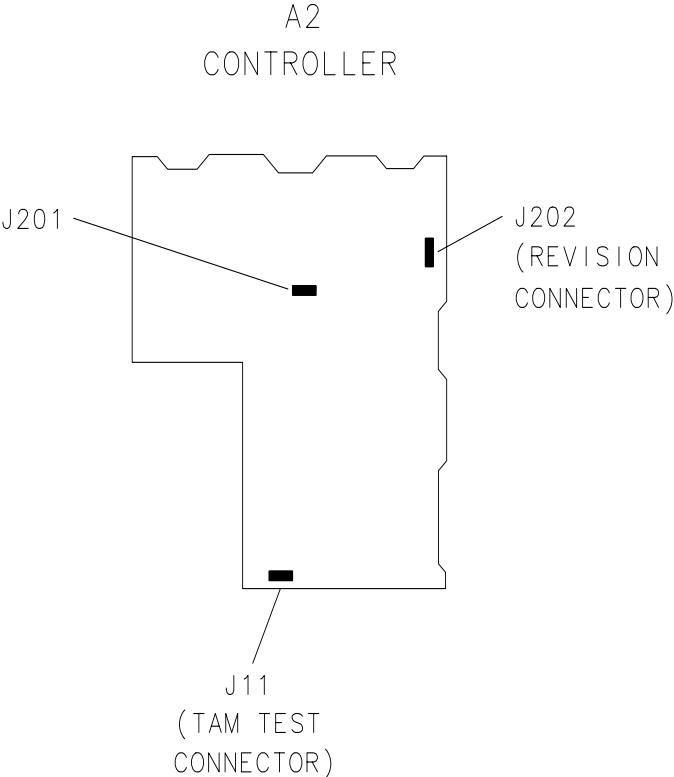

SP17

Figure 10-2 A2 Test Connector Pin Locations

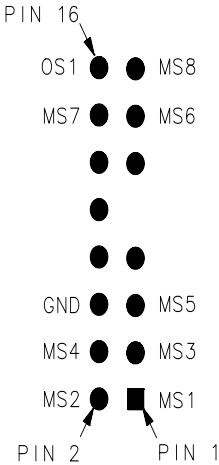

sz144e

Digital Signature Analysis (8564E and 8565E)

Digital signature analysis (DSA) places microprocessor, A2U1, in a simplified known state. This simplified state consists of placing a one-word instruction, 0111 XX10 XXXX XXX0 (MOVEQUICK), on the data bus. The microprocessor cycles through its address range continually reading the instruction. Perform the following DSA procedure to test the operation of microprocessor, A2U1:

1. Press **LINE** to turn the spectrum analyzer off.
2. Move the DSA jumper on J3 (located in the middle of the A2 assembly) from the DISable position to the ENable position.
3. Remove jumper A2E1. A2E1 is a 16 pin dual-in-line package located in the middle of the A2 Assembly. Press **LINE** to turn the spectrum analyzer on.
4. Use an oscilloscope to confirm that address lines, address strobe, and chip selects are toggling at proper levels. If not, microprocessor A2U1 is probably faulty.
5. Use an oscilloscope to check the address line sequencing. The signal on each line (starting with A1 and ending with A23) should be one-half the frequency of the previous line.
6. Press **LINE** to turn the spectrum analyzer off. Replace jumper A2E1. Move the DSA jumper from connecting E5 and E6 back to connecting E6 and E7.

Display Problems (8564E and 8565E)

Line Generators

Refer to function blocks D and I of A2 controller schematic diagram (sheet 1 of 4) in the *8560 E-Series Spectrum Analyzer Component Level Information*.

The line generators convert the digital display information to an analog output suitable to drive the A17 CRT driver assembly. These circuits change the digital words into vectors, or lines, which move the beam of the CRT. The vectors are each 6 μ s long (width of the INTEGRATE pulse) followed by a 1 μ s SAMPLE pulse. When characters of text are being drawn, the vectors are 3 μ s long.

1. On the spectrum analyzer, press **PRESET**.
2. On the spectrum analyzer, press **CAL MORE CRT ADJ PATTERN**. If the display is blank, press the bottom softkey and then the top softkey.
3. Set an oscilloscope to the following settings:

Amplitude scale 3 V/div
Sweep time 1 ms/div
Triggering External

4. Externally trigger the oscilloscope off the signal at A2U207 pin 8 (LBRIGHT).
5. Compare the signals at the following test points with those illustrated in [Figure 10-3 on page 492](#).

X POS: A2J202 pin 14

Y POS: A2J202 pin 3

Z OUT: A2J201 pin 3

BLANKING: A2J202 pin 15

NOTE

Waveforms displayed on an analog scope may show considerably more spikes. This is normal and is due to the wider displayed bandwidth.

6. Troubleshoot the circuits associated with any bad waveforms.

Figure 10-3 Line Generator Output Waveforms

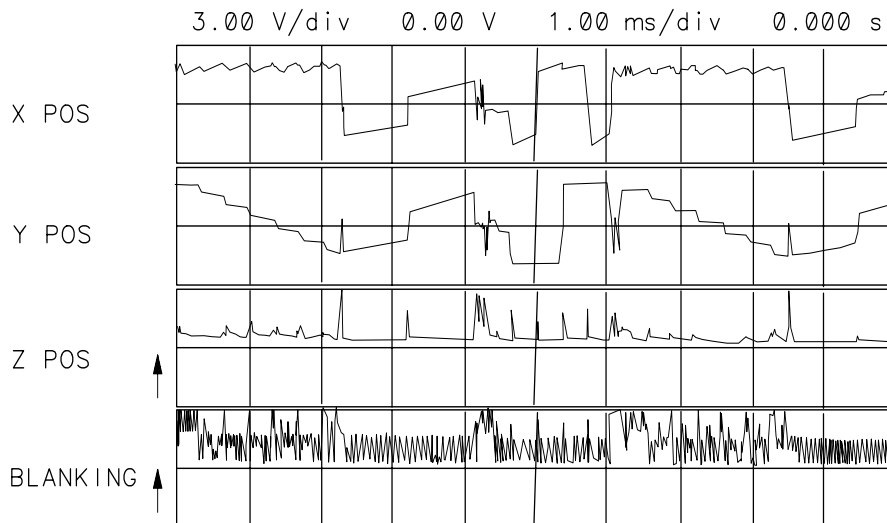

SK191

Blanking

Refer to function block J of A2 Controller Schematic Diagram (sheet 1 of 4) in the *8560 E-Series Component Level Information*.

1. Using an oscilloscope, check for blanking pulses at A2J202 pin 15. A2U206 pin 6 should be at a TTL high. Blanking pulses turn the CRT beam off during the sample time of the line generators and when moving the CRT beam to a new position for drawing the next vector.

2. Set an oscilloscope to the following settings:

Amplitude scale 4 V/div
Amplitude offset +2.5 V
Sweep time 20 μ s/div
Triggering External

3. Externally trigger the oscilloscope off the signal at A2U207 pin 8 (LBRIGHT).
4. Compare the blanking-circuit input signals at the following test points with those illustrated in [Figure 10-4 on page 493](#).

BLANKING: J202 pin 15

BLANK: U214 pin 12

VECTOR: U214 pin 11

U213 pin 13

5. The waveforms in [Figure 10-4](#) must match the timing of the vectors being drawn. To do this, U215B is used to adjust the leading edge, and U215A is used to adjust the trailing edge. The first six horizontal divisions show the line drawing mode where the VECTOR pulses are 6 μs apart. The remaining divisions shows character mode (VECTOR pulses 3 μs apart). The BLANK pulses are synchronized to the VECTOR pulses by U214B. The fourth trace shows the double pulses which delay the leading and trailing edges of the blanking pulses.
6. Set the oscilloscope to the following settings to expand the first and fourth traces. This displays how the rising edges of U213-13 determine the transitions of the blanking pulses. See [Figure 10-5 on page 494](#).

Amplitude scale 4 V/div
 Amplitude offset +2.5 V
 Sweep time 2 $\mu\text{s}/\text{div}$
 Delay from trigger 96 μs
 Triggering External

Figure 10-4 Blanking Waveforms

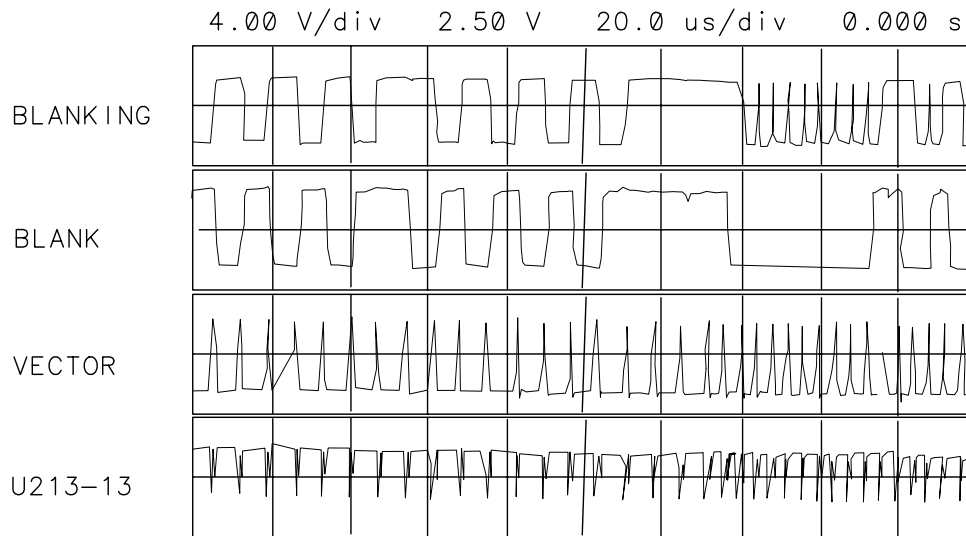

SK 192

Figure 10-5 Expanded Blanking Waveforms

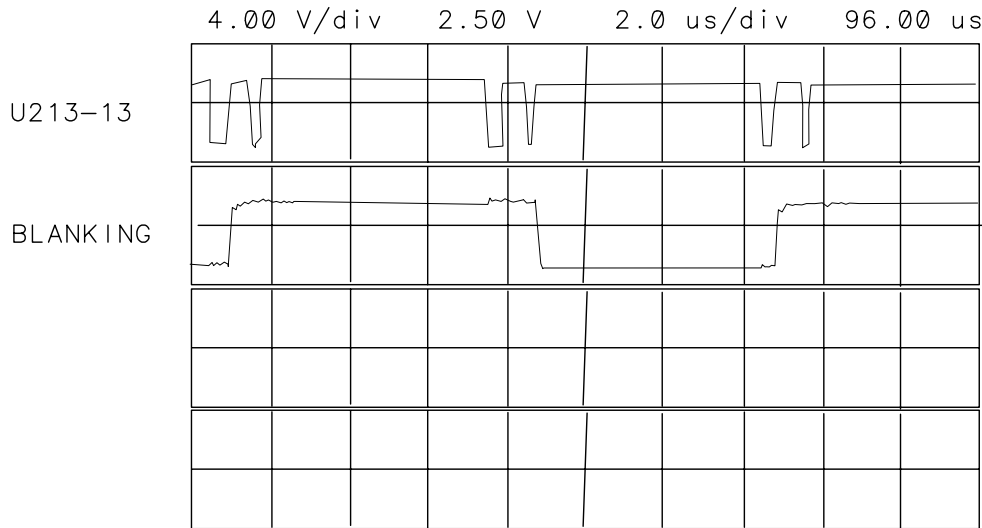

SK193

Display Jumbled or Trace Off Screen

Refer to function blocks D and I of A2 controller schematic diagram (sheet 1 of 4) in the *8560 E-Series Component Level Information*.

The two line generators are identical circuits, so the following steps apply to both. The X generator is referenced below, with Y generator references in parentheses.

Before proceeding, perform the “[15. 16 MHz PLL Adjustment](#)” in [Chapter 3](#) . If the 16 Mhz phase-lock loop is misadjusted or malfunctioning, the ADC ASM clock signal will be incorrect causing distortion.

1. The voltage at A2U202B pin 7 should measure 10.0 V.
2. Perform steps 1 through 5 of "Line Generators" in this chapter. If the X POS and Y POS waveforms look different from those illustrated in [Figure 10-3 on page 492](#), check the waveforms at the input to the low-pass filter (function block E in the component-level information binder).
3. The waveform at the low-pass filter should look like X POS in [Figure 10-3, “Line Generator Output Waveforms,”](#) but have an amplitude from 0 V to +5 V.
4. If the waveform in step 3 is incorrect, set an oscilloscope to the following settings:

Amplitude scale 10 V/div
Sweep time 20 μ s/div

Triggering External

5. Trigger the oscilloscope on the signal at U207 pin 8 (LBRIGHT).
6. Compare the line-generator input signals at the following test points with those illustrated in Figure 10-6 on page 495. INTEGRATE and SAMPLE waveforms are replicas of VECTOR except for polarity and amplitude. LCHAR is low when characters are drawn.

INTEGRATE: Q202 collector

SAMPLE: Q201 collector

LCHAR: U207 pin 9

VECTOR: U213 Pin 9

Figure 10-6 Switch Driver Waveform LCHAR

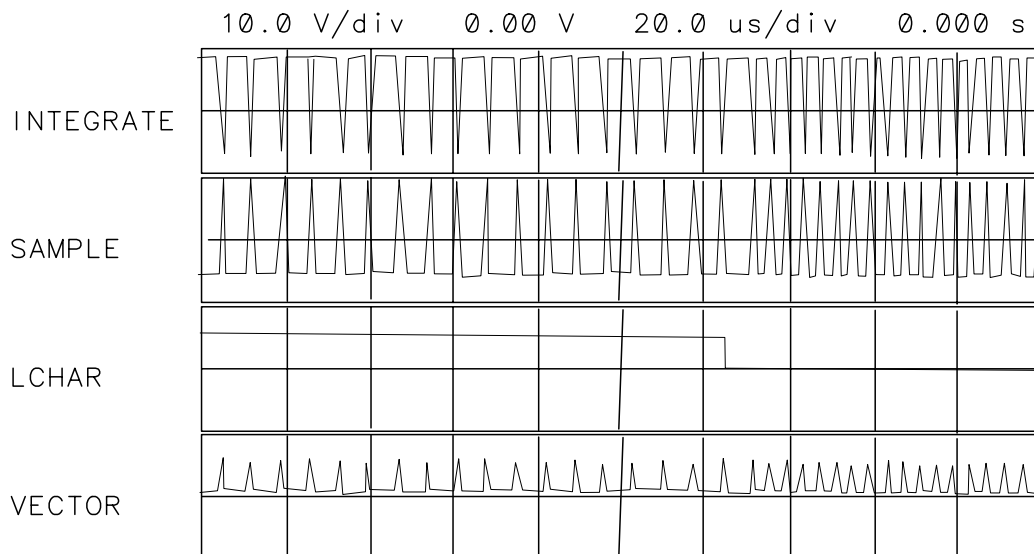

SK194

7. All of the DAC inputs should change state two or more times within a 5 ms window. If one or more DAC bits are not working correctly, this will effect the entire display, especially the diagonal lines that go from lower left to upper right. When these lines are drawn, both the X and Y DACs are stepped one count at a time. A "stuck" bit will distort the diagonal in a repetitive manner. The quicker the repetition, the less significant the "stuck" bit. Horizontal distortions apply to the X LINE GENERATOR DAC, while vertical distortions apply to the Y LINE GENERATOR DAC. The DACS have current outputs so they are not readily observable with an oscilloscope. Continue with step 8 to observe the DAC outputs.

8. To break the effect of feedback in the line generators and to observe the output of the DACs, short J201 pin 13 (J201 pin 1) to TP3 (GND) to observe U201 pin 1 and TP2 (U203 pin 1 and TP1.) Continue with step 9.

9. Set an oscilloscope to the following settings:

Amplitude scale 5 V/div
Sweep time 1 ms/div
Coupling AC
Triggering External

10. Trigger the oscilloscope on the signal at U207 pin 8 (LBRIGHT).

11. The following waveforms should look like [Figure 10-7 on page 497](#) on the oscilloscope. The top two traces are for the X line generator and the bottom two traces for the Y line generator.

X line generator

— U201 pin 1

— TP2

Y line generator

— U203 pin 1

— TP1

12. [Figure 10-8 on page 497](#) illustrates the waveforms in step 11 expanded to show relative timing. the second and fourth traces are delayed by 5 ms from the first and third. The oscilloscope settings are changed as follows:

Sweep time 20 μ s/div

13. [Figure 10-9 on page 498](#) illustrates the waveforms of properly working line generators. Whenever there is a pulse on TP2 (or TP1), the appropriate integrator U201B (or U203B) generates a ramp (the output vector) which feeds back to U201A (U203A) and shows on its output.

Figure 10-7 Distorted X/Y Line Generator Waveforms

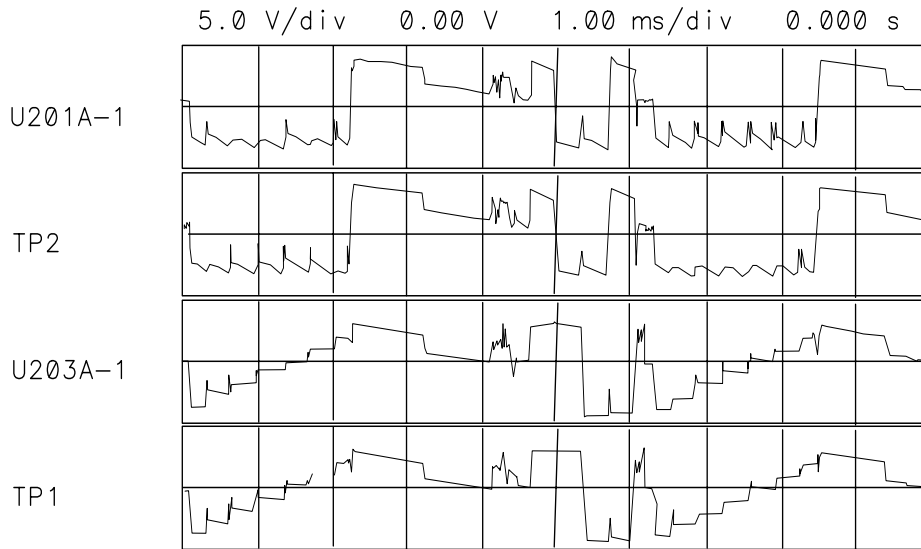

SK195

Figure 10-8 Expanded X/Y Line Generator Waveforms

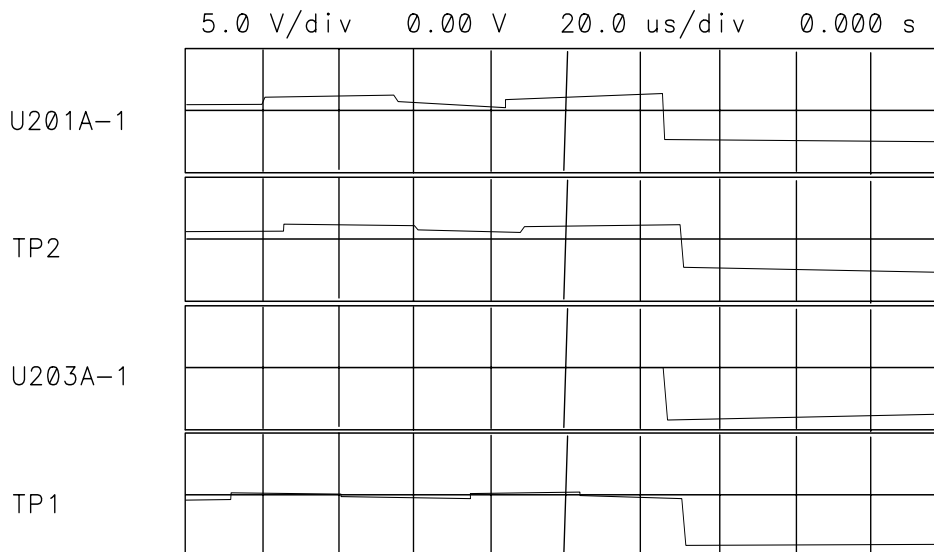

SK196

Figure 10-9 Normal X/Y Line Generator Waveforms



SK197

Intensity

1. The length of the vector being drawn can effect intensity. U210A, U210C, and U210D sum the lengths of the X and Y vectors. Refer to "Long Lines Dimmer than Short Lines" in this chapter.
2. Short A2U207 pin 6 to pin 7. If the display does not brighten, troubleshoot LBRIGHT switch, U207B. This switch intensifies trace A and active softkeys.
3. Short A2U207 pin 2 to pin 3. If the display does not brighten, troubleshoot DEF1 switch, U207A. This switch is used in analog zero span.
4. Change the intensity (under **DISPLAY**). If the intensity does not change, troubleshoot the intensity DAC, A2U212A. (A2U212A is controlled from the front panel.) The amplitude of the waveform at U211A pin 1 should increase or decrease with intensity changes.
5. Clamp U211B limits the voltage to about 4.2 V. Short A2J201-1 to ground and set the intensity DAC to a number greater than 80. A major portion of the waveform should be limited to 4.2 V.
6. If a major portion of the waveform is not limited to 4.2 V, troubleshoot the maximum brightness clamp, A2U211C.

Bad Characters or Graticule

If the displayed characters are bad but the graticule is correct (or if the symptoms are reversed), troubleshoot the X- and Y- generator switches A2U207D and A2U207C. Check that the switch driver signal LCHAR is working properly. Refer to [“Display Jumbled or Trace Off Screen” on page 494](#).

Long Lines Dimmer than Short Lines

Refer to function block M of A2 controller schematic diagram (sheet 1 of 4) in the *8560 E-Series Component Level Information*.

The Z output function block contains the absolute value circuits which determine the intensity of vectors drawn on the display. The vector length is approximated by the sum of the X length and Y length. The voltage corresponding to the X length, ΔX , is converted to current by R274. If the voltage is negative, it is amplified by 2 in A2U210C, converted to current by A2R246, and added to the current from A2R274. This effectively turns both negative and positive voltages into positive currents, hence absolute value.

1. Short A2J201 pin 13 to ground (A2TP3).
2. Connect channel A of an oscilloscope to A2J201 pin 2. Connect channel B to A2U210D-14.
3. Set an oscilloscope to the following settings:

Amplitude scale	10 V/div
Sweep time	1 ms/div
Triggering	External
4. Externally trigger the oscilloscope off the signal at A2U207 pin 8 (LBRIGHT).
5. The waveforms should look like those illustrated in [Figure 10-10 on page 500](#). If the waveform at J201 pin 2 is bad, troubleshoot the X line generator (function block D of the A2 controller schematic, sheet 1 of 4).
6. If the waveform at U210D pin 14 is bad, troubleshoot the Z output circuit (function block M of A2 controller schematic, sheet 1 of 4).
7. Remove the short from J201 pin 13 to ground. Short A2J201 pin 1 to ground.

Figure 10-10 Delta X Waveform

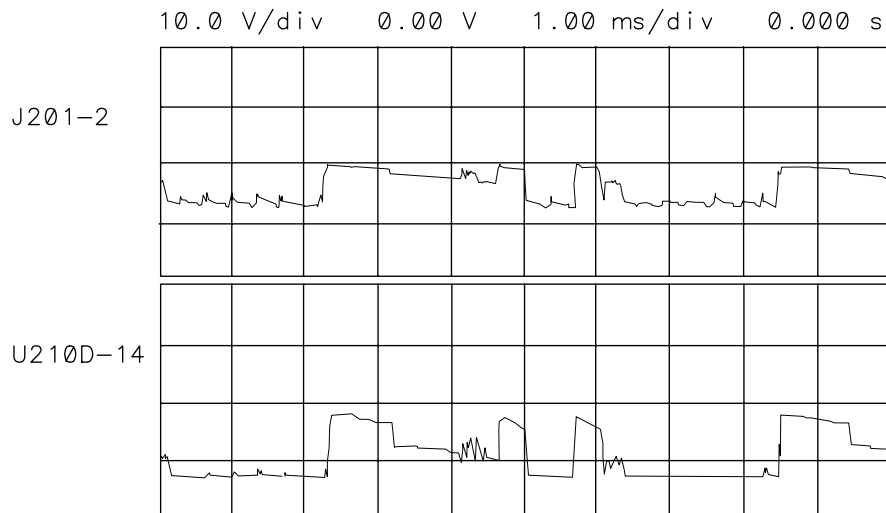

SK198

8. Move the oscilloscope channel A probe to J201 pin 14.
9. The waveforms should look like those illustrated in [Figure 10-11, "Delta Y Waveform,"](#) If the waveform at J201 pin 14 is bad, troubleshoot the Y line generator (function block I of A2 controller schematic, sheet 1 of 4).
10. If the waveform at U210D pin 14 is bad, troubleshoot the Z output circuit (function block M of A2 controller schematic, sheet 1 of 4).
11. Remove the jumpers.

Figure 10-11 **Delta Y Waveform**

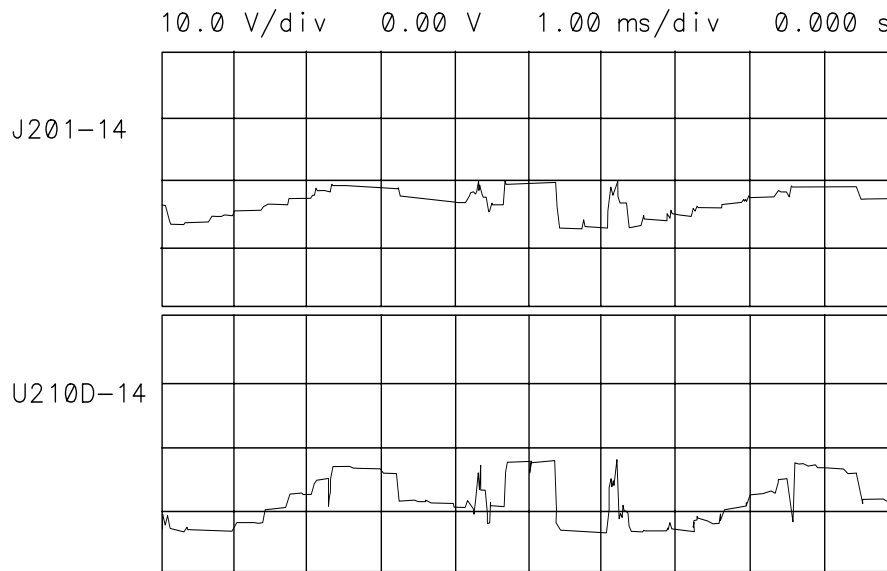

SK199

Analog Zero Span Problems (8564E and 8565E, Non-Option 007)

1. On the spectrum analyzer press **PRESET**, **SPAN**, **ZERO SPAN**, **SWEEP**, **1, ms**, **CAL**, **MORE**, and **CRT ADJ PATTERN**.
2. Set an oscilloscope to the following settings:
Amplitude scale 10 V/div
Sweep time 1 ms/div
Triggering External
3. Externally trigger the oscilloscope off the signal at A2U207 pin 8 (LBRIGHT).
4. The display should be similar to [Figure 10-12, “DEF1 Synchronization,”](#) except that the untriggered trace should show at the left edge of the screen. In these settings, DEF1 causes switching between the line generators and the analog inputs (sweep and video). DEF1 remains high when the CRT adjust pattern is on. Refer to function block M of the A2 controller schematic, sheet 1 of 4.
5. The sweep input from J1-41 should go from 0 V to +10 V; the video In signal should go from about 0 V to 1 V from the bottom to the top of the screen. Apply a dc voltage to A2J4, Video In, to test the circuit.
6. In [Figure 10-12 on page 502](#), there is no synchronization between DEF1 and the video patterns X POS and Y POS when DEF1 is TTL high. The Y POS level when DEF1 is low is the Video In level.

Figure 10-12 **DEF1 Synchronization**

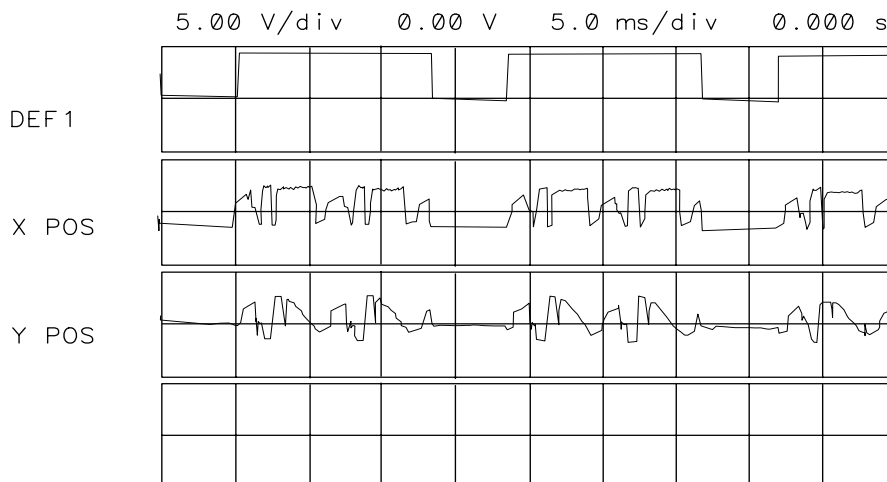

SK1100

Frequency-Count Marker Problems (8564EC and 8565EC)

The FREQ COUNT function works by dividing the 10.7 MHz IF signal by two (prescaling) and counting the divided-down signal using the frequency counter on the A2 controller assembly . The prescaler is on the A4 Log amplifier/cal oscillator assembly . Perform the following steps to determine whether the problem is on the A4 log amplifier/cal oscillator or the A2 controller assembly:

1. Disconnect W53 from A2J13.
2. Connect the output of a synthesized source, such as an 3335A, to A2J13.
3. Set the synthesized source to the following settings:
Amplitude +10 dBm
Frequency 5.35 MHz
4. Set the spectrum analyzer to the following settings:
Center frequency 300 MHz
Span 1 MHz
5. On the spectrum analyzer, press **FREQ COUNT**. The frequency counter actually reads one half the frequency of the 10.7 MHz IF. If the CNT frequency display reads all asterisks, the frequency counter is probably at fault.
6. If a valid frequency is displayed, troubleshoot the prescaler on the A4 log amplifier/cal oscillator assembly.
7. Reconnect W53 to A2J13.Frequency-Count Marker Problems (8564EC and 8565EC)

Frequency-Count Marker Problems (8564E and 8565E)

The FREQ COUNT function works by dividing the 10.7 MHz IF signal by two (prescaling) and counting the divided-down signal using the frequency counter on the A2 controller assembly (block Z of the A2 schematic diagram). The prescaler is on the A4 Log amplifier/cal oscillator assembly (block Q of the A4 schematic diagram). Perform the following steps to determine whether the problem is on the A4 log amplifier/cal oscillator or A2 controller assembly:

1. Disconnect W53 from A2J7.
2. Connect the output of a synthesized source, such as an 3335A, to A2J7.
3. Set the synthesized source to the following settings:

Amplitude	+10 dBm
Frequency	5.35 MHz
4. Set the spectrum analyzer to the following settings:

Center frequency	300 MHz
Span	1 MHz
5. On the spectrum analyzer, press **FREQ COUNT**. The frequency counter actually reads one half the frequency of the 10.7 MHz IF. If the CNT frequency display reads all asterisks, the frequency counter is probably at fault.
6. If a valid frequency is displayed, troubleshoot the prescaler on the A4 log amplifier/cal oscillator assembly.
7. Reconnect W53 to A2J7.

Frequency Counter (8564EC and 8565EC)

The frequency counter counts the frequency of the last IF and provides accurate timing signals for digital zero-spans. The circuit also provides timing signals to the ADC (analog to digital converter) on the A3 interface assembly. The nominal input frequency is 5.35 MHz (10.7 MHz divided by 2). The 10 MHz reference from the A15 RF assembly provides the frequency reference in the frequency count mode. The frequency reference in digitized zero spans (sweep times ≥ 30 ms) is the 4 MHz HPIB_CLK, selected by a clock select multiplexer in U35.

The 10 MHz reference from the A15 RF assembly is first filtered and passed through a comparator to generate a TTL, 50 percent duty cycle signal. C128, L16, and R91 provide a bandpass filter centered at 10 MHz. The output of comparator U33B is the actual reference used for the Frequency Counter. An additional stage of filtering is performed on this signal to provide a 10 MHz signal for the A17 LCD Driver assembly.

In the frequency count mode, the 10 MHz reference is prescaled by 5 to generate a 2 MHz timebase. This timebase feeds through the clock select multiplexer in U35 to the CLK2 input of programmable timer U15. The output (OUT2) of programmable timer U15 is the gating signal (HBKT_PULSE); it performs the frequency count. The gating time interval is a function of the counter resolution which may be set between 10 Hz and 1 MHz. [Table 10-1 on page 506](#) lists the gate time for each setting of COUNTER RES. The gate time is the period during which HBKT_PULSE (pin 20 of U15) is low.

The FREQ COUNT input, A2J13, is gated by HBKT_PULSE. The gated signal clocks divide-by-16 counters within U35. These counters are cascaded to form a divide-by-256 counter. The MSB of this counter, CD7, clocks the CLK0 input of U15. The frequency of CD7 is a function of COUNTER RES as shown in [Table 10-1 on page 506](#). If timer U15 overflows, OUT0 will be set, generating CNTOVFLIRQ, which will interrupt the CPU.

If IRQAK2 is high, HBKT_PULSE will generate FREQCNTLIRQ. Upon receiving the FREQCNTLIRQ interrupt, the CPU latches the CD0 to CD7 onto the BID bus by setting LCDRD (low counter data read) low and reading the counter data from the BID bus. The CPU will also read the data from the timer, U15, by setting L8254CS and LCNTLRD low, placing the timer data on the BID bus. The CPU then resets IRQAK2 low.

Table 10-1 Gate Times

Counter Res	Gate Time* (U15 pin 20 low state)	A2TP16	A2TP15
10 Hz	200 ms	2 MHz	4.18 kHz
100 Hz	20 ms	2 MHz	418 Hz
1 kHz	2 ms	2 MHz	41.8 Hz
10 kHz	2 ms	2 MHz	41.8 Hz
100 kHz	2 ms	2 MHz	41.8 Hz
1 MHz	2 ms	2 MHz	41.8 Hz
* U15 pin 10 = (FREQ COUNT input × Gate Time)/256			

1. Disconnect W22 from A2J9.
2. If a 10 MHz, TTL-level signal is not present at the end of W22, continue with step 3. If a 10 MHz signal is present at W22, proceed as follows:
 - a. Reconnect W22 to A2J9.
 - b. Set the spectrum analyzer to the following settings:
 - Span Zero Span
 - Sweep time 20 ms
 - c. Monitor the signal at A2J2 pin 21. This is an output of the frequency counter, HBUCKET PULSE.
 - d. If HBUCKET PULSE is stuck high, troubleshoot the frequency counter.
3. Check for a 10 MHz signal at A15J302. If the signal is not present at A15J302, the A15 RF assembly is probably defective.

Frequency Counter (8564E and 8565E)

See function block Z of A2 schematic diagram (sheet 4 of 4) in the *8560 E-Series Spectrum Analyzer Component Level Information*.

The frequency counter counts the frequency of the last IF and provides accurate timing signals for digital zero-spans. The circuit also provides timing signals to the A3 interface assembly ADC (analog to digital converter). The nominal input frequency is 5.35 MHz (10.7 MHz divided by 2). The circuit frequency reference in the frequency count mode is the 10 MHz reference from the A15 RF assembly. The frequency reference in digitized zero spans (sweep times ≥ 30 ms) is the 4 MHz HPIB_CLK, selected by MUX U704.

In the frequency count mode, U702 prescales the 10 MHz reference by 5 to generate a 2 MHz timebase. This timebase feeds through MUX U704 to programmable-timer U700 CLK2 input. Programmable-timer U700 output (OUT2) is the gating signal (HBKT_PULSE) for performing the frequency count. The gating time interval is a function of the counter resolution which may be set between 10 Hz and 1 MHz. [Table 10-1 on page 506](#) lists the gate time for each setting of COUNTER RES. The gate time is the period during which U511 pin 3 is high.

The FREQ COUNT input, A2J7, is gated in U511B by HBKT_PULSE. The gated signal clocks divide-by-16 counters U703A and U703B. These counters are cascaded to form a divide-by-256 counter. The MSB of this counter, CD7, clocks the CLK0 input of U700. The frequency of CD7 is a function of COUNTER RES as shown in [Table 10-1 on page 506](#). If timer U700 overflows, OUT0 will be set and U701B clocked, generating CNTOVFLIRQ, which will interrupt the CPU.

If IRQAK2 is high, HBKT_PULSE will clock U701A, generating FREQCNTLIRQ. Upon receiving the FREQCNTLIRQ interrupt, the CPU latches the CD0 to CD7 onto the BID bus by setting LCDRD (low counter data read) low and reading the counter data from the BID bus. The CPU will also read the data from the timer, U700, by setting L8254CS and LCNTLRD low, placing the timer data on the BID bus. The CPU resets U701A by setting IRQAK2 low via the BID bus and latch U506.

Table 10-2

Gate Times

Counter Res	Gate Time* (U511 pin 3 high state)	A2TP16	A2TP15
10 Hz	200 ms	2 MHz	4.18 kHz
100 Hz	20 ms	2 MHz	418 Hz
1 kHz	2 ms	2 MHz	41.8 Hz
10 kHz	2 ms	2 MHz	41.8 Hz
100 kHz	2 ms	2 MHz	41.8 Hz
1 MHz	2 ms	2 MHz	41.8 Hz
* TP15 = (FREQ COUNT input × Gate Time)/256			

1. Disconnect W22 from A2J8.
2. If a 10 MHz, TTL-level signal is not present at the end of W22, continue with step 3. If a 10 MHz signal is present at W22, proceed as follows:
 - a. Reconnect W22 to A2J8.
 - b. Set the spectrum analyzer to the following settings:
 - Span Zero Span
 - Sweep time 20 ms
 - c. Monitor the signal at A2J2 pin 21. This is an output of the frequency counter, HBUCKET PULSE.
 - d. If HBUCKET PULSE is stuck high, troubleshoot the frequency counter.
3. Check for a 10 MHz signal at A15J302. If the signal is not present at A15J302, the A15 RF assembly is probably defective.

Video Input Scaling Amplifiers and Limiter (8564EC and 8565EC)

The video input scaling amplifiers help provide scaling (10 dB/div, 5 dB/div, 2 dB/div, or 1 dB/div) and buffer the flash video output. When the GAINX2 control line is low, switch U44D is open and switch U44C is closed. Thus, the scaled video at TP26 virtually follows the video input (0 - 1 V). When the GAINX2 control line is high, switch U44C is open and switch U44D is closed. Amplifier U43 then provides a gain of $2(V_{in}) - 1$ V. Voltage clamp CR4 prevents the scaled video input to amplifier U45 from going more negative than -0.35 V or more positive than $+1.25$ V.

NOTE

When measuring voltages or waveforms on the Fast ADC section of the A2 controller assembly, connect the ground (or common) lead to the ground-plane trace associated with the shield. This digital ground plane is totally isolated from the chassis.

1. Press **PRESET** on the 8560 EC-series spectrum analyzer and set the controls as follows:

Center frequency	300 MHz
Span	0 Hz
Reference level	-10 dBm
Log/division	10 dB/DIV
Sweep time	20 ms
2. Connect the CAL OUTPUT to the INPUT 50 Ω connector.
3. Adjust the spectrum analyzer reference level to place the signal at the top graticule line on the LCD display.
4. Measure the dc level at pin 3 of U10. If the voltage measured is not $+1.0 \pm 0.15$ V, troubleshoot the A3 interface assembly.
5. Measure the dc level at pin 3 of U17. The level should be approximately the same as the level measured at pin 3 of U10. If not, suspect switch U9.
6. Set the spectrum analyzer scale to 5dB per division.
7. Adjust the spectrum analyzer reference level to place the signal at the top graticule line on the LCD display.
8. Measure the dc level at pin 3 of U10 and pin 3 of U17. The level should be $+1.0 \pm 0.25$ V. If the level measured at pin 3 of U17 differs from the level measured at pin 3 of U10 by more than 0.25 volts, troubleshoot U10 and associated circuitry.

9. Disconnect the CAL OUTPUT signal from the INPUT 50 Ω connector.
10. The level at pin 3 of U10 should drop to -0.35 Vdc. If the level is less (more negative) than -0.35 Vdc, replace voltage clamp D3.
11. Measure the dc level of the flash video at pin 2 of R47. The level should be near 0 Vdc with the signal at the bottom graticule line (no input to the spectrum analyzer).
12. Connect the CAL OUTPUT to the INPUT 50 Ω connector.
13. Measure the dc level of the flash video at pin 2 of R47. The level should be near $+1.7$ Vdc.

12-Bit Flash ADC (8564EC and 8565EC)

The flash ADC (U22) converts the analog video signal into 12-bit digital values at a fixed rate of 12 megasamples per second.

When measuring voltages or waveforms on the Fast ADC of the A2 controller assembly, connect the ground (or common) lead to the ground-plane trace associated with the shield. This digital ground plane is totally isolated from the chassis.

1. Press **PRESET** on the spectrum analyzer and set the controls as follows:

Center frequency	300 MHz
Span	0 Hz
Reference level	-20 dBm
Log/division	5 dB/DIV
Sweep time	20 ms

2. Connect the CAL OUTPUT to the INPUT 50 Ω connector.
3. Pins 2 through 13 (ADC0-ADC11) of U22 should all be high (logic 1), corresponding to an ADC digital count of 255 for the analog input of +2 volts or greater.
4. Disconnect the CAL OUTPUT signal from the INPUT 50 Ω connector.
5. Pins 2 through 13 (ADC0-ADC11) of U22 should all be low (logic 0), corresponding to an ADC digital count of zero for the analog input of 0 volts or less.

32 K-Byte Static RAM (8564EC and 8565EC)

The static RAM stores the ADC samples that are taken when the Fast ADC circuitry is in the "write" mode. When not in the "write" mode, the static RAM is read by the CPU to retrieve the fast ADC data. The 8-bit DFADC bus connects the outputs of latches within U35 to the data port of static RAM U21.

Reference Clock (8564EC and 8565EC)

The reference clock circuitry takes the 8 MHz square wave clock and triples the frequency to 24 MHz. This is accomplished through two stages of filtering of the 8 MHz signal, to extract the third harmonic. The 8 MHz signal is first passed through a high pass filter consisting of C123 and L15. The the signal passes through a bandpass filter centered at 24 MHz, consisting of C106, C08, L13, and R80. The comparator U28B generates a square wave. The signal then passes through a second stage of filtering by using the bandpass filter consisting of C89, C88, L12, and R77. Comparator U28A then regenerates the square wave. A divide-by-two flip flop in U16 divides the 24 MHz signal to create the 12 MHz signal used by the ADC.

16 MHz Harmonic Filter (8564EC and 8565EC)

The 16 MHz Harmonic Filter generates a 16 MHz signal through a series of stages, consisting of a filter and a comparator. The 10 MHz reference signal from the A15 RF assembly is first prescaled by 2.5 to yield a 4 MHz signal with a 20 percent duty cycle. This prescaling is performed within U35. The 4 MHz signal is then passed, first, through a high pass filter, and then, through a bandpass filter at 16 MHz. The high pass filter consists of R85, C122, and L14. The bandpass filter consists of L19 and C139. The filter basically filters the fourth harmonic of the 4 MHz signal to generate a 16 MHz signal. The resulting signal is then passed through comparator U34A to generate a 16 MHz square wave. Three more stages, consisting of a bandpass filter followed by a comparator, further filter the signal so that a clean 16 MHz signal results. The 16 MHz signal which is the result of these successive stages of filtering is output at pin 10 of U34. U35 buffers this signal to provide the 16 MHz clock for the CPU. In addition, divide-by-two flip flops are located within U35, which generate 8 MHz and 4 MHz signals.

State- and Trace-Storage Problems

State storage is in the two of the four Program RAMs and trace storage is in the two display RAMs. With low battery voltage, it is normal for states and traces to be retained if the power is off for less than 1 minute. If the power is left off for more than thirty minutes with low battery voltage, the stored states and traces will be lost.

The following steps test battery backup for EC-series instruments:

1. Measure the voltage on W6 at A2J3. If the voltage is less than 2.6 V, check the BT1 battery.
2. If the battery voltage is correct, reconnect W6 to A2J3, turn the analyzer power off and wait 5 minutes.
3. Measure the voltage at A2U19 pin 32 and A2U26 pin 32.
4. If the voltage is less than 2.0 Vdc, the RAM power battery-backup circuitry on the A2 controller assembly is probably at fault.

The following steps test battery backup for E-series instruments:

1. Measure the voltage on W6 at A2J10. If the voltage is less than 2.6 V, check the BT1 battery.
2. If the battery voltage is correct, reconnect W6 to A2J10, turn the analyzer power off and wait 5 minutes.
3. Measure the voltage at A2U101 pin 28 and A2U102 pin 28.
4. If the voltage is less than 2.0 Vdc, the RAM power battery-backup circuitry on the A2 controller assembly is probably at fault.

Keyboard Problems

If the analyzer does not respond to keys being pressed or the knob being rotated, the fault could be either on the A3 interface assembly or the A2 controller assembly. To isolate the A2 controller assembly, use the following procedure. This procedure tests the analyzer response over GPIB and the keyboard/RPG interrupt request signal.

1. Enter and run the following BASIC program:

```
10 OUTPUT 718; "IP; SP 1 MHz;"
20 WAIT 2 ! Wait 2 seconds
30 OUTPUT 718;"AT 70 DB;"
40 WAIT 2 ! Wait 2 seconds
50 OUTPUT 718;"AT 30 DB;"
60 WAIT 2 ! Wait 2 seconds
70 OUTPUT 718;"AT 10 DB;"
80 END
```

2. When the program runs, three or four clicks should be heard. This is the A9 input attenuator changing attenuation value.
3. If the display shows the analyzer to be in RMT and the ATTEN value displayed on the LCD (CRT on E-series instruments) changed according to the program, the A2 controller assembly is working properly. Refer to [Chapter 8](#) , “ADC/Interface Section.”
4. If there was no response over GPIB, the A2 controller is probably defective. Be sure to also check the A19 GPIB assembly and A19W1.
5. If there was an improper response (for example, the displayed ATTEN value changed but no clicks were heard), the A2 controller is probably working properly.
6. On EC-series instruments, attach a logic probe to A2U35 pin 213. On E-series instruments, attach a logic probe to A2U2 pin 2.

Look for pulses while pressing a key and rotating the knob (RPG). This is the interrupt request signal for the keyboard and RPG.
7. If the interrupt request signal is always low, troubleshoot the A2 controller assembly.
8. If the interrupt request signal is always high, the fault is on either the A3 interface or A1A1 keyboard assembly.

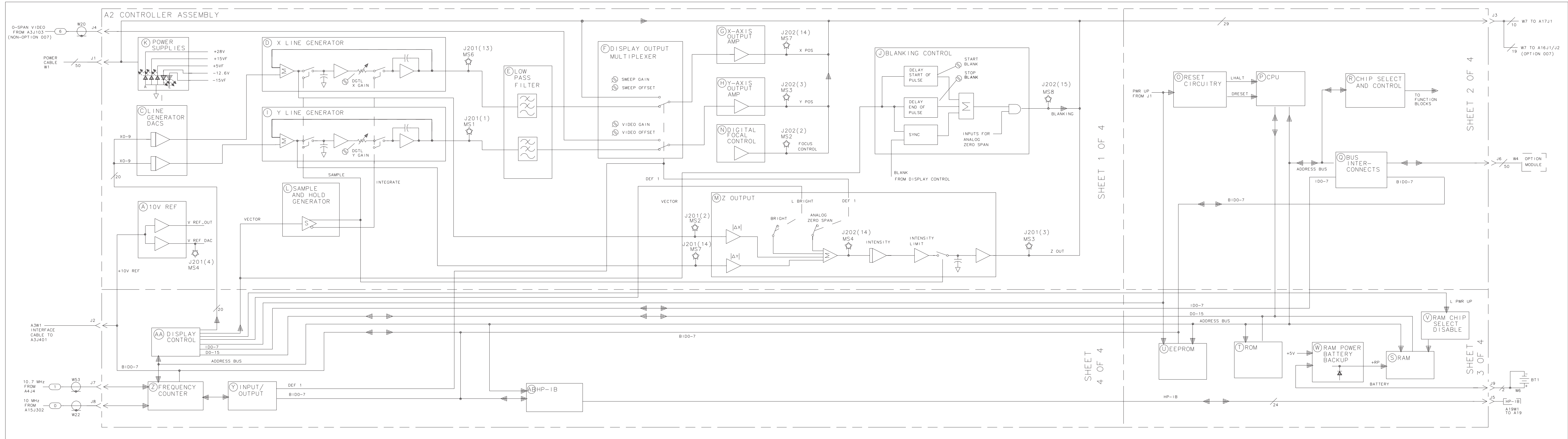

FIGURE 10-13. A2 CONTROLLER BLOCK DIAGRAM

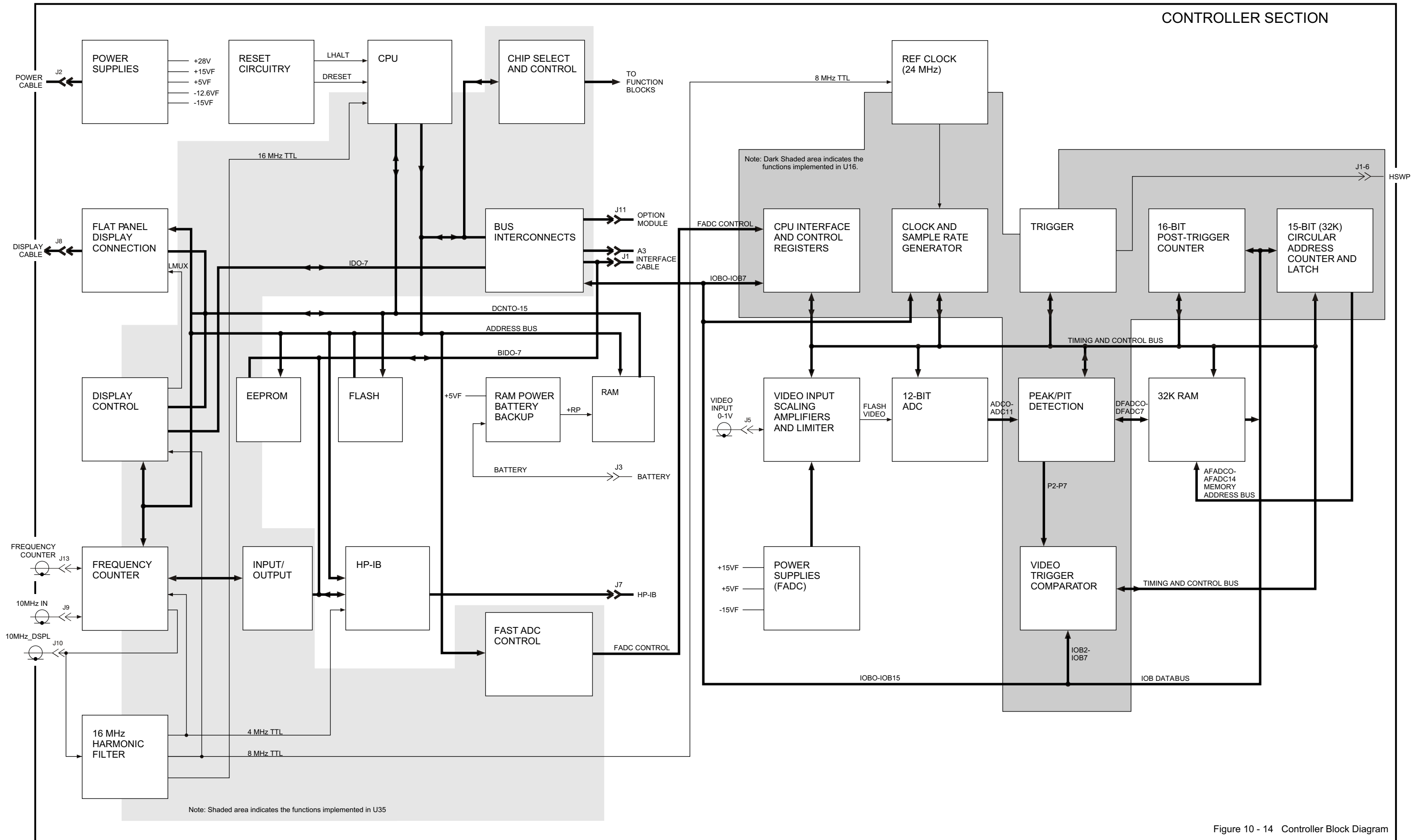

Figure 10 - 14 Controller Block Diagram

11 **Synthesizer Section**

Introduction

The synthesizer section includes the A7 LOMA (LO multiplier/amplifier), the A11 YTO, and parts of the A14 frequency control and A15 RF assemblies. Simplified and detailed block diagrams for each assembly are located at the end of this chapter.

	Page
Test Connector Locations.....	page 524
Troubleshooting Test Setup.....	page 527
Confirming a Faulty Synthesizer Section	page 528
General PLL Troubleshooting	page 534
PLL Locked at Wrong Frequency	page 534
Unlocked PLL	page 535
Unlocked Reference PLL (100 MHz VCXO)	page 537
Operation (100 MHz VCXO)	page 537
Troubleshooting (100 MHz VCXO)	page 537
Third LO Driver Amplifier (100 MHz VCXO)	page 541
Unlocked Reference PLL (600 MHz SAWR)	page 542
Operation (600 MHz SAWR)	page 542
Troubleshooting (600 MHz SAWR)	page 542
Third LO Driver Amplifier (600 MHz SAWR)	page 545
Unlocked Offset Lock Loop (Sampling Oscillator)	page 547
Operation	page 547
Troubleshooting	page 547
Unlocked YTO PLL	page 551
Operation	page 551
Troubleshooting an Unlocked YTO PLL	page 553
Unlocked Fractional N PLL	page 560
Operation	page 560
Confirming an Unlocked Condition	page 560
Fractional N PLL	page 561
Frequency Span Accuracy Problems	page 568
Determining the 1st LO Span	page 568
Confirming Span Problems	page 569
YTO Main Coil Span Problems (LO Spans >20 MHz) .	page 570
YTO FM Coil Span Problems (LO Spans 2.01to 20 MHz) .	page 570
Fractional N Span Problems (LO Spans ≤2 MHz)	page 572
1st LO Span Problems (All Spans)	page 572
1st LO Span Problems (Multiband Sweeps)	page 573
Phase Noise Problems	page 575
Phase Noise in Locked versus Unlocked Spans	page 575
Reference versus Reference PLL Phase Noise	page 576
Fractional N versus Offset PLL or YTO PLL Phase Noise	page 576
Fractional N PLL Phase Noise (08564-60007 Only)	page 576
Sampler and Sampler IF	page 577
Sweep Generator Circuit	page 579
A21 OCXO	page 585

CAUTION All of the assemblies are extremely sensitive to electrostatic discharge (ESD). For further information regarding electrostatic cautions, refer to [“Electrostatic Discharge”](#) “Electrostatic Discharge Information” in [Chapter 1](#) .

CAUTION Using an active probe, such as an 85024A, with a spectrum analyzer is recommended for troubleshooting the RF circuitry. If an 1120A active probe is being used with a spectrum analyzer, such as the 8566A/B, or 8569A/B having dc coupled inputs, either set the active probe for an ac coupled output or use a dc blocking capacitor (11240B) between the active probe and the spectrum-analyzer input. Some spectrum analyzers can be set to ac coupled. Failure to do this can result in damage to the analyzer or the probe.

Test Connector Locations

When troubleshooting suspected faulty circuits, use [Table 11-1 on page 525](#) to determine which procedure to perform.

[Figure 11-1](#) illustrates test connector locations on the A14 and A15 assemblies.

The pin locations of a 16-pin test connector are indicated in [Figure 11-2 on page 525](#).

Figure 11-1 A14 and A15 Assembly Test Connectors

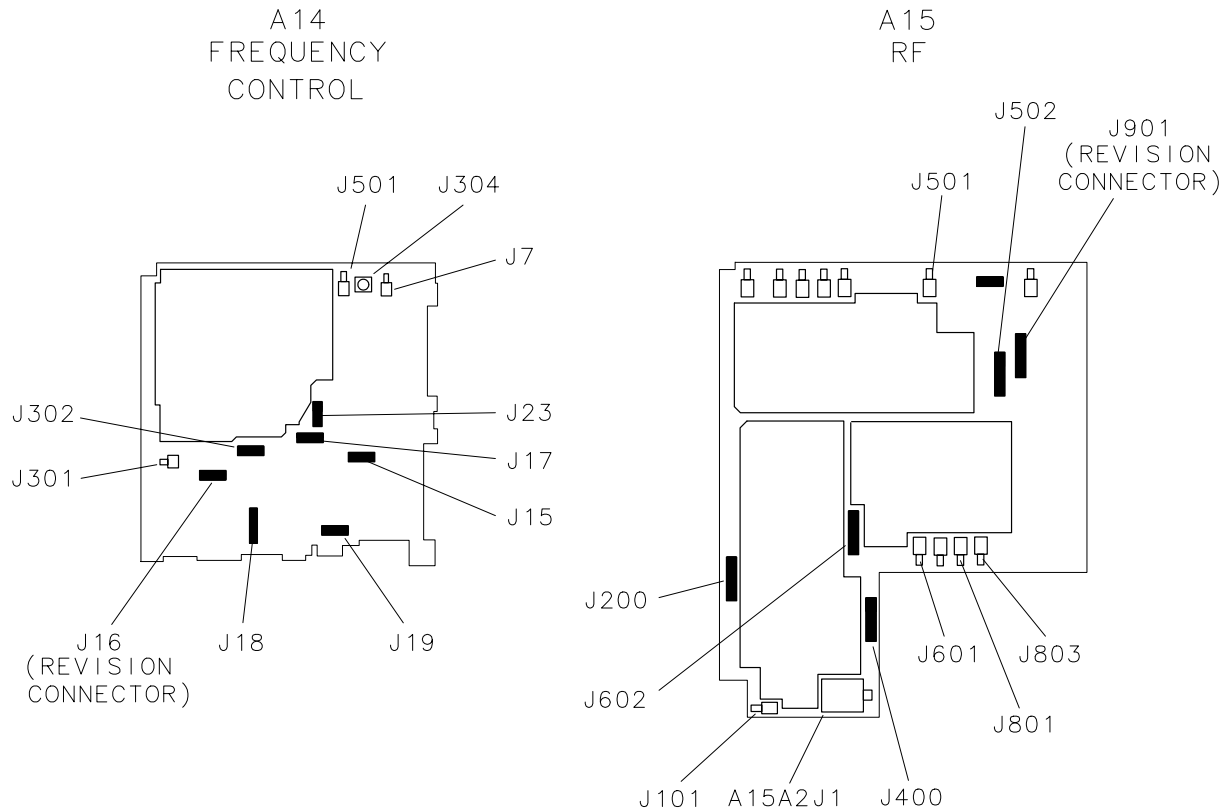

sp 128e

Figure 11-2 Test Connector Pin Locations

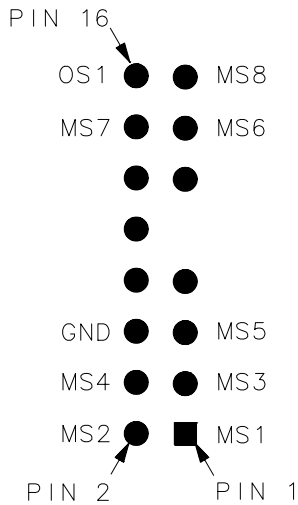

sz 144e

Table 11-1 Troubleshooting Suspected Faulty Circuits

Suspected Circuit	Procedure to Perform
YTO loop	Confirming a Faulty Synthesizer Section (steps 12-33)
1st LO	Confirming a Faulty Synthesizer Section (steps 9-11)
1st LO pretune frequency and amplitude	Unlocked YTO PLL (steps 9-12)
Fractional N oscillator	Unlocked YTO PLL (steps 13-17)
3rd LO drive	Third LO Driver Amplifier (100 MHz VCXO) (steps 1-6)
10 MHz reference to reference PLL	Unlocked Reference PLL (600 MHz SAWR) (steps 8-13)
phase/frequency detector	Unlocked Reference PLL (steps 12 and 13)
10 MHz signal at other input to reference PLL	
phase/frequency detector	Confirming a Faulty Synthesizer Section (steps 1-4)
Sampling oscillator tune voltage	
A14 frequency control assembly	Confirming a Faulty Synthesizer Section (steps 12-18)
A14J301 10 MHz REF input	Confirming a Faulty Synthesizer Section (steps 5-8)
A15 RF assembly	Confirming a Faulty Synthesizer Section (steps 18-25)
Current source A14U307	1st LO Span Problems (All Spans) (steps 14-21)

Table 11-1 Troubleshooting Suspected Faulty Circuits

Suspected Circuit	Procedure to Perform
YTO loop phase/frequency detector	Unlocked YTO PLL (steps 27-34)
YTF gain and offset DACs	YTF Driver Circuit (steps 10-23)
Level at amplifier input	Third LO Driver Amplifier (steps 1-6)
Levels into mixer A15U400	Unlocked YTO PLL (steps 3-13)
Offset PLL	Unlocked YTO PLL (steps 1 and 2)
Main coil tune DAC	Unlocked YTO PLL (steps 45-49)
Main coil coarse and fine DACs	Unlocked YTO PLL (steps 41-44)
Sweeping fractional N	Fractional N Span Problems (LO Spans £2 MHz)
Reference PLL phase/frequency detector	Unlocked Reference PLL (steps 17-22)
Path to offset PLL phase/frequency detector	Unlocked YTO PLL (steps 3-7, 14-19)
Sampler drive output of A7	Unlocked YTO PLL (steps 18-21)
Sampler IF	Unlocked YTO PLL (steps 22-26)
Sampler/sampler IF operation	Sampler and Sampler IF (steps 1-15)
Span attenuator	1st LO Span Problems (All Spans) (steps 6-13)
Sweep generator	Sweep Generator Circuit
Sweep + tune multiplier	YTF Driver Circuit (steps 4-9)
600 MHz reference loop amplifier	Unlocked Reference PLL (steps 23-26)
YTO loop	Unlocked YTO PLL
YTO FM coil driver	1st LO Span Problems (2.01 MHz to 20 MHz) (step 6)
YTO FM coil driver and main loop error voltage driver	Unlocked YTO PLL (steps 35-40)

Troubleshooting Test Setup

Some synthesizer section problems require placing the YTO PLL in an unlocked condition. This is done by moving jumper A14J23 to the TEST position. This grounds the YTO ERROR signal and disables the CPU from detecting an unlocked YTO. The FM coil driver output is set to its mid-range level causing the YTO to be controlled only by the main coil tune DAC.

Synthesizer section troubleshooting is best done with the spectrum analyzer SPAN set to 0 Hz (even though it is still possible to sweep the Main and FM coils of the YTO).

With the YTO in its unlocked conditions and the SPAN set to 0 Hz, the nominal YTO frequency is not necessarily the value listed as LO FREQ in the Frequency Diagnose menu. The YTO has an initial pretune accuracy of ± 20 MHz. To display the nominal YTO frequency, press **CAL, MORE 1 OF 2, FREQ, DIAGNOSE, LO FREQ.**

The fractional N oscillator frequency is the same as the desired sampler IF. To display the fractional N oscillator frequency press **CAL, MORE 1 OF 2, FREQ DIAGNOSE, FRAC N FREQ.** If the sampler IF is negative (YTO frequency is lower than the desired sampling oscillator harmonic), the fractional N frequency will be displayed as a negative number.

Confirming a Faulty Synthesizer Section

The A11 YTO (the 1st LO of the spectrum analyzer) is a YIG-tuned oscillator which tunes from 2.95 to 6.8107 GHz. The A7 LO multiplier/amplifier (LOMA) levels the A11 output and distributes the signal to the following:

- A8 low band mixer
- A10 YIG-tuned mixer/filter (RYTHM)
- A12 switched barium-tuned mixer (SBTX)
- A15U100 sampler
- 1ST LO OUTPUT to the front panel

The synthesizer section includes the following PLLs (Phase Locked Loops):

YTO PLL	A7, A11, A14 and A15 assemblies
Offset PLL (sampling oscillator PLL)	A15 RF assembly
Fractional N PLL	A14 frequency control assembly
Reference PLL	A15 RF assembly

The fractional N PLL is sometimes swept backwards (higher frequency to lower frequency). This is necessary because of the way in which the sampler IF signal is produced.

NOTE

The frequency control board is digitally controlled. If multiple failures appear in unrelated areas of the circuitry, the control may be at fault. Refer to the troubleshooting procedures in this chapter for further help on isolating those failures.

Check Sampling Oscillator Tune Voltage (steps 1-4)

1. Connect the positive lead of a DVM to A15J200 pin 13 and the negative lead to A15J200 pin 6. This measures the sampling oscillator tune voltage which is an input to the ADC MUX of the A3 interface assembly.
2. Set the spectrum analyzer to the following settings:
 - Span 0 Hz
 - Center frequency 389.5 MHz
 - Trigger SINGLE
3. Use the data entry keys to tune the **CENTER FREQ** to the values listed in [Table 11-2 on page 529](#).

4. As the sampling oscillator frequency is increased, the DVM reading should also increase. If the tune voltage is correct, but the ADC measures the voltage and determines it to be out of specification, troubleshoot the A3 assembly ADC MUX.

Table 11-2 Center Frequency Tuning Values

8564E/EC and 8565E/EC Center Frequency (MHz)	Sampling Oscillator Frequency (MHz)
2156.3	285.000
2176.3	286.364
2199.5	287.500
2230.3	288.462
799.3	288.889
2263.3	290.000
2282.3	290.909
2302.3	291.667
2155.3	292.500
2158.3	293.478
2336.3	294.444
2196.3	295.000
1.3	296.000
2378.3	296.471
2410.3	297.000
2422.3	297.222

**Check A14J301
 10 MHz reference
 input (steps 5-8)**

5. Disconnect W37 from A14J301.
6. Connect a test cable from W37 to the input of another spectrum analyzer. Tune the other spectrum analyzer to the following settings:
 - Center frequency 10 MHz
 - Span 2 MHz
7. The amplitude of the 10 MHz reference signal should measure >-1 dBm. If the signal does not measure >-1 dBm, troubleshoot the A15 10 MHz distribution and A21 OCXO (If not Option 103).
8. Reconnect W37 to A14J301.

**Check 1st LO
 (steps 9-11)**

9. Connect the CAL OUTPUT to INPUT 50Ω

10. Set the spectrum analyzer to the following settings:

Center frequency 300 MHz
Span 100 MHz

11. If the 1st LO is present, a signal should be displayed at about -10 dBm (approximately ± 20 MHz from the center frequency). If no signal is displayed and ERR 338 LOMA AGC, ERR 339 SBTX AGC, or ERR 340 SAMP AGC is not present, suspect the A7 LOMA. If no signal is displayed and ERR 338 LOMA AGC, ERR 339 SBTX AGC, or ERR 340 SAMP AGC is present, check the A11 YTO as follows:

a. Set jumper A14J23 to the TEST position.

b. Set the spectrum analyzer to the following settings:

Center frequency 50 Hz
CF step 300 MHz
Span 0 Hz

c. Connect a power meter directly to the output of the A11 YTO.

d. Press the spectrum analyzer step-up key and measure the YTO output power at each step.

e. Make sure that the A11 YTO output power is between +9 and +13 dBm.

f. Set jumper A14J23 to the NORM position and reconnect the A11 YTO.

**Check A14
frequency
control assembly
(steps 12-18)**

12. On the spectrum analyzer press **PRESET, SPAN, ZERO SPAN, CAL, MORE 1 OF 2, FREQ DIAGNOSE, and FRAC N FREQ**. Note the fractional N oscillator frequency. (Ignore the minus sign, if present.)

Fractional N Oscillator Frequency = _____ MHz

13. Check A14J304 (FRAC N TEST) port with a spectrum analyzer for this exact frequency. The amplitude should be approximately -10 dBm.

14. Disconnect W32 from A14J501 and connect the output of a signal source to A14J501. Remove the jumper from A14J23. Connect the positive lead of a DVM to A14J23 pin 1, and the negative lead to A14J23 pin 3. See [Figure 11-3 on page 531](#).

15. Set the signal source to the following settings:

Power 0 dBm
Frequency Frequency recorded in step 12

16. Tune the source 1 kHz below the fractional N frequency. The voltage measured on the DVM should be approximately 12 Vdc.

17. Tune the source 1 kHz above the fractional N frequency. The voltage measured on the DVM should be approximately -12 Vdc.
18. If the DVM reading does not change, the A14 frequency control assembly is defective. Reconnect W32 to A14J501. Replace the jumper on A14J23 to the NORM position.

Figure 11-3 YTO Loop Test Setup

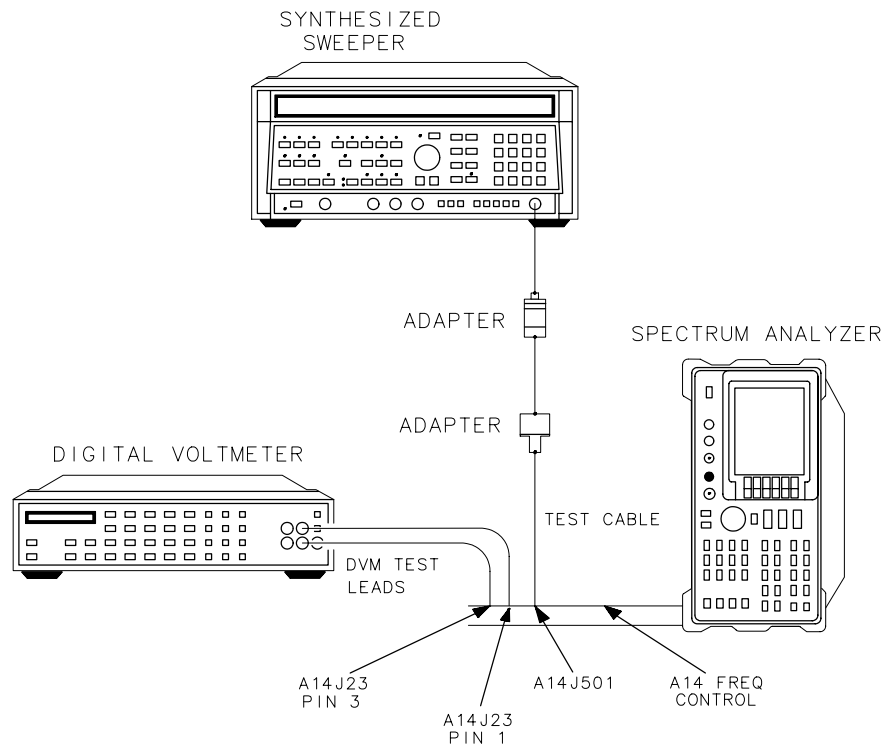

Sp127e

Check A15 RF assembly (steps 19-25)

19. Disconnect W34 from A15U100J1 and disconnect W32 from A15J101.
20. Connect a frequency counter to A15J101. Connect a high-frequency test cable from an 8340A/B synthesized sweeper to A15U100J1. See [Figure 11-4 on page 532](#).
21. Connect a BNC cable from the spectrum analyzer 10 MHz REF IN/OUT to the 8340A/B FREQUENCY STANDARD EXT input.
22. Set the 8340A/B to the following settings:

Frequency standard	EXT
Power level	-5 dBm
23. Set the spectrum analyzer to the following settings:

Span	0 Hz
Trigger	SINGLE

32.If the power is less than -6.5 dBm, suspect W34, A7 LOMA, or A11 YTO.

33.Move jumper A14J23 to the NORM position.

Table 11-3 Sampling Oscillator Test Frequencies

8340A CW Frequency (GHz)	8564/65E Center Frequency (MHz)	Offset PLL Sampling Oscillator Freq (MHz)	Counter Reading Sampler IF (MHz)
6.067000	2156.3	285.000	82.000
6.087000	2176.3	286.364	73.364
6.110200	2199.5	287.500	72.700
6.141000	2230.3	288.462	83.308
4.710000	799.3	288.889	87.778
6.174000	2263.3	290.000	84.000
6.193000	2282.3	290.909	83.909
6.213000	2302.3	291.667	88.000
6.066000	2155.3	292.500	76.500
6.069000	2158.3	293.478	94.044
6.247000	2336.3	294.444	63.667
6.107000	2196.3	295.000	88.000
3.912000	1.3	296.000	64.000
6.289000	2378.3	296.471	63.118
6.321000	2410.3	297.000	84.000
6.333000	2422.3	297.222	91.333

General PLL Troubleshooting

The synthesizer section relies heavily on phase-locked loops (PLL). Typically, faulty PLLs are either locked at the wrong frequency or unlocked. The information below applies to troubleshooting these two classes of problems on a generalized PLL.

PLL Locked at Wrong Frequency

Numbers in the following text identify items in [Figure 11-5 on page 535](#):

- Any frequency errors at reference (1) will be multiplied by N/M on the PLL output.
- A sampler reference-frequency error (2) will be multiplied by its harmonic on the PLL output.
- A mixer reference-frequency error (3) produces the identical error on the PLL output.
- If divider input or output frequencies (4) are wrong, check for incorrect divide numbers and data controlling the dividers.

Figure 11-5 PLL Locked at Wrong Frequency

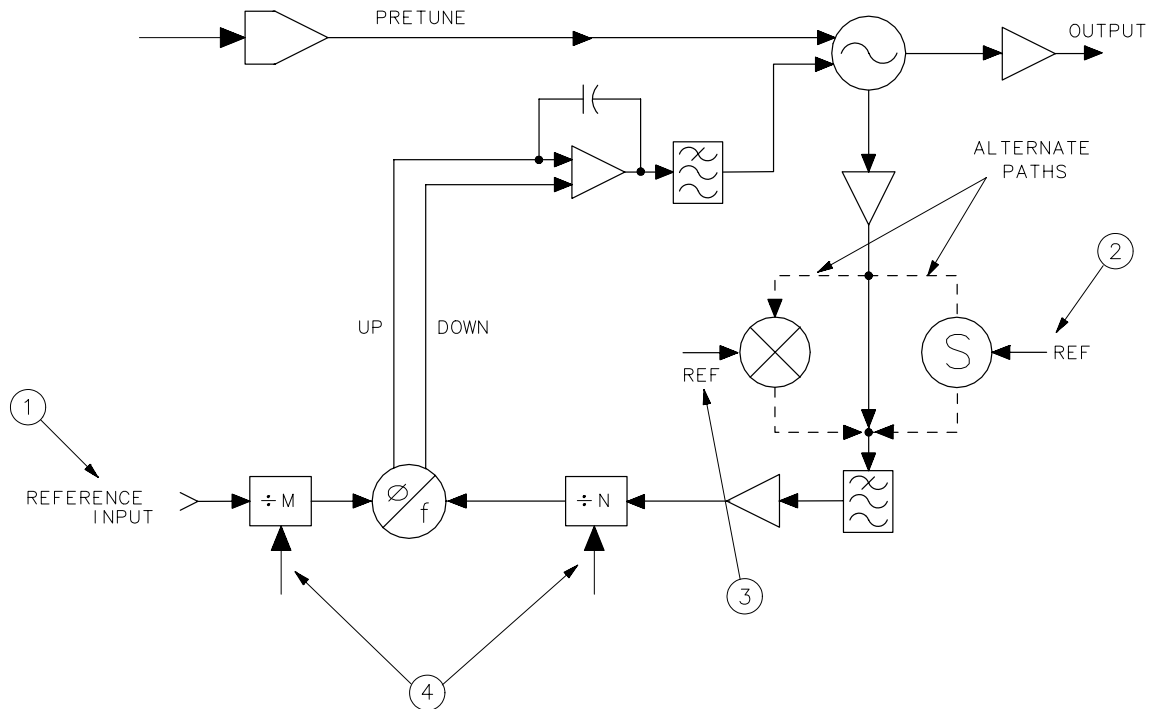

sp129e

Unlocked PLL

An unlocked PLL can be caused by problems inside or outside the PLL. Troubleshoot this problem by working backward from the oscillator as described in the steps below. Numbers in the following text identify items in [Figure 11-6 on page 536](#).

1. The loop integrator output voltage (1) should be attempting to tune the oscillator to the correct frequency:

The voltage at (1) should increase as the frequency increases on all of the PLLs:

Unlocked Reference PLL (100 MHz VCXO)

NOTE

The following information is for A15 RF assemblies 08563-60054 and later. For earlier A15 RF assemblies, proceed to *Unlocked Reference PLL (600 MHz SAWR)* in this chapter.

Operation (100 MHz VCXO)

The 600 MHz reference is generated by tripling, then doubling the output of the 100 MHz phase-locked loop. If the 600 MHz reference is off frequency, the 100 MHz phase-lock circuitry is probably at fault. If there is no signal present at A15J701, or if the level is less than -3 dBm, the 100 MHz VCXO, the tripler, or the doubler circuitry has probably failed. Refer to function blocks Q, R, and S of the A15 RF schematic (sheet 2 of 4) in the *8560 E-Series Spectrum Analyzer Component Level Information* binder.

Troubleshooting (100 MHz VCXO)

Check 100 MHz VCXO, tripler, and doubler (steps 1-7)

1. Using an active probe/spectrum analyzer combination, such as the 85024A/8566B, measure the tripler output at A15TP700. The tripler output should be $+3$ dBm ± 2 dB.
2. If the tripler output is within tolerance, suspect the doubler circuitry. Refer to function block S of the A15 RF schematic (sheet 2 of 4).
3. If the tripler output is too low, probe the output of A15U700 RF amplifier. The level should be $+16.5$ dBm ± 2 dB. The level at the input of A15U700 should be $+8.5$ dBm ± 2 dB.
4. If the level at the input of A15U700 is too low, suspect a faulty 100 MHz VCXO. Refer to function block Q of the A15 RF schematic (sheet 2 of 4).
5. On the spectrum analyzer, press **AUX CTRL**, **REAR PANEL**, and **10 MHz INT**.
6. Measuring the tune voltage indicates if the 100 MHz PLL is locked. Connect the ground lead the voltmeter to A15J1 pin 3 and measure the voltage at A15J700 pin 3.
7. The tune voltage should be between $+1$ and $+24$ Volts. If the tune voltage is incorrect, place the P700 jumper (on A15J700) in the TEST position (pin 1 to pin 2). This sets the tune voltage for varactor A15CR700 to the nominal $+13$ Volts, making it easier to troubleshoot the 100 MHz VCXO, tripler, and doubler. Remember to return P700 jumper to the NORMAL position when you have finished troubleshooting the oscillator circuitry.

8. If the 100 MHz oscillator is working, the reason for the unlocked condition is either a problem in the 10 MHz reference or a fault in the signal path around the loop.

Check 10 MHz reference to phase/frequency detector (steps 9-14)

9. On the spectrum analyzer, press **AUX CTRL, REAR PANEL, and 10 MHz INT.**

10. Check the 10 MHz reference frequency-accuracy by connecting a frequency counter to A15J301 and verify that the reference frequency is 10 MHz \pm 40 Hz after a 5 minute warm-up period.

11. If a 10 MHz signal >1 V peak-to-peak is not present at A15J301, refer to the “10 MHz Reference” in [Chapter 12](#).

12. Measure the signal at TP301 with an oscilloscope. Refer to function block M of A15 RF schematic (sheet 2 of 4).

13. Measure the signal at U502 pin 11 with an oscilloscope. Refer to function block X of A15 RF schematic (sheet 2 of 4). This signal should be TTL levels at 10 MHz with a 60 percent duty cycle.

14. If TTL-level signals (approximately 10 MHz) are not present, check signals backwards through the loop to find a fault in the signal path.

15. Measure the signals at the following test points with an active probe/spectrum analyzer combination:

Junction of C570 and C571 100 MHz, +2.5 dBm \pm 2 dB

**Junction of R715, R716,
R567, and R568** 100 MHz, -3 dBm \pm 2 dB

U700 pin 3 100 MHz, +16.5 dBm \pm 2 dB

U700 pin 1 100 MHz, +8.5 dBm \pm 2 dB

16. If an approximately 10 MHz TTL signal is present at U502 pin 11 with 60 percent duty cycle, and the RF portion of the phase-lock loop is functioning, the fault probably lies in the phase/frequency detector or the 100 MHz lock loop integrator.

Check phase/frequency detector (steps 17-22)

17. Monitor U504 pin 5 and U503 pin 9 with an oscilloscope. These are the two outputs of the phase/frequency detector. Refer to function block O of A15 RF schematic (sheet 2 of 4).

18. A locked loop will exhibit stable, narrow (approximately 20 ns wide), and positive-going TTL pulses occurring at a 10 MHz rate at U504 pin 5 and U503 pin 9.

- 19.If the loop is unlocked, but signals are present on both inputs of the phase/frequency detector, the output pulses will be superimposed on each other.
- 20.If the loop is unlocked, and there is no signal at one of the phase/frequency detector inputs, one phase detector output will be at TTL low and the other will be at TTL high. For example, if there is no input signal at U504 pin 3, U504 pin 5 will be TTL low and U503 pin 9 will be TTL high. If there is no input signal at U503 pin 11, U503 pin 9 will be TTL low and U504 pin 5 will be TTL high.
- 21.To remove the 10 MHz reference input to the phase/frequency detector, press **AUX CTRL**, **REAR PANEL**, and **10 MHz EXT** with no signal applied to the rear panel 10 MHz REF IN/OUT connector.
- 22.To remove the divided-down 100 MHz signal from the phase/frequency detector, short R595. Refer to function block X of A15 RF schematic (sheet 2 of 4).
- 23.Remove 10 MHz reference input to the phase/frequency detector by pressing **AUX CTRL**, **REAR PANEL**, and **10 MHz EXT**. No signal should be connected to the rear panel 10 MHz REF IN/OUT connector.

Check the 100 MHz lock loop integrator (steps 23-27)

NOTE

The outputs of phase/frequency detector are low-pass filtered to reduce the 10 MHz component of the signal. The filtered signals are then integrated by U506 and the result is fed to the tune line of the 100 MHz VCXO.

- 24.Check that the voltage on A15J502 pin 3 is less than 0 Vdc. Refer to function block P of A15 RF schematic (sheet 2 of 4).
- 25.Press **AUX CTRL**, **REAR PANEL**, and **10 MHz INT** and remove the divided-down 100 MHz input to the phase/frequency detector by shorting R572.
- 26.Check that the voltage on A15J502 pin 3 is greater than 13 Vdc.
- 27.If the loop is locked, the voltage on A15J502 pin 3 should be between 0 and +6 Vdc.
- 28.If the front-panel CAL OUTPUT amplitude is out of specification and cannot be brought within specification by adjusting A15R561, CAL AMPTD, check the calibrator AGC amplifier with the following steps. Refer to function block W of A15 RF schematic (sheet 1 of 4).

NOTE

The 300 MHz CAL OUTPUT signal comes from the tripled 100 MHz which is passed through a leveling loop. The 300 MHz signal passes through a low-pass filter for reducing higher harmonics. These harmonics can fool the detector. The 300 MHz signal passes through a variable attenuator controlled by PIN diode CR503 which is controlled by the feedback loop. Diode CR504 is the detector diode (the same type as CR505). Diode CR504 provides temperature compensation between the reference voltage and the detected RF voltage.

- Measure the level of 300 MHz at A15 TP505 with an active probe/spectrum analyzer combination. If the signal is less than +2 dBm, repeat the first 27 steps of this procedure.
 - If the signal at this point is correct, place a short across the PIN diode CR503.
 - If the signal level at the CAL OUTPUT is still less than -10 dBm with CR503 shorted out, troubleshoot the RF forward path through amplifier Q505. (The signal amplitude decreases.)
 - If the CAL OUTPUT signal level is greater than -10 dBm, troubleshoot the PIN diode attenuator, the detector, or the feedback path.
29. Measure the detector voltage at A15J502 pin 14. The voltage should measure approximately +0.3 Vdc when the CAL OUTPUT signal is at -10 dBm. This voltage should change with adjustment of A15R561, CAL AMPTD.
30. Check that the voltage at U507A Pin 3 is +1.7 Vdc. If this voltage is not correct, there may be a problem with the +10 V reference.
31. Measure voltage at U507B pin 5 while adjusting R561. This is the temperature-compensated adjustable voltage reference to which the detected voltage is compared. It should vary between +0.15 V and +0.6 V.
32. Adjust R561 to its limits and verify that the output U507B pin 7 measures approximately +1 Vdc at one limit and -12 Vdc at the other limit.

Third LO Driver Amplifier (100 MHz VCXO)

The third LO driver amplifier (Q503) amplifies the 300 MHz from the 300 MHz distribution amplifier to a sufficient level to drive the LO port of the double balanced mixer. During the SIG ID operation, diodes CR501 and CR502 turn off the 3rd LO driver amplifier in order to minimize the amount of 300 MHz going to the double-balanced mixer.

Check level at amplifier input (steps 1-5)

1. Press **AUX CTRL, INTERNAL MIXER**. Press **SIG ID OFF**, if Option 008 is installed.

Use an active-probe/spectrum-analyzer combination to confirm the power level of the 300 MHz signal at the following test points:

A15X602 pin 5 ≥+7 dBm

A15TP504 ≥+15 dBm

2. If the signal at A15X602 pin 5 is low, but the signal at A15TP504 is correct, press **AUX CTRL, INTERNAL MIXER**. Press **SIG ID OFF**, if present.
3. Check that PIN diode switches CR603 and CR605 are reverse biased by approximately +10 Vdc. Refer to function block F of A15 RF schematic (sheet 4 of 4).
4. Measure 300 MHz signal at A15TP503 using an active probe/spectrum analyzer combination. If the signal is not approximately +10 dBm, refer to "Unlocked Reference PLL" in this chapter.
5. If the level at the TP503 is correct, but signal at TP504 is too low, the fault is probably in the amplifier.

Unlocked Reference PLL (600 MHz SAWR)

NOTE

The following information is for A15 RF assemblies earlier than 08563-60054, 08563-60055, or 08563-60056. For A15 RF assemblies with the aforementioned part numbers or later, refer to *Unlocked Reference PLL (100 MHz VCXO)* earlier in this chapter.

Operation (600 MHz SAWR)

The reference PLL 600 MHz output is generated by a 600 MHz SAWR (surface acoustical wave resonator) VCO. The SAWR provides a high Q feedback path in the oscillator ensuring good phase noise. If the oscillator is off-frequency, the phase-lock circuitry is probably at fault. If there is no signal present at A15J701, or if the level is less than -3 dBm, the oscillator has failed. Transistor Q703 provides active bias for oscillator transistor Q701. Transistor Q704 provides active bias for 600 MHz buffer amplifier Q702. Refer to function blocks Q and R of A15 RF schematic (sheet 2 of 3) in the *8560 E-Series Spectrum Analyzer Component Level Information* binder.

Troubleshooting (600 MHz SAWR)

1. If Q701 and Q703 are functioning, check the bias on varactors CR701 and CR702. The varactors should be reverse-biased between 0 V and 18 V, depending on tune voltage.
2. If the active devices are functioning properly, check the SAWR by placing a 100-ohm resistor across U701 pins 1 and 2. This bypasses the SAWR, but provides the equivalent loss of a correctly functioning SAWR.
3. If the oscillator begins to oscillate, the SAWR is probably defective.
4. On the spectrum analyzer, press **AUX CTRL**, **REAR PANEL**, and **10 MHz INT**.
5. Measuring tune line voltage (LO3 ERR) indicates if the Reference PLL is locked. Measure the voltage at A15J502 pin 3. Connect the ground lead to A15J200 pin 6.
6. If voltage is not between 0 V and 5.75 V the loop is unlocked and ERR 333 600 UNLK should be displayed on the CRT.
7. If the 600 MHz oscillator is working, the reason for the unlocked condition is either a problem in the 10 MHz reference or a fault in the signal path around the loop.

Check 10 MHz reference to phase/frequency detector (steps 8-13)

8. On the spectrum analyzer, press **AUX CTRL, REAR PANEL,** and **10 MHz INT.**
9. Check the 10 MHz reference frequency-accuracy by connecting a frequency counter to A15J301 and verify that the reference frequency is 10 MHz \pm 40 Hz after a 5 minute warm-up period.
- 10.If a 10 MHz signal >1 V peak-to-peak is not present at A15J301, refer to the “10 MHz Reference” in [Chapter 12](#) .
- 11.Measure the signal on U504 pin 3 with an oscilloscope. Refer to function block O of A15 RF schematic (sheet 2 of 4).
- 12.Measure the signal at U504 pin 11 with an oscilloscope. Refer to function block O of A15 RF schematic (sheet 2 of 4). This signal should be TTL levels at 10 MHz with a 90 percent duty cycle.
- 13.If TTL-level signals (approximately 10 MHz) are not present, check signals backwards through the loop to find a fault in the signal path.
- 14.Use an oscilloscope to check for 50 MHz TTL level signal at U503 pin 2. Refer to function block X of A15 RF schematic (sheet 2 of 4).
- 15.Measure the signals at the following test points with an active probe/spectrum analyzer combination such as an 85024A/8566A/B. The signal level at TP701 should be sufficient to drive an ECL input.

U502 pin 2	50 MHz, $\geq+3$ dBm
U502 pin 15	300 MHz, $\geq+3$ dBm
TP503	300 MHz, approximately +8 dBm
TP502	300 MHz (ECL level), approximately +3 dBm
TP701	600 MHz (ECL level), approximately +3 dBm

- 16.If an approximately 10 MHz TTL signal is present at U504 pin 11 with 90 percent duty cycle, and the RF portion of the phase-lock loop is functioning, the fault probably lies in the phase/frequency detector or the 600 MHz reference loop amplifier.

Check phase/frequency detector (steps 17-22)

- 17.Monitor U504 pins 5 and 9 with an oscilloscope. These are the two outputs of the phase/frequency detector. Refer to function block O of A15 RF schematic (sheet 2 of 3).
- 18.A locked loop will exhibit stable, narrow (approximately 20 ns wide), and positive-going TTL pulses occurring at a 10 MHz rate at U504 pins 5 and 9.
- 19.If the loop is unlocked, but signals are present on both inputs of the phase/frequency detector, the output pulses will be superimposed on each other.

20. If the loop is unlocked, and there is no signal at one of the phase/frequency detector inputs, one phase detector output will be at TTL low and the other will be at TTL high. For example, if there is no input signal at U504 pin 3, U504 pin 5 will be TTL low and U504 pin 9 will be TTL high. If there is no input signal at U504 pin 11, U504 pin 9 will be TTL low and U504 pin 5 will be TTL high.
21. To remove the 10 MHz reference input to the phase/frequency detector, press **AUX CTRL**, **REAR PANEL**, and **10 MHz EXT** with no signal applied to the rear panel 10 MHz REF IN/OUT connector.
22. To remove the divided-down 600 MHz signal from the phase/frequency detector, short R572. Refer to function block X of A15 RF schematic (sheet 2 of 4).
23. Remove 10 MHz reference input to the phase/frequency detector by pressing **AUX CTRL**, **REAR PANEL**, and **10 MHz EXT**. No signal should be connected to the rear panel 10 MHz REF IN/OUT connector.

Check the 600 MHz reference loop amplifier (steps 23-26)

NOTE

The outputs of phase/frequency detector are low-pass filtered to reduce the 10 MHz component of the signal. The filtered signals are then integrated by U506 and the result is fed to the tune line of the 600 MHz oscillator.

24. Check that the voltage on A15J502 pin 3 is less than 0 Vdc. Refer to function block P of A15 RF schematic (sheet 2 of 4).
25. Press **AUX CTRL**, **REAR PANEL**, and **10 MHz INT** and remove the divided-down 600 MHz input to the phase/frequency detector by shorting R572.
26. Check that the voltage on A15J502 pin 3 is greater than 5.75 Vdc.
27. If the loop is locked, the voltage on A15J502 pin 3 should be between 0 V and +5.75 Vdc.
28. If the front-panel CAL OUTPUT amplitude is out of specification and cannot be brought within specification by adjusting A15R561, CAL AMPTD, check the calibrator AGC amplifier with the following steps. Refer to function block W of A15 RF schematic (sheet 2 of 4).

NOTE

The 300 MHz CAL OUTPUT signal comes from the divided down 600 MHz which is passed through a leveling loop. The 300 MHz signal passes through a low-pass filter for reducing higher harmonics. These harmonics can fool the detector. The 300 MHz signal passes through a variable attenuator controlled by PIN diode CR503 which is controlled by the feedback loop. Diode CR504 is the detector diode (the same type as CR505). Diode CR504 provides temperature compensation between the reference voltage and the detected RF voltage.

3. If the signal at A15X602 pin 5 is low, but the signal at A15TP504 is correct, press **AUX CTRL**, **INTERNAL MIXER**. Press **SIG ID OFF**, if present.
4. Check that PIN diode switches CR603 and CR605 are reverse biased by approximately +10 Vdc. Refer to function block F of A15 RF schematic (sheet 4 of 4).
5. Measure 300 MHz signal at A15TP503 using an active probe/spectrum analyzer combination. If the signal is not approximately +10 dBm, refer to "Unlocked Reference PLL" in this chapter.
6. If the level at the TP503 is correct, but signal at TP504 is too low, the fault is probably in the amplifier.

Synthesizer Section
 Unlocked Offset Lock Loop (Sampling Oscillator)

6. The voltage required to tune the oscillator should measure between +15 Vdc and +19 Vdc. If the voltage is out of this range, perform the sampling oscillator adjustment in Chapter 2.
7. Vary the voltage to tune the sampling oscillator to 296 MHz.
8. Use an active probe/spectrum analyzer combination to measure the 300 MHz LO signal at the following test point. Refer to function block AI of A15 RF schematic (sheet 3 of 4).

A15TP402 +7 dBm

9. If the signal is not measured near the indicated power, troubleshoot the offset lock loop buffer (function block AM of A15 RF schematic sheet 3 of 4).

Table 11-4 Sampling Oscillator PLL Divide Numbers

Sampling Oscillator Frequency (MHz)	Center Frequency* (MHz)	Reference Divide Chain		Reference Frequency (MHz)
		Prescaler	Postscaler	
285.000	2156.3	10	2	15.000
286.364	2176.3	11	2	13.636
287.500	2199.5	8	3	12.500
288.462	2230.3	13	2	11.538
288.888	799.3	9	3	11.111
290.000	2263.3	10	3	10.000
290.909	2282.3	11	3	9.091
291.666	2302.3	9	4	8.333
292.500	2155.3	8	5	7.500
293.478	2158.3	23	2	6.522
294.444	2336.3	9	6	5.556
295.000	2196.3	10	6	5.000
296.000	1.3	15	5	4.000
296.471	2378.3	17	5	3.529
297.000	2410.3	20	5	3.000
297.222	2422.3	18	6	2.778

* To set the sampling oscillator to a desired frequency, set span to 0 Hz and **CENTER FREQ** to the value listed in the table.

10. Measure the 296 MHz loop feedback signal at the following test point:

A15TP400 +2 dBm

11.If the feedback signal is not near the indicated power, measure the signals at the following test points on the feedback path. Refer to function blocks AD, AG, and AH of A15 RF schematic (sheet 3 of 4).

A15TP200	+4 dBm
A15TP201	+9 dBm
A15TP202	+5.5 dBm

12.Measure the 4 MHz loop-IF signal at the mixer output. The frequency of the IF is the same as the reference frequency and can be found in [Table 11-4 on page 548](#).

A15R447 (end nearest L414)	-6 dBm
-----------------------------------	--------

13.If the IF signal is not near the indicated power, troubleshoot the loop mixer (function block AI).

Check path to phase/frequency detector (steps 14-19)

14.Measure the loop IF signal at the input to the IF amplifier/limiter (function block AK):

A15L428 (end nearest U411)	4 MHz (approximately -6 dBm)
-----------------------------------	------------------------------

15.Confirm the presence of a 4 MHz square-wave reference frequency signal at U406 pin 3. The square wave is TTL and should be less than +0.6 V and greater than +2.2 V.

16.Disconnect the jumper from X201 pins 1 and 5. Disconnect the dc power supply which is connected to A15J200 pin 16.

17.Set the spectrum analyzer to the following settings:

Center frequency	300 MHz
Span	0 Hz

18.Use an oscilloscope to confirm the presence of a 4 MHz TTL-level reference frequency signal at U406 pin 11.

19.Connect a short across A15R425. Connect A15U406 pins 3 and 11 together. This puts the same signal on both the phase/frequency detector inputs.

20.Observe the phase/frequency detector outputs, U406 pins 6 and 9, with an oscilloscope. Narrow TTL pulses should be present. Pin 9 is normally low, pulsing high, and pin 6 is normally high, pulsing low.

21.Check the end of L417 (nearest C445) with an oscilloscope. With the oscilloscope input ac-coupled, a triangle waveform approximately 20 mVp-p should be present.

Unlocked YTO PLL

Operation

The A11 YTO is locked to two other oscillators, the fractional N oscillator and the offset PLL sampling oscillator. For LO spans of 2.01 MHz and greater, either the FM or main coil of the YTO is swept directly. For LO spans less than or equal to 2 MHz, the fractional N oscillator is swept. The sampling oscillator remains fixed-tuned during all sweeps.

The output of A11 YTO feeds through the A7 LO multiplier/amplifier (LOMA) to the A15U100 sampler. The offset PLL sampling oscillator, which drives the sampler, oscillates between 285 and 297.222 MHz. The sampler generates harmonics of the sampling oscillator and one of these harmonics mixes with the YTO frequency to generate the sampler IF frequency. As a result, the frequency of the sampler IF is determined by the following equation:

$$F_{IF} = F_{YTO} - (N \times F_{SAMP})$$

Where:

- F_{IF} is the sampler IF
- F_{YTO} is the YTO frequency
- N is the desired sampling oscillator harmonic
- F_{SAMP} is the sampling oscillator frequency

Notice that F_{IF} can be positive or negative depending upon whether the sampling oscillator harmonic used is less than or greater than the YTO frequency. The actual sampler IF is always positive, but the sign is carried along as a "bookkeeping" function which determines which way to sweep the fractional N oscillator (up or down) and what polarity the YTO error voltage should have (positive or negative) to maintain lock.

To check if a negative sampler IF is selected, press **CAL, MORE 1 OF 2, FREQ DIAGNOSE, FRAC N FREQ**. If the fractional N oscillator frequency is positive, the sampler IF is also positive. A negative fractional N frequency indicates that the sampler IF is negative.

Notice that the polarity of the YTO loop error voltage (YTO ERROR) out of the YTO loop phase/frequency detector changes as a function of the polarity of the sampler IF. That is, for positive sampler IFs, an increasing YTO frequency results in an increasing YTO ERROR signal. For negative sampler IFs, an increasing YTO frequency results in a decreasing YTO ERROR signal. This implies that to maintain lock in both cases, the sense of YTO ERROR must be reversed such that, with a negative sampler IF, an increasing YTO ERROR results in an increasing YTO frequency. This is accomplished with error-sign amplifier, A14U328B. This amplifier can be firmware-controlled to operate as either an inverting or non-inverting amplifier. Digital control line ERRSGN (from A14U313 pin 19) controls the polarity of this amplifier. When ERRSGN is high (positive sampler IF), the amplifier has a positive polarity.

In fractional N spans (LO Spans ≤ 2 MHz) the YTO remains locked to the sweeping fractional N PLL. Thus, the sampler IF must always equal the fractional N oscillator frequency (conditions for lock). Since the YTO must always sweep up in frequency, for negative sampler IFs, the fractional N oscillator must sweep from a higher frequency to a lower frequency. This is necessary since an increasing YTO frequency decreases the sampler IF for negative sampler IFs. The opposite is true for positive sampler IFs, so in these cases, the fractional N oscillator sweeps more conventionally from a lower frequency to a higher frequency.

[Table 11-5 on page 553](#) summarizes the amplifier polarities for the various combinations of sampler IF polarities and LO spans.

The YTO main coil filter is used to improve residual FM in FM spans. See function block I of A14 frequency control schematic (sheet 2 of 5) in the Component-Level Information binder. Transistors Q304 and Q305 switch the filter (capacitor C36 and resistor R48) into the circuit. Transistor Q303 and U333 keep C36 charged during main spans so the frequency does not jump when C36 is switch in.

Table 11-5 Amplifier Polarities

		YTO Error Sign Amplifier	ERRSGN (A14U313 pin 19)
Fractional N Oscillator Swept	Positive Sampler IF	Positive	TTL High
	Negative Sampler IF	Negative	TTL Low
FM/Main YTO Coils Swept	Positive Sampler IF	Positive	TTL High
	Negative Sampler IF	Negative	TTL Low
	Negative Sampler IF	Negative	TTL Low

Troubleshooting an Unlocked YTO PLL

1. If the YTO PLL is unlocked, error code 301 should be displayed. Place the spectrum analyzer in ZERO SPAN. [Figure 11-7 on page 554](#) illustrates the simplified YTO PLL.
2. Move the jumper on A14J23 to connect pins 2 and 3 (TEST position). Refer to [Figure 11-1 on page 524](#) for the location of A14J23. Error code 301 should no longer be displayed. (The YTO PLL feedback path is now open and the YTO error voltage is forced to zero.)
3. On the spectrum analyzer, press **CAL, MORE 1 OF 2, FREQ DIAGNOSE,** and **LO FREQ**. The displayed LO FREQ is the desired YTO frequency calculated. Record the calculated YTO frequency below:

YTO frequency (calculated) = _____ MHz

4. Measure the YTO frequency at the front-panel 1ST LO OUTPUT jack and record below:

YTO frequency (measured) = _____ MHz

Figure 11-7 Troubleshooting an Unlocked YTO PLL

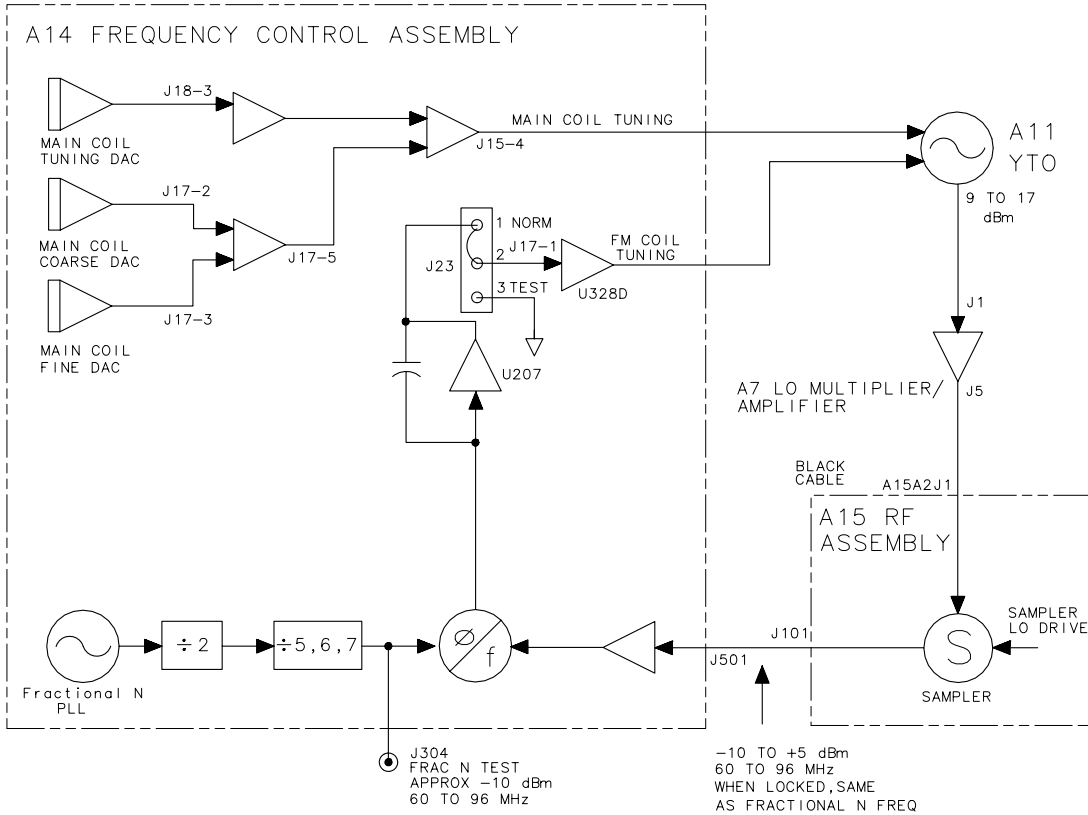

sz125e

- Calculate the YTO frequency error by subtracting the frequency recorded in step 3 from the frequency recorded in step 4. Record the result below:

YTO Frequency Error = _____ MHz

YTO frequency error = YTO frequency (MEASURED) - YTO frequency (CALCULATED)

- On the spectrum analyzer, press **MORE 1 OF 2, FREQ DIAGNOSE**, and **FRAC N FREQ**. Record the fractional N frequency below:

Fractional N frequency = _____ MHz

- If the YTO frequency error recorded in step 5 is greater than 20 MHz, do the following:
 - Check the YTO adjustments using the automated adjustment in Chapter 2 or the manual adjustment in Chapter 3.

- Check the YTO DACs using the procedure in steps 41 through 49 below.
 - Refer to steps 9 through 34 below.
8. If the YTO Frequency error recorded in step 5 is less than 20 MHz, do the following:
- Measure the frequency at A14J304. The frequency should be equal to the frequency recorded in step 6. If not, refer to "Unlocked Fractional N PLL" in this chapter.
 - Measure the input and output levels of the A15U100 sampler. If the sampler appears defective, check the LO drive to the sampler as described in "Sampler and Sampler IF."
 - Refer to steps 34 through 51 below.

Check 1st LO pretune frequency and amplitude (steps 9-12)

9. The pretuned frequency of the 1st LO must be sufficiently accurate for the YTO loop to acquire lock. The amplitude of the 1st LO must be sufficient to drive the A15U100 sampler. Perform the YTO Adjustment procedure, particularly the YTO main coil adjustments. (If available, use a synthesized microwave spectrum analyzer instead of the microwave frequency counter specified in the adjustment procedure.)
10. If the YTO main coil cannot be adjusted, proceed to step 33 to troubleshoot the main coil coarse and fine DACs and main coil tune DAC.
11. The front-panel 1ST LO OUTPUT should measure between +14.5 and +18.5 dBm in amplitude.
12. If the 1ST LO OUTPUT amplitude is out of the specified range, perform the automated LOMA adjustments. Refer to Chapter 2.

Check the fractional N oscillator (steps 13-17)

13. Set the spectrum analyzer to the following settings:
- | | |
|------------------------|---------|
| Center frequency | 300 MHz |
| Span | 0 Hz |
14. Monitor the fractional N PLL output at A14J304 (FRAC N TEST) with a synthesized spectrum analyzer such as an 8568A/B or 8566A/B. Refer to function block AI of A14 frequency control schematic (sheet 4 of 5).
15. The signal at A14J304 (FRAC N TEST) should measure approximately -10 dBm at 66.7 MHz. If the loop is unlocked, the sampler IF frequency can also be seen on A14J304, about 30 dB below the fractional N signal.

16.If a problem exists only at particular CENTER FREQ and SPAN settings, determine the desired fractional N oscillator frequency by pressing **CAL, MORE 1 OF 2, FREQ DIAGNOSE, FRAC N FREQ** and setting the spectrum analyzer to SINGLE trigger mode.

17.If the fractional N oscillator frequency is not correct, refer to "Unlocked Fractional N PLL" in this chapter.

Check sampler drive output of A7 LOMA (steps 18-21)

18.Set A14J23 jumper to the TEST position and set the spectrum analyzer to the following settings:

Center frequency 2.9 GHz
Span 0 Hz

19.Disconnect cable W34 from A15U100J1.

20.Use a power meter to measure the A7 LOMA sampler-drive output at the end of W34. The power should measure greater than -9 dBm.

21.Place A14J23 jumper in the NORMAL position and reconnect W34 to A15U100J1.

Check sampler IF (steps 22-26)

22.Set the spectrum analyzer to the following settings:

Center frequency 300 MHz
Span 0 Hz

23.Place A14J23 jumper in the TEST position.

24.Disconnect W32 from A15J101. Monitor the sampler IF output (A15J101, SAMPLER IF) with a synthesized spectrum analyzer such as an 8568A/B or 8566A/B.

25.The sampler IF should measure between 46 MHz and 86 MHz at -15 dBm to +2 dBm. If the signal frequency or amplitude is incorrect, refer to "Unlocked Offset PLL" in this chapter.

26.Set A14J23 jumper in the NORMAL position. Reconnect W32 to A15J101.

Check FM loop sense (steps 27-34)

27.Set A14J23 jumper in the TEST position.

28.Set the spectrum analyzer to the following settings:

Center frequency 300 MHz
Span 0 Hz

29.Connect an RF signal-generator output to A14J501. Set the signal generator to the following settings:

Frequency 56 MHz
Amplitude 0 dBm

30.Monitor A14J17 pin 1 with a DVM or oscilloscope. Connect ground to A14J17 pin 6.

31. As the signal generator frequency is increased to 76 MHz, the voltage at A14J17 pin 1 should change from approximately +12 V to -12 V.
32. Set the signal generator to the following settings and repeat step 30.
Frequency 56 MHz
Amplitude -15 dBm
33. If the voltage monitored in step 30 is correct with a 0 dBm output but not with -15 dBm output, suspect the limiting amplifier function block AE.
34. Place A14J23 jumper in the NORMAL position and reconnect W32 to A14J501.

Check YTO FM coil driver and main loop error voltage driver (steps 35-40)

35. To troubleshoot the YTO FM coil driver, refer to step 6 of "1st LO Span Problems (2.01 MHz to 20 MHz)."
36. Steps 36 through 40 verify that the YTO-loop error voltage is reaching the FM coil. The main loop error voltage driver has a gain of either 1.5 or 15; the analyzer firmware controls the gain during the locking process. The error voltage is read by the ADC on the A3 interface assembly. U324D calibrates out any offsets from true ground. A14U326A inverts the sense of the YTO loop to lock the YTO on lower sampler-sidebands (YTO frequency (sampler frequency \times sampler harmonic)). The fractional N frequency indicated in the FREQ DIAGNOSE menu will be negative when locking to lower sidebands. Refer to function blocks E, M, and N of A14 frequency control schematic (sheet 2 of 5) in the *8560 E-Series Spectrum Analyzer Component Level Information* binder.

Set the spectrum analyzer to the following settings:

Center frequency 300 MHz
Span 0 Hz

37. Remove A14J23 jumper and connect a dc power supply to A14J23 pin 2. Connect ground to A14J23 pin 3. Set the dc power supply to +7.5 Vdc.
38. Verify the nominal test-point voltages listed in [Table 11-6 on page 558](#).
39. Change the input voltage to -7.5 volts and re-verify that the voltages listed in [Table 11-6 on page 558](#) are the same except for a change in polarity.

40. Change the **CENTER FREQ** to 678.8 MHz with the SPAN remaining 0 Hz. This will change the switch setting of U326A and invert the voltages listed in [Table 11-6 on page 558](#).

Table 11-6 Voltages in FM Coil and Main Loop Drivers

Measurement Points	Voltages
A14U405 pin 6	+3.116 Vdc
A14U322 pin 2	approx. +1.5 Vdc
A14J17 pin 4	>+10 Vdc

Check main coil coarse and fine DACs (steps 41-46)

41. The main coil coarse and fine DACs correct any initial pretune errors in the YTO main coil. The DACs adjust the FM-coil current to zero before any sweep begins. Refer to function block J of A14 frequency control schematic (sheet 2 of 5).

42. Set the spectrum analyzer to the settings listed below. This sets both DACs to 128 (the DAC setting range is 0 to 255).

Center frequency 300 MHz
 Span 0 Hz
 Trigger SINGLE, EXT
 (with no external trigger connected)

43. Press **SAVE, PWR ON STATE** and turn off the spectrum analyzer.

44. Place A14J23 jumper in the TEST position and turn on the spectrum analyzer.

45. Verify the voltages listed in [Table 11-7 on page 558](#).

Table 11-7 Main Coil Coarse and Fine DACs Voltages

Measurement Points	Voltages
A14J17 pin 2	-5 Vdc
A14J17 pin 3	-5 Vdc
A14J17 pin 5	+5 Vdc

46. Place A14J23 jumper in the NORMAL position.

Check main coil tune DAC (steps 47-49)

47. Set the spectrum analyzer to the following settings:

Center frequency 300 MHz
 Span 0 Hz

48. Place A14J23 jumper in the TEST position.

49. Measure the output of the main coil tune DAC (A14J18 pin 3) with a DVM. Refer to function block E of A14 frequency control schematic (sheet 2 of 5).
50. If the spectrum analyzer center frequency is 300 MHz, the voltage at A14J18 pin 3 should measure $-3.35 \text{ V} \pm 0.25 \text{ V}$. The voltage may also be determined from the following equation:
$$V = -(1\text{st LO Frequency} - 2.95 \text{ GHz}) \times 2.654 \text{ V/GHz}$$
51. The voltage at A14U330 pin 2 should measure $-3.4 \text{ V} \pm 0.2 \text{ Vdc}$. This represents a current setting the YTO to approximately 2.95 GHz.
52. Return A14J23 jumper to the NORMAL position.

Unlocked Fractional N PLL

Operation

The fractional N oscillator is used as a reference for the 1st LO phase locked loop. It provides the 1 Hz start-frequency resolution for the 1st LO, and is the means by which the 1st LO is swept in LO spans of 2 MHz or less (fractional N spans). The prescaler, fractional N divider, and the postscaler are preset at power-on.

The PLL operates to produce an output frequency in the range of 60 MHz to 96 MHz selectable in 1 Hz increments. The output frequency can be swept (increasing or decreasing) over a selectable 100 Hz to 2 MHz range.

To determine the fractional N frequency for any given center frequency, press **CAL, MORE 1 OF 2, FREQ DIAGNOSE**, and **FRAC N FREQ**. The FRAC N FREQ frequency displayed is the frequency that will be measured at A14J304 with the spectrum analyzer in zero span.

Confirming an Unlocked Condition

1. Set the spectrum analyzer to the following settings:

Center frequency 300 MHz
Span 0 Hz

2. Connect A14J304 FRAC N TEST to the input of a synthesized spectrum analyzer and view the fractional N PLL output at 66.7 MHz.

NOTE

If a synthesized spectrum analyzer is not available, connect A14J304 to the input of a 20 dB gain amplifier, such as an 8447E. Connect the output of the amplifier to the input of a frequency counter.

3. If the fractional N oscillator measures a stable 66.7 MHz, the fractional N PLL is probably locked.
4. Check the two LEDs visible through the shield on A14. If either LED is lit, the fractional N PLL is not locked.
5. If either LED on A14 is lit, and no error message is displayed, check FC MUX U305. Refer to function block AH of A14 frequency control schematic (sheet 4 of 5).
6. If neither LED is lit, but the output frequency is wrong by more than 1 MHz, check the postscaler, function block AV.

- Check that the postscaler is dividing properly. The frequency at A14J304 should be equal to the frequency at A14TP4 divided by either 5, 6, or 7. Refer to [Table 11-8 on page 561](#). To keep the divide number at a constant value set the spectrum analyzer to:

Span 0 Hz
 Trigger SINGLE, EXT

(with no external trigger connected)

Table 11-8 Postscaler Divide Numbers

Divide Number	D11	D10	D9	Input Range (MHz) (A14J304)	Output Range (MHz) (A14TP4)
7	0	0	1	840 to 973	60.0 to 69.5
6	0	1	0	834 to 987.96	69.5 to 82.33
5	0	1	1	823.2 to 960	82.33 to 96.0

If the output frequency is wrong by less than 1 MHz, the phase locked loop is not unlocked but still requires repair. Continue with the "Fractional N Oscillator PLL" section.

Fractional N PLL

The fractional N PLL provides a synthesized frequency in the range of 60 MHz to 96 MHz. The 800 MHz to 1020 MHz voltage controlled oscillator (VCO) in the loop is divided down to lock with the 2.5 MHz reference. Simultaneously, the VCO is divided by two and then by either 5, 6, or 7 to generate the 60 MHz to 96 MHz output.

The prescaler (function block AR) supplies the clock signal for the fractional divider and is required for the fractional divider to operate. At the start of a fractional N sweep the fractional divider is set to a value for the start frequency and a sweep rate. It then sweeps for as long as HSCAN is high. Use the following procedure to troubleshoot unlocked loop problems or problems of locking to the wrong frequency (by less than 1 MHz):

- Check the two LEDs on A14 frequency control assembly. If either LED is lit, the fractional N phase locked loop is not locked.
- The 10 MHz reference is required for fractional N operation. It is divided by four to 2.5 MHz in the reference divider circuitry, block AN. It is used to lock the divided voltage controlled oscillator (VCO) frequency. Check that the 10 MHz reference is present at A14J301. The 10 MHz reference is derived from the 600 MHz reference on the A15 RF assembly.
- Change the spectrum analyzer from the fractional N span to 0 Hz.

4. Check the frequency at A14TP1. It should equal the value found by pressing **CAL, MORE 1 OF 2, FREQ DIAGNOSE, and RAW OSC FREQ.**
5. Check the tune voltage at R240 in function block AQ.
6. Look up the expected problem area in [Table 11-9 on page 562](#) with the information from steps 4 and 5. Go to the appropriate troubleshooting steps.

Table 11-9 Unlocked Fractional N Troubleshooting Areas (08564-60014 and Above)

Measured VCO Frequency Relative to Expected Value	Tune Voltage				
	Below -4 V	About -3.3 V	Between -2 V and +10 V	About +11 V	Above +12.5 V
Measured > expected	VCO clamp	VCO	Divider or integrator	Divider or integrator	VCO clamp
Measured < expected	VCO clamp	Divider or integrator	Divider or integrator	VCO	VCO clamp
Measured, not oscillating	VCO clamp	VCO	VCO	VCO	VCO clamp

Table 11-10 Table 11-9a. Unlocked Fractional N Troubleshooting Areas (08564-60007)

Measured VCO Frequency Relative to Expected Value	Tune Voltage				
	Below -12.5 V	About -11 V	Between ±10 V	About +11 V	Above +12.5 V
Measured > expected	VCO clamp	VCO	Divider or integrator	Divider or integrator	VCO clamp
Measured < expected	VCO clamp	Divider or integrator	Divider or integrator	VCO	VCO clamp
Measured, not oscillating	VCO clamp	VCO	VCO	VCO	VCO clamp

7. VCO clamp troubleshooting: Q131, Q132 and the associated components should limit the tune voltage at R240 to about -3.3 V to $+11\text{ V}$ ($\pm 11\text{ V}$ for 08564-60007). If the integrator (its output voltage is on TP13) tries to produce a voltage outside this range, excess current is shunted through CR131 and Q131 for positive excursions or CR132 and Q132 for negative excursions. The base of Q131 should be at about $+9.60\text{ V}$, and the base of Q132 should be at about -2.09 V for proper operation. If troubleshooting the earlier A14 frequency control assembly (08564-60007), the bases of Q131 and Q132 should be at about $\pm 9.6\text{ V}$ for proper operation.
8. VCO troubleshooting: Check the dc biases in the VCO function block. The bias voltages, for some points in the VCO, are indicated in [Figure 11-8 on page 564](#) (or Figure 11-8a for earlier instruments).

Figure 11-8 VCO Bias Voltages for A14 Assemblies 08564-60014 and Above

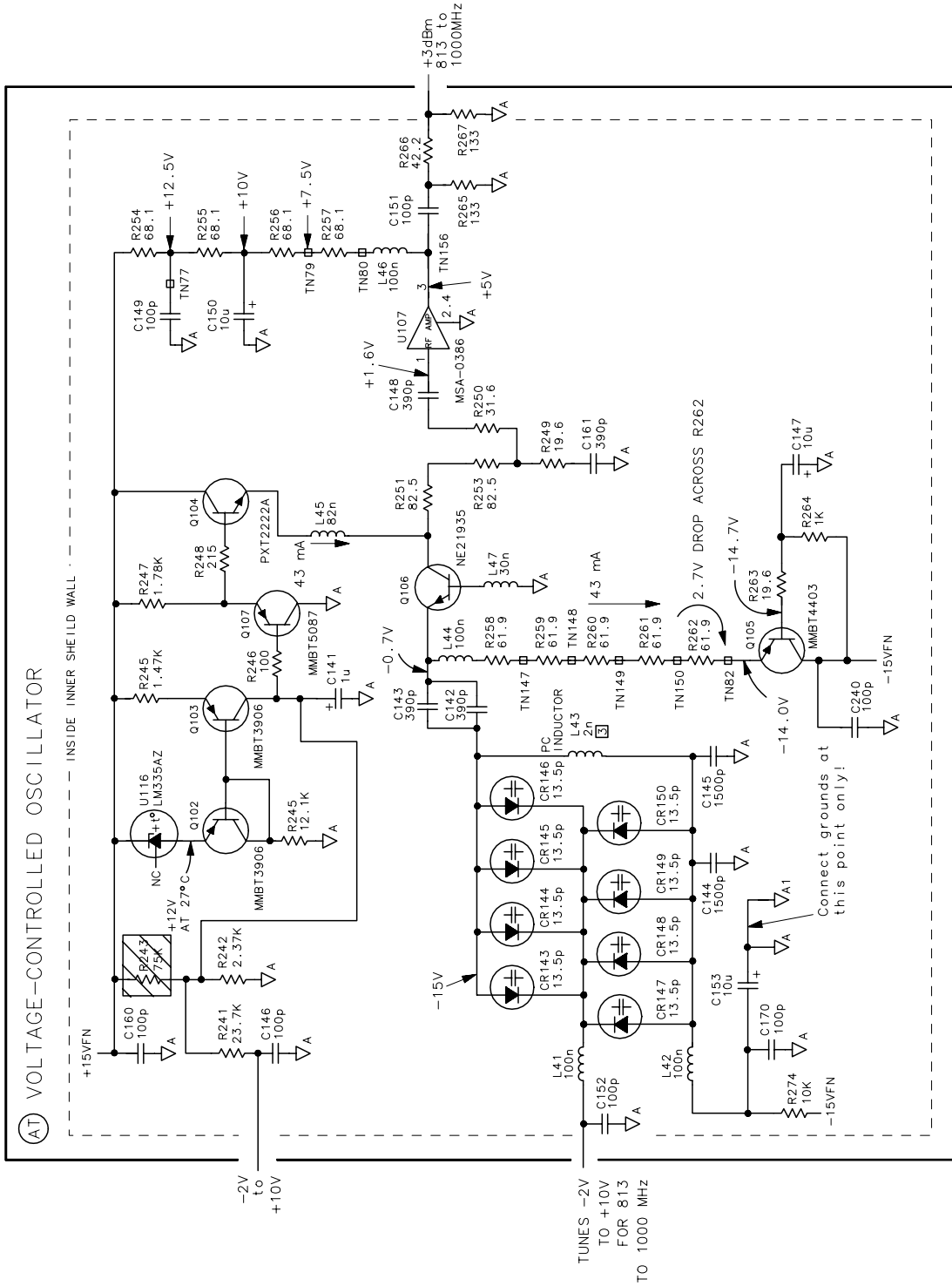

sz139e

Figure 11-8a VCO Bias Voltages for A14 Assembly 08564-60007

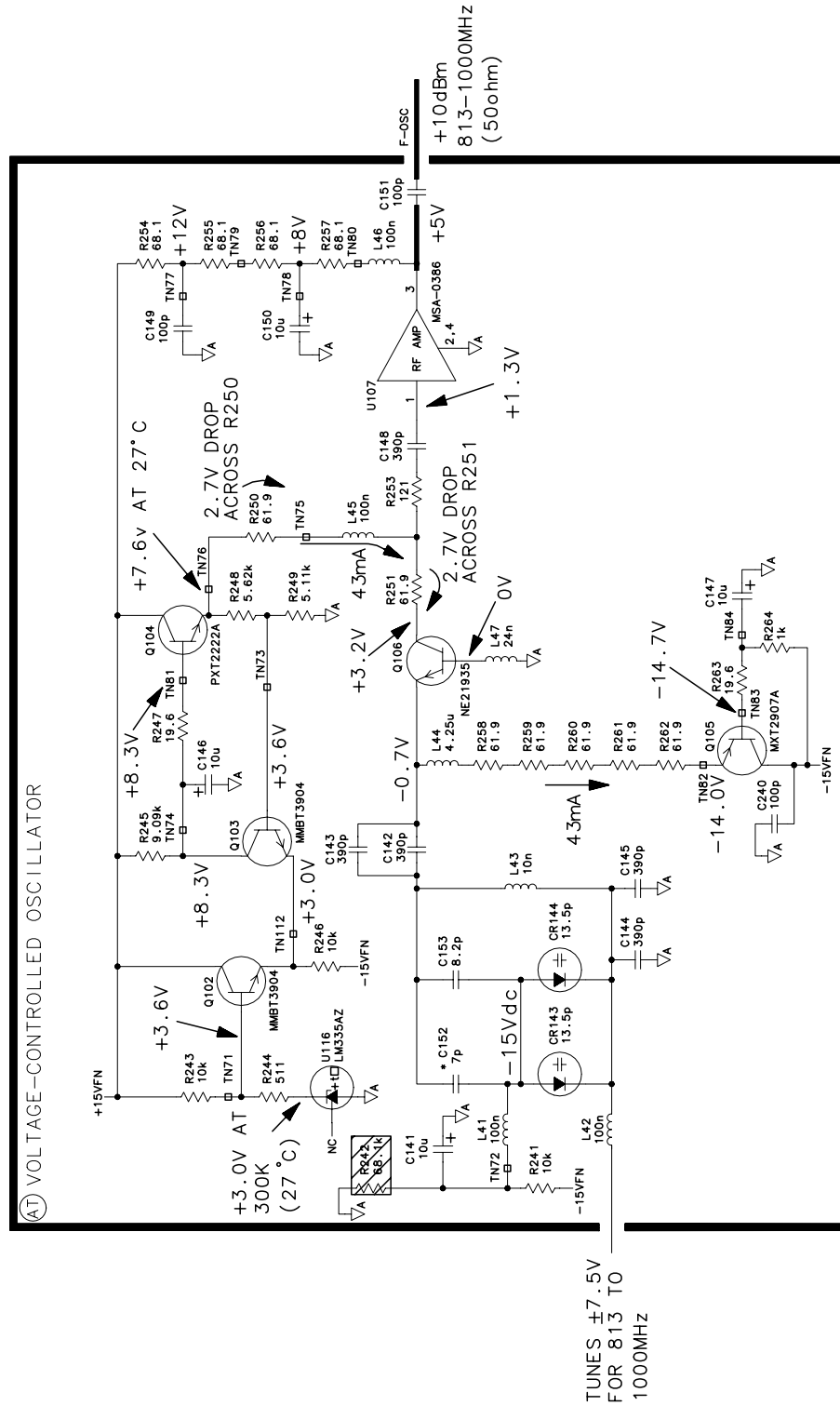

sz161e

9. Divider and integrator troubleshooting: Measure the frequency of the pulses at TP6 in block AO. Look up the expected problem area in [Table 11-11 on page 566](#) and go to the appropriate troubleshooting steps.

Table 11-11 Divider and Integrator Troubleshooting

Measured VCO Frequency Relative to Expected Value	TP6 Frequency			
	zero	<2.5 MHz	2.5 MHz	>2.5 MHz
Measured > expected	Dividers	Dividers	Dividers	Detector or integrator
Measured < expected	Both	Detector or integrator	Dividers	Dividers

10. Divider troubleshooting:

- a. Check the frequency at A14TP2. It should be equal to the frequency at A14TP1 divided by two.
- b. The signal at A14TP3 should be greater than -14 dBm.
- c. Use an analog oscilloscope to view the signal at A14TP5. Adjust the scope triggering to view the divide-by-16 signal. The frequency at this point will be varying as the prescaler changes its divide number to either 16, 17, 20, or 21. The prescaler uses 16 as the divide number most frequently. The frequency displayed on the oscilloscope should equal the frequency from TP2 divided by 16.
- d. Use an oscilloscope to view the signal at pin 8 of U112. Its average frequency should be given by:

$$f = f(A14TP5) \times 80 \text{ MHz/RAW OSC FREQ}$$

where: f(A14TP5) is the frequency measured at TP5, and RAW OSC FREQ comes from step 4 (A14TP1).

If the frequency is in error, the fractional divider, block AS, is not functioning. Check that FRAC N RUN on U113 pin 39 is high.

- e. Use an oscilloscope to verify that the signals at N_in (U112 pin 8) and N_out (TP6) are identical except for a sub-microsecond delay.

Detector and integrator troubleshooting: Check the phase detector output on TP11 in block AO. If F_ref is higher in frequency than TP6 (relocked VCO/N), then the average voltage at TP11 should be positive by 0.05 V to 10 V. If F_ref is lower, TP11 should be -0.05 V to -10 V.

The polarity of the output of the loop gain (block AP, TP12) should be the same as the polarity of the input (TP11).

The integrator op amp (U106) output (TP13) should try to go very positive (about +12 V) if its average input (TP12) is positive. If its average input is negative, it should try to go very negative (about -4 V). If its average input is zero and it is functioning correctly, it may take on any output voltage between -4 V and +12 V (between -12 V and +12 V for 08564-60007).

Frequency Span Accuracy Problems

The spectrum analyzer employs lock-and-roll tuning to sweep the 1st LO for spans greater than 2.0 MHz. The 1st LO is locked to the start frequency immediately after the previous sweep has been completed. The 1st LO is then unlocked, and, when a trigger signal is detected, the 1st LO sweeps (rolls).

When there is a considerable delay between the end of one sweep and the beginning of the next, the actual 1st LO start frequency may differ from the locked start frequency. This start frequency drift will be most noticeable in a 2.01 MHz LO span (the narrowest FM coil span). This drift is not noticeable in either free run or line trigger modes.

The sweep is generated by different oscillators in the synthesizer section depending on the desired 1st LO span (due to harmonic mixing, this is not necessarily the same as the span setting of the analyzer). Refer to [Table 11-12 on page 568](#) for a listing of sweep-signal destinations versus 1st LO spans.

Sweeping the fractional N oscillator results in sweeping the YTO FM coil. There is a one-to-one relationship between the frequency span of the fractional N assembly and the 1st LO span. The fractional N oscillator sweep is generated digitally. The oscillator is always synthesized, rather than employing lock and roll tuning.

Table 11-12 Sweep Signal Destination versus Span

1st LO Span	Sweep Signal Destination
>20 MHz	A11 YTO main coil
2.01 MHz to 20 MHz	A11 YTO FM coil
≤2 MHz	None Fractional N oscillator sweeps without a sweep ramp signal.

Determining the 1st LO Span

The 1st LO span depends on the spectrum analyzer harmonic-mixing number. Use the following steps to determine the 1st LO span:

1. Read the span setting displayed on the spectrum analyzer.

2. Determine the harmonic-mixing number from the information in [Table 11-13 on page 569](#).

Table 11-13

Harmonic Mixing Number versus Center Frequency

Center Frequency	Harmonic Mixing Number
9 kHz to 2.9 GHz	1
2.75 GHz to 6.46 GHz	1
5.86 GHz to 13.2 GHz	2
12.4 GHz to 31.15 GHz	4
30.5 GHz to 50.6 GHz	8
18 GHz to 325 GHz	6 through 54 depending upon lock harmonic selected

3. Use the following equation to determine the 1st LO span used.

$$\text{First LO Span} = \frac{\text{Display Span Setting}}{\text{Current Band Harmonic Mixing Number}}$$

4. Refer to [Table 11-12 on page 568](#) to determine the circuit associated with the span.

Confirming Span Problems

1. First perform either the manual “7. YTO Adjustment” in [Chapter 3](#) , or the automated “2. LO Frequency” and “3. YTO FM Coil” adjustments in [Chapter 2](#) .
 - On the spectrum analyzer press **CAL, REALIGN LO &IF**, and retest all spans.
 - If the YTO adjustment has sufficient range and only LO spans of 2.01 MHz or greater are faulty; test YTO linearity by performing step c.
 - Test the span in question at different center frequencies in the same band. If the span accuracy changes significantly (2% or more), suspect the A11 YTO.
2. If only 1st LO spans of 2 MHz or less are faulty, suspect the A14 fractional N PLL.
3. If there are several spans in the main coil and FM coil ranges affected, suspect the A14 span attenuator.

YTO Main Coil Span Problems (LO Spans >20 MHz)

For YTO main coil spans, the YTO is locked at the beginning of the sweep and the sweep ramp is summed into the main coil tune driver.

1. Perform the “7. YTO Adjustment” in [Chapter 3](#) . If the YTO adjustments cannot be performed, continue with step 2.
2. Set the spectrum analyzer to the following settings:
Start frequency 10 MHz
Stop frequency 2.9 GHz
3. Verify that a -1.2 V to -4.8 V ramp (approximately) is present at A14U331 pin 2.
4. If this ramp is not present, troubleshoot the main/FM sweep switch. See function block H of A14 frequency control schematic (sheet 2 of 5).
5. Measure the output of the main coil tune DAC at A14J18 pin 3. At the frequency settings of step 2, this should be -2.48 V.
If the voltage is not -2.48 V, troubleshoot the main coil tune DAC. See function block E of A14 frequency control schematic (sheet 2 of 5).

YTO FM Coil Span Problems (LO Spans 2.01 MHz to 20 MHz)

In YTO FM coil spans, the YTO loop is locked and then opened while the sweep ramp is summed into the FM coil. The FM coil sensitivity is corrected by changing the sensitivity of the FM coil driver.

1. Perform the “7. YTO Adjustment” in [Chapter 3](#) . If the YTO adjustments cannot be performed, continue with this procedure.
2. Set the spectrum analyzer to the following settings:
Center frequency 300 MHz
Span 20 MHz
Sweep time 50 ms
3. Check for the presence of a 0 V to -10 V sweep ramp at A14J15 pin 14 (input to the main/FM sweep switch). Refer to function block H of A14 frequency control schematic (sheet 2 of 5).
4. Check for the presence of a 0 V to $+5$ V sweep ramp at A14U405 pin 6 (YTO FM coil driver). Refer to function block M of A14 frequency control schematic (sheet 2 of 5).
5. Check the state of the Main/FM sweep switches as indicated in [Table 11-14 on page 571](#).

6. The rest of the procedure troubleshoots the YTO FM coil driver. Refer to function block M of A14 frequency control schematic (sheet 2 of 5).

Table 11-14 Settings of Sweep Switches

Switch	Switch State	Switch Control Line (Pin #)	Control Line State (TTL)
U318A	Closed	1	High
U318B	Open	16	High
U318C	Closed	9	Low
U318D	Open	8	Low

7. Set the spectrum analyzer to the following settings:
- Center frequency 300 MHz
Span 0 Hz
Trigger SINGLE, EXT
- a. On the spectrum analyzer press **SAVE, SAVE STATE, STATE 0**.
 - b. Remove A14J23 jumper and connect a dc voltage source to A14J23 pin 2. Connect the voltage source ground to A14J23 pin 3.
 - c. Connect a microwave frequency counter or another spectrum analyzer to the spectrum analyzer 1ST LO OUTPUT. (front panel output)
 - d. Set the dc-voltage source output for 0 Vdc and note the 1st LO frequency.
 - e. Set the dc-voltage source output for +10 Vdc. The 1st LO frequency should momentarily increase approximately +15.6 MHz.
 - f. The voltage at A14U332 pin 2 should be approximately 19% of the voltage at A14J23 pin 2.
 - g. If the 1st LO frequency did not change in step e, press **LINE** to turn spectrum analyzer off and disconnect W10 from A14J3.
 - h. Place a jumper between A14J3 pins 9 and 10. Place a 50 Ω , 3 watt resistor across A14J3 pins 5 and 6 (resistor, part number 0811-1086). Press **LINE** to turn spectrum analyzer on.
 - i. On the spectrum analyzer, press **RECALL, STATE, STATE 0**.

- j. If the voltage at U332 pin 2 is correct with A14J3 pins 9 and 10 shorted, but was incorrect with W10 connected, the YTO FM coil is probably open; replace the A11 YTO.
- k. Replace A14J23 jumper. Remove the jumper and resistor from A14J3. Reconnect W10 to A14J3.

Fractional N Span Problems (LO Spans ≤ 2 MHz)

If the fractional N spans are inaccurate or non-existent, but the fractional N PLL is locked to the correct frequency and other spans are correct, there may be a problem with the HSCAN signal. Check that HSCAN is present at the fractional divider, U113 pin 41 in function block AS. HSCAN comes from the A3 interface assembly and goes to the sweep generator circuitry in function block A and to fractional N.

1st LO Span Problems (All Spans)

1. Set the spectrum analyzer to the following settings:

Center frequency	300 MHz
Span	20 MHz
Resolution BW	1 MHz
Video BW	1 MHz
Sweep time	50 ms

2. Check that there is 0 V to +10 V ramp of 50 ms duration at A14J15 pin 15.
3. If a scan ramp is not present, refer to "Sweep Generator" in this chapter.
4. If there is a 0 to -10 V ramp at A14J15 pin 14, the fault is probably in the Main/FM sweep switch. See function block H of A14 frequency control schematic (sheet 2 of 5).
5. Check that there is a 0 V to +10 V ramp at U325 pin 1. The ADC of the spectrum analyzer obtains information about the sweep from this node.

Check span attenuator (steps 6-13)

6. Continue with step 7 to check the span attenuator. See function block L of A14 frequency control schematic (sheet 2 of 5).
7. With the spectrum analyzer set to the settings in step 1, monitor A14U323 pin 6 with an oscilloscope. A 0 V to -10 V ramp should be present.
8. Change the spectrum analyzer span to 10 MHz and check for a 0 V to -5 V ramp at U323 pin 6.
9. Change the spectrum analyzer span to 2.01 MHz and check for a 0 V to -1 V ramp at U323 pin 6.

10. Set the spectrum analyzer to the following settings:

Start frequency 10 MHz
Stop frequency 2.9 GHz
Sweep time 80 ms

11. Monitor A14J15 pin 14 for a 0 V to -7.4 V ramp. Switches U317A, U317B, and U317D should be open and U317C should be closed.

12. Change the spectrum analyzer SPAN to 365 MHz and check for a 0 to -936 mV ramp at A14J15 pin 14. Switches U317A, B, and C should be open and U317D closed.

13. Change the spectrum analyzer SPAN to 36.5 MHz and check for a 0 to -93.6 mV ramp at A14J15 pin 14. Switches U317B, C, and D should be open and U317A closed.

1st LO Span Problems (Multiband Sweeps)

During multiband sweeps, the sweep ramp at A14J15 pin 15 should go from 0 V to +10 V for each band or portions of a band covered. See function block A of A14 frequency control schematic (sheet 1 of 5) in the *8560 E-Series Spectrum Analyzer Component Level Information*. However, the scan ramp at A14U325A pin 1 is scaled according to the percentage of the total span that the band is covering. See function block B of A14 schematic (sheet 1 of 5). Also, the sum of the individual ramps is 10 V. For the 8564E/EC, [Figure 11-9 on page 574](#) illustrates both sweep and the scan ramp for a 0 GHz to 40 GHz span with instrument preset conditions. For the 8565E/EC, [Figure 11-10 on page 574](#) illustrates both sweep and the scan ramp for a 0 GHz to 50 GHz span with instrument preset conditions.

Figure 11-9 8564E/EC Sweep and Scan Ramps

hp stopped

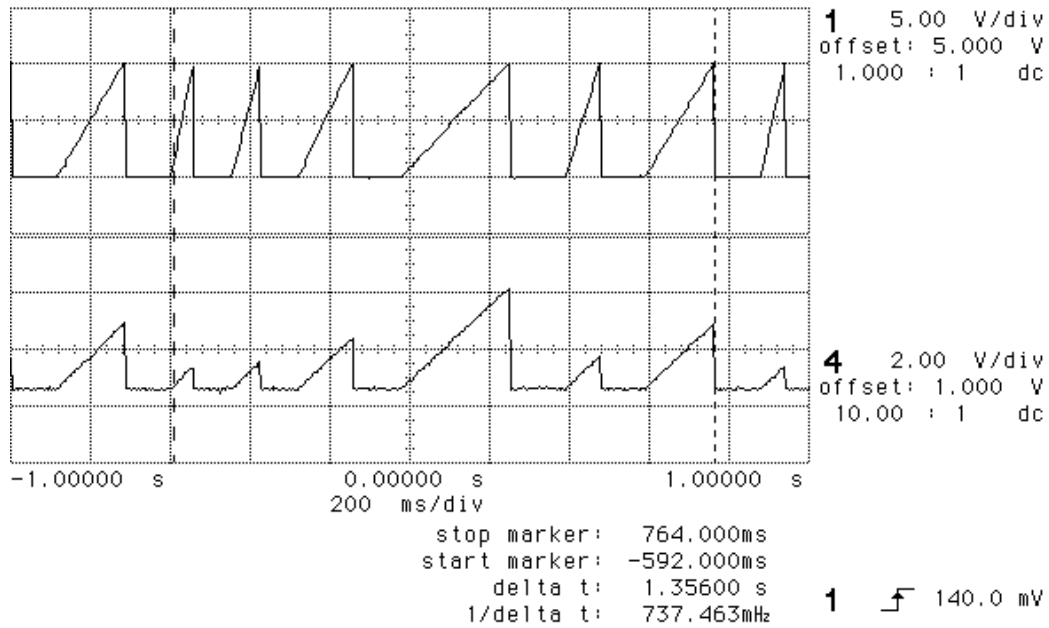
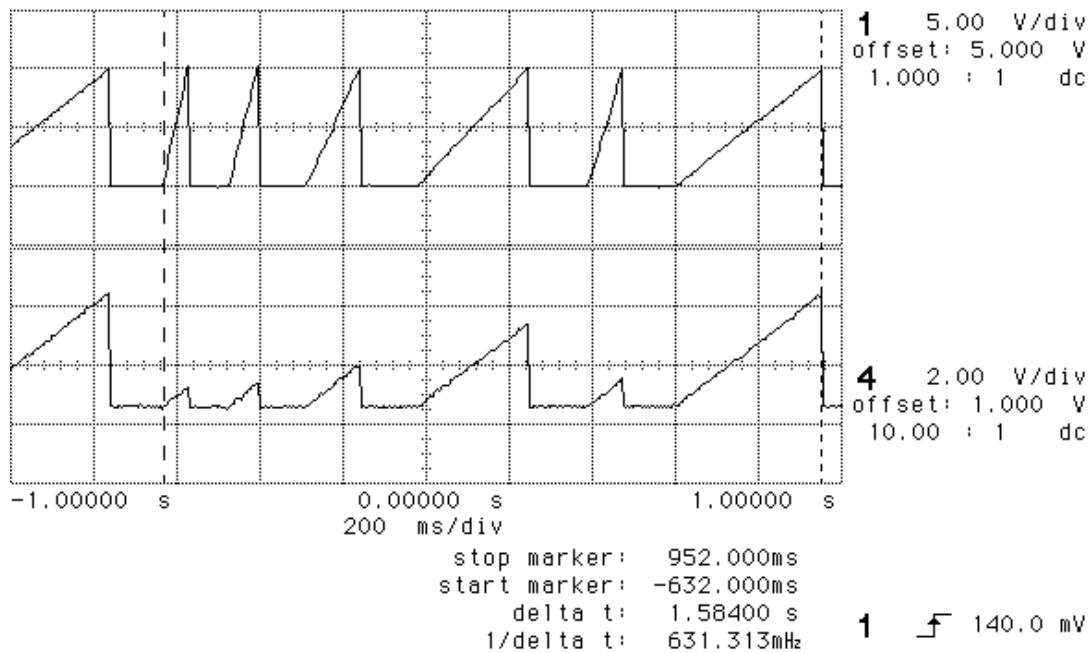

Figure 11-10 8565E/EC Sweep and Scan Ramps

hp stopped



Phase Noise Problems

System phase noise can be a result of noise generated in many different areas of the spectrum analyzer. When the spectrum analyzer is functioning correctly, the noise can be observed as a function of the distance away (the offset) from the carrier frequency. The major contributor to system noise can be characterized as coming from specific circuit areas depending upon the offset frequency.

Some very general recommendations can be made for identifying which circuitry is the cause of the noise at certain offsets. The recommendations below apply with a center frequency of 1 GHz.

Table 11-15 Settings of Sweep Switches

Carrier Frequency Offset	Major Contributor (when working correctly)
100 Hz	Reference (OCXO or TCXO)
1 kHz	100 MHz (or 600 MHz) reference PLL
3 kHz	Fractional N PLL
10 kHz to 150 kHz	Offset lock loop or YTO loop
>150 kHz	YTO

Phase Noise in Locked versus Unlocked Spans

Input a signal to the spectrum analyzer. Set the center frequency to the input signal frequency, set the span to 2 MHz, and plot the display. This plots the system noise for a locked sweep. Plot the display again with a span of 2.01 MHz (lock and roll sweep).

The crossover point of the noise floor of the two plots is typically at an offset of about 50 kHz, for a functioning instrument.

If the crossover point is shifted out to a higher offset frequency, suspect the YTO loop circuitry.

If the crossover point is shifted in to a lower offset frequency, suspect the offset or fractional N loop circuitry.

Reference versus Reference PLL Phase Noise

If the problem seems to be in the frequency reference or reference PLL circuitry, measure the noise with internal and external references. If there is no difference, suspect the circuitry associated with the 100 MHz VCXO (or the SAWR, A15U701, on earlier A15 RF assemblies).

Fractional N versus Offset PLL or YTO PLL Phase Noise

If the spectrum analyzer has excessive noise at >1 kHz offset, measure the noise with center frequencies of 100 MHz and 2.5 GHz.

If the measurements are equal, suspect the fractional N circuitry and the YTO loop circuitry on the A14 frequency control assembly.

If the measurements differ by 2 dB to 5 dB, with the 2.5 GHz measurement at a higher noise level, suspect the offset lock loop circuitry.

Fractional N PLL Phase Noise (08564-60007 Only)

Check the noise on the 5 V regulators on A14, particularly the regulator in the reference divider circuitry A14U121. Refer to function block AN on the A14 frequency control assembly schematic.

- The noise level of the voltage regulator should be <1 mV. The typical noise level is 40 μ V RMS between 10 Hz and 100 kHz.
- A coaxial probe with very little unshielded tip area should be used to avoid picking up radiated 60 Hz. Check that your measurement is valid by probing ground on the circuit and verifying that the measured value is well under the 1 mV threshold that indicates a defective regulator.

There can also be phase noise problems if the loop gain is incorrect. See function block AP for loop gain troubleshooting information.

Sampler and Sampler IF

The A15U100 sampler creates and mixes harmonics of the sampling oscillator with the 1st LO. The resulting sampler IF (60 MHz to 96 MHz) is used to phase-lock the YTO. The sampler IF filters unwanted products from the output of A15U100 and amplifies the IF to a level sufficient to drive the YTO loop. When the IF is between 78 and 87 MHz, PIN diodes switch a 120 MHz notch filter in the sampler IF section.

1. Set the spectrum analyzer to the following settings:

Center frequency 300 MHz
 Span 0 Hz

2. Disconnect W32 from A15J101.
3. Connect the input of a power splitter to A15J101. Connect W32 to one of the splitter outputs. Connect the other splitter output to the input of another spectrum analyzer.
4. If a 66.7 MHz signal, greater than -15 dBm, is not displayed on the other spectrum analyzer, set a microwave source to the following settings:

Frequency 4.2107 GHz
 Amplitude -5 dBm

5. Connect the microwave source to A15U100J1. A 66.7 MHz signal at approximately 0 dBm should be displayed on the other spectrum analyzer.
6. Use an active probe/spectrum analyzer combination to measure the signal at the following test points:

A15TP101	66.7 MHz, -8 dBm
A15TP201	296 MHz, $+9$ dBm

7. If a correct signal is seen at A15TP201 but the signal at A15TP101 is wrong, proceed as follows:

- Use an oscilloscope to measure the signals at the following test points:

A15J400 pin 1 $+0.8$ Vdc to $+1.6$ Vdc (≤ 0.5 Vp-p variation)

A15J400 pin 3 -0.8 Vdc to -1.6 Vdc (≤ 0.5 Vp-p variation)

- If these levels are wrong, perform the "Power and Sampler Match Adjustments" in the sampling oscillator adjustment procedure. Refer to Chapters 2 and 3.

- If adjusting the sampler match does not bring the signal at A15TP101 within specification when the signal at A15TP201 is correct, the A15U100 sampler is defective.
8. The sampler IF signal at A15J101 is 60 MHz to 96 MHz at -10 dBm to $+5$ dBm. If the signal at A15TP101 is correct, but the signal at A15J101 is wrong, the fault lies in the sampler IF circuitry. Continue with the following steps.
 9. Set the spectrum analyzer to the following settings:
Center frequency 300 MHz
Span 0 Hz
 10. Set a microwave source to the following settings:
Frequency 4.2107 GHz
Amplitude -5 dBm
 11. Connect the microwave source to A15U100J1.
 12. Measure the signal at U103 pin 1 using an active probe/spectrum analyzer combination.
 13. If a 94.7 MHz signal, approximately -14 dBm, is present, but the signal at A15J101 is low, suspect U103.
 14. When U104 pin 3 is at TTL low, U104 pin 6 should be near -15 Vdc and PIN diodes CR101, CR102, and CR103 should be reverse-biased.
 15. Set the spectrum analyzer under test to the following settings:
Center frequency 89.3 MHz
Span 0 Hz
 16. Check that U104 pin 3 is at a TTL high and U104 pin 6 is greater than $+7$ V. PIN diodes CR101, CR102, and CR103 should all be turned on with about 7 mA of forward current.
 17. Disconnect the power splitter and reconnect W32 to A15J101.

Sweep Generator Circuit

The sweep generator circuitry generates a ramp from 0 to 10 volts during the sweep time. The available sweep times range from 50 μ s to 2,000 seconds. The sweep times are generated in two different ranges, a 50 μ s to 30 ms range and a 50 ms to 2,000 second range. The 50 μ s to 30 ms range is only needed for analog zero span sweeps.

The sweep generator is controlled with an 8-bit latch and the control signal HSCAN. The latch, U308, controls the sweep rate. HSCAN determines when to reset the scan ramp and when to let it sweep.

Operation of the 50 ms to 2,000 second range will be described using a 50 ms sweep time as the example. For a 50 ms sweep time, Q1 shorts out C16. The D to A converter, U307, has zero output current. U334A is a buffer with zero offset, because there is no current coming out of U307. The buffering of U334 makes the base-emitter voltages on Q3A and Q3B the same. These two transistors are matched, so their collector currents should be identical when their base-emitter voltages are identical. The emitter current of Q3B is 200 μ A, therefore the emitter current of Q3A is 200 μ A and the sweep ramp is generated by C14. The sweep time is given by the formula:

$$sweeptime = capacitance(C14) \times \frac{\Delta V}{current}$$

Where ΔV is equal to 10 Volts.

With a capacitance of 1 μ F and a current of 200 μ A, the sweep time should be 50 ms. The DAC setting is increased for longer sweep times. This increases the current sunk by the DAC output U307 pin 4, which increases the emitter voltage on Q3A, decreasing the base-emitter voltage drop. Q3A acts as an exponentiator and reduces its collector current, creating a slower sweep ramp.

For the shorter sweep times, 50 μ s to 30 ms, Q1 is opened putting C16 in series with C14. This changes the effective capacitance from 1 μ F to 1,000 pF, or a reduction of 1,000 to 1.

The HSCAN signal uses Q2 to reset the ramp. Q2 shorts the integrator and sets its output nominally to ground.

Check the sweep generator circuit

Center frequency 300 MHz
Span 100 MHz
Sweep time 50 ms

Press **PRESET** and set the spectrum analyzer to the following settings:

18. Using an oscilloscope, check that the sweep ramp at A14U320 pin 6 sweeps linearly from 0 to +10 Volts in 50 ms, then resets to 0 Volts.
19. Change the sweep time to 10 seconds and check that the sweep ramp (U320 pin 6) sweeps linearly from 0 to +10 Volts in 10 seconds, then resets to 0 Volts.
20. Change the spectrum analyzer settings as follows:

Span 0 Hz
Sweep time 10 ms

21. Check that the ramp (U320 pin 6) sweeps linearly from 0 to +10 Volts in 10 ms, then resets to 0 Volts.
22. If any of the sweep times were not within specification or the sweep ramp appeared to be non-linear in the preceding steps, proceed with the following checks:
23. Connect the negative lead of a voltmeter to A14Q3 pin 8 and connect the positive lead to A14U312 pin 1 to check the temperature sensor (U312).
24. The voltage at pin 1 should be 10 mV/°C times the temperature of the A14 frequency control assembly. (For example, if the ambient temperature is approximately 20°C, and the A14 frequency control assembly is 10°C warmer, the actual temperature of the A14 assembly is 30°C and U312 pin 1 should measure 300 mV.)
25. To check the temperature-dependent offset voltage generator, connect the positive lead of the voltmeter to A14Q3 pin 6. The voltmeter should read -600 mV ±150 mV.
26. To check the DAC buffer, A14U334A, connect the positive lead of the voltmeter to A14U334 pin 2. The voltmeter should read the same voltage measured at A14Q3 pin 6, within 2 mV. (The same voltage should be present at U334 pin 3.)
27. To check the buffered DAC, press **PRESET** and set the spectrum analyzer as follows:

Center frequency 300 MHz
Span 100 MHz
Sweep time 50 ms

28. Connect the positive lead of the voltmeter to A14U334 pin 1. The voltmeter should read the same voltage measured at U334 pin 2, within 2 mV.
29. Change the spectrum analyzer sweep time to 2000 seconds. The voltage at A14U334 pin 1 should increase by 275 mV ±20 mV (compared to the voltage measured in step 12).

Figure 11-11 Simplified Synthesizer Section

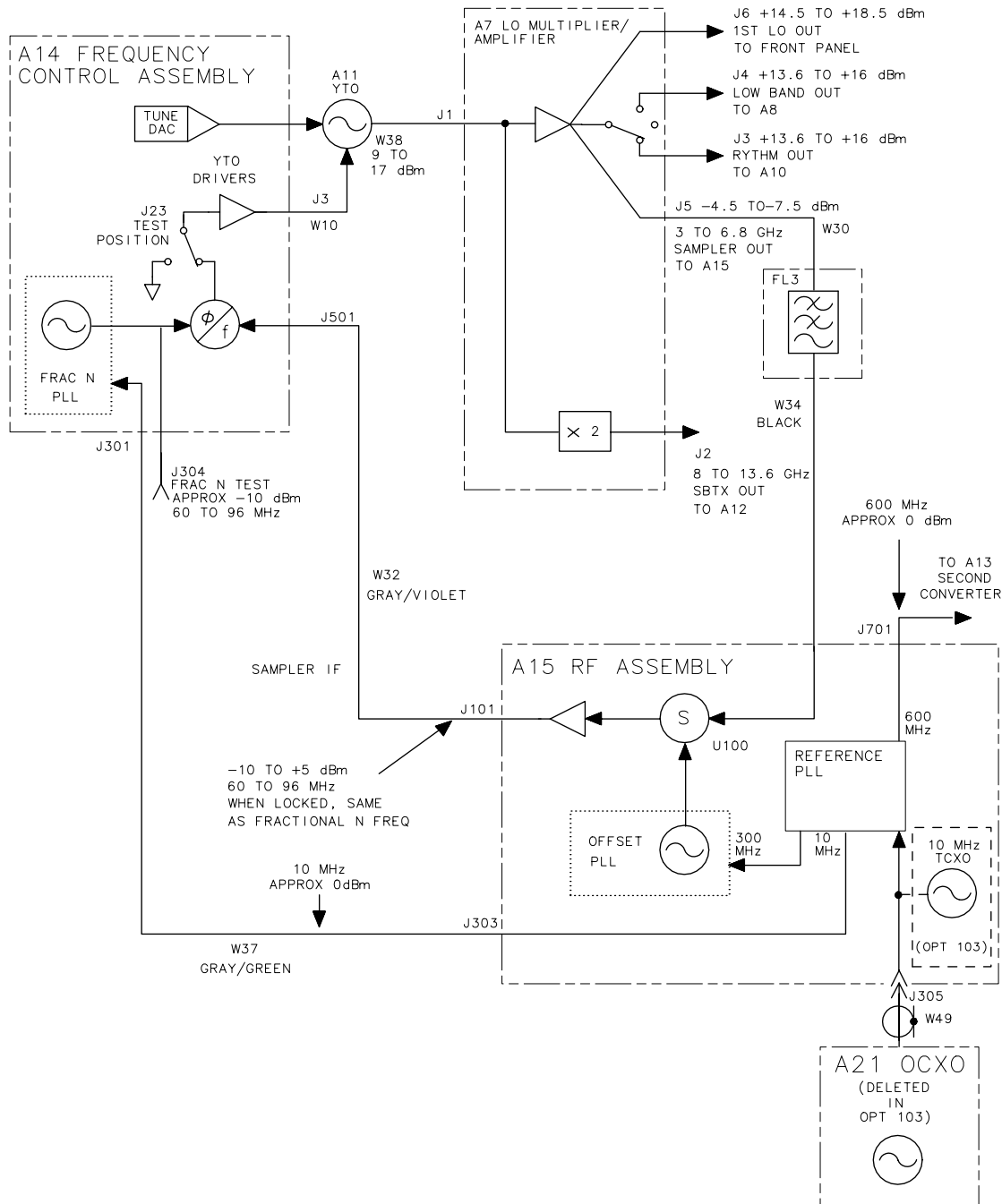

sz137e

Figure 11-12 Simplified A14 Assembly Block Diagram

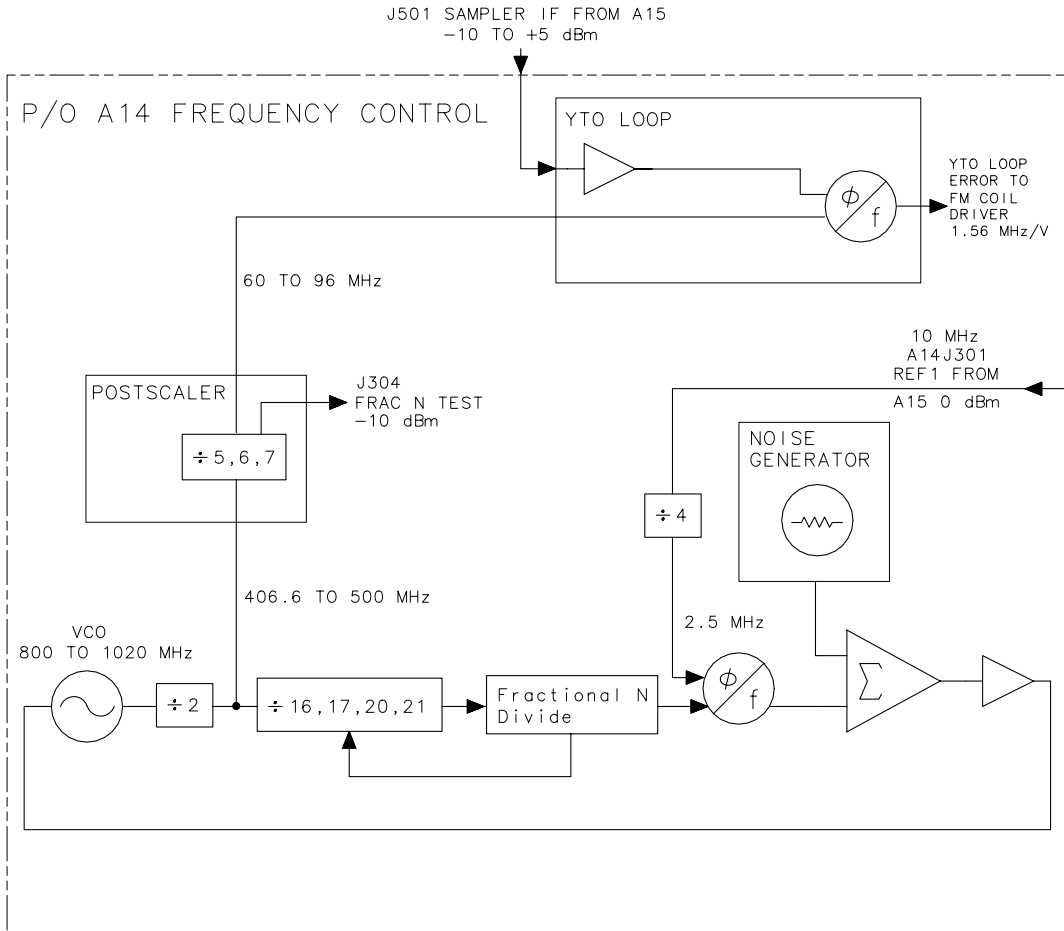

sp135e

Figure 11-13 Simplified A15 Assembly Block Diagram (100 MHz PLL)

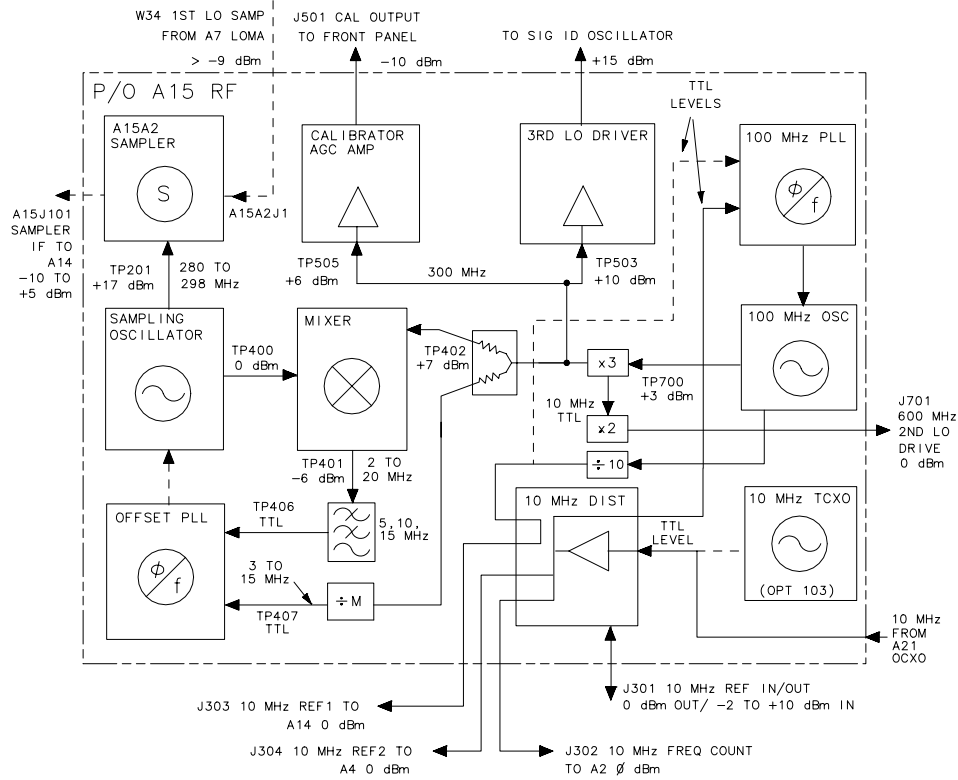

sz 159e

Figure 11-13a Simplified A15 Assembly Block Diagram (600 MHz PLL)

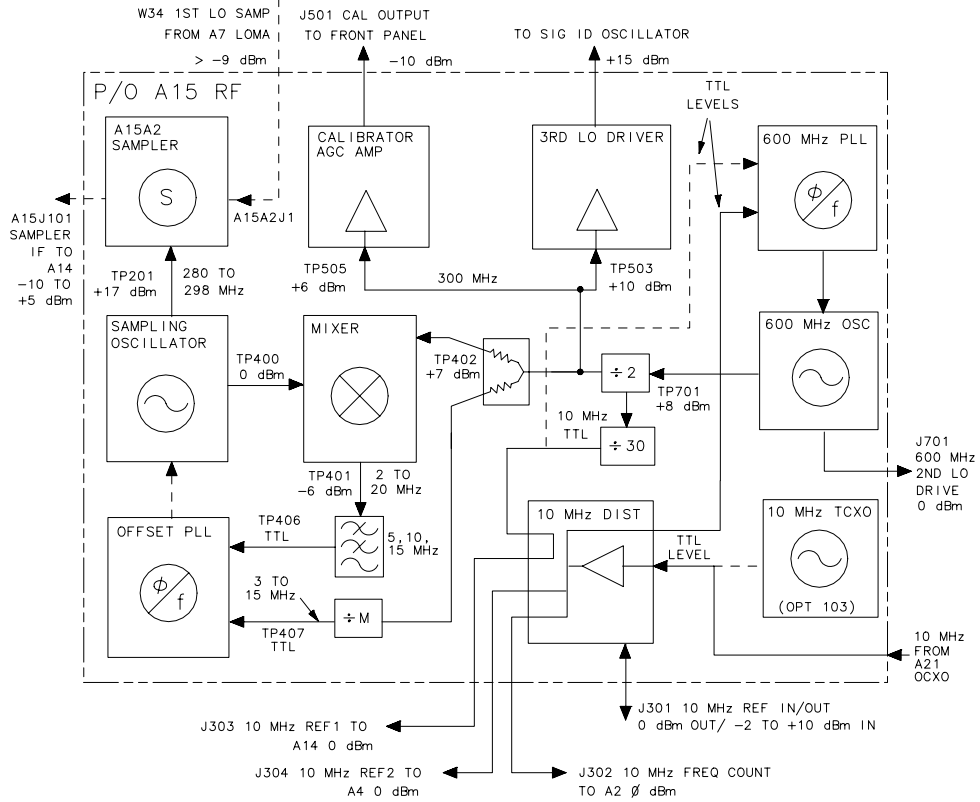

A21 OCXO

The spectrum analyzer uses an oven-controlled crystal oscillator (OCXO). It is deleted in Option 103 and replaced by a temperature-compensated crystal oscillator (TCXO), located on the A15 RF assembly. Connectors J305 and J306 on the A15 RF assembly are located where the TCXO would be installed in an Option 103.

The oven in the OCXO is powered only when the spectrum analyzer is powered on; there is no standby mode of operation. The OCXO oscillator operates only when the internal frequency reference is selected. Control line HEXT (High = EXTERNAL frequency reference) is inverted by A15U303B (Refer to the A15 RF assembly schematic diagram, block M, sheet 2 of 4) to generate LEXT. LEXT is sent to the OCXO via A15J306 pin 4. When LEXT is low, the oscillator in the OCXO will be turned off.

Replacement OCXOs are factory adjusted after a complete warmup and after the specified aging rate has been achieved. Thus, readjustment should typically not be necessary after OCXO replacement, and is generally not recommended.

If adjustment is necessary, the spectrum analyzer must be on continuously for a minimum of 24 hours immediately prior to oscillator adjustment to allow both the temperature and frequency of the oscillator to stabilize. Failure to allow sufficient stabilization time could result in oscillator misadjustment.

Check operation of the A21 OCXO as follows:

1. Disconnect W49 (Coax 82) from A15J305. Connect the output of W49 to the input of another spectrum analyzer.
2. Check that the fundamental frequency is 10 MHz and that the power level is 0 dBm \pm 3 dB. Also check that the harmonics are at least -25 dBc. Excessive harmonics can generate spurious responses on the fractional N oscillator on the A14 frequency control assembly.
3. If the OCXO has no output, check A15J306 pin 1 for +15 Vdc. Check A15J306 pin 4 for a TTL-high level.
4. If A15J306 pin 4 is at a TTL-low level, press **AUX CTRL** and **REAR PANEL**. Press **10 MHz EXT INT** until INT is underlined. A15J306 pin 4 should read a TTL-high level. Press **10 MHz EXT INT** until EXT is underlined. A15J306 pin 4 should read a TTL-low level.

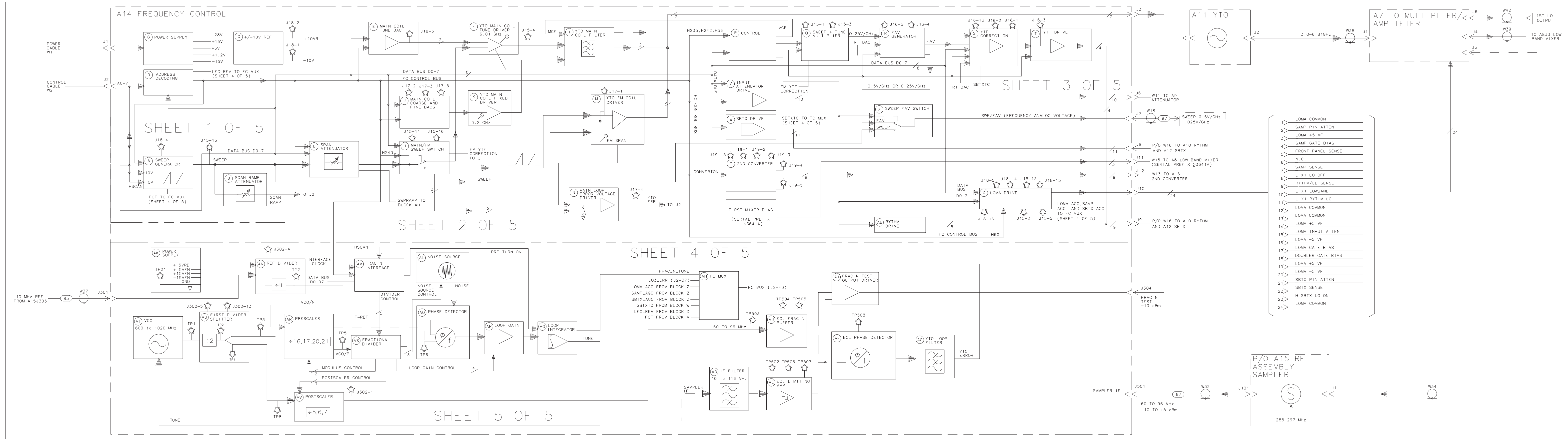

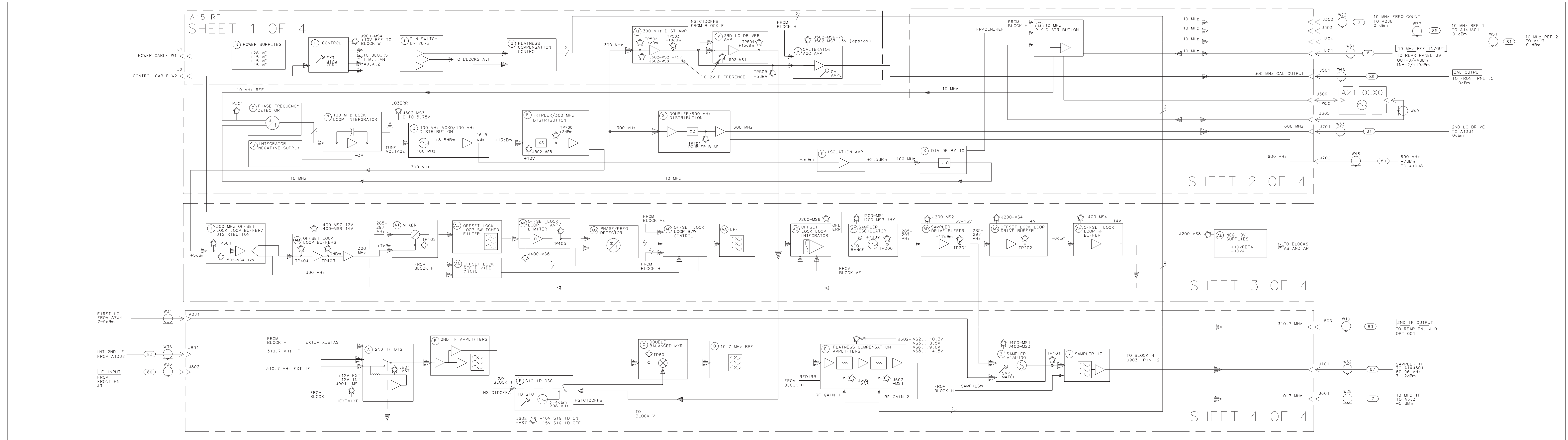
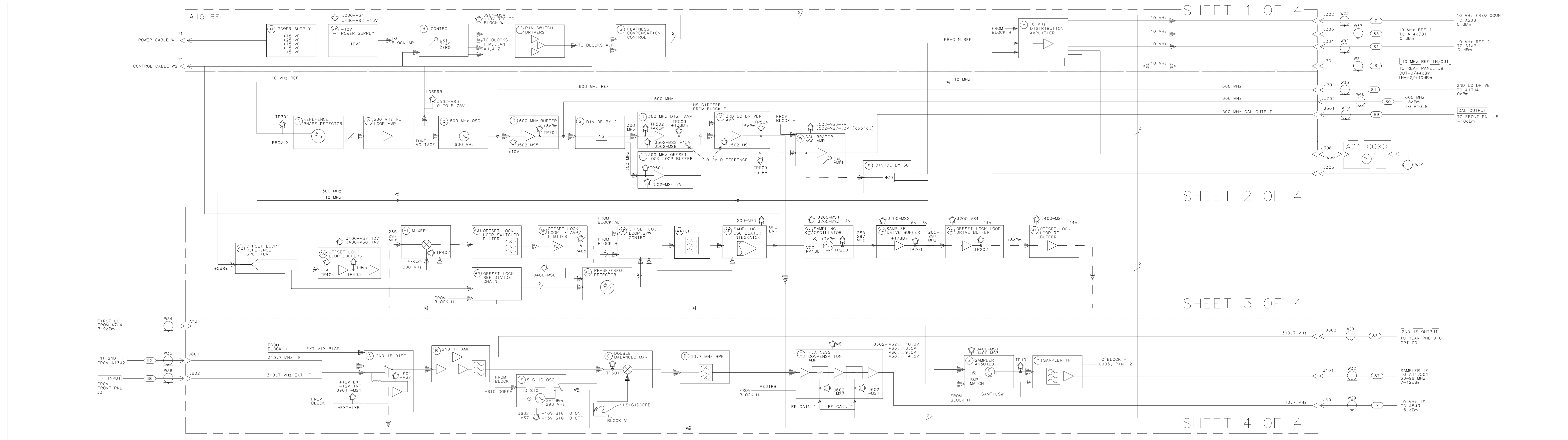

FIGURE 11-15. RF ASSEMBLY BLOCK DIAGRAM (FOR A15 08563-60054, 08563-60055, OR 08563-60056).



sm129c

FIGURE 11-16. RF ASSEMBLY BLOCK DIAGRAM FOR A15 EARLIER THAN 08563-60054, 08563-60055, or 08563-60056.

12 **RF Section**

Introduction

The RF Section converts the input signal to a 10.7 MHz IF (Intermediate Frequency). See [Figure 12-11 on page 631](#) for a detailed block diagram.

NOTE The block diagrams for the A14 and A15 assemblies are located in Chapter 11, Synthesizer Section.

	Page
Troubleshooting Using the Diagnostic Software	page 595
Low Band Problems	page 599
High Band Problems	page 600
Low and High Band Problems	page 601
A7 LO Multiplier and Distribution Amplifier	page 602
A8 Low Band Mixer	page 604
A9 Input Attenuator	page 605
A10 YIG-Tuned Filter/Mixer (RYTHM)	page 608
A12 Switched Barium-Tuned Mixer (SBTX)	page 609
A13 Second Converter	page 610
A14 Frequency Control Assembly	page 612
LO Multiplier/Amplifier Drive	page 612
Control Latch for Band-Switch Drivers	page 615
YTF Driver Circuit	page 615
A15 RF Assembly	page 621
Confirming a Faulty Third Converter	page 621
Confirming Third Converter Output	page 621
Third Converter	page 622
Flatness Compensation Control	page 624
PIN Switch Drivers	page 624
SIG ID Oscillator (Option 008)	page 625
10 MHz Reference	page 626

CAUTION All of the RF assemblies are extremely sensitive to Electrostatic Discharge (ESD). For further information regarding electrostatic cautions, refer to [“Electrostatic Discharge” in Chapter 1](#).

Troubleshooting Using the Diagnostic Software

The adjustment and diagnostic software is documented in [Chapter 2](#) . The software troubleshoots RF failures by testing signal paths and allowing you to control various latches and DACs. The first thing it does is to check that all of the frequency bands are functional. Depending on the results of that testing it may do some other checks.

Using the 8564E and 8565E adjustment/diagnostic software, select the RF diagnostics.

Connect the test board between the A7 LOMA and A10/A12 RYTHM/SBTX microcircuits, and the A14 Frequency Control board. The test board is labeled μ CKT and INSTR SIDE.

1. Disconnect W16 from A14J9 and W12 from A14J10.
2. Connect W16 to J4 on the test board and W12 to J5 on the test board.
3. Connect J2 on the test board to A14J10 (use 24-conductor ribbon cable, part number 08564-60012).
4. Connect J1 on the test board to A14J9 (use 20-conductor ribbon cable, part number 8120-5526).

You will then be prompted to make different connections to the 85629B Test and Adjustment Module (TAM), a source or spectrum analyzer. Connection locations are shown in [Figure 12-1 on page 596](#) and [Figure 12-2 on page 597](#).

The software can be used to control the DACs and latches for troubleshooting. Refer to [Chapter 2](#) , “Adjustment/Diagnostic Software,” for listings of DACs and latches.

Figure 12-1 Diagnostic Software Connection Locations, A14 and A15

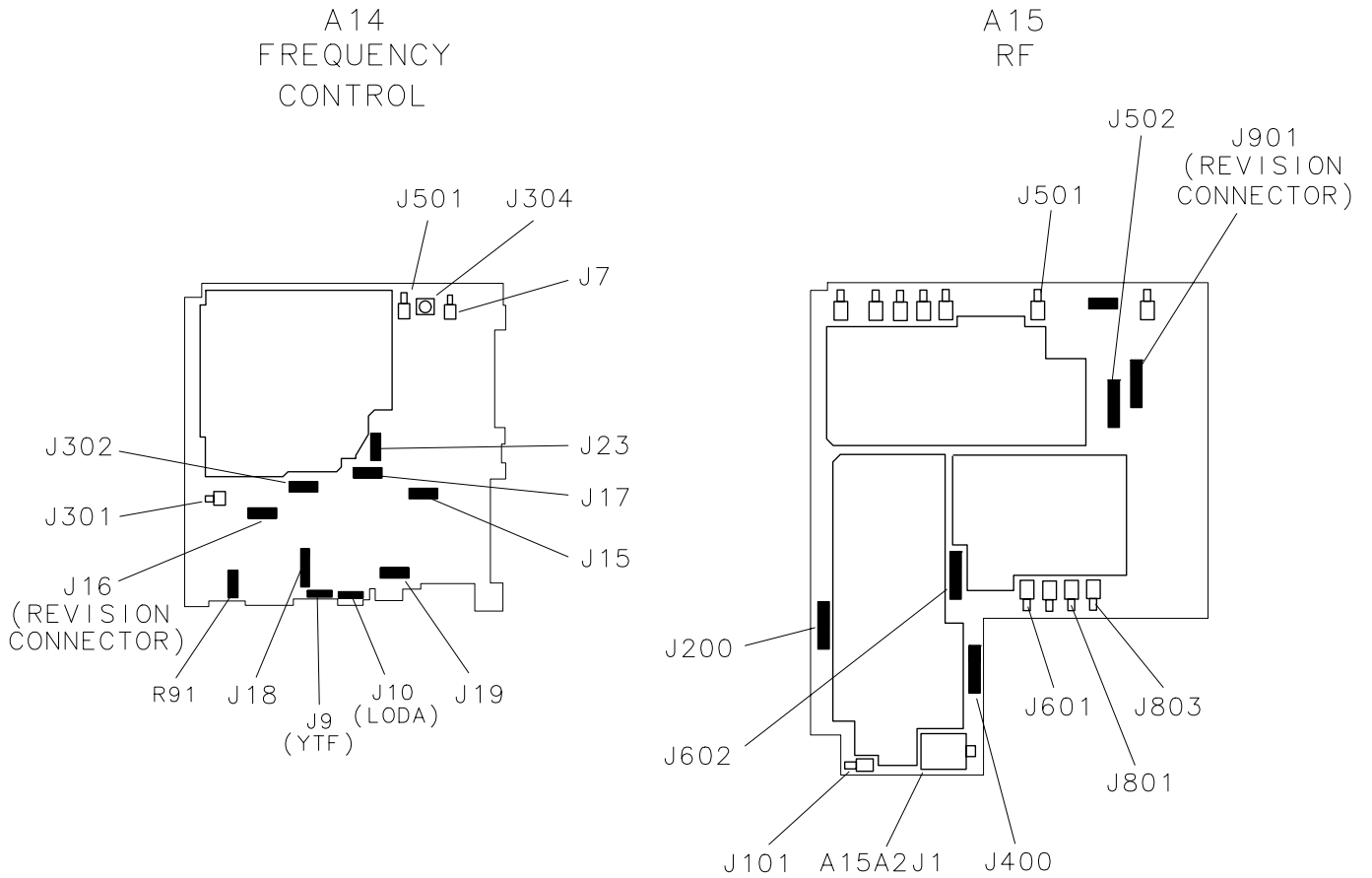

sz151e

Figure 12-2 Diagnostic Software Connection Locations, RF Section

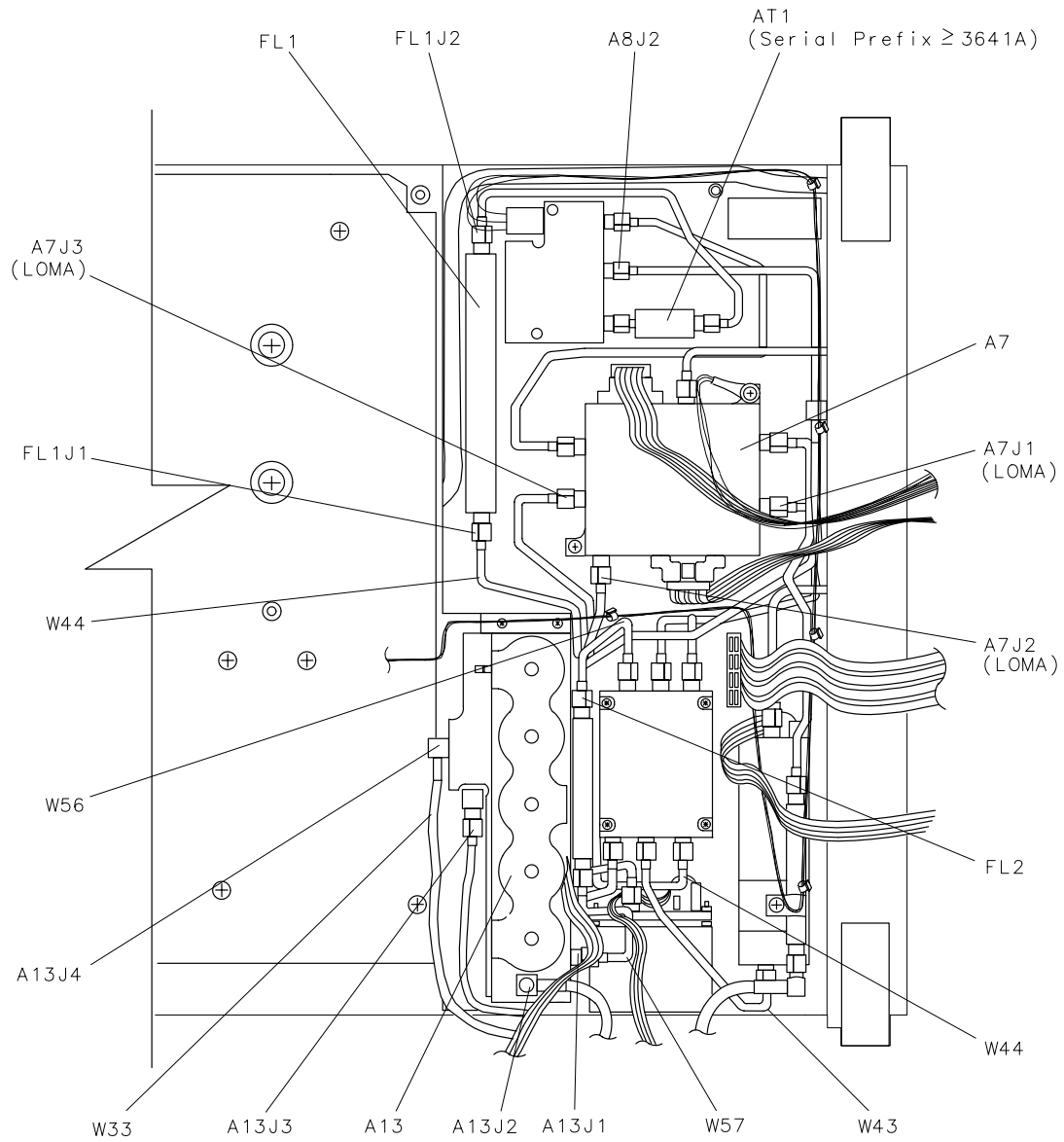

sm16e

Table 12-1 Procedures To Use For Isolating Faults

Suspected Faulty Circuit	Manual Procedure to Perform
2nd IF Amplifier	Third Converter
2nd IF Distribution	Third Converter
10.7 MHz IF Out of Double Balanced Mixer	Third Converter
300 MHz CAL OUTPUT	8. Calibrator Amplitude Adjustment in Chapter 3
A7 LO Multiplier and Distribution Amplifier	A7 LO Multiplier and Distribution Amplifier
A8 Low Band Mixer	A8 Low Band Mixer
A9 Input Attenuator	A9 Input Attenuator
A13 Second Converter	A13 Second Converter
A13J2 INT 2nd IF	A13 Second Converter (steps 1 to 6)
A14 Latch	Control Latch for Band-Switch Drivers
A15 Control Latches	Control Latch for Band-Switch Drivers
A15J601 10.7 MHz	Third Converter
External 10 MHz Reference Operation	10 MHz Reference (steps 5 to 11)
Gain of Flatness Compensation Amplifier	Third Converter
INT 10 MHz Reference Operation	10 MHz Reference (steps 1 to 4)
LO Feedthrough	Low Band Problems (steps 1 to 3)
LO Power	Low and High Band Problems (steps 4 to 9)
PIN Switches in SIG ID Oscillator (Opt 008)	SIG ID Oscillator (Option 008)
Second Converter Control	A13 Second Converter
SIG ID Oscillator (Opt 008)	Signal ID Oscillator Adjustment in Chapter 3
SIG ID Oscillator Operation (Opt 008)	SIG ID Oscillator (Option 008))
Third Converter	Low and High Band Problems (step 10)

CAUTION

Use of an active probe, such as an 85024A, with another spectrum analyzer is recommended for troubleshooting the RF circuitry. If an 1120A Active Probe is being used with a spectrum analyzer, such as the 8566A/B, 8569A/B and the 8562A/B, having dc coupled inputs, either set the active probe for an ac coupled output or use a dc blocking capacitor (11240B) between the active probe and the spectrum analyzer input. Failure to do this can result in damage to the spectrum analyzer or to the probe.

Low Band Problems

1. Disconnect all inputs from the front panel INPUT 50Ω connector.
2. Set the spectrum analyzer to the following settings:
Center frequency 0 Hz
Span 1 MHz
Input attenuator 0 dB
3. The LO feedthrough amplitude observed on the display should be between -6 (above top of screen) and -30 dBm.

NOTE

The marker will not PEAK SEARCH on the LO Feedthrough when in a non-zero span. To measure the LO Feedthrough amplitude with the markers, set the SPAN to 0 Hz and **CENTER FREQ** to 0 Hz. Press **MKR ON**.

4. If the LO feedthrough amplitude is within limits, but signals are low, the RF path following the A8 mixer is probably operating properly.
5. If the LO feedthrough amplitude is higher than -5 dBm (signal will be "clipped" at top of screen) and signals are low in amplitude, suspect a defective A8 mixer assembly.
6. If signal amplitudes <2.9 GHz are bad, but signals >26.8 GHz are good, check the A8 Low Band Mixer or the filter FL1. If both the LO feedthrough and signal amplitudes are low, check the A12 SBTX.
7. Perform the steps located in [“Control Latch for Band-Switch Drivers” on page 615](#).
8. Check A13 second converter mixer diode bias at A14J19 pin 1. The bias voltage should be between -150 and -800 mVdc.
9. Troubleshoot the signal path. Refer to the power levels listed on [Figure 12-11 on page 631](#), RF Section Troubleshooting Block Diagram.

High Band Problems

1. If the low band is functioning, but amplitudes of signals >26.8 GHz are wrong, check the A12 SBTX.
2. If the low band and millimeter band signals are correct, but microwave band signals are wrong, check the A10 RYTHM.
3. Perform the steps located in [“Control Latch for Band-Switch Drivers” on page 615](#).
4. Troubleshoot the signal path. Refer to the power levels listed in [Figure 12-11 on page 631](#), RF Section Troubleshooting Block Diagram.

Low and High Band Problems

1. On the spectrum analyzer, press **PRESET** and **REALIGN LO & IF**. If any error messages are displayed, refer to “[Error Messages](#)” in [Chapter 7](#).
2. Perform "External Mixer Amplitude Adjustment" in Chapter 3. If this adjustment cannot be completed, perform the steps located in "Third Converter" in this chapter.
3. Perform the "1st LO OUTPUT Amplitude" performance test in the calibration guide.
4. If the performance test fails, perform the "LOMA Adjustments" using the adjustment/diagnostic software. If the adjustment fails, set the spectrum analyzer to the following settings:
 - Center frequency 300 MHz
 - Span 0 Hz
5. Place the jumper on A14J23 in the TEST position. Remove W38 from the input of A7.
6. Use a power meter or another spectrum analyzer to measure the output of A11 YTO. The power should be between +2 dBm and +13 dBm.
7. Reconnect W38 to A7. Place the jumper on A14J23 in the NORM position.
8. If ERR 334 (unlevelled output) is present and the A11 YTO power output is correct, the A7 drive circuit may be defective. Refer to “[A7 LO Multiplier and Distribution Amplifier](#)” on page 602.
9. Troubleshoot the signal path. Refer to the power levels listed on [Figure 12-11 on page 631](#), RF Section Troubleshooting Block Diagram.
10. Check Third Converter as follows:
 - a. On the spectrum analyzer, press **PRESET** and set the controls as follows:
 - Center frequency 300 MHz
 - Span 0 Hz
 - b. Inject a -28 dBm, 310.7 MHz signal into A15J801.
 - c. If a flat line is displayed within 2 dB of the reference level, but the External Mixer Amplitude Adjustment fails, troubleshoot the A15 RF Assembly.

A7 LO Multiplier and Distribution Amplifier

NOTE YTO unlock errors may occur if the power delivered to the A15U100 sampler is less than -9.5 dBm. Frequency response will be degraded in both internal and external mixing modes if the output power is low or unlevelled.

CAUTION Connecting or disconnecting the A7 bias with the spectrum analyzer power turned on will destroy the A7 assembly. Always press **LINE** to turn the spectrum analyzer off before removing or reinstalling W12 to either the A7 or A14J10.

NOTE ERR 334 may be displayed if the LO OUTPUT connector on the front panel is not properly terminated into a 50Ω termination.

Figure 12-3 A14J10, Solder Side of A14 (Ignore Pin Numbers on Mating Connector)

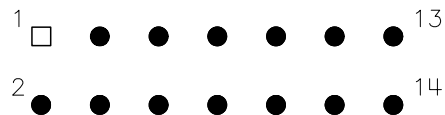

1. Press **LINE** to turn the spectrum analyzer off. Disconnect W12 from A14J10.
2. Connect a jumper between A14J10 pin 5 and A14J19 pin 6. Connect a jumper between A14J18 pin 13 and A14J18 pin 1. See [Figure 12-3 on page 602](#).
3. Connect the positive lead of a DVM to A14J18 pin 14 and the negative lead to A14J18 pin 6.
4. Press **LINE** to turn the spectrum analyzer on.
5. The voltage measured on the DVM should be more negative than -9.4 Vdc.
6. Move the jumper from A14J18 pin 1 to A14J18 pin 2. The voltage measured on the DVM should be more positive than $+12.3$ Vdc.
7. If the voltages do not meet the limits listed in steps 5 and 6, troubleshoot the A14 frequency control assembly.
8. Connect the positive DVM lead to A14J10 pin 1.

9. The measured voltage should be approximately +5 Vdc. If the voltage is not +5 Vdc, troubleshoot the A14 frequency control assembly.
10. Connect the positive lead of a DVM to A14J18 pin 15. The voltage should measure within ± 10 mV of the Gate Bias voltage listed on the A7 label.
11. If this voltage is not within the correct range, refer to the "LO Distribution Amplifier Adjustment" in Chapter 2, adjustment procedures.
12. If the voltage varies between 0 Vdc and -2 Vdc, adjust the Gate Bias for a DVM reading within ± 10 mV of the Gate Bias voltage listed on the A7 label. If the voltage does not vary between 0 Vdc and -2 Vdc, troubleshoot the A14 Frequency Control Assembly.
13. Disconnect the jumper from A14J19 to A14J10. Press **LINE** to turn the spectrum analyzer off. Reconnect W12 to A14J10. Press **LINE** to turn the spectrum analyzer on.
14. If the DVM reading changes significantly, the A7 is probably defective.

A8 Low Band Mixer

1. Connect the spectrum analyzer CAL OUTPUT to the INPUT 50 Ω connector.
2. Set the spectrum analyzer as follows:
Center frequency 300 MHz
Span 0 Hz
Input attenuation 10 dB
3. If the spectrum analyzer serial number prefix is 3641A or greater, make sure A8 is receiving the -5 V and -4 V supply voltages from frequency control board assembly A14 via cable assembly W12.
4. Using another spectrum analyzer, check for approximately -21 dBm (300 MHz) at the input of A8. (This level can easily be measured at the output of FL1 by disconnecting W45 from FL1.)
5. If the level at the input of A8 is less than -25 dBm, suspect FL1 low-pass filter, A10 RYTHM, A12 SBTX, or A9 input attenuator. Refer to power levels shown on [Figure 12-11 on page 631](#), RF Section Troubleshooting Block Diagram.
6. Check for approximately -30 dBm (3.9107 GHz) at the output of A8. (This level can easily be measured at the output of FL2 by disconnecting W57 from FL2.)
7. If the level at the output of A8 is less than -35 dBm, suspect A8 low band mixer or FL2 low-pass filter.

A9 Input Attenuator

1. Perform the "Input Attenuator Accuracy" performance test in the *8560 E-Series Spectrum Analyzer Calibration Guide*.
2. If there is a step-to-step error of approximately 10 dB or more, continue with step 3.
3. On the spectrum analyzer, press **AMPLITUDE**, and **ATTEN AUTO MAN** until **MAN** is highlighted.
4. Step the input attenuator from 0 dB to 60 dB. A "click" should be heard at each step. The absence of a click indicates faulty attenuator drive circuitry. It will be necessary to use the **DATA** keys to enter an input attenuator setting of 0 dB (the step key will not allow selecting 0 dB input attenuation).
5. Monitor the pins of A14U421 with a DVM while setting the input attenuator to the values listed in [Table 12-2 on page 606](#).
6. If one or more logic levels listed in [Table 12-2 on page 606](#) is incorrect, disconnect W11 from A14J6 and repeat step 5 using [Table 12-4 on page 607](#).

NOTE

When W11 is disconnected, the +28 V levels listed in [Table 12-2 on page 606](#) are floating and will read approximately 0.2 V. Refer to [Table 12-4 on page 607](#).

7. If one or more logic levels listed in [Table 12-4 on page 607](#) is incorrect with W11 disconnected, troubleshoot the A14 frequency control assembly.
8. If all logic levels are correct, the A9 input attenuator is probably defective.

Table 12-2 Attenuator Control Truth Table (W11 connected to A14J6)

A14U421						
ATTEN Setting (dB)	10 dB		30 dB		20 dB	
	Pin 16	Pin 15	Pin 14	Pin 13	Pin 12	Pin 11
0	L	H*	L	H*	L	H*
10	H*	L	L	H*	L	H*
20	L	H*	L	H*	H*	L
30	H*	L	L	H*	H*	L
40	H*	L	H*	L	L	H*
50	L	H*	H*	L	H*	L
60	H*	L	H*	L	H*	L
	ON	OFF	ON	OFF	ON	OFF
* reads ≈ 0.2 V (floating) when W11 is disconnected $H \approx 28$ V $L \approx 0.6$ V						

Table 12-3 Attenuator Control Truth Table (W11 connected or disconnected from A14J6)

A14U420						
ATTEN Setting (dB)	10 dB		30 dB		20 dB	
	Pin 1	Pin 2	Pin 3	Pin 4	Pin 5	Pin 6
0	H	L	H	L	H	L
10	L	H	H	L	H	L
20	H	L	H	L	L	H
30	L	H	H	L	L	H
40	L	H	L	H	H	L
50	H	L	L	H	L	H
60	L	H	L	H	L	H
	OFF	ON	OFF	ON	OFF	ON
H TTL High L TTL Low						

Table 12-4 Attenuator Control Truth Table (W11 connected or disconnected from A14J6)

A14U421						
ATTEN Setting (dB)	10 dB		30 dB		20 dB	
	Pin 16	Pin 15	Pin 14	Pin 13	Pin 12	Pin 11
0	L	F	L	F	L	F
10	F	L	L	F	L	F
20	L	F	L	F	F	L
30	F	L	L	F	F	L
40	F	L	F	L	L	F
50	L	F	F	L	F	L
60	F	L	F	L	F	L
F Floating (≈ 0.2 V) L ≈ 0.6 V						

A10 YIG-Tuned Filter/Mixer (RYTHM)

The RF diagnostics routine in the adjustment/diagnostic software is recommended for troubleshooting faults in and around A10. The RF diagnostics will prompt you where to connect a source and another spectrum analyzer to make RF signal level measurements.

A test board, part number 08564-69201, is connected between the A7 LOMA and A10/A12 RYTHM/SBTX ribbon cables, and the A14 frequency control assembly. DC measurements are made using the TAM manual probe cable on several test connectors on the test board. An 3478A DVM is used to measure the voltage across A14R91 (the large power resistor next to A14Q404) to determine the tuning current in the A10 preselector.

Be sure to follow all prompts precisely; failure to do so will result in incorrect fault determinations.

A12 Switched Barium-Tuned Mixer (SBTX)

The RF diagnostics routine in the adjustment/diagnostic software is recommended for troubleshooting faults in and around A12. The RF diagnostics will prompt you where to connect a source and another spectrum analyzer to make RF signal level measurements.

A test board, part number 08564-69201, is connected between the A7 LOMA and A10/A12 RYTHM/SBTX ribbon cables, and the A14 frequency control assembly. DC measurements are made using the TAM manual probe cable on several test connectors on the test board. An 3478A DVM is used to measure the voltage across A14R91 (the large power resistor next to A14Q404) to determine the tuning current in the A12 preselector.

Be sure to follow all prompts precisely; failure to do so will result in incorrect fault determinations.

A13 Second Converter

CAUTION

The A13 assembly is extremely sensitive to Electrostatic Discharge (ESD). For further information regarding electrostatic cautions, refer to “[Electrostatic Discharge](#)” in [Chapter 1](#).

1. Connect the spectrum analyzer CAL OUTPUT to the INPUT 50Ω connector.
2. Set the spectrum analyzer to the following settings:
 - Center frequency 300 MHz
 - Span 0 Hz
 - Input attenuation 10 dB
3. Disconnect W35 (coax 92) from A13J2.
4. Connect a test cable from A13J2 to the input of a second spectrum analyzer.
5. Tune the second spectrum analyzer to 310.7 MHz. The signal displayed on the second spectrum analyzer should be approximately -38 dBm.
6. Remove the test cable from A13J2 and reconnect W35 to A13J2.
7. Disconnect W33 (coax 81) from A13J4 and connect W33 through a test cable to the input of a second spectrum analyzer.
8. Tune the second spectrum analyzer to a center frequency of 600 MHz.
9. If a 600 MHz signal is not present, or its amplitude is less than -5 dBm, the fault is probably on the A15 RF assembly.
10. Reconnect W33 to A13J4.
11. Connect the positive lead of a DVM to A14J19 pin 15 and the negative lead to A14J19 pin 6.
 - If the DVM does not measure between +14.0 Vdc and +15.0 Vdc perform the following:
 - a. Press **LINE** to turn the spectrum analyzer being tested, off and disconnect W13 from A14J12.
 - b. Press **LINE** to turn the spectrum analyzer on again and set the it to the following settings:
 - Center frequency 300 MHz
 - Span 10 MHz

- c. The voltage should measure $+15 \text{ Vdc} \pm 0.2 \text{ V}$. If the voltage measures outside this limit, the A14 frequency control assembly is probably defective.
- d. Press **LINE** to turn the spectrum analyzer off. Reconnect W13 to A14J12, and press **LINE** to turn the spectrum analyzer on. Set it to the following settings:

Center frequency 300 MHz
Span 0 Hz

12. Move the positive lead of the DVM to A14J19 pin 1. The voltage should measure between -150 mVdc and -800 mVdc . If the voltage measures outside this limit, the A13 Second Converter is probably defective.

A14 Frequency Control Assembly

NOTE The block diagrams for the A14 and A15 assemblies are located in [Chapter 11](#), “Synthesizer Section.”

LO Multiplier/Amplifier Drive

Refer to function block Z on the A14 Frequency Control Schematic Diagram in the *8560 E-Series Spectrum Analyzer Component Level Information*.

1. Set the spectrum analyzer to the following settings:
Center frequency 300 MHz
Span 2 MHz
2. On the spectrum analyzer, press **SGL SWP** and measure the signal power at the output of A7J4. See [Figure 12-4 on page 614](#).
3. If the output power is low, the output voltage of A14U602B at A14J18 pin 14 (item (1) of [Figure 12-4 on page 614](#)) should be greater than 0 V. If the output power is high, the voltage should be more negative than -10 V. If the voltages do not measure as indicated, check that the voltages at A14J18 pins 5 and 13 are consistent with the output of the operational amplifier.

NOTE The voltages on A14J18 pins 5, 13, and 14 are referred to as LOMA PIN DRV T, RYTHM/LB SENSE, and LOMA INPUT PIN ATTEN respectively.

4. Set the spectrum analyzer to the following settings:
Center frequency 35 GHz
Span 2 MHz
5. On the spectrum analyzer, press **SGL SWP** and measure the signal power at the output of A7J2. (See item (1) of [Figure 12-4 on page 614](#).)
6. If the output power is low, the output voltage of A14U602D at A14J10-21 (item (3) of [Figure 12-4 on page 614](#)) should be greater than 0 V. If the output power is high, the voltage should be more negative than -10 V. If the voltages do not measure as indicated, check that the voltages at A14J15 pin 5 and A14U602 pin 13 are consistent with the output of the operational amplifier.

NOTE The voltages on A14J10 pin 21 and A14J15 pin 5 are referred to as SBTX PIN ATTEN and SBTX SENSE, respectively.

- If the voltages measure as indicated in step 3 and step 6, measure the A11 YTO output. See [Figure 12-4 on page 614](#).
- If all measurements are within limits, refer to "A7 LO Multiplier and Distribution Amplifier" in this chapter.

Figure 12-4 A7 LO Multiplier/Amplifier Drive

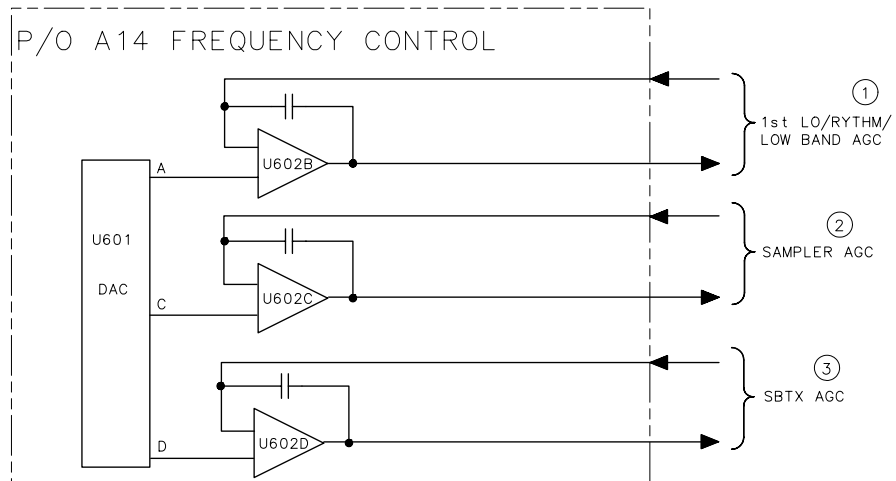
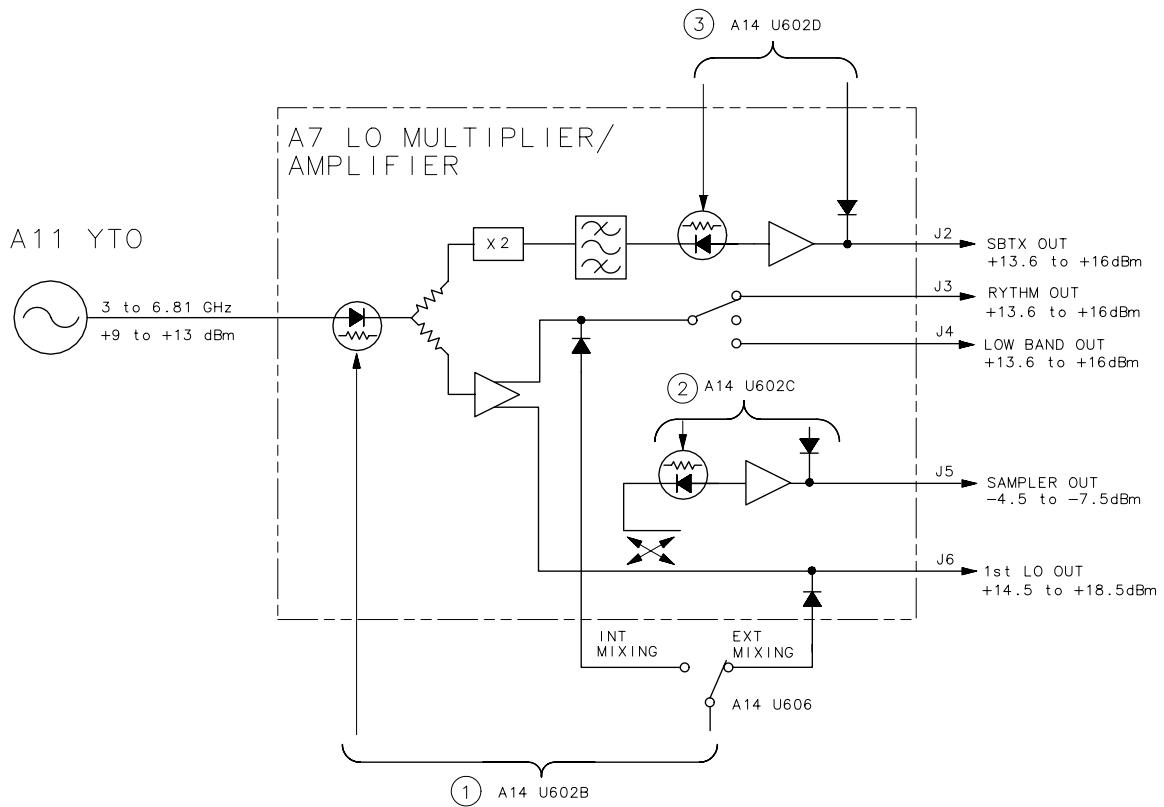

sz154e

Control Latch for Band-Switch Drivers

Refer to function block P on A14 Frequency Control Schematic Diagram in the *8560 E-Series Spectrum Analyzer Component Level Information*.

1. Connect the positive lead of a DVM to A14U417 pin 14 (LLOWBAND) and the negative lead to A14J18 pin 6.
2. Set the spectrum analyzer to the following settings:
Center frequency 300 MHz
Span 0 Hz
3. The voltage should measure approximately 0 Vdc (TTL low).
4. Set the spectrum analyzer center frequency to 3 GHz.
5. The voltage should measure approximately +5 Vdc (TTL high).
6. Move the positive lead of the DVM to A14U406 pin 12 (LSBTX).
7. The voltage should measure approximately +5 Vdc (TTL high).
8. Set the spectrum analyzer center frequency to 35 GHz.
9. The voltage should measure approximately 0 Vdc (TTL low).

YTF Driver Circuit

The YTF driver circuitry consists of the Sweep + Tune Multiplier, FAV (Frequency Analog Voltage) Generator, YTF Gain and Offset, and YTF Drive. Refer to function blocks Q, R, S, and T on A14 frequency control schematic diagram. The FAV generator generates the 0.5 V/GHz signal. The YTF driver circuitry can be half-split by checking the rear panel FAV OUTPUT.

NOTE The rear panel output changes according to the external-mixer mode selected. The preselected external-mixer mode must not be selected while executing this procedure. Make sure that the rear panel output is set for .50 V/GHz and not .25 V/GHz.

The Sweep + Tune Multiplier takes tune information (YTO start frequency) and sweep (based on LO span) and multiplies it so that it is correct for the appropriate YTF band.

C31 of the FAV Generator holds the YTF steady during retraces between multiband sweeps. Switch U606C and R94 provide the YTF dehysteresis pulse. A dehysteresis pulse is activated at the end of spans greater than 1 MHz. In microwave bands, amplifier U402A provides an offset voltage to account for the 310.7 MHz offset (U415A open) between the desired harmonic of the YTO frequency and the center frequency. In low band, switch U415A is closed to account for the negative 3.9107 GHz 1st IF offset between the YTO frequency and the center frequency. In millimeter bands, U415D is closed to account for the

positive 3.9107 GHz 1st IF offset between the desired harmonic of the YTO frequency and the center frequency. This signal is 0.5 V/GHz of tuned frequency and is available at the rear panel. The output can be set for 0.50 V/GHz or 0.25 V/GHz.

1. On the spectrum analyzer, press **PRESET**, and set the controls to the following settings:

Start frequency 0 Hz
Stop frequency 26.5 GHz

2. On the spectrum analyzer, press **AUX CTRL**, **REAR PANEL**, and **V/GHz .25 .50** so that .50 is underlined.
3. Monitor the rear panel LO SWP | FAV OUTPUT with an oscilloscope. The waveform should resemble [Figure 12-5 on page 617](#).

4. Set the spectrum analyzer controls as follows:

Start frequency 8 GHz
Stop frequency 10 GHz

5. Monitor A14J15 pin 1 with an oscilloscope. The waveform should resemble [Figure 12-7 on page 618](#).
6. If the ramp is not correct, confirm the operation of the Main Coil Tune DAC and Sweep Generator. Refer to “[Unlocked YTO PLL](#)” in [Chapter 11](#).

7. Set the spectrum analyzer to the following settings:

Center frequency 5 GHz
Span 0 Hz

8. Monitor A14J15 pin 3 with a DVM. For a center frequency of 5 GHz, the voltage should measure $-1.33 \text{ Vdc} \pm 0.2 \text{ Vdc}$. Use the following formula to calculate the voltage:

$$\text{EQUATION } \{ \text{V}_{\text{sb}} \{ (\text{J15 pin } 3) \} \} = \{ -0.25 \text{ V} \over \text{GHz} \} \cdot (\text{freq in GHz}) + \text{offset} \text{ EQUATION}$$

Offset voltage: -0.98 V in bands 0 and 5
 -0.078 V in bands 1, 2, and 3
 $+0.98 \text{ V}$ in band 4

Figure 12-5 8564E/EC Rear Panel SWP Output

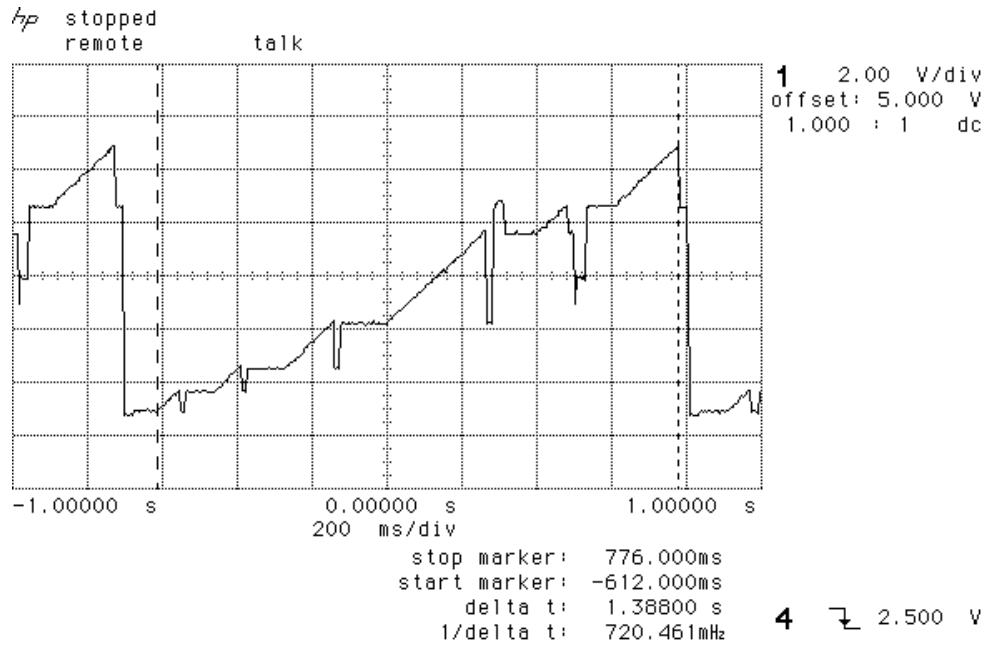

Figure 12-6 8565E/EC Rear Panel SWP Output

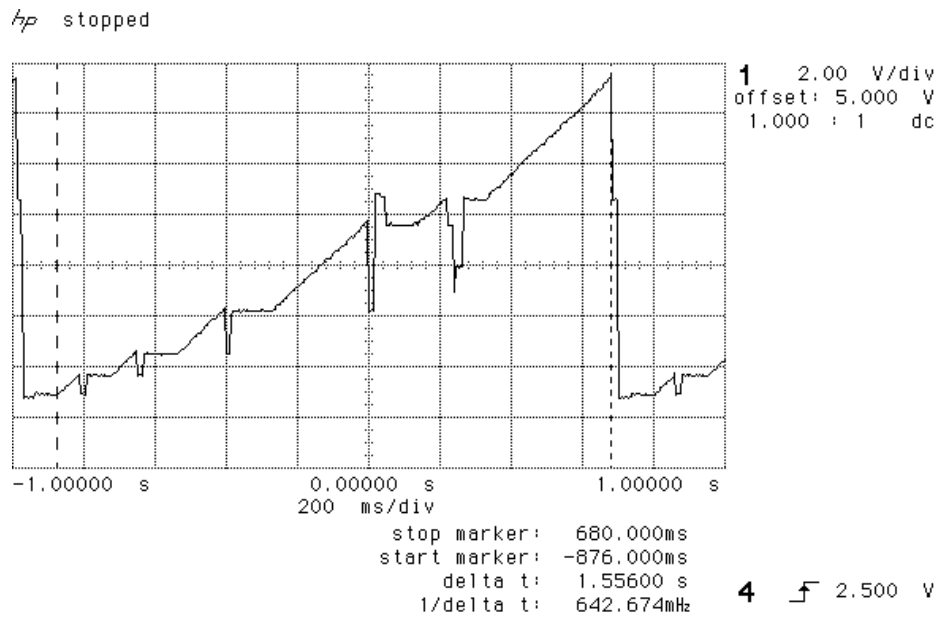

Figure 12-7 8564E/EC Signal at A14J15 Pin 1

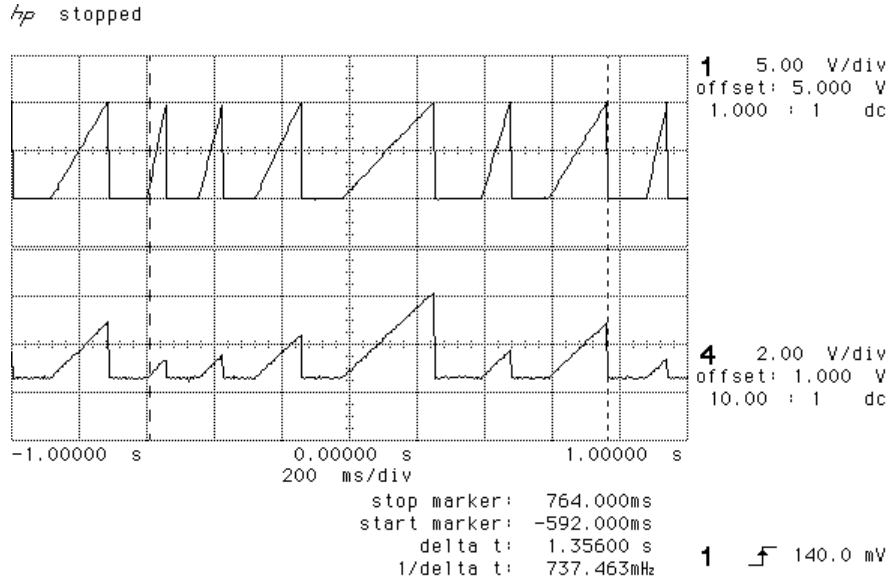
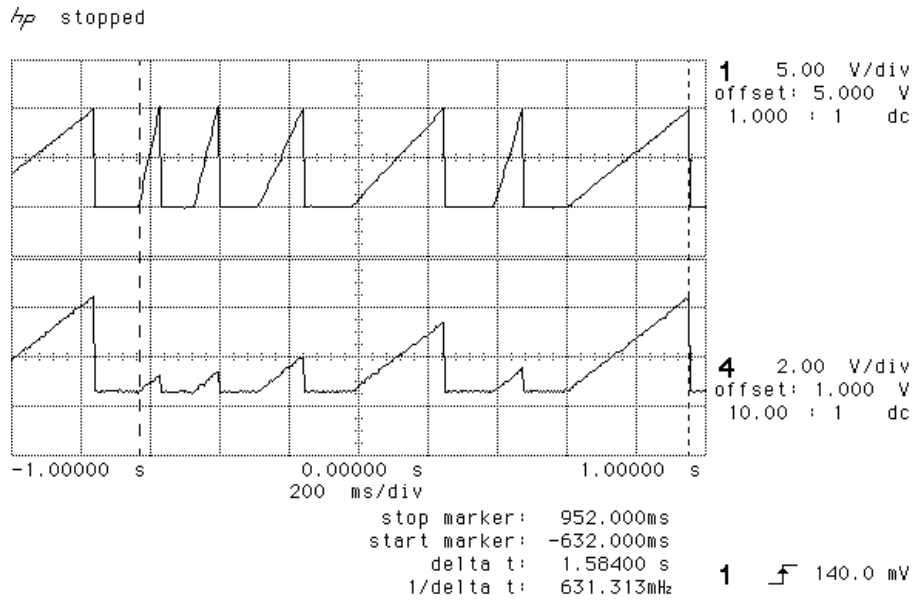

Figure 12-8 8565E/EC Signal at A14J15 Pin 1



9. Check the voltage at A14J15 pin 3 with the spectrum analyzer center frequency set to the frequencies listed in Table 12-5. The following table lists the voltage that should be measured at A14J15 pin 3, the settings for the four switches (U416 in function block Q), and the gain through the Sweep + Tune Multiplier.

Table 12-5 Sweep + Tune Multiplier Values

N*	Center Frequency	A14J15 Pin 3 (Vdc)	U416A	U416B	U416C	U416D	Gain [†]
1	5 GHz	-1.33	Open	Closed	Closed	Closed	-0.208
2	10 GHz	-2.58	Open	Closed	Open	Closed	-0.417
4	15 GHz	-3.83	Open	Closed	Open	Open	-0.833
4	20 GHz	-5.08	Open	Closed	Open	Open	-0.833
4	30 GHz	-6.52	Open	Closed	Open	Open	-0.833
8	40 GHz	-10.98	Open	Open	Open	Open	-1.666
8	50 GHz	-13.48	Open	Open	Open	Open	-1.666

* N is the harmonic mixing mode.

[†]Gain is the ratio of the change in the voltage at A14J15 pin 3 to the change in the voltage at A14J15 pin 1, within a given band.

10. Move the WR PROT/WR ENA jumper on the A2 Controller assembly to the WR ENA position.
11. Set the spectrum analyzer to the following settings:
 - Center frequency 5 GHz
 - Span 0 Hz
12. On the spectrum analyzer, press **CAL, MORE 1 OF 2, SERVICE CAL DATA, PRESEL ADJ,** and **PRESEL OFFSET.**
13. Connect a DVM to A14J16 pin 13.
14. Set the DAC to values from 0 to 255 to yield DVM readings from 0 V to -10 V respectively.
15. Set the spectrum analyzer center frequency to 40 GHz and measure the voltage at A14U414 pin 1: V
16. Connect the DVM to A14J16 pin 1.
17. Press **PRESEL SLOPE.**
18. Set the DAC to values from 0 to 255 to yield DVM readings from 0 V to the voltage measured in step 15.
19. On the spectrum analyzer, press **CAL** and **REALIGN LO & IF.**

20. Connect the DVM to A14J16 pin 3.
21. Change the center frequency in 1 GHz steps and confirm that the voltage changes by 220 mV/GHz in microwave bands and 250 mV/GHz in millimeter bands.
22. Move the WR PROT/WR ENA jumper on the A2 Controller assembly to the WR PROT position.

A15 RF Assembly

NOTE The block diagrams for the A14 and A15 assemblies are located in Chapter 11, Synthesizer Section.

Confirming a Faulty Third Converter

1. Perform the "IF Input Amplitude Accuracy" performance test in the *8560 E-Series Spectrum Analyzer Calibration Guide*. This exercises most of the third converter.
2. If the performance test fails, perform the manual "13. External Mixer Amplitude Adjustment" on page 147 or the automated "6. 3rd Amp/2nd IF Align" on page 71 of this manual.
3. If adjustment cannot be made, disconnect W35 (coax 92) from A15J801.
4. On the spectrum analyzer, press **PRESET** and set the controls to the following settings:

Center frequency 300 MHz
Span 0 Hz

5. Connect a signal generator to A15J801.
6. Set the signal generator to the following settings:
Frequency 310.7 MHz CW
Power -28 dBm
7. If a flat line is displayed within 2 dB of the reference level and the performance test passed, troubleshoot microcircuits A7, A8, A9, A10, A12, and A13.
8. If a flat line is displayed within 2 dB of the reference level and the performance test failed, troubleshoot the 2nd IF distribution circuitry on the A15 RF assembly.
9. Disconnect the signal generator from A15J801 and reconnect W35.

Confirming Third Converter Output

1. Connect the spectrum analyzer CAL OUTPUT to the INPUT 50Ω connector.
2. Set the spectrum analyzer to the following settings:

Center frequency 300 MHz
Span 0 Hz
Input attenuation 10 dB

3. Press **SGL SWP, CAL, IF ADJ OFF**.
4. Disconnect W29 (coax 7) from A15J601.
5. Connect a test cable from A15J601 to the input of another spectrum analyzer.
6. Tune the other spectrum analyzer to 10.7 MHz. The signal displayed on the other spectrum analyzer should be approximately -15 dBm.
7. Remove the test cable from A15J601 and reconnect W29 to A15J601.

Third Converter

Refer to function blocks A, B, C, D, and E on A15 RF Section Schematic Diagram in the *8560 E-Series Spectrum Analyzer Component Level Information*.

The 3rd converter consists of the 2nd IF distribution, 2nd IF amplifier, double balanced mixer, 10.7 MHz bandpass filter, and flatness compensation amplifier. The 2nd IF distribution switches between two possible 2nd IF inputs: the internally generated 2nd IF, or the external mixing IF INPUT. A variable dc bias can be applied to the IF INPUT for external mixers which require such bias. The selected input is fed to the 2nd IF Amplifier. This amplifier consists of four stages of gain and two stages of SAW filters for image frequency rejection.

The flatness compensation amplifier consists of two fixed-gain stages and two stages of variable gain. This provides an overall adjustable gain of 4 dB to 30 dB. This gain is adjusted during a spectrum analyzer sweep to compensate for front end conversion loss versus frequency.

The gain of the flatness compensation amplifiers is driven to a minimum by the REDIR line going low during automatic IF adjustment.

The 10.7 MHz bandpass filter provides a broadband termination to the mixer while filtering out unwanted mixer products. Perform the following steps to test the amplifier gain:

1. On the spectrum analyzer, press **AUX CTRL**, then **INTERNAL MIXER**.
2. In the 2nd IF distribution (function block A), diode CR802 should be forward biased and diode CR801 should be reverse biased.
3. Disconnect W35 (coax 92) and connect a signal source to A15J801. Set the source to the following settings:

Frequency 310.7 MHz
Amplitude -30 dBm

CAUTION

For troubleshooting, it is recommended that you use an active probe, such as an 85024A, and a second spectrum analyzer. If an 1120A active probe is being used with a spectrum analyzer having dc coupled inputs, such as the 8566A/B, 8569A/B and the 8562A/B, either set the active probe for an ac-coupled output or use a dc-blocking capacitor between the active probe and the spectrum analyzer input. Failure to do this can result in damage to the spectrum analyzer or the probe.

4. Use an active probe with a second spectrum analyzer to measure the signal at A15TP601 (function block C). The signal should measure $-17 \text{ dBm} \pm 4 \text{ dB}$ confirming the operation of the 2nd IF Amplifier.
5. Use an active probe with a second spectrum analyzer to measure the 300 MHz into the LO port of the third mixer. The signal should measure at least $+20 \text{ dBm}$.
6. Measure the 10.7 MHz IF output power of the mixer. The signal level should be approximately -22 dBm .
7. Move the WR PROT/WR ENA jumper on the A2 controller assembly to the WR ENA position.
8. While measuring the signal at the mixer 10.7 MHz IF output, adjust the signal source until the level of the 10.7 MHz IF is -40 dBm .
9. On the spectrum analyzer, press **SGL SWP**, **CAL**, **IF ADJ OFF**, **MORE 1 OF 2**, and **FLATNESS**. Increase the gain of the flatness compensation amplifiers to maximum by entering 0 using the data keys. This sets the gains in the flatness compensation amplifiers to their maximum values.
10. Connect the second spectrum analyzer to A15J601 and measure the 10.7 MHz IF signal level. The signal should measure greater than -10 dBm . If the signal level is incorrect, continue with step 13.
11. Enter 4095 into the spectrum analyzer flatness data. The signal level at A15J601 should measure less than -36 dBm . This sets the gain of flatness compensation amplifiers to a minimum. If the signal level is incorrect, continue with step 13.
12. Check that the gain stages are properly biased and functioning.
13. Check the attenuator stages and flatness compensation control circuitry.
 - a. For minimum gain (flatness data equals 4095), RF GAIN (A15U909 pin 10) should be at -1.6 Vdc and the current through each section as measured across R667 or R668 should be about 7 mA.

- b. For maximum gain (flatness data equals 0), RF GAIN (A15U909 pin 10) should be at approximately 0 Vdc and the current through each attenuator section should be close to 0 mA.

CAUTION

As long as the flatness data just entered is not stored, the previously-stored flatness data will be present after the power is cycled.

14. Move the WR PROT/WR ENA jumper on the A2 controller assembly to the WR PROT position.
15. Reconnect the cable to A15J801.

Flatness Compensation Control

Refer to function block G on A15 RF Section Schematic Diagram in the *8560 E-Series Spectrum Analyzer Component Level Information*.

The Flatness Compensation Control consists of a buffer amp (U909C) and two identical voltage-to-current converters (U909B and U909D). The thermistor RT901 in the buffer amp provides temperature compensation for the PIN diodes in the gain stages and the SAW filters.

PIN Switch Drivers

Refer to function block H on A15 RF Section Schematic Diagram in the *8560 E-Series Spectrum Analyzer Component Level Information*.

The control latches control the PIN Switch Drivers illustrated in Function Block I.

1. Connect the positive lead of a DVM to A15J901 pin 15 (HEXTMIX). Connect the negative lead to A15J901 pin 6. The measured signal controls the switching between internal and external IF signals.
2. On the spectrum analyzer, press **AUX CTRL** and **EXTERNAL MIXER**. The voltage on the DVM should measure approximately +5 Vdc (TTL high).
3. On the spectrum analyzer, press **AUX CTRL** and **INTERNAL MIXER**. The voltage on the DVM should measure approximately 0 Vdc (TTL low).
4. Connect the DVM positive lead to A15J901 pin 13 (LSID). The signal measured turns on the SIG ID oscillator.
5. On the spectrum analyzer, press **SIG ID ON** (if present), **SGL SWP**.
6. Subsequent pushes of **SGL SWP** should cause the signal measured on the DVM to toggle between TTL high and low levels.
7. Connect an oscilloscope probe to A15U902 pin 7 (LRDIR) and the probe ground lead to A15J901 pin 6. The signal measured controls the flatness compensation circuit.

8. On the spectrum analyzer, press **PRESET** and set the **SPAN** to 1 MHz.

Set the oscilloscope for the following settings:

Amplitude scale 2 V/div
Sweep time 20 ms/div

9. The waveform should be at a TTL high during part of the retrace period and a TTL low during the sweep (about 50 ms).

SIG ID Oscillator (Option 008)

Refer to function block F on A15 RF Section Schematic Diagram in the *8560 E-Series Spectrum Analyzer Component Level Information*.

SIG ID is available only with Option 008. The SIG ID Oscillator provides a shifted third LO (approximately 298 MHz) to distinguish true signals from false signals (such as image or multiple responses). When the spectrum analyzer is set to **SIG ID ON**, the SIG ID Oscillator turns on during alternate sweeps.

1. Set the spectrum analyzer to the following settings:

Trigger single sweep
SIG ID on

2. Use an active probe with a second spectrum analyzer to measure the signal level at A15X602.
3. On the spectrum analyzer, press **SGL SWP**. With each press of **SGL SWP**, the analyzer alternates between the following two states:

State 1:

A15J901 pin 13 (LSID)..... TTL low
SIG ID Oscillator..... ON
Signal at A15X602..298MHz \pm 50 kHz (at least +1 dBm)

State 1:

A15J901 pin 13 (LSID).....TTL high
SIG ID Oscillator..... OFF
3rd LO Driver Amplifier Provides LO for Double Balanced Mixer

4. With the SIG ID oscillator on, measure the frequency at A15X602 with a frequency counter and an active probe. If the frequency is not 298 MHz \pm 50 kHz, refer to the [“14. Signal ID Oscillator Adjustment \(serial prefix 3517A and below\)” on page 151](#). (There is no adjustment for instruments with A15 RF assembly 08563-60084 or greater.)

5. On the spectrum analyzer, press **SGL SWP** until A15J901 pin 13 is at TTL low. Diodes CR603 and CR605 should be forward biased and CR604 should be reverse biased (approximately 6 Vdc reverse bias). Diodes CR501 and CR502 should be forward-biased, disabling the 3rd LO Driver Amplifier.
6. The voltage at the R622/R623 node should measure approximately -5 Vdc, biasing Q604 on.
7. If oscillator bias voltages are correct, place a 100Ω resistor across SAWR U602 input and output. If the SAWR has failed, this will provide the equivalent loss of a correctly functioning SAWR, and the circuit will begin to oscillate.

10 MHz Reference

The spectrum analyzer 10 MHz reference consists of 10 MHz OCXO (Option 103: TCXO) with associated TTL level generator and distribution circuitry. The OCXO (or TCXO) and TTL level generator are turned off when an external 10 MHz reference is used. Also, with the analyzer set to EXTERNAL frequency reference, U304A output (low) forces the output of U304D to stay high. This allows U304B to control the outputs of U303B, U304C, and U303D. In INTERNAL frequency reference, U304D controls the outputs of these three NAND gates, and the output of U304B is held high.

Check the 10 MHz reference by performing the following steps:

1. Set the spectrum analyzer 10 MHz reference to internal by pressing **AUX CTRL**, **REAR PANEL**, and **10 MHz EXT INT** so that INT is underlined.
2. Use a second spectrum analyzer to confirm the presence of a 10 MHz signal at the following test points:
A15J303 ≥ -10 dBm
A15J304 ≥ -10 dBm
A15J301 ≥ -2 dBm
3. Check for a 1.3 Vp-p waveform at A15J302 using an oscilloscope. See [Figure 12-9 on page 627](#).
4. Check that the signal at A15J301 is 10 MHz ±40 Hz (with Option 103 TCXO reference) using a frequency counter. If necessary, perform the appropriate 10 MHz reference adjustment.
5. If there is no problem with INTERNAL 10 MHz reference operation, check EXTERNAL 10 MHz reference operation as follows.
6. Set the spectrum analyzer 10 MHz reference to external by pressing **10 MHz EXT**.

7. Connect a 10 MHz, -2 dBm, signal to the rear panel 10 MHz REF IN/OUT connector.
8. Check the signals at A15J301, A15J302, A15J303, and A15J304 according to the procedure in steps 2 through 4.
9. If the signals are correct in EXTERNAL operation, but not in INTERNAL operation, the problem lies in A21 OCXO (or Option 103 TCXO), its voltage reference, or the TTL level generator. Check these areas as follows:
 - a. On the spectrum analyzer, press **10 MHz INT**.
 - b. Check U305 pin 3 for approximately +12 Vdc (Option 103 only).
 - c. Check, with an oscilloscope, for a 10 MHz sine wave greater than or equal to 1 V p-p at J305, or at U302 pin 3 (with Option 103).
10. If the signal at U304 pin 13 is correct (see [Figure 12-10 on page 628](#)), but there is a problem with the signals at A15J301, A15J302, A15J303, or A15J304, suspect U303 or U304 in the 10 MHz Distribution circuitry.

Figure 12-9 10 MHz Reference at A15J302

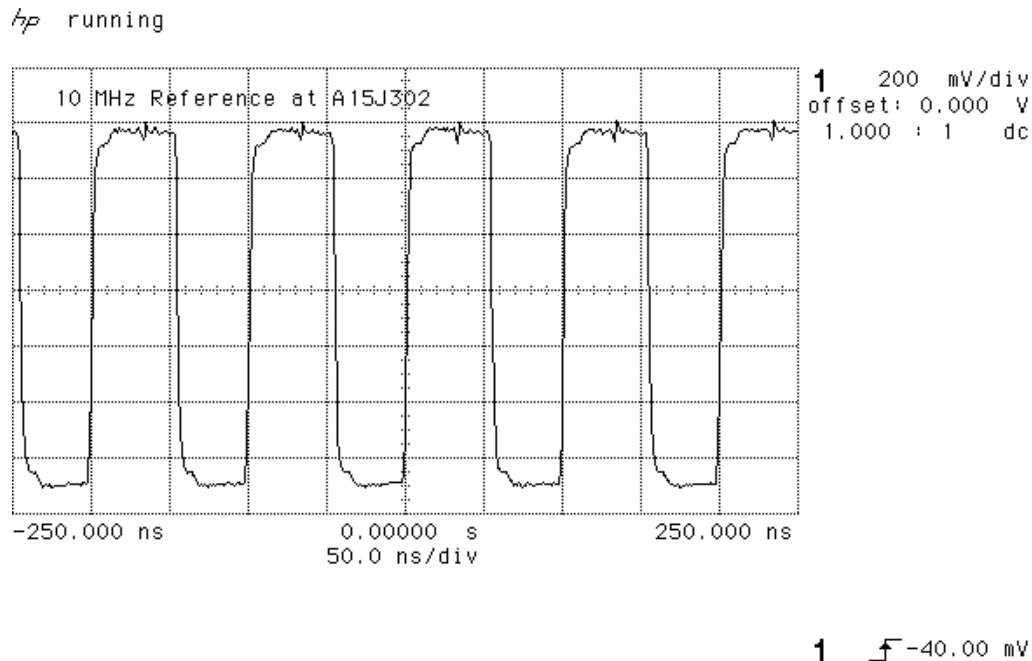
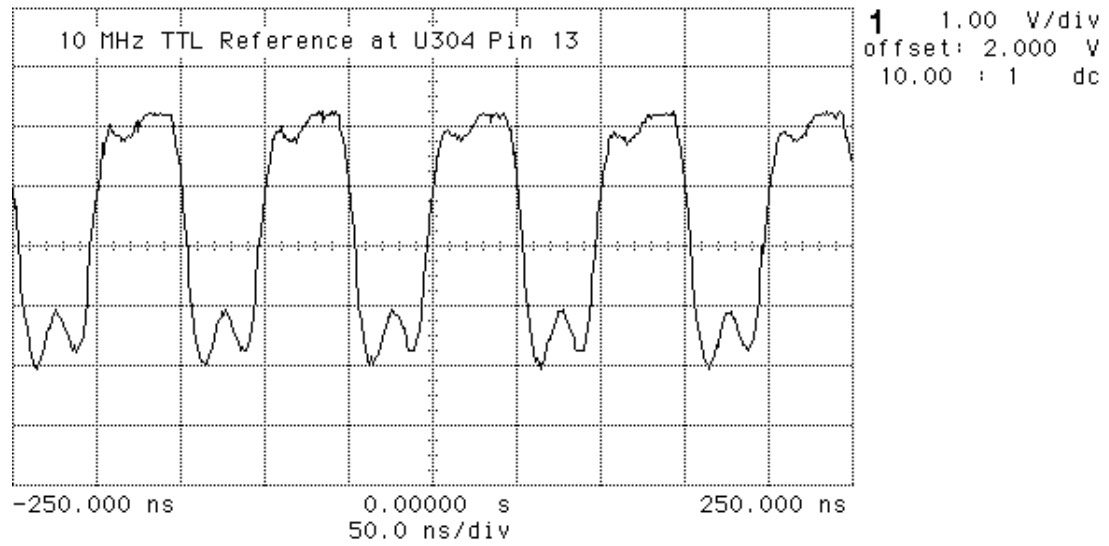

Figure 12-10 10 MHz TTL Reference at U304 Pin 13

hp stopped



1 2.640 V

Table 12-6 on page 629 lists the RF Section mnemonics shown in Figure 12-11 on page 631 and provides a brief description of each.

Table 12-6 RF Section Mnemonic Table

Mnemonic	Description
TUNE+, TUNE-	YTF Tune Signal (SBTX or RYTHM)
HTR+, HTR-	YTF Heater Power
MAIN COIL+, MAIN COIL-	YTO Main Coil Tune Signal
FM+, FM-	YTO FM Coil Tune Signal
LO SENSE	LO Amplitude Sense Voltage
LEVEL ADJUST	LO Amplitude Adjustment Voltage (PIN ATTEN)
GATE BIAS	LOMA Gate Bias Voltage
HEXTMIXB	External Mixer: +12V=EXT MIX -12V=INT MIX
HSIGIDOFFA	SIG ID Oscillator +12V=SIG ID OFF ON: -8V=SIG ID ON
PIN SW	PIN Diode Switch Control (SBTX or RYTHM LO Band/HI Band)
PIN DIODE SWITCH	PIN Diode Switch Control For 2ND Conv. IF Output
MIXER BIAS	Detected Voltage on 2ND Converter Mixer Diode
RFGAIN	Voltage to Control Gain of Flatness Comp. Amps.
RFGAIN1 and RFGAIN2	Currents to Drive PIN Diodes in Flatness Comp. Amps.
L10dB ON, L20dB ON, L30dB ON	Control Lines to Set Attenuator Sections 10, 20, and 30 to Attenuate Position (Active Low)
L10dB OFF, L20dB OFF, L30dB OFF	Control Lines to Set Attenuator Sections 10, 20, and 30 to Bypass Position (Active Low)

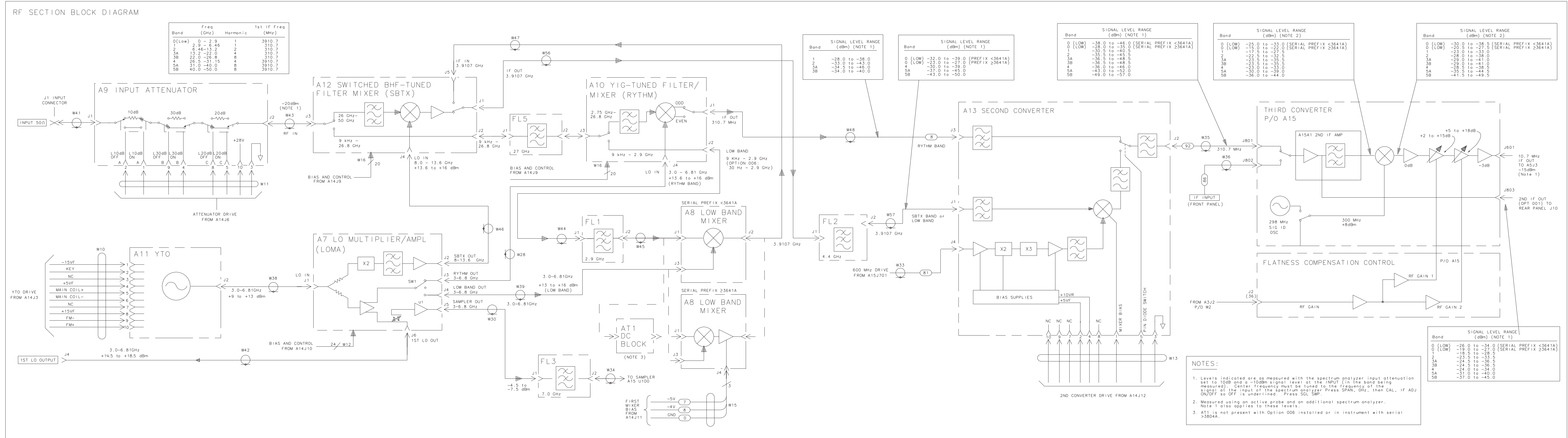

13 **Display/Power Supply Section**

Introduction

The Display/Power Supply chapter consists of the following sections:

A17 LCD Display (8564EC and 8565EC)	page 635
A17 CRT Display (8564E and 8565E).....	page 641
A6 Power Supply	page 654

WARNING

The A6 power supply in 8560 E-series and EC-series instruments, and the A6A1 high voltage assembly in 8560 E-series instruments, contain lethal voltages with lethal currents in all areas. Use extreme care when servicing these assemblies. Always disconnect the power cord from the instrument before servicing these assemblies. Failure to follow this precaution can represent a shock hazard which may result in personal injury.

The voltage potential at A6A1W3, in 8560 E-series instruments, is +9 kV. If the cable must be disconnected, always disconnect it at the CRT with caution! Failure to properly discharge A6A1W3 may result in severe electrical shock to personnel and damage to the instrument. See procedure 2 in [Chapter 3](#) .

Do not discharge the CRT second anode directly to ground, with the A6A1 high voltage cable connected. This can damage the A17 CRT driver assembly. Always discharge through a high resistance, such as a high voltage probe.

Always use an isolation transformer when troubleshooting either the A6 power supply or the A6A1 HV module. When using an isolation transformer, connect a jumper between A6TP101 and A6TP301. This connects the circuit common to earth ground. Remove this jumper when the isolation transformer is not used.

LCD Display (8564EC and 8565EC)

The display section of 8564EC and 8565EC instruments contain the A17 display driver, the A17A1 inverter board, the A18 LCD (liquid crystal display), and the A6 power supply. The A6 power supply is explained in the power supply section which begins on page 590. [Figure 13-1 on page 636](#) illustrates the LCD block diagram.

Troubleshooting the LCD Display.....	page 637
Blank Display	page 637
Dim Display	page 639
Troubleshooting using the VGA port	page 639
Troubleshooting using part substitution	page 639

Figure 13-1 Simplified LCD Block Diagram

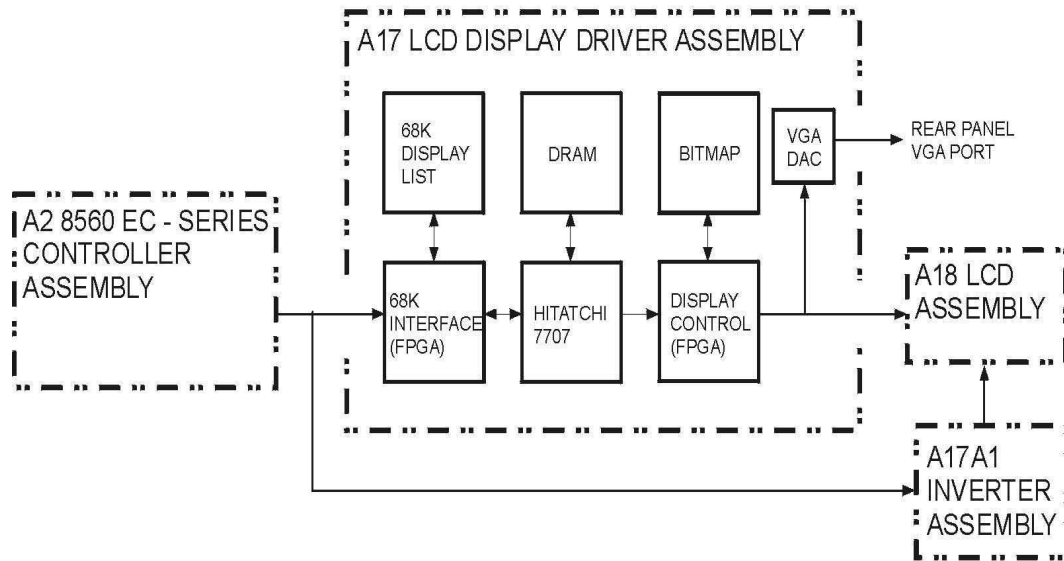

sj136c

Overview of A17 Display Driver Board

The A17 display driver board monitors the 8560 EC-series controller board, copies display instructions to local memory, creates a bitmap from the data, and generates the signals needed to drive the LCD display and a VGA monitor. The display driver consists of a Hitachi 7707 processor, an FPGA, DRAM, SRAM, a filter circuit, and a video DAC.

The FPGA is connected to the address bus, data bus, and the display memory control signals on the controller board. The FPGA monitors the control signals and determines when the Hitachi 7707 processor writes to display memory. When this occurs, the FPGA makes a duplicate of this information on the display driver board. The other main function of the FPGA is to provide the signals necessary to drive a TFT LCD display and a standard VGA monitor.

The processor reads display information received from the controller board, creates a bitmap, and copies the bitmap into SRAM. The FPGA outputs this information to the LCD and VGA displays. The DRAM is used by the processor to run its program. The filter circuit provides the clock signals that are needed to run the display driver board. The video DAC converts the digital color information that goes to the LCD to analog signals; these signals drive the RGB color lines on the VGA port.

Troubleshooting the LCD Display

NOTE There are no adjustments for intensity or focus of the LCD.

Blank Display

1. If the LED above the front-panel LINE switch is lit, most of the A6 power supply is functioning properly.
2. Carefully check the voltages on the front-panel PROBE POWER jack. Be careful to avoid shorting the pins together. See [Figure 13-2 on page 638](#).
3. Check that the fan is operating. If the PROBE POWER voltages are correct, and the fan is turning, the A6 power supply is probably working properly.
4. If all of the power supply indicators along the outside edge of the A2 controller assembly are lit, the A6 power supply is probably working properly.
5. Connect a VGA monitor to the VGA port on the rear of the instrument. If the display is still blank, suspect the A2 controller, a loose cable, or the display driver.
6. If the LED is not lit, or the fan is not working, or the probe power voltages are not correct, or the power supply indicators on the edge of the A2 controller assembly are not working properly, proceed to the section on troubleshooting the power supply on [page 658](#).
7. Open the left side of the instrument (see [“Procedure 2A. A1 Front Frame/A18 LCD \(8562EC\)” on page 166](#)). Make voltage measurements at pins 1, 2, 3, 4, 5, 41, 42, 43, 44, and 45 on J8 of the A2 controller (see [Figure 13-3 on page 640](#)). These pins should measure $5V \pm 0.25V$. If any of these measurements is out of tolerance suspect the A2 controller board or the power supply. If the voltages for these pins are correct, make the same measurements at the identical pins on J1 of the A17 display driver board. If these measurements are correct, suspect the A18 LCD assembly or the A17A1 inverter board. If these measurements are not correct, suspect the A17 LCD driver or A17A1 inverter board.

Figure 13-2 Probe Power Socket

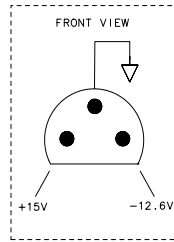

Dim Display

1. If the display is dim, suspect the backlights, which are inserted into the LCD assembly from the backlight assembly. Always replace both backlights at the same time. To replace the backlights, see [page 189](#) of procedure 2A.

Troubleshooting Using the VGA Port

1. Connect a VGA monitor to the rear VGA port of the instrument (the VGA port is always active and requires no user interaction).
2. Observe the display.

If the display on the VGA monitor is working correctly, the problem is probably caused by the LCD, or by a cable problem. Proceed to step 1 in “Troubleshooting using part substitution.”

If the display on the VGA monitor shows the same symptom(s) you have seen on the instrument’s LCD, the problem is probably caused by the A2 controller board, the display driver, or by a cable problem. Proceed to step 2 in “Troubleshooting using part substitution.”

Troubleshooting Using Part Substitution

1. Disconnect the power cord, turn the instrument off, and open the left side. Ensure that W60, W61, W62, W63, and W64 are tight. Reconnect the power cord and check the instrument to see whether the problem is corrected. If not, proceed to step 2.
2. Disconnect the power cord and turn the instrument off. Replace W60, the ribbon cable that connects the A2 board to the display driver board. Reconnect the power cord and check the display to see whether the problem is corrected. If not, proceed to step 3.
3. Disconnect the power cord and turn the instrument off. Replace W61, the 10 MHz reference cable that connects the A2 board to the display driver board. Reconnect the power cord and check to see whether the problem is corrected. If not, proceed to step 4.
4. Disconnect the power cord and turn the instrument off. Remove and replace (see procedure 2A on [page 180](#)) the A17 display driver board. Reconnect the power cord and check the instrument to see whether the problem is corrected. If not, proceed to step 5.
5. Remove and replace (see procedure 5 on [page 202](#)) the A2 controller board. Check to see whether the problem is corrected. If not, proceed to step 6.
6. Disconnect the power cord and turn the instrument off. Remove and replace (see procedure 2A on [page 180](#)) the A18 LCD. Reconnect the power cord and check the instrument to see whether the problem is corrected.

Figure 13-3 Location of +5V supply pins on J1 of A17 and J8 of A2

GND SX	● 80	● 79	addrmsx2
addrmsx 3	● 78	● 77	GND SX
addrmsx 6	● 76	● 75	addrmsx 7
GND SX	● 74	● 73	addrmsx 10
addrmsx 11	● 72	● 71	GND SX
NC	● 70	● 69	NC
6ND SX	● 68	● 67	NC
NC	● 66	● 65	GND SX
NC	● 64	● 53	NC
GND SX	● 62	● 61	DATAM SX 2
DATAM SX 3	● 60	● 59	GND SX
DATAM SX 6	● 58	● 57	DATAM SX 7
GND SX	● 56	● 55	DATAM SX 10
DATAM SX11	● 54	● 53	GND SX
DATAM SX 14	● 52	● 51	DATAM SX 15
GND SX	● 50	● 49	NC
_RESETM SX	● 48	● 47	GND SX
NC	● 46	● 45	+5V BKLT SX
+5VBKLT SX	● 44	● 43	+5VBKLT SX
+5VBKLT SX	● 42	● 41	+5V SX
addrmsx 1	● 40	● 39	GND SX
addrmsx 4	● 38	● 37	addrmsx 5
gnd sx	● 36	● 35	addrmsx 8
addrmsx 9	● 34	● 33	GND SX
addrmsx 12	● 32	● 31	addrmsx 13
GND SX	● 30	● 29	NC
NC	● 28	● 27	GND SX
NC	● 26	● 25	NC
GND SX	● 24	● 23	DATAM SX
DATAM SX 1	● 22	● 21	GND SX
DATAM SX 4	● 20	● 19	DATAM SX 5
GND SX	● 18	● 17	DATAM SX 8
DATAM SX 9	● 16	● 15	GND SX
DATAM SX 12	● 14	● 13	DATAM SX 13
GND SX	● 12	● 11	LMUX-INSX
EN1 SX	● 10	● 9	GND SX
NC	● 8	● 7	NC
GND SX	● 6	● 5	+5VBKLT SX
+5V BKLT SX	● 4	● 3	+5VBKLT SX
+5V BKLT SX	● 2	● 1	+5V SX

sj114c

Figure 13-3 shows A2J8 connections on 8560 EC-Series Instruments. Lines 2 –5 and 42 – 44 supply +5V to the two LCD backlights. Lines 1 and 41 supply +5V to the A17A1 Inverter board. Lines 1 – 6 and 41 – 44 are identical on A17J1.

CRT Display (8564E and 8565E)

The CRT display section contains the A6 power supply, A6A1 HV module, A17 CRT driver, and A18 CRT. The A6 power supply and A6A1 HV module are explained in the section on the power supply which begins on page 590. [Figure 13-4 on page 642](#) illustrates the section block diagram.

Troubleshooting Using the TAM	page 643
Blank Display (Using the TAM)	page 645
Blank Display	page 646
Blanking Signal.....	page 647
Display Distortion	page 648
Focus Problems.....	page 650
Intensity Problems	page 652

WARNING

The A6 power supply and A6A1 high voltage assemblies contain lethal voltages with lethal currents in all areas. Use extreme care when servicing these assemblies. Always disconnect the power cord from the instrument before servicing these assemblies. Failure to follow this precaution can represent a shock hazard which may result in personal injury.

The voltage potential at A6A1W3 is +9 kV. If the cable must be disconnected, always disconnect it at the CRT with caution! Failure to properly discharge A6A1W3 may result in severe electrical shock to personnel and damage to the instrument. See procedure 2 in Chapter 3.

Do not discharge the CRT second anode directly to ground, with the A6A1 high voltage cable connected. This can damage the A17 CRT driver assembly. Always discharge through a high resistance, such as a high voltage probe.

Always use an isolation transformer when troubleshooting either the A6 power supply or the A6A1 HV module. When using an isolation transformer, connect a jumper between A6TP101 and A6TP301. This connects the circuit common to earth ground. Remove this jumper when the isolation transformer is not used.

Figure 13-4 Power Supply and CRT Block Diagram

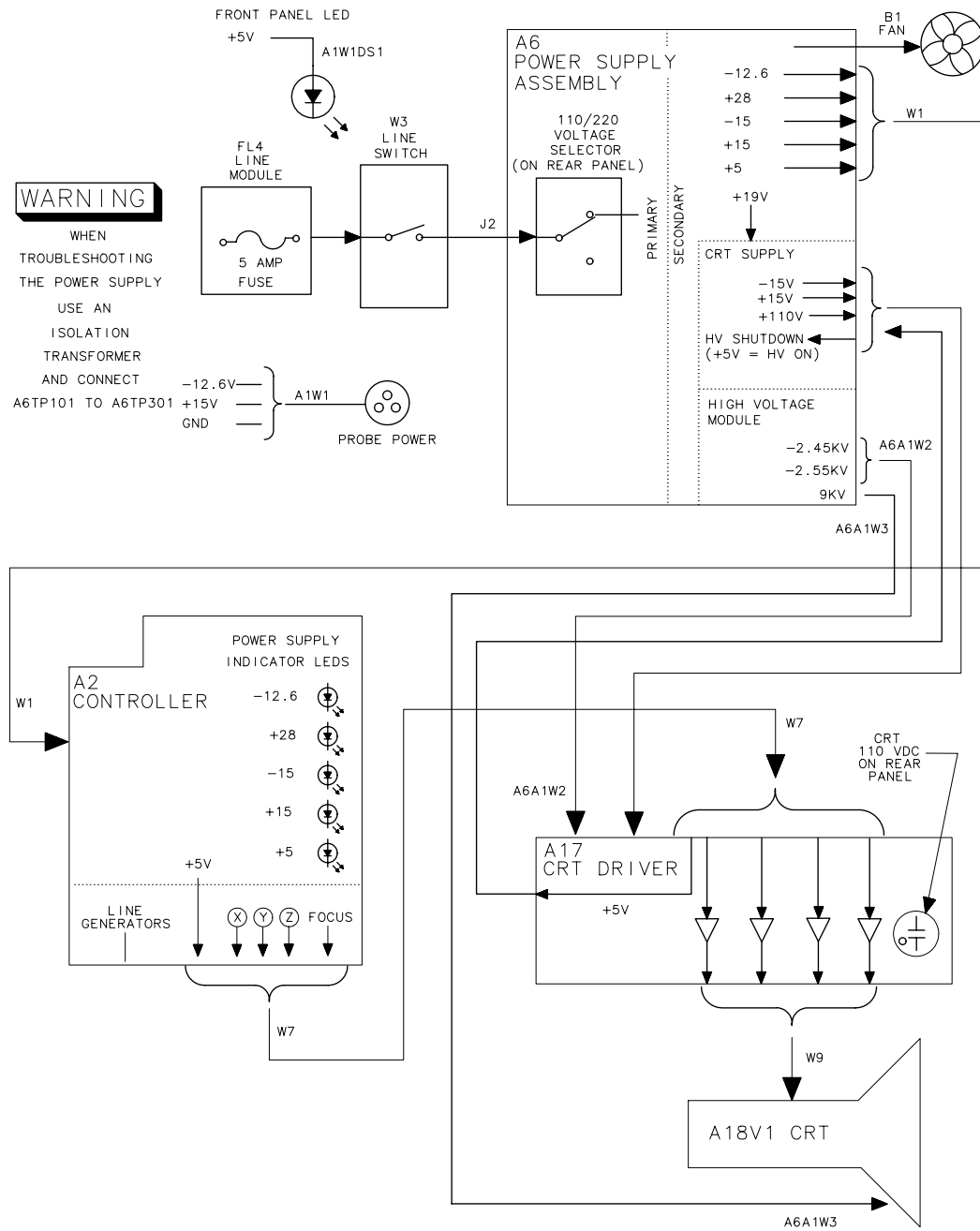

sp141e

Troubleshooting Using the TAM

When using automatic fault isolation, the TAM indicates suspected circuits that need to be manually checked. Use [Table 13-1 on page 643](#) to locate the manual procedure.

[Table 13-2 on page 644](#) lists assembly test connectors associated with each manual probe troubleshooting test. [Figure 13-5 on page 644](#) illustrates the location of A17 test connectors.

Table 13-1 Automatic Fault Isolation References

Suspected Circuit Indicated by Automatic Fault Isolation	Manual Procedure to Perform
Check A2 Controller	Blanking Signal
Check All Power Supply Outputs	Dead Power Supply (<i>steps 1-5</i>)
Check Buck Regulator	Dead Power Supply (<i>steps 13-23</i>)
Check Buck Regulator Control Circuitry	Dead Power Supply (<i>steps 11-21</i>)
Check High-Voltage Supplies	High Voltage Supplies
Check Input Rectifier	Dead Power Supply (<i>steps 6-7</i>)
Check Intensity Adjustments	Intensity Problems (<i>steps 1-4</i>)
Check Kick Start/Bias Circuitry	Dead Power Supply (<i>steps 8-10</i>)
Check Low-Voltage Supplies	Low Voltage Supplies

Figure 13-5 A17 Test Connector

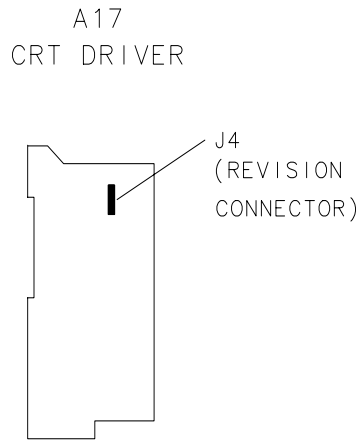

SK1121

Table 13-2 TAM Tests versus Test Connectors

Connector	Manual Probe Troubleshooting Test	Measured Signal Lines
A17J4	Revision Constant current Source Intensity input Intensity offset Blanking control	MS5 MS1 MS7 MS7 MS8
A2J201	10 V reference test Switch drive test Buffered X & Y DAC outputs X line generator test Y line generator test Intensity offset output	MS4 MS3 MS2, MS7 MS6 MS1 MS8
A2J202	Revision X, Y, & Z output offset X output amplifier Y output amplifier Blanking test Focus DAC test	MS1 MS3, MS4, MS7 MS7 MS3 MS4 MS2

Blank Display (Using the TAM)

Use the following procedure if the instrument display is blank. This procedure substitutes a GPIB printer for the display.

1. Connect the printer to the 8564E or 8565E spectrum analyzer and set the printer address to the value required by the TAM. This is usually 1.
2. All of the power-supply indicator LEDs along the edge of the A2 controller assembly should be lit.
3. The rear panel CRT +110 VDC ON indicator should also be lit.
4. Connect the TAM probe cable to A2J11.
5. Press **MODULE**, **SOFT KEY #3**, **▼**, and **SOFT KEY #1**. (The top soft key is #1.)
6. The yellow LED next to A2J11 should blink approximately ten times. If the LED fails to blink correctly, troubleshoot the digital section of the A2 controller assembly.
7. Move the probe cable to A2J202. Press **SOFT KEY #1** and wait 5 seconds.
8. Press **SOFT KEY #4**. The results should be sent to the printer.
9. Move the probe cable to A2J201, press **SOFT KEY #1** and wait 5 seconds.
10. Press **SOFT KEY #4**. The results will be sent to the printer.
11. If a failure is indicated in any of these tests, the fault lies on the A2 controller assembly. To obtain more information:
 - a. Press the down arrow key one less time than the test number. (For example, press it twice for the third test on the list.)
 - b. Press **SOFT KEY #3**, then **SOFT KEY #4**, and when the printout is complete, **SOFT KEY #6**.
12. If no failures were indicated in testing the A2 controller, move the probe cable to A17J4.
13. Press **SOFT KEY #1** and wait 5 seconds.
14. Press **SOFT KEY #4**. The results will be sent to the printer.
15. If no failure is indicated in the printout, check the high-voltage supplies as described “[High Voltage Supplies \(8564E and 8565E\)](#)” on [page 662](#).

Blank Display

1. If the LED above the front panel LINE switch is lit, most of the A6 power supply is functioning properly.
2. Carefully check the voltages on the front panel PROBE POWER jack. Be careful to avoid shorting the pins together. See [Figure 13-6 on page 646](#).
3. Check that the fan is operating. If the PROBE POWER voltages are correct, and the fan is turning, the A6 power supply is probably working properly.
4. If the CRT +110 VDC ON LED on the rear panel is lit, the high-voltage supplies should also be operating. (The high-voltage supplies will be turned off if the HV SHUT_DOWN line is low.) The A6 power supply feeds +5 V to the A2 controller through W1. The A2 assembly distributes this +5 V to the A17 CRT driver through W7. A17 sends +5 V back to A6 as the HV SHUT_DOWN signal on W8. As a result, A2, A17, W1, W7, and W8 must all be in place for the high-voltage supplies to operate.
5. If all of the power supply indicators along the outside edge of the A2 controller assembly are lit, the A6 power supply is probably working properly.

Figure 13-6 Probe Power Socket

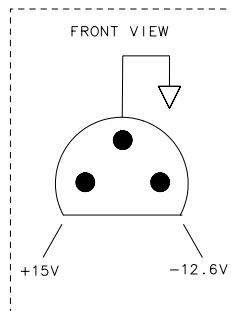

SK1122

6. Press **FREQUENCY, 1, GHz**.
7. Allow the analyzer to warm up for at least 1 minute.
8. While observing the display, press **LINE** to turn the spectrum analyzer off. If a green flash appears on the display, the CRT is probably working properly; troubleshoot either the A2 controller or the A17 CRT driver.
9. If a flash does not appear on the display, the A2 controller, A6A1 HV module, A17 CRT driver, or A18V1 CRT might be at fault.

Blanking Signal

1. Connect an oscilloscope probe to A2J202 pin 3. Connect the oscilloscope ground lead to TP3. Set the oscilloscope to the following settings:

Sweep time 2 ms/div
Vertical scale 1 V/div

2. If a 4 Vp-p signal is not observed, the A2 controller assembly is faulty.
3. Repeat steps 1 and 2 with the oscilloscope probe on A2J202 pin 14.
4. Set the oscilloscope to the following settings:

Sweep time 1 μ s/div
Vertical scale 2 V/div

5. Connect the positive probe lead to A2J202 pin 15. This is the blanking output.
6. TTL-level pulses should be observed. If the signal is either always high or always low, the display will be blanked; suspect the A2 controller assembly.
7. If the signals on A2J202 pins 3, 14, and 15 are correct, troubleshoot the A17 CRT driver.

Display Distortion

The 8564E and 8565E use a vector display. The graticule lines, traces, and characters are composed of a series of straight lines ("vectors") placed end-to-end. If the vectors do not begin and end at the proper points, the display appears distorted, but in focus. Symptoms range from characters appearing elongated and graticule lines not meeting squarely, to an entirely unreadable display.

1. If the spectrum analyzer is in external frequency reference mode (an "X" is displayed along the left side of the display), ensure that an external 10 MHz reference is supplied. Otherwise the 16 MHz CPU clock will be off-frequency, causing distortion.
2. Use the CRT ADJ PATTERN to check for distortion. Press **CAL, MORE 1 OF 2**, and **CRT ADJ PATTERN**. If vector distortion (described above) occurs, perform the "Display Adjustment" in Chapter 2 to test the function of the A2 controller assembly.
3. If there is distortion along with slight focus degradation, but the graticule lines meet (not necessarily squarely), the A17 CRT driver, CRT, DDD/TRACE ALIGN adjustments, or cable connections might be at fault.
4. If the A2 controller assembly is not part number 08563-60017, perform the "16 MHz PLL adjustment" in Chapter 2. If the 16 MHz CPU clock is off-frequency, the display will be distorted.
5. Perform the "Display Adjustment" in Chapter 2. Isolate the problem to either the X or Y axis by noting the behavior of the adjustments. If the line generator or fast zero-span portion of the adjustment fails, troubleshoot the A2 controller assembly.
6. If the adjustments do not remedy the problem, press **LINE** to turn the spectrum analyzer off and place the A17 CRT driver in the service position.
7. Distortion confined to one axis (vertical or horizontal only), indicates a faulty X or Y deflection amplifier on the A17 assembly. Use the alternate good deflection amplifier for obtaining typical voltages. (There is enough symmetry in a typical display that the voltages should be similar between these circuits.)
8. Monitor the waveforms at A17TP11 and A17TP14 (or TP12 and TP13). The 50 to 100 Vp-p ac component of the waveforms at the X and X (or Y and Y) outputs should be mirror images of each other. The dc average should be 55 V.
9. The appropriate POSN adjustment (A17R57 or A17R77) should change the dc component of both X and X (or Y and Y) outputs in opposite directions.

10. The appropriate GAIN adjustment (A17R55 or A17R75) should change the ac component in both outputs by the same amount.
11. If the display is a single dot, check the base of A17Q18 for $-10.3\text{ V} \pm 0.3\text{ V}$. Verify the signals at TP11, TP14, TP12, and TP13.
12. If signals are correct and cables to the CRT are good, suspect the CRT.

Focus Problems

Focus problems may be due to a defective A18V1 CRT, the A17 CRT driver (especially the grid level shifter section), or the A2 controller focus control circuitry. Focus problems may also be due to improper adjustments, improper connections, or absence of high voltage.

Although A17 grid level shifter (function block D) is the leading cause of A17 focus problems, function blocks C, E, F, and H generally have less effect on focus, but may cause poor focus that is a function of screen position, length of line, or intensity.

1. Connect the positive lead of a DVM to A2J202, pin 2. Connect the negative lead to A2J202 pin 6.
2. Use the knob to change the focus DAC value from 0 to 255.
3. If the DVM reads near 0 Vdc with the focus set to 0, and near -10 Vdc with the focus set to 255, the A2 focus control circuitry is working properly.
4. Perform the "Display Adjustment" in [Chapter 2](#). Note that A17R34 COARSE FOCUS has the greatest effect on focus. Adjustment A17R93 ASTIG and A17R92 DDD have a lesser effect, and A17R21 Z FOCUS, A17R26 X FOCUS and front panel adjustment (press **DISPLAY, MORE 1 OF 2, FOCUS**, and turn knob) have less effect on focus.
5. If the focus of some areas of the screen are worse than normal, continue with step 11. If no part of the screen can be brought to sharp focus, continue with step 6. (CRTs have some normal focus variation across their face.)
6. Turn off the analyzer and place A17 in the service position. Connect the ground lead of a high-voltage probe (34111A) to the chassis, and use it with a DVM to measure A17J7(10).
7. The nominal A17J7(10) voltage is -1600 Vdc, but the CRT will function if this voltage is within 200 V of -1600 Vdc.
8. Adjusting A17R34 COARSE FOCUS should vary the A17J7(10) voltage by 150 V. If these voltages are correct, suspect the CRT.
9. Check the A6A1 high voltage module cathode supply output at A17TP16 using a high voltage probe. If the cathode voltage is -2450 V \pm 250 V, check the focus grid level shifter.
10. If the cathode voltage is not correct, check the A6A1 high voltage module and its connections.
11. Connect an oscilloscope probe to A17TP9. This signal corrects the focus for the X position of the CRT beam, and for intensity level. It also provides the front panel focus adjusting voltage.

12. Press **DISPLAY, MORE 1 OF 2**, and **FOCUS**. While turning the front panel knob, verify the dc level of the signal at TP9 adjusts about 30 Vp-p.
13. Verify that the front panel intensity adjustment, when used with the A17R21 Z FOCUS, changes the peak-to-peak voltage at TP9 by 25 V. Access the intensity adjustment by pressing **DISPLAY, INTENSITY**, and turning the front panel knob.
14. Set front panel intensity to minimum. Set A17R21 Z FOCUS and A17R26 X FOCUS fully counterclockwise. Verify that the peak-to-peak voltage at TP9 is about 40 Vp-p (due to X-dynamic focus circuit).
15. If circuit operation seems correct, the A18V1 CRT is probably at fault.

Intensity Problems

Intensity problems, or absence of display, can be due to the A17 assembly intensity amplifier (function block A), intensity grid level shifter (function block B), CRT (A18V1), interconnections, or lack of proper supplies or inputs to A17.

1. On the 8564E or 8565E spectrum analyzer, press **DISPLAY** and **INTENSITY**.
2. Rotate the front panel knob (RPG), and check that the intensity changes from dim, but readable, to bright.
3. If the intensity function does not function properly, troubleshoot the A2 controller assembly.
4. Perform the preliminary and Z-axis portions of the "Display Adjustment" in [Chapter 2](#). Verify that A17R11 CUTOFF functions properly. If A17R11 CUTOFF does not function properly, place the A17 CRT driver in the service position.
5. Verify that blanking pulses are present at A17TP2 using an oscilloscope. The pulses should be normal TTL levels, approximately 1 μ s wide and 4 or 7 μ s apart. If the blanking pulses are not correct, check the BLANKING output of the A2 controller assembly and cable W7.
6. If blanking pulses are present, check A17TP10 with the oscilloscope. The TP10 signal should vary with the front panel intensity adjustment, and be approximately 55 Vp-p maximum. The signal will be composed of both blanking pulses and varying intensity levels for the lines being drawn.
 - If a proper signal is not present at A17TP10, check A17Q1, Q2, CR1, and CR2.
 - If the TP10 signal does not vary with the front panel intensity adjustment, check the signals at A17TP4 and A17TP1. Both signals should vary with the front panel intensity adjustment. The TP4 signal should be up to 4 Vp-p, and the TP1 signal should be up to approximately 12 Vp-p.

WARNING

The A17 CRT Driver contains lethal voltages with lethal currents. Use extreme care when servicing this assembly. Always disconnect the power cord from the instrument before servicing this assembly. Failure to follow this precaution can present a shock hazard which may result in personal injury.

NOTE

The following measurements should be made with a high-voltage probe, such as the 34111A. When using the high-voltage probe, connect the ground lead securely to the 8564E or 8565E chassis.

7. Carefully measure the grid voltage at A17J7 pin 6, and the cathode voltage at A17J7 pin 4. The display will work with a cathode voltage of $-2450\text{ V} \pm 250\text{ V}$, provided the grid voltage (A17J7 pin 6) is 30 to 100 V more negative than the cathode. A17R11, CUTOFF, should be able to adjust the voltage difference over a 60 V range to account for tube variations, and achieve proper intensity.
8. If the grid and cathode voltages are correct, turn off the 8564E or 8565E spectrum analyzer and check A17CR10 with an ohmmeter. If A17CR10 is good, suspect the A18V1 CRT.
9. If the grid and cathode voltages are too low, turn off the power and disconnect W8 from the base of A18V1 CRT, and recheck the grid and cathode voltages.
10. If the grid and cathode voltages are still too low, refer to "CRT Supply" in this chapter and the "High-Voltage Power Supply Adjustment" procedure in [Chapter 2](#).
11. If voltages are correct when the tube is disconnected, the CRT is probably defective.

CAUTION

The pins on the A18V1 CRT bend easily. Be careful not to bend pins when connecting W8 to A18V1.

Power Supply

The power supply section contains the A6 power supply and, in 8564E and 8565E instruments, the A6A1 HV module. [Figure 13-7 on page 655](#) illustrates the power supply block diagram. [Table 13-3 on page 656](#) lists signal versus pin numbers for power cable W1.

A6 Power Supply Assembly	page 658
Dead Power Supply	page 658
Line Fuse Blowing	page 660
Supply Restarting Every 1.5 Seconds (Kick Start)	page 661
Low Voltage Supplies	page 661
High Voltage Supplies (8564E and 8565E only)	page 662
CRT Supply Dropping Out (8564E and 8565E only)	page 663
Blanking Signal (8564E and 8565E only)	page 663
Buck Regulator Control	page 664
DC-DC Converter Control	page 665
Power Up	page 665

WARNING

The A6 power supply in 8560E-series and EC-series instruments, and the A6A1 high voltage assembly in 8560 E-series instruments, contain lethal voltages with lethal currents in all areas. Use extreme care when servicing these assemblies. Always disconnect the power cord from the instrument before servicing these assemblies. Failure to follow this precaution can represent a shock hazard which may result in personal injury.

The voltage potential at A6A1W3, in 8560 E-series instruments, is +9 kV. If the cable must be disconnected, always disconnect it at the CRT with caution! Failure to properly discharge A6A1W3 may result in severe electrical shock to personnel and damage to the instrument. See procedure 2 in [Chapter 3](#) .

Do not discharge the CRT second anode directly to ground, with the A6A1 high voltage cable connected. This can damage the A17 CRT driver assembly. Always discharge through a high resistance, such as a high voltage probe.

Always use an isolation transformer when troubleshooting either the A6 power supply or the A6A1 HV module. When using an isolation transformer, connect a jumper between A6TP101 and A6TP301. This connects the circuit common to earth ground. Remove this jumper when the isolation transformer is not used.

Figure 13-7 Simplified Power Supply Block Diagram

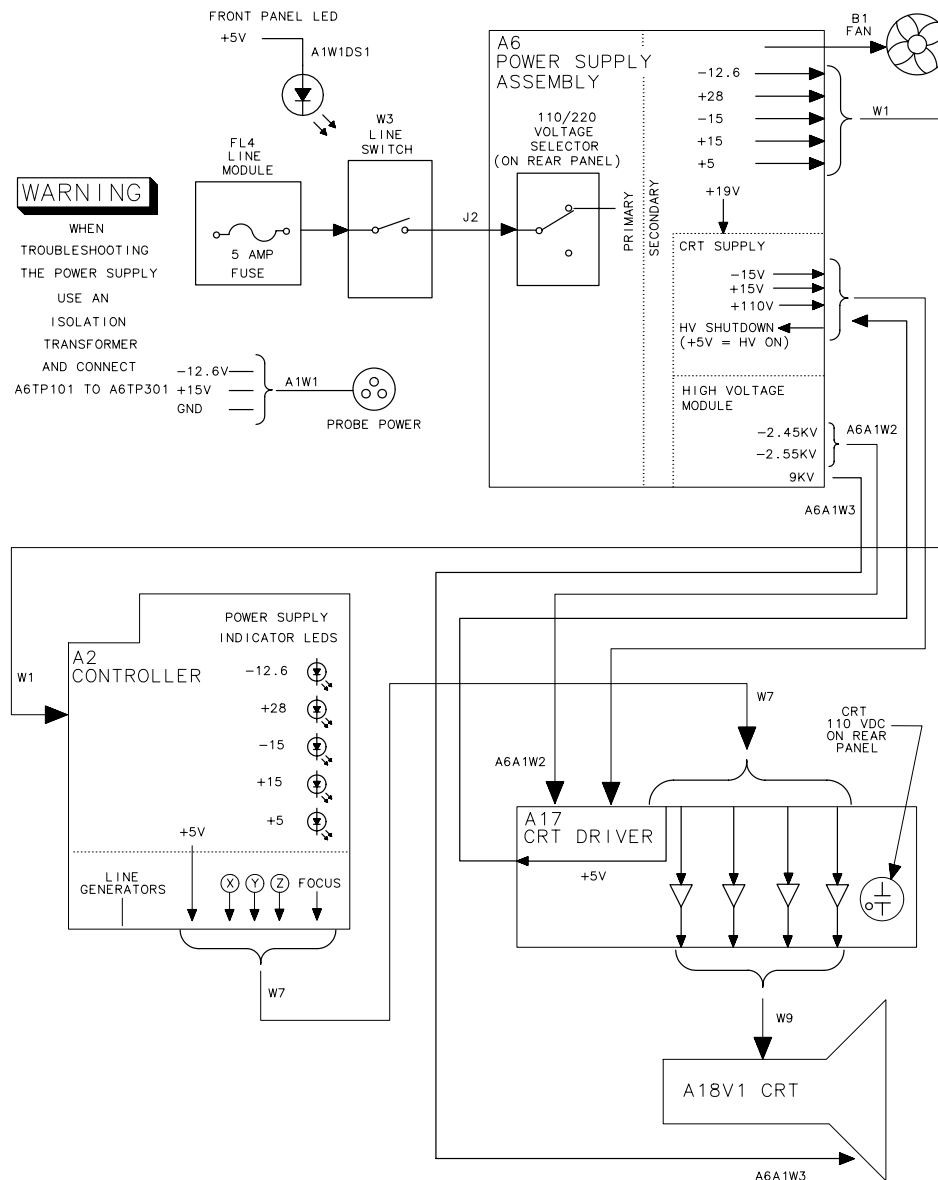

sp141e

NOTE

The block diagram in Figure 13-7 shows the power supply in an E-series instrument. The power supply in EC-series instruments is identical except that the CRT and high voltage supplies in an EC-series instrument are inactive, and are not connected to CRT circuitry.

Table 13-3

W1 Power-Cable Connections

Signal	A2J1 (pins)	A3J1 (pins)	A4J1 (pins)	A5J1 (pins)	A6J1- (pins)	A14J1 (pins)	A15J1 (pins)
NC	-	-	-	-	-	-	-
NC	-	-	-	-	-	-	-
A GND	-	3	3	48	3*	3	3
NC	-	-	-	-	-	-	-
NC	-	-	-	-	-	-	-
A GND	-	6	6	45	6*	6	6
NC	-	-	-	-	-	-	-
NC	-	-	-	-	-	-	-
A GND	-	9	9	42	9*	9	9
SCAN RAMP	41	10	-	-	-	10*	-
NC	-	-	-	-	-	-	-
A GND	-	12	12	39	12*	12	12
-12.6 V	38	13	-	-	13*	-	-
-15 V	-	14	14	37	14*	14	14
A GND	-	15	15	36	15*	15	15
-15 V	-	16	16	35	16*	16	16
+15 V	-	17	17	34	17*	17	17
A GND	-	18	18	33	18*	18	18
+15 V	-	19	19	32	19*	19	19
+28 V	-	20	-	-	20*	20	20
+28 V	-	21	-	-	21*	21	21
PWR UP	29	-	-	-	22*	-	-
-15 V	-	23	23	28	23*	23	23
-15 V	-	24	24	27	24*	24	24
+15 V	-	25	25	26	25*	25	25
+15 V	-	26	26	25	26*	26	26
+5 V	-	27	27	24	27*	27	27
+5 V	-	28	28	23	28*	28	28
+5 V	-	29	29	22	29*	29	29
+5 V	-	30	30	21	30*	30	30
D GND	20	31	31	20	31*	-	31
D GND	19	32	32	19	32*	-	32
A GND	18	33	33	18	33*	33	33
A GND	17	34	34	17	34*	34	34
D GND	16	35	35	16	35*	35	35
D GND	15	36	36	15	36*	36	36
D GND	14	37	37	14	37*	37	37
D GND	13	38	38	13	38*	38	38
+5 V	12	39	-	-	39*	-	-
+5 V	11	40	-	-	40*	-	-
+5 V	10	41	-	-	41*	-	-
+5 V	9	42	-	-	42*	-	-
+5 V	8	43	-	-	43*	-	-
+5 V	7	44	-	-	44*	-	-
+28 V	6	45	-	-	45*	-	-
LINE	-	46	-	-	46*	-	-
TRIGGER	-	-	-	-	-	-	-

* Indicates signal source.

Table 13-3 W1 Power-Cable Connections

Signal	A2J1 (pins)	A3J1 (pins)	A4J1 (pins)	A5J1 (pins)	A6J1- (pins)	A14J1 (pins)	A15J1 (pins)
+15 V	4	47	-	-	47*	-	-
+15 V	3	48	-	-	48*	-	-
-15 V	2	49	49	-	49*	-	-
-15 V	1	50	50	-	50*	-	-

* Indicates signal source.

Troubleshooting Using the TAM (8564E and 8565E only)

When using automatic fault isolation, the TAM indicates suspected circuits that need to be manually checked. Use [Table 13-4 on page 657](#) to locate the manual procedure.

Table 13-4 Automatic Fault Isolation References

Suspected Circuit Indicated by Automatic Fault Isolation	Manual Procedure to Perform
Check A2 Controller	Blanking Signal
Check All Power Supply Outputs	Dead Power Supply (<i>steps 1-5</i>)
Check Buck Regulator	Dead Power Supply (<i>steps 13-23</i>)
Check Buck Regulator Control Circuitry	Dead Power Supply (<i>steps 11-21</i>)
Check High-Voltage Supplies	High Voltage Supplies
Check Input Rectifier	Dead Power Supply (<i>steps 6-7</i>)
Check Intensity Adjustments	Intensity Problems (<i>steps 1-4</i>)
Check Kick Start/Bias Circuitry	Dead Power Supply (<i>steps 8-10</i>)
Check Low-Voltage Supplies	Low Voltage Supplies

A6 Power Supply Assembly

8564E , 8565E , 8564EC , and 8565EC spectrum analyzers use a switching power supply operating at 40 kHz to supply the low voltages for most of the analyzer hardware. In the 8564E and 8565E , the power supply also provides a 30 kHz switching supply (CRT supply) for the high voltages used by the CRT display used in E-series instruments. The CRT supply will be treated as a separate supply since the remainder of A6 must be operating for the CRT supply to operate.

Kick starting occurs when there is a fault either on the power supply or on one of the other assemblies. The power supply will try to start by generating a 200 ms pulse ("kick") every 1.5 seconds. A kick-starting power supply often appears to be dead, but the fan will make one or two revolutions and stop every 1.5 seconds.

Dead Power Supply

1. Use an isolation transformer and connect a jumper between A6TP101 and A6TP301.
2. Connect the negative lead of a DVM to A6TP301.
3. Check TP308 for +5 V.
4. Check TP302 for +15 V.
5. Check TP303 for -15 V.
6. Check TP304 for +28 V.
7. Check TP305 for -12.6 V.
8. Measure the voltage at TP108 to verify the output of the input rectifier. The voltage should be between +215 Vdc and +350 Vdc.
9. If it is not within this range, check the rear panel fuse, input rectifier, input filter, and the rear panel line voltage selector switch.
10. Measure the voltage at TP206 to verify the output of the kick-start/bias-circuitry. The voltage should be approximately +14 Vdc. Test point 206 is on pin 1 of U203.
11. If there is no voltage at TP206, check TP210 for pulses 200 ms wide with an amplitude of 14.7 V. If there are no pulses present, the kick-start circuitry is probably defective. If the pulses are low in amplitude (about 1 V), Q201 is probably shorted.
12. If there are pulses at TP206, or there are pulses at TP210, but not at TP206, the buck regulator control circuitry is probably faulty.
13. Disconnect the power cord from the 8564E or 8565E spectrum analyzer.

14. Connect the positive output of a current-limited dc power supply to the cathode of A6CR201 (TP206) and the ground to A6TP201.
15. Set the current limit of the power supply to about 500 mA and the voltage to 12 Vdc.
16. Make sure a jumper is connected from A6TP101 to A6TP301. This independently powers the buck regulator control circuitry.
17. Connect a jumper from the output of a +12 Vdc power supply to the end of A6R202 physically nearest A6C211.
18. Connect a jumper from +12 Vdc to the end of C207 nearest C209.
19. If the current draw exceeds approximately 50 mA, suspect a short in the buck regulator control circuitry or a shorted CR201.
20. Check TP204 for an 80 kHz sawtooth (4 Vp-p).
21. Check TP203 and TP207 for 40 kHz square (12 Vp-p). If the waveforms at either TP203 or TP207 are bad, one of the FETs in the DC-DC Converter is probably defective.
22. Check TP105 and TP106 for a 12 Vp-p sawtooth waveform that is flattened at the bottom. If the waveform is a squarewave, the FET to which the test point is connected has failed or shorted.
23. Check TP202 for 80 kHz pulses (12 Vp-p).
24. Short TP401 to TP102. Check TP103 for a waveform similar to that in [Figure 13-8 on page 660](#).
25. If the waveform at TP202 is correct but the waveform at TP103 is bad, suspect either Q102 or CR106.

Figure 13-8 **Buck Regulator Waveform**

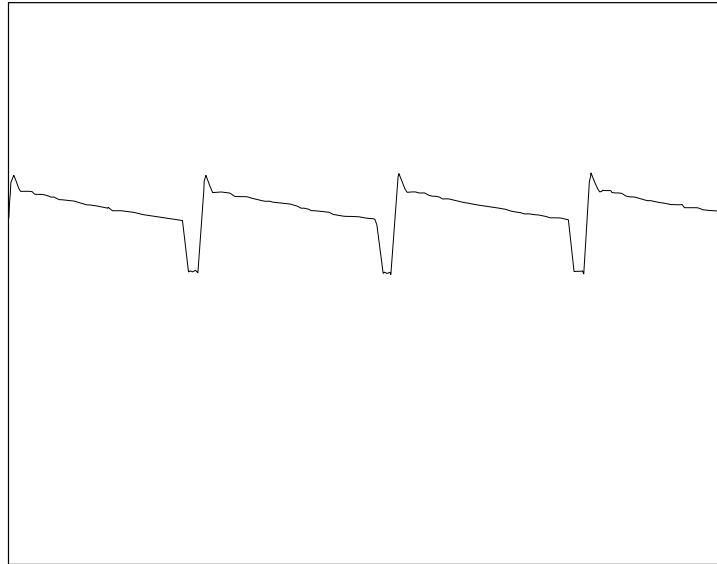

sk 1

Line Fuse Blowing

1. If the line fuse blows with the LINE switch in the off position, suspect either the input filter or the power switch cable assembly.
2. If the line fuse blows when the 8564E /EC and 8565E /EC spectrum analyzers are turned on, disconnect the power cord and lift the drain of A6Q102 from TP108. If the line fuse still blows, suspect CR102 through CR105.
3. If the fuse is not burned out, check A6TP108 for a voltage of between +215 V and +350 V.
4. If the voltage at TP108 is correct, disconnect the power cord. Wait 60 seconds for the high voltage to discharge. Remove and check A6Q102.
5. If Q102 is shorted, Q103, Q104, CR106, and CR108 are also probably shorted. If Q102 is working properly, measure the resistance between TP102 and TP101 (positive ohmmeter lead to TP102).
6. If the resistance is less than 1 k Ω , suspect either Q103 or Q104 in the DC-DC Converter.

Supply Restarting Every 1.5 Seconds (Kick Start)

See function blocks G, H and L of A6 power supply schematic diagram in the component-level information binder.

If there is a short on the power supply or on one of the other assemblies, the power supply will attempt to "kick start." (Every 1.5 seconds the supply will attempt to start, but will be shut down by a fault condition.) The kick start and bias circuits provide power for the control circuitry during power-up. The kick start circuitry is an RC oscillator which emits a 200 ms pulse every 1.5 seconds. These pulses switch current from the Input Rectifier through Q201 to charge C201. When the power supply is up, a winding on T103 provides power to the control circuitry. This voltage is high enough to keep Q201 turned off.

1. Monitor the waveforms at TP206 and TP208 simultaneously on an oscilloscope.
2. If the signal at TP208 goes high before the signal at TP206 goes low, an overcurrent condition has been detected. Suspect a short in the secondary (output rectifier, voltage regulators, or another assembly).

Low Voltage Supplies

1. Connect the negative lead of a DVM to A6TP301.
2. Check A6TP302 for +15 Vdc.
3. Check A6TP303 for -15 Vdc.
4. Check A6TP304 for +28 Vdc.
5. Check A6TP305 for -12.6 Vdc.
6. Check A6TP308 for +5 Vdc.
7. If the voltages measured above are correct but the power supply LEDs on the A2 controller assembly are not lit, check W1.
8. If the voltages are low, disconnect W1 from A6J1 and measure the test point voltages again. Unless a dummy load is connected to the A6 power supply, the voltages should return to their nominal voltages but be unregulated.
9. If the voltages do not return to near their nominal range, the A6 power supply is probably at fault.
10. If the +5 V supply is low, suspect the +5 V regulator or the feedback circuit. To check the feedback circuit, measure the voltage of the +5 V reference (U305 pin 6) and the ± 5 V references to the voltage regulators (U306B pin 7 and U306D pin 14).
11. Check output of U306A pin 1. If the feedback circuit is working properly, the output of U306A should be near +13 Vdc.

12. Check output of U302; its output should be high if the feedback circuit is working properly.

High Voltage Supplies (8564E and 8565E)

1. Press **LINE** to turn spectrum analyzer off, disconnect the power cord, and remove the power supply shield.
2. Connect the negative lead of a DVM to A6TP401 and positive lead to A6TP405.
3. Press **LINE** to turn spectrum analyzer on.
4. If the voltage displayed on the DVM is approximately +110 Vdc and the rear panel CRT +110 VDC ON indicator is lit, the A6A1 HV module is probably at fault.

NOTE

Ideally, the DVM should read the voltage written on the label of the A6A1 HV module. If necessary, perform the "High Voltage Power Supply" adjustment in [Chapter 2](#).

5. If the DVM does not read approximately +110 Vdc, measure the voltage on A6U401 pin 10. This is the HV_SHUT_DOWN signal and should be near +5 Vdc.
6. If HV_SHUT_DOWN is low, suspect a bad connection along W8 between the A6 power supply and the 17 CRT driver.
7. If HV_SHUT_DOWN is correct, connect an oscilloscope to A6TP402. Connect the scope probe negative lead to TP401. Set the oscilloscope to the following settings:

Sweep time 10 μ s/div
Vertical scale 10 V/div

8. A nearly-sinusoidal waveform, greater than 30 Vp-p, with an approximately +18 Vdc offset, should be observed.
9. If the waveform is a dc voltage near 0 Vdc with narrow, positive- and negative-going pulses, the A6A1 HV module is faulty. If the waveform is a dc voltage near +18 Vdc with narrow, positive- and negative-going pulses, connect the probe to TP403.
10. If the waveform at TP403 is a sawtooth waveform with a 1.8 V amplitude, the A6A1 HV module is faulty.

If the TP403 waveform has pulses similar to those on TP402, the A6 power supply is probably faulty.

CRT Supply Dropping Out (8564E and 8565E)

See function block K of A6 power supply schematic diagram in the component-level information binder.

The CRT supply is a separate switching supply which provides the +110 Vdc for the A17 CRT driver from a winding on the A6A1 HV module. The CRT supply operates at approximately 30 kHz. The exact frequency is determined by the inductance of the primary winding of A6A1T1 and A6C407. The supply will only operate if the HV_SHUT_DOWN line is high.

If the power supply keeps dropping out, there is probably a short on the A17 CRT driver assembly.

1. Disconnect W8 from A6J4.
2. Connect an IC clip to U401 and connect a jumper between U401 pin 10 and TP308 (+5 Vdc).
3. Connect voltmeter to TP405 and press **LINE** to turn the analyzer on.
4. Check TP405 for a voltage of approximately +110 Vdc. It will probably measure higher since there is no load on the supply.
5. If the voltage at TP405 is correct, suspect a short on A17. If the voltage at TP405 is not correct, check U401 pin 8 for a sawtooth signal. The sawtooth should be flat-topped and about 5 Vp-p at a frequency of about 30 kHz.
6. If the sawtooth is not flat-topped, suspect U402A and its associated circuitry.
7. If the sawtooth is correct, check the base of Q401 for 30 kHz pulses.
8. If the duty cycle is high, but there is no +110 Vdc, suspect the bridge rectifier, CR401 through CR404.

Blanking Signal (8564E and 8565E)

1. Connect an oscilloscope probe to A2J202 pin 3. Connect the oscilloscope ground lead to TP3. Set the oscilloscope to the following settings:

Sweep time 2 ms/div
Vertical scale 1 V/div

2. If a 4 Vp-p signal is not seen, the A2 controller assembly is faulty.
3. Repeat steps 1 and 2 with the oscilloscope probe on A2J202 pin 14.
4. Set the oscilloscope to the following settings:

Sweep time 1 μ s/div
Vertical scale 2 V/div

5. Connect the positive probe lead to A2J202 pin 15. This is the blanking output.
6. TTL-level pulses should be observed. If the signal is either always high or always low, the display will be blanked; suspect the A2 controller assembly.
7. If the signals on A2J202 pins 3, 14, and 15 are correct, troubleshoot the A17 CRT driver.

Buck Regulator Control

See function block H of the A6 power supply schematic diagram in the component-level information binder.

The buck regulator control pulse-width modulates the buck regulator and provides a synchronized signal to the DC-DC converter control circuitry. The buck regulator control has two feedback paths. The first is the output of the buck regulator, which provides coarse regulation. The second is the feedback circuit which samples and compares the +5 Vdc output of the output rectifier.

U202B and associated circuitry senses the output of the input rectifier and will turn off U203 if the voltage at TP108 is less than approximately +170 Vdc. Also, it will not allow U203 to start up until this voltage exceeds +215 Vdc. A low on the output of U202B will also clear the overcurrent latch in the DC-DC converter control circuitry.

Thermal shutdown occurs when RT201, mounted on the main heatsink, reaches a temperature of 100 C. When this occurs, the voltage at U203 pin 13 exceeds 0.6 V and inhibits pulses to the buck regulator.

R203, R204, U211, and associated circuitry provide feedforward for U203. This makes the loop gain independent of input line voltage and cancels 120 Hz ripple by more than 10 dB.

U202C and its associated circuitry permit the power supply to start up at low line voltages at low temperatures. At low line voltages U202C will draw charge away from C206 through R205. This allows the buck regulator to turn on and draw current through the thermistors in the input rectifier. This warms up the thermistors, thereby decreasing their resistance and increasing the voltage at TP108. When the voltage is sufficiently high at TP108, the output of U202C will open and C206 will be allowed to charge normally.

U202A converts the sawtooth at TP204 to a squarewave to drive the DC-DC Converter Control circuitry. The frequency of the sawtooth is determined by the resistance at pin 7 of U203 and the capacitance at pin 8 of U203.

DC-DC Converter Control

See function block I of A6 power supply schematic diagram in the component-level information binder.

The DC-DC converter control circuitry divides the 80 kHz squarewave from U202A and generates two complementary 40 kHz squarewaves to drive the FETs in the DC-DC converter. Also, U202D and its associated circuitry monitor the voltage across sense resistor R116 in the DC-DC converter. When the current through the FETs in the DC-DC converter exceeds 1.8 A, the voltage across R116 will cause the output of U202D to go high. This sets a latch in U204 which turns off U203.

Power Up

See function block M of the A6 power supply schematic diagram in the component-level information binder.

The power up circuitry generates the PWR UP signal, which tells the microprocessor that the supplies are up and stable. PWR UP will go high when the +5 Vdc supply exceeds +4.99 Vdc. PWR UP will go low when this voltage is less than +4.895 Vdc. Once PWR UP is set low, it will stay low for at least 50 ms before going high, even if the +5 Vdc supply exceeds +4.99 Vdc before 50 ms have elapsed.

POWER SUPPLY ASSEMBLY
BLOCK DIAGRAM

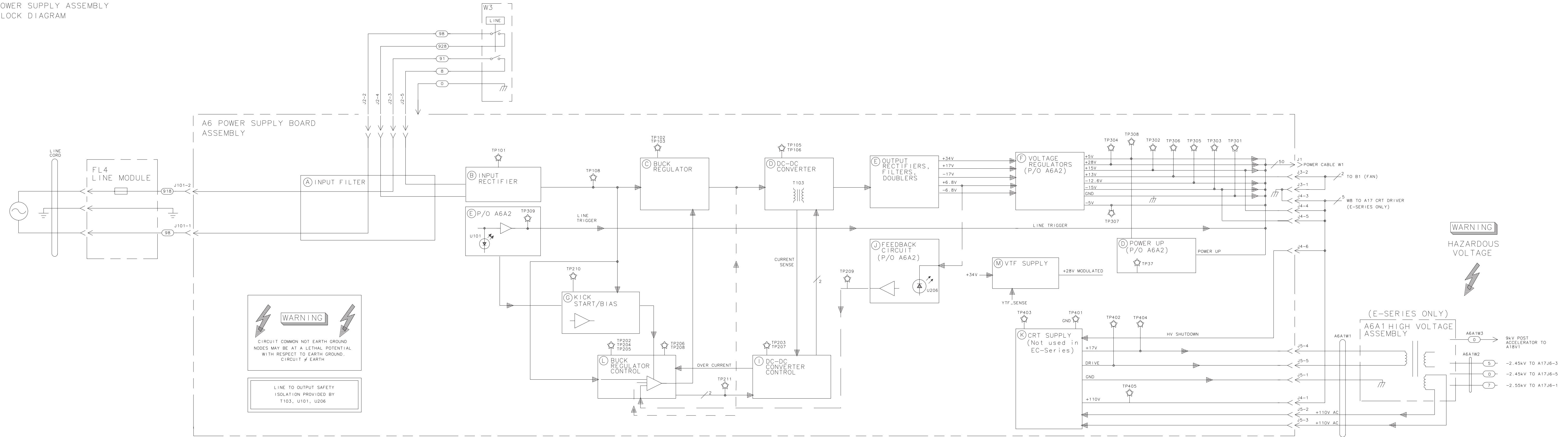
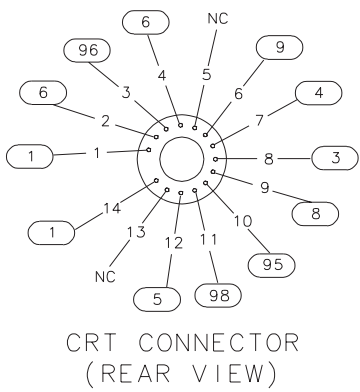
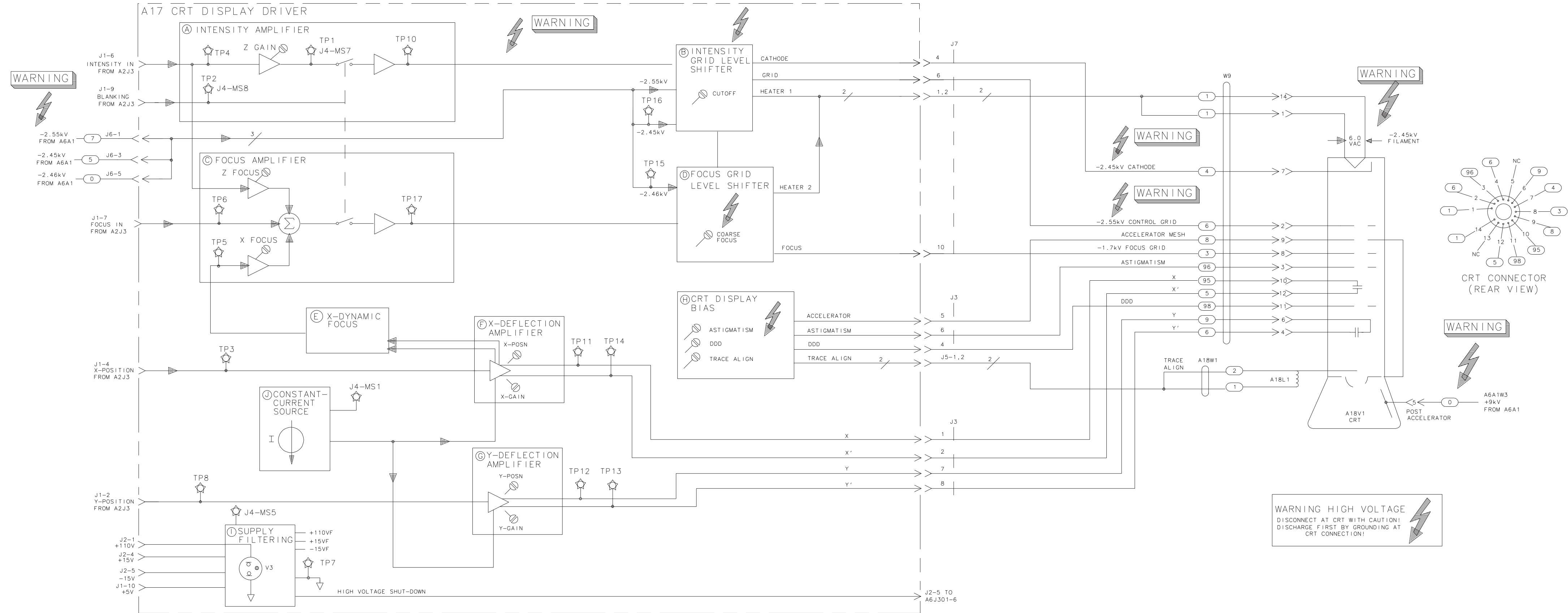

FIGURE 13-9. A6 POWER SUPPLY BLOCK DIAGRAM

A17 CRT DISPLAY DRIVER BLOCK DIAGRAM



WARNING HIGH VOLTAGE
DISCONNECT AT CRT WITH CAUTION!
DISCHARGE FIRST BY GROUNDING AT
CRT CONNECTION!

14

**Component-Level Information
Packets**

Introduction

Component-Level Information Packets (CLIPs) contain a parts list, a component-location diagram, and schematic diagrams for selected instrument assemblies. A new CLIP with a new part number is issued whenever an assembly is changed.

Updated or replacement CLIPs may be ordered through your local Agilent Technologies Sales or Service Office. Use the CLIP part numbers provided in Table 14-1.

A single volume CLIP set that contains all repairable assemblies for the 8560 E-series and EC-series is also available. Order this CLIP set by using part number 5967-8582.

With the exception of the A2 controller board, the A1A1 keyboard, and the A17 display driver board, the E-series assemblies for which CLIPs have been generated are identical to the same assemblies in EC-series instruments.

Each of the CLIPs in the CLIP set can also be ordered individually.

NOTE

CLIPs may be unavailable for recently introduced assemblies.

Table 14-1 CLIPs Available for the 8564E, 8564EC, 8565E, and 8565EC Spectrum Analyzers

Board Assembly	Instrument Serial Prefix	Assembly Part Number	CLIP Part Number
A1A1 Keyboard (E-series)	3337A and above	08562-60140	08562-90188*
A1A1 Keyboard (EC-series only)	New Assembly	08563-60162	08563-90222*
A2 Controller Assembly (EC-series only)	New Assembly	08563-90160	08563-90224*
A2 Controller Assembly (E-series only)	3337A through 3741AA 3743A and above	08564-60010 [†]	08563-90003
		08564-90025	08564-90028*
A3 Interface Assembly (E-series, non-Option 007)	337A through 3515A 3517A through 3610A 3611A and above	08563-60069	08563-90102
		08563-60078	08563-90117
		08563-60098	08563-90141
A3 Interface Assembly (E-series, Option 007)	3337A through 3515A 3517A through 3610A 3611A and above	08563-60070	08563-90103
		08563-60078	08563-90117
		08563-60098	08563-90141
A3 Interface Assembly (E- and EC-series)	3611A and above	08563-60098	08563-90017*
A4 Log Amplifier/Cal Osc	3337A through 3407A 3410A through 3514A 3515A through 3524A 3728A and above	08563-60050	08563-90082
		08563-60074	08563-90090
		08563-60076 [†]	08563-90119
		08563-60103	08563-90166*
A5 IF Filter (8564)	3337A to 3720A00841 3724A00842 and above	08563-60023	08563-90058
		08563-60123	08563-90186*
A5 IF Filter (8565)	3337A to 3720A00713 3724A00714 and above	08563-60023	08563-90058
		08563-60123	08563-90186*
A6 Power Supply	3406A through 3721A 3804A through 3835A 3846A and above	08564-60008	08564-90004
		08564-60028	08564-90032
		08564-60031 [†]	08564-90039*
[†] Denotes refurbished board assemblies available. Refurbished board assembly part numbers have 9 as the second digit of the suffix. For example, 08563-69032 is the refurbished part number for board assembly 08563-60032. [‡] Same as for A15 Option 103 with SIG ID. * Denotes current version of assembly.			

Table 14-1

**CLIPs Available for the 8564E, 8564EC, 8565E, and 8565EC
Spectrum Analyzers**

Board Assembly	Instrument Serial Prefix	Assembly Part Number	CLIP Part Number
A6A2 Power Supply Regulator Board	3337A through 3817A	08564-60009	08564-90006
	3818A and above	08564-60030	08564-90034*
A14 Frequency Control	3337A through 3442A	08564-60007	08564-60005
	3510A through 3635A	08564-60014	08564-60009
	3641A through 3821A	08564-60020 [†]	08564-60017
	3835A and above	08564-60029	08564-90033*
A15 RF Board (Option 103) (with SIG ID)	3337A through 3416A	08563-60045	08563-90072
	3423A through 3510A	08563-60055	08563-90111
	3514A through 3517A	08563-60082	08563-90121
	3551A through 3632A	08563-60085	08563-90128
	3635A through 3818A	08563-60092 [†]	08563-90163
	3821A and above	08563-60133	08563-90200*
A15 RF Board (Option 103) (without SIG ID)	3337A through 3416A	08563-60043	08563-90070
	3423A through 3510A	08563-60055	08563-90111
	3514A through 3517A	08563-60082 [‡]	08563-90121
	3551A through 3632A	08563-60085 ^{†‡}	08563-90128
	3635A through 3818A	08563-60092 [‡]	08563-90163
	3821A and above	08563-60133	08563-90200*
A15 RF Board (Standard) (with SIG ID)	3337A through 3416A	08563-60046	08563-90073
	3423A through 3510A	08563-60056	08563-90112
	3514A through 3517A	08563-60083	08563-90122
	3551A through 3632A	08563-60086	08563-90129
	3635A through 3818A	08563-60093 [†]	08563-90164
	3821A and above	08563-60134	08563-90201*
[†] Denotes refurbished board assemblies available. Refurbished board assembly part numbers have 9 as the second digit of the suffix. For example, 08563-69032 is the refurbished part number for board assembly 08563-60032. [‡] Same as for A15 Option 103 with SIG ID			

Table 14-1 CLIPs Available for the 8564E, 8564EC, 8565E, and 8565EC Spectrum Analyzers

Board Assembly	Instrument Serial Prefix	Assembly Part Number	CLIP Part Number
A15 RF Board (Standard)	3337A through 3416A	08563-60044	08563-90071
	3423A through 3510A	08563-60054	08563-90110
	3514A through 3517A	08563-60081	08563-90120
	3551A through 3632A	08563-60084	08563-90127
	3635A through 3820A	08563-60091 [†]	08563-90162
	3821A and above	08563-60132	08563-90199*
A16 Fast ADC (Option 007 in E-series instruments only)	3337A and above	08563-60030	08563-90076*
A17 LCD Driver (EC-series)	New Assembly	08563-60161	08563-90221*
A17 CRT Driver (E-series)	3337A through 3432A	08562-60166	08562-90193
	3442A through 3623A	08563-60077 [†]	08563-90113
	3626A through 3738A	08563-60101	8563-90153
	3741A and above	08560-60122	08563-90182*
A19 GPIB	3337A and above	08562-60042	08562-90115*
[†] Denotes refurbished board assemblies available. Refurbished board assembly part numbers have 9 as the second digit of the suffix. For example, 08563-69032 is the refurbished part number for board assembly 08563-60032. * Denotes the current version of assembly. [‡] Same as for A15 Option 103 with SIG ID.			

8564EC AND 8565EC INTERCONNECT DIAGRAM

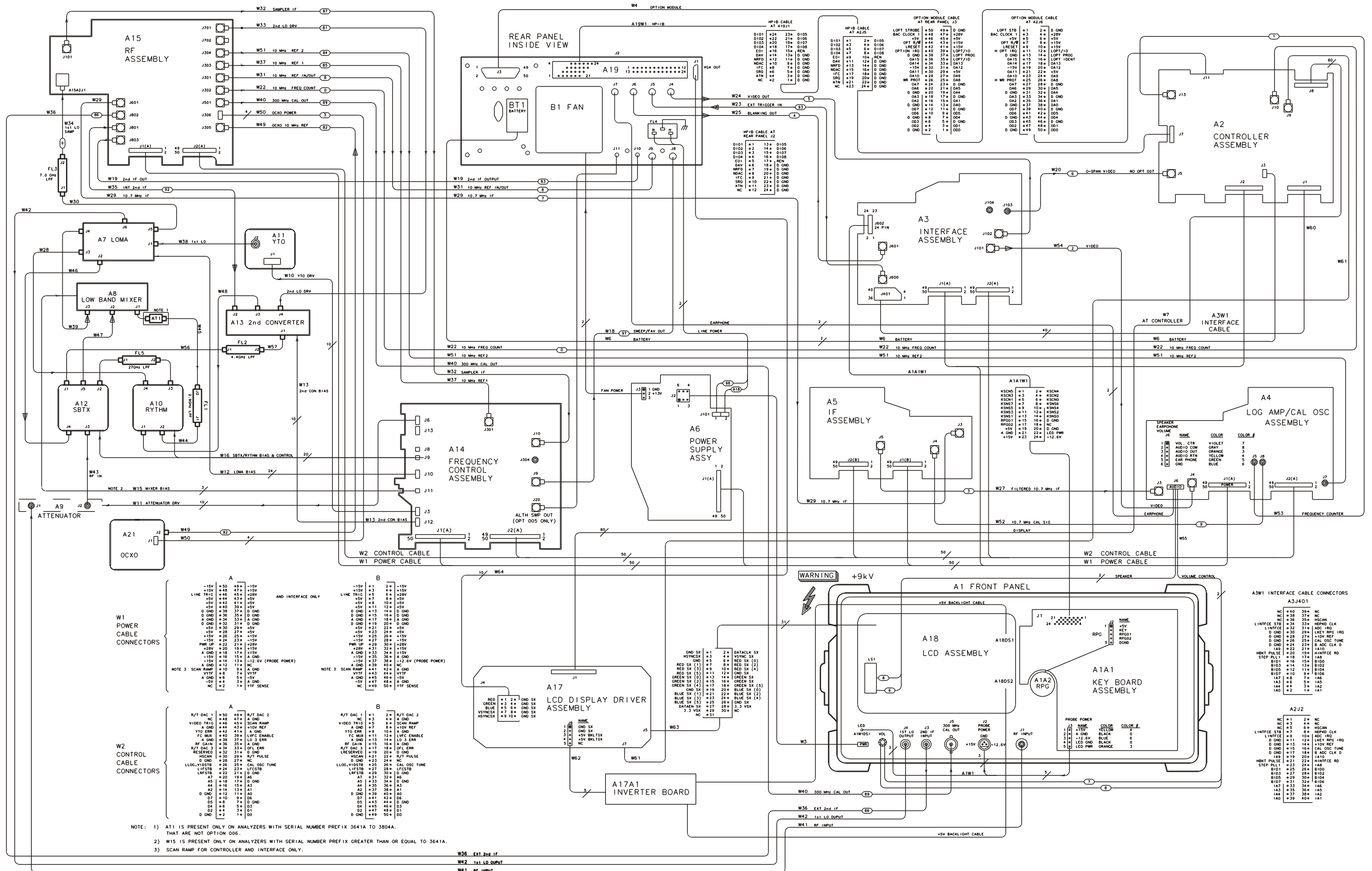

W1 POWER CABLE CONNECTORS

A	-15V	49	-15V
A	+15V	47	+15V
A	+48	45	+28V
A	+5V	44	+5V
A	+5V	42	+5V
A	+5V	40	+5V
A	+5V	38	+5V
A	+5V	36	+5V
A	+5V	34	+5V
A	+5V	32	+5V
A	+5V	30	+5V
A	+5V	28	+5V
A	+5V	26	+5V
A	+5V	24	+5V
A	+5V	22	+5V
A	+5V	20	+5V
A	+5V	18	+5V
A	+5V	16	+5V
A	+5V	14	+5V
A	+5V	12	+5V
A	+5V	10	+5V
A	+5V	8	+5V
A	+5V	6	+5V
A	+5V	4	+5V
A	+5V	2	+5V
A	NC	1	YIF SENSE

W2 CONTROL CABLE CONNECTORS

A	R/T DAC 1	50	49	R/T DAC 2
A	NC	48	47	A GND
A	VIDEO TRIG	46	45	SCAN RAMP
A	A GND	44	43	+10V REF
A	YTO ERR	42	41	A GND
A	FC MUX	40	39	LFC ENABLE
A	A GND	38	37	L3 ERR
A	RF CAL IN	36	35	A GND
A	R/T DAC 3	34	33	OPT. ERR
A	RESERVED	32	31	D GND
A	HSCAN	30	29	R/T PULSE
A	D GND	28	27	NC
A	LOC-VIDSTB	26	25	CAL OSC TUNE
A	LIFSTB	24	23	LFCSTB
A	LRFSTB	22	21	D GND
A	A7	20	19	A GND
A	A5	18	17	D GND
A	A4	16	15	A3
A	A2	14	13	A1
A	D GND	12	11	AO
A	D7	10	9	DE
A	D5	8	7	D GND
A	D4	6	5	D GND
A	D2	4	3	D1
A	D GND	2	1	D GND

NOTE: 1) A11 IS PRESENT ONLY ON ANALYZERS WITH SERIAL NUMBER PREFIX 3641A TO 3804A. THAT ARE NOT OPTION 006.
 2) W15 IS PRESENT ONLY ON ANALYZERS WITH SERIAL NUMBER PREFIX GREATER THAN OR EQUAL TO 3641A.
 3) SCAN RAMP FOR CONTROLLER AND INTERFACE ONLY.

W36 EXT 2ND IF
 W42 1st LO OUTPUT
 W41 RF INPUT

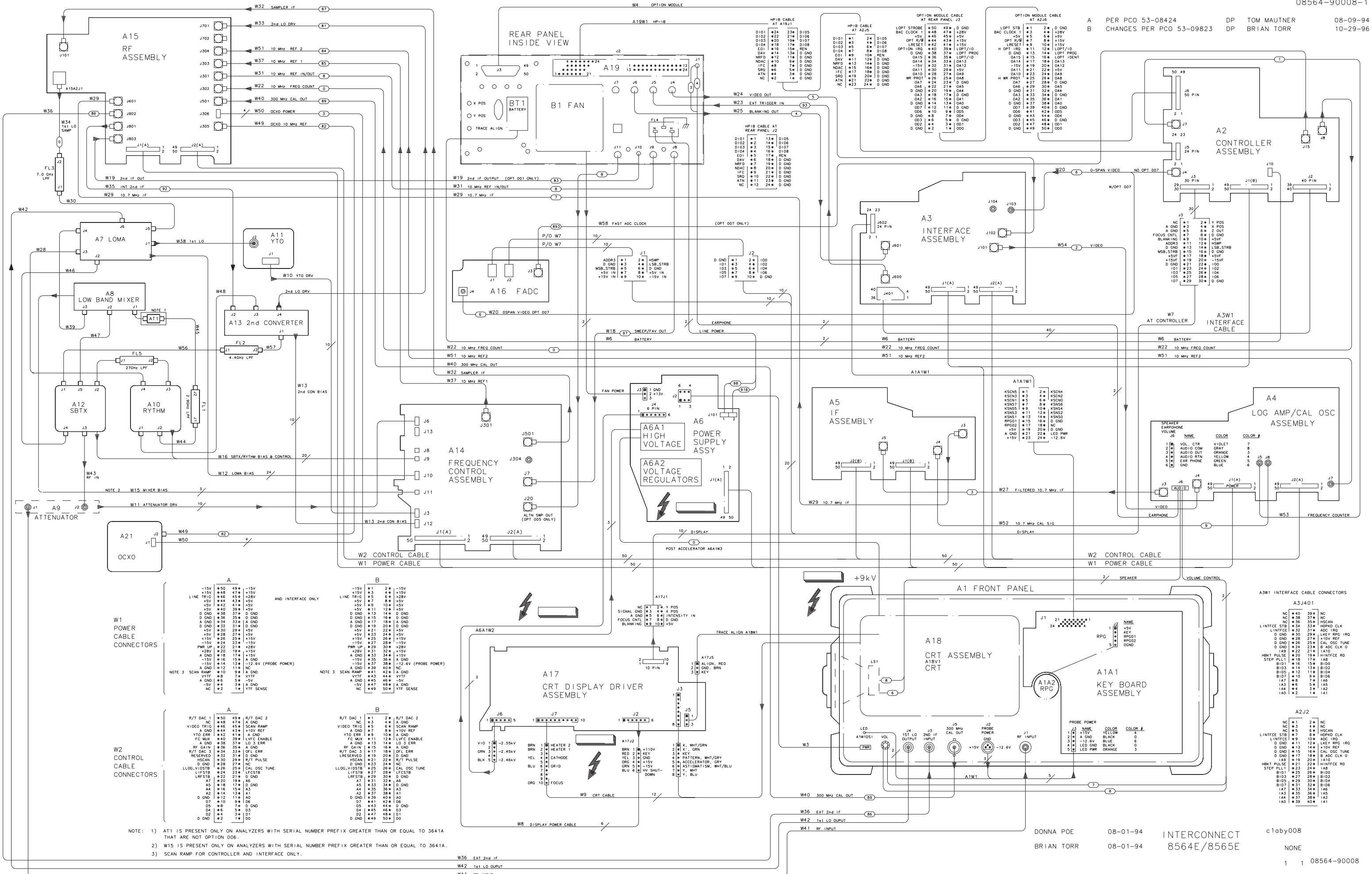

W1 POWER CABLE CONNECTORS

LINE TRIG	#48	#49	#50	#48	#49	#50
D GND	#38	#37	D GND	D GND	#13	#14
A GND	#34	#33	A GND	A GND	#17	#18
D GND	#32	#31	D GND	D GND	#20	#21
+5V	#28	+5V	+5V	+5V	#23	#24
+15V	#24	+15V	+15V	+15V	#25	#26
+28V	#20	+28V	+28V	+28V	#31	#32
A GND	#18	A GND	A GND	A GND	#33	#34
-15V	#16	-15V	-15V	-15V	#35	#36
A GND	#12	A GND	A GND	A GND	#39	#40
A GND	#6	A GND	A GND	A GND	#45	#46
A GND	#5	A GND	A GND	A GND	#47	#48
A GND	#2	A GND	A GND	A GND	#49	#50

W2 CONTROL CABLE CONNECTORS

R/T DAC 1	#50	#49	R/T DAC 2	#1	#2	R/T DAC 2
VIDEO TRIG	#46	#45	SCAN RAMP	#5	#6	SCAN RAMP
YTO ENR	#44	#43	+10V REF	#7	#8	+10V REF
FC MIX	#40	#39	LVC ENAB	#11	#12	LVC ENAB
RF GAIN	#36	#35	A GND	#15	#16	A GND
R/T DAC 2	#34	#33	DEL ERR	#17	#18	DEL ERR
RESERVED	#32	#31	D GND	#19	#20	D GND
HSCAN	#30	#29	R/T PULSE	#21	#22	R/T PULSE
D GND	#28	D GND	YTF	#23	#24	YTF
LLOC-VIDSTB	#26	#25	CAL OSC TUNE	#25	#26	CAL OSC TUNE
LIFSTB	#24	#23	LIFSTB	#27	#28	LIFSTB
LRFTB	#22	#21	D GND	#29	#30	D GND
A7	#20	A6	#31	#32	A6	
A5	#18	A3	#33	#34	A3	
A4	#16	A1	#35	#36	A1	
A2	#14	A1	#38	#39	A1	
D GND	#12	A0	#39	#40	A0	
D7	#10	D6	#41	#42	D6	
D5	#8	D4	#43	#44	D4	
D4	#6	D3	#45	#46	D3	
D2	#4	D1	#47	#48	D1	
D GND	#2	D0	#49	#50	D0	

NOTE: 1) A11 IS PRESENT ONLY ON ANALYZERS WITH SERIAL NUMBER PREFIX GREATER THAN OR EQUAL TO 3641A THAT ARE NOT OPTION 006.
 2) W15 IS PRESENT ONLY ON ANALYZERS WITH SERIAL NUMBER PREFIX GREATER THAN OR EQUAL TO 3641A.
 3) SCAN RAMP FOR CONTROLLER AND INTERFACE ONLY.

W36 EXT 2nd IF
 W42 1st LO OUTPUT
 W41 RF INPUT

A3W1 INTERFACE CABLE CONNECTORS

NC	#40	#39	NC	#1	#2	Y POS
NC	#38	#37	NC	#3	#4	X POS
NC	#36	#35	HSCAN	#5	#6	Z OUT
LINTFC STB	#34	#33	HORPKD CLK	#7	#8	D GND
LINTFC	#32	#31	ADC IRQ	#9	#10	+5V
D GND	#30	#29	LKEY RFG IRQ	#11	#12	HSPW
D GND	#28	#27	CAL OSC TUNE	#13	#14	L5B-STRB
D GND	#26	#25	CAL OSC TUNE	#15	#16	D GND
D GND	#24	#23	B ADC CLK D	#17	#18	D GND
I A9	#22	#21	I A10	#19	#20	I A10
HBT PULSE	#20	#19	HINTFC RD	#21	#22	HINTFC RD
STEP PLL1	#18	#17	I A8	#23	#24	I A8
B101	#16	#15	B100	#25	#26	B100
B103	#14	#13	B102	#27	#28	B102
B105	#12	#11	B104	#29	#30	B104
B107	#10	#9	B106	#31	#32	B106
I A7	#8	#7	I A6	#33	#34	I A6
I A5	#6	#5	I A4	#35	#36	I A4
I A4	#4	#3	I A2	#37	#38	I A2
I A0	#2	#1	I A1	#39	#40	I A1

A2J2

NC	#1	#2	NC	#1	#2	NC
NC	#3	#4	NC	#3	#4	NC
NC	#5	#6	HSCAN	#5	#6	HSCAN
NC	#7	#8	HORPKD CLK	#7	#8	HORPKD CLK
LINTFC STB	#9	#10	ADC IRQ	#9	#10	ADC IRQ
D GND	#11	#12	LKEY RFG IRQ	#11	#12	LKEY RFG IRQ
D GND	#13	#14	+10V REF	#13	#14	+10V REF
D GND	#15	#16	CAL OSC TUNE	#15	#16	CAL OSC TUNE
D GND	#17	#18	B ADC CLK D	#17	#18	B ADC CLK D
I A9	#19	#20	I A10	#19	#20	I A10
D GND	#21	#22	HINTFC RD	#21	#22	HINTFC RD
STEP PLL1	#23	#24	I A8	#23	#24	I A8
B101	#25	#26	B100	#25	#26	B100
B103	#27	#28	B102	#27	#28	B102
I A7	#29	#30	I A6	#29	#30	I A6
B107	#31	#32	B106	#31	#32	B106
I A5	#33	#34	I A4	#33	#34	I A4
I A3	#35	#36	I A2	#35	#36	I A2
I A4	#37	#38	I A2	#37	#38	I A2
I A0	#39	#40	I A1	#39	#40	I A1

DONNA POE 08-01-94
 BRIAN TORR 08-01-94
 INTERCONNECT 8564E/8565E
 c1aby008
 NONE

Numerics

1 MHz resolution bandwidth problems, 465
10 kHz and 3 kHz resolution bandwidth problems, 467
10 MHz reference adjustment
 OCXO, 136
 TCXO, 140
10.6925 MHz VCXO
 troubleshooting, 451
10.7 MHz and 4.8 kHz IF filter
 troubleshooting, 450
10.7 MHz IF filter
 troubleshooting, 450
100 MHz oscillator, 537
100 MHz VCXO, 537
16 MHz PLL adjustment, 155
1st LO distribution amplifier
 removal and replacement, 222
1st LO problems, multiband sweeps, 573
1st LO span problems, 572
3 kHz and 10 kHz resolution bandwidth problems, 467
30 kHz resolution bandwidth problems, 466
300 Hz to 3 kHz resolution bandwidth problems, 472
3rd amp/2nd IF align adjustment, 71
4.8 kHz and 10.7 MHz IF filter
 troubleshooting, 450
4.8 kHz IF filter troubleshooting, 449
600 MHz adjustment, 159
600 MHz oscillator, 542

A

A10 YIG-tuned filter/mixer (RYTHM)
 removal and replacement, 227
A10/A12 RYTHM/SBTX
 removal and replacement, 227
A11 YTO
 removal and replacement, 228
A12 BHF-tuned filter/mixer (SBTX)
 removal and replacement, 227
A13 second converter
 removal and replacement, 230
A14 and A15 RF assembly
 removal, 231
A14 and A15 RF assembly
 replacement, 232
A16 fast adc driver
 removal and replacement, 234
A17 crt driver

 removal and replacement, 234
A2, A3, A4, and A5
 removal, 202
 replacement, 203
A21 OCXO removal and replacement, 256
A4 limiter phase adjustment, 171
A4 linear amplifier failures, 444
A4 linear fidelity adjustment, 172
A4 log amplifier troubleshooting, 443
A4 log fidelity adjustment, 173
A5 IF assembly problems, 455
A6 power supply
 removal, 212
 replacement, 211, 213
A7 LO multiplier/amplifier
 removal and replacement, 222
A8 low band mixer
 removal and replacement, 223
A9 input attenuator
 removal and replacement, 224
abbreviations, 264
access to internal assemblies, 177
accessories, 269
ADC troubleshooting, 400
ADC/interface section, 360
addresses of sales and service offices, 44
adjustment
 adjustable components table, 51, 93
 factory selected components, 96
 related adjustments table, 51, 92
 safety considerations, 49, 91
 tools, 50, 92
adjustment procedures, 90, 159
 10 MHz reference adjustment, OCXO, 136
 10 MHz reference adjustment, TCXO, 140
 16 MHz PLL adjustment, 155
 3rd amp/2nd IF align, 71
 600 MHz reference adjustment, 159
 cal oscillator amplitude, 116, 164
 cal out adjustment, 72
 calibrator amplitude adjustment, 134
 dc log adjustment, 76
 DC log amplifiers, 121, 169
 demodulator adjustment, 142
 display, 102
 external mixer amplitude adjustment, 147

 external mixer bias adjustment, 145
 fast zero span, 69
 front end cal, 73
 high voltage power supply adjustment, 99
 IF amplitude, 75, 116, 164
 IF bandpass adjustment, 110
 IF bandpass poles, 74
 intensity, 106
 LOMA adjustments, 68
 sampling oscillator, 78
 sampling oscillator adjustment, 126
 signal ID oscillator adjustment, 151
 YTO adjustment, 64, 66, 130
adjustments
 recommended test equipment, 163
Agilent 8561E/63E options
 information, 29
Agilent Technologies sales and service offices, 44
AM/FM demodulator
 troubleshooting, 448, 479
amplitude adjustments, 116
analog bus drivers
 troubleshooting, 407
analog bus timing, 408
attenuator, 354
audio amplifier troubleshooting, 479
automatic IF adjustment, 437
automatic IF adjustment parameters, 438

B

B1 fan
 removal and replacement, 237
battery
 caution, 238
 removal and replacement, 238
 warning, 238
BHF-tuned filter/mixer
 removal and replacement, 227
blank display, 637
blanking, 492
blanking signal, 647
block diagram
 description, 351
BT1 battery
 removal and replacement, 238

C

cable color code, 178
cables, 204, 208

- cables, pin out, [319](#)
- cal oscillator, [359](#)
 - amplitude (A4R826) range troubleshooting, [471](#)
 - low-pass filter troubleshooting, [478](#)
 - troubleshooting, [469](#)
 - unlock at start of IF adjust, [470](#)
 - unlock conditions troubleshooting, [470](#)
- cal out adjustment
 - adjustment, [72](#)
- CAL OUTPUT, [539](#), [544](#)
- calibration menu, [322](#)
- calibrator amplitude adjustment, [134](#)
- center frequency, harmonic number, [569](#)
- character problem, [499](#)
- chassis parts, [279](#), [288](#)
- components
 - adjustable components table, [51](#), [93](#)
- controller
 - block diagram, [517](#)
- converter
 - second, [356](#), [610](#)
 - third, [356](#)
- cover assembly parts, [279](#), [287](#)
- cover removal/replacement, [179](#)
- CRT
 - driver, [364](#)
 - removal, [191](#)
 - replacement, [197](#)
- crt
 - driver removal and replacement, [234](#)
- CRT display, [641](#)
- CRT, simplified block diagram, [642](#)
- CRT, troubleshooting using the TAM, [643](#)
- crystal filter adjustments, [114](#)
- D**
- dc log adjustment
 - adjustment, [76](#)
- DC log amplifier adjustments, [121](#), [169](#)
- demodulator adjustment, [142](#)
- demodulator troubleshooting, AM/FM, [448](#)
- detector/mixer troubleshooting, [453](#)
- diagnostic functions, [322](#)
- Diagnostic software
 - troubleshooting A4 cal osc using diagnostic software, [431](#)
 - troubleshooting A5 section using diagnostic software, [435](#)
- diagnostic software
 - RF section, [595](#)
- digital signature analysis
 - microprocessor, [490](#)
- display
 - adjustment, [102](#)
 - ASM, [363](#)
 - jumbled, [494](#)
 - line variations, [499](#)
 - problems, [491](#)
- display section, [363](#)
- E**
- EEROM, [362](#)
 - removal and replacement, [254](#)
- electrostatic discharge, [33](#)
- equipment required, [36](#)
- error codes
 - 200 to 299, [329](#)
- error messages, [326](#), [327](#), [350](#)
 - accessory module error messages 800 to 899, [349](#)
 - AMPC ram check, [349](#)
 - amplitude error message 582, [344](#)
 - automatic IF error messages 400 to 599, [334](#)
 - battery error message 718, [348](#)
 - cal unlock error message 499, [339](#)
 - digital and checksum errors, [346](#)
 - EEROM checksum error messages 700 to 704, [346](#)
 - elimination, [327](#)
 - fractional N PLL error message 337, [331](#)
 - LOMA leveling loop error messages 338 to 340, [332](#)
 - microprocessor error message 717, [348](#)
 - model/option number error messages 719, 720, [348](#)
 - option modules, [349](#)
 - programmed ROM error messages 705 to 710, [347](#)
 - programming errors (100 to 150), [327](#)
 - RAM check error messages 711 to 716, [348](#)
 - sampling oscillator error message 335, [331](#)
- sampling oscillator error message 355, [333](#)
- span accuracy calibration error messages 356 to 361, [333](#)
- system error messages 750 to 759, [349](#)
- user generated error messages 900 to 999, [350](#)
- viewing error messages, [327](#)
- YTO loop error message 331, [331](#)
- YTO loop error messages 300 to 301, [330](#)
- YTO loop error messages 317 to 320, [330](#)
- YTO loop settling error messages 351 to 354, [332](#)
- ESD requirements, [33](#)
- external mixer
 - amplitude adjustment, [147](#)
 - bias adjustment, [145](#)
- F**
- FADC Circuits (Option 007)
 - 8-bit flash ADC, [411](#)
 - control word, [411](#)
 - GAINX2, [411](#)
 - peak/pit detection, [411](#)
 - RAM, static, [411](#)
 - video input section, [411](#)
- FADC Control Circuits (Option 007)
 - circular address, [411](#)
 - clock sample, [411](#)
 - comparator, [411](#)
 - control registers, [411](#)
 - control word, [411](#)
 - counter, [411](#)
 - CPU, [411](#)
 - post-trigger counter, [411](#)
 - reference check, [411](#)
 - reference generator, [411](#)
 - trigger, [411](#)
 - video trigger, [411](#)
- fan
 - removal and replacement, [237](#)
- fast zero span
 - adjustment, [69](#)
- filter adjustment, [110](#)
- firmware, [362](#)
- firmware-dependent part numbers, [264](#)
- flatness compensation amplifiers, [356](#)
- flatness control troubleshooting, [389](#)
- FM coil, [558](#)

- fractional N
 - divider, [566](#)
 - oscillator, [551](#)
 - phase noise, [576](#)
 - span problems, [572](#)
 - troubleshooting, [531](#)
 - fractional N PLL, [359](#), [561](#)
 - unlocked, [560](#)
 - frequency control (A14) assembly
 - removal, [231](#)
 - frequency control (A14) assembly
 - replacement, [232](#)
 - frequency control assembly
 - troubleshooting, [612](#)
 - frequency control block diagram, [581](#)
 - frequency counter, [505](#), [507](#)
 - frequency counter
 - prescaler/conditioner
 - troubleshooting, [448](#)
 - frequency-count marker
 - problems, [503](#), [504](#)
 - front end cal
 - adjustment, [73](#)
 - front frame
 - removal, [191](#)
 - replacement, [197](#)
 - front frame parts, [283](#), [293](#)
 - front frame(EC), assembly, [180](#)
- G**
- general information
 - serial number label description, [30](#)
 - graticule problem, [499](#)
- H**
- harmonic number versus center frequency, [569](#)
 - high and low band problems, [601](#)
 - high band problems, [600](#)
 - high voltage power supply
 - adjustment, [99](#)
- I**
- IF adjustment, automatic, [438](#)
 - IF amplifier, [356](#)
 - IF amplitude
 - adjustment, [75](#)
 - IF amplitude adjustments, [116](#), [164](#)
 - IF assembly, [360](#)
 - IF assembly troubleshooting, [437](#), [455](#)
 - IF bandpass adjustment, [110](#)
 - IF bandpass poles
 - adjustment, [74](#)
 - IF filter troubleshooting, 10.7 MHz, [450](#)
 - IF filter troubleshooting, 4.8 kHz, [449](#)
 - IF filter troubleshooting, 4.8 kHz and 10.7 MHz, [450](#)
 - IF filter, 4.8 kHz and 10.7 MHz
 - problems, [450](#)
 - IF gain uncertainty performance
 - test failures, [441](#)
 - IF parameters adjusted, [438](#)
 - IF section, [359](#)
 - IF section general
 - troubleshooting, [428](#)
 - IF signature problems, [462](#)
 - IF signature troubleshooting, [456](#)
 - input attenuator, [354](#), [605](#)
 - removal and replacement, [224](#)
 - input switch problems, [451](#)
 - instrument variations, [29](#)
 - intensity adjustments, [106](#)
 - intensity problems, [498](#)
 - interface section, [360](#)
 - interface strobe troubleshooting, [409](#)
 - internal assemblies, access to, [177](#)
 - isolation amplifier problems, [453](#)
- J**
- jumper
 - write protect/enable, [322](#)
- K**
- keyboard
 - problems, [382](#), [516](#)
- L**
- LC filter adjustments, [112](#)
 - LCD (EC), assembly, [180](#)
 - LCD, display, [635](#)
 - LCD, simplified block diagram, [636](#)
 - LCD, troubleshooting the, [637](#)
 - limiter phase adjustment, [171](#)
 - limiter problems, [453](#)
 - line generator, [491](#), [495](#)
 - line switch (E), assembly, [244](#)
 - line switch (EC), assembly, [183](#)
 - line switch cable
 - removal, [244](#)
 - replacement, [250](#)
 - linear amplifier troubleshooting, [444](#)
 - linear fidelity adjustment, [124](#), [172](#)
- M**
- lines dim, [499](#)
 - LO distribution amplifier, [551](#)
 - removal and replacement, [222](#)
 - LO Multiplier/Amplifier
 - removal and replacement, [222](#)
 - LO multiplier/amplifier, [354](#)
 - LO multiplier/amplifier
 - adjustments, [68](#)
 - LO multiplier/amplifier
 - troubleshooting, [602](#)
 - LO span problems, [572](#), [573](#)
 - LO switch troubleshooting, [452](#)
 - Log amplifier, [359](#)
 - log amplifier
 - adjustments, [121](#)
 - detector/mixer troubleshooting, [453](#)
 - failures, [443](#)
 - input switch troubleshooting, [451](#)
 - isolation amplifier
 - troubleshooting, [453](#)
 - limiter troubleshooting, [453](#)
 - troubleshooting, [443](#)
 - log expand functions, [361](#)
 - log expand troubleshooting, [393](#)
 - log fidelity adjustment, [124](#), [173](#)
 - log gain compensation
 - troubleshooting, [453](#)
 - log offset compensation
 - troubleshooting, [453](#)
 - log offset troubleshooting, [393](#)
 - LOMA, [354](#)
 - adjustments, [68](#)
 - removal and replacement, [222](#)
 - troubleshooting, [602](#)
 - low and high band problems, [601](#)
 - low band mixer, [604](#)
 - removal and replacement, [223](#)
 - low band mixer (serial prefix 3641A), [354](#)
 - low band problems, [599](#)
 - low-pass filter troubleshooting, [478](#)
- M**
- main chassis parts, [279](#), [288](#)
 - main coil, [558](#)
 - manufacturers code list, [265](#)
 - marker problems, [503](#), [504](#)
 - mechanical parts, [279](#), [288](#)
 - mixer amplitude adjustment, [147](#)
 - mixer bias adjustment, [145](#)
 - mixer/detector log amplifier
 - troubleshooting, [453](#)

O

OCXO, 585
OCXO adjustment, 136
OCXO removal and replacement, 256
offset lock loop, 358, 547
offset PLL phase noise, 576
option 908, 269
option 909, 269
ordering information, 261

P

packaging, 35, 36
 packaging part numbers, 36
part ordering, 261
peak detectors troubleshooting, 397
performance test failures
 troubleshooting, 441
performance tests
 recommended test equipment, 36, 37
phase locked loops, 534
phase noise
 fractional N, 576
 int/ext reference, 576
 locked spans, 575
 offset PLL, 576
 problems, 575
 unlocked spans, 575
 YTO, 576
PLL locked at wrong frequency, 534
postscaler, 548, 561
power cable connections, 636
power supply, 654
 cover, 243
 removal, 212
 replacement, 211, 213
 section, 363
power supply (E), assembly, 212
power supply (EC), assembly, 209
power supply adjustment, high voltage, 99
power supply warning, 635
power supply, simplified block diagram, 655
prescaler, 548
preselector peaking, 388
probe power socket, 637

R

rack slide kit, 269
real time DAC, 388
rear dress panel
 removal, 239

 replacement, 241
rear frame, 295
 removal, 239
 replacement, 241
rear frame parts, 283
recommended test equipment, 36, 37
reference adjustment
 60 MHz, 159
 OCXO, 136
 TCXO, 140
reference attenuator adjustment, 120
reference designations, 264
reference divide chain, 548
reference PLL, 357
 phase noise, 576
 unlocked 100 MHz VCXO, 537
 unlocked 600 MHz SAWR, 542
required tools, 178
resolution bandwidth
 1 MHz problems, 465
 3 kHz and 10 kHz problems, 467
 30 kHz problems, 466
 300 Hz to 3 kHz problems, 472
resolution bandwidth
 performance test failures, 442
returning instruments for service, 35
RF (A15) assembly removal, 231
RF (A15) assembly replacement, 232
RF assembly troubleshooting, 621
RF block diagram, 584
RF gain DACs, 389
RF parts, 279
RF section, 353
RF section parts, 291
rosenfell detector
 troubleshooting, 399
RPG
 problems, 382
RPG, assembly, 201
RYTHM, 354
 removal and replacement, 227

S

sales and service offices, 44
sales offices, 44
sampler, 577
sampler IF, 556, 577
sampler troubleshooting, 532
sampling oscillator, 547, 551
 adjustment, 78
sampling oscillator adjustment, 126
SAWR, 542

SBTX, 355

 removal and replacement, 227
scale fidelity performance test failures, 442
scan ramps, 573
second converter, 356, 610
 removal and replacement, 230
second IF amplifier, 356
serial numbers, 30
service functions, 322
service kit, 32
service kit contents, 32
service menu, 322
service offices, 44
service tools, 32
shipping
 shipping container, 35, 36
signal ID oscillator adjustment, 151
SLODA, 551
Software, diagnostic
 troubleshooting A4 cal osc using diagnostic software, 431
 troubleshooting A5 section using diagnostic software, 435
span
 >20 MHz, 570
 2 MHz, 572
 2.02 MHz to 20 MHz, 570
span accuracy problems, 568
span problems, 569, 572
 multiband sweeps, 573
speaker troubleshooting, 479
state storage problems, 515
step gains troubleshooting, 468
surface acoustic wave resonator, 542
sweep generator, 579
sweep generator troubleshooting, 479
sweep ramp, 573
sweep times, 579
sweeping, 357
 span accuracy, 568
 YTO, 552
switched barium-tuned mixer, 355
switching LO distribution amplifier, 551
synthesizer section, 357, 528
 simplified block diagram, 580
 troubleshooting, 527

T

TCXO adjustment, 140
test equipment, 36

test equipment list, [163](#)
test points, [317](#)
third converter, [356](#)
third converter check, [601](#)
third LO driver amplifier, [541](#),
[545](#)
tools
 adjustment, [50](#), [92](#)
trace storage problems, [515](#)
triggering, [362](#)
triggering problems, [385](#)
troubleshooting
 programming errors (100 to
 150), [327](#)
troubleshooting instrument, [324](#)
troubleshooting, blank CRT, [645](#)
troubleshooting, blank LCD, [637](#)
troubleshooting, blanking signal,
[647](#)
troubleshooting, blown line fuse,
[660](#)
troubleshooting, CRT focus, [650](#)
troubleshooting, CRT intensity,
[652](#)
troubleshooting, dead power
 supply, [658](#)
troubleshooting, dim LCD, [639](#)
troubleshooting, display
 distortion, [648](#)
troubleshooting, high voltage
 supplies, [662](#)
troubleshooting, kickstarting, [661](#)
troubleshooting, low voltage
 supplies, [661](#)
troubleshooting, the LCD, [637](#)

U

unlocked PLL, [535](#)
user generated error messages,
[350](#)

V

VCO, [562](#)
VCO bias voltages, [565](#)
VCXO troubleshooting, 10.6925
 MHz, [451](#)
video circuits troubleshooting,
[391](#)
video filter troubleshooting, [395](#)
video functions, [361](#)
video gating problems, [385](#)
video MUX troubleshooting, [394](#),
[454](#)
video offset troubleshooting, [447](#)
voltage tuned oscillator, [562](#)

W

W1 power-cable connections, [636](#)
W3 line switch cable
 removal, [244](#)
 replacement, [250](#)
wire assembly cables, [269](#)
write protect/enable jumper, [322](#)

Y

YIG-tuned filter/mixer, [354](#)
 removal and replacement, [227](#)
YIG-tuned oscillator adjustment,
[64](#), [66](#), [130](#)
YTO, [355](#)
 adjustment, [64](#), [66](#), [130](#)
 FM coil span problems, [570](#)
 main coil span problems, [570](#)
 phase noise, [576](#)
 removal and replacement, [228](#)
 sweeping, [552](#)
 troubleshooting, [531](#)
YTO PLL, [358](#)
 unlocked, [551](#)

Z

zero span problems, [502](#)