

---

# Agilent Technologies

## 8495D/K Attenuators

Operating and Service  
Manual

---

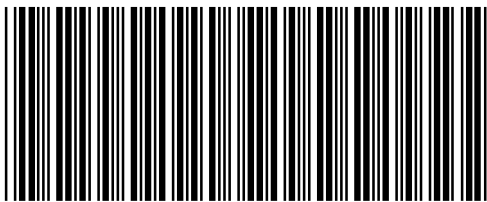

08495-90027

**Agilent Part Number: 08495-90027**  
**Printed in USA**  
**Print Date: July 2004**  
Supersedes: July 2002

---

## Notice

### RESTRICTED RIGHTS LEGEND

If software is for use in the performance of a U.S. Government prime contract or subcontract, Software is delivered and licensed as “Commercial computer software” as defined in DFAR 252.227-7014 (June 1995), or as a “commercial item” as defined in FAR 2.101(a) or as “Restricted computer software” as defined in FAR 52.227-19 (June 1987) or any equivalent agency regulation or contract clause. Use, duplication or disclosure of Software is subject to Agilent Technologies’ standard commercial license terms, and non-DOD Departments and Agencies of the U.S. Government will receive no greater than Restricted Rights as defined in FAR 52.227-19(c)(1-2) (June 1987). U.S. Government users will receive no greater than Limited Rights as defined in FAR 52.227-14 (June 1987) or DFAR 252.227-7015 (b)(2) (November 1995), as applicable in any technical data.

Agilent Technologies, Inc.  
1400 Fountaingrove Parkway  
Santa Rosa, CA 95403-1799, U.S.A.

© Copyright 2000–2002, 2004 Agilent Technologies, Inc.

---

## What You'll Find in This Manual...

- “Instrument Definition” on page 1
- “Description” on page 2
- “Specifications” on page 6
- “Installation” on page 8
- “Operating Instructions” on page 9
- “Operator’s Check” on page 10
- “Replaceable Parts” on page 12

---

## Warranty

Custom systems are warranted by contractual agreement between Agilent Technologies and the customer.

### Certification

*Agilent Technologies, Inc., certifies that this product met its published specifications at the time of shipment from the factory. Agilent Technologies further certifies that its calibration measurements are traceable to the United States National Institute of Standards and Technology (NIST, formerly NBS), to the extent allowed by the Institute's calibration facility, and to the calibration facilities of other International Standards Organization members.*

### Documentation Warranty

THE MATERIAL CONTAINED IN THIS DOCUMENT IS PROVIDED "AS IS," AND IS SUBJECT TO BEING CHANGED, WITHOUT NOTICE, IN FUTURE EDITIONS. FURTHER, TO THE MAXIMUM EXTENT PERMITTED BY APPLICABLE LAW, AGILENT DISCLAIMS ALL WARRANTIES, EITHER EXPRESS OR IMPLIED WITH REGARD TO THIS MANUAL AND ANY INFORMATION CONTAINED HEREIN, INCLUDING BUT NOT LIMITED TO THE IMPLIED WARRANTIES OF MERCHANTABILITY AND FITNESS FOR A PARTICULAR PURPOSE. AGILENT SHALL NOT BE LIABLE FOR ERRORS OR FOR INCIDENTAL OR CONSEQUENTIAL DAMAGES IN CONNECTION WITH THE FURNISHING, USE, OR PERFORMANCE OF THIS DOCUMENT OR ANY INFORMATION CONTAINED HEREIN. SHOULD AGILENT AND THE USER HAVE A SEPARATE WRITTEN AGREEMENT WITH WARRANTY TERMS COVERING THE MATERIAL IN THIS DOCUMENT THAT CONFLICT WITH THESE TERMS, THE WARRANTY TERMS IN THE SEPARATE AGREEMENT WILL CONTROL.

### Assistance

Product maintenance agreements and other customer assistance agreements are available for Agilent Technologies products.

For assistance, call your local Agilent Technologies Sales and Service Office (refer to [“Contacting Agilent” on page v](#)).

## Contacting Agilent

By internet, phone, or fax, get assistance with all your test and measurement needs.

<b>Online assistance:</b> <a href="http://www.agilent.com/find/assist">www.agilent.com/find/assist</a>			
<b>Americas</b>			
<b>Brazil</b> (tel) (+55) 11 4197 3600 (fax) (+55) 11 4197 3800	<b>Canada</b> (tel) 877 894 4414 (fax) (+1) 905 282-6495	<b>Mexico</b> (tel) (+52) 55 5081 9469 (alt) 01800 5064 800 (fax) (+52) 55 5081 9467	<b>United States</b> (tel) 800 829 4444 (alt) (+1) 303 662 3998 (fax) 800 829 4433
<b>Asia Pacific and Japan</b>			
<b>Australia</b> (tel) 1800 629 485 (alt) 1800 143 243 (fax) 1800 142 134	<b>China</b> (tel) 800 810 0189 (alt) (+86) 10800 650 0021 (fax) 800 820 2816	<b>Hong Kong</b> (tel) 800 930 871 (alt) (+852) 3197 7889 (fax) (+852) 2 506 9233	<b>India</b> (tel) 1600 112 929 (fax) 000800 650 1101
<b>Japan</b> (tel) 0120 421 345 (alt) (+81) 426 56 7832 (fax) 0120 421 678	<b>Malaysia</b> (tel) 1800 888 848 (alt) 1800 828 848 (fax) 1800 801 664	<b>Singapore</b> (tel) 1800 375 8100 (alt) (+65) 6 375 8100 (fax) (+65) 6836 0252	<b>South Korea</b> (tel) 080 769 0800 (alt) (+82) 2 2004 5004 (fax) (+82) 2 2004 5115
<b>Taiwan</b> (tel) 0800 047 866 (alt) 00801 651 317 (fax) 0800 286 331	<b>Thailand</b> (tel) 1800 226 008 (alt) (+66) 2 268 1345 (fax) (+66) 2 661 3714		
<b>Europe</b>			
<b>Austria</b> (tel) 0820 87 44 11* (fax) 0820 87 44 22	<b>Belgium</b> (tel) (+32) (0)2 404 9340 (alt) (+32) (0)2 404 9000 (fax) (+32) (0)2 404 9395	<b>Denmark</b> (tel) (+45) 7013 1515 (alt) (+45) 7013 7313 (fax) (+45) 7013 1555	<b>Finland</b> (tel) (+358) 10 855 2100 (fax) (+358) 10 855 2923
<b>France</b> (tel) 0825 010 700* (alt) (+33) (0)1 6453 5623 (fax) 0825 010 701*	<b>Germany</b> (tel) 01805 24 6333* (alt) 01805 24 6330* (fax) 01805 24 6336*	<b>Ireland</b> (tel) (+353) (0)1 890 924 204 (alt) (+353) (0)1 890 924 206 (fax) (+353) (0)1 890 924 024	<b>Israel</b> (tel) (+972) 3 9288 500 (fax) (+972) 3 9288 501
<b>Italy</b> (tel) (+39) (0)2 9260 8484 (fax) (+39) (0)2 9544 1175	<b>Luxemburg</b> (tel) (+32) (0)2 404 9340 (alt) (+32) (0)2 404 9000 (fax) (+32) (0)2 404 9395	<b>Netherlands</b> (tel) (+31) (0)20 547 2111 (alt) (+31) (0)20 547 2000 (fax) (+31) (0)20 547 2190	<b>Russia</b> (tel) (+7) 095 797 3963 (alt) (+7) 095 797 3900 (fax) (+7) 095 797 3901
<b>Spain</b> (tel) (+34) 91 631 3300 (alt) (+34) 91 631 3000 (fax) (+34) 91 631 3301	<b>Sweden</b> (tel) 0200 88 22 55* (alt) (+46) (0)8 5064 8686 (fax) 020 120 2266*	<b>Switzerland (French)</b> (tel) 0800 80 5353 opt. 2* (alt) (+33) (0)1 6453 5623 (fax) (+41) (0)22 567 5313	<b>Switzerland (German)</b> (tel) 0800 80 5353 opt. 1* (alt) (+49) (0)7031 464 6333 (fax) (+41) (0)1 272 7373
<b>Switzerland (Italian)</b> (tel) 0800 80 5353 opt. 3* (alt) (+39) (0)2 9260 8484 (fax) (+41) (0)22 567 5314	<b>United Kingdom</b> (tel) (+44) (0)7004 666666 (alt) (+44) (0)7004 123123 (fax) (+44) (0)7004 444555		
(tel) = primary telephone number; (alt) = alternate telephone number; (fax) = FAX number; * = in country number			

04704

---

## Safety and Regulatory Information

Review this product and related documentation to familiarize yourself with safety markings and instructions before you operate the instrument. This product has been designed and tested in accordance with international standards.

---

### WARNING

---

The **WARNING** notice denotes a hazard. It calls attention to a procedure, practice, or the like, that, if not correctly performed or adhered to, could result in personal injury. Do not proceed beyond a **WARNING** notice until the indicated conditions are fully understood and met.

---









### CAUTION

---

The **CAUTION** notice denotes a hazard. It calls attention to an operating procedure, practice, or the like, which, if not correctly performed or adhered to, could result in damage to the product or loss of important data. Do not proceed beyond a **CAUTION** notice until the indicated conditions are fully understood and met.

## Instrument Markings

---

	When you see this symbol on your instrument, you should refer to the instrument's instruction manual for important information.
	This symbol indicates hazardous voltages.
	The laser radiation symbol is marked on products that have a laser output.
	This symbol indicates that the instrument requires alternating current (ac) input.
	The CE mark is a registered trademark of the European Community. If it is accompanied by a year, it indicates the year the design was proven.
	The CSA mark is a registered trademark of the Canadian Standards Association.
1SM1-A	This text indicates that the instrument is an Industrial Scientific and Medical Group 1 Class A product (CISPER 11, Clause 4).
	This symbol indicates that the power line switch is ON.
	This symbol indicates that the power line switch is OFF or in STANDBY position.

---

### **Safety Earth Ground**

This is a Safety Class I product (provided with a protective earthing terminal). An uninterruptible safety earth ground must be provided from the main power source to the product input wiring terminals, power cord, or supplied power cord set. Whenever it is likely that the protection has been impaired, the product must be made inoperative and secured against any unintended operation.

### **Before Applying Power**

Verify that the product is configured to match the available main power source as described in the input power configuration instructions in this manual. If this product is to be powered by autotransformer, make sure the common terminal is connected to the neutral (grounded) side of the ac power supply.





---

## Instrument Definition

This manual contains installation, operation, and test information for the 8495D and 8495K.

### Instruments Covered by Manual

The instruments covered by this manual have a two-part serial number. The first four digits and letter comprise the serial number prefix. The last five digits form the sequential suffix that is unique to each instrument. The contents of this manual apply to instruments with the following serial prefixes:

8495D:	1711A	2406A	2508A	2544A	2852A	3308A
8495K:	1711A	2406A	2508A	2544A	2808A	

An attenuator manufactured after the printing of this manual may have a serial prefix that is not listed above. This unlisted serial prefix indicates that the attenuator is different from those documented in this manual.

## Description

# Description

The Agilent 8495D and 8495K are 50-ohm, dc to 26.5 GHz, 0-70 dB (in 10 dB steps), coaxial attenuators with APC 3.5 connectors. Each attenuator is made up of four attenuation sections connected in cascade. Each section consists of a precision thin-film attenuator card, a lossless thru-line, and a ganged pair of edge line transmission lines. The edge lines are flexed to make contact with either the attenuator card or the thru-line. The edge line contacts are gold-plated leaf springs which ensure long life and high repeatability. In the 8495D, the edge line controls are flexed by low-torque cams. In the 8495K, the edge line controls are flexed by solenoid plungers (see Figure 1).

Table 1 on page 3 shows the switching arrangement required to increase the amount of attenuation from 0 to 70 dB in 10 dB steps. In the 8495K, to ensure specified performance, it is recommended that the attenuator sections shown in the table below be used. Also, when changing attenuation, it is good practice to insert the required sections before deletion of the unneeded sections. With the attenuator set for 0 dB attenuation, only the insertion loss (residual attenuation) remains.

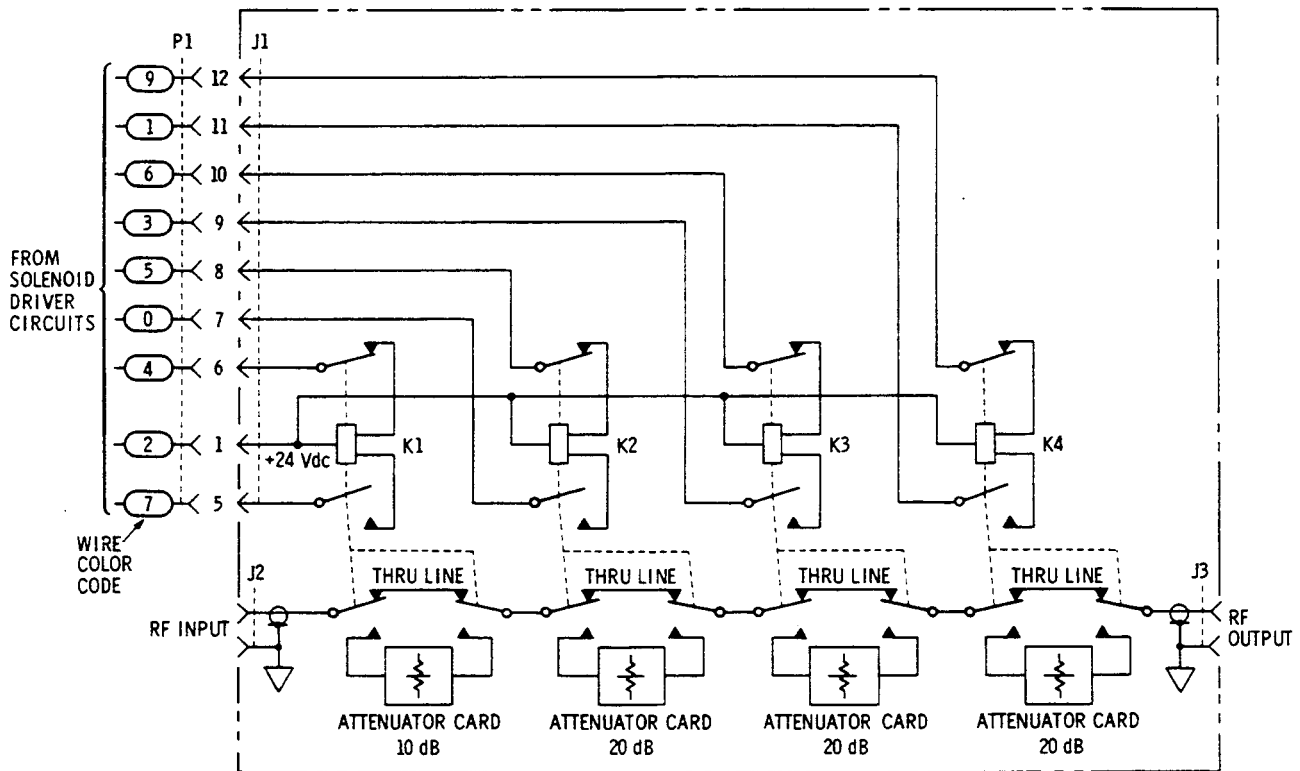

Figure 1 8495K Programmable Four-Section Attenuator Schematic Diagram

In the 8495K, each solenoid requires a drive of 20 to 30 V. The switching current is approximately 125 mA at 24 Vdc per section for the 8495K. The solenoid switching time is less than 20 milliseconds including settling time. Once switched, the solenoid plungers are held in place by permanent magnets and the solenoid plungers automatically disconnect the selected coil drive and connect the opposite coil drive (see [Figure 1 on page 2](#) and [Figure 3 on page 5](#)).

**Table 1 Attenuator Switching**

Attenuation (dB)	Attenuator Sections			
	1 10 dB	2 20 dB	3 20 dB	4 20 dB
10	X			
20			X*	X**
30	X		X*	X**
40		X		X
50	X	X		X
60		X	X	X
70	X	X	X	X

\* D model only

\*\* K model only

---

## CAUTION

---

Do not exceed the RF power rating of 1 W average or 100 W peak with a maximum pulse width of 10  $\mu$ s. Do not connect an attenuator RF input or output connector to greater than  $\pm 7$  Vdc. If the attenuator must be connected to a device with a potential greater than  $\pm 7$  Vdc, use a blocking capacitor.

## Supplied Accessories

A solenoid drive cable is supplied with the 8495K. The cable is 1.5 m (5 ft) long with a mating connector plug on one end and the other end is unterminated (see [Figure 2 on page 4](#)). The part number for this cable is 8120-2178, and is available as a spare or replacement. The cable connector plug and contacts are available from Viking Industries Inc. The part number is TKP12-100-P-TS-100-AU. The connector plug and contacts without the cable can be ordered from a Viking distributor. Information on replaceable parts is available in [Table 3 on page 5](#).

## Solenoid Cable Connectors

Refer also to [Figure 2 on page 4](#).

## Description

**Table 2 Solenoid Cable Connectors**

Section	Section 1		Section 2		Section 3		Section 4		Power
Solenoid Coil	Thru-Line	Atten Card	Thru-Line	Atten Card	Thru-Line	Atten Card	Thru-Line	Atten Card	V+
Cable Wire Color Code <sup>1</sup>	VIO	YEL	BLK	GRN	ORG	BLU	BRN	WHT	RED
Connector Plug Pin Number <sup>2</sup>	5	6	7	8	9	10	11	12	1
8495K	0 dB	10 dB	0 dB	20 dB	0 dB	20 dB	0 dB	20 dB	–
Option 016 Flat Pack Plug Pin Number <sup>3</sup>	13	2	11	5	3	9	4	10	6

1. Five-foot cable and mating plug assembly provided.
2. Pin 1 (red wire) is common for all coils. Pins 2, 3 and 4 are not used.
3. Pin 6 is common for all coils. Pins 1, 7, 8, 12, and 14 are not used.

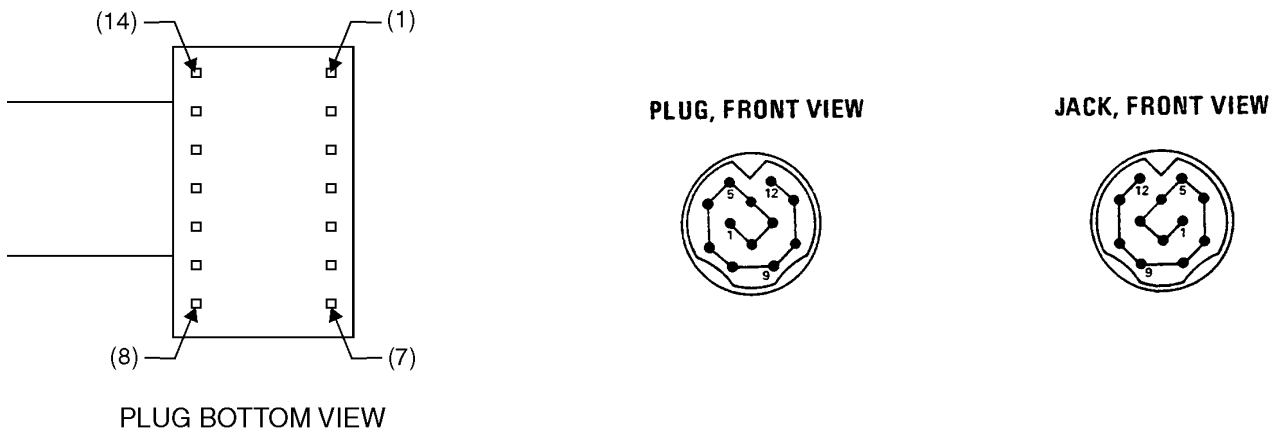

**Figure 2 Solenoid Cable Pin Configuration**

Table 3 Solenoid Cable Replaceable Parts

Part Number	Description
2220-0006	Screw, fillister Head 4-40x7/8 in. (for attaching base)
8120-2178	Cable, solenoid drive, 1.5 meters (5 feet) long, connector plug on one end and other end unterminated (8495K)
0370-1091	Knob (84950)
08496-20008	Base
TKP12-100-P-TS-100-AU <sup>1</sup>	Connector Plug and Contacts only without cable (8495K)

1. Available from Viking Industries, Inc., Chatsworth, California 91311.

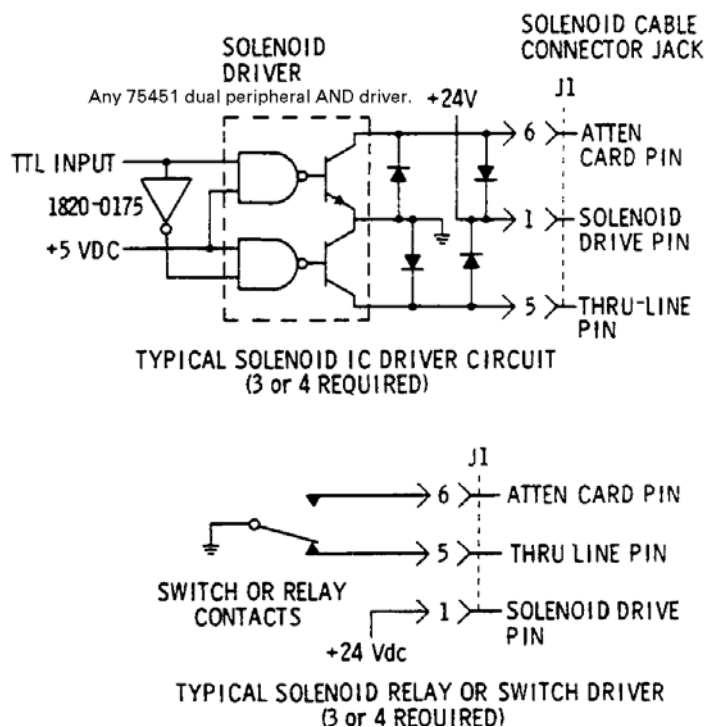

Figure 3 Typical Solenoid Coil Driver Circuit

## Specifications

### Frequency Range and Attenuation

Frequency Range	dc to 26.5 GHz
Attenuation	0 to 70 dB in 10 dB steps

### Attenuation Accuracy

Attenuation Accuracy ( $\pm$ dB, referenced from 0 dB)				
Attenuation Selection (dB)	dc–6.0 GHz	6.0–12.4 GHz	12.4–18.0 GHz	18.0–26.5 GHz
10	0.3	0.4	0.5	0.7
20	0.5	0.5	0.6	0.8
30	0.6	0.7	0.8	1.0
40	0.7	0.9	1.1	1.5
50	0.8	1.0	1.2	1.6
60	1.0	1.3	1.4	1.9
70	1.1	1.5	1.7	2.3

**Maximum Insertion Loss** (0.4 + 0.09 f) dB  
where “f” is the frequency in GHz

**Attenuation Repeatability** 0.01 dB, dc to 18.0 GHz  
0.05 dB, 18.0 to 26.5 GHz

**RF Power Handling Capability** 1 W average, 100 W peak with maximum pulse width of 10 microseconds

**Solenoid Drive** For Agilent 8495K only.

Solenoids Drive	Coil Voltage	Switching Current
8495K	20 to 30 Vdc	125 mA at 24V (approx.)

**Switching speed** Maximum 20 milliseconds including settling time

**Maximum SWR**

Instrument	Frequency Range (GHz)	Maximum SWR
8495D, 8495K	dc to 6.0	1.25
	6.0 to 12.4	1.45
	12.4 to 18	1.9
	18 to 26.5	2.2

**Physical Characteristics**

Instrument	Dimensions <sup>1</sup> (depth x width x height)	Weight
8495D	6.25 in x 2.0625 in x 1.6875 in	15 oz
	159 mm x 52 mm x 43 mm	425 g
8495K	5.625 in x 2.0625 in x 1.6875 in	16 oz
	159 mm x 52 mm x 43 mm	454g

1. Dimensions are in millimeters and inches. Dimensions are for general information only. If dimensions are required for building special enclosures, contact your Agilent field engineer.

**Minimum Life**

>5 million cycles per section

**Environment Limits**

The attenuator should be stored in a clean, dry environment. The storage and operating environments of the instruments should be within the following limits.

Characteristic	Storage Value	Operating Value
Temperature	-40 to +75 °C	0 to 55 °C
Humidity	< 95% relative	< 95% relative
Altitude	< 7600 m (25000 ft)	< 4600 m (15000 ft)

**NOTE**

Containers and materials identical to those used in factory packaging are available through Agilent Technologies offices. If the instrument is being returned to Agilent Technologies for servicing, attach a tag indicating the type of service required, return address, model number, and full serial number. Also, mark the container *FRAGILE* to assure careful handling. In any correspondence, refer to the instrument by model number and full serial number.

---

## Installation

### Initial Inspection

Inspect the shipping container for damage. If the shipping container or cushioning material is damaged, it should be kept until the contents of the shipment have been checked for completeness and the instrument has been checked mechanically and electrically. A procedure for checking electrical performance is given under “[Operator’s Check](#)” on page 10 (also see “[Performance Tests](#)” on page 11). If the contents of the shipment are incomplete, if there is mechanical damage or defect, or if the instrument does not pass the electrical performance test, notify the nearest Agilent Technologies office. If the shipping container is damaged, or the cushioning material shows signs of stress, notify the carrier as well as the Agilent Technologies office. Keep the shipping materials for the carrier's inspection. The Agilent office will arrange for repair or replacement without waiting for claim settlement.

### Mating Connectors

The APC 3.5 connector is a 3.5-mm air line connector that will mate with the SMA type connectors. The SWR performance of this hybrid connection is similar to a mated pair of SMA connectors when used within the frequency range of the SMA connector.

#### Option

The attenuators are configured with the APC 3.5 female connectors and are designated as Option 004.

---

### CAUTION

---

When installing the instrument, make sure that the connectors do not support weight or bear torque. The preferred procedure is to set up all equipment in position before connecting the instrument. Either connector may be used as the input or output connector.

### Installation Instructions

The 8495K solenoid drive cable connector plug is connected by aligning the plug (P1) with the jack (J1) on the attenuator, and then pushing the plug over the jack. The plug is removed by grasping the ribbed sides of the plug and squeezing them together while pulling back until the plug clears the jack.



---

## Operating Instructions

---

### CAUTION

Do not apply power greater than 1 W average, or 100 W peak with a maximum pulse width of 10 microseconds. If these limits are exceeded, the attenuators may be damaged.

---

### CAUTION

For the 8495K, do not ground both solenoid drive pins of the programmable attenuator at the same time. This causes rapid cycling of the solenoid and could reduce the operating life of the attenuator. The rapid cycling may produce a buzzing sound from the attenuator.

---

### Operating Information

Either RF connector may be used as the input or output connector. Connect the solenoid drive cable of the programmable attenuator to the solenoid drive connector (J1). By applying the proper voltage and grounds to the proper pins of J1, the attenuator will either increase or decrease the amount of attenuation as selected.

---

## Operator's Check

The Operator's Check is supplied to allow the operator to make a quick check of the instrument prior to use or if a failure is suspected.

### Description

The attenuator is driven from a 50-ohm signal source at 1 kHz. The output level from the attenuator is detected by a narrow-bandwidth voltmeter. The attenuator and detector range switches are stepped together and the variations in level noted. This verifies that each attenuator section is being properly switched and checks the low-frequency accuracy of the attenuator.

---

### NOTE

The SWR meter used in this check is calibrated for a square-law detector and therefore the range changes and errors (read in dB) are twice that indicated by the meter.

---

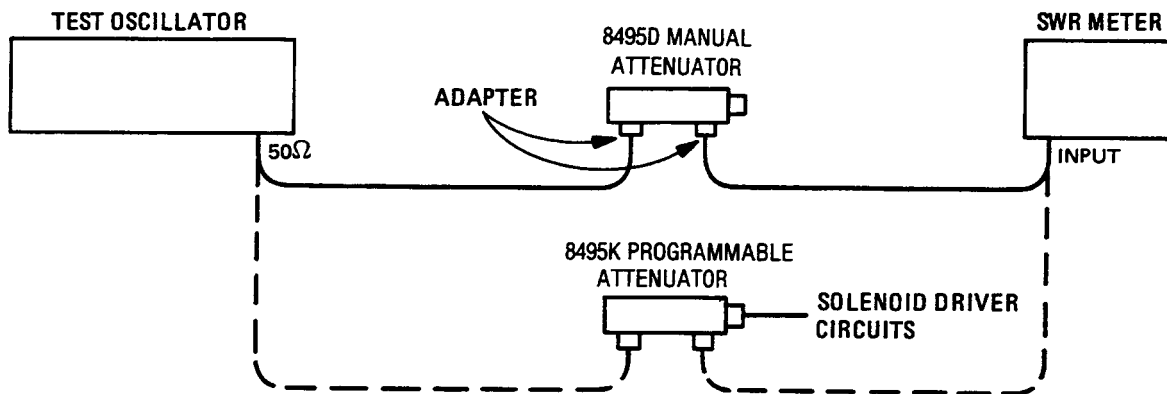

Figure 4 Operator's Check Setup

### Procedure

1. Connect equipment as shown in [Figure 4](#) with the attenuator set to 0 dB.
2. Set the test oscillator to 0.3 Vrms at 1 kHz.
3. Set SWR meter range to 2 dB (expanded) and adjust its bandwidth to center of adjustment range. Fine tune oscillator frequency to obtain maximum meter indication.
4. Set attenuator and SWR meter range switch as shown in [Table 4](#) and verify that SWR meter indicates within the limits shown.

Table 4 Attenuator and SWR Settings

SWR Meter Range (dB)	Attenuation	Meter Indication (dB)		
		8495D/K	Minimum	Actual
2	0		Set to 0.5	
6	10	1.20		1.80
12	20	0.15		0.85
16	30	1.05		1.95
22 <sup>1</sup>	40	-0.40		1.40
26 <sup>1</sup>	50	0.50		2.50
32 <sup>1</sup>	60	-0.60		1.60
36 <sup>1</sup>	70	0.35		2.65

1. Adjust range by 2 dB, if needed, to obtain a on-scale indication.

## Performance Tests

The attenuator can be tested to the accuracy of the [Specifications](#) on page 6 with an automatic network analyzer or equivalent equipment of suitable accuracy. If an automatic network analyzer is available, test the attenuator using the procedures in the analyzer's operating manual.

Refer to the *Agilent 11713A Attenuator/Switch Driver Operating and Service Manual* for programming instructions.

---

### NOTE

---

The attenuators have no internal adjustments and should not be opened. If defective, return the attenuator to the nearest Agilent Technologies office for repair.

---

# Replaceable Parts

Table 5 lists the replaceable parts which are the only parts that can be replaced without access to the interior of the instrument. If any parts not listed below need replacement, return the instrument to Agilent Technologies.

---

### CAUTION

---

Due to special fixtures necessary for assembly, do NOT attempt to replace any parts not listed in the table below. If the instrument is opened, the warranty is void.

**Table 5** *Replaceable Parts*

Description	Part Number
Knob (8495D)	0370-1091
Cable, solenoid drive, 1.5 m (5 ft) long, connector plug on one end and other end un-terminated (8495K)	8120-2178
Screws for both bases: 4-40 x 7/8 in. Fillister head	2220-0006
Base	5041-3888
Connector plug and contacts only without cable (8495K)	*TKP12-100-P-TS-100-AU

\*Available from distributors of Viking Industries, Inc., Chatsworth CA 91311

### Troubleshooting

Troubleshooting consists of performing the “[Operator’s Check](#)” on page 10. If the instrument does not perform within limits, return the instrument to Agilent Technologies.