

# Agilent Technologies 8156A Attenuator Operating and Programming Guide



**Agilent Technologies**

[www.valuetronics.com](http://www.valuetronics.com)

---

## Notices

Copyright © 1994-2000 Agilent Technologies Deutschland GmbH. All rights reserved.

No part of this manual may be reproduced in any form or by any means (including electronic storage and retrieval or translation into a foreign language) without prior agreement and written consent from Agilent Technologies, Inc. as governed by United States and international copyright laws.

continually increasing customer satisfaction through improved process control.

## Warranty

The material contained in this document is subject to change without notice. Agilent Technologies makes no warranty of any kind with regard to this material, including, but not limited to, the implied warranties of merchantability and fitness for a particular purpose. Agilent Technologies shall not be liable for errors contained herein or for incidental or consequential damages in connection with the furnishing, performance, or use of this material.

## Edition/Print Date

All Editions and Updates of this manual and their creation dates are listed below.

08156-91011: E0500

Second Edition ..... May 2000

First Edition W0194, E0694, E0696, E1098

## Assistance

Product maintenance agreements and other customer assistance agreements are available for Agilent Technologies products.

For any assistance, contact your nearest Agilent Technologies Sales and Service Office (see *"Service and Support"* on page 9).

## ISO 9001 Certification

Produced to ISO 9001 international quality system standard as part of Agilent Technologies' objective of

---

Agilent Technologies GmbH  
Herrenberger Str. 130  
71034 Böblingen  
Germany

# Safety Summary

The following general safety precautions must be observed during all phases of operation of this instrument. Failure to comply with these precautions or with specific warnings elsewhere in this manual violates safety standards of design, manufacture, and intended use of the instrument. Agilent Technologies assumes no liability for the customer's failure to comply with these requirements.

## GENERAL

This product is a Safety Class 1 instrument (provided with a protective earth terminal). The protective features of this product may be impaired if it is used in a manner not specified in the operation instructions.

All Light Emitting Diodes (LEDs) used in this product are Class 1 LEDs as per IEC 60825-1.

## ENVIRONMENTAL CONDITIONS

This instrument is intended for indoor use in an installation category II, pollution degree 2 environment. It is designed to operate at a maximum relative humidity of 95% and at altitudes of up to 2000 meters. Refer to the specifications tables for the ac mains voltage requirements and ambient operating temperature range.

## BEFORE APPLYING POWER

Verify that the product is set to match the available line voltage, the correct fuse is installed, and all safety precautions are taken. Note the instrument's external markings described under Safety Symbols.

## **GROUND THE INSTRUMENT**

To minimize shock hazard, the instrument chassis and cover must be connected to an electrical protective earth ground. The instrument must be connected to the ac power mains through a grounded power cable, with the ground wire firmly connected to an electrical ground (safety ground) at the power outlet. Any interruption of the protective (grounding) conductor or disconnection of the protective earth terminal will cause a potential shock hazard that could result in personal injury.

## **FUSES**

Only fuses with the required rated current, voltage, and specified type (normal blow, time delay, etc.) should be used. Do not use repaired fuses or short-circuited fuse holders. To do so could cause a shock or fire hazard.

## **DO NOT OPERATE IN AN EXPLOSIVE ATMOSPHERE**

Do not operate the instrument in the presence of flammable gases or fumes.

## **DO NOT REMOVE THE INSTRUMENT COVER**

Operating personnel must not remove instrument covers. Component replacement and internal adjustments must be made only by qualified service personnel.

Instruments that appear damaged or defective should be made inoperative and secured against unintended operation until they can be repaired by qualified service personnel.

## Other Safety Information

- Adjustments described in this manual are performed with power supplied to the instrument while protective covers are removed. Be aware that energy at many points, if contacted, result in personal injury.
- Do not install substitute parts or perform any unauthorized modification to the instrument.
- Be aware that capacitors inside the instrument may still be charged even if the instrument has been connected from its source of supply.

**WARNING** To avoid hazardous electrical shock, do not operate the instrument if there are any signs of damage to any portion of the outer enclosure (covers, panels, and so on).

**WARNING** To avoid the possibility of injury or death, you must observe the following precautions before powering on the instrument.

- If this instrument is to be energized via an autotransformer for voltage reduction, ensure that the Common terminal connects to the earthed pole of the power source.
- Insert the power cable plug only into a socket outlet provided with a protective earth contact. Do not negate this protective action by the using an extension cord without a protective conductor.
- Before switching on the instrument, the protective earth terminal of the instrument must be connected to a protective conductor. You can do this by using the power cord supplied with the instrument.
- It is prohibited to interrupt the protective earth connection intentionally.

- The following work should be carried out by a qualified electrician. All local electrical codes must be strictly observed:

If the plug on the cable does not fit the power outlet, or if the cable is to be attached to a terminal block, cut the cable at the plug end and rewire it.

The color coding used in the cable depends on the cable supplied. If you are connecting a new plug, it should meet the local safety requirements and include the following features:

- Adequate load-carrying capacity (see table of specifications).
- Ground connection.
- Cable clamp.

**WARNING** To avoid the possibility of injury or death, please note that the Agilent 8156A does not have a floating earth.

**WARNING** The Agilent 8156A is not designed for outdoor use. To prevent potential fire or shock hazard, do not expose the instrument to rain or other excessive moisture.

## Warnings and Cautions

**WARNING** The WARNING sign denotes a hazard. It calls attention to a procedure, practice, or the like, which, if not correctly performed or adhered to, could result in personal injury. Do not proceed beyond a WARNING sign until the indicated conditions are fully understood and met.

## CAUTION

The CAUTION sign denotes a hazard. It calls attention to an operating procedure, or the like, which, if not correctly performed or adhered to, could result in damage to or destruction of part or all of the product. Do not proceed beyond a CAUTION sign until the indicated conditions are fully understood and met.

## Safety Symbols



Caution, refer to accompanying documents



Warning, risk of electric shock



Frame or chassis terminal



Protective earth (ground) terminal



Hazardous laser radiation

# About This Manual

## The Structure of this Manual

This manual is divided into 4 parts:

- Chapter 1 tells you how to set up your Attenuator.
- Chapters 2 to 6 shows you what you can do with your Attenuator.
- Chapters 7 to 9 show you how you can remotely program your Attenuator, using GPIB commands.
- The appendices contain additional information not required for routine day-to-day use.



# Service and Support

Any adjustment, maintenance, or repair of this product must be performed by qualified personnel. Contact your customer engineer through your local Agilent Technologies Service Center. You can find a list of local service representatives on the Web at: <http://www.agilent-tech.com/services/English/index.html>

If you do not have access to the Internet, one of these centers can direct you to your nearest representative:

<b>United States</b>	Test and Measurement Call Center (800) 452-4844 (Toll free in US)
<b>Canada</b>	(905) 206-4725
<b>Europe</b>	(31 20) 547 9900
<b>Japan</b>	Measurement Assistance Center (81) 426 56 7832 (81) 426 56 7840 (FAX)
<b>Latin America</b>	(305) 267 4245 (305) 267 4288 (FAX)
<b>Australia/New Zealand</b>	1 800 629 485 (Australia) 0800 738 378 (New Zealand)
<b>Asia-Pacific</b>	(852) 2599 7777 (852) 2506 9285 (FAX)



## Table of Contents

### 1 Getting Started

<b>1.1 Using the Attenuator .....</b>	<b>29</b>
Using the Modify Keys .....	29
<b>1.2 Making an Attenuation Sweep .....</b>	<b>30</b>
Making an Automatic Sweep .....	30
<b>1.3 The Manual Sweep .....</b>	<b>31</b>
<b>1.4 Using your Attenuator as a Variable Back Reflector</b>	<b>32</b>
<b>1.5 Using the Through-Power Mode .....</b>	<b>33</b>
<b>1.6 Selecting the Wavelength Calibration and Its Function</b>	<b>33</b>

### 2 Using the Attenuator

<b>2.1 Setting Up the Hardware .....</b>	<b>37</b>
<b>2.2 Setting Up the Attenuation .....</b>	<b>38</b>
Entering the Attenuation Factor .....	38
Entering a Calibration Factor .....	39
Entering the Wavelength .....	40
<b>2.3 Example, Setting the Calibration .....</b>	<b>42</b>

### 3 Making an Attenuation Sweep

<b>3.1 Configuring the Hardware .....</b>	<b>47</b>
---	-----------

## Table of Contents

<b>3.2 The Automatic Sweep .....</b>	<b>48</b>
Setting Up an Automatic Sweep .....	48
Executing the Automatic Sweep .....	50
<b>3.3 The Manual Sweep .....</b>	<b>51</b>
Setting Up a Manual Sweep .....	51
Executing the Manual Sweep .....	53
<b>3.4 Example, an Automatic Attenuation Sweep .....</b>	<b>54</b>

## 4 Using your Attenuator as a Variable Back Reflector

<b>4.1 Configuring the Hardware .....</b>	<b>59</b>
<b>4.2 Setting Up the Software .....</b>	<b>60</b>
Editing the Setup .....	60
Executing the Back Reflector Application .....	61
<b>4.3 Example, Setting a Return Loss .....</b>	<b>62</b>

## 5 Setting Up the System

<b>5.1 Setting the GPIB Address .....</b>	<b>67</b>
Resetting the GPIB Address .....	67
<b>5.2 Selecting the Wavelength Calibration and Its Function</b>	<b>67</b>
Setting the Function of the Wavelength Calibration .....	68
Selecting the Wavelength Calibration Data .....	69

## Table of Contents

<b>5.3 Selecting the Through-Power Mode .....</b>	<b>70</b>
Deselecting the Through-Power Mode .....	71
Resetting the Through-Power Mode .....	71
<b>5.4 Setting the Display Brightness .....</b>	<b>71</b>
Resetting the Display Brightness .....	71
<b>5.5 Selecting the Setting used at Power-On .....</b>	<b>72</b>
Resetting the Power-On Setting .....	72
<b>5.6 Locking Out ENB/DIS .....</b>	<b>72</b>
Resetting the ENB/DIS Lock Out .....	73
<b>5.7 Selecting the Shutter State at Power On .....</b>	<b>73</b>
Resetting the Shutter State at Power On .....	73
<b>5.8 Setting the Display Resolution .....</b>	<b>74</b>
Resetting the Display Resolution .....	74

## 6 Storing and Recalling Settings

<b>6.1 Storing the Setting .....</b>	<b>77</b>
<b>6.2 Recalling a Setting .....</b>	<b>77</b>
Resetting the Instrument .....	77
Recalling a User Setting .....	77

## 7 Programming the Attenuator

<b>7.1 GPIB Interface .....</b>	<b>81</b>
<b>7.2 Setting the GPIB Address .....</b>	<b>83</b>

## Table of Contents

<b>7.3 Returning the Instrument to Local Control .....</b>	<b>83</b>
<b>7.4 How the Attenuator Receives and Transmits Messages</b>	<b>83</b>
How the Input Queue Works .....	83
The Output Queue .....	84
The Error Queue .....	84
<b>7.5 Some Notes about Programming and Syntax Diagram</b>	<b>85</b>
<b>Conventions .....</b>	<b>85</b>
Short Form and Long Form .....	85
Command and Query Syntax .....	86

## 8 Remote Commands

<b>8.1 Units .....</b>	<b>89</b>
<b>8.2 Command Summary .....</b>	<b>89</b>
<b>8.3 The Common Commands .....</b>	<b>93</b>
Common Status Information .....	93
*CLS .....	95
*ESE .....	95
*ESR? .....	96
*IDN? .....	97
*OPC .....	98
*OPT? .....	98
*RCL .....	99
*RST .....	99
*SAV .....	100
*SRE .....	101
*STB? .....	102

## Table of Contents

*TST? .....	103
*WAI .....	104
<b>8.4 DISPlay Commands .....</b>	<b>104</b>
:DISPlay:BRIGhtness .....	104
:DISPlay:ENABle .....	105
<b>8.5 INPut Commands .....</b>	<b>106</b>
:INPut:ATTenuation .....	106
:INPut:LCMode .....	107
:INPut:OFFSet .....	107
:INPut:OFFSet:DISPlay .....	108
:INPut:WAVelength .....	109
<b>8.6 OUTPut Commands .....</b>	<b>110</b>
:OUTPut:APMode .....	110
:OUTPut:POWer .....	112
:OUTPut[:STATe] .....	113
:OUTPut[:STATe]:APOWeron .....	114
<b>8.7 STATus Commands .....</b>	<b>114</b>
:STATus:OPERation:CONDition? .....	116
:STATus:OPERation:ENABle .....	117
:STATus:OPERation[:EVENT]? .....	117
:STATus:OPERation:NTRansition .....	118
:STATus:OPERation:PTRansition .....	118
:STATus:QUESTionable:CONDition? .....	119
:STATus:QUESTionable:ENABle .....	119
:STATus:QUESTionable[:EVENT]? .....	120
:STATus:QUESTionable:NTRansition .....	120
:STATus:QUESTionable:PTRansition .....	121
:STATus:PRESet .....	122
<b>8.8 SYSTem Commands .....</b>	<b>122</b>

## Table of Contents

:SYSTem:ERRor? .....	122
<b>8.9 User Calibration Commands .....</b>	<b>123</b>
Entering the User Calibration Data .....	123

## 9 Programming Examples

<b>9.1 Example 1 - Checking Communication .....</b>	<b>131</b>
<b>9.2 Example 2 - Status Registers and Queues .....</b>	<b>132</b>
<b>9.3 Example 3 - Measuring and Including the Insertion Loss .....</b>	<b>135</b>
<b>9.4 Example 4 - Running an Attenuation Sweep .....</b>	<b>139</b>

## A Installation

<b>A.1 Safety Considerations .....</b>	<b>143</b>
<b>A.2 Initial Inspection .....</b>	<b>143</b>
<b>A.3 AC Line Power Supply Requirements .....</b>	<b>144</b>
Line Power Cable .....	144
Replacing the Battery .....	146
Replacing the Fuse .....	146
<b>A.4 Operating and Storage Environment .....</b>	<b>148</b>
Temperature .....	148
Humidity .....	148
Instrument Positioning and Cooling .....	148
<b>A.5 Switching on the Attenuator .....</b>	<b>149</b>



## Table of Contents

<b>A.6 Monitor Output .....</b>	<b>149</b>
<b>A.7 Optical Output .....</b>	<b>150</b>
Disabling the Optical Output .....	150
<b>A.8 GPIB Interface .....</b>	<b>150</b>
Connector .....	151
GPIB Logic Levels .....	152
<b>A.9 Claims and Repackaging .....</b>	<b>152</b>
Return Shipments to Agilent Technologies .....	152

## B Accessories

<b>B.1 Instrument and Options .....</b>	<b>157</b>
<b>B.2 GPIB Cables and Adapters .....</b>	<b>157</b>
<b>B.3 Connector Interfaces and Other Accessories .....</b>	<b>158</b>
Straight Contact Connector .....	158
Option 201, Angled Contact Connector .....	160

## C Specifications

<b>C.1 Definition of Terms .....</b>	<b>165</b>
<b>C.2 Specifications .....</b>	<b>167</b>
Supplementary Performance Characteristics .....	169
<b>C.3 Other Specifications .....</b>	<b>171</b>
<b>C.4 Declaration of Conformity .....</b>	<b>172</b>

## Table of Contents

### D Performance Tests

<b>D.1 Equipment Required</b> .....	<b>175</b>
<b>D.2 Test Record</b> .....	<b>177</b>
<b>D.3 Test Failure</b> .....	<b>177</b>
<b>D.4 Instrument Specification</b> .....	<b>177</b>
<b>D.5 Performance Test</b> .....	<b>178</b>
I. Total Insertion Loss Test .....	179
II. Linearity/Attenuation Accuracy Test .....	182
III. Attenuation Repeatability Test .....	184
IV. Return Loss Test .....	185
<b>D.6 V. Polarization Dependent Loss (PDL): Optional</b>	<b>191</b>
Polarization Dependant Loss Test (Mueller method) .....	192

### E Cleaning Information

Cleaning Instructions for this Instrument .....	248
<b>E.1 Safety Precautions</b> .....	<b>249</b>
<b>E.2 Why is it important to clean optical devices ?</b> .....	<b>249</b>
<b>E.3 What do I need for proper cleaning?</b> .....	<b>250</b>
Standard Cleaning Equipment .....	250
Additional Cleaning Equipment .....	253
<b>E.4 Preserving Connectors</b> .....	<b>256</b>
Making Connections .....	256
Dust Caps and Shutter Caps .....	256
Immersion Oil and Other Index Matching Compounds .....	256

## Table of Contents

<b>E.5 Cleaning Instrument Housings .....</b>	<b>257</b>
<b>E.6 Which Cleaning Procedure should I use ? .....</b>	<b>257</b>
Light dirt .....	257
Heavy dirt .....	257
<b>E.7 How to clean connectors .....</b>	<b>258</b>
Preferred Procedure .....	258
Procedure for Stubborn Dirt .....	258
An Alternative Procedure .....	259
<b>E.8 How to clean connector adapters .....</b>	<b>259</b>
Preferred Procedure .....	259
Procedure for Stubborn Dirt .....	260
<b>E.9 How to clean connector interfaces .....</b>	<b>260</b>
Preferred Procedure .....	260
Procedure for Stubborn Dirt .....	261
<b>E.10 How to clean bare fiber adapters .....</b>	<b>261</b>
Preferred Procedure .....	261
Procedure for Stubborn Dirt .....	262
<b>E.11 How to clean lenses .....</b>	<b>262</b>
Preferred Procedure .....	262
Procedure for Stubborn Dirt .....	263
<b>E.12 How to clean instruments with a fixed connector inter- face .....</b>	<b>263</b>
<b>E.13 How to clean instruments with an optical glass plate</b>	<b>264</b>
<b>E.14 How to clean instruments with a physical contact inter- face .....</b>	<b>264</b>
Preferred Procedure .....	265
Procedure for Stubborn Dirt .....	265

## Table of Contents

<b>E.15 How to clean instruments with a recessed lens interface .....</b>	<b>265</b>
Preferred Procedure .....	266
Procedure for Stubborn Dirt .....	266
<b>E.16 How to clean optical devices which are sensitive to mechanical stress and pressure .....</b>	<b>267</b>
Preferred Procedure .....	267
Procedure for Stubborn Dirt .....	267
Alternative Procedure .....	267
<b>E.17 How to clean metal filters or attenuator gratings</b>	<b>268</b>
Preferred Procedure .....	268
Procedure for Stubborn Dirt .....	268
<b>E.18 Additional Cleaning Information .....</b>	<b>268</b>
How to clean bare fiber ends .....	269
How to clean large area lenses and mirrors .....	269
Preferred Procedure .....	269
Procedure for Stubborn Dirt .....	270
Alternative Procedure A .....	270
Alternative Procedure B .....	271
<b>E.19 Other Cleaning Hints .....</b>	<b>271</b>
Making the connection .....	271
Lens cleaning papers .....	271
Immersion oil and other index matching compounds .....	272
Cleaning the housing and the mainframe .....	272

## F Error messages

<b>F.1 Display Messages .....</b>	<b>275</b>
-----------------------------------	------------

## Table of Contents

<b>F.2 GPIB Messages .....</b>	<b>276</b>
Command Errors .....	276
Execution Errors .....	280
Device-Specific Errors .....	281
Query Errors .....	282
Instrument Specific Errors .....	283

## Table of Contents

## List of Figures

Figure 1-1 The Attenuator Keys .....	29
Figure 1-2 The Modify Keys .....	30
Figure 1-3 The Parameters for an Automatic Sweep .....	31
Figure 1-4 The Hardware Configuration for the Back Reflector (Options 201 and 203) .....	32
Figure 2-1 The Hardware Configuration for the Attenuator .....	37
Figure 2-2 The Attenuation Factor on the Display .....	38
Figure 2-3 The Calibration Factor on the Display .....	39
Figure 2-4 The Wavelength on the Display .....	41
Figure 2-5 Hardware Configuration for Attenuation Example - A .....	42
Figure 2-6 Hardware Configuration for Attenuation Example - B .....	43
Figure 3-1 The Hardware Configuration for the Attenuator .....	47
Figure 3-2 The Parameters for an Automatic Sweep .....	49
Figure 3-3 Selecting the Automatic Sweep Application .....	49
Figure 3-4 Running the Automatic Sweep .....	51
Figure 3-5 Editing the STOP Parameter .....	52
Figure 3-6 Running the Manual Sweep .....	53
Figure 4-1 The Hardware Configuration for the Back Reflector .....	59
Figure 4-2 Editing the Value for the Reference Return Loss .....	61
Figure 4-3 Executing the Back Reflector Application .....	62
Figure 4-4 Hardware Configuration for Variable Return Loss .....	63
Figure 5-1 The LAMBDCAL Indicator on the Display .....	68
Figure 5-2 The USERCAL Indicator on the Display .....	69
Figure 5-3 The Display in Through-Power Mode .....	70
Figure 6-1 The Display when Recalling the Default Setting .....	77
Figure 8-1 Common Status Registers .....	94
Figure 8-2 The Status Registers .....	116
Figure 9-1 Hardware Configuration for Attenuation Example - A .....	135
Figure 9-2 Hardware Configuration for Attenuation Example - B .....	136
Figure A-1 Line Power Cables - Plug Identification .....	144
Figure A-2 Rear Panel Markings .....	145
Figure A-3 Releasing the Fuse Holder .....	147
Figure A-4 The Fuse Holder .....	147
Figure A-5 Correct Positioning of the Attenuator .....	149
Figure A-6 GPIB Connector .....	151
Figure B-1 Straight Contact Connector Configuration .....	159

## List of Figures

Figure B-2 Angled Contact Connector Configuration .....	160
Figure D-1 Total Insertion Loss Test Setup 1, Options 100, 101, 121 .....	179
Figure D-2 Total Insertion Loss Test Setup 1, Options 201, 221 .....	180
Figure D-3 Total Insertion Loss Test Setup 1, Option 350 .....	180
Figure D-4 Total Insertion Loss Test Setup 2, Options 100, 101, 121 .....	181
Figure D-5 Total Insertion Loss Test Setup 2, Options 201, 221 .....	181
Figure D-6 Total Insertion Loss Test Setup 2, Option 350 .....	182
Figure D-7 Return Loss Test Setup 1, Options 100, 101, 121 .....	185
Figure D-8 Return Loss Test Setup 2, Options 100, 101 .....	187
Figure D-9 Return Loss Test Setup 2, Option 121 .....	187
Figure D-10 Return Loss Test Setup 1, Options 201, 221 .....	188
Figure D-11 Return Loss Test Setup 2, Option 201 .....	189
Figure D-12 Return Loss Test Setup 2, Option 221 .....	190
Figure D-13 PDL Test Setup 1: Reference Measurement .....	192
Figure D-14 PDL Test Setup 2: Power after DUT .....	198



## List of Tables

Table 7-1 GPIB Capabilities .....	82
Table 8-1 Units and Allowed Mnemonics .....	89
Table 8-2 Common Command Summary .....	89
Table 8-3 Command List .....	90
Table 8-4 The Event Status Enable Register .....	96
Table 8-5 The Standard Event Status Register .....	97
Table 8-6 Reset State (Default Setting) .....	100
Table 8-7 The Service Request Enable Register .....	101
Table 8-8 The Status Byte Register .....	102
Table 8-9 The Self Test Results.....	103
Table A-1 Temperature .....	148
Table C-1 Specifications - Options 100, 101 and 201 .....	167
Table C-2 Monitor Output Options .....	168
Table C-3 Multimode Options .....	169
Table D-1 Equipment Required for the Agilent 8156A (1310/1550nm) .....	176
Table D-2 Equipment for the PDL test 1 .....	191
Table D-3 Performance Test Agilent 8156A .....	200

## List of Tables

---

## **Getting Started**

---

# Getting Started

This chapter introduces the features of the Agilent Technologies 8156A. More detail is given on these features in the following chapters.

The main features of the Agilent 8156A, other than its use as an attenuator, are its built-in sweep and back reflector applications, its through-power mode (which displays the power at the output of the instrument, rather than the amount of attenuation set) and its selection of wavelength calibration possibilities.

## 1.1 Using the Attenuator

**NOTE**

Before using the instrument, you should make sure that it is properly warmed up. The instrument is properly warmed up when it has been switched on for a minimum of 45 minutes. Failure to do this can cause errors of up to 0.04dB in the attenuation.

Set the attenuation of the filter using **ATT** (attenuation factor),  $\lambda$  (wavelength), and **CAL** (calibration factor).

Figure 1-1

### The Attenuator Keys

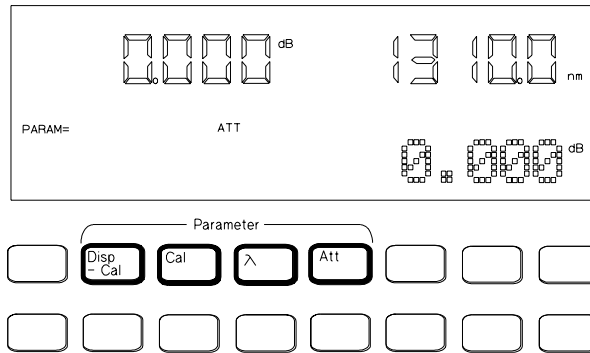

The attenuation factor and the calibration factor set the position of the filter. The calibration factor allows you to offset the value of the attenuation factor.

$$Att(dB) = Cal(dB) + Attenuation_{filter}(dB)$$

In addition, you can use **DISP**→**CAL** to transfer the current attenuation factor to the calibration factor.

### Using the Modify Keys

There are four modify keys on the front panel of the attenuator.

## Getting Started

### Making an Attenuation Sweep

Figure 1-2

#### The Modify Keys

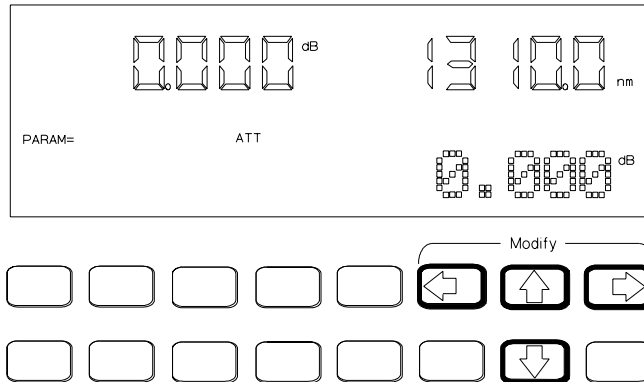

#### Editing a Number

Use  $\leftarrow$  and  $\rightarrow$  to move the cursor from digit to digit when editing a number. Use  $\uparrow$  and  $\downarrow$  to change the value of a digit when editing a number.

#### Editing a Non-Numeric Parameter

Use  $\uparrow$  or  $\Rightarrow$  to increment the parameter.  
Use  $\downarrow$  or  $\Leftarrow$  to decrement the parameter.

---

## 1.2 Making an Attenuation Sweep

There are two types of attenuation sweep, automatic and manual.

#### Making an Automatic Sweep

An automatic sweep is one where stepping from one attenuation factor to the next is done by the instrument.

To select the automatic sweep press **SWP**, and make sure that **SWEEP** is set to **AUTO**. By pressing **SWP** repeatedly you view and

## Getting Started

### The Manual Sweep

can edit the parameters for the sweep. *START* is the attenuation factor at which the sweep begins, *STOP* is the attenuation factor that ends the sweep, *STEP* is the size of the attenuation factor change, and *DWELL* is the time taken for each attenuation factor.

**Figure 1-3** The Parameters for an Automatic Sweep

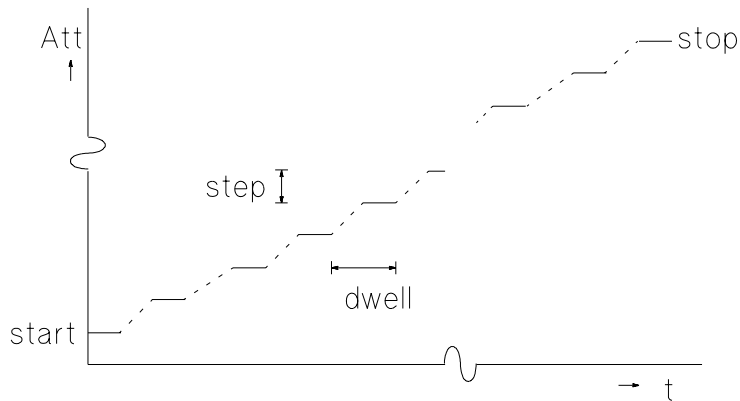

If you have set up your sweep, then you press **EXEC** to run it.

---

## 1.3 The Manual Sweep

A manual sweep is one where stepping from one attenuation factor to the next is done by the user.

To select the manual sweep press **SWP**, and make sure that *SWEEP* is set to *MANUAL*. By pressing **SWP** repeatedly you can view and edit the parameters for the sweep. *START* is the attenuation factor at which the sweep begins, *STOP* is the attenuation factor that ends the sweep, and *STEP* is the size of the attenuation factor change.

If you have set up your sweep, then you press **EXEC** to run it. To go to the next attenuation factor in the sweep, press **↑** or **⇒**. To go to the previous attenuation factor in the sweep, press **↓** or **⇐**.

## 1.4 Using your Attenuator as a Variable Back Reflector

### NOTE

Before using the instrument, you should make sure that it is properly warmed up. The instrument is properly warmed up when it has been switched on for a minimum of 45 minutes. Failure to do this can cause errors of up to 0.04dB in the attenuation.

To use the attenuator as a back reflector, you need to set up the hardware as shown in the figure below.

Figure 1-4

The Hardware Configuration for the Back Reflector (Options 201 and 203)

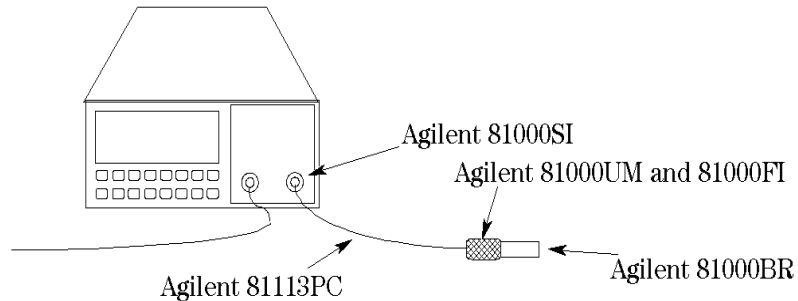

Press **BACK REFL** to start operation as a back reflector. You need to enter measured values for the insertion loss of the attenuator (*INS LOSS*), the return loss of the attenuator (*RL INPUT*), and the reference return loss you are using (*RL REF*). The return loss (*RL*) is calculated according to the equation

$$RL(dB) = -10 \log \left( 10^{\frac{-RLInput(dB)}{10}} + \left( 1 - 10^{\frac{-RLInput(dB)}{10}} \right) 10^{\frac{-(2(Att(dB) + InsLoss(dB)) + RLRef(dB))}{10}} \right)$$

You edit the value for the return loss while the application is running.



## 1.5 Using the Through-Power Mode

---

### NOTE

**Before using the instrument, you should make sure that it is properly warmed up. The instrument is properly warmed up when it has been switched on for a minimum of 45 minutes. Failure to do this can cause errors of up to 0.04dB in the attenuation.**

---

In the through-power mode, the instrument shows the power that gets through the attenuator on the display (that is the power at the output) rather than the attenuation.

When you select the through-power mode the attenuation factor (in dB) becomes the value for the through-power (in dBm). Set the calibration factor (see “Entering a Calibration Factor” on page 39) to get the attenuation factor to the value of the through-power.

After measuring and setting this base power value, press **SYST** repeatedly until **THRUPOWR** is shown at the bottom of the display. Select **ON** to select the through-power mode.

Edit the through-power factor by pressing **ATT**, and then the **Modify** keys.

---

## 1.6 Selecting the Wavelength Calibration and Its Function

The attenuation at any point on the filter is wavelength dependent. This dependence is measured and stored in the instrument, and is used, with the value for the wavelength entered by the user to compensate for the dependence. This is the wavelength calibration data.

There are two ways in which this data can be used:

## Getting Started

### Selecting the Wavelength Calibration and Its Function

- to reposition the filter so that the attenuation stays constant, or
- to change the attenuation factor on the display to show the wavelength dependence. You use this to set the wavelength for an unknown source (you alter the wavelength until the displayed attenuation matches the measured attenuation).

To set the function of the calibration data press **SYST** repeatedly until **LAMBDCAL** is shown at the bottom of the display. Set **LAMBDCAL** to **OFF** to use the calibration data to reposition the filter, and set **LAMBDCAL** to **ON** to use the calibration data to change the attenuation factor.

As well as the wavelength calibration data measured for and stored in your instrument in the factory, there is space reserved in memory for a set of your own user calibration data. (You load this data into the instrument over the GPIB. See “User Calibration Commands” on page 123)

Press **SYST** repeatedly until **USERCAL** is shown at the bottom of the display. **OFF** selects the factory-made wavelength calibration data. **ON** selects the user wavelength calibration data.

---

## Using the Attenuator

---

# Using the Attenuator

This chapter describes the use of the Agilent Technologies 8156A as an attenuator. There is an example given at the end of this chapter.

## 2.1 Setting Up the Hardware

To use the attenuator, you need to set up the hardware as shown in the figure below.

**Figure 2-1**      **The Hardware Configuration for the Attenuator**

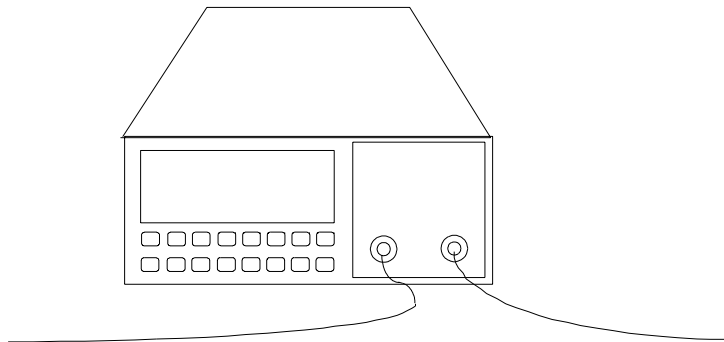

---

**NOTE**

**Before using the instrument, you should make sure that it is properly warmed up. The instrument is properly warmed up when it has been switched on for a minimum of 45 minutes. Failure to do this can cause errors of up to 0.04dB in the attenuation.**

---

The connector interface you need depends on the connector type you are using (see “Connector Interfaces and Other Accessories” on page 158).

If you have option 121 or option 221, then the Monitor Output provides a signal for monitoring the power getting through the attenuator. The signal level is approximately 5% of the output power level. For the most accurate results, you should measure the coupling ratio, and its wavelength dependence, for the Monitor Output yourself.

---

## 2.2 Setting Up the Attenuation

The attenuation can be set in two different ways. This section describes how to set the attenuation by specifying the attenuation factor and an offset (called a calibration factor).

“Selecting the Through-Power Mode” on page 70 describes how to set the attenuation by specifying the power that gets through.

### Entering the Attenuation Factor

The attenuation factor is shown at the top left of the display.

Figure 2-2

The Attenuation Factor on the Display



Edit the attenuation factor using the modify keys.

The filter attenuation is changed while you edit the attenuation factor according to the equation:

$$Att_{filter}(dB) = Att(dB) - Cal(dB)$$

To edit the attenuation factor,

1. press **ATT**, and
2. edit the factor using the Modify keys (see “Using the Modify Keys” on page 29).

## Using the Attenuator

### Setting Up the Attenuation

#### Resetting the Attenuation Factor

To reset the attenuation factor, press and hold **ATT** until the value resets (this takes approximately two seconds). The attenuation factor resets so that the filter attenuation is zero, that is

$$Att(dB) = Cal(dB)$$

#### Entering a Calibration Factor

The calibration factor is shown at the bottom left of the display

Figure 2-3

#### The Calibration Factor on the Display

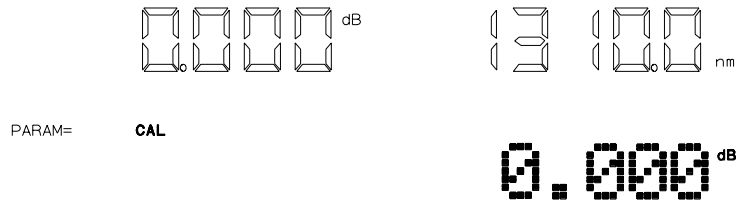

This factor does not affect the filter attenuation. It is used to offset the values for the attenuation factor.

There are two ways of entering the calibration factor.

- by editing, and
- by transferring

#### Editing the Calibration Factor

You would use this, for example, to enter an offset to compensate for the insertion loss (attenuation) of your hardware setup.

The filter attenuation stays constant while you edit the calibration factor. This means that the attenuation factor, shown on the display, changes according to the formula below (from equation (1)):

$$Att_{NEW}(dB) = Att_{filter}(dB) + Cal_{NEW}(dB) = Att_{OLD}(dB) - Cal_{OLD}(dB) + Cal_{NEW}(dB)$$

To edit an external calibration factor,

## Using the Attenuator

### Setting Up the Attenuation

1. press **CAL**, and
2. edit the factor using the Modify keys (see “Using the Modify Keys” on page 29).

### Resetting the Calibration Factor

To reset the calibration factor, press and hold **CAL** until the value resets to zero (this takes approximately two seconds). The calibration factor resets to zero.

### Transferring to the Calibration Factor

You can transfer the attenuation factor shown on the display into the calibration factor, so that the attenuation factor is reset to zero.

You would use this, for example, after you have set the power through the attenuator at a specific level. When you have reset the attenuation factor, you can edit it to get a relative attenuation.

The filter attenuation stays constant when you transfer to the calibration factor. This means that the new calibration factor is calculated from the attenuation factor and the old calibration factor according to the formula below (from equation (1)):

$$Cal_{NEW}(dB) = -Att_{filter}(dB) = Cal_{OLD}(dB) - Att_{OLD}(dB)$$

To transfer to the calibration factor, press **DISP**→**CAL**.

### Entering the Wavelength

The attenuation at any point on the filter is wavelength dependent. This dependence is measured and stored in the instrument, and is used, with the value for the wavelength entered by the user, to compensate for the dependence. This is the wavelength calibration data.

---

#### NOTE

**There are two ways of using the wavelength calibration data,**

- **to reposition the filter so that the attenuation stays constant, or**
- **to change the attenuation factor on the display to show the wavelength dependence. You use this to set the wavelength for an**



## Using the Attenuator Setting Up the Attenuation

**unknown source (you alter the wavelength until the displayed attenuation matches the measured attenuation).**

**There are two sets of wavelength calibration data, one made in the factory, individually, for your instrument. The user defines the other.**

**For more details on these topics, see “Selecting the Wavelength Calibration and Its Function” on page 67.**

The wavelength is shown at the top right of the display.

**Figure 2-4**

### The Wavelength on the Display

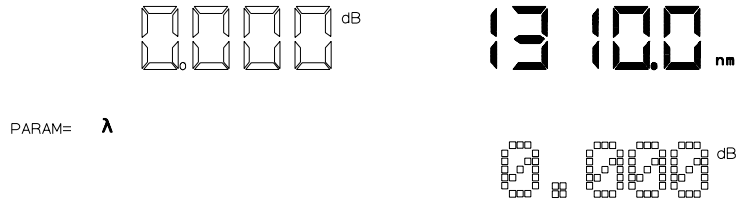

Edit the wavelength using the modify keys.

To edit the wavelength,

1. press  $\lambda$ , and
2. edit the value using the Modify keys (see “Using the Modify Keys” on page 29).

### Resetting the Wavelength

To reset the wavelength, press and hold **ATT** until the value resets (this takes approximately two seconds). The wavelength resets to 1310nm.

## 2.3 Example, Setting the Calibration

This example uses the Agilent 8156A Attenuator, with a HP 8153A multimeter with one source and one sensor. The connectors for this system are all HMS-10.

We set up the hardware, and measure the insertion loss of the system and use this value to set a calibration factor.

1. Configure the hardware as shown in the figure below, making sure that all the connectors are clean:

Figure 2-5

### Hardware Configuration for Attenuation Example - A

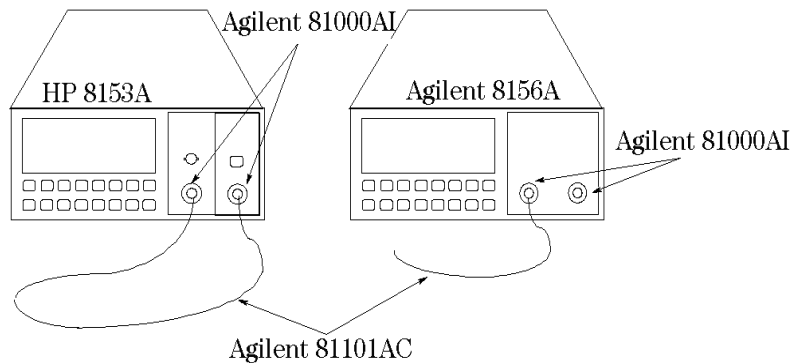

- a. Make sure that the power sensor is installed in the multimeter mainframe in channel A, and the source is in channel B.
- b. Connect both instruments to the electric supply.
- c. Switch on both instruments.

Using the Attenuator  
Example, Setting the Calibration

---

**NOTE**

---

**Under normal circumstances you should leave the instruments to warmup. (The multimeter needs around 20 minutes to warmup. The attenuator needs around 45 minutes with the shutter open to warmup.) Warming up is necessary for accuracy of the sensor, and the output power of the source.**

- d. Connect a patchcord from the source to the input of the sensor.
2. Measure the insertion loss of the Hardware setup:
    - a. On the multimeter:
      - i. Set the wavelength for the sensor to that of the source.
      - ii. Activate the source, by pressing the gray button on its front panel.
      - iii. Start the loss application (press **MODE** and then **LOSS**, and **EXEC**).
    - b. Reconfigure the hardware to include the attenuator:
      - i. Disconnect the source from the sensor, and connect it to the input of the attenuator.

**Figure 2-6**

**Hardware Configuration for Attenuation Example - B**

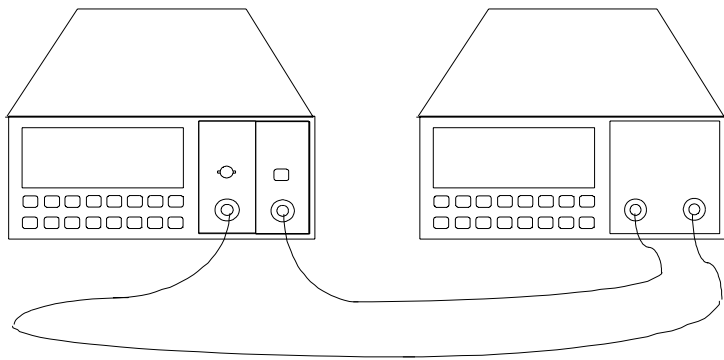

- ii. Connect a patchcord from the output of the attenuator to the sensor.

## Using the Attenuator

### Example, Setting the Calibration

- c. Set the wavelength on the attenuator to that of the source:
    - i. Press  $\lambda$ .
    - ii. Use the modify keys to edit the value for the wavelength.
  - d. Reset the calibration factor, by pressing and holding **CAL** for two seconds.
  - e. Reset the attenuation factor, by pressing and holding **ATT** for two seconds.
  - f. Enable the output of the attenuator (press **ENB/DIS** so that the LED lights).
  - g. Note the value for the loss read by the multimeter.
3. Enter the insertion loss of the hardware setup.
    - a. Press **CAL**.
    - b. Edit the calibration factor so that it has the value shown on the multimeter display, using the modify keys.

You should notice that the value for the attenuation factor changes, and always has the same value as that for the calibration factor. This is because the filter attenuation stays at zero (you should also notice that the display on the multimeter does not change).

The attenuator now shows its full attenuation (including its own insertion loss) on the display.

---

## **Making an Attenuation Sweep**

---

# Making an Attenuation Sweep

This chapter describes how to make an attenuation sweep with the Agilent Technologies 8156A Attenuator. An example is given at the end of the chapter.

### 3.1 Configuring the Hardware

To use the attenuator for a sweep, you need to set up the hardware as shown in the figure below. (This is the configuration as given for simple attenuation in chapter 2).

**Figure 3-1**      **The Hardware Configuration for the Attenuator**

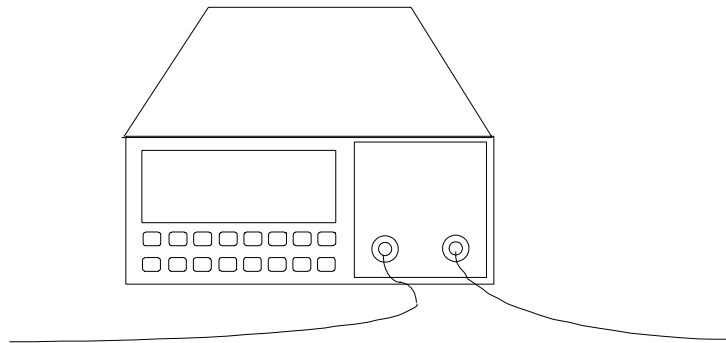

---

**NOTE**

**Before using the instrument, you should make sure that it is properly warmed up. The instrument is properly warmed up when it has been switched on for a minimum of 45 minutes. Failure to do this can cause errors of up to 0.04dB in the attenuation.**

---

The connector interface you need depends on the connector type you are using (see “Connector Interfaces and Other Accessories” on page 158).

If you have option 121 or option 221 (the monitor output), then the Monitor Output provides a signal for monitoring the power getting through the attenuator. The signal level is approximately 5% of the output power level. For the most accurate results, you should measure the coupling ratio, and its wavelength dependence, for the Monitor Output yourself.

## 3.2 The Automatic Sweep

An automatic sweep is one where stepping from one attenuation factor to the next is done by the instrument.

### Setting Up an Automatic Sweep

There are four parameters for the automatic sweep

- `START` is the attenuation factor at which the sweep begins.
- `STOP` is the attenuation factor that ends the sweep. If `START` and `STEP` are such that the sweep does not end exactly at `STOP`, then the sweep ends at the immediately previous value.
- `STEP` is the size of the attenuation factor change. This value is always positive, even for a sweep of decreasing attenuation factor. `STEP` cannot be set to a value greater than the difference between `START` and `STOP`.
- `DWELL` is the time taken for each attenuation factor.

---

#### NOTE

**The dwell time includes the time it takes for the filter attenuation to change. The time taken to change depends on the size of the attenuation factor change, and is in the range 20 to 400ms (typical value is 200ms).**

---



## Making an Attenuation Sweep The Automatic Sweep

Figure 3-2

### The Parameters for an Automatic Sweep

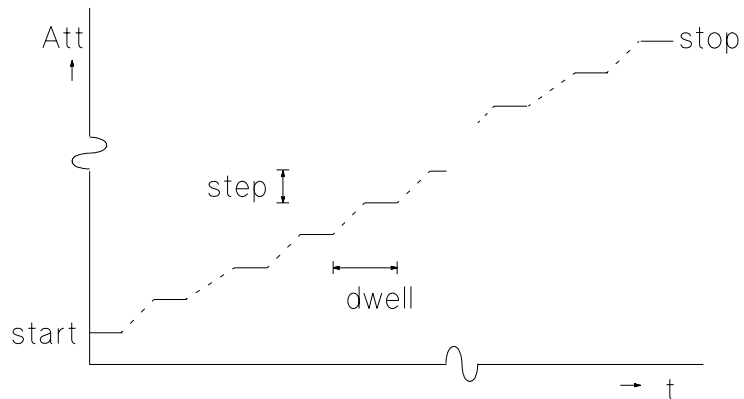

### Starting the Setting Up

To select the automatic sweep

1. Press **SWP**.
2. If it is not already set, use  $\uparrow$  or  $\downarrow$  to set **SWEEP** to **AUTO**.

Figure 3-3

### Selecting the Automatic Sweep Application

**SWP**

**AUTO**

### Editing the Parameters

To edit the value of the parameters

3. Press **SWP** again to get **START**.
4. Edit the value of **START** with the **Modify** keys.
5. Press **SWP** again to get **STOP**.

## Making an Attenuation Sweep

### The Automatic Sweep

6. Edit the value of `STOP` with the Modify keys.
7. Press **SWP** again to get `STEP`.
8. Edit the value of `STEP` with the Modify keys.
9. Press **SWP** again to get `DWELL`.
10. Edit the value of `DWELL` with the Modify keys.

See “Using the Modify Keys” on page 29 for information on editing with the Modify keys.

### Resetting the Parameters

To reset any of the sweep parameters, press and hold **SWP** until the value resets (this takes approximately two seconds).

`START` and `STOP` reset so that the filter attenuation (inside the instrument) is zero, that is

*Start = Cal*

or

*Stop = Cal*

See “Entering a Calibration Factor” on page 39 for information about setting the calibration factor, `Cal`.

`STEP` resets to zero.

`DWELL` resets to 0.2 seconds.

### Executing the Automatic Sweep

If you have just set up your sweep, then you only need to press **EXEC** to run the application.

If you have already set up the sweep, and are currently operating the instrument as an attenuator,

1. Press **SWP**, and then,
2. Press **EXEC**.

## Making an Attenuation Sweep The Manual Sweep

Figure 3-4

### Running the Automatic Sweep

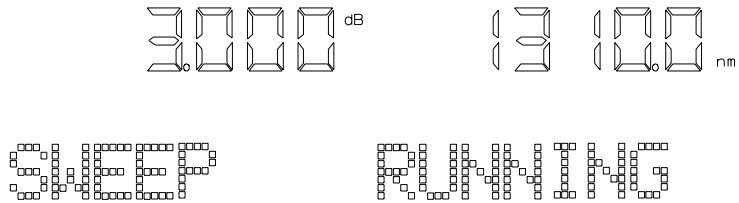

If there is something wrong with a parameter (if `STEP` is zero, for example), this parameter is shown on the display for editing. Edit the parameter, and press **EXEC** again.

### Repeating the Sweep

When the sweep is finished (`SWEEP READY` is shown at the bottom of the display), you can press **EXEC** to start it again.

### Restarting the Sweep

To restart the sweep at any time while it is running, press **EXEC**.

---

## 3.3 The Manual Sweep

A manual sweep is one where stepping from one attenuation factor to the next is done by the user.

### Setting Up a Manual Sweep

There are three parameters for a manual sweep

- `START` is the attenuation factor at which the sweep begins.
- `STOP` is the attenuation factor that ends the sweep. If `START` and `STEP` are such that the sweep does not end exactly at `STOP`, then the sweep ends at the immediately previous value.

## Making an Attenuation Sweep

### The Manual Sweep

- **STEP** is the size of the attenuation factor change. This value is always positive, even for a sweep of decreasing attenuation factor. **STEP** cannot be set to a value greater than the difference between **START** and **STOP**.

### Starting the Setting Up

To select the manual sweep

1. Press **SWP**.
2. If it is not already set, use the modify keys to set **SWEEP** to **MANUAL**.

### Editing the Parameters

To edit the value of the parameters

3. Press **SWP** again to get **START**.
4. Edit the value of **START** with the Modify keys.
5. Press **SWP** again to get **STOP**.
6. Edit the value of **STOP** with the Modify keys.

Figure 3-5

### Editing the **STOP** Parameter



7. Press **SWP** again to get **STEP**.
8. Edit the value of **STEP** with the Modify keys.

See “Using the Modify Keys” on page 29 for information on editing with the Modify keys.

## Making an Attenuation Sweep The Manual Sweep

### Resetting the Parameters

To reset any of the sweep parameters, press and hold SWP until the value resets (this takes approximately two seconds).

START and STOP reset so that the filter attenuation (inside the instrument) is zero, that is

*Start = Cal*

or

*Stop = Cal*

See “Entering a Calibration Factor” on page 39 for information about setting the calibration factor, Cal.

STEP resets to zero.

### Executing the Manual Sweep

If you have just set up your sweep, then you only need to press EXEC to run the application.

If you have already set up the sweep, and are currently operating the instrument as an attenuator,

1. Press SWP, and then,
2. Press EXEC.

Figure 3-6

### Running the Manual Sweep

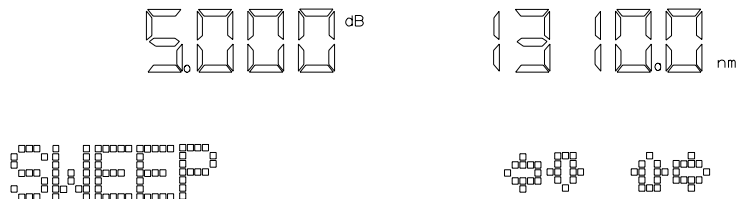

If there is something wrong with a parameter (if STEP is zero, for example), this parameter is shown on the display for editing. Edit the parameter, and press EXEC again.

## Making an Attenuation Sweep

### Example, an Automatic Attenuation Sweep

### Changing the Attenuation in a Manual Sweep

To go to the next attenuation factor in the sweep, press  $\uparrow$  or  $\Rightarrow$ .

To go to the previous attenuation factor in the sweep, press  $\downarrow$  or  $\Leftarrow$ .

---

## 3.4 Example, an Automatic Attenuation Sweep

This example uses the Agilent 8156A Attenuator on its own.

We set up the instrument to sweep from 5dB to 0dB with an interval of 0.5dB, dwelling for a second at each attenuation factor.

1. First we want to reset the instrument.

---

### NOTE

---

**If someone else is using this instrument, please check with them before resetting, or store their setting for later recall.**

- a. Press **RECALL**.
- b. Press **EXEC**.
2. Start the automatic sweep application.
  - a. Press **SWP**.
  - b. If the sweep parameter is set to **MANUAL**, press  $\uparrow$ , or  $\downarrow$  to set it to **AUTO**.
3. Set the start attenuation factor.
  - a. Press **SWP**.
  - b. Use the Modify keys to set **START** to 5.000dB.
4. Set the attenuation factor step size.
  - a. Press **SWP**, to get the stop parameter. We do not need to edit this parameter.
  - b. Press **SWP** to get the step parameter.

## Making an Attenuation Sweep

### Example, an Automatic Attenuation Sweep

- c. Use the Modify keys to set `STEP` to 0.500dB.
  5. Set the dwell time.
    - a. Press **SWP**.
    - b. Use the Modify keys to set `DWELL` to 1.00s.
  6. Execute the sweep
    - a. Press **SWP**.
    - b. Make sure the output is enabled (press **ENB/DIS** until the LED lights).
    - c. Press **EXEC**.

Making an Attenuation Sweep  
Example, an Automatic Attenuation Sweep



---

**Using your Attenuator as a  
Variable Back Reflector**

---

# Using your Attenuator as a Variable Back Reflector

This chapter describes how you can use your attenuator as a variable back reflector. An example using the back reflector kit (option 203 with option 201) is given at the end of the chapter.

---

## 4.1 Configuring the Hardware

To use the attenuator as a back reflector, you need to set up the hardware as shown in the figure below.

---

**NOTE**

**If this your first time to use the attenuator as a back reflector, you first need to make some measurements. These require other setups before setting up the hardware as shown below (see “Setting Up the Software” on page 60).**

---

**Figure 4-1**

**The Hardware Configuration for the Back Reflector**

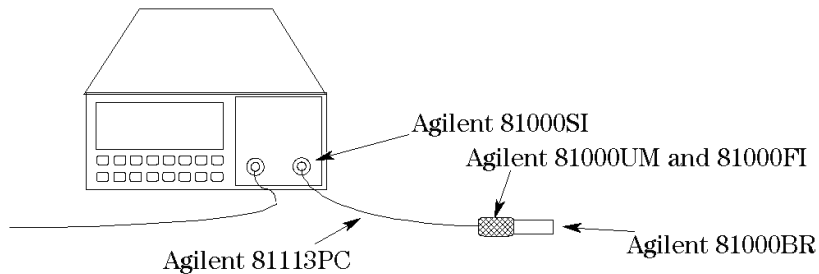

---

**NOTE**

**Before using the instrument, you should make sure that it is properly warmed up. The instrument is properly warmed up when it has been switched on for a minimum of 45 minutes. Failure to do this can cause errors of up to 0.04dB in the attenuation.**

---

If you are not using option 201, the connector interfaces you need depends on the connector type you are using. Option 121 or option 221 (the monitor output) is of no use when using the attenuator as a back reflector. The disruption to the back reflection performance by leaving this output open is negligible, though you may want to terminate it to eliminate any small effect it might have.

## 4.2 Setting Up the Software

There are four factors that influence the back reflection of the attenuator. These are

1. the insertion loss of the attenuator (INS LOSS),
2. the return loss of the attenuator (RL INPUT),
3. the reference return loss you are using (RL REF), and
4. the filter attenuation.

The return loss (RL) is calculated according to the equation

$$RL(dB) = -10 \log \left( 10^{\frac{-RLInput(dB)}{10}} + \left( 1 - 10^{\frac{-RLInput(dB)}{10}} \right) 10^{\frac{-(2(Att(dB) + InsLoss(dB)) + RLRef(dB))}{10}} \right)$$

You edit the values for the insertion loss, the reference return loss, and the return loss of the attenuator while you are setting up the application.

You edit the value for the return loss while the application is executing. The instrument calculates and sets the required value for the filter attenuation.

### Editing the Setup

Before you start setting up the back reflector application, you may need to measure the following values, if you do not already know them:

- The insertion loss of the instrument (see “Example, Setting the Calibration” on page 42,
- The return loss of the instrument (with the output properly terminated), and
- The reference return loss value.

## Using your Attenuator as a Variable Back Reflector

### Setting Up the Software

To start setting up the Back Reflector application

1. Press **BACK REFL**.

After pressing this the first parameter (INS LOSS) is ready to for editing.

2. Edit the value insertion loss with the Modify keys.
3. Press **BACK REFL**.
4. Edit the value reference return loss with the Modify keys.

Figure 4-2

### Editing the Value for the Reference Return Loss



5. Press **BACK REFL**.
6. Edit the value attenuator return loss with the Modify keys.

See “Using the Modify Keys” on page 29 for information on editing with the Modify keys.

### Resetting the Parameters

To reset any of the back reflector parameters, press and hold **BACK REFL** until the value resets (this takes approximately two seconds).

INS LOSS resets to 2.000dB.

RL REF resets to 14.700dB (the return loss for the glass/air interface at an open connector)

RL INPUT resets to 60.000dB.

### Executing the Back Reflector Application

If you have just set up the application, then you only need to press **EXEC** to run the application.

## Using your Attenuator as a Variable Back Reflector

### Example, Setting a Return Loss

If you have already set up the application, and are currently operating the instrument as an attenuator,

1. Press **BACK REFL**, and then,
2. Press **EXEC**.

Figure 4-3

#### Executing the Back Reflector Application

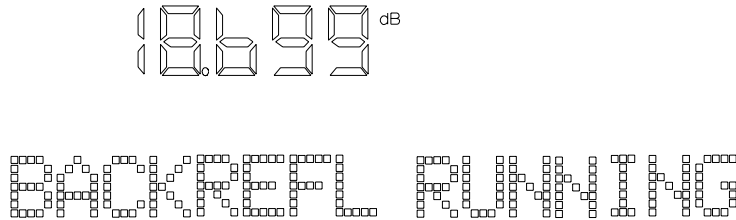

The value shown at the top left of the display is the return loss of the instrument. You can edit the value of the return loss with the Modify keys.

---

### 4.3 Example, Setting a Return Loss

This example uses the Ahilent Technologies 8156A Attenuator with options 201, and 203.

Assuming an insertion loss of 2.00dB and a return loss of 60.000dB for the instrument we set up the instrument to have a return loss of 20dB.

## Using your Attenuator as a Variable Back Reflector

### Example, Setting a Return Loss

1. Configure the hardware as shown in the figure below:

**Figure 4-4**

#### Hardware Configuration for Variable Return Loss

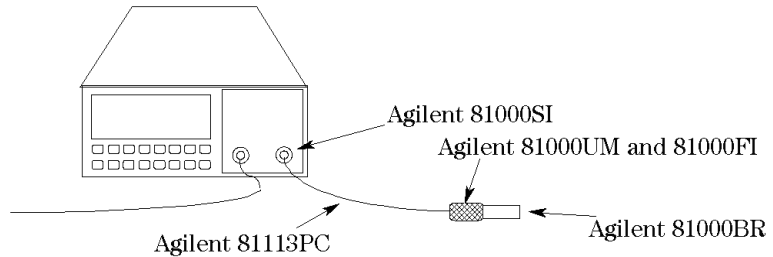

- a. Connect the instrument to the electric supply.
  - b. Switch on the instrument.
2. Reset the instrument.

---

#### NOTE

---

**If someone else is using this instrument, please check with them before resetting, or store their setting for later recall.**

- a. Press **RECALL**.
  - b. Press **EXEC**.
3. Set the return loss reference value for the Agilent 81000BR reference reflector.
    - a. Press **BACK REFL** twice to select the RL REF parameter.
    - b. Edit the value, with the Modify keys to set it to 0.180dB
  4. Press **EXEC** to start the application
  5. Edit the return loss value, with the Modify keys, to set it to 20.000dB.

Using your Attenuator as a Variable Back Reflector  
Example, Setting a Return Loss



---

## **Setting Up the System**

---

# Setting Up the System

This chapter describes how to set the various system parameters for your attenuator.

## 5.1 Setting the GPIB Address

To set the GPIB address of the attenuator

1. Press **SYST**.
2. Edit the value for **ADDRESS** using the Modify keys.

### Resetting the GPIB Address

To reset **ADDRESS**, press and hold **SYST** until the value resets (this takes approximately two seconds).

**ADDRESS** resets to 28.

---

## 5.2 Selecting the Wavelength Calibration and Its Function

The attenuation at any point on the filter is wavelength dependent. This dependence is measured and stored in the instrument, and is used, with the value for the wavelength entered by the user to compensate for the dependence. This is the wavelength calibration data.

As well as the wavelength calibration data measured for and stored in your instrument in the factory, there is space reserved in memory for a set of your own user calibration data.

There are two choices concerning the use of wavelength calibration data.

- Whether or not the data should be used to position the filter to compensate for wavelength dependence.
  - Whether the factory-made wavelength calibration data is used, or the data entered by the user.
-

## Setting Up the System

### Selecting the Wavelength Calibration and Its Function

#### Setting the Function of the Wavelength Calibration

This compensation can be used

- to reposition the filter so that the attenuation stays constant, or
- to change the attenuation factor on the display to show the wavelength dependence. You use this to set the wavelength for an unknown source (you alter the wavelength until the displayed attenuation matches the measured attenuation).

To set the function of the wavelength calibration data

1. Press **SYST** repeatedly until **LAMBD**CAL is shown at the bottom of the display.
2. Select the wavelength calibration data function using the Modify keys. Set **LAMBD**CAL to **OFF** so that the function of the wavelength calibration data is not visible to the user. This keeps the attenuation value fixed, and alters the filter position. Set **LAMBD**CAL to **ON** to keep the filter position fixed, and for the function of the wavelength calibration data to be visible to the user.

While it is **ON**, **LAMBD**CAL is shown at the bottom left of the display (**U/L-CAL** is shown if the **USERCAL** is also on).

Figure 5-1

#### The **LAMBD**CAL Indicator on the Display

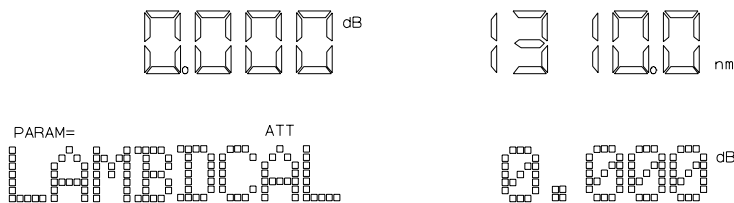

#### Resetting the Function of the Wavelength Calibration Data

To reset **LAMBD**CAL, press and hold **SYST** until the value resets (this takes approximately two seconds).

**LAMBD**CAL resets to **OFF**.

## Setting Up the System

### Selecting the Wavelength Calibration and Its Function

#### Selecting the Wavelength Calibration Data

You enter the user wavelength calibration data over the GPIB (see “User Calibration Commands” on page 123).

Using your own wavelength calibration data, you can use the attenuator to compensate for the total wavelength dependence of your hardware configuration.

---

#### NOTE

---

**If you are using the instrument in an environment where the temperature changes, you should not use the user wavelength calibration data, as it lacks correction for temperature changes.**

To select the wavelength calibration data to use

1. Press **SYST** repeatedly until **USERCAL** is shown at the bottom of the display.
2. Select the wavelength calibration data using the Modify keys.

OFF means that the instrument uses the factory-made wavelength calibration data

ON means that the user wavelength calibration data is used.

While it is ON, **USERCAL** is shown at the bottom left of the display (U/L-CAL is shown if the **LAMBDCAL** is also on).

Figure 5-2

#### The USERCAL Indicator on the Display

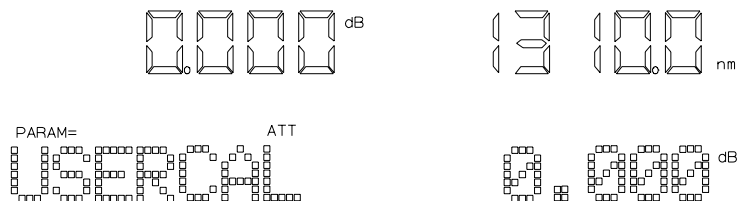

#### Resetting the Wavelength Calibration Data Set

To reset **USERCAL**, press and hold **SYST** until the value resets (this takes approximately two seconds).

**USERCAL** resets to OFF.

## 5.3 Selecting the Through-Power Mode

In the through-power mode, the instrument shows the power that gets through the attenuator on the display (that is the power at the display) rather than the attenuation.

When you select the through-power mode the attenuation factor (in dB) becomes the value for the through-power (in dBm). That is, if the attenuation factor is at 32.000dB, and you switch the absolute power mode on, then the base value for the through-power is 32.000dBm.

Measure the power at the output of the attenuator, and then use the calibration factor (see “Entering a Calibration Factor” on page 39) to set the attenuation factor to the required value for use as the base value for the through-power

$$Cal_{New} = (ThruhPower_{Base} - Att) + Cal_{Current}$$

After setting the calibration factor,

1. Press **SYST** repeatedly until **THRUPOWER** is shown at the bottom of the display.
2. Select **ON** to switch on the through-power mode.

The through-power factor is shown at the upper left on the display, and you can edit it by pressing **ATT**, and using the Modify keys (see “Using the Modify Keys” on page 29).

Figure 5-3

### The Display in Through-Power Mode

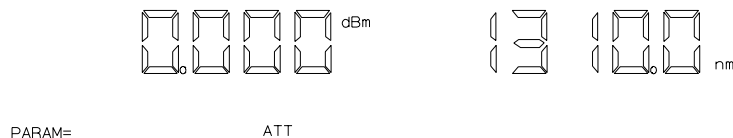

## Setting Up the System

### Setting the Display Brightness

#### **Deselecting the Through-Power Mode**

When you switch the through-power mode off, the last set calibration factor becomes active, and the attenuation factor is set so that the filter attenuation does not change.

1. Press **SYST** repeatedly until **THRUPOWER** is shown at the bottom of the display.
2. Select **OFF** to switch off the through-power mode.

#### **Resetting the Through-Power Mode**

To reset **THRUPOWER**, press and hold **SYST** until the value resets (this takes approximately two seconds).

**THRUPOWER** resets to **OFF**.

---

## **5.4 Setting the Display Brightness**

This parameter sets the brightness of the display. To set the brightness,

1. Press **SYST** repeatedly until **BRIGHT** is shown at the bottom of the display.
2. Use Modify keys to set the brightness.

#### **Resetting the Display Brightness**

To reset **BRIGHT**, press and hold **SYST** until the value resets (this takes approximately two seconds).

**BRIGHT** resets to full brightness.

## 5.5 Selecting the Setting used at Power-On

This parameter selects the instrument setting that is used at power-on.

1. Press **SYST** repeatedly until **P ON SET** is shown at the bottom of the display.
2. Use **Modify** keys to select the setting.

**LAST** is the setting that was in use when the instrument was switched off.

**DEFAULT** is the default setting.

**a number** is the number of the setting location where the user has saved a setting.

### Resetting the Power-On Setting

To reset **P ON SET** press and hold **SYST** until the value resets (this takes approximately two seconds).

**P ON SET** is reset to **LAST**.

---

## 5.6 Locking Out **ENB/DIS**

This selects how the shutter enabling and disabling key operates while the instrument is being operated over the GPIB.

1. Press **SYST** repeatedly until **SHUTTER** is shown at the bottom of the display.
2. Use **Modify** keys to select the setting.

**NORMAL** means that the shutter can be enabled and disabled as usual with **ENB/DIS**.



## Setting Up the System

### Selecting the Shutter State at Power On

LOCKOUT means that the shutter cannot be enabled or disabled (Local Lock Out) while the instrument is being operated over the GPIB.

### Resetting the ENB/DIS Lock Out

To reset SHUTTER, press and hold SYST until the value resets (this takes approximately two seconds).

SHUTTER resets to NORMAL.

---

## 5.7 Selecting the Shutter State at Power On

This selects whether the shutter is open or closed at power-on.

1. Press **SYST** repeatedly until SHUTTER@ PON is shown at the bottom of the display.
2. Use Modify keys to select the setting.

DIS means that the shutter is disabled at power-on.

LAST means that the shutter is set to the state that was in use when the instrument was switched off.

### Resetting the Shutter State at Power On

To reset SHUTTER@ PON press and hold SYST until the value resets (this takes approximately two seconds).

SHUTTER@ PON resets to LAST.

## 5.8 Setting the Display Resolution

This parameter sets the resolution of the attenuation factor and the calibration factor on the screen.

1. Press **SYST** repeatedly until **RESOLUT** is shown at the bottom of the display.
2. Use **Modify** keys to select the setting.
  - 1/100 sets a resolution of 0.01.
  - 1/1000 sets a resolution of 0.001.

### Resetting the Display Resolution

To reset **RESOLUT**, press and hold **SYST** until the value resets (this takes approximately two seconds).

**RESOLUT** resets to 1/100.

---

## **Storing and Recalling Settings**

---

# Storing and Recalling Settings

This chapter describes how to store instrument settings to memory, and how to recall them.

A setting consists of the wavelength, calibration and attenuation factors, all the application parameters, and the system parameters with the exceptions of the display resolution, the power on setting, and the GPIB address and command set.

## 6.1 Storing the Setting

To store the current instrument setting

1. Press **STORE**.
  2. Select the location where you want to store the setting, using the  $\uparrow$  or the  $\downarrow$ .
  3. Press **EXEC**.
- 

## 6.2 Recalling a Setting

### Resetting the Instrument

To reset the instrument, you should recall the default setting

1. Press **RECALL**. The **DEFAULT** location is shown on the display.

Figure 6-1

### The Display when Recalling the Default Setting



RECALL                      DEFAULT

2. Press **EXEC**.

### Recalling a User Setting

To recall a setting that is stored

---

## Storing and Recalling Settings

### Recalling a Setting

1. Press **RECALL**.
2. Select the location from which you want to recall the setting, using the  $\uparrow$  or the  $\downarrow$ .
3. Press **EXEC**.

---

## **Programming the Attenuator**

---

# Programming the Attenuator

This chapter gives general information on how to control the attenuator remotely. Descriptions for the actual commands for the attenuator are given in the following chapters. The information in these chapters is specific to the attenuator, and assumes that you are already familiar with programming the GPIB.



## 7.1 GPIB Interface

The interface used by the attenuator is the GPIB (General Purpose Interface Bus).

This is the interface used for communication between a controller and an external device, such as the attenuator. The GPIB conforms to IEEE standard 488-1978, ANSII standard MC 1.1 and IEC recommendation 625-1.

If you are not familiar with the GPIB, then refer to the following books:

- Hewlett-Packard Company. *Tutorial Description of Hewlett-Packard Interface Bus*, 1987.
- The International Institute of Electrical and Electronics Engineers. *IEEE Standard 488.1-1987, IEEE Standard Digital Interface for Programmable Instrumentation*. New York, NY, 1987
- The International Institute of Electrical and Electronics Engineers. *IEEE Standard 488.2-1987, IEEE Standard Codes, Formats, Protocols and Common Commands For Use with ANSI/IEEE Std 488.1-1987*. New York, NY, 1987

To obtain a copy of either of these last two documents, write to:  
The Institute of Electrical and Electronics Engineers, Inc.  
345 East 47th Street  
New York, NY 10017  
USA.

In addition, the commands not from the IEEE-488.2 standard, are defined according to the Standard Commands for Programmable Instruments (SCPI). For an introduction to SCPI, and SCPI programming techniques, refer to the following documents:

- Hewlett-Packard Press (Addison-Wesley Publishing Company, Inc). *A Beginners Guide to SCPI*. Barry Eppler. 1991.

## Programming the Attenuator

### GPIB Interface

- The SCPI Consortium. *Standard Commands for Programmable Instruments*. Published periodically by various publishers. To obtain a copy of this manual, contact your Agilent Technologies representative.

The attenuator interfaces to the GPIB as defined by the IEEE Standards 488.1 and 488.2. The table shows the interface functional subset that the attenuator implements.

**Table 7-1**                      **GPIB Capabilities**

<b>Mnemonic</b>	<b>Function</b>
SH1	Complete source handshake capability
AH1	Complete acceptor handshake capability
T6	Basic talker; serial poll; unaddressed to talk if addressed to listen
L4	Basic listener; unaddressed to listen if addressed to talk; no listen only
SR1	Complete service request capability
RL1	Complete remote/local capability
PP0	No parallel poll capability
DC1	Device clear capability
DT0	No device trigger capability
C0	No controller capability

## 7.2 Setting the GPIB Address

You can only set the GPIB address from the front panel. See “Setting the GPIB Address” on page 67.

The default GPIB address is 28.

---

## 7.3 Returning the Instrument to Local Control

If the instrument has been operated in remote the only keys you can use are **Local** and **ENB/DIS**. The **Local** key returns the instrument to local control. **Local** does not operate if local lockout has been enabled. **ENB/DIS** enables and disables the output from the attenuator. **ENB/DIS** does not operate if **SHUTTER** is set to **LOCKOUT** (see “Locking Out Enb/Dis” on page 72).

---

## 7.4 How the Attenuator Receives and Transmits Messages

The attenuator exchanges messages using an input and an output queue. Error messages are kept in a separate error queue.

### How the Input Queue Works

The input queue is a FIFO queue (first-in first-out). Incoming bytes are stored in the input queue as follows:

1. Receiving a byte:
    - a. Clears the output queue.
-

## Programming the Attenuator

### How the Attenuator Receives and Transmits Messages

- b. Clears Bit 7 (MSB).
2. No modification is made inside strings or binary blocks. Outside strings and binary blocks, the following modifications are made:
  - a. Lower-case characters are converted to upper-case.
  - b. The characters  $00_{16}$  to  $09_{16}$  and  $0B_{16}$  to  $1F_{16}$  are converted to spaces ( $20_{16}$ ).
  - c. Two or more blanks are truncated to one.
3. An EOI (End Or Identify) sent with any character is put into the input queue as the character followed by a line feed (LF,  $0A_{16}$ ). If EOI is sent with a LF, only one LF is put into the input queue.
4. The parser starts if the LF character is received or if the input queue is full.

### Clearing the Input Queue

Switching the power off, or sending a Device Interface Clear signal, causes commands that are in the input queue, but have not been executed to be lost.

### The Output Queue

The output queue contains responses to query messages. The attenuator transmits any data from the output queue when a controller addresses the instrument as a talker.

Each response message ends with a LF ( $0A_{16}$ ), with EOI=TRUE. If no query is received, or if the query has an error, the output queue remains empty.

The Message Available bit (MAV, bit 4) is set in the Status Byte register whenever there is data in the output queue.

### The Error Queue

The error queue is 30 errors long. It is a FIFO queue (first-in first-out). That is, the first error read is the oldest error to have occurred. A new error is only put into the queue if it is not already in it.

If more than 29 errors are put into the queue, the message '-350 <Queue Overflow>' is placed as the last message in the queue.

---

## 7.5 Some Notes about Programming and Syntax Diagram Conventions

A program message is a message containing commands or queries that you send to the attenuator. The following are a few points about program messages:

- You can use either upper-case or lower-case characters.
- You can send several commands in a single message. Each command must be separated from the next one by a semicolon (;).
- You end a program message with a line feed (LF) character, or any character sent with End-Or-Identify (EOI).
- You can use any valid number/unit combination.

*Example*     1500nm, 1.5 $\mu$ m and 1.5e-6m are all equivalent.

If you do not specify a unit, then the default unit is assumed. The default unit for the commands are given with command description in the next chapter.

### Short Form and Long Form

The instrument accepts messages in short or long forms. For example, the message `:INPUT:WAVELENGTH 1313` is in long form, the short form of this message is `:INP:WAV 1313`.

In this manual the messages are written in a combination of upper and lower case. Upper case characters are used for the short form of the message. For example, the above command would be written `:INPut:WAVelength`.

## Programming the Attenuator

### Some Notes about Programming and Syntax Diagram Conventions

The first colon can be left out for the first command or query in your message. That is, the example given above could also be sent as `INP:WAV 1313`.

### Command and Query Syntax

All characters not between angled brackets must be sent exactly as shown.

The characters between angled brackets (<...>) indicate the kind of data that you send, or that you get in a response. You do not type the angled brackets in the actual message. Descriptions of these items follow the syntax description. The most common of these are:

**string** is ascii data. A string is contained between a ' at the start and the end, or a ' at the start and the end.

**value** is numeric data in integer (12), decimal (34.5) or exponential format (67.8E-9).

**wsp** is a white space.

Other kinds of data are described as required.

The characters between square brackets ([...]) show optional information that you can include with the message.

The bar (|) shows an either-or choice of data, for example, *a|b* means either *a* or *b*, but not both simultaneously.

Extra spaces are ignored; they can be inserted to improve readability.

---

## **Remote Commands**

---

# Remote Commands

This chapter gives a list of the remote commands, for use with the GPIB.

In the remote command descriptions the parts given in upper-case characters must be given. The parts in lower-case characters can also be given, but they are optional.



## 8.1 Units

The units and all the allowed mnemonics are given in the table below.

**Table 8-1** Units and Allowed Mnemonics

Unit	Default	Allowed Mnemonics
deciBel	DB	DB
deciBel/1mW	DBM	DBM DBMW
meter	M	PM, NM, UM, MM, M

Where units are specified with a command, only the Default is shown, by the full range of mnemonics can be used.

## 8.2 Command Summary

**Table 8-2** Common Command Summary

Command	Parameter/ Response	Min	Max	Function
*CLS				Clear Status Command
*ESE	<value>	0	255	Standard Event Status Enable Command
*ESE?	<value>	0	255	Standard Event Status Enable Query
*ESR?	<value>	0	255	Standard Event Status Register Query
*IDN?	<string>			Identification Query
*OPC				Operation Complete Command

Remote Commands  
Command Summary

Command	Parameter/ Response	Min	Max	Function
*OPC?	<value>			Operation Complete Query
*OPT?	<string>			Options Query
*RCL	<location>	0	9	Recall Instrument Setting
*RST				Reset Command
*SAV	<location>	1	9	Save Instrument Setting
*SRE	<value>	0	255	Service Request Enable Command
*SRE?	<value>	0	255	Service Request Enable Query
*STB?	<value>	0	255	Read Status Byte Query
*TST?	<value>	0	65535	Self Test Query
*WAI				Wait Command

**Table 8-3**                      **Command List**

Command	Parameter Response	Unit	Min	Max	Default
:DISPlay					
:BRIGHtness	<value>		0	1	
:BRIGHtness?	<value>				
:DISPlay					
:ENABle	OFF ON 0 1				
:ENABle?	0 1				
:INPut					
:ATTenuation	<value> MIN DEF MAX	DB	0.000dB <sup>†</sup>	60.000dB <sup>†</sup>	0.000dB <sup>†</sup>
:ATTenuation?	<value>	DB			
:ATTenuation? MIN	<value>	DB			
:ATTenuation? DEF	<value>	DB			
:ATTenuation? MAX	<value>	DB			
:INPut					

## Remote Commands Command Summary

Command	Parameter Response	Unit	Min	Max	Default
:LCMode	OFF ON 0 1				
:LCMode?	0 1				
:INPut					
:OFFSet	<value> MIN DEF MAX	DB	-99.999dB	99.999dB	0.000dB
:DISPlay					
:OFFSet?	<value>	DB			
:OFFSet? MIN	<value>	DB			
:OFFSet? DEF	<value>	DB			
:OFFSet? MAX	<value>	DB			
:INPut					
:WAVelength	<value> MIN DEF MAX	M	1200nm	1650nm	1310nm
:WAVelength?	<value>	M			
:WAVelength? MIN	<value>	M			
:WAVelength? DEF	<value>	M			
:WAVelength? MAX	<value>	M			
:OUTPut					
:APMode	OFF ON 0 1				
:APMode?	0 1				
:OUTPut					
:POWer	<value> MIN DEF MAX	DBM	0.000dB <sup>†</sup>	60.000dB <sup>†</sup>	0.000dB <sup>†</sup>
:POWer?	<value>	DBM			
:POWer? MIN	<value>	DBM			
:POWer? DEF	<value>	DBM			
:POWer? MAX	<value>	DBM			
:OUTPut					

## Remote Commands Command Summary

Command	Parameter Response	Unit	Min	Max	Default
[ :STATe]	OFF ON 0 1				
[ :STATe?]	0 1				
:APOWeron	DIS LAST 0 1				
:APOWeron?	0 1				
:STATus					
:OPERation					
[:EVENT]?	<value>				
:CONDition?	<value>				
:ENABle	<value>				
:ENABle?	<value>				
:NTRansition	<value>				
:NTRansition?	<value>				
:PTRansition	<value>				
:PTRansition?	<value>				
:QUEStionable					
[:EVENT]?	<value>				
:CONDition?	<value>				
:ENABle	<value>				
:ENABle?	<value>				
:NTRansition	<value>				
:NTRansition?	<value>				
:PTRansition	<value>				
:PTRansition?	<value>				
:PRESet					
:SYSTem					
:ERRor?	<value>		-32768	32767	
:UCALibration					
:START	<start_value>, <step_value>	M,M	1200nm,0.0	‡	1nm

## Remote Commands

### The Common Commands

Command	Parameter Response	Unit	Min	Max	Default
:START?	<start_value>, <step_value>, <no_of_steps>				
		M,M			
:STATE	OFF ON 0 1				
:STATE?	0 1				
:STOP					
:VALue	<value>	DB	-99.999dB	99.999dB	
:VALue?	<value>	DB			

† These are specified minimum and maximum values, with the calibration factor (:INPut:OFFSet) set to zero. Actual values depend on the instrument, and the calibration factor.

‡ These values are interdependent  
 $start\ value + ((number\ of\ step - 1) \times step\ value) \leq 1650nm$

## 8.3 The Common Commands

The IEEE 488.2 standard has a list of reserved commands, called common commands. These are the commands that start with an asterisk. Some of these commands must be implemented by any instrument using the standard, others are optional. This section describes the implemented commands.

### Common Status Information

There are four registers for the common status information. Two of these are status-registers and two are enable-registers. These registers conform to the *IEEE Standard 488.2-1987*. You can find further descriptions of these registers under “\*ESE” on page 95, “\*ESR?” on page 96, “\*SRE” on page 101, and “\*STB?” on page 102.

## Remote Commands

### The Common Commands

The following figure shows how the registers are organized.

**Figure 8-1 Common Status Registers**

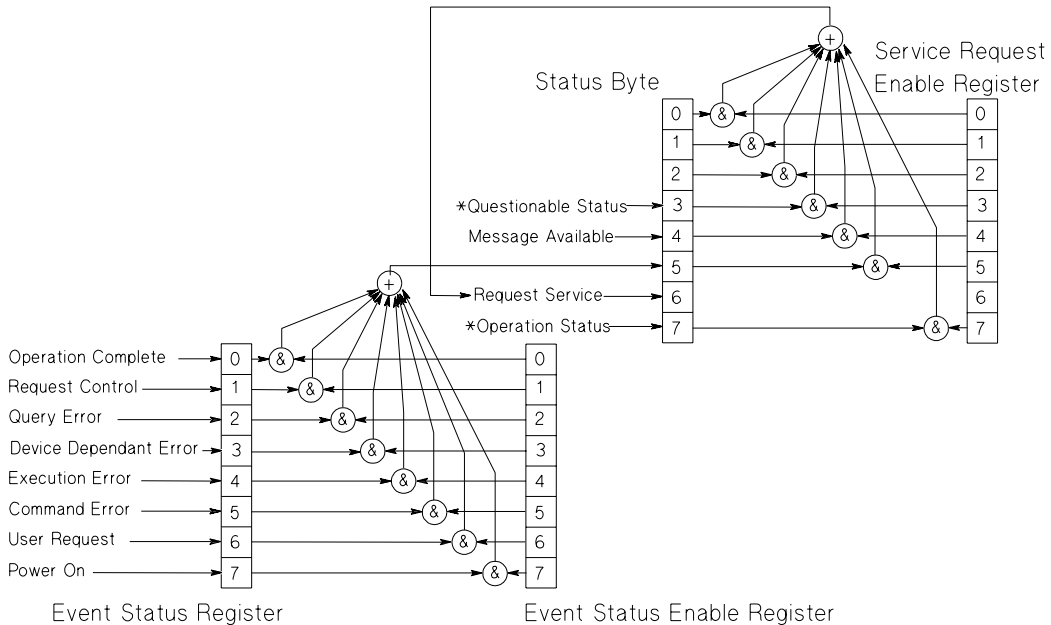

\*The questionable and operation status trees are described in “STATus Commands” on page 114.

### NOTE

Unused bits in any of the registers return 0 when you read them.

### SRQ, The Service Request

A service request (SRQ) occurs when a bit in the Status Byte register goes from 0 → 1 AND the corresponding bit in the Service Request Enable Mask is set.

The Request Service (RQS) bit is set to 1 at the same time that the SRQ is caused. This bit can only be reset by reading it by a serial

## Remote Commands

### The Common Commands

poll. The RQS bit is not affected by the condition that caused the SRQ. The serial poll command transfers the value of the Status Byte register to a variable.

#### **\*CLS**

**Syntax**            \*CLS

**Definition**        The \*CLS command clears the following:

- Error queue
- Standard event status register (ESR)
- Status byte register (STB)

After the \*CLS command the instrument is left waiting for the next command. The instrument setting is unaltered by the command, though \*OPC/\*OPC? actions are canceled.

If the \*CLS command occurs directly after a program message terminator, the output queue and MAV, bit 4, in the status byte register are cleared, and if condition bits 2-0 of the status byte register are zero, MSS, bit 6 of the status byte register is also zero.

**Example**            OUTPUT 728; "\*CLS"

#### **\*ESE**

**Syntax**            \*ESE <wsp><value>  
0 ≤ value ≤ 255

**Definition**        The \*ESE command sets bits in the standard event status enable register (ESE) that enable the corresponding bits in the standard event status register (ESR).

The register is cleared:

- At power-on

Remote Commands  
**The Common Commands**

- By sending a value of zero

The register is not changed by the \*RST and \*CLS commands.

**Table 8-4 The Event Status Enable Register**

<b>BIT</b>	<b>MNEMONIC</b>	<b>BIT VALUE</b>
7	Power On	128
6	User Request	64
5	Command Error	32
4	Execution Error	16
3	Device dependent Error	8
2	Query Error	4
1	Request Control	2
0	Operation Complete	1

**\*ESE?**

The standard event status enable query returns the contents of the standard event status enable register.

**Example**

```
OUTPUT 728; "*ESE 21"
OUTPUT 728; "*ESE?"
ENTER 728; A$
```

**\*ESR?**

**Syntax**

\*ESR?

**Definition**

The standard event status register query returns the contents of the standard event status register. The register is cleared after being read.

$0 \leq \text{contents} \leq 255$



Remote Commands  
The Common Commands

**Table 8-5**

**The Standard Event Status Register**

BITS	MNEMONICS	BIT VALUE
7	Power On	128
6	User Request	64
5	Command Error	32
4	Execution Error	16
3	Device Dependent Error	8
2	Query Error	4
1	Request Control	2
0	Operation Control	1

**Example**            OUTPUT 728; "\*ESR?"  
                         ENTER 728; A\$

**\*IDN?**

**Syntax**            \*IDN?

**Definition**        The identification query commands the instrument to identify itself over the interface.

**Response:** HEWLETT-PACKARD,  
HP8156A, mmmmmmmmmmm, n.n.n

HEWLETT-PACKARD:    manufacturer  
                         HP8156A:            instrument model number  
                         mmmmmmmmmmm:    serial number (not supplied)  
                         n.n.n:                firmware revision level

**Example**            DIM A\$ [100]  
                         OUTPUT 728; "\*IDN?"  
                         ENTER 728; A\$

## Remote Commands

### The Common Commands

#### **\*OPC**

**Syntax**                   \*OPC

**Definition**               The instrument parses and executes all program message units in the input queue and sets the operation complete bit in the standard event status register (ESR). This command can be used to avoid filling the input queue before the previous commands have finished executing.

#### **\*OPC?**

This query causes all the program messages in the input queue to be parsed and executed. Once it has completed it places an ASCII '1' in the output queue. There is a short delay between interpreting the command and putting the '1' in the queue.

**Example**

```
OUTPUT 728; "*CLS; *ESE 1; *SRE
32"
OUTPUT 728; "*OPC"

OUTPUT 728; "*CLS; *ESE 1; *SRE
32"OUTPUT 728; "*OPC?"
ENTER 728; A$
```

#### **\*OPT?**

**Syntax**                   \*OPT?

**Definition**               This query returns a string with the options installed in the attenuator. There are three fields, separated by commas. If an option is not present in the instrument, the corresponding field returns a "0".

The three fields are High Performance, Monitor Output, High Return Loss. For example, if you have option 201

## Remote Commands

### The Common Commands

(High performance, high return loss version), the string returned is High Performance, 0, High Return Loss.

**Example**            OUTPUT 728;"\*OPT?"  
                      ENTER 728;A\$

#### **\*RCL**

**Syntax**            \*RCL <wsp> <location>  
  
 $0 \leq \text{location} \leq 9$

**Definition**        An instrument setting from the internal RAM is made the actual instrument setting (this does not include GPIB address or parser, the attenuation resolution or the power on setting).  
  
You recall user settings from locations 1-9. See “\*SAV” on page 100. Location 0 contains the default setting, which is the same as that obtained by \*RST.

**Example**            OUTPUT 728;"\*RCL 3"

#### **\*RST**

**Syntax**            \*RST

**Definition**        The reset setting (default setting) stored in ROM is made the actual setting.  
  
Instrument state: the instrument is placed in the idle state awaiting a command.  
  
The following are not changed:

- GPIB (interface) state
- Instrument interface address
- Output queue

Remote Commands  
The Common Commands

- Service request enable register (SRE)
- Standard event status enable register (ESE)

The commands and parameters of the reset state are listed in the following table.

**Table 8-6**                      **Reset State (Default Setting)**

<b>Parameter</b>	<b>Reset Value</b>
Attenuation Factor	0dB
Calibration Factor	0dB
Wavelength	1310nm
Sweep	Manual
Start	0.00dB
Stop	0.00dB
Step	0.00dB
Dwell	0.2s
Back Refl.	
Ins. Loss	2.00dB
RL Ref	14.70dB
RL-Input	60.00dB
$\lambda$ Cal	Off
User Cal	Off
Through Power Mode	Off
Display Brightness	Full
Power On Setting	Last
Shutter enable under GPIB	Normal
Shutter at Power ON	Disabled
Resolution	1/100

**Example**                      `OUTPUT 728; "*RST"`

**\*SAV**

**Syntax**                      `*SAV <wsp> <location>`  
`1 ≤ location ≤ 9`

## Remote Commands

### The Common Commands

**Definition** The instrument setting is stored in RAM. You can store settings in locations 1-9. The scope of the saved setting is identical with the scope of the standard setting described in “\*RST” on page 99.

**Example** OUTPUT 728; " \*SAV 3 "

### \*SRE

**Syntax** \*SRE <wsp> <value>

$0 \leq \text{value} \leq 255$

**Definition** The service request enable command sets bits in the service request enable register that enable the corresponding status byte register bits.

The register is cleared:

- At power-on
- By sending a value of zero.

The register is not changed by the \*RST and \*CLS commands.

**Table 8-7**

### The Service Request Enable Register

<b>BITS</b>	<b>MNEMONICS</b>	<b>BIT VALUE</b>
7	Operation Status	128
6	Request Status	64
5	Event Status Byte	32
4	Message Available	16
3	Questionable Status	8
2	Not used	0
1	Not used	0
0	Not used	0

Remote Commands  
The Common Commands

---

**NOTE**

---

**Bit 6 cannot be masked.**

**\*SRE?**

The service request enable query returns the contents of the service request enable register.

**Example**

OUTPUT 728; "\*SRE 48"

OUTPUT 728; "\*SRE?"

ENTER 728; A\$

**\*STB?**

**Syntax**

\*STB?

**Definition**

The read status byte query returns the contents of the status byte register.

$0 \leq \text{contents} \leq 255$

**Table 8-8**

**The Status Byte Register**

<b>BITS</b>	<b>MNEMONICS</b>	<b>BIT VALUE</b>
7	Operation Status	128
6	Request Service	64
5	Event Status Byte	32
4	Message Available	16
3	Questionable Status	8
2	Not used	0
1	Not used	0
0	Not used	0

**Example**

OUTPUT 728; "\*STB?"

ENTER 728; A\$

## Remote Commands

### The Common Commands

#### \*TST?

**Syntax** \*TST?

**Definition** The self-test query commands the instrument to perform a self-test and place the results of the test in the output queue.

Returned value:  $0 \leq \text{value} \leq 65535$ . This value is the sum of the results for the individual tests

**Table 8-9**                      **The Self Test Results**

<b>BITS</b>	<b>MNEMONICS</b>	<b>BIT VALUE</b>
8	Counter	256
7	Analog to Digital Converter	128
6	General DSP Hardware	64
5	DSP Timeout	32
4	DSP Communications	16
3	Calibration Data Corrupt	8
2	Keypad	4
1	Battery RAM	2
0	Calibration Data	
	Not Present/ Checksum Fail	1

So 16 would mean that the DSP (Digital Signal Processor) Communications had failed, 18 would mean that the DSP Communications had failed, and so had the Battery RAM. A value of zero indicates no errors.

No further commands are allowed while the test is running.

The instrument is returned to the setting that was active at the time the self-test query was processed.

Remote Commands  
**DISPlay Commands**

The self-test does not require operator interaction beyond sending the \*TST? query.

**Example**            OUTPUT 728; "\*TST?"  
                      ENTER 728; A\$

**\*WAI**

**Syntax**            \*WAI

**Definition**        The wait-to-continue command prevents the instrument from executing any further commands, all pending operations are completed.

**Example**            OUTPUT 728; "\*WAI"

---

## 8.4 DISPlay Commands

### **:DISPlay:BRIGhtness**

**Syntax**            :DISPlay:BRIGhtness <wsp> <value>

**Description**        This command sets the brightness of the display. The brightness is a floating point number in the range 0 (least bright) to 1 (brightest). There are seven possible levels of intensity. The value input for the brightness is rounded to the closest of these seven values.

The default brightness is 1.

### **:DISPlay:BRIGhtness?**

**Syntax**            :DISPlay:BRIGhtness?



## Remote Commands

### DISPlay Commands

**Description** The query returns the brightness of the display, where 0 means least brightness, and 1 means full brightness.

**Example** OUTPUT 728;" :DISP:BRIG 0.5"  
OUTPUT 728;" :DISP:BRIG?"  
ENTER 728;A\$

### :DISPlay:ENABLE

**Syntax** :DISPlay:ENABle <wsp> OFF|ON|0|1

**Description** This command enables or disables the front panel display.

Set the state to OFF or 0 to switch the display off, set the state to ON or 1 to switch the display on. The default is for the display to be on.

### :DISPlay:ENABLE?

**Syntax** :DISPlay:ENABle?

**Description** The query returns the current state of the display.

A returned value of 0 indicates that the display is off. A returned value of 1 indicates that the display is on.

**Example** OUTPUT 728;" :DISP:ENAB ON"  
OUTPUT 728;" :DISP:ENAB?"  
ENTER 728;A\$

## 8.5 INPut Commands

### :INPut:ATTenuation

**Syntax**                   :INPut:ATTenuation <wsp>  
                              <value>[DB][MIN|DEF|MAX]

**Description**            This command sets the attenuation factor for the instrument. The attenuation factor is used, with the calibration factor (see ) to set the filter attenuation.

$$Attenuation_{filter}(dB) = Att(dB) - Cal(dB)$$

You set the attenuation factor by sending a value (default units are dB), or by sending MIN, DEF or MAX, which specify the minimum, default and maximum values for the attenuation factor.

The minimum value and the default value are those values for which  $Attenuation_{filter} = 0dB$ . The maximum value is that value for which  $Attenuation_{filter}$  is at its greatest.

### :INPut:ATTenuation?

**Syntax**                   :INPut:ATTenuation? [<wsp>  
                              MIN|DEF|MAX]

**Description**            The query returns the current attenuation factor, in dB.

$$Attenuation_{filter}(dB) = Att(dB) - Cal(dB)$$

By sending MIN, DEF, or MAX with the query the minimum, default or maximum value possible for the attenuation factor is returned.

**Example**                   OUTPUT 728; ":INP:ATT 32.15"

## Remote Commands

### INPut Commands

```
OUTPUT 728;" : INP : ATT?"
```

```
ENTER 728;A$
```

### **:INPut:LCMode**

**Syntax** : INPut : LCMode <wsp> OFF|ON|0|1

**Description** This command sets the function of the wavelength calibration. That is, whether the wavelength calibration data is to be used to reposition the filter to keep the attenuation factor constant, or to alter the attenuation factor with the filter kept in a fixed position.

Switch the mode on (using OFF or 0) to keep the attenuation value fixed, and alter the filter position. Switch the mode off (using ON or 1) to keep the filter position fixed, and alter the attenuation factor.

### **:INPut:LCMode?**

**Syntax** : INPut : LCMode?

**Description** The query returns the current function of the wavelength calibration.

0 indicates that the instrument is keeping the attenuation value fixed, and altering the filter position. 1 indicates the instrument is keeping the filter position fixed, and altering the attenuation factor.

**Example** OUTPUT 728;" : INP : LCM ON"

```
OUTPUT 728;" : INP : LCM?"
```

```
ENTER 728;A$
```

### **:INPut:OFFSet**

**Syntax** : INPut : OFFSet <wsp>  
<value>[DB][MIN|DEF|MAX]

## Remote Commands

### INPut Commands

**Description** This command sets the calibration factor for the instrument. This factor does not affect the filter attenuation. It is used to offset the values for the attenuation factor. The calibration factor is used, with the attenuation factor (see “:INPut:ATTenuation” on page 106) to set the attenuation of the filter.

$$\text{Attenuation}_{\text{filter}}(\text{dB}) = \text{Att}(\text{dB}) - \text{Cal}(\text{dB})$$

You set the calibration by sending a value (default units are dB), or by sending MIN, DEF or MAX, which specify the minimum, default and maximum values for the calibration factor.

The minimum value for the calibration factor is -99.999dB. The default value is 0dB. The maximum value is 99.999dB.

### :INPut:OFFSet?

**Syntax** :INPut:OFFSet? [<wsp> MIN|DEF|MAX]

**Description** The query returns the current calibration factor, in dB.

By sending MIN, DEF, or MAX with the query the minimum, default or maximum value possible for the calibration factor is returned.

**Example** OUTPUT 728; ":INP:OFFS 32.15"

OUTPUT 728; ":INP:OFFS?"

ENTER 728; A\$

### :INPut:OFFSet:DISPlay

**Syntax** :INPut:OFFSet:DISPlay

## Remote Commands

### INPut Commands

**Description** This command sets the calibration factor for the instrument from the current attenuation factor. The filter attenuation is not affected. The offset is set so that the attenuation factor becomes zero.

$$Cal_{NEW}(dB) = -Att_{filter}(dB) = Cal_{OLD}(dB) - Att_{OLD}(dB)$$

**Example**

```
OUTPUT 728; " : INP : OFFS : DISP "  
OUTPUT 728; " : INP : OFFS ? "  
ENTER 728; A$
```

### :INPut:WAVelength

**Syntax** :INPut:WAVelength <wsp>  
<value>[DB][MIN|DEF|MAX]

**Description** This command sets the wavelength for the instrument. The value is used to make the compensation for the wavelength dependence of the filter, using the wavelength calibration data.

---

#### NOTE

There are two sets of wavelength calibration data, one is made in the factory, individually, for your instrument. The other is left for the you to define. Using your own wavelength calibration data, you can use the attenuator to compensate for the total wavelength dependence of your hardware configuration.

For more details on this topic, see “Selecting the Wavelength Calibration and Its Function” on page 67.

---

You set the wavelength by sending a value (default units are meters), or by sending MIN, DEF or MAX, which specify the minimum, default and maximum values for the wavelength.

## Remote Commands

### OUTPut Commands

The minimum value for the wavelength is 1200nm. The default value is 1310nm. The maximum value is 1650nm.

#### **:INPut:WAVelength?**

<b>Syntax</b>	<code>:INPut:WAVelength? [&lt;wsp&gt;MIN DEF MAX]</code>
<b>Description</b>	<p>The query returns the current wavelength, in meters.</p> <p>By sending MIN, DEF, or MAX with the query the minimum, default or maximum value possible for the wavelength is returned.</p>
<b>Example</b>	<pre>OUTPUT 728; ":INP:WAV 1550nm" OUTPUT 728; ":INP:WAV?" ENTER 728; A\$</pre>

---

## 8.6 OUTPut Commands

#### **:OUTPut:APMode**

<b>Syntax</b>	<code>:OUTPut:APMode &lt;wsp&gt; OFF ON 0 1</code>
<b>Description</b>	<p>This command sets the whether you set the attenuation factor, or the through-power to alter the attenuation of the filter.</p> <p>When you are switching the absolute power mode ON, the attenuation factor (in dB) becomes the base value for the through-power (in dBm), at the time at which this command is processed. That is, if the attenuation factor is set to 32.000dB, and the absolute power mode is switched on, then the base value for the through-power is set to 32.000dBm. Use the</p>

## Remote Commands

### OUTPut Commands

calibration factor (see ) to set the attenuation factor to the required value for use as the base value for the through-power

$$Cal_{New} = (Through - Power_{Base} - Att) + Cal_{Current}$$

When you switch the absolute power mode OFF, the last set calibration factor becomes active, and the attenuation factor is set so that the filter attenuation does not change. That is

$$Att(dB) = Attenuation_{filter}(dB) + Cal(dB)$$

---

#### NOTE

---

Using any of the **:INPut:ATTenuation** commands or queries, or any of the **:INPut:OFFSet** commands or queries, switches the absolute power mode off automatically.

See “:OUTPut:POWer” on page 112 for information on setting the through-power.

Switch the mode off (using OFF or 0) to set the attenuation of the filter by specifying the attenuation and calibration factors. Switch the mode on (using ON or 1) to set the attenuation of the filter by specifying the through-power.

### **:OUTPut:APMode?**

**Syntax** :OUTPut:APMode?

**Description** The query returns whether the attenuation of the filter is set by the attenuation and calibration factors, or by the through-power.

0 indicates the instrument sets the attenuation of the filter from the attenuation and calibration factors. 1 indicates that the instrument sets the attenuation of the filter from the through-power.

## Remote Commands

### OUTPut Commands

**Example**

```
OUTPUT 728;" : INP:ATT?"
ENTER 728; Att
OUTPUT 728;" : INP:OFFS?"
ENTER 728; Cal
Newcal = Basepow - Att + Cal
OUTPUT 728;" : INP:OFFS ";Newcal
OUTPUT 728;" :OUTP:APM ON"

OUTPUT 728;" :OUTP:APM?"
ENTER 728;A$
```

### :OUTPut:POWer

**Syntax** :OUTPut:POWer <wsp>  
<value>[DBM]|MIN|DEF|MAX

**Description** This command sets the through-power for the instrument. The through-power is used to set the attenuation of the filter.

$$Att_{filter}(dB) = ThroughPower_{Base}(dBm) - ThroughPower(dBm) + Att_{filter@Base}(dB)$$

You set the through-power by sending a value (default units are dBm), or by sending MIN, DEF or MAX, which specify the minimum, default and maximum values for the through-power.

The maximum value and the default value are those values for which  $Attenuation_{filter} = 0dB$ . The minimum value is that value for which  $Attenuation_{filter}$  is at its greatest. For example, if you have set INP:ATT 10 and INP:OFFS 2 and then switched UTP:APM ON, then the through power is set to 12dBm. The maximum through power, and the default through power, in this case is 22dBm. The minimum through power in this case is -38dBm.



## Remote Commands

### OUTPut Commands

#### :OUTPut:POWer?

**Syntax** :OUTPut :POWer? [<wsp> MIN|DEF|MAX]

**Description** The query returns the current through-power, in dBm.

$$\text{ThroughPower}(dBm) = \text{ThroughPower}_{Base}(dBm) + \text{Att}_{filter@Base}(dB) - \text{Att}_{filter}(dB)$$

By sending MIN, DEF, or MAX with the query the minimum, default or maximum value possible for the through-power is returned.

**Example**

```
OUTPUT 728; ":OUTP:POW 32.15"
OUTPUT 728; ":OUTP:POW?"
ENTER 728;A$
```

#### :OUTPut[:STATe]

**Syntax** :OUTPut [:STATe] <wsp> OFF|ON|0|1

**Description** This command sets the state of the output shutter, that is, whether it is open or closed.

OFF or 0 closes the shutter, and no power gets through. ON or 1 opens the shutter, and power gets through.

#### :OUTPut[:STATe]?

**Syntax** :OUTPut [:STATe] ?

**Description** The query returns whether the output shutter is open or closed.

0 indicates the shutter is closed (no power is getting through). 1 indicates that the shutter is open (power is getting through).

**Example**

```
OUTPUT 728; ":OUTP ON"
OUTPUT 728; ":OUTP?"
ENTER 728;A$
```

Remote Commands  
STATus Commands

### **:OUTPut[:STATe]:APOWeron**

**Syntax**                   :OUTPut [ :STATe ] :APOWeron <wsp>  
DIS|LAST|0|1

**Description**            This command sets the state of the output shutter at power on, that is, whether it is closed, or takes the state at power-off.

DIS or 0 closes the shutter at power on, and no power gets through. LAST or 1 sets the shutter to the state at power-off.

### **:OUTPut[:STATe]:APOWeron?**

**Syntax**                   :OUTPut [ :STATe ] :APOWeron?

**Description**            The query returns whether the output shutter is closed at power on, or set to the state at power-off.

0 indicates the shutter is closed (no power is getting through). 1 indicates that the shutter is set to the state at power-off.

**Example**                 OUTPUT 728; " :OUTP:APOW OFF "  
OUTPUT 728; " :OUTP:APOW? "  
ENTER 728;A\$

---

## **8.7 STATus Commands**

There are two 'nodes' in the status circuitry. The OPERation node indicates things that can happen during normal operation. The QUEStionable node indicates error conditions.

Each node of the status circuitry has five registers:

## Remote Commands

### STATus Commands

- A condition register (CONDition), which contains the current status. This register is updated continuously. It is not changed by having its contents read.
- The event register (EVENT), which contains the output from the transition registers. The contents of this register are cleared when it is read.
- A positive transition register (PTRansition), which, when enabled, puts a 1 into the event register, when the corresponding bit in the condition register goes from 0 to 1.

The power-on condition for this register is for all the bits to be disabled.

- A negative transition register (NTRansition), which, when enabled, puts a 1 into the event register, when the corresponding bit in the condition register goes from 1 to 0.

The power-on condition for this register is for all the bits to be disabled.

- The enable register (ENABle), which enables changes in the event register to affect the Status Byte.

The status registers for the attenuator are organized as shown:

Remote Commands  
**STATUS Commands**

**Figure 8-2 The Status Registers**

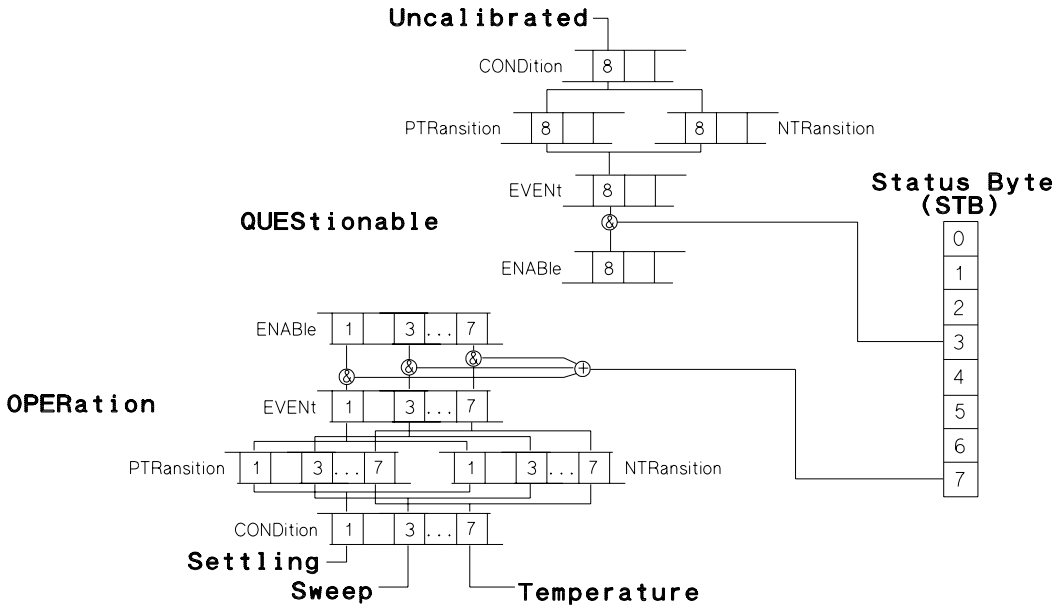

**:STATUS:OPERation:CONDition?**

**Syntax** :STATUS:OPERation:CONDition?

**Description** This query reads the contents of the OPERation:CONDition register. Only three bits of the condition register are used:

- Bit 1, which is 1 when the motor that positions the attenuator filter is settling.
- Bit 3, which is 1 while the instrument is performing an attenuation sweep.

## Remote Commands

### STATus Commands

- Bit 7, which is 1 after the instrument has repositioned the attenuator filter due to a change in temperature.

**Example**            OUTPUT 728; " : STAT : OPER : COND ? "  
                      ENTER 728; A\$

### **:STATus:OPERation:ENABLE**

**Syntax**            : STATus : OPERation : ENABLE <wsp>  
                      <value>

**Description**        This command sets the bits in the ENABLE register that enable the contents of the EVENT register to affect the Status Byte (STB). Setting a bit in this register to 1 enables the corresponding bit in the EVENT register to affect bit 7 of the Status Byte.

### **:STATus:OPERation:ENABLE?**

**Syntax**            : STATus : OPERation : ENABLE ?

**Description**        This query returns the current contents of the OPERATION:ENABLE register.

**Example**            OUTPUT 728; " : STAT : OPER : ENAB  
                      138 "  
  
                      OUTPUT 728; " : STAT : OPER : ENAB ? "  
                      ENTER 728; A\$

### **:STATus:OPERation[:EVENT]?**

**Syntax**            : STATus : OPERation [ : EVENT ] ?

**Description**        This query reads the contents of the OPERATION:EVENT register. Only three bits of the event register are used (whether these bits contain information depends on the transition register configuration):

## Remote Commands

### STATus Commands

- Bit 1, which is 1 when the motor that positions the attenuator filter is settling.
- Bit 3, which is 1 while the instrument is performing an attenuation sweep.
- Bit 7, which is 1 after the instrument has repositioned the attenuator filter due to a change in temperature.

**Example**            OUTPUT 728; " :STAT:OPER?"  
                      ENTER 728;A\$

### **:STATus:OPERation:NTRansition**

**Syntax**            :STATus:OPERation:NTRansition  
                      <wsp> <value>

**Description**        This command sets the bits in the NTRansition register. Setting a bit in this register enables a negative transition (1→0) in the corresponding bit in the CONDition register to set the bit in the EVENt register.

### **:STATus:OPERation:NTRansition?**

**Syntax**            :STATus:OPERation:NTRansition?

**Description**        This query returns the current contents of the OPERation:NTRansition register.

**Example**            OUTPUT 728; " :STAT:OPER:NTR 138"  
                      OUTPUT 728; " :STAT:OPER:NTR?"  
                      ENTER 728;A\$

### **:STATus:OPERation:PTRansition**

**Syntax**            :STATus:OPERation:PTRansition  
                      <wsp> <value>

## Remote Commands

### STATUS Commands

**Description** This command sets the bits in the PTRansition register. Setting a bit in this register enables a positive transition (0→1) in the corresponding bit in the CONDition register to set the bit in the EVENt register.

#### **:STATus:OPERation:PTRansition?**

**Syntax** :STATus:OPERation:PTRansition?

**Description** This query returns the current contents of the OPERation:PTRansition register.

**Example** OUTPUT 728; ":STAT:OPER:PTR 138"  
OUTPUT 728; ":STAT:OPER:PTR?"  
ENTER 728;A\$

#### **:STATus:QUESTionable:CONDition?**

**Syntax** :STATus:QUESTionable:CONDition?

**Description** This query reads the contents of the QUESTionable:CONDition register. Only one bit of the condition register is used:

- Bit 8, which is 1 when the wavelength is not within the range of the user wavelength calibration data.

**Example** OUTPUT 728; ":STAT:QUES:COND?"  
ENTER 728;A\$

#### **:STATus:QUESTionable:ENABLE**

**Syntax** :STATus:QUESTionable:ENABLE  
<wsp> <value>

**Description** This command sets the bits in the ENABLE register that enable the contents of the EVENt register to affect the Status Byte (STB). Setting

## Remote Commands

### STATus Commands

a bit in this register to 1 enables the corresponding bit in the EVENT register to affect bit 3 of the Status Byte.

#### **:STATus:QUEStionable:ENABle?**

**Syntax** :STATus:QUEStionable:ENABle?

**Description** This query returns the current contents of the QUEStionable:ENABle register.

**Example**

```
OUTPUT 728; ":STAT:QUES:ENAB
256"

OUTPUT 728; ":STAT:QUES:ENAB?"
ENTER 728; A$
```

#### **:STATus:QUEStionable[:EVENT]?**

**Syntax** :STATus:QUEStionable[:EVENT]?

**Description** This query reads the contents of the QUEStionable:EVENT register. Only one bit of the event register is used (whether these bits contain information depends on the transition register configuration):

- Bit 8, which is 1 when the wavelength is not within the range of the user wavelength calibration data.

**Example**

```
OUTPUT 728; ":STAT:QUES 256"
OUTPUT 728; ":STAT:QUES?"
ENTER 728; A$
```

#### **:STATus:QUEStionable:NTRansition**

**Syntax** :STATus:QUEStionable:NTRansition <wsp> <value>



## Remote Commands

### STATus Commands

**Description** This command sets the bits in the NTRansition register. Setting a bit in this register enables a negative transition (1→0) in the corresponding bit in the CONDition register to set the bit in the EVENt register.

#### **:STATus:QUEStionable:NTRansition?**

**Syntax** :STATus:QUEStionable:NTRansition?

**Description** This query returns the current contents of the QUEStionable:NTRansition register.

**Example** OUTPUT 728; ":STAT:QUES:NTR 256"  
OUTPUT 728; ":STAT:QUES:NTR?"  
ENTER 728; A\$

#### **:STATus:QUEStionable:PTRansition**

**Syntax** :STATus:QUEStionable:PTRansition <wsp> <value>

**Description** This command sets the bits in the PTRansition register. Setting a bit in this register enables a positive transition (0→1) in the corresponding bit in the CONDition register to set the bit in the EVENt register.

#### **:STATus:QUEStionable:PTRansition?**

**Syntax** :STATus:QUEStionable:PTRansition?

**Description** This query returns the current contents of the QUEStionable:PTRansition register.

**Example** OUTPUT 728; ":STAT:QUES:PTR 256"

## Remote Commands

### SYSTem Commands

```
OUTPUT 728; " : STAT : QUES : PTR ? "  
ENTER 728; A$
```

#### **:STATus:PRESet**

**Syntax** : STATus : PRESet

**Description** This command presets all the enable registers and transition filters for both the OPERATION and QUESTIONable nodes.

- All the bits in the ENABLE registers are set to 0
- All the bits in the PTRansition registers are set to 1
- All the bits in the NTRansition registers are set to 0

**Example** OUTPUT 728; " : STAT : PRES "

---

## 8.8 SYSTem Commands

#### **:SYSTem:ERRor?**

**Syntax** : SYSTem : ERRor ?

**Description** This query returns the next error from the error queue (see “The Error Queue” on page 84). Each error consists of the error code and a short description of the error, separated by a comma, for example 0, "No error". Error codes are numbers in the range -32768 and +32767. Negative error numbers are defined by the SCPI standard. Positive error numbers are device dependent. The errors are listed in “Display Messages” on page 275

## Remote Commands

### User Calibration Commands

**Example**            OUTPUT 728;" :SYST:ERR?"  
                      ENTER 728;A\$

---

## 8.9 User Calibration Commands

Entering user calibration data can only be done over the GPIB. This is done using the commands described here.

### Entering the User Calibration Data

To enter the data for the user calibration data, you will need a power meter, a tunable laser source and the attenuator. If you are going to use the attenuator to compensate for some other device, this should be included in the setup as well.

The steps to enter the user calibration data are

1. Set up the hardware.

The following steps can be programmed to make the procedure easy, as the calibration values must be entered using the GPIB anyway.

2. Disable the tunable laser source.
3. Execute a zero on the power meter.
4. Set the attenuation to 0.
5. Set the wavelength on the tunable laser source, the attenuator and the power meter to the start wavelength.
6. Enable the tunable laser source and the attenuator.
7. Set the power meter to dB, and execute a Display-to-Reference.
8. Set the desired attenuation on the attenuator.
9. Start the user calibration (with the data for the start wavelength and the wavelength stepsize).

## Remote Commands

### User Calibration Commands

This is done with the `:UCALibration:START` command

10.  $\lambda = \lambda_{\text{Start}}$

11. Repeat the following steps until  $\lambda > \lambda_{\text{Stop}}$ .

- a. Set  $\lambda$  on the tunable laser source, the attenuator and the power meter.
- b. Read the power (*Power*).
- c.  $\text{Power} = -\text{Power}$ .
- d. Set the user calibration value to *Power*.

This is done with the `:UCALibration:VALue` command

e.  $\lambda = \lambda + \lambda_{\text{Stepsize}}$

12. Stop the user calibration.

This is done with the `:UCALibration:STOP` command

### **:UCALibration:START**

**Syntax** `:UCALibration:START <wsp>  
<start_value> , <step_value>`

**Description** This command starts the entering of the user calibration data.

You must send two values with this command, the wavelength of the first calibration point, and the spacing between the calibration points. The default units for both values are meters.

The minimum value for the start wavelength is 1200nm, and the minimum value for the step size is 0.1nm, the maximum value for the step size is 10nm. Other than this, the start and step values must satisfy the formula

$$\text{start value} + ((\text{number of step} - 1) \times \text{step value}) \leq 1650\text{nm}$$

where the number of steps must be in the range 10 to 401.

## Remote Commands

### User Calibration Commands

The error -221 indicates that there is a conflict inherent in the start parameters for the user calibration. That is, the start\_value and/or step\_value is invalid.

The error 201 indicates that the user calibration is currently on, and calibration data cannot be changed. Switch the user calibration state off (see “:UCALibration:STAtE” on page 125) and try again.

#### **:UCALibration:STArT?**

**Syntax** :UCALibration:STArT?

**Description** The query starts returning the data for the user wavelength calibration.

Three values are returned in response to this query.

1. The wavelength value for the first calibration data point (in meters).
2. The step-size between the data calibration points (in meters).
3. The number of data points that have been stored for the full calibration.

#### **:UCALibration:STAtE**

**Syntax** :UCALibration:STAtE <wsp>  
OFF|ON|0|1

**Description** This command selects the wavelength calibration to be used. The choice is the factory made calibration for the instrument, or the calibration data entered into the instrument by the user (see “Selecting the Wavelength Calibration and Its Function” on page 67).

## Remote Commands

### User Calibration Commands

Switch the state off (using OFF or 0) to use the factory-made calibration. Switch the state on (using ON or 1) to use the user calibration data.

---

#### NOTE

---

**If you are using the instrument in an environment where the temperature changes, you should not use the user wavelength calibration data, as it lacks correction for temperature changes.**

#### **:UCALibration:STATe?**

**Syntax** :UCALibration:STATe?

**Description** The query returns the current wavelength calibration state.

0 indicates the instrument is using the factory-made wavelength calibration data. 1 indicates that the instrument is using the user calibration data.

**Example** OUTPUT 728;" :UCAL:STAT ON"  
OUTPUT 728;" :UCAL:STAT?"  
ENTER 728;A\$

#### **:UCALibration:STOP**

**Syntax** :UCALibration:STOP

**Description** This command ends the entering of the user calibration data.

The error 203 indicates that entering the data points cannot be stopped, because it has not been started.

#### **:UCALibration:VALue**

**Syntax** :UCALibration:VALue <wsp> <value>

**Description** This command enters a value for the user wavelength calibration data.

## Remote Commands

### User Calibration Commands

The value that you send with this command, is the attenuation for the next calibration point. The wavelength of the calibration point is updated automatically. The first piece of data is for the start wavelength specified by the :UCAL:START command. The default value for the value is dB.

The value can be in the range 0.001dB to 99.999dB.

### **:UCALibration:VALue?**

**Syntax** :UCALibration:VALue?

**Description** The query returns a value from the user wavelength calibration data.

The value returned is the attenuation for the next calibration point. The wavelength of the calibration point is updated automatically. The first piece of data is for the start wavelength as returned by the :UCAL:START? query. The values returned are in dB.

The error 204 indicates that there are no more data points to be read.

Remote Commands  
User Calibration Commands



---

## **Programming Examples**

---

# Programming Examples

This chapter gives some programming examples. The language used for the programming is BASIC 5.1 Language System used on HP 9000 Series 200/300 computers.

These programming examples do not cover the full command set for the instrument. They are intended only as an introduction to the method of programming the instrument. The programming examples use the GPIB.

## 9.1 Example 1 - Checking Communication

### Function

This program sends a queries, and displays the reply.

### Listing

```
10      !-----
20      !
30      ! Agilent 8156A Programming Example 1
40      !
50      ! A Simple Communications Check
60      !
70      !-----
80      !
90      ! Definitions and initialisations
100     !

110     Att=728
       This statement sets the address of the attenuator. The first 7 is to
       access the GPIB card in the controller, the 28 is the GPIB address
       of the attenuator
120     DIM String$(50)
130     !
150     PRINT TABXY(5,10);"Programming Example 1, Simple Communica
tions"
160     !
170     ! Send an IDN query and get the Identification
180     !
190     OUTPUT Att;"*IDN?"
200     ENTER Att;String$
210     PRINT TABXY(10,12);"Identification : ";String$
220     !
230     END
```





## Programming Examples

### Example 2 - Status Registers and Queues

```
890         Value=Value-Bit
900         !
910         ! If MAV is set, then get and display the output que
ue contents
920         !
930         IF Z=0 THEN
940             IF Bit=16 THEN
950                 ENTER Att;A$
960                 PRINT TABXY(21,18);A$
970             END IF
980         END IF
990         !
1000        ! If the bit is not set, then display 0
1010        !
1020        ELSE
1030            PRINT TABXY(Xpos,Ypos);"0"
1040        END IF
1050        !
1060        ! Set up for the next iteration
1070        !
1080        Bit=Bit DIV 2
1090        Xpos=Xpos+4
1100        UNTIL Bit=0
1110        !
1120        ! Now that the status byte is displayed, get the Standar
d Events
1130        ! Status Register
1140        !
1150        OUTPUT Att;"*ESR?"
1160        ENTER Att;Value
1170        !
1180        ! Set up to display the ESR
1190        !
1200        Ypos=12
1210        NEXT Z
1220        !
1230        ! Read and display any messages in the error queue
1240        !
1250        REPEAT
1260            OUTPUT Att;"SYSTEM:ERROR?"
1270            ENTER Att;Value,A$
The SYSTEM:ERROR? query gets the number of the last error in the error queue.
1280        IF Value<>0 THEN PRINT TABXY(21,17);Value,A$
1290        UNTIL Value=0
1300        !
1310        ! Clear the Status structure and reenable the interrupt be
fore returning
1320        !
1330        OUTPUT Att;"*CLS"
1340        ENABLE INTR 7
1350        !
1360        RETURN
1370        !
1380        END
```

---

## 9.3 Example 3 - Measuring and Including the Insertion Loss

### Function

This program performs the same sequence as the sample session given in chapter 1. That is, to measure the insertion loss of the attenuator, and put this into the calibration factor so that it is included in all future loss values.

### Requirements

This example uses the Agilent 8156A Attenuator, with a 8153A multimeter with one source and one sensor. The connectors for this system are all HMS-10.

### Setting Up the Equipment

1. At the beginning, configure the hardware as shown in the figure below, making sure that all the connectors are clean:

Figure 9-1

#### Hardware Configuration for Attenuation Example - A

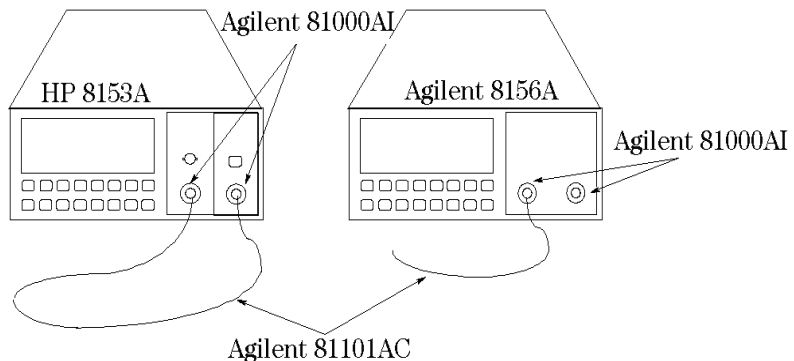

- a. Make sure that the power sensor is installed in the multimeter mainframe in channel A, and the source is in channel B.

## Programming Examples

### Example 3 - Measuring and Including the Insertion Loss

- b. Connect both instruments to the electric supply.
- c. Switch on both instruments.

---

**NOTE**

---

**Under normal circumstances you should leave the instruments to warmup. (The multimeter needs around 20 minutes to warmup. The attenuator needs around 45 minutes with the shutter open to warmup.) Warming up is necessary for accuracy of the sensor, and the output power of the source.**

- d. Connect a patchcord from the source to the input of the sensor.
2. For the second part of the example reconfigure the hardware to include the attenuator:
- a. Disconnect the source from the sensor, and connect it to the input of the attenuator.

**Figure 9-2**

#### **Hardware Configuration for Attenuation Example - B**

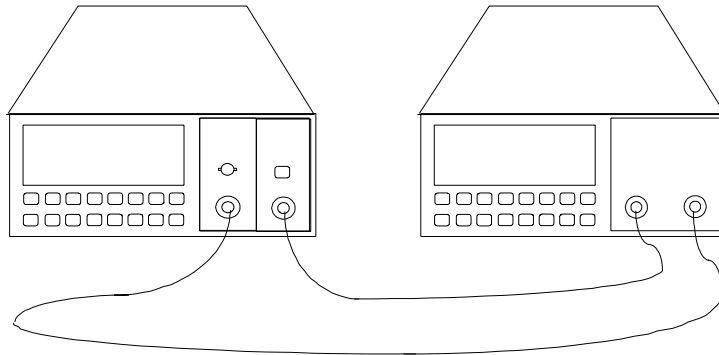

- b. Connect a patchcord from the output of the attenuator to the sensor.



## Programming Examples

### Example 3 - Measuring and Including the Insertion Loss

#### Listing

```
10  !-----
20  !
30  ! Programming Example 3
40  !
50  ! Measuring the Insertion Loss and using it as a Cal factor
60  !
70  !-----
80  !
90  ! Definitions and Initializations
100 !
110 Att=728
120 Mm=722
130 !
140 OUTPUT Mm;"*rst;*cls"
150 OUTPUT Att;"*rst;*cls"
160 !
170 ! Setup the instruments, with the output of the source connected
180 ! to the input of the sensor and wait for the ENTER key to
190 ! be pressed before continuing
200 !
210 CLEAR SCREEN
220 PRINT TABXY(4,17);""
230 INPUT "Connect the Source to the Sensor and then press ENTER",Inp$
240 !
250 ! Set the sensor wavelength to that of the source
260 !
270 OUTPUT Mm;"sour2:pow:wave?"
280 ENTER Mm;Wvl
290 OUTPUT Mm;"sens1:pow:wave ";Wvl
300 !
310 ! Activate the source
320 !
330 OUTPUT Mm;"sour2:pow:stat on"
340 !
350 ! Set the instrument to measure in dB, and take the current power
360 ! as the reference.
370 !
380 OUTPUT Mm;"sens1:pow:ref:stat on"
390 WAIT 2
Let everything settle before making a reading
400 OUTPUT Mm;"sens1:pow:ref:disp"
410 !
420 ! Switch off the source and prompt for the next hardware se
430 !
440 OUTPUT Mm;"sour2:pow:stat off"
450 PRINT TABXY(4,17);""
460 INPUT "Connect the Attenuator into the setup and press ENTE
470 !
480 ! Set the wavelength on the attenuator
490 !
500 OUTPUT Att;"inp:wave ";Wvl
510 !
520 ! Switch on the source, enable the attenuator
```

## Programming Examples

### Example 3 - Measuring and Including the Insertion Loss

```
530  !
540  OUTPUT Mm; "sour2:pow:stat on"
550  OUTPUT Att; "outp on"
560  !
570  ! Read in the power now (the insertion loss of the attenuat
or)
580  ! and put it into the calibration factor on the attenuator.
590  !
600  OUTPUT Mm; "read1:pow?"
610  ENTER Mm; Insloss
620  OUTPUT Att; "inp:offs "; -Insloss
The '-' sign is here because the value from the attenuator is the insertion gain
630  END
```

## 9.4 Example 4 - Running an Attenuation Sweep

### Function

We set up the instrument to sweep from 0dB to 5dB with an interval of 0.5dB, dwelling for a second at each attenuation factor.

The requirements are an Agilent 8156A Attenuator.

### Listing

```
10  !-----
20  !
30  ! Agilent 8156A Programming Example 4
40  !
50  ! Running an Attenuation Sweep
60  !
70  !-----
80  !
90  ! Definitions and Initializations
100 !
110 Att=728
130 !
140 Startatt=0.0
150 Stopatt=5.0
160 Stepatt=0.5
170 Dwell=1
180 !
190 ! Initialise the instrument
200 !
210 OUTPUT Att;"*rst;*cls"
220 !
230 ! Do the sweep
240 !
250 FOR Value=Startatt TO Stopatt STEP Stepatt
260     OUTPUT Att;"inp:att ";Value
270     WAIT Dwell
280 NEXT Value
290 END
```

## Programming Examples

### Example 4 - Running an Attenuation Sweep

---

A

---

## **Installation**

---

# Installation

This appendix provides installation instructions for the attenuator. It also includes information about initial inspection and damage claims, preparation for use, packaging, storage, and shipment.

## A.1 Safety Considerations

The attenuator is a Class 1 instrument (that is, an instrument with an exposed metal chassis directly connected to earth via the power supply cable). The symbol used to show a protective earth terminal in the instrument is



Before operation, review the instrument and manual for safety markings and instructions. You must follow these to ensure safe operation and to maintain the instrument in safe condition.

---

## A.2 Initial Inspection

Inspect the shipping container for damage. If there is damage to the container or cushioning, keep them until you have checked the contents of the shipment for completeness and verified the instrument both mechanically and electrically.

The Function Test gives a procedure for checking the operation of the instrument. If the contents are incomplete, mechanical damage or defect is apparent, or if an instrument does not pass the operator's checks, notify the nearest Agilent Technologies office.

---

### WARNING

**To avoid hazardous electrical shock, do not perform electrical tests when there are signs of shipping damage to any portion of the outer enclosure (covers, panels, etc.).**

---

## A.3 AC Line Power Supply Requirements

The Agilent Technologies 8156A can operate from any single-phase AC power source that supplies between 100V and 240V at a frequency in the range from 50 to 60Hz. The maximum power consumption is 40VA with all options installed.

### Line Power Cable

In accordance with international safety standards, this instrument has a three-wire power cable. When connected to an appropriate AC power receptacle, this cable earths the instrument cabinet. The type of power cable shipped with each instrument depends on the country of destination. Refer to Figure A-1 for the part numbers of the power cables available.

Figure A-1

#### Line Power Cables - Plug Identification

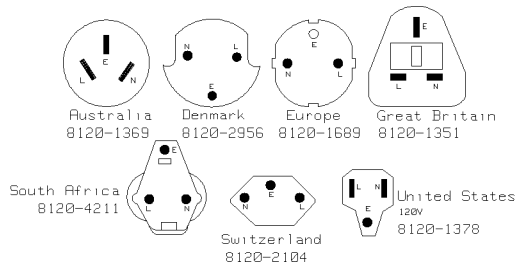

#### WARNING

To avoid the possibility of injury or death, you must observe the following precautions before switching on the instrument.

- If this instrument is to be energized via an autotransformer for voltage reduction, ensure that the Common terminal connects to the earth pole of the power source.
- Insert the power cable plug only into a socket outlet provided with a protective earth contact. Do not negate this protective action by the using an extension cord without a protective conductor.



## Installation

### AC Line Power Supply Requirements

- **Before switching on the instrument, the protective earth terminal of the instrument must be connected to a protective conductor. You can do this by using the power cord supplied with the instrument.**
- **It is prohibited to interrupt the protective earth connection intentionally.**

---

The following work should be carried out by a qualified electrician. All local electrical codes must be strictly observed. If the plug on the cable does not fit the power outlet, or if the cable is to be attached to a terminal block, cut the cable at the plug end and rewire it.

The color coding used in the cable depends on the cable supplied. If you are connecting a new plug, it should meet the local safety requirements and include the following features:

- Adequate load-carrying capacity (see table of specifications).
- Ground connection.
- Cable clamp.

The AC power requirements are summarized on the rear panel of the instrument.

Figure A-2

### Rear Panel Markings

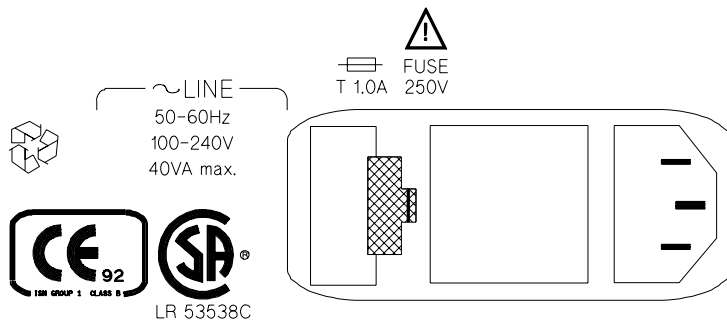

## Replacing the Battery

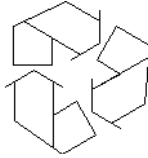

This instrument contains a lithium battery. Replacing the battery should be carried out only by a qualified electrician or by Agilent Technologies service personnel.

There is a danger of explosion if the battery is incorrectly replaced. Replace only with the same or an equivalent type (Agilent part number 1420-0394). Discard used batteries according to local regulations.

## Replacing the Fuse



There is one fuse in this instrument. This is a T1A/250V (time-lag) (Agilent Part No. 2110-0007). The fuse holder is at the rear of the instrument, beside the line power connector. To replace the fuse,

1. Release the fuse holder: use the blade of a flat-headed screwdriver to depress the catch at the side of the holder and then pull the holder out a little.

Installation  
AC Line Power Supply Requirements

**Figure A-3**                    **Releasing the Fuse Holder**

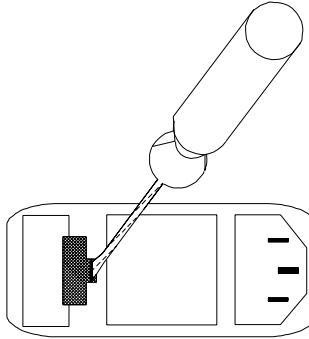

2. Pull the fuse holder out of the instrument.

**Figure A-4**                    **The Fuse Holder**

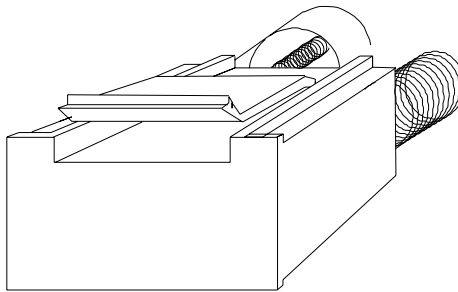

3. Check and replace the fuse as necessary making sure that the fuse is always in the top position of the fuse holder, and the bridge is in the bottom.
4. Place the fuse holder back in the instrument, and push it until the catch clicks back into place.

## A.4 Operating and Storage Environment

The following summarizes the Agilent 8156A operating environment ranges. In order for the attenuator to meet specifications, the operating environment must be within these limits.

---

### WARNING

---

**The Agilent 8156A is not designed for outdoor use. To prevent potential fire or shock hazard, do not expose the instrument to rain or other excessive moisture.**

### Temperature

Protect the instrument from temperature extremes and changes in temperature that may cause condensation within it.

The storage and operating temperature for the Agilent 8156A is given in the table below.

Table A-1

Temperature

	Operating Range	Storage Range
Specified	0°C to 55°C	-40°C to 70°C

### Humidity

The operating humidity for the Agilent 8156A is 15% to 95% from 0°C to 40°C.

### Instrument Positioning and Cooling

The attenuator has a cooling fan mounted internally. Mount or position the instrument upright and horizontally so that air can circulate through it freely. When operating the attenuator, choose a location that provides at least 75mm (3inches) of clearance at the

## Installation

### Switching on the Attenuator

rear, and at least 25mm (1 inch) of clearance at each side. Failure to provide adequate air clearance may result in excessive internal temperature, reducing instrument reliability.

**Figure A-5**      **Correct Positioning of the Attenuator**

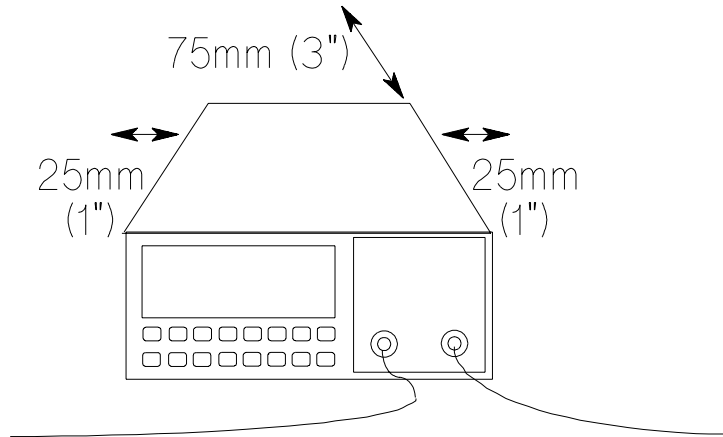

---

## A.5 Switching on the Attenuator

When you switch on the attenuator it goes through self test. This is the same as the self test described in “\*TST?” on page 103.

---

## A.6 Monitor Output

If you have option 121 or option 221 (the monitor output), then the Monitor Output provides a signal for monitoring the power getting through the attenuator. The signal level is approximately 5% of the output power level. For the most accurate results, measure the

Installation  
**Optical Output**

coupling ratio, and its wavelength dependence, for the Monitor Output yourself.

---

## A.7 Optical Output

---

### CAUTION

**The attenuator is supplied with either a straight contact connector or an angled contact connector (Option 201). Make sure that you only use the correct cables with your chosen output. See “Connector Interfaces and Other Accessories” on page 158 for further details on connector interfaces and accessories.**

---

### Disabling the Optical Output

If the optical output is enabled (that is, the green LED is lit), you can disable it by pressing **ENB/DIS**.

---

### NOTE

**Depending on the attenuation setting, it can take up to 3 seconds for the output to be disabled (typically delay, 1 second).**

---

---

## A.8 GPIB Interface

You can connect your GPIB interface into a star network, a linear network, or a combination star and linear network. The limitations imposed on this network are as follows:

- The total cable length cannot exceed 20 meters
- The maximum cable length per device is 2 meters
- No more than 15 devices may be interconnected on one bus.

Installation  
GPIB Interface

**Connector**

The following figure shows the connector and pin assignments.

Connector Part Number: 1251-0293

**Figure A-6**

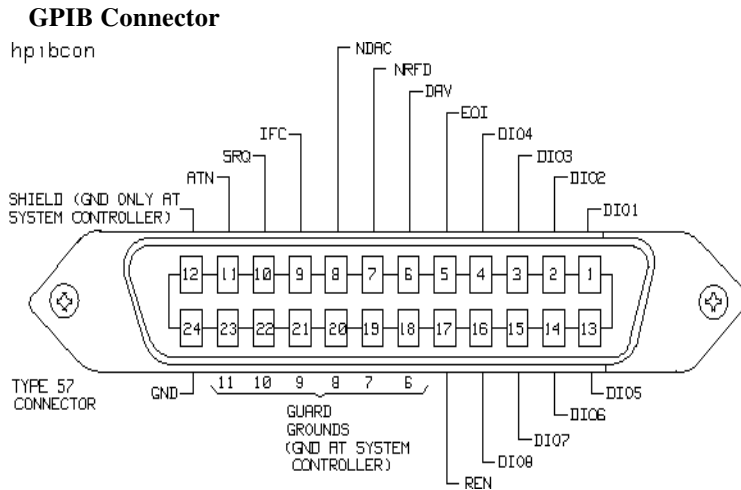

---

**CAUTION**

Agilent Technologies products delivered now are equipped with connectors having ISO metric- threaded lock screws and stud mounts (ISO M3.5×0.6) that are black in color. Earlier connectors may have lock screws and stud mounts with imperial-threaded lock screws and stud mounts (6-32 UNC) that have a shiny nickel finish.

---

**CAUTION**

It is recommended that you do not stack more than three connectors, one on top of the other.

Hand-tighten the connector lock screws. Do not use a screwdriver.

---

Installation

## Claims and Repackaging

### GPIB Logic Levels

The attenuator GPIB lines use standard TTL logic, as follows:

- True = Low = digital ground or 0Vdc to 0.4Vdc
- False = High = open or 2.5Vdc to 5Vdc

All GPIB lines have LOW assertion states. High states are held at 3.0Vdc by pull-ups within the instrument. When a line functions as an input, it requires approximately 3.2mA to pull it low through a closure to digital ground. When a line functions as an output, it can sink up to 48mA in the low state and approximately 0.6mA in the high state.

---

**NOTE**

---

**The GPIB line screens are not isolated from ground.**

---

---

## A.9 Claims and Repackaging

If physical damage is evident or if the instrument does not meet specification when received, notify the carrier and the nearest Agilent Technologies Service Office. The Sales/Service Office will arrange for repair or replacement of the unit without waiting for settlement of the claim against the carrier.

### Return Shipments to Agilent Technologies

If the instrument is to be shipped to an Agilent Technologies/Service Office, attach a tag showing owner, return address, model number and full serial number and the type of service required.

The original shipping carton and packing material may be reusable, but the Agilent Technologies/Service Office will provide information and recommendation on materials to be used if the original packing is no longer available or reusable. General instructions for repacking are as follows:



## Installation

### Claims and Repackaging

1. Wrap instrument in heavy paper or plastic.
2. Use strong shipping container. A double wall carton made of 350-pound test material is adequate.
3. Use enough shock absorbing material (3 to 4 inch layer) around all sides of the instrument to provide a firm cushion and prevent movement inside container. Protect control panel with cardboard.
4. Seal shipping container securely.
5. Mark shipping container FRAGILE to encourage careful handling.
6. In any correspondence, refer to instrument by model number and serial number.

Installation  
Claims and Repackaging

---

**B**

---

**Accessories**

---

# Accessories

---

## B.1 Instrument and Options

**Table B-1**      **Mainframe**

<b>Description</b>	<b>Model No.</b>
Optical Attenuator	Agilent 8156A
Standard	Option 100
High Performance Version	Option 101
High Performance, High Return Loss Version	Option 201
Monitor Output	Option 121
Monitor Output	Option 221
Back Reflector Kit for option 201*	Option 203
(Additional) Operating and Programming Manual	Option 0B2

\* Kit consists of 1 ea Agilent 81000SI, Agilent 81000FI,  
Agilent 81113PC, Agilent 81000UM, Agilent 81000BR

---

## B.2 GPIB Cables and Adapters

The GPIB connector is compatible with the connectors on the following cables and adapters.

- GPIB Cable, 10833A, 1 m (3.3 ft.)
- GPIB Cable, 10833B, 2 m (6.6 ft.)
- GPIB Cable, 10833C, 4 m (13.2 ft.)

### Connector Interfaces and Other Accessories

- GPIB Cable, 10833D, 0.5 m (1.6 ft.)
- GPIB Adapter, 10834A, 2.3 cm extender.

---

## B.3 Connector Interfaces and Other Accessories

The attenuator is supplied with one of three connector interface options.

- All options other than option 201 are supplied with a straight contact connector
- Option 201 with an angled contact connector

### **Straight Contact Connector**

If you want to use straight connectors (such as FC/PC, Diamond HMS-10, DIN, Biconic, SC, ST, or D4) to connect to the instrument, you must

1. attach your connector interface (see the list of connector interfaces below) to the interface adapter,
2. then connect your cable.

Figure B-1

**Straight Contact Connector Configuration**

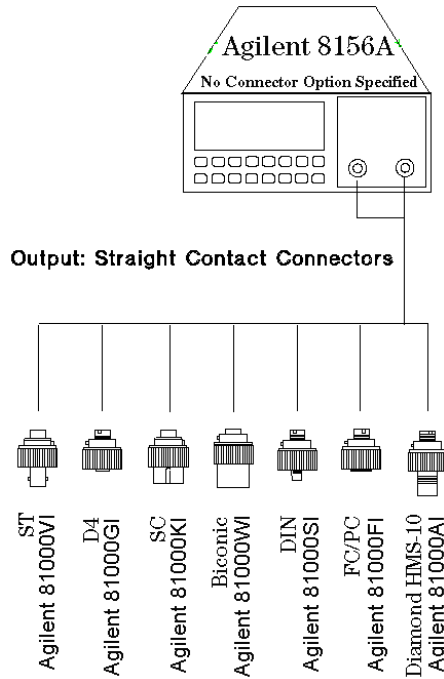

Table B-2

**Connector Interface**

Description	Agilent Model No.
Biconic	81000WI
D4	81000GI
Diamond HMS-10/HP	81000AI
DIN 47256	81000SI
FC/PC	81000FI
SC	81000KI
ST	81000VI

### Option 201, Angled Contact Connector

If you want to use angled contact connectors (such as FC/APC, Diamond HRL-10, DIN, or SC/APC) to connect to the instrument, you must

1. attach your connector interface (see the list of connector interfaces below) to the interface adapter,
2. then connect your cable.

**Figure B-2 Angled Contact Connector Configuration**

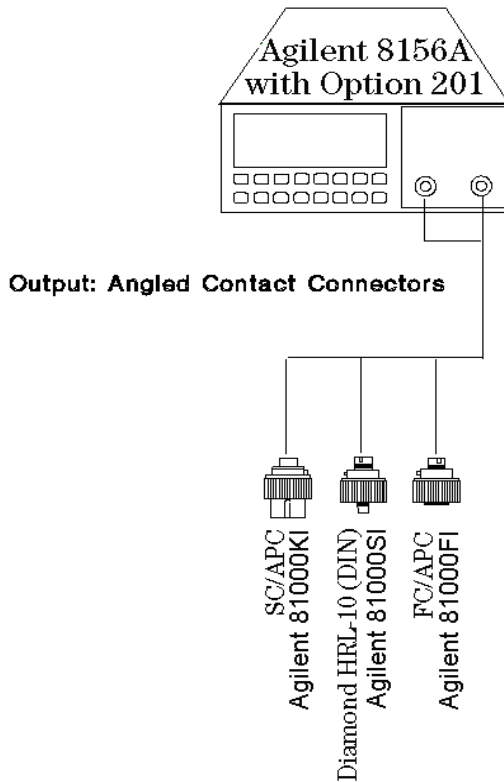



Accessories  
Connector Interfaces and Other Accessories

**Table B-3**                      **Connector Interface**

<b>Description</b>	<b>AgilentModel No.</b>
Diamond HRL-10 (DIN)	81000SI
FC/APC	81000FI
SC/APC	81000KI

Accessories

**Connector Interfaces and Other Accessories**

---

C

---

## Specifications

---

# Specifications

## C.1 Definition of Terms

### **Attenuation accuracy**

The difference between the displayed loss and  $\rightarrow$ excess loss.

**Conditions:** Attenuation adjustment prior to measurement. That is, adjustment of the measured attenuation at the highest setting so that it equals the attenuation setting, for example by adjusting the wavelength setting.

**Measurement:** with laser source or LED and optical power meter.

### **Attenuation range**

The range of displayed attenuations.

### **Excess loss**

The difference between actual loss (at an arbitrary attenuation setting) and  $\rightarrow$ insertion loss (at 0 dB setting).

### **Insertion loss**

The change of power levels after inserting the attenuator between two connectorized patchcords, with the attenuation set to 0 dB.

**Conditions:** Arbitrary wavelength setting, temperature within operating temperature range, jumper cables with high quality connectors.

**Measurement:** with laser source or LED and optical power.

### **Polarization dependent loss**

The dependence of the attenuation on the input polarization state, expressed as the difference between the highest and the lowest displayed attenuation, in dB.

**Conditions:** Fabry-Perot type laser source with variable polarization state and polarization-independent power, generation of all polarization states (covering the entire Poincar sphere), jumper cables with high-quality connectors.

## Specifications

### Definition of Terms

**Measurement:** either with a fiber-loop type polarization controller using the polarization scanning method, or with a wavelength type polarization controller using the Mueller method.

#### **Polarization mode dispersion**

The change of transit time caused by changing the input polarization state, expressed in fs ( $10^{-15}$  seconds).

**Conditions:** Generation of all polarization states (covering the entire Poincar sphere).

**Measurement:** with the Agilent Technologies polarization analyzer.

#### **Repeatability**

The random uncertainty in reproducing the attenuation after changing and re-setting the attenuation. The repeatability is  $\pm$  half the span between the maximum and the minimum attenuations, expressed in dB.

**Conditions:** uninterrupted line voltage, constant wavelength setting, temperature within  $\pm 1$  K, constant input polarization state.

**Measurement:** with an optical power meter.

#### **Return loss**

The ratio of the incident power to the reflected power, expressed in dB.

**Conditions:** jumper cables with high-quality connectors on both attenuator ports. Arbitrary attenuation setting. Applicable to both attenuator ports, with the respective second port terminated (zero reference).

**Measurement:** with a return loss meter, using a Fabry-Perot type laser source. The measurement result includes attenuator-internal reflectances and reflectances from both attenuator ports.

**Wavelength range** The range of wavelengths to which the specifications apply.

## C.2 Specifications

Specifications describe the instrument's warranted performance. Supplementary performance characteristics describe the instrument's non-warranted typical performance.

Specifications are measured at 1310nm and 1550nm using a laser source, single-mode fiber and Agilent 81000AI or Agilent 81000SI connector interfaces.

**Table C-1 Specifications - Options 100, 101 and 201**

	<b>Option 100</b>	<b>Option 101</b>	<b>Option 201</b>
	Standard	High Performance	High Return Loss
<b>Wavelength Range</b>	1200 - 1650nm		
<b>Attenuation Range</b>	60dB (excluding insertion loss)		
<b>Fiber Type</b>	9/125µm single-mode		
<b>Connector Type</b>	straight contact		angled contact
<b>Return Loss<sup>[1]</sup></b>	>35dB	>45dB	>60dB
<b>Insertion Loss (typ)<sup>[2]</sup></b>	4.5dB	2.5dB	
<b>Attenuation Accuracy (linearity)<sup>[3]</sup> typical</b>	<±0.2dB <sup>[4]</sup> <±0.1dB <sup>[4]</sup>	<±0.1dB <±0.05dB	
<b>Repeatability typical</b>	<±0.01dB		
	<±0.005dB		
<b>Polarization Dependent Loss typical</b>	<0.15dBpp <0.075dBpp	<0.08dBpp <0.02dBpp	
<b>Polarization Mode Dispersion</b>	4fs		
<b>Useful Back-Reflection Range</b>	9.0 to 35dB	5.0 to 45dB	5.0 to 60dB

- <sup>[1]</sup> Typical, depends on performance of external connector

Specifications  
Specifications

- <sup>[2]</sup> Includes insertion loss of two HMS-10 connectors. Typical variation over temperature range <0.3dBpp.
- <sup>[3]</sup> Measured at constant temperature.
- <sup>[4]</sup> With narrow linewidth lasers, such as DFB lasers, power fluctuations up to 0.2dBpp may occur.

**Table C-2**                      **Monitor Output Options**

	<b>Option 121</b>	<b>Option 221</b>
	High Performance	High Return Loss
<b>Wavelength Range</b>	1200 - 1650nm	
<b>Attenuation Range</b>	60dB (excluding insertion loss)	
<b>Fiber Type</b>	9/125μm single-mode	
<b>Connector Type</b>	straight contact	angled contact
<b>Return Loss<sup>[1]</sup></b>	>45dB	>60dB
<b>Insertion Loss (typ)<sup>[2]</sup></b>	3.3dB	
<b>Attenuation Accuracy (linearity)<sup>[3]</sup> typical</b>	<±0.1dB <±0.05dB	
<b>Repeatability typical</b>	<±0.01dB <±0.005dB	
<b>Polarization Dependent Loss typical</b>	<0.1dBpp <0.03dBpp	
<b>Polarization Mode Dispersion</b>	6fs	
<b>Monitor Output (typ.)</b>	13dB tap (1:20)	
<b>Useful Back-Reflection Range</b>	6.6 to 45dB	6.6 to 60dB

- <sup>[1]</sup> Typical, depends on performance of external connector
- <sup>[2]</sup> Includes insertion loss of two HMS-10 connectors. Typical variation over temperature range <0.3dBpp.
- <sup>[3]</sup> Measured at constant temperature.



**Table C-3**

**Multimode Options**

	<b>Option 350</b>
<b>Wavelength Range</b>	1200 - 1650nm
<b>Attenuation Range</b>	60dB (excluding insertion loss)
<b>Fiber Type</b>	50/125µm multimode
<b>Connector Type</b>	straight contact
<b>Return Loss<sup>[1]</sup></b>	22dB
<b>Insertion Loss (typ)<sup>[2]</sup></b>	3dB
<b>Attenuation Accuracy (linearity)<sup>[3]</sup> typical</b>	<±0.1dB <±0.08dB
<b>Repeatability typical</b>	<±0.01dB <±0.005dB

- <sup>[1]</sup> Typical, depends on performance of external connector
- <sup>[2]</sup> Includes insertion loss of two HMS-10 connectors. Typical variation over temperature range <0.3dBpp.
- <sup>[3]</sup> Measured at constant temperature.

**Supplementary Performance Characteristics**

**Minimum Attenuation Step:** 0.001dB

**Switching Time:** 20ms to 400ms (depending on actual setting)

**Maximum Input Power:** 23dBm (200mW)

**Operating Modes**

**Att:** Attenuation is shown on the display and can be varied.

## Specifications

### Specifications

**$\lambda$ :** Entering of wavelength for automatic correction of attenuation using typical correction values.

**Cal:** Offset factor to adjust the attenuation factor on the display within  $\pm 99.999$ dB range.

**Disp**→**Cal:** Sets attenuation value on the display to 0.000dB.

**Swp:** Manual or automatic up or down attenuation sweep. Start, stop, step size and dwell time (not for manual sweep) can be entered.

**Back Refl:** Desired return loss (back reflection level) can be entered. Requires Agilent 81000BR back reflector, or Option 203.

**Enb/Dis:** Optical signal path interrupted with shutter (>80dB isolation).

**Store/Recall:** 9 user-selectable parameter settings may be stored and recalled. Recall of default setting.

### General

Recalibration period: 1 year.

Warm-up time: 45 Minutes. Not required if previously stored within operating temperature range.

**GPIB Capability:** All modes and parameters can be programmed, SCPI command set, 8157A compatibility mode.

**GPIB Interface Function Code:** SH1, AH1, T6, L4, SR1, RL1, PP0, DC2, DT0, C0

### Environmental

Storage temperature: -40 to +70°C

Operating temperature: 0 to +55°C

Humidity: <95% R.H. (to 40°C)

Altitude: to 10,000 feet

## Specifications

### Other Specifications

Installation Category (IEC 664) II

Pollution Degree (IEC 664) 2

Specifications valid at non-condensing conditions.

#### **Power:**

100/110/220/240V<sub>rms</sub>, ±10%, 90VA max, 48-400Hz.

**Battery Back-Up:** (for non-volatile memory) With the instrument switched off all current modes and data will be maintained for at least 10 years after delivery when stored at room temperature.

**Dimensions:** 89mm H, 21s2.35mm W, 345mm D  
(3.5"×8.36"×13.6")

**Weight:** net 5.3kg (11.8lbs), shipping 9.6kg (21.2lbs)

---

## C.3 Other Specifications

<p><b>Acoustic Noise Emission:</b> For ambient temperature up to 30°C L<sub>p</sub> = 41 dB(A) L<sub>w</sub> = 4.3 Bel Typical operator position, normal operation.</p> <p>Data are results from type tests per ISO 7779(EN 27779).</p>	<p><b>Geräuschemissionswerte:</b> Bei einer Umgebungstemperatur bis 30°C L<sub>p</sub> = 41 dB(A) L<sub>w</sub> = 4.3 Bel am Arbeitsplatz, normaler Betrieb.</p> <p>Die Angabe ist das Ergebnis einer Typprüfung gemäß ISO 7779(EN 27779).</p>
---	--

## C.4 Declaration of Conformity

**Manufacturer:** Agilent Technologies  
Deutschland GmbH  
Optical Communication Measurement Division  
Herrenberger Str. 130  
D-71034 Böblingen

### We declare the system

**Product Name:** Optical Attenuator  
**Model Numbers:** 8156A  
**Product Options:** All

### conforms to the following standards

**Safety:** IEC 1010-1+A1:1992 EN 61010:1993

**EMC:** EN 55011 1990/CINSPR 11 Group 1, Class B <sup>(1)</sup>  
EN 50082-1 (1992)

IEC 801-2 (1991)	ESD	4 kV cd, 8 kV ad
IEC 801-3: (1991)	Radiated Immunity	3 V/m
IEC 801-4: (1988)	Fast Transients	0.5 kV, 1 kV

### Supplementary Information:

The product also conforms to other standards not listed here. If further information on conformance is needed, please contact your local Agilent Technologies Representative.

<sup>(1)</sup> The product was tested in a typical configuration with Agilent systems (Type test).

Böblingen, September 1st, 1993  
Updated, February 2000

Hans Baisch  
BID Regulations Consultant

---

**D**

---

**Performance Tests**

---

# Performance Tests

The procedures in this section test the optical performance of the instrument. The complete specifications to which the Agilent Technologies 8156A is tested are given in Appendix C. All tests can be performed without access to the interior of the instrument. The performance tests referspecifically to tests using the Diamond HMS-10/Agilent connector.

## **D.1 Equipment Required**

The equipment required for the performance test is listed in the table below. Any equipment which satisfies the critical specifications of the equipment given in the table, may be substituted for the recommended models.

Performance Tests  
Equipment Required

**Table D-1 Equipment Required for the Agilent 8156A (1310/1550nm)**

Instrument/Accessory	Recommended HP/ Agilent Model	Required for Option					
		100	101	121	201	221	350
Power Meter	8153A Mainframe with	x	x	x	x	x	x
CW Laser Sources 1310/1550nm	81552SM and 81553SM						
	or 81554SM	x	x	x	x	x	-
LED Source 1300nm	81542MM	-	-	-	-	-	x
Opt. Sensor Module	81532A	x	x	x	x	x	x
Return Loss Module	81534A	x	x	x	x	x	-
Reference Reflector	81000BR	x	x	x	-	-	-
Universal Through Adapter	81000UM	x	x	x	-	-	-
Back Reflector Kit	8156A Option 203	-	-	-	x	x	-
DIN Through Adapter	1005-0255	-	-	-	x	x	-
Optical Isolator		x	x	x	-	-	-
Optical Isolator		x	x	x	-	-	-
Connector Interface (6ea)	81000AI	x	x	x	-	-	-
Connector Interface (4ea)	81000AI	-	-	-	-	-	x
Connector Interface (1ea)	81000AI	-	-	x	x	x	-
Connector Interface (1ea)	81000FI	-	-	-	x	x	-
Connector Interface (4ea)	81000SI	-	-	-	x	x	-
Connector Interface (1ea)	81000SI	-	-	-	-	x	-
Single Mode Fiber (1ea)	81101AC	x	x	x	-	-	-
Single Mode Fiber (1ea)	81101AC	-	-	x	-	-	-
Single Mode Fiber (1ea)	81102SC	-	-	-	x	x	-
Single Mode Fiber (1ea)	81102SC	-	-	-	-	x	-
Single Mode Fiber (1ea)	81109AC	x	x	x	-	-	-
Single Mode Fiber (1ea)	81113PC	-	-	-	x	x	-
Multi Mode Fiber (2ea)	81501AC	-	-	-	-	-	x



## D.2 Test Record

Results of the performance test may be tabulated on the Test Record provided at the end of the test procedures. It is recommended that you fill out the Test Record and refer to it while doing the test. Since the test limits and setup information are printed on the Test Record for easy reference, the record can also be used as an abbreviated test procedure (if you are already familiar with the test procedures). The Test Record can also be used as a permanent record and may be reproduced without written permission from Agilent Technologies.

---

## D.3 Test Failure

If the Agilent 8156A fails any performance test, return the instrument to the nearest Agilent Technologies Sales/Service Office for repair.

---

## D.4 Instrument Specification

Specifications are the performance characteristics of the instrument which are certified. These specifications, listed in “Definition of Terms” on page 165, are the performance standards or limits against which the Agilent 8156A can be tested. The specifications also list some supplemental characteristics of the Agilent 8156A. Supplemental characteristics should be considered as additional information.

Any changes in the specifications due to manufacturing changes, design, or traceability to the National Institute of Standards and

Technology (NIST), will be covered in a manual change supplement, or revised manual. Such specifications supersede any that were previously published.

---

## D.5 Performance Test

The performance test given in this section includes the Total Insertion Loss Test, the Attenuation Accuracy Test, the Attenuation Repeatability Test, and the Return Loss Test. Perform each step in the order given, using the corresponding test equipment.

The performance test should be performed once at 1310nm, and then repeated at 1550nm.

---

### NOTE

**If you are testing options 100, 101 or 121, you will need to change the isolator when changing wavelength.**

**If you are using two separate sources, you will need to change them when changing wavelength.**

---

### NOTE

**Make sure that all optical connections of the test setups given in the procedure are dry and clean. DO NOT USE INDEX MATCHING OIL. Make sure that all optical connectors are undamaged. The value for insertion loss depends on the quality of the connectors.**

**The optical cables from the laser source to and from the Agilent 8156A Attenuator to the power meter must be fixed on the table to ensure minimum cable movement during the tests.**

**The environmental conditions (temperature and relative humidity) must remain constant during the tests.**

## I. Total Insertion Loss Test

Specifications	Agilent 8156A	Typ.
Insertion loss (including both connectors)	Option 100	<5.4dB
	Option 101	<3.0dB
	Option 121	<4.2dB
	Option 201	<3.0dB
	Option 221	<3.3dB
	Option 350	<3.0dB

Carry out the following Insertion Loss Test at 1310nm and 1550nm with single-mode fibers using the the equipment listed previously.

1. Turn the instruments on and allow the instruments to warm up.
2. Connect the equipment as shown in the appropriate Total Insertion Loss Test Setup 1.

Figure D-1

Total Insertion Loss Test Setup 1, Options 100, 101, 121

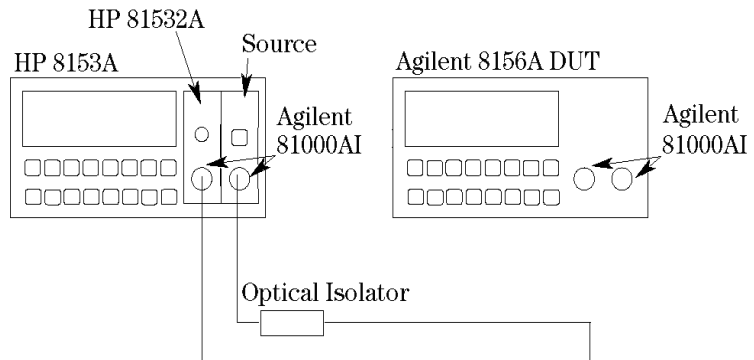

Figure D-2

Total Insertion Loss Test Setup 1, Options 201, 221

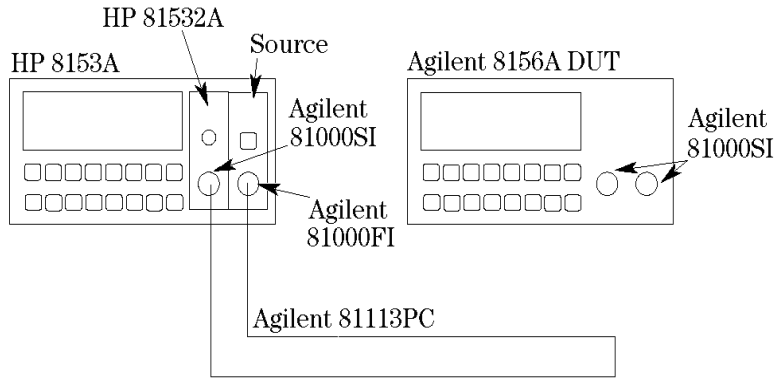
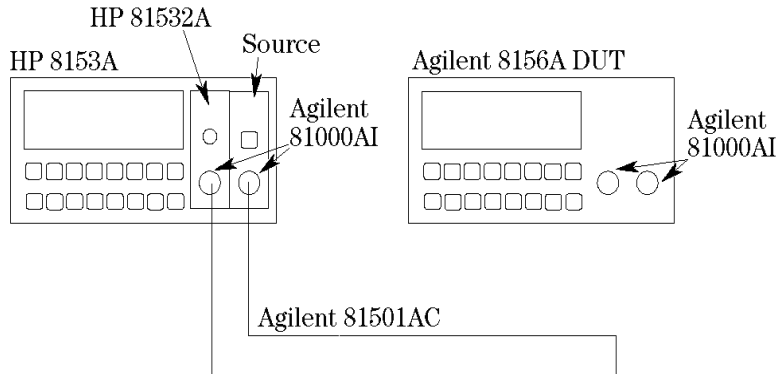

Figure D-3

Total Insertion Loss Test Setup 1, Option 350



3. On the DUT, press and hold **ATT** to reset the attenuation to minimum (any attenuation shown on the display is due to the calibration factor).
4. Zero the Power-meter and select Autorange. Display [dB]
5. Enable the laser source and set Display to Reference on the power meter.
6. Connect the equipment as shown in the appropriate Total Insertion Loss Test Setup 2.

Performance Tests  
Performance Test

Figure D-4

Total Insertion Loss Test Setup 2, Options 100, 101, 121

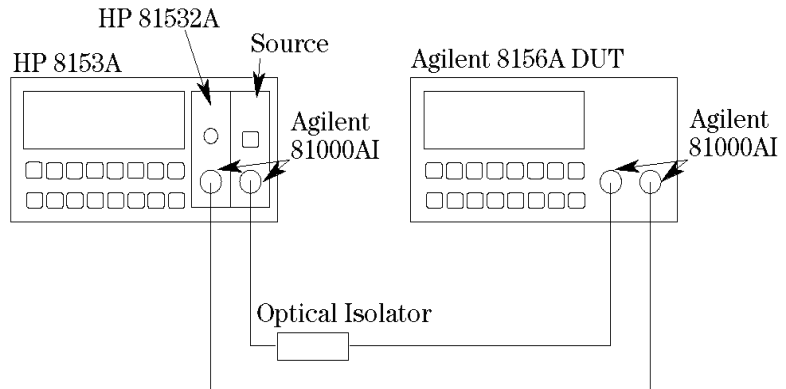
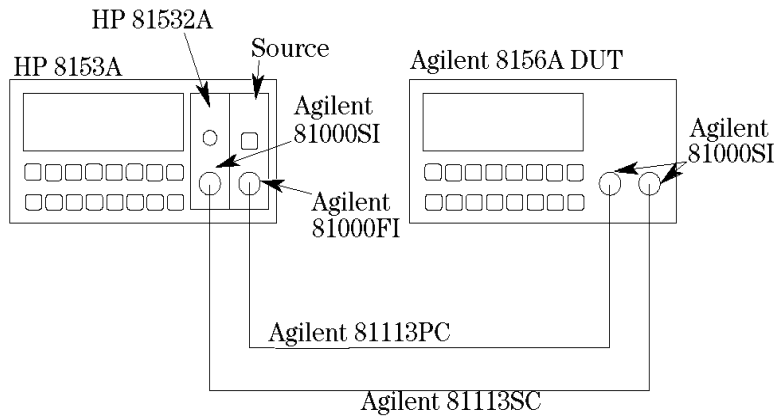

Figure D-5

Total Insertion Loss Test Setup 2, Options 201, 221



**Figure D-6**

**Total Insertion Loss Test Setup 2, Option 350**

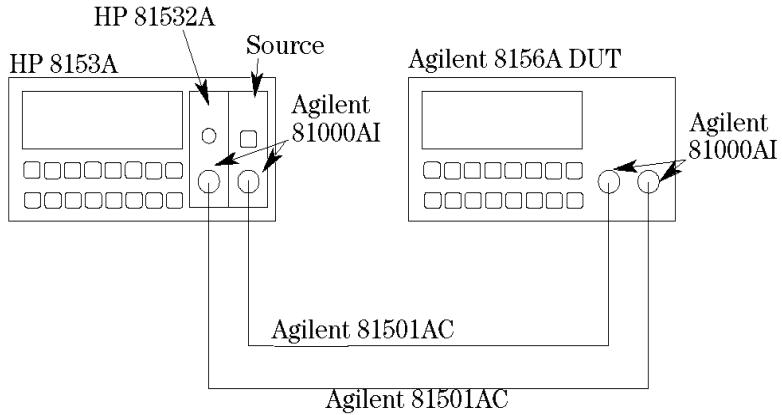

7. Enable the attenuator output and record the power meter reading (in dB) in the Test Record and check that it is within specifications.

**II. Linearity/Attenuation Accuracy Test**

Specifications	Agilent 8156A	
Linearity	Option 100	<±0.2dB
	Option 101	<±0.1dB
	Option 121	<±0.1dB
	Option 201	<±0.1dB
	Option 221	<±0.1dB
	Option 350	<±0.1dB

Carry out the following Attenuation Accuracy tests at 1310nm and 1550nm with single-mode fibers using the equipment listed previously.

## Performance Tests

### Performance Test

1. Set the attenuator as follows:

$\lambda$  as required

**CAL** to 0.00 dB

**ATT** to 0.00 dB

2. Connect the equipment as shown in the appropriate Total Insertion Loss Test Setup 2.

---

#### NOTE

---

**Use a tape to fix the fibers on the table. Don't touch the fibers during the measurement to prevent changes of state of polarization.**

3. Zero the power meter channel and make sure that the parameters are set as follows:

$\lambda$  as required

**CAL** to 0.000 dB

**T** to 500ms

4. Set the power meter to AUTOrange, then enable the laser source and the attenuator output.
5. On the power meter select display in dB (dB key)
6. Press **DISP**→**REF** for the power meter.
7. Set the DUT attenuation to 60dB
8. If the powermeter does not show 60.00dB, set [lambda] on the DUT so that the power meter shows 60.00dB. Tuning the DUT in 0.1nm steps is sufficient to accomplish this. This is necessary to eliminate the wavelength dependence of the DUT.
9. Press and hold **ATT** until the attenuation resets to 0.000dB.
10. Press **DISP**→**REF** for the power meter.
11. Increase the DUT attenuation in steps as shown below and note the power meter reading in the Test Record.

## Performance Tests

### Performance Test

#### 0.00dB REFERENCE

1 dB	2 dB	3 dB	4 dB
5 dB	6 dB	7 dB	8 dB
9 dB	10 dB	11 dB	12 dB
13 dB	14 dB	24 dB	34 dB
44 dB	54 dB	60 dB	

### III. Attenuation Repeatability Test

#### Specifications

#### Agilent 8156A

Repeatability after any parameter has been changed and reset  $<\pm 0.01$  dB.

Use the same equipment, test setup and instrument settings as used for the Attenuation Accuracy test (see the appropriate Total Insertion Loss Test Setup 2).

1. Set the Agilent 8156A attenuation to 1 dB and press **DISP**→**REF** on the power meter.
2. Set the Agilent 8156A attenuation to any other value (e.g. 0.00 dB), wait until it settles at this value (The time taken to change depends on the size of the attenuation factor change, and is in the range 20 to 400ms (typical value is 200ms)). Then change the attenuation back to the previous value. Note the deviation (dB) in the Test Record and check that it is within  $\pm 0.01$  dB.
3. Repeat steps 1 and 2 for the following attenuation settings:

5 dB	12 dB	24 dB	36 dB
48 dB	53 dB	60 dB	



## IV. Return Loss Test

### Options 100, 101, and 121

Specifications	Agilent 8156A	
Return Loss	Option 100	>35dB
	Option 101	>45dB
	Option 121	>45dB

1. Make sure that all connectors are carefully cleaned.
2. Connect the source to the HP 81534A Input. Attach the high return loss connector of the patchcord to the Output (the high return loss connector on these cables is the connector with the orange sleeve). Using tape, fix the cables to the table.

Figure D-7

Return Loss Test Setup 1, Options 100, 101, 121

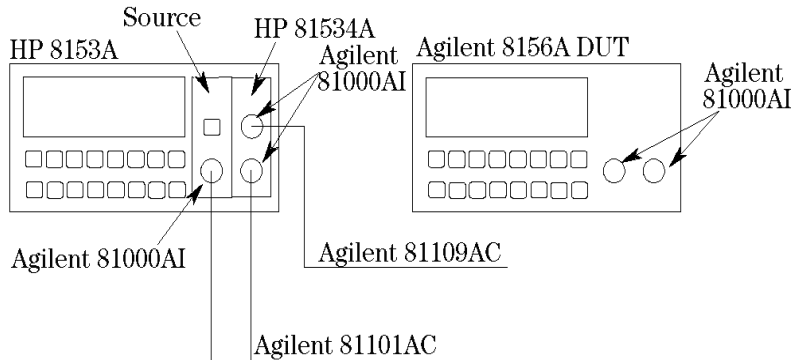

3. Make sure that the instrument has warmed up.
4. Disable the source, cover the end of the patchcord (for instance, using the blue cap supplied with the fiber) and press **ZERO** to remove offsets in the power meter.
5. Press **PARAM** to select the T parameter. Set the averaging time to 1s.

## Performance Tests

### Performance Test

6. Press **PARAM** to select the  $[\lambda]$  parameter. Edit this parameter and set it to the current wavelength of the source.
7. Enable the source.
8. Press **PARAM** to select the CAL REF parameter (the current value for the known return loss is displayed with R: at the side of the character field).
9. Attach the Agilent 81000BR Reference Reflector to the patchcord. (Use the Agilent 81000UM, with a connector interface to do this)
10. Set the reflection reference (R:) to 0.18dB, the default value of the return loss of the reference reflector.
11. Press **DISP**→**REF** (the value read should now be 0.18dB, the same as the value entered for R:).

---

#### NOTE

---

**If this is the first time that you have transferred this value to the reference after switch on, it might not be displayed properly. In this case, repeat the step to correct the display.**

12. Press **PARAM** to select the REF AUX parameter.
13. Terminate the cable by wrapping the fiber five times around the shaft of a screwdriver.
14. Press **DISP**→**REF** (the instrument sets the termination parameter).
15. Disable the DUT.

---

#### NOTE

---

**If you have the monitor option (option 121), make sure that the cable at the monitor output is terminated.**

16. Connect the 81109AC patchcord to the 8156A input, and note the Return Loss result in the Test Record.
17. Connect the 81109AC patchcord to the 8156A output, and note the Return Loss result in the Test Record.

Performance Tests  
Performance Test

Figure D-8

Return Loss Test Setup 2, Options 100, 101

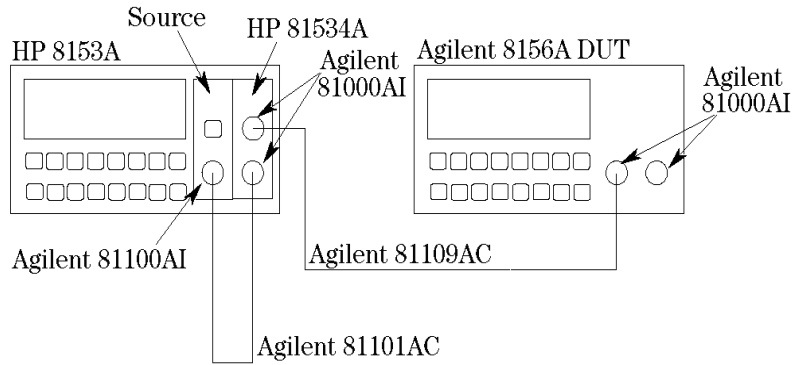
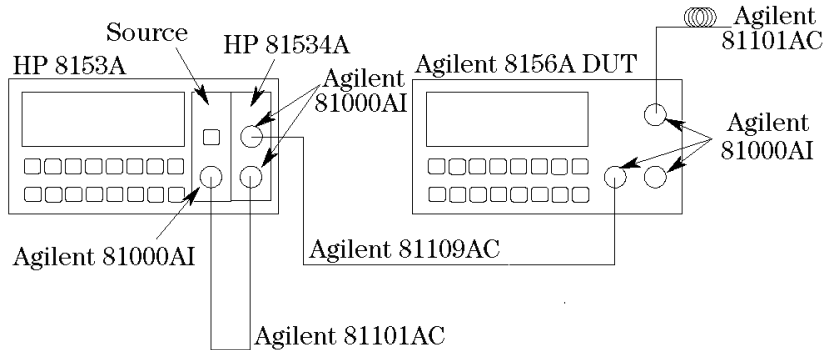

Figure D-9

Return Loss Test Setup 2, Option 121



Options 201 and 221

Specifications	Agilent 8156A	
Return Loss	Option 201	>60dB
	Option 221	>60dB

Performance Tests  
Performance Test

1. Make sure that all connectors are carefully cleaned.
2. Connect the source to the HP 81534A Input. Attach the high return loss connector of the patchcord to the Output (the high return loss connector on these cables is the connector with the orange sleeve). Using tape, fix the cables to the table.

Figure D-10

Return Loss Test Setup 1, Options 201, 221

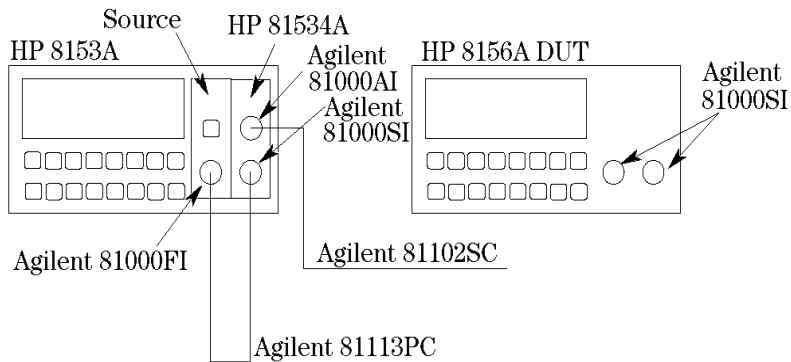

3. Make sure that the instrument has warmed up.
4. Disable the source, cover the end of the patchcord (for instance, using the blue cap supplied with the fiber) and press **ZERO** to remove offsets in the power meter.
5. Press **PARAM** to select the T parameter. Set the averaging time to 1s.
6. Press **PARAM** to select the  $\lambda$  parameter. Edit this parameter and set it to the current wavelength of the source.
7. Enable the source.
8. Press **PARAM** to select the CAL REF parameter (the current value for the known return loss is displayed with R: at the side of the character field).
9. Attach the option 203 to the patchcord. (Use the DIN Through Adapter (Agilent P/N 1005-0255) to do this)
10. Set the reflection reference (R:) to 0.98dB, the default value of the return loss of the reference reflector.

## Performance Tests

### Performance Test

11. Press **DISP**→**REF** (the value read should now be 0.98dB, the same as the value entered for R:).
12. Press **PARAM** to select the REF AUX parameter.
13. Terminate the cable by wrapping the fiber five times around the shaft of a screwdriver.
14. Press **DISP**→**REF** (the instrument sets the termination parameter).
15. Disable the DUT.

---

**NOTE**

---

**If you have the monitor option (option 221), make sure that the cable at the monitor output is terminated.**

16. Connect the 81102SC patchcord to the 8156A input, and note the Return Loss result in the Test Record.
17. Connect the 81102SC patchcord to the 8156A output, and note the Return Loss result in the Test Record.

**Figure D-11**

#### Return Loss Test Setup 2, Option 201

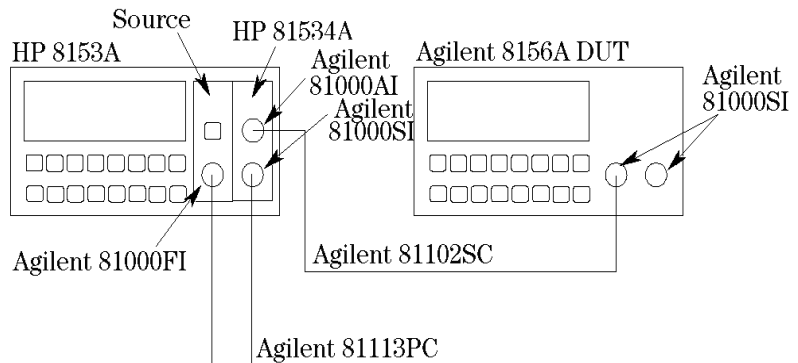
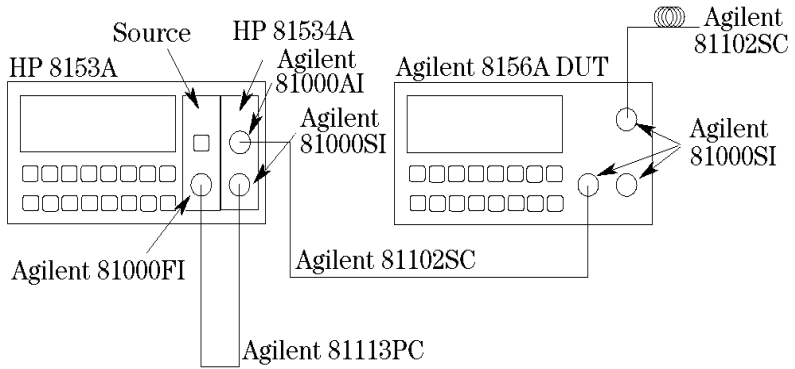

Figure D-12

Return Loss Test Setup 2, Option 221



## D.6 V. Polarization Dependent Loss (PDL): Optional

**Table D-2**                      **Equipment for the PDL test 1**

Instrument/Accessory	Recommended HP/ Agilent Model	Required for Option				
		100	101	102	201	202
Polarization Controller	8169A #021 <sup>1</sup>	1	1	1	1	1
Lightwave Multimeter Mainframe	8153A	1	1	1	1	1
Optical Head Interface	81533B	1	1	1	1	1
CW Laser Source 1310nm	81552SM and	1	1	1	1	1
	1550nm 81533SM	1	1	1	1	1
	<b>or</b> 1310/1550nm 81544SM	1	1	1	1	1
Optical Head <sup>2</sup>	81521B	1	1	1	1	1
Depolarizing Filter	81000DF	1	1	1	1	1
Connector Interface	81000AI	6	6	6	2	2
Connector Interface	81000FI	-	-	-	1	1
Connector Interface	81000SI	-	-	-	2	2
Connector Adapter	81000AA	1	1	1	-	-
Connector Adapter	81000SA	-	-	-	1	1
Single Mode Fiber	81101AC	3	3	3	1	1
Single Mode Fiber	81113PC	-	-	-	1	1
Single Mode Fiber	81113SC	-	-	-	1	1
Isolator		1	1	1	1	1

<sup>1</sup> The equipment is described for a test setup with a polarization controller with option 021 (straight connector). If you want to use a polarization controller with a different connector option you have to use interfaces, adapters and patchcords depending on this option.

## Performance Tests

### V. Polarization Dependent Loss (PDL): Optional

<sup>2</sup> Instead of a standard HP 81521B+ Depolarizing Filter Agilent 81000DF, an HP 81521B #001 can also be used, as this option is especially designed for low PDL.

#### Polarization Dependent Loss Test (Mueller method)

1. Connect the equipment as shown in Figure D-13
  - a. Make sure that the connectors, lenses and detector windows are clean. Refer to the cleaning procedure.
  - b. Ensure that the instruments have warmed up.

Figure D-13

#### PDL Test Setup 1: Reference Measurement

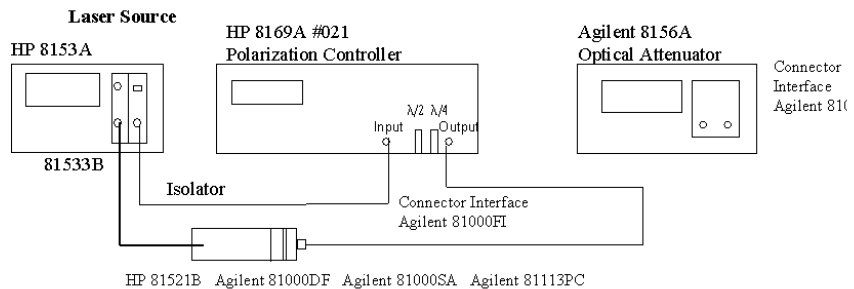

#### PDL Test Setup 1 with options 201, 221 (angled connectors)

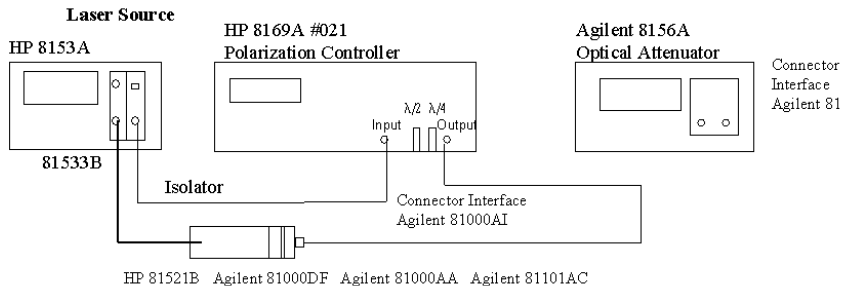

#### PDL Test Setup 1 with options 100, 101, 121 (straight connectors)

2. Using the setup of Figure D-13:  
Use a tape to fix the patchcords on the table.



---

**CAUTION**

---

**The patchcord from the source to the polarization controller - with the isolator - must not move during and between all measurements.**

**The patchcords between the polarization controller and the optical head must not move from the beginning of the reference measurements until these are finished.**

---

3. Zero the 8153A.
  - a. Ensure that the laser source is switched off.
  - b. Press **MENU** to change the Measure Mode.
  - c. Press **ZERO** and wait while zeroing.
4. Set up the laser source.
  - a. Set the laser source to 1550 nm (nominal), switch the laser on, and allow 5 minutes for the laser to settle.
  - b. Note the actual wavelength in the test record.
5. Set up the power meter.
  - a. Set the power meter to the actual wavelength.  
Press **PARAM** until the wavelength is displayed, then use the modify cursor keys to set the actual wavelength.
  - b. Set the averaging time to 100 ms.  
Press **PARAM** until the averaging time is displayed, then use the modify cursor keys to set the averaging time to 100 ms.
  - c. Set the display to W.  
Press **DBM/W**.
6. Set the polarization filter of the 8169A to maximize the signal.
  - a. Reset the position of all plates.  
Press **HOME** on the polarization controller.
  - b. Select the polarization filter.  
You may need to press **POS** and/or **Pol** if the filter is not

## Performance Tests

### V. Polarization Dependent Loss (PDL): Optional

already selected.

- c. Modify the filter setting to find the maximum signal transmission through the polarization controller:
  - Select the most significant digit by using the cursor key.  
Use the Modify knob to adjust the displayed angle slowly until the power reading on the multimeter shows the maximum value.
  - Select the next digit with the cursor key.  
Use the Modify knob to adjust the displayed angle slowly until the power reading on the multimeter shows the maximum value.
  - Select the least significant digit by using the cursor key.  
Use the Modify knob to adjust the displayed angle slowly until the power reading on the multimeter shows the maximum value.
  - Press **ENTER**
  - Note the displayed angle of the polarization filter as "Polarizer Setting, Linear Horizontal Polarization" in the Test Record.

For the following steps, the polarizer is kept constant.

#### **Set plates for Linear Horizontal polarization**

7. Set the  $\lambda/4$  Retarder Plate for Linear Horizontal polarization.
  - a. Select the  $\lambda/4$  Retarder Plate.  
Press  $\lambda/4$
  - b. Modify the  $\lambda/4$  plate setting to the same angle as the polarization filter found in item 6c.
  - c. Press **ENTER**
  - d. Note the angle as " $\lambda/4$  Plate Setting, Linear Horizontal Polarization" in the Test Record.
8. Set the  $\lambda/2$  Retarder Plate for Linear Horizontal polarization.

## Performance Tests

### V. Polarization Dependent Loss (PDL): Optional

- a. Select the  $\lambda/2$  Retarder Plate.  
Press  $\lambda/2$
- b. Modify the  $\lambda/2$  plate setting to the same angle as the polarization filter found in item 6c.
- c. Press **ENTER**
- d. Note the angle as " $\lambda/2$  Plate Setting, Linear Horizontal Polarization" in the Test Record.

#### **Determine settings for Linear Vertical, Linear Diagonal, and Right Hand Circular Polarization**

9. In order to get the required polarization, the  $\lambda/2$  and  $\lambda/4$  retarder plates need to be set to the appropriate values. The corrected positions of the polarizer plates depend on the actual wavelength and have to be taken from Table D-3.

In the case of Linear Horizontal polarized light no correction is to be done. The table lists corrections for every 20 nm step. For wavelengths between listed values, a linear approximation should be used.

The value taken from the table (possible by approximation) is to be added to the values of the  $\lambda/4$  and  $\lambda/2$  retarder plate setting for Linear Horizontal polarized light determined in steps 7. and 8. respectively:

- Get the values for the wavelength dependent offset positions for each type of polarization from Table D-3.
- Add these values to those for Linear Horizontal polarized light.
- Note the calculated "corrected wavelength dependent position" values in the Test Record for the  $\lambda/4$  Plate Setting and the  $\lambda/2$  Plate setting for Linear Vertical, Linear Diagonal and Right Hand Circular polarization.

**Example:** actual wavelength 1552 nm. Find the maximum transmission for the Linear Horizontal polarized light at a polarization filter setting of  $15.4^\circ$ .

In Table D-3, wavelength dependent positions can be found and

Performance Tests

**V. Polarization Dependent Loss (PDL): Optional**

approximated:

$\lambda$	Linear vertical		Linear diagonal		RH circular	
	$\lambda/4$ Plate	$\lambda/2$ Plate	$\lambda/4$ Plate	$\lambda/2$ Plate	$\lambda/4$ Plate	$\lambda/2$ Plate
1560nm	1.2°	45.6°	0.8°	22.9°	44°	-16.5°
1552nm	0.7°	45.4°	0.5°	22.7°	44.4°	-15.9°
1540nm	0°	45°	0°	22.5°	45°	-15.1°

The associated Test record will look like this by adding the appropriate values to those of the Linear Horizontal polarized light.

	Polarization			
	Linear Horizontal	Linear Vertical	Linear Diagonal	Right Hand Circular
Polarizer Setting	15.4°	n/a	n/a	n/a
$\lambda/4$ Plate Setting	15.4°	n/a	n/a	n/a
$\lambda/2$ Plate Setting	15.4°	n/a	n/a	n/a
Corrected wavelength dependent positions:				
$\lambda/4$ Plate Setting	n/a	16.1°	15.9°	59.8°
$\lambda/2$ Plate Setting	n/a	60.8°	38.1°	-0.5°

**10. Measure the Reference Power**

a. Linear Horizontal polarized light.

Keep the setting from the polarizer and the  $\lambda/4$  and  $\lambda/2$  Retarder Plates from steps 6. to 8.

- Read the power that is displayed on the power meter and note it as  $P_{01}$  in the test record.

## Performance Tests

### V. Polarization Dependent Loss (PDL): Optional

#### b. Linear Vertical polarized light.

- Set the  $\lambda/4$  and  $\lambda/2$  Retarder Plates to the "corrected wavelength dependent positions" for Linear Vertical polarized light.

You need to select the  $\lambda/4$  and  $\lambda/2$  Retarder plates by pressing  $\lambda/4$  and  $\lambda/2$  respectively.

Type the appropriate value and press **ENTER** after each entry.

- Read the power that is displayed on the power meter and note it as  $P_{02}$  in the test record.

#### c. Linear Diagonal polarized light.

- Set the  $\lambda/4$  and  $\lambda/2$  Retarder Plates to the "corrected wavelength dependent positions" for Linear Diagonal polarized light.

You need to select the  $\lambda/4$  and  $\lambda/2$  Retarder plates by pressing  $\lambda/4$  and  $\lambda/2$  respectively.

Type the appropriate value and press **ENTER** after each entry.

- Read the power that is displayed on the power meter and note it as  $P_{03}$  in the test record.

#### d. Right Hand Circular polarized light.

- Set the  $\lambda/4$  and  $\lambda/2$  Retarder Plates to the "corrected wavelength dependent positions" for Right Hand Circular polarized light.

You need to select the  $\lambda/4$  and  $\lambda/2$  Retarder plates by pressing  $\lambda/4$  and  $\lambda/2$  respectively.

Type the appropriate value and press **ENTER** after each entry.

- Read the power that is displayed on the power meter and note it as  $P_{04}$  in the test record.

11. Connect the equipment as shown in Figure D-14.

**CAUTION**

The patchcords between the polarization controller and the optical head must not move until the measurements are finished.

12. Set the 8156A Attenuator (DUT) to 0dB using the modify keys.

**Figure D-14 PDL Test Setup 2: Power after DUT**

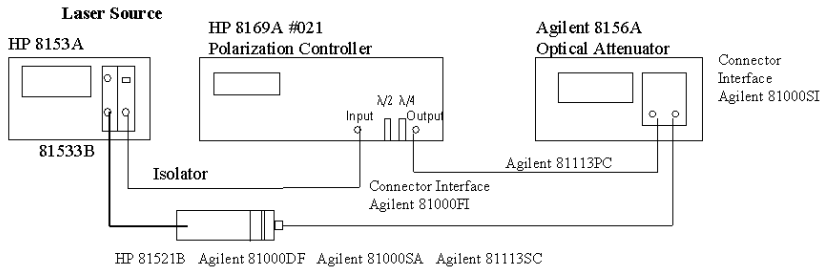

**PDL Test Setup 2 with options 201, 221 (angled connectors)**

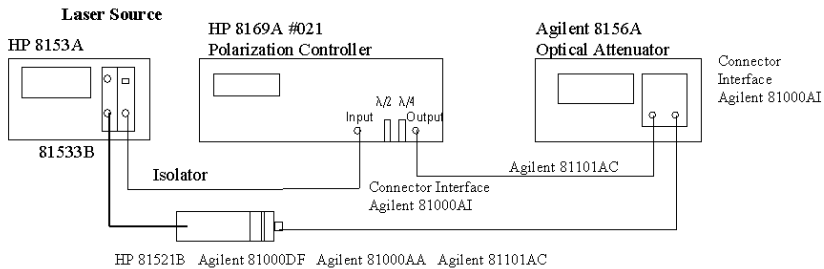

**PDL Test Setup 2 with options 100, 101, 121 (straight connectors)**

**13. Measure the optical power after the DUT**

- a. Linear Horizontal polarized light.
  - Set the  $\lambda/4$  and  $\lambda/2$  Retarder Plates for Linear Horizontal polarization. You need to select the  $\lambda/4$  and  $\lambda/2$  Retarder plates by pressing  $\lambda/4$  and  $\lambda/2$  respectively.

Type the appropriate value and press **ENTER** after each entry.

## Performance Tests

### V. Polarization Dependent Loss (PDL): Optional

- Read the power that is displayed on the power meter and note it as  $P_{DUT01}$  in the test record.
- b. Linear Vertical polarized light.
  - Set the  $\lambda/4$  and  $\lambda/2$  Retarder Plates to the "corrected wavelength dependent positions" for Linear Vertical polarized light.

You need to select the  $\lambda/4$  and  $\lambda/2$  Retarder plates by pressing  $\lambda/4$  and  $\lambda/2$  respectively.

Type the appropriate value and press **ENTER** after each entry.
  - Read the power that is displayed on the power meter and note it as  $P_{DUT02}$  in the test record.
- c. Linear Diagonal polarized light.
  - Set the  $\lambda/4$  and  $\lambda/2$  Retarder Plates to the "corrected wavelength dependent positions" for Linear Diagonal polarized light.

You need to select the  $\lambda/4$  and  $\lambda/2$  Retarder plates by pressing  $\lambda/4$  and  $\lambda/2$  respectively.

Type the appropriate value and press **ENTER** after each entry.
  - Read the power that is displayed on the power meter and note it as  $P_{DUT03}$  in the test record.
- d. Right Hand Circular polarized light.
  - Set the  $\lambda/4$  and  $\lambda/2$  Retarder Plates to the "corrected wavelength dependent positions" for Right Hand Circular polarized light.

You need to select the  $\lambda/4$  and  $\lambda/2$  Retarder plates by pressing  $\lambda/4$  and  $\lambda/2$  respectively.

Type the appropriate value and press **ENTER** after each entry.
  - Read the power that is displayed on the power meter and note it as  $P_{DUT04}$  in the test record.

## Performance Tests

### V. Polarization Dependent Loss (PDL): Optional

#### 14. Calculate

- a. the Mueller coefficients
  - b. the Minimum and Maximum transmission, and finally
  - c. the Polarization Dependent Loss (PDL)
- as described in the test record.

#### 15. Laser set up for the higher wavelength

- a. Set the laser source to 1310nm (nominal)
- b. Switch the laser on and allow to settle for about 5 minutes
- c. Note the actual wavelength in the test record
- d. Repeat steps 6. to 14. for this wavelength as well.

**Table D-3 Performance Test Agilent 8156A**

$\lambda$	Linear vertical		Linear diagonal		RH Circular	
	$\lambda/4$ -Plate	$\lambda/2$ -Plate	$\lambda/4$ -Plate	$\lambda/2$ -Plate	$\lambda/4$ -Plate	$\lambda/2$ -Plate
1580nm	2.5°	46.2°	1.7°	23.3°	42.9°	-17.1°
1560nm	1.2°	45.6°	0.8°	22.9°	44.0°	-16.5°
1540nm	0°	45.0°	0°	22.5°	45.0°	-15.1°
1520nm	-1.4°	44.3°	-1°	22.0°	46.2°	-13.8°
1500nm	-2.7°	43.6°	-2°	21.4°	47.4°	-12.4°
1340nm	-14.7°	36.2°	-13.9°	12.8°	58.1°	-0.7°
1320nm	-16.3°	35.1°	-16°	11.0°	59.6°	1°
1300nm	-17.9°	34.0°	-18.5°	8.9°	61.2°	3°
1280nm	-19.6°	32.9°	-21.2°	6.5°	62.9°	5.1°
1260nm	-21.2°	31.7°	-24.2°	3.9°	64.7°	7.4°



Performance Tests

V. Polarization Dependent Loss (PDL): Optional

**Performance Test for the Agilent 8156A**

Page 1 of 8

Test Facility:

\_\_\_\_\_ Report No. \_\_\_\_\_

\_\_\_\_\_ Date: \_\_\_\_\_

\_\_\_\_\_ Customer: \_\_\_\_\_

\_\_\_\_\_ Tested By: \_\_\_\_\_

Model: Agilent 8156A Attenuator

Serial No. \_\_\_\_\_ Ambient temperature \_\_\_\_\_ °C

Options \_\_\_\_\_ Relative humidity \_\_\_\_\_ %

Firmware Rev. \_\_\_\_\_ Line frequency \_\_\_\_\_ Hz

Special Notes:

\_\_\_\_\_  
\_\_\_\_\_  
\_\_\_\_\_  
\_\_\_\_\_  
\_\_\_\_\_  
\_\_\_\_\_  
\_\_\_\_\_  
\_\_\_\_\_

**Performance Test for the Agilent 8156A Option 100**

Page 2 of 8

**Model** \_\_\_\_\_ **Module** \_\_\_\_\_ **Report No.** \_\_\_\_\_ **Date** \_\_\_\_\_

**Test Equipment Used:**

Description	Model No.	Trace No.	Cal. Due Date
1. Power Meter	8153A	_____	__ / __ / __
2a1. CW Laser Sources 1310nm	81552SM	_____	__ / __ / __
2a2. CW Laser Sources 1550nm	81553SM	_____	__ / __ / __
2b. CW Laser Sources 1310/1550nm	or 81554SM	_____	__ / __ / __
3. Opt Sensor Module	81532A	_____	__ / __ / __
4. Return Loss Module	81534A	_____	__ / __ / __
5. Reference Reflector	81000BR	_____	__ / __ / __
6. Universal Through Adapter	81000UM	_____	__ / __ / __
7.1 Optical Isolator 1310nm	81210LI	_____	__ / __ / __
	Opt011		
7.2 Optical Isolator 1550nm	81310LI	_____	__ / __ / __
	Opt011		
8. Connector Interface (6ea)	81000AI	_____	__ / __ / __
9.1 Single Mode Fiber (1ea)	81101AC	_____	__ / __ / __
9.2 Single Mode Fiber	81109AC	_____	__ / __ / __
10. _____	_____	_____	__ / __ / __
11. _____	_____	_____	__ / __ / __
12. _____	_____	_____	__ / __ / __
13. _____	_____	_____	__ / __ / __
14. _____	_____	_____	__ / __ / __
15. _____	_____	_____	__ / __ / __
16. _____	_____	_____	__ / __ / __

Performance Tests

V. Polarization Dependent Loss (PDL): Optional

**Performance Test for the Agilent 8156A Option 100**

Page 3 of 8

Model Agilent 8156A Attenuator Option 100 No. \_\_\_\_\_ Date \_\_\_\_\_

Test No.	Test Description performed at _____ nm	Minimum Spec.	Result	Maximum Spec.	Measurement Uncertainty
I.	<b>Total Insertion Loss Test</b> typ. <4.5dB  measured at _____ nm with singlemode fiber		dB	5.4 dB	±0.60dB
II.	<b>Linearity/Att. Acc.</b>  Attenuation Setting:				±0.05dB
	0dB		REF		
	1dB	0.8dB		1.2dB	
	2dB	1.8dB		2.2dB	
	3dB	2.8dB		3.2dB	
	4dB	3.8dB		4.2dB	
	5dB	4.8dB		5.2dB	
	6dB	5.8dB		6.2dB	
	7dB	6.8dB		7.2dB	
	8dB	7.8dB		8.2dB	
	9dB	8.8dB		9.2dB	
	10dB	9.8dB		10.2dB	

Performance Tests

V. Polarization Dependent Loss (PDL): Optional

**Performance Test for the Agilent 8156A Option 100**

Page 4 of 8

Model Agilent 8156A Attenuator Option 100 No. \_\_\_\_\_ Date \_\_\_\_\_

Test No.	Test Description performed at _____ nm	Minimum Spec.	Result	Maximum Spec.	Measurement Uncertainty
II.	<b>Linearity/Att. Acc.</b>				$\pm 0.05\text{dB}$
	Attenuation Setting:				
	11dB	10.8dB	_____	11.2dB	
	12dB	11.8dB	_____	12.2dB	
	13dB	12.8dB	_____	13.2dB	
	14dB	13.8dB	_____	14.2dB	
	24dB	23.8dB	_____	24.2dB	
	34dB	33.8dB	_____	34.2dB	
	44dB	43.8dB	_____	44.2dB	
	54dB	53.8dB	_____	54.2dB	
	60dB	59.8dB	_____	60.2dB	

Performance Tests

V. Polarization Dependent Loss (PDL): Optional

**Performance Test for the Agilent 8156A Option 100**

Page 5 of 8

Model Agilent 8156A Attenuator Option 100 No. \_\_\_\_\_ Date \_\_\_\_\_

Test No.	Test Description performed at _____ nm	Minimum Spec.	Result	Maximum Spec.	Measurement Uncertainty
III.	<b>Att. Repeatability Test</b>				±0.01dB
	Attenuation Setting:				
	1dB Disp→ Ref	-0.01dB	_____	+ 0.01dB	
	5dB Disp→ Ref	-0.01dB	_____	+ 0.01dB	
	12dB Disp→ Ref	-0.01dB	_____	+ 0.01dB	
	24dB Disp→ Ref	-0.01dB	_____	+ 0.01dB	
	36dB Disp→ Ref	-0.01dB	_____	+ 0.01dB	
	48dB Disp→ Ref	-0.01dB	_____	+ 0.01dB	
	53dB Disp→ Ref	-0.01dB	_____	+ 0.01dB	
	60dB Disp→ Ref	-0.01dB	_____	+ 0.01dB	
IV.	<b>Return Loss Test</b>				
	typ. >35dB				
	Input	30dB	_____		±0.60dB
	Output	30dB	_____		±0.60dB

Performance Tests

V. Polarization Dependent Loss (PDL): Optional

**Performance Test for the Agilent 8156A Option 100**

Page 6 of 8

Model Agilent 8156A Attenuator Option 100 No. \_\_\_\_\_ Date \_\_\_\_\_

Test No.	Test Description performed at _____ nm	Minimum Spec.	Result	Maximum Spec.	Measurement Uncertainty
I.	<b>Total Insertion Loss Test</b> typ. <4.5dB  measured at _____ nm with SM fiber		dB	5.4 dB	±0.60dB
II.	<b>Linearity/Att. Acc.</b>  Attenuation Setting:				±0.05dB
	0dB		REF		
	1dB	0.8dB		1.2dB	
	2dB	1.8dB		2.2dB	
	3dB	2.8dB		3.2dB	
	4dB	3.8dB		4.2dB	
	5dB	4.8dB		5.2dB	
	6dB	5.8dB		6.2dB	
	7dB	6.8dB		7.2dB	
	8dB	7.8dB		8.2dB	
	9dB	8.8dB		9.2dB	
	10dB	9.8dB		10.2dB	

Performance Tests

V. Polarization Dependent Loss (PDL): Optional

**Performance Test for the Agilent 8156A Option 100**

Page 7 of 8

Model Agilent 8156A Attenuator Option 100 No. \_\_\_\_\_ Date \_\_\_\_\_

Test No.	Test Description performed at _____ nm	Minimum Spec.	Result	Maximum Spec.	Measurement Uncertainty
II.	<b>Linearity/Att. Acc.</b>				±0.05dB
	Attenuation Setting:				
	11dB	10.8dB	_____	11.2dB	
	12dB	11.8dB	_____	12.2dB	
	13dB	12.8dB	_____	13.2dB	
	14dB	13.8dB	_____	14.2dB	
	24dB	23.8dB	_____	24.2dB	
	34dB	33.8dB	_____	34.2dB	
	44dB	43.8dB	_____	44.2dB	
	54dB	53.8dB	_____	54.2dB	
	60dB	59.8dB	_____	60.2dB	

Performance Tests

V. Polarization Dependent Loss (PDL): Optional

**Performance Test for the Agilent 8156A Option 100**

Page 8 of 8

Model Agilent 8156A Attenuator Option 100 No. \_\_\_\_\_ Date \_\_\_\_\_

Test No.	Test Description performed at _____ nm	Minimum Spec.	Result	Maximum Spec.	Measurement Uncertainty
III.	<b>Att. Repeatability Test</b>				±0.01dB
	Attenuation Setting:				
	1dB Disp→ Ref	-0.01dB	_____	+ 0.01dB	
	5dB Disp→ Ref	-0.01dB	_____	+ 0.01dB	
	12dB Disp→ Ref	-0.01dB	_____	+ 0.01dB	
	24dB Disp→ Ref	-0.01dB	_____	+ 0.01dB	
	36dB Disp→ Ref	-0.01dB	_____	+ 0.01dB	
	48dB Disp→ Ref	-0.01dB	_____	+ 0.01dB	
	53dB Disp→ Ref	-0.01dB	_____	+ 0.01dB	
	60dB Disp→ Ref	-0.01dB	_____	+ 0.01dB	
IV.	<b>Return Loss Test</b>				
	typ. >35dB	Input 30dB	_____		±0.60dB
		Output 30dB	_____		±0.60dB



**Performance Test for the Agilent 8156A Option 101**

Page 2 of 8

**Model** \_\_\_\_\_ **Module** \_\_\_\_\_ **Report No.** \_\_\_\_\_ **Date** \_\_\_\_\_

**Test Equipment Used:**

Description	Model No.	Trace No.	Cal. Due Date
1. Power Meter	8153A	_____	__ / __ / __
2a1. CW Laser Sources 1310nm	81552SM	_____	__ / __ / __
2a2. CW Laser Sources 1550nm	81553SM	_____	__ / __ / __
2b. CW Laser Sources 1310/1550nm	or 81554SM	_____	__ / __ / __
3. Opt Sensor Module	81532A	_____	__ / __ / __
4. Return Loss Module	81534A	_____	__ / __ / __
5. Reference Reflector	81000BR	_____	__ / __ / __
6. Universal Through Adapter	81000UM	_____	__ / __ / __
7.1 Optical Isolator 1310nm	81210LI	_____	__ / __ / __
7.2 Optical Isolator 1550nm	or 81310LI	_____	__ / __ / __
8. Connector Interface (6ea)	Opt 011 81000AI	_____	__ / __ / __
9.1 Single Mode Fiber (1ea)	81101AC	_____	__ / __ / __
9.2 Single Mode Fiber	81109AC	_____	__ / __ / __
10. _____	_____	_____	__ / __ / __
11. _____	_____	_____	__ / __ / __
12. _____	_____	_____	__ / __ / __
13. _____	_____	_____	__ / __ / __
14. _____	_____	_____	__ / __ / __
15. _____	_____	_____	__ / __ / __
16. _____	_____	_____	__ / __ / __

Performance Tests

V. Polarization Dependent Loss (PDL): Optional

**Performance Test for the Agilent 8156A Option 101**

Page 3 of 8

Model Agilent 8156A Attenuator Option 101 No. \_\_\_\_\_ Date \_\_\_\_\_

Test No.	Test Description performed at _____ nm	Minimum Spec.	Result	Maximum Spec.	Measurement Uncertainty
I.	<b>Total Insertion Loss Test</b> typ. <2.5dB  measured at _____ nm with singlemode fiber		dB		±0.60dB
				3.0 dB	
II.	<b>Linearity/Att. Acc.</b>  Attenuation Setting:				±0.05dB
	0dB		REF		
	1dB	0.9dB		1.1dB	
	2dB	1.9dB		2.1dB	
	3dB	2.9dB		3.1dB	
	4dB	3.9dB		4.1dB	
	5dB	4.9dB		5.1dB	
	6dB	5.9dB		6.1dB	
	7dB	6.9dB		7.1dB	
	8dB	7.9dB		8.1dB	
	9dB	8.9dB		9.1dB	
	10dB	9.9dB		10.1dB	

Performance Tests

V. Polarization Dependent Loss (PDL): Optional

**Performance Test for the Agilent 8156A Option 101**

Page 4 of 8

Model Agilent 8156A Attenuator Option 101 No. \_\_\_\_\_ Date \_\_\_\_\_

Test No.	Test Description performed at _____ nm	Minimum Spec.	Result	Maximum Spec.	Measurement Uncertainty
II.	<b>Linearity/Att. Acc. (cont.)</b>				±0.05dB
	Attenuation Setting:				
	11dB	10.9dB	_____	11.1dB	
	12dB	11.9dB	_____	12.1dB	
	13dB	12.9dB	_____	13.1dB	
	14dB	13.9dB	_____	14.1dB	
	24dB	23.9dB	_____	24.1dB	
	34dB	33.9dB	_____	34.1dB	
	44dB	43.9dB	_____	44.1dB	
	54dB	53.9dB	_____	54.1dB	
	60dB	59.9dB	_____	60.1dB	

Performance Tests

V. Polarization Dependent Loss (PDL): Optional

**Performance Test for the Agilent 8156A Option 101**

Page 5 of 8

Model Agilent 8156A Attenuator Option 101 No. \_\_\_\_\_ Date \_\_\_\_\_

Test No.	Test Description performed at _____ nm	Minimum Spec.	Result	Maximum Spec.	Measurement Uncertainty
III.	<b>Att. Repeatability Test</b>				±0.01dB
	Attenuation Setting:				
	1dB Disp→ Ref	-0.01dB	_____	+ 0.01dB	
	5dB Disp→ Ref	-0.01dB	_____	+ 0.01dB	
	12dB Disp→ Ref	-0.01dB	_____	+ 0.01dB	
	24dB Disp→ Ref	-0.01dB	_____	+ 0.01dB	
	36dB Disp→ Ref	-0.01dB	_____	+ 0.01dB	
	48dB Disp→ Ref	-0.01dB	_____	+ 0.01dB	
	53dB Disp→ Ref	-0.01dB	_____	+ 0.01dB	
	60dB Disp→ Ref	-0.01dB	_____	+ 0.01dB	
IV.	<b>Return Loss Test</b>				
	typ. >45dB	Input 40dB	_____		±0.60dB
		Output 40dB	_____		±0.60dB

Performance Tests

V. Polarization Dependent Loss (PDL): Optional

**Performance Test for the Agilent 8156A Option 101**

Page 6 of 8

Model Agilent 8156A Attenuator Option 101		No. _____	Date _____		
Test No.	Test Description performed at _____ nm	Minimum Spec.	Result	Maximum Spec.	Measurement Uncertainty
I.	<b>Total Insertion Loss Test</b> typ. <2.5dB  measured at _____ nm with SM fiber		dB	3.0 dB	±0.60dB
II.	<b>Linearity/Att. Acc.</b>  Attenuation Setting:  0dB  1dB  2dB  3dB  4dB  5dB  6dB  7dB  8dB  9dB  10dB		REF		±0.05dB
		0.9dB		1.1dB	
		1.9dB		2.1dB	
		2.9dB		3.1dB	
		3.9dB		4.1dB	
		4.9dB		5.1dB	
		5.9dB		6.1dB	
		6.9dB		7.1dB	
		7.9dB		8.1dB	
		8.9dB		9.1dB	
		9.9dB		10.1dB	

Performance Tests

V. Polarization Dependent Loss (PDL): Optional

**Performance Test for the Agilent 8156A Option 101**

Page 7 of 8

Model Agilent 8156A Attenuator Option 101 No. \_\_\_\_\_ Date \_\_\_\_\_

Test No.	Test Description performed at _____ nm	Minimum Spec.	Result	Maximum Spec.	Measurement Uncertainty
II.	<b>Linearity/Att. Acc. (cont.)</b>				$\pm 0.05\text{dB}$
	Attenuation Setting:				
	11dB	10.9dB	_____	11.1dB	
	12dB	11.9dB	_____	12.1dB	
	13dB	12.9dB	_____	13.1dB	
	14dB	13.9dB	_____	14.1dB	
	24dB	23.9dB	_____	24.1dB	
	34dB	33.9dB	_____	34.1dB	
	44dB	43.9dB	_____	44.1dB	
	54dB	53.9dB	_____	54.1dB	
	60dB	59.9dB	_____	60.1dB	

Performance Tests

V. Polarization Dependent Loss (PDL): Optional

**Performance Test for the Agilent 8156A Option 101**

Page 8 of 8

Model Agilent 8156A Attenuator Option 101 No. \_\_\_\_\_ Date \_\_\_\_\_

Test No.	Test Description performed at _____ nm	Minimum Spec.	Result	Maximum Spec.	Measurement Uncertainty
III.	<b>Att. Repeatability Test</b>				±0.01dB
	Attenuation Setting:				
	1dB Disp→ Ref	-0.01dB	_____	+ 0.01dB	
	5dB Disp→ Ref	-0.01dB	_____	+ 0.01dB	
	12dB Disp→ Ref	-0.01dB	_____	+ 0.01dB	
	24dB Disp→ Ref	-0.01dB	_____	+ 0.01dB	
	36dB Disp→ Ref	-0.01dB	_____	+ 0.01dB	
	48dB Disp→ Ref	-0.01dB	_____	+ 0.01dB	
	53dB Disp→ Ref	-0.01dB	_____	+ 0.01dB	
	60dB Disp→ Ref	-0.01dB	_____	+ 0.01dB	
IV.	<b>Return Loss Test</b>				
	typ. >45dB	Input 40dB	_____		±0.60dB
		Output 40dB	_____		±0.60dB

**Performance Test for the Agilent 8156A Option 121**

Page 2 of 8

**Model** \_\_\_\_\_ **Module** \_\_\_\_\_ **Report No.** \_\_\_\_\_ **Date** \_\_\_\_\_

**Test Equipment Used:**

Description	Model No.	Trace No.	Cal. Due Date
1. Power Meter	8153A	_____	__ / __ / __
2a1. CW Laser Sources 1310nm	81552SM	_____	__ / __ / __
2a2. CW Laser Sources 1550nm	81553SM	_____	__ / __ / __
2b. CW Laser Sources 1310/1550nm	or 81554SM	_____	__ / __ / __
3. Opt Sensor Module	81532A	_____	__ / __ / __
4. Return Loss Module	81534A	_____	__ / __ / __
5. Reference Reflector	81000BR	_____	__ / __ / __
6. Universal Through Adapter	81000UM	_____	__ / __ / __
7.1 Optical Isolator 1310nm	81210LI	_____	__ / __ / __
7.2 Optical Isolator 1550nm	81310LI	_____	__ / __ / __
8. Connector Interface (7ea)	Opt011 81000AI	_____	__ / __ / __
9.1 Single Mode Fiber (1ea)	81101AC	_____	__ / __ / __
9.2 Single Mode Fiber	81109AC	_____	__ / __ / __
10. _____	_____	_____	__ / __ / __
11. _____	_____	_____	__ / __ / __
12. _____	_____	_____	__ / __ / __
13. _____	_____	_____	__ / __ / __
14. _____	_____	_____	__ / __ / __
15. _____	_____	_____	__ / __ / __
16. _____	_____	_____	__ / __ / __



Performance Tests

V. Polarization Dependent Loss (PDL): Optional

**Performance Test for the Agilent 8156A Option 121**

Page 3 of 8

Model Agilent 8156A Attenuator Option 121					
		No. _____	Date _____		
Test No.	Test Description performed at _____ nm	Minimum Spec.	Result	Maximum Spec.	Measurement Uncertainty
I.	<b>Total Insertion Loss Test</b> typ. <3.3dB  measured at _____ nm with singlemode fiber		dB		±0.60dB
				4.2 dB	
II.	<b>Linearity/Att. Acc.</b>  Attenuation Setting:				±0.05dB
	0dB		REF		
	1dB	0.9dB		1.1dB	
	2dB	1.9dB		2.1dB	
	3dB	2.9dB		3.1dB	
	4dB	3.9dB		4.1dB	
	5dB	4.9dB		5.1dB	
	6dB	5.9dB		6.1dB	
	7dB	6.9dB		7.1dB	
	8dB	7.9dB		8.1dB	
	9dB	8.9dB		9.1dB	
	10dB	9.9dB		10.1dB	

Performance Tests

V. Polarization Dependent Loss (PDL): Optional

**Performance Test for the Agilent 8156A Option 121**

Page 4 of 8

Model Agilent 8156A Attenuator Option 121 No. \_\_\_\_\_ Date \_\_\_\_\_

Test No.	Test Description performed at _____ nm	Minimum Spec.	Result	Maximum Spec.	Measurement Uncertainty
II.	<b>Linearity/Att. Acc. (cont.)</b>				$\pm 0.05\text{dB}$
	Attenuation Setting:				
	11dB	10.9dB	_____	11.1dB	
	12dB	11.9dB	_____	12.1dB	
	13dB	12.9dB	_____	13.1dB	
	14dB	13.9dB	_____	14.1dB	
	24dB	23.9dB	_____	24.1dB	
	34dB	33.9dB	_____	34.1dB	
	44dB	43.9dB	_____	44.1dB	
	54dB	53.9dB	_____	54.1dB	
	60dB	59.9dB	_____	60.1dB	

Performance Tests

V. Polarization Dependent Loss (PDL): Optional

**Performance Test for the Agilent 8156A Option 121**

Page 5 of 8

Model Agilent 8156A Attenuator Option 121 No. \_\_\_\_\_ Date \_\_\_\_\_

Test No.	Test Description performed at _____ nm	Minimum Spec.	Result	Maximum Spec.	Measurement Uncertainty
III.	<b>Att. Repeatability Test</b>				±0.01dB
	Attenuation Setting:				
	1dB Disp→ Ref	-0.01dB	_____	+ 0.01dB	
	5dB Disp→ Ref	-0.01dB	_____	+ 0.01dB	
	12dB Disp→ Ref	-0.01dB	_____	+ 0.01dB	
	24dB Disp→ Ref	-0.01dB	_____	+ 0.01dB	
	36dB Disp→ Ref	-0.01dB	_____	+ 0.01dB	
	48dB Disp→ Ref	-0.01dB	_____	+ 0.01dB	
	53dB Disp→ Ref	-0.01dB	_____	+ 0.01dB	
	60dB Disp→ Ref	-0.01dB	_____	+ 0.01dB	
IV.	<b>Return Loss Test</b>				
	typ. >45dB	Input 40dB	_____		±0.60dB
		Output 40dB	_____		±0.60dB

Performance Tests

V. Polarization Dependent Loss (PDL): Optional

**Performance Test for the Agilent 8156A Option 121**

Page 6 of 8

Model Agilent 8156A Attenuator Option 121		No. _____	Date _____		
Test No.	Test Description performed at _____ nm	Minimum Spec.	Result dB	Maximum Spec.	Measurement Uncertainty
I.	<b>Total Insertion Loss Test</b> typ. <3.3dB  measured at _____ nm with SM fiber			4.2 dB	±0.60dB
II.	<b>Linearity/Att. Acc.</b>  Attenuation Setting:  0dB  1dB  2dB  3dB  4dB  5dB  6dB  7dB  8dB  9dB  10dB		REF		±0.05dB
		0.9dB		1.1dB	
		1.9dB		2.1dB	
		2.9dB		3.1dB	
		3.9dB		4.1dB	
		4.9dB		5.1dB	
		5.9dB		6.1dB	
		6.9dB		7.1dB	
		7.9dB		8.1dB	
		8.9dB		9.1dB	
		9.9dB		10.1dB	

Performance Tests

V. Polarization Dependent Loss (PDL): Optional

**Performance Test for the Agilent 8156A Option 121**

Page 7 of 8

Model Agilent 8156A Attenuator Option 121 No. \_\_\_\_\_ Date \_\_\_\_\_

Test No.	Test Description performed at _____ nm	Minimum Spec.	Result	Maximum Spec.	Measurement Uncertainty
II.	<b>Linearity/Att. Acc. (cont.)</b>				$\pm 0.05\text{dB}$
	Attenuation Setting:				
	11dB	10.9dB	_____	11.1dB	
	12dB	11.9dB	_____	12.1dB	
	13dB	12.9dB	_____	13.1dB	
	14dB	13.9dB	_____	14.1dB	
	24dB	23.9dB	_____	24.1dB	
	34dB	33.9dB	_____	34.1dB	
	44dB	43.9dB	_____	44.1dB	
	54dB	53.9dB	_____	54.1dB	
	60dB	59.9dB	_____	60.1dB	

Performance Tests

V. Polarization Dependent Loss (PDL): Optional

**Performance Test for the Agilent 8156A Option 121**

Page 8 of 8

Model Agilent 8156A Attenuator Option 121 No. \_\_\_\_\_ Date \_\_\_\_\_

Test No.	Test Description performed at _____ nm	Minimum Spec.	Result	Maximum Spec.	Measurement Uncertainty
III.	<b>Att. Repeatability Test</b>				±0.01dB
	Attenuation Setting:				
	1dB Disp→ Ref	-0.01dB	_____	+ 0.01dB	
	5dB Disp→ Ref	-0.01dB	_____	+ 0.01dB	
	12dB Disp→ Ref	-0.01dB	_____	+ 0.01dB	
	24dB Disp→ Ref	-0.01dB	_____	+ 0.01dB	
	36dB Disp→ Ref	-0.01dB	_____	+ 0.01dB	
	48dB Disp→ Ref	-0.01dB	_____	+ 0.01dB	
	53dB Disp→ Ref	-0.01dB	_____	+ 0.01dB	
	60dB Disp→ Ref	-0.01dB	_____	+ 0.01dB	
IV.	<b>Return Loss Test</b>				
	typ. >45dB	Input 40dB	_____		±0.60dB
		Output 40dB	_____		±0.60dB

**Performance Test for the Agilent 8156A Option 201**

Page 2 of 8

**Model** \_\_\_\_\_ **Module** \_\_\_\_\_ **Report No.** \_\_\_\_\_ **Date** \_\_\_\_\_

**Test Equipment Used:**

Description	Model No.	Trace No.	Cal. Due Date
1. Power Meter	8153A	_____	__ / __ / __
2a1. CW Laser Sources 1310nm	81552SM	_____	__ / __ / __
2a2. CW Laser Sources 1550nm	81553SM	_____	__ / __ / __
2b. CW Laser Sources 1310/1550nm	81554SM	_____	__ / __ / __
3. Opt Sensor Module	81532A	_____	__ / __ / __
4. Return Loss Module	81534A	_____	__ / __ / __
5. Back Reflector Kit	8156A #203	_____	__ / __ / __
6. DIN Through Adapter	1005-0255	_____	__ / __ / __
7.1. Connector Interface (4ea)	81000SI	_____	__ / __ / __
7.2. Connector Interface	81000FI	_____	__ / __ / __
7.3. Connector Interface	81000AI	_____	__ / __ / __
8.1 Single Mode Fiber	81113PC	_____	__ / __ / __
8.2 Single Mode Fiber	81102SC	_____	__ / __ / __
9. _____	_____	_____	__ / __ / __
10. _____	_____	_____	__ / __ / __
11. _____	_____	_____	__ / __ / __
12. _____	_____	_____	__ / __ / __
13. _____	_____	_____	__ / __ / __
14. _____	_____	_____	__ / __ / __
15. _____	_____	_____	__ / __ / __
16. _____	_____	_____	__ / __ / __

Performance Tests

V. Polarization Dependent Loss (PDL): Optional

**Performance Test for the Agilent 8156A Option 201**

Page 3 of 8

Model Agilent 8156A Attenuator Option 201 No. \_\_\_\_\_ Date \_\_\_\_\_

Test No.	Test Description performed at _____ nm	Minimum Spec.	Result	Maximum Spec.	Measurement Uncertainty
I.	<b>Total Insertion Loss Test</b> typ. <2.5dB  measured at _____ nm with singlemode fiber		dB		$\pm 0.60\text{dB}$
II.	<b>Linearity/Att. Acc.</b>  Attenuation Setting:			3.0 dB	$\pm 0.05\text{dB}$
	0dB		REF		
	1dB	0.9dB		1.1dB	
	2dB	1.9dB		2.1dB	
	3dB	2.9dB		3.1dB	
	4dB	3.9dB		4.1dB	
	5dB	4.9dB		5.1dB	
	6dB	5.9dB		6.1dB	
	7dB	6.9dB		7.1dB	
	8dB	7.9dB		8.1dB	
	9dB	8.9dB		9.1dB	
	10dB	9.9dB		10.1dB	



Performance Tests

V. Polarization Dependent Loss (PDL): Optional

**Performance Test for the Agilent 8156A Option 201**

Page 4 of 8

Model Agilent 8156A Attenuator Option 201 No. \_\_\_\_\_ Date \_\_\_\_\_

Test No.	Test Description performed at _____ nm	Minimum Spec.	Result	Maximum Spec.	Measurement Uncertainty
II.	<b>Linearity/Att. Acc. (cont.)</b>				$\pm 0.05\text{dB}$
	Attenuation Setting:				
	11dB	10.9dB	_____	11.1dB	
	12dB	11.9dB	_____	12.1dB	
	13dB	12.9dB	_____	13.1dB	
	14dB	13.9dB	_____	14.1dB	
	24dB	23.9dB	_____	24.1dB	
	34dB	33.9dB	_____	34.1dB	
	44dB	43.9dB	_____	44.1dB	
	54dB	53.9dB	_____	54.1dB	
	60dB	59.9dB	_____	60.1dB	

Performance Tests

V. Polarization Dependent Loss (PDL): Optional

**Performance Test for the Agilent 8156A Option 201**

Page 5 of 8

Model Agilent 8156A Attenuator Option 201 No. \_\_\_\_\_ Date \_\_\_\_\_

Test No.	Test Description performed at _____ nm	Minimum Spec.	Result	Maximum Spec.	Measurement Uncertainty
III.	<b>Att. Repeatability Test</b>				±0.01dB
	Attenuation Setting:				
	1dB Disp→ Ref	-0.01dB	_____	+ 0.01dB	
	5dB Disp→ Ref	-0.01dB	_____	+ 0.01dB	
	12dB Disp→ Ref	-0.01dB	_____	+ 0.01dB	
	24dB Disp→ Ref	-0.01dB	_____	+ 0.01dB	
	36dB Disp→ Ref	-0.01dB	_____	+ 0.01dB	
	48dB Disp→ Ref	-0.01dB	_____	+ 0.01dB	
	53dB Disp→ Ref	-0.01dB	_____	+ 0.01dB	
	60dB Disp→ Ref	-0.01dB	_____	+ 0.01dB	
IV.	<b>Return Loss Test</b>				
	typ. >60dB	Input 55dB	_____		±0.60dB
		Output 55dB	_____		±0.60dB

Performance Tests

V. Polarization Dependent Loss (PDL): Optional

**Performance Test for the Agilent 8156A Option 201**

Page 6 of 8

Model Agilent 8156A Attenuator Option 201 No. \_\_\_\_\_ Date \_\_\_\_\_

Test No.	Test Description performed at _____ nm	Minimum Spec.	Result dB	Maximum Spec.	Measurement Uncertainty
I.	<b>Total Insertion Loss Test</b> typ. <2.5dB  measured at _____ nm with SM fiber			3.0 dB	±0.60dB
II.	<b>Linearity/Att. Acc.</b>  Attenuation Setting:  0dB  1dB  2dB  3dB  4dB  5dB  6dB  7dB  8dB  9dB  10dB		REF		±0.05dB
		0.9dB		1.1dB	
		1.9dB		2.1dB	
		2.9dB		3.1dB	
		3.9dB		4.1dB	
		4.9dB		5.1dB	
		5.9dB		6.1dB	
		6.9dB		7.1dB	
		7.9dB		8.1dB	
		8.9dB		9.1dB	
		9.9dB		10.1dB	

Performance Tests

V. Polarization Dependent Loss (PDL): Optional

**Performance Test for the Agilent 8156A Option 201**

Page 7 of 8

Model Agilent 8156A Attenuator Option 201 No. \_\_\_\_\_ Date \_\_\_\_\_

Test No.	Test Description performed at _____ nm	Minimum Spec.	Result	Maximum Spec.	Measurement Uncertainty
II.	<b>Linearity/Att. Acc. (cont.)</b>				±0.05dB
	Attenuation Setting:				
	11dB	10.9dB	_____	11.1dB	
	12dB	11.9dB	_____	12.1dB	
	13dB	12.9dB	_____	13.1dB	
	14dB	13.9dB	_____	14.1dB	
	24dB	23.9dB	_____	24.1dB	
	34dB	33.9dB	_____	34.1dB	
	44dB	43.9dB	_____	44.1dB	
	54dB	53.9dB	_____	54.1dB	
	60dB	59.9dB	_____	60.1dB	

Performance Tests

V. Polarization Dependent Loss (PDL): Optional

**Performance Test for the Agilent 8156A Option 201**

Page 8 of 8

Model Agilent 8156A Attenuator Option 201 No. \_\_\_\_\_ Date \_\_\_\_\_

Test No.	Test Description performed at _____ nm	Minimum Spec.	Result	Maximum Spec.	Measurement Uncertainty
III.	<b>Att. Repeatability Test</b>				±0.01dB
	Attenuation Setting:				
	1dB Disp→ Ref	-0.01dB	_____	+ 0.01dB	
	5dB Disp→ Ref	-0.01dB	_____	+ 0.01dB	
	12dB Disp→ Ref	-0.01dB	_____	+ 0.01dB	
	24dB Disp→ Ref	-0.01dB	_____	+ 0.01dB	
	36dB Disp→ Ref	-0.01dB	_____	+ 0.01dB	
	48dB Disp→ Ref	-0.01dB	_____	+ 0.01dB	
	53dB Disp→ Ref	-0.01dB	_____	+ 0.01dB	
IV.	<b>Return Loss Test</b>				
	typ. >60dB	Input 55dB	_____		±0.60dB
		Output 55dB	_____		±0.60dB

**Performance Test for the Agilent 8156A Option 221**

Page 2 of 8

**Model** \_\_\_\_\_ **Module** \_\_\_\_\_ **Report No.** \_\_\_\_\_ **Date** \_\_\_\_\_

**Test Equipment Used:**

	Description	Model No.	Trace No.	Cal. Due Date
1.	Power Meter	8153A	_____	__ / __ / __
2a1.	CW Laser Sources 1310nm	81552SM	_____	__ / __ / __
2a2.	CW Laser Sources 1550nm	81553SM	_____	__ / __ / __
2b.	CW Laser Sources 1310/1550nm	81554SM	_____	__ / __ / __
3.	Opt Sensor Module	81532A	_____	__ / __ / __
4.	Return Loss Module	81534A	_____	__ / __ / __
5.	Back Reflector Kit	8156A #203	_____	__ / __ / __
6.	DIN Through Adapter	1005-0255	_____	__ / __ / __
7.1.	Connector Interface (5ea)	81000SI	_____	__ / __ / __
7.2.	Connector Interface	81000FI	_____	__ / __ / __
7.3.	Connector Interface	81000AI	_____	__ / __ / __
8.1	Single Mode Fiber	81113PC	_____	__ / __ / __
8.2	Single Mode Fiber (2ea)	81102SC	_____	__ / __ / __
9.	_____	_____	_____	__ / __ / __
10.	_____	_____	_____	__ / __ / __
11.	_____	_____	_____	__ / __ / __
12.	_____	_____	_____	__ / __ / __
13.	_____	_____	_____	__ / __ / __
14.	_____	_____	_____	__ / __ / __
15.	_____	_____	_____	__ / __ / __
16.	_____	_____	_____	__ / __ / __

Performance Tests

V. Polarization Dependent Loss (PDL): Optional

**Performance Test for the Agilent 8156A Option 221**

Page 3 of 8

Model Agilent 8156A Attenuator Option 221 No. \_\_\_\_\_ Date \_\_\_\_\_

Test No.	Test Description performed at _____ nm	Minimum Spec.	Result	Maximum Spec.	Measurement Uncertainty
I.	<b>Total Insertion Loss Test</b> typ. <3.3dB  measured at _____ nm with singlemode fiber		dB		±0.60dB
				4.2 dB	
II.	<b>Linearity/Att. Acc.</b>  Attenuation Setting:				±0.05dB
	0dB		REF		
	1dB	0.9dB		1.1 dB	
	2dB	1.9dB		2.1 dB	
	3dB	2.9dB		3.1 dB	
	4dB	3.9dB		4.1 dB	
	5dB	4.9dB		5.1 dB	
	6dB	5.9dB		6.1 dB	
	7dB	6.9dB		7.1 dB	
	8dB	7.9dB		8.1 dB	
	9dB	8.9dB		9.1 dB	
	10dB	9.9dB		10.1dB	

Performance Tests

V. Polarization Dependent Loss (PDL): Optional

**Performance Test for the Agilent 8156A Option 221**

Page 4 of 8

Model Agilent 8156A Attenuator Option 221 No. \_\_\_\_\_ Date \_\_\_\_\_

Test No.	Test Description performed at _____ nm	Minimum Spec.	Result	Maximum Spec.	Measurement Uncertainty
II.	<b>Linearity/Att. Acc. (cont.)</b>				±0.05dB
	Attenuation Setting:				
	11dB	10.9dB	_____	11.1dB	
	12dB	11.9dB	_____	12.1dB	
	13dB	12.9dB	_____	13.1dB	
	14dB	13.9dB	_____	14.1dB	
	24dB	23.9dB	_____	24.1dB	
	34dB	33.9dB	_____	34.1dB	
	44dB	43.9dB	_____	44.1dB	
	54dB	53.9dB	_____	54.1dB	
	60dB	59.9dB	_____	60.1dB	



Performance Tests

V. Polarization Dependent Loss (PDL): Optional

**Performance Test for the Agilent 8156A Option 221**

Page 5 of 8

Model Agilent 8156A Attenuator Option 221 No. \_\_\_\_\_ Date \_\_\_\_\_

Test No.	Test Description performed at _____ nm	Minimum Spec.	Result	Maximum Spec.	Measurement Uncertainty
III.	<b>Att. Repeatability Test</b>				±0.01dB
	Attenuation Setting:				
	1dB Disp→ Ref	-0.01dB	_____	+ 0.01dB	
	5dB Disp→ Ref	-0.01dB	_____	+ 0.01dB	
	12dB Disp→ Ref	-0.01dB	_____	+ 0.01dB	
	24dB Disp→ Ref	-0.01dB	_____	+ 0.01dB	
	36dB Disp→ Ref	-0.01dB	_____	+ 0.01dB	
	48dB Disp→ Ref	-0.01dB	_____	+ 0.01dB	
	53dB Disp→ Ref	-0.01dB	_____	+ 0.01dB	
	60dB Disp→ Ref	-0.01dB	_____	+ 0.01dB	
IV.	<b>Return Loss Test</b>				
	typ. >60dB	Input 55dB	_____		±0.60dB
		Output 55dB	_____		±0.60dB

Performance Tests

V. Polarization Dependent Loss (PDL): Optional

**Performance Test for the Agilent 8156A Option 221**

Page 6 of 8

Model Agilent 8156A Attenuator Option 221 No. \_\_\_\_\_ Date \_\_\_\_\_

Test No.	Test Description performed at _____ nm	Minimum Spec.	Result dB	Maximum Spec.	Measurement Uncertainty
I.	<b>Total Insertion Loss Test</b> typ. <3.3dB  measured at _____ nm with SM fiber			4.2 dB	±0.60dB
II.	<b>Linearity/Att. Acc.</b>  Attenuation Setting:  0dB  1dB  2dB  3dB  4dB  5dB  6dB  7dB  8dB  9dB  10dB		REF		±0.05dB
		0.9dB		1.1dB	
		1.9dB		2.1dB	
		2.9dB		3.1dB	
		3.9dB		4.1dB	
		4.9dB		5.1dB	
		5.9dB		6.1dB	
		6.9dB		7.1dB	
		7.9dB		8.1dB	
		8.9dB		9.1dB	
		9.9dB		10.1dB	

Performance Tests

V. Polarization Dependent Loss (PDL): Optional

**Performance Test for the Agilent 8156A Option 221**

Page 7 of 8

Model Agilent 8156A Attenuator Option 221 No. \_\_\_\_\_ Date \_\_\_\_\_

Test No.	Test Description performed at _____ nm	Minimum Spec.	Result	Maximum Spec.	Measurement Uncertainty
II.	<b>Linearity/Att. Acc. (cont.)</b>				$\pm 0.05\text{dB}$
	Attenuation Setting:				
	11dB	10.9dB	_____	11.1dB	
	12dB	11.9dB	_____	12.1dB	
	13dB	12.9dB	_____	13.1dB	
	14dB	13.9dB	_____	14.1dB	
	24dB	23.9dB	_____	24.1dB	
	34dB	33.9dB	_____	34.1dB	
	44dB	43.9dB	_____	44.1dB	
	54dB	53.9dB	_____	54.1dB	
	60dB	59.9dB	_____	60.1dB	

Performance Tests

V. Polarization Dependent Loss (PDL): Optional

**Performance Test for the Agilent 8156A Option 221**

Page 8 of 8

Model Agilent 8156A Attenuator Option 221 No. \_\_\_\_\_ Date \_\_\_\_\_

Test No.	Test Description performed at _____ nm	Minimum Spec.	Result	Maximum Spec.	Measurement Uncertainty
III.	<b>Att. Repeatability Test</b>				±0.01dB
	Attenuation Setting:				
	1dB Disp→ Ref	-0.01dB	_____	+ 0.01dB	
	5dB Disp→ Ref	-0.01dB	_____	+ 0.01dB	
	12dB Disp→ Ref	-0.01dB	_____	+ 0.01dB	
	24dB Disp→ Ref	-0.01dB	_____	+ 0.01dB	
	36dB Disp→ Ref	-0.01dB	_____	+ 0.01dB	
	48dB Disp→ Ref	-0.01dB	_____	+ 0.01dB	
	53dB Disp→ Ref	-0.01dB	_____	+ 0.01dB	
IV.	<b>Return Loss Test</b>				
	typ. >60dB	Input 55dB	_____		±0.60dB
		Output 55dB	_____		±0.60dB

Performance Tests

V. Polarization Dependent Loss (PDL): Optional

**Performance Test for the Agilent 8156A Option 350**

Page 2 of 5

**Model** \_\_\_\_\_ **Module** \_\_\_\_\_ **Report No.** \_\_\_\_\_ **Date** \_\_\_\_\_

**Test Equipment Used:**

	Description	Model No.	Trace No.	Cal. Due Date
1.	Power Meter	8153A	_____	__ / __ / __
2.	LED Source 1300nm	81542SM	_____	__ / __ / __
3.	Opt Sensor Module	81532A	_____	__ / __ / __
4.	Connector Interface (4ea)	81000AI	_____	__ / __ / __
5.	Multi Mode Fiber (2ea)	81501AC	_____	__ / __ / __
6.	_____	_____	_____	__ / __ / __
7.	_____	_____	_____	__ / __ / __
8.	_____	_____	_____	__ / __ / __
9.	_____	_____	_____	__ / __ / __
10.	_____	_____	_____	__ / __ / __
11.	_____	_____	_____	__ / __ / __
12.	_____	_____	_____	__ / __ / __

Performance Tests

V. Polarization Dependent Loss (PDL): Optional

**Performance Test for the Agilent 8156A Option 350**

Page 3 of 5

Model Agilent 8156A Attenuator Option 350					
		No. _____	Date _____		
Test No.	Test Description performed at _____ nm	Minimum Spec.	Result	Maximum Spec.	Measurement Uncertainty
I.	<b>Total Insertion Loss Test</b> typ. <3.0dB  measured at _____ nm with multimode fiber		dB		±0.60dB
				3.9 dB	
II.	<b>Linearity/Att. Acc.</b>  Attenuation Setting:				±0.05dB
	0dB		REF		
	1dB	0.9dB		1.1 dB	
	2dB	1.9dB		2.1 dB	
	3dB	2.9dB		3.1 dB	
	4dB	3.9dB		4.1 dB	
	5dB	4.9dB		5.1 dB	
	6dB	5.9dB		6.1 dB	
	7dB	6.9dB		7.1 dB	
	8dB	7.9dB		8.1 dB	
	9dB	8.9dB		9.1 dB	
	10dB	9.9dB		10.1dB	

Performance Tests

V. Polarization Dependent Loss (PDL): Optional

**Performance Test for the Agilent 8156A Option 350**

Page 4 of 5

Model Agilent 8156A Attenuator Option 350 No. \_\_\_\_\_ Date \_\_\_\_\_

Test No.	Test Description performed at _____ nm	Minimum Spec.	Result	Maximum Spec.	Measurement Uncertainty
II.	<b>Linearity/Att. Acc. (cont.)</b>				±0.05dB
	Attenuation Setting:				
	11dB	10.9dB	_____	11.1dB	
	12dB	11.9dB	_____	12.1dB	
	13dB	12.9dB	_____	13.1dB	
	14dB	13.9dB	_____	14.1dB	
	24dB	23.9dB	_____	24.1dB	
	34dB	33.9dB	_____	34.1dB	
	44dB	43.9dB	_____	44.1dB	
	54dB	53.9dB	_____	54.1dB	
	60dB	59.9dB	_____	60.1dB	

Performance Tests

V. Polarization Dependent Loss (PDL): Optional

**Performance Test for the Agilent 8156A Option 350**

Page 5 of 5

Model Agilent 8156A Attenuator Option 350 No. \_\_\_\_\_ Date \_\_\_\_\_

Test No.	Test Description performed at _____ nm	Minimum Spec.	Result	Maximum Spec.	Measurement Uncertainty
III.	<b>Att. Repeatability Test</b>				±0.01dB
	Attenuation Setting:				
	1dB Disp→ Ref	-0.01dB	_____	+ 0.01dB	
	5dB Disp→ Ref	-0.01dB	_____	+ 0.01dB	
	12dB Disp→ Ref	-0.01dB	_____	+ 0.01dB	
	24dB Disp→ Ref	-0.01dB	_____	+ 0.01dB	
	36dB Disp→ Ref	-0.01dB	_____	+ 0.01dB	
	48dB Disp→ Ref	-0.01dB	_____	+ 0.01dB	
	53dB Disp→ Ref	-0.01dB	_____	+ 0.01dB	
	60dB Disp→ Ref	-0.01dB	_____	+ 0.01dB	



Performance Tests

**V. Polarization Dependent Loss (PDL): Optional**

**Performance Test Agilent 8156A:**

V. Polarization Dependent Loss Test (optional)

Page 1 of 6

**Test Facility:**

\_\_\_\_\_ Report No. \_\_\_\_\_

\_\_\_\_\_ Date: \_\_\_\_\_

\_\_\_\_\_ Customer: \_\_\_\_\_

\_\_\_\_\_ Tested By: \_\_\_\_\_

Model: \_\_\_\_\_

Serial No. \_\_\_\_\_ Ambient temperature \_\_\_\_\_ °C

Options \_\_\_\_\_ Relative humidity \_\_\_\_\_ %

Firmware Rev. \_\_\_\_\_ Line frequency \_\_\_\_\_ Hz

**Special Notes:**

\_\_\_\_\_  
\_\_\_\_\_  
\_\_\_\_\_  
\_\_\_\_\_  
\_\_\_\_\_  
\_\_\_\_\_  
\_\_\_\_\_  
\_\_\_\_\_  
\_\_\_\_\_

Performance Tests

V. Polarization Dependent Loss (PDL): Optional

**Performance Test Agilent 8156A:**

V. Polarization Dependent Loss Test

Page 2 of 6

**Test Equipment Used:**

Description	HP/Agilent Model No.	Trace No.	Cal. Due Date
1. Polarization Controller 8169A #021	_____	_____	___/___/___
2. Lightwave Multimeter Mainframe	_____	_____	___/___/___
3. Optical Head Interface 81533B	_____	_____	___/___/___
4a. CW Laser Source 1310nm	_____	_____	___/___/___
4b. CW Laser Source 1550nm	_____	_____	___/___/___
4c. CW Laser Source 1310/1550nm	_____	_____	___/___/___
5. Optical Head 81521B	_____	_____	___/___/___

Performance Tests

**V. Polarization Dependent Loss (PDL): Optional**

**Performance Test Agilent 8156A:**

**V. Polarization Dependent Loss Test**

Page 3 of 6

Model Agilent 8156A Optical Attenuator

Date \_\_\_\_\_

Option: \_\_\_\_\_

No. \_\_\_\_\_

Wavelength 1310nm (nominal)

Actual wavelength: \_\_\_\_\_ nm

**Polarization**

	Linear Horizontal	Linear Vertical	Linear Diagonal	Right Hand Circular
Polarizer Setting	_____ deg	n/a	n/a	n/a
$\lambda/4$ Plate Setting	_____ deg	n/a	n/a	n/a
$\lambda/2$ Plate Setting	_____ deg	n/a	n/a	n/a

Corrected wavelength  
dependent positions:

$\lambda/4$ Plate Setting	n/a	_____ deg	_____ deg	_____ deg
$\lambda/2$ Plate Setting	n/a	_____ deg	_____ deg	_____ deg

Measurement Results  
of the Reference Power

$P_{01}$ = \_\_\_\_\_  $\mu$ W  $P_{02}$ = \_\_\_\_\_  $\mu$ W  $P_{03}$ = \_\_\_\_\_  $\mu$ W  $P_{04}$ = \_\_\_\_\_  $\mu$ W

Measurement Results  
of the Power  
after the DUT

$P_{DUT01}$ = \_\_\_\_\_  $\mu$ W  $P_{DUT02}$ = \_\_\_\_\_  $\mu$ W  $P_{DUT03}$ = \_\_\_\_\_  $\mu$ W  $P_{DUT04}$ = \_\_\_\_\_  $\mu$ W

**Mueller Coefficients:**

$$m_{11} = (P_{DUT01} / P_{01} + P_{DUT02} / P_{02}) / 2 = \underline{\hspace{2cm}}$$

$$m_{12} = (P_{DUT01} / P_{01} - P_{DUT02} / P_{02}) / 2 = \underline{\hspace{2cm}}$$

$$m_{13} = (P_{DUT03} / P_{03}) - m_{11} = \underline{\hspace{2cm}}$$

$$m_{14} = (P_{DUT04} / P_{04}) - m_{11} = \underline{\hspace{2cm}}$$

Performance Tests

**V. Polarization Dependent Loss (PDL): Optional**

**Performance Test Agilent 8156A:**

V. Polarization Dependent Loss Test

Page 4 of 6

**Minimum and maximum transmission:**

$$T_{Max} = m_{11} + \sqrt{m_{12}^2 + m_{13}^2 + m_{14}^2} = \underline{\hspace{10em}}$$

$$T_{Min} = m_{11} - \sqrt{m_{12}^2 + m_{13}^2 + m_{14}^2} = \underline{\hspace{10em}}$$

Polarization Dependent Loss $PDL_{dB} = 10\log(T_{Max}/T_{Min})$	Maximum Specification			Measurement Uncertainties
	#100	#101, #201	#121, #221	
<hr/> dBpp	0.15dBpp	0.08dBpp	0.10dBpp	0.02dBpp

Performance Tests

**V. Polarization Dependent Loss (PDL): Optional**

**Performance Test Agilent 8156A:**

V. Polarization Dependent Loss Test

Page 5 of 6

Model Agilent 8156A Optical Attenuator

Date \_\_\_\_\_

Option: \_\_\_\_\_

No. \_\_\_\_\_

Wavelength 1550nm (nominal)

Actual wavelength: \_\_\_\_\_ nm

**Polarization**

	Linear Horizontal	Linear Vertical	Linear Diagonal	Right Hand Circular
Polarizer Setting	_____ deg	n/a	n/a	n/a
$\lambda/4$ Plate Setting	_____ deg	n/a	n/a	n/a
$\lambda/2$ Plate Setting	_____ deg	n/a	n/a	n/a

Corrected wavelength  
dependent positions:

$\lambda/4$  Plate Setting                      n/a                      \_\_\_\_\_ deg                      \_\_\_\_\_ deg                      \_\_\_\_\_ deg

$\lambda/2$  Plate Setting                      n/a                      \_\_\_\_\_ deg                      \_\_\_\_\_ deg                      \_\_\_\_\_ deg

Measurement Results  
of the Reference Power

$P_{01}$ = \_\_\_\_\_  $\mu$ W    $P_{02}$ = \_\_\_\_\_  $\mu$ W    $P_{03}$ = \_\_\_\_\_  $\mu$ W    $P_{04}$ = \_\_\_\_\_  $\mu$ W

Measurement Results  
of the Power  
after the DUT

$P_{DUT01}$ = \_\_\_\_\_  $\mu$ W    $P_{DUT02}$ = \_\_\_\_\_  $\mu$ W    $P_{DUT03}$ = \_\_\_\_\_  $\mu$ W    $P_{DUT04}$ = \_\_\_\_\_  $\mu$ W

**Mueller Coefficients:**

$$m_{11} = (P_{DUT01} / P_{01} + P_{DUT02} / P_{02}) / 2 = \underline{\hspace{2cm}}$$

$$m_{12} = (P_{DUT01} / P_{01} - P_{DUT02} / P_{02}) / 2 = \underline{\hspace{2cm}}$$

$$m_{13} = (P_{DUT03} / P_{03}) - m_{11} = \underline{\hspace{2cm}}$$

$$m_{14} = (P_{DUT04} / P_{04}) - m_{11} = \underline{\hspace{2cm}}$$

Performance Tests

**V. Polarization Dependent Loss (PDL): Optional**

**Performance Test Agilent 8156A:**

V. Polarization Dependent Loss Test

Page 6 of 6

**Minimum and maximum transmission**

$$T_{Max} = m_{11} + \sqrt{m_{12}^2 + m_{13}^2 + m_{14}^2} = \underline{\hspace{10em}}$$

$$T_{Min} = m_{11} - \sqrt{m_{12}^2 + m_{13}^2 + m_{14}^2} = \underline{\hspace{10em}}$$

Polarization Dependent Loss $PDL_{dB} = 10\log(T_{Max}/T_{Min})$	Maximum Specification			Measurement Uncertainties
	#100	#101, #201	#121, #221	
_____dBpp	0.15dBpp	0.08dBpp	0.10dBpp	0.02dBpp

---

**Cleaning Information**

---

# Cleaning Information

The following Cleaning Instructions contain some general safety precautions, which must be observed during all phases of cleaning. Consult your specific optical device manuals or guides for full information on safety matters.

Please try, whenever possible, to use physically contacting connectors, and dry connections. Clean the connectors, interfaces, and bushings carefully after use.

Agilent Technologies assume no liability for the customer's failure to comply with these requirements.

## **Cleaning Instructions for this Instrument**

The Cleaning Instructions apply to a number of different types of Optical Equipment. The following section is relevant for this instrument.

- “How to clean instruments with a physical contact interface” on page 264



## E.1 Safety Precautions

Please follow the following safety rules:

- Do not remove instrument covers when operating.
- Ensure that the instrument is switched off throughout the cleaning procedures.
- Use of controls or adjustments or performance of procedures other than those specified may result in hazardous radiation exposure.
- Make sure that you disable all sources when you are cleaning any optical interfaces.
- Under no circumstances look into the end of an optical device attached to optical outputs when the device is operational. The laser radiation is not visible to the human eye, but it can seriously damage your eyesight.
- To prevent electrical shock, disconnect the instrument from the mains before cleaning. Use a dry cloth, or one slightly dampened with water, to clean the external case parts. Do not attempt to clean internally.
- Do not install parts or perform any unauthorized modification to optical devices.
- Refer servicing only to qualified and authorized personnel.

---

## E.2 Why is it important to clean optical devices ?

In transmission links optical fiber cores are about 9  $\mu\text{m}$  (0.00035") in diameter. Dust and other particles, however, can range from tenths to hundredths of microns in diameter. Their comparative size

## Cleaning Information

### What do I need for proper cleaning?

means that they can cover a part of the end of a fiber core, and as a result will reduce the performance of your system.

Furthermore, the power density may burn dust into the fiber and cause additional damage (for example, 0 dBm optical power in a single mode fiber causes a power density of approximately 16 million W/m<sup>2</sup>). If this happens, measurements become inaccurate and non-repeatable.

Cleaning is, therefore, an essential yet difficult task. Unfortunately, when comparing most published cleaning recommendations, you will discover that they contain several inconsistencies. In this section, we want to suggest ways to help you clean your various optical devices, and thus significantly improve the accuracy and repeatability of your lightwave measurements.

---

## E.3 What do I need for proper cleaning?

Some Standard Cleaning Equipment is necessary for cleaning your instrument. For certain cleaning procedures, you may also require certain Additional Cleaning Equipment.

### Standard Cleaning Equipment

Before you can start your cleaning procedure you need the following standard equipment:

- Dust and shutter caps
- Isopropyl alcohol
- Cotton swabs
- Soft tissues
- Pipe cleaner
- Compressed air

## Cleaning Information

### What do I need for proper cleaning?

#### **Dust and shutter caps**

All of Agilent Technologies' lightwave instruments are delivered with either laser shutter caps or dust caps on the lightwave adapter. Any cables come with covers to protect the cable ends from damage or contamination.

We suggest these protected coverings should be kept on the equipment at all times, except when your optical device is in use. Be careful when replacing dust caps after use. Do not press the bottom of the cap onto the fiber too hard, as any dust in the cap can scratch or pollute your fiber surface.

If you need further dust caps, please contact your nearest Agilent Technologies sales office.

#### **Isopropyl alcohol**

This solvent is usually available from any local pharmaceutical supplier or chemist's shop.

If you use isopropyl alcohol to clean your optical device, do not immediately dry the surface with compressed air (except when you are cleaning very sensitive optical devices). This is because the dust and the dirt is solved and will leave behind filmy deposits after the alcohol is evaporated. You should therefore first remove the alcohol and the dust with a soft tissue, and then use compressed air to blow away any remaining filaments.

If possible avoid using denatured alcohol containing additives. Instead, apply alcohol used for medical purposes.

Never try to drink this alcohol, as it may seriously damage to your health.

Do not use any other solvents, as some may damage plastic materials and claddings. Acetone, for example, will dissolve the epoxy used with fiber optic connectors. To avoid damage, only use isopropyl alcohol.

#### **Cotton swabs**

We recommend that you use swabs such as Q-tips or other cotton swabs normally available from local distributors of medical and

## Cleaning Information

### **What do I need for proper cleaning?**

hygiene products (for example, a supermarket or a chemist's shop). You may be able to obtain various sizes of swab. If this is the case, select the smallest size for your smallest devices.

Ensure that you use natural cotton swabs. Foam swabs will often leave behind filmy deposits after cleaning.

Use care when cleaning, and avoid pressing too hard onto your optical device with the swab. Too much pressure may scratch the surface, and could cause your device to become misaligned. It is advisable to rub gently over the surface using only a small circular movement.

Swabs should be used straight out of the packet, and never used twice. This is because dust and dirt in the atmosphere, or from a first cleaning, may collect on your swab and scratch the surface of your optical device.

### **Soft tissues**

These are available from most stores and distributors of medical and hygiene products such as supermarkets or chemists' shops.

We recommend that you do not use normal cotton tissues, but multi-layered soft tissues made from non-recycled cellulose. Cellulose tissues are very absorbent and softer. Consequently, they will not scratch the surface of your device over time.

Use care when cleaning, and avoid pressing on your optical device with the tissue. Pressing too hard may lead to scratches on the surface or misalignment of your device. Just rub gently over the surface using a small circular movement.

Use only clean, fresh soft tissues and never apply them twice. Any dust and dirt from the air which collects on your tissue, or which has gathered after initial cleaning, may scratch and pollute your optical device.

### **Pipe cleaner**

Pipe cleaners can be purchased from tobacconists, and come in various shapes and sizes. The most suitable one to select for

## Cleaning Information

### What do I need for proper cleaning?

cleaning purposes has soft bristles, which will not produce scratches.

There are many different kinds of pipe cleaner available from tobacco shops.

The best way to use a pipe cleaner is to push it in and out of the device opening (for example, when cleaning an interface). While you are cleaning, you should slowly rotate the pipe cleaner.

Only use pipe cleaners on connector interfaces or on feed through adapters. Do not use them on optical head adapters, as the center of a pipe cleaner is hard metal and can damage the bottom of the adapter.

Your pipe cleaner should be new when you use it. If it has collected any dust or dirt, this can scratch or contaminate your device.

The tip and center of the pipe cleaner are made of metal. Avoid accidentally pressing these metal parts against the inside of the device, as this can cause scratches.

### Compressed air

Compressed air can be purchased from any laboratory supplier.

It is essential that your compressed air is free of dust, water and oil. Only use clean, dry air. If not, this can lead to filmy deposits or scratches on the surface of your connector. This will reduce the performance of your transmission system.

When spraying compressed air, hold the can upright. If the can is held at a slant, propellant could escape and dirty your optical device. First spray into the air, as the initial stream of compressed air could contain some condensation or propellant. Such condensation leaves behind a filmy deposit.

Please be friendly to your environment and use a CFC-free aerosol.

### Additional Cleaning Equipment

Some Cleaning Procedures need the following equipment, which is not required to clean each instrument:

## Cleaning Information

### What do I need for proper cleaning?

- Microscope with a magnification range about 50X up to 300X
- Ultrasonic bath
- Warm water and liquid soap
- Premoistened cleaning wipes
- Polymer film
- Infrared Sensor Card

### **Microscope with a magnification range about 50X up to 300X**

A microscope can be found in most photography stores, or can be obtained through or specialist mail order companies. Special fiber-scopes are available from suppliers of splicing equipment.

Ideally, the light source on your microscope should be very flexible. This will allow you to examine your device closely and from different angles.

A microscope helps you to estimate the type and degree of dirt on your device. You can use a microscope to choose an appropriate cleaning method, and then to examine the results. You can also use your microscope to judge whether your optical device (such as a connector) is severely scratched and is, therefore, causing inaccurate measurements.

### **Ultrasonic bath**

Ultrasonic baths are also available from photography or laboratory suppliers or specialist mail order companies.

An ultrasonic bath will gently remove fat and other stubborn dirt from your optical devices. This helps increase the life span of the optical devices.

Only use isopropyl alcohol in your ultrasonic bath, as other solvents may damage.

### **Warm water and liquid soap**

Only use water if you are sure that there is no other way of cleaning your optical device without corrosion or damage. Do not use hot

## Cleaning Information

### **What do I need for proper cleaning?**

water, as this may cause mechanical stress, which can damage your optical device.

Ensure that your liquid soap has no abrasive properties or perfume in it. You should also avoid normal washing-up liquid, as it can cover your device in an iridescent film after it has been air-dried.

Some lenses and mirrors also have a special coating, which may be sensitive to mechanical stress, or to fat and liquids. For this reason we recommend you do not touch them.

If you are not sure how sensitive your device is to cleaning, please contact the manufacturer or your sales distributor.

### **Premoistened cleaning wipes**

Use pre-moistened cleaning wipes as described in each individual cleaning procedure. Cleaning wipes may be used in every instance where a moistened soft tissue or cotton swab is applied.

### **Polymer film**

Polymer film is available from laboratory suppliers or specialist mail order companies.

Using polymer film is a gentle method of cleaning extremely sensitive devices, such as reference reflectors and mirrors.

### **Infrared Sensor Card**

Infrared sensor cards are available from laboratory suppliers or specialist mail order companies.

With this card you are able to control the shape of laser light emitted. The invisible laser beam is projected onto the sensor card, then becomes visible to the normal eye as a round spot.

Take care never to look into the end of a fiber or any other optical component, when they are in use. This is because the laser can seriously damage your eyes.

## **E.4 Preserving Connectors**

Listed below are some hints on how best to keep your connectors in the best possible condition.

### **Making Connections**

Before you make any connection you must ensure that all cables and connectors are clean. If they are dirty, use the appropriate cleaning procedure.

When inserting the ferrule of a patchcord into a connector or an adapter, make sure that the fiber end does not touch the outside of the mating connector or adapter. Otherwise you will rub the fiber end against an unsuitable surface, producing scratches and dirt deposits on the surface of your fiber.

### **Dust Caps and Shutter Caps**

Be careful when replacing dust caps after use. Do not press the bottom of the cap onto the fiber as any dust in the cap can scratch or dirty your fiber surface.

When you have finished cleaning, put the dust cap back on, or close the shutter cap if the equipment is not going to be used immediately.

Keep the caps on the equipment always when it is not in use.

All of Agilent Technologies' lightwave instruments and accessories are shipped with either laser shutter caps or dust caps. If you need additional or replacement dust caps, contact your nearest Agilent Technologies Sales/Service Office.

### **Immersion Oil and Other Index Matching Compounds**

Where it is possible, do not use immersion oil or other index matching compounds with your device. They are liable to impair



Cleaning Information  
**Cleaning Instrument Housings**

and dirty the surface of the device. In addition, the characteristics of your device can be changed and your measurement results affected.

---

## **E.5 Cleaning Instrument Housings**

Use a dry and very soft cotton tissue to clean the instrument housing and the keypad. Do not open the instruments as there is a danger of electric shock, or electrostatic discharge. Opening the instrument can cause damage to sensitive components, and in addition your warranty will be voided.

---

## **E.6 Which Cleaning Procedure should I use ?**

### **Light dirt**

If you just want to clean away light dirt, observe the following procedure for all devices:

- Use compressed air to blow away large particles.
- Clean the device with a dry cotton swab.
- Use compressed air to blow away any remaining filament left by the swab.

### **Heavy dirt**

If the above procedure is not enough to clean your instrument, follow one of the procedures below. Please consult XXXX for the procedure relevant for this instrument.

If you are unsure of how sensitive your device is to cleaning, please contact the manufacturer or your sales distributor

## E.7 How to clean connectors

Cleaning connectors is difficult as the core diameter of a single-mode fiber is only about 9  $\mu\text{m}$ . This generally means you cannot see streaks or scratches on the surface. To be certain of the condition of the surface of your connector and to check it after cleaning, you need a microscope.

In the case of scratches, or of dust that has been burnt onto the surface of the connector, you may have no option but to polish the connector. This depends on the degree of dirtiness, or the depth of the scratches. This is a difficult procedure and should only be performed by skilled personal, and as a last resort as it wears out your connector.

---

### WARNING

---

**Never look into the end of an optical cable that is connected to an active source.**

To assess the projection of the emitted light beam you can use an infrared sensor card. Hold the card approximately 5 cm from the output of the connector. The invisible emitted light is project onto the card and becomes visible as a small circular spot.

### Preferred Procedure

Use the following procedure on most occasions.

1. Clean the connector by rubbing a new, dry cotton-swab over the surface using a small circular movement.
2. Blow away any remaining lint with compressed air.

### Procedure for Stubborn Dirt

Use this procedure particularly when there is greasy dirt on the connector:

## Cleaning Information

### How to clean connector adapters

1. Moisten a new cotton-swab with isopropyl alcohol.
2. Clean the connector by rubbing the cotton-swab over the surface using a small circular movement.
3. Take a new, dry soft-tissue and remove the alcohol, dissolved sediment and dust, by rubbing gently over the surface using a small circular movement.
4. Blow away any remaining lint with compressed air.

### An Alternative Procedure

A better, more gentle, but more expensive cleaning procedure is to use an ultrasonic bath with isopropyl alcohol.

1. Hold the tip of the connector in the bath for at least three minutes.
2. Take a new, dry soft-tissue and remove the alcohol, dissolved sediment and dust, by rubbing gently over the surface using a small circular movement.
3. Blow away any remaining lint with compressed air.

---

## E.8 How to clean connector adapters

---

### CAUTION

**Some adapters have an anti-reflection coating on the back to reduce back reflection. This coating is extremely sensitive to solvents and mechanical abrasion. Extra care is needed when cleaning these adapters.**

---

### Preferred Procedure

Use the following procedure on most occasions.

## Cleaning Information

### How to clean connector interfaces

1. Clean the adapter by rubbing a new, dry cotton-swab over the surface using a small circular movement.
2. Blow away any remaining lint with compressed air.

### Procedure for Stubborn Dirt

Use this procedure particularly when there is greasy dirt on the adapter:

1. Moisten a new cotton-swab with isopropyl alcohol.
2. Clean the adapter by rubbing the cotton-swab over the surface using a small circular movement.
3. Take a new, dry soft-tissue and remove the alcohol, dissolved sediment and dust, by rubbing gently over the surface using a small circular movement.
4. Blow away any remaining lint with compressed air.

---

## E.9 How to clean connector interfaces

---

### CAUTION

**Be careful when using pipe-cleaners, as the core and the bristles of the pipe-cleaner are hard and can damage the interface.**

**Do not use pipe-cleaners on optical head adapters, as the hard core of normal pipe cleaners can damage the bottom of an adapter.**

---

### Preferred Procedure

Use the following procedure on most occasions.

1. Clean the interface by pushing and pulling a new, dry pipe-cleaner into the opening. Rotate the pipe-cleaner slowly as you do this.
2. Then clean the interface by rubbing a new, dry cotton-swab over

## Cleaning Information

### How to clean bare fiber adapters

the surface using a small circular movement.

3. Blow away any remaining lint with compressed air.

### Procedure for Stubborn Dirt

Use this procedure particularly when there is greasy dirt on the interface:

1. Moisten a new pipe-cleaner with isopropyl alcohol.
2. Clean the interface by pushing and pulling the pipe-cleaner into the opening. Rotate the pipe-cleaner slowly as you do this.
3. Moisten a new cotton-swab with isopropyl alcohol.
4. Clean the interface by rubbing the cotton-swab over the surface using a small circular movement.
5. Using a new, dry pipe-cleaner, and a new, dry cotton-swab remove the alcohol, any dissolved sediment and dust.
6. Blow away any remaining lint with compressed air.

---

## E.10 How to clean bare fiber adapters

Bare fiber adapters are difficult to clean. Protect from dust unless they are in use.

---

### CAUTION

**Never use any kind of solvent when cleaning a bare fiber adapter as solvents can damage the foam inside some adapters.**

**They can deposit dissolved dirt in the groove, which can then dirty the surface of an inserted fiber.**

---

### Preferred Procedure

Use the following procedure on most occasions.

## Cleaning Information

### How to clean lenses

1. Blow away any dust or dirt with compressed air.

### Procedure for Stubborn Dirt

Use this procedure particularly when there is greasy dirt on the adapter:

1. Clean the adapter by pushing and pulling a new, dry pipe-cleaner into the opening. Rotate the pipe-cleaner slowly as you do this.

---

**CAUTION**

---

**Be careful when using pipe-cleaners, as the core and the bristles of the pipe-cleaner are hard and can damage the adapter.**

2. Clean the adapter by rubbing a new, dry cotton-swab over the surface using a small circular movement.
3. Blow away any remaining lint with compressed air.

---

## E.11 How to clean lenses

Some lenses have special coatings that are sensitive to solvents, grease, liquid and mechanical abrasion. Take extra care when cleaning lenses with these coatings.

Lens assemblies consisting of several lenses are not normally sealed. Therefore, use as little alcohol as possible, as it can get between the lenses and in doing so can change the properties of projection.

### Preferred Procedure

Use the following procedure on most occasions.

1. Clean the lens by rubbing a new, dry cotton-swab over the surface using a small circular movement.
2. Blow away any remaining lint with compressed air.

## Cleaning Information

### How to clean instruments with a fixed connector interface

#### Procedure for Stubborn Dirt

Use this procedure particularly when there is greasy dirt on the lens:

1. Moisten a new cotton-swab with isopropyl alcohol.
2. Clean the lens by rubbing the cotton-swab over the surface using a small circular movement.
3. Using a new, dry cotton-swab remove the alcohol, any dissolved sediment and dust.
4. Blow away any remaining lint with compressed air.

---

## E.12 How to clean instruments with a fixed connector interface

You should only clean instruments with a fixed connector interface when it is absolutely necessary. This is because it is difficult to remove any used alcohol or filaments from the input of the optical block.

It is important, therefore, to keep dust caps on the equipment at all times, except when your optical device is in use.

If you do discover filaments or particles, the only way to clean a fixed connector interface and the input of the optical block is to use compressed air.

If there are fluids or fat in the connector, please refer the instrument to the skilled personnel of Agilent's service team.

---

### CAUTION

**Only use clean, dry compressed air. Make sure that the air is free of dust, water, and oil. If the air that you use is not clean and dry, this can lead to filmy deposits or scratches on the surface of your connector interface. This will degrade the performance of your transmission system.**

**Never try to open the instrument and clean the optical block by yourself, because it is easy to scratch optical components, and cause them to be misaligned.**

---

---

### **E.13 How to clean instruments with an optical glass plate**

Some instruments, for example, the optical heads from Agilent Technologies have an optical glass plate to protect the sensor. Clean this glass plate in the same way as optical lenses (see “How to clean lenses” on page 262).

---

### **E.14 How to clean instruments with a physical contact interface**

Remove any connector interfaces from the optical output of the instrument before you start the cleaning procedure.

Cleaning interfaces is difficult as the core diameter of a single-mode fiber is only about 9  $\mu\text{m}$ . This generally means you cannot see streaks or scratches on the surface. To be certain of the degree of pollution on the surface of your interface and to check whether it has been removed after cleaning, you need a microscope.

---

#### **WARNING**

**Never look into an optical output, because this can seriously damage your eyesight.**

---

To assess the projection of the emitted light beam you can use an infrared sensor card. Hold the card approximately 5 cm from the



## Cleaning Information

### How to clean instruments with a recessed lens interface

interface. The invisible emitted light is project onto the card and becomes visible as a small circular spot.

### Preferred Procedure

Use the following procedure on most occasions.

1. Clean the interface by rubbing a new, dry cotton-swab over the surface using a small circular movement.
2. Blow away any remaining lint with compressed air.

### Procedure for Stubborn Dirt

Use this procedure particularly when there is greasy dirt on the interface:

1. Moisten a new cotton-swab with isopropyl alcohol.
2. Clean the interface by rubbing the cotton-swab over the surface using a small circular movement.
3. Take a new, dry soft-tissue and remove the alcohol, dissolved sediment and dust, by rubbing gently over the surface using a small circular movement.
4. Blow away any remaining lint with compressed air.

---

## E.15 How to clean instruments with a recessed lens interface

---

### WARNING

**For instruments with a deeply recessed lens interface (for example the Agilent Technologies 81633A and 81634A Power Sensors) do NOT follow this procedure. Alcohol and compressed air could damage your lens even further.**

**Keep your dust and shutter caps on, when your instrument is not in use. This should prevent it from getting too dirty. If you must clean such instruments, please refer the instrument to the skilled personnel of Agilent's service team.**

---

### **Preferred Procedure**

Use the following procedure on most occasions.

1. Blow away any dust or dirt with compressed air. If this is not sufficient, then
2. Clean the interface by rubbing a new, dry cotton-swab over the surface using a small circular movement.
3. Blow away any remaining lint with compressed air.

### **Procedure for Stubborn Dirt**

Use this procedure particularly when there is greasy dirt on the interface, and using the procedure for light dirt is not sufficient. Using isopropyl alcohol should be your last choice for recessed lens interfaces because of the difficulty of cleaning out any dirt that is washed to the edge of the interface:

1. Moisten a new cotton-swab with isopropyl alcohol.
2. Clean the interface by rubbing the cotton-swab over the surface using a small circular movement.
3. Take a new, dry soft-tissue and remove the alcohol, dissolved sediment and dust, by rubbing gently over the surface using a small circular movement.
4. Blow away any remaining lint with compressed air.

## **E.16 How to clean optical devices which are sensitive to mechanical stress and pressure**

Some optical devices, such as the Agilent 81000BR Reference Reflector, which has a gold plated surface, are very sensitive to mechanical stress or pressure. Do not use cotton-swabs, soft-tissues or other mechanical cleaning tools, as these can scratch or destroy the surface.

### **Preferred Procedure**

Use the following procedure on most occasions.

1. Blow away any dust or dirt with compressed air.

### **Procedure for Stubborn Dirt**

To clean devices that are extremely sensitive to mechanical stress or pressure you can also use an optical clean polymer film. This procedure is time-consuming, but you avoid scratching or destroying the surface.

1. Put the film on the surface and wait at least 30 minutes to make sure that the film has had enough time to dry.
2. Remove the film and any dirt with special adhesive tapes.

### **Alternative Procedure**

For these types of optical devices you can often use an ultrasonic bath with isopropyl alcohol. Only use the ultrasonic bath if you are sure that it won't cause any damage anything to the device.

1. Put the device into the bath for at least three minutes.
2. Blow away any remaining liquid with compressed air.

If there are any streaks or drying stains on the surface, repeat the cleaning procedure.

## **E.17 How to clean metal filters or attenuator gratings**

This kind of device is extremely fragile. A misalignment of the grating leads to inaccurate measurements. Never touch the surface of the metal filter or attenuator grating. Be very careful when using or cleaning these devices. Do not use cotton-swabs or soft-tissues, as there is the danger that you cannot remove the lint and that the device will be destroyed by becoming mechanically distorted.

### **Preferred Procedure**

Use the following procedure on most occasions.

1. Use compressed air at a distance and with low pressure to remove any dust or lint.

### **Procedure for Stubborn Dirt**

Do not use an ultrasonic bath as this can damage your device.

Use this procedure particularly when there is greasy dirt on the device:

1. Put the optical device into a bath of isopropyl alcohol, and wait at least 10 minutes.
2. Remove the fluid using compressed air at some distance and with low pressure. If there are any streaks or drying stains on the surface, repeat the whole cleaning procedure.

---

## **E.18 Additional Cleaning Information**

The following cleaning procedures may be used with other optical equipment:

## Cleaning Information

### Additional Cleaning Information

- How to clean bare fiber ends
- How to clean large area lenses and mirrors

### **How to clean bare fiber ends**

Bare fiber ends are often used for splices or, together with other optical components, to create a parallel beam. The end of a fiber can often be scratched. You make a new cleave. To do this:

1. Strip off the cladding.
2. Take a new soft-tissue and moisten it with isopropyl alcohol.
3. Carefully clean the bare fiber with this tissue.
4. Make your cleave and immediately insert the fiber into your bare fiber adapter in order to protect the surface from dirt.

### **How to clean large area lenses and mirrors**

Some mirrors, as those from a monochromator, are very soft and sensitive. Therefore, never touch them and do not use cleaning tools such as compressed air or polymer film.

Some lenses have special coatings that are sensitive to solvents, grease, liquid and mechanical abrasion. Take extra care when cleaning lenses with these coatings.

Lens assemblies consisting of several lenses are not normally sealed. Therefore, use as little liquid as possible, as it can get between the lenses and in doing so can change the properties of projection.

### **Preferred Procedure**

Use the following procedure on most occasions.

## Cleaning Information

### Additional Cleaning Information

1. Blow away any dust or dirt with compressed air.

### Procedure for Stubborn Dirt

Use this procedure particularly when there is greasy dirt on the lens:

---

#### CAUTION

**Only use water if you are sure that your device does not corrode. Do not use hot water as this can lead to mechanical stress, which can damage your device.**

**Make sure that your liquid soap has no abrasive properties or perfume in it, because they can scratch and damage your device. Do not use normal washing-up liquid as sometimes an iridescent film remains.**

---

1. Moisten the lens or the mirror with water.
2. Put a little liquid soap on the surface and gently spread the liquid over the whole area.
3. Wash off the emulsion with water, being careful to remove it all, as any remaining streaks can impair measurement accuracy.
4. Take a new, dry soft-tissue and remove the water, by rubbing gently over the surface using a small circular movement.
5. Blow away remaining lint with compressed air.

### Alternative Procedure A

To clean lenses that are extremely sensitive to mechanical stress or pressure you can also use an optical clean polymer film. This procedure is time-consuming, but you avoid scratching or destroying the surface.

1. Put the film on the surface and wait at least 30 minutes to make sure that the film has had enough time to dry.
2. Remove the film and any dirt with special adhesive tapes.

### **Alternative Procedure B**

If your lens is sensitive to water then:

1. Moisten the lens or the mirror with isopropyl alcohol.
2. Take a new, dry soft-tissue and remove the alcohol, dissolved sediment and dust, by rubbing gently over the surface using a small circular movement.
3. Blow away remaining lint with compressed air.

---

## **E.19 Other Cleaning Hints**

Selecting the correct cleaning method is an important element in maintaining your equipment and saving you time and money. This Appendix highlights the main cleaning methods, but cannot address every individual circumstance.

This section contain some additional hints which we hope will help you further. For further information, please contact your local Agilent Technologies representative.

### **Making the connection**

Before you make any connection you must ensure that all lightwave cables and connectors are clean. If not, then use appropriate the cleaning methods.

When you insert the ferrule of a patchcord into a connector or an adapter, ensure that the fiber end does not touch the outside of the mating connector or adapter. Otherwise, the fiber end will rub up against something which could scratch it and leave deposits.

### **Lens cleaning papers**

Note that some special lens cleaning papers are not suitable for cleaning optical devices like connectors, interfaces, lenses, mirrors

## Cleaning Information

### Other Cleaning Hints

and so on. To be absolutely certain that a cleaning paper is applicable, please ask the salesperson or the manufacturer.

### **Immersion oil and other index matching compounds**

Do not use immersion oil or other index matching compounds with optical sensors equipped with recessed lenses. They are liable to dirty the detector and impair its performance. They may also alter the property of depiction of your optical device, thus rendering your measurements inaccurate.

### **Cleaning the housing and the mainframe**

When cleaning either the mainframe or the housing of your instrument, only use a dry and very soft cotton tissue on the surfaces and the numeric pad.

Never open the instruments as they can be damaged. Opening the instruments puts you in danger of receiving an electrical shock from your device, and renders your warranty void.



---

**F**

---

**Error messages**

---

# Error Messages

## F.1 Display Messages

### **FAILnnnn**

indicates that the self test has failed. The number nnnn is a four digit hexadecimal number that indicates which part of the self test has failed.

<b>Bits</b>	<b>Mnemonics</b>	<b>Hexadecimal Value</b>
8	Counter	0100 <sub>16</sub>
7	Analog to Digital Convertor	0080 <sub>16</sub>
6	General DSP Hardware	0040 <sub>16</sub>
5	DSP Timeout	0020 <sub>16</sub>
4	DSP Communications	0010 <sub>16</sub>
3	Calibration Data	0008 <sub>16</sub>
2	Keypad	0004 <sub>16</sub>
1	Battery RAM	0002 <sub>16</sub>
0	Calibration Data Checksum	0001 <sub>16</sub>

So FAIL0010 would mean that the DSP (Digital Signal Processor) Communications had failed, FAIL0012 would mean that the DSP Communications had failed, and so had the Battery RAM.

## F.2 GPIB Messages

### Command Errors

These are error messages in the range -100 to -199. They indicate that a syntax error has been detected by the parser in a command, such as incorrect data, incorrect commands, or misspelled or mistyped commands.

A command error is signaled by the command error bit (bit 5) in the event status register.

#### **-100 Command error**

This indicates that the parser has found a command error but cannot be more specific.

#### **-101 Invalid character**

The command contains an invalid or unrecognized character.

#### **-102 Syntax error**

The command or data could not be recognized.

#### **-103 Invalid separator**

The parser was expecting a separator (for example, a semicolon (;) between commands) but did not find one.

#### **-104 Data type error**

The parser was expecting one data type, but found another (for example, was expecting a string, but received numeric data).

#### **-105 GET not allowed**

A Group Execute Trigger was received within a program message (see IEEE 488.2, 7.7)

**-108 Parameter not allowed**

More parameters were received for a command than were expected.

**-109 Missing parameter**

Fewer parameters were received than the command requires.

**-110 Command header error**

A command header is the mnemonic part of the command (the part not containing parameter information). This error indicates that the parser has found an error in the command header but cannot be more specific.

**-111 Header separator error**

A character that is not a valid header separator was encountered.

**-112 Program mnemonic too long**

The program mnemonic must be 12 characters or shorter.

**-113 Undefined header**

This header is not defined for use with the instrument.

**-114 Header suffix out of range**

The header contained an invalid character. This message sometimes occurs because the parser is trying to interpret a non-header as a header.

**-120 Numeric data error**

This error indicates that the parser has found an error in numeric data (including nondecimal numeric data) but cannot be more specific.

**-121 Invalid character in number**

An invalid character was found in numeric data (note, this may include and alphabetic character in a decimal data, or a "9" in octal data).

**-123 Exponent too large**

The exponent must be less than 32000.

**-124 Too many digits**

The mantissa of a decimal number can have a maximum of 255 digits (leading zeros are not counted).

**-128 Numeric data not allowed**

Another data type was expected for this command.

**-130 Suffix error**

The suffix is the unit, and the unit multiplier for the data. This error indicates that the parser has found an error in suffix but cannot be more specific.

**-131 Invalid suffix**

The suffix is incorrect or inappropriate.

**-134 Suffix too long**

A suffix can have a maximum of 12 characters.

**-138 Suffix not allowed**

A suffix was found where none is allowed.

**-140 Character data error**

This error indicates that the parser has found an error in character data but cannot be more specific.

Error Messages  
GPIB Messages

**-141 Invalid character data**

The character data is incorrect or inappropriate.

**-144 Character data too long**

Character data can have a maximum of 12 characters.

**-148 Character data not allowed**

Character data was found where none is allowed.

**-150 String data error**

This error indicates that the parser has found an error in string data but cannot be more specific.

**-151 Invalid string data**

The string data is incorrect, (for example, an END message was received before the terminal quote character).

**-158 String data not allowed**

String data was found where none is allowed.

**-160 Block data error**

This error indicates that the parser has found an error in block data but cannot be more specific.

**-161 Invalid block data**

The block data is incorrect (for example, an END message was received before the length was satisfied).

**-168 Block data not allowed**

Block data was found where none is allowed.

### **Execution Errors**

These are error messages in the range -200 to -299. They indicate that an execution error has been detected by the execution control block.

An execution error is signaled by the execution error bit (bit 4) in the event status register.

#### **-200 Execution error**

This indicates that an execution error has occurred but the control block cannot be more specific.

#### **-201 Invalid while in local**

This command is invalid because it conflicts with the configuration under local control.

#### **-202 Settings lost due to rtl**

A local setting was lost when the instrument was changing from remote to local control, or from local to remote control.

#### **-220 Parameter error**

This indicates that a parameter error has occurred but the control block cannot be more specific.

#### **-221 Settings conflict**

A valid parameter was received, but could not be used during execution because of a conflict with the current state of the instrument.

#### **-222 Data out of range**

The data, though valid, was outside the range allowed by the instrument.



Error Messages  
GPIB Messages

**-223 Too much data**

The block, expression, or string data was too long for the instrument to handle.

**-224 Illegal parameter value**

One value from a list of possible values was expected. The parameter received was not found in the list.

**-240 Hardware error**

Indicates that a command could not be executed due to a hardware error but the control block cannot be more specific.

**-241 Hardware missing**

Indicates that a command could not be executed because of missing instrument hardware.

**Device-Specific Errors**

These are error messages in the range -300 to -399, or between 1 and 32767. They indicate that an error has been detected that is specific to the operation of the attenuator.

An device-specific error is signaled by the device-specific error bit (bit 3) in the event status register.

**-300 Device-specific error**

This indicates that a device-specific error has occurred. No more specific information is available.

**-310 System error**

An instrument system error has occurred.

**-311 Memory error**

A memory error has been detected.

## Error Messages

### GPIB Messages

#### **-314 Save/recall memory lost**

The nonvolatile data saved by the \*SAV command has been lost.

#### **-315 Configuration memory lost**

The nonvolatile configuration data saved by the instrument has been lost.

#### **-330 Self-test failed**

Further information about the self-test failure is available by using \*TST?.

#### **-350 Queue overflow**

The error queue has overflowed. This error is written to the last position in the queue, no further errors are recorded.

### **Query Errors**

These are error messages in the range -400 to -499. They indicate that an error has been detected by the output queue control.

An device-specific error is signaled by the query error bit (bit 2) in the event status register.

#### **-300 Query error**

This indicates that a query error has occurred. No more specific information is available.

#### **-410 Query INTERRUPTED**

A condition occurred which interrupted the transmission of the response to a query (for example, a query followed by a DAB or a GET before the response was completely sent).

#### **-420 Query UNTERMINATED**

A condition occurred that interrupted the reception of a query (for example, the instrument was addressed to talk and an incomplete program message was received).

Error Messages  
GPIB Messages

**-430 Query DEADLOCKED**

A condition causing a deadlocked query has occurred (for example, both the input and the output buffer are full and the device cannot continue).

**-440 Query UNTERMINATED after indefinite response**

Two queries were received in the same message. The error occurs on the second query if the first requests an indefinite response, and was already executed.

**Instrument Specific Errors**

These are errors with positive error numbers, and are specific to this instrument.

**201**

The user calibration is currently on, and calibration data cannot be changed. Switch the user calibration state to off (see ) and try again.

**202**

There is no user wavelength calibration data, or the data is invalid.

**203**

Entering the data points cannot be stopped, because it has not been started.

**204**

There no more data points to be read.

Error Messages

**GPIB Messages**

## Index

### Symbols

\*CLS .....95,  
96, .....101  
\*ESE .....95  
\*ESE? .....96  
\*ESR? .....96  
\*IDN? .....97  
\*OPC .....95, 98  
\*OPC? .....95, 98  
\*OPT? .....98  
\*RCL .....99  
\*RST .....96,  
99, .....101  
\*SAV .....100  
\*SRE .....101  
\*SRE? .....102  
\*STB? .....102  
\*TST? .....103  
\*WAI .....104  
? .....113,  
117, .....120

### A

AC power cable .....144  
AC power requirements 144  
ADDRESS .....67  
ANSI MC 1.1 .....81  
APMode .....110  
APMode? .....111  
APOWeron .....114  
APOWeron? .....114  
ATTenuation .....106  
Attenuation  
Calculation .....29, 38  
Hardware setup ....37, 43  
Attenuation accuracy 165

Attenuation factor ....29,  
38, .....39,  
106  
Default .....39,  
106  
Maximum .....106  
Minimum .....106  
Resetting .....39  
Attenuation range ...165  
Attenuation Sweep ...116,  
118  
Attenuation sweep ....30, 47  
ATTenuation? .....106  
AUTO .....49, 54  
Autotransformer .....144

### B

#### BACK REFL

Hardware setup ....59  
Back Reflector .....32, 59  
Back reflector  
Calculation .....60  
Battery  
Replacing .....146  
BRIGHT .....71  
BRIGHTness .....104  
BRIGHTness? .....104

### C

Cable  
 GPIB .....157  
Calibration  
Wavelength .....33, 67  
Calibration factor ....29,  
39, .....44,  
107, .....108

Default .....40,  
108  
Maximum .....108  
Minimum .....108  
Resetting .....40  
Transferring to ....29, 40  
Capital letters (when pro-  
gramming) .....85  
Case sensitivity .....85  
Common commands .93  
CONDition register ..115  
CONDition? .....116,  
119  
Connector Interface ..150,  
159, .....160  
Cooling .....148

### D

Declaration of Conformity  
171  
DEFAULT .....72, 77  
DIS .....73  
Disabling the Optical Output  
150  
DISPlay .....104,  
105, .....108  
DIsplay  
Brightness .....104  
Brightness, Default 104  
Display  
Brightness .....71  
Brightness, Default 71  
Brightness, Resetting 71  
Resolution .....74  
DWELL  
Automatic sweep ..30,  
48, ....49, 55  
Default .....50

## Index

- Resetting .....50
- E**
- Earth .....144
- Editing  
Non-numeric .....30  
Numeric .....30
- ENABLE .....105,  
117, .....119
- ENABLE register .....115,  
122
- ENABLE? .....105,  
117, .....120
- Error queue .....84,  
95, .....122
- ERRor? .....122
- Errors .....122,  
275
- OPERation .....117
- QUESTionable .....120
- EVENTt register .....115
- Event Status Enable Register  
96
- Event Status Enable register  
94, .....95,  
96, .....100
- Event Status Register 94,  
95, .....96,  
98, .....101,  
102
- Excess loss .....165
- F**
- Filter  
Fixed .....33,  
34, .....68
- Repositioning .....33,  
34, .....68,  
116, ...118
- Settling .....116,  
118
- Firmware revision ....97
- Function Test .....143
- Fuse  
Replacing .....146
- G**
- General Purpose Interface  
Bus .....81
- GPIB .....81  
Address .....67, 83  
Capabilities .....82  
Command summary 89  
Default address ....67, 83  
Interface functional subset  
82  
Reference works ..81  
Resetting address .67
- GPIB Adapter .....157
- GPIB Cable .....157
- GPIB Connector .....151
- GPIB Interface .....150
- GPIB Logic Levels ...152
- H**
- HP-IB  
Address .....99
- Humidity  
Operating .....148
- I**
- IEC 625-1 .....81
- IEEE  
Address .....81
- IEEE 488.1-1987 .....81
- IEEE 488.2-1987 .....81, 93
- IEEE 488-1978 .....81
- If .....83
- Initial Inspection .....143
- INPut .....106,  
107, .....108,  
109, .....110
- Input queue .....83, 98  
Clearing .....84
- INS LOSS .....60  
Default .....61  
Resetting .....61
- Insertion loss .....165  
Measuring .....43
- Inspection  
Initial .....143
- Institute of Electrical and  
Electronics Engineers,  
Inc.  
Address .....81
- Interface Adapter .....158,  
160
- L**
- LAMBDCAL .....34,  
68, .....107  
Default .....68  
Resetting .....68
- LAST .....72, 73
- LCMode .....107
- LCMode? .....107

## Index

Local .....83  
LOCKOUT .....72  
Long form .....85

### M

Maintenance .....143  
MANUAL .....52  
Manufacturer .....97  
MAV .....84,  
95, .....101,  
102  
Message available ....84  
Message exchange ...83  
Reception .....83  
Message terminator  
Input .....84, 85  
Output .....84  
Messages  
Long form .....85  
Short form .....85  
Model number .....97  
Modify keys .....29  
Monitor Output  
Coupling ratio ....37, 47  
MSS .....95  
Multiple commands (in one  
message) .....85

### N

Node (STATUS) .....114  
NORMAL .....72  
Notices .....2  
NTRansition .....118,  
120  
NTRansition register 115,  
122

NTRansition? .....118,  
121

### O

OFFSet .....107,  
108  
OFFSet? .....108  
OPERation .....116,  
117, .....118,  
119  
Operation .....143  
Operation Complete .98  
Operation status .....101,  
102, .....114,  
115, .....122  
Condition register .116  
Enable register ....117  
Event register .....117  
Negative transition register  
118  
Positive transition register  
118, ...119  
Optical Output .....150  
Disabling .....150  
Optical Termination .150  
Option .....157  
201 .....59  
Query .....98  
OUTPut .....110,  
111, .....112,  
113, .....114  
Output queue .....84,  
98, .....99,  
103

### P

P ON SET .....72  
Default .....72  
Resetting .....72  
Parser .....98  
Starting .....84  
Polarization dependent loss  
165  
Polarization mode dispersion  
166  
POWER .....112  
Power cable .....144  
Power plug  
rewiring .....145  
Power requirements ..144  
POWER? .....113  
Power-on .....144  
Power-on Setting ....72  
PRESet .....122  
Press .....49,  
50, .....52,  
53, .....54,  
63, .....77, 78

Programming  
General .....85  
Protective earth symbol 143  
PTRansition .....118,  
121  
PTRansition register .115,  
122  
PTRansition? .....119,  
121

### Q

QUEStionable .....119,  
120, .....121

## Index

- Questionable status ..101,  
 102, .....114,  
 115, .....122  
 Condition register .119  
 Enable register ....119,  
 120  
 Event register .....120  
 Negative transition register  
 120, ...121  
 Positive transition register  
 121
- R**
- Repeatability .....166  
 Request Service .....94  
 Resetting the instrument 54,  
 63, .....77  
 RESOLUT .....74  
 Default .....74  
 Resetting .....74  
 Return loss .....166  
 Calculation .....32  
 RL INPUT .....60  
 Default .....61  
 Resetting .....61  
 RL REF .....60  
 Default .....61  
 Resetting .....61  
 RQS .....94,  
 101, .....102
- S**
- Safety .....143  
 Safety class .....143  
 SCPI .....81  
 Long form .....85  
 Reference works ..81
- Short form .....85  
 Selftest .....103  
 Serial number .....97  
 Serial poll .....94  
 Service Request .....94  
 Service Request Enable 94  
 Service Request Enable regis-  
 ter .....94,  
 99, .....101,  
 102  
 Setting .....99  
 Contents .....77,  
 100  
 Default .....77, 99  
 Power-on .....72  
 Recalling .....77, 99  
 Storing .....77,  
 100  
 Settling time  
 Filter .....48  
 Short form .....85  
 SHUTTER .....72, 83  
 Default .....73  
 Resetting .....73  
 Shutter .....113  
 Power-on .....73,  
 114  
 SHUTTER@ PON ...73  
 Default .....73  
 Resetting .....73  
 Specifications .....165  
 SRQ .....94  
 Standard Commands for Pro-  
 grammable Instruments  
 81  
 START  
 Automatic sweep ..30,  
 48, ....49, 54  
 Default .....50, 53  
 Manual sweep ....31,  
 51, ....52  
 Resetting .....50, 53  
 51, ....52  
 Resetting .....50, 53
- START .....124  
 START? .....125  
 OUTPut .....113,  
 114  
 STATE .....125  
 STATE? .....126  
 STATus .....116,  
 117, .....118,  
 119, .....120,  
 121, .....122
- Status  
 Common .....93  
 Status Byte .....94,  
 95, .....101,  
 102, .....115,  
 117  
 Status byte .....84  
 STATus nodes .....114  
 STEP  
 Automatic sweep ..30,  
 48, ....49, 54  
 Default .....50, 53  
 Manual sweep ....31,  
 51, ....52  
 Resetting .....50, 53  
 STOP .....126  
 Automatic sweep ..30,  
 48, ....49  
 Default .....50, 53  
 Manual sweep ....31,  
 51, ....52  
 Resetting .....50, 53
- SWP**  
 Hardware setup ....47  
 Syntax .....86  
 SYSTEM .....122



## Index

- T**
- Temperature
    - Cooling .....148
    - Operating .....148
    - Storing .....148
  - Temperature variation 116,  
118
    - Wavelength calibration data  
.....69
  - The .....60
  - the .....60
  - Through power .....112,  
113
    - Default .....113
    - Maximum .....113
    - Minimum .....113
  - Through power mode 33,  
70, .....110,  
111
  - THRUPOWR .....33,  
70, .....71
    - Default .....71
    - Resetting .....71
    - Setting up .....33, 70
- U**
- U/L-CAL .....68, 69
  - UCALibration .....124,  
125, .....126,  
127
  - Units
    - Mnemonics .....89
    - Programming .....85, 89
  - USERCAL .....34, 69
    - Default .....69
    - Factory .....34, 67
    - Resetting .....69
- Temperature considerations  
69
- User .....34,  
67, .....69
- V**
- VALue .....126
  - VALue? .....127
- W**
- WAVelength .....109
  - Wavelength .....33,  
40, .....67,  
109, .....110
    - Default .....41,  
109, ...110
    - Maximum .....109,  
110
    - Minimum .....109,  
110
    - Resetting .....41
  - Wavelength calibration data  
33, .....67,  
107
  - Invalid .....119,  
120
  - User .....123
  - Wavelength range ....166
  - WAVelength? .....110