

## Agilent Technologies 8133A 3 GHz Pulse Generator

### Technical Specifications



The Standard in Pulse Generator  
Technology

#### Key Features

- 33 MHz to 3 GHz Frequency
- <100 ps transition times
- <5 ps pulse jitter
- $\pm 0.5\%$  ps Width Accuracy
- $\pm 100$  ps Width Accuracy
- $\pm 150$  ps Delay Accuracy
- 1 or 2 Output Channels
- $2^{23-1}$  PRBS Generation
- SCPI Programming Commands

#### Agilent Technologies 8133A 3 GHz Pulse Generator

The need for pulse generation is fundamental to any device characterization task. The ability to emulate the pulse conditions to which the device will be subjected is essential. This emulation should include both typical and worst case conditions. Such accurate emulation requires superlative signal integrity and timing performance.

#### Setting Standards

The Agilent 8133A 3 GHz Pulse Generator provides pulses with programmable period from 333 ps to 30 ns, full 3 GHz pulse capability on all channels. The pulse width can be programmed too, along with a delay or the interchannel delay. At these frequency ranges the transition time performance becomes critical; less than 100 ps is specified, less than 60 ps is typical, so excellent signal integrity is assured. And last but not least, a typical jitter of 1 ps creates precise and accurate timing conditions.



Agilent Technologies

### Pulse and Data Functionality

The 8133A 's standard configuration includes one pulse channel. A second channel can be added. This can be either:

- pulse/data channel (option 002)
- pulse channel (option 003)

Option 002 allows 32 bit, digital pattern generation in NRZ and RZ (50%duty cycle) mode. Pulse/data channel 2 can also be programmed to provide a pseudo-random binary~sequence (PRBS) of data,a PRBS of  $2^{23-1}$ , which conforms to CCITT 0.151.PRBS generation capability finds a particular application,in allowing the instrument to be used as a data source for eye diagram measurements.

### Human Interface

You will particularly appreciate the interactive human interface when you are operating the Agilent 8133A on the bench. The easy access to all parameters helps you concentrate on the measurement task and react immediately to unexpected problems. The constant vernier steps for parameters allow you to increment or decrement through the entire parameter range with a fixed step-size,using only one key, which is especially helpful when doing margin testing.

The immediate error-guidance lets you know what 's wrong,with messages like "width> Period ", and how to fix it,with arrows indicating that a parameter should be increased or decreased. You can quickly recall last valid setting if you prefer.

The Agilent 8133A is available in four different configurations. The differences are timing capabilities and number of channels with different functionality.

	8133A	Option 001	Option 002	Option 003
Channel 1	Width or Delay with Square	Delay also in Width Mode	Delay also in Width Mode	Delay also in Width Mode
Channel 2			32-bit data PRBS $2^{23-1}$ Divided Square	Second Pulse Channel with Width or Delay with Square

Note: option 002 and 003 contain option 001

### Specifications

Specifications describe the instrument's warranted performance. Non-warranted values are described as typical. All specifications apply after a 30 minute warm-up phase with 50 Ω source/load resistance and separate channels. All specifications are valid from 0°C to 55°C ambient temperature.

### Timing Characteristics

Measured at 50% amplitude at fastest transitions in continuous mode and 50 Ω source impedance.

Mainframe Output module	Agilent 8133A Pulse Channel 1	Delay Pulse Channel 1 Option 001	Pulse Channel 2 Option 003	Pulse/Data Channel 2 Option 002
Frequency Range	33.0 MHz to 3.0000 GHz			
Period Range	333 ps to 30.303 ns			
Timing resolution	3.5 digits, 1 ps best case			
RMS Jitter (period, delay, width)	less than 5 ps (1 ps typical)			10 ps ( f < 2 GHz: 5ps)
Accuracy	± 0.5% (± 0.1% typical)			
Width range <sup>(1)</sup>	150 ps to (period – 150 ps) maximum 10.000 ns			
Resolution	1ps			
Accuracy	± 100 ps (± 30 ps typical)			
Duty Cycle <sup>(2)</sup>	0% to 100%			
Resolution	0.1%, best case 1			
Add. Variable delay	Pulse mode: no	Pulse mode: -5.000 to + 5.000ns	<sup>(3)</sup> Pulse mode: no	
	Square mode: 0.000 ns to 10.000 ns	Square mode: -5.000 ns to 15.000 ns	Square mode: 0.000 ns to 10.000 ns	
Channel 1 to Channel 2 Delay <sup>(4)</sup>			Pulse mode: -5.000 ns to + 5.000 ns	Square mode: -5.000 ns to 15.000 ns
Resolution	1 ps			
Accuracy	<sup>(5)</sup> ± 150 ps (± 30 ps typical)	<sup>(6)</sup> ± 50 ps		
Phase <sup>(7)</sup>	0° to 3600°	-3600° to 3600°	-3600° to 3600°	-3600° to 3600°
Resolution	0.1°, best case 1 ps			
Skew <sup>(8)</sup>			± 5 ns	

#### Notes:

- <sup>(1)</sup> The width can only be varied in Pulse mode. In square mode the duty cycle is fixed at 50%
- <sup>(2)</sup> Width and duty cycle are mutually exclusive. Duty Cycle settings and limits are subject to the same specifications and settings as Width.
- <sup>(3)</sup> Delay variation Channel 2 to Channel 1
- <sup>(4)</sup> The interchannel delay between Channel 1 and Channel 2 is the programmed delay of Channel
- <sup>(5)</sup> Any parameter variation
- <sup>(6)</sup> Only delay variation
- <sup>(7)</sup> Delay and Phase are mutually exclusive. Phase settings and limits are subject to the same specifications and settings as
- <sup>(8)</sup> Delay or Phase, plus Skew must be within the Delay Range

**Repeatability:** is typ. four times better than accuracy.

#### Internal Clock Generation

The internal clock can be set in frequency or period mode

#### External Clock

The external input signal determines the timebase of the instrument. The external period or frequency is measured and displayed, allowing the correct setting of Duty Cycle and Phase also in External Clock mode.

#### External Frequency Counter Period

**Range:** 333 ps to 30.303 ns (300 ps to 500 ns typical)  
**Resolution:** 1 ps  
**Accuracy:** ± 0. 1 %

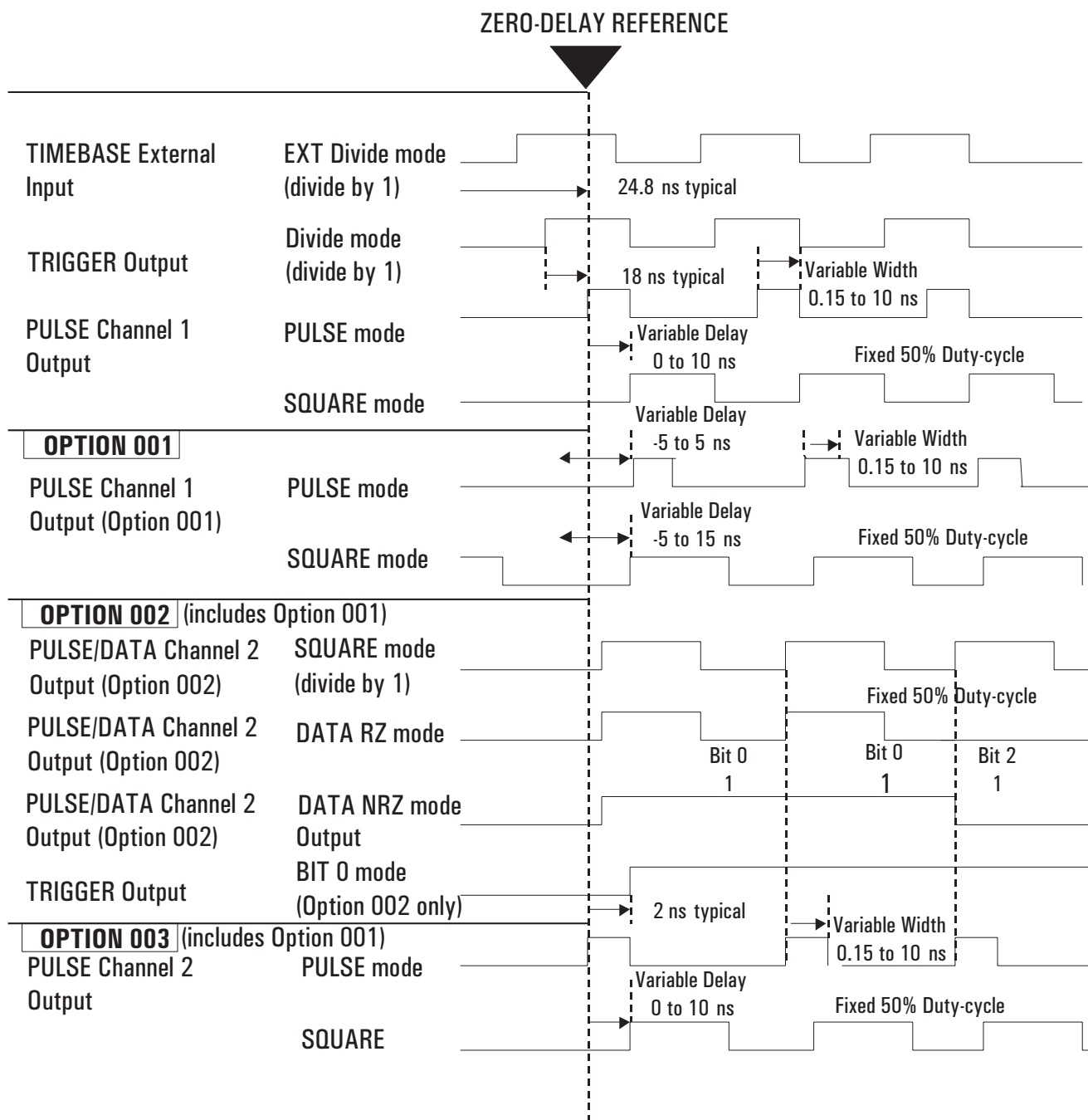

Interchannel Timing Diagram

**Frequency**

**Range:** 33.0 MHz to 3.0000 GHz (2 MHz to 3.33 GHz typical)

**Resolution:** 100 kHz

**Accuracy:** ± 0.1 %

**External Input Divide**

The external supplied frequency can be divided.

Divide by: (1), 2, 4, 8, 16, 32, and 64.

The internal available frequency has to be ≥33 MHz to ensure that all specifications are met.

The instrument will perform all functions down to 3 MHz, except the functions of the PULSE/DATA/CHANNEL2.

**External Input**

**Range:** 33 MHz - 3 GHz

**Interface:** ac-coupled

**Impedance:** 50 Ω nominal

**Minimum Swing**

Pulse: 50% duty cycle, 300 mV,

tr < 3 ns

Sine: 0 dBm

**Maximum amplitude:** 3 Vpp, + 20 Vdc

**PULSE CHANNEL 1**

**Delay**

Delay has no period limitations.

Fixed delay between TRIGGER

Output to CHANNEL 1 Outputs: 18.8 ns nominal for trigger output divide by 1

**PULSE/DATA CHANNEL 2 (# 002)**

**Delay**

Fixed delay from TRIGGER Output to CHANNEL 2 Outputs.

**Trigger on pulse:** 18.8ns nominal for trigger output divide by 1

**Trigger on Bit 0:** - 2.0 ns before Bit 0 nominal

**Data**

Selects Data mode. Further selection between 32bit programmable data or PRBS is required.

**Divide**

In Square mode the frequency of CHANNEL 2 can be divided. Divide by: (1), 2, 4, 8, 16, 32

To meet all timing specifications, the internal (CHANNEL 2) frequency has to be ≥ 33 MHz.

**32 BIT**

32 bit of programmable data are selectable.

**PRBS**

PRBS: 2<sup>23</sup>-1, CCITT 0.151Norm

**RZ / NRZ**

Sets 32 bit data to Return To Zero/ Non Return to Zero mode.

RZ fixed duty cycle: 50% nominal

**PULSE CHANNEL 2 (# 003)**

**Divide**

In Pulse and Square modes, the frequency of Channel 2 can be divided by 2, 4, 8, 16, 32 or 64.

The minimum Channel 2 frequency is 1 MHz.

**Level/Pulse Performance Characteristics**

Mainframe	Agilent 8133A
Amplitude	0.30 V to 3.00 V
Level window	-2 V to +4 V (-3 to +4 V typical)
Level Accuracy	± 2% of amplitude ± 2% of setting ± 20 mV
Resolution	10 mV
Output connectors	SMA Connectors on the front panel
Source Impedance	50 Ω
Skew between differential outputs	< 20 ps nominal
Max. external voltage	± 3 V nominal
Short circuit current	-120 mA max. ≤ I <sub>sc</sub> ≤ 160 mA nominal
Transition Times (10/90)	< 100 ps (60 ps typical)
Transition Times (20/80)	< 60 ps (40 ps typical)
Settling time	1 ns
Overshoot/preshoot/ringing	< 15% of amplitude ± 20 mV Differential Outputs

The output voltage can be set in amplitude/offset or high-/low level mode. Levels double when driving into open circuits.

**Limit**

Maximum high and low levels into 50 W can be limited to protect the device under test. Pushing the limit key declares present levels as limits which then cannot be exceeded as long as this mode is active.

**Complement** (not #002 PULSE/ DATA CHANNEL 2)

Normal/complement selectable

**Data** (only #002 PULSE/DATA CHANNEL2)

Provides logical complement of data

**Disable**

Relays connect/disconnect outputs

**Connector Type**

SMA (f) for all outputs and inputs

#### TRIGGER Output

Conditions:  $f_{out} > 33\text{MHz}$

#### Trigger Channel Output

The output voltage can be set in amplitude/offset or high- and low level mode ( $50\ \Omega$  to  $0\ \text{V}$ ).

**Amplitude:** (0.20 V typical) 0.50 V to 1.80 V nominal

**Level Window:** -4.00 V to +4.00 V

**Resolution:** 10 mV

**Format:** fixed Duty Cycle 50% nominal

**Prop. delay External Input to Trigger**

**Channel Output:** 6 ns nominal for trigger output divide by 1 Maximum external voltage:  $\pm 4\ \text{V}$

#### Transition Times

**20% - 80% of amplitude:**  $< 100\ \text{ps}$   
( $< 60\ \text{ps}$  typical)

#### Disable

A relay connects/disconnects the trigger output

#### Divide

The trigger output frequency can be divided.

Divide by: (1), 2, 4, 8, 16, 32, 64

**Minimum output frequency:** 33 MHz (3 MHz typical)

#### Bit 0 (PULSE/DATA CHANNEL 2 only)

The trigger output is synchronized to Bit 0 of the 32 bit word in data mode. It's a square wave signal divided by 32 with respect to the timebase frequency.

#### Rearpanel Connectors

Agilent8133A: CHANNEL 1 ~ Output, CHANNEL 1 - Input

Option 002: CHANNEL 2 - Output, CHANNEL 2 ~ Input, Start/Stop - Input

Option 003: CHANNEL 2 - Output, CHANNEL 2 ~ Input

CHANNEL X Output amplitude: 2

V<sub>pp</sub>, ac-coupled

CHANNEL X Input amplitude: max.

2.5 V<sub>pp</sub>, ac-coupled, min. 1.0 V<sub>pp</sub>, ac-coupled

50% duty cycle

For proper operation the CHANNEL X Outputs and Inputs have to be connected through the supplied rigid coaxial links.

#### Start/Stop Input

Interface: dc-coupled

Impedance: 50n nominal

Transitions:  $< 1\ \text{ns}$

Start level: 0 V (default)

Stop level: - 0.4 V

The Start/Stop Input is used for the PULSE/DATA CHANNEL 2 to hold the data stream to setup a data pattern and to start data generation on a specific bit.

#### Additional Features

Non-volatile Memory

Current settings are saved on power-down. Additionally 20 complete settings can be stored.

#### GP-IB Capabilities

All modes and parameters are programmable. Operates according to IEEE standard 488.1 and 488.2, 1987. Conforms to the Standard Commands for Programmable Instruments (SCPI) 1992.0.

#### General Information

##### Environmental

**Storage temperature:**  $-40^{\circ}\text{C}$  to  $+70^{\circ}\text{C}$

**Operating temperature:**  $0^{\circ}\text{C}$  to  $55^{\circ}\text{C}$

**Humidity** ( $0^{\circ}\text{C}$  to  $40^{\circ}\text{C}$ ): 95% R.H.

##### Power

110-120/220-240Vrms,  $\pm 10\%$ ,  
250VA max., 47-63Hz

##### Weight

Net: 21.5 kg (48 lb)

Shipping: 29.0 kg (65 lb)

##### Dimensions

(HxWxD) 145 mm x 426 mm x 525 mm

(5.7 in x 16.75 in x 20.65 in)

## Ordering Information

**Agilent 8133A** 3 GHz Pulse Generator

**Option 001** Delay CHANNEL 1

**Option 002** PULSE/DATA CHANNEL 2

**Option 003** PULSE CHANNEL 2

**Option 004** Standard Instrument

**Note:** Option 002 and Option 003 contain Option 001

### Accessories

**Agilent 1250-1462** Adapter SMA (m) to SMA (f)

**Agilent 8120-4948** 50  $\Omega$  Cable, SMA (m-m)

**Agilent 8710-1582** Torque Wrench 5 in/lbs

**Agilent 8493A** Series Attenuators

**Agilent 11667B** Power Splitter

**Agilent 15435A** Transition Time Converter 150 ps

**Agilent 15432B** Transition Time Converter 250 ps

**Agilent 15433B** Transition Time Converter 500 ps

**Agilent 15434B** Transition Time Converter 1000 ps

**Agilent 15438A** Transition Time Converter 2000 ps

## Related Agilent Literature

Agilent Family of Pulse/Pattern Generators, brochure, p/n 5980-0489E

For more information, please visit us:  
[www.agilent.com/find/pulse\\_generator](http://www.agilent.com/find/pulse_generator)



## Agilent Email Updates

[www.agilent.com/find/emailupdates](http://www.agilent.com/find/emailupdates)

Get Free Email Updates

Keep up to date with Agilent's free Email Updates. As a subscriber, you will receive regular, customized email updates on the topics you select. Updates cover support, products and services, applications, promotions, events, and other areas. It is easy to unsubscribe or change your preferences. Subscribe today:  
<http://www.agilent.com/find/emailupdates>.

Agilent is committed to respecting and protecting your privacy. Our Privacy Statement at <http://www.agilent.com/go/privacy> describes our commitment to you. Please direct any questions about Agilent's privacy program to [privacy\\_advocate@agilent.com](mailto:privacy_advocate@agilent.com).

## Agilent Technologies' Test and Measurement Support, Services, and Assistance

Agilent Technologies aims to maximize the value you receive, while minimizing your risk and problems. We strive to ensure that you get the test and measurement capabilities you paid for and obtain the support you need. Our extensive support resources and services can help you choose the right Agilent products for your applications and apply them successfully. Every instrument and system we sell has a global warranty. Support is available for at least five years beyond the production life of the product. Two concepts underlay Agilent's overall support policy: "Our Promise" and "Your Advantage."

### Our Promise

Our Promise means your Agilent test and measurement equipment will meet its advertised performance and functionality. When you are choosing new equipment, we will help you with product information, including realistic performance specifications and practical recommendations from experienced test engineers. When you use Agilent equipment, we can verify that it works properly, help with product operation, and provide basic measurement assistance for the use of specified capabilities, at no extra cost upon request. Many self-help tools are available.

### Your Advantage

Your Advantage means that Agilent offers a wide range of additional expert test and measurement services, which you can purchase according to your unique technical and business needs. Solve problems efficiently and gain a competitive edge by contracting with us for calibration, extra-cost upgrades, out-of-warranty repairs, and on-site education and training, as well as design, system integration, project management, and other professional services. Experienced Agilent engineers and technicians worldwide can help you maximize your productivity, optimize the return on investment of your Agilent instruments and systems, and obtain dependable measurement accuracy for the life of those products.

By internet, phone, or fax, get assistance with all your test & measurement needs

**Online assistance:**  
[www.agilent.com/find/assist](http://www.agilent.com/find/assist)

**Phone or Fax  
United States:**  
(tel) 1 800 452 4844

**Canada:**  
(tel) 1 877 894 4414  
(fax) (905) 206 4120

**Europe:**  
(tel) (31 20) 547 2000

**Japan:**  
(tel) (81) 426 56 7832  
(fax) (81) 426 56 7840

**Latin America:**  
(tel) (305) 267 4245  
(fax) (305) 267 4286

**Australia:**  
(tel) 1 800 629 485  
(fax) (61 3) 9272 0749

**New Zealand:**  
(tel) 0 800 738 378  
(fax) 64 4 495 8950

**Asia Pacific:**  
(tel) (852) 3197 7777  
(fax) (852) 2506 9284

Product specifications and descriptions in this document subject to change without notice.

Copyright © 2000 Agilent Technologies  
Printed in Germany  
28th November 2002  
**5980-1214E**



**Agilent Technologies**