

Agilent Technologies 8110A 150 MHz Pulse Generator

Technical Specifications



Flexible pulses or patterns for digital designs

Key Features

- 150 MHz Timing
- 2 ns Variable Transitions
- 10 Vpp (20 Vpp) into 50 Ω
- 10 ps Resolution
- 0.1% Frequency Accuracy
- 4 kbit Pattern per Channel
- 3 and 4 Level Signals
- 1 or 2 Output Channels
- SCPI Programming Commands
- Small Size
- Graphic Display

Agilent Technologies 8110A 150 MHz Pulse Generator

The Agilent 8110A 150 MHz Pulse Generator is a test instrument that provides sufficient speed and performance for testing designs to their limits; testing under real-world conditions to verify the proper function of the design.

- pulses, digital patterns and multilevel waveforms for testing current logic technologies (CMOS, TTL, LVDS, ECL, etc.)
- credible measurements
- easy set-up and operation
- upgrade capability

Real World Pulses

With the pattern feature and the optional second channel of the Agilent 8110A, real world signals, like reflections, distorted pulses, or three or even four-level signals can be simulated.

Pattern Based Timing

The Agilent 8110A simulates all the clock and data signals needed to test digital designs. Conditions such as extended delays can be generated using pattern based timing features.

Clean Pulses

The Agilent 8110A generates clean pulses with 10 ps resolution, low jitter and good pulse performance across all operating temperatures or settings. Parameters and trigger modes can be changed without generating unwanted pulses, so that reliable measurements are guaranteed.



Agilent Technologies
Innovating the HP Way

High Accuracy

Excellent accuracy over a wide temperature range guarantees repeatable measurement results. Frequency accuracy, jitter, resolution and range can be enhanced further when the Agilent 8110A is used with the internal phase locked loop (PLL) of the Agilent 81106A as pulse period source.

Delay Calibration

Systematic delays caused by cables, connections and adapters can be compensated when the Agilent 81107A is installed. It offers enough additional delay range to compensate for 5 m of BNC cable.

External Clock or Reference Frequency¹

An external synthesizer or system clock can be used as clock source at the clock input of the Agilent 8110A to achieve the frequency accuracy and required. This feature is ideal for simulating digital control signals synchronously to the clock of the microprocessor.

Up to 10 channels in parallel²

Up to 4 Agilent 8110As can be slaved to a master, so that 10 synchronous channels can be programmed independently. With the Agilent 81107A multichannel deskew installed, the propagation delay of the set-up can be compensated, and all other output channels zeroed to the reference channel.

Smooth Integration into Automated Test Systems

The Agilent 8110A can be smoothly integrated into automated test systems, ensuring:

- low integration costs
- low costs of ownership

All Digital Waveforms

The waveform and trigger flexibility of the Agilent 8110A make it a universal digital stimulus for any automated test system.

Reliable Measurements

Accuracy is specified over the whole temperature range that exists in a test rack. Setting check and built-in diagnostics allow you to monitor the correct operation of the Agilent 8110A in an automated test system.

Easy Rack Integration

The small size of the Agilent 8110A saves valuable rack space. Rear panel connectors and rack mount kits are optional.

Reduced Programming Investment

The local user interface eases the transition from manual to automated measurements and from the R&D bench to automated manufacturing test. All parameters of the Agilent 8110A are programmable via GPIB. SCPI (Standard Commands for Programmable Instruments) facilitates the standardization of test programs.

Low Cost of Ownership

The proven hardware reliability of Agilent test and measurement products results in high uptime of test systems and low maintenance costs. The Agilent 8110A offers a 3 year standard warranty.

Easy Set-up and Operation

View all timing parameters for both channels at a glance. Timing and level parameters can be entered in any format, e.g. period as frequency. The alternative graphic display shows the timing relationship of all pulse parameters on both channels graphically, making setting up the pulse generator easy - no extra oscilloscope is required.

Pulses and patterns can be set up quickly using the convenient cursor keys, knob and data entry keys. You can even use the Autoselect Key to resolve all timing conflicts.

Memory Card

Settings can be stored permanently either internally or on the memory card for duplication in another test set-up.

¹only with the Agilent 81106A PLL/External Clock

²only with the Agilent 81107A Multichannel Deskew

Specifications

Specifications describe the instrument's warranted performance. Non-warranted values are described as typical. All specifications apply after a 30 minute warm-up phase with 50 Ω source/load resistance and separate channels. All specifications are valid from 0°C to 55°C ambient temperature.

Timing Characteristics

Measured at 50% amplitude at fastest transitions in continuous mode and 50 Ω source impedance.

Mainframe Output module	Agilent 8110A Agilent 81103A	Agilent 8110A Agilent 81103A with 81106A PLL
Frequency range	1 Hz to 150 MHz	1 mHz to 150 MHz
Timing resolution	3 digits, 10 ps best case	4 digits, 10ps best case
RMS jitter (period, width, delay)	0.03% + 25 ps	0.003% + 20 ps
Period range	6.65 ns to 999 ms	6.65 ns to 999 s
Accuracy	$\pm 5\% \pm 100\text{ps}$	$\pm 0.1\%$
Width range	3.30ns to (period - 3.3 ns), maximum 999ms	
Accuracy	$\pm 5\% \pm 250\text{ps}$	
Add. variable delay range ⁽¹⁾	0.00 ns to (period - 6.6 ns), maximum 999 ms	
Accuracy	$\pm 5\% \pm 1\text{ns}$	
Double pulse delay range	6.65ns to (period - width - 3.3 ns), maximum 999 ms	
Min. period	13.3 ns (75 MHz)	
Accuracy	$\pm 5\% \pm 250\text{ps}$	
Transition time range (10/90)	2.00 ns to 200 ms variable	
Minimum (with overprogramming)	$\leq 2.0\text{ns}$ for levels within $\pm 5\text{V}$ window. < 2.5 ns for all levels 1.4 ns typ. for ECL levels (20/80)	
Accuracy	$\pm 10\% \pm 200\text{ps}$	
Linearity	3% typ. for transitions > 100 ns	

Notes:

[1] Additional 0 ns to 28 ns delay range with the Agilent 81107A Multichannel

Burst Count: 2 to 65536 (single or double pulses).

Delay: delay, phase or % of period.

Fixed delay: 34 ns typical

Double pulse and delay:

mutually exclusive.

Duty cycle: set between 0.1% and 94.0% (subject to width limits.

99.9% with overprogramming).

Repeatability: is typ. four times better than accuracy.

Transition times: leading/ trailing edge or % of width. Leading and trailing edges are independent within one of the following

overlapping segments

(1:20 ratio): 2 ns (3 ns) - 20 ns,

10 ns - 200 ns, 100 ns - 2 ms,

1 μ s - 20 μ s, 10 μ s - 200 μ s,

100 μ s - 2 ms, 1 ms - 20 ms,

10 ms - 200 ms.

Overprogramming: values can be entered exceeding the specified range.

Level/Pulse Performance Characteristics

	separate channels		channel addition (at output channel1)			
	50 Ω	1 KΩ	Channel 1	Channel 2	Channel 1	Channel 2
source impedance	50 Ω	1 KΩ	48 Ω		500 Ω	
accuracy	typ. ± 1%					
voltage (50 Ω load)						
amplitude	100 mV to 10.0 V (doubles into open)	200 mV to 20.0V	0 V to 19.5 V [1]		0 V to 20.0 V	
high level	-9.90 V to + 10.0 V	-18.8 V to 19.0 V	-19.3 V to + 19.5 V		-20.0 V to 20.0 V	
low level	-10.0V to +9.90 V	-19.0V to +18.8 V	-19.5 V to + 19.3 V		-20.0 V to + 20.0 V	
level accuracy	± (1% ampl + 50 mV)	± (1% ampl + 100 mV)	-		-	
resolution	10mV	20 mV	10 mV		20 mV	
current (into short)						
amplitude	-	4 mA to 400 mA	-		0 mA to 800 mA	
high level	-	-396 mA to 400 mA	-		-792 mA to + 800 mA	
low level	-	-400 mA to + 396 mA	-		-800 mA to + 792 mA	
minimum transition	2.0 ns [2] 2.5 ns	7.5 ns typ.	2.5 ns typ.	7.5 ns typ.	30 ns typ.	30 ns typ.
minimum period	6.65 ns	24 ns typ.	24 ns typ.		90 ns typ.	
minimum width	3.3 ns	12 ns typ.	3.5 ns typ	12 ns typ.	45 ns typ.	45 ns typ.
delay accuracy	± (5% + 1 ns)	-	-		-	
add. fixed delay (typical)	0	-	-	+ 0.6 ns typ.	+0.6 ns typ.	
Max. external voltage	± 25 V					
Short circuit current	± 400 mA max.					
Dynamic Crosstalk	< 0.1% typ.					
Baseline noise	8 mV RMS typ.					
Overshoot/preshoot/ringing	± 5% of amplitude ± 20 mV					
Settling Time	30 ns typical					

Note:

[1] max. amplitude of bipolar signals is limited to values between 10 Vpp (-0.2 V/+ 10.3 V peak levels) and 14 Vpp (- 7 V/+ 7 V peak levels).

[2] for levels within ± 5 V window.

Level parameters: voltage or current, high or low level, offset or amplitude.

Load compensation: the actual load value can be entered (for loads ≠ 50 Ω to display actual output values.

Normal/complement: selectable.

Limit: programmable high and low levels can be limited to protect the device-under-test.

On/off: relays connect/disconnect output (HiZ)

Channel Addition

If the instrument is equipped with 2 output modules, channel 2 can be added to channel 1 internally. In this case the second output is disabled. 2, 3 an 4 level signals can be generated.

Pattern Mode

Pattern length: 4 kbit/channel and strobe output.

Output format: RZ (return to zero), NRZ (non-return to zero), DNRZ (delayed non-return to zero).

Random pattern:

PRBS $2^{(n-1)}$ n = 7,8,...,12

Trigger Modes

Continuous: continuous pulses, double pulses, bursts (single or double pulses) or patterns.

External triggered: each active input transition (rising, falling or both) generates a single or double pulse, burst or pattern.

External gated: the active input level (high or low) enables pulses, double pulses, bursts or patterns. The last single/double pulse, burst or pattern is always completed.

External width: the pulse shape can be recovered. Period and width of an external input signal is maintained. Delay, levels and transitions can be set.

Manual: simulates an external input signal.

Internal triggered (only with Agilent 81106A): internal PLL replaces an external trigger source. Pulses, double pulses, bursts or patterns can be set.

Inputs and Outputs

External input

used for trigger, gate or external width.

Input impedance: 50 Ω / 10 k Ω selectable.

Threshold: - 10 V to + 10 V.

Max. input voltage: \pm 15 Vpp.

Sensitivity: \leq 300 mVpp typical.

Transitions: < 100 ns.

Frequency: dc to 150 MHz

Min. pulsewidth: 3.3 ns.

Strobe output and trigger output

Level: TTL or ECL selectable.

Output impedance: 50 Ω typical.

Strobe output: user-defined, 16 kbit pattern (NRZ) when in pattern mode.

Max. external voltage: - 2 V/+7 V.

Transition times: 2 ns typical.

Pattern: 4096 bits NRZ in pattern mode.

Delay from external input to strobe

output: in pattern mode same as for trigger output.

Trigger Output

Level: TTL or ECL selectable

Output impedance: 50 Ω typical

Trigger pulse width: typically 50% of period

Maximum external voltage: -2 V/+7 V

Transition times: 2 ns typical

Delay from external input to trigger

output: 18.5 ns typical

Agilent 81106A PLL/External Clock for the Agilent 8110A

Can be retrofitted without recalibration. Useful for applications which require a phase locked loop (PLL) or an external clock:

Locking to an external frequency

reference: the internal PLL is locked to the 5 MHz or 10 MHz frequency at the PLL reference input.

High accuracy: the output period is determined by the internal PLL.

Period accuracy, range, resolution, and jitter are improved as shown in the diagram. Asynchronous triggering possible.

Internal triggered burst: the internal PLL replaces an external trigger source.

External clock: the output period is determined by signal at clock input. Frequency accuracy can be increased by using a precise external clock.

Trigger synchronously to external

clock: the output period is synchronous to the signal at clock input. The signal at external input is used for arming.

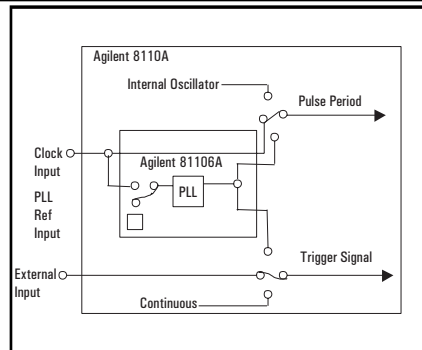

Figure 1

Period

Range: 6.65 ns to 999 s

Accuracy: \pm 0.1%

Resolution: 4 digits, 10ps best case

RMS-jitter: 0.003% + 20ps

Stability: 50 ppm/year typical

Trigger Modes

Standard trigger modes and:

Internal triggered: pulses, double pulses, bursts or patterns

Clock Input/ PLL Reference Input to be used as:

a) external system clock input pulse frequency = input frequency,

b) 5 MHz or 10 MHz frequency reference input for internal PLL. Frequency can be measured. Rear panel BNC connector.

Input impedance: 50 Ω or 10 k Ω selectable

Threshold: -10 V to +10 V

Maximum input voltage: \pm 15 V

Input transitions: <100 ns

Input Frequency: dc to 150 MHz

Minimum Pulse width: 3.3 ns

Input sensitivity: -300 mVpp typical

Delay from clock input to trigger

output: 22 ns typical

Agilent 81107A Multichannel Deskew for the Agilent 8110A

Can be retrofitted without recalibration. Supports two output channels. The multichannel deskew can be used for two applications:

Up to 10 channels: compensates delay between external input and trigger outputs when using up to five 8110As synchronously.

Delay calibration: compensates for measurement system delays or pre-trigger delays of oscilloscopes.

Variable range: 0 ns to 28 ns

Additional fixed delay: 6.5 ns typical

Resolution: 10 ps

User Interface

Overprogramming: all parameters can be overprogrammed (exceeding specifications) to fully exploit the hardware limits.

Setting check: warning messages indicate potentially conflicting parameters due to inaccuracy.

Error messages indicate conflicting parameters.

Help key: displays a context-sensitive message.

Autoset key: resolves all timing conflicts.

Non-volatile memory: current setting is saved on power-down. Up to nine user settings and one fixed default setting can be stored in the instrument.

Clear memory: clears all nine user settings.

Memory card: 320 settings can be stored on a 1 MB PCMCIA card (MS-DOS®).

Remote Control

Operates according to IEEE standard 488.2, 1987 and SCPI 1992.0.

Function Code: SH1, AH1, T6, L4, SR1, RL1, PP0, DC1, DT1, C0.

Programming times: all checks and display off.

General

Operating temperature:

0°C to +55°C.

Storage temperature:

-40°C to +70°C.

Humidity: 95% r.h. up to 40°C ambient temperature.

EMC: conforms to EN50082-1, EN 55011, Class A.

Noise emission: 5.7 bel typical.

Battery: Lithium CR2477-N.

Safety: IEC1010, CSA1010.

Power requirements:

100-240 Vac, ± 10%, 50-60 Hz;

100-120 Vac, ± 10%, 400 Hz.

Power consumption:

300 VA max.

Max. dimensions (H * W * D):

89 mm * 426 mm * 521 mm.

Weight: 9.2 kg net, 13.8 kg shipping.

Recalibration period:

one year recommended.

Warranty: three years standard.

ASCII command	Typ. exec. time
One parameter or mode	30 ms typ.
Recall setting	250 ms typ.
16 k pattern transfer	600 ms typ.

Ordering Information - 8110A

The minimum order must include the 8110A mainframe and one 81103A output channel. A second output channel, the 81106A PLL/external clock or the 81107A multichannel deskew are optional. All configurations are available from the factory. Alternatively, additional modules can be ordered later and fitted by the user or an Agilent service facility.

Category	Qty per Mainframe		Description	Number
	min	max		
Mainframe⁽¹⁾	1		150 MHz Pulse Generator Mainframe	Agilent 8110A
Modules	1	2	10 V/2 ns Output Channel	Agilent 81103A
	0	1	PLL/External Clock	Agilent 81106A
	0	1	Multichannel Deskew	Agilent 81107A

All options are orderable with the mainframes.

Accessories

Opt UN2	Rear Panel Connectors
Opt 1CP	Rack Mount and Handle Kit (5062-3975)
Opt 1CN	Handle Kit (5062-3988)
Opt 1CM	Rack Mount Kit (5062-3974)
Opt 1CR	Rack Slide Kit (1494-0060)
Opt UFJ	1 MB SRAM Memory Card
Agilent 15104A	Pulse Adder/Splitter

Language options

Opt ABD	German Localization (08110-91112)
Opt ABF	French Localization (08110-91212)
Opt ABZ	Italian Localization (08110-91312)
Opt ABE	Spanish Localization (08110-91412)
Opt ABJ	Japanese Localization (08110-91512)
Opt AB0	Chinese Localization (08110-91612)

Additional documentation options

Opt OB2	Additional English Operating Manual (08110-91012)
Opt OBW	Service Manual (08110-91021)
08110-91031	Service Documentation (Component Level)

Support Options

Opt 1BP	MIL Std. 45662A Calibration with Test Data
Opt W32	3 Year Customer Return Calibration Coverage
Opt W34	3 Year MIL Calibration Service
Opt W50	5 Year Customer Return Repair Coverage
Opt W52	5 Year Customer Return Calibration Coverage
Opt W54	5 Year MIL Calibration Service

Related Agilent Literature

· Agilent Family of Pulse/Pattern Generators, brochure, p/n 5980-0489E

For more information, please visit us :
www.agilent.com/find/pulse_generator

Agilent Technologies' Test and Measurement Support, Services, and Assistance

Agilent Technologies aims to maximize the value you receive, while minimizing your risk and problems. We strive to ensure that you get the test and measurement capabilities you paid for and obtain the support you need. Our extensive support resources and services can help you choose the right Agilent products for your applications and apply them successfully. Every instrument and system we sell has a global warranty. Support is available for at least five years beyond the production life of the product. Two concepts underlay Agilent's overall support policy: "Our Promise" and "Your Advantage."

Our Promise

Our Promise means your Agilent test and measurement equipment will meet its advertised performance and functionality. When you are choosing new equipment, we will help you with product information, including realistic performance specifications and practical recommendations from experienced test engineers. When you use Agilent equipment, we can verify that it works properly, help with product operation, and provide basic measurement assistance for the use of specified capabilities, at no extra cost upon request. Many self-help tools are available.

Your Advantage

Your Advantage means that Agilent offers a wide range of additional expert test and measurement services, which you can purchase according to your unique technical and business needs. Solve problems efficiently and gain a competitive edge by contracting with us for calibration, extra-cost upgrades, out-of-warranty repairs, and on-site education and training, as well as design, system integration, project management, and other professional services. Experienced Agilent engineers and technicians worldwide can help you maximize your productivity, optimize the return on investment of your Agilent instruments and systems, and obtain dependable measurement accuracy for the life of those products.

By internet, phone, or fax, get assistance with all your test & measurement needs

Online assistance:
www.agilent.com/find/assist

Phone or Fax

United States:
(tel) 1 800 452 4844

Canada:
(tel) 1 877 894 4414
(fax) (905) 206 4120

Europe:
(tel) (31 20) 547 2000

Japan:
(tel) (81) 426 56 7832
(fax) (81) 426 56 7840

Latin America:
(tel) (305) 267 4245
(fax) (305) 267 4286

Australia:
(tel) 1 800 629 485
(fax) (61 3) 9272 0749

New Zealand:
(tel) 0 800 738 378
(fax) 64 4 495 8950

Asia Pacific:
(tel) (852) 3197 7777
(fax) (852) 2506 9284

Product specifications and descriptions in this document subject to change without notice.

Copyright © 2000 Agilent Technologies
Printed in Germany 10/2000
5980-1212E



Agilent Technologies

Innovating the HP Way