



Agilent 75000 SERIES B

**Agilent E1368A/E1369A/E1370A
18 GHz Microwave Switch &
Driver Modules**

User's Manual



Agilent Technologies

Copyright© Agilent Technologies, Inc., 1995 - 2006



E1368-90003
E0606

Manual Part Number: E1368-90003
Microfiche Part Number: E1368-99003

Printed: June 2006 Edition 3 Rev 2
Printed in Malaysia E0606

Contents

Agilent E1368A/69A/70A Microwave Switch & Driver

Warranty	5
WARNINGS	6
Safety Symbols	6
Declaration of Conformity	7
User Notes	8
Chapter 1. Getting Started with the Agilent E1368A/69A/70A	11
Using This Chapter	11
Microwave Switch Description	11
Power Supply Circuit	13
Agilent E1368A Switches	13
Instrument Definition	14
Programming the Microwave Switch	14
Card Numbers	14
Channel Numbers	15
Channel Address	15
SCPI Command Format Used in This Manual	16
Initial Operation	16
Chapter 2. Configuring the Agilent E1368A/69A/70A Modules	17
Using This Chapter	17
Warnings and Cautions	17
Setting the Address Switch	18
Selecting the Interrupt Priority	19
Installing Switches on the Agilent E1369A	20
Installing Switches on the Module	20
Connecting Switches External to the Module	23
Selecting Switch Power	24
Connecting Field Wiring	25
Installing a Switch or Attenuator on the Agilent E1370A Microwave Switch/Attenuator Card	26
Installing a Switch or Attenuator on the Module	26
Connecting Field Wiring	28
Chapter 3. Using the Agilent E1368A/69A/70A Modules	29
Using This Chapter	29
Microwave Switch Commands	29
Reset Conditions	30
Switching Channels	31
Example: Single Channel Switching	31
Example: Single Channel Switching using EXTERNAL POWER	32
Example: Channel Switching using the E1370A and the 33366K Microwave Switch	33
Example: Multiple Channel Switching using EXTERNAL POWER	35

Example: Transfer Switch Using Two 3-Port Switches	36
Example: Transfer Switch Using One 5-Port Switch	37
Example: 4 x 1 Multiplexer	38
Scanning Channels	39
Example: Scanning Channels	40
Example: Using the Scan Complete Bit	41
Recalling and Saving States	43
Storing States	43
Recalling States	43
Detecting Error Conditions	43
Synchronizing the Microwave Switch	45
Synchronizing Instruments	45
Querying the Microwave Switch	46
 Chapter 4. Agilent E1368A/69A/70A Command Reference	 47
Using This Chapter	47
Command Types	47
Common Command Format	47
SCPI Command Format	47
Linking Commands	49
SCPI Command Reference	50
ABORt	50
ARM	51
:COUNT	51
:COUNT?	52
DISPlay	53
:MONitor:CARD	53
:MONitor[:STATe]	54
:MONitor[:STATe]?	54
INITiate	55
:CONTinuous	55
:CONTinuous?	56
[:IMMediate]	56
OUTPut	57
[:STATe]	57
[:STATe]?	57
[ROUte:]	58
CLOSE	58
CLOSE?	59
OPEN	59
OPEN?	60
SCAN	60
SCAN:MODE	61
SCAN:MODE?	61
STATus	62
:OPERation:ENABle	63
:OPERation:ENABle?	63
:OPERation[:EVENT]?	64

SYSTem	65
:CDEscription?	65
:CPON	65
:CTYPe?	66
:ERRor?	66
TRIGger	67
[:IMMediate]	67
:SOURce	67
:SOURce?	69
IEEE 488.2 Common Commands	70
Command Quick Reference	71
 Appendix A. Agilent E1368A/69A/70A Specifications	 73
 Appendix B. Agilent E1368A/69A/70A Registers	 75
Register Definitions	75
Addressing the Registers	76
Reading the Registers	76
ID and Device Type Registers	76
Status/Control Register	77
Channel Enable Register	77
Writing to the Registers	77
Channel Enable Register	77
 Appendix C. Agilent E1368A/69A/70A Error Messages	 79
 Index	 81

Notes

Certification

Agilent Technologies certifies that this product met its published specifications at the time of shipment from the factory. Agilent Technologies further certifies that its calibration measurements are traceable to the United States National Institute of Standards and Technology (formerly National Bureau of Standards), to the extent allowed by that organization's calibration facility, and to the calibration facilities of other International Standards Organization members.

Warranty

This Agilent Technologies product is warranted against defects in materials and workmanship for a period of one (1) year from date of shipment. Duration and conditions of warranty for this product may be superseded when the product is integrated into (becomes a part of) other Agilent products. During the warranty period, Agilent Technologies will, at its option, either repair or replace products which prove to be defective.

For warranty service or repair, this product must be returned to a service facility designated by Agilent Technologies. Buyer shall prepay shipping charges to Agilent and Agilent shall pay shipping charges to return the product to Buyer. However, Buyer shall pay all shipping charges, duties, and taxes for products returned to Agilent from another country.

Agilent warrants that its software and firmware designated by Agilent for use with a product will execute its programming instructions when properly installed on that product. Agilent does not warrant that the operation of the product, or software, or firmware will be uninterrupted or error free.

Limitation Of Warranty

The foregoing warranty shall not apply to defects resulting from improper or inadequate maintenance by Buyer, Buyer-supplied products or interfacing, unauthorized modification or misuse, operation outside of the environmental specifications for the product, or improper site preparation or maintenance.

The design and implementation of any circuit on this product is the sole responsibility of the Buyer. Agilent does not warrant the Buyer's circuitry or malfunctions of Agilent products that result from the Buyer's circuitry. In addition, Agilent does not warrant any damage that occurs as a result of the Buyer's circuit or any defects that result from Buyer-supplied products.

NO OTHER WARRANTY IS EXPRESSED OR IMPLIED. Agilent SPECIFICALLY DISCLAIMS THE IMPLIED WARRANTIES OF MERCHANTABILITY AND FITNESS FOR A PARTICULAR PURPOSE.

Exclusive Remedies

THE REMEDIES PROVIDED HEREIN ARE BUYER'S SOLE AND EXCLUSIVE REMEDIES. Agilent SHALL NOT BE LIABLE FOR ANY DIRECT, INDIRECT, SPECIAL, INCIDENTAL, OR CONSEQUENTIAL DAMAGES, WHETHER BASED ON CONTRACT, TORT, OR ANY OTHER LEGAL THEORY.

Notice

The information contained in this document is subject to change without notice. Agilent Technologies MAKES NO WARRANTY OF ANY KIND WITH REGARD TO THIS MATERIAL, INCLUDING, BUT NOT LIMITED TO, THE IMPLIED WARRANTIES OF MERCHANTABILITY AND FITNESS FOR A PARTICULAR PURPOSE. Agilent shall not be liable for errors contained herein or for incidental or consequential damages in connection with the furnishing, performance or use of this material. This document contains proprietary information which is protected by copyright. All rights are reserved. No part of this document may be photocopied, reproduced, or translated to another language without the prior written consent of Agilent Technologies, Inc. Agilent assumes no responsibility for the use or reliability of its software on equipment that is not furnished by Agilent.

U.S. Government Restricted Rights

The Software and Documentation have been developed entirely at private expense. They are delivered and licensed as "commercial computer software" as defined in DFARS 252.227-7013 (Oct 1988), DFARS 252.211-7015 (May 1991) or DFARS 252.227-7014 (Jun 1995), as a "commercial item" as defined in FAR 2.101(a), or as "Restricted computer software" as defined in FAR 52.227-19 (Jun 1987)(or any equivalent agency regulation or contract clause), whichever is applicable. You have only those rights provided for such Software and Documentation by the applicable FAR or DFARS clause or the Agilent standard software agreement for the product involved.

Agilent E1368A/E1369A/E1370A 18 GHz Microwave Switch & Driver Module User's Manual
Edition 3 Rev 2

Copyright © 1995 - 2006 Agilent Technologies, Inc. All Rights Reserved.

Printing History

The Printing History shown below lists all Editions and Updates of this manual and the printing date(s). The first printing of the manual is Edition 1. The Edition number increments by 1 whenever the manual is revised. Updates, which are issued between Editions, contain replacement pages to correct the current Edition of the manual. Updates are numbered sequentially starting with Update 1. When a new Edition is created, it contains all the Update information for the previous Edition. Each new Edition or Update also includes a revised copy of this printing history page. Many product updates or revisions do not require manual changes and, conversely, manual corrections may be done without accompanying product changes. Therefore, do not expect a one-to-one correspondence between product updates and manual updates.

Edition 1 December 1989
Edition 2 August 1990
Edition 3 (Part Number E1368-90003)..... June 1995
Edition 3 Rev 2 (Part Number E1368-90003) June 2006

Safety Symbols



Instruction manual symbol affixed to product. Indicates that the user must refer to the manual for specific WARNING or CAUTION information to avoid personal injury or damage to the product.



Alternating current (AC).



Direct current (DC).



Indicates hazardous voltages.



Indicates the field wiring terminal that must be connected to earth ground before operating the equipment—protects against electrical shock in case of fault.

WARNING

Calls attention to a procedure, practice, or condition that could cause bodily injury or death.

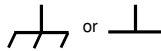

Frame or chassis ground terminal—typically connects to the equipment's metal frame.

CAUTION

Calls attention to a procedure, practice, or condition that could possibly cause damage to equipment or permanent loss of data.

WARNINGS

The following general safety precautions must be observed during all phases of operation, service, and repair of this product. Failure to comply with these precautions or with specific warnings elsewhere in this manual violates safety standards of design, manufacture, and intended use of the product. Agilent Technologies assumes no liability for the customer's failure to comply with these requirements.

Ground the equipment: For Safety Class 1 equipment (equipment having a protective earth terminal), an uninterruptible safety earth ground must be provided from the mains power source to the product input wiring terminals or supplied power cable.

DO NOT operate the product in an explosive atmosphere or in the presence of flammable gases or fumes.

For continued protection against fire, replace the line fuse(s) only with fuse(s) of the same voltage and current rating and type. DO NOT use repaired fuses or short-circuited fuse holders.

Keep away from live circuits: Operating personnel must not remove equipment covers or shields. Procedures involving the removal of covers or shields are for use by service-trained personnel only. Under certain conditions, dangerous voltages may exist even with the equipment switched off. To avoid dangerous electrical shock, DO NOT perform procedures involving cover or shield removal unless you are qualified to do so.

DO NOT operate damaged equipment: Whenever it is possible that the safety protection features built into this product have been impaired, either through physical damage, excessive moisture, or any other reason, REMOVE POWER and do not use the product until safe operation can be verified by service-trained personnel. If necessary, return the product to an Agilent Technologies Sales and Service Office for service and repair to ensure that safety features are maintained.

DO NOT service or adjust alone: Do not attempt internal service or adjustment unless another person, capable of rendering first aid and resuscitation, is present.

DO NOT substitute parts or modify equipment: Because of the danger of introducing additional hazards, do not install substitute parts or perform any unauthorized modification to the product. Return the product to an Agilent Technologies Sales and Service Office for service and repair to ensure that safety features are maintained.

DECLARATION OF CONFORMITY

According to ISO/IEC Guide 22 and CEN/CENELEC EN 45014

Manufacturer's Name: Agilent Technologies, Incorporated
Manufacturer's Address: *Measurement Product Generation Unit*
815 14th ST. S.W.
Loveland, CO 80537 USA

Declares, that the product

Product Name: 18 GHz Microwave Switch
Model Number: E1368A
Product Options: *This declaration covers all options of the above product(s).*

Conforms with the following European Directives:

The product herewith complies with the requirements of the Low Voltage Directive 73/23/EEC and the EMC Directive 89/336/EEC and carries the CE Marking accordingly

Conforms with the following product standards:

EMC	Standard	Limit
	<i>IEC 61326-1:1997+A1:1998 / EN 61326-1:1997+A1:1998 CISPR 11:1997 +A1:1997 / EN 55011:1998 IEC 61000-4-2:1995+A1:1998 / EN 61000-4-2:1995 IEC 61000-4-3:1995 / EN 61000-4-3:1995 IEC 61000-4-4:1995 / EN 61000-4-4:1995 IEC 61000-4-5:1995 / EN 61000-4-5:1995 IEC 61000-4-6:1996 / EN 61000-4-6:1996 IEC 61000-4-11:1994 / EN 61000-4-11:1994</i>	<i>Group 1 Class A ^[1] 4kV CD, 8kV AD 3 V/m, 80-1000 MHz 0.5kV signal lines, 1kV power lines 0.5 kV line-line, 1 kV line-ground 3V, 0.15-80 MHz 1 cycle, 100%</i>
	<i>Canada: ICES-001:1998 Australia/New Zealand: AS/NZS 2064.1</i>	
Safety	<i>IEC 61010-1:1990+A1:1992+A2:1995 / EN 61010-1:1993+A2:1995 Canada: CSA C22.2 No. 1010.1:1992 UL 3111-1:1994</i>	

Supplemental Information:

^[1] *The product was tested in a typical configuration with Agilent Technologies test systems.*

September 5, 2000

Date



Name

Quality Manager

Title

For further information, please contact your local Agilent Technologies sales office, agent or distributor.

Authorized EU-representative: Agilent Technologies Deutschland GmbH, Herrenberger Straße 130, D 71034 Böblingen, Germany

DECLARATION OF CONFORMITY

According to ISO/IEC Guide 22 and CEN/CENELEC EN 45014

Manufacturer's Name: Agilent Technologies, Incorporated
Manufacturer's Address: *Measurement Product Generation Unit*
815 14th ST. S.W.
Loveland, CO 80537 USA

Declares, that the product

Product Name: Microwave Switch Driver
Model Number: E1369A
Product Options: *This declaration covers all options of the above product(s).*

Conforms with the following European Directives:

The product herewith complies with the requirements of the Low Voltage Directive 73/23/EEC and the EMC Directive 89/336/EEC and carries the CE Marking accordingly

Conforms with the following product standards:

EMC	Standard	Limit
	<i>IEC 61326-1:1997+A1:1998 / EN 61326-1:1997+A1:1998 CISPR 11:1997 +A1:1997 / EN 55011:1998 IEC 61000-4-2:1995+A1:1998 / EN 61000-4-2:1995 IEC 61000-4-3:1995 / EN 61000-4-3:1995 IEC 61000-4-4:1995 / EN 61000-4-4:1995 IEC 61000-4-5:1995 / EN 61000-4-5:1995 IEC 61000-4-6:1996 / EN 61000-4-6:1996 IEC 61000-4-11:1994 / EN 61000-4-11:1994</i>	<i>Group 1 Class A ^[1] 4kV CD, 8kV AD 3 V/m, 80-1000 MHz 0.5kV signal lines, 1kV power lines 0.5 kV line-line, 1 kV line-ground 3V, 0.15-80 MHz 1 cycle, 100%</i>
	<i>Canada: ICES-001:1998 Australia/New Zealand: AS/NZS 2064.1</i>	
Safety	<i>IEC 61010-1:1990+A1:1992+A2:1995 / EN 61010-1:1993+A2:1995 Canada: CSA C22.2 No. 1010.1:1992 UL 3111-1:1994</i>	

Supplemental Information:

^[1] *The product was tested in a typical configuration with Agilent Technologies test systems.*

September 5, 2000

Date



Name

Quality Manager

Title

For further information, please contact your local Agilent Technologies sales office, agent or distributor.

Authorized EU-representative: Agilent Technologies Deutschland GmbH, Herrenberger Straße 130, D 71034 Böblingen, Germany

DECLARATION OF CONFORMITY

According to ISO/IEC Guide 22 and CEN/CENELEC EN 45014

Manufacturer's Name: Agilent Technologies, Incorporated
Manufacturer's Address: *Measurement Product Generation Unit*
815 14th ST. S.W.
Loveland, CO 80537 USA

Declares, that the product

Product Name: Microwave Switch / Step Attenuator Driver
Model Number: E1370A
Product Options: *This declaration covers all options of the above product(s).*

Conforms with the following European Directives:

The product herewith complies with the requirements of the Low Voltage Directive 73/23/EEC and the EMC Directive 89/336/EEC and carries the CE Marking accordingly

Conforms with the following product standards:

EMC	Standard	Limit
	<i>IEC 61326-1:1997+A1:1998 / EN 61326-1:1997+A1:1998 CISPR 11:1997 +A1:1997 / EN 55011:1998 IEC 61000-4-2:1995+A1:1998 / EN 61000-4-2:1995 IEC 61000-4-3:1995 / EN 61000-4-3:1995 IEC 61000-4-4:1995 / EN 61000-4-4:1995 IEC 61000-4-5:1995 / EN 61000-4-5:1995 IEC 61000-4-6:1996 / EN 61000-4-6:1996 IEC 61000-4-11:1994 / EN 61000-4-11:1994</i>	<i>Group 1 Class A ^[1] 4kV CD, 8kV AD 3 V/m, 80-1000 MHz 0.5kV signal lines, 1kV power lines 0.5 kV line-line, 1 kV line-ground 3V, 0.15-80 MHz 1 cycle, 100%</i>
	<i>Canada: ICES-001:1998 Australia/New Zealand: AS/NZS 2064.1</i>	
Safety	<i>IEC 61010-1:1990+A1:1992+A2:1995 / EN 61010-1:1993+A2:1995 Canada: CSA C22.2 No. 1010.1:1992 UL 3111-1:1994</i>	

Supplemental Information:

^[1] *The product was tested in a typical configuration with Agilent Technologies test systems.*

September 5, 2000

Date



Name

Quality Manager

Title

For further information, please contact your local Agilent Technologies sales office, agent or distributor.

Authorized EU-representative: Agilent Technologies Deutschland GmbH, Herrenberger Straße 130, D 71034 Böblingen, Germany

Notes

Chapter 1

Getting Started with the Agilent E1368A/69A/70A

Using This Chapter

This chapter describes the Microwave Switch modules, and contains information on how to program them using SCPI (Standard Commands for Programmable Instruments) commands. This chapter contains the following:

- Microwave Switch Description Page 11
- Instrument Definition Page 14
- Programming the Microwave Switch Page 14
- Initial Operation Page 16

Microwave Switch Description

All three Microwave Switch modules provide switching of up to five microwave coaxial switches or channels. The difference between the E1368A Microwave Switch, the E1369A Microwave Switch Driver, and the E1370A Microwave Switch/Attenuator Driver modules are described below:

- The Agilent E1368A Microwave Switch is a 3-channel, single-pole, double-throw coaxial switch module. The three coaxial switches provided have excellent electrical characteristics for 502 transmission systems operating from DC to 18 GHz. The module panels are numbered 00, 01, and 02 to indicate the channel number of each coaxial switch installed.
- The Agilent E1369A Microwave Switch Driver is identical to the E1368A, except the coaxial switches are not installed. The module panel has three cutouts and various mounting holes that allow the user to install up to three 3-port, 4-port, or 5-port, 42Vpk drive level coaxial switches. Drive level voltage can be internal (+5 and +12Vdc) or external (42Vpk). The module panel is numbered 00, 01, and 02 to indicate the channel number of each coaxial switch. Channel 03 and 04 are not labeled on the panel. Up to five coaxial switches can be controlled (e.g. three internal, two external; five external; etc) using the 14-pin connector.
- The Agilent E1370A Microwave Switch/Attenuator Driver is identical to the E1369A, except the module panel and mounting holes have been modified to allow the user to install one Single-pole, Multi-throw Switch or one Step Attenuator. Because of the size of the switches and the attenuators, the module takes up two B-size slots. Drive level voltage can be internal (+5 and +12Vdc) or external (42Vpk). Up to a Single-pole, Six-throw Switch can be mounted on to the assembly or used externally using the 14-pin connector.

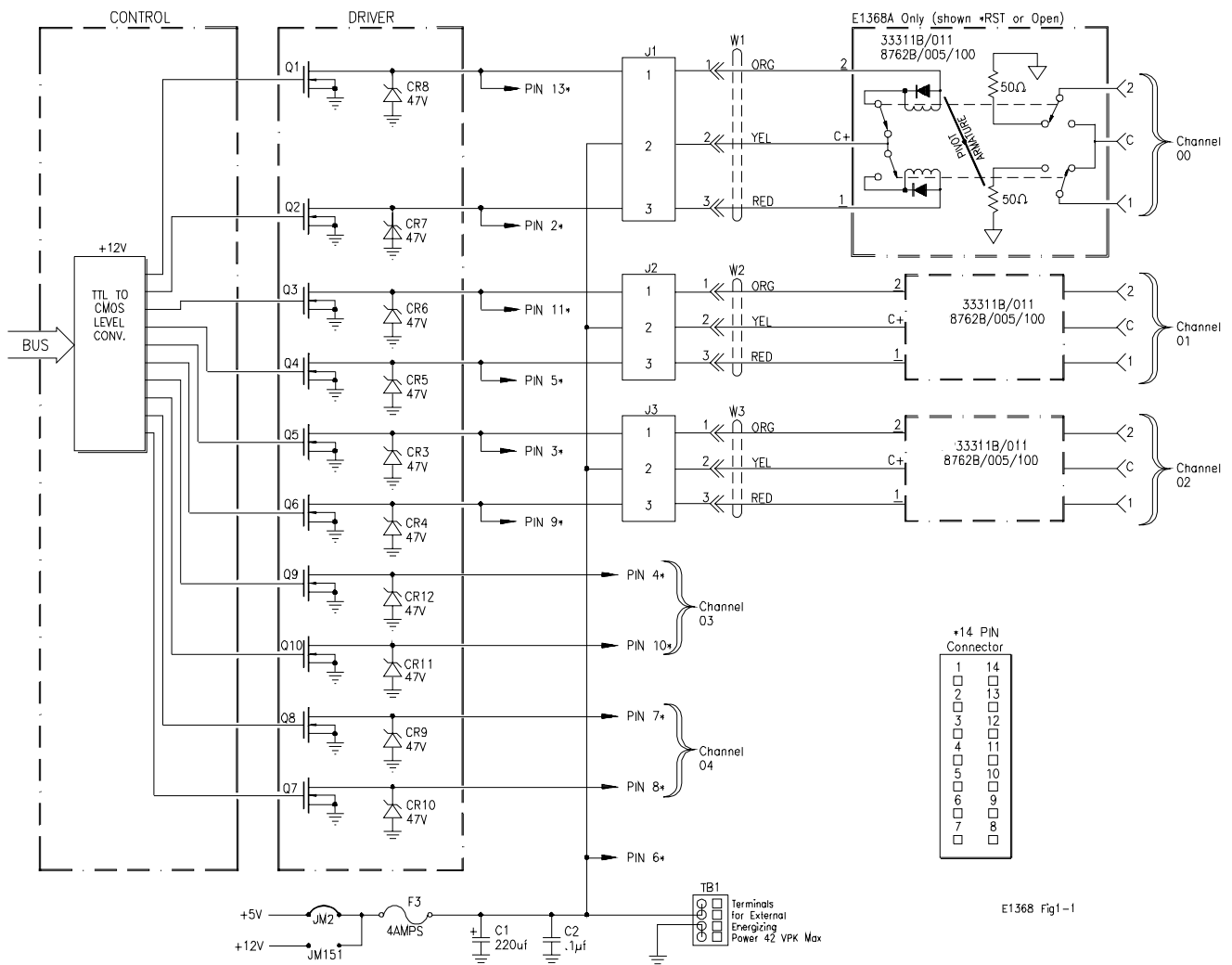

Figure 1-1. Agilent Microwave Switch Block Diagram

Power Supply Circuit

Power to operate the coaxial switches can be supplied internally or externally, dependent on the type of coaxial switch used.

- Internal voltages of either +5V or +12V can be selected using jumpers on the board. These voltages are routed through the module from the mainframe backplane.

Note

Check mainframe power availability before using internal voltages.

-
- External voltages of up to 42Vpk can be connected using the EXTERNAL POWER terminal block.

Caution

MAXIMUM VOLTAGE. The maximum voltage that may be applied to the EXTERNAL POWER terminal is 42Vpk. Remove the F3 fuse when using external switch power.

MAXIMUM CURRENT. The maximum current that the control circuit can accommodate is 1 amp per switch. Maximum current also depends on the output capacity of the mainframe or power supply used.

Agilent E1368A Switches

The Agilent E1368A Microwave Switch module contains three Agilent 33311B Option 011 (8672B Option 005 and 100) microwave Switches:

- Broad bandwidth (DC - 18 GHz).
- High isolation (>90 dB to 18 GHz).
- Excellent repeatability (typically 0.03 dB after 1,000,000 switchings).
- Internal 50Ω terminations.

These coaxial switches allow +5V coil voltage electrical characteristics (drive voltage) operation instead of the standard +24V. This is necessary since the Microwave Switch module provides only +5V or +12V for driving microwave switches.

These coaxial switches are break-before-make switches controlled by a latching solenoid. Internal coil contacts open and remove coil voltage after a switching operation to minimize the amount of heat dissipated near the switch contacts.

When a coil is energized and a switching operation occurs, a pivot armature in the microwave switch also operates both sets of contacts, either closing the switch or connecting it to the 50Ω termination.

Instrument Definition

Agilent plug-in modules installed in an Agilent mainframe or used with an Agilent command module are treated as independent instruments each having a unique secondary GPIB address. Each instrument is also assigned a dedicated error queue, input and output buffers, status registers and, if applicable, dedicated mainframe/command module memory space for readings or data. An instrument may be composed of a single plug-in module (such as a counter) or multiple plug-in modules (for a switchbox or scanning voltmeter instrument).

Programming the Microwave Switch

To program the modules using SCPI commands, you must select the controller Module language, interface address, and appropriate commands. See the *Agilent 75000 Series B Installation and Getting Started Guide* or the appropriate *Agilent Command Module Manual* for interface addressing and controller language information of Microwave Switch modules in a switchbox or scanning voltmeter configuration.

Note This discussion applies to SCPI programming. See Appendix B (Microwave Switch Registers) for details on Microwave Switch modules registers.

Selecting Channels: To address specific channels within a Microwave Switch module in a switchbox, you must:

- send the appropriate SCPI command string to the switchbox (e.g., CLOSe, OPEN, etc.). For the Microwave Switch modules, use the CLOSe command to connect the 2-port to the C-port. Use the OPEN command to connect the 1-port to the C-port.
- specify the card number (01-99)
- specify the channel number (00-04) } = *channel_list*

Card Numbers The card number identifies the module within a switchbox. The Microwave Switch card number depends on the switchbox configuration (single-module or multiple-module) set for the switches.

- **Single-module.** For a single-module switchbox, the card number is always 01.
- **Multiple-module.** For a multiple-module switchbox, the switch module with the lowest logical address is always card number 01. The card number with the next successive logical address is 02, and so on. Figure 1-2 illustrates the card numbers and logical addresses of a typical multiple-module switchbox.

The logical addresses noted in Figure 1-2 apply to modules installed in an Agilent 75000 Series B Mainframe (Agilent Model Number E1300/E1301) or in a mainframe with an Agilent E1405/E1406 Command Module. See the *Agilent 75000 Series B Installation and Getting Started Guide* or the appropriate *Agilent Command Module Manual* for more information on switchboxes and logical addressing.

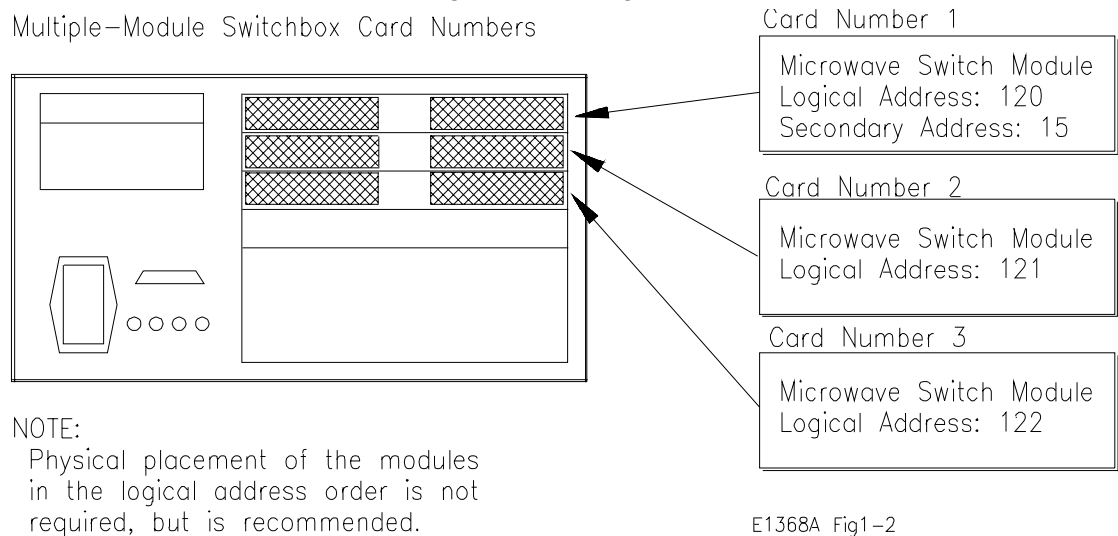

Figure 1-2. Card Numbers for Multiple-Module Switchboxes

Channel Numbers

The channel number identifies the channel within a module. The Microwave Switch channel number depends on the module (Agilent E1368A Microwave Switch or Agilent E1369A Microwave Switch Driver).

- **Agilent E1368A.** Valid channel numbers are 00-04 (channels 03 and 04 are valid but not connected).
- **Agilent E1369A.** Valid channel numbers are 00-04.
- **Agilent E1370A.** Valid channel numbers are 00-04.

Channel Address

For the Microwave Switch Modules, the channel address (channel_list) is in the form:

- (@ccnn) for a single channel
- (@ccnn, ccnn) for multiple channels
- (@ccnn:ccnn) for sequential channels
- (@ccnn:ccnn, ccnn:ccnn) for groups of sequential channels
- or any combination of the above

where "cc" is the card number and "nn" is the channel number. For example, command string to close channel 02 of card number 1 is:

CLOSE (@0102)

Since "cc" (the card number) must be sent, it becomes part of the channel number. Also, you can ignore leading zeros in the card numbers. Thus, to close channel 02, send "102" instead of "0102". To close the above channel, execute:

CLOSE (@102)

SCPI Command Format Used in This Manual

You can send SCPI commands in either short or long form. Refer to Chapter 4 for more information. A long form example is:

```
CLOSe (@102)
```

The same command shown without the lower case letters is the short form. The command then becomes:

```
CLOS (@102)
```

Some commands in this manual are shown with brackets ([]). These are implied or optional commands that you do not have to execute. For example, the ROUTE command is an implied command and is shown in this manual as:

```
[ROUT:]CLOS (@102)
```

Thus, to execute these commands, simply enter:

```
CLOS (@102)
```

Initial Operation

Use the following program example to verify initial Microwave Switch operation by closing a channel and querying channel closure. The example first resets the switchbox and then closes channel 02 of a single Microwave Switch module (card number 1) in the switchbox. The program next queries the channel closure state. A returned "1" shows that the command to close the channel has been sent to the switchbox. A returned "0" shows that the command to close the channel has not been sent to the switchbox.

The computer used in the example is an HP Series 200/300 computer with BASIC as the program language. The computer interfaces to the mainframe using the General Purpose Interface Bus (GPIB).* The GPIB interface select code is 7, the GPIB primary address is 09, and the GPIB secondary address is 15. Refer to the *Agilent 75000 Series B Installation and Getting Started Guide* for addressing information.

Example: Reset the switchbox and close channel 02.

```
10 OUTPUT 70915;"*RST"           !Resets the module; opens all
                                channels.
20 OUTPUT 70915;"CLOS (@102)"     !Close channel 02.
30 OUTPUT 70915;"CLOS? (@102)"   !Query channel 02.
40 ENTER 70915;Value             !Enter results into value.
50 PRINT Value                   !Display results (should return
                                "1").
60 END                           !Terminate program.
```

* GPIB is the implementation of IEEE Std 488.1-1984

Chapter 2

Configuring the Agilent E1368A/69A/70A Modules

Using This Chapter

This chapter shows how to connect external wiring to the Microwave Switch Modules connectors, and how to configure the module for operation.

- Setting the Address Switch Page 18
- Selecting the Interrupt Priority. Page 19
- Installing Switches on the Agilent E1369A. Page 20
- Installing a Switch or Attenuator on the Agilent E1370A Page 26

Warnings and Cautions

Warning **SHOCK HAZARD.** Only service-trained personnel who are aware of the hazards involved should install, remove, or configure the Microwave Switch modules. Before you remove any installed module, disconnect AC power from the mainframe and from other modules that may be connected to the Microwave Switch.

Caution **MAXIMUM POWER.** The maximum power that may be applied to any SMA input connector is 1 W (CW). The maximum voltage that may be applied to the EXTERNAL B+ terminal is 42Vpk.

CONNECTING +5V/+12V. For the Microwave Switch, the mainframe backplane +5V is fused at 4A, and the +12V line at 4A. The total current drawn by all coaxial switches connected to the Microwave Switch module must not exceed the fuse rating of the supplies (mainframe and/or external) used.

STATIC ELECTRICITY. Static electricity is a major cause of component failure. To prevent damage to the electrical components in the Microwave Switch modules, observe anti-static techniques whenever removing a module from the mainframe or whenever working on a module.

Setting the Address Switch

The logical address switch (LADDR) factory setting is 120. You may have changed the setting during module installation. Valid address values are from 0 to 255. If the Microwave Switch modules are used in a Agilent E1300/E1301 Mainframe, refer to the *Agilent 75000 Series B System Installation and Getting Started Guide* for addressing information. Otherwise, use Figure 2-1 to change the setting.

Note The address switch selected value must be a multiple of 8 if the module is the first module in a "switchbox" used in a VXIbus mainframe, and being instructed by SCPI commands.

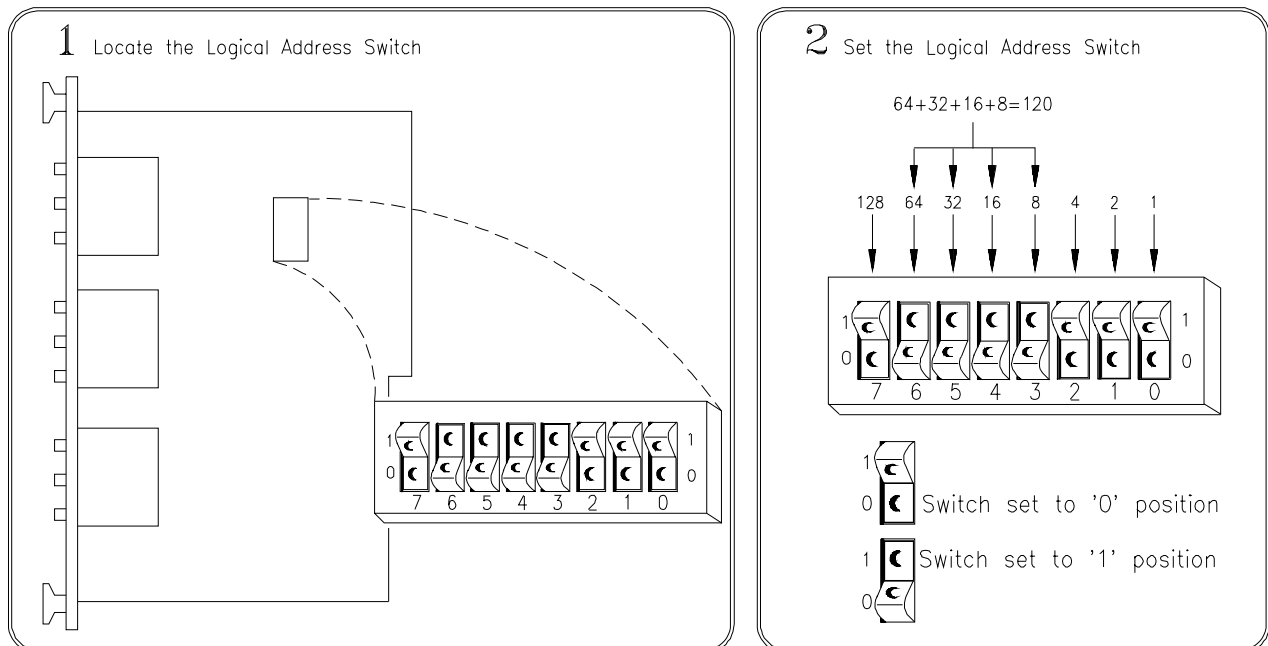

Figure 2-1. Logical Address Selection

Selecting the Interrupt Priority

The Microwave Switch modules generate interrupts after a channel has been closed or opened. These interrupts are sent to, and acknowledgments are received from, the slot 0 module via the VXIbus backplane interrupt lines.

For most applications where the Microwave Switch modules are installed in an Agilent 75000 Series B or Series C mainframe, these jumpers do not have to be moved. This is because the VXIbus interrupt lines have the same priority and interrupt priority is established by installing modules in slots numerically closest to the slot 0 module. Thus, slot 1 (internal to the Series B mainframe) has a higher priority than slot 2 (also internal), slot 2 has a higher priority than slot 3, etc.

Refer to Figure 2-2 to change the interrupt priority. You can select seven different interrupt priority levels. Level 1 is the lowest priority and Level 7 is the highest priority. The Module's factory setting is Level 1. To change, clip out and remove two jumpers from the old priority location. Install and solder two new jumpers in the new priority location (Figure 2-2 shows a priority change from 1 to 7).

Note Both jumper locations must have the same interrupt priority level jumper installed. Changing the priority level jumpers is not recommended. Do not change unless specifically instructed to do so.

NOTE:
In this example, the priority jumpers are moved from position 1 to position 7 (lowest priority to highest priority).

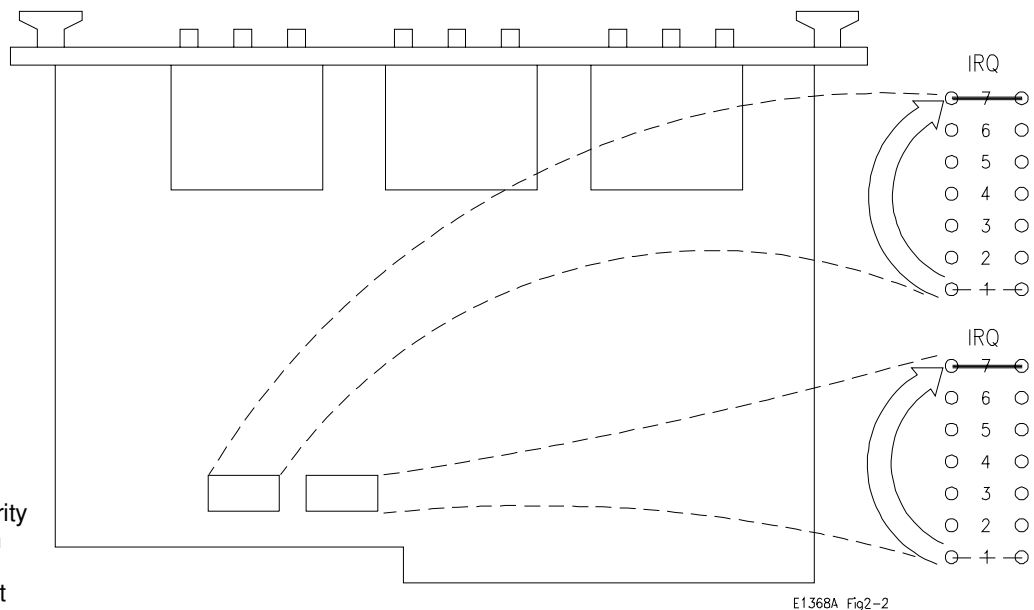

Figure 2-2. Interrupt Priority Selection

Installing Switches on the Agilent E1369A

Because the Agilent E1369A Microwave Switch modules do not have Microwave Switches installed by the factory, it is necessary to install or connect switches before operating. Determine the number of switches, and whether the switches are to be installed on, or connected to, the module and proceed as instructed below.

Installing Switches on the Module

Installation described for up to three coaxial switches (channels 00-02) is below. Figure 2-3 shows the wiring diagram and mounting hole centers for each switch installed.

Agilent SWITCHES. The following 5V Agilent 333XX series and Agilent 876X series switches will function in the Agilent E1369A Microwave Switch module.

Note

The corresponding Agilent 876X and 333XX series switches shown in the table below are electrically and physically identical. The Agilent 8761, 8766 (33363), 8767 (33364), 8768 (33365), 8769 (33366) series coaxial switches will not function in the Agilent E1369A Microwave Switch module because the switch coils are not split (separate for each contact).

Part Number	Frequency	Characteristic Impedance	Ports	Internal 50Ω Termination	Auto Coil Interrupt	MTG Hole
33311B/011 or 8762B/005/100	DC to 18 GHz	50Ω	3	All ports	Yes	C
33311C/011 or 8762C/005/100	DC to 26.5 GHz	50Ω	3	All ports	Yes	C
33312B/011 or 8763B/005/100	DC to 18 GHz	50Ω	4	One port	Yes	D
33312C/011 or 8763C/005/100	DC to 26.5 GHz	50Ω	4	One port	Yes	D
33313B/011 or 8764B/005/100	DC to 18 GHz	50Ω	5	No ports	Yes	D
33313C/011 or 8764C/005/100	DC to 26.5 GHz	50Ω	5	No ports	Yes	D
33314A/011 or 8765A/005/100	DC to 4 GHz	50Ω	3	No ports	No	B
33314B/011 or 8765B/005/100	DC to 20 GHz	50Ω	3	No ports	No	B
33314C/011 or 8765C/005/100	DC to 26.5 GHz	50Ω	3	No ports	No	B

NON-AGILENT SWITCHES. K&L Microwave Inc., Dynatech Microwave Technology Inc., and RLC Electronics Inc. currently manufacture split coil coaxial switches that will physically mount in the E1369A Microwave Switch module rear panel. All switches mount using the "A" hole centers (see Figure 2-3). When selecting switches, refer to the diagram shown in Figure 1-1 to verify that the switch will electrically function in the Agilent E1369A Microwave Switch module. Remember, switches must have split coil operation with 42V maximum drive level.

Caution

The maximum current that the control circuit can accommodate is 1 amp per switch. Maximum current also depends on the output capacity of the mainframe or power supply used.

After selecting the coaxial switch, install as follows:

1. Position the coaxial switch behind the channel 00 panel cut-out. Secure to rear panel using two M2.5 x .45 metric screws (P/N 0515-1373).
2. Route the 3-wire cable (P/N E1368-61601) from J1 to the coaxial switch terminals. Solder the "RED" wire to pin 1. Solder the "YEL" wire to pin C. Solder the "ORN" wire to pin 2.

Note On the Agilent 33314 (8765) series switches, it is necessary to jumper the two C terminals so that both connect to the "YEL" wire.

3. Repeat steps 1 and 2 with remaining coaxial switches. The channel 01 switch connects to J2 connector, and channel 02 connects to J3.

Caution **Do not leave an unused 3-wire cable installed in J1, J2, or J3 if a coaxial switch is not installed. The center conductor of all three connectors is connected to the switch operating voltage at all times. Contact of this conductor to ground may cause the fuse to open, or damage to the power supply or module.**

4. Route the 3-wire cables behind the coaxial switches as not to catch or snag on any objects during module installation in the mainframe or control module (see Figure 2-3).
5. Select correct switch operating voltages (see "Selecting Switch Power" later in this chapter).

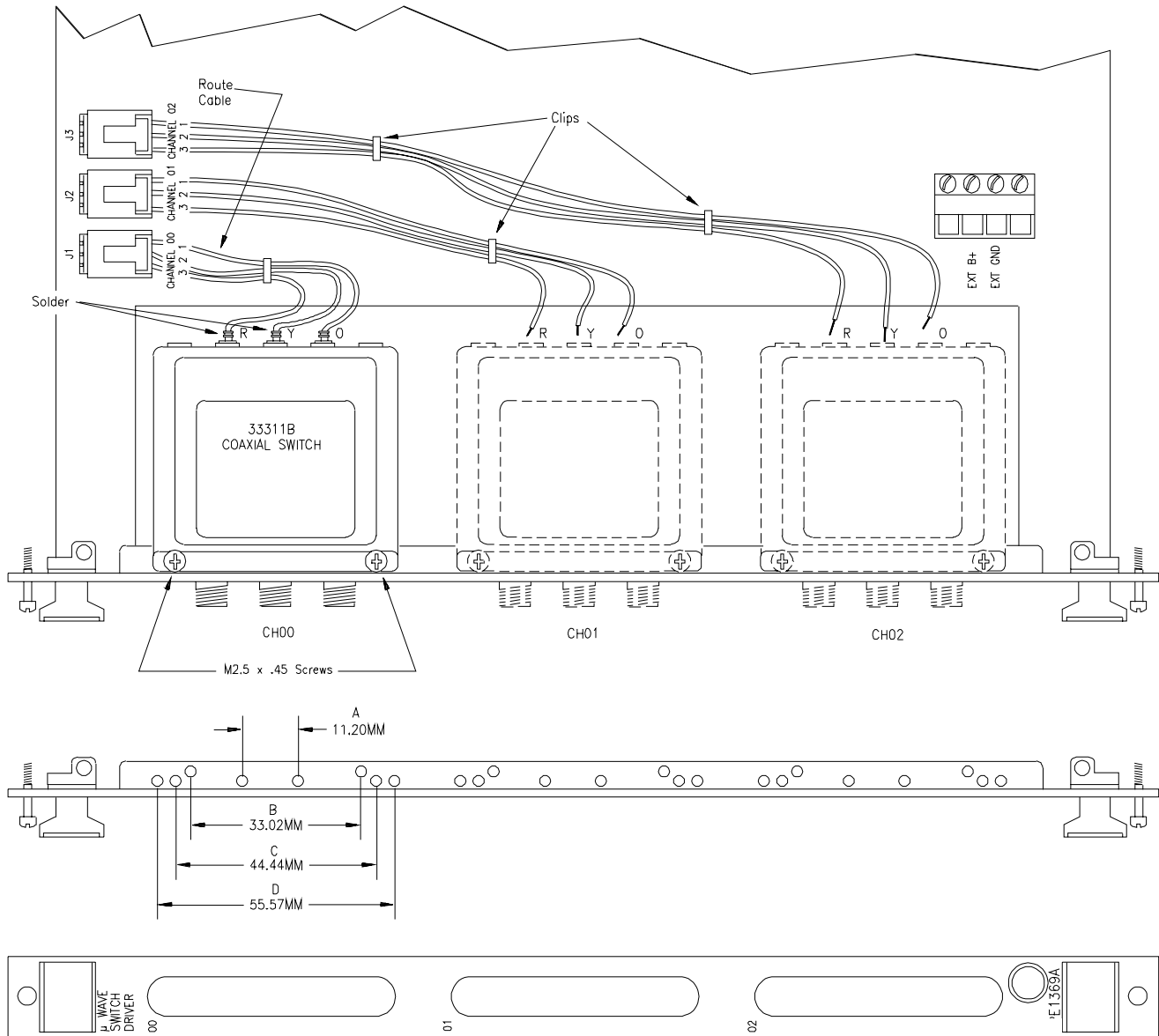

E1368 Fig2-3

Figure 2-3. Microwave Switch Installation

Connecting Switches External to the Module

Connection of up to five coaxial switches (channels 00-04) is described below. Figure 2-4 shows the wiring diagram for each switch connected.

Caution

The maximum current that the control circuit can accommodate is 1 amp per switch. Maximum current also depends on the output capacity of the mainframe or power supply used.

After selecting the coaxial switches, connect to the 14-pin connector as follows:

1. Route an 11-wire cable (not-supplied) from the 14-pin connector on the Microwave Switch module to the switch location. Route the wires through the panel holes as not to catch or snag on any objects during module installation in the mainframe or control module.
2. Connect all C+ terminals on all the coaxial switches to pin 6.
3. Connect CH00 through CH04 switch terminals as required.
 - CH00 1 terminal to pin 13, and the 2 terminal to pin 2.
 - CH01 1 terminal to pin 11, and the 2 terminal to pin 5.
 - CH02 1 terminal to pin 3, and the 2 terminal to pin 9.
 - CH03 1 terminal to pin 4, and the 2 terminal to pin 10.
 - CH04 1 terminal to pin 7, and the 2 terminal to pin 8.
4. Select correct switch operating voltages (see “Selecting Switch Power” later in this chapter).

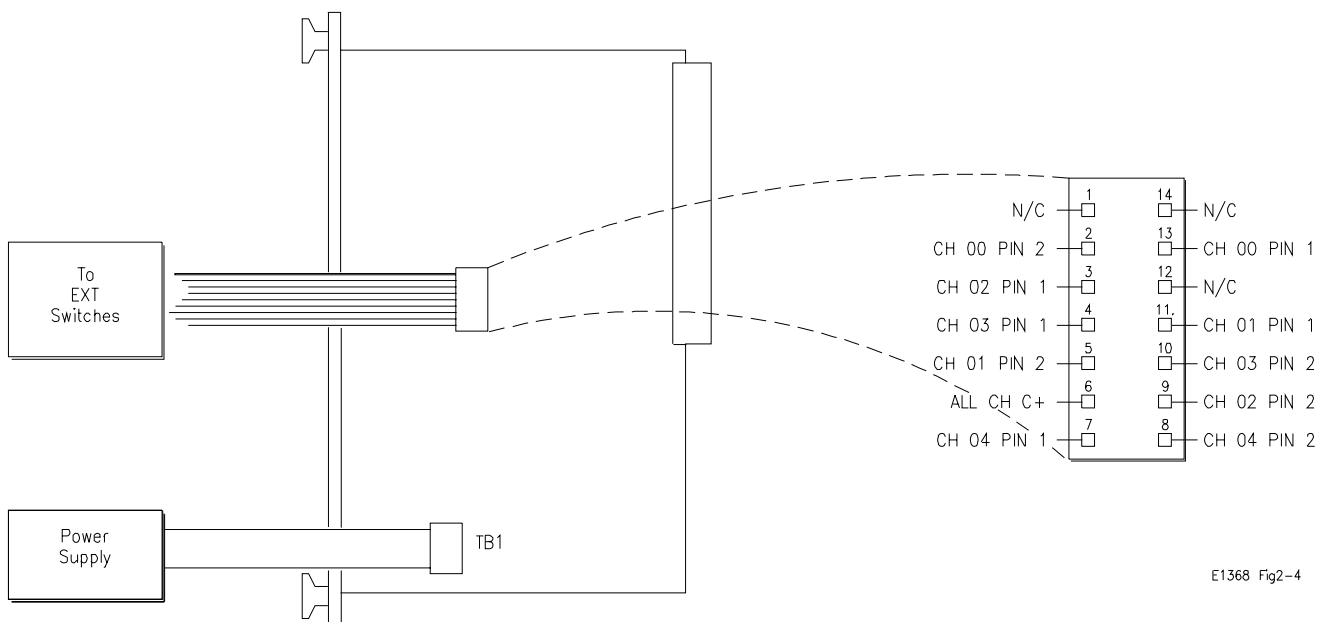

E1368 Fig2-4

Figure 2-4. Microwave Switch Connection

Selecting Switch Power

After the coaxial switches have been installed (refer to “Installing Switches on the Agilent E1369A” earlier in this chapter), the correct operating voltage must be selected. See installed switch specifications.

The Microwave Switch modules are capable of providing +5V (set at factory) or +12V using the mainframe power supply, or external voltages of up to 42Vpk can be connected. Determine the required operating voltage and proceed as instructed below. Refer to Figure 2-5 as required.

Caution **MAXIMUM CURRENT.** The maximum current that the control circuit can accommodate is 1 amp per switch. Maximum current also depends on the output capacity of the mainframe or power supply used.

Internal Power Verify that the F3 fuse (P/N 2110-0712) is installed. Position jumpers as instructed:

- For 5V, jumper JM2 installed, and jumper JM151 removed.
- For 12V, jumper JM151 installed, and jumper JM2 removed.

External Power Verify that the F3 fuse (P/N 2110-0712) is removed (unsolder if necessary). Connect the positive lead to EXT B+ on TB1, and the negative lead to EXT GND on TB1. Connect leads to external power supply. Observe polarity.

Caution **MAXIMUM VOLTAGE.** The maximum voltage that may be applied to the EXTERNAL POWER terminal is 42Vpk.

- Maximum wire size is No. 16 AWG. Wire ends should be stripped 6 mm (~ 0.25 in.) and tinned to prevent single strands from shorting adjacent terminals.
- It is recommended that each channel wire be identified (color coded or marked) as the connection is not visible when the Microwave Switch module is installed.
- Verify that wires make good connections on screw terminals.

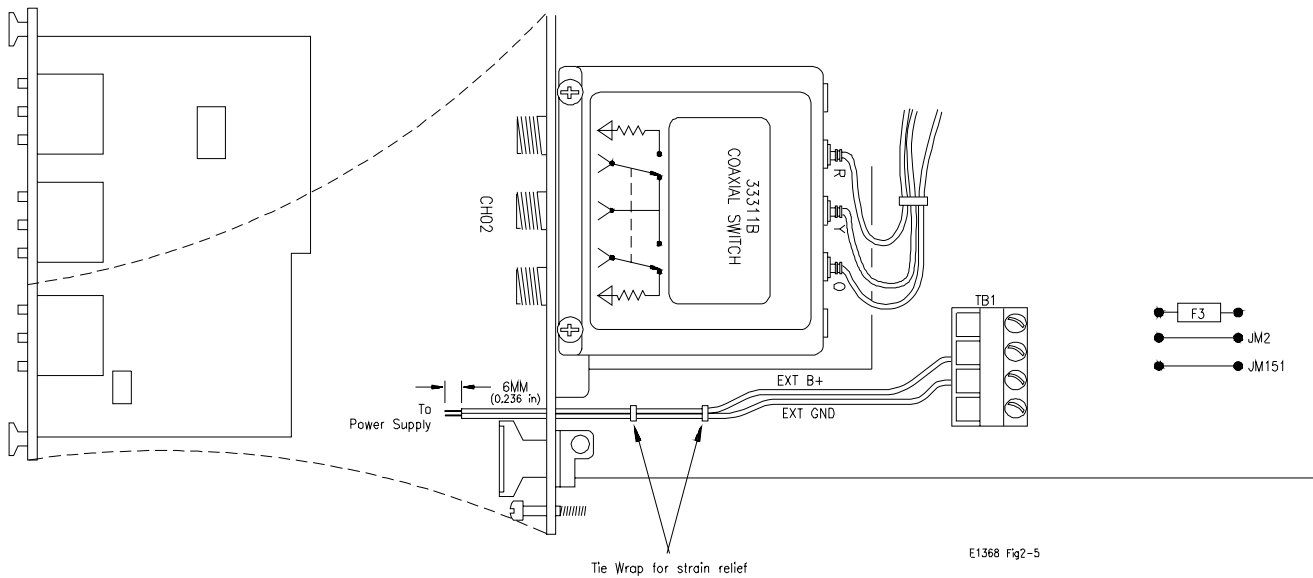

Figure 2-5. Selecting Switch Voltage

Connecting Field Wiring

Figure 2-6 shows the internal switch diagram for the various Agilent 3-port, 4-port, and 5-port coaxial switches. All switches are shown in the "OPEN" position. To minimize loss at high frequencies, use the following guidelines when making connections.

Cabling Guidelines

For frequencies to 18 GHz, use a good quality flexible type cable and SMA connectors. For frequencies 18 GHz, use semi-rigid type cable and APC 3.5 connectors.

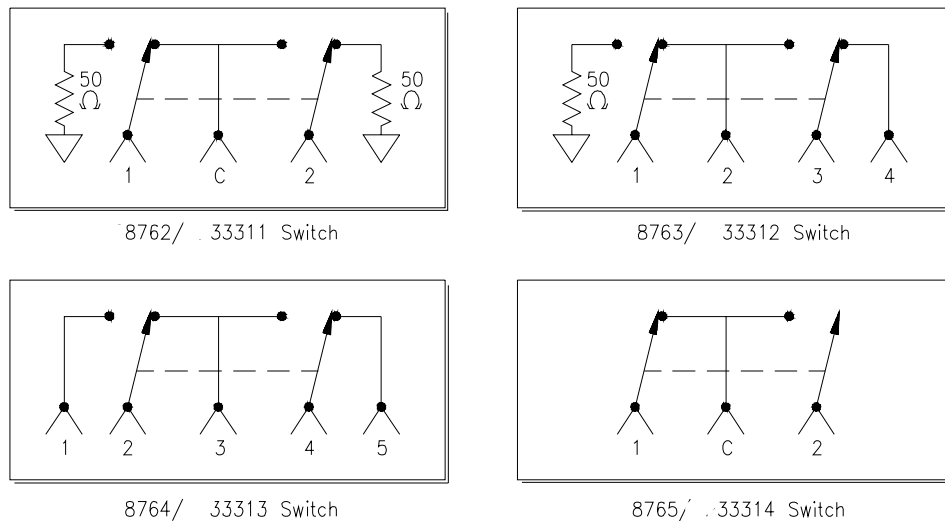

All Switches Shown in the Open Position.

E1368 Fig2-5

Figure 2-6. Switch Configurations

Installing a Switch or Attenuator on the Agilent E1370A Microwave Switch/Attenuator Card

Because the Agilent E1370A Microwave Switch/Attenuator modules do not have a Microwave Switch or Attenuator installed by the factory, it is necessary to install or connect a switch or attenuator before operating. Determine whether the switch or attenuator is to be installed on, or connected to, the module and proceed as instructed below.

Installing a Switch or Attenuator on the Module

Installation of a Microwave Switch or Attenuator is described below. Figure 2-7 shows the wiring diagram and mounting hole centers for the switch or attenuator installed.

AGILENT SWITCHES. The following 5V Agilent 3336xx series switches will function in the Agilent E1370A Microwave Switch/Attenuator module.

Agilent Part Number	Frequency	Ports
33363K	DC to 26.5GHz	Single-Pole, three-throw
33364K	DC to 26.5GHz	Single-Pole, four-throw
33365K	DC to 26.5GHz	Single-Pole, five-throw
33366K	DC to 26.5GHz	Single-Pole, six-throw

Order all of the above with Option 011 (5 volt solenoid assembly) and Option 008 (8 inch ribbon cable).

AGILENT ATTENUATORS. The following 5V Agilent 3332X Step Attenuators will function in the Agilent E1370A Microwave Switch/Attenuator module.

Agilent Part Number	Frequency	Attenuation	Attenuation Step Size
33320G	DC to 4 GHz	0 - 11 dB	1 dB
33320H	DC to 18 GHz	0 - 11 dB	1 dB
33321G	DC to 4 GHz	0 - 70 dB	10 dB
33321H	DC to 18 GHz	0 - 70 dB	10 dB
33322G	DC to 4 GHz	0 - 110 dB	10 dB
33322H	DC to 18 GHz	0 - 110 dB	10 dB
33323K	DC to 26.5 GHz	0 - 90 dB	10 dB

Order all of the above with Option 011 (5 volt solenoid operation) and Option 008 (8 inch ribbon cable).

After selecting the coaxial switch or attenuator, install as follows:

1. Position the coaxial switch or attenuator behind the panel cut-out. Use two M3.0 x 8mm (P/N 0515-0372) metric screws to secure the rear panel. Use two 4-40 x .25 inch screws (P/N 2200-0521) to secure the attenuator to the rear panel.
2. Route the ribbon cable from the Microwave Switch or Attenuator to the 14-pin connector on the PC board.
3. Install the correct filler panel on the switch so that minimal air can flow through the slot.

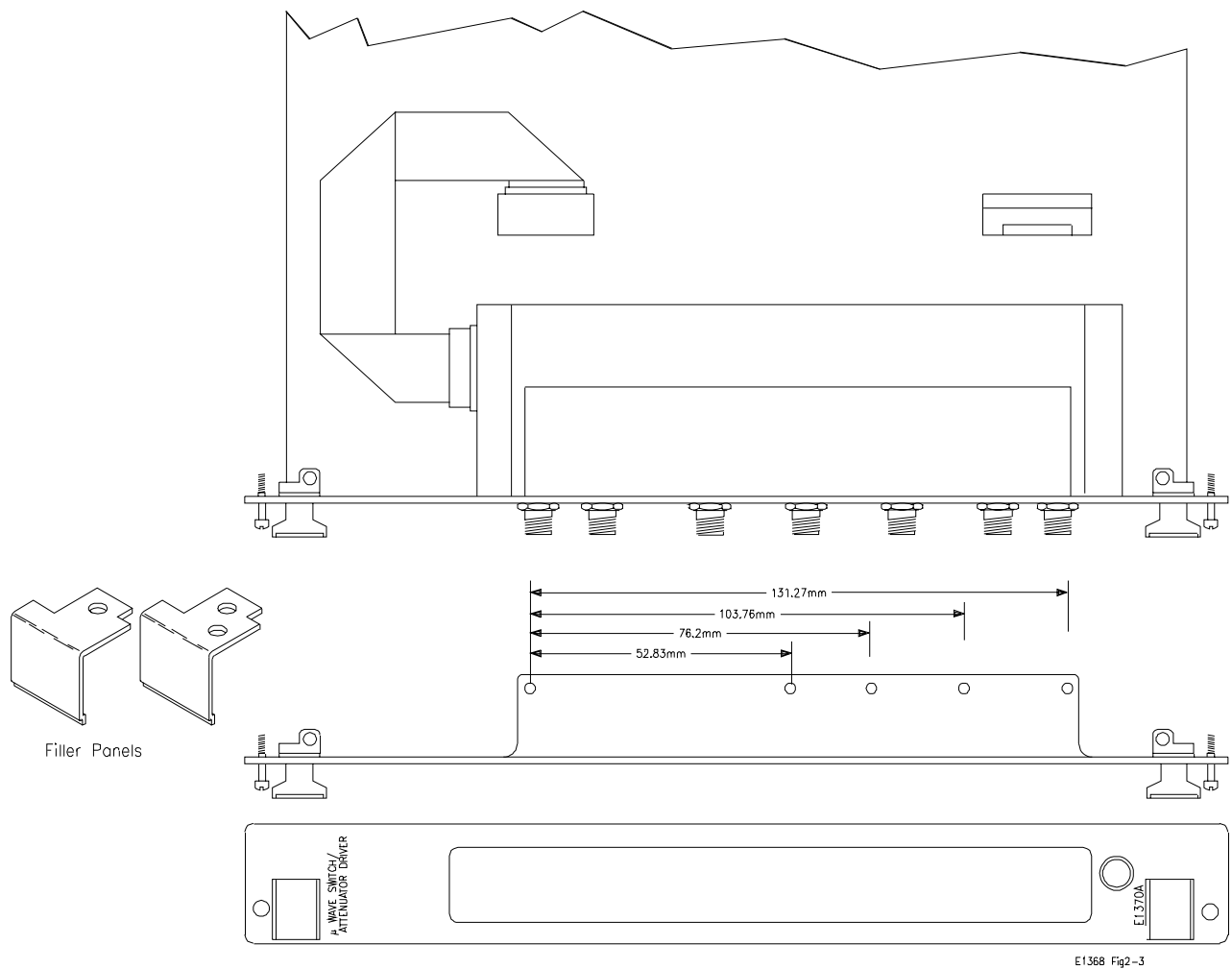

Figure 2-7. Microwave Switch/Attenuator Installation

Connecting Field Wiring

Figure 2-8 shows the internal switch diagram for the various Agilent single-pole, multi-throw switches. All switches are shown in the "OPEN" position. To minimize loss at high frequencies, use the following guidelines when making connections.

- For frequencies up to 18 GHz, use a good quality flexible type cable and SMA connectors.
- For frequencies >18 GHz, use semi-rigid type cable and APC 3.5 connectors.

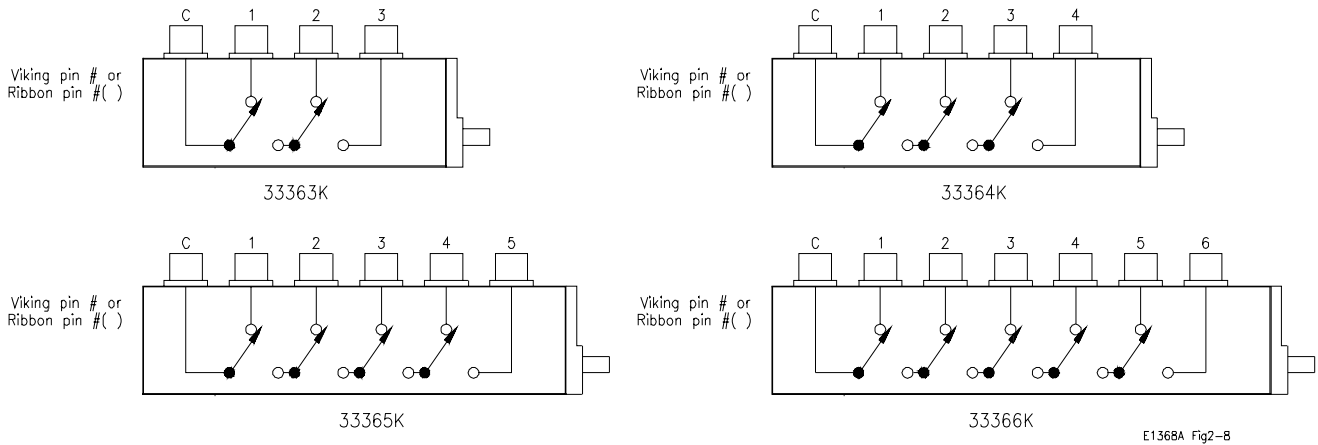

Figure 2-8. Internal Switch Diagrams

Figure 2-9 shows the internal schematic of a single attenuator section.

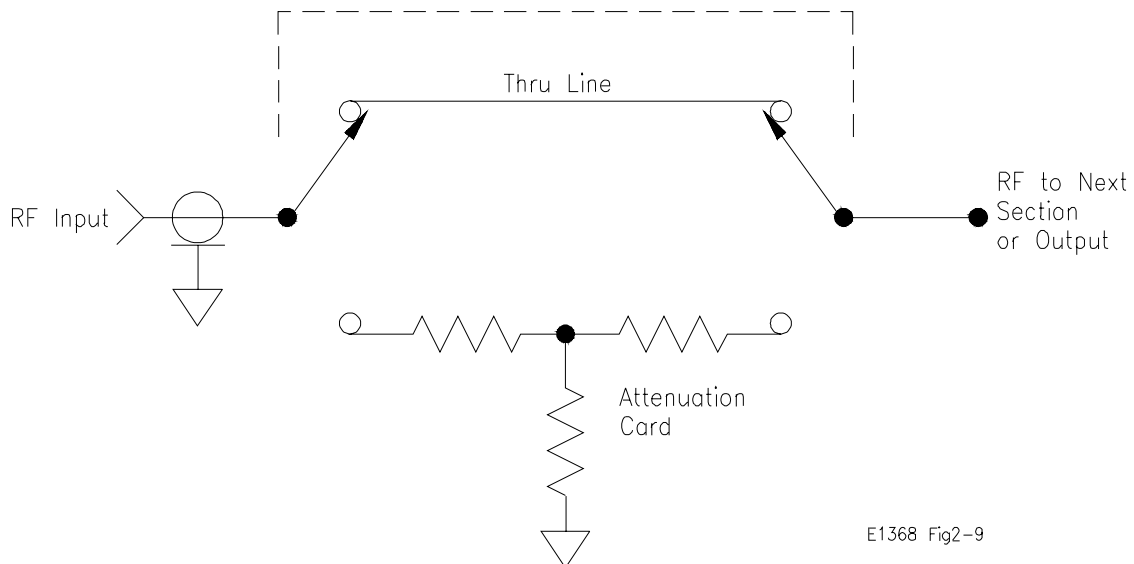

Figure 2-9. Attenuator

Chapter 3

Using the Agilent E1368A/69A/70A Modules

Using This Chapter

This chapter uses typical examples to show how to use the Microwave Switch modules. This chapter contains the following sections:

- Microwave Switch Commands Page 29
- Reset Conditions Page 30
- Switching Channels Page 31
- Scanning Channels Page 39
- Recalling and Saving States Page 43
- Detecting Error Conditions Page 43
- Synchronizing the Microwave Switch Page 45
- Querying the Microwave Switch Page 46

Microwave Switch Commands

Table 3-1. Microwave Switch Commands in Chapter 3

Command	Command Description
INIT[:IMM]	Starts the scan sequence and closes the first channel in the <i>channel list</i> .
OUTP[:STAT] ON	Enables the Agilent E1300B/E1301B "Trig Out" port to output pulses.
[ROUT:]CLOS <channel_list>	Close the channels in the <i>channel list</i> .
[ROUT:]CLOS? <channel_list>	Query the state of the channels in the <i>channel list</i> .
[ROUT:]OPEN <channel_list>	Open the channels in the <i>channel list</i> .
[ROUT:]SCAN <channel_list>	Closes the channels in the <i>channel list</i> one at a time.
TRIG:SOUR BUS EXT HOLD IMM	Select the trigger source to advance the scan.
*CLS	Clears all switchbox Status Registers.
*ESE	Enables the Event Status Register.
*RST	Sets the hardware and software to a known state.
*SRE	Enables the Status Register.

Reset Conditions

When the Microwave Switch is switched on or *RST (reset), all channels are set to open (refer to Figure 2-6), and the current channel list for scanning is invalidated. Table 3-2 lists the parameters and default values for the functions described in Chapter 3.

Table 3-2. *RST (Reset) Default Conditions and Values

Parameter	Default	Description
ARM:COUNT	1	Number of scanning cycles is one.
TRIGger:SOURce	IMM	Will advance scanning cycles automatically.
INITiate:CONTinuous	OFF	Number of scanning cycles is determined by ARM:COUNT.
OUTPut:STATe	OFF	"Trig Out" port on mainframe is disabled.
SCAN:MODE	NONE	Not used by the Microwave Switch modules.
SCAN:PORT	NONE	Not used by the Microwave Switch modules.

Caution When the Microwave Switch is powered up, signals connected to the normally closed (N/C) port will also be connected to the output port (refer to Figure 2-6).

Note The Microwave Switch modules do not support 4-wire resistance scanning (FRES).

Switching Channels

For general purpose switch operation, you can connect or disconnect a signal by opening or closing a specific channel.

- Use CLOS <channel_list> to close coaxial switch channel(s), and OPEN <channel_list> to open coaxial switch channel(s). Refer to Figure 2-6 for the various Agilent coaxial switch configurations. <channel_list> has the form (@ccnn) where cc = card number (01-99) and nn = channel number (00-04).

Example: Single Channel Switching

This example illustrates closing and opening channel 00 in a Agilent E1368A Microwave Switch module. Figure 3-1 shows how the channel is configured.

To close channel 00, execute:

CLOS (@100)

Connect channel 00 switch port 2 to port C, and terminate port 1 into 50; 1 is the card number and 00 is the channel number.

To open channel 00, execute:

OPEN (@100)

Connect channel 00 switch port 1 to port C, and terminate port 2 into 50; 1 is the card number and 00 is the channel number.

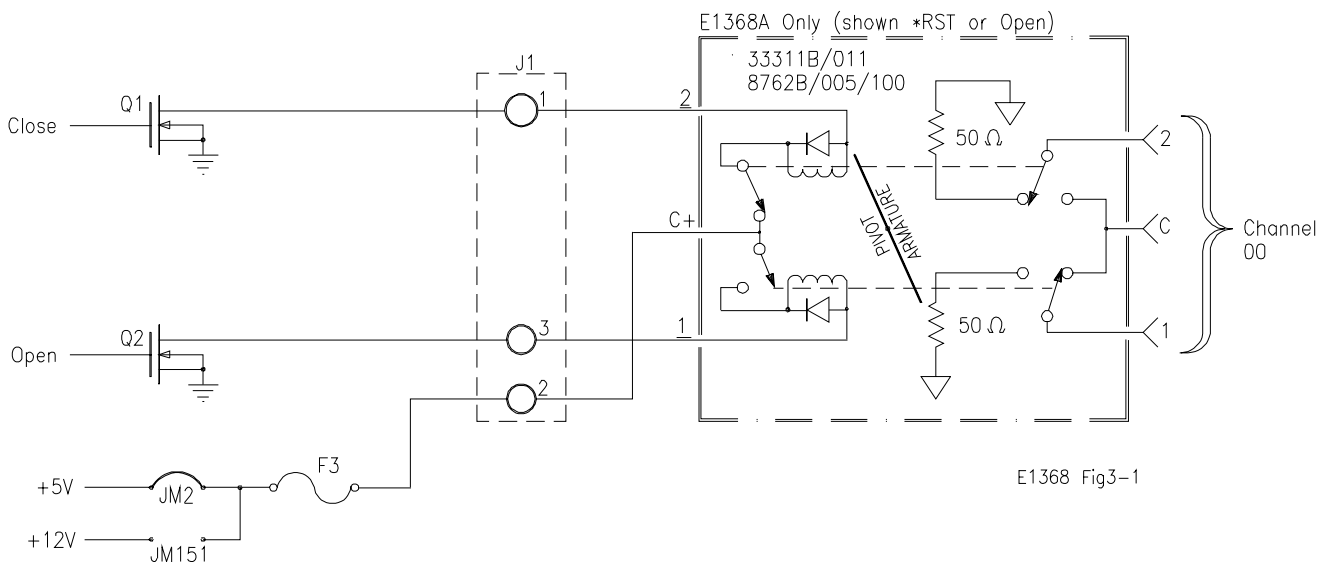

Figure 3-1. Example: E1368A Single Channel Switching

Example: Single Channel Switching using EXTERNAL POWER

This example illustrates closing and opening coaxial switch channel 01 in a Agilent E1369A Microwave Switch Driver module. For the example, the type of switch installed in the Agilent E1369A is a Agilent 33311B (8762B), with 24Vdc drive requirements. Figure 3-2 shows how to connect an external power supply to the EXTERNAL POWER terminals to provide the necessary 24Vdc drive for the coaxial switch.

To close channel 01, execute:

CLOS (@101)

Connect channel 01 switch port 2 to port C, and terminate port 1 into 50; 1 is the card number and 01 is the channel number.

To open channel 01, execute:

OPEN (@101)

Connect channel 01 switch port 1 to port C, and terminate port 2 into 50; 1 is the card number and 01 is the channel number.

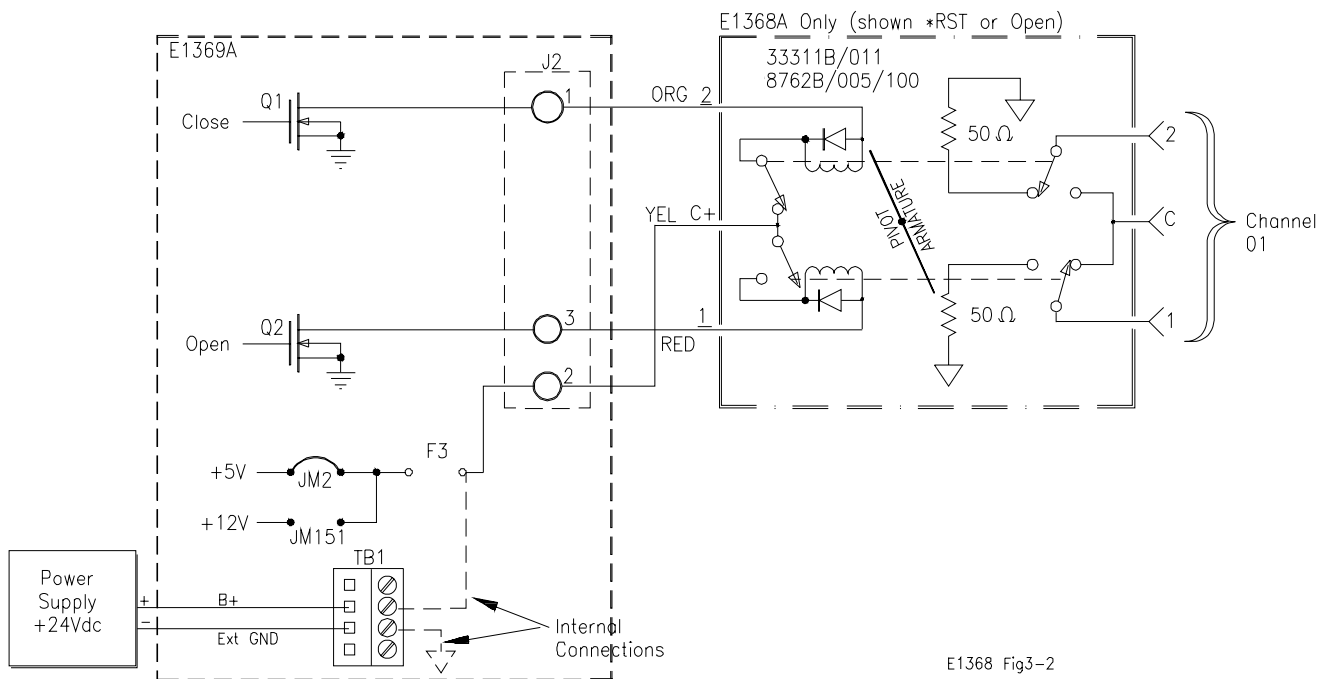
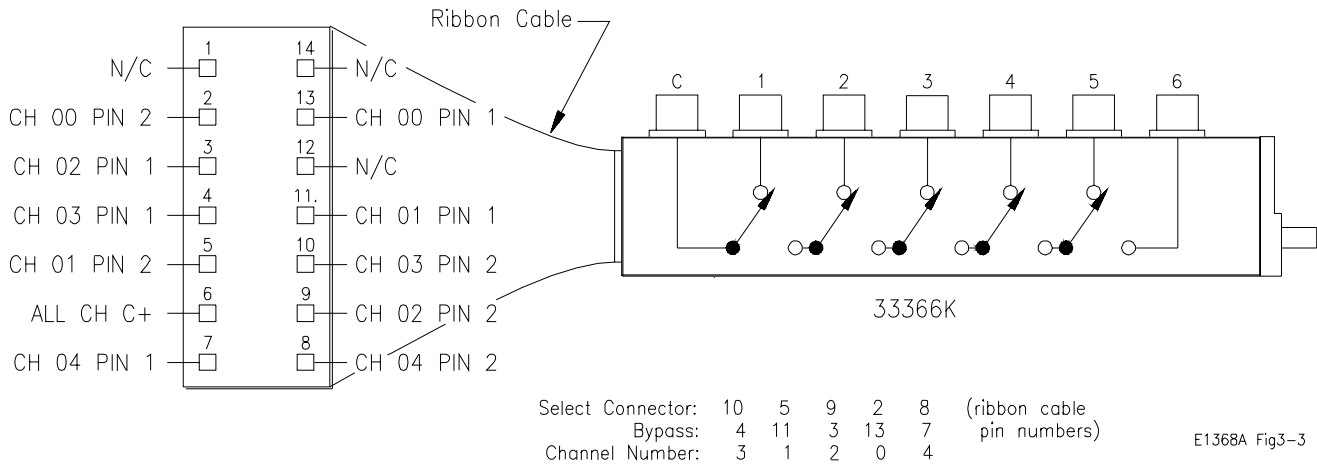

Figure 3-2. Example: Single Channel Switching using External Power

Example: Channel Switching using the E1370A and the 33366K Microwave Switch

This example illustrates how to make connections to different ports on the Agilent E1370A Microwave Switch/Attenuator Driver and the Agilent 33366K Single-pole, Six-throw Microwave Switch. Figure 3-3 shows how the board and switch are configured.



E1368A Fig3-3

Figure 3-3. Example: E1370A Multiple Channel Switching

To connect C to Port 1, execute:

CLOS (@103)

To connect C to Port 2, execute:

OPEN (@103)

Opens the connection to port 1.

CLOS (@101)

Closes the connection to port 2.

To connect C to Port 3, execute:

OPEN (@101)

Opens the connection to port 2.

CLOS (@102)

Closes the connection to port 3.

To connect C to Port 2, execute:

OPEN (@102)

Opens the connection to port 3.

CLOS (@100)

Closes the connection to port 4.

To connect C to Port 2, execute:

OPEN (@100)

Opens the connection to port 4.

CLOS (@104)

Closes the connection to port 5.

Note: Because of the specific ribbon cable configurations, the channel number does not directly correspond to the same port number. Table 3-3 maps the port numbers to the corresponding channel numbers for all of the Agilent333XXK Microwave Switches. For example, to connect C to port 3 on the Agilent3365K Single-pole, Four-throw Switch, channel 2 would have to be closed.

Table 3-3. Map of Channel Numbers to Port Numbers.

Switch Part Number	C (Connected to Port)				
	1	2	3	4	5
33363K	0	1			
33364K	1	2	0		
33365K	3	1	2	0	
33366K	3	1	2	0	4

Example: Multiple Channel Switching using EXTERNAL POWER

This example illustrates closing and opening coaxial switch channels 00 through 04 in a Agilent E1369A Microwave Switch Driver module. For the example, the switches are not installed on the Agilent E1369A card, and have 24Vdc drive requirements (Agilent 33311B or 8762B). Figure 3-4 shows how to connect an external power supply to the EXTERNAL POWER terminals to provide the necessary 24Vdc drive for the coaxial switches, and how to connect the 14-pin cable to the external switches.

To close channels 00 through 04, execute:

CLOS (@100:104)

Connect channels 00, 01, 02, 03, and 04 switch port 2 to port C, and terminate port 1 into 50; 1 is the card number and 00-04 are the channel numbers.

To open channel 00 through 04, execute:

OPEN (@100:104)

Connect channels 00, 01, 02, 03, and 04 switch port 1 to port C, and terminate port 2 into 50; 1 is the card number and 00-04 are the channel numbers.

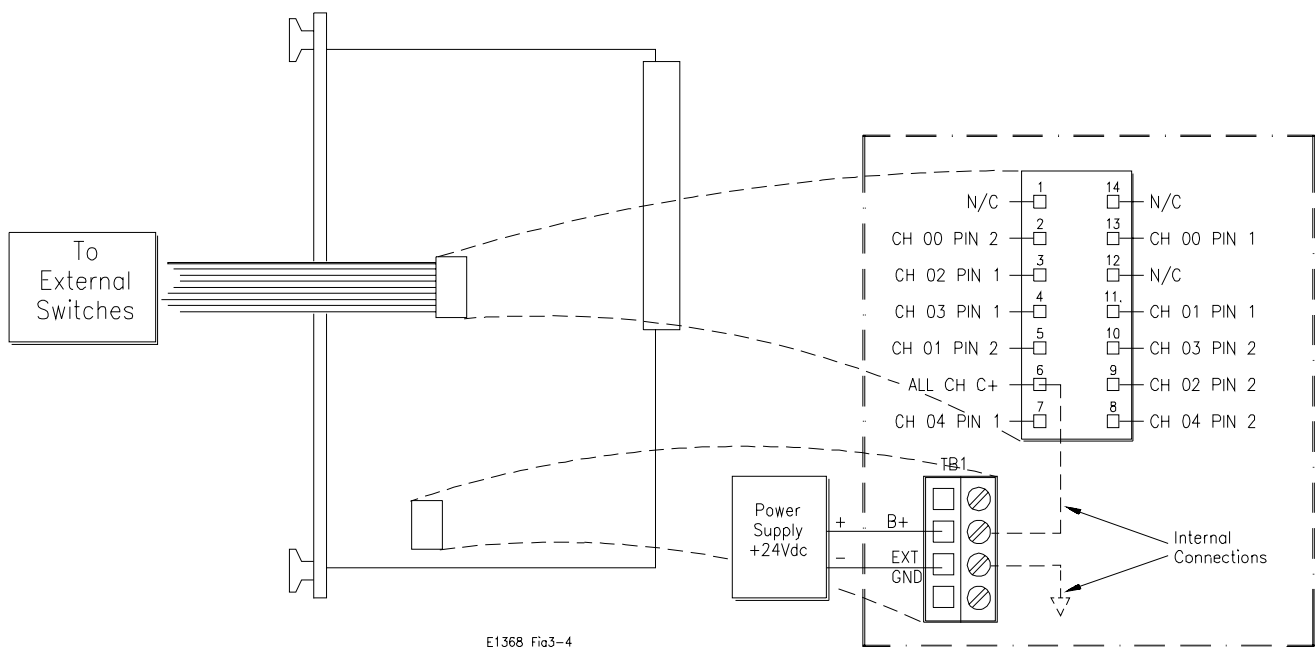

Figure 3-4. Example: Multiple External Channel Switching using External Power

Example: Transfer Switch Using Two 3-Port Switches

This example shows how to configure the Agilent E1368A Microwave Switch to either route a signal directly to the output, or route it through an external device before being output. For the example, two switches (channels 00 and 01) will be used. Figure 3-5 shows how to connect channels 00 and 01.

To route the signal directly, execute:

OPEN (@100,101)

Connects port C to port 1 of both channels and routes the signal directly to the output.

To route the signal through the external device, execute:

CLOS (@100,101)

Connects port C to port 2 of both channels and routes the signal through the external device to the output.

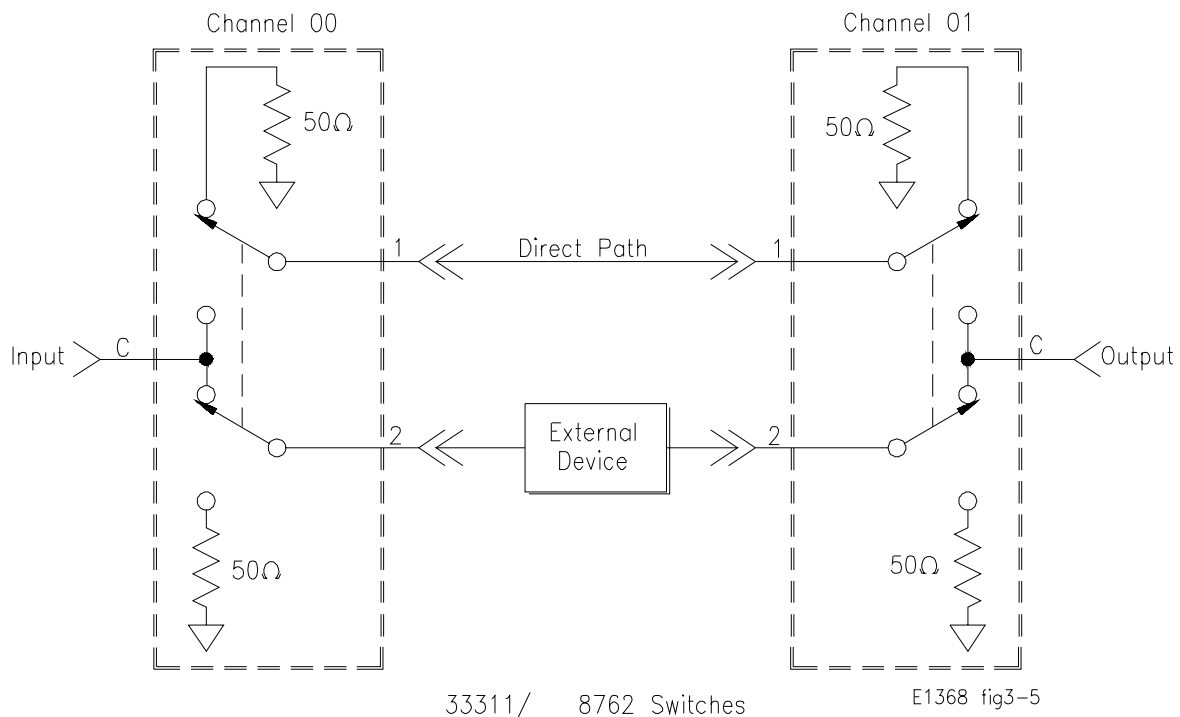

Figure 3-5. Example: Transfer Switch (two channel)

Example: Transfer Switch Using One 5-Port Switch

This example shows how to configure the Agilent E1369A Microwave Switch Driver with a 5-port switch (Agilent 33313 or 8764) installed, to either route a signal directly to the output, or route it through an external device before being output. For the example, one switch (channel 02) will be used. Figure 3-6 shows how to connect channel 02.

To route the signal directly, execute:

OPEN (@102)

Connects port 3 to port 2 and routes the signal directly to the output.

To route the signal through the external device, execute:

CLOS (@102)

Connects port 1 to port 2 and port 3 to port 4 routing the signal through the external device to the output.

Comments

The one channel 5-port transfer switch example does not terminate the External Device into 50Ω when not connected to the input.

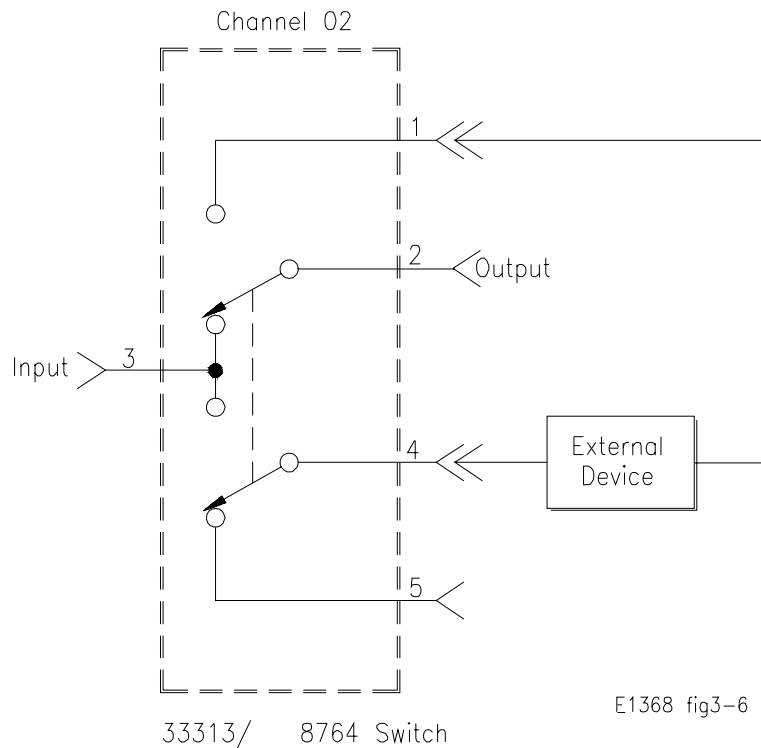

Figure 3-6. Example: Transfer Switch (one channel)

Example: 4 x 1 Multiplexer

This example shows how to configure the Agilent E1368A Microwave Switch to select one of four signals for output. For the example, all three switches (channels 00 through 02) will be used. Figure 3-6 shows how to connect channels 00 through 02.

To route signal "A" to the output, execute:

OPEN (@100,102)

Connects signal "A" (channel 00 port 1) to the output (channel 02 port C).

To route signal "B" to the output, execute:

CLOS (@100);OPEN (@102)

Connects signal "B" (channel 00 port 2) to the output (channel 02 port C). To route signal "C" to the output, execute:

OPEN (@101);CLOS (@102)

Connects signal "C" (channel 01 port 1) to the output (channel 02 port C).

To route signal "D" to the output, execute:

CLOS (@101,102)

Connects signal "D" (channel 01 port 2) to the output (channel 02 port C).

Comments

Unused signals are terminated into 50Ω (internal to the switch).

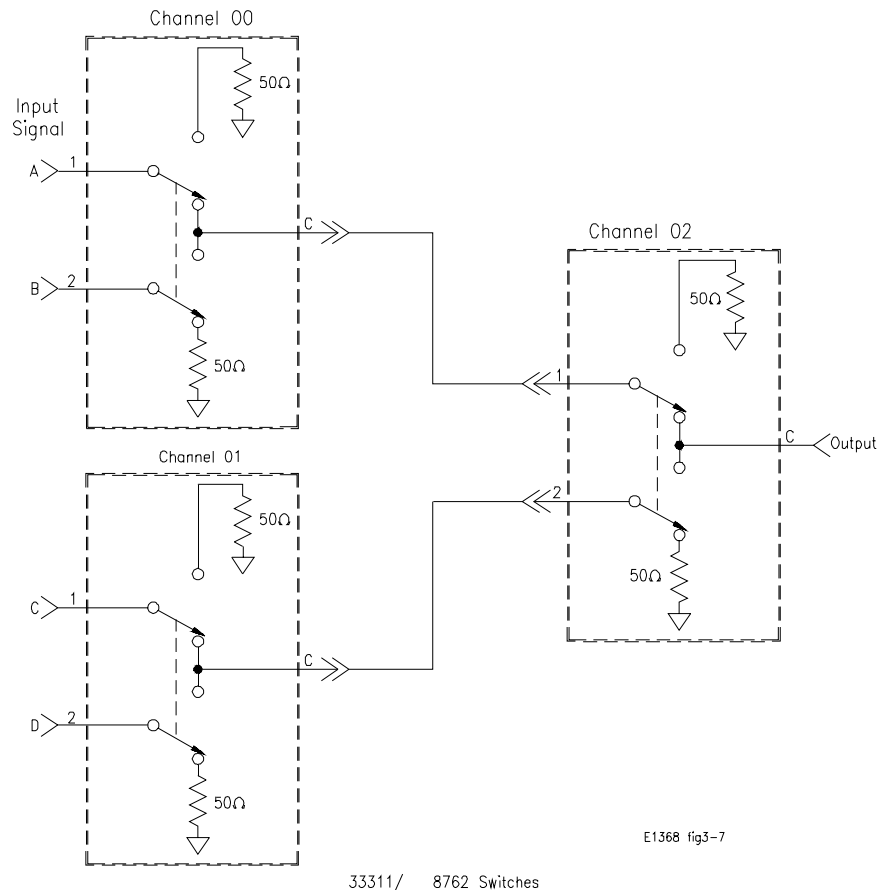

Figure 3-7. Example: 4-Channel Multiplexer

Scanning Channels

Scanning the Microwave Switch module channels consists of closing a set of channels (connecting the 2 port to the C port) one channel at a time. Single scan, multiple scans (2 to 32767), or continuous scanning modes are available.

The TRIGger:SOURce command specifies the source to advance the scan. The OUTPut command can be used to enable the E1300B/E1301B or E1405/E1406 "Trig Out" port. Figure 3-8 illustrates the scanning sequence.

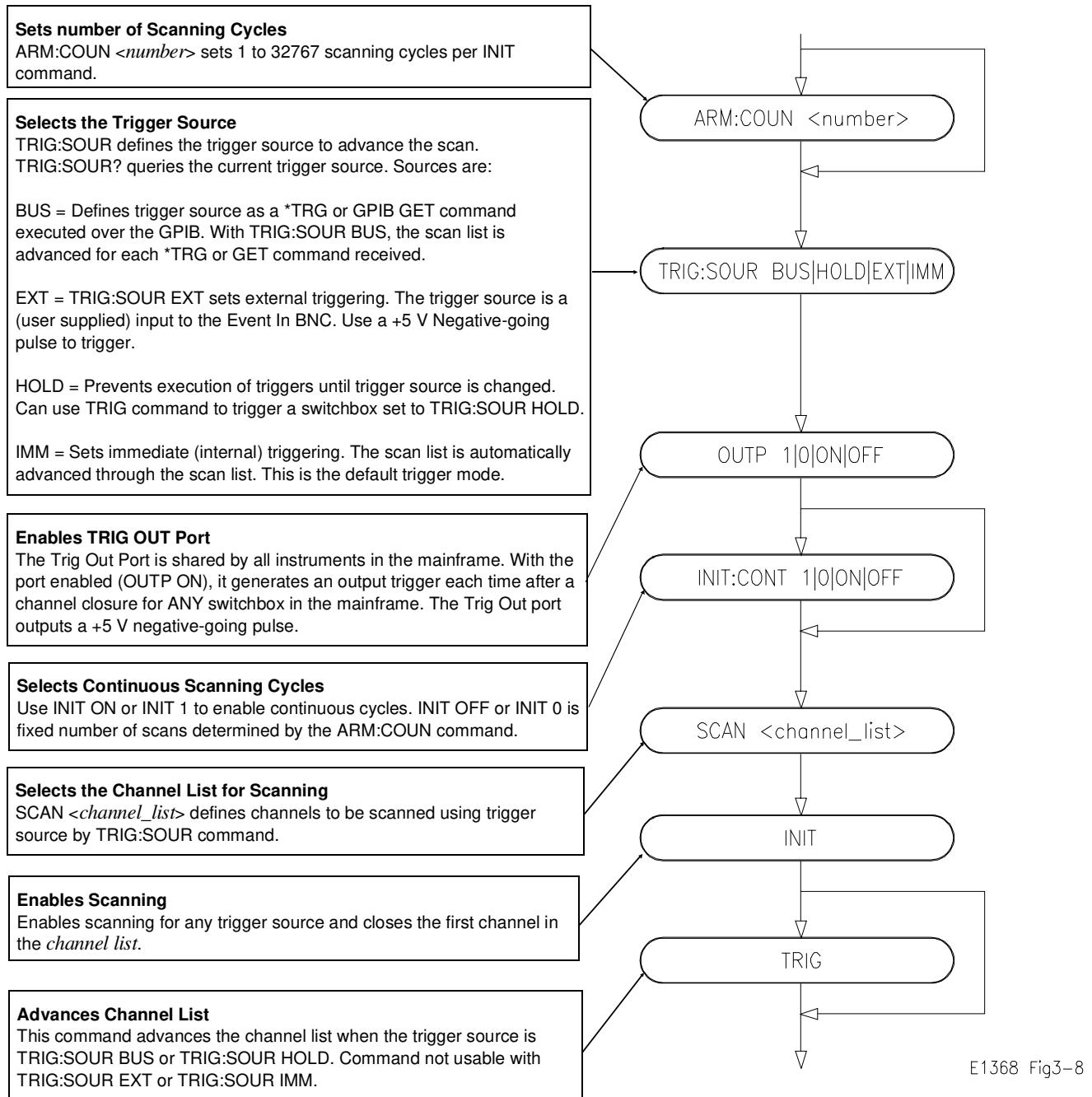

Figure 3-8. Example: Scanning Commands

Example: Scanning Channels

This example uses the mainframe's "Trig Out" port to synchronize Microwave Switch channel 00 to 02 closures to an external measurement device (e.g. Frequency Counter, Spectrum Analyzer). For measurement synchronization, the Agilent E1300B/E1301B "Trig Out" port is connected to the external instrument's "EXT Trig In" port.

Figure 3-9 shows how to connect the Microwave Switch module to the external instrument. The mainframe and external instrument are connected to the computer's GPIB port, and the measurement results are transferred directly to the computer. For the example, use:

- an GPIB select code of 7, primary address of 09, and secondary address of 15 for the Microwave Switch
- an GPIB select code of 7, primary address of 22 for the External Instrument
- an HP Series 200/300 Computer with BASIC

Execute:

```
10 OUTPUT 722;"TRIG EXT;..."      !Configures the external
                                     instrument. Appropriate instrument
                                     commands must be added to make
                                     the measurement.

20 OUTPUT 70915;"*RST"             !Opens all channels, resets
                                     Microwave Switch module to
                                     known state.

30 OUTPUT 70915;"OUTP ON"          !Enable "Trig Out" port.
40 OUTPUT 70915;"TRIG:SOUR BUS"    !Sets trigger source to bus
                                     triggering.
50 OUTPUT 70915;"SCAN (@100:102)" !Defines channel list to scan
                                     channels 00, 01, and 02.
60 OUTPUT 70915;"INIT"             !Closes channel 00 and enables the
                                     scan. Causes a trigger output from
                                     mainframe's "Trig Out" port which
                                     initiates the external instrument to
                                     make a measurement.

70 FOR I=1 to 3                    !Start counting loop (3 channels).
80 WAIT 1                           !Allows external instrument time to
                                     settle and make measurement.
90 ENTER 722;A                      !Enters measurement result.
100 PRINT A                          !Displays measurement result.
110 TRIGGER 70915                   !Advance scan to channel 01 (then
                                     02).
120 NEXT I                          !Increment the count and repeats
                                     measurement process for a total of
                                     three measurements (channels 00,
                                     01, and 02).
130 END                             !Terminate program.
```

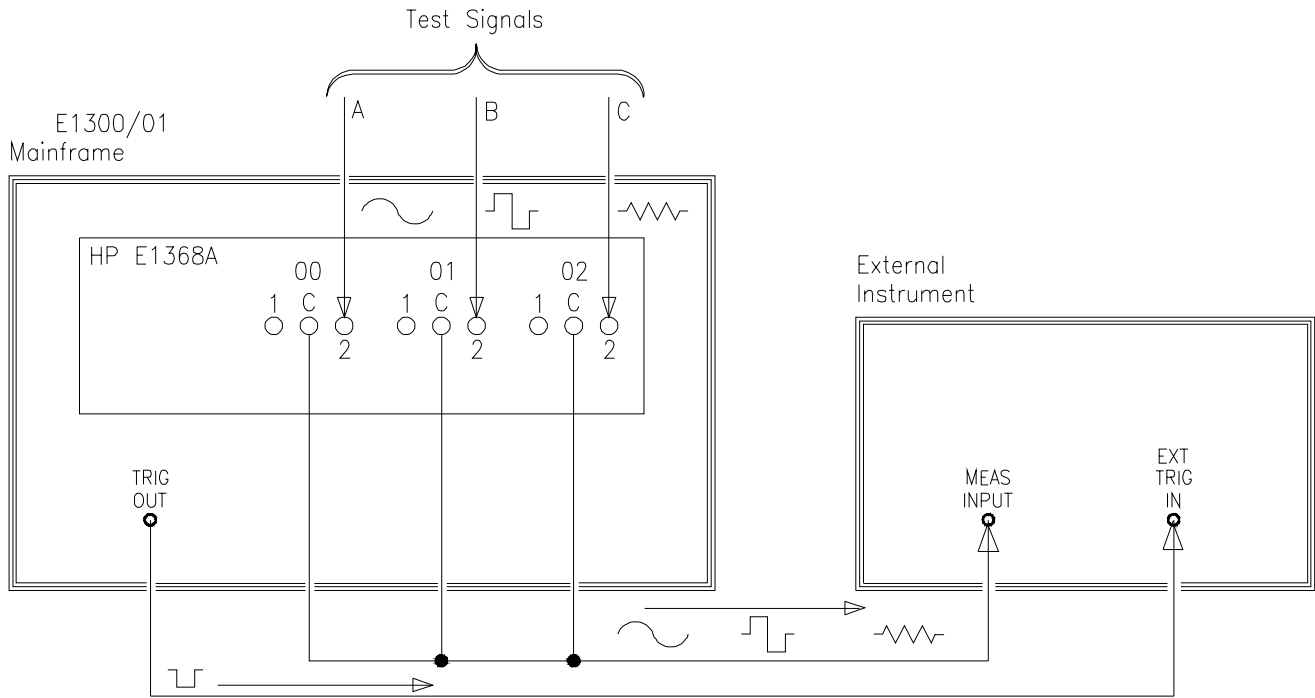

E1368 Fig3-9

Figure 3-9. Example: Multiple Channel Scanning

Example: Using the Scan Complete Bit

You can use the Scan Complete Bit (bit 8) in the Operation Status Register of a switchbox to determine when a scanning cycle completes (no other bits in the register apply to the switchbox). Bit 8 has a decimal value of 256 and you can read it directly with the `STAT:OPER?` command (refer to the `STATus:OPERation[:EVENT]?` command in Chapter 4 for an example).

When enabled by the `STAT:OPER:ENAB 256` command, the Scan Complete Bit will be reported as bit 7 of the Status Register. Use the GPIB Serial Poll or the IEEE 488.2 Common Command `*STB?` to read the Status Register.

When bit 7 of the Status Register is enabled by the `*SRE 128` Common Command to assert an GPIB Service Request (SRQ), you can interrupt the computer when the Scan Complete Bit is set, after scanning cycle completes. This allows the controller to do other operations while the scanning cycle is in progress.

The following example monitors bit 7 in the Status Register to determine when the scanning cycle completes. For the example, use:

- an GPIB select code of 7, primary address of 09, and secondary address of 15 for the Microwave Switch
- an HP Series 200/300 Computer with BASIC

Execute:

```
10 OUTPUT 70915;"*CLS"           !Clear all switchbox status  
                                structure.  
20 OUTPUT 70915;"STAT:OPER:ENAB 256" !Enable Scan Complete Bit to  
                                set bit 7 in Status Register.  
30 OUTPUT 70915;"*SRE 128"      !Enable bit 7 of Status Register to  
                                assert SRQ.  
40 OUTPUT 70915;"TRIG:SOUR EXT" !Set to external trigger mode.  
50 OUTPUT 70915;"SCAN (@100:103)" !Select channels to be scanned.  
60 OUTPUT 70915;"INIT"          !Start scanning cycle.  
70 WHILE NOT BIT (SPOLL(70915),7) !Waiting for scan complete.  
80 PRINT "DO OTHER OPERATION HERE" !Enter program lines for  
                                computer to do other operations.  
90 END WHILE  
100 PRINT "INTERRUPT GENERATED" !Program goes to this line after  
                                interrupt is generated by a  
                                completed scanning cycle.  
110END                            !Terminate program.
```

Comments **Channel List Can Be Extended Across Boundaries.** For multiple module switchbox instruments, the channels to be scanned can extend across switch modules. For example, for a two module switchbox instrument, SCAN (@100:203) will scan all channels of both Microwave Switch modules.

Setting Multiple Continuous Scans. Use ARM:COUNT number to set from 1 to 32767 scans. Use INITiate:CONTInuous ON to set continuous scanning.

Recalling and Saving States

This section contains information about saving and recalling switch states.

Storing States

The `*SAV <numeric_state>` command saves the current instrument state. The state number (0-9) is specified in the `<numeric_state>` parameter. The following settings are saved:

- Channel States (open or closed)
- ARM:COUNT
- TRIGGER:SOURCE
- OUTPUT:STATE
- INITIATE:CONTINUOUS
- SCAN:MODE (not used)
- SCAN:PORT (not used)

Recalling States

The `*RCL <numeric_state>` command recalls a previously saved state. Enter the number (0-9) in the `<numeric_state>` parameter of the desired saved state. If `*SAV` was not previously executed using the selected number, the Microwave Switch will configure to the reset values.

Detecting Error Conditions

This section discusses using the various Microwave Switch registers to detect if a switching operation has generated an error. There are two general approaches to error checking. The simplest, but most time consuming, is to ask the instrument whether there are errors at every step of the switching process. This is called "polling" and is illustrated in the following example .

```
05 DIM Err_num$ [256]
10 OUTPUT 70915; "CLOS(@100);:SYST:ERR?"
20 ENTER 70915;Err_num$
30 IF VAL (Err_num$) 0 THEN
40 PRINT "Error";Err_num$
50 STOP
60 END IF
70 ... (program continues)
```

The other approach involves the use of interrupts. The following program is a method of checking for errors using interrupts as you program the Microwave Switch. The program monitors the Microwave Switch's Standard Event Status Register for an error condition. If no errors occur, the Microwave Switch functions as programmed. If errors do occur, the Microwave Switch interrupts the computer, and the error codes and messages are read from the error queue. This approach requires less checking, but is more complex.

For the example, use:

- an GPIB select code of 7, primary address of 09, and secondary address of 15 for the Microwave Switch
- an HP Series 200/300 Computer with BASIC

Execute:

```
10 !Call computer subprogram "Errmsg" if a Microwave
20 !Switch programming error occurs. Enable the computer to respond
30 !to an interrupt from the Microwave Switch.
35 !
40 ON INTR 7 CALL Errmsg
50 ENABLE INTR 7:2
60 !
70 !Unmask the Event Status bit in the Microwave Switch's Status
80 !Register. Unmask the Microwave Switch error conditions in its
90 !Standard Event Status Register.
95 !
100 OUTPUT 70915;"*SRE 32"
110 OUTPUT 70915;"*ESE 60"
120 !
130 !At this point, the Microwave Switch is programmed for the intended
140 !application.
145 !
150 OUTPUT 70915;" . . .
160 OUTPUT 70915;" . . .
170 ENTER 70915; . . .
180 PRINT . . .
190 END
200 !
210 !When an error occurs, clear the Microwave Switch to regain
220 !control. Execute a Serial Poll to clear the service request
230 !bit in the Status Register. Read all error messages in the
240 !Microwave Switch error queue. Clear all bits in the counter
250 !Standard Event Status Register.
255 !
260 SUB Errmsg
270 DIM Message$(256)
280 CLEAR 70915
290 B=SPOLL (70915)
300 REPEAT
310 OUTPUT 70915; "SYST:ERR?"
320 ENTER 70915; Code, Message$
330 PRINT Code,Message$
340 UNTIL Code=0
```

```
350 OUTPUT 70915;"*CLS"  
360 STOP  
370 SUBEND
```

Comments If you have an Agilent 75000 Series B mainframe with a front panel keyboard, errors can be monitored by selecting "Monitor" from the Switch menu. If errors occur when the program executes, the "err" annunciator will appear. Entering SYST:ERR? repeatedly from the keyboard reads all of the messages in the error queue. The *Agilent 75000 Series B Mainframe User's Manual* contains detailed information on the Status and Standard Event Status Registers.

Synchronizing the Microwave Switch

This section discusses synchronizing the Microwave Switch module to other instruments when making measurements.

Synchronizing Instruments

The following example shows how you synchronize instruments. In this example, the Microwave Switch switches a signal to be measured by a counter. This program verifies that the switching is complete before the counter begins a measurement. For the example, use:

- an GPIB select code of 7, primary address of 09, and secondary address of 06 for the Counter
- an GPIB select code of 7, primary address of 09, and secondary address of 15 for the Microwave Switch
- an HP Series 200/300 Computer with BASIC

Execute:

```
10 !Close channel 101 and request confirmation that the channel is  
15 !closed.  
20 OUTPUT 70915;"CLOSE (@101);*OPC?"  
30 !Read confirmation.  
35 OUTPUT 70915;"CLOSE? (@101)"  
40 ENTER 70915;A  
50 !At this point (channel is closed) the measurement can be made.  
60 OUTPUT 70906: "MEAS1:FREQ?"  
70 ENTER 70906:Meas_value  
80 END
```

Querying the Microwave Switch

This section summarizes the query commands you can use to determine the configuration or state of the Microwave Switch. All commands end with the question mark (?) which puts the data into the output buffer where you can retrieve it to your computer. See Chapter 4 for more information.

Channel Closed:	CLOS?
Channel Opened:	OPEN?
Mainframe TRIG OUT State:	OUTP:STAT?
Module Description:	SYST:CDES?
Module Type:	SYST:CTYP?
Number of Scanning Cycles:	ARM:COUN?
Scanning Mode:	SCAN:MODE?
Scanning State	INIT:CONT?
Status Operation Enable:	STAT:OPER:ENAB?
Status Operation Event:	STAT:OPER:EVEN?
System Error:	SYST:ERR?
Trigger Source:	TRIG:SOUR?

Chapter 4

Agilent E1368A/69A/70A Command Reference

Using This Chapter

This chapter describes Standard Commands for Programmable Instruments (SCPI) commands and summarizes IEEE 488.2 Common (*) Commands applicable to the Microwave Switch. See the *Agilent 75000 Series B Mainframe Agilent E1300B/E1301B User's Manual* or the *Agilent 75000 Series C Agilent E1406 User's Manual* for additional information on SCPI and common commands. This chapter contains the following sections:

- Command Types Page 47
- SCPI Command Reference Page 50
- IEEE 488.2 Common Commands Page 70
- Command Quick Reference. Page 71

Command Types

Commands are separated into two types: IEEE 488.2 Common Commands and SCPI Commands.

Common Command Format

The IEEE 488.2 standard defines the Common Commands that perform functions like reset, self-test, status byte query, etc. Common Commands are four or five characters in length, always begin with the asterisk character (*), and may include one or more parameters. The command keyword is separated from the first parameter by a space character. Some examples of Common Commands are shown below:

*RST *ESR 32 *STB?

SCPI Command Format

SCPI commands perform functions like closing switches, making measurements, querying instrument states, or retrieving data. A subsystem command structure is a hierarchical structure that usually consists of a top level (or root) command, one or more lower level commands, and their parameters. The following example shows part of a typical subsystem:

```
[ROUTE:]  
  CLOSe <channel_list>  
  SCAN <channel_list>  
    :MODE?
```

[ROUTE:] is the root command, CLOSe and SCAN are second level commands with parameters, and :MODE? is a third level command.

Command Separator

A colon (:) always separates one command from the next lower level command as shown below:

```
ROUTe:SCAN:MODE?
```

Colons separate the root command from the second level command (ROUTe:SCAN) and the second level from the third level (SCAN:MODE?).

Abbreviated Commands

The command syntax shows most commands as a mixture of upper and lower case letters. The upper case letters indicate the abbreviated spelling for the command. For shorter program lines, send the abbreviated form. For better program readability, you may send the entire command. The instrument will accept either the abbreviated form or the entire command.

For example, if the command syntax shows MEASure, then MEAS and MEASURE are both acceptable forms. Other forms of MEASure, such as MEASU or MEASUR will generate an error. You may use upper or lower case letters. Therefore, MEASURE, measure, and MeAsUrE are all acceptable.

Implied Commands

Implied commands are those which appear in square brackets ([]) in the command syntax. (Note that the brackets are not part of the command and are not sent to the instrument.) Suppose you send a second level command but do not send the preceding implied command. In this case, the instrument assumes you intend to use the implied command and it responds as if you had sent it. Examine the SOURce subsystem shown below:

```
[SOURce:]  
  PULSe  
    :COUNt <count>  
    :COUNt? [<MIN | MAX>]  
    :PERiod <period>  
    :PERiod? [<MIN | MAX>]
```

The root command [SOURce:] is an implied command. To set the instrument's pulse count to 25, you can send either of the following command statements:

```
SOUR:PULS:COUN 25    or    PULS:COUN 25
```

Parameters **Parameter Types.** The following table contains explanations and examples of parameter types you might see later in this chapter.

Parameter Type	Explanations and Examples
Numeric	Accepts all commonly used decimal representations of numbers including optional signs, decimal points, and scientific notation. 123, 123E2, -123, -1.23E2, .123, 1.23E-2, 1.23000E-01. Special cases include MIN, MAX, and DEF. MIN selects minimum value available, MAX selects maximum value available, and DEF selects default or reset value.
Boolean	Represents a single binary condition that is either true or false. 1 or ON; 0 or OFF.
Discrete	Selects from a finite number of values. These parameters use mnemonics to represent each valid setting. An example is the TRIGger:SOURce <source> command where <i>source</i> can be BUS, EXT, HOLD, or IMM.

Optional Parameters. Parameters shown within square brackets ([]) are optional parameters. (Note that the brackets are not part of the command and are not sent to the instrument.) If you do not specify a value for an optional parameter, the instrument chooses a default value. For example, consider the ARM:COUNT? [<MIN | MAX>] command. If you send the command without specifying a parameter, the present ARM:COUNT value is returned. If you send the MIN parameter, the command returns the minimum count available (1). If you send the MAX parameter, the command returns the maximum count available (32,767). Be sure to place a space between the command and the parameter.

Linking Commands

Linking IEEE 488.2 Common Commands with SCPI Commands. Use a semicolon between the commands. For example:

*RST;OUTP ON *or* TRIG:SOUR HOLD;*TRG

Linking Multiple SCPI Commands. Use both a semicolon and a colon between the commands. For example:

ARM COUN 1;:TRIG:SOUR EXT

SCPI allows several commands within the same subsystem to be linked with a semicolon. For example:

ROUT:CLOS (@100);:ROUT:OPEN (A101)

or

ROUT:CLOS (@100);OPEN (@101)

SCPI Command Reference

This section describes the Standard Commands for Programmable Instruments (SCPI) commands for the Microwave Switch modules. Commands are listed alphabetically by subsystem and also within each subsystem.

ABORt

The ABORt subsystem stops a scan in progress when the scan is enabled via the interface, and the trigger modes are TRIGger:SOURce BUS or TRIGger:SOURce HOLD.

Subsystem Syntax

ABORt

Comments

- **ABORt Operation** invalidates the current channel list and sets ARM:COUNT 1 (one scanning cycle per INITiate command), sets INITiate CONTInuous OFF (no continuous scanning cycles), and sets TRIGger:SOURce IMMEDIATE (continuous internal triggering).
- **Stopping Scans Enabled from Interface:** When a scan is enabled from the interface, use an interface CLEAR command or the Agilent E1301 front panel "Reset Instr" or "Clear Instr" key to stop the scan.

When the scan is enabled from the interface and the trigger source is TRIGger:SOURce BUS or TRIGger:SOURce HOLD, use ABORt or the Agilent E1301 front panel "Reset Instr" or "Clear Instr" keys to stop the scan.

- **Stopping Scans Enabled from Front Panel:** When a scan is enabled from the Agilent E1301 front panel, execute *RST over the interface or the front panel "Reset Instr" or "Clear Instr" keys to stop the scan.
- **Related Commands:** ARM, INITiate:CONTInuous, [ROUTE:]SCAN, TRIGger

Example Stopping a Scan with ABORt

This example stops a (continuous) scan in progress.

TRIG:SOUR BUS	<i>BUS is trigger source.</i>
INIT:CONT ON	<i>Set continuous scanning.</i>
SCAN (@100:102)	<i>Scan channels 00-02.</i>
INIT	<i>Starts scanning cycle, close channel 00.</i>
ABOR	<i>Aborts scan in progress.</i>

ARM

The ARM subsystem selects the number of scanning cycles (1 through 32767) for each INITiate command.

ARM
:COUNT <number> MIN | MAX
:COUNT? [MIN | MAX]

:COUNT **ARM:COUNT <number> MIN | MAX** allows scanning cycles to occur a multiple of times (1 to 32767) with one INITiate command when INITiate:CONTInuous OFF | 0 is set. MIN sets 1 cycle and MAX sets 32,767 cycles.

Parameters

Parameter Name	Parameter Type	Range of Values	Default Value
<i>number</i>	numeric	1 - 32767 MIN MAX	1

Comments

- **Number of Scans:** Use only numeric values between 1 and 32767 for the number of scanning cycles (default is 1).
- **Related Commands:** ABORt, INITiate:IMMediate
- ***RST Condition:** ARM:COUNT 1

Example Setting Ten Scanning Cycles

This example sets a Microwave Switch for 10 scans of channels 00 through 02. When the scan sequence completes, channels 00 through 02 (switches 00 through 02) are closed.

```
ARM:COUN 10           Set 10 scans per INIT command.  
SCAN (@100:102)      Scan channels 00-02.  
INIT                  Start scan, close channel 00.
```

:COUNT? **ARM:COUNT? [MIN | MAX]** returns the current number of scanning cycles set by ARM:COUNT. The current number of scans cycles is returned when no MIN or MAX parameter is sent. With MIN or MAX passed as parameters, MIN returns 1 and MAX returns 32767.

Parameters

Parameter Name	Parameter Type	Range of Values	Value
MIN MAX	numeric	MIN = 1, MAX = 32767	cycles

Comments • **Related Commands:** INITiate:IMMEDIATE

Example Query Number of Scanning Cycles

This example sets a Microwave Switch for 10 scanning cycles of channels 00 through 02, and queries the number of scan cycles set. The ARM:COUNT? command returns 10.

ARM:COUNT 10

Set 10 scans per INIT command.

ARM:COUNT?

Query number of scanning cycles.

DISPlay

The DISPlay subsystem monitors the channel state of a selected module (or card) in a switchbox. This subsystem only operates with mainframes that have a display, such as the Agilent 75000 Series B Mainframe (Agilent Model Number E1301B).

Subsystem Syntax

```
DISPlay
:MONitor
:CARD <number | AUTO>
[:STATe] <mode>
[:STATe]?
```

:MONitor:CARD

DISPlay:MONitor:CARD <number | AUTO> selects the module in a switchbox to be monitored when the monitor mode is enabled. Use the DISPlay:MONitor:STATe command to enable and disable the monitor mode.

Parameters

Parameter Name	Parameter Type	Range of Values	Default Value
<i>number</i> AUTO	numeric	1 - 99 or AUTO	AUTO

Comments

- **Selecting a Specific Module to be Monitored:** Use the DISPlay:MONitor:CARD command to send the card number in a switchbox to be monitored.
- **Selecting the Present Module to be Monitored:** Use the DISPlay:MONitor AUTO command to select the last module addressed by a switching command (e.g.,[ROUTE:]CLOSE).
- ***RST Condition:** DISPlay:MONitor:CARD AUTO

Example

Select Module #2 in a Switchbox for Monitoring

```
DISP:MON:CARD 2
```

Selects module #2 in a switchbox to be monitored when the mode is enabled.

:MONitor[:STATe] **DISPlay:MONitor[:STATe]** <mode> turns the monitor mode ON or OFF.

Parameters

Parameter Name	Parameter Type	Range of Values	Default Value
<i>mode</i>	boolean	0 1 ON OFF	0 OFF

Comments

- **Monitoring Switchbox Channels:** DISPlay:MONitor[:STATe] ON or DISPlay:MONitor[:STATe] 1 turns the monitor mode ON to show the channel state of the selected module. DISPlay:MONitor[:STATe] OFF or DISPlay:MONitor[:STATe] 0 turns the monitor mode OFF.

- **Selecting the Module to be Monitored:** Use the DISPlay:MONitor:CARD <number> | AUTO command to select the module.

- **Monitor Mode on an Agilent E1301B Mainframe Display:** A typical display for the Agilent E1368A/E1369A Microwave Switch module follows, where all channels (all relays) are closed.

SWITCH_120: Chan: 0,1,2,3,4, , , , , ,

The example shows that channels 00, 01, 02, 03, and 04 are closed.

- **Disabling Monitor Mode:** Pressing any Agilent E1301B front panel key while in monitor mode will automatically disable the function.

- ***RST Condition:** DISPlay:MONitor[:STATe] OFF | 0

Example Enabling the Monitor Mode

DISP:MON:CARD 2 *Selects module #2 in a switchbox.*
DISP:MON 1 *Turns the monitor mode ON.*

:MONitor[:STATe]? **DISPlay:MONitor[:STATe]?** returns a number indicating whether the monitor mode is enabled or disabled: "1" = ON, "0" = OFF. The value is sent to the output buffer.

Comments

- This command is valid only when executed from your computer via the interface. The monitor mode is automatically disabled if you attempt to execute the command from the mainframe's front panel.

Example Querying the Monitor Mode

DISP:MON? *Query the present state of the monitor mode.*

INITiate

The INITiate subsystem selects continuous scanning cycles and starts the scanning cycle.

Subsystem Syntax

```
INITiate
:CONTinuous <mode>
:CONTinuous?
[:IMMediate]
```

:CONTinuous

INITiate:CONTinuous <mode> enables or disables continuous scanning cycles for the switchbox.

Parameters

Parameter Name	Parameter Type	Range of Values	Default Value
<i>mode</i>	boolean	0 1 ON OFF	OFF 0

Comments

- **Continuous Scanning Operation:** Continuous scanning is enabled with the INITiate:CONTinuous ON or INITiate:CONTinuous 1 command. Sending the INITiate[:IMMediate] command closes the first channel in the *channel list*. Each trigger from a trigger source selected by the TRIGger:SOURce command advances the scan through the *channel list*. A trigger at the end of the *channel list* closes the first channel in the list and the scan cycle repeats.
- **Non-Continuous Scanning Operation:** Non-continuous scanning is enabled with the INITiate:CONTinuous OFF or INITiate:CONTinuous 0 command. Sending the INITiate[:IMMediate] command closes the first channel in the *channel list*. Each trigger from a trigger source selected by the TRIGger:SOURce command advances the scan through the *channel list*. At the end of the scanning cycle, the last channel in the channel list is closed.
- **Stopping Continuous Scans:** See the ABORt command.
- **Related Commands:** ABORt, ARM:COUNT, TRIGger, TRIGger:SOURce

Example Enabling Continuous Scans

This example enables continuous scanning of channels 00 through 02 of a single-module switchbox. Since TRIGger:SOURce IMMediate (default) is set, use an interface clear command (such as CLEAR) to stop the scan.

```
INIT:CONT ON           Enables continuous scanning.
SCAN (@100:102)       Defines channel list.
INIT                   Start scan cycle, close channel 00.
```

:CONTInuous? **INITiate:CONTInuous?** queries the scanning state. With continuous scanning enabled, the command returns 1. With continuous scanning disabled, the command returns 0.

Example Query Continuous Scanning State

This example enables continuous scanning of a switchbox and queries the state. Since continuous scanning is enabled, query should return 1.

```
INIT:CONT ON Enables continuous scanning.
INIT:CONT? Query continuous scanning state.
```

[:IMMediate] **INITiate[:IMMediate]** starts the scanning process and closes the first channel in the *channel list*. Successive triggers from the source specified by the TRIGger:SOURce command advances the scan through the *channel list*.

Comments

- **Starting the Scanning Cycle:** The INITiate[:IMMediate] command starts scanning by closing the first channel in the *channel list*. Each trigger received advances the scan to the next channel in the *channel list*. An invalid *channel list* definition generates an error (see the [ROUTE:]SCAN command).
- **Stopping Scanning Cycles:** See the ABORt command.

Example Enabling a Single Scan

This example enables a single scan of channels 00 through 02 of a single-module switchbox. The trigger source to advance the scan is immediate (internal) triggering, set with (default) TRIGger:SOURce IMMEDIATE.

```
SCAN (@100:102) Scan channels 00-02.
INIT Begin scan, close channel 00 (use immediate triggering).
```

OUTPut

The OUTPut subsystem enables or disables the "Trig Out" port of the Agilent E1300/E1301 Mainframe or on the Agilent Command Module.

Subsystem Syntax OUTPut
 [:STATe] <state>
 [:STATe]?

[:STATe] **OUTPut[:STATe] <state>** enables/disables the "Trig Out" port on the rear panel of the Agilent E1300B/E1301B Mainframe or on the Agilent Command Module. OUTPut[:STATe] ON | 1 enables the port and OUTPut[:STATe] OFF | 0 disables the port.

Parameters

Parameter Name	Parameter Type	Range of Values	Default Value
<i>state</i>	boolean	0 1 ON OFF	OFF 0

Comments

- **Enabling "Trig Out" Port:** When enabled, a pulse is output from the "Trig Out" port after each switchbox channel is closed. If disabled, a pulse is not output from the "Trig Out" port after channel closures. The output pulse is a +5V negative-going pulse.
- **"Trig Out" Port Shared by Switchboxes:** When enabled, the "Trig Out" port may be pulsed by any switchbox each time a scanned channel is closed. To disable the output for a specific switchbox, send the OUTPut[:STATe] OFF or OUTPut[:STATe] 0 command for that switchbox.
- **Related Commands:** [ROUTE:]SCAN, TRIGger:SOURce
- ***RST Condition:** OUTPut[:STATe] OFF (port disabled)

Example Enabling "Trig Out" Port

OUTP:STAT ON *Enables "Trig Out" port to output pulse after each scanned channel is closed.*

[:STATe]? **OUTPut[:STATe]?** queries the present state of the "Trig Out" port. The command returns 1 if the port is enabled, or 0 if disabled.

Example Query "Trig Out" Port Enable State

This example enables the "Trig Out" port and queries the enable state. The OUTPut[:STATe]? command returns 1 since the port is enabled.

OUTP:STAT ON *Enables "Trig Out" port for pulse output.*
OUTP:STAT? *Query port enable state.*

[ROUTe:]

The ROUTe subsystem controls switching and scanning operations for the Microwave Switch modules in a switchbox.

Subsystem Syntax

```
[ROUTe:]  
  CLOSe <channel_list>  
  CLOSe? <channel_list>  
  OPEN <channel_list>  
  OPEN? <channel_list>  
  SCAN <channel_list>  
    :MODE NONE | VOLT  
    :MODE?
```

CLOSe [ROUTe:]CLOSe <channel_list> closes the Microwave Switch channels specified in the *channel_list*. The *channel_list* is in the form (@ccnn) where cc = card number (00-99) and nn = channel number (00-04).

Parameters

Parameter Name	Parameter Type	Range of Values	Default Value
<i>channel_list</i>	numeric	cc00 - cc04	N/A

Comments

- **Closing Channels:** To close:
 - a single channel, use [ROUTe:]CLOSe (@ccnn);
 - multiple channels, use [ROUTe:]CLOSe (@ccnn,ccnn);
 - sequential channels, use [ROUTe:]CLOSe (@ccnn:ccnn);
 - a group of sequential channels, use [ROUTe:]CLOSe (@ccnn:ccnn,ccnn:ccnn);
 - or any combination.

Closure order for multiple channels with a single command is not guaranteed.

- **Related Commands:** [ROUTe:]OPEN, [ROUTe:]CLOSe?
- ***RST Condition:** All channels are open.

Example Closing Microwave Switch Channels

This example closes channels 100 and 202 of a two-module switchbox (card numbers 01-02).

```
CLOS (@100,202)           100 closes channel 00 of card #1;  
                           202 closes channel 02 of card #2.
```

CLOSe? [ROUTE:]CLOSe? <channel_list> returns the current state of the channel(s) queried. The *channel_list* is in the form (@ccnn). The command returns 1 if the channel is closed or returns 0 if the channel is open.

- Comments**
- **Query is Software Readback:** The [ROUTE:]CLOSe? command returns the current software state of the channel specified. It does not account for relay hardware failures. A maximum of 127 channels at a time can be queried for a multi-module switchbox.

Example Query Channel Closure

This example closes channels 100 and 202 of a two-module switchbox (card numbers 01 and 02) and queries channel closure. Since the channels are programmed to be closed 1,1 is returned.

```
CLOS (@100,202)           100 closes channel 00 of card #1;
                          202 closes channel 02 of card #2.
CLOS? (@202)             Query channel 02 of card #2.
```

OPEN [ROUTE:]OPEN <channel_list> opens the Microwave Switch channels specified in the *channel_list*. The *channel_list* is in the form (@ccnn) where cc = card number (00-99) and nn = channel number (00-04).

Parameters

Parameter Name	Parameter Type	Range of Values	Default Value
<i>channel_list</i>	numeric	cc00 - cc04	N/A

- Comments**
- **Opening Channels:** To open:
 - a single channel, use [ROUTE:]OPEN (@ccnn);
 - for multiple channels, use [ROUTE:]OPEN (@ccnn,ccnn);
 - sequential channels, use [ROUTE:]OPEN (@ccnn:ccnn);
 - a group of sequential channels, use [ROUTE:]OPEN (@ccnn:ccnn,ccnn:ccnn);
 - or any combination.

Opening order for multiple channels with a single command is not guaranteed.
 - **Related Commands:** [ROUTE:]CLOSe, [ROUTE:]OPEN?
 - ***RST Condition:** All channels are open.

Example Opening Microwave Switch Channels

This example opens channel 00 of a card number #1 and channel 02 of a card number #2 in a two-module switchbox.

```
OPEN (@100,202)          100 opens channel 00 of card #1;
                          202 opens channel 02 of card #2
```

OPEN? [ROUTE:]OPEN? <channel_list> returns the current state of the channel(s) queried. The *channel_list* is in the form (@ccnn). The command returns 1 if the channel is open or returns 0 if the channel is closed.

- Comments**
- **Query is Software Readback:** The [ROUTE:]OPEN? command returns the current software state of the channels specified. It does not account for relay hardware failures. A maximum of 127 channels at a time can be queried for a multi-module switchbox.

Example Query Channel Open State

This example opens channels 100 and 202 of a two-module switchbox (card numbers 01 and 02) and queries channel state. Since the channels are programmed to be open 1,1 is returned.

```
OPEN (@100,202)           100 opens channel 00 of card #1;
                          202 opens channel 02 of card #2.
OPEN? (@202)             Query channel 02 of card #2.
```

SCAN [ROUTE:]SCAN <channel_list> defines the channels to be scanned. The *channel_list* is in the form (@ccnn) where cc = card number (00-99) and nn = channel number (00-04).

Parameters

Parameter Name	Parameter Type	Range of Values	Default Value
<i>channel_list</i>	numeric	cc00 - cc04	N/A

- Comments**
- **Defining the Scan List:** When executing [ROUTE:]SCAN, the *channel list* is checked for valid card and channel numbers. An error is generated for an invalid *channel list*.
 - **Scanning Channels:** To scan:
 - a single channel, use [ROUTE:]SCAN (@ccnn);
 - for multiple channels, use [ROUTE:]SCAN (@ccnn,ccnn,...);
 - sequential channels, use [ROUTE:]SCAN (@ccnn:ccnn);
 - a group of sequential channels, use [ROUTE:]SCAN (@ccnn:ccnn,ccnn:ccnn);
 - or any combination.
 - **Scanning Operation:** With a valid *channel list*, INITiate[:IMMEDIATE] starts the scanning cycle and closes the first channel in the *channel list*. Successive triggers from the source specified by TRIGger:SOURce advances the scan through the *channel list*.
 - **Stopping Scan:** See the ABORt command.
 - **Related Commands:** TRIGger, TRIGger:SOURce
 - ***RST Condition:** All channels open.

Example Scanning Using External Device

See the section in Chapter 3 titled “Scanning Channels” for examples of scanning programs using external instruments.

SCAN:MODE [ROUTE:]SCAN:MODE *<mode>* is accepted by the Microwave Switch. NONE, VOLT, and RES set the *mode* for "no measurements" while FRES is not supported and will generate an error. This command has no effect on Microwave Switch operation.

SCAN:MODE? [ROUTE:]SCAN:MODE? returns the current scanning mode of the Microwave Switch. NONE, VOLT, or RES are placed in the output buffer as a result.

STATus

The STATus subsystem reports the bit values of the Operation Status Register. Only bit 8 in the Standard Operation Status Register is used to notify that a scan is complete.

Subsystem Syntax

```

STATus
:OPERation
:ENABle <number>
:ENABle?
[:EVENT]?
    
```

The STATus system contains four registers, two of which are under IEEE 488.2 control. These are the Standard Event Status Register (*ESE) and the Status Byte Register (*STB?). Refer to the appropriate mainframe or command module operating manual for more information on these registers.

The two registers under Microwave Switch control are the Standard Operation Status Register, and the Questionable Data/Signal Register. The Questionable Data/Signal Register is not used in the Microwave Switch and will not be discussed. The Standard Operation Status Register is discussed below. The figure shown below illustrates the Status System Registers.

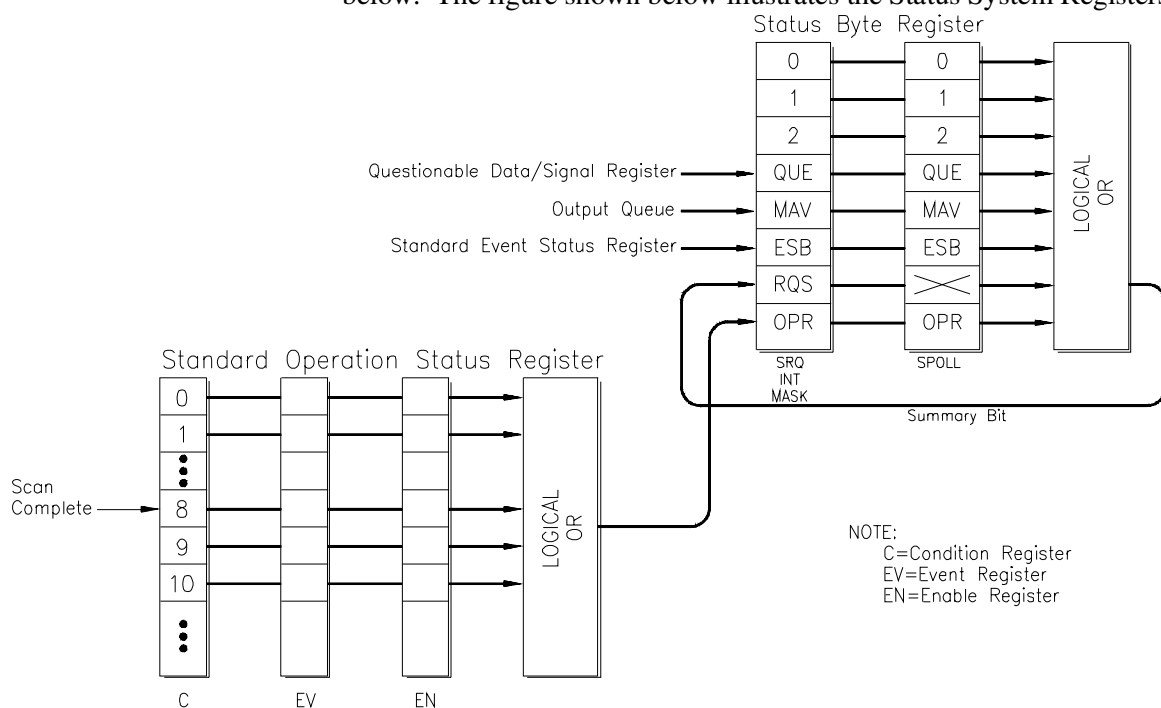

The various registers are set and queried using decimal weighted bit values. The decimal equivalent for bits 0 to 15 is shown below.

Bit Number to Decimal Value

Bit Number	0	1	2	3	4	5	6	7	8	9	10	11	12	13	14	15
Decimal Value	1	2	4	8	16	32	64	128	256	512	1024	2048	4096	8192	16384	32768

For example, sending a decimal value of 4608 will set bits 9 and 12 true (1).

:OPERation:ENABLE

STATus:OPERation:ENABLE <number> enables the Standard Operation Status Register to set a bit in the Status Byte Register. For the Microwave Switch, when bit 8 in the Standard Operation Status Register is set to 1, bit 7 in the Status Byte Register is set to 1.

Parameters

Parameter Name	Parameter Type	Range of Values	Default Value
<i>number</i>	numeric	0 - 32767	0

Comments

- **Summary Bit:** If bit 8 is 1 in the Standard Operation Status Enable Register, a transition of Event Register bit 8 to 1 will cause the associated summary bit to be true.
- **Maximum Value Entered:** The maximum decimal weighted value used in the Microwave Switch module is 256 (bit 8 set true).
- **Setting Bit 7 of the Status Byte Register:** STATus:OPERation:ENABLE 256 sets bit 7 of the Status Byte Register to 1 after bit 8 of the Standard Operation Status Enable Register is set to 1.
- **Related Commands:** [ROUTe:]SCAN

Example

Enable the Status Byte Register Bit 7

STAT:OPER:ENAB 256

Enables bit 7 of the Standard Operation Status Enable Register, which enables bit 7 of Status Byte Register.

:OPERation:ENABLE?

STATus:OPERation:ENABLE? returns the bit value of the Standard Operation Status Enable Register.

Comments

- **Output Format:** Returns a decimal weighted value from 0 to 65535 indicating which bits are set true.
- **Maximum Value Returned:** The maximum decimal weighted value used in the Microwave Switch module is 256 (bit 8 set true).

Example

Query the Standard Operation Status Enable Register

STAT:OPER:ENAB?

Queries the Standard Operation Status Enable Register.

:OPERation[:EVENT]? **STATus:OPERation[:EVENT]?** queries the status of the Standard Operation Status Event Register.

- Comments**
- **Output Format:** Returns a decimal weighted value from 0 to 256 indicating which bits are set true.
 - **Related Commands:** [ROUTe:]SCAN

Example **Reading the Operation Status Event Register after a Scanning Cycle**

STAT:OPER?

Returns the bit values of the Standard Operation Status Event Register. Returns +256 if bit 8 is set to 1; +0 if bit 8 is set to 0.

SYSTEM

The SYSTem subsystem returns error numbers/messages in the error queue of a switchbox, and returns the types and descriptions of modules (cards) in a switchbox.

Subsystem Syntax

SYSTem
:CDEscription? <number>
:CPON <number | ALL>
:CTYPe? <number>
:ERRor?

:CDEscription?

SYSTem:CDEscription? <number> returns the description of a selected module (card) in a switchbox.

Parameters

Parameter Name	Parameter Type	Range of Values	Default Value
<i>number</i>	numeric	01 - 99	N/A

Comments

- **Microwave Switch Switch Module Description:** The SYSTem:CDEscription? <number> command returns:

18 GHz Microwave Switch/Switch Driver

for both the Agilent E1368A Microwave Switch and the Agilent E1369A Microwave Switch Driver.

Example

Reading the Description of a Card #1 Module

SYST:CDES? 1 *Returns the description.*

:CPON

SYSTem:CPON <number | ALL> sets the selected module (card) in a switchbox to its power-on state.

Parameters

Parameter Name	Parameter Type	Range of Values	Default Value
<i>number</i>	numeric	01 - 99 ALL	ALL

Comments

- **Microwave Switch Switch Module Power-On State:** The power-on state is all channels (relays) open. Note that SYSTem:CPON ALL and *RST opens all channels of all modules in a switchbox, while SYSTem:CPON <number> opens the channels in only the module (card) specified in the command.

Example

Setting Card #1 Module to its Power-On State

SYST:CPON 1 *Sets card #1 to power-on state.*

:CTYPE? **SYSTem:CTYPE? <number>** returns the module (card) type of a selected module in a switchbox.

Parameters

Parameter Name	Parameter Type	Range of Values	Default Value
<i>number</i>	numeric	01 - 99	N/A

Comments **Microwave Switch Module Model Number:**
The SYSTem:CTYPE? <number> command returns (for both modules):

HEWLETT-PACKARD, E1368A, 0, A.01.00

Note: The 0 after the module number is the serial number of the module (always 0). A.01.00 is an example of the module revision code number.

Example **Reading the Model Number of a Card #1 Module**

SYST:CTYP? 1 *Returns the model number.*

:ERRor? **SYSTem:ERRor?** returns the error numbers and corresponding error messages in the error queue of a switchbox. See Appendix C for a listing of the switchbox error numbers and messages.

Comments

- **Error Numbers/Messages in the Error Queue:** Errors generated by a switchbox store an error number and corresponding error message in the error queue. Each error message can be up to 255 characters long.
- **Clearing the Error Queue:** An error number/message is removed from the queue each time the SYSTem:ERRor? command is sent. The errors are cleared first-in, first-out. When the queue is empty, each following SYSTem:ERRor? command returns 0, "No error". To clear all error numbers/messages in the queue, execute the *CLS command.
- **Maximum Error Numbers/Messages in the Error Queue:** The queue holds a maximum of 30 error numbers/messages for each switchbox. If the queue overflows, the last error number/message in the queue is replaced by -350, "Too many errors". The oldest error numbers/messages remain in the queue and the most recent are lost.
- ***RST Condition:** *RST does not clear the error queue.

Example **Reading the Error Queue**

SYST:ERR? *Query the error queue, read and print the numbers/message.*

TRIGger

The TRIGger subsystem controls the triggering operation of the Microwave Switch modules in a switchbox.

Subsystem Syntax

TRIGger
[:IMMediate]
:SOURce BUS | EXTernal | HOLD | IMMEDIATE
:SOURce?

[:IMMediate] TRIGger[:IMMediate] causes a trigger to occur when the defined trigger source is TRIGger:SOURce HOLD or TRIGger:SOURce BUS.

Comments

- **Executing the TRIGger[:IMMediate] Command:** A channel list must be defined with [ROUTE:]SCAN <channel_list> and an INITiate[:IMMediate] command must be executed before TRIGger[:IMMediate] can trigger the switchbox.
- **HOLD or BUS Source Remains:** If selected, the TRIGger:SOURce HOLD or TRIGger:SOURce BUS commands remain in effect after triggering the switchbox with the TRIGger[:IMMediate] command.
- **Related Commands:** INITiate, [ROUTE:]SCAN

Example Advancing Scan Using the TRIGger Command

This example uses the TRIGger command to advance the scan of a single-module switchbox from channel 00 through 02. Since TRIGger:SOURce HOLD is set, the scan is advanced one channel each time TRIGger is executed.

TRIG:SOUR HOLD	<i>Sets trigger source to HOLD.</i>
SCAN (@100:202)	<i>Defines channel list.</i>
INIT	<i>Begin scan, close channel 00.</i>
loop statement	<i>Start count loop.</i>
TRIG	<i>Advance scan to next channel.</i>
increment loop	<i>Increment loop count.</i>

:SOURce TRIGger:SOURce BUS | EXTernal | HOLD | IMMEDIATE specifies the trigger source to advance the channel list during scanning.

Parameters

Parameter Name	Parameter Type	Range of Values
BUS	discrete	*TRG command
EXTernal	discrete	Event In BNC port
HOLD	discrete	Hold triggering
IMMediate	discrete	Continuous triggering

Comments

- **Enabling the Trigger Source:** The TRIGger:SOURce command only selects the trigger source. The INITiate[:IMMediate] command enables the trigger source.
- **Using the TRIG Command:** You can use TRIGger[:IMMediate] to advance the scan when TRIGger:SOURce BUS or TRIGger:SOURce HOLD is selected.
- **Using External Trigger Inputs:** With TRIGger:SOURce EXTERNAL selected, only one switchbox at a time can use the external trigger input at the Agilent E1300/E1301 Mainframe's "Event In" port. The trigger input is assigned to the first switchbox requesting the external trigger source (with a TRIGger:SOURce EXTERNAL command).
- **Assigning External Trigger:** A switchbox assigned with TRIG:SOUR EXT remains assigned to that source until it receives a command to change the source to BUS, HOLD, or IMMEDIATE. When the source is changed, the external trigger source is available to the next switchbox which requests it (with a TRIGger:SOURce EXTERNAL command). If a switchbox requests an external trigger input already assigned to another switchbox, an error is generated.
- **Using Bus Triggers:** To trigger the switchbox with TRIGger:SOURce BUS selected, use the IEEE 488.2 common command *TRG or the GPIB Group Execute Trigger (GET).
- **"Trig Out" Port Shared by Switchboxes:** See the OUTPUT command.
- **Related Commands:** [ROUTE:]SCAN, TRIGger, ABORT
- ***RST Condition:** TRIGger:SOURce IMMEDIATE

Example Scanning Using External Triggers

This example uses external triggering (TRIG:SOUR EXT) to scan channels 00 through 02 of a single-module switchbox. The trigger source to advance the scan is the input to the "Event In" port on an Agilent E1300B/E1301B mainframe. When INIT is executed, the scan is started and channel 00 is closed. Then each trigger received at the "Event In" port advances the scan to the next channel.

TRIG:SOUR EXT	<i>Sets trigger source to external.</i>
SCAN (@100:102)	<i>Scan channels 00 through 02.</i>
INIT	<i>Begin scan, close channel 00.</i>
trigger externally	<i>Advance scan to next channel.</i>

Scanning Using Bus Triggers

This example uses bus triggering (TRIG:SOUR BUS) to scan channels 00 through 02 of a single-module switchbox. The trigger source to advance the scan is the *TRG command (as set with TRIGger:SOURce BUS). When INIT is executed, the scan is started and channel 00 is closed. Then, each *TRG command advances the scan to the next channel.

TRIG:SOUR BUS	<i>Select interface (BUS) triggering.</i>
SCAN (@100:102)	<i>Scan channels 00 through 02.</i>
INIT	<i>Start scan, close channel 00.</i>
*TRG	<i>Advances scan using BUS triggering.</i>
increment loop	<i>Increment loop count.</i>

:SOURce? **TRIGger:SOURce?** returns the current trigger source for the switchbox. Command returns either BUS, EXT, HOLD, or IMM for trigger sources BUS, EXTERNAL, HOLD, or IMMEDIATE, respectively.

Example Query the Trigger Source

TRIG:SOUR EXT	<i>Sets trigger source to external.</i>
TRIG:SOUR?	<i>Query trigger source.</i>

IEEE 488.2 Common Commands

The following table lists the IEEE 488.2 Common (*) Commands that can be executed by the Microwave Switch modules. The operation of some of these commands is described in Chapter 3 of this manual. For more information on Common Commands, refer to the *Agilent 75000 Series B Mainframe User's Manual* (Agilent Model Number E1300/E1301), appropriate *Agilent Command Module User's Manual*, or the ANSI/IEEE Standard 488.2-1987.

Command	Title	Description
*IDN?	Identification query	Returns identification string of the switchbox.
*RST	Reset	Opens all channels, and invalidates current <i>channel list</i> for scanning. Sets ARM:COUN 1, TRIG:SOUR IMM, and INIT:CONT OFF.
*TST?	Self-Test	Always returns 0.
*OPC	Operation Complete	Sets the request for OPC flag when all pending operations have completed. Also sets OPC bit in the Standard Event Register.
*OPC?	Operation Complete Query	Returns a 1 to the output queue when all pending operations have completed. Used to synchronize between multiple instruments.
*WAI	Wait to Complete	Halts execution of commands and queries until the "No Operation Pending" message is true.
*CLS	Clear status	Clears all Event Registers, the Request for OPC flag, and all queues (except output queue).
*ESE<mask>	Event status enable	Used to set the bits in the Event Status Enable Register.
*ESE?	Event status enable query	Queries the current contents in the Event Status Enable Register.
*ESR?	Event status register query	Queries and clears the contents in the Standard Event Status Register.
*SRE<mask>	Service request enable	Used to set the Service Request Enable Register bits, and corresponding Serial Poll Status Byte Register bits, to generate a service request.
*SRE?	Service request enable query	Queries the current contents in the Service Request Enable Register.
*STB?	Read status byte query	Queries the current contents in the Status Byte Register.
*TRG	Trigger	Triggers the switchbox to advance the scan when scan is enabled and trigger source is TRIGger:SOURce BUS.
*RCL<n>	Recall saved state	Recalls previously stored Microwave Switch module configuration. <n> (0 to 9) is the location in memory where the desired (previously stored) set-up is located.
*SAV<n>	Save state	Stores present settings of ARM:COUNT, TRIGger:SOURce, OUTPut[:STATe], INITiate:CONTInuous, SCAN:MODE, and SCAN:PORT. <n> (0 to 9) is the location in memory where the current set-up is located.
<p>Note: See the <i>Agilent 75000 Series B E1300/E1301 Mainframe User's Manual</i> or the ANSI/IEEE Standard 488.2-1987 for more information about these commands.</p>		

Command Quick Reference

The following tables summarize SCPI and IEEE 488.2 Common (*) Commands for the Microwave Switch modules.

SCPI Commands for Quick Reference

Command	Description
ABORt	Abort a scan in progress.
ARM :COUNt <number> MIN MAX :COUNt? [MIN MAX]	Multiple scans per INIT command. Query number of scans.
DISPlay:MONitor:CARD <number> AUTO :MONitor[:STATe] <mode> :MONitor[:STATe]?	Selects module to be monitored. Selects monitor mode. Query the monitor mode state.
INITiate :CONTinuous <mode> :CONTinuous? [:IMMediate]	Enables/disables continuous scanning. Query continuous scan state. Starts a scanning cycle.
OUTPut [:STATe] <mode> [:STATe]?	Enables/disables "Trig Out" pulse. Query port enable state.
[ROUte:] CLOSE <channel_list> CLOSE? <channel_list> OPEN <channel_list> OPEN? <channel_list> SCAN <channel_list> SCAN:MODE NONE VOLT RES SCAN:MODE?	Close channel(s). Query channel(s) closed. Open channel(s). Query channel(s) opened. Define channels for scanning. Selects scan mode. Query state of scan mode.
STATus:OPERation:ENABLE :OPERation:ENABLE :OPERation[:EVENT]?	Enables the Operation Status Register to set a bit in the Status Register. Query the contents in the Operation Status Register. Returns status of the Operation Status Register.
SYSTem :CDEscription? <number> :CPON <number> ALL :CTYPe? <number> :ERRor?	Returns description of module in a switchbox. Sets specified module to its power-on state. Returns the module type. Returns error number/message in a switchbox Error Queue.
TRIGger [:IMMediate] :SOURce BUS :SOURce EXternal :SOURce HOLD :SOURce IMMediate :SOURce?	Causes a trigger to occur. Trigger source is *TRG. Trigger source is "Event In" BNC. Hold off triggering. Continuous (internal) triggers. Query scan trigger source.

IEEE 488.2 Common Commands Quick Reference

Command	Title	Description
*RST	Reset	Opens all channels, and invalidates current <i>channel list</i> for scanning. Sets ARM:COUN 1, TRIG:SOUR IMM, and INIT:CONT OFF.
*TRG	Bus Trigger	When scan is enabled and trigger source is TRIG:SOUR BUS, use the *TRG command to trigger the switchbox to advance the scan.
*TST?	Self Test query	Always returns 0.

Appendix A

Agilent E1368A/69A/70A Specifications

E1368A Microwave Switch

Frequency Range:

DC-18 GHz

Characteristic Impedance:

50Ω

Insertion Loss:

DC-2GHz: <0.25dB

DC-18GHz: <0.50dB

Isolation:

DC-18GHz: >90dB

VSWR (50Ω load):

DC-2GHz: <1.15dB

DC-12.4GHz: <1.25dB

DC-18GHz: <1.40dB

Maximum Input Power:

1 Watt average.

100 Watts peak.

<±7Vdc

Repeatability (typical):

0.03dB after 10⁶ switching

E1369A Microwave Switch Driver

Switching Dwell Time:

35msec

Driver OutPut per switch:

5V or 12V (see note 1)

Maximum Energizing Voltage:

42Vpk (see note 1)

STANDARD VXIbus

INFORMATION

(Applies to both the E1368A and E1369A unless otherwise noted)

Module Size/Device Type:

B, register-based

Connectors Used: P1

No. Slots:

E1368, E1369 1

E1370 2

VXIbus interface capability:

Slave, Interrupter, A16, D16

Interrupt level:

1-7, selectable

POWER REQUIREMENTS:

E1368A

Voltage: +5

Peak module current,

IPM(A): 1.30

Dynamic module current,

IDM(A): 0.01

Watts/slot: 5.00

Cooling/slot:

0.08mm H₂O @ 0.42 liter/sec

E1369A

Voltage: +5

Peak module current,

IPM(A): 0.01

Dynamic module current,

IDM(A): (see note 2)

Watts/slot: 0.50

Cooling/slot:

0.08mm H₂O @ 0.05 liter/sec

(see note 2)

E1370A

Voltage: +5

Peak module current,

IPM(A): 0.01

Dynamic module current,

IDM(A): (see note 2)

Watts/slot: 0.50

Cooling/slot:0.08mm H₂O

@0.05 liter/sec

(see note 2)

MISCELLANEOUS:

Humidity:

65%, 0° to 40° C

Operating Temperature:

0° to +55° C

Storage Temperature:

-40° to +75° C

EMC, RFI, Safety:

meets FTZ 1046/1984, CSA 556B,

IEC 348, UL 1244

Net weight (kg):

Agilent E1368A: 0.5

Agilent E1369A: 0.2

Agilent E1370A: ??

NOTES:

- Control circuit can switch a maximum of 1A per switch. Maximum current also depends on the output capability of the mainframe used.
- Power and cooling requirements depend on switches installed; see E1368A for an example of the requirements for three 3331X or 876X switches.

Appendix B

Agilent E1368A/69A/70A Registers

Register Definitions

All three Microwave Switch modules are register-based devices. See the tables below for register definitions.

Manufacturer ID Register

$b + 00_{16}$	15	14	13	12	11	10	9	8	7	6	5	4	3	2	1	0
Write	Undefined															
Read**	Manufacturer ID															

*Returns $FFFF_{16}$ = Agilent Technologies A16 only register-based.

Device Type Register

$b + 02_{16}$	15	14	13	12	11	10	9	8	7	6	5	4	3	2	1	0
Write	Undefined															
Read**	Manufacturer ID															

Status/Control Register

$b + 04_{16}$	15	14	13	12	11	10	9	8	7	6	5	4	3	2	1	0
Write*	Undefined															
Read**	Manufacturer ID								B	$7F_{16}$						

*R = Switch reset to power-on state (all switches open)

**R = Status “busy” is true low in bit #7 ($FF7F_{16}$)

Channel Enable Registers

$b + 08_{16}$	15	14	13	12	11	10	9	8	7	6	5	4	3	2	1	0
Write*												CH04	CH03	CH02	CH01	CH00
Read*	Always Returns $FFFF_{16}$															

Addressing the Registers

To read or write to specific registers, you must use the register address. Register addresses for Agilent 75000 Series C plug-in modules are in address space VXI A16. The location of A16 within the mainframe/command module memory map depends on the mainframe/command module used. For example, the A16 location of the Agilent E1300/E1301 Mainframe starts at 1F0000₁₆ (16 = HEX).

The A16 space is divided so modules are addressed only at locations beginning with C000₁₆ within A16. Allocated for each module are 64 register addresses (40₁₆). The module base address is related to the logical address set by the module's logical address switch (LADDR). The module address is:

$$\text{module address}_{16} = (\text{logical address}_{16}) * 40_{16} + \text{C000}_{16}$$

For the Microwave Switch modules, the default logical address is 120 (78₁₆), thus the module address within A16=

$$78_{16} * 40_{16} + \text{C000}_{16} = \text{DE00}_{16}$$

For example, to address the Status/Control Register of a Microwave Switch module in an Agilent E1300/E1301 Mainframe, the command register address is:

$$[\text{A16 location}]_{16} + [\text{module address}]_{16} + [\text{register offset}]_{16} = \\ 1\text{f000}_{16} + \text{DE00}_{16} + 04_{16} = 1\text{FDE04}_{16}$$

Reading the Registers

You can read the following Microwave Switch registers:

- Manufacturer ID Register (base + 00₁₆)
- Device Type Register (base + 02₁₆)
- Status/Control Register (base + 08₁₆)
- Channel Enable Register (base + 08₁₆)

ID and Device Type Registers

ID Register: Reading the register returns: FFFF₁₆. This shows Hewlett-Packard as the manufacturer and that the module is an A16 register-based device.

Device Type Register: Reading this register returns FF28₁₆ if the device is either the E1368A Microwave Switch module, or the E1369A Microwave Switch Driver module.

Status/Control Register

Each coaxial switch requires about 30 msec execution time (close to open or open to close) during which time the switch is "busy". A read of the Status/Control Register (base + 04₁₆) returns FFFF₁₆ when the module is not busy or returns FF7F₁₆ (bit 7 is low-true) when the module is busy.

Channel Enable Register

A read of the Channel Register (base + 08₁₆) always returns FFFF₁₆, regardless of the channel states.

Writing to the Registers

You can write the following Microwave Switch registers:

Channel Enable Register (base + 08₁₆)

Channel Enable Register

Writes to the Channel Enable Register (base + 08₁₆) enable you to open or close the desired channel. For example, write a "1" to bit 2 of the Channel Enable Register to close channel 02. Or, write a "0" to bit of the register to open channel 00.

Note

All Agilent 3331X and Agilent 876X Microwave Switches are latching and will remain in the last state during power down. Performing a reset (or at power-up) opens all channels (refer to Figure 2-6). Any combination of channel open or closed states is allowed.

Appendix C

Agilent E1368A/69A/70A Error Messages

Table C-1 lists the error messages associated with the Microwave Switch module programmed by SCPI. See the appropriate mainframe manual for a complete list of error messages.

Table C-1. Microwave Switch Error Messages

No.	Title	Potential Cause(s)
-211	Trigger ignored	Trigger received when scan not enabled. Trigger received after scan complete. Trigger too fast.
-213	INIT ignored	Attempted to execute an INIT command when a scan is already in progress.
-224	Illegal parameter value	Attempting to execute a command with a parameter not applicable to the command.
1500	External trigger source already allocated	Assigning an external trigger source to a switchbox when the trigger source has already been assigned to another switchbox.
2000	Invalid card number	Addressing a module (card) in a switchbox that is not part of the switchbox.
2001	Invalid channel number	Attempting to address a channel of module in a switchbox that is not supported by the module (e.g., channel 99 of a multiplexer module).
2006	Command not supported on this card	Sending a command to a module (card) in a switchbox that is unsupported by the module.
2008	Scan list not initialized	Executing a scan without the INIT command.
2009	Too many channels in channel list	Attempting to address more channels than available in the switchbox.
2010	Scan mode not supported on this card	Sending a command to a module (card) in a switchbox that is unsupported by the module
2012	Invalid Channel Range	Invalid channel(s) specified in SCAN <channel_list> command. Attempting to begin scanning when no valid channel list is defined.
2600	Function not supported on this card	Sending a command to a module (card) in a switchbox that is not supported by the module or switchbox.
2601	Channel list required	Sending a command requiring a channel list without the channel list.

- *CLS, 29, 70
- *ESE, 29, 70
- *ESE?, 70
- *ESR?, 70
- *IDN, 70
- *OPC, 70
- *OPC?, 70
- *RCL, 43, 70
- *RST, 29 - 30, 70 - 71
- *SAV, 43, 70
- *SRE, 29, 70
- *SRE?, 70
- *STB?, 41, 70
- *TRG, 70 - 71
- *TST?, 70 - 71
- *WAI, 70

A

- Abbreviated Commands, 48
- ABORT Subsystem, 50, 71
- Address
 - channels, 14 - 15, 31
 - logical, 15, 18
 - primary GPIB, 40 - 41
 - register, 76
 - secondary GPIB, 14, 40 - 41
 - switch, setting, 18
- ARM Subsystem, 51 - 52, 71
- ARM:COUNT, 30, 51, 71
- ARM:COUNT?, 46, 52, 71
- Attenuators
 - installing on E1370A, 26 - 27
 - internal schematic, 28
 - listing of, 26

B

- Block Diagram, 12
- Boolean Command Parameters, 49
- Bus Triggers, 69

C

- Cabling, 25
- Card Numbers, 14 - 15, 31
- Cautions, 17
- CDEescription?, (SYSTem:CDEescription?), 46, 65, 71
- Certification, 5
- Channel
 - address, 14 - 15, 31
 - closing, 31, 58
 - enable register, 75 - 77
 - lists, 15, 58 - 60
 - number, 14 - 15, 31, 34
 - opening, 31, 59
 - query open/closed, 59 - 60
 - scanning, 39 - 40, 60
 - states, 43
 - switching, 31 - 33, 35
 - switching multiple, 33, 35
 - switching with E1369A, 35
 - switching with E1370A, 33
- CLOSE, ([ROUTE:]CLOSE), 14, 29, 58, 71
- CLOSE?, ([ROUTE:]CLOSE?), 29, 46, 59, 71
- Closing Channels, 31, 58
- *CLS, 29, 70
- Coaxial Switches
 - coil voltage allowed, 13
 - connecting externally, 23
 - description, 13
 - electrical characteristics, 11
 - execution time, 77
 - installing, 20 - 22
 - listing, 20
 - split coil, 20
- Coil Voltage Allowed, 13
- Command Reference, 47 - 69
- Commands
 - abbreviated, 48
 - IEEE 488.2, 47, 70
 - implied, 16, 48
 - linking, 49
 - optional, 16, 48
 - optional parameters, 49

C (continued)

Commands (*continued*)
 parameters, 49
 query, 46
 Quick Reference, 71
 SCPI, 47
 SCPI format, 16, 47
 separator, 48
 types, 47
Common (*) Commands, 47
 *CLS, 29, 70
 *ESE, 29, 70
 *ESE?, 70
 *ESR?, 70
 *IDN?, 70
 *OPC, 70
 *OPC?, 70
 *RCL, 43, 70
 *RST, 29 - 30, 70 - 71
 *SAV, 43, 70
 *SRE, 29, 70
 *SRE?, 70
 *STB?, 41, 70
 *TRG, 70 - 71
 *TST?, 70 - 71
 *WAI, 70
 format, 47
 list of, 70
 Quick Reference, 71
Conformity, declaration, 7
Connecting
 field wiring, 25, 28
 ribbon cable to devices, 35
 switches external to module, 23
 switches to connector, 23
 to different ports, 14, 33
Continuous Scanning, 42, 55
 query, 56
 stopping, 50
CONTInuous, (INITiate:CONTInuous), 30, 55, 71
CONTInuous?, (INITiate:CONTInuous?), 46, 56, 71
Control Register, 77
COUNT, (ARM:COUNT), 30, 51, 71
COUNT?, (ARM:COUNT?), 46, 52, 71
CPON, (SYSTem:CPON), 65, 71
CTYPe?, (SYSTem:CTYPe?), 46, 66, 71
Current, maximum allowed, 13, 17, 20, 23 - 24, 73

D

Decimal Weighted Bit Values, 62
Declaration of conformity, 7
Detecting Error Conditions, 43 - 44
Device Type Register, 75
Discrete Command Parameters, 49
DISPlay Subsystem, 53 - 54, 71
DISPlay:MONitor:CARD, 53, 71
DISPlay:MONitor[:STATe], 54, 71
DISPlay:MONitor[:STATe]?, 54, 71
Documentation history, 6

E

E1368A
 channel numbers, 15
 coaxial switches, 11
 description, 11
 module panel, 11
 power requirements, 73
 routing a signal, 36, 38
 single channel switching, 31
 switches, 13
E1369A
 channel numbers, 15
 channel switching, 35
 coaxial switches, 11
 description, 11
 drive level voltage, 11
 installing switches, 20 - 22
 module panel, 11
 power requirements, 73
 routing a signal, 37
 single channel switching, 32
E1370A
 channel numbers, 15
 channel switching, 33
 description, 11
 field wiring, 28
 installing attenuators, 26 - 27
 installing switches, 26 - 27
 module panel, 11
 power requirements, 73
Error
 conditions, detecting, 43 - 44
 messages, 66, 79 - 80
 numbers, 66, 79 - 80
 queue, 45, 66
ERRor?, (SYSTem:ERRor?), 46, 66, 71
*ESE, 29, 70

E (continued)

*ESE?, 70

*ESR?, 70

Event In Port, 68

Examples

channel switching with E1369A, 35

channel switching with E1370A, 33

checking for errors, 43 - 44

multiple channel switching, 35

multiplexer (4x1), 38

resetting the switchbox, 16

scan complete bit, 41

scanning channels, 40

single channel switching, 31 - 32

synchronizing instruments, 45

transfer switch, 36 - 37

External

power supply, 13, 35

power terminals, 13, 32, 35

switches, 23 - 24

voltage, 13

F

Field Wiring, connecting, 25, 28

Fuse, 24

removing, 13

G

Getting Started, 11

GPIB

description of, 16

primary address, 40 - 41

secondary address, 14, 40 - 41

select code, 40 - 41

service request (SRQ), 41

I

*IDN, 70

[:IMMEDIATE], (INITiate[:IMMEDIATE]), 29, 56, 71

[:IMMEDIATE], (TRIGger[:IMMEDIATE]), 67, 71

Implied Commands, 16, 48

Initial Operation, 16

INITiate Subsystem, 55 - 56, 71

INITiate:CONTinuous, 30, 55, 71

INITiate:CONTinuous?, 46, 56, 71

INITiate[:IMMEDIATE], 29, 56, 71

Installing

attenuators on E1370A, 26 - 27

external switches, 23

jumpers, 24

switches on E1369A, 20 - 22

switches on E1370A, 26 - 27

Instrument Definition, 14

Internal

power, 13, 24

switch diagram, 25

switches, 20 - 22

voltage, 13

Interrupt

checking for errors, 43 - 44

jumpers, 19

priority, selecting, 19

J

Jumpers

installing, 24

interrupt priority, 19

removing, 24

L

Linking Commands, 49

Logical Address, 15, 18

changing, 18

factory setting, 18

switch, setting, 18, 76

switchbox, 15

M

Manufacturer ID Register, 75 - 76

Maximum

current, 13, 17, 20, 23 - 24, 73

input power, 73

voltage, 13, 17, 24, 73

wire size, 24

Module Description, 11

MONitor:CARD,

(DISPlay:MONitor:CARD), 53, 71

MONitor[:STATE],

(DISPlay:MONitor[:STATE]), 54, 71

MONitor[:STATE]?,

(DISPlay:MONitor[:STATE]?), 54, 71

Microwave Switches (33311B), 13

Multi-throw Switches, 11, 28

M (continued)

Multiple

- channel switching, 35
- continuous scans, 42
- module switchbox, 14 - 15, 42
- SCPI commands, linking, 49

Multiplexer, example, 38

N

Non-Agilent Switches, 20

Numeric Command Parameters, 49

O

*OPC, 70

*OPC?, 70

OPEN, ([ROUTE:]OPEN), 14, 29, 59, 71

OPEN?, ([ROUTE:]OPEN?), 46, 60, 71

Opening Channels, 31, 59

Operation Status Register, 41, 62 - 63

OPERation:ENABLE,

(STATus:OPERation:ENABLE), 41, 63, 71

OPERation:ENABLE?,

(STATus:OPERation:ENABLE?), 46, 63, 71

OPERation[:EVENT]?,

(STATus:OPERation[:EVENT]?), 41, 46, 64, 71

Optional Command Parameters, 49

Optional Commands, 16, 48

OUTPut Subsystem, 57, 71

OUTPut[:STATe], 29 - 30, 57, 71

OUTPut[:STATe]?, 46, 57, 71

P

Parameters, 49

Pin-out, ribbon cable, 33

Pivot Armature, 13

Polling for Errors, 43

Port

connecting to different, 14, 33

Event In, 68

ext trig in, 40

numbers, 34

trig out, 39, 57

Power Supply, 13, 24

Programming the Switches, 14

Q

Query

commands, 46

error queue, 66

monitor mode state, 54

number of scanning cycles, 52

open/closed channels, 59 - 60

scanning mode state, 61

scanning states, 56

the microwave switch, 46

trig out port, 57

trigger sources, 69

R

*RCL, 43, 70

Reading the Registers, 76

Recalling Switch States, 43

Registers, 75 - 78

addressing, 76

channel enable, 75 - 77

definitions, 75

device type, 75

manufacturer ID, 75 - 76

operation status, 41, 62 - 63

reading, 76

standard event status, 43

standard operation status, 62

status, 41, 63

status/control, 75, 77

writing to, 77

Removing Jumpers, 24

Reset

conditions, 30

default values, 30

switchbox, 16

Ribbon Cable

connecting to external device, 35

pin numbers, 33

[ROUTE:] Subsystem, 58 - 61, 71

[ROUTE:]CLOSE, 14, 29, 58, 71

[ROUTE:]CLOSE?, 29, 46, 59, 71

[ROUTE:]OPEN, 14, 29, 59, 71

[ROUTE:]OPEN?, 46, 60, 71

[ROUTE:]SCAN, 29, 60, 71

[ROUTE:]SCAN:MODE, 30, 61, 71

[ROUTE:]SCAN:MODE?, 46, 61, 71

[ROUTE:]SCAN:PORT, 30

Routing Signals, 36 - 38

*RST, 29 - 30, 70 - 71

S

Safety warnings, 6, 17

*SAV, 43, 70

Saving Switch States, 43

Scan Complete Bit, 41

SCAN, ([ROUTE:]:SCAN), 29, 60, 71

SCAN:MODE, ([ROUTE:]:SCAN:MODE), 30, 61, 71

SCAN:MODE?,

([ROUTE:]:SCAN:MODE?), 46, 61, 71

SCAN:PORT, ([ROUTE:]:SCAN:PORT), 30

Scanning

channels, 39 - 40, 60

channels, example, 40

continuous cycles, 55

cycle, 56

cycles, 51 - 52

cycles, continuous, 55

modes, 39

query state, 56

trigger sources, 39, 67 - 69

using bus triggers, 69

using external triggers, 68

with external instruments, 40

SCPI Commands, 47

abbreviated, 48

ABORT subsystem, 50, 71

ARM subsystem, 51 - 52, 71

DISPlay subsystem, 53 - 54, 71

format used, 16, 47

implied, 16, 48

INITiate subsystem, 55 - 56, 71

linking, 49

optional, 16, 48

optional parameters, 49

OUTPut subsystem, 57, 71

parameters, 49

query commands, 46

quick reference, 71

reference, 50, 71

[ROUTE:] subsystem, 58 - 61, 71

STATus subsystem, 62 - 64, 71

SYSTem subsystem, 65 - 66, 71

TRIGger subsystem, 67 - 69, 71

Selecting

channels, 14

interrupt priority, 19

switch power, 24

Service Request (SRQ), GPIB, 41

Setting

address switch, 18

multiple continuous scans, 42

Signals

routing, 36 - 38

unused, 38

Single Channel Switching, 31 - 32

Single-pole Switches, 11, 26

listing, 26

SOURce, (TRIGger:SOURce), 29, 67 - 68, 71

SOURce?, (TRIGger:SOURce?), 46, 69, 71

Specifications, 73 - 74

*SRE, 29, 70

*SRE?, 70

Standard Event Status Register, 43

Standard Operation Status Register, 62

[:STATE], (OUTPut[:STATE]), 29 - 30, 57, 71

[:STATE]?, (OUTPut[:STATE]?), 46, 57, 71

Static Electricity, 17

Status Register, 41, 63

STATus Subsystem, 62 - 64, 71

Status/Control Register, 75, 77

STATus:OPERation:ENABLE, 41, 63, 71

STATus:OPERation:ENABLE?, 46, 63, 71

STATus:OPERation[:EVENT]?, 41, 46, 64, 71

*STB?, 41, 70

Storing States, 43

Switchbox

card numbers, 14 - 15

channel list, 42

continuous scanning, 55 - 56

logical address, 15, 18

module identification, 14 - 15

multiple module, 14 - 15, 42

resetting, 16

scan complete bit, 41

single module, 14

Switches

Agilent 33311B Microwave, 13

coaxial, 13, 20 - 23

connecting externally, 23

E1368A, 13

external coaxial, 23

installing on E1369A, 20 - 22

installing on E1370A, 26 - 27

internal diagram, 25

logical address, 18

multi-throw, 11, 28

non-Agilent, 20

power supply, 24

programming, 14

recalling states, 43

saving states, 43

single-pole, 11, 26

split coil coaxial, 20

synchronizing, 45

S *(continued)*

Switches *(continued)*
transfer, 36 - 37

Switching
channels, 31, 33, 35
channels with E1369A, 35
channels with E1370A, 33
multiple channels, 33, 35
single channels, 31 - 32

Synchronizing
instruments, 45
switches, 45

SYSTem Subsystem, 65 - 66, 71
SYSTem:CDEscription?, 46, 65, 71
SYSTem:CPON, 65, 71
SYSTem:CTYPe?, 46, 66, 71
SYSTem:ERRor?, 46, 66, 71

T

Transfer Switch
example, 36 - 37
one channel, 37
two channel, 36

*TRG, 70 - 71

Trig In Port, 40

Trig Out Port, 39, 57

Trigger Sources, scanning, 67 - 69

TRIGger Subsystem, 67 - 69, 71

TRIGger:SOURce, 29, 67 - 68, 71

TRIGger:SOURce?, 46, 69, 71

TRIGger[:IMMEDIATE], 67, 71

*TST?, 70 - 71

U

Using the Modules, 29 - 46

V

Voltage
drive level, 11, 13
external, 13
internal, 13
maximum allowed, 13, 17, 24, 73
operating, 24

W

*WAI, 70

WARNINGS, 6, 17

Warranty, 5

Wire Size, 24

Wiring, 25, 28

Writing to the Registers, 77