

USER'S GUIDE
Agilent Technologies
Series 661xxA
MPS POWER MODULES
& Model 66001A MPS KEYBOARD



Agilent Technologies

Agilent Part No. 5959-3386
Microfiche Part No. 5959-3387

Printed in Malaysia
September 2004

CERTIFICATION

Agilent Technologies certifies that this product met its published specifications at time of shipment from the factory. Agilent Technologies further certifies that its calibration measurements are traceable to the United States National Bureau of Standards, to the extent allowed by the Bureau's calibration facility, and to the calibration facilities of other International Standards Organization members.

WARRANTY

This Agilent Technologies hardware product is warranted against defects in material and workmanship for a period of one year from date of delivery. Agilent Technologies software and firmware products, which are designated by Agilent Technologies for use with a hardware product and when properly installed on that hardware product, are warranted not to fail to execute their programming instructions due to defects in material and workmanship for a period of 90 days from date of delivery. During the warranty period Agilent Technologies, Inc will, at its option, either repair or replace products which prove to be defective. Agilent Technologies does not warrant that the operation of the software, firmware, or hardware shall be uninterrupted or error free.

For warranty service, with the exception of warranty options, this product must be returned to a service facility designated by Agilent Technologies. Customer shall prepay shipping charges by (and shall pay all duty and taxes) for products returned to Agilent Technologies for warranty service. Except for products returned to Customer from another country, Agilent Technologies shall pay for return of products to Customer.

Warranty services outside the country of initial purchase are included in Agilent Technologies product price, only if Customer pays Agilent Technologies international prices (defined as destination local currency price, or U.S. or Geneva Export price).

If Agilent Technologies is unable, within a reasonable time to repair or replace any product to condition as warranted, the Customer shall be entitled to a refund of the purchase price upon return of the product to Agilent Technologies.

LIMITATION OF WARRANTY

The foregoing warranty shall not apply to defects resulting from improper or inadequate maintenance by the Customer, Customer-supplied software or interfacing, unauthorized modification or misuse, operation outside of the environmental specifications for the product, or improper site preparation and maintenance. **NO OTHER WARRANTY IS EXPRESSED OR IMPLIED. AGILENT TECHNOLOGIES SPECIFICALLY DISCLAIMS THE IMPLIED WARRANTIES OF MERCHANTABILITY AND FITNESS FOR A PARTICULAR PURPOSE.**

EXCLUSIVE REMEDIES

THE REMEDIES PROVIDED HEREIN ARE THE CUSTOMER'S SOLE AND EXCLUSIVE REMEDIES. AGILENT TECHNOLOGIES SHALL NOT BE LIABLE FOR ANY DIRECT, INDIRECT, SPECIAL, INCIDENTAL, OR CONSEQUENTIAL DAMAGES, WHETHER BASED ON CONTRACT, TORT, OR ANY OTHER LEGAL THEORY.

ASSISTANCE

The above statements apply only to the standard product warranty. Warranty options, extended support contracts, product maintenance agreements and customer assistance agreements are also available. Contact your nearest Agilent Technologies Sales and Service office for further information on Agilent Technologies' full line of Support Programs.

SAFETY SUMMARY

The following general safety precautions must be observed during all phases of operation of this power module. Failure to comply with these precautions or with specific warnings elsewhere in this guide violates safety standards of design, manufacture, and intended use of the power module. Agilent Technologies assumes no liability for the customer's failure to comply with these requirements.

GENERAL

When installed in a properly wired mainframe, this product is a Safety Class 1 instrument (provided with a protective earth terminal). Any LEDs used in this product are Class 1 LEDs as per IEC 825-1.

This ISM device complies with Canadian ICES-001. Cet appareil ISM est conforme à la norme NMB-001 du Canada.

ENVIRONMENTAL CONDITIONS

With the exceptions noted, all instruments are intended for indoor use in an installation category II, pollution degree 2 environment. They are designed to operate at a maximum relative humidity of 95% and at altitudes of up to 2000 meters. Refer to the specifications tables for the ac mains voltage requirements and ambient operating temperature range.

BEFORE APPLYING POWER.

Verify that the power module line voltage switch is set to match the available line voltage.

GROUND THE INSTRUMENT.

To minimize shock hazard, the mainframe must be connected to an electrical ground. The mainframe must be connected to the ac power supply mains through a three-conductor power cable, with the third wire firmly connected to an electrical ground (safety ground) at the power outlet. Any interruption of the protective (grounding) conductor or disconnection of the protective earth terminal will cause a potential shock hazard that could result in personal injury. If

DO NOT OPERATE IN AN EXPLOSIVE ATMOSPHERE.

Do not operate the instrument in the presence of flammable gases or fumes.

KEEP AWAY FROM LIVE CIRCUITS.

Operating personnel must not remove instrument covers. Component replacement and internal adjustments must be made by qualified service personnel. Do not replace components with power cable connected. Under certain conditions, dangerous voltages may exist even with the power cable removed. To avoid injuries, always disconnect power, discharge circuits and remove external voltage sources before touching components.

DO NOT SERVICE OR ADJUST ALONE.

Do not attempt internal service or adjustment unless another person, capable of rendering first aid and resuscitation, is present.

DO NOT EXCEED INPUT RATINGS.

This mainframe is equipped with a power line filter to reduce electromagnetic interference and must be connected to a properly grounded receptacle to minimize electric shock hazard. Operation at line voltages or frequencies in excess of those stated on the line rating label may cause leakage currents in excess of 5.0 mA peak.

SAFETY SYMBOLS.



The WARNING sign denotes a hazard. It calls attention to a procedure, practice, or the like, which, if not correctly performed or adhered to, could result in personal injury. Do not proceed beyond a WARNING sign until the indicated conditions are fully understood and met.





















The CAUTION sign denotes a hazard. It calls attention to an operating procedure, or the like, which, if not correctly performed or adhered to, could result in damage to or destruction of part or all of the product. Do not proceed beyond a CAUTION sign until the indicated conditions are fully understood and met.

DO NOT SUBSTITUTE PARTS OR MODIFY INSTRUMENT.

Because of the danger of introducing additional hazards, do not install substitute parts or perform any unauthorized modification to the instrument. Return the instrument to an Agilent Technologies Sales and Service Office for service and repair to ensure that safety features are maintained.

Instruments that appear damaged or defective should be made inoperative and secured against unintended operation until they can be repaired by qualified service personnel.

SAFETY SYMBOL DEFINITIONS

Symbol	Description	Symbol	Description
	Direct current		Terminal for Line conductor on permanently installed equipment
	Alternating current		Caution, risk of electric shock
	Both direct and alternating current		Caution, hot surface
	Three-phase alternating current		Caution (refer to accompanying documents)
	Earth (ground) terminal		In position of a bi-stable push control
	Protective earth (ground) terminal		Out position of a bi-stable push control
	Frame or chassis terminal		On (supply)
	Terminal for Neutral conductor on permanently installed equipment		Off (supply)
	Terminal is at earth potential (Used for measurement and control circuits designed to be operated with one terminal at earth potential.)		Standby (supply) - Units with this symbol are not completely disconnected from ac mains when this switch is off. To completely disconnect the unit from ac mains, either disconnect the power cord or have a qualified electrician install an external switch.

Herstellerbescheinigung

Diese Information steht im Zusammenhang mit den Anforderungen der Maschinenläminformationsverordnung vom 18 Januar 1991. * Schalldruckpegel $L_p < 70 \text{ dB(A)}$ * Am Arbeitsplatz * Normaler Betrieb * Nach EN 27779 (Typprüfung).

Manufacturer's Declaration

This statement is provided to comply with the requirements of the German Sound Emission Directive, from 18 January 1991. * Sound Pressure $L_p < 70 \text{ dB(A)}$ * At Operator Position * Normal Operation * According to EN 27779 (Type Test).

Printing History

The current edition of this guide is indicated below. Reprints of this guide containing minor corrections and updates may have the same printing date. New editions are identified by a new printing date and, in some cases, by a new part number. A new edition incorporates all new or corrected material since the previous edition. Changes to the guide occurring between editions are covered by change sheets shipped with the guide.

Edition 1 Feb, Apr, Oct, 1992
 July 1993; June 1997
 April 2000; September 2004

© Copyright 1992 Agilent Technologies, Inc.

This document contains proprietary information protected by copyright. All rights are reserved. No part of this document may be photocopied, reproduced, or translated into another language without the prior consent of Agilent Technologies. The information contained in this document is subject to change without notice.



Agilent Technologies

DECLARATION OF CONFORMITY

According to ISO/IEC Guide 22 and CEN/CENELEC EN 45014



Manufacturer's Name and Address

Responsible Party

Agilent Technologies, Inc.
550 Clark Drive, Suite 101
Budd Lake, New Jersey 07828
USA

Alternate Manufacturing Site

Agilent Technologies (Malaysia) Sdn. Bhd
Malaysia Manufacturing
Bayan Lepas Free Industrial Zone, PH III
11900 Penang,
Malaysia

Declares under sole responsibility that the product as originally delivered

Product Names a) Modular Power System Mainframe
b) Keyboard
c) dc Power Modules

Model Numbers a) 66000A
b) 66001A
c) 66101A; 66102A; 6103A; 66104A; 66105A; 66106A

Product Options This declaration covers all options and customized products based on the above products.

Complies with the essential requirements of the Low Voltage Directive 73/23/EEC and the EMC Directive 89/336/EEC (including 93/68/EEC) and carries the CE Marking accordingly.

EMC Information ISM Group 1 Class A Emissions

As detailed in Electromagnetic Compatibility (EMC), Certificate of Conformance Number CC/TCF/00/077 based on Technical Construction File (TCF) HPNJ4, dated Oct. 30, 1997

Assessed by: Celestica Ltd, Appointed Competent Body
Westfields House, West Avenue
Kingsgrove, Stoke-on-Trent
Staffordshire, ST7 1TL
United Kingdom

Safety Information and Conforms to the following safety standards.

IEC 61010-1:2001 / EN 61010-1:2001
UL 1244
CSA C22.2 No. 1010.1:1992

This DoC applies to above-listed products placed on the EU market after:

January 1, 2004

Date

Bill Darcy/ Regulations Manager

For further information, please contact your local Agilent Technologies sales office, agent or distributor, or *Agilent Technologies Deutschland GmbH, Herrenberger Straße 130, D71034 Böblingen, Germany*

Table of Contents

1. General Information	
Introduction	9
Safety Considerations.....	9
Instrument Identification	9
Options	9
Accessories.....	10
Description	10
Programming	10
Output Characteristic.....	10
Specifications and Supplemental Characteristics	11
2. Installation	
Inspection	17
Damage.....	17
Items Supplied.....	17
Switches	17
Line Voltage Switches.....	17
Configuration Switch.....	17
Remote Inhibit (RI) Function Switches	19
Display Function Switch.....	19
Calibration Function Switch.....	19
Power On Function Switch.....	19
Installing the Module in the Mainframe	20
Connecting the Load.....	20
Output Connector	20
Output Connections	21
Selecting the Proper Wire Size	21
Output Isolation	21
Local Voltage Sensing.....	21
Remote Voltage Sensing	22
Voltage Readback	22
Output Rating	23
Output Noise	23
Parallel Operation.....	23
Series Operation	24
Multiple Loads	25
Optional Relay Connector	25
Capacitive Loads	26
Inductive Loads	26
OVP Considerations	26
Battery Charging	26
Connecting the Controller	26
3. Turn-On Checkout	
Introduction	27
Module Panel Display	27
Module Turn-On State.....	28
Checking Basic Module Functions.....	28
In Case of Trouble.....	29
Mainframe Failure	29
Module Line Fuse.....	29

Table of Contents (continued)

Module Output Connector	29
Error Messages	29-30
4. Basic Power Module Commands	
Introduction	31
GPIB Controller	31
MPS Keyboard	31
Synopsis of Commands	31
Controlling the Output State	32
Controlling Protection Functions	32
Controlling Fixed-Mode Output	32
Controlling List-Mode Output	33
Controlling Triggers	33
Using RI/DFI Functions	34
Changing the Power-On State	34
A. Calibration	
Introduction	35
Enabling or Disabling the Calibration Function	35
Hardware Control	35
Software Control	35
Changing the Calibration Password	35
Performing a Calibration	35
Equipment Required	36
Calibrating Voltage	36
Calibrating Current	37
Using the CAL:AUTO Command	38
Recovering the Factory Calibration Constants	38
Recovering from a Lost Calibration Password	38
Calibration Error Messages	38
Agilent BASIC Calibration Program	38
B. Using the Agilent 66001A MPS Keyboard	
Introduction	41
Connecting the Keyboard	41
Keyboard Description	42
Using the Display	45
Changing or Entering Values	45
Displaying Status	45
Sending SCPI Commands	46
Command Example	46
Query Example	47
Error Example	48
SCPI Command Tree	50
Index	51
Agilent Sales and Support Offices	54

General Information

Introduction

This guide describes how to install, check out, operate, and calibrate the Agilent Series 661xxA power modules used in the Agilent 66000 Modular Power System. Programming the power module from the optional Agilent 66001A Keyboard is described in Appendix B of this guide. Programming the power module over the GPIB bus is covered in the module *Programming Guide* (see "Related Documents", below). Setting the GPIB address is described in the mainframe *Installation Guide*. For complete verification procedures, see the module *Service Guide* (listed under "Related Documents", below). The *Agilent 66000A Modular Power System Product Note* has specific application programs in several DOS-compatible languages and GPIB interface drivers.

Related Documents

Document	Agilent Part No.
Programming Guide for Agilent Series 661xxA MPS Power Modules	5959-3362
Installation Guide for DC Module Connectors	5959-3366
Service Guide for Agilent Series 661xxA Power Modules	5959-3364
Installation Guide for Agilent 66000A Modular Power System Mainframe	66000-90001
Service Guide for Agilent 66000A Modular Power System Mainframe	66000-90003
Quick Reference Card for Optional Agilent 66001A MPS Keyboard*	66001-90001
Agilent 66000A Modular Power System Product Note	5988-2800EN

* A Quick Reference Card is shipped with each Agilent 66000 mainframe.

Safety Considerations

When properly installed in the mainframe, the power module is part of a subsystem that constitutes a Safety Class 1 instrument. The power module has a protective earth connection that is completed through a contact spring in the mainframe backplane. When the power module is moved in and out of the mainframe, the earth ground connection is made before ac power is connected and is removed after ac power is disconnected.

Instrument Identification

Agilent Technologies instruments are identified by a 10-digit serial number. The format is described as follows: first two letters indicate the country of manufacture. The next four digits are a code that identify either the date of manufacture or of a significant design change. The last four digits are a sequential number assigned to each instrument.

Item Description

- US** The first two letters indicates the country of manufacture, where US = USA; MY = Malaysia; SG = Singapore.
- 3648** This is a code that identifies either the date of manufacture or the date of a significant design change.
- 0101** The last four digits are a unique number assigned to each power supply.

Options

Option	Description
760	Output Connector with Isolation/Polarity Reversal Relays
0L2	Extra set of Documentation
0B3	Series 661xxA Service Guide

Accessories

Agilent No.	Description
34551A	Rack mount for Agilent 66001A MPS keyboard

Description

The Agilent 66lxxA Series Power Modules are used in the Agilent 66000 Modular Power System (MPS) mainframe to provide a range of dc output voltages and currents. The modules are installed or removed from the front of the mainframe without the need for disconnecting any wires. Modules may be connected in series or parallel to provide increased output voltages or currents. The modules can be equipped with optional isolation and polarity reversal relays that are built into the module output connector.

The power module front panel has digital readouts of output voltage and current. It also has annunciators that indicate:

- constant voltage, constant current, or unregulated operation
- activation of a protection circuit
- disabling of the output
- remote operation (addressed by the controller)

Programming

The power module is programmed over the GPIB from a controller using SCPI (Standard Commands for Programmable Instruments). This makes power module programs compatible with those of all other instruments controlled with this language. Among the functions that can be programmed are output voltage and current, OVP (overvoltage protection), OCP (overcurrent protection), status registers, output relays, and output voltage and current calibration.

In addition, the power module has programmable trigger, list, and RI/DFI (remote inhibit/discrete fault indicator) subsystems. Triggers can occur from signals at the mainframe TRIG IN jack or from selected internal events. The list subsystem generates preprogrammed sequential outputs in response to triggers. The RI/DFI subsystem generates an output on the mainframe FLT line in response to selected internal events or turns off the output in response to an input on the mainframe INH line.

The power module also can be programmed locally from the optional Agilent 66001A MPS Keyboard. The keyboard has an alphabetical command menu for all power module SCPI commands. By scrolling through the menu and entering the appropriate parameters, commands may be created for development or debugging.

Output Characteristic

The power module can operate in either CV (constant voltage) or CC (constant current) mode over its voltage and current output range (see Table 1-1). The operating locus (see Output Characteristic Curve in Table 1-2) shows a single-range, limited two-quadrant capability. The operating point is determined by the voltage setting (V_S), the current setting (I_S) and the load impedance (R_L). Two operating points are shown. Point 1 is defined by the load line cutting the operating locus in the CV region, which defines the CV mode (curve A). In this mode, the power module will maintain the voltage at V_S for varying load currents (determined by $V \div R_L$) up to I_S . If the load demands a current greater than I_S , the power module switches to CC mode. CC mode (curve B) is defined by the load line cutting the operating locus in the CC region (see Point 2). Under this condition, the power module maintains the current at I_S at some voltage determined by $I_S \times R_L$.

When the power module is operated beyond either rated output, the performance specifications are not guaranteed, although typical performance may be good. Operation in quadrant 2 is limited to about 10% of the maximum rated positive output current. This allows the power module to sink current for more rapid downprogramming in the CV mode.

Specifications and Supplemental Characteristics

Table 1-1 lists the specifications of the power modules. Specifications are warranted over the specified temperature range. Table 1-2 lists the supplemental characteristics, which are not warranted but are descriptions of performance determined either by design or type testing.

Table 1-1. Performance Specifications

Parameter	Agilent Model					
	66101A	66102A	66103A	66104A	66105A	66106A
Specifications are warranted over the temperature range 0 to 55° C with a resistive load and the output connected for local sensing. Derate the output current 1% per °C from 40° C to 55° C.						
Output Ratings						
Voltage:	0 - 8 V	0 - 20 V	0 - 35 V	0 - 60 V	0 - 120 V	0 - 200 V
Current:	0 - 16 A	0 - 7.5 A	0 - 4.5 A	0 - 2.5 A	0 - 1.25 A	0 - 0.75 A
Power:	128 W	150 W	157.5 W	150 W	150 W	150 W
Programming Accuracy @ calibration temperature ± 5 °C)*						
Voltage: 0.03% +	3 mV	8 mV	13 mV	27 mV	54 mV	90 mV
Current: 0.03% +	6 mA	3 mA	2 mA	1.2 mA	0.6 mA	0.4 mA
*Factory calibration temperature = 25 °C						
Ripple & Noise (from 20 Hz to 20 MHz with outputs ungrounded, or with either output terminal grounded)						
Constant Voltage: rms	2 mV	3 mV	5 mV	9 mV	18 mV	30 mV
Constant Voltage: p-p	5 mV	7 mV	10 mV	15 mV	25 mV	50 mV
Constant Current: rms	8 mA	4 mA	2 mA	1 mA	1 mA	1 mA
Readback Accuracy With respect to actual output @ calibration temperature following self calibration.*						
Voltage: 0.02% +	2 mV	5 mV	8 mV	16 mV	32 mV	54 mV
Current: 0.02% +	6 mA	3 mA	2 mA	1 mA	0.6 mA	0.3 mA
*Factory calibration temperature = 25 °C						
Load Regulation (change in output voltage or current for any load change within ratings)						
Voltage:	1 mV	1 mV	1 mV	2 mV	4 mV	7 mV
Current:	0.5 mA	0.2 mA	0.2 mA	0.1 mA	50 µA	30 µA

Table 1-1. Performance Specifications (continued)

Parameter	Agilent Model					
	66101A	66102A	66103A	66104A	66105A	66106A
Line Regulation (change in output voltage or current for any line change within ratings) Voltage: Current:	0.5 mV 0.75 mA	0.5 mV 0.5 mA	1 mV 0.3 mA	2 mV 0.1 mA	3 mV 50 µA	5 mV 30 µA
Transient Response Time (for output voltage to recover to within 100 mV of its previous level following a step change in load current that is up to 10% of the power module rated output current.	< 1 ms					
AC Input Ratings (selectable via module switch- see Chapter 2) Nominal line voltage (Vac) 115 V switch setting 230 V switch setting Frequency range:	87- 132 Vac 174- 250 Vac 47 - 63 Hz					
Output Terminal Isolation (maximum, from output to the mainframe chassis ground):	±240 Vdc					

Table 1-2. Supplemental Characteristics

Parameter	Agilent Model					
	66101A	66102A	66103A	66104A	66105A	66106A
Output Programming Range (Maximum programmable values): Voltage: Current: OV Protection:	8.190 V 16.380 A 9.6 V	20.475 V 7.678 A 24.0 V	35.831 V 4.607 A 42.0 V	61.425 V 2.559 A 72.0 V	122.85 V 1.280 A 144.0 V	204.75 V 0.768 A 240.0 V
Average Programming Resolution Voltage: Current: OV Protection:	2.4 mV 4.6 mA 50 mV	5.9 mV 2.3 mA 120 mV	10.4 mV 1.4 mA 200 mV	18.0 mV 0.75 mA 375 mV	36.0 mV 0.39 mA 750 mV	60.0 mV 0.23 mA 1.25 V
OVP Accuracy (@ calibration temperature ±5° C):* * Factory calibration temp = 25° C	250 mV	500 mV	800 mV	1 V	1.5 V	2.5 V
Readback Resolution Voltage: Current:	0.305 mV 0.587 mA	0.763 mV 0.293 mA	1.335 mV 0.169 mA	2.289 mV 0.099 mA	4.577 mV 0.049 mA	7.629 mV 0.030 mA
Drift (Temperature Stability) (following a 30-minute warmup, change in output over 8 hours under constant line, load, and ambient temperature)						
Voltage: Current:	0.02% + 0.4 mV 8 mA	0.02% + 1 mV 5 mA	0.02% + 2 mV 2.5 mA	0.02% + 3 mV 1.3 mA	0.02% + 6 mV 0.63 mA	0.02% + 10 mV 0.38 mA

Table 1-2. Supplemental Characteristics (continued)

Parameter	Agilent Model					
	66101A	66102A	66103A	66104A	66105A	66106A
Trigger Response Time (average time for the output voltage or current to begin to change upon receipt of an external trigger) With GPIB activity: 5 ms Without GPIB activity: 3 ms Trigger Maximum Frequency (for repetitive external triggering, the maximum frequency for which the Trigger Response Time is valid) With GPIB activity: 75 Hz Without GPIB activity: 85 Hz						
Dwell Time Programmable range: 10 ms to 65 s Resolution: 2 ms Accuracy With GPIB activity: ± 5 ms Without GPIB activity: ± 2.5 ms						
Downprogramming:	Active downprogrammer sinks approximately 10% of rated output current					
Monotonicity:	Output is monotonic over entire rated voltage, current, and temperature range					
GPIB Interface Capabilities Interface Signals (see IEEE 488.1): AH1,C0,DC1, DT1,EI,LE4,PP0, RL1,SH1,SR1,TE6 Programming Language: SCPI (Standard Commands for Programmable Instruments)						
Serial Link Capabilities (maximum power modules sharing one GPIB primary address)	16					
Savable States Nonvolatile memory locations: 5 (0 through 4) Volatile memory locations: 5 (5 through 9) Nonvolatile memory write cycles: 40,000 (typical)	10					
Recommended Calibration Interval:	1 year					
Safety Compliance Complies with: CSA 22.2 No.231 & IEC 348 Designed to comply with: UL 1244 & VDE 0411						
RFI Suppression (designed to comply with):	FTZ 1046/84, Level B					
Dimensions Width: 48.3 mm (1.9 in) Height: 141.2 mm (5.6 in) Depth Pull tab inserted: 571.4 mm (22.5 in) Pull tab extended: 606.4 mm (23.8 in)						
Weight Net: 2.7 kg (6 lb) Shipping: 4.1 kg (9 lb)						

Table 1-2. Supplemental Characteristics (continued)

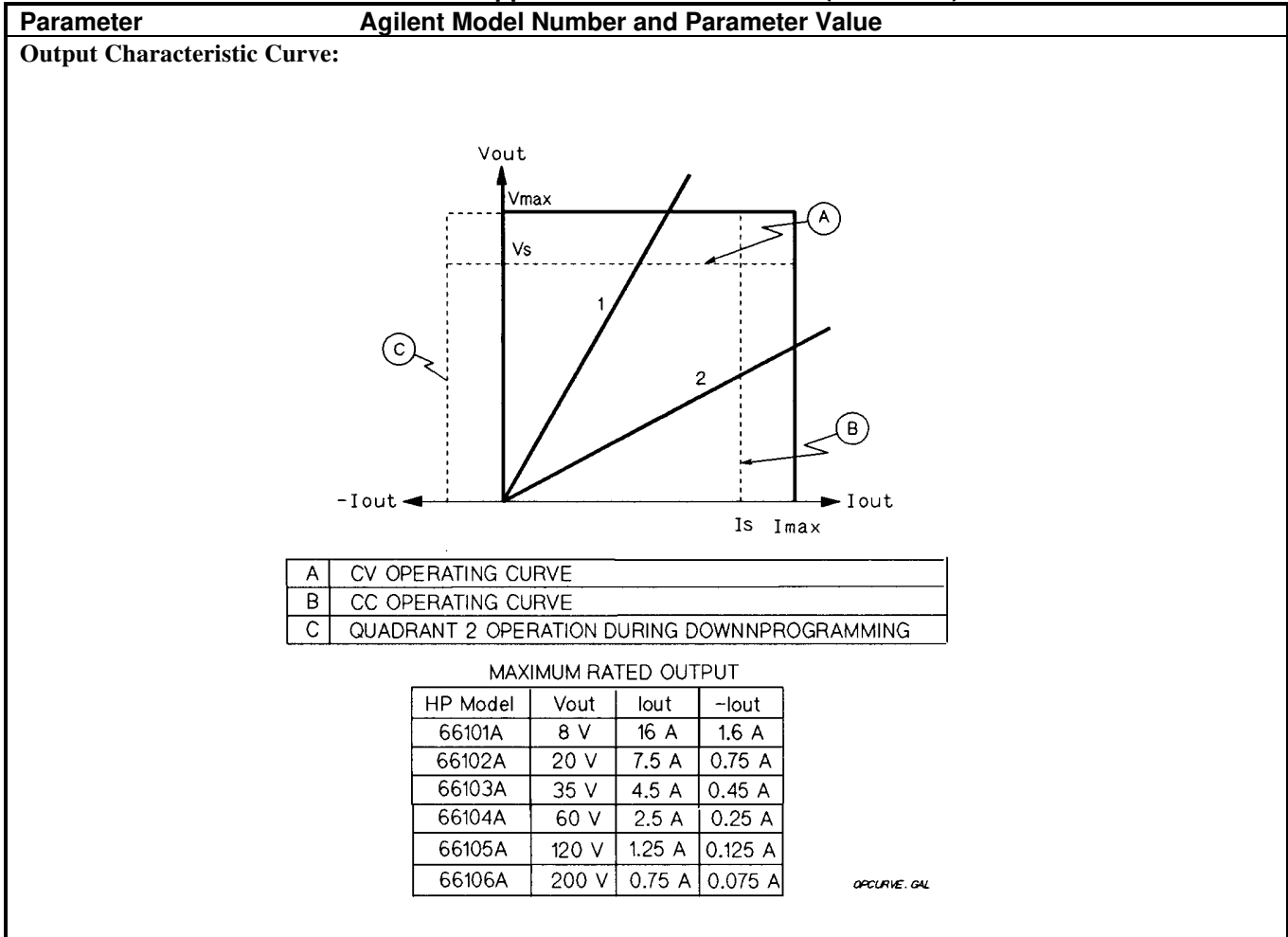

Table 1-3. Replaceable Parts List

Description	Agilent Part No.
Cable assembly, mainframe GPIB	
0.5 meters (1.6 ft)	10833D
1 meter (3.3 ft)	10833A
2 meters (6.6 ft)	10833B
4 meters (13.2 ft)	10833C
Cable assembly, mainframe serial link	5080-2148
Fuse, ac-line, 6 A	2110-0056
Output connector, standard	5060-3386
Output connector, with relays	5060-3387
Output connector converter board (converts 5060-3386 to 5060-3387)	5060-3351
Plug, mainframe INH/RFI input	1252-1488
Resistor, calibration	(see Appendix A)

Installation

Inspection

Damage

When you receive your power module, inspect it for any obvious damage that may have occurred during shipment. If there is damage, notify the shipping carrier and the nearest Agilent Sales and Support Office immediately. Warranty information is printed in the front of this guide.

Items Supplied

In addition to this manual, check that the following items are included with each power module (see Table 1-3 for part numbers):

- One output connector
- One Series 66lxxA *Programming Guide*
- One or more Manual Change Sheets may be included with each guide. If there are change sheets, make the indicated corrections to the guides.

Switches

Before inserting the power module in the mainframe, read the following information to determine if you need to change any of the switch settings.

Line Voltage Switches

Figure 2-1 shows the location of the line voltage switches and the ac line fuse. **The line voltage switches are shipped in the 230-volt position.** If required, use a flat-bladed screwdriver or similar tool to move both switches to the proper position for your nominal line voltage.

Line Voltage	Switch Position
110, 120 Vac	115
200, 220, 230, 240 Vac	230

Note If you change the line switch position, remember to also correct the line voltage label on the rear of the mainframe. The mainframe contains no line voltage switches.

Configuration Switch

Figure 2-2 shows the location of the power module configuration switch. Table 2-1 indicates the functions of the switch and the factory-default settings. If you need to change any of the settings, refer to the applicable function.

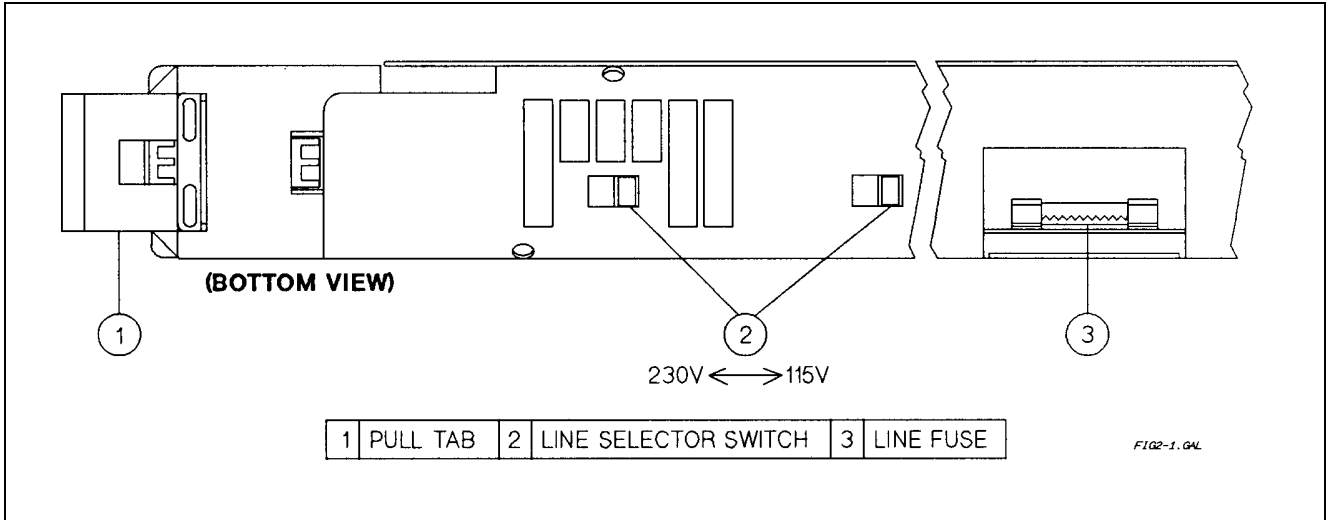

Figure 2-1. Power Module Line Fuse and Switches

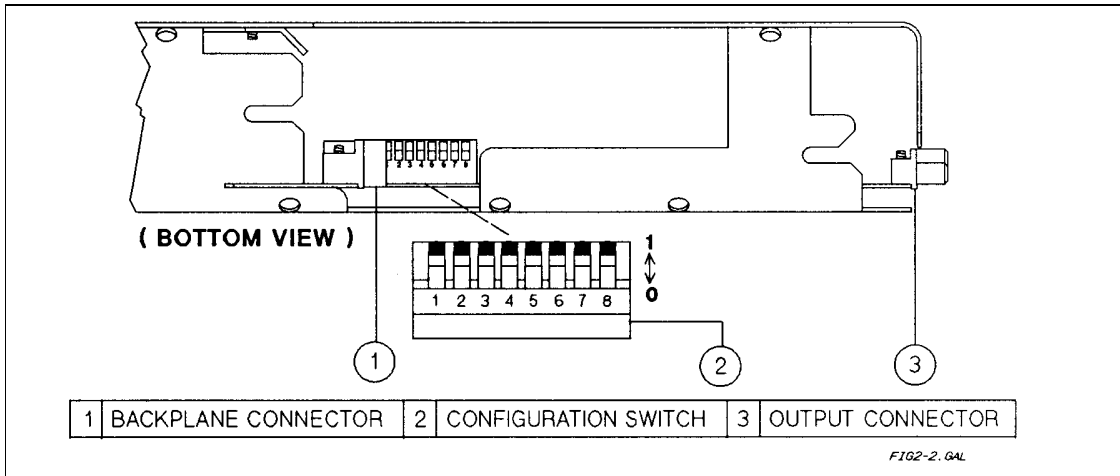

Figure 2-2. Power Module Configuration Switch

Table 2-1. Settings for Power Module Configuration Switch

Desired Function	Required Switch Setting							
	1	2	3	4	5	6	7*	8*
RI disabled	0	0					1	1
RI unlatched (live)	0	1					1	1
RI latching †	1	1					1	1
Display disabled			0				1	1
Display enabled †			1				1	1
Inhibit calibration				0	0		1	1
Factory calibration				0	1		1	1
Normal calibration †				1	1		1	1
Power on state is *RCL 0						0	1	1
Power on state is *RST †						1	1	1

†= factory default setting "0" Off or open "1" On or closed.
 *Positions 7 and 8 are for service functions. For normal operation, they must be set to 1.

Remote Inhibit (RI) Function Switches

This function allows the power module outputs to be shut down from a signal (low-true TTL level) applied to the mainframe INH input. The INH input is internally connected to the mainframe remote inhibit (RI) line. This line is normally high and is distributed to all power modules in the mainframe. An external switch closure that shorts the mainframe INH input is detected by the power module as an RI signal.

Note See "Chapter 3 - Connections" in the mainframe *Installation Guide* for more information on external INH connections.

Within each power module, the RI signal is applied to the RI section of the configuration switch (see Figure 2-2). The RI switch allows you to select one of the following responses to the RI input signal:

Switch Setting	RI Action
RI disabled	The module ignores the RI input signal
RI latched	The module shuts down and remains shut down when the RI signal goes true. A software command is required to restore the output (see "Chapter 4 - Basic Power Module Commands").
RI nonlatched (real-time)	The module shuts down only as long as the RI signal is true (TTL low). The output is restored when the RI signal goes false (TTL high).

Display Function Switch

A single switch configures the display function. Use it to permanently turn the power module voltage and current display indicators off or on (the annunciators are unaffected by this switch). If the switch is left in the ON position, the display may be turned on or off by software commands (see the power module *Programming Guide*).

Calibration Function Switches

The calibration switches allow you to select one of the following modes of calibration:

Switch Setting	Calibration Mode
Normal calibration	Permits normal calibration (requires entry of a password)
Factory calibration	Restores original factory calibration (no password is required)
Inhibit calibration	Prevents calibration

The factory position is useful if the power module has been miscalibrated or if the calibration password has been lost.

Power-On Function Switch

This switch allows you to determine the operating state of the power module when it is turned on. With the switch set to 1 (on), the power module will be in the factory-default reset state (see *RST in "Chapter 3 - Language Dictionary" of the power module *Programming Guide*). If you move the switch to 0, the power module will turn on to whatever state you save to memory location 0. See "Chapter 4 - Basic Power Module Commands" for more information.

Installing The Module In The Mainframe

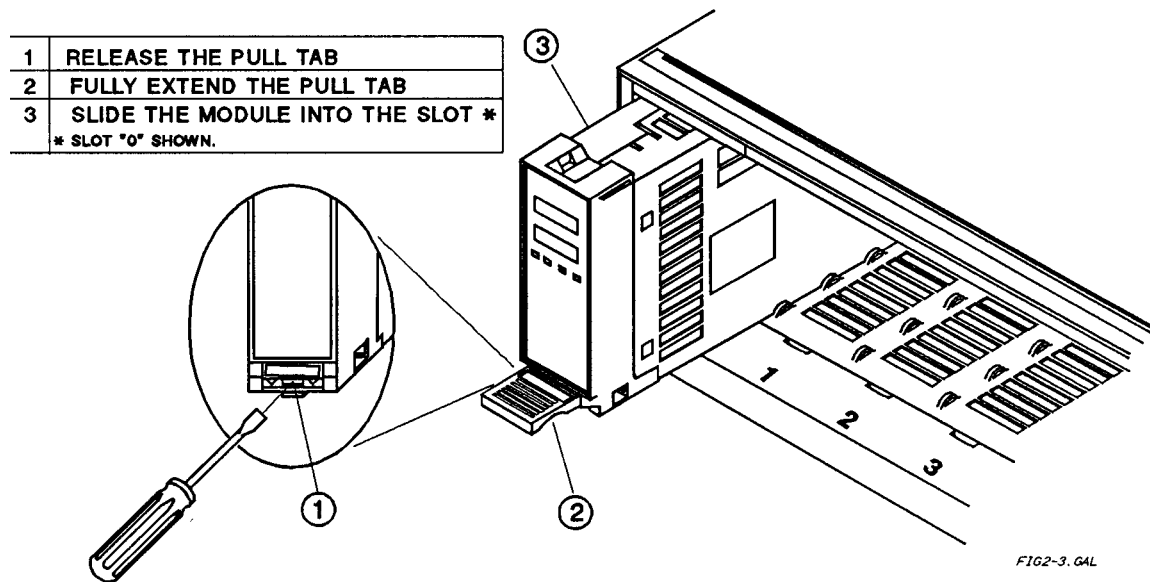

Figure 2-3. Power Module Installation

Note A fully loaded mainframe can weigh over 36 kg (80 lbs). Install the mainframe into the rack (see the "Mainframe Users Guide") before installing the modules into the mainframe.

1. Turn off the mainframe power switch.
2. Make certain the pull tab extends from the module (see Figure 2-3).
3. Slide the module into the mainframe slot. You may use any available slot.
4. Push the module into the backplane connector until you feel the module connector snap into the backplane connector.
5. Push the lock tab into the front of the module. If the module is not properly plugged into the backplane connector, the lock tab will not retract into the module.
6. If desired, mark or label the power module with its slot address.

Important Marking or labeling the power module will prevent replacing it in the wrong slot if it is subsequently removed from the mainframe. Also, with two mainframes linked together, a slot can be either of two numbers, depending on whether it is in the main or the auxiliary mainframe (see "Connecting the Controller" in this chapter).

Connecting The Load

Output Connector

One output connector (see Table 1-3) is shipped with each power module. This can be either a standard or relay type. The *Installation Guide* supplied with the connector shows how to open the connector, connect the wires, and secure the connector to the mainframe.

Output Connections

Before making the actual connections, you must decide on the system configuration. The following factors are described in the rest of this chapter:

- using the correct wire size
- maintaining isolation guidelines
- selecting local or remote voltage sensing
- connecting modules in series or in parallel
- using output relays
- connecting to capacitive or inductive loads

Selecting the Proper Wire Size

WARNING

Fire Hazard. To satisfy safety requirements, load wires must be large enough not to overheat when carrying the short-circuit output current of the device connected to the power module. See Table 2-2 for the characteristics of AWG (American Wire Gauge) copper wire.

Table 2-2. Current Capacity and Resistance of Stranded Copper Conductors

AWG No.	*Ampacity	**Resistance	
		(Ω /m)	(Ω /ft)
20	8.33	0.0345	0.01054
18	15.4	0.0217	0.00663
16	19.4	0.0137	0.00417
14	31.2	0.0086	0.00262

AWG No.	*Ampacity	**Resistance	
		(Ω /m)	(Ω /ft)
12	40	0.0054	0.00165
*In free air		**At 20 °C	

Output Isolation

WARNING

The output connector ground terminal is a low-noise ground provided for convenience, such as for grounding wire shields. This terminal is not designed to function as an equipment safety ground.

The power module output terminals are isolated from earth ground. If required, either output terminal may be grounded.

CAUTION

The potential between either output terminal and ground must not exceed ± 240 Vdc. Failure to observe this restriction may damage the power module.

Local Voltage Sensing

Figure 2-4A shows the load connection for local sensing. There is a switch on the output connector that selects either local or remote sensing of the output voltage. The connector is shipped with the switch in the **LOCAL** position. In order to configure the output for local sensing, make certain this switch is set to **LOCAL**.

Note The position of the Local/Remote switch also can be determined by software (see VOLT:SENS:SOUR? in "Chapter 3 - Language Dictionary" of the *Programming Guide*).

With local sensing, the power module voltage readback circuit senses the voltage at the output terminals. Since this does not compensate for voltage drops in the terminal screw connections and output leads, use Local sensing only in applications requiring low output currents or where the load regulation is not critical.

Remote Voltage Sensing

Figure 2-4B shows the wiring for remote sensing. There is a switch on the output connector that selects either local or remote sensing of the output voltage. To configure the output for remote sensing, do the following:

- Connect sense leads to the load
- Make certain that the connector switch is set to **REMOTE**

Note If you leave the connector switch in **LOCAL**, the power module will regulate the programmed voltage at the connector, not at the load.

Because they do not carry load current, you may use smaller gauge wire for the remote sense leads.

Be careful to avoid open circuits in the sense leads, such as leaving the output connector sense switch in the **Local** position. If this happens, the power module will regulate at its output terminals instead of at the load.

Note If the sense terminals are left open, the voltage at the output terminals will increase approximately 3 to 5% over the programmed value. The readback voltage will not indicate this increase because readback is measured at the sense terminals.

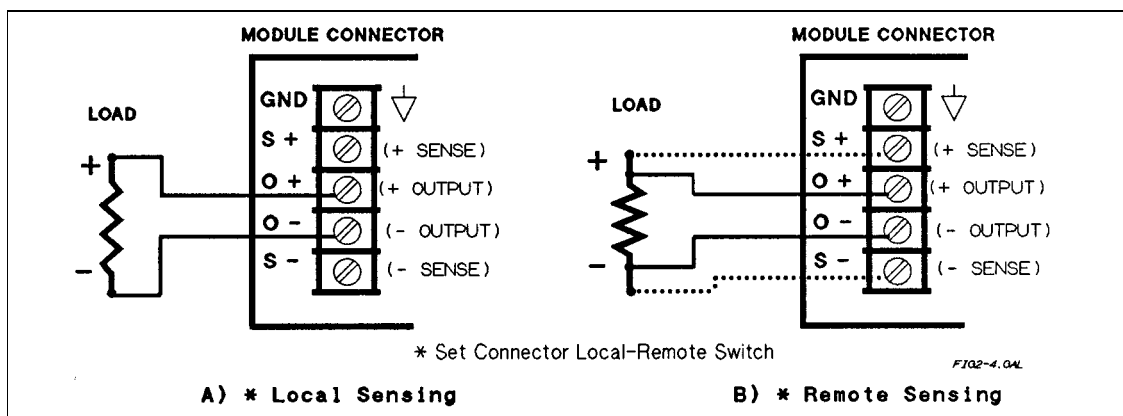

Figure 2-4. Load Connection

The dashed lines in the connection drawings illustrate remote sense connections. In this case, the remote sense terminals of the power module are connected to the load rather than the output terminals. This allows the power module to automatically compensate for the voltage drop in the load leads as well as to accurately read back the voltage at the load. In remote-sense applications, the voltage readback from across the load is not the output voltage of the power module. The actual output voltage is the sum of the load voltage and the voltage drop in the load lead. Keep this output voltage within the power module's maximum voltage rating. Failure to do this may result in an unregulated condition, especially when the line voltage is low.

Voltage Readback

In remote sense applications, the voltage readback occurs directly at the load. This allows the power module to automatically compensate for the voltage drop in the load leads and to provide an accurate voltage readback directly across the load.

Output Rating

The rated output voltage and current specified in Table 1-1 applies at the output terminals of the power module. With remote sensing, the power module must increase its output to compensate for voltage dropped in the load leads. If you attempt to provide full rated output voltage at the sense terminals (load), the power module's output voltage may exceed its maximum rating. This may trip the OV protection circuit, which senses the voltage at the output terminals, or cause an unregulated output condition, particularly when the ac line voltage is low.

Output Noise

Noise picked up by the sense leads may appear at the output of the power module and can adversely affect the load regulation. To minimize noise pickup, twist the sense leads and route them parallel and close to the load leads. It may be necessary to use shielded sense leads in noisy environments. If you do, ground the shield only at the output connector ground screw. *Do not use the shield as one of the sense leads.*

Parallel Operation

Power modules may be connected in parallel to obtain increased output current. The power modules must be individually programmed; they **do not** function in the autoparallel mode that is commonly used by many Agilent power supplies.

Figure 2-5 shows two power modules connected in parallel. You must keep the same impedance to the load by using leads of equal length and wire size from each module to the load. Select one module (usually the one with the lesser current capacity) to operate in the "CV Mode". The other module then must operate in the "CC Mode" module. If you are using remote sensing, connect the sense leads to the module operating in the CV mode.

Since you must program one module to operate in CV mode and the other to operate in CC mode, refer to the output characteristic curve shown at the end of Chapter 1 to see what this means. Curve ① shows a module operating in CV mode; its output voltage remains constant over the range of its operating current. Curve ② shows a module operating in CC mode; its output current remains constant over the range of its operating voltage.

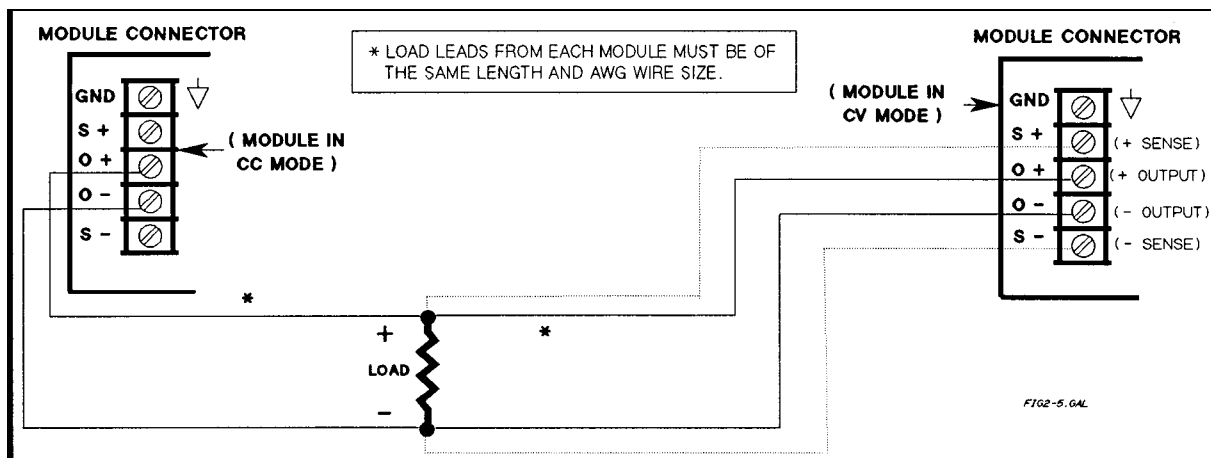

Figure 2-5. Connecting Power Modules in Parallel

For proper parallel operation, observe the following rules:

1. Program both module outputs **OFF**.
2. Program the CV mode module for the desired output voltage.
3. Program the CV mode module's OVP voltage to the desired value; always higher than the output voltage.
4. Program the output and OVP voltages of the CC module slightly higher (about 1 volt) than those of the CV module. This is to ensure that the CC module stays in CC mode.

5. In order to maintain proper regulation, the load must always draw at least as much current as is programmed for the module that is in CC mode. You can maintain regulation over a range of current only as long as this condition remains true.
6. As near as is permitted by condition 5, program the current levels of both modules for a balanced distribution of the total output current. Do not program the CV module near its maximum output current level.
7. Program the outputs of both modules **ON**.
8. When the system is operating, observe that the **CV** annunciator of the CV module stays on and the **CC** annunciator on the CC module stays on. If not, repeat steps 1 through 7.
9. Once the modules are properly set up, **do all subsequent voltage programming from the CV module**; the CC module will track that module.

CAUTION

Remember that although the CV module is controlling the output voltage, the CC module is programmed to a slightly higher voltage. Do not allow the CC module to go into CV mode. **Do not program the CV module to 0 volts without first disabling the outputs of both power modules.** Otherwise, the CV module could sink up to 10% of its rated output current from the CC module.

As an example, assume that an Agilent 66102A (20 V @ 7.5 A) and an Agilent 66103A (35 V @ 4.5 A) are connected in parallel to supply a load of 10 amperes at 18 volts. The Agilent 66102A is selected as CC mode module and will supply approximately 7.6 A, maximum. The Agilent 66103A will be the CV module and will supply the remaining current (2.4 A). When the two modules are operated in parallel, you may expect the system to regulate at 18 Volts and 10 amperes as long as the load current remains above 7.6 amperes (see rule 5, above).

The following program shows how to program the two power modules. Generic code (SCPI commands) are shown; they may be sent either from the keyboard or from a GPIB controller.

OUTP OFF	<i>Send to both modules</i>
VOLT:LEV 18	<i>Program the CV mode module</i>
VOLT:PROT 18.5	
CURR:LEV 2.4	
VOLT:LEV 19	<i>Program the CC mode module</i>
VOLT:PROT 19.5	
CURR:LEV MAX	
OUTP ON	<i>Restore the outputs of both modules</i>

Series Operation

CAUTION

To prevent damage to the equipment, floating voltages must not exceed 240 Vdc. No output terminal may be more than 240 V from chassis ground.

Figure 2-6 shows how the outputs of two power modules may be connected in series to increase the output voltage. **Connect only power modules that have the same maximum output current ratings.** It is recommended that you set up both modules to operate in CV mode with their current outputs equal to the full load current. If the external load is a storage device, such as a battery or large capacitance, be careful how you shut down the system. For example, turning off just one module could damage the remaining module by subjecting it to double its maximum output voltage from the storage device.

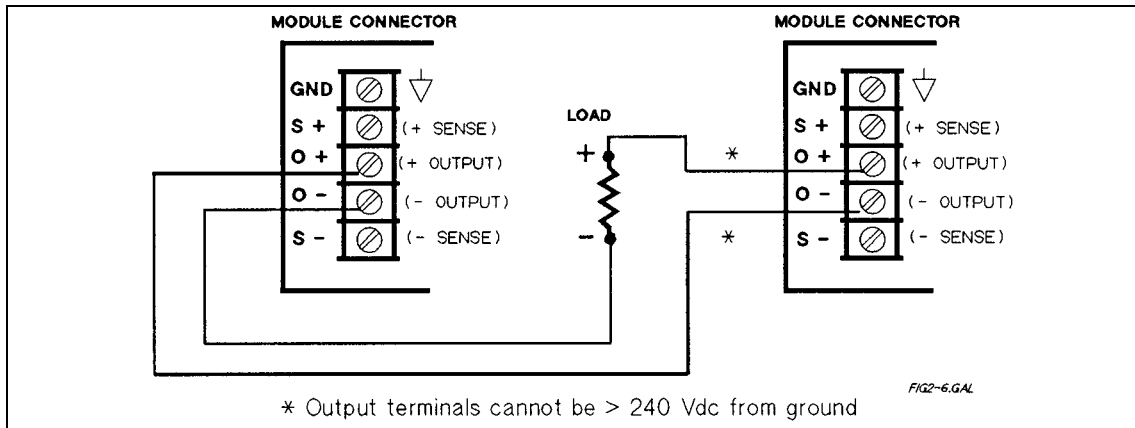

Figure 2-6. Connecting Power Modules in Series

CAUTION

Each power module has a reverse voltage protection diode across its output. If a reverse voltage is applied, the power module has no control over the current through this diode. To avoid damaging the power module, never connect it to a reverse voltage that can force it to conduct current in excess of the power module's maximum reverse current (see Table 1-2).

Multiple Loads

When connecting multiple loads to the power module with local sensing, use a separate pair of wires for each load (see Figure 2-7). Each pair of wires should be as short as possible and twisted or bundled to reduce lead inductance and noise pickup. If cabling or terminal considerations require the use of distribution terminals located outside the output connector, then remote voltage sensing is recommended. Connect the sense leads either at the distribution terminals or directly at one of the loads if it is more critical than the others.

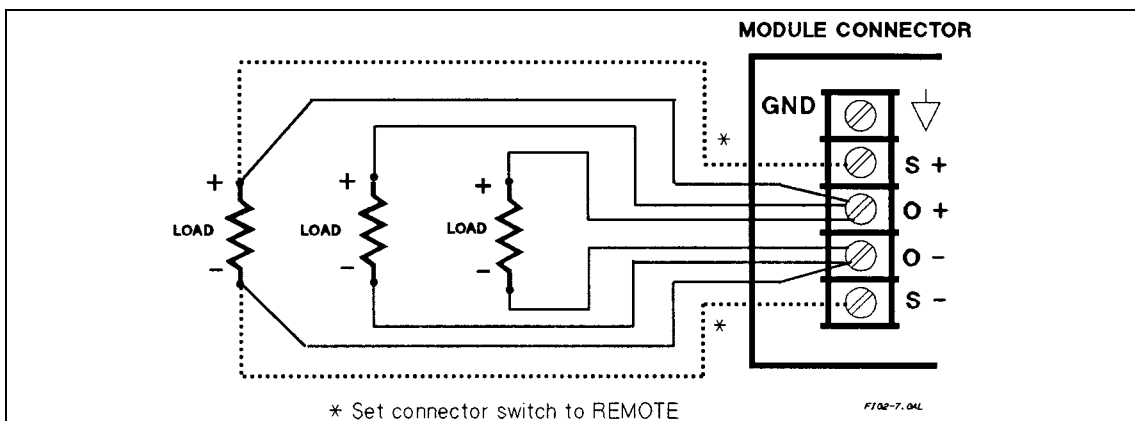

Figure 2-7. Connecting Multiple Loads

Optional Relay Connector

If you are using the Option 760 output connector with isolation or polarity reversal relays, the output and sense lead terminal connections are the same as those of the standard output connector. When the output connector **Remote/Local** switch is in **Remote**, both the output leads and the sense leads are under relay control. An existing standard connector can be converted into a relay connector. The Installation Guide provided with the connector (see "Related Documents" in Chapter 1) includes instructions for doing this.

Capacitive Loads

The power module is designed to be stable for load capacitances up to the following values:

Agilent 66101A	50,000 μ F	Agilent 66104A	4,500 μ F
Agilent 66102A	20,000 μ F	Agilent 66105A	2,750 μ F
Agilent 66103A	10,000 μ F	Agilent 66106A	1,650 μ F

Inductive Loads

You may safely connect the power module output to inductive loads up to 100 mH. (Higher inductances are possible with a modified module. Consult the factory for details.)

OVP Considerations

The OVP circuit senses the voltage at the output terminals, not at the sense terminals. Therefore the voltage sensed by the OVP circuit can be significantly higher than the voltage being regulated at the load. You must program the OVP trip voltage high enough to compensate for the expected drop from the power module output to the load.

Battery Charging

The power module OVP trip circuit has a downprogrammer that discharges the output whenever OVP trips. If the output is connected to a battery and the OVP is tripped (or the power module voltage is programmed below the battery voltage), the power module will sink current from the battery. The down programmer limits the value of this current to no more than 10% of the power module's maximum rated output current.

Connecting The Controller

The Agilent 66000A Mainframe has a GPIB port for connection to the controller. Each power module has a GPIB primary address determined by a switch on the mainframe, and a GPIB subaddress determined by the mainframe slot in which the module is installed. If the mainframe GPIB address is set to 705, this becomes the power module's primary address.

The Agilent 66000A Mainframe mode switch determines the IEEE 488 secondary addresses (also referred to as subaddresses) of the modules that are installed in the mainframe. With the mainframe mode switch set to **MAIN**, modules are assigned secondary addresses of 00 to 07, which correspond to the slot locations indicated on the mainframe. The mainframe mode switch must be set to **MAIN** when the mainframe is connected directly to the GPIB. For example, if a module is installed in slot 3 of a mainframe that is set to GPIB address 705, the complete address of the module is 70503.

The mainframe mode switch must be set to **AUX** (auxiliary) when the mainframe is serially-linked to another mainframe that is directly connected to the GPIB. In mainframes that have the mode switch set to **AUX**, modules are assigned secondary addresses of 08 to 15. Secondary address 08 corresponds to slot location 0 on the mainframe and secondary address 15 corresponds to slot location 7 on the mainframe. For example, if a module is installed in slot 3 of a mainframe that is serially linked to another mainframe at GPIB address 705, the complete address of the module is 70511.

Module Slot Locations/Addresses

	Mainframe Mode Switch = MAIN							Mainframe Mode Switch = AUX								
Slot Location	0	1	2	3	4	5	6	7	0	1	2	3	4	5	6	7
Secondary Address	00	01	02	03	04	05	06	07	08	09	10	11	12	13	14	15

For details concerning GPIB cabling and addressing, see "Chapter 2 - Installation" in the Agilent 66000A Mainframe *Users Guide*.

Turn-On Checkout

Introduction

This chapter provides a quick test of the power module functions. See "Chapter 4 - Basic Power Module Commands" for more details of power module operation.

Note

These procedures assume you have checked and, if required, correctly set the following switches for each module:

- the line voltage switch (see Figure 2-1)
- the configuration switch (see Table 2-2)
- the output connector **Local/Remote** switch

The procedures for doing this are given in Chapter 2.

Module Panel Display

The power module display provides the information shown in Table 3-1. There are no operating controls on the power module.

Table 3-1. Power Module Front Panel Display

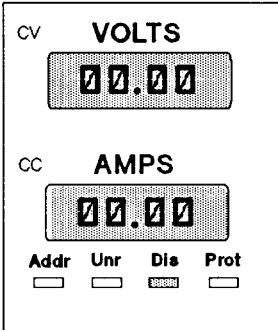
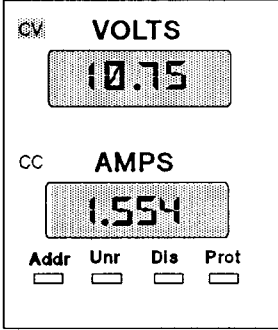
 <p>A) NORMAL TURN-ON RESPONSE</p>	 <p>B) CONSTANT VOLTAGE OPERATION</p>
INDICATOR	FUNCTION
VOLTS	Digital readout of output voltage
AMPS	Digital readout of output current
CV	Lights when power module is in constant voltage mode
CC	Lights when power module is in constant current mode
Addr	Lights when power module is addressed over GPIB
Unr	Lights when power module output is unregulated
Dis	Lights when power module output is disabled
Prot	Lights when power module protection circuit is activated (overvoltage, overcurrent, overtemperature, or remote inhibit)

Power Module Turn-On State

When you turn on the mainframe, the power module goes through a self-test. All front panel readout digits and annunciators turn on briefly. The panel then remains in the state shown in Table 3-1A.

Note The figure assumes the power module still retains its factory default turn-on state. You can change this state if desired (see "Chapter 4 - Basic Power Module Commands").

Checking Basic Module Functions

The power module is designed for remote programming over the GPIB. It also can be locally programmed from the optional Agilent 66001A MPS Keyboard. Table 3-2 gives the SCPI commands for the remotely programmed tests. You can send these same commands from the keyboard (see "Appendix B").

Table 3-2. Testing Basic Functions with SCPI Commands

Command	Action	Display Response						
		VOLTS	AMPS	CV	CC	Addr*	Dis	Prot
Output Voltage (Disconnect Load)								
VOLT 5.1	Set output voltage to 5.1 V	0.00	0.00	Off	Off	On	On	Off
OUTP ON	Enable the output	5.10	0.00	On	Off	On	Off	Off
Overvoltage Protection								
VOLT:PROT 4.9	Activate OVP circuit (by setting protection voltage below output voltage)	0.00	0.00	Off	Off	On	Off	On
VOLT:PROT MAX	Clear OVP circuit	5.10	0.00	Off	Off	On	Off	Off
OUTP:PROT:CLE	Clear OVP circuit	5.10	0.00	On	Off	On	Off	Off
Save and Recall Functions								
*SAV 5	Save present state to location 5	5.10	0.00	On	Off	On	Off	Off
VOLT 3.55	Set output voltage to 3.55 V	3.55	0.00	On	Off	On	Off	Off
OUTP OFF	Turn off the output	0.00	0.00	Off	Off	On	On	Off
*SAV 6	Save present state to location 6	0.00	0.00	Off	Off	On	On	Off
*RCL 5	Restore state 5	5.10	0.00	On	Off	On	Off	Off
*RCL 6	Restore state 6	0.00	0.00	Off	Off	On	On	Off
Output Current (With output disabled, short the output terminals with a wire size sufficient to carry the maximum current of the module.)								
CURR 3.1	Set output current to 3.1 amps	0.00	0.00	Off	Off	On	On	Off
OUTP ON	Enable the output	0.00	3.10	Off	On	On	Off	Off
Overcurrent Protection								
CURR:PROT:STAT ON	Activate OCP circuit (by enabling OCP when the output is shorted)	0.00	0.00	Off	Off	On	Off	On
CURR:PROT:STAT OFF	Clear OCP circuit	0.00	0.00	Off	On	On	On	Off
OUTP:PROT:CLE	Clear OCP circuit	0.00	3.10	Off	On	On	Off	Off
*Addr will not light if the module is controlled from the keyboard.								

In Case Of Trouble

Mainframe Failure

You can assume there is a problem with the mainframe if there is more than one module in the mainframe and none of the module fans are on. The trouble also is probably in the mainframe if the module fans are on and their displays are enabled (see "Configuration Switch" in "Chapter 2 - Installation") but their **VOLTS** and **AMPS** displays do not light. If a module does not appear to be operating but its **VOLTS** and **AMPS** display light, move the module to another address slot. If the above condition still occurs, then the problem probably is in the module.

Module Line Fuse

If a power module's fan is on but its front panel does not light, the module line fuse may be blown. Proceed as follows:

1. Remove the power module from the mainframe.

Note You can remove and insert the power module without turning off the mainframe power provided the module output is either disabled or is programmed to zero and there is no GPIB bus, trigger bus, or RI/DFI activity. If you are in doubt, turn off the mainframe power.

2. Check the line fuse (see Figure 2-1). If it is defective, replace it with one of the same type and rating (for the Agilent part number, see Table 1-3).



Do not use a slow-blow fuse as a replacement.

3. Replace the power module in the mainframe.

Module Output Connector

If the module panel indicates a normal voltage but there is no output at the load, the problem may be in the output connector. This is even more probable if the connector has relays. The following tests may isolate the problem:

- If another module is working normally, use its mainframe slot for the suspected module (be careful to guard against any difference in module output voltage). If there is still no output, the problem is in the module. If the module has an output in the new slot, the problem is with its original output connector.
- To check a suspected connector with a good module, proceed as follows (see *DC Module Connectors Installation Guide* for details of the connector and its jumpers):
 1. Disable the power module output (**Dis** annunciator on).
 2. Remove the output connector from mainframe.
 3. Examine the connector plug for bent pins.
 4. Remove the cover from the output connector.
 5. If there is no relay board, go to step 6. Otherwise, proceed as follows:
 - a. Remove the relay board by pulling it straight up.
 - b. Examine relay board connector for bent pins.
 - c. Examine the connector board to ensure that the required jumpers have been cut to enable relay operation.
 6. Examine the jumpers on the connector board. If any jumpers have been cut, they must be replaced.

Error Messages

A power module may fail either during selftest or while operating (runtime). In either case, the module display may show an error message indicating the reason for the failure.

Selftest Error Messages

Table 3-3 lists the displayed selftest error messages. All these errors are hardware failures that require service.

Note If you are using the optional Agilent 66001A MPS Keyboard, it will also display selftest error messages.

Table 3-3. Selftest Error Messages

Display	Failed Test	Display	Failed Test
U 1	Internal RAM	U 8	Ambient temperature reading
U 2	External RAM	U 9	(Not used)
U 3	ROM checksum	U 10	Voltage programming, low range
U 4	(Not used)	U 11	Current programming, low range
U 5	(Not used)	U 12	Voltage programming, high range
U 6	12 V supply	U 13	Current programming, high range
U 7	5 V supply		

The power module also can detect an EEPROM checksum error. This error is not identified by number, but causes the following symptoms:

- The power module starts up with both the VOLTS and AMPS full-scale programming and metering ranges accepting values up to 1000.
- Self-test error code 330 is stored in the SCPI error queue where it can be read by software (see "Chapter 5 - Error Messages" in the Programming Guide).
- The software identify query (*IDN?) returns 0A in the model field.
- The calibration password is set to 0.

An EEPROM checksum error can occur due to the following operating conditions:

- Excessive number of write cycles to an EEPROM (see Table 1-2). This condition is not recoverable and requires service.
- Loss of ac input power during a checksum calculation. This condition, which is very unlikely, is recoverable. You may be able to recover by performing the following steps from the controller or keyboard:
 1. Enable the calibration mode (CAL:STAT ON,0)
 2. Save an operating state to EEPROM. (e.g., *SAV 2)
- This forces the power module to write to EEPROM and establishes a new checksum.

Runtime Error Messages

Table 3-4 lists the runtime error messages. Runtime errors cease normal power module operation, disable the output, and display a code on the front panel. The error code is preceded by "U" and is displayed on both the **VOLTS** and **AMPS** displays. Runtime errors are hardware malfunctions that require service.

Table 3-4. Runtime Error Messages

Display	Meaning	Display	Meaning	Display	Meaning
U 101	EEPROM write error	U 102	Internal software error	U 103	Unexpected interrupt

Basic Power Module Commands

Introduction

"Chapter 3 - Language Dictionary" of the *Programming Guide* describes all the power module commands. This chapter introduces you to the commands that control the following basic functions:

- output state
- protection circuits
- fixed-mode output
- list-mode output
- triggers
- the RFI function
- the DFI function

The power module can be programmed from a controller over the GPIB or from an optional Agilent 66001A MPS Keyboard plugged into the mainframe. In order to apply the information in this chapter, you must have a working knowledge of either method. Information concerning programming is presented as follows:

Method of Control	Consult
GPIB Controller	<i>Programming Guide for Agilent Series 66lxxA MPS Power Modules</i>
MPS Keyboard	Appendix B of this guide

GPIB Controller

The power module is programmed by SCPI (Standard Commands for Programmable Instruments) commands sent as strings within your language statements. "Chapter 2 Introduction to Programming" of the *Programming Guide* explains how to do this. The syntax of each command is given in Chapter 3 of that guide.

MPS Keyboard

If you have installed the optional MPS keyboard, you can execute the commands given here. You do not have to understand the details of SCPI programming, because the keyboard menu allows you to step through all commands. If you have a keyboard, it is highly recommended that you use it until you are familiar with the general concepts of power module operation.

Note The keyboard menu omits optional SCPI headers. That is why some commands displayed on the keyboard will not look exactly like the syntax given in Chapter 3 of the *Programming Guide*.

Synopsis Of Commands

The following tables summarize the SCPI commands by function. The short form without optional headers is used in this chapter. For example, the full command for turning on the output as given in the *Programming Guide* is **OUTPut [: STATE] ON**. Here the optional [STATE] (in brackets) is omitted and only the short form (in capital letters) **OUTP ON** is used.

The query form of a command (**OUTP?**) is omitted unless the command is only of the query form (such as **MEAS:VOLT?**).

Controlling the Output State

The following commands control the power module output state:

Table 4-1. Power Module Output Commands

Command	Function
OUTP <i>ON</i>	Enables the output.
OUTP <i>OFF</i>	Disables the output. (If an optional output relay is installed, the command is executed in a sequence that prevents "hot switching".)
OUTP <i>I,NOR</i>	Enables the output without affecting the output relay.
OUTP <i>O,NOR</i>	Disables the output without affecting the output relay.
OUTP:REL <i>I</i>	Closes the (optional) output relay contacts.
OUTP:REL <i>O</i>	Opens the (optional) output relay contacts.
OUTP:REL:POL <i>NORM</i>	Makes the (optional) output relay polarity the same as the module output.
OUTP:REL:POL <i>REV</i>	Makes the (optional) output relay polarity opposite to the module output. The output is disabled while the relay polarity is being reversed.)

Controlling Protection Functions

The following commands control the power module protection circuits.

Table 4-2. Power Module Protection Commands

Command	Function
CURR:PROT:STAT <i>ON</i>	Turns on the OCP (overcurrent protection), which disables the output if the output current exceeds the programmed current.
CURR:PROT:STAT <i>OFF</i>	Turns off the current protection.
VOLT:PROT <value>	Programs the OVP (overvoltage protection) level. The protection circuit will trip if the output voltage exceeds the OVP level.
OUTP:PROT:CLE	Clears any active protection conditions (panel Prot annunciator goes off). Before the command can comply, you must remove the condition that caused the protection circuit to trip.
OUTP:PROT:DEL .05	Specifies a delay (in seconds) between the time a protection condition is detected and the actual activation of the protection circuit. (Does not apply to OVP.)

Controlling Fixed-Mode Output

The following commands control the power module fixed-mode voltage and current output.

Table 4-3. Power Module Fixed-Mode Output Commands

Command	Function
CURR:MODE <i>FIX</i>	Sets the current mode to fixed (as opposed to list). <i>FIX</i> is the factory default power on state.
CURR <value>	Programs the immediate output current level (in amperes).
CURR:TRIG <value>	Programs the triggered output current level (in amperes). See "Trigger Commands".
MEAS:CURR?	Returns the present value of the output current.
VOLT:MODE <i>FIX</i>	Sets the voltage mode to fixed (as opposed to list). <i>FIX</i> is the factory default power on state.
VOLT <value>	Programs the immediate output voltage level (in amperes).
VOLT:TRIG <value>	Programs the triggered output voltage level (in amperes). See "Trigger Commands".
MEAS:VOLT?	Returns the present value of the output voltage.
VOLT:SENS?	Returns the position of the output connector sense switch (<i>INT</i> is local; <i>EXT</i> is remote).

Controlling List-Mode Output

The following commands control the power module list-mode voltage and current output. Lists require a trigger to begin execution. For an explanation of lists and triggers, see "Chapter 5 - Synchronizing Power Module Output Changes": in the *Programming Guide*.

Table 4-4. Power Module List-Mode Output Commands

Command	Function
CURR:MODE LIST	Sets the current mode to list (as opposed to fixed).
LIST:CURR <value>,<value>	Programs the output current values (or points) in the list. When you execute the list, the output will sequentially step through the list values.
LIST:CURR:POIN?	Returns the number of points programmed in the current list.
VOLT:MODE LIST	Sets the voltage mode to list (as opposed to fixed).
LIST:VOLT <value>,<value>	Programs the output voltage values (or points) in the list. When you execute the list, the output will sequentially step through the list values.
LIST:VOLT:POIN?	Returns the number of points programmed in the voltage list.
LIST:DWEL <value>,<value>	Programs the dwell value, in seconds, for each value in a voltage or current list. There must be one dwell value for each value in the voltage or current list.
LIST:DWEL:POIN?	Returns the number of points programmed in the dwell list.
LIST: STEP ONCE	Commands the list to execute only one value (point) when a trigger is received. This specifies a trigger-paced list.
LIST: STEP AUTO	Commands the list to execute all values (points) when a trigger is received. This specifies a dwell-paced list.

Controlling Triggers

The following commands control the power module trigger subsystem. For a detailed description of this subsystem, see "Chapter 5 - Synchronizing Power Module Output Changes": in the *Programming Guide*.

Table 4-5. Power Module Trigger Commands

Command	Function
INIT	Initiates the trigger subsystem to detect one trigger. No triggers will be processed unless the subsystem is initiated.
INIT:CONT	Keeps the trigger subsystem continuously initiated so it will process each incoming trigger.
TRIG:SOUR BUS EXT HOLD LINK TTLT TRIG:DEL <value>	Specifies which trigger source is to be accepted by the trigger subsystem (see the <i>Programming Guide</i>). <i>HOLD</i> prevents response to all triggers. Programs the delay time (in seconds) between the detection of a trigger and its execution.
TRIG *TRG TRIG:LINK <parameter>	Either command sends a trigger signal to the power module over the GPIB bus. When TRIG:SOUR <i>LINK</i> is programmed, this command specifies the link parameter for the trigger (see <i>Programming Guide</i>).
OUTP: TILT ON OUTP: TTLT OFF OUTP:TTLT:SOUR BUS EXT HOLD LINK OUTP:TTLT:LINK	Enables the power module Trigger Out signal, which is a 20- μ s negative-true TTL pulse available at the mainframe TRIGGER OUT jack. To use this output, you must program a TTLT trigger source (OUTP:TTLT:SOUR). Disables the power module Trigger Out signal. Specifies which trigger source is to be used for the Trigger Out signal. <i>HOLD</i> prevents a response to any source. When OUTP: SOUR <i>LINK</i> is programmed, this command specifies the link parameter for the trigger (see <i>Programming Guide</i>).

Using the RI/DFI Functions

RI (Remote Inhibit) Input

The signal applied to the mainframe digital connector INH input (see "Chapter 3 Connections" of the mainframe *Installation Guide*) is the RI (remote inhibit). The module function switch described in "Chapter 2 - Installation" allows you to enable or disable the RI input and, when enabled, to specify RI as either latching or nonlatching. If the module function switch is set to enable RI, then the input signal will disable the power module output. If the function switch is also set to RI nonlatching, then removing the signal from the INH input restores the power module output. If the function switch is set to RI latching, an RI status bit is latched and the power module remains disabled after the input signal is removed. The RI status bit is removed either by reading the Status Questionable Event register (**STAT: QUES?**) or by clearing it (***CLS**). See the *Programming Guide* for specifics.

The detected RI bit can be used to generate a DFI signal that appears at the mainframe FLT output. This signal, in turn, can be wired to the RI inputs of other power modules to also disable their outputs (see the wiring diagram in Chapter 3 of the mainframe *Installation Guide*).

DFI (Discrete Fault Indicator) Output

When the DFI function is enabled (OUTP:DFI ON), you can program the Status Subsystem to cause any status condition (including RI) to generate a DFI output, which appears as a TTL low-true signal at the mainframe digital connector FLT output. See "Chapter 4 - Status Reporting" in the *Programming Guide* for details of programming the Status Subsystem.

Table 4-6. DFI Output Commands

Command	Function
OUTP:DFI ON	Enables the DFI function.
OUTP:DFI OFF	Disables the DFI function.
OUTP: DFI: SOUR LINK	Specifies the source for DFI events. The only source is LINK.
OUTP: DFI: LINK <parameter>	Specifies what power module status events are linked to the DFI function. Table 3-1 in the <i>Programming Guide</i> identifies all the DFI link parameters.

Only one parameter may be specified for OUTP: DFI: LINK, such as OUTP: DFI: LINK CC. However, you can specify entire status groups by specifying a summary bit. For example, OUTP: DFI: LINK QUES specifies the Questionable Status summary bit, which is the logical OR of OV, OC, OT, RI, and UNR. The default link parameter SUM3 is the logical OR of the QUES, OPER, and ESB summary bits. This gives DFI access to all three status register groups (see "Chapter 4 - Status Reporting" in the *Programming Guide* for more information).

Changing The Power On State

Switch 6 of the module function switches (see "Chapter 2 - Installation") determines the state of the power module when you turn it on. With the switch in the factory-default position (1), the module turns on in the reset (***RST**) state. You will find the parameters for this state listed under the ***RST** command in "Chapter 3 - Language Dictionary" of the *Programming Guide*. If you store your own parameters in location 0 (***SAV 0**), and set the switch to 0, then the module will assume that state when you turn it on.

Note The ***RST** state is a safe turn-on state that should not be replaced without careful consideration.

Calibration

Introduction

The power module may be calibrated either over the GPIB from a controller or from an Agilent 66001A Modular Power System keyboard. Instructions are included for either method. The procedures given here apply to all Series 6610xA Power Modules.

Note The Agilent 66000A mainframe does not require calibration.

Enabling Or Disabling The Calibration Function

There are two ways of controlling access to the calibration function. One is by hardware and the other is with software.

Hardware Control

The CAL positions of the power module function switch (see Table 2-1 in "Chapter 2 Installation") allows hardware control over the calibration function. The factory-default setting is for normal calibration. Setting the switches to the Inhibit calibration position prevents any calibration from being performed.

Software Control

The password parameter of the CAL: STAT command allows software control over the calibration function. The standard factory password is the module model number (for example, *66102* for the Agilent 66102A). By changing the password, you can either restrict or allow unlimited access to the calibration function (see "Changing the Calibration Password").

Changing The Calibration Password

You can change the password only when the module is in the calibration mode (which requires you to know the present password). To change the password from *66101* to *81591*, send the following commands:

```
CAL:STAT ON, 66102  
CAL:PASS 81591
```

If you change the password to *0*, then all password protection is removed. The Calibration Subsystem then will accept the CAL: STAT ON command without a password.

Performing a Calibration

Perform the procedures in the order given. The assumed password is *66102*; use your actual password in the procedures.

Important These instructions do not include verification procedures. If you need to perform verification as part of your calibration procedure, refer to the Series Agilent 6610xA Service Manual.

Equipment Required

The equipment listed in Table A-1, or equivalent, is required for calibration.

Table A-1. Equipment Required for Calibration

Equipment	Characteristics	Recommended Model
Voltmeter	D-c accuracy 0.005%, 6 digits; resolution 1 μ V	Agilent 3458A
Shunt		
Agilent 66101A, 66102A	0.01 Ω , 100 A, 100 W, 0.04% @ 100 W, 0.01% @ 1W, power coeff. 0.0004%/watt in air	Guildline 9230/100
Agilent 66103A, 66104A, 66105A, 66106A	0.1 Ω , 15 A, 25 W, 0.04% @ 25 W, 0.01% @ 1W, power coeff. 0.002%/watt in air	Guildline 9230/15
GPIB Controller or Keyboard	HP Vectra (or IBM compatible) with GPIB Interface or Agilent BASIC series Agilent 66001A MPS	

Calibrating Voltage

WARNING

Calibration may cause dangerous voltages to be present at the power module output.

The following procedure calibrates the output voltage and the overvoltage protection (OVP). During voltage calibration, you will enter two readings from the external DVM. You must calibrate the voltage before calibrating the OVP. You do not have to enter any external readings when calibrating the OVP.

Table A-2. Voltage Calibration Procedure

Keyboard Entry	Controller Entry †	Function
Connect the equipment as shown in Figure A-1A		
Output Voltage Calibration		
*R ↓ Enter	*RST	Reset the power module
(Before proceeding, set the module output, via the keyboard or the GPIB, for 1.0 V at 0.5 A)		
O ↓ Enter	OUTP ON	Enable the output
C ↓ S ↓ I ↓ 66102 ↓ Enter	CAL:STAT 1,66102	Using your password, enable the calibration mode
C ↓ V ↓ L ↓ M ↓ Enter	CAL:VOLT:LEV MIN	Select the lower calibration point
C ↓ V ↓ ‡ ↓ ‡ ↓ ‡ ↓ ‡ ↓ Enter	CAL: VOLT: DATA <NRf>	Enter the digital voltmeter reading
C ↓ V ↓ L ↓ M ↓ Enter	CAL:VOLT:LEV MAX	Select the upper calibration point
C ↓ V ↓ ‡ ↓ ‡ ↓ ‡ ↓ ‡ ↓ Enter	CAL:VOLT:DATA <NRf>	Enter the digital voltmeter reading
Note: The following step overwrites the existing voltage calibration constants stored in nonvolatile memory.		
C ↓ S ↓ Enter	CAL:SAV	Save the new calibration constants
Overvoltage Protection Calibration		
If the optional output relay is installed, either disconnect it or set it to the <i>OFF</i> (open) state.		
C ↓ V ↓ P ↓ Enter	CAL:VOLT:PROT	Perform OVP calibration
Note: It takes a few seconds for the power module to make the measurement. When completed, the new constant is automatically stored in nonvolatile memory.		
† See Figure A-2 for program listing.		
‡ Enter the voltage measured by the external digital multimeter.		

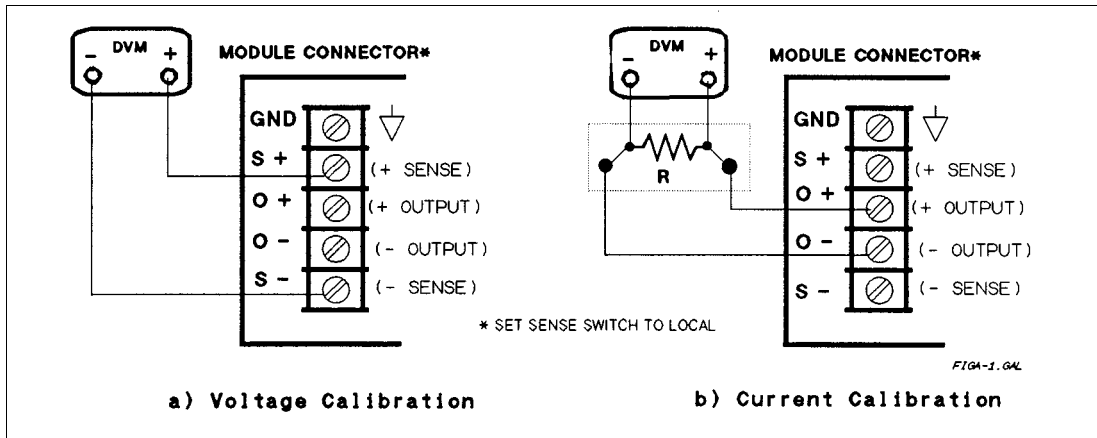

Figure A-1. Calibration Test Setup

Calibrating Current

The following procedure calibrates the output current. During the calibration, you will make two voltage measurements across the output shunt and enter the computed current.

Table A-3. Current Calibration Procedure

Keyboard Entry	Controller Entry †	Function
O 0 Enter	OUTP OFF	Disable the output
	Connect the equipment as shown in Figure A-1B. (Before proceeding, set the module output, via the keyboard or the GPIB, for 1.0 V at 0.5 A.)	
O 1 Enter	OUTP ON	Enable the output
C S ↓ 1 66102 Enter	CAL:STAT 1,66102	Using your password, enable the calibration mode
C C L M ↓ Enter	CAL:CURR:LEV MIN	Select the lower calibration point
	Wait for the meter reading to stabilize. Then read the meter and enter the calculated current value.‡	
C C † † † † Enter	CAL: CURR:DATA <NRf>	Enter lower current value
C C L M Enter	CAL:CURR:LEV MAX	Select the upper calibration point
	Wait for the meter reading to stabilize. Then read the meter and enter the calculated current value.‡	
C C † † † † Enter	CAL: CURR: DATA < NRf>	Enter the upper current value
	Note: The following step overwrites the existing current calibration constants stored in nonvolatile memory.	
C S Enter	CAL:SAV	Save the new calibration constants
	† See Figure A-2 for program listing.	
	‡ Calculate the current value as follows:	
	$I = \frac{V_R}{R}$	

Using The CAL:AUTO Command

Normal calibration procedures also calibrate the readback circuits that respond to the MEAS: CURR? and MEAS: VOLT? commands. During normal operation, the readback accuracy is affected by temperature changes within the power module. Use of the CAL:AUTO command reduces the temperature error component of the readback accuracy specification. See "Chapter 3 - Language Dictionary" of the *Programming Guide* for information about this command.

Recovering The Factory Calibration Constants

The original factory calibration constants are stored in EPROM and can be recovered. This may prove helpful in situations where miscalibration is suspected and it is not possible to recalibrate. To restore factory calibration, proceed as follows:

1. Remove the power module from the mainframe and set the calibration switches to the factory position (see Table 2-1 in "Chapter 2 - Installation").
2. Replace the power module and cycle the power (on and then off).
3. Remove the power module from the mainframe and restore the calibration switches to the normal position.
4. Replace the module in the mainframe.

The module now has its original factory calibration constants. However, *password protection has been removed* from the CAL:STAT ON command.

Recovering From A Lost Calibration Password

The standard factory password is the module model number (for example, 66102). If no one has changed the password, entering the model number will enable the calibration mode (for example, CAL:STAT ON,66102).

If the password is unknown, then the only alternative is to perform the procedure given under "Recovering the Factory Calibration Constants". This removes the password protection from the CAL: STAT ON command. However, it also *changes the calibration constants to their original factory values*.

Calibration Error Messages

If you enter calibration commands from the keyboard, it will display the error messages listed in Table A-4.

Table A-4. Keyboard Calibration Error Messages

CAL ERROR	An entered value is not within acceptable range
DOES NOT CAL	Computed calibration constant is out of range
PASSWD ERROR	You entered an incorrect password
WRONG MODE	The power module is not in CV or CC mode, as required

Agilent Basic Calibration Program

The following program can be run on any controller operating under Agilent BASIC. The assumed slot address is 0 and calibration password is 66101. If required, change these parameters in the appropriate statements.

```

10      ! VOLTAGE CALIBRATION PROGRAM
20      ! CONNECT INSTRUMENTS AS SHOWN IN FIGURE A-1a
30      !
40      DIM Resp$(255),Err_msg$(255)
50 Volt_cal:      !
60      Err_found=0
70      INPUT "CONNECT INSTRUMENTS AS SHOWN IN FIGURE A-1a ... Press any key to continue.",Resp$
80      Resp$=""
90      ASSIGN @Ps TO 70500                                ! ASSIGN POWER SUPPLY GPIB ADDRESS
100                                           ! NOTE: DEFAULT MODULE SLOT IS 0
110                                           !
120      OUTPUT @Ps;"*RST;OUTPUT ON"                    ! INITIALIZE POWER SUPPLY
130      OUTPUT @Ps;"VOLT MAX"
140      OUTPUT @Ps;"CURR MAX"
150      OUTPUT @Ps;"CAL:STATE ON, 66101"                ! PASSWORD IS OPTIONAL - ONLY
160                                           ! REQUIRED IF SET TO NON-ZERO
170                                           ! NOTE: DEFAULT = MODEL NUMBER
180      OUTPUT @Ps;"CAL:VOLTAGE:LEVEL MIN"
190      INPUT "ENTER VOLTAGE MEASUREMENT FROM EXTERNAL VOLTMETER",Volt_read
200      OUTPUT @Ps;"CAL:VOLTAGE ";Volt_read
210      OUTPUT @Ps;"CAL:VOLTAGE:LEVEL MAX"
220      INPUT "ENTER VOLTAGE MEASUREMENT FROM EXTERNAL VOLTMETER",Volt_read
230      OUTPUT @Ps;"CAL:VOLTAGE ";Volt_read
240      OUTPUT @Ps;"CAL:VOLTAGE:PROT"                    ! CALIBRATE OVERVOLTAGE PROTECTION
250                                           ! CIRCUITRY
260      GOSUB Save_cal
270      IF Err_found THEN
280          INPUT "ERRORS have occurred, REPEAT VOLTAGE CALIBRATION (Y OR N)?",Resp$
290          IF TRIM$(UPC$(Resp$(1,1)))="Y" THEN GOTO Volt_cal
300      END IF
310      IF Err_found THEN
320          PRINT "VOLTAGE CALIBRATION NOT SAVED"
330      ELSE
340          PRINT "VOLTAGE CALIBRATION COMPLETE"
350      END
360      !
370      ! CURRENT CALIBRATION PROGRAM
380      ! CONNECT INSTRUMENTS AS SHOWN IN FIGURE A-1b
390      !
400      Current_cal:      !
410      Err_found=0
420      INPUT "CONNECT INSTRUMENTS AS SHOWN IN FIGURE A-1b ... Press any key to continue.",Resp$
430      Resp$=""
440      OUTPUT @Ps;"CAL:STATE ON, 66101"                ! PASSWORD IS OPTIONAL - ONLY
450                                           ! REQUIRED IF SET TO NON-ZERO
460                                           ! NOTE: DEFAULT = MODEL NUMBER
470                                           !
480      ! REFER TO TABLE A-1 FOR CORRECT SHUNT VALUE FOR MODEL BEING CALIBRATED
490      !

```

Figure A-2. Agilent BASIC Calibration Program

```

500 INPUT "ENTER VALUE OF CURRENT SHUNT BEING USED",Shunt_val
510 OUTPUT @Ps;"CAL:CURRENT:LEVEL MIN"
520 INPUT "ENTER VOLTAGE MEASUREMENT FROM EXTERNAL VOLTMETER",Volt_read
530 Current=Volt_read/Shunt_val
540 OUTPUT @Ps;"CAL:CURRENT ";Current
550 OUTPUT @Ps;"CAL:CURRENT:LEVEL MAX"
560 INPUT "ENTER VOLTAGE MEASUREMENT FROM EXTERNAL VOLTMETER",Volt_read
570 Current=Volt_read/Shunt_val
580 OUTPUT @Ps;"CAL:CURRENT ";Current
590 GOSUB Save_cal
600 IF Err_found THEN
610 INPUT "ERRORS have occurred, REPEAT CURRENT
CALIBRATION (Y OR N)?",Resp$
620 IF TRIM$(UPC$(Resp$[1,1]))="Y" THEN GOTO
Current_cal
630 END IF
640 IF Err_found THEN
650 PRINT "CURRENT CALIBRATION NOT SAVED"
660 ELSE
670 PRINT "CURRENT CALIBRATION COMPLETE"
680 END IF
690 STOP
700 Save_cal: ! SAVE CALIBRATION CONSTANTS
710 REPEAT
720 OUTPUT @Ps;"SYSTEM:ERROR?"
730 ENTER @Ps;Err_num,Err_msg$
740 IF Err_num<>0 THEN
750 PRINT "ERROR: ";Err_msg$
760 Err_found=1
770 END IF
780 UNTIL Err_num=0
790 IF NOT Err_found THEN
800 INPUT "SAVE CALIBRATION CONSTANTS (Y OR N)?",Resp$
810 IF TRIM$(UPC$(Resp$[1,1]))="Y" THEN
820 OUTPUT @Ps;"CAL:SAVE"
830 END IF
840 END IF
850 OUTPUT @Ps;"CAL:STATE 0"
860 RETURN
870 END

```

Figure A-2. Agilent BASIC Calibration Program (continued)

Using The Agilent 66001A MPS Keyboard

Introduction

This appendix describes the Agilent 66001A Modular Power System (MPS) Keyboard, which is available as an option for the Agilent 66000A Modular Power System.

The Agilent 66001A MPS Keyboard lets you program the Agilent 66000A Modular Power System without having to connect it to a computer. With the keyboard, you can:

- Access any module in the mainframe that the keyboard is plugged into.
- Display operating and status information from the selected module.
- Control the module from the fields that appear on the display.
- Program the module using SCPI commands and queries.
- Read error messages.

Connecting The Keyboard

The keyboard plugs into a jack on the front of the mainframe as indicated in the following figure. A keyboard jack is also available on the rear panel. The keyboard can be plugged in or out while the mainframe is on.

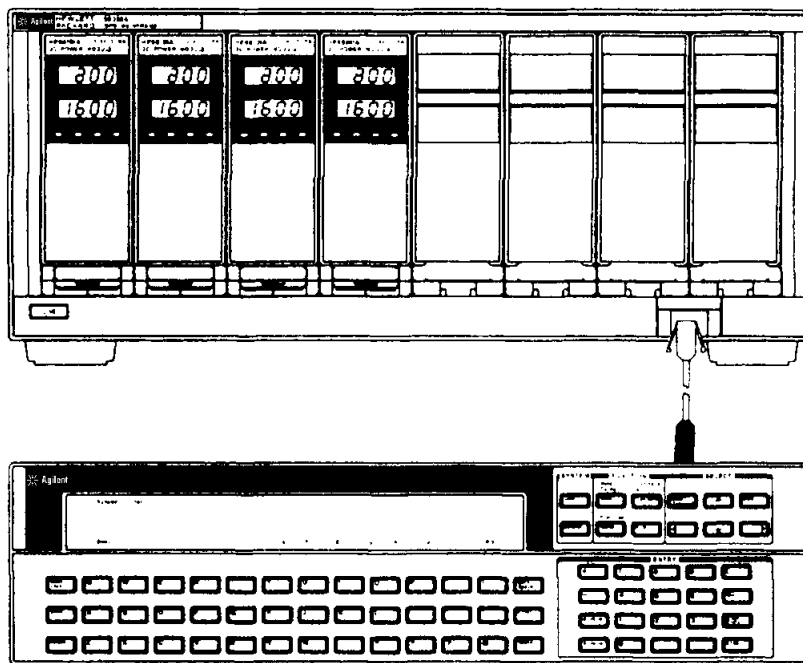

Note Do not connect more than one keyboard to a mainframe.

Keyboard Description

This section briefly explains the various areas on the keyboard as indicated in the following figure:

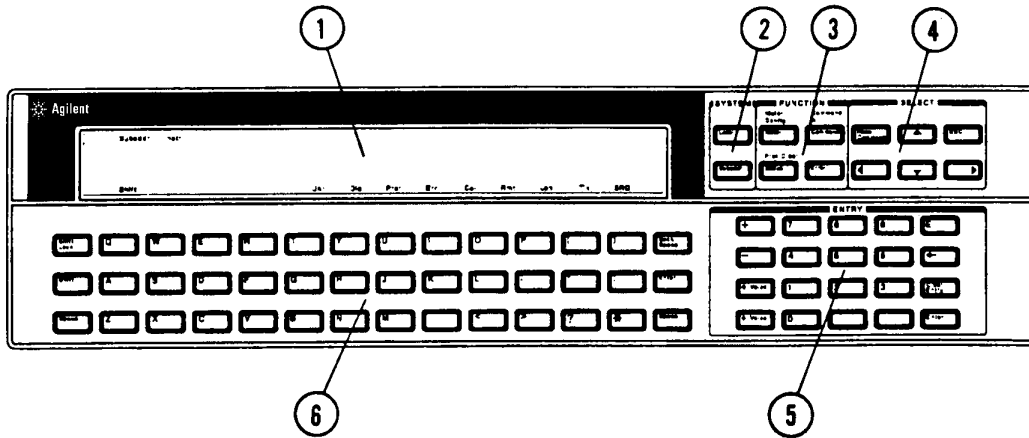

① DISPLAY

Subaddress and Instrument	The subaddress of the presently selected module appears on the left side of the display. The instrument field displays an instrument number when the module contains more than one instrument. Power supply modules do not use this field.
Meter Area	<p>The predominant area of the display presents operating and status information about the selected module. This is referred to as the meter area of the display. Power supply modules display the output voltage and current as well as the operating mode in the meter area of the display. Refer to "Using the Display" for more information.</p> <p>The meter area is also used to display the SCPI commands when the Command function is active. Use the meter area to construct the SCPI command and then send the command to the module.</p>
Annunciators	Annunciators on the bottom of the display provide additional information on the operation of the presently selected module. Active annunciators can indicate:
Shift	The Shift or Shift Lock Lock key has been pressed.
Unr	The module is unregulated.
Dis	The module's output is disabled.
Prot	One of the protection features has been activated.
Err	There is an error message in the SCPI error queue.
Cal	Calibration mode is enabled.
Rmt	The module is in remote mode (keyboard disabled).
Lsn	The module is addressed to listen over the GPIB.
Tlk	The module is addressed to talk over the GPIB.
SRQ	The module has generated a service request.

② SYSTEM KEYS

Local

This key switches from remote operation (over the GPIB) to local operation using the keyboard. Press **Local** when the **Rmt** annunciator is on to enable the keyboard.

Subaddr

This key moves the cursor to the subaddress field so you can select another module. Use the **Entry** or **Select** keys to enter another subaddress.

③ FUNCTION KEYS

Meter

This function continuously displays operating information about the selected module. The Meter function is the turn-on default function, and is also in effect whenever the mainframe is in remote mode.

Command

This function lets you send a SCPI command or query to the selected module. Use the letter keys or the **Select** keys to select the SCPI command. Refer to the power module *Programming Guide* for a complete description of the SCPI commands. Refer to the end of this appendix for the SCPI command tree used by the keyboard.

Status

This function displays status information about the following QUESTIONable and CONDition status register bits: CV, CC, OV, OC, OT, RT, WTG, and DWE. Refer to the power module *Programming Guide* for a complete description of the QUESTIONable and CONDition status registers.

Error

This function displays the error messages whenever the **Err** annunciator on the display indicates that an error has occurred.

Meter Config

([Shift] [Meter])

This function lets you format the meter area of the display. Power supply modules do not use additional meter formats.

Command All

([Shift] [Command])

This function lets you send the next command entered from the keypad to all the modules in the mainframe. The subaddress field on the display indicates "ALL" when this function is active. You must press **Command All** each time you want to send a command to all modules.

Prot Clear

([Shift] [Status])

This function clears any latched protection features that have tripped.

④ SELECT KEYS

◀ ▶

When the Meter function is active, these keys let you move across the display so that you can enter or change values in the selected fields. When the Command function is active, these keys let you move across the various levels of the command tree structure. Numeric command parameters default either to zero or the last programmed value.

▲ ▼

When the Meter function is active, these keys let you increment and decrement the numeric values in the selected field. When the Command function is active, these keys let you scroll up and down through the choices at each level of the command tree.

Recall Command

This key lets you recall up to five previous commands that were sent. You can edit any recalled command. Press **Enter** to send the command.

ESC

This key exits any action and returns the display to the Meter function. If the Command function is active, the displayed command is not executed (same as **Meter**).

⑤ ENTRY KEYS

0 through 9	These keys let you enter numeric values. Values can be entered directly. If the Meter function is active, the display automatically switches to the Command function with the appropriate command for programming the metered mode on the display.
.	This key enters the decimal point.
,	This key is used to separate multiple command arguments such as those used with a List command.
▲ Value ▼ Value	These keys let you increment and decrement the numeric values in the selected field when the Meter function is active. Note that numeric values change in larger steps the longer these keys are held down. When the Command function is active, these keys let you increment and decrement numeric command parameters.
+ -	These keys let you assign a polarity to a value that is entered with the numeric Entry keys. You must enter the polarity before you enter the number.
E	This key lets you enter the exponent of a value that is entered with the numeric Entry keys. Enter the exponent after you enter the number.
←	This key backspaces over and deletes individual digits in a numeric entry field (same as Back Space).
Clear Entry	This key clears the entire numeric entry field.
Enter	This key executes a command.

⑥ LETTER KEYS

A through Z	These keys let you select SCPI commands when the Command function is active. Letter keys select the choices that begin with the letter that is pressed and move across the command tree when additional selections are available. Shift ed letters make selections by scrolling through the choices at the present command level that start with the shifted letter.
-------------	---

Note Nothing happens if a letter is pressed that has no corresponding SCPI command.

:	This key is the prompt for the SCPI instrument commands.
*	This key is the prompt for the GPIB commands (IEEE-488.2).
?	This key is the prompt for SCPI queries. Append the prompt to the query. The result of the query appears on the display after it is entered.
Shift	This key accesses the shifted key functions. The Shift annunciator on the display indicates that the Shift key was depressed. The annunciator turns off when the next key is pressed.
Shift Lock	This key locks the shift key functions. The Shift annunciator on the display indicates when the shift functions are locked.
Back Space	This key backspaces over and deletes individual digits in a numeric entry field (same as ←).
Enter	This key executes a command.

Using The Display

Changing or Entering Values

The following figure is an example of the keyboard display when a power module is addressed and the Meter function is active:

```
Subaddr Instr
02 -- 7.530V 5.005A MODE: CV --
```

The keyboard continuously displays measured voltage and current. The blinking cursor initially highlights the voltage field, which indicates that the value in that field can be changed using the numeric **Entry** keys. You can also use the **Left Arrow** and **Right Arrow** keys to move the cursor across the display to select other fields that you want to change.

Press **▲ Value** repeatedly to increment the voltage value.

▲ Value
▲ Value

```
Subaddr Instr
02 -- 8.921V 5.005A MODE: CV --
```

You can also use the numeric **Entry** keys to enter a new value directly into the field. The display will switch to the Command function when the numeric **Entry** keys are used. Enter the new value next to the SCPI command, and execute the command with the **Enter** key.

5 **.** **2**

```
Subaddr Instr
02 -- :VOLT 5.2
```

Enter

```
Subaddr Instr
02 -- 5.200V 5.005A MODE: CV --
```

Displaying Status

Use the **Status** key to view the present state of the following status bits of the addressed module: CV, CC, OV, OC, OT, RT, WTG, and DWE. A Status mnemonic appears on the display only if the corresponding bit has been set in the status registers. In the following example, the display indicates that the module is in constant voltage (CV) mode and is waiting (WTG) for a trigger input.

Status

```
Subaddr Instr
02 -- CV -- -- -- -- -- WTG ---
```

The status response remains on the display until you press another key to do something else, or until the module goes into remote mode. Press **ESC** or **Meter** to return to the meter function.

Sending SCPI Commands

As described in the power module *Programming Guide*, SCPI commands are organized into message units. The keyboard can only send one message unit at a time; you cannot combine message units. Also, optional headers within a command do not appear on the display. There are two ways to construct message units using the keyboard:

- locate and append each SCPI header to the message unit with the **Select** keys, or
- directly construct the message using only the first letter of each header with the letter keys.

The figure at the end of this appendix shows the SCPI command tree structure that is used by the keyboard. When the command function is selected with the **Command** key, the **VOLTage** command appears on the display for power supply modules.

The **Select** keys let you move up and down as well as across the various levels of the command tree. When numeric parameters are accessed with the **Select** keys, the value either defaults to zero or the last programmed value.

Letter keys let you directly access headers by typing the first letter of the header. Letter keys select headers by moving across the levels of the command tree. If more than one header starts with the same letter at a specific level in the command tree, the first choice in that level is selected. Use the **▲** or **▼** key to select the command you want to use. You can also use the **Shift** ed letters to scroll through the available choices at the present command level that start with the shifted letter.

Command Example

The following examples show you how to use the **Select** keys or the letter keys to construct and send commands to the addressed module. In this example, the voltage protection level of a power supply module is being set to 7 volts.

Command

Subaddr Instr
02 -- : █

▶

Subaddr Instr
02 -- :VOLTage █

▶

Subaddr Instr
02 -- :VOLT 0.0E+0 █

▼

Subaddr Instr
02 -- :VOLT MAX █

▼

Subaddr Instr
02 -- :VOLT MIN █

▼

```
Subaddr Instr
02 -- :VOLT:MODE
```

▼

```
Subaddr Instr
02 -- :VOLT:PROTection
```

▶

```
Subaddr Instr
02 -- :VOLT:PROT 0.0E+0
```

7

```
Subaddr Instr
02 -- :VOLT:PROT 7
```

Press **Enter** to execute the command.

Using the letter keys to directly access and send commands is much faster than using the **Select** keys to find and then send commands. Of course, this method is faster only if you know which commands you are going to program. The following sequence shows the same example using the letter keys:

V

```
Subaddr Instr
02 -- :VOLTage
```

P

```
Subaddr Instr
02 -- :VOLT:PROTection
```

7

```
Subaddr Instr
02 -- :VOLT:PROT 7
```

Press **Enter** to execute the command.

Query Example

Queries return data from the addressed module. Use the **Select** keys or the letter keys to construct and send queries to the addressed module in the same way that you send commands. When you enter the query, the display returns a value. In the following example, the power module is queried as to its actual voltage output:

M

```
Subaddr Instr
02 -- :MEASure
```

V

```
Subaddr Instr
02 -- :MEAS:VOLT?
```

Enter

```
Subaddr Instr
02 -- 5.00000E+0
```

The query response remains on the display until you press another key to do something else, or until the module goes into remote mode. Press **ESC** or **Meter** to return to the meter function.

To query the programmed setting of any command parameter, use the cursor control keys to access the parameter field of the command. The value that appears is the last programmed value. In the following example, the module is queried as to its voltage protection setting:

V

```
Subaddr Instr
02 -- :VOLTage
```

P

```
Subaddr Instr
02 -- :VOLT:PROtection
```

▶

```
Subaddr Instr
02 -- :VOLT:PROT 9.00000E+0
```

You can now change the voltage protection level or press **ESC** or **Meter** to return to the meter function.

Note

If a SCPI command has a corresponding query, you can also add the **?** after the command to turn the command into a query. If a command does not have a corresponding query, the **?** key is ignored.

Error Example

If you make an error when you are constructing a command, the display will inform you that an error has occurred when you enter the command. The following message is an example of an error that has occurred because the data entered for a parameter was out of the range of the power module.

Enter

```
Subaddr Instr
02 -- Data out of range
```

Either press **Recall Command** to recall and edit the command that caused the error or press **ESC** or **Meter** to clear the message and return to the meter function.

With the keyboard, you can also read back any system error that has occurred when the module is operating in remote mode. The **Err** annunciator on the display indicates that there is an error in the SCPI error queue. If the module is in remote mode, you must first press **Local** to get out of remote mode. The following example shows how to read error messages when the module is in remote mode:

Local Error

```
Subaddr Instr
 02 -- ERR-113, Undefined header
          ▼
Shift      Unr Dis Prot Err Cal Rmt Lsn Tlk SRQ
```

If the **Err** annunciator is still on after the error message is displayed, it means there are additional error messages in the SCPI error queue. Press **Error** to display the other messages. Each time you press the **Error** key it removes one error from the error queue.

SCPI Command Tree

The following figure illustrates the SCPI command tree used by the keyboard.

GPIB COMMANDS

*CLS	*OPC	*RST	*TRG
*ESE <NRf>	*OPT?	*SAV <NRf>	*TST?
*ESR?	*PSC 0 1	*SRE <NRf>	*WAI
*IDN?	*RCL <NRf>	*STB?	

SCPI COMMAND TREE
 FOR Agilent SERIES 661xxA MODULES

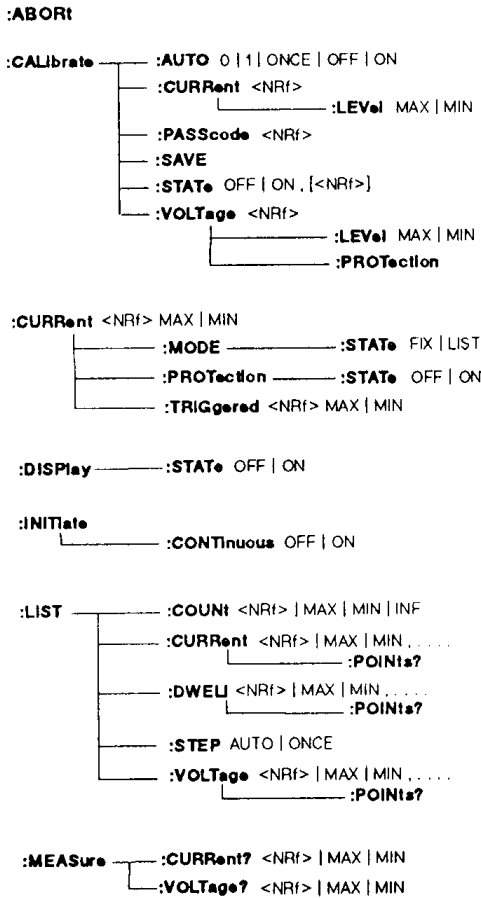

SCPI COMMAND TREE
 FOR Agilent SERIES 661xxA MODULES (continued)

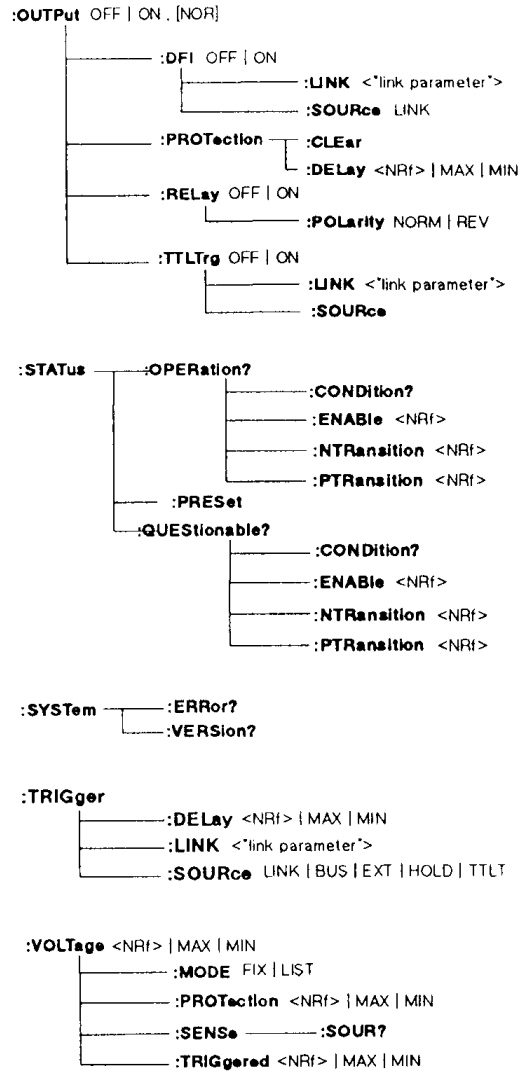

NRf = permissible number format (see Modules Programming Guide)

Figb-3.gsl

Index

A

address slot, 20
ampere capacity, 21
annunciators, display panel
 Addr, 27
 CC, 27
 Dis, 27
 Prot, 27
 Unr, 27

C

cables
 GPIB, 15
 serial link, 15
calibrating current, 37
calibrating voltage, 36
calibration, 35
 constants, 38
 equipment for, 36
 password, 35, 38
 program for, 39
 verification of, 35
capacitive loads, 26
CC mode, 11
checkout, output, 28
checksum error, 28
commands (see SCPI)
commands, common, 46, 50
commands, subsystem, 46, 50
connector, FLT/INH, 34
connector, output, 21, 22, 25, 29
controller, GPIB, 31
CV mode, 11

D

default state (see power-on state)
DFI
 description of, 1-2
 digital connector pins for (see Chapter 3 in
 Installation Guide)
 examples of use, 34
 OUTP:DFI commands for (see Chapter 3 in
 Programming Guide)
 signal electrical characteristics (see Chapter 1 in
 Installation Guide)
 status parameter links for (see Chapter 3 in
 Programming Guide)
SUM3 status bit for (see Chapter 4 in Programming
 Guide)

display panel, 27
downprogramming, 11

E

EEPROM, 30
error messages, display panel
 calibration, 38
 runtime, 30
 selftest, 30
 system, 30
error messages, keyboard, 49

F

factory-default state, 18
fault indicator (see FLT)
fixed-mode operation, 28, 32
FLT input (see DFI)
fuse, line, 15, 18, 29

G

ground, earth, 9, 21
ground, signal, 21
GPIB address
 changing, 26
 determining, 26
 primary, 26
 subaddress, 26, 42
GPIB capabilities, 14

H

hardware, 15

I

identification, module, 9
impedance, output, 11
indicators, display panel
 AMPS, 27
 VOLTS indicator, 27
inductive loads, 26
INH (see RI)
initiating triggers, 33
isolation, 32

K

keyboard, 41
keyboard annunciators
 Cal, 42
 Dis, 42
 Err, 42

Index (continued)

Lsn, 42
Prot, 42
Rmt, 42
Shift, 42
SRQ, 42
Tlk, 42
Unr, 42
keyboard cursor, 45
keyboard display, 42, 45
keyboard entry keys, 44, 45
keyboard function keys, 43
keyboard jack, 41
keyboard keys
 * , 44
 0 , 44
 1 , 44
 2 , 44
 3 , 44
 4 , 44
 5 , 43, 45, 47
 6 , 43, 45
 7 , 43, 46
 8 , 43, 46, 47
 Back Space , 44
 Clear Entry , 44
 Command , 43, 46, 47
 Command All , 43
 E , 44
 Enter , 44, 45, 47, 48
 Error , 43
 ESC , 43, 48
 Local , 43, 49
 Meter , 43, 48
 Meter Config , 43
 + - , 44
 Prot Clear , 43
 Recall Command , 43, 48
 Shift , 44, 46
 Shift Lock , 44
 Status , 43, 45
 Subaddr , 43
 ▲ Value , 44, 45
 ▼ Value , 44
keyboard letter keys, 44
keyboard number keys, 44

keyboard select keys, 43, 46
keyboard system keys, 43
keyword, optional, 31

L

language, SCPI (see SCPI)
LCD (see display)
lists, 10, 33
list-mode operation, 33
load, capacitive, 26
load impedance, 11
load, inductive, 26
local sensing, 21

M

manual, change sheet, 17
manuals, instruction, 9, 10

N

nonvolatile memory, 29

O

OCP, 28, 32
output connector, 15, 29
output curve, 15
output impedance, 11
output noise, 23
output rating, 15, 23
overcurrent protection (see OCP)
overvoltage protection (see OVP)
OVP, and battery charging, 26
OVP, clearing, 32
OVP, and remote sensing, 26
OVP, and status, 45

P

parallel operation, 23
password, calibration, 35, 38
power-on state, 28
 location 0 state, 34
 *RST state, 34
primary address (see GPIB address)
programming, from a controller, 31
programming, from a keyboard, 31, 41
programming current, 28, 32
programming protection circuits, 28, 32
programming triggers, 33
programming voltage, 28, 32
pull tab, 20

Index (continued)

R

remote inhibit (see RI)
RI
description of , 10
digital connector pins for (see Chapter 3 in Installation Guide)
examples of use , 34
example of wiring (see Chapter 3 in Installation Guide)
mainframe input signal (see Chapter 5 in Programming Guide)
RI Questionable Status bit (see Chapters 3 and 4 in Programming Guide)
signal electrical characteristics (see Chapter 1 in Installation Guide)
***RST** state (see power-on state)
recalling states, 28
relay, output, 10, 25, 29
remote sensing, 13, 21, 22, 23
reverse current, 13, 25
reverse voltage, 25

S

safety class, 9
saving states, 28
SCPI
command headers, 31, 50
command tree, 50
error queue, 50
optional commands, 31, 50
query form, 31, 48
SCPI commands, 10, 28, 32, 33
CURR, 32
CURR: MODE, 32
CURR:PROT:STAT, 32
CURR: TRIG, 32
INIT, 33
INIT:CONT, 33
LIST: CURR, 33
LIST: CURR: POIN, 34
LIST: DWEL, 34
LIST:DWEL:POIN, 34
LIST: STEP, 34
LIST: VOLT, 33
MEAS:CURR?, 32
MEAS: VOLT?, 32, 50
OUTP, 32
OUTP: REL, 32
OUTP: DFI, 34
OUTP:DFI: LINK, 34
OUTP: DFI: SOUR, 34
OUTP:TTLT, 33

OUTP:TTLT:LINK, 33
OUTP:TTLT:SOUR, 33
***TRG**, 33
TRIG, 33
TRIG: LINK, 33
TRIG: SOUR, 33
VOLT, 32, 46
VOLT:PROT, 32, 47
VOLT:PROT: CLE, 32
VOLT: TRIG, 32
secondary address (see GPIB subaddress)
selftest, power-on, 28
sense leads, 22
serial cable, 15
serial number, 9
series operation, 24
shunt, calibration, 35
status bits, 34
CC, 45
CV, 45
DWE, 45
OC, 34, 45
OT, 34, 45
OV, 34, 45
RI, 34
RT, 45
UNR, 34
WTG, 45
switch, configuration, 17, 18
calibration, 18, 19
display, 18, 19
power-on state, 18, 19
RI, 18, 19
switch, line voltage, 18
switch, Local/Remote, 19, 25

T

triggers, 10, 33
trigger commands, 33, 49
triggers, initiating, 33
TRIG IN, 10
turn-on state (see power-on state)

U

unregulated operation, 10

V

voltage readback, 22, 32

W

wire size, 21, 23

Agilent Sales and Support Offices

For more information about Agilent Technologies test and measurement products, applications, services, and for a current sales office listing, visit our web site: <http://www.agilent.com/find/tmdir>

You can also contact one of the following centers and ask for a test and measurement sales representative.

United States:

Agilent Technologies
Test and Measurement Call Center
P.O. Box 4026
Englewood, CO 80155-4026
(tel) 1 800 452 4844

Latin America:

Agilent Technologies
Latin American Region Headquarters
5200 Blue Lagoon Drive, Suite #950
Miami, Florida 33126
U.S.A.
(tel) (305) 267 4245
(fax) (305) 267 4286

Canada:

Agilent Technologies Canada Inc.
5150 Spectrum Way
Mississauga, Ontario
L4W 5G1
(tel) 1 877 894 4414

Australia/New Zealand:

Agilent Technologies Australia Pty Ltd
347 Burwood Highway
Forest Hill, Victoria 3131
(tel) 1-800 629 485 (Australia)
(fax) (61 3) 9272 0749
(tel) 0 800 738 378 (New Zealand)
(fax) (64 4) 802 6881

Europe:

Agilent Technologies
Test & Measurement European Marketing Organisation
P.O. Box 999
1180 AZ Amstelveen
The Netherlands
(tel) (31 20) 547 9999

Asia Pacific:

Agilent Technologies
24/F, Cityplaza One, 1111 King's Road,
Taikoo Shing, Hong Kong
tel: (852)-3197-7777
fax: (852)-2506-9284

Japan:

Agilent Technologies Japan Ltd.
Measurement Assistance Center
9-1, Takakura-Cho, Hachioji-Shi,
Tokyo 192-8510, Japan
(tel) (81) 426 56 7832
(fax) (81) 426 56 7840

Technical data is subject to change.

Manual Updates

The following updates have been made to this manual since the print revision indicated on the title page.

4/15/00

All references to HP have been changed to Agilent.
All references to HP-IB have been changed to GPIB.

6/21/02

The serial number and option number information in chapter 1 has been updated.

9/21/04

The Declaration of Conformity has been updated.