

SERVICE MANUAL

**AUTORANGING
DC POWER SUPPLY
AGILENT MODELS
6023A and 6028A**

Agilent Part No. 5964-8283

FOR INSTRUMENTS WITH SERIAL NUMBERS

Agilent Model 6023A; Serials US36490101 and above

Agilent Model 6028A; Serials US36520101 and above

For instruments with higher serial numbers, a change page may be included.



Microfiche Part No. 5964-8284

Printed in USA: July 2001

CERTIFICATION

Agilent Technologies certifies that this product met its published specifications at time of shipment from the factory. Agilent Technologies further certifies that its calibration measurements are traceable to the United States National Institute of Standards and Technology, to the extent allowed by the Institute's calibration facility, and to the calibration facilities of other International Standards Organization members.

WARRANTY

This Agilent Technologies hardware product is warranted against defects in material and workmanship for a period of three years from date of delivery. Agilent Technologies software and firmware products, which are designated by Agilent Technologies for use with a hardware product and when properly installed on that hardware product, are warranted not to fail to execute their programming instructions due to defects in material and workmanship for a period of 90 days from date of delivery. During the warranty period Agilent Technologies will, at its option, either repair or replace products which prove to be defective. Agilent Technologies does not warrant that the operation of the software, firmware, or hardware shall be uninterrupted or error free.

For warranty service, with the exception of warranty options, this product must be returned to a service facility designated by Agilent Technologies. Customer shall prepay shipping charges by (and shall pay all duty and taxes) for products returned to Agilent Technologies for warranty service. Except for products returned to Customer from another country, Agilent Technologies shall pay for return of products to Customer.

Warranty services outside the country of initial purchase are included in Agilent Technologies' product price, only if Customer pays Agilent Technologies international prices (defined as destination local currency price, or U.S. or Geneva Export price).

If Agilent Technologies is unable, within a reasonable time to repair or replace any product to condition as warranted, the Customer shall be entitled to a refund of the purchase price upon return of the product to Agilent Technologies.

LIMITATION OF WARRANTY

The foregoing warranty shall not apply to defects resulting from improper or inadequate maintenance by the Customer, Customer-supplied software or interfacing, unauthorized modification or misuse, operation outside of the environmental specifications for the product, or improper site preparation and maintenance. **NO OTHER WARRANTY IS EXPRESSED OR IMPLIED. AGILENT TECHNOLOGIES SPECIFICALLY DISCLAIMS THE IMPLIED WARRANTIES OF MERCHANTABILITY AND FITNESS FOR A PARTICULAR PURPOSE.**

EXCLUSIVE REMEDIES

THE REMEDIES PROVIDED HEREIN ARE THE CUSTOMER'S SOLE AND EXCLUSIVE REMEDIES. AGILENT TECHNOLOGIES SHALL NOT BE LIABLE FOR ANY DIRECT, INDIRECT, SPECIAL, INCIDENTAL, OR CONSEQUENTIAL DAMAGES, WHETHER BASED ON CONTRACT, TORT, OR ANY OTHER LEGAL THEORY.

ASSISTANCE

The above statements apply only to the standard product warranty. Warranty options, extended support contracts, product maintenance agreements and customer assistance agreements are also available. Contact your nearest Agilent Technologies Sales and Service office for further information on Agilent Technologies' full line of Support Programs.

SAFETY SUMMARY

The following general safety precautions must be observed during all phases of operation, service and repair of this instrument. Failure to comply with these precautions or with specific warnings elsewhere in this manual violates safety standards of design, manufacture, and intended use of the instrument. Agilent Technologies, Inc. assumes no liability for the customer's failure to comply with these requirements.

BEFORE APPLYING POWER.

Verify that the product is set to match the available line voltage and the correct fuse is installed.

GROUND THE INSTRUMENT.

This product is a Safety Class 1 instrument (provided with a protective earth terminal). To minimize shock hazard, the instrument chassis and cabinet must be connected to an electrical ground. The instrument must be connected to the ac power supply mains through a three-conductor power cable, with the third wire firmly connected to an electrical ground (safety ground) at the power outlet. For instruments designed to be hard wired to the ac power lines (supply mains), connect the protective earth terminal to a protective conductor before any other connection is made. Any interruption of the protective (grounding) conductor or disconnection of the protective earth terminal will cause a potential shock hazard that could result in personal injury. If the instrument is to be energized via an external autotransformer for voltage reduction, be certain that the autotransformer common terminal is connected to the neutral (earth pole) of the ac power lines (supply mains).

INPUT POWER MUST BE SWITCH CONNECTED.

For instruments without a built-in line switch, the input power lines must contain a switch or another adequate means for disconnecting the instrument from the ac power lines (supply mains).

DO NOT OPERATE IN AN EXPLOSIVE ATMOSPHERE.

Do not operate the instrument in the presence of flammable gases or fumes.

KEEP AWAY FROM LIVE CIRCUITS.

Operating personnel must not remove instrument covers. Component replacement and internal adjustments must be made by qualified service personnel. Do not replace components with power cable connected. Under certain conditions, dangerous voltages may exist even with the power cable removed. To avoid injuries, always disconnect power, discharge circuits and remove external voltage sources before touching components.

DO NOT SERVICE OR ADJUST ALONE.

Do not attempt internal service or adjustment unless another person, capable of rendering first aid and resuscitation, is present.

DO NOT EXCEED INPUT RATINGS.

This instrument may be equipped with a line filter to reduce electromagnetic interference and must be connected to a properly grounded receptacle to minimize electric shock hazard. Operation at the line voltage or frequencies in excess of those stated on the data plate may cause leakage currents in excess of 5.0mA peak.

SAFETY SYMBOLS.



Instruction manual symbol: the product will be marked with this symbol when it is necessary for the user to refer to the instruction manual (refer to Table of Contents) .



Indicates hazardous voltages.

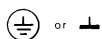

Indicate earth (ground) terminal.

WARNING

The WARNING sign denotes a hazard. It calls attention to a procedure, practice, or the like, which, if not correctly performed or adhered to, could result in personal injury. Do not proceed beyond a WARNING sign until the indicated conditions are fully understood and met.

CAUTION



















The CAUTION sign denotes a hazard. It calls attention to an operating procedure, or the like, which, if not correctly performed or adhered to, could result in damage to or destruction of part or all of the product. Do not proceed beyond a CAUTION sign until the indicated conditions are fully understood and met.

DO NOT SUBSTITUTE PARTS OR MODIFY INSTRUMENT.

Because of the danger of introducing additional hazards, do not install substitute parts or perform any unauthorized modification to the instrument. Return the instrument to a Agilent Technologies, Inc. Sales and Service Office for service and repair to ensure that safety features are maintained.

Instruments which appear damaged or defective should be made inoperative and secured against unintended operation until they can be repaired by qualified service personnel.

SAFETY SYMBOL DEFINITIONS

Symbol	Description	Symbol	Description
	Direct current		Terminal for Line conductor on permanently installed equipment
	Alternating current		Caution, risk of electric shock
	Both direct and alternating current		Caution, hot surface
	Three-phase alternating current		Caution (refer to accompanying documents)
	Earth (ground) terminal		In position of a bi-stable push control
	Protective earth (ground) terminal		Out position of a bi-stable push control
	Frame or chassis terminal		On (supply)
	Terminal for Neutral conductor on permanently installed equipment		Off (supply)
	Terminal is at earth potential (Used for measurement and control circuits designed to be operated with one terminal at earth potential.)		Standby (supply) Units with this symbol are not completely disconnected from ac mains when this switch is off. To completely disconnect the unit from ac mains, either disconnect the power cord or have a qualified electrician install an external switch.

Printing History

The edition and current revision of this manual are indicated below. Reprints of this manual containing minor corrections and updates may have the same printing date. Revised editions are identified by a new printing date. A revised edition incorporates all new or corrected material since the previous printing date. Changes to the manual occurring between revisions are covered by change sheets shipped with the manual. Also, if the serial number prefix of your power supply is higher than those listed on the title page of this manual, then it may or may not include a change sheet. That is because even though the higher serial number prefix indicates a design change, the change may not affect the content of the manual.

Edition 1 July, 2001

© Copyright 2001 Agilent Technologies, Inc.

This document contains proprietary information protected by copyright. All rights are reserved. No part of this document may be photocopied, reproduced, or translated into another language without the prior consent of Agilent Technologies, Inc. The information contained in this document is subject to change without notice.

TABLE OF CONTENTS

Introduction	7
Scope	7
Calibration and Verification	7
Troubleshooting	7
Principles of Operation	7
Replaceable Parts	7
Circuit Diagrams	7
Safety Considerations	7
Manual Revisions	8
Calibration and Verification.....	9
Introduction.....	9
Test Equipment Required	9
Operation Verification Tests.....	9
Calibration Procedure	9
Initial Setup.....	11
Performance Tests	14
Measurement Techniques	14
Constant Voltage (CV) Tests.....	15
Constant Current (CC) Tests.....	21
Troubleshooting.....	23
Introduction.....	23
Initial Troubleshooting Procedures.....	23
Electrostatic Protection.....	25
Repair and Replacement	25
A2 Control Board Removal	26
A4 Power Mesh Board Removal	27
A3 Front-Panel Board Removal.....	27
A1 Main Board Removal.....	27
Overall Troubleshooting Procedure.....	27
Using the Tables	28
Main Troubleshooting Setup	29
Troubleshooting No-Output Failures.....	31
Front-Panel Troubleshooting	31
Troubleshooting Bias Supplies	33
Power Section Blocks	35
Troubleshooting AC-Turn-on Circuits.....	35
Troubleshooting PWM & Clock.....	36
Troubleshooting DC-To-DC Converter.....	37
Troubleshooting CV Circuit	38
Troubleshooting CC Circuit.....	38
Troubleshooting Down Programmer	39
Troubleshooting OVP Circuit.....	39
Principles of Operation	43
Autoranging Power	43
Block Diagram Overview	43
Simplified Schematic.....	45
DC-to-DC Converter.....	47
Down Programmer.....	47
Constant-Voltage (CV) Circuit	48
Constant-Current (CC) Circuit.....	49

Overvoltage Protection (OVP) Circuit.....	49
Power-Limit Comparator.....	49
Control-Voltage Comparator.....	49
Initial-Ramp Circuit.....	50
Pulse-Width Modulator (PWM).....	50
Bias Voltage Detector.....	50
AC-Surge Dropout Detector.....	50
1-Second-Delay Circuit.....	51
Display Circuits.....	51
Replaceable Parts.....	53
Introduction.....	53
Ordering Information.....	54
Component Location and Circuit Diagrams.....	69
System Option 002.....	79
General Information.....	79
Specifications.....	79
Option 002 Hardware.....	79
Installation.....	83
Connector Assembly Procedure.....	83
Operation.....	84
Local/Remote Programming.....	85
Remote Resistance Programming.....	87
Remote Monitoring.....	89
Status Indicators.....	90
Remote Control.....	90
Power-On Preset.....	92
AC Dropout Buffer Circuit.....	93
Multiple Supply System Shutdown.....	93
Bias Supplies.....	94
Maintenance.....	94
Troubleshooting.....	95
Troubleshooting Resistance and Voltage Programming.....	95
Troubleshooting Current Programming.....	95
Backdating.....	107

Introduction

Scope

This manual contains information for troubleshooting the Agilent 6023A or 6028A 200W Autoranging Power Supply to the component level. Wherever applicable, the service instructions given in this manual refer to pertinent information provided in the Operation Manual. Both manuals cover Agilent Models 6023A/28A; differences between models are described as required.

The following information is contained in this manual.

Calibration and Verification

Contains calibration procedures for Agilent Models 6023A/28A. Also contains verification procedures that check the operation of the supplies to ensure they meet the specifications of Chapter 1 in the Operating Manual.

Troubleshooting

Contains troubleshooting procedures to isolate a malfunction to a defective component on the main circuit board or to a defective assembly (front-panel, power transformer, or cable assembly). Board and assembly level removal and replacement procedures are also given in this section.

Principles of Operation

Provides block diagram level descriptions of the supply's circuits. The regulation & control, protection, input power, dc power conversion and output circuits are described. These descriptions are intended as an aid in troubleshooting.

Replaceable Parts

Provides a listing of replaceable parts for all electronic components and mechanical assemblies for Agilent Models 6023A/28A.

Circuit Diagrams

Contains functional schematics and component location diagrams for all Agilent 6023A/28A circuits. The names that appear on the functional schematics also appear on the block diagrams in Chapter 4. Thus, the descriptions in Chapter 4 can be correlated with both the block diagrams and the schematics.

Safety Considerations

This product is a Safety Class 1 instrument, which means that it is provided with a protective earth terminal. Refer to the Safety Summary page at the beginning of this manual for a summary of general safety information. Safety information for specific procedures is located at appropriate places in the manual.

Manual Revisions

Agilent Technologies instruments are identified by a 10-digit serial number. The format is described as follows: first two letters indicate the country of manufacture. The next four digits are a code that identify either the date of manufacture or of a significant design change. The last four digits are a sequential number assigned to each instrument.

Item	Description
-------------	--------------------

US	The first two letters indicates the country of manufacture, where US = USA; MY = Malaysia.
-----------	--------------------------------------------------------------------------------------------

3648	This is a code that identifies either the date of manufacture or the date of a significant design change.
-------------	-----------------------------------------------------------------------------------------------------------

0101	The last four digits are a unique number assigned to each power supply.
-------------	-------------------------------------------------------------------------

If the serial number prefix on your unit differs from that shown on the title page of this manual, a yellow Manual Change sheet may be supplied with the manual. It defines the differences between your unit and the unit described in this manual. The yellow change sheet may also contain information for correcting errors in the manual.

Note that because not all changes to the product require changes to the manual, there may be no update information required for your version of the supply.

Older serial number formats used with these instruments had a two-part serial number, i.e. 2701A-00101. This manual also applies to instruments with these older serial number formats. Refer to Appendix B for backdating information.

Calibration and Verification

Introduction

This section provides test and calibration procedures. The operation-verification tests comprise a short procedure to verify that the unit is performing properly, without testing all specified parameters. After troubleshooting and repair of a defective power supply you can usually verify proper operation with the turn-on checkout procedure in the Operating Manual. Repairs to the A1 main board and the A2 control board can involve circuits which, although functional, may prevent the unit from performing within specified limits. So, after A1 or A2 board repair, decide if recalibration and operation verification tests are needed according to the faults you discover. Use the calibration procedure both to check repairs and for regular maintenance.

When verifying the performance of this instrument as described in this chapter, check only those specifications for which a performance test procedure is included.

Test Equipment Required

Table 2-1 lists the equipment required to perform the tests of this section. You can separately identify the equipment for performance tests, calibration and troubleshooting using the USE column of the table.

Operation Verification Tests

To assure that the unit is performing properly, without testing all specified parameters, first perform the turn-on checkout procedure in the Operating Manual. Then perform the following performance tests, in this section.

CV Load Effect
CC Load Effect

Calibration Procedure

Calibrate the unit twice per year and when required during repair. The following calibration procedures which follow should be performed in the sequence given. Table 2-2 describes in detail these calibration procedures and lists the expected results to which each adjustment must be made.

Note: Some of the calibration procedures for this instrument can be performed independently, and some procedures must be performed together and/or in a prescribed order. If a procedure contains no references to other procedures, you may assume that it can be performed independently.

To return a serviced unit to specifications as quickly as possible with minimal calibration, the technician need only perform calibration procedures that affect the repaired circuit. Table 2-3 lists various power supply circuits with calibration procedures that should be performed after those circuits are serviced.

Table 2-1. Test Equipment Required

TYPE	REQUIRED CHARACTERISTICS	USE	RECOMMENDED MODEL
Oscilloscope	Sensitivity: 1 mV Bandwidth: 20MHz & 100MHz Input: differential, 50Ω & 10MΩ	P,T	Agilent 1740A
RMS Voltmeter	True rms, 10MHz bandwidth Sensitivity: 1 mV Accuracy: 5%	P	Agilent 3400B
Logic Pulser	4.5 to 5.5Vdc @ 35mA	T	Agilent 546A
Multimeter	Resolution: 100nV Accuracy: 0.0035%, 6½ digit	P,A,T	Agilent 3458A
CC PARD Test Current Probe	No saturation at 30Adc Bandwidth: 20Hz to 20MHz	P	Tektronix P6303 Probe/AM503 Amp/ TM500 Power Module
Electronic Load*	Voltage range: 60Vdc Current range: 60Adc Power range: 300 watts Open and short switches	P,A	Agilent 6060B
CC PARD Test & I _p Cal Resistive Load*	Value: 0.25 ohms >250W Accuracy: 1% Rheostat or Resistor Bank	P,A	
Current-Monitoring Resistors	6023A Value: 30mV @ 30A (1mΩ) Accuracy: 1% TC: 30ppm/°C Value: 30mV @ 30A (1mΩ) Accuracy: 0.05% ** TC: 30ppm/°C (A,P) 6028A Value 100MΩ ± 0.04% @ 25W Accuracy: 1% PC: 0.0004% 1W	P,A	Guideline 9230/15
Calibration and Test Resistors	Value: 100Ω, 5%, 1W 1Ω, 5%, 1/2W 1KΩ, 5% 1/4W 5KΩ, 5% 1/4W (6023A) 2KΩ, 0.01% 1/4W	A,T	
Terminating Resistors (4)	Value: 50Ω ±5%, noninductive	P	
Blocking Capacitors (2)	Value: 0.01μF, 100Vdc	P	
Common-mode Toroidal Core		P	Ferrox-Cube 500T600-3C8, Agilent 9170-0061

Table 2-1. Test Equipment Required (continued)

TYPE	REQUIRED CHARACTERISTICS	USE	RECOMMENDED MODEL
Switch	SPST, 30A @ 20V	P	
DC Power Supply	Voltage range: 0-60Vdc Current range: 0-3Adc	T,P	Agilent 6296A
Variable Voltage Transformer (autotransformer)	Range greater than -13% to +6% of nominal input AC voltage 1KVA	P,A	

P = performance testing A = calibration adjustments T = troubleshooting

* Resistors may be substituted for test where an electronic load is not available.

** Less accurate, and less expensive, current-monitor resistors can be used, but the accuracy to which current programming and current meter reading can be checked must be reduced accordingly.

Initial Setup

WARNING

Maintenance described herein is performed with power supplied to the instrument, and protective covers removed. Such maintenance should be performed only by service trained personnel who are aware of the hazards involved (for example, fire and electrical shock). Turn off ac power when making or removing connections to the power supply. Where maintenance can be performed without power applied, the power should be removed.

- a. Unplug the line cable and remove the top cover by removing three screws; the rear handle screw and the two top-rear corner screws. Do not remove the front handle screw as the retaining nut will fall into the unit.
- b. Slide the cover to the rear.
- c. Plug a control board test connector A2P3 onto the A2J3 card-edge fingers.
- d. Turn OVERVOLTAGE ADJUST control A3R59 fully clockwise.
- e. Disconnect all loads from output terminals.
- f. Connect power supply for local sensing, and ensure that MODE switches are set as shown below.

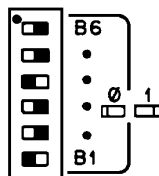

- g. Reconnect the line cable and turn on ac power.
- h. Allow unit to warm up for 30 minutes.
- i. When attaching the DVM, the minus lead of the DVM should be connected to the first node listed, and the plus lead should be connected to the second node listed.
- j. At the beginning of each calibration procedure, the power supply should be in its power-off state, with no external circuitry connected except as instructed.
- k. The POWER LIMIT adjustment (A2R25) must be adjusted at least coarsely before many of the calibration procedures can be performed. If you have no reason to suspect that the Power Limit circuit is out of adjustment, and you do not intend to recalibrate it, do not disturb its setting. Otherwise, center A2R25 before you begin to calibrate the power supply.
- l. To disable the power supply, short INHIBIT line A2J3 pin 8 to COMMON A2J3 pin 4.

Table 2-2. Calibration Procedure

TEST	TESTED VARIABLE	TEST POINTS	TEST SEQUENCE AND ADJUSTMENTS	EXPECTED RESULTS
Meter F/S Adjust.	Meter Ref. Voltage	A2J3 pin 6 (+) ↕M (-)	a. Connect DVM across test points and turn on ac power. b. Adjust A2R24 to obtain the voltage range specified in the results.	$0.5V \pm 50\mu V$
Resistance Programming F/S Adjust.	Prog. Voltage	VP (+) ↕P (-)	a. Connect a $2K\Omega$ 0.01%, $\frac{1}{4}W$ programming resistor and DVM between test points. b. Set MODE switch as in Figure 2-1 and turn on ac power. c. Adjust A2R23 to obtain the voltage range specified in the results.	$2.5V \pm 4mV$
V-MON Zero Adjust.	V-MON	VM (+) ↕M (-)	a. Set voltage and current controls to minimum settings. b. Disable power supply as in Initial Setup step i. c. Short circuit output terminals and connect the DVM between test points. Turn on power supply. d. Adjust V-MON Zero trim pot A2R22 to voltage range specified in the results.	$0 \pm 20\mu V$
Common Mode Adjust.	Residual Output Voltage VM(+)	VM (+) ↕M (-)	a. Set voltage and current controls to minimum. b. Disable power supply as Initial Setup step i. c. Turn on ac power and record the initial voltage (IR) with DVM across test points. d. Remove the - S(+) and - OUT(-) and connect a 1Vdc power supply between - S(+) and - OUT(-). See Figure 2-1. e. Adjust A2R21 to the voltage range specified. f. Remove the 1V supply and replace jumpers.	$IR \pm 20\mu V$
I-MON Zero Adjust.	I-MON	IM (+) ↕M (-)	a. Set voltage and current controls to minimum. b. Turn on ac power. c. Connect DVM across test points and adjust I-MON Zero trim pot A2R8 as shown in results.	$0 \pm 100\mu V$ (6023A) $0 \pm 25\mu V$ (6028A)
I-MON F / S Adjust.	I-MON	IM (+) ↕M (-)	a. Perform I-MON Zero Adjust before proceeding . b. Connect a 0.001Ω 0.05% (6023A), 0.100Ω 0.05% (6028A) current monitoring resistor Rm across the output terminals. c. Turn on ac power and using the “Display Setting”, set current control to 30A (6023A), 10A (6028A), and voltage control to 5V. d. Connect DVM across test points and take an initial reading (IR).	IR* $0.006 IR^*$ $+40\mu V$ (6023A), $0.200 \pm 1\mu V$ (6028A)
		Rm (+) Rm (-)	e. Connect DVM across Rm monitoring terminals and adjust A2R9 as shown in the results.	

*IR = Initial Reading

Table 2-2. Calibration Procedure (continued)

TEST	TESTED VARIABLE	TEST POINTS	TEST SEQUENCE AND ADJUSTMENTS	EXPECTED RESULTS
Power Limit Adjust.	V(OUT) I(OUT)		<ol style="list-style-type: none"> Perform I-MON F/S Adjust before proceeding. Connect the unit to the ac power line via the external variable auto-transformer which is set to nominal line voltage. Connect a 0.25Ω, 250W (6023A), 2.3Ω, 250W (6028A) resistor across the unit's output and turn on ac power. Set voltage control to 9V (6023A) 9V ≥ 3V (6028A) and current control to 30.2A (6023A), 10.2A (6028A) Set auto-transformer to minimum line voltage. Turn A2R25 fully counterclockwise. Slowly adjust A2R25 clockwise until CC LED just lights. 	<p>30.2A 7.55V for CC operation (6023A)</p> <p>10.2A, 23V for CC operation (6028A)</p>

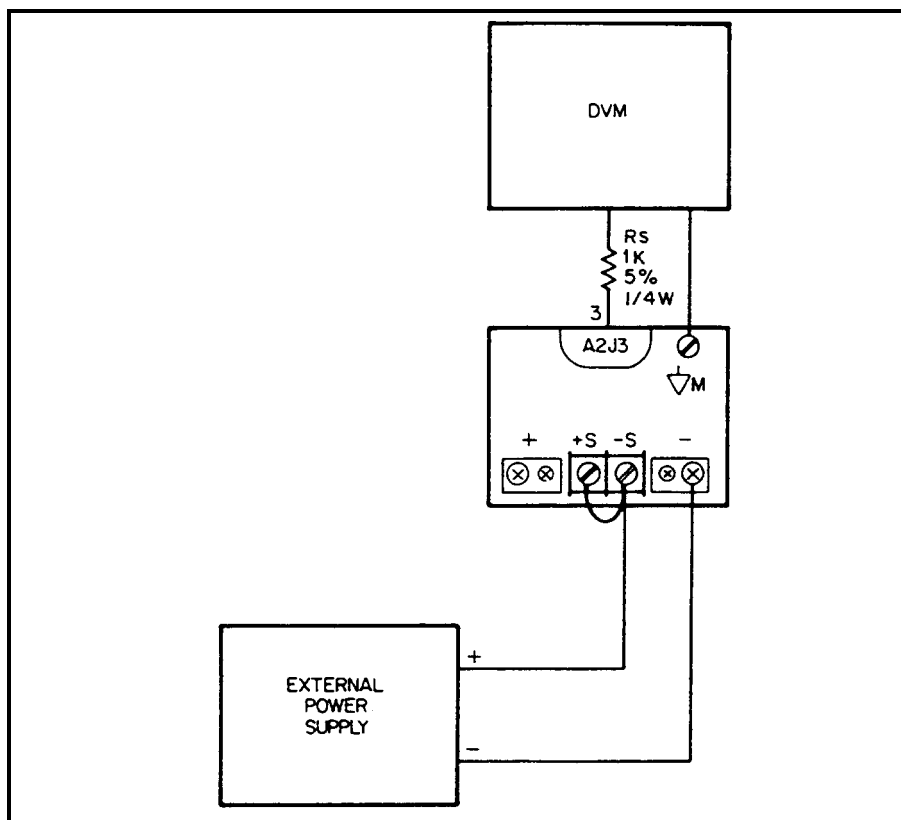

Figure 2-1. Common Mode Setup

Table 2-3. Guide to Recalibration After Repair

Printed Circuit Board	Block Name	Circuit Within Block	Ref. Designator	Perform These Procedures*
A1 Main Board			R3	4
A1 Main Board			T1	4 then 5
A4 Power Mesh			T3	4 then 5 Board
A4 Power Mesh			CR7	4 then 5 Board
A2 Control Board	Constant Voltage (CV) Circuit	All Except Current Source	All	1 then 2
A2 Control Board	Constant Voltage (CV) Circuit	Current Source	All	6
A2 Control Board	Constant Current (CC) Circuit		All	3 then 4
A2 Control Board	Power Limit Comparator		All	4 then 5
A2 Control Board	Bias Power Supplies	± 15V Supplies	All	All
A2 Control Board			U9, R79, R80, R24	7
* Code To Calibration Procedure To Be Performed				
1. V-MON Zero Calibration		4. I-MON Full Scale (F/S) Calibration		
2. Common-Mode Calibration		5. Power Limit Calibration		
3. I-MON Full Scale (F/S) Zero Calibration		6. Resistance Programming Full Scale (F/S) Calibration		
		7. Meter Full Scale (F/S) Calibration		

Performance Tests

The following paragraphs provide test procedures for verifying the unit's compliance with the specifications of Table 1-1 in the Operating Manual. Please refer to CALIBRATION PROCEDURE or TROUBLESHOOTING if you observe out-of-specification performance.

Measurement Techniques

Setup For All Tests. Measure the output voltage directly at the + S and - S terminals. Connect unit for local sensing, and ensure that MODE switches are set as shown below. Select an adequate wire gauge for load leads using the procedures given in the Operating Manual for connecting the load.

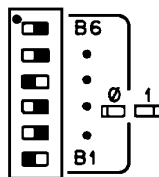

Electronic Load. The test and calibration procedures use an electronic load to test the unit quickly and accurately. If an electronic load is not available, you may substitute a 2Ω 250W load resistor for the electronic load in these tests:

- CV Source Effect (Line Regulation)
- CC Load Effect (Load Regulation)

You may substitute a 0.25Ω 250W load resistor in these tests:

- CV Load Effect (Load Regulation)
- CV PARD (Ripple and Noise)
- CC Source Effect (Line Regulation)
- CC PARD (Ripple and Noise)

The substitution of the load resistor requires adding a load switch to open and short the load in the CC or CV load regulation tests. The load transient recovery time test procedure cannot be performed using load resistors.

An electronic load is considerably easier to use than a load resistor. It eliminates the need for connecting resistors or rheostats in parallel to handle the power, it is much more stable than a carbon-pile load, and it makes easy work of switching between load conditions as is required for the load regulation and load transient-response tests.

Current-Monitoring Resistor R_M . To eliminate output current measurement error caused by voltage drops in the leads and connections, connect the current-monitoring resistor between -OUT and the load as a four-terminal device. Figure 2-2 shows correct connections. Select a resistor with stable characteristics: 0.001, 1% accuracy, 30 ppm/°C or lower temperature coefficient and 20W power rating (20 times actual power if other than 0.001Ω is used).

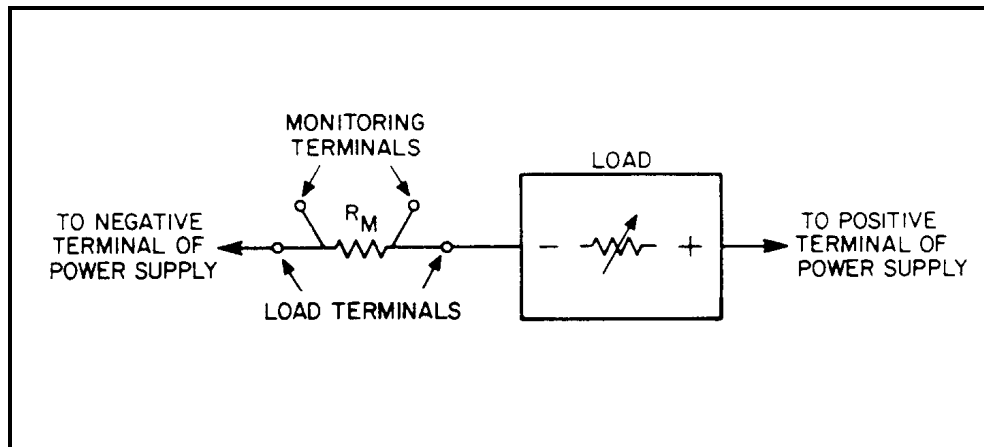

Figure 2-2. Current-Monitoring Resistor Setup

Constant Voltage (CV) Tests

CV Setup. If more than one meter or a meter and an oscilloscope are used, connect each to the + S and - S terminals by a separate pair of leads to avoid mutual coupling effects. Connect only to + S and - S (except for peak-to-peak PARD) because the unit regulates the output voltage between + S and - S, not between + OUT and - OUT. Use coaxial cable or shielded 2-wire cable to avoid pickup on test leads. For all CV tests set the output current at full output to assure CV operation.

Load Effect (Load Regulation). Constant-voltage load effect is the change in dc output voltage (E_o) resulting from a load-resistance change from open-circuit to full-load. Full-load is the resistance which draws the maximum rated output current at voltage E_o . Proceed as follows:

- Connect the test equipment as shown in Figure 2-3. Operate the load in constant resistance mode (Amps/Volt) and set resistance to maximum.
- Turn the unit's power on, and turn up current setting to full output.
- Turn up output voltage to:
 - 7.0Vdc (6023A)
 - 20.0Vdc (6028A)as read on the digital voltmeter.

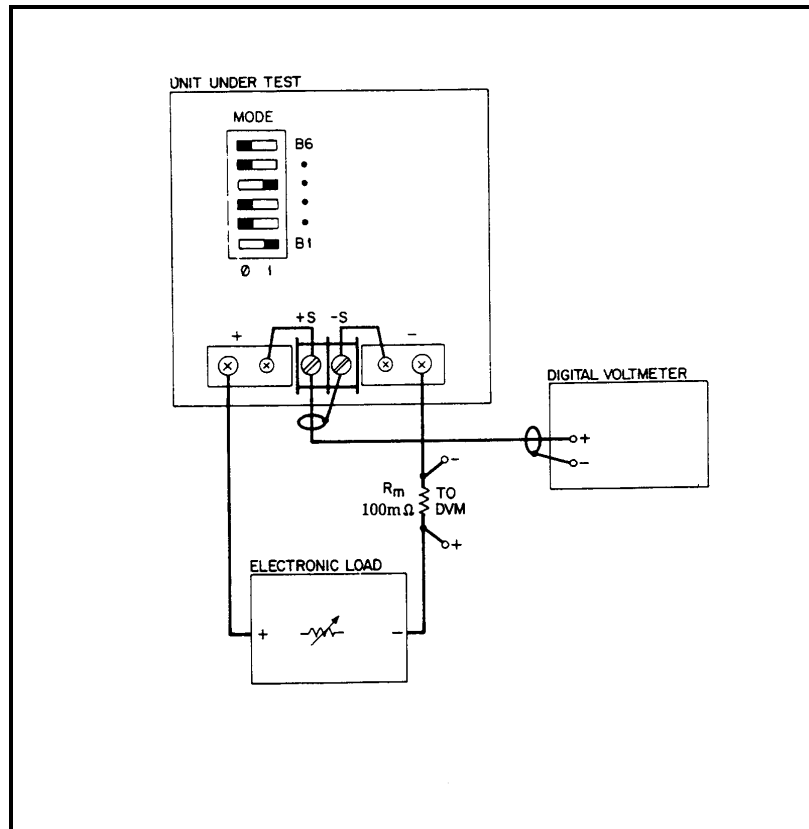

Figure 2-3. Basic Test Setup

- d. Reduce the resistance of the load to draw an output current of:
 - 29A_{dc} (6023A)
 - 10A_{dc} (6028A)
 Check that the unit's CV LED remains lighted.
- e. Record the output voltage at the digital voltmeter.
- f. Open-circuit the load.
- g. When the reading settles, record the output voltage again. Check that the two recorded readings differ no more than:
 - $\pm 0.0027\text{V}_{dc}$ (6023A)
 - $\pm 0.0090\text{V}_{dc}$ (6028A)

Source Effect (Line Regulation). Source effect is the change in dc output voltage resulting from a change in ac input voltage from the minimum to the maximum value as specified in Input Power Requirements in the Specifications Table, in the Operating Manual. Proceed as follows:

- a. Connect the test equipment as shown in Figure 2-3. Operate the load in constant resistance mode (Amps/Volt) and set resistance to maximum.
- b. Connect the unit to the ac power line through a variable autotransformer which is set for low line voltage (104Vac for 120Vac).
- c. Turn the unit's power on, and turn up current setting to full output.
- d. Turn up output voltage to:
 - 20.0V_{dc} (6023A)
 - 60V_{dc} (6028A)
 as read on the digital voltmeter.
- e. Reduce the resistance of the load to draw an output current of:
 - 10A_{dc} (0.010V_{dc} across R_m) (6023A)
 - 3.3A_{dc} (0.33V_{dc} across R_m) (6028A)
 Check that the unit's CV LED remains lighted.

- f. Record the output voltage at the digital voltmeter.
- g. Adjust autotransformer to the maximum for your line voltage.
- h. When the reading settles record the output voltage again. Check that the two recorded readings differ no more than:
 - $\pm 0.0030\text{Vdc}$ (6023A)
 - $\pm 0.0080\text{Vdc}$ (6028A)

PARD (Ripple And Noise). Periodic and random deviations (PARD) in the unit's output-ripple and noise-combine to produce a residual ac voltage superimposed on the dc output voltage. Constant-voltage PARD is specified as the root-mean-square (rms) or peak-to-peak (pp) output voltage in a frequency range of 20Hz to 20MHz.

RMS Measurement Procedure. Figure 2-4 shows the interconnections of equipment to measure PARD in Vrms. To ensure that there is no voltage difference between the voltmeter's case and the unit's case, connect both to the same ac power outlet or check that the two ac power outlets used have the same earth-ground connection.

Use the common-mode choke as shown to reduce ground-loop currents from interfering with measurement. Reduce noise pickup on the test leads by using 50Ω coaxial cable, and wind it five turns through the magnetic core to form the common-mode choke. Proceed as follows:

- a. Connect the test equipment as shown in Figure 2-4. Operate the load in constant resistance mode (Amps/Volt) and set resistance to maximum.
- b. Turn the unit's power on, and turn up current setting to full output.
- c. Turn up output voltage to:
 - 7Vdc (6023A)
 - 20Vdc (6028A)
- d. Reduce the resistance of the load to draw an output current of:
 - 29Adc (6023A)
 - 10Adc (6028A)
 Check that the unit's CV LED remains lighted.
- e. Check that the rms noise voltage at the true rms voltmeter is no more than:
 - 3.0mV rms (6023A)
 - 3.0mV rms (6028A)

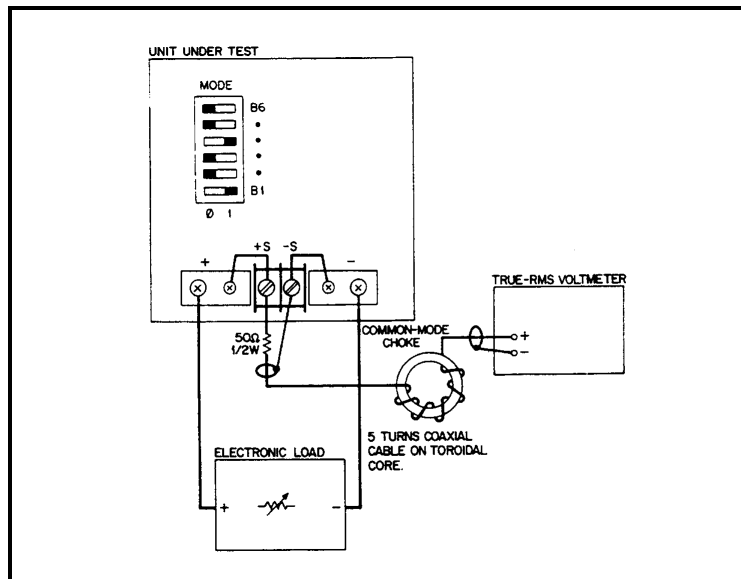

Figure 2-4. RMS Measurement Test Setup, CV PARD Test

Peak Measurement Procedure. Figure 2-5 shows the interconnections of equipment to measure PARD in Vpp. The equipment grounding and power connection instructions of PARD rms test apply to this setup also. Connect the oscilloscope to the + OUT and - OUT terminals through 0.01μF blocking capacitors to protect the oscilloscope's input from

the unit's output voltage. To reduce common-mode noise pickup, set up the oscilloscope for a differential, two-channel voltage measurement. To reduce normal-mode noise pickup, use twisted, 1 meter or shorter, 50Ω coaxial cables with shields connected to the oscilloscope case and to each other at the other ends. Proceed as follows:

- a. Connect the test equipment as shown in Figure 2-5. Operate the load in constant resistance mode (Amps/Volt) and set resistance to maximum.
- b. Turn the unit's power on, and turn up current setting to full output.
- c. Turn up output voltage to:
7.0Vdc (6023A)
20Vdc (6028A)
- d. Reduce the resistance of the load to draw an output current of:
29.0Adc (6023A)
10Adc (6028A)
Check that the unit's CV LED remains lighted.
- e. Set the oscilloscope's input impedance to 50Ω and bandwidth to 20MHz. Adjust the controls to show the 20KHz and higher frequency output-noise waveform of Figure 2-6.
- f. Check that the peak-to-peak is no more than 30mV.

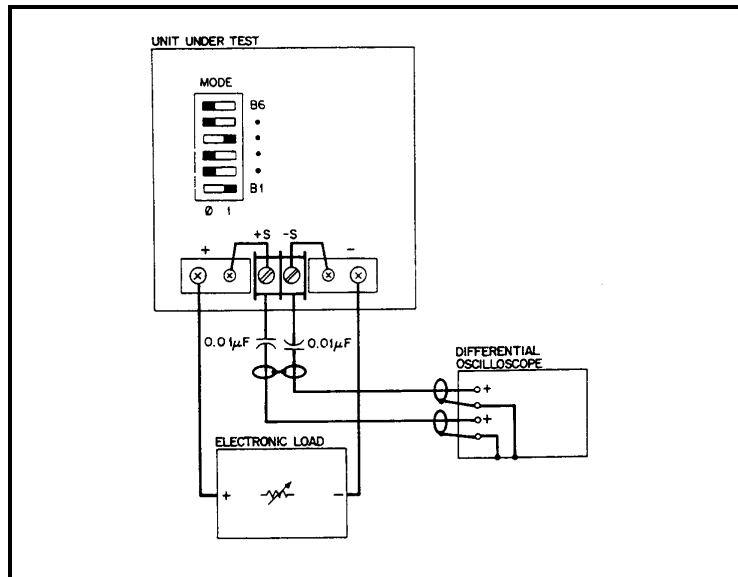

Figure 2-5. Peak-To-Peak Measurement Test Setup, CV PARD Test

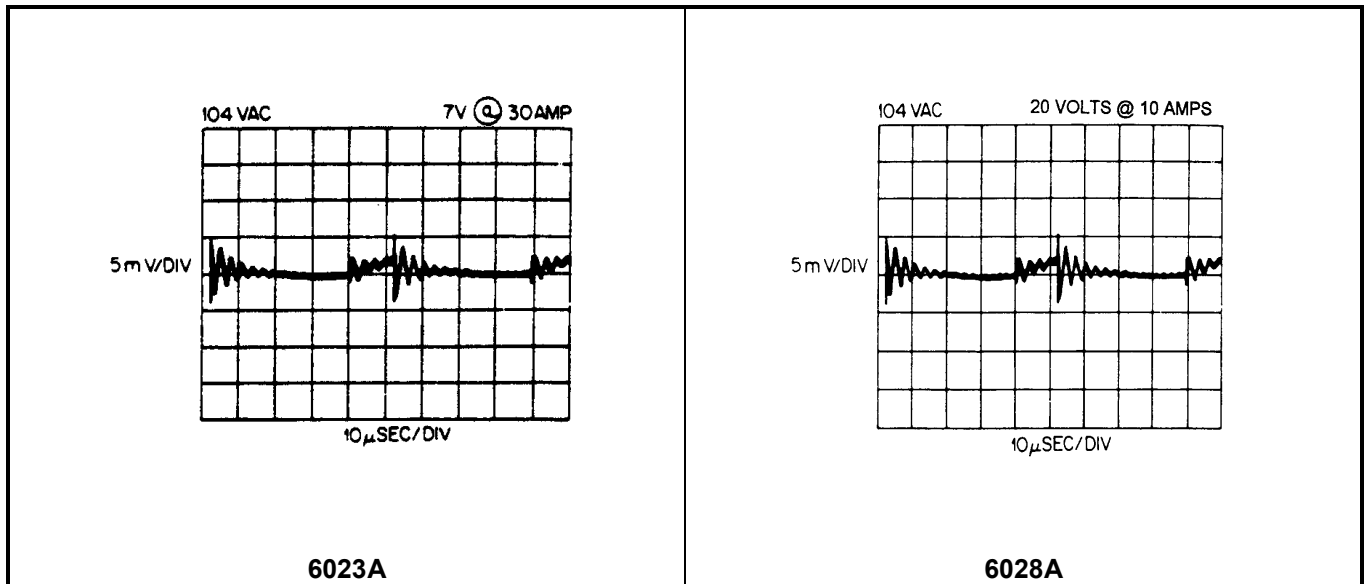

Figure 2-6. 20KHz Noise, CV Peak-to-Peak PARD

Load Transient Recovery Time. Specified for CV operation only; load transient recovery time is the time for the output voltage to return to within a specified band around its set voltage following a step change in load.

Proceed as follows:

- a. Connect the test equipment as shown in Figure 2-3. Operate the load in constant-current mode and set for minimum current.
- b. Turn the unit's power on, and turn up current setting to full output.
- c. Turn up output voltage to:
 - 6.70Vdc (6023A)
 - 20.0Vdc (6028A)
 as read on the digital voltmeter.
- d. Set the load to vary the load current between:
 - 27 and 30A dc (6023A)
 - 9 and 10A dc (6028A)
 at a 30Hz rate.
- e. Set the oscilloscope for ac coupling, internal sync and lock on either the positive or negative load transient.
- f. Adjust the oscilloscope to display transients as in Figure 2-7.
- g. Check that the pulse width of the transient pulse is no more than:
 - 50mV (6023A)
 - 75mV (6028A)

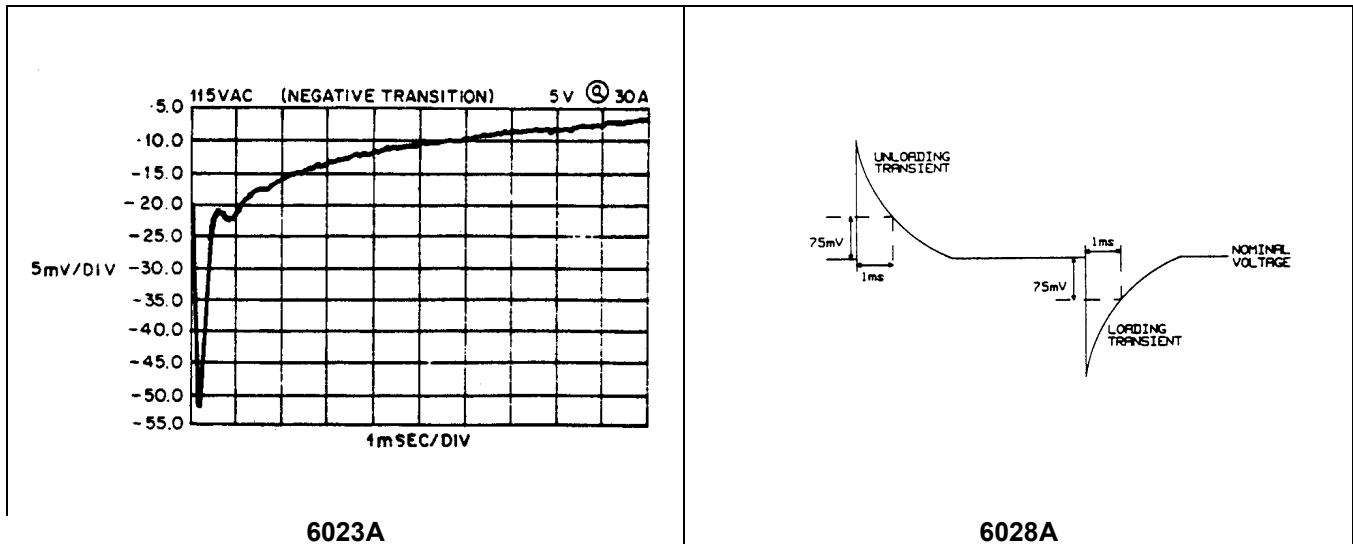

Figure 2-7. Load Transient Recovery Waveform

Temperature Coefficient. (6023A) Temperature coefficient (TC) is the change in output voltage for each °C change in ambient temperature with constant ac line voltage, constant output voltage setting and constant load resistance. Measure temperature coefficient by placing the unit in an oven, varying the temperature over a range within the unit's operating temperature range, and measuring the change in output voltage. Use a large, forced air oven for even temperature distribution. Leave the unit at each temperature measurement for half hour to ensure stability in the measured variable. Measure the output voltage with a stable DVM located outside the oven so voltmeter drift does not affect the measurement accuracy. To measure offset TC, repeat the procedure with output voltage set to 0.10Vdc. Proceed as follows:

- a. Connect DVM between +S and -S.
- b. Place power supply in oven, and set temperature to 30°C.
- c. Turn the unit's power on and turn up current setting to full output.
- d. Turn up output voltage to 20Vdc as read on the DVM.
- e. After 30 minutes stabilization record the temperature to the nearest 0.1°C. Record the output voltage at the DVM.
- f. Set oven temperature to 50°C.
- g. After 30 minutes stabilization, record the temperature to the nearest 0.1°C. Record output voltage.
- h. Check that the magnitude of the output voltage change is no greater than 32mV.

Drift (Stability) (6023A). Drift is the change in output voltage beginning after a 30-minute warm-up during 8 hours operation with constant ac input line voltage, constant load resistance and constant ambient temperature. Use a DVM and record the output at intervals, or use a strip-chart recorder to provide a continuous record. Check that the DVM's or recorder's specified drift during the 8 hours will be no more than 0.001%. Place the unit in a location with constant air temperature preferably a large forced-air oven set to 30°C and verify that the ambient temperature does not change by monitoring with a thermometer near the unit. Typically the drift during 30 minute warm-up exceeds the drift during the 8-hour test. To measure offset drift, repeat the procedure with output voltage set to 0.10Vdc.

- a. Connect DVM between + S and - S.
- b. Turn the unit's power on and turn up current setting to full output.
- c. Turn up output voltage to 20Vdc as read on the digital voltmeter.
- d. After a 30 minute warmup, note reading on DVM.
- e. The output voltage should not deviate more than 5mV from the reading obtained in step d over a period of 8 hours.

Constant Current (CC) Tests

CC Setup. Constant-current tests are analogous to constant-voltage tests, with the unit's output short circuited and the voltage set to full output to assure CC operation. Follow the general setup instructions.

Load Effect (Load Regulation). Constant current load effect is the change in dc output current (I_o) resulting from a load-resistance change from short-circuit to full-load, or full-load to short-circuit. Full-load is the resistance which develops the maximum rated output voltage at current I_o . Proceed as follows:

- a. Connect the test equipment as shown in Figure 2-3. Operate the load in constant resistance mode (Amps/Volt) and set resistance to minimum.
- b. Turn the unit's power on, and turn up voltage setting to full output.
- c. Turn up output current to:
10.0Adc (0.010Vdc across R_m) (6023A). Check that the AMPS display reads about 10 amps.
3.3Adc (0.335Vdc across R_m) (6028A) Check that the AMPS display reads about 3.3 amps.
- d. Increase the load resistance until the output voltage at +S and -S increases to:
20Vdc (6023A).
60Vdc (6028A).
Check that the CC LED is lighted and AMPS display still reads \approx current setting.
- e. Record voltage across R_m .
- f. Short circuit the load.
- g. When the reading settles (\approx 10s), record the voltage across R_m again. Check that the two recorded readings differ no more than:
 $\pm 0.010\text{mVdc}$ (6023A)
 $\pm 0.0053\text{mVdc}$ (6028A)
- h. Disconnect the short across the load.

Source Effect (Line Regulation). Constant current source effect is the change in dc output current resulting from a change in ac input voltage from the minimum to the maximum values listed in the Specifications Table in the Operating Manual. Proceed as follows:

- a. Connect the test equipment as shown in Figure 2-3. Operate the load in constant resistance mode (Amps/Volt) and set resistance to minimum.
- b. Connect the unit to the ac power line through a variable autotransformer set for low line voltage (e.g. 104Vac for 120Vac).
- c. Switch the unit's power on and turn up output voltage setting to full output.
- d. Turn up output current to:
29.0Adc (0.029Vdc across R_m) (6023A)
10.0Adc (1.0Vdc across R_m) (6028A)
Check that the AMPS display reads \approx current setting.
- e. Increase the load resistance until the output voltage between + S and - S increases to:
7.0Vdc (603A)
20.0Vdc (6028A)
Check that the CC LED is still on and the AMPS display still reads \approx current setting.
- f. Record the voltage across R_m .
- g. Adjust autotransformer to the maximum for your line voltage.
- h. When the reading settles record the voltage across R_m again. Check that the two recorded readings differ no more than:
 $\pm 0.0090\text{mVdc}$ (6023A)
 $\pm 0.030\text{mVdc}$ (6028A)

PARD Ripple And Noise. Periodic and random deviations (PARD) in the unit's output (ripple and noise) combine to produce a residual ac current as well as an ac voltage super-imposed on the dc output. The ac voltage is measured as constant-voltage PARD. Constant-current PARD is specified as the root-mean-square (rms) output current in a frequency range 20Hz to 20MHz with the unit in CC operation. To avoid incorrect measurements, with the unit in CC operation, caused by the impedance of the electronic load at noise frequencies, use a:

0.25Ω (6023A)

2.0Ω (6028A)

load resistor that is capable of safely dissipating 250 watts. Proceed as follows:

- a. Connect the test equipment as shown in Figure 2-8.
- b. Switch the unit's power on and turn the output voltage all the way up.
- c. Turn up output current to:
29.0Vdc (6023A)
10Vdc (6028A)

Check that the unit's CC LED remains lighted.

- d. Check that the rms noise current measured by the current probe and rms voltmeter is no more than:
15mA rms (6023A).
5mA rms (6028A)

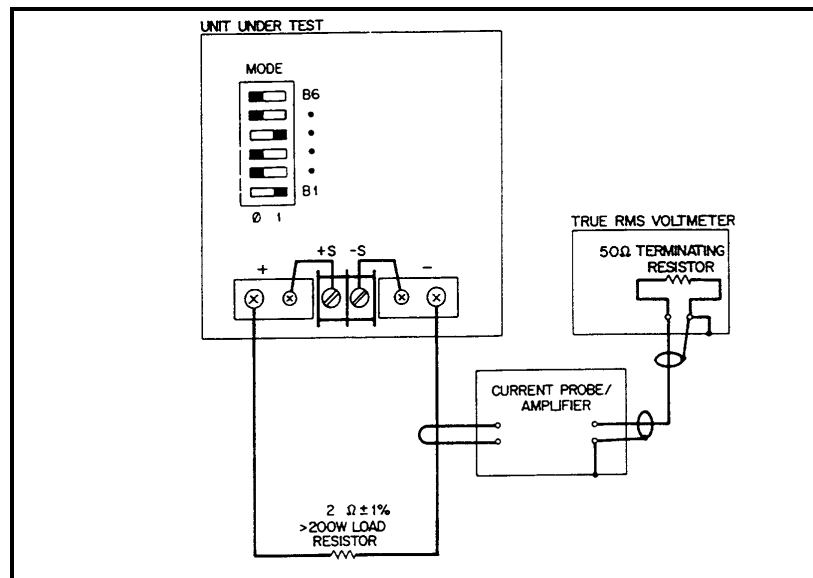

Figure 2-8. CC PARD Test Setup

Troubleshooting

WARNING

Maintenance described herein is performed with power supplied to the instrument, and protective covers removed. Such maintenance should be performed only by service-trained personnel who are aware of the hazards involved (for example, fire and electrical shock). Where maintenance can be performed without power applied, the power should be removed.

Introduction

Before attempting to troubleshoot this instrument, ensure that the fault is with the instrument itself and not with an associated circuit. The performance test enables this to be determined without having to remove the covers from the supply.

The most important aspect of troubleshooting is the formulation of a logical approach to locating the source of trouble. A good understanding of the principles of operation is particularly helpful, and it is recommended that Chapter 4 of this manual be reviewed before attempting to troubleshoot the unit. Often the user will then be able to isolate a problem simply by using the operating controls and indicators. Once the principles of operation are understood, refer to the following paragraphs.

Table 2-1 lists the test equipment for troubleshooting. Chapter 6 contains schematic diagrams and information concerning the voltage levels and waveforms at many of the important test points. Most of the test points used for troubleshooting the supply are located on the control board test "fingers", which are accessible close to the top of the board. See Table 3-1.

If a component is found to be defective, replace it and re-conduct the performance test. When a component is replaced, refer to Calibration Procedure (Chapter 2). It may be necessary to perform one or more of the adjustment procedures after a component is replaced.

Initial Troubleshooting Procedures

If a problem occurs, follow the steps below in sequence:

- a. Check that input power is available, and check the power cord and rear-panel circuit breaker.
- b. Check that the settings of mode switch A2S1 are correct for the desired mode of operation. (See Operating Manual).
- c. Check that all connections to the power supply are secure and that circuits between the supply and external devices are not interrupted.
- d. If the power supply fails turn-on self-test or gives any other indication of malfunction, remove the unit from the operating system before proceeding with further testing.

WARNING

Some circuits on the power mesh are connected directly to the ac power line. Exercise extreme caution when working on energized circuits. Energize the supply through an isolation transformer to avoid shorting ac energized circuits through the test instrument's input leads. The isolation transformer must have a power rating of at least 1KVA. During work on energized circuits, the safest practice is to disconnect power, make or change the test connections, and then re-apply power.

Make certain that the supply's ground terminal (\perp) is securely connected to an earth ground before applying power. Failure to do so will cause a potential shock hazard that could result in personal injury.

Table 3-1. Control Board Test Connector, A2J7

PIN NO.	SIGNAL NAME	Vdc	WAVEFORM/CONDITIONS	SOURCE
Digital-Circuits Bias & Reference Voltages				
1	+5V	5.0		A2Q3 (emitter)
22	+ 20V(5V UNREG)	20.0	with 120Hz & 45KHz ripple	A1CR6, A1CR7
14	2.5V ref	2.50		A2U9 (OUT)
6	0.5V ref	0.50		A2R79,A2R80
Analog-Circuits Bias Voltages				
2	+ 15V	15.0		A2U12 (OUT)
21	- 15V	-15.0		A2U4 (OUT)
Status Signals				
17	\overline{CV}	TTL Lo	if in CV operation	A2Q6C-7 (collector)
16	\overline{CC}	TTL Lo	if in CC operation	A2Q6F-14 (collector)
13	\overline{OV}	TTL Hi	if not OVP shutdown	A2U11D-11
11	$\overline{DROPOUT}$	TTL Hi	if ac mains okay	A2U17D-11
12	\overline{OT}	TTL Hi	if not overtemp shutdown	A2U11B-6
Control Signals				
25	PWM OFF	<0.5	1.7 μ s TTL pulses, 20KHz	U1A-5
26	PWM ON	<1.0	1.7 μ s TTL pulses, 20KHz	U2B-6
18	I _p MONITOR	<0.5	1V pk, 1/2 sawtooth, 20KHz	A2CR26 (cathode)
8	$\overline{INHIBIT}$	TTL hi	if not remotely inhibited	A2R185C, U19A-2
15	$\overline{DOWN PROGRAM}$	1.2-3.0		A2CR21, A2CR27
7	OVP PROGRAM	1/10 OVP (6023A) 1/30 OVP (6028A)	e.g.: 2Vdc if OVP set to 20	A3R6 (wiper)
5	$\overline{OV CLR}$	+5V	inverted OV reset line	A7U29-5
19	$\overline{PCLR 2}$	+5V	if +5V bias OK	A2Q60-9
Commons & Current-Monitor				
4	L COMMON	0.0	common return for all bias voltages, and status and control signals	A2C20 (-), A2R50, A2U6-4
9	M COMMON	0.0	common return for 2.5V ref. and 0.5V ref.	A2R83, A21-20
10	I-TEST	≈ 0.005 (I _{out})	inboard-side monitoring res.	A1R3,A1T2
3	NOT USED			

The diagram shows the physical layout of the test connector J3. On the left, the 'COMPONENT SIDE' shows pins 1 through 25. Pin 1 is labeled '+5V'. Pin 2 is 'V-MON'. Pin 3 is '+5V CLEAR'. Pin 4 is 'OVP PROG'. Pin 5 is 'COMMON (M)'. Pin 6 is 'AC DROPOUT'. Pin 7 is 'OVERVOLTAGE'. Pin 8 is 'DOWN PROGRAM'. Pin 9 is 'CV'. Pin 10 is 'PCLR 2'. Pin 11 is '-15V'. Pin 12 is 'NC.'. Pin 13 is 'PWM OFF'. Pin 14 is 'R25'. Pin 15 is '1'. Pin 16 is '2'. Pin 17 is '3'. Pin 18 is '4'. Pin 19 is '5'. Pin 20 is '6'. Pin 21 is '7'. Pin 22 is '8'. Pin 23 is '9'. Pin 24 is '10'. Pin 25 is '11'. On the right, the 'CIRCUIT SIDE' shows pins 26 through 4. Pin 26 is 'PWM ON'. Pin 27 is 'NC.'. Pin 28 is '+20V UNREG'. Pin 29 is 'NC.'. Pin 30 is 'I_p MONITOR'. Pin 31 is 'CC'. Pin 32 is '2.5V REF'. Pin 33 is 'OT'. Pin 34 is 'I-TEST'. Pin 35 is 'INHIBIT'. Pin 36 is '0.5V REF'. Pin 37 is 'COMMON (L)'. Pin 38 is '+15V'. Pin 39 is '26'. Pin 40 is '4'.

Electrostatic Protection

The following caution outlines important precautions which should be observed when working with static sensitive components in the power supply.

CAUTION

This instrument uses components which can be damaged by static charge. Most semiconductors can suffer serious performance degradation as a result of static charges, even though complete failure may not occur. The following precautions should be observed when handling static-sensitive devices.

- a. Always turn power off before removing or installing printed-circuit boards.
- b. Always stored or transport static-sensitive devices (all semiconductors and thin-film devices) in conductive material. Attach warning labels to the container or bag enclosing the device.
- c. Handle static-sensitive devices only at static-free work stations. These work stations should include special conductive work surfaces (such as Agilent Part No. 9300-0797) grounded through a one-megohm resistor. Note that metal table tops and highly conductive carbon-impregnated plastic surfaces are too conductive; they can act as large capacitors and shunt charges too quickly. The work surfaces should have distributed resistance of between 10^6 and 10^{12} Ω per square.
- d. Ground all conductive equipment or devices that may come in contact with static-sensitive devices or subassemblies containing same.
- e. Where direct grounding of objects in the work area is impractical, a static neutralizer should be used (ionized air blower directed at work). Note that this method is considerably less effective than direct grounding and provides less protection for static-sensitive devices.
- f. While working with equipment on which no point exceeds 500 volts, use a conductive wrist strap in contact with skin. The wrist strap should be connected to ground through a one-megohm resistor. A wrist strap with insulated cord and built-in resistor is recommended, such as 3M Co. No. 1066 (Agilent Part No. 9300-0969 (small) and 9300-0970 [large]).

WARNING

Do not wear a conductive wrist strap when working with potentials in excess of 500 volts; the one-megohm resistor will provide insufficient current limiting for personal safety.

- g. All grounding (device being repaired, test equipment, soldering iron, work surface, wrist strap, etc.) should be done to the same point.
- h. Do not wear nylon clothing. Keep clothing of any kind from coming within 12 inches of static-sensitive devices.
- i. Low-impedance test equipment (signal generators, logic pulsers, etc.) should be connected to static-sensitive inputs only while the components are powered.
- j. Use a mildly activated rosin core solder (such as Alpha Metal Reliacor No. 1, Agilent Part No. 8090-0098) for repair. The flux residue of this type of solder can be left on the printed circuit board. Generally, it is safer not to clean the printed-circuit board after repair. Do not use Freon or other types of spray cleaners. If necessary, the printed-circuit board can be brushed using a natural-bristle brush only. Do not use nylon-bristle or other synthetic-bristle brushes. Do not use high-velocity air blowers (unless ionized).
- k. Keep the work area free of non-conductive objects such as Styrofoam-type cups, polystyrene foam, polyethylene bags, and plastic wrappers. Non-conductive devices that are necessary in the area can be kept from building up a static charge by spraying them with an anti-static chemical (Agilent Part No. 8500-3397).
- l. Do not allow long hair to come in contact with static-sensitive assemblies.
- m. Do not exceed the maximum rated voltages specified for the device.

Repair and Replacement

Repair and replacement of most components in the power supply require only standard techniques that should be apparent to the technician. The following paragraphs provide instructions for removing certain assemblies and components for which the procedure may not be obvious upon inspection.

WARNING

To avoid the possibility of personal injury, remove the power supply from operation before opening the cabinet. Turn off ac power and disconnect the line cord, load, and remote sense leads before attempting any repair or replacement.

CAUTION

When replacing any heatsink-mounted components except thermostat, smear a thin coating of heatsink compound between the component and heatsink. If a mica insulator is used, smear a thin coating of heatsink compound on both sides of the mica insulator.

Do not use any heatsink compound containing silicone, which can migrate and foul electrical contacts elsewhere in the system. An organic zinc oxide cream, such as American Oil and Supply Company Heatsink Compound #100, is recommended.

CAUTION

Most of the attaching hardware in this unit is metric. The only non-metric (sometimes called English or inch) fittings are listed below. Be careful when both types of screws are removed not to get them mixed up.

- a. Lock-link/shelf-mounting blocks (4 on rear panel, one at each corner).
- b. Rear-panel fuse holder.
- c. Rear-panel ground binding post.
- d. Strap-handle screws (2).
- e. Screws that secure side chassis to front-frame casting (8, 4 on each side).
- f. Screws that secure front-panel to front-frame casting (4, 2 on top and 2 on bottom).

Top Outside Cover Removal. Remove three screws, the rear handle screw (Phillips, 10x32) and two top-rear corner screws (Pozi driv, M4x.7) using a Size 1, Pozi driv screwdriver. A Phillips head screwdriver does not fully seat into Pozi driv screws and risks stripping the heads. Do not remove the front handle screw, as the retaining nut will fall into the unit. Remove the top cover by sliding it to the rear and lifting at the front.

Bottom Cover Removal. Remove only for repair of main board. Remove two bottom-rear corner screws. (Pozi driv, M4x.7) and remove the bottom cover by sliding it to the rear. You do not need to remove the unit's feet.

Inside Top Cover Removal. The unit includes an inside cover which secures the vertical board assemblies. Remove the inside cover for repair but not for calibration. Remove the six mounting screws (Pozi driv, M4x.7) – three on each side and five board fastening screws (Pozi driv, M4x.7) all on top. Remove the inside cover by lifting at the front edge.

When installing the inside cover, insert it first at the right side. While holding it tilted up at the left, reach through the cutouts in the cover and fit the top tabs of the A2 control board into the mating slots in the cover. With the top cover in place reach through the cutout above the A4 power mesh board, align the board-fastening screw holes, and replace the rear-most screw to secure the A4 board. Press the inside cover down firmly while tightening screws that secure cover to chassis. Complete the installation by replacing the remaining ten screws. Be careful when replacing printed-circuit assemblies and covers not to bend any boards or components.

A2 Control Board Removal

After removing the inside cover, remove the A2 board by lifting first at the front edge and then pulling it up and out of the unit. Two connectors hold the A2 board at its bottom edge.

When installing the A2 board, insert it first at the rear of the unit. While holding it tilted up at the front, fit the A2TB1 terminal strip into the mating cutout in the rear panel. Then lower the A2 board's bottom connectors into the mating connectors on the main board. Press the A2 board into the connectors.

A4 Power Mesh Board Removal

After removing the inside cover, remove the A4 power mesh board by lifting, using the large aluminum heatsink as a handle. Two connectors hold the A4 board at its bottom edge.

When installing the A4 power mesh board, lower it vertically into its connectors and press in place.

A3 Front-Panel Board Removal

Remove the A3 front-panel board by first removing the entire front-panel assembly. You do not need to remove the top cover. Follow this procedure:

- a. Remove the top plastic insert by prying up with a flat-blade screwdriver, and remove the front feet by lifting the tabs and sliding toward the front of the unit.
- b. Remove the four front-panel assembly mounting screws (Phillips 8-32) on the top and bottom at the corners using a Pozidriv or Phillips head screwdriver (Phillips head screwdriver may be used only with these four screws).
- c. Gently pull the front-panel assembly away from the unit as far as permitted by the connecting cables.
- d. Remove the ground-wire screw (Pozidriv, M4x.7) holding the green-yellow ground wire.
- e. Note the locations of the four power-wire connections to the power switch and then unplug the quick-connect plugs.
- f. Unplug the W3 3-wire cable from connector A1J3 on the A1 main board.
- g. Remove the A3 board from the front-panel assembly by removing the five mounting screws (Pozidriv, M4x.7)

Install the A3 Board by reversing the steps above. The power wires are correctly connected to the power switch wires if they do not cross each other.

A1 Main Board Removal

Removing the A1 main board requires removing the rear panel, all boards except the A3 front-panel board, and 17 A1 board mounting screws. Component-access cutouts in the bottom inside cover allow unsoldering most A1-board components for repair without removing the A1 board.

To remove the A1 board, proceed as follows:

- a. Remove the A2 and A4 boards according to the above instructions.
- b. Detach the rear panel by removing the four mounting screws (Pozidriv, M4x.7) two on each side. Gently pull the rear panel away from the unit as far as permitted by the four wires connected to the A1 board.
- c. Unplug the W1 ribbon cable from connector A1J1.
- d. Remove the A1 board by removing the 17 mounting screws (Pozidriv, M4x.7).
- e. Note locations and the unplug the two ac power wires and the two fan wires to the A1 board.

Overall Troubleshooting Procedure

WARNING

Perform the troubleshooting and repair procedures which follow only if you are trained in equipment service and are aware of the danger from fire and electrical-shock hazards. Some of the procedures include removing the unit's protective covers which may expose you to potentially lethal electrical shock. Whenever possible, make test connections and perform service with the power removed.

After performing the Initial Troubleshooting Procedures, focus on developing a logical approach to locating the source of the trouble. The underlying strategy for the troubleshooting procedures here is to guide you to the faulty circuit nodes which have improper signals or voltages. It relies on you to identify the particular functional circuit to troubleshoot from symptom tables and by understanding how the unit works. It then relies on you to discover the defective component or components which cause the faulty circuit nodes. So, read the BLOCK DIAGRAM overview in Chapter 4 and read the functional circuit descriptions for the circuits that you suspect may be defective. Then return to this section for help finding the faulty circuit nodes.

Table 3-1 gives the signals for each of the test points on the control board test connector. This connector is provided in service kit P/N 06033-60005. The measurements given here include bias and reference voltages as well as power supply status signals and waveform information.

Table 3-2 provides troubleshooting information based on the status of the PWM-ON and PWM-OFF signals which drive the PFETs. This table is used for no-output failures.

Tables 3-3 and 3-4 give measurements for the test points on the A3 front-panel board and possible failure symptoms respectively.

Table 3-5 describes possible symptoms for overall performance failures of the power supply. It is necessary to have a properly working front-panel before using this table.

Chapter 6 contains schematic diagrams and voltage levels, and component location diagrams to help you locate components and test points.

Make most voltage measurements (except DC-to-DC Converter and ac mains-connected circuits) referenced to the unit's output common which is accessible at rear-panel terminal VM. All voltages are $\pm 5\%$ unless a range is given.

Using the Tables

Typically there will be two types of power supply failures; no-output and performance failures.

1. **No-OUTPUT FAILURE:** Start with the TROUBLESHOOTING NO-OUTPUT FAILURES section which references Tables 3-1 and 3-3.
2. **PERFORMANCE FAILURE:** If the power supply produces an output but does not perform to specifications, begin by verifying the measurements at the A2J7 test connector using Table 3-1. Next, verify the front-panel by doing the procedure outlined in the FRONT-PANEL TROUBLESHOOTING section. After the front-panel has been verified consult Table 3-5 for the performance failure symptom which seems closest to the one observed and proceed to the functional circuit given for that failure.

The circuits referenced in Tables 3-2 and 3-5 are derived from functional blocks of circuits in the power supply. These blocks are given in the Power Supply Blocks section starting on page 35. Troubleshooting information for each block will include a brief description of the circuit involved. The columns provided in each block are as follows:

NODE:	This column lists the nodes where the measurements should be taken. In some cases this will be stated as NODE (+) and NODE (-) where the first is the test node and the second is the reference.
SETUP:	If a certain setup is required for the measurement, it will be given in this column.
MEASUREMENT:	This column indicates what the expected measurement is for the given node.
SOURCE:	If applicable, the components which generate the signal will be provided in this column .

Some blocks will have Input and Output sections. The input section will have a source column to indicate which components generated the measured signal. The output section will list all the important output signals from that block. However, because the outputs of one block are the inputs to another, the schematic should be consulted if an output measurement is incorrect. This will indicate the next circuit block to be trouble shot.

Main Troubleshooting Setup

Figure 3-1 shows the troubleshooting setup for troubleshooting all of the unit except the front-panel and initial no output failures (See page 31). The external power supply provides the unit's internal bus voltage. The ac mains cord connects to the unit's A1T3 bias transformer via an isolation transformer, thereby energizing the bias supplies, but it does not connect to the input rectifier and filter because that would create the bus voltage. With the external supply the unit operates as a dc-to-dc converter. The supply biases the A4Q3 and A4Q4 PFETs with a low voltage rather than the 320Vdc bus voltage. This protects the PFETs from failure from excess power dissipation if the power-limit comparator or the off-pulse circuitry are defective. It also reduces the possibility of electrical shock to the troubleshooter.

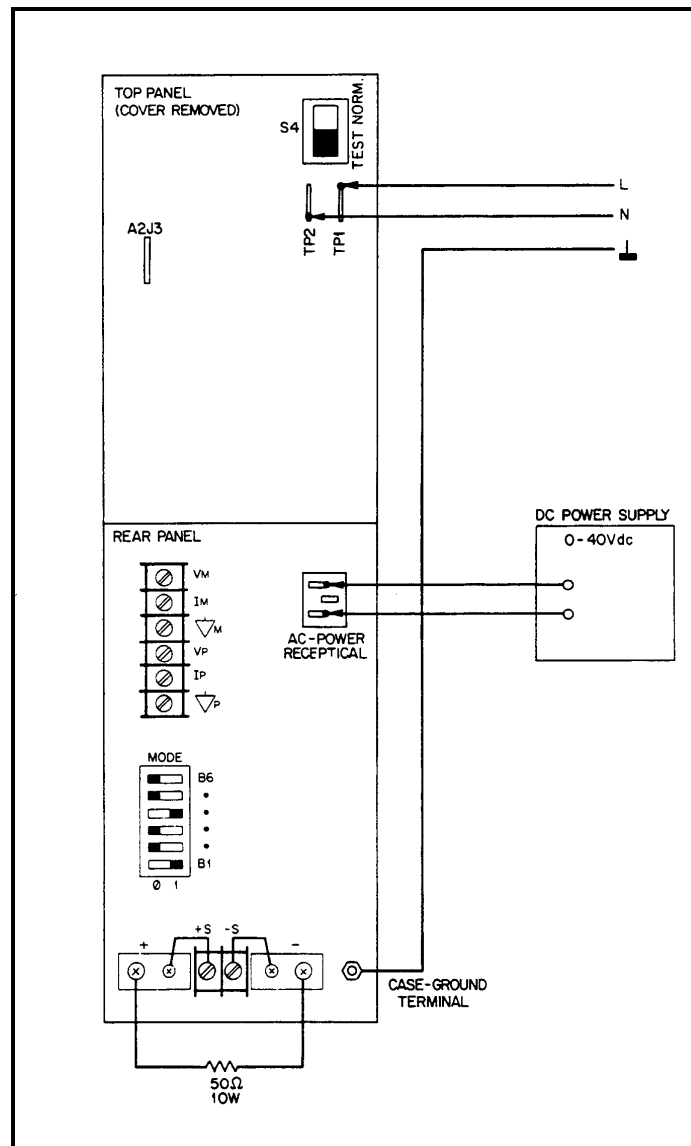

Figure 3-1. Main Troubleshooting Setup

WARNING

The troubleshooting setup of Figure 3-1 connects high ac mains voltage to the A1F2 fuse, the A1S2 Mains-Voltage Select Switch, the fan and printed-circuit traces at the left edge of the A1 main board. Be extremely careful when working on the unit with the protective inside cover removed to avoid touching the ac mains voltage.

As a convenience in implementing the troubleshooting setup, prepare cord sets as shown in Figure 3-2. This facilitates connecting the unit's input power receptacle to the external supply and connecting the bias transformer to the ac mains.

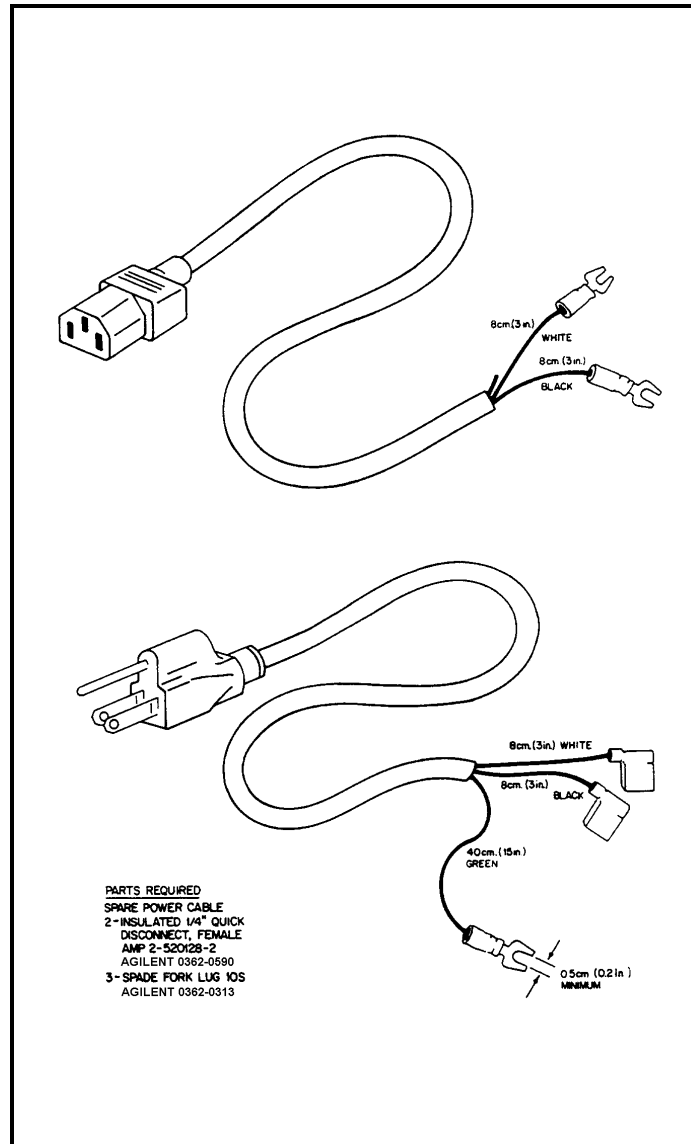

Figure 3-2. Modified Mains Cord Set For Troubleshooting

With the mains cord unplugged proceed as follows:

- a. Remove the top cover and the inside cover as described on page 26. Set switch S4 (front-left corner of the A1 main board) in TEST position.

WARNING If switch is not in the TEST position and remains in the NORM position, completion of step e below will allow the unit to develop its 320Vdc bus voltage across PFETs A3Q3 and A3Q4 and will connect the ac mains voltage to the output of the external power supply. This will probably damage the external supply and is a shock hazard to you.

- b. Install control board test connector onto the A2J3 card edge fingers.
- c. Connect a 50Ω, 10W, load resistor to the unit's output terminals.

- d. With the LINE switch off, connect an external dc supply to the outside prongs of the unit's power receptacle. Ignore polarity as the unit's input rectifying diodes steer the dc power to the correct nodes.
- e. Complete the setup of Figure 3-1 by attaching an ac mains cord to test points TP1 (L, black wire) and TP2 (N, white wire) and connect the green ground wire to the unit's case ground terminal or a suitably grounded cabinet screw. TP1 and TP2 are accessible through the cutout on the left side of the unit and are at the left edge of the A1 main board.

Troubleshooting No-Output Failures

No-output failures often include failure of the A4Q3 and A4Q4 PFETs and their fuses, A4F1 and A4F2. When either the off-pulses or the power-limit comparator fails, the PFETs can fail from excessive power dissipation. The strategy for localizing no-output failures is to check the voltages and waveforms at the control board test connector to predict if that circuit failure would cause the PFETs to fail. This makes it possible to develop your troubleshooting approach without an extensive equipment setup. Proceed as follows:

- a. With the mains cord unplugged remove the A4 power mesh board as described on page 27. Plug in the mains cord and switch on power.
- b. Using Table 3-1 check the bias voltages, the PWM-OFF, PWM-ON and other signals of interest at the A2 control board test fingers, A2J3.
- c. Check for the presence of program voltages, VP and IP, at the rear panel.
- d. Check for presence of the 320Vdc rail voltage between the cathodes of diodes A1CR3 and A1CR4. If there is no rail voltage, check diodes A1CR1 through A1CR4.

WARNING

Diodes A1CR1 through A1CR4 connect to the ac mains voltage. Use a voltmeter with both input terminals floating to measure the rail voltage.

- e. Select the functional circuit for troubleshooting based on your measurements and Table 3-2, which provides direction based on the status of the PWM OFF and PWM ON signals .

Front-Panel Troubleshooting

The A3 front-panel board can be troubleshot by first doing the following setup.

- a. Remove the top cover of the unit.
- b. Remove the 4 side screws holding the front-panel assembly to the power supply chassis and pull the entire assembly forward.
- c. Disconnect the W1 ribbon cable from connector A1J1 on the A1 main board and remove the ground wire screw holding the green/yellow ground wire. Unplug the four wires to the LINE switch noting the configuration.
- d. Detach the A3 board from the front-panel assembly by removing the five mounting screws.
- e. Reconnect the W1 jumper to connector A1J1 and place the A3 board vertically against the supply with a piece of insulating material between. The test connector can then be attached to the A3 board. The rest of the front-panel assembly can stand vertically so that the pots and the switches can be accessed while troubleshooting.
- f. Attach the external line cord and place switch A1S4 in the TEST position.

WARNING

The ac mains voltage connects directly to the LINE switch and to components and traces at the front of the A1 main board. Be extremely careful to avoid touching the ac mains voltage.

Start troubleshooting by performing the tests given in Table 3-3. This table provides the measurements for the test points on the test connector as well as the source components for that measurement. Switch A1S4 should be in the TEST position for all measurements except where noted. Table 3-4 gives front-panel symptoms as well as the circuits or components that may cause the supply to exhibit those symptoms. Both Tables 3-3 and 3-4 should be used to check out and troubleshoot the front-panel.

**Table 3-2. No-Output Failures
(Bias supplies and AC turn-on circuit functioning)**

Status of PFET on/off-Pulses

PWM-ON A2J7-26	PWM-OFF A2J7-25	DEFECTIVE BOARD	CHECK FUNCTIONAL CIRCUITS
lo	lo	A2	Control ckts: CV & CC thru on- & off-Pulse Oneshots *
lo	hi	A2 & A4	PWM and DC-to-DC Converter: A4Q3 and A4Q4 probably failed
hi	lo	A2 & A4	PWM and DC-to-DC Converter: A4Q3 and A4Q4 probably failed
hi	hi	A2 & A4	PWM and DC-to-DC Converter: A4Q3 and A4Q4 probably failed
lo	N	A2	A2U17B,on-Pulse Oneshot and A2Q6A
N	lo	A2 & A4	Off-Pulse Oneshot and DC-to-DC: A4Q3 and A4Q4 probably failed
hi	N	A2 & A4	A2U17A, on-Pulse Oneshot & DC-to-DC: A4Q3, and A4Q4 probably failed
N	hi	A2 & A4	off-Pulse Oneshot and DC-to-DC: A4Q3 and A4Q4 probably failed
N	N	A2 & A4	Power-Limit Comparator and DC-to-DC: A4Q3 and A4Q4 probably failed

lo= TTL low hi= TTL high N = normal 20KHz pulse train, TTL levels

* Decide which to troubleshoot -- the CV Circuit, the CC Circuit, or the PWM and Off-Pulse & On-Pulse Oneshots -- by measuring the CV CONTROL (A2CR24, cathode) and the CC CONTROL (A2CR19 cathode) voltages. Troubleshoot whichever is negative, and if neither is negative, troubleshoot the PWM. Make these voltage measurements after you have implemented the Main Troubleshooting Setup.

Table 3-3. Front-Panel Board Tests

Pin No	Signal Name	Measurement	Description	Source
1	+7.5V	7.5V	Derived from + 15V bias.	A3VR2, A3R3
2	-1V	-1.0V	Derived from -15V bias.	A3R86, A3R85, A3C17
*3	CV VOLTAGE	0-5V	For 0 to full scale output voltage.	A3U2-2, A3R1, A3R87.
*4	CC VOLTAGE	0-5V	For 0 to full scale output current.	A3U3A-1, A3R67
5	VOLTS test	-1888 on volts display	Jumper to + 5V on A3 board.	A3U4-37
6	AMPS test	-1888 on amps display	Jumper to + 5V on A3 board.	A3U5-37
*7	VOLTS input	0-1V	For 0 to full scale output voltage.	A3R8,A3U7-2,3,10
8	VOLTS low range	TTL high	If VOLTS display is below 20 volts (press DISPLAY SETTINGS).	A3U9C-13, A3U6B
9	DISPLAY SETTINGS	TTL high	If DISPLAY SETTINGS switch on front-panel is depressed.	A3S1,A3R80
10	DISPLAY OVP	TTL high	If DISPLAY OVP switch on front-panel is depressed.	A3S2,A3R82, A3U6C-8
*11	AMPS input	0-150mV	For 0 to full scale output current.	A3R65,A3R66,A3R67
12	-5 V	-5.0V	Derived from -15 V bias.	A3VR1, A3R2
13	buffered OVP	0-2.2V	1/10 of OVP voltage setting when DISPLAY OVP switch is depressed. Varies with OVP ADJUST pot.	A3U3B-6,A3CR5,A3R72

* Switch A1S4 should be in the NORM position for these tests.

Troubleshooting Bias Supplies

+5V on A2 Control Board. The PWM A2U6 includes a clock generator (45KHz set by A2R53 and A2C26), and a current limit (2Adc set by 0.15Vdc across A2R50). It turns off each output pulse using the difference between the voltage at voltage divider A2R46-A2R47 and the 2.5Vdc set by voltage regulator A2U5.

Circuit Included. + 5Vdc bias supply circuitry from connector pin A2P1-15 through jumper A2W3 on A2 control board.

Setup. The Main Troubleshooting Setup, page 29. Apply the ac mains voltage to the bias transformer, and set the external supply to 0Vdc.

Input:

NODE +	MEASUREMENT	SOURCE
A2J3-22	≈ 20Vdc	A1CR6,A1CR7

Outputs

NODE	MEASUREMENT
A2U6-6	≈ 2 to 4Vdc sawtooth, 45KHz
A2U6-12,13	≈ 19Vpk, 15μs pulses, 45KHz
A2Q3 (emit)	≈ 20Vpk, 5μs pulses, 45KHz
A2U5 (OUT)	2.5 Vdc
A2R50, A2CR11 (anode)	≈ 0 > V > -0.07Vdc
A2R161, A2R163	2.5 Vdc

To check if load on + 5 V is shorted, remove jumper A2W3

Table 3-4. A3 Front-Panel Board Failure Symptoms

SYMPTOMS	DEFECTIVE CIRCUIT	CHECK COMPONENTS
Error when pressing DISPLAY SETTINGS	Limits display.	A3U1, A3U9
Error in VOLTS or AMPS	Input ranging or DVMS.	A3U1,A3U2,A3U4,A3U5,A3U7
* one or more display digits out	Display LEDs.	A3DS1 through A3DS7
Unable to adjust VOLTAGE or CURRENT or always max	Potentiometers.	A3R4, A3R5
VOLTS decimal point error	Decimal drivers.	A3U6

* Note that the Volts and Amps tests (Table 3-3 pins 5 and 6) verify that all the current and voltage display segments light except for the decimal points.

Table 3 5. Performance Failure Symptoms

SYMPTOMS	DEFECTIVE BOARD	CHECK FUNCTIONAL CIRCUITS
Unexplained OVP shutdowns	A2	OVP Circuit, CV Circuit
No current limit	A2	CC Circuit
Max current < 30Adc	A2	CC Clamp, CC Circuit
Max power < specified	A2, A1	Power Limit, 20KHz clock, transformer A1T1
Max voltage < 20Vdc	A2, A1	CV Circuit, diodes A1CR1-CR4
Cycles on & off randomly	A2, A1	AC-Surge-&-Dropout Detector, Mains Voltage Select switch A1S2

Table 3 5. Performance Failure Symptoms (continued)

SYMPTOMS	DEFECTIVE BOARD	CHECK FUNCTIONAL CIRCUITS
CV overshoots	A2	A2U10A, A2CR20, A2R94
Output noise (< 1KHz)	A2, A1	CV Circuit
Output noise (> 1KHz)	A1, A4	Transformer A1T1, Output Filter, snubbers A4R7 /R8 /C5 / CR5, A4R13/ 14 / C6 /CR6, A4R33 /C13
CV regulation, transient response, programming time	A2, A1	Wrong sensing (paragraph 3-40), low ac mains voltage, CV Circuit
CC regulation	A2	Low ac mains voltage, CC circuit
CV oscillates with capacitive loads	A2	A2U10, A2C51, A2R95, A2R96, A2R86, A2C47, A2R71, A2C36
CC oscillates with inductive loads	A2	A2U10, A2R86, A2C47, A2C43, A2R77, A2U3D, A2R30, A2C44, A2R76, A2R75, A2C42, A2C41, A2R16

+15V on A2 Control Board. Voltage regulator A2U12 regulates the voltage across resistor A2R29 to be 1.25Vdc. That sets the current through zener diode A2VR1 at 7.5mA_{dc}. The output voltage is 1.25Vdc plus 11.7Vdc across A2VR1 plus the voltage across A2R34.

Circuit Included. + 15Vdc bias supply circuitry from connector pin A2P1-27 through test point A2J3-2 on A2 control board.

Setup. The Main Troubleshooting Setup, page 29. Apply the ac mains voltage to the bias transformer, and set the external supply to 0Vdc.

Input:

NODE (+)	MEASUREMENT	SOURCE
A2U12(IN), A2C17(+)	≈ 24Vdc	A1U1, A1C1 (+)

Outputs:

NODE (+)	NODE (-)	MEASUREMENT
A2U12 (OUT)	A2U12 (ADJ)	1.25Vdc
A2U12 (cath.)		
A2U12 (anode.)	11.7Vdc	
A2VR1 (anode.)		
A2R34, A2R33	2.05Vdc	
A2LR3 (cath.)		
A2VR3 (anode.)	6.2Vdc	

To check if load on + 15V is shorted, remove jumper A2W1 .

-15V on A2 Control Board. Voltage regulator A2U4 regulates the voltage across resistor A2R32 to be 1.25Vdc.

Circuit Included. -15Vdc bias supply circuitry from connector pin A2P1-30 through test point A2J3-21 on A2 control board.

Setup. The Main Troubleshooting Setup, page 29. Apply the ac mains voltage to the bias transformer, and set the external supply to 0Vdc.

Input:

NODE (+)	MEASUREMENT	SOURCE
A2U4 (IN), A2C16 (-)	≈ -24Vdc	A1U1, A1C1 (+)

Outputs:

NODE (+)	NODE (-)	MEASUREMENT
A2U4 (ADJ)	A2U4 (OUT)	1.25Vdc
A2VR2 (cath.)	A2VR2 (anode)	11.7Vdc
A2R33, A2R34	A2VR2 (cath.)	2.05Vdc

To check if load on -15V is shorted, remove jumper A2W3.

Refer to Down Programmer, page 39, for the + 8.9V bias supply, and refer to OVP Circuit, page 39, for the +2.5V bias supply.

Power Section Blocks

This section contains the blocks referenced in Tables 3-2 and 3-5.

Troubleshooting AC-Turn-on Circuits

Relay A1K1 closes at 1.0 seconds and DROPOUT goes high at 1.1 seconds after 20V (5V UNREG) reaches about 11Vdc. DROPOUT high enables the PWM if OVERVOLTAGE, and OVERTEMPERATURE are also high.

Circuits Included. AC-Surge-&-Dropout Detector, Bias Voltage Detector, U11A, 1-Second Delay and Relay Driver--all on A2 control board.

Setup. The Main Troubleshooting Setup, page 29. Apply the ac mains voltage to the bias transformer, and set the external supply to 0Vdc.

Inputs:

NODE (+) *	SETUP	MEASUREMENT	SOURCE
A2J3-1	wait 2s	5.0Vdc	A2Q3 (emit.)
A2J3-22		20Vdc	A1CR6, A1CR7
A2U20-8,10		f.w.rect., 1-2Vpk	A1CR8, A1CR9
A2U22-13		TTL sq wave, 20KHz	A2U22-6

Outputs:

NODE (+) *	SETUP	MEASUREMENT
A2U20-5	cycle power	transition 0 to 13.5Vdc
A2U20-2	cycle power	transition 0 to 1.4Vdc
A2Q6-1	cycle power	transition 0 to 5.0 to 0.3Vdc
A2Q6-9	cycle power	transition 0 to 0.3 to 5.0Vdc
A2U20-6	wait 2s	< 0.25Vdc
A2U20-1,14	wait 2s	hi (5Vdc)
A2U11-3	cycle power	transition lo to hi to lo
A2U18-10	cycle power	burst 1.25 KHz sq. wave 1.1s

A2U18-13	cycle power	five 100ms pulses then hi
A2U18-12	cycle power	two 200ms pulses then hi
A2U18-15	cycle power	transition lo to hi at 800 msec
A2U17-8	cycle power	transition lo to hi at 1.0 sec
A2U17-11	cycle power	transition lo to hi at 1.1 sec
$\overline{\text{DROPOUT}}$ A2Q5 (col)	cycle power	transistion 5.0 to 0.3Vdc at 1.0s
(RELAY ENABLE)		

Troubleshooting PWM & Clock

The inputs to inhibit Gate A2U19A and PWM gate A2U19B are the keys to PWM troubleshooting. The 20KHz clock starts each PWM output pulse, and the pulse stops when any of the inputs to A2U19A or A2U19B goes low. The PWM is inhibited and prevented from initiating output pulses as long as any of the eight inputs is low.

Circuit Included. Pulse Width Modulator (PWM), Inhibit Gate A2U19A, Off-Pulse Oneshot, On-Pulse Oneshot, A2U17B, 20KHz Clock.

Setup. The Main Troubleshooting Setup, page 29. Apply the ac mains voltage to the bias transformer and switch on the LINE switch. Adjust the units current setting above 1.0Adc. Set the external supply (EXTERNAL) and adjust the unit's voltage setting (INTERNAL) as instructed below.

Inputs:

NODE (-) = A2J7-4

NODE (+)	SETUP	MEASUREMENT	SOURCE
A2J3-1		5.0Vdc	A2Q3 (emitter)
A2U19-1		Hi	A2U17D-11
A2U19-2		Hi	remote inhibit
A2U19-4		Hi	A2U14-1,8
A2U19-5		Hi	A2U11B-6
A2U19-10		Hi	A2U16-7
A2U19-12	POWER LIMIT fully CCW	Lo	A2U14-2
A2U19-12	POWER LIMIT fully CW	Hi	A2U14-2

Outputs:

NODE (+)	SET VOLTAGE (Vdc)		SETUP	MEASUREMENT
	EXTERNAL	INTERNAL		
A2U21-7	0	0		TTL sq wave, 320KHz
A2U22-3	0	0		TTL sq wave, 160KHz
A2U22-6	0	0		TTL sq wave, 20KHz
A2U13-5	0	0		23.5 μ s TTL pulses, 20KHz
A2U13-9	0	0		23.5 μ s TTL pulses, 20KHz
A2U14-2	40	0	POWER LIMIT fully CCW	lo
A2U19-5	40	0		lo
A2U13-9	40	0		lo
A2U17-6	40	0		lo
A2U15-13	40	0		lo
A2U15-5	40	0		lo
A2U17-6	40	0	POWER LIMIT fully CW	groups of 4 pulses 1.7 μ s, TTL, 20KHz
A2U17-5	40	0		1.7 μ s, TTL, 20KHz

+ OUT	40	10		3.8Vdc (OVERRANGE)
+ OUT	40	2		2.0Vdc (CV)
+ OUT	40	2	short A2J3-4 to A2J3-8	0.0Vdc

Troubleshooting DC-To-DC Converter

Parallel NOR gates A4U2A, A4U2B and A4U1A act as drivers and switch on FETs A4Q3 and A4Q4 through pulse transformer A4T1. NOR gate A4U1B turns off the PFETs through pulse transformer A4T2 and transistors A4Q1 and A4Q2.

Circuits Included. On-Pulse Driver, Off-Pulse Driver, PFET Switches and Drivers on A4 power mesh board.

Setup. The Main Troubleshooting Setup, page 29. Apply the ac mains voltage to the bias transformer, set the external supply to 40Vdc and switch on the LINE switch. Set the unit's output voltage to 20Vdc and current to above 1Adc. Verify the UNREGULATED LED lights.

Inputs:

NODE (+)	NODE (-)	MEASUREMENT	SOURCE
A2J3-26 (PWM-ON)	VM	waveform 1	A2U17-6, A2P1-7, A4P1-24,C
A2J3-25 (PWM-OFF)	VM	waveform 2	A2U15-5, A2P1-13, A4P1-26,A
A4Q2-D	A4Q4-S	39Vdc	A1C4 (+), A4P1-10, A,C A1C4 (-), A4P1-4,A,C

Outputs:

NODE (+)	NODE (-)	MEASUREMENT
A4Q3-G	A4Q3-S	Waveform 3
A4Q4-G	A4Q4-S	Waveform 3
A4Q3-D	A4Q3-S	Waveform 4
A4Q4-D	A4Q4-S	Waveform 4
A2J3-18	A2J3-4	Waveform 5

Note The Gate (G) and Source (S) leads of PFETs A4Q3 and A4Q4 can be accessed from the circuit side of the board and used as test points. The Drain (D) of A4Q3 can be picked up at its case or from the cathode of A4CR13. The Drain of A4Q4 can be picked up at its case or from the anode of A4CR14.

If all the INPUT measurements are correct but the OUTPUT Vgs waveform (3) is incorrect, the problem may be caused by weak PFETs. Two 6800pF capacitors (Agilent P/N 0160-0159) can be substituted for the PFETs (G to S) to check waveform 3. If the waveform is still incorrect, the problem may be located in the drive components.

CAUTION

The PFETs are static sensitive and can be destroyed by relatively low levels of electrostatic voltage. Handle the A4 power mesh board and the PFETs only after you, your work surface and your equipment are properly grounded with appropriate resistive grounding straps. Avoid touching the PFET's gate and source pins.

Troubleshooting CV Circuit

V-MON, the output of CV Monitor Amp A2U7, is 1/4 the voltage between + S and - S. CV Error Amp A2U8 compares V-MON to CV PROGRAM. Innerloop Amp A2U10A stabilizes the CV loop with IVS input from A2U10C. The measurements below verify that the operational amplifier circuits provide expected positive and negative dc voltage excursion when the CV loop is open and the power mesh shut down.

Circuits Included. Constant Voltage (CV) Circuit and buffer amplifier A2U10C.

Setup. The Main Troubleshooting Setup, page 29. Apply the ac mains voltage to the bias transformer, and disconnect the external supply Remove the + S jumper and connect A2J3-2 (+ 15V) to + S. Set MODE switch settings B4, B5 and B6 all to 0. Set VP to 0Vdc by connecting to \downarrow P or set VP to + 5Vdc by connecting to A2J3-1 according to SETUP below.

Outputs:

NODE (+)	SETUP	MEASUREMENT
VM		3.75Vdc
A2U10C-8		4.7Vdc
A2U8-6	VP = 0	-14Vdc
A2U10A-1	VP = 0	-14Vdc
A2U8-6	VP = 5	4.7Vdc
A2U10A-1	VP = 5	5.1Vdc

If the failure symptoms include output voltage oscillation, check if the CV Error Amp circuit is at fault by shorting A2U8-6 to A2U8-2. If oscillations stop, the CV Error Amp circuit is probably at fault.

Troubleshooting CC Circuit

I-MON, the output of CC Monitor Amp A2U1, in volts is 1/6 the output current in amperes. CC Error Amp A2U2B compares I-MON to CC PROGRAM. Differentiator circuit A2U3D and A2U3C stabilizes the CC loop. It differentiates IVS and has a voltage gain of 16. Its output is summed with CC PROGRAM at CC Error Amp A2U2B.

The measurements below verify that the operational amplifier circuits provide expected positive and negative do voltage gain when the CC loop is open and the power mesh shut down.

Circuits Included. Constant Current (CC) Circuit on A2 control board.

Setup. The Main Troubleshooting Setup, page 29, except connect the external supply with polarity reversed to the unit's + OUT (-) and - OUT (+) terminals. Apply the ac mains voltage to the bias transformer. Set the external supply to 3.0Adc constant current with a voltage limit in the range 5 to 20Vdc. Set IP to 0Vdc by connecting to \downarrow P or set IP to + 5Vdc by connecting to A2J3-1 according to SETUP below.

Outputs:

NODE (+)	SETUP	MEASUREMENT
IM		0.50Vdc
A2U2B-7	IP = 0	-14Vdc
A2U2B-7	IP = 5	+14Vdc
A2U3D-13	+0.015Vdc	
A2U3C-9	+0.015Vdc	
A2U3C-8	+0.25Vdc	

If the failure symptoms include output current oscillation, check if the differentiator circuit is at fault by removing resistor A2R16 (3.3M ohm). If oscillations stop, the differentiator is probably at fault.

Troubleshooting Down Programmer

The down programmer decreases the output when either MASTER ENABLE is low or CV ERROR is more negative than about - 6Vdc. Comparator A4U3B triggers down programming when the voltage at A4U3B-5 is less than about 3Vdc. The collector-emitter current through transistor A4Q6 increases as the output voltage decreases because of feedback from voltage divider A4R24-A4R27 at A4U3A-2

Circuit Included. Down programmer and 8.9V bias supply on A4 power mesh board.

Setup. The Main Troubleshooting Setup, Paragraph 5-73, except connect the external supply to the unit's + OUT (+) and - OUT (-) terminals. Apply the ac mains voltage to the bias transformer. Set the external supply (EXTERNAL) and adjust unit's voltage setting (INTERNAL) as instructed below.

Outputs:

NODE (+)	SET VOLTAGE (Vdc)			MEASUREMENT
	EXT	INT	SETUP	
A4U4(OUT)	-	-		8.9Vdc
A4U3B-7	0	2	unplug TS1	0Vdc
A4U3B-7	10	0	reconnect TS1	0Vdc
A4U3B-7	0	2		0Vdc
A4U3A-2	0	2	unplug TS1	0.43Vdc
A4F1	0	2		0.2Vdc
A4Q6(base)	0	2		1.0Vdc
A4U3A-1	20	2		4.0Vdc
A4F1	20	2		0.11Vdc

Troubleshooting OVP Circuit

Comparator A2U14D sets and gate A2U17A resets, flipflop A2U14B-A2U14C. TTL low at A2U14-1,8,13 inhibits the PWM.

Circuit included. OVP Circuit and 2.5V bias supply on A2 control board.

Setup. The Main Troubleshooting Setup, page 29, except connect the external supply to the unit's + OUT (+) and - OUT (-) terminals. Apply the ac mains voltage to the bias transformer. Adjust the unit's OVP limit to 15Vdc. Set the external supply (EXTERNAL) as instructed below.

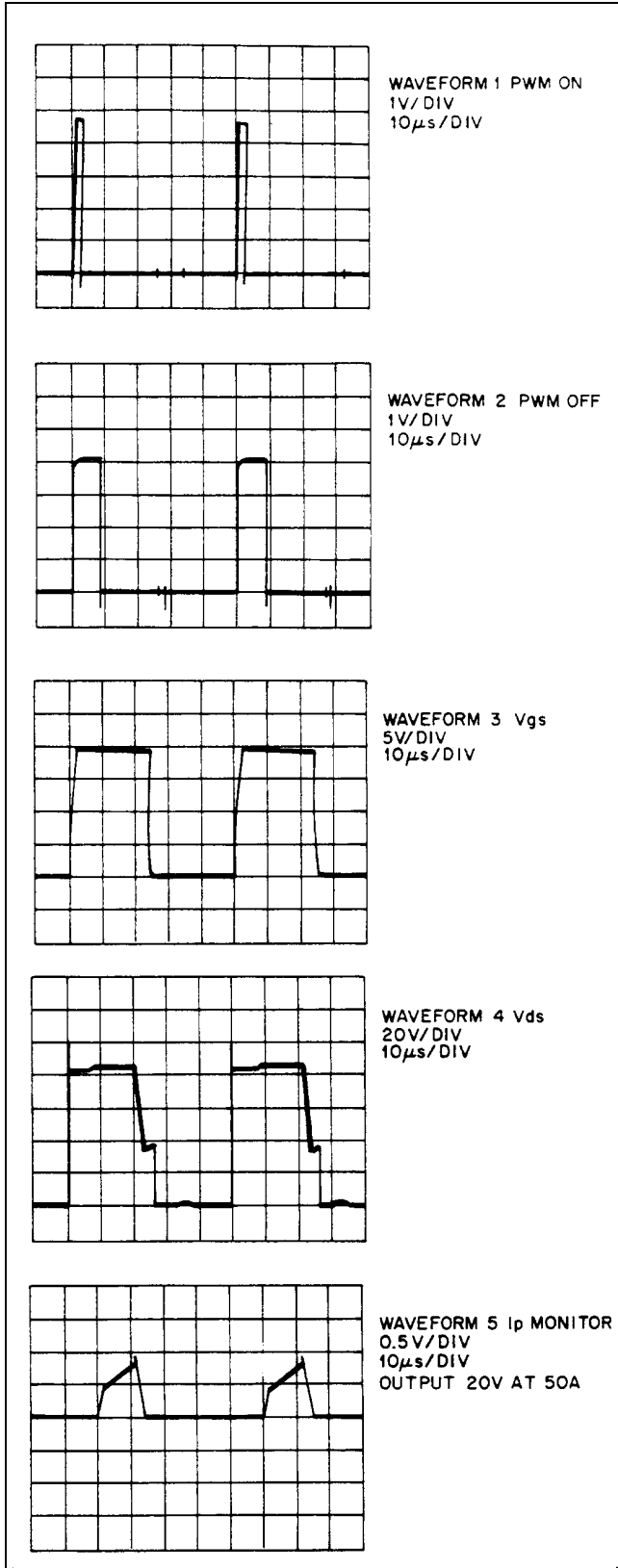

Figure 3-3. Waveforms

Outputs:

NODE (-) = A2J7-4

NODE (+)	SET VOLTAGE (Vdc)		SETUP	MEASUREMENT
	EXTERNAL	INTERNAL		
A2U9 (OUT)	-			2.5Vdc
A2U14-10	10			1.0Vdc
A2U14-11	-			1.5Vdc
A2J3-13	10			hi
A2J3-13	20			lo
A2J3-13	10			lo
A2J3-13	10		cycle power	hi

Note Connecting a test probe to either input of either comparator in the OV Flip flop (pins A2U14-1, 6, 7, 8, 9, 14 or A2U11-13) may cause the flip flop to change states and cause the probed input to be low.

Principles of Operation

Autoranging Power

Autoranging allows the unit to be compact and light weight and yet to deliver a range of output voltage current combinations which otherwise would require the use of more than one supply or a higher rated-power supply. Autoranging is a name for circuitry which automatically makes full power available at all but low rated output voltages and currents. By comparison, a conventional constant-voltage/constant-current (CV/CC) power supply can provide full output power only at maximum rated output voltage and current. For example the power available from a 200 watt, 20V, 10A CV/CC supply adjusted to deliver 10V is only 100 watts.

The power available from the unit when adjusted to 10V is more than 200 watts. The permitted maximum voltage and current of the unit change as current and voltage are adjusted by the user. Thus the unit can be a 20V, 10A supply; a 10V, 20A supply; a 6.7V 30A supply, or any other supply in the range shown graphically in Figure 4-1.

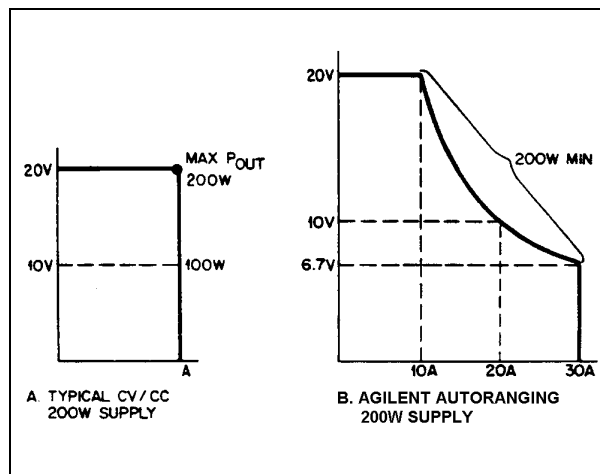
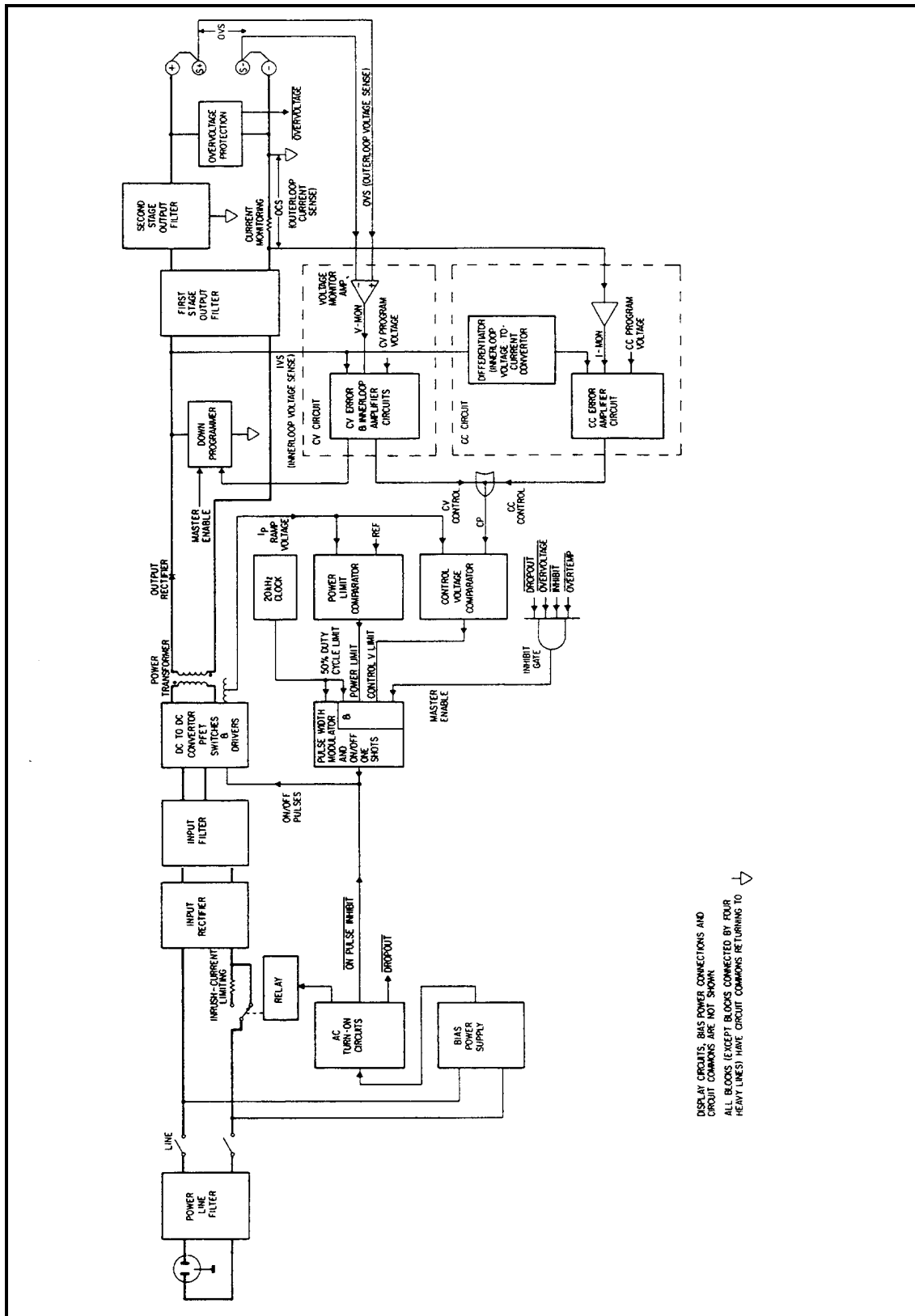

Figure 4-1. Output Characteristics: Typical CV/CC and Autoranging Power Supplies

Block Diagram Overview

This section is an overview. Using the block diagram, Figure 4-2, it explains how the unit works, how major circuits are interconnected and what signals are called. The next section, explains more thoroughly how major circuits operate and uses the simplified schematic, Figure 4-3. Power flows from the ac mains at the left of the block diagram through circuit blocks connected by heavy lines to the load on the output terminals at the right. The Down Programmer lowers the output voltage when required by the CV Circuit. Overvoltage Protection senses the output and shuts down the unit by inhibiting the Pulse Width Modulator (PWM) through the MASTER ENABLE input when an overvoltage is detected. Other protection circuits (not shown) can also inhibit the PWM through the Inhibit Gate.



DISPLAY CIRCUITS, BIAS POWER CONNECTIONS AND CIRCUIT COMMONS ARE NOT SHOWN
 ALL BLOCKS (EXCEPT BLOCKS CONNECTED BY FOUR HEAVY LINES) HAVE CIRCUIT COMMONS RETURNING TO

Figure 4-2. Block Diagram

Control signals flow from right to left with separate circuits for constant-voltage, constant-current and power-limit control. These three control circuits jointly provide the Autoranging characteristic of Figure 4-1B. AC Turn-on Circuits limit inrush current to the input filter and assure transient free turn-on. Internal Bias Supplies provide five bias and two reference voltages to the unit's circuits and provide input signals to the AC Turn-on Circuits.

The unit is a flyback switching power supply. The power transformer stores energy in its magnetic field while current flows in its primary, and energy transfers to the secondary when current flow in the primary turns off. A pair of PFET switches in series with the primary turns on and off at a 20KHz rate controlling the current flow; and the PWM varies the on-time of the PFET switches to regulate the output voltage or current.

In CV or CC operation the PWM turns the PFET switches on at each clock pulse and turns them off when the IpRAMP VOLTAGE exceeds the CP control-port voltage. The IpRAMP VOLTAGE is derived from a sensing transformer in series with the power transformer primary and is proportional to the primary current. The CP control-port voltage is determined by the CV Control Circuit when the unit is in constant-voltage operation and is determined by the CC Control Circuit when in constant-current operation. Follow the block diagram from right to left to see how the output voltage is regulated during CV mode of operation. The output voltage is monitored both at the output sense terminals + S and--S (OVS outerloop voltage) and also before the two stages of output filter (IVS innerloop voltage). Sensing with output sense terminals provides accurate load-voltage control, and sensing before the output filter stabilizes the supply and permits it to power highly reactive loads.

The CV Monitor Amplifier buffers the OVS outerloop voltage to produce the VMON output monitoring voltage. A buffer amplifier (not shown) monitors the voltage before the output filter to produce the IVS innerloop voltage. CV Error and Innerloop Amplifiers compare V-MON and IVS with the CV PROGRAM Voltage which is set by the front-panel VOLTAGE control or by remote programming to develop the CV CONTROL Voltage. When the CV CONTROL Voltage is lower than the CC CONTROL Voltage, CV determines CP and regulates the output voltage by controlling the turn-off of the PWM.

While the PWM turns off when any of the four inputs shown go low, in CV and CC operation it is controlled by the CONTROL V LIMIT input from the Control Voltage Comparator. When the Ip-RAMP VOLTAGE exceeds CP, CONTROL V LIMIT goes low and the PWM turns off the PFET switches. The next clock pulse causes the PWM to turn on the PFET switches, and thus the cycle repeats at a 20KHz rate. Power is transferred through the transformer as required to produce the output voltage determined by the CV PROGRAM Voltage.

When in CC operation, the output current is regulated in a similar manner. Output current is sensed as the OCS outerloop voltage across a Current Monitoring resistor. OCS is buffered to produce I-MON. IVS is differentiated to produce an innerloop current-sensing voltage; and CC Error amplifier compares these to the CC PROGRAM Voltage from the front-panel CURRENT control or remote programming to develop the CC CONTROL Voltage.

Simplified Schematic

The simplified schematic, Figure 4-3, shows the basic operating circuits of the unit. Detailed descriptions follow for major circuits and components in clockwise order. The circuit names and layout of the simplified schematic are the same as used on the complete schematic in Section 7. The heavy lines are the path of power flow through the unit. Please see Figure 4-5 for the display circuits.

Primary power comes to the Input Rectifier through a resistor which limits turn-on inrush current to the input filter. Jumper A1W1 connects the Input Rectifier and Filter as a voltage doubler for 120Vac mains. This jumper is not used for 220/240Vac; thus the Input Filter develops a dc bus voltage of about 300Vdc for either 120 or 220/240Vac ac mains voltages. Primary power also comes through Mains-Voltage Select switches to the Bias Power Supplies which provide the internal operating voltages for the unit. The Mains-Voltage Select switches connect the primary windings of the bias supplies transformer for operation at 120, 220, or 240Vac.

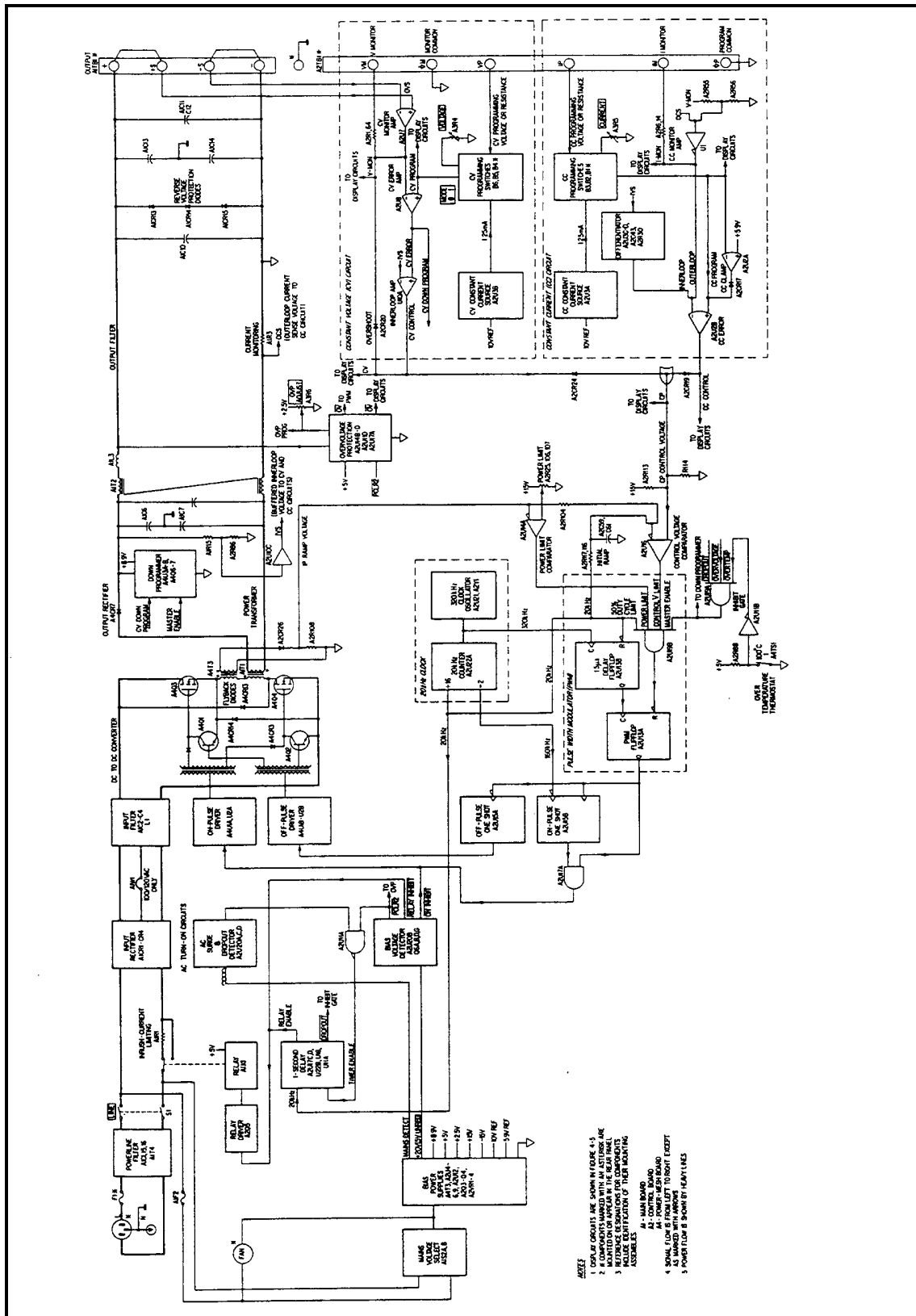

Figure 4-3. Simplified Schematic

The unit checks that the + 5Vdc bias voltage and the ac mains voltage are within acceptable limits as part of its turn on sequence. When + 5Vdc comes up, the Bias Voltage Detector resets the Overvoltage-Protection circuit, enables the On Pulse Driver for the PFET switches, and with the AC Surge-Dropout Detector starts the 1-Second-Delay circuit. After one second, relay A1K1 bypasses the Inrush-Current Limiting resistor. After 0.1 seconds more, the 1-Second-Delay circuit enables the PWM through the DROPOUT signal. The unit is then ready to deliver power.

When the AC-Surge and Dropout Detector detects high or low mains voltage, the unit shuts down until an acceptable ac mains voltage returns. Then it repeats the above turn-on sequence. This protects the unit from damage from ac mains surges and brownouts.

DC-to-DC Converter

PFET switches A4Q3 and A4Q4 control current flow from the Input Filter through power transformer T1. The PWM triggers on-pulses and off-pulses for the PFETs. A train of on-pulses comes through diodes A4CR4 and A4CR3 to the PFETs' gates to turn on the PFETs. The PFETs' input capacitances hold the PFETs on between on-pulses. Off-pulses turn on transistors A4Q1 and A4Q2 which then short the PFETs input capacitances and turn off the PFETs .

The on-Pulse one-shot A2U15B and off-Pulse one-shot A2U15A generate the on- and off-pulses. A2U15B produces a train of up-to four 160KHz on-pulses during the PWM output pulse. A2U15A triggers an off-pulse at each trailing edge of the PWM pulses. Figure 4-4 shows the timing.

When the PFETs turn on, current flows through the primary of power transformer A1T1 and primary-current monitor transformer, A4T3. The Output Rectifier, A4CR7, is reverse biased and blocks current flow in the A1T1 secondary. consequently, the A1T1 transformer stores energy. When the PFETs apply the dc bus voltage to the primary, the primary current ramps up storing more and more energy. The A4T3 transformer senses the A1T1 primary current, and the secondary of A4T3 develops the Ip-Ramp Voltage across resistor A2R108. This linearly increasing voltage predicts the correction in the supply's output voltage or current which will occur when the PFETs are turned off. Comparators monitoring the Ip-Ramp Voltage signal the PWM to turn off the PFETs when it exceeds either the CP control-port voltage or the Power-Limit reference voltage.

When the PFETs turn off, the collapsing magnetic field reverses the polarity of the voltages across the A1T1 primary and secondary, and current flows from the A1T1 secondary through output Rectifier A4CR7 to charge output capacitors A1C8, A1C9 and A1C10. When the PFETs turn off, the leakage inductance of T1 forces current to continue to flow in the primary. Flyback Diodes A4CR13 and A4CR14 protect the PFETs from excess reverse voltage by conducting this current around the PFETs and back to the input filter.

Down Programmer

The Down Programmer lowers the output voltage by rapidly discharging the output-filter capacitors. The Down Programmer causes the output voltage to drop more quickly than it would if only the load discharged the capacitors. Its negative resistance load characteristic discharges the output-filter capacitors at about a 1 ampere rate when the output voltage is high 60Vdc and increases to about a 4 ampere rate when the output voltage is low (1Vdc). Five conditions can trigger down programming: Programming of a lower output voltage, an overvoltage, an overtemperature, a remote disable, or a primary power failure.

The Down-Programmer's input circuit is the diode-OR connection of the Master enable output from Inhibit Gate A2U19B and the CV Error Voltage from CV Error Amplifier A2U8. The Down Programmer turns on when either the Master Enable is low or when the CV Error Voltage is more negative than about -6Vdc. The + 8.9Vdc bias supply for the Down Programmer stores enough energy in its input capacitor to operate the Down Programmer after loss of primary power. This ensures that the Down Programmer will be able to discharge the output circuit when primary power is turned off.

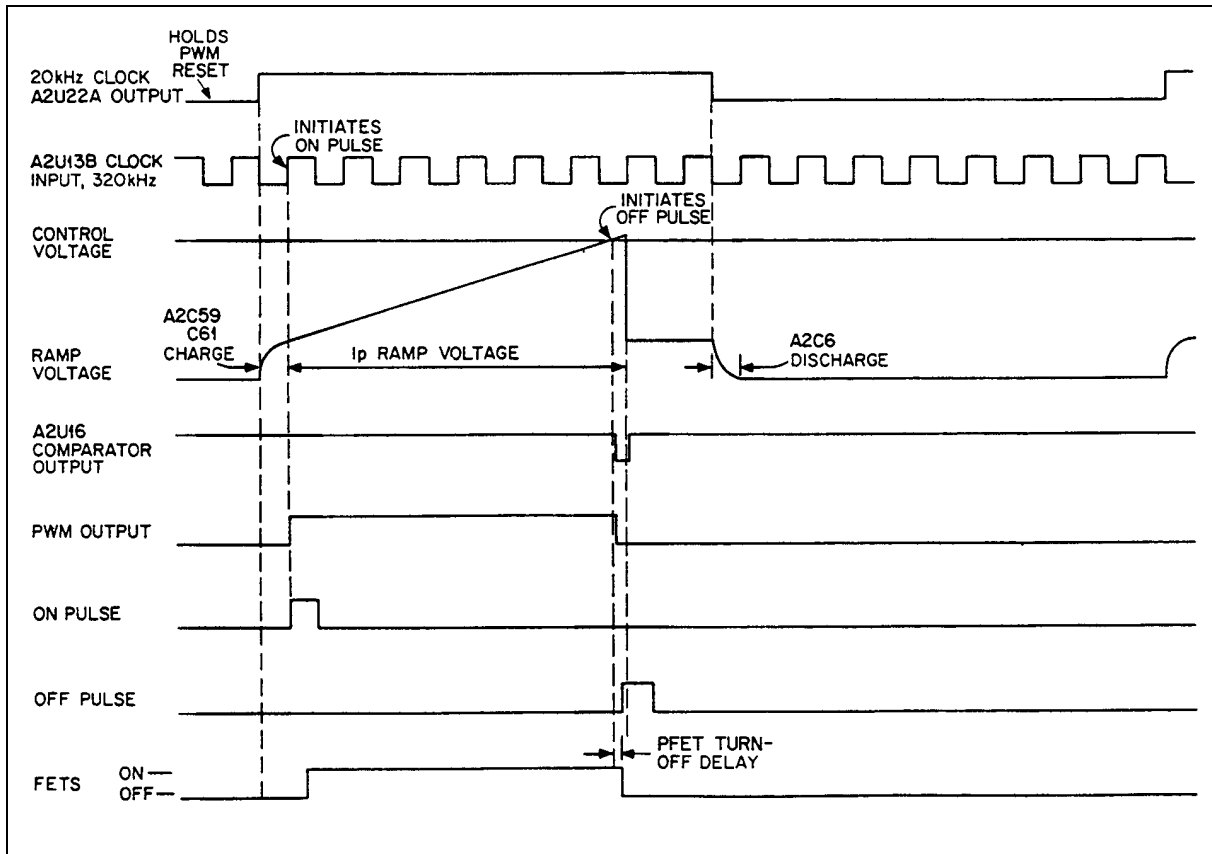

Figure 4-4. PFET Control Signals Timing Diagram

Constant-Voltage (CV) Circuit

The Constant-Voltage Circuit compares the output voltage to the user-set CV PROGRAM Voltage to produce the CV CONTROL Voltage. Two comparison amplifier loops accomplish the comparison. In the outerloop, CV Error Amplifier A2U8 compares V-MON, a buffered fraction of the sensed output voltage OVS, to the program voltage from the CV Programming Switches to create the CV ERROR Voltage. Then in the innerloop, Innerloop Amplifier A2U10A compares this error voltage to IVS, a buffered fraction of the innerloop output voltage, to produce the CV CONTROL Voltage. The CV ERROR Voltage is also diode-OR connected through diode A2CR21 as an input to the Down Programmer.

V-MON also connects through protective circuitry to rear-panel terminal VM for remote monitoring of the output voltage. It is equal to 1/4 of the sensed output voltage OVS, and is 5Vdc for 60Vdc full output.

Settings of the CV Programming Switches, the B6, B5, and B4 MODE switch settings allow the CV PROGRAM Voltage to come from the front-panel VOLTAGE Control; from an external voltage applied between rear-panel terminals VP and ∇ P; or from an external resistor between VP and ∇ P. When using either the VOLTAGE Control or external resistor, current from the CV Constant-Current Source flows through the applicable resistance to develop the CV PROGRAM Voltage.

In CV mode, the CV CONTROL Voltage varies between about -0.5Vdc and about + 1.0Vdc. It is most negative when the load is drawing no power. As the load draws more power, the voltage becomes more positive. The CV CONTROL Voltage is at the cathode of diode A2CR24, part of the diode-OR input to the Control-Voltage Comparator. Diode A2CR20 prevents voltage overshoots during transient load changes and program changes.

Constant-Current (CC) Circuit

The Constant-Current Circuit compares the output current to the user-set CC PROGRAM Voltage to produce the CC CONTROL Voltage. As with the CV Circuit, two comparison amplifier loops accomplish the comparison. OCS is the voltage across Current-Monitoring resistor A1R3, and it senses the output current for the outer loop which is the unit's output current.

To compensate for the fraction of the output current which flows through the unit's output-voltage sensing resistors and not through the load, CC Monitor Amplifier A2U1 adds a fraction of V-MON to OCS. It amplifies that sum to produce the outerloop current-sense voltage, I-MON. I-MON also connects through protective circuitry to rear-panel terminal IM for remote monitoring of the output current. In volts it is equal to 1/6 of the output current in amperes, and is 5Vdc for 10Adc full output.

Differentiation of IVS develops a current-proportional voltage which senses the innerloop current flowing into the capacitive output filter. CC Error Amplifier A2U2B sums this differentiated innerloop voltage with I-MON and subtracts the sum from the CC PROGRAM Voltage to produce the CC CONTROL Voltage. In CC mode the CC CONTROL Voltage varies from about -0.5Vdc to +1.0Vdc at the cathode of diode A2CR19. CC Clamp A2U2A limits the CC PROGRAM Voltage to about 5.6 peak volts.

Settings of the rear-panel CC Programming Switches the B3, B2 and B1 MODE switch settings allow the CC PROGRAM Voltage to come from the front-panel CURRENT Control, from an external voltage applied between terminals IP and /P, or from an external resistor between IP and /P. When using either the CURRENT Control or external resistor, current from the CC Constant-Current Source flows through the applicable resistance to develop the CC PROGRAM Voltage.

Overvoltage Protection (OVP) Circuit

The Overvoltage Protection Circuit (OVP) shuts down the unit when a monitored 1/30 fraction of the output voltage exceeds the limit voltage set by the front-panel op ADJUST Control. If the output voltage exceeds the preset limit, the OVP inhibits the PWM, triggers the Down Programmer, lights the OV LED and latches itself on until the unit is turned off. The Bias Voltage Detector resets the OVP at turn-on of the unit. **option 002** allows remote reset of OVP.

Power-Limit Comparator

Two comparisons with the Ip-RAMP VOLTAGE provide POWER LIMIT and CONTROL V LIMIT, two of the four inputs for the PWM. POWER LIMIT is the output of the Power Limit Comparator A2U14A. The comparator compares the IpRAMP VOLTAGE with the power-limit reference voltage of about 1.0Vdc. The reference is adjustable with the POWER LIMIT calibration trim pot A2R25. The POWER LIMIT sets the maximum primary current in power transformer A1T1 by going low and turning off the PWM when the Ip-RAMP VOLTAGE exceeds the reference.

Primary current is proportional to output power, and POWER LIMIT turns off the PWM when the CONTROL V LIMIT would otherwise allow the unit to deliver more than about 200 watts. This occurs during transient load increases, step increases in CV Program Voltage and when the combination of the CV PROGRAM Voltage and the CC PROGRAM Voltage calls for more than 200 watts. The Power-Limit Comparator produces the power-limited portion of the unit's output characteristic curve in Figure 4-1 and is the essence of the unit's Autoranging power.

Control-Voltage Comparator

The Control-Voltage Comparator A2U16 produces the CONTROL V LIMIT input to the PWM by comparing the IpRAMP VOLTAGE to the CP control-port voltage. In CV or CC operation CP is one diode-drop more than the lower of the CV and CC CONTROL Voltages. CONTROL V LIMIT goes low and turns off the PWM when the Ip-RAMP VOLTAGE exceeds CP. The A2R113-A2R114 voltage divider steers control of CP by its connection at the anodes of series diodes A2CR19 and

A2CR24. The A2R113-A2R114 voltage divider sets the maximum CP voltage to + 1.5Vdc and assures that the diode with the lower control voltage will be forward biased when its control voltage is less than + 1.5Vdc. As an illustration of CV-CC selection, suppose the unit is in CV operation and diode A2CR24 is forward biased by a low CV CONTRL Voltage: Then CV sets CP to less than + 1.5Vdc.

CV keeps diode A2CR19 reverse biased and prevents CC control until the CC CONTROL Voltage is even lower.

The lower of the control voltages varies between about -0.5Vdc and + 1.0Vdc regulating the unit's output. The higher control voltage has no effect on the output and increases in response to the error voltage in its circuit. When higher, the CC CONTROL Voltage limits at about 6Vdc. When higher, the CV CONTROL Voltage increases only slightly. In CV or CC mode CP remains one diode-drop more than the lower control voltage and varies from about 0.0 to + 1.5Vdc. In UNREGULATED mode CP is +1.5Vdc and both control voltages are more than about + 1.0Vdc.

Initial-Ramp Circuit

The Control Voltage and Ramp Voltage waveforms in Figure 4-4 show that there is a time delay between when the control voltage is exceeded and when the PFETs turn off. This cumulative circuit delay would cause the PFETs to deliver power even when no power is requested by the control circuits. To eliminate the delay, the Initial-Ramp Circuit adds a ramp voltage to the Ip-RAMP VOLTAGE at the input to the Control Voltage Comparator. The added ramp voltage starts with the 20KHz clock pulse and causes the combined-ramp voltage to exceed the control voltage earlier thereby essentially eliminating the PFET turn-off delay. A two-stage RC integrating network consisting of resistors A2R116 and A2R117 and capacitors A2C59 and A2C61 creates the Initial-Ramp by shaping the 20KHz clock pulses.

Pulse-Width Modulator (PWM)

The PWM generates 20KHz repetition-rate pulses which vary in length according to the unit's output requirements. The pulses start 1.5 μ after each 20KHz clock pulse and turn off when any of these four inputs go low. The output of the Control-Voltage Comparator (CONTROL V LIMIT), the output of the Power-Limit Comparator (POWER LIMIT), the 20KHz clock pulse (50%-DUTY-CYCLE LIMIT), or the output of the Inhibit Gate A2U19A (MASTER ENABLE). As discussed earlier, the PFETs turn on during, and turn off at the trailing edges of PWM output pulses.

The PWM generates pulses as follows: A 20KHz clock pulse holds the 1.5 μ Delay Flip-flop A2U13B reset; 1.5 μ after the trailing edge of the 20KHz pulse, the next pulse from the 320KHz Clock oscillator clocks the output of A2U13B high, and this initiates the PWM pulse from PWM Flip-flop A2U13A. When one of the above four inputs to AND-gate A2U19B goes low. A2U19B resets A2U13A, and the PWM pulse turns off.

Bias Voltage Detector

The Bias Voltage Detector prevents spurious operation which might occur at power-on of the unit if circuits tried to operate before the + 5Vdc bias voltage is at the clock, PWM, and logic circuits. After power-on, as the output of the + 5Vdc bias supply rises from 0Vdc through about 1Vdc, three transistor switches in the Bias Voltage Detector turn on. They inhibit the Relay Driver and the on-Pulse Driver, and they create the power-clear signal, PCLR2. The transistors inhibit the circuits and hold PCLR2 low until the unregulated input to the +5Vdc bias supply is greater than about 11Vdc, an input voltage sufficient to assure + 5Vdc bias output. PCLR2 resets the OVP at turn-on, and **Option 002** uses PCLR2 in creating its DROPOUT, OVERVOLTAGE, and POWER-ON RESET outputs.

AC-Surge Dropout Detector

Dropout Detector protects the unit from damage from ac mains voltage surges and dropouts by shutting down the unit when there is either a 40% overvoltage or a 20 ms voltage interruption in the ac mains voltage. The detector shuts down the unit

by inhibiting the PWM through the DROPOUT signal from the 1-Second-Delay Circuit. Mains Detect signal, which is fullwave-rectified ac from the + 5Vdc secondary of the bias-supplies transformer, senses the ac mains voltage. The Dropout Detector, including comparators A2U20A and A2U20C, operates by enabling a capacitor-timing ramp when Mains-Detect ceases. Comparator A2U20D monitors the amplitude of Mains-Detect to provide ac surge voltage detection.

1-Second-Delay Circuit

The 1-Second-Delay Circuit is the heart of the unit's controlled turn-on. It causes relay A1K1 to bypass inrush current-limiting resistor A1R1 one second after turn-on, and it enables the PWM 0.1 seconds later. When either the output of the AC-Surge and Dropout Detector or PCLR2 is low, NAND gate A2U11A holds the circuit reset. The circuit starts counting at 1/16 the clock frequency (1.25 kHz) when both inputs to A2U11A are high and causes Relay Enable to go high in 1.0 seconds and DROPOUT to go high in 1.1 seconds. When DROPOUT goes high, it stops the count, and it enables the PWM. **option 002** uses DROPOUT in creating its DROPOUT output.

Display Circuits

Figure 4-5 is a simplified schematic for the display circuits. The named signals from the CV and CC Circuits are connected through semiconductor bilateral switches to the VOLTS digital voltage display and to the AMPS digital current display. Either a blank display or a depressing of the DISPLAY OVP switch changes the VOLTS display from low range to high range. A blank display occurs when the Voltage DVM A3U4 receives an over-range voltage, a voltage greater than 0.999Vdc. The blank display is detected by the Voltage-Range Switching Circuit. The diode-AND connection at inverting amplifier A3U9A senses when two selected segments of the 7-segment LED for the second digit are both not lighted. The detection scheme works because at least one of the selected segments is lighted for all digits 0 through 9.

The normal display is the actual output voltage and current and has bilateral switches A3U1A and A3U1D closed. Switch A3U1A connects V-MON through buffer amplifier A3U2 and range-switching bilateral switches to the VOLTS DVM. Switch A3U1 D connects I-MON through buffer amplifier A3U3A to the AMPS DVM. Depress the DISPLAY LIMITS Switch, and CV and CC PROGRAM Voltages connect through bilateral switches A3U1B and A3U1C to display the programmed output voltage and current. Depress the DISPLAY OVP Switch, and OV PROGRAM Voltage from the OVP ADJUST Control connects through buffer amplifier A3U3B and bilateral switch A3U7B to display the programmed OVP voltage limit. The CV and CC CONTROL Voltages also control the front-panel mode LEDs. When CV CONTROL Voltage is more negative than CP, transistor A2Q6C lights CV LED A3DS9 showing that the unit is operating in constant-voltage mode. When CC CONTROL is more negative than CP, transistor A2Q6F lights CC LED A3DS10 showing that the unit is operating in constant-current mode. And when both CV and CC are more positive than CP, NAND-gate A2U11C lights UNREGULATED LED A3DS11 showing the unit is operating in power-limited, unregulated mode.

Replaceable Parts

Introduction

This chapter contains information for ordering replacement parts. Table 5-3 lists parts in alpha-numeric order by reference designators and provides the following information:

- a. Reference Designators. Refer to Table 5-1.
- b. Agilent Model in which the particular part is used.
- c. Agilent Part Number.
- d. Description. Refer to Table 5-2 for abbreviations.

Parts not identified by reference designator are listed at the end of Table 5-3 under Mechanical and/or Miscellaneous.

Table 5-1. Reference Designators

A	Assembly
B	Blower
C	Capacitor
CR	Diode
DS	Signaling Device (light)
F	Fuse
FL	Filter
G	Pulse Generator
J	Jack
K	Relay
L	Inductor
Q	Transistor
R	Resistor
RT	Thermistor Disc
S	Switch
T	Transformer
TB	Terminal Block
TS	Thermal Switch
U	Integrated Circuit
VR	Voltage Regulator (Zener diode)
W	Wire (Jumper)
X	Socket*
Y	Oscillator

* Reference designator following "X" (e.g. XA2) indicates assembly or device mounted in socket.

Ordering Information

To order a replacement part, address order or inquiry to your local Agilent Technologies sales office. Specify the following information for each part: Model, complete serial number, and any option or special modification (J) numbers of the instrument; Agilent part number; circuit reference designator; and description. To order a part not listed in Table 5-3, give a complete description of the part, its function, and its location.

Table 5-2. Description Abbreviations

ADDR	Addressable
ASSY	Assembly
AWG	American Wire Gauge
BUFF	Buffer
CER	Ceramic
COMP	Carbon Film Composition
CONV	Converter
DECODER/DEMULTI	Decoder/Demultiplexer
ELECT	Electrolytic
EPROM	Erasable Programmable Read-Only Memory
FET	Field Effect Transistor
FF	Flip-Flop
FXD	Fixed
IC	Integrated Circuit
INP	Input
LED	Light Emitting Diode
MET	Metalized
MOS	Metal-Oxide Silicon
OP AMP	Operational Amplifier
OPTO	Optical
OVP	Over Voltage Protection
PCB	Printed Circuit Board
PORC	Porcelain
POS	Positive
PRIOR	Priority
ROM	Read-Only Memory
RAM	Random Access Memory
RECT	Rectifier
REGIS	Register
RES	Resistor
TBAX	Tube Axial
TRIG	Triggered
UNI	Universal
VAR	Variable
VLTG REG	Voltage Regulator
WW	Wire Wound

Table 5-3. A1 Main Board Parts List

Ref. Desig.	Agilent Model	Agilent Part Number	Description
		ELECTRICAL PARTS	
A1	6023A	06038-60021	Main Board Assembly
A1	6028A	06038-61021	Main Board Assembly
C1	All	0160-4962	Capacitor, 1 μ F + 10% 50Vac
C2,3	All	0180-3426	Capacitor, 590 μ F + 50-10% 400V
C4	All	0180-3427	Capacitor, 300 μ F + 50-10% 200V
C5	All	0160-4962	Capacitor, 1 μ F + 10% 50V
C6,7	All	0160-5933	Capacitor, 0.022 μ F + 10% 1500V
C8-10	6023A	0180-3425	Capacitor, 5500 μ F +50-10% 40V
C8-10	6028A	0160-3548	Capacitor, 1700 μ F 75V
C11-12	6023A	0160-5377	Capacitor, 2.2 μ F +10% 6.3V
C11-12	6028A	0160-6167	Capacitor, 2.2 μ F 63V
C13,14	6023A	0160-7731	Capacitor, 0.22 μ F + 10% 1500V
C13,14	6028A	0160-5933	Capacitor, 0.022 μ F + 10% 1500V
C15,16	All	0160-4355	Capacitor, 0.01 μ F + 10% 250V
C17	6023A	0160-5422	Capacitor, 0.047 μ F + 20% 50V
C17	6028A	0160-4834	Capacitor, 0.047 μ F + 20% 50V
C20,21	All	0180-3428	Capacitor, 1000 μ F 50V
C22,23	All	0160-4439	Capacitor, 4700 μ F 20% 250V
C24,25	6028A	0160-4281	Capacitor, 2200 μ F 20% 250V
C26	6028A	0160-4323	Capacitor, 0.047 μ F 20% 250V
CR1-4	6023A	1901-1199	Diode power rectifier 600V 3A
CR1	6028A	1901-1087	Diode power rectifier 600V 3A
CR2	6028A	1901-0759	Diode power rectifier 600V 3A
CR3	6028A	1901-1087	Diode power rectifier 600V 3A
CR4	6028A	1901-0759	Diode power rectifier 600V 3A
CR6, 7	All	1901-0731	Diode power rectifier 600V 3A
CR8, 9	All	1901-0050	Diode power rectifier 600V 3A
CR13, 15	All	1901-0731	Diode power rectifier 600V 3A
F2	All	2110-0007	Fuse 1A 250V
F3	6028A	2110-0763	Fuse 1/4A 125V
J1	All	1251-5927	Connector, 26-contact
J2	All	1251-5384	Connector, 3-contact
J3	All	1251-8676	Connector, 5-contact
K1	All	0490-1417	Relay, DPST
L1	All	06024-80094	Choke RFI 3A (magnetic core 9170-0721)
L3	6023A	5080-1981	Choke, output 0.5 μ H
L3	6028A	9140-0987	Choke 3 μ H
Q1	6028A	1854-0087	Transistor NPN SI
Q2	6028A	1854-0799	Transistor NPN SI TIP41C
R1	All	0811-3667	Resistor 20 Ω 5% 7W
R2	All	0811-1865	Resistor 2k Ω 10% 5W
R3	6023A	5080-2007	Sensing resistor 0.005
R4	All	0683-1025	Resistor 1K Ω 5% 1/4W
R5	6023A	8151-0013	Wire, 22 AWG
R5	6028A	7175-0057	Wire, tinned copper, AWG 22
R6	All	0683-1025	Resistor 1K Ω 5% 1/4W
R7	6028A	0699-1210	Resistor 80K Ω 0.1% 0.1W
R8-10	6023A	8151-0013	Wire, 22 AWG

Table 5-3. A1 Main Board Parts List (continued)

Ref. Desig.	Agilent Model	Agilent Part Number	Description
R8	6028A	0699-0118	Resistor 20Ω 0.1% 0.1W
R9	6028A	7175-0057	Wire tinned copper AWG 22
R10	6028A	0698-6359	Resistor 80KΩ 0.1% 1/8W
R11	All	0698-6322	Resistor 4KΩ 0.1% 1/8W
R12	All	0698-8695	Resistor 36KΩ 0.1% 1/8W
R14	6023A	0698-3572	Resistor 60.4Ω 1% 1/8W
R15	6023A	8151-0013	Wire 22 AWG
R15	6028A	0757-0270	Resistor 249KΩ 1% 1/4W
R17,18	All	0683-1005	Resistor 10Ω 5% 1/4W
R19	All	0683-1055	Resistor 1MΩ 5% 1/4W
R20,21	All	0811-1867	Resistor 15KΩ 5% 5W
R22,23	All	0686-1065	Resistor 10MΩ 5% 1/2W
R24,25	All	0686-1035	Resistor 10KΩ 5% 1/2W
R26	All	0683-3315	Resistor 330Ω 5% 1/4W
R27A,28B	6028A	0811-3823	Resistor 0.1Ω 5% 20W
R29	6028A	0686-3335	Resistor 33KΩ 5% 1/2W
R30	6028A	0811-1865	Resistor 2KΩ 1% 5W
R31	6028A	0812-0098	Resistor 135Ω 5% 5W
R32	6028A	0683-1035	Resistor 10KΩ 5% 1/4W
R33	6028A	0683-4745	Resistor 470Ω 5% 1/4W
R34	6028A	0683-2035	Resistor 20KΩ 5% 1/4W
S1	6023A	3101-0402	Switch DPST rocker (mounted on front-panel)
S2	All	3101-1914	Switch 2-DPDT slide
S4	All	3101-2046	Switch DPDT slide
T1	6023A	5080-1978	Transformer, power
T1	6028A	06038-80090	Transformer, power
T2	All	9170-1264	Core magnetic (used with primary wire 06023-80004)
T3	All	9100-4864	Transformer bias
T4	All	5080-1984	Choke line 2mH
TP1, 2	All	1251-5613	Connector single contact
U1	All	1906-0006	Rectifier bridge 400V 1A
VR1, 2	6028A	1902-1377	Diode zener 6.19V 2%
W1, 2	All	06023-80003	Jumper output 10 AWG
XA2P1	All	1251-8665	Connector, 30-contact
XA2P2	All	1251-8667	Connector, 20 contact
XA4P1, 2	All	1251-8806	Connector, DIN 32-contact
		MECHANICAL PARTS	
	6028A	1480-0552	Pin, escutcheon (L1)
	6028A	0380-1489	Snap-in-spacer
	6028A	2110-0269	Fuseholder, clip type F2
	6028A	0360-2190	Jumper, local sensing (2)
	6028A	0360-1833	Barrier block, 6-position
	6023A	0515-0964	screw
	6023A	2190-0586	washer, lock
	6023A	3050-0893	washer, flat

Table 5-4. A2 Control Board Parts List

Ref. Desig.	Agilent Model	Agilent Part Number	Description
		ELECTRICAL PARTS	
A2		06038-61023	Control Board Assembly
A2		06023-60023	Control Board Assembly
C1	All	0160-5469	Capacitor, 1μF + 10% 50V
C2	All	0160-5422	Capacitor, 0.047μF 20% 50V
C3	6023A	0160-4801	Capacitor, 100pF 5% 100V
C3	6028A	0160-4812	Capacitor, 220pF 5%
C7	All	0160-5422	Capacitor, 0.047μF 20% 50V
C8	All	0160-4812	Capacitor, 220pF 5% 100V
C9	All	0160-5377	Capacitor, 2.2μF 10% 63V
C10,11	All	0160-5469	Capacitor, 1μF 10% 50V
C12,13	All	0160-5422	Capacitor, 0.047μF 20% 50V
C14	All	0180-0291	Capacitor, 1μF 10% 35V
C15	All	0180-1731	Capacitor, 4.7μF 10% 50V
C16,17	All	0180-0230	Capacitor, 1μF + 20% 50V
C18,19	6023A	0180-0291	Capacitor, 1μF 10% 35V
C18,19	6028A	0180-0230	Capacitor, 1μF 20% 50V
C20	All	0180-2624	Capacitor, 2000μF 75-25% 10V
C21	All	0180-5098	Capacitor, 0.22μF 10% 50V
C22	All	0180-4832	Capacitor, 0.01μF 10% 100V
C23	All	0180-3407	Capacitor, 2200pF +50-10% 35V
C24	All	0180-5098	Capacitor, 0.22μF 10% 50V
C25	All	0160-4833	Capacitor, 0.022μF 10% 100V
C26	All	0160-0154	Capacitor, 2200pF 10% 200V
C27,28	All	0160-5422	Capacitor, 0.047μF 20% 50V
C29	6023A	0160-4808	Capacitor, 470pF 5% 100V
C29	6028A	0160-4812	Capacitor, 220pF 5% 100V
C30	All	0160-4830	Capacitor, 2200pF 10% 100V
C31	6023A	0160-4808	Capacitor, 470pF 5% 100V
C31	6028A	0160-4801	Capacitor, 100pF 5% 100V
C32	All	0160-4801	Capacitor, 100pF 5% 100V
C33-37	6023A	0160-5422	Capacitor, 0.047μF 20% 50V
C33-35	6028A	0160-5422	Capacitor, 0.047μF 20% 50V
C36	6028A	0160-4833	Capacitor, 0.022μF 10% 100V
C37	6028A	0160-5422	Capacitor, 0.047μF 20% 50V
C38	6023A	0160-4801	Capacitor, 100pF 5% 100V
C38	6028A	0160-4803	Capacitor, 68pF 5% 100V
C39,40	All	0160-5422	Capacitor, 0.047μF 20% 50V
C41	All	0160-4835	Capacitor, 0.1μF 10% 50V
C42	All	0160-4805	Capacitor, 47pF 5% 100V
C43	All	0160-5422	Capacitor, 0.047μF 20% 50V
C44	All	0160-4805	Capacitor, 47pF 5% 100V
C45	6023A	0160-4808	Capacitor, 470pF 5% 100V
C45	6028A	0160-4810	Capacitor, 330pF 5% 100V
C46	All	0160-4807	Capacitor, 33pF 5% 100V
C47	All	0160-4822	Capacitor, 1000pF 5% 100V
C48	All	0160-5422	Capacitor, 0.047μF 20% 50V
C49	6023A	0160-5644	Capacitor, 0.033μF 10% 50V
C49	6028A	0160-4833	Capacitor, 0.022μF 10% 100V

Table 5-4. A2 Control Board Parts List (continued)

Ref. Desig.	Agilent Model	Agilent Part Number	Description
C50	6023A	0160-0167	Capacitor, 0.082 μ F 10% 200V
C50	6028A	0160-0168	Capacitor, 0.1 μ F 10% 200V
C51	All	0160-4801	Capacitor, 100pF 5% 100V
C52,53	All	0160-4831	Capacitor, 4700pF 10% 100V
C54	All	0160-5422	Capacitor, 0.047 μ F 20% 50V
C55,56	All	0160-4801	Capacitor, 100pF 5% 100V
C57,58	All	0160-5422	Capacitor, 0.047 μ F 20% 50V
C59	All	0160-4812	Capacitor, 220pF 5% 100V
C60	All	0160-5422	Capacitor, 0.047 μ F 20% 50V
C61	All	0160-4812	Capacitor, 220pF 5% 100V
C62	All	0160-5422	Capacitor, 0.047 μ F 20% 50V
C63	All	0180-0116	Capacitor, 6.8 μ F 10% 35V
C64,65	All	0160-5422	Capacitor, 0.047 μ F 20% 50V
C66	All	0180-0376	Capacitor, 0.47 μ F 10% 35V
C67,68	All	0160-4812	Capacitor, 220pF 5% 100V
C69	All	0180-4832	Capacitor, 0.01 μ F 10% 100V
C70	All	0180-1980	Capacitor, 1 μ F 5% 35V
C71	All	0160-5422	Capacitor, 0.047 μ F 20% 50V
C72	6028A	0160-5422	Capacitor, 0.047 μ F 20% 50V
CR1,2	All	1901-0033	Diode general purpose 180V 200mA
CR3	All	1901-0050	Diode switching 80V 200A
CR5-7	All	1901-0033	Diode general purpose 180V 200mA
CR8-10	All	1901-0050	Diode switching 80V 200A
CR11	All	1901-0992	Diode power rectifier 40V 3A
CR12-16	All	1901-0033	Diode general purpose 180V 200mA
CR18	All	1901-0033	Diode general purpose 180V 200mA
CR19	All	1901-0050	Diode switching 80V 200A
CR20	All	1901-0033	Diode general purpose 180V 200mA
CR21-30	All	1901-0050	Diode switching 80V 200A
J1,2	All	1251-8417	Connector, 16-contact
L1	All	06023-80090	Choke bias 820 μ H
P1	All	1251-8664	Connector 30-contact
P2	All	1251-8666	Connector 20-contact
Q1,2	All	1855-0413	Transistor J-FET P-chan 2N5116
Q3	All	1854-0635	Transistor NPN SI D44H5
Q4	All	1853-0012	Transistor PNP SI 2N2904A
Q5	All	1854-0823	Transistor NPN SI
Q6	All	1858-0023	Transistor array CA3081E
Q7	6028A	1854-0087	Transistor NPN SI
R1	All	0683-5125	Resistor 51k Ω 1/2W
R2	6023A	0683-3925	Resistor 39K Ω 5% 1/4W
R2	6028A	0757-0419	Resistor 681 Ω 1% 1/8W
R3	6023A	0698-6329	Resistor 845 Ω 1% 1/8W
R3	6028A	0698-6393	Resistor 585 Ω 1% 1/8W
R4	All	0683-1035	Resistor 10K Ω 5% 1/4W
R5	6023A	0698-7880	Resistor 28.7K Ω 1% 1/8W
R5	6028A	0699-0774	Resistor 6.65K Ω 1% 1/8W

Table 5-4. A2 Control Board Parts List (continued)

Ref. Desig.	Agilent Model	Agilent Part Number	Description
R6	All	0683-5125	Resistor 5.1K Ω 5% 1/4W
R7	All	0683-4745	Resistor 470K 5% 1/4W
R8	All	2100-3353	Trimmer 20K Ω side adjust
R9	6023A	2100-3350	Trimmer 200 side adjust
R9	6028A	2100-3993	Trimmer 200 side adjust
R10	6023A	0683-5625	Resistor 5.6K Ω 5% 1/4W
R10	6028A	0757-0427	Resistor 1.5K Ω 1% 1/8W
R11	6023A	0698-3136	Resistor 17.8K Ω 1% 1/8W
R11	6028A	0683-1025	Resistor 12K Ω 5% 1/4W
R12	All	0683-1025	Resistor 1K Ω 5% 1/4W
R13	All	0683-2735	Resistor 27K Ω 5% 1/4W
R14	All	0686-5125	Resistor 5.1K Ω 5% 1/4W
R15	All	0683-2015	Resistor 200 Ω 5% 1/4W
R16	6023A	0683-3355	Resistor 3.3M Ω 5% 1/4W
R16	6028A	0683-2255	Resistor 2.2M Ω 5% 1/4W
R17	6023A	0683-6835	Resistor 68K Ω 5% 1/4W
R17	6028A	0757-0289	Resistor 13.3K Ω 1% 1/8W
R18	6023A	0683-3035	Resistor 50K Ω 5% 1/4W
R18	6028A	0757-0449	Resistor 20K Ω 1% 1/8W
R19	6023A	0683-4735	Resistor 47K Ω 5% 1/4W
R19	6028A	0757-0449	Resistor 20K Ω 1% 1/8W
R20	All	0683-1035	Trimmer 200 Ω side adjust
R21	6023A	2100-3350	Resistor 3.3M Ω 5% 1/4W
R21	6028A	2100-3273	Trimmer 2K Ω side adjust
R22	All	2100-3353	Trimmer 20K Ω side adjust
R23	All	2100-3273	Trimmer 2K Ω side adjust
R24	All	2100-3350	Trimmer 200 Ω side adjust
R25	All	2100-3207	Trimmer 5K Ω side adjust
R26	All	0683-1045	Resistor 100K Ω 5% 1/4W
R27	All	0698-6322	Resistor 4K Ω 0.1% 1/8W
R28	All	0683-1045	Resistor 100K Ω 5% 1/4W
R29	All	0698-4416	Resistor 169 Ω 1% 1/8W
R30	All	0683-7545	Resistor 750K Ω 5% 1/4W
R31	All	0698-6322	Resistor 4K Ω 0.1% 1/8W
R32	All	0698-4416	Resistor 169 Ω 1% 1/8W
R33	All	0698-4447	Resistor 280 Ω 1% 1/8W
R34	All	0757-0404	Resistor 130 Ω 1% 1/8W
R35	All	0698-4608	Resistor 806 Ω 1% 1/8W
R36	All	0757-0438	Resistor 5.11k Ω 1% 1/8W
R37,38	All	0683-1035	Resistor 10K Ω 5% 1/4W
R39	All	0686-2005	Resistor 20 Ω 5% 1/2W
R40	All	0683-1005	Resistor 10 Ω 5% 1/4W
R41,42	All	0683-6215	Resistor 620 Ω 5% 1/2W
R43	All	0683-1515	Resistor 150 Ω 5% 1/4W
R44	All	0757-0434	Resistor 3.65K Ω 1% 1/8W
R45	All	0757-0442	Resistor 10K Ω 1% 1/8W
R46,47	All	0757-0283	Resistor 2K Ω 1% 1/8W

Table 5-4. A2 Control Board Parts List (continued)

Ref. Desig.	Agilent Model	Agilent Part Number	Description
R48,49	All	0686-1315	Resistor 130Ω 5% 1/2W
R50	All	0811-3174	Resistor 0.07Ω 5% 5W
R51	All	0698-6076	Resistor 39KΩ 1% 1/8W
R52	All	0757-0280	Resistor 1KΩ 1% 1/8W
R53	All	0698-4121	Resistor 11.3KΩ 1% 1/8W
R54	All	0683-2015	Resistor 200Ω 5% 1/4W
R55	6023A	0683-5655	Resistor 5.6MΩ 5% 1/4W
R55	6028A	0683-1055	Resistor 1MΩ 5% 1/4W
R56	6023A	0757-0408	Resistor 243Ω 1% 1/4W
R56	6028A	0757-0269	Resistor 270Ω 1/4W
R57	6023A	0683-1325	Resistor 1.3KΩ 5% 1/4W
R57	6028A	0683-2015	Resistor 200Ω 5% 1/4W
R58	All	0683-1045	Resistor 100KΩ 5% 1/4W
R59	All	0698-8816	Resistor 2.15Ω 1% 1/8W
R60	All	0757-0199	Resistor 21.5KΩ 1% 1/8W
R61	6023A	0699-0059	Resistor 5KΩ 0.1% 0.1W
R61	6028A	0698-6360	Resistor 10KΩ 0.1% 1/8W
R62	6023A	0698-3432	Resistor 26.1Ω 1% 1/8W
R62	6028A	8159-0005	Wire tinned copper AWG 22
R63	6023A	0699-0059	Resistor 5KΩ 0.1% 0.1W
R63	6028A	0698-6360	Resistor 10KΩ 1/8W
R64	All	0683-5125	Resistor 5.1KΩ 5% 1/4W
R65,66	6023A	0699-0118	Resistor 20KΩ 0.1% 0.1W
R65	6028A	0699-1210	Resistor 80KΩ 0.1% 0.1W
R66	6028A	0699-1211	Resistor 95KΩ 0.1% 0.1W
R67,68	All	0686-5125	Resistor 5.1KΩ 5% 1/2W
R69	All	0683-2225	Resistor 2.2KΩ 5% 1/4W
R70	All	0683-2015	Resistor 200Ω 5% 1/4W
R71	6023A	0683-2735	Resistor 27KΩ 5% 1/4W
R71	6028A	0698-5089	Resistor 33KΩ 1% 1/8W
R72	6023A	0757-0465	Resistor 100KΩ 1% 1/8W
R72	6028A	0757-0470	Resistor 162KΩ 1% 1/8W
R73,74	6023A	0683-2035	Resistor 20KΩ 5% 1/4W
R73,74	6028A	0757-0452	Resistor 27.4KΩ 1% 1/8W
R75	All	0683-7545	Resistor 750KΩ 5% 1/4W
R76	6023A	0683-4735	Resistor 47KΩ 5% 1/4W
R76	6028A	0757-0446	Resistor 15KΩ 1% 1/8W
R77	6023A	0683-7545	Resistor 750KΩ 5% 1/4W
R77	6028A	0757-0469	Resistor 150KΩ 1% 1/8W
R78	6023A	0757-0415	Resistor 475Ω 1% 1/8W
R78	6028A	0698-4014	Resistor 787Ω 1% 1/8W
R79	All	0698-6983	Resistor 20.4KΩ 0.1% 1/8W
R80	All	0698-6320	Resistor 5KΩ 0.1% 1/8W
R81	All	0757-0459	Resistor 56.2KΩ 0.1% 1/8W
R82	All	0683-3325	Resistor 3.3KΩ 5% 1/8W
R83	All	0757-0270	Resistor 249KΩ 1% 1/8W
R84	6023A	0683-5125	Resistor 5.1KΩ 5% 1/4W
R84	6023A	0757-0442	Resistor 10KΩ 1% 1/8W

Table 5-4. A2 Control Board Parts List (continued)

Ref. Desig.	Agilent Model	Agilent Part Number	Description
R85	All	0698-3450	Resistor 42.2K Ω 1% 1/8W
R86	All	0757-0452	Resistor 27.4K Ω 1% 1/8W
R87	All	0683-2715	Resistor 270 Ω 5% 1/8W
R88,89	All	0683-2225	Resistor 2.2K Ω 5% 1/4W
R90	All	0683-2715	Resistor 270 Ω 5% 1/8W
R91	All	0683-2225	Resistor 2.2K Ω 5% 1/4W
R92	All	0683-2015	Resistor 200 Ω 5% 1/4W
R93	All	0686-5125	Resistor 5.1K Ω 5% 1/4W
R94	All	0686-1035	Resistor 10K Ω 5% 1/4W
R95	All	0757-0472	Resistor 200K Ω 1% 1/8W
R96	6023A	0698-3572	Resistor 60.4K Ω 1% 1/8W
R96	6028A	0757-0455	Resistor 36.5K Ω 1% 1/8W
R97	All	0686-5125	Resistor 5.1K Ω 5% 1/4W
R98	All	0686-2735	Resistor 27K Ω 5% 1/4W
R99	All	0686-1035	Resistor 10K Ω 5% 1/4W
R100,101	All	1810-0365	Network sip 2.2K Ω X5
R102,103	All	0757-0449	Resistor 20K Ω 1% 1/8W
R104	All	0757-0280	Resistor 1K Ω 1% 1/8W
R105	All	0698-3430	Resistor 21.5K Ω 1% 1/8W
R106	All	0698-3449	Resistor 28.7K Ω 1% 1/8W
R107	All	0698-3153	Resistor 3.38K Ω 1% 1/8W
R108	All	0683-2035	Resistor 20K Ω 5% 1/4W
R109	All	0683-2225	Resistor 2.2K Ω 5% 1/4W
R110	All	0683-4725	Resistor 4.7K Ω 5% 1/4W
R111	All	0683-2025	Resistor 2K Ω 5% 1/4W
R112	All	0683-1125	Resistor 1.1K Ω 5% 1/4W
R113	All	0757-0442	Resistor 10K Ω 1% 1/8W
R114	All	0757-0424	Resistor 1.1K Ω 1% 1/8W
R115	All	0683-1015	Resistor 100 Ω 5% 1/4W
R116	All	0683-3498	Resistor 8.66K Ω 1% 1/8W
R117	All	0757-0438	Resistor 5.11K Ω 1% 1/8W
R118	All	1810-0365	Network sip 2.2K Ω X5
R119	All	0757-0288	Resistor 9.09 Ω 1% 1/8W
R120	All	0683-1005	Resistor 10 Ω 5% 1/4W
R121	All	0757-0442	Resistor 10K Ω 1% 1/8W
R122	All	0683-5135	Resistor 51K Ω 5% 1/4W
R123-126	All	0683-4725	Resistor 4.7K Ω 5% 1/4W
R127	All	0683-1855	Resistor 1.8M Ω 5% 1/4W
R128	All	0683-6835	Resistor 68K Ω 5% 1/4W
R129	All	0757-0439	Resistor 6.8K Ω 1% 1/8W
R130	All	0683-1055	Resistor 1M Ω 5% 1/4W
R131	All	0683-3335	Resistor 33K Ω 5% 1/4W
R132	All	0683-2225	Resistor 2.2K Ω 5% 1/4W
R133	All	0683-2735	Resistor 27K Ω 5% 1/4W
R134	All	0757-0466	Resistor 110K Ω 1% 1/8W
R135,136	All	0757-0442	Resistor 10K Ω 1% 1/8W
R137	All	0698-3455	Resistor 261K Ω 1% 1/8W
R138	All	0683-2045	Resistor 200K Ω 5% 1/4W

Table 5-4. A2 Control Board Parts List (continued)

Ref. Desig.	Agilent Model	Agilent Part Number	Description
R139	All	0757-0442	Resistor 10K Ω 1% 1/8W
R140	All	0698-3160	Resistor 31.6K Ω 1% 1/8W
R141	All	0683-1025	Resistor 1K Ω 5% 1/4W
R142	All	0683-2225	Resistor 2.2K Ω 5% 1/4W
R143	All	0683-1045	Resistor 100K Ω 5% 1/4W
R144	All	0683-4725	Resistor 4.7K Ω 5% 1/4W
R145	All	0683-4715	Resistor 470 Ω 5% 1/4W
R146,147	All	0683-1125	Resistor 1.1K Ω 5% 1/4W
R148	All	0683-3925	Resistor 3.9K Ω 5% 1/4W
R149	All	1810-0365	Network sip 2.2K Ω X5
R150,151	All	0683-1815	Resistor 180 Ω 5% 1/4W
R152	All	0683-1025	Resistor 1K Ω 5% 1/4W
R153	6028A	0683-1035	Resistor 10K Ω 5% 1/4W
R155,158	6023A	8159-0005	Resistor 0 Ω
R155	6028A	0683-1005	Resistor 10 Ω 5% 1/4W
R156-158	6028A	0683-1005	Resistor 10 Ω 5% 1/4W
S1	All	3101-2097	Switch 6-1A slide
U1	All	1826-0493	IC op amp lo-bias hi-impedance
U2	All	1826-0346	IC op amp dual general purpose
U3	All	1826-0161	IC op amp quad general purpose
U4	All	1826-0527	IC voltage regulator 1.2/37V
U5	All	1826-0544	IC voltage reference 2.5V
U6	All	1826-0428	IC voltage regulator 1/40V
U7,8	All	1826-0493	IC op amp lo-bias hi-impedance
U9	All	1826-0544	IC voltage reference 2.5V
U10	All	1826-0161	IC op amp quad general purpose
U11	All	1820-1209	IC flip flop D-type
U12	All	1826-0393	IC voltage regulator 1.2/37V
U13	All	1820-1112	IC flip flop D-type
U14	All	1820-0138	IC comparator quad
U15	All	1820-1437	IC multivibrator monostable dual
U16	All	1820-0065	IC comparator precision
U17	All	1820-1246	IC gate quad AND
U18	All	1820-0935	IC counter binary CMOS
U19	All	1820-1205	IC gate dual AND
U20	All	1826-0138	IC comparator quad
U21	All	1826-0065	IC comparator precision
U22	All	1820-2096	IC counter binary dual
VR1,2	All	1902-0018	Diode zener 11.7V 5%
VR3	All	1902-0777	Diode zener 6.2V 5%
VR4	All	1902-3110	Diode zener 5.9V 2%
VR5	All	1902-0575	Diode zener 6.5V 2%
W1-3	All	7175-0057	Jumper wire 22 AWG
Y1	All	0960-0586	Resonator 320kHz
		MECHANICAL PARTS	
	6028A	5060-2942	Heatsink (Q2, U15, 16)
	6028A	1200-0181	Insulator
	6028A	1200-0485	Socket (S1)
	6028A	0360-2195	Terminal block, 6-position
	6028A	1531-0309	Clevis, tapped

Table 5-5. A3 Front-Panel Board Parts List

Ref. Desig.	Agilent Model	Agilent Part Number	Description
		ELECTRICAL PARTS	
A3	6023A	06023-60020	Front-Panel Board Assembly
A3	6028A	06028-61020	Front-Panel Board Assembly
C1	All	0160-4807	Capacitor, fixed ceramic 33pF ±5% 100V
C2-4	All	0160-5422	Capacitor, fixed ceramic 0.047µF ±20% 50V
C5	All	0160-4805	Capacitor, fixed ceramic 47pF ±5% 100V
C6	All	0160-4835	Capacitor, fixed ceramic 0.1µF ±10% 50V
C7	All	0160-0168	Capacitor, fixed ceramic 0.1/1F ±10% 200V
C8	All	0160-5893	Capacitor, fixed met 0.047µF ±10% 100V
C9	All	0160-5422	Capacitor, fixed ceramic 0.047µF ±20% 50V
C10	All	0160-4805	Capacitor, fixed ceramic 47pF ±5% 100V
C11	All	0160-4835	Capacitor, fixed ceramic 0.1µF ±10% 50V
C12	All	0160-0168	Capacitor, fixed ceramic 0.1µF ±10% 200V
C13	All	0160-5893	Capacitor, fixed ceramic 0.047µF ±10% 100V
C14-15	All	0160-5422	Capacitor, fixed ceramic 0.047µF ±20% 50V
C16	All	0160-4831	Capacitor, fixed ceramic 4700pF 10% 100V
C17	All	0160-5422	Capacitor, fixed ceramic 0.047µF ±20% 50V
C80	All	0160-4835	Capacitor, fixed ceramic 0.1µF ±10% 50V
CR1,2	All	1901-0033	Diode general purpose 180V 200mA
CR3,4	All	1901-0050	Diode switching 80V 200mA
CR5	All	1901-0033	Diode general purpose 180V 200mA
DS1-8	6023A	1990-0985	Display kit
DS1	6028A	1990-0681	Display, analog
DS2-4	6028A	1990-0540	Display, numeric
DS5	6028A	1990-0681	Display, analog
DS6-8	6028A	1990-0540	Display, numeric
DS9,10	All	1990-0951	LED, green
J1	All	1251-5055	Connector, post type 26-contacts
R1	All	0683-3925	Resistor, composition 3.9KΩ 5% 1/4W
R2	All	0683-6815	Resistor, composition 680Ω 5% 1/2W
R3	All	0683-2025	Resistor, composition 2KΩ 5% 1/4W
R4,5	6023A		See Chassis Electrical
R6	All	2100-1775	Termistor 5KΩ 5% 1-turn side adjust
R7	6023A	0757-0415	Resistor, fixed film 475Ω 1% 1/8W
R7	6028A	0698-4457	Resistor, fixed film 576Ω 1% 1/8W
R8	All	0683-1045	Resistor, fixed composition 100KΩ 5% 1/4W
R10-57	All	0683-2015	Resistor, fixed composition 200Ω 5% 1/4W
R58	All	0683-6215	Resistor, fixed composition 620Ω 5% 1/2W
R59	All	0757-0458	Resistor, fixed film 51.1KΩ 1% 1/8W
R60	All	0757-0270	Resistor, fixed film 249KΩ 1% 1/8W
R61,62	All	0683-5615	Resistor, fixed composition 560Ω 5% 1/4W
R63	All	0757-0458	Resistor, fixed film 51.1KΩ 1% 1/8W
R64	All	0757-0270	Resistor, fixed film 249KΩ 1% 1/8W
R65	All	0683-1045	Resistor, fixed composition 100KΩ 5% 1/4W
R66	All	0698-8498	Resistor, fixed film 1.02KΩ 0.1% 1/8W
R67	6023A	0699-0721	Resistor, fixed film 33KΩ 0.1% 1/8W
R67	6028A	0757-7929	Resistor, fixed film 9.09KΩ 1% 1/8W

Table 5-5. A3 Front-Panel Board Parts List

Ref. Desig.	Agilent Model	Agilent Part Number	Description
R68	All	0698-6362	Resistor, fixed film 1K Ω 0.1% 1/8W
R69	All	0698-6343	Resistor, fixed film 9K Ω 0.1% 1/8W
R71	6023A	0698-6363	Resistor, fixed film 40K Ω 0.1% 1/8W
R71	6028A	0698-8861	Resistor, fixed film 6.66K Ω 0.1% 1/8W
R72	6023A	0698-7353	Resistor, fixed film 19K Ω 1% 1/8W
R72	6028A	0698-4493	Resistor, fixed film 34K Ω 1% 1/8W
R73	6023A	0757-0280	Resistor, fixed film 1K Ω 1% 1/8W
R73	6028A	0698-3476	Resistor, fixed film 6.00K Ω 1% 1/8W
R74	All	0683-1025	Resistor, fixed film 1K Ω 5% 1/4W
R75	All	0683-3025	Resistor, fixed composition 3K Ω 5% 1/4W
R77	All	0757-0458	Resistor, fixed film 51.1K Ω 1% 1/8W
R78	All	0698-3159	Resistor, fixed film 26.1K Ω 1% 1/8W
R79	All	0757-0441	Resistor, fixed film 8.25K Ω 1% 1/8W
R80	All	0757-0438	Resistor, fixed film 5.11K Ω +1% 1/8W
R81	All	0683-5135	Resistor, fixed composition 51K Ω \pm % 1/4W
R82	All	0683-1025	Resistor, fixed composition 1K Ω 5% 1/4W
R83	All	0683-5125	Resistor, fixed composition 5.1K Ω ~5% 1/4W
R84	All	0683-1025	Resistor, fixed composition 1K Ω 5% 1/4W
R85	All	0757-0280	Resistor, fixed film 1K Ω 1% 1/8W
R86	All	0698-5808	Resistor, fixed film 4K Ω 1% 1/8W
R87	6023A	0698-3201	Resistor, fixed film 80K Ω 1% 1/8W
R87	6028A	0757-0449	Resistor, fixed film 20K Ω 1% 1/8W
R88	6023A	0757-0449	Resistor, fixed film 20K Ω 1% 1/8W
R88	6028A	0757-0453	Resistor, fixed film 30.1K Ω 1% 1/8W
R89	All	0683-5135	Resistor, fixed composition 51K Ω 5% 1/4W
R90	All	0757-0199	Resistor, fixed film 21.5K Ω + 1% 1/4W
R91	All	0683-5235	Resistor, fixed composition 51K Ω 5% 1/4W
R92,93	All	0757-0452	Resistor, fixed film 27.4K Ω 1% 1/8W
S1,2	All	5060-9436	Switch lighted pushbutton
U1	All	1826-0502	IC switch analog quad
U2	All	1826-0493	IC op amp lo-bias hi-impedance
U3	All	1826-0346	IC op amp dual general purpose
U4,5	All	1826-0876	IC A/D CMOS 3-1/2 DGT
U6	All	1820-1144	IC gate TTL LS NOR quad
U7	All	1826-0502	IC switch analog quad
U9	All	1826-0138	IC comparator GP quad
VR1	All	1902-3092	Diode zener 4.99V 2%
VR2	All	1902-0064	Diode zener 7.5V 5%
W4	All	7175-0057	Wire 22 AWG
W7	6028A	7175-0057	Wire 22 AWG
W8	6023A	7175-0057	Wire 22 AWG
W11	All	7175-0057	Wire 22 AWG

Table 5-6. A4 Power Mesh Parts List

Ref. Desig.	Agilent Model	Agilent Part Number	Description
A4		06038-61022	Power Mesh Assembly
C1	All	0160-5891	Fixed met 0.47 μ F +10% 630V
C2	All	0160-5422	Fixed cer 0.047 μ F +20% 50V
C5,6	All	0160-4960	Fixed film 2200pF +10% 1.6kV
C7	All	0180-0155	Fixed elect 2.2 μ F +20% 20V
C8	All	0160-0127	Fixed ceramic 1 μ F +20% 25V
C9	All	0180-2780	Fixed elect 470 μ F +75-10% 16V
C10	All	0160-4834	Fixed cer 0.047 μ F +10% 100V
C11,12	All	0160-4835	Fixed cer 0.1 μ F +10% 50V
C13	All	0160-0161	Fixed poly 0.01 μ F +10% 200V
CR1-4	All	1901-0050	Switching 80V 200mA
CR5,6	All	1901-1065	Pwr rect 400V 1A
CR7	All	1901-1127	Pwr rect 150V 70A
CR10,11	All	1901-0050	Switching 80V 200mA
CR13,14	All	1901-1087	Pwr rect 600V 3A
F1,2	All	2110-0671	Axial lead, 1/8A
F3	6023A	2110-0699	Fuse, 5A 125V
F3	6028A	2110-0688	Fuse, 5A 125V
L3	All	06024-80096	Inductor, 3A
L4	All	9170-1265	Core, ferrite, 5uH
P1,2	All	1251-8807	Connector, DIN type 32-contact F
Q1,2	All	1854-0477	NPN SI
Q3,4	6023A	1855-0916	MOSFET N-channel
Q3,4	6028A	1855-0547	PFET
Q6	All	1854-0264	NPN SI
Q7	All	1855-0549	PFET
R1,2	All	0686-0275	Fixed comp. 2.7 5% 1/2W
R3	All	0683-3915	Fixed comp. 390 5% 1/4W
R4	All	0683-1015	Fixed comp. 100 5% 1/4W
R5	All	0683-4705	Fixed comp. 47 5% 1/4W
R6	All	0683-1045	Fixed comp. 100K 5% 1/4W
R7	All	0811-1857	Fixed ww 400 5% 5W
R8	All	0698-3601	Fixed met ox 10 5% 2W
R9	All	0683-3915	Fixed comp. 390 5% 1/4W
R10	All	0683-1015	Fixed comp. 100 5% 1/4W
R11	All	0683-4705	Fixed comp. 47 5% 1/4W
R12	All	0683-1045	Fixed comp. 100K 5% 1/4W
R13	All	0811-1857	Fixed ww 400 5% 5W
R14	All	0698-3601	Fixed met ox 10 5% 2W
R15	All	0757-0403	Fixed film 121 1% 1/8W
R16	All	0683-3305	Fixed comp. 33 5% 1/4W
R17	All	0683-1025	Fixed comp. 1K 5% 1/4W
R18	All	0683-0475	Fixed comp. 4.7 5% 1/4W
R19	All	0683-2025	Fixed comp. 2K 5% 1/4W
R20	All	0683-0275	Fixed comp. 2.7 5% 1/4W
R21,22	All	0683-0475	Fixed comp. 4.7 5%. 1/4W
R23	All	0683-2725	Fixed comp. 2.7K 5% 1/4W

Table 5-6. A4 Power Mesh Parts List (continued)

Ref. Desig.	Agilent Model	Agilent Part Number	Description
R24	All	0757-0464	Fixed film 90.9K 1% A 1/8W
R25	All	0686-1005	Fixed comp. 10 5% 1/2W
R26	All	0811-2490	Fixed ww 0.1 3% 5W
R27	All	0698-3225	Fixed film 1.43k 1% 1/8W
R28	All	0757-0279	Fixed film 3.16K 1%1/8W
R29	All	0698-3159	Fixed film 26.1K 1%1/8W
R30	All	0698-3202	Fixed film 1.74K 1% 1/8W
R31	All	0698-4046	Fixed film 732 1% 1/8W
R32	All	0757-0442	Fixed film 10K 1% 1/8W
R33	All	0698-3601	Fixed met ox 10 5% 2W
R34	All	0698-4484	Fixed film 19.1K 1% 1/8W
R35,36	All	0683-3305	Fixed comp. 33 5% 1/4W
R37	All	0683-3325	Fixed comp. 3.3k 5% 1/4W
R39	All	0683-1055	Fixed comp. 1M 5% 1/4W
T1,2	All	5080-1983	transformer, FET driver
T3	All	9100-4350	transformer, current
TS1	All	3103-0116	Switch, thermal 100 C
TP1-4	All	1251-0646	Contact connector, post type
U1,2	All	1820-1050	IC DRVR TTL NOR dual
U3	All	1826-0346	IC op amp GP dual
U4	All	1826-0393	IC voltage regulator 1.2/37V
VR2	All	1902-3002	Zener 2.37V 5V
VR3	All	1902-0057	Zener 6.49V 5V
VR4	All	1902-0575	Zener 6.5V 2V
		CHASSIS ELECTRICAL	
R4,R5	6023A	2100-4060	Resistor, variable, 5K (ref. front-panel)
	All	3160-0343	Fan, axial tube
	All	9135-0223	Line filter, IEC
	All	8120-1348	Cable assembly (power cord) 18 AWG
	All	8120-4353	Cable assembly (A1 board to A3 board)
	All	8120-4383	Cable assembly (Line Cord)

Table 5-7. Other Replacement Assemblies

Ref. Desig.	Agilent Model	Agilent Part Number	Description
A1 Board Mechanical Parts			
	6023A	1251-0600	Contact-conn M (Ref Fan)
A1J1	All	1251-5927	Connector post type header
A1J2	All	1251-5384	Connector post type header
A1J3	All	1251-8676	Connector post type
XA2P1	All	1251-8665	Connector post type
XA2P2	All	1251-8667	Connector post type
XA4P1,P2	All	1251-8806	Din Connector
	All	1251-5613	Single contact connector (ref. AC line voltage select)
	All	1480-0552	Pin, escutcheon (ref. L1)
A1TB1	All	2110-0269	Fuseholder, clip type (ref. F2)
	All	0360-2192	Barrier block
	All	0360-2190	Jumper, barrier block
A2 Board Mechanical Parts			
A2P1	All	1251-8664	Connector post type
A2P2	All	1251-8666	Connector post type
A2J1, J2	All	1251-8417	Din Connector
	All	1200-0485	Socket, IC 14-contact (ref.
	All	1205-0282	Heatsink (ref. Q2, U15, U16)
	All	1531-0309	Clevis (ref. A2 Board)
	All	0360-2195	Barrier block
A3 Board Mechanical Parts			
	All	4040-2121	Plastic (ref. DS9-12)
A1J1	All	1251-5055	Connector post type header
A4 Board Mechanical Parts			
A4P1,P2	All	1251-8807	Din Connector
	All	0362-0335	Single contact Connector (AC)
	6023A	1205-0919	Heatsink (ref. Q3, Q4)
	6028A	1205-0256	Heatsink (ref. Q3, Q4)
	All	1205-0282	Heatsink (ref. Q7)
	All	1531-0309	Clevis (ref. A4 Board)
	All	06023-20001	Heatsink (ref. CR7)
	All	06023-80002	Jumper, 10 AWG
	6028A	0380-1679	Hex head stand off (ref.Q3, Q4)
TP1-4	All	1251-0646	Connector single contact (pin)
CHASSIS MECHANICAL PARTS			
	All	0380-1489	Spacer, snap in
	All	0370-1091	Knob, base round
	All	0403-0282	Bumper feet
	All	1510-0044	Binding post, single
	6023A	2110-0564	Fuseholder body (chassis fuse)
	6023A	2110-0565	Fuseholder cap (chassis fuse)
	6023A	2110-0569	Fuseholder nut (chassis fuse)
	6028A	2110-0926	Fuseholder assembly, (chassis fuse)
	All	3160-0309	Finger guard (ref. fan)

Table 5-7. Other Replacement Assemblies (continued)

Ref. Desig.	Agilent Model	Agilent Part Number	Description
	All	4040-1954	Window, display
	6023A	5020-8847	Trim strip
	All	5041-8803	Trim strip, top
	All	5001-0540	Trim, side 7in
	All	5021-8417	Frame front
	All	5041-8801	Foot
	All	5041-8819	Retainer, strap handle
	All	5041-8820	Retainer, strap handle
	All	5041-0309	Key cap, quarter
	All	5062-3703	Assembly, handle strap
	All	7120-1254	Nameplate
	All	7120-8572	Canadian Standards Association Label (ref. rear panel)
	All	7121-2527	Metric and Inch Label (ref. rear panel)
	All	7121-2794	Serial Identification Label (ref. rear panel)
	6023A	06023-00016	Chassis
	6028A	06023-00001	Chassis
	All	06023-00020	Cover, top
	All	06023-00022	Cover, bottom
	6023A	06023-00004	Bracket, upper
	6023A	06023-00014	Panel, sub
	6023A	06023-00018	Sub panel, front
	6023A	06023-00007	Bus bar, negative
	6023A	06023-00008	Bus bar, positive
	All	06023-00009	Cover, bar block
	6023A	06023-00010	Cover,(top plate screened)
	6028A	06023-00026	Cover,(top plate screened)
	6023A	06023-00019	Rear panel, screened
	6028A	06023-00011	Rear panel, screened
	All	06028-00021	Front-panel, screened
	All	06023-81003	Line Voltage Label (ref. rear panel) 28480
	6023A	06023-90001	Operating and Service manual
	6028A	06028-90001	Operating and Service manual
	6023A	1990-0521	Cover, terminal block
Option 220 (220V Operation)			
	All	2110-0055	Fuse 4A 250V (rear chassis)
	All	2110-0383	Fuse 8A 250V (rear chassis)
	All	7120-8572	Label, info
	All	06023-81001	Label, info
Option 240 (240V Operation)			
	All	2110-0055	Fuse 4A 250V (rear chassis)
	All	2110-0383	Fuse 8A 250V (rear chassis)
	All	7120-8572	Label, info
	All	06023-81002	Label, info

Component Location and Circuit Diagrams



This chapter contains component location diagrams, schematics, and other drawings useful for maintenance of the power supply. Included in this section are:

- a. Component location illustrations (Figures 6-1 through 6-5), showing the physical location and reference designators of almost all electrical parts. (Components located on the rear panel are easily identified.)
- b. Notes (Table 6-1) that apply to all schematic diagrams.
- c. Figures 6-6 and 6-7 illustrate the detailed schematic of the unit. Test points are called out and short explanatory notes are positioned close to the related circuit to enhance schematic readability.

WARNING

AC line voltage is present on the A1 Main Board Assembly whenever the power cord is connected to an ac power source.

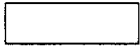
Table 6-1. Schematic Diagram Notes

1.  denotes front-panel marking.
2.  denotes rear-panel marking.
3. Complete reference designator consists of component reference designator prefixed with assembly number (e.g.: A2R14).
4. Resistor values are in ohms. Unless otherwise noted, resistors are either 1/4W, 5% or 1/8W, 1%. Parts list provides power rating and tolerance for all resistors.
5. Unless otherwise noted, capacitor values are in microfarads.
6. Square p.c. pads indicate one of the following:
 - a. pin 1 of an integrated circuit.
 - b. the cathode of a diode or emitter of a transistor.
 - c. the positive end of a polarized capacitor.
7. In schematic symbols drawn to show right-to-left signal flow, blocks of information are still read left to right. For example:

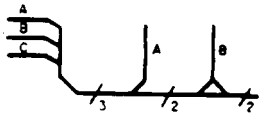

→ indicates shift away from control block (normally down and to right). ← indicates shift toward control block (normally up and to left).

8.  indicates multiple paths represented by only one line. Reference designators with pin numbers indicate destination, or signal names identify individual paths. Numbers indicate number of paths represented by the line.
9. Inter-board commons have letter identifications (e.g. :); commons existing on a single assembly have number identifications (e.g. :).
10. For single in-line resistor packages, pin 1 is marked with a dot. For dual in-line integrated circuit packages, pin 1 is either marked with a dot, or pin 1 is to the left (as viewed from top) of indication at end of integrated circuit package. e.g.:

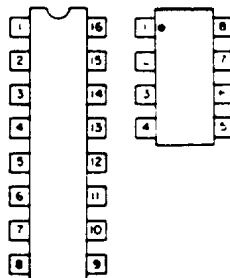
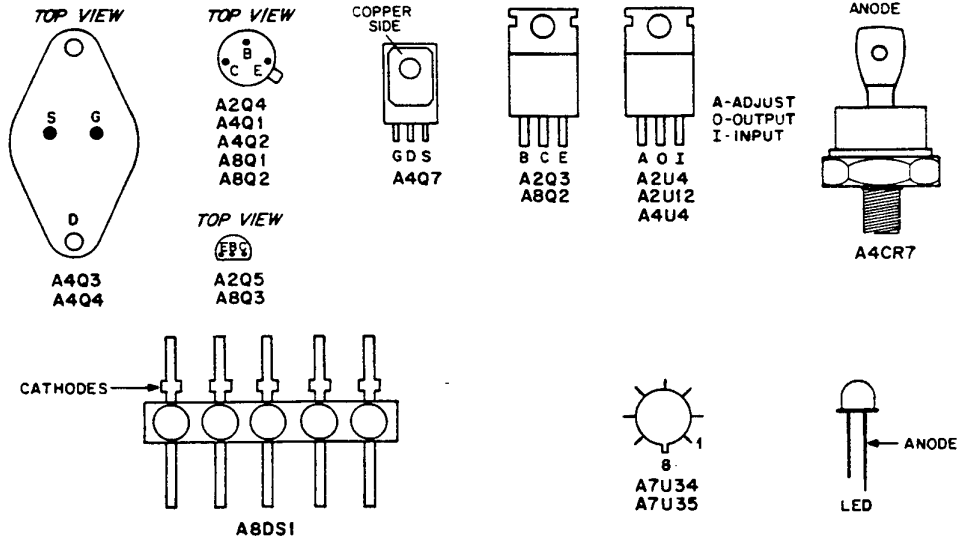

Table 6-1. Schematic Diagram Notes (continued)

Pin locations for other semi-conductors are shown below:



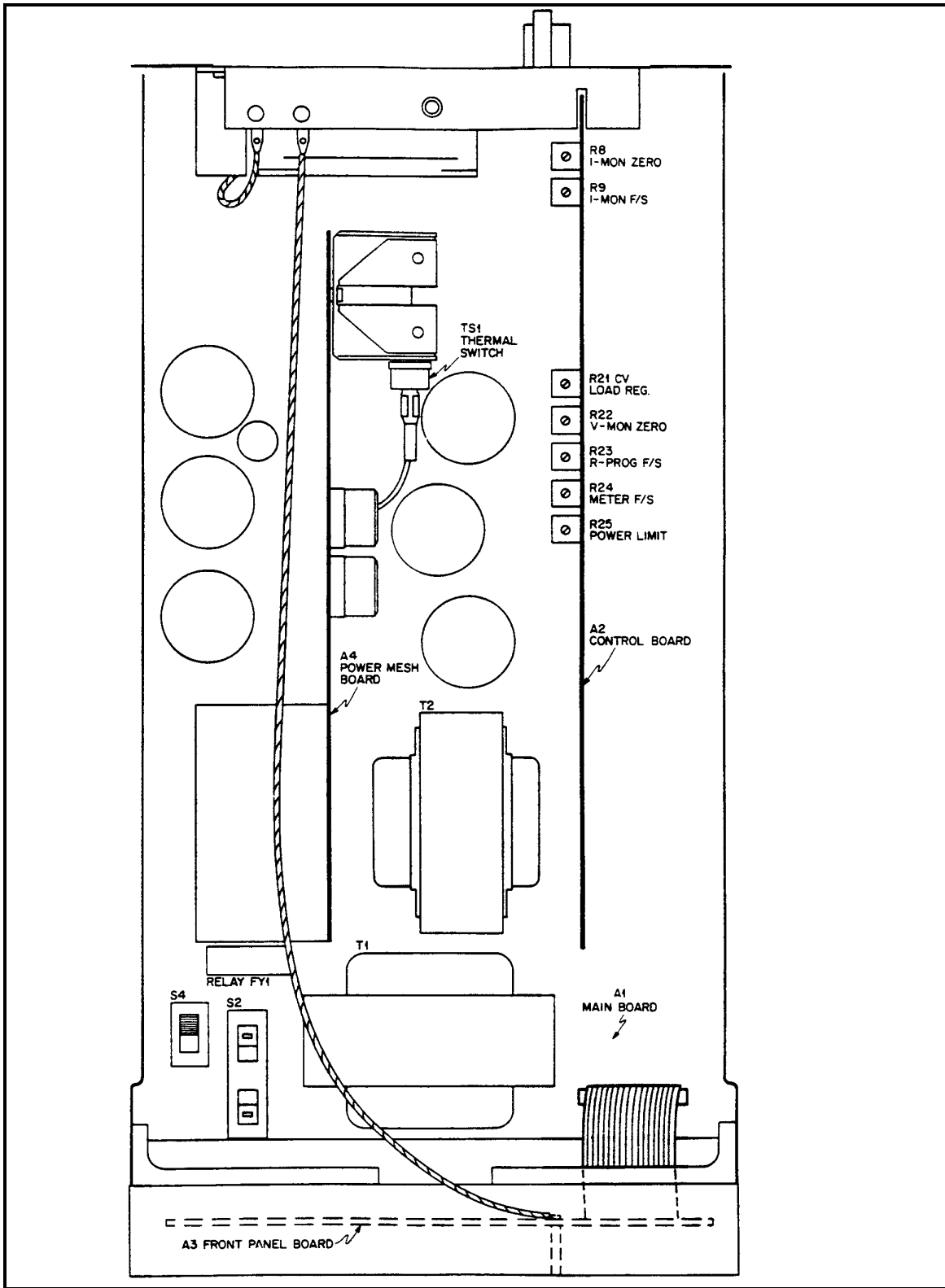

Figure 6-1. Top View, Top Covers Removed

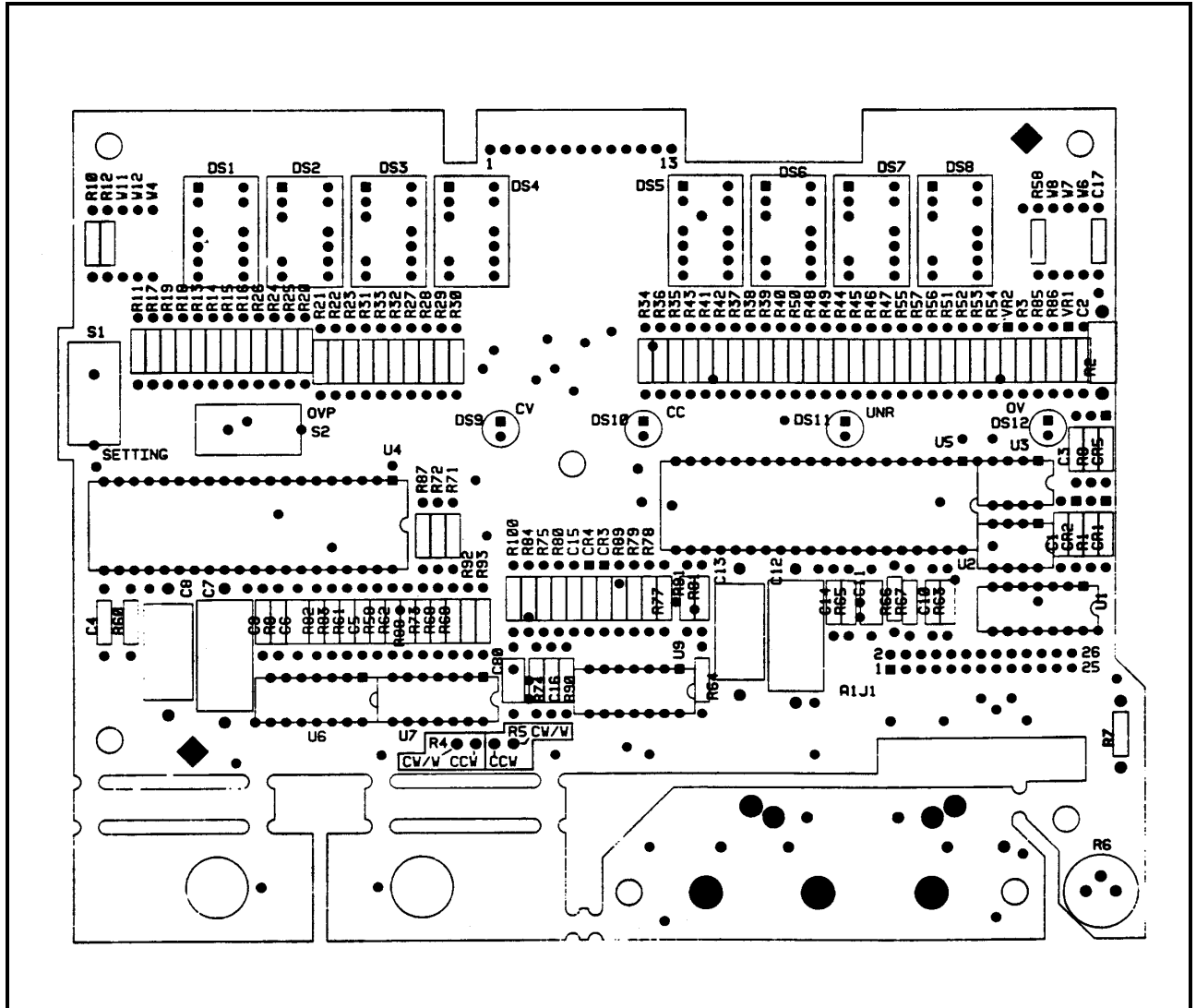

Figure 6-4. Front-Panel Board (A3) Component Location

Power Mesh/Control Board Schematic Notes

1. Line voltage select switch S2 is shown set for 120 Vac input. Jumper W5 is shown set for 100 Vac or 120 Vac input.
2. MODE switches are shown set for normal operating mode.

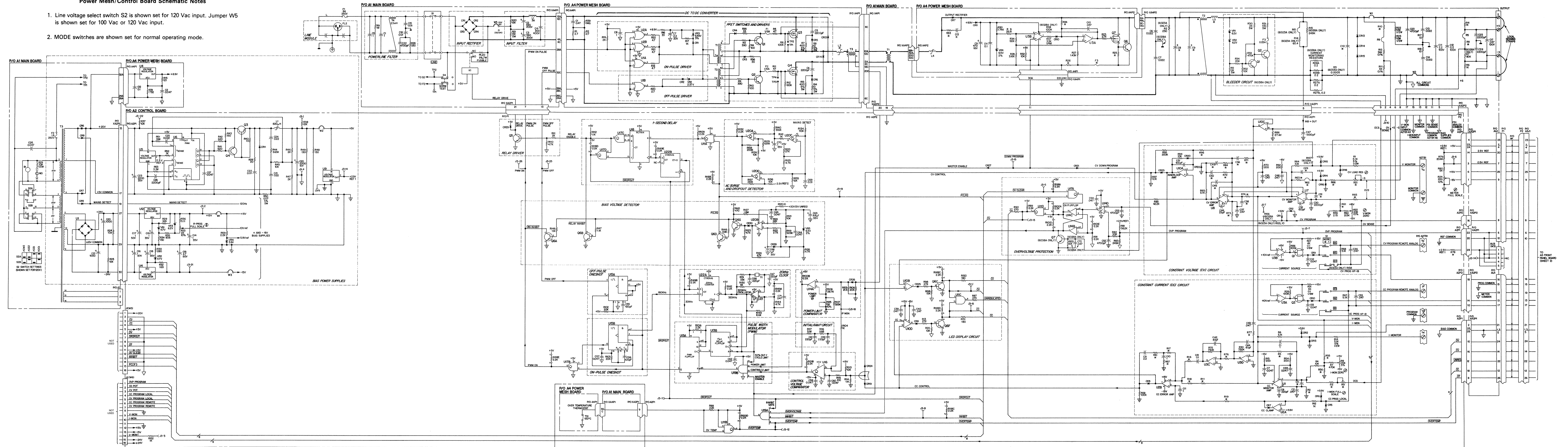

Figure 6-6. Power Mesh and Control Board Schematic Diagram 77

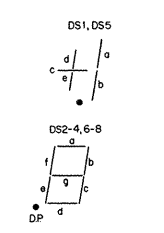
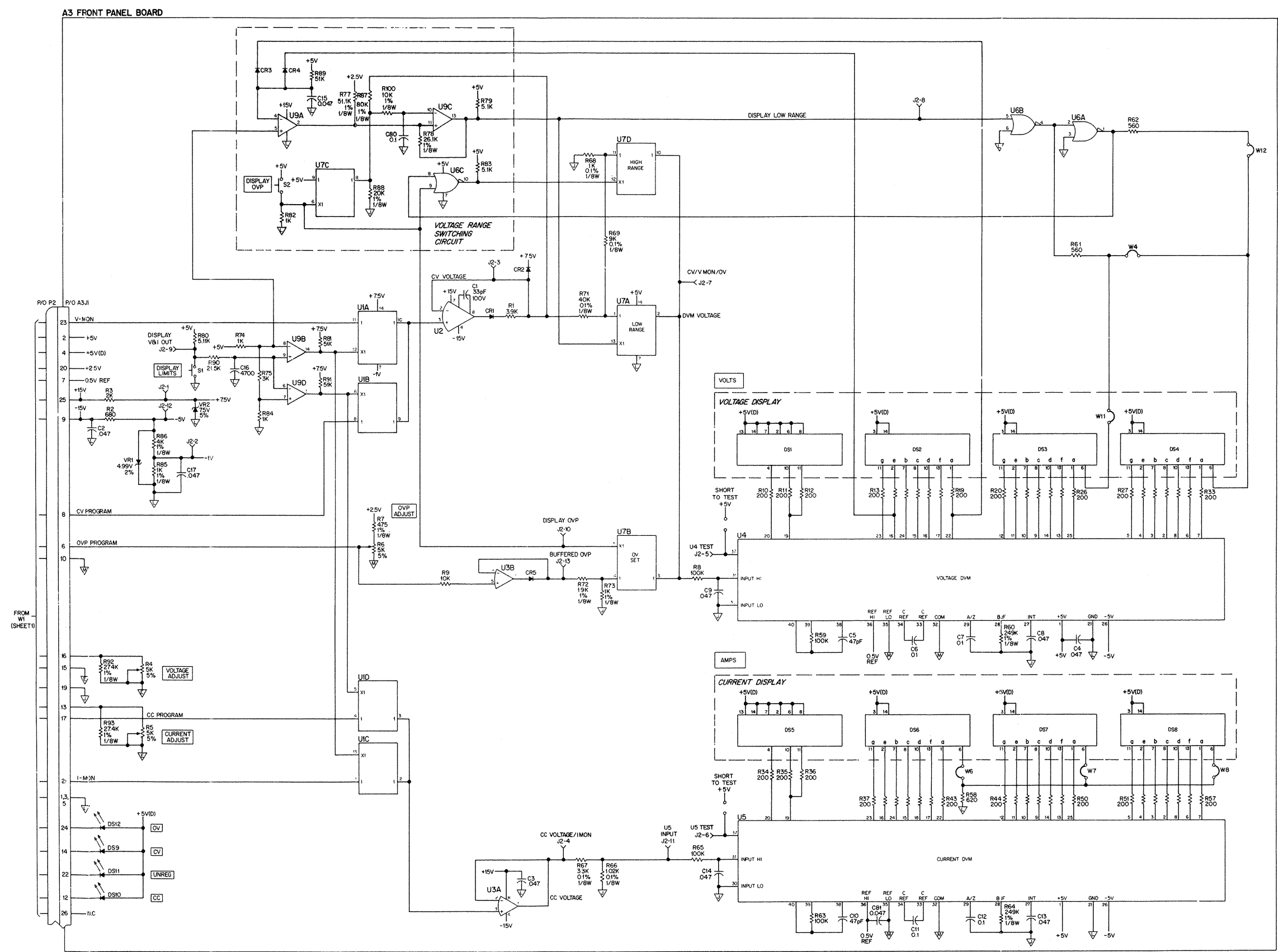

Figure 6-7. Front Panel Board Schematic Diagram

System Option 002

General Information

This option facilitates the operation of the power supply in an automated system. Four major circuit blocks provide: 1) remote analog programming of the supply's output by three different control methods; 2) signals indicating the power supply modes and conditions; 3) two different digital methods of remote control; and 4) the outputs of three bias supplies for use with external circuitry.

The power supply equipped with this option can be operated from either a 6940B Multiprogrammer equipped with a 69520A power supply programming card or a 6942A Multiprogrammer equipped with a 69709A power supply programming card.

Remote Programming. Through this interface both the output voltage and current can be remote programmed by either an external voltage source, resistance, or a current sink.

Status Indicators. Six optically isolated lines provide open-collector digital outputs which indicate the following states: constant voltage mode, constant current mode, output unregulated, ac dropout, overvoltage, and overtemperature.

Remote Control. Two optically isolated methods of remote control are available. One method requires a negative going edge, which sets a latch on the 002 card to inhibit the power supply. The latch and OVP are reset by a negative-going pulse on another input line. The second method of remote control requires a low logic level to inhibit the power supply for the duration of the low level.

Bias Supplies. The outputs of three bias supplies are also available at the option connector. These outputs are +15V, -15V, and +5V.

Monitoring. The 002 Option Board provides two monitoring outputs (I.MON. and V.MON) available at the option connector. They both vary from 0 to 5V corresponding to a 0 to full scale output.

Other modes of operation, such as multiple supply system control, are described in detail in later paragraphs. Modes such as Auto Series, Auto Parallel, and Auto Tracking Operation are described in the Operating Manual.

Specifications

Table A-1 provides specifications for the Option 002. This table is referred to periodically throughout the text of this Appendix.

Option 002 Hardware

The Option 002 hardware consists of a single printed circuit board installed at the right side (facing the front-panel) of the chassis. Two cables connect the option board to the A2 control board at A2J1 and A2J2. Connections between the option board and external circuits are made via the 37-pin connector mounted on the option board and available at the rear of the power supply. A mating connector is also included for the user's convenience.

Table A-1. Specifications, Option 002

Remote Programming	
Resistance Programming: 0 to 4K ohm provides 0 to maximum rated voltage or current output.	
Accuracy:	@25°C
CV: 0.5% + 12mV (6023A)	0.5% + 70mV (6028A)
CC: 1.0% + 110mA (6023A)	1.0% + 500mA (6028A)
Voltage Programming: 0 to 5V provides 0 to maximum rated voltage or current output.	
Accuracy:	@25°C
CV: 0.25% + 12mV (6023A)	0.33% + 70mV (6028A)
CC: 0.30% + 110mA (6023A)	0.36% ± 500mA (6028A)
Current Programming: 0 to 2mA current sink provides 0 to maximum rated voltage or current output.	
Accuracy:	@25°C
CV: 0.38% + 16mV (6023A)	0.43% ± 71mV (6028A)
CC: 0.43% + 115mA (6023A)	0.50% + 500mV (6028A)
Input Compliance Voltage: ± 1V	
Current Programming Enable:	
Relays K2 (CV) and K1 (CC) are biased from the Control Isolator Bias input (See Remote Shutdown and OVP Clear).	
Relay Bias Voltage: +4V minimum + 7V maximum	
Relay Resistance: 500Ω ± 10%	
Note	
For Control Isolator Bias voltages greater than 7V, a series resistor must be used to maintain the relay bias voltage within specified limits.	
Enabling either relay is accomplished by bringing CV or CC enable line to Control Isolator Bias common via a suitable driver; maximum driver off-state leakage =5mA.	
Output Voltage and Current Monitor: 0 to 5V output indicates 0 to maximum rated output voltage or current.	
Accuracy:	@25°C
CV: 0.25% + 2mV (6023A)	0.39% + 15mV (6028A) TC: 10ppm +0.2mV/°C
CC: 0.30% + 15mA (6023A)	0.36% + 20mA (6028A) TC: 70ppm +1.5mA/°C
Output Impedance: 10.2 k ohm ± 5%	
Temperature Coefficient:	
CV: 70 ppm/°C +600μV/°C (6023A)	12.5 ppm/°C +810μV/°C (6028A)
CC: 100 ppm/°C + 2.0mA/°C (6023A)	47 ppm/°C + 1.6mA/°C (6028A)
Status Indicators:	
Status Isolator Bias input (referred to Status Isolator Common).	

Table A-1. Specifications, Option 002 (continued)

Voltage Range: +4.75V to 16V
Current Drain: 20mA maximum

Status Indicator output:
 Open collector output:

Maximum Output Voltage (logic high): + 16V
Logic Low output: + 0.4V maximum at 8mA

Remote Control (Trip, Reset, Inhibit) Control Isolator Bias Input

Voltage Range: +4.75V to 16V

Remote Control Inputs ($\overline{\text{Remote Trip}}$, $\overline{\text{Remote Reset}}$) $\overline{\text{Remote Inhibit}}$.

On State (logic low):

Minimum forward current required (I_f): 1.6mA Isolator forward voltage (V_f) at 1.6mA (I_f): 1.4V typical, 1.75 maximum

For Control Isolator Bias voltage greater than $\pm 5V$, an optional resistor (R_{opt}) may be added to reduce drive current .

Off state (logic high) maximum leakage current: 100 μ A.

REMOTE TRIP and REMOTE RESET Timing

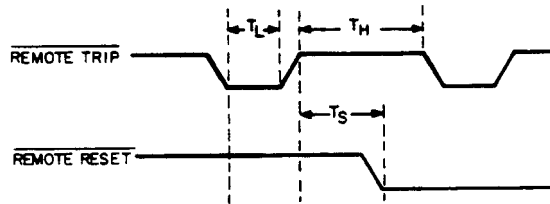

Pulse duration (T_L): 15 μ S minimum
 Reset time (T_H): 125 μ s minimum
 Set-up time (T_S): 25 μ s minimum
 OVP clear delay: 1 sec \pm 30%

Power-on Preset

Output Ratings: open collector output (referred to power supply common)

Maximum output voltage (logic high): + 16V
Logic low output: +0.4V maximum at 8mA

Table A-1. Specifications, Option 002 (continued)

Pulse Timing

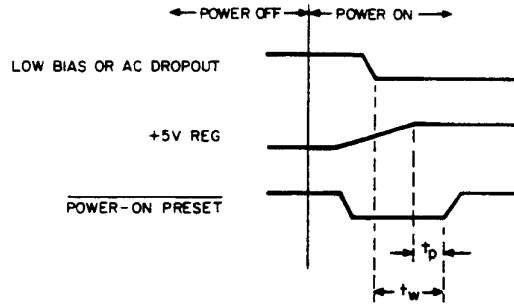

Low Bias or AC DROPOUT will go false after 5V supply stabilizes.

Bias Supplies

DC Output Ratings: (25°C ± 5)

No Load to Full Load 104V to 127V line.

+ 5V ± 3% at 100mA

+15V ± 3% at 75mA

-15V ± 4% at 75mA

Short Circuit Output Current:

+5V 125mA ± 6%

+ 15V 103mA ± 6%

-15V 103mA ± 6%

PARD (Typical):

+ 5V 25mV pk-pk 1.5mV Rms

+ 15V Same Same

-15V Same Same

Isolation:

Status Indicator lines and Remote Control lines may be floated a maximum of 240Vdc (6010A, 250Vdc, 6011A, 6012B) from ground from the power supply or from each other. These lines may not be connected to any primary circuits.

Jumpers Designation

W1--jumpered: OV indication @ A7J3-17 is active (lo) if OVP; Remote Trip or Remote Inhibit is active.

W1--open: OV indication is active (lo) if OVP or Remote Trip is active.

Normal operation as shipped: W3 and W4 jumpered W2 and W5 open.

OVP Programmable CV: W2 jumpered; W3 open or
 CC: W5 jumpered; W4 open
 S1A,B in open position

Installation

When installing the board, perform the following steps:

- a. Remove the top and inner cover of the power supply as discussed in Section 3 under Repair and Replacement.
- b. Remove the plate next to the barrier strip on the rear panel of the supply by unscrewing the 2 M3 screws.
- c. Insert the already prepared 002 board in the slot closest to the right side (looking from the front-panel) of the supply.
- d. Use the two M3 screws to connect the rear end of the 002 board to the rear panel of the supply.
- e. Attach ribbon cables from the A2 Control Board A2J1 to A7J1 and A2J2 to A7J2.
- f. Replace the inner and outer cover of the supply.

Connector Assembly Procedure

The following instructions describe assembly of the mating connector provided to interface the user's system with the option connector, J3. Figure A-1 identifies the parts of the mating connector.

Proceed as follows:

Note: It may be desirable to set up a test interface before final assembly of the mating connector to allow checkout of the system. A mating connector with pins accessible for temporary wiring is available from Agilent Technologies, Agilent part number 1251-4464. If the cable assembly presents RFI or ESD problems, a shielded cable assembly accessory Agilent Part Number 5060-2890 can be ordered.

- a. If a multi-wire cable is being used (as opposed to individual wires), remove approximately 1 1/2 inches of cable insulation from the end. Be careful not to cut the insulation on the individual wires.
- b. Strip 3/16 inch of insulation from the end of each wire to be used.
- c. Insert each wire into a contact pin (1) and crimp firmly.
- d. Insert each pin into a proper hole in connector-pin house (2) from rear. Pins will lock into housing when fully inserted.

Note Once the pins are locked into the connector-pin housing, they are extremely difficult to remove. Therefore, be certain pin is in proper hole before inserting fully.

- e. Screw a slotted setscrew (3) partially into a square nut (4) and place in position in connector shield assembly (6).
- f. Place strain relief (5) in position in connector shield assembly (6), just under set screw (3). Be certain that strain relief is oriented as shown in Figure A-1.
- g. Place connector pin housing (2) in shield assembly (6) and route cable through cable entrance.
- h. Fold connector assembly (6) and secure with three screws.
- i. Strain relief set screw (3) can now be adjusted from top of connector to clamp firmly on cable.
- j. Clip fasteners (7) onto ends of connector pin housing (2).
- k. Connector can now be plugged onto option connector J3 and secured with two screws (8) into the threaded stand-offs on either side of J3.

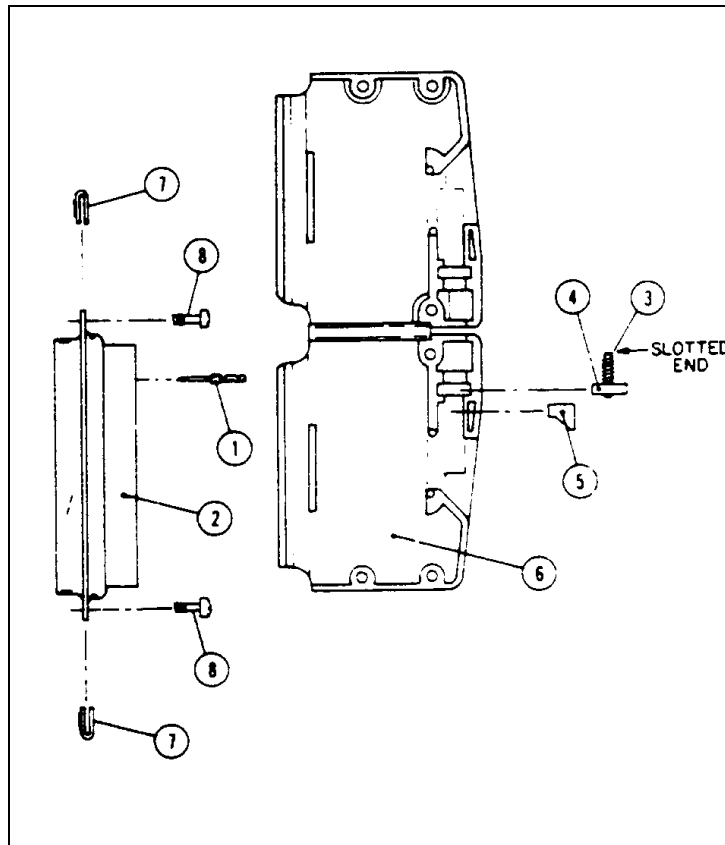

Figure A-1. Mating Connector Assembly

Operation

The following paragraphs provide the operating instructions necessary to interface a 002-equipped power supply into an automated system. A brief description of some circuits is also provided. The unit is shipped for front-panel operation with mode switch settings as follows:

B1	B2	B3	B4	B5	B6
0	1	1	0	1	1

Before beginning, switch the power supply's rear panel MODE switches B1 through B6 to their correct positions for the programming source being used, (See Table A-2).

Next switch A1 and A2 also on the rear panel, to the correct program source function, See Figure A-2. All connections are made at the 37-pin rear panel connector J3, and can be wired directly into the mating connector supplied for this purpose.

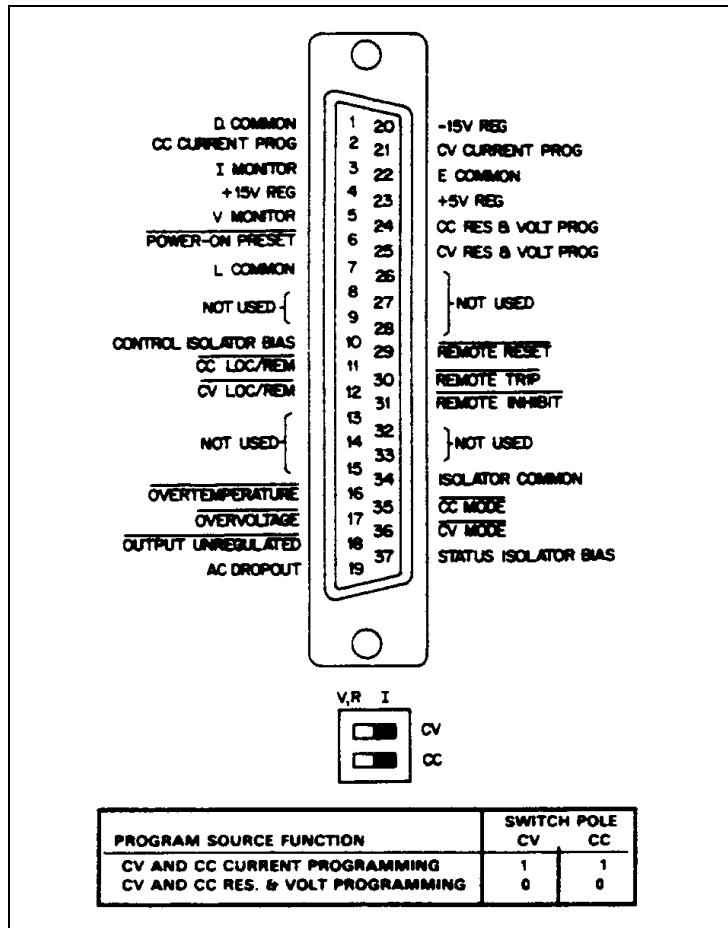

Figure A-2. 002 Option Rear Panel Connector J3 and Switches A1 and A2.

Local/Remote Programming

WARNING

When switching to local/ control, remember to set Front-Panel Voltage and Current Control to safe levels.

Local Programming (Figure A-3). The supply can be switched back and forth between remote and local programming while initially checking out a remote programming circuit. For proper operation of local programming, the user must supply the bias voltage (CONTROL ISOLATOR BIAS). The Control Isolator Bias voltage can range from +4.75V to +16V depending upon the user's interface circuits. Refer to Specifications Table A-1. For local programming, take the Control Isolator Bias common and connect it to both of the LOC/REM terminals, and position mode switch as indicated in Operation.

CAUTION

Although CONTROL ISOLATOR BIAS can be +4.75V to +16V, a supply voltage of more than 7V may damage the relays. Therefore, if CONTROL ISOLATOR BIAS exceeds 7V it is necessary to use a resistor in series with each of the LOC/REM terminals. Figure A-4 provides a graph from which the proper series resistance value can be determined. Note that the tolerances of both the Control Isolator Bias and the resistor must be taken into account. The actual Control Bias used in Figure A-4 is obtained after subtracting any driver gate voltage drop.

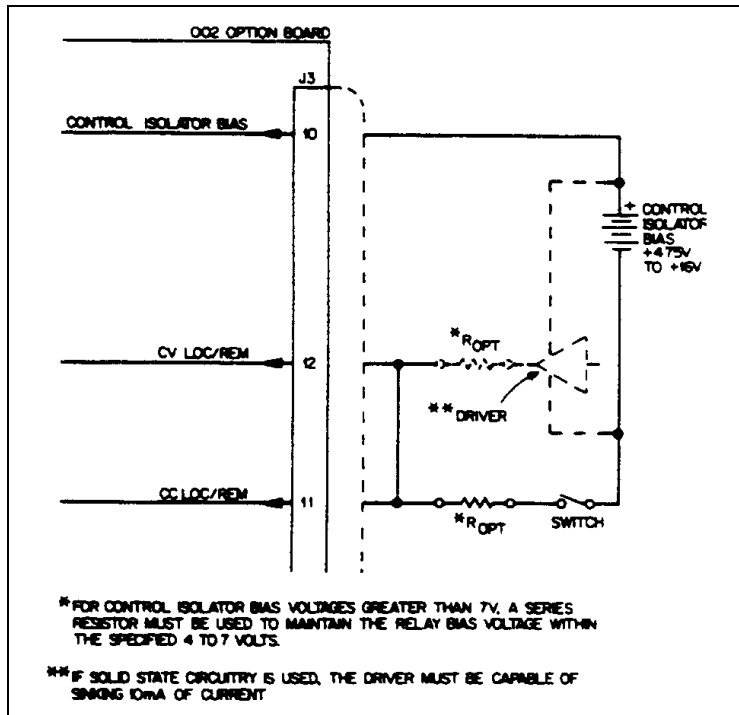

Figure A-3. Accessing Local Programming While In Remote Programming Mode

If solid state circuitry is used, connect the Control Isolator Bias to a driver capable of sinking 10mA of current, then connect the driver's output to both of the LOC/REM terminals. Refer to Figure A-3. Either method will enable relays K1 (CV) and K2 (CC) to switch regulation to the front-panel VOLTAGE and CURRENT controls. For Control Isolator Bias voltages greater than 7V, a resistor (R_{opt}) must be used in series with the Control Isolator Bias common or the Driver's output. Figure A-4 provides a graph for determining the proper series resistance value depending on the Control Isolator Bias voltage being used.

The supply can be returned to the remote programming mode by switching off the Control Isolator Bias common or by increasing the Driver's output signal to within 1V of the Control Isolator Bias voltage. If remote programming is solely desired, leave the LOC/REM terminals open and make the proper connections to the RESISTOR/VOLTAGE PROG. or CURRENT PROG. terminals (See Figures A-5, A-6, A-7).

Table A-2. Mode Switch Settings For Enabling Different Programming Sources

Program Source	Switch Pole Settings					
	B1	B2	B3	B4	B5	B6
Resistance	0	0	1	0	0	1
Voltage or Current	0	1	0	0	1	0

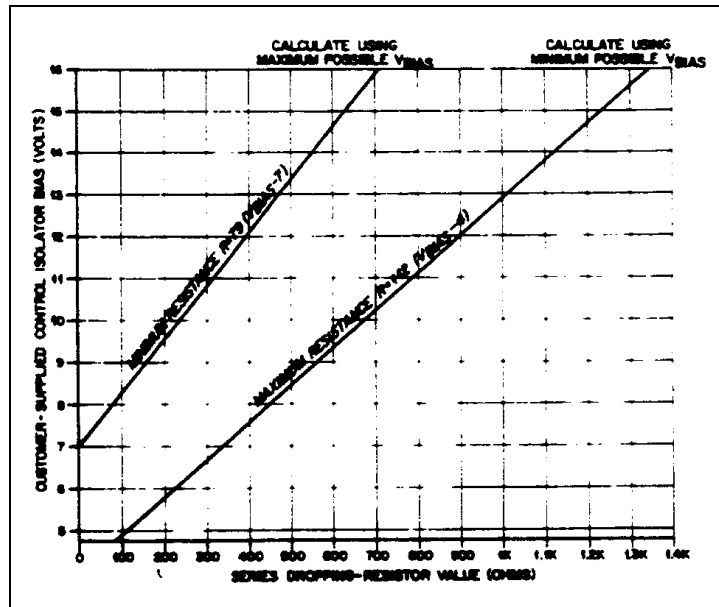

Figure A-4. Calculating Value of Series Dropping Resistor

Remote Resistance Programming

Check switches A1 and A2 on the rear panel, they must be in their correct positions for CV and CC resistance/voltage programming (See Figure A-2). A resistance variable from 0 to 4K ohms can be used to program the output voltage or current from 0 to full scale. To program the output voltage, connect the variable resistance between J3-25 (CV RES/VOLT PROG.) and J3-22 (E COM.). To program the output current, connect the variable resistance from J3-24 (CC RES/VOLT PROG.) to J3-22 (E COM.).

CAUTION

If the programming lines become open circuited during resistance programming (user's system becomes disconnected from J3), the power supply's output will tend to rise above rating. The supply will not be damaged if this occurs, but the user's load may be damaged. To protect the load, be sure that the overvoltage trip point is properly adjusted. The unit includes clamp circuits to prevent it from supplying more than about 120% of rated output voltage or current when the remote programming voltage is greater than 5Vdc or remote programming resistance is greater than 4K ohm. Do not intentionally operate the unit above 100% rated output. Limit your programming voltage to 5Vdc and programming resistance to 4K ohm to assure reliable operation.

Remote Voltage Programming (Figure A-6). Check switches A1 and A2 on the rear panel, they must be in the correct positions for CV and CC resistance/ voltage programming (See Figure A-2). A voltage source variable from 0 to 5 volts, can be used to program the output voltage or current from 0 to full scale. The load on the programming source is less than 1mA. To program voltage, the voltage source should be connected from J3-25 (CV RES & VOLT PROG) to J3-22 (E COM). To program current, the voltage source should be connected from J3-24 (CC RES & VOLT PROG) to J3-22 (E. COMMON). If the programming lines become open circuited (user's system becomes disconnected from J3) during voltage programming, the Programming Protection circuit will reduce the power supply output to zero.

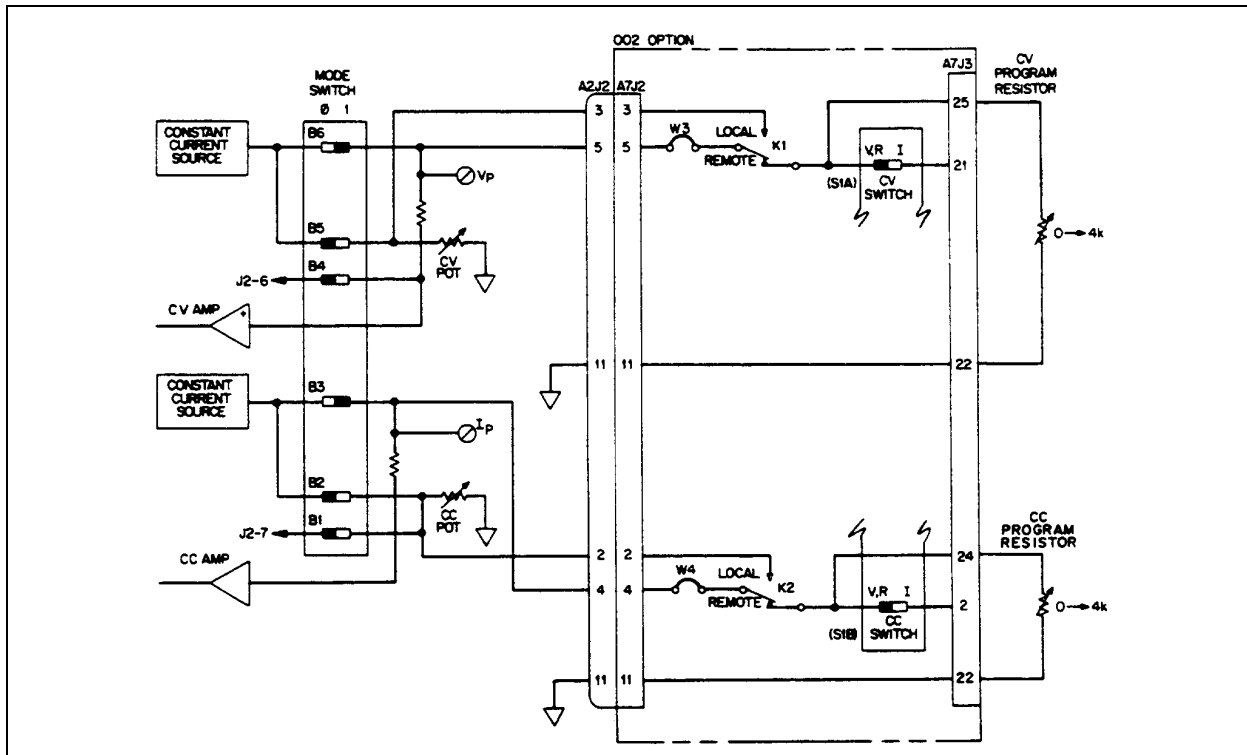

Figure A-5. Remote Resistance Programming

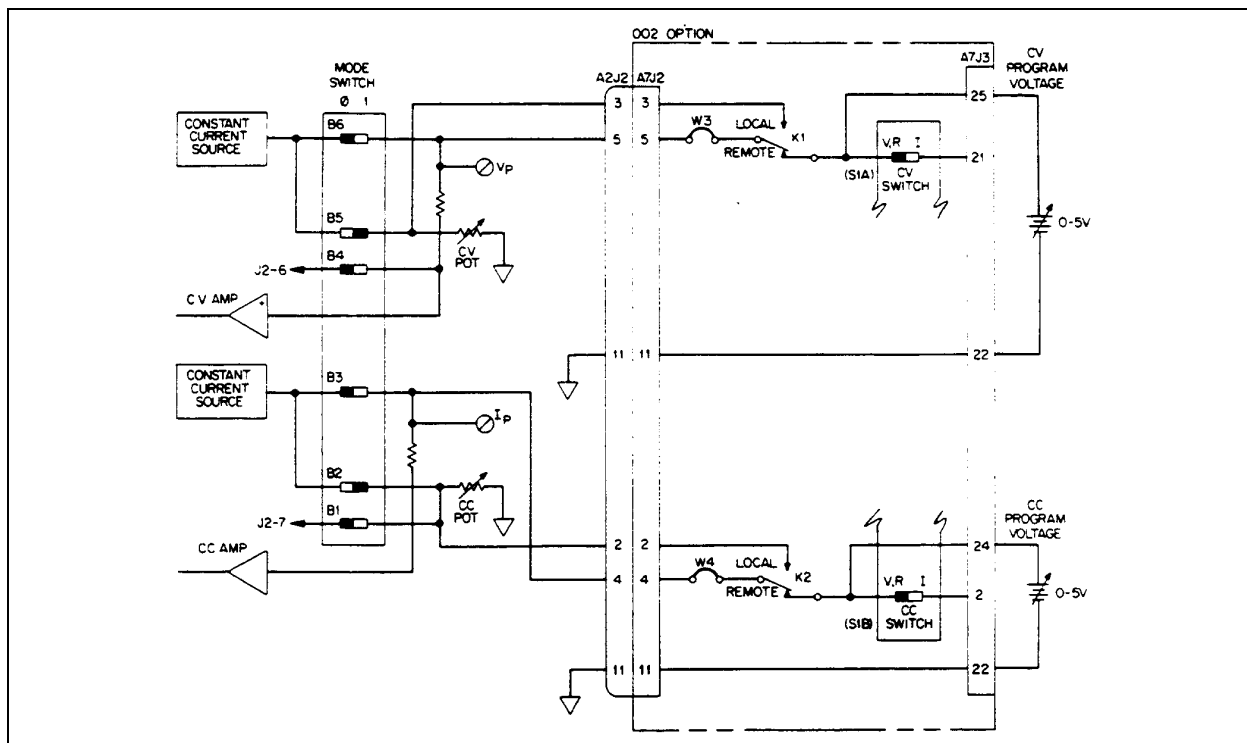

Figure A-6. Voltage Programming of Output Voltage and Current

Current Programming (Figure A-7). Check switches A1 and A2 on the rear panel, they must be in the correct positions for CV and CC current programming (See Figure A-2). A current sink variable from 0 to 2mA, can be used to program the output voltage or current from 0 to full scale (See Figure A-7). The following paragraph provides a brief circuit description, refer to schematic diagram.

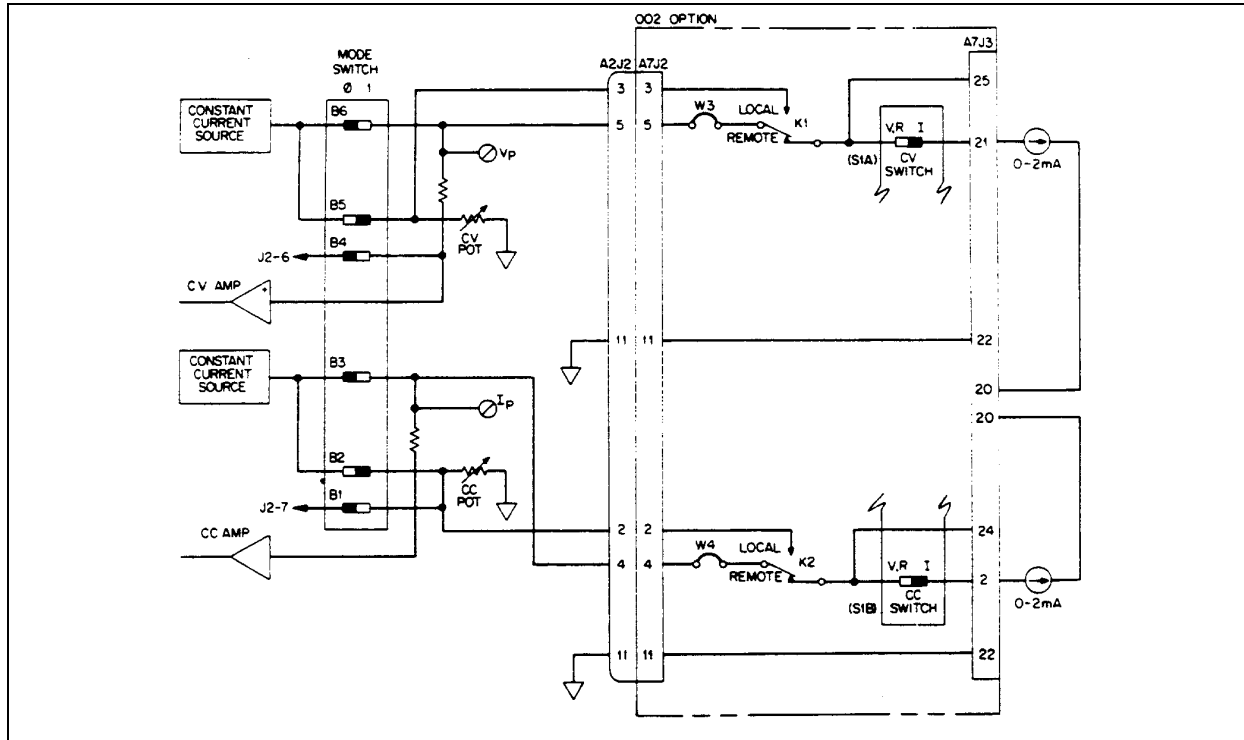

Figure A-7. Current Programming of Output Voltage and Current

To program voltage, the current sink can be connected from J3-21 (CV CURRENT PROG) to J3-20 (-15V). To program current, the current sink can be connected from J3-2 (CC CURRENT PROG) to J3-20 (-15V). Current sinks can either be connected to the power supply (-15V) or to an external negative supply that is referenced to the L. COMMON of the power supply.

The 0 to 2mA current sink will cause the output signal of op-amps U17 and U18 to vary proportionally from 0 to 5 volts. These signals are then coupled through relays K1 and K2 and then on to the A2 Board's CV and CC circuits which, in-turn, will program the supply's output from 0 to full scale. If the programming lines become open circuited (user's system becomes disconnected from J3) during current programming, the Programming Protection circuit will bring the power supply output to zero.

Remote Monitoring

The 002 Option board provides a protected 0 to 5V output corresponding to a full scale voltage output. The voltage monitor output is available between pins J3-5 (V. Monitor) and J3-1 (D COMMON).



Observe the caution described in Local Programming paragraph, page 85 (Figure A-3).

Output impedance is 10K ohm: the monitoring device input impedance should be at least 1M ohm to limit error to 1% + basic accuracy; 10M ohm to limit error to 0.1% + basic accuracy.

The I. MON signal from the mainframe is also brought out through the 002 Option board. A 0 to full scale current-monitor output is available between pins J3-3 (I. MON) and J3-1 (D COMMON). Output impedance is 10K ohms: the monitoring device input impedance should be at least 1M ohm to limit error to 1% + basic accuracy.

In some applications it may be desirable to install a noise-suppression capacitor on these monitor outputs to lessen the effects of noise induced in the monitor leads. The capacitors should be ceramic or tantalum type, from 0.1 to 1 μ F. The capacitor is installed directly across the monitor device input terminals .

Status Indicators

Six optically isolated lines provide open collector digital outputs which indicate certain modes and conditions of power supply operation. For proper supply operation of the opto-isolators, the user must supply the bias voltage, (ISOLATOR BIAS). This voltage can be from +4.75V to + 16V depending upon the user's interface circuits, refer to the specifications Table A-1. Connect the bias voltage (+) between J3-37, (ISOLATOR BIAS) and J3-34 (ISOLATOR COMMON). The status indicator outputs are open collector (referenced to ISOLATOR common); therefore, it is necessary to connect a pull-up resistor from each output to ISOLATOR BIAS. When choosing the resistor value observe the current sink capabilities of these lines as described in the Specifications Table A-1.

Because of the relatively slow rise and fall times of opto-isolators, Schmitt-triggered devices should be used to interface these output lines to logic circuits.

The following signals are in active low-form:

- a. $\overline{\text{CV MODE}}$, J3-36, indicates that the power supply is in constant voltage operation.
- b. $\overline{\text{CC MODE}}$, J3-35, indicates that the power supply is in constant current operation.
- c. $\overline{\text{OUTPUT UNREGULATED}}$, J3-18, indicates that the power supply is in neither constant voltage nor constant current operation and cannot be guaranteed to meet specifications.
- d. $\overline{\text{OVERVOLTAGE}}$, J3-17, indicates power supply shutdown because of: the voltage output exceeding the OV trip point set at the front-panel; or, a system-initiated shutdown as described in multiple supply system shutdown section, page 93.
- e. $\overline{\text{OVERTEMPERATURE}}$, J3-16, indicates power supply shutdown due to an excessive temperature rise on the FET or output diode heatsink.

The Low Bias AC DROPOUT signal, J3-19, is in active high form. This signal indicates: loss of primary power, momentary AC dropout. or "brownout" conditions where the AC line voltage drops below approximately 70% nominal.

Remote Control

For operation of the opto-isolators, the user must supply the bias voltage (CONTROL ISOLATOR BIAS). This voltage can be from + 4.75V to + 16V depending on the requirements of the driving circuits. The type of driving logic and bias voltage will determine the amplitude of the high and low logic levels, refer to the Specification Table A-1 under Remote Control.

Connect the bias voltage (+) to J3-10 CONTROL ISOLATOR BIAS, and reference the input signals to this bias supply's negative terminal.

Two optically isolated methods of remote control are available. They are described in the following paragraphs.

Remote Trip. A negative-going edge applied to terminal J3-30 ($\overline{\text{REMOTE TRIP}}$) will shut down the power supply, reducing the output voltage to near zero. For minimum pulse duration and timing considerations with respect to $\overline{\text{REMOTE RESET}}$, See Table A-1. The following paragraph provides a brief circuit description (See schematic diagram and Figure A-8).

A negative going edge at $\overline{\text{REMOTE TRIP}}$ coupled through opto-isolator (U9) causes one-shot U13B to set the TRIP/RESET latch (U5A) low. This sets terminal J1-13 ($\overline{\text{INHIBIT}}$) low, thus inhibiting the Pulse Width Modulator of the power supply. It also lights the unregulated indicator on the front-panel and generates an unregulated signal from the opto-isolator U3.

The low signal generated by the Trip/Reset Latch is also coupled through opto-isolator U2 and appears at J3-17 as an $\overline{\text{OVERVOLTAGE}}$ status signal. This signal does not affect the state of the power supply's OVP circuit.

Remote Reset. A negative-going edge applied to terminal J3-29 ($\overline{\text{REMOTE RESET}}$) will return the supply to its initial state following a system-initiated shutdown or an OVP shutdown caused by a temporary over voltage condition. For minimum pulse duration and timing considerations with respect to $\overline{\text{REMOTE TRIP}}$ See Table A-1 under Remote Control. The following paragraphs provide a brief description of this circuit (See schematic diagram and Figure A-8).

A negative-going pulse applied to terminal J3-29 ($\overline{\text{REMOTE RESET}}$) is coupled through opto-isolator U10. One-Shot U13A then triggers and resets the TRIP/RESET latch output high. This sets terminal J1-13 ($\overline{\text{INHIBIT}}$) high, thus enabling the power supply's Pulse Width Modulator.

The $\overline{\text{REMOTE RESET}}$ signal will also reset the power supply OVP circuit in the event that an overvoltage condition has shut down the supply. When a $\overline{\text{REMOTE RESET}}$ signal is present, ONE SHOT U13A goes low, this will produce an OV CLEAR pulse at terminal J1-12. The $\overline{\text{OV CLEAR}}$ pulse will cause the output of A2U2 to go low thus, resetting the OV FLIP FLOP. When this occurs the output of A2U24D goes high and simultaneously causes the front-panel OV LED to turn off and the OV signal (J1-6) to go high. The $\overline{\text{OVERVOLTAGE}}$ signal to U4B also goes high and enables the PWM of the power supply.

Note By observing the $\overline{\text{OVERVOLTAGE}}$ status indicator or the power supply's output while applying a reset pulse to $\overline{\text{REMOTE RESET}}$, the user can determine the cause of shutdown. If the output returns and $\overline{\text{OVERVOLTAGE}}$ goes high immediately, this indicates a controller-initiated shutdown. If the output takes about one second to return, this indicates that the output voltage had exceeded the OVP trip point. If the OVP circuit trips continually, check the load and/or the trip point setting.

Alternate Method of Remote Control. The $\overline{\text{REMOTE INHIBIT}}$ input, J3-31, provides an alternate method of remote shutdown. By maintaining a low logic level at this input, the supply's output will be inhibited until $\overline{\text{REMOTE INHIBIT}}$ is returned to its initial high state. The following paragraph provides a brief description of this circuit (See schematic diagram and Figure A-8).

A low logic level applied to terminal J3-31 ($\overline{\text{REMOTE INHIBIT}}$) is coupled through opto-isolator U8 and causes U4B to inhibit the power supply's (PWM) Pulse Width Modulator. If jumper W1 is used (See Figure A-8) while a $\overline{\text{REMOTE INHIBIT}}$ signal is applied, an $\overline{\text{OVERVOLTAGE}}$ signal will appear at terminal J3-17 $\overline{\text{OVERVOLTAGE}}$ thus, indicating the power supply shut down.

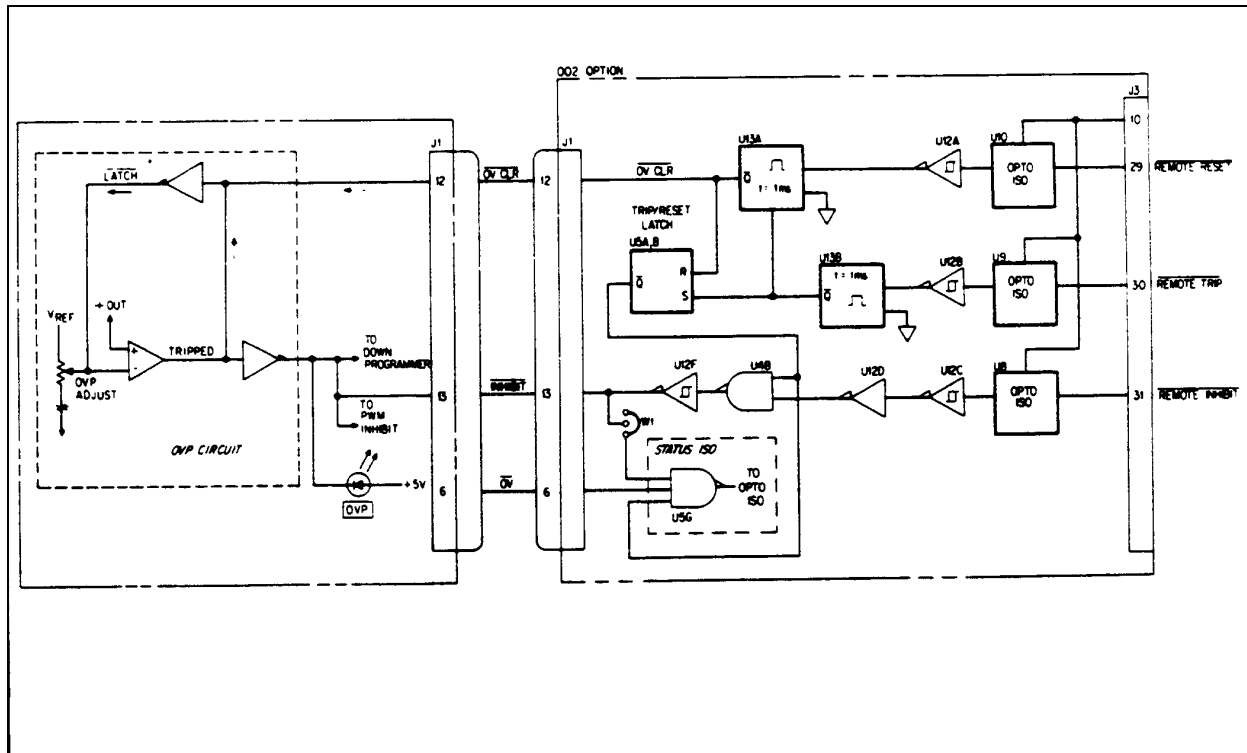

Figure A-8. Remote Control

Power-On Preset

This open collector output line J3-6, provides a logic low pulse (Power - On - Preset) to the user that can be used to initialize or delay a system's operation until + 5V Reg. supply has stabilized. The pulse is generated after primary power is turned on and also after resumption of power following momentary ac dropout or conditions in which line voltage drops below approximately 70% of the nominal. See Table A1 for Power - On - Preset signal specifications.

The Power - On - Preset circuit also ensures that terminal J3-17 (OVERVOLTAGE) will be high when the supply is turned on. This protects against unwanted Multiple Supply System Shutdowns when using J3-17 (OVERVOLTAGE) to remote trip additional power supplies.

The following paragraphs provide a brief description of the power-on preset circuit, refer to schematic diagram:

Circuits on the Power Supply's A2 Control Board produce a power-clear signal, (PCLR), when the supply is turned on. These circuits hold PCLR low until the unregulated input to the A2 Board's + 5Vdc bias supply is greater than about 11Vdc, an input voltage sufficient to assure + 5Vdc bias output.

This PCLR signal is coupled through terminal J1-15 to the 002 Option board's power-on preset circuit. When the power-on preset circuit receives the PCLR signal, transistors U14A and U14C turn off.

Turning U14A off causes a DROPOUT signal to appear at terminal J3-19 (DROPOUT). Turning U14C off causes U14B and U14D to turn on. When U14B is on, it holds output J3-17 (OVERVOLTAGE) high. Holding J3-17 high will prevent any unwanted Multiple Supply Shutdowns from occurring when the supply is wired for such an application. When U10D is

on, it causes J3-6 (Power - On - Preset) to be low thus, if used, can initialize or delay a customer's system operation.

AC Dropout Buffer Circuit

This circuit couples, inverts and isolates the DROPOUT signal (received from the A2 Control Board) of status output terminal J3-19 (DROPOUT). The dropout signal indicates loss of primary power, momentary AC dropout, or "brownout" conditions where the AC line voltage drops below approximately 70% normal. The following paragraph provides a brief description of the AC Dropout Buffer circuit. Refer to the Schematic Diagram

The AC Dropout Buffer Circuit receives a DROPOUT signal from the A2 Control Board. This causes the bias voltage supplied to the Dropout Buffer U14A to be pulled down through diode CR4 thus, turning U14A off. This in turn will cause opto-isolator U3 to turn off. Since external pull up resistors are used, terminal J3-19 (DROPOUT) will go high and remain high until the dropout signal from the A2 Control Board is removed.

Multiple Supply System Shutdown

When using more than one 002 Option equipped power supply in a system, it may be desirable to implement a system shutdown. In this configuration, an OVP trip or remote shutdown of a single unit will cause all of the supplies to shut down

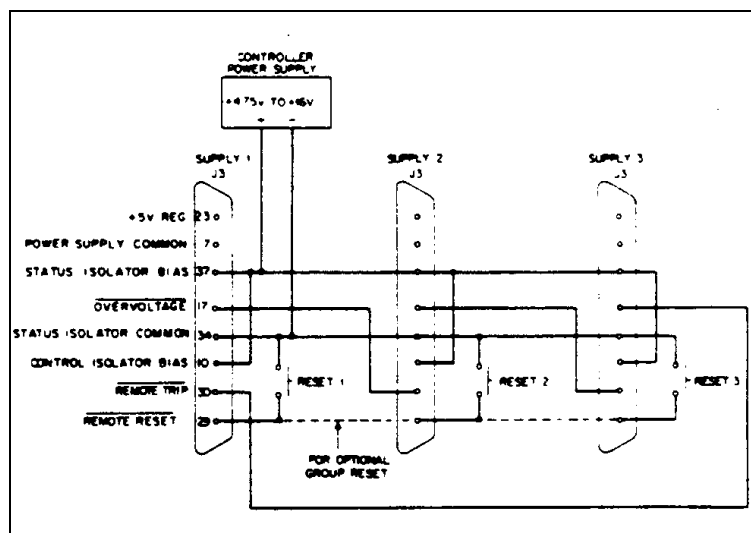

Figure A-9. System Shutdown using Controller Power Supply

Figure A-9 shows one method of system shutdown. The advantages of this method are that one common is used for all status and control lines (useful for controller-operated systems), and the capability of system reset. As shown in Figure A-9, one supply's OVERVOLTAGE line is connected to the next supply's REMOTE TRIP line, and so on in a continuous chain.

Note

+5V REG/POWER SUPPLY common from Supply 1 can be used instead of the bias voltage from the controller. However, because of current limits of the + 5V REG, no more than four units can be connected together in this configuration. To prevent ground loops, do not parallel connect + 5V REG from more than one supply.

The note on page 91 tells how to determine if a shutdown was initiated through the remote trip line or by a supply's OVP. This allows the controller to determine which supply initiated the shutdown. Following a multiple supply shutdown, each unit can be reset individually or all the REMOTE RESET lines can be tied together for a system reset.

If it is necessary to have all the supplies come up simultaneously after a system shutdown, follow this procedure:

- a. First bring the $\overline{\text{REMOTE INHIBIT}}$ line low.
- b. Provide a negative-going pulse to the $\overline{\text{REMOTE RESET}}$.
- c. After at least one second, return $\overline{\text{REMOTE INHIBIT}}$ to a high level.

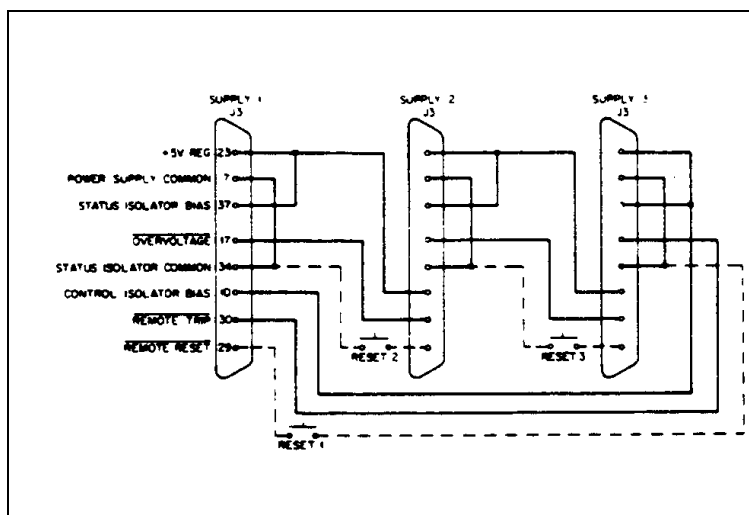

Figure A-10. System Shutdown Using Bias Supply Output

Figure A-10 shows a second method of system shutdown. This method is appropriate in systems which are not controller-operated and in which more than four supplies must be shutdown simultaneously. Because each supply derives its CONTROL ISOLATOR BIAS from the previous supply's + 5V REG, there is no limit to the number of supplies that can be shutdown. Each supply must be reset individually.

Using either method of system shutdown, $\overline{\text{PCLR}}$ inhibits the $\overline{\text{OVERVOLTAGE}}$ indicator from going low and shutting down succeeding supplies upon initial sum-on. After the supplies have stabilized, $\overline{\text{PCLR}}$ returns to a high state.

Bias Supplies

The outputs of three current-limited bias supplies are available for user-supplied circuitry. These are + 15V @ 75mA at J3-4, -15V @ 75mA at J3-20, and +5 V @ 100mA at J3-23; all with respect to J3-7, L Common.

It may be desirable to install noise-suppression capacitors on the bias supply outputs near the load circuits. The capacitors should be ceramic or tantalum type, approximately 0.1 μ F to 10 μ F.

Maintenance

The following paragraphs provide procedures and setups to aid in checking and troubleshooting the 002 Option Board. This information, used in conjunction with the schematic drawing and the Operation section of this Appendix, will help in the isolation and repair of faulty circuits.

When testing the option, use of the test connector on page 83 will allow easier access to the J3 contacts.

Troubleshooting

Before attempting to troubleshoot the 002 Option Board, ensure that the fault is with the option itself and not with the main power supply. This can be accomplished by removing the top cover, inside cover and disconnecting the two ribbon cables from the A2 Control board and checking the operation of the main supply. Otherwise troubleshoot the option board as described in the following paragraphs.

Removal of the Option Board. To facilitate troubleshooting the 002 Option the board can be removed from the power supply and electrically connected via the ribbon cables from Service Kit's 06033-60005 or 5060-2665. To remove the circuit board proceed as follows:

- a. Turn off power supply and disconnect line cord.
- b. Disconnect option I/O cable from J3 on rear panel and remove the two screws that secure option board to rear panel.
- c. Disconnect the ribbon cables from the A2 Control board.
- d. Remove option board by lifting the board by the front edge and sliding the board toward the front of the power supply.
- e. Reconnect the option board to the A2 Control board using the extended ribbon cables from the Service Kit, and place the option board on an insulated surface next to the power supply.
- f. Be careful that the option board lies securely on insulating material and does not touch any part of the main power supply.

Isolating Faulty Circuit. It is apparent which function is not operating properly, proceed to the appropriate paragraph. If the problem involves more than one function check the bias voltages from connectors J1 and J2 and the $\pm 11.8V$ on the option board.

Troubleshooting Resistance and Voltage Programming

- a. Confirm that the problem is on the option board by disconnecting the ribbon cables from the A2 Control Board and attempting to program the supply via the rear panel terminal strip.
- b. Check $\pm 15V$ and $\pm 11.8V$ supplies.
- c. Check for a problem in the programming protection circuit. This circuit should draw about $2\mu A$ from the programming lines.
- d. Check that W3 and W4 are installed and S1 is in proper position .

Troubleshooting Current Programming

- a. Check $\pm 15V$ and $\pm 11.8V$ supplies.
- b. Proceed to test set-up shown in Figure A-11 and/or A-12.
- c. Put S1 in V, R position and see if varying the 0-20V voltage source produces a 0-5 volt DC level across R44 or R39. If not, check op-amps and associated circuitry.
- d. Put S1 in I position and see if varying voltage source from 0 to 20 volts produces a 0-5Vdc level at W3 or W4. If not check relay and programming protection circuit.

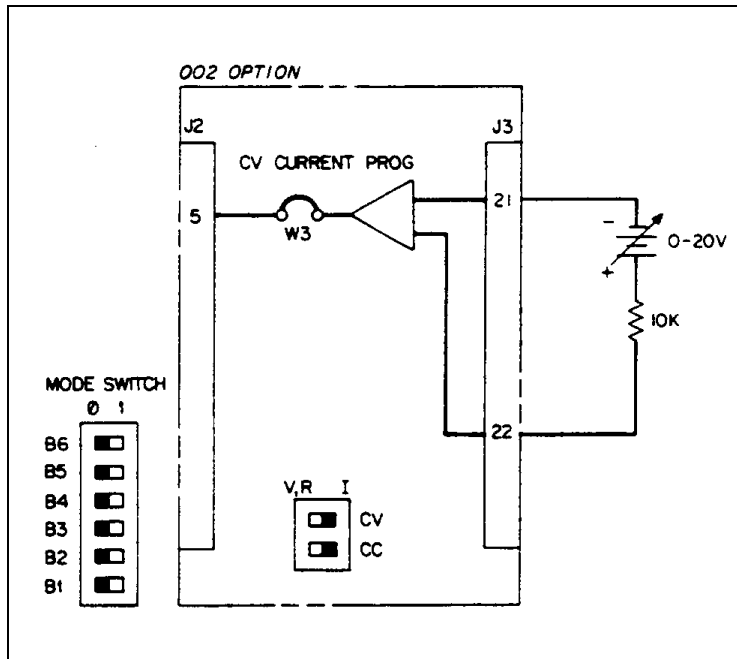

Figure A-11. Troubleshooting Current Programming of CV Mode

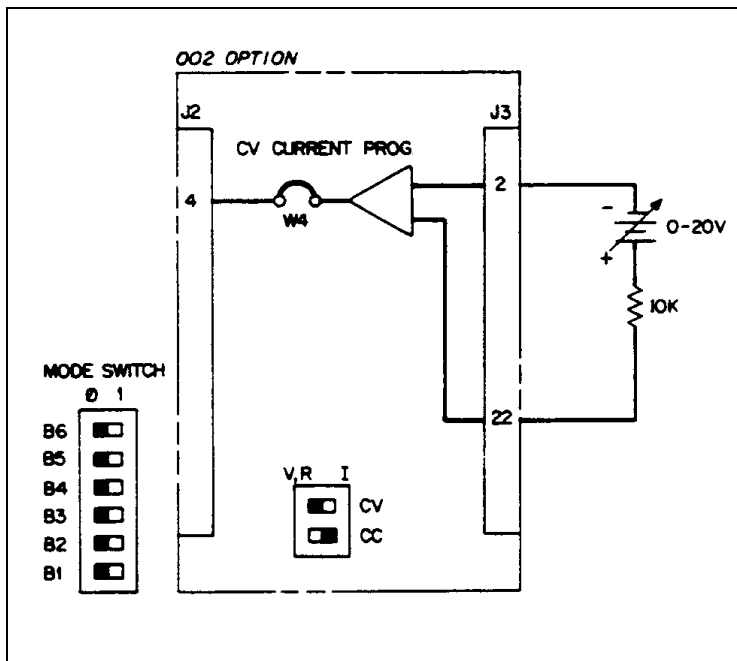

Figure A-12. Troubleshooting Current Programming of CC Mode

Troubleshooting Status Indicators. The test set-up shown in Figure A-13 can be used to check each of the six status indicators. This set-up will temporarily defeat the isolation of the status lines. Before attempting to troubleshoot a status indicator, check for + 5V Bias for proper operation of the opto-couplers.

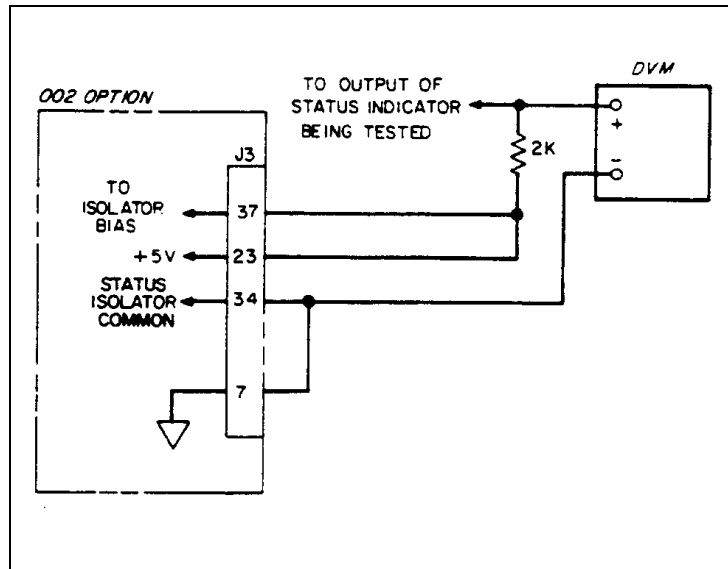

Figure A-13. Troubleshooting Status Indicators

To check CV Mode proceed as follows:

- Using test set-up, Figure A-13, connect to end of 2K Ω resistor to J3-36.
- Turn on power supply.
- Using "Display Setting" set voltage and current or power supply for 1 volt and 1 amp.
- DVM should read between 0 and 0.4Vdc.
- Turn off power supply and short to output terminals.
- Turn on power supply.
- DVM should read approximately 5Vdc.

To check CC Mode proceed as follows:

- Using test set-up, Figure A-13, connect top end of 2K Ω resistor to J3-35.
- Turn on power supply.
- Using "Display Settings" set voltage for 1 volt and current for 1 Amp.
- DVM should read = 5Vdc.
- Turn off power supply and short the output terminals.
- Turn on power supply.
- DVM should read between 0 and 0.4Vdc.

To check OVERVOLTAGE proceed as follows:

- Using test set-up, Figure A-13, connect top end of 2K Ω resistor to J3-17.
- Turn "OVP Adjust" fully clockwise and voltage control fully counter clockwise.
- Open power supply output terminals and turn on power.
- DVM should read approximately 5Vdc.
- Press "Display Settings" and increase voltage control for 15Vdc output.
- Turn "OVP Adjust" counterclockwise until supply goes into overvoltage.
- DVM should read between 0 and 0.4Vdc.
- Turn "OVP Adjust" fully clockwise and turn off input power for 5 seconds.
- Turn on input power and DVM should read approximately 5Vdc.

To check OUTPUT UNREGULATED proceed as follows:

- Using test set-up, Figure A-13, connect to end of 2K Ω to J3-18.
- Connect output terminals of power supply to an electronic load capable of exceed the power supplies output power rating by 50%.

- c. Turn on power supply.
- d. DVM should read approximately 5Vdc.
- e. Set voltage and current controls of power supply to maximum.
- f. Decrease resistance of electronic load until "UNREGULATED" LED on front-panel lights.
- a. DVM should now read between 0 and 0.4Vdc.

To check LOW BIAS or AC Dropout proceed as follows:

- a. Using test set-up, Figure A-13, connect top end of 2K Ω resistor to J3-19.
- b. Substitute an oscilloscope in place of DVM. Set vertical deflection for 1 volt/div on the DC input.
- c. Turn power on and observe oscilloscope trace. Voltage should increase to 5V at power-on and drop to between 0 and 0.4Vac approximately 3 sec.
- d. Turn power off. Voltage should go to about 5Vdc before decaying back to 0V.

Note In this test, the Low BIAS or AC Dropout signal decays to 0V only because of loss of power to the + 5V REG Bias Supply used in the test set-up. If in doubt, use an external + 5V supply for this test.

To check OVERTEMPERATURE proceed as follows:

- a. Turn off power supply and disconnect line cord.
- b. Wait at least two minutes for input capacitors to discharge .
- c. Remove top cover and inside cover.
- d. Using test set-up, Figure A-13, connect top end of 2K Ω resistor to J3-16.
- e. Turn on power supply.
- f. DVM should read approximately 5VAC.
- g. Turn off power and wait two minutes.
- h. Remove the A4 FET Assembly from the unit.
- i. Turn on power supply. DVM should read between 0 to 0.4Vdc.

Note The FET heatsinks are connected to the primary circuit and hazardous voltage (up to between 300 to 400V) exists between the heatsinks and the heatsink and the chassis. These potentials remain for up to 2 minutes if the power supply is turned off. Do not touch the heatsinks or any components on the heatsink assemblies while the power supply is turned on or for at least two minutes after primary power is removed. Do not place any of the heatsink assemblies on extender boards.

Troubleshooting Remote Shutdown. The following procedures check the Remote Shutdown features of 002 Option. Troubleshooting can be accomplished by using a logic probe and referring to the schematic and the circuit description on page 93. Before attempting to troubleshoot the Remote Shutdown section of the option, check for + 5Vdc internal bias. This voltage must be present for proper operation of these circuits

To check the REMOTE TRIP and REMOTE RESET proceed as follows:

- a. Connect +5V (J3-23) to Control Isolator bias (J3-10).
- b. Turn unit on and short REMOTE TRIP (J3-30) to + 5V common (J3-7) momentarily. Output should go into unregulated condition with output off.
- c. Short REMOTE RESET (J3-29) to + 5V common (J3-7) momentarily and OUTPUT should return to its initial state.

To check REMOTE INHIBIT proceed as follows:

- a. Table A-3. Replacement Connect +5V (J3-23) to control isolator bias (J3-10).
- b. Turn unit on and short REMOTE INHIBIT (J3-31) to + 5V common (J3-7). Output should go to an unregulated output off condition.
- c. Remove short between REMOTE INHIBIT (J3-31) and + 5V common (J3-7) and output should return to its initial state.

Table A-3. Replacement Parts

REF. DESIG.	MODEL NO.	PART NO.	DESCRIPTION
A7	All	5060-2854	Opt. 002 Interface Board
C1,2	All	0180-0230	fxd elect. 1 μ F 20% 50V
C3	All	0180-2825	fxd elect. 22 μ F 50V
C4	All	0160-4835	fxd cer. 0.1 μ F 10% 50V
C5	All	0160-4554	fxd cer. 0.0 μ F 20% 50V
C6	All	0160-4835	fxd cer. 0.1 μ F 10% 50V
C7	All	0160-4554	fxd cer. 0.0 μ F 20% 50V
C8,9	All	0180-0230	fxd elect. 1 μ F 20% 50V
C10	All	0180-2825	fxd elect. 22 μ F 50V
C11	All	0160-4801	fxd cer. 100pf 5% 100V
C12,13	All	0160-5422	fxd cer. 0.047 μ F 20% 50V
C14	All	0160-4801	fxd cer. 100pf 5% 100V
C15	All	0160-5422	fxd cer. 0.047 μ F 20% 50V
C16	All	0160-5422	fxd cer. 0.047 μ F 20% 50V
C17,18	All	0180-0230	fxd elect. 1 μ F 20% 50V
C19	All	0180-2825	fxd elect. 22 μ F 50V
C20-22	All	0160-0128	fxd cer. 2.2 μ F 20% 50V
CR1-4	All	1901-0050	switching 80V 200ma
CR5-10	All	1901-0327	pwr. rect. 300V 40A
CR11-14	All	1901-0033	gen. prp. 180V 200ma
CR15	All	1901-0327	zener 9.09V 10% PD=1.5W
CR16,17	All		NOT USED
CR18,19	All	1901-0050	switching 80V 200ma
CR20	All	1901-0033	gen. prp. 180V 200ma
CR21,22	All	1901-0050	switching 80V 200ma
CR23	All	1901-0033	gen. prp. 180V 200ma
CR24,25	All	1901-0050	switching 80V 200ma
CR26-29	All	1901-0033	gen. prp. 180V 200ma
CR30	All	1901-0327	zener 9.09V 10% PD=1.5W
K1,2	All	0490-1418	relay 250ma 28V,5V -coil 3VA
L1-3	All	9170-1223	core shielding bead
Q1,2	All	1854-0823	NPN SI PD=300mW FT=200MHZ
R1-3	All	0683-2015	fxd. film 200 5% 1/4W
R4	All	0683-3925	fxd. film 3.9K 5% 1/4W
R5	All	0683-2035	fxd. film 20K 5% 1/4W
R6	All	0683-3035	fxd. film 30K 5% 1/4W
R7	All	0683-6225	fxd. film 6.2K 5% 1/4W
R8,9	All	0683-2035	fxd. film 20K 5% 1/4W
R10	All	0683-1035	fxd. film 10K 5% 1/4W
R11	All	0683-5125	fxd. film 5.1K 5% 1/4W
R12	All	0757-0984	fxd. film 10 1% 1/2W
R13	All	0683-1615	fxd. film 160 5% 1/4W
R14	All	0683-4715	fxd. film 410 5% 1/4W
R15,16	All	0683-1235	fxd. film 12K 5% 1/4W
R17	All	0686-1525	fxd. film 1.5K 5% 1/4W
R18	All	0683-1535	fxd. film 15K 5% 1/4W
R19	All	0683-4715	fxd. film 470 5% 1/4W
R20,21	All	0683-1235	fxd. film 12K 5% 1/4W

Table A-3. Replacement Parts

REF. DESIG.	MODEL NO.	PART NO.	DESCRIPTION
R22	All	0686-1525	fxd. film 1.5K 5% 1/4W
R23	All	0683-1535	fxd. film 15K 5% 1/4W
R24	All	0683-4715	fxd. film 470 5% 1/4W
R25,26	All	0683-1235	fxd. film 12K 5% 1/4W
R27	All	0686-1525	fxd. film 1.5K 5% 1/4W
R28	All	0683-1535	fxd. film 15K 5% 1/4W
R29,30	All	0698-4479	fxd. film 14K 1% 1/8W
R31	All	0686-5125	fxd. comp. 5.1K 5% 1/2W
R32	All	0683-5125	fxd. film 5.1K 5% 1/4W
R33	All	0686-5125	fxd. comp. 5.1K 5% 1/4W
R34	All	0683-5125	fxd. film 5.1K 5% 1/4W
R35	All	0757-0986	fxd. film 12.1K 1% 1/2W
R36	All	0757-0269	fxd. film 270 1% 1/8W
R37	All	0683-4715	fxd. film 470 5% 1/4W
R38	All	0683-1035	fxd. film 10K 5% 1/4W
R39	All	0698-6631	fxd. film 2.5K .1% 1/8W
R40	All	0683-4715	fxd. film 470 5% 1/4W
R41	All	0813-0001	fxd. ww. 1K 5% 3W
R42	All	0683-4715	fxd. film 470 5% 1/4W
R43	All	0683-1035	fxd. film 10K 5% 1/4W
R44	All	0698-6631	fxd. film 2.5K .1% 1/8W
R45	All	0683-4715	fxd. film 470 5% 1/4W
R46	All	0813-0001	fxd. ww. 1K 5% 3W
R47	All	0683-1525	fxd. film 1.5K 5% 1/4W
R48	All	0683-3325	fxd. film 3.3K 5% 1/4W
R49	All	0683-2225	fxd. film 2.2K 5% 1/4W
R50,51	All	0683-3355	fxd. film 3.3M 5% 1/4W
R52,53	All	0683-1055	fxd. film 1M 5% 1/4W
R54	All	0757-0441	fxd. film 8.25K 1% 1/8W
R55	All	0757-0986	fxd. film 12.1K 1% 1/2W
R56	All	0757-0269	fxd. film 270 1% 1/8W
R57	All	0698-3226	fxd film 6.49K 1% 1/8W
S1	All	3101-2715	Switch-Slide 2-1A .1A 50V
U1-3	All	1990-0732	Opto-Isolator IF=20mA max.
U4	All	1820-1197	IC NAND gate TTL LS quad
U5	All	1820-1202	IC NAND gate TTL LS
U6	6023A	1826-0393	IC Voltage Reg.
U6	6028A	5060-2942	IC Voltage Reg. heatsink assy.
U7	6023A	1826-0551	IC Voltage Reg.
U7	6028A	5060-2945	IC Voltage Reg. heat sink assy.
U8-10	All	1990-0494	Opto-Isolator IF=20mA max.
U11	All	1820-1491	IC Buffer TTL LS, hex
U12	All	1820-1416	IC Schmitt-Trig. TTL LS, hex
U13	All	1820-1437	IC Multi. Vib. TTL LS
U14	All	1858-0023	Trans. Array 16-pin
U15	6023A	1826-0527	IC Voltage Reg.
U15	6028A	5060-2943	IC Voltage Reg. heatsink assy.
U16	6023A	1826-0277	IC Voltage Reg.
U16	6028A	5060-2950	IC Voltage Reg. heatsink assy.
U17,18	All	1826-0493	IC Op Amp Low-bias-High-Impd.







Table A-3. Replacement Parts





REF. DESIG.	MODEL NO.	PART NO.	DESCRIPTION
U19	6023A	1826-0393	IC Voltage Reg.
U19	6028A	5060-2942	IC Voltage Reg. heatsink assy.
U20	6023A	1826-0607	IC Voltage Reg.
U20	6028A	5060-2946	IC Voltage Reg. heatsink assy.
VR1-8	All	1902-0556	zener 20V 5% PD=1W IR=5 μ A
VR9	All	1902-3185	zener 12.4V 5% PD=.4W
VR10	All	1902-0556	zener 20V 5% PD=1W IR=5 μ A
VR11	All	1902-3256	zener 23.7V 5% PD=.4W
VR12	All	1902-0779	zener 11.8V 5% PD=.4W
VR13	All	1902-3180	zener 11.8V 2% PD=.4W
VR14	All	1902-3110	zener 5.9V 2% PD=.4W
VR15	All	1902-0575	zener 6.5V 2% PD=.4W
VR16	All	1902-0556	zener 20V 5% PD=.4W IR=5 μ A
VR17	All	1902-3256	zener 23.7V 5% PD=.4W
Z1	All	1810-0276	network res. 1.5K x 9
		Mechanical	
	All	06023-00013	plate (ref. A7J3)
A7J3	All	1251-6075	connector 37-pin
	All	1205-0282	heatsink (ref. U6, 7, 15, 16, 19, 20)
W1	All	1258-0189	jumper
W2	All	NOT USED	
W3,4	All	7175-0057	jumper, solid tinned copper
W5,6	All	8120-4356	ribbon cable, 16 cond.
	All	1251-8417	post type header (ref. J1, J2)
	All	0360-1300	solder pin

Definitions

High = more positive
 Low = less positive

Indicator and Qualifier Symbols

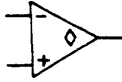
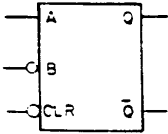
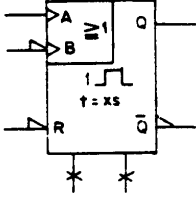
	OR function
	Polarity indicator, shown outside logic symbol. Any marked input or output is active low; any unmarked input or output is active high.
	(Dynamic indicator) Any marked input is edge-triggered, ie, active during transition between states. any unmarked input is level sensitive.
	(Schmitt trigger) indicates that hysteresis exists in device.
	(Non-logic indicator) Any marked input or output does not carry logic information.
	Open-collector or open emitter output
	Monostable (one-shot) multivibrator.
<p>t = xSec</p>	Indicates pulse width usually determined by external RC network.
<p>G</p>	Gate input (a number following G indicates which inputs are gated)
<p>C</p>	Control input (clock)
<p>R</p>	Reset (clear)
<p>S</p>	Set

OLD SYMBOL	NEW SYMBOL	NOTES
		
		Output requires external components to achieve logic state
		A positive-going transition at A or a negative-going transition at B triggers the one-shot. External timing components connect to non-logic inputs.
		Output changes state rapidly regardless of input rate of change.

Logic Symbols and Definitions

SCHEMATIC NOTES

1. ALL RESISTORS ARE IN OHMS, $\pm 5\%$, 1/4W, UNLESS OTHERWISE INDICATED.
2. ALL CAPACITORS ARE IN MICROFARADS, UNLESS OTHERWISE INDICATED.
3. WHITE SILKSCREENED DOTS ON P. C. BOARDS INDICATE ONE OF THE FOLLOWING:
 - A. PIN 1 OF AN I. C. (EXCEPT FOR U18 SEE NOTE 4).
 - B. POSITIVE END OF A POLARIZED CAPACITOR.
 - C. CATHODE OF A DIODE OR THE EMITTER OF A TRANSISTOR.
4. PIN LOCATIONS FOR SEMICONDUCTORS ARE SHOWN BELOW:

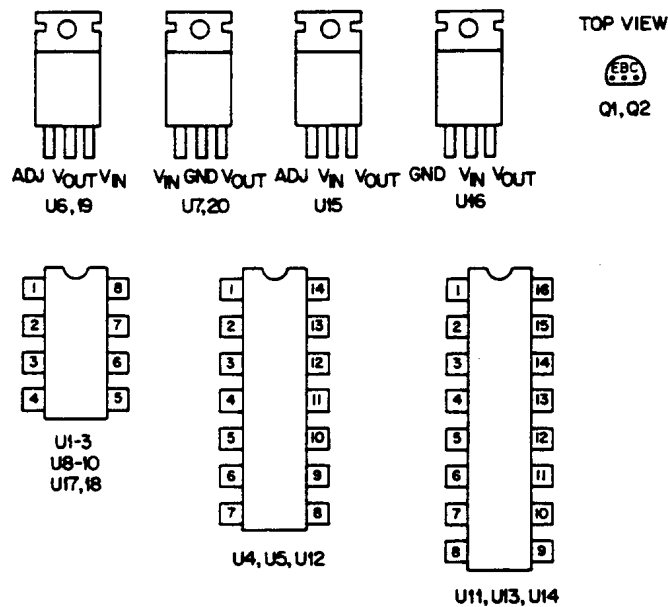

5. ON VOLTAGE REGULATOR DEVICES,
 REF SUPPLY BIAS FOR REGULATORS INTERNAL REFERENCE.
 REF = OUTPUT FROM REGULATORS INTERNAL REFERENCE.
 BOOST OUTPUT = CONTROL FOR EXTERNAL PASS TRANSISTOR
 CS = CURRENT SENSE
 CL = CURRENT LIMIT
 INV = INVERTING INPUT TO REGULATORS ERROR AMPLIFIER
 NI = NON-INVERTING INPUT TO REGULATORS ERROR AMPLIFIER.
 COMP = FREQUENCY COMPENSATION

Schematic Diagram Notes

Schematic Notes

1. W1 in normally open position.
2. W3 & W4 jumpered
3. Relays K1, K2 normally closed
4. S1A and S1B are located at the rear panel

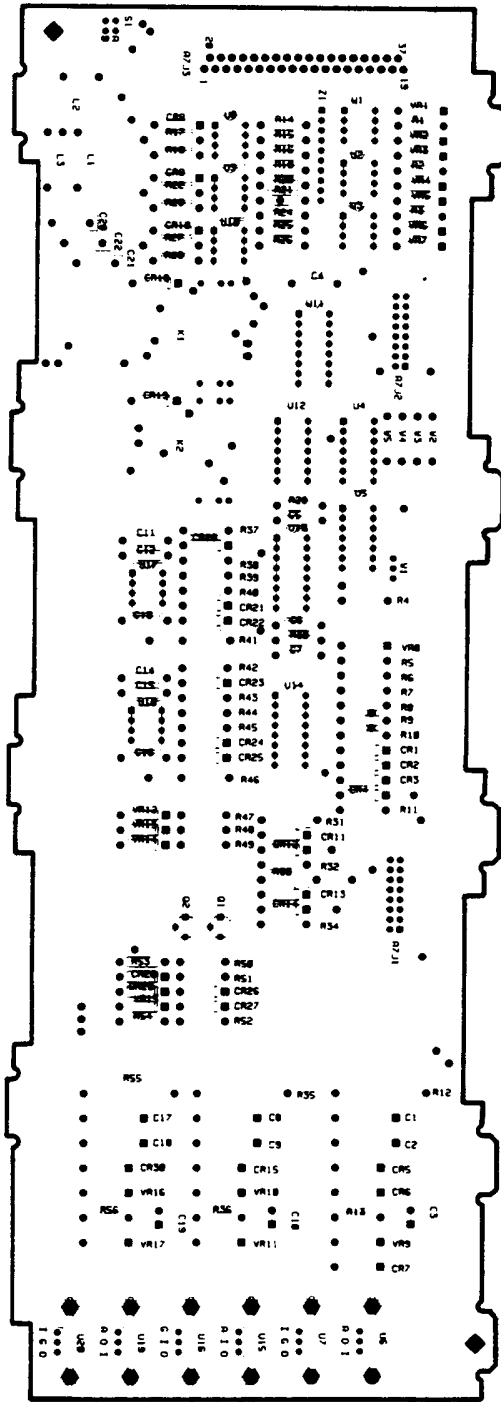

Figure A-15. Option 002 Board, Component Location

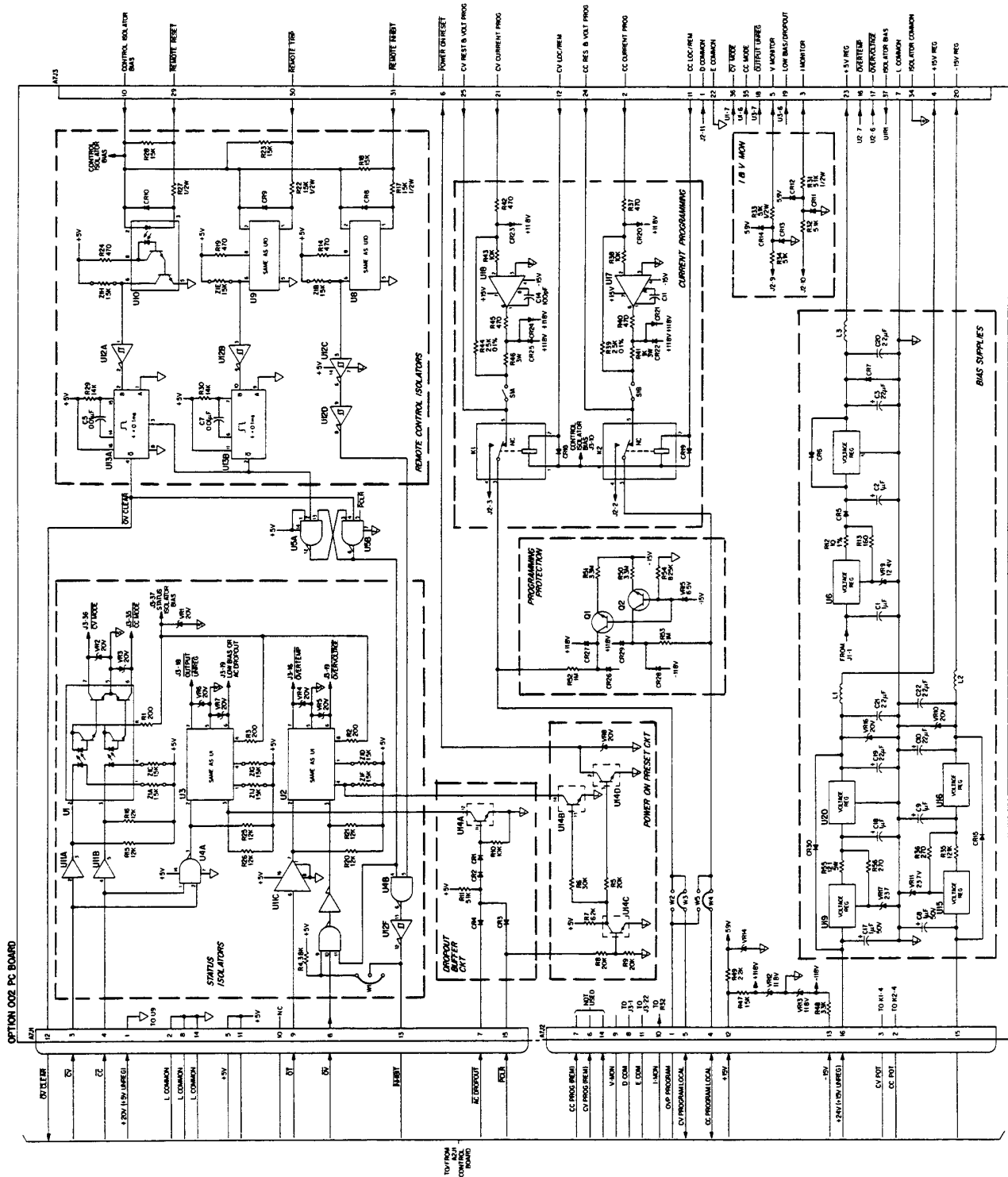

Figure A-16. Option 002 Board, Schematic Diagram

Backdating

Manual backdating describes changes that must be made to this manual for power supplies whose serial numbers are lower than those listed in the title page to this manual.

Look in the following table and located your Agilent Model. Then look at each serial number listed for this group. If the serial number of your power supply is prior to any of the serial number(s) listed, perform the change indicated in the Change column. Note that several changes can apply to your supply. You may also be instructed to update your power supply if certain components are being replaced during repair.

Model 6023A		Change
Serial Numbers		
PREFIX	NUMBER	
3332A	01839-02233	1
3302A	01789-01838	1,2
3215A	01709-01788	1-3
3047A	01559-01708	1-3
2845A	01069-01558	1-4
2704A	00619-01068	1-5
2541A	00364-00618	1-6
2508A	00184-00363	1-7
2428A	00139-00183	1-8
2420A	00124-00136	1-9
2407A	00101-00123	1-10

Model 6028A		Change
Serial Numbers		
PREFIX	NUMBER	
3544A	00101-00165	1

CHANGE 1

All In the parts list for the A4 Power Mesh Board change Q3, Q4 to PFET p/n 1855-0547. Under A4 Power Mesh Board Mechanical change heatsink (Q3, Q4) to p/n 1205-0256. Add hex head standoff (Q3, Q4) p/n 0380-1679.

CHANGE 2

6023A In the parts list for the A1 Main Board Assembly change CR1, 3 to p/n 1901-1087. Change CR2, CR4 to p/n 1901-0759.

CHANGE 3

6023A In the parts list for the A1 Main Board Assembly change C13, C14 to 0.022 μ F 10% 1500V p/n 0160-5933.

CHANGE 4

6023A In the parts list for the A1 Main Board Assembly change T3 bias transformer to p/n 5080-1982. Delete screw p/n 0515-0964, lock washer p/n 2190-0586 and flat washer p/n 3050-0893.

CHANGE 5

6023A	In the parts list for the Chassis Mechanical change the following:		
		FROM	TO
	Cover-top	06023-00020	06023-00002
	Cover bottom	06023-00022	06023-00003
	Trim top	5041-8803	5040-7203
	Trim sides	5001-0540	5001-0440
	Front Frame	5021-8417	5021-5817
	Feet	5041-8801	5040-7201
	Strap Handle Assy	5062-3703	5060-9803
	Strap Retain Rear	5041-8820	5041-6820
	Strap Retain Front	5041-8819	5041-6819

CHANGE 6

6023A In the parts list for the Appendix A delete resistor R57 .49K 1%, 1/8W p/n 0698-3226 and solder pin p/n 0360-1300.

CHANGE 7

6023A In the parts list for the A2 Control Board Assembly delete R152, 1K 1/4W, R155, R158, 0 ohms p/n 8159-0005.

CHANGE 8

6023A	In the parts list for the Chassis Mechanical change the following:		
		FROM	TO
	Retainer Strap Handle	5041-6819	5040-7219
	Retainer Strap Handle	5041-6820	5040-7220
	Chassis	06023-00016	06023-00001
	Rear panel screened	06023-00019	06023-00011
	Front Frame	5021-5817	5020-8817

Delete sub panel, front p/n 06023-00018

CHANGE 9

6023A In the parts list for the A3 Front-Panel Board Assembly change DS1, DS5 to p/n 1990-0681, DS2-DS4, DS6-DS8 to p/n 1990-0050.

CHANGE 10

6023A In the parts list for the Chassis change panel sub from 06023-00014 to 06023-0006, change front-panel from 06023-00015 to 06023-00012.